



Manufactured by:  
Backyard Discovery  
3305 Airport Drive, Pittsburg, KS  
66762 800-856-4445

Basepoint Business Centre: Rivermead Drive, Westlea, Swindon SN5 7EX Phone: 0800-118-2476  
J.P. Coenstraat 7, The Bridge, The Hague, 2595 WP, Netherlands Phone: 08005678990

# CEDAR SPRINGS OUTDOOR BAR

## MODEL # : 2304086



Please visit [www.backyarddiscovery.com](http://www.backyarddiscovery.com)  
For the most up to date assembly manual, to register your product, or to order replacement parts *Para obtener instrucciones en español, visite* [www.backyarddiscovery.com](http://www.backyarddiscovery.com)



EASY STEP-BY-STEP  
3D INTERACTIVE INSTRUCTIONS  
DOWNLOAD THE FREE APP



# OWNER'S MANUAL - BASIC SETUP DIMENSIONS & ASSEMBLY NOTES

It is critically important that you start with square and level footings, concrete pad or deck to attach your structure

- Pay close attention to the items needed for each step. Make sure you are using the correct hardware for each step. Using incorrect hardware may result in improper assembly
- Remember to double check for underground utilities and overhead electrical lines

Post mounts are provided with your structure which allows you to permanently install your structure to a pre-existing or new wood or concrete surface. See Anchor Instructions for further details and recommendations.

- The hardware to attach the post mounts to the structure is included.
- The hardware to mount the structure permanently to a concrete surface is included.
- The hardware to mount the structure permanently to a wood deck is NOT included and will need to be purchased separately. You must ensure there is ample structural support under the deck before permanently attaching.

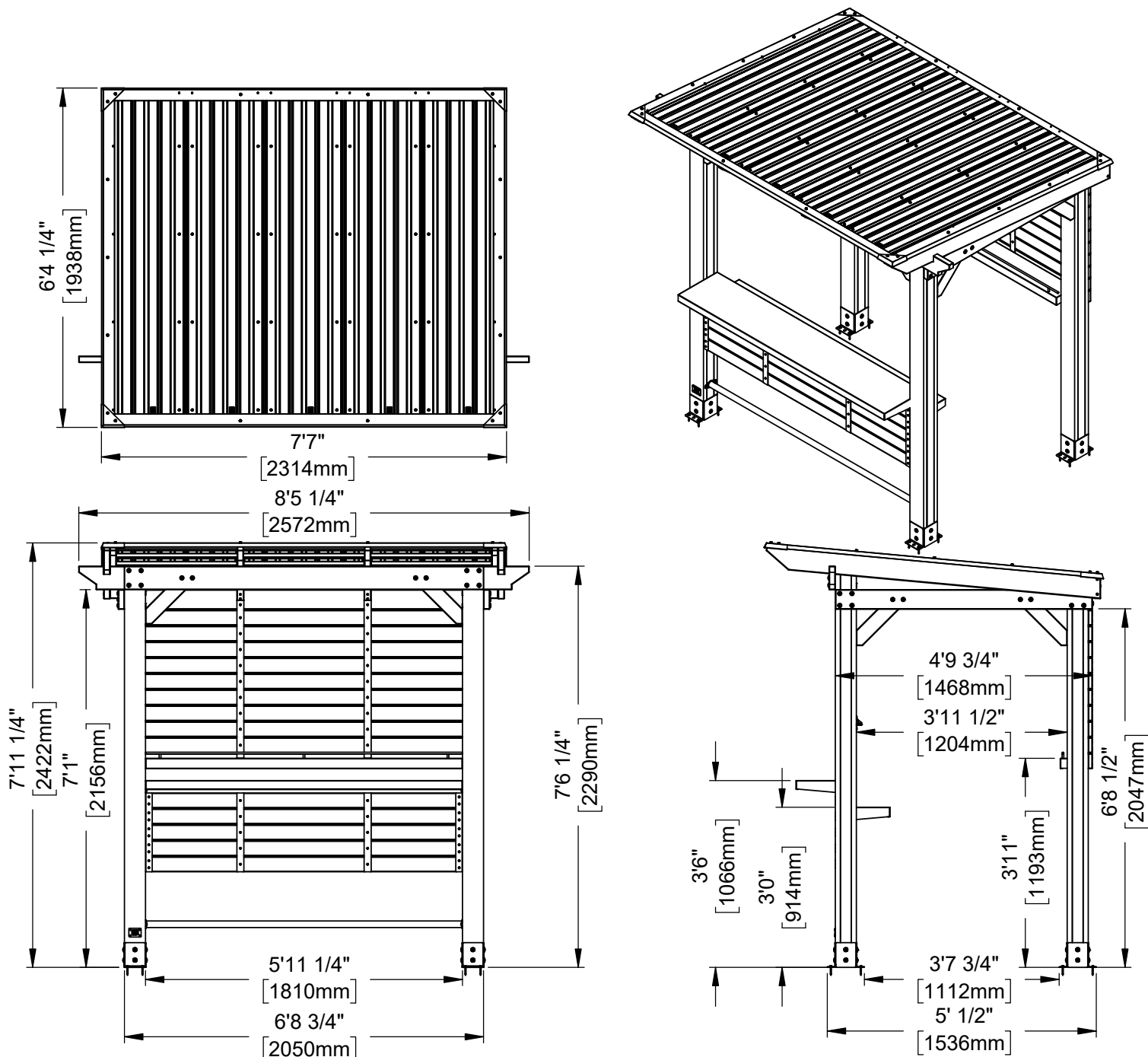

# OWNER'S MANUAL - ANCHORING LAYOUT

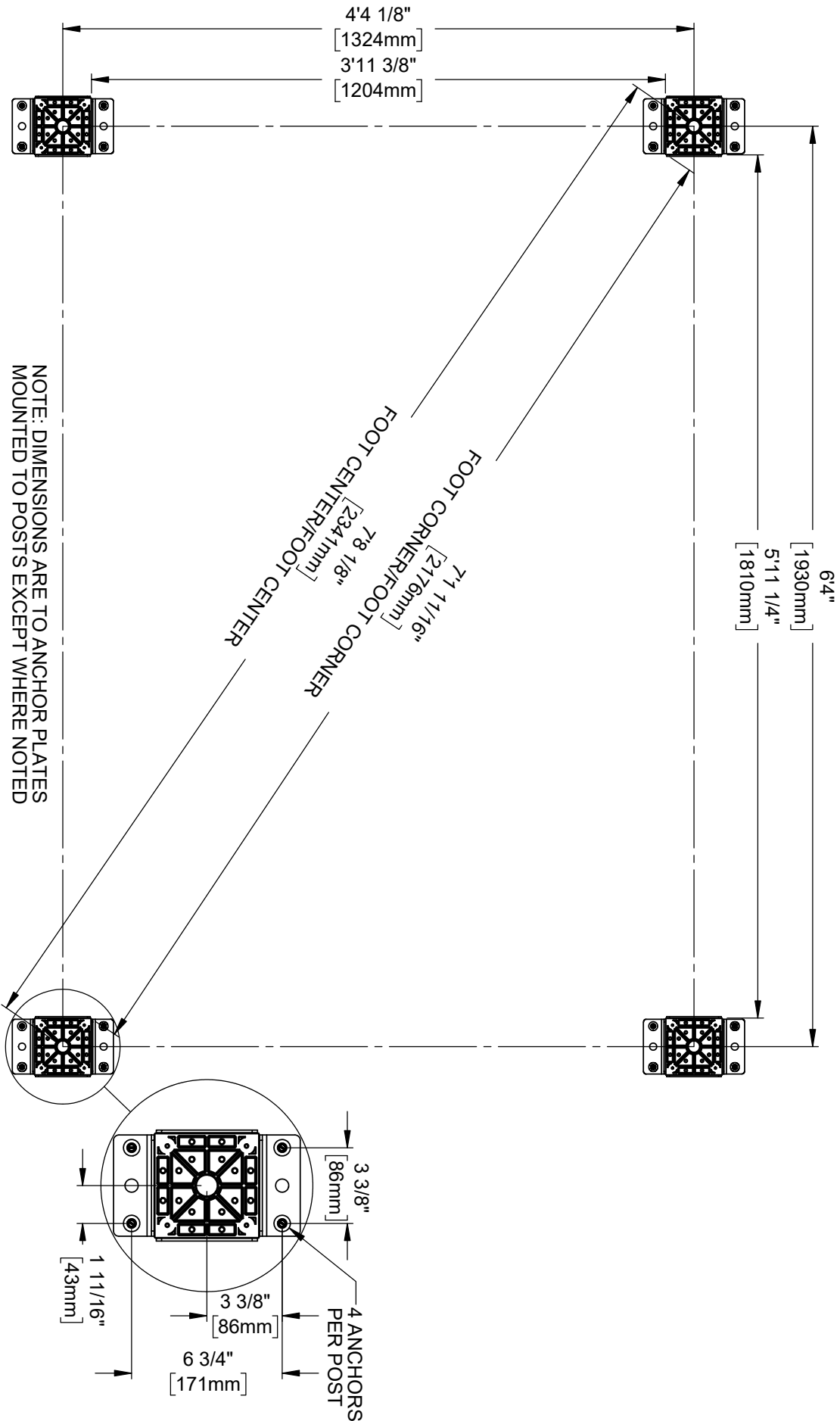

# OWNER'S MANUAL - PARTS IDENTIFICATION

## WOOD COMPONENTS (NOT TO SCALE)

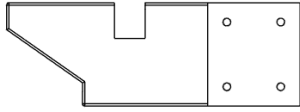

D01 JOIST END - W4L18000  
(x1) 1 7/16"x5 1/4"x15" (36x134x381)

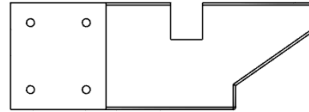

D03 JOIST END - W4L18002  
(x1) 1 7/16"x5 1/4"x15" (36x134x381)



D02 JOIST - W4L18001  
(x1) 1 7/16"x5 1/4"x80 11/16" (36x134x2050)



D04 RAIL - W4L18004  
(x2) 1 7/16"x4 7/16"x57 13/16" (36x112x1468)



D05 BEAM - W4L18005  
(x1) 1 7/16"x5 1/4"x75 13/16" (36x134x1926)



D06 BEAM - W4L18006  
(x1) 1 7/16"x5 1/4"x75 13/16" (36x134x1926)



D07 BEAM - W4L18007  
(x1) 1 7/16"x5 1/4"x87 1/4" (36x134x2216)



E01 CORBEL - W4L18012  
(x5) 1 7/16"x3 3/8"x17" (36x86x432)

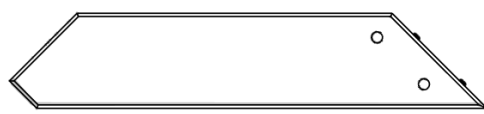

E02 CORBEL WITH TAG - W2A03897  
(x1) 1 7/16"x3 3/8"x17" (36x86x432)



E03 RAFTER - W4L18008  
(x2) 1 7/16"x3 3/8"x74 3/16" (36x86x1884)



# OWNER'S MANUAL - PARTS IDENTIFICATION

## WOOD COMPONENTS (NOT TO SCALE)



F01 RAFTER - W4L18010  
(x2) 1 7/16"x2 3/8"x74 1/8" (36x60x1882)



H01 PURLIN - W4L18009  
(x4) 15/16"x3 3/8"x87 1/16" (24x86x2212)



H02 BACK SLATS - W4L18011  
(x10) 15/16"x3 3/8"x80 1/2" (24x86x2044)



H03 FRONT SLAT - W4L18013  
(x5) 15/16"x3 3/8"x70 11/16" (24x86x1796)



Q01 RAIL - W4L18003  
(x1) 15/16"x4 7/16"x80 11/16" (24x112x2050)



P01 POST - W2A03893  
(x1) 4 3/4"x4 3/4"x89 1/2" (120x120x2274)



P02 POST - W2A03894  
(x1) 4 3/4"x4 3/4"x89 1/2" (120x120x2274)



P03 POST - W2A03895  
(x1) 4 3/4"x4 3/4"x84 1/4" (120x120x2140)



P04 POST - W2A03896  
(x1) 4 3/4"x4 3/4"x84 1/4" (120x120x2140)

# OWNER'S MANUAL - PARTS IDENTIFICATION

## HARDWARE COMPONENTS (NOT TO SCALE)

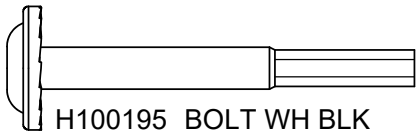

H100195 BOLT WH BLK  
(x12) 5/16x2-3/4

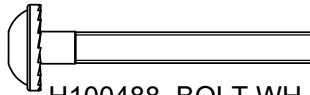

H100488 BOLT WH BLK  
(x4) 1/4x2

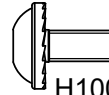

H100401 BOLT WH BLK  
(x3) 1/4x1/2

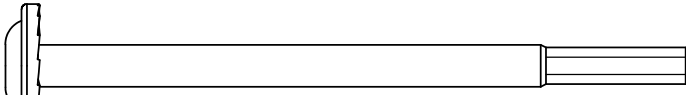

H100480 BOLT WH BLK  
(x8) 5/16x4-3/4



H100653 NUT LOCK BLK  
(x4) 1/4

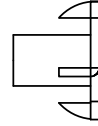

H100379 T-NUT BLK  
(x44) 5/16

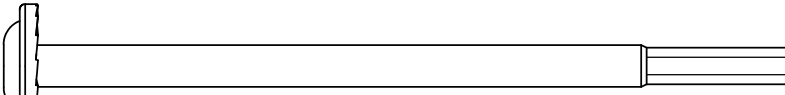

H100964 BOLT WH BLK  
(x8) 5/16x5-1/2

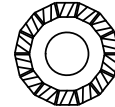

H100198 WASHER LOCK EXT BLK  
(x44) 8x19

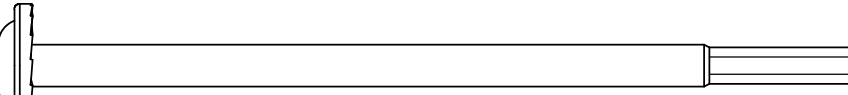

H100363 BOLT WH BLK  
(x24) 5/16x6



H100405 WASHER LOCK EXT BLK  
(x6) 6x15

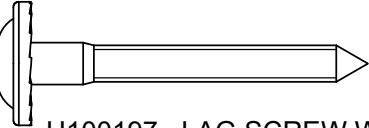

H100197 LAG SCREW WH BLK  
(x24) 5/16x2-1/2



H100471 LAG SCREW WH BLK  
(x16) 5/16x1-1/2

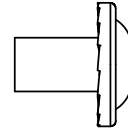

H100469 NUT BARREL WH BLK  
(x8) 5/16x5/8



H100792 LAG SCREW WH BLK  
(x6) 1/4x3



H100200 SCREW PFH BLK  
(x16) 8x1-1/2



H100201 SCREW PFH BLK  
(x6) 8x2-1/2



H100387 SCREW PFH BLK  
(x2) 8x1-1/4



H100382 SCREW PFH BLK  
(x32) 8x1-3/4



H100391 SCREW PFH BLK  
(x40) 8x2



H100392 SCREW PWH BLK  
(x58) 8x3/4



H100823 SCREW PWH BLK  
(x8) 8x1-1/2

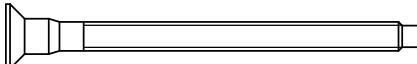

H101008 SCREW CONFIRMAT BLK  
(x8) 7x3

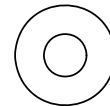

H100630 WASHER FLAT BLK  
(x20) 8x19

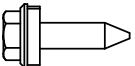

H101117 SCREW WOODGRIP  
(x50) 10x3/4

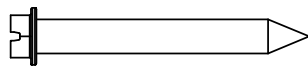

H100120 CONCRETE ANCHOR  
(x16) 1/4x2

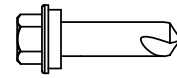

H101116 SCREW TAPPING  
(x18) 1/4 x 1

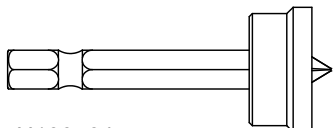

H100764 SCREW SETTER  
(x1)

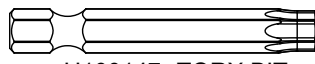

H100147 TORX BIT  
(x1) T-30

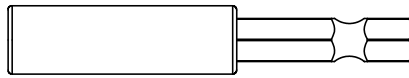

H101100 MAGNETIC DRIVER  
(x1)

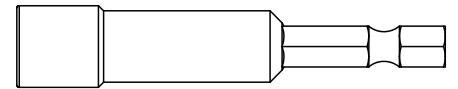

H101106 HEX DRIVER  
(x1) 5/16

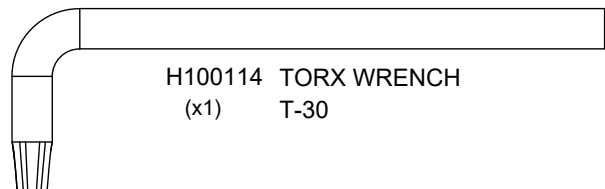

H100114 TORX WRENCH  
(x1) T-30

# OWNER'S MANUAL - PARTS IDENTIFICATION

## ACCESSORY COMPONENTS (NOT TO SCALE)

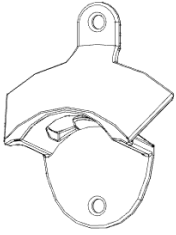

A4M01187 BOTTLE CAP OPENER  
(x1)

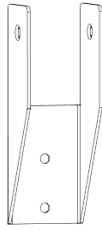

A4M01228 RAFTER CLIP  
(x4)

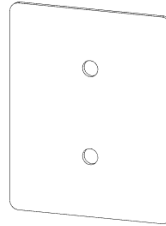

A4M01477 POST PLATE  
(x8)

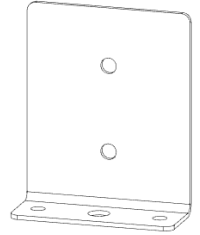

A4M01478 POST ANCHORING PLATE  
(x8)



A4M01485 29GA STEEL SHEETING  
(x5)



A4M01491 ROOF EDGE TRIM  
(x2)

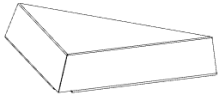

A4M01494 CORNER SPLICE TRIM  
(x4)

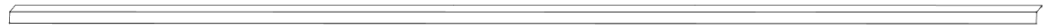

A4M02031 EDGE TRIM  
(x2)

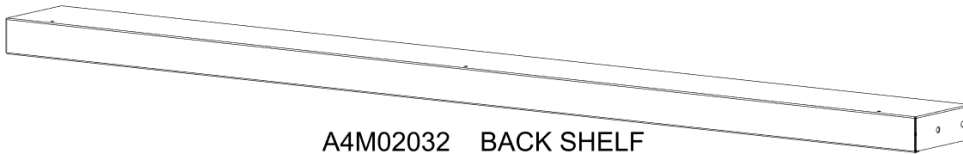

A4M02032 BACK SHELF  
(x1)



A4M02033 SHELF RAIL  
(x1)

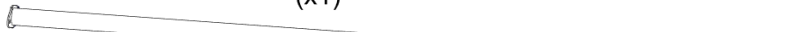

A4M02034 FOOT REST  
(x1)



A4M02035 BACK METAL STRAP  
(x2)

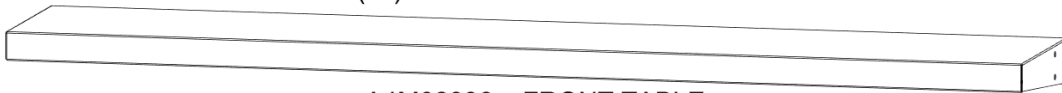

A4M02036 FRONT TABLE  
(x1)



A4M02037 FRONT SHELF  
(x1)



A4M02038 L BRACKET  
(x2)



A4M02040 FRONT METAL STRAP  
(x2)

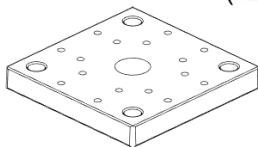

A6P00500 PLASTIC POST FOOT  
(x4)



A4M02158 BYD ID TAG PATIO  
(x1)

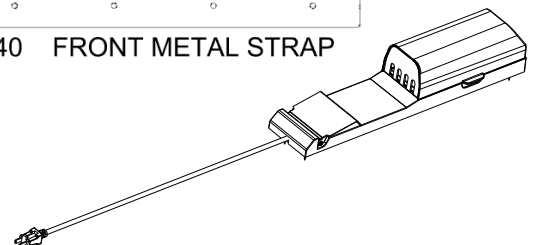

9205413 ELECTRICAL ENCLOSURE  
(x1)

# PRE-ASSEMBLY STEP 1 - SORTING PARTS

It is critical for ease of assembly that you take the time to sort and organize the wood and hardware.

---

## WOOD PARTS:

- Organize wood parts by the three-digit, alpha-numeric number stamped on each board (ex. P01).
- If there are multiple boards with the same stamped number, stack those pieces together.
- Stamps can be found on the flat surface of the boards or on the end of the boards.
- Allow yourself plenty of room - the wood pieces can take up a significant amount of space.

**NOTE: CARTONS ARE NOT ORGANIZED BY BOARD NUMBER.**

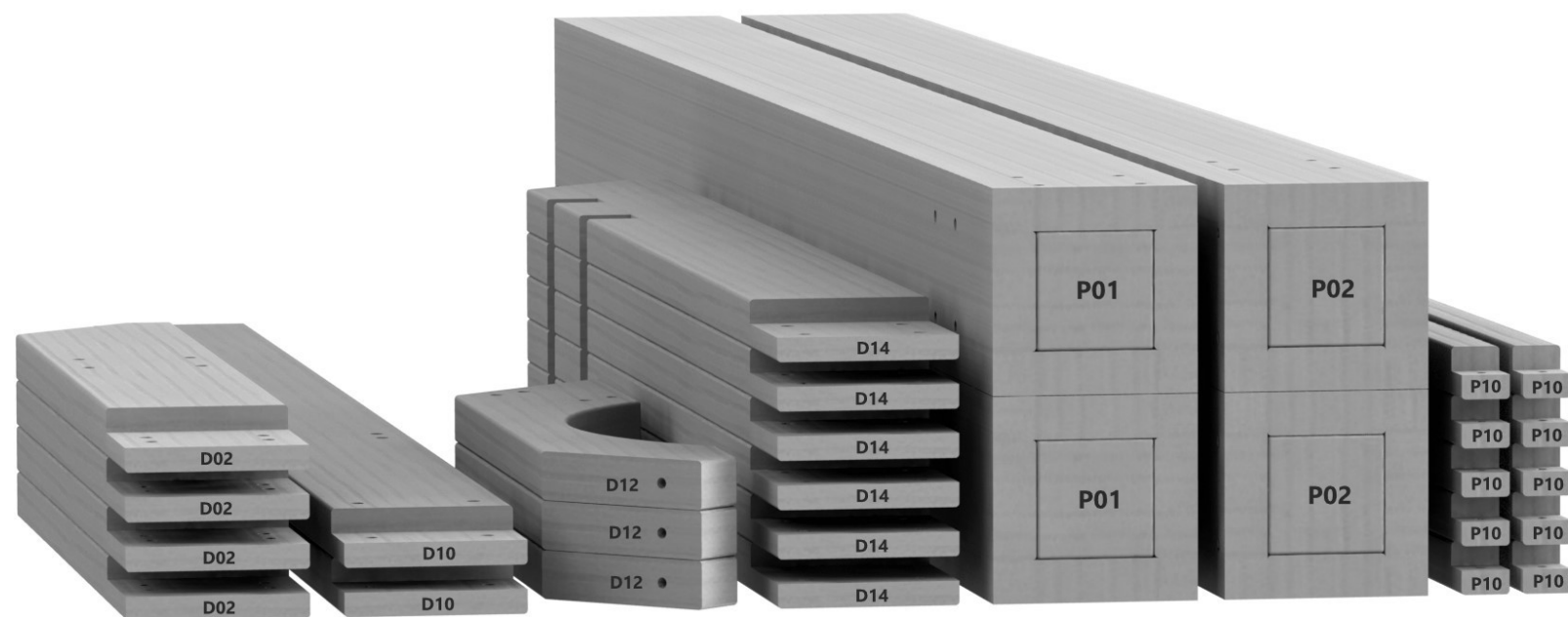

---

## HARDWARE PARTS:

- We recommend that you have a separate table to organize the hardware.
- Hardware bags are printed with a seven-digit, alpha-numeric part number.
- You can organize your hardware by part number or group by hardware type (i.e. bolts, nuts, etc.).
- During assembly you only need to reference the last four digits of the number.

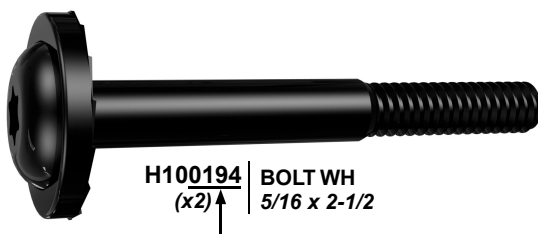

H100194 | BOLT WH  
(x2) ↑ 5/16 x 2-1/2

# PRE-ASSEMBLY STEP 2 - TOOLS REQUIRED



Cordless Drill  
or Electric Drill



Drill  
Attachments:  
Phillips Head

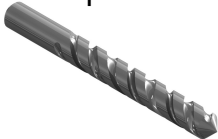

1/8", 3/16", 3/8" &  
7/16" Drill Bits



Phillips Screw Driver

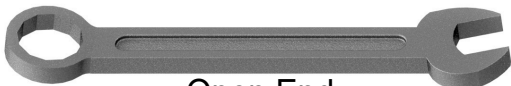

Open End  
Wrenches 1/2" &  
9/16"



3/8" Drive Ratchet, 1/2" &  
7/16" STD Sockets 1/2" & 7/16"  
Deep Sockets



Claw Hammer



Rubber Mallet  
- Optional

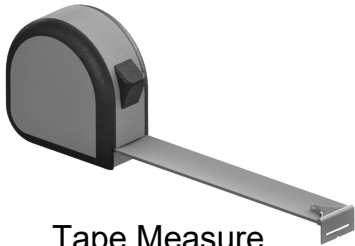

Tape Measure

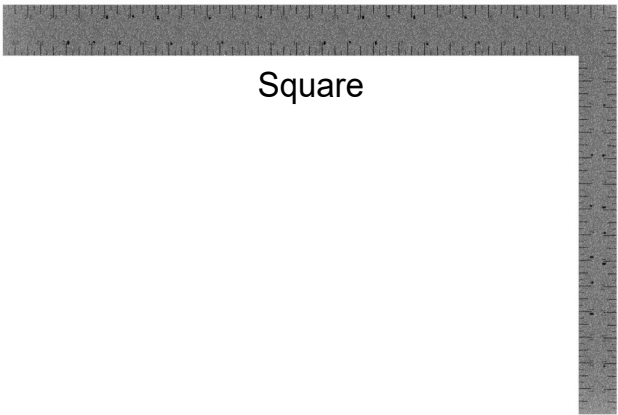

Square



Level 24"

# PRE-ASSEMBLY STEP 3 - CHOOSE YOUR ASSEMBLY METHOD

There are several types of assembly instructions available to you.

1. Printed Assembly Manual included with your set
2. BILT APP - 3D interactive instructions
3. Combination of the Printed Manual and BILT APP (Note: Step numbers can differ between the two methods)



**BILT.**

Scan for easy  
**3D instructions**

Download the BILT app  
before you begin

Download on the  
App Store

GET IT ON  
Google Play

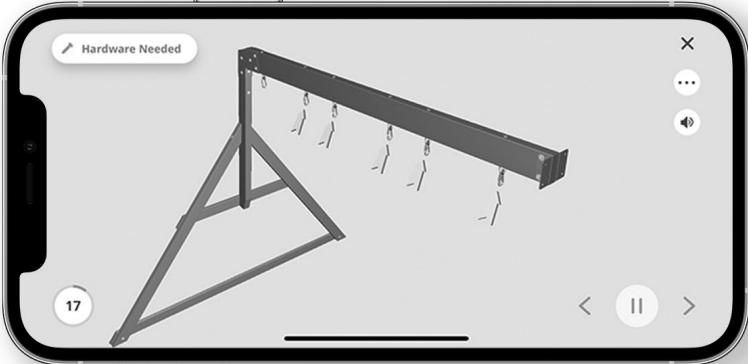

Hardware Needed

17

< || >

The image shows a smartphone screen displaying a 3D assembly instruction. The screen features a 3D model of a metal frame with a horizontal bar and several hanging components. The interface includes a 'Hardware Needed' button at the top left, a close button (X) at the top right, a menu button (three dots) and a volume icon below it, and a page number '17' in a circle at the bottom left. At the bottom center, there are navigation arrows and a pause button.

# STEP 4 - POST ASSEMBLY

QTY	PART NUMBER	DESCRIPTION
16	H100200	SCREW PFH 8x1 1/2 BLK

P01 POST - W2A03893  
(x1) 4 3/4"x4 3/4"x89 1/2" (120x120x2274)

P02 POST - W2A03894  
(x1) 4 3/4"x4 3/4"x89 1/2" (120x120x2274)

P03 POST - W2A03895  
(x1) 4 3/4"x4 3/4"x84 1/4" (120x120x2140)

P04 POST - W2A03896  
(x1) 4 3/4"x4 3/4"x84 1/4" (120x120x2140)

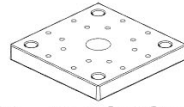

A6P00500 PLASTIC POST FOOT  
(x4)

**REPEAT FOR THE 2 OTHER  
POSTS LABELED P03 AND P04.**

P01 (x1)  
POST

P02 (x1)  
POST

500 (x1)  
PLASTIC POST FOOT

200 (x4)  
SCREW - 1 1/2"

**ALIGN POST FOOT AND DRILL  
1/8" [3mm] PILOT HOLES FOR THE  
ATTACHMENT OF HARDWARE.**

# STEP 5 - GAZEBO ASSEMBLY

QTY	PART NUMBER	DESCRIPTION
8	H100198	WASHER LOCK EXT 8x19
8	H100363	BOLT WH 5/16x6 BLK
8	H100379	T-NUT 5/16 BLK



D04 RAIL - W4L18004  
(x1) 1 7/16"x4 7/16"x57 13/16" (36x112x1468)

**INSERT T-NUTS FIRST**

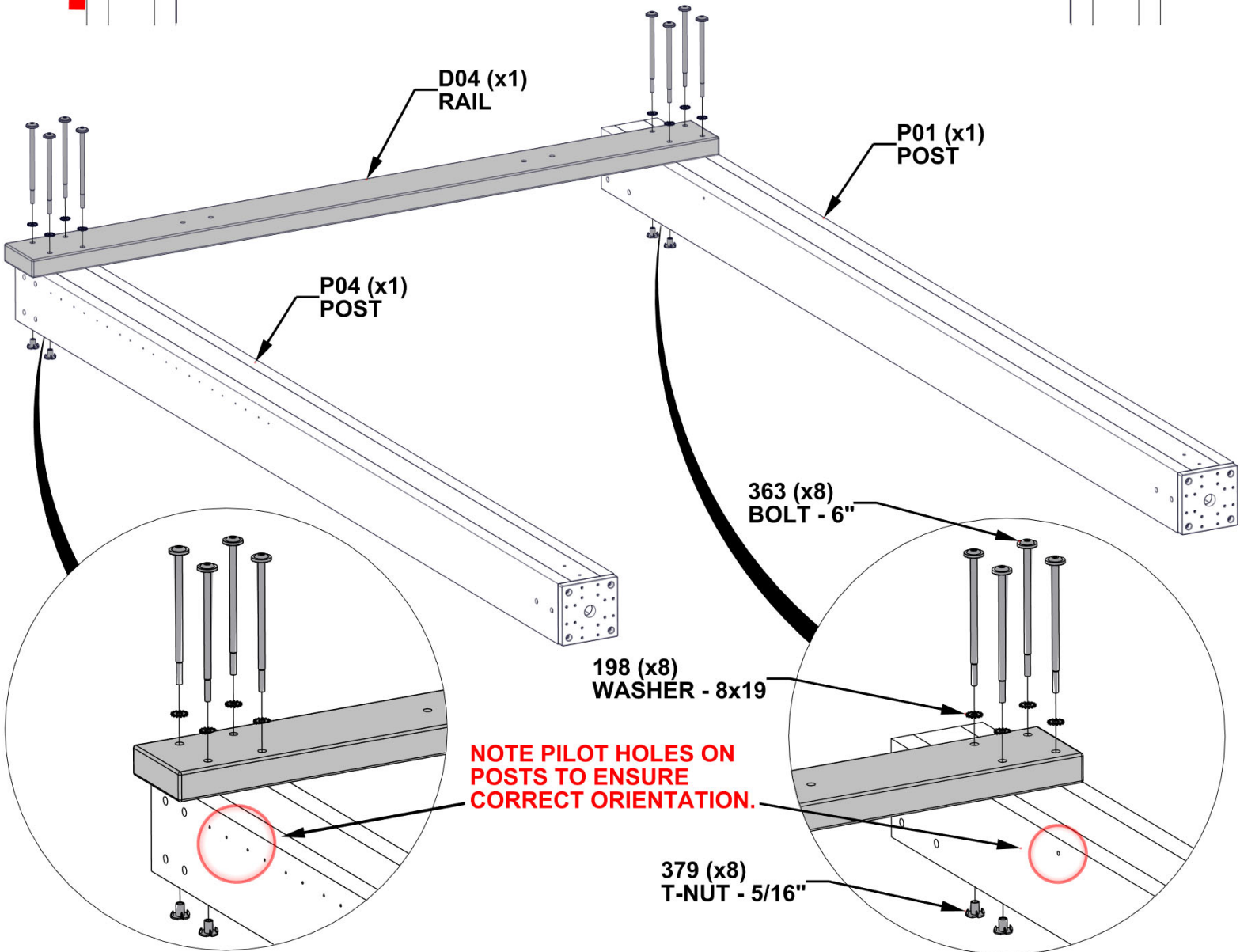
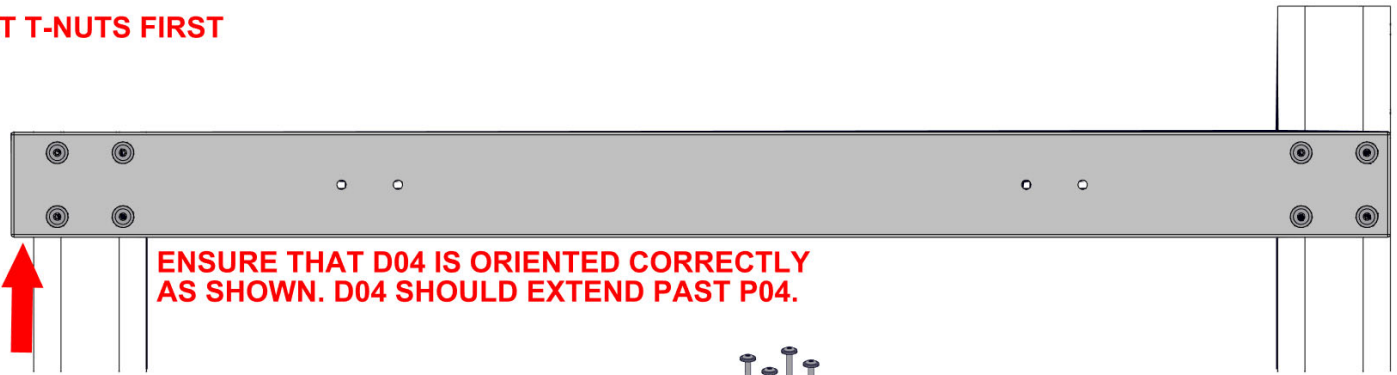



# STEP 6 - GAZEBO ASSEMBLY

QTY	PART NUMBER	DESCRIPTION
8	H100198	WASHER LOCK EXT 8x19
8	H100363	BOLT WH 5/16x6 BLK
8	H100379	T-NUT 5/16 BLK



D04 RAIL - W4L18004  
(x1) 1 7/16"x4 7/16"x57 13/16" (36x112x1468)

## INSERT T-NUTS FIRST

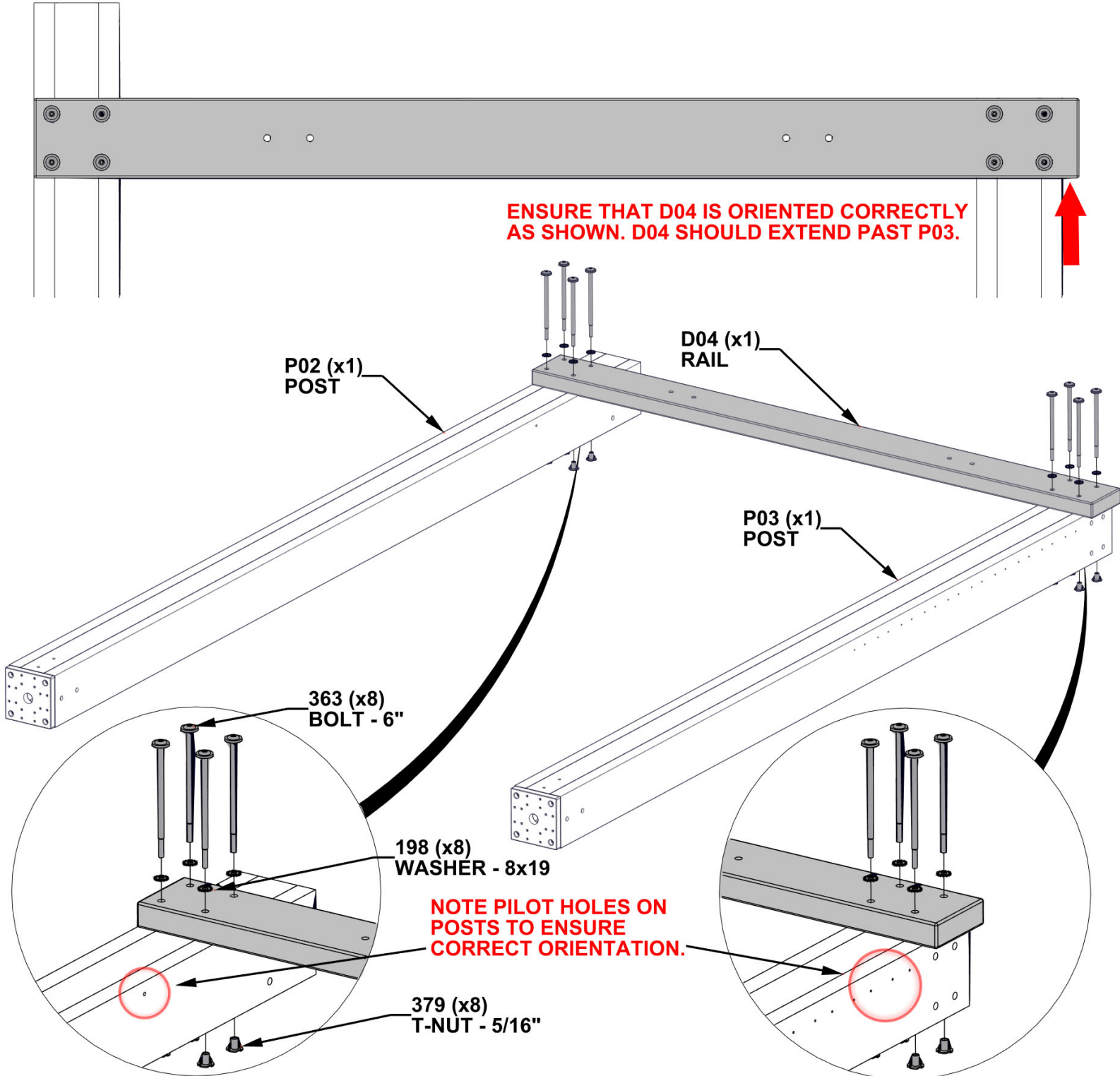

# STEP 7 - GAZEBO ASSEMBLY

QTY	PART NUMBER	DESCRIPTION
8	H100195	BOLT WH 5/16x2 3/4 BLK
8	H100198	WASHER LOCK EXT 8x19
8	H100379	TNUT-5/16" BLK
4	H100405	WASHER LOCK EXT 6x15
4	H100792	LAG SCREW WH 1/4x3 BLK



E01 CORBEL - W4L18012  
(x4) 1 7/16"x3 3/8"x17" (36x86x432)

**INSERT T-NUTS FIRST**

**COMPLETE THIS STEP TWICE FOR EACH SIDE ASSEMBLY.**

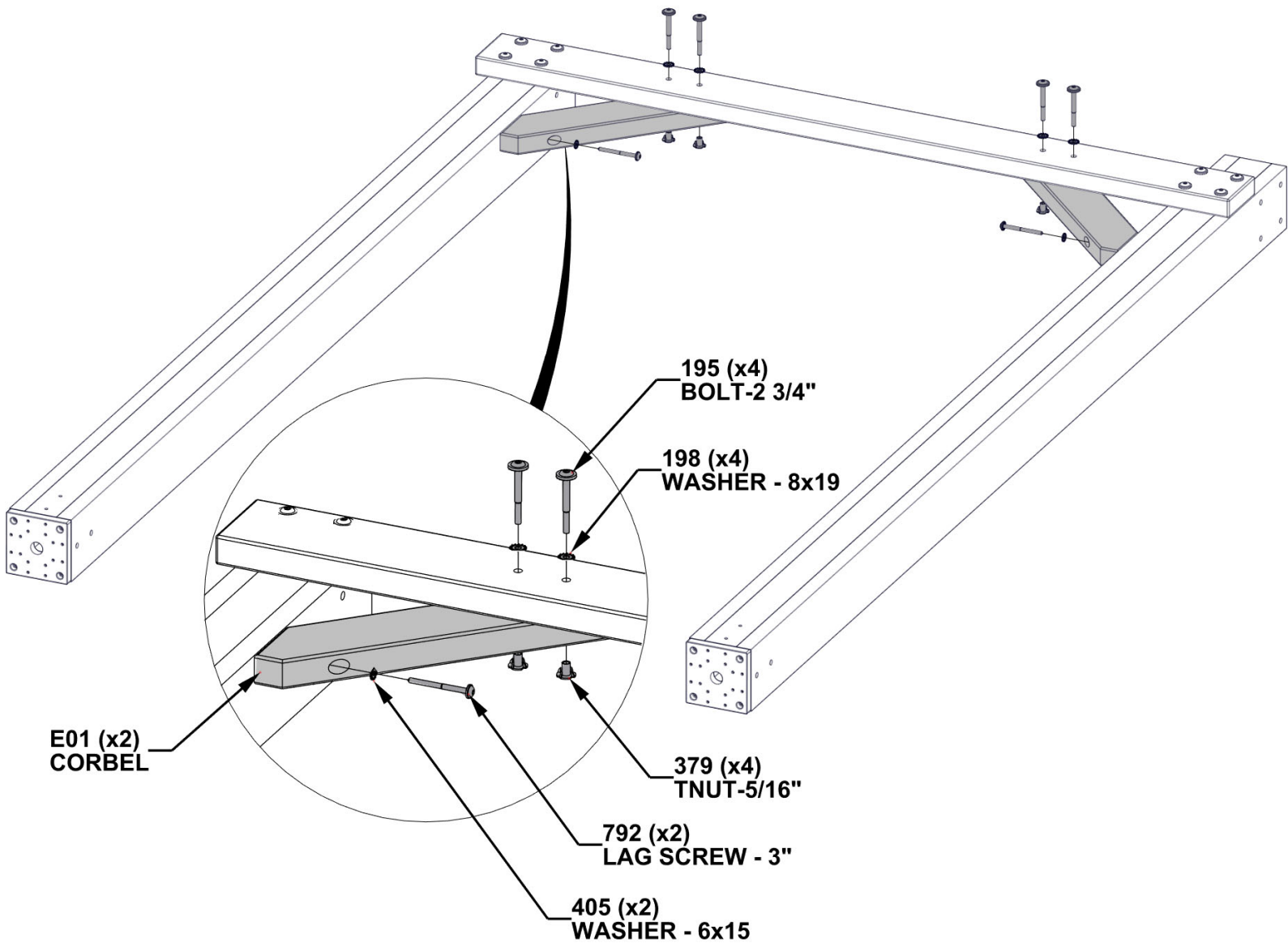

# STEP 8 - GAZEBO ASSEMBLY

QTY	PART NUMBER	DESCRIPTION
8	H100198	WASHER LOCK EXT 8x19
8	H100379	T-NUT 5/16 BLK
8	H100964	BOLT WH 5/16x5 1/2 BLK



Q01 RAIL - W4L18003  
 (x1) 15/16"x4 7/16"x80 11/16" (24x112x2050)

**STAND UP EACH SIDE OF THE GAZEBO AND ATTACH Q01.**

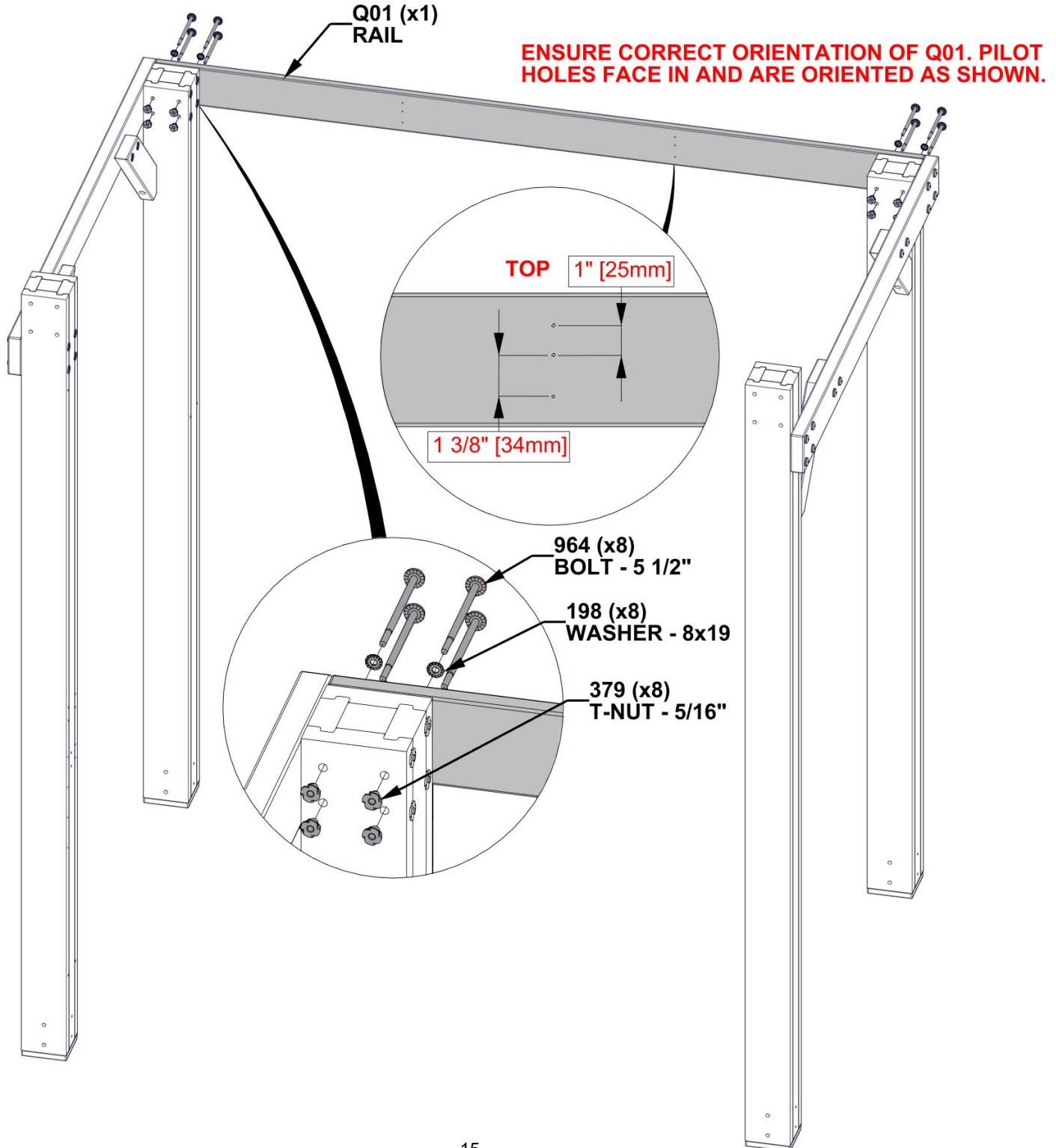

# STEP 9 - GAZEBO ASSEMBLY

QTY	PART NUMBER	DESCRIPTION
8	H100198	WASHER LOCK EXT 8x19
8	H100363	BOLT WH 5/16x6 BLK
8	H100379	T-NUT 5/16 BLK

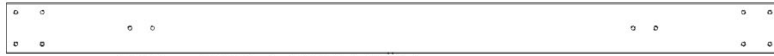

D02 JOIST - W4L18001  
(x1) 1 7/16"x5 1/4"x80 11/16" (36x134x2050)

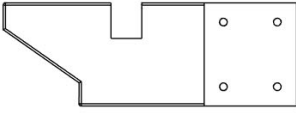

D01 JOIST END - W4L18000  
(x1) 1 7/16"x5 1/4"x15" (36x134x381)

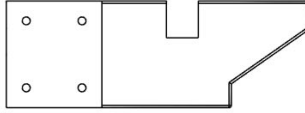

D03 JOIST END - W4L18002  
(x1) 1 7/16"x5 1/4"x15" (36x134x381)

## INSERT T-NUTS FIRST

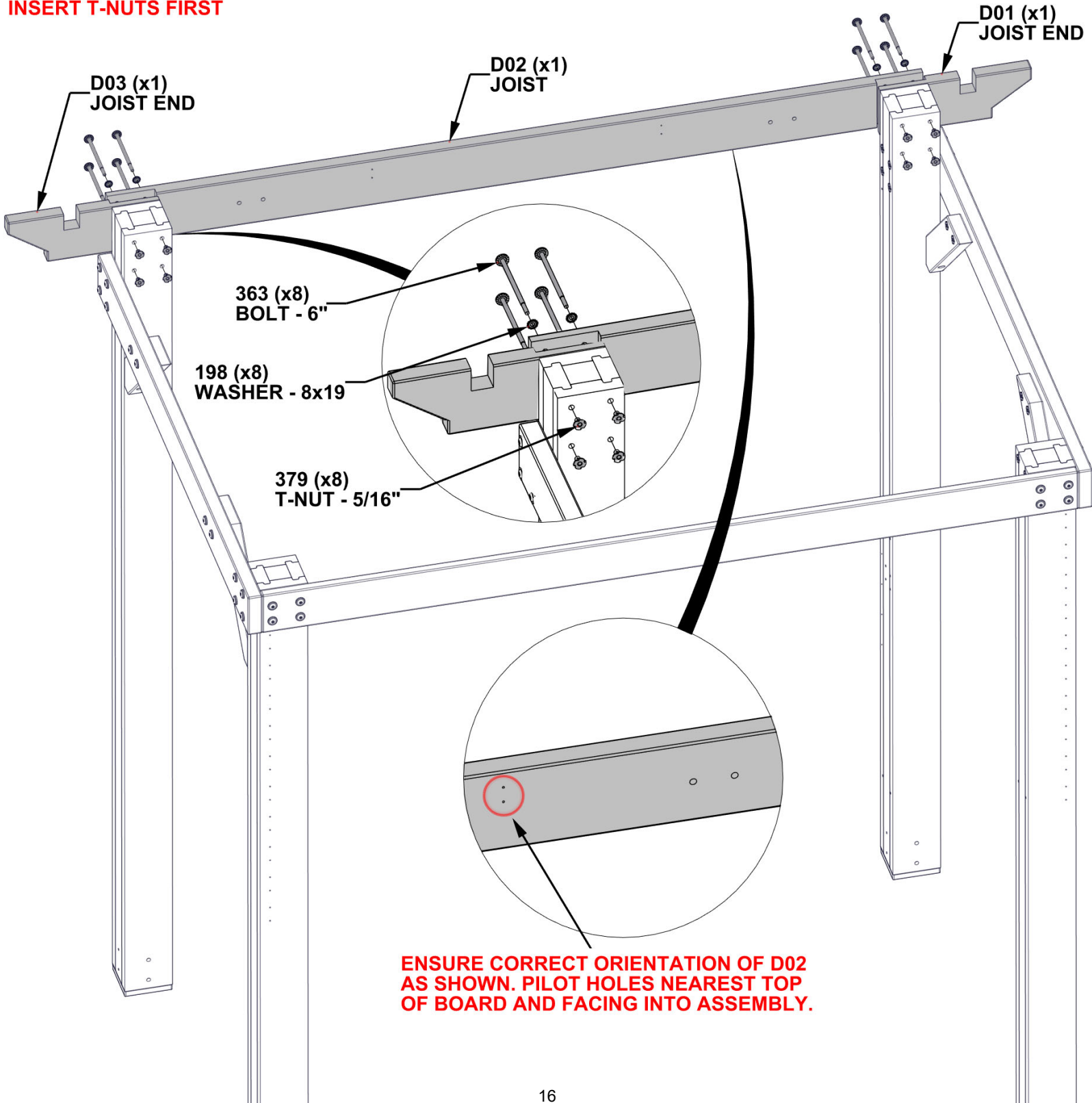



# STEP 10A - GAZEBO ASSEMBLY

QTY	PART NUMBER	DESCRIPTION
4	H100195	BOLT WH 5/16x2 3/4 BLK
4	H100198	WASHER LOCK EXT 8x19
4	H100379	TNUT-5/16" BLK
2	H100405	WASHER LOCK EXT 6x15
2	H100792	LAG SCREW WH 1/4x3 BLK

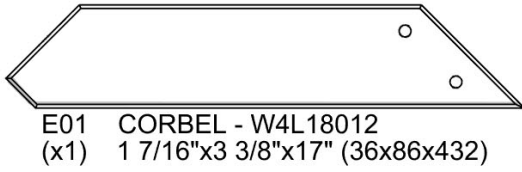
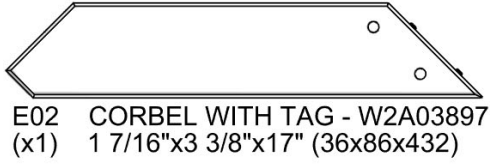

**INSERT T-NUTS FIRST**

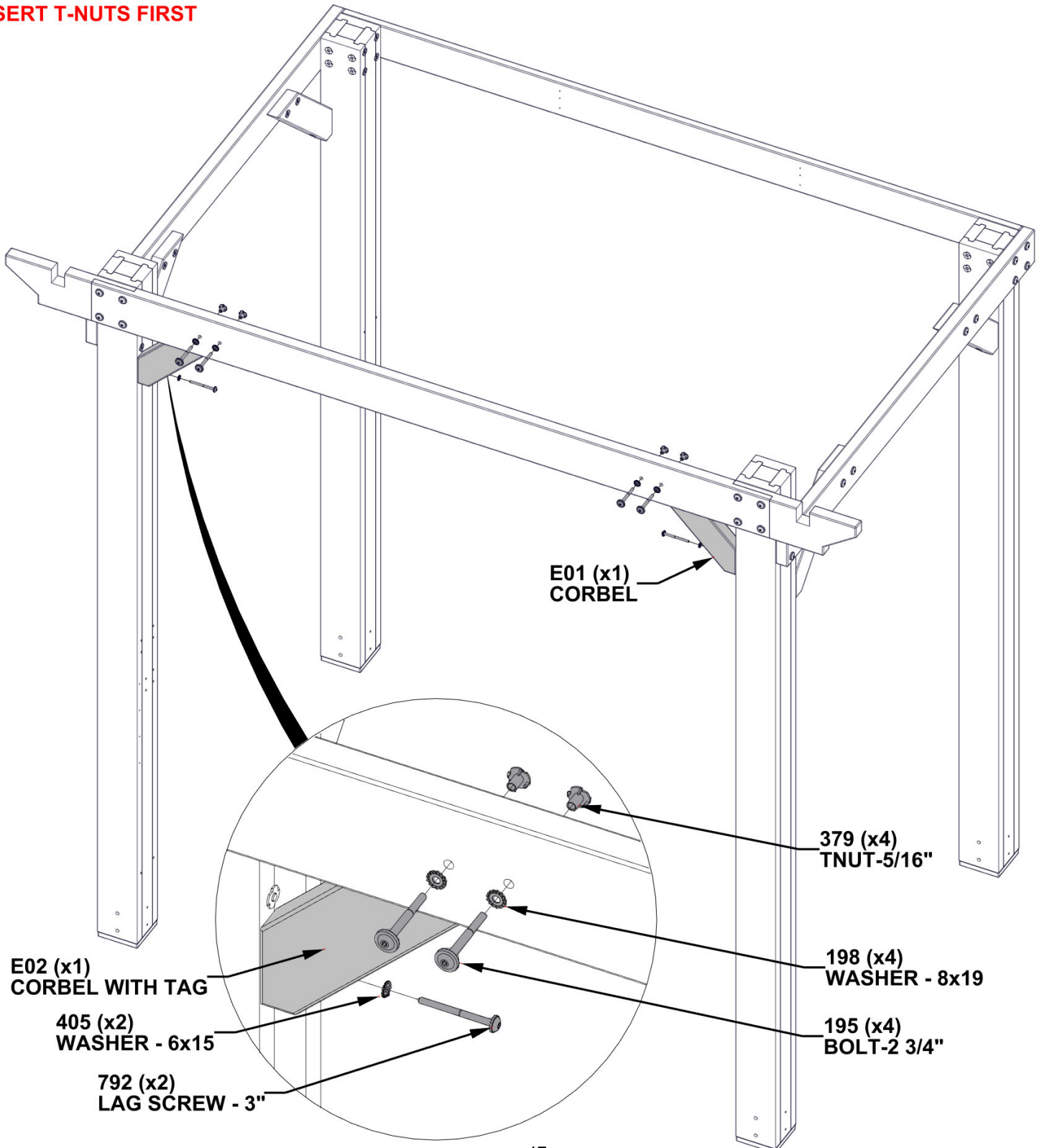

# STEP 10B - GAZEBO ASSEMBLY

ONCE CORBELS ARE ATTACHED, ENSURE THAT THE GAZEBO IS SQUARED. MEASURE FROM CORNER OF POST TO CORNER OF POST. MEASUREMENT SHOULD BE 7' 1 1/2" [2174mm]

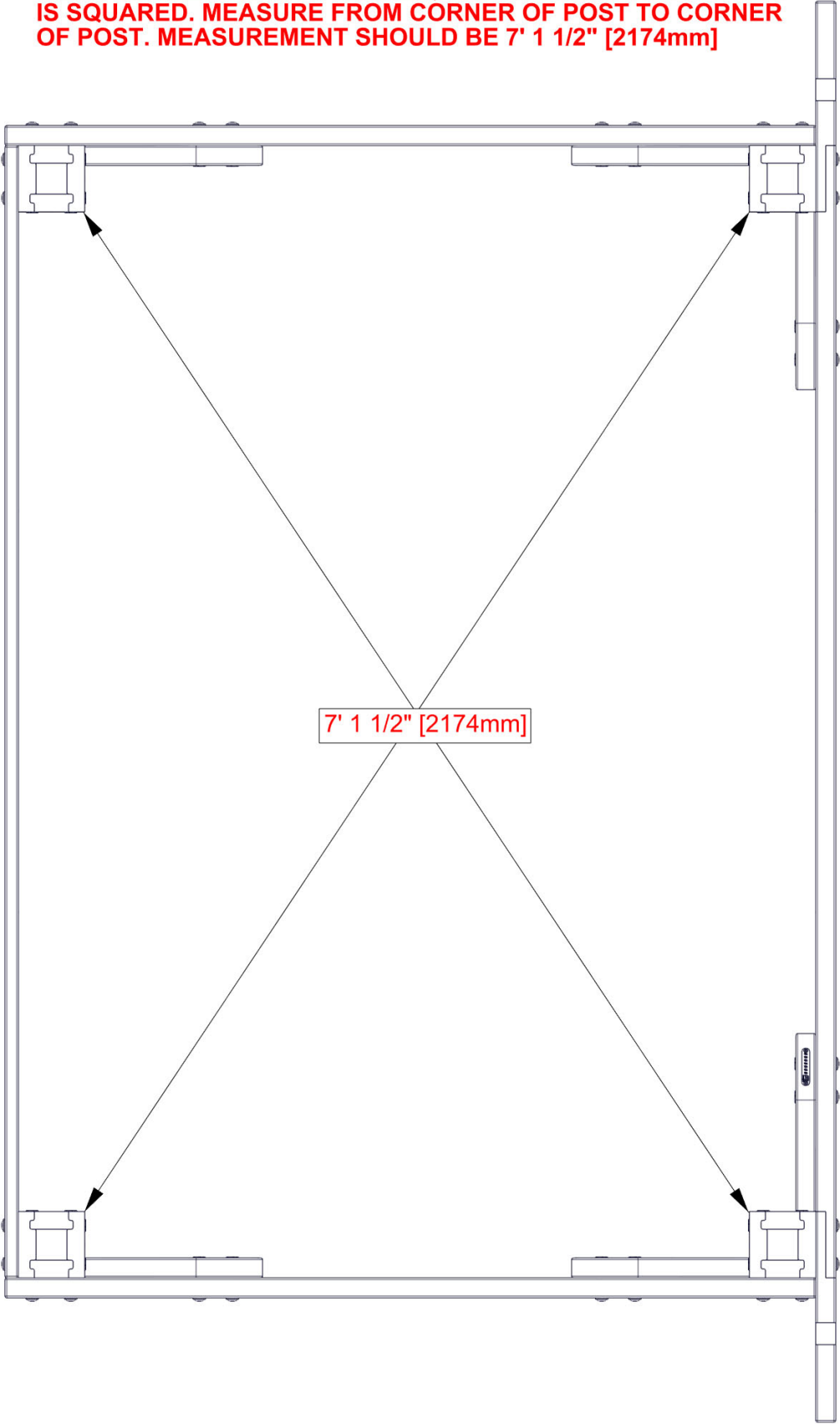

# STEP 11A - GAZEBO ASSEMBLY

QTY	PART NUMBER	DESCRIPTION
3	H100401	BOLT WH 1/4x1/2 BLK

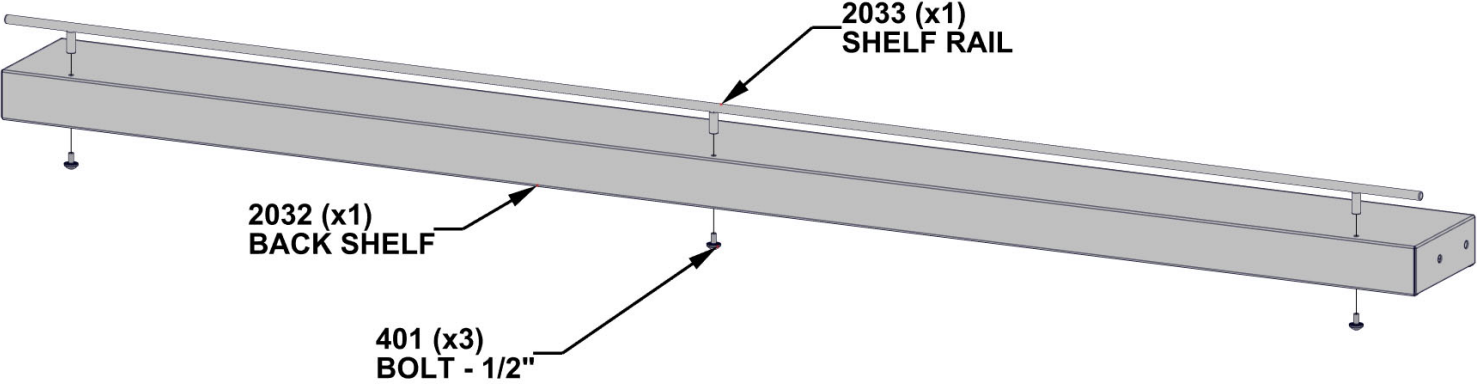
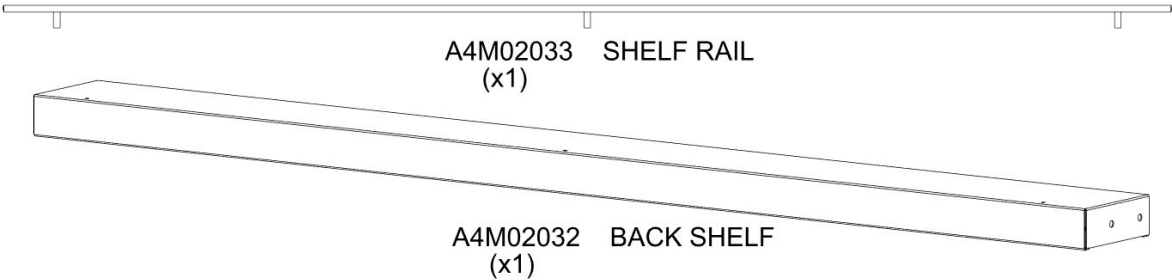

# STEP 11B - GAZEBO ASSEMBLY

QTY	PART NUMBER	DESCRIPTION
4	H100197	LAG SCREW WH 5/16x2 1/2 BLK

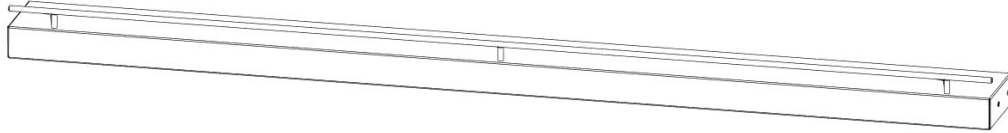

BACK SHELF ASSEMBLY - FROM PREVIOUS STEP

**SHELF ASSEMBLY IS ORIENTED WITH SHELF RAIL TOWARD INSIDE OF GAZEBO.**

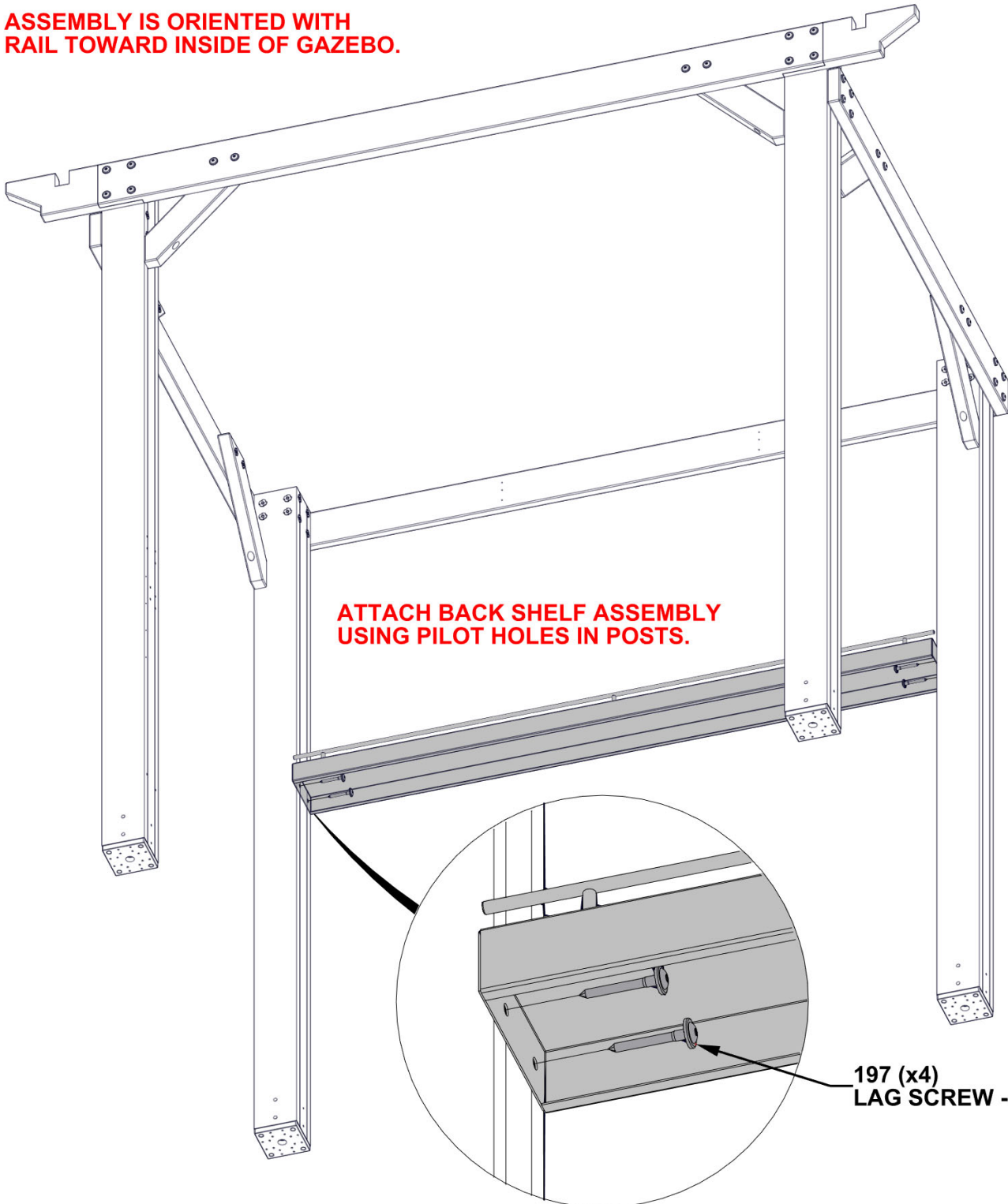

**ATTACH BACK SHELF ASSEMBLY USING PILOT HOLES IN POSTS.**

**197 (x4)  
LAG SCREW - 2 1/2"**



# STEP 12 - GAZEBO ASSEMBLY

QTY	PART NUMBER	DESCRIPTION
8	H100823	SCREW PWH 8x1 1/2 BLK

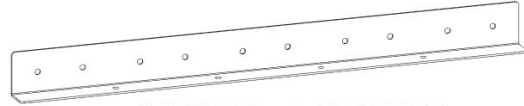

A4M02038 L BRACKET  
(x2)

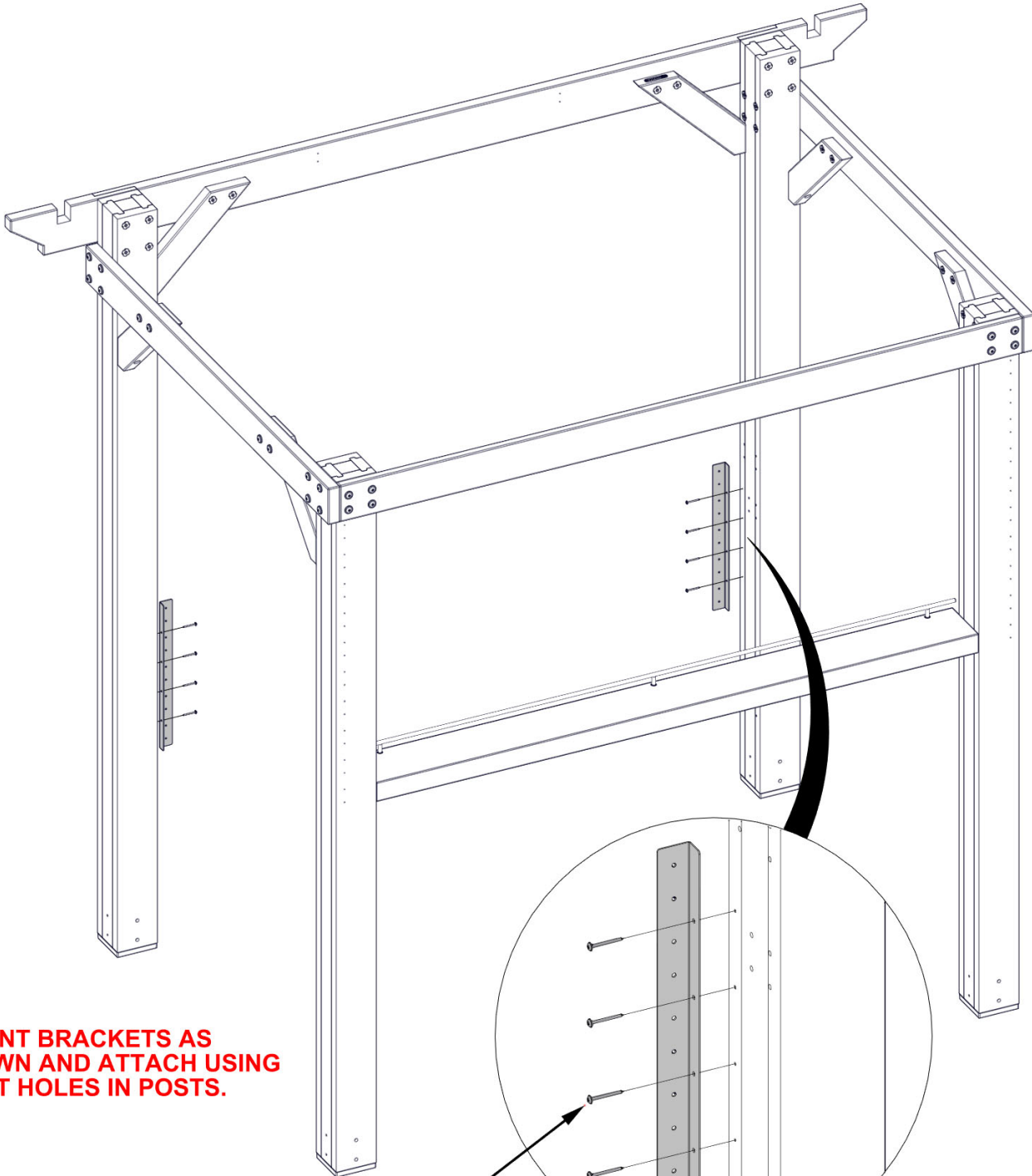

**ORIENT BRACKETS AS SHOWN AND ATTACH USING PILOT HOLES IN POSTS.**

823 (x8)  
SCREW - 1 1/2"

2038 (x2)  
L BRACKET

# STEP 13 - GAZEBO ASSEMBLY

QTY	PART NUMBER	DESCRIPTION
20	H100197	LAG SCREW WH 5/16x2 1/2 BLK

A4M02036 FRONT TABLE  
(x1)

A4M02037 FRONT SHELF  
(x1)

A4M02034 FOOT REST  
(x1)

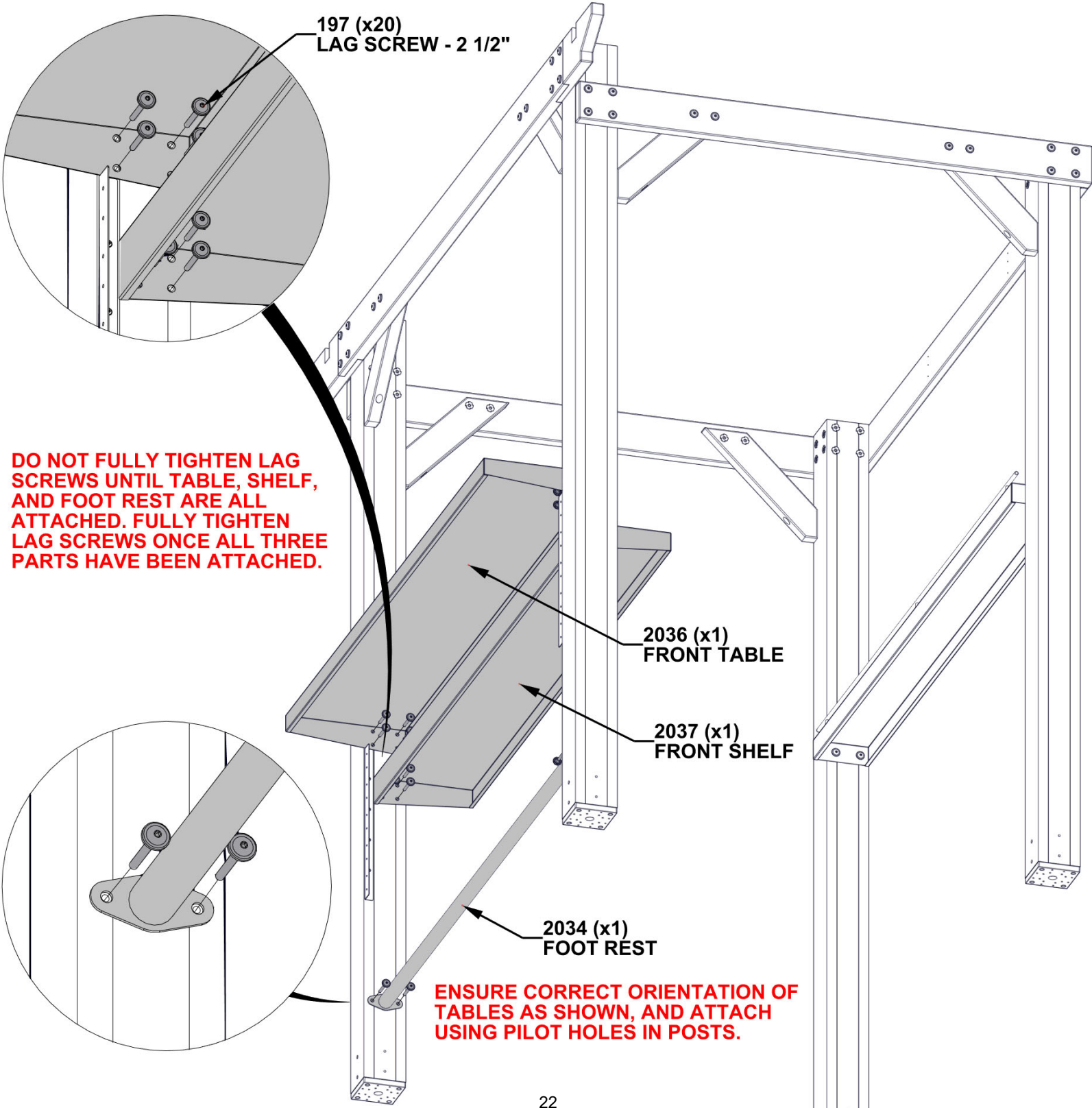

# STEP 14 - GAZEBO ASSEMBLY

QTY	PART NUMBER	DESCRIPTION
20	H100392	SCREW PWH 8x3/4 BLK



H03 FRONT SLAT - W4L18013  
(x5) 15/16"x3 3/8"x70 11/16" (24x86x1796)

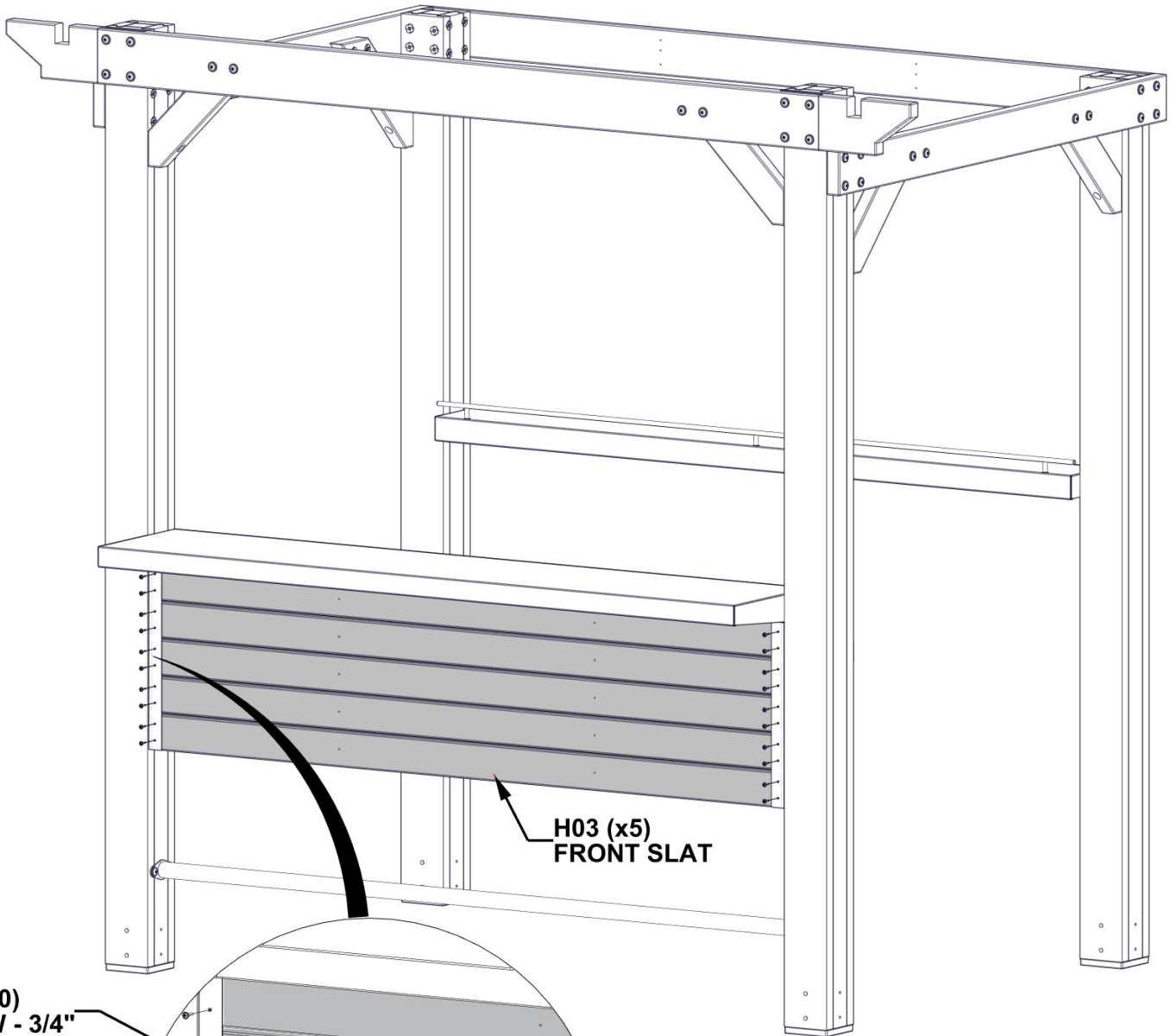

392 (x20)  
SCREW - 3/4"

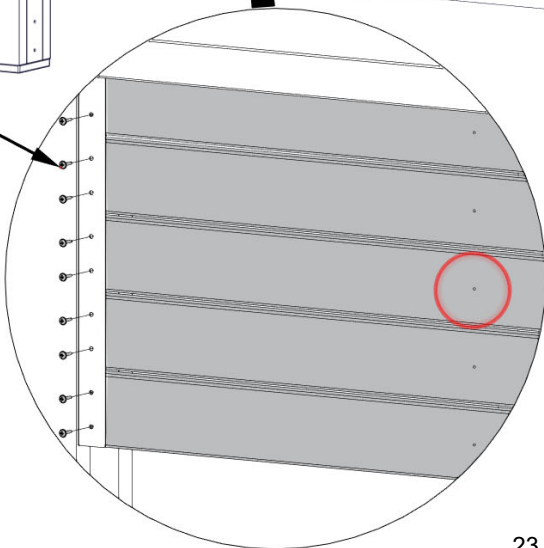

**ATTACH H03 BOARDS TO L BRACKETS. THE TOP TWO MUST BE SLID UP IN BETWEEN BRACKET AND TABLE. ENSURE PILOT HOLES ARE FACING OUT.**

# STEP 15 - GAZEBO ASSEMBLY

QTY	PART NUMBER	DESCRIPTION
40	H100391	SCREW PFH 8x2 BLK



H02 BACK SLATS - W4L18011  
(x10) 15/16"x3 3/8"x80 1/2" (24x86x2044)



**MIDDLE PILOT HOLES IN H02 BOARDS FACE IN.**

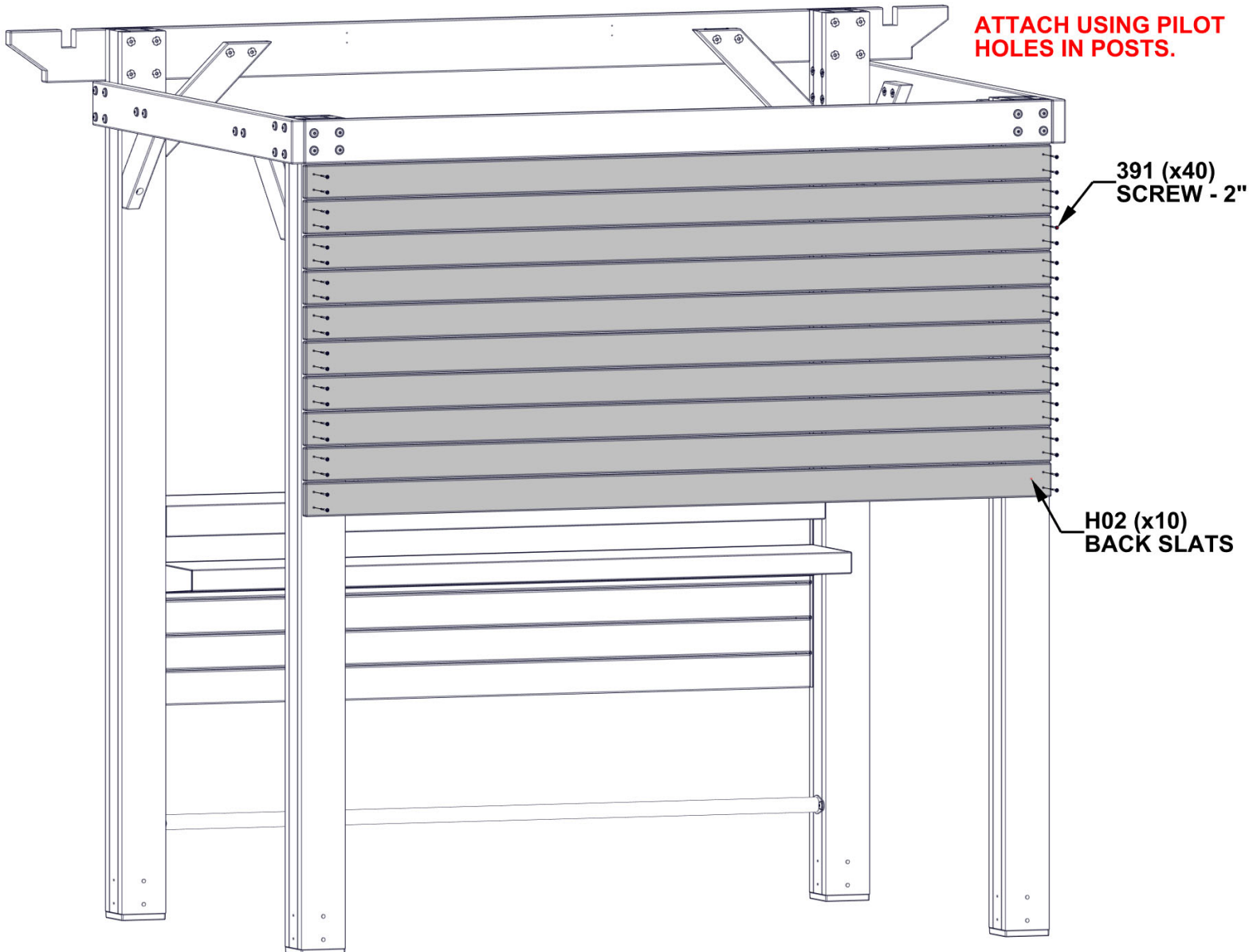



# STEP 16 - GAZEBO ASSEMBLY

QTY	PART NUMBER	DESCRIPTION
30	H100392	SCREW PWH 8x3/4 BLK



A4M02035 BACK METAL STRAP  
(x2)



A4M02040 FRONT METAL STRAP  
(x2)

**ENSURE CORRECT ORIENTATION OF BACK METAL STRAP. HOLE IS CLOSER TO EDGE AT TOP.**

**TOP**

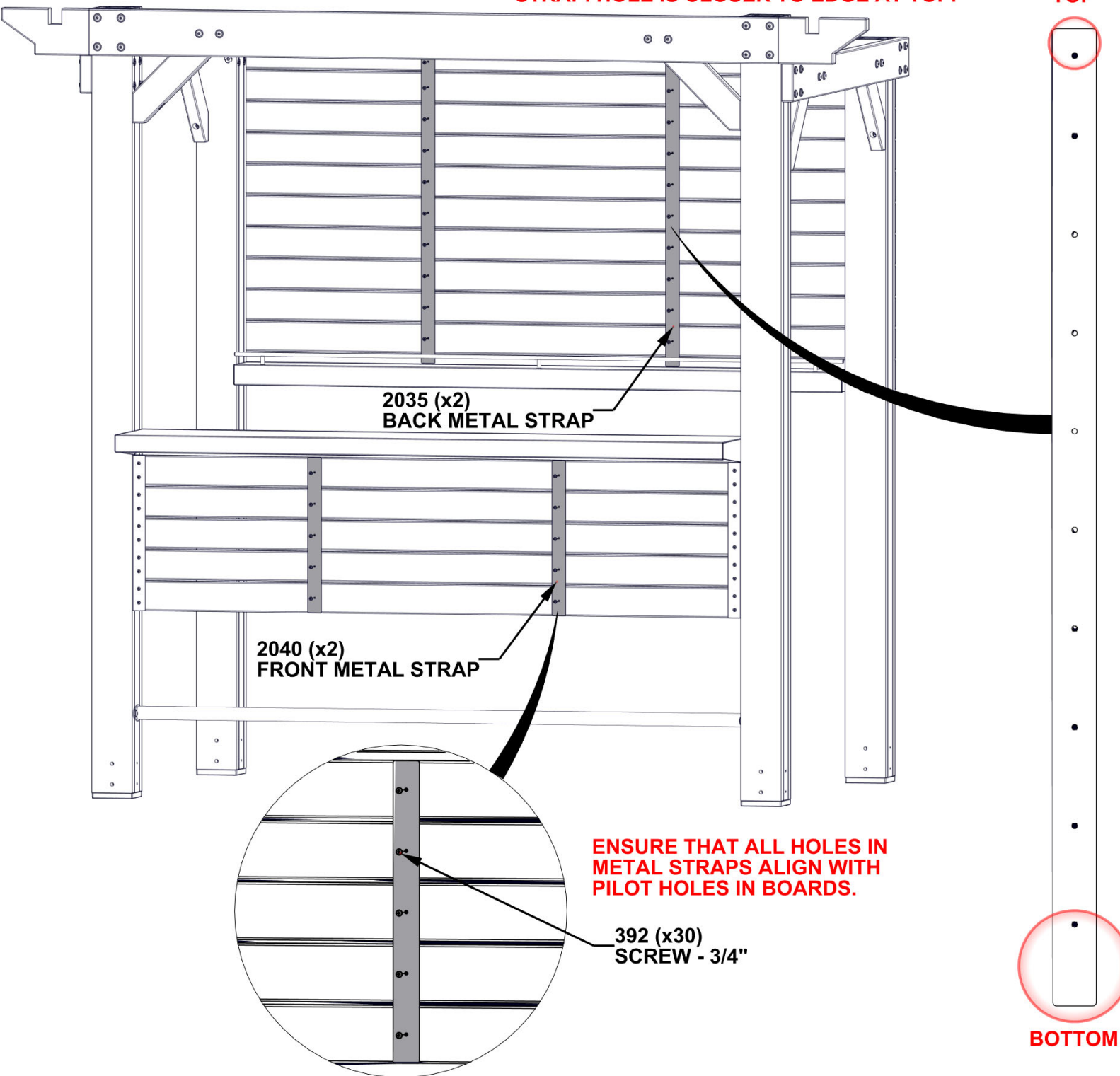

2035 (x2)  
BACK METAL STRAP

2040 (x2)  
FRONT METAL STRAP

**ENSURE THAT ALL HOLES IN METAL STRAPS ALIGN WITH PILOT HOLES IN BOARDS.**

392 (x30)  
SCREW - 3/4"

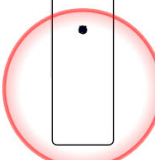

**BOTTOM**

# STEP 17 - ROOF ASSEMBLY

QTY	PART NUMBER	DESCRIPTION
6	H100201	SCREW PFH 8x2 1/2 BLK



D05 BEAM - W4L18005  
(x1) 1 7/16"x5 1/4"x75 13/16" (36x134x1926)



D06 BEAM - W4L18006  
(x1) 1 7/16"x5 1/4"x75 13/16" (36x134x1926)



F01 RAFTER - W4L18010  
(x2) 1 7/16"x2 3/8"x74 1/8" (36x60x1882)

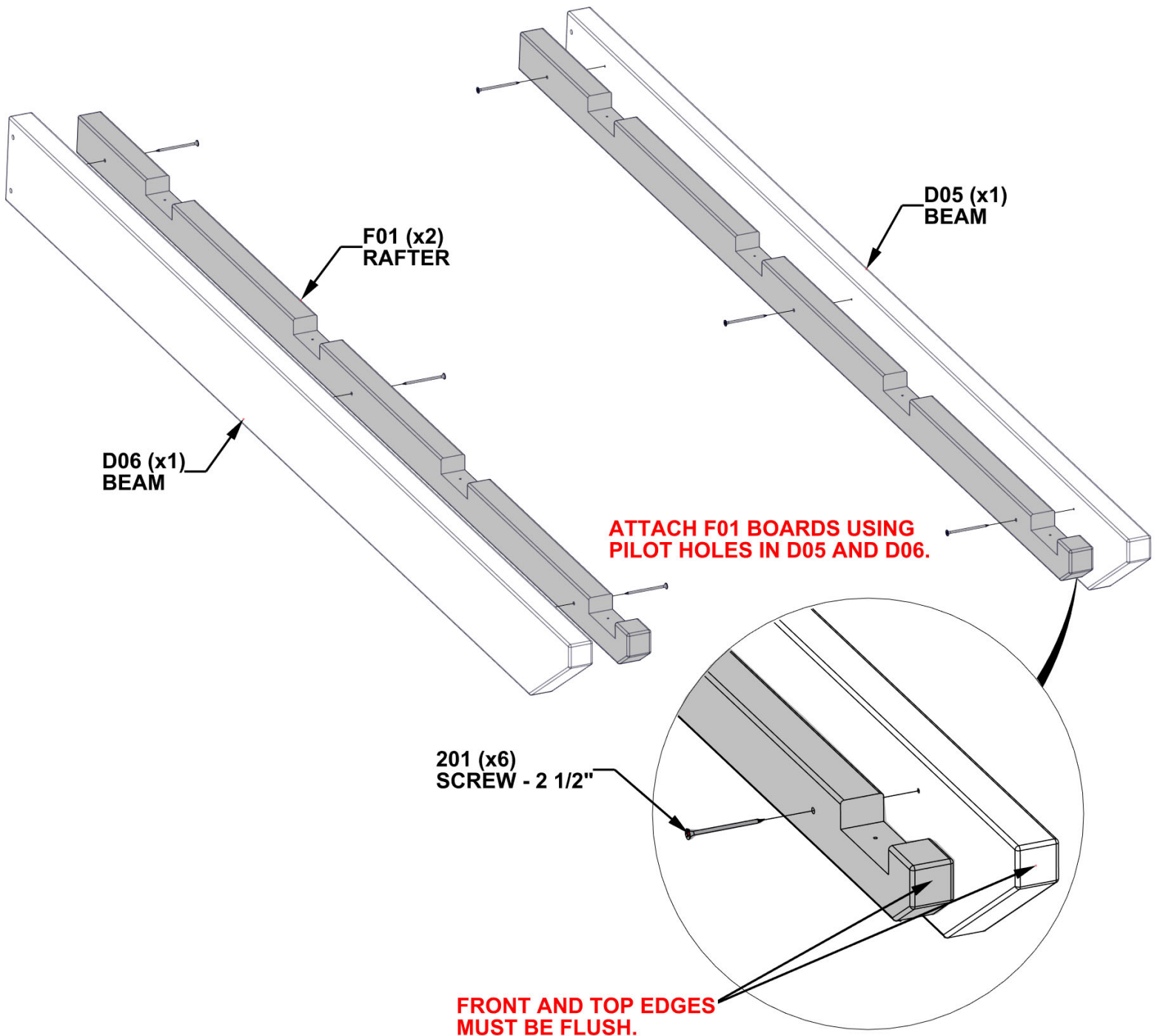

# STEP 18 - ROOF ASSEMBLY

QTY	PART NUMBER	DESCRIPTION
4	H101008	SCREW CONFIRMAT 7x3 BLK



D07 BEAM - W4L18007  
(x1) 1 7/16"x5 1/4"x87 1/4" (36x134x2216)

**ATTACH D07 USING PILOT HOLES. ENSURE F01 BOARDS ARE POSITIONED TOWARD THE INSIDE.**

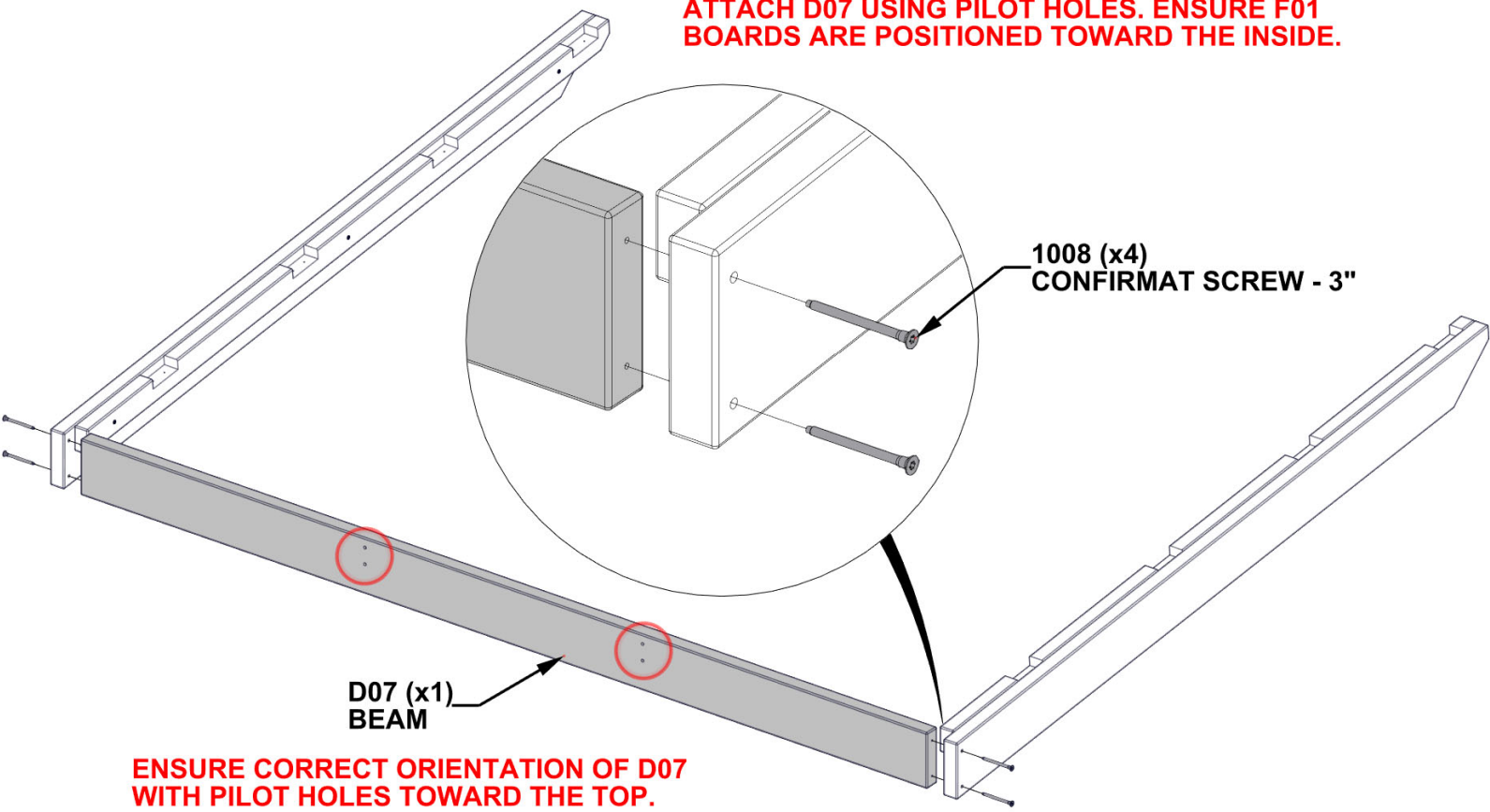

# STEP 19 - ROOF ASSEMBLY

QTY	PART NUMBER	DESCRIPTION
4	H101008	SCREW CONFIRMAT 7x3 BLK



E03 RAFTER - W4L18008  
(x2) 1 7/16"x3 3/8"x74 3/16" (36x86x1884)

**FLIP ASSEMBLY OVER FROM PREVIOUS STEP. LAY RAFTERS FLAT, AND ALIGN PILOT HOLES WITH HOLES IN D07.**

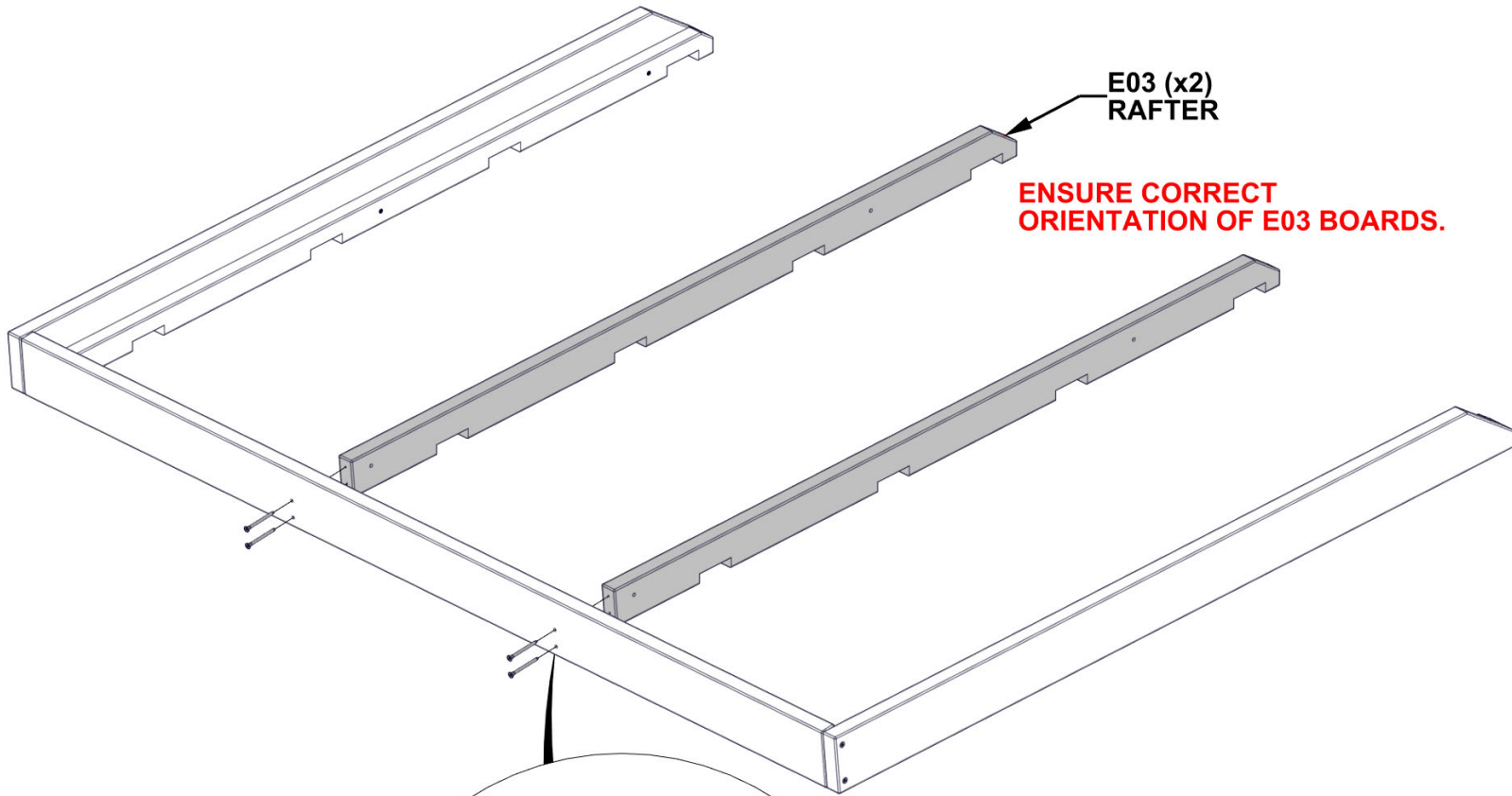

E03 (x2)  
RAFTER

**ENSURE CORRECT ORIENTATION OF E03 BOARDS.**

1008 (x4)  
CONFIRMAT SCREW - 3"

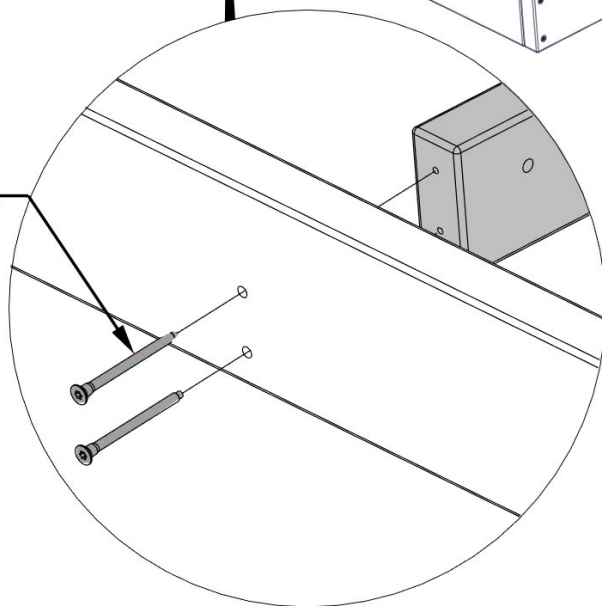



# STEP 20 - ROOF ASSEMBLY

QTY	PART NUMBER	DESCRIPTION
8	H100382	SCREW PFH 8x1 3/4 BLK



H01 PURLIN - W4L18009  
(x1) 15/16"x3 3/8"x87 1/16" (24x86x2212)

**FLIP ASSEMBLY OVER FROM PREVIOUS STEP. PLACE H01 INTO POSITION. MEASURE DIAGONALLY AND SQUARE AS NEEDED. MEASUREMENT SHOULD BE 117 1/4" [2980mm]**

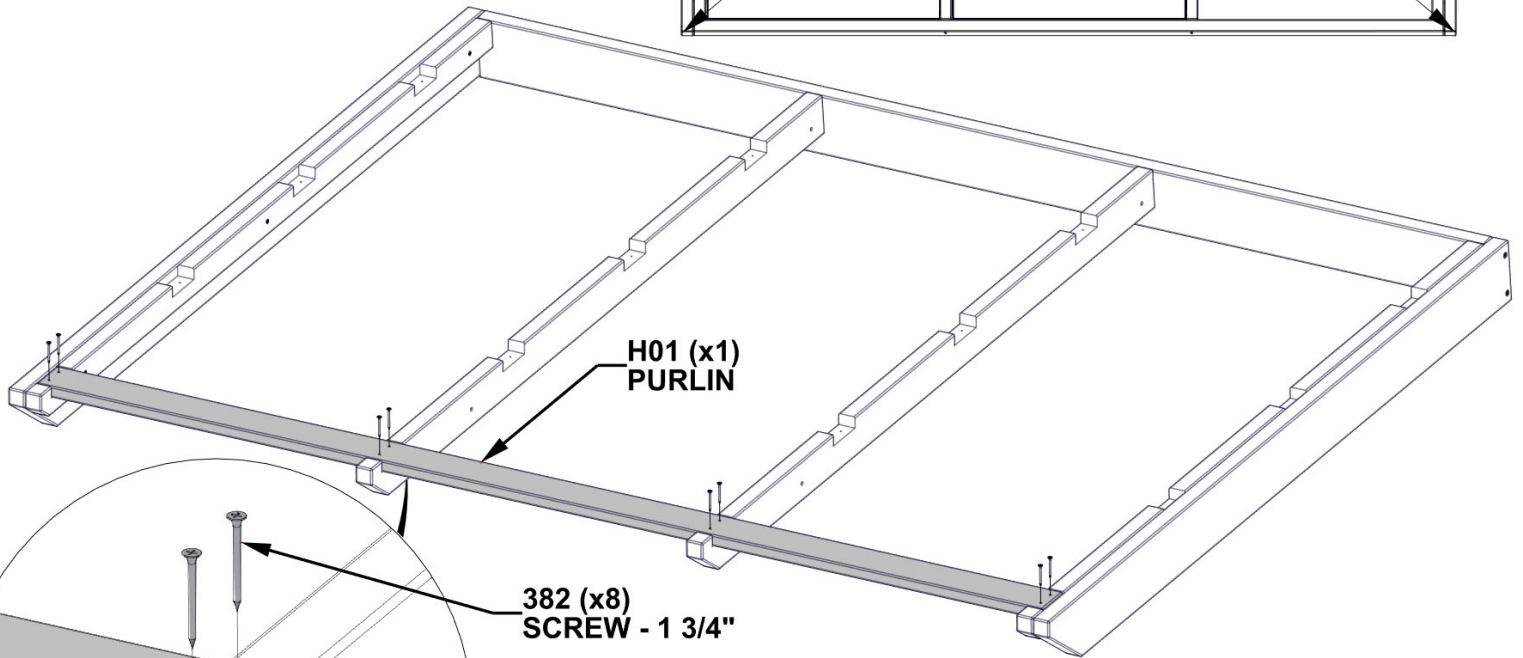
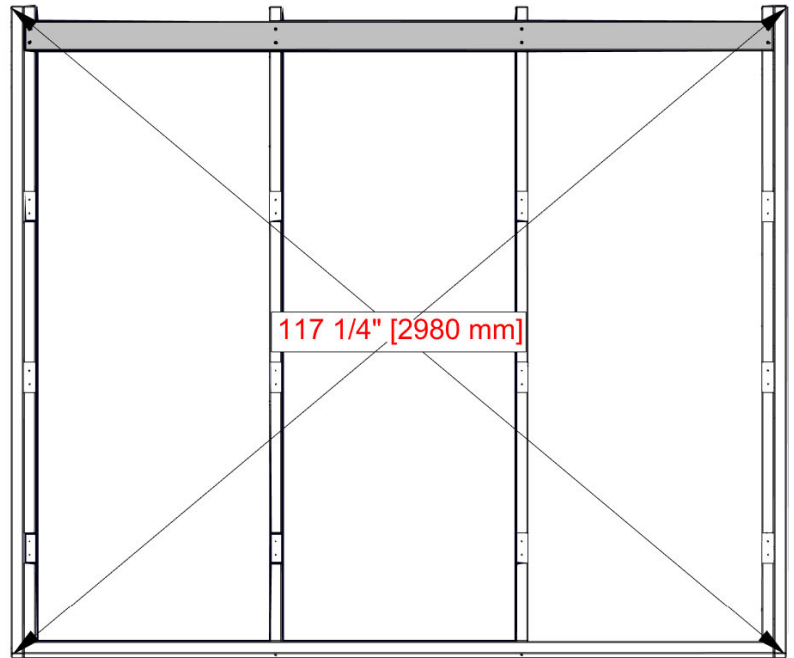

**ONCE SQUARED, INSERT SCREWS AND RE-MEASURE.**

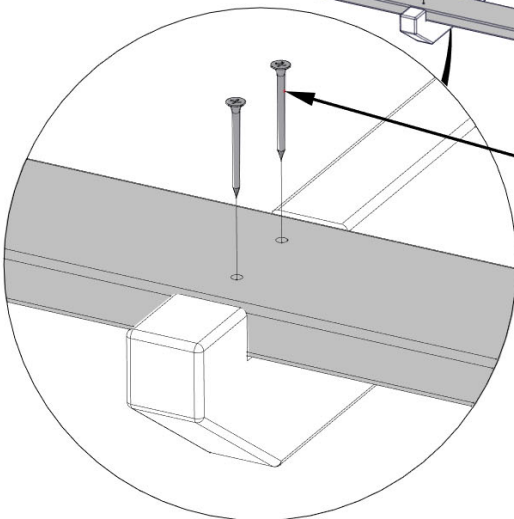

# STEP 21 - ROOF ASSEMBLY

QTY	PART NUMBER	DESCRIPTION
24	H100382	SCREW PFH 8x1 3/4 BLK



H01 PURLIN - W4L18009  
(x3) 15/16"x3 3/8"x87 1/16" (24x86x2212)

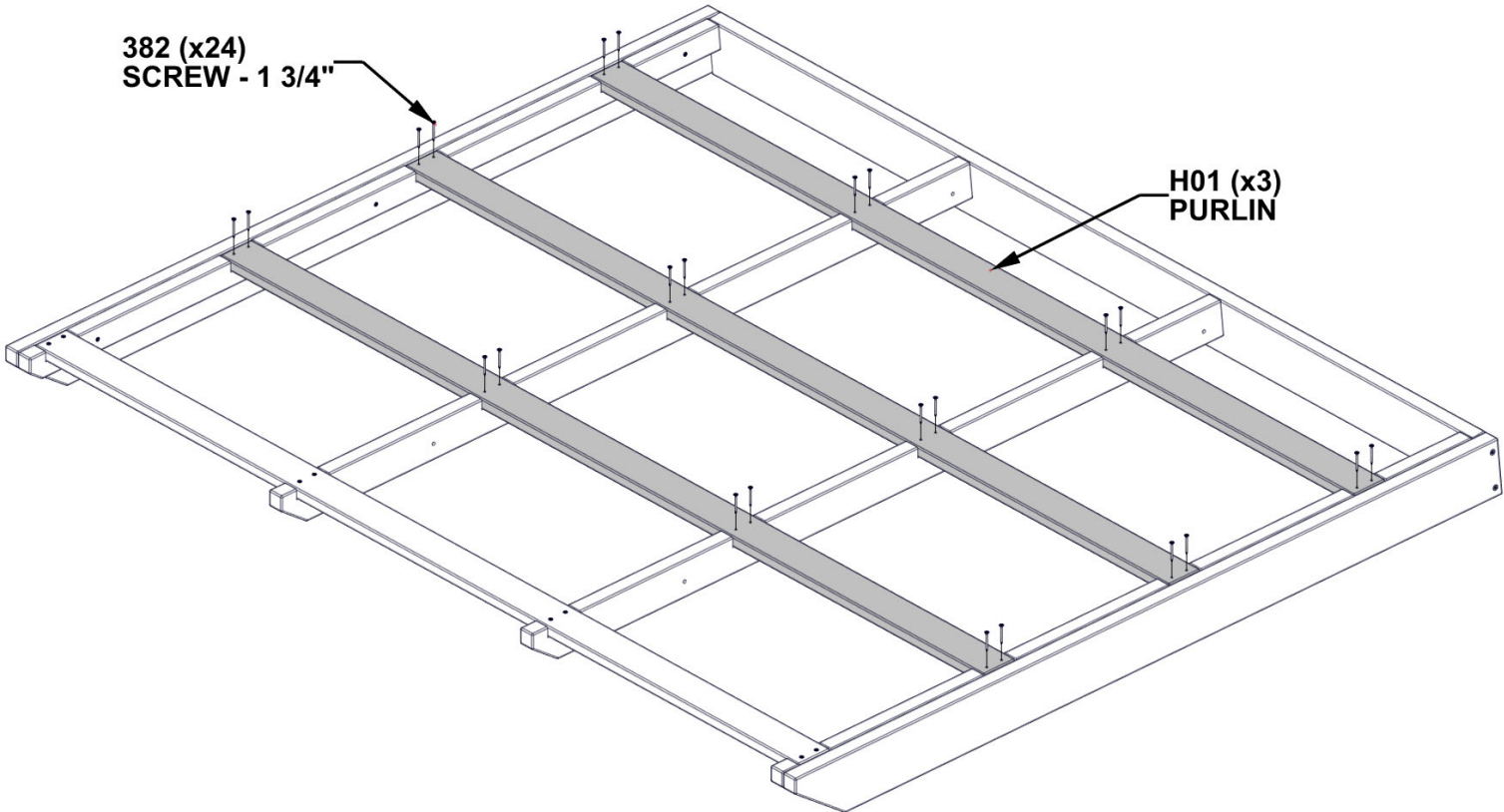

# STEP 22 - ROOF ASSEMBLY

QTY	PART NUMBER	DESCRIPTION
50	H101117	SCREW WOODGRIP 10-16x3/4" BLK



A4M01485 29GA STEEL SHEETING  
(x5)

REMOVE BLUE FILM FROM EACH SHEET BEFORE ATTACHING.

**GLOVES SHOULD BE WORN WHEN HANDLING ROOF PANELS: EDGES ARE SHARP.**

117 (x50)  
SCREW - 3/4"

**SHEETS OVERLAP BY ONE RIB.**

1485 (x5)  
29GA STEEL SHEETING

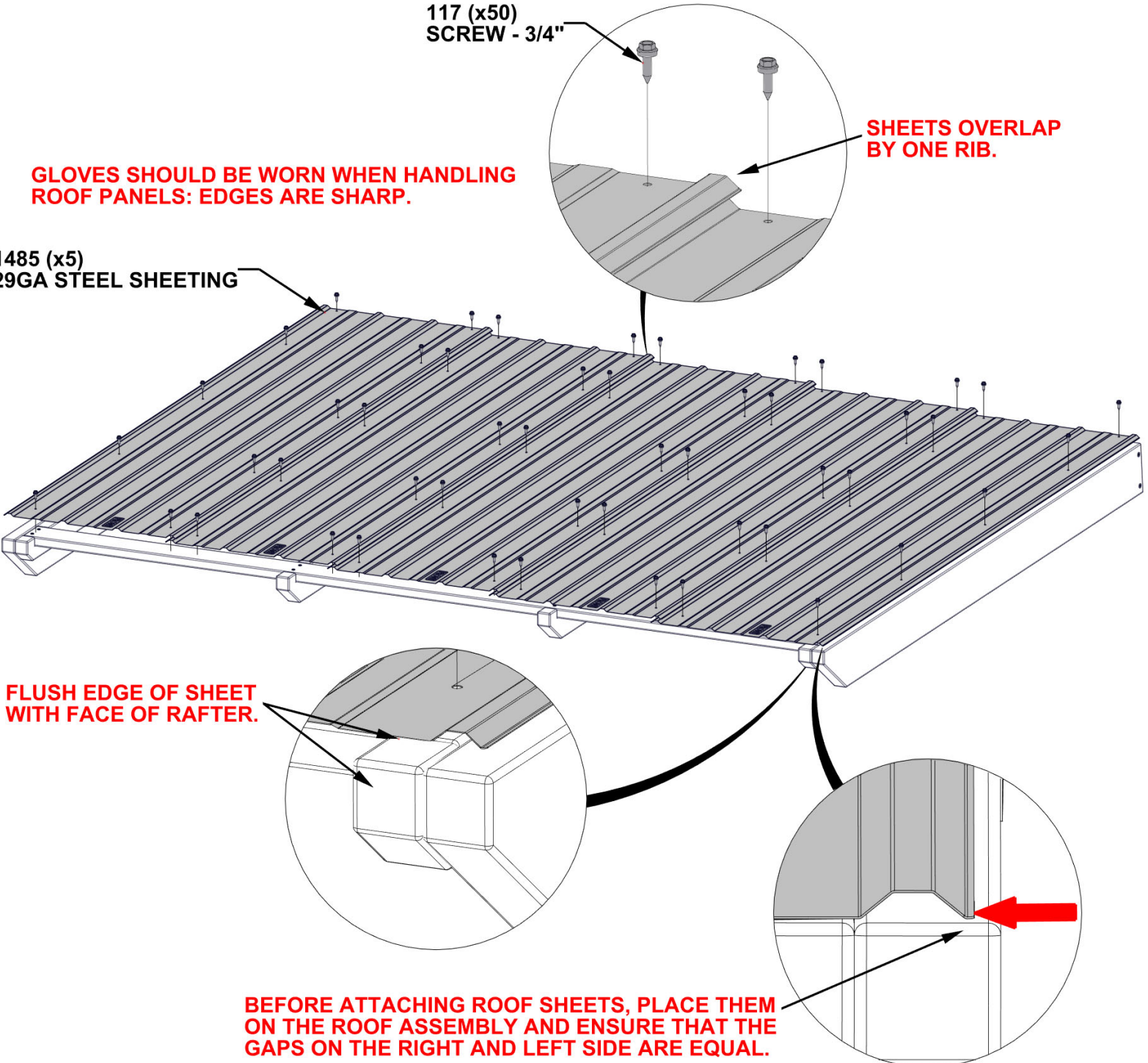

**FLUSH EDGE OF SHEET WITH FACE OF RAFTER.**

**BEFORE ATTACHING ROOF SHEETS, PLACE THEM ON THE ROOF ASSEMBLY AND ENSURE THAT THE GAPS ON THE RIGHT AND LEFT SIDE ARE EQUAL.**



# STEP 23 - ROOF ASSEMBLY

QTY	PART NUMBER	DESCRIPTION
18	H101116	SCREW SELF TAPPING 1/4x1 BLK

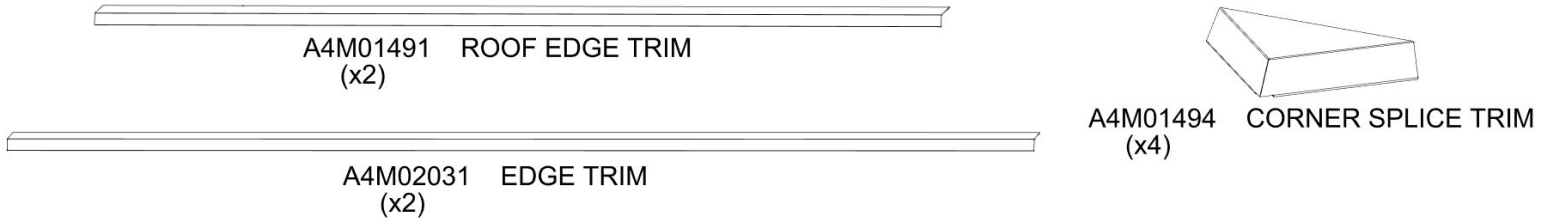

**INSTALL ROOF EDGE TRIM WITH THE LONGER SIDE ON TOP OF THE ROOF PANEL. ENSURE THAT EACH PIECE OF TRIM IS CENTERED AND SCREW INTO PLACE. THEN ATTACH CORNER TRIM.**

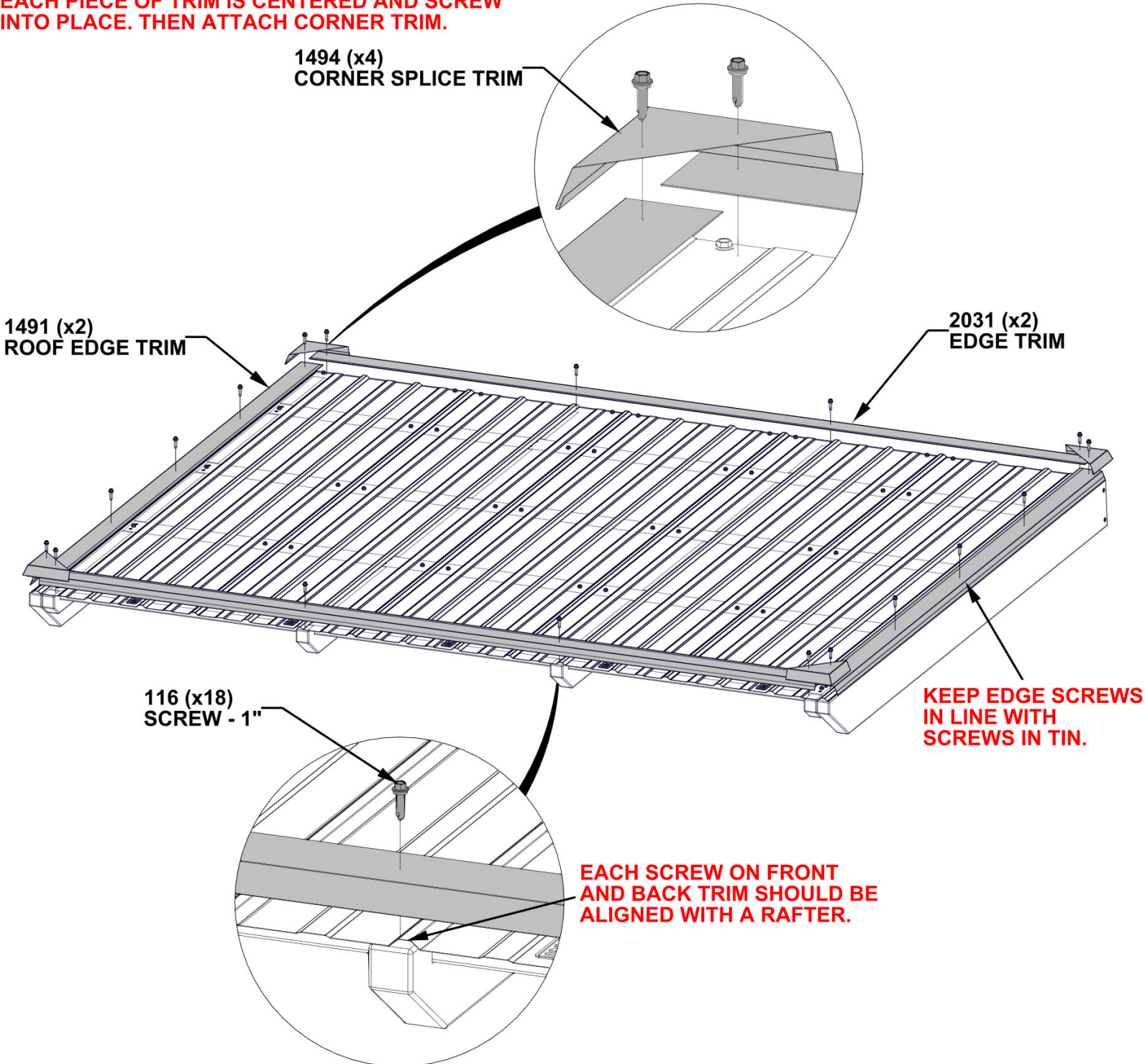

# STEP 24 - GAZEBO ASSEMBLY

QTY	PART NUMBER	DESCRIPTION
8	H100392	SCREW PWH 8x3/4 BLK
4	H100488	BOLT WH 1/4x2 BLK
4	H100630	WASHER FLAT 8x19 BLK
4	H100653	NUT LOCK 1/4 BLK

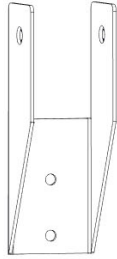

A4M01228 RAFTER CLIP  
(x4)

**SLIDE ROOF PANEL ON FROM BACK SIDE TO LINE UP HOLES FOR BRACKETS IN RAFTERS.**

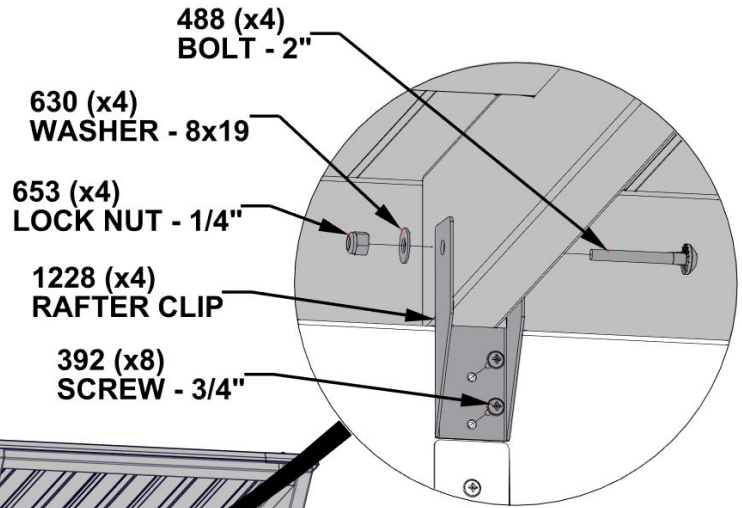

488 (x4)  
BOLT - 2"

630 (x4)  
WASHER - 8x19

653 (x4)  
LOCK NUT - 1/4"

1228 (x4)  
RAFTER CLIP

392 (x8)  
SCREW - 3/4"

**ATTACH BRACKETS WITH PILOT HOLES IN FRONT AND BACK BEAMS. ALIGN BRACKET WITH HOLES IN RAFTER AND ATTACH BOLTS.**

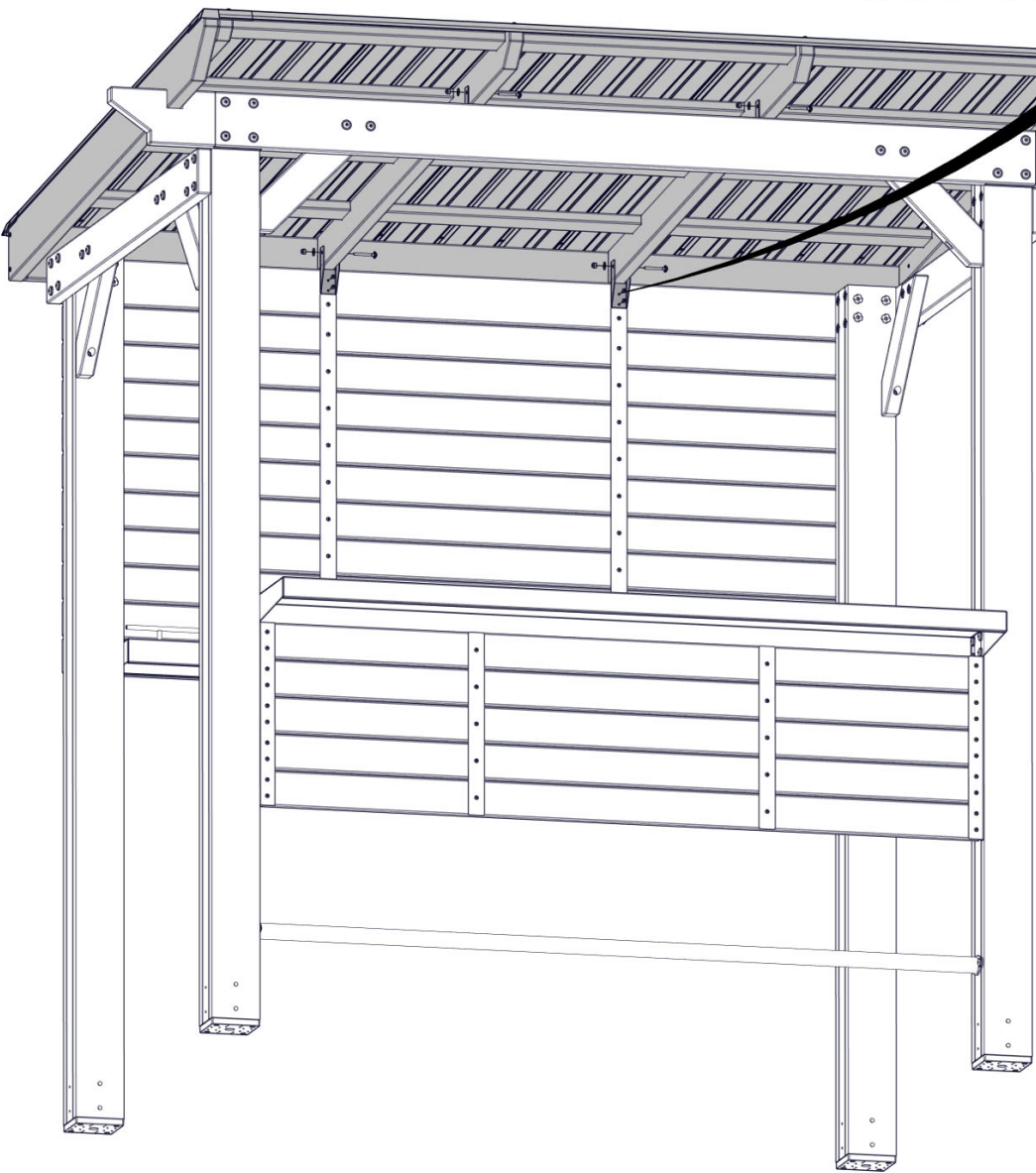

# STEP 25 - GAZEBO ASSEMBLY

QTY	PART NUMBER	DESCRIPTION
2	H100387	SCREW PFH 8x1 1/4 BLK

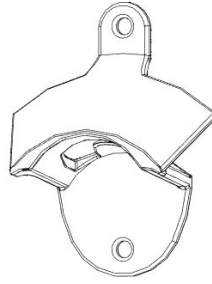

A4M01187 BOTTLE CAP OPENER  
(x1)

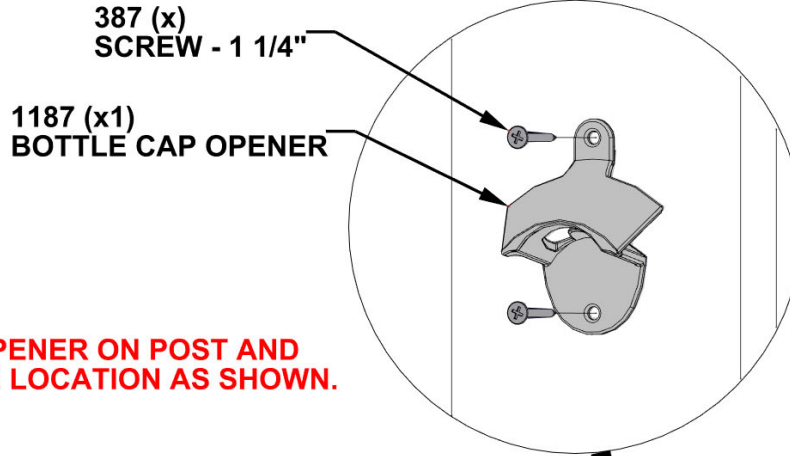

**CENTER BOTTLE CAP OPENER ON POST AND PLACE IN APPROXIMATE LOCATION AS SHOWN.**

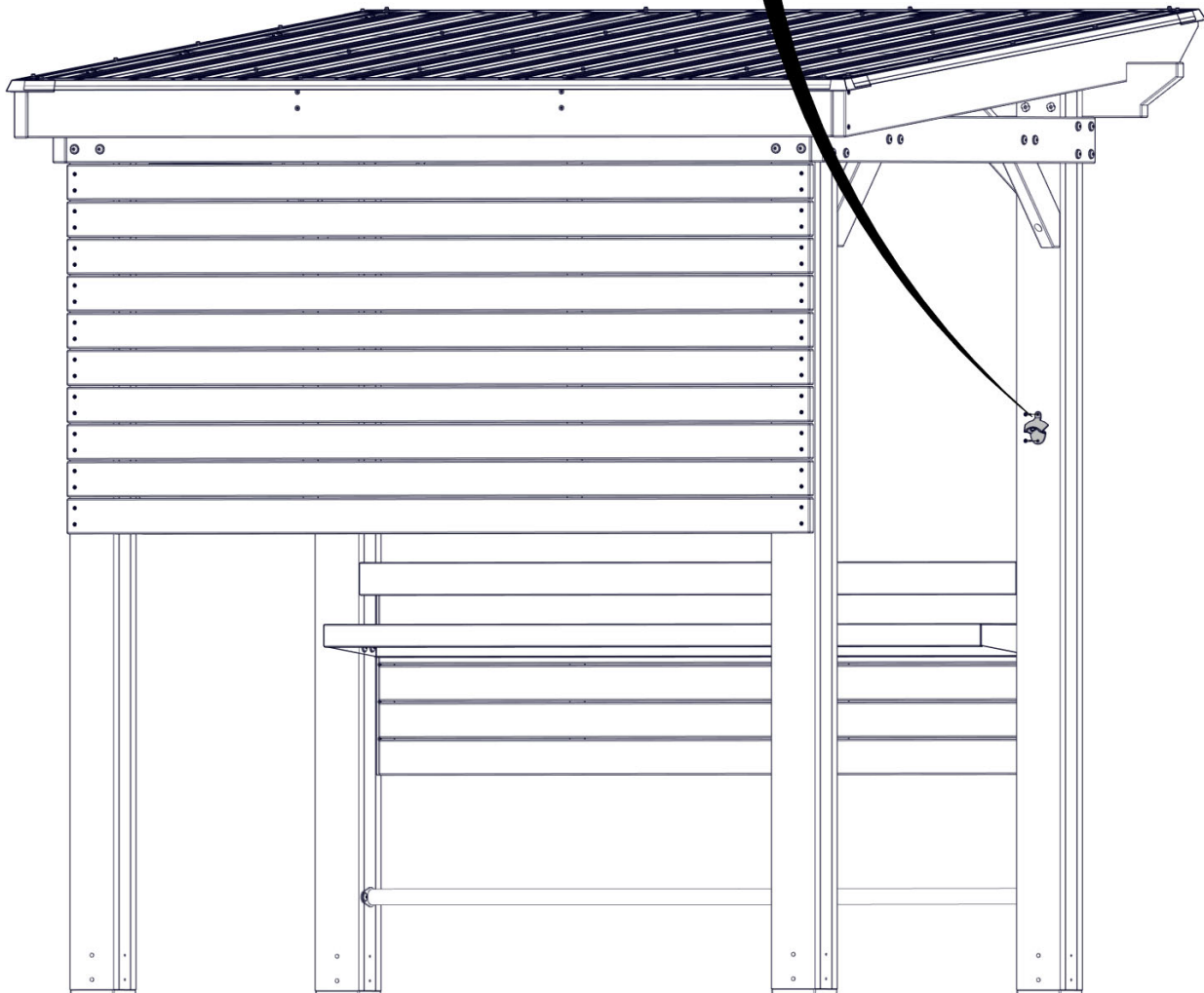



# STEP 26 - GAZEBO ASSEMBLY

QTY	PART NUMBER	DESCRIPTION
8	H100469	NUT BARREL WH 5/16X5/8 BLK
16	H100471	LAG SCREW WH 5/16x1 1/2 BLK
8	H100480	BOLT WH 5/16x4 3/4 BLK

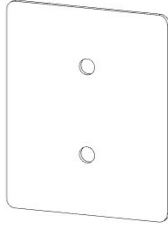

A4M01477 POST PLATE  
(x8)

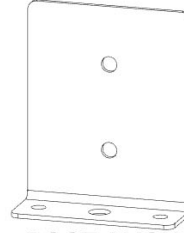

A4M01478 POST ANCHORING PLATE  
(x8)

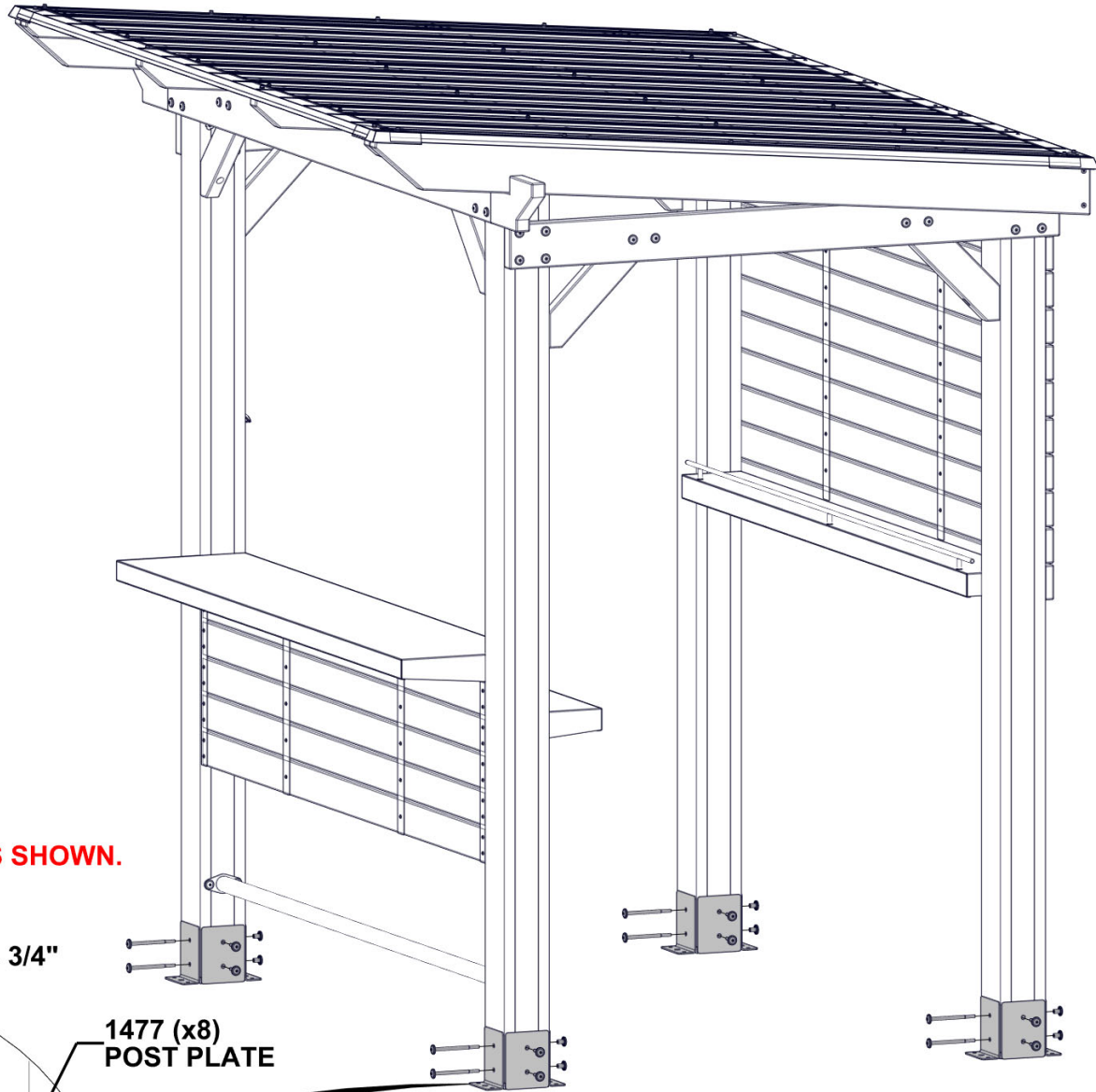

**ATTACH POST PLATES AS SHOWN.**

480 (x8)  
BOLT - 4 3/4"

1477 (x8)  
POST PLATE

469 (x8)  
BARREL NUT - 5/8"

471 (x16)  
LAG SCREW - 1 1/2"

1478 (x8)  
POST ANCHORING PLATE

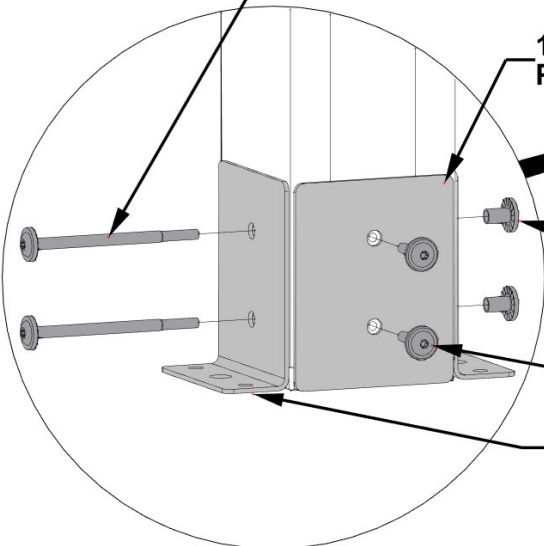

# STEP 27 - GAZEBO ASSEMBLY

QTY	PART NUMBER	DESCRIPTION
4	H100823	SCREW PWH 8x1 1/2 BLK



A4M02158 BYD ID TAG PATIO  
(x1)

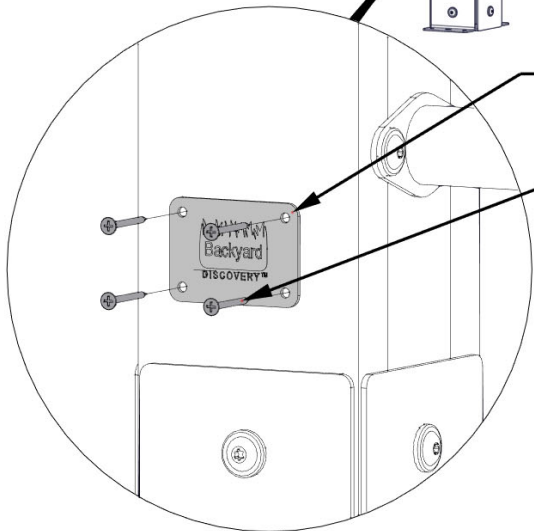
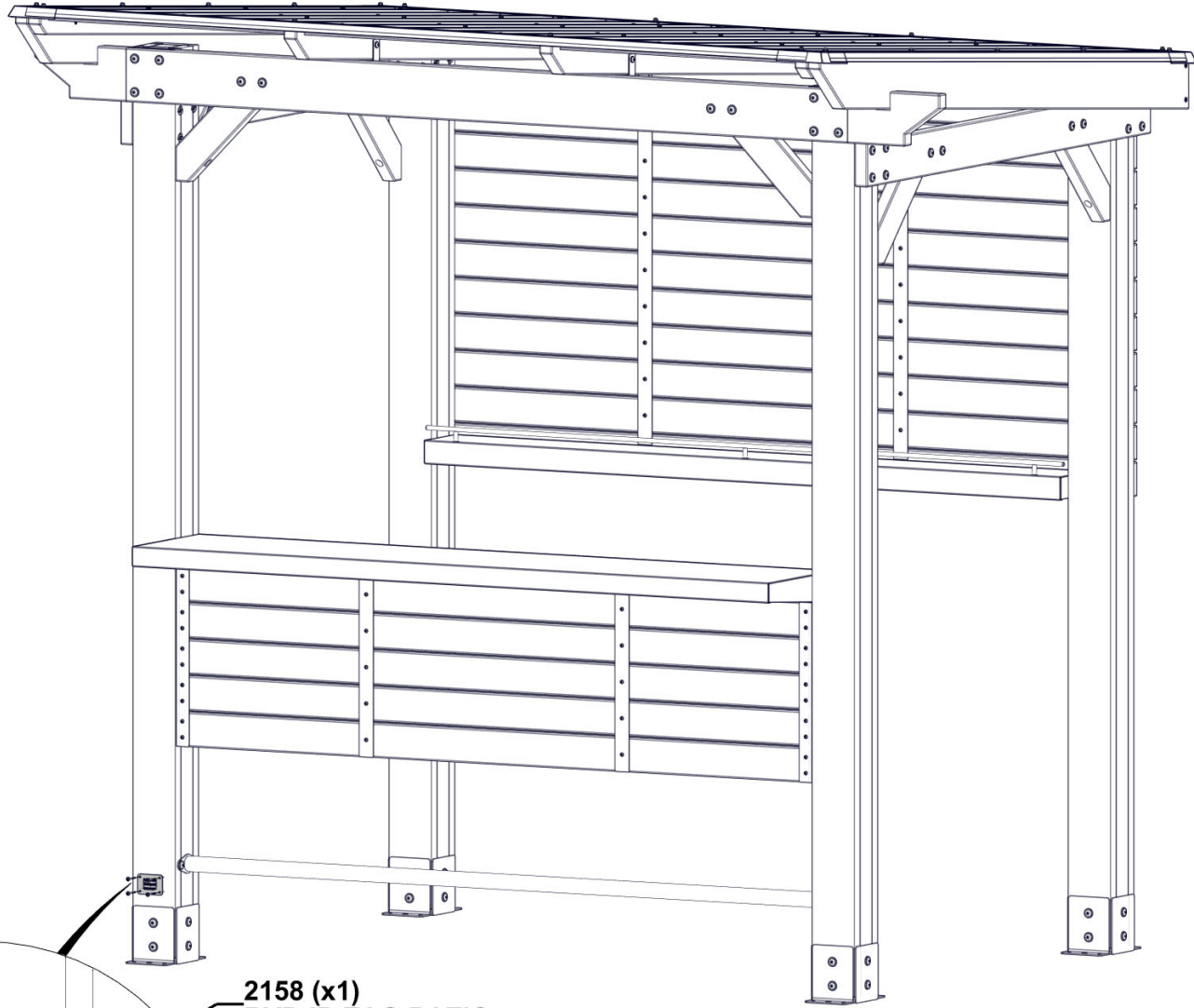

2158 (x1)  
BYD ID TAG PATIO

823 (x4)  
SCREW - 1 1/2"



# STEP 28 - GAZEBO ASSEMBLY

QTY	PART NUMBER	DESCRIPTION
16	H100120	CONCRETE ANCHOR 1/4"x2"
16	H100630	WASHER FLAT 8x19 BLK

**MANUFACTURER RECOMMENDS INSTALLATION ON CONCRETE SURFACE OR CONCRETE POST PAD AS SHOWN BELOW.**

**FOR INSTALLATION ON WOOD DECK, YOU MUST ENSURE THERE IS AMPLE STRUCTURAL SUPPORT UNDER THE DECK. HARDWARE NOT INCLUDED FOR DECK ATTACHMENT.**

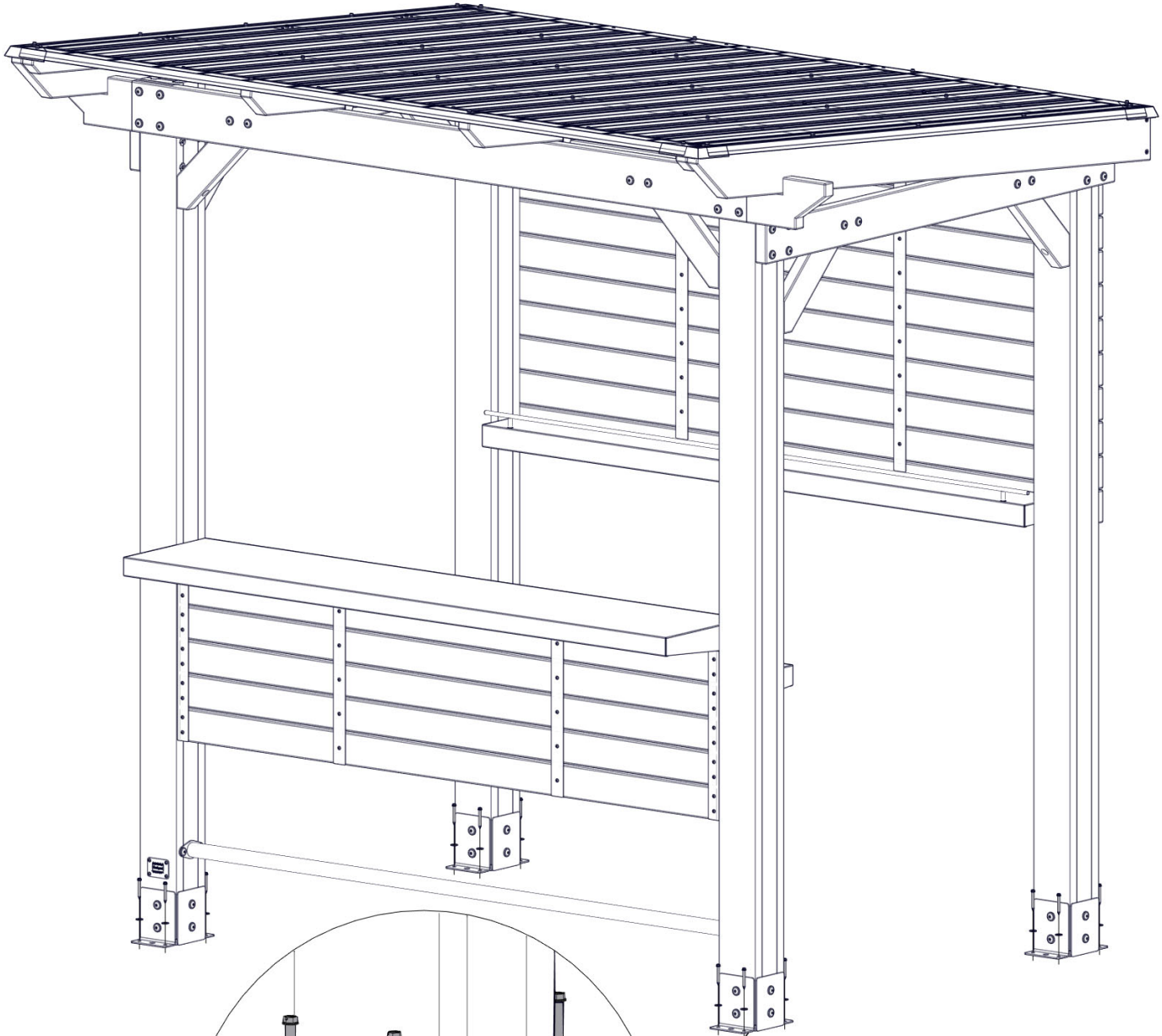

**120 (x16)  
CONCRETE SCREW-2"**

**630 (x16)  
WASHER - 8x19**

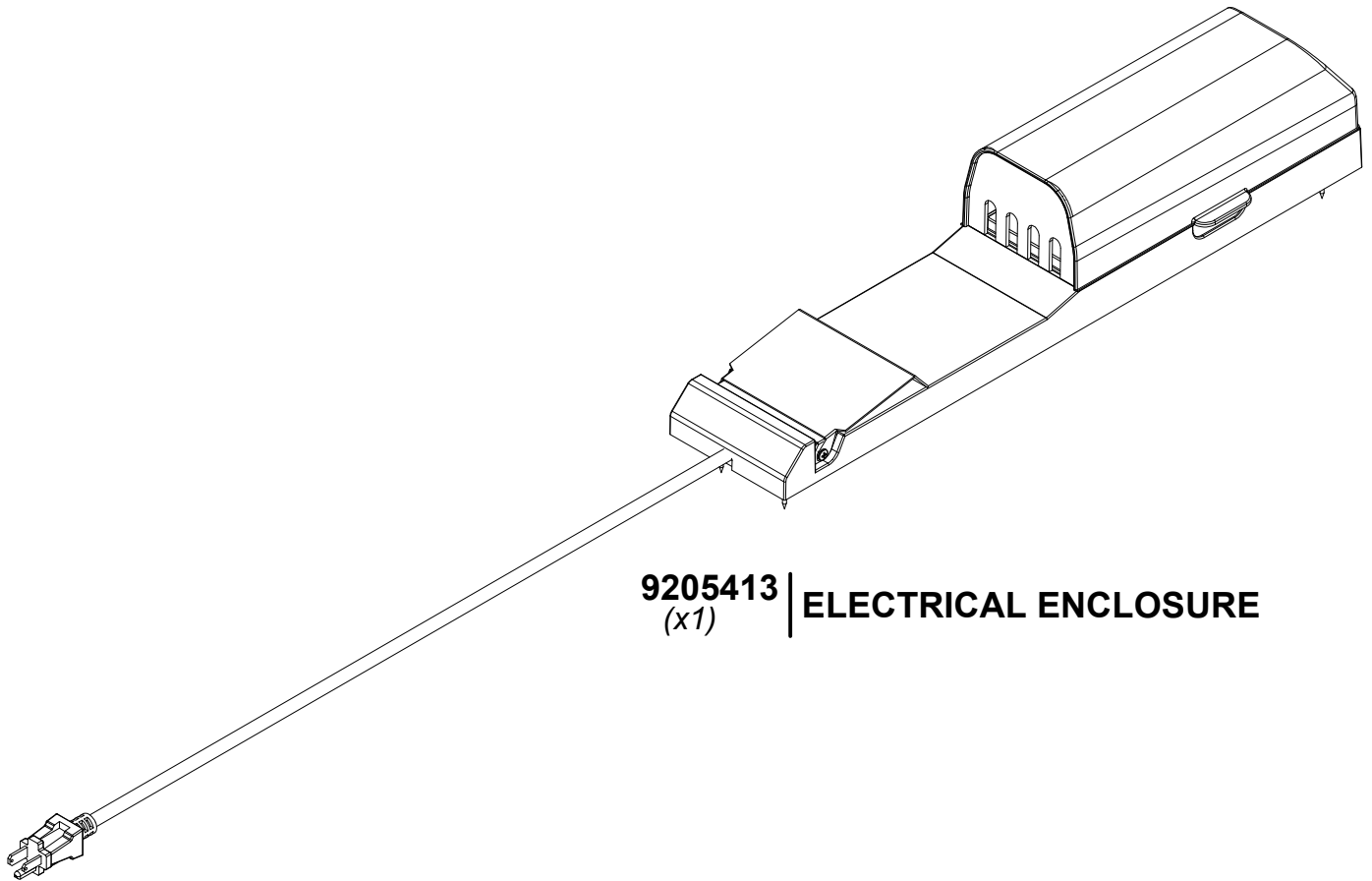

**9205413** | **ELECTRICAL ENCLOSURE**  
*(x1)*

FOR POWERPORT INSTALLATION REFER TO ASSEMBLY INSTRUCTIONS THAT COME PACKAGED WITH THE POWERPORT KIT. INSTALL ON ANY POST THAT IS DESIRED. FOLLOW DIRECTIONS FOR PROPER INSTALLATION.