



MANUFACTURED BY:
Backyard Discovery
3305 Airport Drive, Pittsburg, KS 66762
800-856-4445

Basepoint Business Centre: Rivermead Drive, Westlea, Swindon SN5 7EX Phone: 0800-118-2476 J.P. Coenstraat 7,
The Bridge, The Hague, 2595 WP, Netherlands

SKYFORT

Swing Set

Model # 2106031B, 2300071, & 2300330



WARNING

Adult Assembly Required.

Not suitable for children under 36 months due to small parts.

FOR DOMESTIC USE ONLY. INTENDED FOR OUTDOOR USE.



Please visit www.backyarddiscovery.com

For the most up to date assembly manual, to register your set, or to order replacement parts

Para obtener instrucciones en español, visite www.backyarddiscovery.com



EASY STEP-BY-STEP
3D INTERACTIVE INSTRUCTIONS

DOWNLOAD THE FREE APP



Made in China

INS-2106031B, 2300071, & 2300330-SKYFORT-ENG 10-3-2023



Place the set on level ground, not less than 6'-7" [2 m] from any structure or obstruction such as a fence, garage, house, overhanging branches, laundry lines, or electrical wires.

- While assembling unit, take time before and after each phase to make sure fort is level. If fort is not level, assembly will be difficult and improper assembly may result. Extra care must be taken to insure the fort is square.
- The safe play area refers to a zone extending 6'-7" (2 m) beyond the play product on all sides, including the space above the play product.

SAFE PLAY AREA DIAGRAM

Ground Dimension

22'-0" [6.7 m] x 16'-11 1/2" [5.2 m]

Safe Play Area

35'-2" [10.7 m] x 30'-1 1/2" [9.2 m] x 18'-11" [5.8 m]

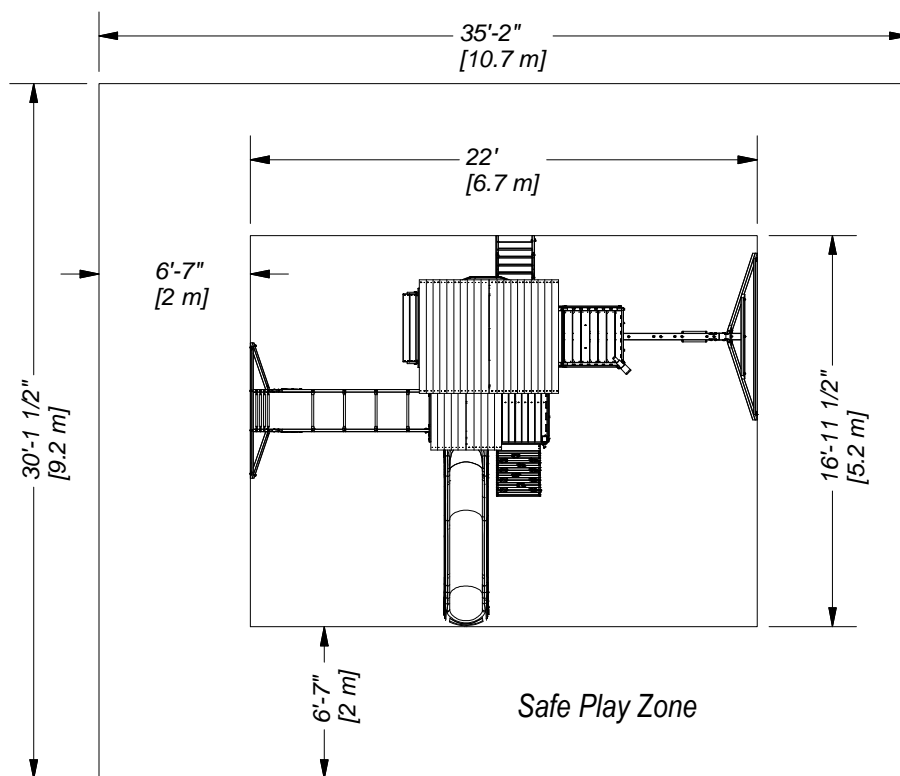

SAFE PLAY HEIGHT: 18'-11" [5.8 m]
MAXIMUM FALL HEIGHT: 7'-5 1/2" [2.3 m]

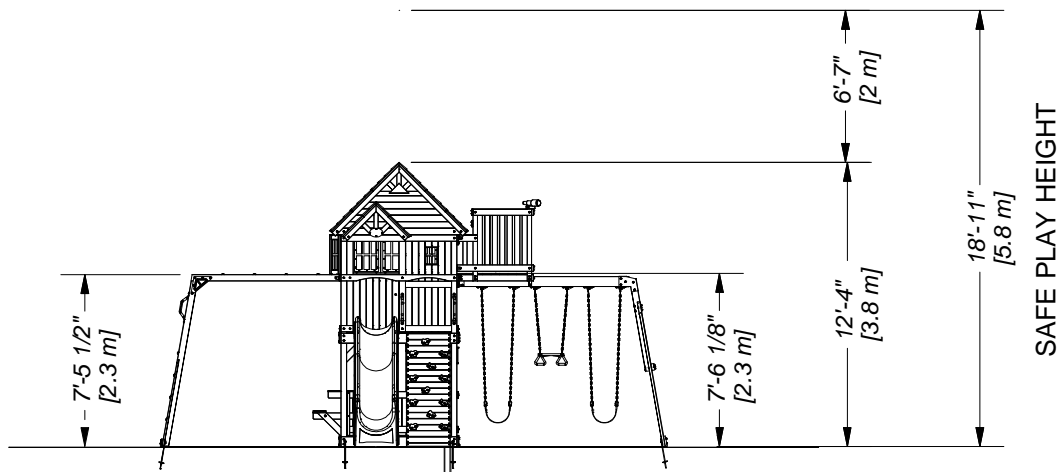

General Information:

Your set has been designed and engineered for children only and for residential use only.
 A maximum of 150 lbs. per child is recommended for play activities designed for individual use.
 A maximum of 120 lbs. per child is recommended for play activities designed for multiple child use.
 A maximum of 9 children is recommended for this swing set.



Wood Components (Not to Scale)



A1 | SWING BEAM - W4L15713
(x1) | 3 3/8"x5 1/4"x89 1/2" (86x134x2274)

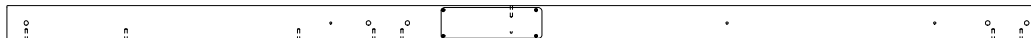

B1 | TOWER LEG - W2A03275
(x1) | 3"x3"x89 1/2" (76x76x2274)

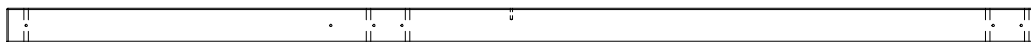

B2 | TOWER LEG - W4L15731
(x1) | 3"x3"x89 1/2" (76x76x2274)



B3 | TOWER LEG - W4L12682
(x1) | 3"x3"x59" (76x76x1500)



B4 | TOWER LEG - W4L12683
(x1) | 3"x3"x59" (76x76x1500)



B5 | BACK LEFT CLUB HOUSE CORNER - W4L14722
(x1) | 3"x3"x53 7/8" (76x76x1370)

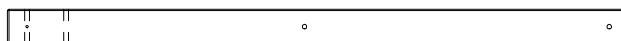

B6 | FRONT LEFT CLUB HOUSE CORNER - W4L14723
(x1) | 3"x3"x53 7/8" (76x76x1370)



B7 | FRONT RIGHT FORT CORNER - W4L12686
(x1) | 3"x3"x53 7/8" (76x76x1370)



B8 | BACK RIGHT FORT CORNER - W4L12687
(x1) | 3"x3"x53 7/8" (76x76x1370)

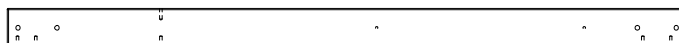

E1 | TOWER LEG - W4L12688
(x1) | 1 3/8"x3 3/8"x59" (36x86x1500)



E2 | TOWER LEG - W4L14727
(x1) | 1 3/8"x3 3/8"x59" (36x86x1500)

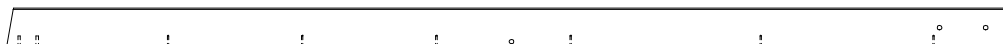

E3 | MONKEY BAR UPRIGHT - W4L08127
(x2) | 1 3/8"x3 3/8"x87 5/8" (36x86x2226)



E04 | ANGLE BRACE - W4L15649
(x2) | 1 3/8"x3 3/8"x87 1/8" (36x86x2212)



E05 | DECK BRACE - W4L15452
(x8) | 1 7/16"x3 3/8"x17 11/16" (36x86x450)

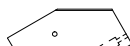

E06 | CROWS NEST DECK BRACE - W4L15451
(x2) | 1 7/16"x3 3/8"x10 7/8" (36x86x276)



Wood Components (Not to Scale)



E07 | CROWS NEST FLOOR RAIL - W4L15712
(x2) | 1 3/8"x3 3/8"x38" (36x86x964)

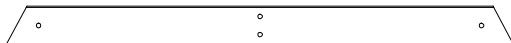

E50 | END SUPPORT - W4L15651
(x1) | 1 3/8"x3 3/8"x44 1/8" (36x86x1120)



E72 | ROCKWALL RAIL - W4L15490
(x2) | 1 3/8"x3 3/8"x64 5/8" (36x86x1640)



E74 | MONKEY BAR RAIL - W4L15732
(x2) | 1 3/8"x3 3/8"x77 1/8" (36x86x1959)



E77 | LEFT UPRIGHT - W4L14734
(x1) | 1 3/8"x3 3/8"x64 3/8" (36x86x1634)



E78 | RIGHT UPRIGHT - W4L14735
(x1) | 1 3/8"x3 3/8"x64 3/8" (36x86x1634)

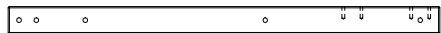

F2 | CROWS NEST WALL SUPPORT - W4L14738
(x2) | 1 3/8"x2 3/8"x37 1/2" (36x60x952)



F3 | CROWS NEST WALL SUPPORT - W4L14739
(x2) | 1 3/8"x2 3/8"x37 1/2" (36x60x952)

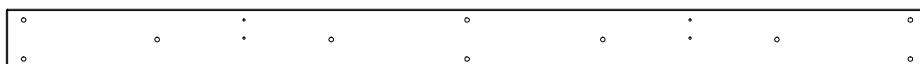

G1 | TOP FLOOR RAIL - W4L14740
(x1) | 1"x5 1/4"x80" (24x134x2032)

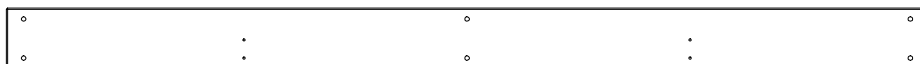

G2 | TOP FLOOR RAIL - W4L14741
(x1) | 1"x5 1/4"x80" (24x134x2032)



G3 | FLOOR RAIL - W4L16849
(x1) | 1"x5 1/4"x60 1/2" (24x134x1537)



G4 | FLOOR RAIL - W4L14743
(x1) | 1"x5 1/4"x60 1/2" (24x134x1537)



G5 | BAY WINDOW HEADER - W4L14744
(x4) | 1"x5 1/4"x45 1/4" (24x134x1150)



Wood Components (Not to Scale)

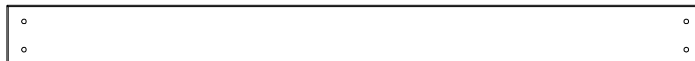

G6 | FLOOR RAIL - W4L14745
(x1) | 1"x5 1/4"x60 1/2" (24x134x1537)

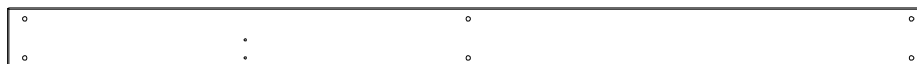

G7 | BOTTOM FLOOR RAIL - W4L14746
(x2) | 1"x5 1/4"x80" (24x134x2032)



G08 | GROUND BOARD - W4L15652
(x1) | 1"x5 1/4"x86 3/4" (24x134x2202)



H1 | WALL RAIL - W4L14748
(x1) | 1"x3 3/8"x80" (24x86x2032)



H2 | WALL RAIL - W4L12707
(x1) | 1"x3 3/8"x80" (24x86x2032)



H3 | PICNIC TABLE RAIL - W4L14750
(x1) | 1"x3 3/8"x67 1/4" (24x86x1708)



H4 | ROOF SUPPORT RAIL - W4L14751
(x2) | 1"x3 3/8"x67 1/4" (24x86x1709)



H5 | FLOOR RAIL - W4L14752
(x1) | 1"x3 3/8"x60 1/2" (24x86x1537)

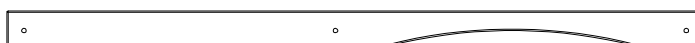

H6 | BACK CLUB HOUSE RAIL - W4L14753
(x1) | 1"x3 3/8"x60 1/2" (24x86x1537)

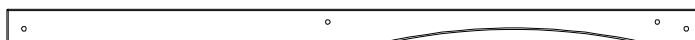

H7 | FRONT CLUB HOUSE WALL RAIL - W4L14754
(x1) | 1"x3 3/8"x60 1/2" (24x86x1537)

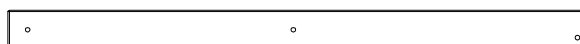

H8 | FORT UPRIGHT - W4L12713
(x1) | 1"x3 3/8"x50 1/2" (24x86x1284)



H9 | FORT WALL BOARD - W4L12714
(x2) | 1"x3 3/8"x50 1/2" (24x86x1284)



H10 | PORCH LEG - W4L14757
(x1) | 1"x3 3/8"x50 1/2" (24x86x1282)



H11 | PORCH LEG - W4L14758
(x1) | 1"x3 3/8"x50 1/2" (24x86x1282)



Wood Components (Not to Scale)



H12 | ROOF RAFTER - W4L14759
(x4) | 1"x3 3/8"x50 3/8" (24x86x1278)



H13 | CLUB HOUSE WALL RAIL - W4L14760
(x1) | 1"x3 3/8"x50 1/4" (24x86x1277)



H14 | SWING BEAM MOUNT - W4L12719
(x1) | 1"x3 3/8"x50 1/4" (24x86x1277)



H15 | PICNIC TABLE SEAT - W4L14762
(x4) | 1"x3 3/8"x35 3/8" (24x86x897)

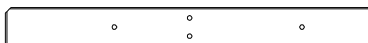

H16 | PICNIC TABLE SEAT RAIL - W4L14763
(x1) | 1"x3 3/8"x32" (24x86x812)

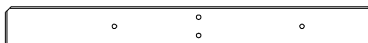

H17 | PICNIC TABLE SEAT RAIL - W4L14764
(x1) | 1"x3 3/8"x32" (24x86x812)



H18 | CLUB HOUSE WALL RAIL - W4L14765
(x1) | 1"x3 3/8"x29 7/8" (24x86x758)



H19 | CROWS NEST FLOOR RAIL - W4L14766
(x1) | 1"x3 3/8"x27" (24x86x686)



H20 | PORCH ROOF RAFTER - W4L14767
(x4) | 1"x3 3/8"x24 1/2" (24x86x622)



H21 | CROWS NEST FLOOR SUPPORT - W4L14768
(x1) | 1"x3 3/8"x24 1/8" (24x86x614)



H23 | PICNIC TABLE BRACE - W4L14769
(x2) | 1"x3 3/8"x17 1/2" (24x86x444)



H24 | PICNIC TABLE TOP SUPPORT - W4L14770
(x1) | 1"x3 3/8"x16 1/2" (24x86x418)



H25 | TOP FLOOR SUPPORT - W4L14771
(x2) | 1"x3 3/8"x3" (24x86x76)

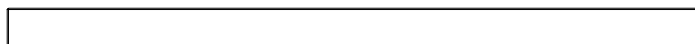

H26 | FLOOR JOIST - W4L14772
(x3) | 1"x3 3/8"x60 1/2" (24x86x1537)



Wood Components (Not to Scale)



H27 | PICNIC TABLE SUPPORT - W4L14773
(x1) | 1"x3 3/8"x28 5/8" (24x86x728)



H28 | FRONT WALL RAIL - W4L14774
(x1) | 1"x3 3/8"x60 1/2" (24x86x1537)



H29 | CROWS NEST WALL RAIL - W4L14775
(x2) | 1"x3 3/8"x30 5/8" (24x86x778)



H30 | CROWS NEST WALL RAIL - W4L14776
(x2) | 1"x3 3/8"x29 7/8" (24x86x758)

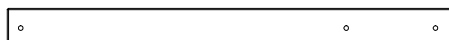

H31 | CROWS NEST WALL RAIL - W4L14777
(x2) | 1"x3 3/8"x38 7/8" (24x86x988)



H76 | LADDER RUNG - W4L14779
(x5) | 1"x3 3/8"x18 1/8" (24x86x460)



H77 | ATTACHMENT BOARD - W4L14780
(x1) | 1"x3 3/8"x20 1/8" (24x86x512)



H81 | MONKEY BAR BRACE - W4L15710
(x2) | 1"x3 3/8"x51 5/8" (24x86x1311)



H82 | MONKEY BAR GROUND BOARD - W4L15714
(x1) | 1"x3 3/8"x70 3/8" (24x86x1786)



K2 | FLOOR RAIL - W4L14783
(x1) | 5/8"x5 1/4"x60 1/2" (16x134x1537)



K3 | FLOOR RAIL - W4L14784
(x1) | 5/8"x5 1/4"x60 1/2" (16x134x1537)



K5 | CLUB HOUSE WALL RAIL - W4L14785
(x1) | 5/8"x5 1/4"x50 1/4" (16x134x1277)



K6 | TRIANGLE SUNBURST - W4L14786
(x2) | 5/8"x5 1/4"x10 3/8" (16x134x265)



L1 | CROWS NEST FLOOR BOARD - W4L14787
(x7) | 5/8"x4 3/8"x27" (16x112x686)



L2 | SAND BOX SEAT - W4L14788
(x2) | 5/8"x4 3/8"x24" (16x112x610)



L3 | CROWS NEST FLOOR BOARD - W4L15100
(x2) | 5/8"x4 3/8"x27" (16x112x686)



Wood Components (Not to Scale)



M1 | TOP WALL RAIL - W4L14789
(x1) | 5/8"x3 3/8"x80" (16x86x2032)

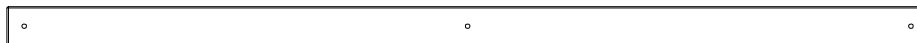

M2 | BOTTOM WALL RAIL - W4L14790
(x2) | 5/8"x3 3/8"x80" (16x86x2032)



M3 | BOTTOM WALL RAIL - W4L14791
(x1) | 5/8"x3 3/8"x60 1/2" (16x86x1537)



M4 | CROWS NEST WALL RAIL - W4L14792
(x2) | 5/8"x3 3/8"x29 7/8" (16x86x758)



M5 | GABLE BOARD - W4L14793
(x2) | 5/8"x3 3/8"x59 1/2" (16x86x1510)



M6 | CLUB HOUSE WALL BOARD - W4L14794
(x1) | 5/8"x3 3/8"x53 7/8" (16x86x1370)



M7 | GABLE BOARD - W4L14795
(x2) | 5/8"x3 3/8"x52 5/8" (16x86x1338)



M8 | FORT WALL BOARD - W4L12750
(x7) | 5/8"x3 3/8"x50 1/2" (16x86x1284)

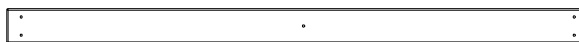

M9 | FORT WALL BOARD - W4L12751
(x2) | 5/8"x3"x50 1/2" (16x76x1284)



M10 | CLUB HOUSE WALL RAIL - W4L14798
(x1) | 5/8"x3 3/8"x50 1/4" (16x86x1277)



M11 | SOFFIT CAP - W4L14799
(x1) | 5/8"x3 3/8"x50 1/4" (16x86x1277)

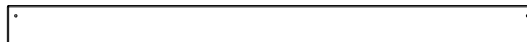

M12 | GABLE BOARD - W4L14800
(x1) | 5/8"x3 3/8"x45 7/8" (16x86x1166)



M13 | PICNIC TABLE TOP - W4L14801
(x4) | 5/8"x3 3/8"x41 1/4" (16x86x1049)

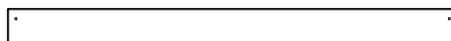

M14 | GABLE BOARD - W4L14802
(x1) | 5/8"x3 3/8"x39 1/8" (16x86x994)

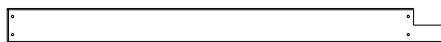

M16 | CENTER PICNIC TABLE TOP - W4L14803
(x1) | 5/8"x3"x38 1/4" (16x76x973)



Wood Components (Not to Scale)



M17 | FRONT WINDOW WALL BOARD - W4L12758
(x2) | 5/8"x3 3/8"x35" (16x86x889)



M18 | GABLE BOARD - W4L14805
(x1) | 5/8"x3 3/8"x32 3/8" (16x86x822)

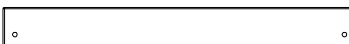

M19 | FRONT PORCH ROOF SUPPORT - W4L14806
(x1) | 5/8"x3 3/8"x30 5/8" (16x86x779)

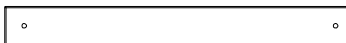

M21 | FORT WALL RAIL - W4L12761
(x3) | 5/8"x3 3/8"x30 1/4" (16x86x768)



M22 | FORT WALL BOARD - W4L12762
(x4) | 5/8"x3 3/8"x29 7/8" (16x86x758)



M23 | FORT WALL BOARD - W4L12763
(x2) | 5/8"x3 1/8"x29 7/8" (16x80x758)



M24 | WALL BOARD - W4L15625
(x23) | 5/8"x3 3/8"x29 5/8" (16x86x752)



M26 | WALL BOARD - W4L14811
(x2) | 5/8"x3 3/8"x26 1/8" (16x86x664)



M27 | BOTTOM WALL BOARD - W4L15711
(x18) | 5/8"x3 3/8"x21 1/8" (16x86x538)



M28 | GABLE WINDOW BOARD - W4L14813
(x2) | 5/8"x3 3/8"x19 1/2" (16x86x496)



M29 | GABLE WINDOW BOARD - W4L14814
(x2) | 5/8"x3 3/8"x16 1/8" (16x86x410)



M30 | PICNIC TABLE TOP CLEAT - W4L14815
(x1) | 5/8"x3 3/8"x16" (16x86x406)



M31 | GABLE WINDOW BOARD - W4L14816
(x2) | 5/8"x3 3/8"x12 3/4" (16x86x324)



Wood Components (Not to Scale)



M32 | CROWS NEST WALL RAIL - W4L14817
(x2) | 5/8"x3 3/8"x10" (16x86x254)



M33 | FRONT WINDOW WALL BOARD - W4L12769
(x2) | 5/8"x3 3/8"x6 3/8" (16x86x162)



M34 | WALL RAIL - W4L14819
(x1) | 5/8"x3 3/8"x6 3/8" (16x86x162)



M61 | ATTACHMENT BOARD - W4L15629
(x1) | 5/8"x3 3/8"x22 7/8" (16x86x580)

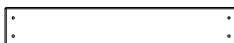

M73 | REAR SUPPORT - W4L14821
(x1) | 5/8"x3 3/8"x20 1/8" (16x86x512)



M74 | ROCK WALL BOARD - W4L15631
(x10) | 5/8"x3 3/8"x22 7/8" (16x86x580)

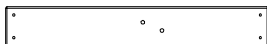

M75 | ROCK WALL BOARD - W4L15632
(x4) | 5/8"x3 3/8"x22 7/8" (16x86x580)



M76 | ROCK WALL BOARD - W4L15633
(x4) | 5/8"x3 3/8"x22 7/8" (16x86x580)

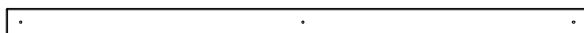

N1 | FORT WALL BOARD - W4L12776
(x2) | 5/8"x2 3/8"x50 1/2" (16x60x1284)



N2 | SOFFIT CAP - W4L14826
(x1) | 5/8"x2 3/8"x50 1/4" (16x60x1277)

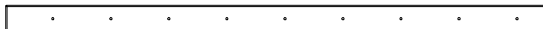

N3 | ROOF SUPPORT - W4L14827
(x2) | 5/8"x2 3/8"x47" (16x60x1193)



N4 | CROWS NEST WALL BOARD - W4L14828
(x2) | 5/8"x2 3/8"x19" (16x60x483)



N5 | FRONT PORCH GABLE TRIM - W4L14829
(x1) | 5/8"x2 3/8"x15" (16x60x381)



N6 | WINDOW TRIM - W4L14830
(x2) | 5/8"x2 3/8"x12 1/4" (16x60x310)



Wood Components (Not to Scale)



N07 | ROCK WALL BOARD - W4L15626
(x1) | 5/8"x2"x22 7/8" (16x50x580)



N8 | FRONT PORCH GABLE TRIM - W4L14832
(x2) | 5/8"x2 3/8"x9 1/2" (16x60x241)



N9 | GABLE TRIM - W4L14833
(x4) | 5/8"x2 3/8"x6 1/2" (16x60x165)



N10 | GABLE BOARD - W4L14834
(x2) | 5/8"x2 3/8"x27 5/8" (16x60x702)

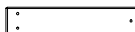

N11 | GABLE TRIM - W4L15716
(x2) | 5/8"x2 3/8"x11 1/2" (16x60x292)



O01 | CROWS NEST WALL BOARD - W4L15641
(x18) | 5/8"x1 3/8"x32 1/4" (16x34x819)



O2 | SAFETY BOARD - W4L14836
(x1) | 5/8"x1 3/8"x28 5/8" (16x34x726)



O70 | SLIDE MOUNTING BOARD - W4L14837
(x1) | 5/8"x1 3/8"x20 3/8" (16x34x517)



SP1 | SWING BEAM SUPPORT - W4L15647
(x1) | 3 3/8"x3 3/8"x48 3/8" (86x86x1229)

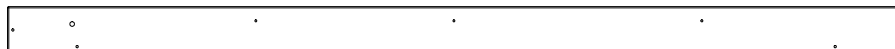

Y1 | TOP FLOOR BOARD - W4L15730
(x2) | 5/8"x4"x78" (16x102x1980)

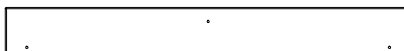

Y2 | BOTTOM FLOOR BOARD - W4L14840
(x2) | 5/8"x4"x35 1/4" (16x102x895)



Y03 | ROCK WALL END BOARD - W4L15644
(x1) | 5/8"x3 5/8"x22 7/8" (16x92x580)

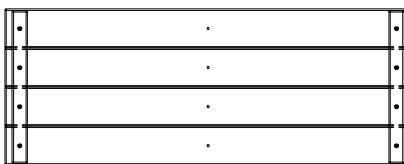

FP1 | BOTTOM FLOOR PANEL - W2A03140
(x4) | 1 5/8"x13 1/2"x35 3/8" (40x344x897)

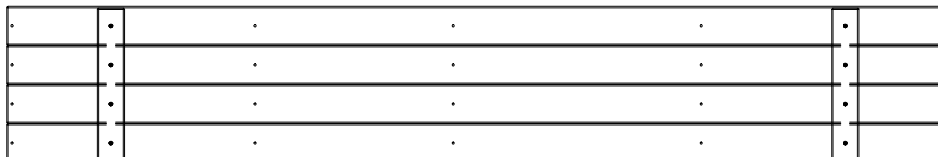

FP2 | FLOOR PANEL - W2A03141
(x4) | 1 1/4"x13 1/2"x81 7/8" (32x344x2080)



Wood Components (Not to Scale)

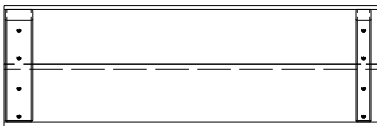

RP1 | LEFT PORCH PEAK ROOF PANEL - W2A03142
(x1) | 1 5/8"x10 1/2"x32 7/8" (42x268x834)

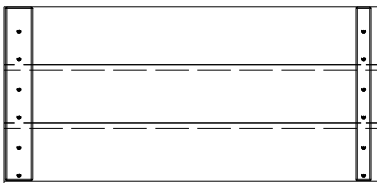

RP2 | LEFT PORCH ROOF PANEL - W2A03143
(x1) | 1 5/8"x15 5/8"x32 7/8" (42x396x834)

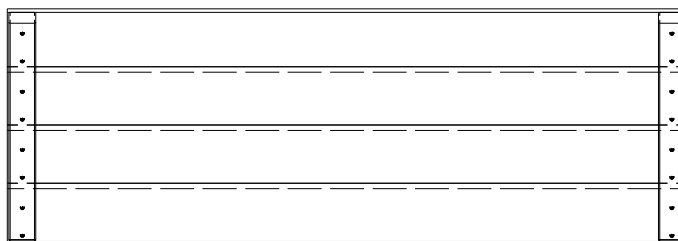

RP3 | PEAK ROOF PANEL - W2A03144
(x2) | 1 5/8"x20 5/8"x59" (42x524x1499)

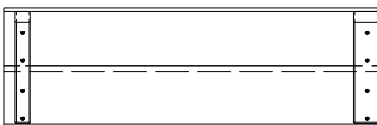

RP4 | RIGHT PORCH PEAK ROOF PANEL - W2A03145
(x1) | 1 5/8"x10 1/2"x32 7/8" (42x268x834)

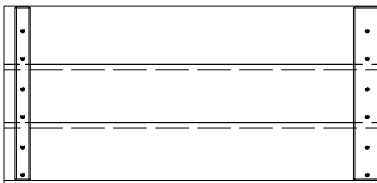

RP5 | RIGHT PORCH ROOF PANEL - W2A03146
(x1) | 1 5/8"x15 5/8"x32 7/8" (42x396x834)

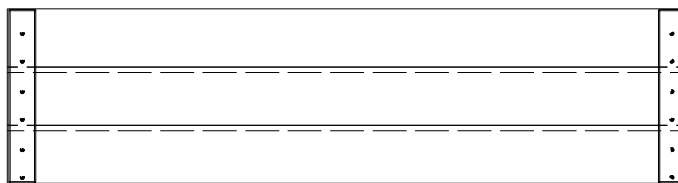

RP6 | ROOF PANEL - W2A03147
(x4) | 1 5/8"x15 5/8"x59" (42x396x1499)

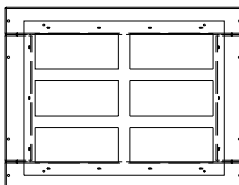

WP1 | BAY WINDOW PANEL - W2A03148
(x6) | 7/8"x15 3/4"x20 3/4" (21x400x526)



Hardware Components



H100415 | BOLT WH BLK
(x34) | 5/16x3 3/4



H100503 | BOLT WH BLK
(x4) | 5/16x3-1/2



H100484 | BOLT WH BLK
(x3) | 5/16x3 1/4



H100416 | BOLT WH BLK
(x10) | 5/16x3



H100195 | BOLT WH BLK
(x10) | 5/16x2-3/4



H100194 | BOLT WH BLK
(x3) | 5/16x2 1/2



H100205 | BOLT WH BLK
(x32) | 5/16x2-1/4



H100457 | BOLT WH BLK
(x7) | 5/16x2



H100193 | NUT BARREL WH BLK
(x2) | 5/16x1-1/2



H100469 | NUT BARREL WH BLK
(x2) | 5/16x5/8

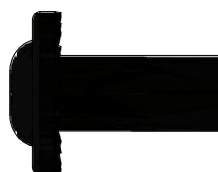

H100192 | NUT BARREL WH BLK
(x36) | 5/16x7/8



H100396 | BOLT WH BLK
(x13) | 5/16x1 1/2

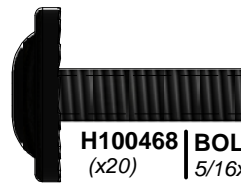

H100468 | BOLT WH BLK
(x20) | 5/16x1

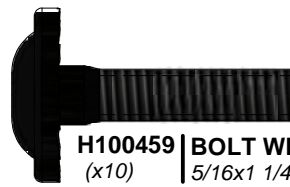

H100459 | BOLT WH BLK
(x10) | 5/16x1 1/4



H100407 | BOLT WH BLK
(x26) | 5/16x1 1/2

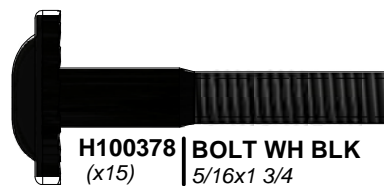

H100378 | BOLT WH BLK
(x15) | 5/16x1 3/4



H100471 | LAG SCREW WH BLK
(x7) | 5/16x1 1/2



H100458 | LAG SCREW WH BLK
(x46) | 5/16x2



H100197 | LAG SCREW WH BLK
(x42) | 5/16x2 1/2



Hardware Components

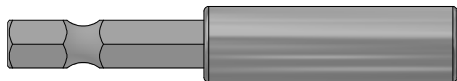

H101100 | MAGNETIC DRIVER
(x1)



H100764 | SCREW SETTER
(x1)

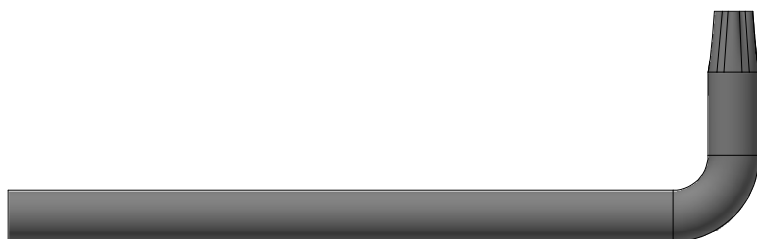

H100114 | TORX WRENCH
(x2) | T-30



H100147 | TORX BIT
(x2) | T-30



H100654 | BOLT HEX
(x13) | 3/8x5-1/2



H100091 | SCREW PFH
(x4) | 8x2 1/4



H100072 | T-NUT
(x26) | 1/4

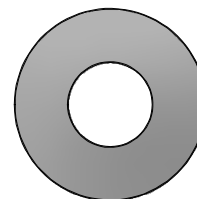

H100102 | WASHER FLAT
(x13) | 11x25



H100111 | SCREW PFH
(x17) | 8x2

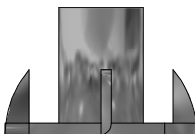

H100073 | T-NUT
(x13) | 3/8

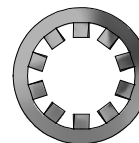

H100107 | WASHER LOCK INT
(x13) | 10x18

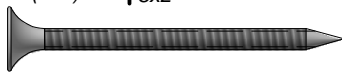

H100089 | SCREW PFH
(x4) | 8x1 3/4



H100086 | SCREW PFH
(x250) | 8x1 1/2



H100128 | SCREW PWH
(x30) | 8x5/8



H100063 | BOLT PTH
(x26) | 1/4x3/4

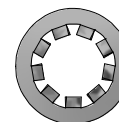

H100108 | WASHER LOCK INT
(x26) | 8x15



H100087 | SCREW PFH
(x4) | 8x1 1/4

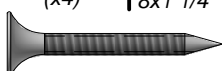

H100088 | SCREW PFH
(x346) | 8x1 1/8



H100070 | SCREW PWH
(x9) | 8x3/4



Hardware Components



H100201 | SCREW PFH BLK
(x17) | 8x2-1/2



H100483 | SCREW PFH BLK
(x30) | 8x2 1/4



H100391 | SCREW PFH BLK
(x72) | 8x2

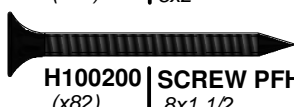

H100200 | SCREW PFH BLK
(x82) | 8x1 1/2

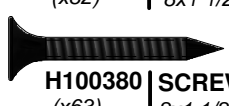

H100380 | SCREW PFH BLK
(x63) | 8x1 1/8

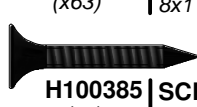

H100385 | SCREW PFH BLK
(x9) | 8x1

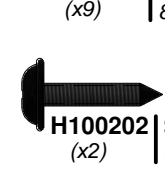

H100202 | SCREW PWH BLK
(x2) | 8x5/8



H100472 | BOLT HEX BLK
(x2) | 5/16x2 3/4



H100761 | BOLT HEX BLK
(x4) | 5/16x2



H100657 | BOLT HEX BLK
(x4) | 5/16x1 3/4



H100481 | BOLT HEX BLK
(x4) | 5/16x1 1/4



H100659 | LAG SCREW BLK
(x9) | 5/16x1 1/2



H100479 | NUT LOCK BLK
(x2) | 5/16



H100379 | T-NUT BLK
(x149) | 5/16



H100403 | LAG SCREW WH BLK
(x22) | 1/4x1 1/2

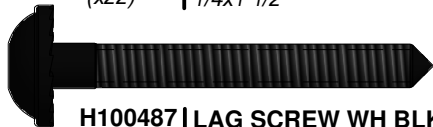

H100487 | LAG SCREW WH BLK
(x2) | 1/4x2



H100456 | LAG SCREW WH BLK
(x11) | 1/4x2 1/2

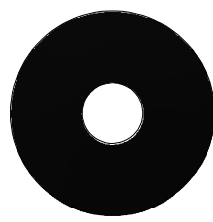

H100478 | WASHER FLAT BLK
(x24) | 8x27



H100474 | WASHER FLAT BLK
(x2) | 9x18



H100477 | WASHER SPLIT BLK
(x22) | 5/16

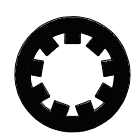

H100473 | WASHER LOCK INT BLK
(x2) | 8x15



H100405 | WASHER LOCK EXT BLK
(x13) | 6x15



H100198 | WASHER LOCK EXT BLK
(x187) | 8x19



H100199 | WASHER LOCK EXT BLK
(x34) | 12x19

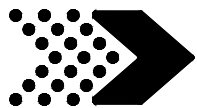

Accessory Components (Not to Scale)



A100047 | CHAIN GREEN 57"
(x4)



A100177 | CHAIN GREEN 31"
(x2)

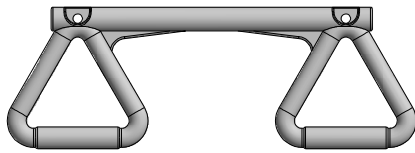

A6P00034 | TRAPEZE YELLOW
(x1)

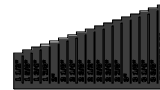

A6P00410 | PICKET PAL
(x1)

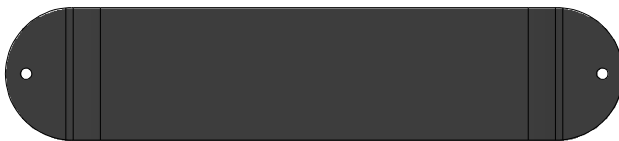

A100027 | SWING SEAT GREEN 26"
(x2)



A100045 | METAL RUNG 559 GREEN
(x8)

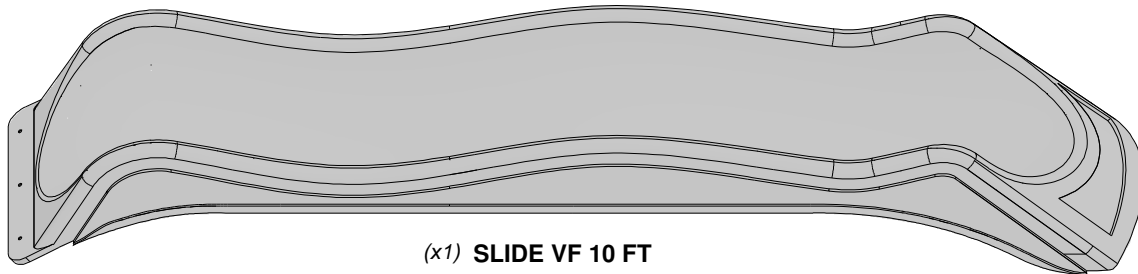

(x1) SLIDE VF 10 FT

10 FT VACUUM FORMED SLIDES		
PART NUMBER	COLOR	MODEL NUMBER
A100287	GREEN	2106031B
A6P00540	YELLOW	2300330
A6P00539	GREY	2300071

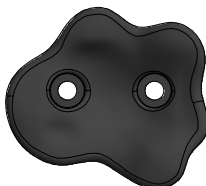

A6P00036 | GREEN HC ROCK #1
(x6)



A6P00037 | GREEN HC ROCK #2
(x6)



A100164 | BYD ID TAG
(LARGE) AGES 3-10
(x1)

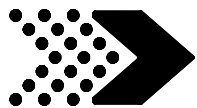

Accessory Components (Not to Scale)

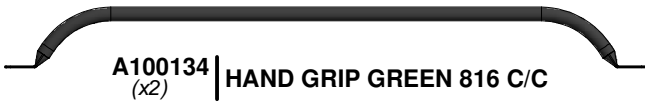

A100134 (x2) | HAND GRIP GREEN 816 C/C

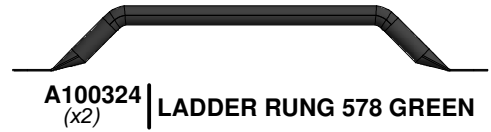

A100324 (x2) | LADDER RUNG 578 GREEN



A100118 (x6) | HAND GRIP METAL GREEN 381 c/c

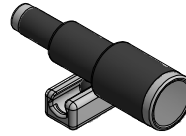

A6P00096 (x1) | TELESCOPE

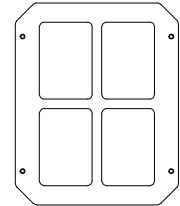

A100014 (x2) | PLASTIC WINDOW WHITE

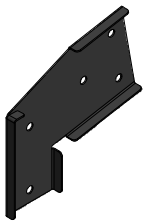

A100325 (x1) | SWING BEAM EXTENSION BRACKET-LEFT

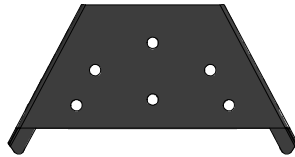

A4M01169 (x1) | A-FRAME BRACKET

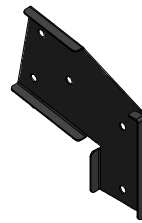

A100326 (x1) | SWING BEAM EXTENSION BRACKET-RIGHT

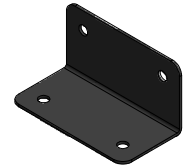

A100140 (x2) | L BRACKET 66x66x127

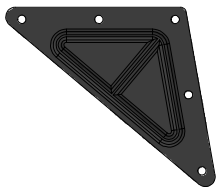

A100294 (x2) | TRIANGLE PLATE 100° 5 HOLE



A100396 (x4) | L BRACKET 51x32x82x3.175



A4M01046 (x15) | L BRACKET 2.5x38x55x55



A100314 (x1) | "A" REVISION TAG



A100069 (x6) | QUICK LINK

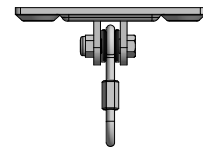

A4M00505 (x6) | SWINGER HANGER



A100178 (x8) | AUGER GROUND STAKE



A4M00527 (x2) | GROUND STAKE REBAR

PRE-ASSEMBLY STEP 1 - SORTING PARTS

It is critical for ease of assembly that you take the time to sort and organize the wood and hardware.

WOOD PARTS:

- Organize wood parts by the three-digit, alpha-numeric number stamped on each board (ex. P01).
- If there are multiple boards with the same stamped number, stack those pieces together.
- Stamps can be found on the flat surface of the boards or on the end of the boards.
- Allow yourself plenty of room - the wood pieces can take up a significant amount of space.

NOTE: CARTONS ARE NOT ORGANIZED BY BOARD NUMBER.

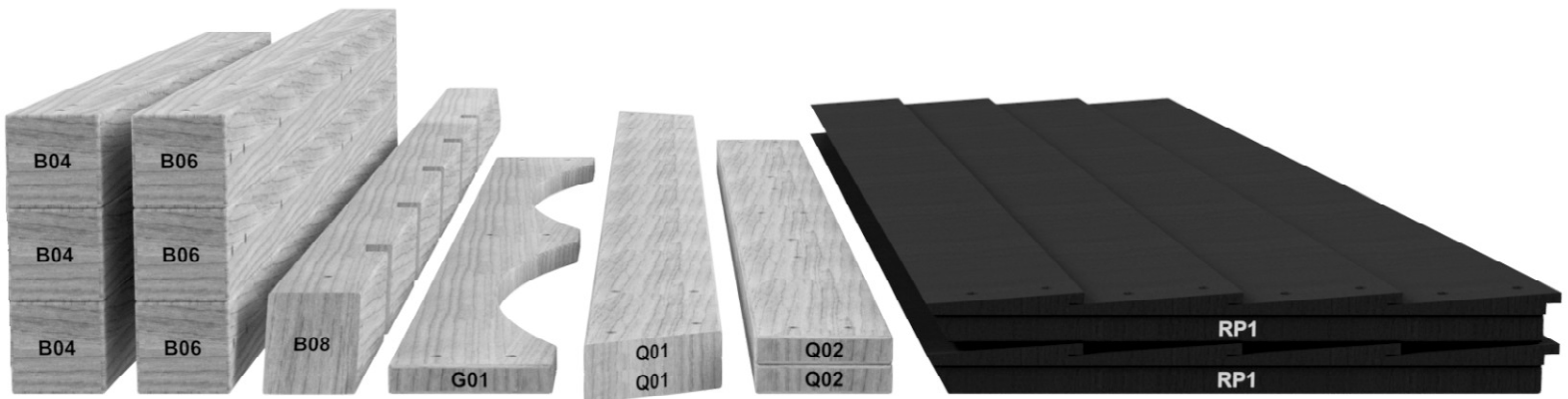

HARDWARE PARTS:

- We recommend that you have a separate table to organize the hardware.
- Hardware bags are printed with a seven-digit, alpha-numeric part number.
- You can organize your hardware by part number or group by hardware type (i.e. bolts, nuts, etc.).
- During assembly you only need to reference the last four digits of the number.

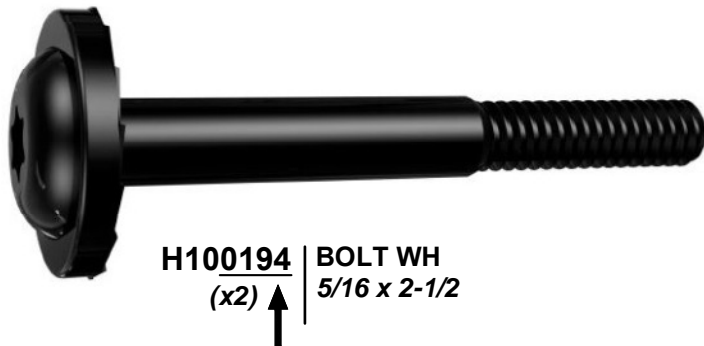

PRE-ASSEMBLY STEP 2 - TOOLS REQUIRED



**Cordless Drill or
Electric Drill**



**Drill Attachments:
Phillips Head**



**1/8", 3/16", 3/8" & 7/16"
Drill Bits**



Phillips Screw Driver



Open End Wrenches 1/2" & 9/16"



**3/8" Drive Ratchet, 1/2" &
9/16" STD Sockets 1/2" & 9/16" Deep
Sockets**



Claw Hammer



Rubber Mallet - Optional



Tape Measure

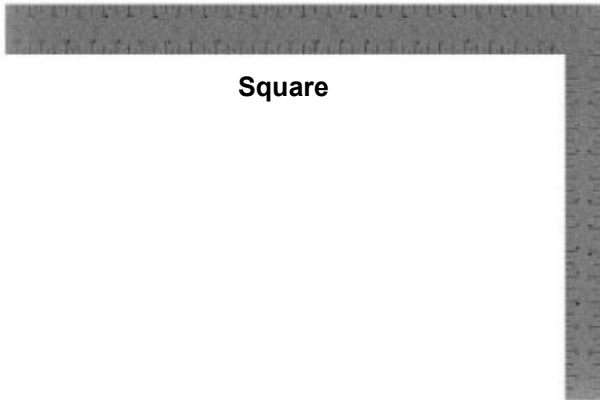

Square



Level 24"

PRE-ASSEMBLY STEP 3 - CHOOSE YOUR ASSEMBLY METHOD

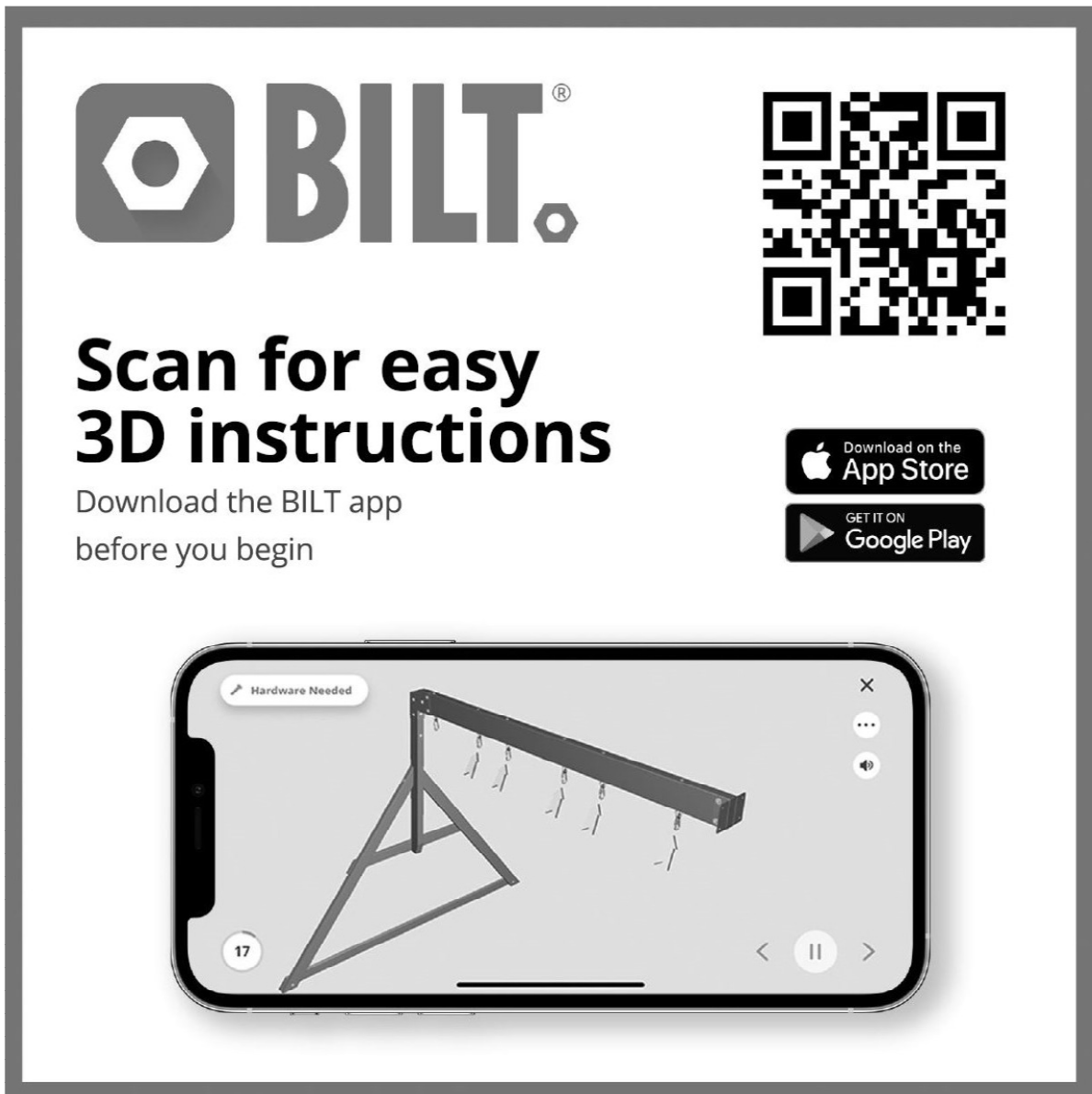

There are several types of assembly instructions available to you.

1. Printed Assembly Manual included with your set
2. BILT APP - 3D interactive instructions
3. Combination of the Printed Manual and BILT APP (Note: Step numbers can differ between the two methods)

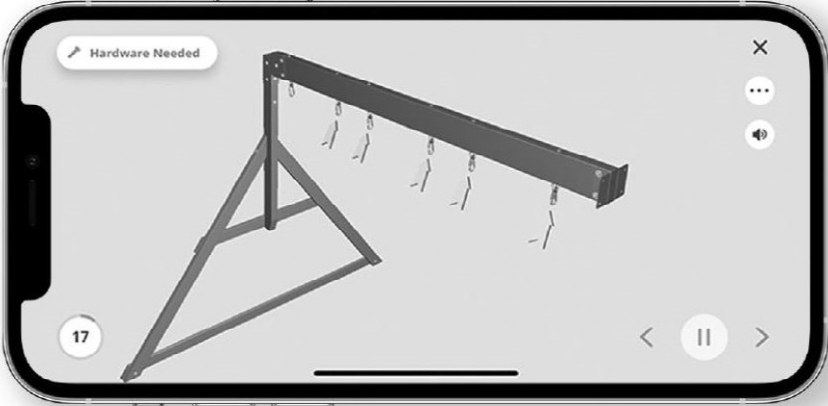

Scan for easy 3D instructions

Download the BILT app before you begin



The image shows a smartphone screen displaying the BILT app interface. At the top left, there is a button labeled "Hardware Needed". The main area of the screen shows a 3D assembly diagram of a metal frame with a horizontal beam and several hanging components. In the bottom left corner, there is a circular icon with the number "17". In the bottom right corner, there are navigation icons: a back arrow, a pause button, and a forward arrow. The top right corner of the screen has a close button (X), a menu button (three dots), and a volume icon.

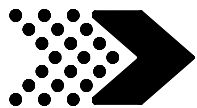

MONKEY BARS

STEP 1

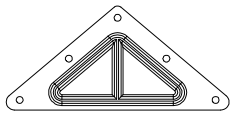

A100294 | TRIANGLE
PLATE 100° 5
HOLE
(x2)



A4M01046 | L BRACKET
(x4) | 2.5x38x55x55

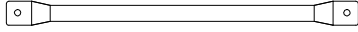

A100045 | METAL RUNG
(x4) | 559 GREEN

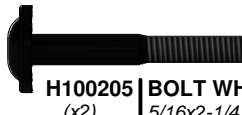

H100205 | BOLT WH BLK
(x2) | 5/16x2-1/4



H100407 | BOLT WH BLK
(x6) | 5/16x1 1/2



H100379 | T-NUT BLK
(x6) | 5/16



H100403 | LAG SCREW
(x8) | WH BLK
1/4x1 1/2



H100478 | WASHER FLAT
(x2) | BLK
8x27



H100479 | NUT LOCK BLK
(x2) | 5/16



E74 | MONKEY BAR RAIL - W4L15732
(x2) | 1 3/8"x3 3/8"x77 1/8" (36x86x1959)



TIP:
INSTALL T-NUTS INTO BOARDS
BEFORE ASSEMBLY

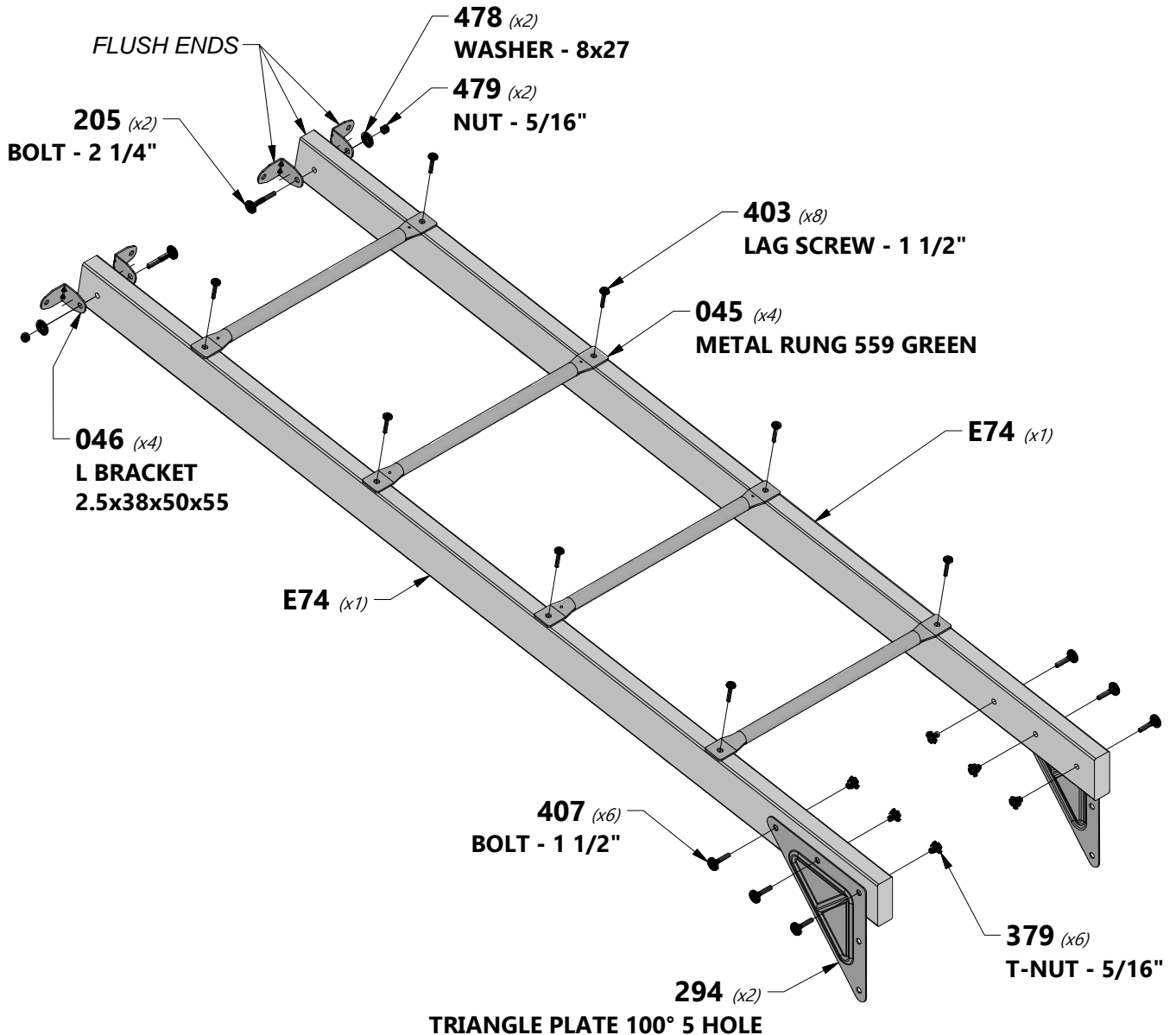

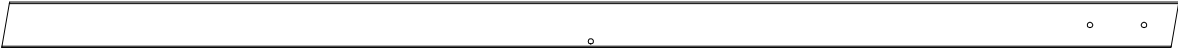
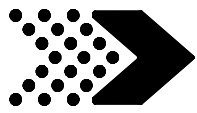

E3 | MONKEY BAR UPRIGHT - W4L08127
(x2) | 1 3/8"x3 3/8"x87 5/8" (36x86x2226)



H100407 | BOLT WH BLK
(x4) | 5/16x1 1/2



H100379 | T-NUT BLK
(x4) | 5/16

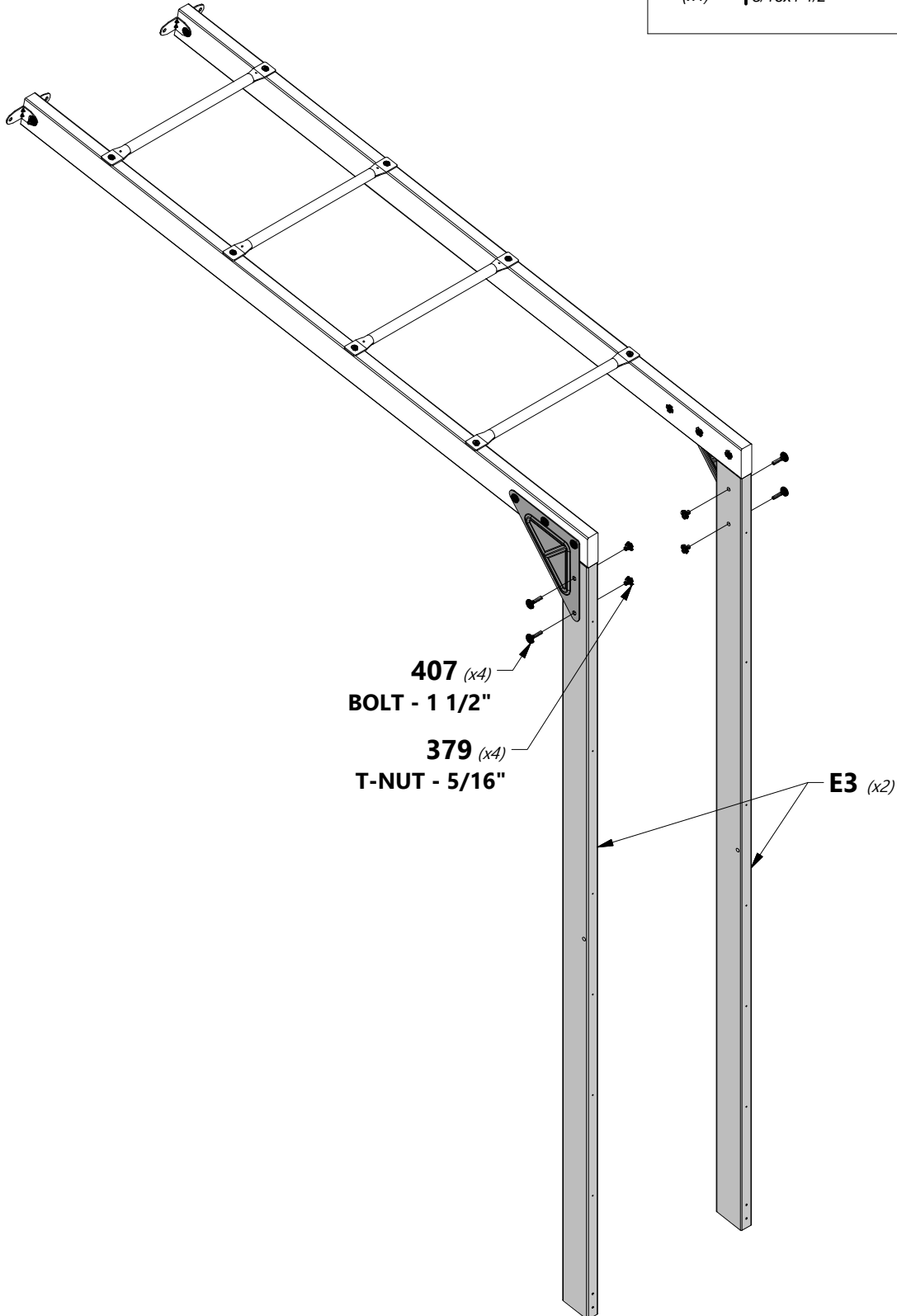

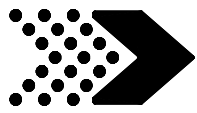

MONKEY BARS

STEP 3



H82 | MONKEY BAR GROUND BOARD - W4L15714
(x1) | 1"x3 3/8"x70 3/8" (24x86x1786)



H81 | MONKEY BAR BRACE - W4L15710
(x2) | 1"x3 3/8"x51 5/8" (24x86x1311)



H100472 | BOLT HEX BLK
(x2) | 5/16x2 3/4



H100197 | LAG SCREW
(x4) | WH BLK
5/16x2 1/2



H100407 | BOLT WH BLK
(x4) | 5/16x1 1/2



H100192 | NUT BARREL
(x4) | WH BLK
5/16x7/8



H100379 | T-NUT BLK
(x2) | 5/16



H100473 | WASHER LOCK
(x2) | INT BLK
8x15



H100474 | WASHER FLAT
(x2) | BLK
9x18



H100198 | WASHER LOCK
(x8) | EXT BLK
8x19



H100199 | WASHER LOCK
(x4) | EXT BLK
12x19

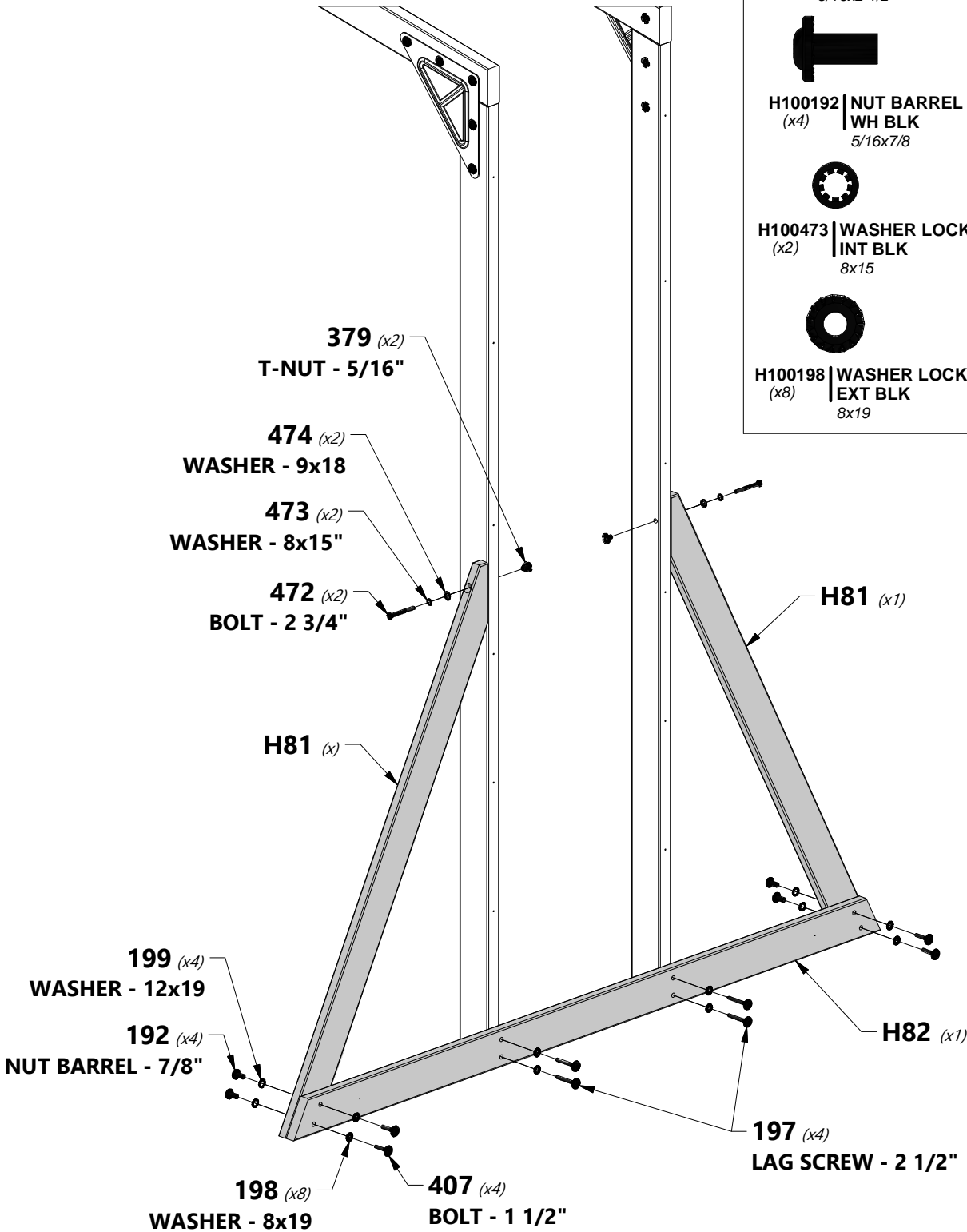

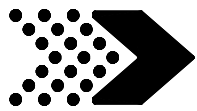

MONKEY BARS

STEP 4

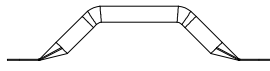

A100118 | **HAND GRIP**
(x2) | **METAL GREEN**
381 c/c

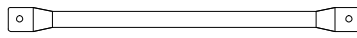

A100045 | **METAL RUNG**
(x4) | **559 GREEN**



H100403 | **LAG SCREW**
(x12) | **WH BLK**
1/4x1 1/2

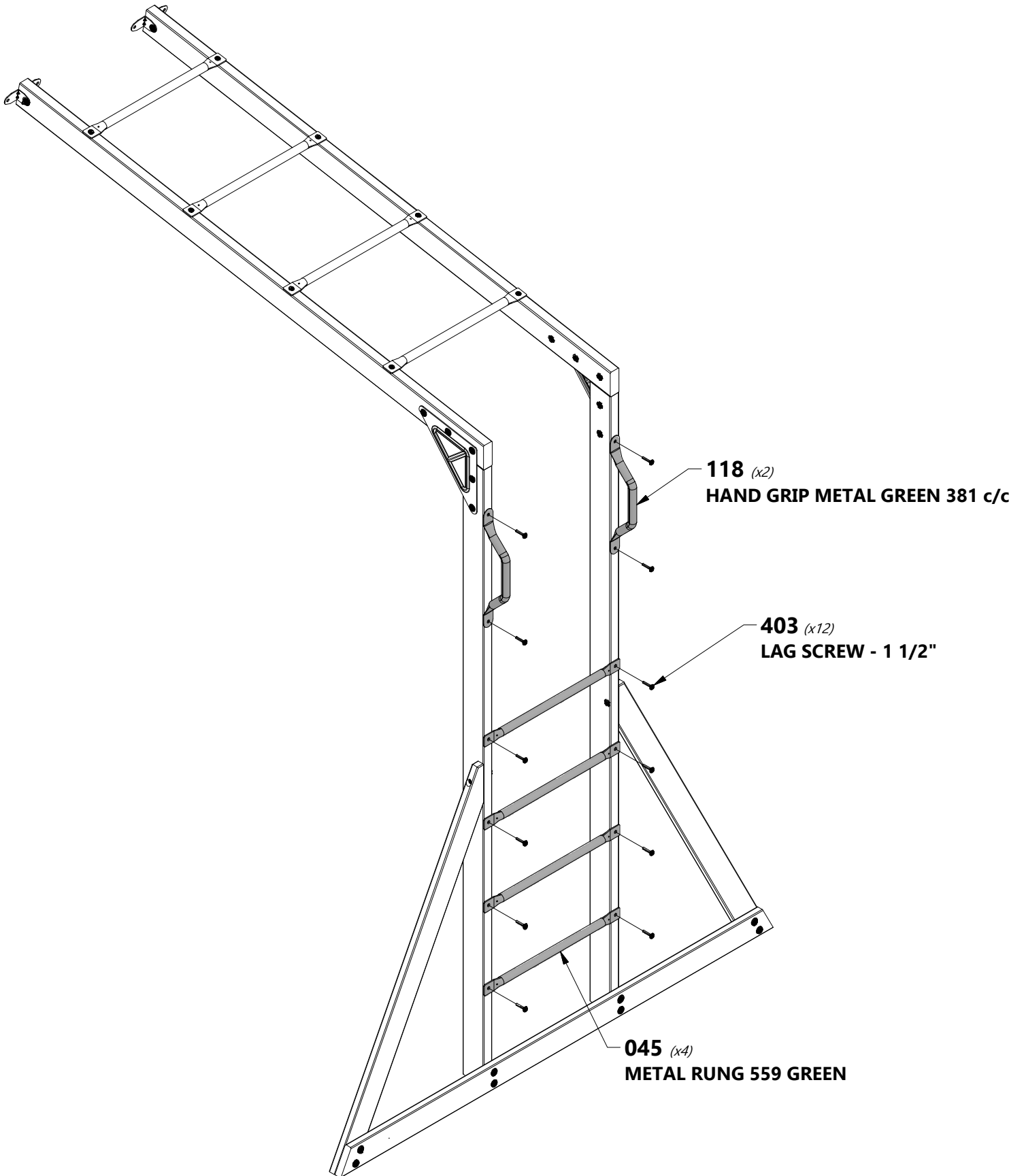

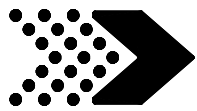

LADDER ASSEMBLY

STEP 1

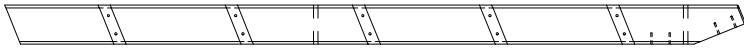

E77 | LEFT UPRIGHT - W4L14734
(x1) | 1 3/8"x3 3/8"x64 3/8" (36x86x1634)



H76 | LADDER RUNG - W4L14779
(x5) | 1"x3 3/8"x18 1/8" (24x86x460)



H100391 | SCREW PFH BLK
(x10) | 8x2

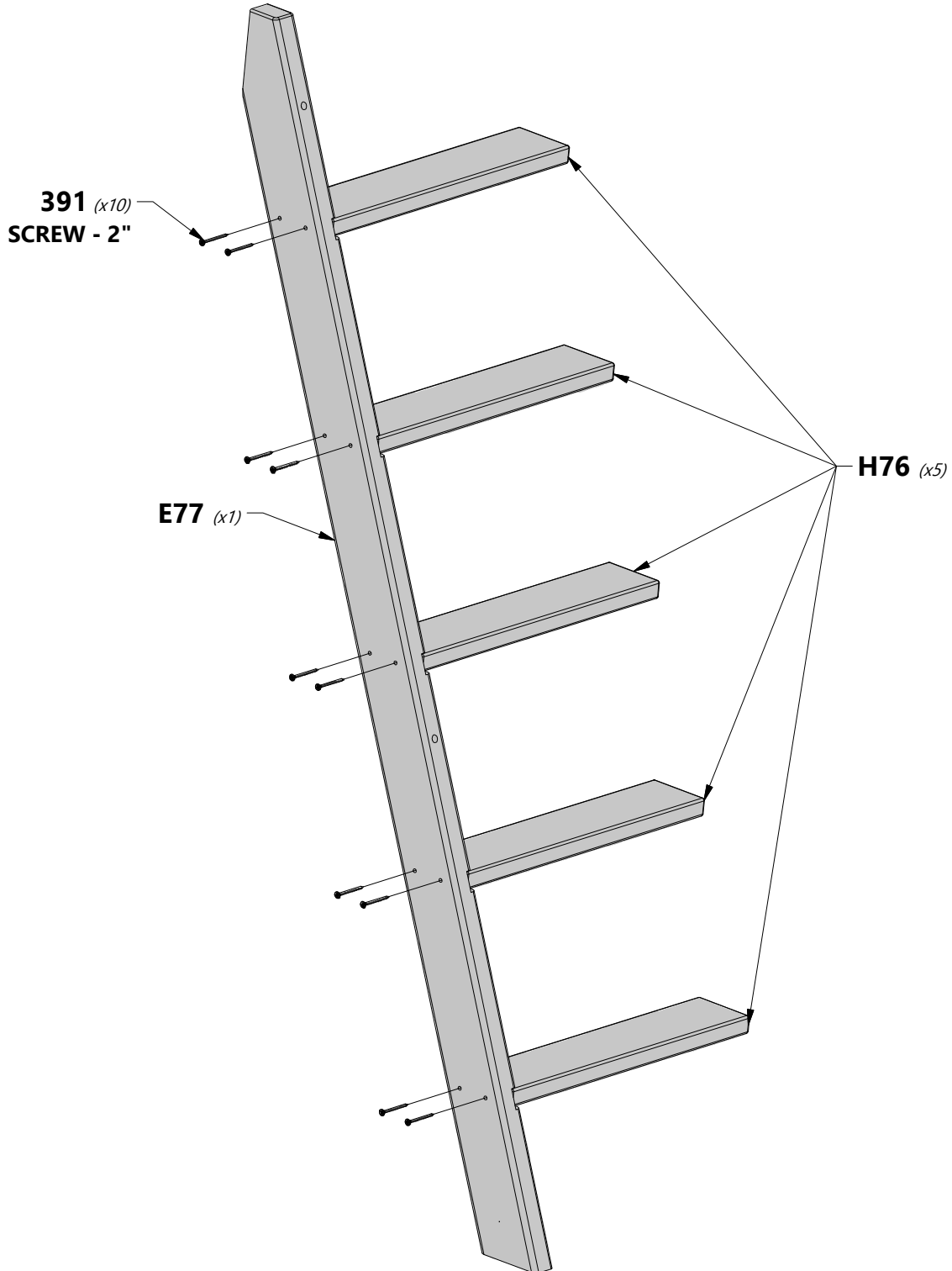

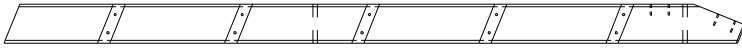
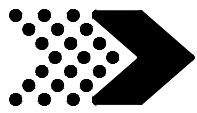

E78 | RIGHT UPRIGHT - W4L14735
(x1) | 1 3/8"x3 3/8"x64 3/8" (36x86x1634)



H100391 | SCREW PFH BLK
(x10) | 8x2

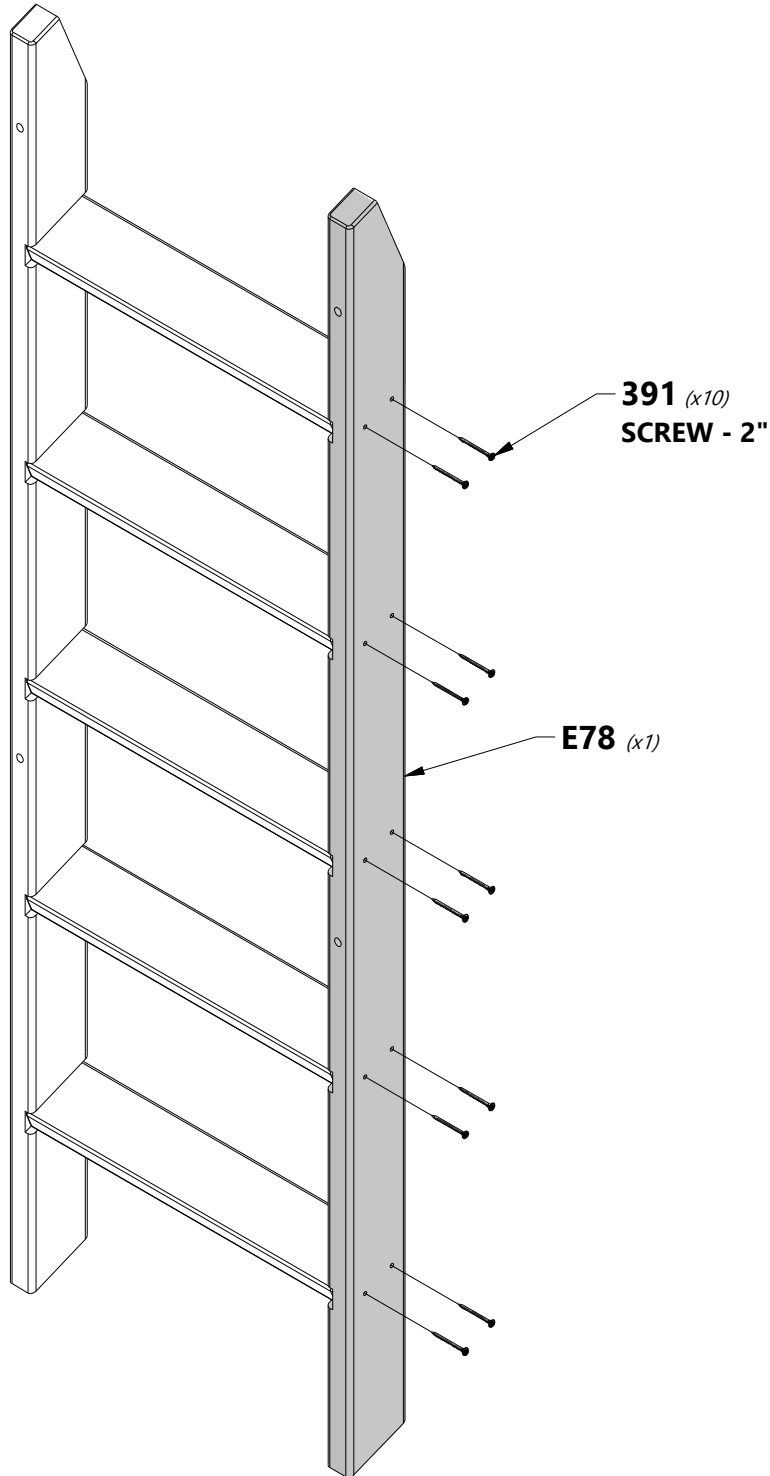

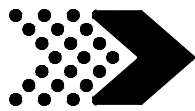

LADDER ASSEMBLY

STEP 3

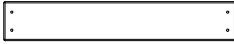

M73 | REAR SUPPORT - W4L14821
(x1) | 5/8"x3 3/8"x20 1/8" (16x86x512)



H77 | ATTACHMENT BOARD - W4L14780
(x1) | 1"x3 3/8"x20 1/8" (24x86x512)



H100391 | SCREW PFH BLK
(x8) | 8x2

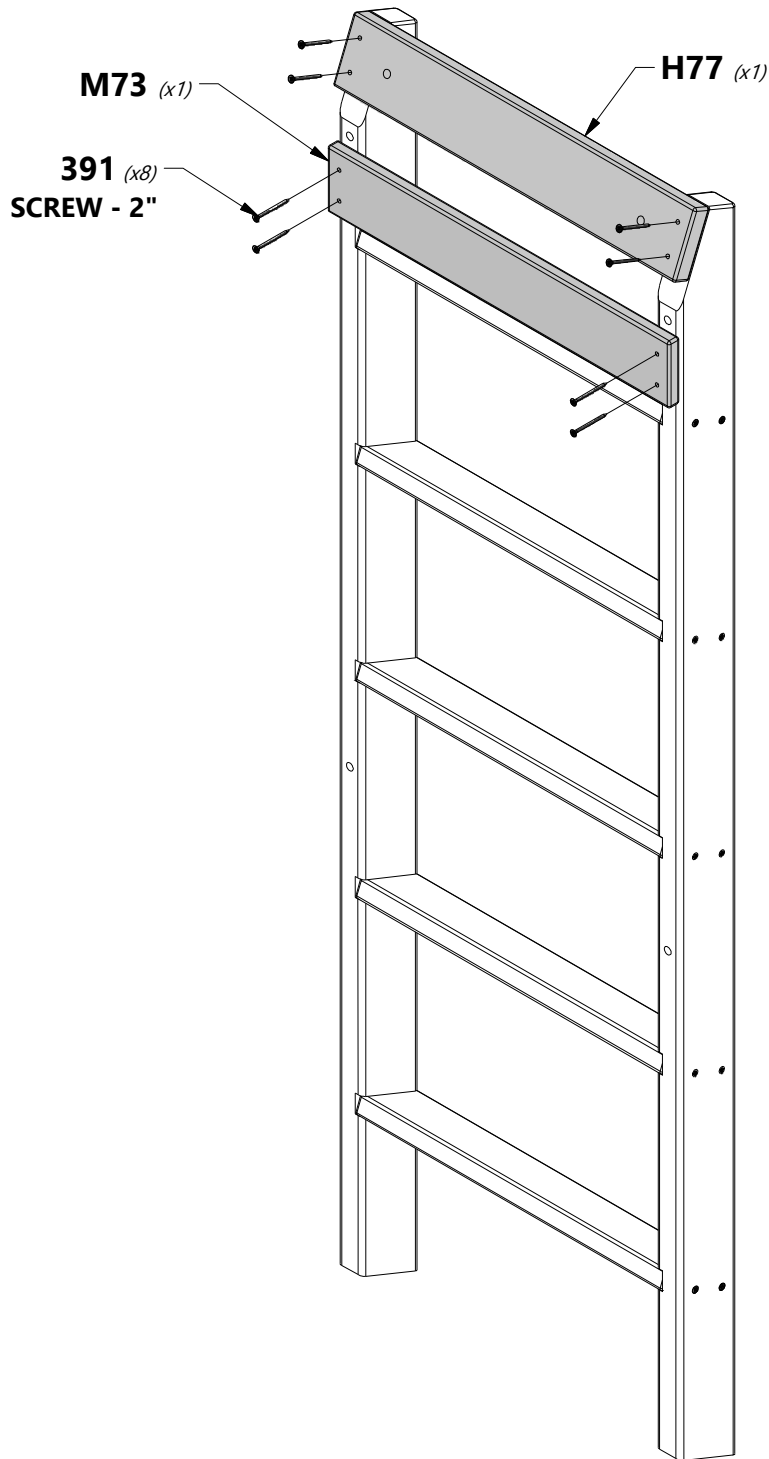

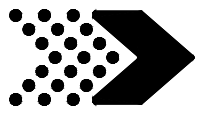

LADDER ASSEMBLY

STEP 4



A100134 | **HAND GRIP GREEN 816 C/C**
(x2)



H100503 | **BOLT WH BLK**
(x4) | 5/16x3-1/2



H100379 | **T-NUT BLK**
(x4) | 5/16

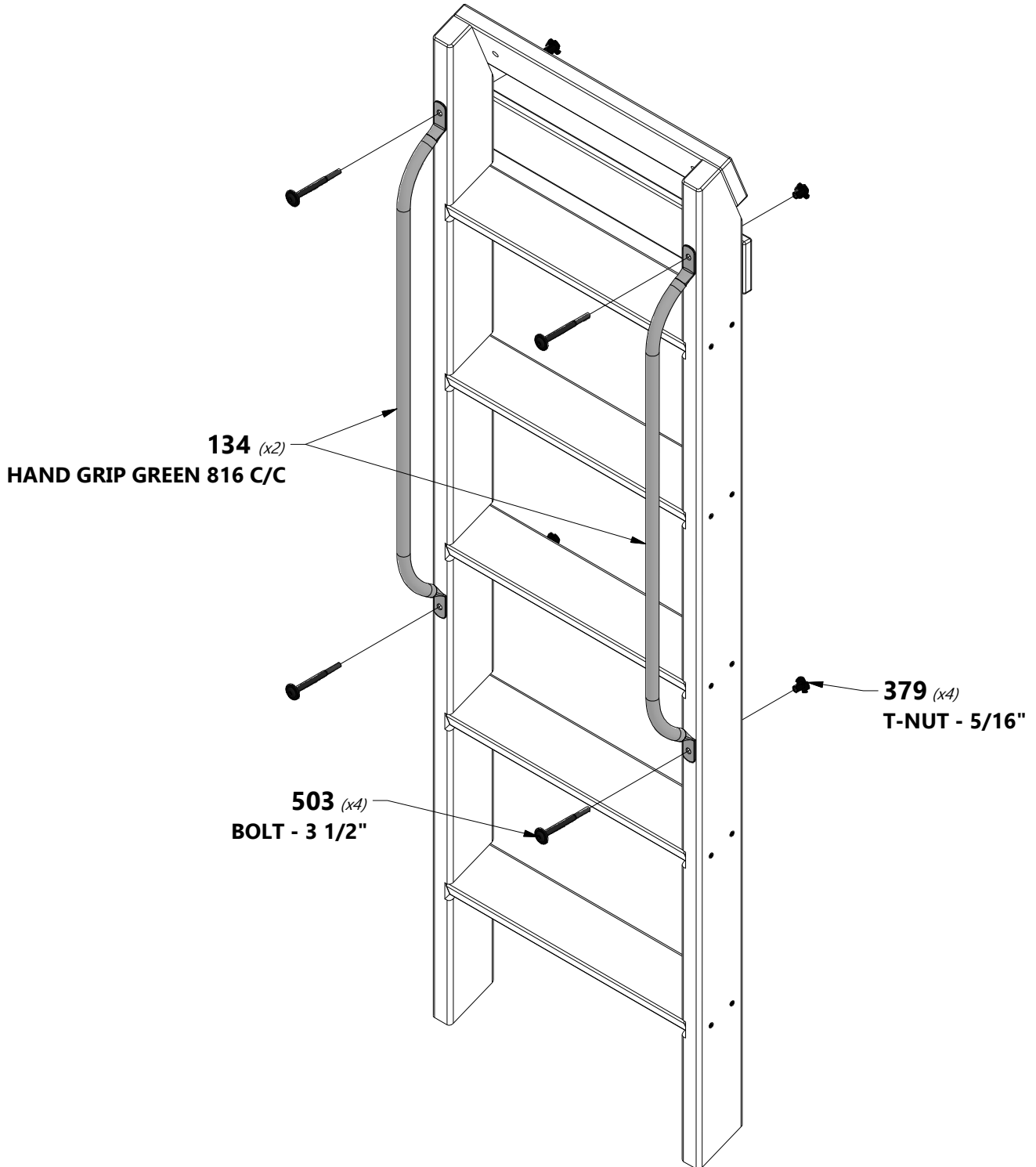



ROCKWALL ASSEMBLY

STEP 1



M75 | ROCK WALL BOARD - W4L15632
(4) | 5/8"x3 3/8"x22 7/8" (16x86x580)



M76 | ROCK WALL BOARD - W4L15633
(4) | 5/8"x3 3/8"x22 7/8" (16x86x580)

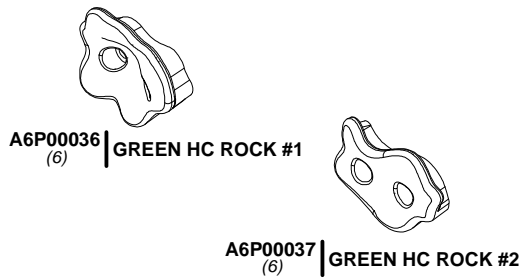

A6P00036 | GREEN HC ROCK #1
(6)

A6P00037 | GREEN HC ROCK #2
(6)

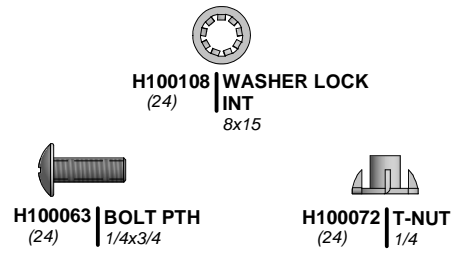

H100108 | WASHER LOCK
(24) | INT
8x15

H100063 | BOLT PTH
(24) | 1/4x3/4

H100072 | T-NUT
(24) | 1/4



TIP:
INSTALL T-NUTS INTO BOARDS
BEFORE ASSEMBLY

**INSTALL WITH FINGER GRIPS UPWARD.
PLACE ROCKS AS DESIRED**

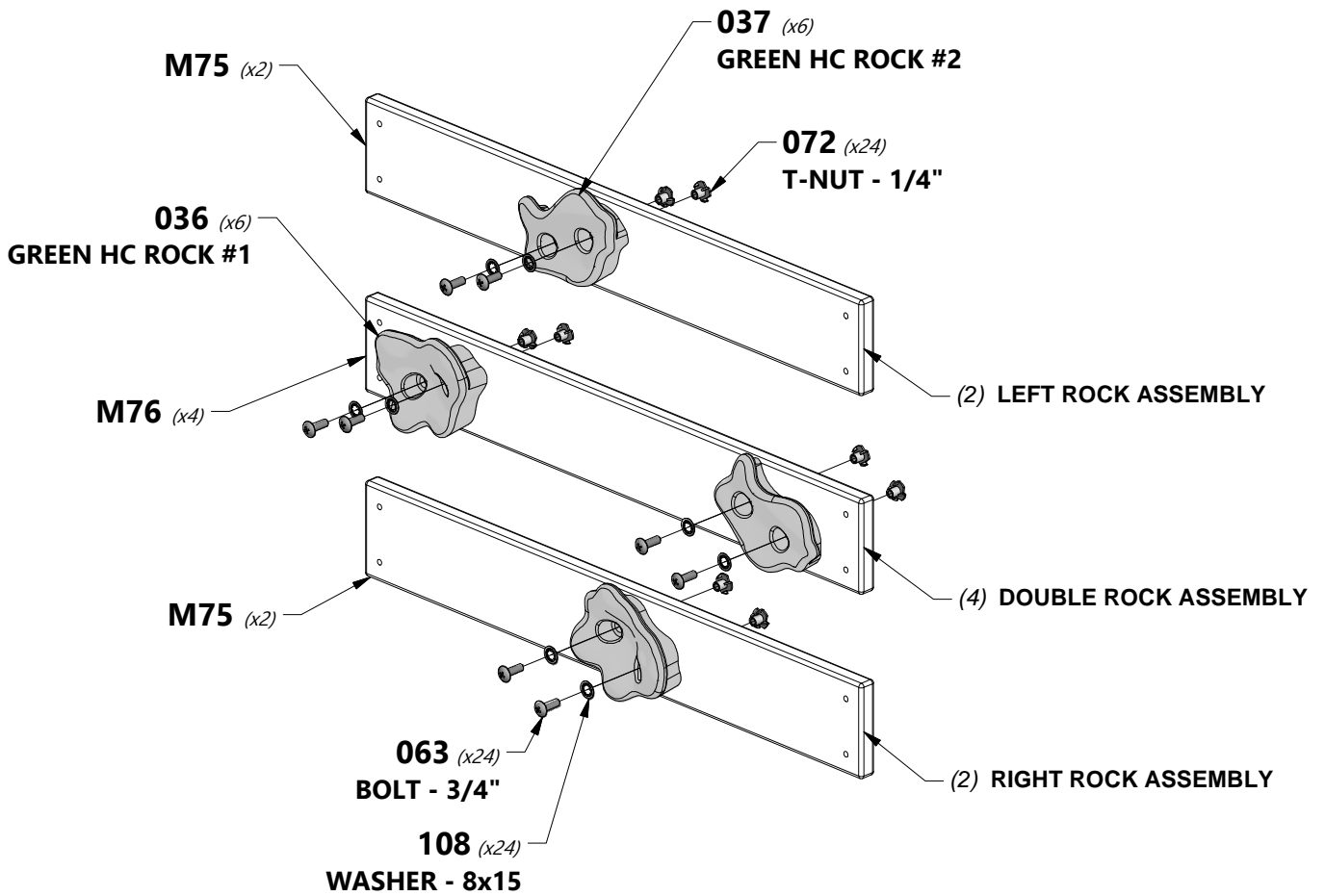
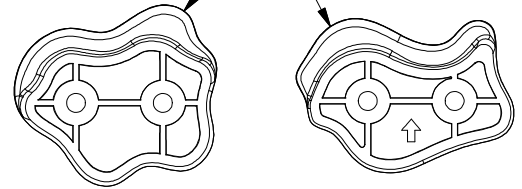



ROCKWALL ASSEMBLY

STEP 2

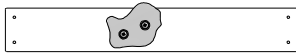

(2) LEFT ROCK ASSEMBLY



(4) DOUBLE ROCK ASSEMBLY

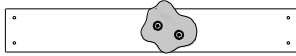

(2) RIGHT ROCK ASSEMBLY

N07 | ROCK WALL BOARD - W4L15626
(1) 5/8"x2"x22 7/8" (16x50x580)

M74 | ROCK WALL BOARD - W4L15631
(10) 5/8"x3 3/8"x22 7/8" (16x86x580)

E72 | ROCKWALL RAIL - W4L15490
(2) 1 3/8"x3 3/8"x64 5/8" (36x86x1640)



H100086 | SCREW PFH
(74) 8x1 1/2

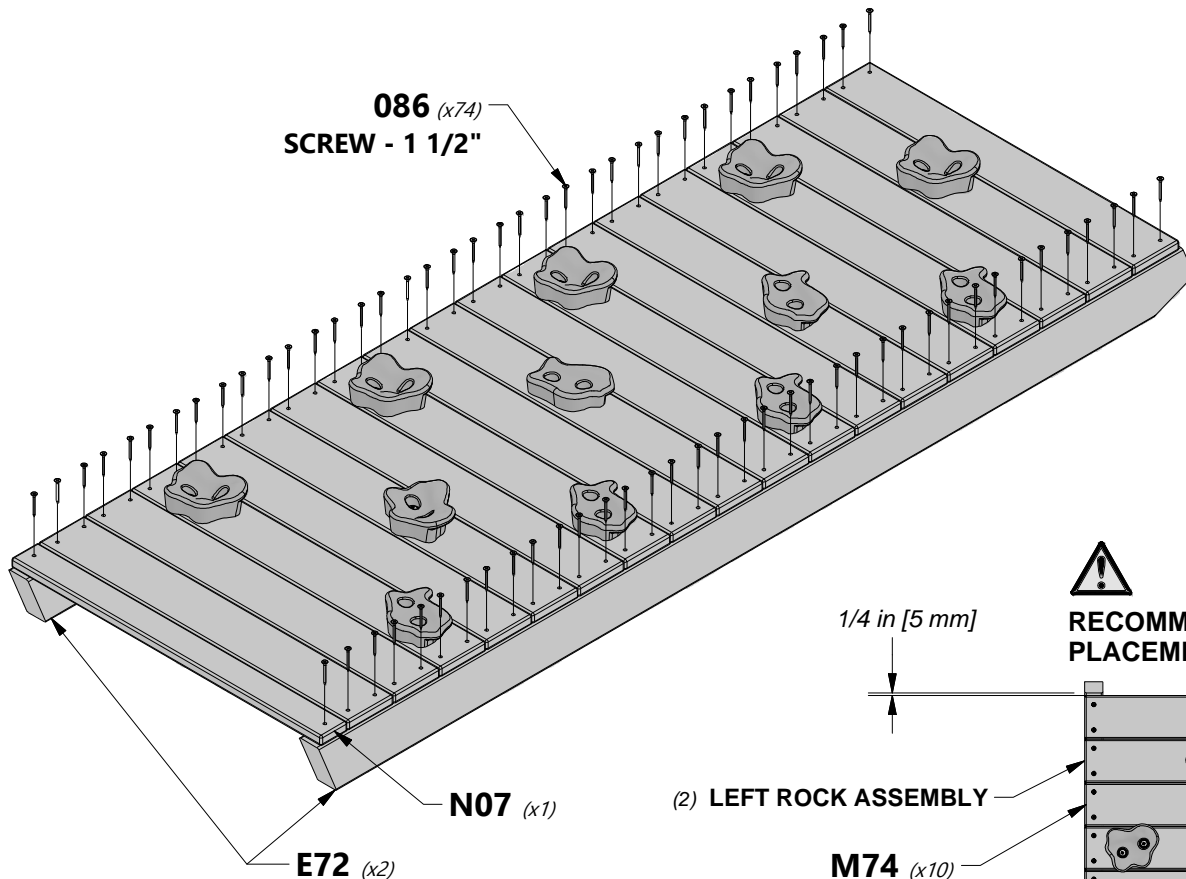

086 (x74)
SCREW - 1 1/2"

N07 (x1)

E72 (x2)

(2) LEFT ROCK ASSEMBLY

M74 (x10)

(2) RIGHT ROCK ASSEMBLY

(4) DOUBLE ROCK ASSEMBLY



TOP

RECOMMENDED BOARD
PLACEMENT PATTERN

1/4 in [5 mm]



(2) LEFT ROCK ASSEMBLY

M74 (x10)

(2) RIGHT ROCK ASSEMBLY

(4) DOUBLE ROCK ASSEMBLY



1/4 in [5 mm]

TOP

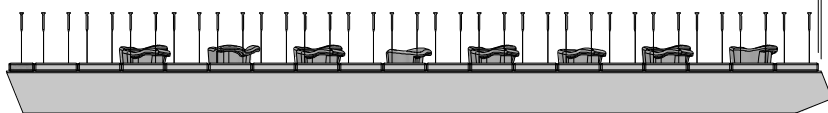

SIDE VIEW

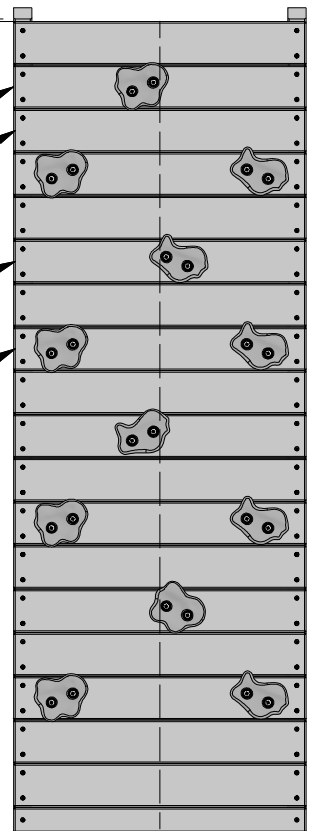



ROCKWALL ASSEMBLY

STEP 3



Y03 | ROCK WALL END BOARD - W4L15644
(1) | 5/8"x3 5/8"x22 7/8" (16x92x580)



H100200 | SCREW PFH BLK
(4) | 8x1 1/2

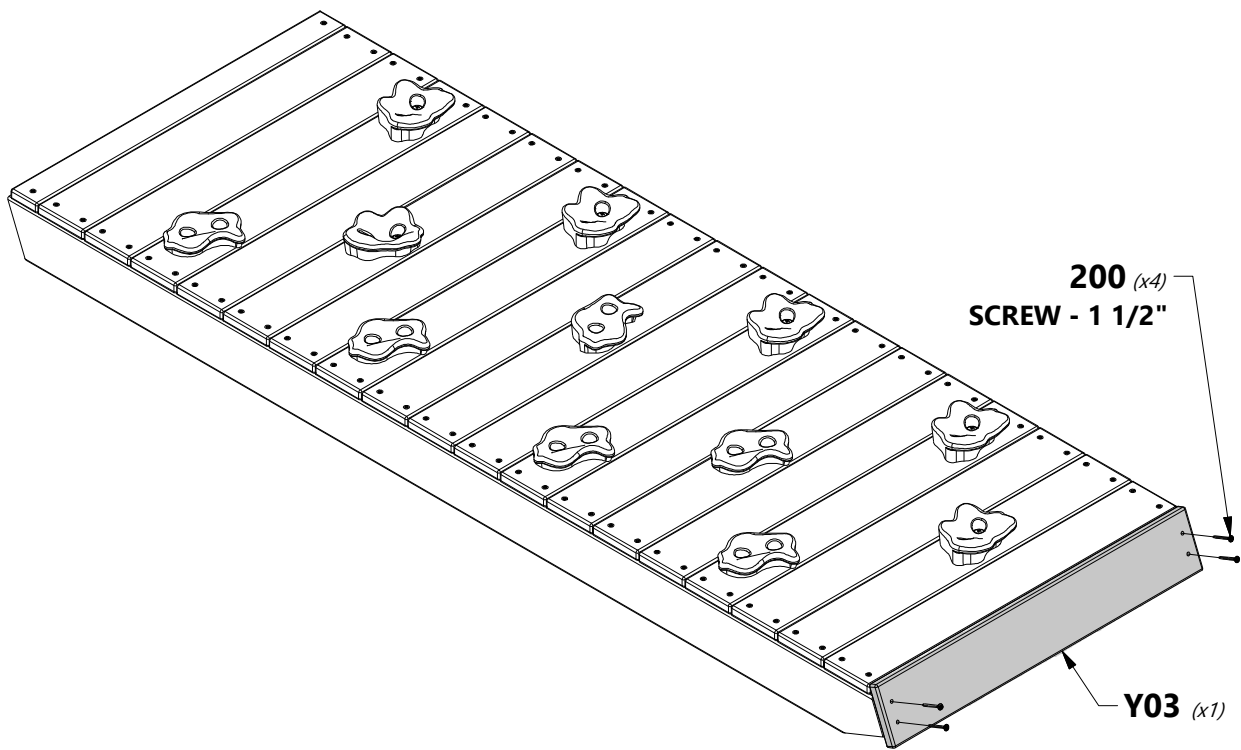

SIDE VIEW

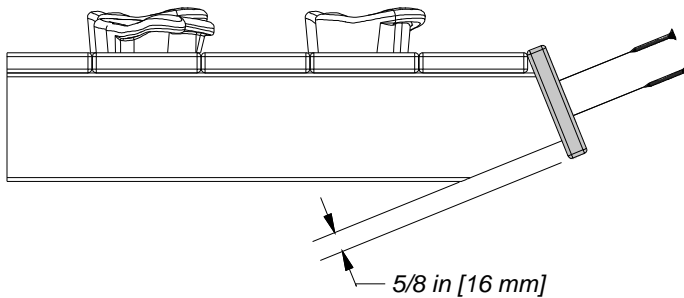



ROCKWALL ASSEMBLY

STEP 4



M61 | ATTACHMENT BOARD - W4L15629
(1) | 5/8"x3 3/8"x22 7/8" (16x86x580)

 **H100200** | SCREW PFH BLK
(4) | 8x1 1/2

 **H100379** | T-NUT BLK
(2) | 5/16

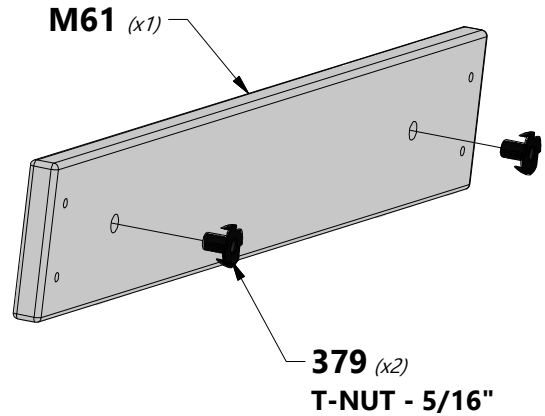

M61 (x1)

379 (x2)
T-NUT - 5/16"

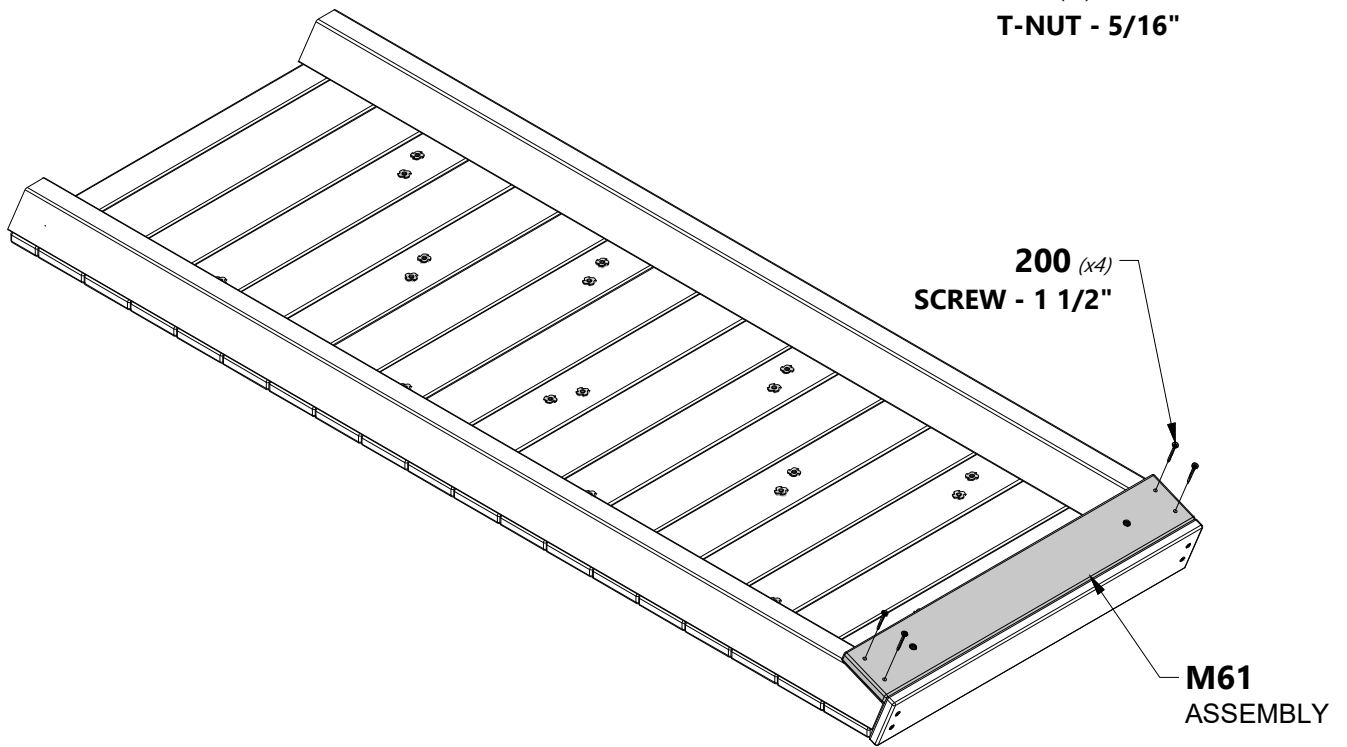

200 (x4)
SCREW - 1 1/2"

M61
ASSEMBLY

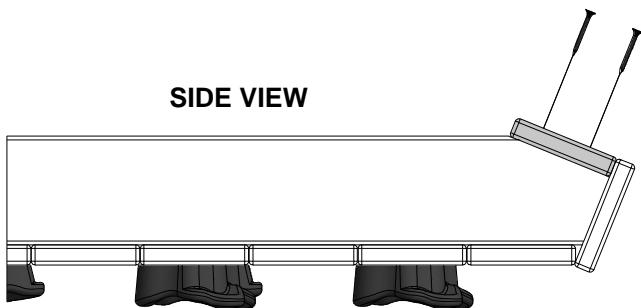

SIDE VIEW



**T-NUTS TO THE INSIDE
WHEN INSTALLING BOARD**

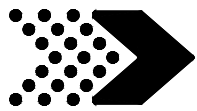

BAY WINDOW ASSEMBLY

STEP 1

G5 | BAY WINDOW HEADER - W4L14744
(x4) | 1"x5 1/4"x45 1/4" (24x134x1150)

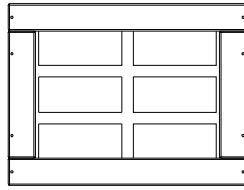

WP1 | BAY WINDOW PANEL - W2A03148
(x6) | 7/8"x15 3/4"x20 3/4" (21x400x526)

H100200 | SCREW PFH BLK
(x40) | 8x1 1/2

H100385 | SCREW PFH BLK
(x8) | 8x1



NOTE:

MAKE (2) WINDOW ASSEMBLIES.

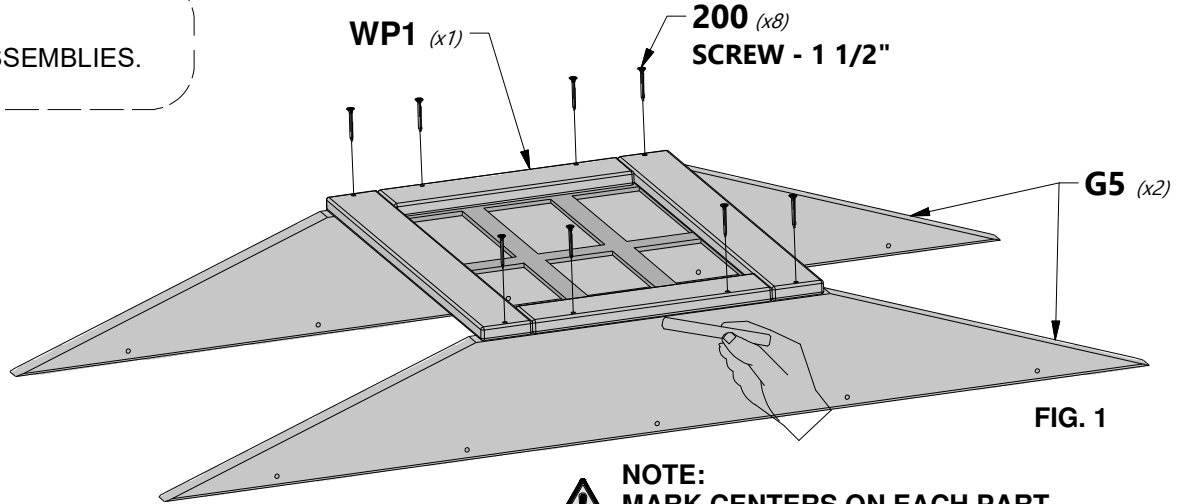

FIG. 1



NOTE:
MARK CENTERS ON EACH PART
THEN ALIGN PARTS ON MARKS.

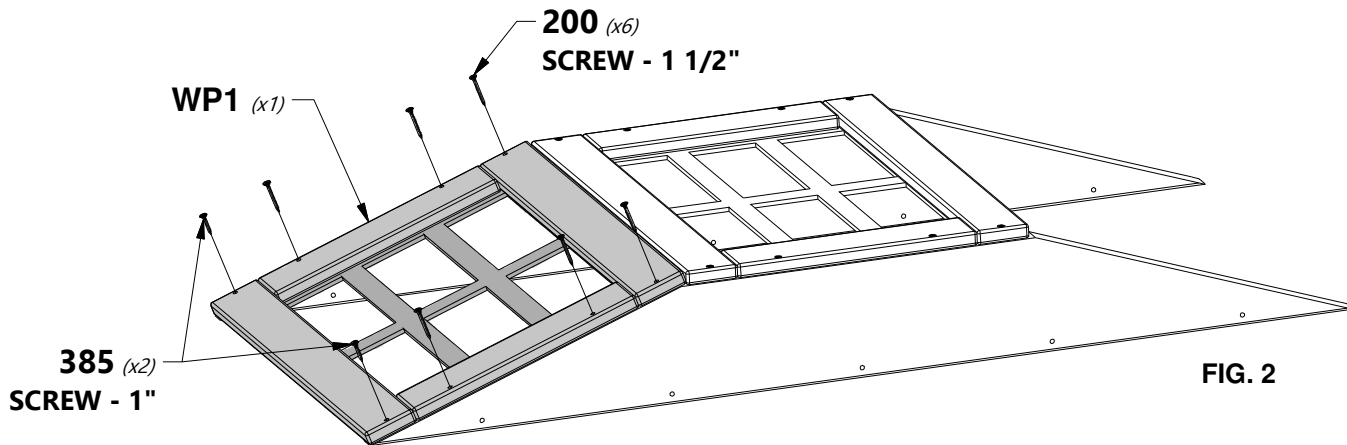

FIG. 2

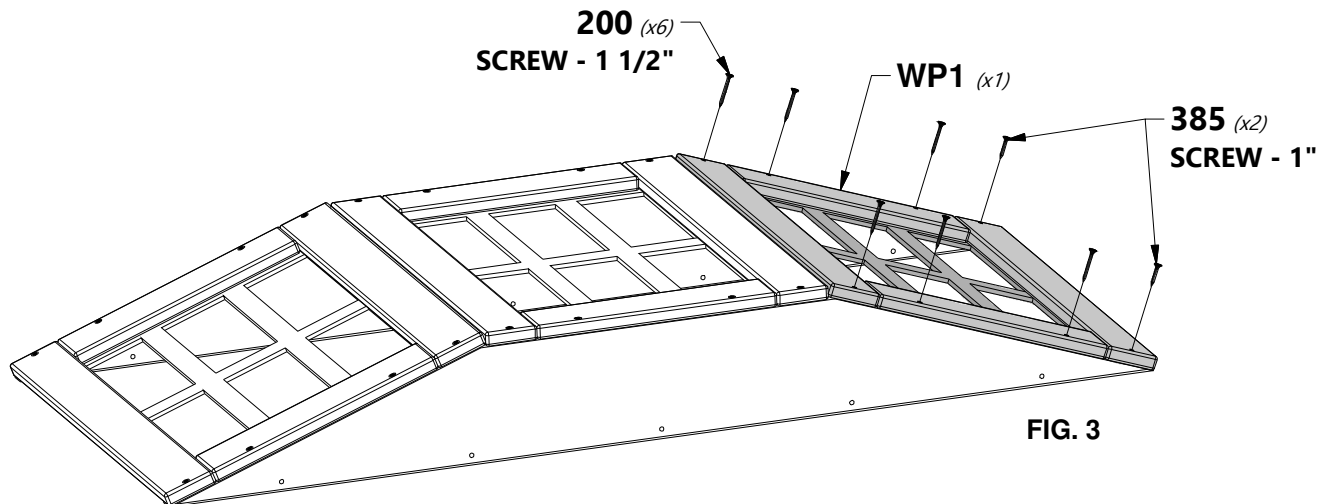
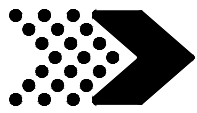

FIG. 3



PORCH ROOF ASSEMBLY

STEP 1



H20 | PORCH ROOF RAFTER - W4L14767
(x4) | 1"x3 3/8"x24 1/2" (24x86x622)



H100091 | SCREW PFH
(x2) | 8X2 1/4

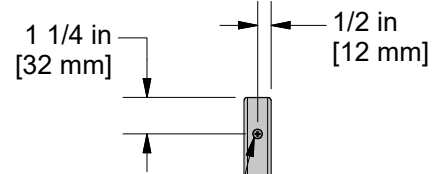
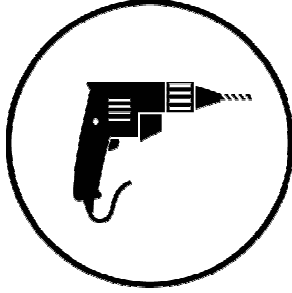
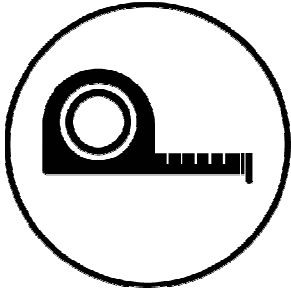

 USING A 3/16" [5 mm] DRILL BIT, MARK AND DRILL A PILOT HOLE INTO 'H20' RAFTER TO PREVENT SPLITTING. ONLY DRILL THROUGH ONE RAFTER NOT BOTH.



NOTE:

MAKE (2) RAFTER ASSEMBLIES.

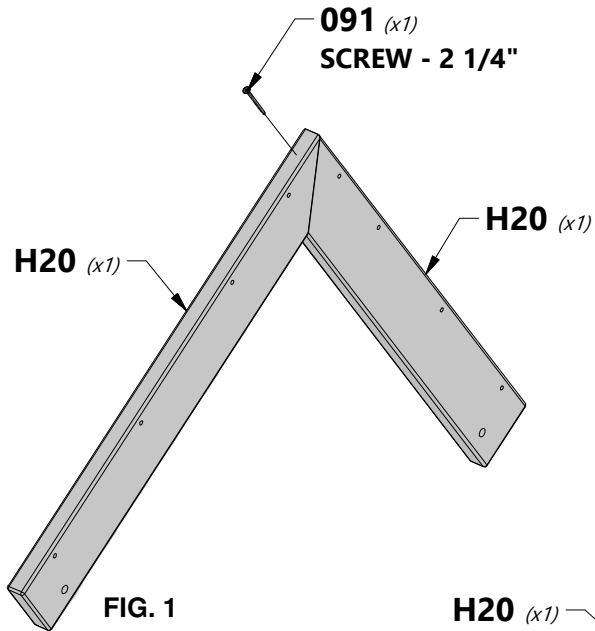

FIG. 1

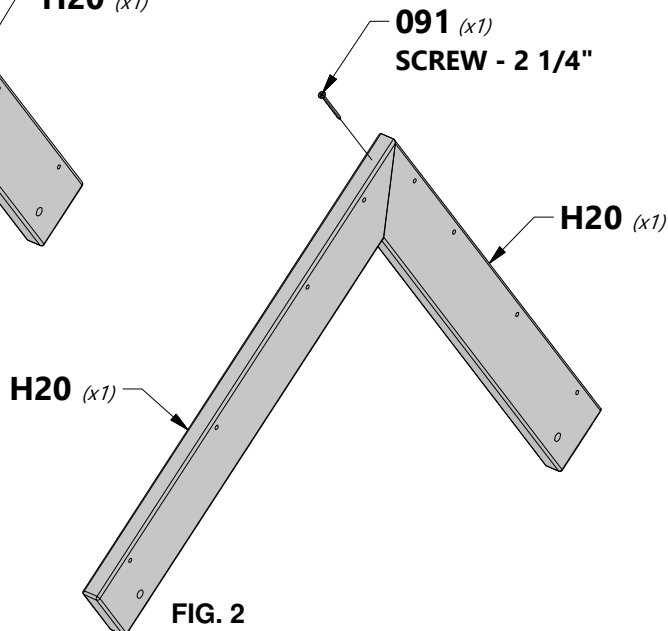
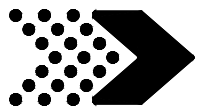

FIG. 2



PORCH ROOF ASSEMBLY

STEP 2



M19 | FRONT PORCH ROOF SUPPORT - W4L14806
(x1) | 5/8"x3 3/8"x30 5/8" (16x86x779)



N5 | FRONT PORCH GABLE TRIM - W4L14829
(x1) | 5/8"x2 3/8"x15" (16x60x381)

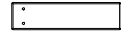

N8 | FRONT PORCH GABLE TRIM - W4L14832
(x2) | 5/8"x2 3/8"x9 1/2" (16x60x241)



A100164 | BYD ID TAG (LARGE) AGES 3-10
(x1)



H100380 | SCREW PFH BLK
(x6) | 8x1 1/8



H100128 | SCREW PWH
(x4) | 8x5/8

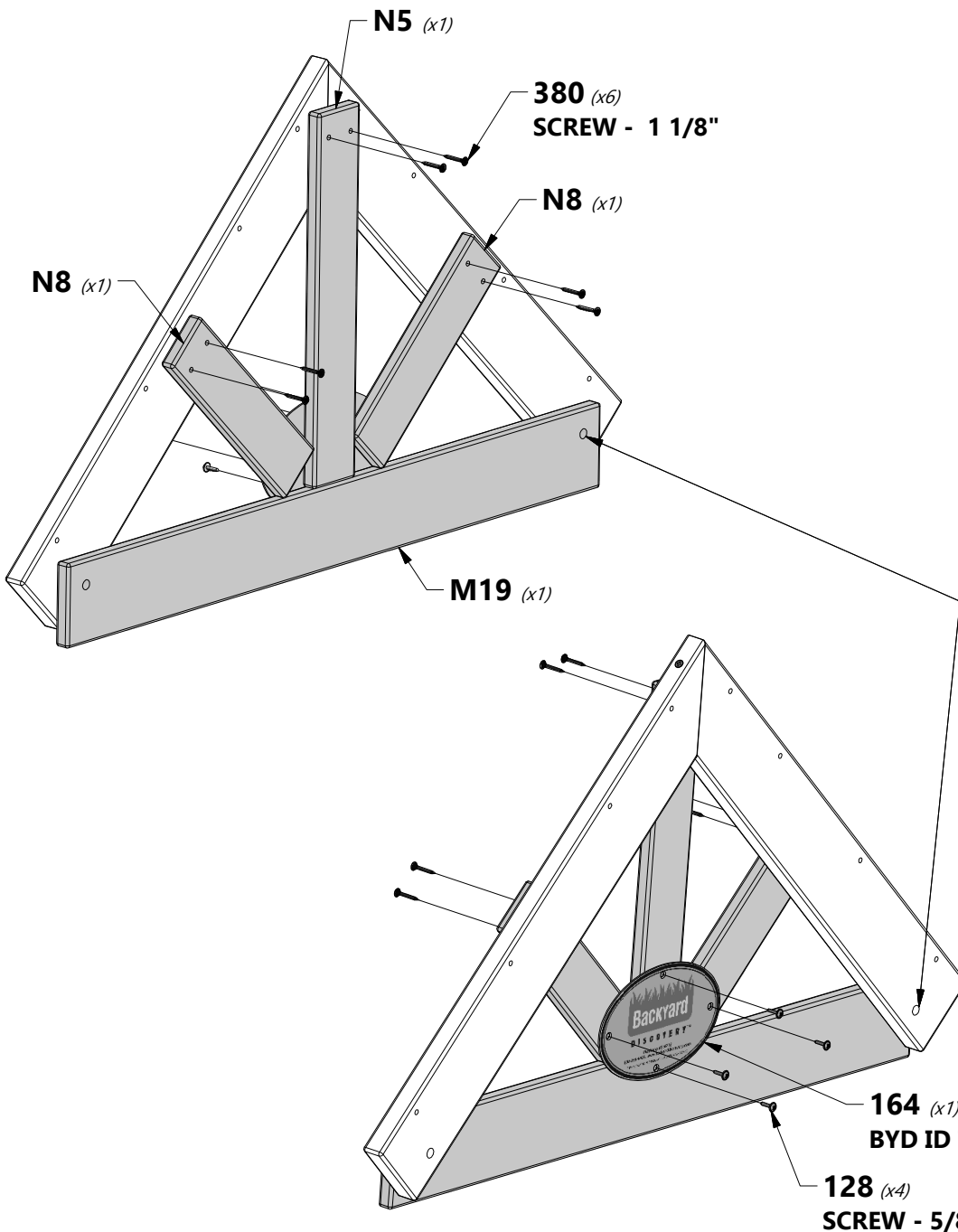

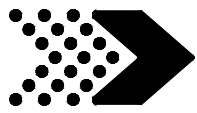

PORCH ROOF ASSEMBLY

STEP 3

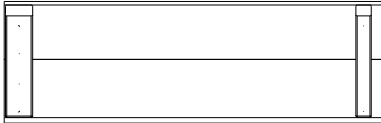

RP1 | LEFT PORCH PEAK ROOF PANEL - W2A03142
(x1) | 1 5/8"x10 1/2"x32 7/8" (42x268x834)

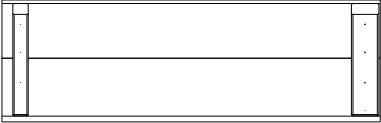

RP4 | RIGHT PORCH PEAK ROOF PANEL - W2A03145
(x1) | 1 5/8"x10 1/2"x32 7/8" (42x268x834)



H100391 | SCREW PFH BLK
(x8) | 8x2

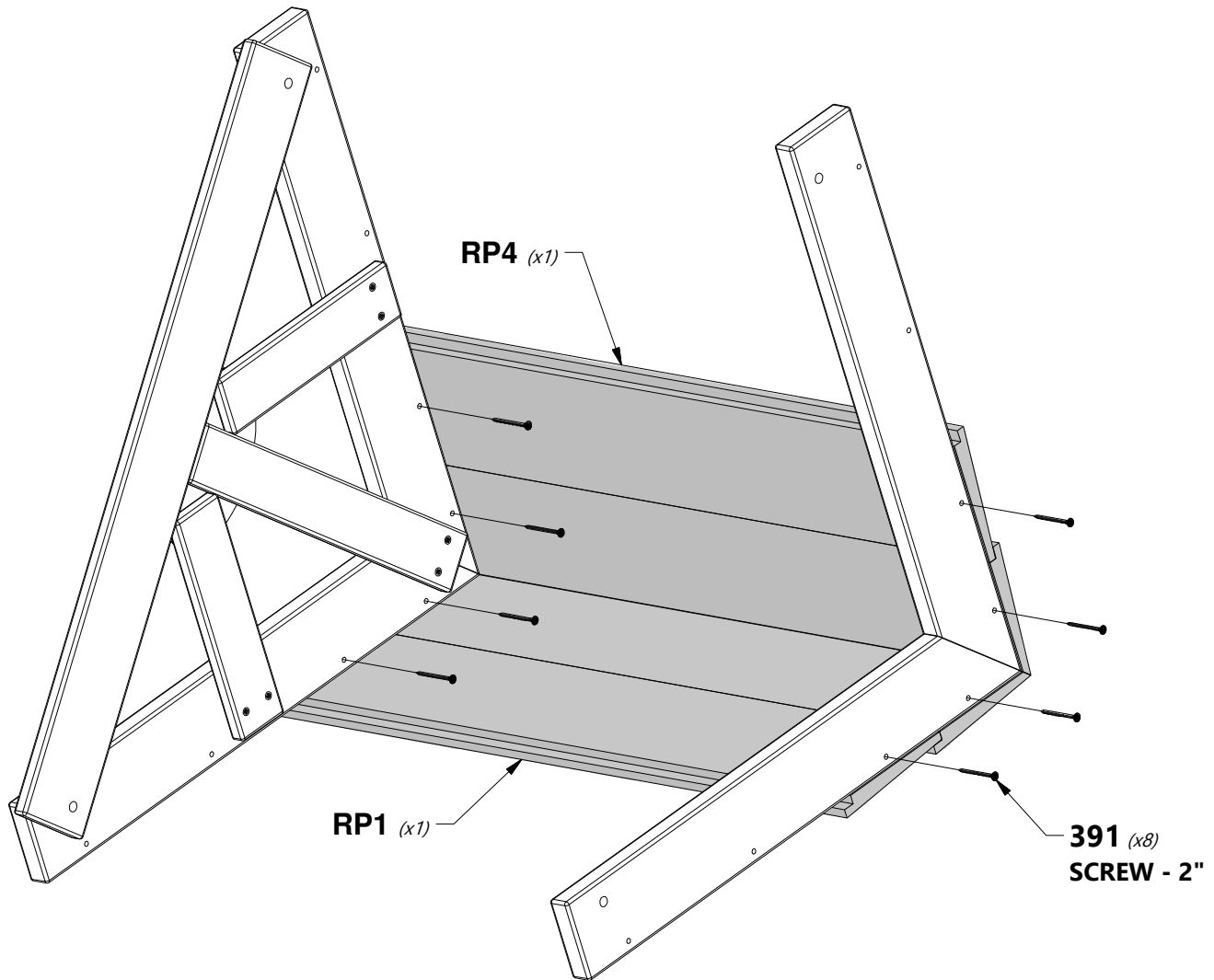

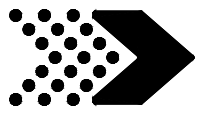

PORCH ROOF ASSEMBLY

STEP 4

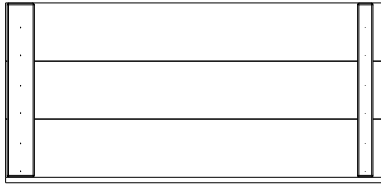

RP2 | LEFT PORCH ROOF PANEL - W2A03143
(x1) | 1 5/8"x15 5/8"x32 7/8" (42x396x834)

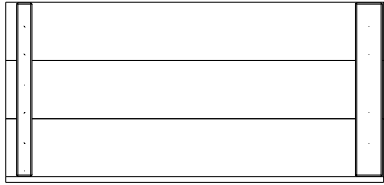

RP5 | RIGHT PORCH ROOF PANEL - W2A03146
(x1) | 1 5/8"x15 5/8"x32 7/8" (42x396x834)



H100391 | SCREW PFH BLK
(x8) | 8x2

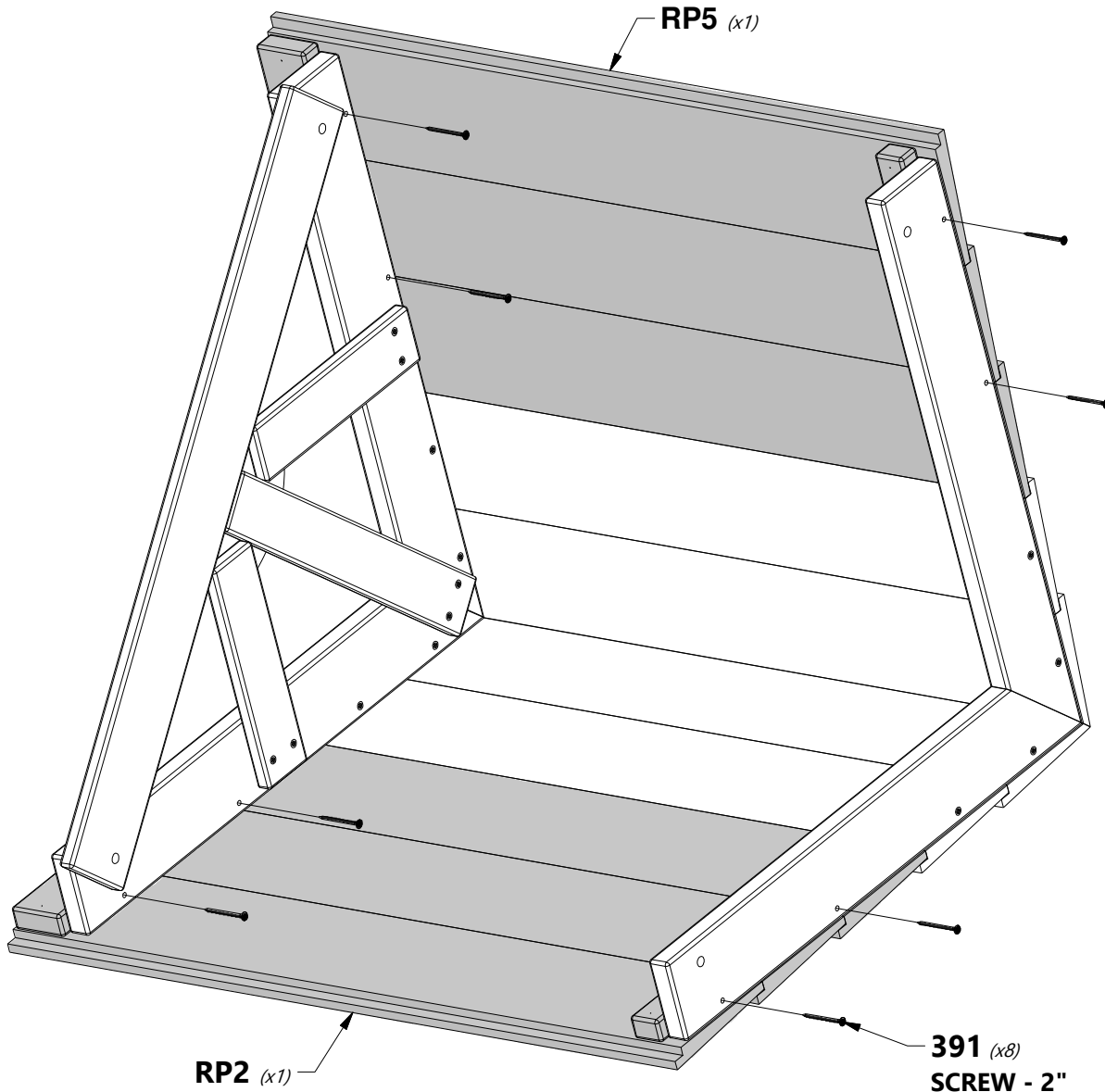

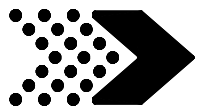

SWING BEAM ASSEMBLY

STEP 1

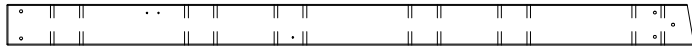

A1 | SWING BEAM - W4L15713
(x1) 3 3/8"x5 1/4"x89 1/2" (86x134x2274)



A100325 | SWING BEAM EXTENSION BRACKET-LEFT
(x1)



A100140 | L BRACKET
(x2) 66x66x127

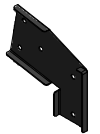

A100326 | SWING BEAM EXTENSION BRACKET-RIGHT
(x1)

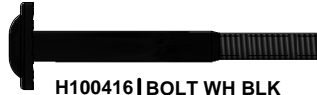

H100416 | BOLT WH BLK
(x5) 5/16x3



H100192 | NUT BARREL WH BLK
(x5) 5/16x7/8



NOTE:
LEAVE HARDWARE LOOSE FOR EASE OF ASSEMBLY.



NOTE THIS EDGE UPWARD

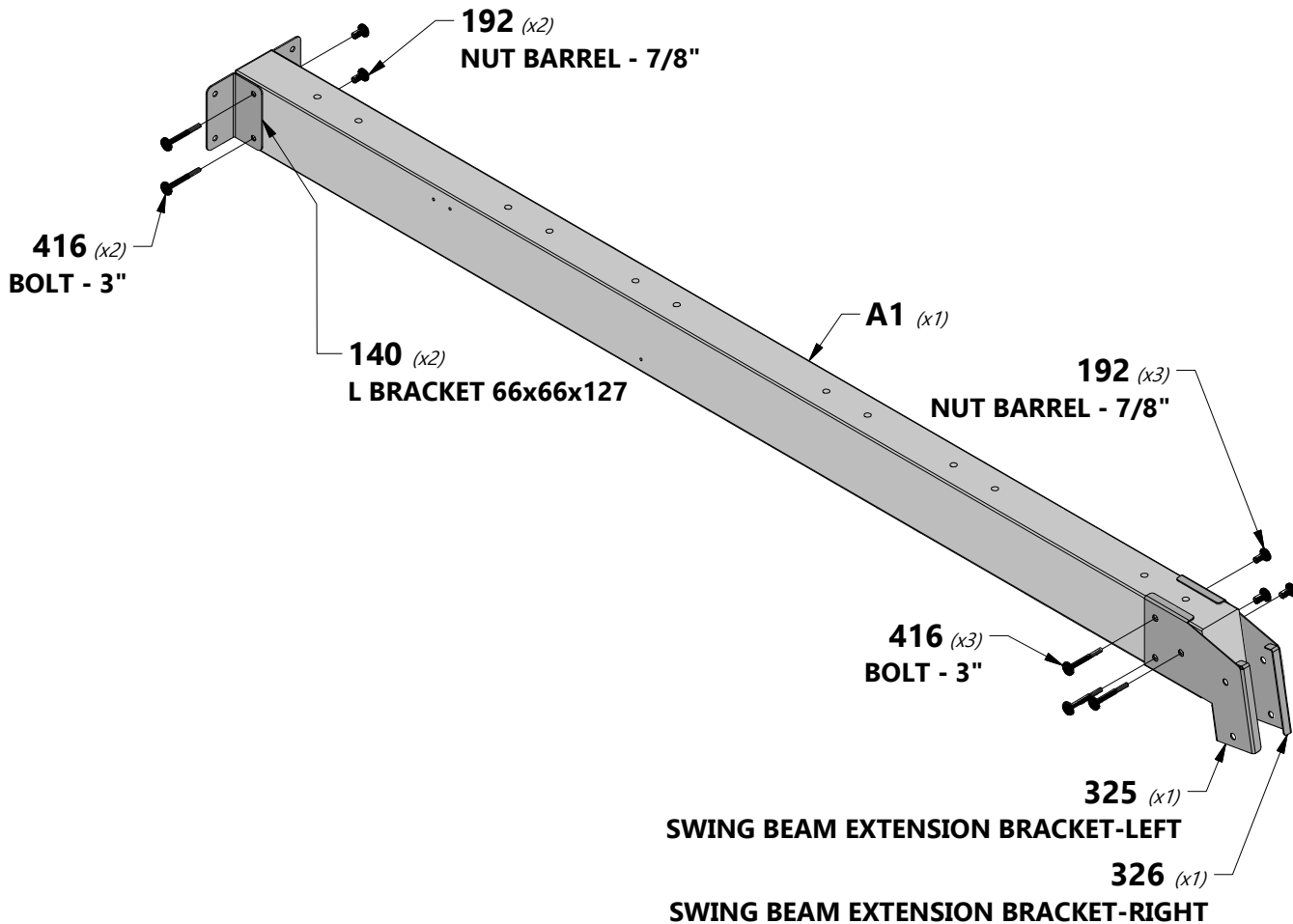
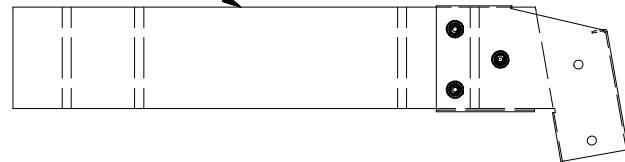

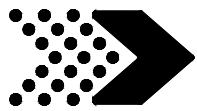

SWING BEAM ASSEMBLY

STEP 2



H100654 | BOLT HEX
(x12) | 3/8x5-1/2



H100107 | WASHER LOCK INT
(x12) | 10x18

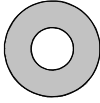

H100102 | WASHER FLAT
(x12) | 11x25

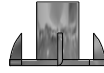

H100073 | T-NUT
(x12) | 3/8



A4M00505 | SWINGER HANGER
(x6)

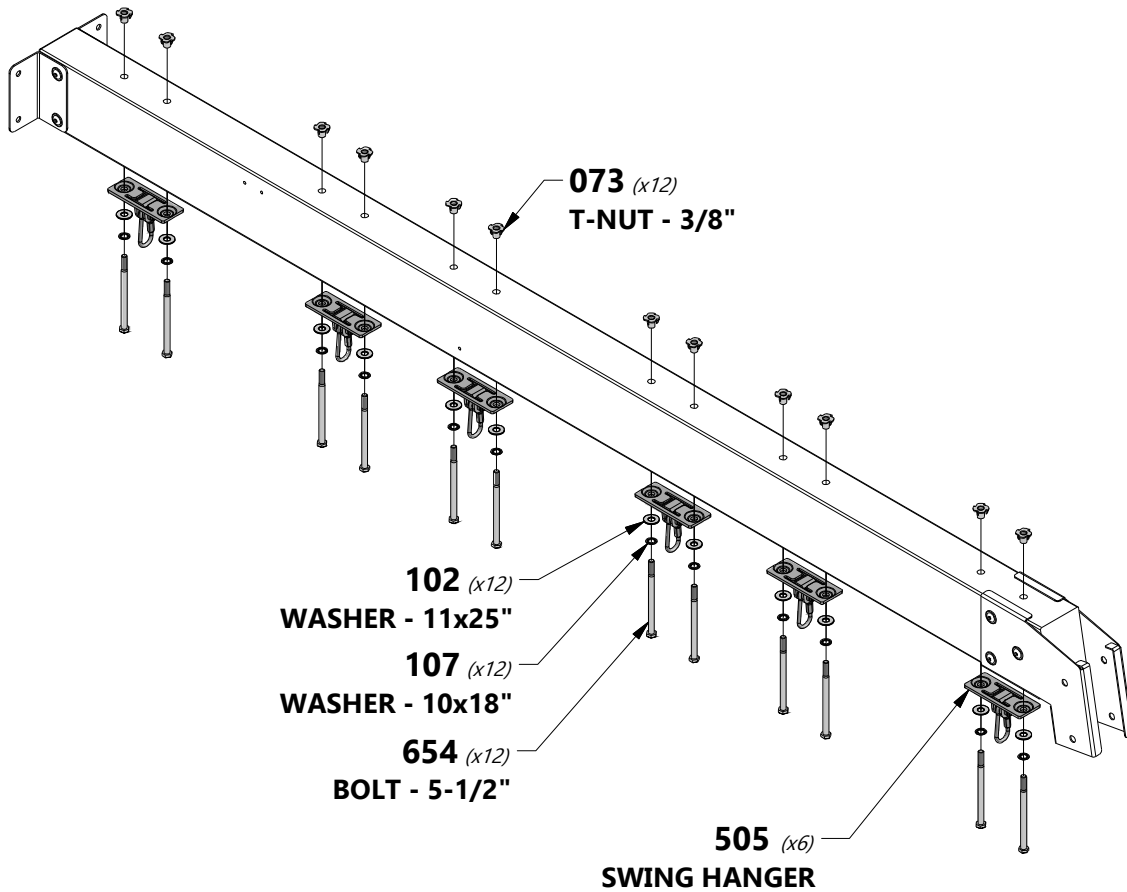

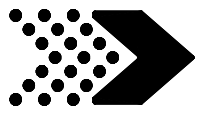

SWING BEAM ASSEMBLY

STEP 3



SP1 | SWING BEAM SUPPORT - W4L15647
(x1) | 3 3/8"x3 3/8"x48 3/8" (86x86x1229)

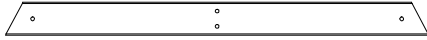

E50 | END SUPPORT - W4L15651
(x1) | 1 3/8"x3 3/8"x44 1/8" (36x86x1120)

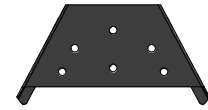

A4M01169 | A-FRAME BRACKET
(x1)



H100415 | BOLT WH BLK
(x2) | 5/16x3 3/4



H100416 | BOLT WH BLK
(x2) | 5/16x3



H100199 | WASHER LOCK
(x4) | EXT BLK
12x19



H100193 | NUT BARREL WH BLK
(x2) | 5/16x1-1/2



H100192 | NUT BARREL WH BLK
(x2) | 5/16x7/8



H100198 | WASHER LOCK
(x2) | EXT BLK
8x19

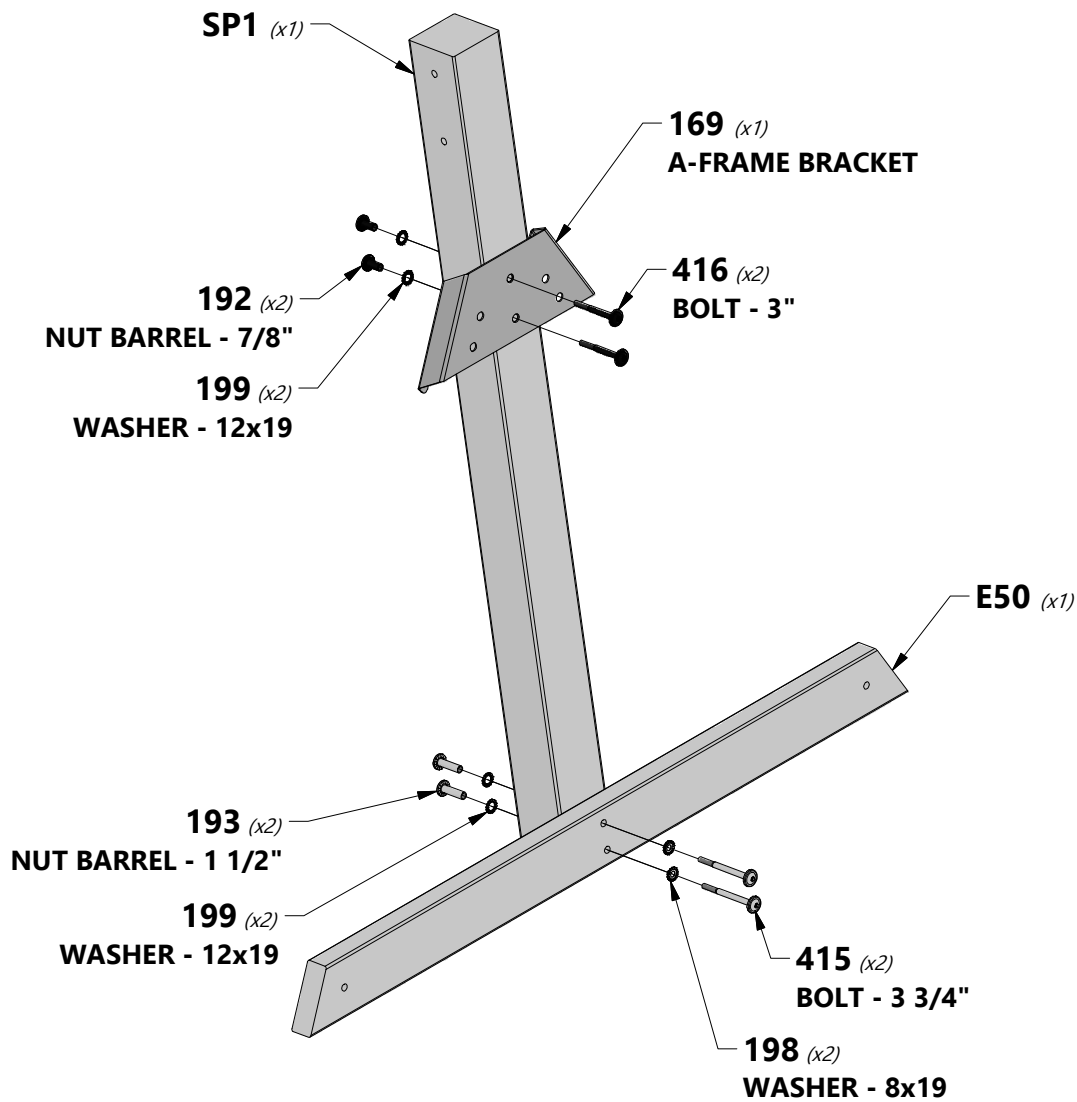

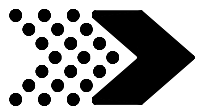

SWING BEAM ASSEMBLY

STEP 4



G08 | GROUND BOARD - W4L15652
(x1) | 1"x5 1/4"x86 3/4" (24x134x2202)



E04 | ANGLE BRACE - W4L15649
(x2) | 1 3/8"x3 3/8"x87 1/8" (36x86x2212)



H100205 | BOLT WH BLK
(x2) | 5/16x2-1/4



H100457 | BOLT WH BLK
(x4) | 5/16x2

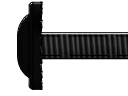

H100468 | BOLT WH BLK
(x4) | 5/16x1



H100192 | NUT BARREL WH BLK
(x10) | 5/16x7/8



H100199 | WASHER LOCK
(x10) | EXT BLK
12x19



H100198 | WASHER LOCK
(x6) | EXT BLK
8x19

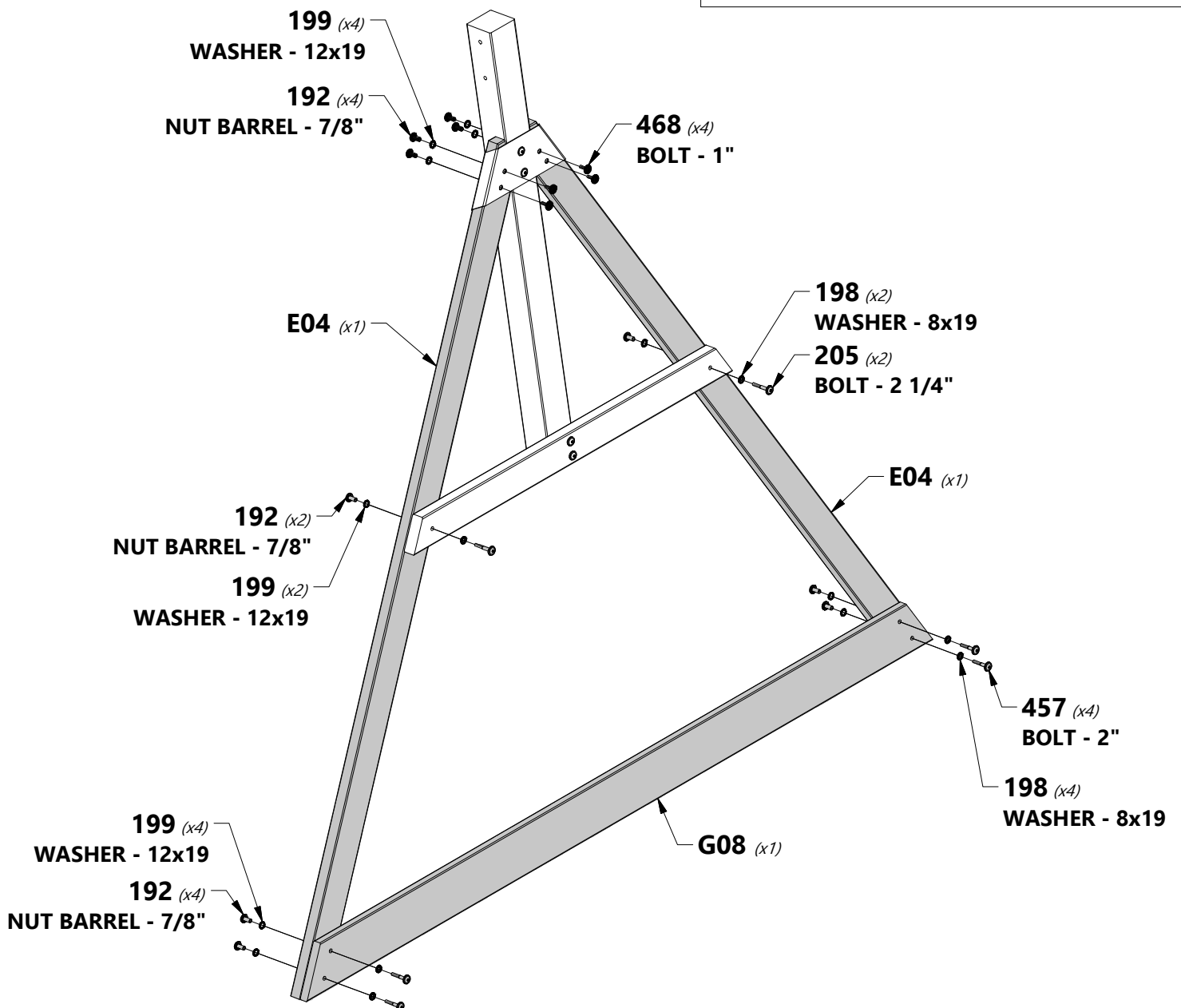

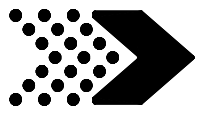

SWING BEAM ASSEMBLY

STEP 5



H100416 | BOLT WH BLK
(x2) | 5/16x3



H100192 | NUT BARREL WH BLK
(x2) | 5/16x7/8



NOTE:
TIGHTEN ALL SWING BEAM
HARDWARE AT THIS TIME.

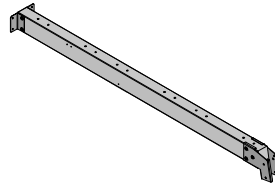

(x1) SWING BEAM ASSEMBLY

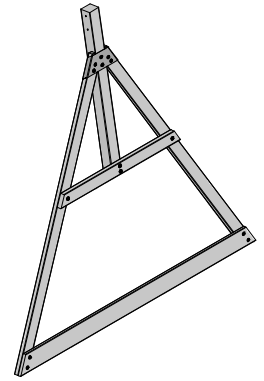

(x1) A-FRAME ASSEMBLY

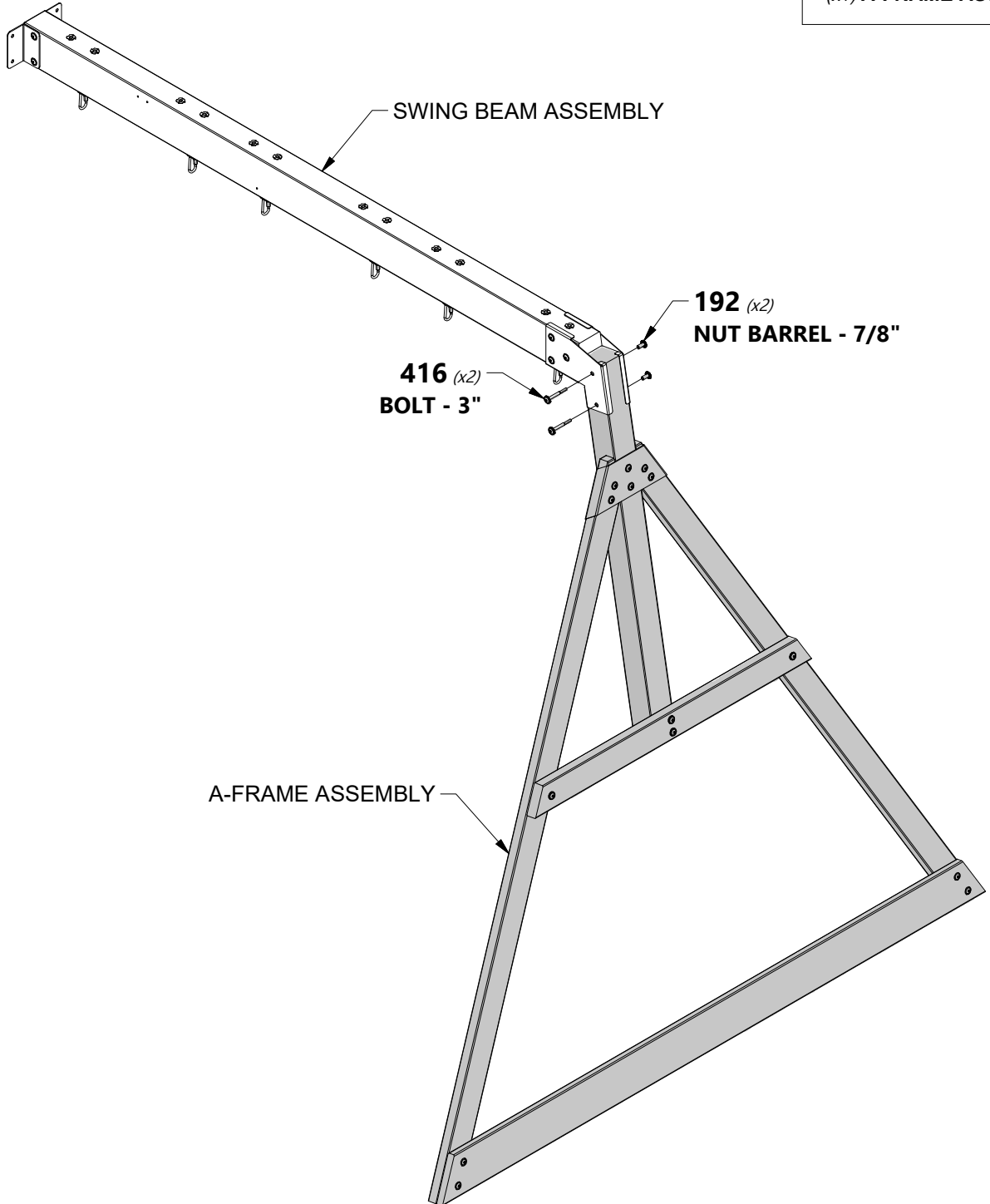

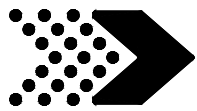

CROWS NEST DECK ASSEMBLY

STEP 1



E07 | CROWS NEST FLOOR RAIL - W4L15712
(x2) | 1 3/8"x3 3/8"x38" (36x86x964)

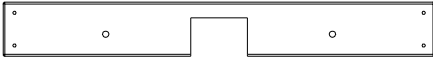

H19 | CROWS NEST FLOOR RAIL - W4L14766
(x1) | 1"x3 3/8"x27" (24x86x686)



H100201 | SCREW PFH BLK
(x4) | 8x2-1/2



H100379 | T-NUT BLK
(x4) | 5/16



NOTE:
ASSEMBLE T-NUTS INTO BOARDS
BEFORE ASSEMBLY.

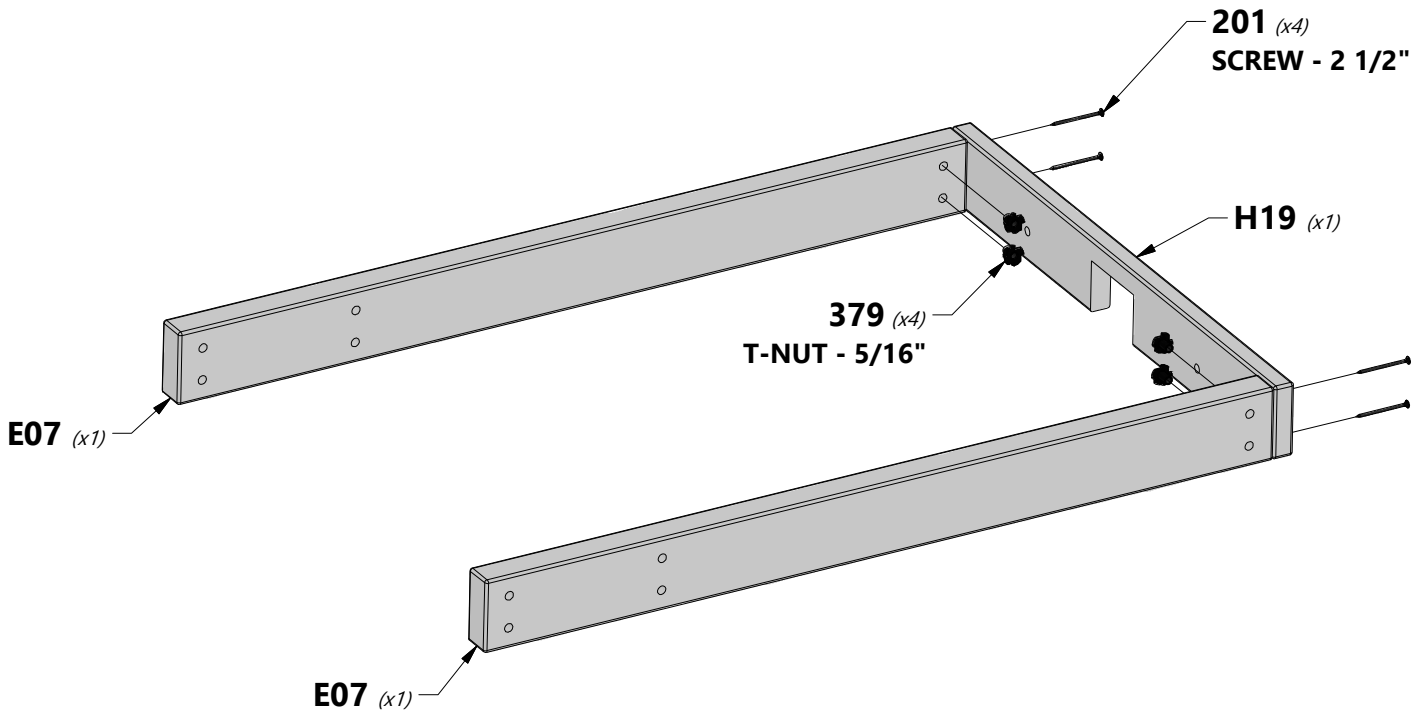

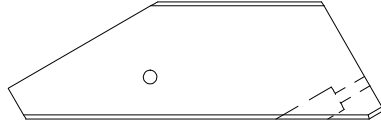
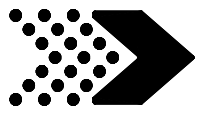

E06 | CROWS NEST DECK BRACE - W4L15451
(x2) | 1 7/16"x3 3/8"x10 7/8" (36x86x276)



H100205 | BOLT WH BLK
(x2) | 5/16x2-1/4



H100379 | T-NUT BLK
(x2) | 5/16



H100198 | WASHER LOCK EXT BLK
(x2) | 8x19



NOTE:
ASSEMBLE T-NUTS INTO BOARDS
BEFORE ASSEMBLY.

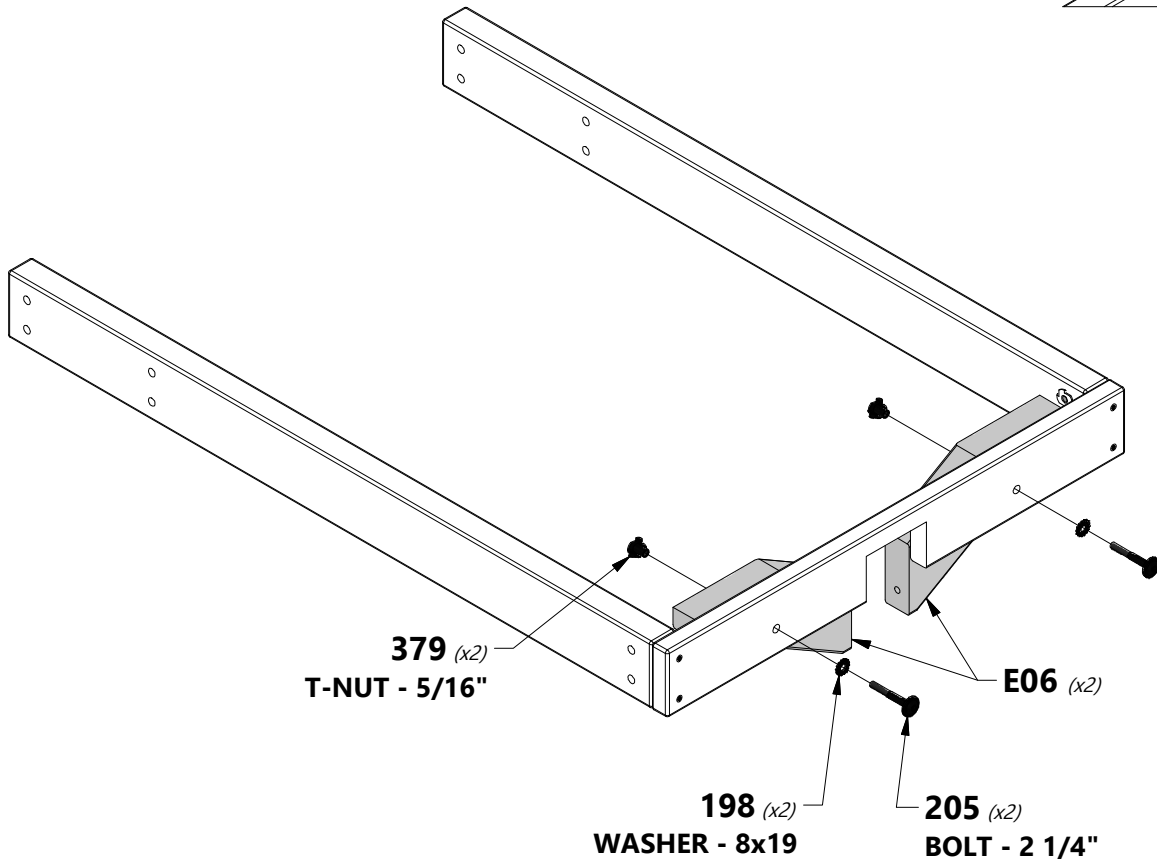
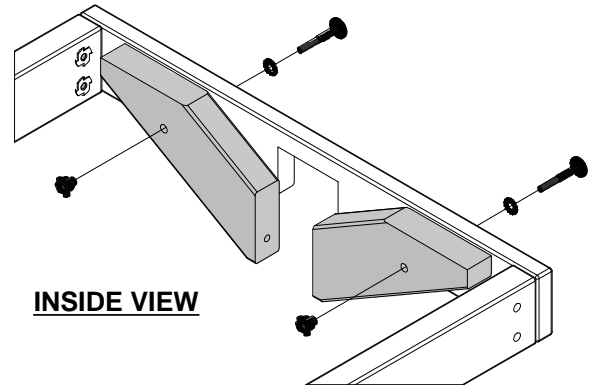

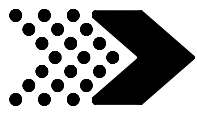

CROWS NEST DECK ASSEMBLY

STEP 3

L1 CROWS NEST FLOOR BOARD - W4L14787
(x7) 5/8"x4 3/8"x27" (16x112x686)

L3 CROWS NEST FLOOR BOARD - W4L15100
(x2) 5/8"x4 3/8"x27" (16x112x686)



H100086 SCREW PFH
(x34) 8x1 1/2

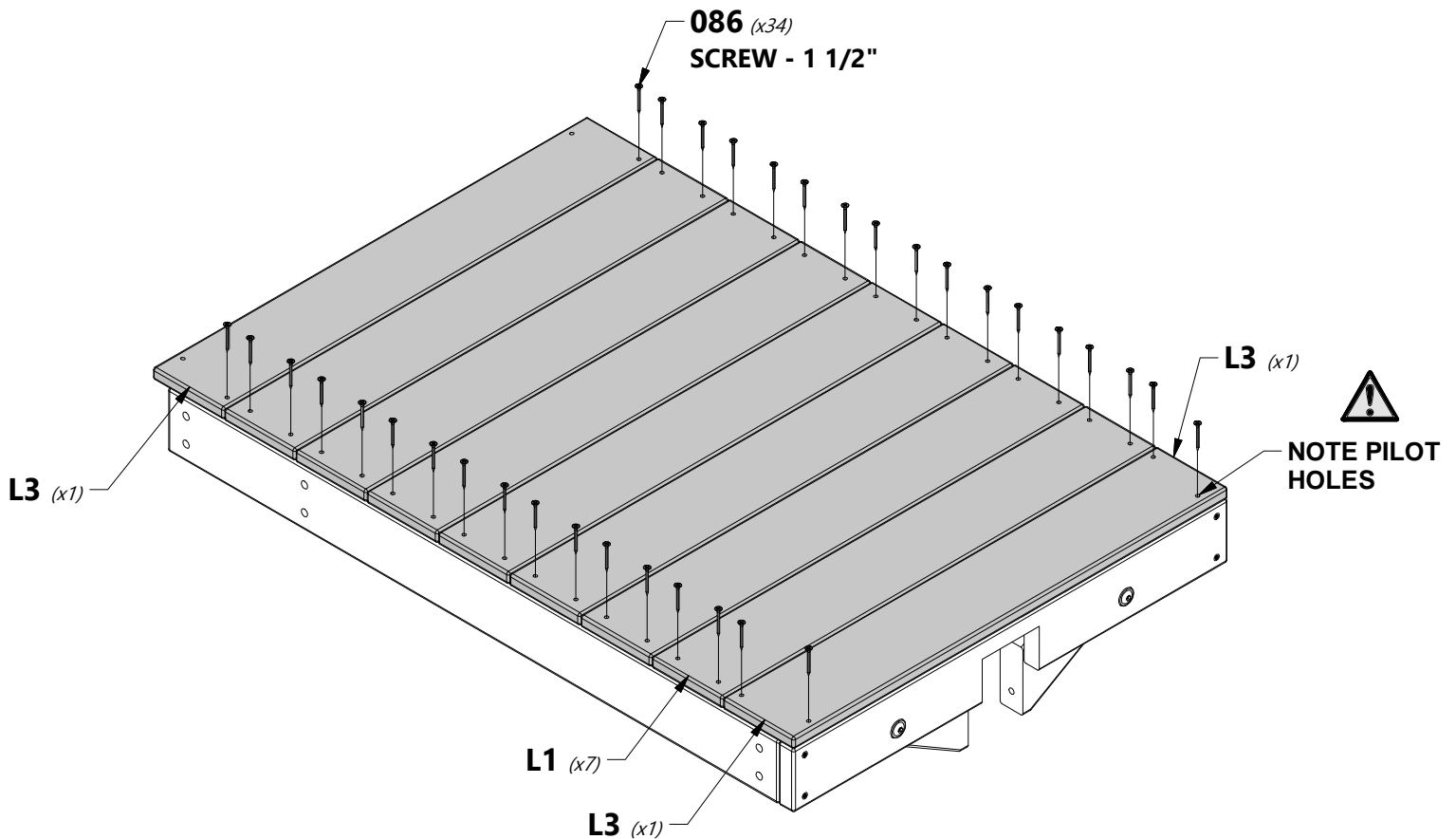
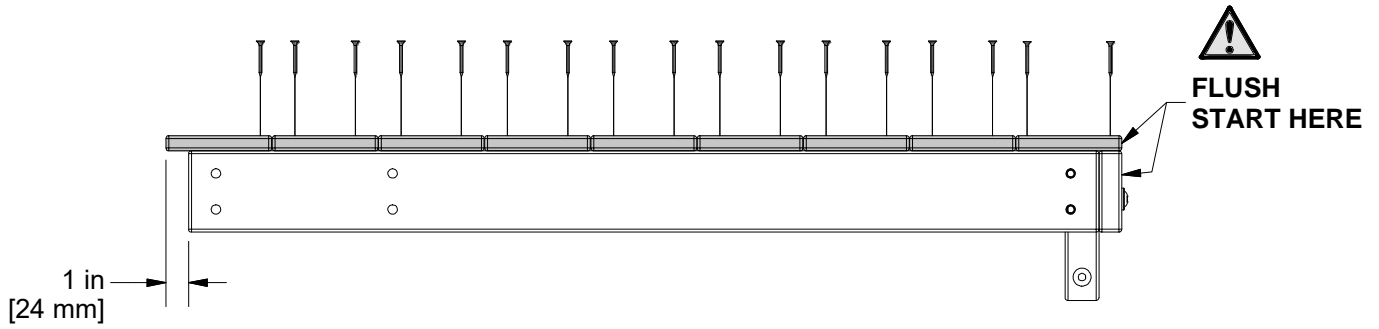

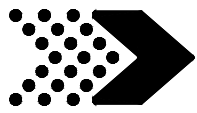

CROWS NEST DECK ASSEMBLY

STEP 4



H21 | CROWS NEST FLOOR SUPPORT - W4L14768
(x1) | 1"x3 3/8"x24 1/8" (24x86x614)



H100087 | SCREW PFH
(x2) | 8x1 1/4

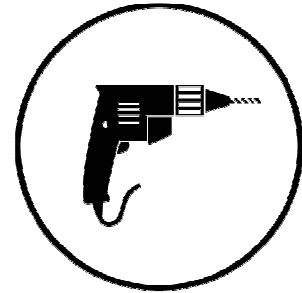
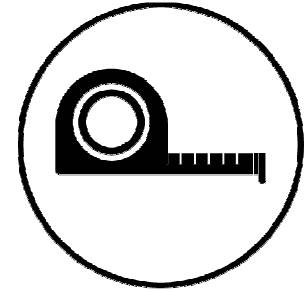
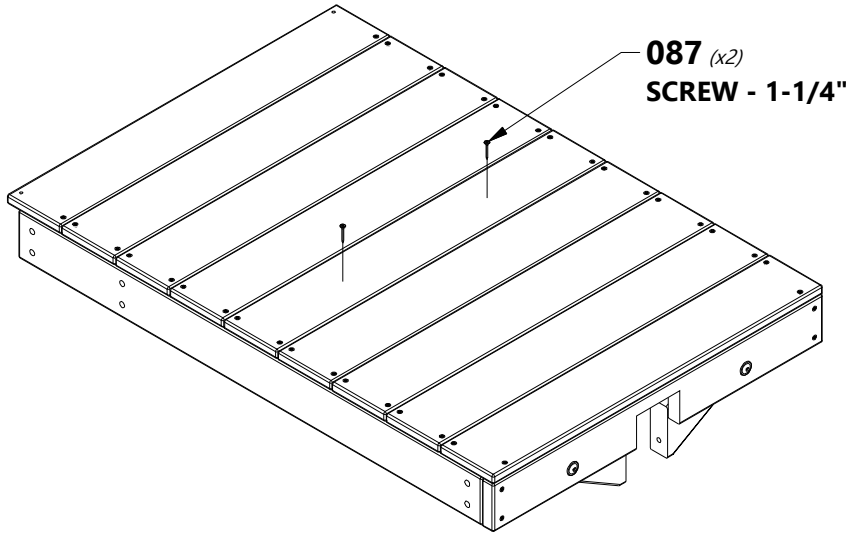

**MARK LOCATIONS SHOWN.
USING AN 3/16" [5mm] DRILL
BIT DRILL (2) PILOT HOLES.**

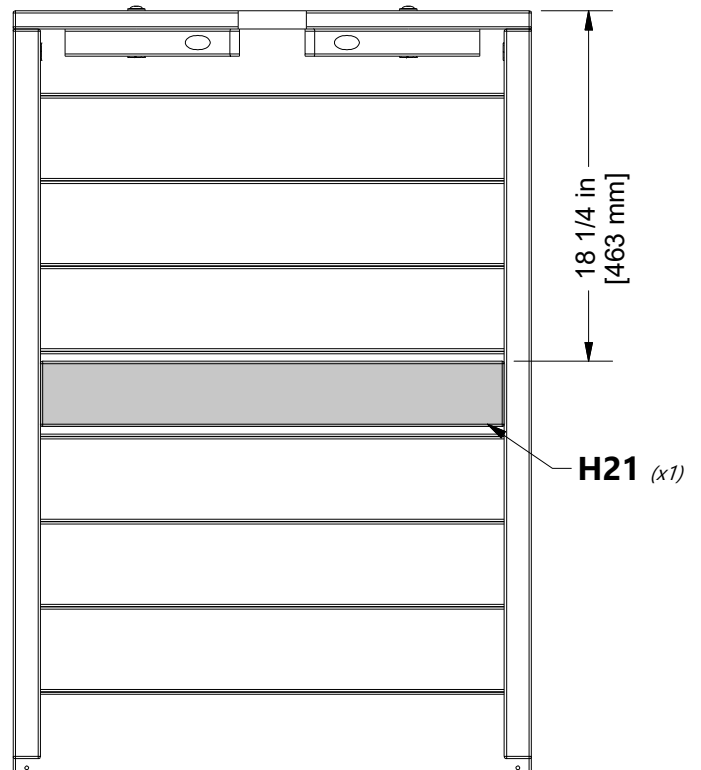
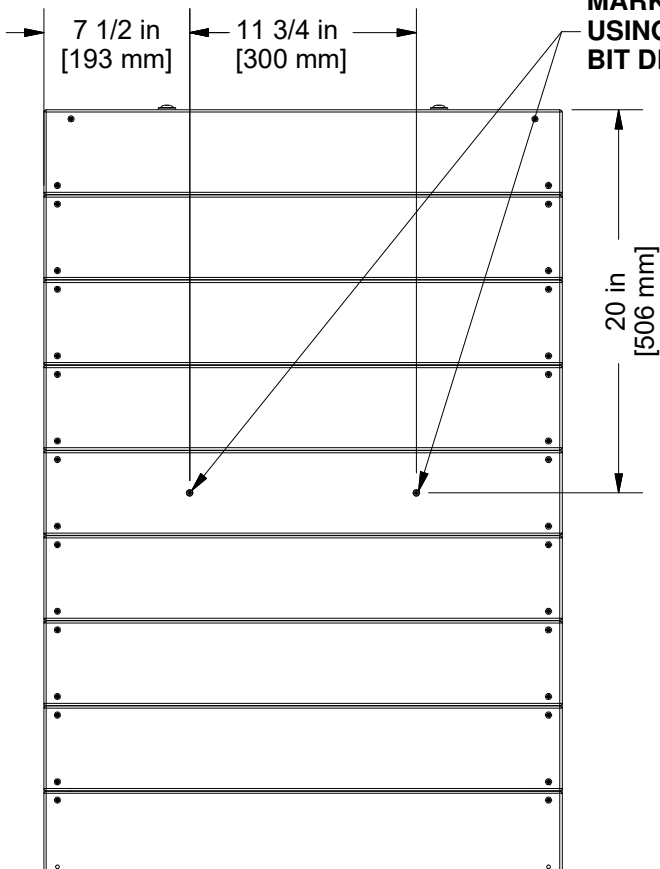



B1 | TOWER LEG - W2A03275
 (x1) | 3"x3"x89 1/2" (76x76x2274)

B3 | TOWER LEG - W4L12682
 (x1) | 3"x3"x59" (76x76x1500)

E1 | TOWER LEG - W4L12688
 (x1) | 1 3/8"x3 3/8"x59" (36x86x1500)

G1 | TOP FLOOR RAIL - W4L14740
 (x1) | 1"x5 1/4"x80" (24x134x2032)

G7 | BOTTOM FLOOR RAIL - W4L14746
 (x1) | 1"x5 1/4"x80" (24x134x2032)



H100415 | BOLT WH BLK
 (x8) | 5/16x3 3/4



H100205 | BOLT WH BLK
 (x4) | 5/16x2-1/4



H100198 | WASHER LOCK EXT BLK
 (x12) | 8x19



H100379 | T-NUT BLK
 (x12) | 5/16

NOTE:
 ASSEMBLE T-NUTS INTO PARTS
 BEFORE ASSEMBLY.

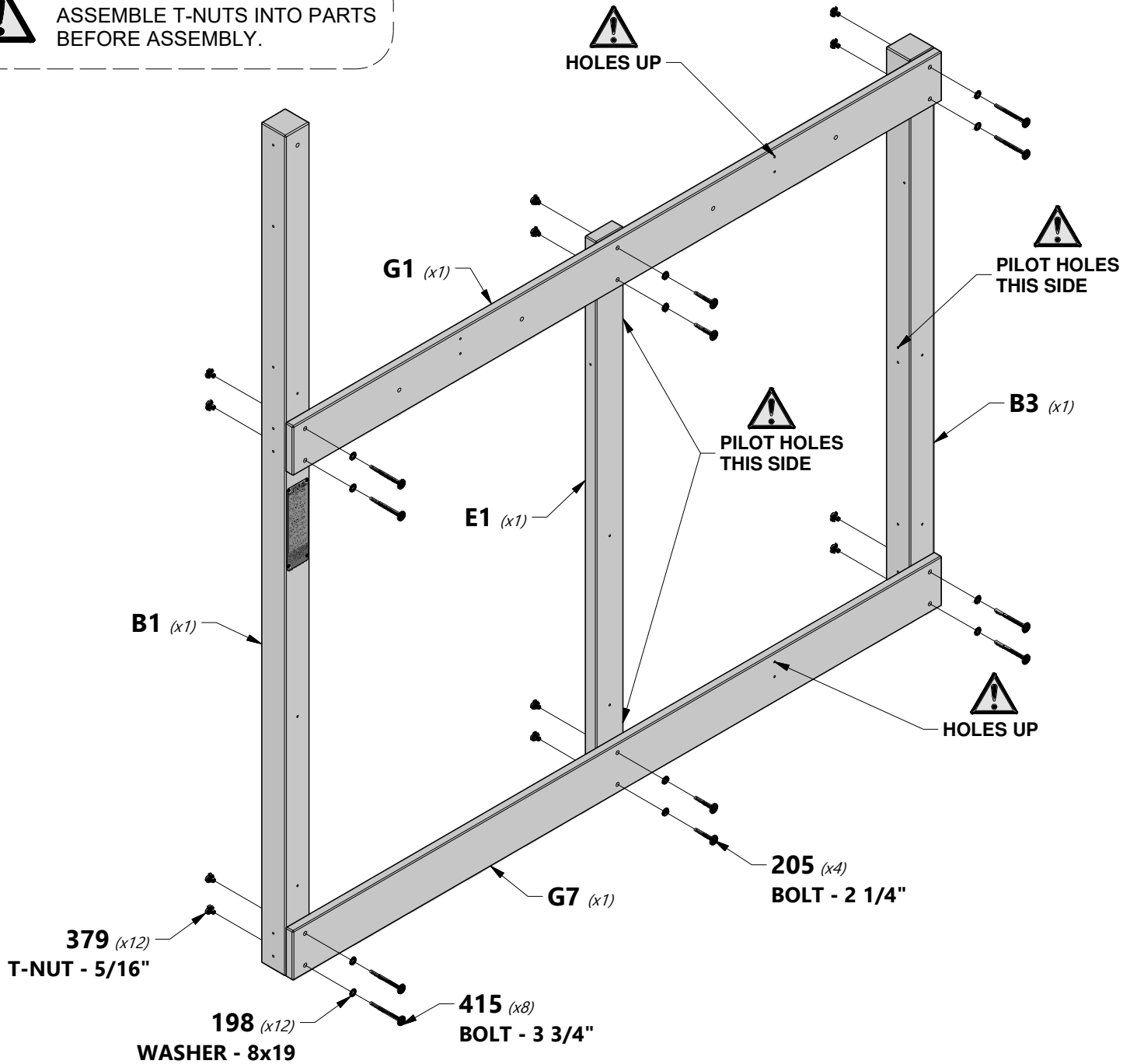

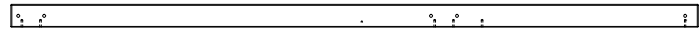

B2 | TOWER LEG - W4L15731
(x1) | 3"x3"x89 1/2" (76x76x2274)



B4 | TOWER LEG - W4L12683
(x1) | 3"x3"x59" (76x76x1500)

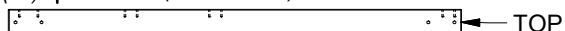

E2 | TOWER LEG - W4L14727
(x1) | 1 3/8"x3 3/8"x59" (36x86x1500)

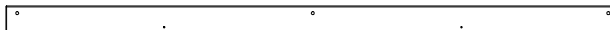

G2 | TOP FLOOR RAIL - W4L14741
(x1) | 1"x5 1/4"x80" (24x134x2032)

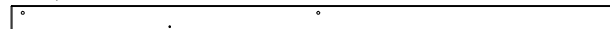

G7 | BOTTOM FLOOR RAIL - W4L14746
(x1) | 1"x5 1/4"x80" (24x134x2032)



H100415 | BOLT WH BLK
(x8) | 5/16x3 3/4



H100205 | BOLT WH BLK
(x4) | 5/16x2-1/4



H100198 | WASHER LOCK EXT BLK
(x12) | 8x19



H100379 | T-NUT BLK
(x12) | 5/16

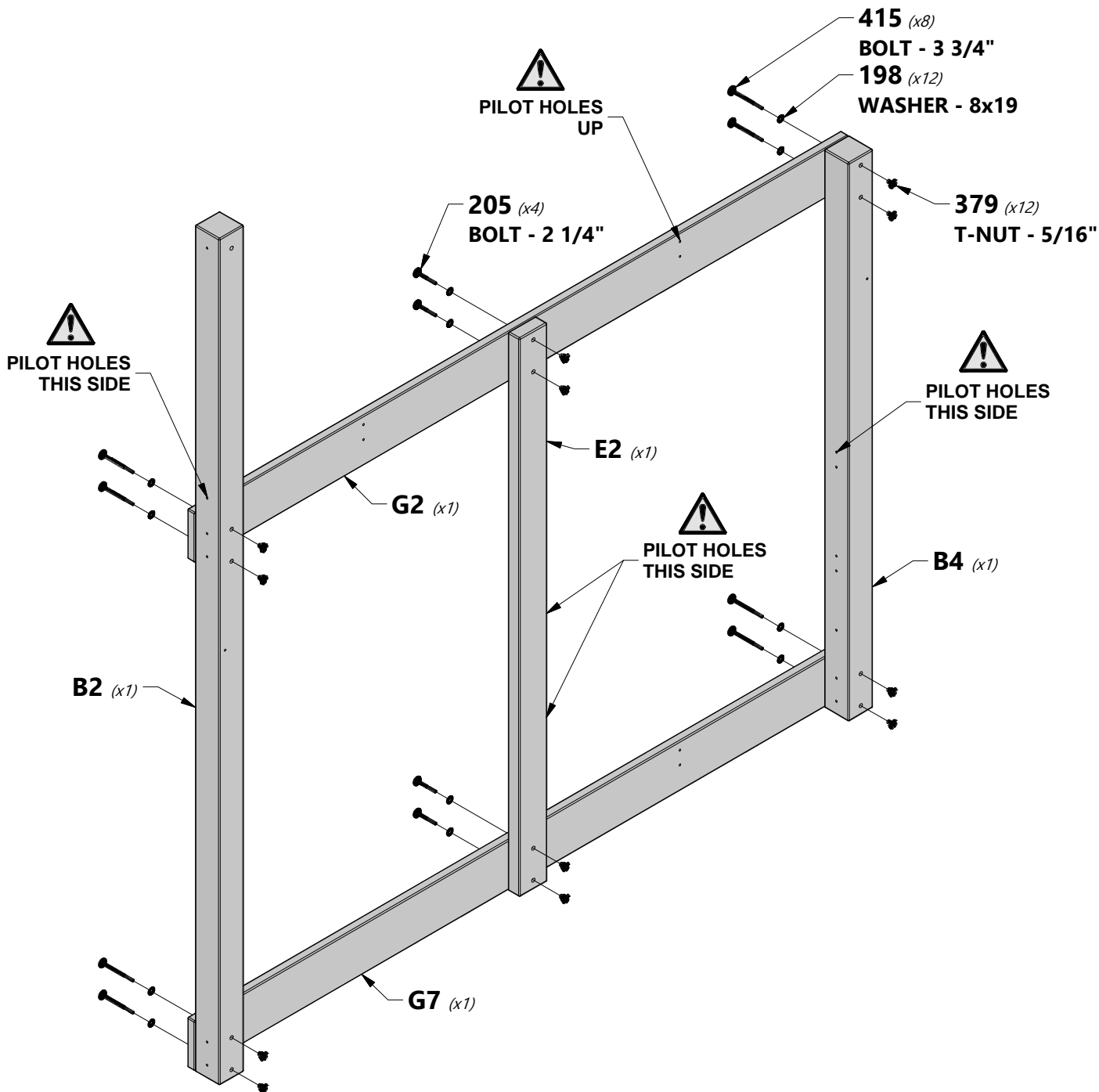



H28 | FRONT WALL RAIL - W4L14774
(x1) | 1"x3 3/8"x60 1/2" (24x86x1537)



G3 | FLOOR RAIL - W4L16849
(x1) | 1"x5 1/4"x60 1/2" (24x134x1537)



G6 | FLOOR RAIL - W4L14745
(x1) | 1"x5 1/4"x60 1/2" (24x134x1537)



H100197 | LAG SCREW WH BLK
(x8) | 5/16x2 1/2



H100458 | LAG SCREW WH BLK
(x2) | 5/16x2



H100198 | WASHER LOCK EXT BLK
(x10) | 8x19

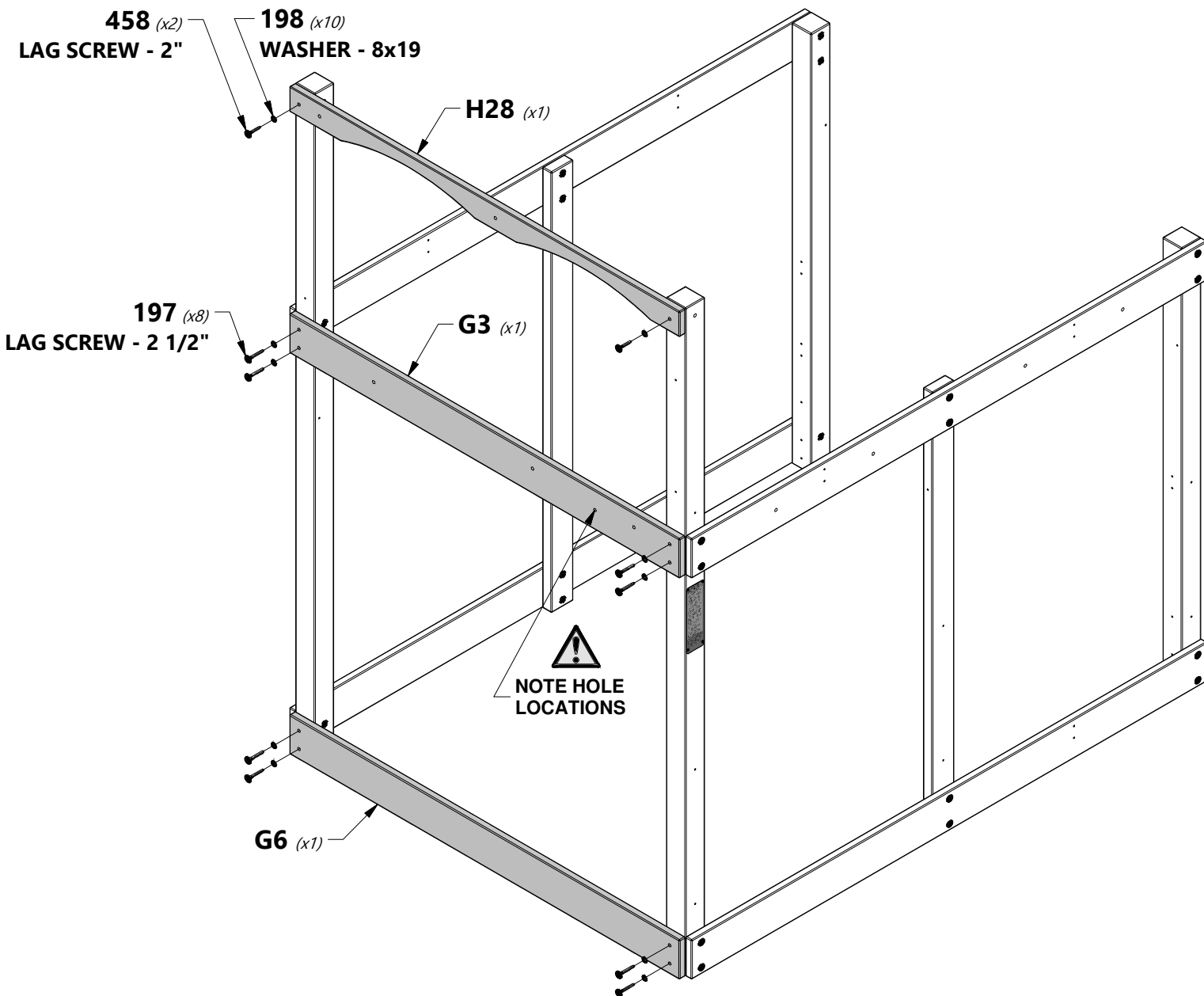



G4 | FLOOR RAIL - W4L14743
(x1) | 1"x5 1/4"x60 1/2" (24x134x1537)



K2 | FLOOR RAIL - W4L14783
(x1) | 5/8"x5 1/4"x60 1/2" (16x134x1537)



H100197 | LAG SCREW WH BLK
(x4) | 5/16x2 1/2



H100458 | LAG SCREW WH BLK
(x4) | 5/16x2



H100198 | WASHER LOCK EXT BLK
(x8) | 8x19

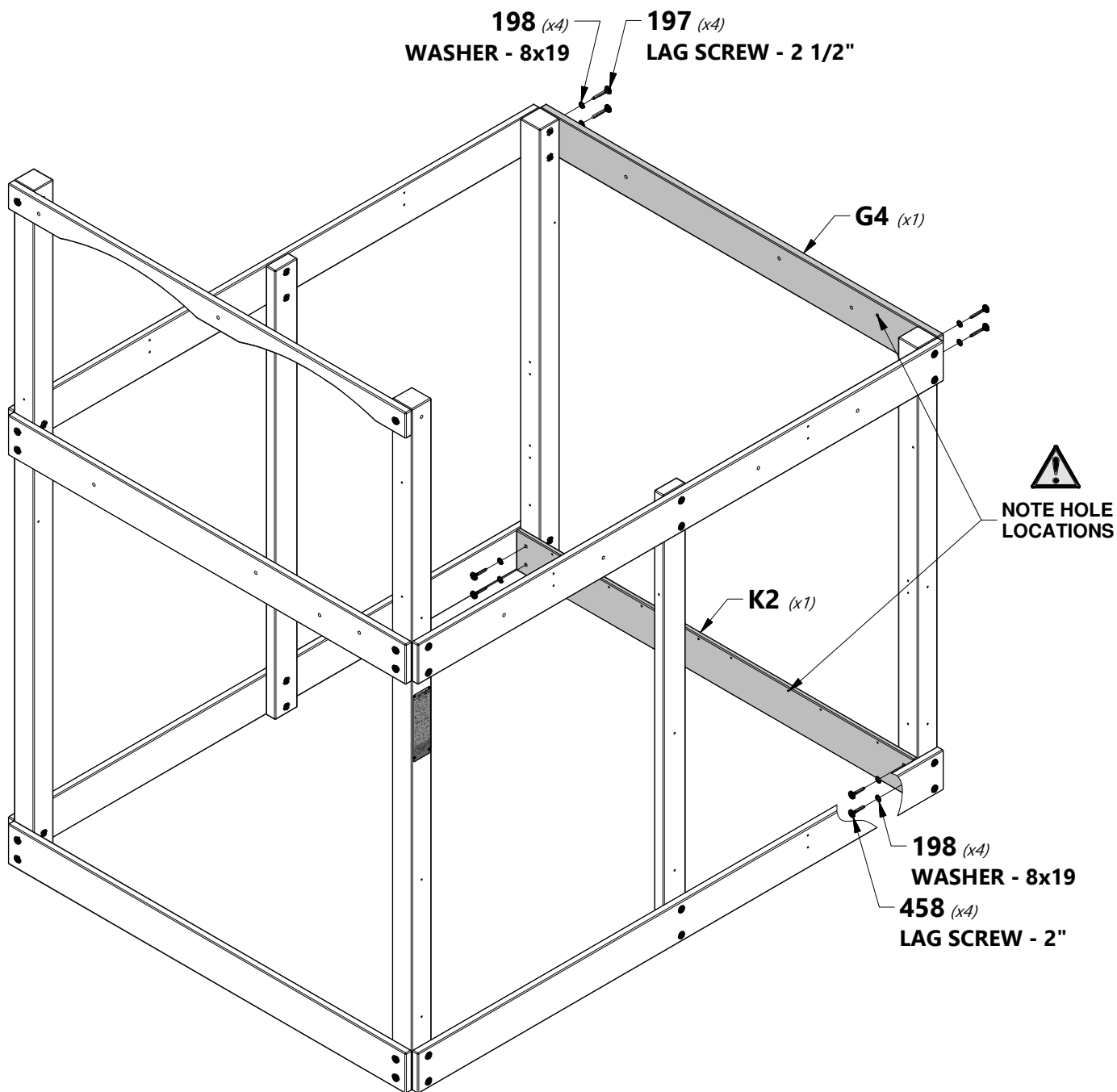

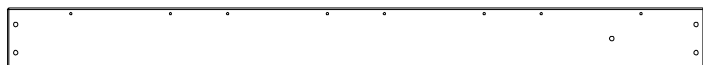

K3 | FLOOR RAIL - W4L14784
(x1) | 5/8"x5 1/4"x60 1/2" (16x134x1537)

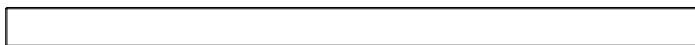

H26 | FLOOR JOIST - W4L14772
(x1) | 1"x3 3/8"x60 1/2" (24x86x1537)



H100201 | SCREW PFH BLK
(x4) | 8x2-1/2



H100458 | LAG SCREW WH BLK
(x4) | 5/16x2



H100198 | WASHER LOCK EXT BLK
(x4) | 8x19

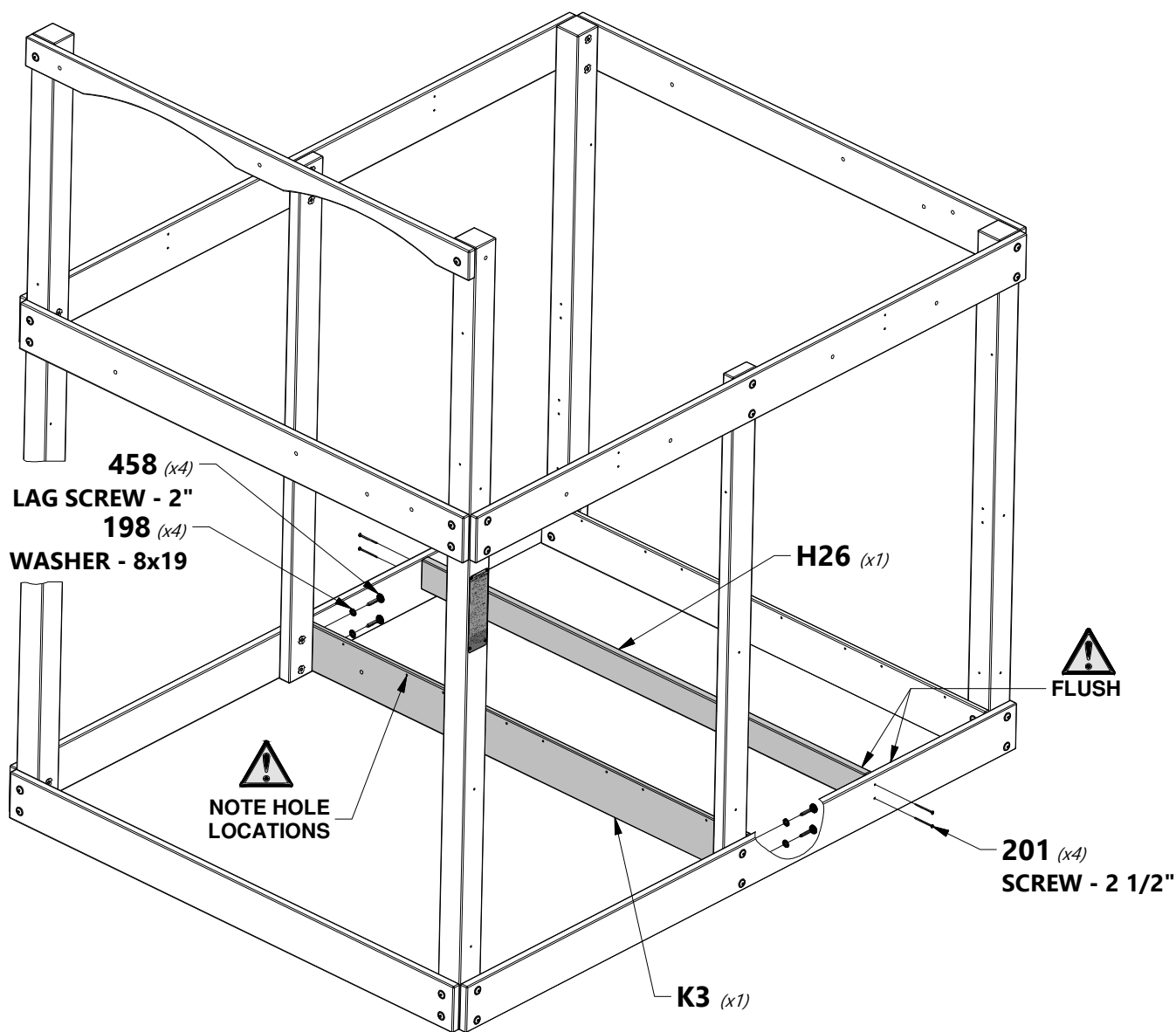

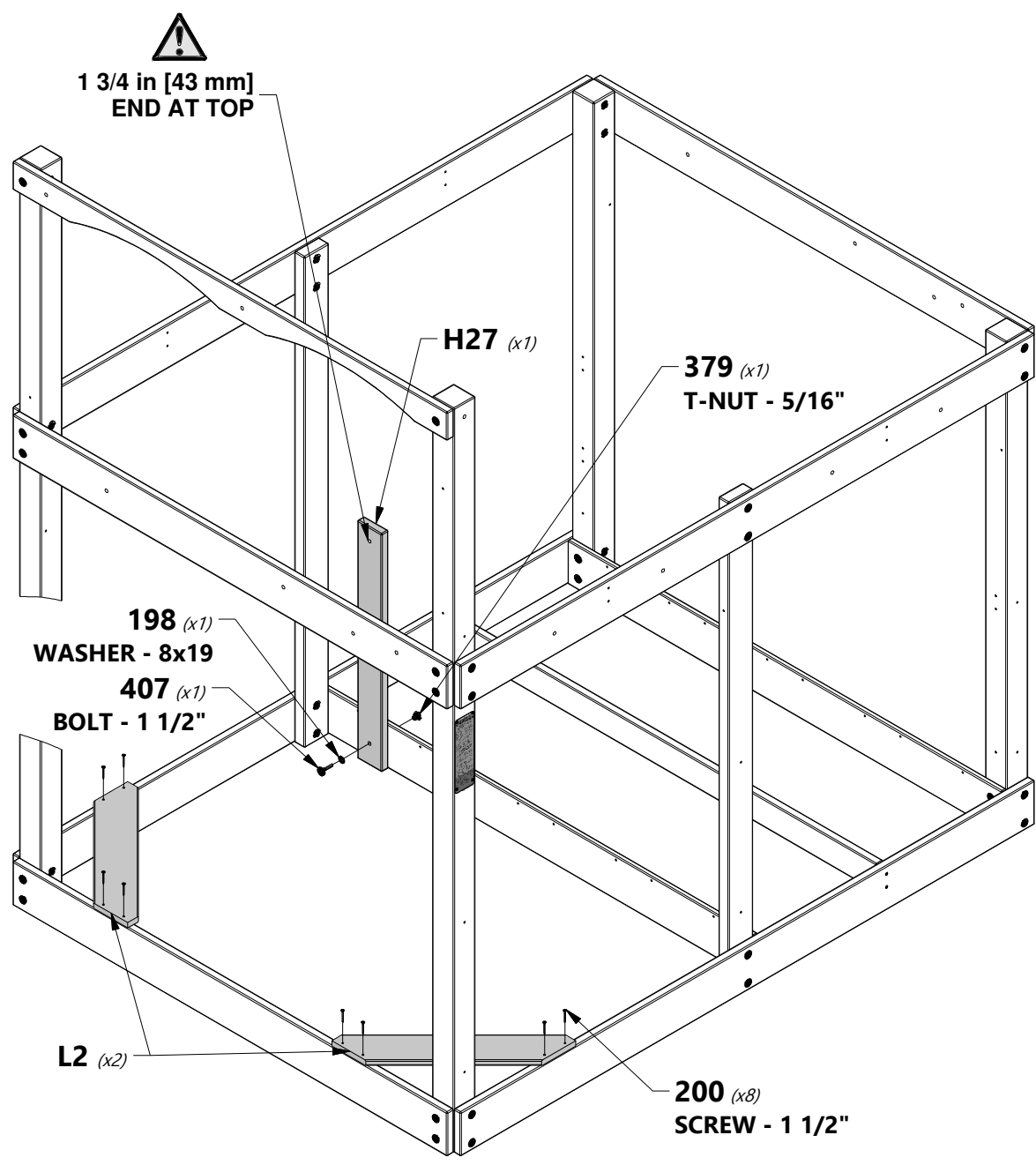
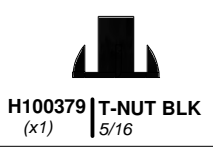
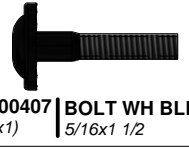
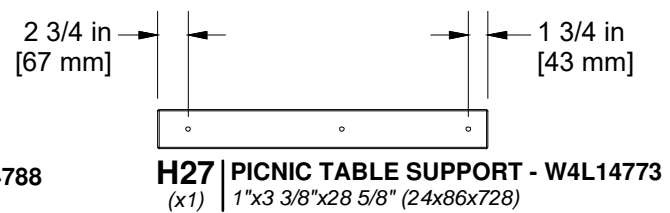
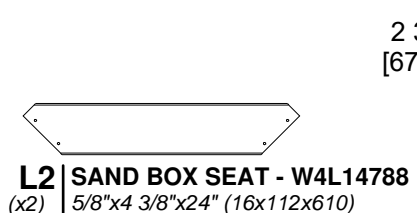

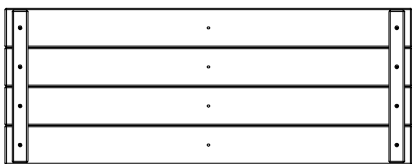

FP1 | **BOTTOM FLOOR PANEL - W2A03140**
(x4) | 1 5/8"x13 1/2"x35 3/8" (40x344x897)

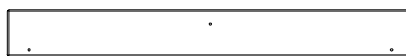

Y2 | **BOTTOM FLOOR BOARD - W4L14840**
(x2) | 5/8"x4"x35 1/4" (16x102x895)



H100086 | **SCREW PFH**
(x22) | 8x1 1/2



H100200 | **SCREW PFH BLK**
(x16) | 8x1 1/2

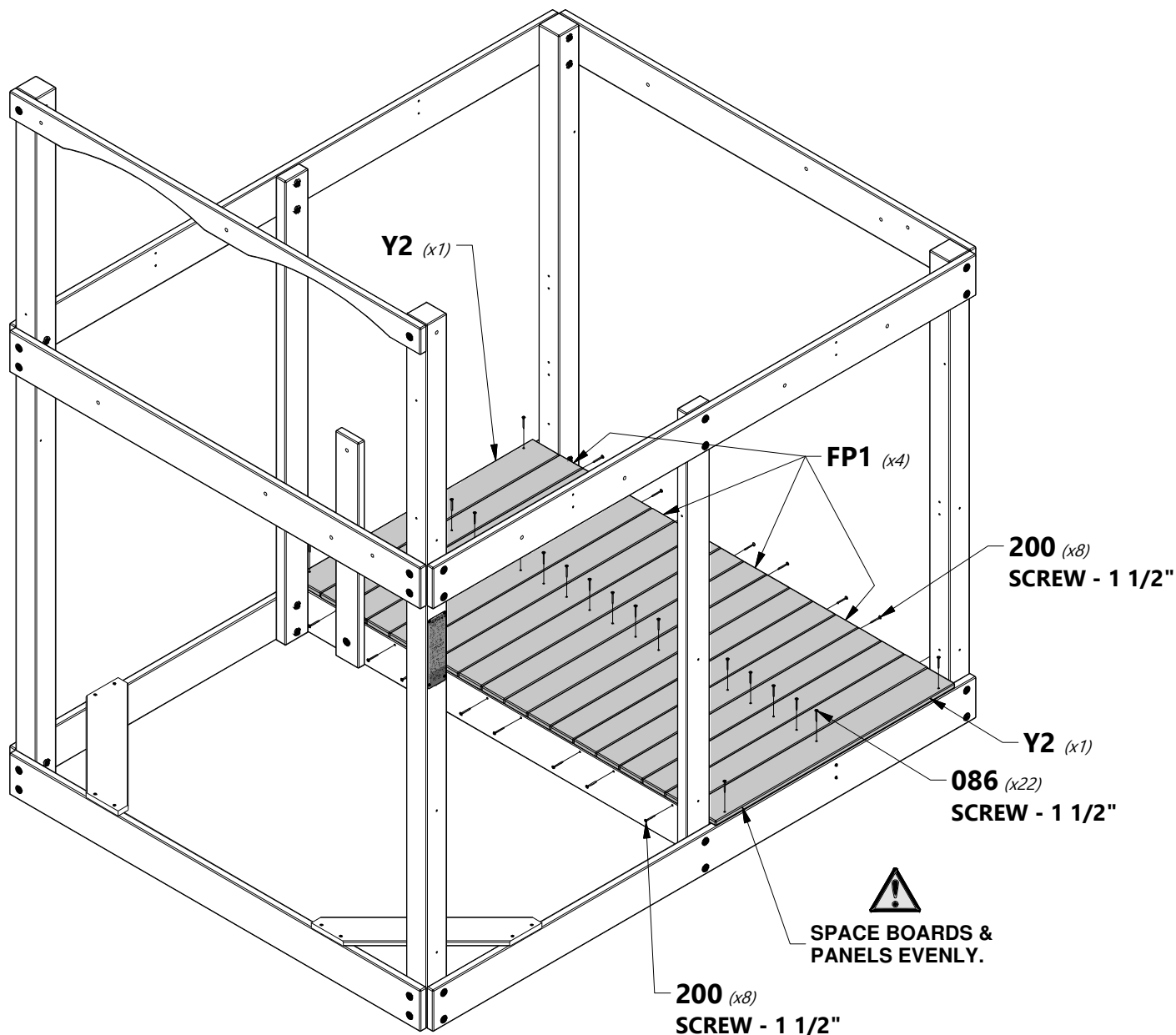



H3 | PICNIC TABLE RAIL - W4L14750
(x1) | 1"x3 3/8"x67 1/4" (24x86x1708)



M3 | BOTTOM WALL RAIL - W4L14791
(x1) | 5/8"x3 3/8"x60 1/2" (16x86x1537)



H100197 | LAG SCREW WH BLK
(x4) | 5/16x2 1/2



H100458 | LAG SCREW WH BLK
(x2) | 5/16x2



H100198 | WASHER LOCK EXT BLK
(x6) | 8x19



NOTE ANGLE CUT
FACES DOWNWARD

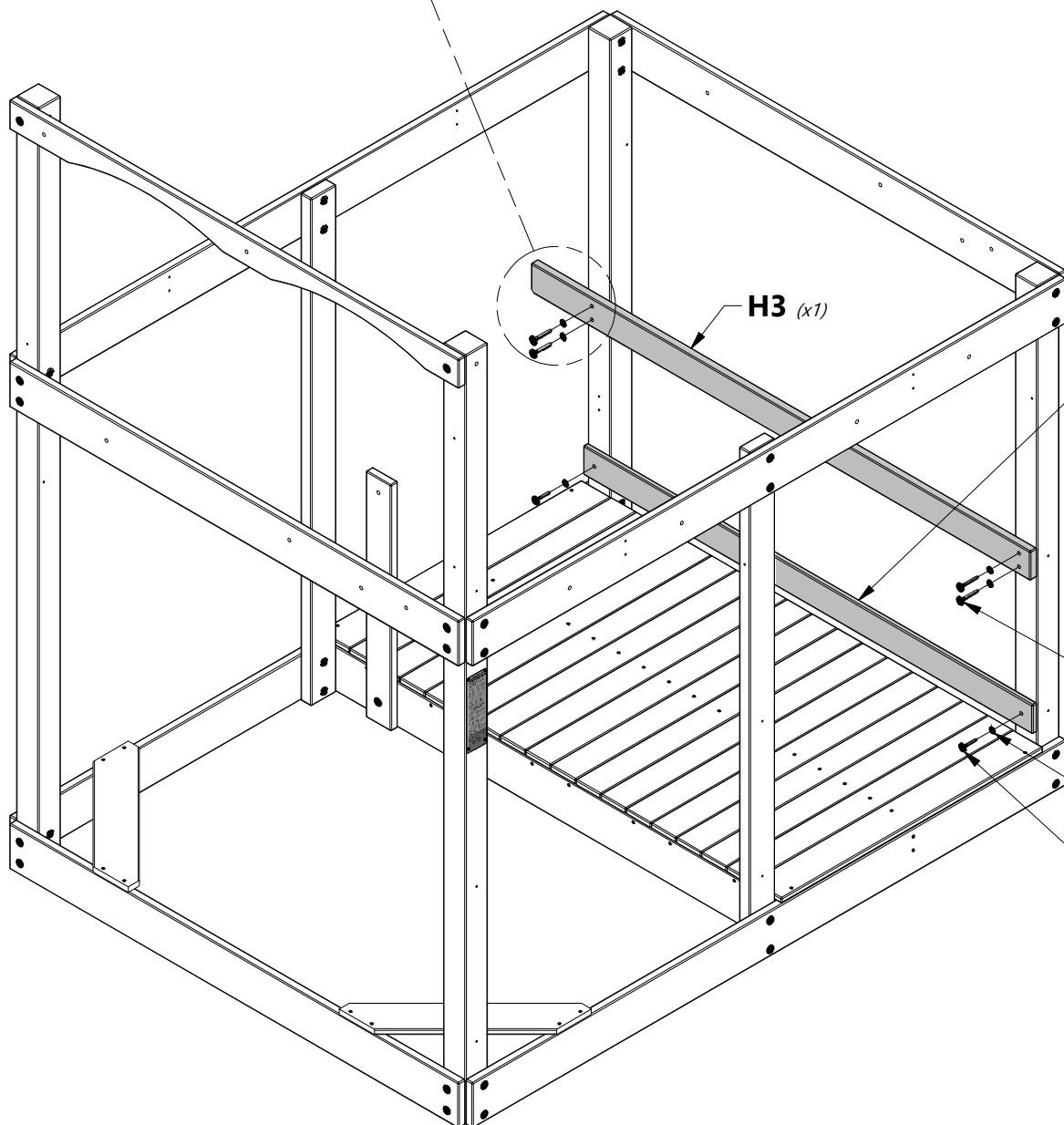
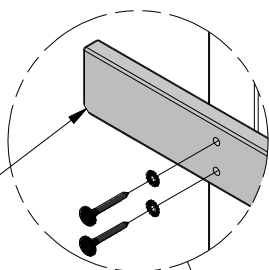

M3 (x1)

197 (x4)
LAG SCREW - 2 1/2"

198 (x6)
WASHER - 8x19

458 (x2)
LAG SCREW - 2"



M27 | BOTTOM WALL BOARD - W4L15711
(x8) | 5/8"x3 3/8"x21 1/8" (16x86x538)



H100088 | SCREW PFH
(x32) | 8x1 1/8

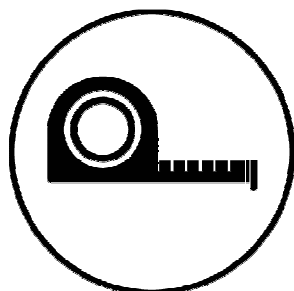

088 (x32)
SCREW - 1 1/8"

APPROXIMATELY
3 1/8 in
[78 mm]
EQUAL SPACING

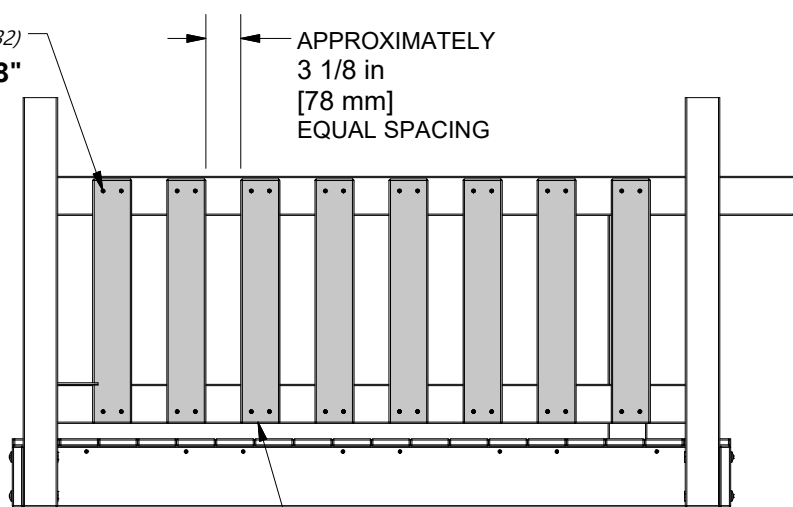

M27 (x8)
FLUSH BOTTOM EDGES

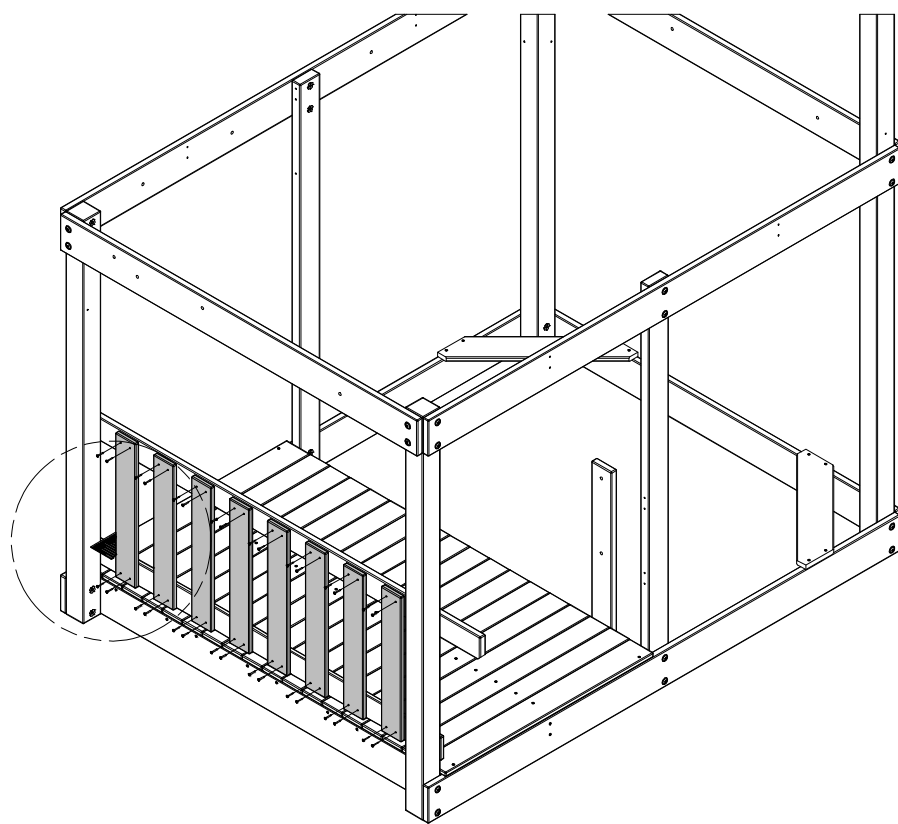
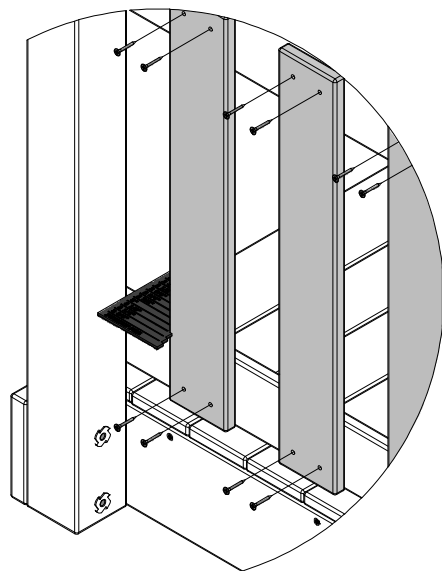

TIP:
PLACE THE FLAT EDGE OF THE PICKET PAL AGAINST THE EDGE OF AN ALREADY INSTALLED PART. INSTALL THE PICKET AT THE REQUIRED DISTANCE AND REPEAT PROCESS UNTIL COMPLETED.

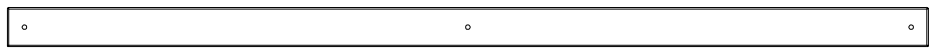

M2 | BOTTOM WALL RAIL - W4L14790
(x2) | 5/8"x3 3/8"x80" (16x86x2032)



H100458 | LAG SCREW WH BLK
(x4) | 5/16x2



H100471 | LAG SCREW WH BLK
(x2) | 5/16x1 1/2



H100198 | WASHER LOCK EXT BLK
(x6) | 8x19

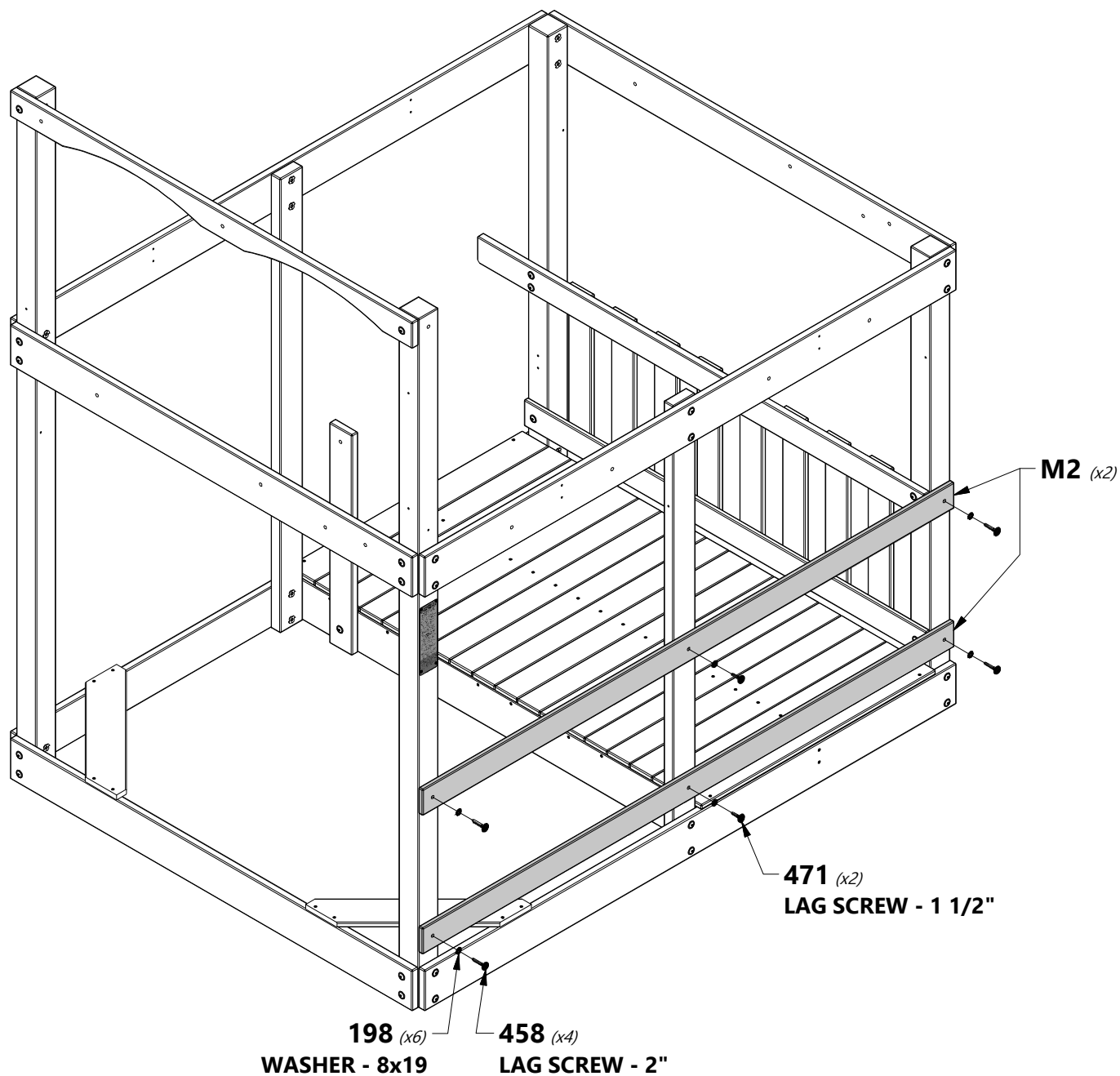

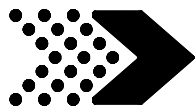

M27 | BOTTOM WALL BOARD - W4L15711
(x10) | 5/8"x3 3/8"x2 1 1/8" (16x86x538)



H100088 | SCREW PFH
(x40) | 8x1 1/8

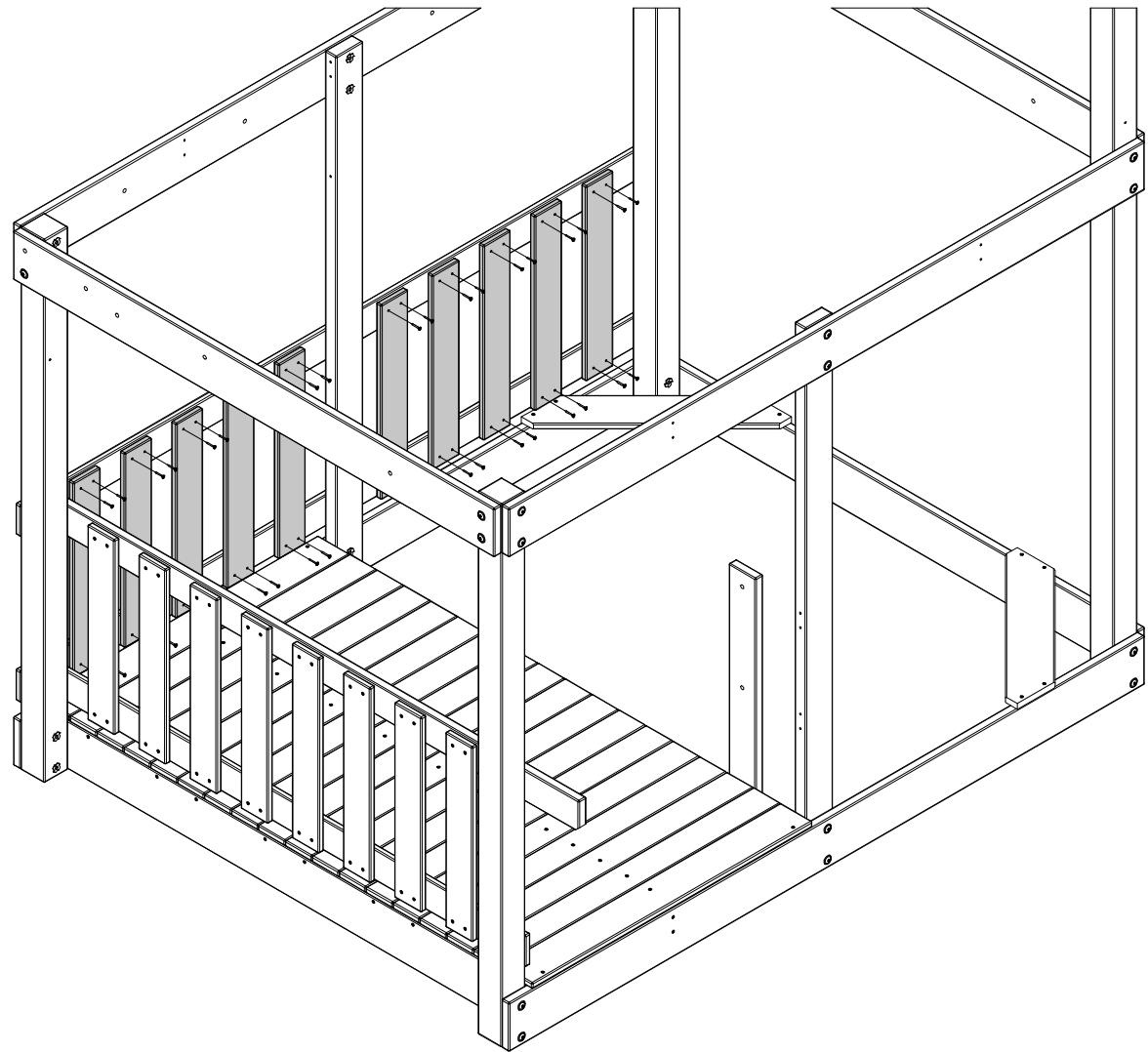
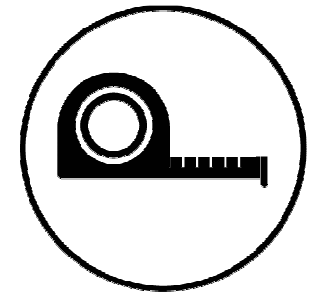
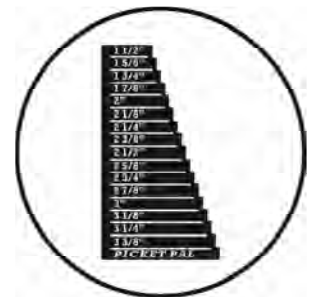
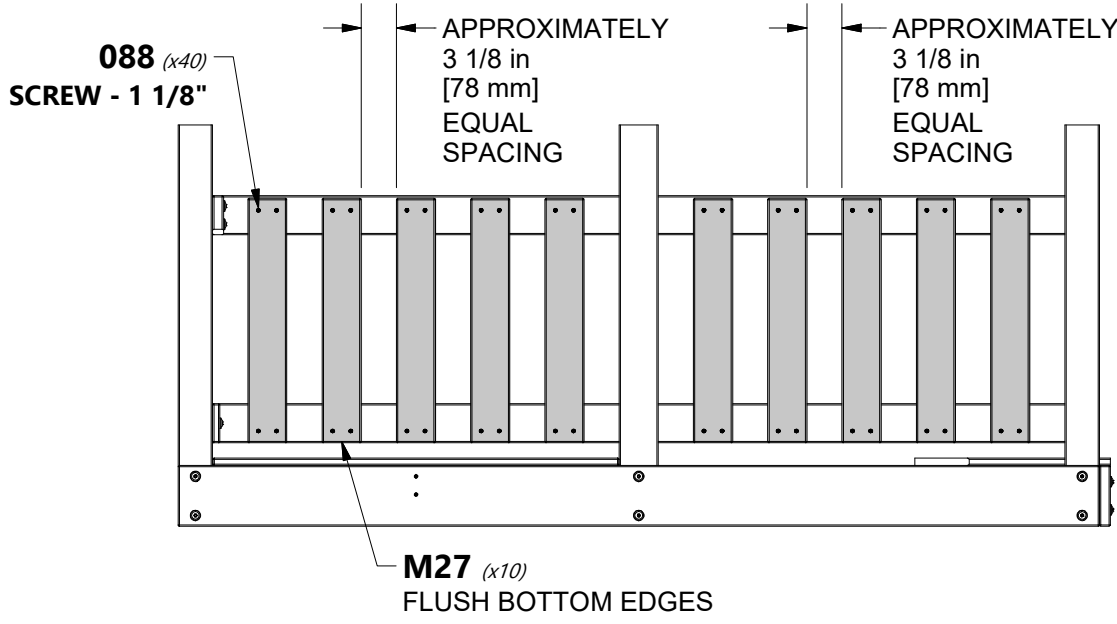

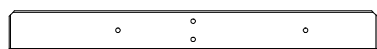

H16 | PICNIC TABLE SEAT RAIL - W4L14763
(x1) | 1"x3 3/8"x32" (24x86x812)



H23 | PICNIC TABLE BRACE - W4L14769
(x1) | 1"x3 3/8"x17 1/2" (24x86x444)



H100197 | LAG SCREW WH BLK
(x2) | 5/16x2 1/2



H100378 | BOLT WH BLK
(x1) | 5/16x1 3/4



H100407 | BOLT WH BLK
(x1) | 5/16x1 1/2



H100487 | LAG SCREW WH BLK
(x1) | 1/4x2



H100198 | WASHER LOCK EXT BLK
(x4) | 8x19



H100405 | WASHER LOCK EXT BLK
(x1) | 6x15



H100379 | T-NUT BLK
(x2) | 5/16

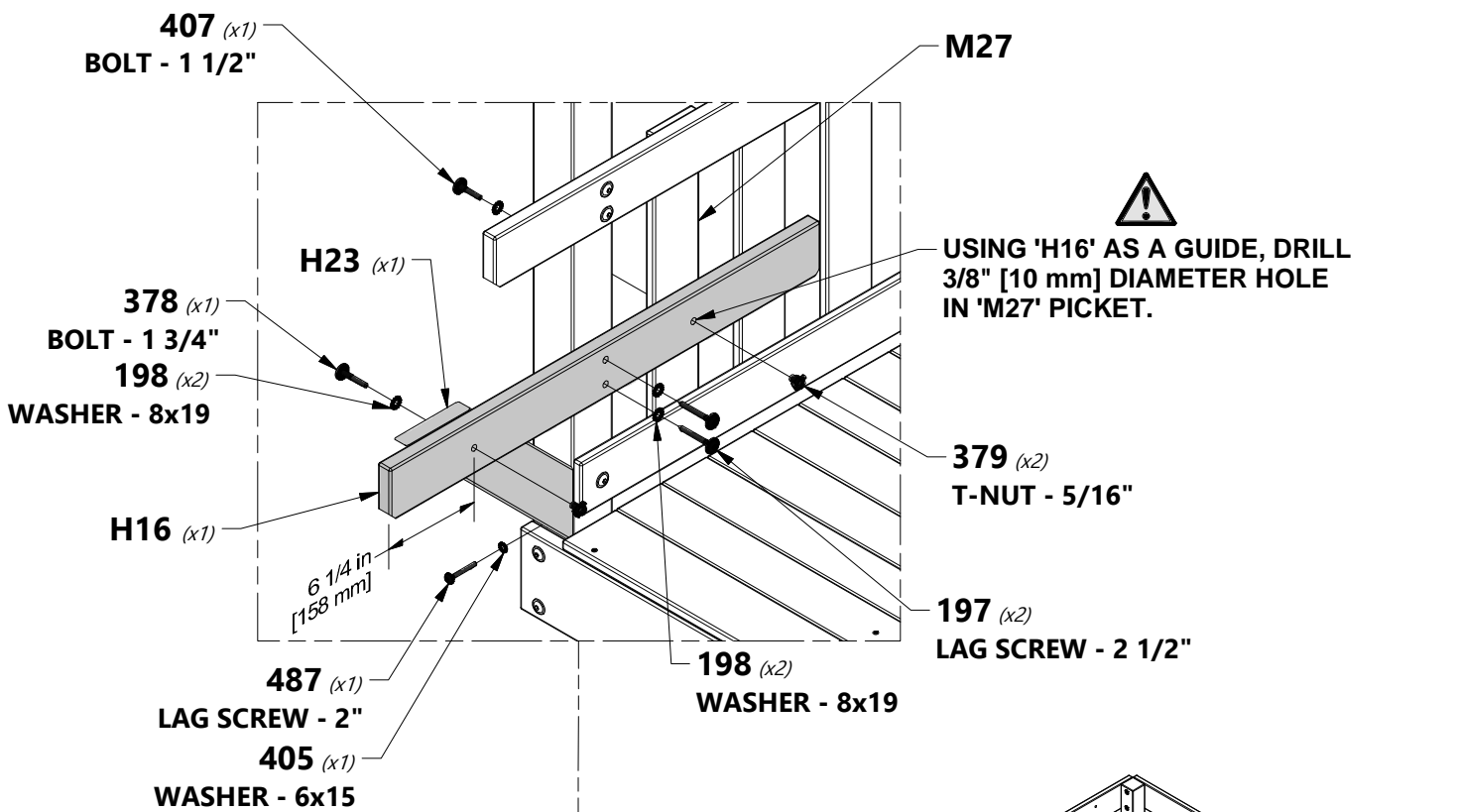

USING 'H16' AS A GUIDE, DRILL 3/8" [10 mm] DIAMETER HOLE IN 'M27' PICKET.

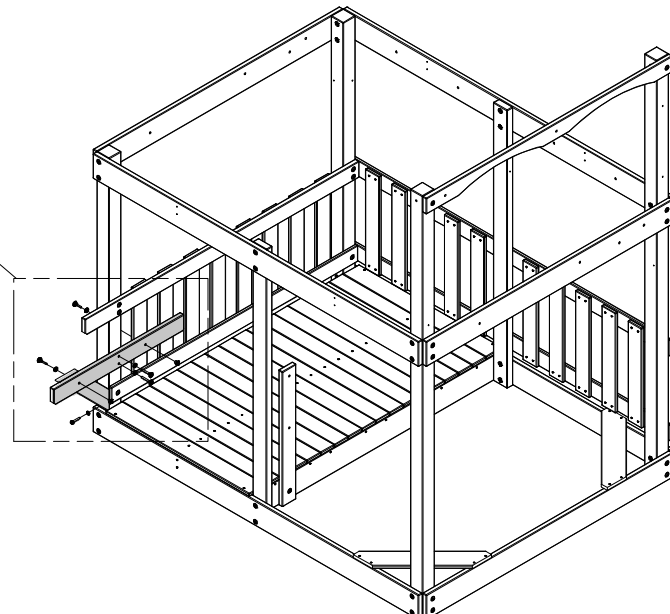
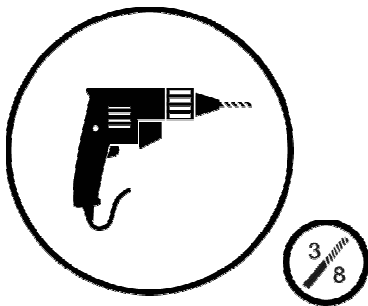

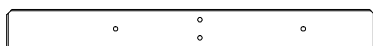

H17 | PICNIC TABLE SEAT RAIL - W4L14764
(x1) | 1"x3 3/8"x32" (24x86x812)



H23 | PICNIC TABLE BRACE - W4L14769
(x1) | 1"x3 3/8"x17 1/2" (24x86x444)



H100197 | LAG SCREW WH BLK
(x2) | 5/16x2 1/2



H100378 | BOLT WH BLK
(x2) | 5/16x1 3/4



H100487 | LAG SCREW WH BLK
(x1) | 1/4x2



H100198 | WASHER LOCK EXT BLK
(x4) | 8x19



H100405 | WASHER LOCK EXT BLK
(x1) | 6x15



H100379 | T-NUT BLK
(x2) | 5/16

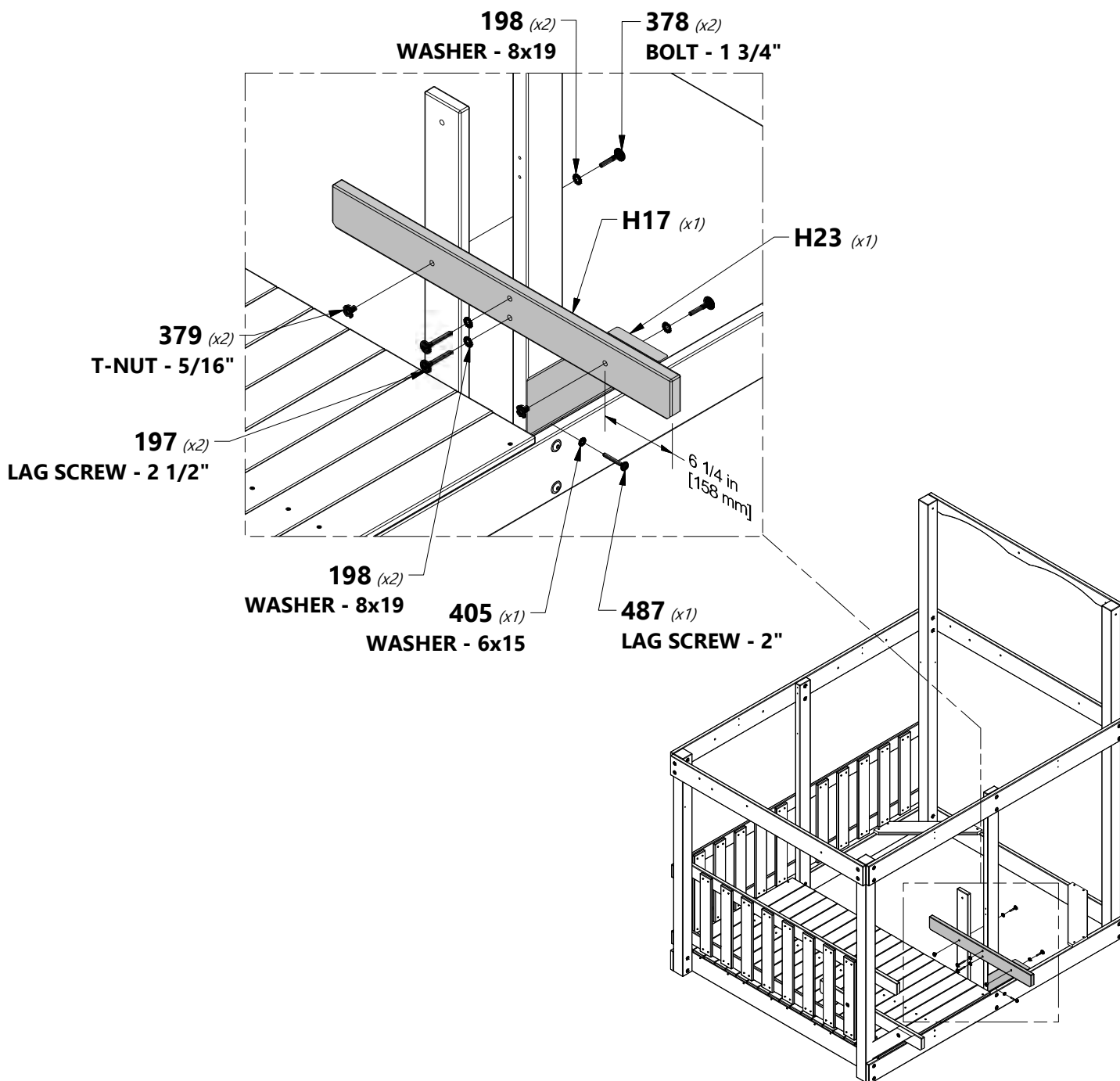



H15 | PICNIC TABLE SEAT - W4L14762
(x4) 1"x3 3/8"x35 3/8" (24x86x897)



H100111 | SCREW PFH
(x16) 8x2

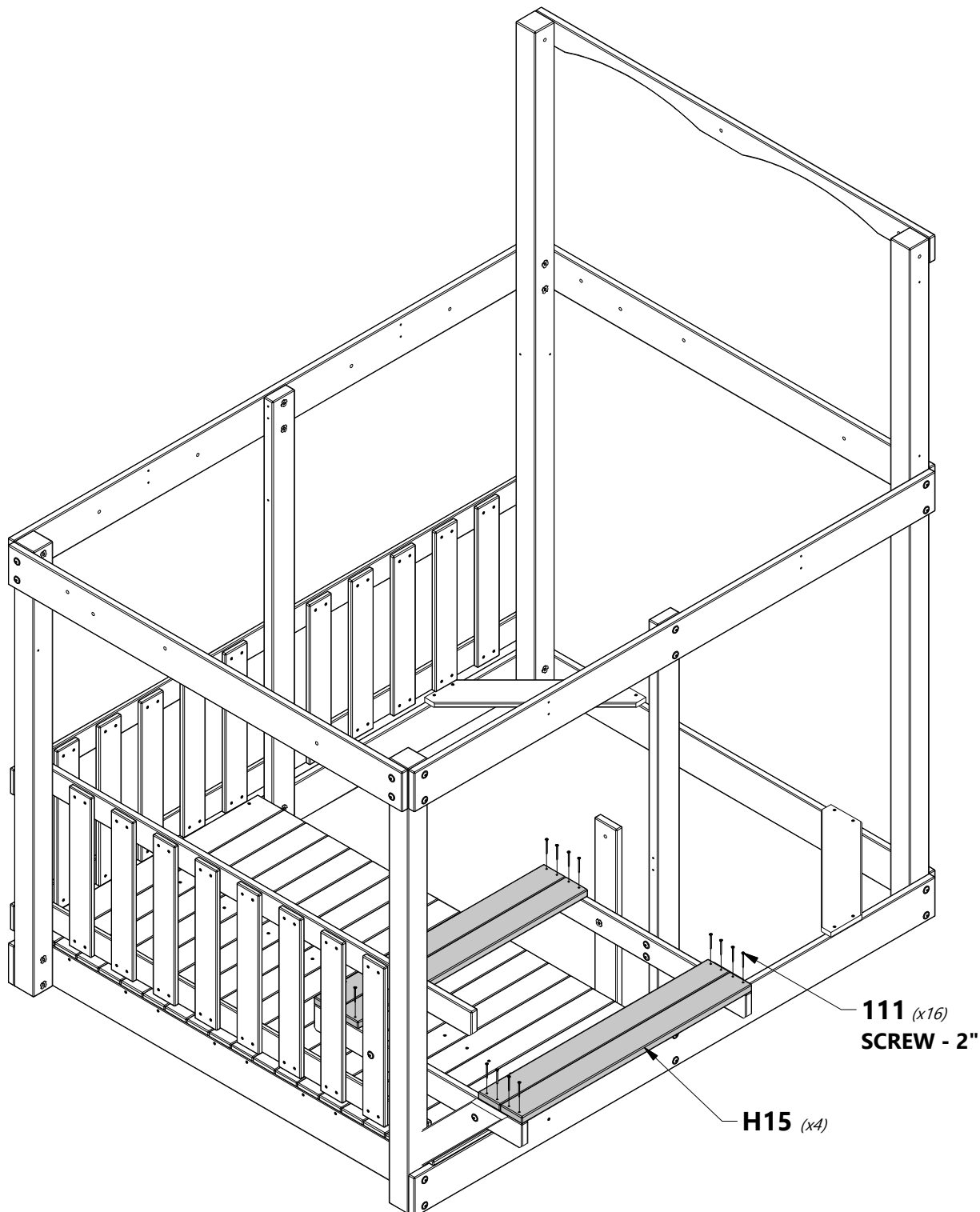

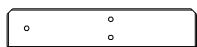

H24 | PICNIC TABLE TOP SUPPORT - W4L14770
(x1) | 1"x3 3/8"x16 1/2" (24x86x418)



H100197 | LAG SCREW WH BLK
(x2) | 5/16x2 1/2



H100378 | BOLT WH BLK
(x1) | 5/16x1 3/4



H100198 | WASHER LOCK EXT BLK
(x3) | 8x19



H100379 | T-NUT BLK
(x1) | 5/16

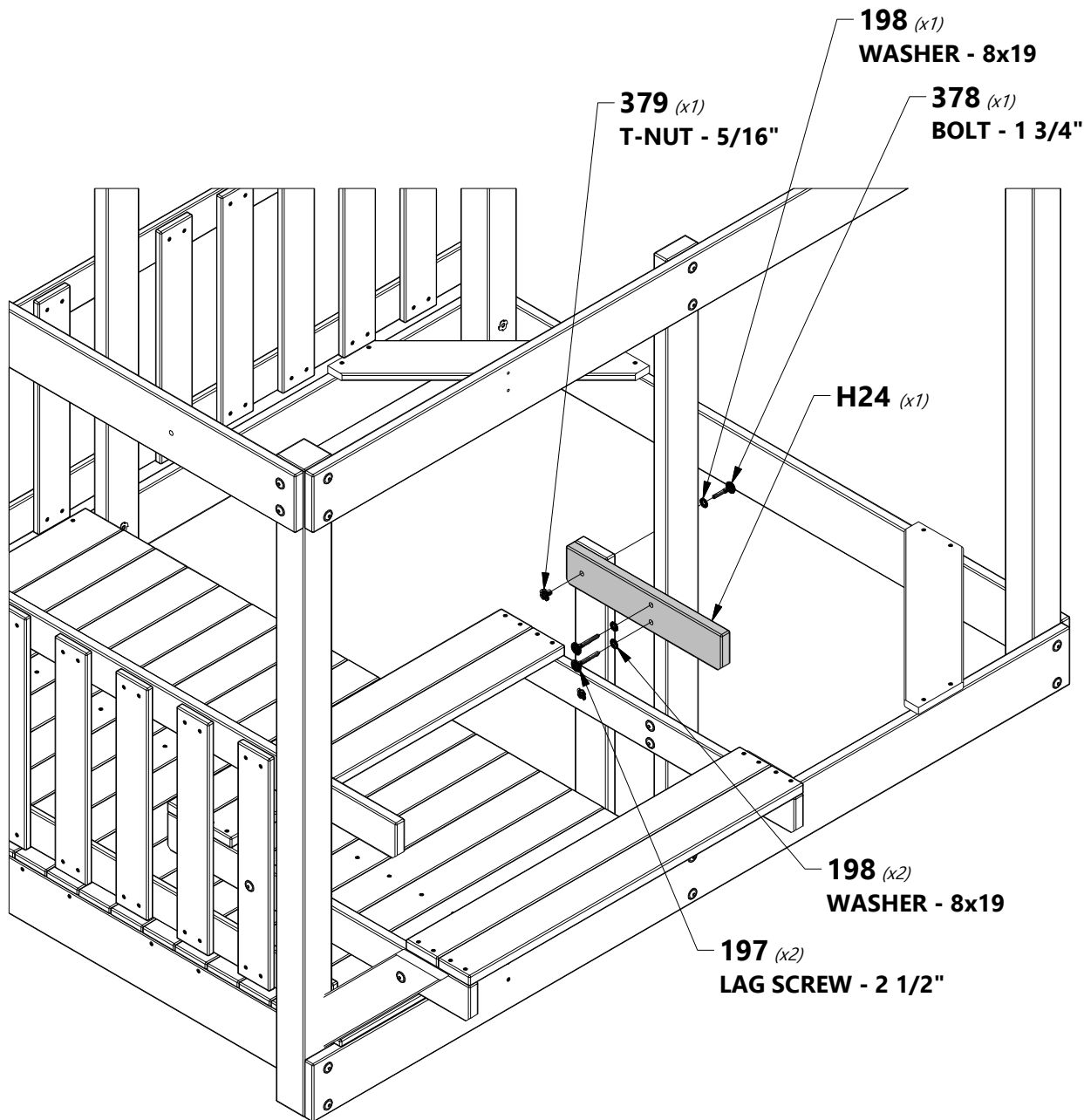



M13 | PICNIC TABLE TOP - W4L14801
(x4) | 5/8"x3 3/8"x41 1/4" (16x86x1049)



M30 | PICNIC TABLE TOP CLEAT - W4L14815
(x1) | 5/8"x3 3/8"x16" (16x86x406)



M16 | CENTER PICNIC TABLE TOP - W4L14803
(x1) | 5/8"x3"x38 1/4" (16x76x973)



H100086 | SCREW PFH
(x20) | 8x1 1/2



H100088 | SCREW PFH
(x5) | 8x1 1/8

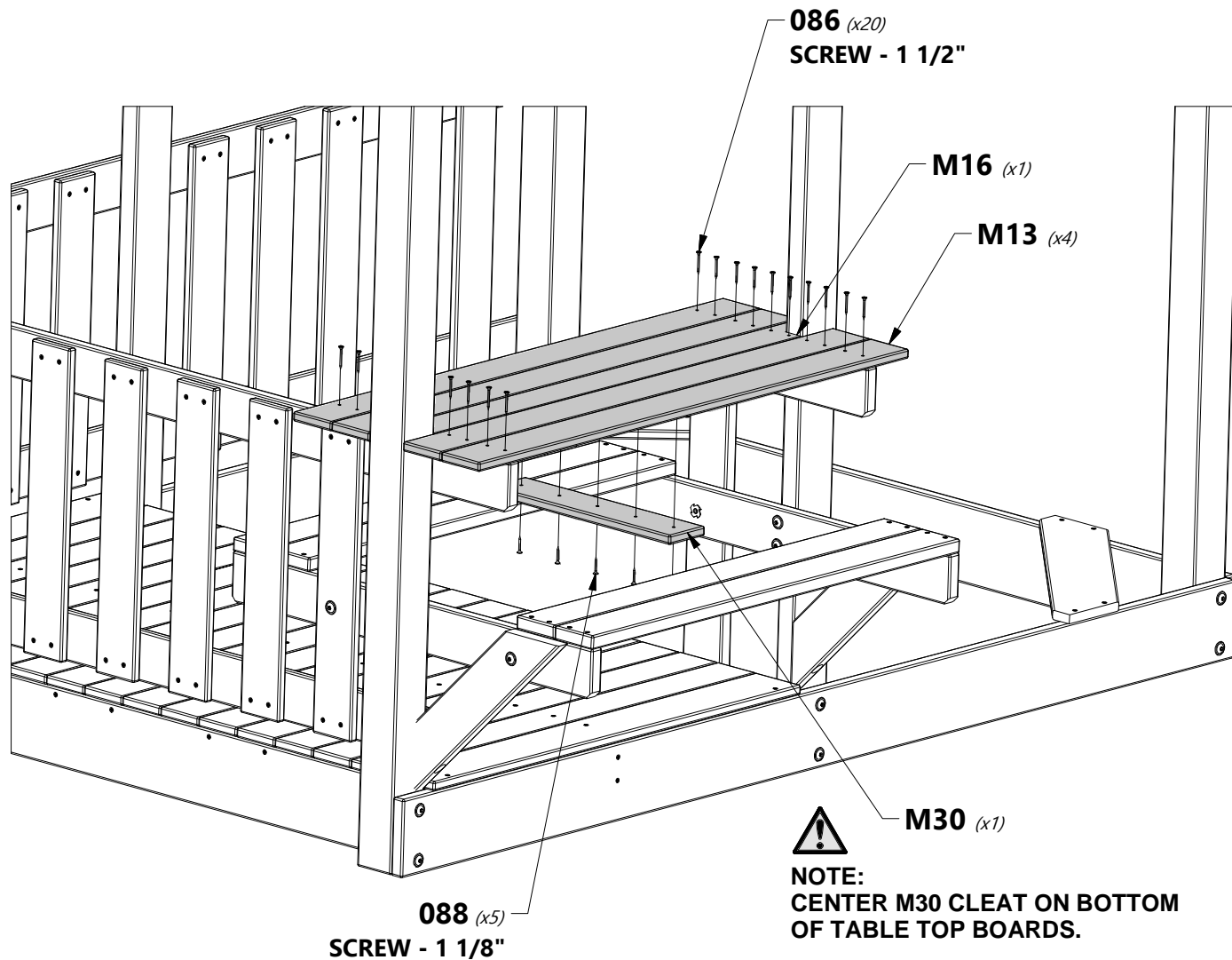



H25 | TOP FLOOR SUPPORT - W4L14771
(x2) | 1"x3 3/8"x3" (24x86x76)



H100391 | SCREW PFH BLK
(x4) | 8x2

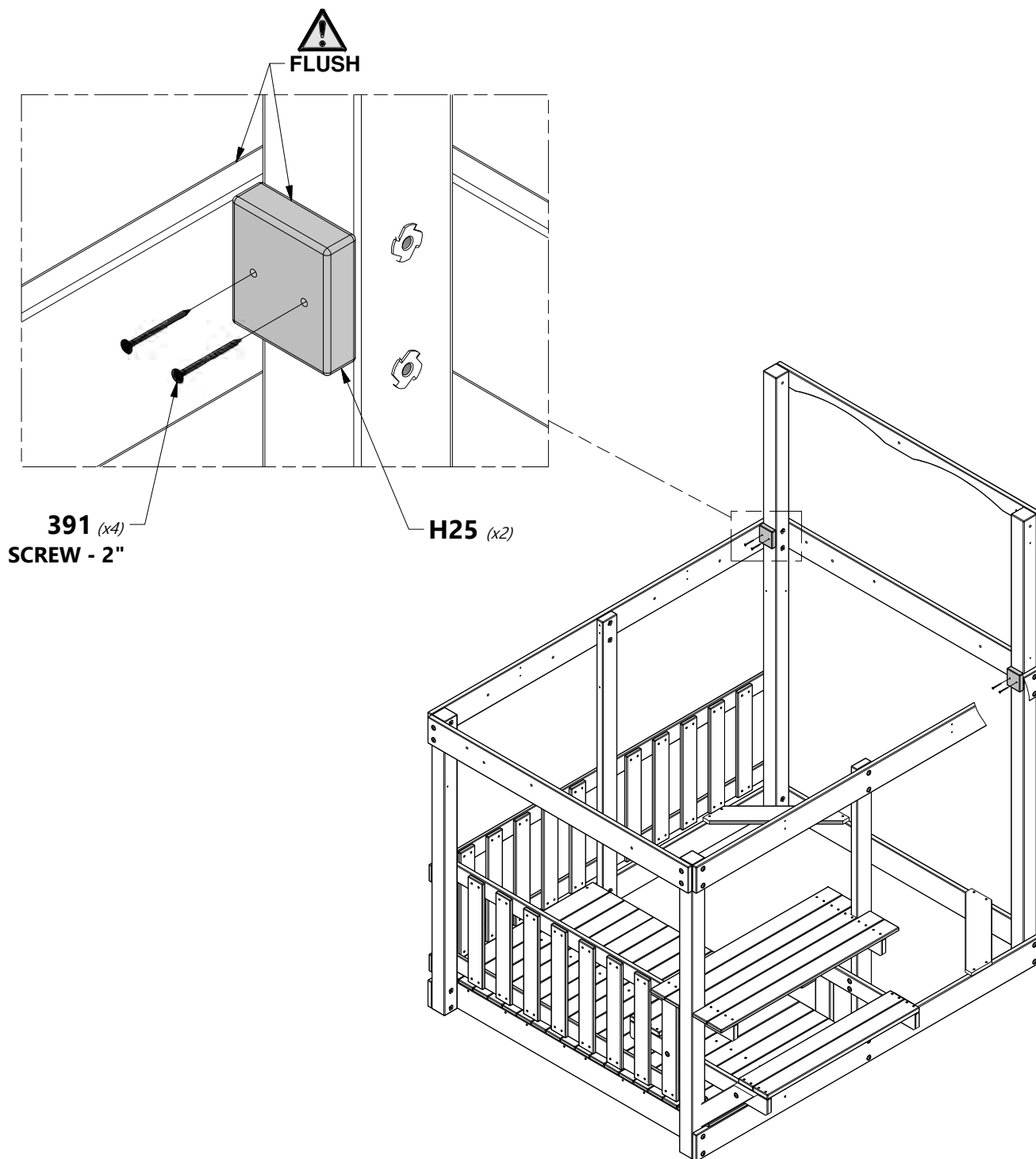

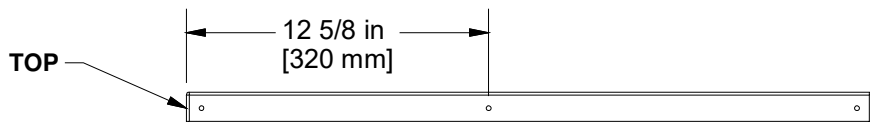

O2 SAFETY BOARD - W4L14836
(x1) | 5/8"x1 3/8"x28 5/8" (16x34x726)



H100380 SCREW PFH BLK
(x3) | 8x1 1/8

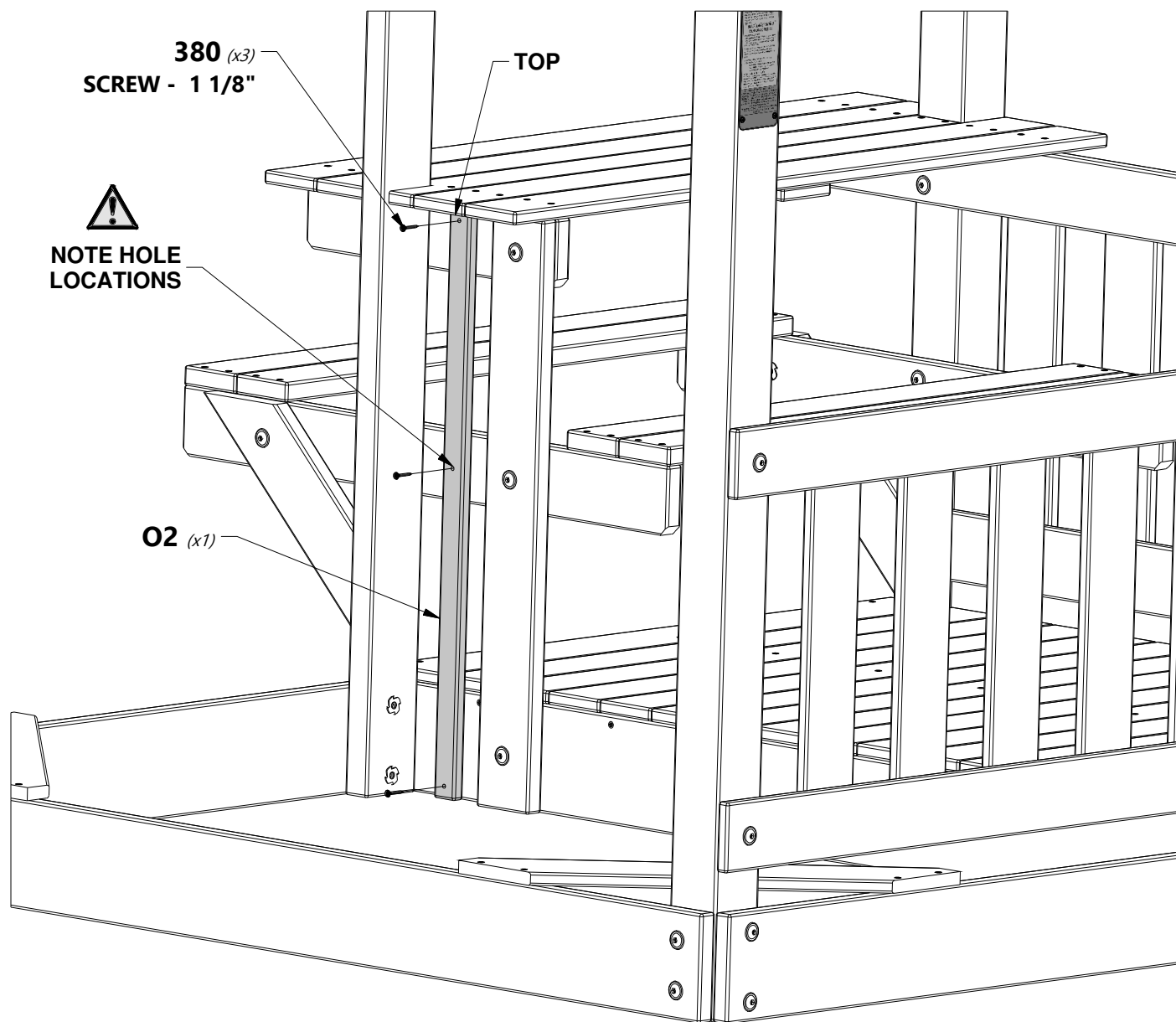



E05 | DECK BRACE - W4L15452
 (x8) | 1 7/16"x3 3/8"x17 11/16" (36x86x450)

H100205 | BOLT WH BLK
 (x8) | 5/16x2-1/4

H100456 | LAG SCREW WH BLK
 (x8) | 1/4x2 1/2

H100198 | WASHER LOCK
 (x8) | EXT BLK
 8x19

H100405 | WASHER LOCK
 (x8) | EXT BLK
 6x15

H100379 | T-NUT BLK
 (x8) | 5/16

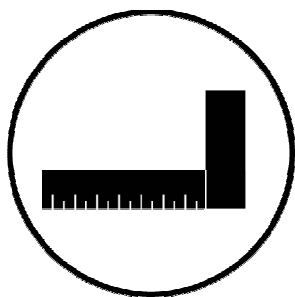

E05 (x8)

379 (x8)
T-NUT - 5/16"

198 (x8)
WASHER - 8x19

205 (x8)
BOLT - 2 1/4"

**NOTE ORIENTATION
 OF T-NUTS**

456 (x8)
LAG SCREW - 2 1/2"

405 (x8)
WASHER - 6x15

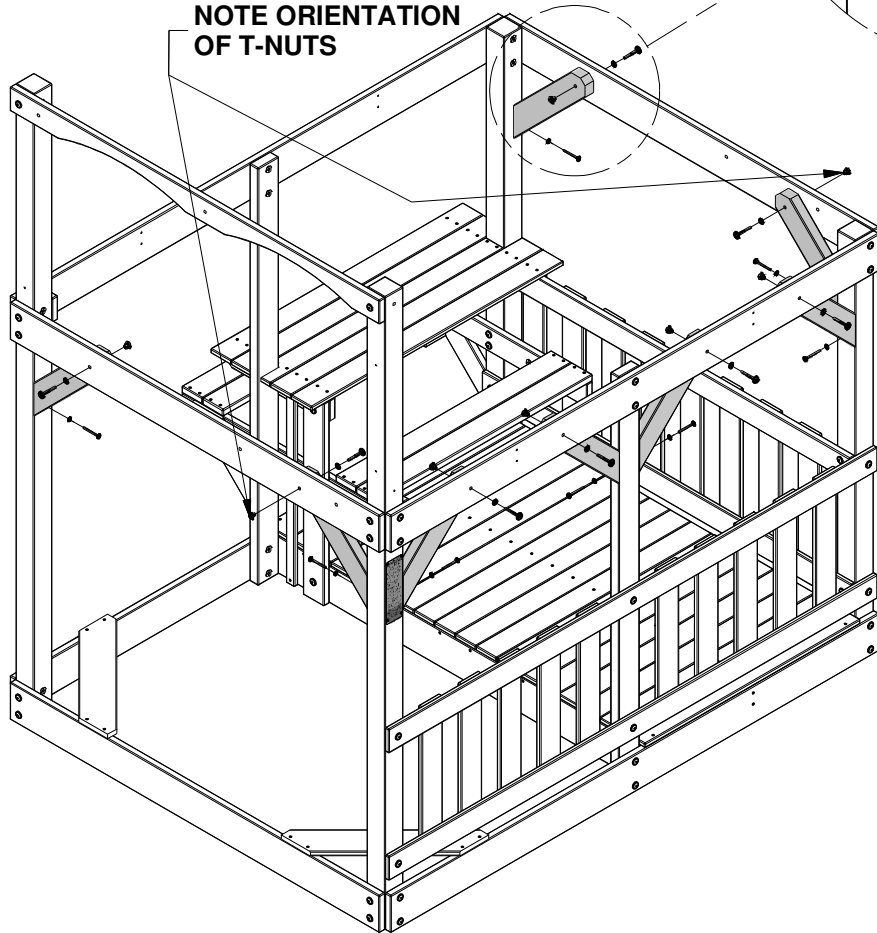

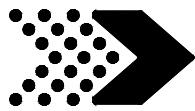

H5 | FLOOR RAIL - W4L14752
(x1) | 1"x3 3/8"x60 1/2" (24x86x1537)



H26 | FLOOR JOIST - W4L14772
(x2) | 1"x3 3/8"x60 1/2" (24x86x1537)



H100458 | LAG SCREW WH BLK
(x4) | 5/16x2



H100198 | WASHER LOCK EXT BLK
(x4) | 8x19



H100201 | SCREW PFH BLK
(x8) | 8x2-1/2

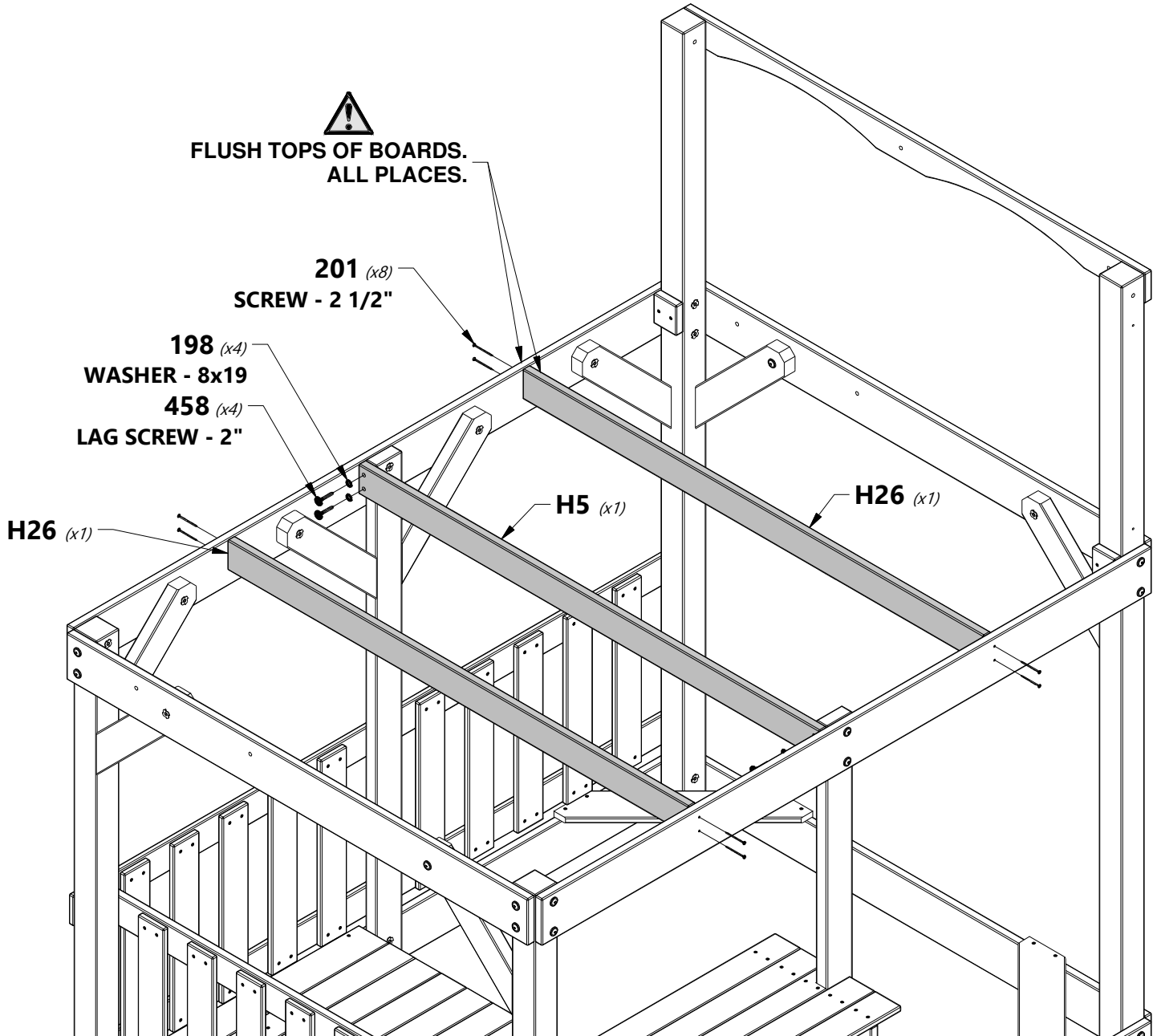

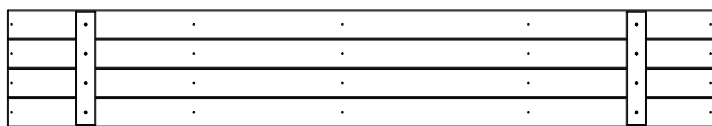

FP2 FLOOR PANEL - W2A03141
(x4) 1 1/4"x13 1/2"x81 7/8" (32x344x2080)

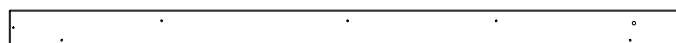

Y1 TOP FLOOR BOARD - W4L15730
(x2) 5/8"x4"x78" (16x102x1980)



H100086 SCREW PFH
(x94) 8x1 1/2



H100379 T-NUT BLK
(x2) 5/16

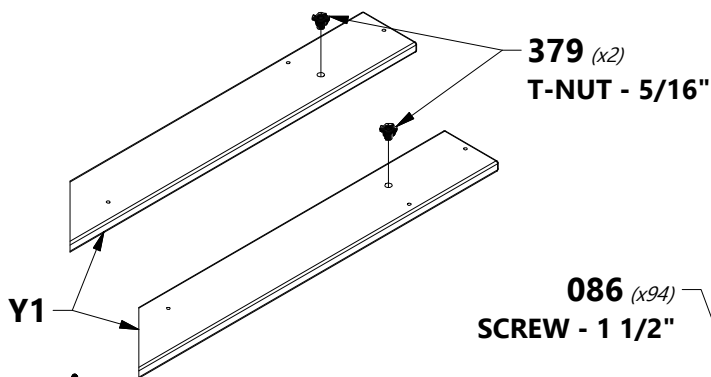

TIP:
INSTALL T-NUTS ON BOTTOM SIDE OF BOTH Y1 FLOOR BOARDS BEFORE ATTACHING TO FORT.



NOTE:
T-NUTS ON BOTTOM SIDE.



NOTE:
ENSURE PILOT HOLES ARE CENTERED ON FLOOR JOISTS.

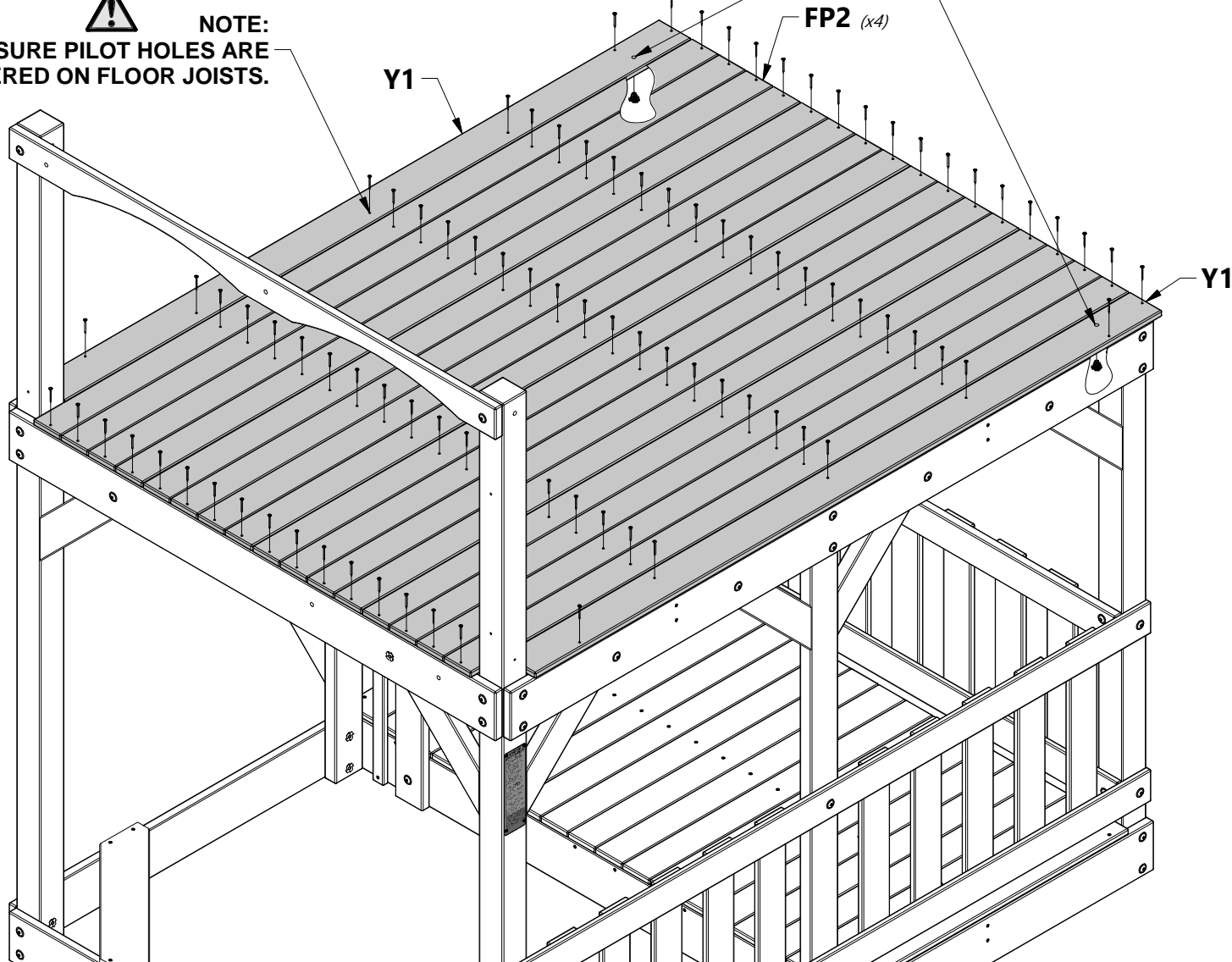



B5 | BACK LEFT CLUB HOUSE CORNER - W4L14722
(x1) | 3"x3"x53 7/8" (76x76x1370)

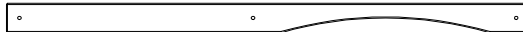

H6 | BACK CLUB HOUSE RAIL - W4L14753
(x1) | 1"x3 3/8"x60 1/2" (24x86x1537)

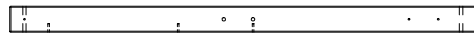

B8 | BACK RIGHT FORT CORNER - W4L12687
(x1) | 3"x3"x53 7/8" (76x76x1370)



H4 | ROOF SUPPORT RAIL - W4L14751
(x1) | 1"x3 3/8"x67 1/4" (24x86x1709)

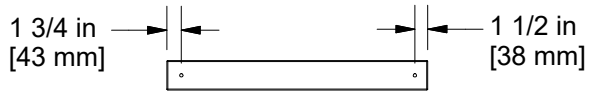

M21 | FORT WALL RAIL - W4L12761
(x1) | 5/8"x3 3/8"x30 1/4" (16x86x768)



A4M01046 | L BRACKET
(x2) | 2.5x38x55x55



H100194 | BOLT WH BLK
(x1) | 5/16x2 1/2



H100396 | BOLT WH BLK
(x2) | 5/16x1/2



H100415 | BOLT WH BLK
(x2) | 5/16x3 3/4



H100379 | T-NUT BLK
(x2) | 5/16



H100484 | BOLT WH BLK
(x1) | 5/16x3 1/4



H100192 | NUT BARREL WH BLK
(x2) | 5/16x7/8



H100458 | LAG SCREW WH BLK
(x2) | 5/16x2



H100199 | WASHER LOCK
EXT BLK
(x2) | 12x19



H100198 | WASHER LOCK
EXT BLK
(x4) | 8x19

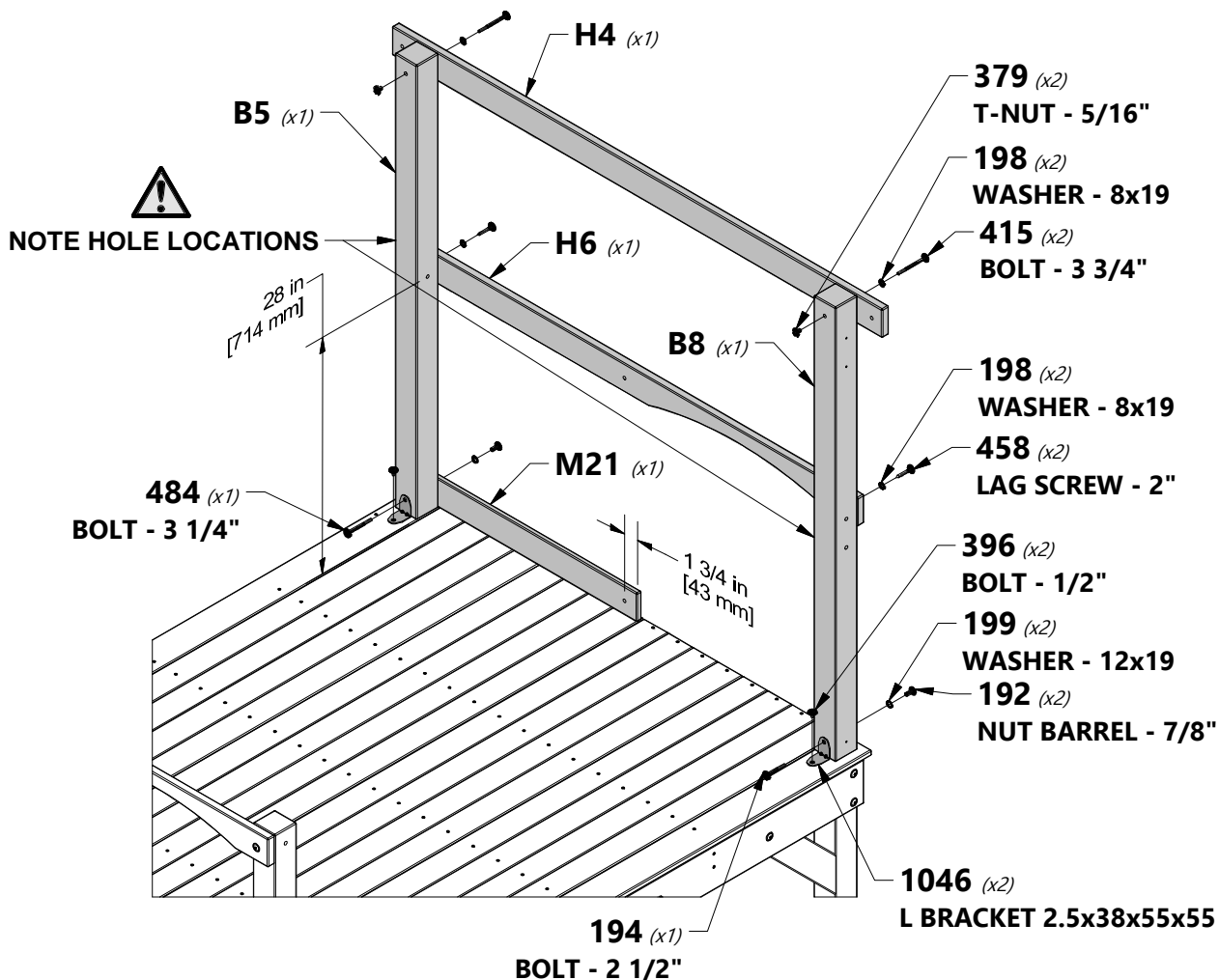

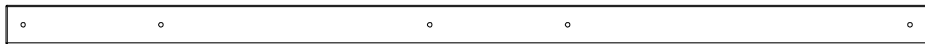

M1 | TOP WALL RAIL - W4L14789
(x1) | 5/8"x3 3/8"x80" (16x86x2032)



M10 | CLUB HOUSE WALL RAIL - W4L14798
(x1) | 5/8"x3 3/8"x50 1/4" (16x86x1277)

1 1/2 in [38 mm] 1 3/4 in [43 mm]



M34 | WALL RAIL - W4L14819
(x1) | 5/8"x3 3/8"x6 3/8" (16x86x162)



H100458 | LAG SCREW WH BLK
(x4) | 5/16x2



H100198 | WASHER LOCK
(x4) | EXT BLK
8x19

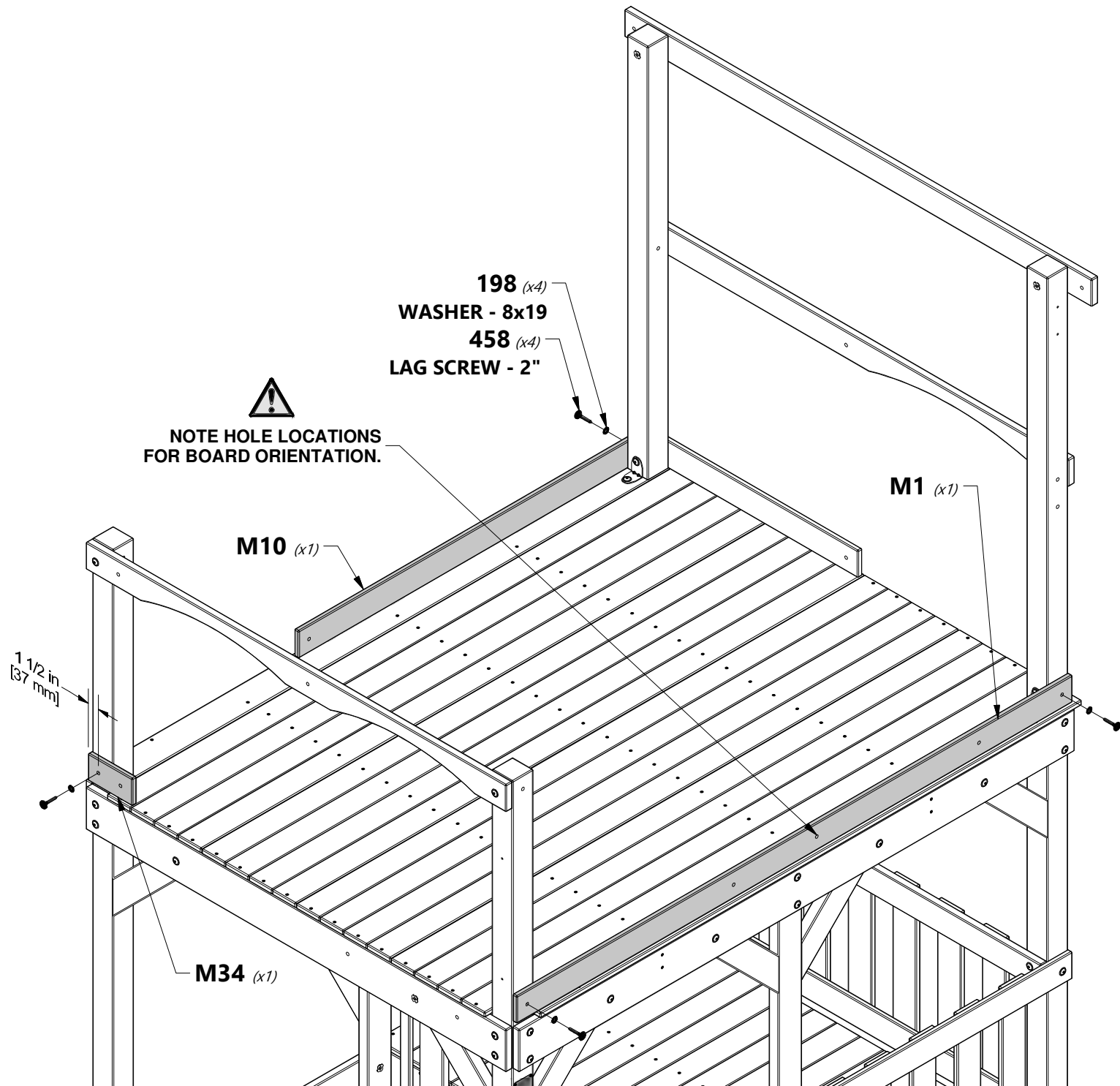



H18 | CLUB HOUSE WALL RAIL - W4L14765
(x1) | 1"x3 3/8"x29 7/8" (24x86x758)



A4M01046 | L BRACKET
(x1) | 2.5x38x55x55



H100378 | BOLT WH BLK
(x1) | 5/16x1 3/4



H100459 | BOLT WH BLK
(x1) | 5/16x1 1/4



H100396 | BOLT WH BLK
(x1) | 5/16x1/2



H100192 | NUT BARREL WH BLK
(x1) | 5/16x7/8



H100199 | WASHER LOCK
(x1) | EXT BLK
12x19



H100198 | WASHER LOCK
(x1) | EXT BLK
8x19



H100379 | T-NUT BLK
(x2) | 5/16

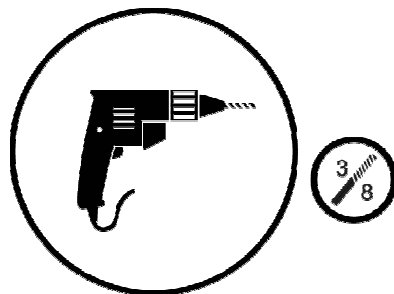
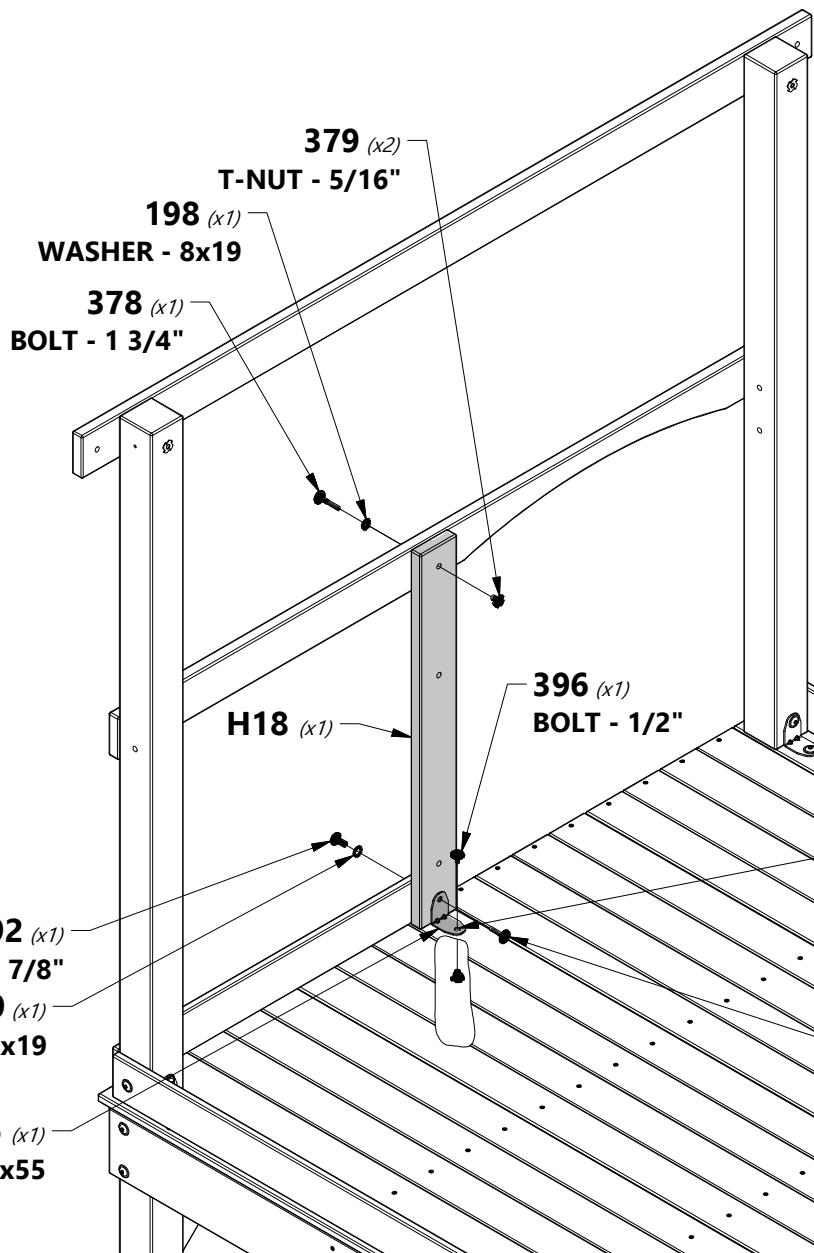

USING BRACKET AS A GUIDE, DRILL 3/8" [10 mm] HOLE THROUGH DECK.



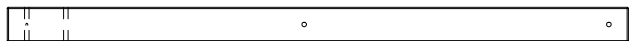

B6 | FRONT LEFT CLUB HOUSE CORNER - W4L14723
(x1) | 3"x3"x53 7/8" (76x76x1370)



H1 | WALL RAIL - W4L14748
(x1) | 1"x3 3/8"x80" (24x86x2032)



A4M01046 | L BRACKET
(x1) | 2.5x38x55x55



H100415 | BOLT WH BLK
(x3) | 5/16x3 3/4



H100198 | WASHER LOCK
(x3) | EXT BLK
8x19



H100484 | BOLT WH BLK
(x1) | 5/16x3 1/4



H100199 | WASHER LOCK
(x1) | EXT BLK
12x19



H100396 | BOLT WH BLK
(x1) | 5/16x1/2



H100379 | T-NUT BLK
(x4) | 5/16



H100192 | NUT BARREL WH BLK
(x1) | 5/16x7/8

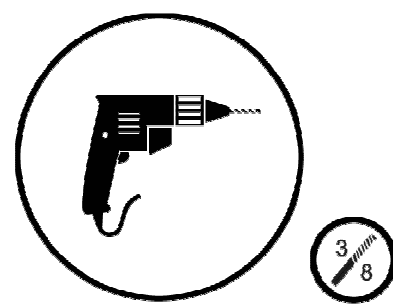
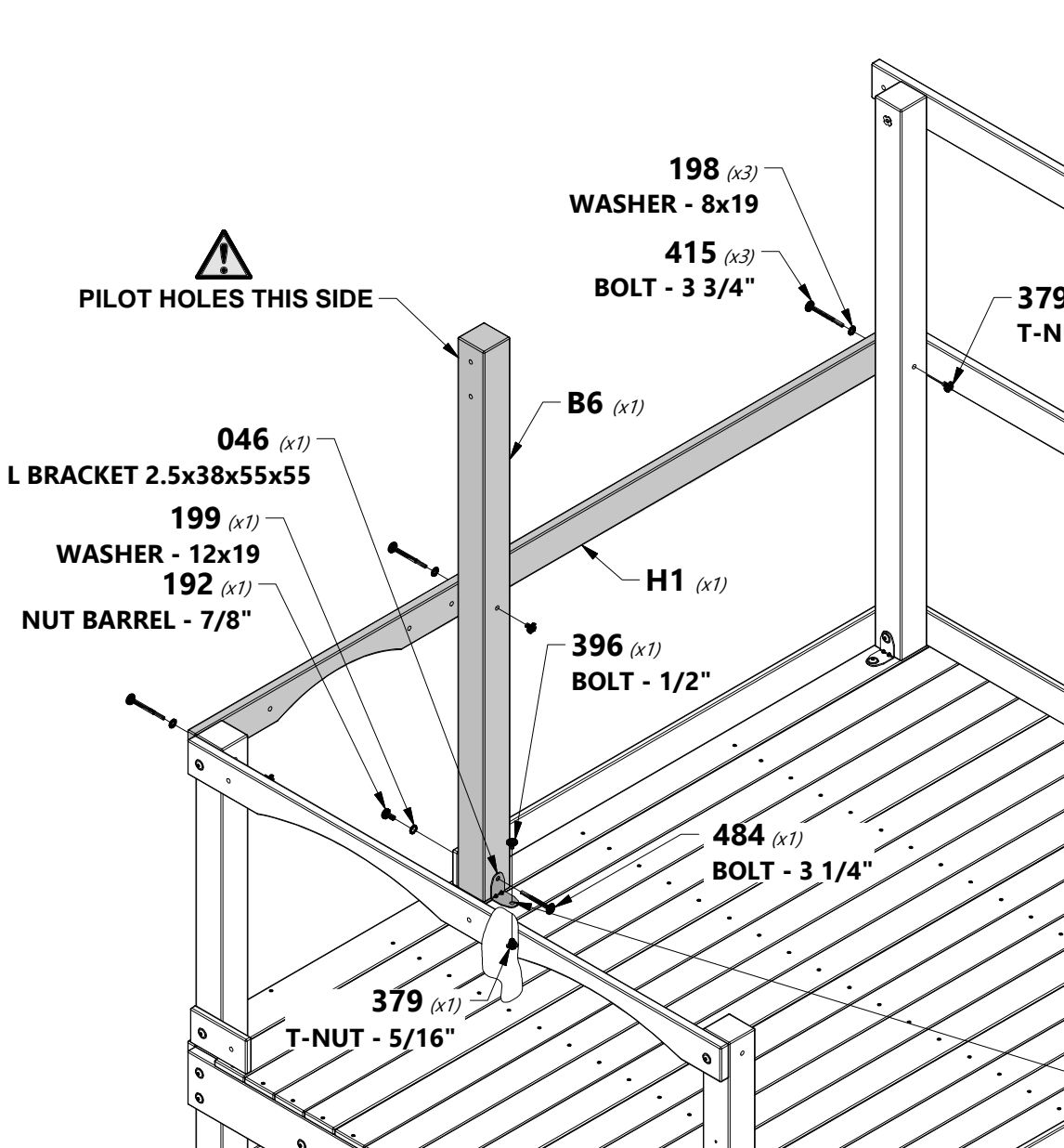

USING BRACKET AS A GUIDE, DRILL 3/8" [10 mm] HOLE THROUGH DECK

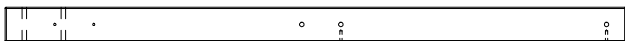

B7 FRONT RIGHT FORT CORNER - W4L12686
(x1) 3"x3"x53 7/8" (76x76x1370)



H2 WALL RAIL - W4L12707
(x1) 1"x3 3/8"x80" (24x86x2032)



A4M01046 L BRACKET
(x1) 2.5x38x55x55



H100415 BOLT WH BLK
(x3) 5/16x3 3/4



H100198 WASHER LOCK
(x3) EXT BLK
8x19



H100484 BOLT WH BLK
(x1) 5/16x3 1/4



H100199 WASHER LOCK
(x1) EXT BLK
12x19



H100396 BOLT WH BLK
(x1) 5/16x1/2



H100379 T-NUT BLK
(x4) 5/16



H100192 NUT BARREL WH BLK
(x1) 5/16x7/8

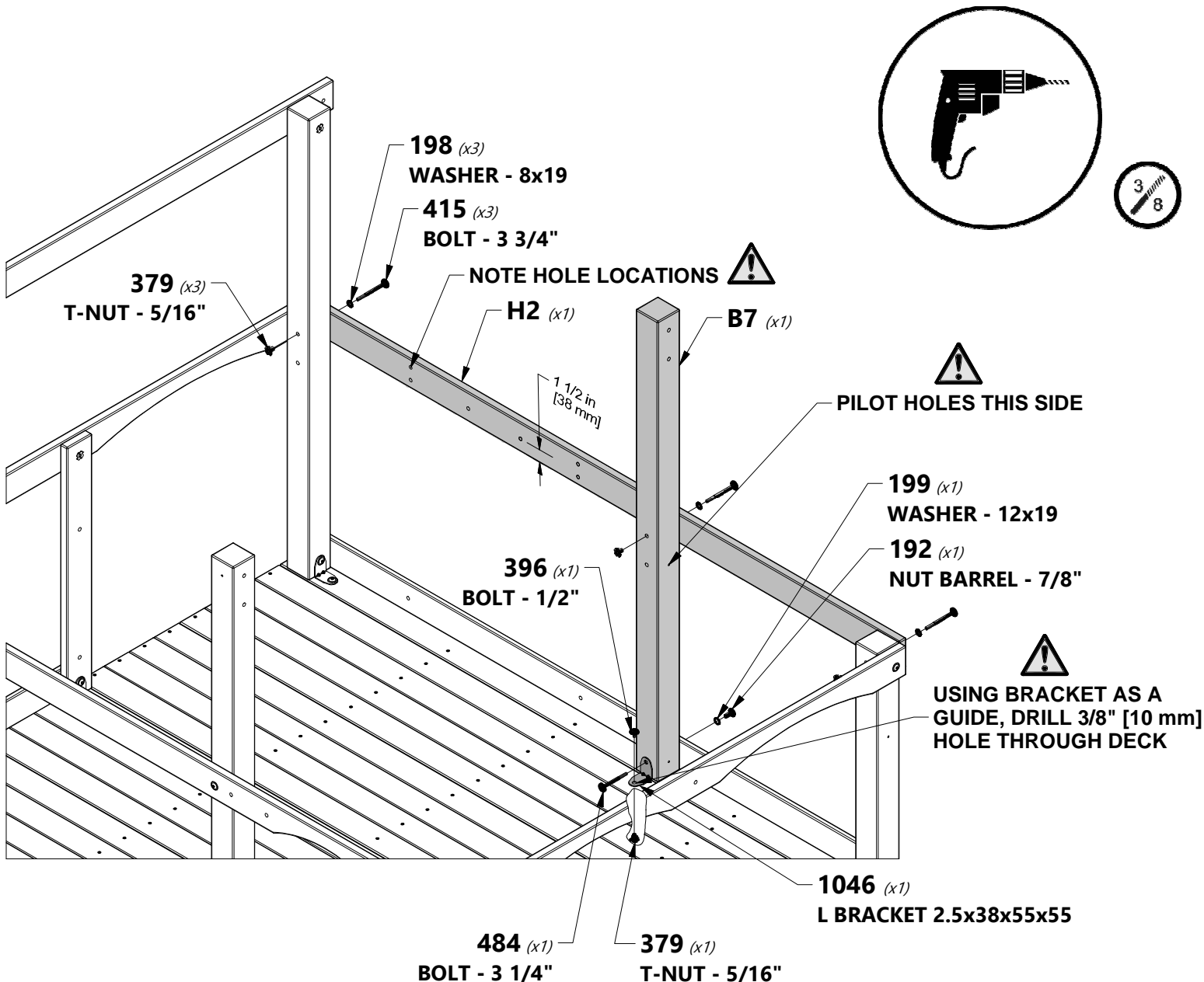



H9 | FORT WALL BOARD - W4L12714
(x2) | 1"x3 3/8"x50 1/2" (24x86x1284)



A100396 | L BRACKET
(x2) | 51x32x82x3.175



H100407 | BOLT WH BLK
(x2) | 5/16x1 1/2



H100761 | BOLT HEX BLK
(x4) | 5/16x2



H100198 | WASHER LOCK
(x2) | EXT BLK
8x19



H100477 | WASHER SPLIT
(x4) | BLK
5/16



H100478 | WASHER FLAT
(x4) | BLK
8x27



H100379 | T-NUT BLK
(x6) | 5/16



NOTE:
INSERT T-NUTS INTO BOARDS
BEFORE ASSEMBLY.

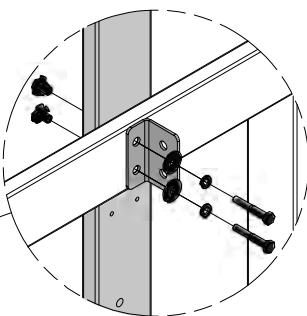

REFERENCE VIEW

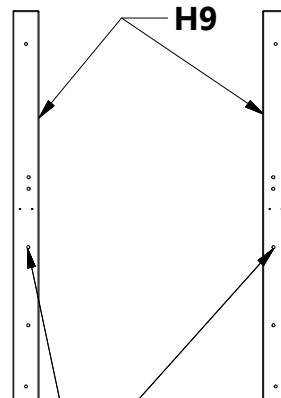

H9



NOTE:
HOLES ARE CLOSER
TO THE INSIDE WHEN
INSTALLED.

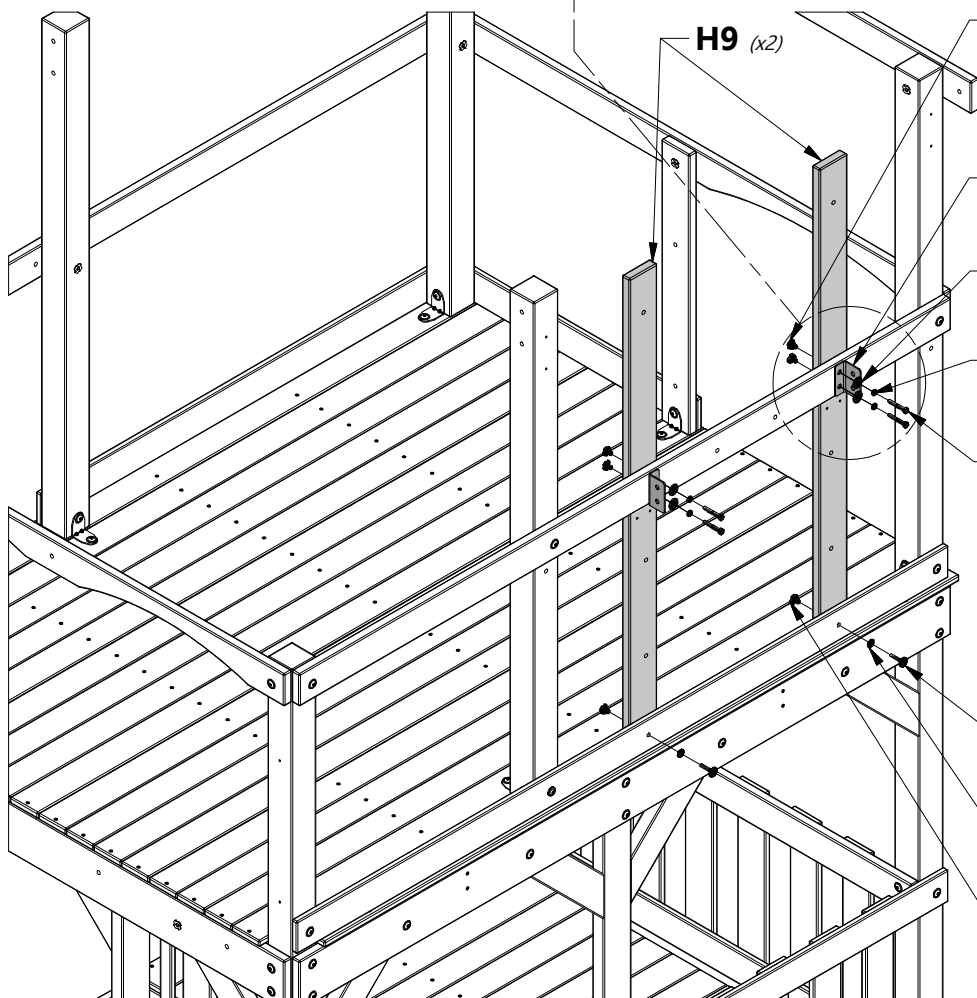

379 (x4)
T-NUT - 5/16"

396 (x2)
L BRACKET 51x32x82x3.175

478 (x4)
WASHER - 8x27

477 (x4)
WASHER - 5/16

761 (x4)
BOLT - 5/-16x2" BLK

407 (x2)
BOLT - 1 1/2"

198 (x2)
WASHER - 8x19

379 (x2)
T-NUT - 5/16"



H14 | SWING BEAM MOUNT - W4L12719
(x1) | 1"x3 3/8"x50 1/4" (24x86x1277)



K5 | CLUB HOUSE WALL RAIL - W4L14785
(x1) | 5/8"x5 1/4"x50 1/4" (16x134x1277)



H100415 | BOLT WH BLK
(x2) | 5/16x3 3/4



H100407 | BOLT WH BLK
(x2) | 5/16x1 1/2



H100458 | LAG SCREW WH BLK
(x4) | 5/16x2



H100089 | SCREW PFH
(x4) | 8x1 3/4



**H100198 | WASHER LOCK
EXT BLK**
(x8) | 8x19



H100379 | T-NUT BLK
(x4) | 5/16

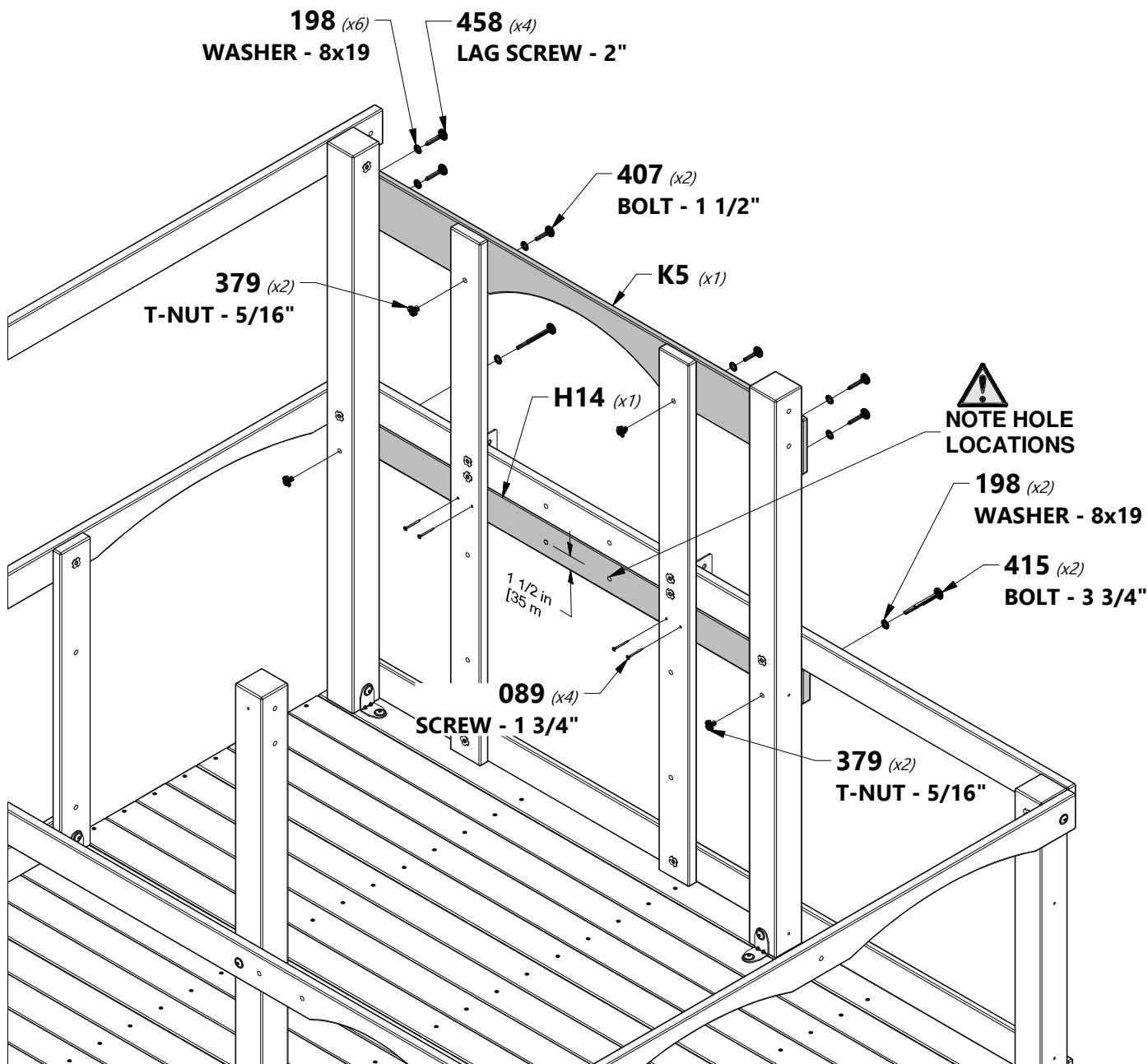

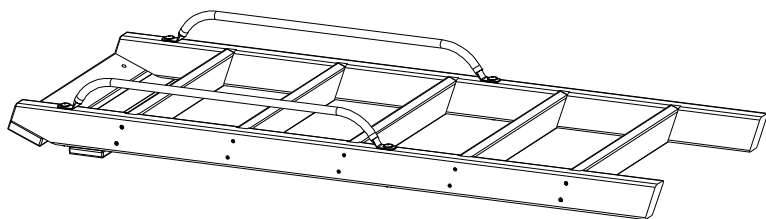

(x1) LADDER ASSEMBLY



H100378 BOLT WH BLK (x2) 5/16x1 3/4



H100198 WASHER LOCK (x2) EXT BLK 8x19



H100379 T-NUT BLK (x2) 5/16

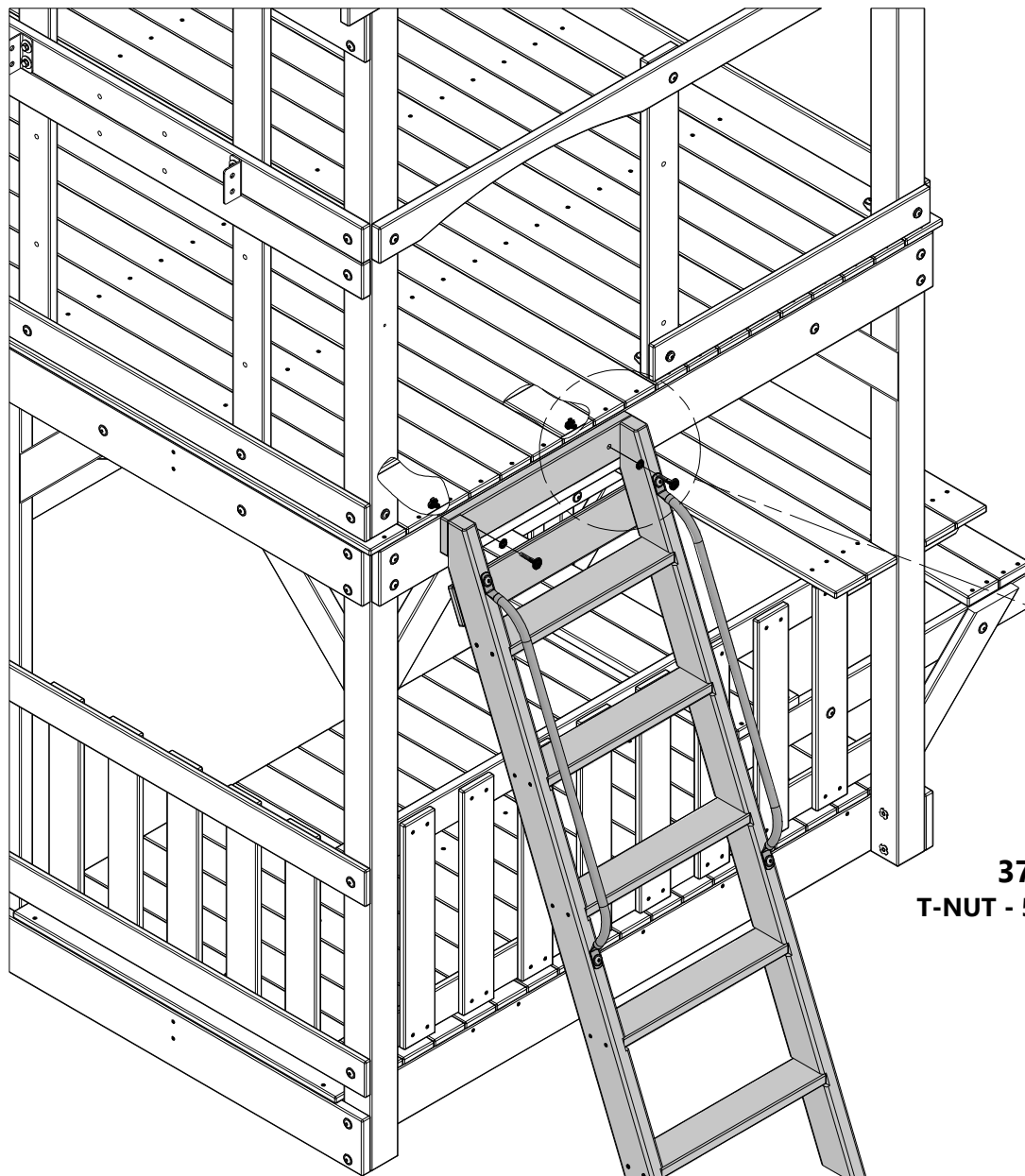

379 (x2) T-NUT - 5/16"

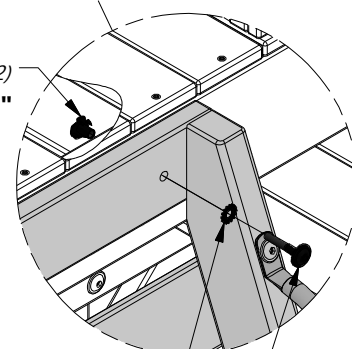

198 (x2) WASHER - 8x19

378 (x2) BOLT - 1 3/4"

LADDER ASSEMBLY

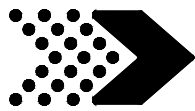

H4 | ROOF SUPPORT RAIL - W4L14751
(x1) | 1"x3 3/8"x67 1/4" (24x86x1709)



H7 | FRONT CLUB HOUSE WALL RAIL - W4L14754
(x1) | 1"x3 3/8"x60 1/2" (24x86x1537)

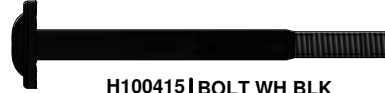

H100415 | BOLT WH BLK
(x4) | 5/16x3 3/4



H100198 | WASHER LOCK
(x4) | EXT BLK
8x19



H100379 | T-NUT BLK
(x4) | 5/16

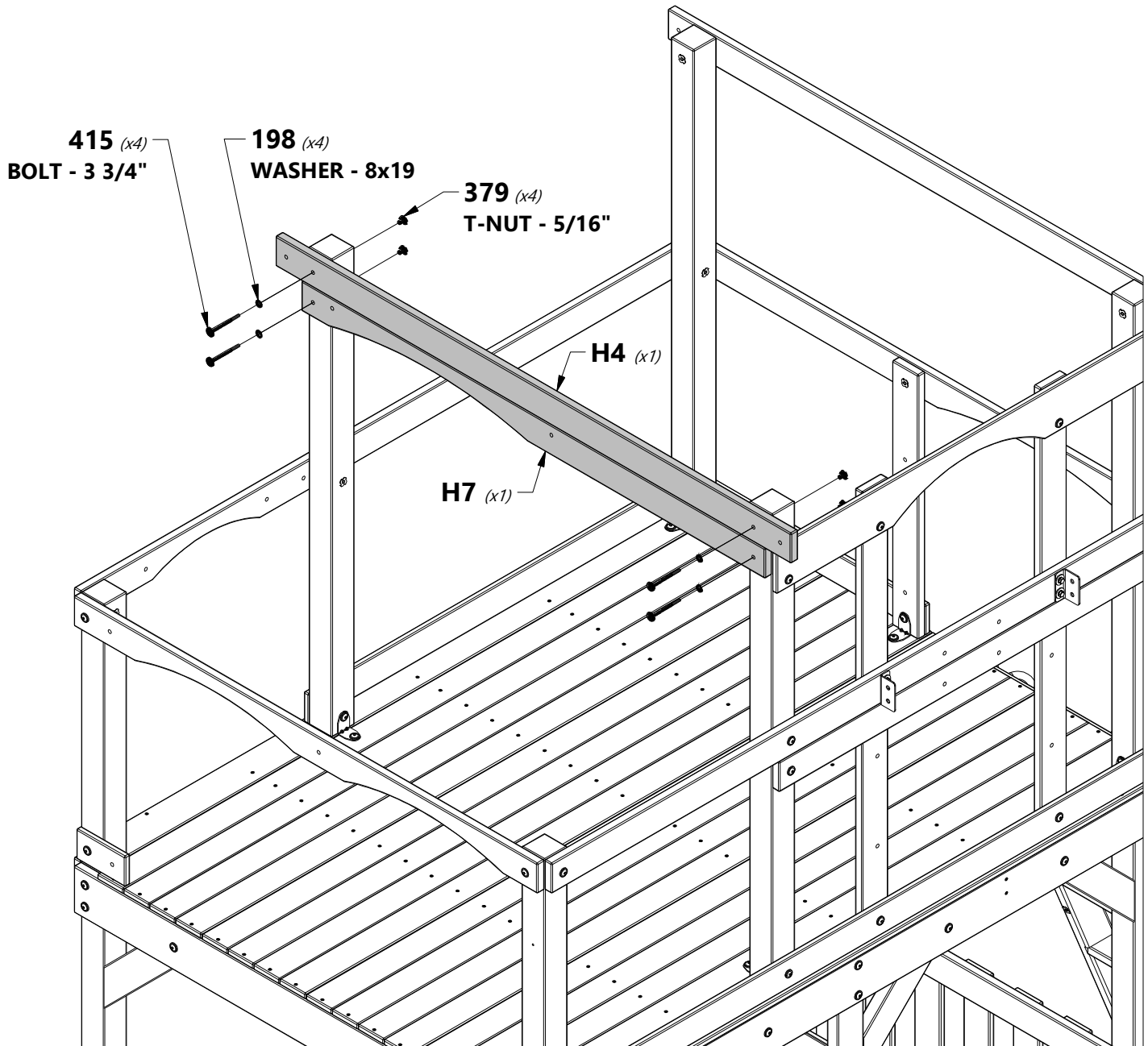

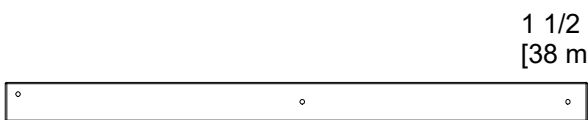

H8 FORT UPRIGHT - W4L12713
(x1) | 1"x3 3/8"x50 1/2" (24x86x1284)

1 1/2 in
[38 mm]



M21 FORT WALL RAIL - W4L12761
(x2) | 5/8"x3 3/8"x30 1/4" (16x86x768)

1 3/4 in
[43 mm]



A4M01046 L BRACKET
(x1) | 2.5x38x55x55



H100458 LAG SCREW WH BLK
(x2) | 5/16x2



H100407 BOLT WH BLK
(x1) | 5/16x1 1/2



H100459 BOLT WH BLK
(x1) | 5/16x1 1/4



H100396 BOLT WH BLK
(x1) | 5/16x1/2



H100199 WASHER LOCK
(x1) | EXT BLK
12x19



H100198 WASHER LOCK
(x3) | EXT BLK
8x19



H100379 T-NUT BLK
(x2) | 5/16



H100192 NUT BARREL WH BLK
(x1) | 5/16x7/8

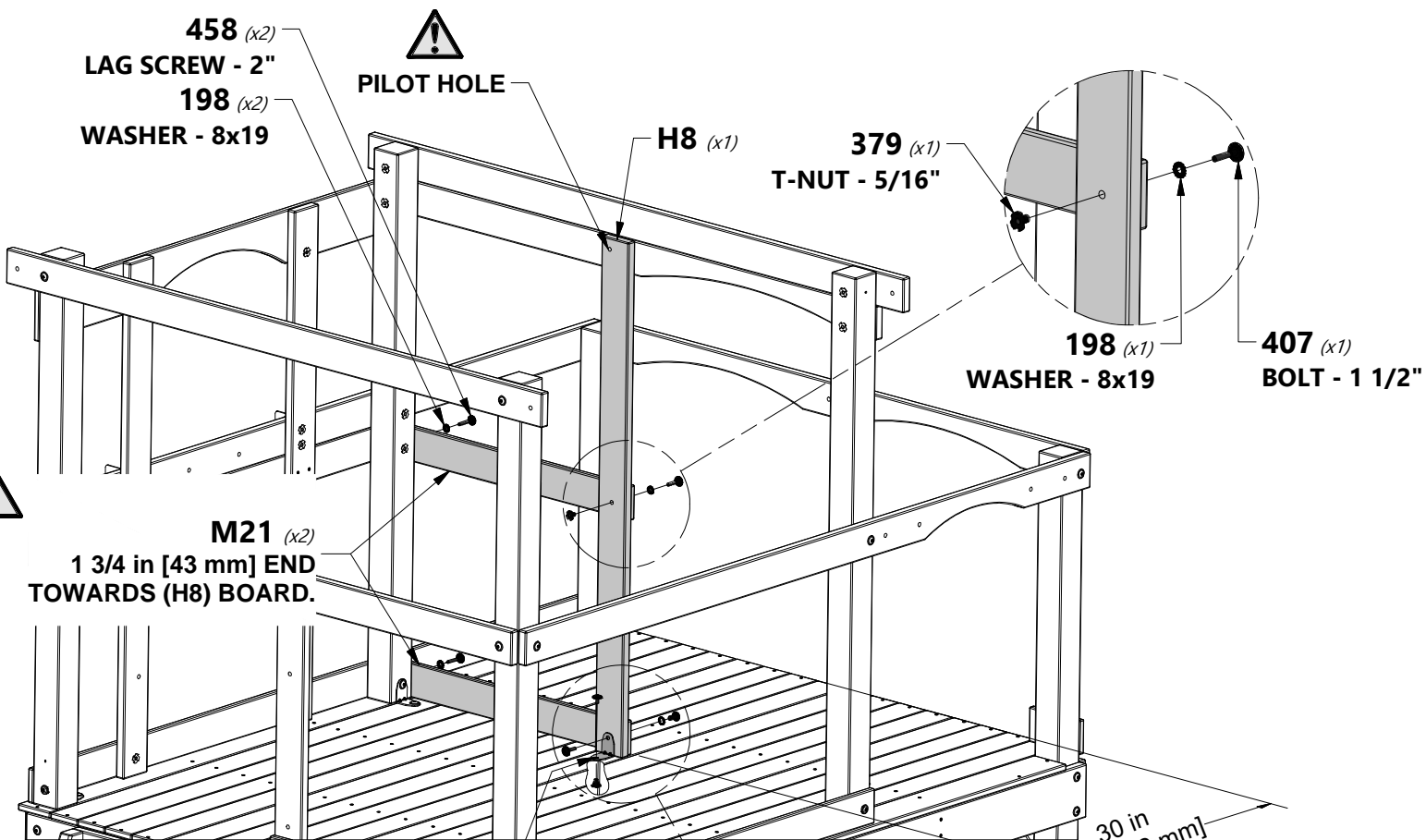

USING BRACKET AS A GUIDE, DRILL 3/8" [10 mm] HOLE THROUGH DECK

NOTE: 30 in [762mm] FROM M31 TO EDGE OF FORT

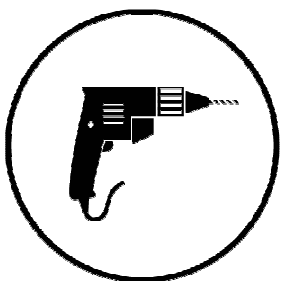

046 (x1) L BRACKET 2.5x38x55x55

396 (x1) BOLT - 1/2"

459 (x1) BOLT - 1 1/4"

379 (x1) T-NUT - 5/16"

192 (x1) NUT BARREL - 7/8"

199 (x1) WASHER - 12x19



H13 | CLUB HOUSE WALL RAIL - W4L14760
(x1) | 1"x3 3/8"x50 1/4" (24x86x1277)



H100458 | LAG SCREW WH BLK
(x2) | 5/16x2



H100198 | WASHER LOCK
(x2) | EXT BLK
8x19

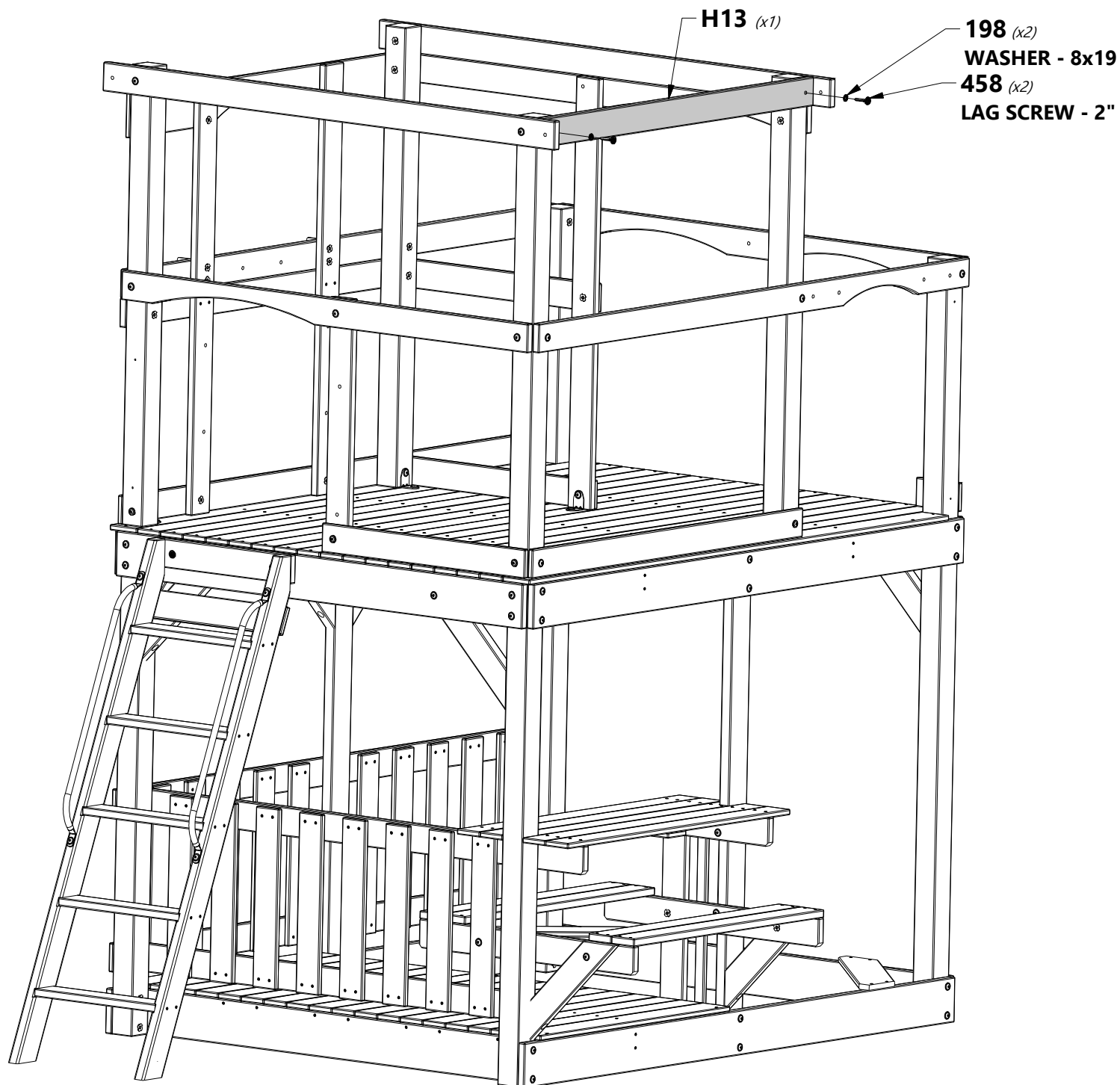

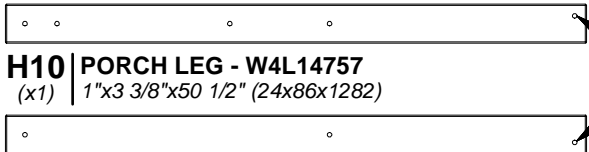
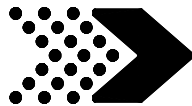

H10 | PORCH LEG - W4L14757
(x1) | 1"x3 3/8"x50 1/2" (24x86x1282)

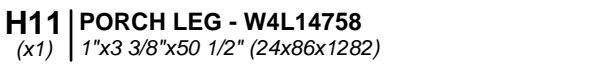

H11 | PORCH LEG - W4L14758
(x1) | 1"x3 3/8"x50 1/2" (24x86x1282)

NOTE: HOLES ON OUTER EDGE WHEN INSTALLED.



A4M01046 | L BRACKET
(x1) | 2.5x38x55x55



H100378 | BOLT WH BLK
(x2) | 5/16x1 3/4



H100198 | WASHER LOCK
(x3) | EXT BLK
8x19



H100407 | BOLT WH BLK
(x1) | 5/16x1 1/2



H100199 | WASHER LOCK
(x1) | EXT BLK
12x19



H100396 | BOLT WH BLK
(x2) | 5/16x1/2



H100379 | T-NUT BLK
(x4) | 5/16



H100192 | NUT BARREL WH BLK
(x1) | 5/16x7/8

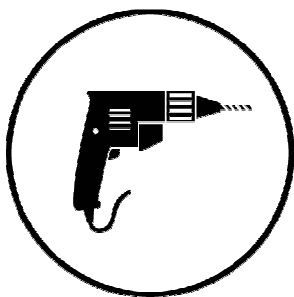

NOTE: HOLES ON OUTER EDGE WHEN INSTALLED.

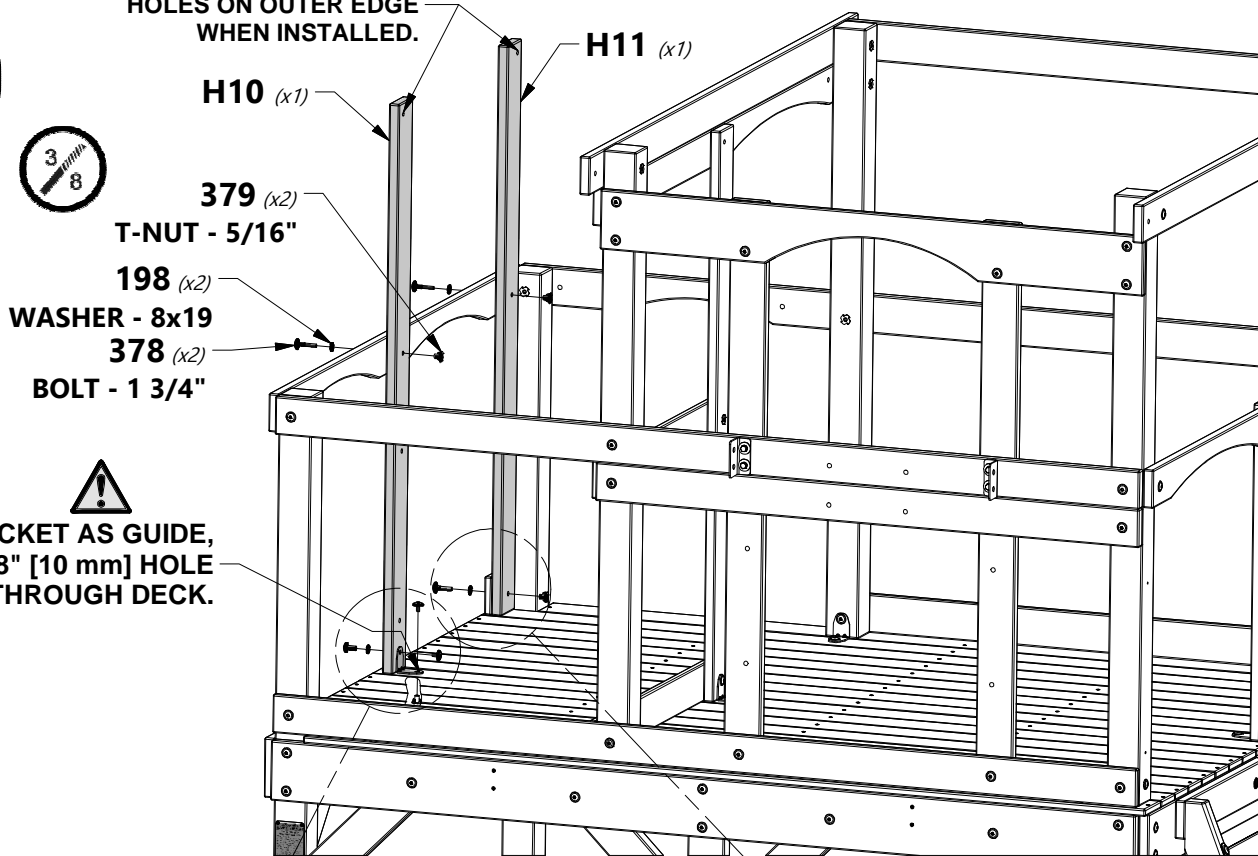

USING BRACKET AS GUIDE,
DRILL 3/8" [10 mm] HOLE
THROUGH DECK.

199 (x1)
WASHER - 12x19
192 (x1)
NUT BARREL - 7/8"

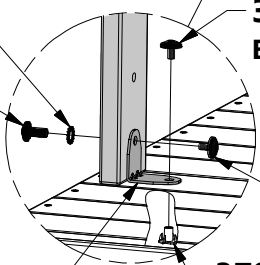

396 (x1)
BOLT - 1/2"

396 (x1)
BOLT - 1/2"

046 (x1)
L BRACKET 2.5x38x55x55

379 (x1)
T-NUT - 5/16"

407 (x1)
BOLT - 1 1/2"

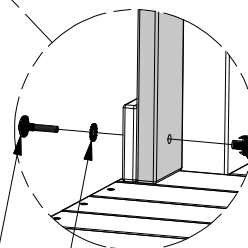

379 (x1)
T-NUT - 5/16"

198 (x1)
WASHER - 8x19

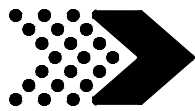

M8 | FORT WALL BOARD - W4L12750
(x2) | 5/8"x3 3/8"x50 1/2" (16x86x1284)



M9 | FORT WALL BOARD - W4L12751
(x2) | 5/8"x3"x50 1/2" (16x76x1284)

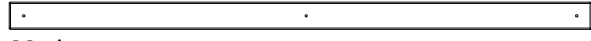

N1 | FORT WALL BOARD - W4L12776
(x2) | 5/8"x2 3/8"x50 1/2" (16x60x1284)



M22 | FORT WALL BOARD - W4L12762
(x4) | 5/8"x3 3/8"x29 7/8" (16x86x758)



M23 | FORT WALL BOARD - W4L12763
(x2) | 5/8"x3 1/8"x29 7/8" (16x80x758)



H100088 | SCREW PFH
(x56) | 8x1 1/8

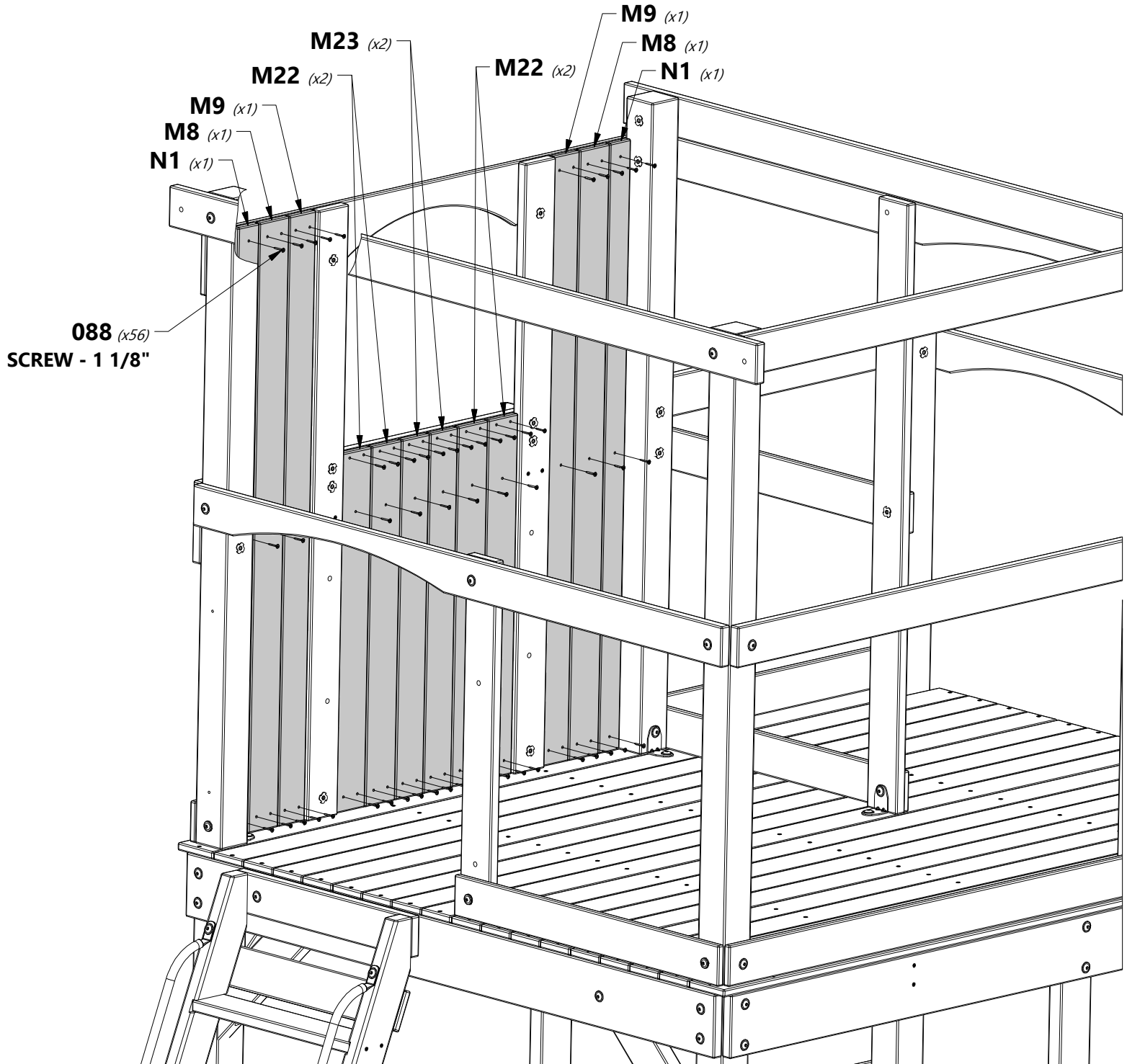

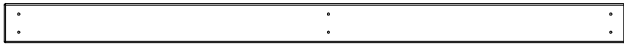
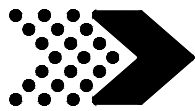

M6 | CLUB HOUSE WALL BOARD - W4L14794
(x1) | 5/8"x3 3/8"x53 7/8" (16x86x1370)



M24 | WALL BOARD - W4L15625
(x6) | 5/8"x3 3/8"x29 5/8" (16x86x752)



M26 | WALL BOARD - W4L14811
(x2) | 5/8"x3 3/8"x26 1/8" (16x86x664)



H100088 | SCREW PFH
(x38) | 8x1 1/8"

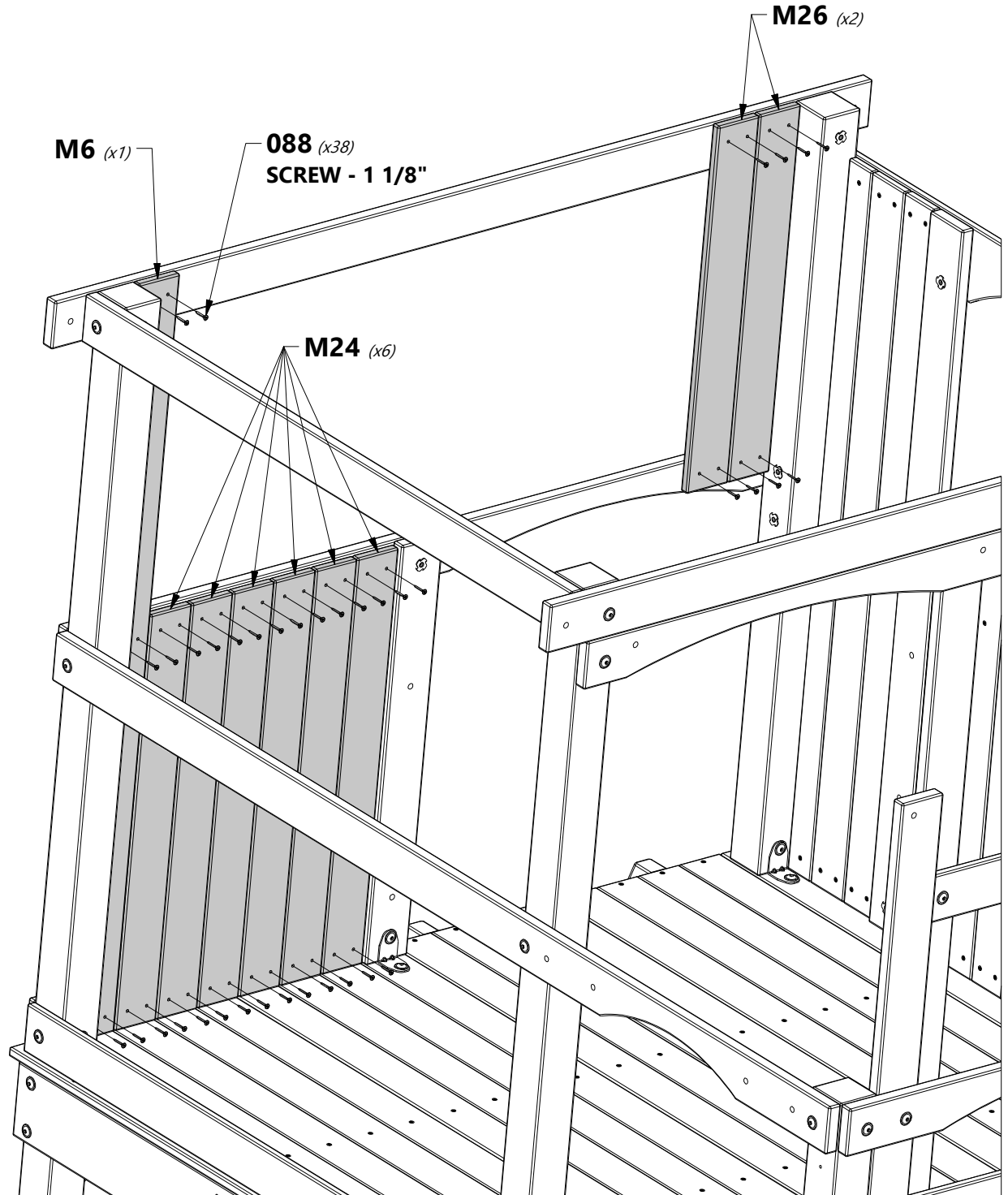

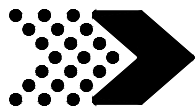

M8 | FORT WALL BOARD - W4L12750
(x5) | 5/8"x3 3/8"x50 1/2" (16x86x1284)



M17 | FRONT WINDOW WALL BOARD - W4L12758
(x2) | 5/8"x3 3/8"x35" (16x86x889)



M33 | FRONT WINDOW WALL BOARD - W4L12769
(x2) | 5/8"x3 3/8"x6 3/8" (16x86x162)



H100088 | SCREW PFH
(x35) | 8x1 1/8

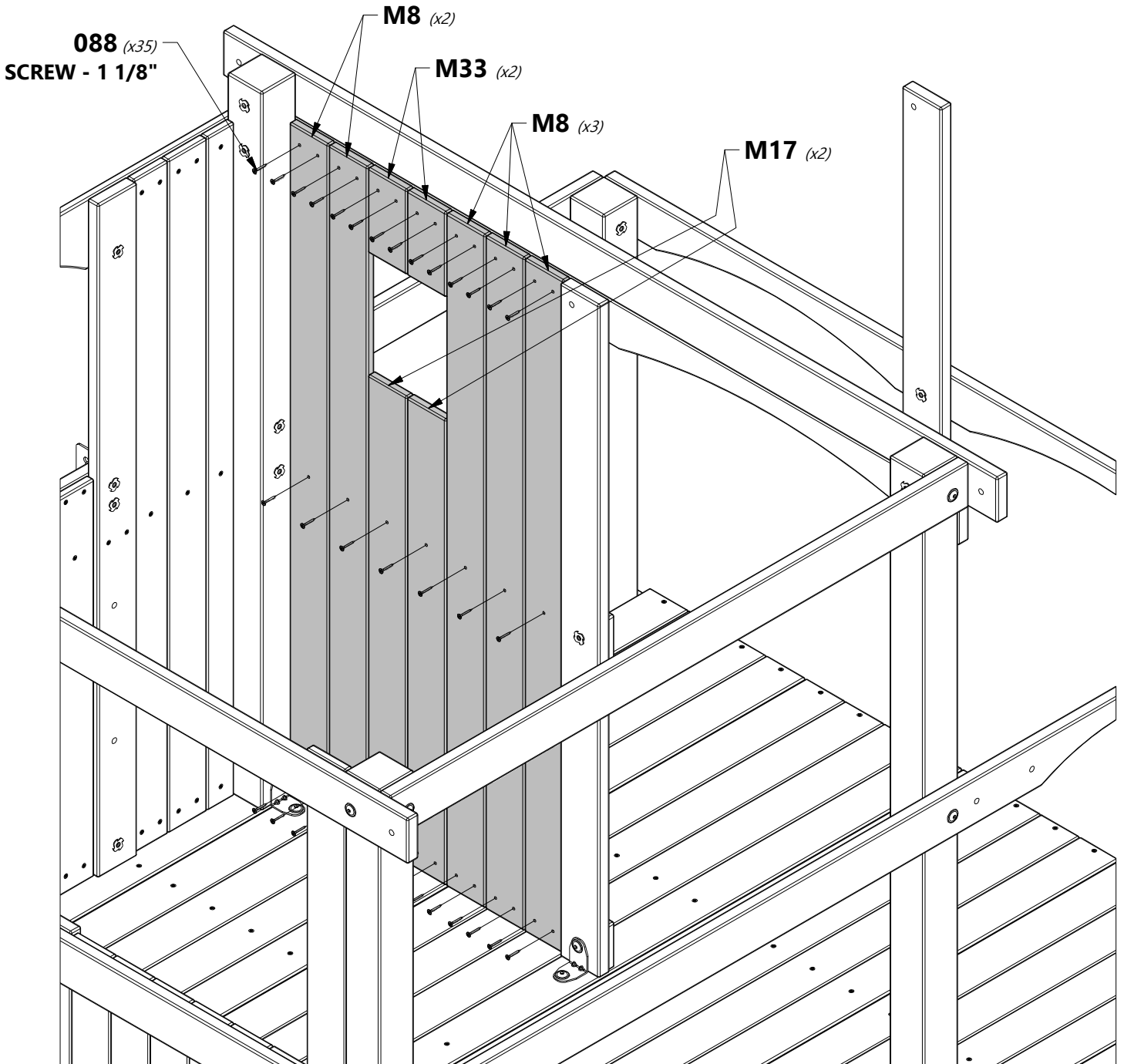

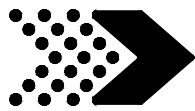

M24 | WALL BOARD - W4L15625
(x13) | 5/8"x3 3/8"x29 5/8" (16x86x752)



H100088 | SCREW PFH
(x52) | 8x1 1/8"

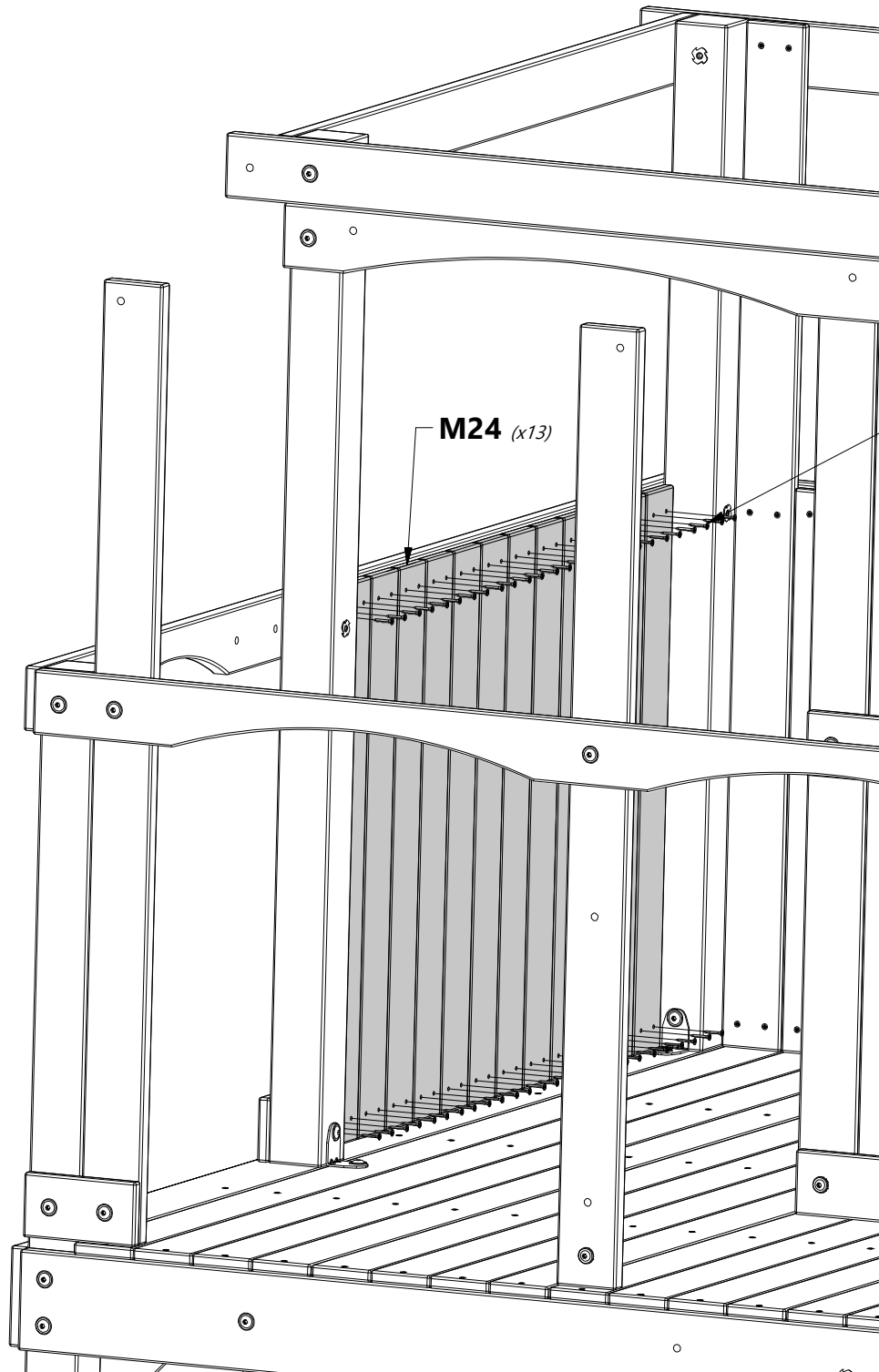



M24 | WALL BOARD - W4L15625
(x4) | 5/8"x3 3/8"x29 5/8" (16x86x752)



H100088 | SCREW PFH
(x16) | 8x1 1/8

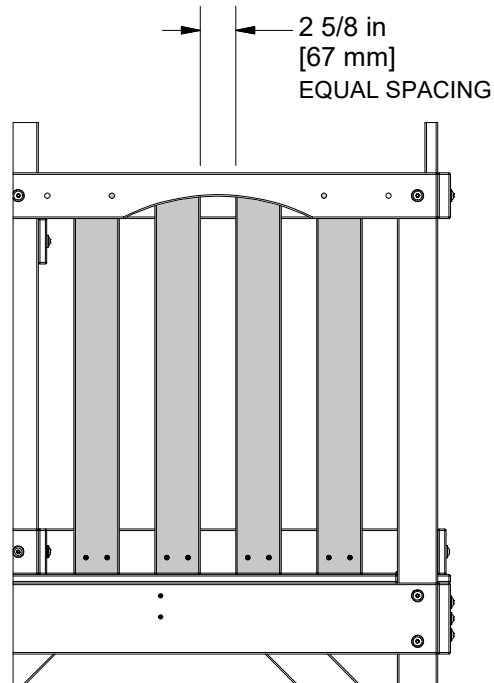
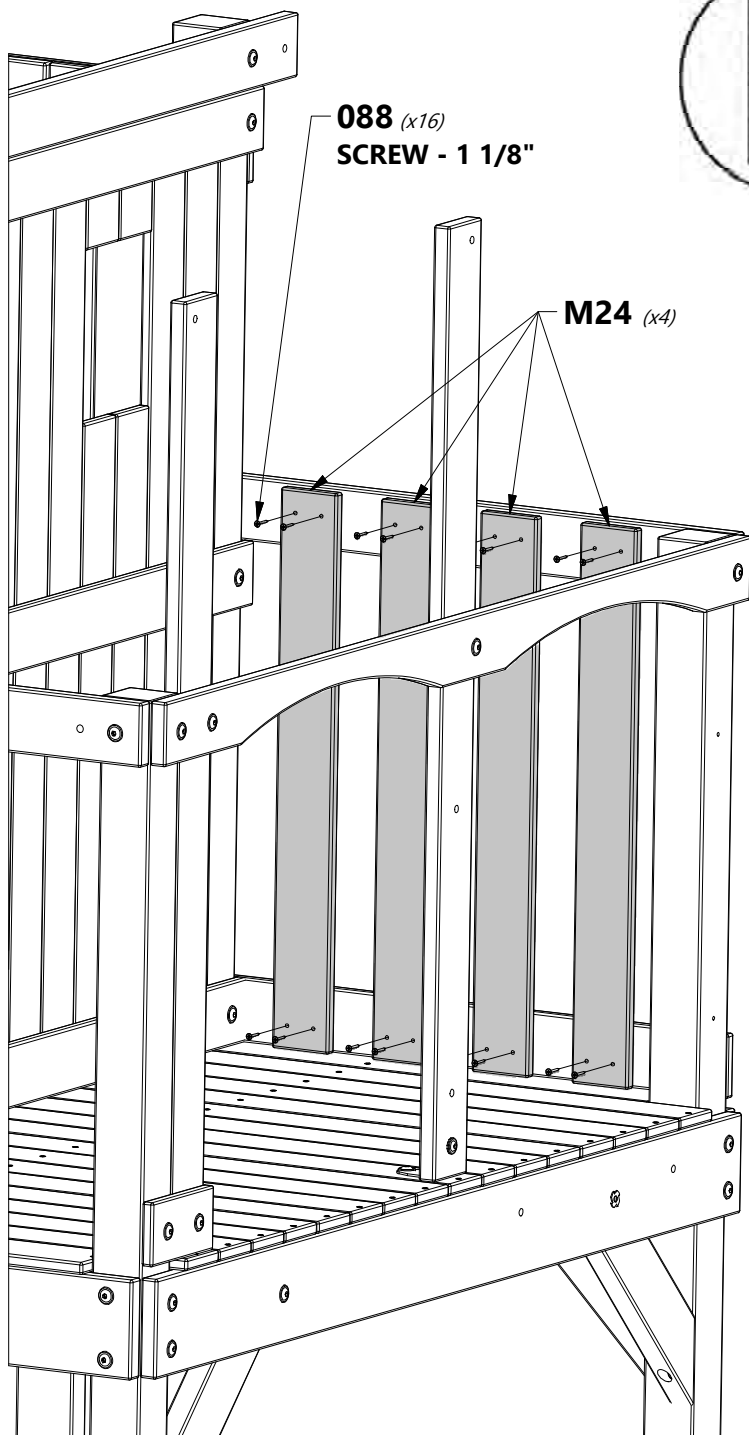

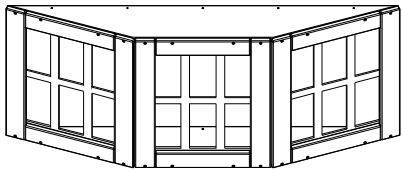
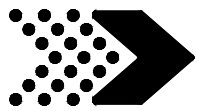

(x2) **BAY WINDOW ASSEMBLY**



H100391 | SCREW PFH BLK
(x20) | 8x2



H100128 | SCREW PWH
(x24) | 8x5/8

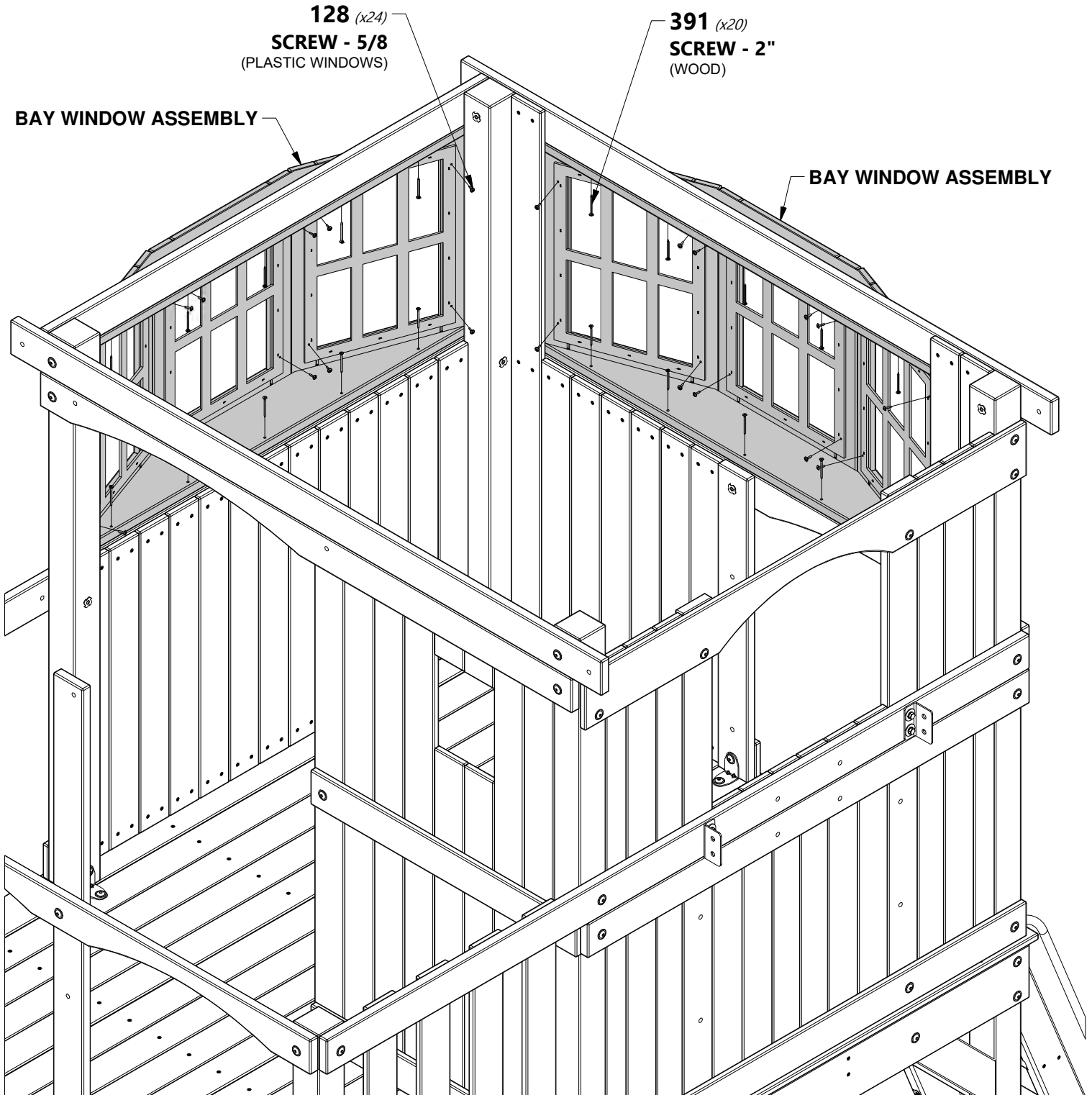

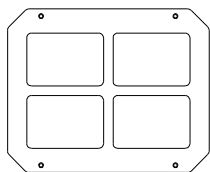

A100014 | PLASTIC WINDOW WHITE
(x1)



H100070 | SCREW PWH
(x4) 8x3/4

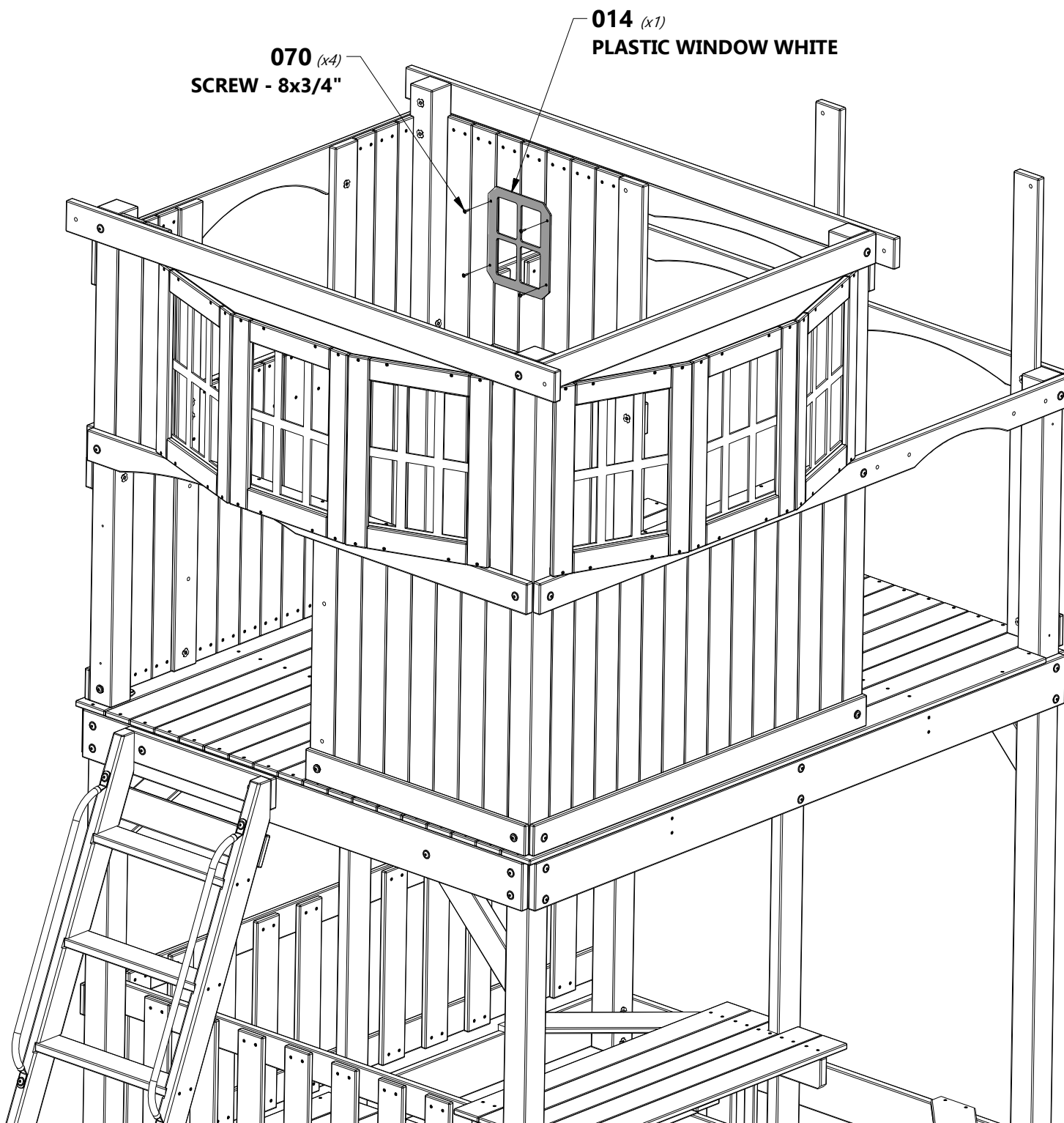



A100324 | LADDER RUNG 578 GREEN
(x2)



H100468 | BOLT WH BLK
(x4) | 5/16x1



H100379 | T-NUT BLK
(x4) | 5/16

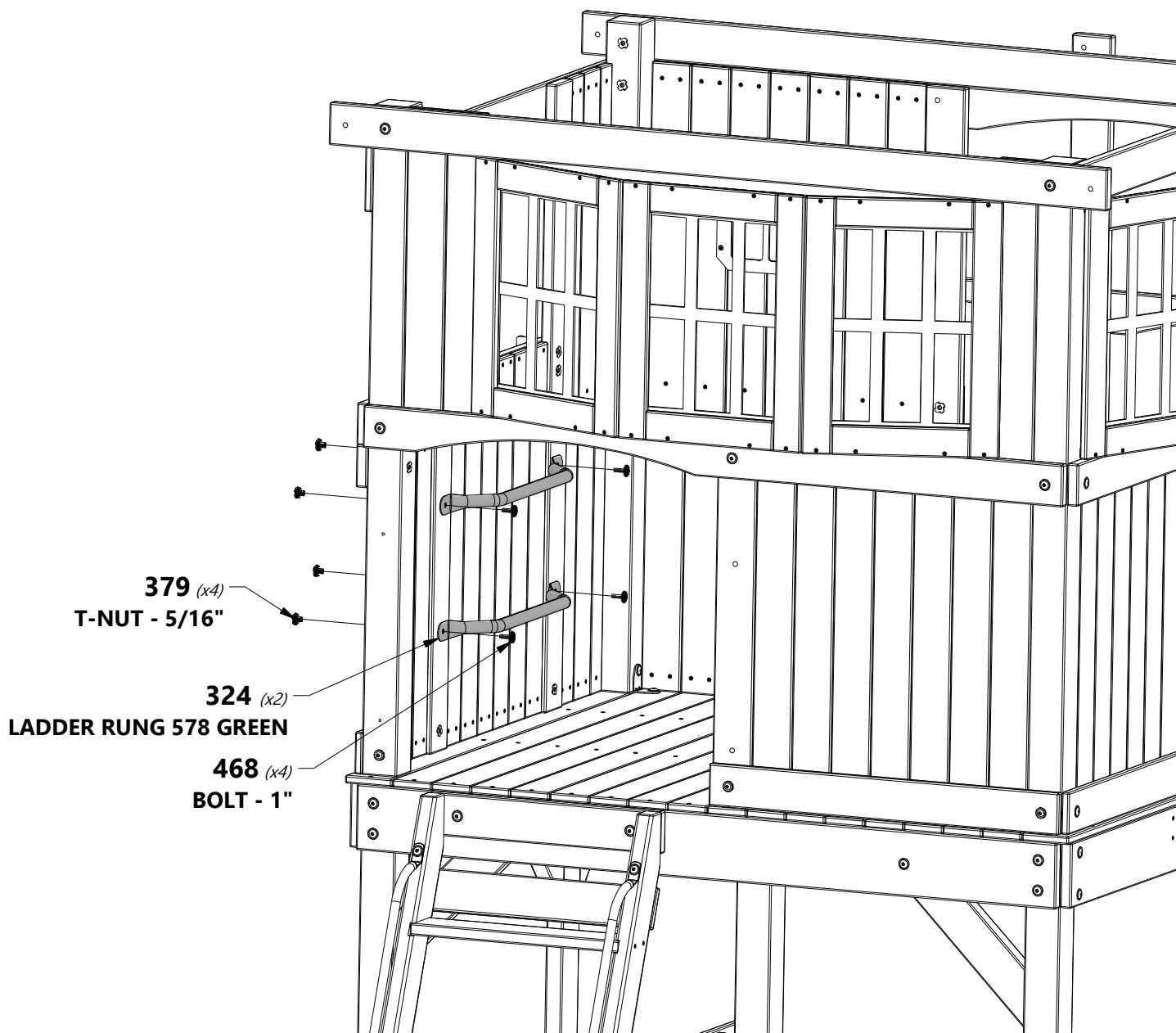



H12 | ROOF RAFTER - W4L14759
(x4) | 1"x3 3/8"x50 3/8" (24x86x1278)



H100378 | BOLT WH BLK
(x4) | 5/16x1 3/4



H100091 | SCREW PFH
(x2) | 8X2 1/4



H100198 | WASHER LOCK
(x4) | EXT BLK
8x19



H100379 | T-NUT BLK
(x4) | 5/16

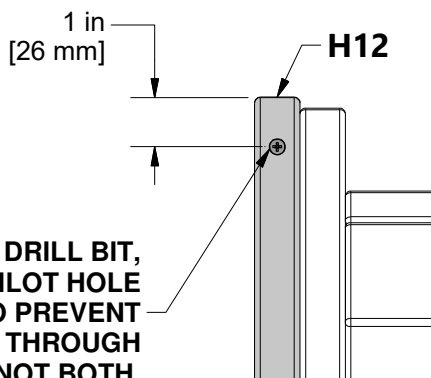

USING A 3/16" [5 mm] DRILL BIT, MARK AND DRILL A PILOT HOLE INTO 'H12' RAFTER TO PREVENT SPLITTING. ONLY DRILL THROUGH ONE RAFTER NOT BOTH.

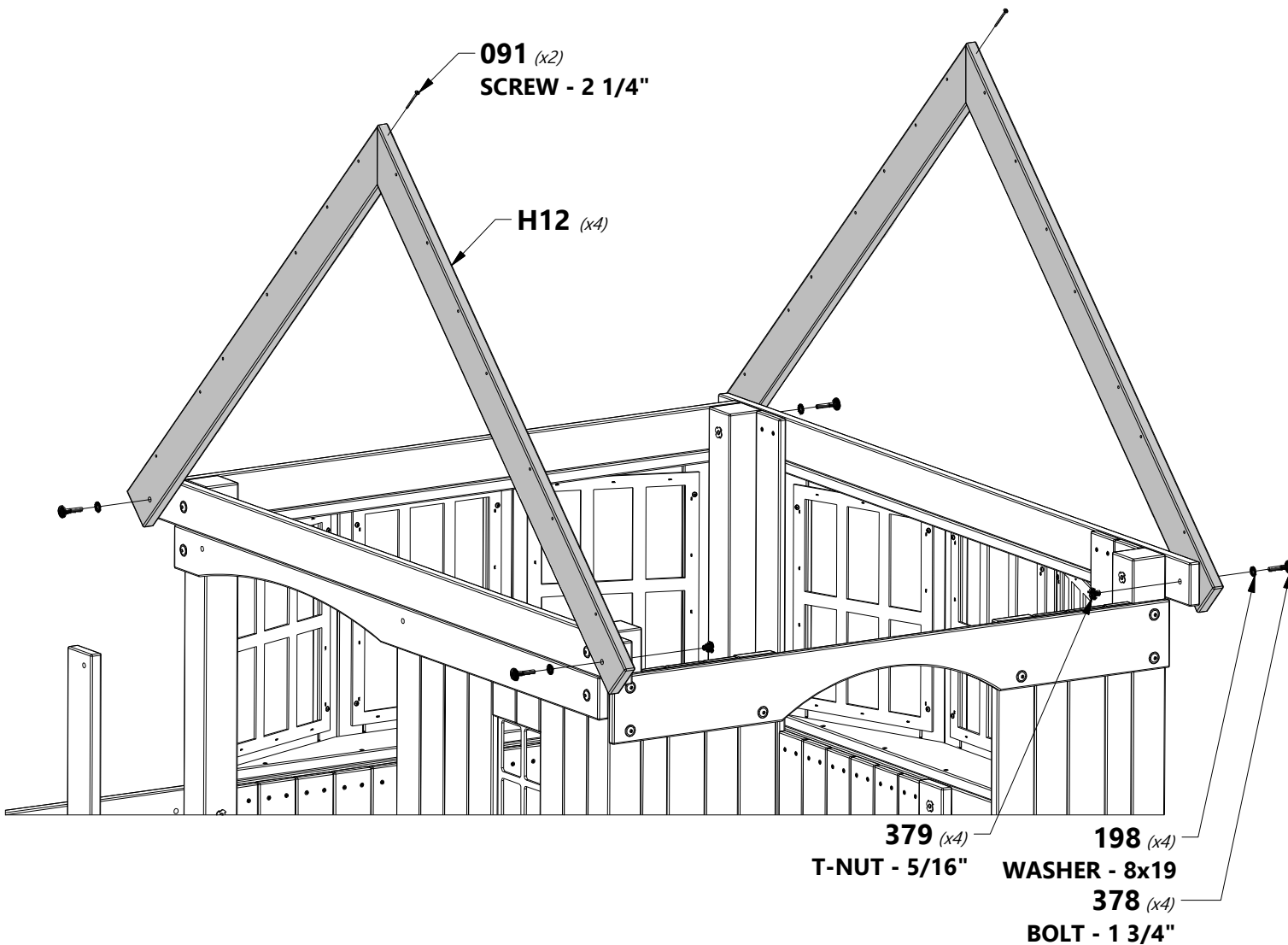
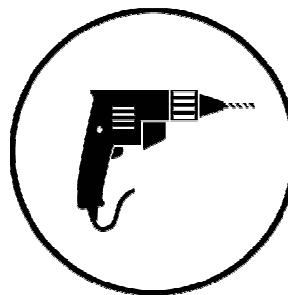

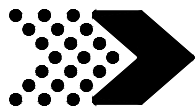

M5 GABLE BOARD - W4L14793
(x2) 5/8"x3 3/8"x59 1/2" (16x86x1510)



M7 GABLE BOARD - W4L14795
(x2) 5/8"x3 3/8"x52 5/8" (16x86x1338)



H100088 SCREW PFH
(x8) 8x1 1/8

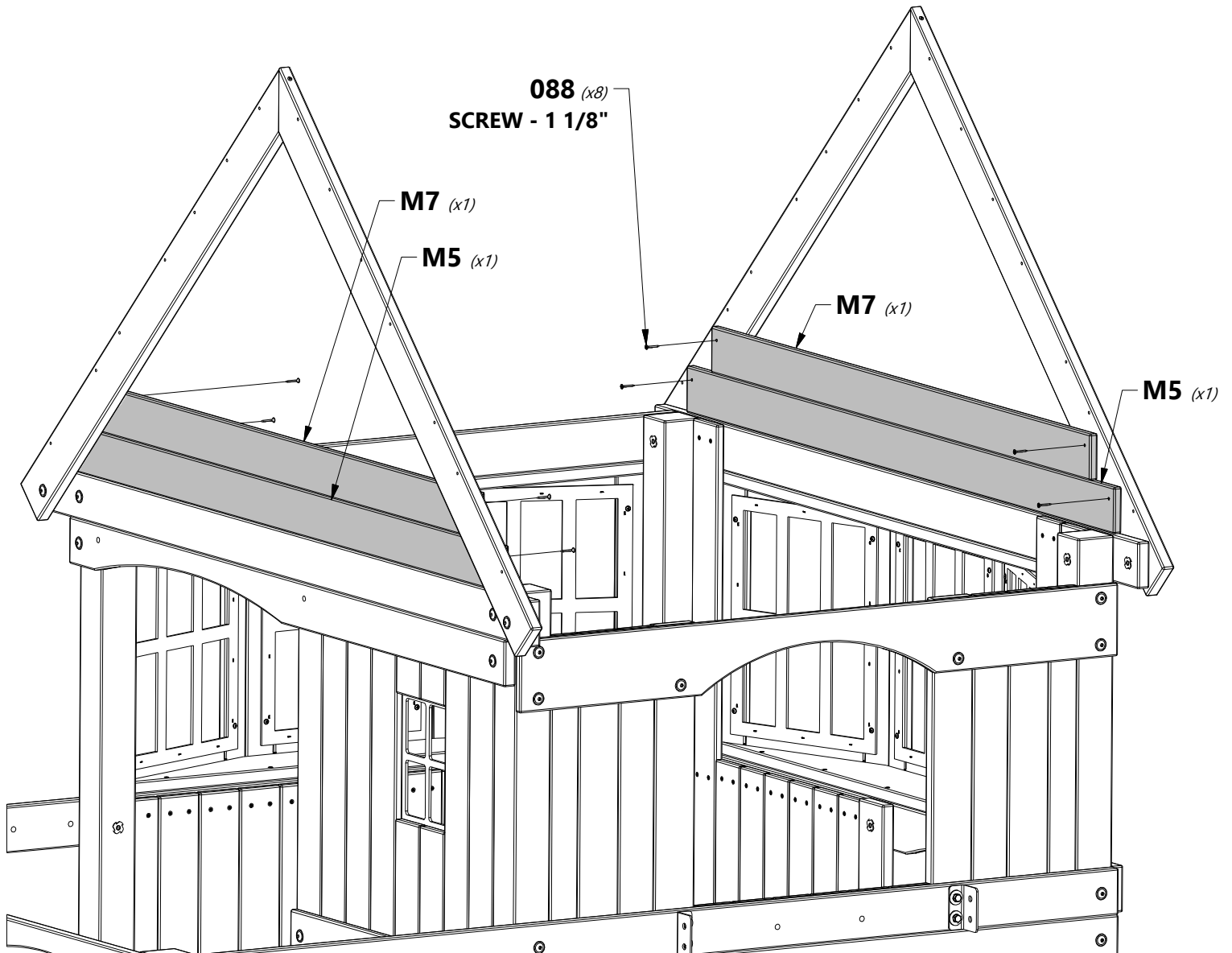



M28 | GABLE WINDOW BOARD - W4L14813
(x2) | 5/8"x3 3/8"x19 1/2" (16x86x496)



M31 | GABLE WINDOW BOARD - W4L14816
(x2) | 5/8"x3 3/8"x12 3/4" (16x86x324)



M29 | GABLE WINDOW BOARD - W4L14814
(x2) | 5/8"x3 3/8"x16 1/8" (16x86x410)

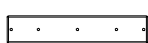

N6 | WINDOW TRIM - W4L14830
(x2) | 5/8"x2 3/8"x12 1/4" (16x60x310)



N10 | GABLE BOARD - W4L14834
(x1) | 5/8"x2 3/8"x27 5/8" (16x60x702)



H100088 | SCREW PFH
(x8) | 8x1 1/8



H100380 | SCREW PFH BLK
(x10) | 8x1 1/8

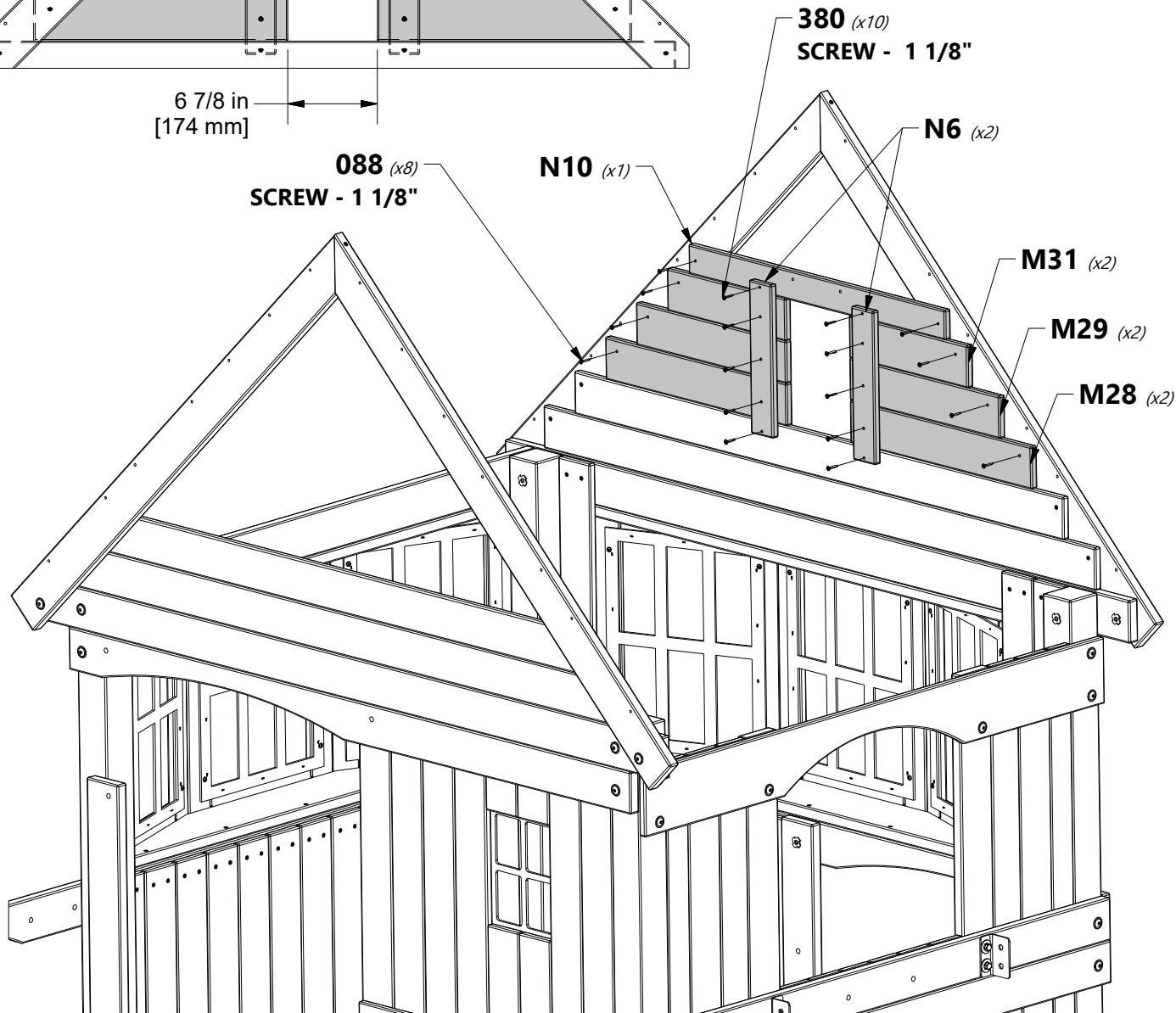
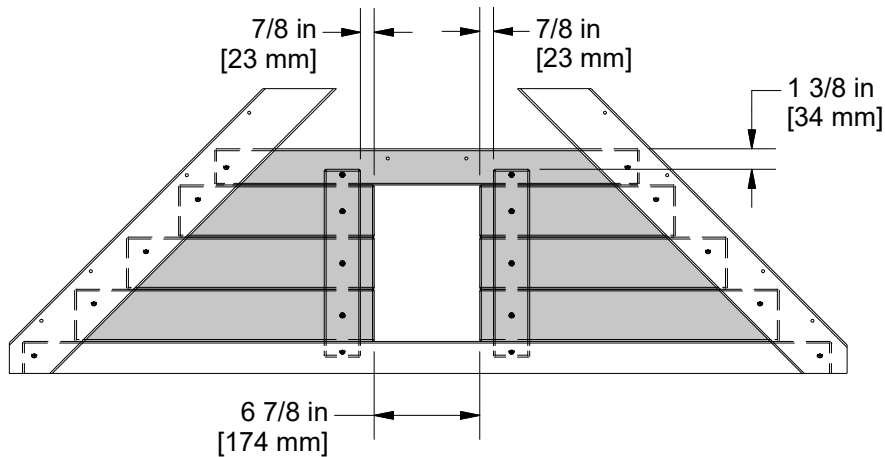



M12 | GABLE BOARD - W4L14800
(x1) | 5/8"x3 3/8"x45 7/8" (16x86x1166)



M14 | GABLE BOARD - W4L14802
(x1) | 5/8"x3 3/8"x39 1/8" (16x86x994)



M18 | GABLE BOARD - W4L14805
(x1) | 5/8"x3 3/8"x32 3/8" (16x86x822)



N10 | GABLE BOARD - W4L14834
(x1) | 5/8"x2 3/8"x27 5/8" (16x60x702)



H100088 | SCREW PFH
(x8) | 8x1 1/8



NOTE HOLE LOCATIONS

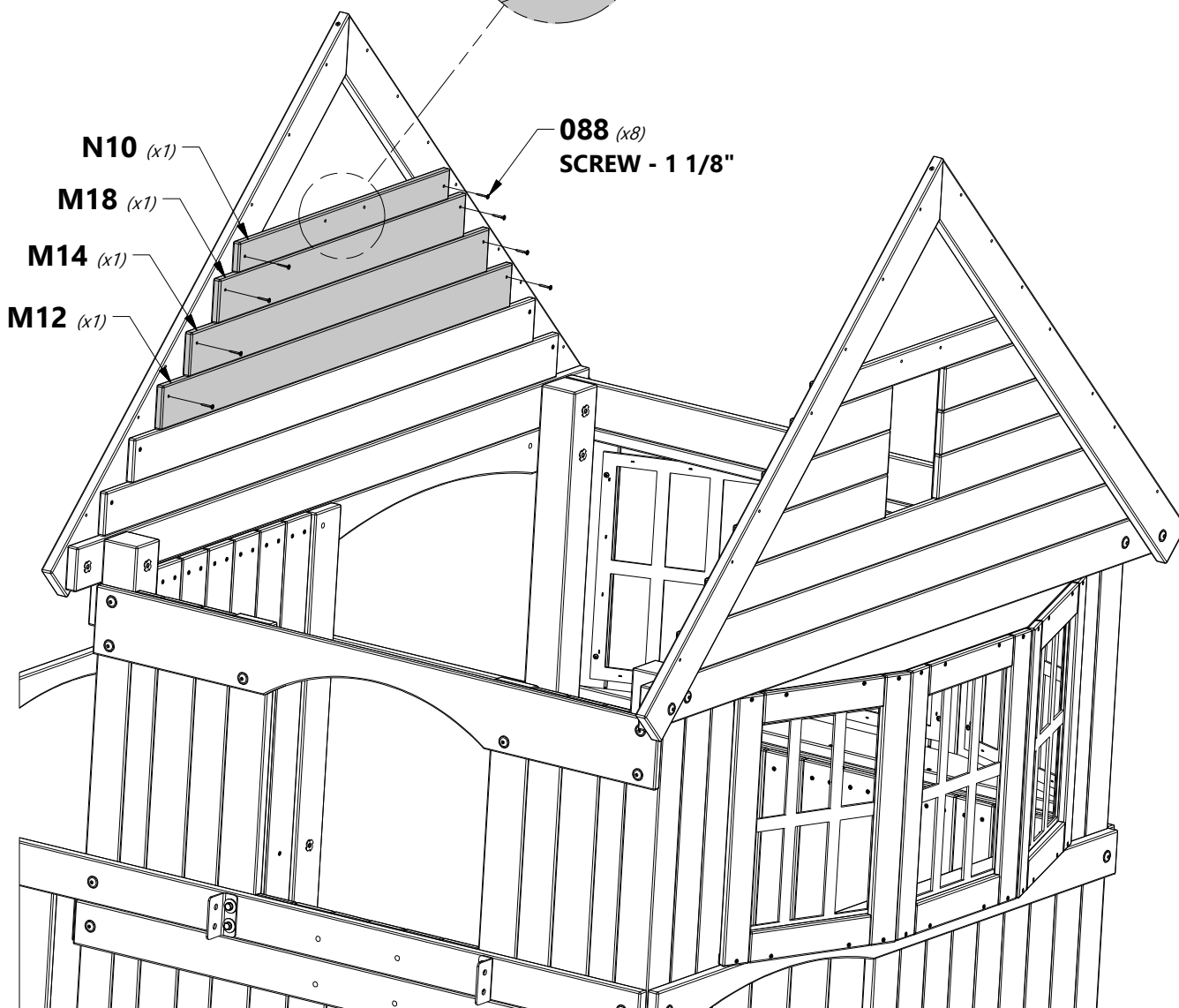
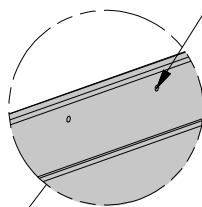

N10 (x1)

M18 (x1)

M14 (x1)

M12 (x1)

088 (x8)
SCREW - 1 1/8"



N11 | GABLE TRIM - W4L15716
(x2) | 5/8"x2 3/8"x11 1/2" (16x60x292)



N9 | GABLE TRIM - W4L14833
(x4) | 5/8"x2 3/8"x6 1/2" (16x60x165)

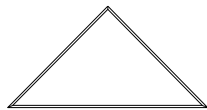

K6 | TRIANGLE SUNBURST - W4L14786
(x2) | 5/8"x5 1/4"x10 3/8" (16x134x265)



H100088 | SCREW PFH
(x4) | 8x1 1/8



H100380 | SCREW PFH BLK
(x18) | 8x1 1/8



NOTE:

ASSEMBLE THE STAR BURST THE SAME FOR BOTH GABLE ENDS.

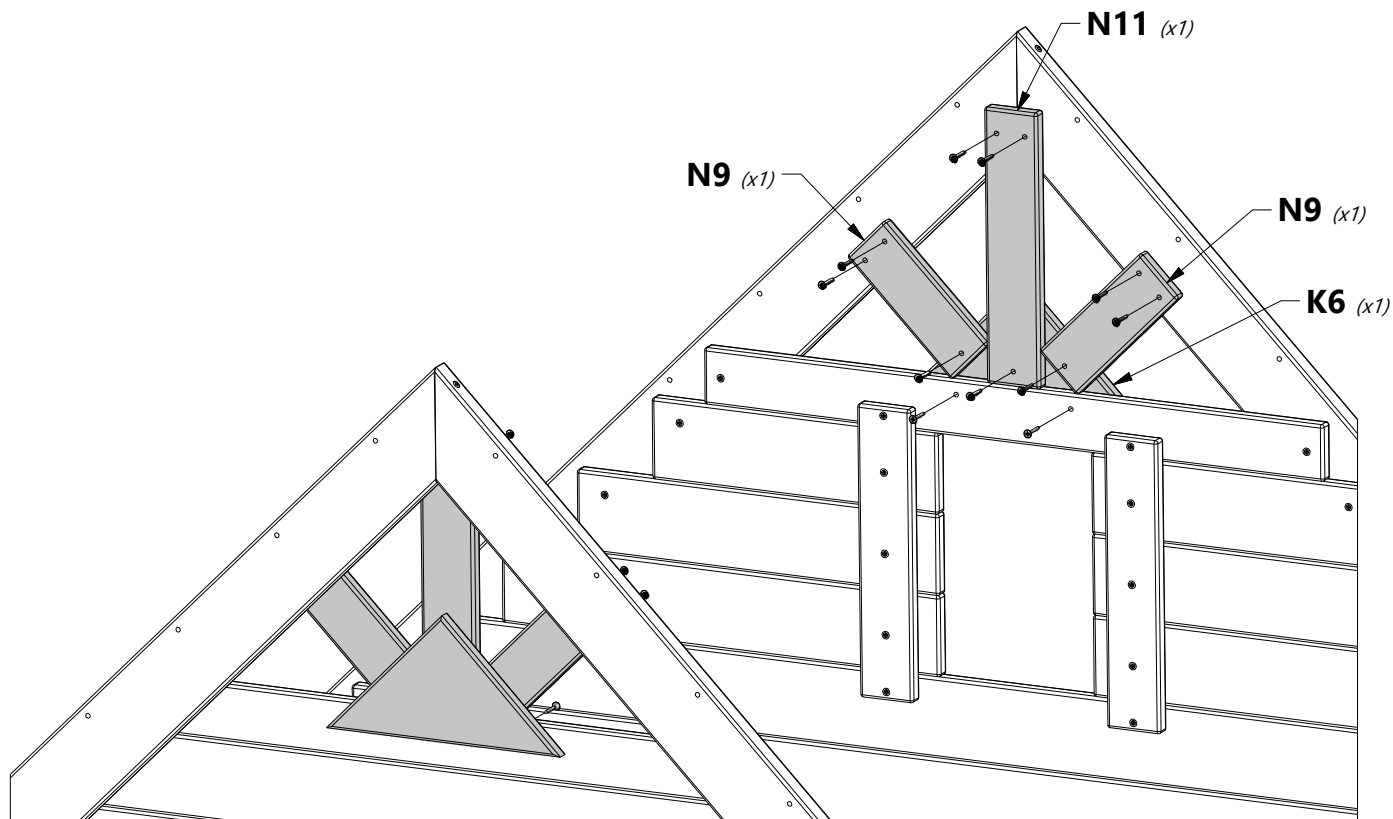
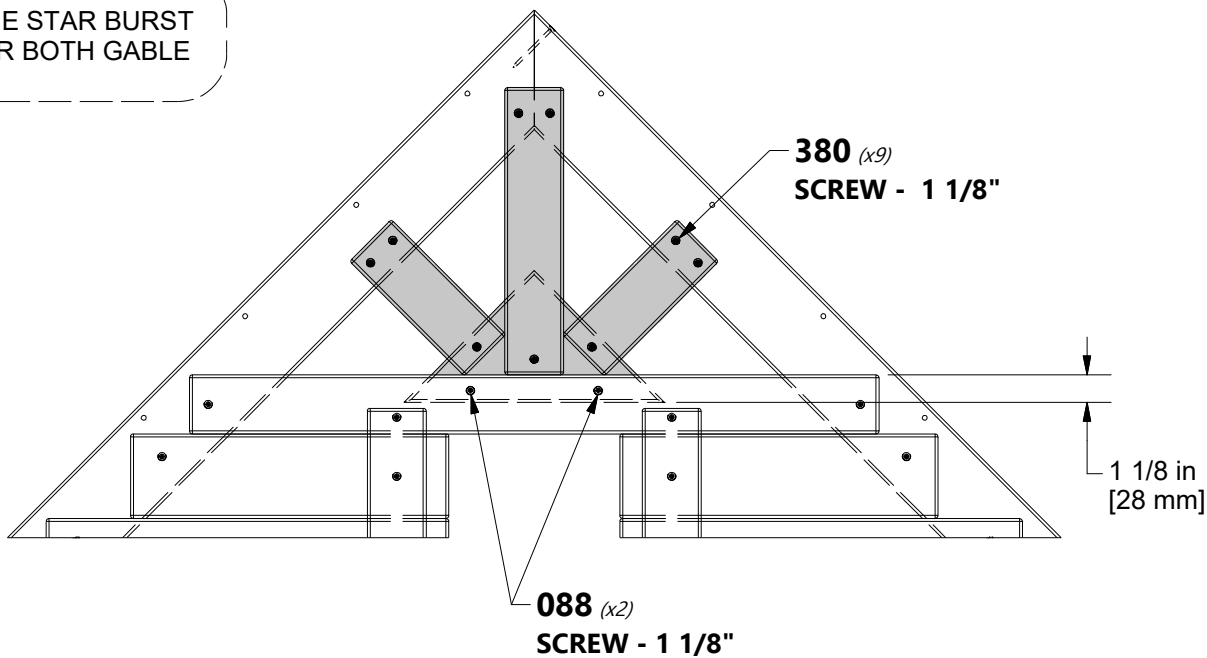

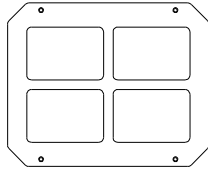
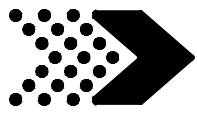

A100014 | **PLASTIC WINDOW WHITE**
(x1)



H100070 | **SCREW PWH**
(x4) | **8x3/4**

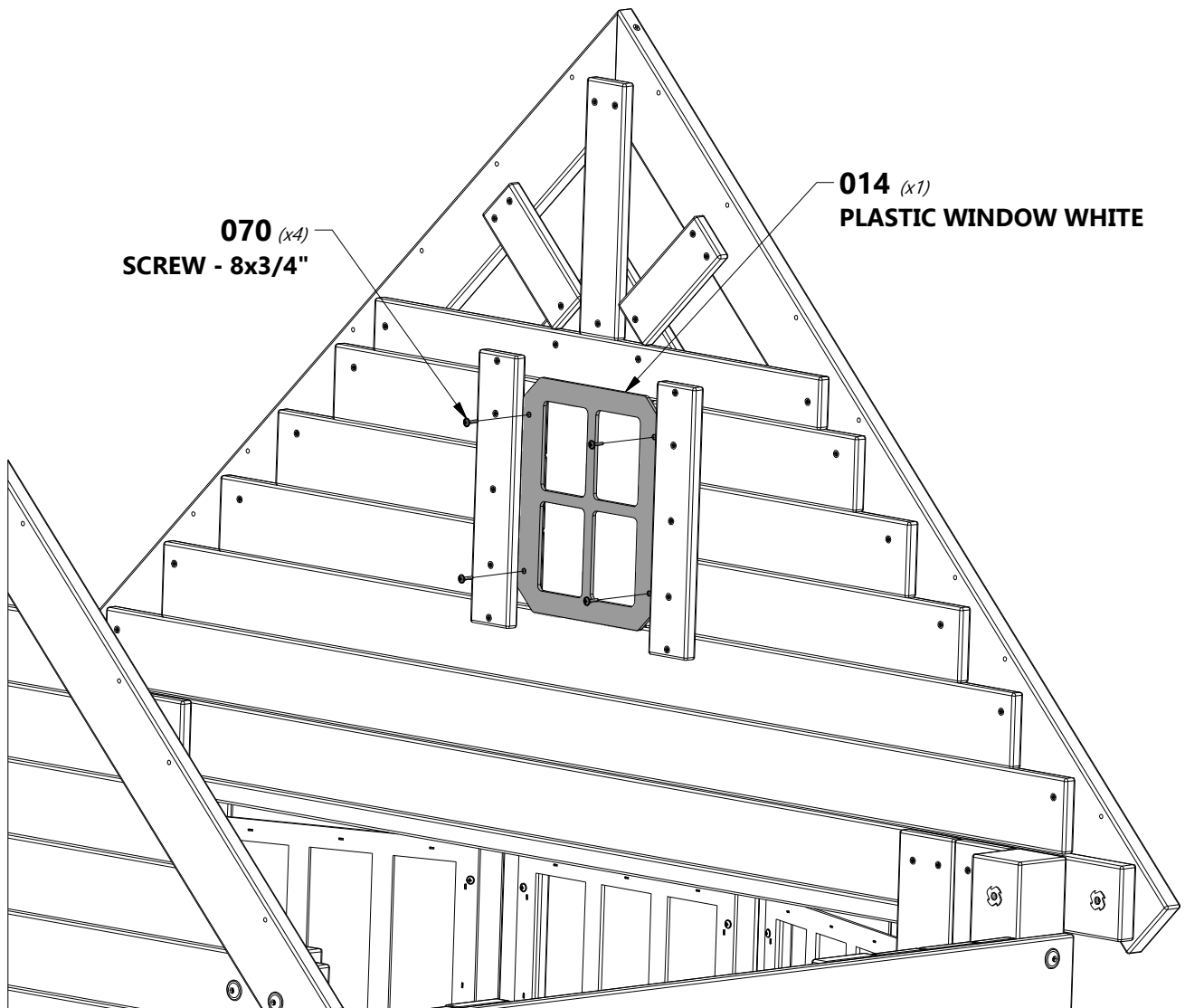

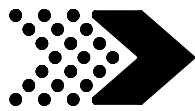

M11 | SOFFIT CAP - W4L14799
(x1) | 5/8"x3 3/8"x50 1/4" (16x86x1277)



N2 | SOFFIT CAP - W4L14826
(x1) | 5/8"x2 3/8"x50 1/4" (16x60x1277)



H100200 | SCREW PFH BLK
(x6) | 8x1 1/2

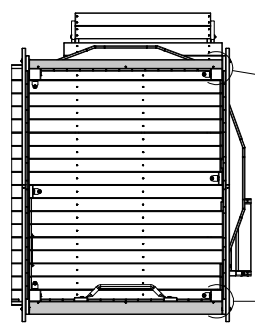

TOP VIEW

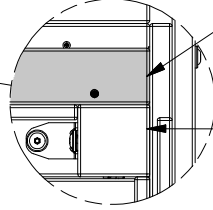

N2

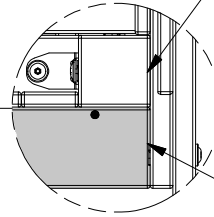

M11



**INSTALL (N2) & (M11) BOARDS
BESIDE UPRIGHTS**

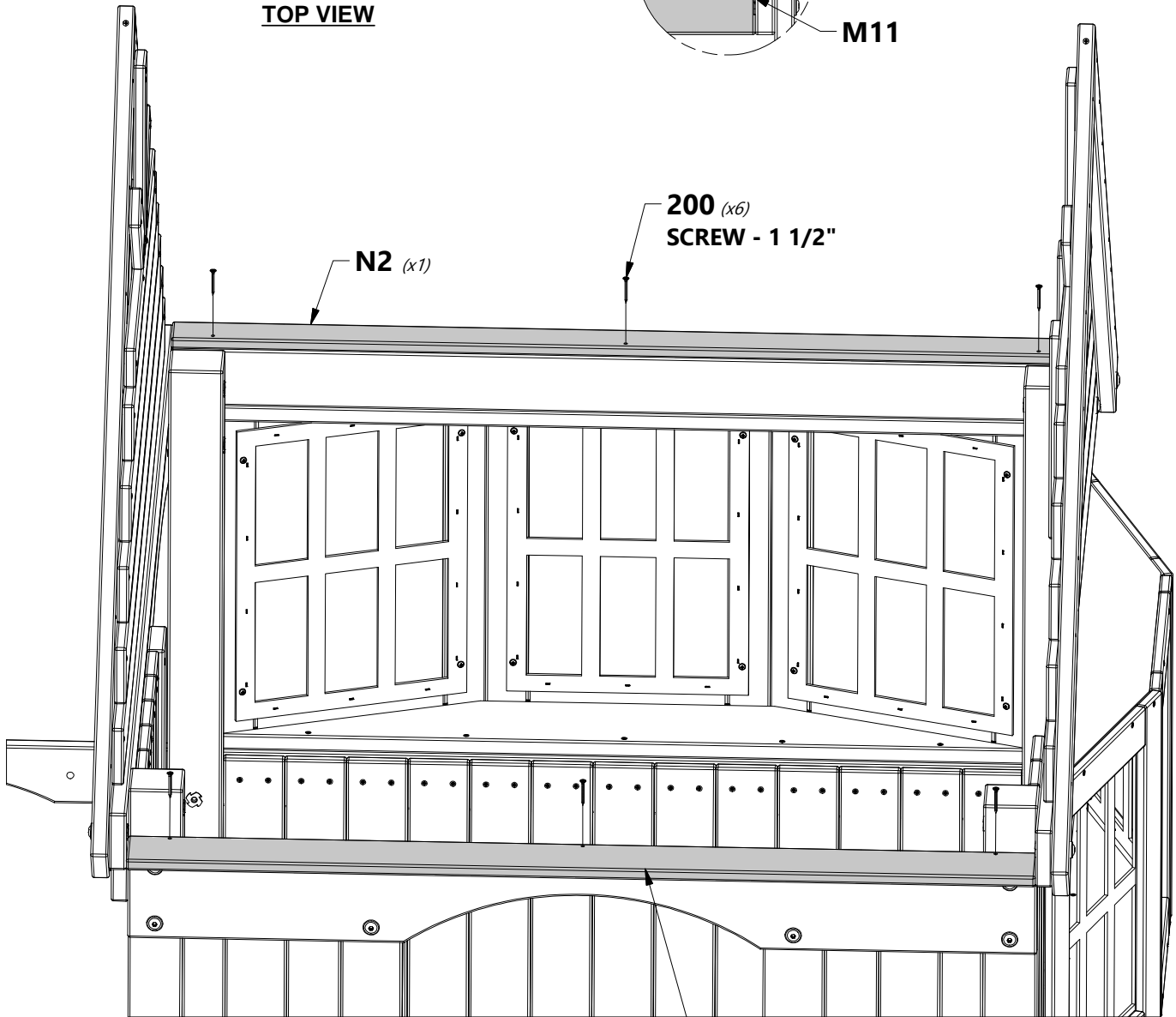

N2 (x1)

**200 (x6)
SCREW - 1 1/2"**

M11 (x1)

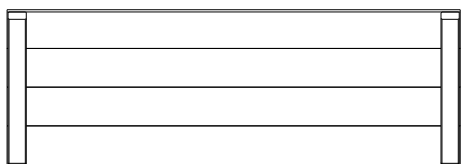

RP3 | PEAK ROOF PANEL - W2A03144
(x1) | 1 5/8"x20 5/8"x59" (42x524x1499)

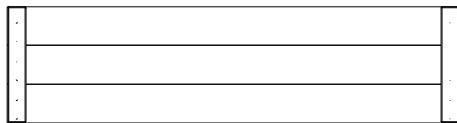

RP6 | ROOF PANEL - W2A03147
(x2) | 1 5/8"x15 5/8"x59" (42x396x1499)



H100483 | SCREW PFH BLK
(x14) | 8x2 1/4



NOTE:
START WITH TOP PANEL
FIRST AND FLUSH EDGES.

483 (x14)
SCREW - 8x2 1/4"

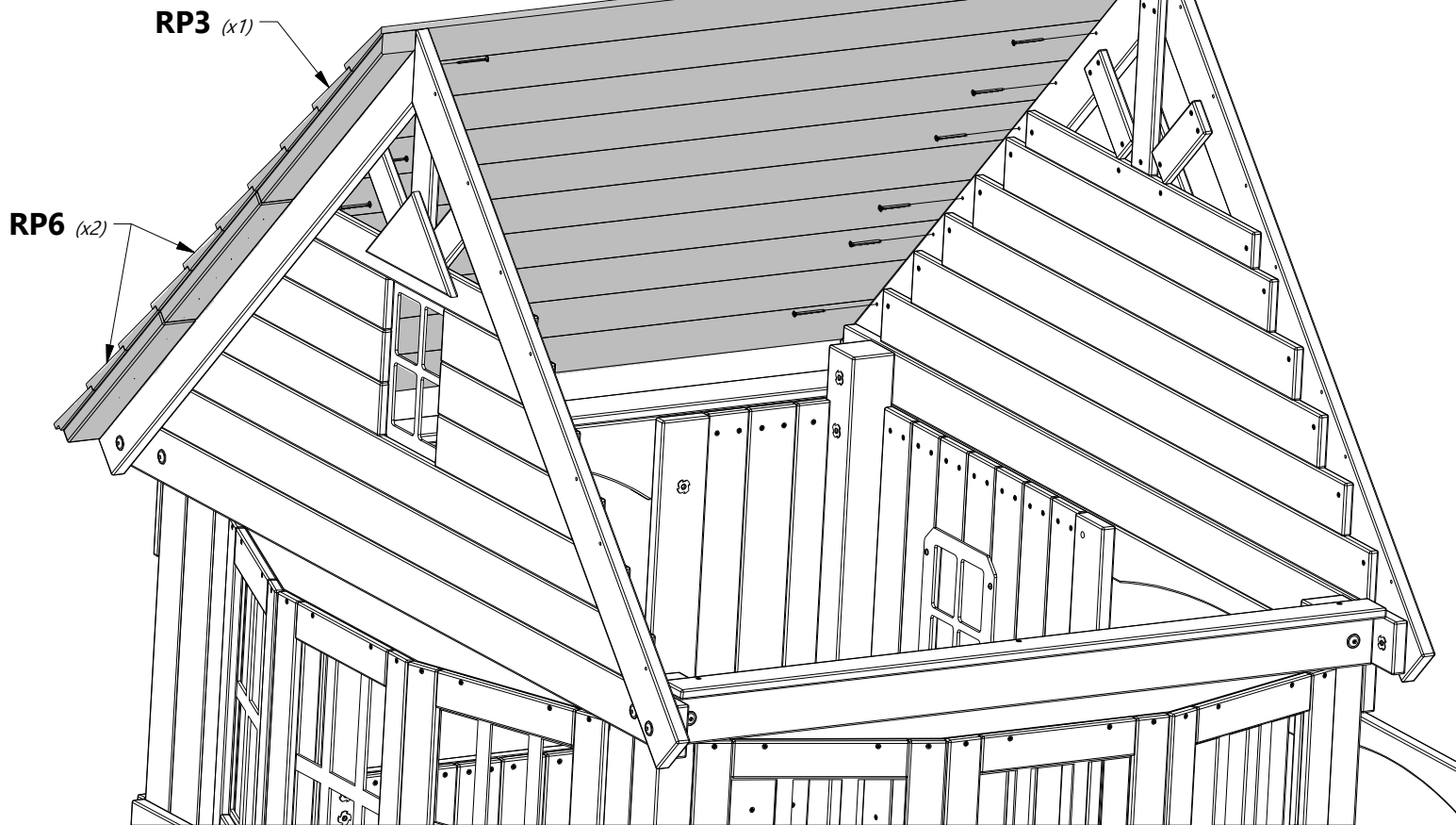



N3 ROOF SUPPORT - W4L14827
 (x1) 5/8"x2 3/8"x47" (16x60x1193)



H100380 SCREW PFH BLK
 (x9) 8x1 1/8

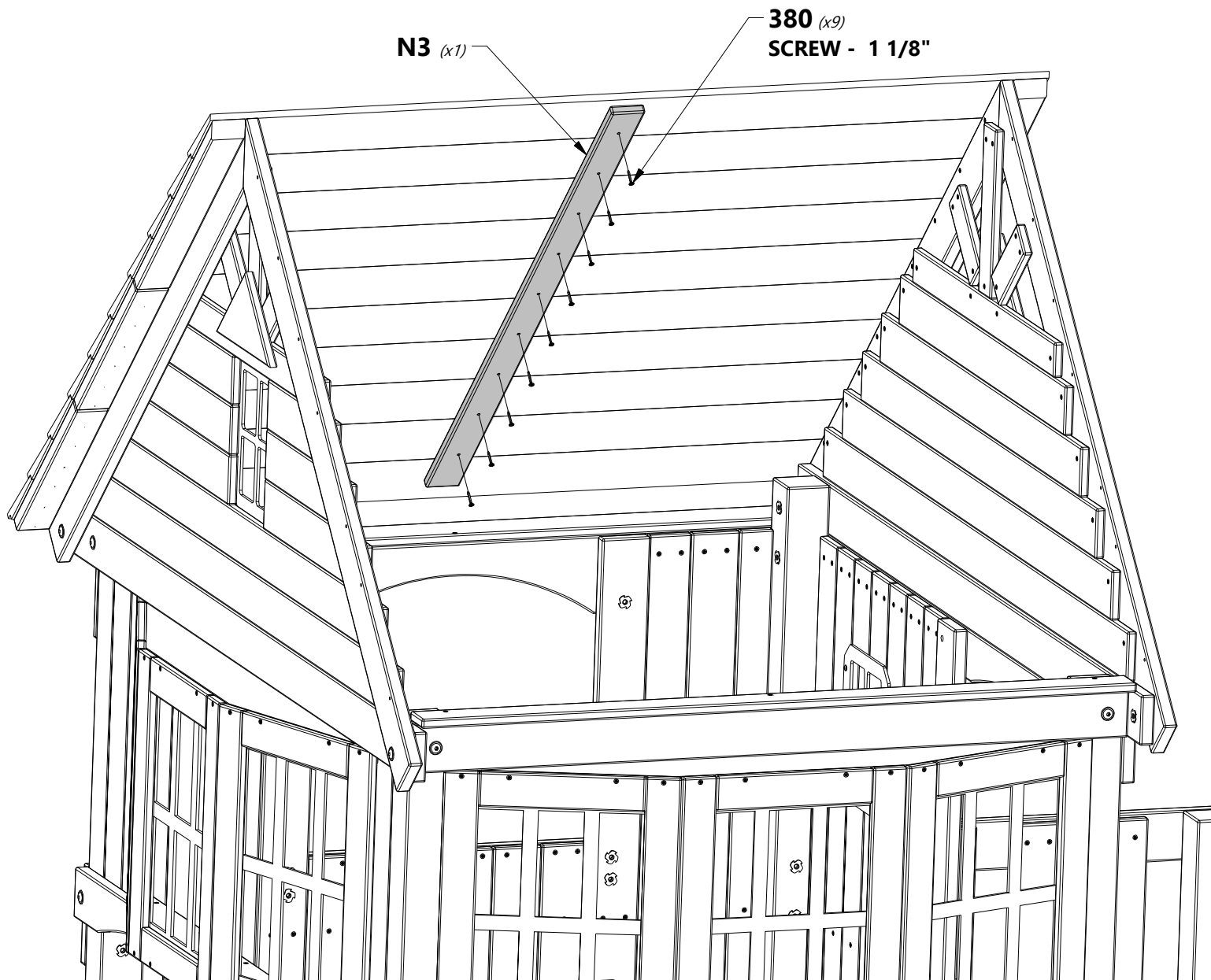
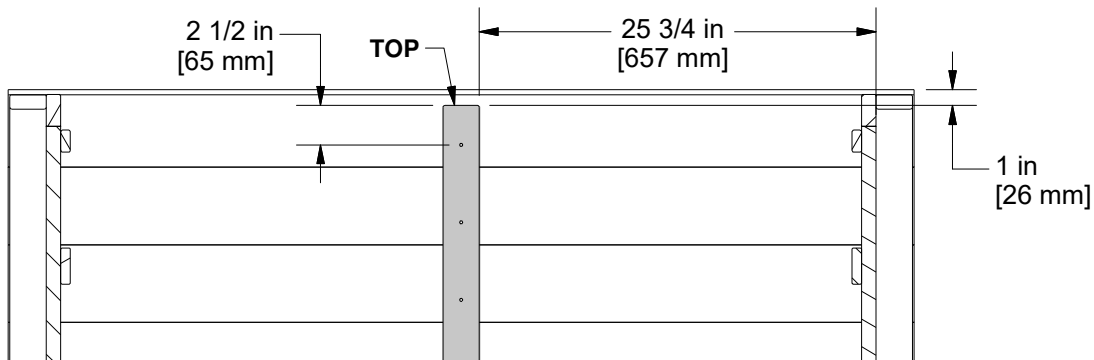



REPEAT STEPS 49 & 50 TO ATTACH LEFT SIDE ROOF PANELS.

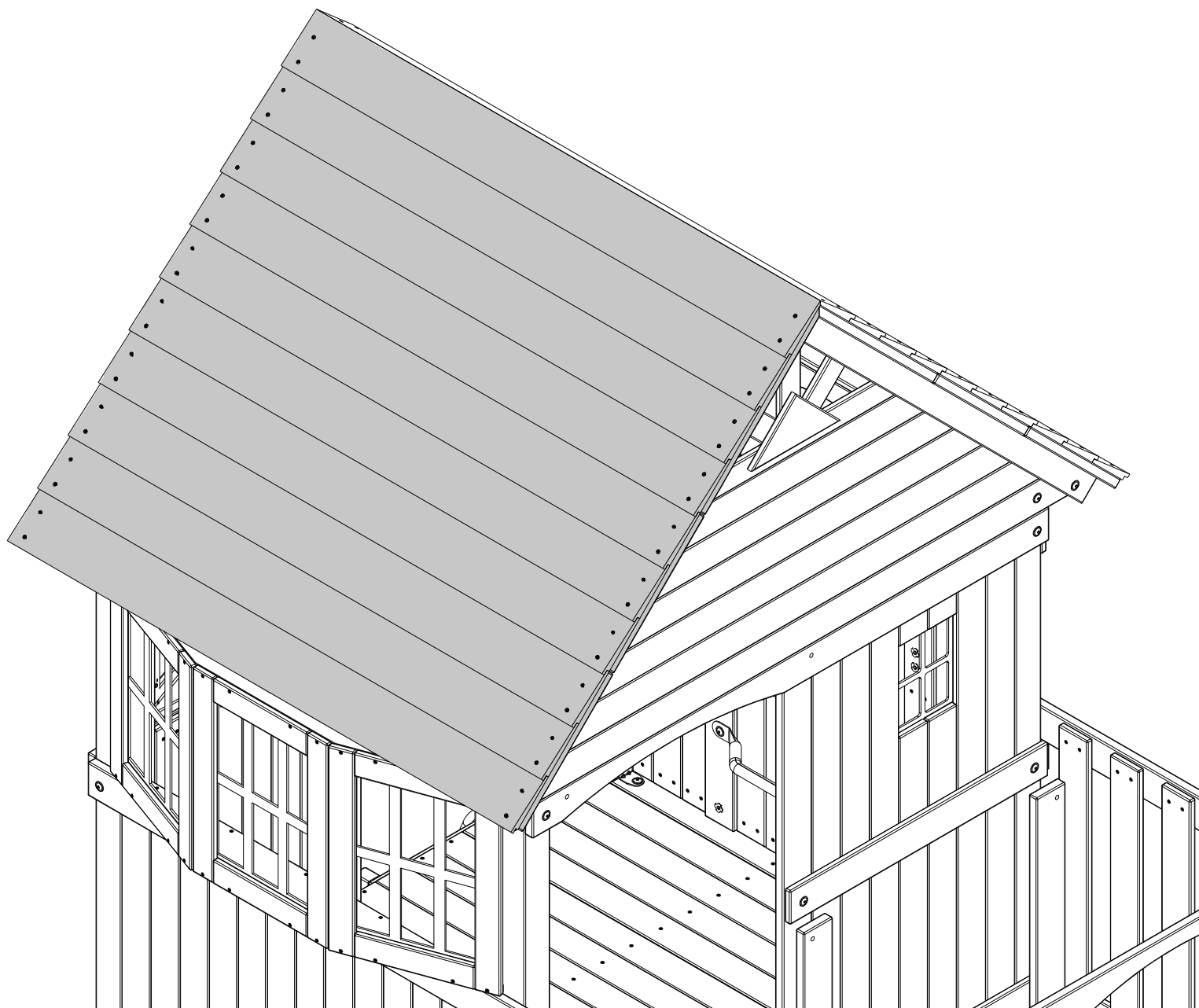



FORT ASSEMBLY

STEP 52

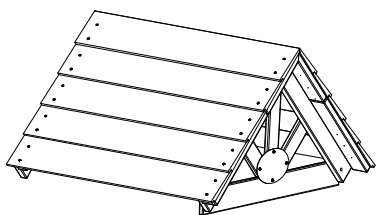

(x1) | PORCH ROOF ASSEMBLY



H100195 | BOLT WH BLK
(x1) | 5/16x2-3/4



H100194 | BOLT WH BLK
(x2) | 5/16x2 1/2



H100378 | BOLT WH BLK
(x1) | 5/16x1 3/4



H100198 | WASHER LOCK
(x4) | EXT BLK
8x19



H100379 | T-NUT BLK
(x4) | 5/16

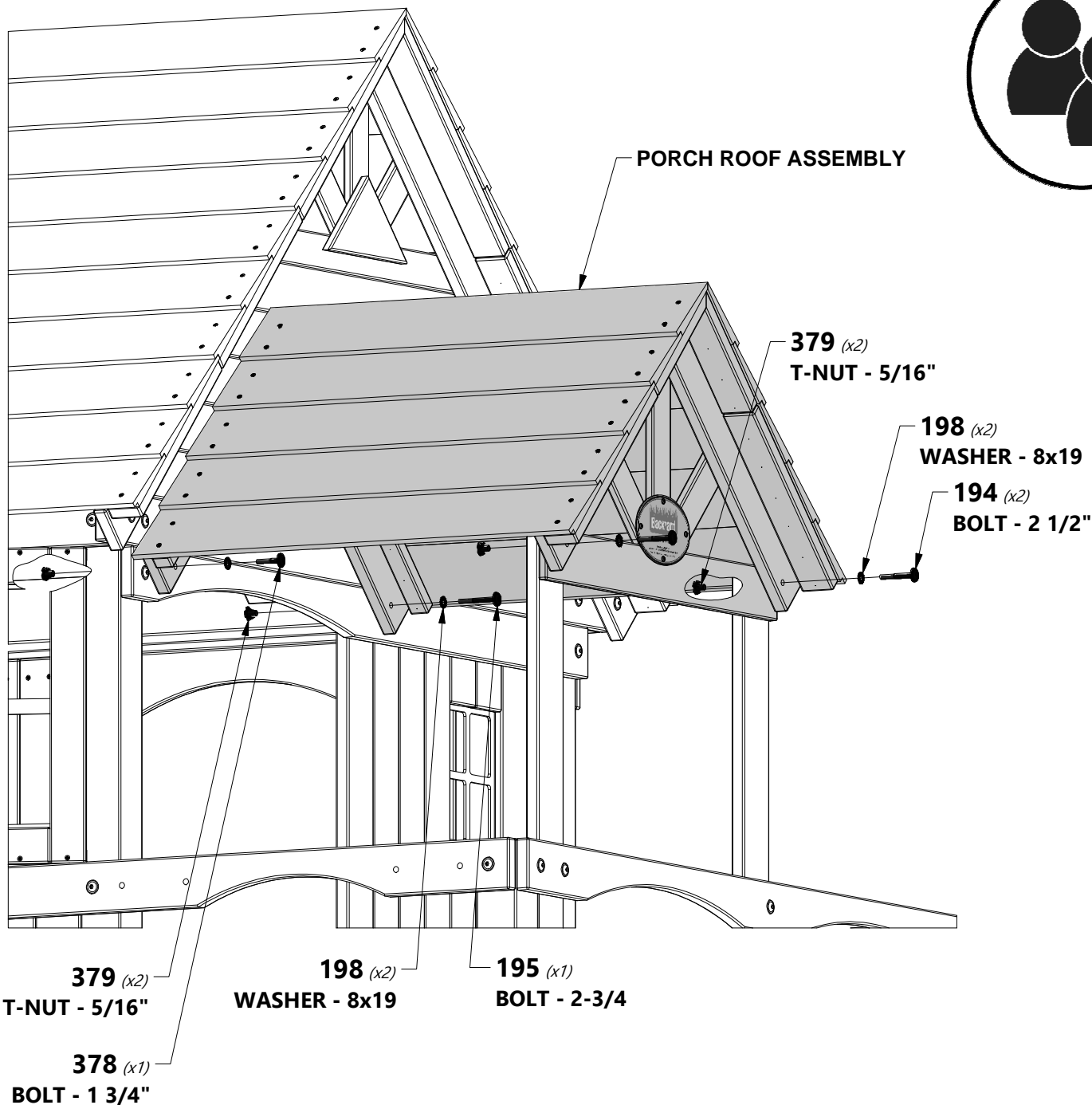

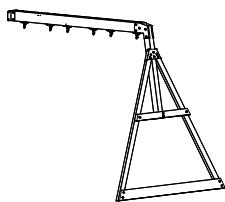

(x1) SWING BEAM ASSEMBLY



H100657 | BOLT HEX BLK
(x4) 5/16x1 3/4



H100477 | WASHER SPLIT
(x4) BLK 5/16



H100478 | WASHER FLAT
(x4) BLK 8x27



H100379 | T-NUT BLK
(x4) 5/16

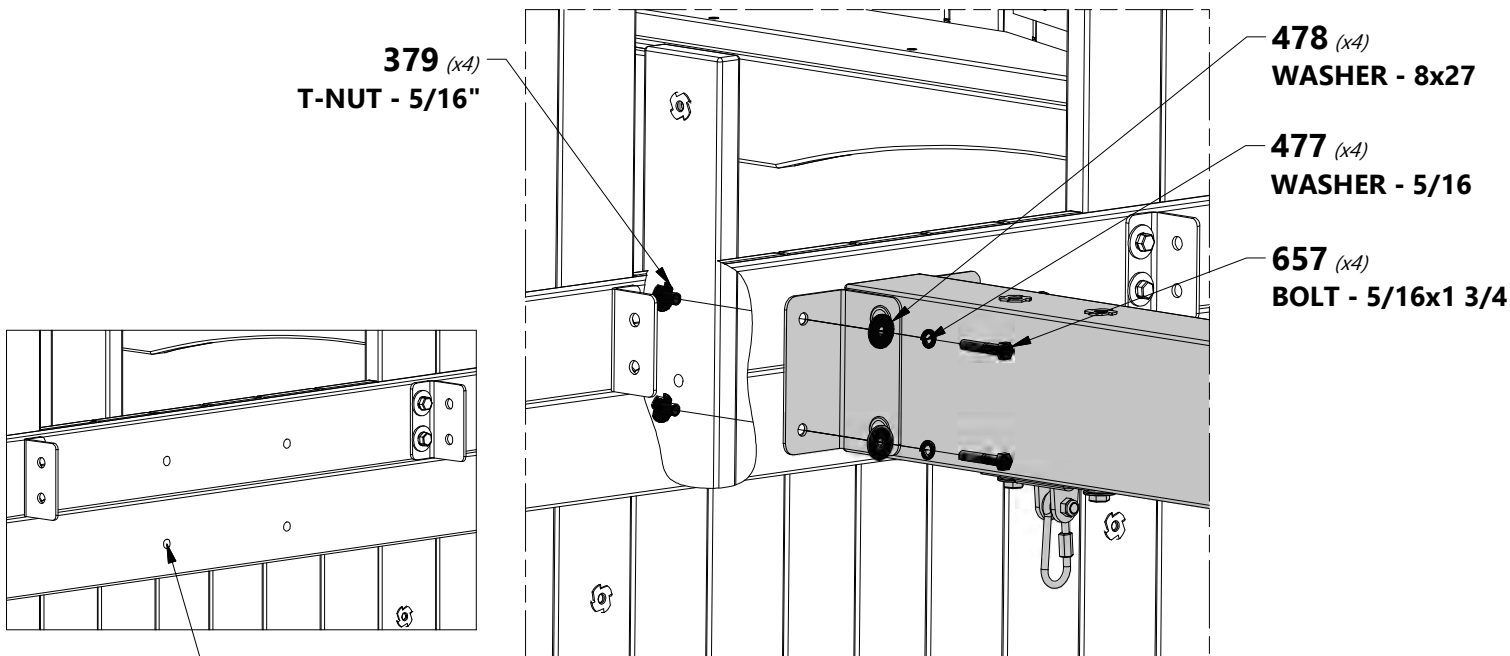

1ST  USING BOARDS AS A GUIDE, DRILL 3/8" (10mm) HOLES THRU INSIDE PICKETS (4X).

2ND INSTALL SWING BEAM ASSEMBLY.

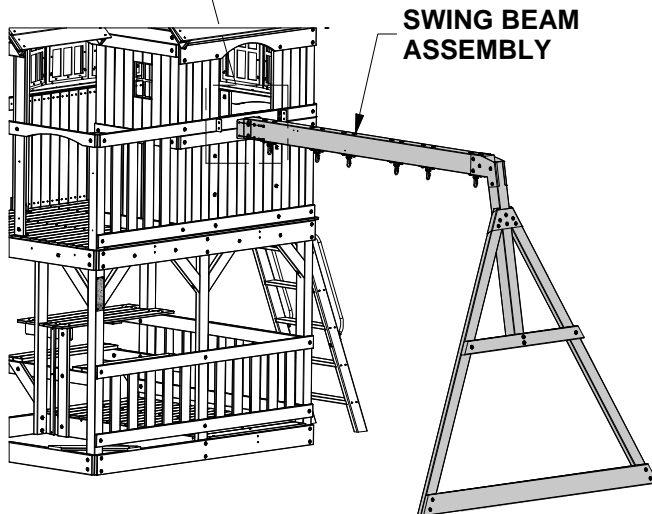
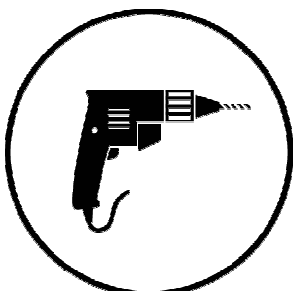

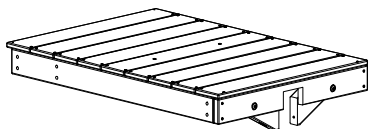

(x1) CROWS NEST DECK ASSEMBLY



H100456 LAG SCREW WH BLK 1/4x2 1/2 (x2)



H100192 NUT BARREL WH BLK 5/16x7/8 (x4)



H100481 BOLT HEX BLK 5/16x1 1/4 (x4)



H100086 SCREW PFH 8x1 1/2 (x2)



H100478 WASHER FLAT BLK 8x27 (x4)



H100477 WASHER SPLIT BLK 5/16 (x4)



H100405 WASHER LOCK EXT BLK 6x15 (x2)



H100199 WASHER LOCK EXT BLK 12x19 (x4)

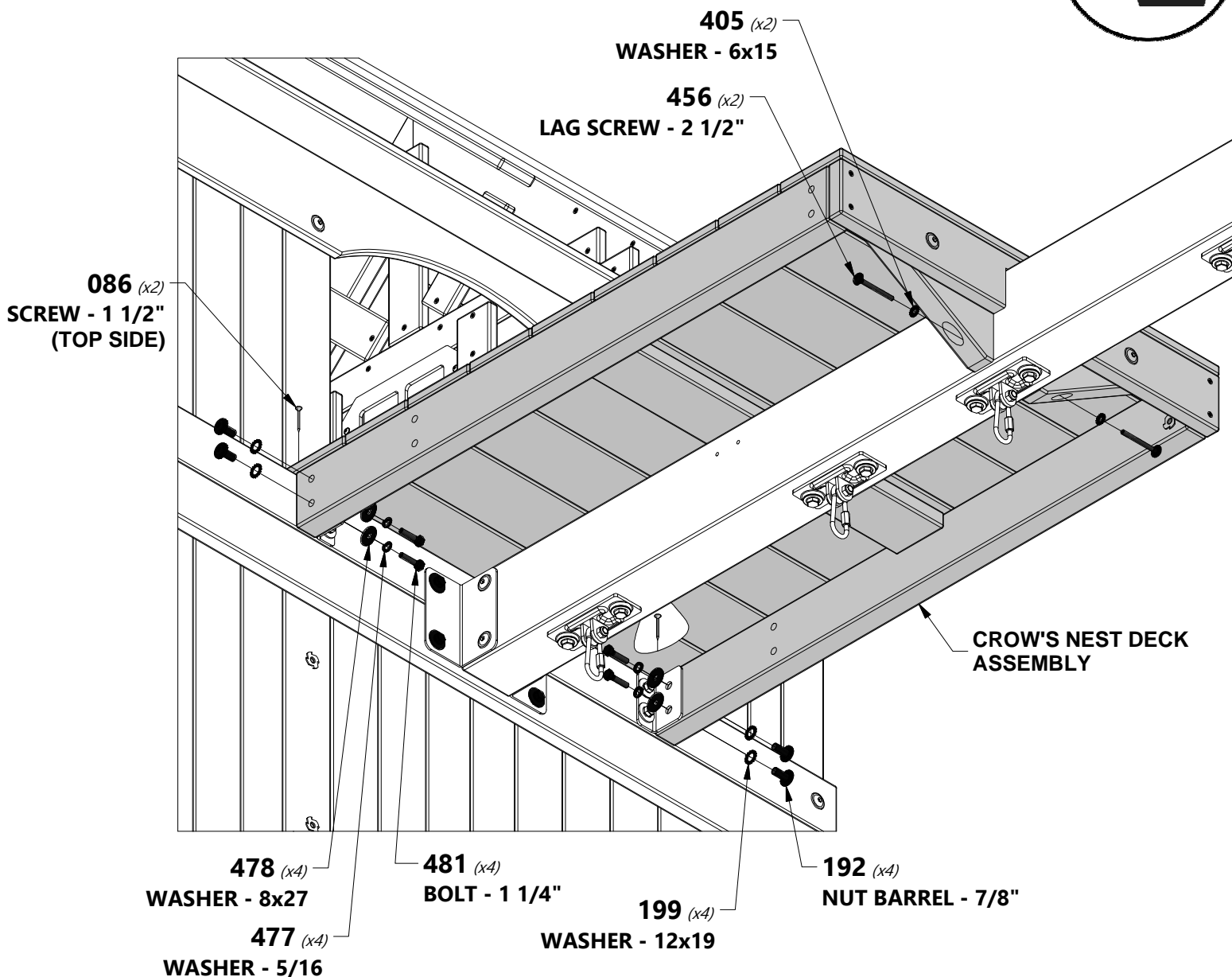



A100396 | L BRACKET
(x2) | 51x32x82x3.175



H100659 | LAG SCREW BLK
(x8) | 5/16x1 1/2



H100477 | WASHER SPLIT
(x8) | BLK
5/16



H100478 | WASHER FLAT
(x8) | BLK
8x27

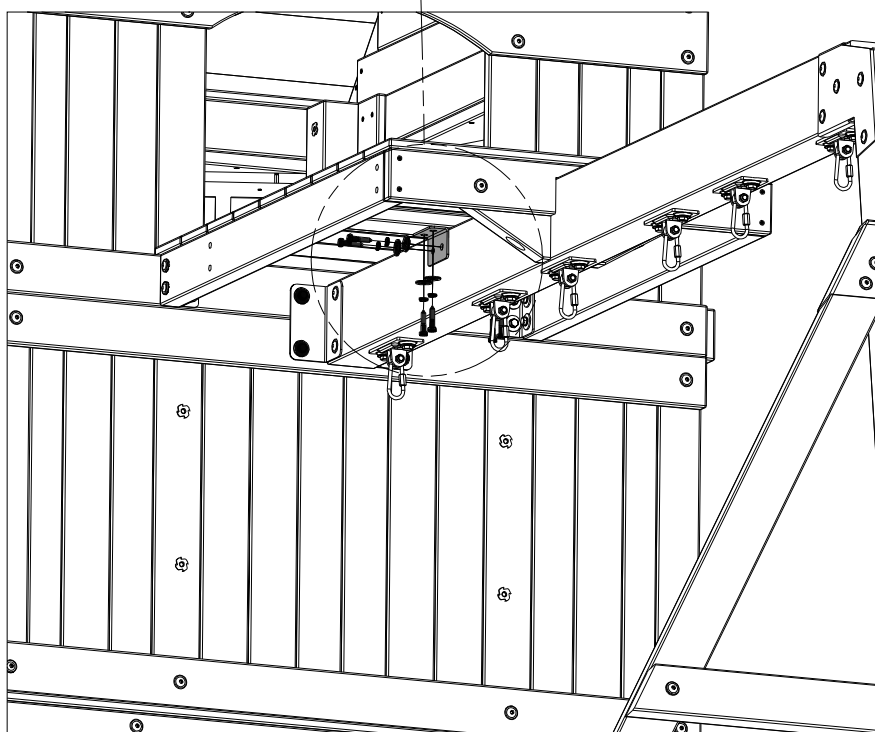
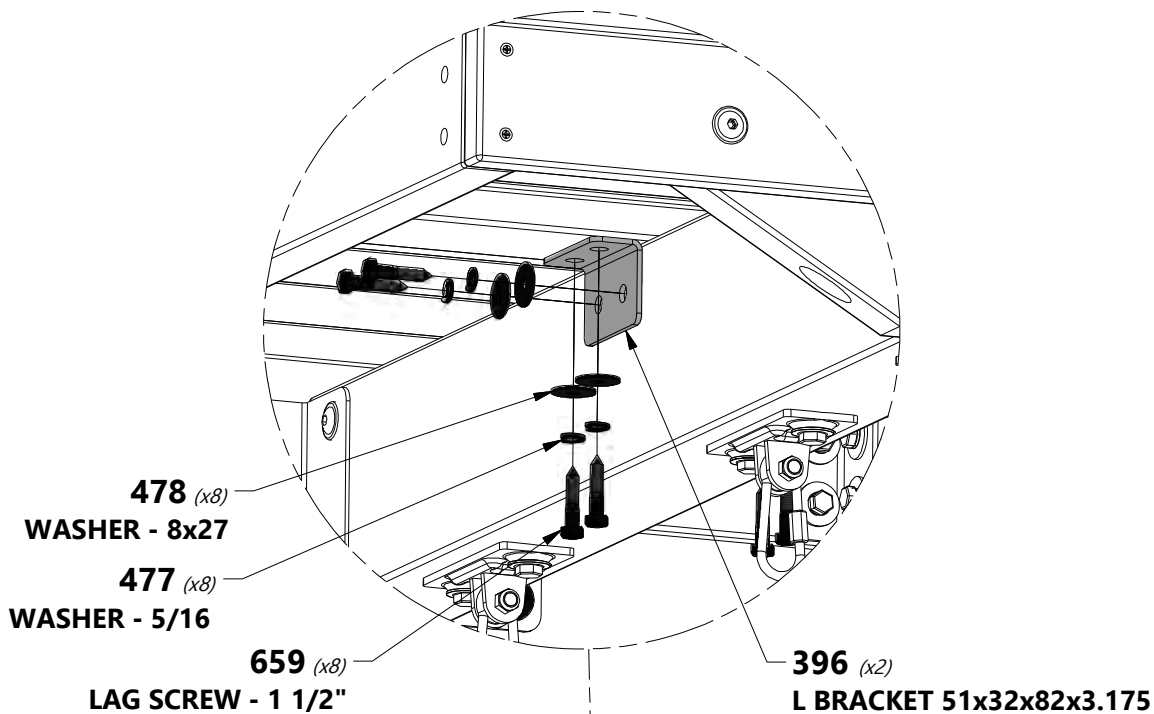



F2 | CROWS NEST WALL SUPPORT - W4L14738
(x2) | 1 3/8"x2 3/8"x37 1/2" (36x60x952)



F3 | CROWS NEST WALL SUPPORT - W4L14739
(x2) | 1 3/8"x2 3/8"x37 1/2" (36x60x952)



H100195 | BOLT WH BLK
(x8) | 5/16x2-3/4



H100198 | WASHER LOCK
(x8) | EXT BLK
8x19



H100379 | T-NUT BLK
(x4) | 5/16

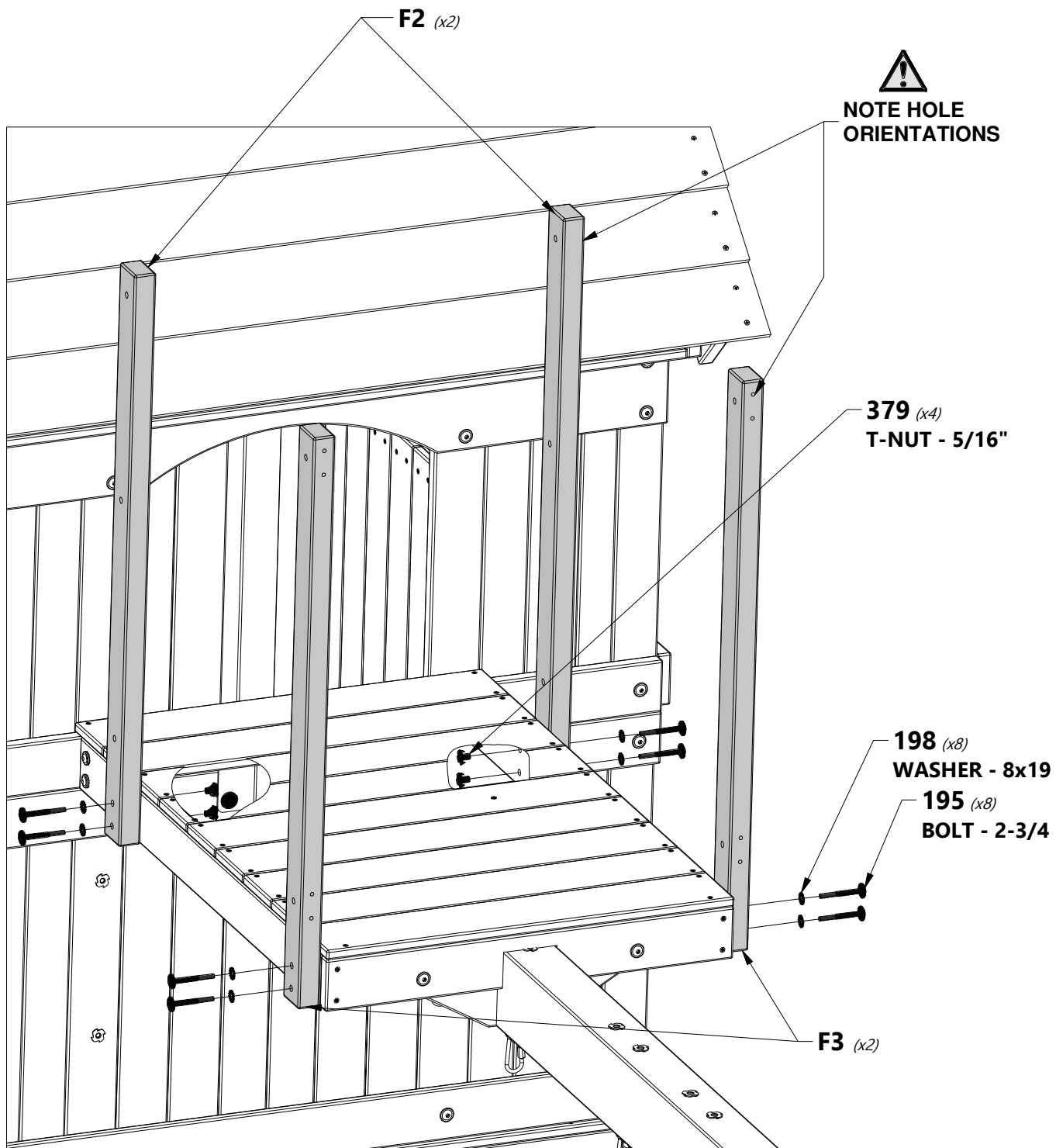



H30 | CROWS NEST WALL RAIL - W4L14776
(x1) | 1"x3 3/8"x29 7/8" (24x86x758)



H31 | CROWS NEST WALL RAIL - W4L14777
(x2) | 1"x3 3/8"x38 7/8" (24x86x988)



H100197 | LAG SCREW WH BLK
(x4) | 5/16x2 1/2



H100205 | BOLT WH BLK
(x4) | 5/16x2-1/4



H100198 | WASHER LOCK
(x8) | EXT BLK
8x19



H100379 | T-NUT BLK
(x4) | 5/16

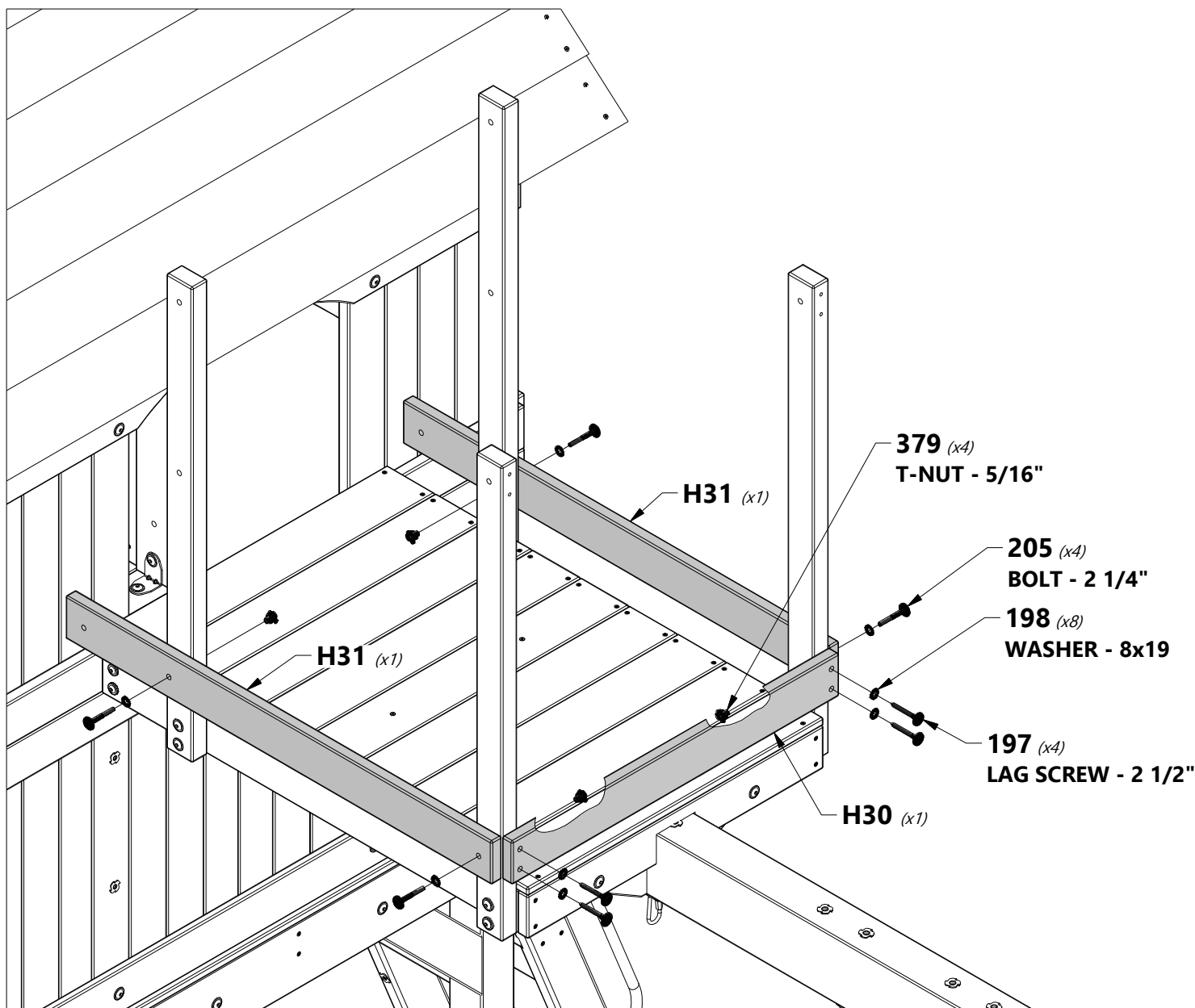



A4M01046 | L BRACKET
(x2) | 2.5x38x55x55



H100468 | BOLT WH BLK
(x2) | 5/16x1



H100396 | BOLT WH BLK
(x2) | 5/16x1/2



H100379 | T-NUT BLK
(x4) | 5/16

046 (x2)
L BRACKET 2.5x38x55x55

379 (x4)
T-NUT - 5/16"

468 (x2)
BOLT - 1"

396 (x2)
BOLT - 1/2"

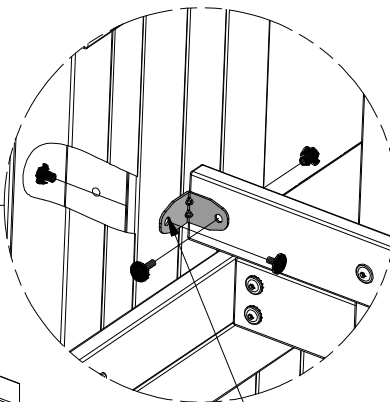
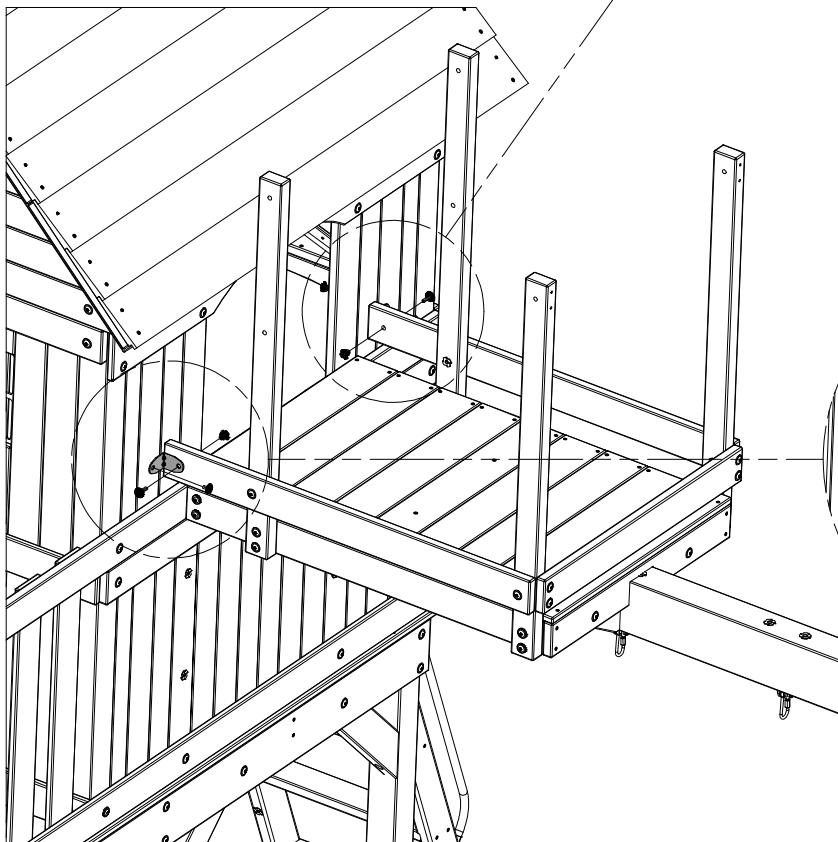
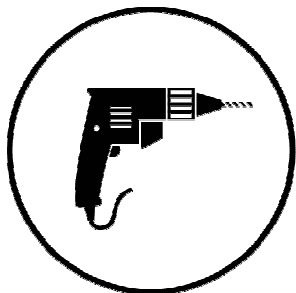

**USING BRACKETS AS A GUIDE,
DRILL 3/8" [10 mm] HOLES
THROUGH WALL BOARD.**



H29 | CROWS NEST WALL RAIL - W4L14775
(x2) | 1"x3 3/8"x30 5/8" (24x86x778)



H30 | CROWS NEST WALL RAIL - W4L14776
(x1) | 1"x3 3/8"x29 7/8" (24x86x758)



M4 | CROWS NEST WALL RAIL - W4L14792
(x2) | 5/8"x3 3/8"x29 7/8" (16x86x758)



H100205 | BOLT WH BLK
(x4) | 5/16x2-1/4



H100197 | LAG SCREW WH BLK
(x4) | 5/16x2 1/2



H100458 | LAG SCREW WH BLK
(x8) | 5/16x2



H100198 | WASHER LOCK
(x16) | EXT BLK
8x19



H100379 | T-NUT BLK
(x4) | 5/16

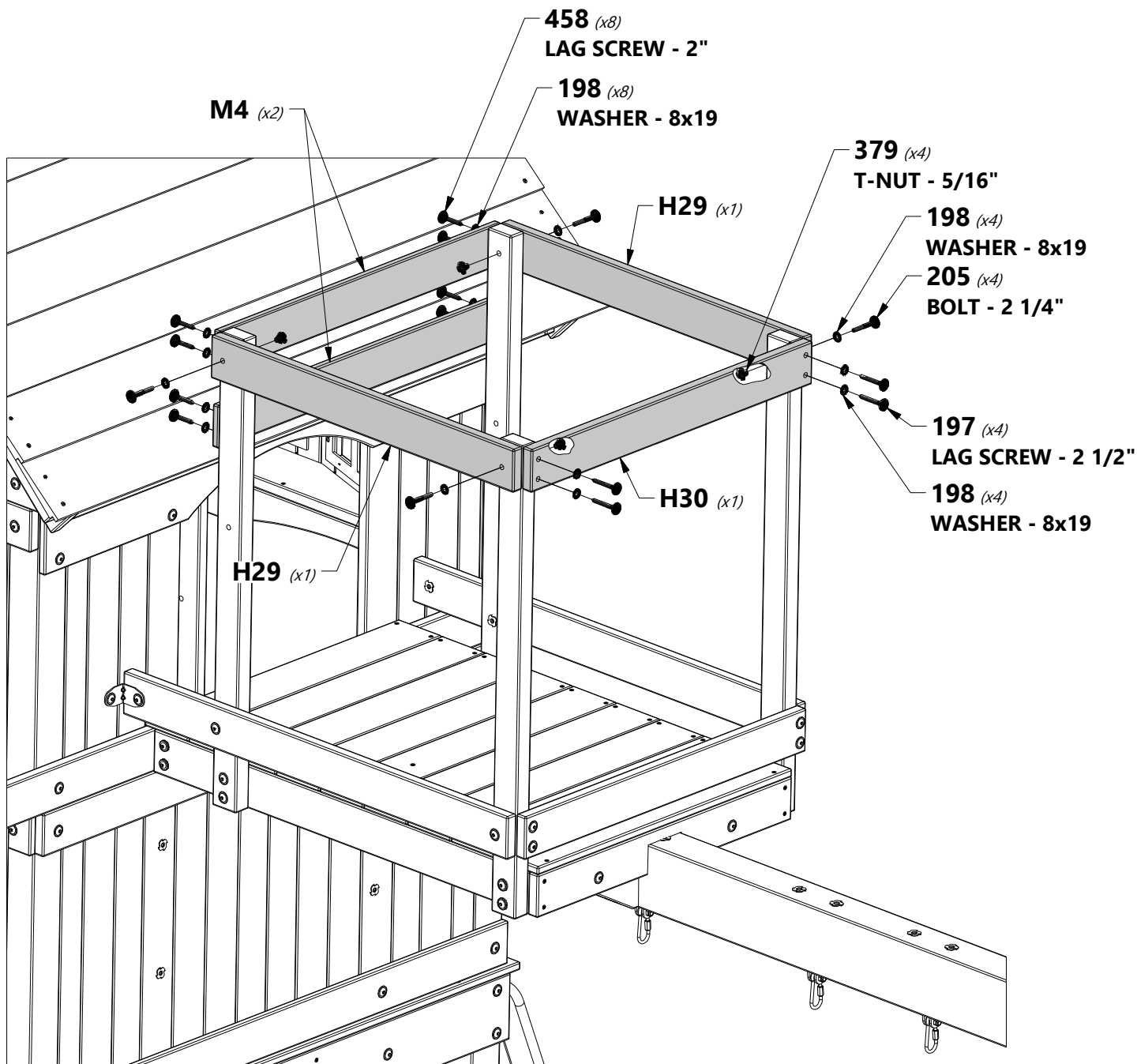



1 1/8 in [30 mm] 1 3/4 in [43 mm]



M32 | CROWS NEST WALL RAIL - W4L14817
(x2) | 5/8"x3 3/8"x10" (16x86x254)



A4M01046 | L BRACKET
(x2) | 2.5x38x55x55



H100457 | BOLT WH BLK
(x2) | 5/16x2



H100459 | BOLT WH BLK
(x2) | 5/16x1 1/4



H100396 | BOLT WH BLK
(x2) | 5/16x1/2



H100198 | WASHER LOCK
(x2) | EXT BLK
8x19



H100379 | T-NUT BLK
(x6) | 5/16



USING BRACKETS AS A GUIDE, DRILL 3/8" [10 mm] HOLES THROUGH THE WALL.

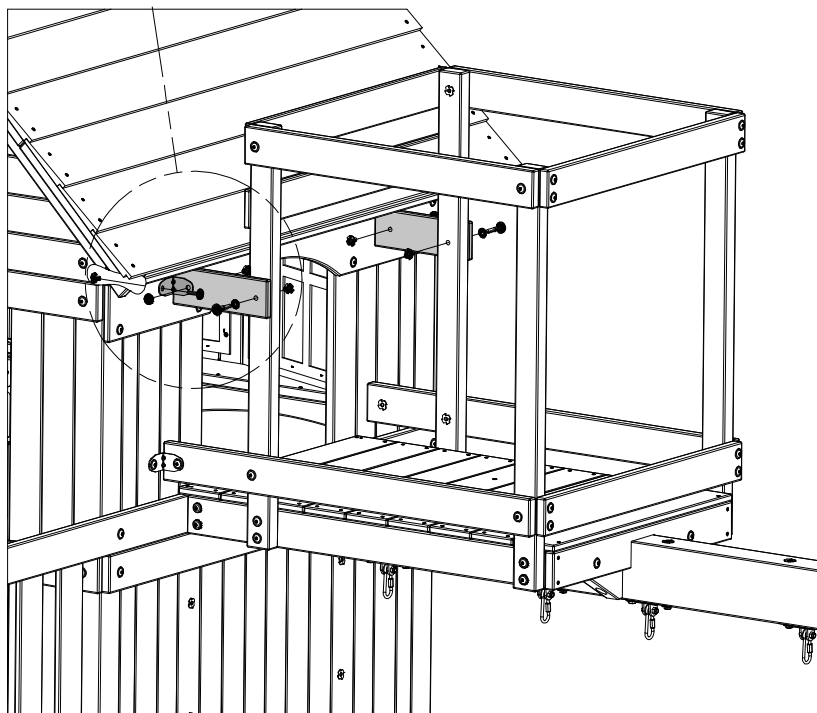
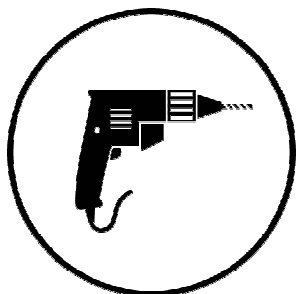
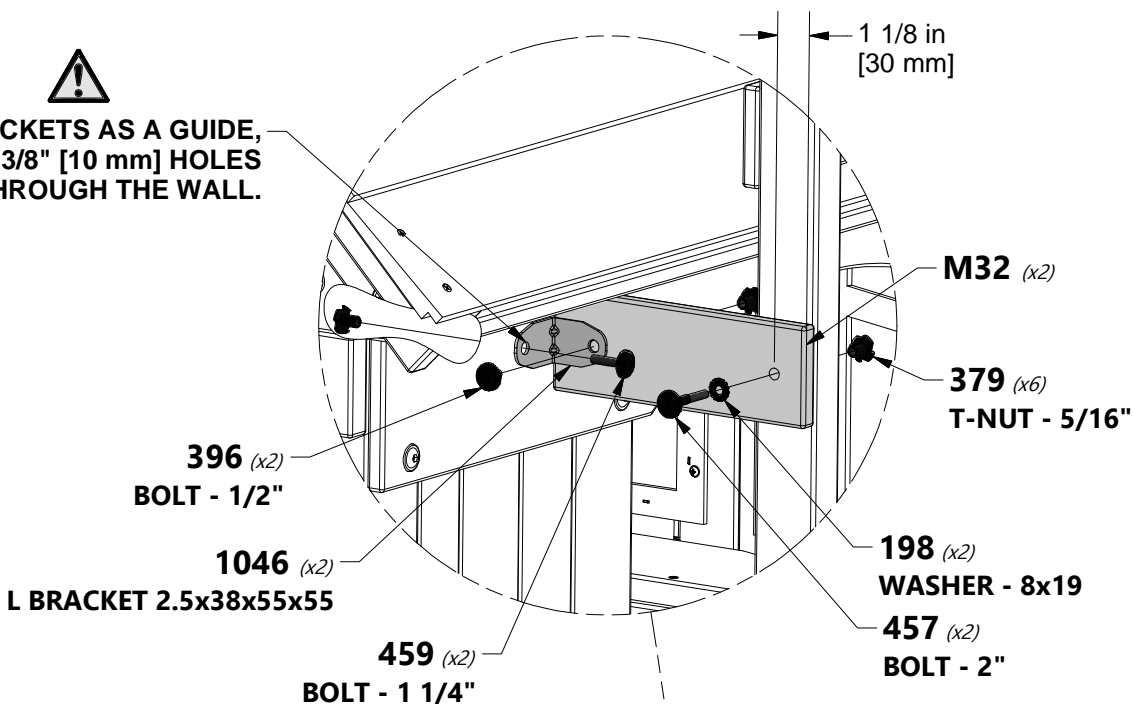

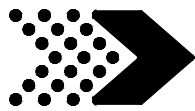

N4 | CROWS NEST WALL BOARD - W4L14828
(x2) | 5/8"x2 3/8"x19" (16x60x483)



H100380 | SCREW PFH BLK
(x4) | 8x1 1/8"

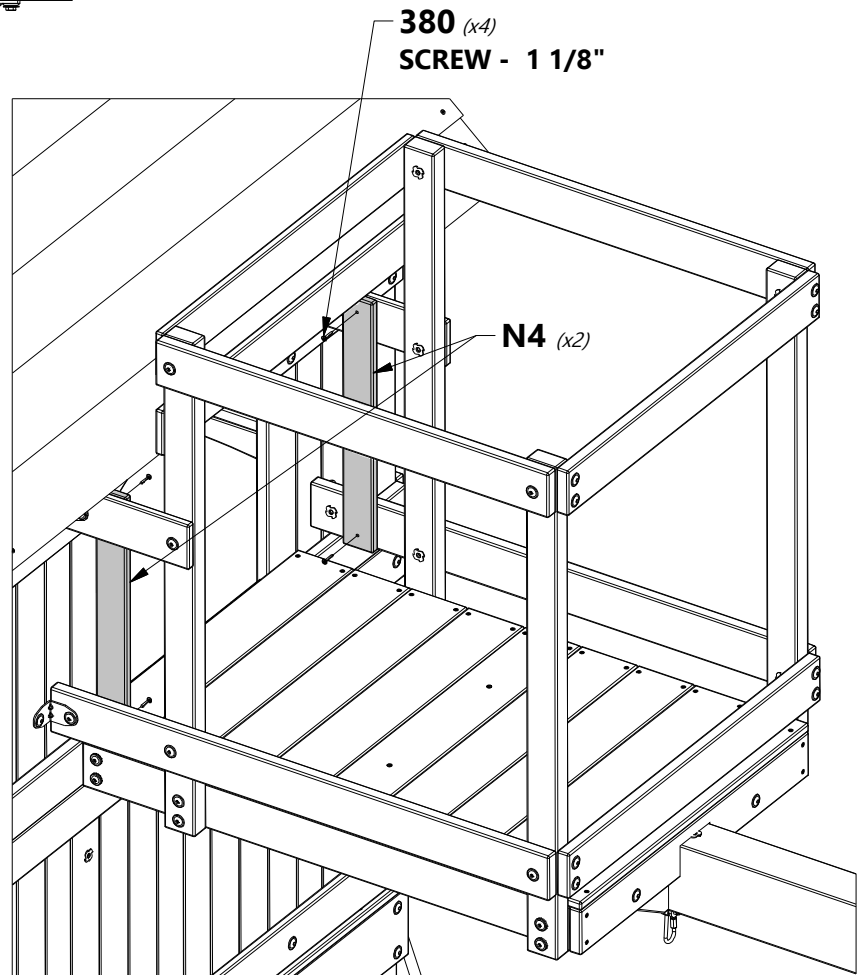
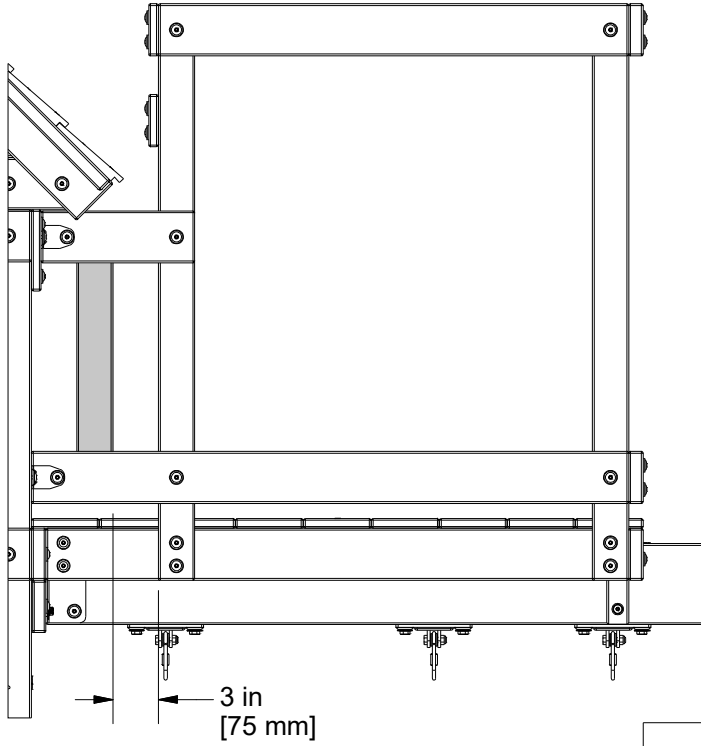



O01 | CROWS NEST WALL BOARD - W4L15641
 (x6) | 5/8"x1 3/8"x32 1/4" (16x34x819)

H100088 | SCREW PFH
 (x12) | 8x1 1/8"

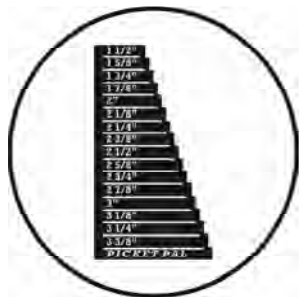

2 3/4 in
 [69 mm]
 EQUAL SPACING

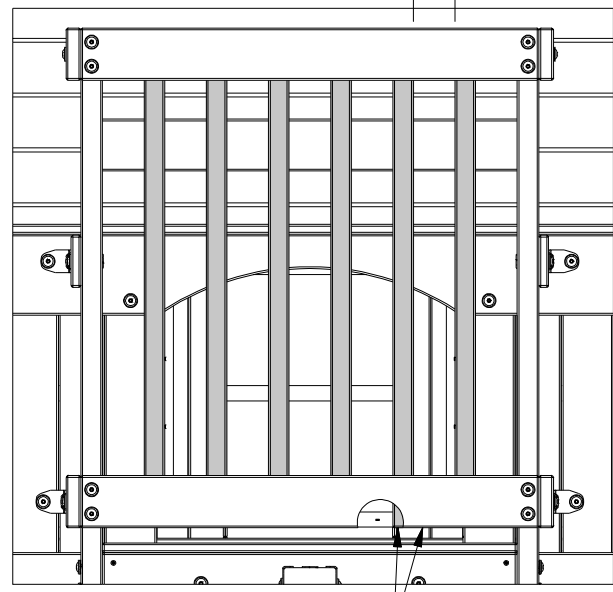

088 (x12)
 SCREW - 1 1/8" **O01** (x6)

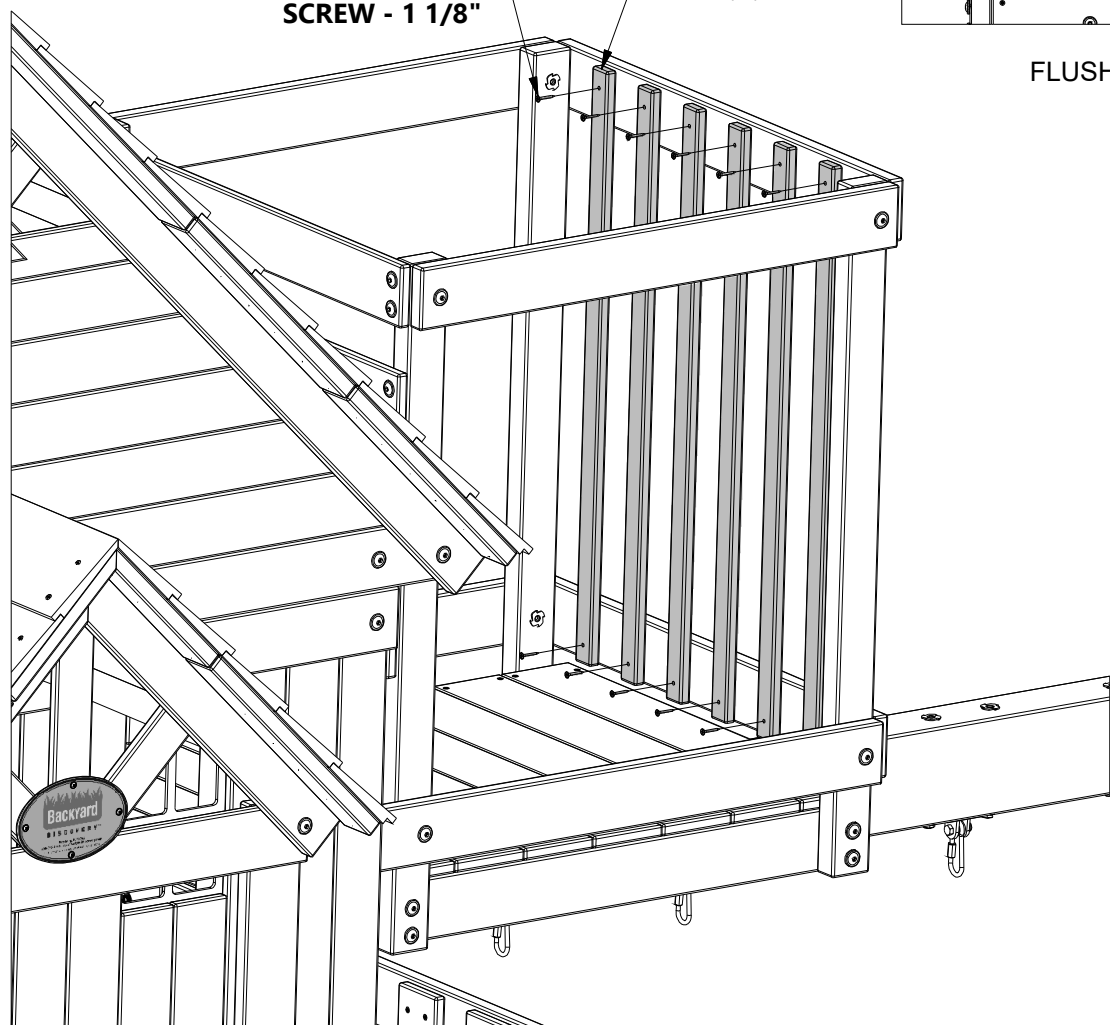



O01 | CROWS NEST WALL BOARD - W4L15641
(x12) | 5/8"x1 3/8"x32 1/4" (16x34x819)



H100088 | SCREW PFH
(x24) | 8x1 1/8

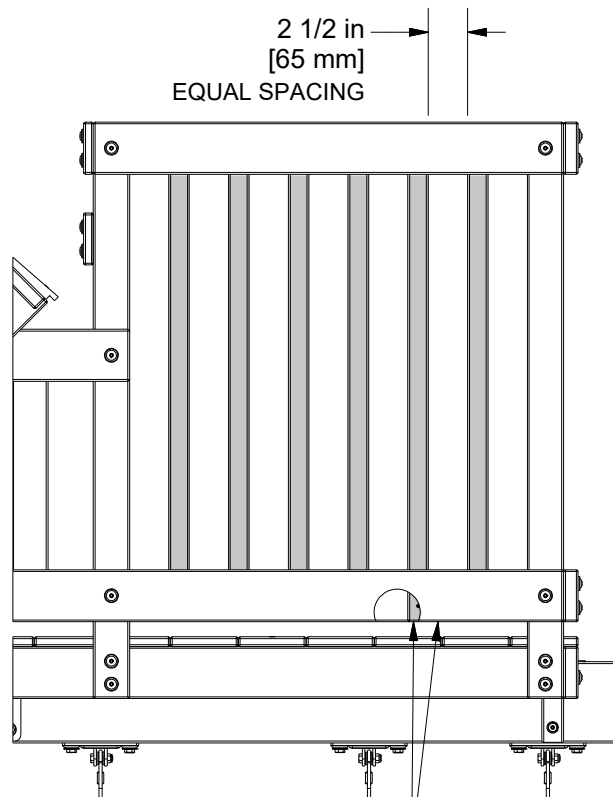

088 (x24)
SCREW - 1 1/8"

O01 (x12)

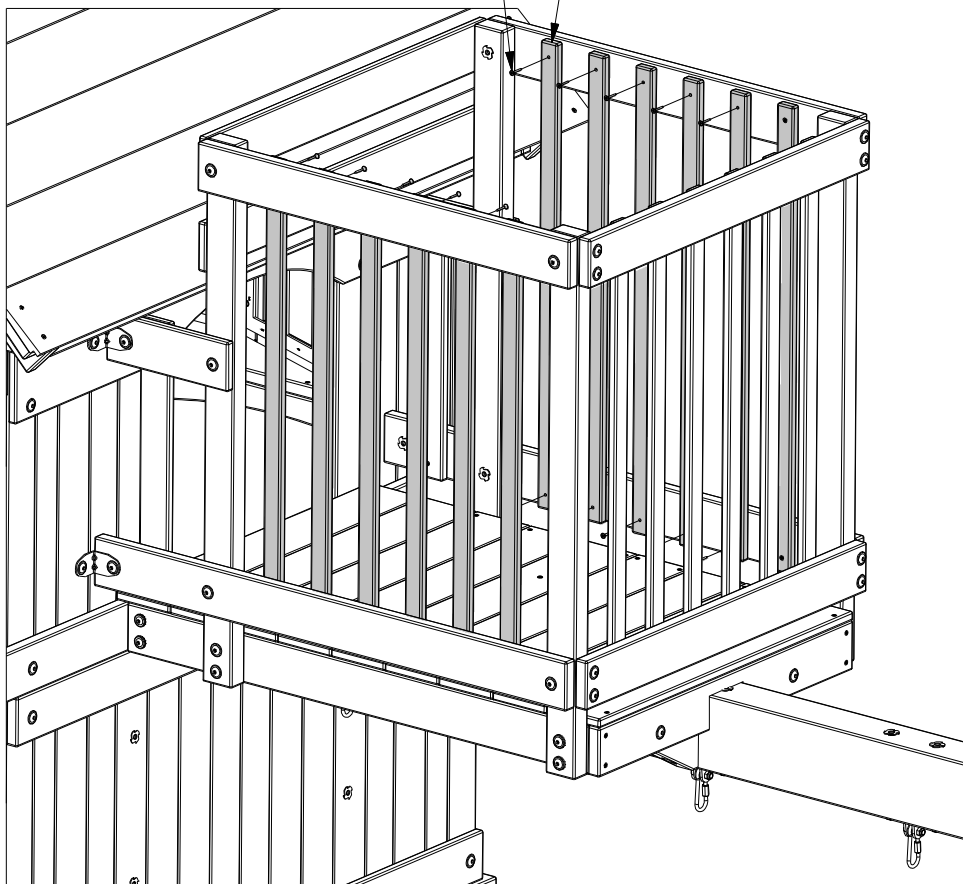

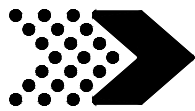

A6P00096 | TELESCOPE
(x1)



H100087 | SCREW PFH
(x2) | 8x1 1/4"

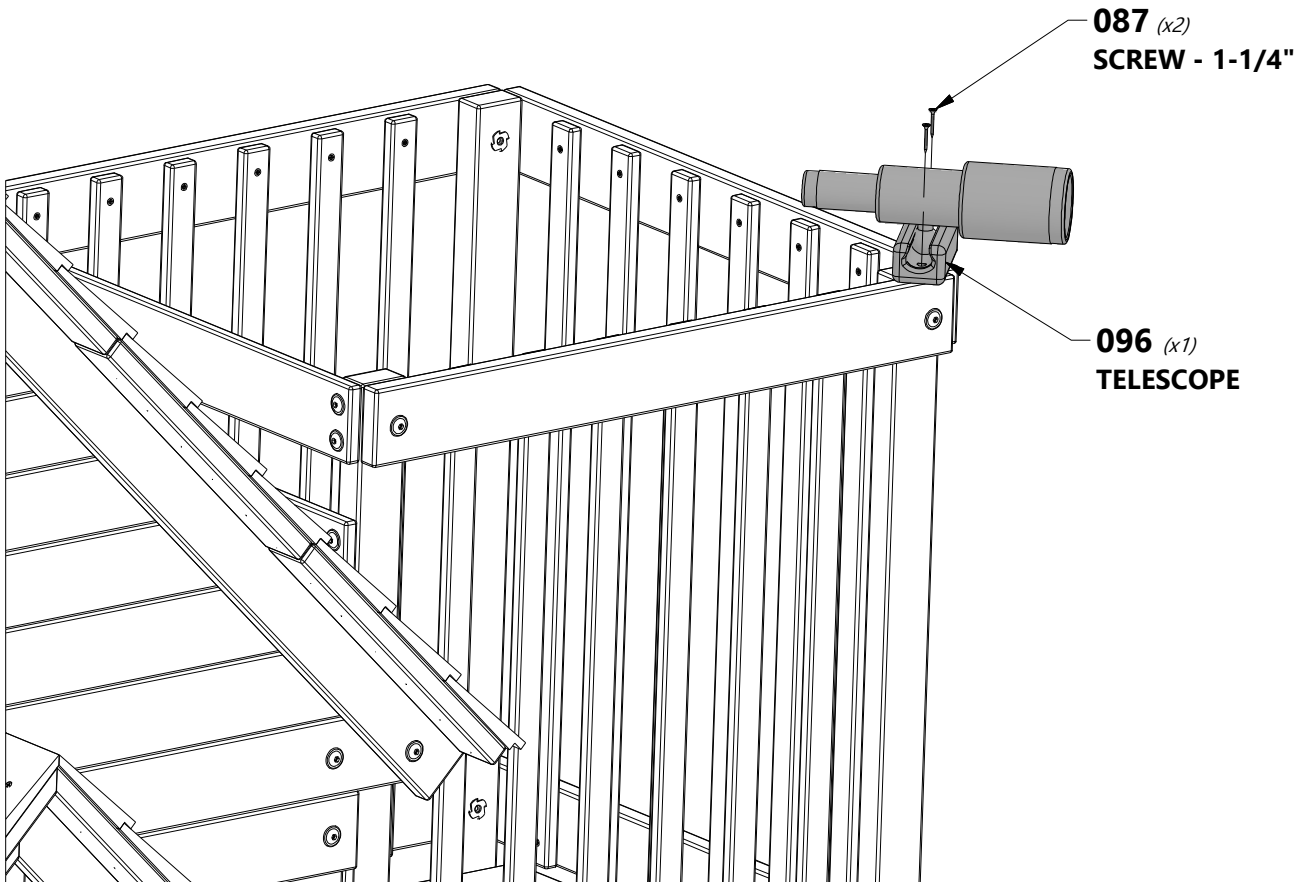

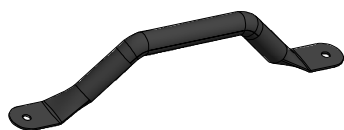

A100118 | **HAND GRIP METAL GREEN 381 c/c**
(x4)



H100471 | **LAG SCREW WH BLK**
(x4) | 5/16x1 1/2



H100468 | **BOLT WH BLK**
(x4) | 5/16x1



H100379 | **T-NUT BLK**
(x4) | 5/16

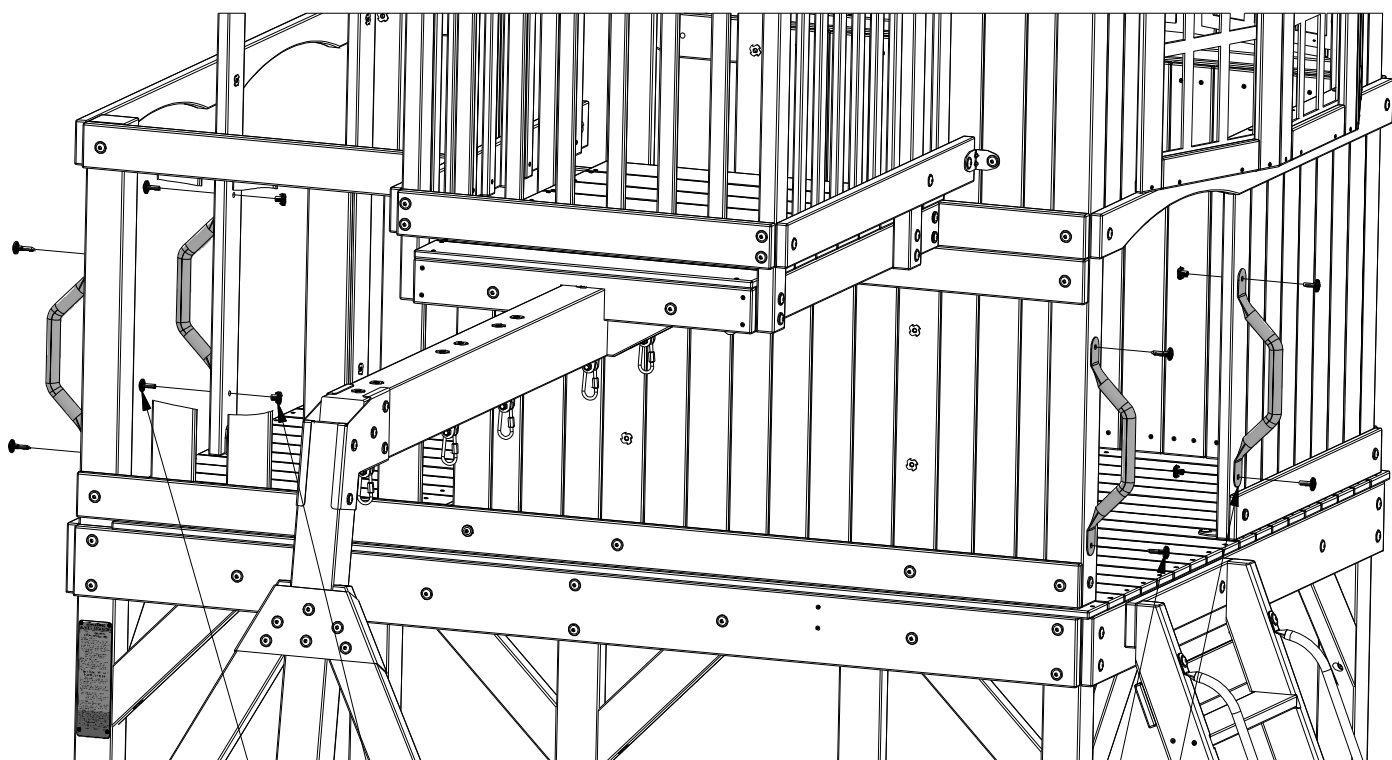

468 (x4)
BOLT - 1"

379 (x4)
T-NUT - 5/16"

471 (x4)
LAG SCREW - 1 1/2"

118 (x4)
HAND GRIP METAL GREEN 381 c/c

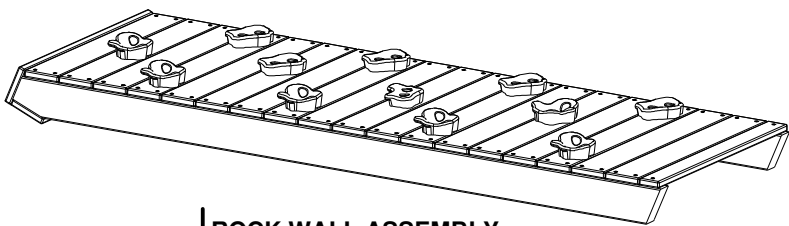

(x1) | **ROCK WALL ASSEMBLY**



H100407 | **BOLT WH BLK**
(x2) | 5/16x1 1/2



H100198 | **WASHER LOCK**
(x2) | **EXT BLK**
8x19

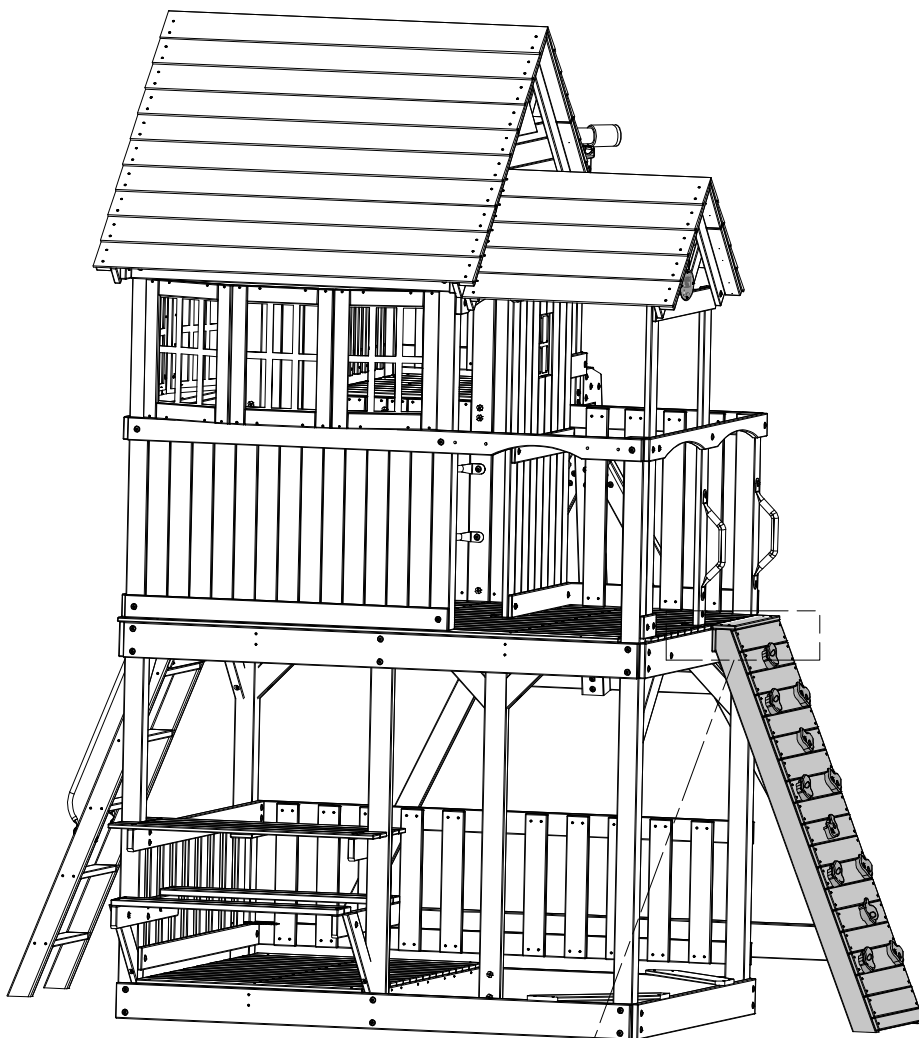

198 (x2)
WASHER - 8x19

407 (x2)
BOLT - 1 1/2"

ROCK WALL ASSEMBLY

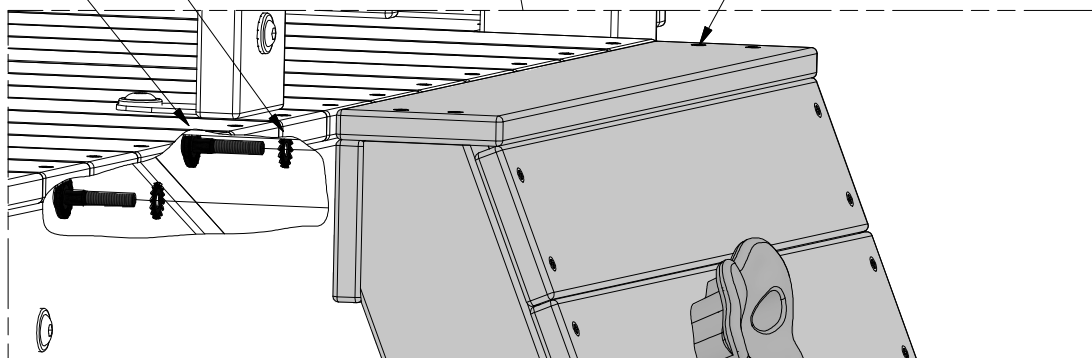



(x1)

MONKEY BAR ASSEMBLY



H100468 | BOLT WH BLK
(x4) | 5/16x1



H100379 | T-NUT BLK
(x4) | 5/16

379 (x4)
T-NUT - 5/16"

468 (x4)
BOLT - 1"

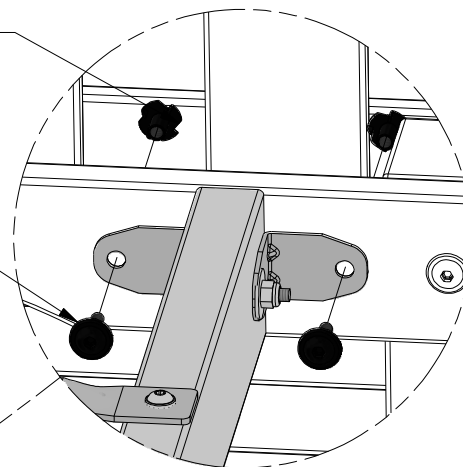

MONKEY BAR ASSEMBLY

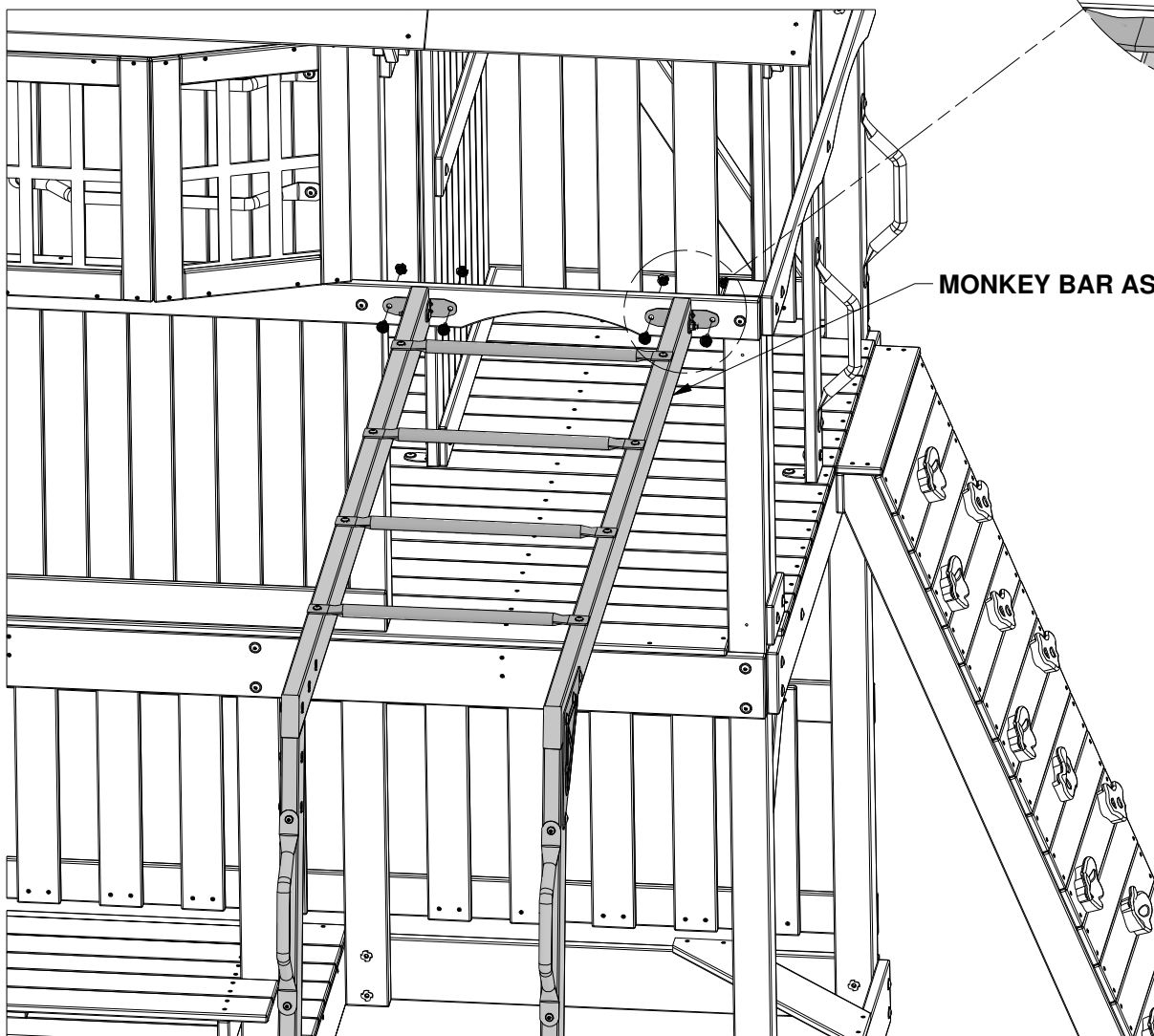

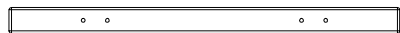

O70 | SLIDE MOUNTING BOARD - W4L14837
(x1) | 5/8"x1 3/8"x20 3/8" (16x34x517)



(x1) 10 FT VF SLIDE



H100088 | SCREW PFH
(x4) | 8x1 1/8



H100459 | BOLT WH BLK
(x3) | 5/16x1 1/4



H100379 | T-NUT BLK
(x3) | 5/16

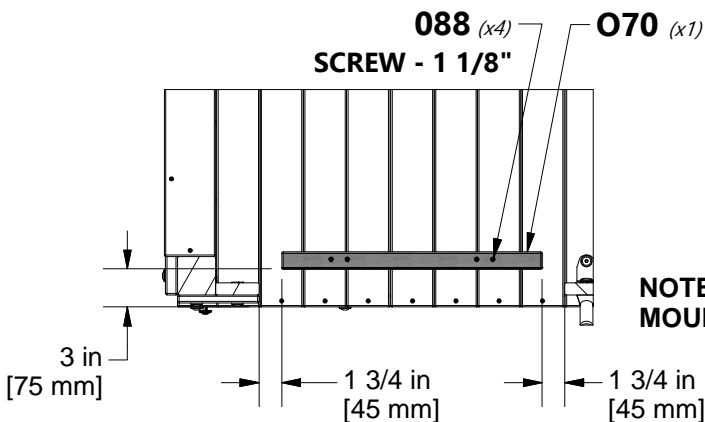

10 FT VACUUM FORMED SLIDES		
PART NUMBER	COLOR	MODEL NUMBER
A100287	GREEN	2106031B
A6P00539	GREY	2300071
A6P00540	YELLOW	2300330

NOTE: MOUNT 'O70' BOARD 1ST.

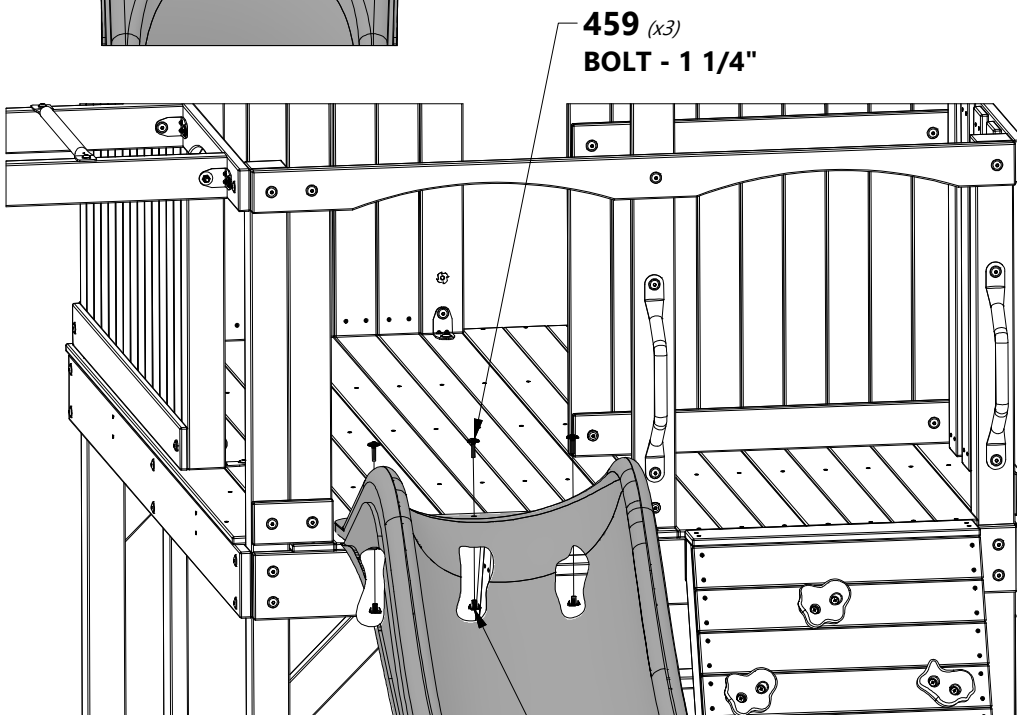
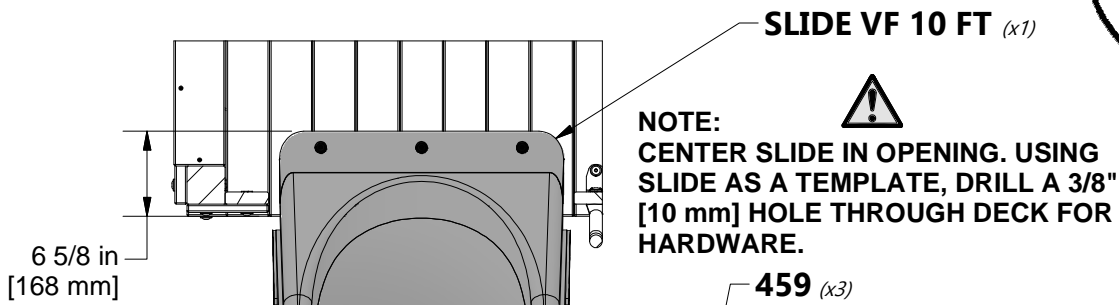
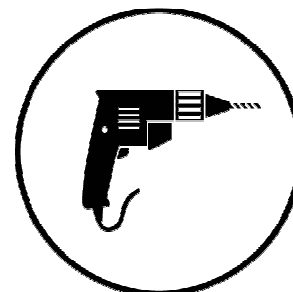

379 (x3) | T-NUT - 5/16"
(UNDER FLOOR)

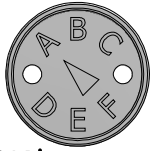
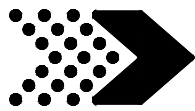

A100314 | "A" REVISION TAG
(x1)



H100202 | SCREW PWH BLK
(x2) | 8x5/8

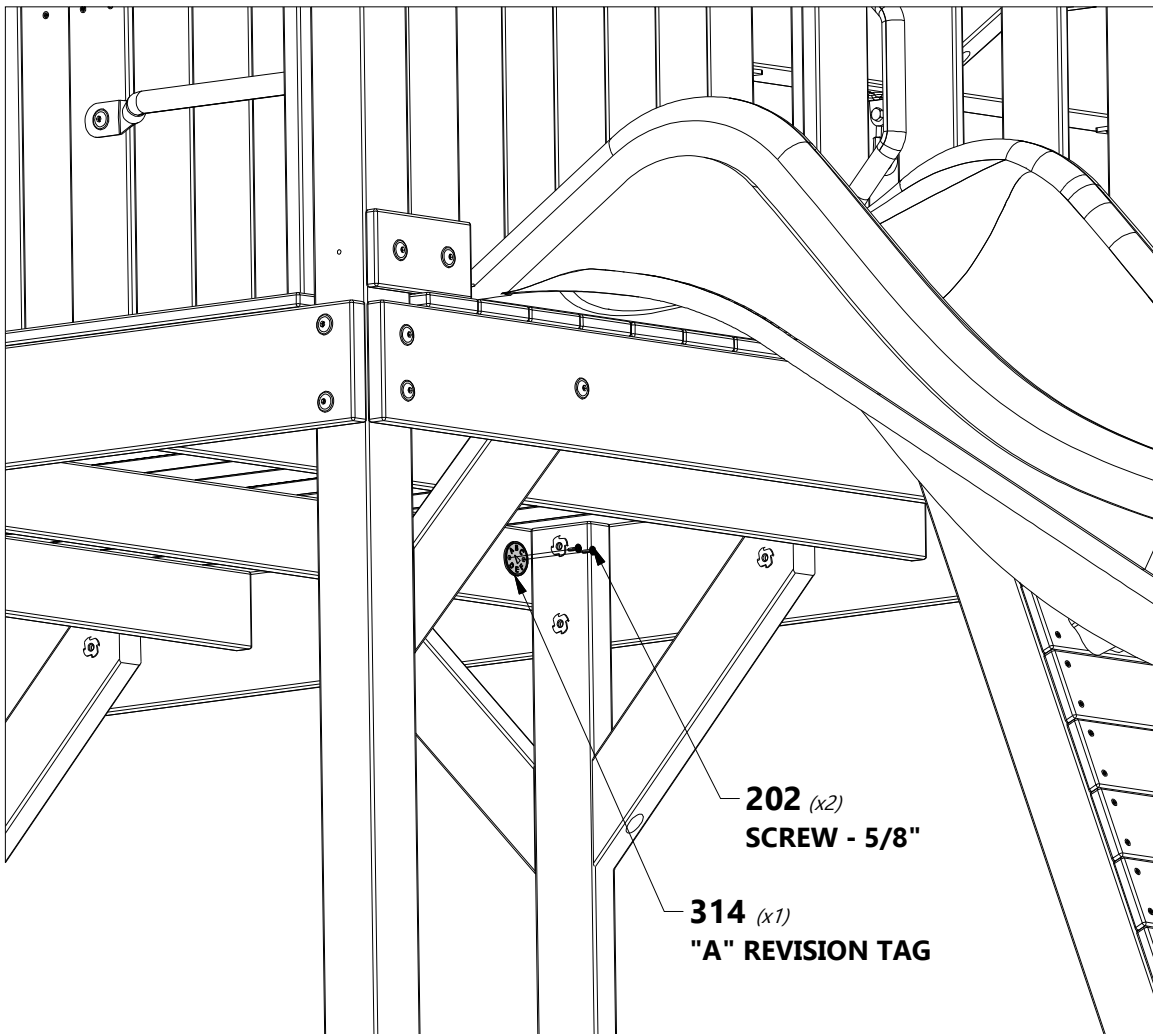



A100069 | QUICK LINK
(x6)



A100027 | SWING SEAT GREEN 26"
(x2)

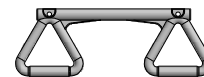

A6P00034 | TRAPEZE YELLOW
(x1)



A100047 | CHAIN GREEN 57"
(x4)



A100177 | CHAIN GREEN 31"
(x2)

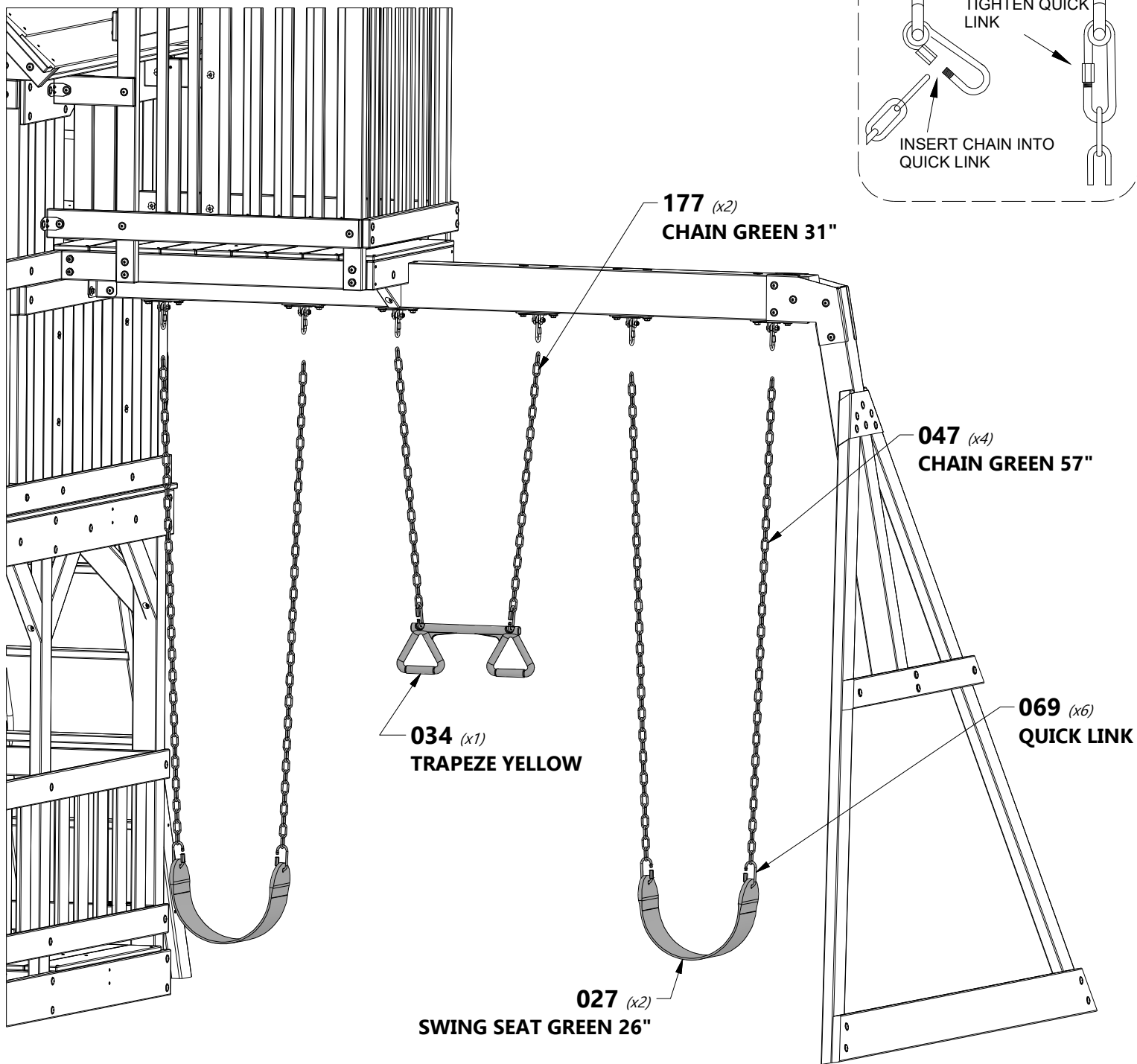

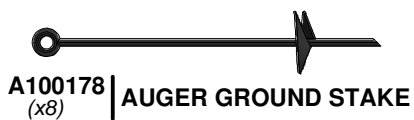

FINAL STEP
 DOUBLE CHECK EVERY BOLT, SCREW AND NUT FOR TIGHTNESS. MAKE SURE EVERY BOARD IS SECURE AND MAKE SURE THE PLAY SET IS LEVEL.

NOTE:
 FAILURE TO ATTACH GROUND STAKES COULD CAUSE INJURY AND WILL VOID WARRANTY!

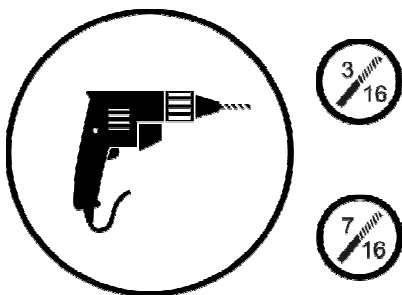

DETAIL 'A'
 TWIST STAKES INTO GROUND AGAINST GROUND BOARDS AND CORNER POSTS IN LOCATIONS SHOWN. USING STAKE AS A TEMPLATE, DRILL A 3/16" [5 mm] HOLE FOR LAGS.

DETAIL 'B'
 TWIST STAKES INTO GROUND AGAINST GROUND BOARDS AND CORNER POSTS IN LOCATIONS SHOWN. USING STAKE AS A TEMPLATE, DRILL A 3/16" [5 mm] HOLE FOR LAGS.

DETAIL 'C' & 'D'
 DRIVE STAKE INTO GROUND AT LOCATIONS SHOWN. USING STAKE AS A TEMPLATE, DRILL A 7/16" [10 mm] HOLE FOR HARDWARE.

