



Manufactured by: Backyard  
Discovery  
3305 Airport Drive, Pittsburg,  
KS 66762 800-856-4445

Basepoint Business Centre: Rivermead Drive, Westlea, Swindon SN5 7EX Phone: 0800-118-2476  
J.P. Coenstraat 7, The Bridge, The Hague, 2595 WP, Netherlands Phone: 08005678990

# 9x6 POPPY GREENHOUSE

## MODEL # : 2404281

### For Horticulture Use Only



Please visit [www.backyarddiscovery.com](http://www.backyarddiscovery.com)  
For the most up to date assembly manual, to register your product, or to order  
replacement parts *Para obtener instrucciones en español, visite*  
[www.backyarddiscovery.com](http://www.backyarddiscovery.com)



EASY STEP-BY-STEP  
3D INTERACTIVE INSTRUCTIONS  
DOWNLOAD THE FREE APP



# OWNER'S MANUAL - BASIC SETUP DIMENSIONS & ASSEMBLY NOTES

It is critically important that you start with square and level footings or concrete pad to attach your structure

1. Check you local building and city codes for permit requirements or restrictions, including any Home Owner's Association (HOA) restrictions.
2. Select a location with lots of sun, good drainage, and the ability to create a level, firm surface for your greenhouse.
  - A firm, level surface is critically important to the longevity of your greenhouse
  - Ensure it is accessible on all sides to clean and conduct annual maintenance
  - Consider a site location with a close proximity to both water and electrical sources
  - Make sure site drains well and avoid low lying areas
  - For recommended area for site preparation see ANCHORING LAYOUT page
3. Before preparing your site - double check for underground utilities (ex: gas, cable, or sprinkler lines)
4. Pay close attention to the items needed for each step. Make sure you are using the correct hardware for each step. Using incorrect hardware may result in improper assembly.
5. Permanently Anchoring your Greenhouse:
  - The hardware to mount your greenhouse permanently to a concrete surface is included. This is the recommended anchoring method.
  - The hardware to mount your greenhouse into a ground surface, such as through gravel into the ground, is included.
    - It is NOT recommended to set your greenhouse directly on soil or grass as this will shorten the lifespan of your greenhouse.
  - The hardware to mount the greenhouse to a wood deck is NOT included and will need to be purchased separately. You must ensure there is ample structural support under the deck before permanently attaching.

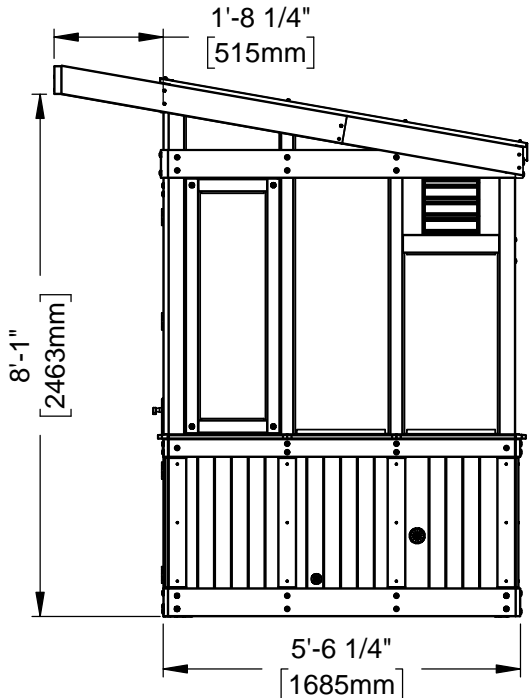
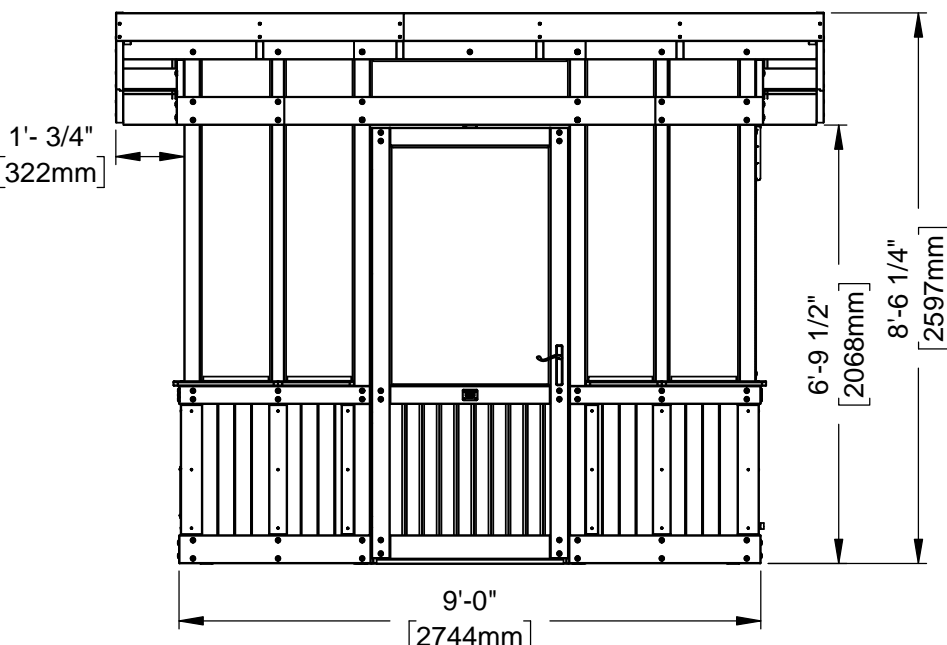
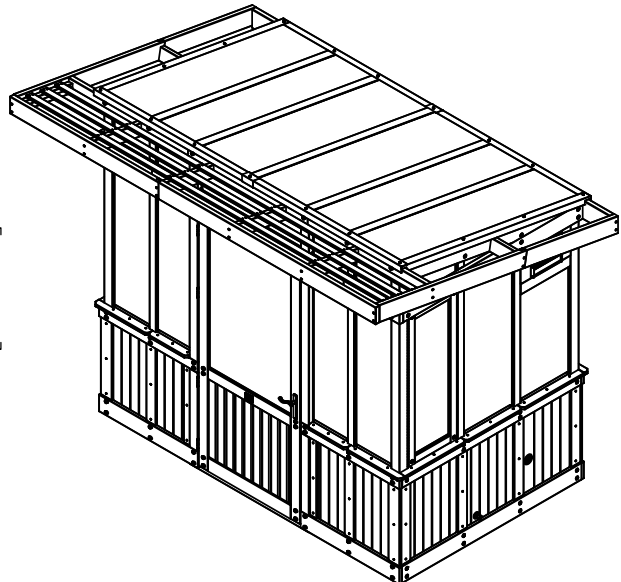
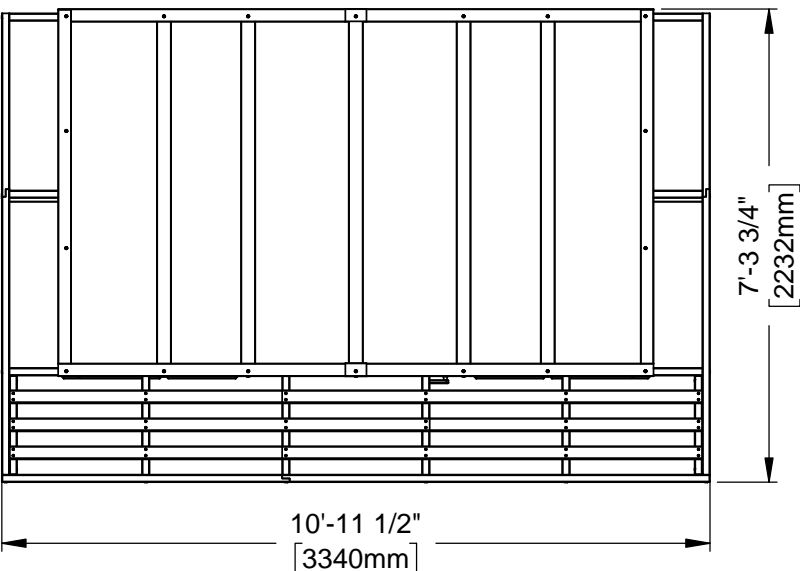



# OWNER'S MANUAL - PARTS IDENTIFICATION

## WOOD COMPONENTS (NOT TO SCALE)



AA01 DOOR STOP - W4L20574  
(x1) 1 7/8"x1 15/16"x36 15/16" (47x50x938)



AD01 ELECTRICAL ENCLOSURE BOARD - W4L20755  
(x1) 15/16"x4"x22 1/16" (24x102x560)



AG01 HEADER - W4L20632  
(x2) 1 7/16"x5 13/16"x65 1/2" (36x148x1664)



AJ01 PERGOLA RAFTER - W4L20716  
(x4) 1 7/16"x4"x19 3/8" (36x102x492)



AJ02 PERGOLA SPACER - W4L20717  
(x2) 1 7/16"x4"x9 13/16" (36x102x250)



AJ03 WINDOW SILL - W4L20589  
(x1) 1 7/16"x4"x22 1/16" (36x102x561)



B01 POST - W4L20558  
(x1) 3"x3"x86 11/16" (76x76x2202)



B02 POST - W4L20560  
(x1) 3"x3"x86 11/16" (76x76x2202)



B03 POST TOP - W4L20564  
(x1) 3"x3"x16 13/16" (76x76x427)



B04 POST TOP - W4L20565  
(x1) 3"x3"x16 13/16" (76x76x427)



B05 POST - W4L20581  
(x1) 3"x3"x84 1/16" (76x76x2135)



B06 POST - W4L20585  
(x1) 3"x3"x86 11/16" (76x76x2202)



B07 POST TOP - W4L20601  
(x1) 3"x3"x14 3/16" (76x76x360)



B08 POST - W4L20613  
(x1) 3"x3"x84 1/16" (76x76x2135)



B09 POST - W4L20615  
(x1) 3"x3"x86 11/16" (76x76x2202)



B10 POST TOP - W4L20618  
(x1) 3"x3"x14 3/16" (76x76x360)



B11 POST - W4L20619  
(x1) 3"x3"x88 9/16" (76x76x2250)



D01 HEADER - W4L20562  
(x1) 1 7/16"x5 1/4"x73 5/8" (36x134x1870)



D02 HEADER - W4L20563  
(x2) 1 7/16"x5 1/4"x20 1/16" (36x134x509)



D03 HEADER - W4L20567  
(x1) 1 7/16"x5 1/4"x45 13/16" (36x134x1164)



D04 HEADER - W4L20568  
(x1) 1 7/16"x5 1/4"x43" (36x134x1092)

# OWNER'S MANUAL - PARTS IDENTIFICATION

## WOOD COMPONENTS (NOT TO SCALE)



D05 HEADER - W4L20579  
(x1) 1 7/16"x5 1/4"x45 13/16" (36x134x1164)



D06 HEADER - W4L20583  
(x1) 1 7/16"x5 1/4"x64 7/16" (36x134x1637)



D07 HEADER - W4L20595  
(x1) 1 7/16"x5 1/4"x65 9/16" (36x134x1666)



D08 HEADER - W4L20616  
(x1) 1 7/16"x5 1/4"x64 7/16" (36x134x1637)



D09 HEADER - W4L20617  
(x1) 1 7/16"x5 1/4"x65 9/16" (36x134x1666)



D10 WINDOW FRAME - W4L20629  
(x2) 1 7/16"x4 3/16"x11 7/16" (36x106x290)



D11 FASCIA - W4L20718  
(x2) 1 7/16"x5 1/4"x35 1/2" (36x134x902)



D12 FASCIA - W4L20719  
(x1) 1 7/16"x5 1/4"x53 13/16" (36x134x1367)



D13 FASCIA - W4L20720  
(x1) 1 7/16"x5 1/4"x53 13/16" (36x134x1367)



D14 FASCIA - W4L20721  
(x1) 1 7/16"x5 1/4"x53 7/16" (36x134x1358)



D15 FASCIA - W4L20722  
(x1) 1 7/16"x5 1/4"x79 7/16" (36x134x2018)



E01 WINDOW SILL - W4L20569  
(x2) 1 7/16"x3 3/8"x19 7/16" (36x86x493)

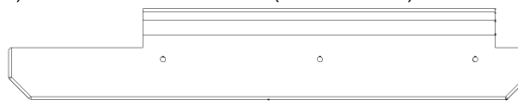

E02 WINDOW SILL - W4L20570  
(x2) 1 7/16"x3 3/8"x19 7/16" (36x86x493)



E03 WINDOW SILL - W4L20572  
(x1) 1 7/16"x3 3/8"x14 1/8" (36x86x358)

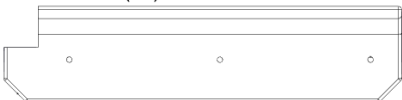

E04 WINDOW SILL - W4L20573  
(x1) 1 7/16"x3 3/8"x14 1/8" (36x86x358)



E05 WINDOW SILL - W4L20587  
(x1) 1 7/16"x3 3/8"x20 1/4" (36x86x515)



E06 WINDOW SILL - W4L20588  
(x2) 1 7/16"x3 3/8"x22 1/16" (36x86x561)

# OWNER'S MANUAL - PARTS IDENTIFICATION

## WOOD COMPONENTS (NOT TO SCALE)

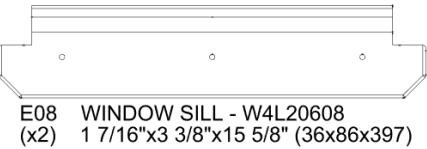

E08 WINDOW SILL - W4L20608  
(x2) 1 7/16"x3 3/8"x15 5/8" (36x86x397)

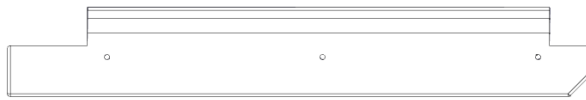

E10 WINDOW SILL - W4L20625  
(x1) 1 7/16"x3 3/8"x22 1/16" (36x86x561)



E11 WINDOW SILL - W4L20626  
(x1) 1 7/16"x3 3/8"x20 1/4" (36x86x515)



E12 FAN FRAME - W4L20628  
(x1) 1 7/16"x3 3/8"x18 11/16" (36x86x475)



E13 WINDOW SILL - W4L20633  
(x2) 1 7/16"x3 3/8"x20" (36x86x508)

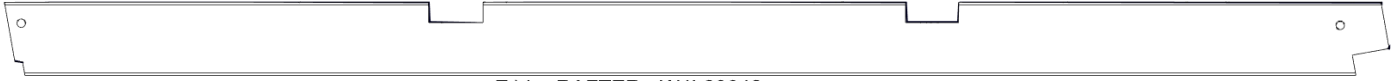

E14 RAFTER - W4L20642  
(x3) 1 7/16"x3 3/8"x64 3/16" (36x86x1630)



E15 JOIST - W4L20643  
(x2) 1 7/16"x3 3/8"x60 7/16" (36x86x1535)



E16 RAFTER - W4L20644  
(x2) 1 7/16"x3 3/8"x63 9/16" (36x86x1614)



E17 FAN FRAME - W4L20614  
(x1) 1 7/16"x3 3/8"x18 11/16" (36x86x475)



F01 UPRIGHT - W4L20557  
(x2) 1 7/16"x2 3/8"x86 11/16" (36x60x2202)



F02 UPRIGHT TOP - W4L20566  
(x2) 1 7/16"x2 3/8"x16 13/16" (36x60x427)



F03 WINDOW CAP - W4L20577  
(x1) 1 7/16"x2 3/8"x36 15/16" (36x60x938)



F04 UPRIGHT - W4L20582  
(x1) 1 7/16"x2 3/8"x86 11/16" (36x60x2202)



F05 UPRIGHT TOP - W4L20594  
(x1) 1 7/16"x2 3/8"x10 3/4" (36x60x273)



F06 UPRIGHT - W4L20596  
(x1) 1 7/16"x2 3/8"x88 9/16" (36x60x2250)



F07 TABLE CLEAT - W4L20599  
(x1) 1 7/16"x2 3/8"x13 1/4" (36x60x336)



F08 WINDOW CAP - W4L20600  
(x1) 1 7/16"x2 3/8"x17 13/16" (36x60x453)



F09 UPRIGHT - W4L20607  
(x3) 1 7/16"x2 3/8"x85 1/4" (36x60x2166)



F10 ANGLE BRACE - W4L20611  
(x1) 1 7/16"x2 3/8"x17" (36x60x432)



F11 ANGLE BRACE - W4L20612  
(x4) 1 7/16"x2 3/8"x18 1/16" (36x60x458)



F12 UPRIGHT - W4L20620  
(x1) 1 7/16"x2 3/8"x86 11/16" (36x60x2202)

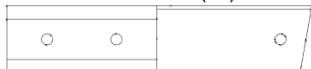

F13 UPRIGHT TOP - W4L20622  
(x1) 1 7/16"x2 3/8"x10 3/4" (36x60x273)



F14 ANGLE BRACE - W4L20631  
(x2) 1 7/16"x2 3/8"x18 1/16" (36x60x458)

# OWNER'S MANUAL - PARTS IDENTIFICATION

## WOOD COMPONENTS (NOT TO SCALE)



F15 UPRIGHT - W4L20639  
(x2) 1 7/16" x 2 3/8" x 85 1/4" (36x60x2166)



G01 BASE BOARD - W4L20561  
(x2) 15/16" x 5 1/4" x 35 1/2" (24x134x902)



G02 BASE BOARD - W4L20584  
(x2) 15/16" x 5 1/4" x 64 7/16" (24x134x1637)



G03 BASE BOARD - W4L20597  
(x2) 15/16" x 5 1/4" x 55 3/16" (24x134x1402)



H01 RUNNING BOARD - W4L20559  
(x2) 15/16" x 3 3/8" x 35 1/2" (24x86x902)



H02 RUNNING BOARD - W4L20586  
(x2) 15/16" x 3 3/8" x 64 7/16" (24x86x1637)



H03 RUNNING BOARD - W4L20598  
(x2) 15/16" x 3 3/8" x 55 3/16" (24x86x1402)



H04 SHELF BOARD - W4L20635  
(x2) 15/16" x 3 3/8" x 75 3/8" (24x86x1914)



J01 SHELF UPRIGHT - W4L20621  
(x2) 15/16" x 2 3/8" x 71 15/16" (24x60x1827)



J02 PURLIN - W4L20645  
(x2) 15/16" x 2 3/8" x 73 11/16" (24x60x1872)



J03 PURLIN - W4L20646  
(x2) 15/16" x 2 3/8" x 33 11/16" (24x60x856)



M01 COVER BOARD - W4L20556  
(x15) 5/8" x 3 3/8" x 24 3/16" (16x86x614)



M02 WINDOW FRAME - W4L20602  
(x1) 5/8" x 3" x 51 5/16" (16x76x1303)



M03 TABLE TRIM - W4L20623  
(x2) 5/8" x 3 3/8" x 51 15/16" (16x86x1320)



M04 SPIGOT BOARD - W4L20640  
(x1) 5/8" x 3 3/8" x 17 11/16" (16x86x450)



M05 SHELF BOARD - W4L20752  
(x1) 5/8" x 3 3/8" x 37 13/16" (16x86x960)



M06 SHELF BOARD - W4L20753  
(x1) 5/8" x 3 3/8" x 37 13/16" (16x86x960)

# OWNER'S MANUAL - PARTS IDENTIFICATION

## WOOD COMPONENTS (NOT TO SCALE)



N01 COVER BOARD - W4L20580  
(x2) 5/8"x2 3/8"x25" (16x60x614)



N02 WINDOW FRAME - W4L20603  
(x1) 5/8"x2 3/8"x17 3/16" (16x60x437)



N03 TABLE TOP BOARD - W4L20609  
(x1) 5/8"x2 3/8"x16 1/16" (16x60x408)



N04 SLAT UPRIGHT - W4L20637  
(x2) 5/8"x2 3/8"x33 1/16" (16x60x840)



N05 SLAT - W4L20638  
(x7) 5/8"x2 3/8"x42 3/8" (16x60x1076)

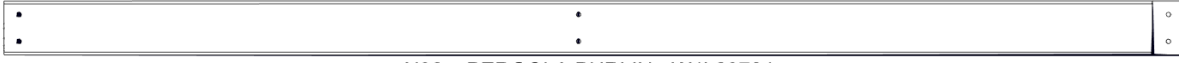

N06 PERGOLA PURLIN - W4L20724  
(x3) 5/8"x2 3/8"x52" (16x60x1321)



N07 PERGOLA PURLIN - W4L20725  
(x3) 5/8"x2 3/8"x78" (16x60x1981)



O01 DOOR TRIM - W4L20578  
(x2) 5/8"x1 5/16"x80 5/16" (16x34x2040)



O02 VENT BOARD - W4L20593  
(x2) 5/8"x1 5/16"x16 15/16" (16x34x430)



O03 LATCH BLOCK - W4L20610  
(x1) 5/8"x1 5/16"x4" (16x34x100)



P01 WINDOW CAP - W4L20571  
(x6) 1 7/16"x1 7/16"x13 3/16" (36x36x335)



P02 WINDOW CAP - W4L20575  
(x2) 1 7/16"x1 7/16"x12 7/8" (36x36x327)



P03 WINDOW CAP - W4L20576  
(x1) 1 7/16"x1 7/16"x36 15/16" (36x36x938)



P04 WINDOW CAP - W4L20590  
(x3) 1 7/16"x1 7/16"x18 3/8" (36x36x466)



P05 PURLIN CLEAT - W4L20591  
(x2) 1 7/16"x1 7/16"x45 13/16" (36x36x1163)



P06 WINDOW CAP - W4L20627  
(x1) 1 7/16"x1 7/16"x18 1/16" (36x36x458)



P07 TABLE CLEAT - W4L20630  
(x2) 1 7/16"x1 7/16"x50 3/4" (36x36x1289)



P08 WINDOW CAP - W4L20634  
(x2) 1 7/16"x1 7/16"x17 9/16" (36x36x446)



P09 PURLIN CLEAT - W4L20723  
(x2) 1 7/16"x1 7/16"x18 3/4" (36x36x476)



P10 WINDOW CAP - W4L20754  
(x1) 1 7/16"x1 7/16"x17 1/2" (36x36x445)



Y01 COVER BOARD - W4L20592  
(x4) 5/8"x4"x24 3/16" (16x102x614)

# OWNER'S MANUAL - PARTS IDENTIFICATION

## WOOD COMPONENTS (NOT TO SCALE)

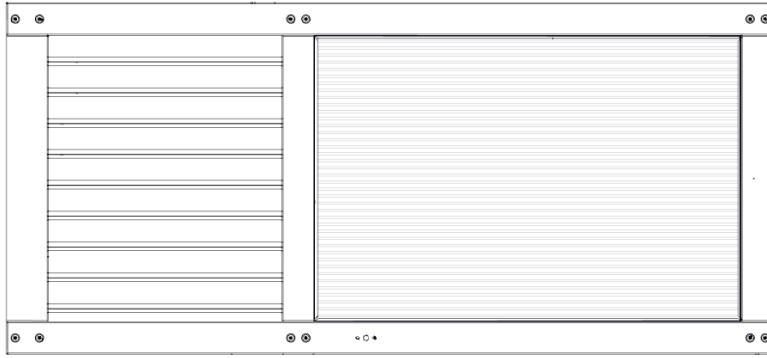

DA01 DOOR ASSEMBLY - W2A04009  
(x1) 1 7/8"x36 9/16"x80" (48x928x2032)

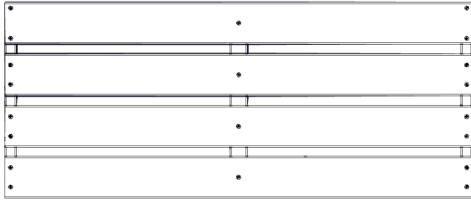

SH01 SHELF ASSEMBLY - W2A04437  
(x3) 3"x15 7/8"x37 13/16" (76x404x960)

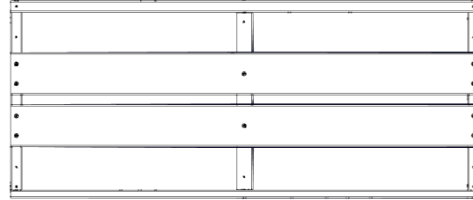

SH02 SHELF ASSEMBLY - W2A04446  
(x1) 3"x15 7/8"x37 13/16" (76x404x960)

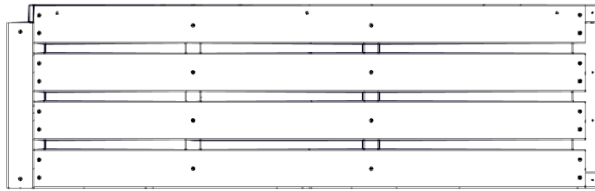

TB01 TABLE ASSEMBLY - W2A04439  
(x1) 2 1/16"x16 1/16"x51 15/16" (52x408x1319)

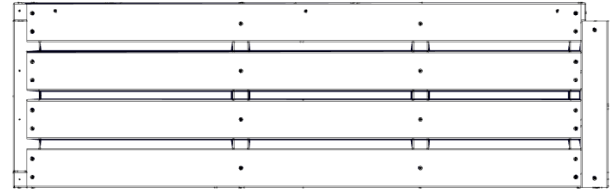

TB02 TABLE ASSEMBLY - W2A04444  
(x1) 2 1/16"x16 1/16"x51 15/16" (52x408x1319)

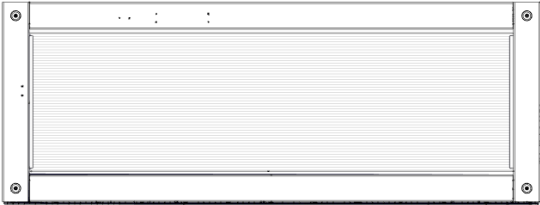

WA01 WINDOW ASSEMBLY - W2A04438  
(x1) 1 7/8"x17 1/2"x47 3/16" (48x444x1198)

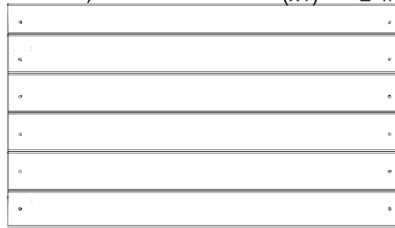

WP01 WALL PANEL - W2A04433  
(x2) 1 1/16"x17 13/16"x31 9/16" (27x453x801)

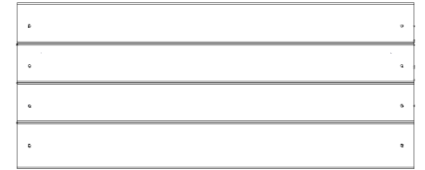

WP02 WALL PANEL - W2A04434  
(x6) 1 1/16"x13 3/16"x31 9/16" (27x335x801)

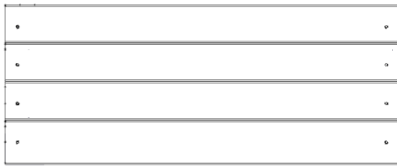

WP03 WALL PANEL - W2A04435  
(x2) 1 1/16"x12 7/8"x31 9/16" (27x327x801)

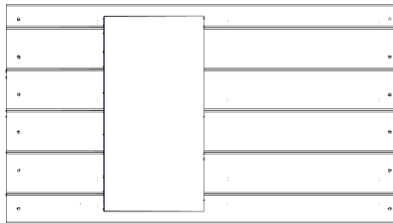

WP04 WALL PANEL - W2A04436  
(x1) 1 1/16"x17 1/2"x31 9/16" (27x445x801)



WP05 WALL PANEL - W2A04440  
(x1) 1 1/16"x17 1/2"x31 9/16" (27x445x801)

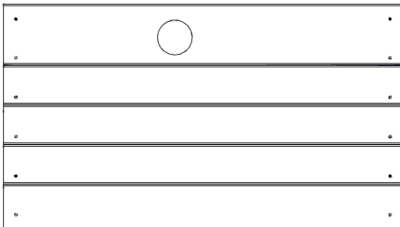

WP06 WALL PANEL - W2A04441  
(x1) 1 1/16"x17 13/16"x31 9/16" (27x453x801)

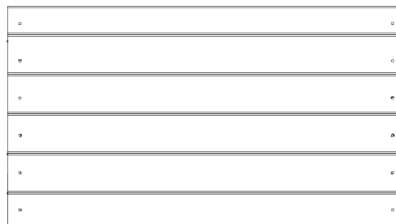

WP07 WALL PANEL - W2A04443  
(x2) 1 1/16"x17 9/16"x31 9/16" (27x446x801)

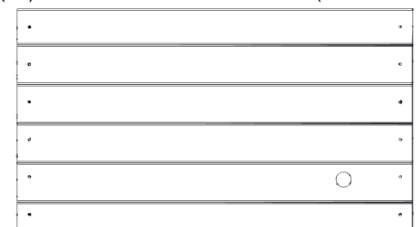

WP08 WALL PANEL - W2A04447  
(x1) 1 1/16"x17 13/16"x31 9/16" (27x453x801)

# OWNER'S MANUAL - PARTS IDENTIFICATION

## ACCESSORY COMPONENTS (NOT TO SCALE)

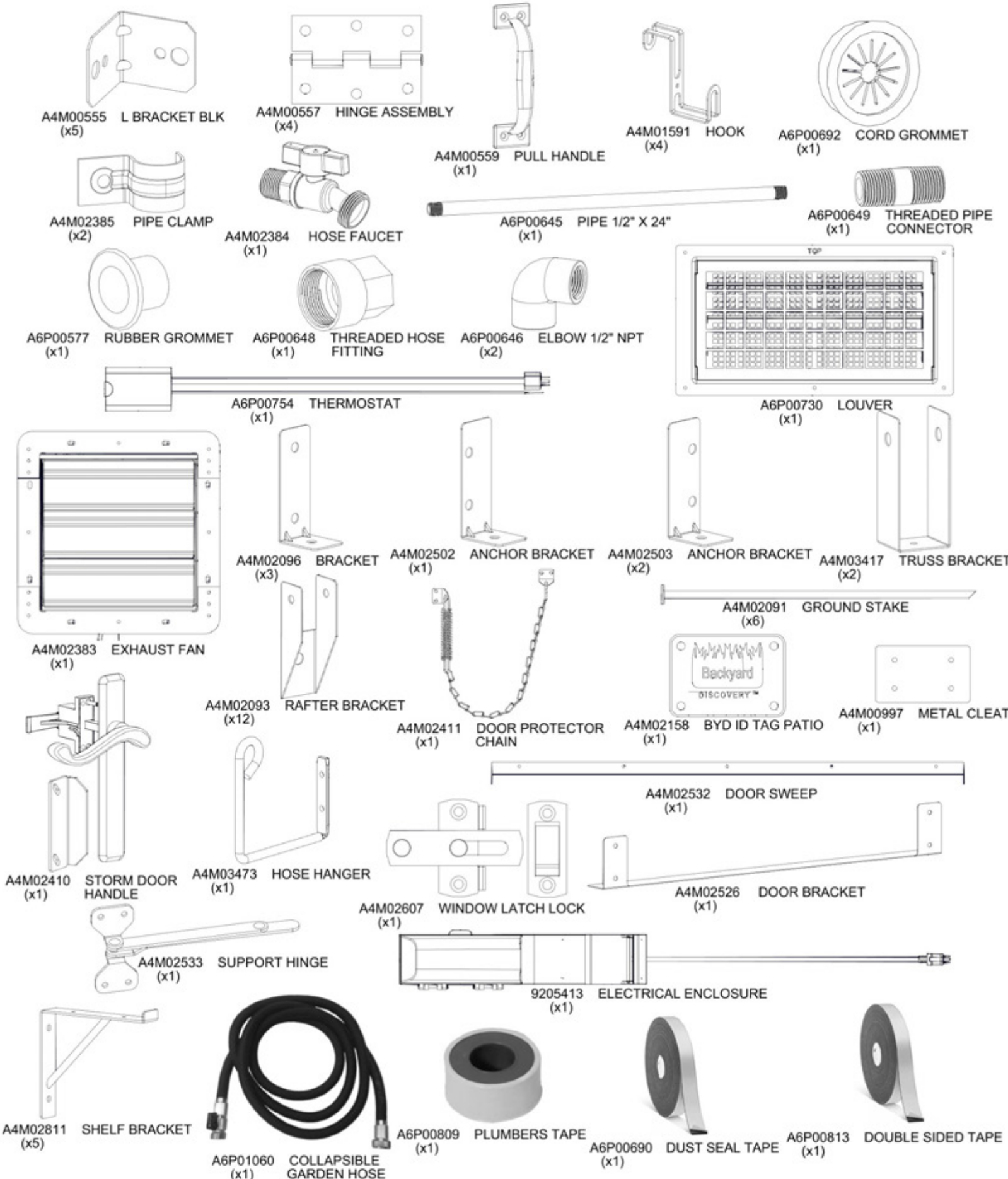

# OWNER'S MANUAL - PARTS IDENTIFICATION

## ACCESSORY COMPONENTS (NOT TO SCALE)



A4M04033 SPLICE COVER  
(x5)

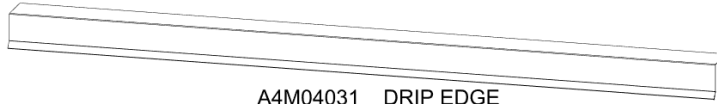

A4M04031 DRIP EDGE  
(x2)

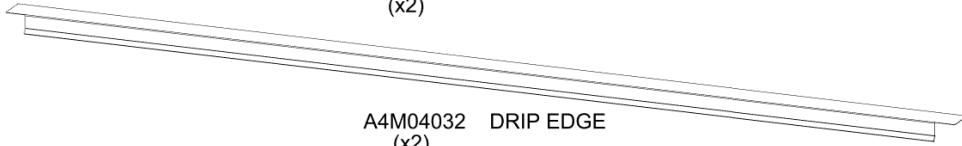

A4M04032 DRIP EDGE  
(x2)

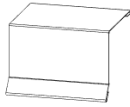

A4M03419 DRIP EDGE SPLICE  
(x1)

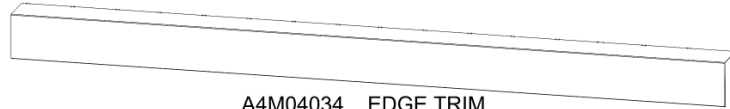

A4M04034 EDGE TRIM  
(x2)



A4M04035 EDGE TRIM  
(x2)

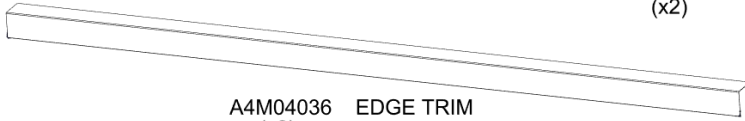

A4M04036 EDGE TRIM  
(x2)

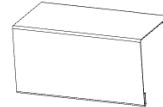

A4M03423 EDGE TRIM SPLICE  
(x1)

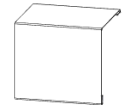

A4M03424 EDGE TRIM SPLICE  
(x1)



A6P01009 POLY SHEET  
(x1)



A6P01025 POLY SHEET  
(x3)



A6P01068 POLY SHEET  
(x2)



A6P01069 POLY SHEET  
(x2)



A6P01072 POLY SHEET  
(x1)



A6P01074 POLY SHEET  
(x4)



A6P01076 POLY SHEET  
(x4)



A6P01077 POLY SHEET  
(x2)



A6P01085 POLY SHEET  
(x1)



A6P01087 POLY SHEET  
(x1)



A6P01088 POLY SHEET  
(x1)



A6P01089 POLY SHEET  
(x1)

# OWNER'S MANUAL - PARTS IDENTIFICATION

## ACCESSORY COMPONENTS (NOT TO SCALE)

A6P01004 POLY CHANNEL  
(x2)

A6P01006 POLY CHANNEL  
(x1)

A6P01007 POLY CHANNEL  
(x3)

A6P01008 POLY CHANNEL  
(x2)

A6P01014 POLY CHANNEL  
(x12)

A6P01020 POLY CHANNEL  
(x10)

A6P01023 POLY CHANNEL  
(x2)

A6P01026 POLY CHANNEL  
(x4)

A6P01031 POLY CHANNEL  
(x2)

A6P01066 POLY CHANNEL  
(x4)

A6P01067 POLY CHANNEL  
(x4)

A6P01070 POLY CHANNEL  
(x8)

A6P01071 POLY CHANNEL  
(x2)

A6P01073 POLY CHANNEL  
(x8)

A6P01079 POLY CHANNEL  
(x2)

A6P01080 POLY CHANNEL  
(x8)

A6P01081 POLY CHANNEL  
(x4)

A6P01083 POLY CHANNEL  
(x2)

A6P01084 POLY CHANNEL  
(x1)

A6P01086 POLY CHANNEL  
(x1)

A6P01075 POLY SHEET SPLICE  
(x5)



A6P00796 SILICONE

# OWNER'S MANUAL - PARTS IDENTIFICATION

## HARDWARE COMPONENTS

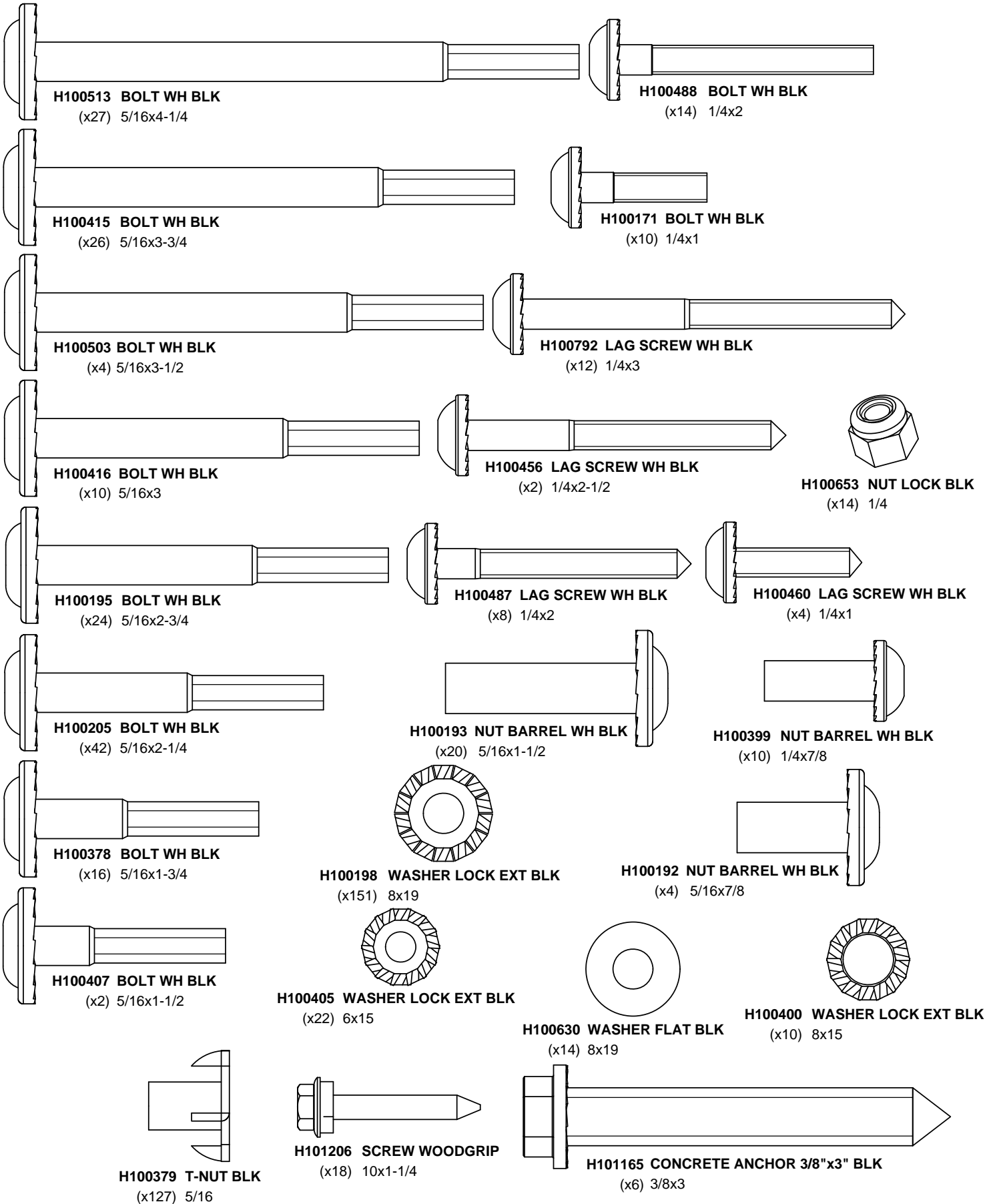

# OWNER'S MANUAL - PARTS IDENTIFICATION

## HARDWARE COMPONENTS

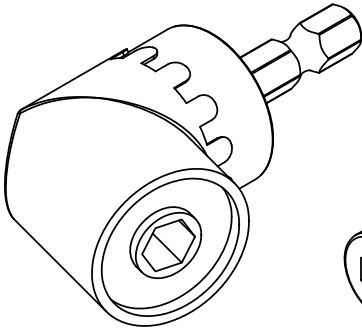
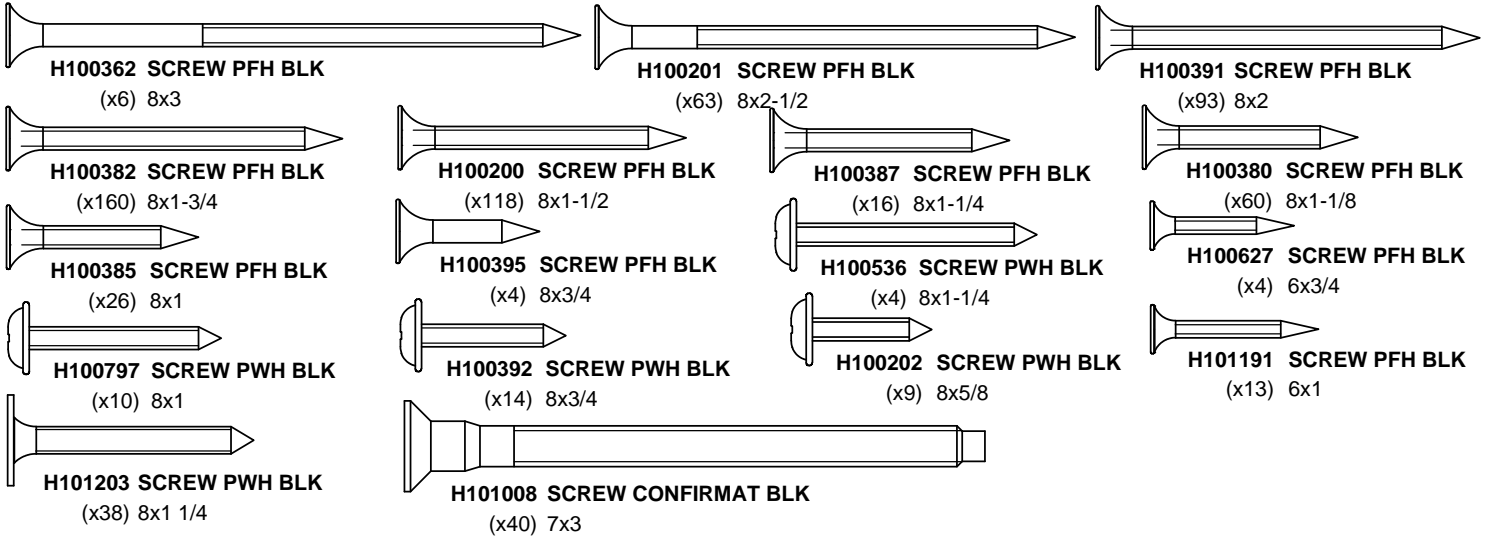

**H101114 RIGHT HAND  
 (x1) DRILL ADAPTER**

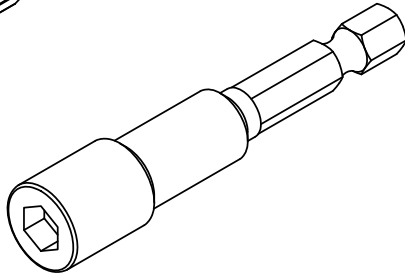

**H101106 SOCKET DRIVER  
 (x1)**

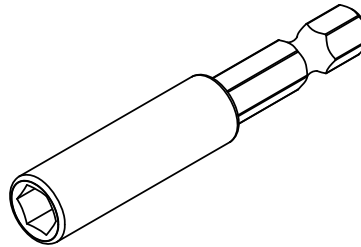

**H101100 MAGNETIC DRIVER  
 (x1)**

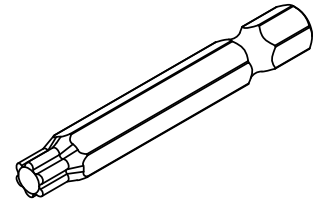

**H100147 TORX BIT  
 (x1) T-30**

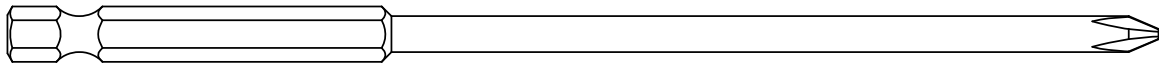

**H101261 PHILLIPS EXTENSION BIT  
 (x1)**

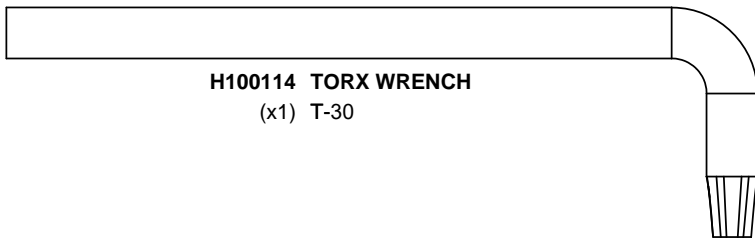

**H100114 TORX WRENCH  
 (x1) T-30**

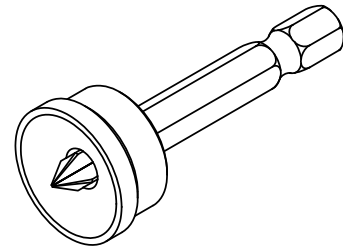

**H100764 SCREW SETTER  
 (x1)**

# PRE-ASSEMBLY STEP 1 - SORTING PARTS

It is critical for ease of assembly that you take the time to sort and organize the wood and hardware.

---

## WOOD PARTS:

- Organize wood parts by the three-digit, alpha-numeric number stamped on each board (ex. P01).
- If there are multiple boards with the same stamped number, stack those pieces together.
- Stamps can be found on the flat surface of the boards or on the end of the boards.
- Allow yourself plenty of room - the wood pieces can take up a significant amount of space.

**NOTE: CARTONS ARE NOT ORGANIZED BY BOARD OR STEP NUMBER.**



## HARDWARE PARTS:

- We recommend that you have a separate table to organize the hardware.
- Hardware bags are printed with a seven-digit, alpha-numeric part number.
- You can organize your hardware by part number or group by hardware type (e.g. bolts, nuts, etc.).
- During assembly you only need to reference the last four digits of the number.

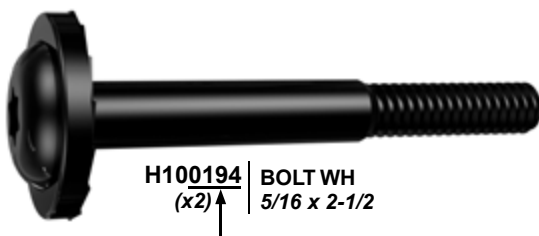

H100194 | BOLT WH  
(x2) ↑ 5/16 x 2-1/2

# PRE-ASSEMBLY STEP 2 - TOOLS REQUIRED



Cordless Drill  
or Electric Drill



Drill  
Attachments:  
Phillips Head

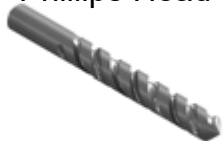

1/8", 3/16", 3/8" &  
7/16" Drill Bits



Phillips Screw Driver



Open End  
Wrenches  
1/2" & 9/16"



3/8" Drive Ratchet, 1/2" &  
7/16" STD Sockets 1/2" & 7/16"  
Deep Sockets



Claw Hammer

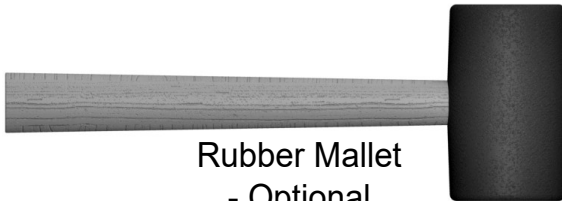

Rubber Mallet  
- Optional



Tape Measure

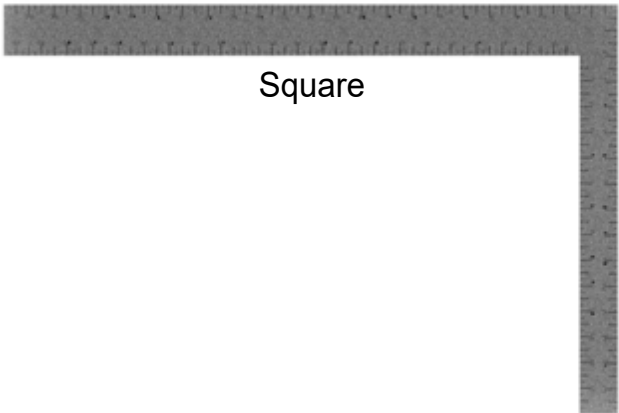

Square



Level 24"

# PRE-ASSEMBLY STEP 3 - CHOOSE YOUR ASSEMBLY METHOD

There are several types of assembly instructions available to you.

1. Printed Assembly Manual included with your set
2. BILT APP - 3D interactive instructions
3. Combination of the Printed Manual and BILT APP (Note: Step numbers can differ between the two methods)

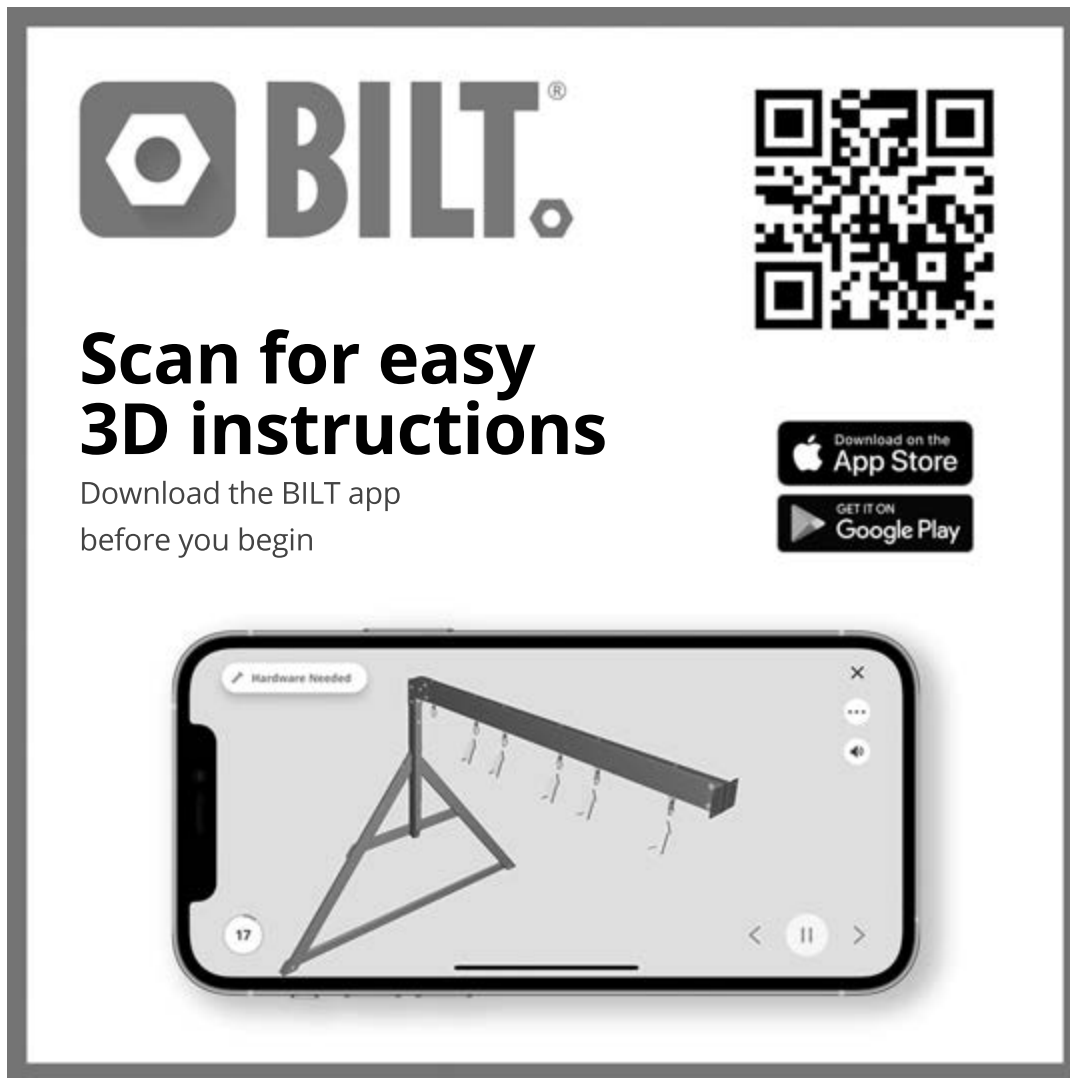

The graphic features the BILT logo (a hexagon with a bolt head inside) and the word "BILT." in a bold, sans-serif font. To the right is a large QR code. Below the logo, the text "Scan for easy 3D instructions" is written in a large, bold font. Underneath this, it says "Download the BILT app before you begin". To the right of the text are two buttons: "Download on the App Store" and "GET IT ON Google Play". At the bottom, a smartphone screen displays a 3D assembly instruction for step 17, showing a metal frame with a horizontal bar being attached. The screen includes a "Hardware needed" label, a close button (X), a menu button (three dots), a back button (left arrow), a play/pause button (II), and a forward button (right arrow).

# POLYCARBONATE SHEETING INFORMATION - IMPORTANT!

**The Polycarbonate Sheeting has UV protection on ONE (1) SIDE.**

**CRITICAL to install with the UV protection facing the OUTSIDE**

- Wear safety gloves to protect against any sharp edges during handling or install.
- Do NOT use knife or sharp object to remove protective film as it may result in damage to polycarbonate sheeting
- Leave film on during install to ensure UV side is facing outside.
- Peel protective film back from edges approximately 2" (5cm) during installation.
- Remove film completely after installation.

NOTE: Do not store polycarbonate sheeting with film outside in direct sunlight or rain. It may make removal of film more difficult.

# STEP 4 - BACK WALL ASSEMBLY

QTY	PART NUMBER	DESCRIPTION
5	H100195	BOLT WH 5/16x2 3/4 BLK
15	H100198	WASHER LOCK EXT 8x19
10	H100205	BOLT WH 5/16x2 1/4 BLK
15	H100379	TNUT-5/16" BLK



AG01 HEADER - W4L20632  
(x2) 1 7/16"x5 13/16"x65 1/2" (36x148x1664)



H03 RUNNING BOARD - W4L20598  
(x2) 15/16"x3 3/8"x55 3/16" (24x86x1402)



F09 UPRIGHT - W4L20607  
(x3) 1 7/16"x2 3/8"x85 1/4" (36x60x2166)



F15 UPRIGHT - W4L20639  
(x2) 1 7/16"x2 3/8"x85 1/4" (36x60x2166)

- THE USE OF SAWHORSES IS RECOMMENDED DURING THE ASSEMBLY OF ALL WALL ASSEMBLIES.

- INSERT T-NUTS FIRST.  
- HAND TIGHTEN ONLY.

NOTE ORIENTATION OF PILOT HOLES ON H03.

THE SIDE OF F09 & F15 WITH THREE PILOT HOLES IN THIS AREA FACES OUT AS SHOWN.

205 (x10)  
BOLT - 2 1/4"

198 (x15)  
WASHER - 8x19

379 (x15)  
TNUT-5/16"

195 (x5)  
BOLT-2 3/4"

NOTE THROUGH HOLES FOR CORRECT ORIENTATION OF AG01 BOARDS.

LEAVE THE TOP HOLE OPEN ON ALL F09 & F15 BOARDS.

# STEP 5 - BACK WALL ASSEMBLY

QTY	PART NUMBER	DESCRIPTION
2	H100193	NUT BARREL WH 5/16 X 1 1/2 BLK
10	H100198	WASHER LOCK EXT 8x19
8	H100205	BOLT WH 5/16x2 1/4 BLK
8	H100379	TNUT-5/16" BLK
2	H100407	BOLT WH 5/16x1 1/2 BLK



G03 BASE BOARD - W4L20597  
(x2) 15/16"x5 1/4"x55 3/16" (24x134x1402)



A4M02096 BRACKET  
(x1)

**- INSERT T-NUTS FIRST.**

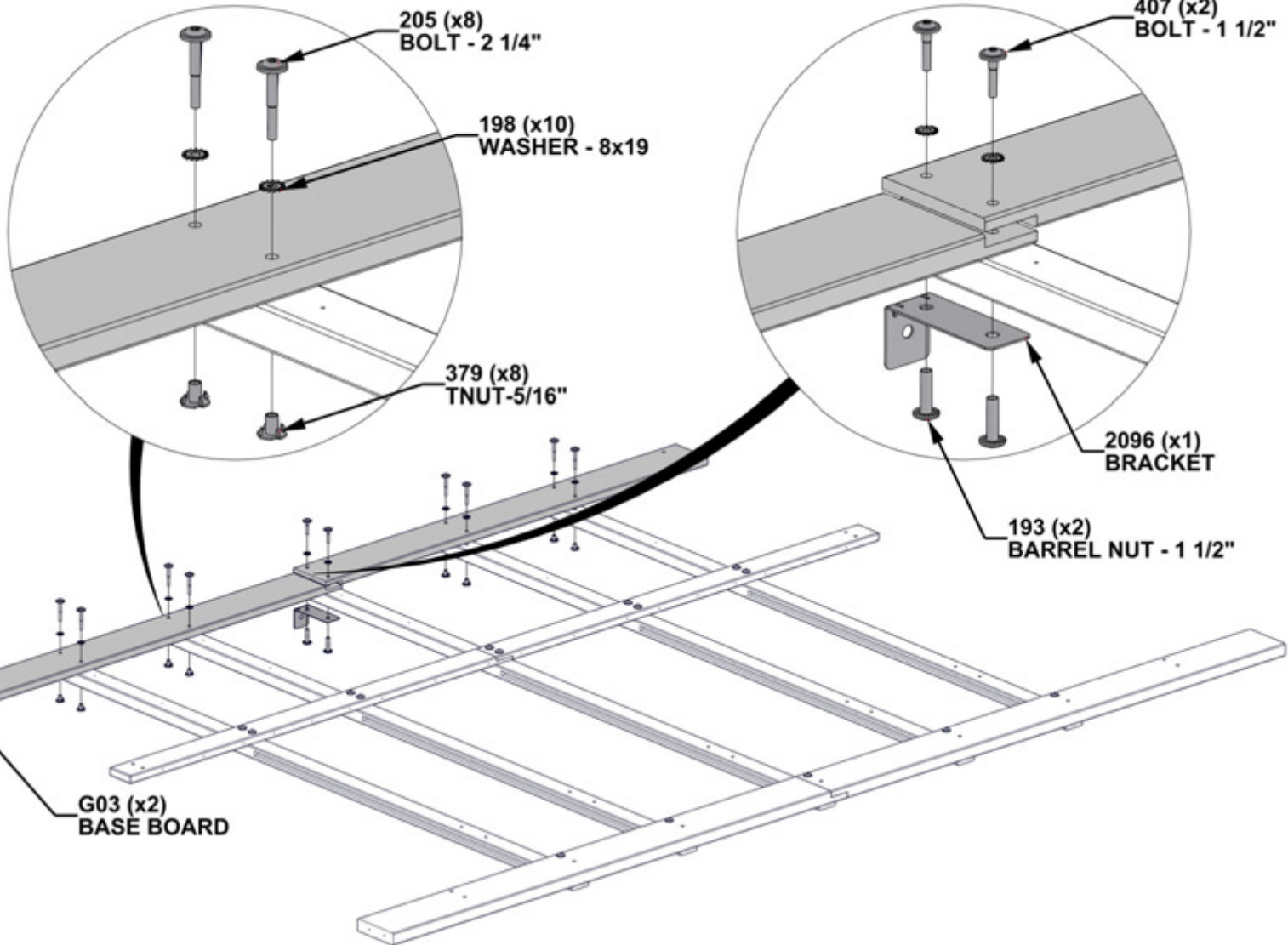

# STEP 6 - BACK WALL ASSEMBLY

QTY	PART NUMBER	DESCRIPTION
12	H100198	WASHER LOCK EXT 8x19
12	H100379	TNUT-5/16" BLK
8	H100415	BOLT WH 5/16x3 3/4 BLK
4	H100513	BOLT WH 5/16x4 1/4 BLK

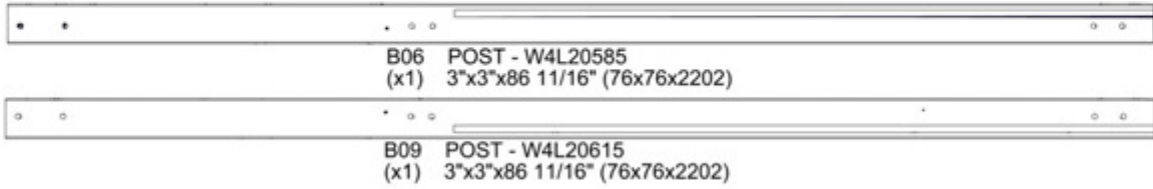

**- INSERT T-NUTS FIRST.  
- HAND TIGHTEN ONLY.**

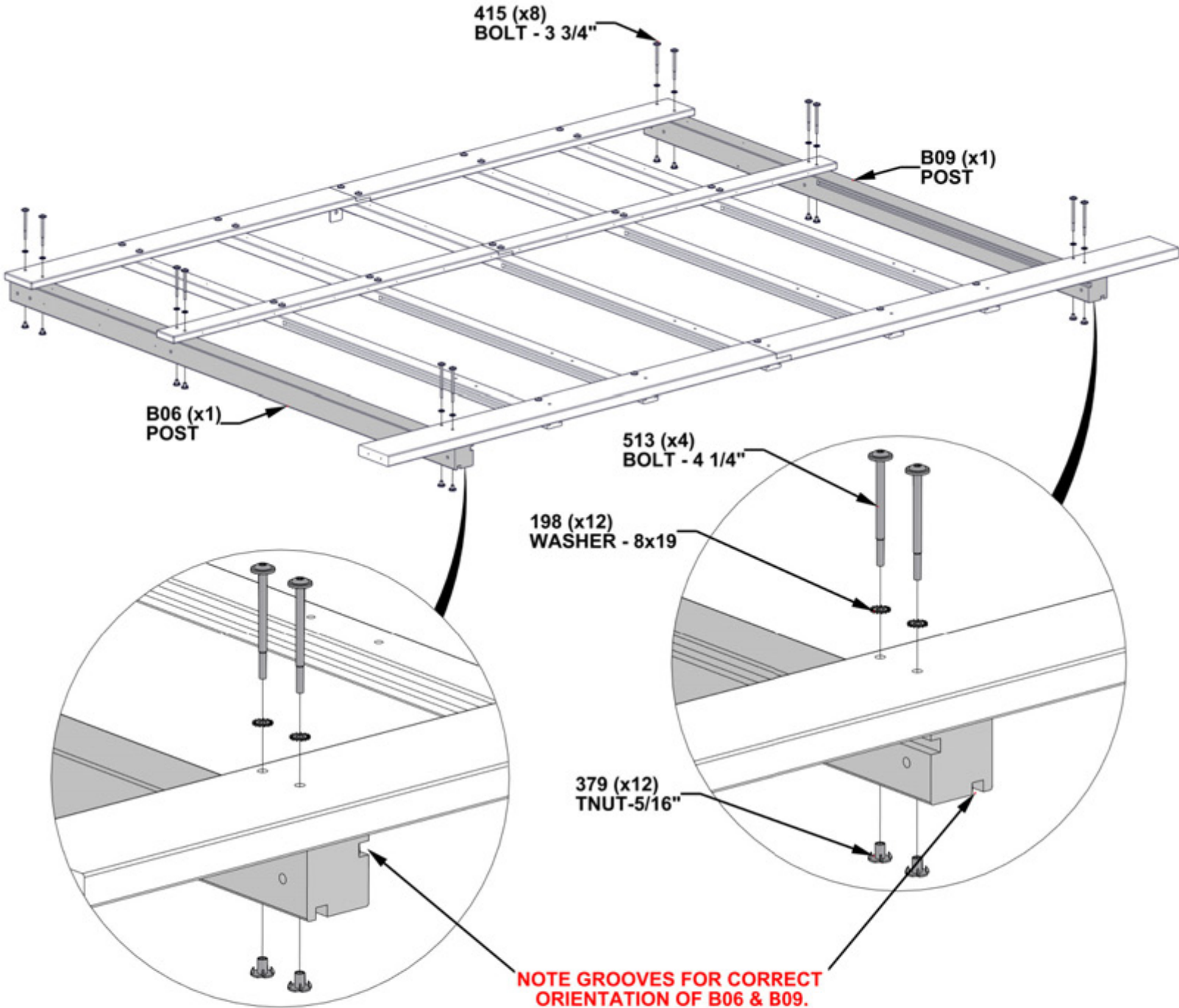

# STEP 7 - BACK WALL ASSEMBLY

QTY	PART NUMBER	DESCRIPTION
5	H100193	NUT BARREL WH 5/16 X 1 1/2 BLK
5	H100198	WASHER LOCK EXT 8x19
5	H100378	BOLT WH 5/16x1 3/4 BLK



A4M02093 RAFTER BRACKET  
(x5)

**- HAND TIGHTEN ONLY.**

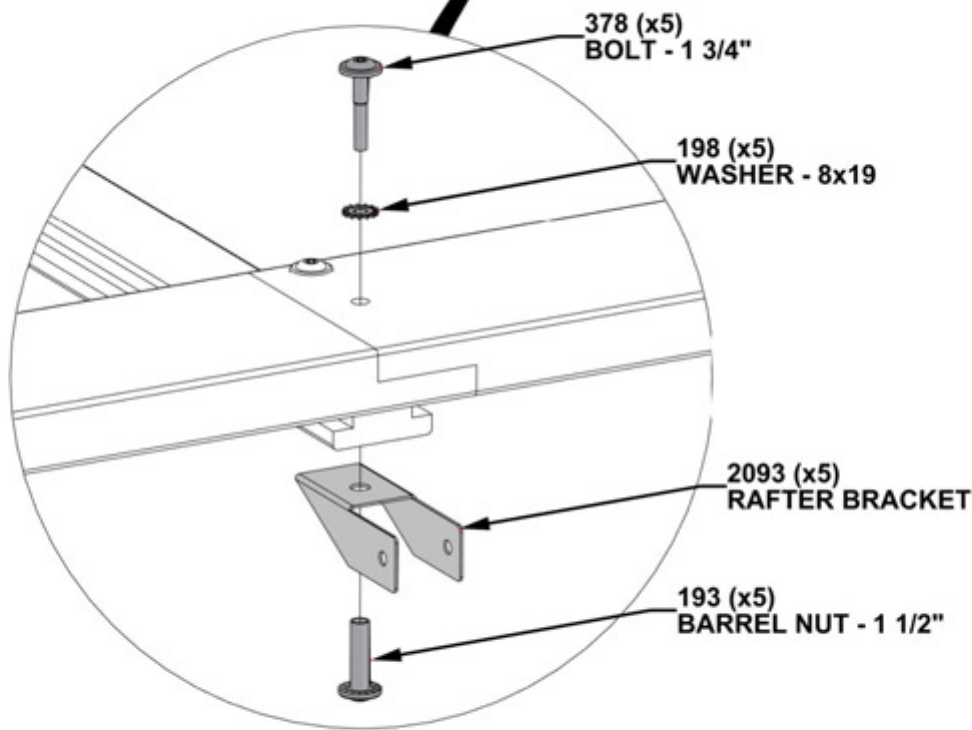
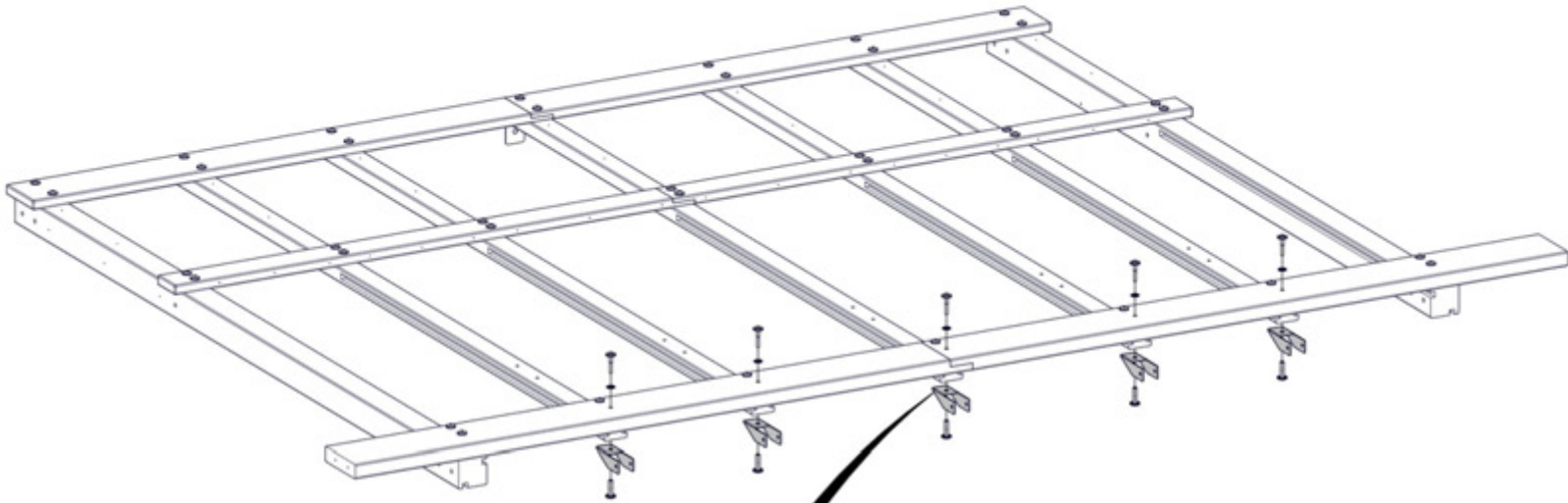

378 (x5)  
BOLT - 1 3/4"

198 (x5)  
WASHER - 8x19

2093 (x5)  
RAFTER BRACKET

193 (x5)  
BARREL NUT - 1 1/2"

**SET ASSEMBLY ASIDE FOR FUTURE STEP.**

# STEP 8 - SIDE WALL ASSEMBLY

QTY	PART NUMBER	DESCRIPTION
8	H100198	WASHER LOCK EXT 8x19
4	H100205	BOLT WH 5/16x2 1/4 BLK
8	H100379	TNUT-5/16" BLK
4	H100415	BOLT WH 5/16x3 3/4 BLK

B11 POST - W4L20619  
(x1) 3"x3"x88 9/16" (76x76x2250)

F04 UPRIGHT - W4L20582  
(x1) 1 7/16"x2 3/8"x86 11/16" (36x60x2202)

H02 RUNNING BOARD - W4L20586  
(x1) 15/16"x3 3/8"x64 7/16" (24x86x1637)

G02 BASE BOARD - W4L20584  
(x1) 15/16"x5 1/4"x64 7/16" (24x134x1637)

- INSERT T-NUTS FIRST.
- HAND TIGHTEN ONLY.

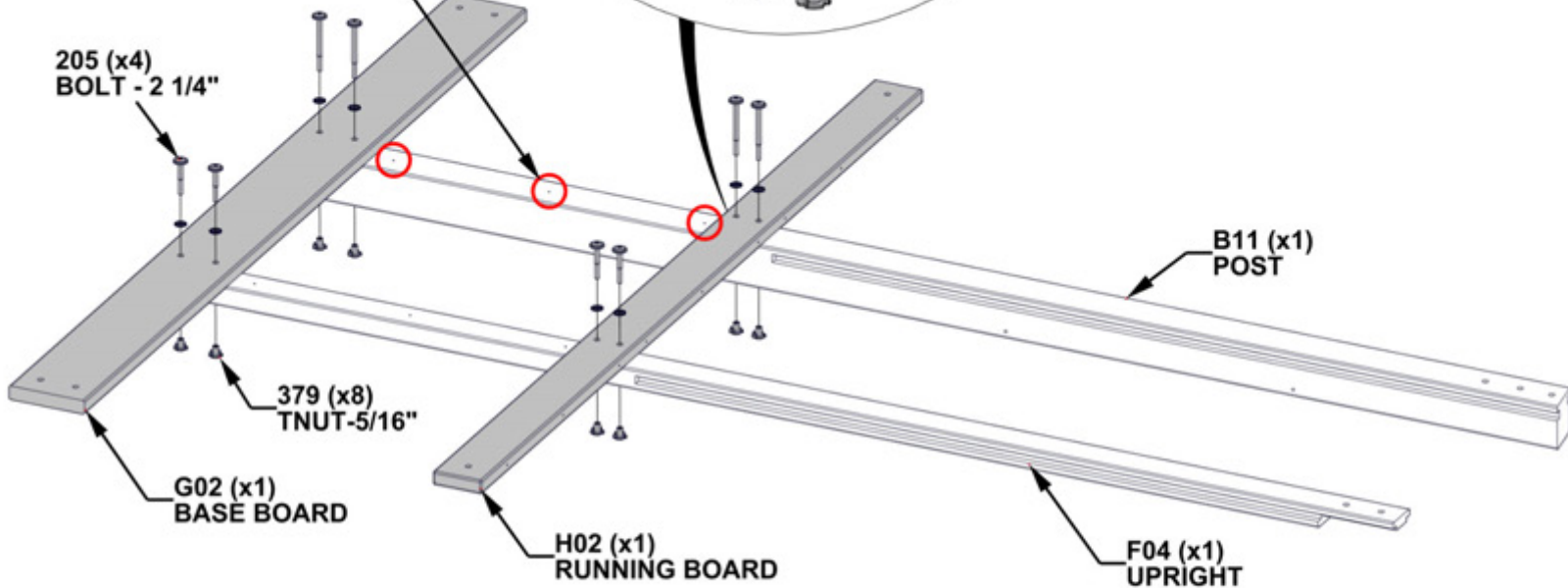
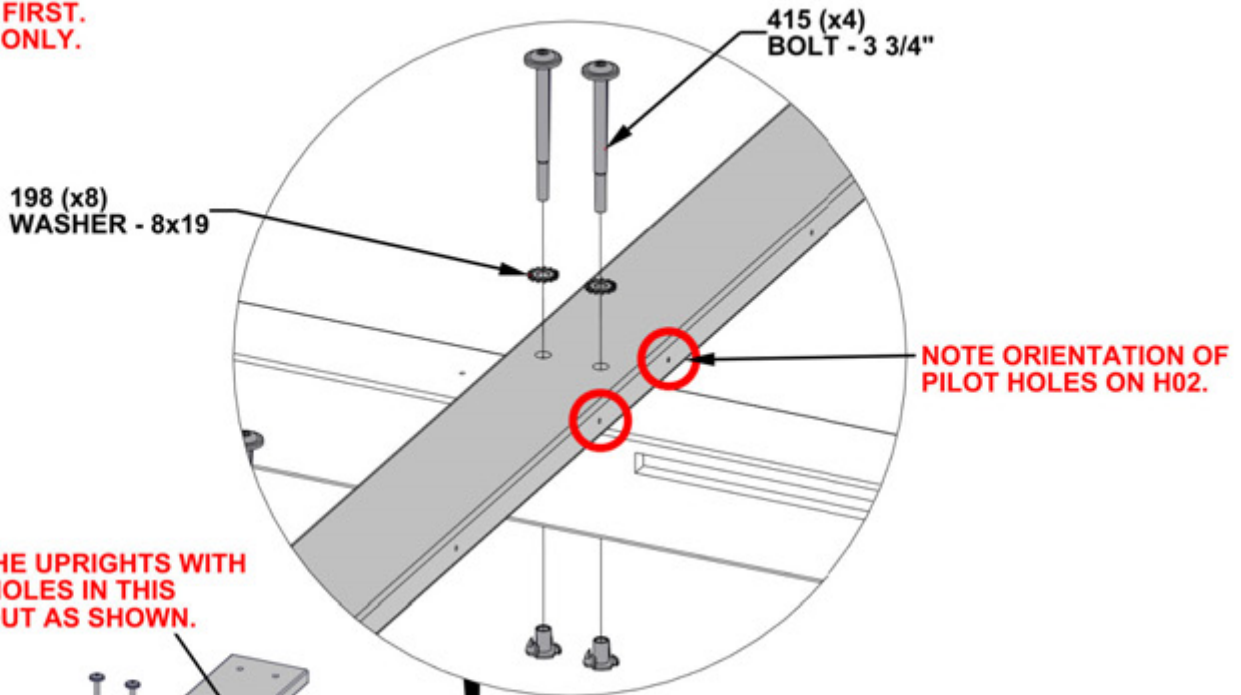

# STEP 9 - SIDE WALL ASSEMBLY

QTY	PART NUMBER	DESCRIPTION
2	H100195	BOLT WH 5/16x2 3/4 BLK
4	H100198	WASHER LOCK EXT 8x19
4	H100379	TNUT-5/16" BLK
2	H100513	BOLT WH 5/16x4 1/4 BLK



D06 HEADER - W4L20583  
(x1) 1 7/16"x5 1/4"x64 7/16" (36x134x1637)



F05 UPRIGHT TOP - W4L20594  
(x1) 1 7/16"x2 3/8"x10 3/4" (36x60x273)

**- INSERT T-NUTS FIRST.  
- HAND TIGHTEN ONLY.**

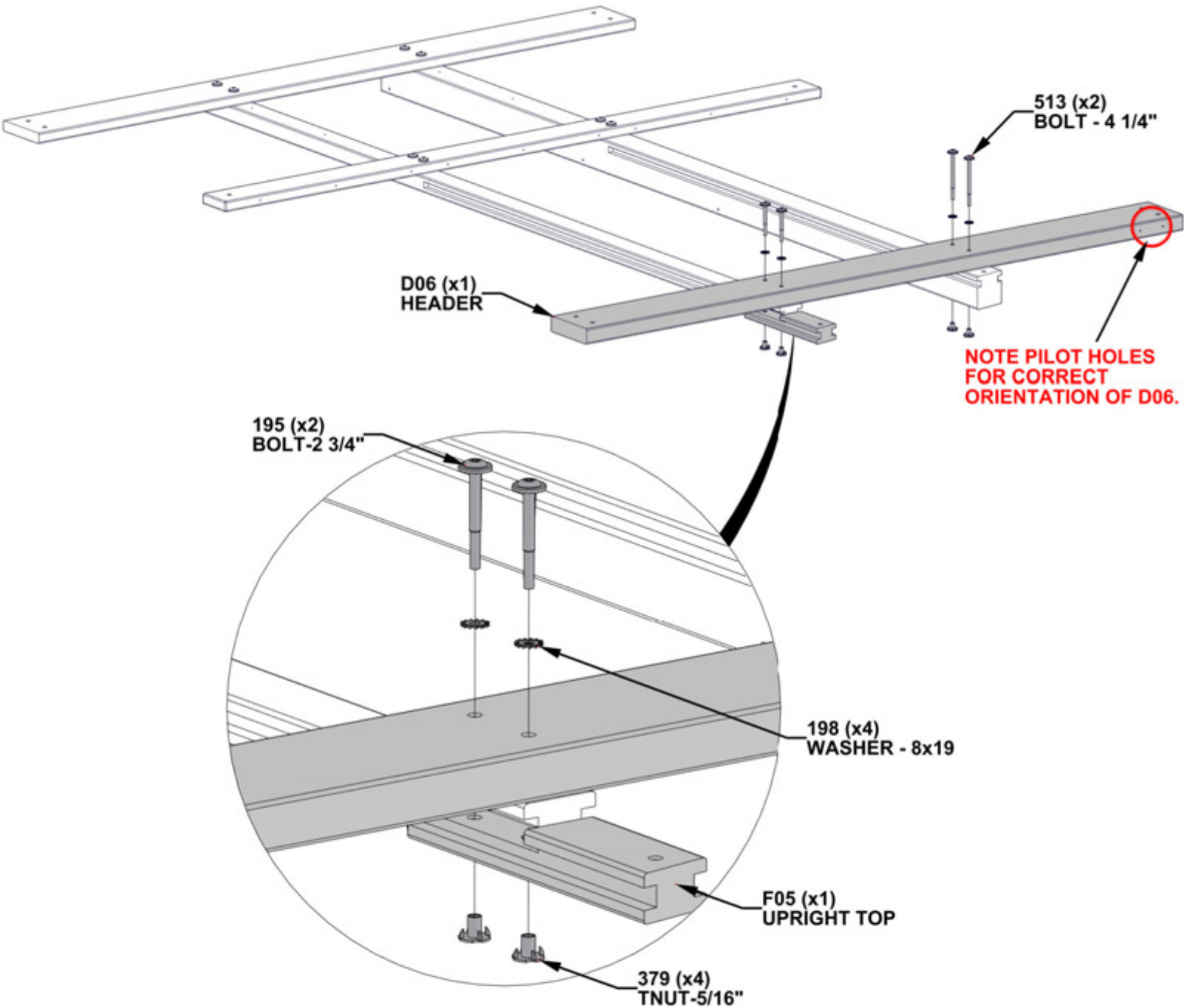

# STEP 10 - SIDE WALL ASSEMBLY

QTY	PART NUMBER	DESCRIPTION
1	H100195	BOLT WH 5/16x2 3/4 BLK
2	H100198	WASHER LOCK EXT 8x19
2	H100379	TNUT-5/16" BLK
1	H100513	BOLT WH 5/16x4 1/4 BLK
2	H101008	SCREW CONFIRMAT 7x3 BLK



D07 HEADER - W4L20595  
(x1) 1 7/16"x5 1/4"x65 9/16" (36x134x1666)

- INSERT T-NUTS FIRST.
- HAND TIGHTEN ONLY.

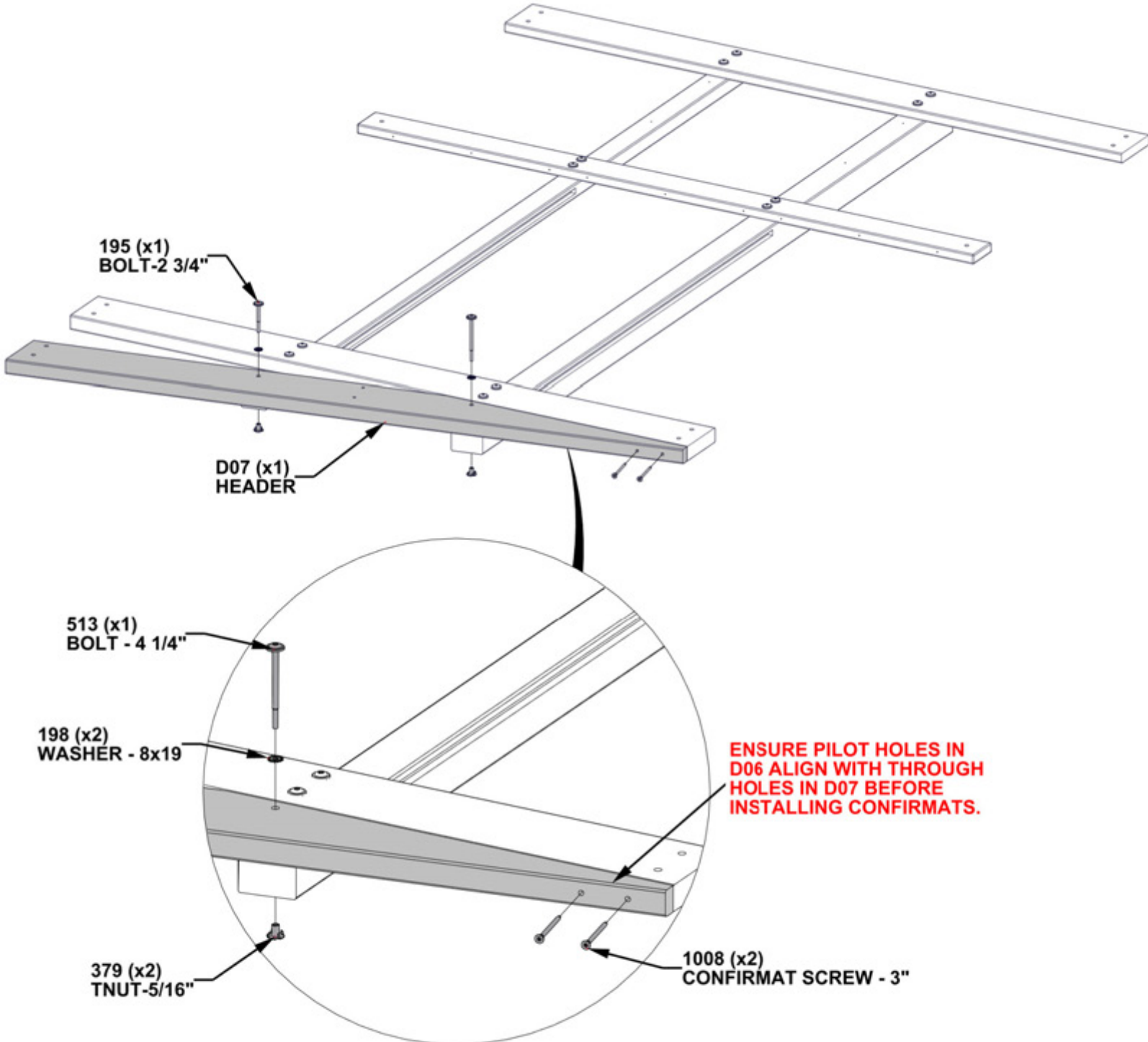

# STEP 11 - GREENHOUSE ASSEMBLY

QTY	PART NUMBER	DESCRIPTION
2	H100193	NUT BARREL WH 5/16 X 1 1/2 BLK
5	H100198	WASHER LOCK EXT 8x19
3	H100379	TNUT-5/16" BLK
1	H100415	BOLT WH 5/16x3 3/4 BLK
2	H100416	BOLT WH 5/16x3 BLK
2	H100513	BOLT WH 5/16x4 1/4 BLK



- INSERT T-NUTS FIRST.
- HAND TIGHTEN ONLY.

STAND UP THE SIDE AND BACK ASSEMBLIES AND BOLT TOGETHER.

SIDE ASSEMBLY FROM STEP 10

513 (x2)  
BOLT - 4 1/4"

198 (x5)  
WASHER - 8x19

379 (x3)  
TNUT-5/16"

415 (x1)  
BOLT - 3 3/4"

416 (x2)  
BOLT - 3"

193 (x2)  
BARREL NUT - 1 1/2"

2503 (x1)  
ANCHOR BRACKET

BACK ASSEMBLY FROM STEP 7

# STEP 12 - SIDE WALL ASSEMBLY

QTY	PART NUMBER	DESCRIPTION
8	H100198	WASHER LOCK EXT 8x19
8	H100205	BOLT WH 5/16x2 1/4 BLK
8	H100379	TNUT-5/16" BLK

F12 UPRIGHT - W4L20620  
(x1) 1 7/16"x2 3/8"x86 11/16" (36x60x2202)

F06 UPRIGHT - W4L20596  
(x1) 1 7/16"x2 3/8"x88 9/16" (36x60x2250)

H02 RUNNING BOARD - W4L20586  
(x1) 15/16"x3 3/8"x64 7/16" (24x86x1637)

G02 BASE BOARD - W4L20584  
(x1) 15/16"x5 1/4"x64 7/16" (24x134x1637)

- INSERT T-NUTS FIRST.
- HAND TIGHTEN ONLY.

NOTE ORIENTATION OF PILOT HOLES ON H02.

205 (x8)  
BOLT - 2 1/4"

198 (x8)  
WASHER - 8x19

379 (x8)  
TNUT-5/16"

G02 (x1)  
BASE BOARD

H02 (x1)  
RUNNING BOARD

F12 (x1)  
UPRIGHT

F06 (x1)  
UPRIGHT

THE SIDE OF F06 & F12 WITH THREE PILOT HOLES IN THIS AREA FACES OUT AS SHOWN.

# STEP 13 - SIDE WALL ASSEMBLY

QTY	PART NUMBER	DESCRIPTION
4	H100195	BOLT WH 5/16x2 3/4 BLK
4	H100198	WASHER LOCK EXT 8x19
4	H100379	TNUT-5/16" BLK



D08 HEADER - W4L20616  
(x1) 1 7/16"x5 1/4"x64 7/16" (36x134x1637)

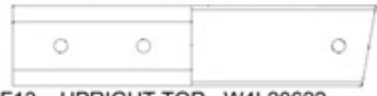

F13 UPRIGHT TOP - W4L20622  
(x1) 1 7/16"x2 3/8"x10 3/4" (36x60x273)

**- INSERT T-NUTS FIRST.  
- HAND TIGHTEN ONLY.**

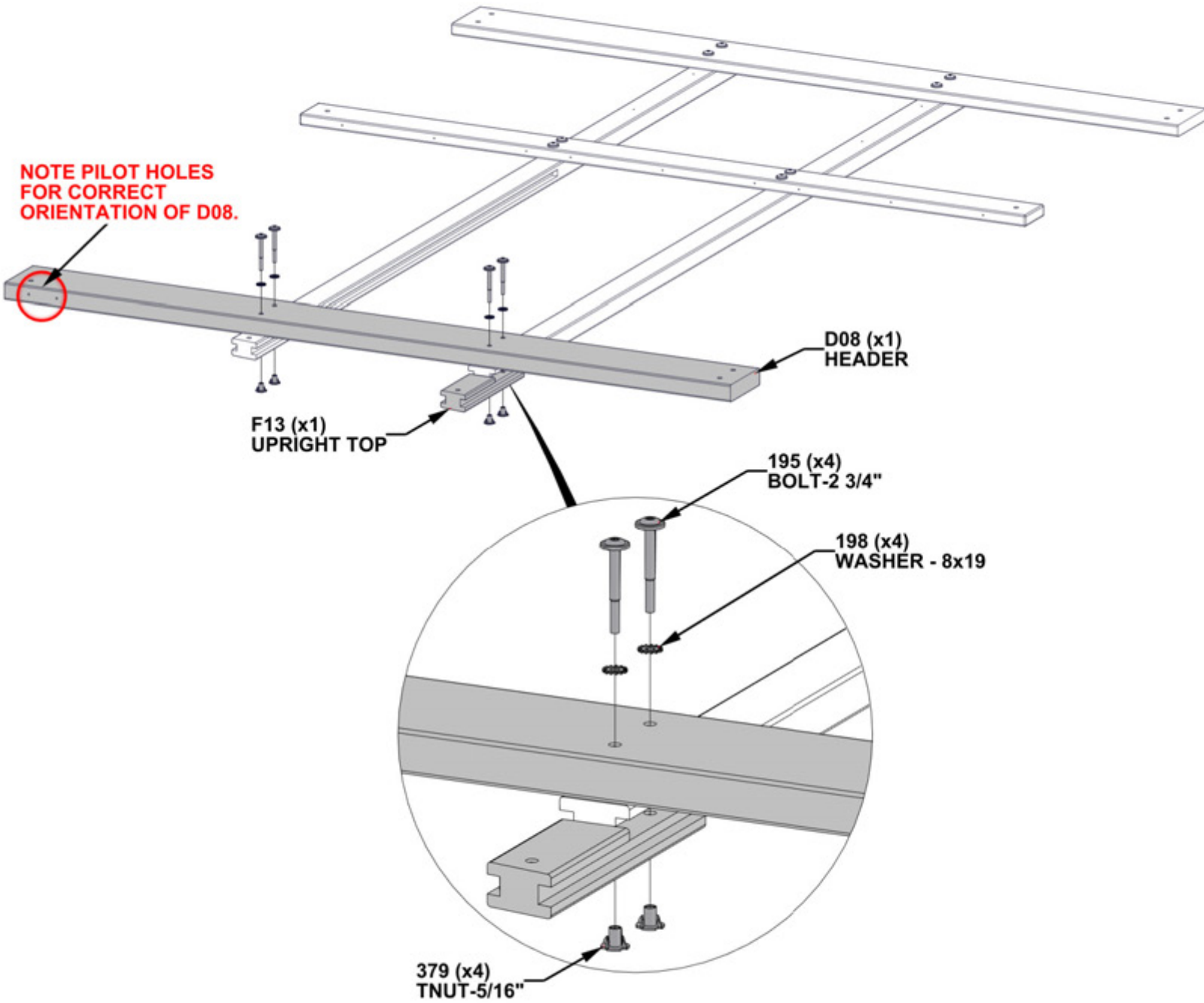

# STEP 14 - SIDE WALL ASSEMBLY

QTY	PART NUMBER	DESCRIPTION
2	H100195	BOLT WH 5/16x2 3/4 BLK
2	H100198	WASHER LOCK EXT 8x19
2	H100379	TNUT-5/16" BLK
2	H101008	SCREW CONFIRMAT 7x3 BLK



D09 HEADER - W4L20617  
(x1) 1 7/16"x5 1/4"x65 9/16" (36x134x1666)

- INSERT T-NUTS FIRST.
- HAND TIGHTEN ONLY.

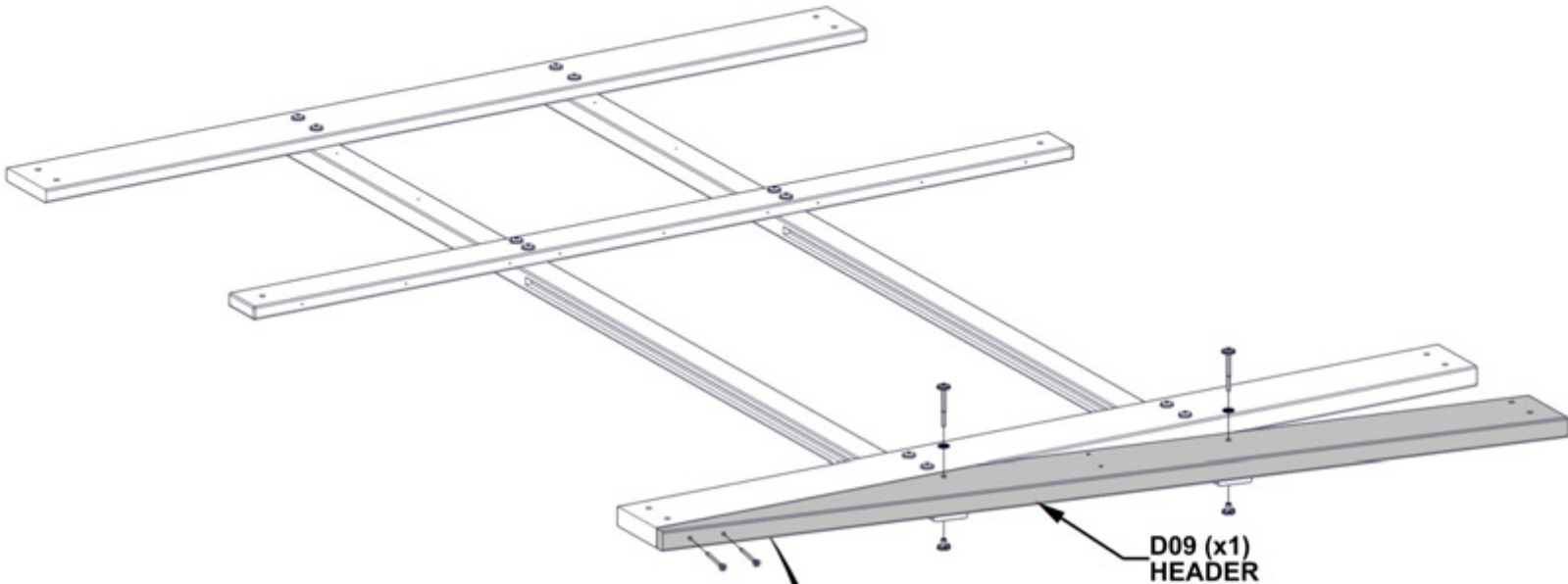

D09 (x1)  
HEADER

**ENSURE PILOT HOLES IN D09 ALIGN WITH THROUGH HOLES IN D08 BEFORE INSTALLING CONFIRMATS.**

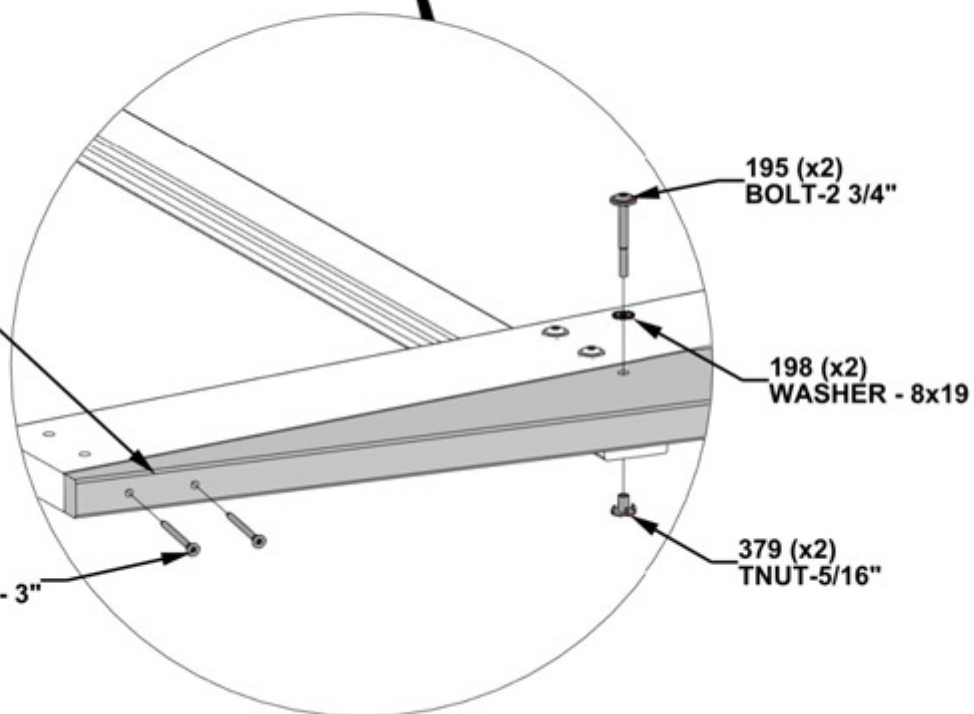

195 (x2)  
BOLT-2 3/4"

198 (x2)  
WASHER - 8x19

379 (x2)  
TNUT-5/16"

1008 (x2)  
CONFIRMAT SCREW - 3"

# STEP 15 - GREENHOUSE ASSEMBLY

QTY	PART NUMBER	DESCRIPTION
2	H100193	NUT BARREL WH 5/16 X 1 1/2 BLK
5	H100198	WASHER LOCK EXT 8x19
3	H100379	TNUT-5/16" BLK
1	H100415	BOLT WH 5/16x3 3/4 BLK
2	H100416	BOLT WH 5/16x3 BLK
2	H100513	BOLT WH 5/16x4 1/4 BLK



A4M02502 ANCHOR BRACKET (x1)

- INSERT T-NUTS FIRST.  
- HAND TIGHTEN ONLY.

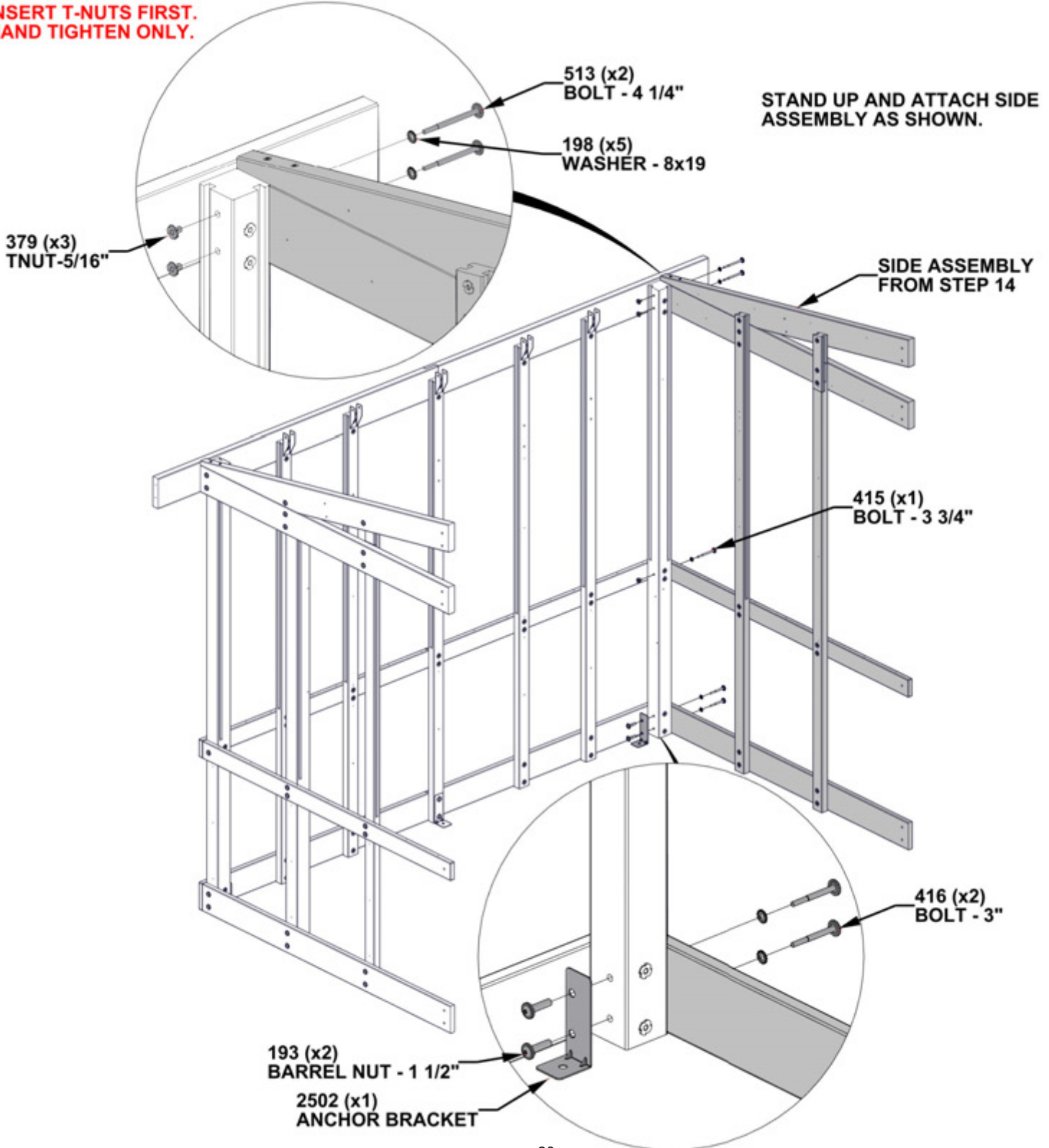

# STEP 16 - FRONT WALL ASSEMBLY

QTY	PART NUMBER	DESCRIPTION
4	H100193	NUT BARREL WH 5/16 X 1 1/2 BLK
4	H100195	BOLT WH 5/16x2 3/4 BLK
8	H100198	WASHER LOCK EXT 8x19
4	H100205	BOLT WH 5/16x2 1/4 BLK
4	H100379	TNUT-5/16" BLK

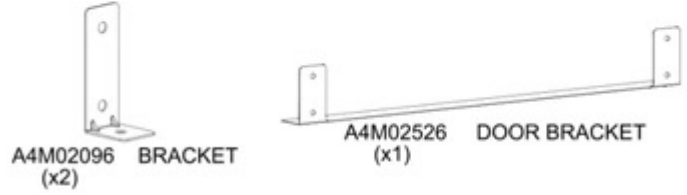
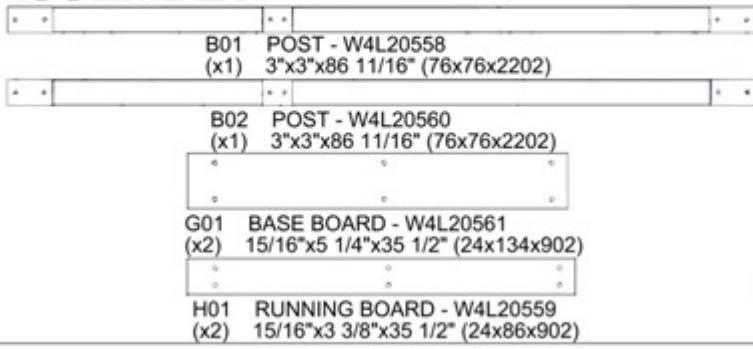

- INSERT T-NUTS FIRST.  
- HAND TIGHTEN ONLY.

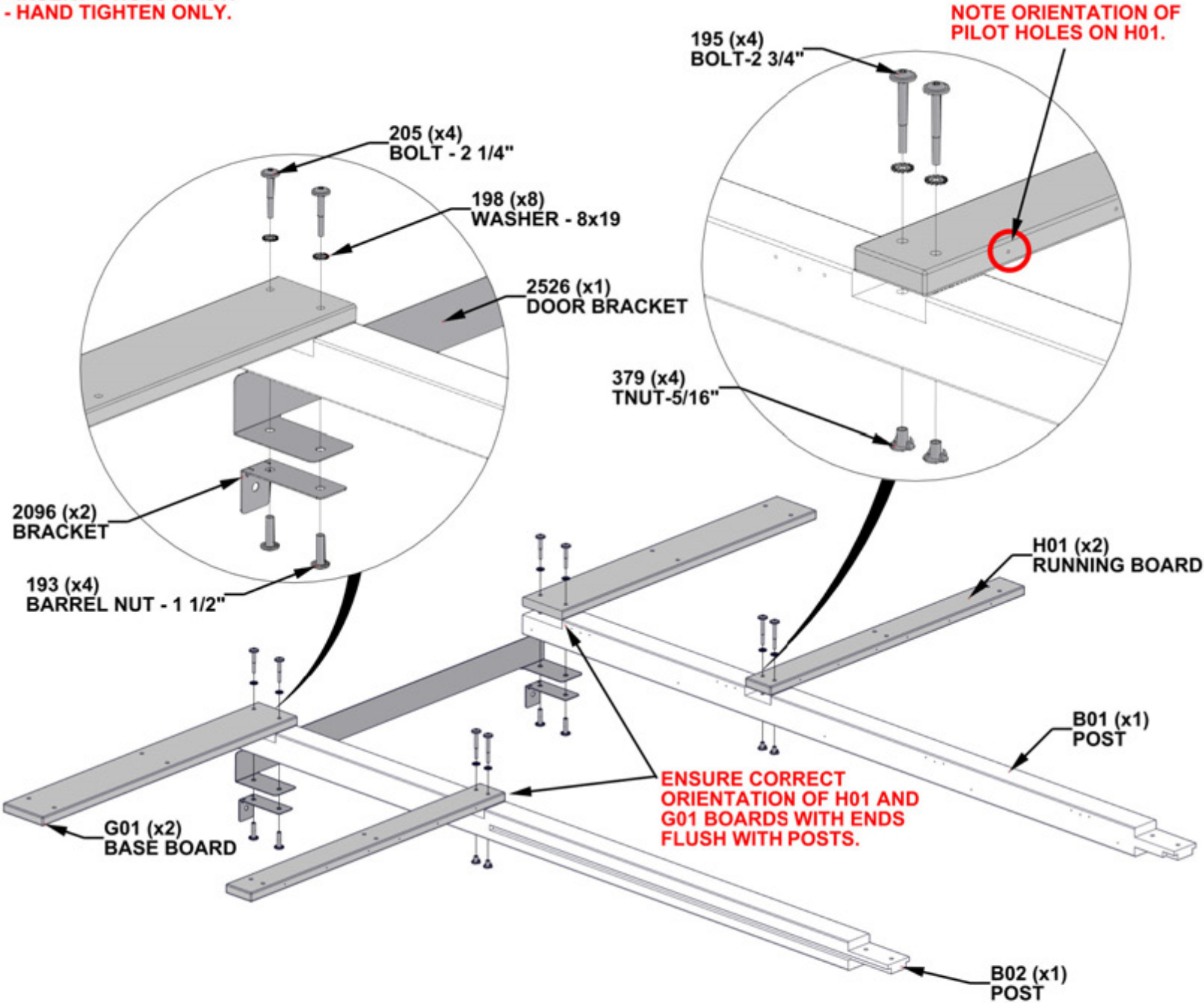

# STEP 17 - FRONT WALL ASSEMBLY

QTY	PART NUMBER	DESCRIPTION
4	H100198	WASHER LOCK EXT 8x19
4	H100379	T-NUT 5/16 BLK
4	H100503	BOLT WH 5/16x3 1/2 BLK



D01 HEADER - W4L20562  
(x1) 1 7/16"x5 1/4"x73 5/8" (36x134x1870)



D03 HEADER - W4L20567  
(x1) 1 7/16"x5 1/4"x45 13/16" (36x134x1164)



D04 HEADER - W4L20568  
(x1) 1 7/16"x5 1/4"x43" (36x134x1092)



D05 HEADER - W4L20579  
(x1) 1 7/16"x5 1/4"x45 13/16" (36x134x1164)



B03 POST TOP - W4L20564  
(x1) 3"x3"x16 13/16" (76x76x427)



B04 POST TOP - W4L20565  
(x1) 3"x3"x16 13/16" (76x76x427)

- INSERT T-NUTS FIRST.
- HAND TIGHTEN ONLY.
- NOTE NOTCHES FOR CORRECT ORIENTATION OF ALL BOARDS. THIS IS CRITICAL FOR LATER STEPS.

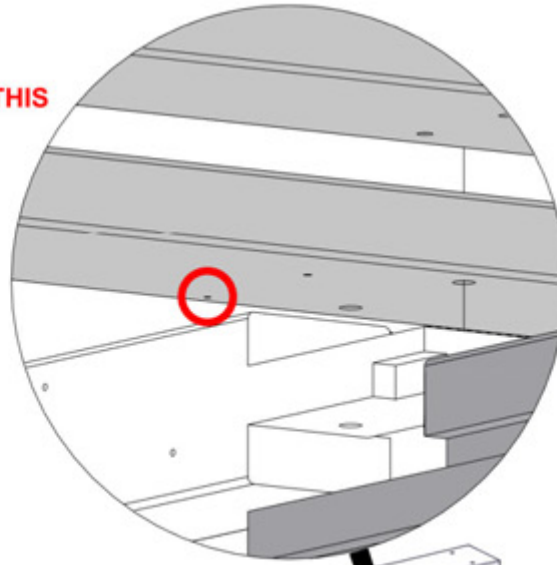

ORIENT PILOT HOLES ON BACK OF D01 AS SHOWN.

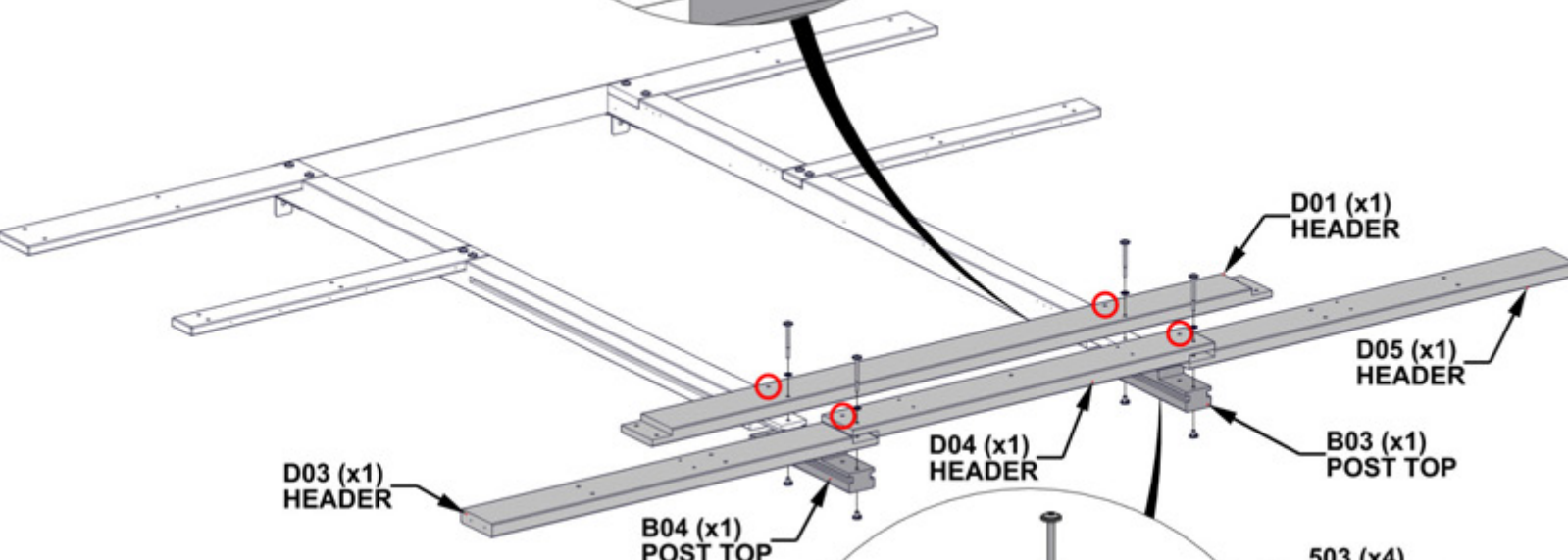

DO NOT INSERT HARDWARE IN HIGHLIGHTED HOLES.

THROUGH HOLE TOWARDS THE BOTTOM ON D04.

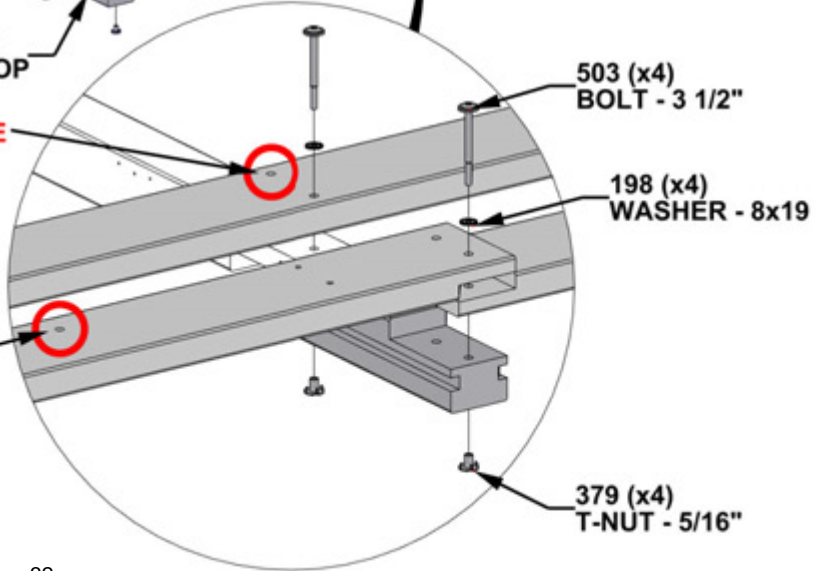

# STEP 18 - FRONT WALL ASSEMBLY

QTY	PART NUMBER	DESCRIPTION
6	H100195	BOLT WH 5/16x2 3/4 BLK
14	H100198	WASHER LOCK EXT 8x19
8	H100205	BOLT WH 5/16x2 1/4 BLK
14	H100379	TNUT-5/16" BLK



D02 HEADER - W4L20563  
(x2) 1 7/16"x5 1/4"x20 1/16" (36x134x509)



F01 UPRIGHT - W4L20557  
(x2) 1 7/16"x2 3/8"x86 11/16" (36x60x2202)



F02 UPRIGHT TOP - W4L20566  
(x2) 1 7/16"x2 3/8"x16 13/16" (36x60x427)

**- INSERT T-NUTS FIRST.  
- HAND TIGHTEN ONLY.**

**NOTE NOTCHES FOR CORRECT ORIENTATION OF ALL BOARDS. THIS IS CRITICAL FOR LATER STEPS.**

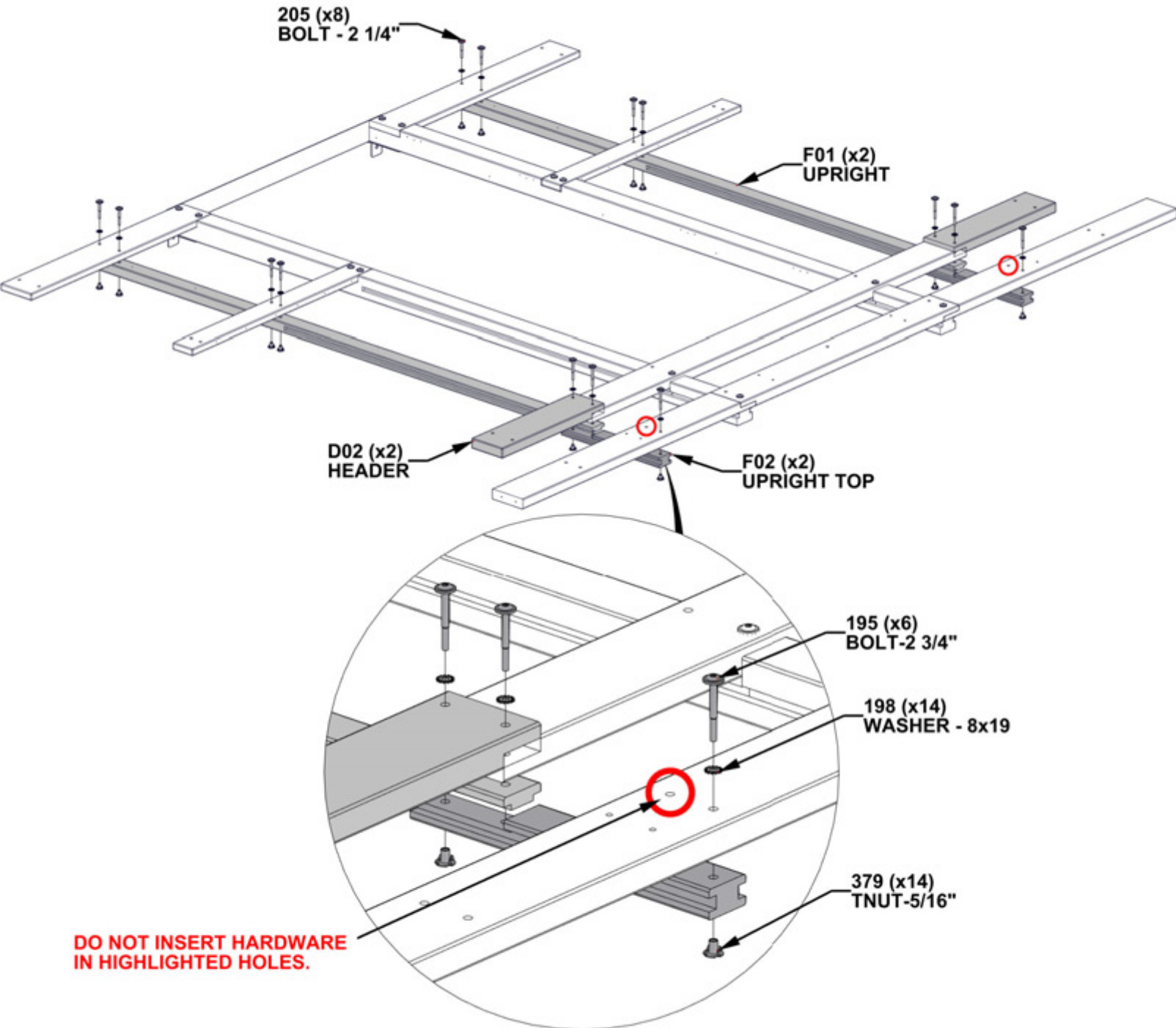

**DO NOT INSERT HARDWARE  
IN HIGHLIGHTED HOLES.**

# STEP 19 - FRONT WALL ASSEMBLY

QTY	PART NUMBER	DESCRIPTION
16	H100198	WASHER LOCK EXT 8x19
16	H100379	TNUT-5/16" BLK
8	H100415	BOLT WH 5/16x3 3/4 BLK
8	H100513	BOLT WH 5/16x4 1/4 BLK



B05 POST - W4L20581  
(x1) 3"x3"x84 1/16" (76x76x2135)



B07 POST TOP - W4L20601  
(x1) 3"x3"x14 3/16" (76x76x360)



B08 POST - W4L20613  
(x1) 3"x3"x84 1/16" (76x76x2135)



B10 POST TOP - W4L20618  
(x1) 3"x3"x14 3/16" (76x76x360)

**- INSERT T-NUTS FIRST.  
- HAND TIGHTEN ONLY.**

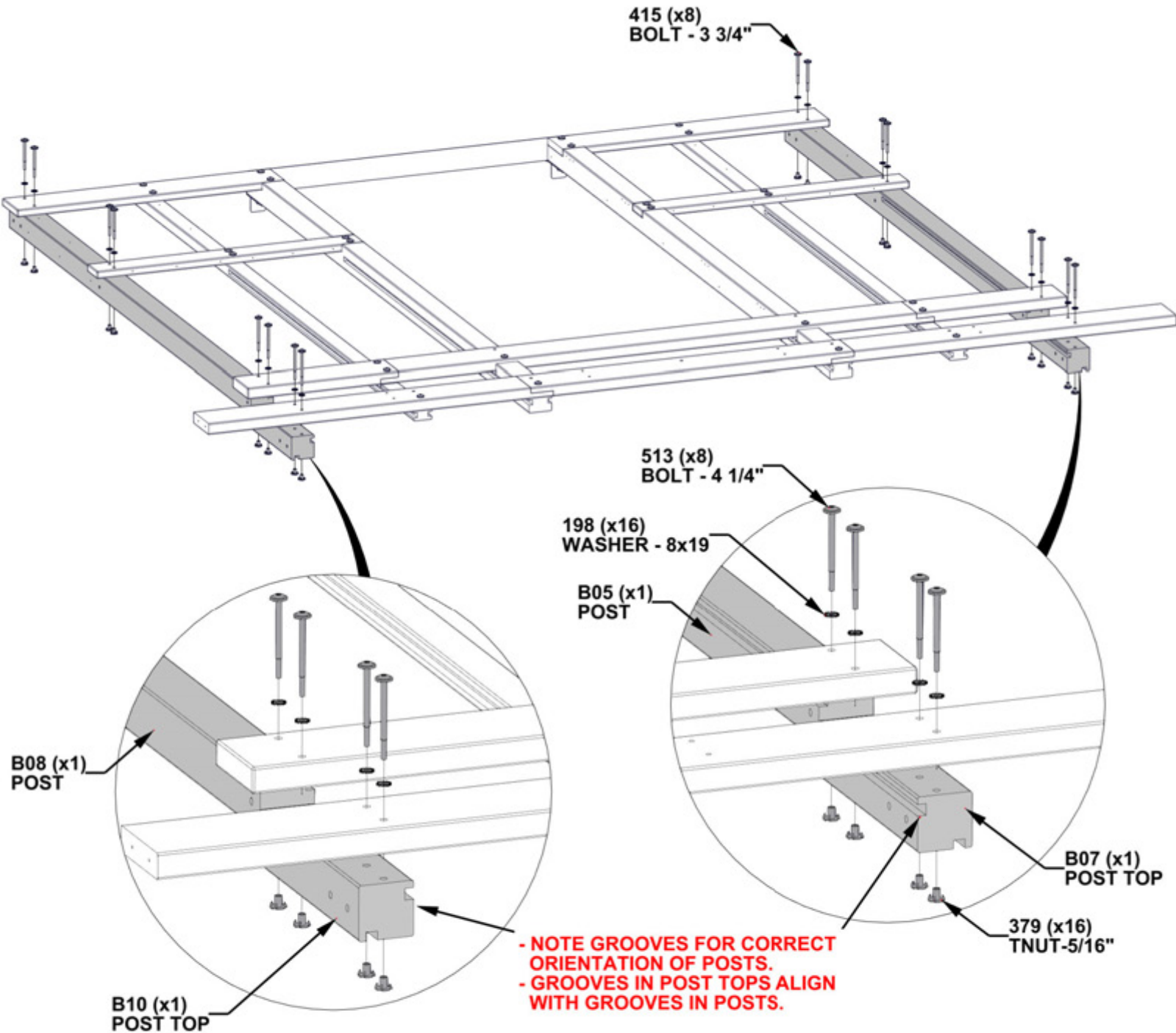

# STEP 20 - FRONT WALL ASSEMBLY

QTY	PART NUMBER	DESCRIPTION
4	H100192	NUT BARREL WH 5/16X7/8 BLK
2	H100193	NUT BARREL WH 5/16 X 1 1/2 BLK
6	H100198	WASHER LOCK EXT 8x19
2	H100378	BOLT WH 5/16x1 3/4 BLK
4	H100416	BOLT WH 5/16x3 BLK



A4M02093 RAFTER BRACKET (x6)

**- HAND TIGHTEN ONLY.**

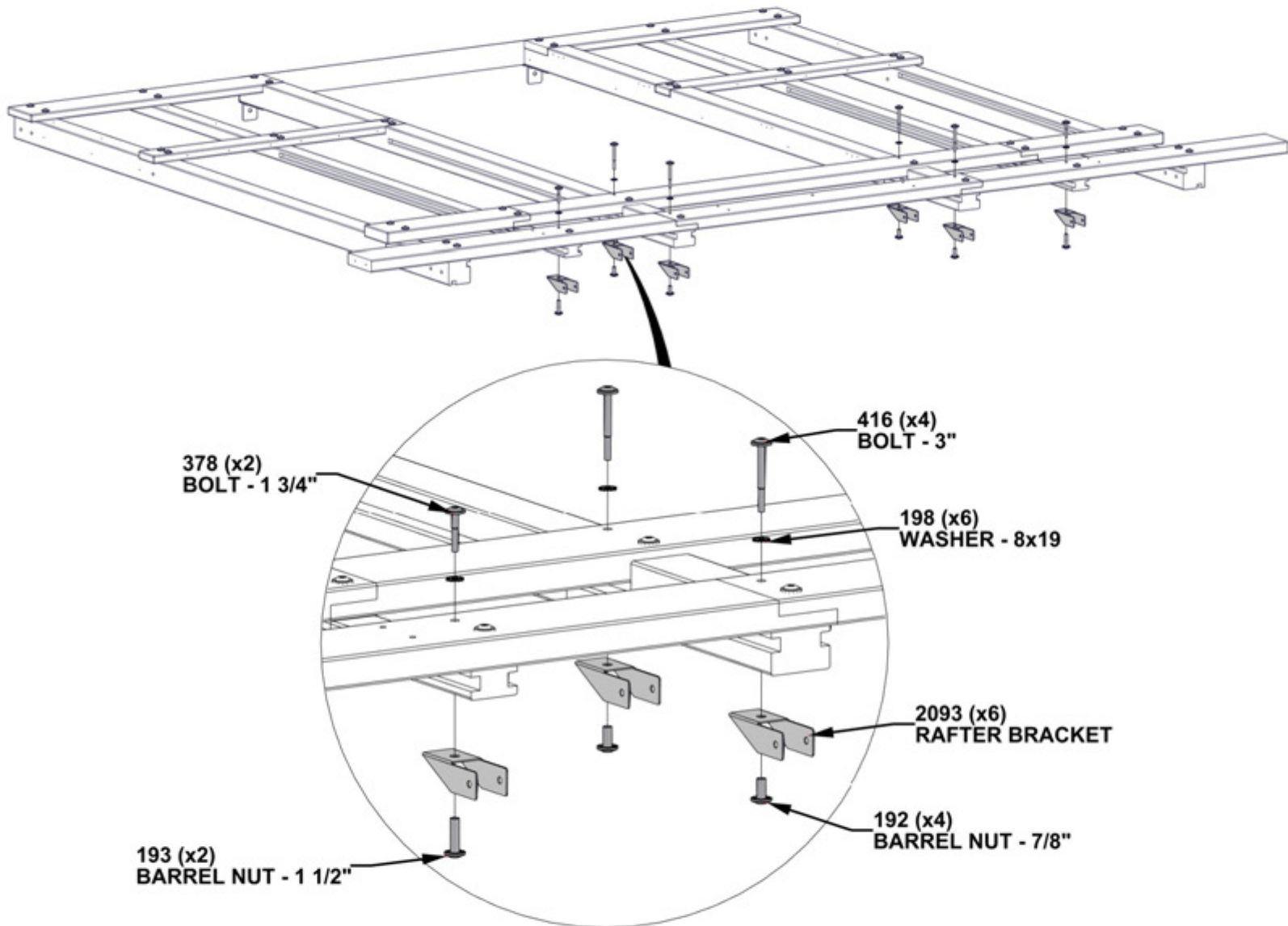

# STEP 21 - GREENHOUSE ASSEMBLY

QTY	PART NUMBER	DESCRIPTION
2	H100193	NUT BARREL WH 5/16 X 1 1/2 BLK
14	H100198	WASHER LOCK EXT 8x19
12	H100379	TNUT-5/16" BLK
4	H100415	BOLT WH 5/16x3 3/4 BLK
2	H100416	BOLT WH 5/16x3 BLK
8	H100513	BOLT WH 5/16x4 1/4 BLK



A4M02503 ANCHOR BRACKET (x1)

- INSERT T-NUTS FIRST.
- HAND TIGHTEN ONLY.

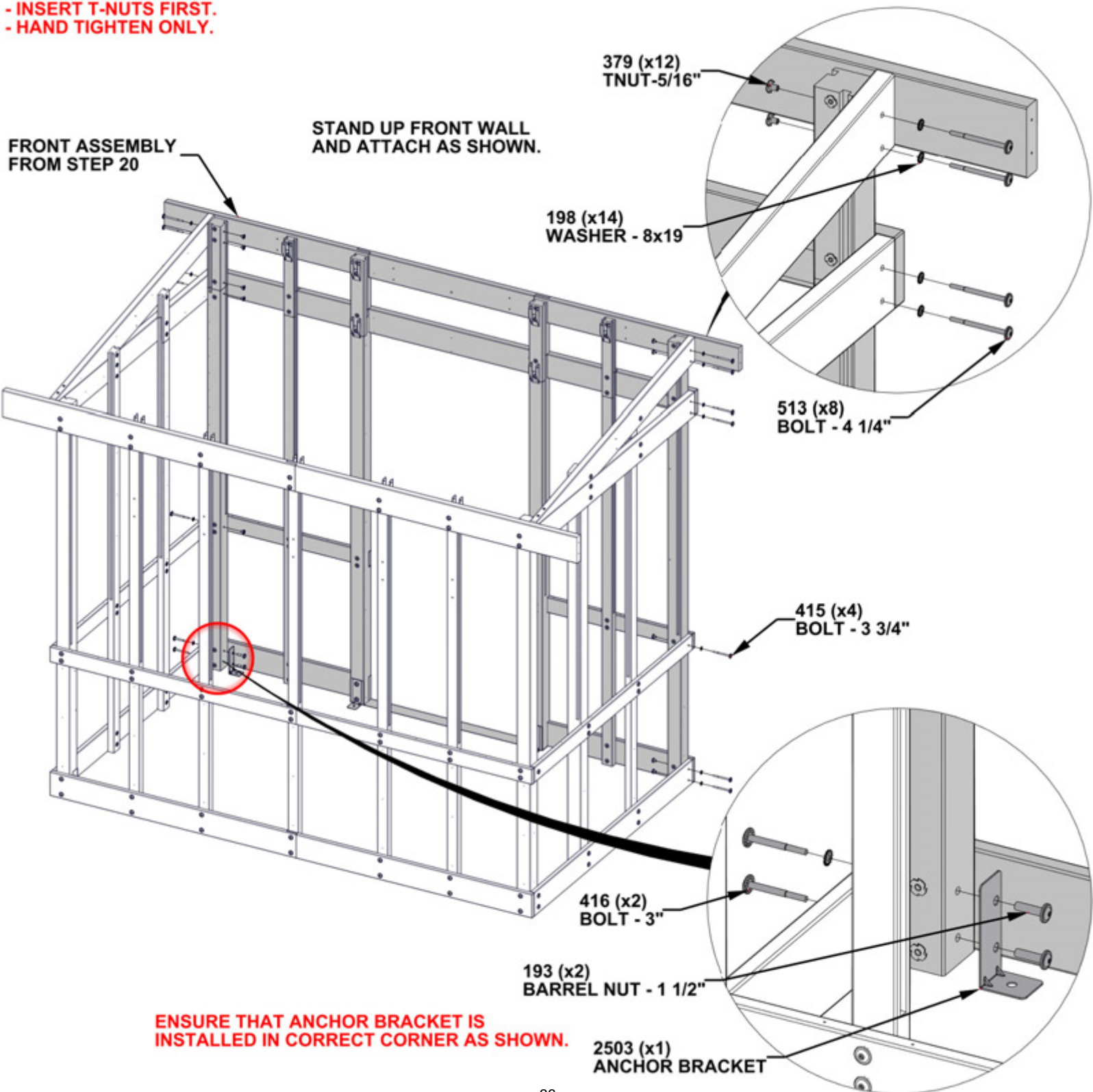

## STEP 22 - GREENHOUSE ASSEMBLY

### IMPORTANT!

- STARTING WITH THE SIDE WALL ASSEMBLY, THE FOLLOWING STEPS ARE CRITICAL:
- POSTS AND UPRIGHTS ARE PLUMB (STRAIGHT UP AND DOWN) WITH A LEVEL.
  - MEASUREMENTS BETWEEN POSTS AND UPRIGHTS ARE AS SHOWN +/- 1/8".
  - RUNNING AND BASE BOARDS ARE SQUARED TO THE UPRIGHTS.
  - ALL HARDWARE ON THIS SIDE IS FULLY TIGHTENED.

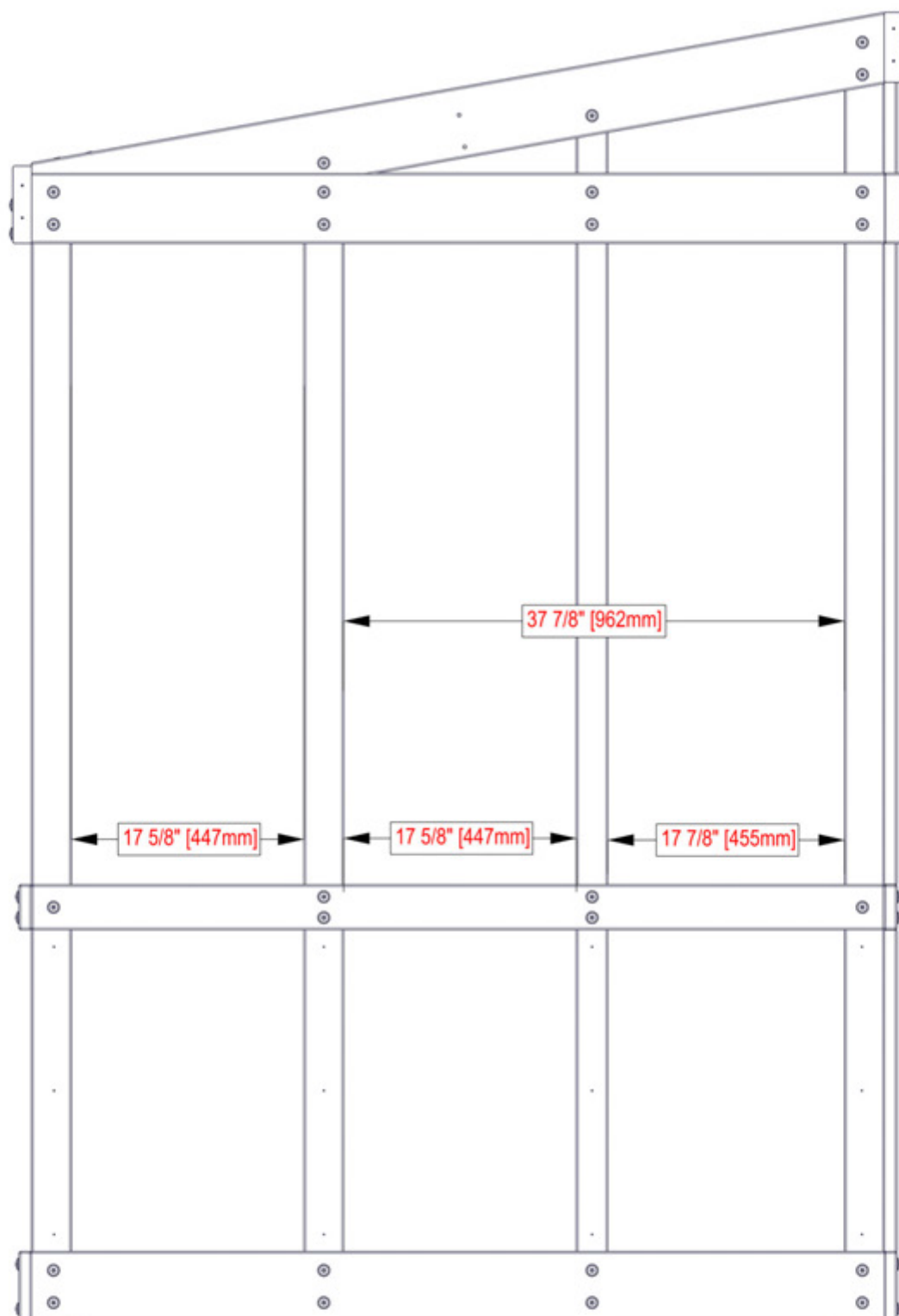

# STEP 23 - GREENHOUSE ASSEMBLY

**IMPORTANT!**

- ON THE BACK WALL ASSEMBLY, THE FOLLOWING STEPS ARE CRITICAL:**
- POSTS AND UPRIGHTS ARE PLUMB (STRAIGHT UP AND DOWN) WITH A LEVEL.
  - MEASUREMENTS BETWEEN POSTS AND UPRIGHTS ARE AS SHOWN +/- 1/8".
  - RUNNING AND BASE BOARDS ARE SQUARED TO THE UPRIGHTS.
  - ALL HARDWARE ON THIS SIDE IS FULLY TIGHTENED.

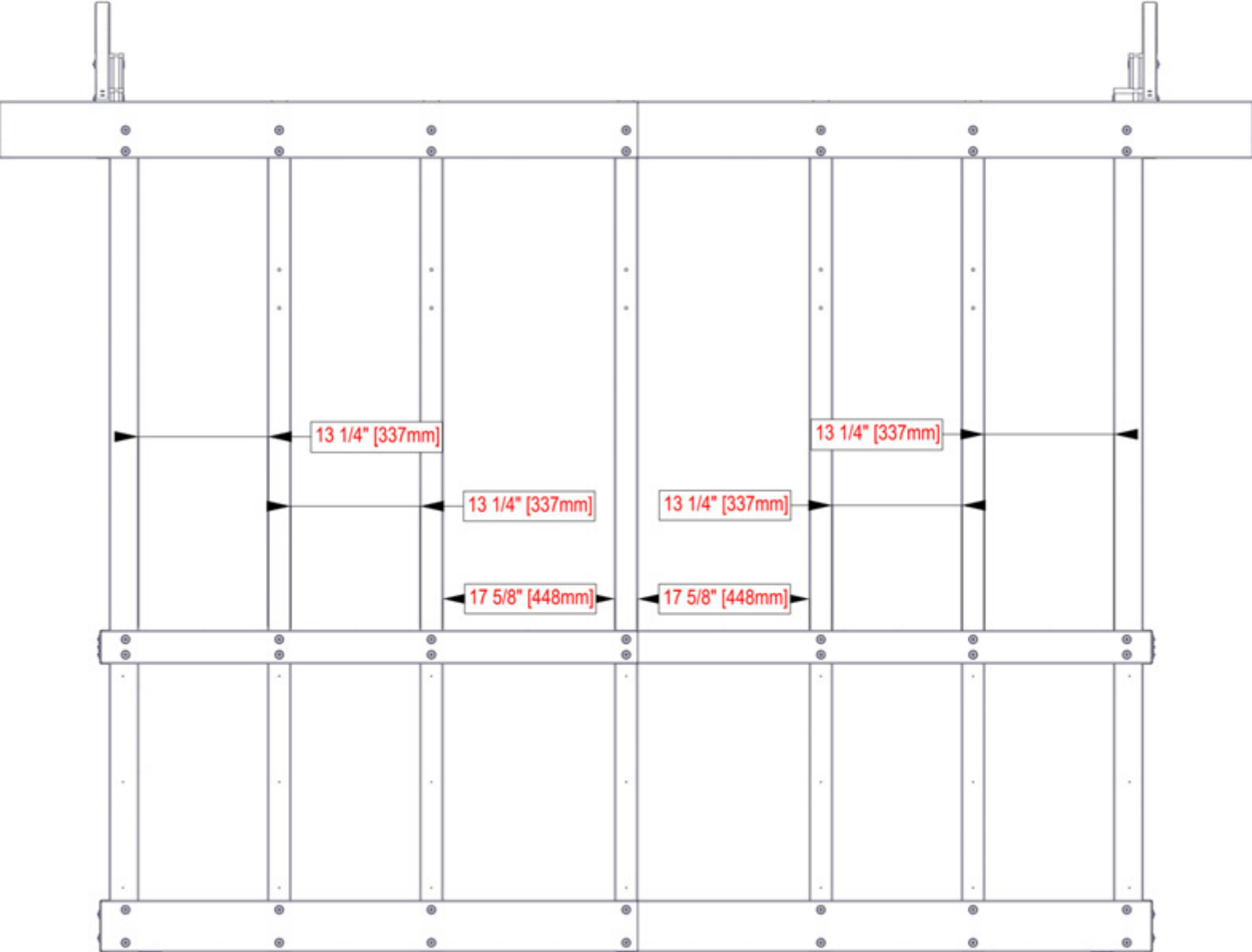

# STEP 24 - GREENHOUSE ASSEMBLY

**IMPORTANT!**

- ON THE REMAINING SIDE WALL ASSEMBLY, THE FOLLOWING STEPS ARE CRITICAL:**
- POSTS AND UPRIGHTS ARE PLUMB (STRAIGHT UP AND DOWN) WITH A LEVEL.
  - MEASUREMENTS BETWEEN POSTS AND UPRIGHTS ARE AS SHOWN +/- 1/8".
  - RUNNING AND BASE BOARDS ARE SQUARED TO THE UPRIGHTS.
  - ALL HARDWARE ON THIS SIDE IS FULLY TIGHTENED.

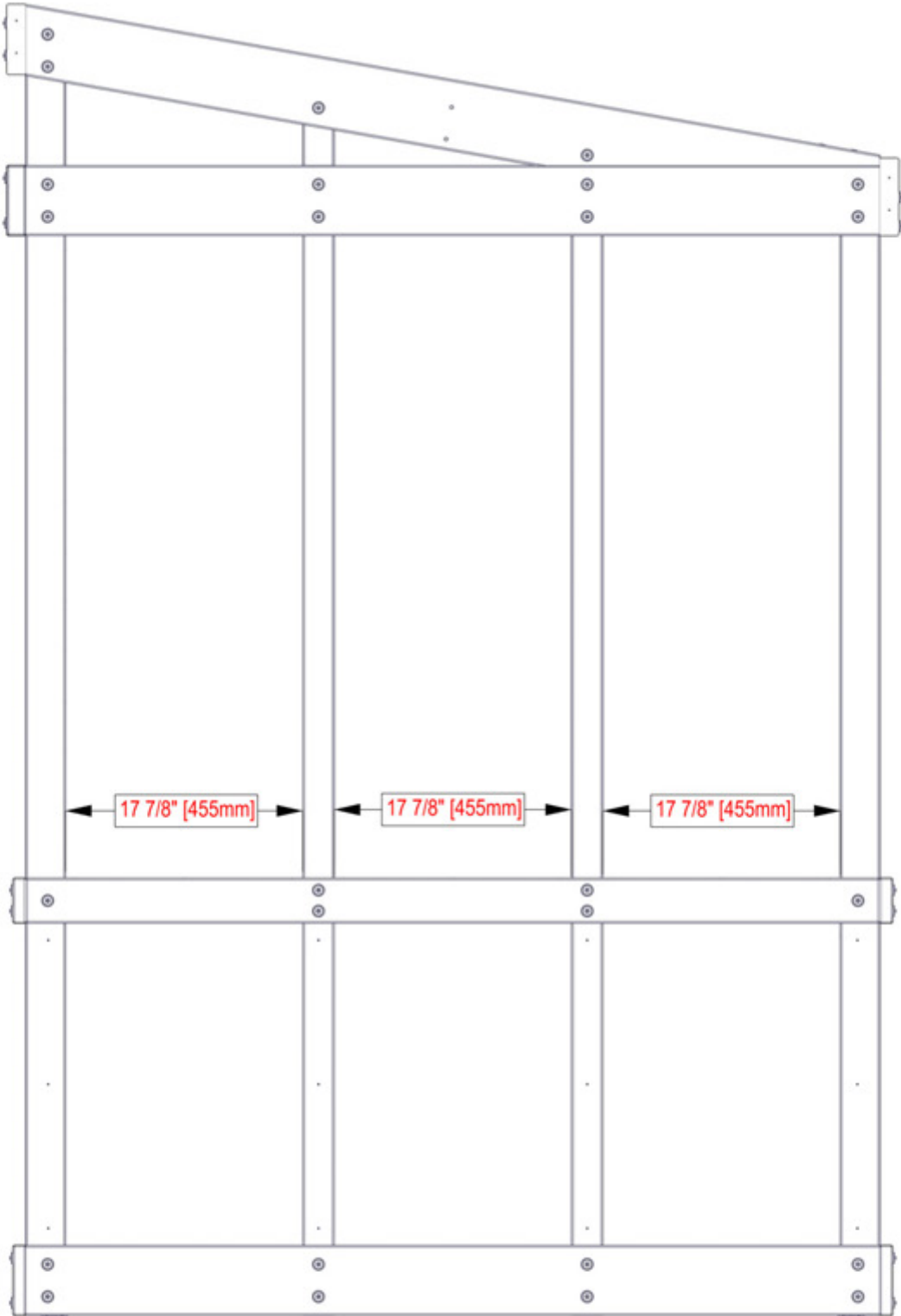

# STEP 25 - GREENHOUSE ASSEMBLY

## IMPORTANT!

- ON THE FRONT WALL ASSEMBLY, THE FOLLOWING STEPS ARE CRITICAL:
- POSTS AND UPRIGHTS ARE PLUMB (STRAIGHT UP AND DOWN) WITH A LEVEL.
  - MEASUREMENTS BETWEEN POSTS AND UPRIGHTS ARE AS SHOWN +/- 1/8".
  - RUNNING AND BASE BOARDS ARE SQUARED TO THE UPRIGHTS.
  - ALL HARDWARE ON THIS SIDE IS FULLY TIGHTENED.

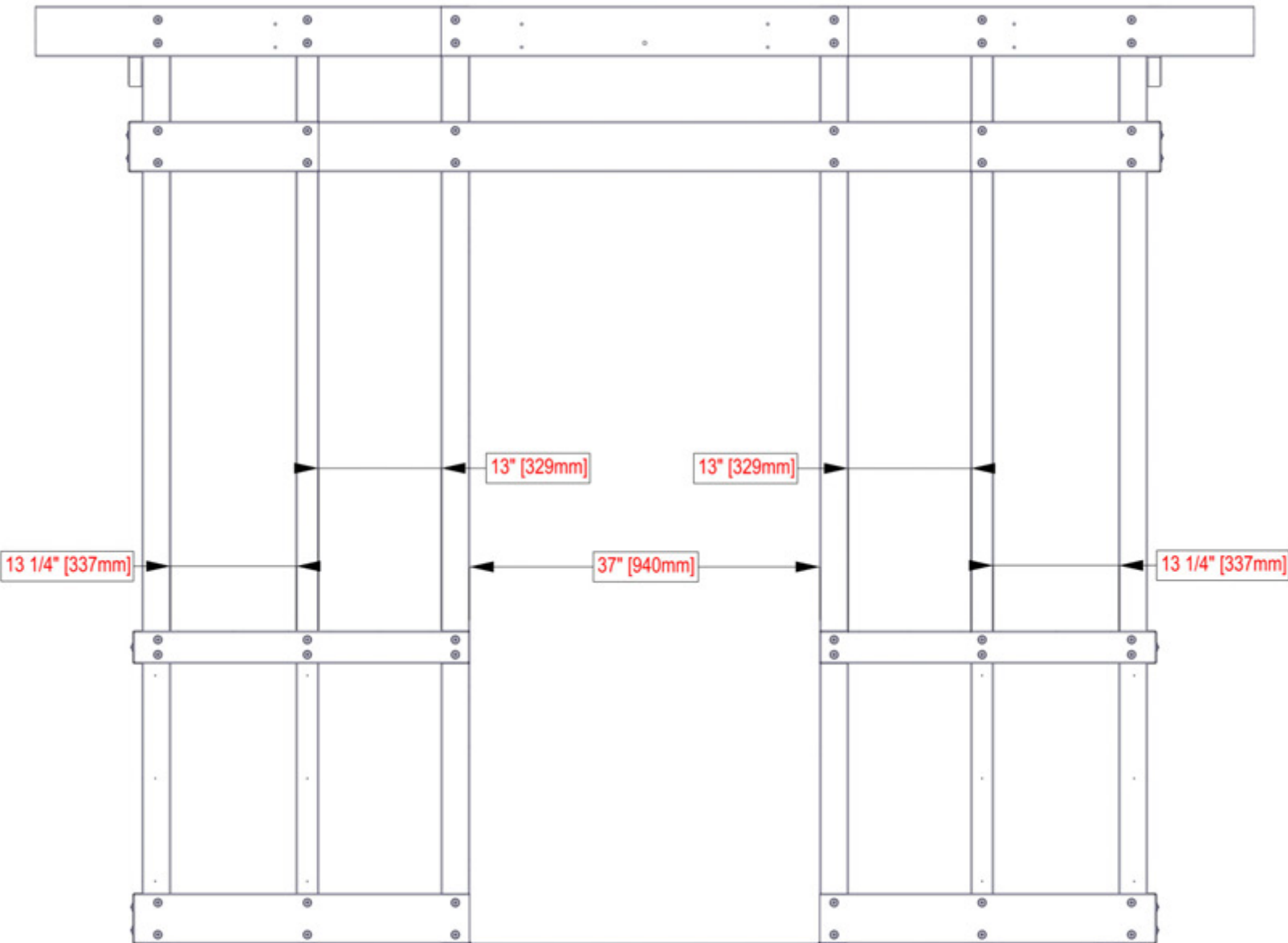

# STEP 26 - GREENHOUSE ASSEMBLY

**CRITICAL: SQUARE ASSEMBLY BEFORE PROCEEDING TO NEXT STEPS.**

**WARNING: THERE WILL BE ALIGNMENT ISSUES IF THE STRUCTURE IS NOT PROPERLY SQUARED.**

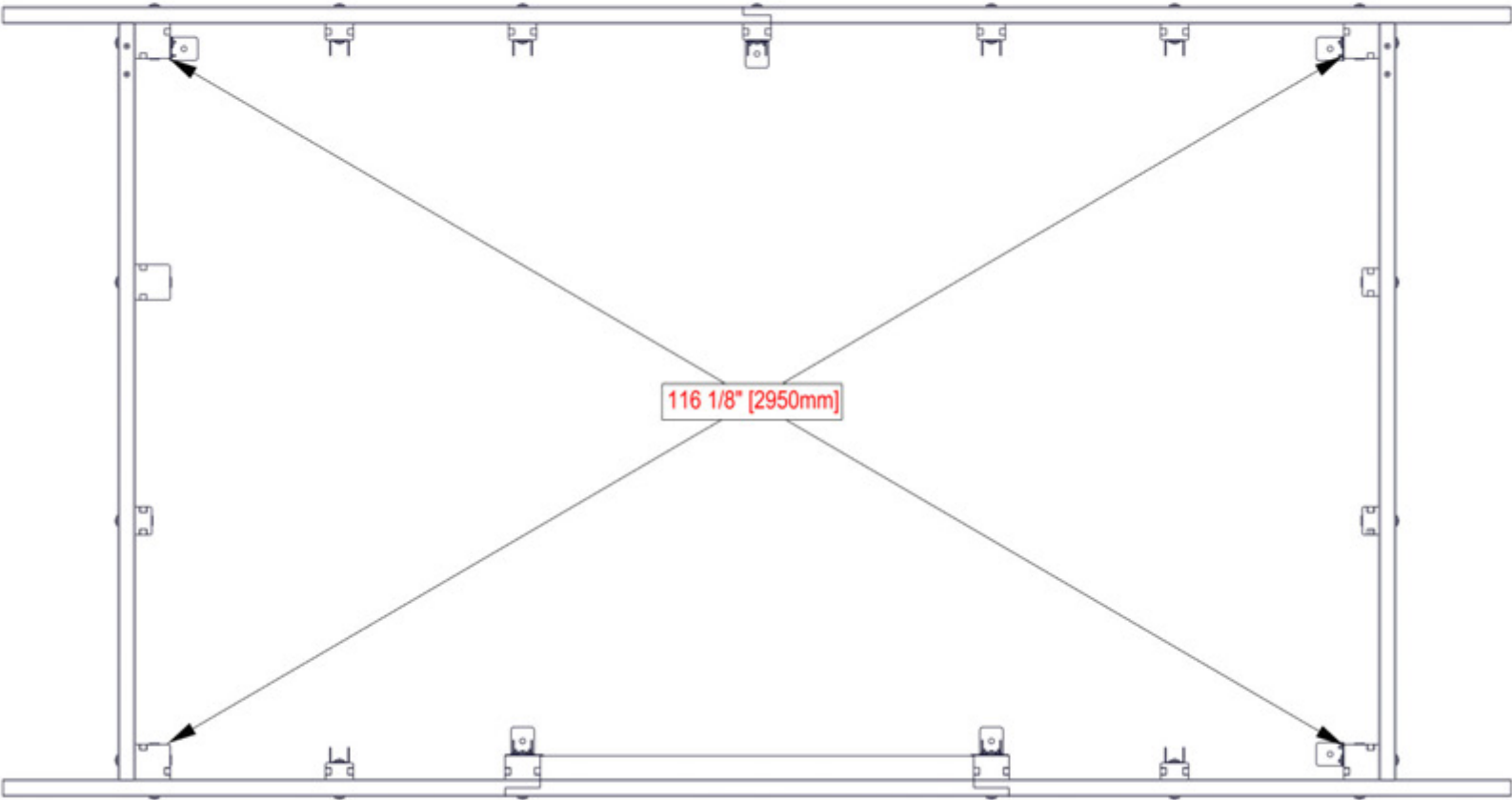

# STEP 27 - SIDE WALL ASSEMBLY

QTY	PART NUMBER	DESCRIPTION
36	H100382	SCREW PFH 8x1 3/4 BLK

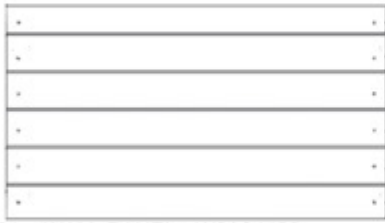

WP01 WALL PANEL - W2A04433  
(x1) 1 1/16"x17 13/16"x31 9/16" (27x453x801)

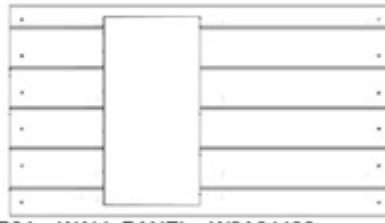

WP04 WALL PANEL - W2A04436  
(x1) 1 1/16"x17 1/2"x31 9/16" (27x445x801)



WP05 WALL PANEL - W2A04440  
(x1) 1 1/16"x17 1/2"x31 9/16" (27x445x801)

- TOP OF PANELS SHOULD BE FLUSH WITH TOP OF RUNNING BOARD.
- CENTER BETWEEN POSTS AND UPRIGHTS.
- ATTACH AS SHOWN.

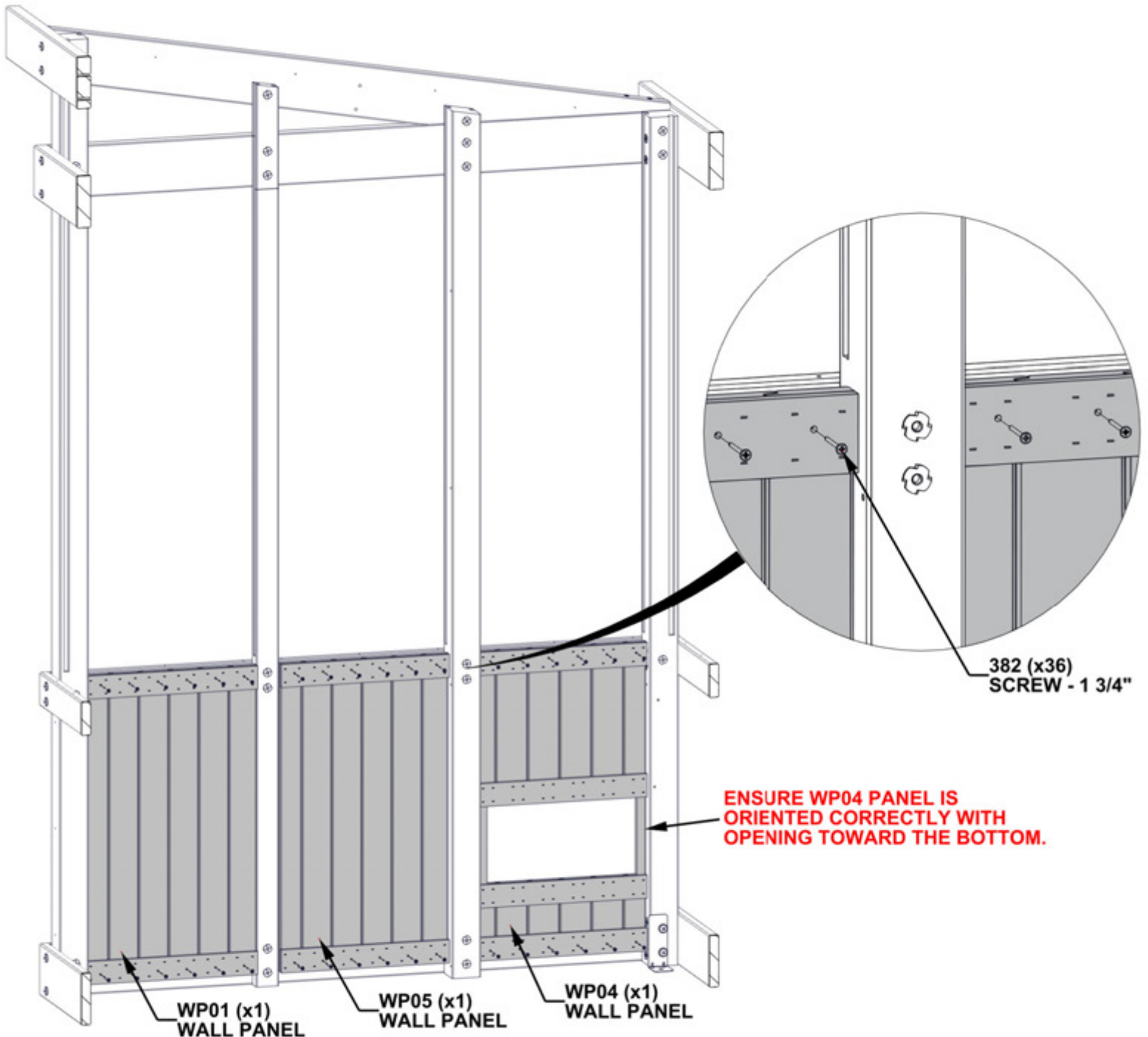

ONLY LEFT SIDE OF GREENHOUSE SHOWN FOR DETAIL.

# STEP 28 - BACK WALL ASSEMBLY

QTY	PART NUMBER	DESCRIPTION
56	H100382	SCREW PFH 8x1 3/4 BLK



WP02 WALL PANEL - W2A04434  
(x4) 1 1/16"x13 3/16"x31 9/16" (27x335x801)



WP07 WALL PANEL - W2A04443  
(x2) 1 1/16"x17 9/16"x31 9/16" (27x446x801)

- TOP OF PANELS SHOULD BE FLUSH WITH TOP OF RUNNING BOARD.
- CENTER BETWEEN POSTS AND UPRIGHTS.
- ATTACH AS SHOWN.

382 (x56)  
SCREW - 1 3/4"

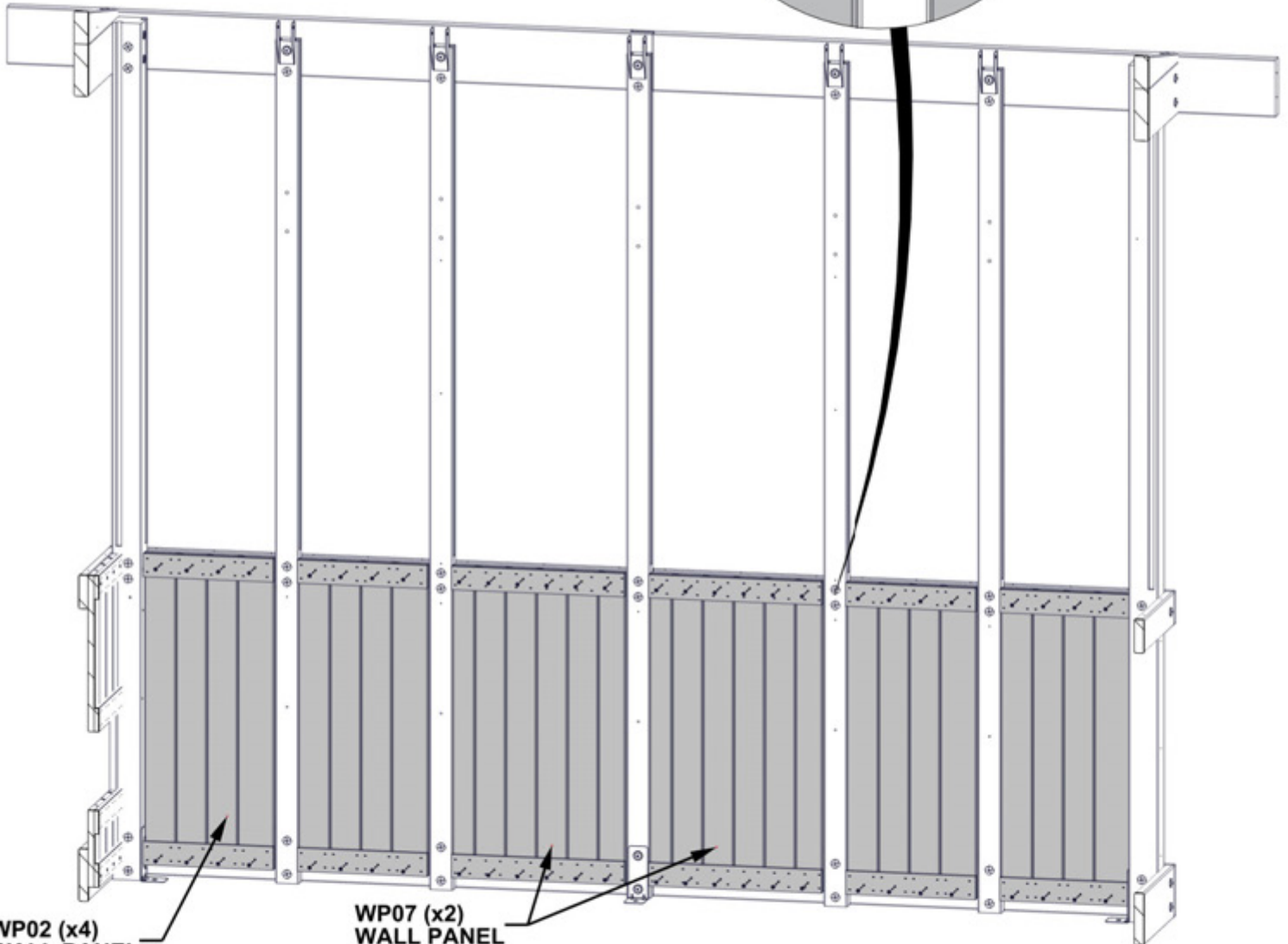
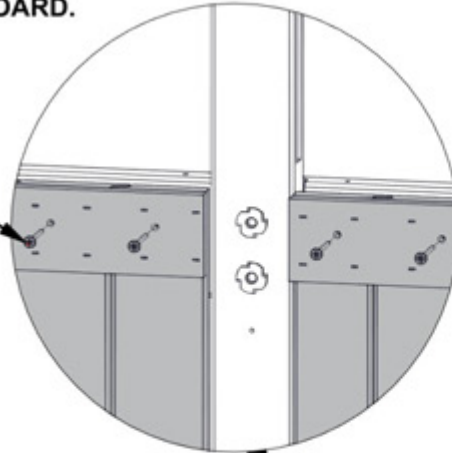

ONLY BACK OF GREENHOUSE SHOWN FOR DETAIL.

# STEP 29 - SIDE WALL ASSEMBLY

QTY	PART NUMBER	DESCRIPTION
36	H100382	SCREW PFH 8x1 3/4 BLK

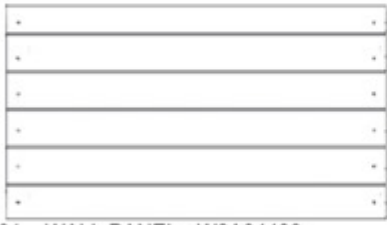

WP01 WALL PANEL - W2A04433  
(x1) 1 1/16"x17 13/16"x31 9/16" (27x453x801)

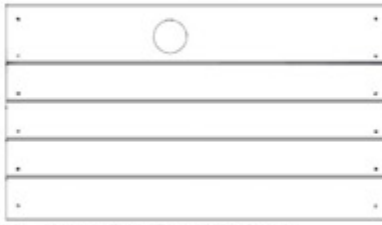

WP06 WALL PANEL - W2A04441  
(x1) 1 1/16"x17 13/16"x31 9/16" (27x453x801)



WP08 WALL PANEL - W2A04447  
(x1) 1 1/16"x17 13/16"x31 9/16" (27x453x801)

- TOP OF PANELS SHOULD BE FLUSH WITH TOP OF RUNNING BOARD.
- CENTER BETWEEN POSTS AND UPRIGHTS.
- ATTACH AS SHOWN.

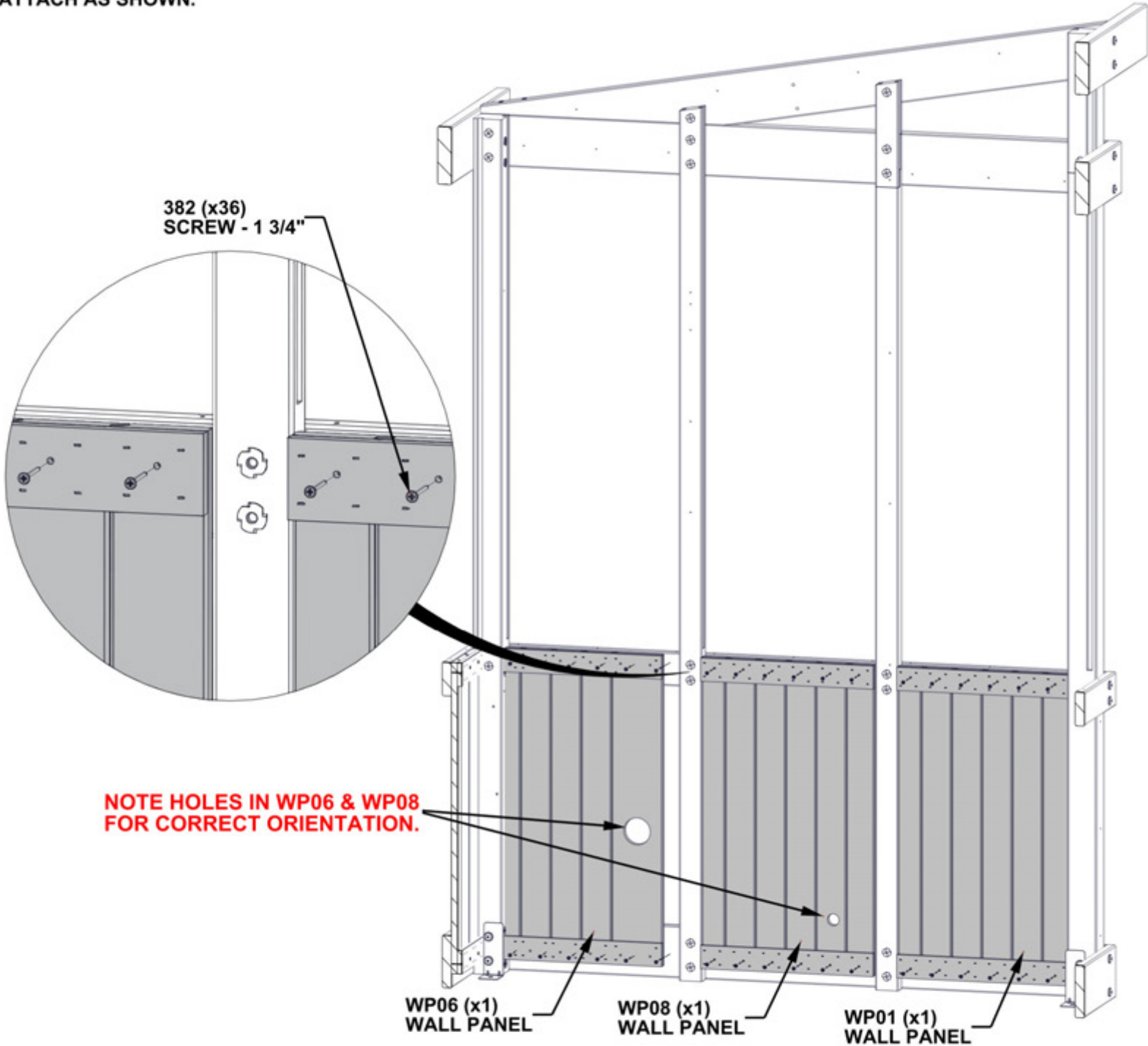

ONLY RIGHT SIDE OF GREENHOUSE SHOWN FOR DETAIL.

# STEP 30 - FRONT WALL ASSEMBLY

QTY	PART NUMBER	DESCRIPTION
32	H100382	SCREW PFH 8x1 3/4 BLK



WP02 WALL PANEL - W2A04434  
(x2) 1 1/16"x13 3/16"x31 9/16" (27x335x801)

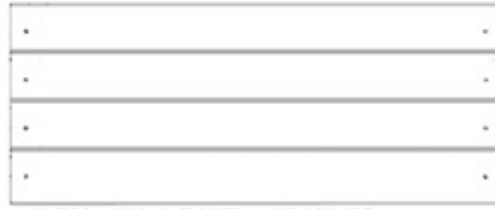

WP03 WALL PANEL - W2A04435  
(x2) 1 1/16"x12 7/8"x31 9/16" (27x327x801)

- TOP OF PANELS SHOULD BE FLUSH WITH TOP OF RUNNING BOARD.
- CENTER BETWEEN POSTS AND UPRIGHTS.
- ATTACH AS SHOWN.

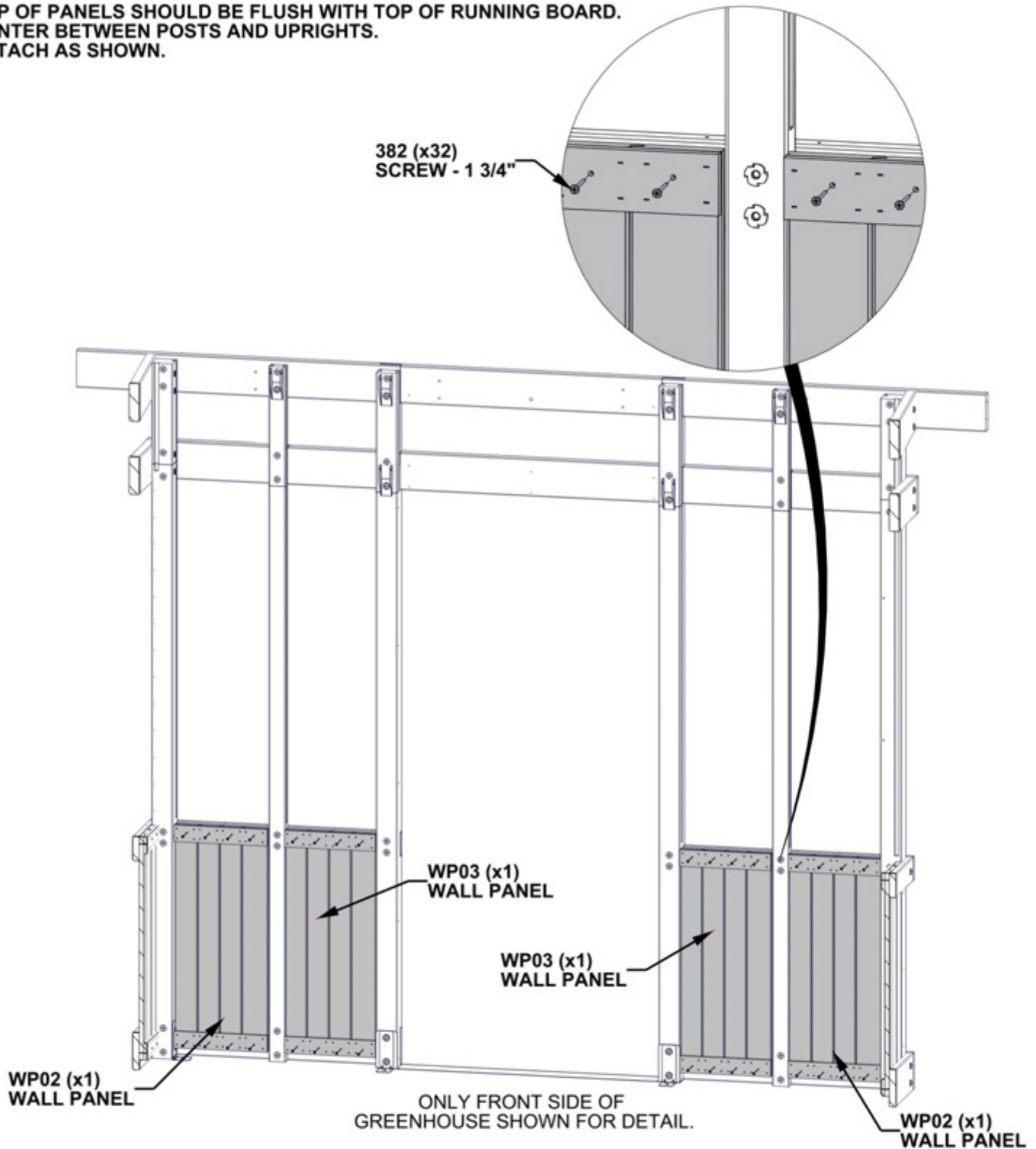

# STEP 31 - COVER BOARD ASSEMBLY

QTY	PART NUMBER	DESCRIPTION
12	H100200	SCREW PFH 8x1 1/2 BLK



M01 COVER BOARD - W4L20556  
(x4) 5/8"x3 3/8"x24 3/16" (16x86x614)

- ALIGN PILOT HOLES IN COVER BOARDS WITH PILOT HOLES IN POSTS AND UPRIGHTS.
- ATTACH AS SHOWN.

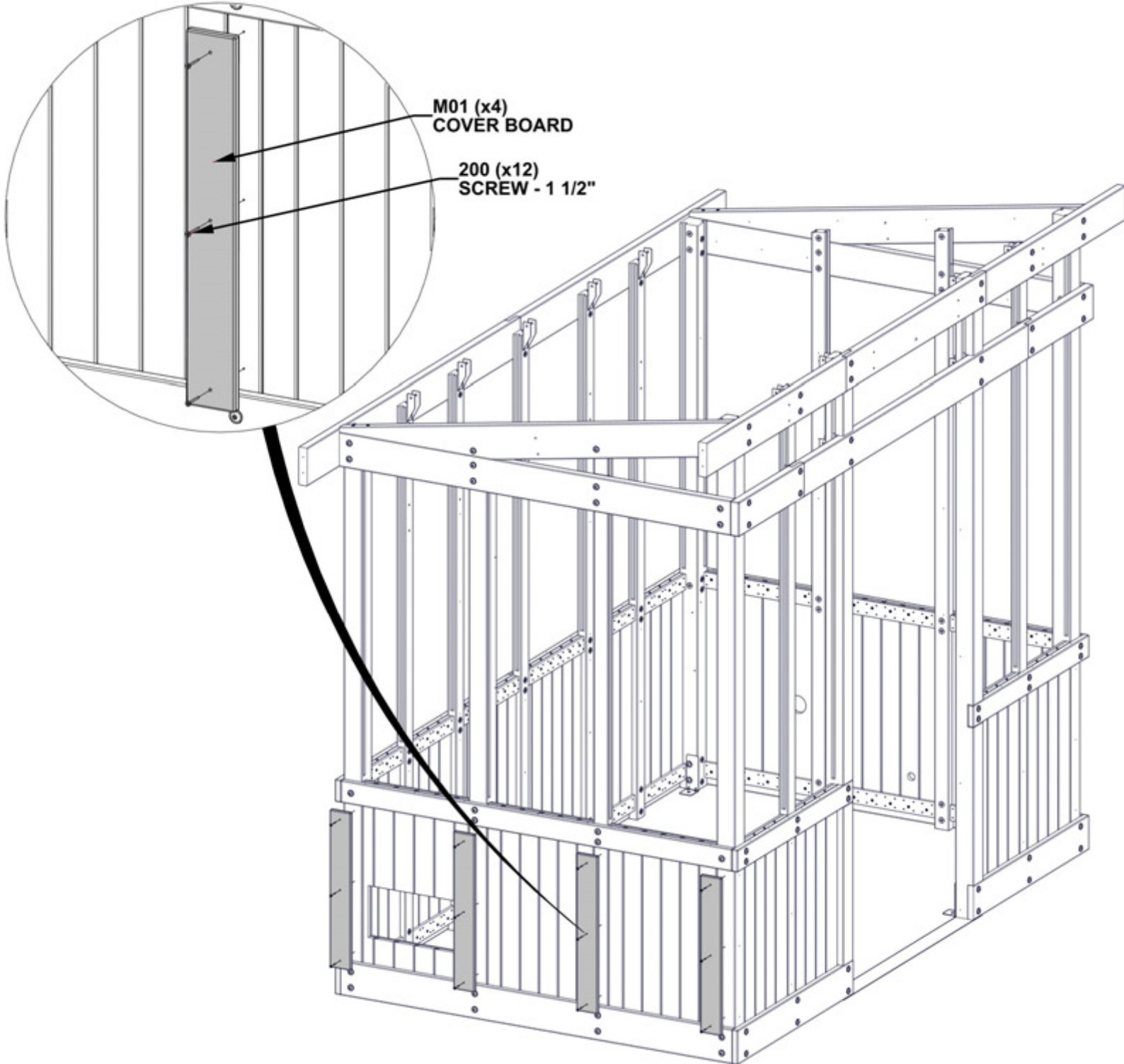

M01 (x4)  
COVER BOARD

200 (x12)  
SCREW - 1 1/2"

# STEP 32 - COVER BOARD ASSEMBLY

QTY	PART NUMBER	DESCRIPTION
21	H100200	SCREW PFH 8x1 1/2 BLK



M01 COVER BOARD - W4L20556  
(x5) 5/8"x3 3/8"x24 3/16" (16x86x614)



Y01 COVER BOARD - W4L20592  
(x2) 5/8"x4"x24 3/16" (16x102x614)

- ALIGN PILOT HOLES IN COVER BOARDS WITH PILOT HOLES IN POSTS AND UPRIGHTS.
- ATTACH AS SHOWN.

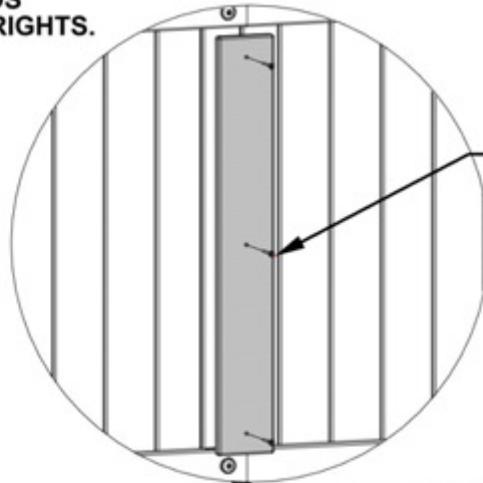

200 (x21)  
SCREW - 1 1/2"

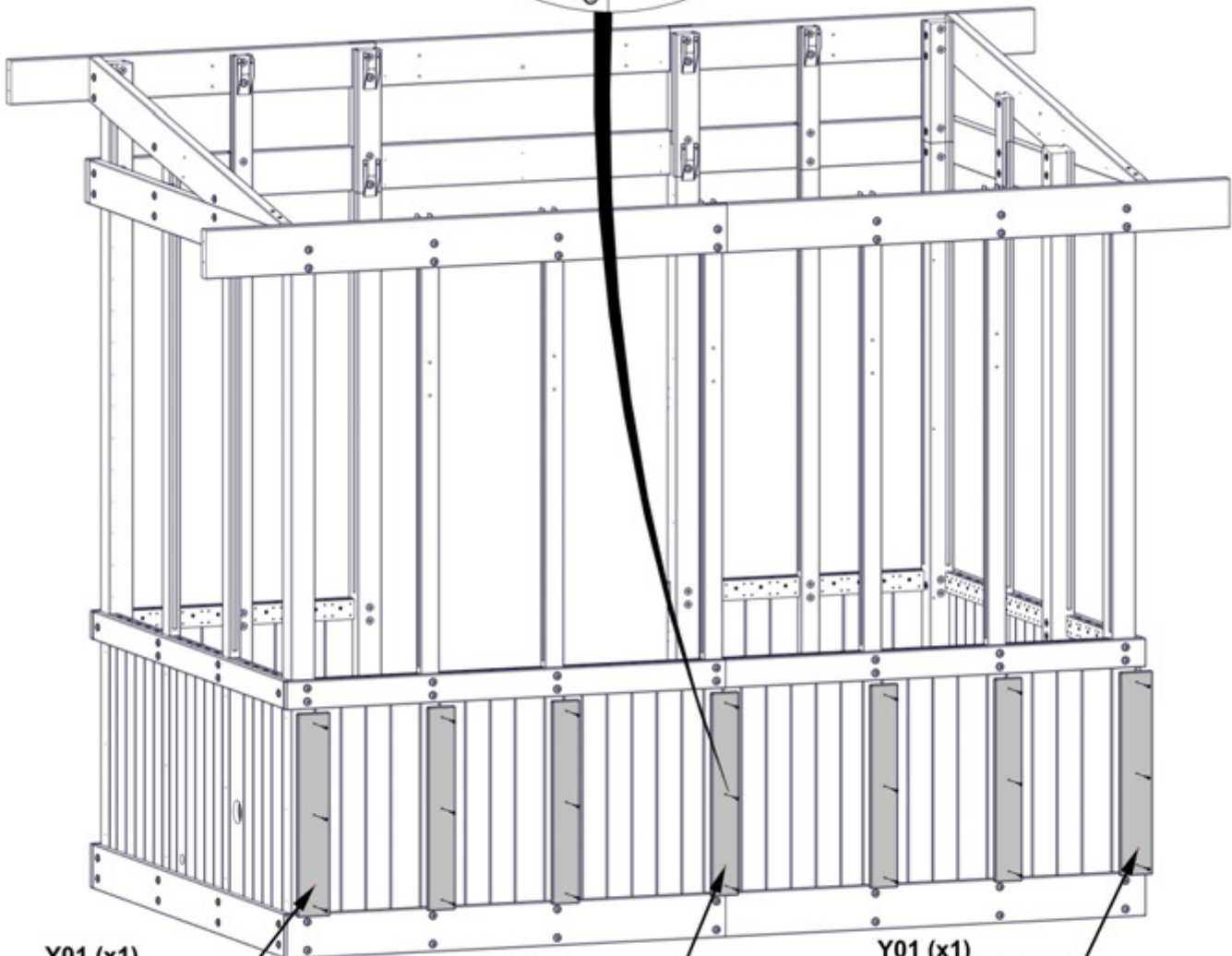

Y01 (x1)  
COVER BOARD

M01 (x5)  
COVER BOARD

Y01 (x1)  
COVER BOARD

# STEP 33 - COVER BOARD ASSEMBLY

QTY	PART NUMBER	DESCRIPTION
12	H100200	SCREW PFH 8x1 1/2 BLK



M01 COVER BOARD - W4L20556  
(x4) 5/8"x3 3/8"x24 3/16" (16x86x614)

- ALIGN PILOT HOLES.

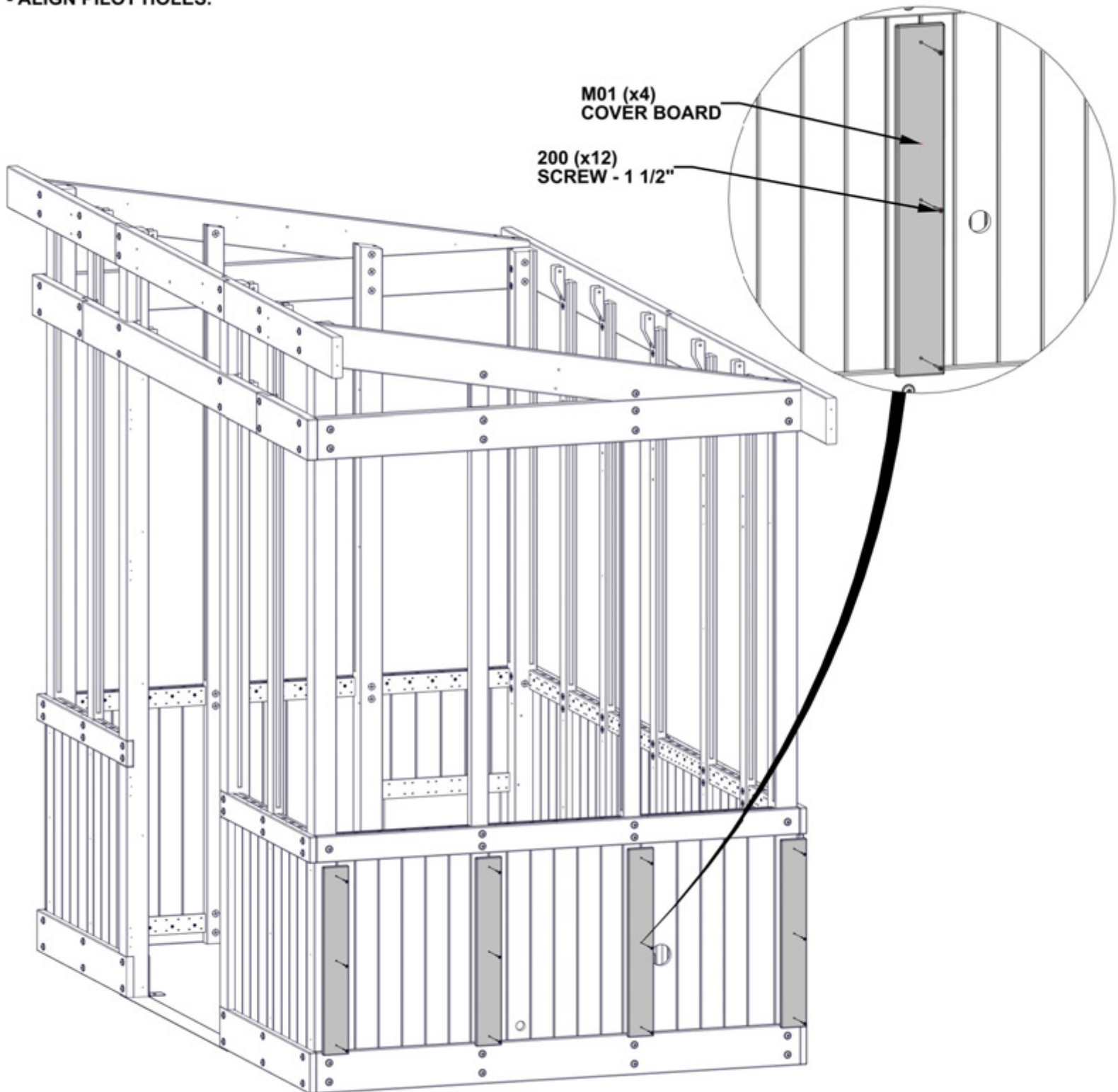

# STEP 34 - COVER BOARD ASSEMBLY

QTY	PART NUMBER	DESCRIPTION
12	H100200	SCREW PFH 8x1 1/2 BLK
6	H100380	SCREW PFH 8x1 1/8 BLK



N01 COVER BOARD - W4L20580  
(x2) 5/8"x2 3/8"x25" (16x60x614)



M01 COVER BOARD - W4L20556  
(x2) 5/8"x3 3/8"x24 3/16" (16x86x614)



Y01 COVER BOARD - W4L20592  
(x2) 5/8"x4"x24 3/16" (16x102x614)

- ALIGN PILOT HOLES IN COVER BOARDS WITH PILOT HOLES IN POSTS AND UPRIGHTS.
- ATTACH AS SHOWN.

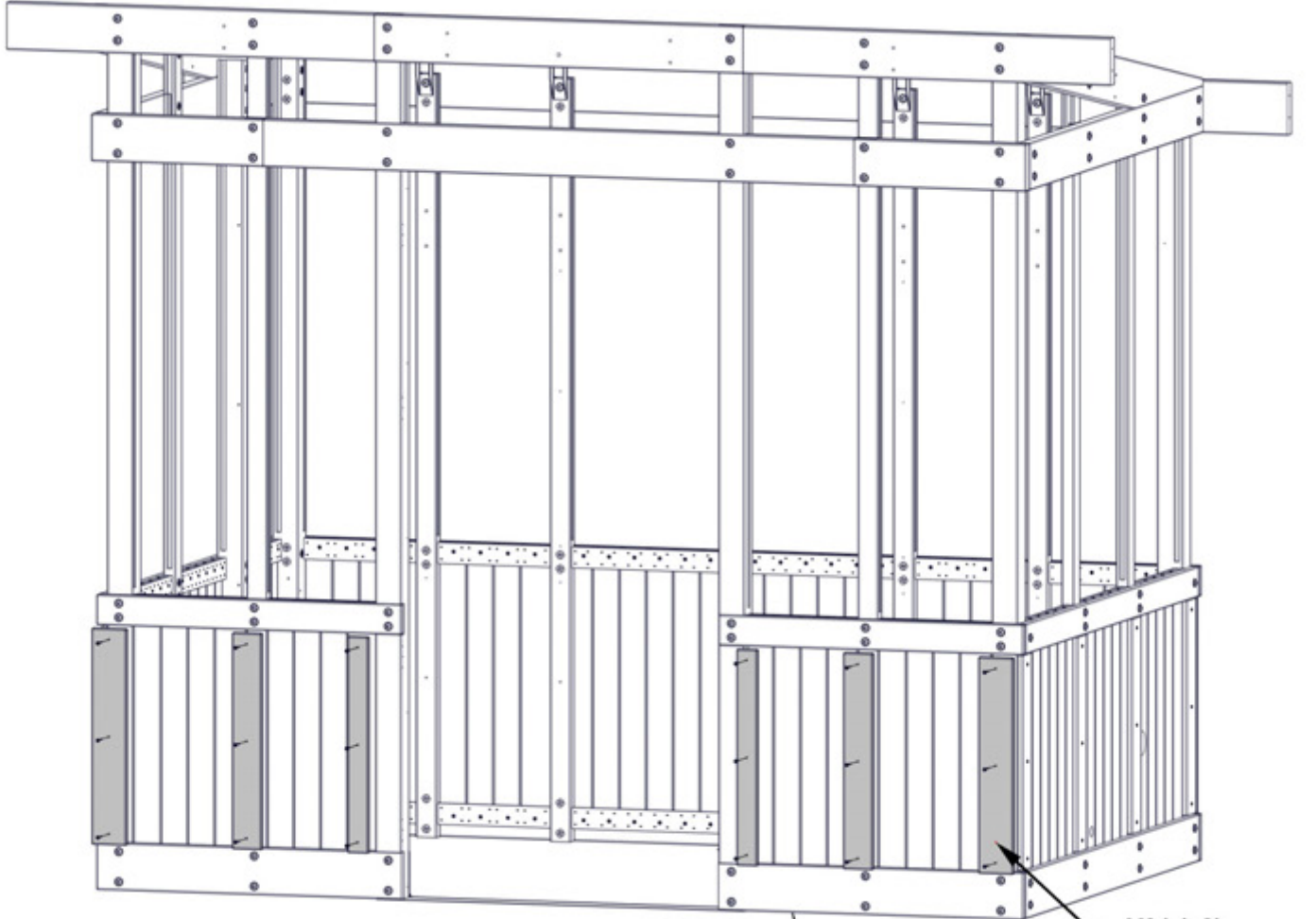

Y01 (x2)  
COVER BOARD

N01 (x2)  
COVER BOARD

M01 (x2)  
COVER BOARD

**WITH N01 BOARDS AGAINST POSTS AS SHOWN, PRE-DRILL PILOT HOLES WITH AN 1/8" [3mm] DRILL BIT USING THE BOARD AS A GUIDE THEN ATTACH.**

380 (x6)  
SCREW - 1 1/8"

200 (x12)  
SCREW - 1 1/2"

# STEP 35 - WINDOW SILL ASSEMBLY

QTY	PART NUMBER	DESCRIPTION
9	H100391	SCREW PFH 8x2 BLK



E06 WINDOW SILL - W4L20588  
(x1) 1 7/16"x3 3/8"x22 1/16" (36x86x561)



E10 WINDOW SILL - W4L20625  
(x1) 1 7/16"x3 3/8"x22 1/16" (36x86x561)



E11 WINDOW SILL - W4L20626  
(x1) 1 7/16"x3 3/8"x20 1/4" (36x86x515)

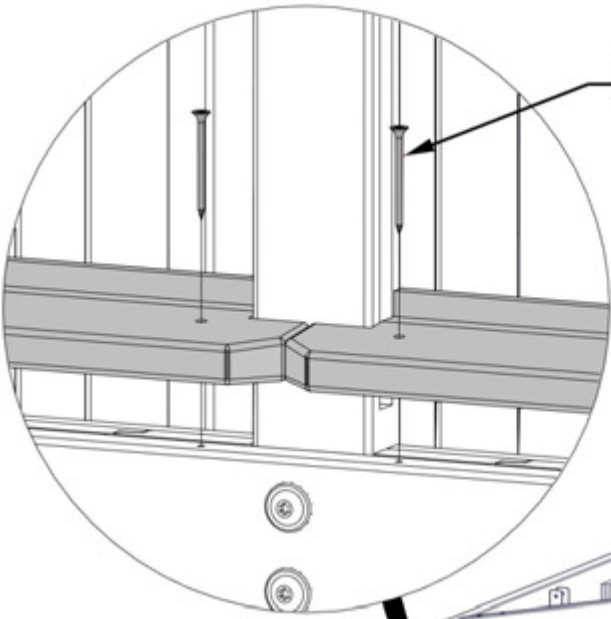

391 (x9)  
SCREW - 2"

ATTACH WINDOW SILLS USING PILOT HOLES IN RUNNING BOARD.

E10 (x1)  
WINDOW SILL

E11 (x1)  
WINDOW SILL

E06 (x1)  
WINDOW SILL

# STEP 36 - WINDOW SILL ASSEMBLY

QTY	PART NUMBER	DESCRIPTION
18	H100391	SCREW PFH 8x2 BLK

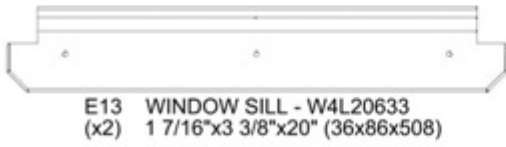
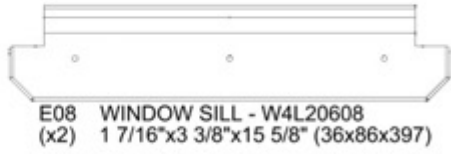
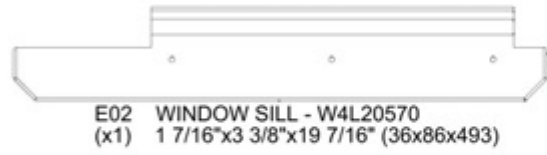
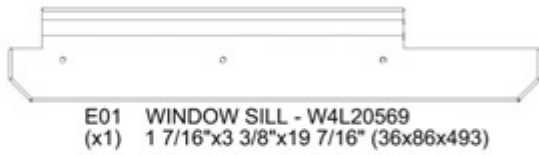

ATTACH WINDOW SILLS USING PILOT HOLES IN RUNNING BOARD.

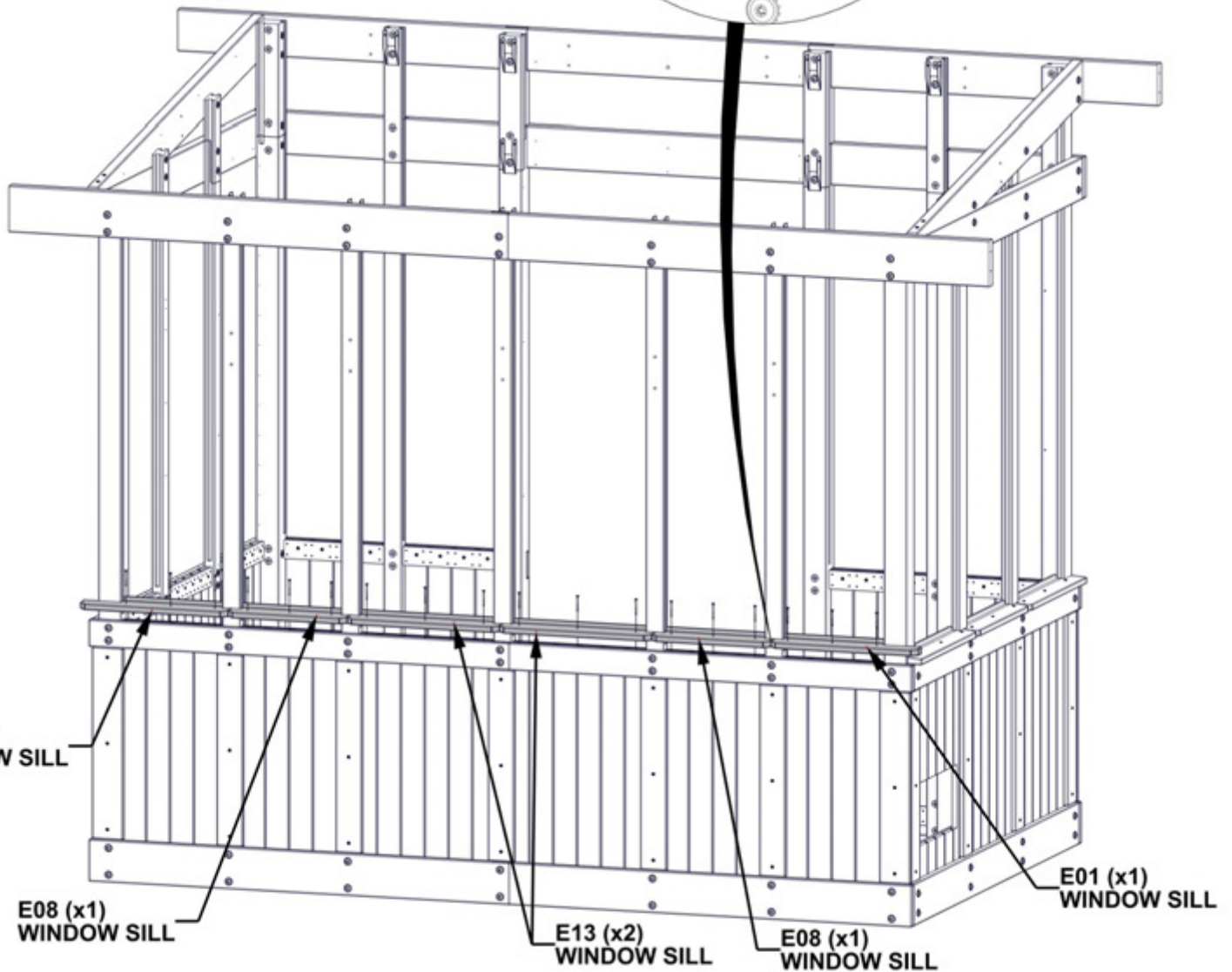
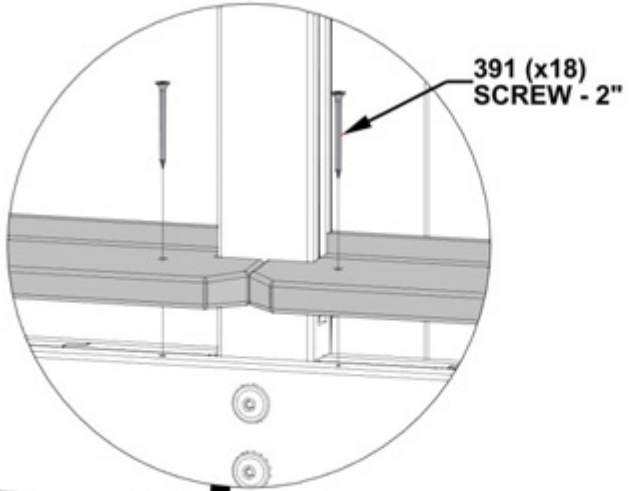

# STEP 37 - WINDOW SILL ASSEMBLY

QTY	PART NUMBER	DESCRIPTION
9	H100391	SCREW PFH 8x2 BLK



AJ03 WINDOW SILL - W4L20589  
(x1) 1 7/16"x4"x22 1/16" (36x102x561)



E05 WINDOW SILL - W4L20587  
(x1) 1 7/16"x3 3/8"x20 1/4" (36x86x515)



E06 WINDOW SILL - W4L20588  
(x1) 1 7/16"x3 3/8"x22 1/16" (36x86x561)

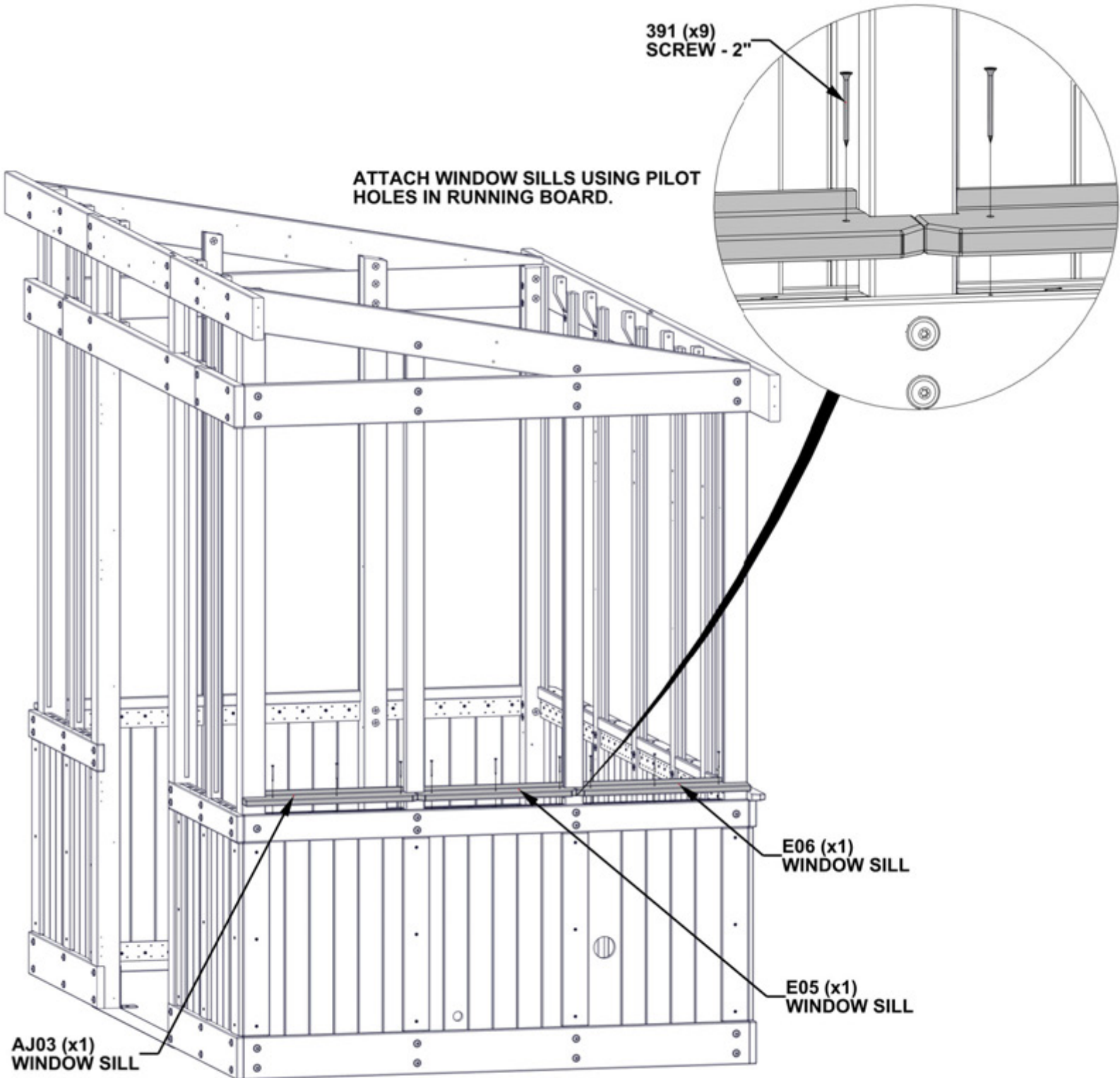

# STEP 38 - WINDOW SILL ASSEMBLY

QTY	PART NUMBER	DESCRIPTION
12	H100391	SCREW PFH 8x2 BLK



E01 WINDOW SILL - W4L20569  
(x1) 1 7/16"x3 3/8"x19 7/16" (36x86x493)



E02 WINDOW SILL - W4L20570  
(x1) 1 7/16"x3 3/8"x19 7/16" (36x86x493)



E03 WINDOW SILL - W4L20572  
(x1) 1 7/16"x3 3/8"x14 1/8" (36x86x358)



E04 WINDOW SILL - W4L20573  
(x1) 1 7/16"x3 3/8"x14 1/8" (36x86x358)

ATTACH WINDOW SILLS USING  
PILOT HOLES IN RUNNING BOARD.

391 (x12)  
SCREW - 2"

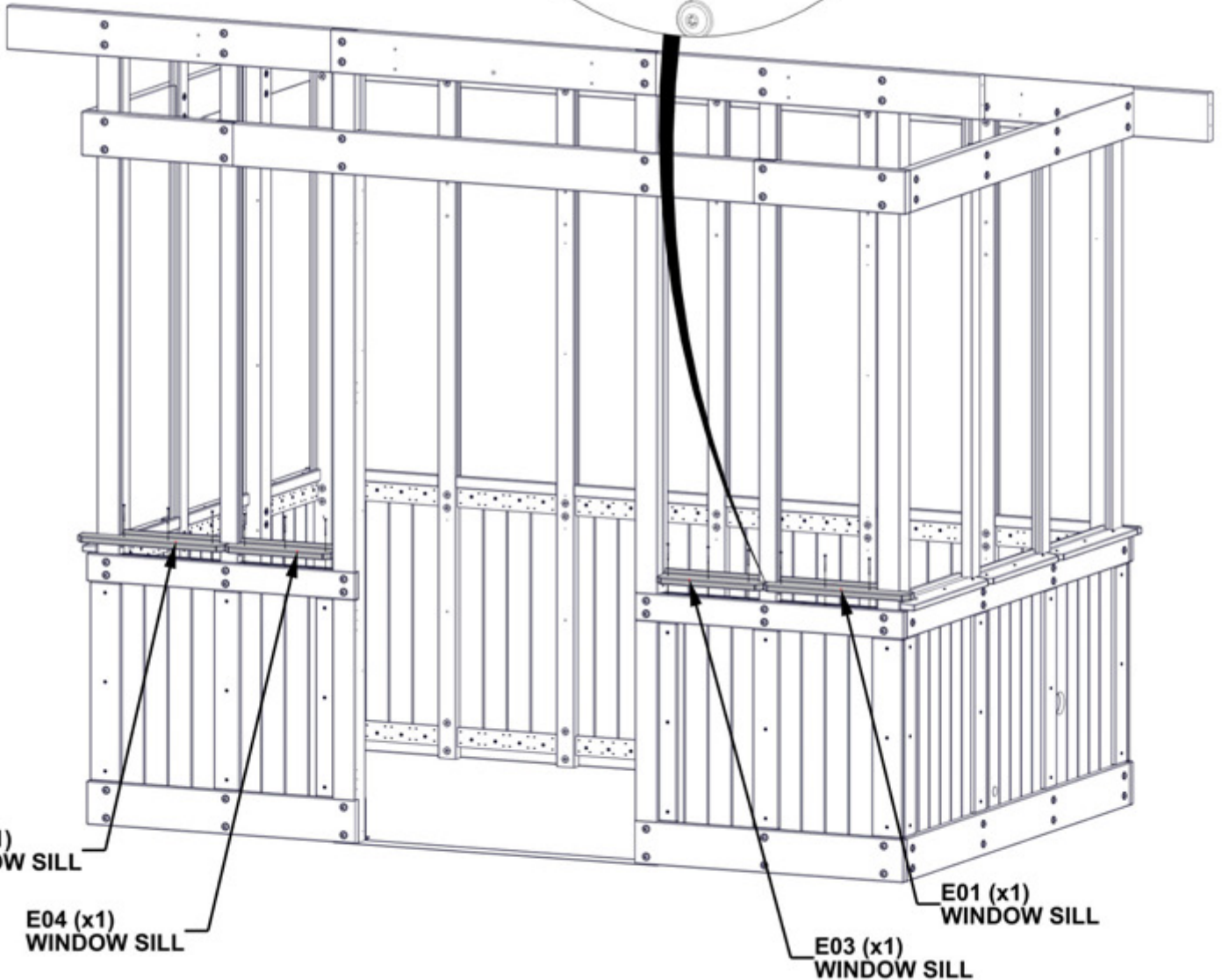
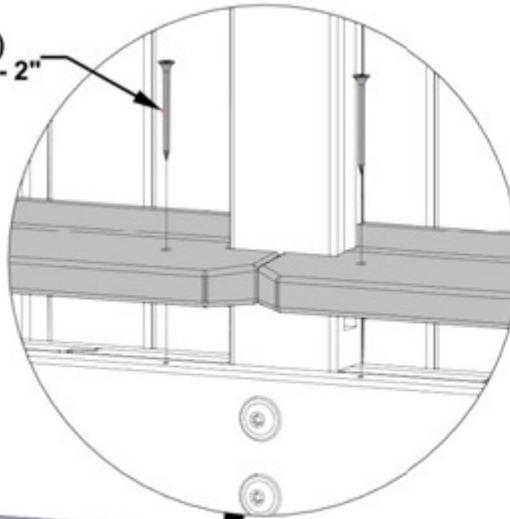

E02 (x1)  
WINDOW SILL

E04 (x1)  
WINDOW SILL

E03 (x1)  
WINDOW SILL

E01 (x1)  
WINDOW SILL

# STEP 39 - PERGOLA ASSEMBLY

QTY	PART NUMBER	DESCRIPTION
8	H101008	SCREW CONFIRMAT 7x3 BLK



AJ01 PERGOLA RAFTER - W4L20716  
(x4) 1 7/16"x4"x19 3/8" (36x102x492)

- ATTACH PERGOLA RAFTERS USING PILOT HOLES IN THE END OF BOARD.
- ENSURE PILOT HOLES ON THE EDGE FACE UP.

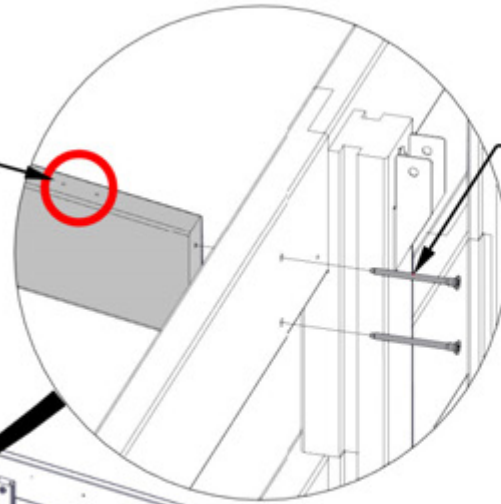

1008 (x8)  
CONFIRMAT SCREW - 3"

AJ01 (x4)  
PERGOLA RAFTER

ENSURE PERGOLA  
RAFTERS ARE  
ANGLED UP.

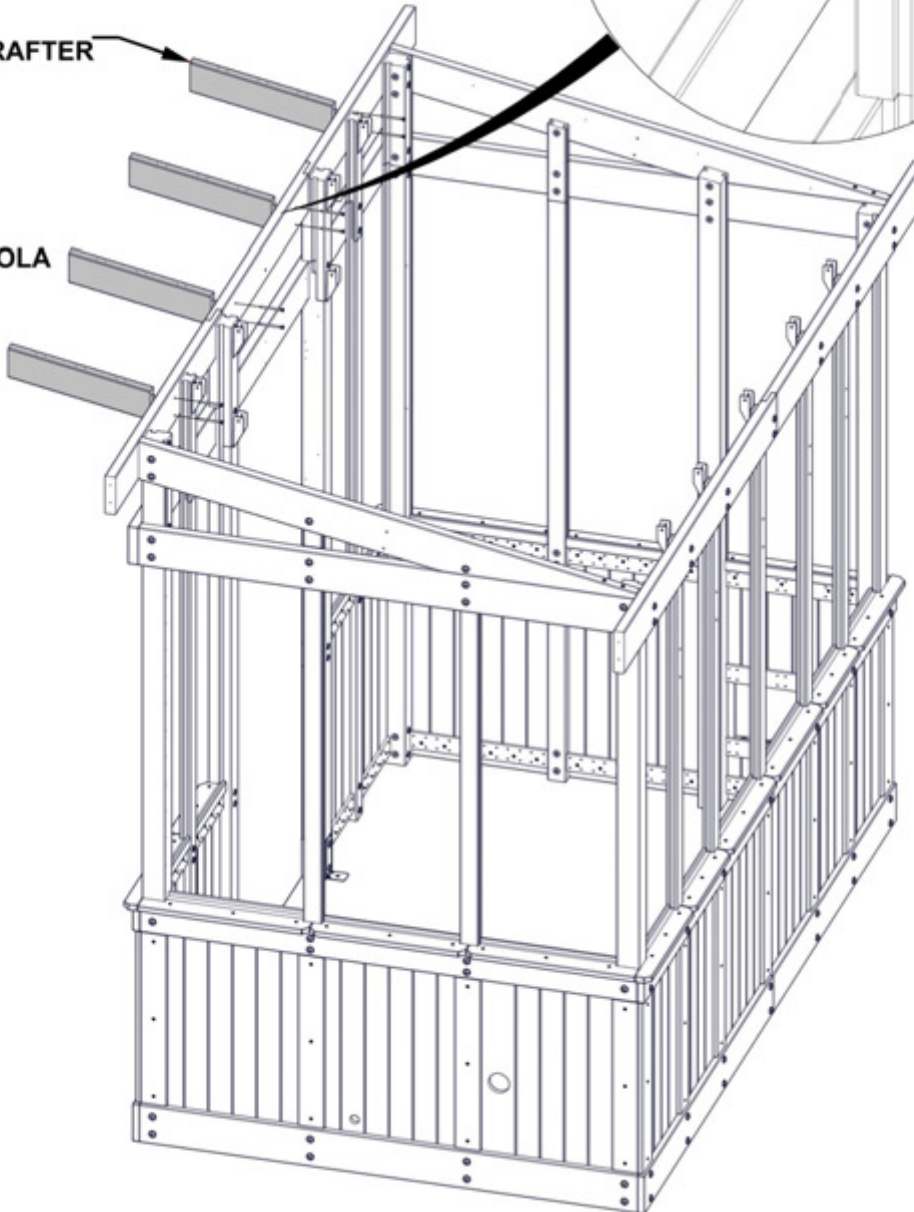

# STEP 40 - PERGOLA ASSEMBLY

QTY	PART NUMBER	DESCRIPTION
2	H101008	SCREW CONFIRMAT 7x3 BLK



AJ02 PERGOLA SPACER - W4L20717  
(x1) 1 7/16"x4"x9 13/16" (36x102x250)

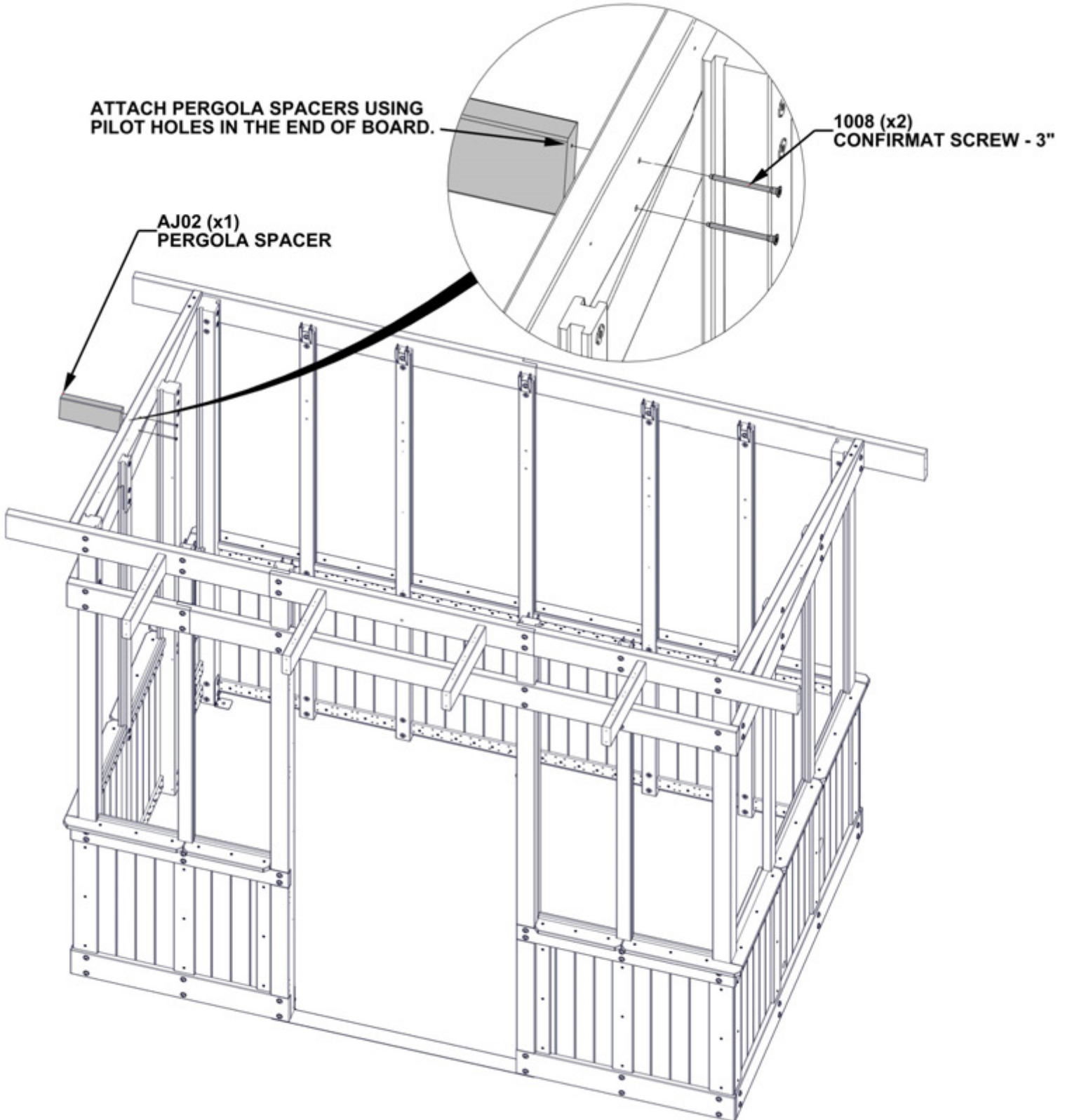

# STEP 41 - PERGOLA ASSEMBLY

QTY	PART NUMBER	DESCRIPTION
2	H101008	SCREW CONFIRMAT 7x3 BLK



AJ02 PERGOLA SPACER - W4L20717  
(x1) 1 7/16"x4"x9 13/16" (36x102x250)

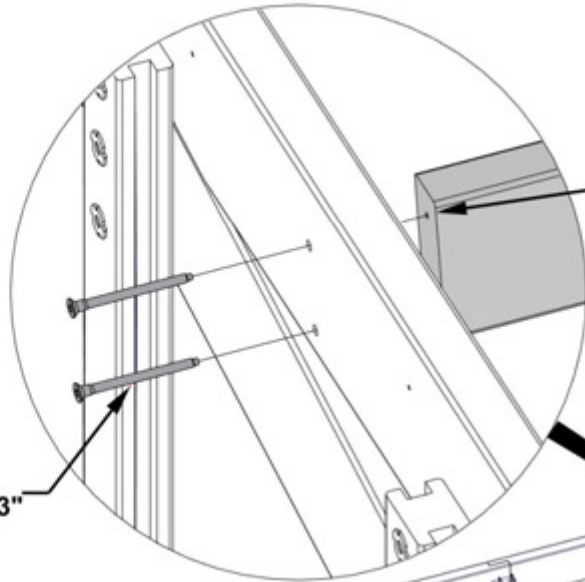

ATTACH PERGOLA SPACERS USING  
PILOT HOLES IN THE END OF BOARD.

AJ02 (x1)  
PERGOLA SPACER

1008 (x2)  
CONFIRMAT SCREW - 3"

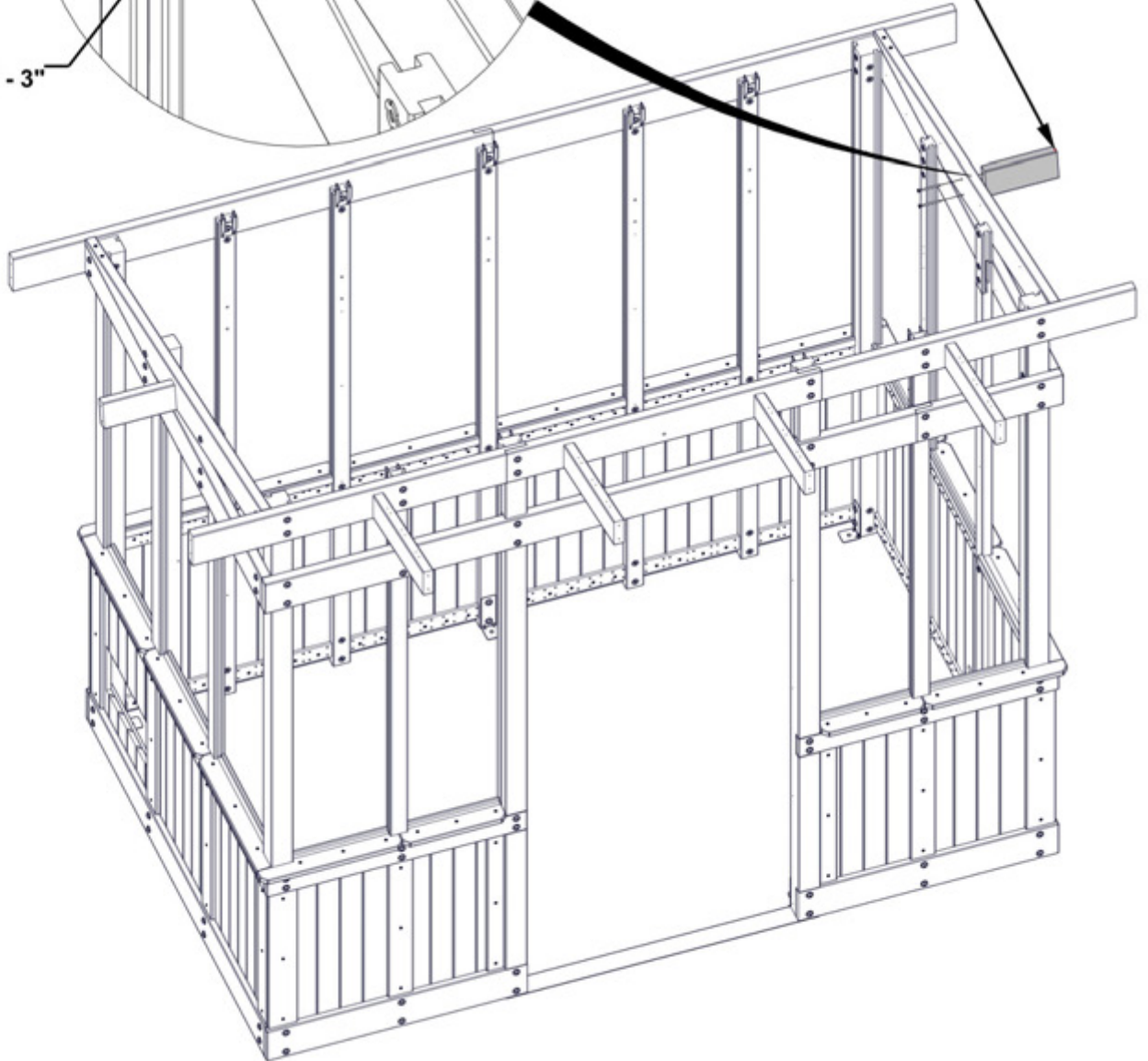

# STEP 42 - PERGOLA ASSEMBLY

QTY	PART NUMBER	DESCRIPTION
6	H101008	SCREW CONFIRMAT 7x3 BLK



D11 FASCIA - W4L20718  
(x1) 1 7/16"x5 1/4"x35 1/2" (36x134x902)



D12 FASCIA - W4L20719  
(x1) 1 7/16"x5 1/4"x53 13/16" (36x134x1367)

- NOTE ORIENTATION OF NOTCHES IN D11 AND D12 FOR CORRECT ORIENTATION.
- ATTACH USING PILOT HOLES IN ENDS OF BOARDS AS SHOWN.

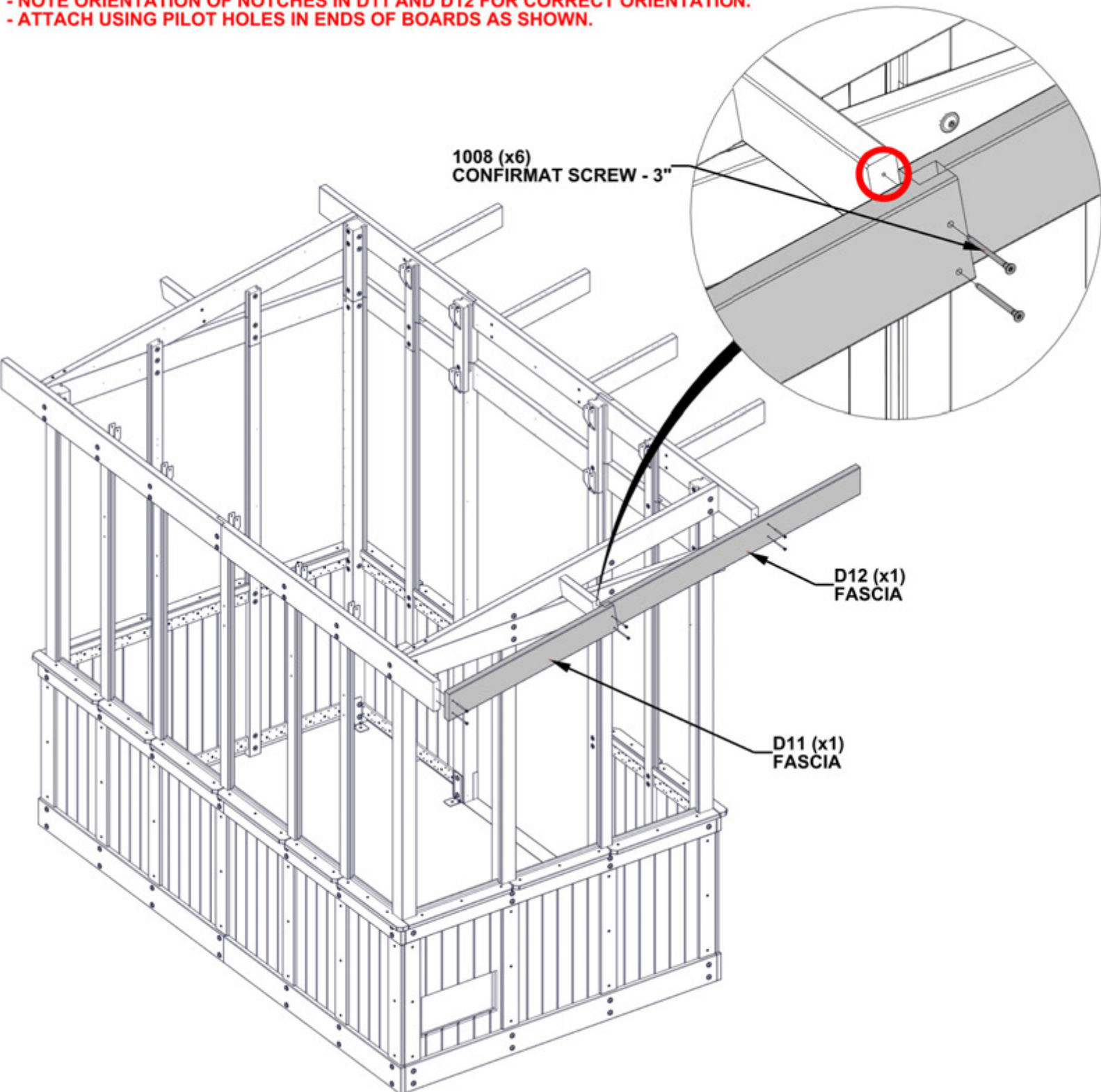

# STEP 43 - PERGOLA ASSEMBLY

QTY	PART NUMBER	DESCRIPTION
6	H101008	SCREW CONFIRMAT 7x3 BLK



D11 FASCIA - W4L20718  
(x1) 1 7/16"x5 1/4"x35 1/2" (36x134x902)



D13 FASCIA - W4L20720  
(x1) 1 7/16"x5 1/4"x53 13/16" (36x134x1367)

- NOTE ORIENTATION OF NOTCHES IN D11 AND D13 FOR CORRECT ORIENTATION.
- ATTACH USING PILOT HOLES IN ENDS OF BOARDS AS SHOWN.

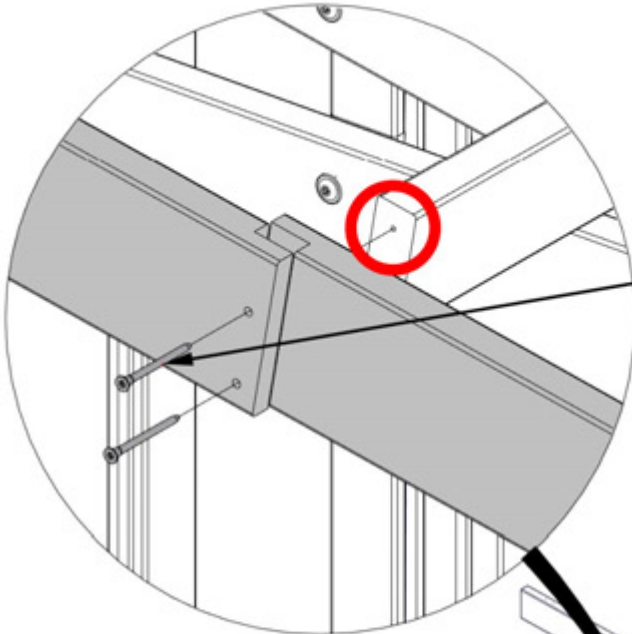

1008 (x6)  
CONFIRMAT SCREW - 3"

D13 (x1)  
FASCIA

D11 (x1)  
FASCIA

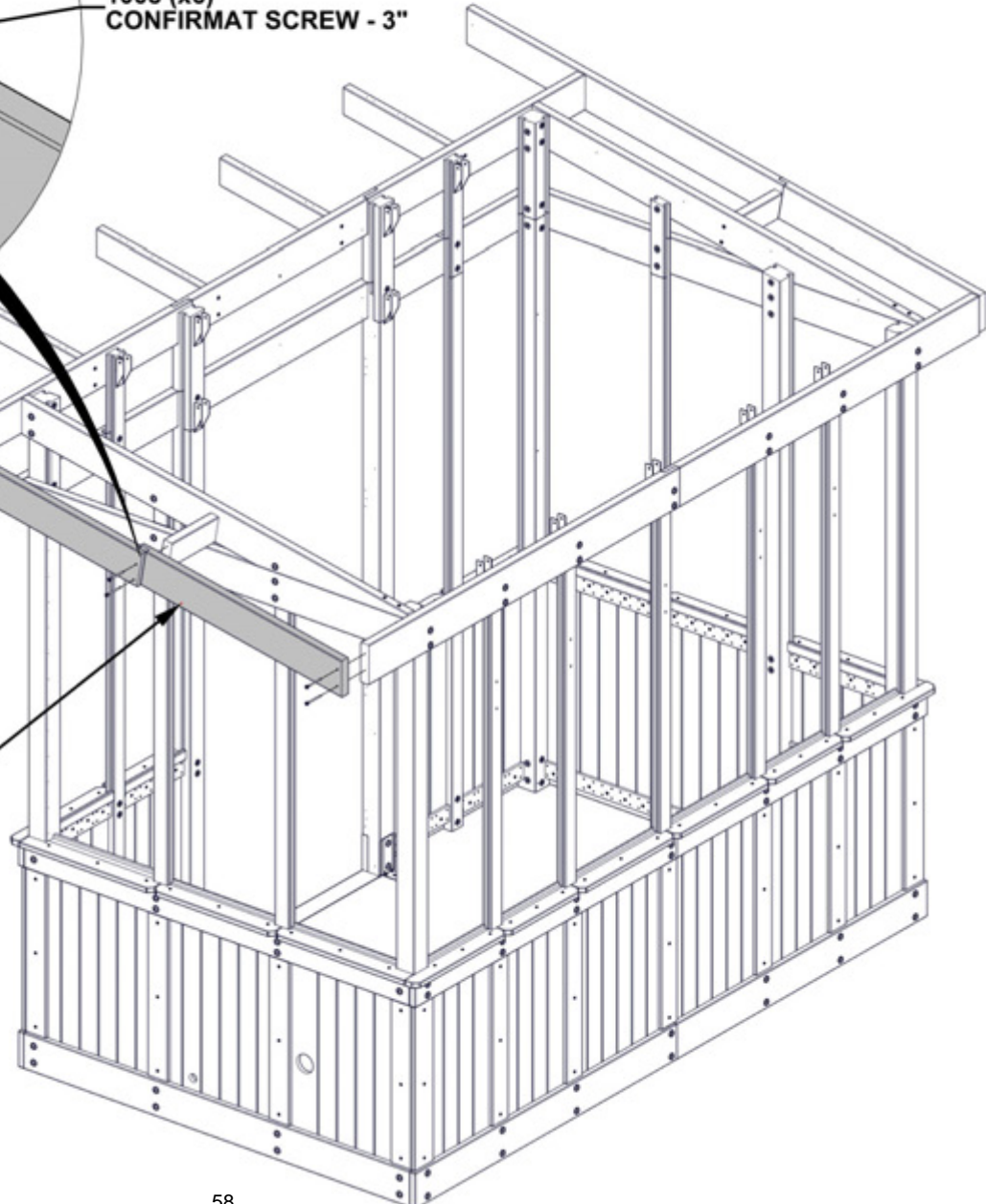

# STEP 44 - PERGOLA ASSEMBLY

QTY	PART NUMBER	DESCRIPTION
12	H101008	SCREW CONFIRMAT 7x3 BLK



D14 FASCIA - W4L20721  
(x1) 1 7/16"x5 1/4"x53 7/16" (36x134x1358)



D15 FASCIA - W4L20722  
(x1) 1 7/16"x5 1/4"x79 7/16" (36x134x2018)

- NOTE ORIENTATION OF NOTCHES IN D14 AND D15 FOR CORRECT ORIENTATION.
- ATTACH USING PILOT HOLES IN ENDS OF BOARDS AS SHOWN.

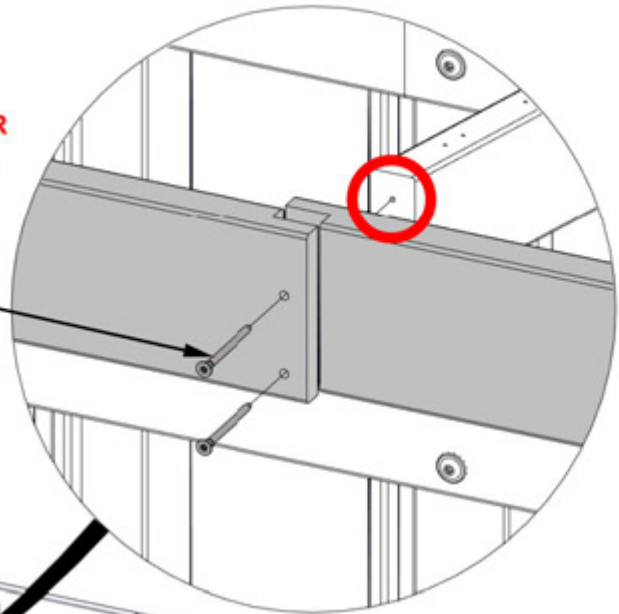

1008 (x12)  
CONFIRMAT SCREW - 3"

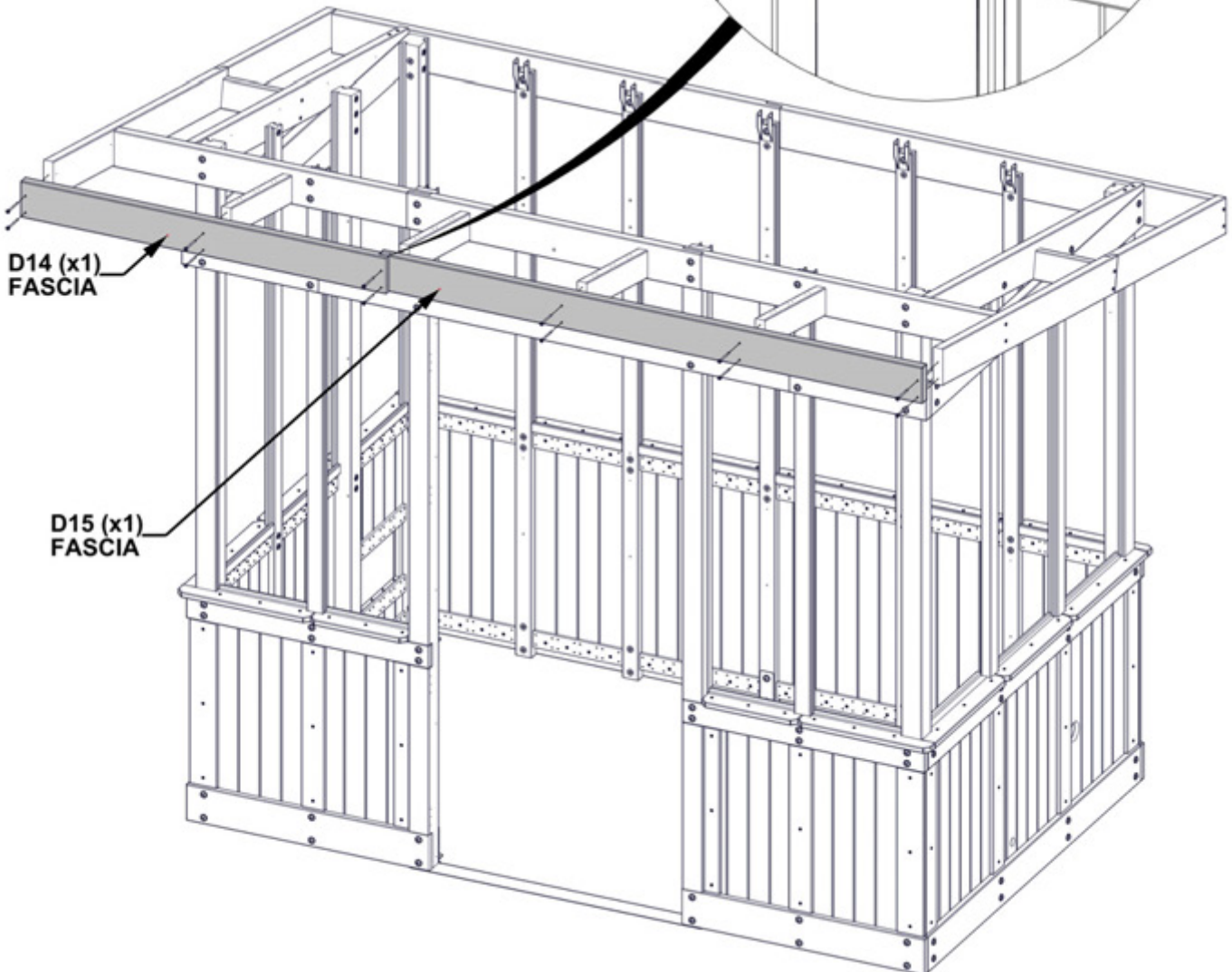

D14 (x1)  
FASCIA

D15 (x1)  
FASCIA

# STEP 45 - DOOR TRIM ASSEMBLY

QTY	PART NUMBER	DESCRIPTION
10	H100391	SCREW PFH 8x2 BLK

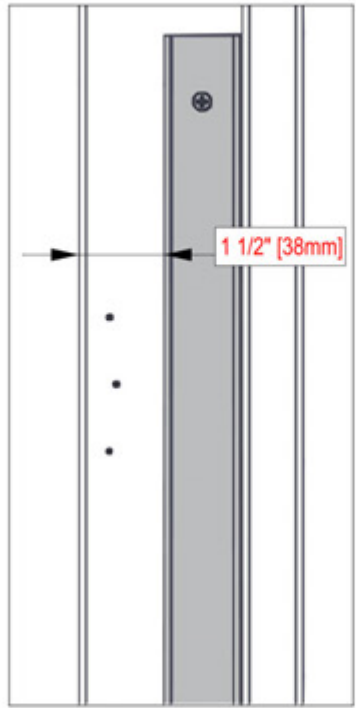
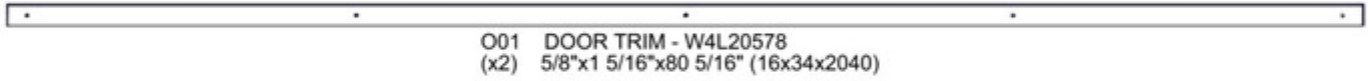

**ENSURE DOOR STOP IS 1 1/2" [38mm] FROM FRONT OF POST AS SHOWN.**

**ALIGN PILOT HOLES AND ATTACH AS SHOWN.**

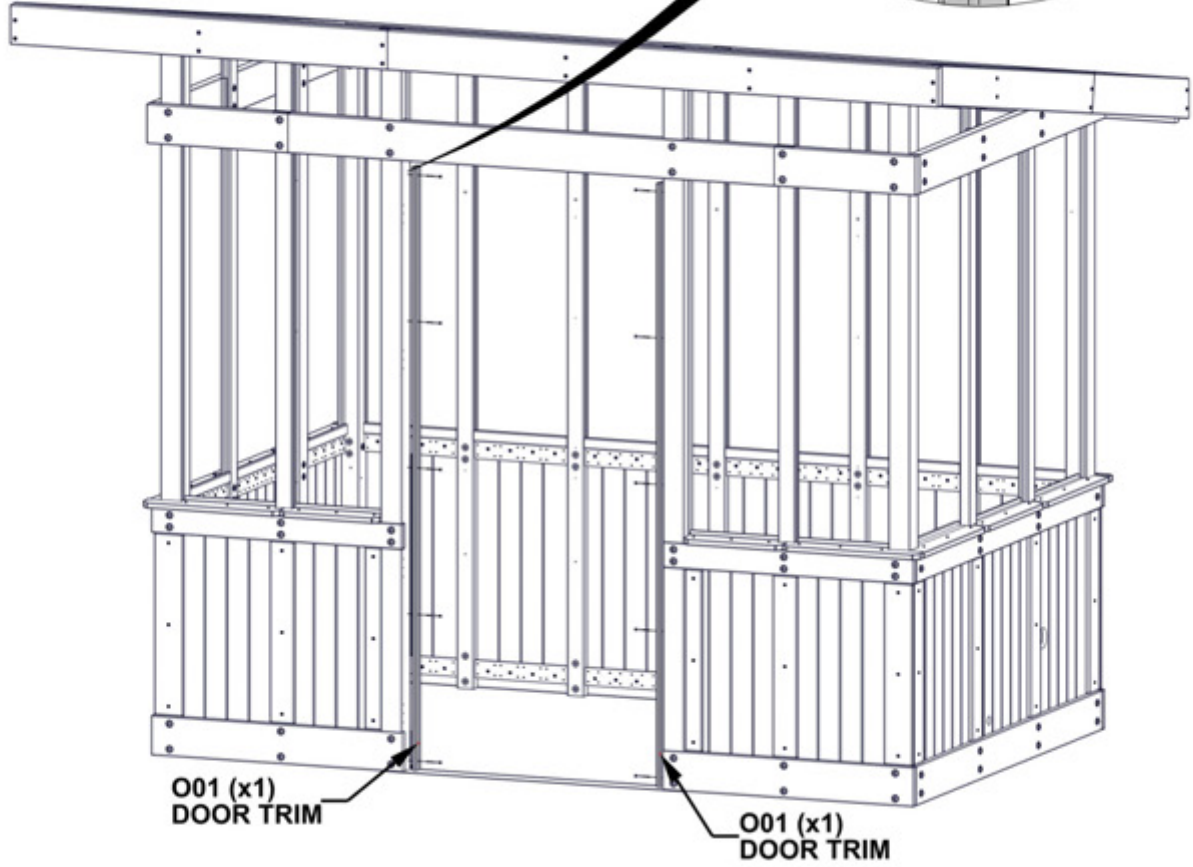
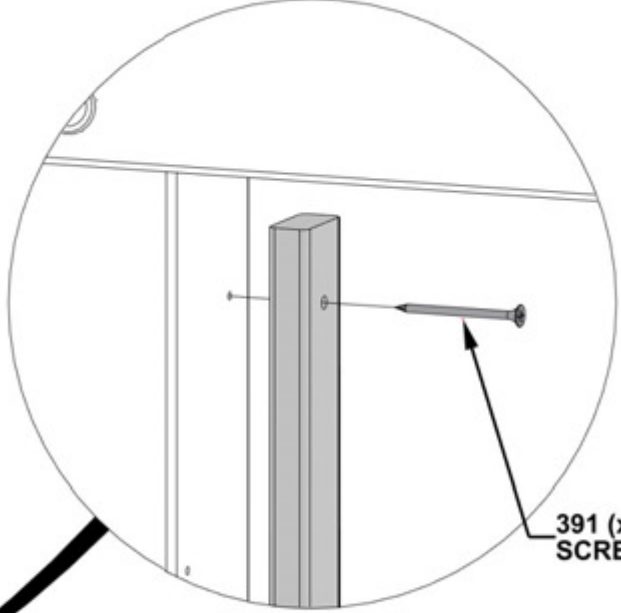

# STEP 46 - DOOR TRIM ASSEMBLY

QTY	PART NUMBER	DESCRIPTION
6	H100201	SCREW PFH 8x2 1/2 BLK

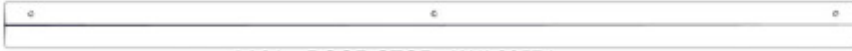
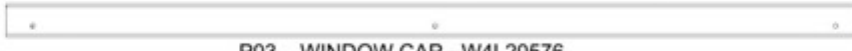
	AA01 DOOR STOP - W4L20574 (x1) 1 7/8"x1 15/16"x36 15/16" (47x50x938)
	P03 WINDOW CAP - W4L20576 (x1) 1 7/16"x1 7/16"x36 15/16" (36x36x938)

- ALIGN PILOT HOLES AND ATTACH AS SHOWN.
- NOTE THE NOTCH IN AA01 AND THE GROOVE IN P03 FOR CORRECT ORIENTATION.

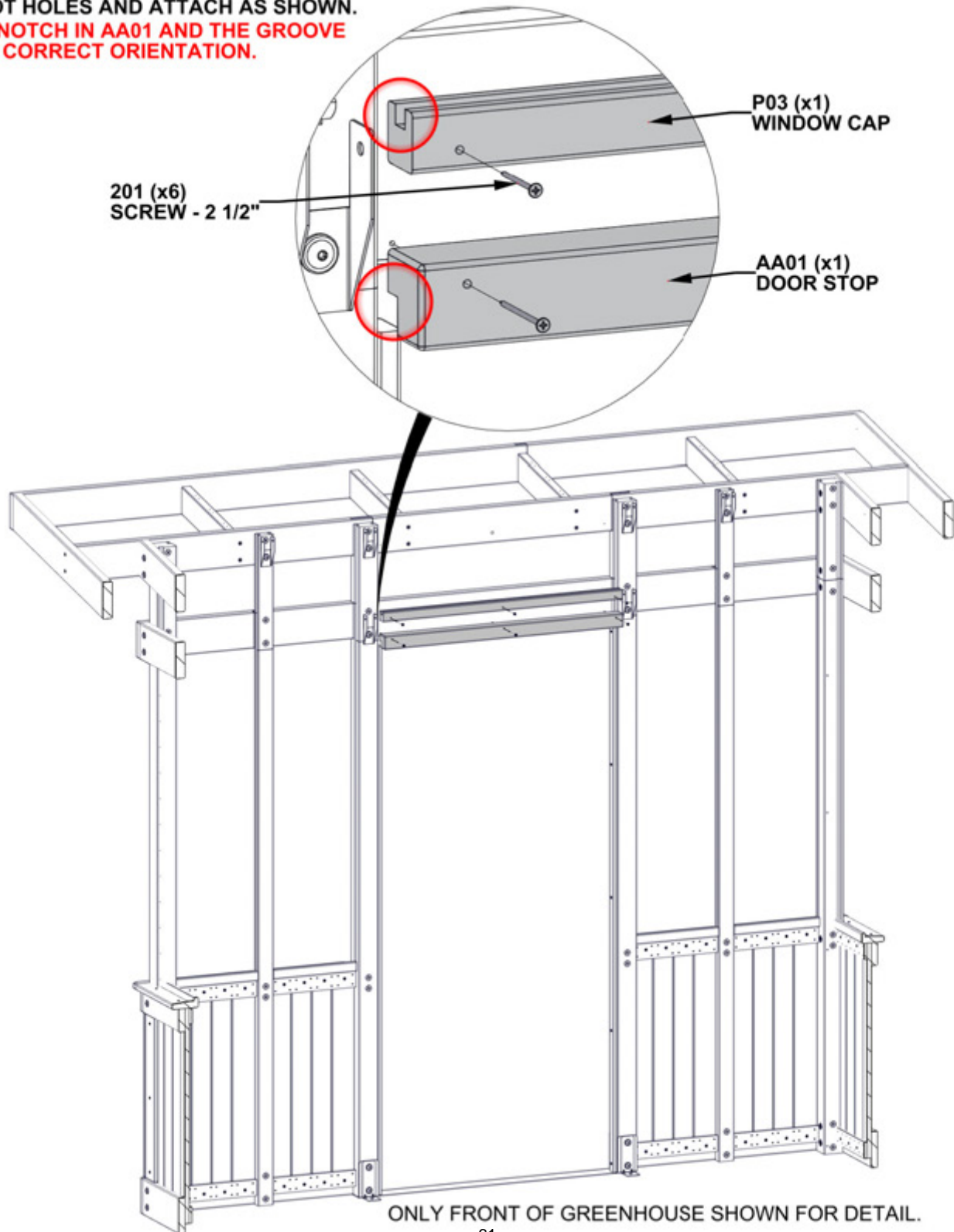

# STEP 47 - WINDOW TRIM ASSEMBLY

QTY	PART NUMBER	DESCRIPTION
3	H100201	SCREW PFH 8x2 1/2 BLK



F08 WINDOW CAP - W4L20600  
(x1) 1 7/16"x2 3/8"x17 13/16" (36x60x453)

ALIGN THROUGH HOLES IN F08 WITH PILOT HOLES IN HEADER.

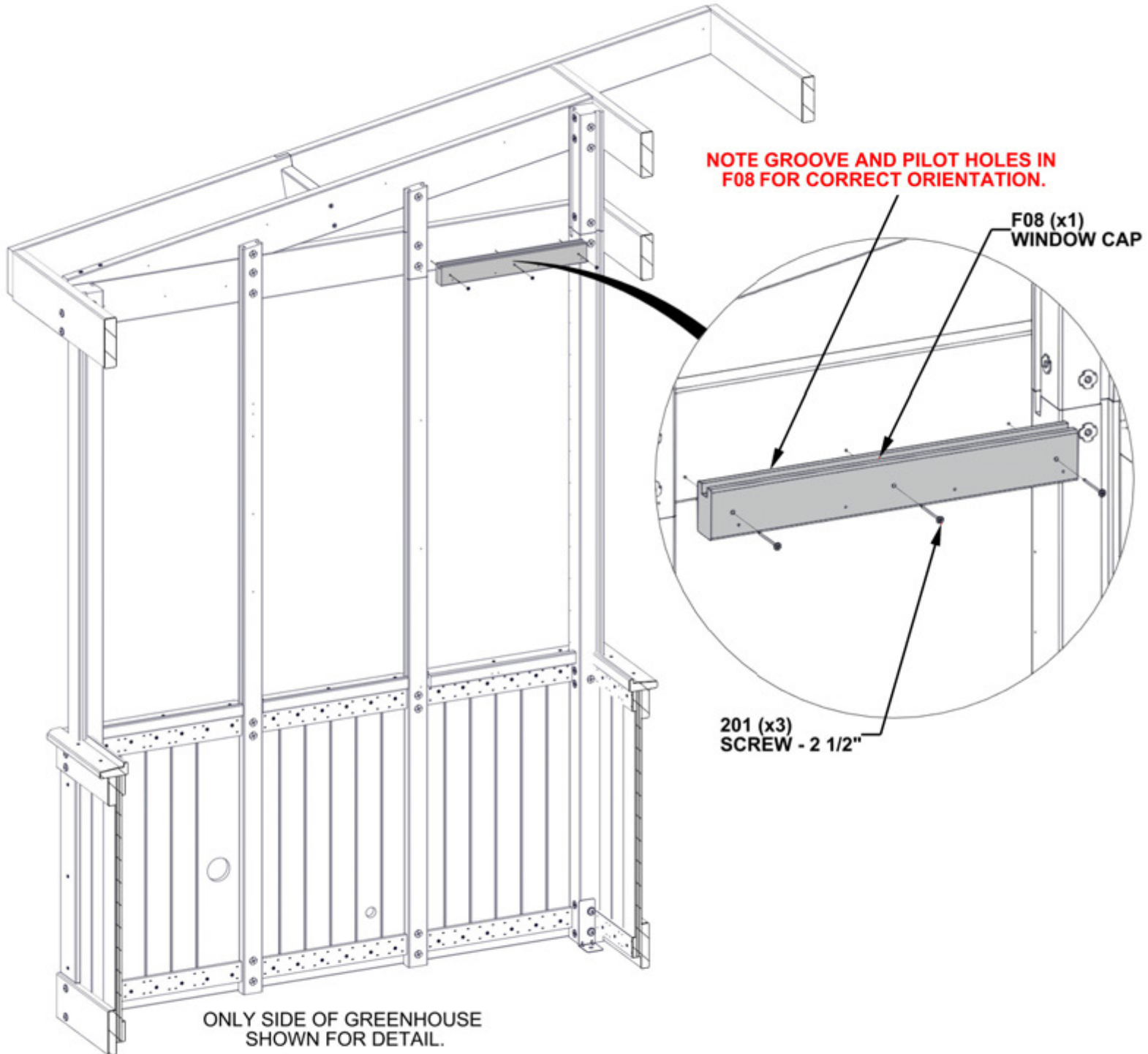

# STEP 48 - WINDOW TRIM ASSEMBLY

QTY	PART NUMBER	DESCRIPTION
8	H100200	SCREW PFH 8x1 1/2 BLK



N02 WINDOW FRAME - W4L20603  
(x1) 5/8"x2 3/8"x17 3/16" (16x60x437)



M02 WINDOW FRAME - W4L20602  
(x1) 5/8"x3"x51 5/16" (16x76x1303)

- NOTE NOTCH FOR CORRECT ORIENTATION OF M02 BOARD.
- ALIGN THE 4 THROUGH HOLES IN M02 WITH PILOT HOLES IN UPRIGHTS.
- ALIGN THROUGH HOLES IN N02 WITH PILOT HOLES IN BOARDS FROM PREVIOUS STEP.
- ATTACH AS SHOWN.

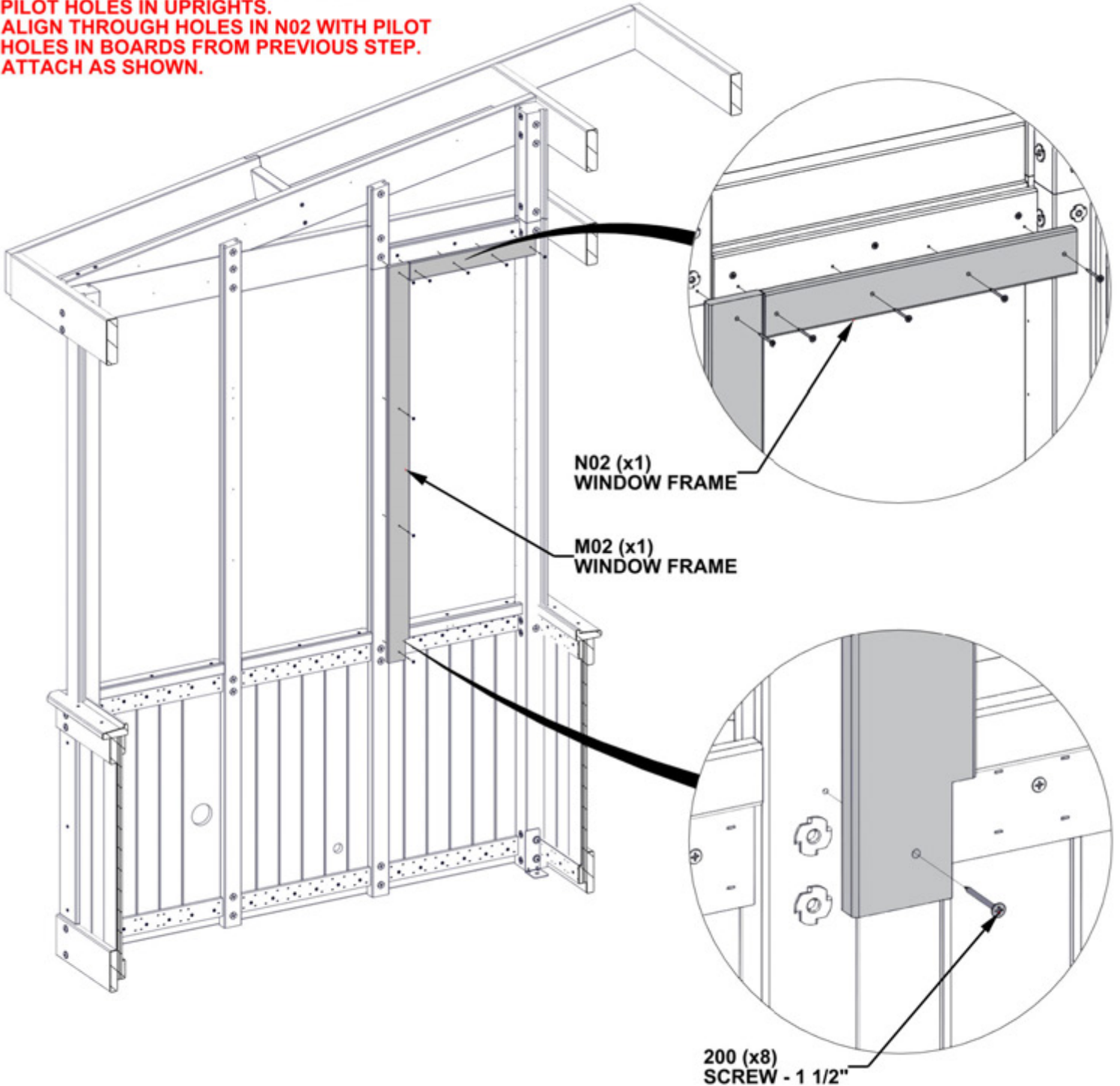

# STEP 49 - SHELF BRACKET ASSEMBLY

QTY	PART NUMBER	DESCRIPTION
10	H100171	BOLT WH 1/4x1 BLK
10	H100399	NUT BARREL WH 1/4X7/8 BLK
10	H100400	WASHER LOCK EXT 8x15



A4M02811 SHELF BRACKET  
(x5)

- ATTACH SHELF BRACKETS TO UPRIGHTS AS SHOWN.
- USE 90 DEGREE DRILL ADAPTER OR WRENCH FOR TOP BOLT.

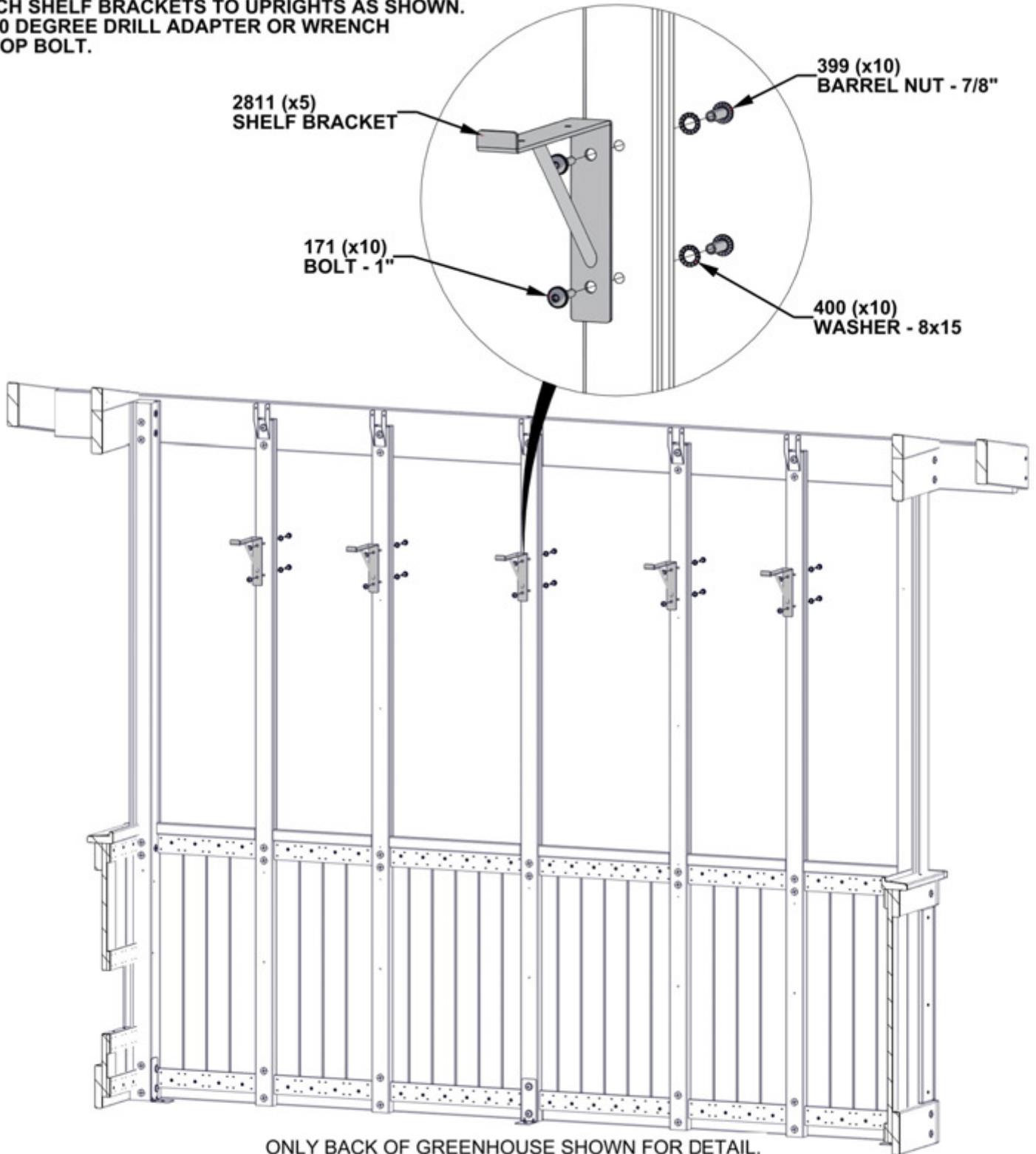

# STEP 50 - WINDOW ASSEMBLY

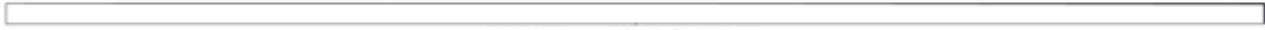

A6P01014 POLY CHANNEL  
(x12)

**REMOVE TAPE LINER ON POLY CHANNELS BEFORE INSTALLING.**

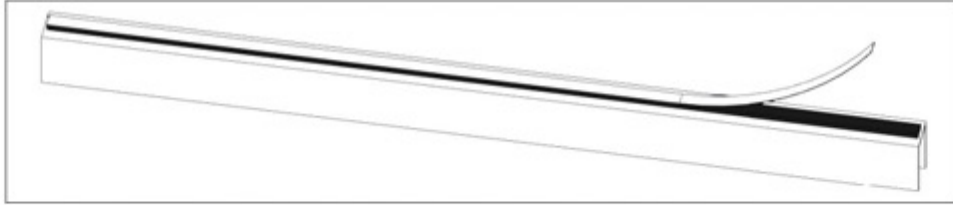

- INSERT POLY CHANNEL INTO GROOVE STARTING AT THE WINDOW SILL AND WORK UPWARDS.
- FIRMLY PRESS CHANNEL INTO GROOVE TO ENSURE TAPE ADHESION.

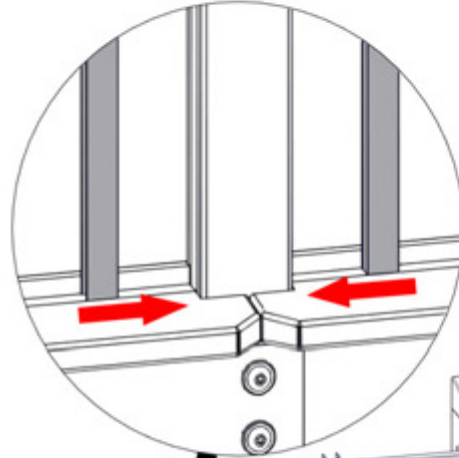

1014 (x12)  
POLY CHANNEL

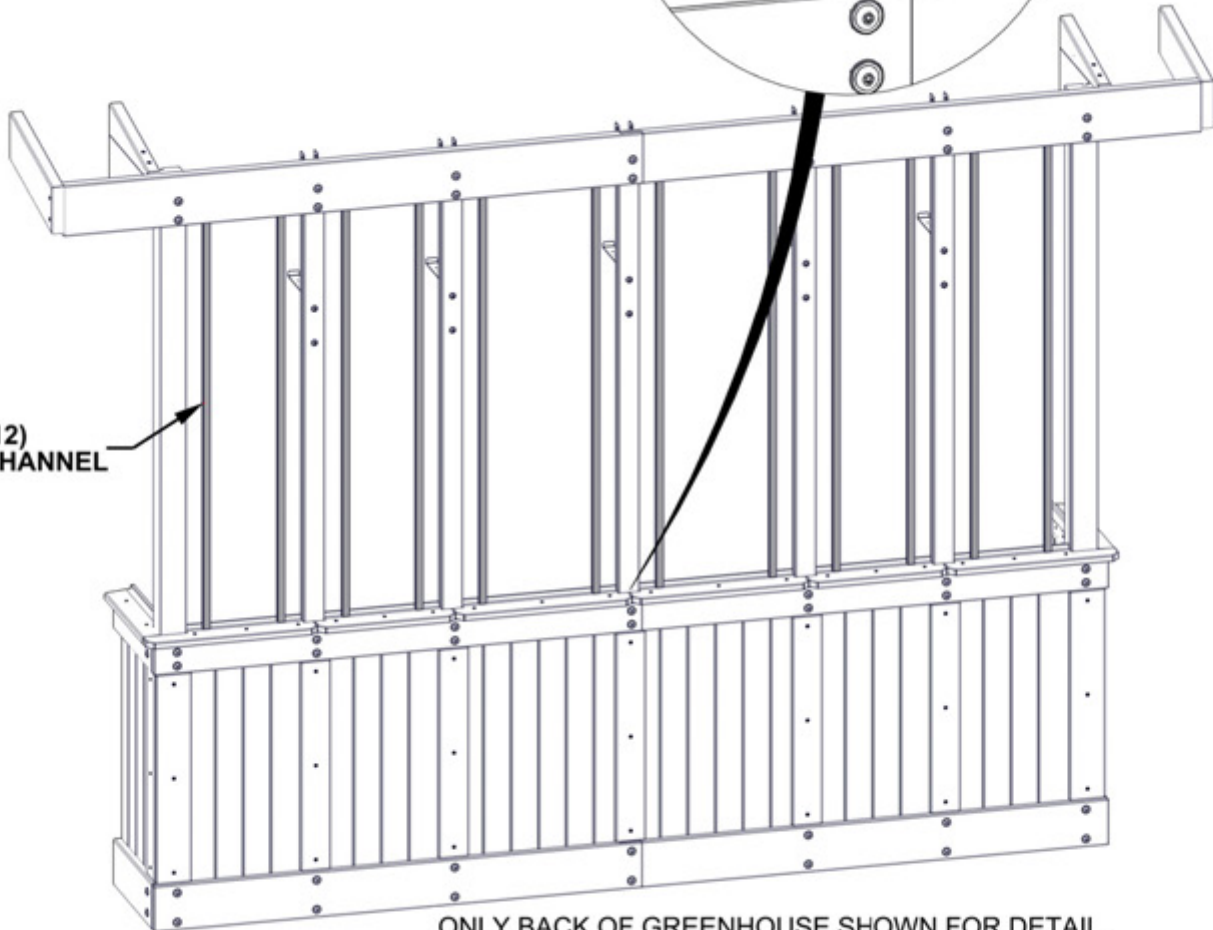

ONLY BACK OF GREENHOUSE SHOWN FOR DETAIL.

# STEP 51 - WINDOW ASSEMBLY

A6P01006 (x1)	POLY CHANNEL
A6P01007 (x2)	POLY CHANNEL
A6P01008 (x1)	POLY CHANNEL
A6P01083 (x2)	POLY CHANNEL

**REMOVE TAPE LINER ON POLY CHANNELS BEFORE INSTALLING.**

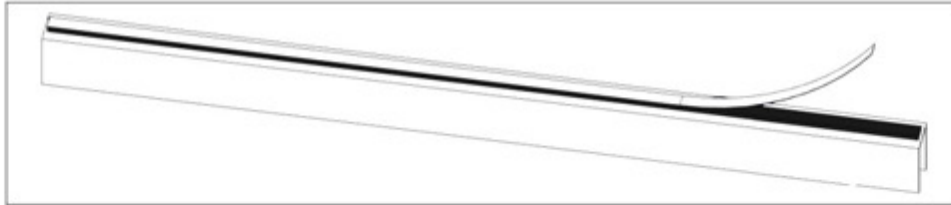

- INSERT POLY CHANNEL INTO GROOVE STARTING AT THE WINDOW SILL AND WORK UPWARDS.
- FIRMLY PRESS CHANNEL INTO GROOVE TO ENSURE TAPE ADHESION.

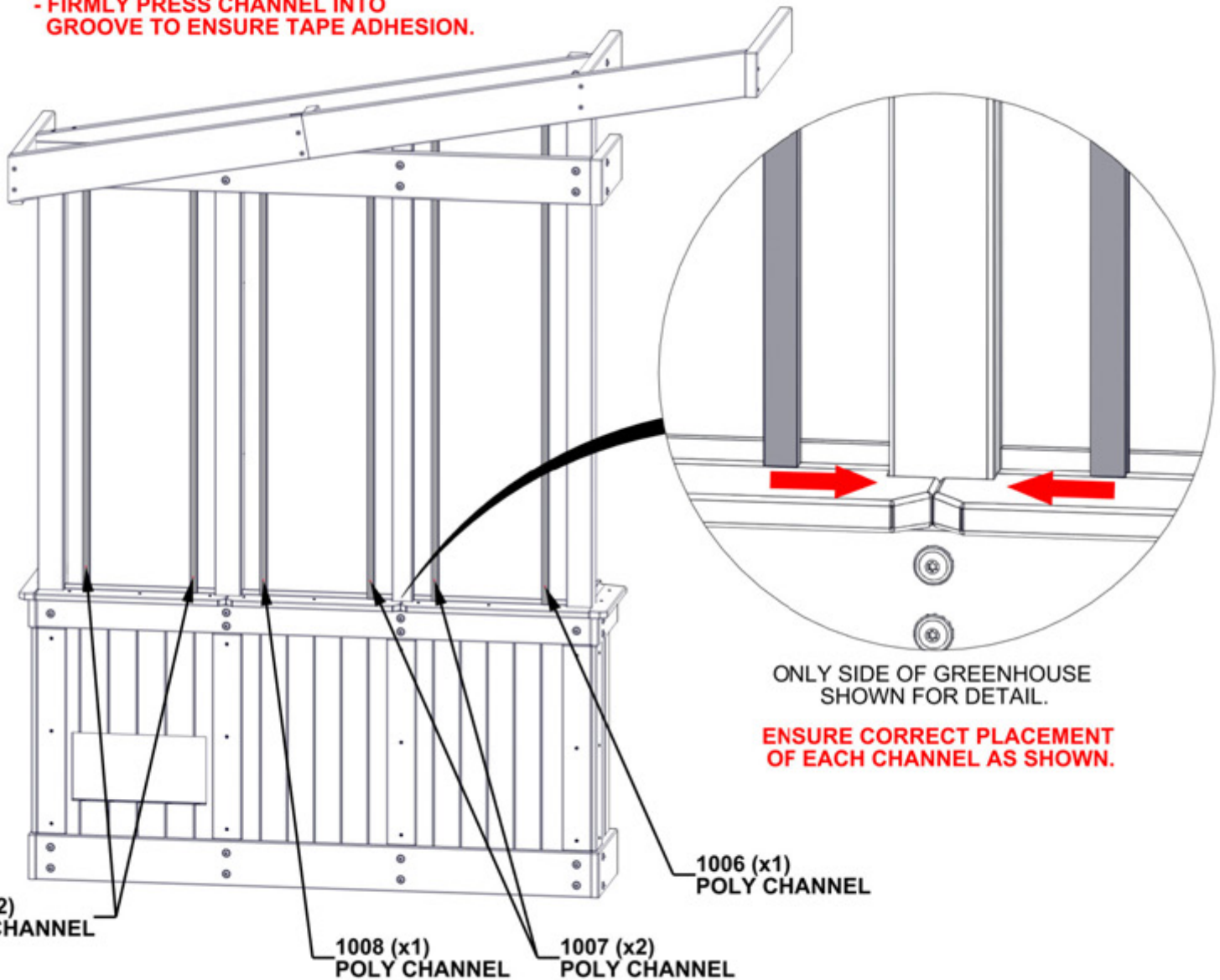

# STEP 52 - WINDOW ASSEMBLY

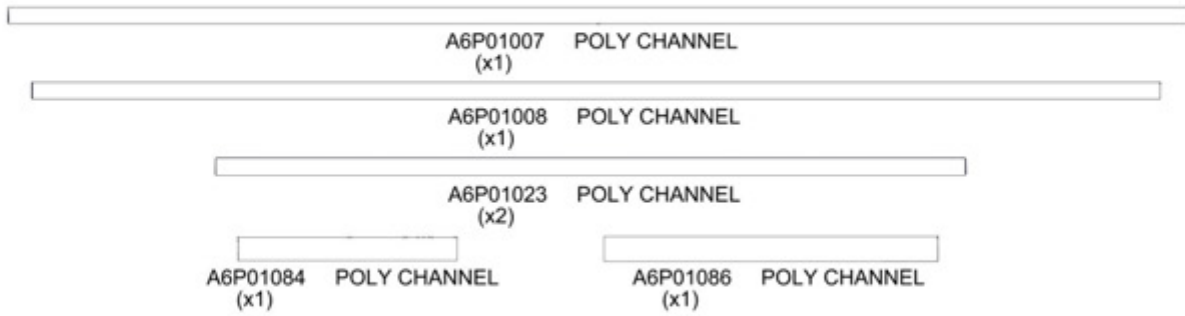

**REMOVE TAPE LINER ON POLY CHANNELS BEFORE INSTALLING.**

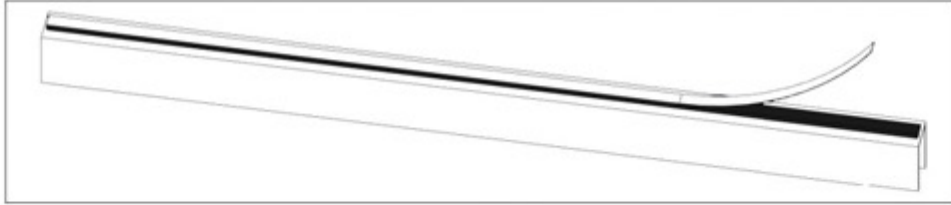

- INSERT POLY CHANNEL INTO GROOVE STARTING AT THE WINDOW SILL AND WORK UPWARDS.
- FIRMLY PRESS CHANNEL INTO GROOVE TO ENSURE TAPE ADHESION.

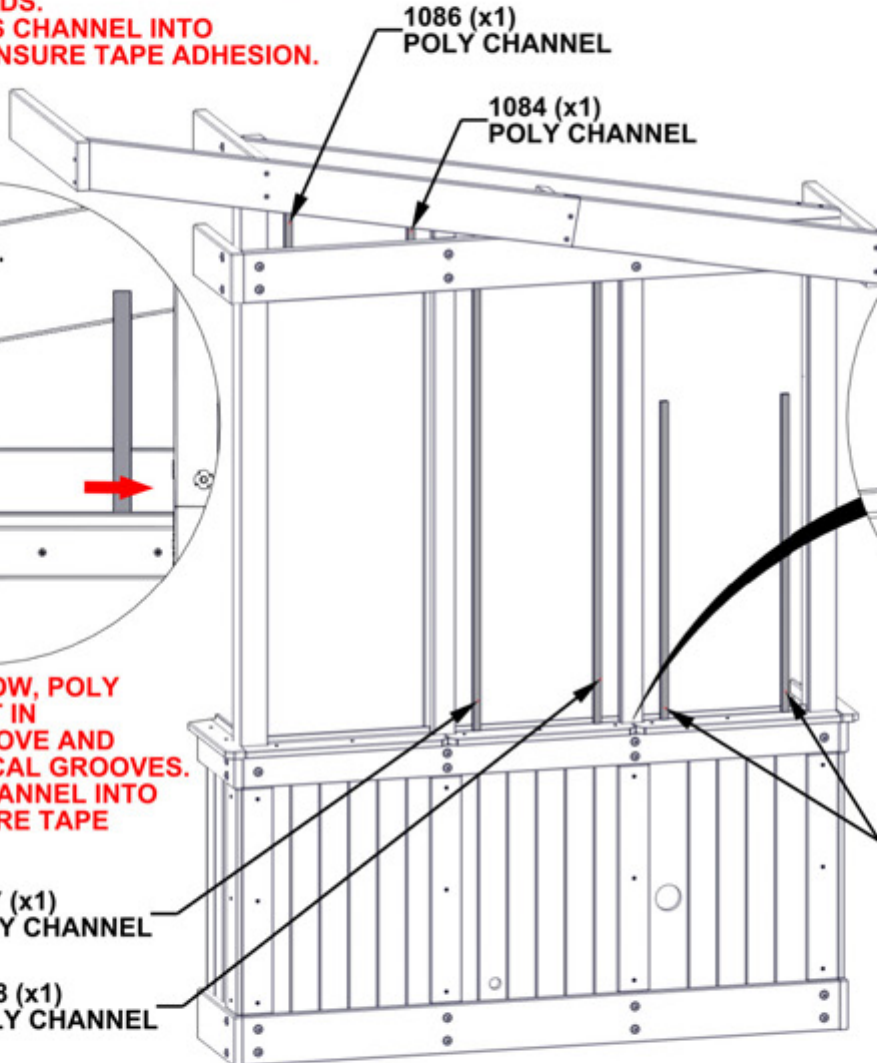

- FOR UPPER WINDOW, POLY CHANNEL WILL SIT IN HORIZONTAL GROOVE AND SLIDE INTO VERTICAL GROOVES.
- FIRMLY PRESS CHANNEL INTO GROOVE TO ENSURE TAPE ADHESION.

ONLY SIDE OF GREENHOUSE SHOWN FOR DETAIL.

**ENSURE CORRECT PLACEMENT OF EACH CHANNEL AS SHOWN.**

# STEP 53 - WINDOW ASSEMBLY

A6P01070 POLY CHANNEL  
(x8)

A6P01071 POLY CHANNEL  
(x2)

**REMOVE TAPE LINER ON POLY CHANNELS BEFORE INSTALLING.**

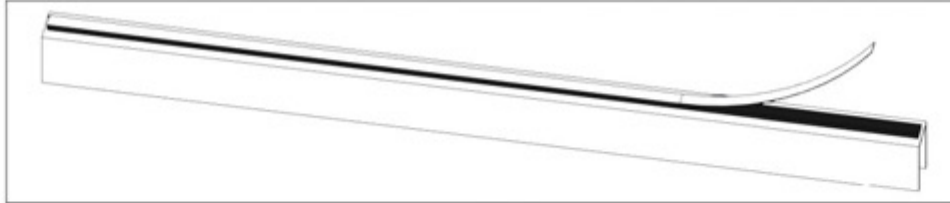

1071 (x2)  
POLY CHANNEL

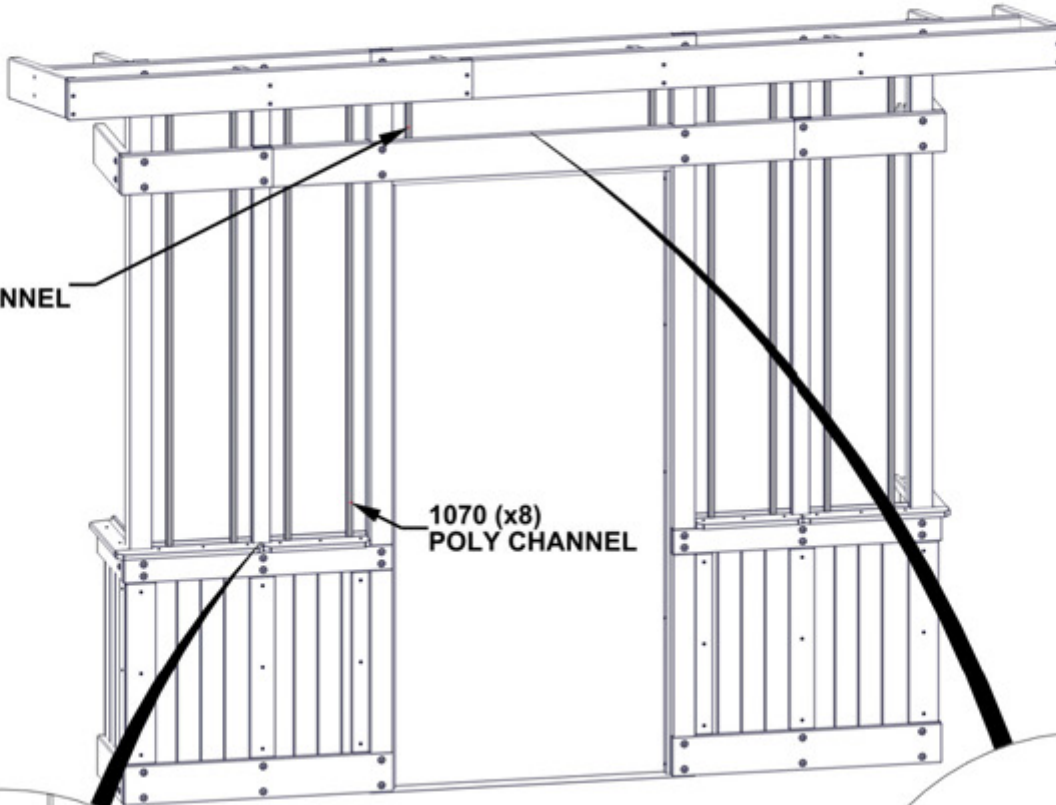

1070 (x8)  
POLY CHANNEL

ONLY FRONT OF GREENHOUSE  
SHOWN FOR DETAIL.

- INSERT POLY CHANNEL INTO GROOVE STARTING AT THE WINDOW SILL AND WORK UPWARDS.
- FIRMLY PRESS CHANNEL INTO GROOVE TO ENSURE TAPE ADHESION.
- FOR UPPER WINDOW, POLY CHANNEL WILL SIT IN HORIZONTAL GROOVE AND SLIDE INTO VERTICAL GROOVES.
- FIRMLY PRESS CHANNEL INTO GROOVE TO ENSURE TAPE ADHESION.

1071 (x2)  
POLY CHANNEL

# STEP 54 - WINDOW ASSEMBLY



A6P01074 POLY SHEET  
(x4)



A6P01073 POLY CHANNEL  
(x8)



A6P00690 DUST SEAL TAPE

## TO APPLY DUST SEAL TAPE AND POLY CHANNEL:

- CUT 2 STRIPS OF DUST SEAL TAPE THE SAME WIDTH AS THE POLY SHEET.
- WRAP DUST SEAL TAPE ALONG EDGE OF POLY SHEET WIDTH.
- AFTER TAPE IS SECURE, PUSH CHANNEL ON OVER THE TAPE, CENTERING ON THE POLY SHEET.
- REPEAT ON THE BOTTOM SIDE OF POLY SHEET.
- **REPEAT FOR ALL FOUR WINDOW ASSEMBLIES.**

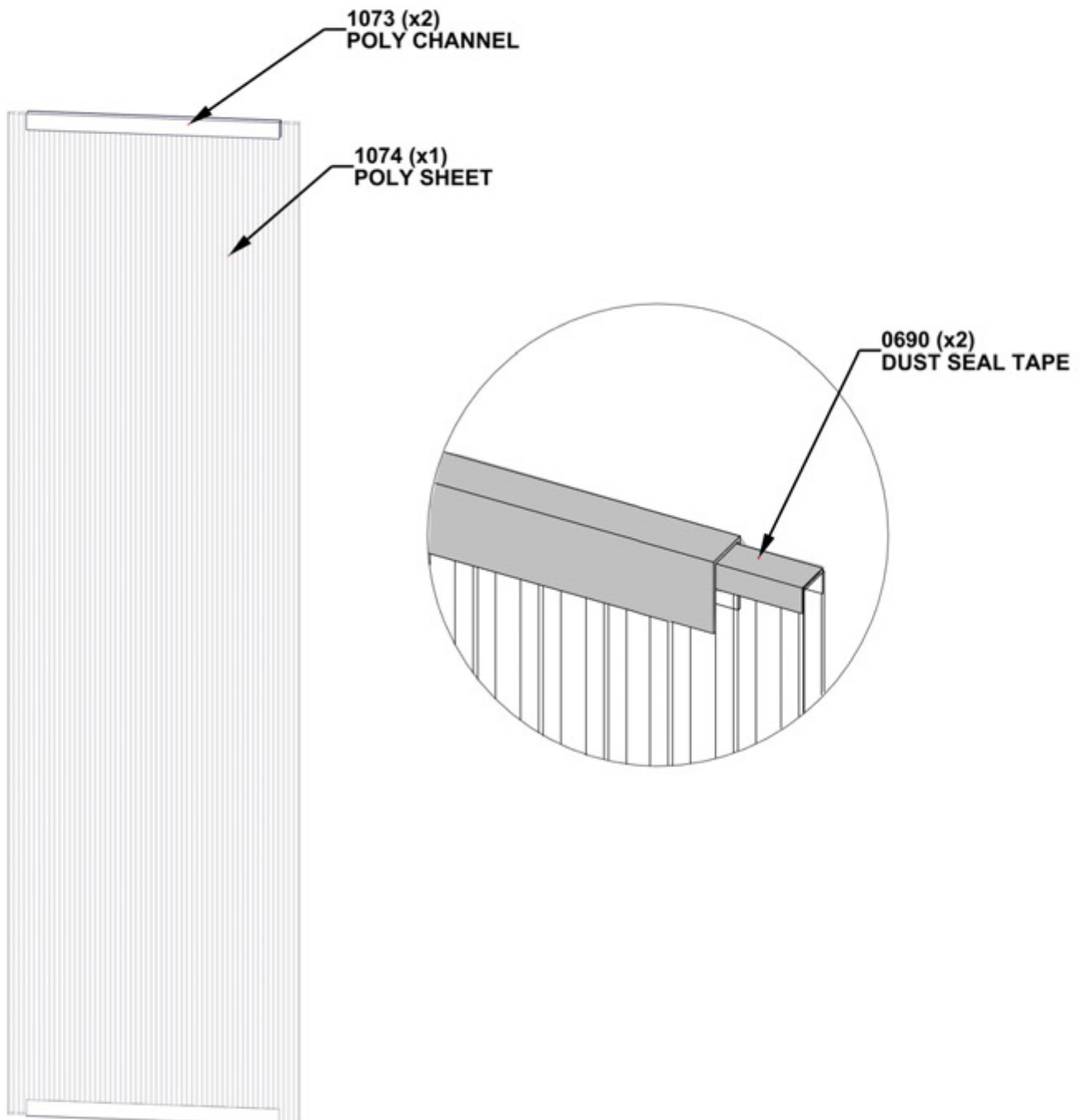

# STEP 55 - WINDOW ASSEMBLY

## IMPORTANT!

- ENSURE UV SIDE OF WINDOW IS FACING OUTSIDE.
- ONCE WINDOW IS INSTALLED, IT IS SAFE TO REMOVE THE PROTECTIVE FILM.

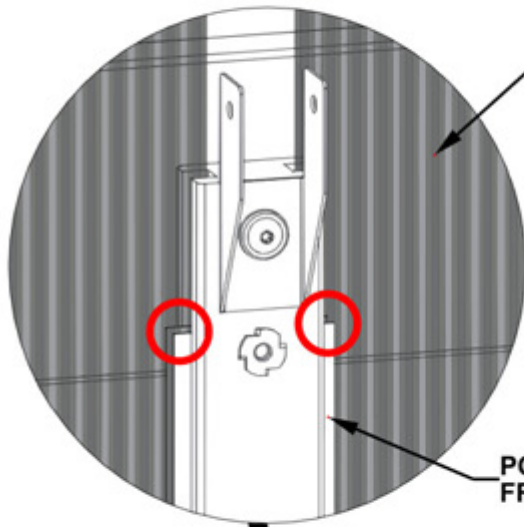

WINDOW ASSEMBLY  
FROM STEP 54

- INSERT WINDOW ASSEMBLY INTO PREVIOUSLY INSTALLED CHANNEL ON BOTH SIDES OF WINDOW.
- GENTLY SLIDE WINDOW DOWN UNTIL SEATED ON WINDOW SILL.

POLY CHANNEL  
FROM STEP 50

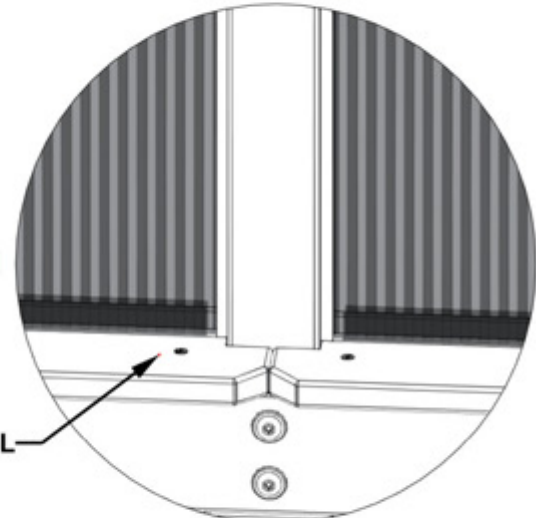

WINDOW SILL

OUTSIDE VIEW

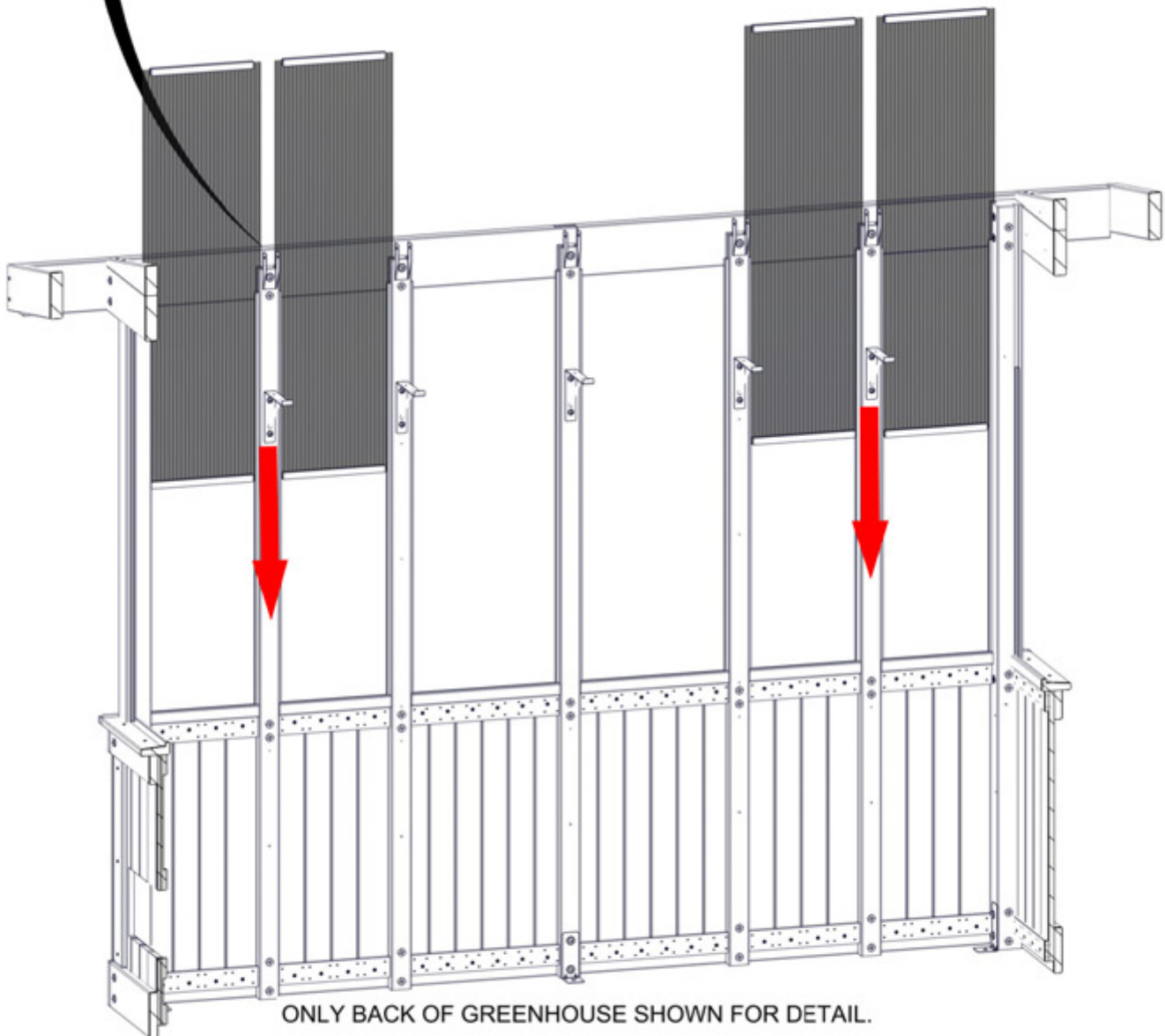

ONLY BACK OF GREENHOUSE SHOWN FOR DETAIL.

# STEP 56 - WINDOW ASSEMBLY



A6P01025 POLY SHEET  
(x2)



A6P01026 POLY CHANNEL  
(x4)



A6P00690 DUST SEAL TAPE

## TO APPLY DUST SEAL TAPE AND POLY CHANNEL:

- CUT 2 STRIPS OF DUST SEAL TAPE THE SAME WIDTH AS THE POLY SHEET.
- WRAP DUST SEAL TAPE ALONG EDGE OF POLY SHEET WIDTH.
- AFTER TAPE IS SECURE, PUSH CHANNEL ON OVER THE TAPE, CENTERING ON THE POLY SHEET.
- REPEAT ON THE BOTTOM SIDE OF POLY SHEET.
- **REPEAT FOR BOTH WINDOW ASSEMBLIES.**

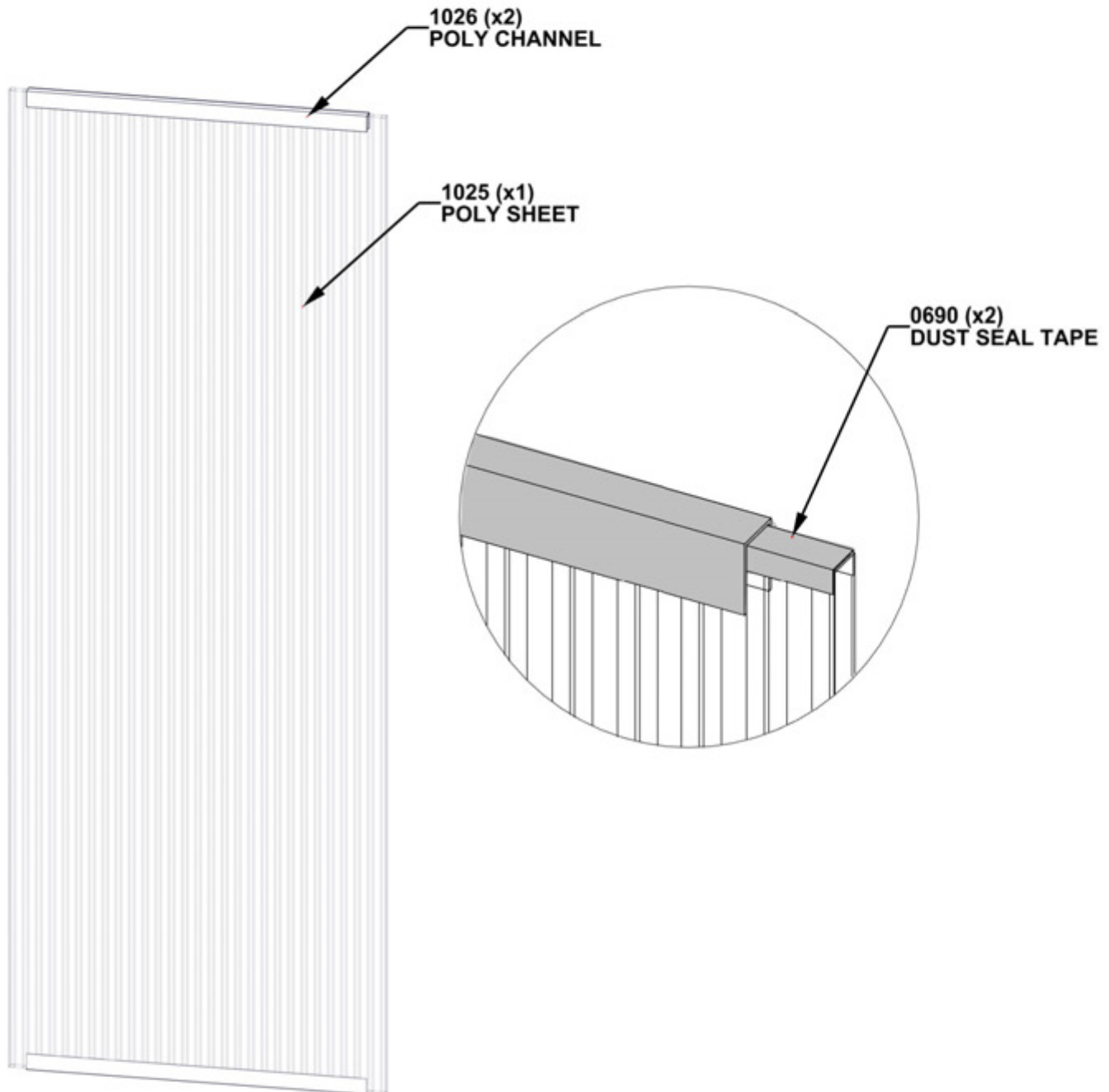

# STEP 57 - WINDOW ASSEMBLY

## IMPORTANT!

- ENSURE UV SIDE OF WINDOW IS FACING OUTSIDE.
- ONCE WINDOW IS INSTALLED, IT IS SAFE TO REMOVE THE PROTECTIVE FILM.

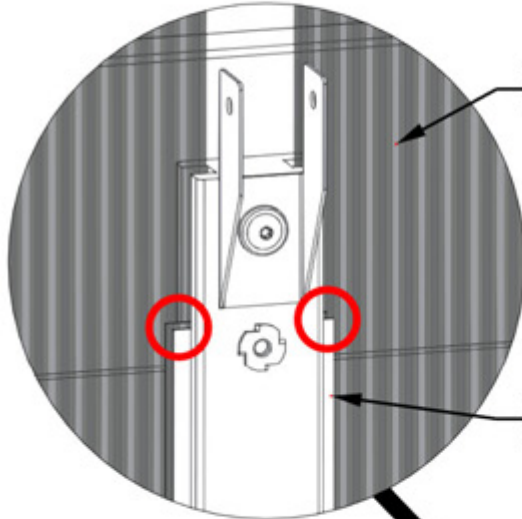

WINDOW ASSEMBLY FROM STEP 56

- INSERT WINDOW ASSEMBLY INTO PREVIOUSLY INSTALLED CHANNEL ON BOTH SIDES OF WINDOW.
- GENTLY SLIDE WINDOW DOWN UNTIL SEATED ON WINDOW SILL.

POLY CHANNEL FROM STEP 50

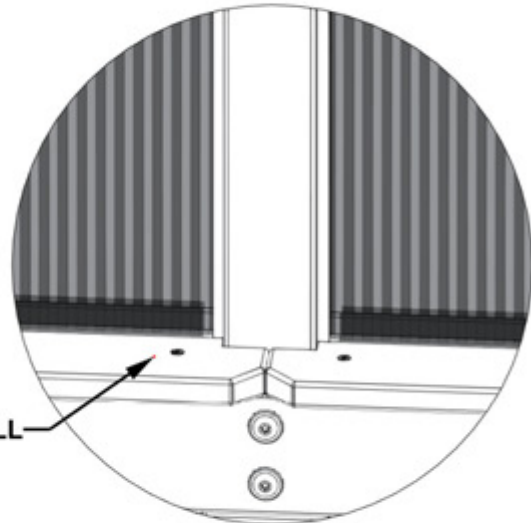

WINDOW SILL

OUTSIDE VIEW

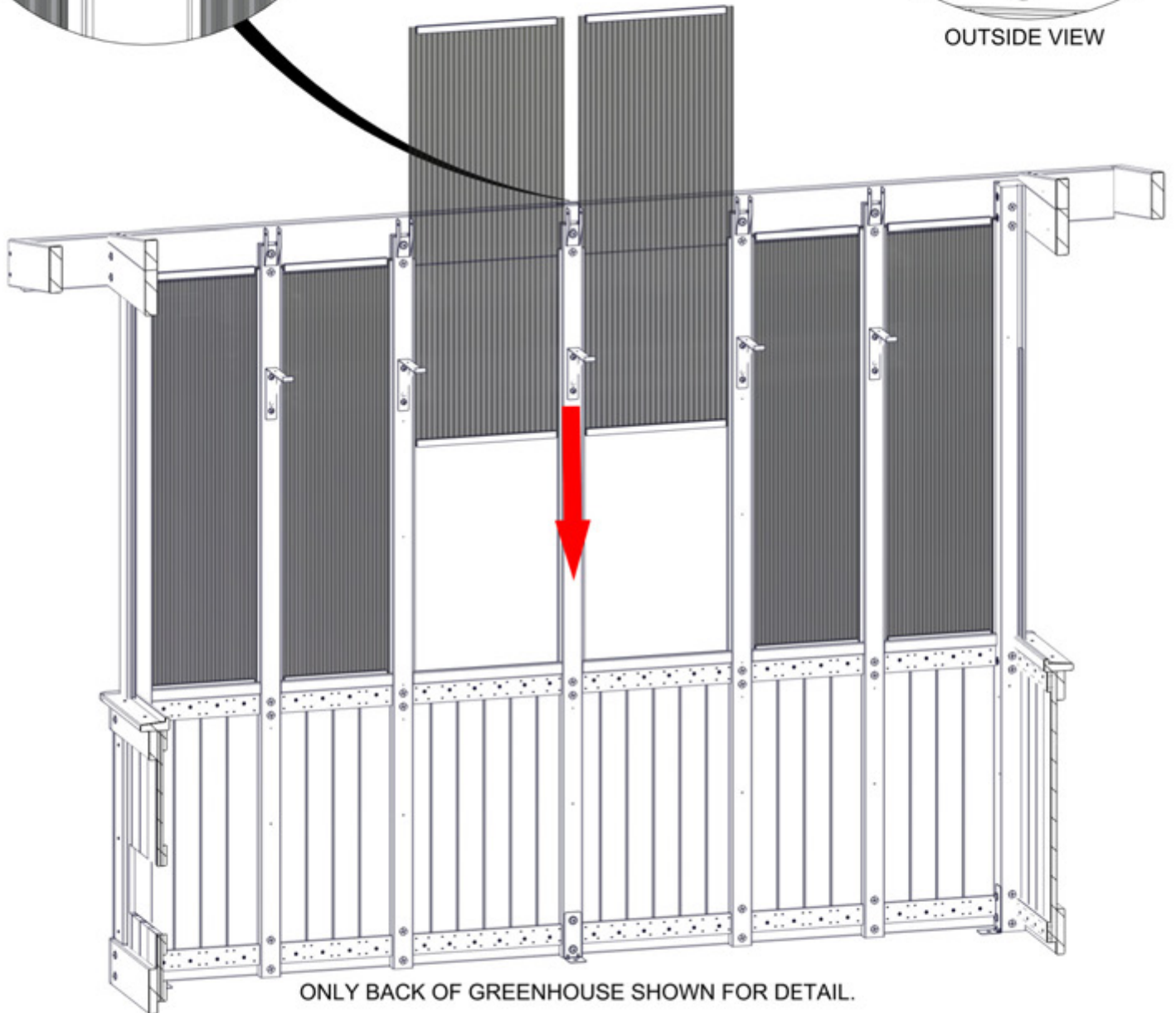

ONLY BACK OF GREENHOUSE SHOWN FOR DETAIL.

# STEP 58 - WINDOW ASSEMBLY

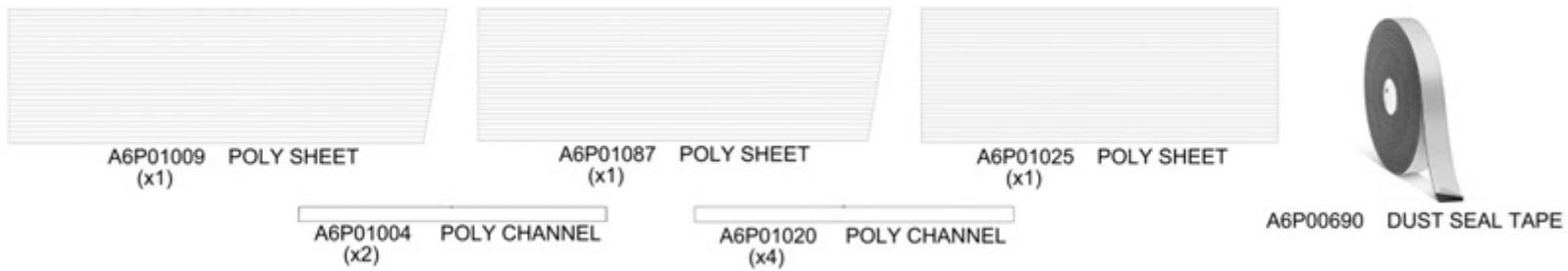

**TO APPLY DUST SEAL TAPE AND POLY CHANNEL:**

- CUT 2 STRIPS OF DUST SEAL TAPE THE SAME WIDTH AS THE POLY SHEET.
- WRAP DUST SEAL TAPE ALONG EDGE OF POLY SHEET WIDTH.
- AFTER TAPE IS SECURE, PUSH CHANNEL ON OVER THE TAPE, CENTERING ON THE POLY SHEET.
- REPEAT ON THE BOTTOM SIDE OF POLY SHEET.

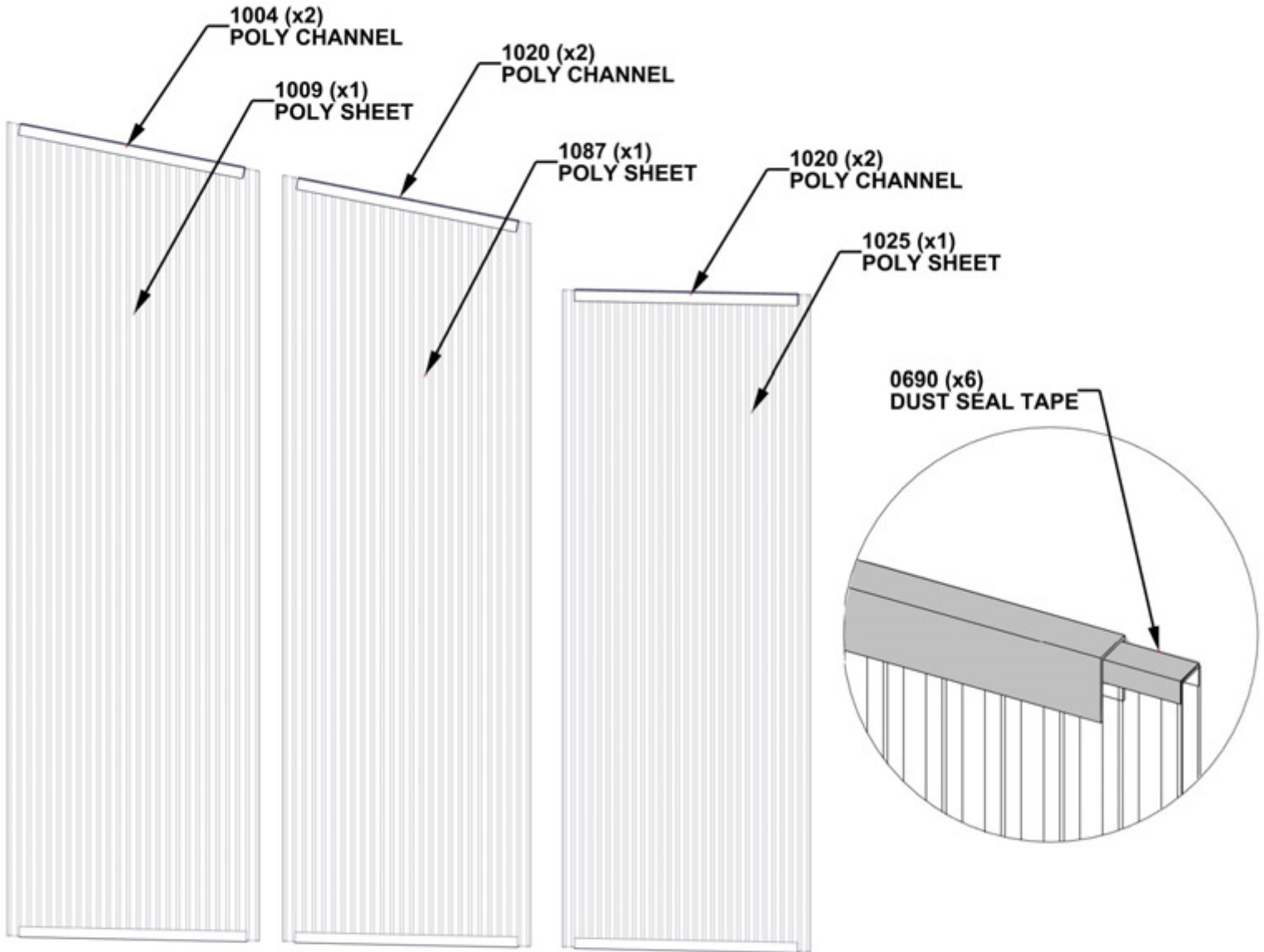

# STEP 59 - WINDOW ASSEMBLY

## IMPORTANT!

- ENSURE UV SIDE OF WINDOW IS FACING OUTSIDE.
- ONCE WINDOW IS INSTALLED, IT IS SAFE TO REMOVE THE PROTECTIVE FILM.

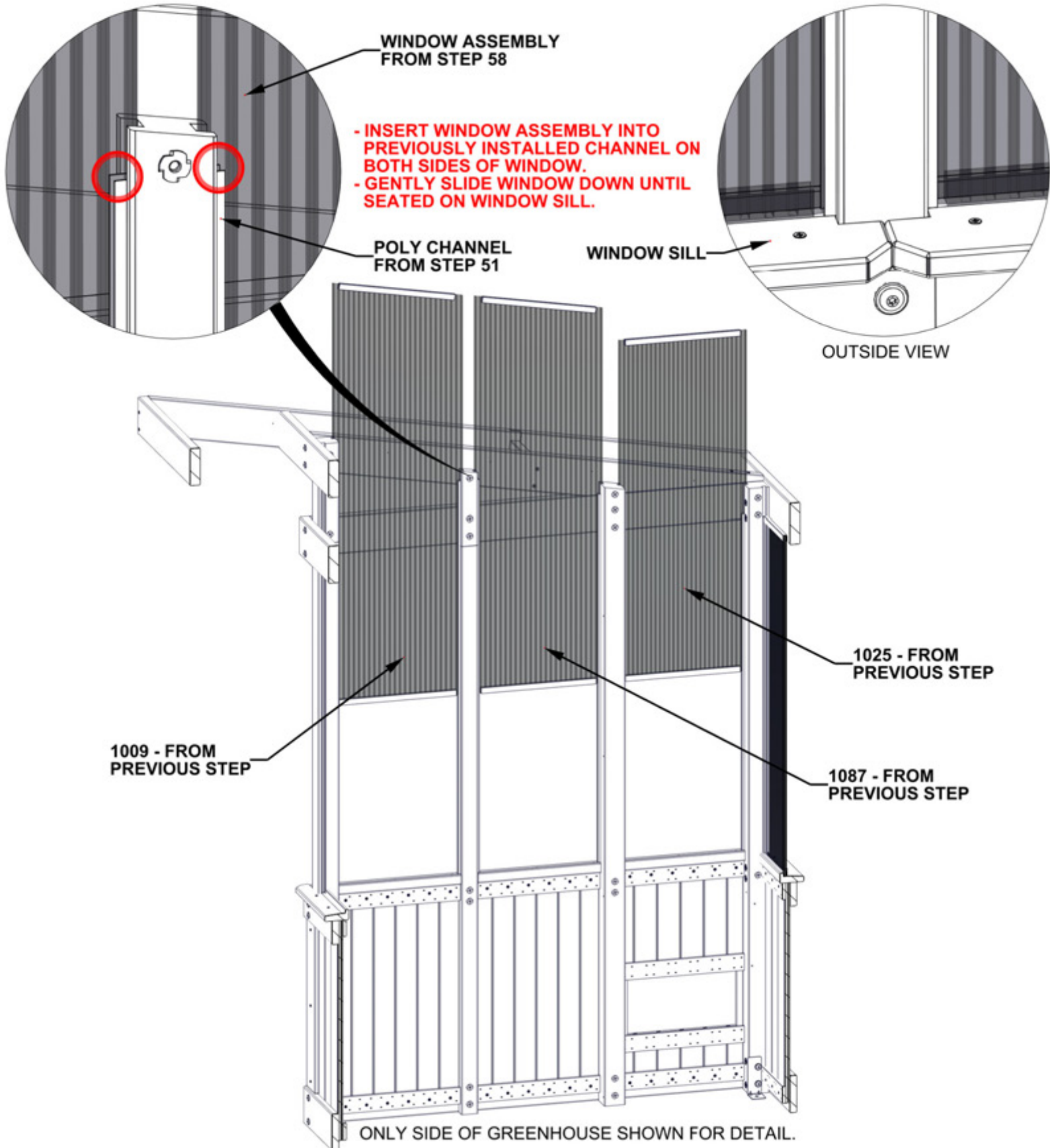

# STEP 60 - WINDOW ASSEMBLY



## TO APPLY DUST SEAL TAPE AND POLY CHANNEL:

- CUT 2 STRIPS OF DUST SEAL TAPE THE SAME WIDTH AS THE POLY SHEET.
- WRAP DUST SEAL TAPE ALONG EDGE OF POLY SHEET WIDTH.
- AFTER TAPE IS SECURE, PUSH CHANNEL ON OVER THE TAPE, CENTERING ON THE POLY SHEET.
- REPEAT ON THE BOTTOM SIDE OF POLY SHEET.

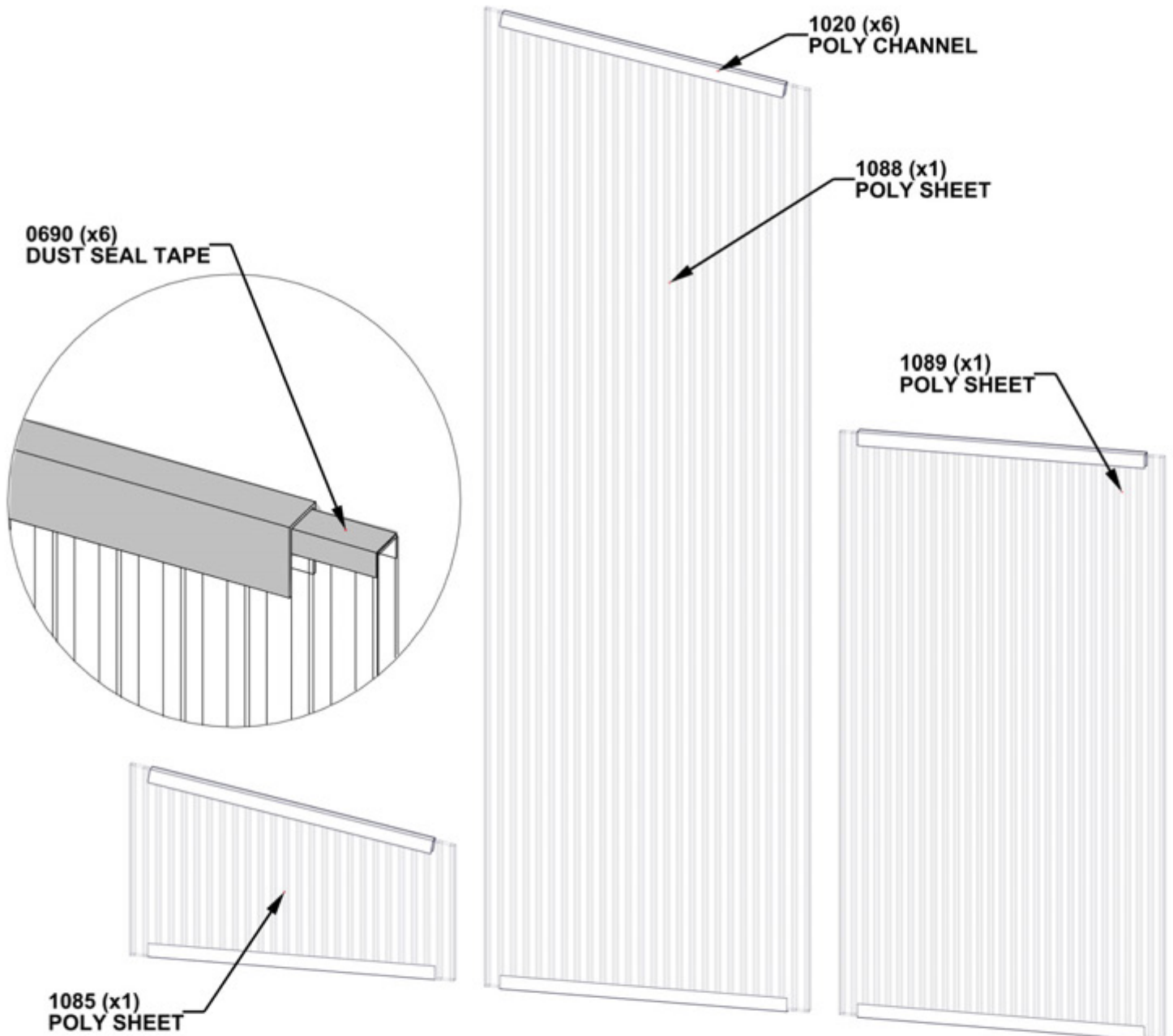

# STEP 61 - WINDOW ASSEMBLY

## IMPORTANT!

- ENSURE UV SIDE OF WINDOW IS FACING OUTSIDE.
- ONCE WINDOW IS INSTALLED, IT IS SAFE TO REMOVE THE PROTECTIVE FILM.

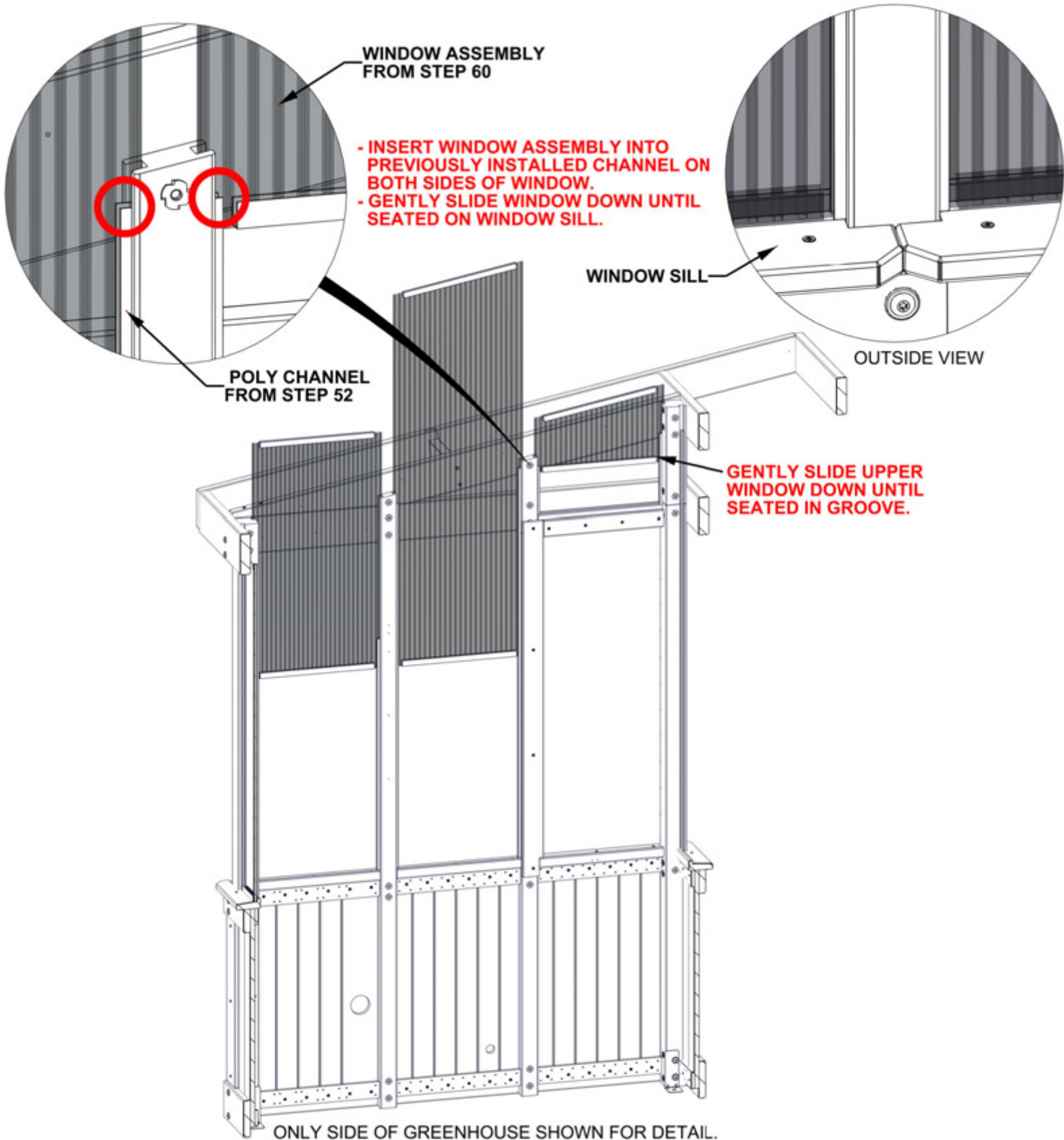

# STEP 62 - WINDOW ASSEMBLY



A6P01068 POLY SHEET  
(x2)



A6P01066 POLY CHANNEL  
(x4)



A6P00690 DUST SEAL TAPE

## TO APPLY DUST SEAL TAPE AND POLY CHANNEL:

- CUT 2 STRIPS OF DUST SEAL TAPE THE SAME WIDTH AS THE POLY SHEET.
- WRAP DUST SEAL TAPE ALONG EDGE OF POLY SHEET WIDTH.
- AFTER TAPE IS SECURE, PUSH CHANNEL ON OVER THE TAPE, CENTERING ON THE POLY SHEET.
- REPEAT ON THE BOTTOM SIDE OF POLY SHEET.
- **REPEAT FOR BOTH WINDOW ASSEMBLIES.**

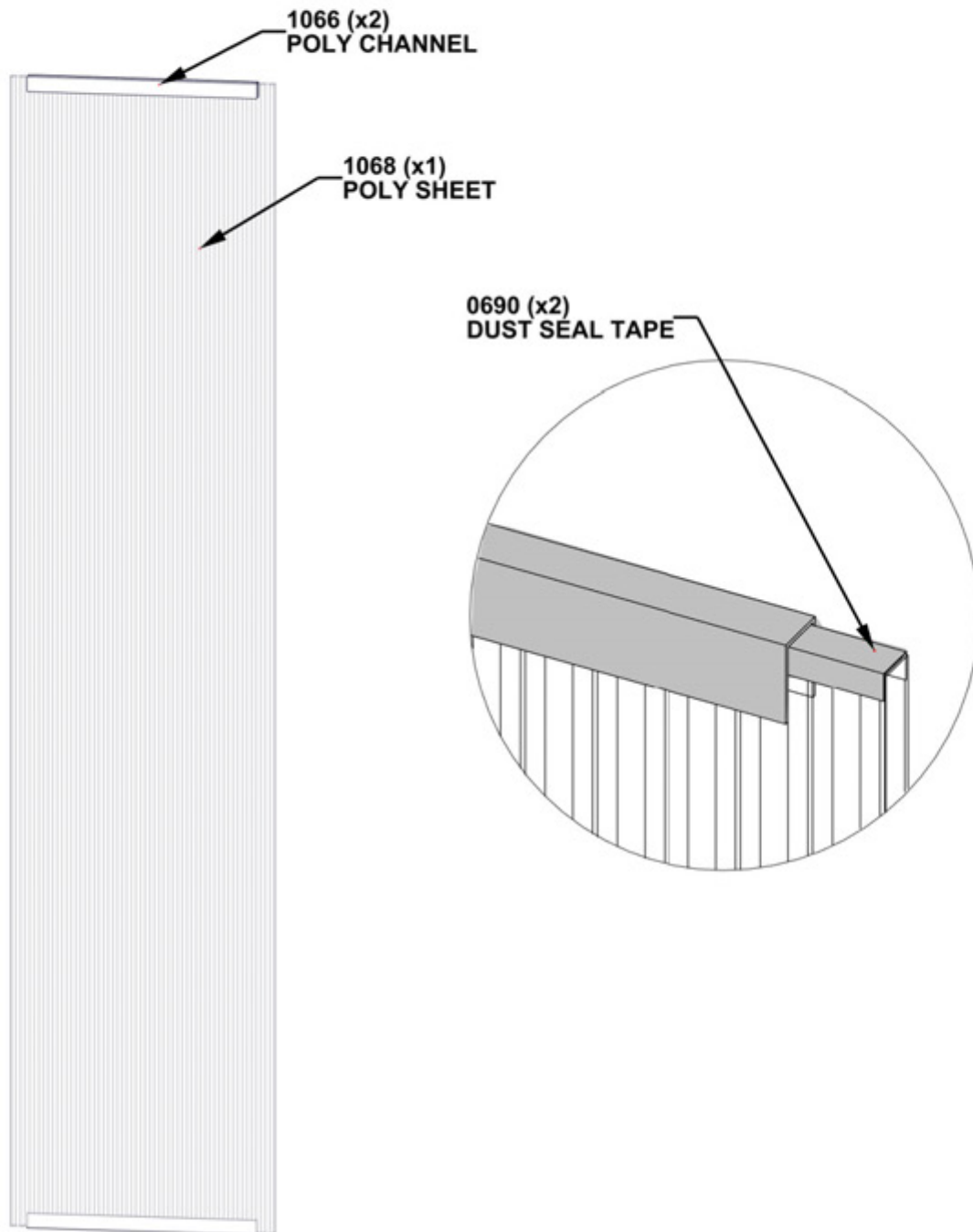

# STEP 63 - WINDOW ASSEMBLY

## IMPORTANT!

- ENSURE UV SIDE OF WINDOW IS FACING OUTSIDE.
- ONCE WINDOW IS INSTALLED, IT IS SAFE TO REMOVE THE PROTECTIVE FILM.

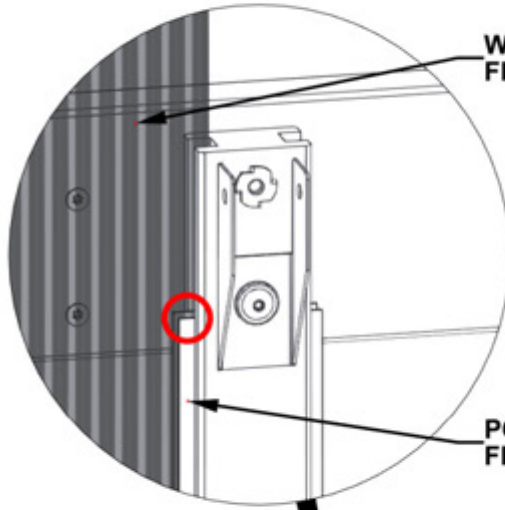

WINDOW ASSEMBLY  
FROM STEP 62

- INSERT WINDOW ASSEMBLY INTO  
PREVIOUSLY INSTALLED CHANNEL ON  
BOTH SIDES OF WINDOW.
- GENTLY SLIDE WINDOW DOWN UNTIL  
SEATED ON WINDOW SILL.

POLY CHANNEL  
FROM STEP 53

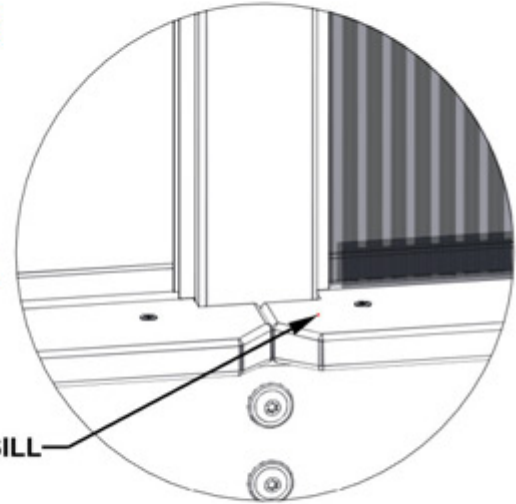

WINDOW SILL

OUTSIDE VIEW

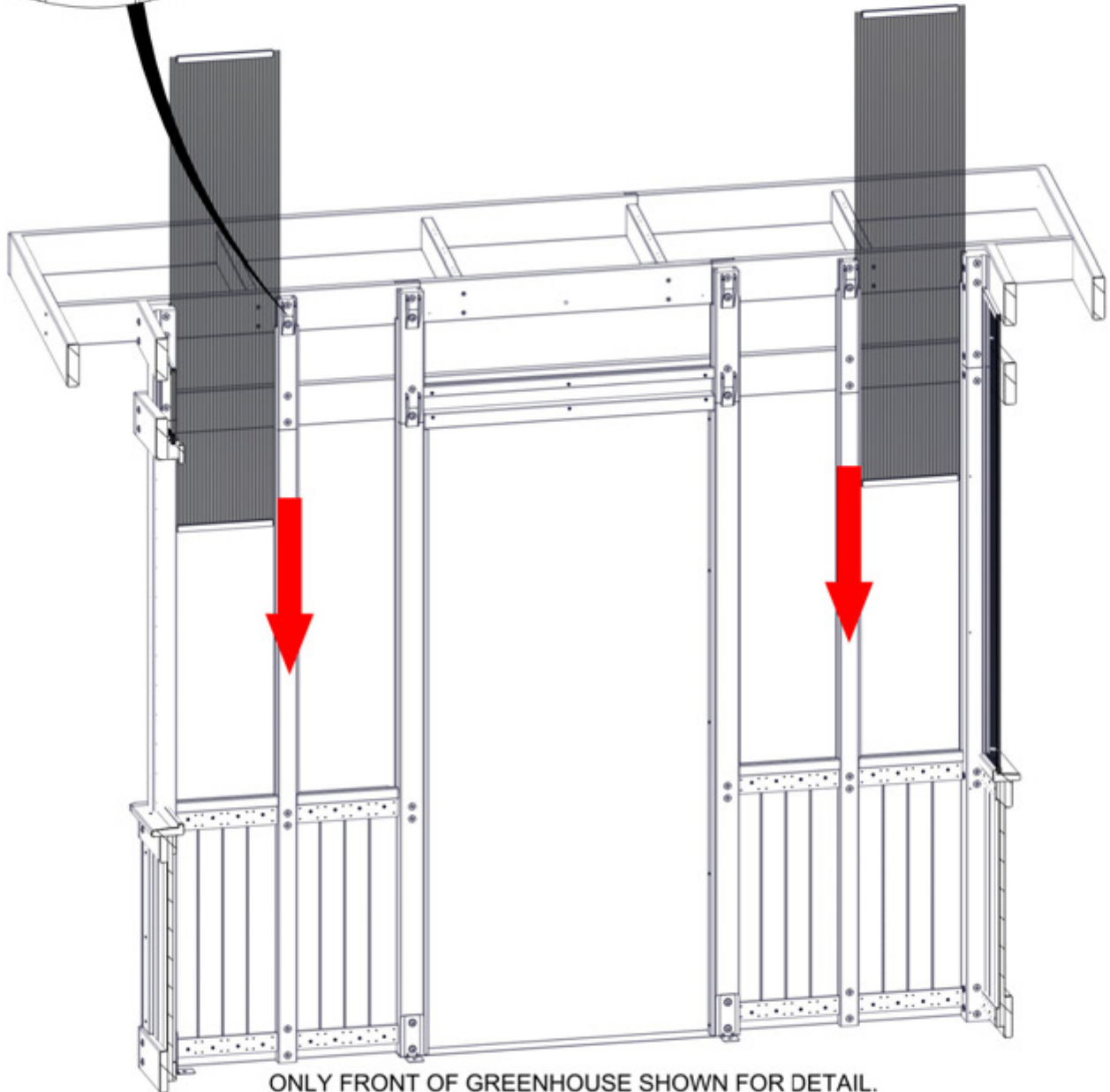

ONLY FRONT OF GREENHOUSE SHOWN FOR DETAIL.

# STEP 64 - WINDOW ASSEMBLY

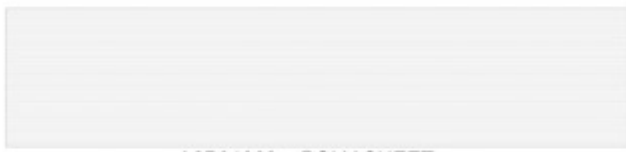

A6P01069 POLY SHEET  
(x2)



A6P01067 POLY CHANNEL  
(x4)



A6P00690 DUST SEAL TAPE

## TO APPLY DUST SEAL TAPE AND POLY CHANNEL:

- CUT 2 STRIPS OF DUST SEAL TAPE THE SAME WIDTH AS THE POLY SHEET.
- WRAP DUST SEAL TAPE ALONG EDGE OF POLY SHEET WIDTH.
- AFTER TAPE IS SECURE, PUSH CHANNEL ON OVER THE TAPE, CENTERING ON THE POLY SHEET.
- REPEAT ON THE BOTTOM SIDE OF POLY SHEET.
- **REPEAT FOR BOTH WINDOW ASSEMBLIES.**

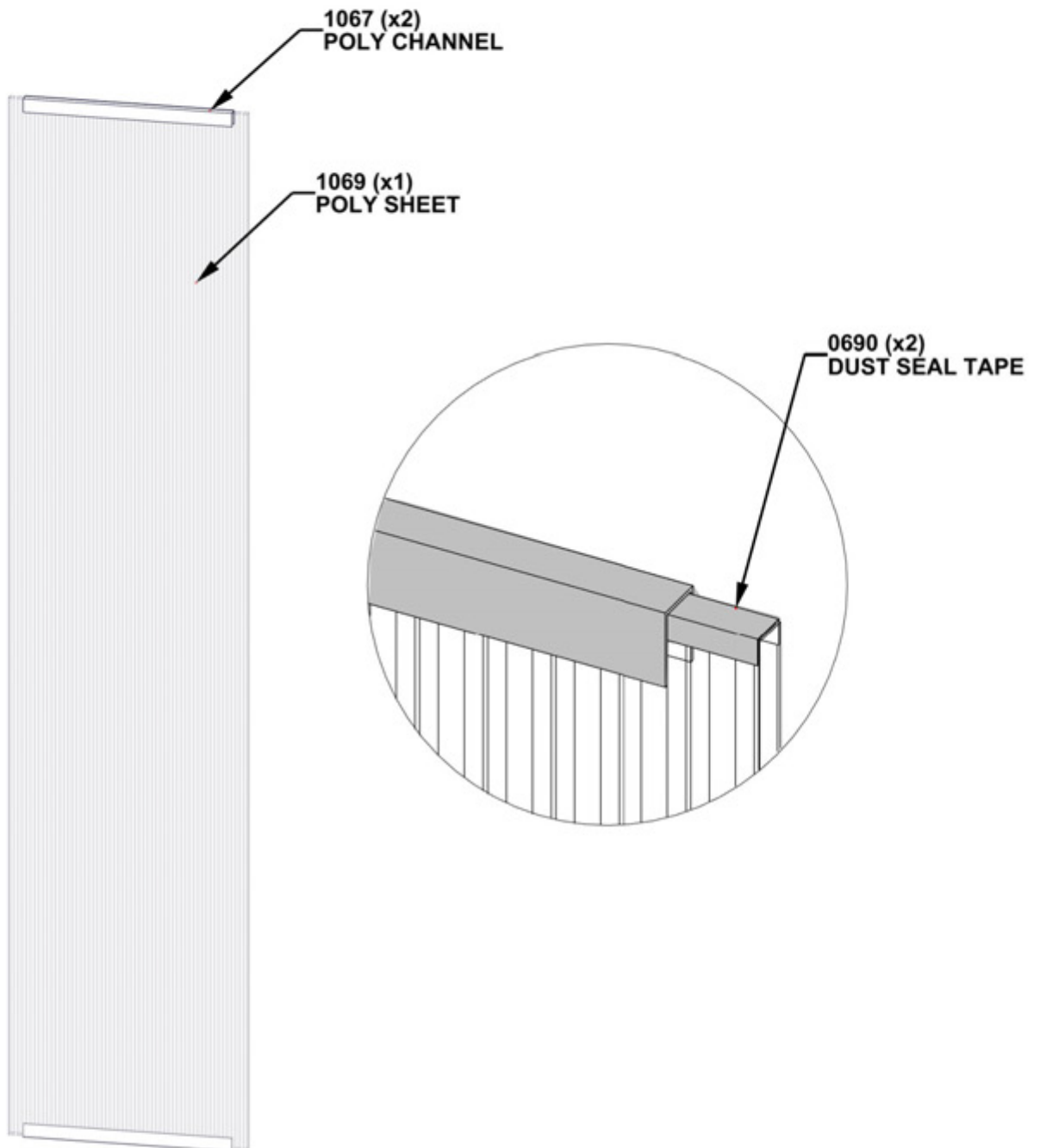

# STEP 65 - WINDOW ASSEMBLY

## IMPORTANT!

- ENSURE UV SIDE OF WINDOW IS FACING OUTSIDE.
- ONCE WINDOW IS INSTALLED, IT IS SAFE TO REMOVE THE PROTECTIVE FILM.

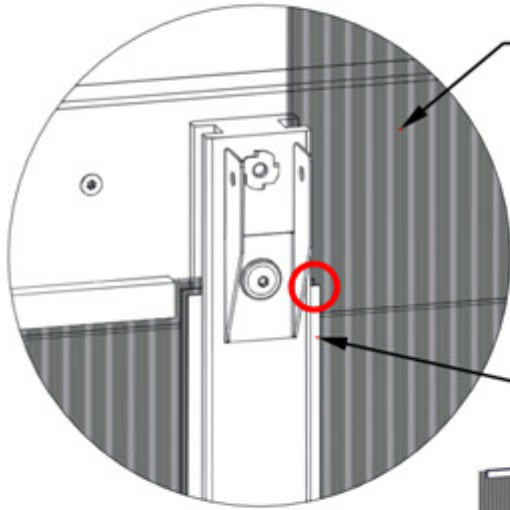

WINDOW ASSEMBLY FROM STEP 64

- INSERT WINDOW ASSEMBLY INTO PREVIOUSLY INSTALLED CHANNEL ON BOTH SIDES OF WINDOW.
- GENTLY SLIDE WINDOW DOWN UNTIL SEATED ON WINDOW SILL.

POLY CHANNEL FROM STEP 53

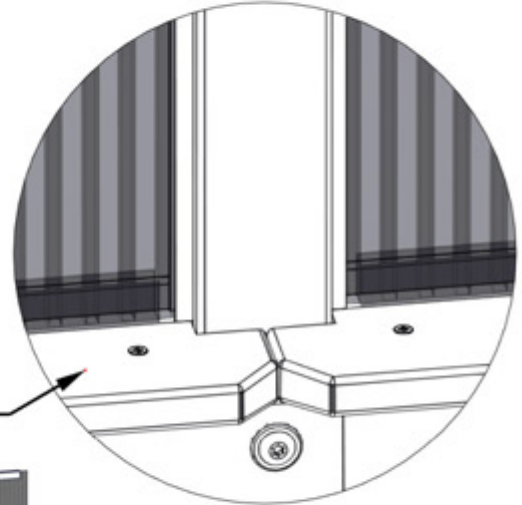

WINDOW SILL

OUTSIDE VIEW

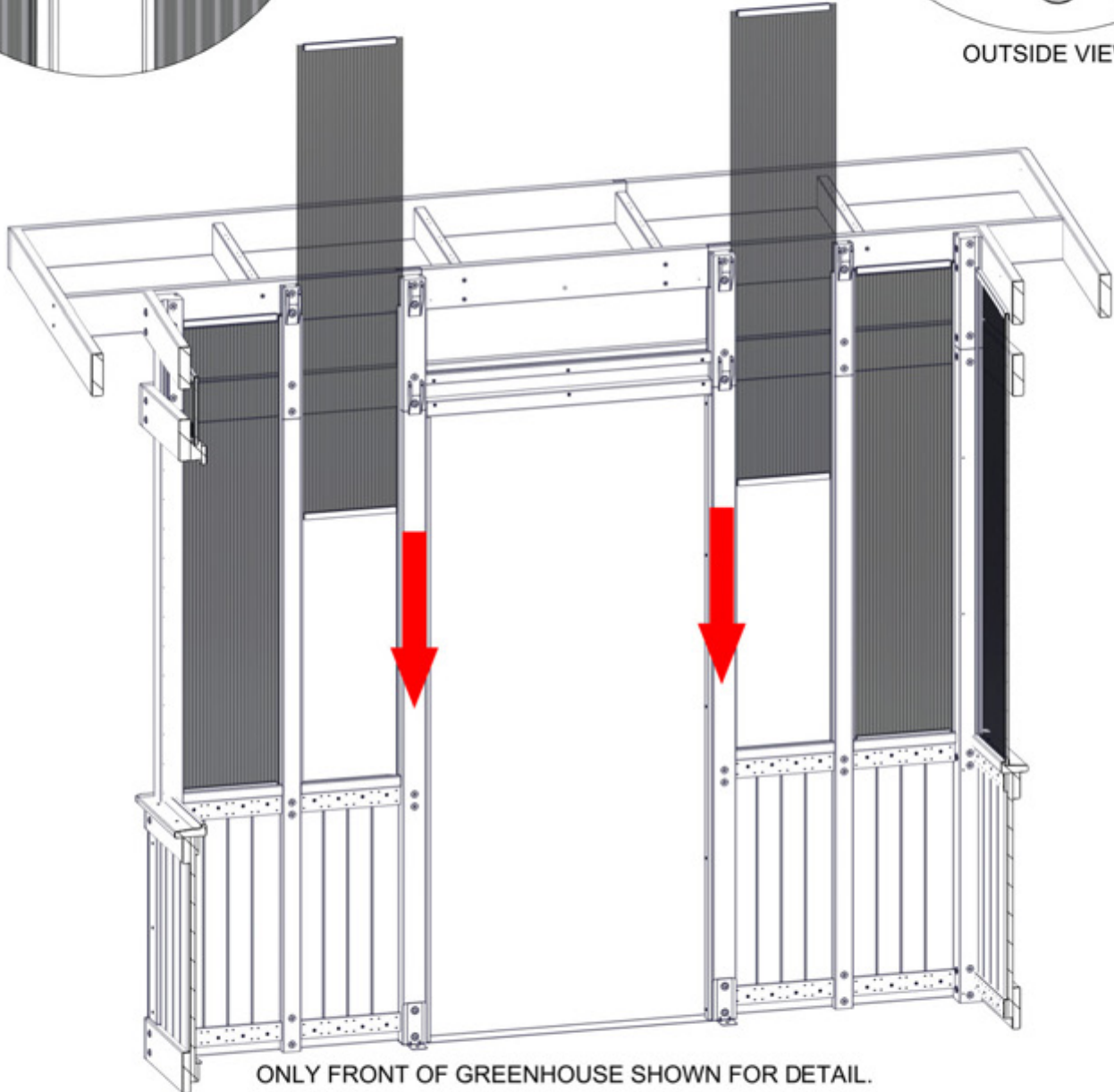

ONLY FRONT OF GREENHOUSE SHOWN FOR DETAIL.

# STEP 66 - WINDOW ASSEMBLY



A6P01072 POLY SHEET  
(x1)



A6P01031 POLY CHANNEL  
(x2)



A6P00690 DUST SEAL TAPE

## TO APPLY DUST SEAL TAPE AND POLY CHANNEL:

- CUT 2 STRIPS OF DUST SEAL TAPE THE SAME WIDTH AS THE POLY SHEET.
- WRAP DUST SEAL TAPE ALONG EDGE OF POLY SHEET WIDTH.
- AFTER TAPE IS SECURE, PUSH CHANNEL ON OVER THE TAPE, CENTERING ON THE POLY SHEET.
- REPEAT ON THE BOTTOM SIDE OF POLY SHEET.

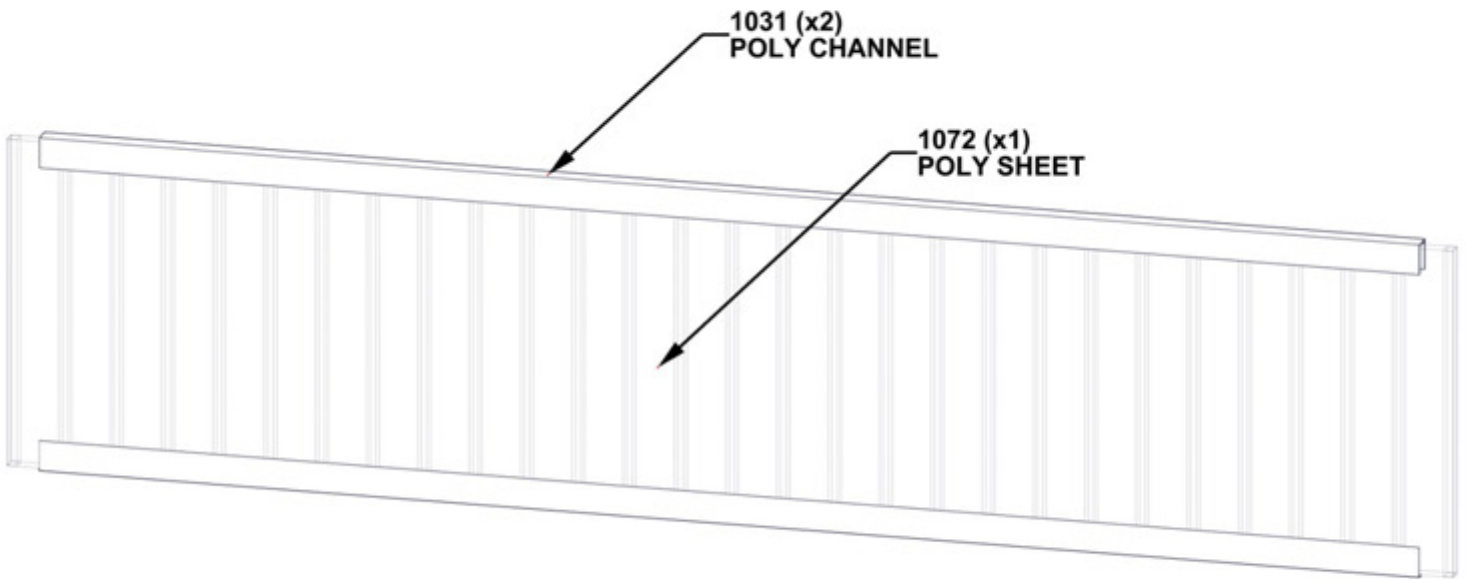

1031 (x2)  
POLY CHANNEL

1072 (x1)  
POLY SHEET

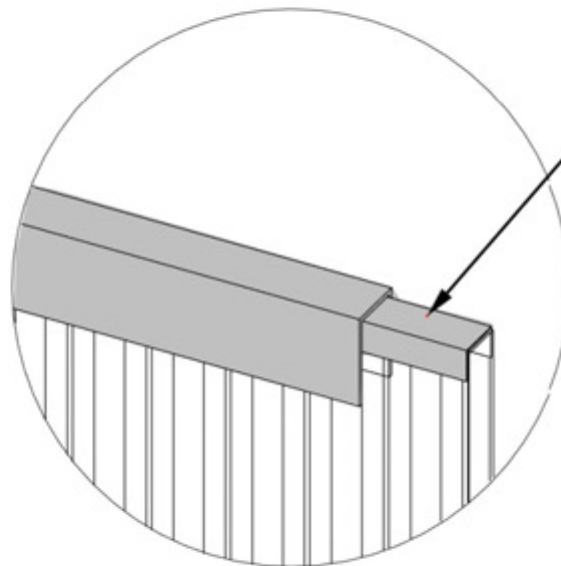

0690 (x2)  
DUST SEAL TAPE

# STEP 67 - WINDOW ASSEMBLY

## IMPORTANT!

- ENSURE UV SIDE OF WINDOW IS FACING OUTSIDE.
- ONCE WINDOW IS INSTALLED, IT IS SAFE TO REMOVE THE PROTECTIVE FILM.

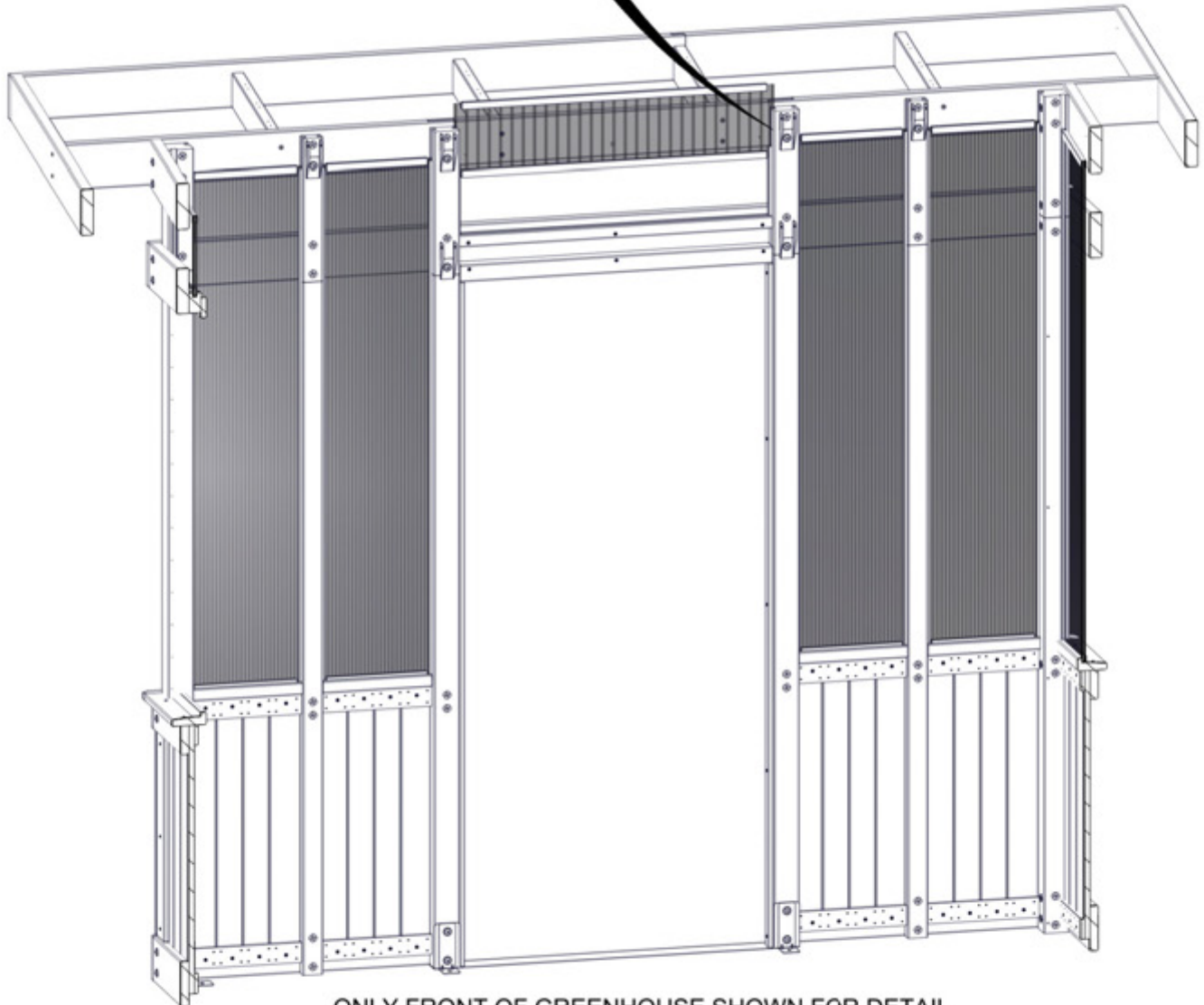
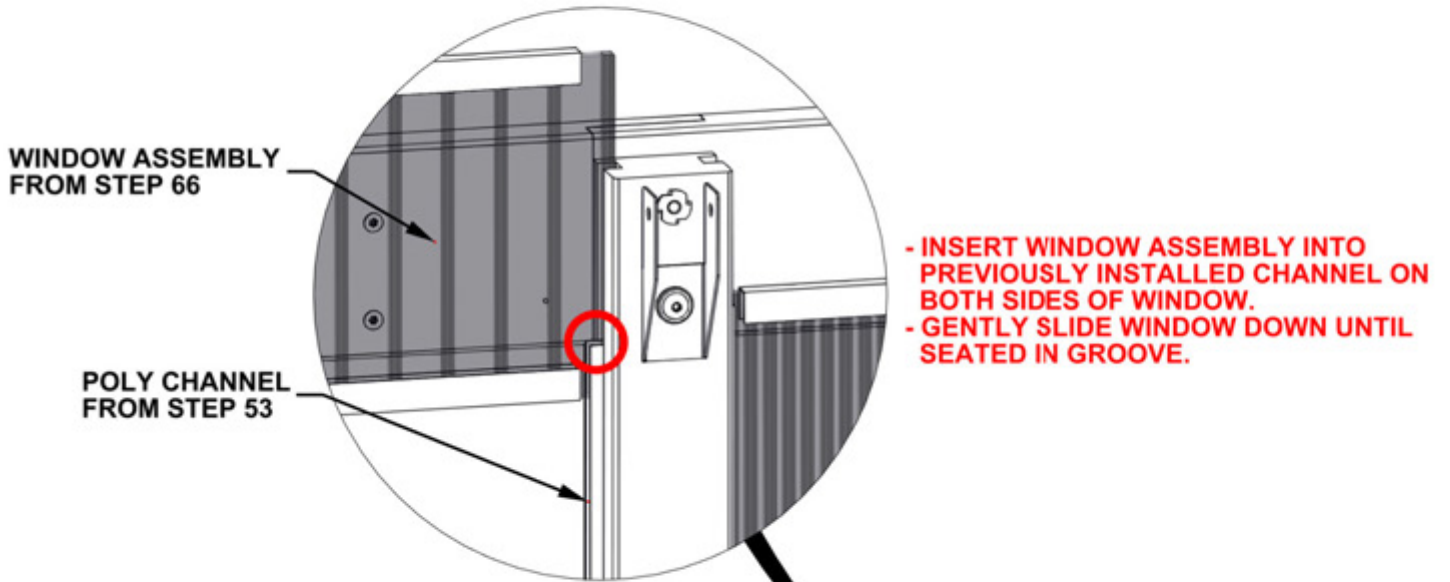

# STEP 68 - WINDOW ASSEMBLY

QTY	PART NUMBER	DESCRIPTION
12	H100201	SCREW PFH 8x2 1/2 BLK



P01 WINDOW CAP - W4L20571  
(x4) 1 7/16"x1 7/16"x13 3/16" (36x36x335)



P08 WINDOW CAP - W4L20634  
(x2) 1 7/16"x1 7/16"x17 9/16" (36x36x446)

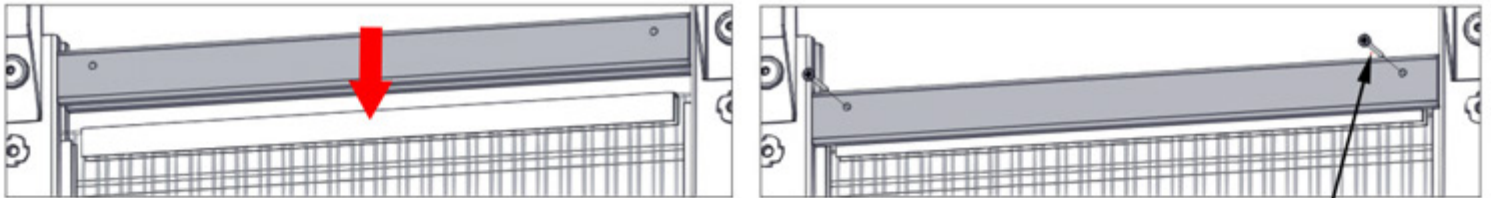

SLIDE GROOVE IN WINDOW CAP OVER WINDOW ASSEMBLY AND SCREW INTO PLACE.

201 (x12)  
SCREW - 2 1/2"

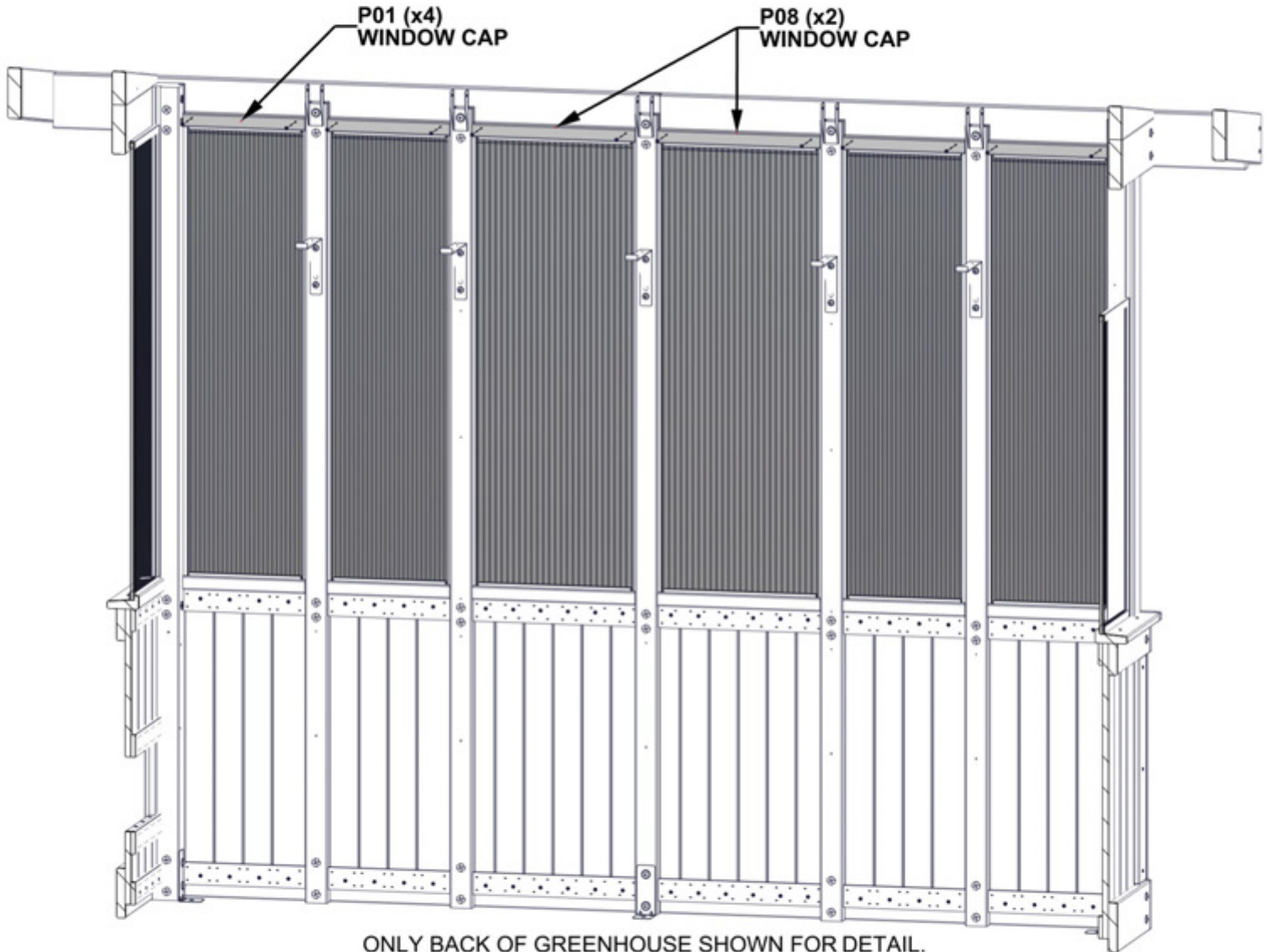

ONLY BACK OF GREENHOUSE SHOWN FOR DETAIL.

# STEP 69 - WINDOW ASSEMBLY

QTY	PART NUMBER	DESCRIPTION
6	H100201	SCREW PFH 8x2 1/2 BLK



P04 WINDOW CAP - W4L20590  
(x1) 1 7/16"x1 7/16"x18 3/8" (36x36x466)



P06 WINDOW CAP - W4L20627  
(x1) 1 7/16"x1 7/16"x18 1/16" (36x36x458)



P10 WINDOW CAP - W4L20754  
(x1) 1 7/16"x1 7/16"x17 1/2" (36x36x445)

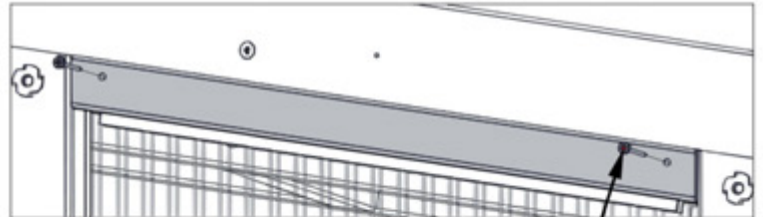
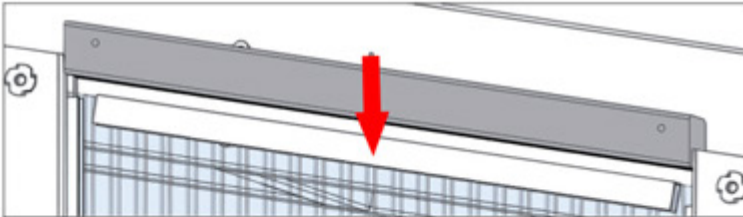

SLIDE GROOVE IN WINDOW CAP OVER WINDOW ASSEMBLY AND SCREW INTO PLACE.

201 (x6)  
SCREW - 2 1/2"

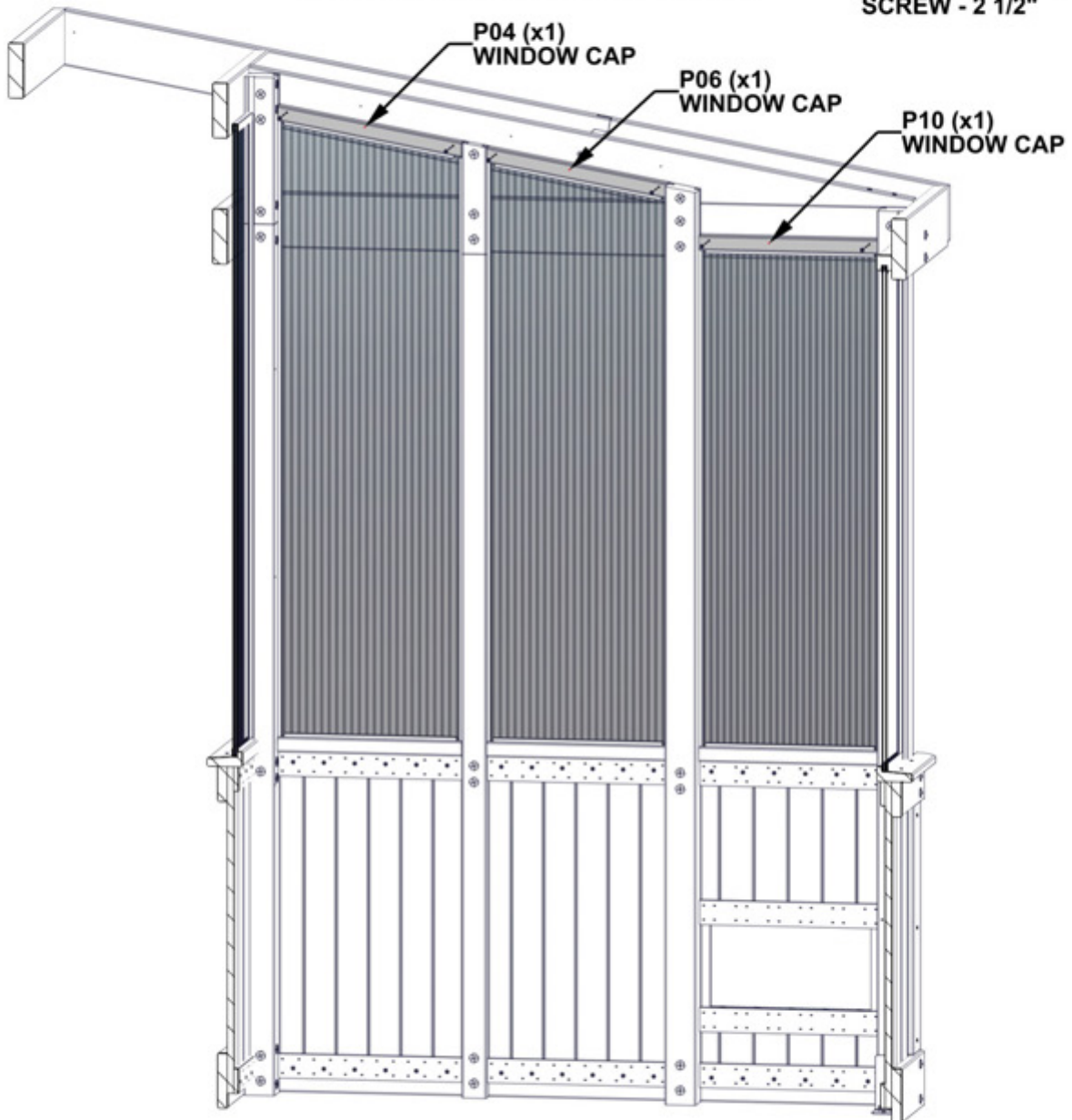

ONLY SIDE OF GREENHOUSE SHOWN FOR DETAIL.

# STEP 70 - WINDOW ASSEMBLY

QTY	PART NUMBER	DESCRIPTION
4	H100201	SCREW PFH 8x2 1/2 BLK



P04 WINDOW CAP - W4L20590  
(x2) 1 7/16"x1 7/16"x18 3/8" (36x36x466)

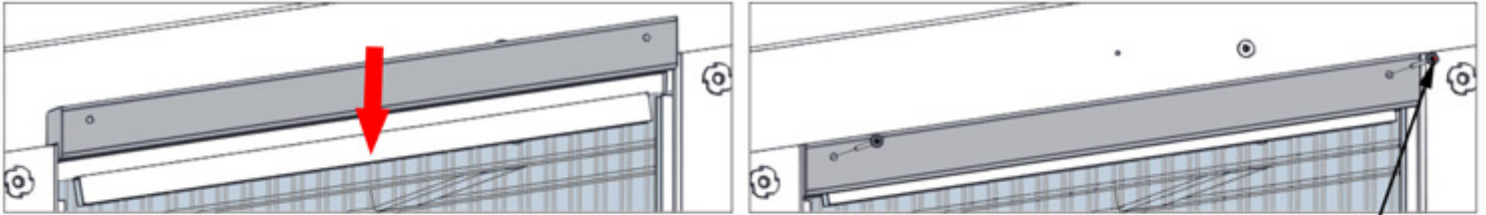

SLIDE GROOVE IN WINDOW CAP OVER WINDOW ASSEMBLY AND SCREW INTO PLACE.

201 (x4)  
SCREW - 2 1/2"



P04 (x2)  
WINDOW CAP

ONLY SIDE OF GREENHOUSE SHOWN FOR DETAIL.

# STEP 71 - WINDOW ASSEMBLY

QTY	PART NUMBER	DESCRIPTION
8	H100201	SCREW PFH 8x2 1/2 BLK



P01 WINDOW CAP - W4L20571  
(x2) 1 7/16"x1 7/16"x13 3/16" (36x36x335)



P02 WINDOW CAP - W4L20575  
(x2) 1 7/16"x1 7/16"x12 7/8" (36x36x327)

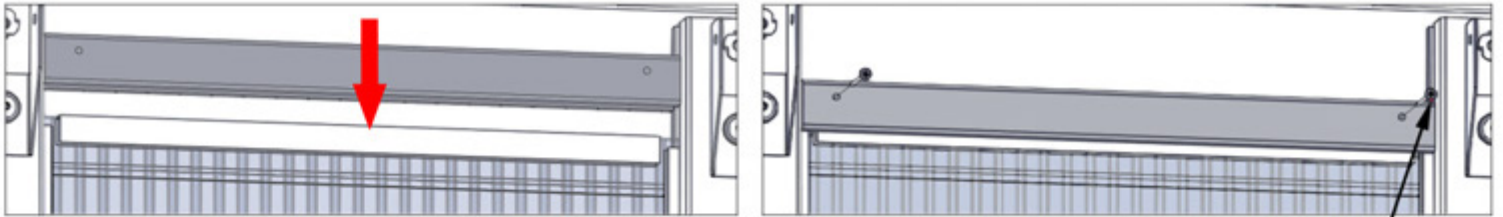

SLIDE GROOVE IN WINDOW CAP OVER WINDOW ASSEMBLY AND SCREW INTO PLACE.

201 (x8)  
SCREW - 2 1/2"

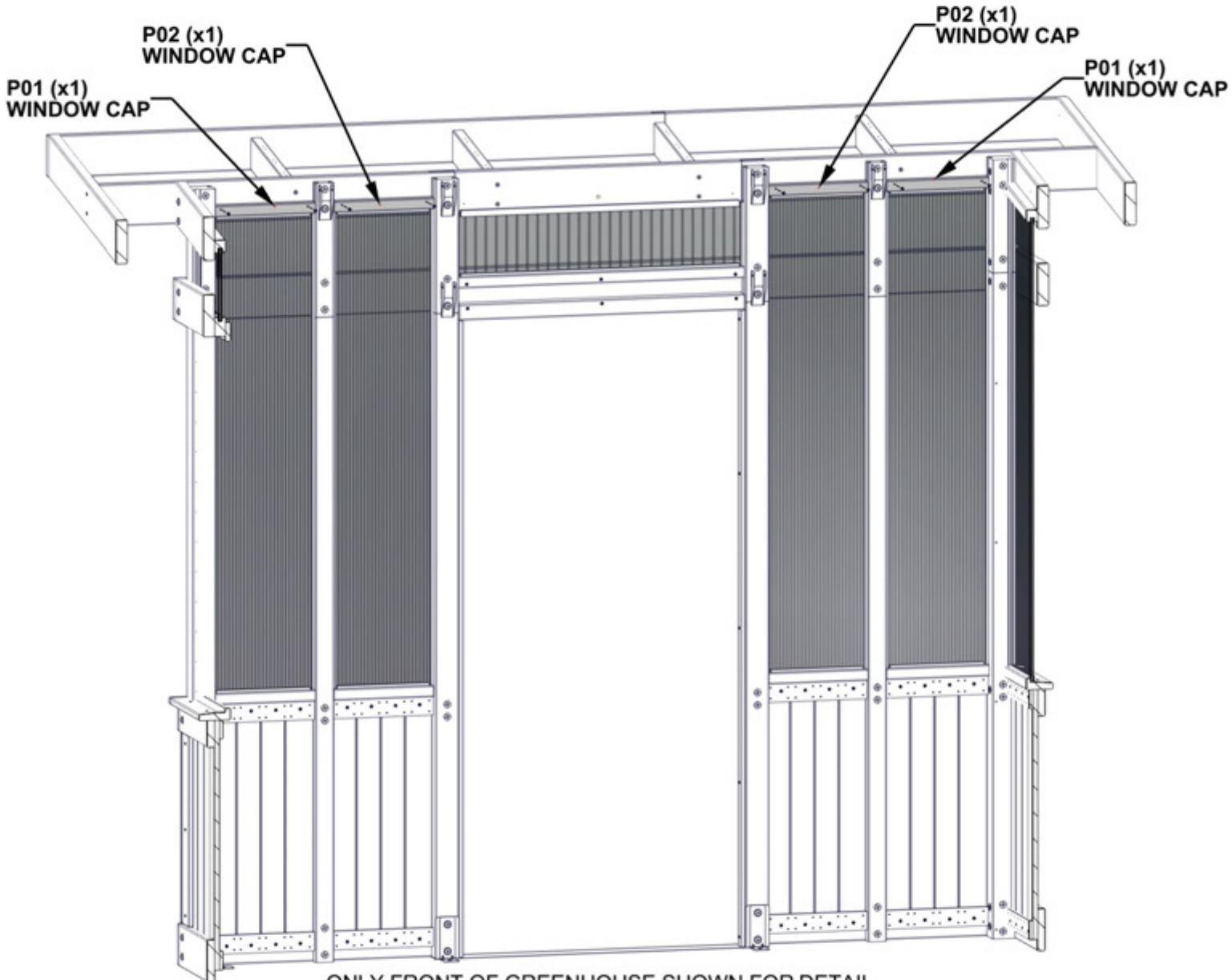

ONLY FRONT OF GREENHOUSE SHOWN FOR DETAIL.

# STEP 72 - WINDOW ASSEMBLY

QTY	PART NUMBER	DESCRIPTION
1	H100193	NUT BARREL WH 5/16 X 1 1/2 BLK
1	H100198	WASHER LOCK EXT 8x19
2	H100201	SCREW PFH 8x2 1/2 BLK
1	H100378	BOLT WH 5/16x1 3/4 BLK

F03 WINDOW CAP - W4L20577  
(x1) 1 7/16"x2 3/8"x36 15/16" (36x60x938)



A4M02093 RAFTER BRACKET  
(x1)

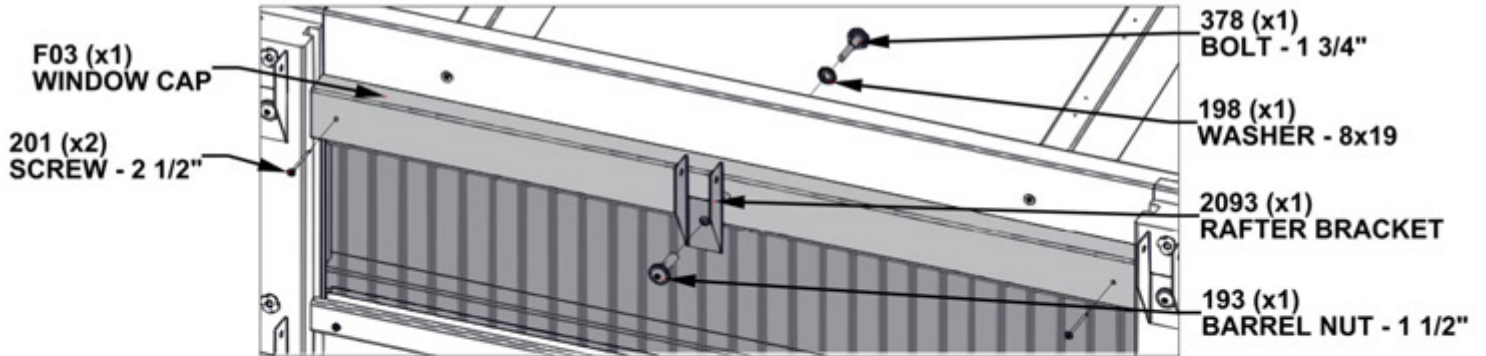

**WITH THE GROOVE IN WINDOW CAP FACING DOWN, ALIGN THROUGH HOLE WITH THROUGH HOLE IN HEADER AND ATTACH AS SHOWN.**

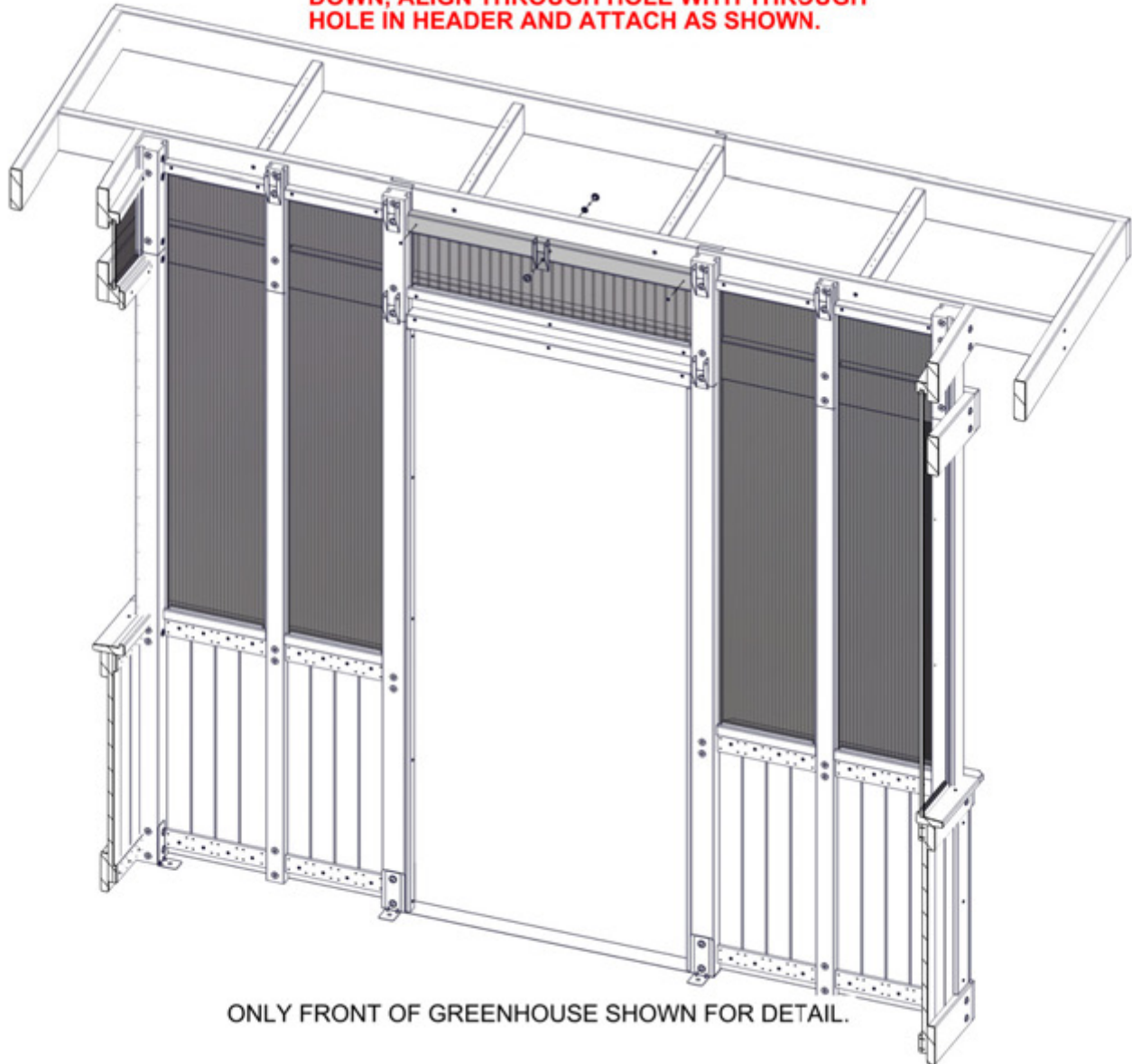

ONLY FRONT OF GREENHOUSE SHOWN FOR DETAIL.

# STEP 73 - FAN FRAME ASSEMBLY

QTY	PART NUMBER	DESCRIPTION
6	H100387	SCREW PFH 8x1 1/4 BLK



E12 FAN FRAME - W4L20628  
(x1) 1 7/16"x3 3/8"x18 11/16" (36x86x475)



A4M00997 METAL CLEAT  
(x1)

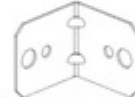

A4M00555 L BRACKET BLK  
(x1)

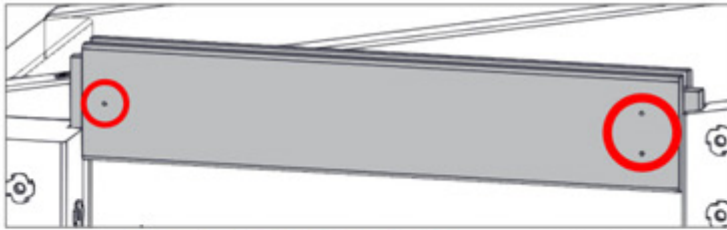

**NOTE PILOT HOLES FOR CORRECT INSTALLATION.**

SLIDE E12 INTO PLACE USING GROOVES IN POSTS.

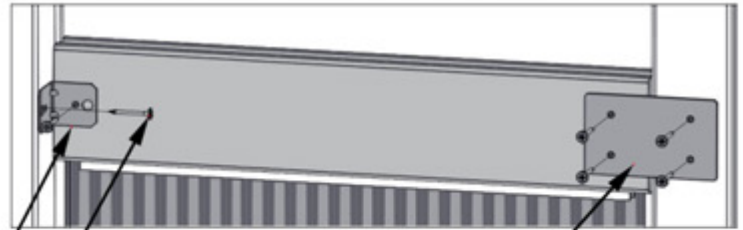

555 (x1)  
L BRACKET BLK

997 (x1)  
METAL CLEAT

387 (x6)  
SCREW - 1 1/4"

E12 (x1)  
FAN FRAME

**ATTACH BRACKETS BY ALIGNING WITH PILOT HOLES IN POST, UPRIGHT, AND E12.**

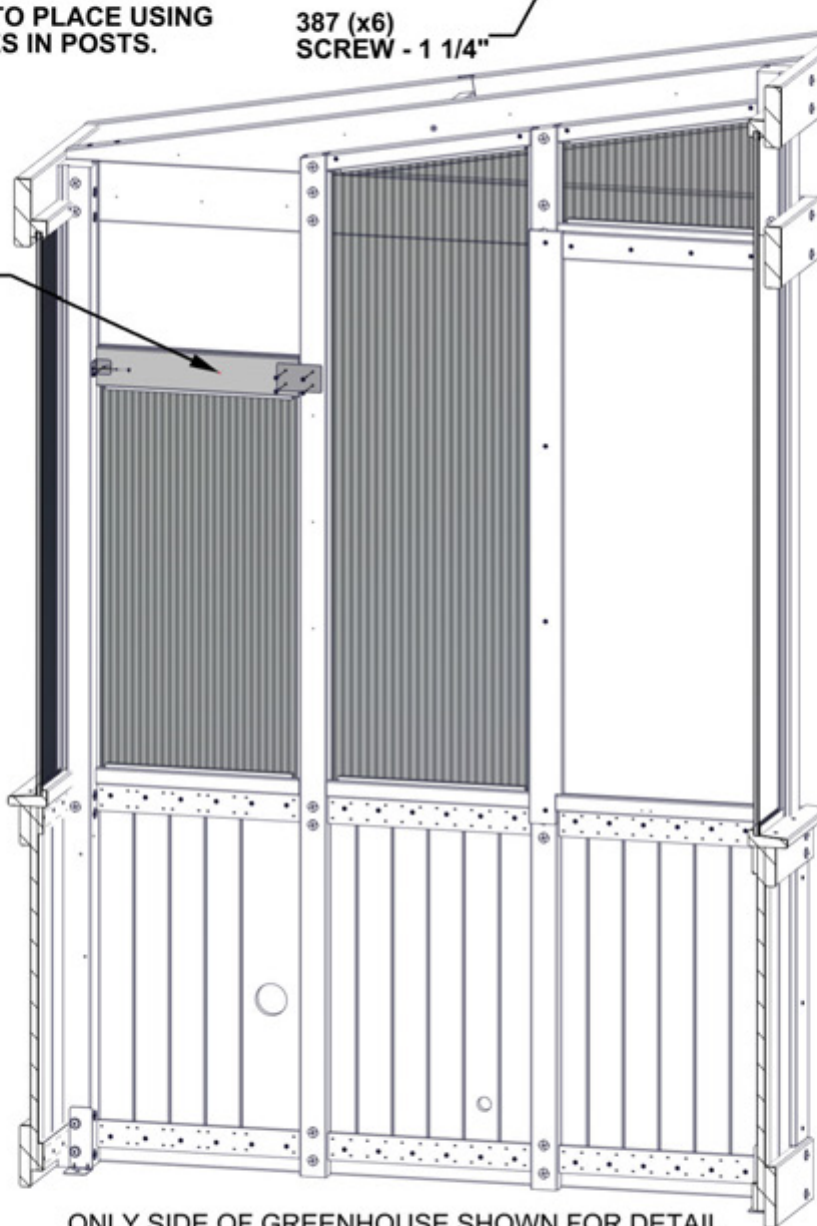

ONLY SIDE OF GREENHOUSE SHOWN FOR DETAIL.

# STEP 74 - FAN FRAME ASSEMBLY



D10 WINDOW FRAME - W4L20629  
(x2) 1 7/16"x4 3/16"x11 7/16" (36x106x290)

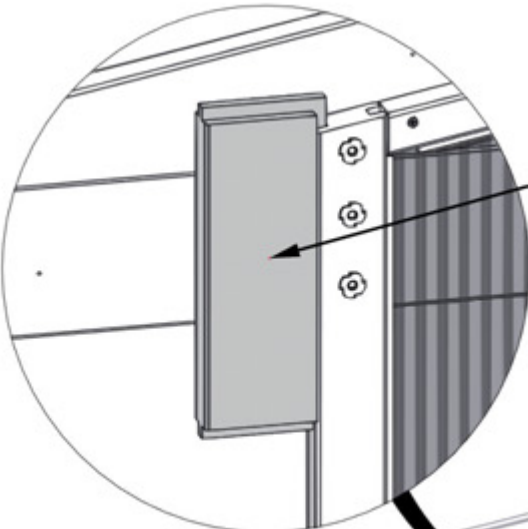

D10 (x2)  
WINDOW FRAME

SLIDE D10 BOARDS INTO PLACE AS SHOWN.

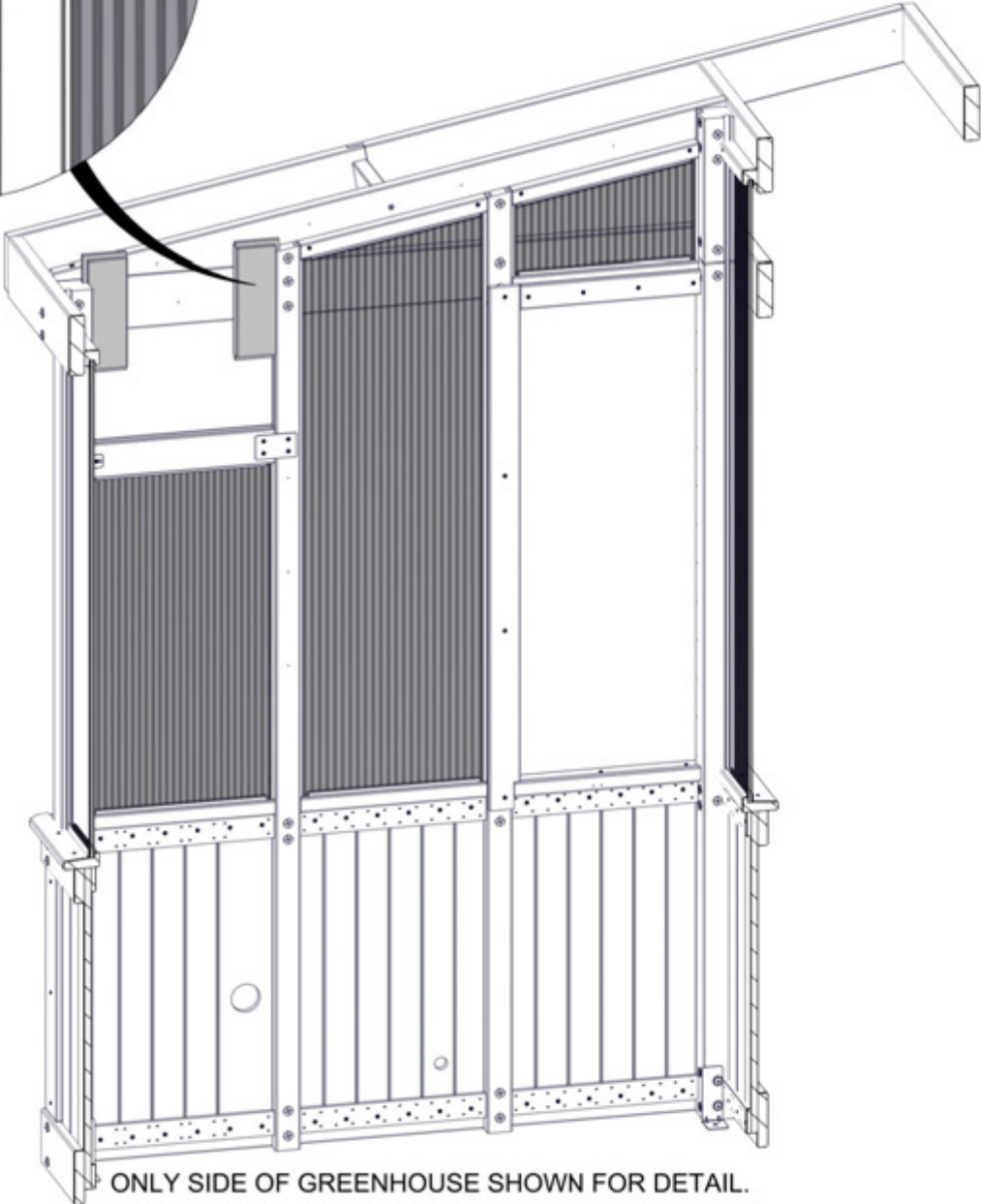

ONLY SIDE OF GREENHOUSE SHOWN FOR DETAIL.

# STEP 75 - FAN FRAME ASSEMBLY

QTY	PART NUMBER	DESCRIPTION
3	H100201	SCREW PFH 8x2 1/2 BLK



E17 FAN FRAME - W4L20614  
(x1) 1 7/16"x3 3/8"x18 11/16" (36x86x475)

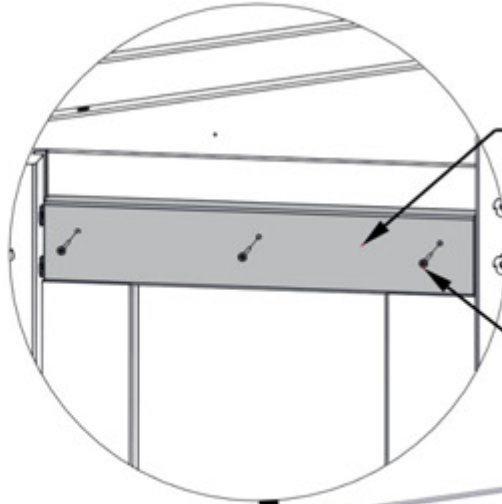

E17 (x1)  
FAN FRAME

- WITH GROOVE FACING DOWN, SLIDE E17 INTO PLACE.  
- ALIGN PILOT HOLES AND ATTACH.

201 (x3)  
SCREW - 2 1/2"

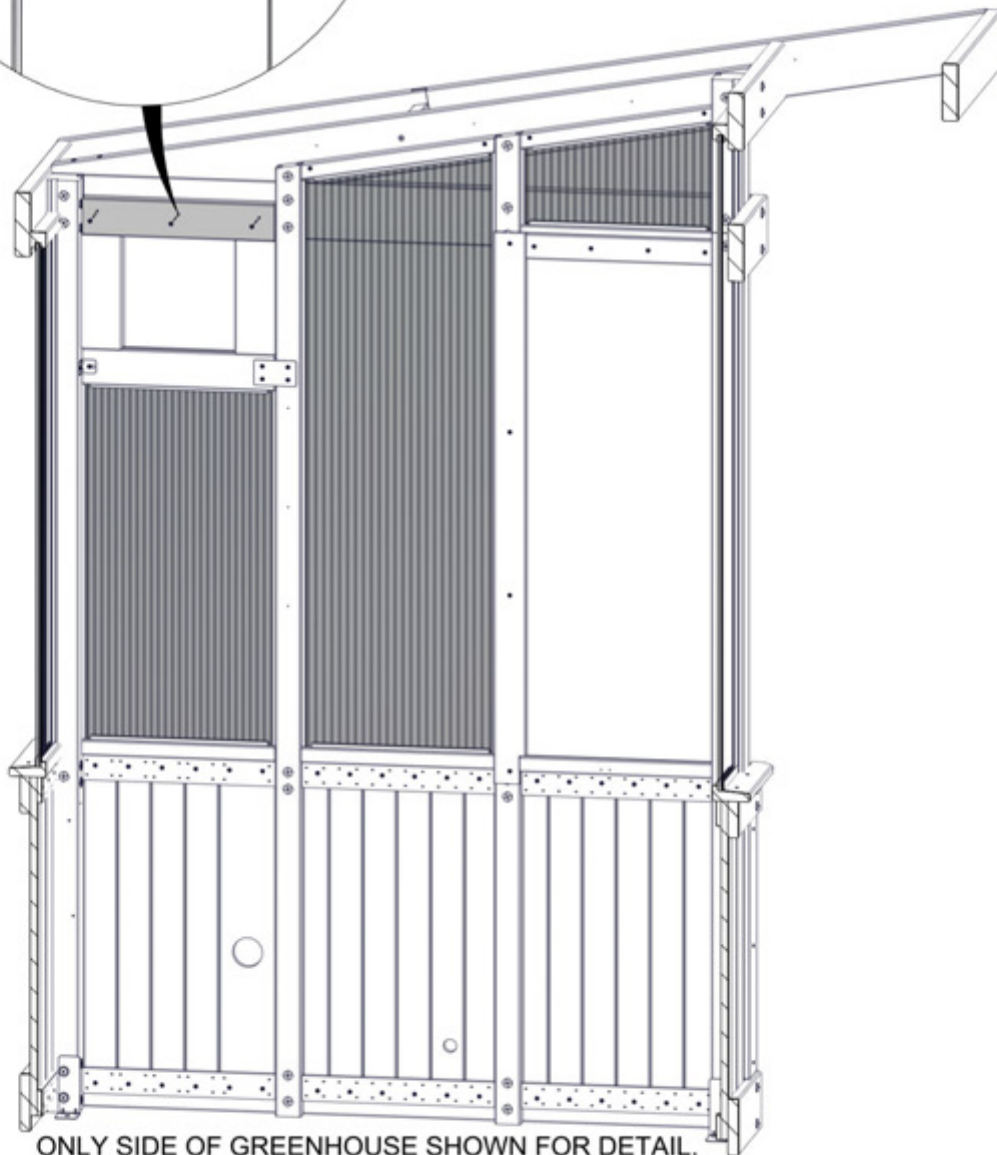

ONLY SIDE OF GREENHOUSE SHOWN FOR DETAIL.

# STEP 76 - ROOF ASSEMBLY

QTY	PART NUMBER	DESCRIPTION
8	H100201	SCREW PFH 8x2 1/2 BLK



P05 PURLIN CLEAT - W4L20591  
(x2) 1 7/16"x1 7/16"x45 13/16" (36x36x1163)

ALIGN THROUGH HOLES IN P05 WITH  
PILOT HOLES IN HEADER AND ATTACH.

P05 (x2)  
PURLIN CLEAT

201 (x8)  
SCREW - 2 1/2"

**ENSURE PILOT HOLES FACE UP AS SHOWN.**

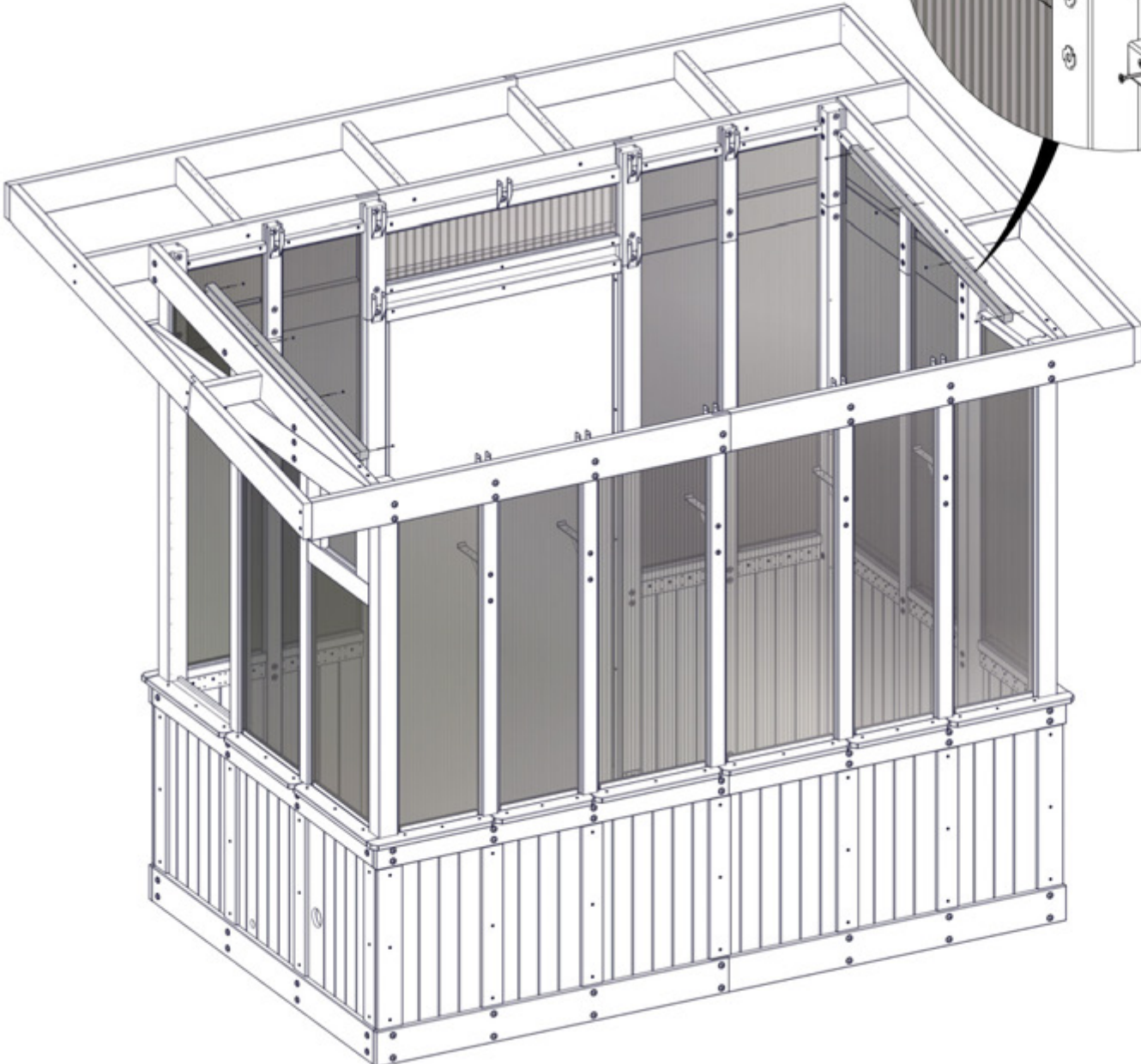
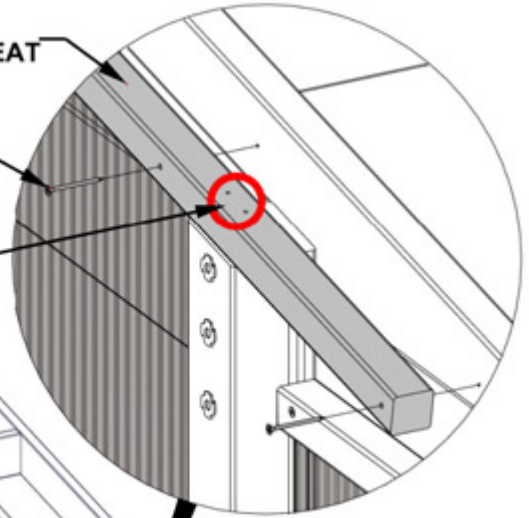

# STEP 77 - ROOF ASSEMBLY

QTY	PART NUMBER	DESCRIPTION
20	H100391	SCREW PFH 8x2 BLK

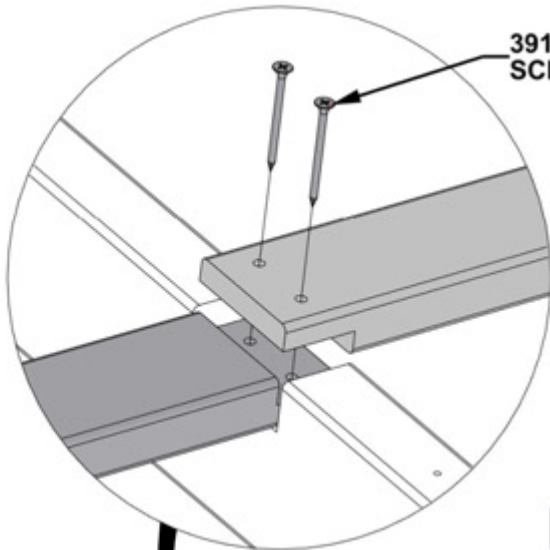
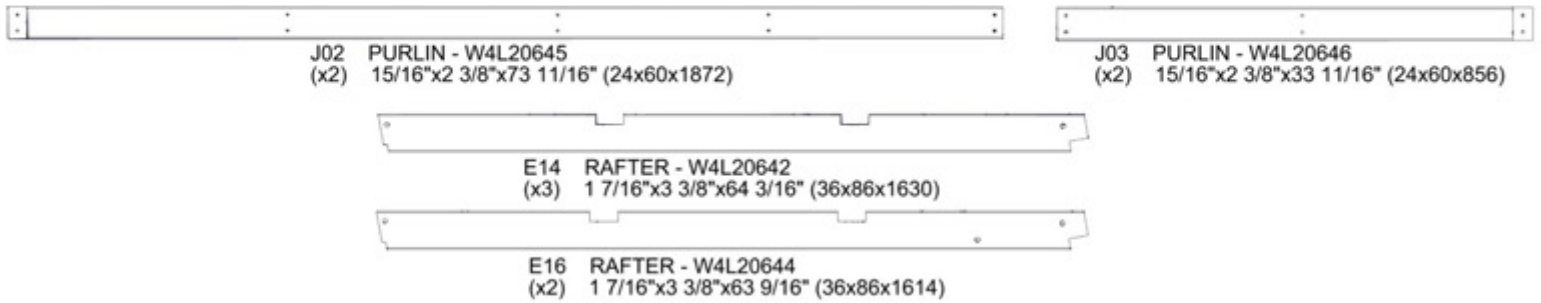

- ALIGN PILOT HOLES.
- NOTE NOTCHES FOR CORRECT ORIENTATION OF RAFTERS.
- THE END WITH THE SMALLER NOTCH WILL FACE TOWARD THE FRONT.

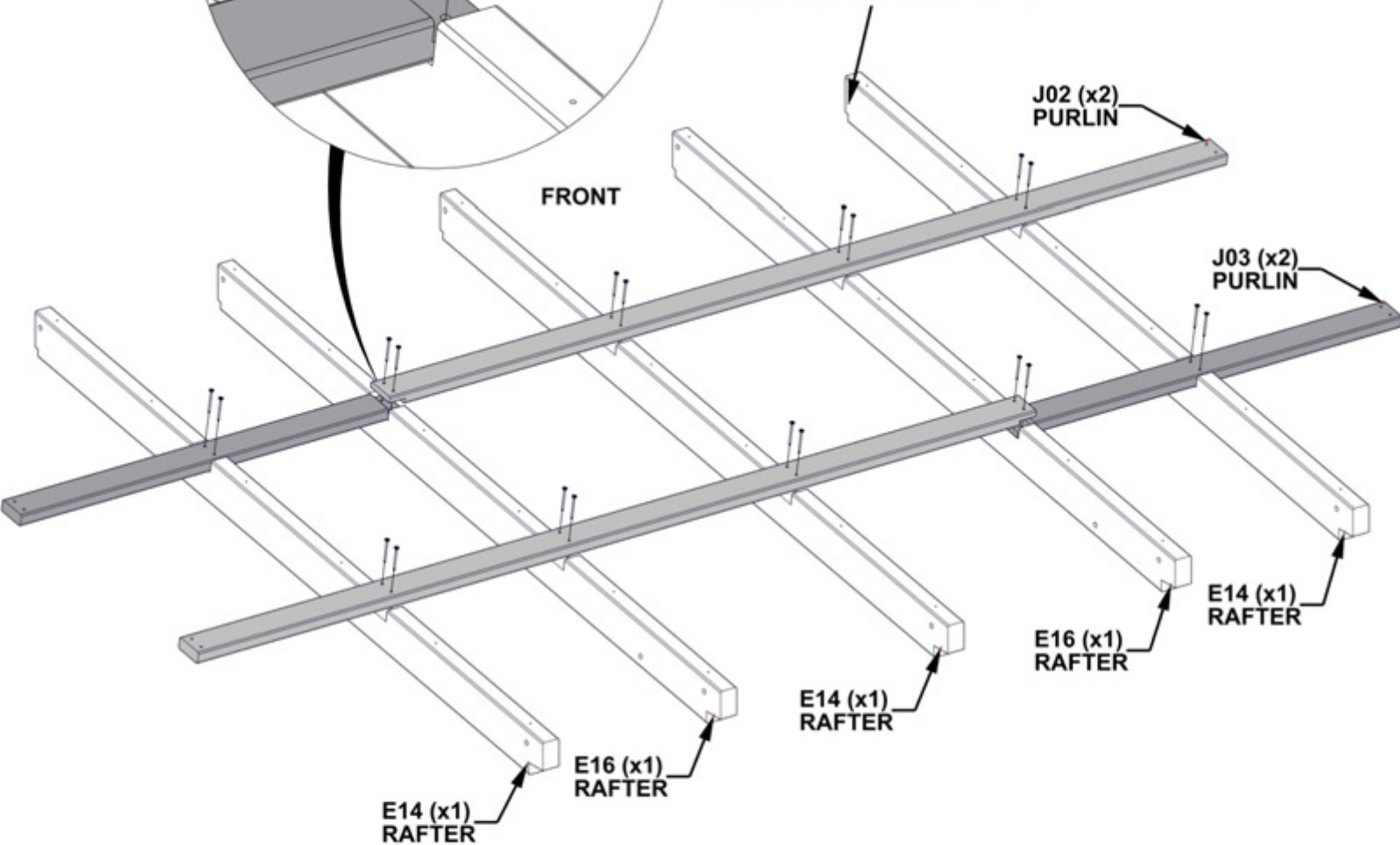

**IT IS CRITICAL FOR LATER STEPS TO ENSURE CORRECT PLACEMENT OF RAFTERS.**

# STEP 78 - ROOF ASSEMBLY

## IMPORTANT!

### BEFORE PROCEEDING:

- ENSURE UNIT IS SQUARE.
- THE BELOW DIMENSIONS ARE CRITICAL TO THE FINAL ROOF ASSEMBLY.
- MEASUREMENTS SHOULD BE HELD WITHIN +/- 1/4" [6mm].
- MEASUREMENTS OUTSIDE OF TOLERANCE WILL LEAD TO INABILITY TO ASSEMBLY THE ROOF.

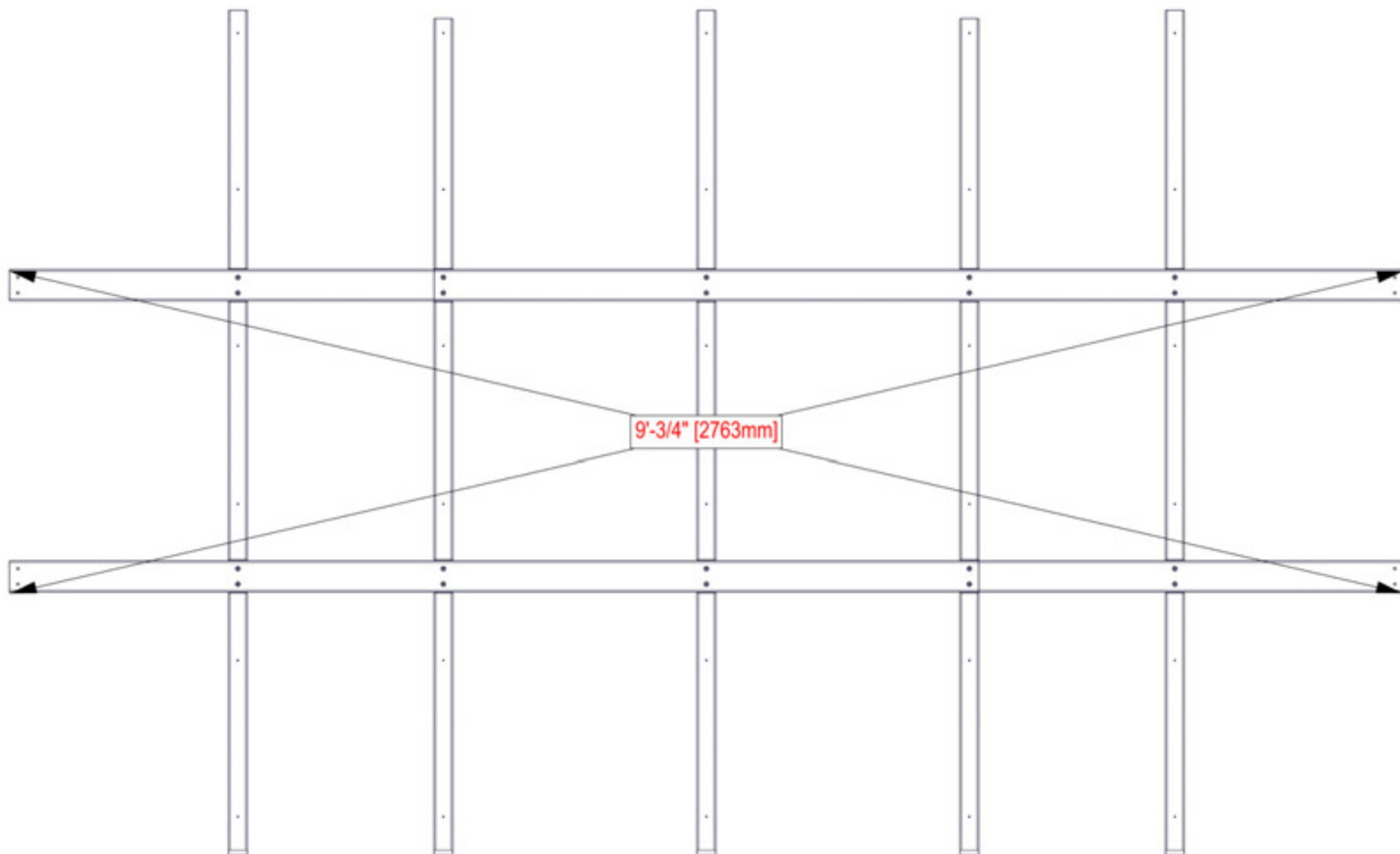

LOOSEN HARDWARE TO ADJUST FOR SQUARING IF NEEDED.

# STEP 79 - ROOF ASSEMBLY

QTY	PART NUMBER	DESCRIPTION
30	H101203	SCREW PWH 8x15x1 1/4 BLK

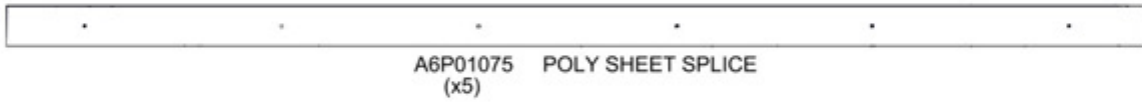

- ALIGN HOLES IN POLY SHEET SPLICES WITH PILOT HOLES IN RAFTERS.
- DO NOT OVERTIGHTEN.

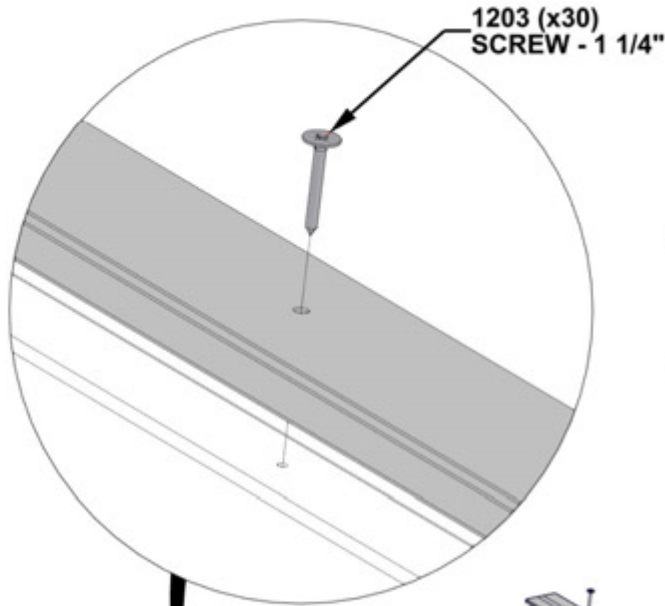

ENSURE THE NARROWER SIDE  
OF POLY SPLICE FACES UP.

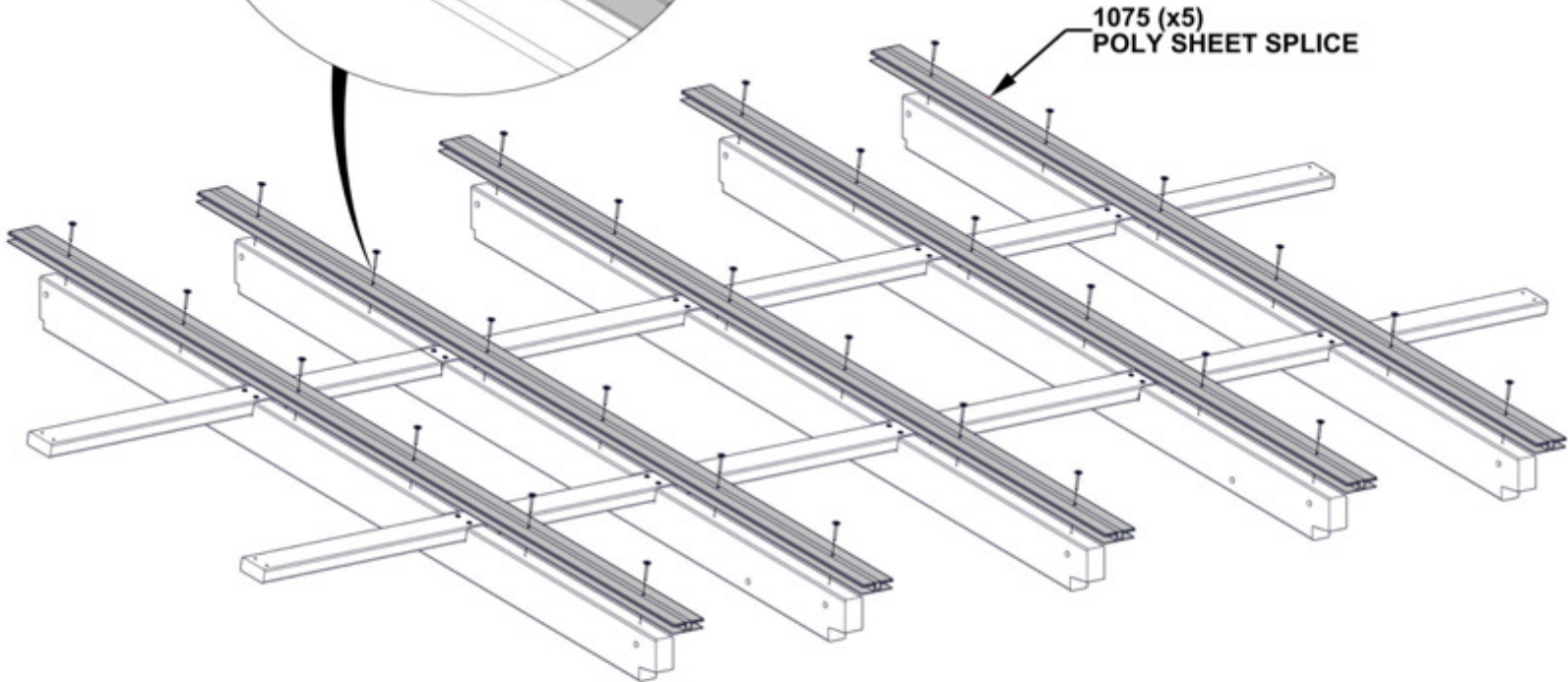
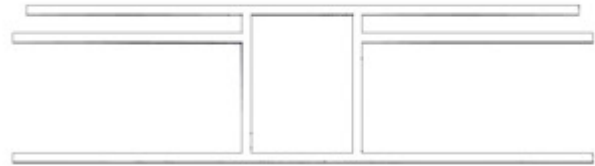

# STEP 80 - ROOF ASSEMBLY

QTY	PART NUMBER	DESCRIPTION
10	H100488	BOLT WH 1/4x2 BLK
10	H100630	WASHER FLAT 8x19 BLK
10	H100653	NUT LOCK 1/4 BLK

- WITH AT LEAST TWO PEOPLE, LIFT ROOF ASSEMBLY AND PLACE INTO RAFTER BRACKETS.

ALIGN HOLES ON RAFTERS WITH RAFTER BRACKETS.

**SMALLER NOTCHES ORIENTED TO FRONT OF GREENHOUSE.**

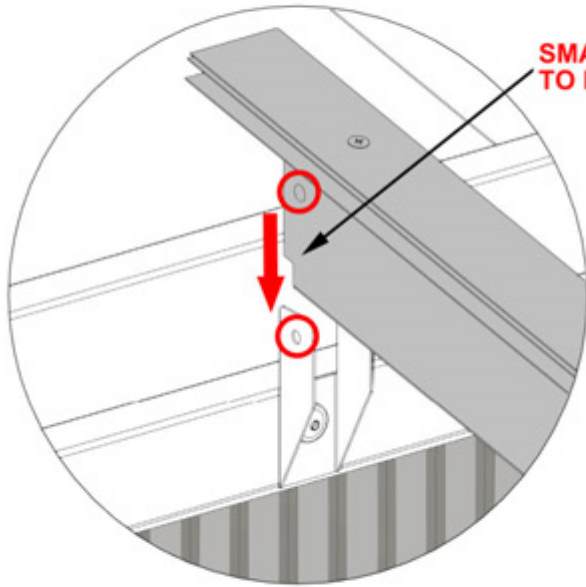

488 (x10)  
BOLT - 2"

630 (x10)  
WASHER - 8x19

653 (x10)  
LOCK NUT - 1/4"

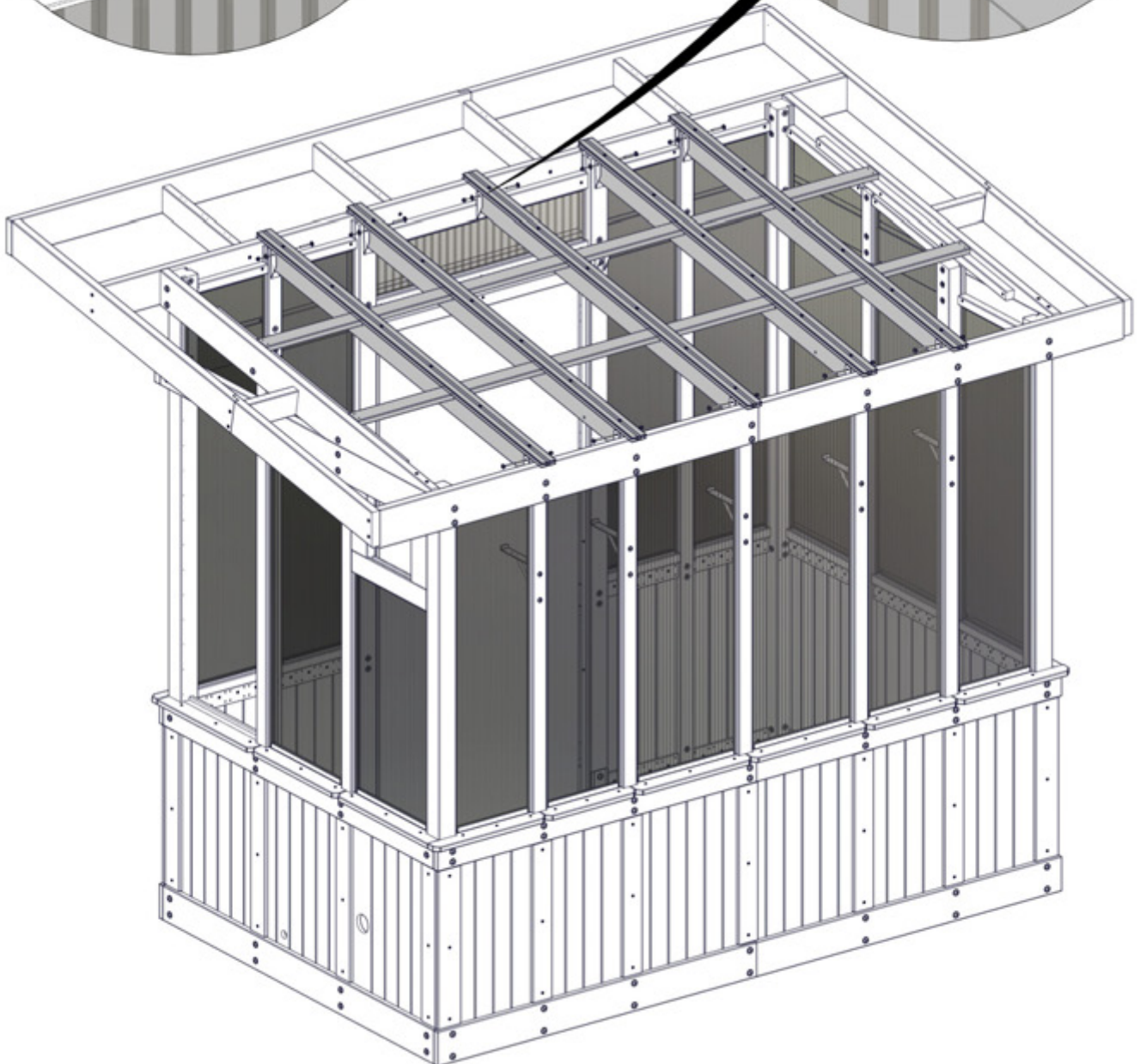
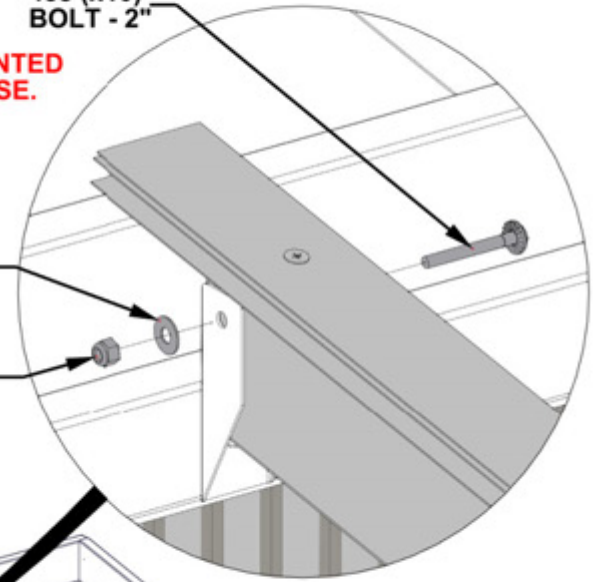

# STEP 81 - ROOF ASSEMBLY

QTY	PART NUMBER	DESCRIPTION
8	H100391	SCREW PFH 8x2 BLK

INSERT SCREWS THROUGH PILOT HOLES IN PURLINS INTO PURLIN CLEATS AS SHOWN.

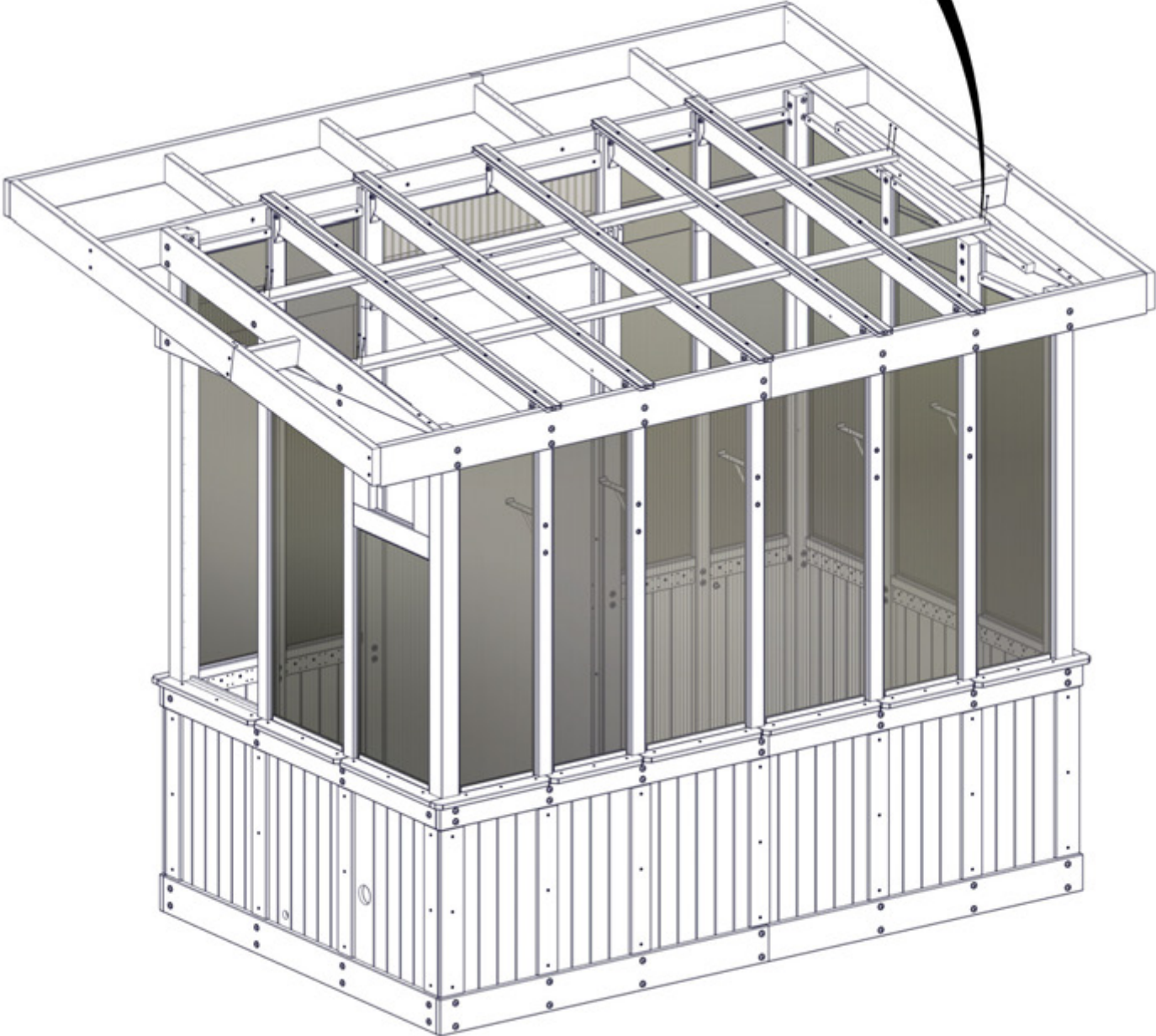
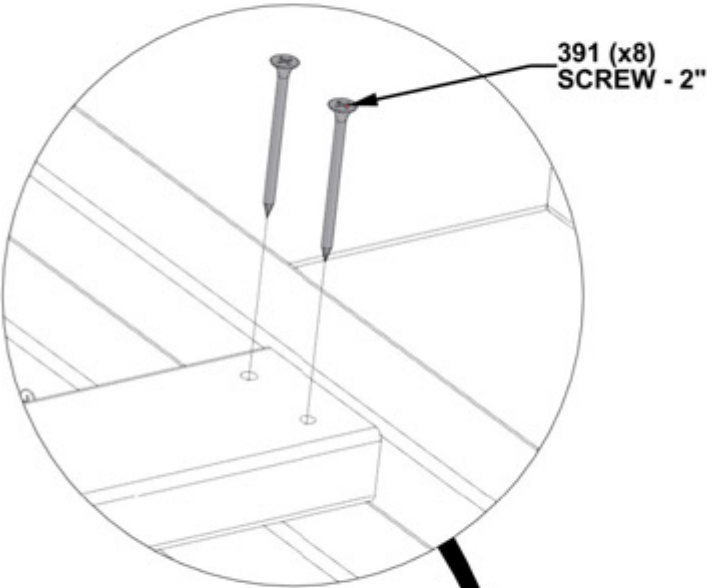

# STEP 82 - ROOF ASSEMBLY

QTY	PART NUMBER	DESCRIPTION
2	H100200	SCREW PFH 8x1 1/2 BLK
4	H100488	BOLT WH 1/4x2 BLK
4	H100630	WASHER FLAT 8x19 BLK
4	H100653	NUT LOCK 1/4 BLK



E15 JOIST - W4L20643  
(x2) 1 7/16"x3 3/8"x60 7/16" (36x86x1535)

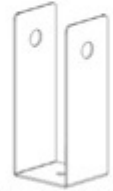

A4M03417 TRUSS BRACKET  
(x2)

- ATTACH JOISTS AND TRUSS BRACKETS AS SHOWN.  
- ALIGN PILOT HOLES AND INSERT SCREWS AFTER ALL OTHER HARDWARE IS ATTACHED.

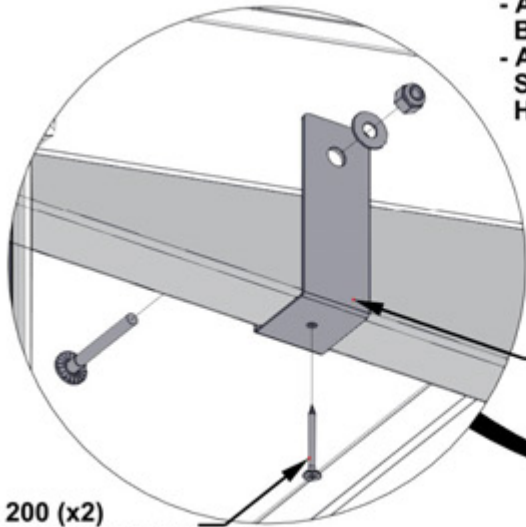

200 (x2)  
SCREW - 1 1/2"

3417 (x2)  
TRUSS BRACKET

488 (x4)  
BOLT - 2"

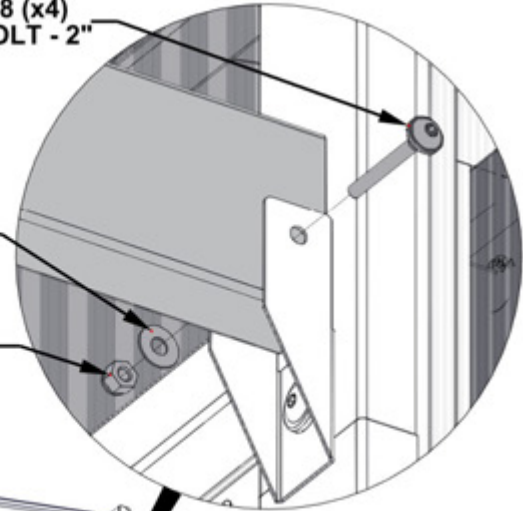

630 (x4)  
WASHER - 8x19

653 (x4)  
LOCK NUT - 1/4"

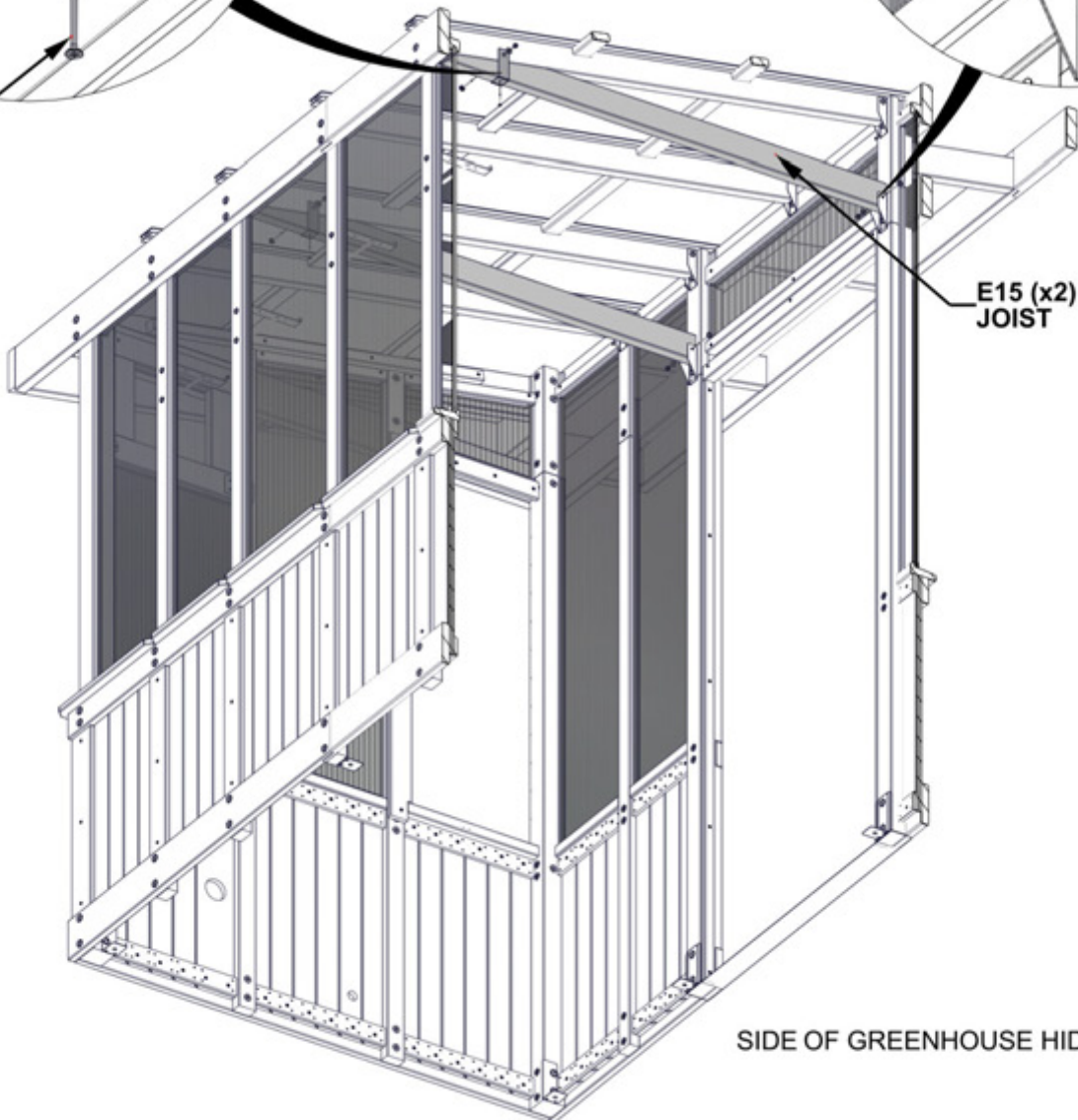

E15 (x2)  
JOIST

SIDE OF GREENHOUSE HIDDEN FOR DETAIL.

# STEP 83 - ROOF ASSEMBLY

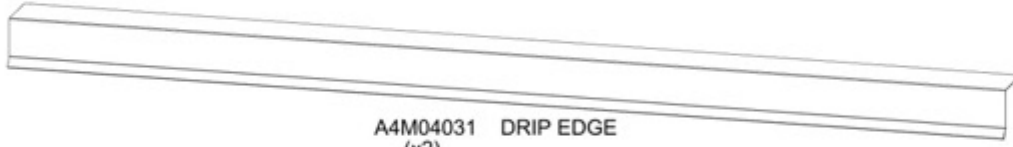

A4M04031 DRIP EDGE  
(x2)

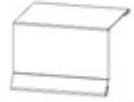

A4M03419 DRIP EDGE SPLICE  
(x1)

**WARNING: GLOVES ARE RECOMMENDED WHEN HANDLING STEEL.**

**REMOVE BLUE FILM FROM SHEET METAL.**

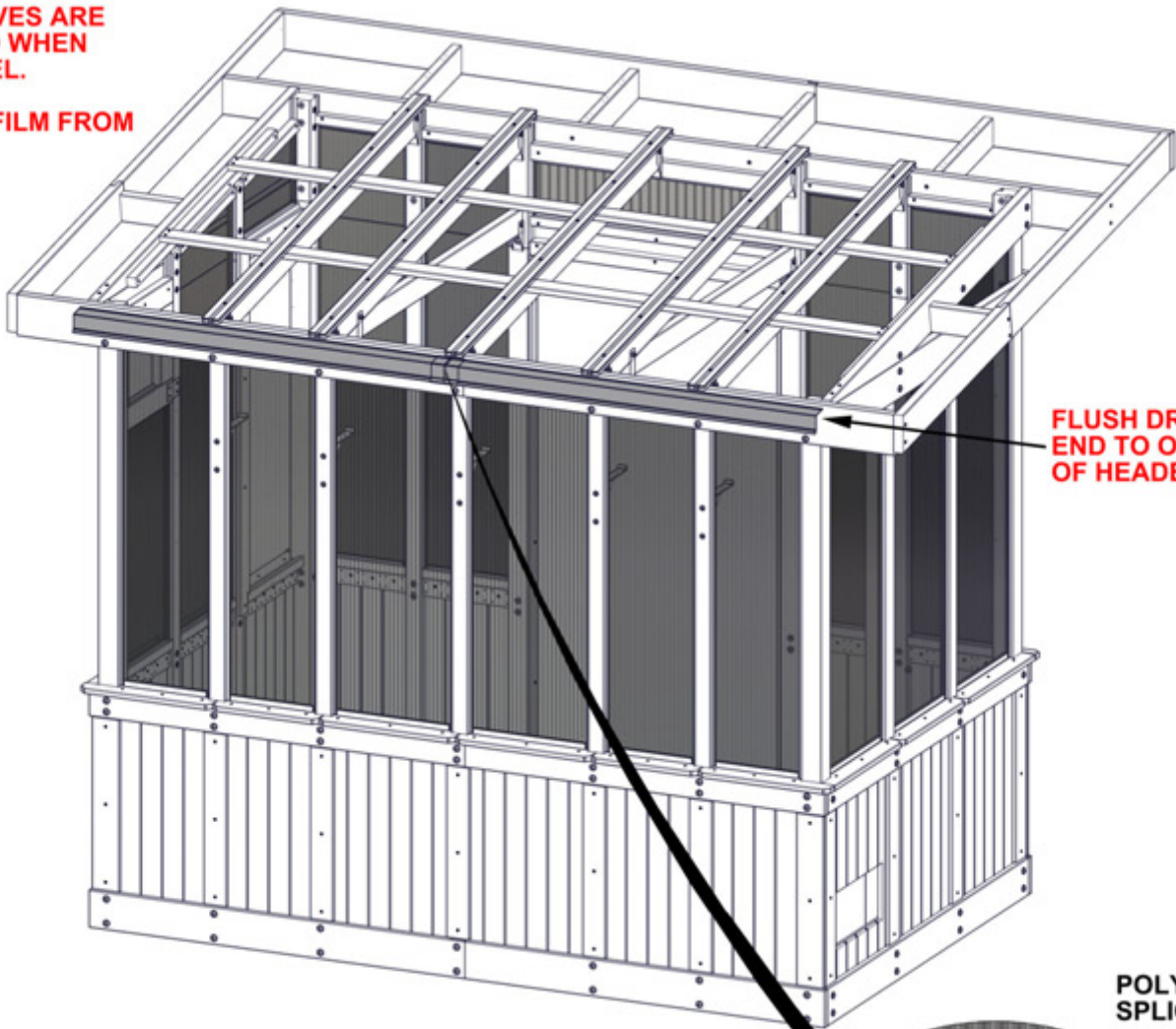

**FLUSH DRIP EDGE END TO OUTSIDE OF HEADER.**

**POLY SHEET SPLICE**

- SLIDE DRIP EDGE INTO DRIP EDGE SPLICE.
- THEN SLIDE ASSEMBLY UNDER POLY SHEET SPLICE ON TOP OF THE HEADER.
- THE LOWER SCREWS ON THE POLY SHEET SPLICE MAY NEED TO BE LOOSENED TO INSERT THE ASSEMBLY.

**HEADER**

**4031 (x2)  
DRIP EDGE**

**3419 (x1)  
DRIP EDGE SPLICE**

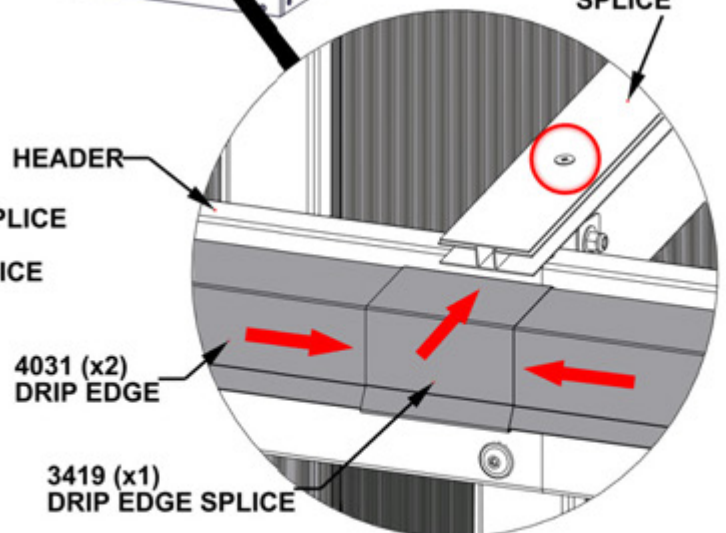

# STEP 84 - ROOF ASSEMBLY

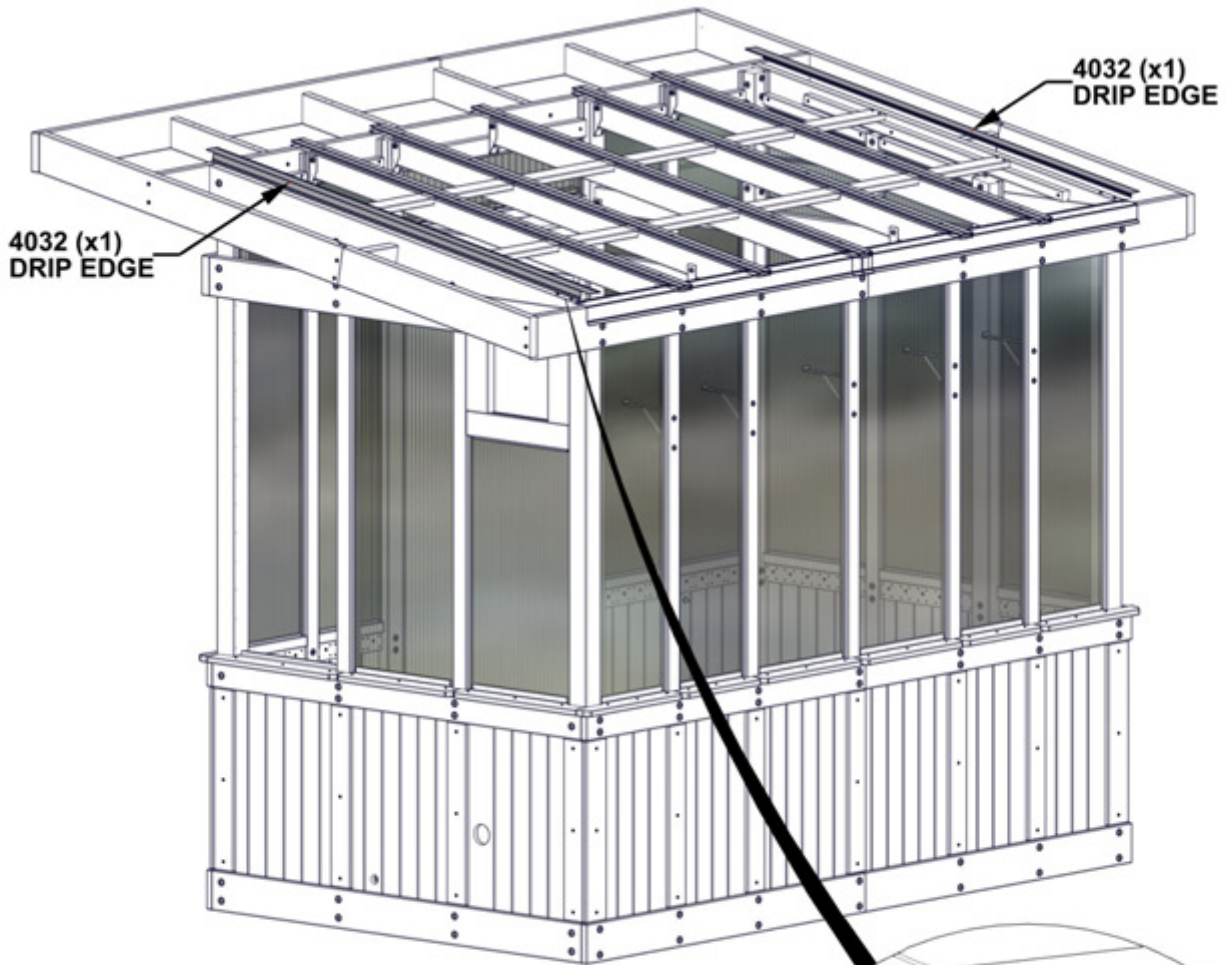

- BEFORE INSTALLING DRIP EDGE, APPLY DOUBLE SIDED TAPE TO TOP OF HEADERS AS SHOWN.
- WITH THE SHORTER SIDE OF THE DRIP EDGE AGAINST THE OUTSIDE OF THE HEADER, PRESS DRIP EDGE INTO PLACE TO ENSURE TAPE ADHESION.

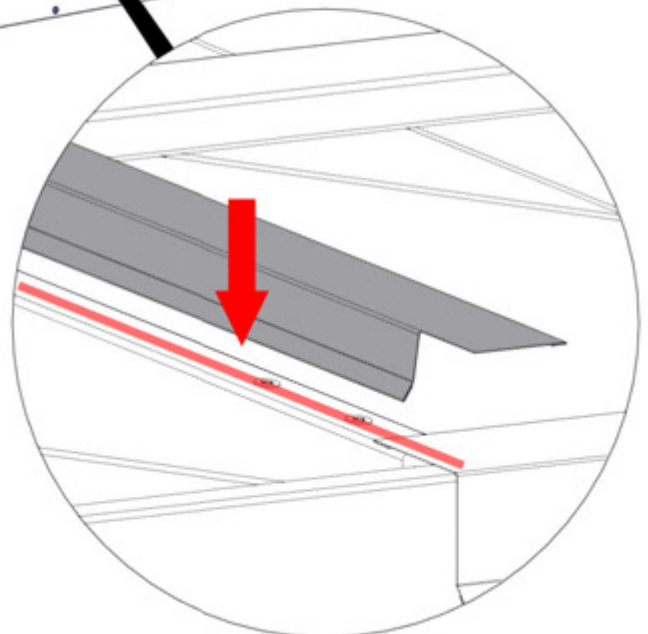

# STEP 85 - ROOF ASSEMBLY



A6P01076 POLY SHEET  
(x2)



A6P01080 POLY CHANNEL  
(x4)



A6P00690 DUST SEAL TAPE

## TO APPLY DUST SEAL TAPE AND POLY CHANNEL:

- CUT 2 STRIPS OF DUST SEAL TAPE THE SAME WIDTH AS THE POLY SHEET.
- WRAP DUST SEAL TAPE ALONG EDGE OF POLY SHEET WIDTH.
- AFTER TAPE IS SECURE, PUSH CHANNEL ON OVER THE TAPE, CENTERING ON THE POLY SHEET.
- REPEAT ON THE BOTTOM SIDE OF POLY SHEET.
- **REPEAT FOR BOTH WINDOW ASSEMBLIES.**

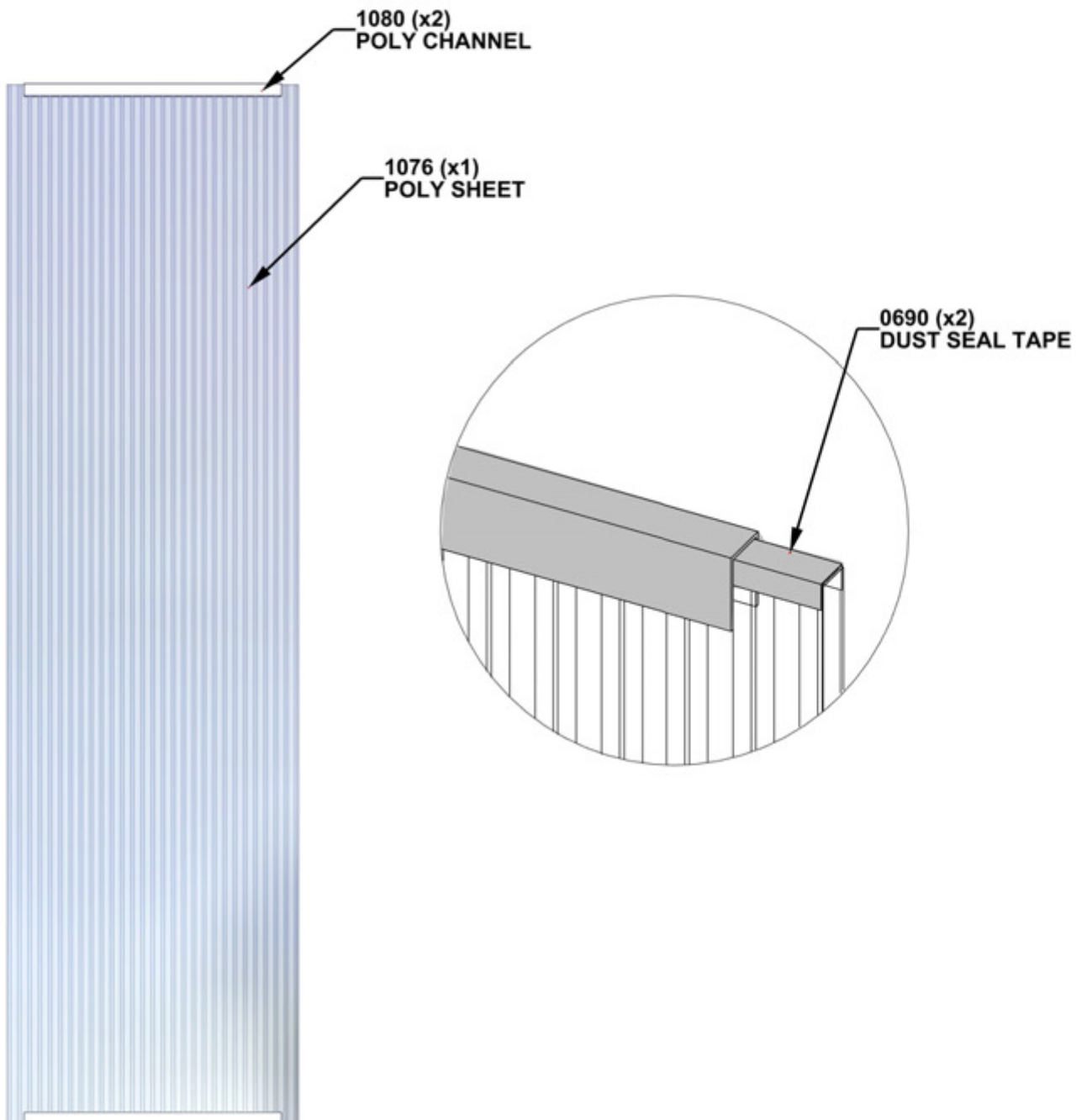

# STEP 86 - ROOF ASSEMBLY

## IMPORTANT!

- ENSURE UV SIDE OF ROOF PANELS ARE FACING OUTSIDE.
- REMOVE THE PROTECTIVE FILM PRIOR TO INSTALLATION OF ROOF PANELS.

POLY SHEET  
SPLICE

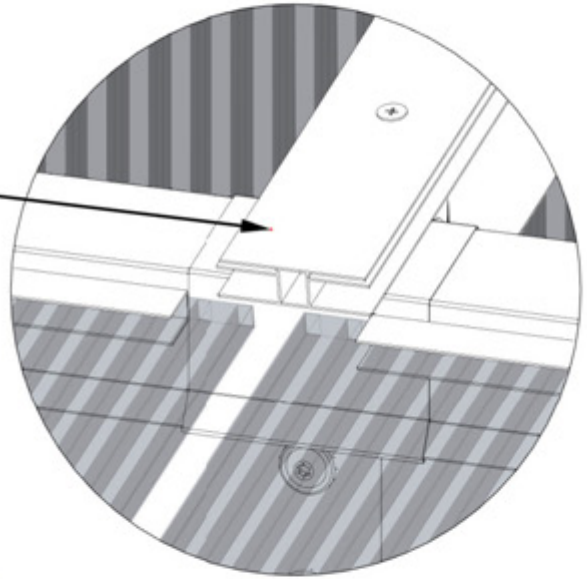

- SLIDE POLY SHEETS INTO POLY SHEET SPLICES.
- PUSH THE SHEETS UNTIL BOTTOM OF SHEET IS FLUSH WITH END OF POLY SHEET SPLICE.

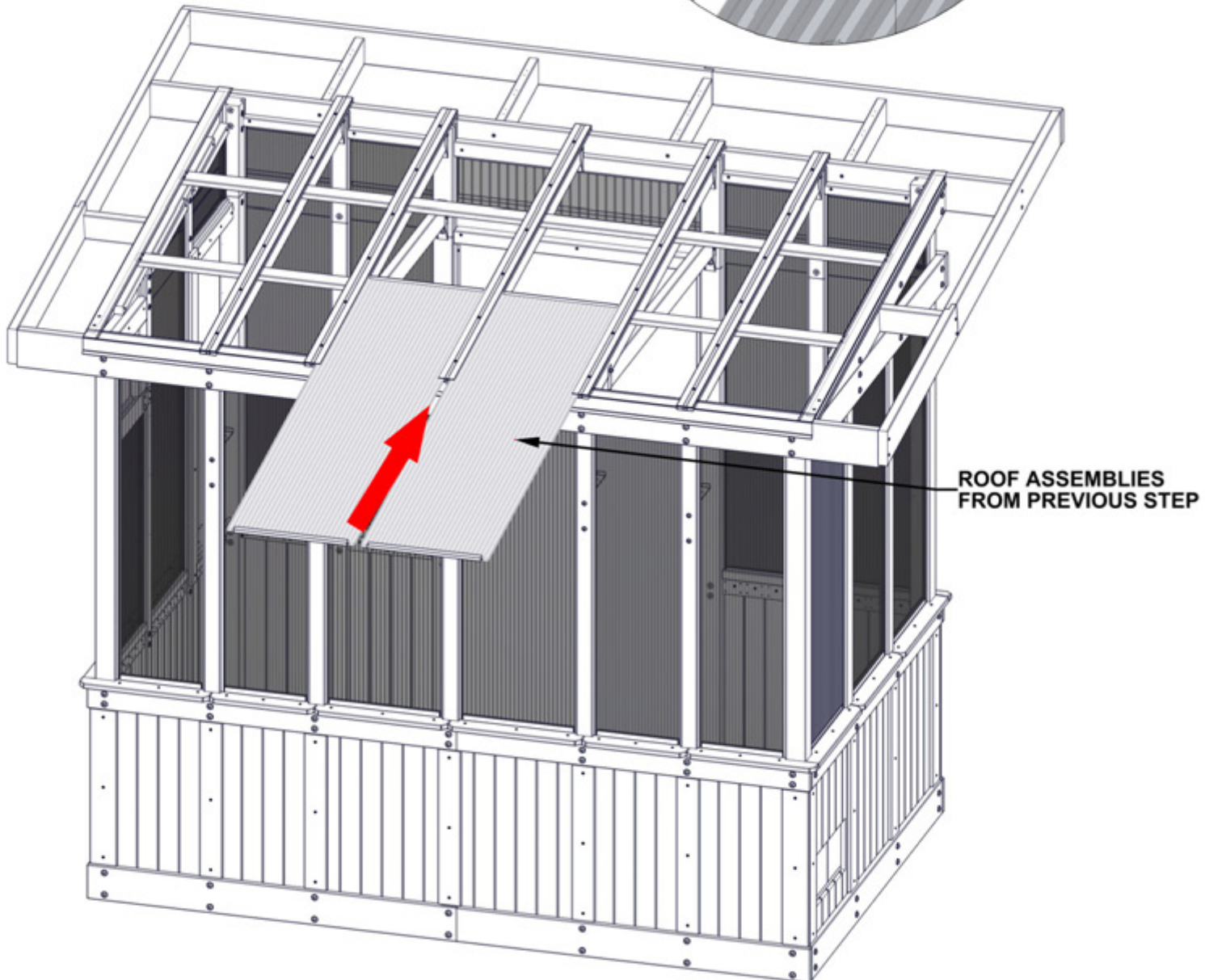

ROOF ASSEMBLIES  
FROM PREVIOUS STEP

# STEP 87 - ROOF ASSEMBLY



A6P01077 POLY SHEET  
(x2)



A6P01081 POLY CHANNEL  
(x4)



A6P00690 DUST SEAL TAPE

## TO APPLY DUST SEAL TAPE AND POLY CHANNEL:

- CUT 2 STRIPS OF DUST SEAL TAPE THE SAME WIDTH AS THE POLY SHEET.
- WRAP DUST SEAL TAPE ALONG EDGE OF POLY SHEET WIDTH.
- AFTER TAPE IS SECURE, PUSH CHANNEL ON OVER THE TAPE, CENTERING ON THE POLY SHEET.
- REPEAT ON THE BOTTOM SIDE OF POLY SHEET.
- **REPEAT FOR BOTH WINDOW ASSEMBLIES.**

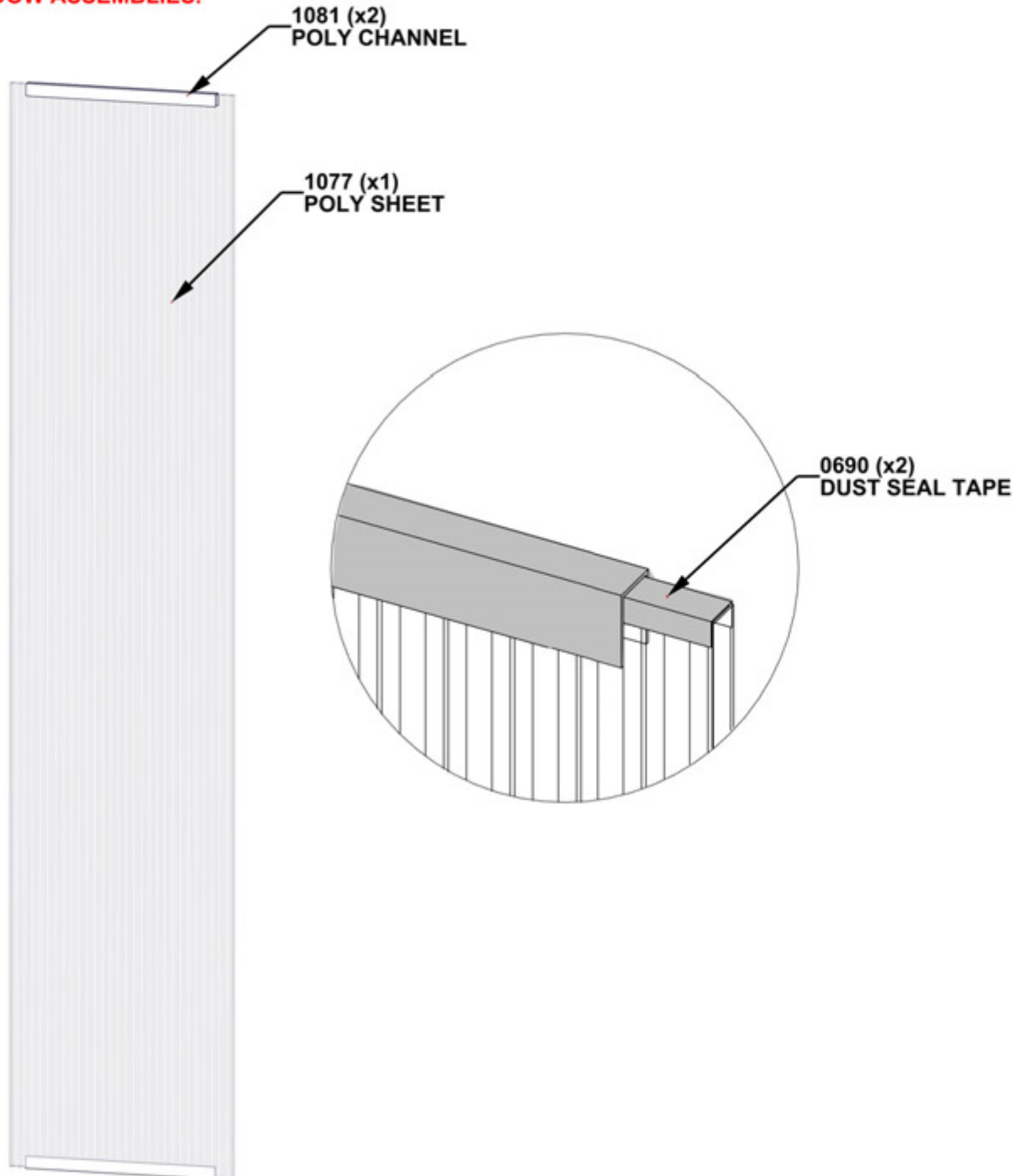

# STEP 88 - ROOF ASSEMBLY

## IMPORTANT!

- ENSURE UV SIDE OF ROOF PANELS ARE FACING OUTSIDE.
- REMOVE THE PROTECTIVE FILM PRIOR TO INSTALLATION OF ROOF PANELS.

POLY SHEET  
SPLICE

- SLIDE POLY SHEETS INTO POLY SHEET SPLICES.
- PUSH THE SHEETS UNTIL BOTTOM OF SHEET IS FLUSH WITH END OF POLY SHEET SPLICE.

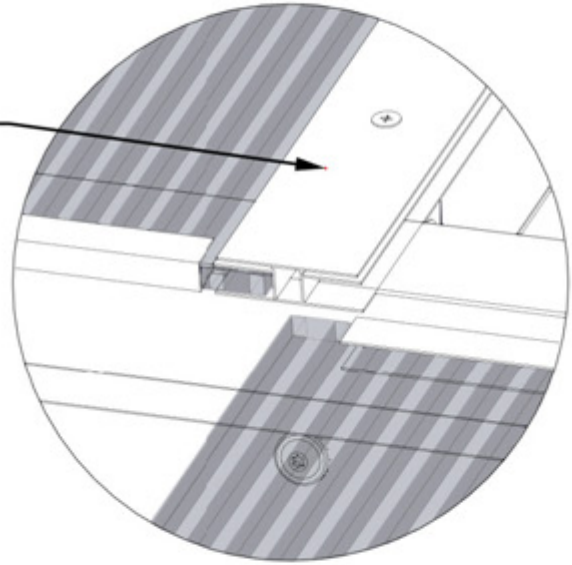

ROOF ASSEMBLIES  
FROM PREVIOUS STEP

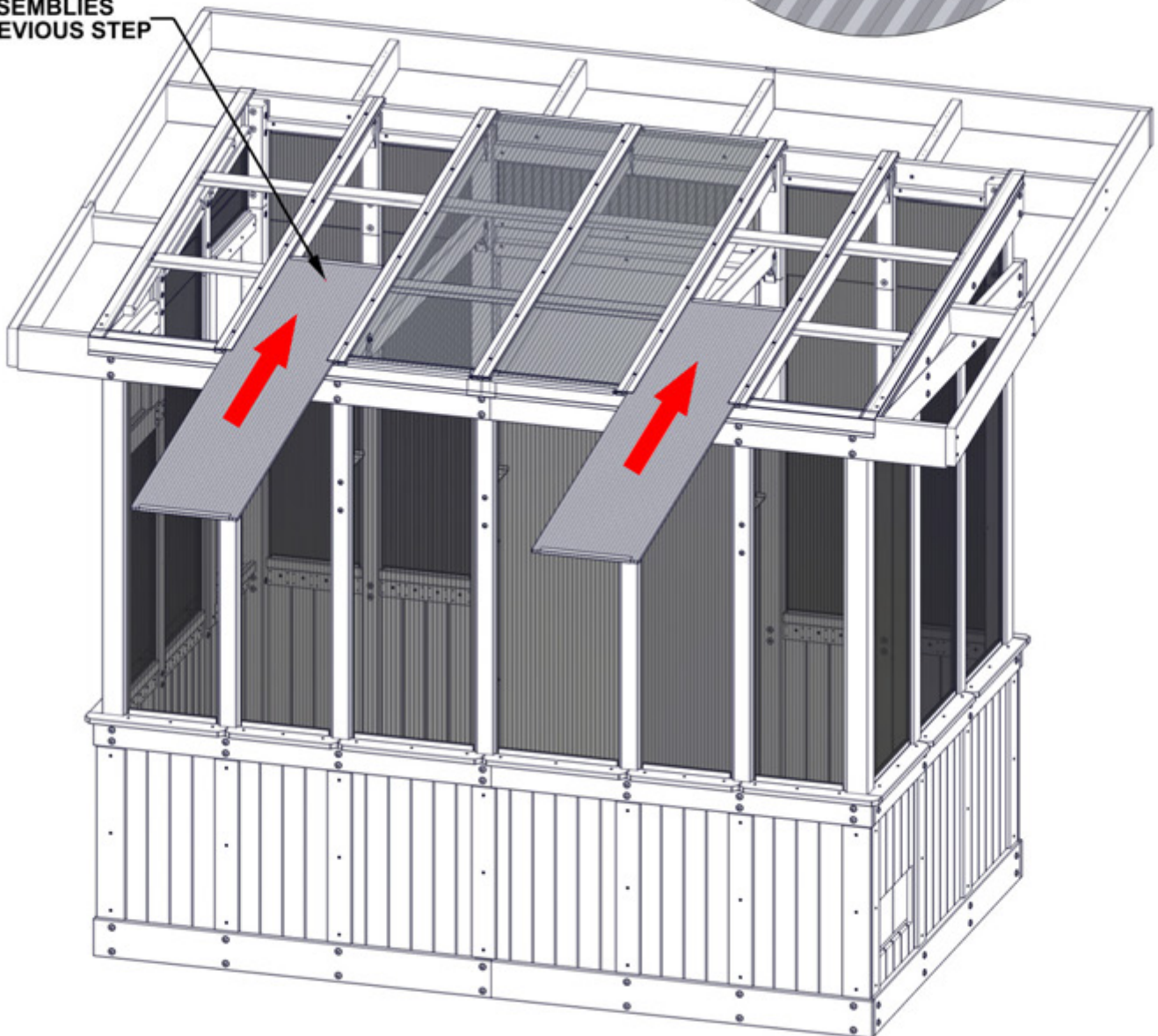

# STEP 89 - ROOF ASSEMBLY



A6P01076 POLY SHEET  
(x2)



A6P01080 POLY CHANNEL  
(x4)



A6P00690 DUST SEAL TAPE

## TO APPLY DUST SEAL TAPE AND POLY CHANNEL:

- CUT 2 STRIPS OF DUST SEAL TAPE THE SAME WIDTH AS THE POLY SHEET.
- WRAP DUST SEAL TAPE ALONG EDGE OF POLY SHEET WIDTH.
- AFTER TAPE IS SECURE, PUSH CHANNEL ON OVER THE TAPE, CENTERING ON THE POLY SHEET.
- REPEAT ON THE BOTTOM SIDE OF POLY SHEET.
- **REPEAT FOR BOTH WINDOW ASSEMBLIES.**

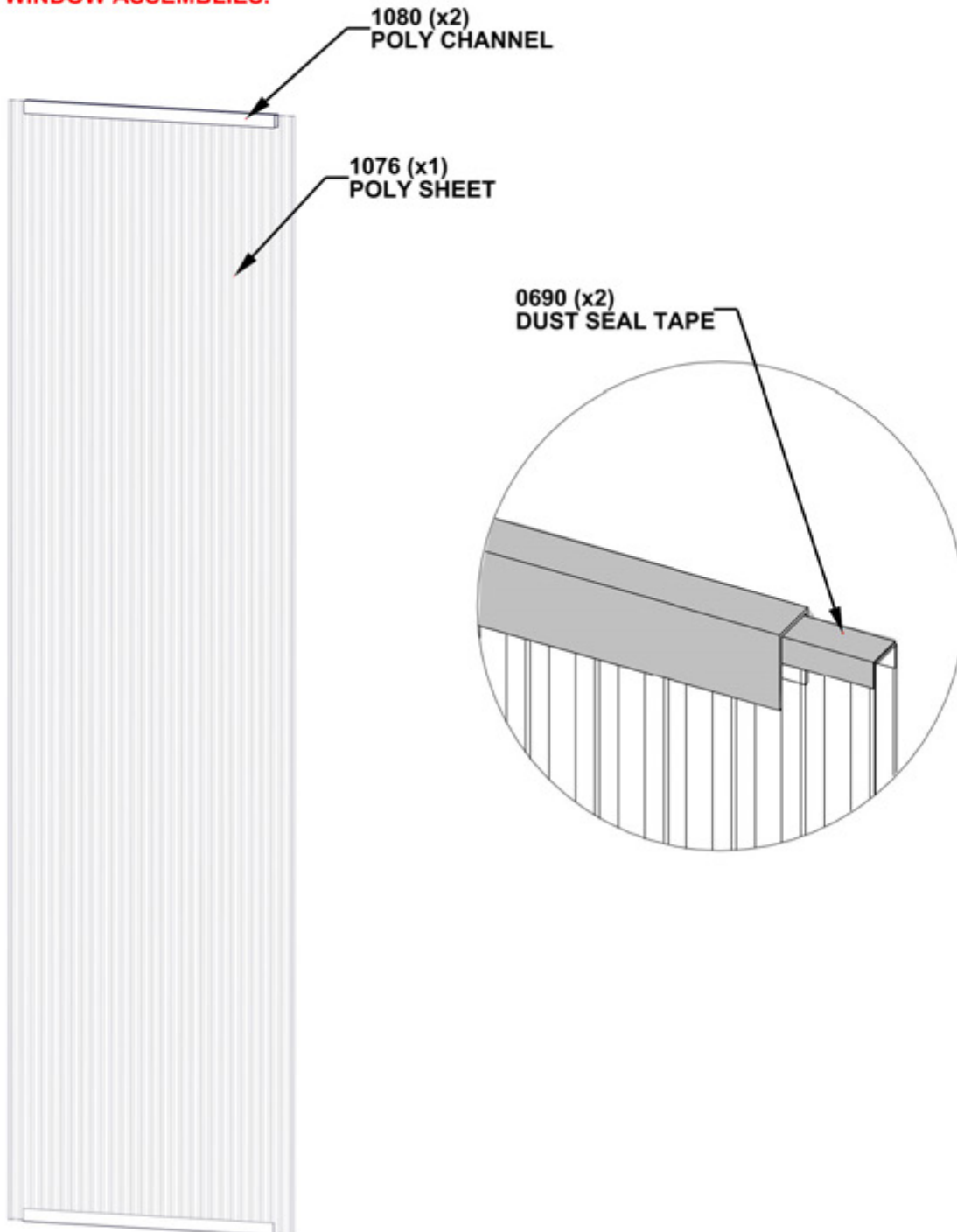

# STEP 90 - ROOF ASSEMBLY

## IMPORTANT!

- ENSURE UV SIDE OF ROOF PANELS ARE FACING OUTSIDE.
- REMOVE THE PROTECTIVE FILM PRIOR TO INSTALLATION OF ROOF PANELS.

- SLIDE POLY SHEETS INTO POLY SHEET SPLICES.
- PUSH THE SHEETS UNTIL BOTTOM OF SHEET IS FLUSH WITH END OF POLY SHEET SPLICE.

POLY SHEET  
SPLICE

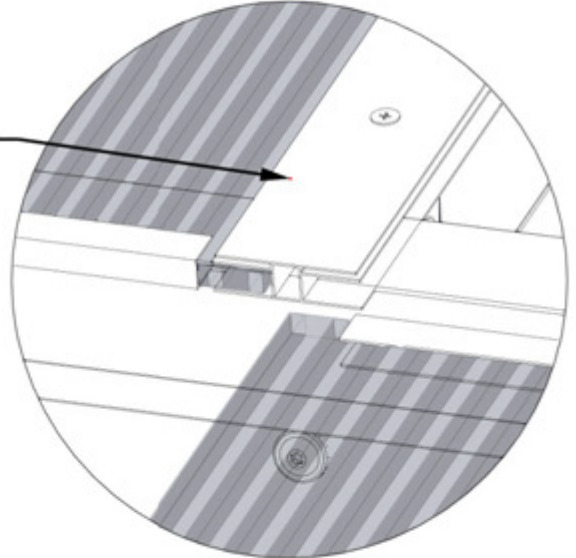

ROOF ASSEMBLIES  
FROM PREVIOUS STEP

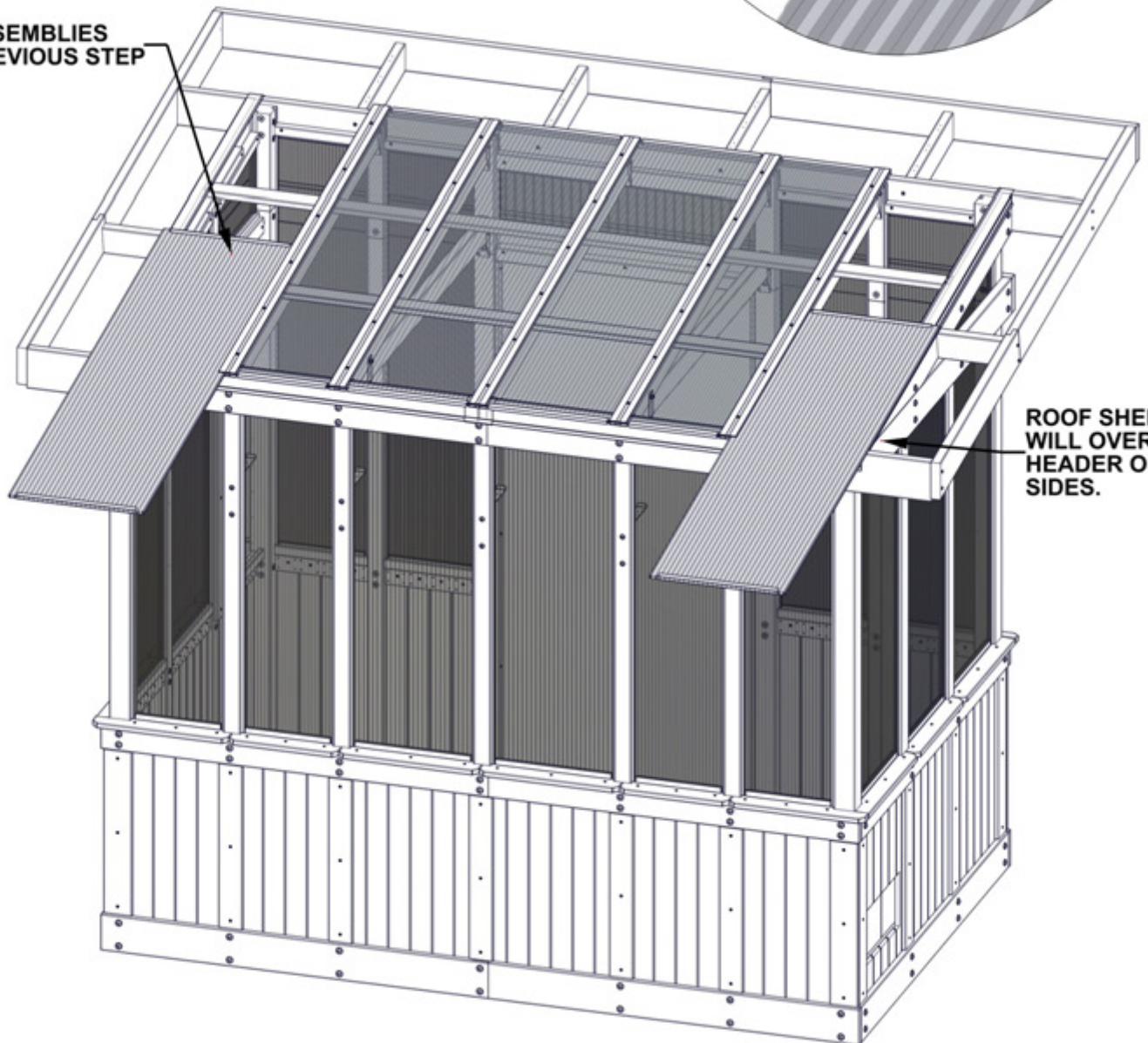

ROOF SHEETS  
WILL OVERHANG  
HEADER ON THE  
SIDES.

# STEP 91 - ROOF ASSEMBLY

A6P01079 POLY CHANNEL  
(x2)

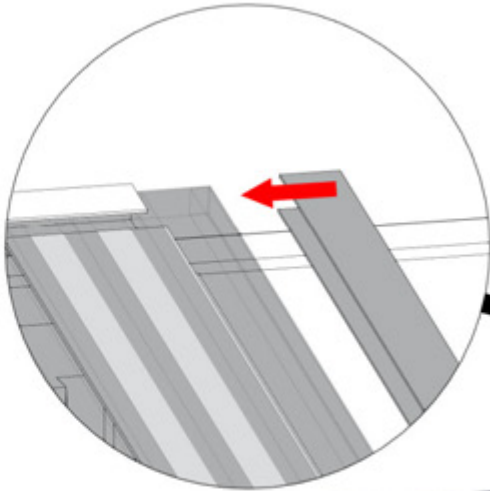

SLIDE POLY CHANNEL ON EACH SIDE OF ROOF. CENTER EACH CHANNEL ON THE POLY SHEET EDGE.

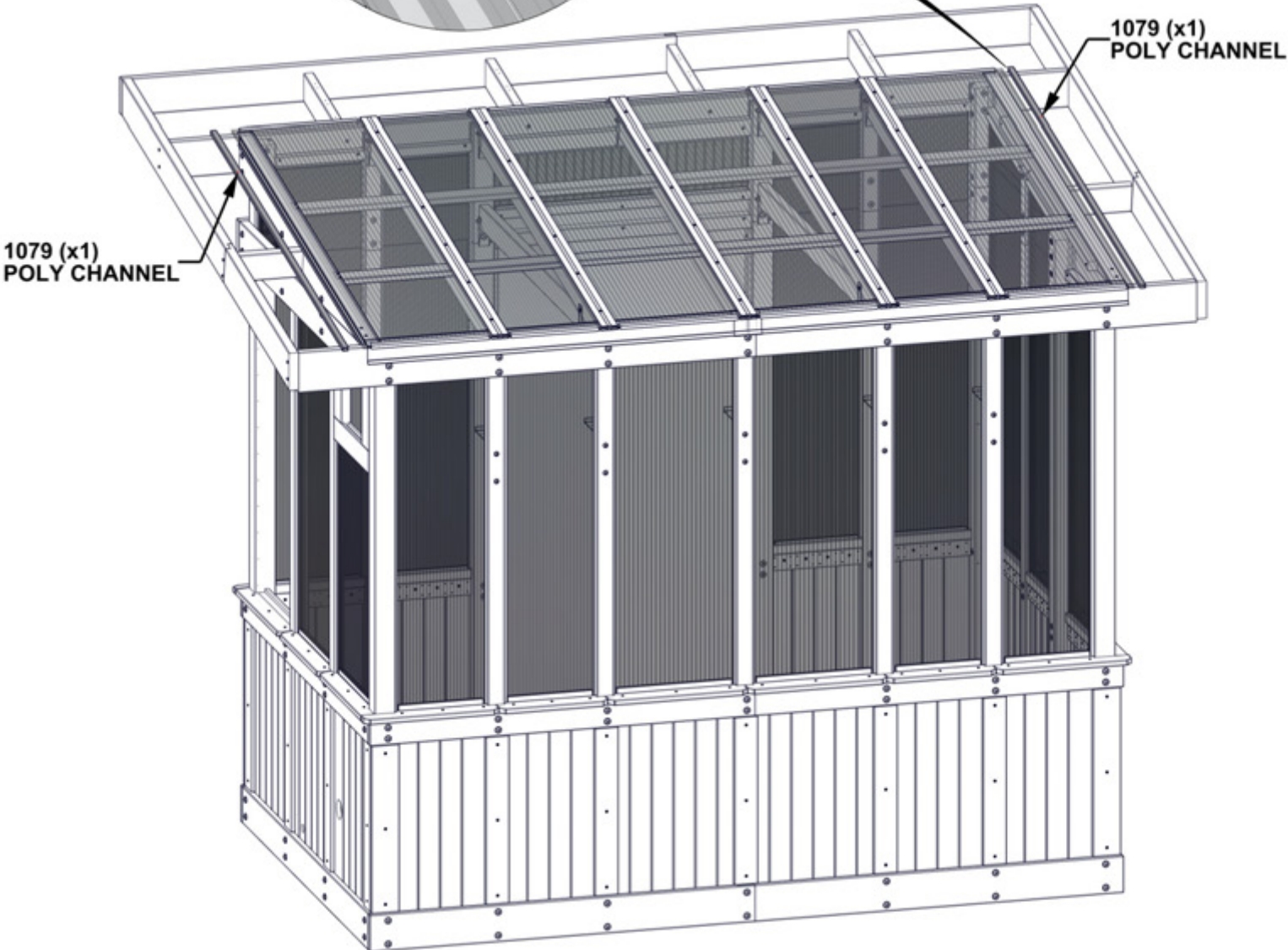

# STEP 92 - ROOF ASSEMBLY



A4M04033 SPLICE COVER  
(x5)

**WARNING: GLOVES ARE RECOMMENDED  
WHEN HANDLING STEEL.**

**REMOVE BLUE FILM FROM SHEET METAL.**

**SLIDE TABS ON SPLICE COVERS  
BETWEEN THE TABS ON THE POLY  
CHANNEL AND SLIDE UP UNTIL THE  
BOTTOM OF THE SPLICE IS FLUSH  
WITH BOTTOM OF THE CHANNEL.**

**FLUSH**

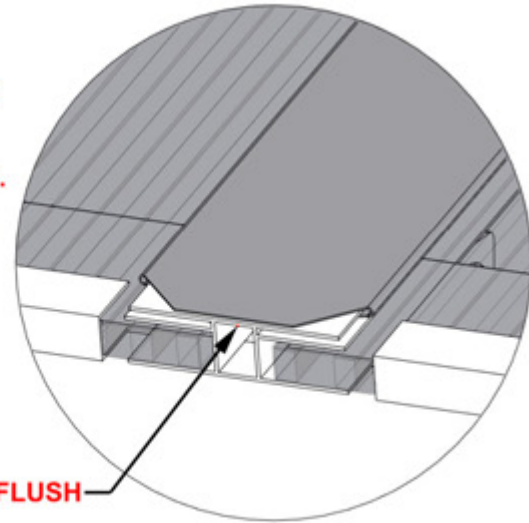
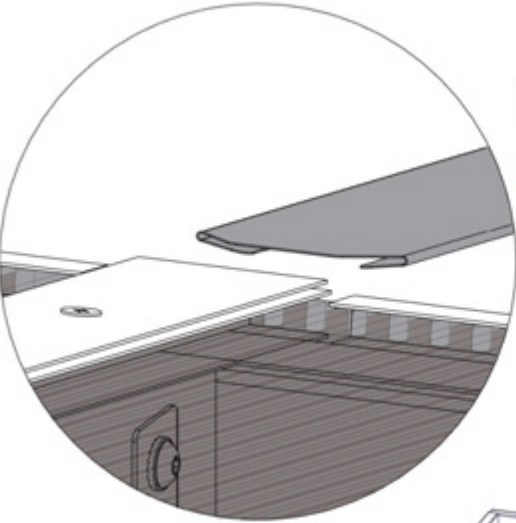

4033 (x5)  
SPLICE COVER

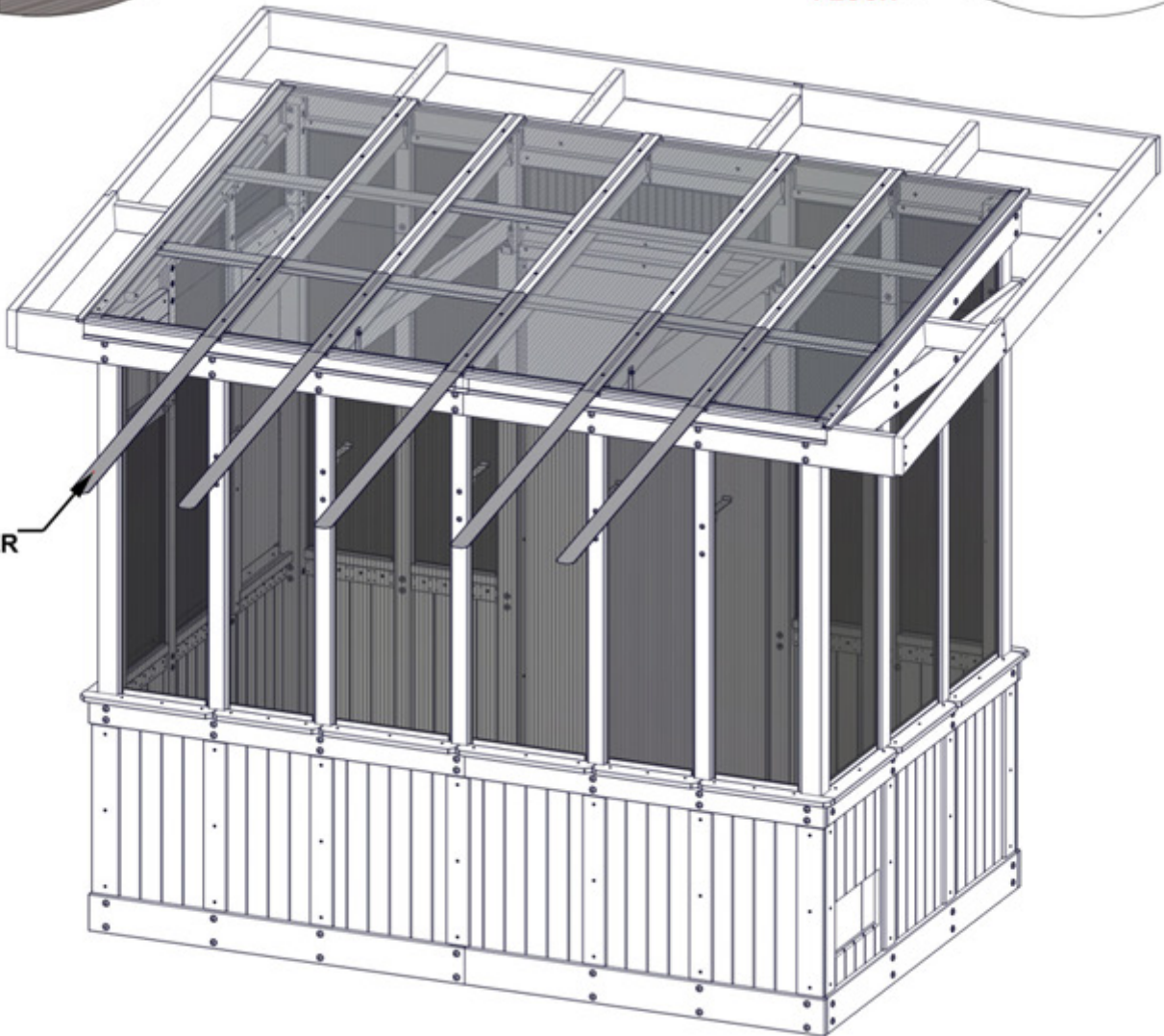

# STEP 93 - ROOF ASSEMBLY

QTY	PART NUMBER	DESCRIPTION
5	H101206	SCREW WOODGRIP 10-16x1-1/4"

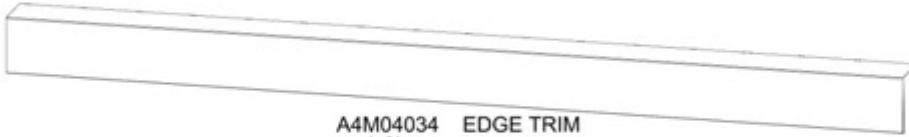

A4M04034 EDGE TRIM  
(x2)

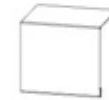

A4M03424 EDGE TRIM SPLICE  
(x1)

**WARNING: GLOVES ARE RECOMMENDED WHEN HANDLING STEEL.**

**REMOVE BLUE FILM FROM SHEET METAL.**

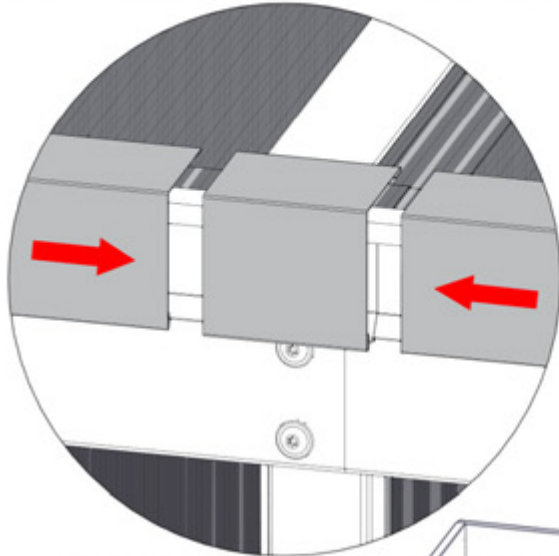

**SLIDE EDGE TRIM INTO EDGE TRIM SPLICE. ADJUST AS NEEDED.**

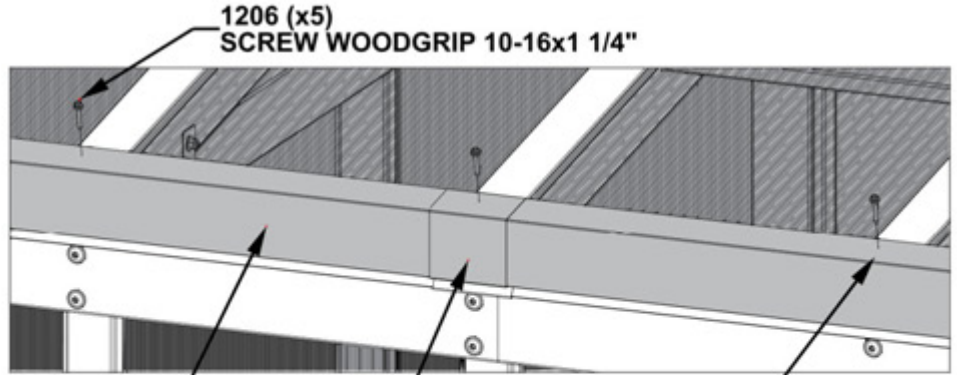

4034 (x2)  
EDGE TRIM

3424 (x1)  
EDGE TRIM SPLICE

1206 (x5)  
SCREW WOODGRIP 10-16x1 1/4"

**ONCE EDGE TRIM IS IN PLACE, INSERT SCREWS AS SHOWN PLACED 1 1/2" [38mm] FROM OUTSIDE EDGE OF EDGE TRIM.**

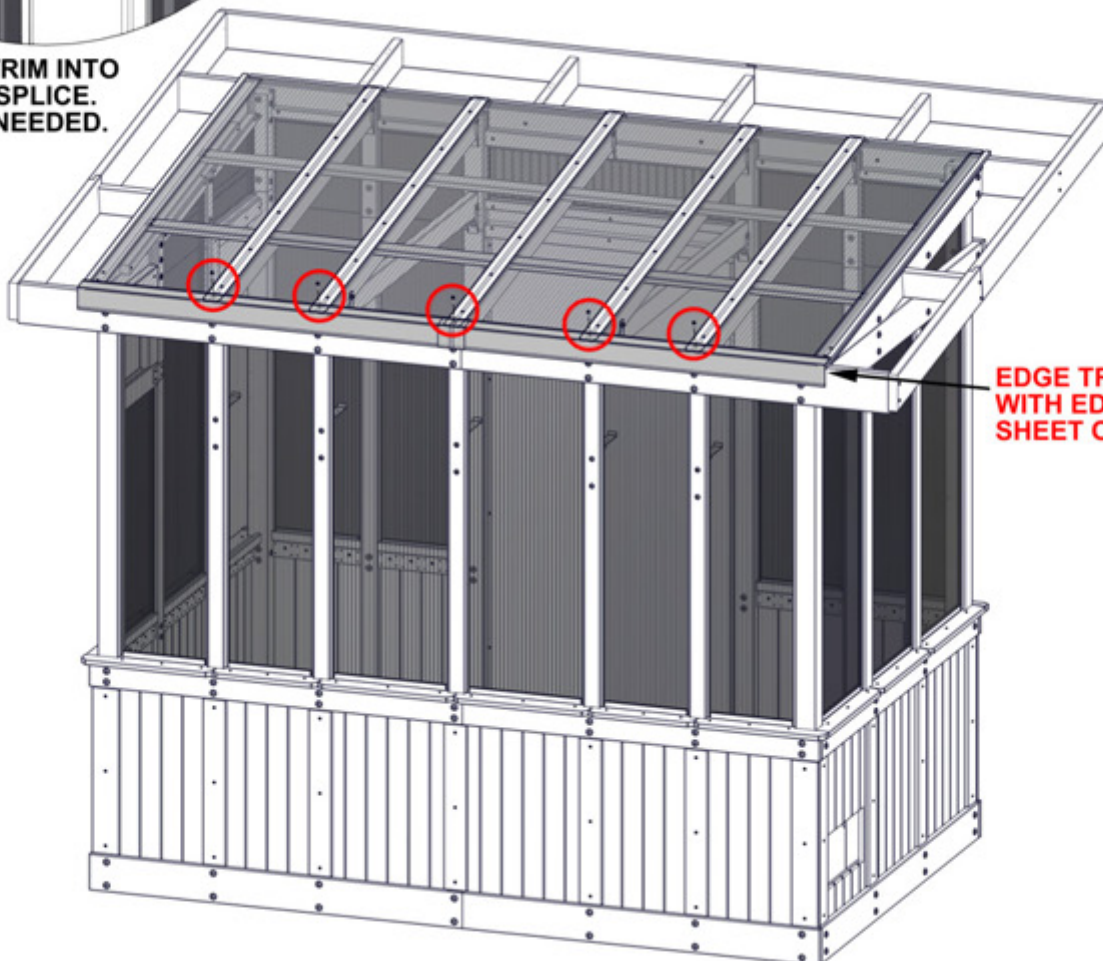

**EDGE TRIM IS FLUSH WITH EDGE OF POLY SHEET ON BOTH SIDES.**

# STEP 94 - ROOF ASSEMBLY

QTY	PART NUMBER	DESCRIPTION
6	H101206	SCREW WOODGRIP 10-16x1-1/4"

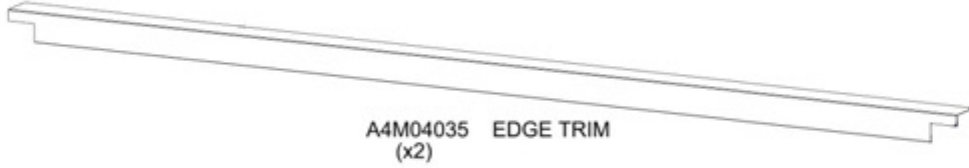

**WARNING: GLOVES ARE RECOMMENDED WHEN HANDLING STEEL.**  
**REMOVE BLUE FILM FROM SHEET METAL.**

1206 (x6)  
SCREW WOODGRIP 10-16x1-1/4"

**ONCE EDGE TRIM IS IN PLACE,  
INSERT SCREWS AS SHOWN  
PLACED 1 1/2" [38mm] FROM  
OUTSIDE EDGE OF EDGE TRIM.**

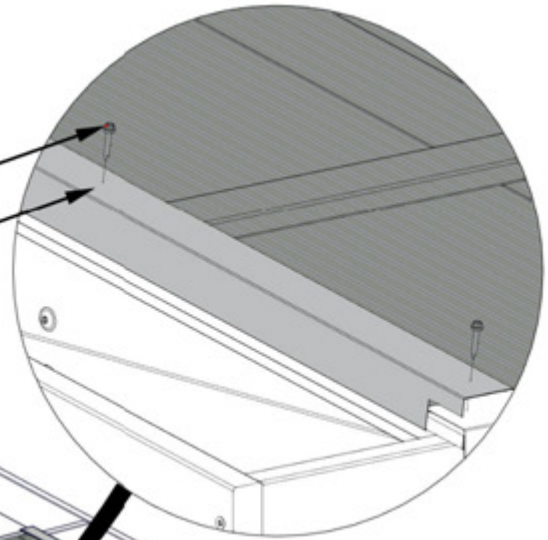

4035 (x2)  
EDGE TRIM

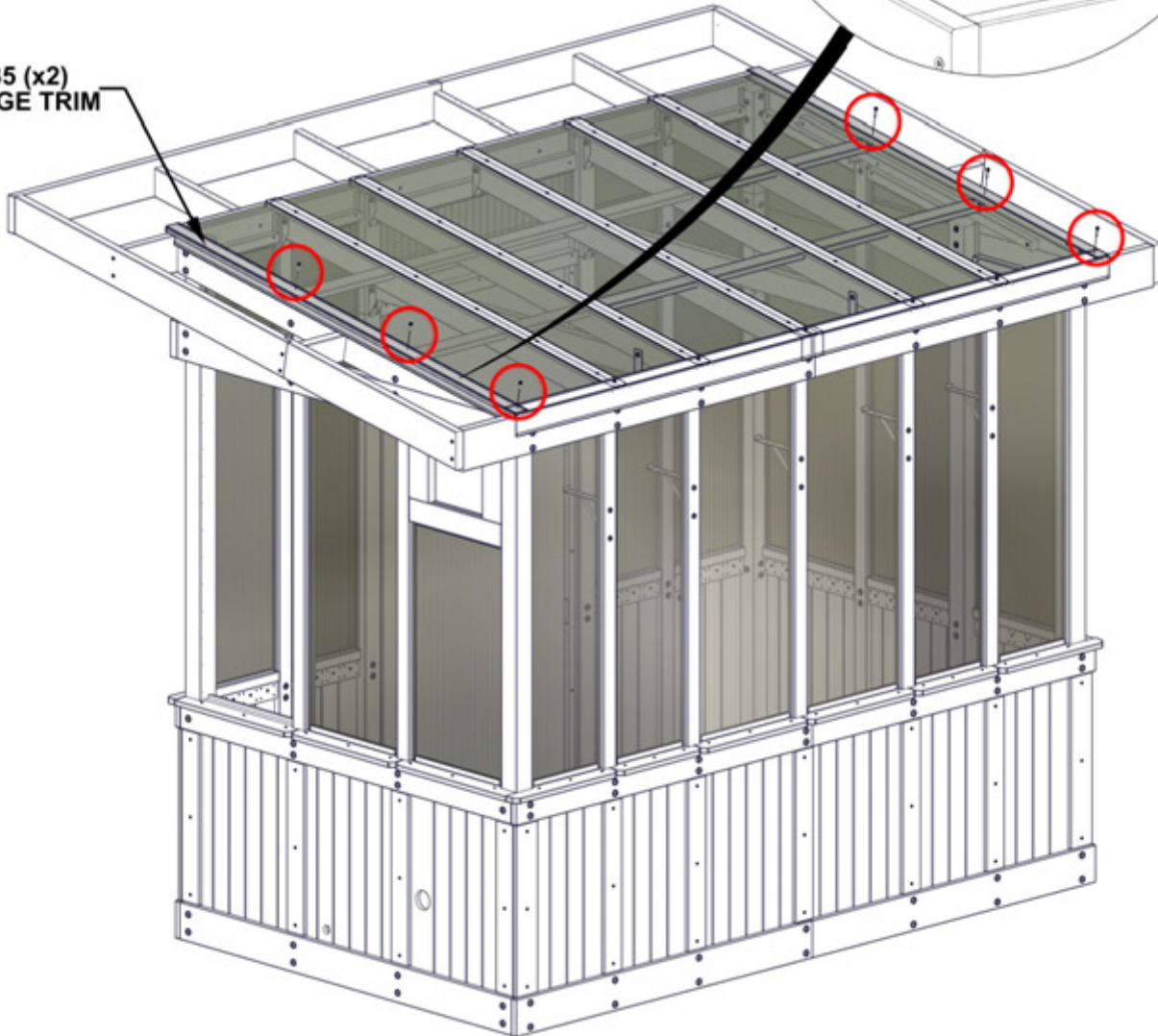

# STEP 95A - ROOF ASSEMBLY

QTY	PART NUMBER	DESCRIPTION
7	H101206	SCREW WOODGRIP 10-16x1-1/4"

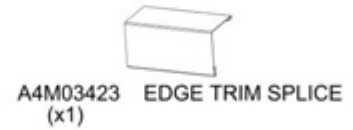

**WARNING: GLOVES ARE RECOMMENDED WHEN HANDLING STEEL. REMOVE BLUE FILM FROM SHEET METAL.**

WIDER SIDE FACES UP.

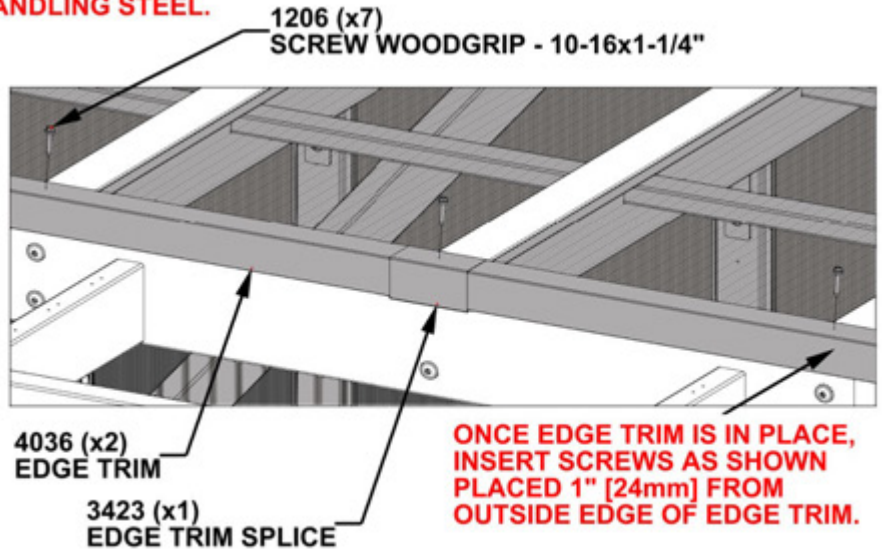
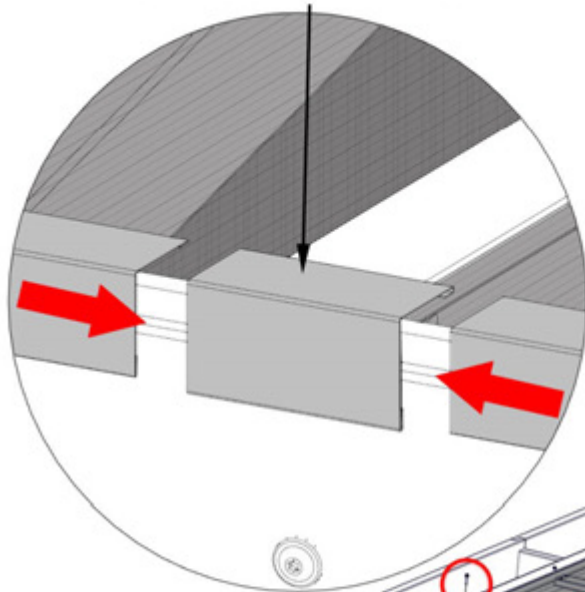

SLIDE EDGE TRIM INTO EDGE TRIM SPLICE. ADJUST AS NEEDED.

**EDGE TRIM IS FLUSH WITH EDGE OF POLY SHEET ON BOTH SIDES.**

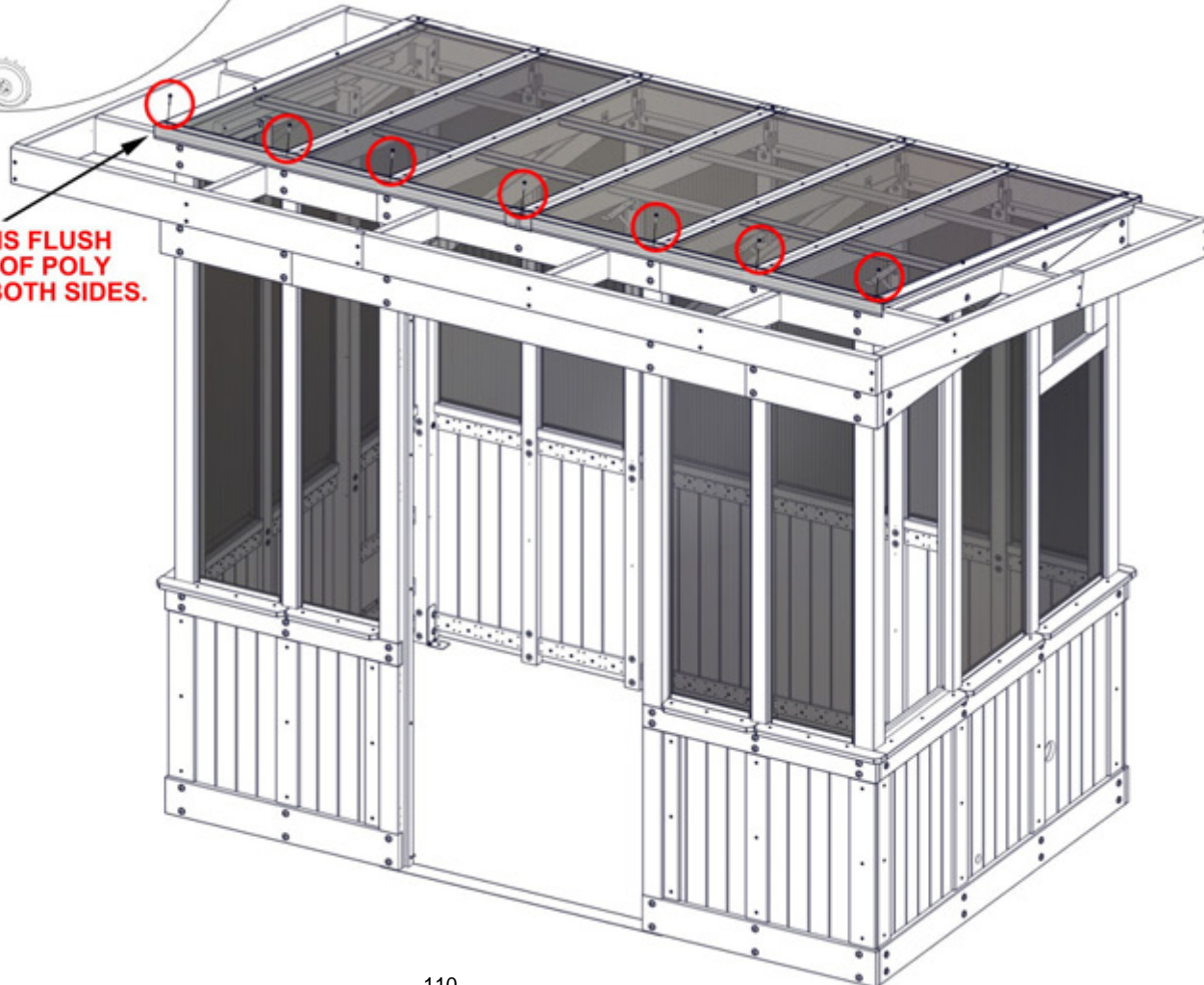

# STEP 95B - ROOF ASSEMBLY



A6P00796 SILICONE

**APPLY SILICONE TO ROOF PANEL SEAMS AS SHOWN.**

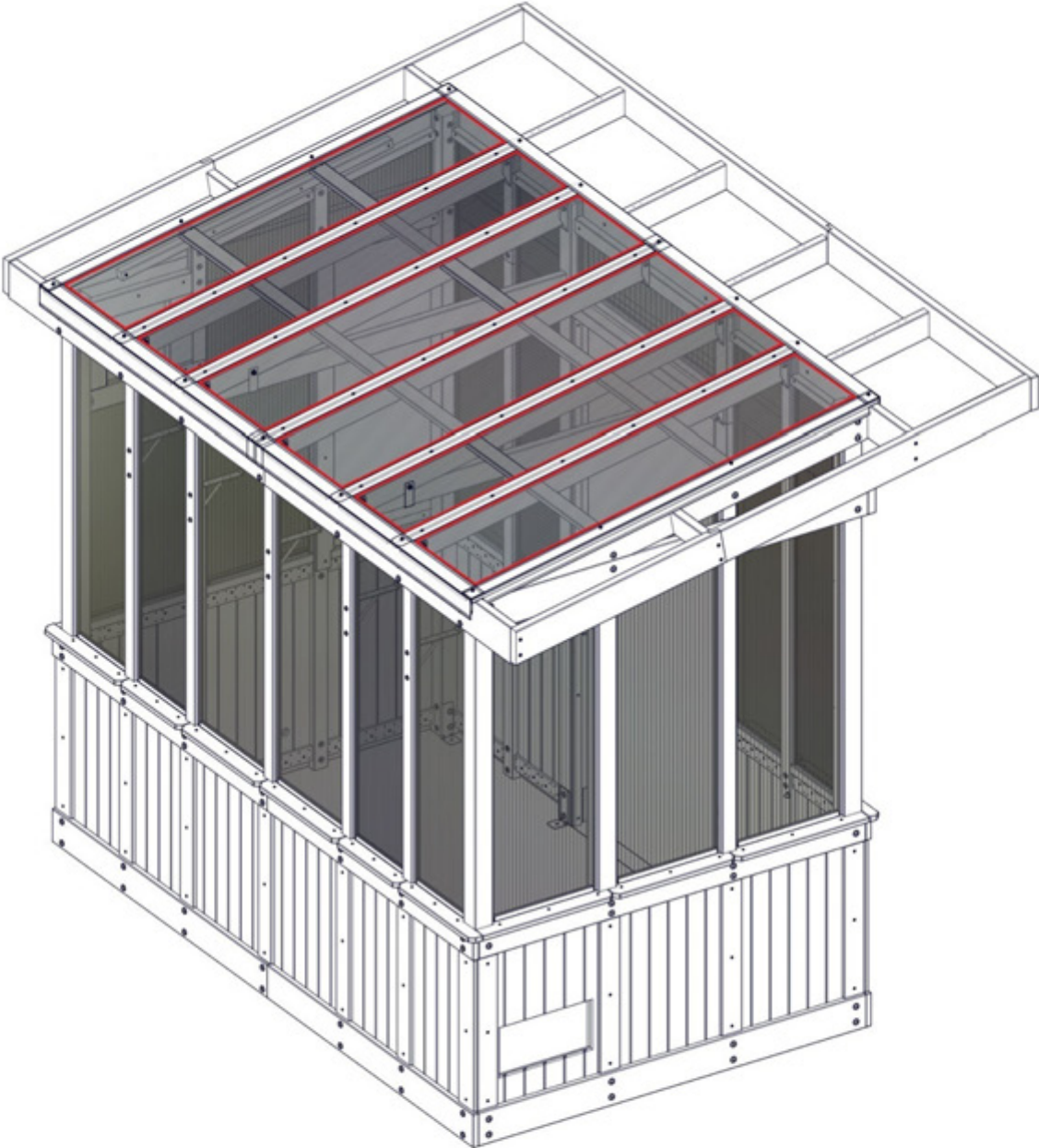

# STEP 96 - PERGOLA ASSEMBLY

QTY	PART NUMBER	DESCRIPTION
4	H100391	SCREW PFH 8x2 BLK



P09 PURLIN CLEAT - W4L20723  
(x2) 1 7/16"x1 7/16"x18 3/4" (36x36x476)

**- ALIGN PILOT HOLES.**

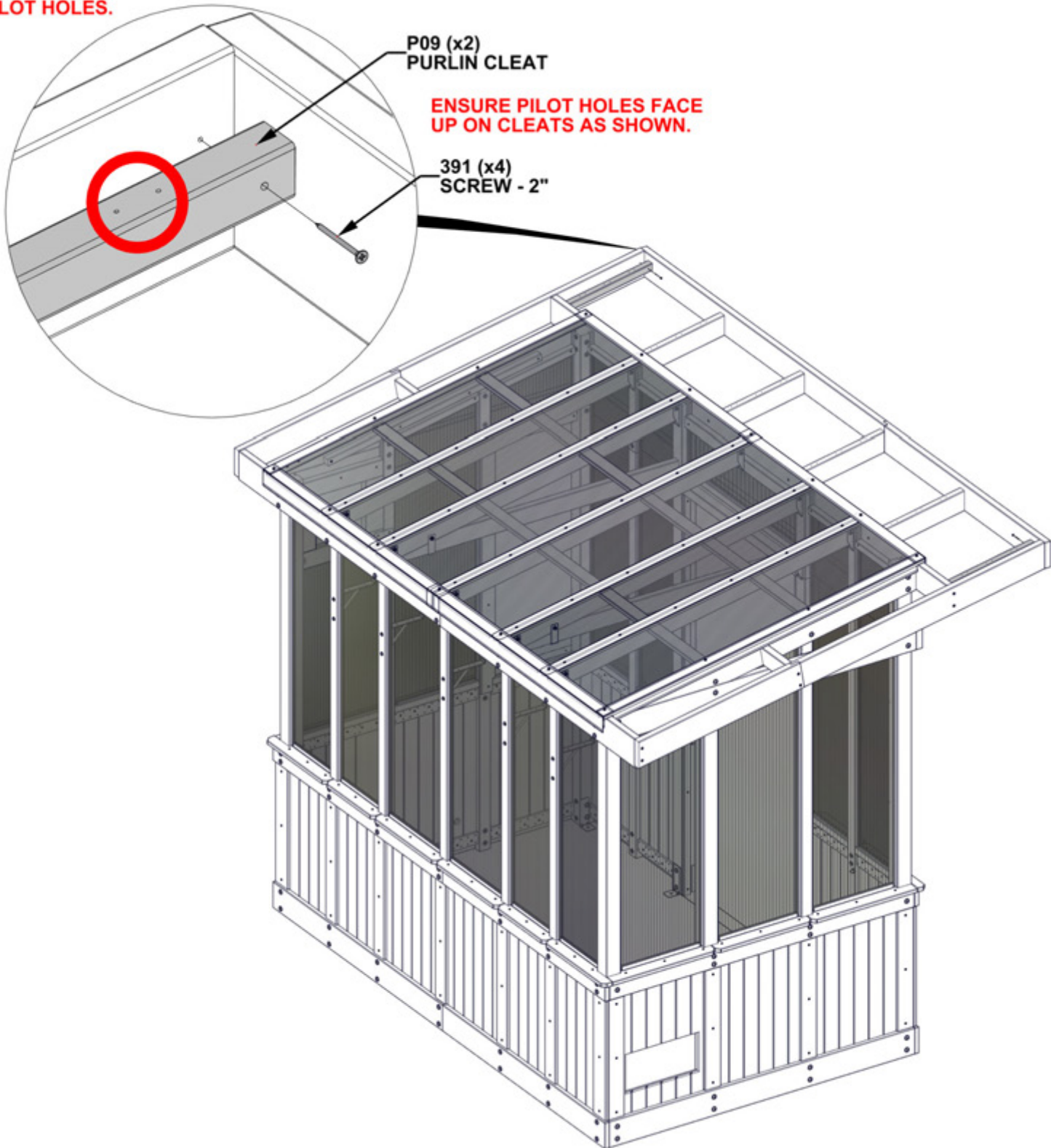

# STEP 97 - PERGOLA ASSEMBLY

QTY	PART NUMBER	DESCRIPTION
36	H100200	SCREW PFH 8x1 1/2 BLK



N06 PERGOLA PURLIN - W4L20724  
(x3) 5/8"x2 3/8"x52" (16x60x1321)



N07 PERGOLA PURLIN - W4L20725  
(x3) 5/8"x2 3/8"x78" (16x60x1981)

ATTACH PURLINS USING PILOT HOLES IN PERGOLA RAFTERS AND PURLIN CLEATS.

200 (x36)  
SCREW - 1 1/2"

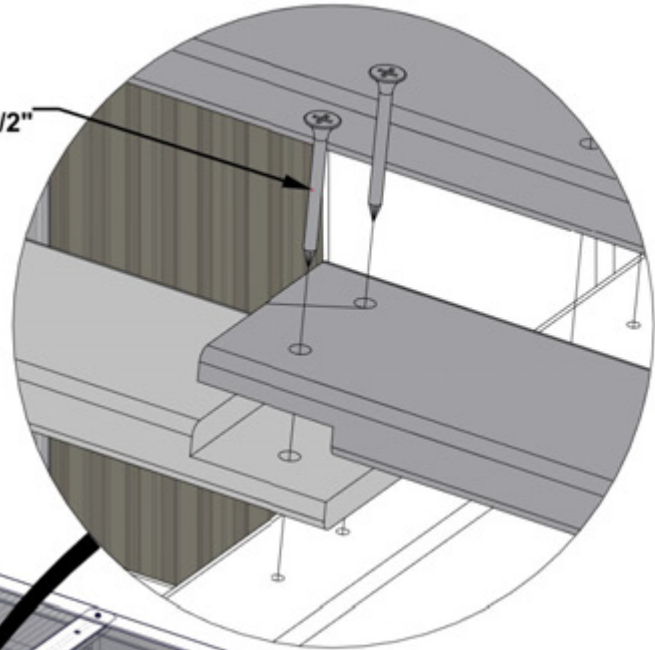

N07 (x3)  
PERGOLA PURLIN

N06 (x3)  
PERGOLA PURLIN

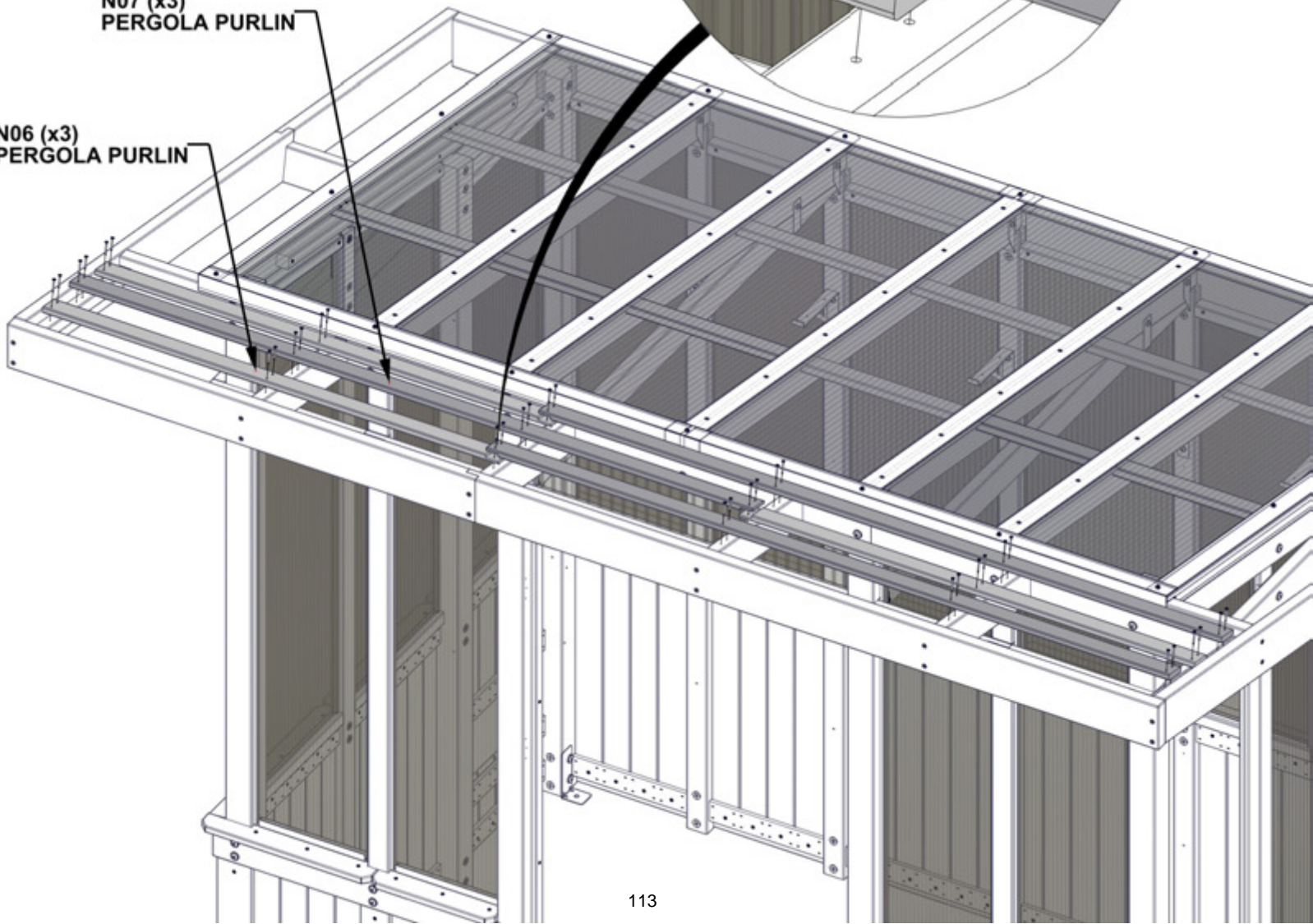

# STEP 98 - VENT FRAME ASSEMBLY

QTY	PART NUMBER	DESCRIPTION
6	H100380	SCREW PFH 8x1 1/8 BLK



O02 VENT BOARD - W4L20593  
(x2) 5/8"x1 5/16"x16 15/16" (16x34x430)

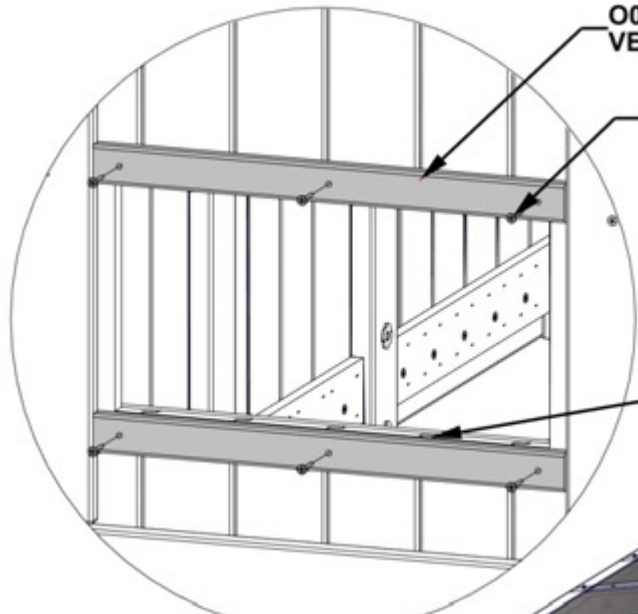

O02 (x2)  
VENT BOARD

380 (x6)  
SCREW - 1 1/8"

FLUSH

- CENTER VENT BOARDS BETWEEN COVER BOARDS.
- ENSURE THAT VENT BOARDS ARE FLUSH WITH VENT OPENINGS AS SHOWN.
- USE HOLES TO PRE-DRILL PILOT HOLES USING AN 1/8" [3mm] DRILL BIT.
- ATTACH AS SHOWN.

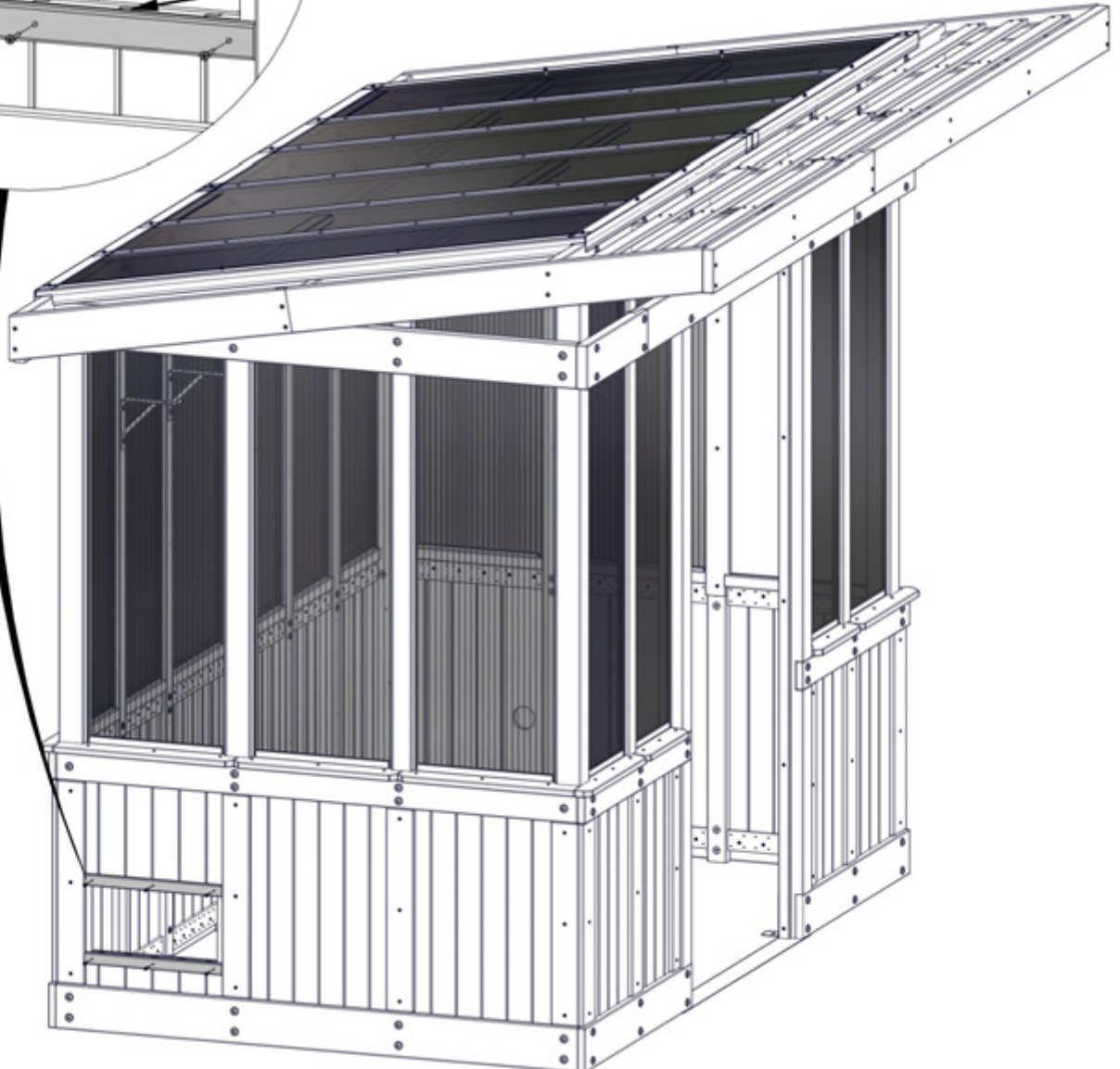

# STEP 99 - VENT ASSEMBLY

QTY	PART NUMBER	DESCRIPTION
6	H100797	SCREW PWH 8x1 BLK

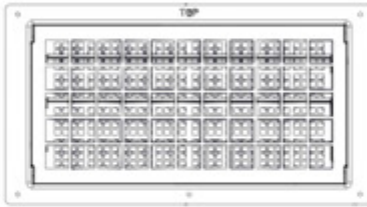

A6P00730 LOUVER  
(x1)

- SLIDE VENT INTO OPENING
- USE VENT FLANGE AS A GUIDE AND AN 1/8" [3mm] DRILL BIT TO CREATE PILOT HOLES INTO WALL PANEL
- DO NOT DRILL ALL THE WAY THROUGH THE WALL PANEL
- ATTACH AS SHOWN

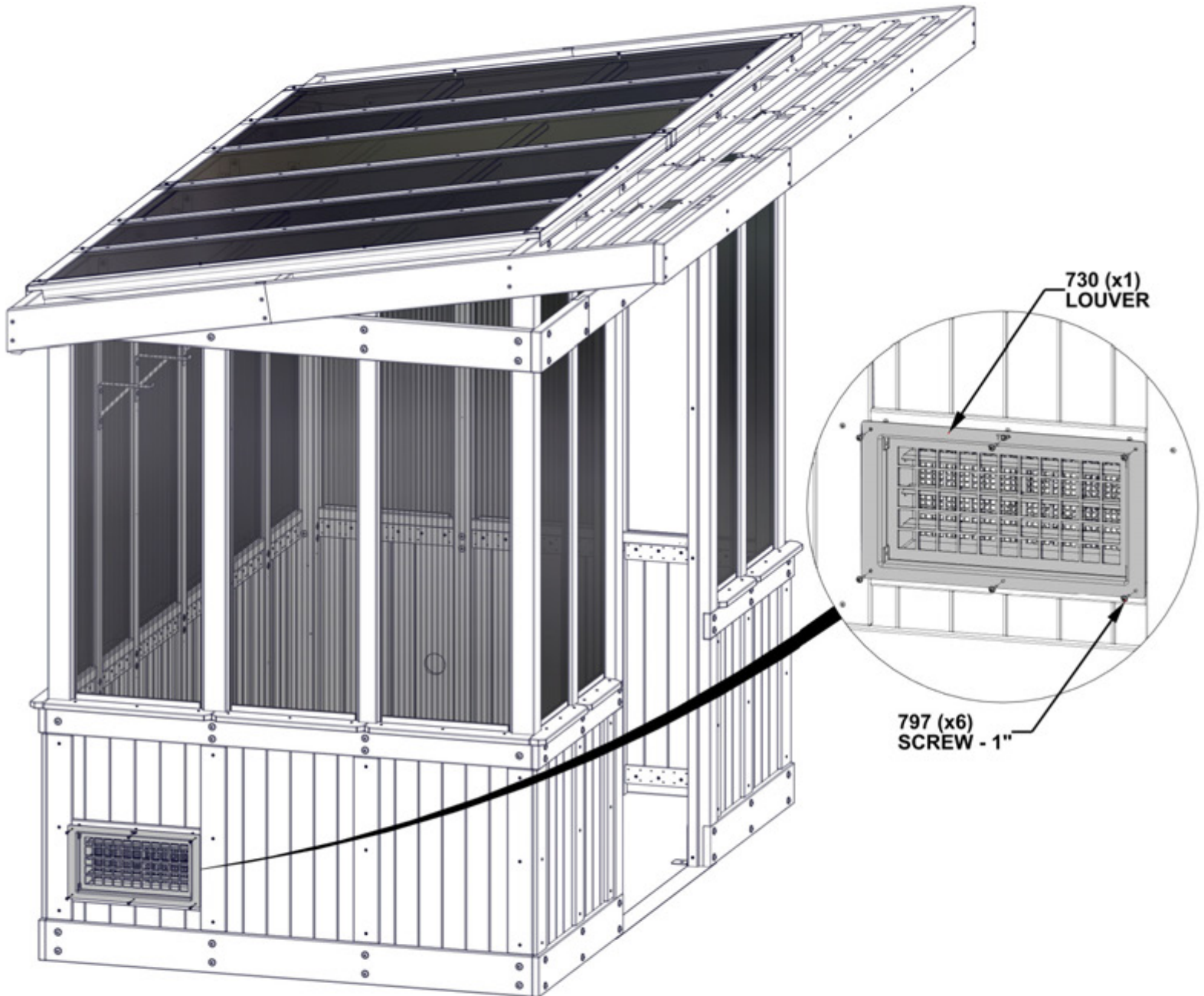

# STEP 100 - WINDOW ASSEMBLY

QTY	PART NUMBER	DESCRIPTION
2	H100380	SCREW PFH 8x1 1/8 BLK



WA01 WINDOW ASSEMBLY - W2A04438  
(x1) 1 7/8"x17 1/2"x47 3/16" (48x444x1198)



O03 LATCH BLOCK - W4L20610  
(x1) 5/8"x1 5/16"x4" (16x34x100)

**- ALIGN PILOT HOLES.**

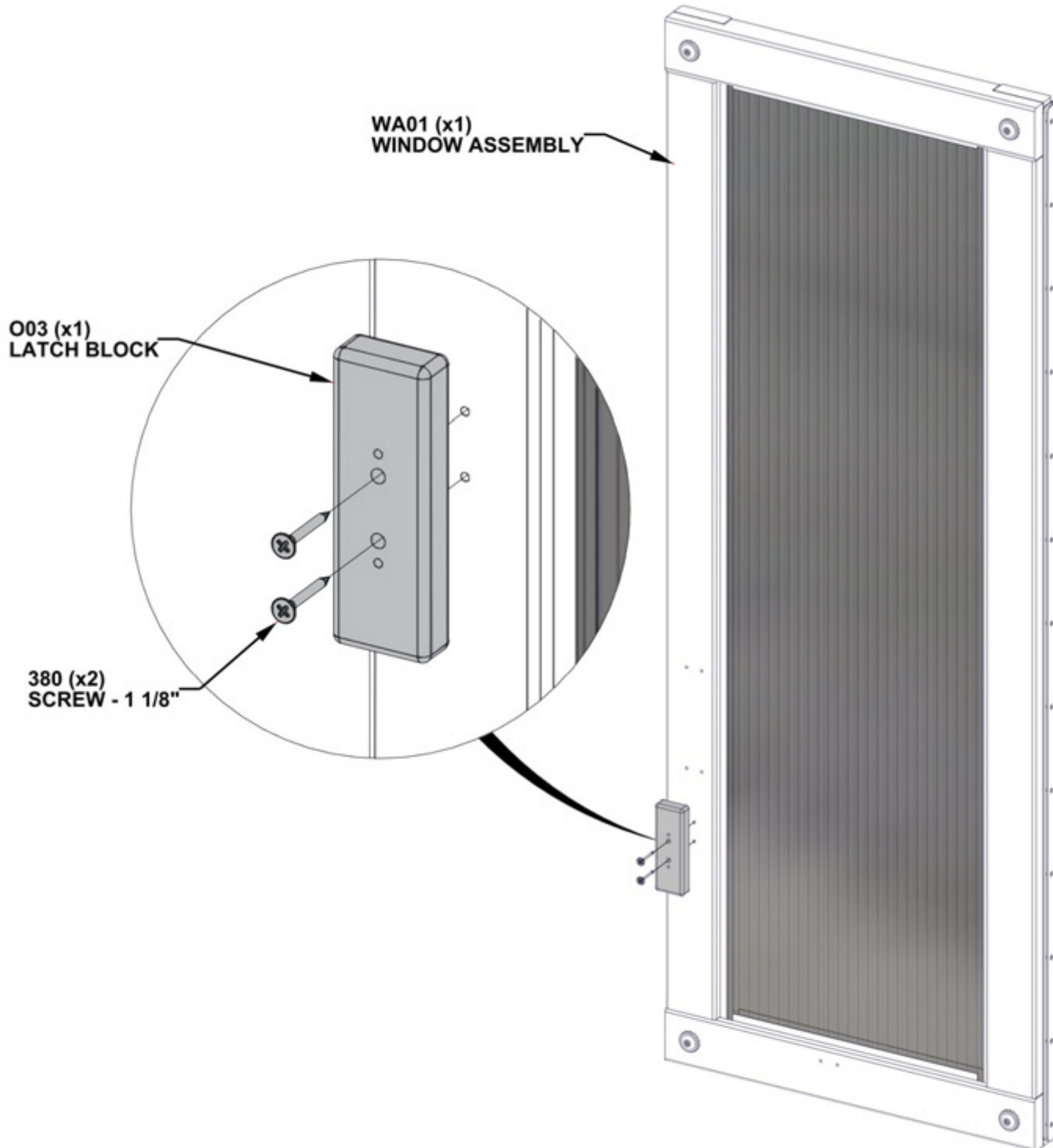

# STEP 101 - WINDOW ASSEMBLY

QTY	PART NUMBER	DESCRIPTION
4	H100380	SCREW PFH 8x1 1/8 BLK
2	H100627	SCREW PFH 6x3/4 BLK

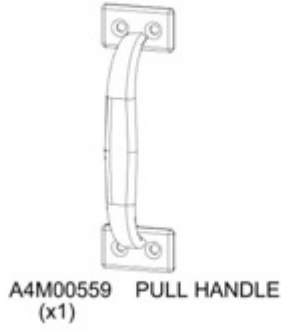

## - ALIGN PILOT HOLES

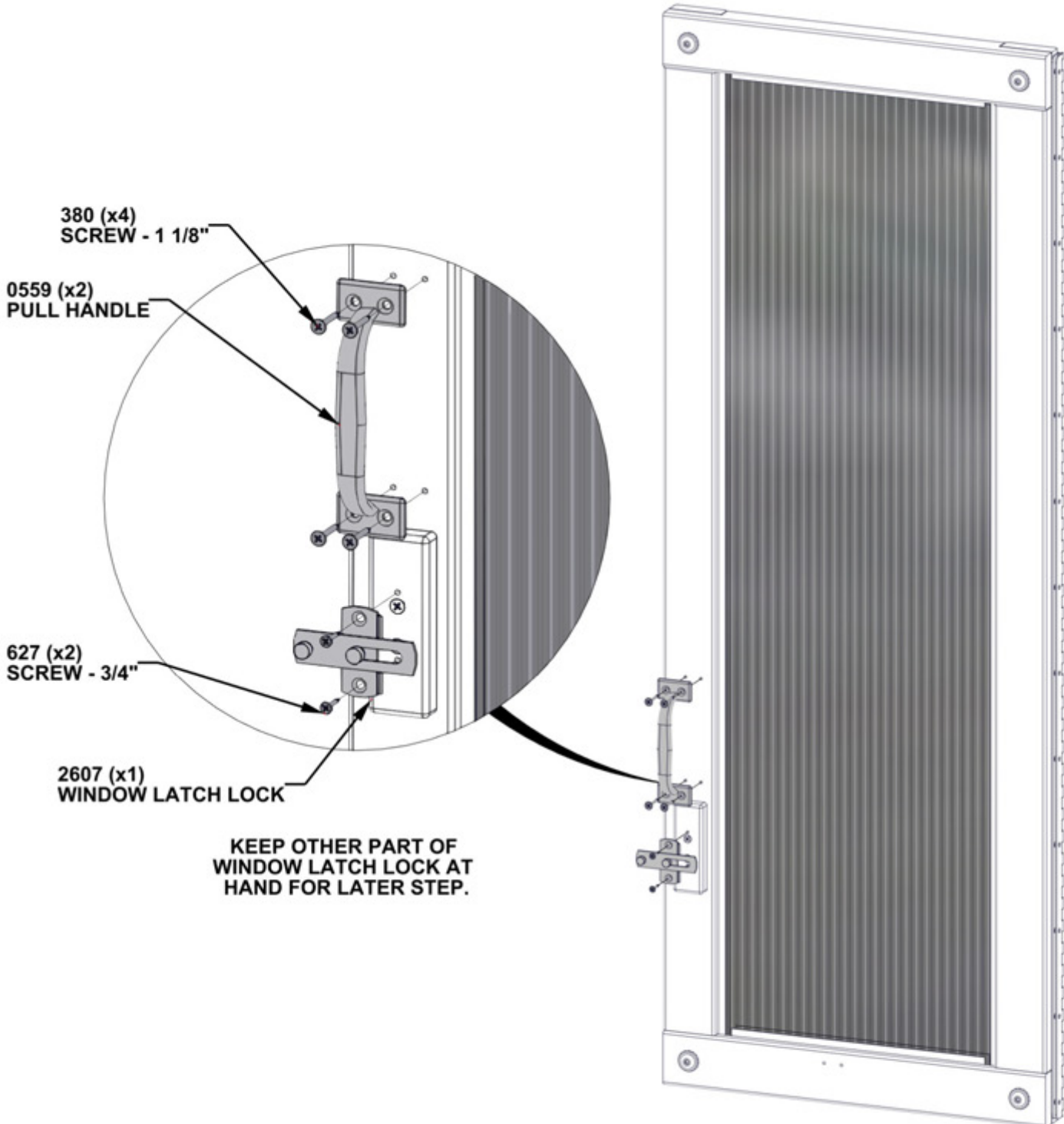

# STEP 102 - WINDOW ASSEMBLY

QTY	PART NUMBER	DESCRIPTION
13	H101191	SCREW PFH 6x1 BLK

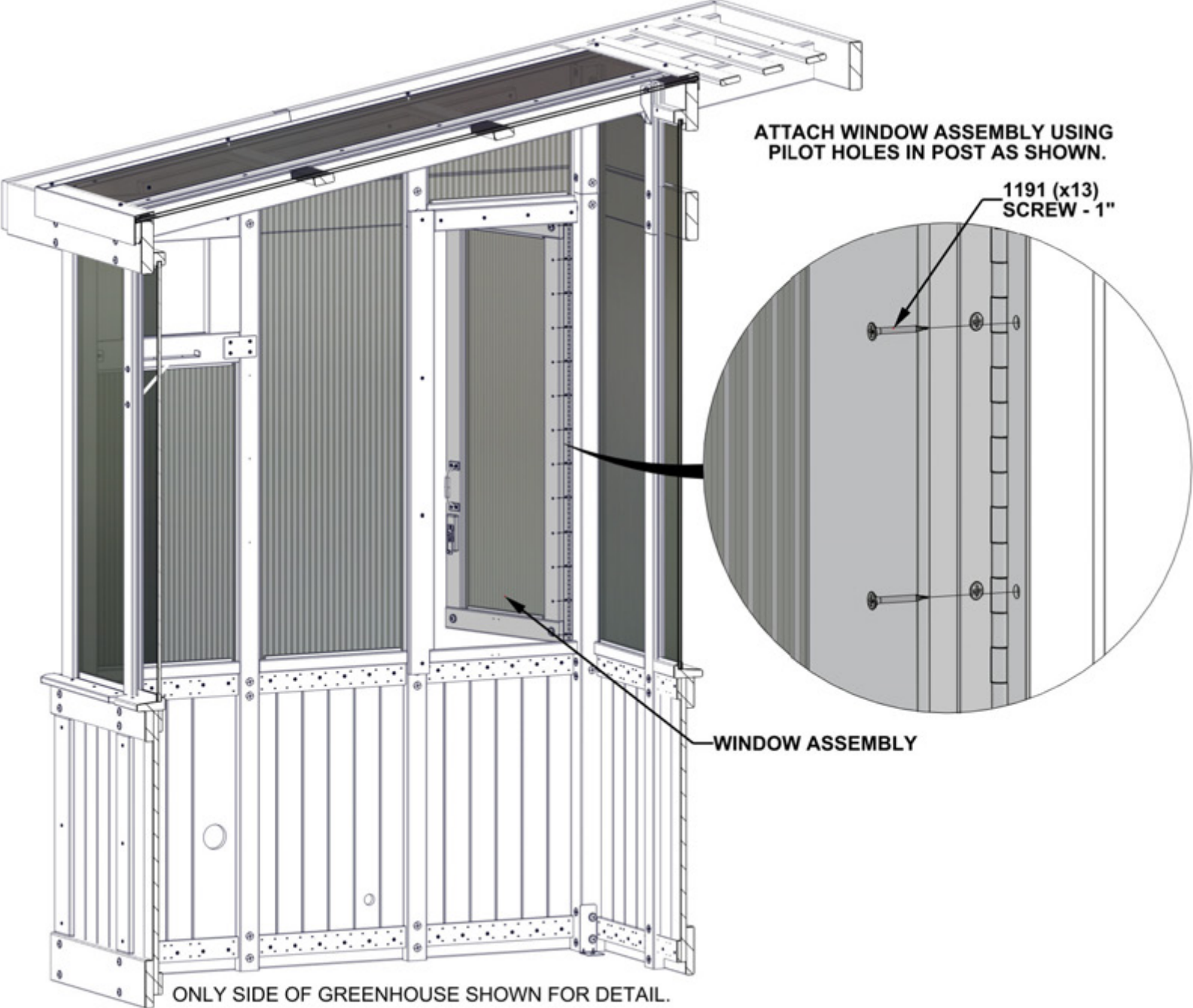

# STEP 103 - WINDOW ASSEMBLY

QTY	PART NUMBER	DESCRIPTION
2	H100627	SCREW PFH 6x3/4 BLK



A4M02607 WINDOW LATCH LOCK  
(x1)

REMAINING PART FROM STEP 101

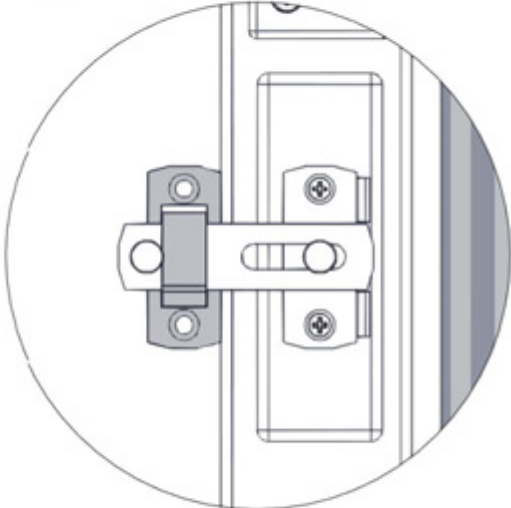
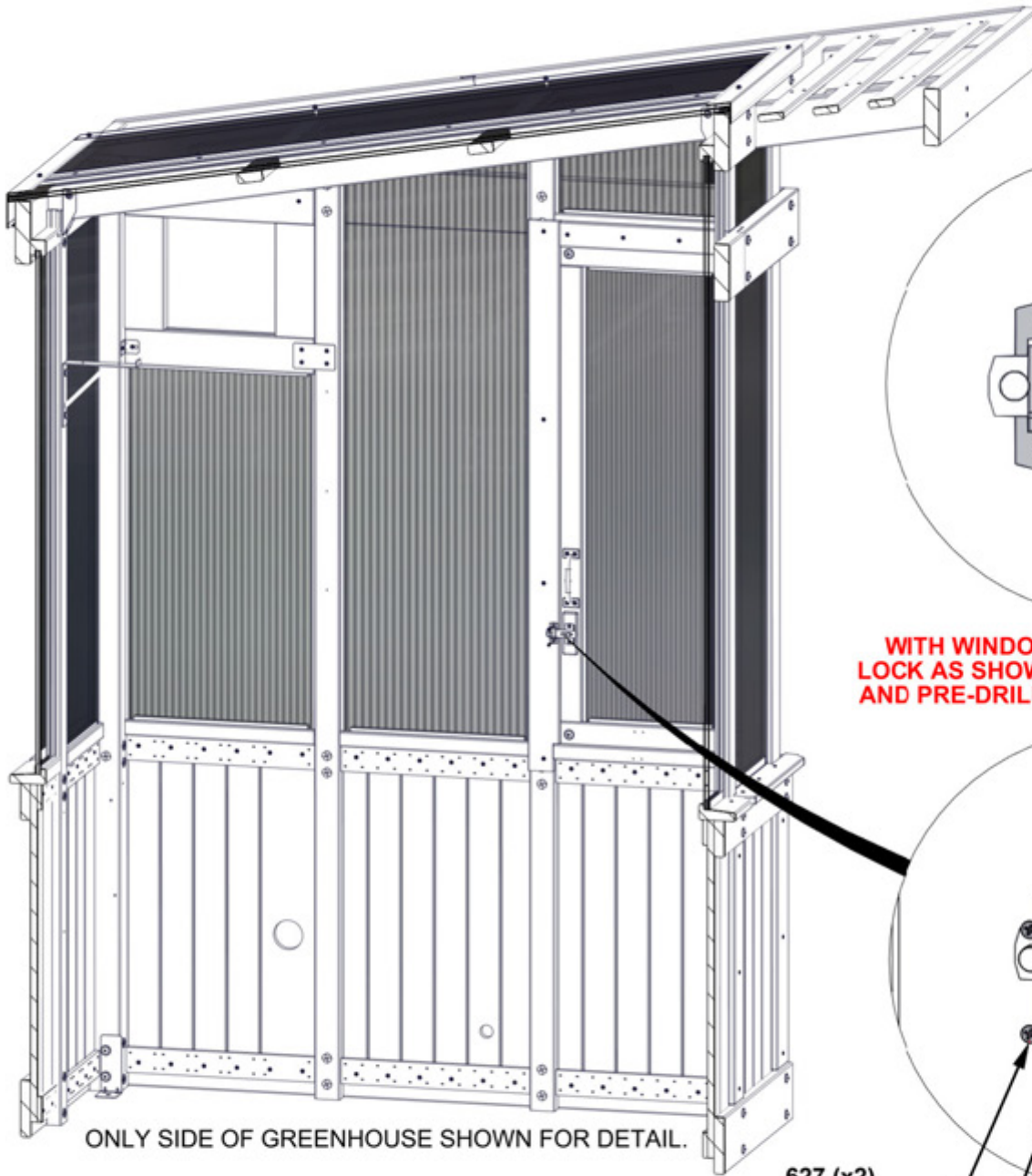

**WITH WINDOW CLOSED, ALIGN LATCH LOCK AS SHOWN. MARK HOLE LOCATIONS AND PRE-DRILL WITH 1/8" [3mm] DRILL BIT.**

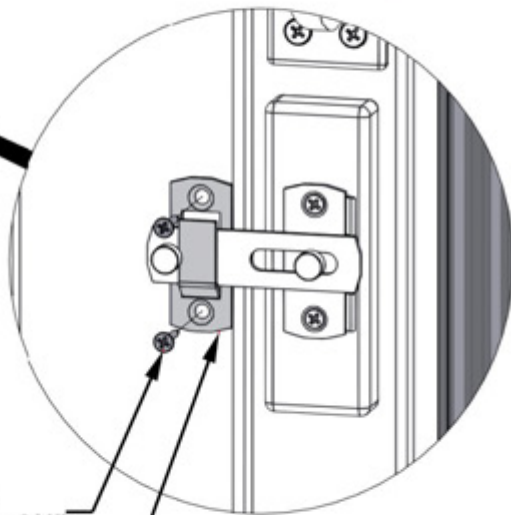

ONLY SIDE OF GREENHOUSE SHOWN FOR DETAIL.

627 (x2)  
SCREW - 3/4"

2607 (x1)  
WINDOW LATCH LOCK

# STEP 104 - WINDOW ASSEMBLY

QTY	PART NUMBER	DESCRIPTION
4	H100797	SCREW PWH 8x1 BLK



A4M02533 SUPPORT HINGE  
(x1)

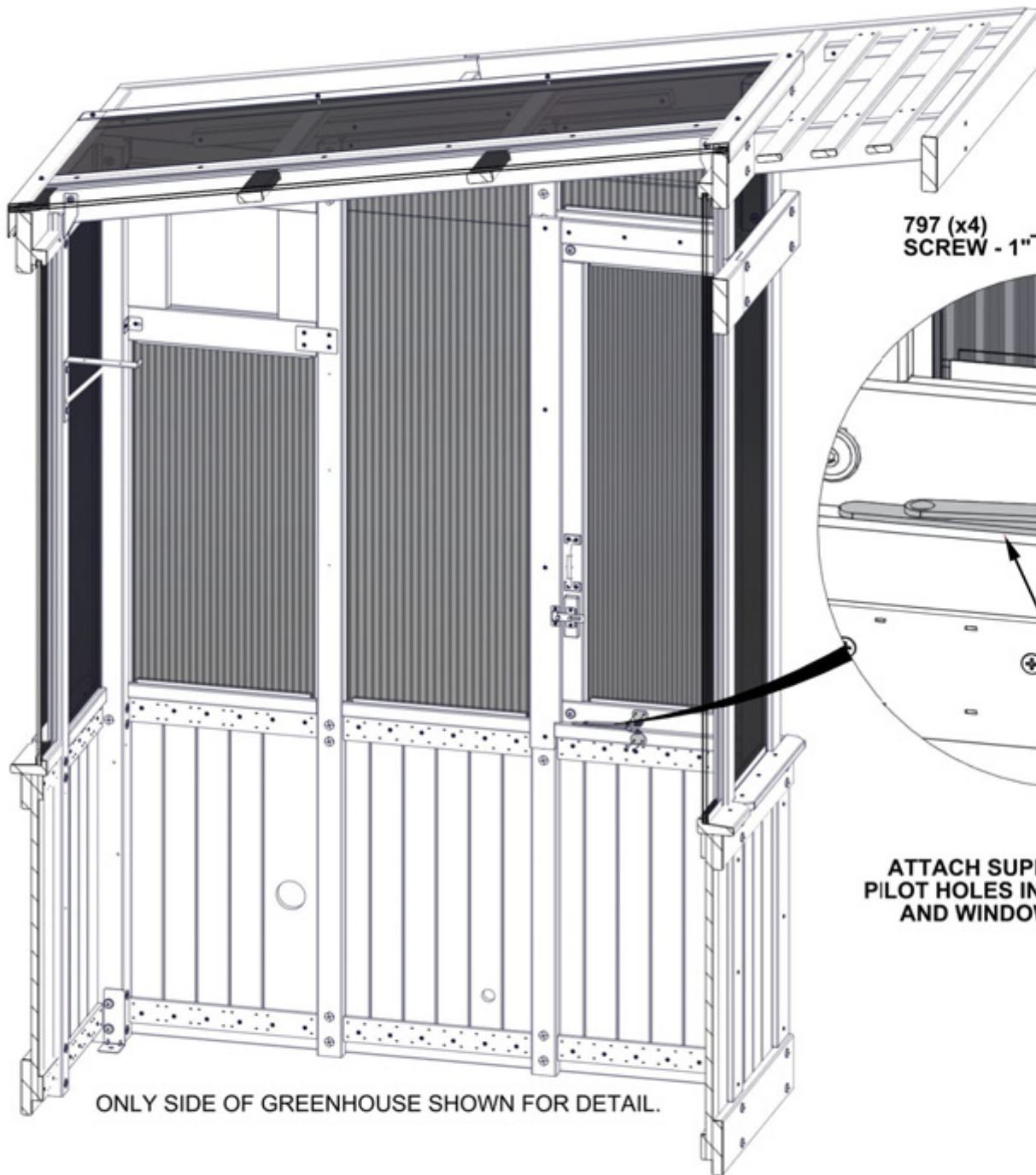

797 (x4)  
SCREW - 1"

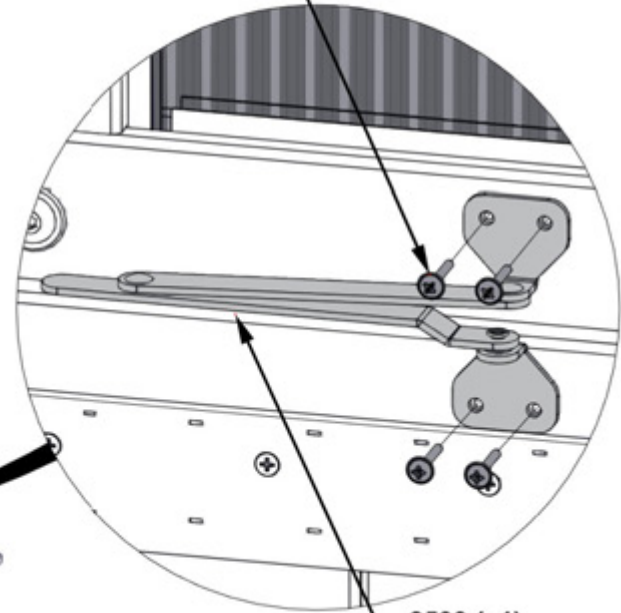

2533 (x1)  
SUPPORT HINGE

ATTACH SUPPORT HINGE USING  
PILOT HOLES IN WINDOW ASSEMBLY  
AND WINDOW SILL AS SHOWN.

ONLY SIDE OF GREENHOUSE SHOWN FOR DETAIL.

# STEP 105 - SHELF ASSEMBLY

QTY	PART NUMBER	DESCRIPTION
10	H100392	SCREW PWH 8x3/4 BLK



H04 SHELF BOARD - W4L20635  
(x2) 15/16"x3 3/8"x75 3/8" (24x86x1914)

ALIGN PILOT HOLES IN H04 BOARDS WITH HOLES IN SHELF BRACKETS AND ATTACH.

USE PHILLIPS EXTENSION BIT FOR INSTALLING SCREWS.

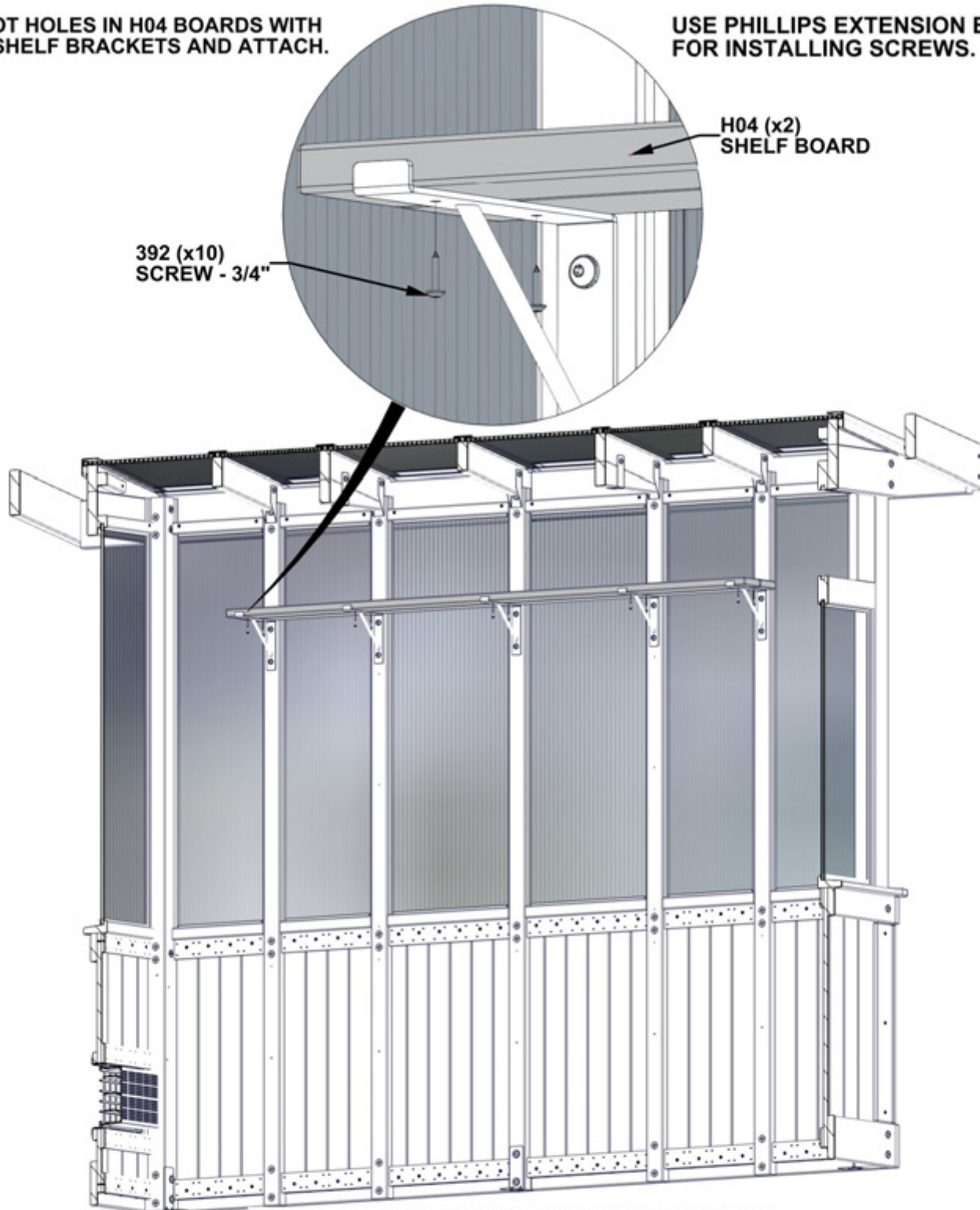

ONLY BACK OF GREENHOUSE SHOWN FOR DETAIL.

# STEP 106 - SLAT ASSEMBLY

QTY	PART NUMBER	DESCRIPTION
6	H100200	SCREW PFH 8x1 1/2 BLK



N04 SLAT UPRIGHT - W4L20637  
(x2) 5/8"x2 3/8"x33 1/16" (16x60x840)

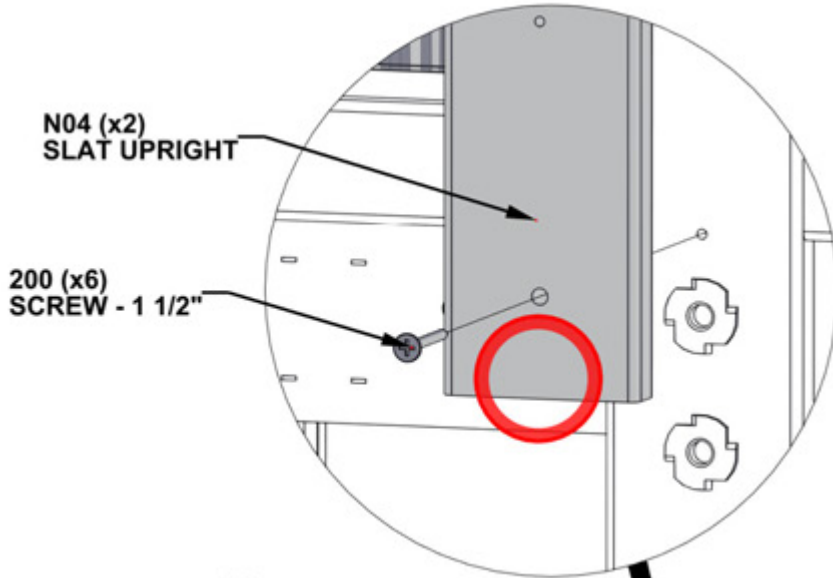

- NOTE NO PILOT HOLES IN BOTTOM END OF N04.
- ALIGN THE 3 LARGER PILOT HOLES IN N04 WITH PILOT HOLES IN UPRIGHTS.
- ATTACH AS SHOWN.

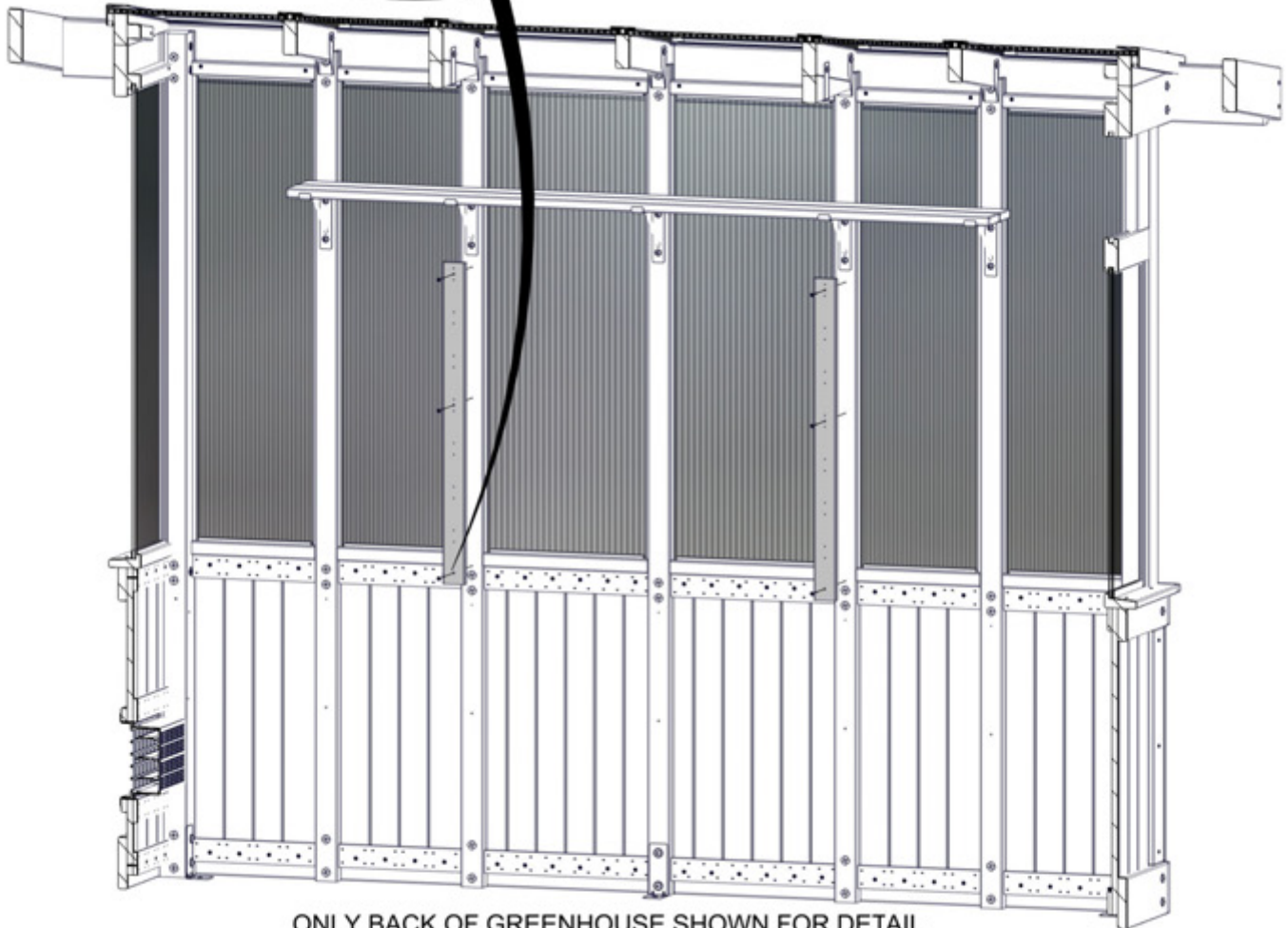

ONLY BACK OF GREENHOUSE SHOWN FOR DETAIL.

# STEP 107 - SLAT ASSEMBLY

QTY	PART NUMBER	DESCRIPTION
28	H100380	SCREW PFH 8x1 1/8 BLK



N05 SLAT - W4L20638  
(x7) 5/8"x2 3/8"x42 3/8" (16x60x1076)

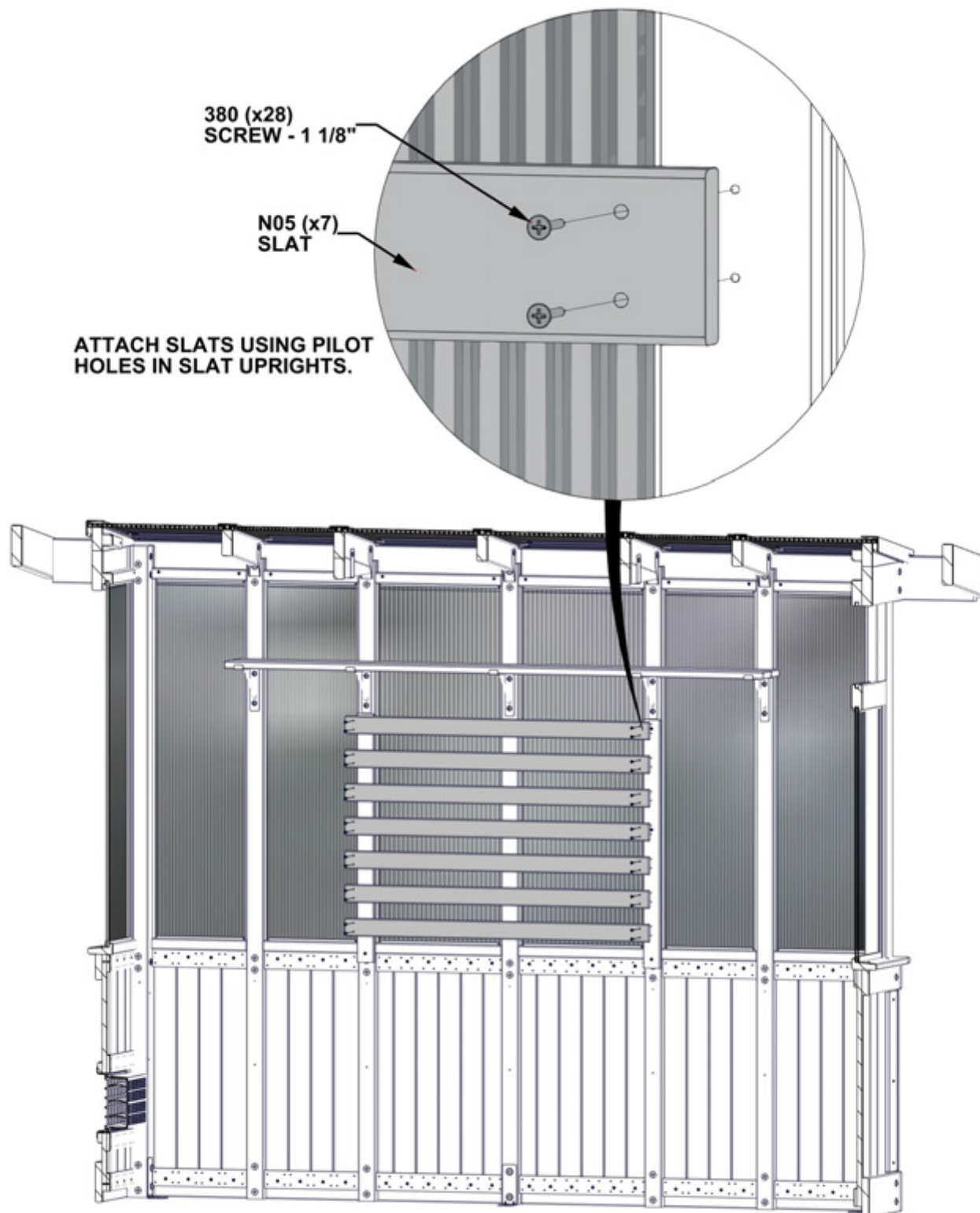

# STEP 108 - FAN ASSEMBLY

QTY	PART NUMBER	DESCRIPTION
8	H101203	SCREW PWH 8x15x1 1/4 BLK

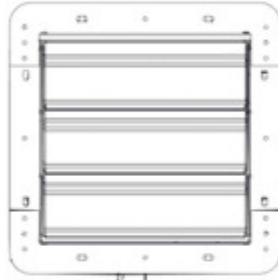

A4M02383 EXHAUST FAN  
(x1)

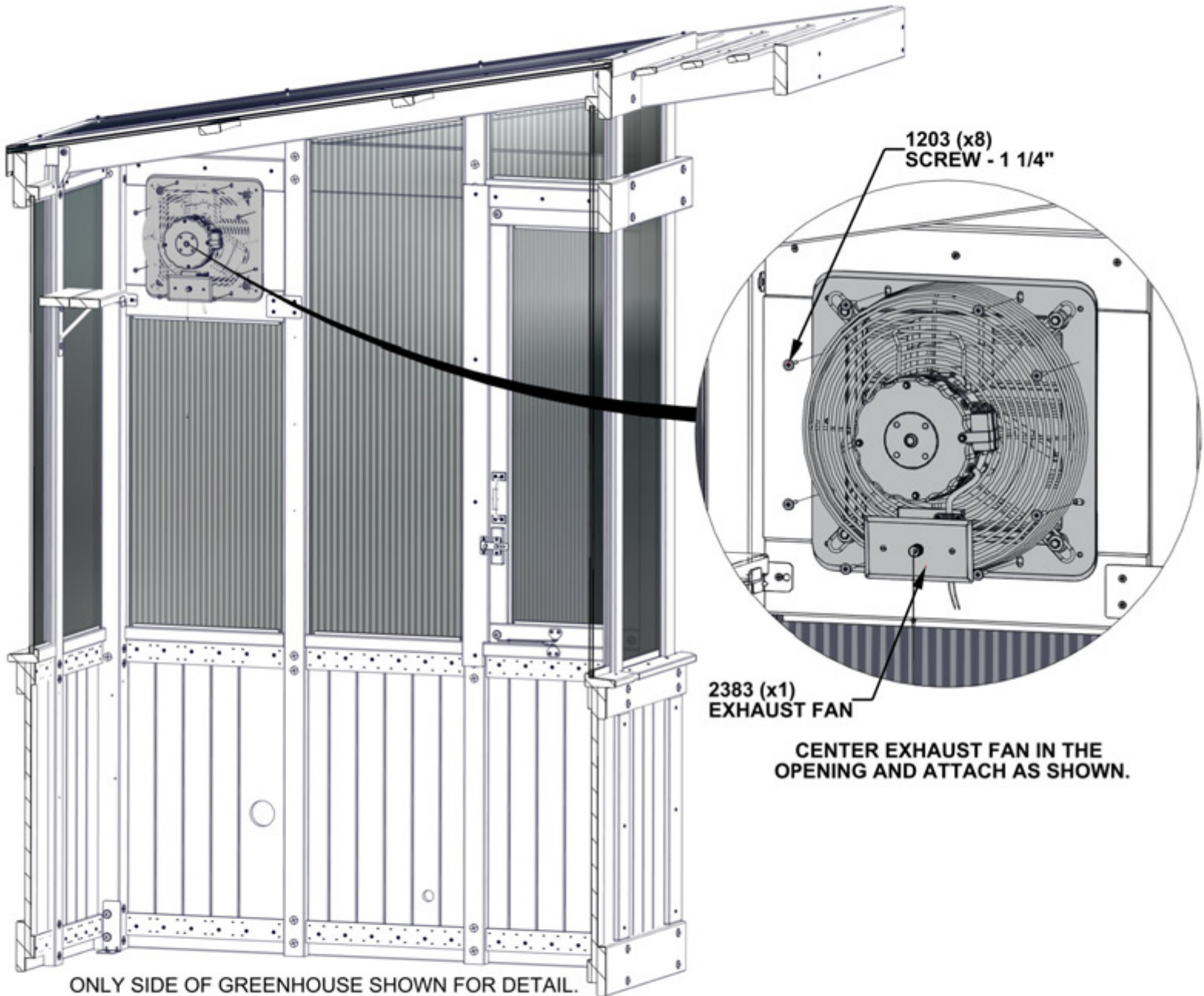

# STEP 109 - TABLE ASSEMBLY

QTY	PART NUMBER	DESCRIPTION
5	H100201	SCREW PFH 8x2 1/2 BLK
2	H100460	LAG SCREW WH 1/4x1 BLK
2	H100536	SCREW PWH 8x1 1/4 BLK



P07 TABLE CLEAT - W4L20630  
(x2) 1 7/16"x1 7/16"x50 3/4" (36x36x1289)

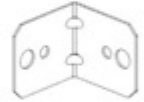

A4M00555 L BRACKET BLK  
(x2)

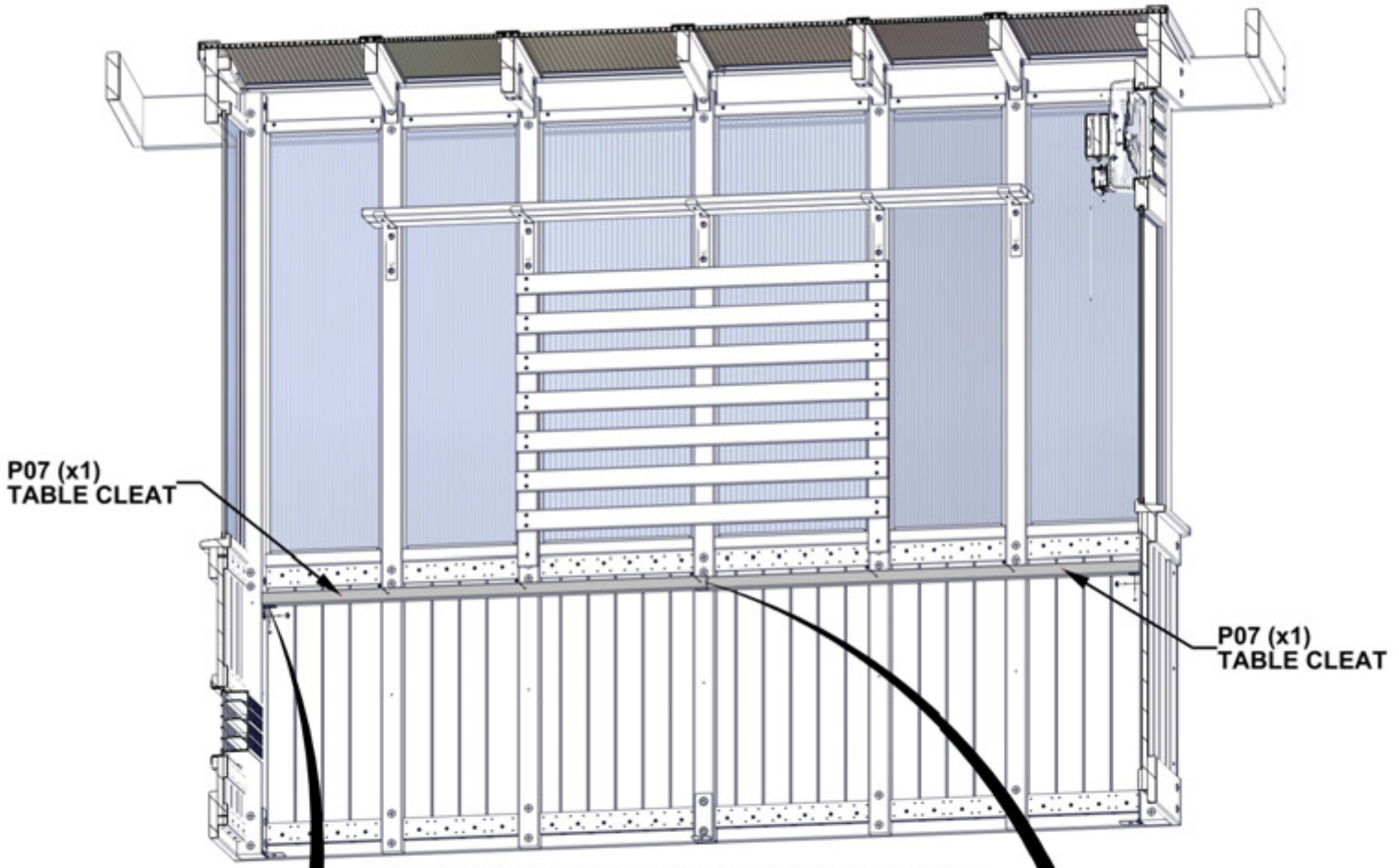

ONLY BACK OF GREENHOUSE SHOWN FOR DETAIL.

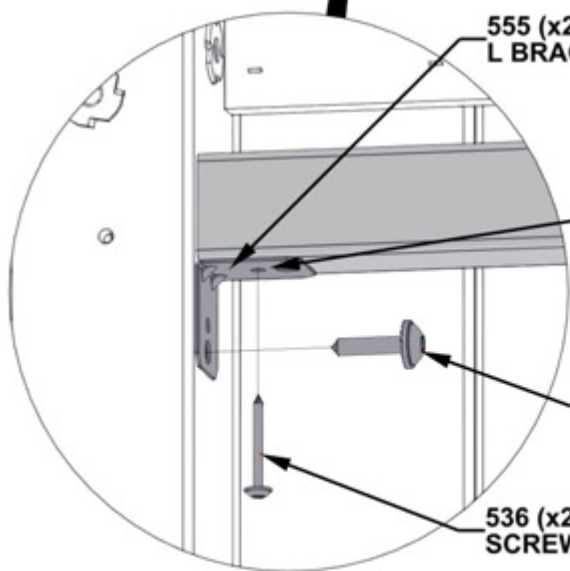

555 (x2)  
L BRACKET BLK

**PILOT HOLES TOWARDS  
END OF P07 FACE DOWN  
AND ALIGN WITH BRACKET.**

460 (x2)  
LAG SCREW - 1"

536 (x2)  
SCREW - 1 1/4"

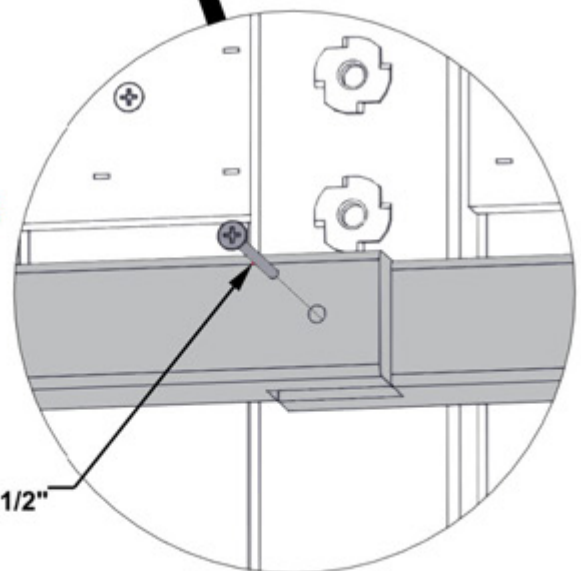

201 (x5)  
SCREW - 2 1/2"

# STEP 110 - TABLE ASSEMBLY

QTY	PART NUMBER	DESCRIPTION
3	H100362	SCREW PFH 8x3 BLK
1	H100460	LAG SCREW WH 1/4x1 BLK
1	H100536	SCREW PWH 8x1 1/4 BLK

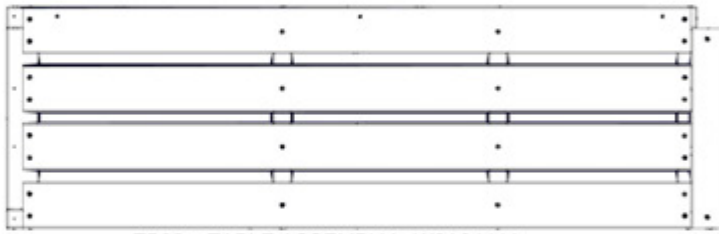

TB02 TABLE ASSEMBLY - W2A04444  
(x1) 2 1/16"x16 1/16"x51 15/16" (52x408x1319)

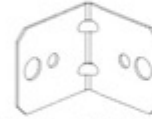

A4M00555 L BRACKET BLK  
(x1)

**DO NOT LEAN ON OR PUT ANY WEIGHT ON TABLE UNTIL ANGLE BRACES ARE INSTALLED IN NEXT STEPS.**

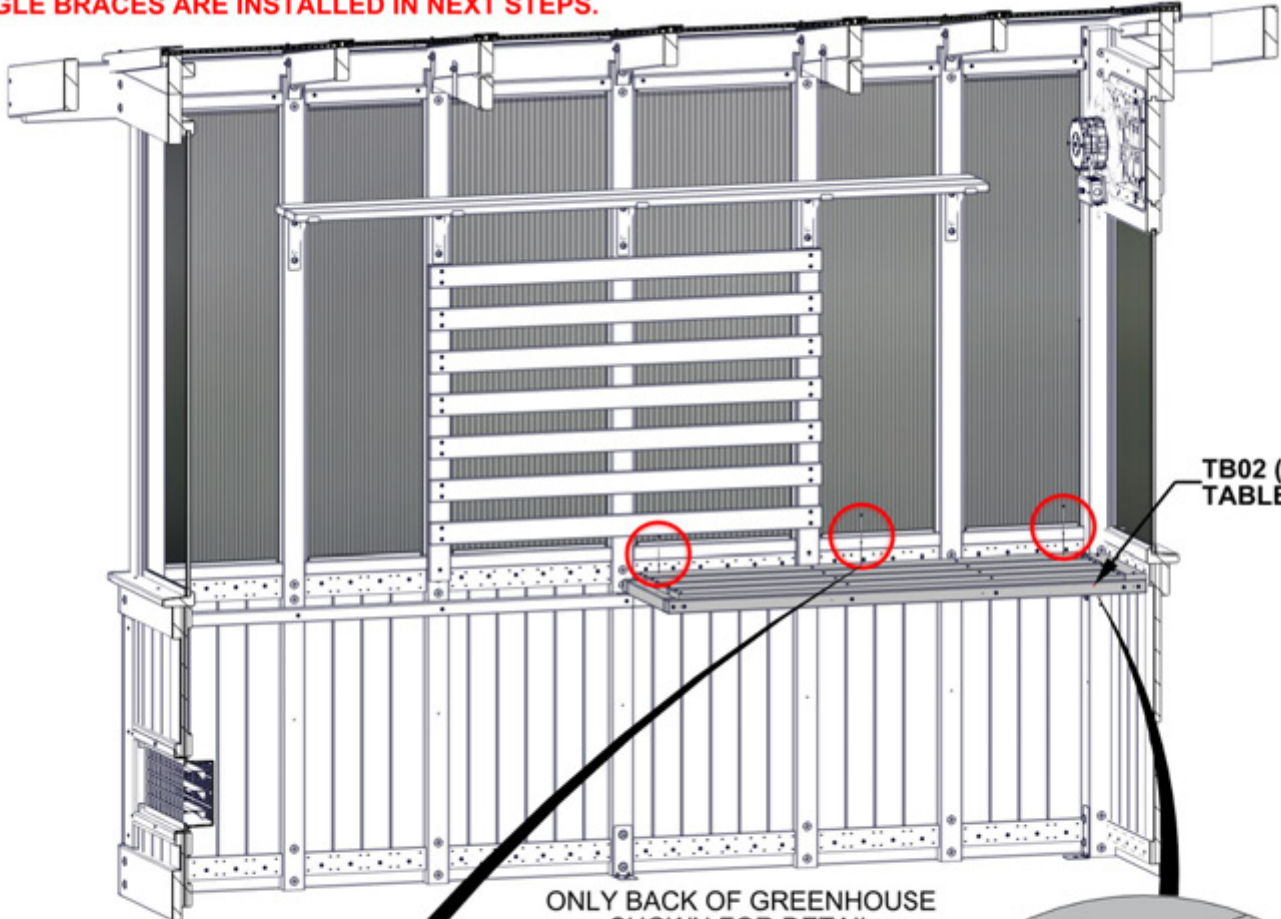

TB02 (x1)  
TABLE ASSEMBLY

ONLY BACK OF GREENHOUSE SHOWN FOR DETAIL.

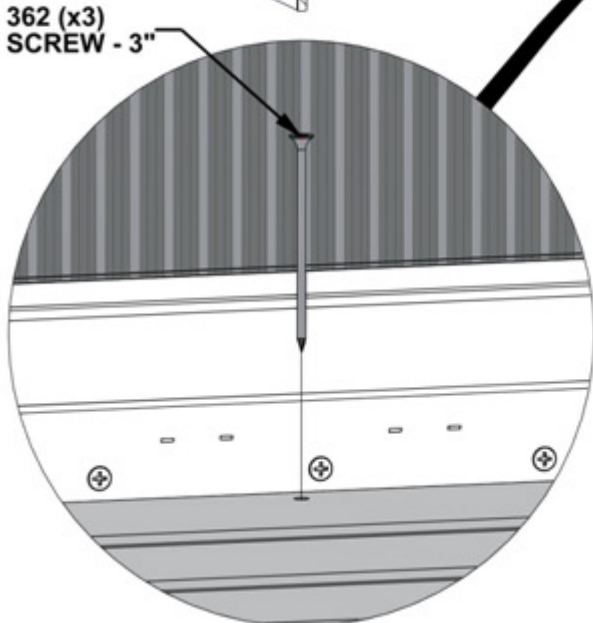

362 (x3)  
SCREW - 3"

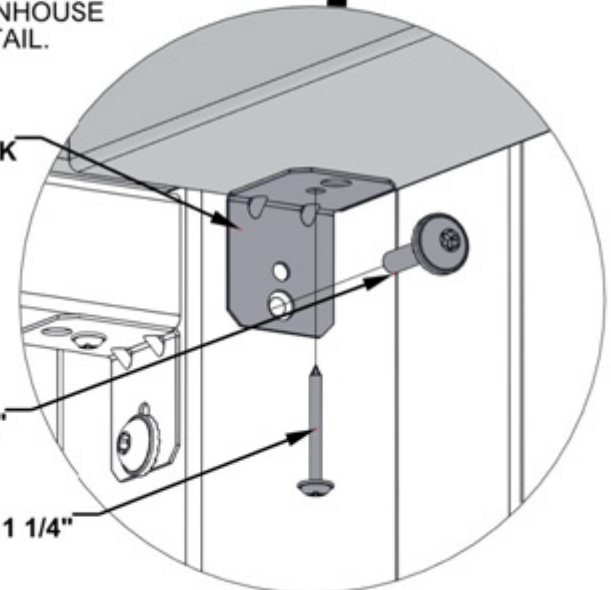

555 (x1)  
L BRACKET BLK

460 (x1)  
LAG SCREW - 1"

536 (x1)  
SCREW - 1 1/4"

**HAVE A SECOND PERSON HOLD TABLE IN PLACE UNTIL ANGLE BRACES ARE INSTALLED IN NEXT STEP.**

# STEP 111 - TABLE ASSEMBLY

QTY	PART NUMBER	DESCRIPTION
6	H100405	WASHER LOCK EXT 6x15
1	H100456	LAG SCREW WH 1/4x2 1/2 BLK
5	H100792	LAG SCREW WH 1/4x3 BLK



F11 ANGLE BRACE - W4L20612  
(x2) 1 7/16"x2 3/8"x18 1/16" (36x60x458)



F14 ANGLE BRACE - W4L20631  
(x1) 1 7/16"x2 3/8"x18 1/16" (36x60x458)

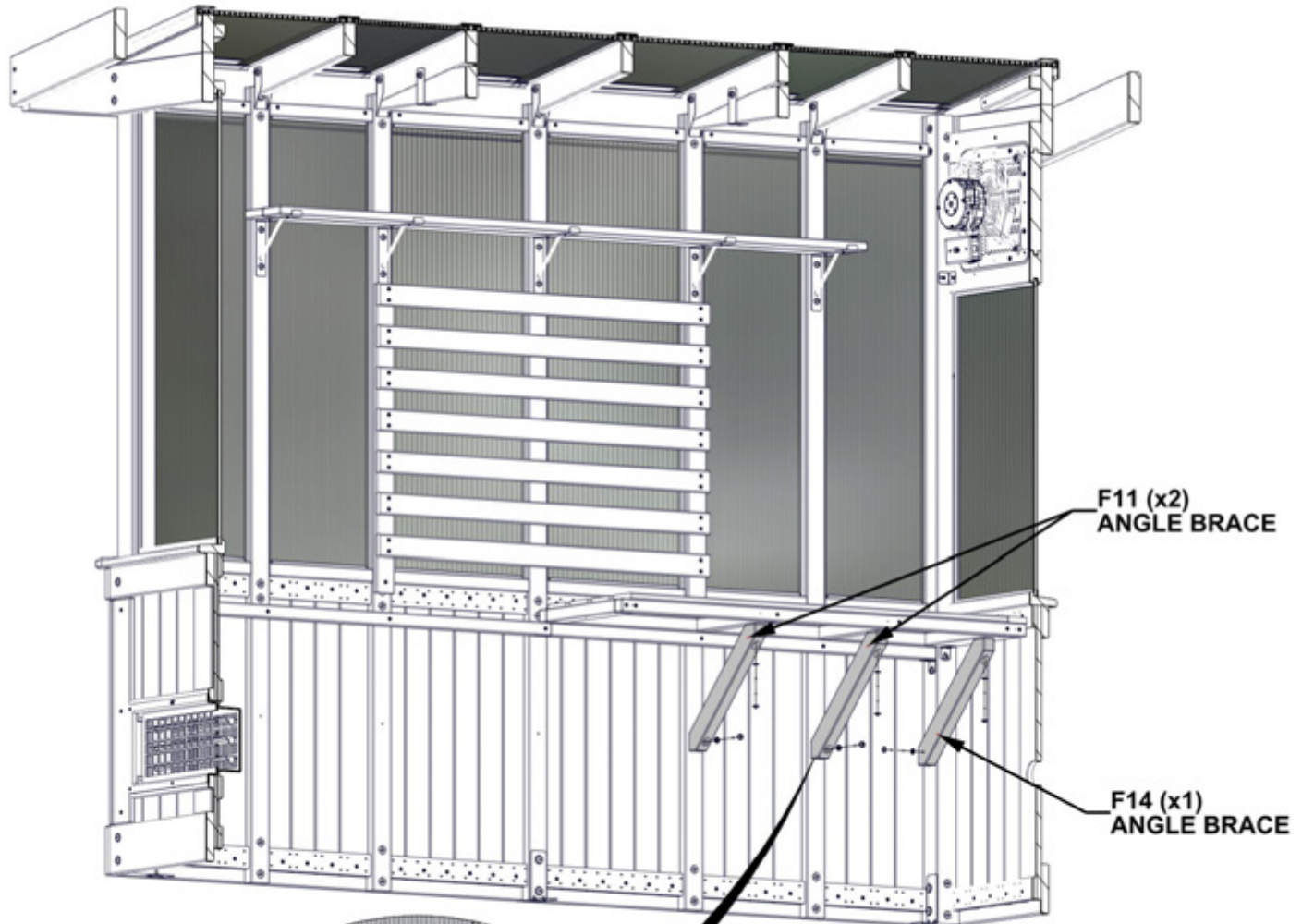

F11 (x2)  
ANGLE BRACE

F14 (x1)  
ANGLE BRACE

ONLY BACK OF GREENHOUSE  
SHOWN FOR DETAIL.

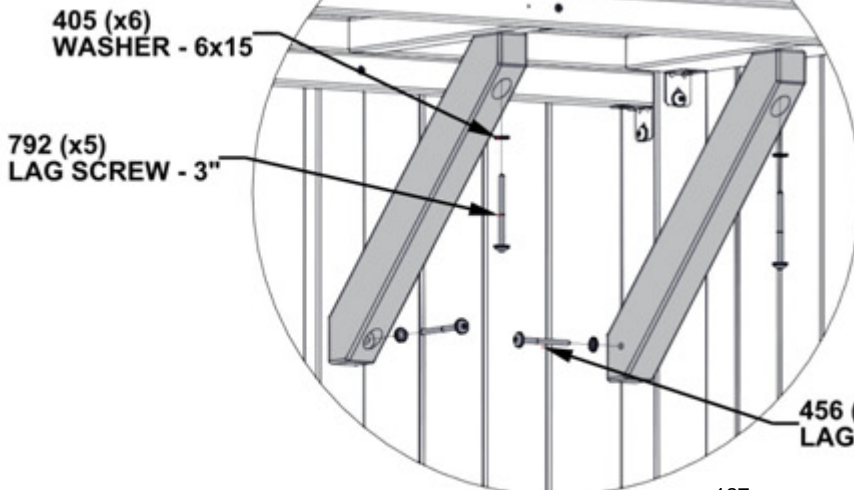

405 (x6)  
WASHER - 6x15

792 (x5)  
LAG SCREW - 3"

456 (x1)  
LAG SCREW - 2 1/2"

ATTACH ANGLE BRACES AS SHOWN  
USING PILOT HOLES IN TABLE  
CLEATS, UPRIGHTS, AND POSTS.

# STEP 112 - TABLE ASSEMBLY

QTY	PART NUMBER	DESCRIPTION
3	H100362	SCREW PFH 8x3 BLK
1	H100460	LAG SCREW WH 1/4x1 BLK
1	H100536	SCREW PWH 8x1 1/4 BLK

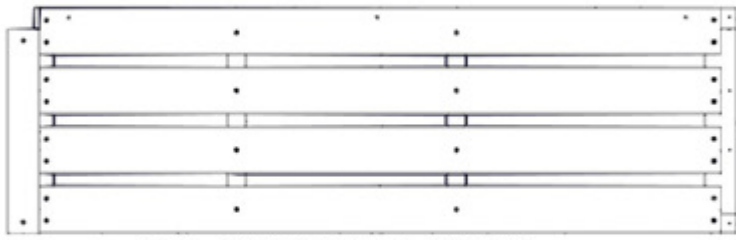

TB01 TABLE ASSEMBLY - W2A04439  
(x1) 2 1/16"x16 1/16"x51 15/16" (52x408x1319)

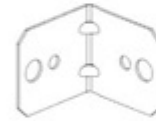

A4M00555 L BRACKET BLK  
(x1)

**DO NOT LEAN ON OR PUT ANY WEIGHT ON TABLE UNTIL ANGLE BRACES ARE INSTALLED IN NEXT STEPS.**

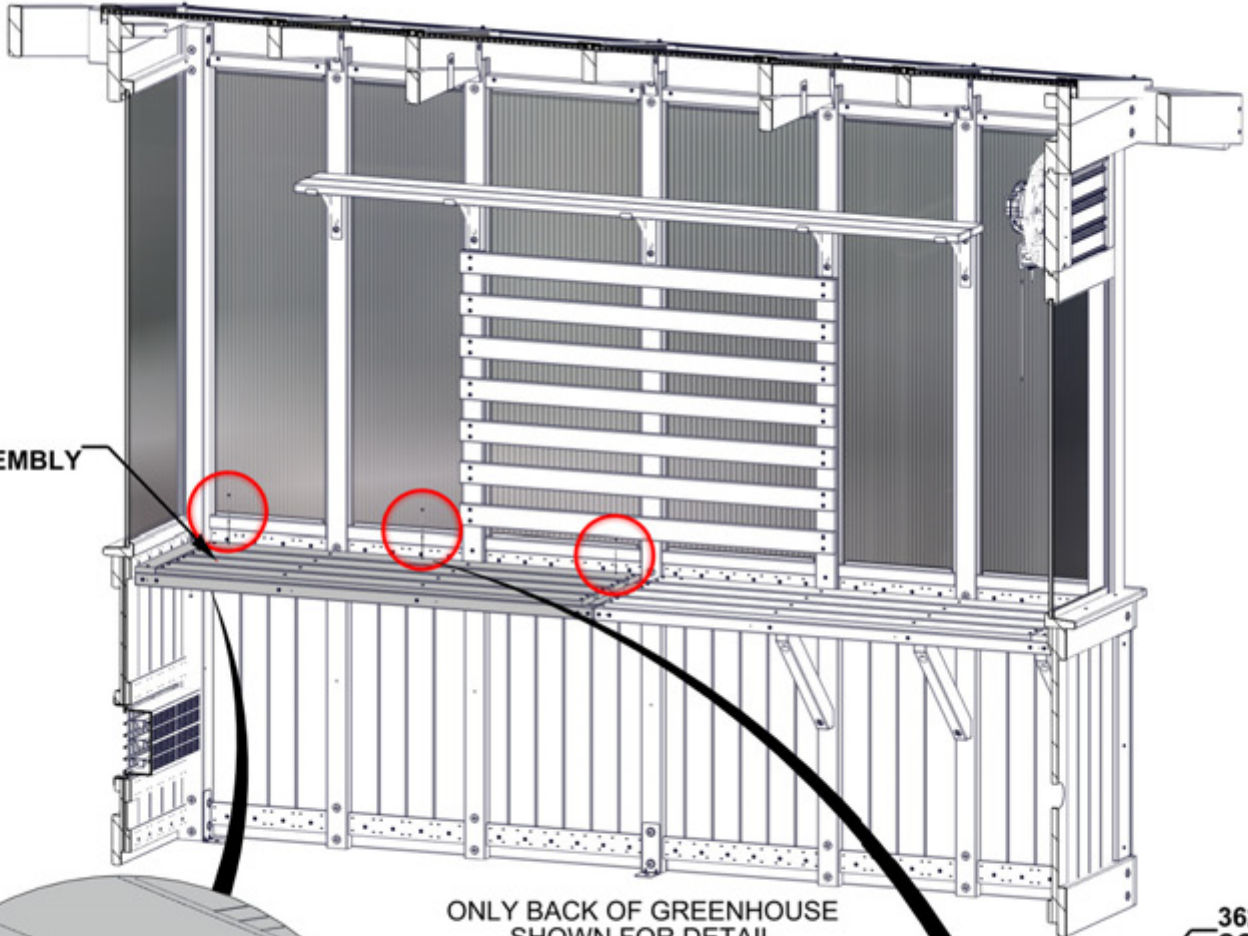

TB01 (x1)  
TABLE ASSEMBLY

ONLY BACK OF GREENHOUSE SHOWN FOR DETAIL.

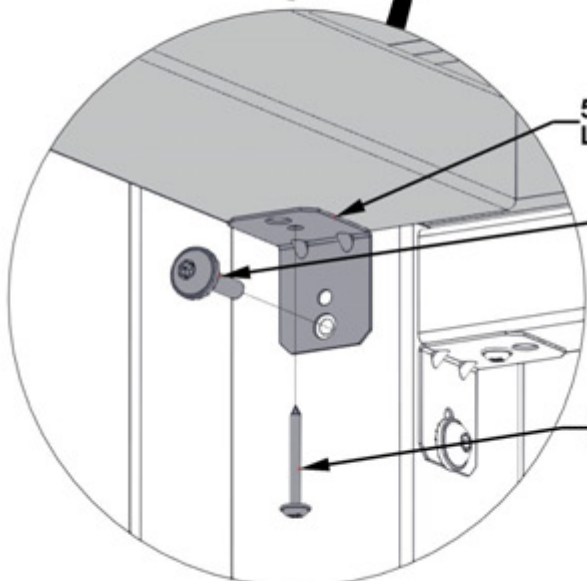

555 (x1)  
L BRACKET BLK  
460 (x1)  
LAG SCREW - 1"  
536 (x1)  
SCREW - 1 1/4"

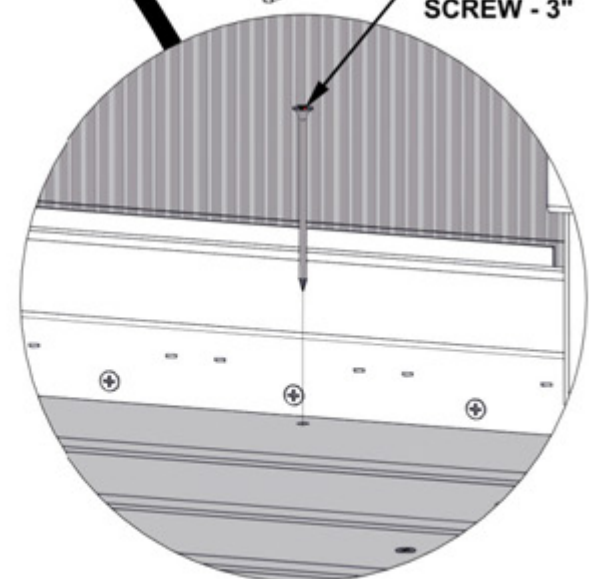

362 (x3)  
SCREW - 3"

**HAVE A SECOND PERSON HOLD TABLE IN PLACE UNTIL ANGLE BRACES ARE INSTALLED IN NEXT STEP.**

# STEP 113 - TABLE ASSEMBLY

QTY	PART NUMBER	DESCRIPTION
6	H100405	WASHER LOCK EXT 6x15
1	H100456	LAG SCREW WH 1/4x2 1/2 BLK
5	H100792	LAG SCREW WH 1/4x3 BLK



F11 ANGLE BRACE - W4L20612  
(x2) 1 7/16"x2 3/8"x18 1/16" (36x60x458)



F14 ANGLE BRACE - W4L20631  
(x1) 1 7/16"x2 3/8"x18 1/16" (36x60x458)

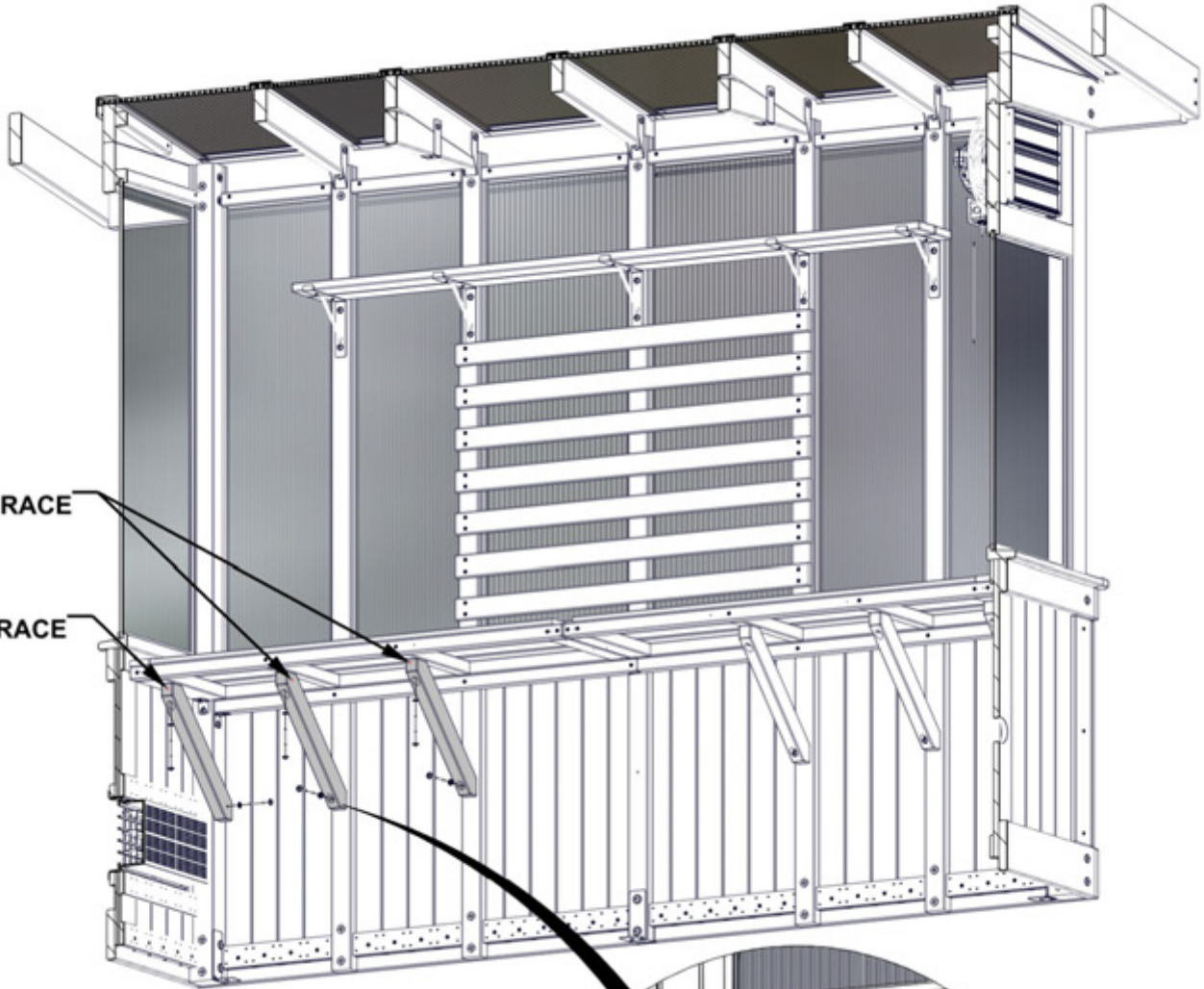

F11 (x2)  
ANGLE BRACE

F14 (x1)  
ANGLE BRACE

ONLY BACK OF GREENHOUSE  
SHOWN FOR DETAIL.

ATTACH ANGLE BRACES AS SHOWN  
USING PILOT HOLES IN TABLE  
CLEATS, UPRIGHTS, AND POSTS.

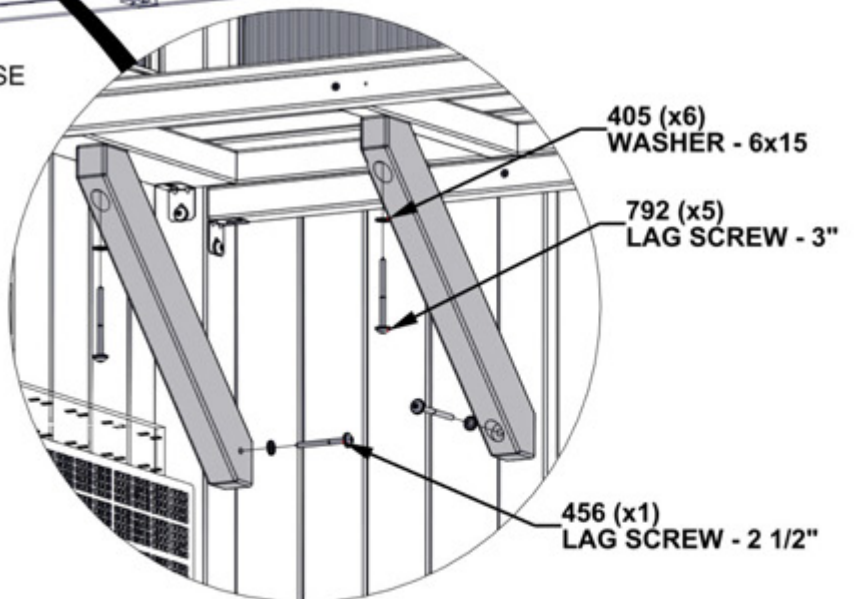

405 (x6)  
WASHER - 6x15

792 (x5)  
LAG SCREW - 3"

456 (x1)  
LAG SCREW - 2 1/2"

# STEP 114 - TABLE ASSEMBLY

QTY	PART NUMBER	DESCRIPTION
6	H100201	SCREW PFH 8x2 1/2 BLK



F07 TABLE CLEAT - W4L20599  
(x1) 1 7/16"x2 3/8"x13 1/4" (36x60x336)

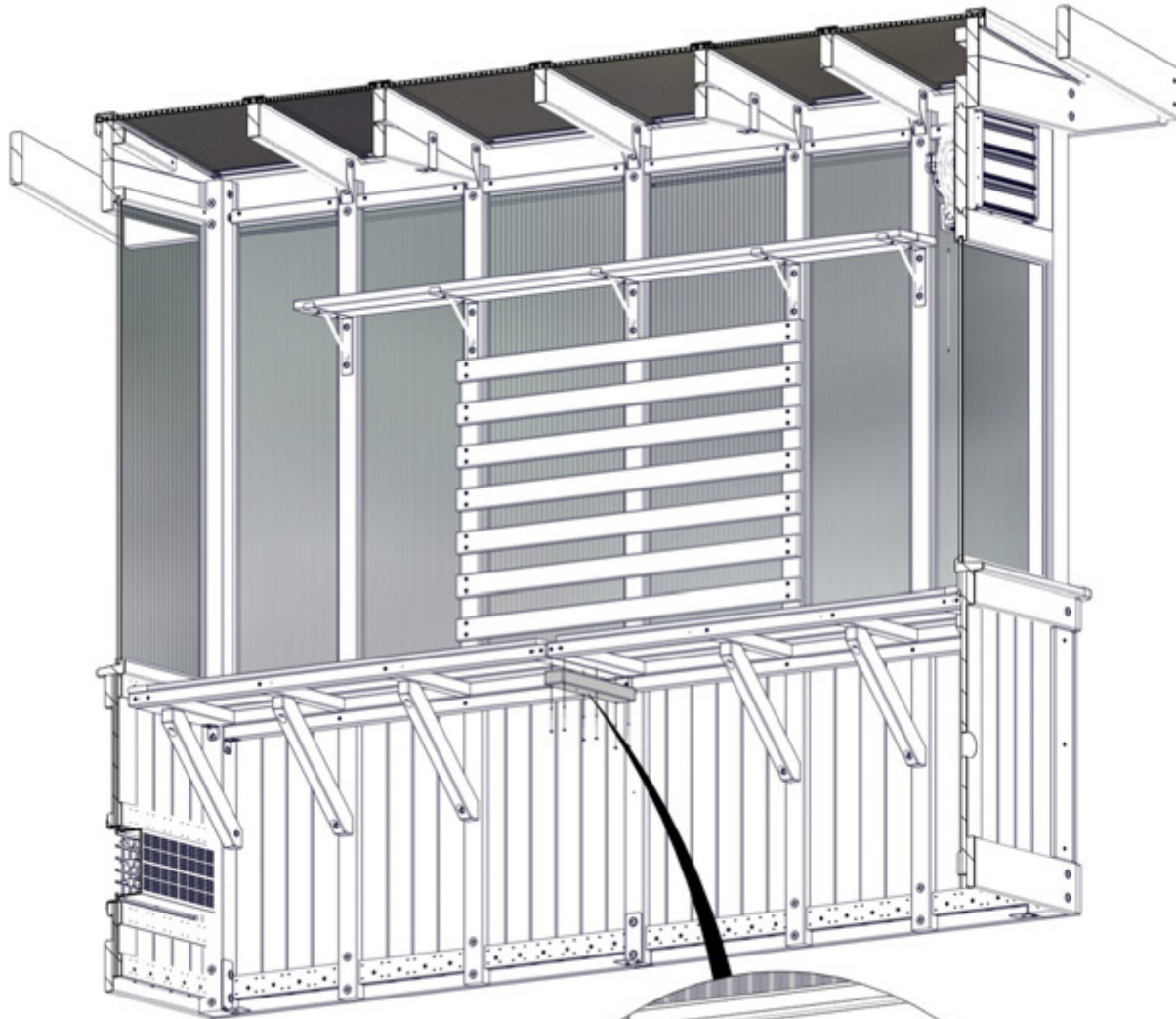

ONLY BACK OF GREENHOUSE SHOWN FOR DETAIL.

**ENSURE PILOT HOLE IS ORIENTED TO THE FRONT AS SHOWN.**

**- ALIGN PILOT HOLES.**

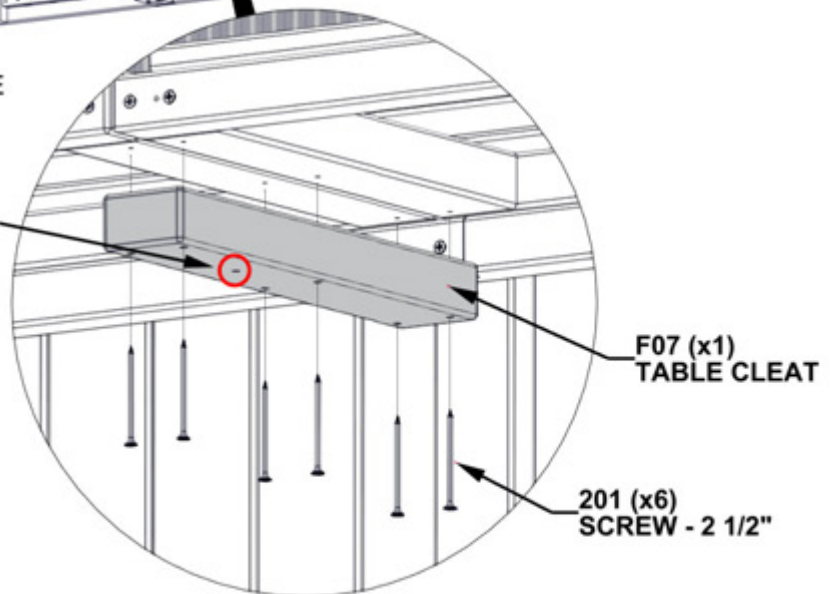

F07 (x1)  
TABLE CLEAT

201 (x6)  
SCREW - 2 1/2"

# STEP 115 - TABLE ASSEMBLY

QTY	PART NUMBER	DESCRIPTION
2	H100405	WASHER LOCK EXT 6x15
2	H100792	LAG SCREW WH 1/4x3 BLK



F10 ANGLE BRACE - W4L20611  
(x1) 1 7/16"x2 3/8"x17" (36x60x432)

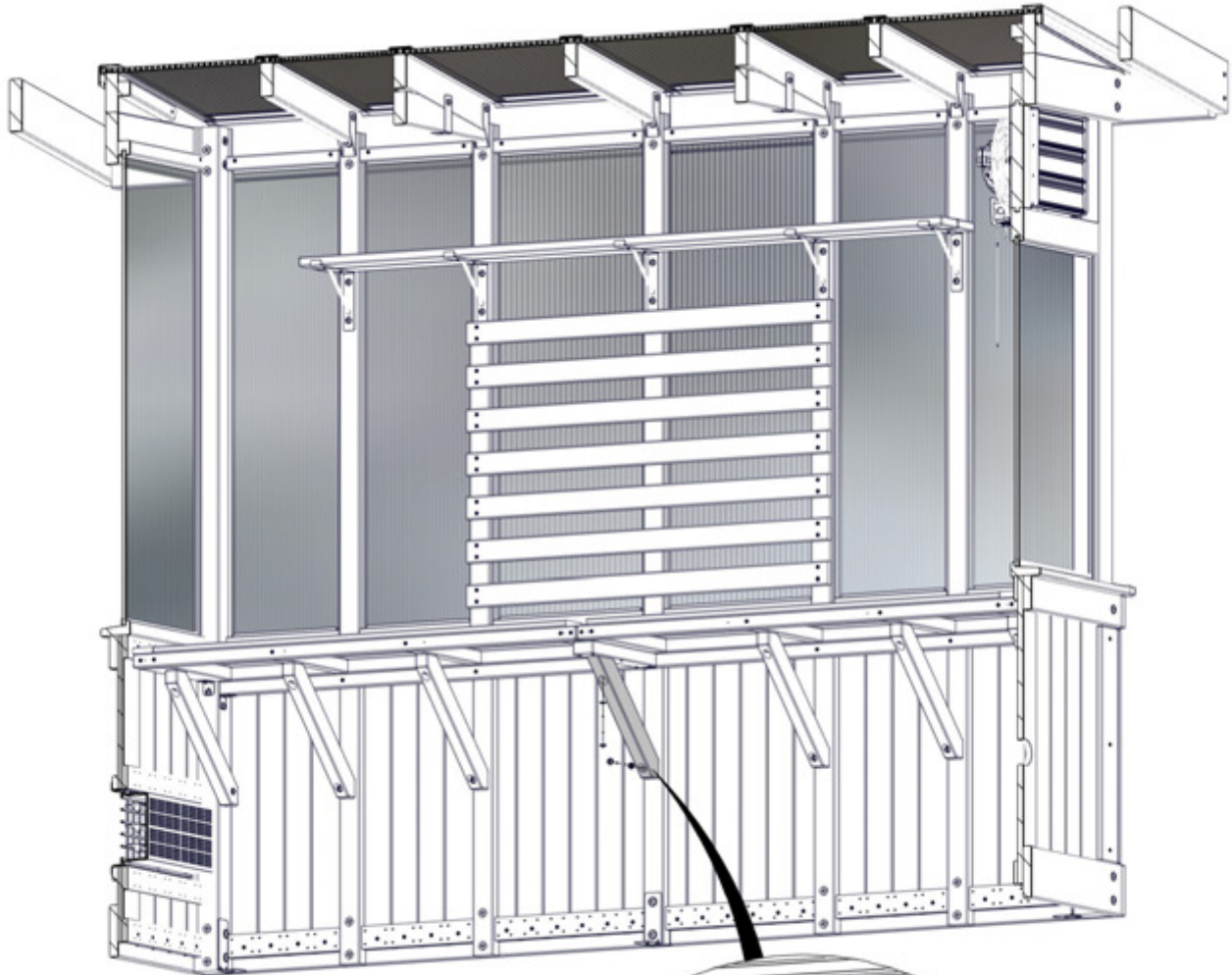

ONLY BACK OF GREENHOUSE  
SHOWN FOR DETAIL.

ATTACH ANGLE BRACE AS  
SHOWN USING PILOT HOLES.

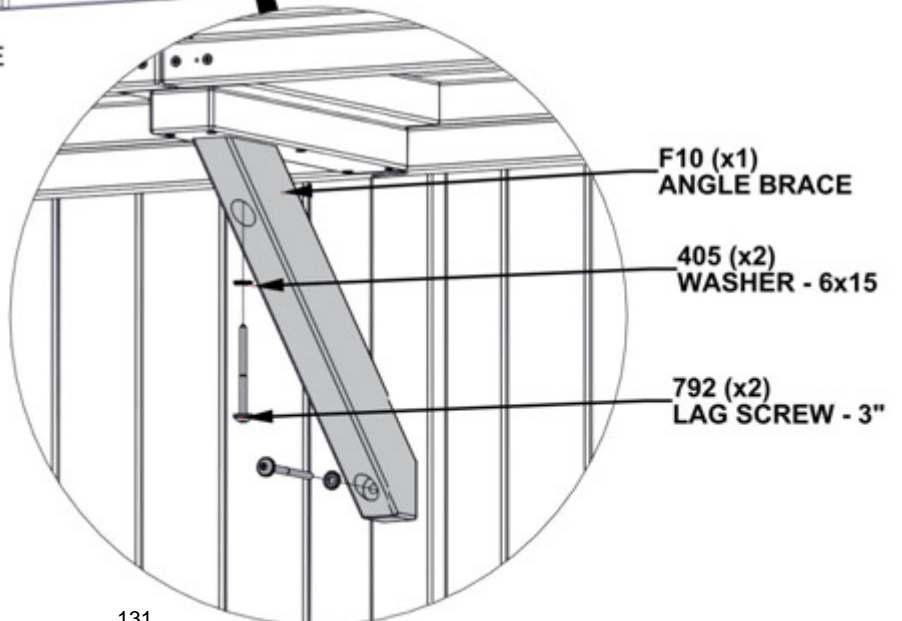

F10 (x1)  
ANGLE BRACE

405 (x2)  
WASHER - 6x15

792 (x2)  
LAG SCREW - 3"

# STEP 116 - TABLE ASSEMBLY

QTY	PART NUMBER	DESCRIPTION
8	H100387	SCREW PFH 8x1 1/4 BLK



N03 TABLE TOP BOARD - W4L20609  
(x1) 5/8"x2 3/8"x16 1/16" (16x60x408)

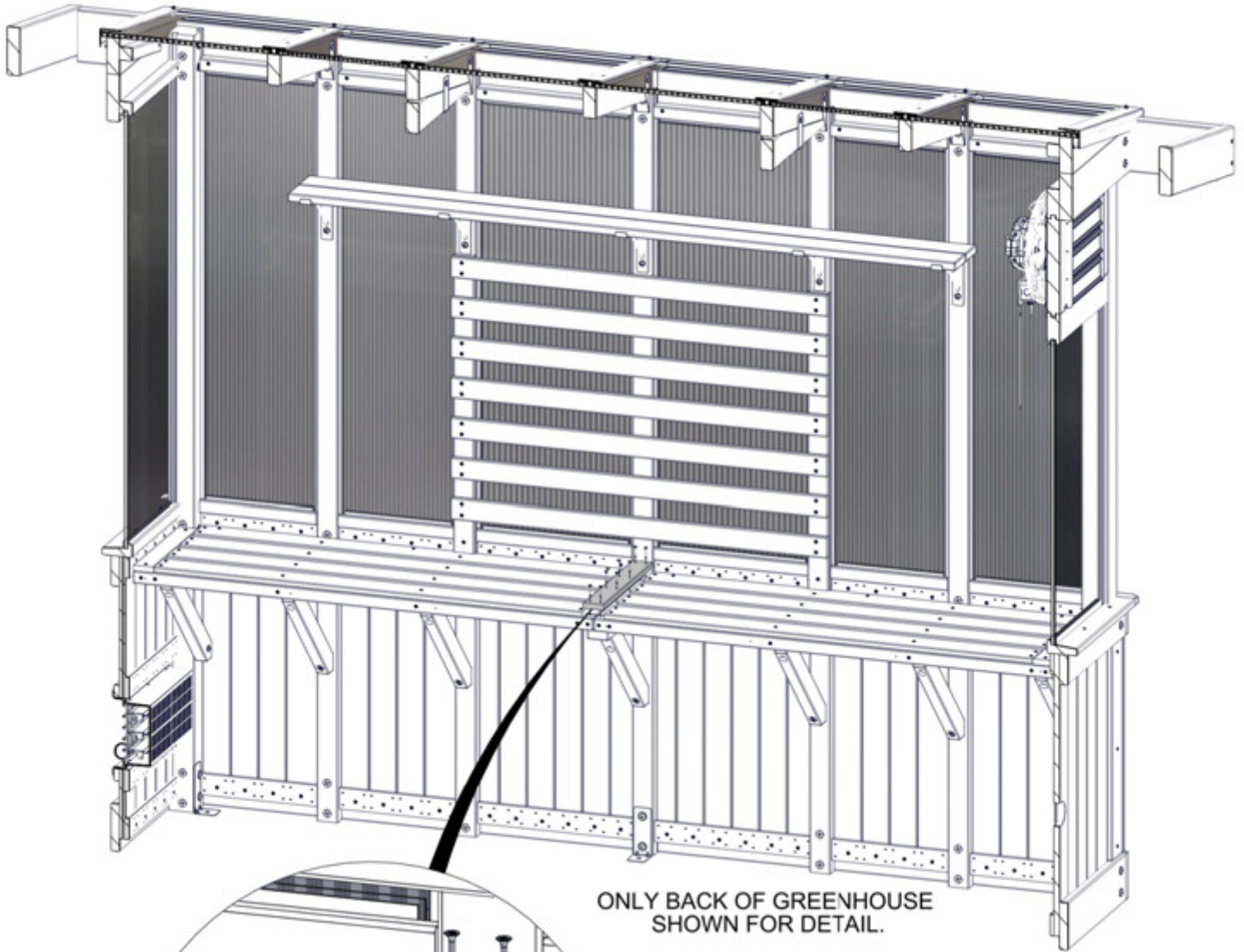

ONLY BACK OF GREENHOUSE  
SHOWN FOR DETAIL.

387 (x8)  
SCREW - 1 1/4"

- ALIGN PILOT HOLES.

N03 (x1)  
TABLE TOP BOARD

# STEP 117 - TABLE ASSEMBLY

QTY	PART NUMBER	DESCRIPTION
8	H100200	SCREW PFH 8x1 1/2 BLK



M03 TABLE TRIM - W4L20623  
(x2) 5/8"x3 3/8"x51 15/16" (16x86x1320)

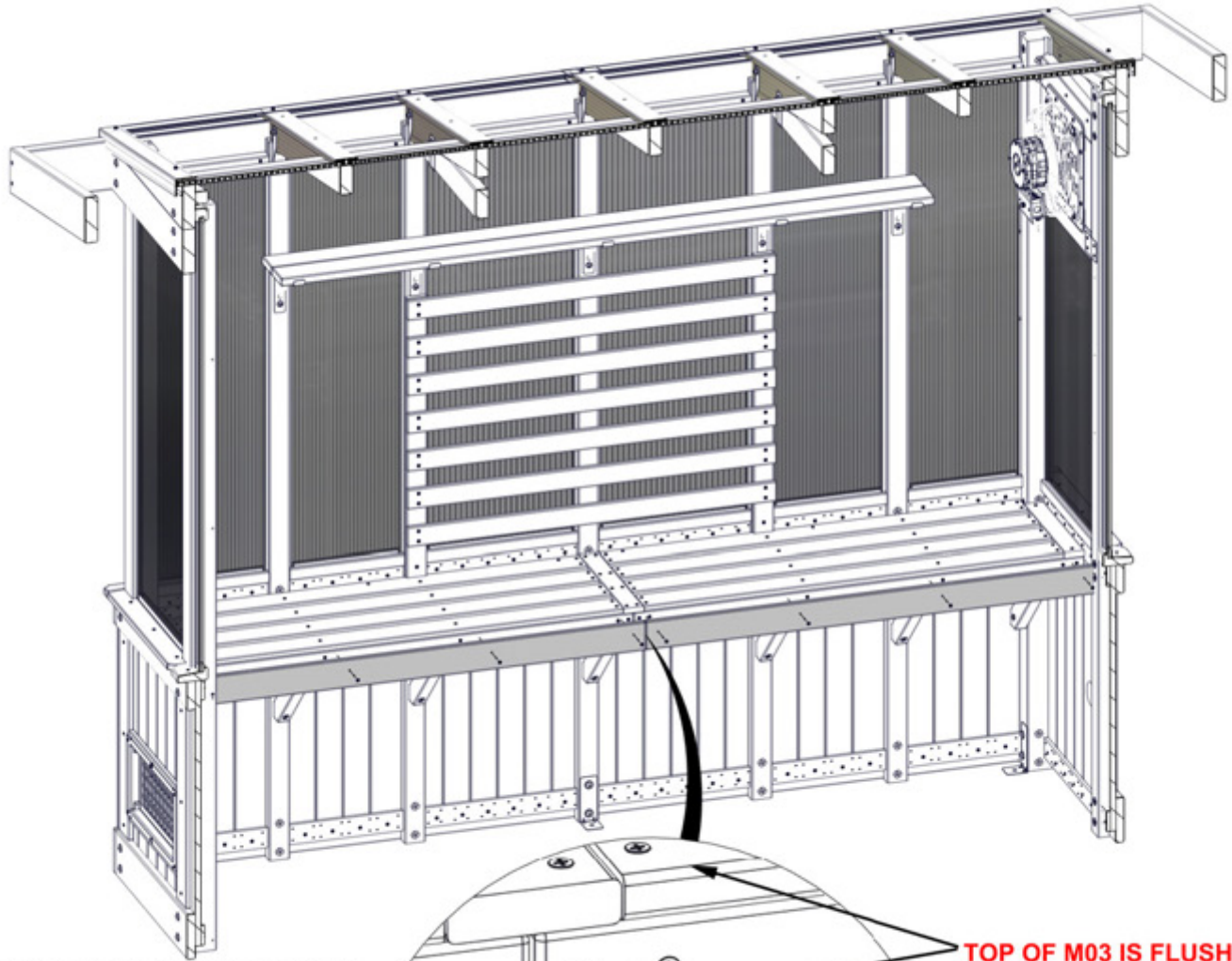

ONLY BACK OF GREENHOUSE  
SHOWN FOR DETAIL.

**TOP OF M03 IS FLUSH  
WITH TABLE TOP.**

M03 (x2)  
TABLE TRIM

200 (x8)  
SCREW - 1 1/2"

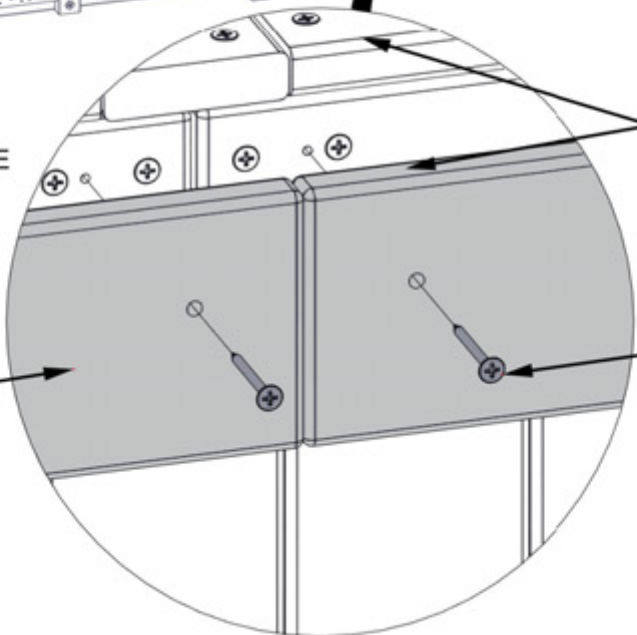

# STEP 118 - SHELF ASSEMBLY

QTY	PART NUMBER	DESCRIPTION
2	H100405	WASHER LOCK EXT 6x15
2	H100487	LAG SCREW WH 1/4x2 BLK

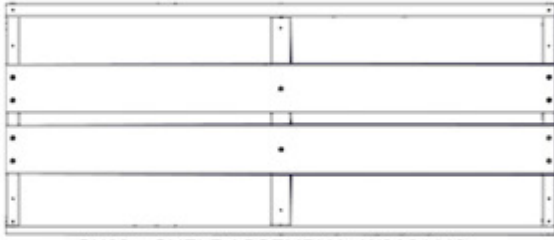

SH02 SHELF ASSEMBLY - W2A04446  
(x1) 3"x15 7/8"x37 13/16" (76x404x960)

ATTACH SHELF ASSEMBLY  
USING PILOT HOLES IN POSTS.

487 (x2)  
LAG SCREW - 2"

405 (x2)  
WASHER - 6x15

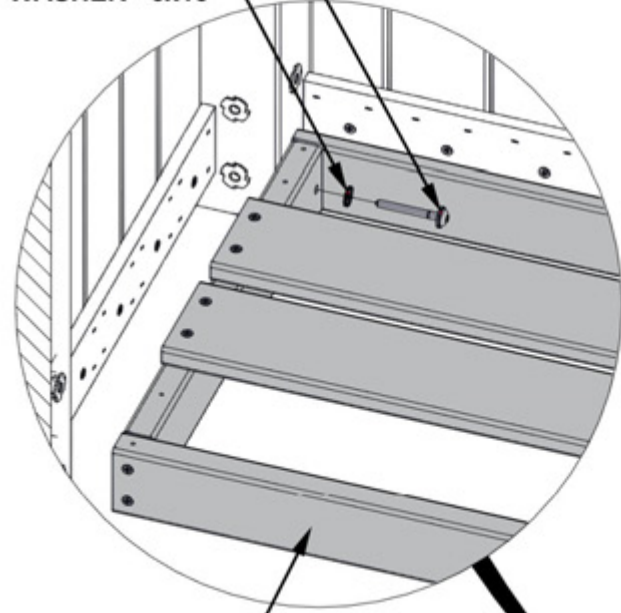

**THICKER BOARD  
ORIENTED TO THE FRONT.**

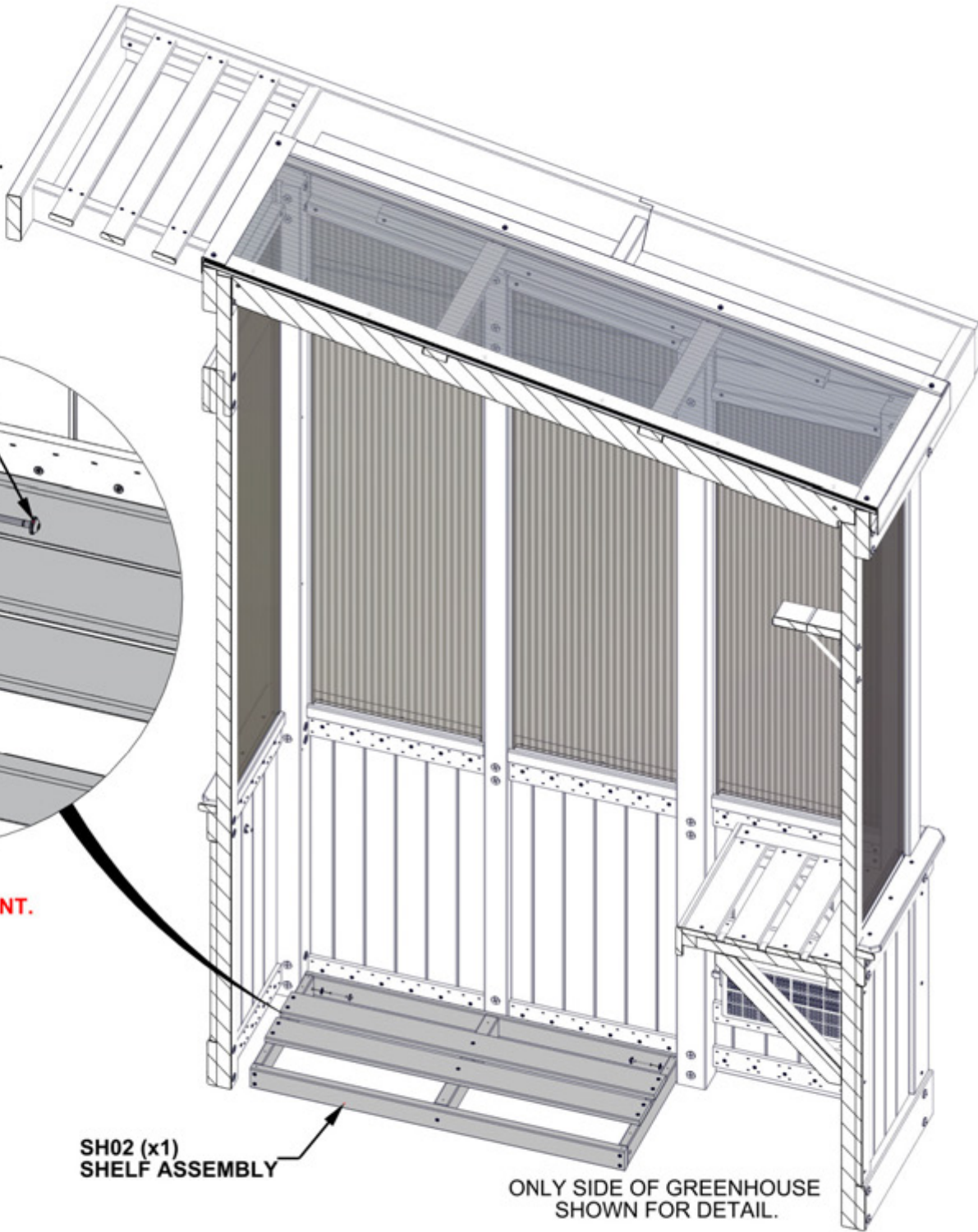

SH02 (x1)  
SHELF ASSEMBLY

ONLY SIDE OF GREENHOUSE  
SHOWN FOR DETAIL.

# STEP 119 - SHELF ASSEMBLY

QTY	PART NUMBER	DESCRIPTION
2	H100198	WASHER LOCK EXT 8x19
2	H100378	BOLT WH 5/16x1 3/4 BLK
5	H100379	T-NUT 5/16 BLK

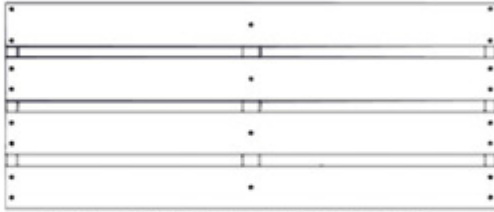

SH01 SHELF ASSEMBLY - W2A04437  
(x1) 3"x15 7/8"x37 13/16" (76x404x960)



J01 SHELF UPRIGHT - W4L20621  
(x2) 15/16"x2 3/8"x71 15/16" (24x60x1827)

- INSERT T-NUTS FIRST.
- SQUARE J01 TO SH01 AND FULLY TIGHTEN HARDWARE.

FLUSH WITH SHELF ASSEMBLY ON THE FRONT AND TOP.

379 (x5)  
T-NUT - 5/16"

THICKER FACE BOARD IS ORIENTED TO THE FRONT AS SHOWN.

378 (x2)  
BOLT - 1 3/4"

198 (x2)  
WASHER - 8x19

J01 (x2)  
SHELF UPRIGHT

SH01 (x1)  
SHELF ASSEMBLY

# STEP 120 - SHELF ASSEMBLY

- FULLY TIGHTEN ALL HARDWARE.
- ATTACH SHELF ASSEMBLY FROM STEP 119 USING PILOT HOLES IN POSTS.

QTY	PART NUMBER	DESCRIPTION
2	H100198	WASHER LOCK EXT 8x19
2	H100378	BOLT WH 5/16x1 3/4 BLK
1	H100379	T-NUT 5/16 BLK
2	H100405	WASHER LOCK EXT 6x15
2	H100487	LAG SCREW WH 1/4x2 BLK

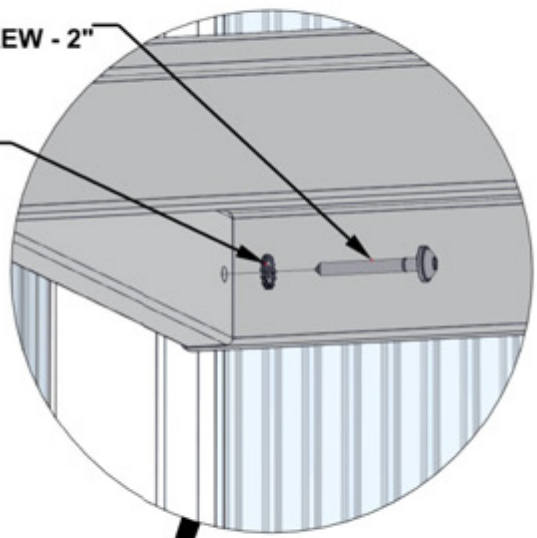
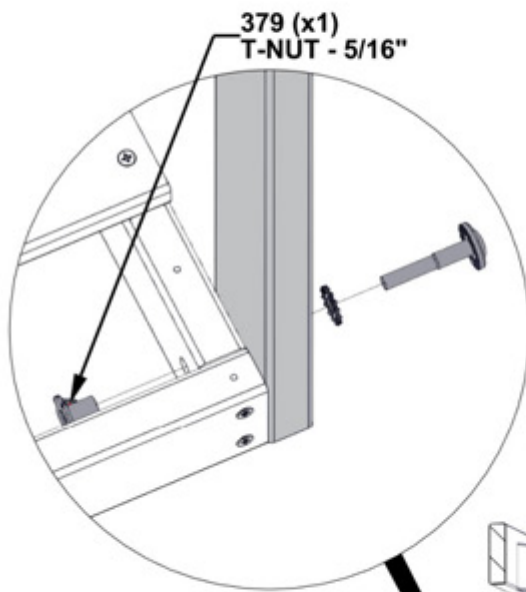

405 (x2)  
WASHER - 6x15

**INSTALL LAGS BEFORE  
OTHER HARDWARE.**

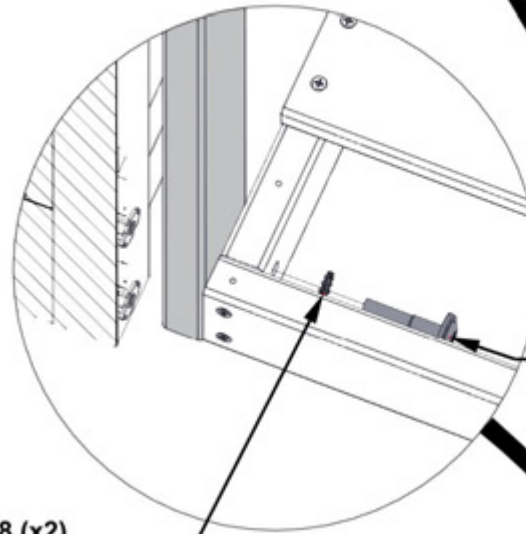

198 (x2)  
WASHER - 8x19

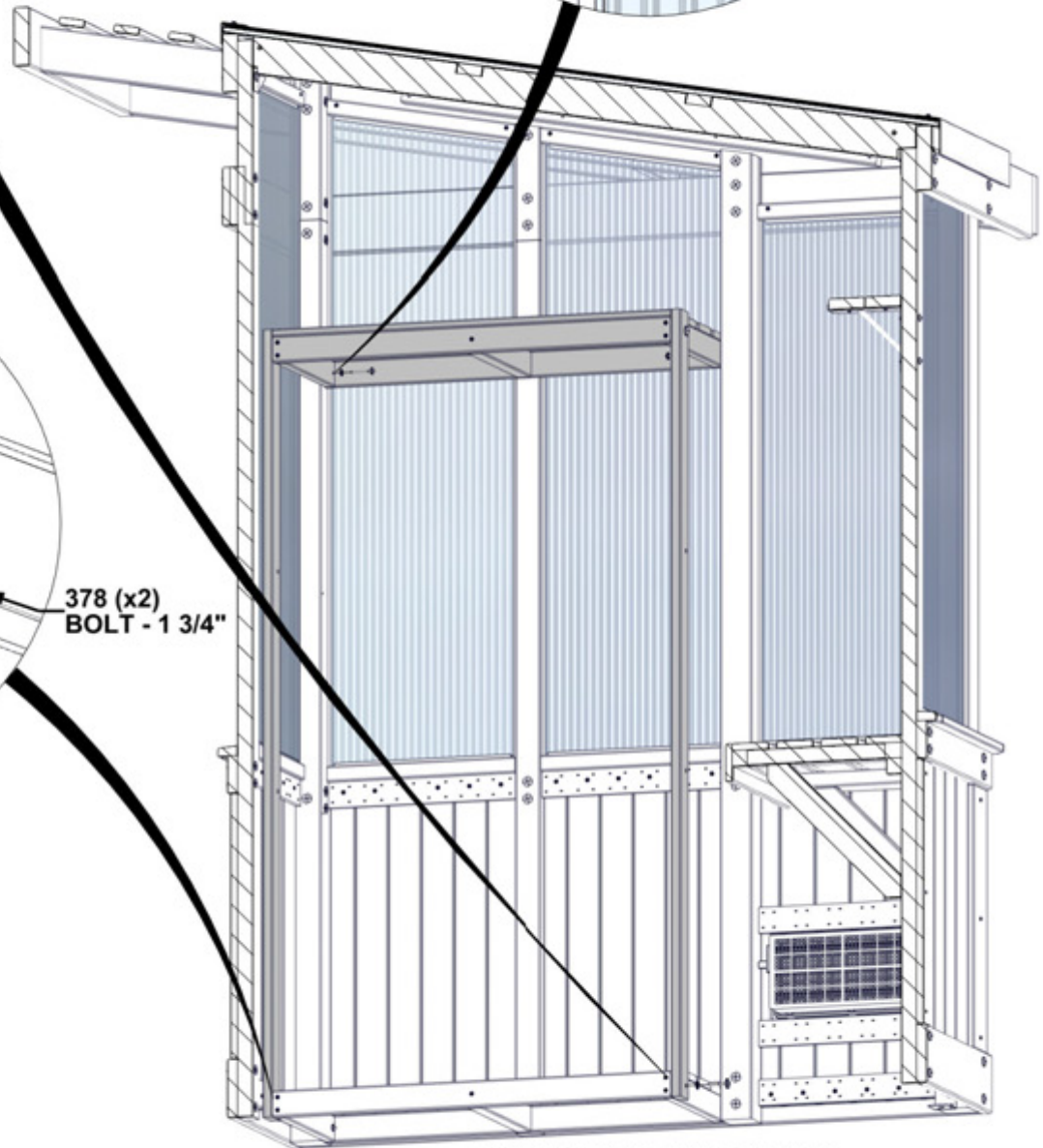

ONLY SIDE OF GREENHOUSE  
SHOWN FOR DETAIL.

# STEP 121 - SHELF ASSEMBLY

QTY	PART NUMBER	DESCRIPTION
10	H100380	SCREW PFH 8x1 1/8 BLK



M05 SHELF BOARD - W4L20752  
(x1) 5/8"x3 3/8"x37 13/16" (16x86x960)



M06 SHELF BOARD - W4L20753  
(x1) 5/8"x3 3/8"x37 13/16" (16x86x960)

- ALIGN PILOT HOLES.

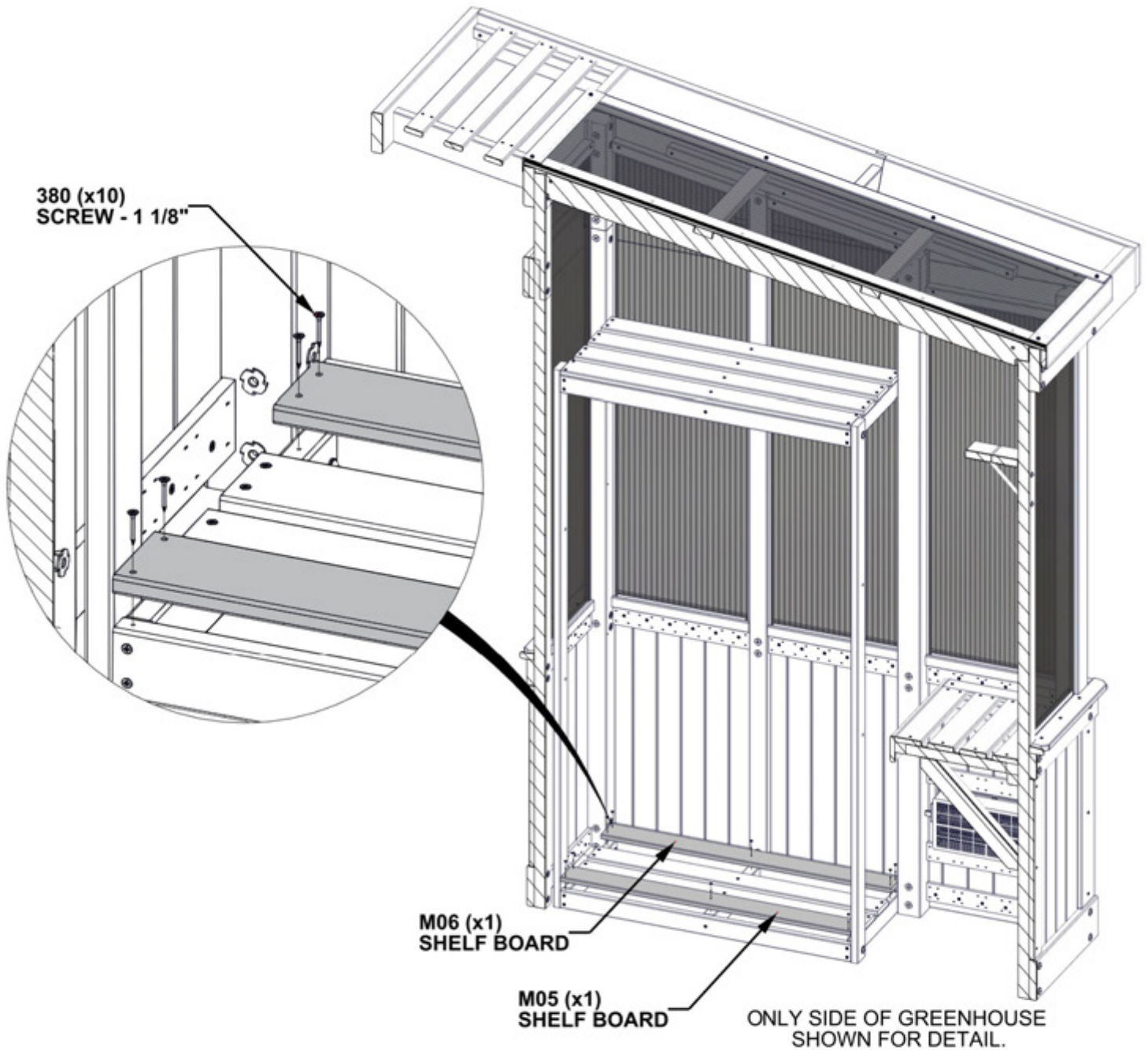

# STEP 122 - SHELF ASSEMBLY

QTY	PART NUMBER	DESCRIPTION
4	H100198	WASHER LOCK EXT 8x19
4	H100378	BOLT WH 5/16x1 3/4 BLK
2	H100379	T-NUT 5/16 BLK
4	H100405	WASHER LOCK EXT 6x15
4	H100487	LAG SCREW WH 1/4x2 BLK

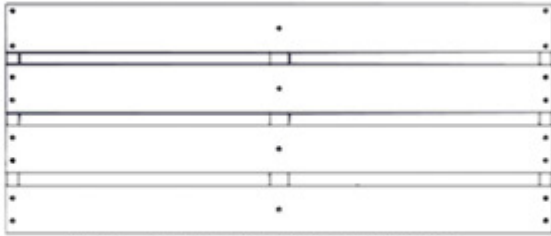

SH01 SHELF ASSEMBLY - W2A04437  
(x2) 3"x15 7/8"x37 13/16" (76x404x960)

- INSERT T-NUTS FIRST.
- INSTALL LAGS BEFORE OTHER HARDWARE.

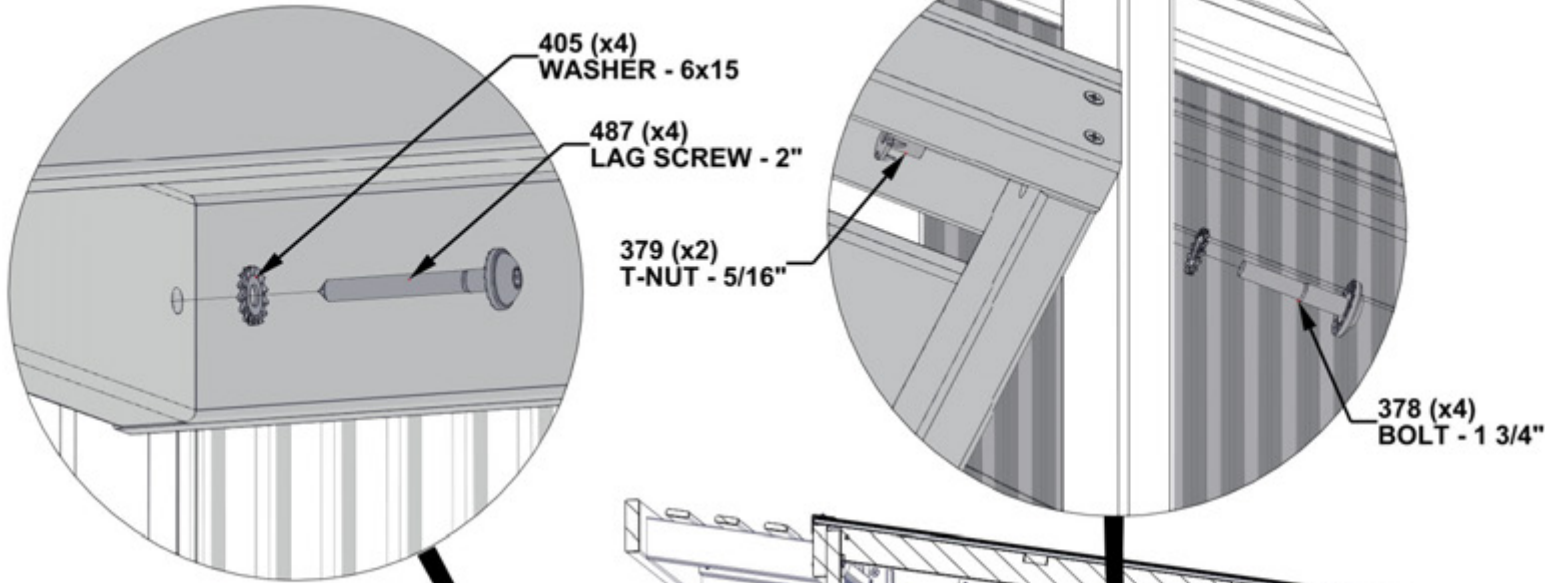

**THICKER FACE BOARD IS ORIENTED TO THE FRONT AS SHOWN.**

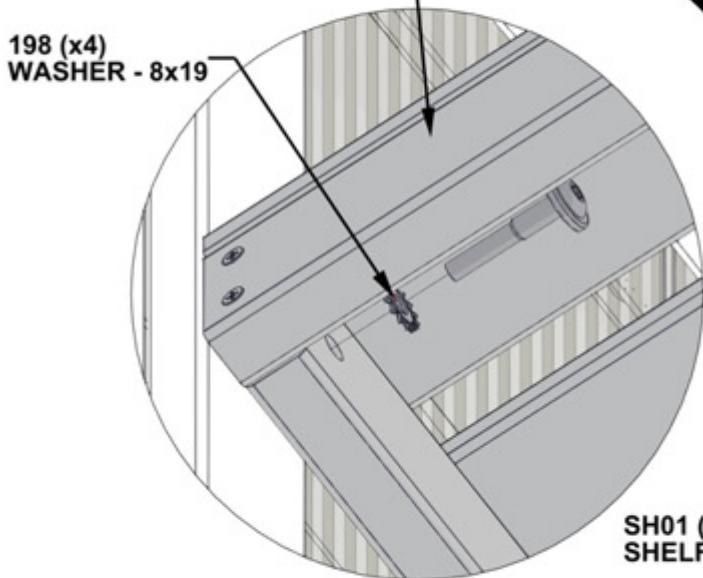

SH01 (x2) SHELF ASSEMBLY

ONLY SIDE OF GREENHOUSE SHOWN FOR DETAIL.

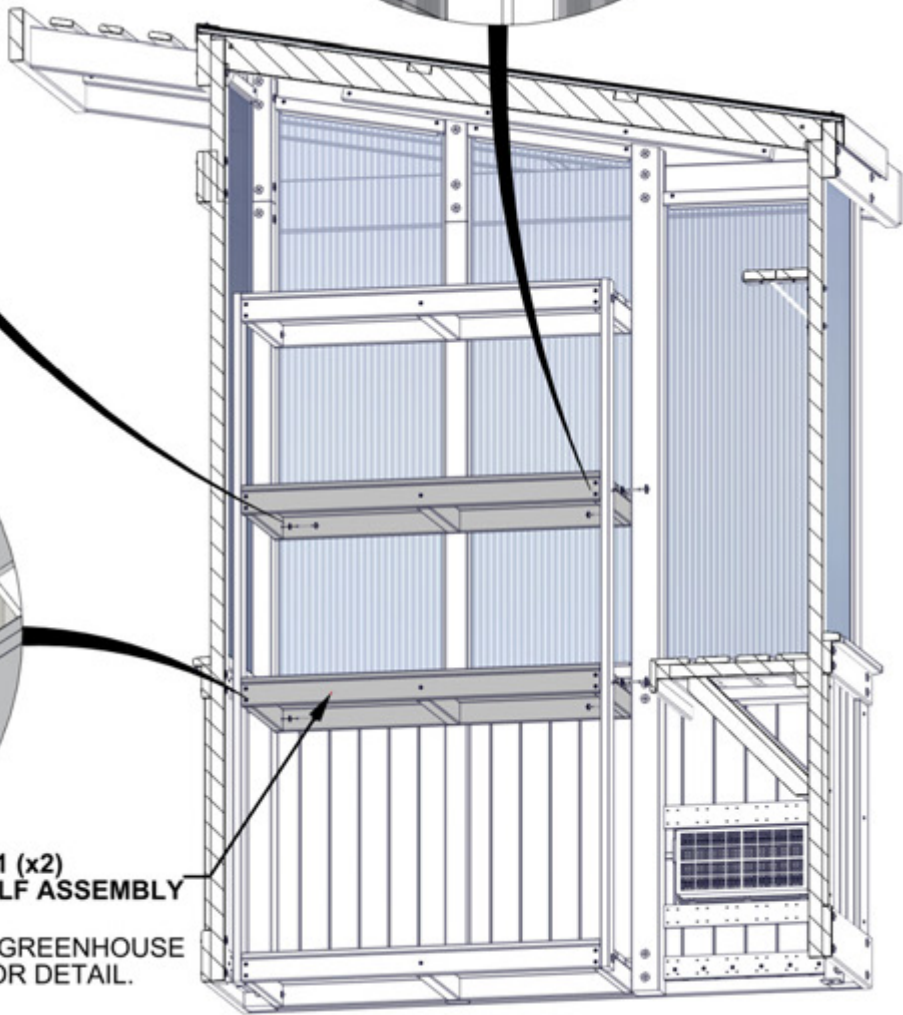

# STEP 123 - ELECTRICAL ENCLOSURE MOUNTING

QTY	PART NUMBER	DESCRIPTION
3	H100391	SCREW PFH 8x2 BLK

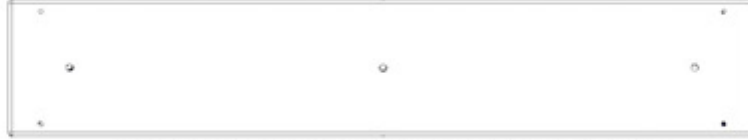

AD01 ELECTRICAL ENCLOSURE BOARD - W4L20755  
(x1) 15/16"x4"x22 1/16" (24x102x560)

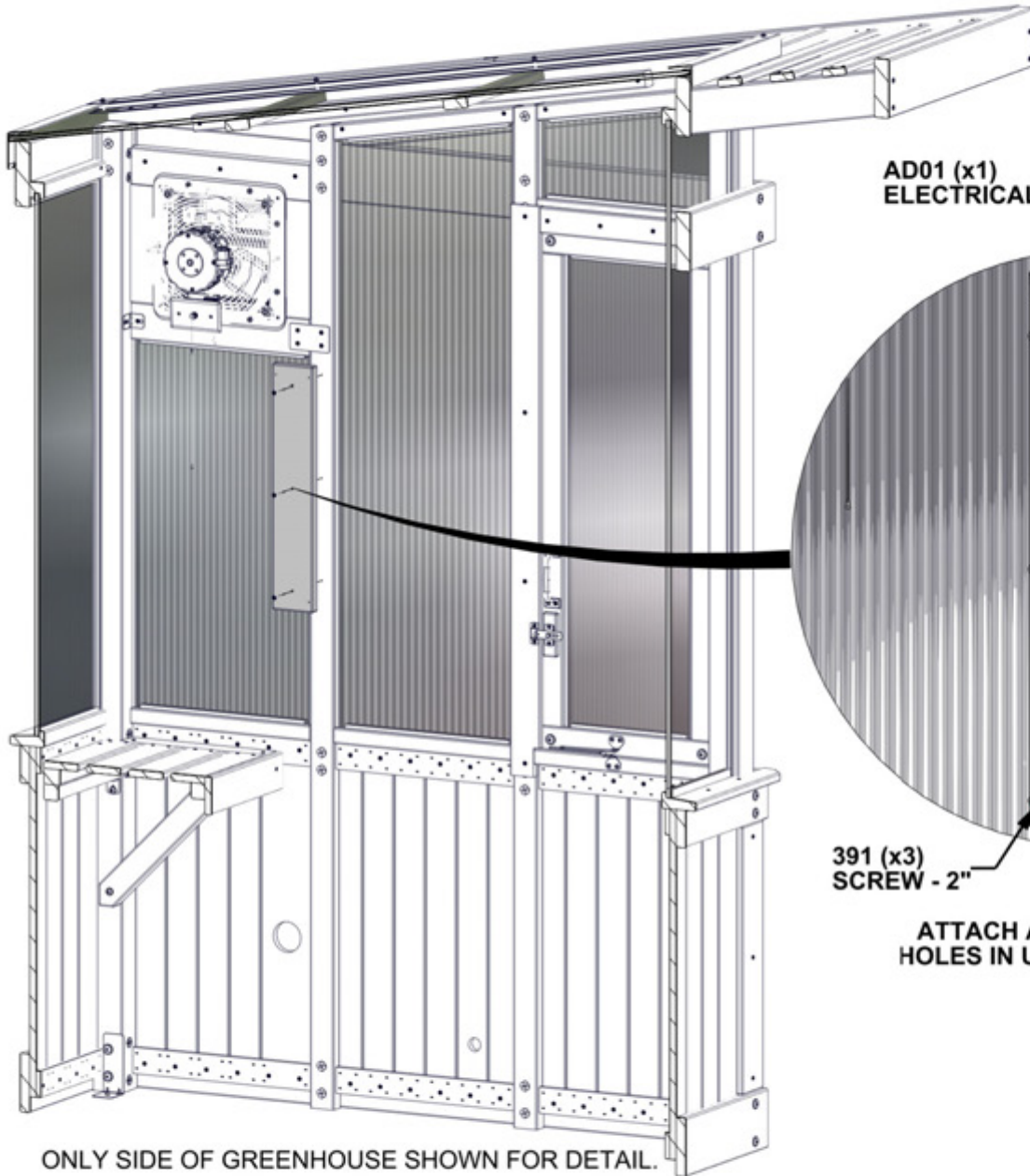

AD01 (x1)  
ELECTRICAL ENCLOSURE BOARD

391 (x3)  
SCREW - 2"

ATTACH AD01 USING PILOT HOLES IN UPRIGHT AS SHOWN.

ONLY SIDE OF GREENHOUSE SHOWN FOR DETAIL.

# STEP 124 - ELECTRICAL ENCLOSURE MOUNTING

QTY	PART NUMBER	DESCRIPTION
4	H100395	SCREW PFH 8x3/4 BLK

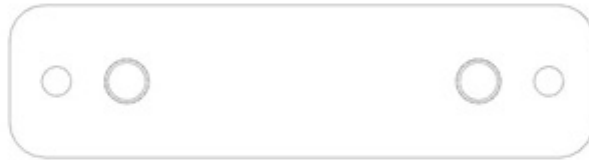

A4M01292 MOUNTING BRACKET  
(x2)

INCLUDED WITH THE ELECTRICAL ENCLOSURE

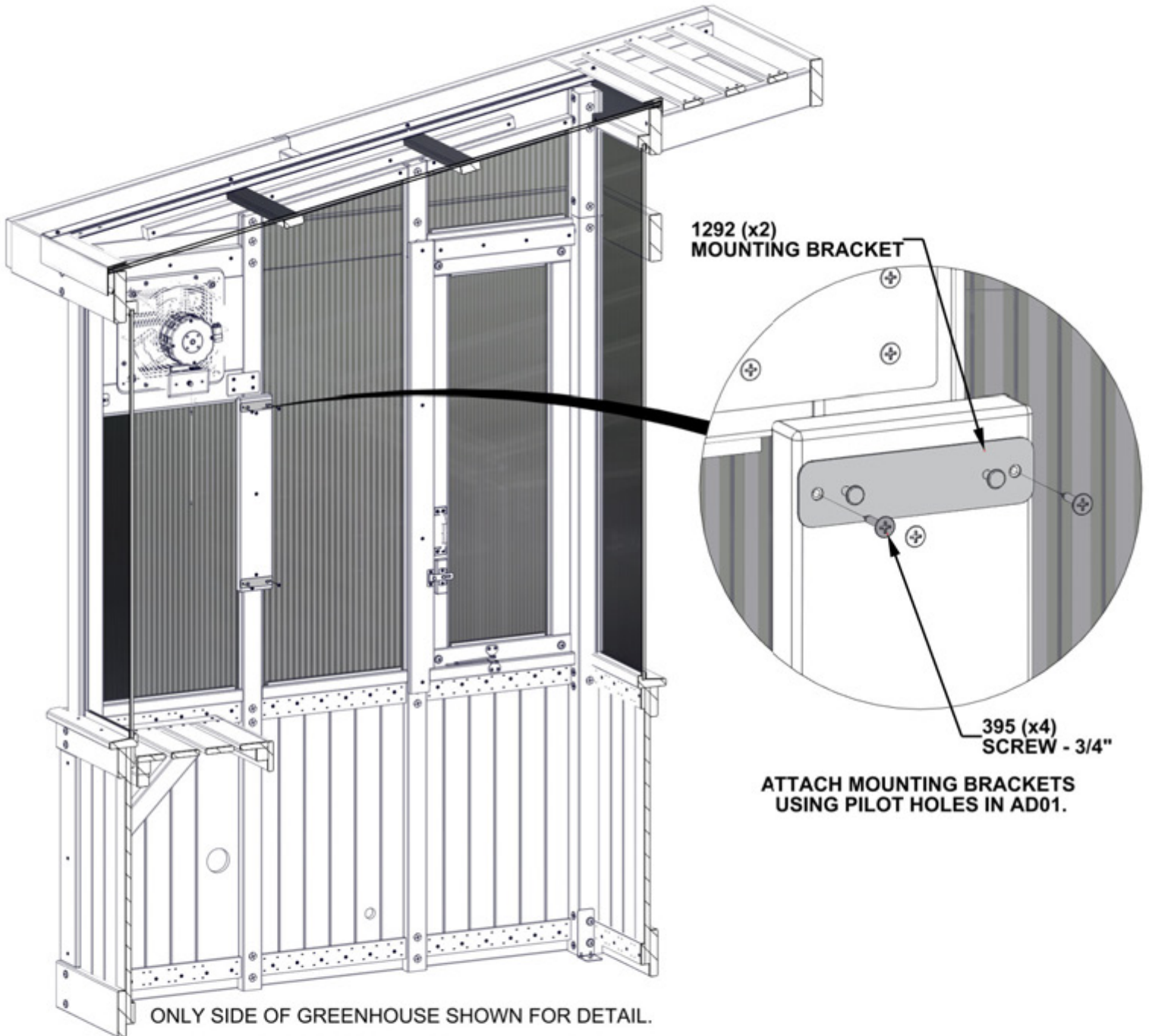

1292 (x2)  
MOUNTING BRACKET

395 (x4)  
SCREW - 3/4"

ATTACH MOUNTING BRACKETS  
USING PILOT HOLES IN AD01.

ONLY SIDE OF GREENHOUSE SHOWN FOR DETAIL.

# STEP 125 - ELECTRICAL ENCLOSURE MOUNTING



- HANG ELECTRICAL ENCLOSURE ON THE MOUNTING BRACKETS.

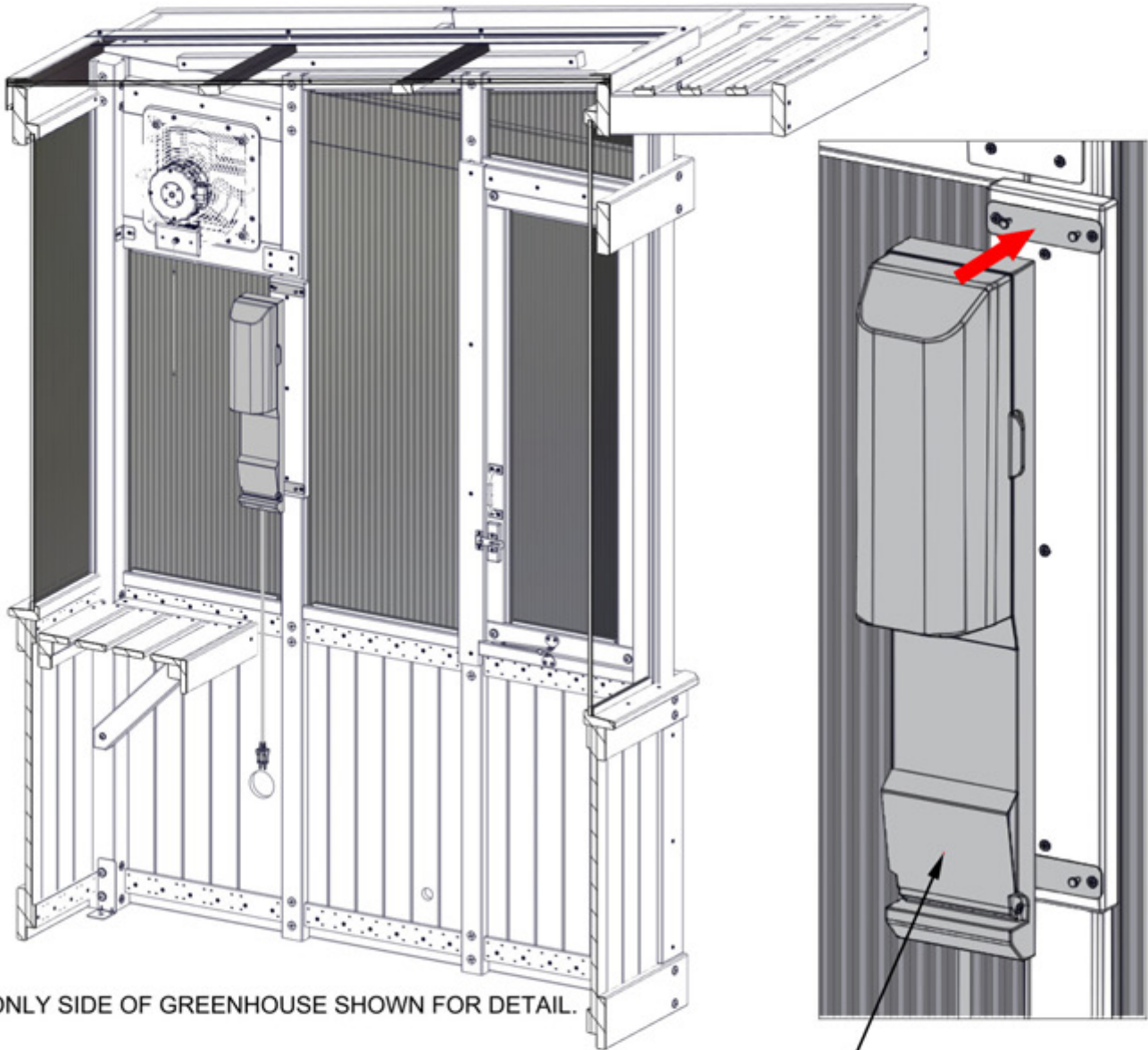

5413 (x1)  
ELECTRICAL ENCLOSURE

# STEP 126 - THERMOSTAT MOUNTING

QTY	PART NUMBER	DESCRIPTION
1	H100200	SCREW PFH 8x1 1/2 BLK



- LOCATE THERMOSTAT IN A DESIRED LOCATION CLOSE TO THE ELECTRICAL ENCLOSURE.
- INSTALL SCREW LEAVING IT PARTIALLY STICKING OUT AND HANG THERMOSTAT.
- HANG THE PROBE IN AN ELEVATED LOCATION.
- SEE THERMOSTAT MANUAL FOR OPERATING INSTRUCTIONS.

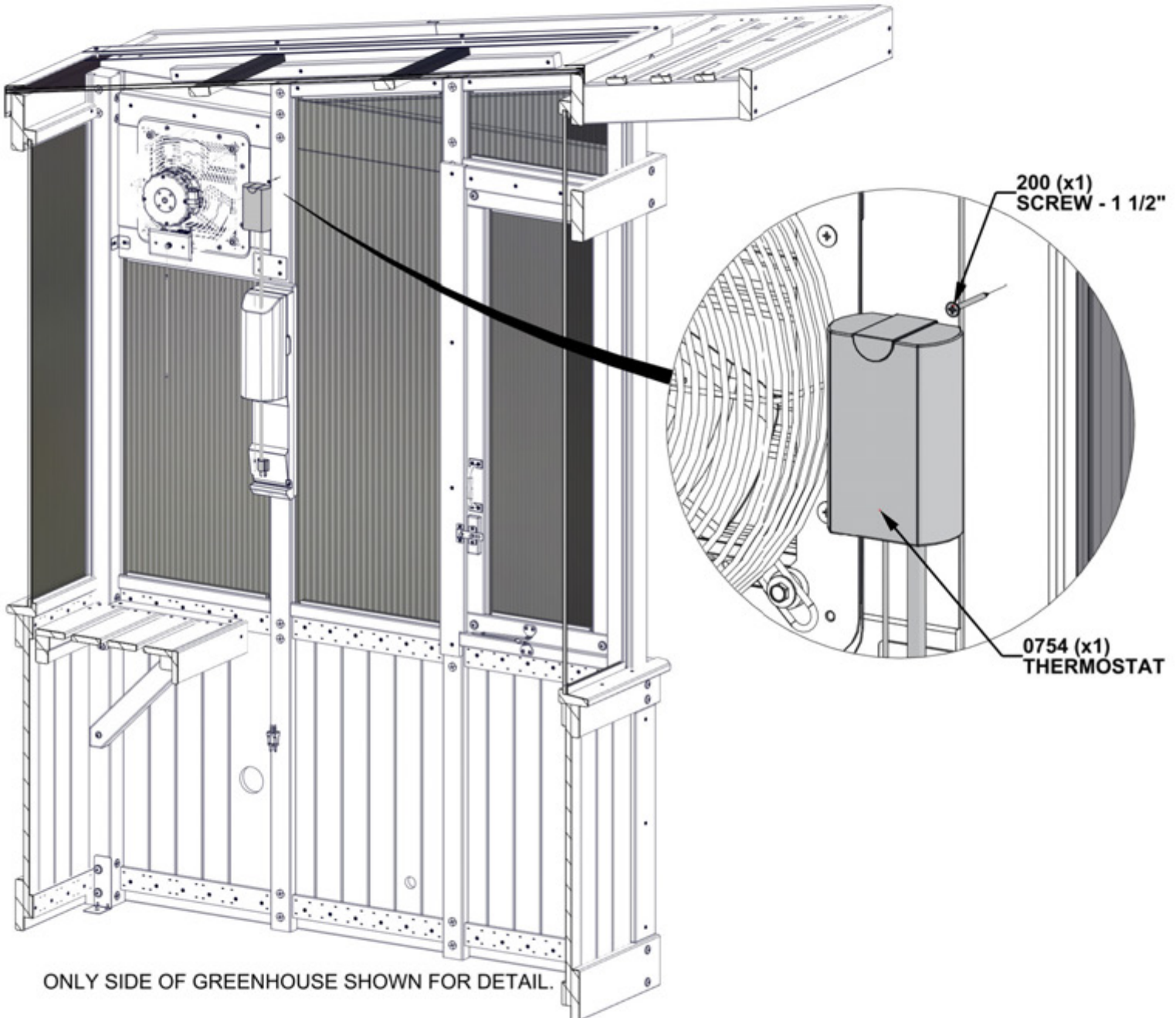

# STEP 127 - DOOR ASSEMBLY

QTY	PART NUMBER	DESCRIPTION
12	H100385	SCREW PFH 8x1 BLK

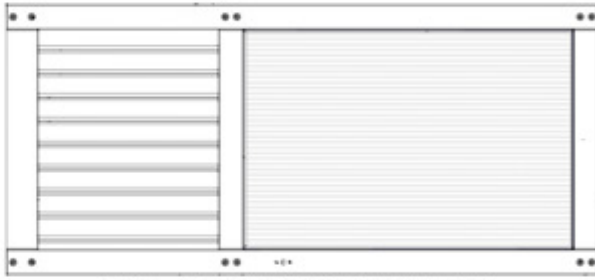

DA01 DOOR ASSEMBLY - W2A04009  
(x1) 1 7/8"x36 9/16"x80" (48x928x2032)

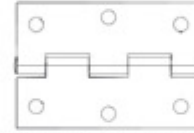

A4M00557 HINGE ASSEMBLY  
(x4)

**ALIGN PILOT HOLES IN HINGES WITH PILOT HOLES ON DOOR.**

DA01 (x1)  
DOOR ASSEMBLY

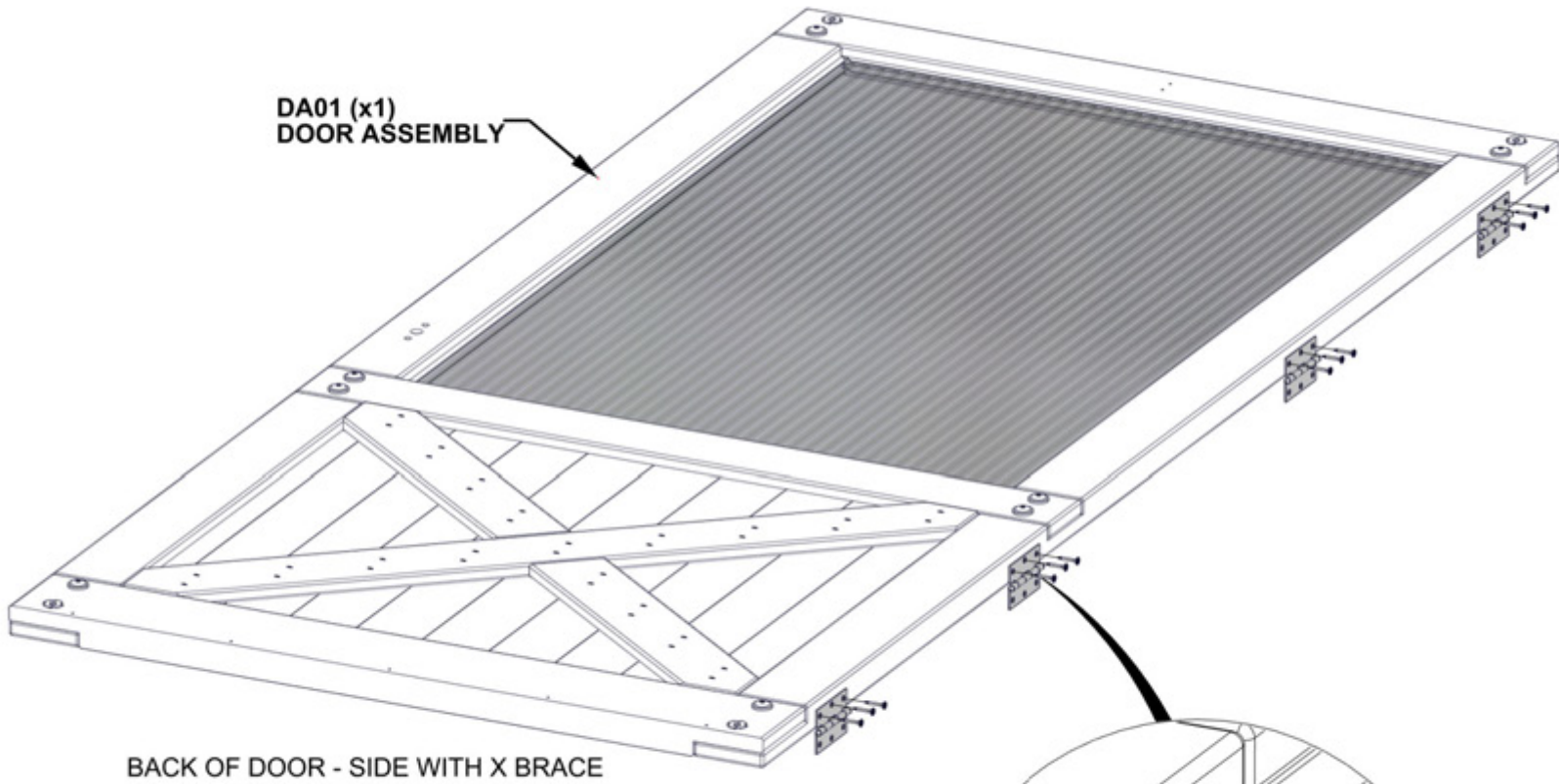

BACK OF DOOR - SIDE WITH X BRACE

**WITH THE DOOR LAYING WITH THE BACK FACING UP AS SHOWN, ATTACH HINGES. CORRECT ORIENTATION OF HINGES IS CRITICAL.**

0557 (x4)  
HINGE ASSEMBLY

**NOTE DIRECTION OF BARREL ON HINGES.**

385 (x12)  
SCREW - 1"

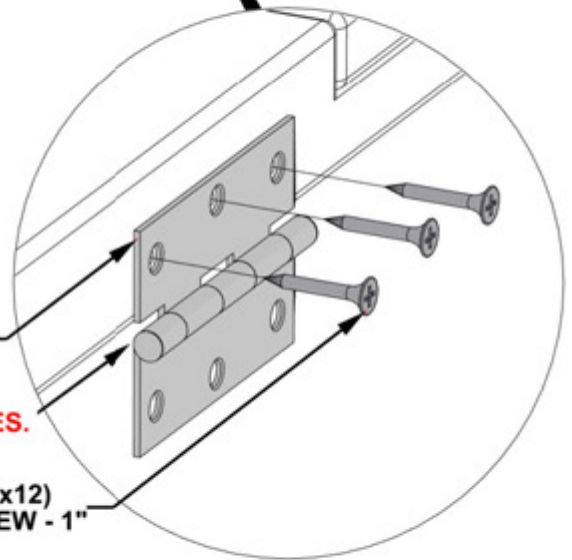

# STEP 128 - DOOR ASSEMBLY

QTY	PART NUMBER	DESCRIPTION
12	H100385	SCREW PFH 8x1 BLK

385 (x12)  
SCREW - 1"

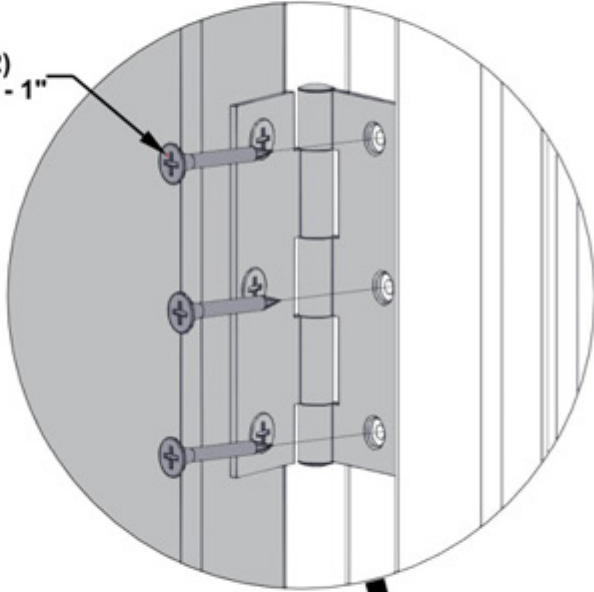

LIFT DOOR INTO PLACE AND ATTACH AS SHOWN.

**ALIGN HOLES IN HINGES WITH  
PILOT HOLES IN DOOR FRAME.**

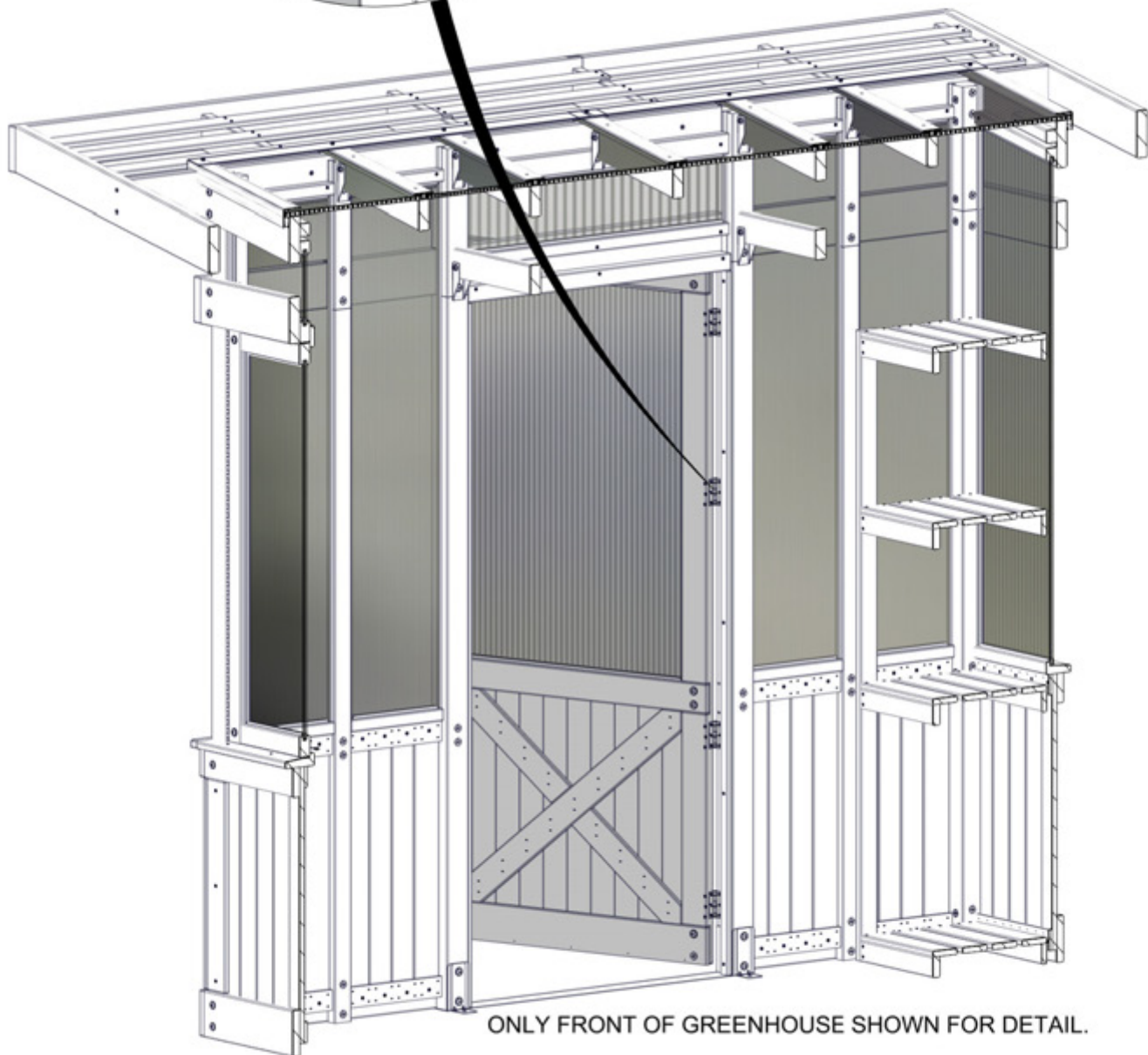

ONLY FRONT OF GREENHOUSE SHOWN FOR DETAIL.

# STEP 129 - DOOR ASSEMBLY

QTY	PART NUMBER	DESCRIPTION
2	H101259	SCREW POH 8x1 3/4 SS

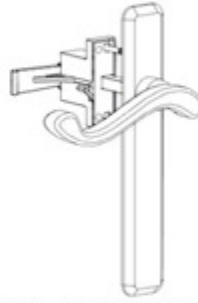

A4M02410 STORM DOOR HANDLE  
(x1)

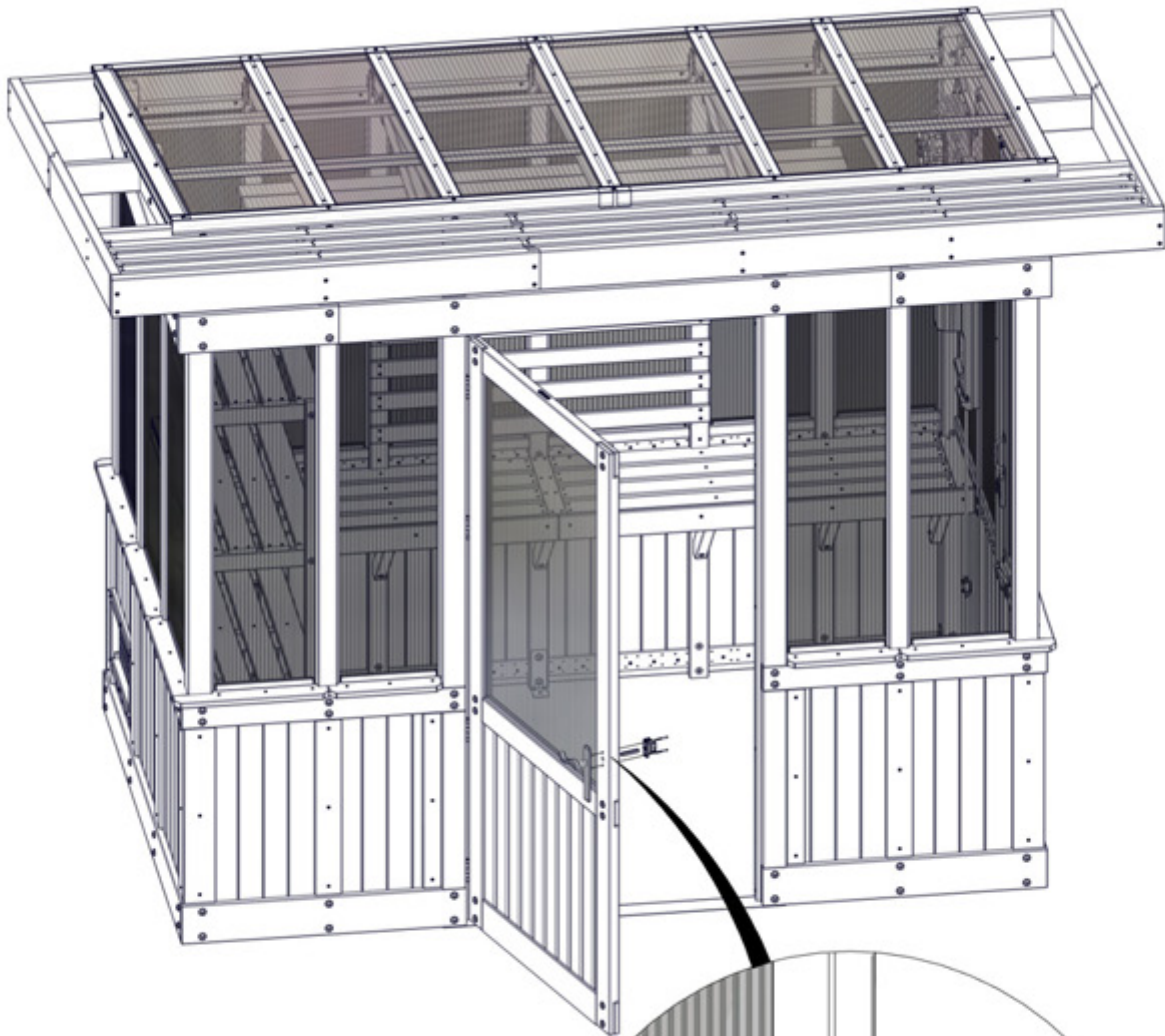

ENSURE CORRECT ORIENTATION  
OF DOOR HANDLE AS SHOWN.

**USE SCREWDRIVER.  
DO NOT OVERTIGHTEN.**

2410 (x1)  
STORM DOOR HANDLE

1259 (x2)  
SCREW - 1 3/4"

# STEP 130 - DOOR ASSEMBLY

QTY	PART NUMBER	DESCRIPTION
2	H101260	SCREW PRH 8x1 1/4 BLK



A4M02410 STORM DOOR HANDLE LATCH  
(x1)

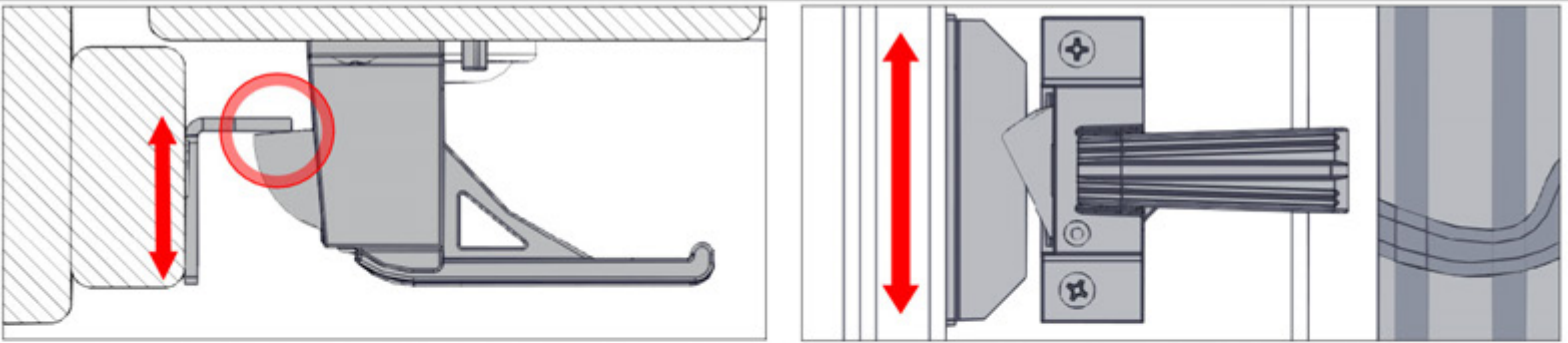

**WITH THE DOOR SHUT, POSITION THE DOOR LATCH AS SHOWN. ADJUST FRONT TO BACK TO ENSURE THE LATCH MAKES CONTACT. ADJUST UP AND DOWN TO ENSURE THE LATCH IS CENTERED WITH THE HANDLE. MARK THE SLOTTED HOLE LOCATIONS AND PRE-DRILL WITH AN 1/8" [3mm] DRILL BIT.**

1260 (x2)  
SCREW - 1 1/4"

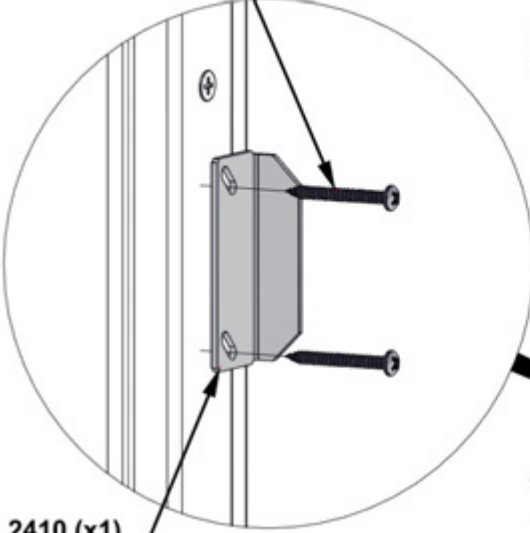

2410 (x1)  
LATCH

ATTACH USING PILOT HOLES.

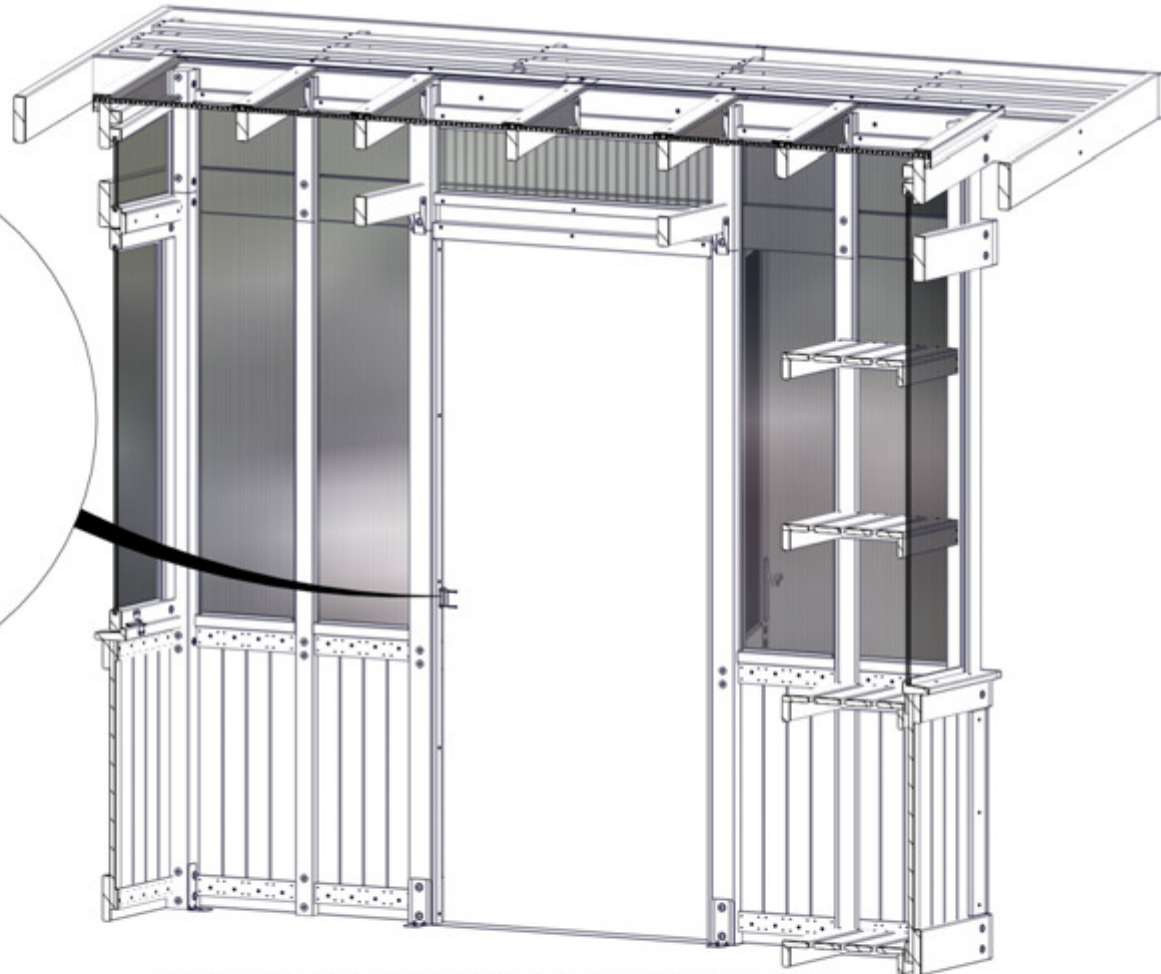

ONLY FRONT OF GREENHOUSE SHOWN FOR DETAIL.

# STEP 131 - DOOR ASSEMBLY

QTY	PART NUMBER	DESCRIPTION
5	H100202	SCREW PWH 8x5/8 BLK



A4M02532 DOOR SWEEP  
(x1)

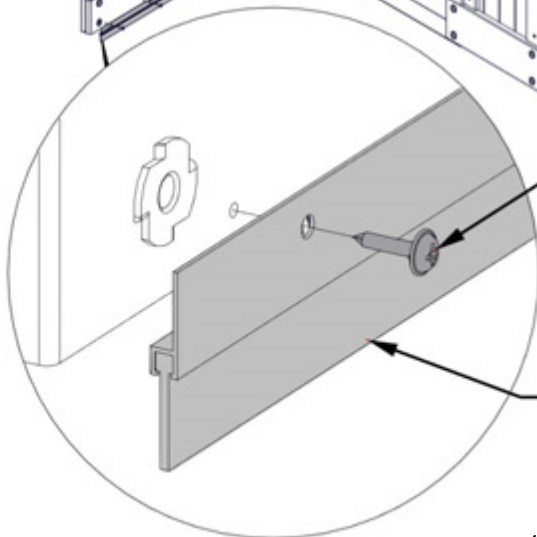

202 (x5)  
SCREW - 5/8"

ATTACH DOOR SWEEP USING PILOT  
HOLES IN DOOR ASSEMBLY AS SHOWN.

2532 (x1)  
DOOR SWEEP

# STEP 132 - DOOR ASSEMBLY

QTY	PART NUMBER	DESCRIPTION
4	H100392	SCREW PWH 8x3/4 BLK



A44M02411 DOOR PROTECTOR CHAIN  
(x1)

ATTACH DOOR CHAIN IN APPROXIMATE LOCATION AS SHOWN.

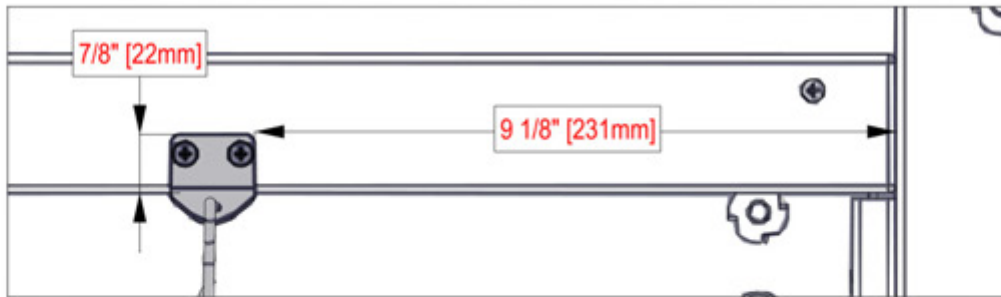

2411 (x1)  
DOOR PROTECTOR CHAIN

392 (x4)  
SCREW - 3/4"

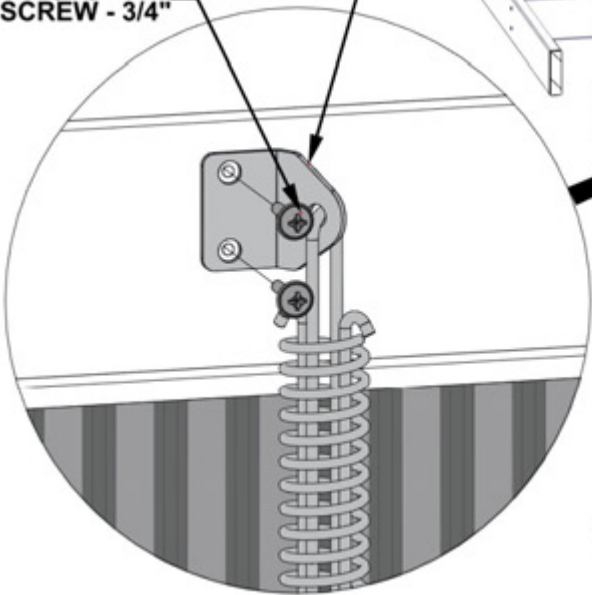

ATTACH SPRING SIDE OF BRACKET TO  
DOOR USING PILOT HOLES AS SHOWN.

ONCE DOOR CHAIN IS ATTACHED,  
ADJUST CHAIN LENGTH AS DESIRED.

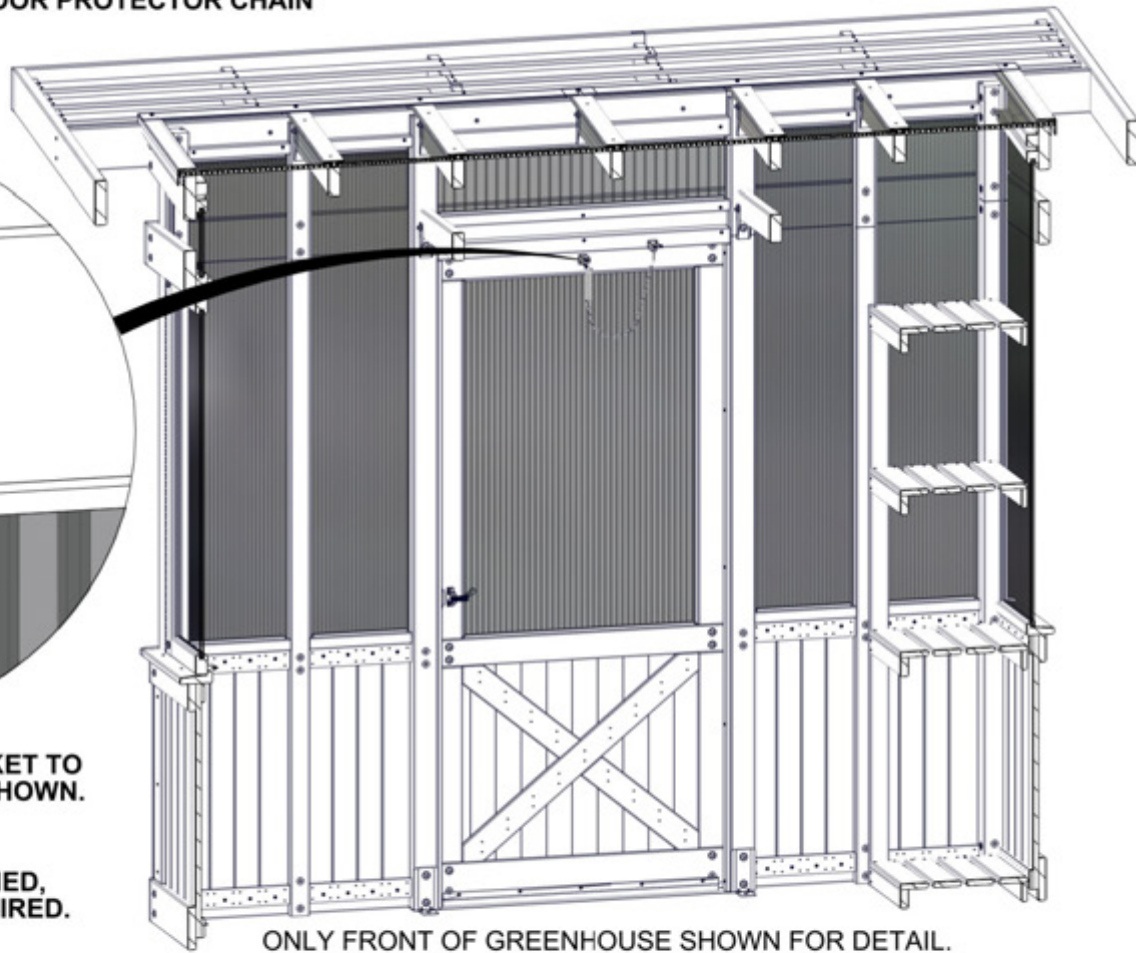

ONLY FRONT OF GREENHOUSE SHOWN FOR DETAIL.

# STEP 133 - CORD GROMMET INSTALLATION



A6P00692 CORD GROMMET  
(x1)

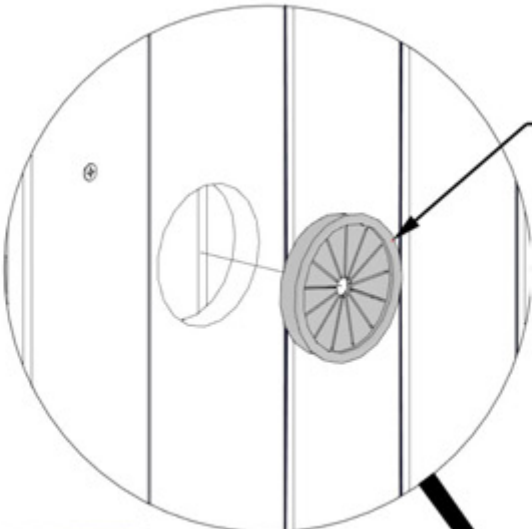

0692 (x1)  
CORD GROMMET

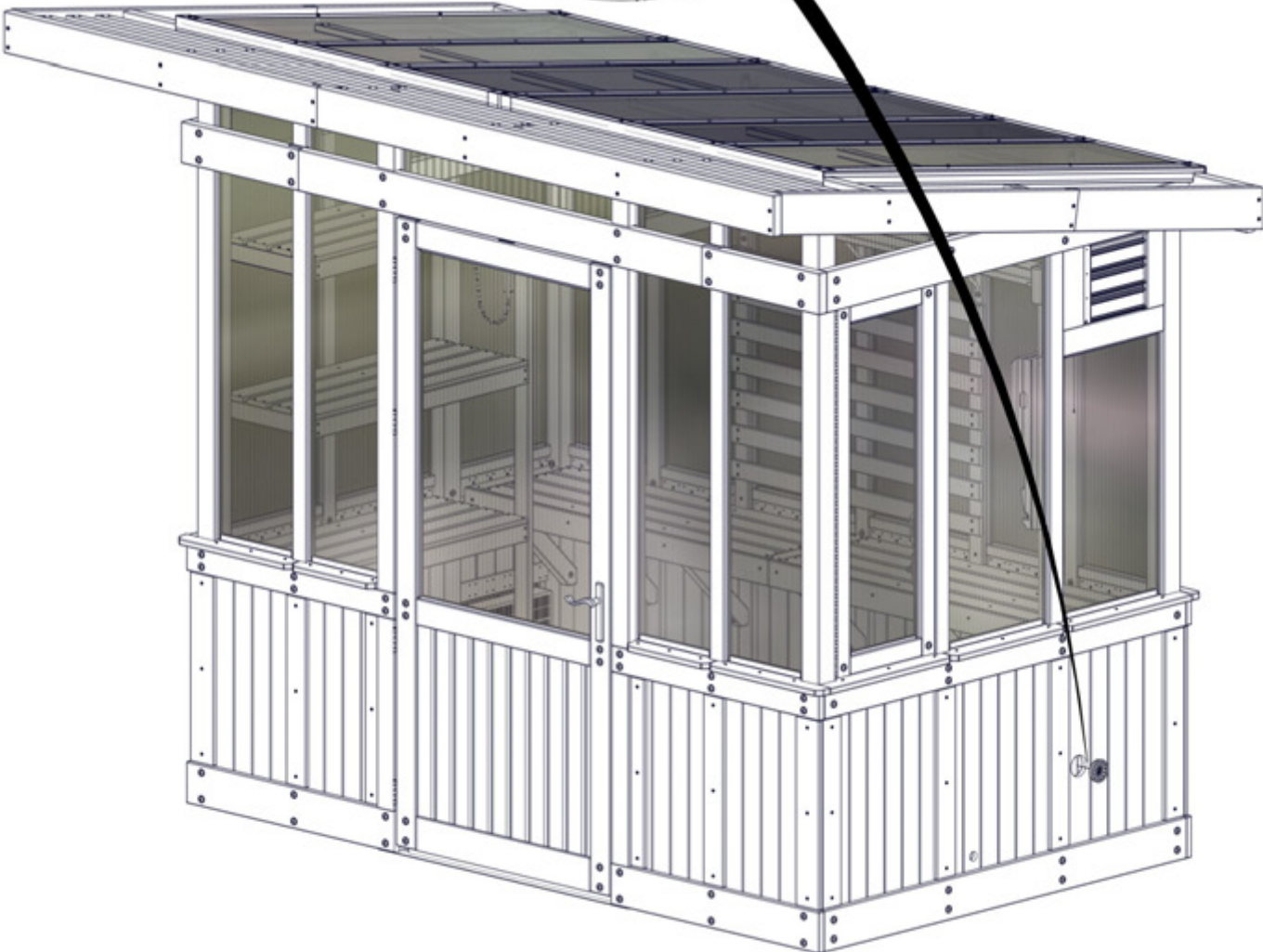

# STEP 134 - PLANT HOOK INSTALLATION



A4M01591 HOOK  
(x4)

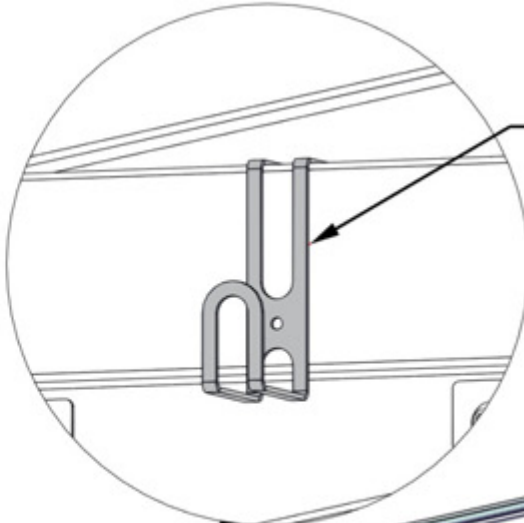

591 (x4)  
HOOK

HANG PLANT HOOKS ON INTERIOR  
RAFTERS OR ON EXTERIOR  
PERGOLA WHERE DESIRED.

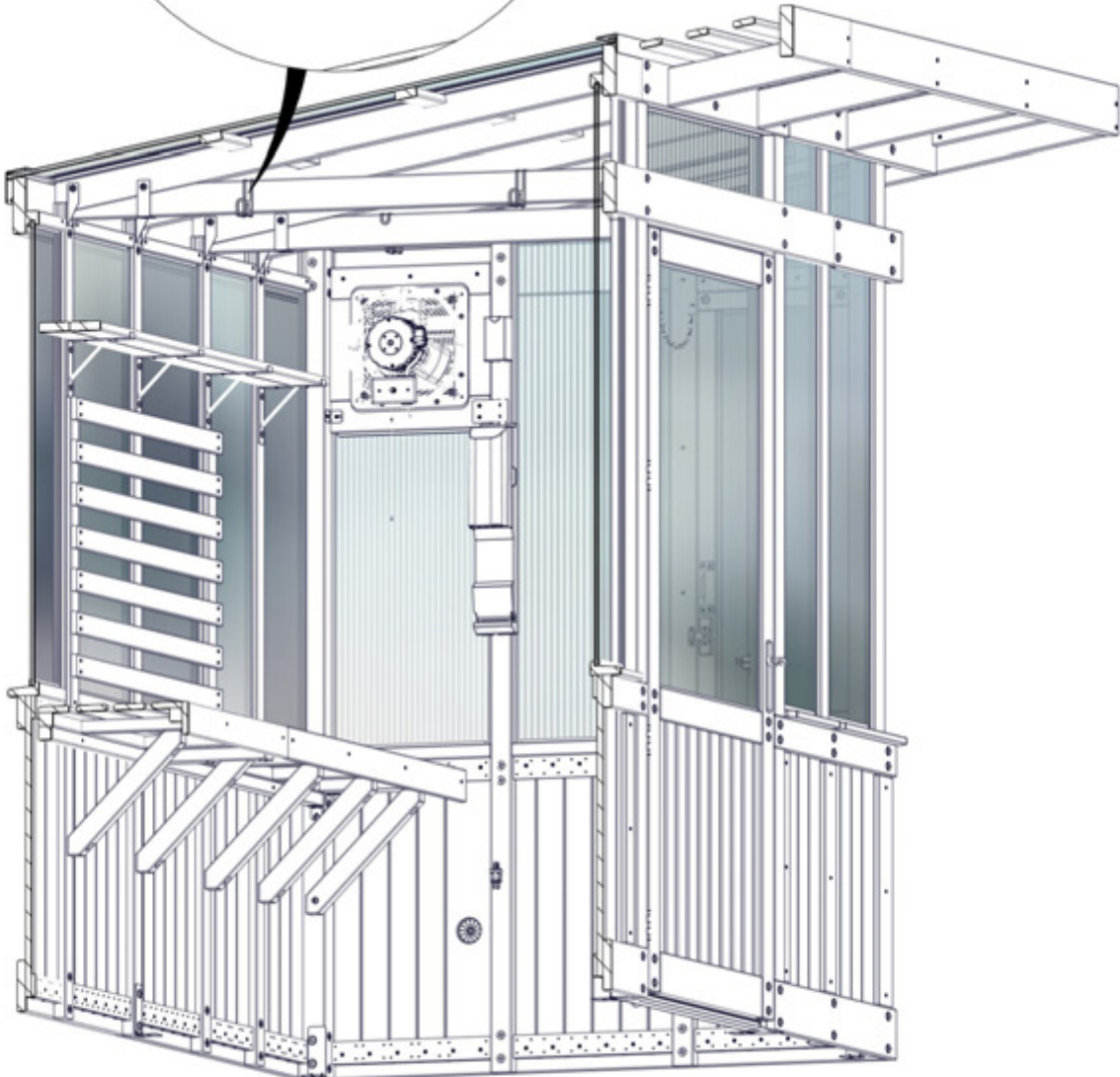

SIDE OF GREENHOUSE HIDDEN FOR DETAIL.

# STEP 135 - HOSE HANGER ASSEMBLY

QTY	PART NUMBER	DESCRIPTION
2	H100387	SCREW PFH 8x1 1/4 BLK

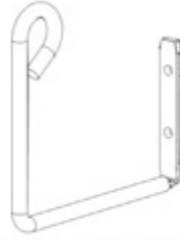

A4M03473 HOSE HANGER  
(x1)

- CENTER HOSE HANGER ON UPRIGHT AND ATTACH APPROXIMATELY 4 1/2" BELOW WINDOW TRIM, OR IN DESIRED LOCATION.

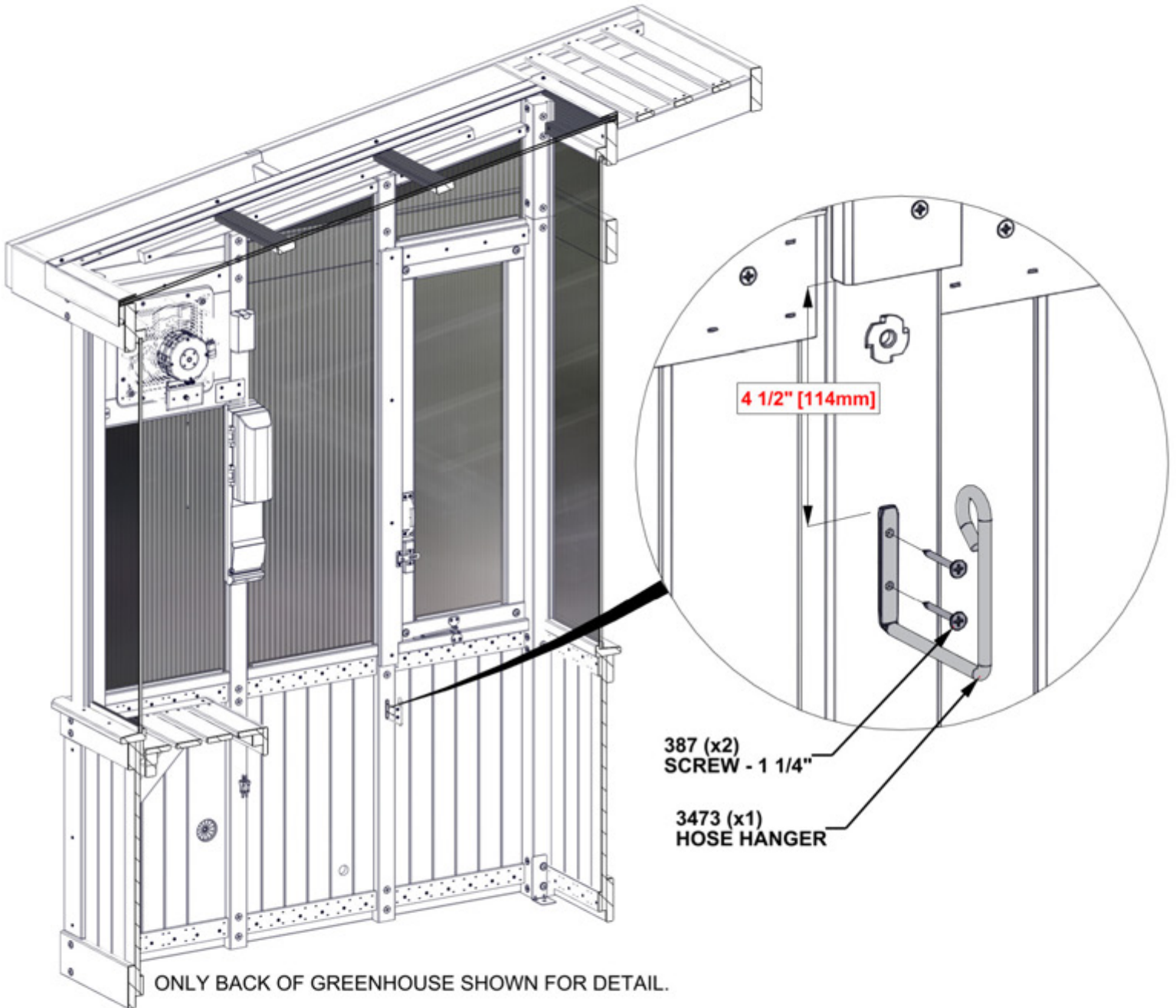

# STEP 136 - WATER LINE ASSEMBLY

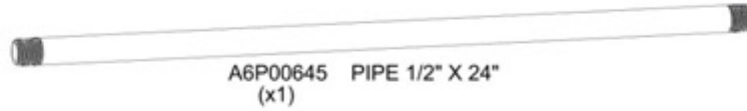

- USE PLUMBERS TAPE AND WRAP THREADS OF MALE FITTINGS.
- FASTEN FITTINGS TO FORM THE COMPLETED WATER LINE ASSEMBLY BELOW.

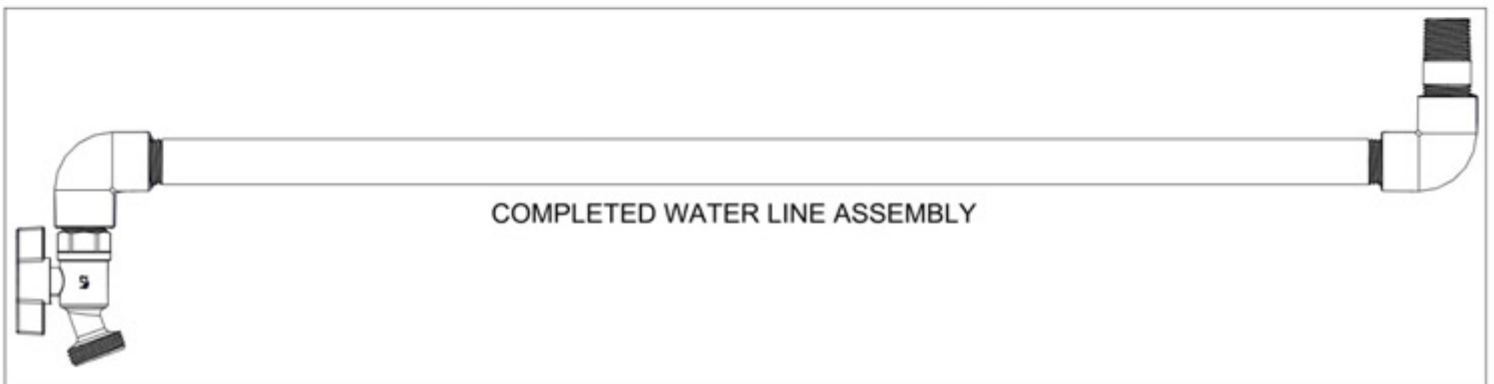
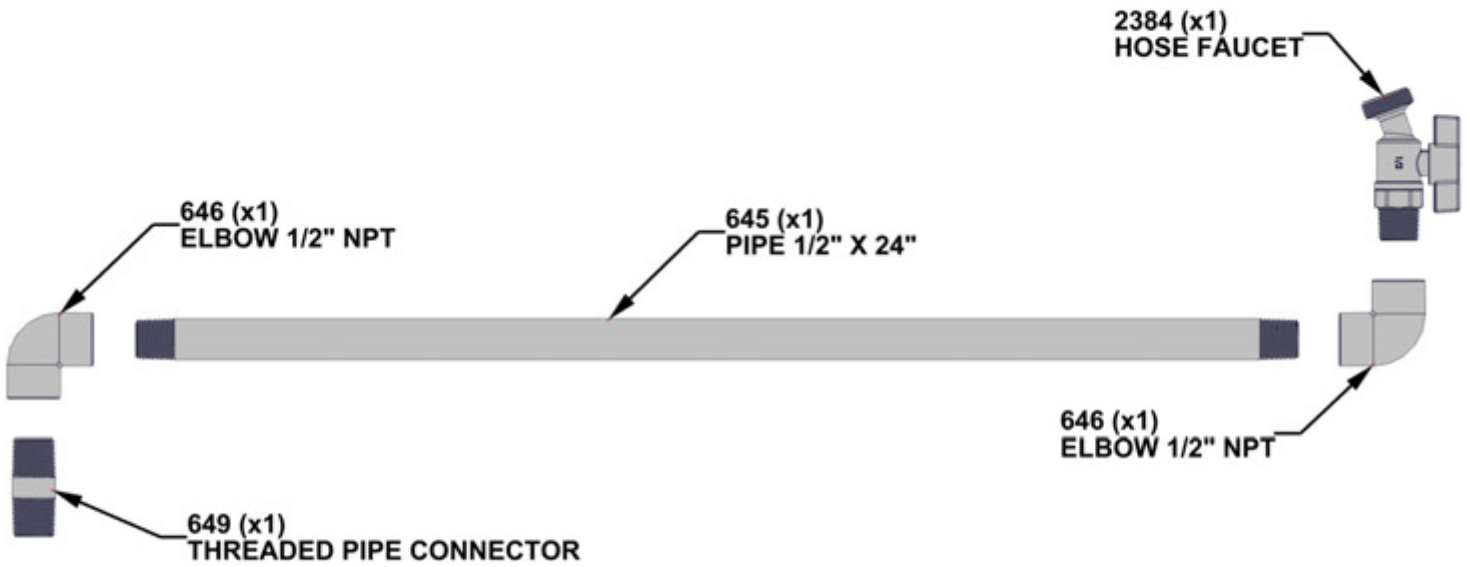

# STEP 137 - WATER LINE ASSEMBLY

QTY	PART NUMBER	DESCRIPTION
4	H100380	SCREW PFH 8x1 1/8 BLK



M04 SPIGOT BOARD - W4L20640  
(x1) 5/8"x3 3/8"x17 11/16" (16x86x450)

- USE THE DIMENSION SHOWN TO LOCATE SPIGOT BOARD.
- USE THE SPIGOT BOARD AS A GUIDE TO DRILL PILOT HOLES WITH AN 1/8" [3mm] DRILL BIT.

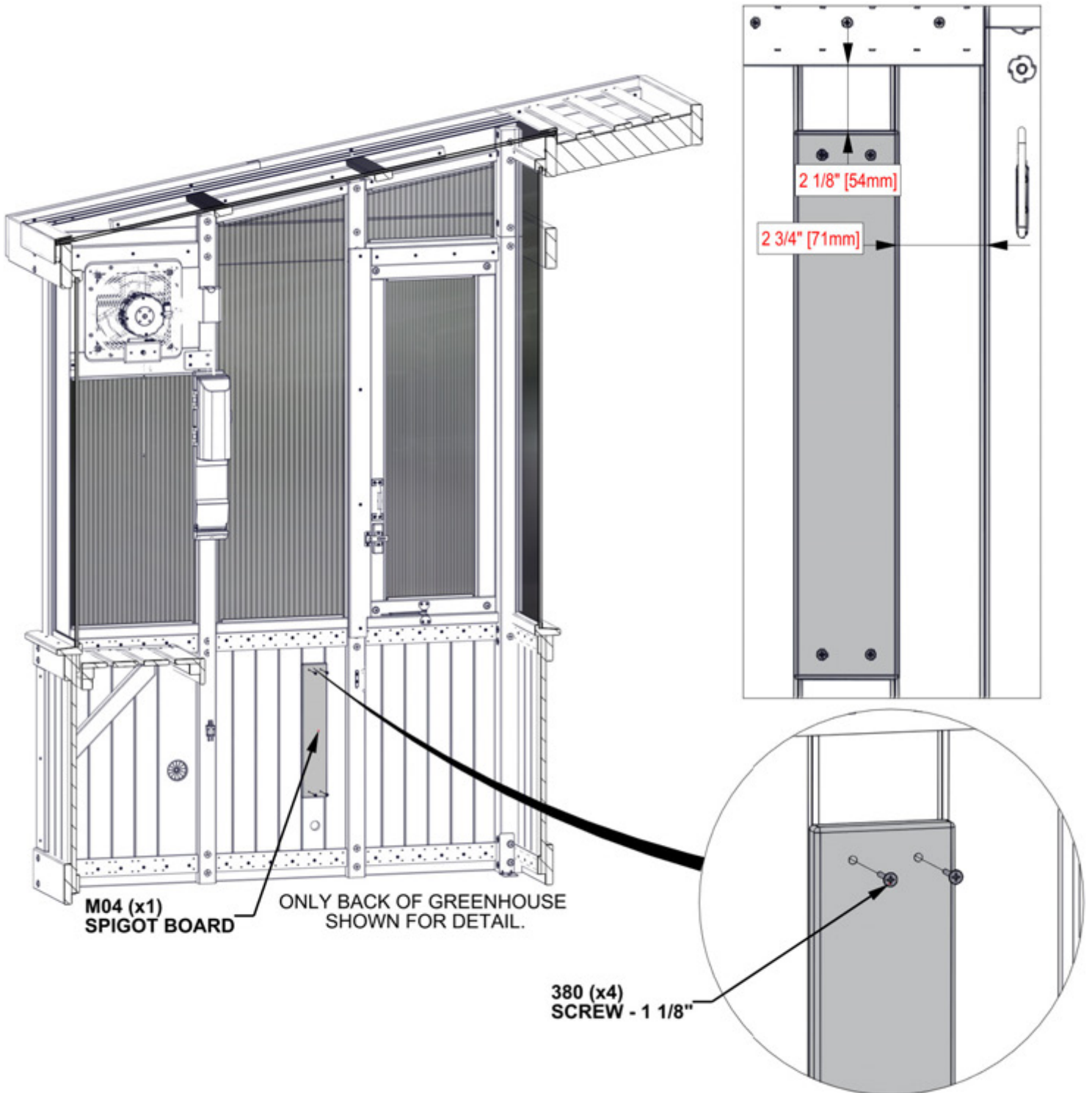

# STEP 138 - WATER LINE ASSEMBLY

QTY	PART NUMBER	DESCRIPTION
2	H100385	SCREW PFH 8x1 BLK

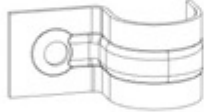

A4M02385 PIPE CLAMP (x2)

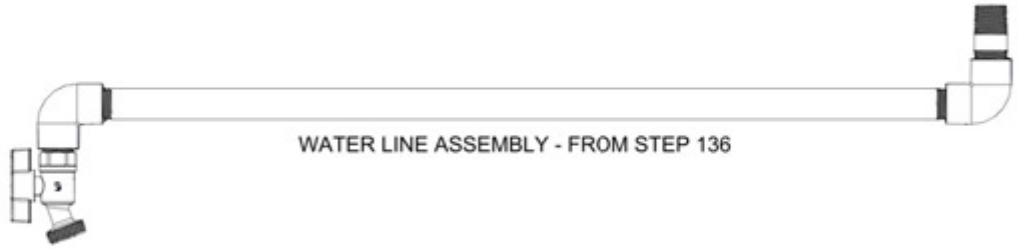

WATER LINE ASSEMBLY - FROM STEP 136

- INSERT WATER LINE ASSEMBLY THROUGH HOLE IN WALL PANEL.
- SECURE WATER LINE TO BOARD FROM PREVIOUS STEP WITH PIPE CLAMPS.
- PRE-DRILL WITH AN 1/8" [3mm] DRILL BIT WITH CLAMPS LINED UP IN POSITION.
- FASTEN CLAMPS IN APPROXIMATE LOCATIONS AS SHOWN.

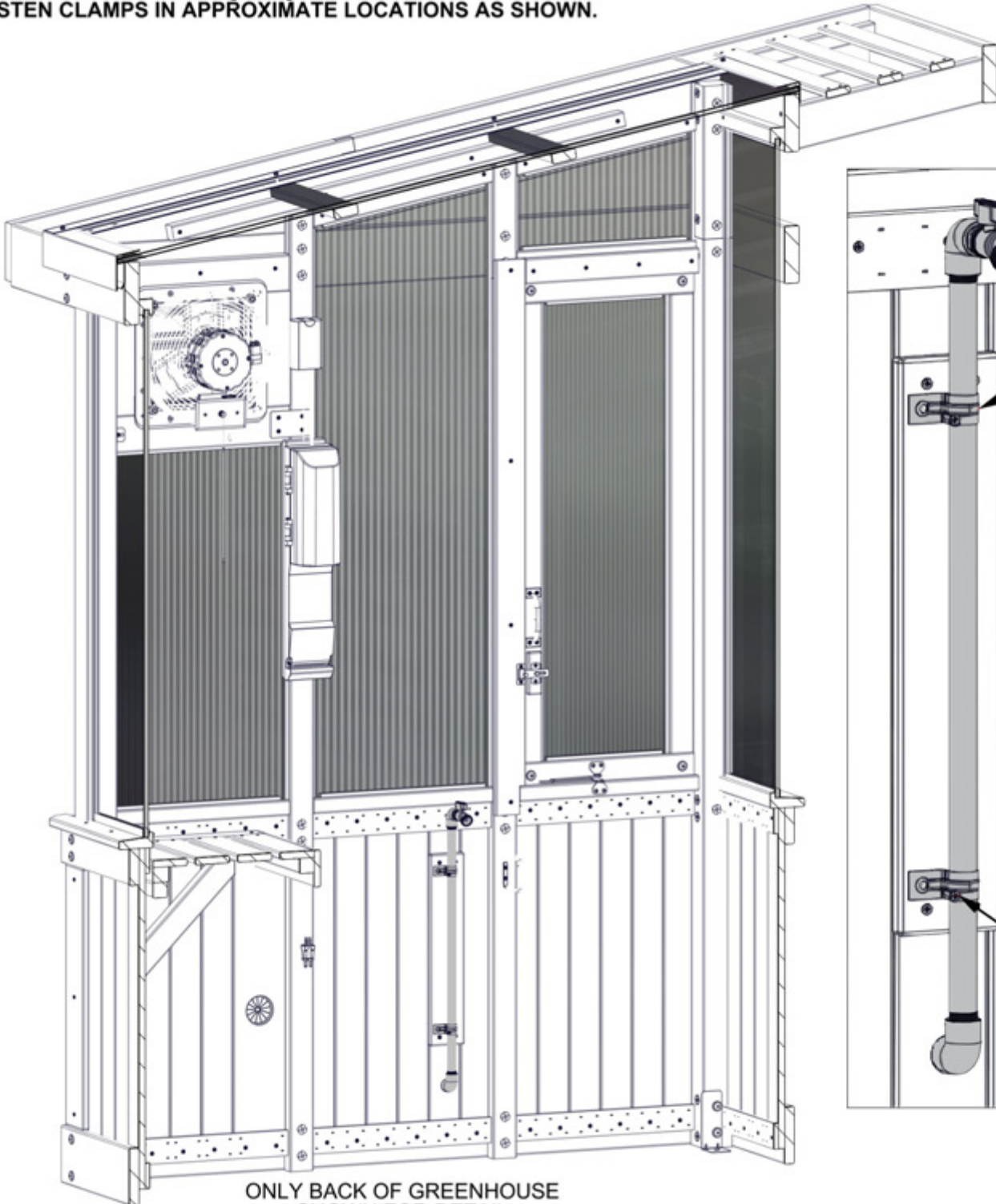

ONLY BACK OF GREENHOUSE SHOWN FOR DETAIL.

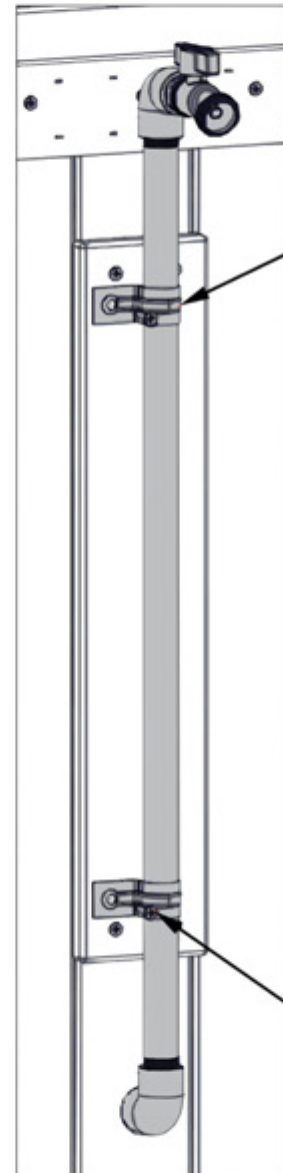

2385 (x2) PIPE CLAMP

385 (x2) SCREW - 1"

# STEP 139 - WATER LINE ASSEMBLY



A6P00648 THREADED HOSE FITTING  
(x1)



A6P00577 RUBBER GROMMET  
(x1)



A6P00809 PLUMBERS TAPE

- PUSH RUBBER GROMMET IN HOLE AROUND THE WATER LINE ASSEMBLY FROM PREVIOUS STEPS.
- USE PLUMBERS TAPE AND WRAP THREADS OF MALE FITTINGS.
- FASTEN THREADED HOSE FITTING.

**INSTALL RUBBER GROMMET  
BEFORE THREADED HOSE FITTING.**

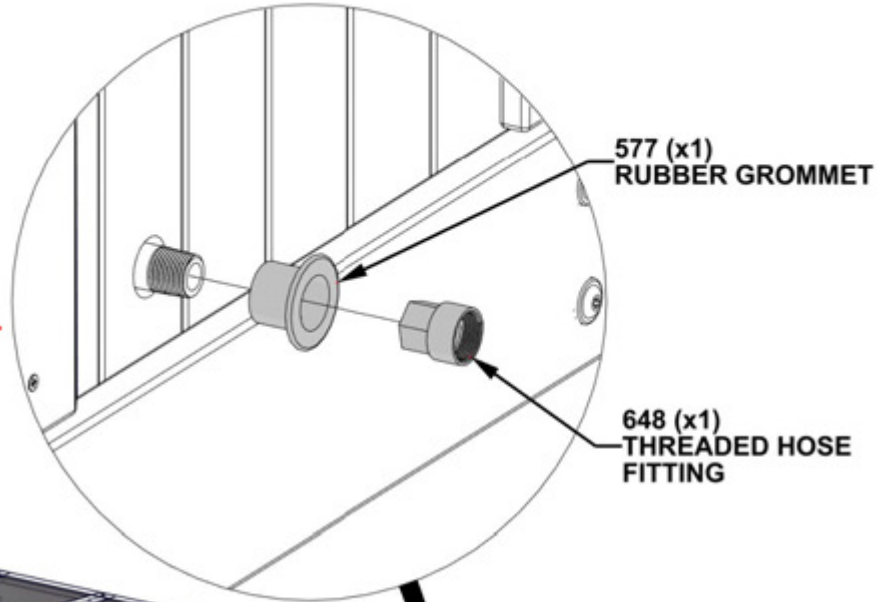

577 (x1)  
RUBBER GROMMET

648 (x1)  
THREADED HOSE  
FITTING

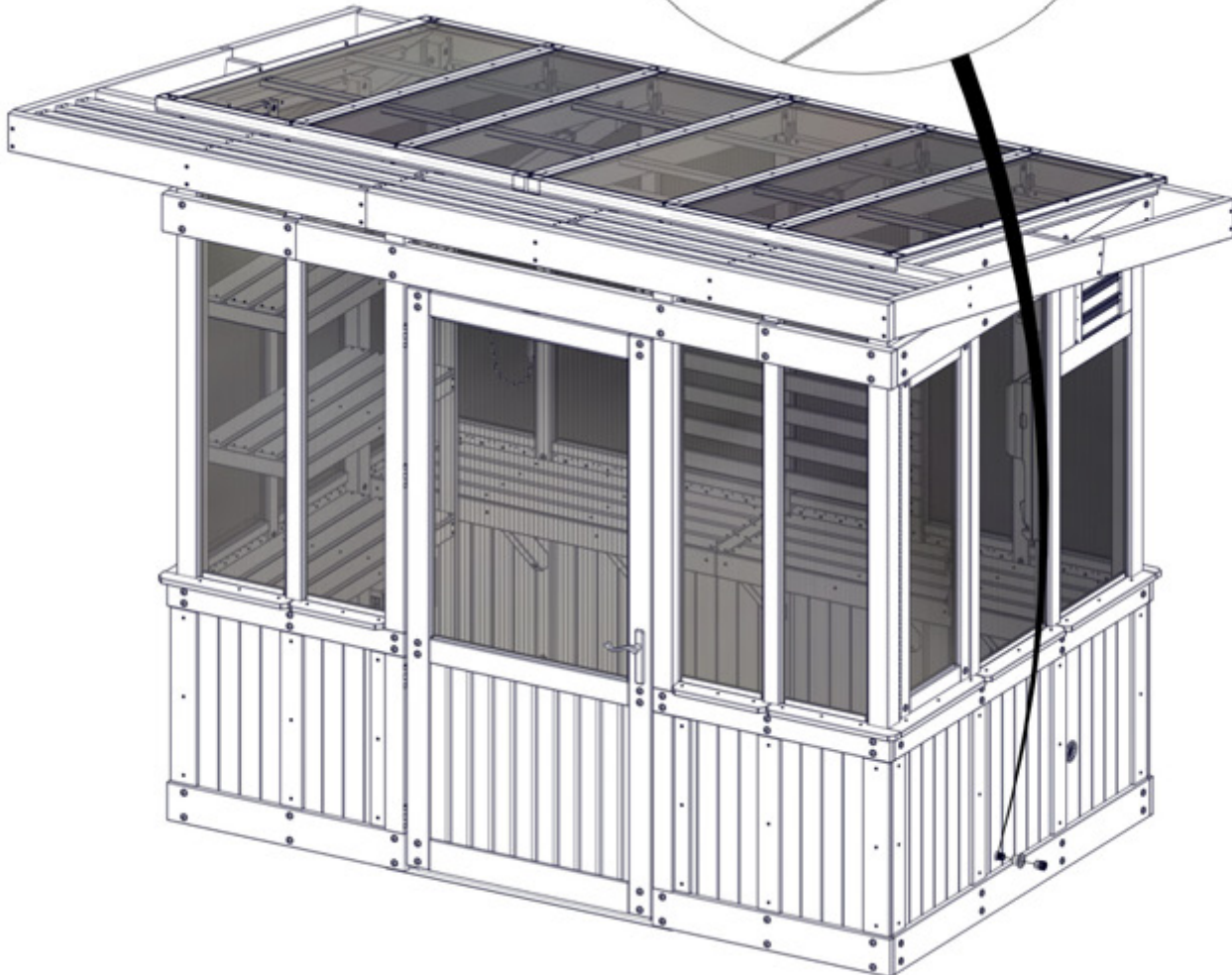

# STEP 140 - ANCHORING TO CONCRETE

QTY	PART NUMBER	DESCRIPTION
6	H101165	CONCRETE ANCHOR 3/8x3" BLK

**IF GREENHOUSE IS NOT ON A CONCRETE SURFACE, SEE STEP 141 FOR ANCHORING STRUCTURE.**

**IT IS RECOMMENDED TO ANCHOR YOUR GREENHOUSE INTO CONCRETE PAD OR POSTS.**

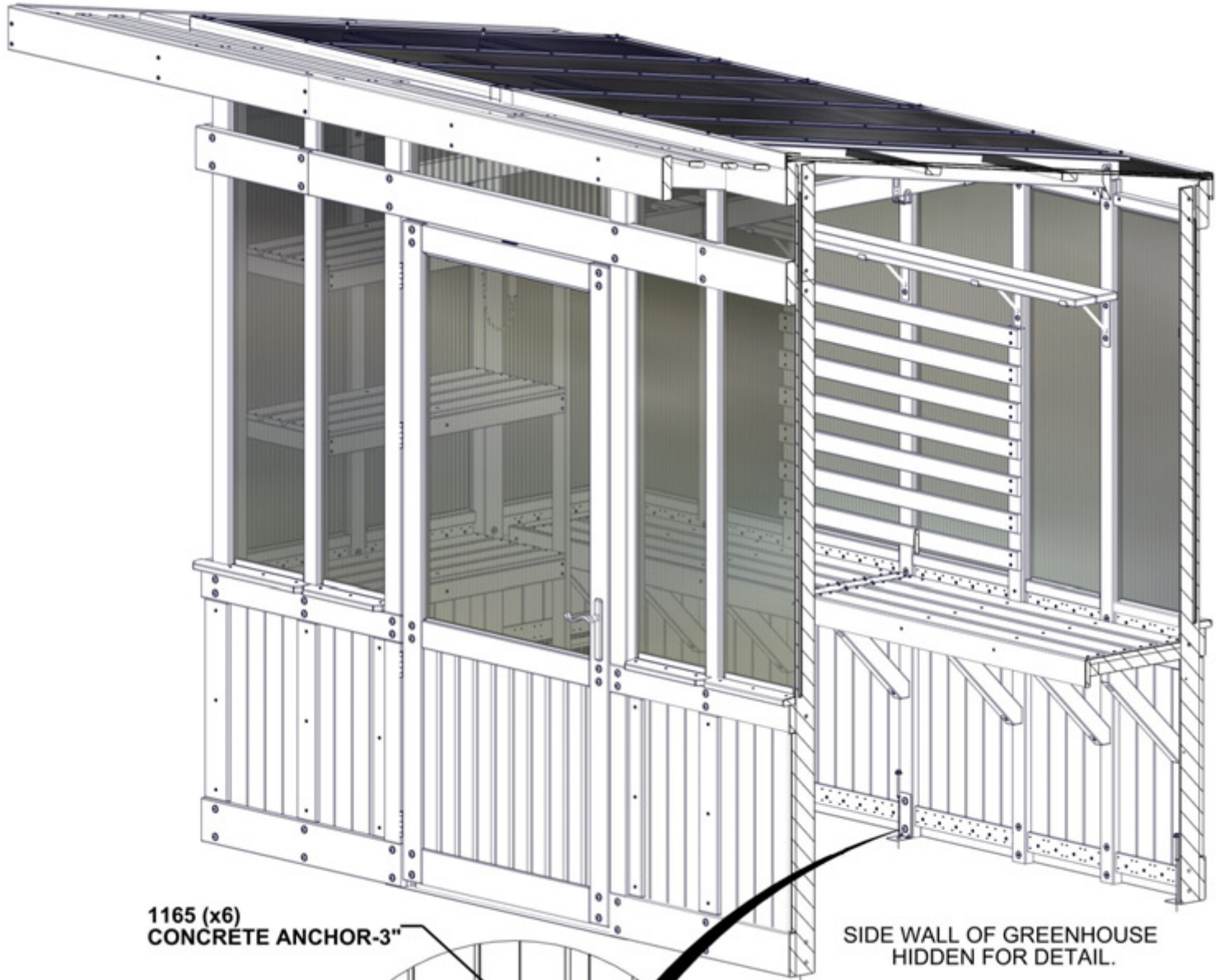

1165 (x6)  
CONCRETE ANCHOR-3"

SIDE WALL OF GREENHOUSE  
HIDDEN FOR DETAIL.

**PRE-DRILL HOLES FOR  
CONCRETE ANCHORS USING A  
5/16" [8mm] CONCRETE DRILL BIT.**

# STEP 141 - ANCHORING IN GROUND



**IF GREENHOUSE IS ON A CONCRETE SURFACE, SEE STEP 140 FOR ANCHORING STRUCTURE.**

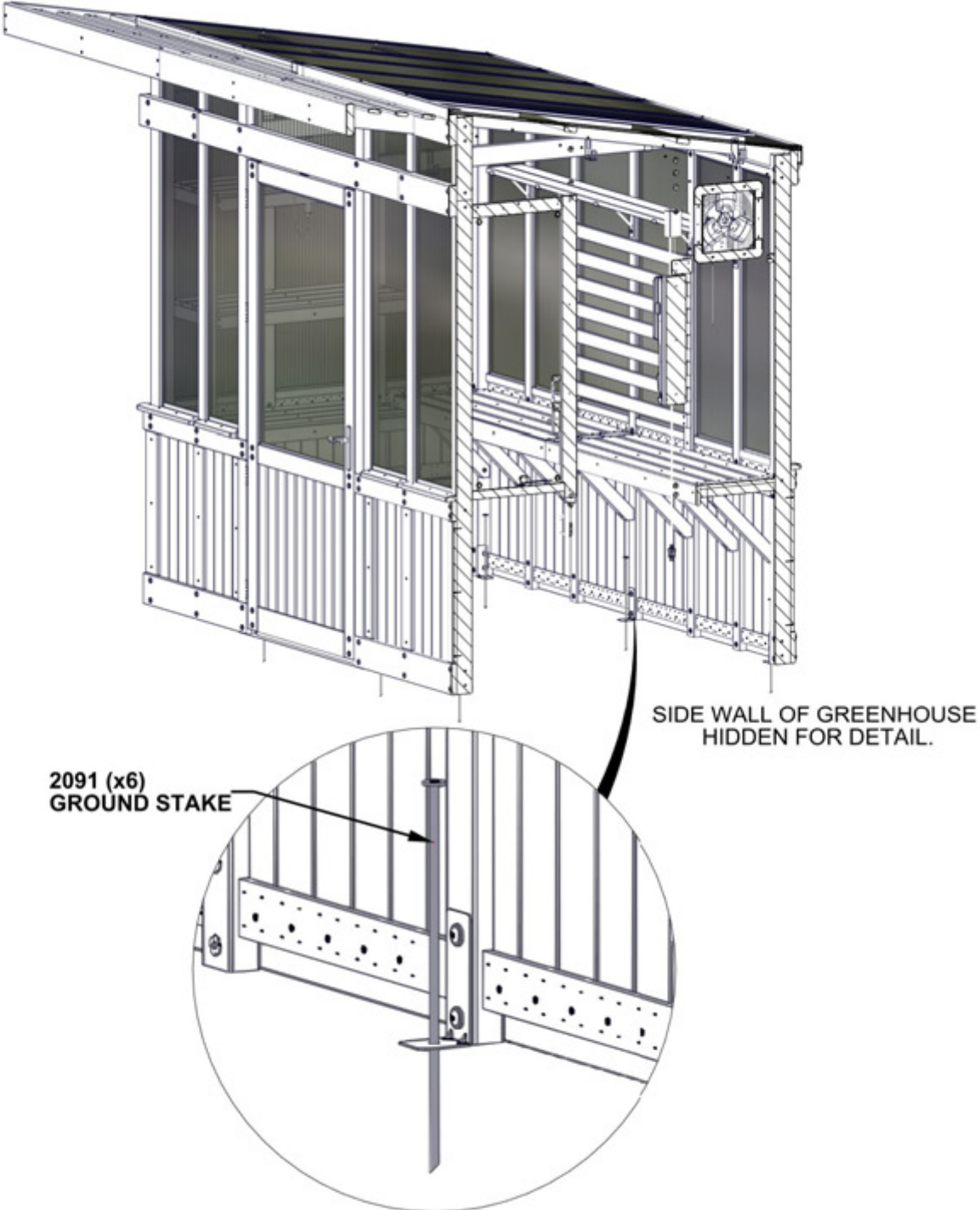

# STEP 142 - DOOR ASSEMBLY

QTY	PART NUMBER	DESCRIPTION
4	H100202	SCREW PWH 8x5/8 BLK



A4M02158 BYD ID TAG PATIO  
(x1)

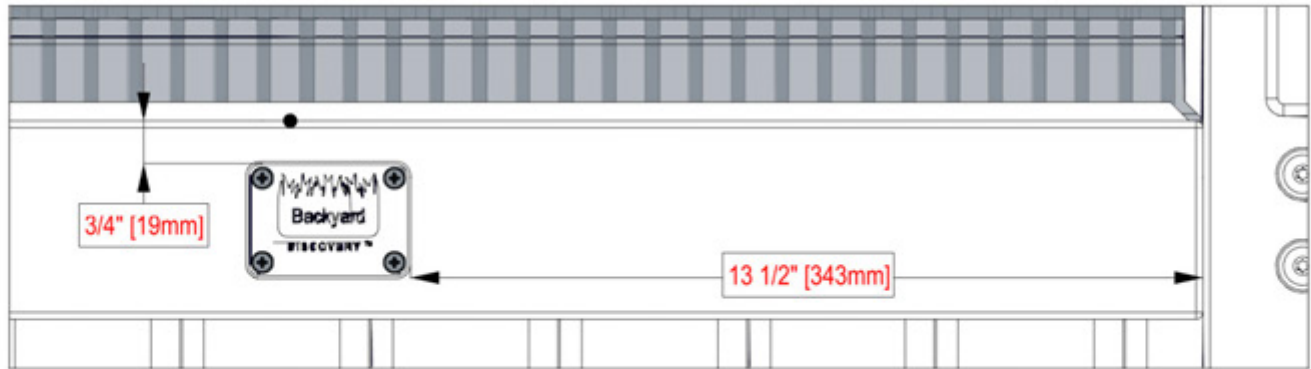

CENTER ID TAG ON BOARD WITH MEASUREMENTS GIVEN.

