



Manufactured by:
 Backyard Discovery
 3305 Airport Drive, Pittsburg, KS 66762
 800-856-4445

Basepoint Business Centre: Rivermead Drive, Westlea, Swindon SN5 7EX Phone: 0800-118-2476
 J.P. Coenstraat 7, The Bridge, The Hague, 2595 WP, Netherlands Phone: 08005678990

BEAUMONT 20X12 PERGOLA

MODEL: # 2505117

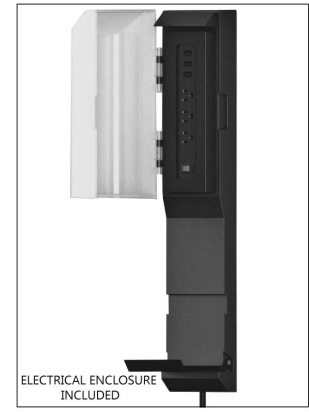
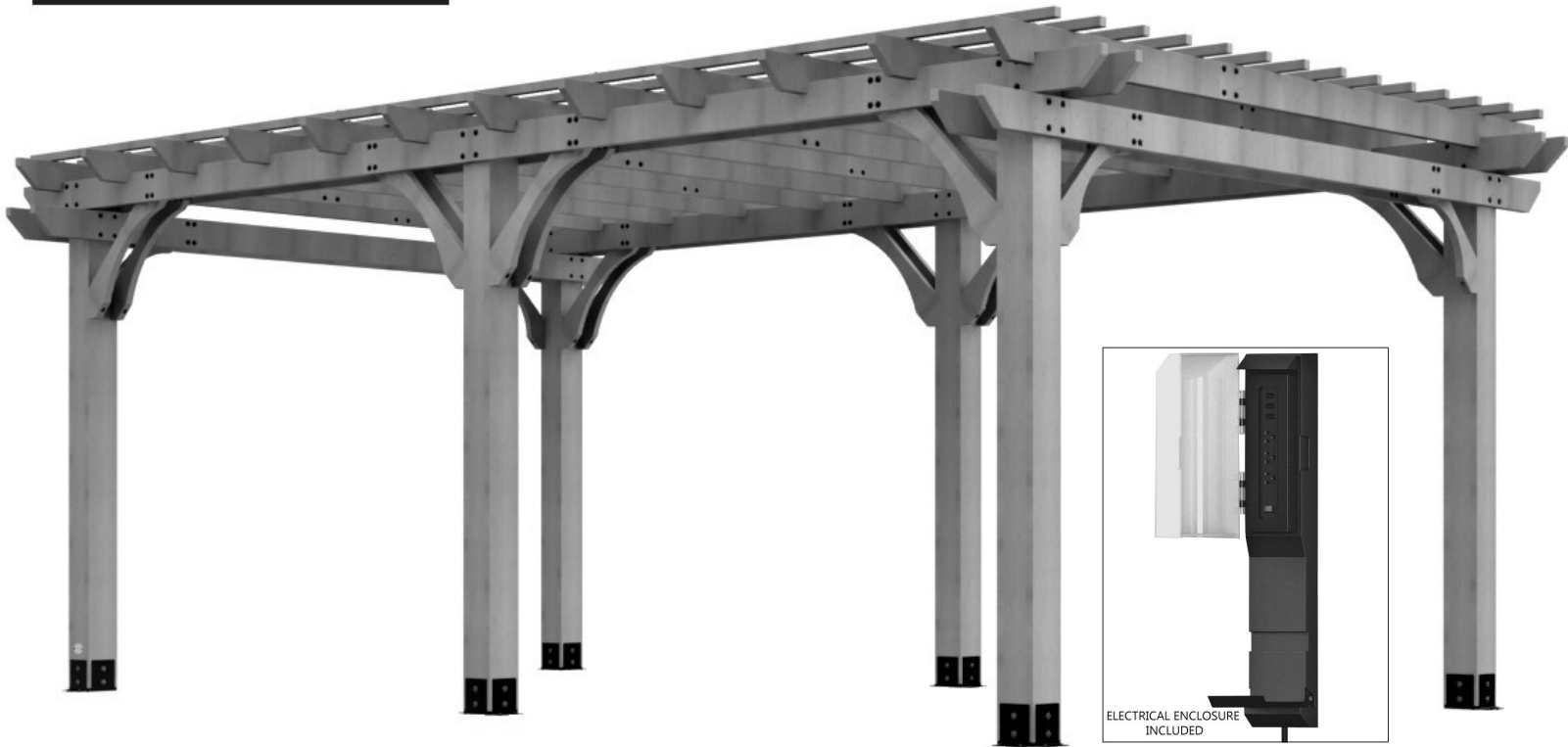

ELECTRICAL ENCLOSURE INCLUDED
 ONLY AVAILABLE IN NORTH AMERICA

Please visit www.backyarddiscovery.com
 For the most up to date assembly manual, to register your product, or to order replacement parts
Para obtener instrucciones en español, visite www.backyarddiscovery.com



EASY STEP-BY-STEP
 3D INTERACTIVE INSTRUCTIONS



OWNER'S MANUAL - BASIC SETUP DIMENSIONS & ASSEMBLY NOTES

It is critically important that you start with square and level footings, concrete pad or deck to attach your structure

- Pay close attention to the items needed for each step. Make sure you are using the correct hardware for each step. Using incorrect hardware may result in improper assembly
- Remember to double check for underground utilities and overhead electrical lines

Post mounts are provided with your structure which allows you to permanently install your structure to a pre-existing or new wood or concrete surface. See Anchor Instructions for further details and recommendations.

- The hardware to attach the post mounts to the structure is included.
- The hardware to mount the structure permanently to a concrete surface is included.
- The hardware to mount the structure permanently to a wood deck is NOT included and will need to be purchased separately. You must ensure there is ample structural support under the deck before permanently attaching.

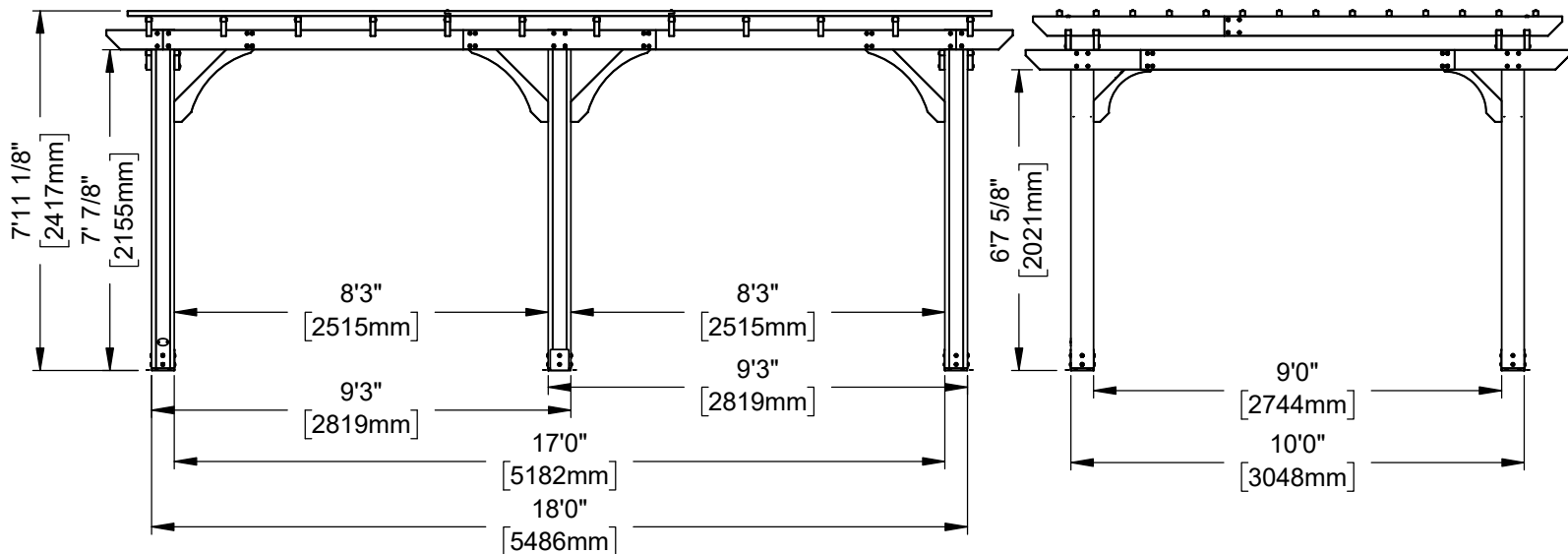
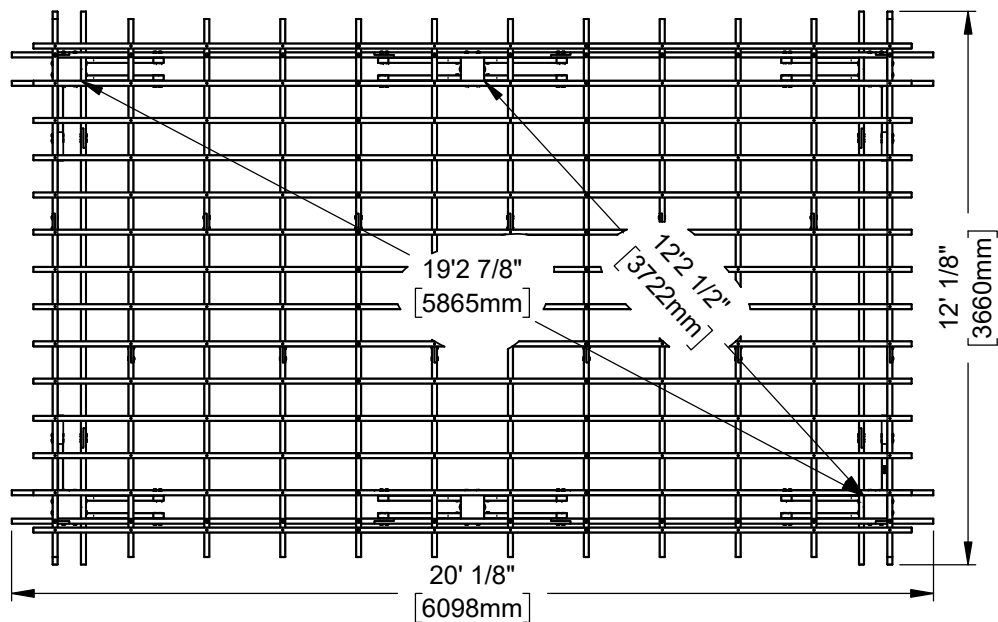

OWNER'S MANUAL - ANCHORING LAYOUT

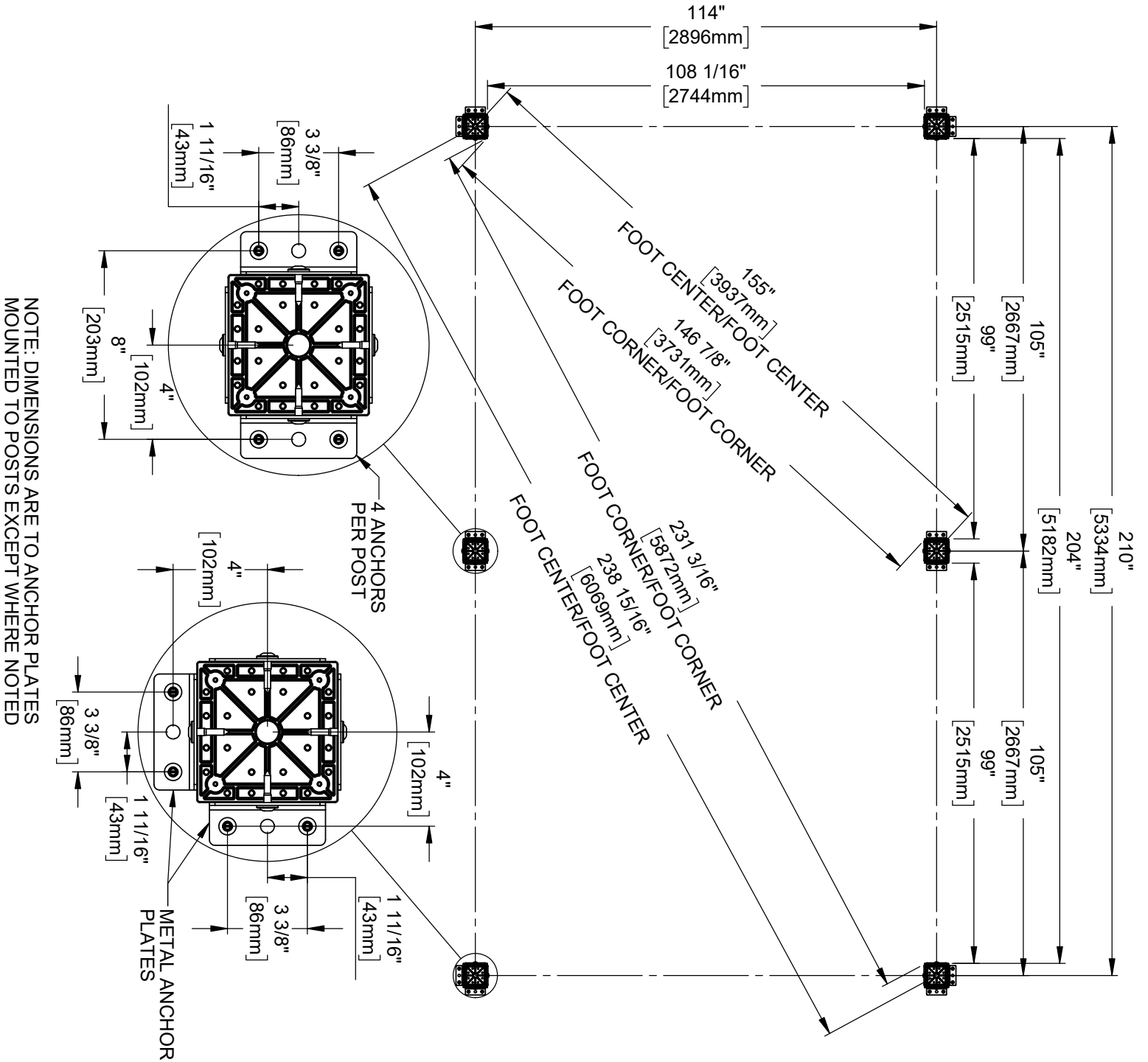

OWNER'S MANUAL - PARTS IDENTIFICATION

Wood Components (Not to Scale)

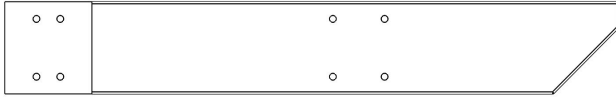

D01 | JOIST END - W4L15500
(4) | 1 3/8"x5 1/4"x35 1/2" (36x134x902)

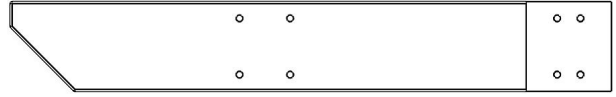

D02 | JOIST END - W4L15501
(4) | 1 3/8"x5 1/4"x35 1/2" (36x134x902)



D03 | JOIST END - W4L15502
(2) | 1 3/8"x5 1/4"x15" (36x134x382)



D04 | JOIST END - W4L15503
(2) | 1 3/8"x5 1/4"x15" (36x134x382)



D05 | JOIST END - W4L15529
(2) | 1 3/8"x5 1/4"x15" (36x134x382)



D06 | JOIST END - W4L15530
(2) | 1 3/8"x5 1/4"x15" (36x134x382)



D07 | JOIST - W4L15506
(4) | 1 3/8"x5 1/4"x83 1/8" (36x134x2112)



D08 | JOIST - W4L15523
(2) | 1 3/8"x5 1/4"x87 1/2" (36x134x2223)



D09 | JOIST - W4L15524
(2) | 1 3/8"x5 1/4"x87 1/2" (36x134x2223)



D10 | JOIST - W4L15525
(2) | 1 3/8"x5 1/4"x87 1/2" (36x134x2223)



D16 | JOIST - W4L15526
(2) | 1 3/8"x5 1/4"x87 1/2" (36x134x2223)

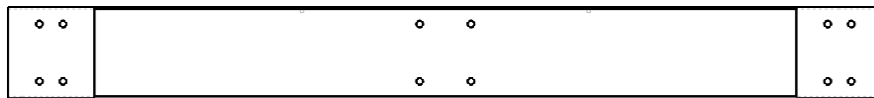

D17 | JOIST - W4L15527
(2) | 1 3/8"x5 1/4"x51" (36x134x1296)

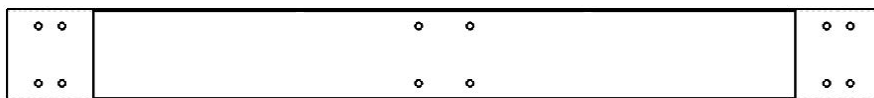

D18 | JOIST - W4L15528
(2) | 1 3/8"x5 1/4"x51" (36x134x1296)

OWNER'S MANUAL - PARTS IDENTIFICATION

Wood Components (Not to Scale)

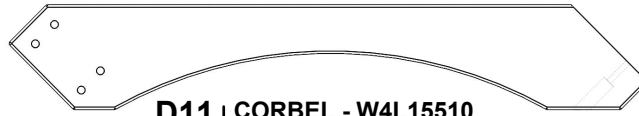

D11 | CORBEL - W4L15510
(16) | 1 3/8"x5 1/4"x32 1/2" (36x134x826)



D12 | CORBEL - W4L15513
(3) | 1 3/8"x5 1/4"x28 1/4" (36x134x719)



D13 | CORBEL - W2A03243
(1) | 1 3/8"x5 1/4"x28 1/4" (36x134x719)



D14 | SLOTTED JOIST - W4L15515
(12) | 1 3/8"x5 1/4"x55 3/4" (36x134x1416)



D15 | SLOTTED JOIST - W4L15517
(12) | 1 3/8"x5 1/4"x89 1/2" (36x134x2274)



P10 | PURLIN END - W4L15531
(28) | 1 3/8"x1 3/8"x85 1/2" (36x36x2171)



P11 | PURLIN - W4L15532
(14) | 1 3/8"x1 3/8"x60 3/4" (36x36x1542)

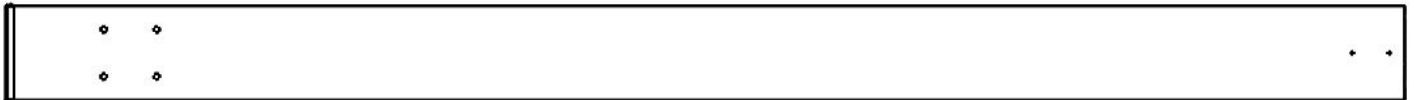

P01 | POST - W2A03241
(2) | 6"x6"x89 1/2" (152x152x2274)

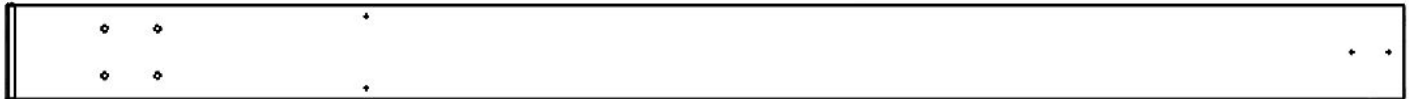

P02 | POST - W2A03242
(2) | 6"x6"x89 1/2" (152x152x2274)

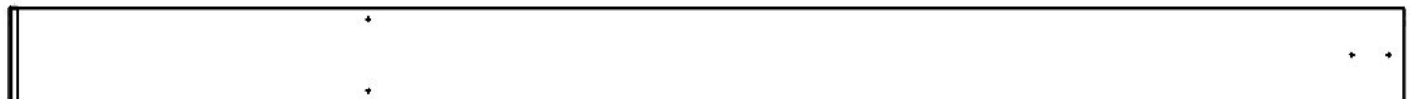

P03 | POST - W2A03244
(2) | 6"x6"x89 1/2" (152x152x2274)

OWNER'S MANUAL - PARTS IDENTIFICATION

Hardware Components

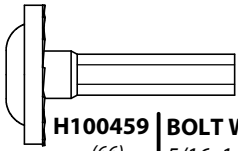

H100459 | BOLT WH BLK
(66) | 5/16x1 1/4

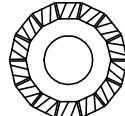

H100198 | WASHER LOCK
(214) | EXT BLK 8x19

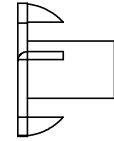

H100379 | T-NUT BLK
(187) | 5/16x5/8

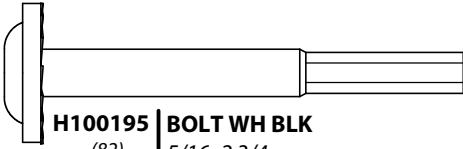

H100195 | BOLT WH BLK
(82) | 5/16x2 3/4

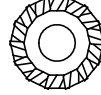

H100405 | WASHER LOCK
(52) | EXT BLK 6x15



H100398 | T-NUT BLK
(30) | 1/4x7/16

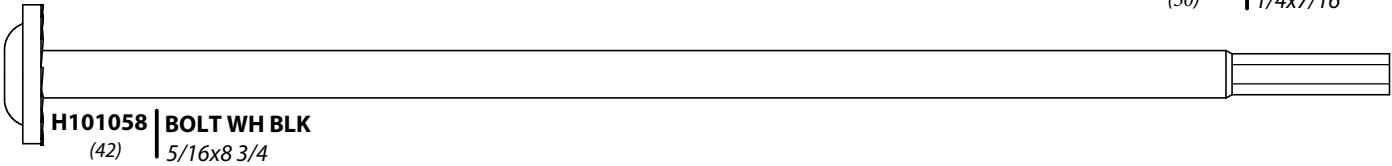

H101058 | BOLT WH BLK
(42) | 5/16x8 3/4

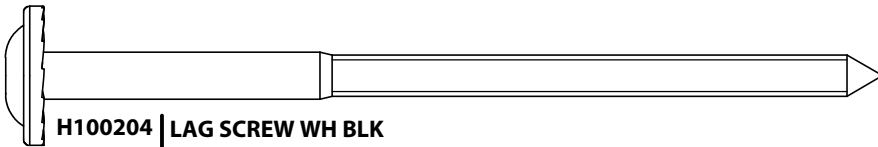

H100204 | LAG SCREW WH BLK
(26) | 5/16x5 1/2



H100201 | SCREW PFH BLK
(145) | 8x2 1/2

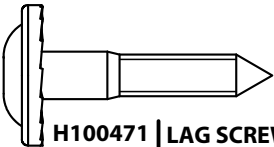

H100471 | LAG SCREW WH BLK
(50) | 5/16x1 1/2

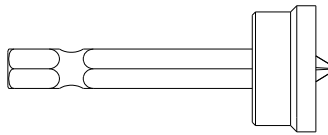

H100764 | SCREW SETTER
(1)



H100200 | SCREW PFH BLK
(26) | 8x1 1/2

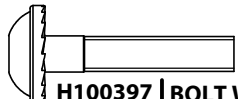

H100397 | BOLT WH BLK
(30) | 1/4x1 1/4

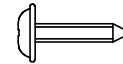

H100202 | SCREW PWH BLK
(4) | 8x5/8



H100792 | LAG SCREW WH BLK
(22) | 1/4x3

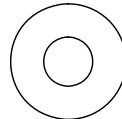

H100630 | WASHER FLAT BLK
(26) | 8x19

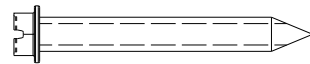

H100120 | SCREW CONCRETE ANCHOR
(26) | 1/4x2

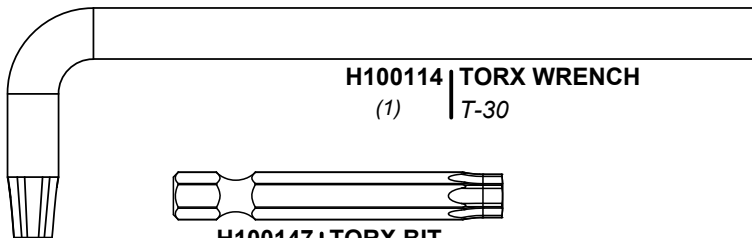

H100114 | TORX WRENCH
(1) | T-30

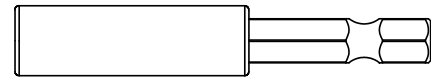

H101100 | MAGNETIC DRIVER
(1)

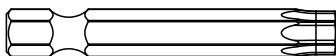

H100147 | TORX BIT
(1) | T-30

OWNER'S MANUAL - PARTS IDENTIFICATION

Accessory Components (Not to Scale)



A4M02158 | BYD ID TAG PATIO
(1)

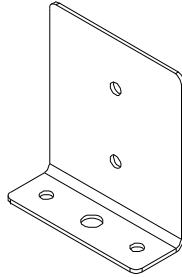

A4M00977 | POST ANCHORING PLATE
(12)

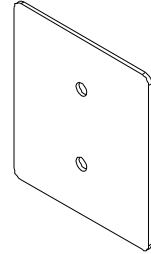

A4M00978 | POST PLATE
(12)

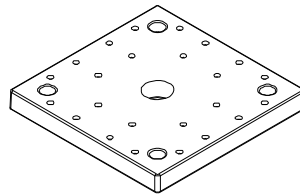

A6P00308 | 6x6 POST FOOT
(6)

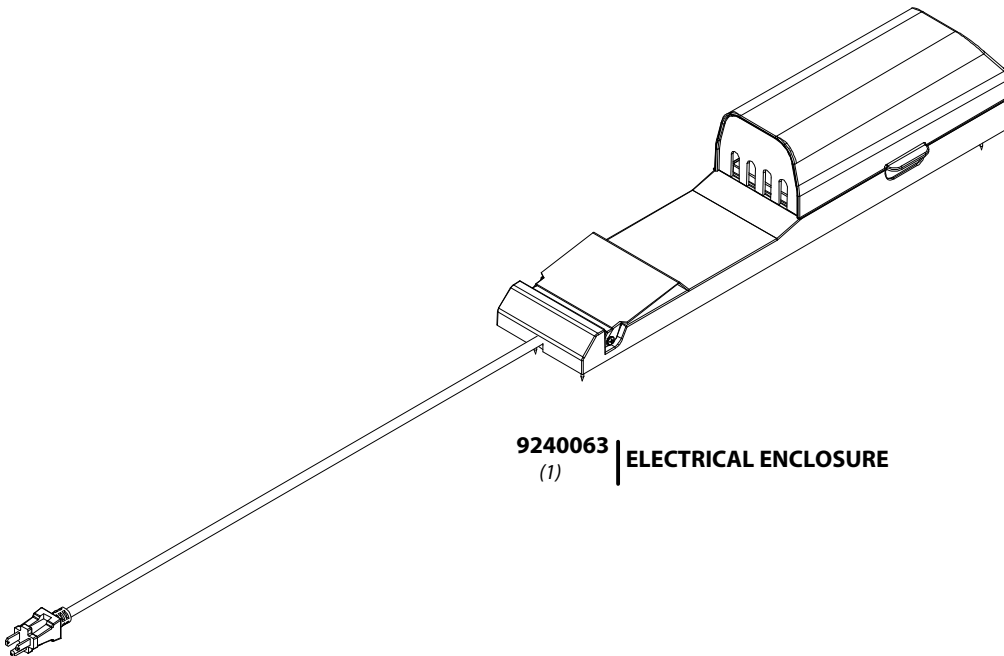

9240063 | ELECTRICAL ENCLOSURE
(1)

PRE-ASSEMBLY STEP 1 - SORTING PARTS

It is critical for ease of assembly that you take the time to sort and organize the wood and hardware.

WOOD PARTS:

- Organize wood parts by the three-digit, alpha-numeric number stamped on each board (ex. P01).
- If there are multiple boards with the same stamped number, stack those pieces together.
- Stamps can be found on the flat surface of the boards or on the end of the boards.
- Allow yourself plenty of room - the wood pieces can take up a significant amount of space.

NOTE: CARTONS ARE NOT ORGANIZED BY BOARD NUMBER.



HARDWARE PARTS:

- We recommend that you have a separate table to organize the hardware.
- Hardware bags are printed with a seven-digit, alpha-numeric part number.
- You can organize your hardware by part number or group by hardware type (i.e. bolts, nuts, etc.).
- During assembly you only need to reference the last four digits of the number.

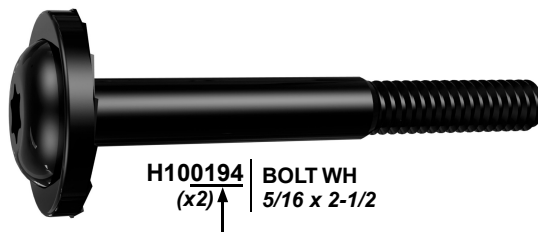

H100194 | BOLT WH
(x2) ↑ 5/16 x 2-1/2

PRE-ASSEMBLY STEP 2 - TOOLS REQUIRED



Cordless Drill
or Electric Drill



Drill
Attachments:
Phillips Head

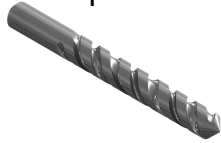

1/8", 3/16", 3/8" &
7/16" Drill Bits



Phillips Screw Driver



Open End
Wrenches 1/2" &
9/16"



3/8" Drive Ratchet, 1/2" &
7/16" STD Sockets 1/2" & 7/16"
Deep Sockets



Claw Hammer



Rubber Mallet
- Optional

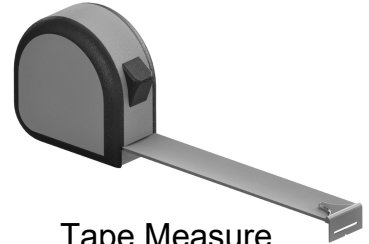

Tape Measure

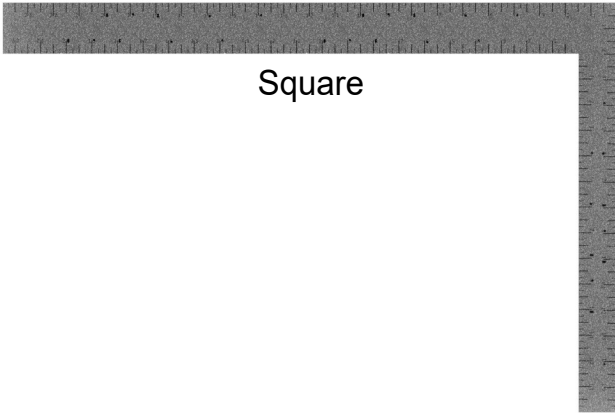

Square



Level 24"

PRE-ASSEMBLY STEP 3 - CHOOSE YOUR ASSEMBLY METHOD

There are several types of assembly instructions available to you.

1. Printed Assembly Manual included with your set
2. BILT APP - 3D interactive instructions
3. Combination of the Printed Manual and BILT APP (Note: Step numbers can differ between the two methods)



BILT.

Scan for easy
3D instructions

Download the BILT app
before you begin

Download on the
App Store

GET IT ON
Google Play

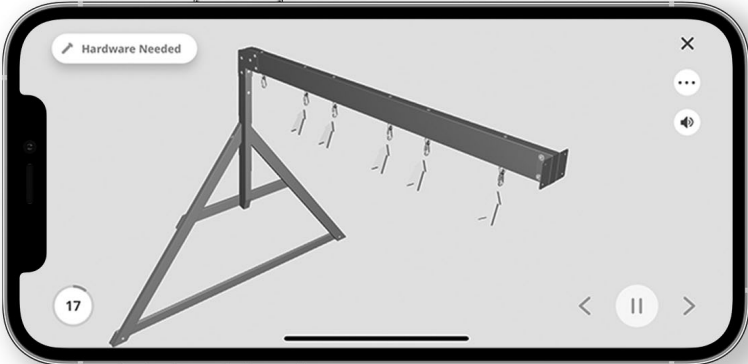

The image shows a smartphone screen displaying a 3D assembly instruction. The screen features a 3D model of a metal frame structure. At the top left, there is a button labeled "Hardware Needed". At the bottom left, a circular icon contains the number "17". At the bottom right, there are navigation icons: a back arrow, a pause button, and a forward arrow. The entire advertisement is enclosed in a grey border.

STEP 4 - PERGOLA ASSEMBLY



P01 | POST - W2A03241
(2) | 6"x6"x89 1/2" (152x152x2274)



P02 | POST - W2A03242
(2) | 6"x6"x89 1/2" (152x152x2274)



P03 | POST - W2A03244
(2) | 6"x6"x89 1/2" (152x152x2274)

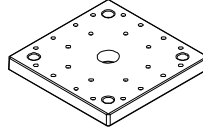

A6P00308 | 6x6 POST FOOT
(6)



H100200 | SCREW PFH BLK
(24) | 8x1 1/2

COMPLETE THIS STEP TWICE.

FOR EASE OF ASSEMBLY, WE RECOMMEND USING SAW HORSES FOR STEPS 4-14.

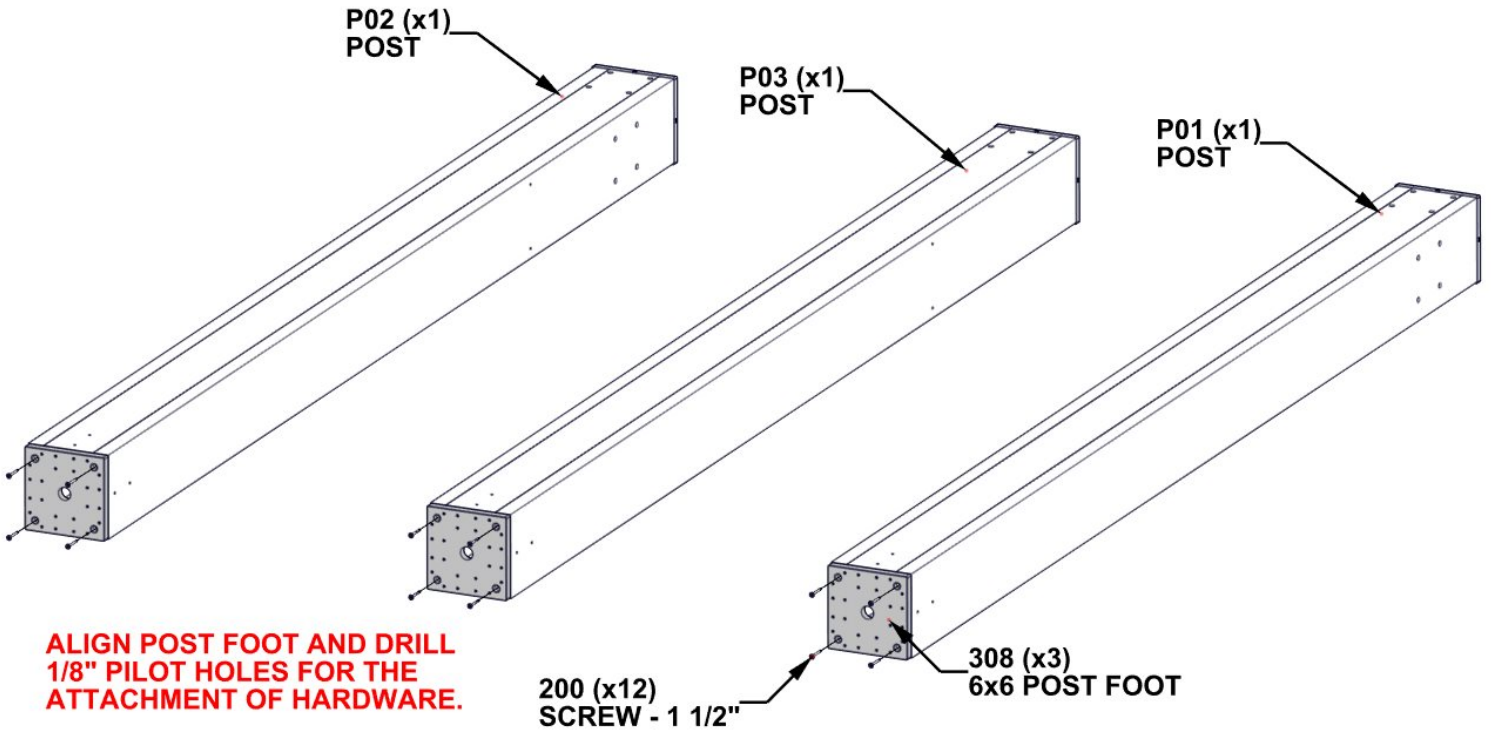

STEP 5 - PERGOLA ASSEMBLY

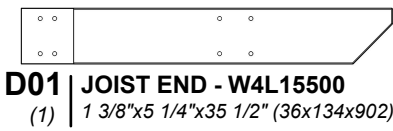

D01 | JOIST END - W4L15500
(1) | 1 3/8"x5 1/4"x35 1/2" (36x134x902)

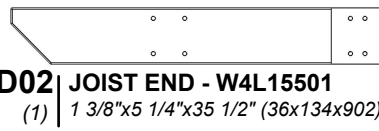

D02 | JOIST END - W4L15501
(1) | 1 3/8"x5 1/4"x35 1/2" (36x134x902)



D07 | JOIST - W4L15506
(1) | 1 3/8"x5 1/4"x83 1/8" (36x134x2112)

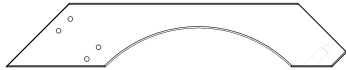

D12 | CORBEL - W4L15513
(1) | 1 3/8"x5 1/4"x28 1/4" (36x134x719)



D13 | CORBEL - W2A03243
(1) | 1 3/8"x5 1/4"x28 1/4" (36x134x719)

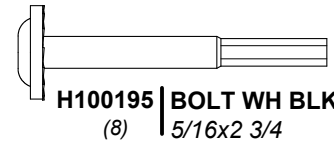

H100195 | BOLT WH BLK
(8) | 5/16x2 3/4

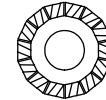

H100198 | WASHER LOCK
(8) | EXT BLK 8x19

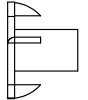

H100379 | T-NUT BLK
(8) | 5/16x5/8

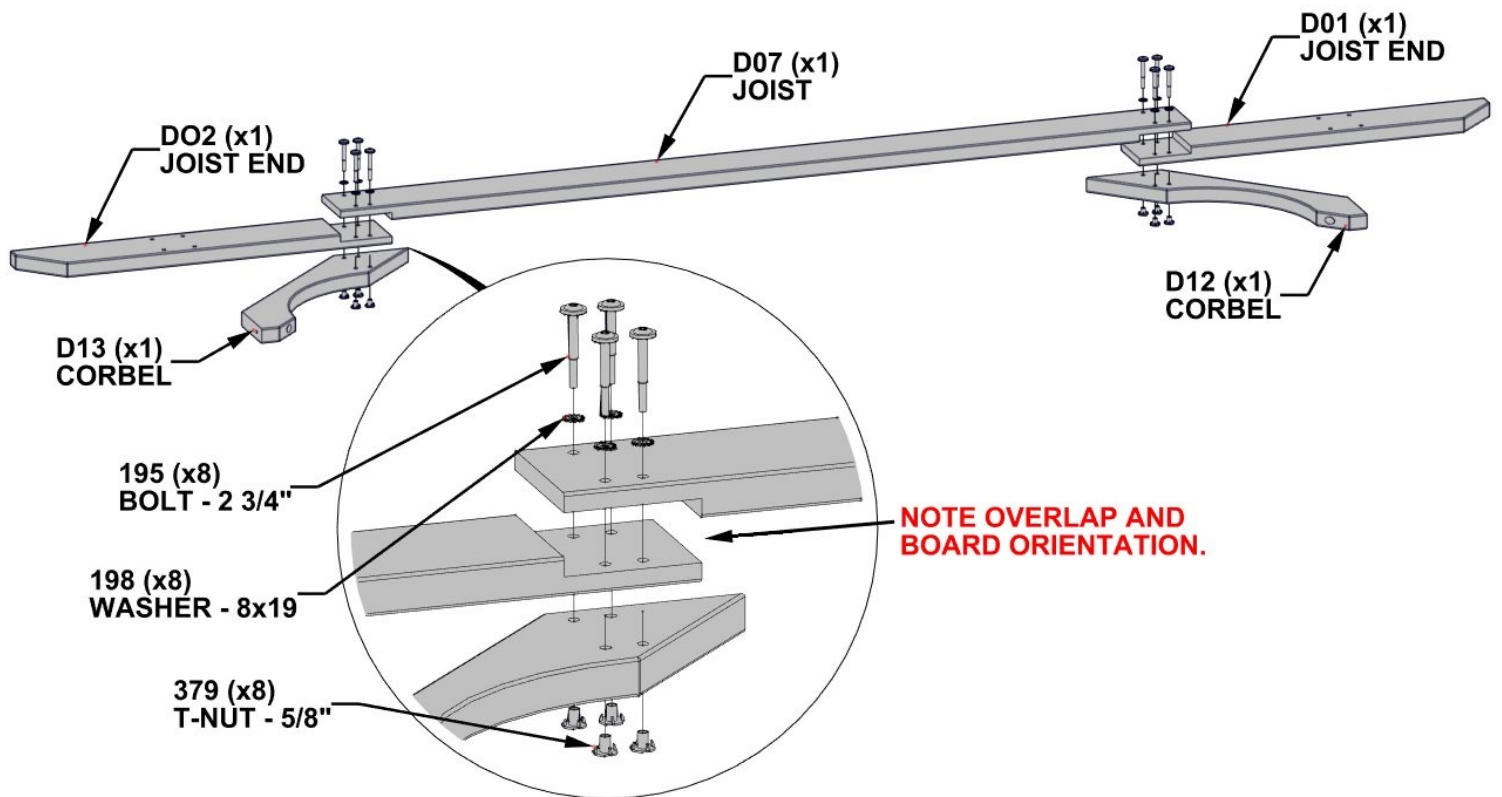

STEP 6 - PERGOLA ASSEMBLY

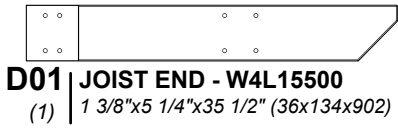

D01 | JOIST END - W4L15500
(1) | 1 3/8"x5 1/4"x35 1/2" (36x134x902)

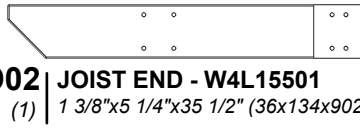

D02 | JOIST END - W4L15501
(1) | 1 3/8"x5 1/4"x35 1/2" (36x134x902)



D07 | JOIST - W4L15506
(1) | 1 3/8"x5 1/4"x83 1/8" (36x134x2112)

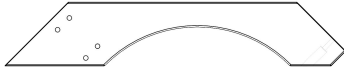

D12 | CORBEL - W4L15513
(2) | 1 3/8"x5 1/4"x28 1/4" (36x134x719)

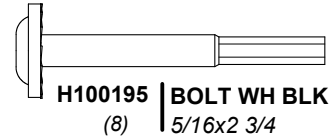

H100195 | BOLT WH BLK
(8) | 5/16x2 3/4

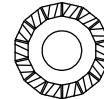

**H100198 | WASHER LOCK
EXT BLK 8x19**
(8)



H100379 | T-NUT BLK
(8) | 5/16x5/8

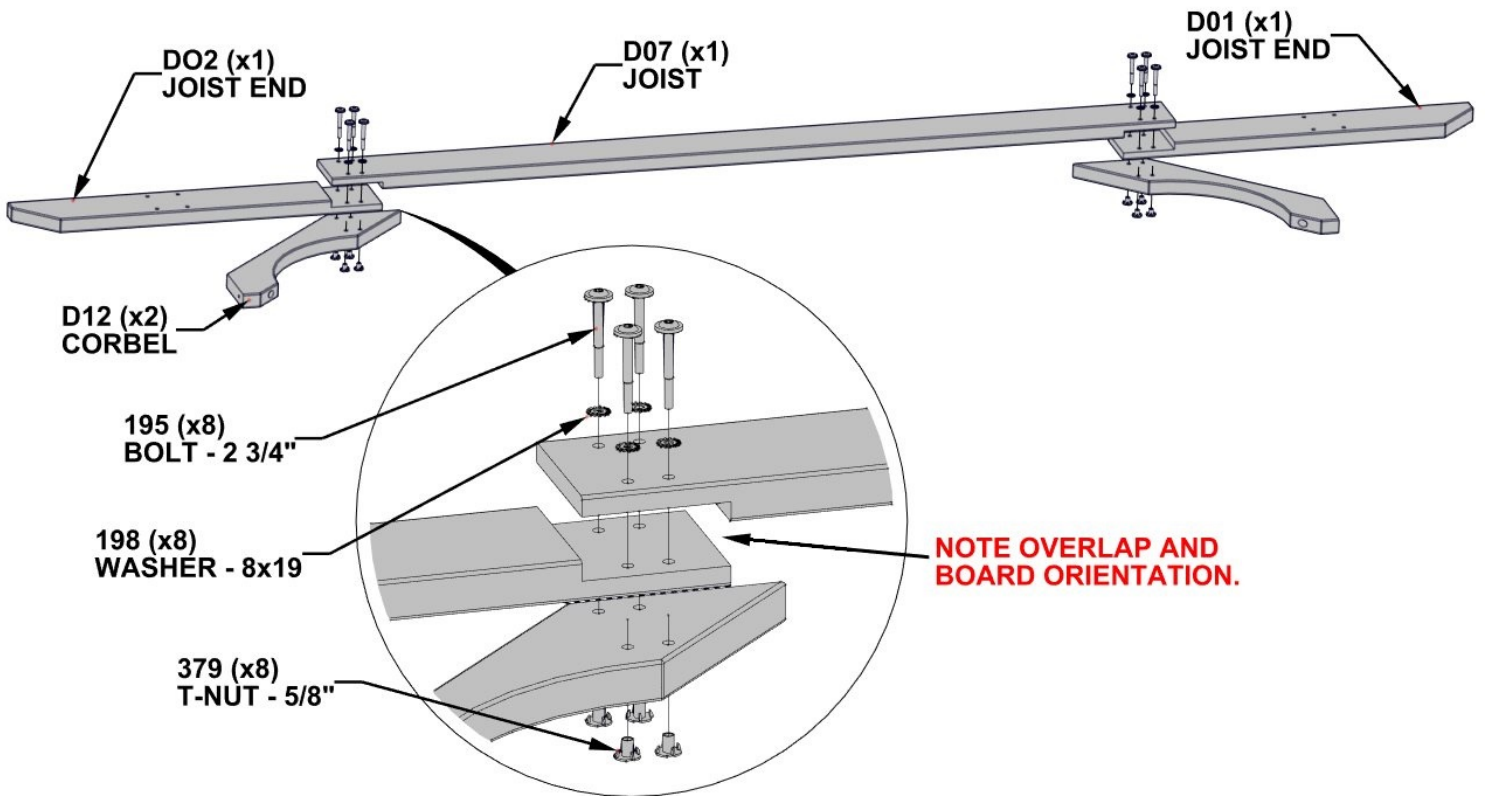

STEP 7 - PERGOLA ASSEMBLY

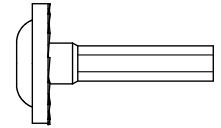
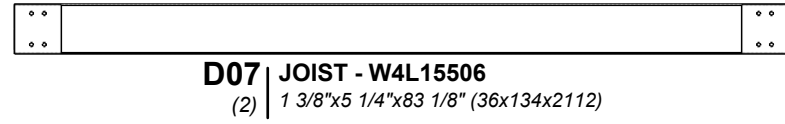
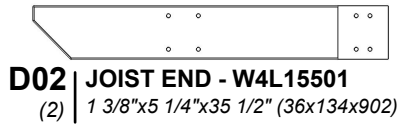
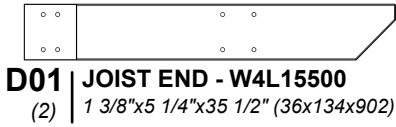

H100459 | BOLT WH BLK
(16) | 5/16x1 1/4

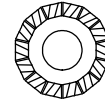

H100198 | WASHER LOCK
(16) | EXT BLK 8x19

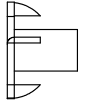

H100379 | T-NUT BLK
(16) | 5/16x5/8

COMPLETE THIS STEP TWICE.

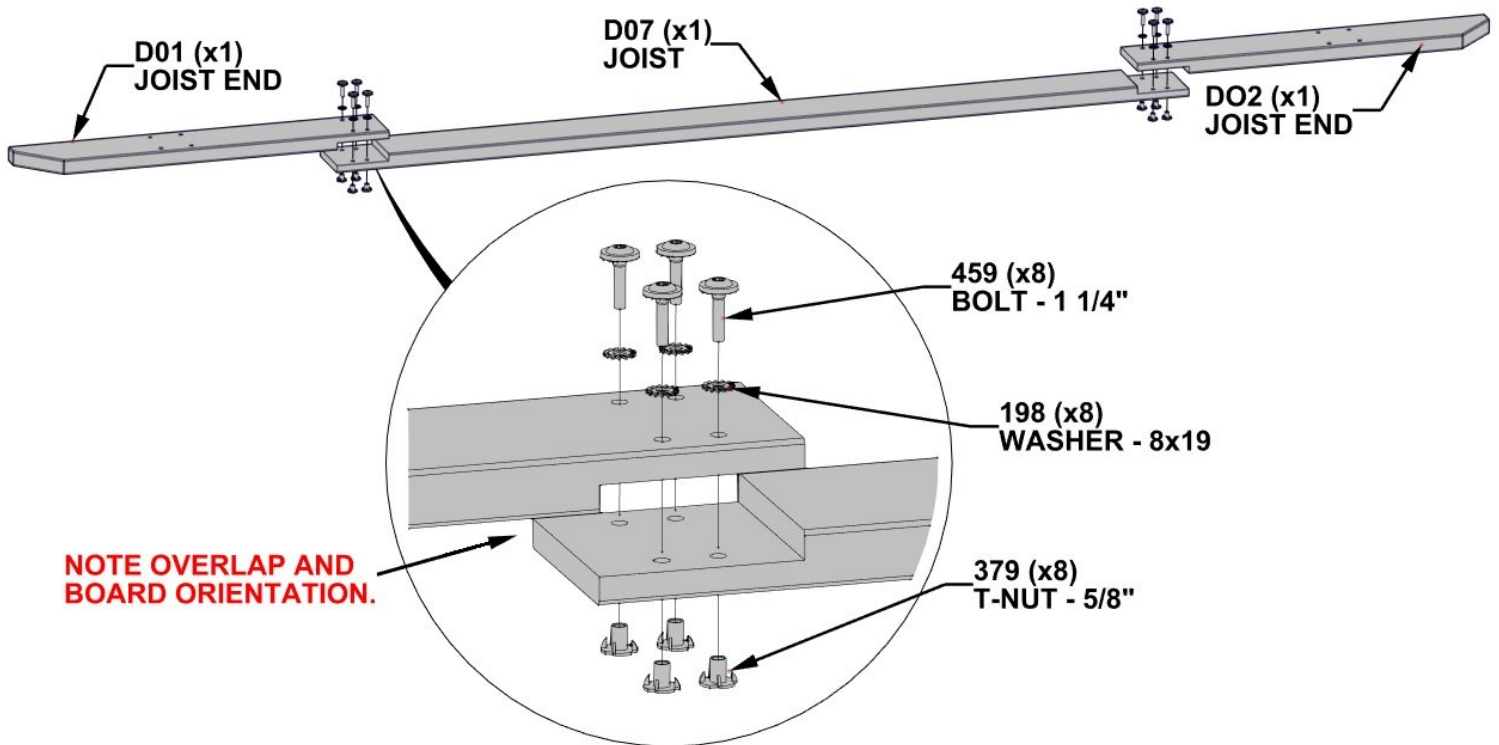

STEP 8 - PERGOLA ASSEMBLY

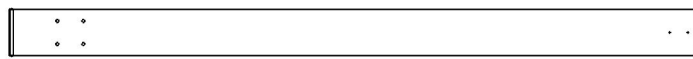

P01 | POST - W2A03241
(2) 6"x6"x89 1/2" (152x152x2274)



P02 | POST - W2A03242
(2) 6"x6"x89 1/2" (152x152x2274)

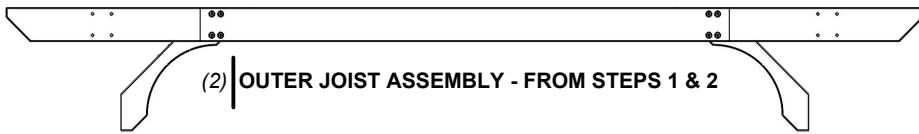

(2) **OUTER JOIST ASSEMBLY - FROM STEPS 1 & 2**



(2) **INNER JOIST ASSEMBLY - FROM STEP 3**

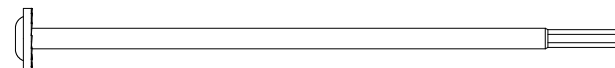

H101058 | BOLT WH BLK
(16) 5/16x8 3/4



H100379 | T-NUT BLK
(16) 5/16x5/8

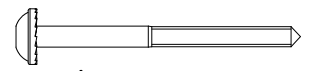

H100792 | LAG SCREW WH BLK
(4) 1/4x3



H100198 | WASHER LOCK
(16) EXT BLK 8x19



H100405 | WASHER LOCK
(4) EXT BLK 6x15

COMPLETE THIS STEP TWICE.

ASSEMBLE AS SHOWN USING THE PRE-DRILLED PILOT HOLES IN POSTS.

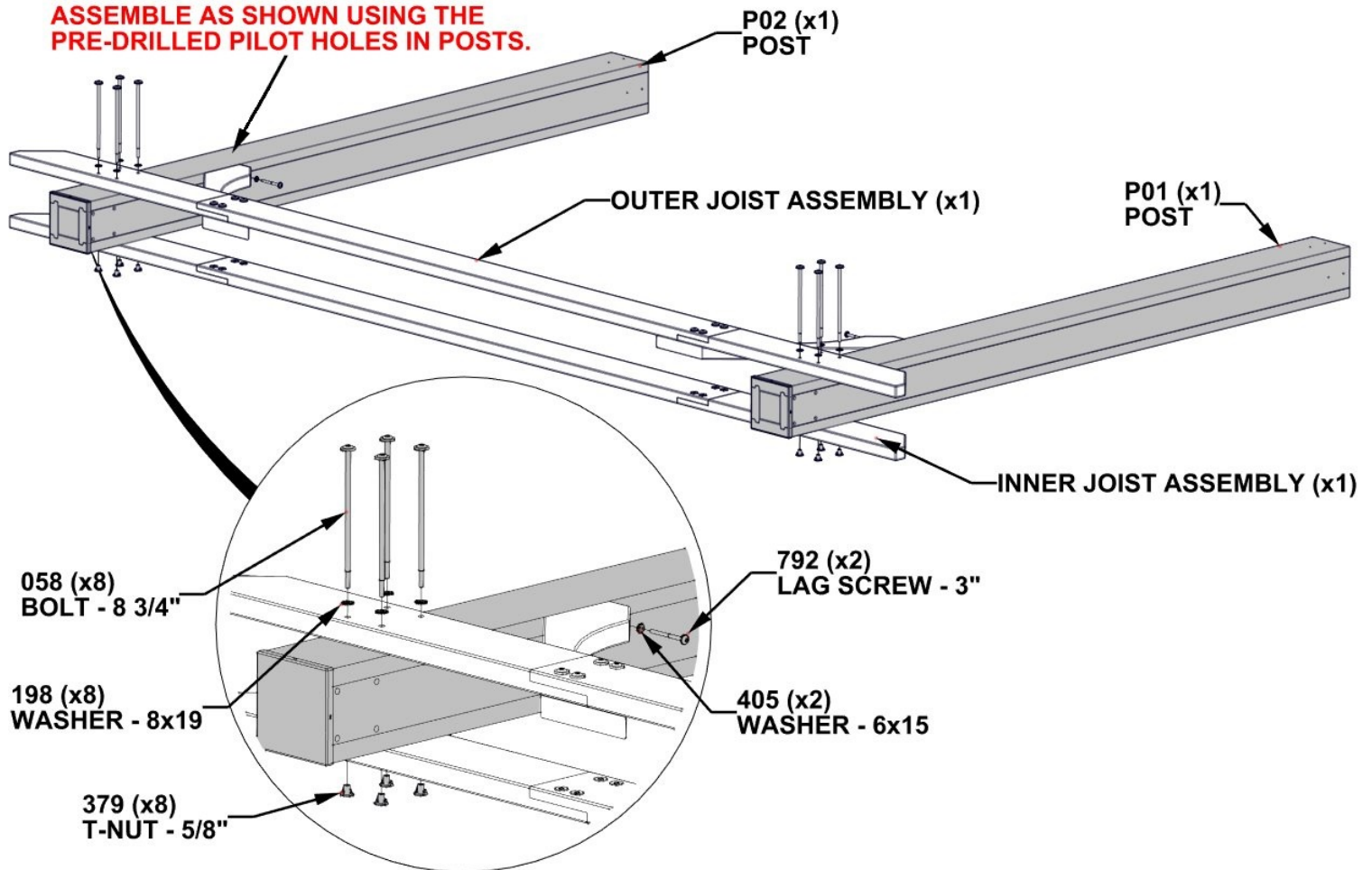

STEP 9 - PERGOLA ASSEMBLY

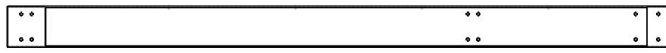

D08 | JOIST - W4L15523
 (1) | 1 3/8"x5 1/4"x87 1/2" (36x134x2223)

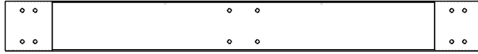

D17 | JOIST - W4L15527
 (1) | 1 3/8"x5 1/4"x51" (36x134x1296)



D11 | CORBEL - W4L15510
 (2) | 1 3/8"x5 1/4"x32 1/2" (36x134x826)

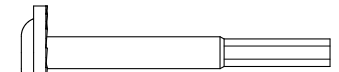

H100195 | BOLT WH BLK
 (8) | 5/16x2 3/4

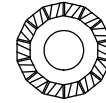

H100198 | WASHER LOCK
 (8) | EXT BLK 8x19

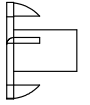

H100379 | T-NUT BLK
 (8) | 5/16x5/8

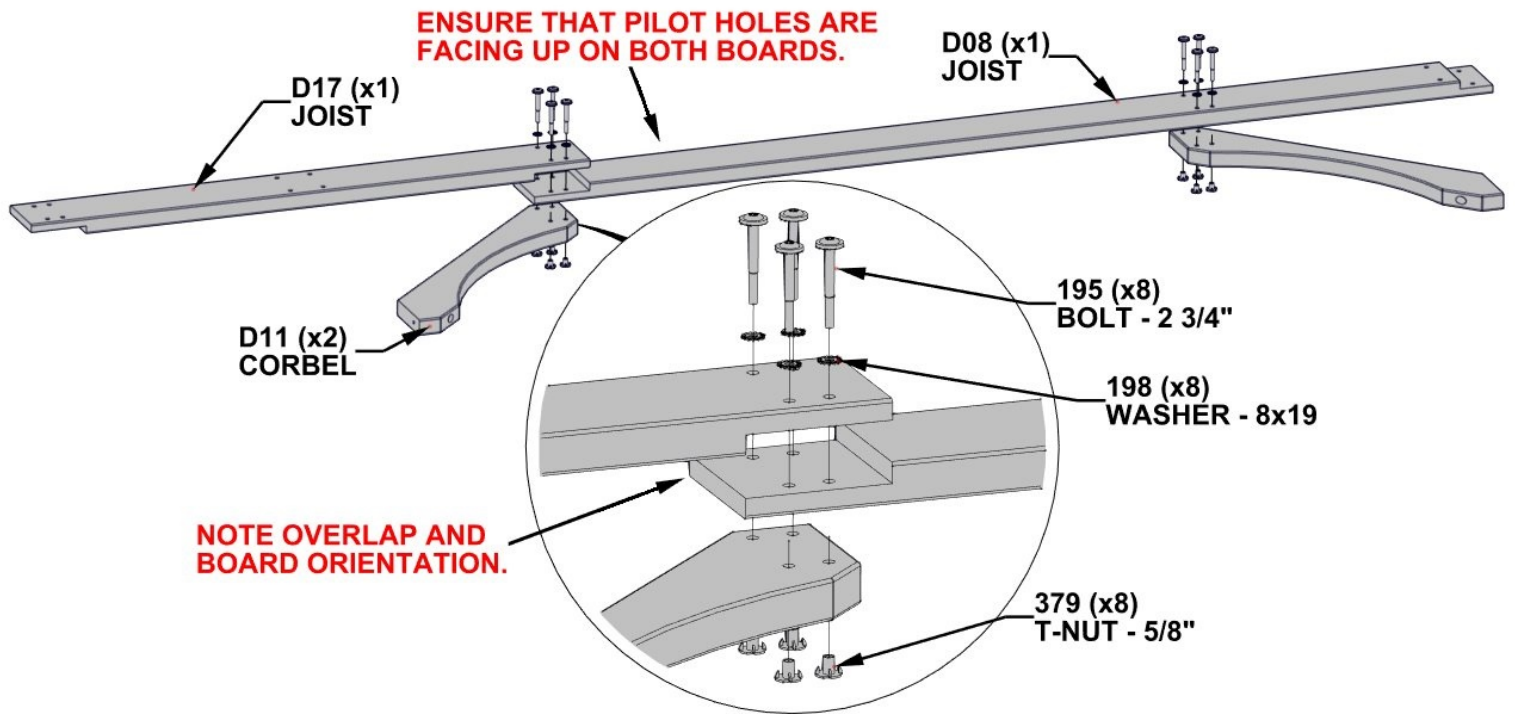

STEP 10 - PERGOLA ASSEMBLY



D16 | JOIST - W4L15526
 (1) | 1 3/8"x5 1/4"x87 1/2" (36x134x2223)

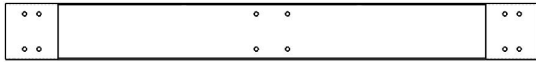

D18 | JOIST - W4L15528
 (1) | 1 3/8"x5 1/4"x51" (36x134x1296)



D11 | CORBEL - W4L15510
 (2) | 1 3/8"x5 1/4"x32 1/2" (36x134x826)

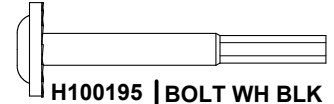

H100195 | BOLT WH BLK
 (8) | 5/16x2 3/4

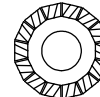

H100198 | WASHER LOCK
 (8) | EXT BLK 8x19

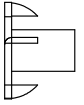

H100379 | T-NUT BLK
 (8) | 5/16x5/8

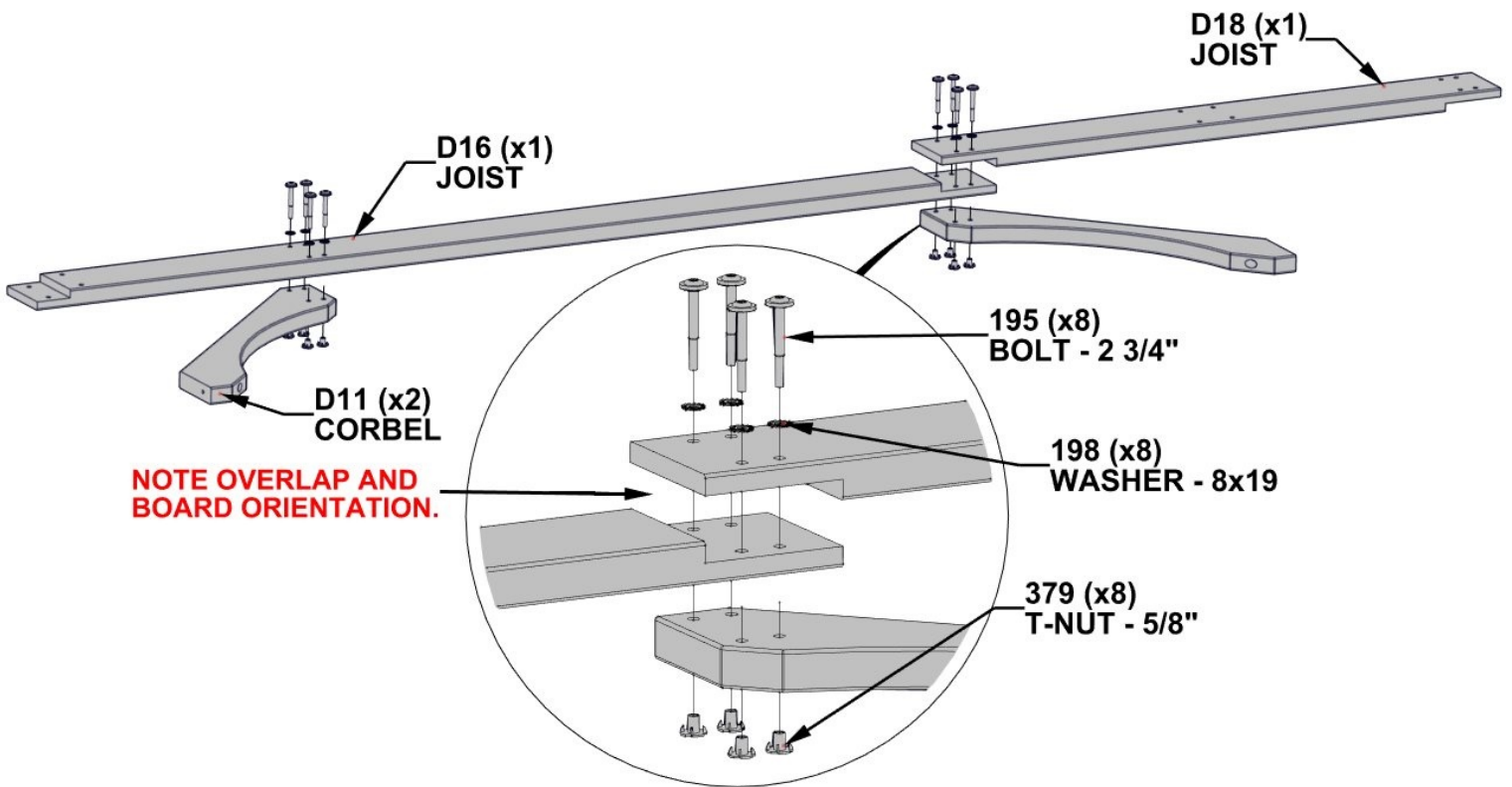

STEP 11 - PERGOLA ASSEMBLY

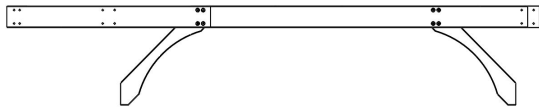

(1) OUTER JOIST ASSEMBLY - FROM STEP 9

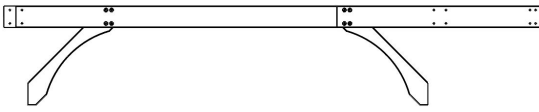

(1) INNER JOIST ASSEMBLY - FROM STEP 10

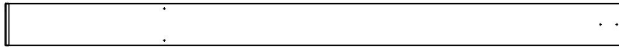

P03 | POST - W2A03244
(1) 6"x6"x89 1/2" (152x152x2274)

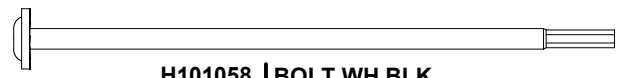

H101058 | BOLT WH BLK
(4) 5/16x8 3/4



H100379 | T-NUT BLK
(4) 5/16x5/8

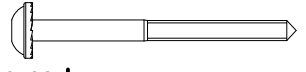

H100792 | LAG SCREW WH BLK
(2) 1/4x3



H100198 | WASHER LOCK
(4) EXT BLK 8x19



H100405 | WASHER LOCK
(2) EXT BLK 6x15

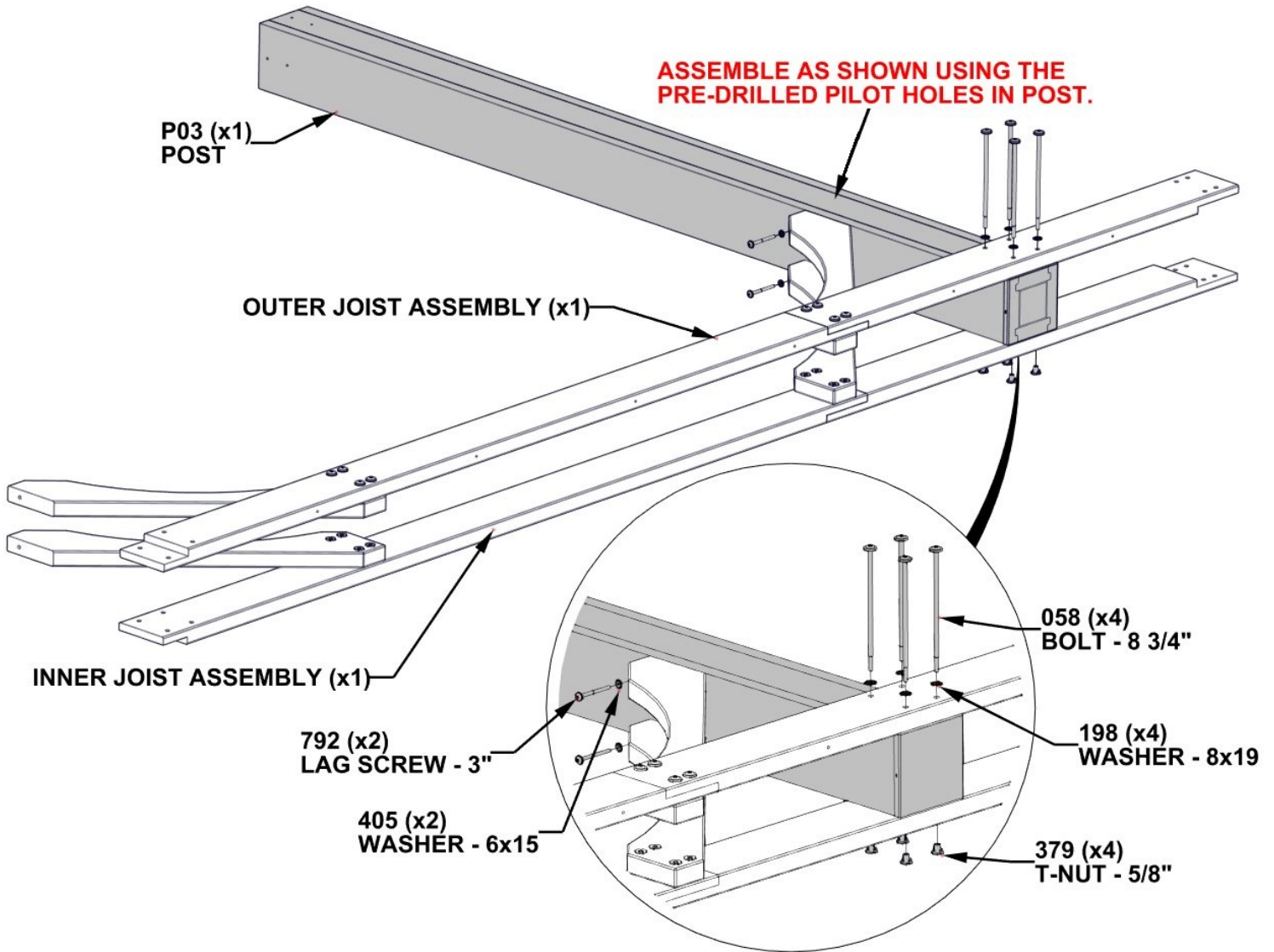

SIDE ASSEMBLY A

STEP 12 - PERGOLA ASSEMBLY



D09 | JOIST - W4L15524
 (1) 1 3/8"x5 1/4"x87 1/2" (36x134x2223)

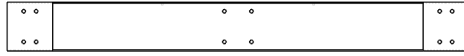

D17 | JOIST - W4L15527
 (1) 1 3/8"x5 1/4"x51" (36x134x1296)



D11 | CORBEL - W4L15510
 (2) 1 3/8"x5 1/4"x32 1/2" (36x134x826)

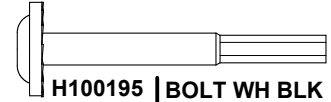

H100195 | BOLT WH BLK
 (8) 5/16x2 3/4

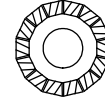

H100198 | WASHER LOCK
 (8) EXT BLK 8x19

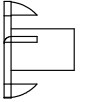

H100379 | T-NUT BLK
 (8) 5/16x5/8

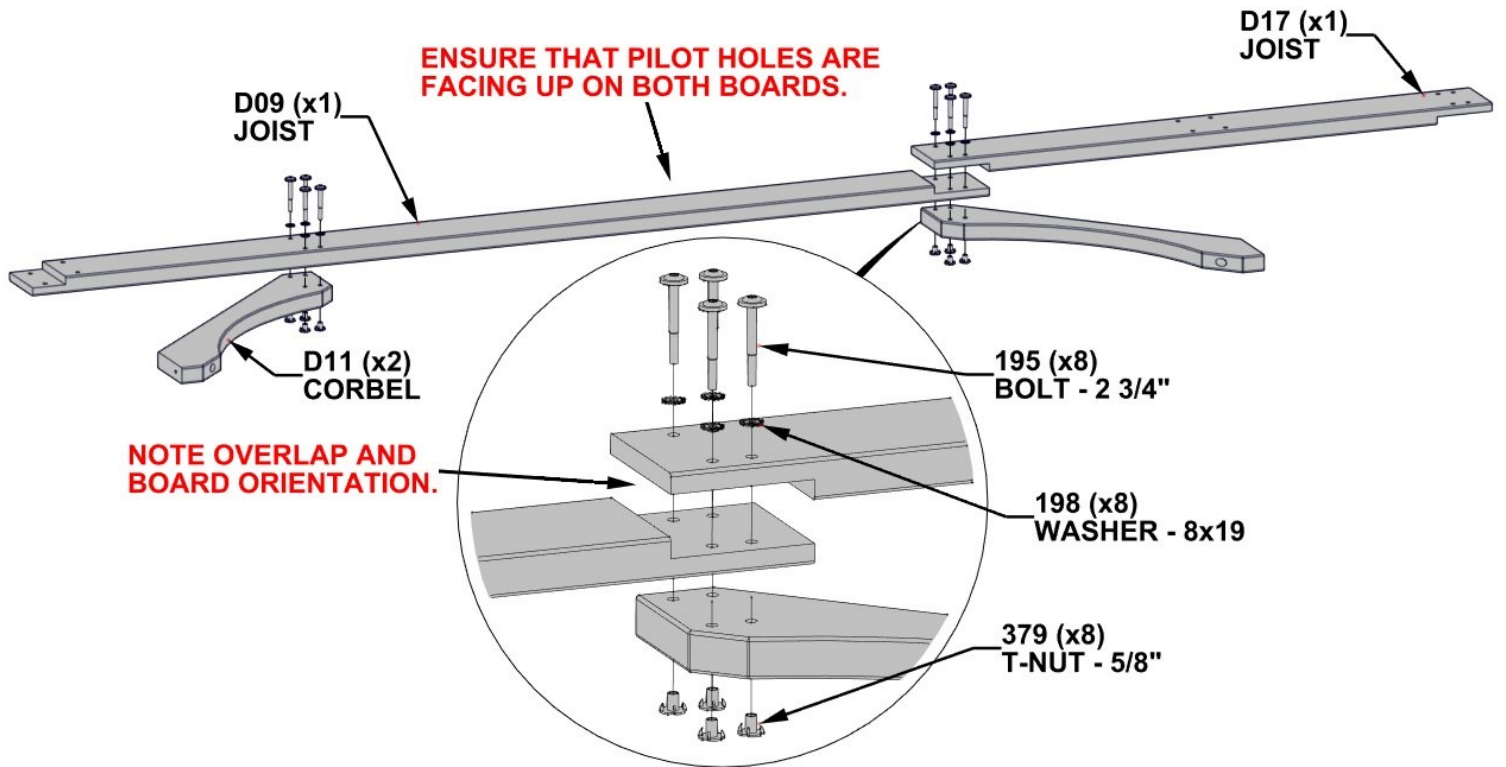

STEP 13 - PERGOLA ASSEMBLY



D10 | JOIST - W4L15525
 (1) | 1 3/8"x5 1/4"x87 1/2" (36x134x2223)

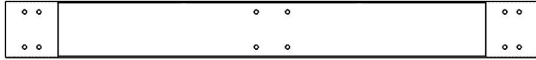

D18 | JOIST - W4L15528
 (1) | 1 3/8"x5 1/4"x51" (36x134x1296)



D11 | CORBEL - W4L15510
 (2) | 1 3/8"x5 1/4"x32 1/2" (36x134x826)

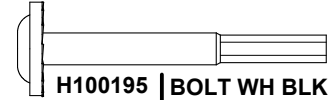

H100195 | BOLT WH BLK
 (8) | 5/16x2 3/4

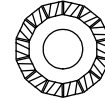

H100198 | WASHER LOCK
 (8) | EXT BLK 8x19

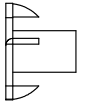

H100379 | T-NUT BLK
 (8) | 5/16x5/8

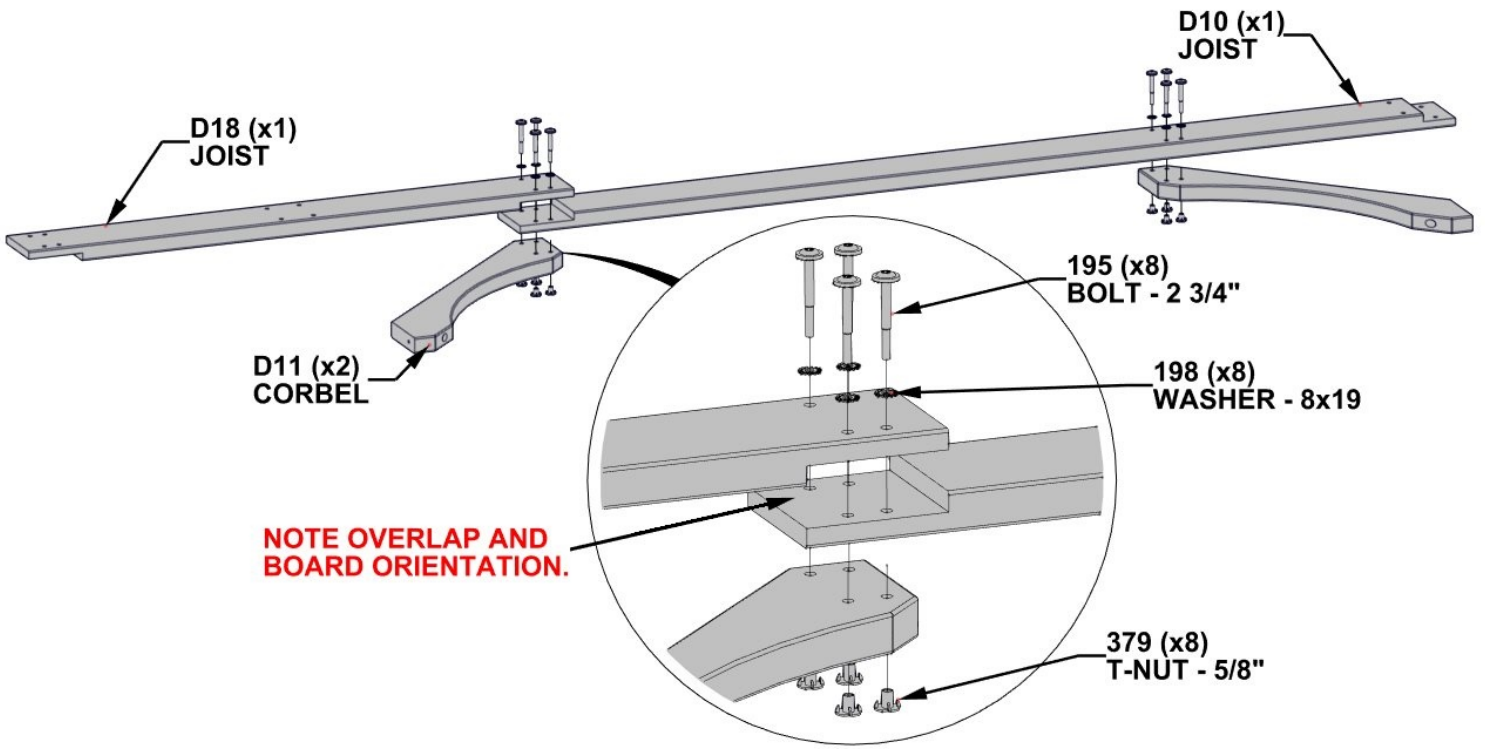

STEP 14 - PERGOLA ASSEMBLY

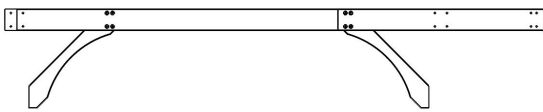

(1) OUTER JOIST ASSEMBLY - FROM STEP 12

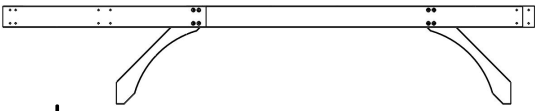

(1) INNER JOIST ASSEMBLY - FROM STEP 13

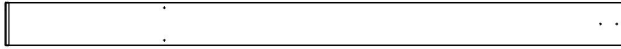

P03 | POST - W2A03244

(1) 6"x6"x89 1/2" (152x152x2274)

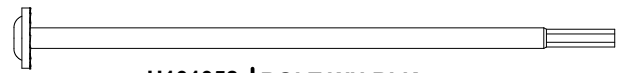

H101058 | BOLT WH BLK
(4) 5/16x8 3/4



H100379 | T-NUT BLK
(4) 5/16x5/8

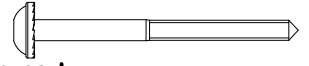

H100792 | LAG SCREW WH BLK
(2) 1/4x3



H100198 | WASHER LOCK
(4) EXT BLK 8x19



H100405 | WASHER LOCK
(2) EXT BLK 6x15

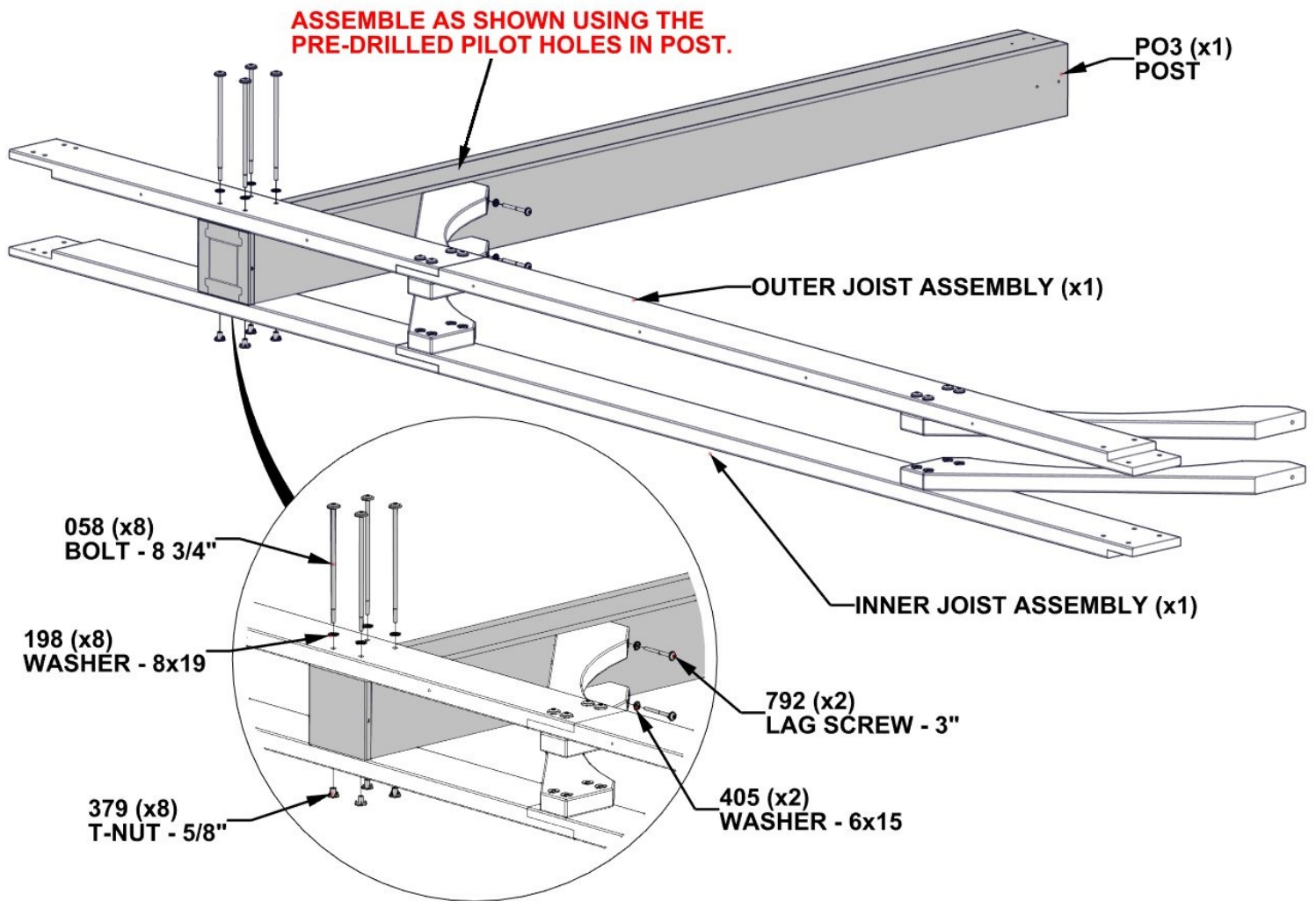

SIDE ASSEMBLY B

STEP 15 - PERGOLA ASSEMBLY

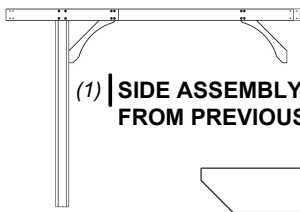

(1) SIDE ASSEMBLY A
FROM PREVIOUS STEPS

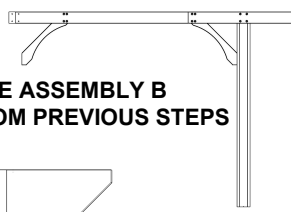

(1) SIDE ASSEMBLY B
FROM PREVIOUS STEPS

D03 JOIST END - W4L15502
(1) 1 3/8"x5 1/4"x15" (36x134x382)

D04 JOIST END - W4L15503
(1) 1 3/8"x5 1/4"x15" (36x134x382)

D05 JOIST END - W4L15529
(1) 1 3/8"x5 1/4"x15" (36x134x382)

D06 JOIST END - W4L15530
(1) 1 3/8"x5 1/4"x15" (36x134x382)

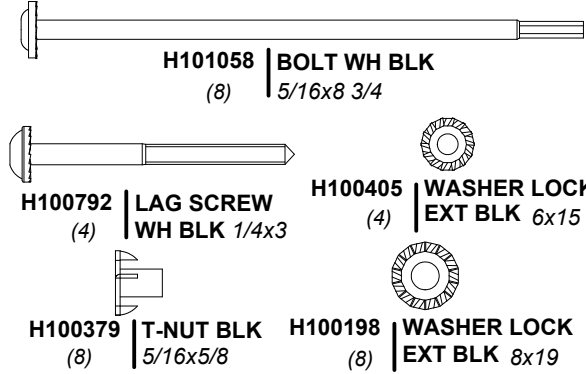

STAND UP THE UPRIGHT ASSEMBLY AND ATTACH ONE SIDE ASSEMBLY AT A TIME. ENSURE THAT THE SIDE ASSEMBLIES ARE ORIENTED CORRECTLY.

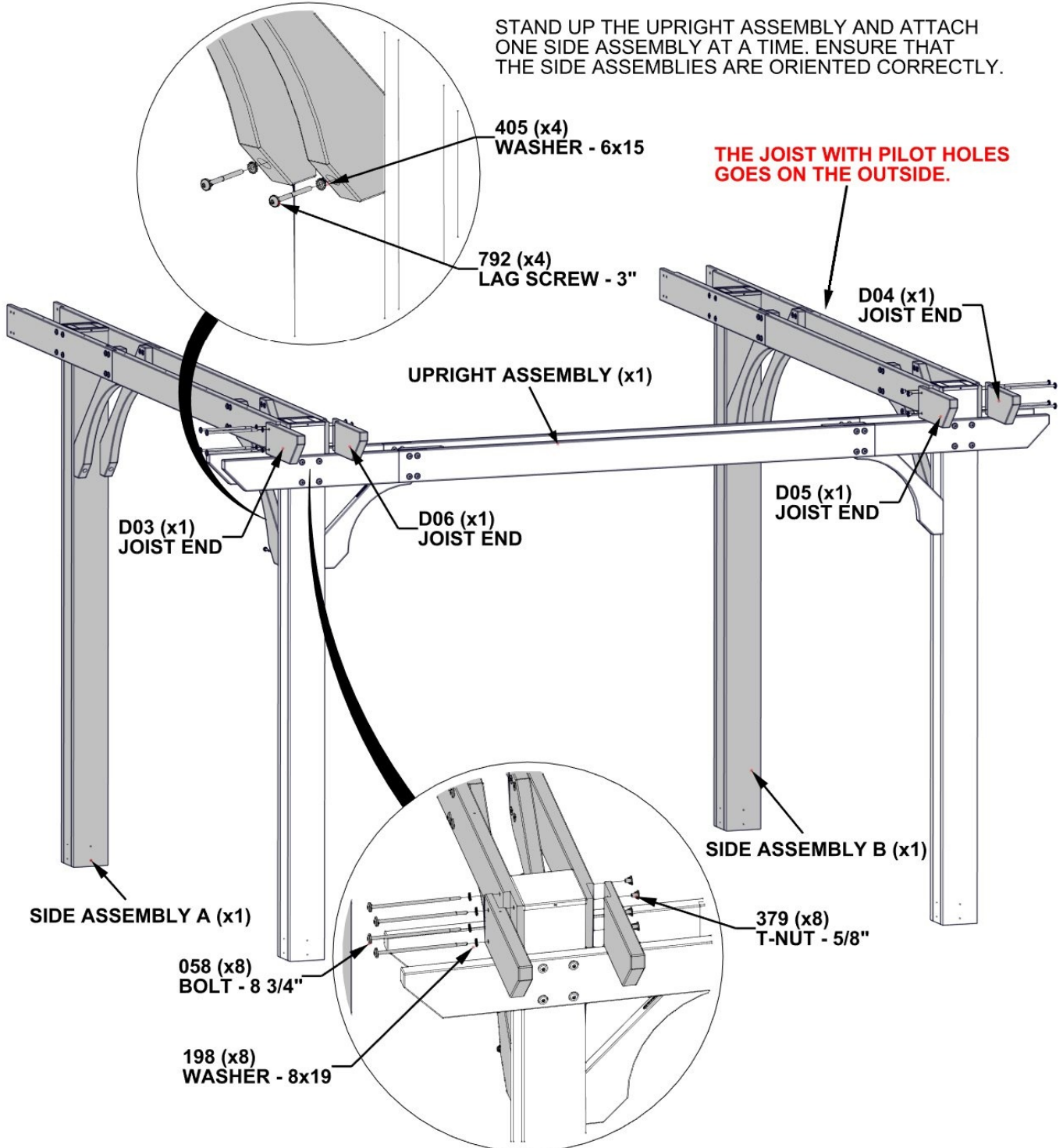

NOTE: A THIRD PERSON MAY BE HELPFUL.

STEP 16 A - PERGOLA ASSEMBLY

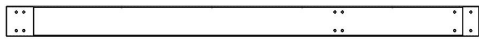

D08 | JOIST - W4L15523
(1) | 1 3/8"x5 1/4"x87 1/2" (36x134x2223)

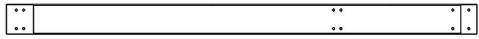

D10 | JOIST - W4L15525
(1) | 1 3/8"x5 1/4"x87 1/2" (36x134x2223)

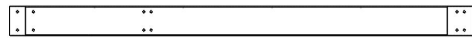

D09 | JOIST - W4L15524
(1) | 1 3/8"x5 1/4"x87 1/2" (36x134x2223)

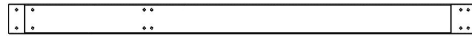

D16 | JOIST - W4L15526
(1) | 1 3/8"x5 1/4"x87 1/2" (36x134x2223)

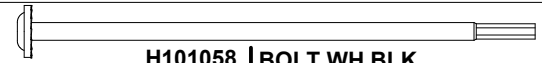

H101058 | BOLT WH BLK
(4) | 5/16x8 3/4

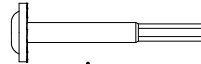

H100195 | BOLT WH BLK
(16) | 5/16x2 3/4



H100198 | WASHER LOCK
(4) | EXT BLK 8x19



H100379 | T-NUT BLK
(4) | 5/16x5/8

STAND UP UPRIGHT ASSEMBLY, THEN PUT D09 INTO POSITION AS SHOWN. ATTACH JOISTS AS SHOWN IN THE NUMBERED ORDER.

INSERT BOLTS INTO BOLT HOLES TO HOLD THE ASSEMBLY TOGETHER UNTIL THE NEXT STEP.

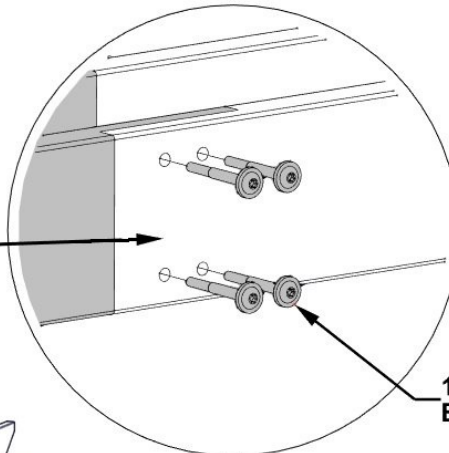

**195 (x16)
BOLT - 2 3/4"**

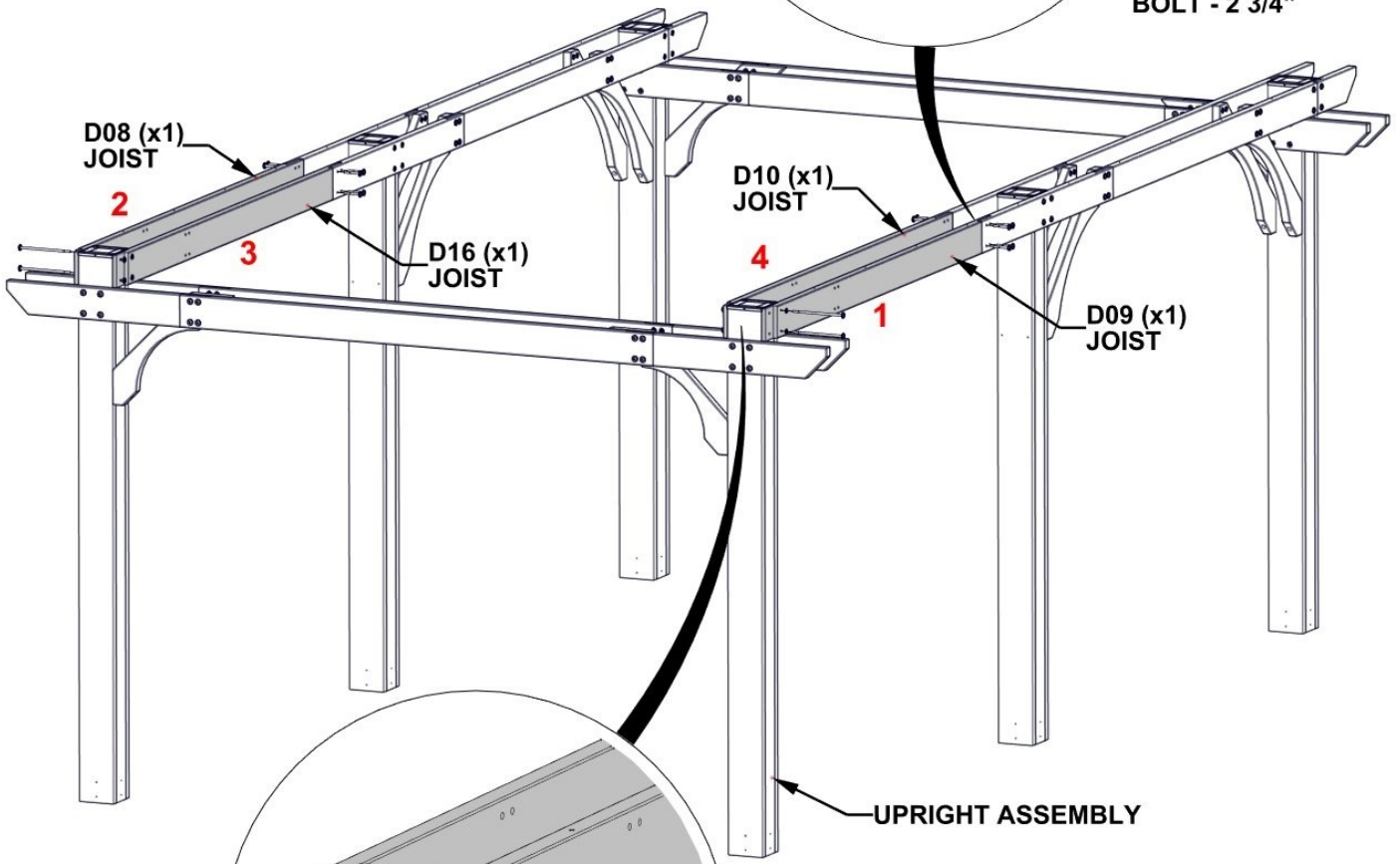

**D08 (x1)
JOIST**

2

3

**D16 (x1)
JOIST**

**D10 (x1)
JOIST**

4

**D09 (x1)
JOIST**

UPRIGHT ASSEMBLY

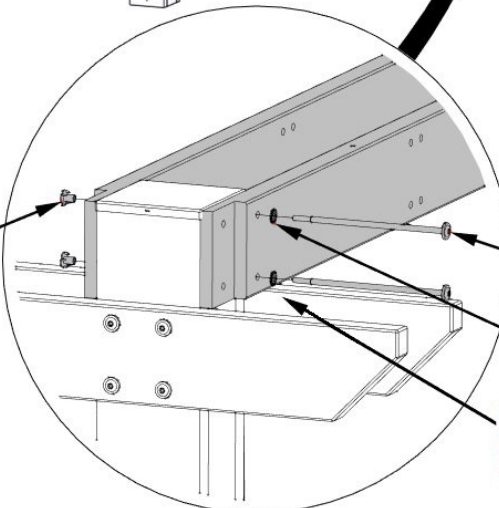

**379 (x4)
T-NUT - 5/8"**

**058 (x4)
BOLT - 8 3/4"**

**198 (x4)
WASHER - 8x19**

INSERT BOLTS WITH WASHERS ON TO HOLD THE ASSEMBLY IN POSITION UNTIL INNER JOISTS ARE ATTACHED, THEN TIGHTEN BOLTS WITH T-NUTS.

STEP 16 B - PERGOLA ASSEMBLY

- D03** | JOIST END - W4L15502
(1) 1 3/8"x5 1/4"x15" (36x134x382)
- D04** | JOIST END - W4L15503
(1) 1 3/8"x5 1/4"x15" (36x134x382)
- D05** | JOIST END - W4L15529
(1) 1 3/8"x5 1/4"x15" (36x134x382)
- D06** | JOIST END - W4L15530
(1) 1 3/8"x5 1/4"x15" (36x134x382)
- D11** | CORBEL - W4L15510
(8) 1 3/8"x5 1/4"x32 1/2" (36x134x826)

- H101058** | BOLT WH BLK
(4) 5/16x8 3/4
- H100195** | BOLT WH BLK
(16) 5/16x2 3/4
- H100792** | LAG SCREW WH BLK
(8) 1/4x3
- H100405** | WASHER LOCK
(8) EXT BLK 6x15
- H100198** | WASHER LOCK
(36) EXT BLK 8x19
- H100379** | T-NUT BLK
(36) 5/16x5/8

ATTACH CORBELS BEFORE ATTACHING JOIST ENDS.

ATTACH ONE CORBEL AT A TIME BY REMOVING BOLTS FROM ONE JOIST AND BOLTING THEM BACK ON WITH WASHER AND T-NUT.

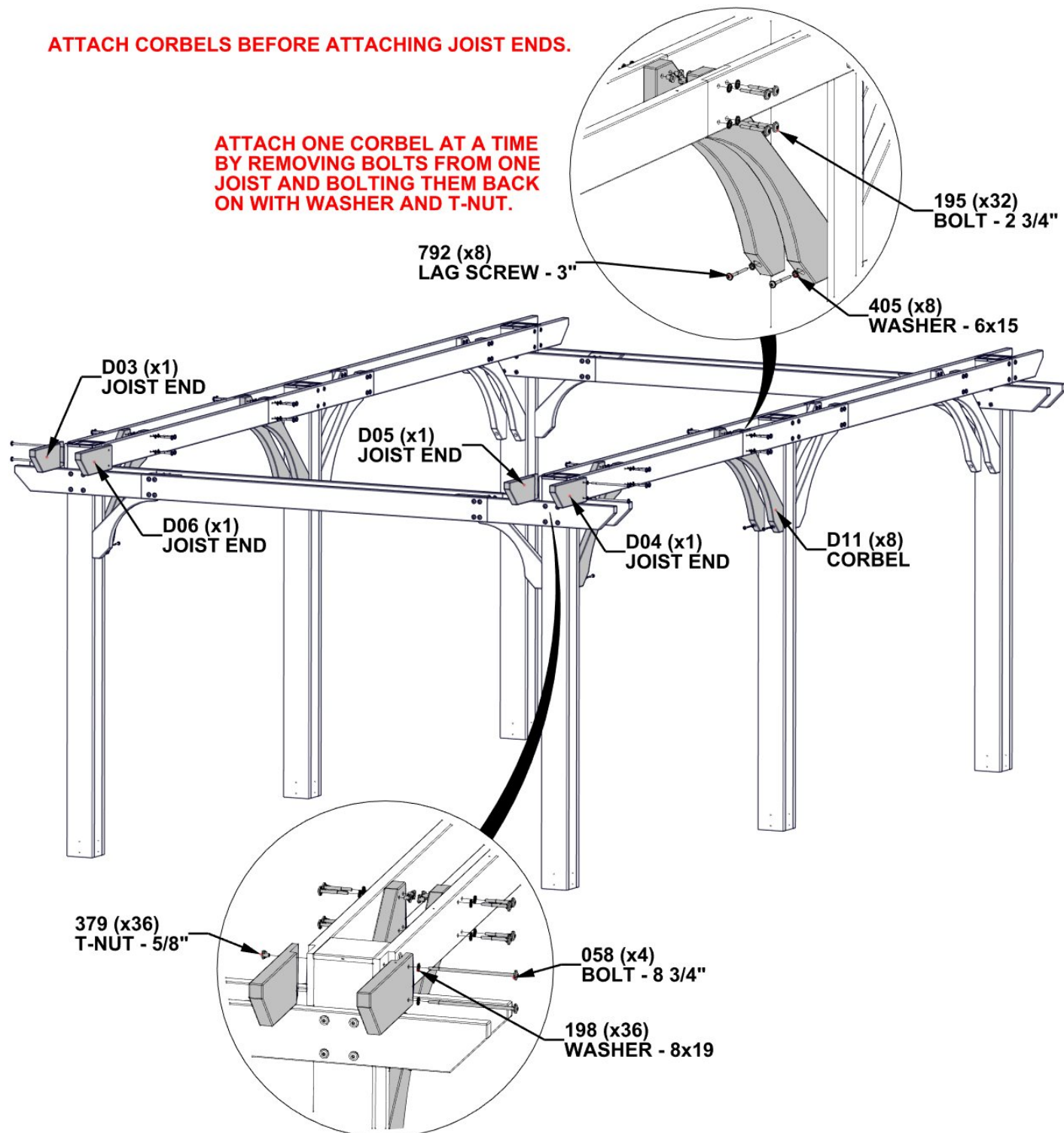

STEP 17 - PERGOLA ASSEMBLY



D14 | SLOTTED JOIST - W4L15515
(12) | 1 3/8"x5 1/4"x55 3/4" (36x134x1416)

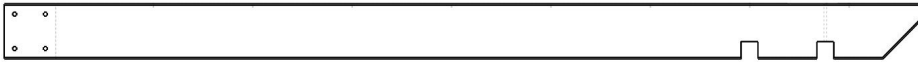

D15 | SLOTTED JOIST - W4L15517
(12) | 1 3/8"x5 1/4"x89 1/2" (36x134x2274)

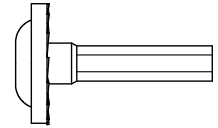

H100459 | BOLT WH BLK
(48) | 5/16x1 1/4

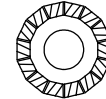

H100198 | WASHER LOCK
(48) | EXT BLK 8x19



H100379 | T-NUT BLK
(48) | 5/16x5/8

COMPLETE THIS STEP TWELVE TIMES.

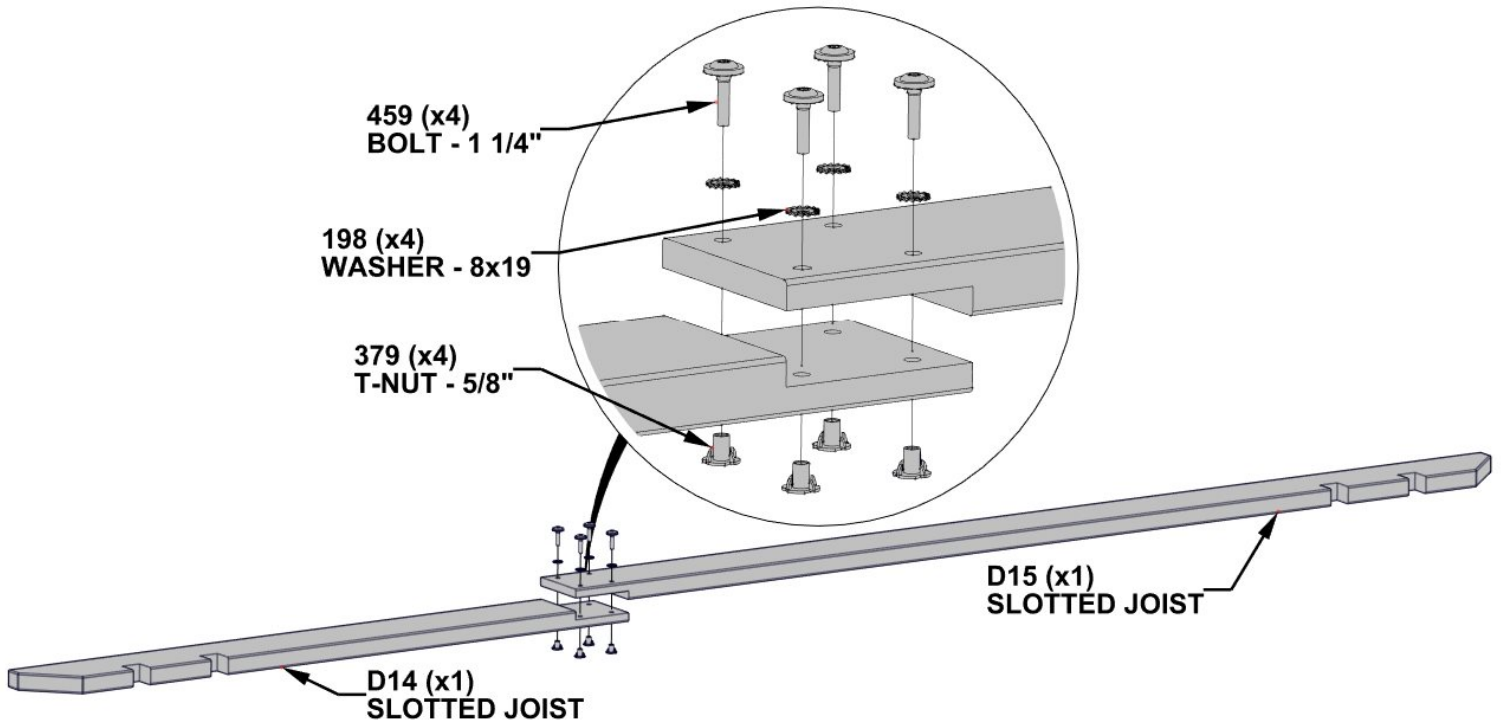

STEP 18 - PERGOLA ASSEMBLY

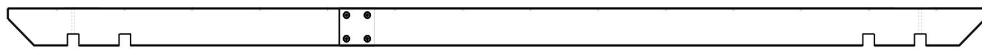

(12) | SLOTTED JOIST ASSEMBLY - FROM STEP 14

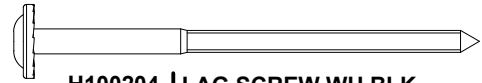

H100204 | LAG SCREW WH BLK
(24) | 5/16x5 1/2



H100198 | WASHER LOCK
(24) | EXT BLK 8x19

**ATTACH SLOTTED JOIST ASSEMBLIES USING
PILOT HOLES IN OUTER JOIST ASSEMBLY.**

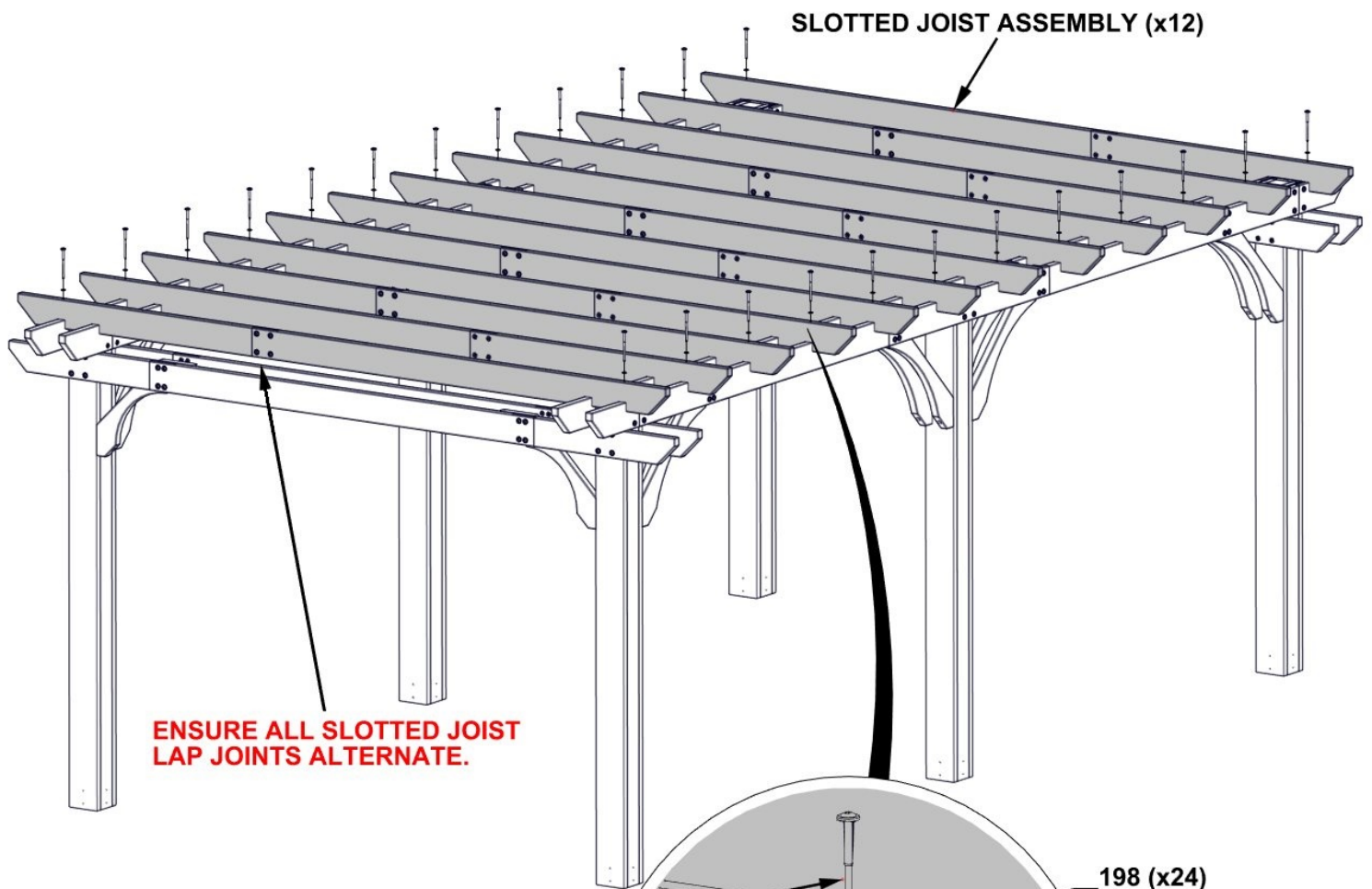

SLOTTED JOIST ASSEMBLY (x12)

**ENSURE ALL SLOTTED JOIST
LAP JOINTS ALTERNATE.**

204 (x24)
LAG SCREW - 5 1/2"

198 (x24)
WASHER - 8x19

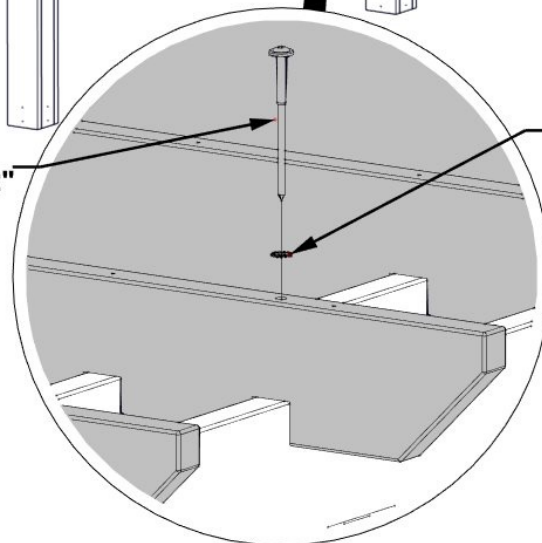

STEP 19 - PERGOLA ASSEMBLY



P10 | PURLIN END - W4L15531
 (28) | 1 3/8"x1 3/8"x85 1/2" (36x36x2171)



P11 | PURLIN - W4L15532
 (14) | 1 3/8"x1 3/8"x60 3/4" (36x36x1542)

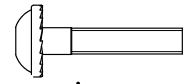

H100397 | BOLT WH BLK
 (28) | 1/4x1 1/4



H100405 | WASHER LOCK
 (28) | EXT BLK 6x15



H100398 | T-NUT BLK
 (28) | 1/4x7/16

COMPLETE THIS STEP FOURTEEN TIMES.

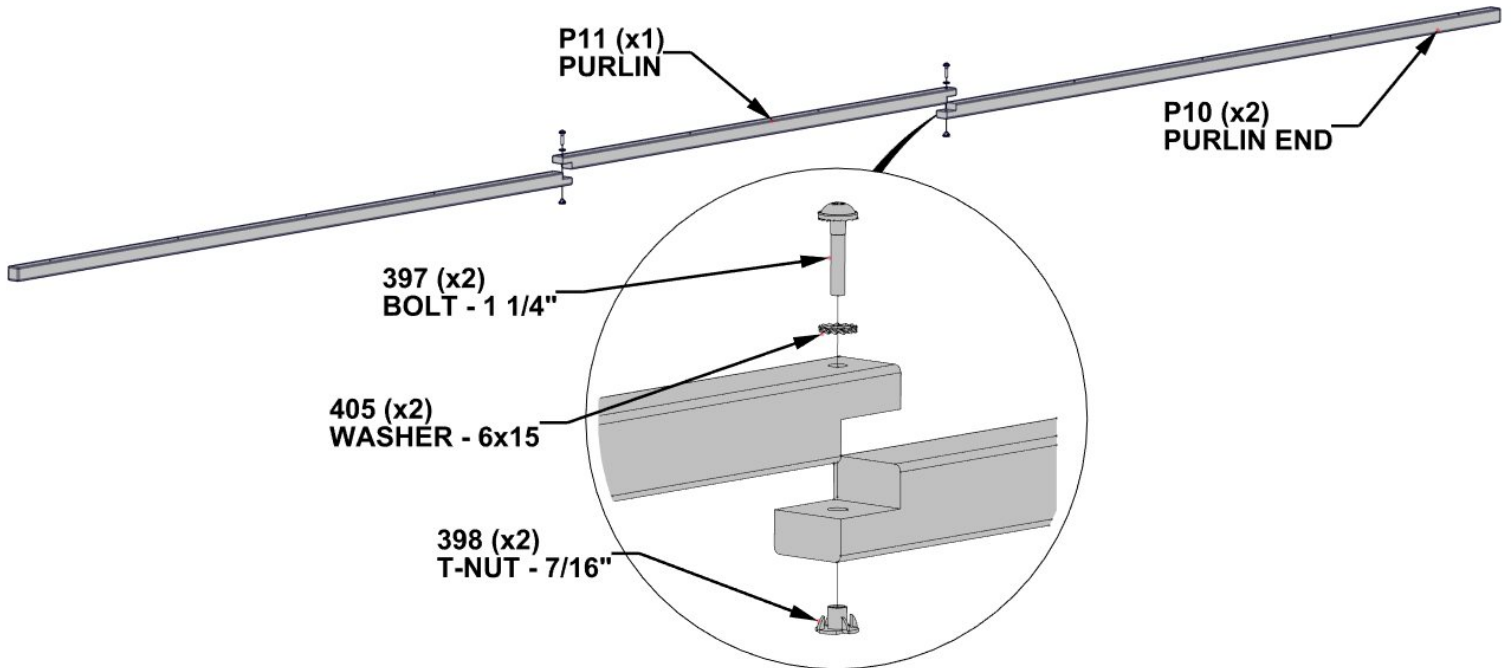

STEP 20 - PERGOLA ASSEMBLY

(14) PURLIN ASSEMBLY - FROM PREVIOUS STEPS



H100201 | SCREW PFH BLK
(140) | 8x2 1/2

WHEN LIFTING UP EACH PURLIN ASSEMBLY ENSURE THAT JOINTS ARE SUPPORTED AND PURLIN IS KEPT LEVEL.

PURLIN ASSEMBLY (x14)

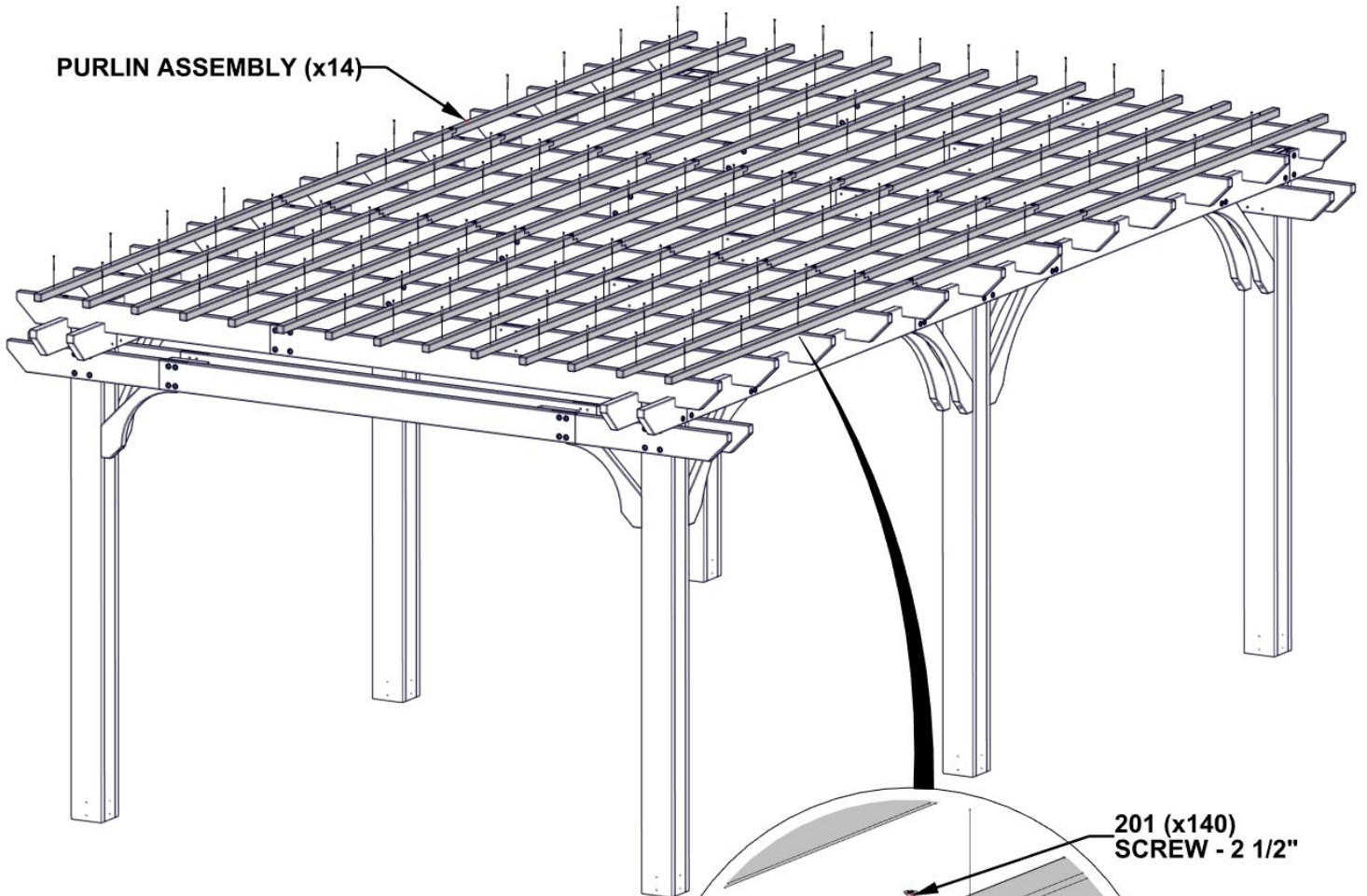

ATTACH PURLIN ASSEMBLIES USING PILOT HOLES IN SLOTTED JOIST ASSEMBLIES.

201 (x140)
SCREW - 2 1/2"

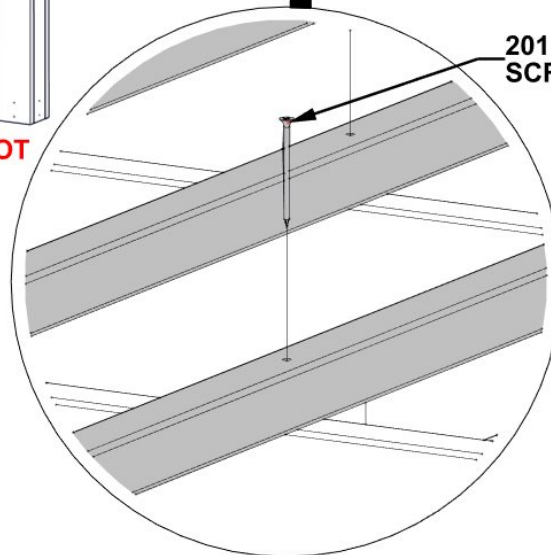

STEP 21 - PERGOLA ASSEMBLY

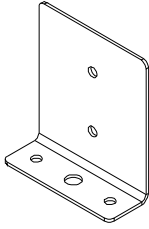

A4M00977 | POST ANCHORING PLATE
(12)

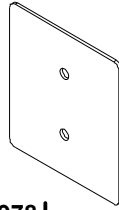

A4M00978 | POST PLATE
(12)

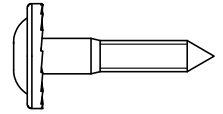

H100471 | LAG SCREW WH BLK
(48) 5/16x1 1/2

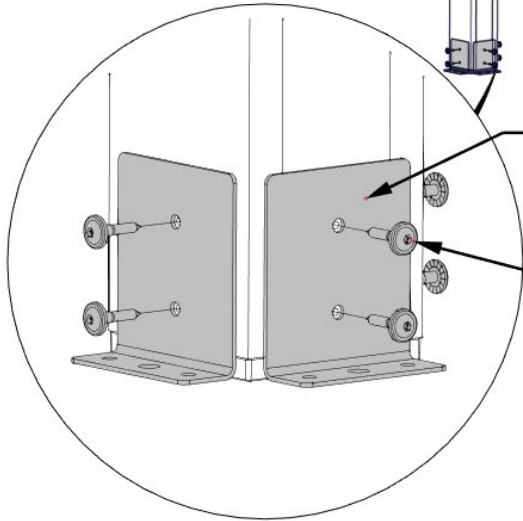
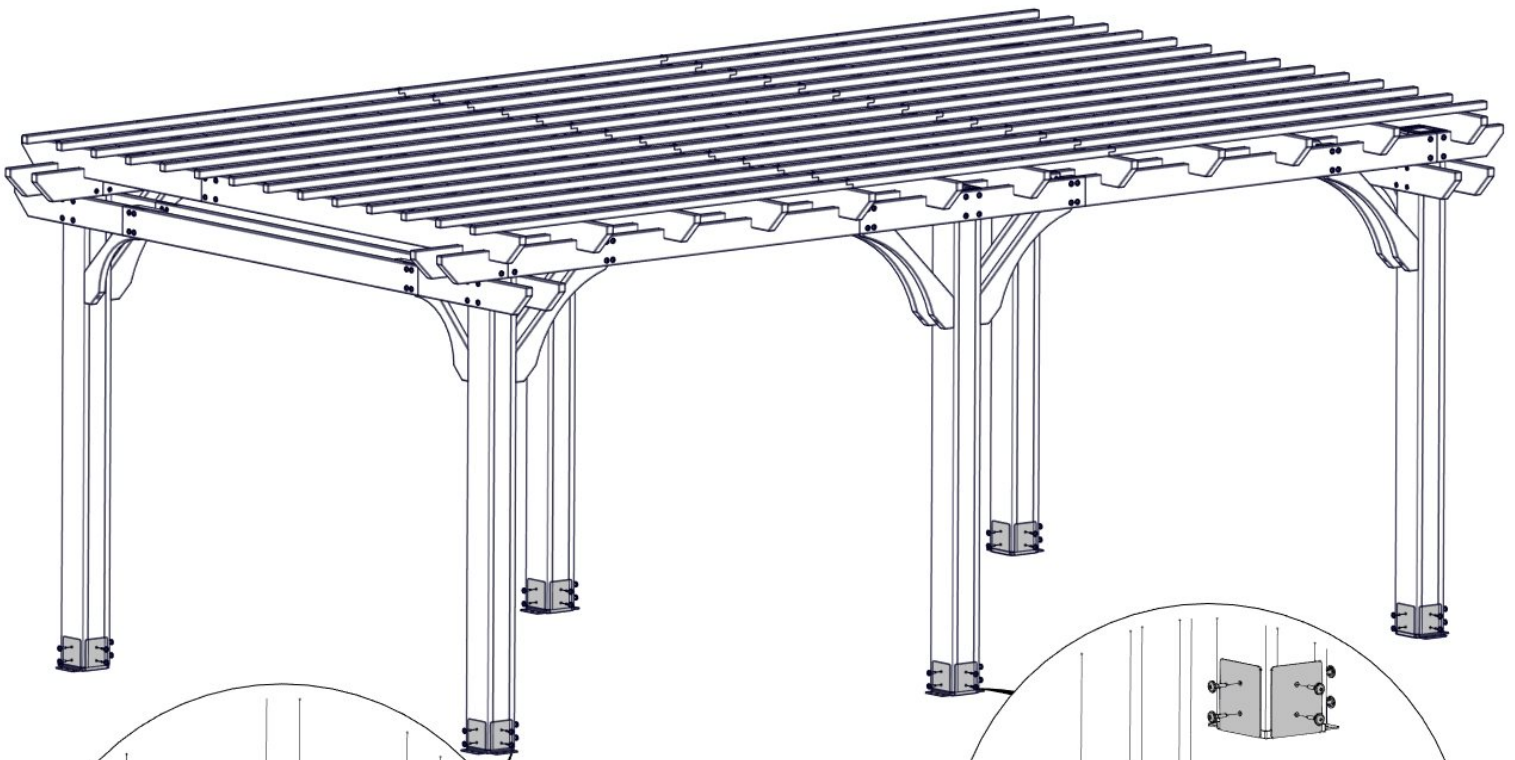

977 (x12)
POST ANCHORING PLATE

471 (x48)
LAG SCREW - 1 1/2"

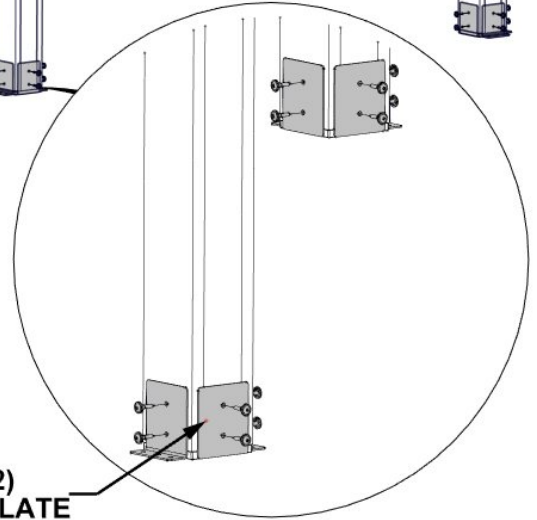

978 (x12)
POST PLATE

STEP 22 - PERGOLA ASSEMBLY



A4M02158 | BYD ID TAG PATIO
(1)

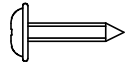

H100202 | SCREW PWH BLK
(4) | 8x5/8

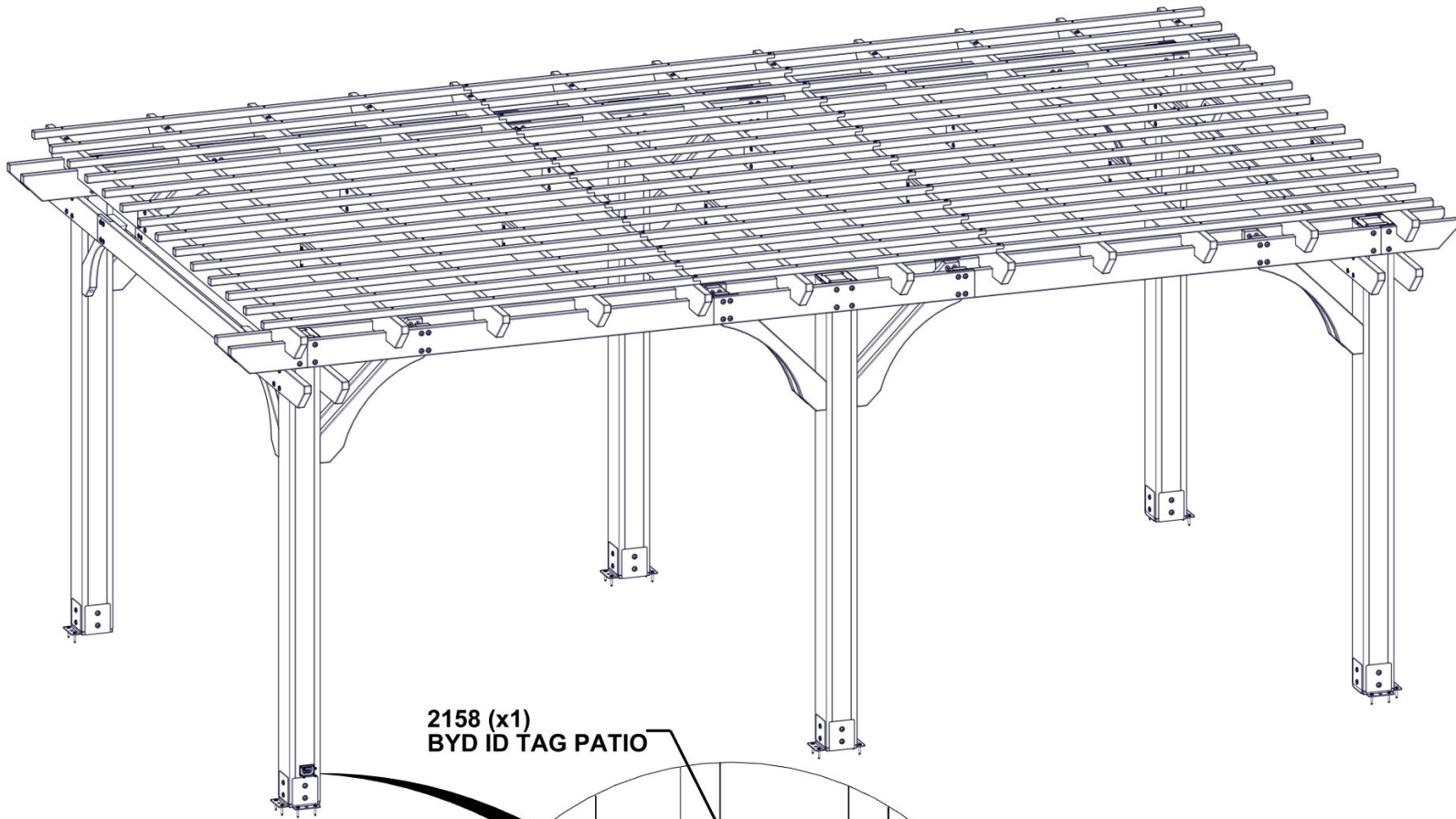

**2158 (x1)
BYD ID TAG PATIO**

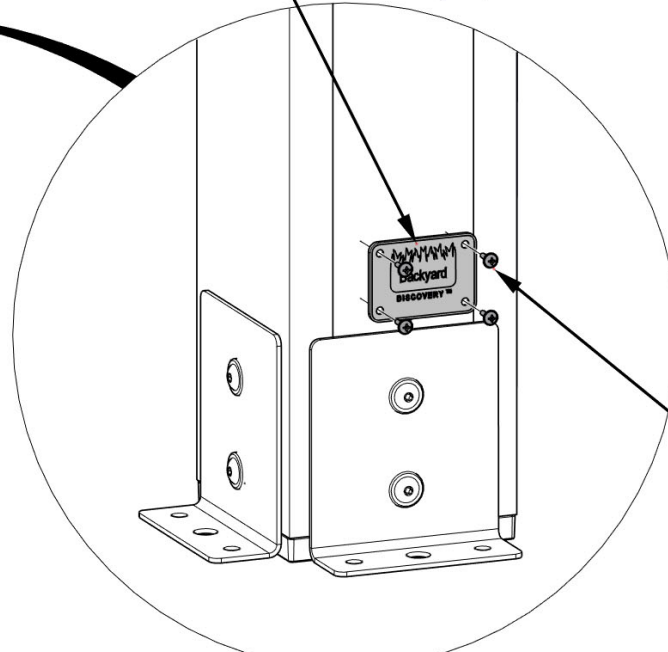

**202 (x4)
SCREW - 5/8"**

STEP 23 - PERGOLA ASSEMBLY

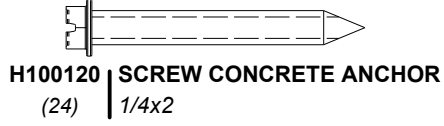

MANUFACTURER RECOMMENDS INSTALLATION ON CONCRETE SURFACE OR CONCRETE POST PAD AS SHOWN BELOW.

FOR INSTALLATION ON WOOD DECKS, YOU MUST ENSURE THERE IS AMPLE STRUCTURAL SUPPORT UNDER THE DECK. HARDWARE NOT INCLUDED FOR DECK ATTACHMENT.

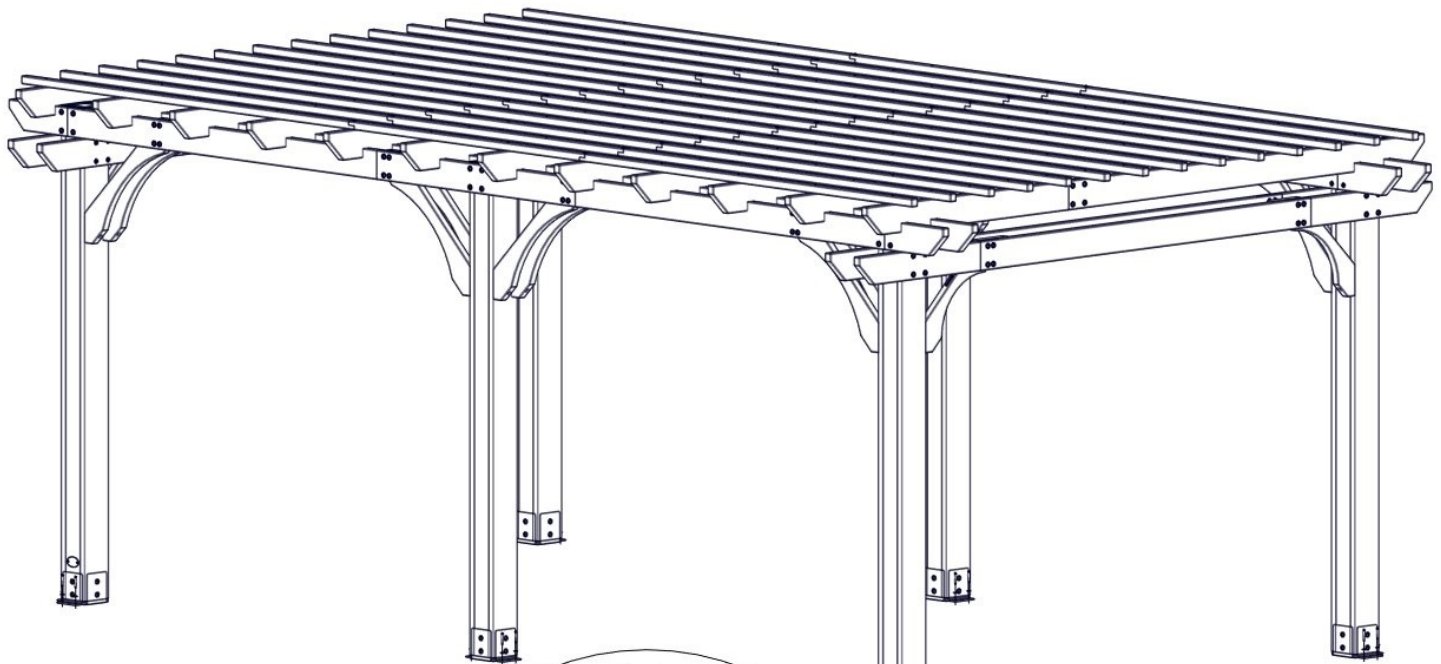

120 (x24)
SCREW - 2"

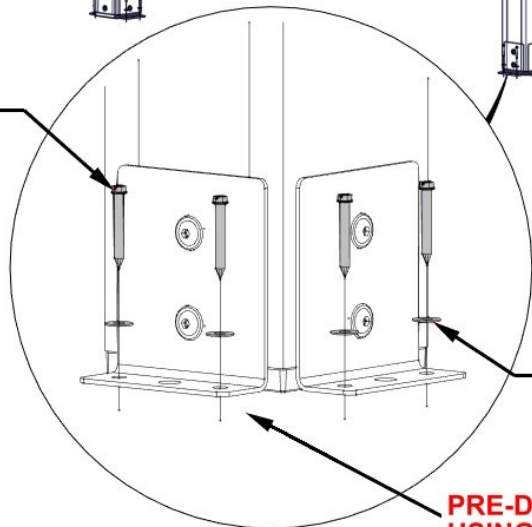

630 (x24)
WASHER - 8x19

PRE-DRILL HOLES FOR CONCRETE ANCHORS USING A 3/16" CONCRETE DRILL BIT.

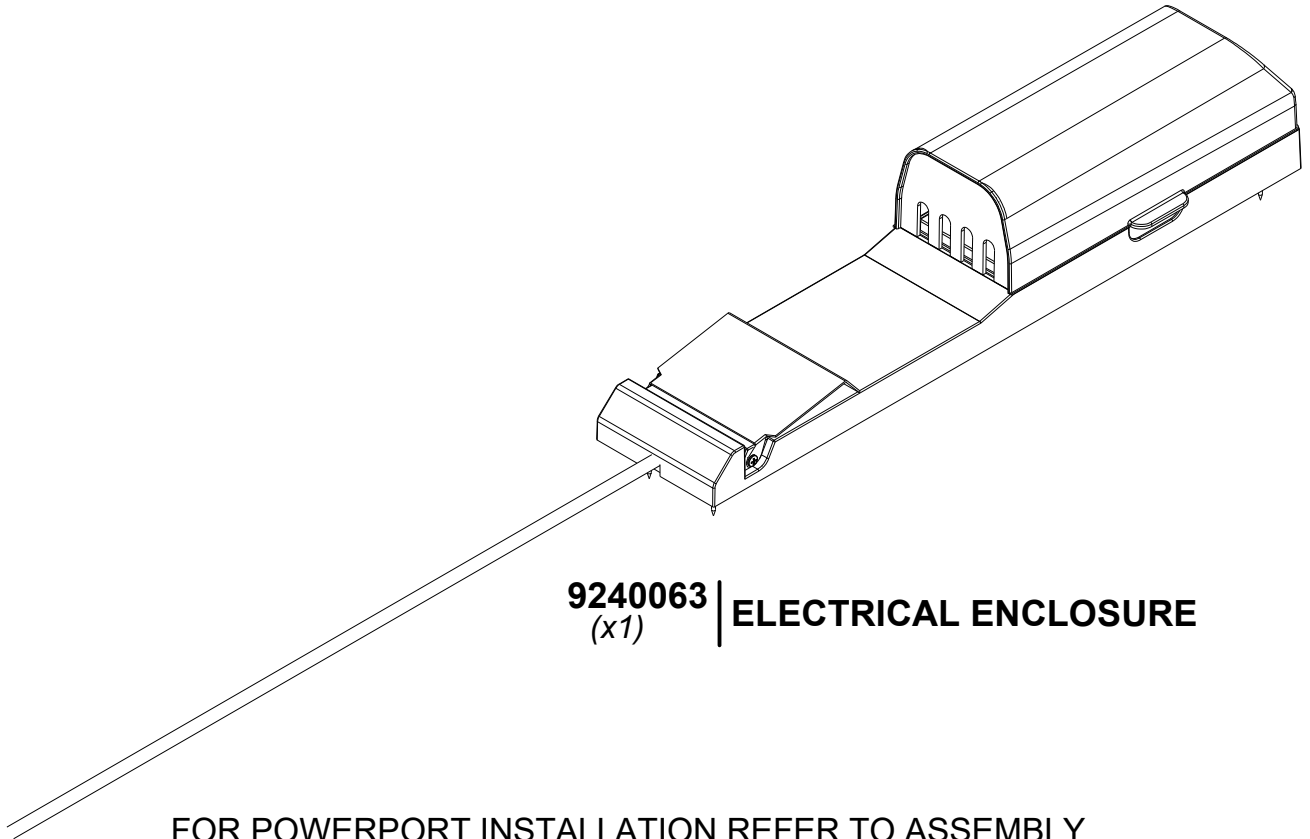

9240063 | **ELECTRICAL ENCLOSURE**
(x1)

FOR POWERPORT INSTALLATION REFER TO ASSEMBLY INSTRUCTIONS THAT COME PACKAGED WITH THE ELECTRICAL ENCLOSURE KIT. INSTALL ON ANY POST THAT IS DESIRED. FOLLOW DIRECTIONS FOR PROPER INSTALLATION.