



**MANUFACTURED BY:**  
**Backyard Discovery**  
 3305 Airport Drive, Pittsburg, KS 66762  
 800-856-4445

Basepoint Business Centre: Rivermead Drive, Westlea, Swindon SN5 7EX Phone: 0800-118-2476  
 J.P. Coenstraat 7, The Bridge, The Hague, 2595 WP, Netherlands Phone: 0800-567-8990

# 10x10 PERGOLA

## PERGOLA

### Model # 1505513

The assembly manual must be retained since it contains important information



**Please visit [www.backyarddiscovery.com](http://www.backyarddiscovery.com)**

For the most up to date assembly manual, to register your set, or to order replacement parts  
*Para obtener instrucciones en español, visite [www.backyarddiscovery.com](http://www.backyarddiscovery.com)*



**EASY STEP-BY-STEP**  
**3D INTERACTIVE INSTRUCTIONS**

DOWNLOAD THE FREE APP



**INSTALLATION SERVICES AVAILABLE!**  
*See inside for details*

Made in China

INS-1505513-A-(10x10) PERGOLA-ENG 3-10-22

# Basic Setup Dimensions

Place the set on level ground, concrete or grass. Backyard Discovery recommends at least 6 ft [2 m] from any structure or obstruction such as a fence, garage, house, overhanging branches, laundry lines, or electrical wires.

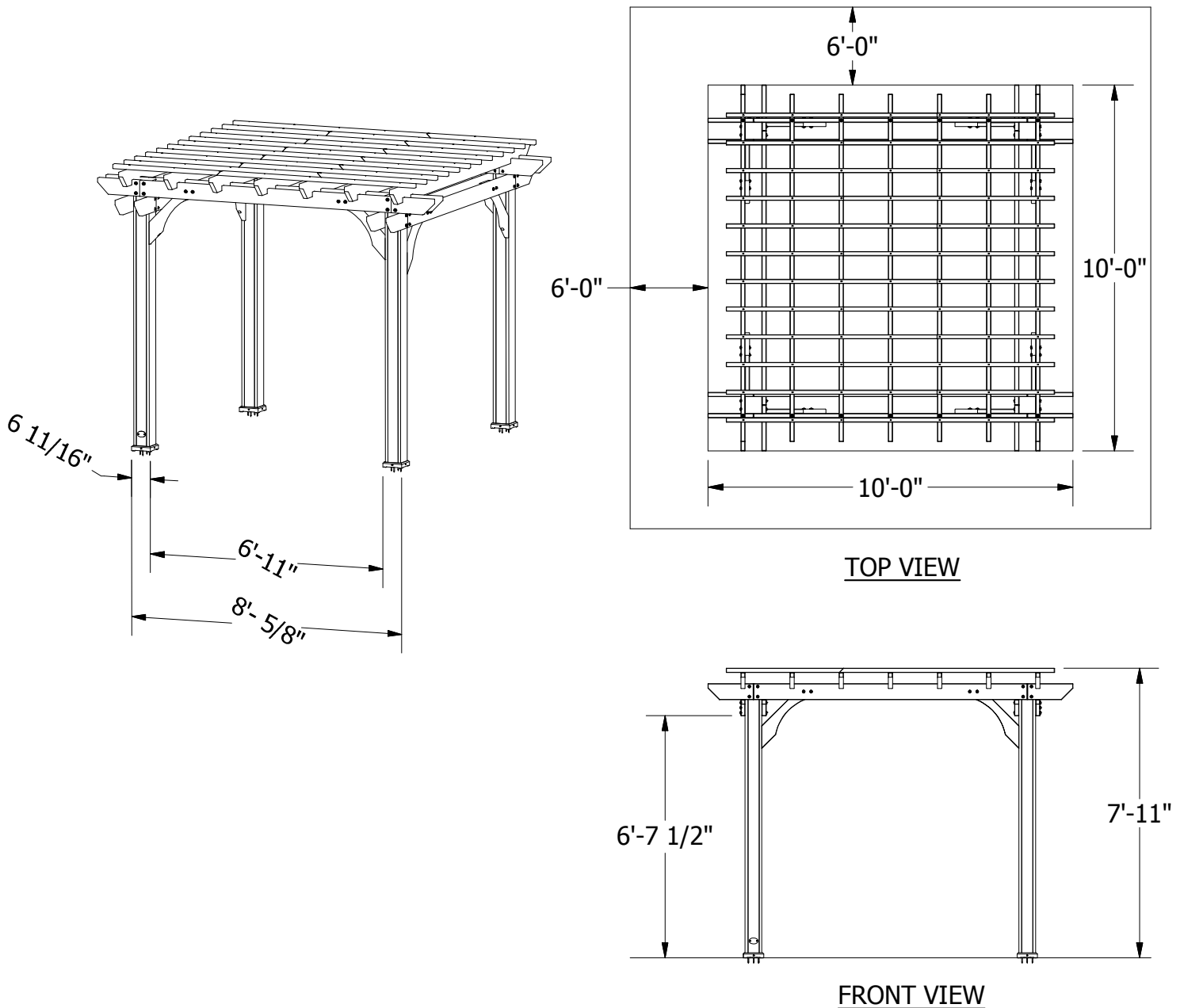

## Important Assembly Notes

- 1) While assembling unit, take time before and after each phase to make sure pergola is square and level. If pergola is not square and level, assembly will be difficult and improper assembly may result. Extra care must be taken to insure the pergola is square and level.
- 2) Tighten bolts securely.
- 3) Pay close attention to the **ITEMS NEEDED FOR EACH PHASE**. They can be a valuable aid when sorting your wood and hardware. Assembly will be made easier if items are sorted by step.
- 4) Pay close attention to make sure you are using the correct hardware in the correct steps. Using incorrect hardware may result in improper assembly.
- 5) Read each step thoroughly. The written steps may include important information not shown in the illustrations.

# Parts Identification

## Wood Components

(NOT TO SCALE)



- (7) **D3 - SLOTTED JOIST - W4L04586**  
1 3/8"x5 1/4"x114" (36x134x2896)



- (2) **D4 - JOIST - W4L04587**  
1 3/8"x5 1/4"x90" (36x134x2286)



- (4) **D5 - JOIST - W4L04591**  
1 3/8"x5 1/4"x90" (36x134x2286)



- (12) **D6 - JOIST END - W4L04588**  
1 3/8"x5 1/4"x15" (36x134x381)



- (4) **D7 - JOIST END - W4L04592**  
1 3/8"x5 1/4"x15" (36x134x381)



- (8) **D9 - SHORT ANGLE BRACE - W4L04594**  
1 3/8"x5 1/4"x29 3/4" (36x134x755)



- (2) **D10 - JOIST - W4L05827**  
1 3/8"x5 1/4"x90" (36x134x2286)



- (12) **P1 - LONG PURLIN - W4L05476**  
1 3/8"x1 3/8"x70 3/4" (36x36x1798)

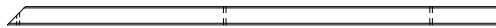

- (12) **P2 - SHORT PURLIN - W4L05477**  
1 3/8"x1 3/8"x38 5/8" (36x36x981)

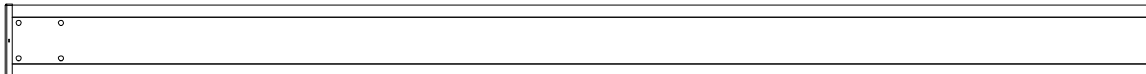

- (4) **WP1 - PERGOLA POST - W4L04584**  
5 1/2"x5 1/2"x89 1/2" (140x140x2273)

# Parts Identification

## Hardware

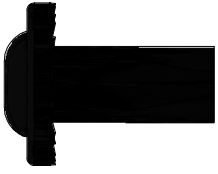

(18) - NUT BARREL WH 5/16x7/8 BLK - H100192



(34) - NUT BARREL WH 5/16x1-1/2 BLK - H100193



(1) - T-30 TORX WRENCH - H100114



(1) - SCREW SETTER - H100764

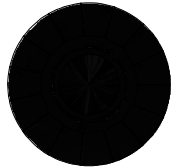

(1) - MAGNETIC DRIVER - H101100



(1) - T-30 TORX BIT - H100147

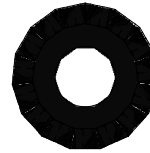

(74) - WASHER LOCK EXT 8x19 BLK - H100198



(2) - SCREW PFH 8x1/2 BLK - H100203



(17) - SCREW PFH 8x1-1/2 BLK - H100200



(88) - SCREW PFH 8x2-1/2 BLK - H100201

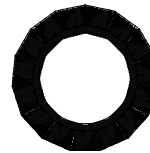

(52) - WASHER LOCK EXT 12x19 BLK - H100199



(9) - LAG SCREW WH 5/16x3 BLK - H100206



(2) - SCREW PWH 8x5/8 BLK - H100202



(15) - LAG SCREW WH 5/16x5-1/2 BLK - H100204



(18) - BOLT WH 5/16x2-1/2 BLK - H100194



(18) - CONCRETE ANCHOR 1/4"x2" - H100120



(34) - BOLT WH 5/16x7-1/4 BLK - H100196

Parts Identification  
**Accessories**  
(NOT TO SCALE)



(4) HT - FOOT 142 SQUARE POST - A100029



(1) XR - BYD ID TAG (SMALL) WITHOUT AGES - A100241

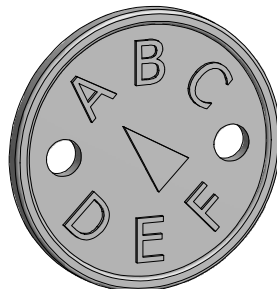

(1) SQ - "A" REVISION TAG - A100314

# PRE-ASSEMBLY STEP 1 - SORTING PARTS

It is critical for ease of assembly that you take the time to sort and organize the wood and hardware.

---

## WOOD PARTS:

- Organize wood parts by the three-digit, alpha-numeric number stamped on each board (ex. P01).
- If there are multiple boards with the same stamped number, stack those pieces together.
- Stamps can be found on the flat surface of the boards or on the end of the boards.
- Allow yourself plenty of room - the wood pieces can take up a significant amount of space.

**NOTE: CARTONS ARE NOT ORGANIZED BY BOARD NUMBER.**



## HARDWARE PARTS:

- We recommend that you have a separate table to organize the hardware.
- Hardware bags are printed with a seven-digit, alpha-numeric part number.
- You can organize your hardware by part number or group by hardware type (i.e. bolts, nuts, etc.).
- During assembly you only need to reference the last four digits of the number.

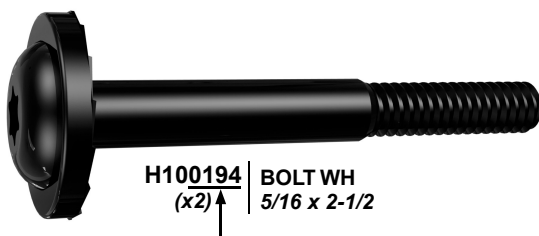

H100194 | BOLT WH  
(x2) ↑ 5/16 x 2-1/2

# PRE-ASSEMBLY STEP 2 - TOOLS REQUIRED



Cordless Drill or  
Electric Drill



Drill Attachments:  
Phillips Head



1/8", 3/16", 3/8" &  
7/16" Drill Bits

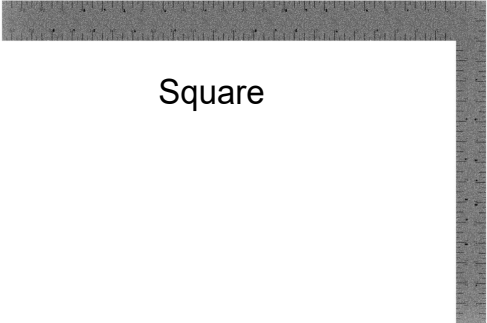

Square



Phillips Screw Driver



Tape Measure



Claw Hammer



3/8 & 5/16" Nut Drivers



Level 24"

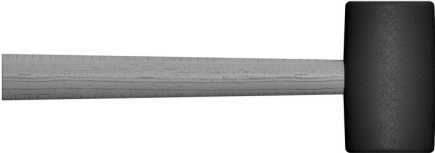

Rubber Mallet -  
Optional

# PRE-ASSEMBLY STEP 3 - CHOOSE YOUR ASSEMBLY METHOD

There are several types of assembly instructions available to you.

1. Printed Assembly Manual included with your set
2. BILT APP - 3D interactive instructions
3. Combination of the Printed Manual and BILT APP (Note: Step numbers can differ between the two methods)







(2) **D4 - JOIST - W4L04587**  
 1 3/8"x5 1/4"x90" (36x134x2286)



(4) **D9 - SHORT ANGLE BRACE - W4L04594**  
 1 3/8"x5 1/4"x29 3/4" (36x134x755)

**STEP 1**

REPEAT PROCESS FOR OPPOSITE SIDE.

\*\*\*HAND TIGHTEN ONLY AT THIS TIME.\*\*\*

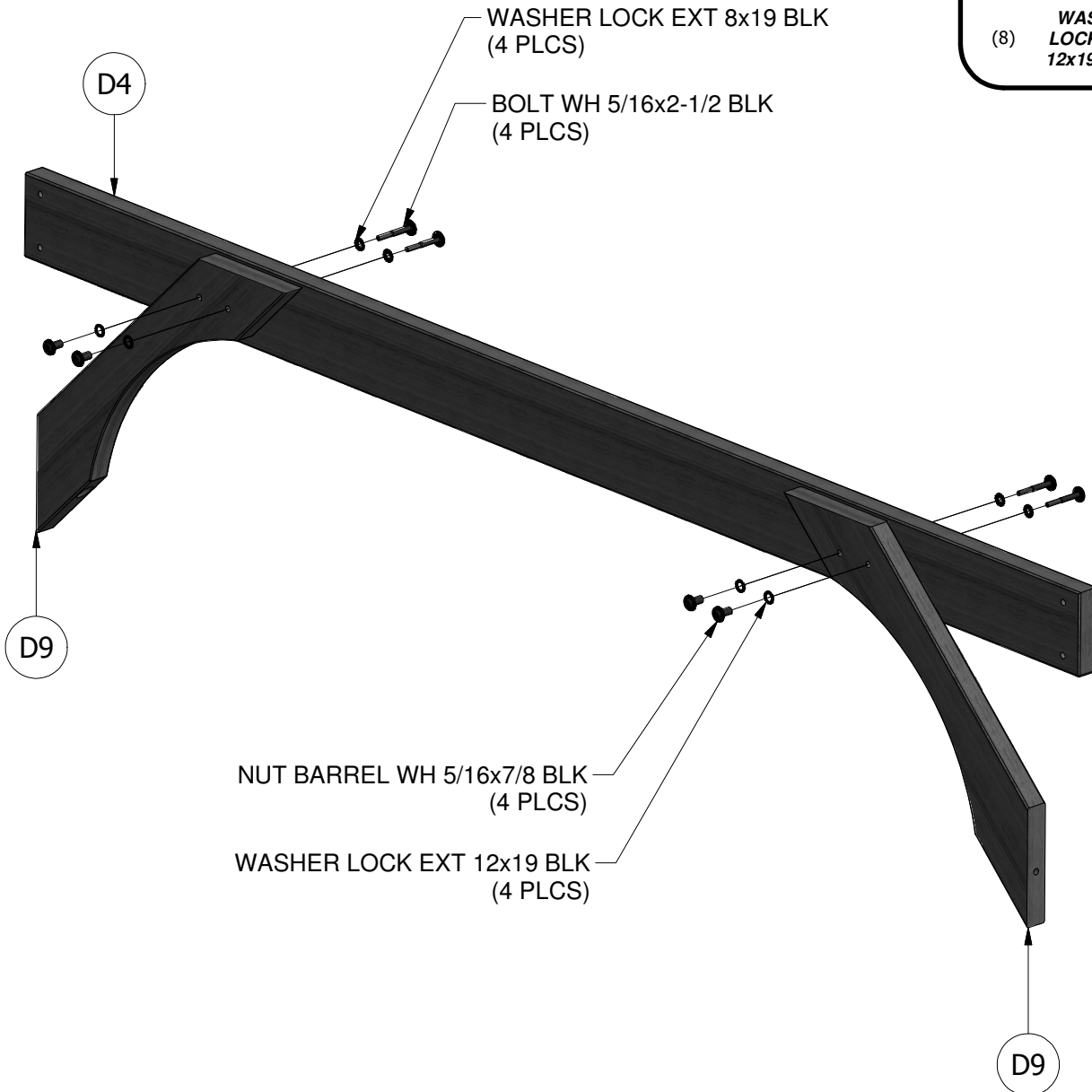
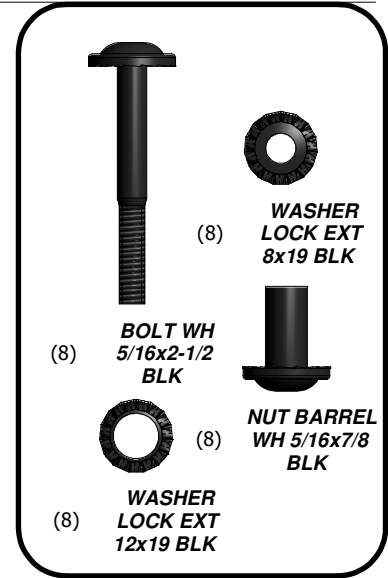



PILOT HOLES UP.

(2) **D10 - JOIST - W4L05827**  
 1 3/8"x5 1/4"x90" (36x134x2286)

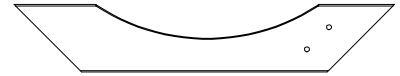

(4) **D9 - SHORT ANGLE BRACE - W4L04594**  
 1 3/8"x5 1/4"x29 3/4" (36x134x755)

**STEP 2**

REPEAT PROCESS FOR OPPOSITE SIDE.

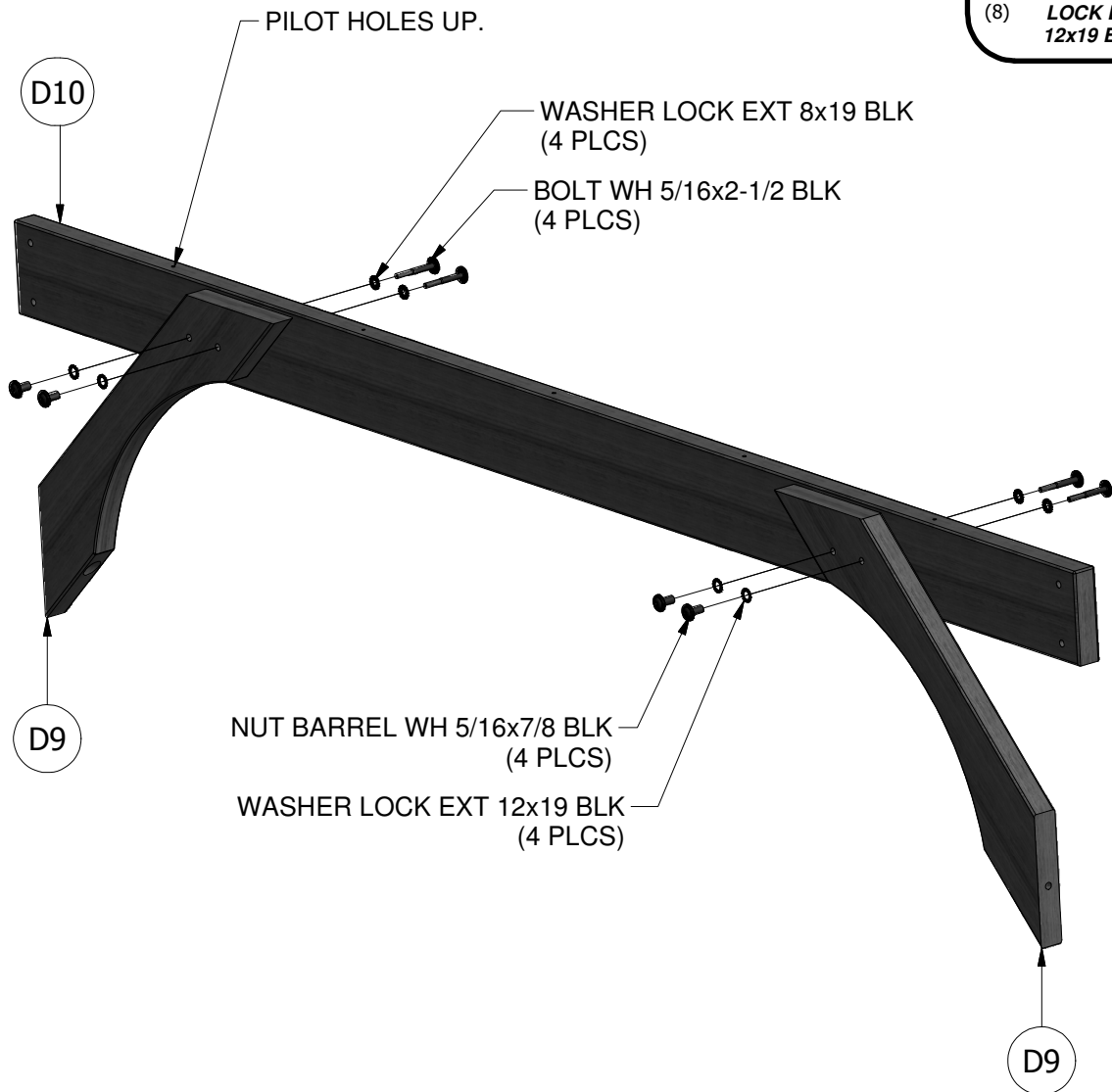
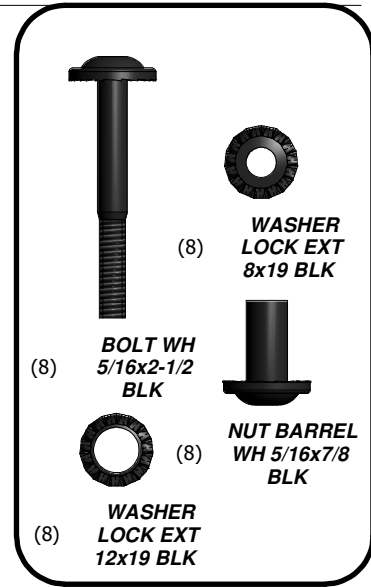

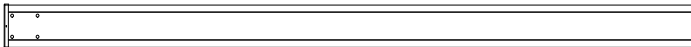

(4) **WP1 - PERGOLA POST - W4L04584**  
 5 1/2"x5 1/2"x89 1/2" (140x140x2273)

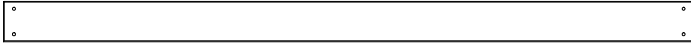

(2) **D5 - JOIST - W4L04591**  
 1 3/8"x5 1/4"x90" (36x134x2286)

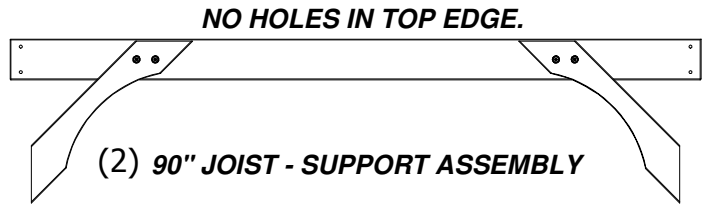

**STEP 3**

**REPEAT PROCESS FOR OPPOSITE SIDE.**

ATTACH 'D5' TO  
 INSIDE HOLE  
 LOCATIONS.

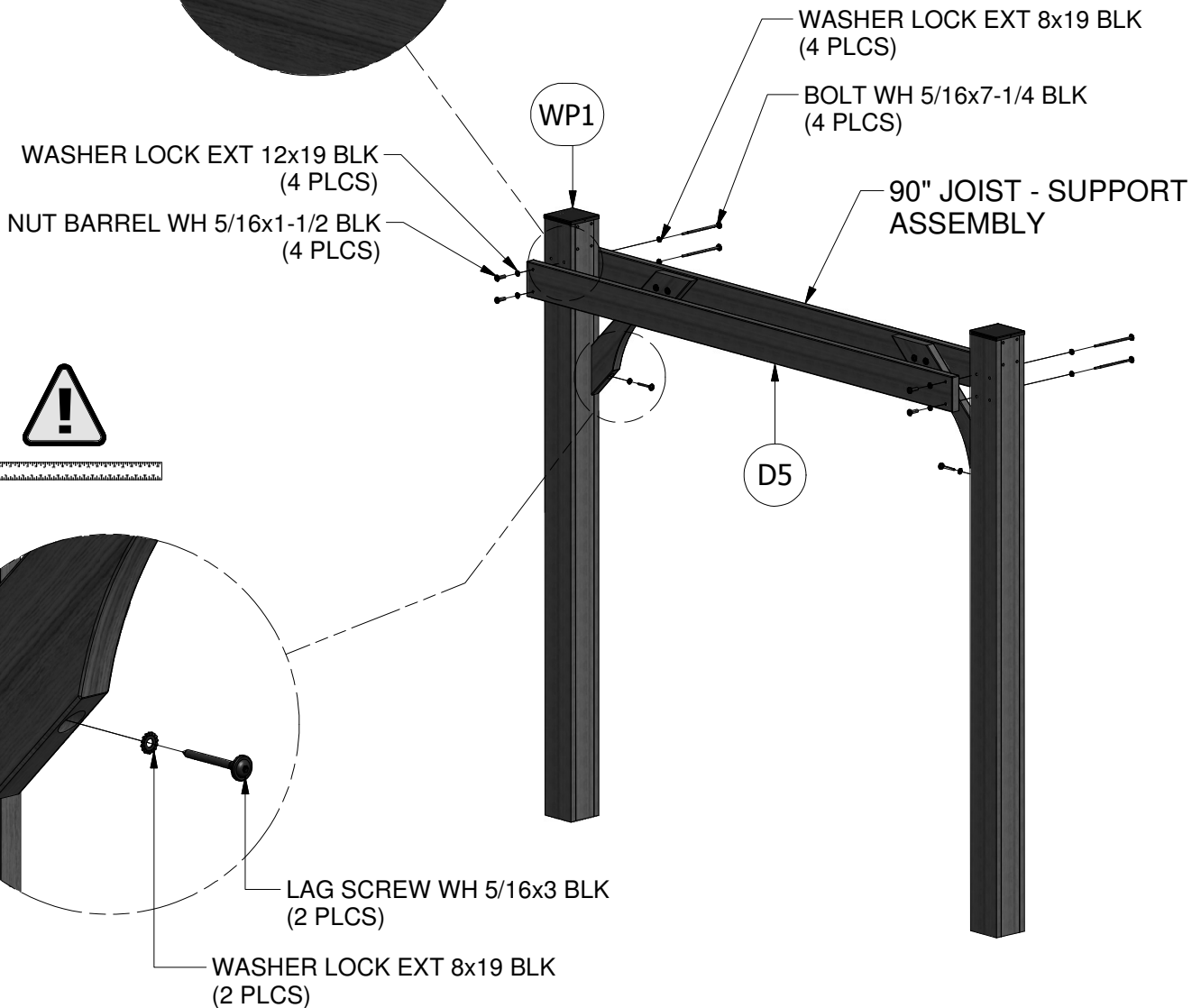
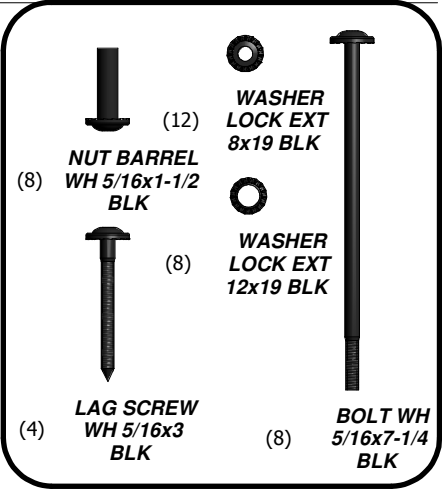
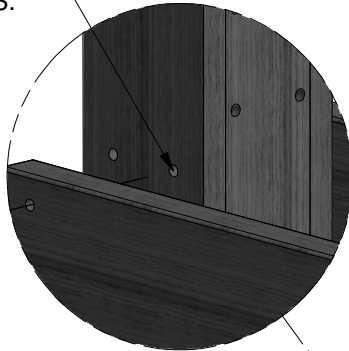



**D5 - JOIST - W4L04591**  
 (2) 1 3/8"x5 1/4"x90" (36x134x2286)



**HOLE IN TOP EDGE.**  
 (2) 90" JOIST - SUPPORT ASSEMBLY

**STEP 4**

REPEAT PROCESS FOR OPPOSITE SIDE.

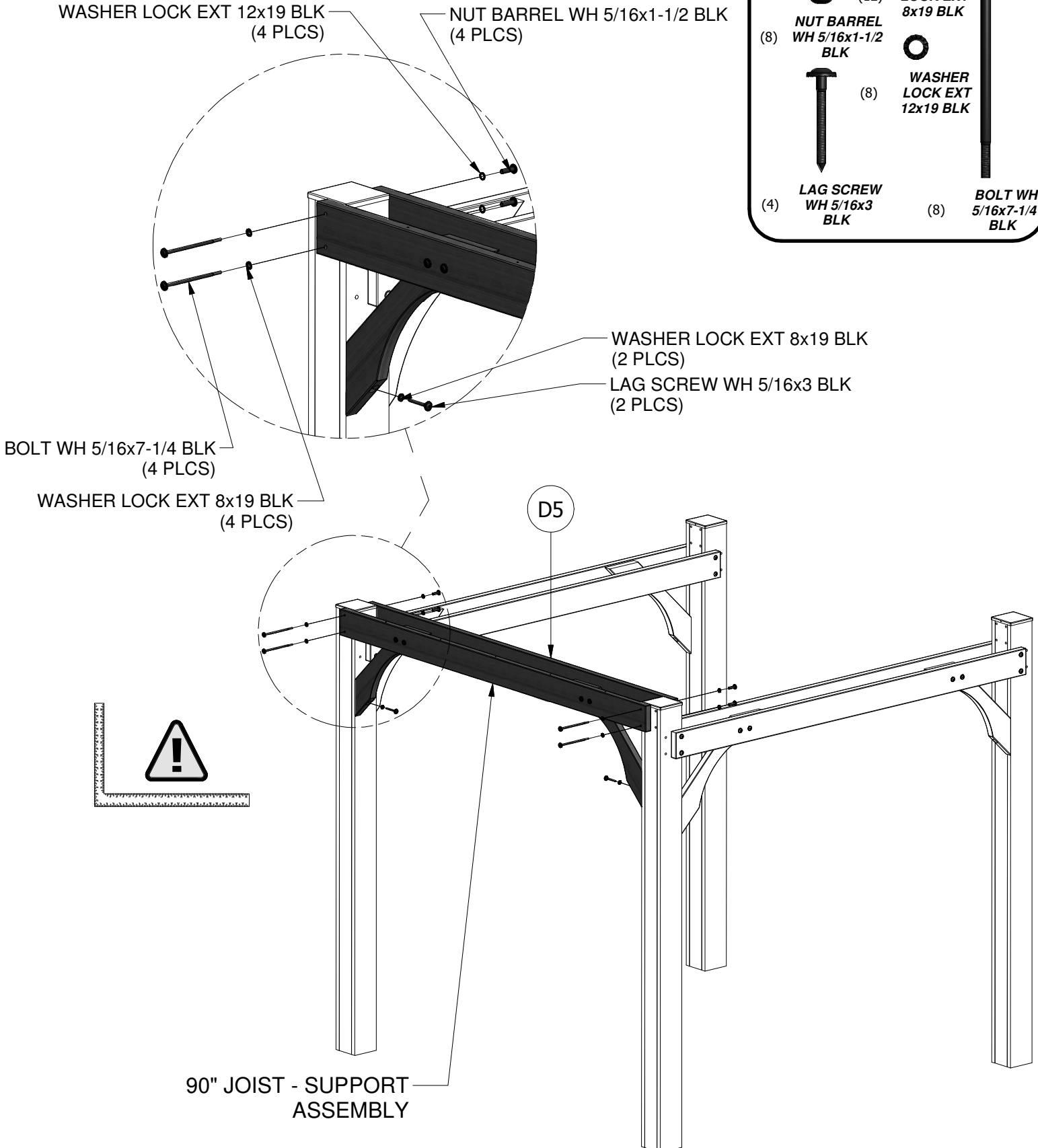



(4) **D6 - JOIST END - W4L04588**  
 1 3/8"x5 1/4"x15" (36x134x381)

**STEP 5**

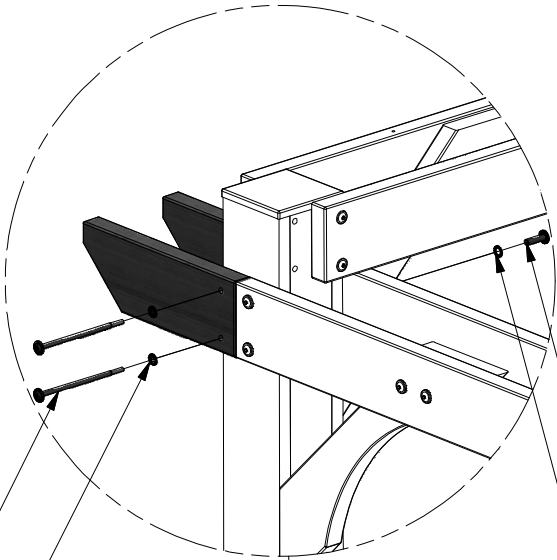

NUT BARREL WH 5/16x1-1/2 BLK  
 (4 PLCS)

WASHER LOCK EXT 12x19 BLK  
 (4 PLCS)

WASHER LOCK EXT 8x19 BLK  
 (4 PLCS)

BOLT WH 5/16x7-1/4 BLK  
 (4 PLCS)

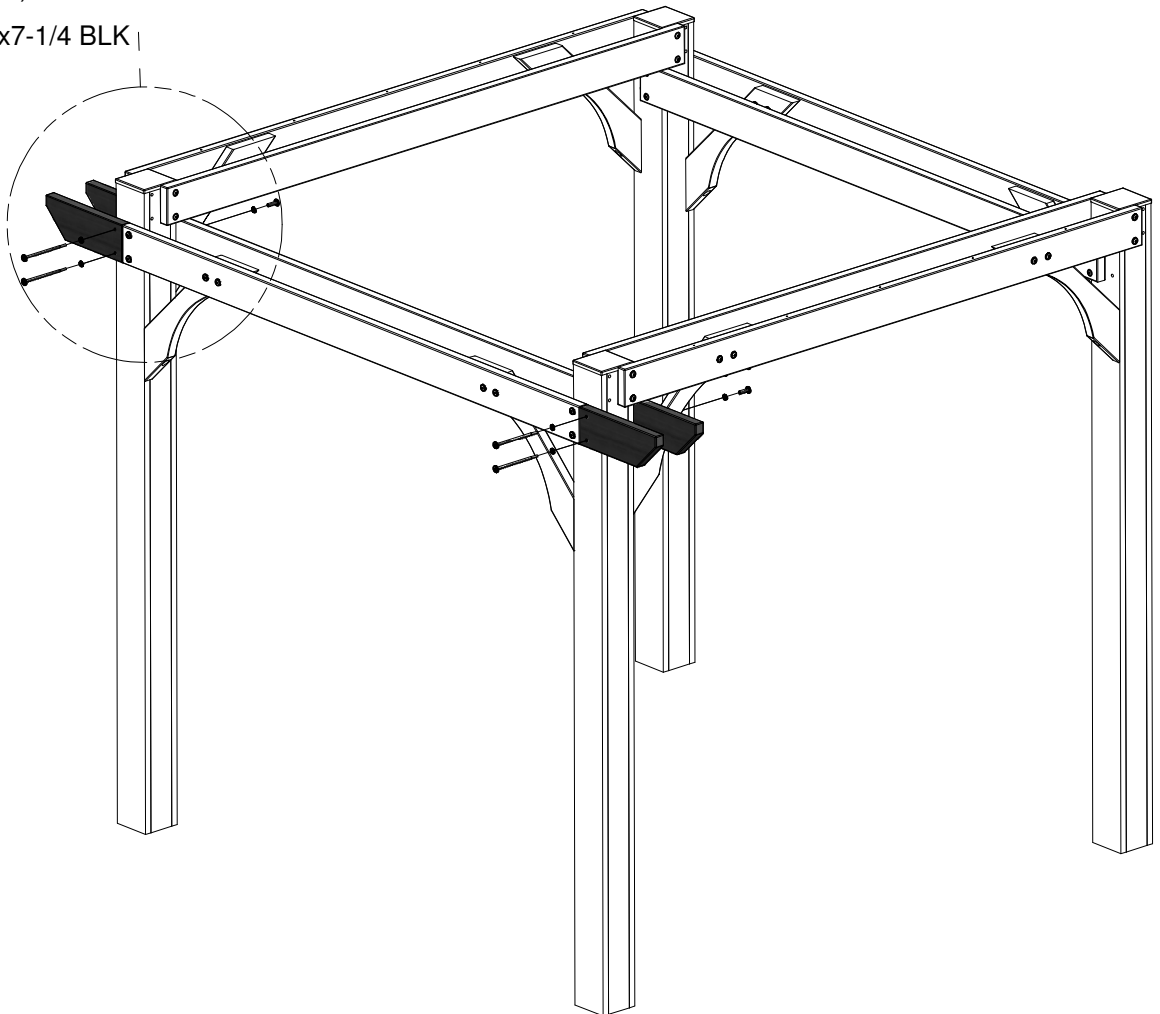
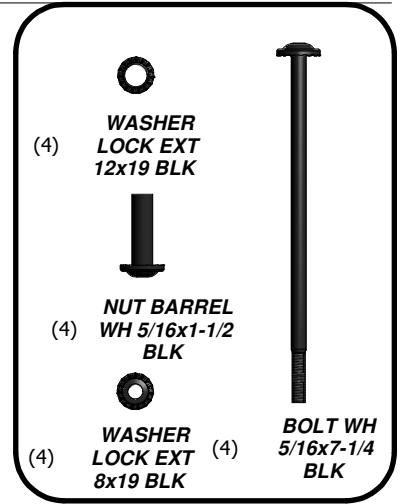



(2) **D6 - JOIST END - W4L04588**  
1 3/8"x5 1/4"x15" (36x134x381)

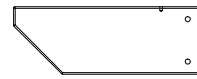

(2) **D7 - JOIST END - W4L04592**  
1 3/8"x5 1/4"x15" (36x134x381)

**STEP 6**

WASHER LOCK EXT 12x19 BLK  
(4 PLCS)  
NUT BARREL WH 5/16x1-1/2 BLK  
(4 PLCS)

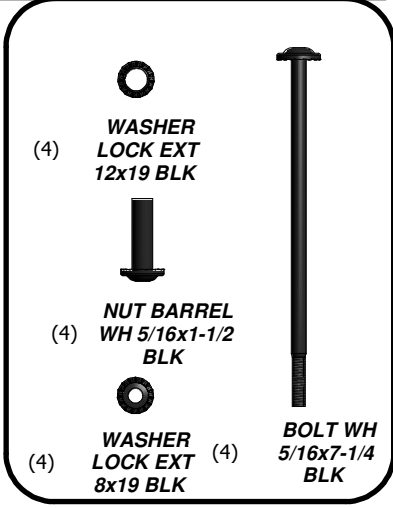
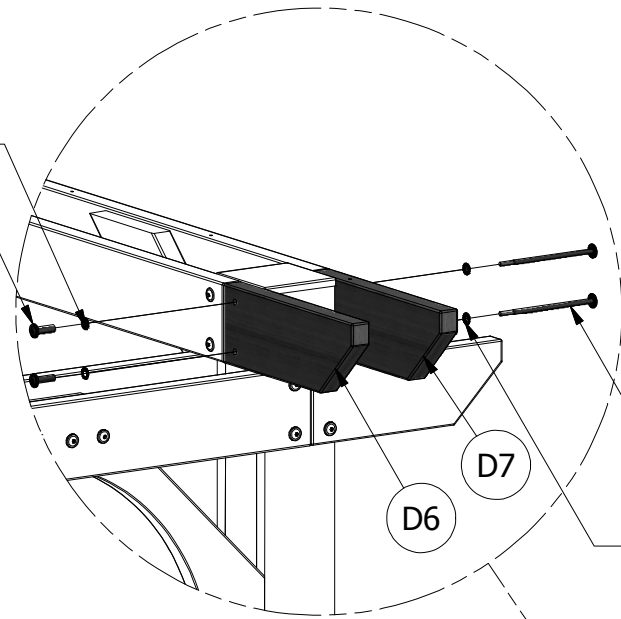

BOLT WH 5/16x7-1/4 BLK  
(4 PLCS)  
WASHER LOCK EXT 8x19 BLK  
(4 PLCS)

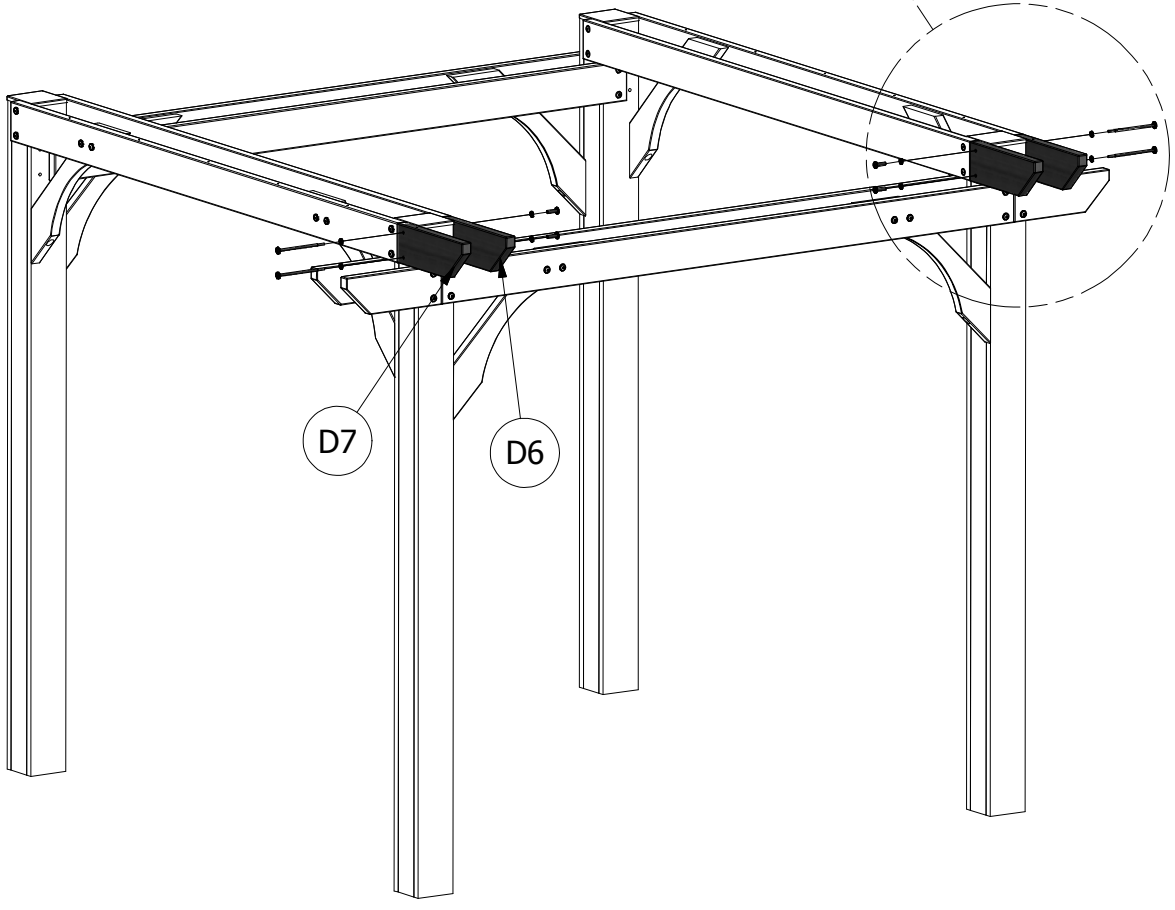



(4) **D6 - JOIST END - W4L04588**  
1 3/8"x5 1/4"x15" (36x134x381)

**STEP 7**

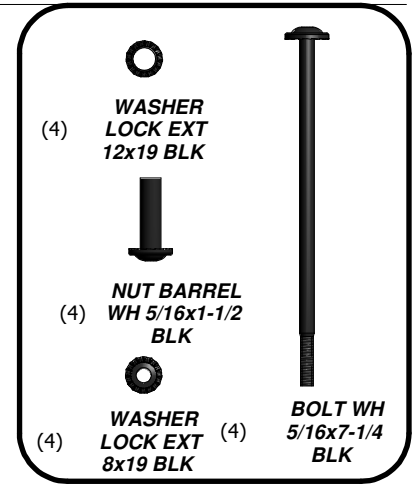
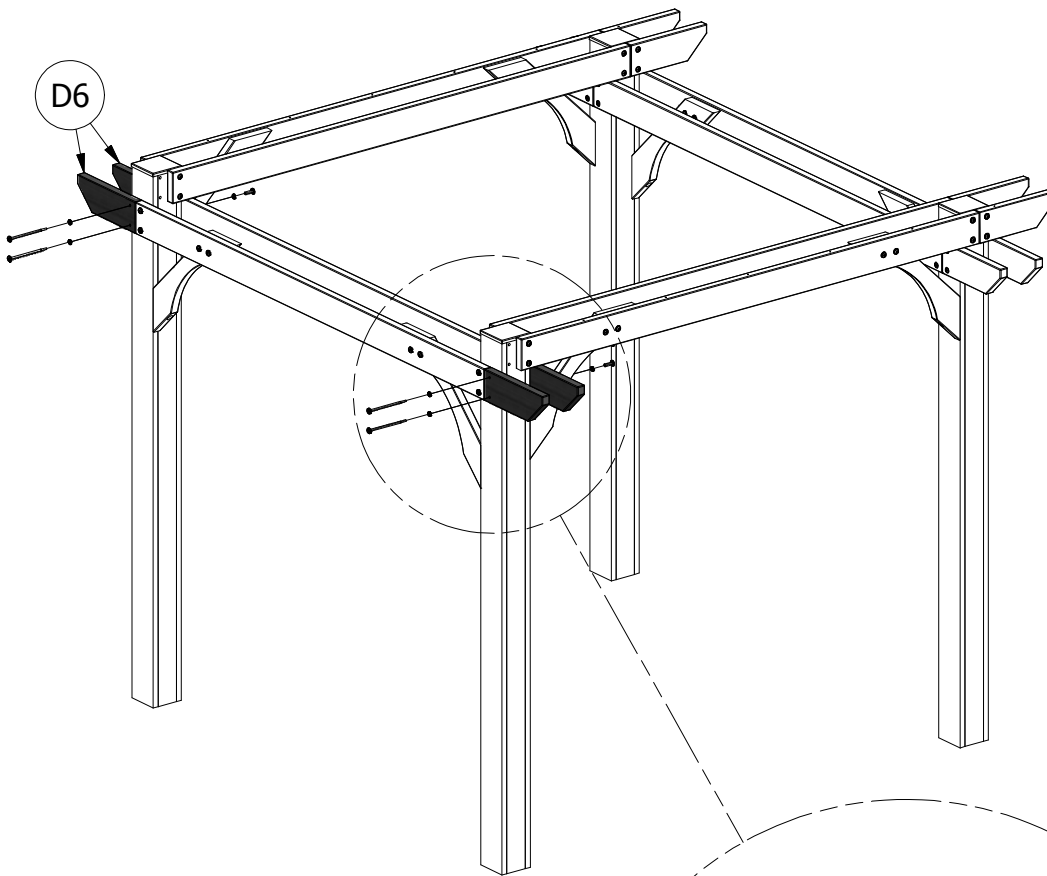

WASHER LOCK EXT 8x19 BLK  
(4 PLCS)

BOLT WH 5/16x7-1/4 BLK  
(4 PLCS)

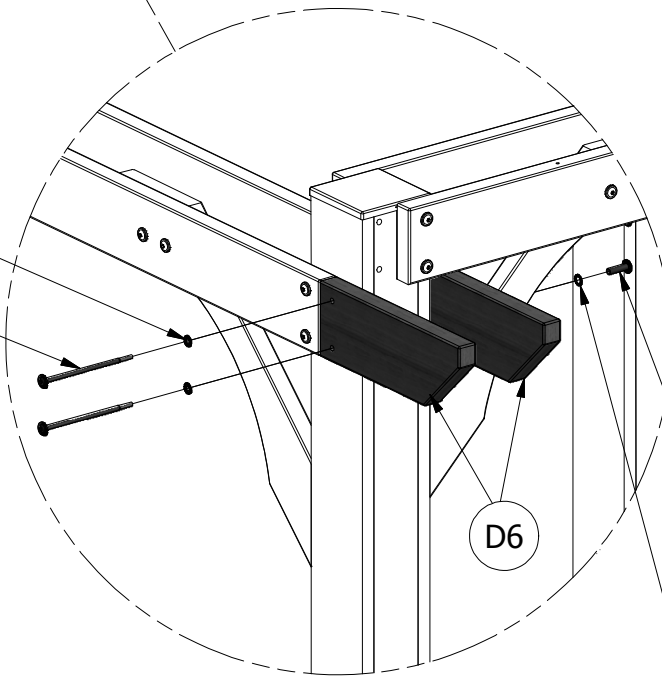

WASHER LOCK EXT 12x19 BLK  
(4 PLCS)

NUT BARREL WH 5/16x1-1/2 BLK  
(4 PLCS)

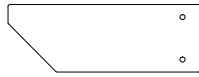

(2) **D6 - JOIST END - W4L04588**  
 1 3/8"x5 1/4"x15" (36x134x381)



(2) **D7 - JOIST END - W4L04592**  
 1 3/8"x5 1/4"x15" (36x134x381)

**STEP 8**

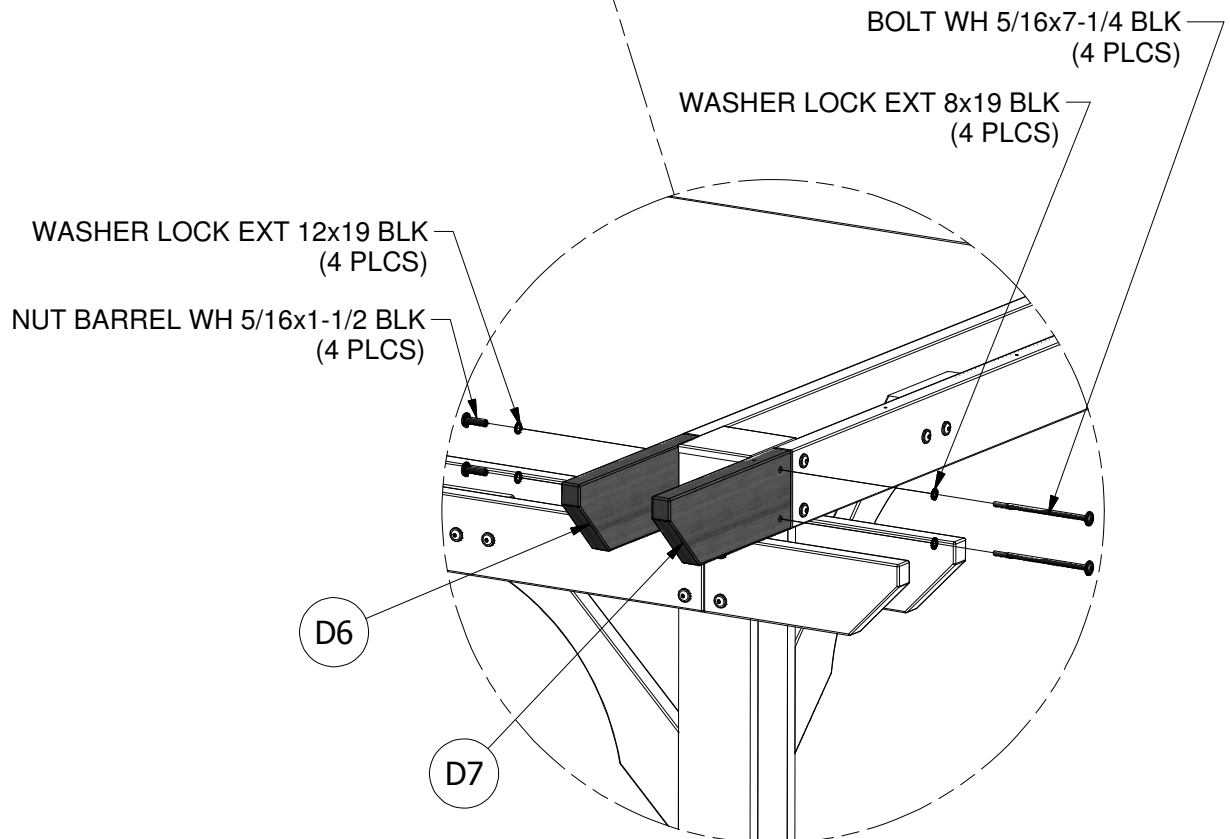
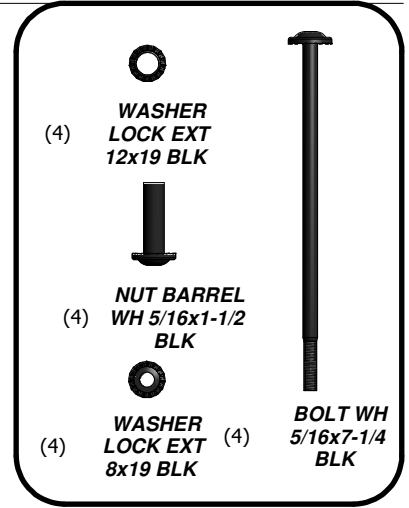
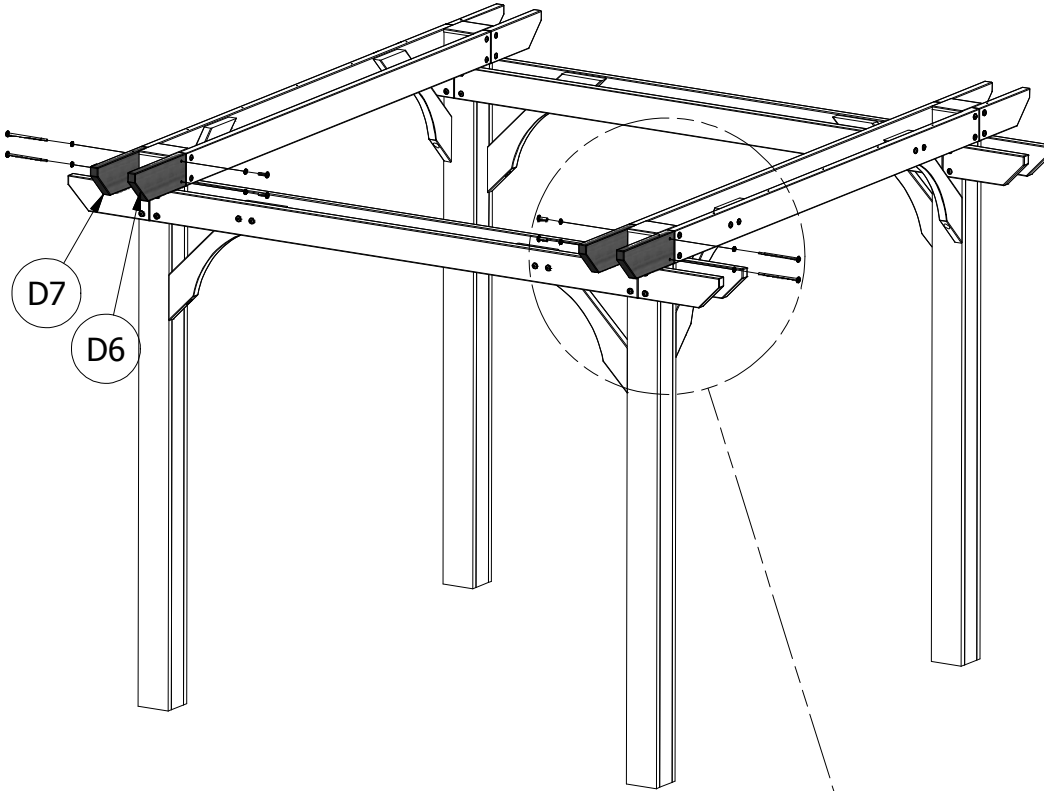





(7) **D3 - SLOTTED JOIST - W4L04586**  
**1 3/8"x5 1/4"x114" (36x134x2896)**

**STEP 9**

**ALIGN COUNTER BORED HOLES IN SLOTTED JOISTS WITH PRE-DRILLED HOLES IN BOTTOM JOISTS AND ENDS.**

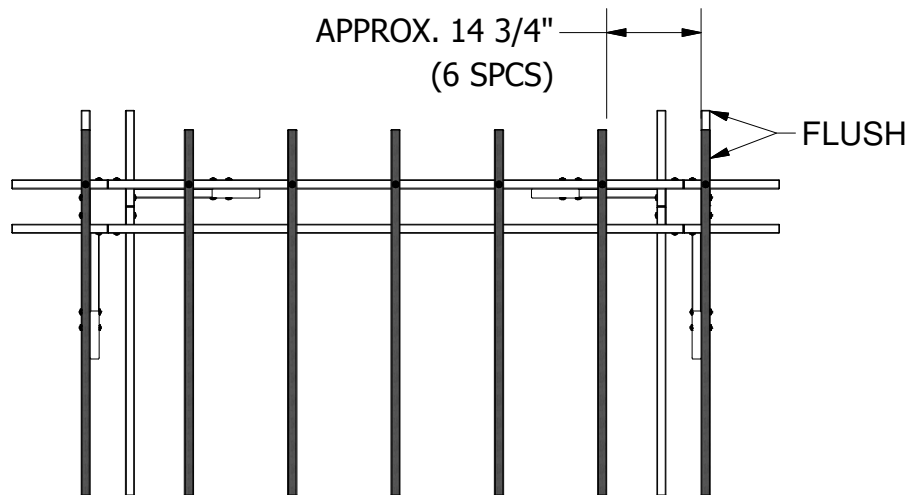
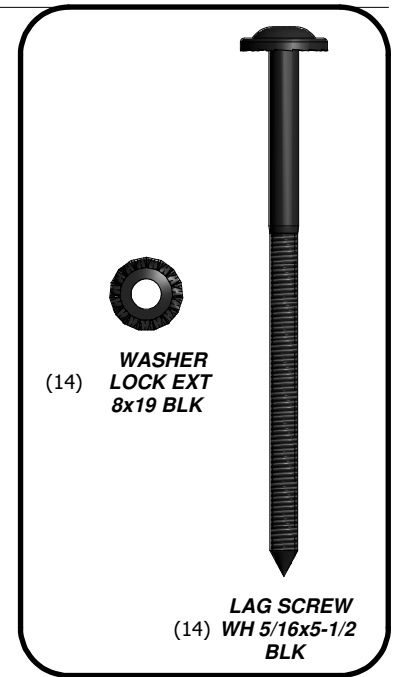
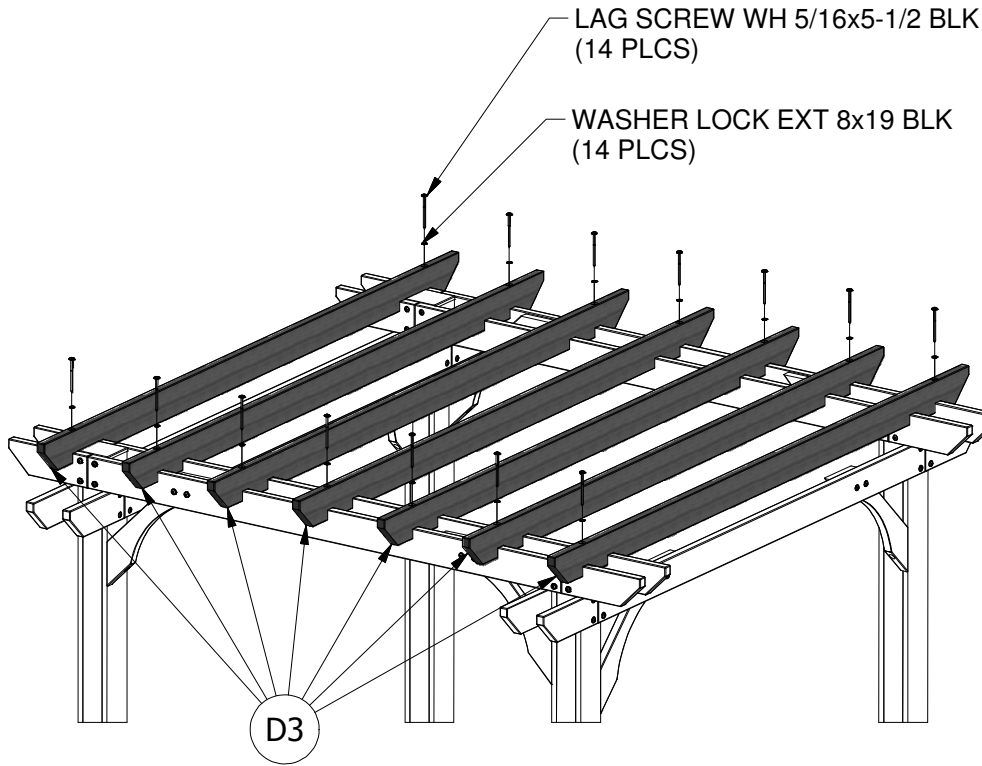

JOIST SPACING



(1) **P1 - LONG PURLIN - W4L05476**  
1 3/8"x1 3/8"x70 3/4" (36x36x1798)



(1) **P2 - SHORT PURLIN - W4L05477**  
1 3/8"x1 3/8"x38 5/8" (36x36x981)

**STEP 10**

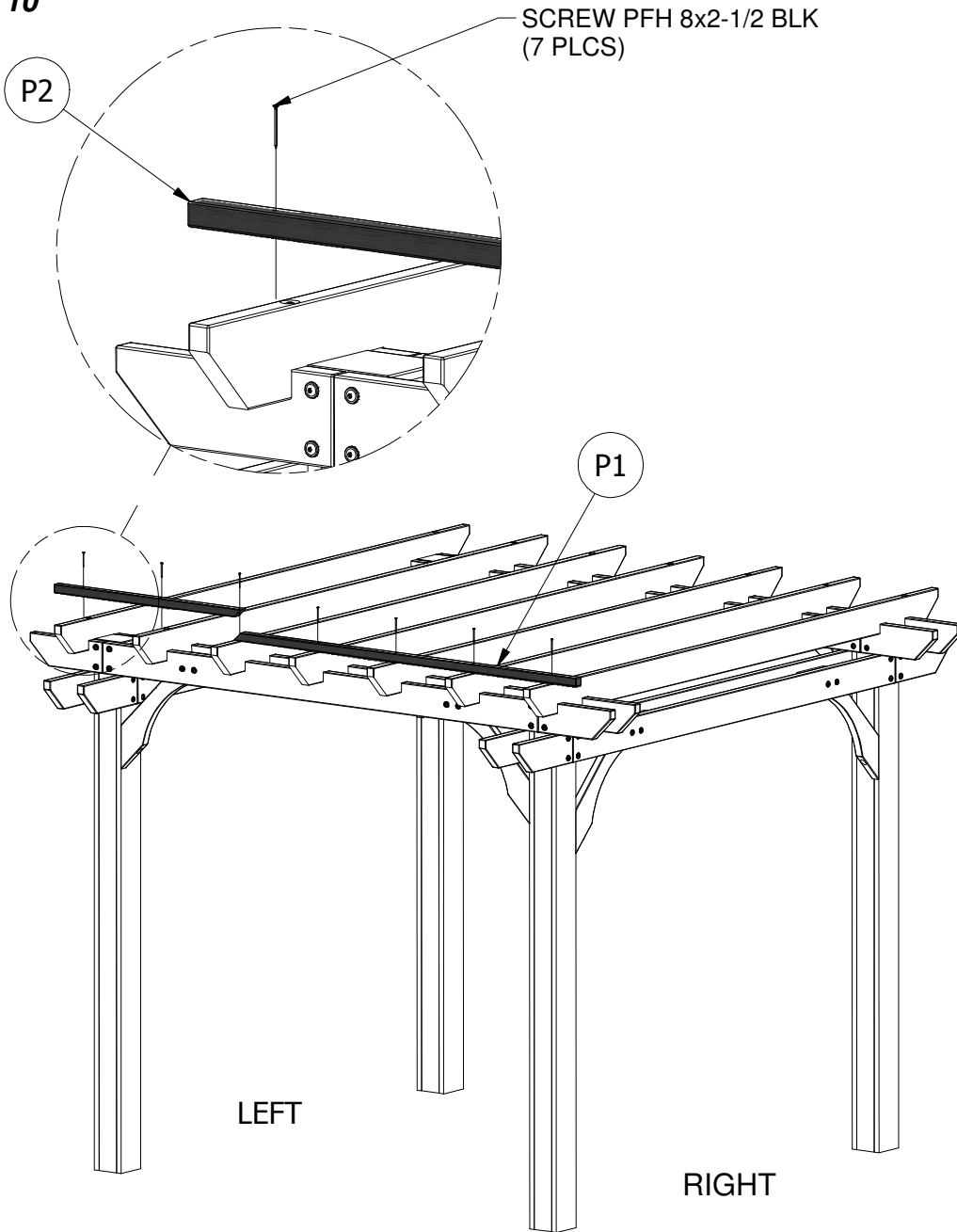

SCREW PFH 8x2-1/2 BLK  
(7 PLCS)

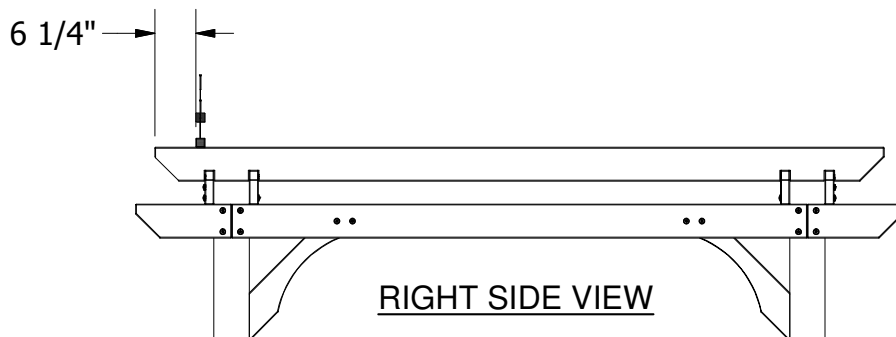
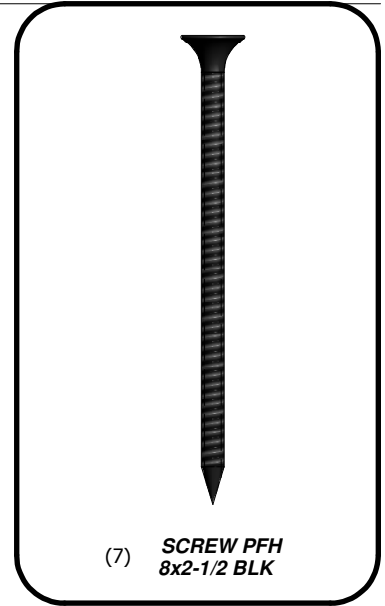



(1) **P1 - LONG PURLIN - W4L05476**  
 1 3/8"x1 3/8"x70 3/4" (36x36x1798)



(1) **P2 - SHORT PURLIN - W4L05477**  
 1 3/8"x1 3/8"x38 5/8" (36x36x981)

**STEP 11**

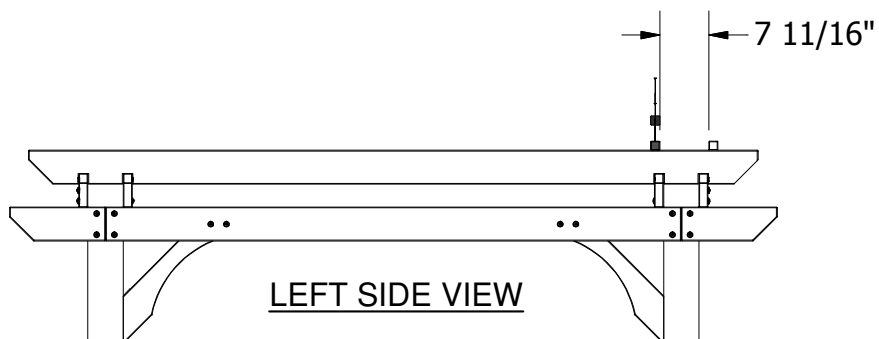
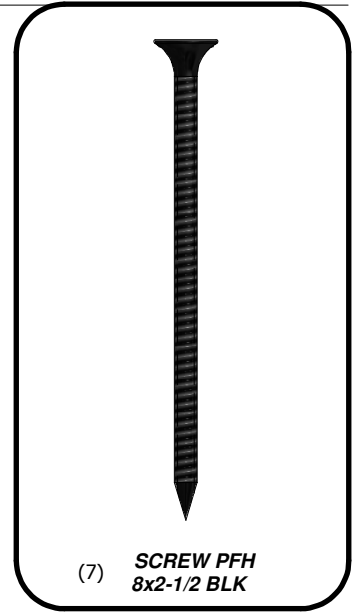
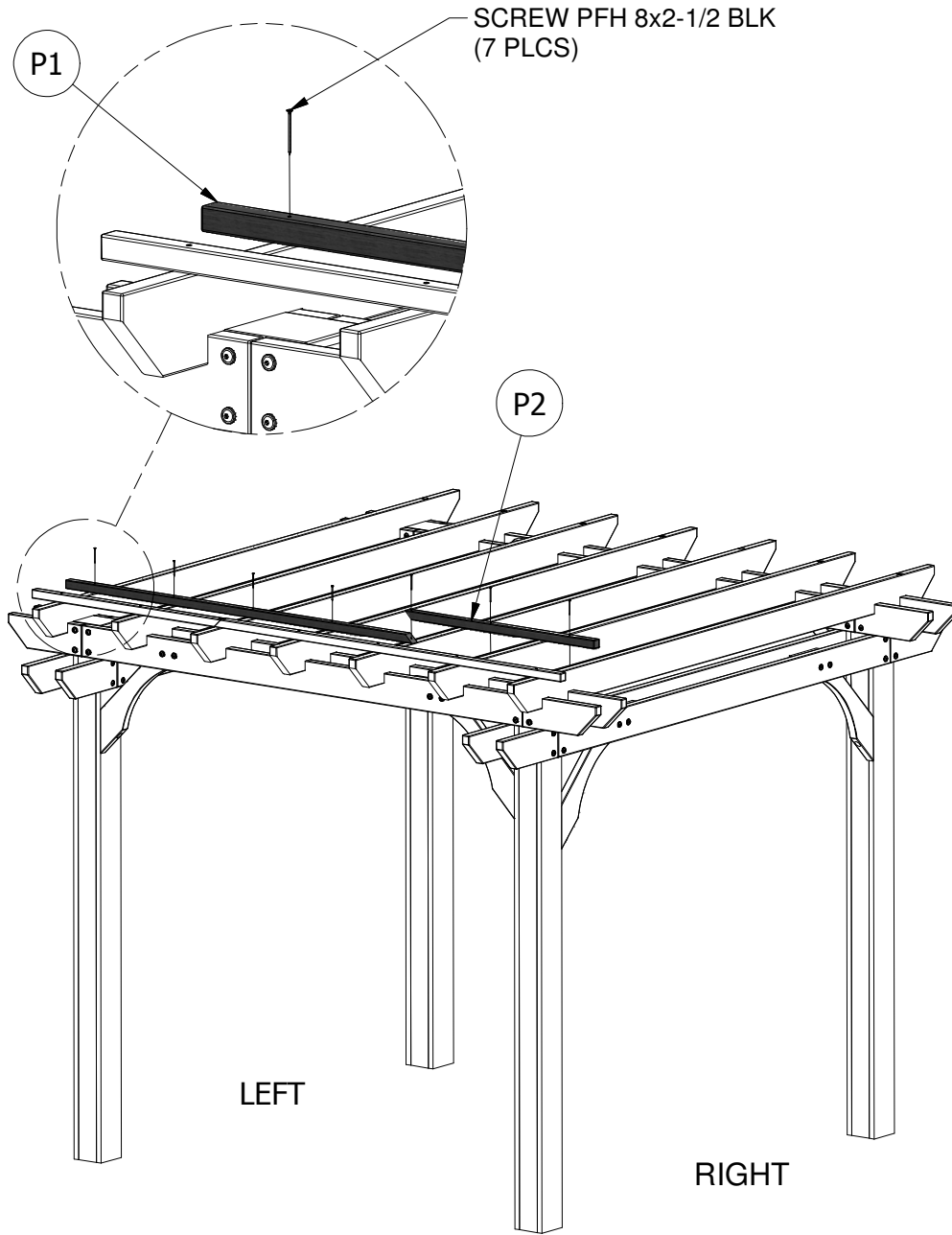



**P1 - LONG PURLIN - W4L05476**  
 (10) 1 3/8"x1 3/8"x70 3/4" (36x36x1798)



**P2 - SHORT PURLIN - W4L05477**  
 (10) 1 3/8"x1 3/8"x38 5/8" (36x36x981)

**STEP 12**

**ASSEMBLE REMAINING P1 AND P2 PURLINS ALTERNATING LOCATIONS AS SHOWN IN STEPS 10 AND 11.**

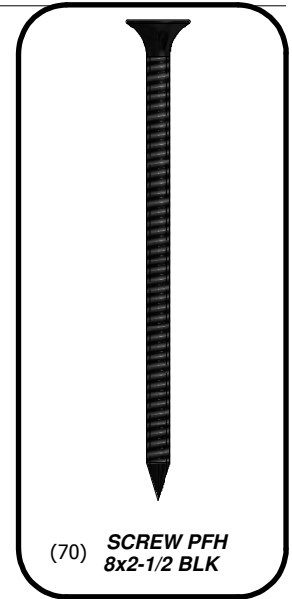
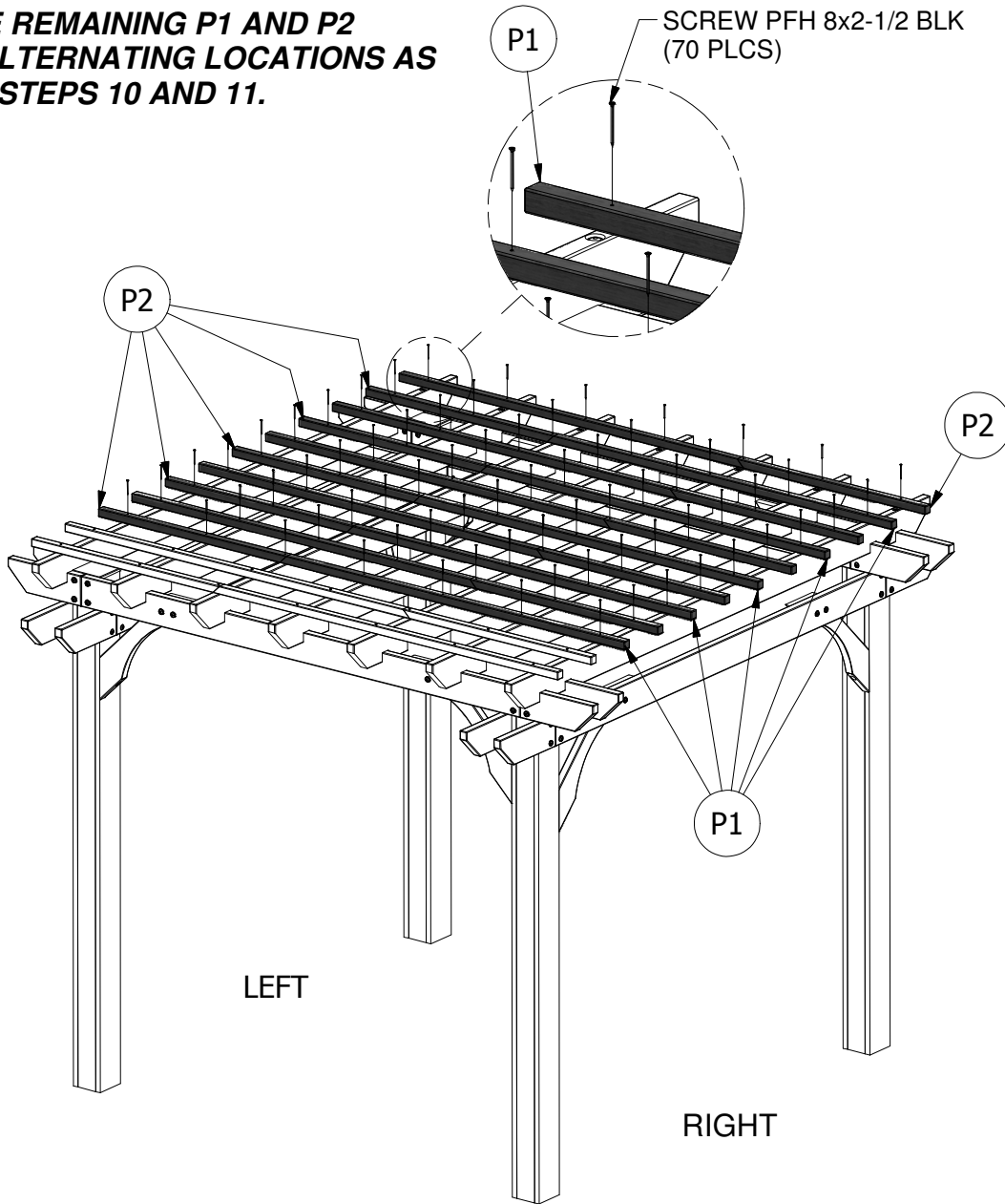

7 11/16"  
 (10 SPCS)

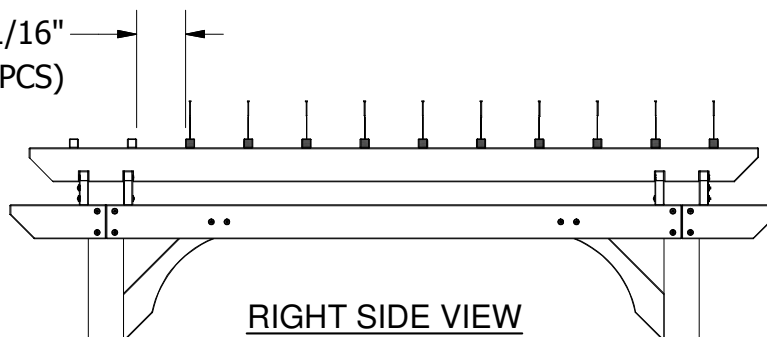



(4) HT - FOOT 142 SQUARE POST - A100029

**STEP 13**

**DECIDE WHERE TO PLACE THE PERGOLA; GRASS, CONCRETE OR OTHER MATERIAL. PLACE THE PERGOLA EXACTLY WHERE IT WILL BE ANCHORED WHEN COMPLETED AND SLIDE A FOOT 'HT' UNDER EACH POST 'WP1'.**

**NOTE:  
IF NOT PLACING ON CONCRETE, PROCEED TO STEP 17.**

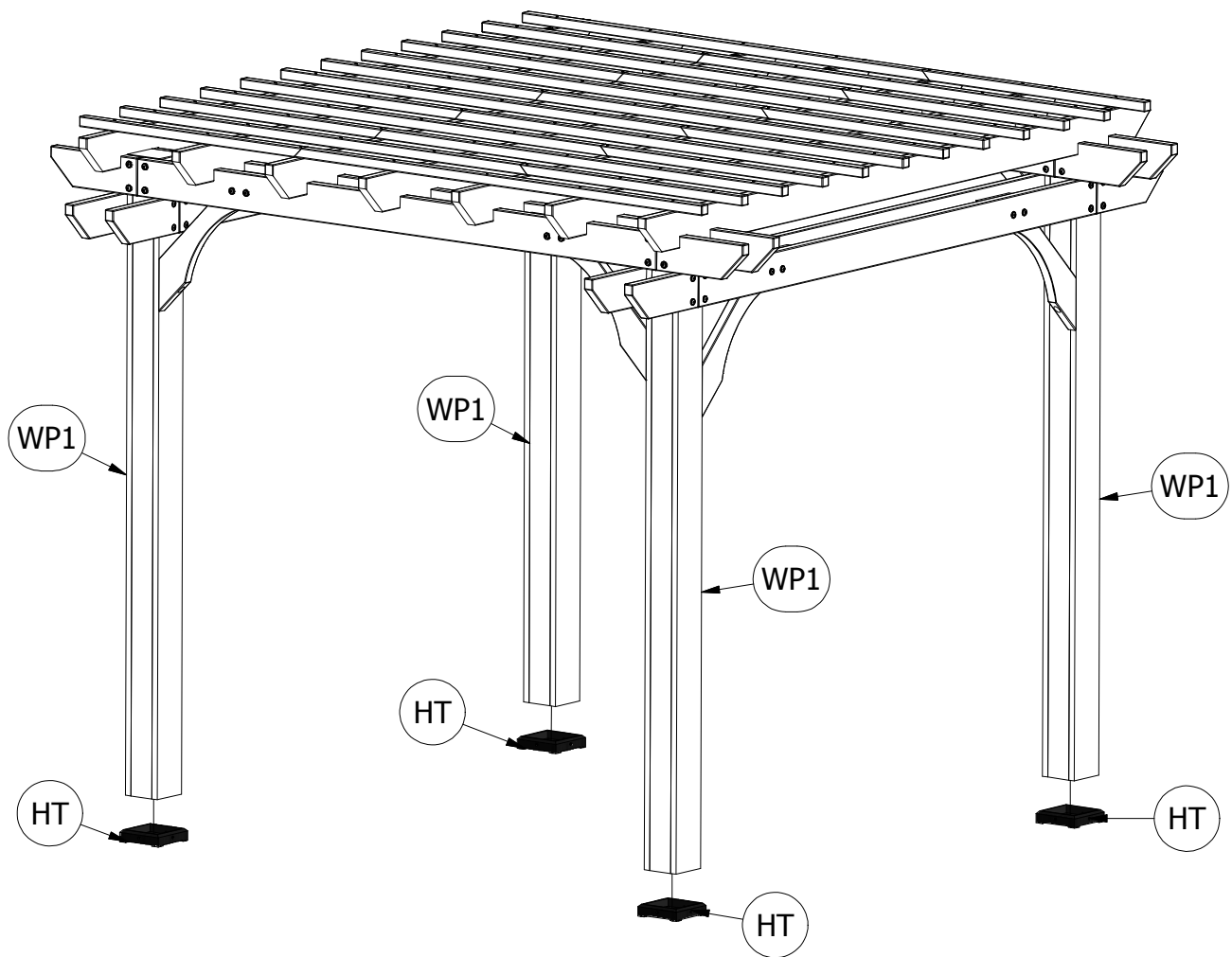

**STEP 14**

**USE CHALK TO TRACE AROUND THE EDGES OF EACH FOOT 'HT'.**

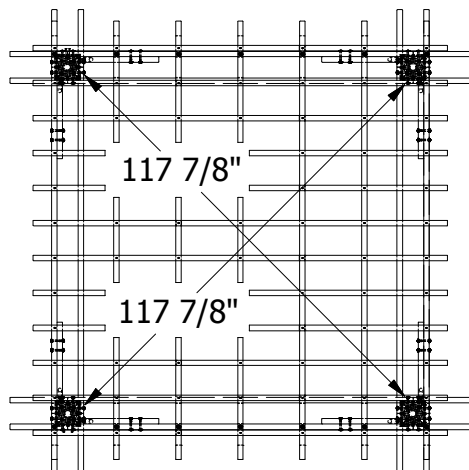
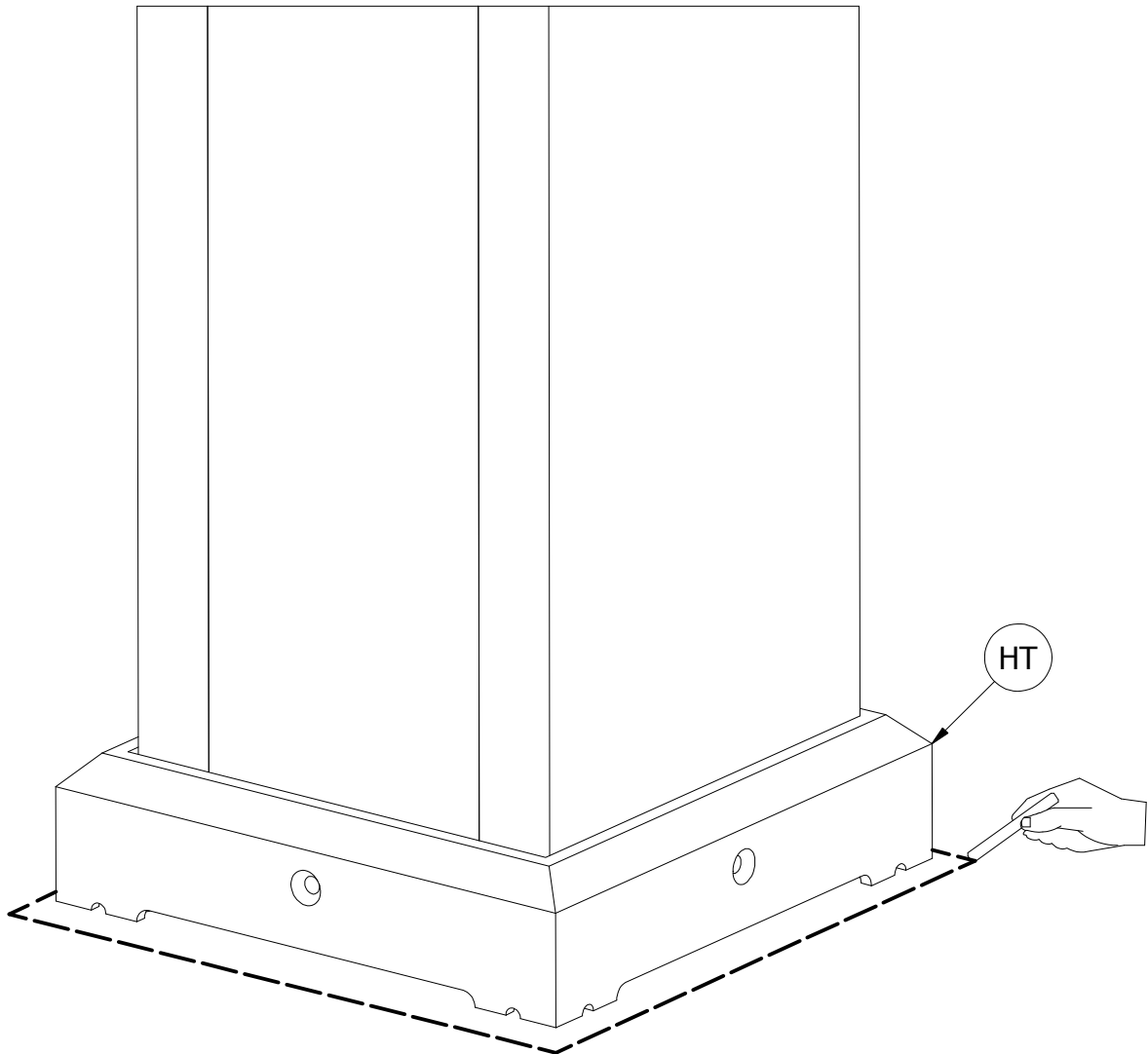

**SQUARE POSTS AND TIGHTEN ALL BOLTS AND SCREWS AT THIS TIME.**

**STEP 15**

**MOVE THE PERGOLA ASIDE. PLACE EACH FOOT 'HT' INSIDE OF THE LINES DRAWN IN STEP 14. USING A 3/16" CONCRETE DRILL BIT, PILOT DRILL ATTACHMENT HOLES INTO THE CONCRETE PAD.**

**NEXT, USE THE 1/4"x2" CONCRETE ANCHORS TO ATTACH EACH FOOT TO THE CONCRETE SURFACE.**

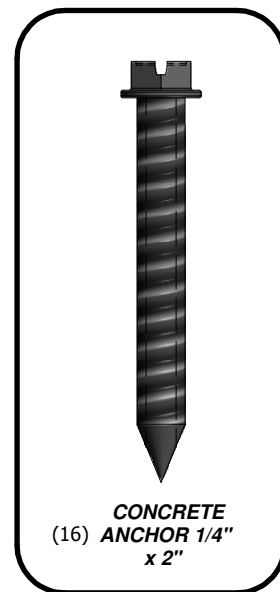

CONCRETE ANCHOR 1/4" x 2"  
(16 PLCS)

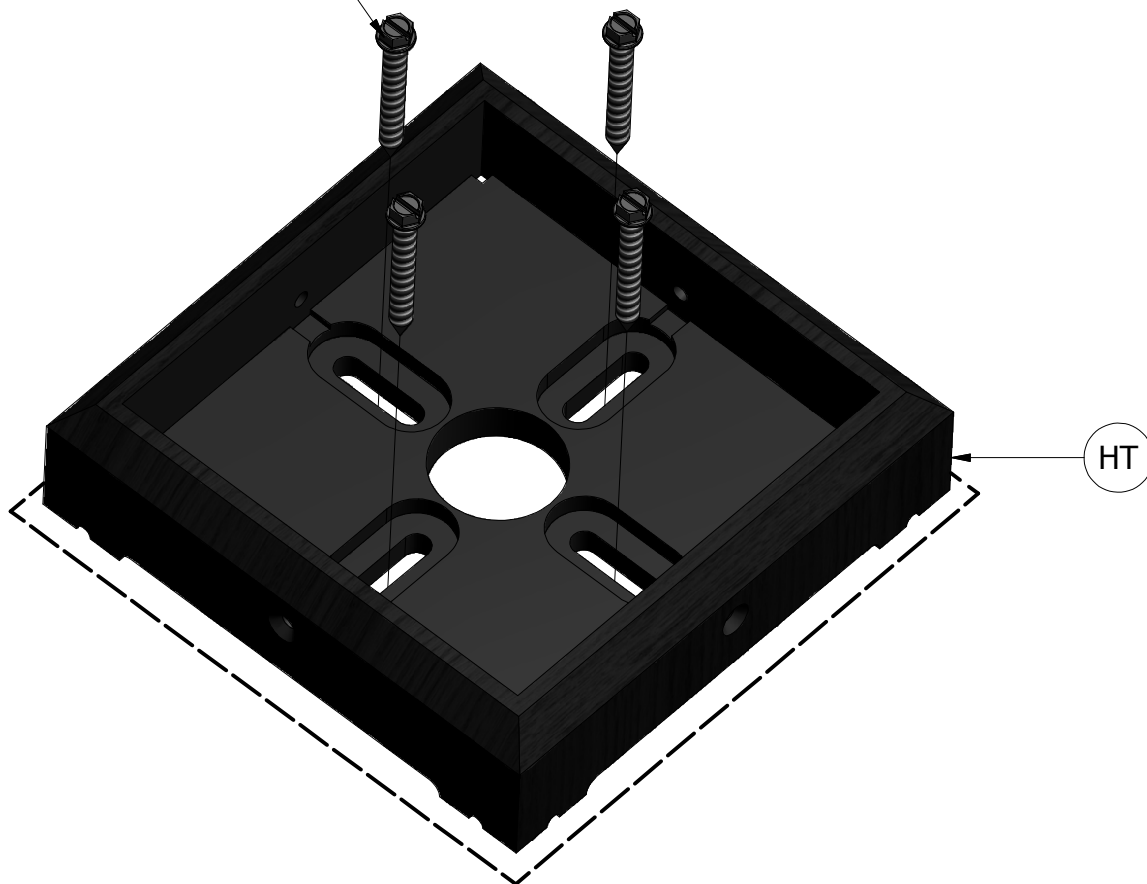

**STEP 16**

**SET THE PERGOLA BACK IN PLACE, SETTING EACH POST 'WP1' INSIDE AN 'HT' FOOT..**

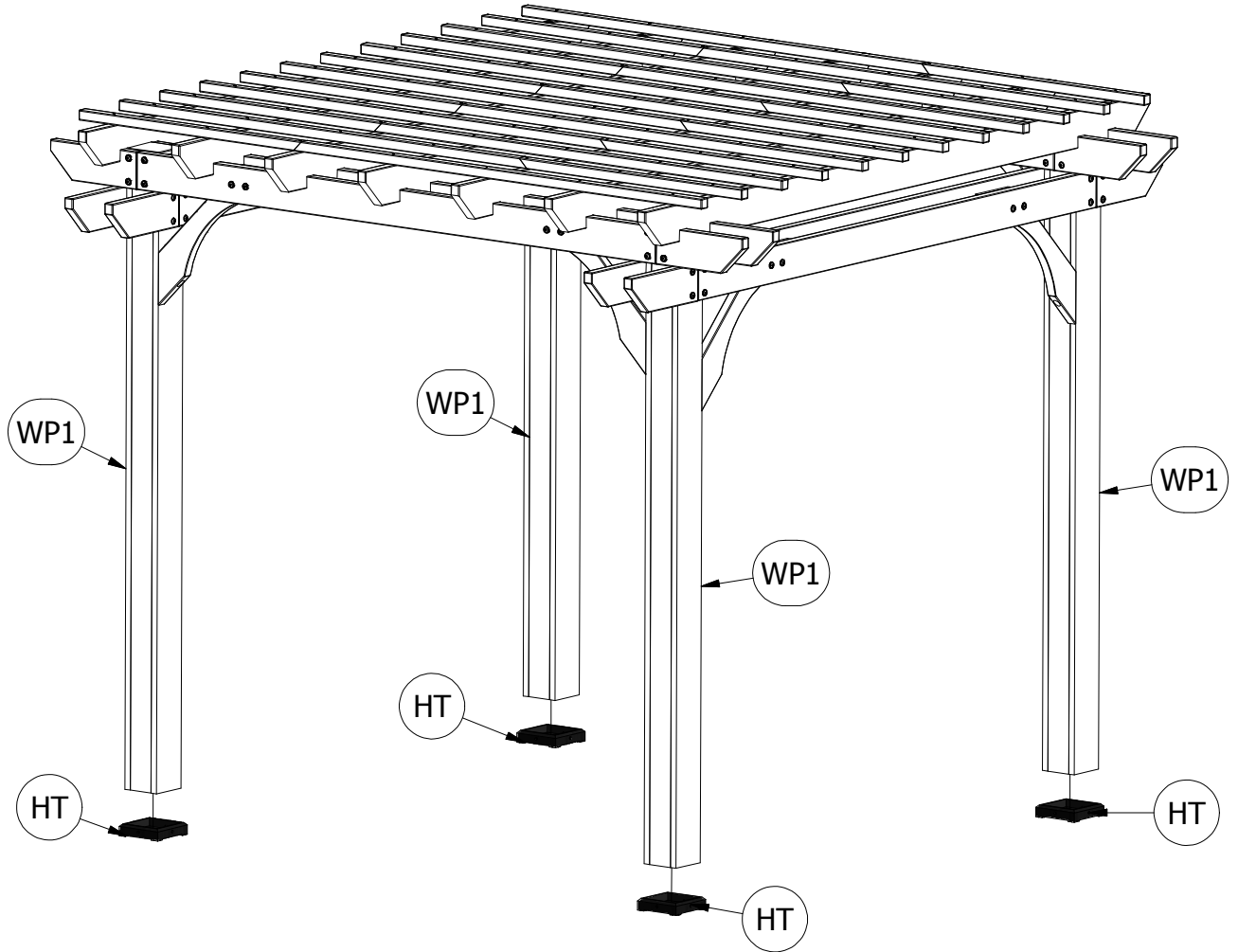



**STEP 17**

**ATTACH 'HT' FEET TO EACH 'WP1' POST USING 1-1/2" DECK SCREWS INTO EACH SIDE OF FOOT, AS SHOWN.**

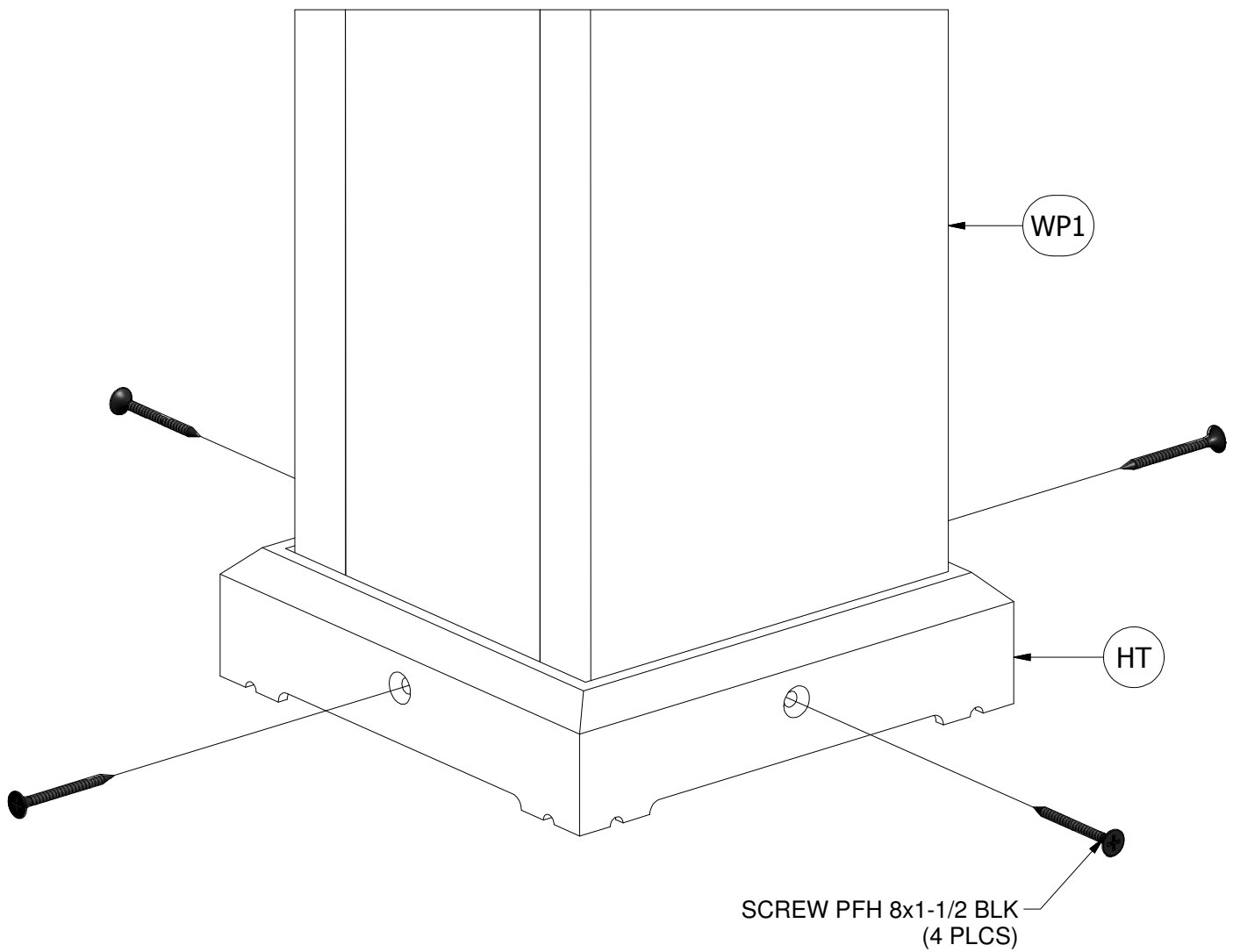
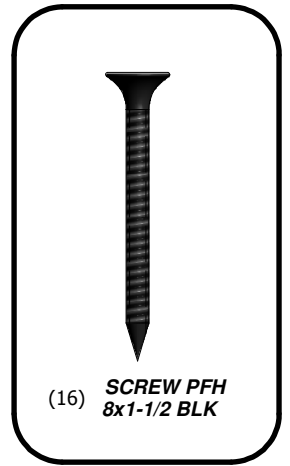



(1) SQ - "A" REVISION TAG - A100314

(1) XR - BYD ID TAG (SMALL) WITHOUT AGES - A100241

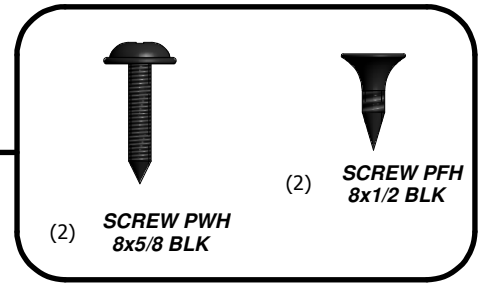

**STEP 18**

**PLACE I.D. PLACARD ON FRONT OF POST APPROXIMATELY AS SHOWN.  
PLACE REVISION TAG ON REAR OF POST APPROXIMATELY AS SHOWN.**

