



Beach Front Wooden Swing Set

Model # 1605022D

Owner's Manual & Assembly Instructions

MANUFACTURED BY:
Backyard Discovery
3305 Airport Drive
Pittsburg, KS 66762
800-856-4445



average 2 person assembly time



assembly time may vary based on skill level

Before you begin

FOR QUICK & EASY ASSEMBLY

FIND 3D INSTRUCTIONS FOR THIS PRODUCT IN

BILT.

DOWNLOAD THE FREE APP



For the most up to date assembly manual, to register your set, or to order replacement parts please visit www.backyarddiscovery.com

SAVE THIS ASSEMBLY MANUAL FOR FUTURE REFERENCE IN THE EVENT THAT YOU NEED TO ORDER REPLACEMENT PARTS.

Para obtener instrucciones en español, visite www.backyarddiscovery.com

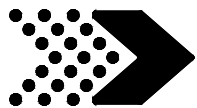

Place the set on level ground, not less than 6'-7" [2 m] from any structure or obstruction such as a fence, garage, house, overhanging branches, laundry lines, or electrical wires.

- While assembling unit, take time before and after each phase to make sure fort is level. If fort is not level, assembly will be difficult and improper assembly may result. Extra care must be taken to insure the fort is square.
- The safe play area refers to a zone extending 6'-7" (2m) beyond the play product on all sides, including the space above the play product.

SAFE PLAY AREA DIAGRAM

Ground Dimension

EXAMPLE: 14' - 5" (4.4m) x 14' - 2" (4.3m) x 9' - 10 1/2" (3.0m)

Safe Play Area

EXAMPLE: 27' - 7 1/2" (8.4m) x 27' - 4" (8.3m)

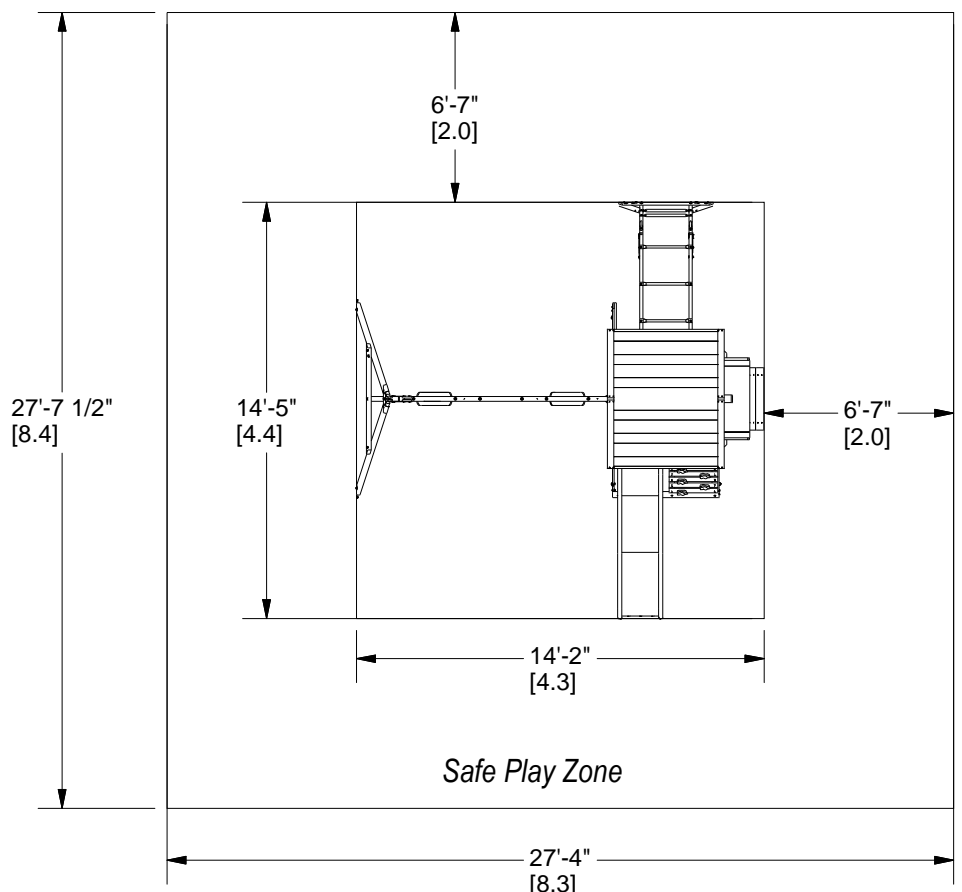

SAFE PLAY HEIGHT: 16'-5 1/2" [5.0 m]

MAXIMUM FALL HEIGHT: 6'-10" [2.1 m]

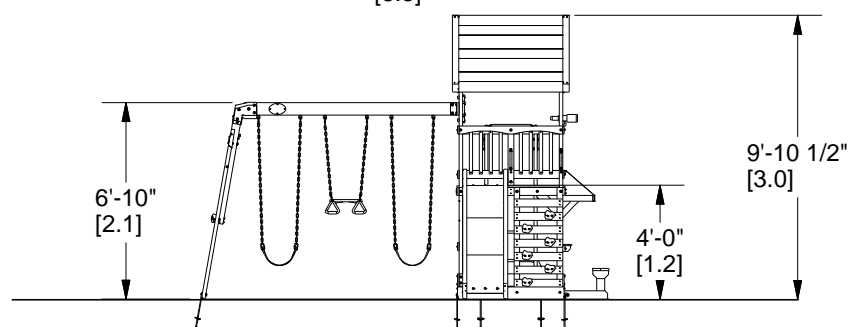

General Information:

Your set has been designed and engineered for children only and for residential use only.
 A maximum of 150 lbs. per child is recommended for play activities designed for individual use.
 A maximum of 120 lbs. per child is recommended for play activities designed for multiple child use.
 A maximum of 9 children is recommended for this swing set.



Wood Components (Not to Scale)

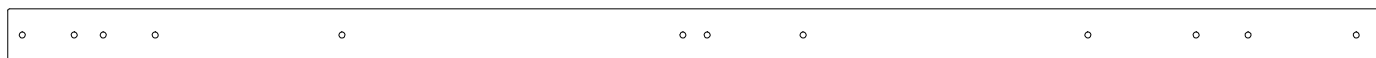

E1 | UPRIGHT - W4L06890
(1) 1 3/8"x3 3/8"x89 1/2" (36x86x2274)

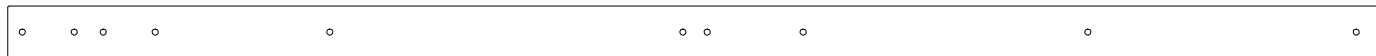

E2 | UPRIGHT - W4L06891
(1) 1 3/8"x3 3/8"x89 1/2" (36x86x2274)

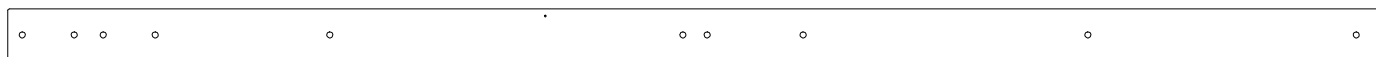

E3 | UPRIGHT - W4L06892
(1) 1 3/8"x3 3/8"x89 1/2" (36x86x2274)



E4 | UPRIGHT - W2A01970
(1) 1 3/8"x3 3/8"x89 1/2" (36x86x2274)



E5 | MONKEY BAR UPRIGHT - W4L13840
(2) 1 3/8"x3 3/8"x70 3/8" (36x86x1786)



E7 | MONKEY BAR RAIL - W4L13841
(2) 1 3/8"x3 3/8"x48" (36x86x1219)

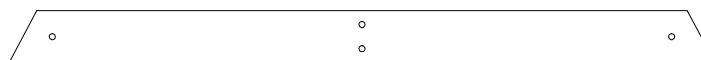

E50 | END SUPPORT - W4L13843
(1) 1 3/8"x3 3/8"x46" (36x86x1168)



E77 | ANGLE BRACE - W4L13842
(2) 1 3/8"x3 3/8"x81 3/8" (36x86x2068)

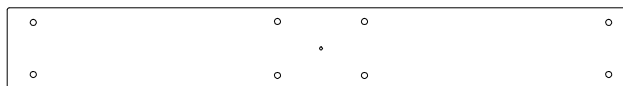

G1 | SWING BEAM MOUNT - W4L06945
(1) 1"x5 1/4"x40 7/8" (24x134x1038)



G2 | SANDBOX SEAT - W4L06433
(2) 1"x5 1/4"x14 5/8" (24x134x370)



H1 | FLOOR RAIL - W4L06898
(1) 1"x3 3/8"x42 1/8" (24x86x1070)

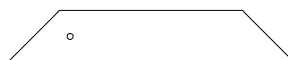

H2 | DECK BRACE - W4L06909
(4) 1"x3 3/8"x18 3/4" (24x86x475)

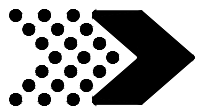

Wood Components (Not to Scale)



H3 | FLOOR SUPPORT - W4L06915
(1) | 1"x3 3/8"x40 7/8" (24x86x1038)



H4 | HORIZONTAL TARP SUPPORT - W4L13838
(2) | 1"x3 3/8"x56 1/8" (24x86x1425)



H5 | HORIZONTAL TARP SUPPORT - W4L13839
(2) | 1"x3 3/8"x48 3/4" (24x86x1237)



H6 | ROOF BOARD - W4L06950
(4) | 1"x3 3/8"x40 3/8" (24x86x1025)



H7 | BENCH GROUND BOARD - W4L06967
(2) | 1"x3 3/8"x18 1/8" (24x86x460)



H8 | BENCH UPRIGHT - W4L06968
(2) | 1"x3 3/8"x11 3/4" (24x86x300)



H9 | BENCH SEAT SUPPORT - W4L06969
(2) | 1"x3 3/8"x6 1/2" (24x86x166)



H10 | FLOOR RAIL - W4L07317
(1) | 1"x3 3/8"x42 1/8" (24x86x1070)



H12 | BENCH SEAT - W4L13837
(2) | 1"x3 3/8"x26" (24x86x660)



H81 | MONKEY BAR BRACE - W4L13849
(2) | 1"x3 3/8"x18 5/8" (24x86x474)



J1 | WALL RAIL - W4L06900
(1) | 1"x2 3/8"x40 7/8" (24x60x1038)



J2 | SHELF SUPPORT - W4L06903
(2) | 1"x2 3/8"x2 3/8" (24x60x60)



J3 | ANGLE BRACE - W4L06905
(1) | 1"x2 3/8"x47 1/4" (24x60x1200)



J4 | AWNING BOARD - W4L06906
(2) | 1"x2 3/8"x14 1/8" (24x60x358)



J5 | AWNING SUPPORT - W4L06908
(2) | 1"x2 3/8"x11 3/4" (24x60x298)



J6 | LADDER RAIL - W4L13845
(1) | 1"x2 3/8"x50 3/8" (24x60x1279)



J7 | LADDER RAIL - W4L13846
(1) | 1"x2 3/8"x50 3/8" (24x60x1279)



J8 | WALL BOARD - W4L06947
(1) | 1"x2 3/8"x25" (24x60x634)



J9 | SUPPORT BOARD - W4L06064
(4) | 1"x2 3/8"x3" (24x60x76)



J10 | ROOF BOARD - W4L06952
(2) | 1"x2 3/8"x4" (24x60x102)



Wood Components (Not to Scale)



K1 | GROUND BOARD - W4L13848
(1) 5/8"x5 1/4"x80 3/8" (16x134x2043)



K2 | GROUND BOARD - W4L06894
(4) 5/8"x5 1/4"x43 1/4" (16x134x1097)



K3 | GROUND BOARD - W4L06896
(2) 5/8"x5 1/4"x42 1/8" (16x134x1070)

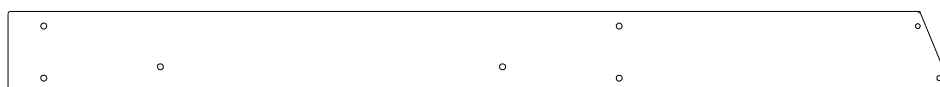

K4 | GROUND BOARD - W4L13847
(1) 5/8"x5 1/4"x61 1/2" (16x134x1564)



K5 | SERVING SHELF - W4L06902
(1) 5/8"x5 1/4"x40 7/8" (16x134x1038)



K6 | GROUND BOARD - W4L13852
(1) 5/8"x5 1/4"x44 1/2" (16x134x1129)



M1 | SAFETY BOARD - W4L06895
(1) 5/8"x3 3/8"x40 7/8" (16x86x1038)

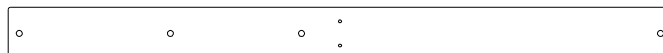

M2 | FLOOR RAIL - W4L06897
(1) 5/8"x3 3/8"x43 1/4" (16x86x1097)



M3 | LADDER RUNG - W4L06912
(1) 5/8"x3 3/8"x20 1/4" (16x86x515)



M4 | LADDER RUNG - W4L06913
(6) 5/8"x3 3/8"x20 1/4" (16x86x515)



M5 | FLOOR RAIL - W4L06914
(1) 5/8"x3 3/8"x43 1/4" (16x86x1097)



M6 | FLOOR BOARD - W4L06918
(10) 5/8"x3 3/8"x45 1/8" (16x86x1145)



M7 | WALL RAIL - W4L06919
(2) 5/8"x3 3/8"x41 1/2" (16x86x1054)



M8 | WALL RAIL - W4L06920
(2) 5/8"x3 3/8"x42 1/8" (16x86x1070)



M9 | WALL RAIL - W4L06941
(1) 5/8"x3 3/8"x43 1/4" (16x86x1097)



M10 | WALL RAIL - W4L06942
(1) 5/8"x3 3/8"x43 1/4" (16x86x1097)

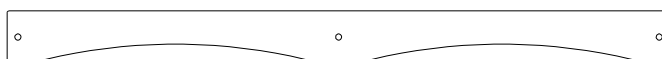

M11 | ARCHED WALL RAIL - W4L06943
(1) 5/8"x3 3/8"x43 1/4" (16x86x1097)



Wood Components (Not to Scale)

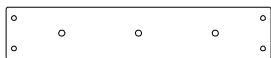

M77 | SLIDE BRACE - W100544
(1) 5/8"x3 3/8"x17 1/4" (16x86x438)



M78 | CENTER SLIDE BRACE - W100545
(2) 5/8"x3 3/8"x17 1/4" (16x86x438)



M82 | MONKEY BAR GROUND BOARD - W4L13850
(1) 5/8"x3 3/8"x39 5/8" (16x86x1006)



N1 | AWNING BOARD - W4L06907
(1) 5/8"x2 3/8"x34 1/8" (16x60x866)



N2 | ROOF BOARD - W4L06953
(2) 5/8"x2 3/8"x33 1/8" (16x60x840)



N3 | SUNBURST BOARD - W4L06955
(2) 5/8"x2 3/8"x11 3/4" (16x60x299)



N4 | SUNBURST BOARD - W4L06956
(4) 5/8"x2 3/8"x8 1/8" (16x60x205)



O1 | PICKET - W4L06901
(7) 5/8"x1 3/8"x13 1/4" (16x34x336)



O2 | PICKET - W4L06944
(23) 5/8"x1 3/8"x18 1/4" (16x34x465)



O3 | SAFETY BOARD - W4L06948
(2) 5/8"x1 3/8"x40 7/8" (16x34x1038)



O4 | AWNING BOARD - W4L06957
(1) 5/8"x1 3/8"x32 1/4" (16x34x818)

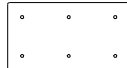

Q2 | SANDBOX SEAT SUPPORT - W4L06434
(4) 1"x4 3/8"x8" (24x112x202)



SB74 | SWING BEAM EXTENDED - W4L06961
(1) 2"x5 1/4"x89 1/2" (50x134x2274)



T1 | ROOF BOARD - W4L06951
(1) 1"x1 3/8"x48 3/4" (24x34x1237)



T2 | SAFETY BOARD - W4L13853
(2) 1"x1 3/8"x15 3/4" (24x34x400)



W71 | SWING BEAM SUPPORT - W4L13844
(1) 2"x3 3/8"x49 5/8" (50x86x1260)

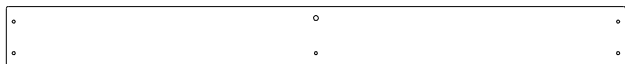

Y1 | FLOOR BOARD - W4L13851
(1) 5/8"x4"x40 3/8" (16x102x1024)

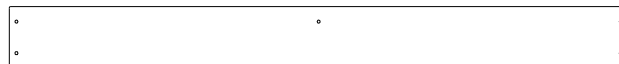

Y2 | FLOOR BOARD - W4L06917
(1) 5/8"x4"x40 3/8" (16x102x1024)



Y3 | SUNBURST HALF MOON - W4L06954
(2) 5/8"x4"x12" (16x102x306)

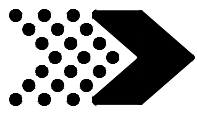

Hardware Components

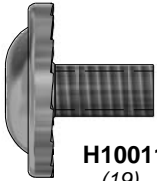

H100115 | BOLT WH
(19) | 5/16x1/2

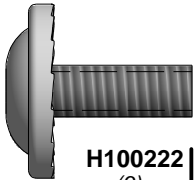

H100222 | BOLT WH
(9) | 5/16x3/4

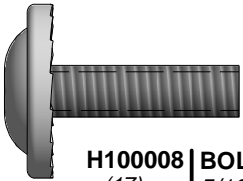

H100008 | BOLT WH
(17) | 5/16x1

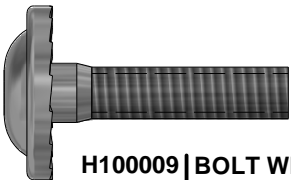

H100009 | BOLT WH
(2) | 5/16x1 1/4

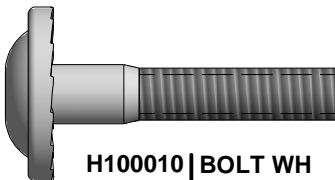

H100010 | BOLT WH
(19) | 5/16x1-1/2

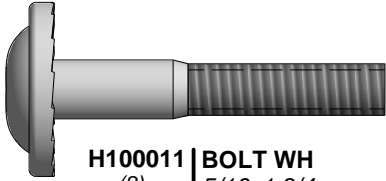

H100011 | BOLT WH
(8) | 5/16x1 3/4

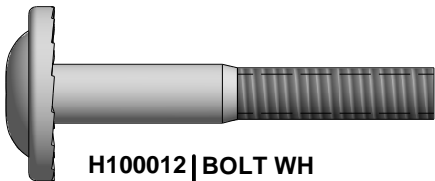

H100012 | BOLT WH
(28) | 5/16x2



H100013 | BOLT WH
(20) | 5/16x2 1/4



H100014 | BOLT WH
(3) | 5/16x2 1/2

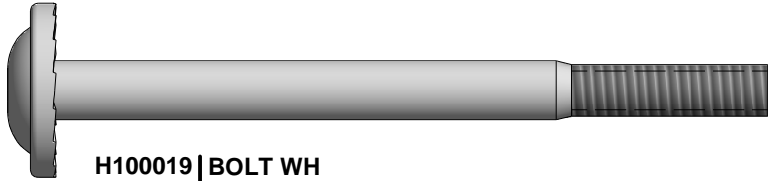

H100019 | BOLT WH
(2) | 5/16x3 3/4

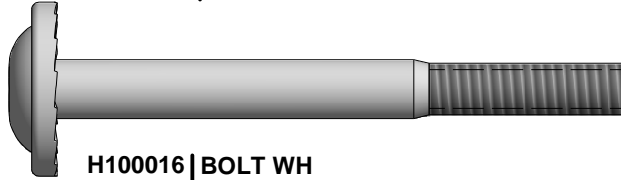

H100016 | BOLT WH
(2) | 5/16x3



H100029 | LAG SCREW WH
(1) | 5/16x3



H100027 | LAG SCREW WH
(12) | 5/16x2

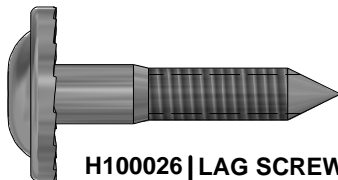

H100026 | LAG SCREW WH
(27) | 5/16x1 1/2

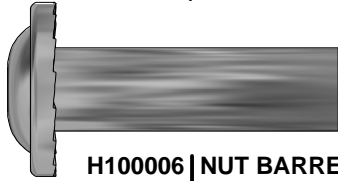

H100006 | NUT BARREL
WH
(3) | 5/16x1 1/2

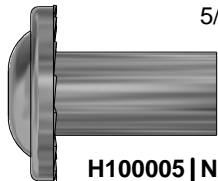

H100005 | NUT BARREL
WH
(30) | 5/16x7/8

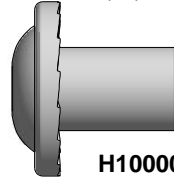

H100004 | NUT BARREL
WH
(9) | 5/16 x 5/8

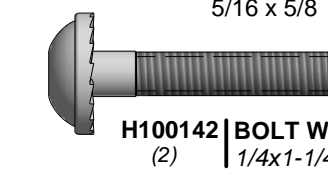

H100142 | BOLT WH
(2) | 1/4x1-1/4

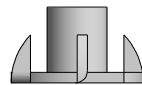

H100072 | T-NUT
(15) | 1/4

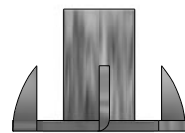

H100074 | T-NUT
(86) | 5/16

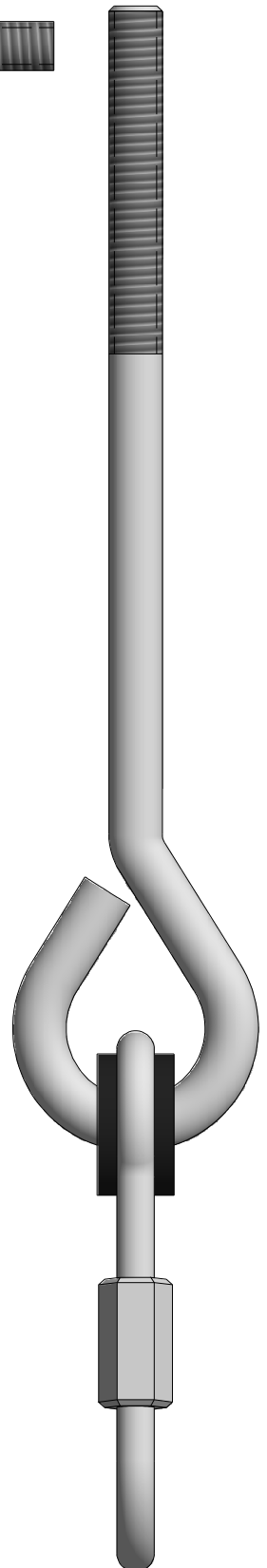

H100099 | SWING
HANGER
(6) | 5/16x9 1/2



Hardware Components



H100084 | SCREW PFH
(4) | 6x3/4



H100085 | SCREW PFH
(13) | 8x1



H100088 | SCREW PFH
(92) | 8x1 1/8



H100087 | SCREW PFH
(39) | 8x1 1/4



H100086 | SCREW PFH
(96) | 8x1 1/2



H100089 | SCREW PFH
(60) | 8x1 3/4



H100111 | SCREW PFH
(4) | 8x2



H100090 | SCREW PFH
(26) | 8x2 1/2"

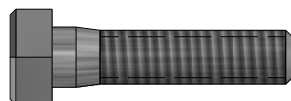

H100042 | BOLT HEX
(4) | 5/16x1 1/4

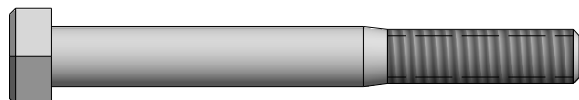

H100047 | BOLT HEX
(4) | 5/16x2 3/4



H100063 | BOLT PTH
(13) | 1/4x3/4



H100128 | SCREW PWH
(17) | 8x5/8

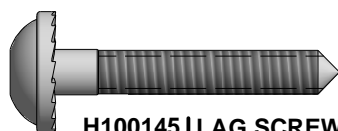

H100145 | LAG SCREW WH
(30) | 1/4x1 1/2

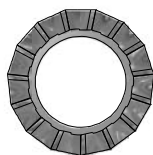

H100031 | WASHER
(35) | LOCK EXT
12x19

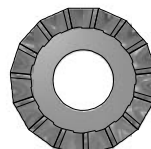

H100030 | WASHER
(105) | LOCK EXT
8x19

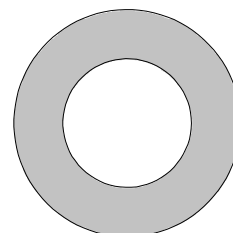

H100103 | WASHER
(7) | SAFETY
17x30

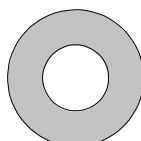

H100106 | WASHER
(2) | FLAT
9x18

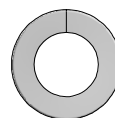

H100095 | WASHER
(4) | SPLIT
5/16

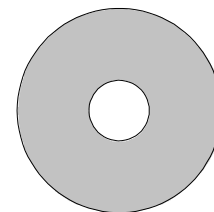

H100105 | WASHER
(16) | FLAT
8x27

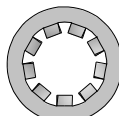

H100108 | WASHER
(17) | LOCK INT
8x15

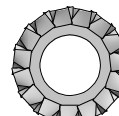

H100138 | WASHER
(18) | LOCK EXT
6x15

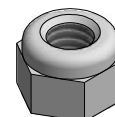

H100110 | NUT LOCK
(9) | 5/16



H100764 | SCREW SETTER
(1)



A100042 | T-40 TORX BIT
(2)



H100147 | T-30 TORX BIT
(2)

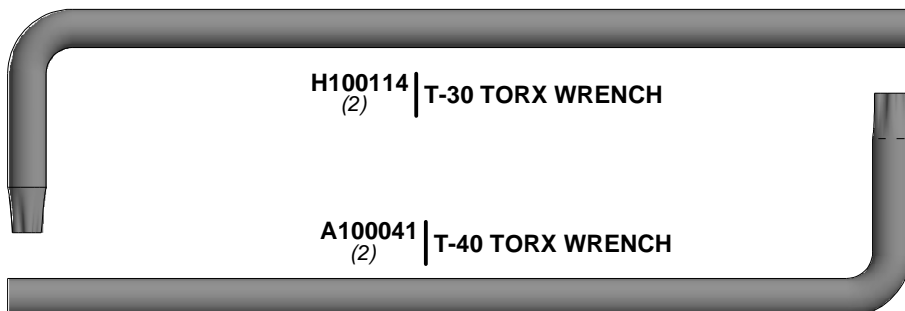

H100114 | T-30 TORX WRENCH
(2)

A100041 | T-40 TORX WRENCH
(2)

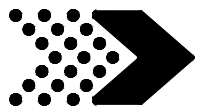

Accessory Components (Not to Scale)

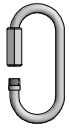

A100069 | QUICK LINK
(6)



A4M00646 | L BRACKET
(2) | BLUE 32x51



A4M01048 | L BRACKET
(8) | 2.5x38x55x55

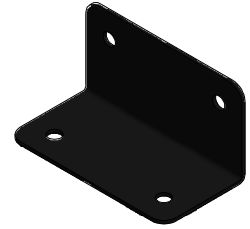

A100153 | L BRACKET
(2) | 66x66x127 BLUE

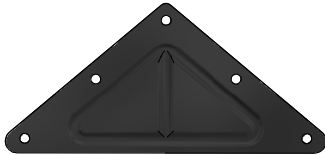

A100309 | TRIANGLE
(2) | PLATE BLUE 100
5 HOLE

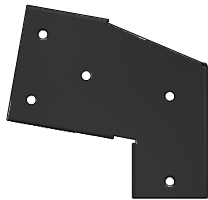

A4M00511 | SWING BEAM
(1) | EXT. BRACKET
BLUE - LEFT

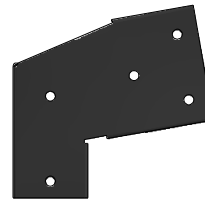

A4M00512 | SWING BEAM
(1) | EXT BRACKET
BLUE - RIGHT



A100314 | "A" REVISION
(1) | TAG



A4M00524 | CHAIN BLUE 51.25"
(4)



A4M00525 | CHAIN BLUE 31"
(2)



A4M00585 | METAL RUNG 559 BLUE
(5)



A100178 | AUGER GROUND STAKE
(8)



A6P00125 | SHIPS WHEEL
(1) | BLUE/LIME

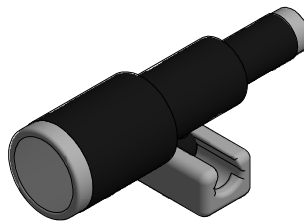

A6P00126 | TELESCOPE
(1) | BLUE/LIME

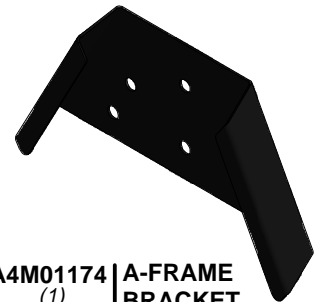

A4M01174 | A-FRAME
(1) | BRACKET

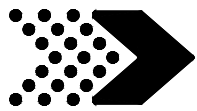

Accessory Components (Not to Scale)

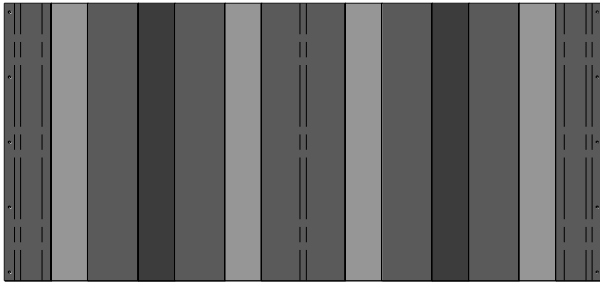

A6P00123 | TARP
(1)



A6P00124 | AWNING
(1)

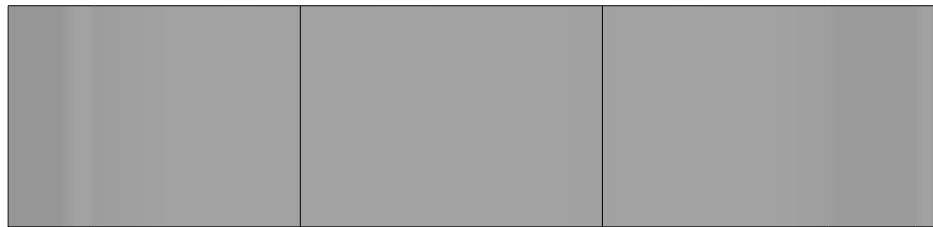

A6P00131 | SLIDE BED 8' LIME
(1)



A100161 | SLIDE RAIL 8' BLUE RIGHT
(1)



A100162 | SLIDE RAIL 8' BLUE LEFT
(1)



A6P00133 | SWING SEAT BLUE 22"
(2)



A100164 | BYD ID TAG (LARGE) AGES 3-10
(1)



A6P00128 | LIME HC ROCK #2
(2)



A6P00040 | BLUE HC ROCK #2
(2)



A6P00129 | CRANBERRY HC ROCK #1
(2)



A6P00127 | HAND GRIP LIME PLASTIC
(4)



A6P00134 | BLUE TRAPEZE
(1)

PRE-ASSEMBLY STEP 1 - SORTING PARTS

It is critical for ease of assembly that you take the time to sort and organize the wood and hardware.

WOOD PARTS:

- Organize wood parts by the three-digit, alpha-numeric number stamped on each board (ex. P01).
- If there are multiple boards with the same stamped number, stack those pieces together.
- Stamps can be found on the flat surface of the boards or on the end of the boards.
- Allow yourself plenty of room - the wood pieces can take up a significant amount of space.

NOTE: CARTONS ARE NOT ORGANIZED BY BOARD NUMBER.

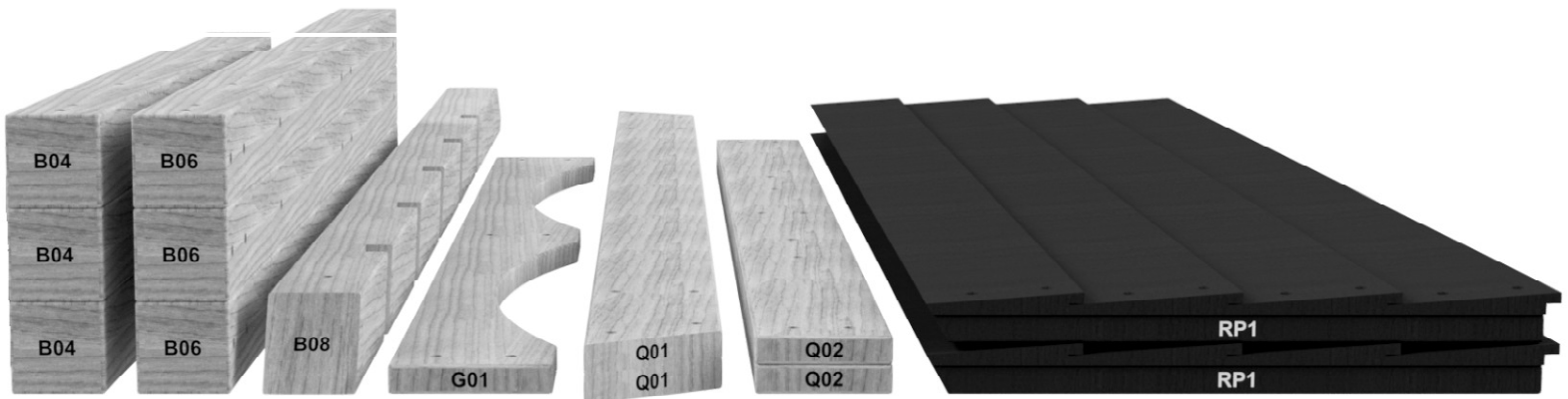

HARDWARE PARTS:

- We recommend that you have a separate table to organize the hardware.
- Hardware bags are printed with a seven-digit, alpha-numeric part number.
- You can organize your hardware by part number or group by hardware type (i.e. bolts, nuts, etc.).
- During assembly you only need to reference the last four digits of the number.

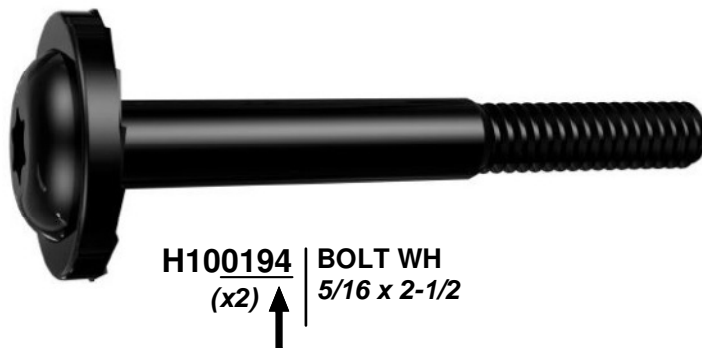

PRE-ASSEMBLY STEP 2 - TOOLS REQUIRED



**Cordless Drill or
Electric Drill**



**Drill Attachments:
Phillips Head**



**1/8", 3/16", 3/8" & 7/16"
Drill Bits**



Phillips Screw Driver



Open End Wrenches 1/2" & 9/16"



**3/8" Drive Ratchet, 1/2" &
9/16" STD Sockets 1/2" & 9/16" Deep
Sockets**



Claw Hammer



Rubber Mallet - Optional



Tape Measure

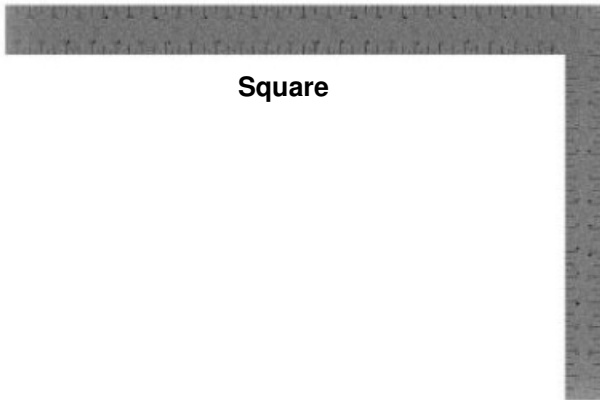

Square



Level 24"

PRE-ASSEMBLY STEP 3 - CHOOSE YOUR ASSEMBLY METHOD

There are several types of assembly instructions available to you.

1. Printed Assembly Manual included with your set
2. BILT APP - 3D interactive instructions
3. Combination of the Printed Manual and BILT APP (Note: Step numbers can differ between the two methods)

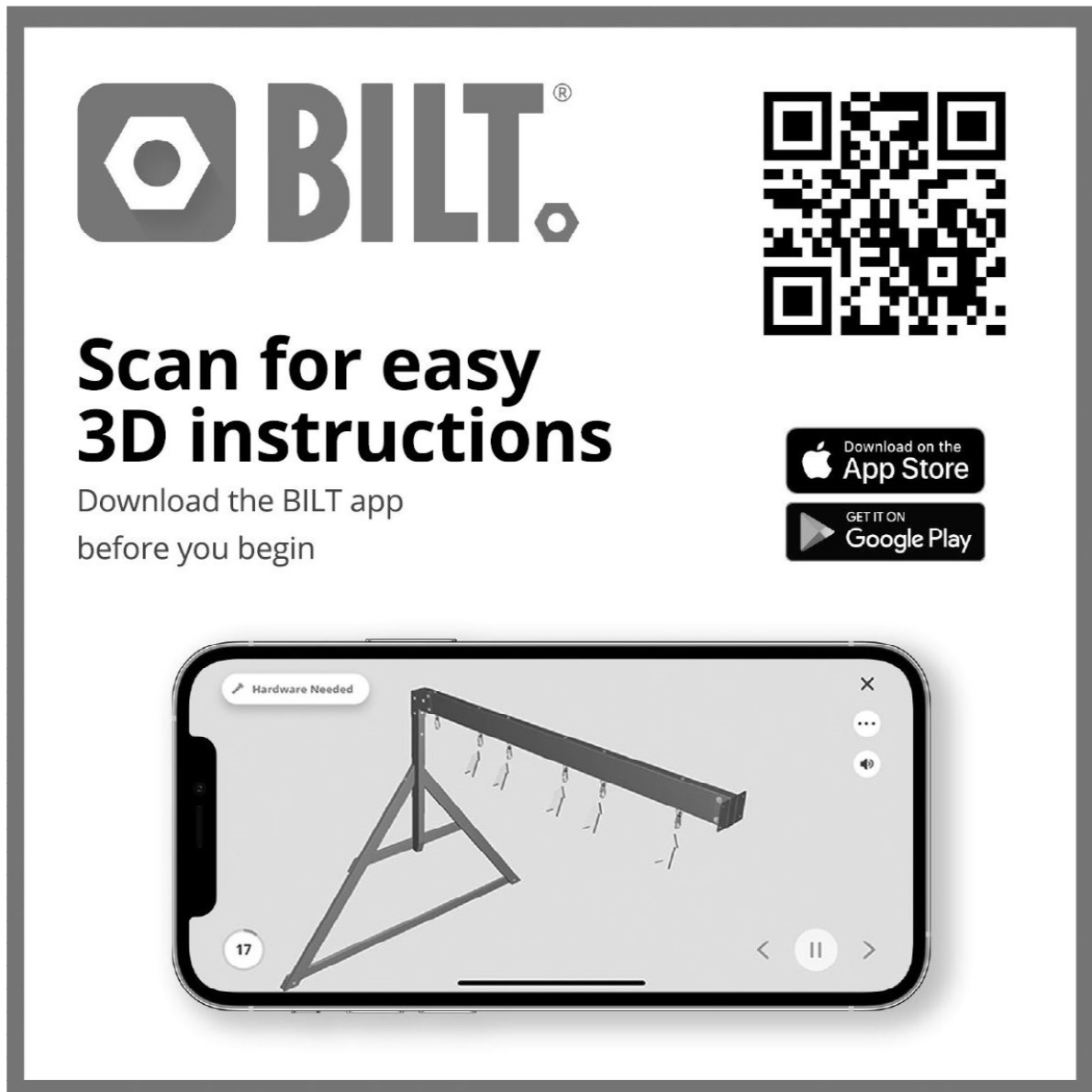

The advertisement features the BILT logo (a hexagon with a dot) and the word "BILT." in a bold, sans-serif font. To the right is a large QR code. Below the logo, the text "Scan for easy 3D instructions" is written in a large, bold font, followed by "Download the BILT app before you begin" in a smaller font. Two buttons are present: "Download on the App Store" with the Apple logo and "GET IT ON Google Play" with the Google Play logo. At the bottom, a smartphone screen displays a 3D assembly instruction for step 17, showing a metal frame with a horizontal bar and several hanging components. The screen includes a "Hardware Needed" label, a close button (X), a menu button (three dots), a volume icon, and navigation arrows.

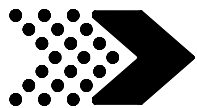

SWING BEAM

STEP 1



SB74 | SWING BEAM EXTENDED - W4L06961
(1) | 2"x5 1/4"x89 1/2" (50x134x2274)



H100011 | BOLT WH
(3) | 5/16x1 3/4

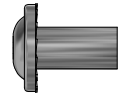

H100005 | NUT BARREL WH
(3) | 5/16x7/8



H100047 | BOLT HEX
(2) | 5/16x2 3/4



H100110 | NUT LOCK
(2) | 5/16

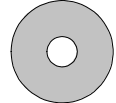

H100105 | WASHER FLAT
(4) | 8x27

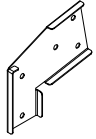

A4M00511 | SWING BEAM
EXT. BRACKET
BLUE - LEFT
(1)

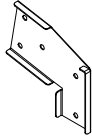

A4M00512 | SWING BEAM
EXT BRACKET
BLUE - RIGHT
(1)



A100153 | L BRACKET
(2) | 66x66x127 BLUE

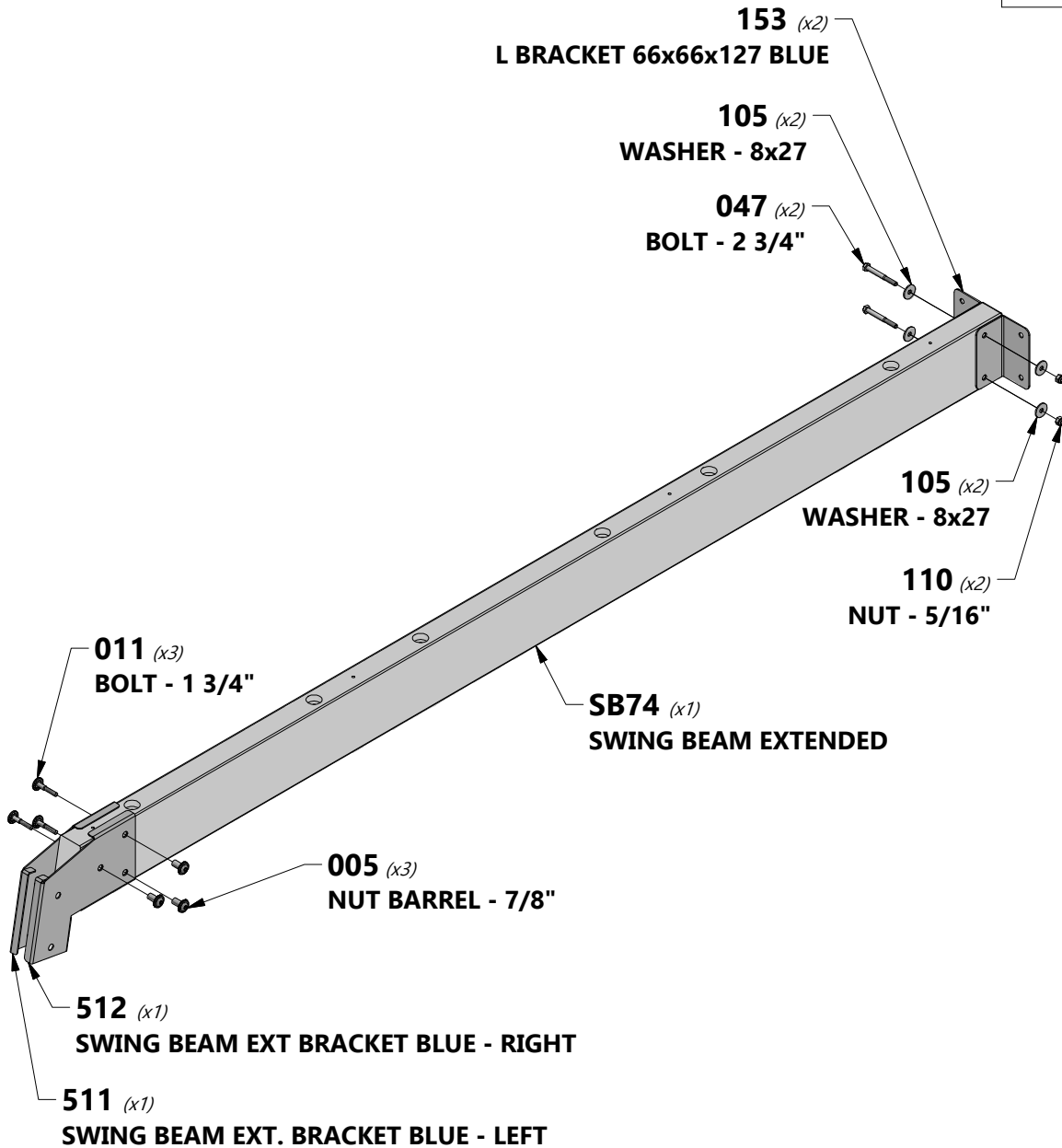

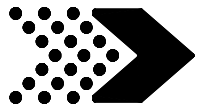

SWING BEAM

STEP 2



E50 | END SUPPORT - W4L13843
(1) | 1 3/8"x3 3/8"x46" (36x86x1168)

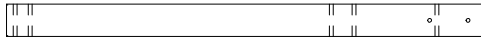

W71 | SWING BEAM SUPPORT - W4L13844
(1) | 2"x3 3/8"x49 5/8" (50x86x1268)

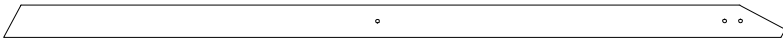

E77 | ANGLE BRACE - W4L13842
(2) | 1 3/8"x3 3/8"x81 3/8" (36x86x2068)

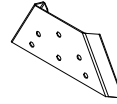

A4M01174 | A-FRAME
(1) | BRACKET



H100019 | BOLT WH
(2) | 5/16x3 3/4



H100016 | BOLT WH
(2) | 5/16x3

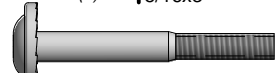

H100014 | BOLT WH
(2) | 5/16x2 1/2



H100006 | NUT BARREL
(2) | WH
5/16x1 1/2



H100008 | BOLT WH
(4) | 5/16x1



H100005 | NUT BARREL
(8) | WH
5/16x7/8



H100031 | WASHER
(10) | LOCK EXT
12x19



H100030 | WASHER
(4) | LOCK EXT
8x19

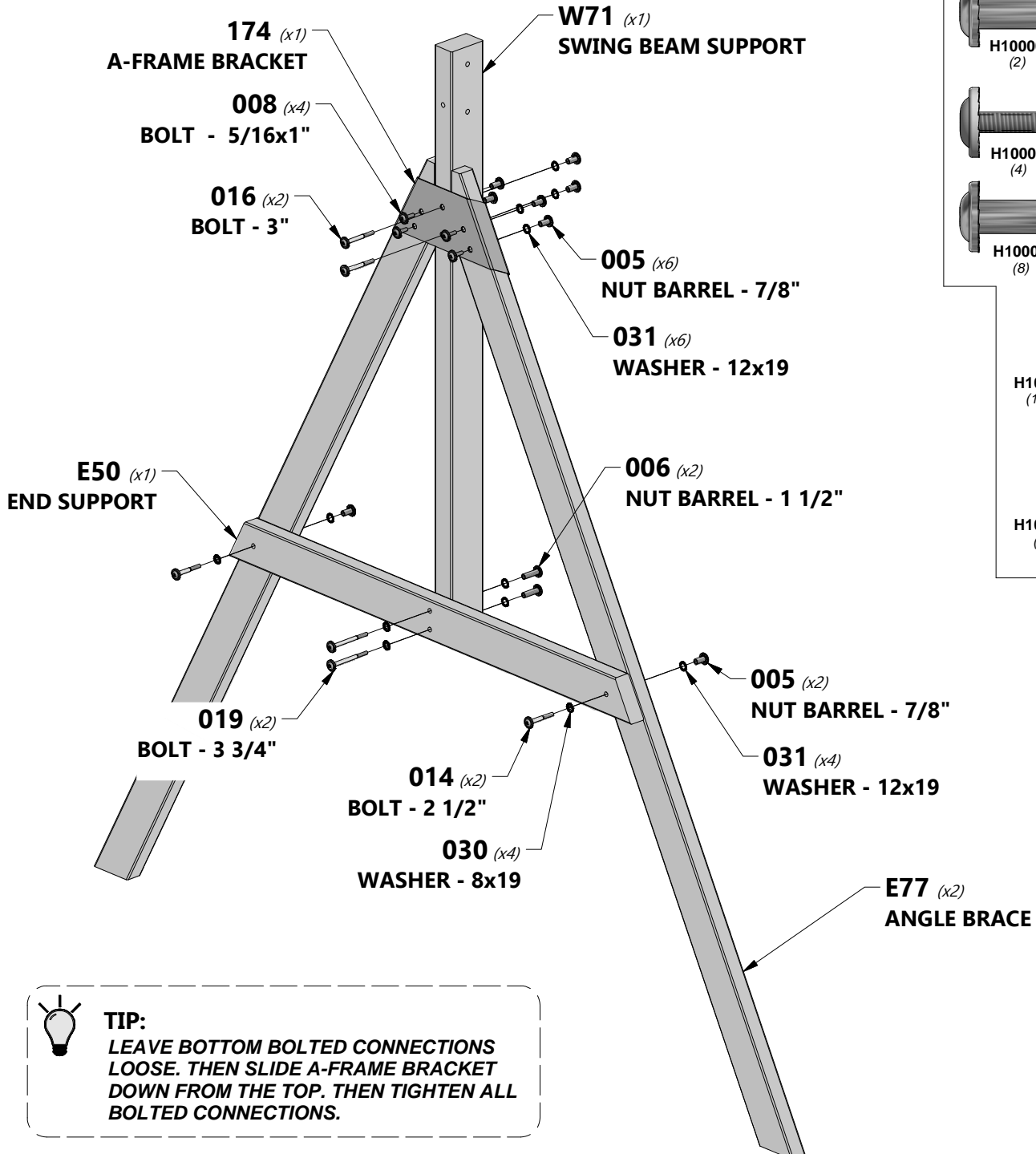

TIP:
LEAVE BOTTOM BOLTED CONNECTIONS LOOSE. THEN SLIDE A-FRAME BRACKET DOWN FROM THE TOP. THEN TIGHTEN ALL BOLTED CONNECTIONS.

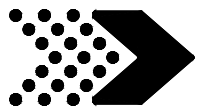

SWING BEAM

STEP 3

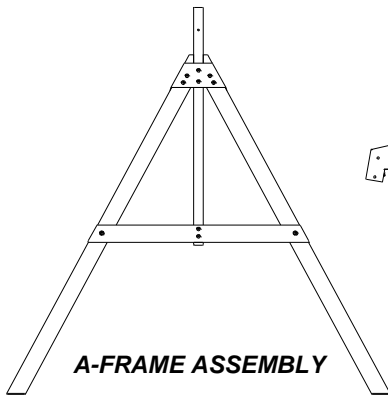

A-FRAME ASSEMBLY



BEAM ASSEMBLY



H100014 | BOLT WH
(1) | 5/16x2 1/2



H100011 | BOLT WH
(2) | 5/16x1 3/4



H100006 | NUT BARREL
(1) | WH
5/16x1 1/2



H100005 | NUT BARREL
(2) | WH
5/16x7/8



H100031 | WASHER
(1) | LOCK EXT
12x19



H100030 | WASHER
(1) | LOCK EXT
8x19

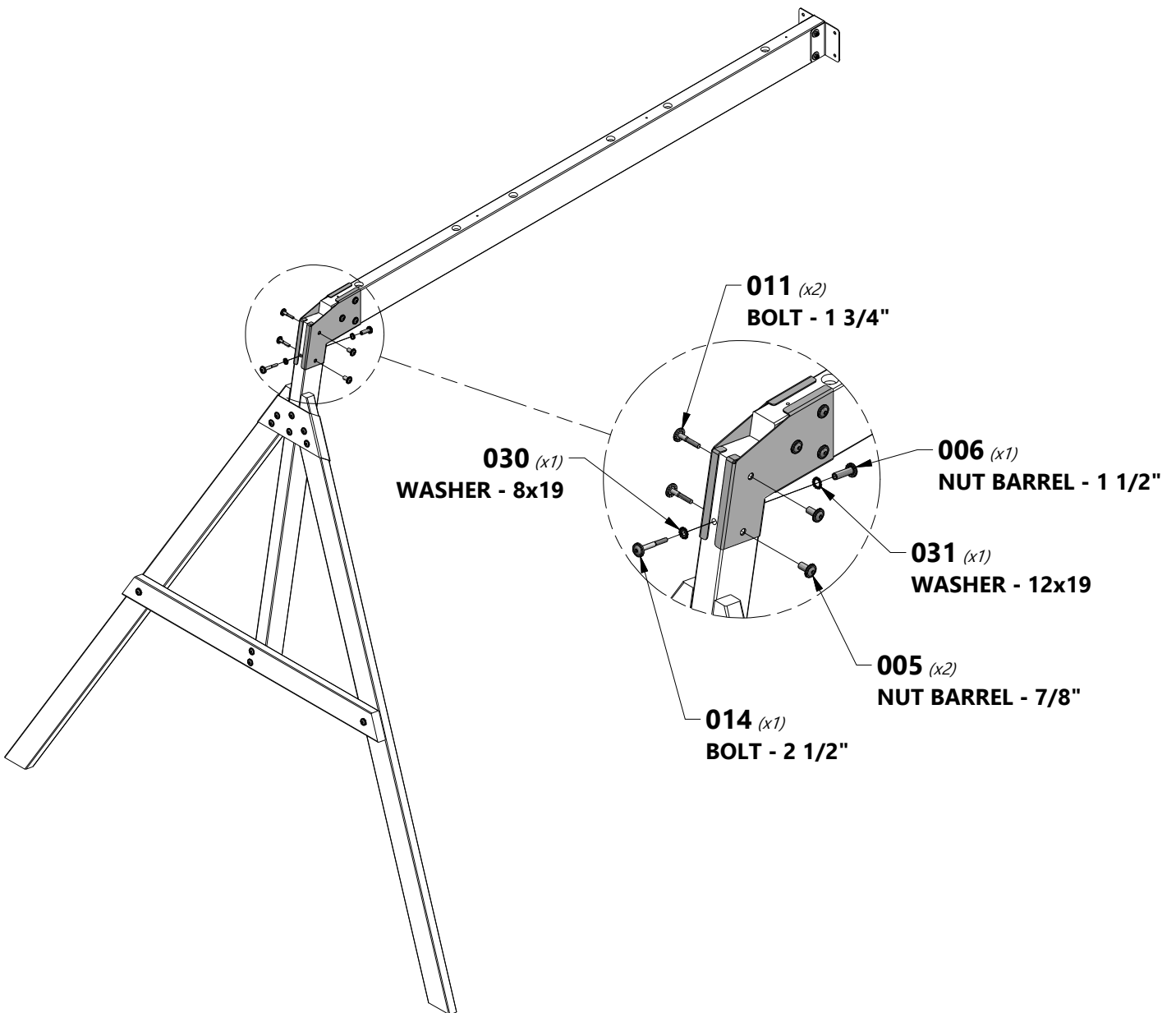

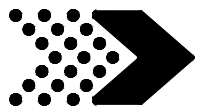

SWING BEAM

STEP 4

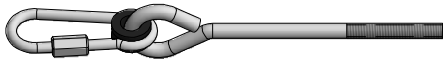

H100099 | 9 1/2" SWING
(6) | HANGER QUICK
LINK

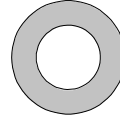

H100103 | WASHER
(6) | SAFETY
17x30

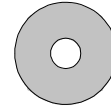

H100105 | WASHER
(6) | FLAT
8x27



H100110 | NUT LOCK
(6) | 5/16

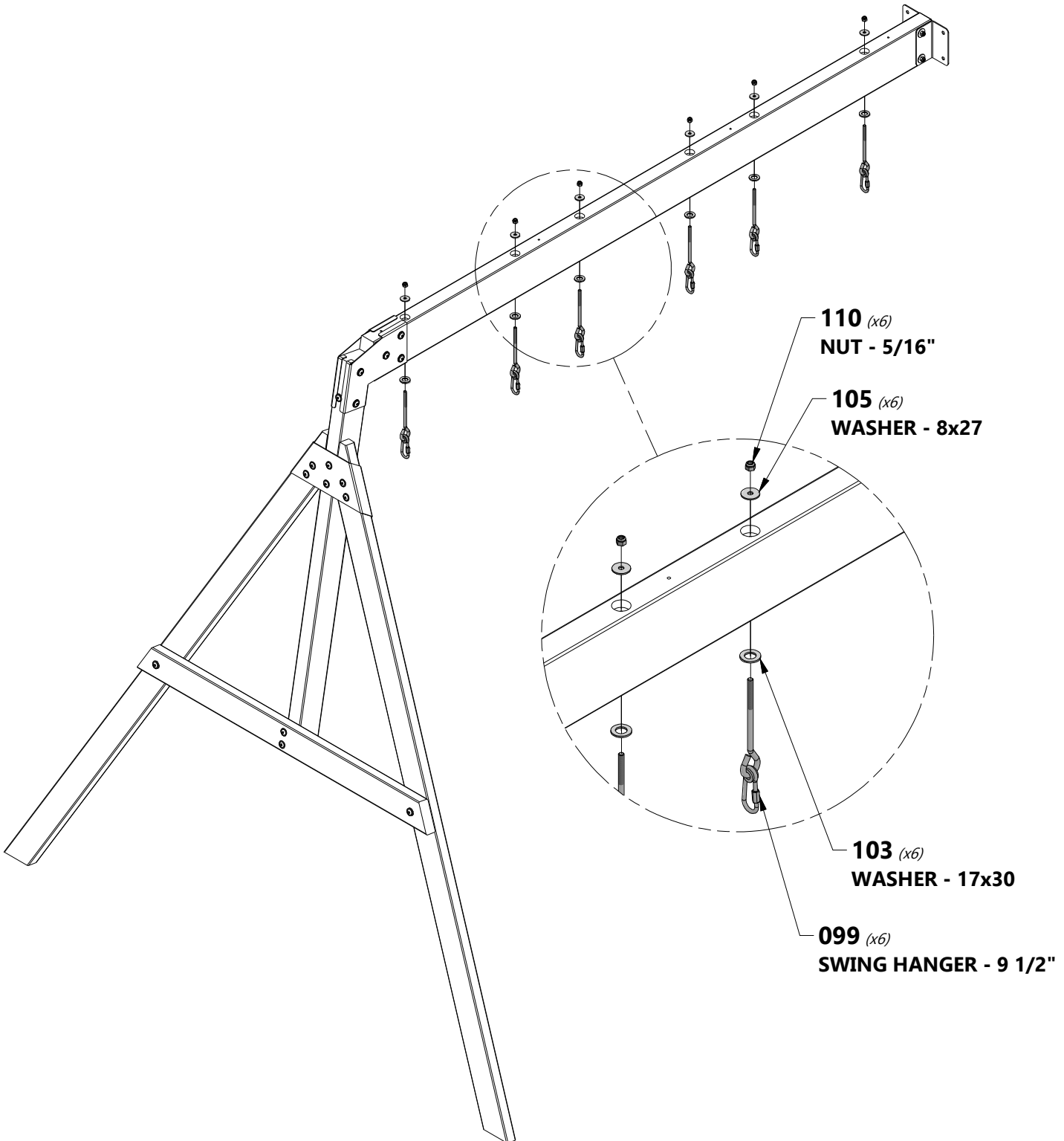

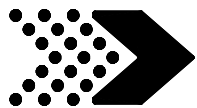

MONKEY BAR

STEP 1



E7 | MONKEY BAR RAIL - W4L13841
(1) | 1 3/8"x3 3/8"x48" (36x86x1219)

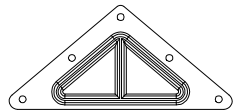

A100309 | TRIANGLE
(1) | PLATE BLUE 100
5 HOLE



A4M01048 | L BRACKET
(1) | 2.5x38x55x55



H100010 | BOLT WH
(3) | 5/16x1-1/2

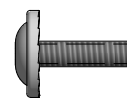

H100008 | BOLT WH
(1) | 5/16x1

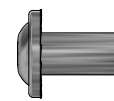

H100005 | NUT BARREL
(1) | WH
5/16x7/8



H100074 | T-NUT
(3) | 5/16



H100030 | WASHER
(1) | LOCK EXT
8x19

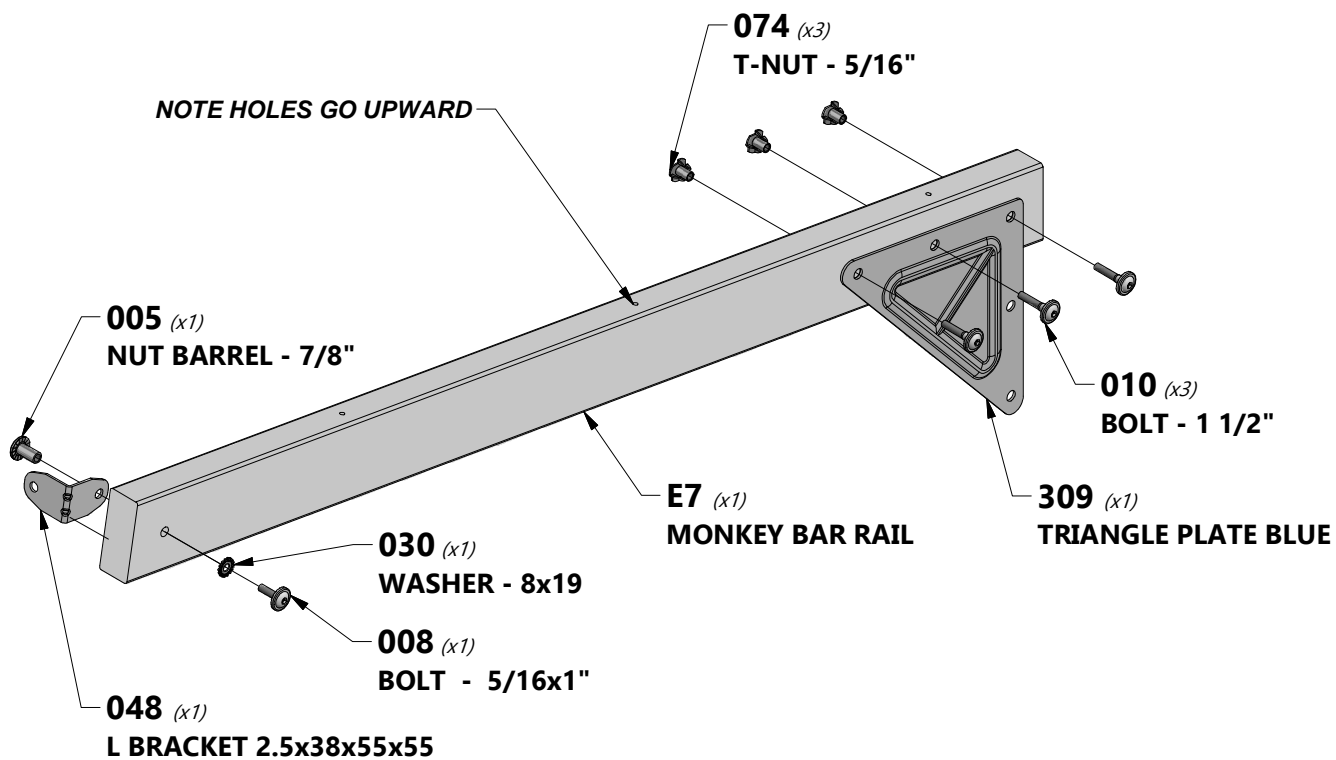

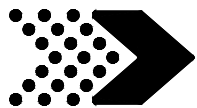

MONKEY BAR

STEP 2

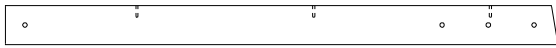

E7 | MONKEY BAR RAIL - W4L13841
(1) | 1 3/8"x3 3/8"x48" (36x86x1219)

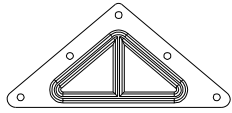

A100309 | TRIANGLE
(1) | PLATE BLUE 100
5 HOLE



A4M01048 | L BRACKET
(1) | 2.5x38x55x55



H100010 | BOLT WH
(3) | 5/16x1-1/2

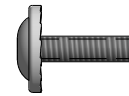

H100008 | BOLT WH
(1) | 5/16x1

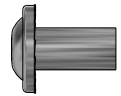

H100005 | NUT BARREL
(1) | WH
5/16x7/8



H100074 | T-NUT
(3) | 5/16



H100030 | WASHER
(1) | LOCK EXT
8x19

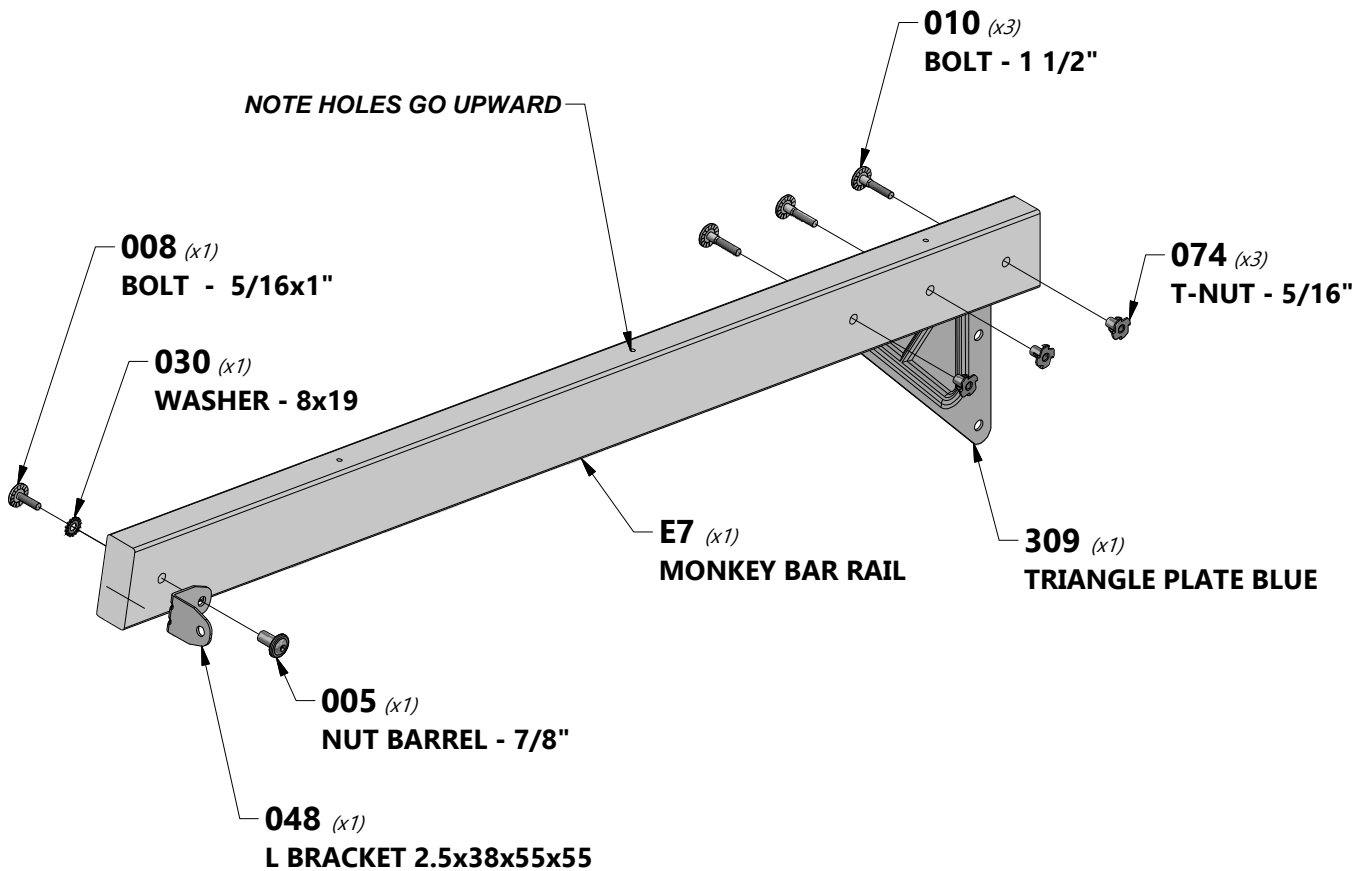

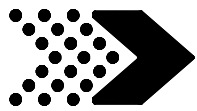

MONKEY BAR

STEP 3



E5 | MONKEY BAR UPRIGHT - W4L13840
(1) | 1 3/8"x3 3/8"x70 3/8" (36x86x1786)

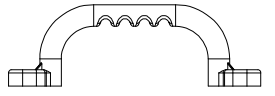

A6P00127 | HAND GRIP LIME PLASTIC
(1)



H100010 | BOLT WH
(2) | 5/16x1-1/2



H100145 | LAG SCREW WH
(2) | 1/4x1 1/2



H100138 | WASHER LOCK EXT
(2) | 6x15



H100074 | T-NUT
(2) | 5/16

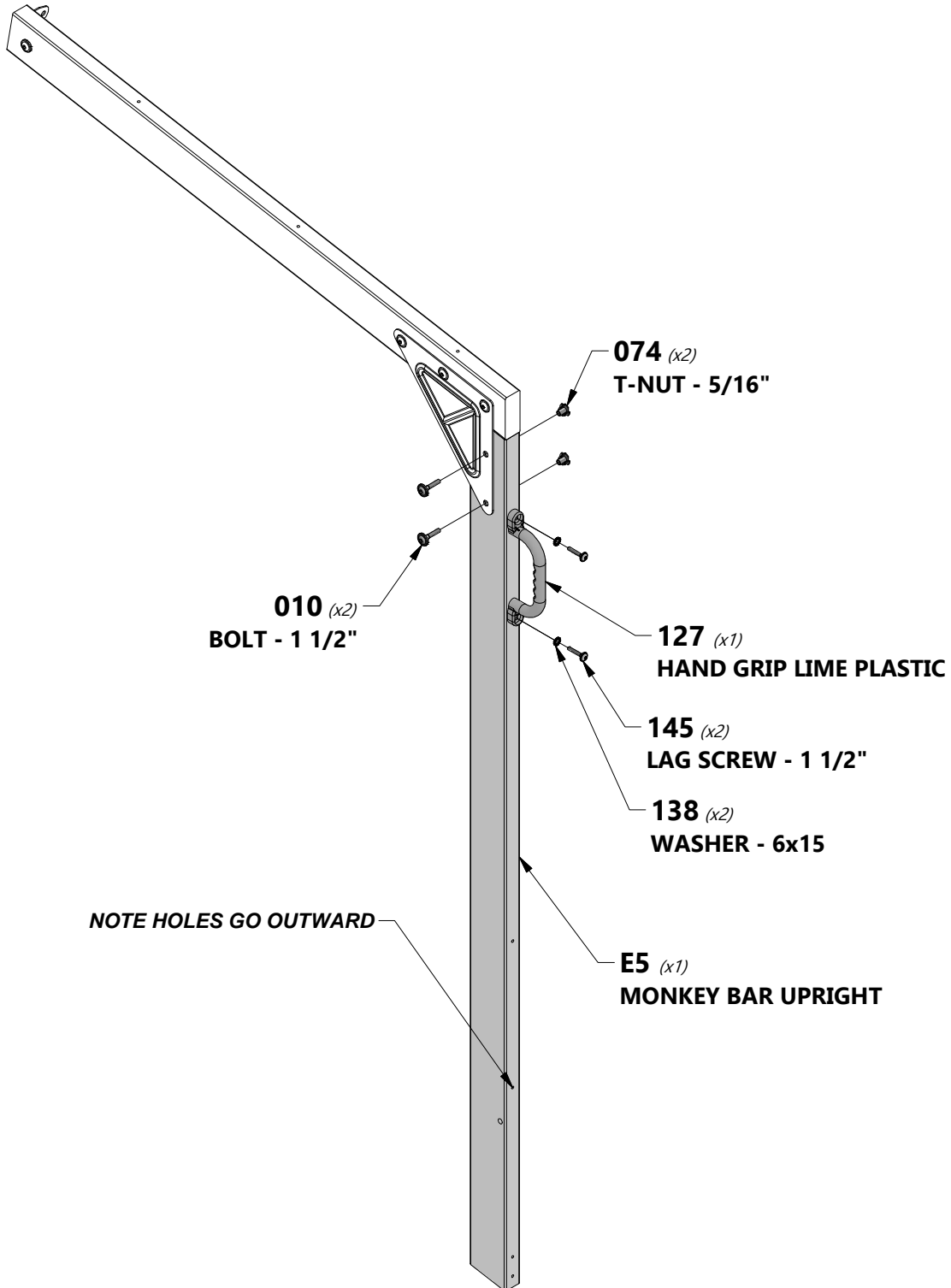

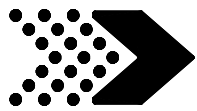

MONKEY BAR

STEP 4



E5 | MONKEY BAR UPRIGHT - W4L13840
(1) | 1 3/8"x3 3/8"x70 3/8" (36x86x1786)

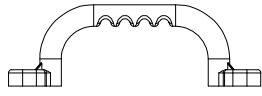

A6P00127 | HAND GRIP LIME PLASTIC
(1)



H100010 | BOLT WH
(2) | 5/16x1-1/2



H100145 | LAG SCREW WH
(2) | 1/4x1 1/2



H100138 | WASHER LOCK EXT
(2) | 6x15



H100074 | T-NUT
(2) | 5/16

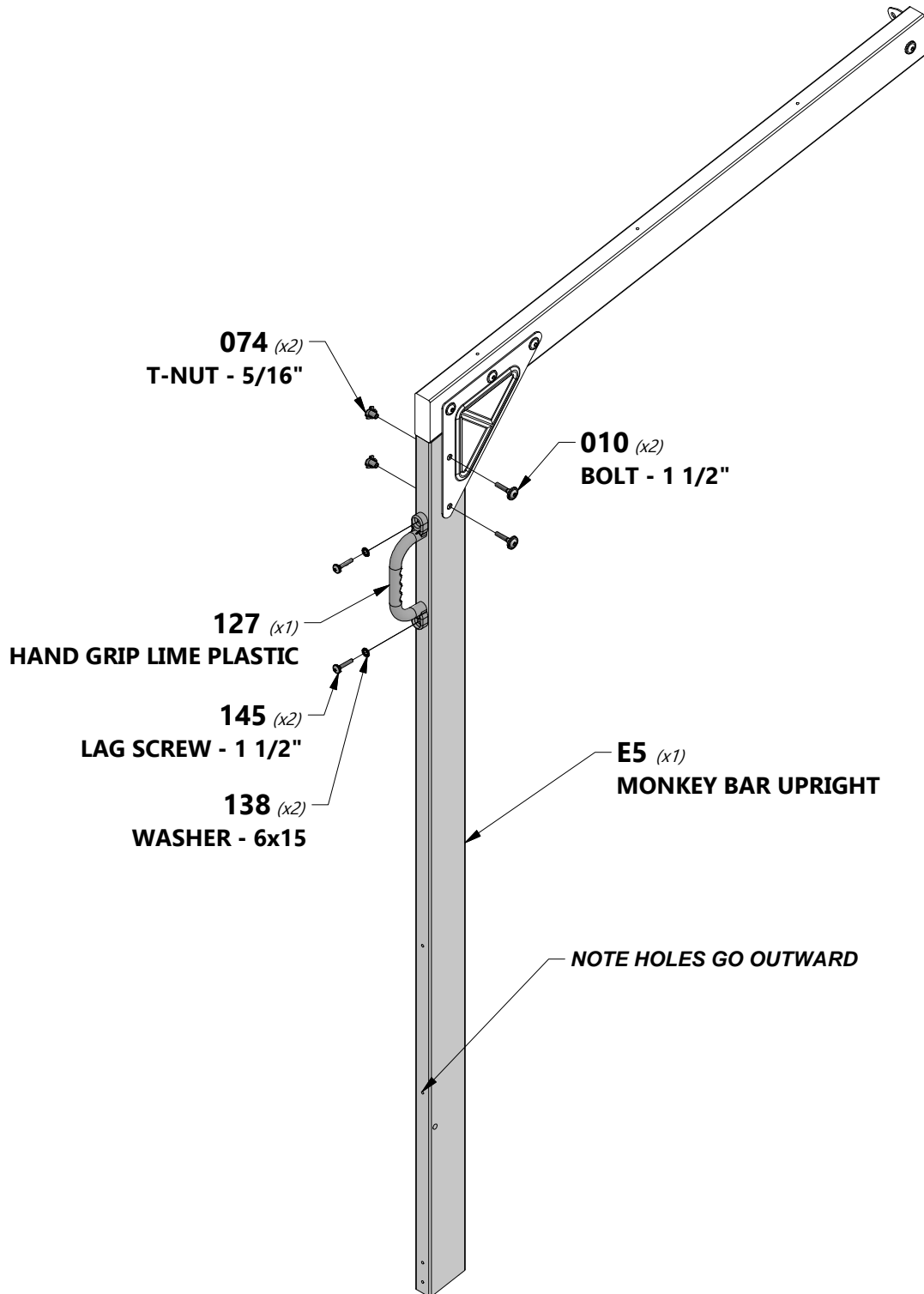

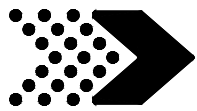

MONKEY BAR

STEP 5

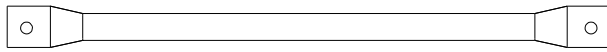

A4M00585 | METAL RUNG 559 BLUE
(5)



H100145 | LAG SCREW WH
(10) | 1/4x1 1/2

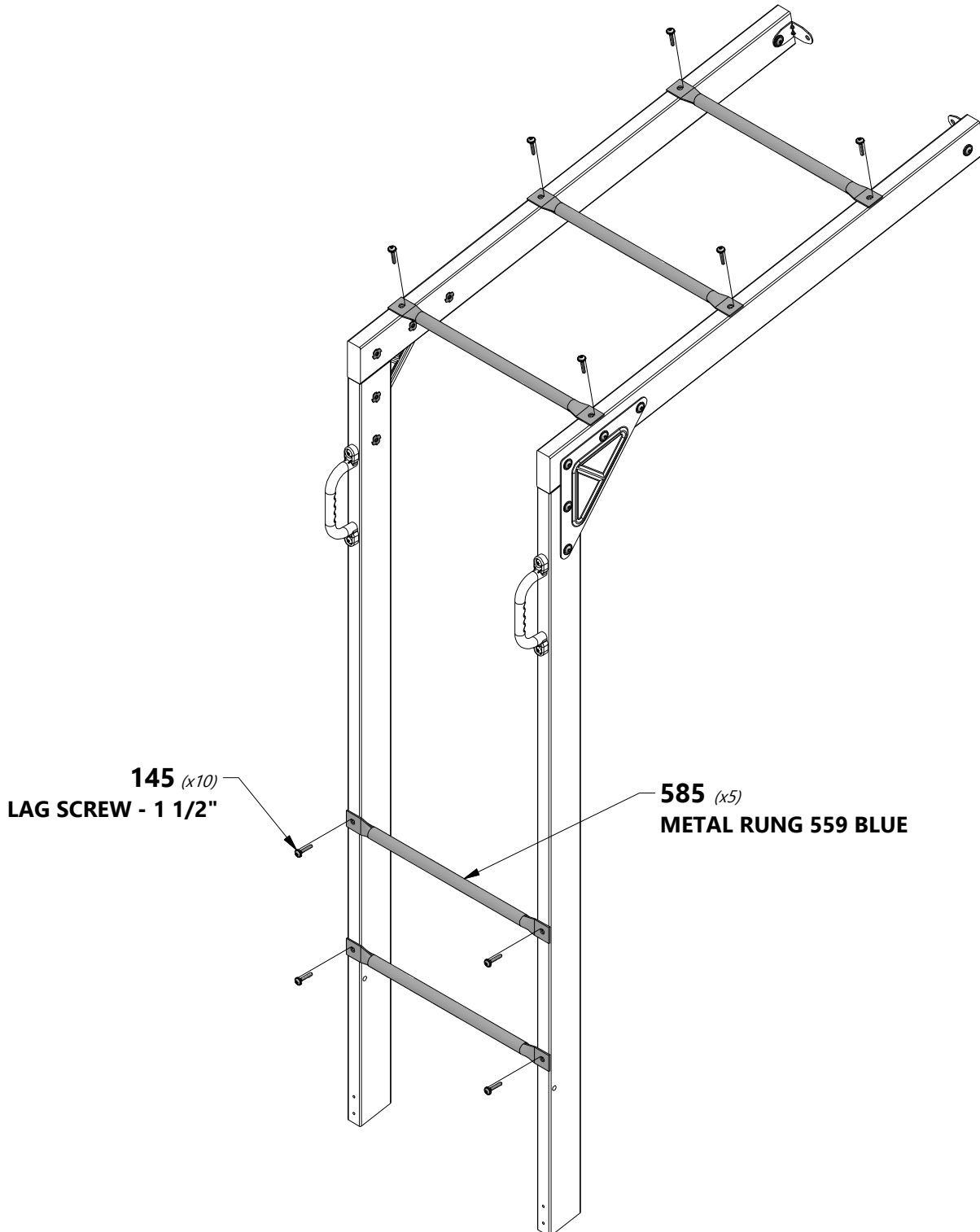

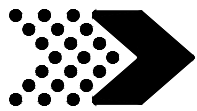

MONKEY BAR

STEP 6

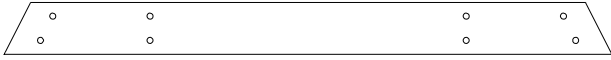

M82 | MONKEY BAR GROUND BOARD - W4L13850
(1) | 5/8"x3 3/8"x39 5/8" (16x86x1006)



H81 | MONKEY BAR BRACE - W4L13849
(2) | 1"x3 3/8"x18 5/8" (24x86x474)



H100047 | BOLT HEX
(2) | 5/16x2 3/4

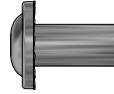

H100005 | NUT BARREL
(4) | WH
5/16x7/8



H100027 | LAG SCREW
(4) | WH
5/16x2



H100008 | BOLT WH
(4) | 5/16x1



H100108 | WASHER
(2) | LOCK INT
8x15

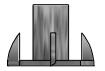

H100074 | T-NUT
(2) | 5/16



H100106 | WASHER
(2) | FLAT
9x18



H100031 | WASHER
(4) | LOCK EXT
12x19



H100030 | WASHER
(8) | LOCK EXT
8x19

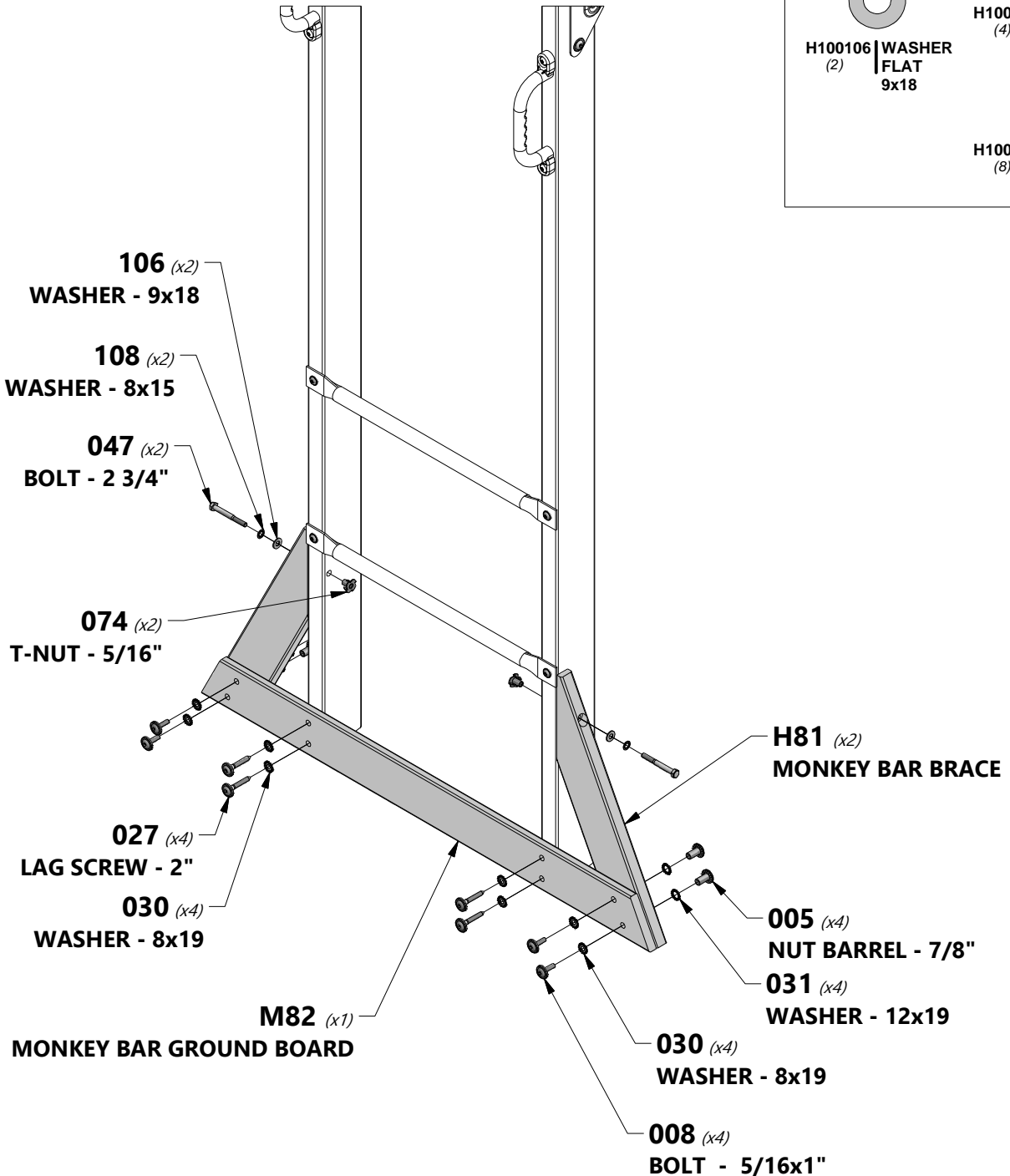



BENCH ASSEMBLY

STEP 1



H7 | BENCH GROUND BOARD - W4L06967
(2) 1"x3 3/8"x18 1/8" (24x86x460)



A4M00646 | L BRACKET
(2) BLUE 32x51

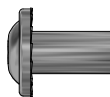

H100005 | NUT BARREL WH
(2) 5/16x7/8



H100115 | BOLT WH
(2) 5/16x1/2



H100031 | WASHER
(2) LOCK EXT
12x19

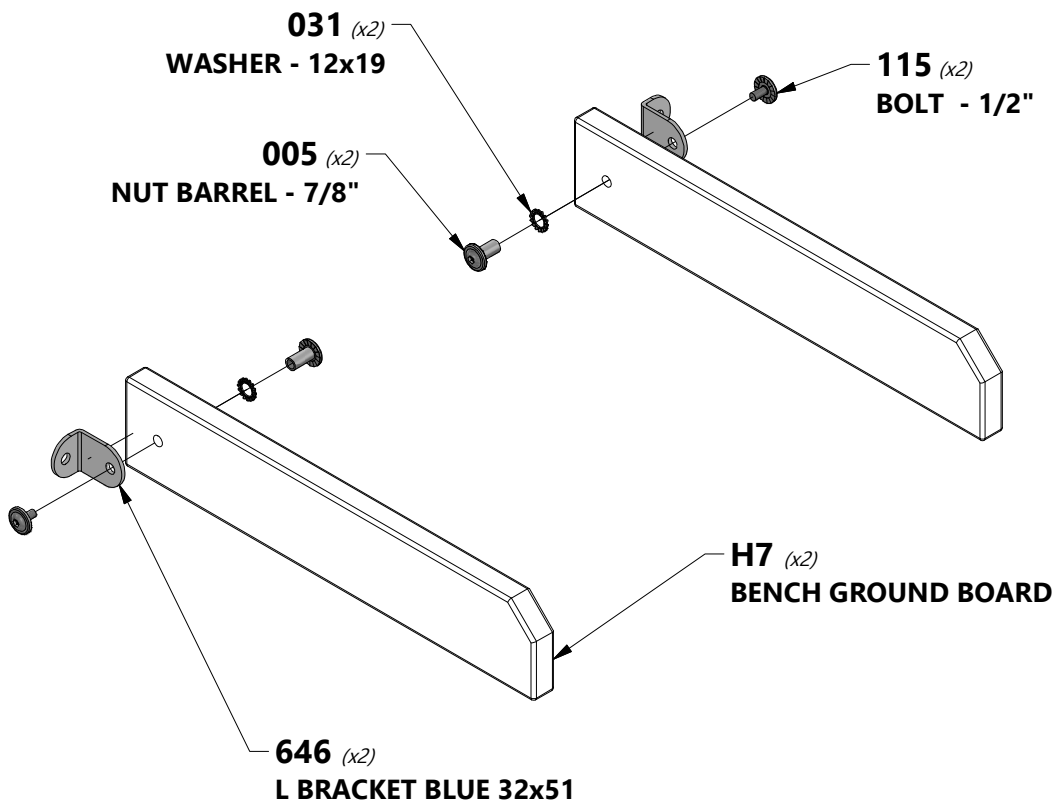

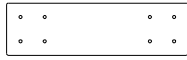
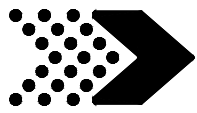

H8 | BENCH UPRIGHT - W4L06968
(2) | 1"x3 3/8"x11 3/4" (24x86x300)



H100089 | SCREW PFH
(8) | 8x1 3/4

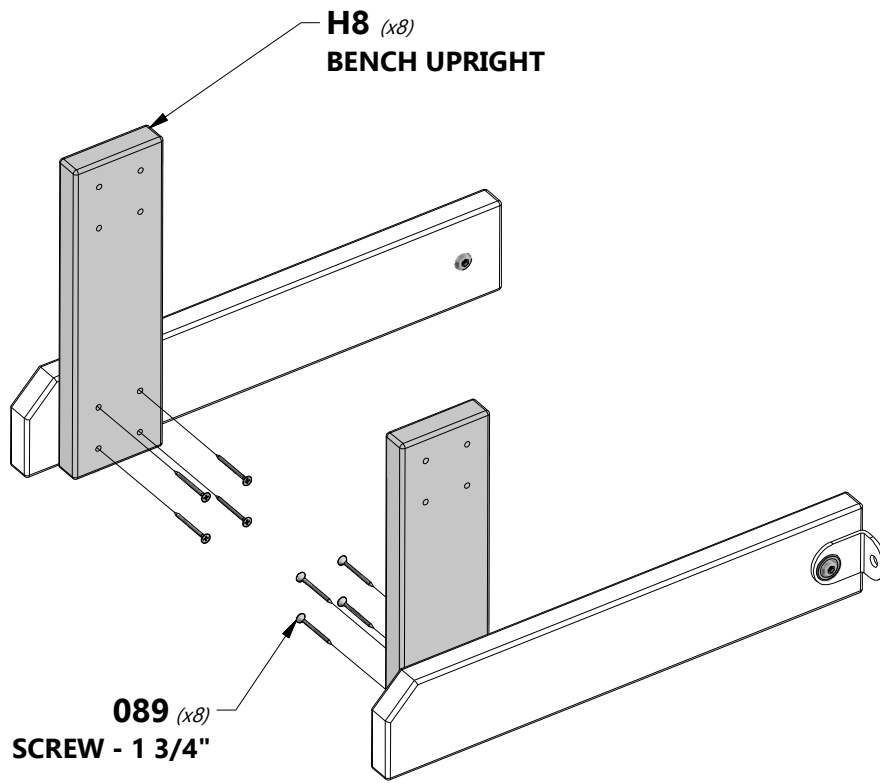

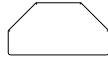
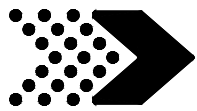

H9 | BENCH SEAT SUPPORT - W4L06969
(2) | 1"x3 3/8"x6 1/2" (24x86x166)



H100089 | SCREW PFH
(8) | 8x1 3/4

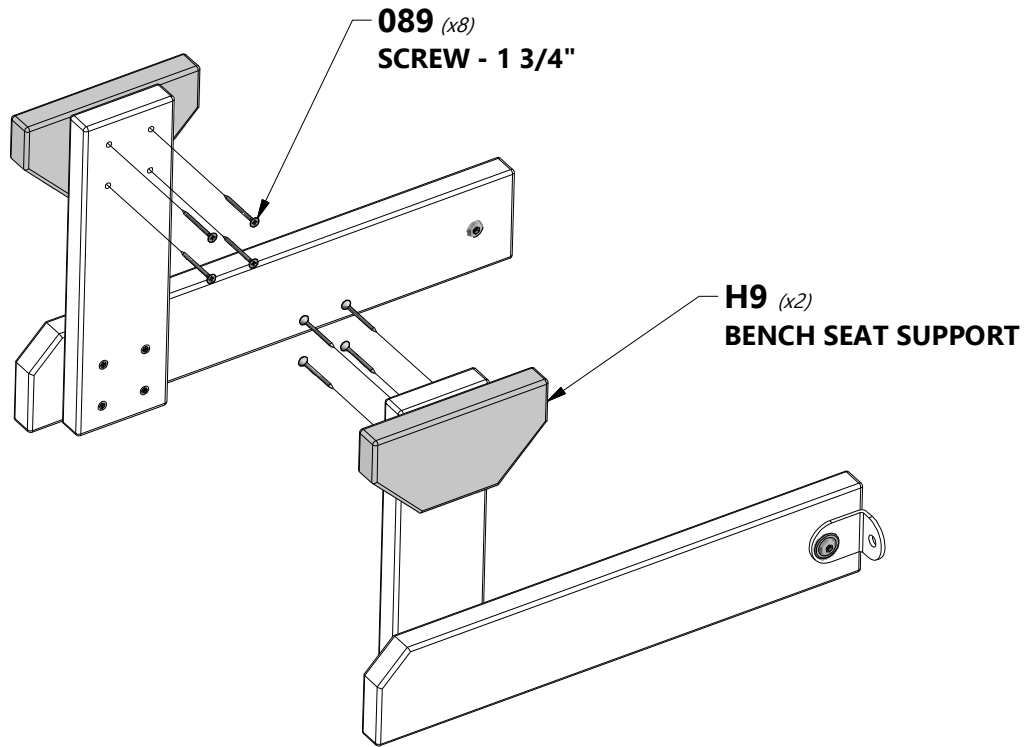

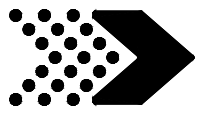

H12 | BENCH SEAT - W4L13837
(2) | 1"x3 3/8"x26" (24x86x660)



H100089 | SCREW PFH
(8) | 8x1 3/4

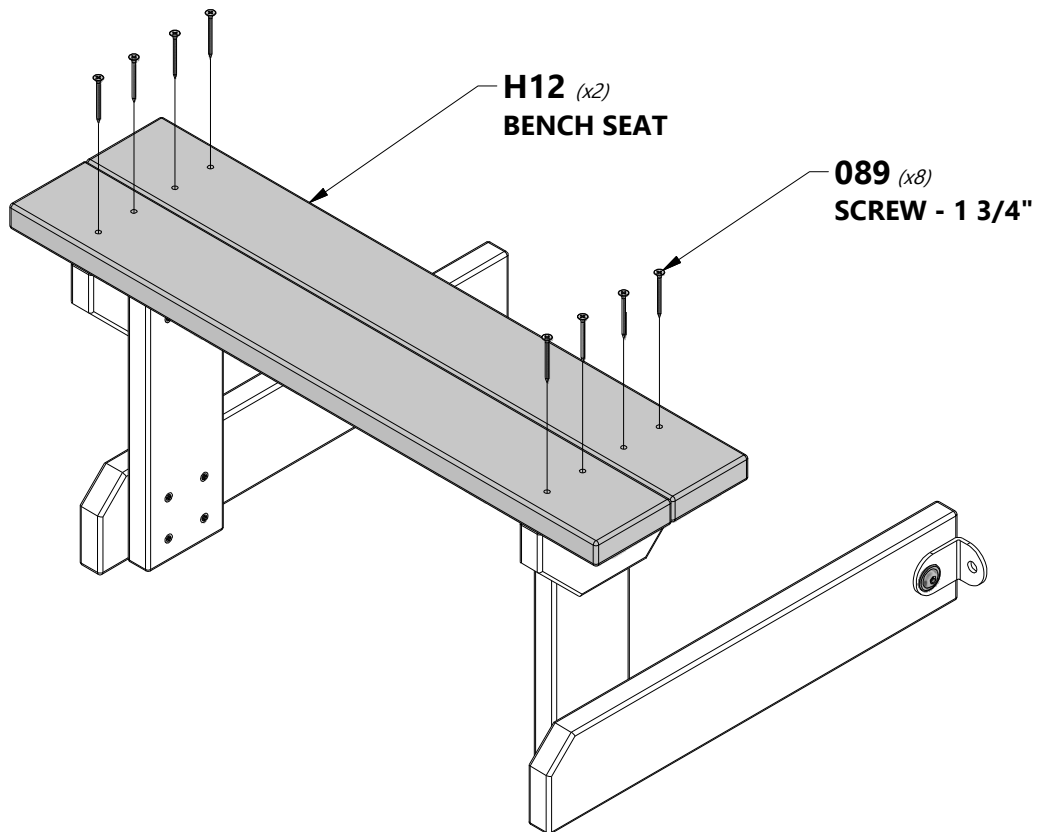



SLIDE ASSEMBLY

STEP 1



A6P00131 | SLIDE BED 8' LIME
(x1)

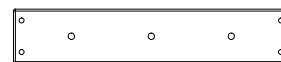

M77 | SLIDE BRACE - W100544
(x1) | 5/8"x3 3/8"x17 1/4" (16x86x438)



H100115 | BOLT WH
(x3) | 5/16x1/2



H100074 | T-NUT
(x3) | 5/16



NOTE:

PLACE 'M77' SLIDE BRACE BOARD 1/2" FROM THE BOTTOM EDGE OF THE SLIDE BED. USING THE BOARD AS A TEMPLATE, MARK WHERE THE PILOT HOLES WILL BE DRILLED. USE A 3/8" DRILL BIT TO DRILL THE PILOT HOLES INTO THE SLIDE BED. ATTACH THE SLIDE BED SUPPORT BOARD USING THE HARDWARE PROVIDED.



TIP:

PREBENDING THE ENDS WILL EASE ASSEMBLY.

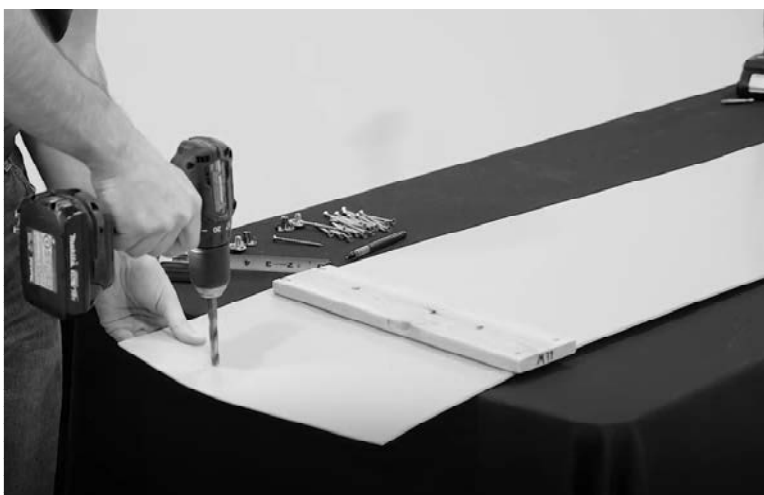
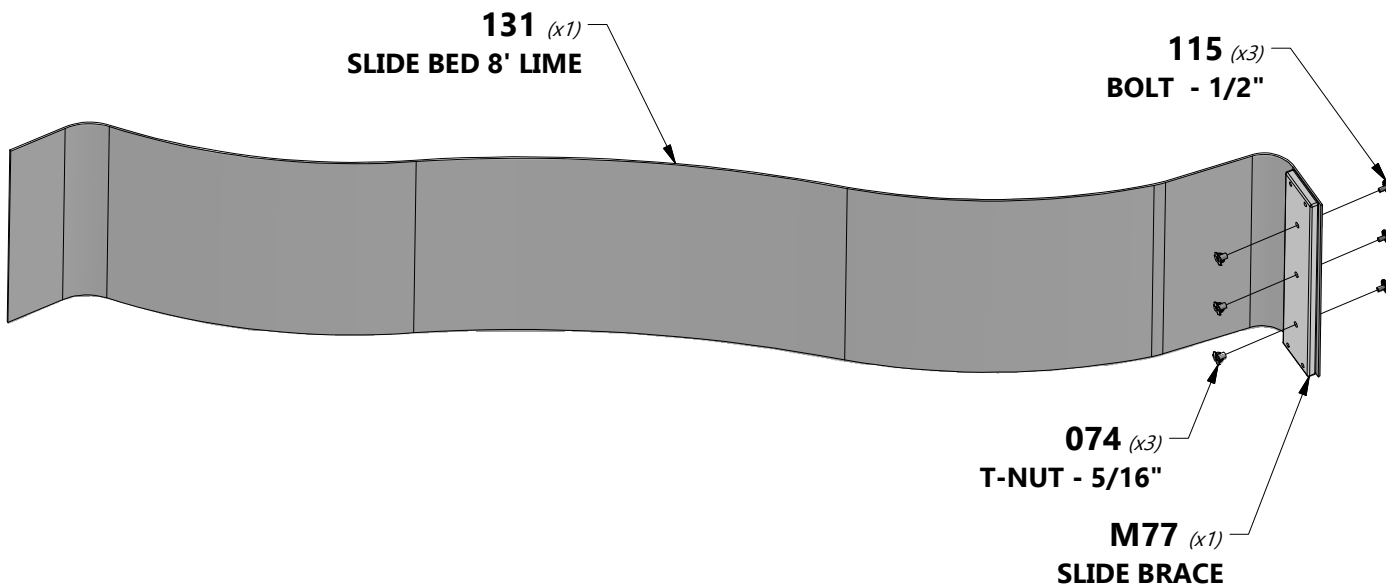



SLIDE ASSEMBLY

STEP 2



M78 | CENTER SLIDE BRACE - W100545
(x2) | 5/8"x3 3/8"x17 1/4" (16x86x438)



A100162 | SLIDE RAIL 8' BLUE LEFT
(x1)



A100161 | SLIDE RAIL 8' BLUE RIGHT
(x1)



H100090 | SCREW PFH
(x24) | 8x2 1/2"



NOTE:

USING A 1/8" DRILL BIT, DRILL PILOT HOLES IN EACH INDENTATION ALONG EACH SIDE RAIL. THERE SHOULD BE 8 INDENTIONS ON EACH RAIL.

PLACE THE SLIDE RAIL ON FLAT SURFACE. STARTING AT THE BOTTOM, INSERT THE SLIDE BED INTO THE CHANNEL ON THE INSIDE OF THE RAIL. HOLD THE SLIDE BED IN PLACE WHILE A HELPER BENDS THE SLIDE BED INTO THE CHANNEL. MAKE SURE THE SLIDE BED IS COMPLETELY INSERTED INTO THE CHANNEL.

INSERT THE CENTER SLIDE BRACE INTO THE RESPECTIVE LOCATION. SECURE THE SLIDE BED AND CENTER USING THE PROVIDED HARDWARE.

REPEAT THIS PROCESS FOR THE OPPOSITE SLIDE RAIL.



TIP:

A HELPER IS REQUIRED FOR THIS STEP.

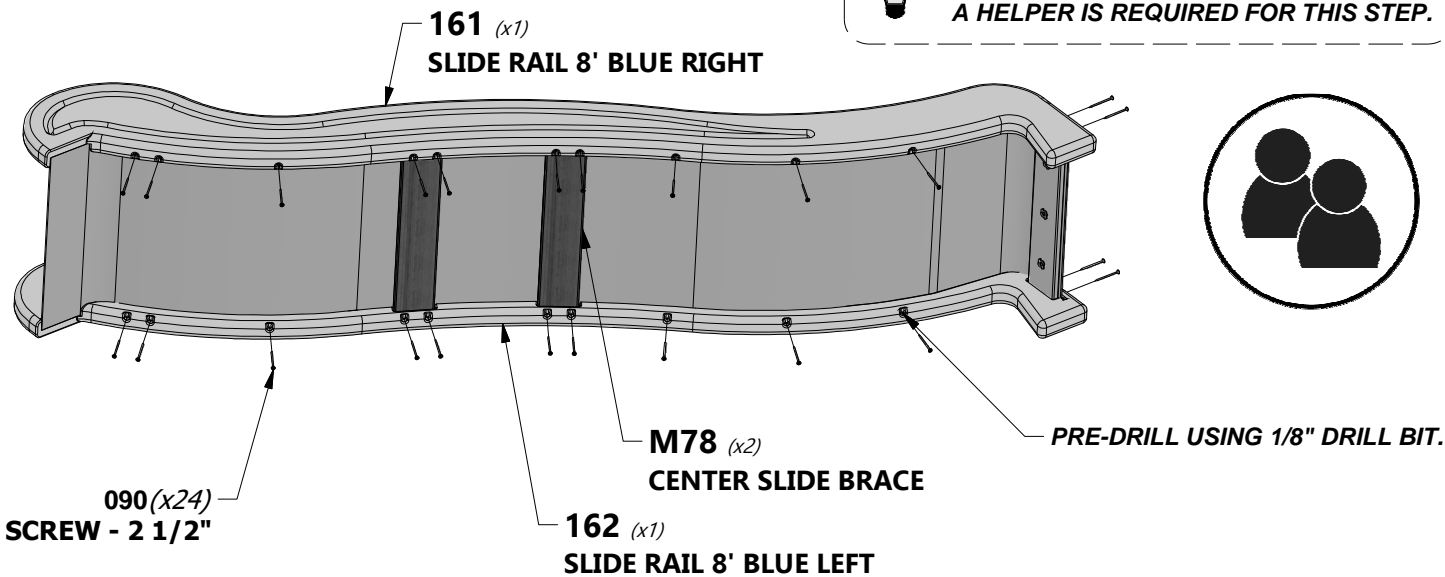

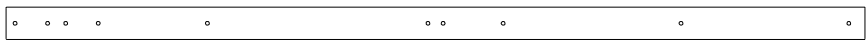

E2 | UPRIGHT - W4L06891
(1) | 1 3/8"x3 3/8"x89 1/2" (36x86x2274)

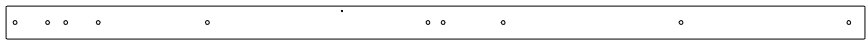

E3 | UPRIGHT - W4L06892
(1) | 1 3/8"x3 3/8"x89 1/2" (36x86x2274)

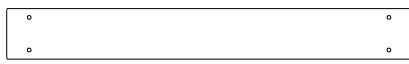

K3 | GROUND BOARD - W4L06896
(1) | 5/8"x5 1/4"x42 1/8" (16x134x1070)



M8 | WALL RAIL - W4L06920
(1) | 5/8"x3 3/8"x42 1/8" (16x86x1070)

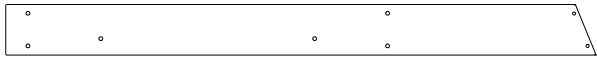

K4 | GROUND BOARD - W4L13847
(1) | 5/8"x5 1/4"x61 1/2" (16x134x1564)

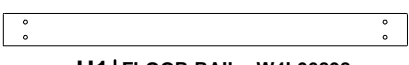

H1 | FLOOR RAIL - W4L06898
(1) | 1"x3 3/8"x42 1/8" (24x86x1070)

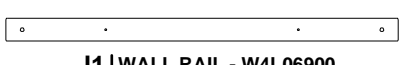

J1 | WALL RAIL - W4L06900
(1) | 1"x2 3/8"x40 7/8" (24x60x1038)



H100013 | BOLT WH
(6) | 5/16x2 1/4



H100074 | T-NUT
(18) | 5/16



H100012 | BOLT WH
(10) | 5/16x2

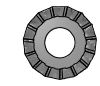

**H100030 | WASHER
LOCK EXT**
(16) | 8x19

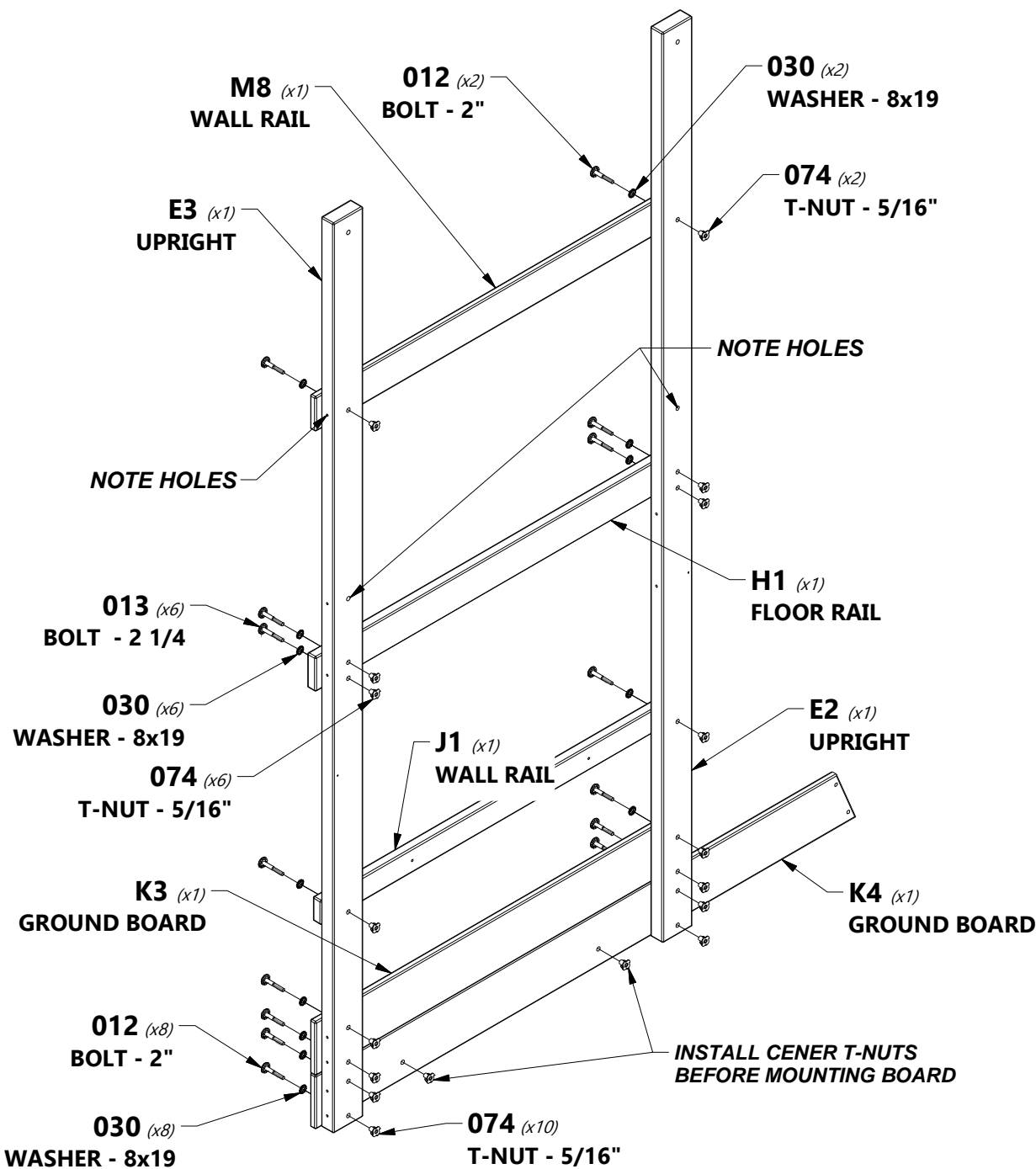

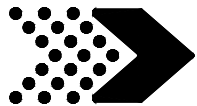

E4 UPRIGHT - W2A01970
(1) 1 3/8"x3 3/8"x57 3/8" (36x86x2274)

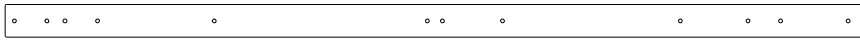

E1 UPRIGHT - W4L06890
(1) 1 3/8"x3 3/8"x89 1/2" (36x86x2274)

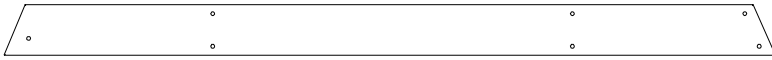

K1 GROUND BOARD - W4L13848
(1) 5/8"x5 1/4"x80 3/8" (16x134x2043)

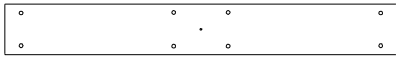

G1 SWING BEAM MOUNT - W4L06945
(1) 1"x5 1/4"x40 7/8" (24x134x1038)

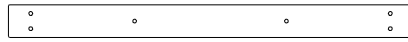

H10 FLOOR RAIL - W4L07317
(1) 1"x3 3/8"x42 1/8" (24x86x1070)

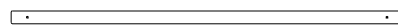

O3 SAFETY BOARD - W4L06948
(2) 5/8"x1 3/8"x40 7/8" (16x34x1038)



K3 GROUND BOARD - W4L06896
(1) 5/8"x5 1/4"x42 1/8" (16x134x1070)



M8 WALL RAIL - W4L06920
(1) 5/8"x3 3/8"x42 1/8" (16x86x1070)

M1 SAFETY BOARD - W4L06895
(1) 5/8"x3 3/8"x40 7/8" (16x86x1038)

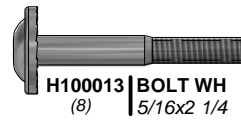

H100013 BOLT WH
(8) 5/16x2 1/4

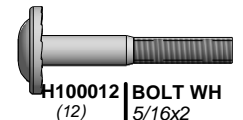

H100012 BOLT WH
(12) 5/16x2



H100030 WASHER
LOCK EXT
(20) 8x19

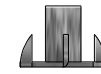

H100074 T-NUT
(24) 5/16

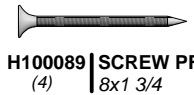

H100089 SCREW PFH
(4) 8x1 3/4



H100128 SCREW PWH
(2) 8x5/8



A100314 "A" REVISION
TAG
(1)

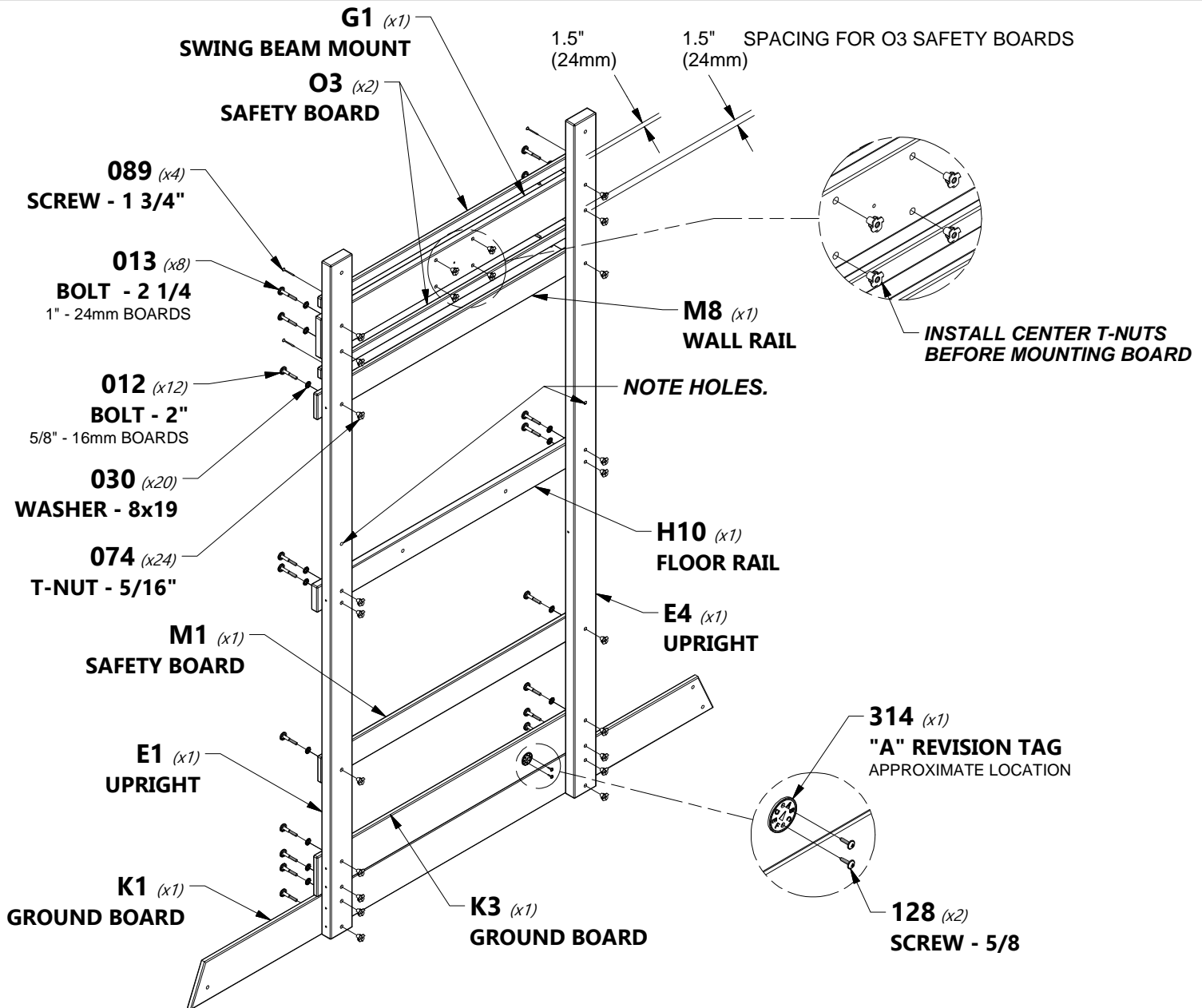

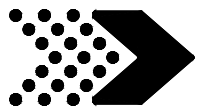

K2 | GROUND BOARD - W4L06894
(4) | 5/8"x5 1/4"x43 1/4" (16x134x1097)

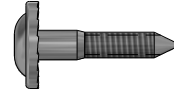

H100026 | LAG SCREW WH
(16) | 5/16x1 1/2



H100030 | WASHER
LOCK EXT
(16) | 8x19

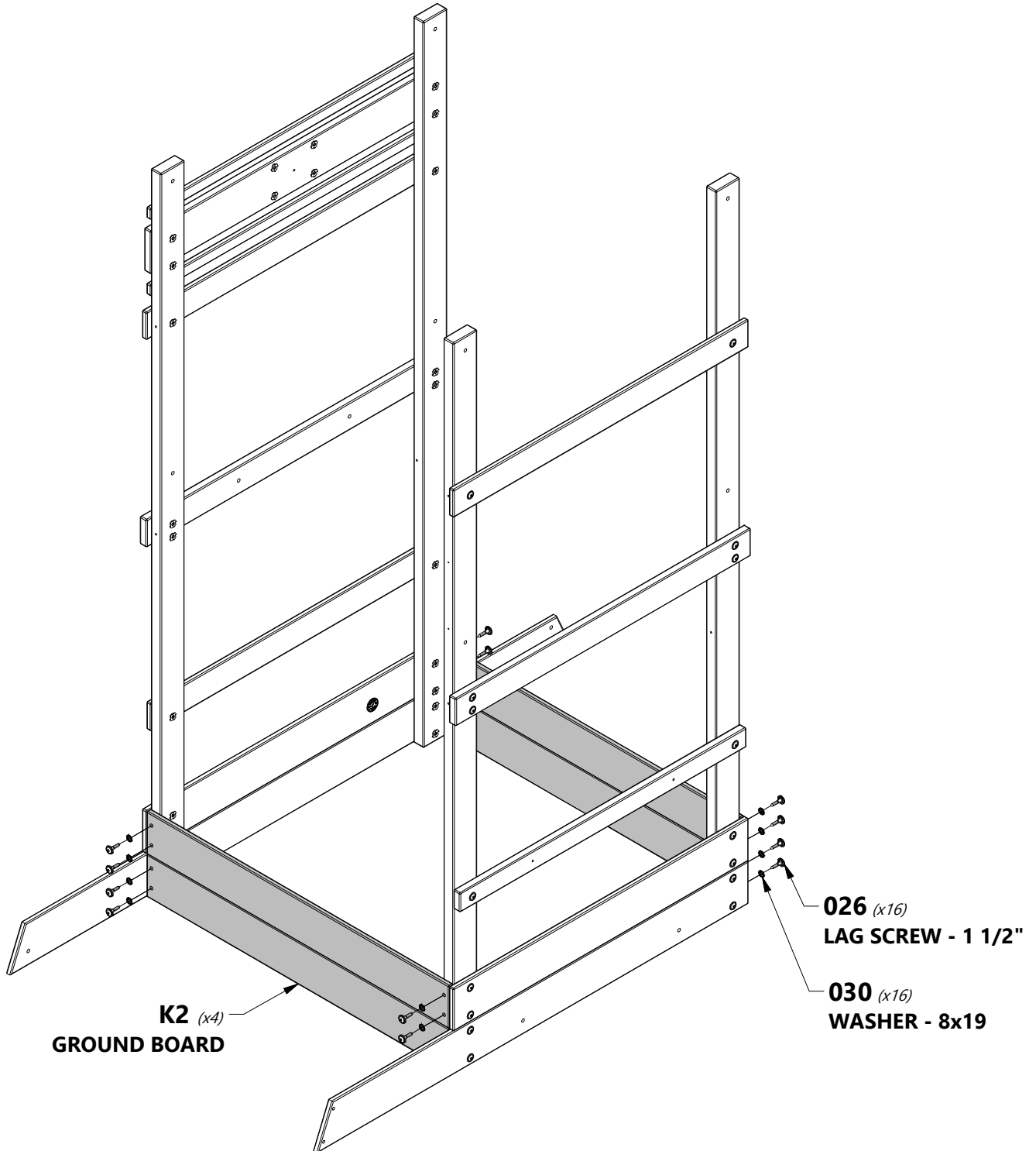

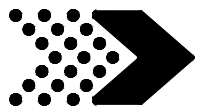

G2 | **SANDBOX SEAT - W4L06433**
(2) 1"x5 1/4"x14 5/8" (24x134x370)



Q2 | **SANDBOX SEAT SUPPORT - W4L06434**
(4) 1"x4 3/8"x8" (24x112x202)



H100089 | **SCREW PFH**
(8) | 8x1 3/4



H100086 | **SCREW PFH**
(24) | 8x1 1/2

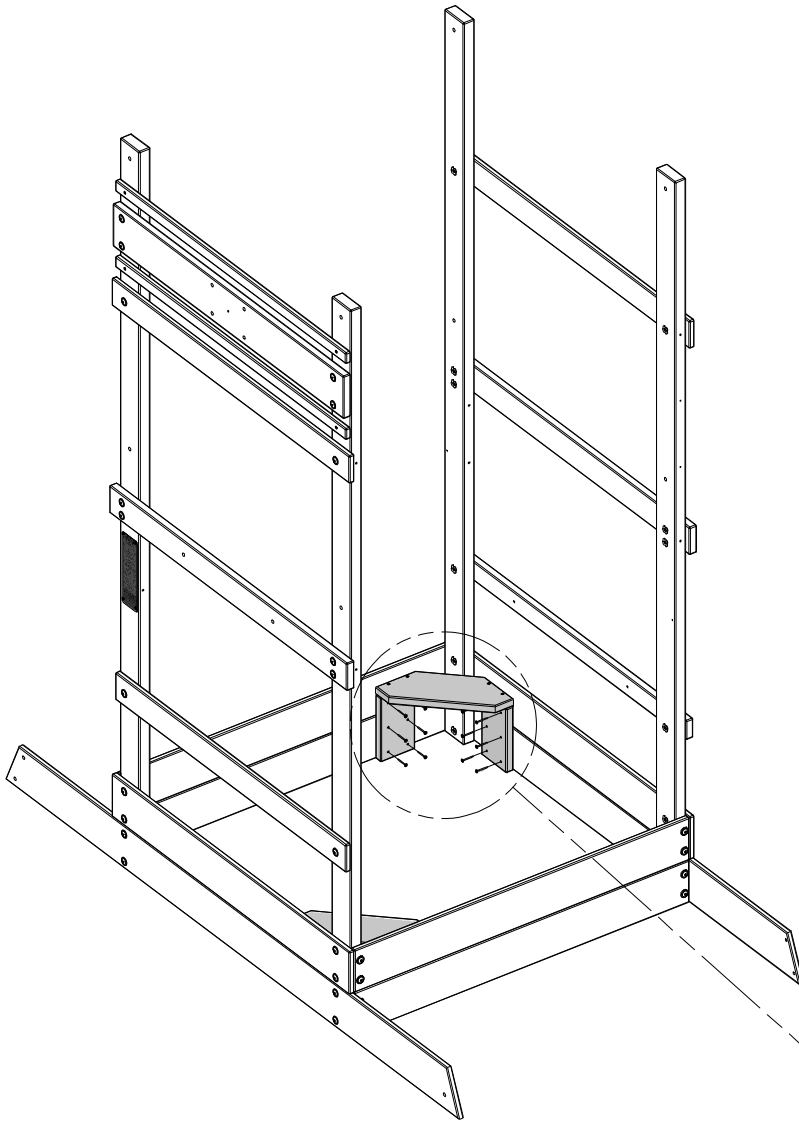

BENCH SUB ASSEMBLY

089 (x8)
SCREW - 1 3/4"

G2 (x2)
SANDBOX SEAT

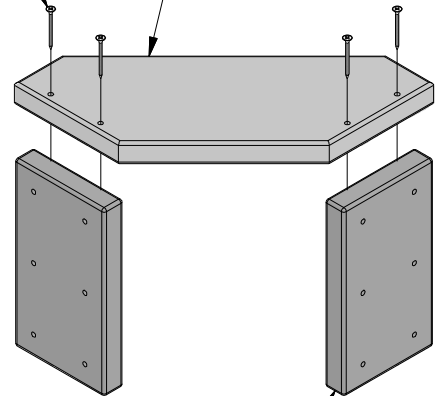

Q2 (x4)

SANDBOX SEAT SUPPORT

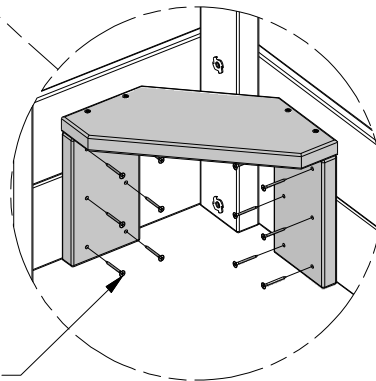

086 (x24)
SCREW - 1 1/2"

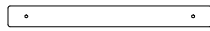
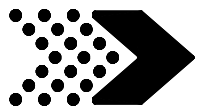

O1 PICKET - W4L06901
 (7) 5/8"x1 3/8"x13 1/4" (16x34x336)



H100088 SCREW PFH
 (14) 8x1 1/8"

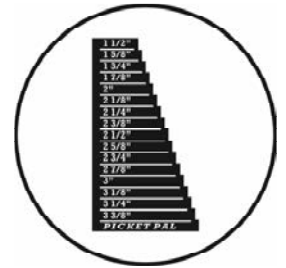
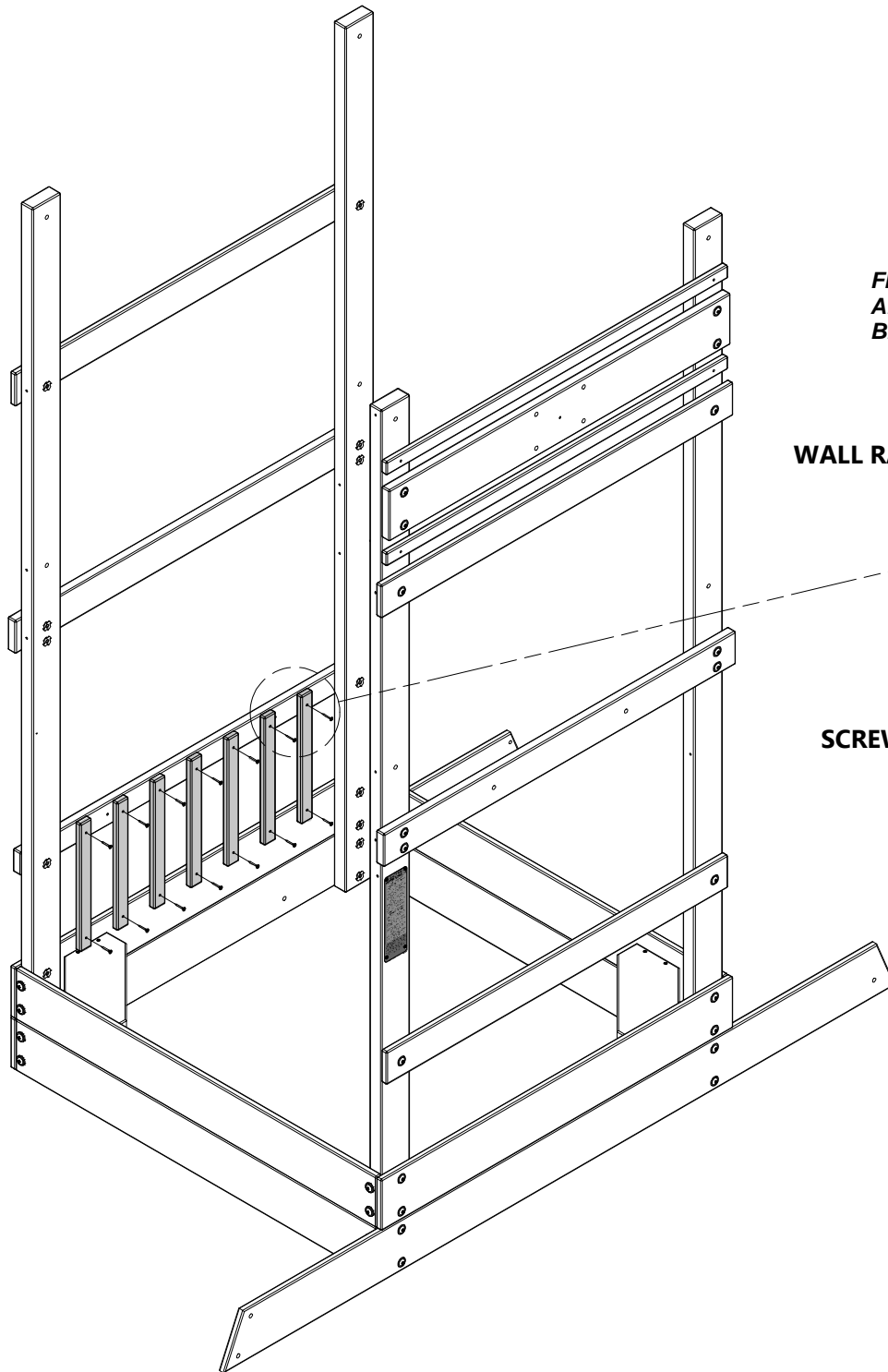

**FLUSH O1 BOARDS TO TOP OF J1 BOARD.
 APPROXIMATELY 3 1/8" - 79mm SPACING
 BETWEEN PICKETS.**

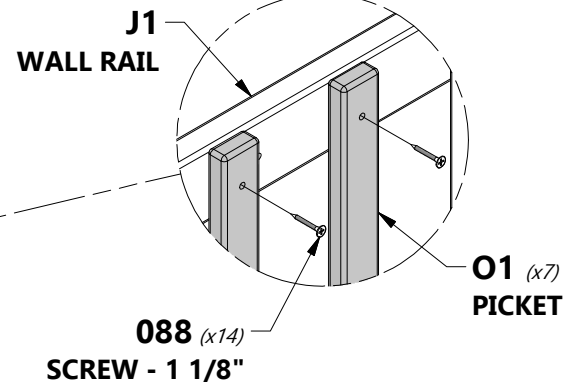

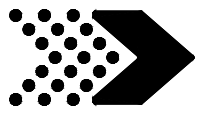

K5 | SERVING SHELF - W4L06902
(1) | 5/8"x5 1/4"x40 7/8" (16x134x1038)



J2 | SHELF SUPPORT - W4L06903
(2) | 1"x2 3/8"x2 3/8" (24x60x60)



H100089 | SCREW PFH
(8) | 8x1 3/4

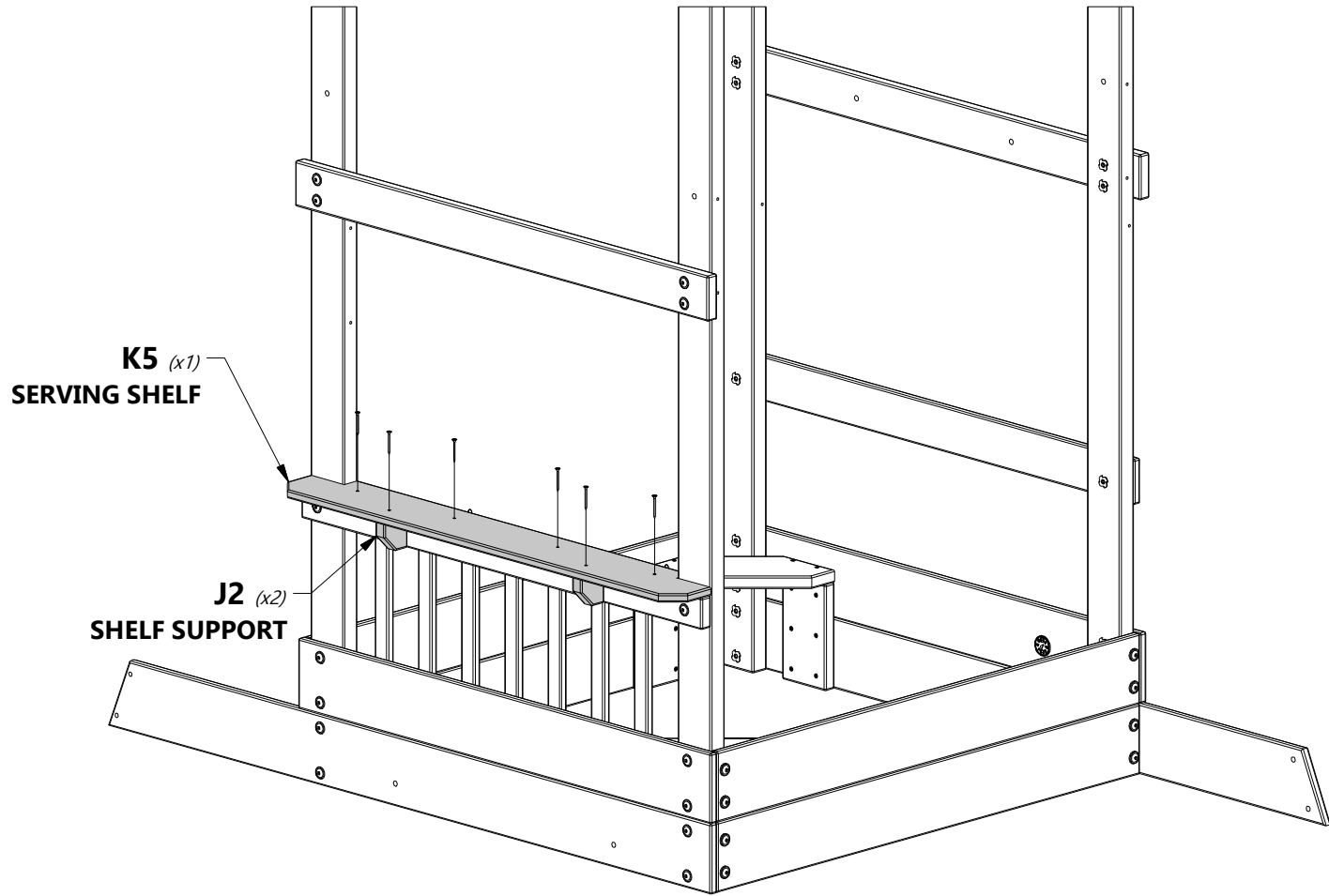

K5 (x1)
SERVING SHELF

J2 (x2)
SHELF SUPPORT

089 (x8)
SCREW - 1 3/4"

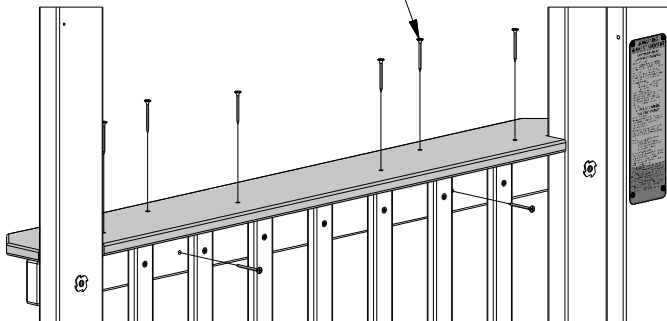

BACK VIEW

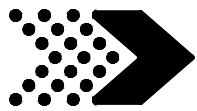

J6 | LADDER RAIL - W4L13845
(1) | 1"x2 3/8"x50 3/8" (24x60x1279)

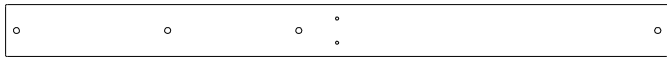

M2 | FLOOR RAIL - W4L06897
(1) | 5/8"x3 3/8"x43 1/4" (16x86x1097)



M5 | FLOOR RAIL - W4L06914
(1) | 5/8"x3 3/8"x43 1/4" (16x86x1097)



H100027 | LAG SCREW WH
(1) | 5/16x2



H100026 | LAG SCREW WH
(3) | 5/16x1 1/2



H100145 | LAG SCREW WH
(2) | 1/4x1 1/2



H100030 | WASHER
(4) | LOCK EXT
8x19



H100138 | WASHER
(2) | LOCK EXT
6x15

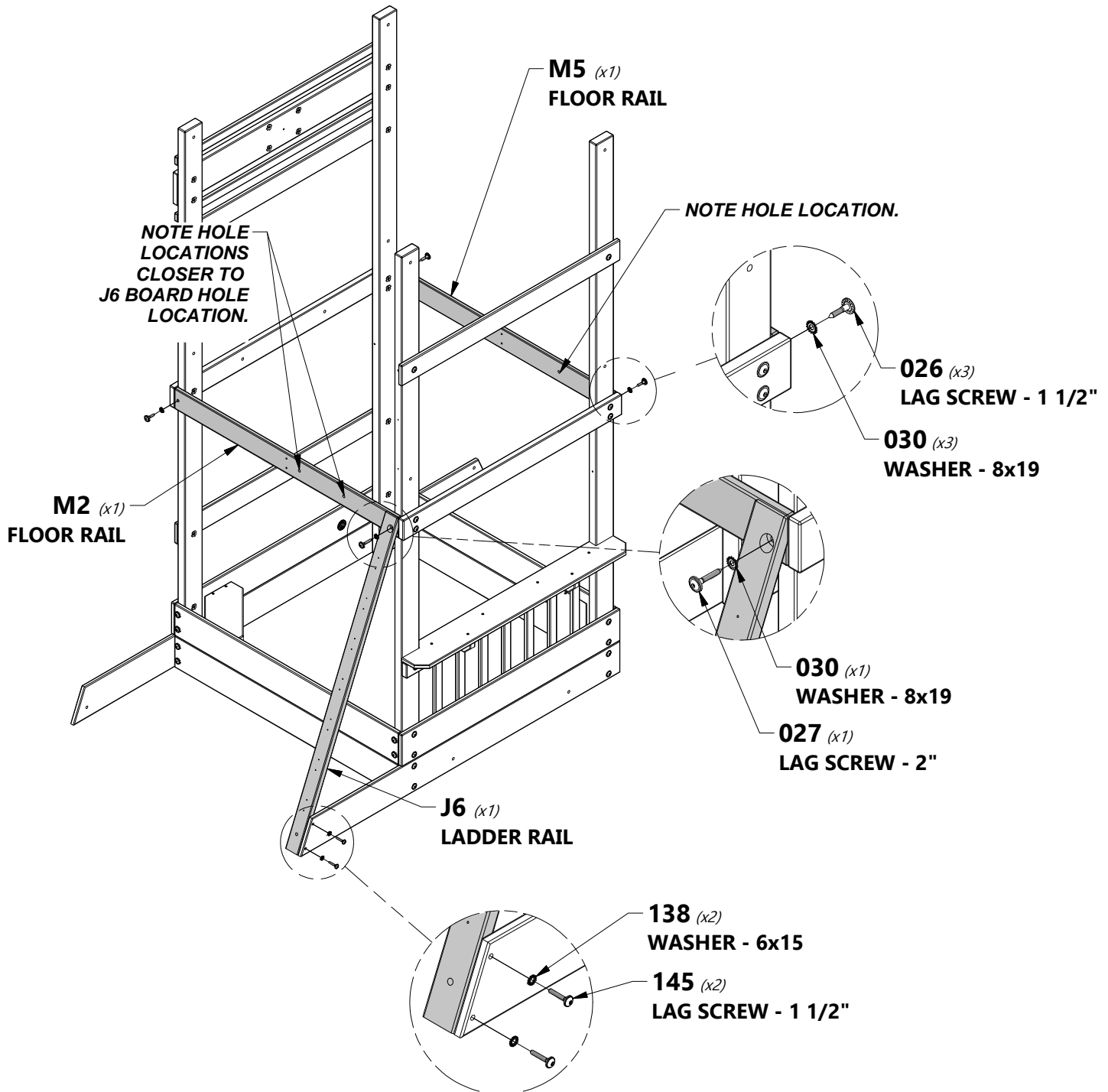



J3 ANGLE BRACE - W4L06905
(1) 1"x2 3/8"x47 1/4" (24x60x1200)



H100010 BOLT WH
(2) 5/16x1-1/2



H100145 LAG SCREW WH
(1) 1/4x1 1/2



H100138 WASHER LOCK EXT
(1) 6x15



H100030 WASHER LOCK EXT
(2) 8x19



H100074 T-NUT
(2) 5/16

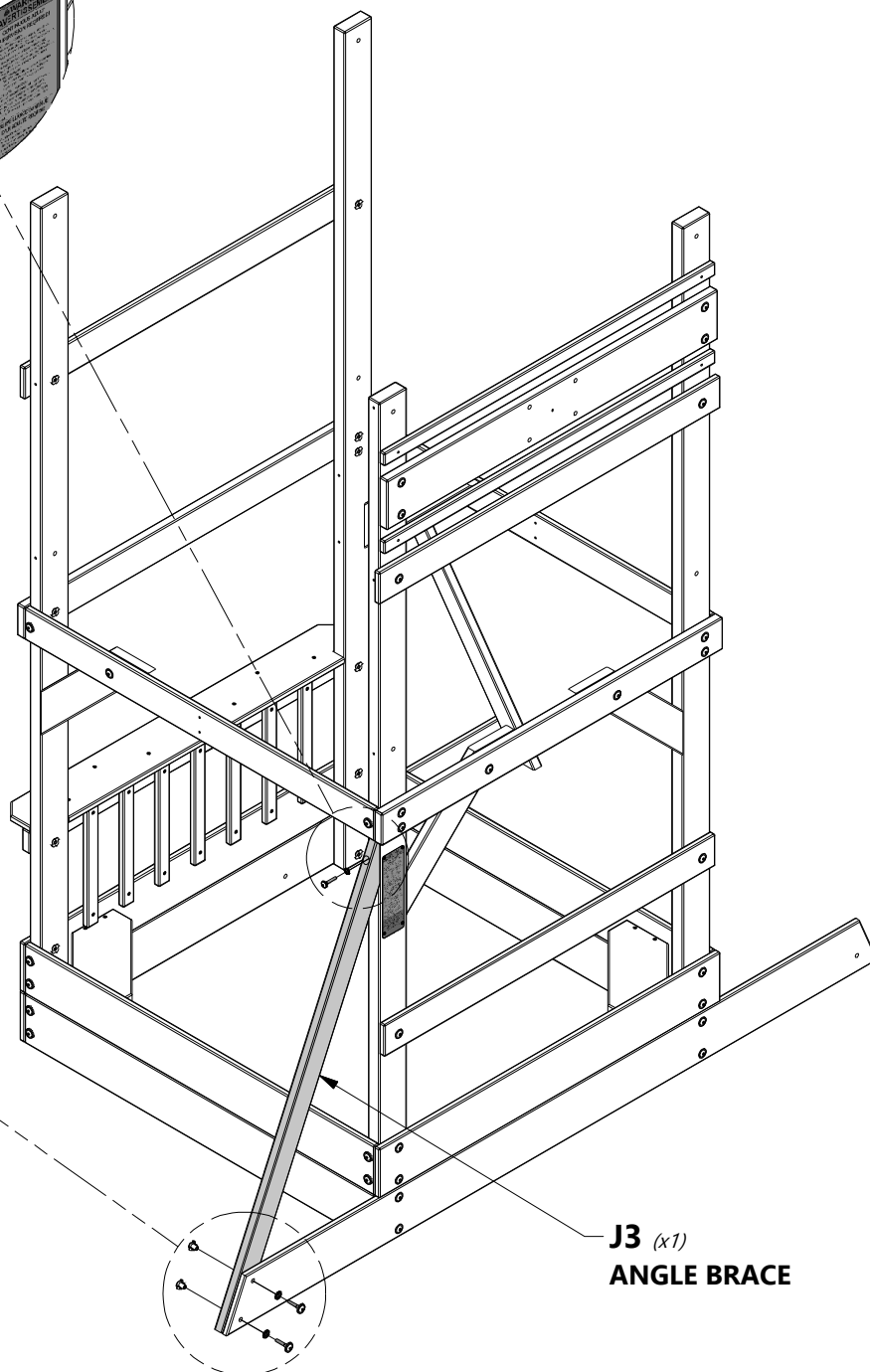
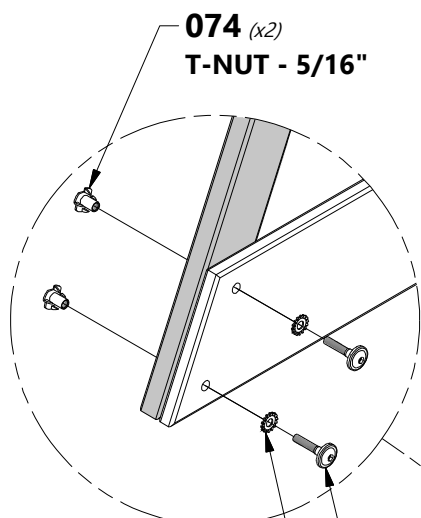
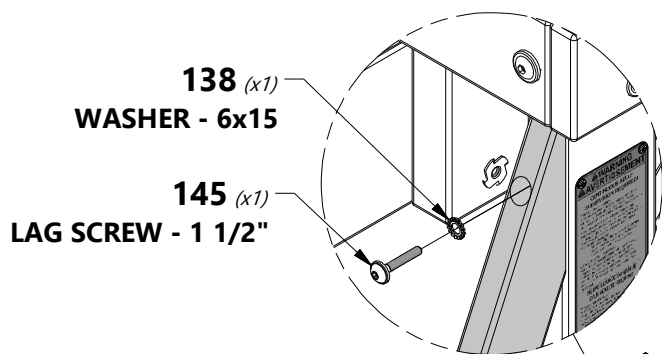

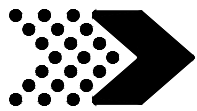

J9 | SUPPORT BOARD - W4L06064
(4) | 1"x2 3/8"x3" (24x60x76)



H100089 | SCREW PFH
(8) | 8x1 3/4

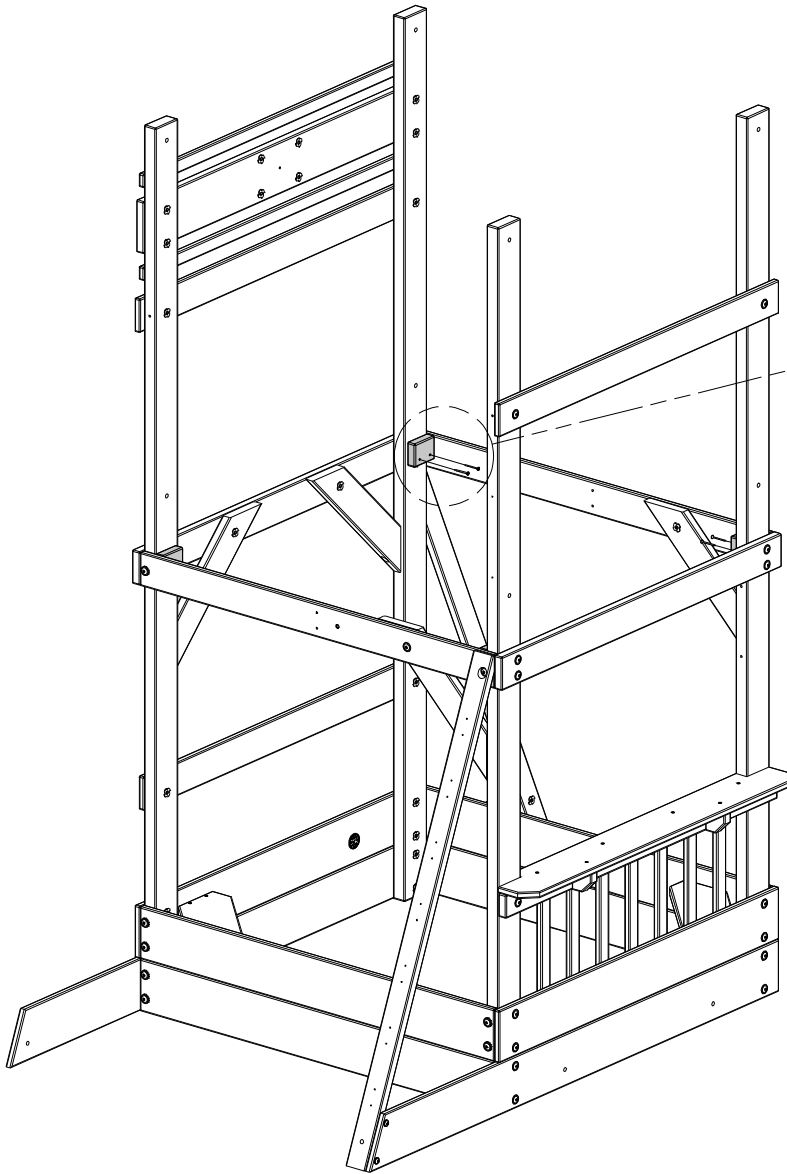

FLUSH TOPS

J9 (x4)
SUPPORT BOARD

089 (x8)
SCREW - 1 3/4"

J9
SUPPORT BOARD

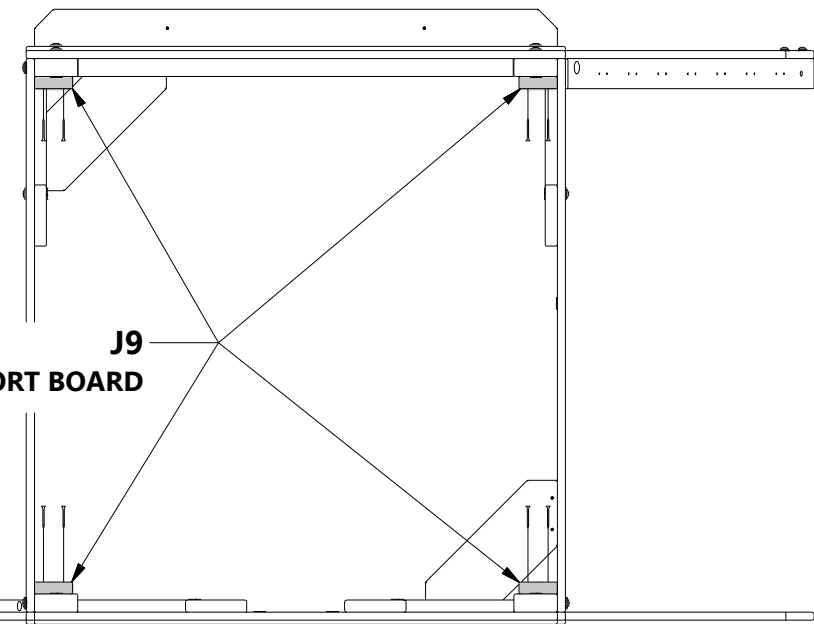

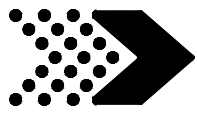

H3 | FLOOR SUPPORT - W4L06915
(1) | 1"x3 3/8"x40 7/8" (24x86x1038)



H100111 | SCREW PFH
(4) | 8x2

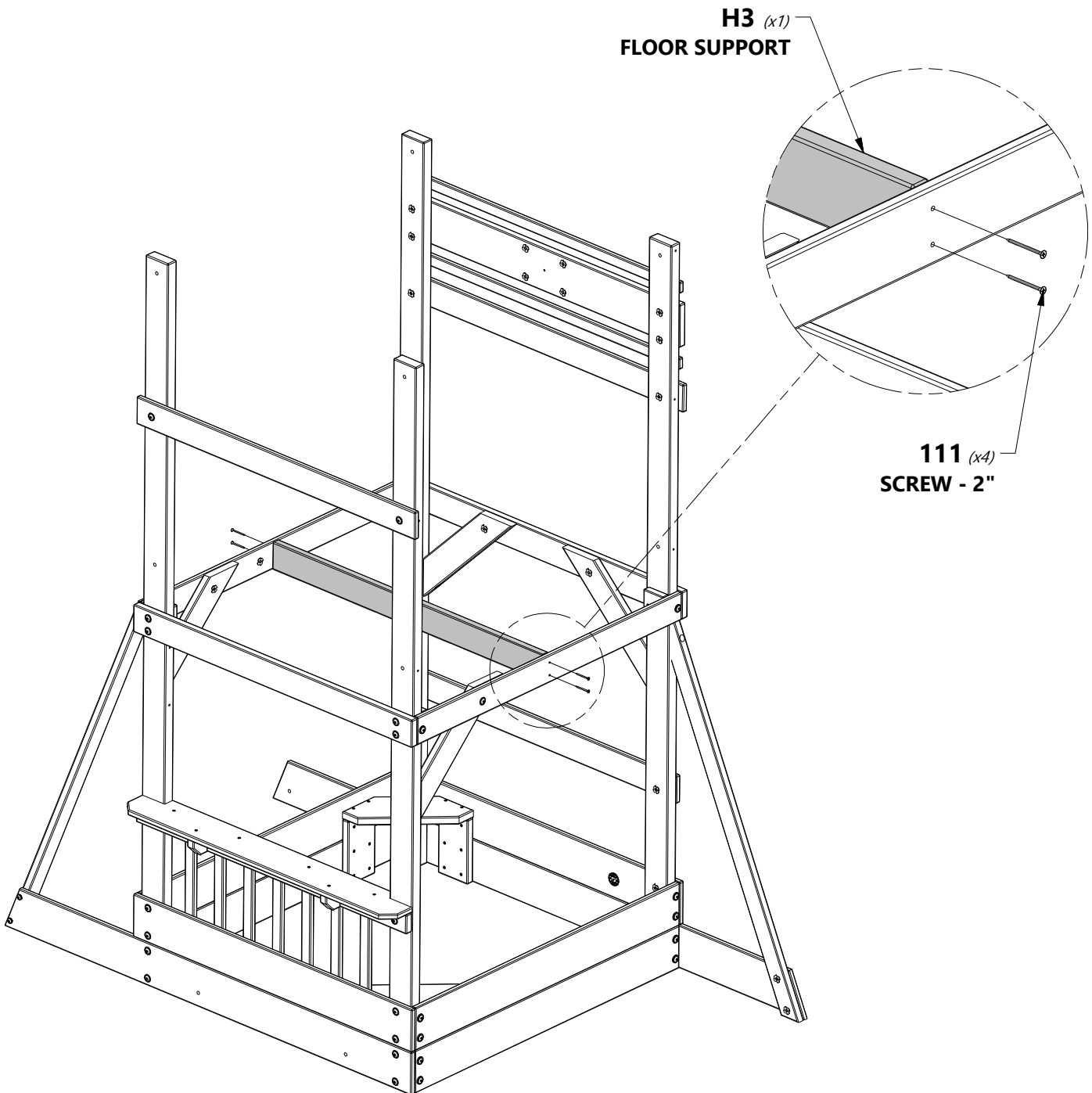

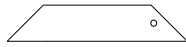
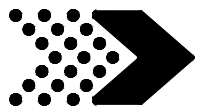

J5 | AWNING SUPPORT - W4L06908
(2) | 1"x2 3/8"x11 3/4" (24x60x298)



H100027 | LAG SCREW WH
(2) | 5/16x2



**H100030 | WASHER
LOCK EXT**
(2) | 8x19

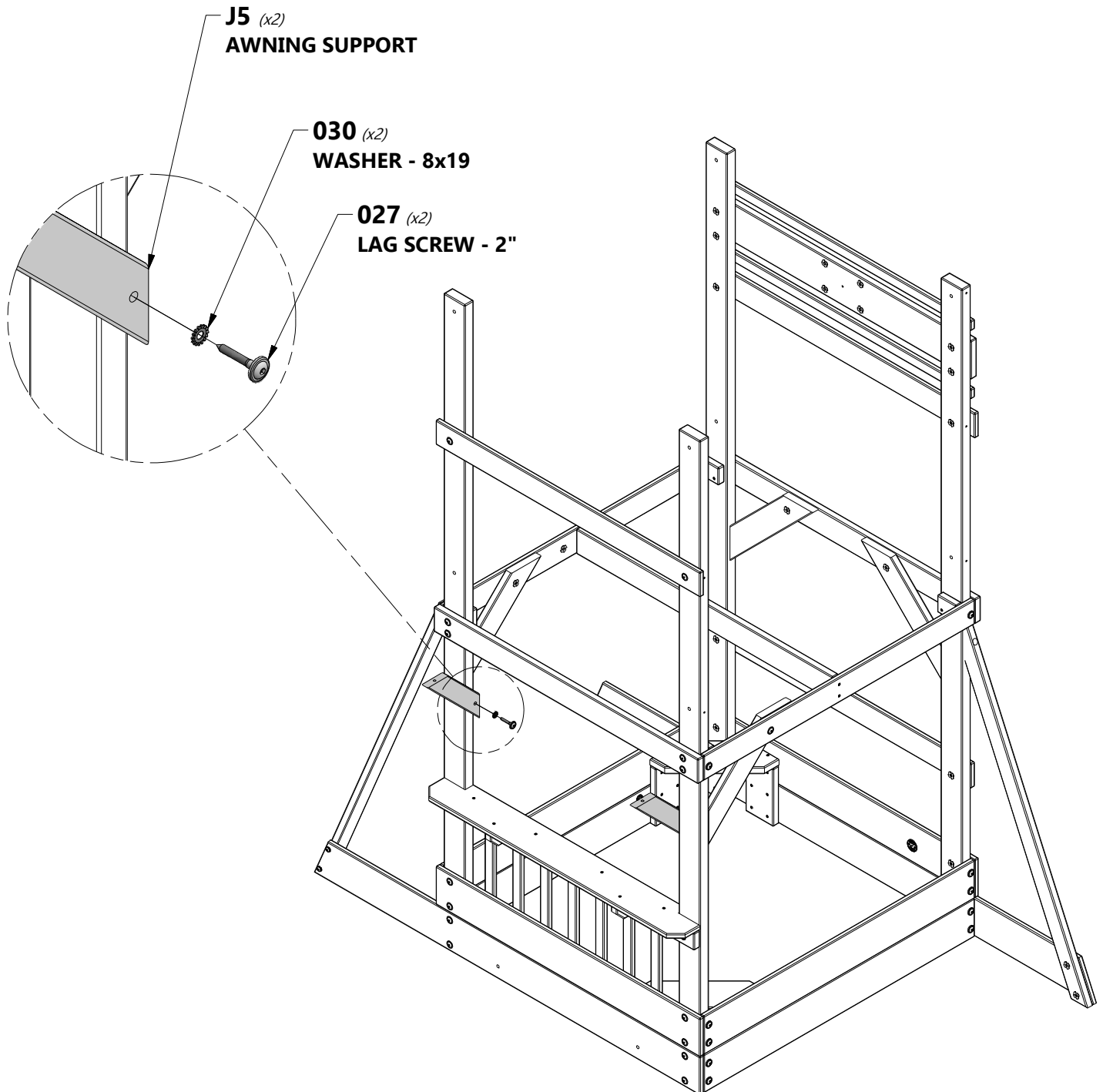



N1 | AWNING BOARD - W4L06907
(1) 5/8"x2 3/8"x34 1/8" (16x60x866)

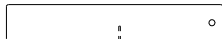

J4 | AWNING BOARD - W4L06906
(2) 1"x2 3/8"x14 1/8" (24x60x358)

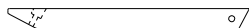

T2 | SAFETY BOARD - W4L13853
(2) 1"x1 3/8"x15 3/4" (24x34x400)



H100027 | LAG SCREW WH
(4) 5/16x2



H100145 | LAG SCREW WH
(4) 1/4x1 1/2



H100089 | SCREW PFH
(4) 8x1 3/4



H100138 | WASHER LOCK EXT
(4) 6x15



H100030 | WASHER LOCK EXT
(4) 8x19

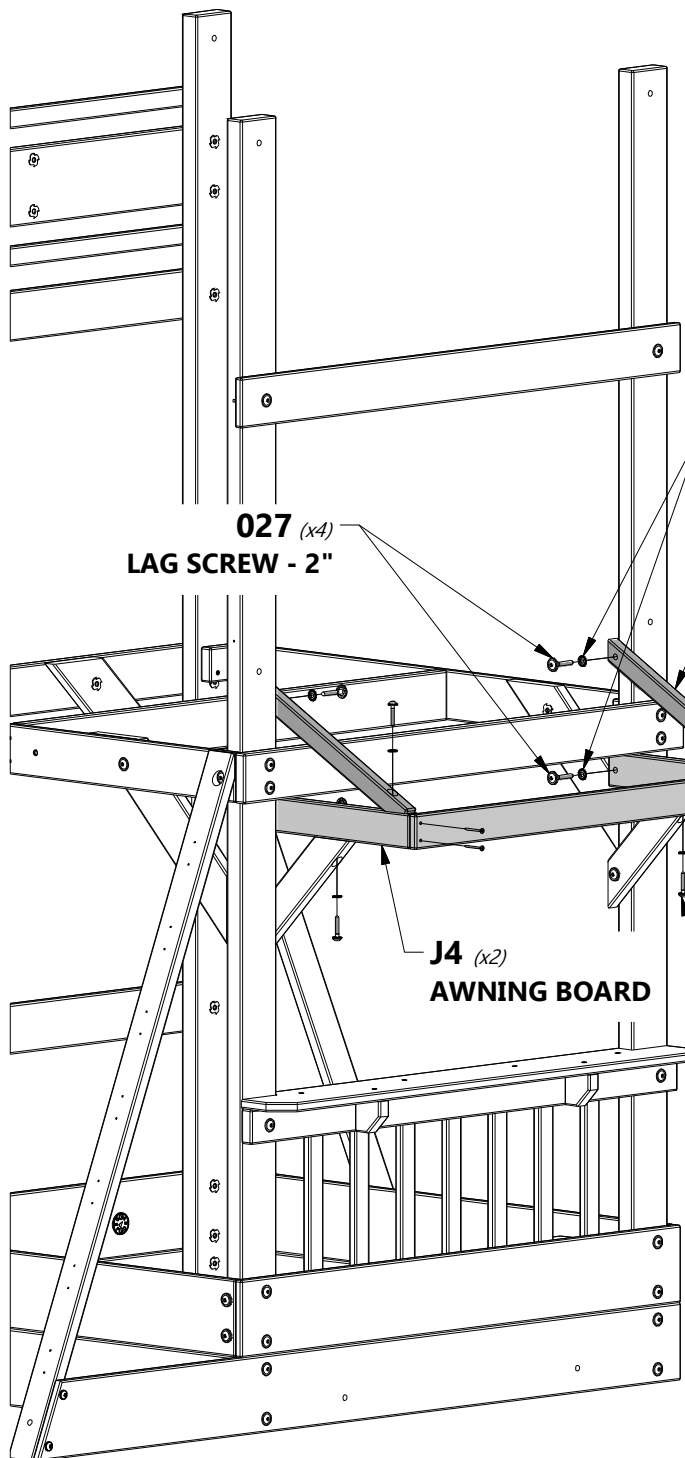
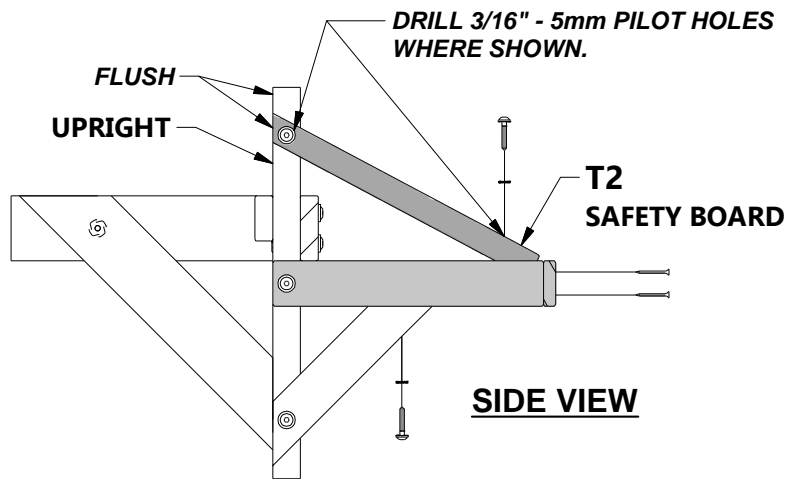

- 027 (x4) LAG SCREW - 2"**
- 030 (x4) WASHER - 8x19**
- T2 (x2) SAFETY BOARD**
- 145 (x2) LAG SCREW - 1 1/2"**
- 138 (x2) WASHER - 6x15**
- 089 (x4) SCREW - 1 3/4"**
- N1 (x1) AWNING BOARD**
- 138 (x2) WASHER - 6x15**
- 145 (x2) LAG SCREW - 1 1/2"**
- J4 (x2) AWNING BOARD**

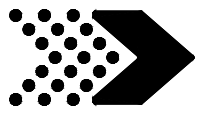

Y1 | FLOOR BOARD - W4L13851
(1) | 5/8"x4"x40 3/8" (16x102x1024)

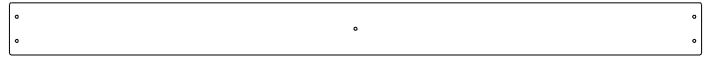

M6 | FLOOR BOARD - W4L06918
(10) | 5/8"x3 3/8"x45 1/8" (16x86x1145)



Y2 | FLOOR BOARD - W4L06917
(1) | 5/8"x4"x40 3/8" (16x102x1024)



H100086 | SCREW PFH
(60) | 8x1 1/2

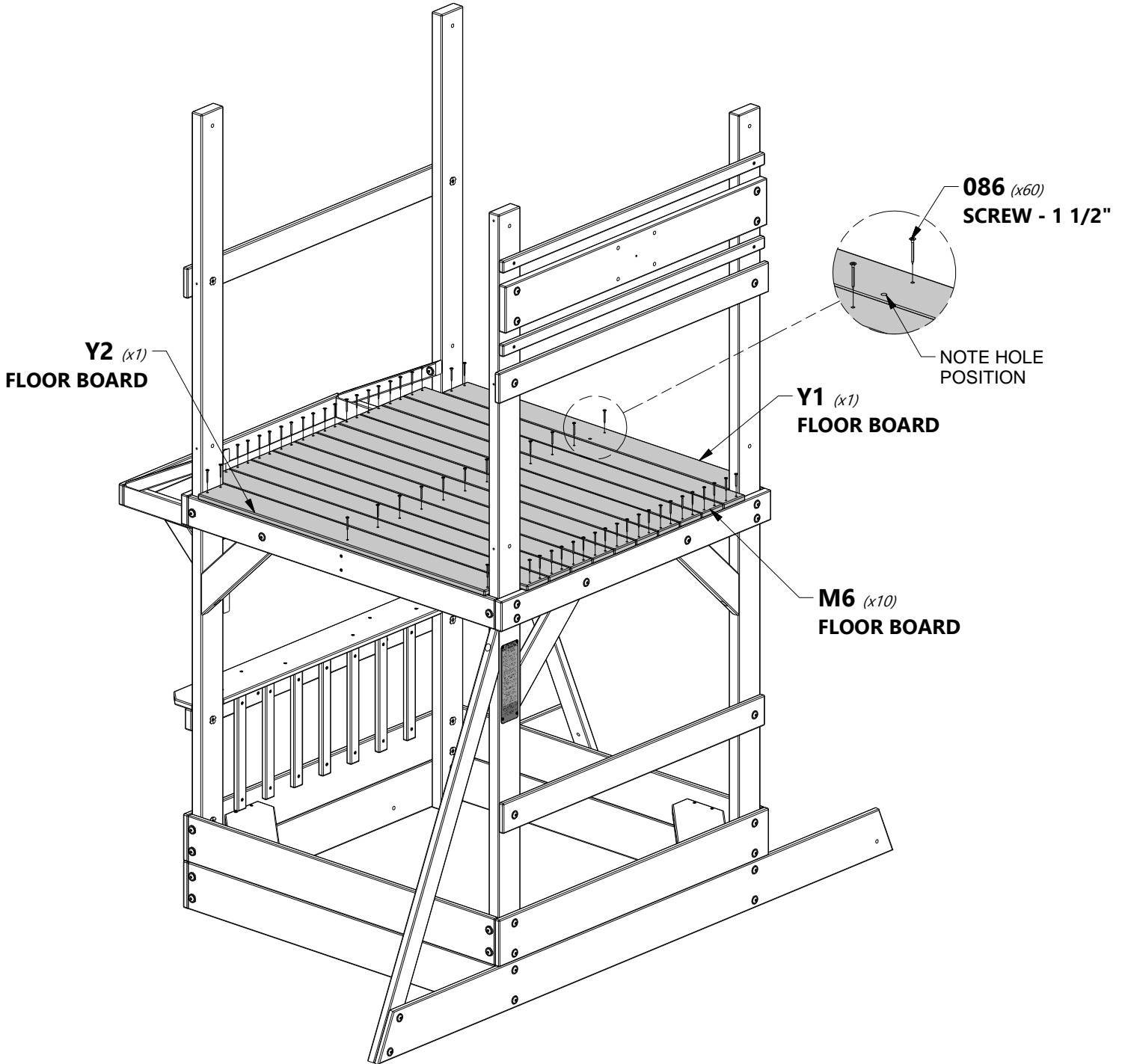



K6 | GROUND BOARD - W4L13852
(1) | 5/8"x5 1/4"x44 1/2" (16x134x1129)



J7 | LADDER RAIL - W4L13846
(1) | 1"x2 3/8"x50 3/8" (24x60x1279)



A4M01048 | L BRACKET
(1) | 2.5x38x55x55

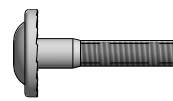

H100010 | BOLT WH
(2) | 5/16x1-1/2

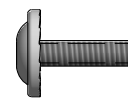

H100008 | BOLT WH
(1) | 5/16x1



H100004 | NUT BARREL
(2) | WH
5/16 x 5/8



H100115 | BOLT WH
(2) | 5/16x1/2



H100030 | WASHER
(3) | LOCK EXT
8x19



H100031 | WASHER
(2) | LOCK EXT
12x19



H100074 | T-NUT
(2) | 5/16

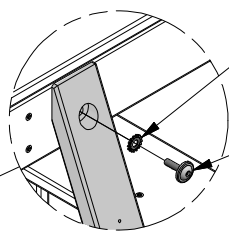
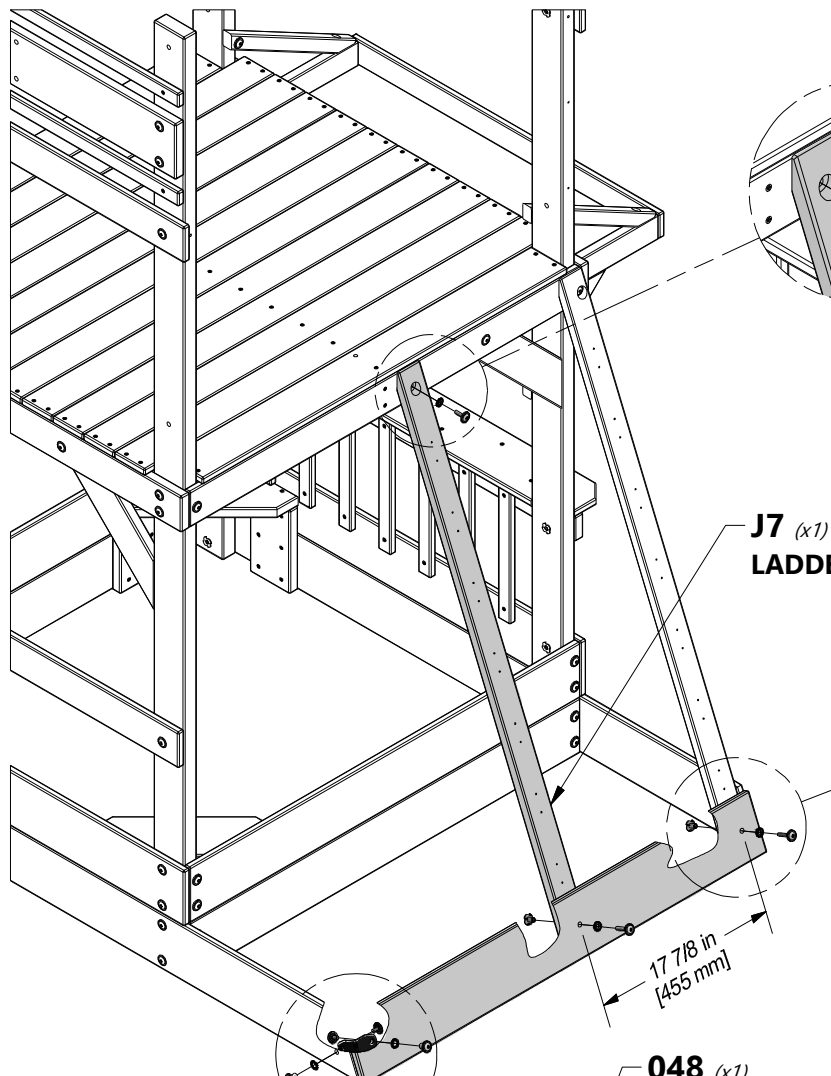

030 (x1)
WASHER - 8x19

008 (x1)
BOLT - 5/16x1"

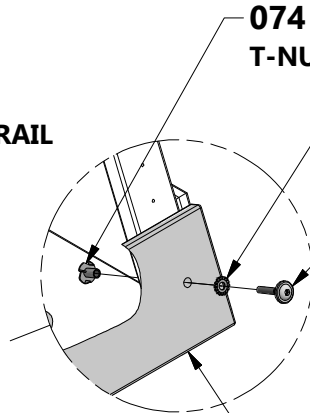

074 (x2)
T-NUT - 5/16"

030 (x2)
WASHER - 8x19

010 (x2)
BOLT - 1 1/2"

K6 (x1)
GROUND BOARD

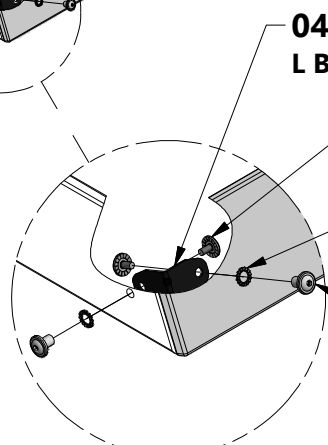

048 (x1)
L BRACKET 2.5x38x55x55

115 (x2)
BOLT - 1/2"

031 (x2)
WASHER - 12x19

004 (x2)
NUT BARREL - 5/8"



M7 | WALL RAIL - W4L06915
(2) | 5/8"x3 3/8"x41 1/2" (16x86x1054)



H100012 | BOLT WH
(4) | 5/16x2



H100026 | LAG SCREW WH
(2) | 5/16x1 1/2



H100030 | WASHER LOCK EXT
(6) | 8x19

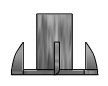

H100074 | T-NUT
(4) | 5/16



M9 | WALL RAIL - W4L06941
(1) | 5/8"x3 3/8"x43 1/4" (16x86x1097)

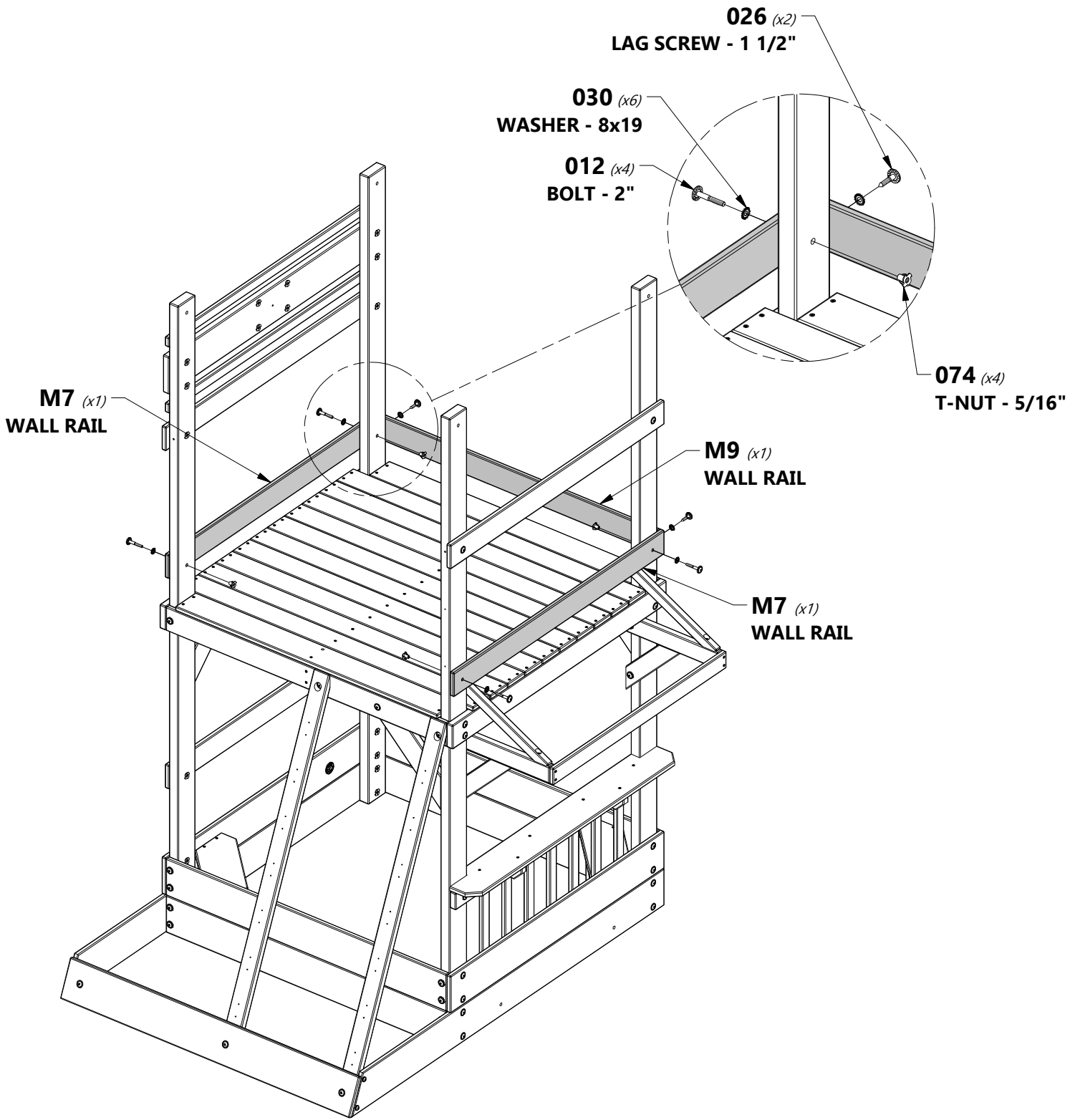



O4 | AWNING BOARD - W4L06957
(1) | 5/8"x1 3/8"x32 1/4" (16x34x818)



A6P00124 | AWNING
(1)



H100088 | SCREW PFH
(4) | 8x1 1/8

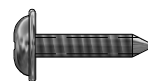

H100128 | SCREW PWH
(4) | 8x5/8

HOLD O4 BOARD DOWN 1" - 25mm FROM TOP & CENTERED IN OPENING.

O4 (x1)
AWNING BOARD

088 (x4)
SCREW - 1 1/8"

1" (25mm)

124 (x1)
AWNING

128 (x4)
SCREW - 5/8

GROMMETS THIS END

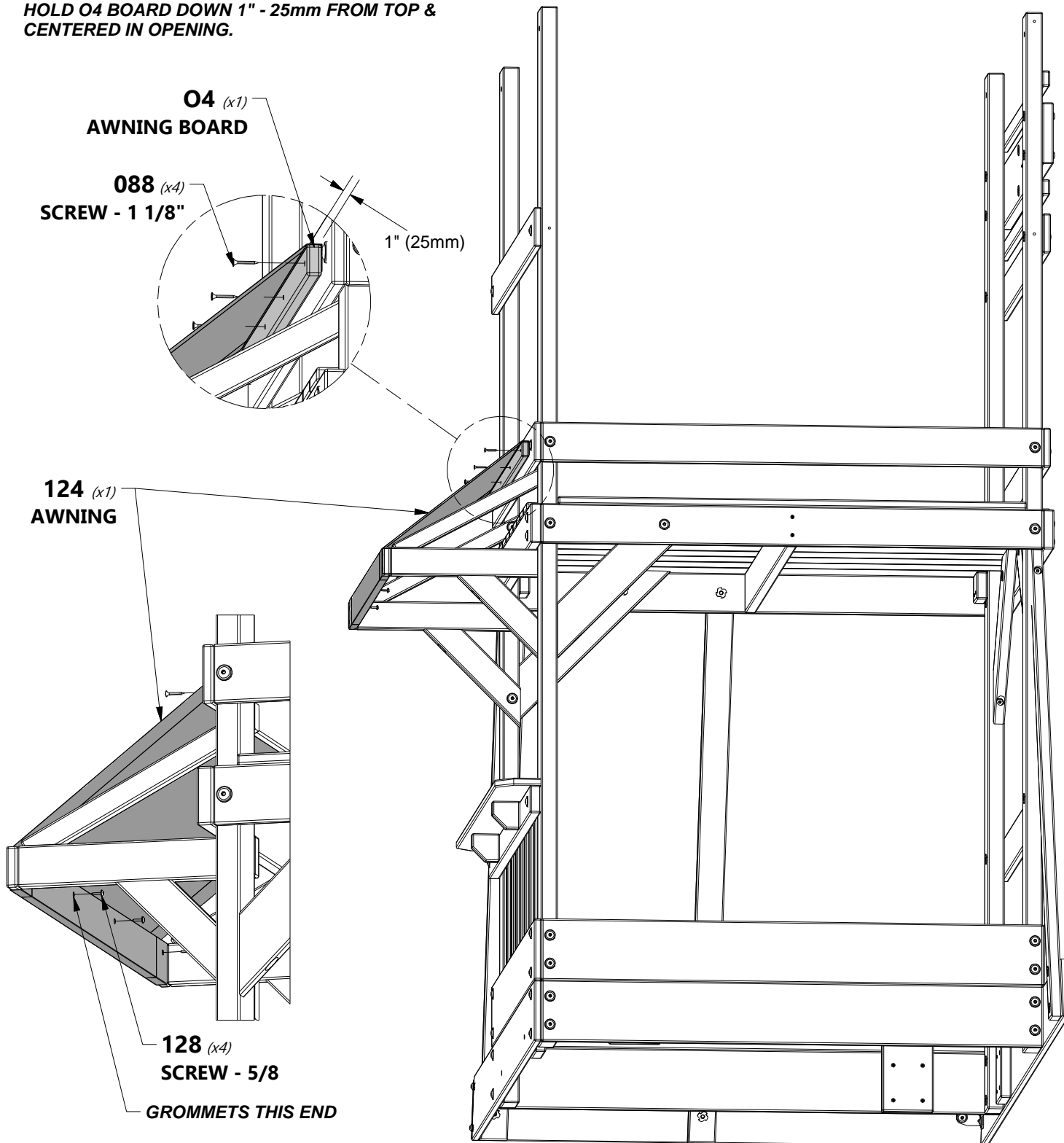



M10 | WALL RAIL - W4L06942
(1) 5/8"x3 3/8"x43 1/4" (16x86x1097)

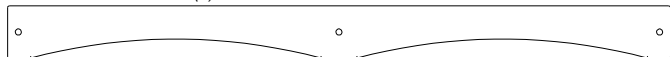

M11 | ARCHED WALL RAIL - W4L06943
(1) 5/8"x3 3/8"x43 1/4" (16x86x1097)

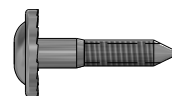

H100026 | LAG SCREW WH
(4) 5/16"x1 1/2"



**H100030 | WASHER
LOCK EXT**
(4) 8x19



H100074 | T-NUT
(2) 5/16"

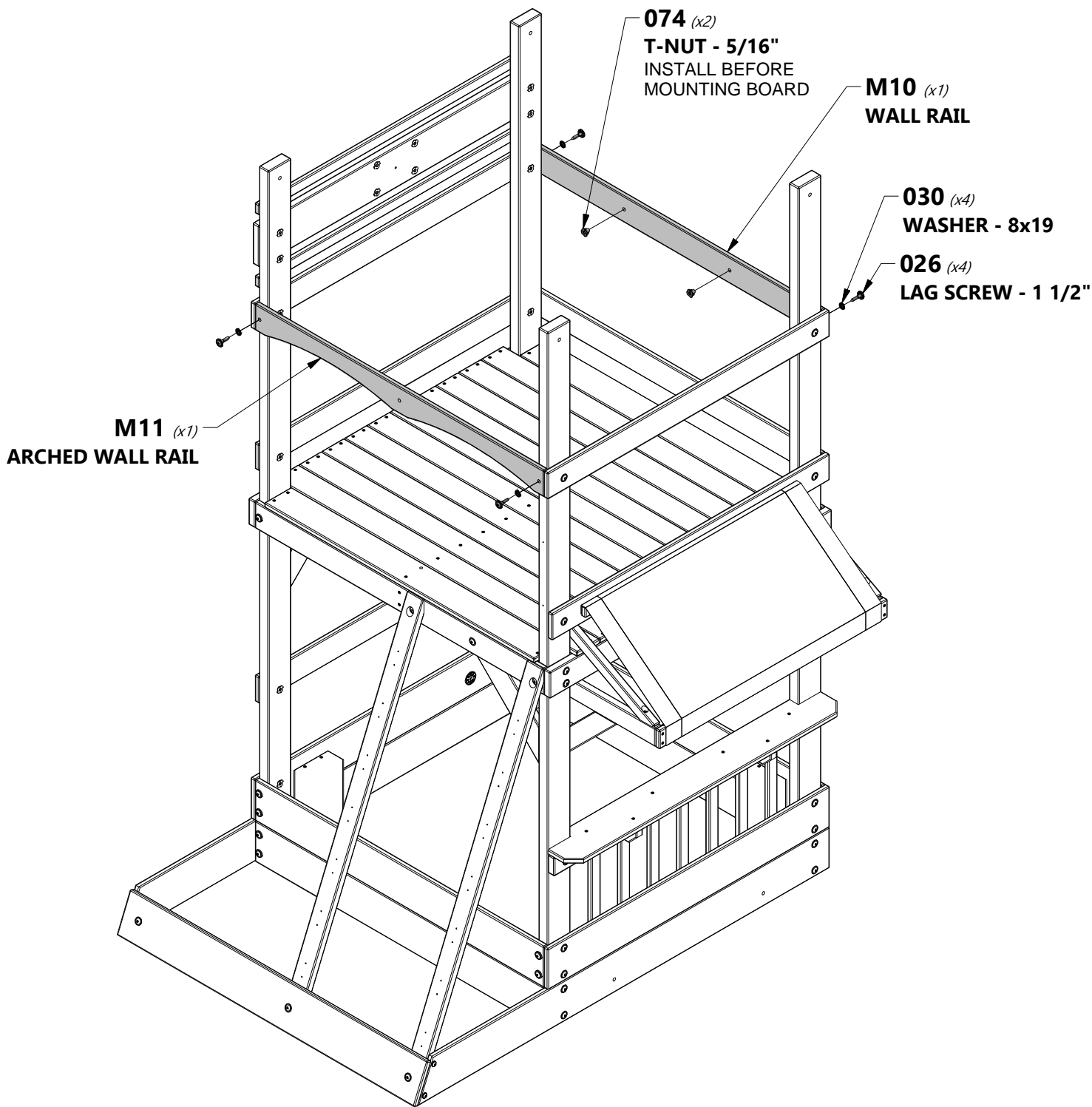

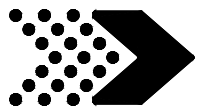

J8 WALL BOARD - W4L06947
(1) 1"x2 3/8"x25" (24x60x634)



A4M01048 L BRACKET
(1) 2.5x38x55x55



H100010 BOLT WH
(1) 5/16x1-1/2



H100115 BOLT WH
(1) 5/16x1/2



H100145 LAG SCREW WH
(1) 1/4x1 1/2

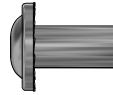

H100005 NUT BARREL
(1) WH
5/16x7/8



H100030 WASHER
(1) LOCK EXT
8x19



H100031 WASHER
(1) LOCK EXT
12x19

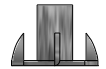

H100074 T-NUT
(1) 5/16

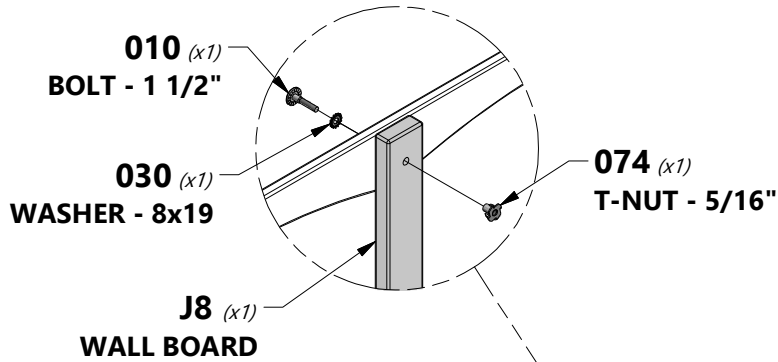

NOTE CENTER HOLES ON J8 BOARD LOCATED CLOSER TO THE DECK.

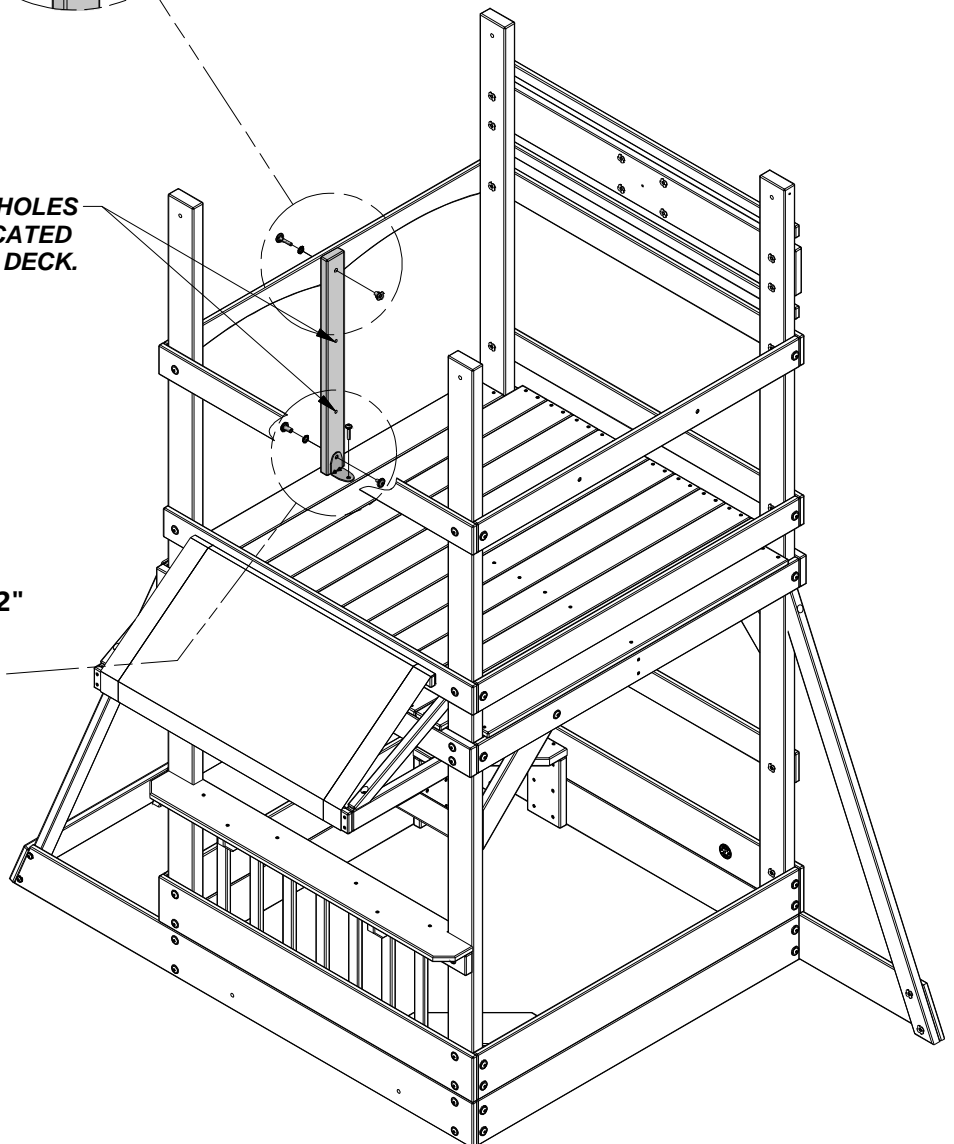
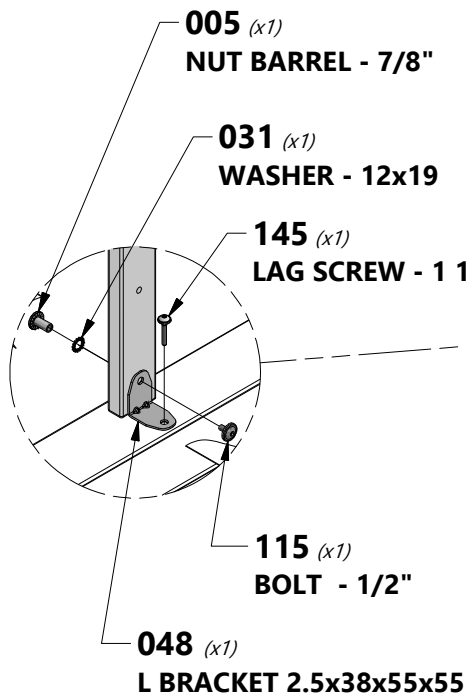

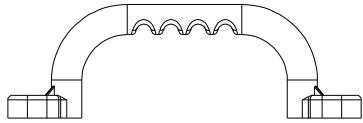
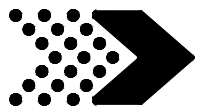

A6P00127 | HAND GRIP LIME PLASTIC
(2)



H100142 | BOLT WH
(2) | 1/4x1-1/4



H100145 | LAG SCREW WH
(2) | 1/4x1 1/2



H100138 | WASHER LOCK EXT
(2) | 6x15



H100108 | WASHER LOCK INT
(2) | 8x15



H100072 | T-NUT
(2) | 1/4

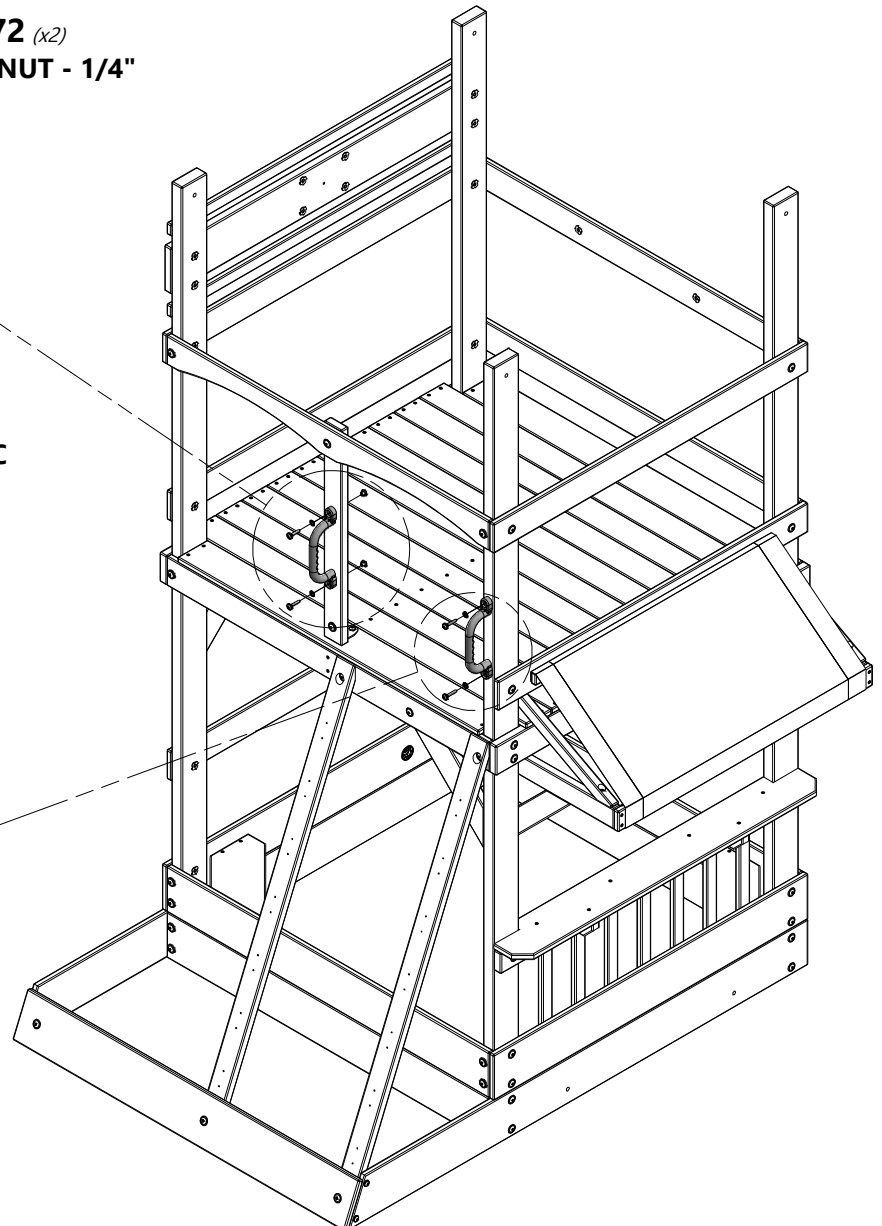
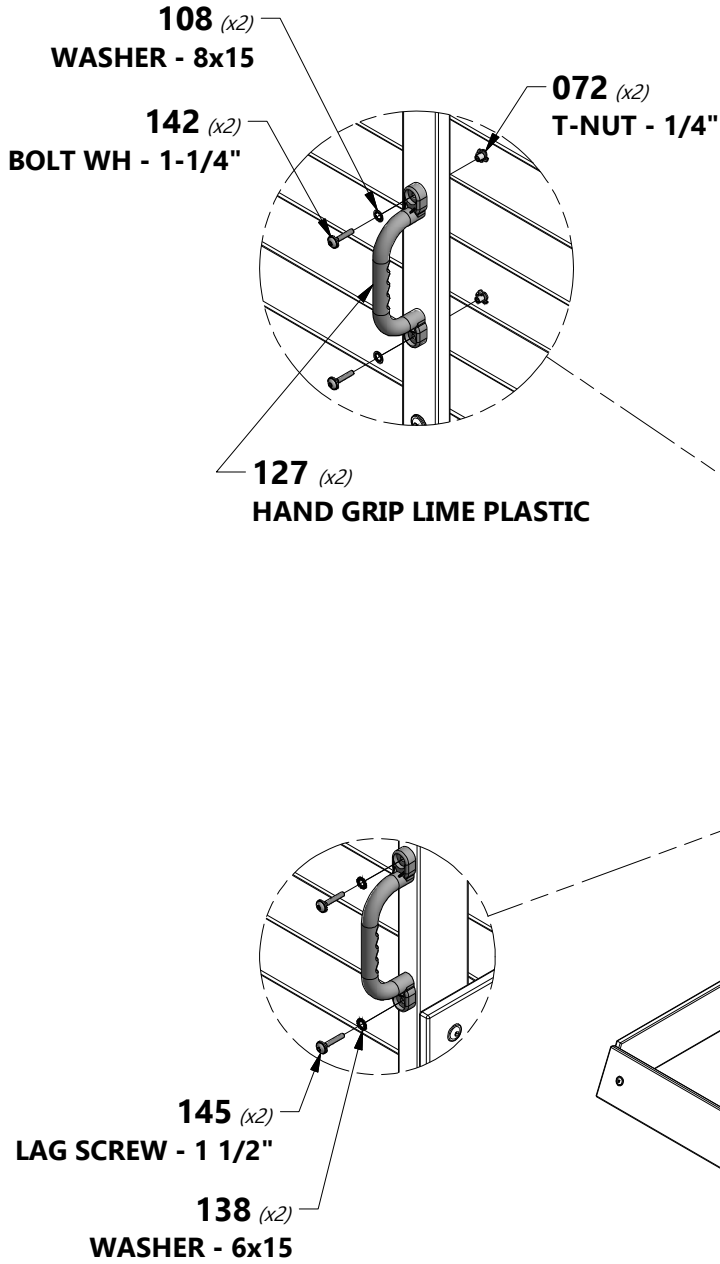

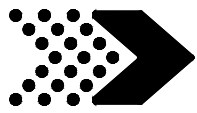

O2 PICKET - W4L06944
(7) 5/8"x1 3/8"x18 1/4" (16x34x465)



H100088 SCREW PFH
(14) 8x1 1/8

CENTER O2 BOARDS IN OPENING, APPROXIMATELY 1 7/8" - 46mm DOWN FROM M8 BOARD. APPROXIMATELY 3 1/8" - 79mm SPACING BETWEEN PICKETS.

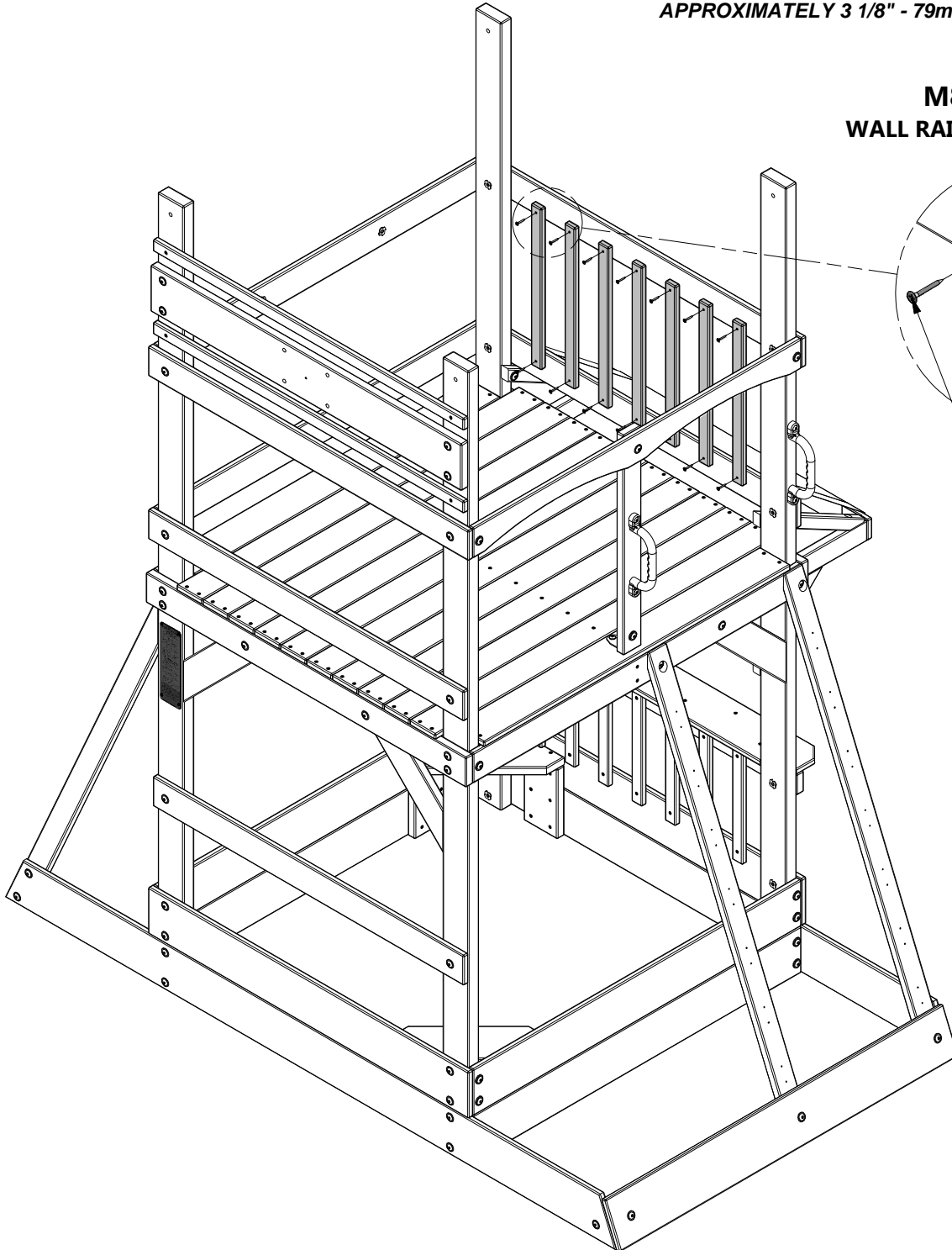

M8
WALL RAIL

O2 (x7)
PICKET

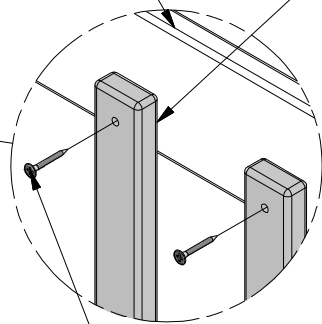

088 (x14)
SCREW - 1 1/8"



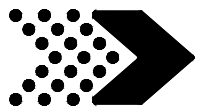

O2 PICKET - W4L06944
(9) 5/8"x1 3/8"x18 1/4" (16x34x465)



H100088 SCREW PFH
(18) 8x1 1/8"

**CENTER O2 BOARDS IN OPENING, APPROXIMATELY
1 7/8" - 46mm DOWN FROM M10 BOARD.
2 7/8" - 72mm SPACING BETWEEN PICKETS.**

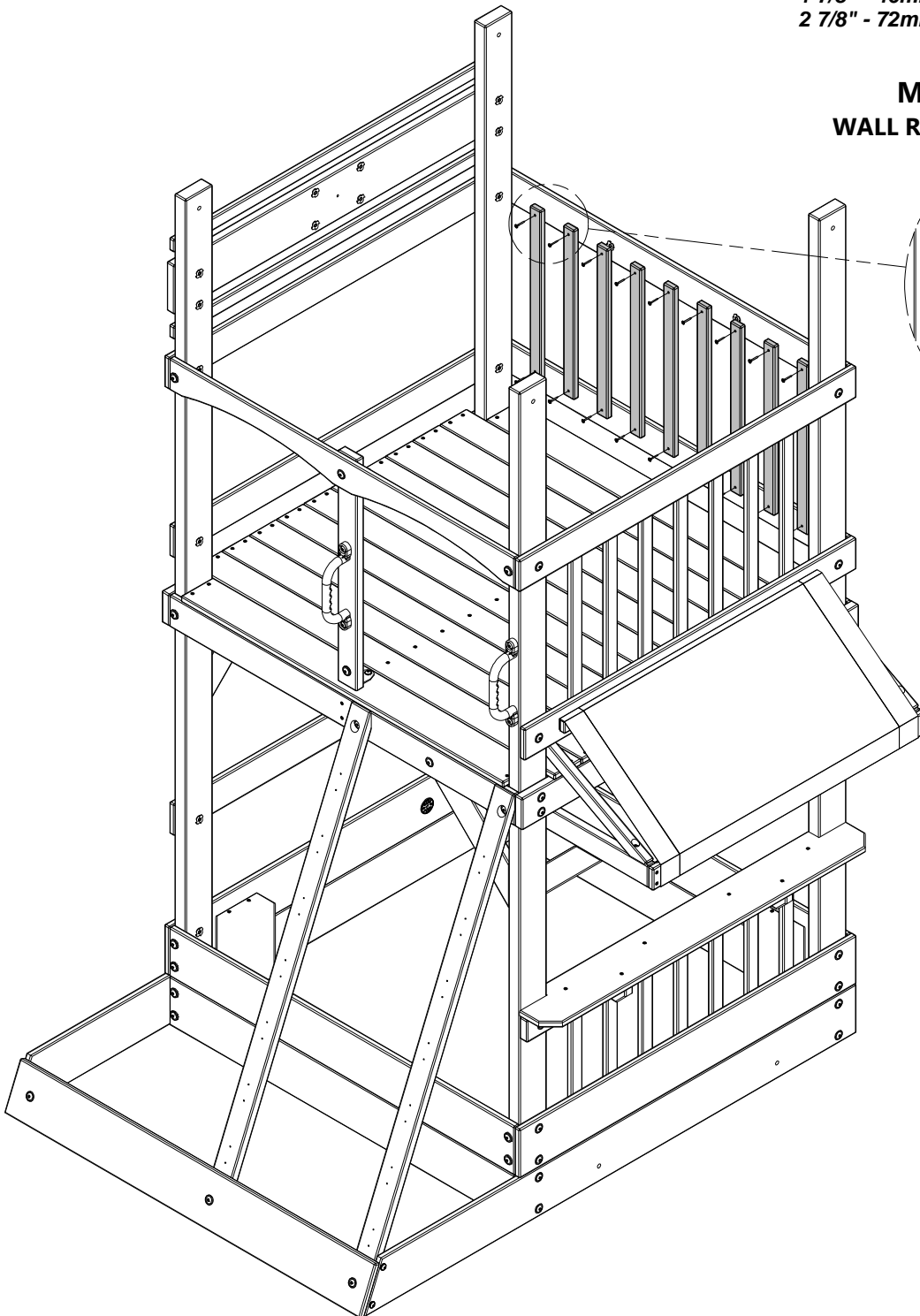

**M10
WALL RAIL**

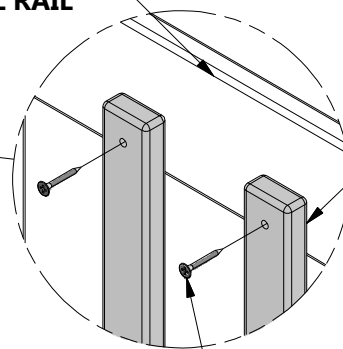

**O2 (x9)
PICKET**

**088 (x18)
SCREW - 1 1/8"**

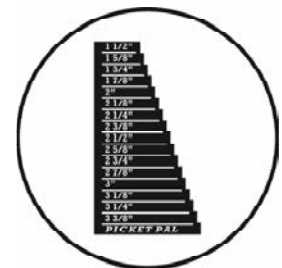

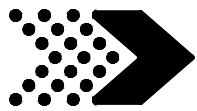

O2 PICKET - W4L06944
(7) 5/8"x1 3/8"x18 1/4" (16x34x465)



H100088 | SCREW PFH
(14) 8x1 1/8

CENTER O2 BOARDS IN OPENING, APPROXIMATELY 1 7/8" - 46mm DOWN FROM M8 BOARD. APPROXIMATELY 3 1/8" - 79mm SPACING BETWEEN PICKETS.

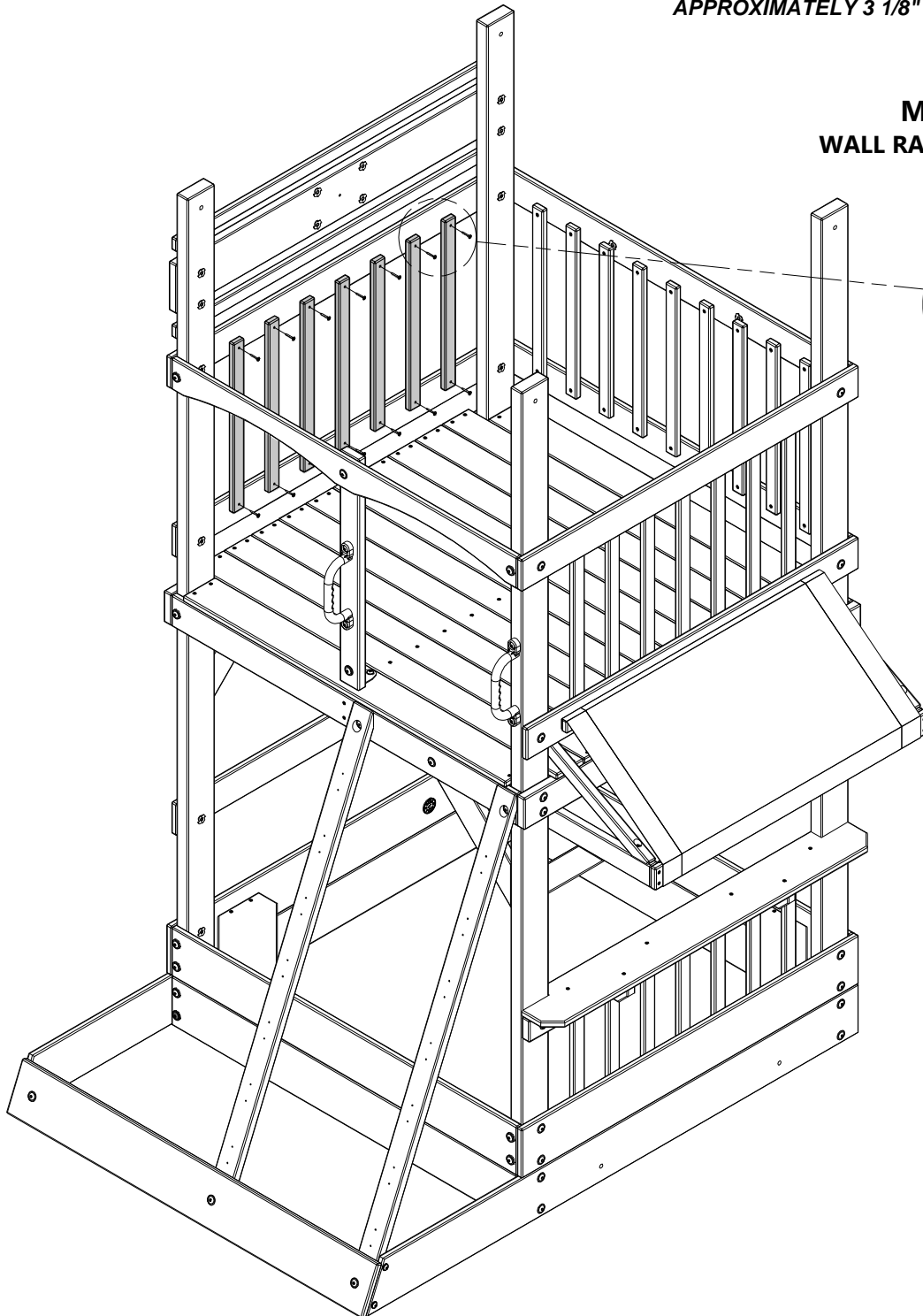

M8 WALL RAIL

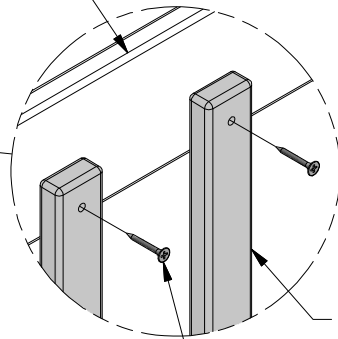

O2 (x7) PICKET

088 (x14) SCREW - 1 1/8"





H4 | HORIZONTAL TARP SUPPORT - W4L13838
(2) | 1"x3 3/8"x56 1/8" (24x86x1425)



H5 | HORIZONTAL TARP SUPPORT - W4L13839
(2) | 1"x3 3/8"x48 3/4" (24x86x1237)

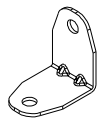

A4M01048 | L BRACKET
(4) | 2.5x38x55x55



H100013 | BOLT WH
(4) | 5/16x2 1/4

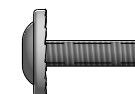

H100008 | BOLT WH
(4) | 5/16x1

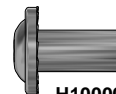

H100005 | NUT BARREL
(4) | WH
5/16x7/8



H100115 | BOLT WH
(4) | 5/16x1/2



H100030 | WASHER
(4) | LOCK EXT
8x19



H100031 | WASHER
(4) | LOCK EXT
12x19



H100074 | T-NUT
(8) | 5/16

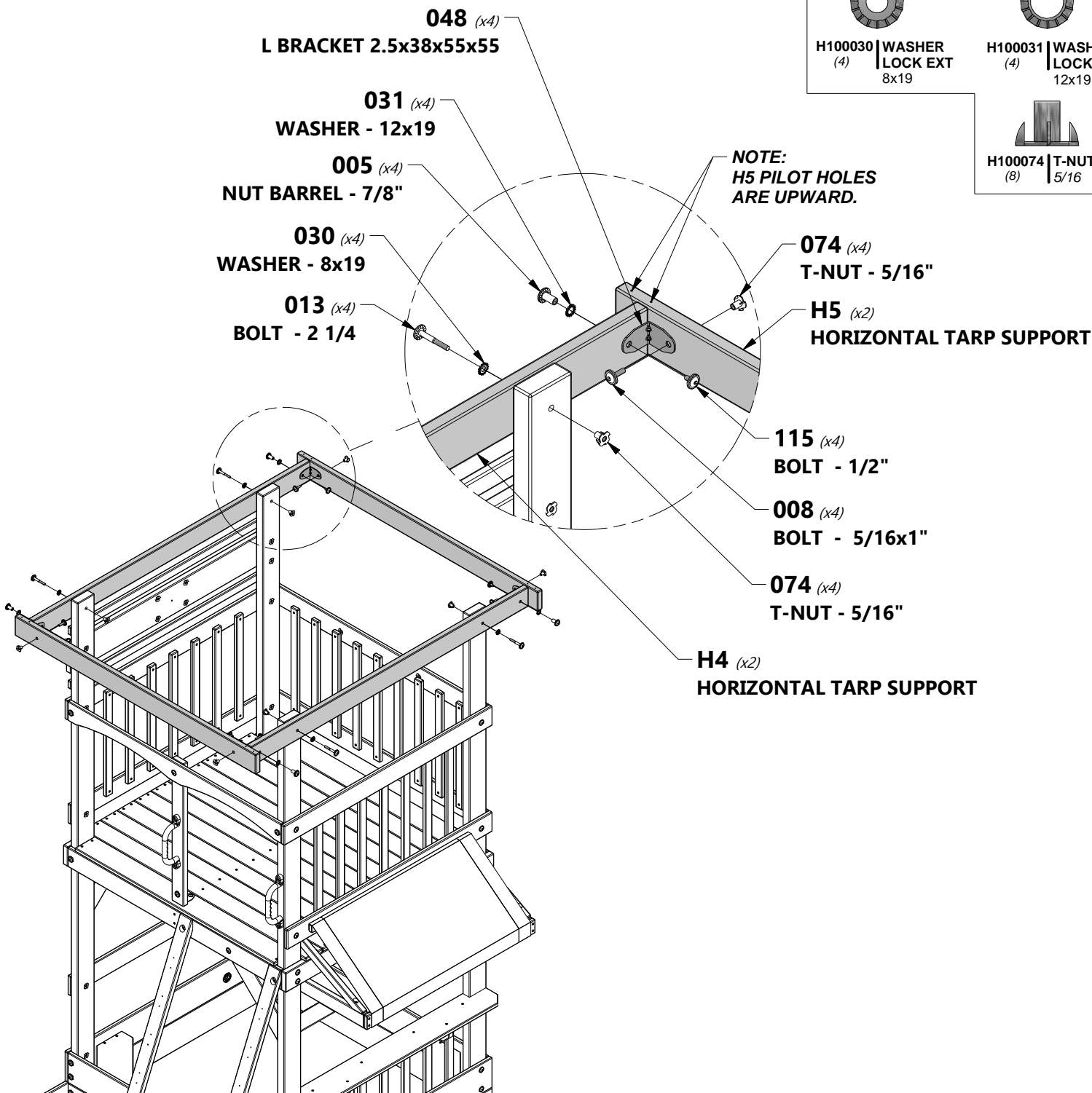

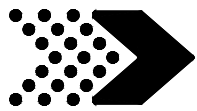

FORT ASSEMBLY

STEP 25

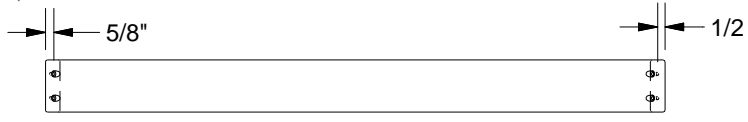

H6 | ROOF BOARD - W4L06950
(4) | 1"x3 3/8"x40 3/8" (24x86x1025)

T1 | ROOF BOARD - W4L06951
(1) | 1"x1 3/8"x48 3/4" (24x34x1237)

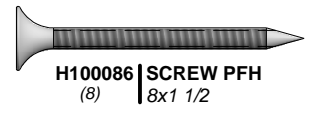

H100086 | SCREW PFH
(8) | 8x1 1/2

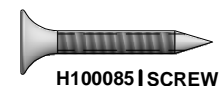

H100085 | SCREW PFH
(8) | 8x1

085 (x8)
SCREW - 1"

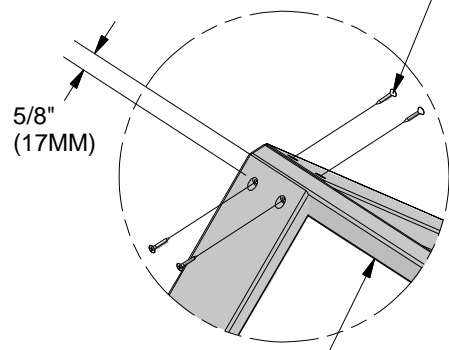

T1 (x1)
ROOF BOARD

H6 (x4)
ROOF BOARD

086 (x8)
SCREW - 1 1/2"

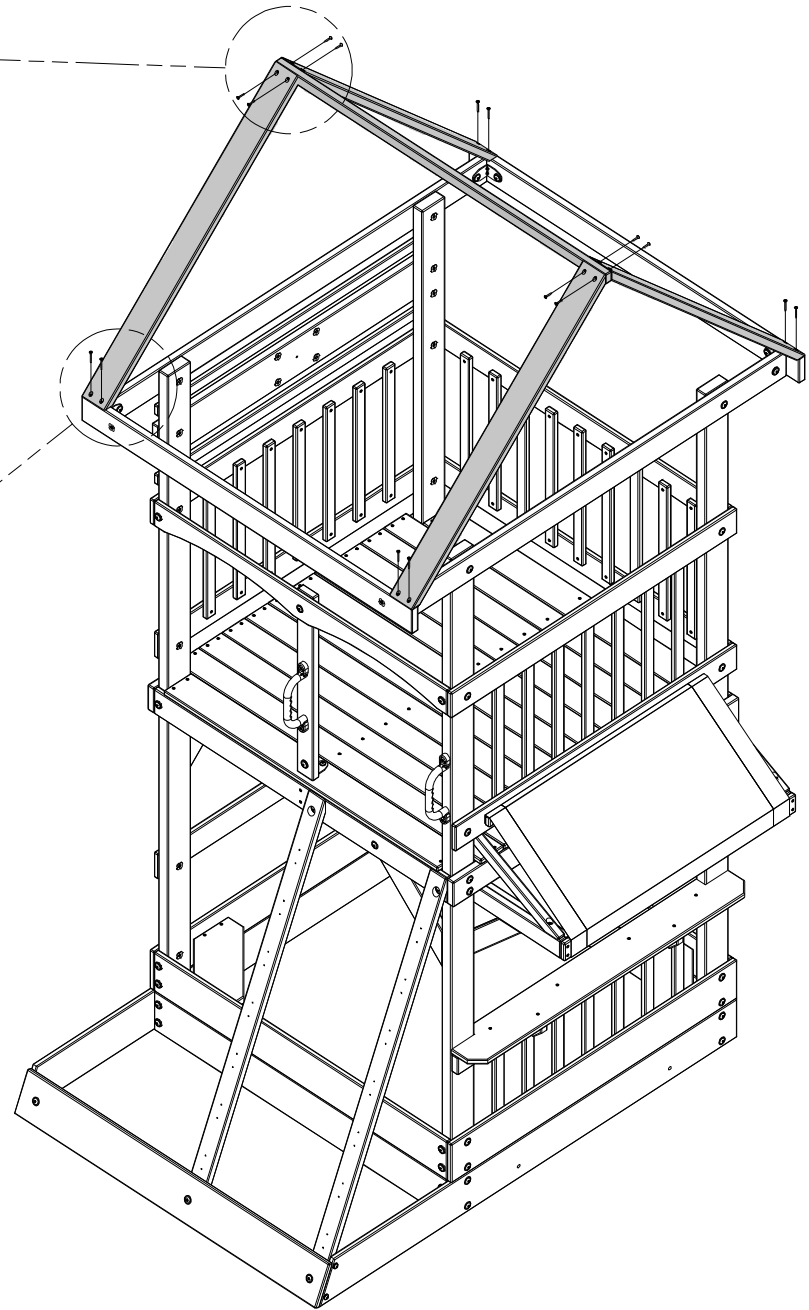
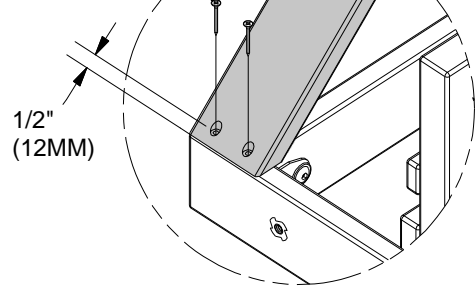

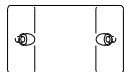

J10 ROOF BOARD - W4L06952
(2) | 1"x2 3/8"x4" (24x60x102)



H100085 | SCREW PFH
(4) | 8x1

FLUSH J10 BOARD TO THE INSIDE OF H6 BOARDS.

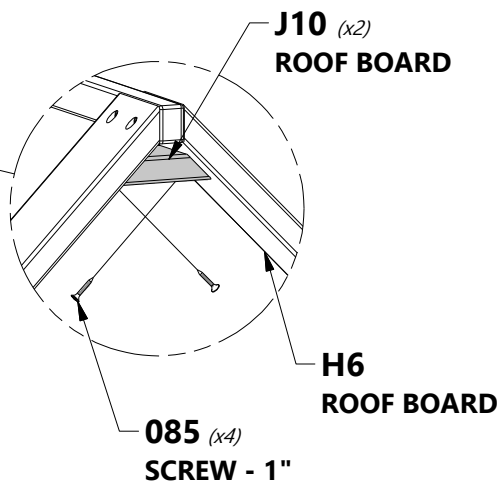
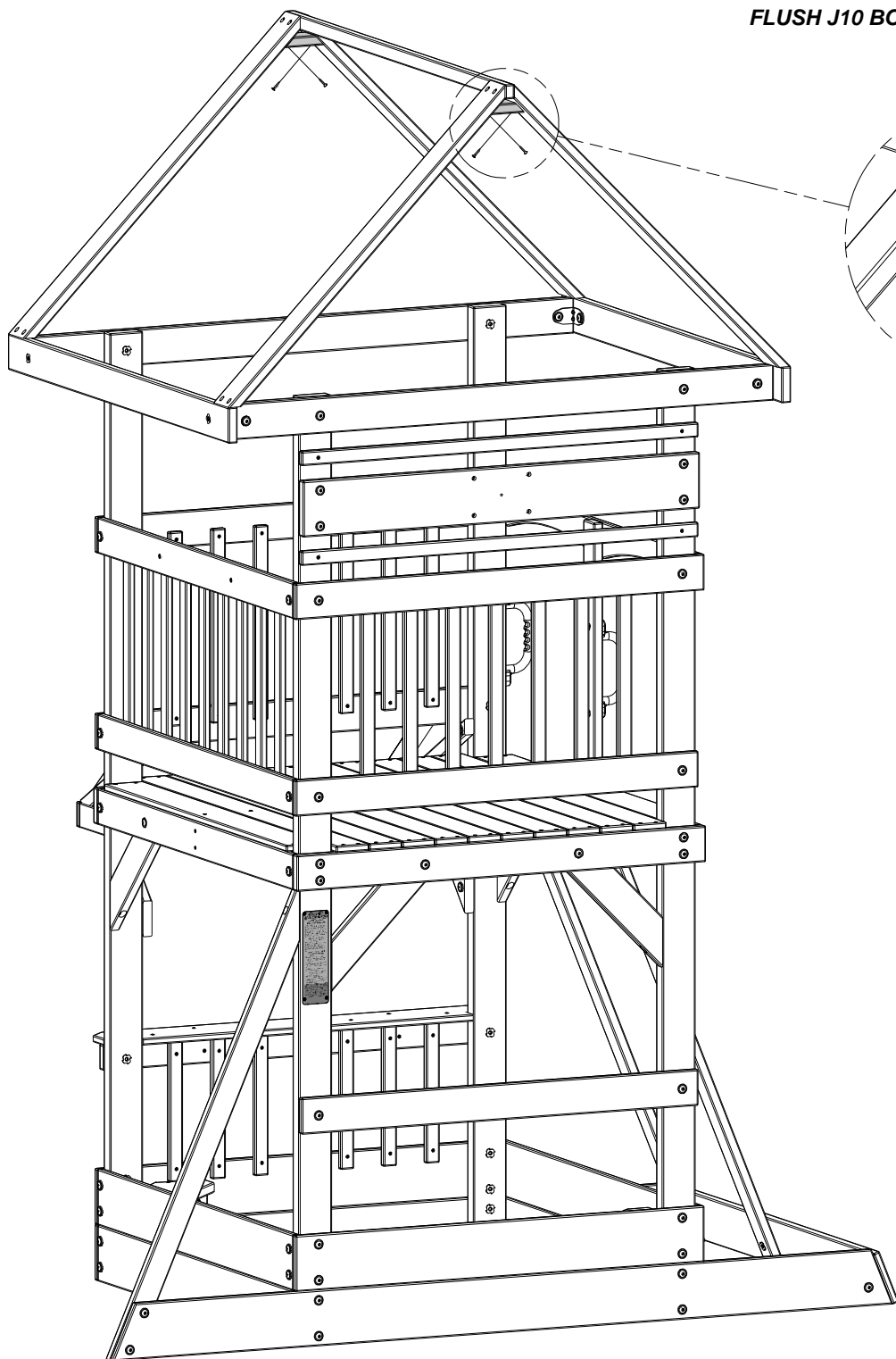

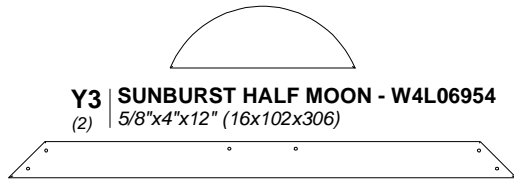
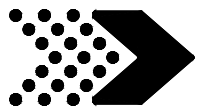

Y3 | **SUNBURST HALF MOON - W4L06954**
(2) | 5/8"x4"x12" (16x102x306)

N2 | **ROOF BOARD - W4L06953**
(2) | 5/8"x2 3/8"x33 1/8" (16x60x840)



H100087 | **SCREW PFH**
(8) | 8x1 1/4



H100088 | **SCREW PFH**
(4) | 8x1 1/8

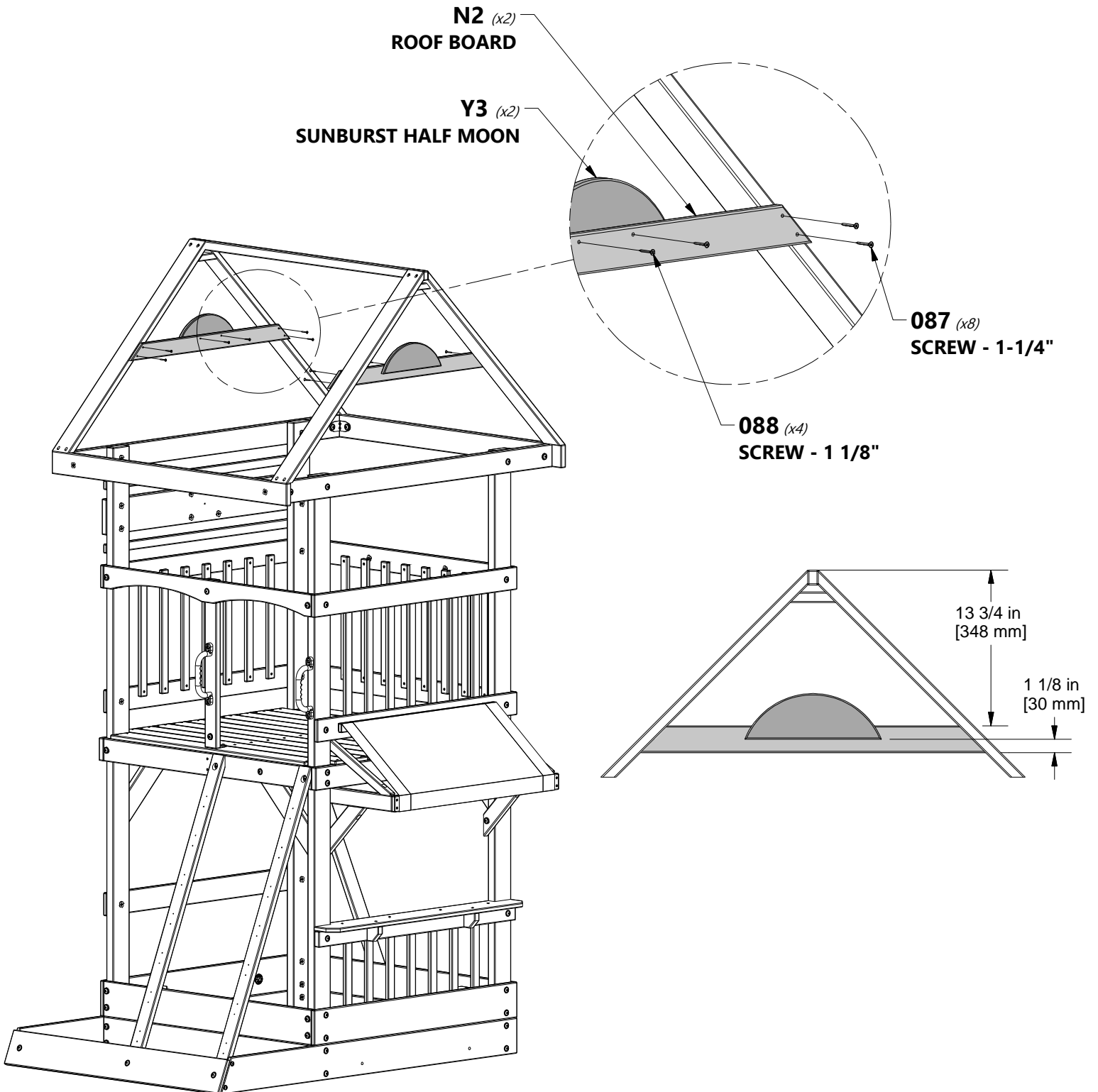

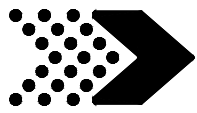

N4 | SUNBURST BOARD - W4L06956
(4) | 5/8"x2 3/8"x8 1/8" (16x60x205)



N3 | SUNBURST BOARD - W4L06955
(2) | 5/8"x2 3/8"x11 3/4" (16x60x299)



H100088 | SCREW PFH
(18) | 8x1 1/8"

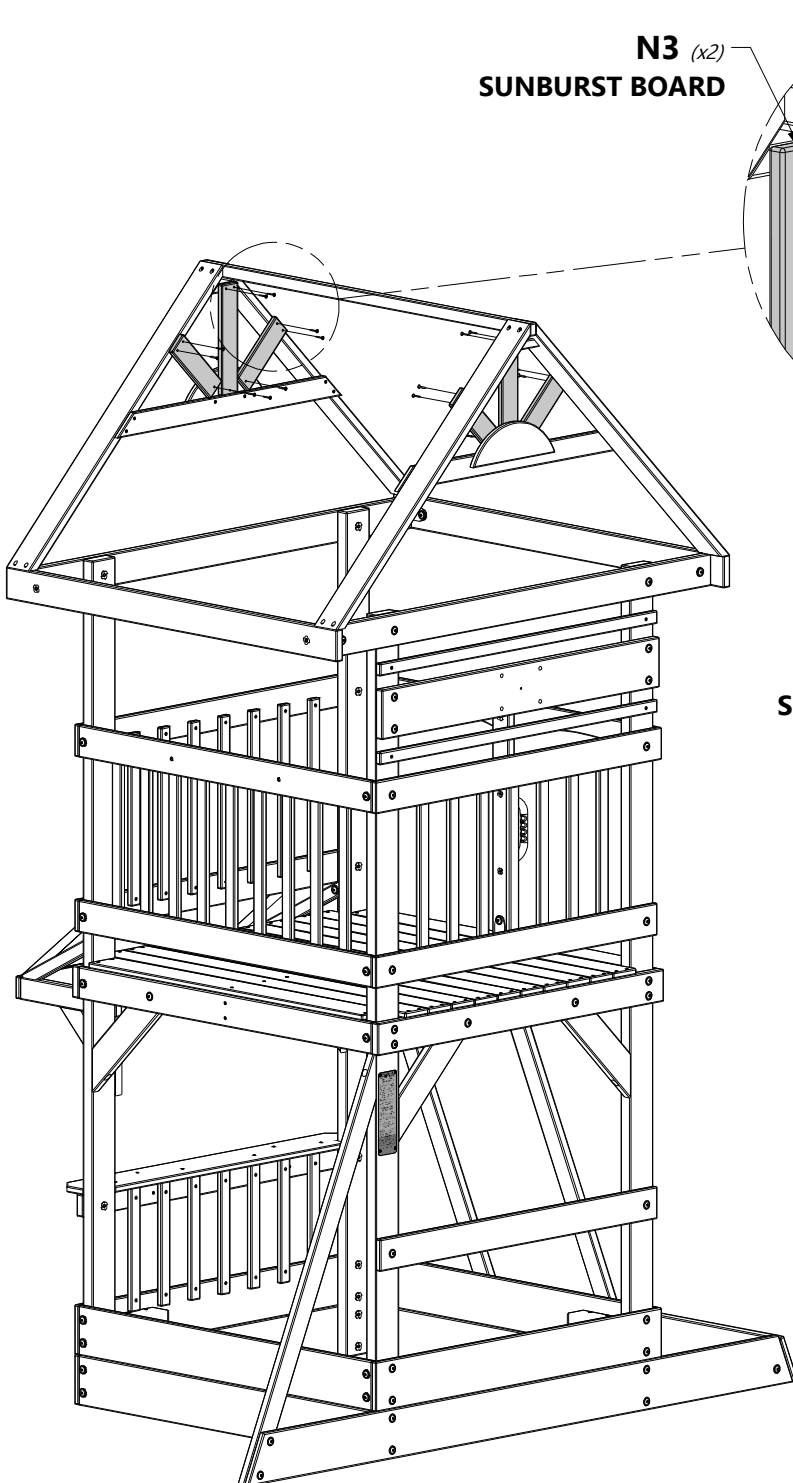

N3 (x2)
SUNBURST BOARD

N4 (x4)
SUNBURST BOARD

088 (x18)
SCREW - 1 1/8"

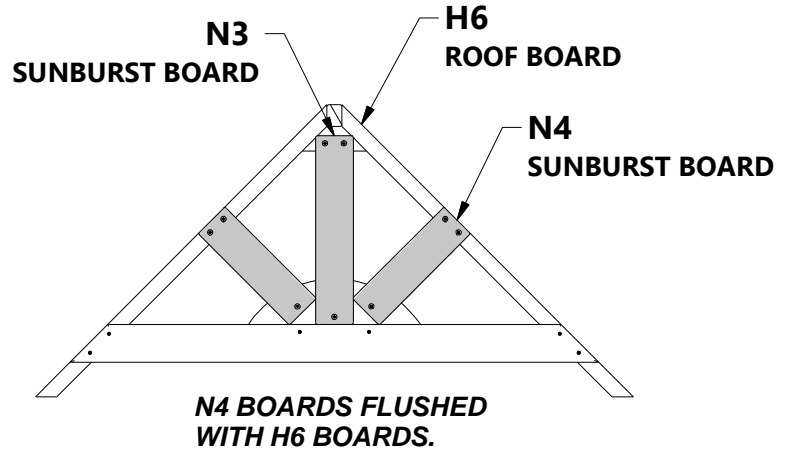

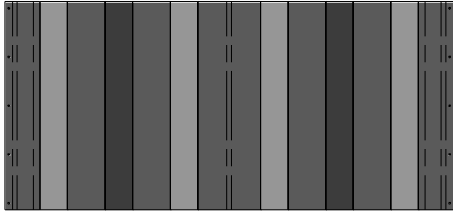
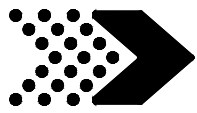

A6P00123 | TARP
(1)

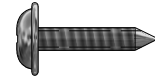

H100128 | SCREW PWH
(10) | 8x5/8

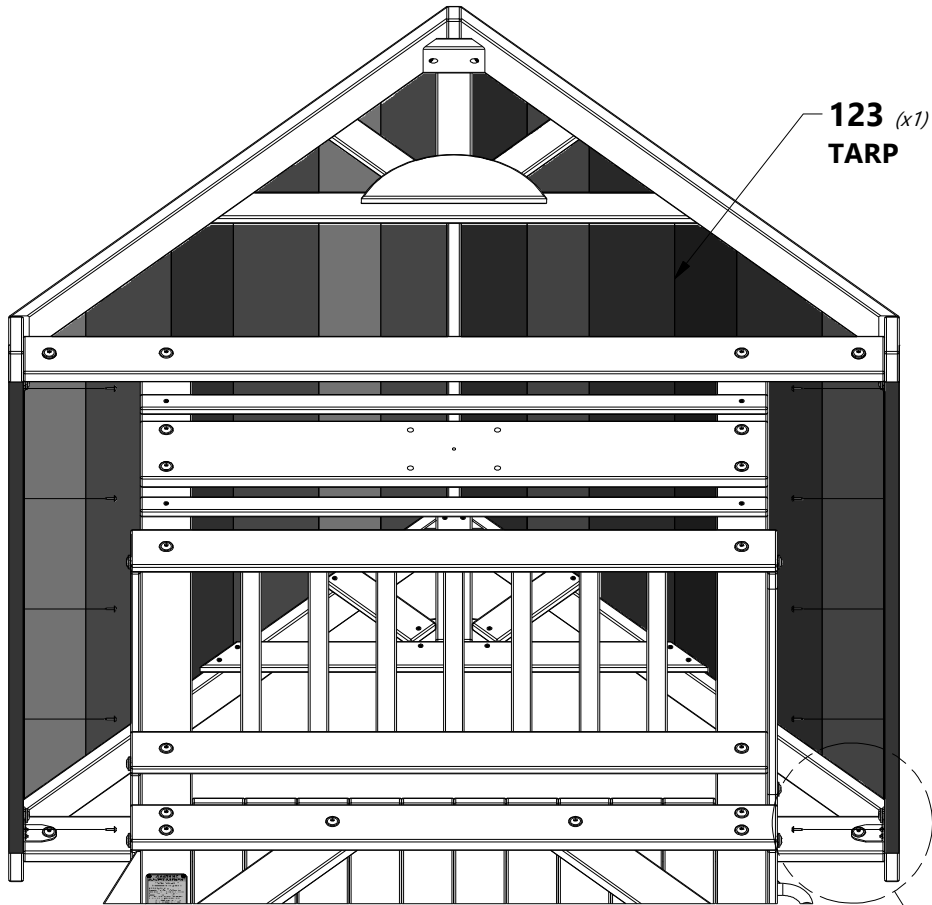

128 (x10)
SCREW - 5/8

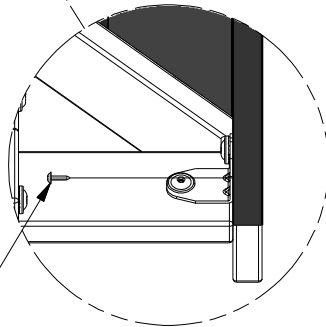

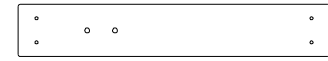
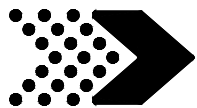

M4 | LADDER RUNG - W4L06913
(6) 5/8"x3 3/8"x20 1/4" (16x86x515)



M3 | LADDER RUNG - W4L06912
(1) 5/8"x3 3/8"x20 1/4" (16x86x515)



A6P00040 | BLUE HC ROCK #2
(2)



A6P00128 | LIME HC ROCK #2
(2)



A6P00129 | CRANBERRY HC ROCK #1
(2)



H100063 | BOLT PTH
(12) 1/4x3/4



H100087 | SCREW PFH
(28) 8x1 1/4



H100108 | WASHER
(12) LOCK INT
8x15



H100072 | T-NUT
(12) 1/4

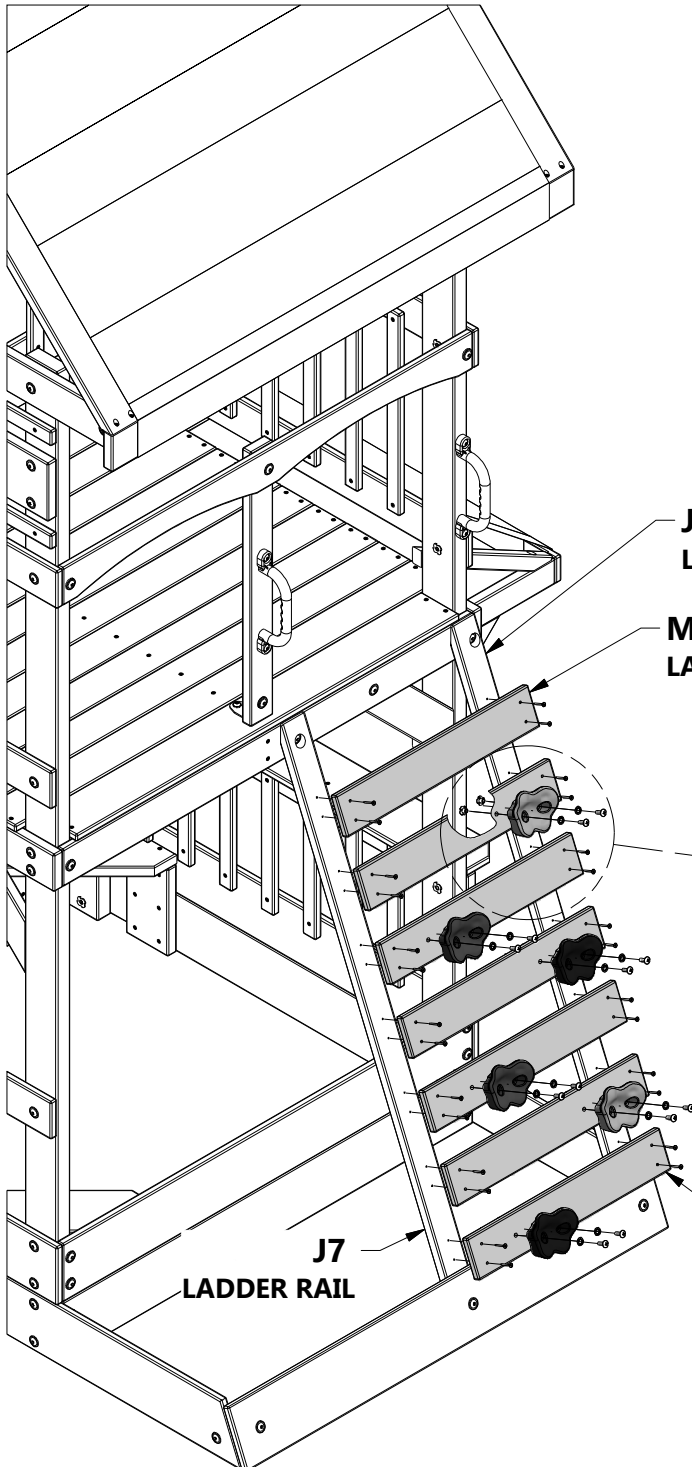

FINGER GRIP UPWARDS
ON ROCKS

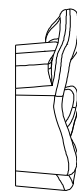

NOTE:
PLACE THE ROCKS AND HARDWARE ONTO THE M4 BOARDS
BEFORE PLACING ON J6 AND J7 BOARDS.
ARRANGE COLORS AS DESIRED.

J6
LADDER RAIL

M3 (x1)
LADDER RUNG

072 (x12)
T-NUT - 1/4"

108 (x12)
WASHER - 8x15

063 (x12)
BOLT - 3/4"

087 (x28)
SCREW - 1-1/4"

M4 (x6)
LADDER RUNG

J7
LADDER RAIL

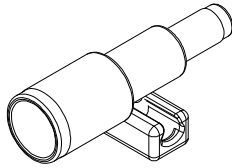
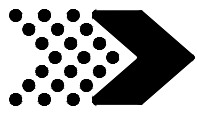

A6P00126 | TELESCOPE BLUE/LIME
(1)



H100088 | SCREW PFH
(2) | 8x1 1/8

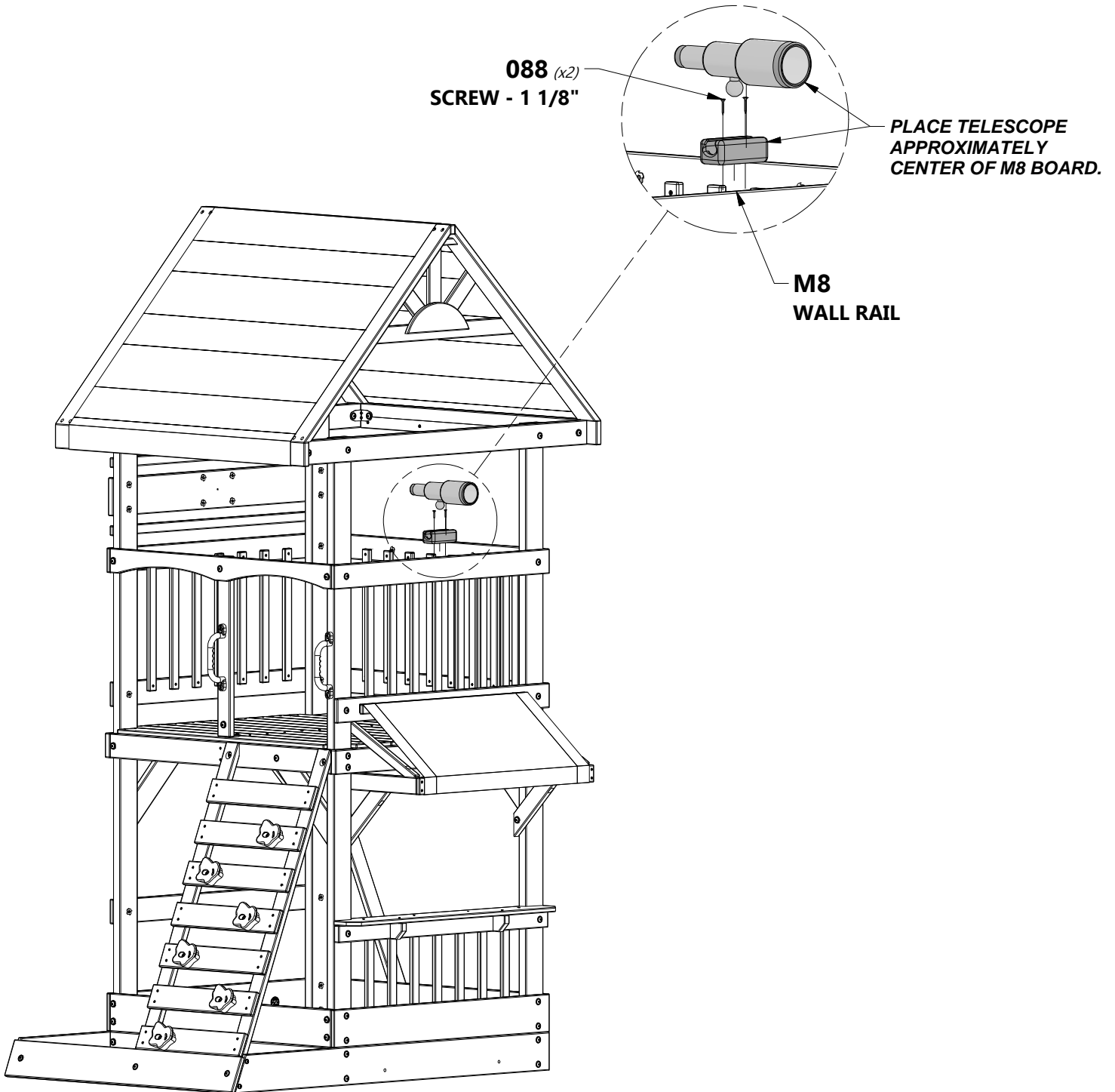

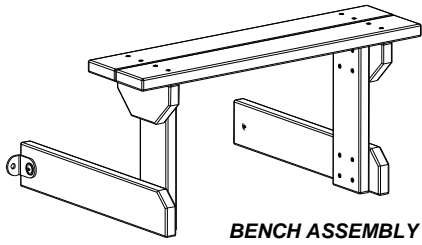
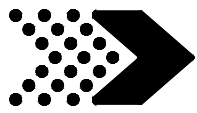

BENCH ASSEMBLY



H100115 | BOLT WH
(2) | 5/16x1/2

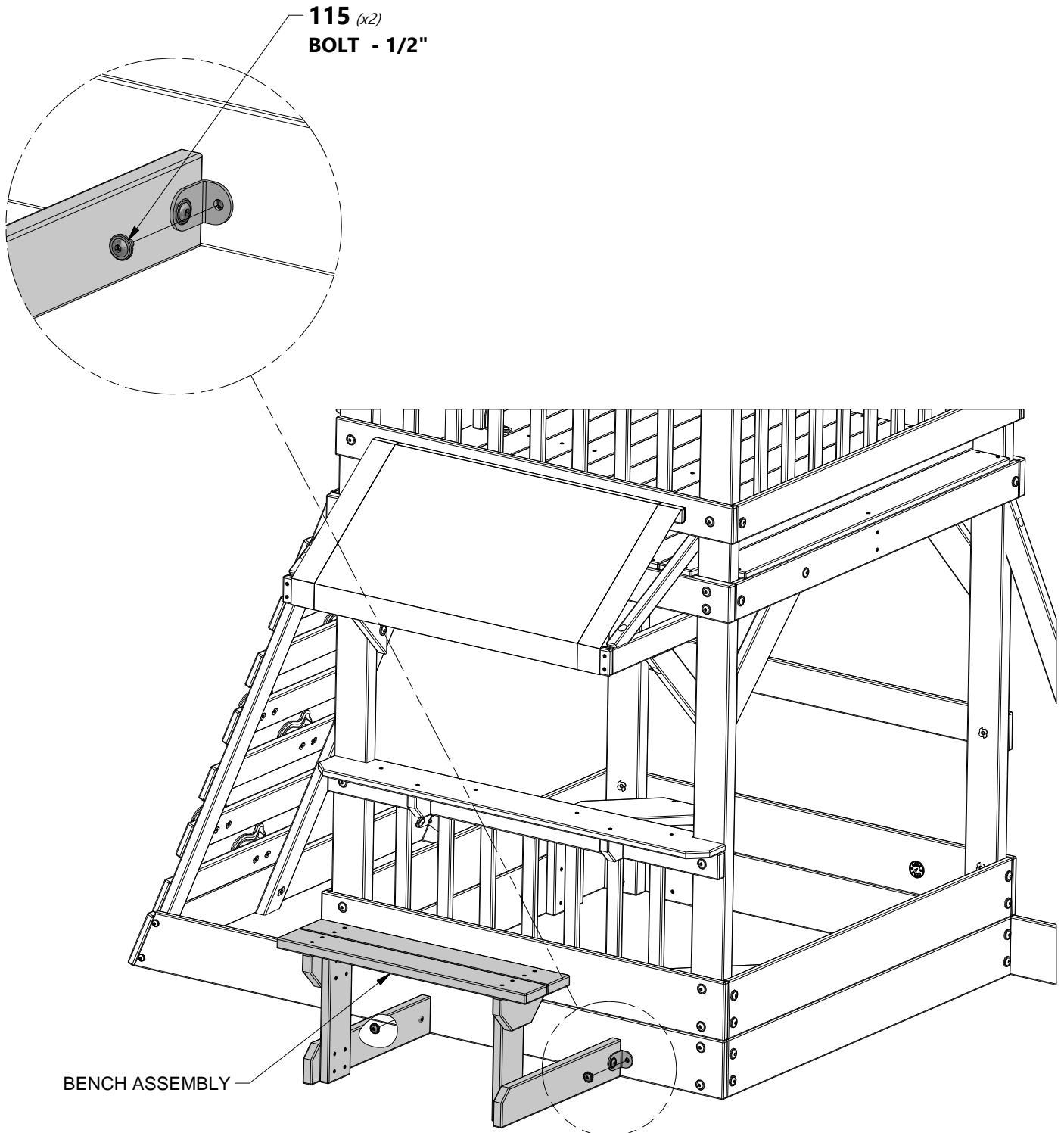

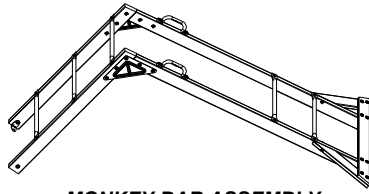
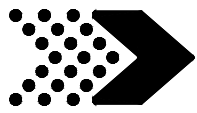

MONKEY BAR ASSEMBLY

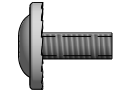

H100222 | BOLT WH
(2) | 5/16x3/4

222 (x2)
BOLT - 3/4"

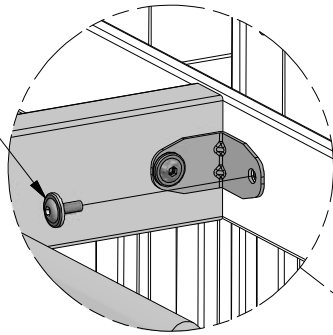

MONKEY BAR ASSEMBLY

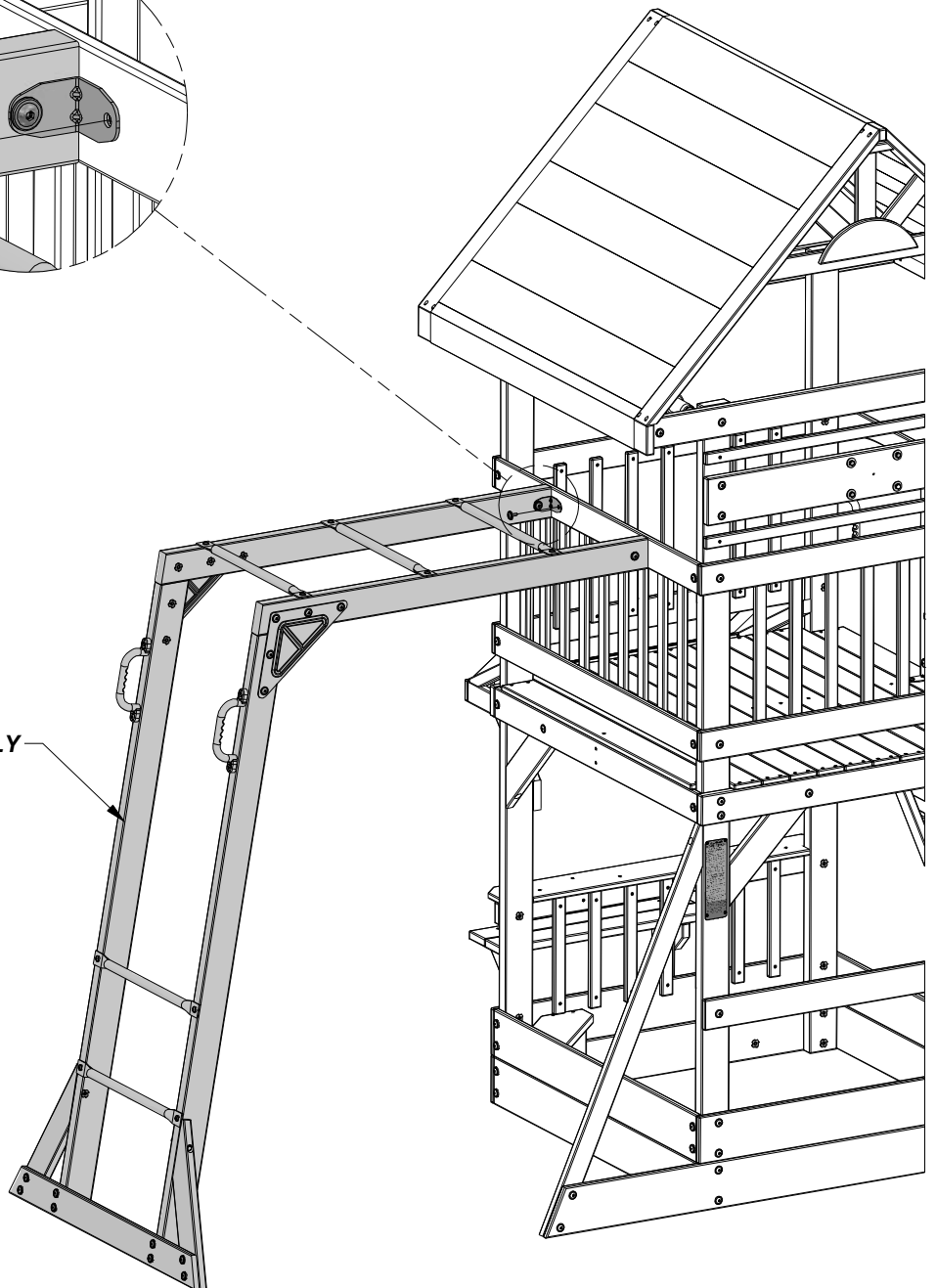

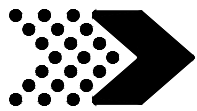

FORT ASSEMBLY

STEP 34

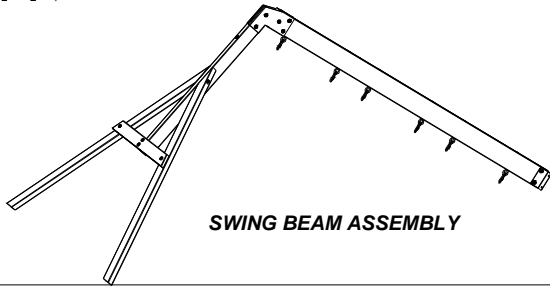

SWING BEAM ASSEMBLY



A100164 (1) BYD ID TAG (LARGE) AGES 3-10



H100042 (4) BOLT HEX 5/16x1 1/4



H100084 (4) SCREW PFH 6x3/4



H100095 (4) WASHER SPLIT 5/16

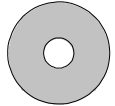

H100105 (4) WASHER FLAT 8x27

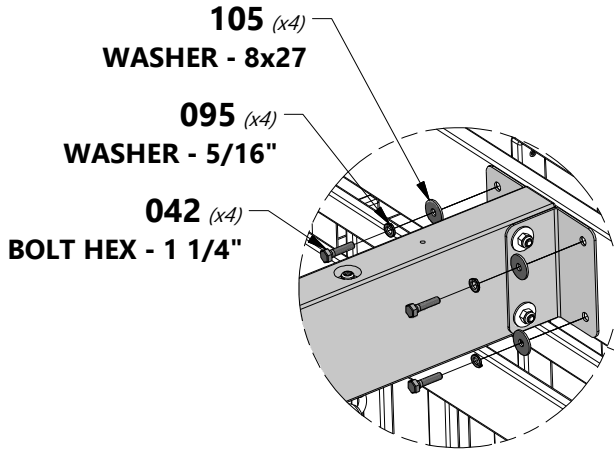

105 (x4) WASHER - 8x27

095 (x4) WASHER - 5/16"

042 (x4) BOLT HEX - 1 1/4"

164 (x1) BYD ID TAG (LARGE) AGES 3-10

SWING BEAM ASSEMBLY

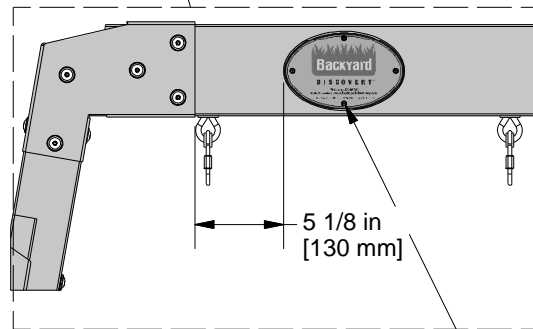
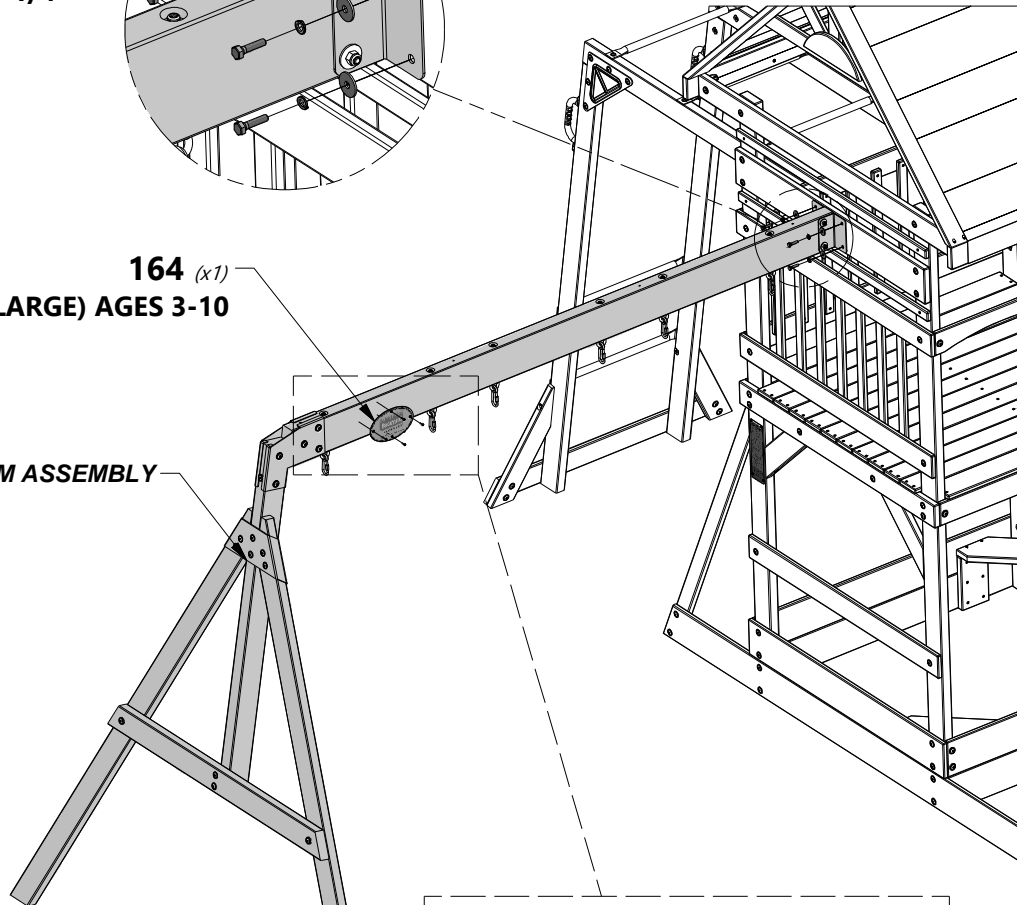

5 1/8 in [130 mm]

084 (x4) SCREW - 6x3/4

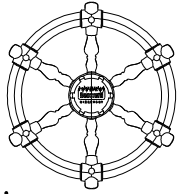
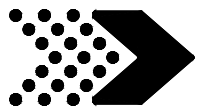

A6P00125 | SHIPS WHEEL BLUE/LIME
(1)

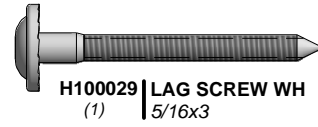

H100029 | LAG SCREW WH
(1) | 5/16x3

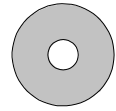

H100105 | WASHER FLAT
(1) | 8x27

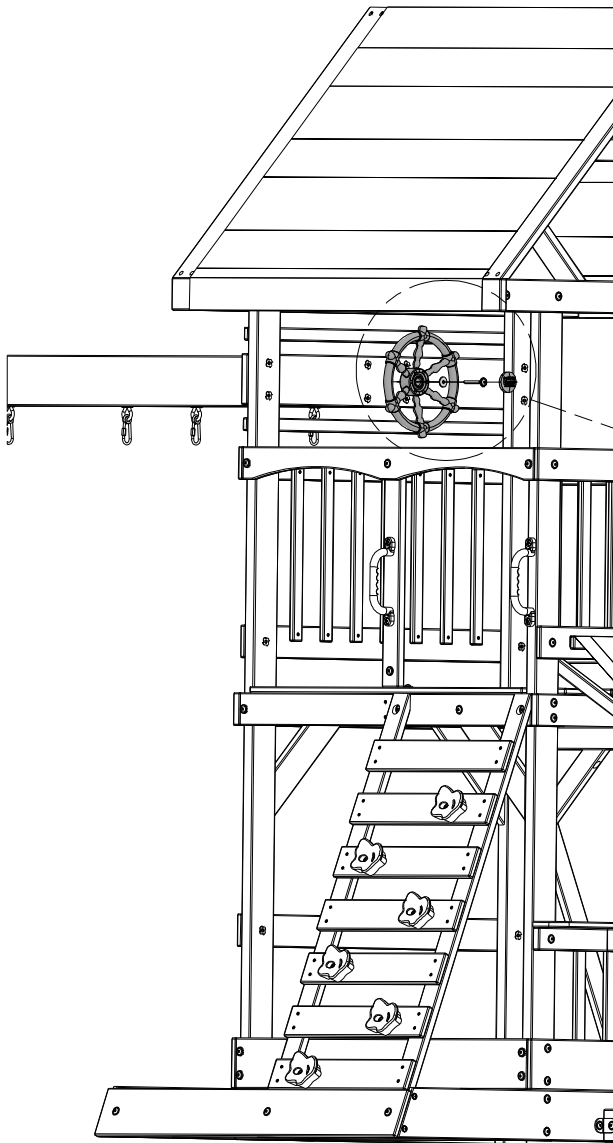

(x1)
SHIPS WHEEL BLUE/LIME

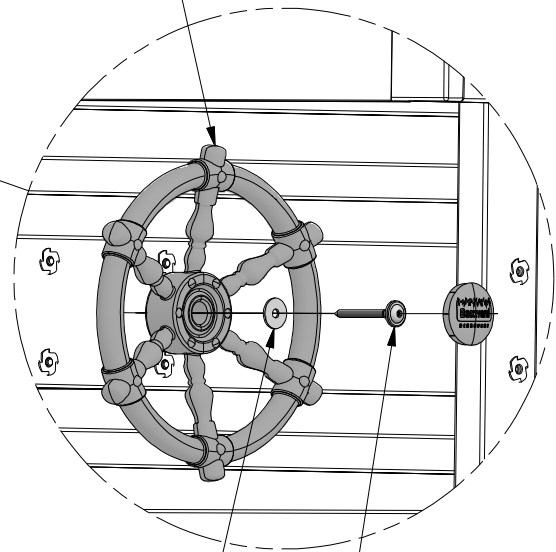

105 (x1)
WASHER - 8x27

029 (x1)
LAG SCREW - 3"

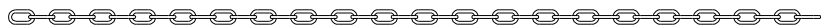

A4M00524 | CHAIN BLUE 51.25"
(4)

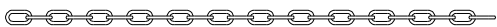

A4M00525 | CHAIN BLUE 31"
(2)



A100069 | QUICK LINK
(6)

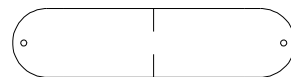

A6P00133 | SWING SEAT BLUE 22"
(2)

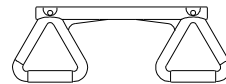

A6P00134 | BLUE TRAPEZE
(1)

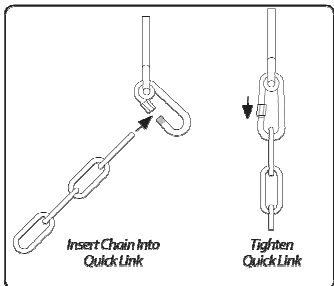

524 (x4)
CHAIN BLUE 51.25"

525 (x2)
CHAIN BLUE 31"

069 (x2)
QUICK LINK

134 (x1)
BLUE TRAPEZE

069 (x4)
QUICK LINK

405 (x2)
SWING SEAT BLUE 22"

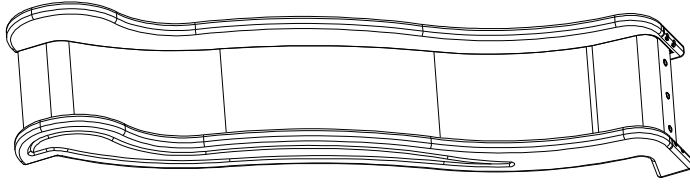
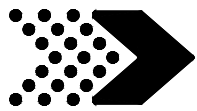

SLIDE ASSEMBLY



H100115 BOLT WH
(3) 5/16x1/2

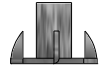

H100074 T-NUT
(3) 5/16

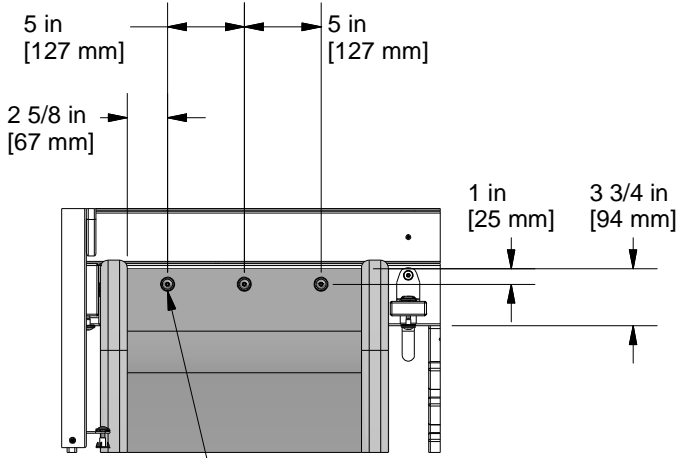

DRILL (3) 3/8" - (10mm) HOLES THROUGH SLIDE BED AND FLOOR BOARDS.

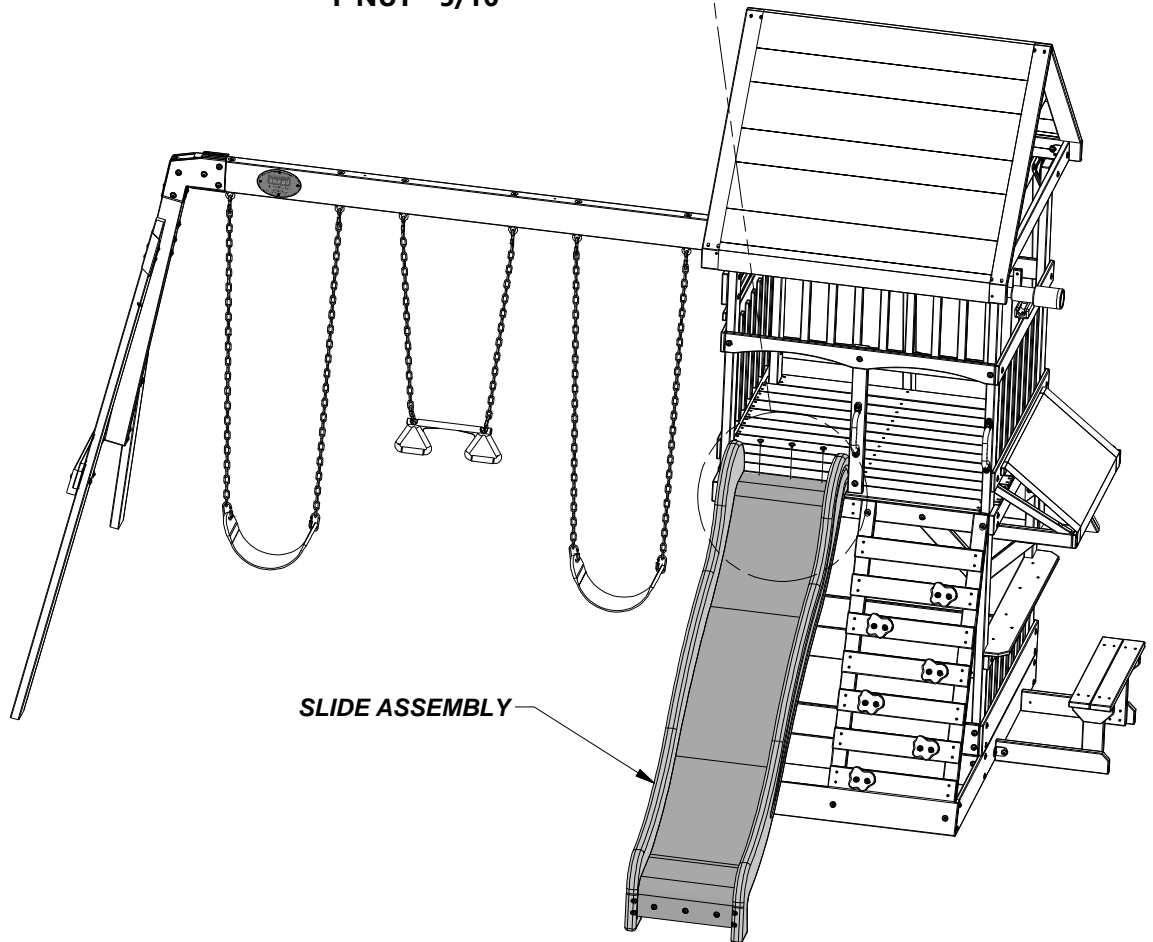
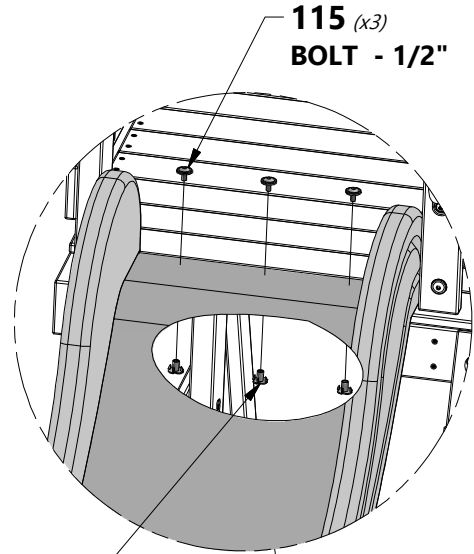

SLIDE ASSEMBLY

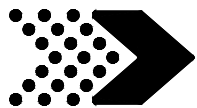

ANCHORING

STEP 38

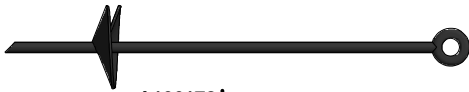

A100178 (8) | AUGER GROUND STAKE

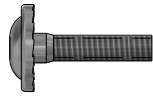

H100009 (2) | BOLT WH 5/16x1 1/4

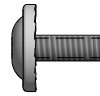

H100222 (6) | BOLT WH 5/16x3/4

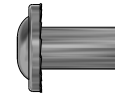

H100005 (2) | NUT BARREL WH 5/16x7/8

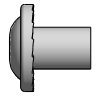

H100004 (6) | NUT BARREL WH 5/16 x 5/8



H100031 (8) | WASHER LOCK EXT 12x19

NOTE:
FAILURE TO USE GROUND STAKES CAN VOID WARRANTY & CAUSE INJURY!

SCREW AUGER INTO GROUND AT LOCATIONS SHOWN. USING AUGER AS A TEMPLATE DRILL 3/8" - (10mm) HOLES THRU BOARD, & ATTACH USING SUPPLIED HARDWARE.

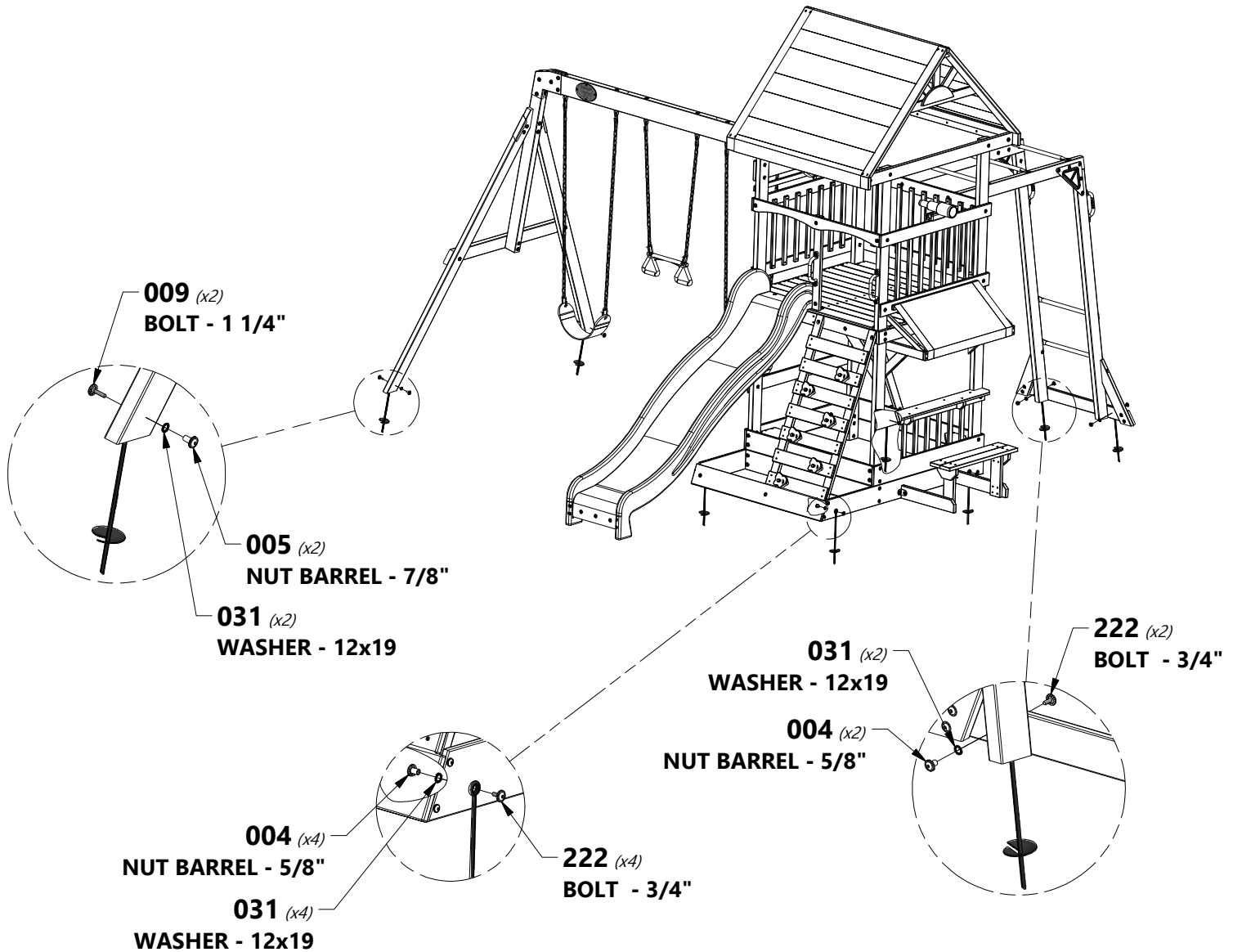

FINAL STEP

DOUBLE CHECK EVERY BOLT, SCREW AND NUT FOR TIGHTNESS. MAKE SURE EVERY BOARD IS SECURE AND MAKE SURE THE PLAY SET IS LEVEL.

ENJOY YOUR NEW PLAY SET!