



MANUFACTURED BY:
Backyard Discovery
3305 Airport Drive, Pittsburg, KS 66762
800-856-4445

Basepoint Business Centre: Rivermead Drive, Westlea, Swindon SN5 7EX Phone: 0800-118-2476
J.P. Coenstraat 7, The Bridge, The Hague, 2595 WP, Netherlands Phone: 0800-567-8990

CARIBBEAN

Swing Set

Model # 1606029B

The assembly manual must be retained
since it contains important information



WARNING

Adult Assembly Required.

Not suitable for children under 36 months due to small parts.

FOR DOMESTIC USE ONLY. INTENDED FOR OUTDOOR USE.



Please visit www.backyarddiscovery.com

For the most up to date assembly manual, to register your set, or to order replacement parts

Para obtener instrucciones en español, visite www.backyarddiscovery.com



EASY STEP-BY-STEP
3D INTERACTIVE INSTRUCTIONS

DOWNLOAD THE FREE APP



Owner's Manual - Basic Setup Dimensions & Assembly Notes

Place the set on level ground, not less than 6'-7" [2007 mm] from any structure or obstruction such as a fence, garage, house, overhanging branches, laundry lines, or electrical wires.

- While assembling unit, take time before and after each phase to make sure fort is level. If fort is not level, assembly will be difficult and improper assembly may result. Extra care must be taken to insure the fort is square.
- The safe play area refers to a zone extending 6'-7" (2007 mm) beyond the play product on all sides, including the space above the play product.

SAFE PLAY AREA DIAGRAM

Ground Dimensions

21'-4 1/2" [6516 mm] x 16'-6 1/4" [5034 mm] x 11'-5" [3480 mm]

Safe Play Area

34'-6 1/2" [10530 mm] x 29'-8 1/4" [9048 mm] x 18'-0" [5487 mm]

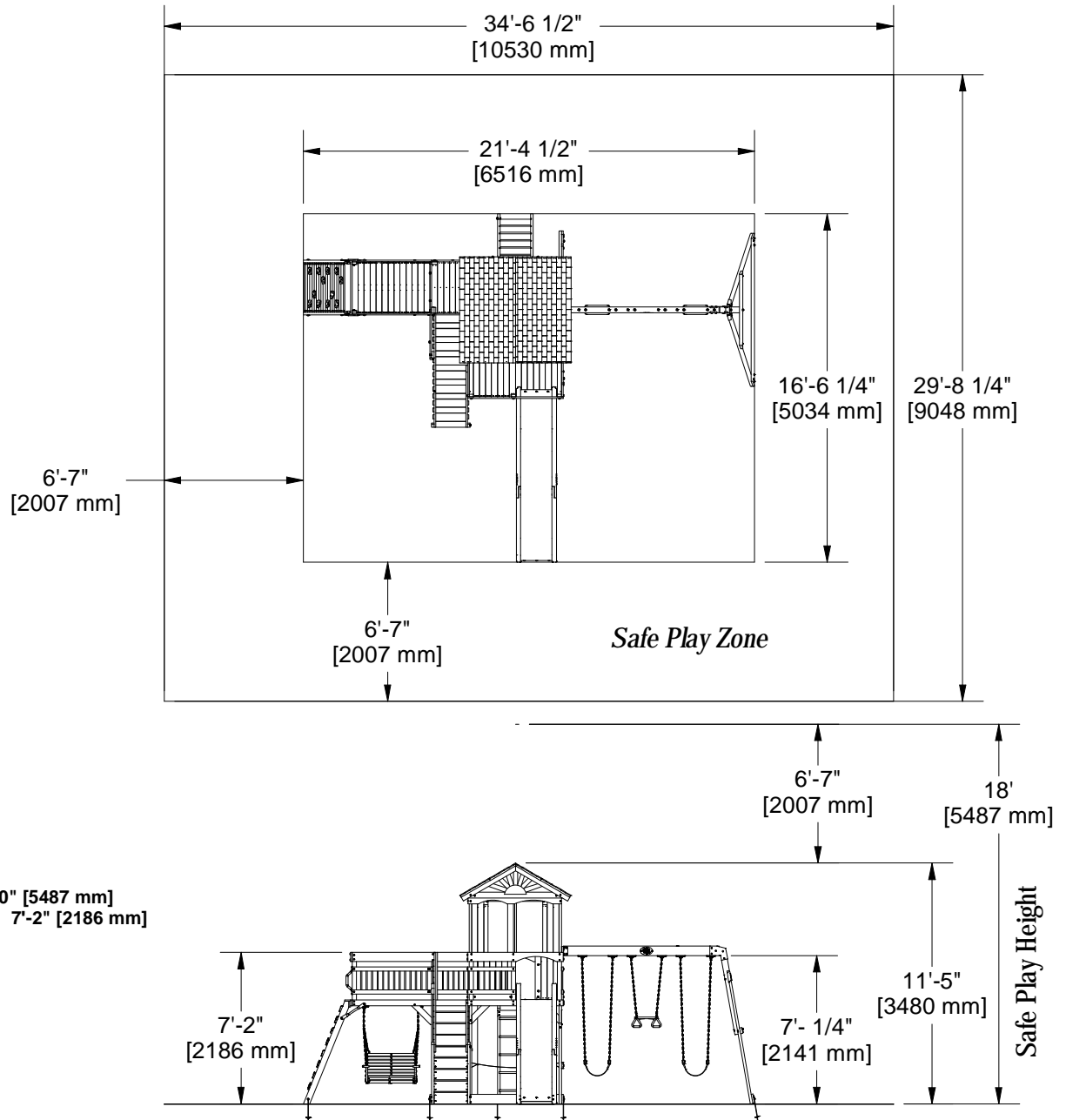

SAFE PLAY HEIGHT: 18'-0" [5487 mm]
 MAXIMUM FALL HEIGHT: 7'-2" [2186 mm]

General Information:

Your set has been designed and engineered for children only and for residential use only.
 A maximum of 150 lbs. per child is recommended for play activities designed for individual use.
 A maximum of 120 lbs. per child is recommended for play activities designed for multiple child use.
 A maximum of 15 children is recommended for this swing set.

OWNER'S MANUAL - PARTS IDENTIFICATION

Wood Components (Not to Scale)



A50 SWING BEAM - W4L20352
(x1) 3 3/8"x5 1/4"x89 1/2" (86x134x2274)

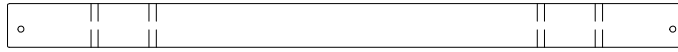

B09 SWING SUPPORT - W4L20353
(x1) 2 7/8"x3"x44 1/8" (72x76x1122)



D01 STAIR SUPPORT - W4L20354
(x1) 1 3/8"x5 1/4"x17 1/8" (36x134x435)

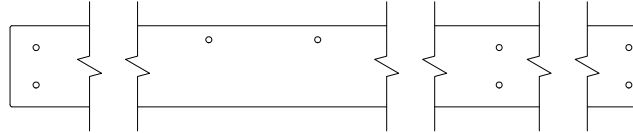

D02 WALL RAIL - W4L20387
(x1) 1 7/16"x5 1/4"x76 3/4" (36x134x1948)



E02 DECK BRACE - W4L20356
(x2) 1 3/8"x3 3/8"x16 7/16" (36x86x418)



E01 UPRIGHT - W4L20355
(x1) 1 3/8"x3 3/8"x86 1/8" (36x86x2186)



E03 UPRIGHT - W4L20357
(x1) 1 3/8"x3 3/8"x86 1/8" (36x86x2186)



E04 UPRIGHT - W4L20358
(x1) 1 3/8"x3 3/8"x63" (36x86x1600)

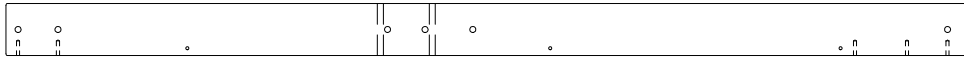

E05 UPRIGHT - W4L20359
(x1) 1 3/8"x3 3/8"x63" (36x86x1600)



E06 RIGHT RAIL - W4L20360
(x1) 1 3/8"x3 3/8"x63 7/8" (36x86x1623)

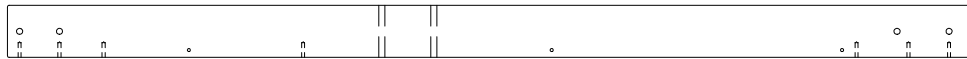

E07 UPRIGHT - W4L20361
(x1) 1 3/8"x3 3/8"x63" (36x86x1600)



E08 LEFT RAIL - W4L20362
(x1) 1 3/8"x3 3/8"x63 7/8" (36x86x1623)



E09 UPRIGHT - W4L20363
(x1) 1 3/8"x3 3/8"x63" (36x86x1600)



E10 UPRIGHT - W4L20364
(x1) 1 3/8"x3 3/8"x57 3/8" (36x86x1457)

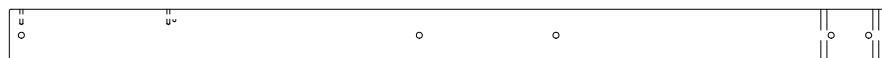

E11 UPRIGHT - W4L20365
(x1) 1 3/8"x3 3/8"x57 3/8" (36x86x1457)

OWNER'S MANUAL - PARTS IDENTIFICATION

Wood Components (Not to Scale)



E12 UPRIGHT - W4L20366
(x1) 1 3/8"x3 3/8"x57 3/8" (36x86x1457)



E13 UPRIGHT - W4L20367
(x1) 1 3/8"x3 3/8"x67 13/16" (36x86x1723)

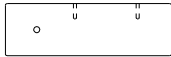

E14 UPRIGHT - W4L20368
(x1) 1 3/8"x3 3/8"x10 7/8" (36x86x275)



E16 DECK BRACE - W4L20369
(x3) 1 3/8"x3 3/8"x18 3/8" (36x86x466)



E17 DECK BRACE - W4L20370
(x4) 1 3/8"x3 3/8"x16 1/2" (36x86x418)



E18 ANGLE BRACE - W4L20371
(x2) 1 3/8"x3 3/8"x46 1/4" (36x86x1174)



E19 WALL RAIL - W4L20401
(x1) 1 7/16"x3 3/8"x54 1/2" (36x86x1384)



E50 END SUPPORT - W4L20372
(x1) 1 3/8"x3 3/8"x44 1/8" (36x86x1120)



E51 ANGLE BRACE - W4L20373
(x2) 1 3/8"x3 3/8"x87 1/4" (36x86x2217)

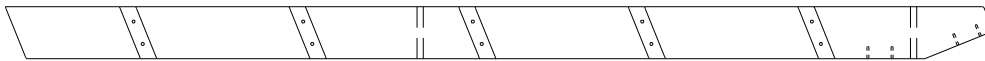

E77 LEFT UPRIGHT - W4L20374
(x1) 1 3/8"x3 3/8"x64 3/8" (36x86x1634)



E78 RIGHT UPRIGHT - W4L20375
(x1) 1 3/8"x3 3/8"x64 3/8" (36x86x1634)



F01 UPRIGHT - W4L20376
(x2) 1 3/8"x2 3/8"x34 7/8" (36x60x887)



F02 POST - W4L20377
(x1) 1 3/8"x2 3/8"x30 3/8" (36x60x772)



F03 POST - W4L20378
(x1) 1 3/8"x2 3/8"x30 3/8" (36x60x772)



F04 POST - W4L20379
(x1) 1 3/8"x2 3/8"x30 3/8" (36x60x772)



F05 UPRIGHT - W4L20380
(x2) 1 3/8"x2 3/8"x30 3/8" (36x60x772)



F06 SUPPORT RAIL - W4L20381
(x2) 1 3/8"x2 3/8"x63 1/2" (36x60x1613)



G01 GROUND BOARD - W4L20382
(x1) 1"x5 1/4"x74 7/8" (24x134x1901)



G02 GROUND BOARD - W4L20383
(x1) 1"x5 1/4"x74 7/8" (24x134x1901)



G03 GROUND BOARD - W4L20384
(x1) 1"x5 1/4"x87 9/16" (24x134x2224)

OWNER'S MANUAL - PARTS IDENTIFICATION

Wood Components (Not to Scale)



G04 GROUND BOARD - W4L20385
(x1) 1"x5 1/4"x54 1/2" (24x134x1384)



G05 GROUND BOARD - W4L20386
(x1) 1"x5 1/4"x54 1/2" (24x134x1384)



G08 WALL RAIL - W4L20389
(x1) 1"x5 1/4"x46 5/8" (24x134x1184)

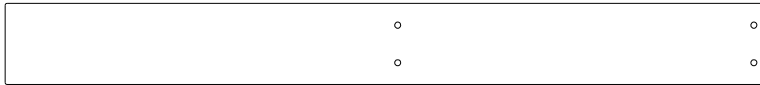

G09 WALL RAIL - W4L20390
(x1) 1"x5 1/4"x49 1/2" (24x134x1256)



G11 WALL RAIL - W4L20392
(x1) 1"x5 1/4"x48 1/4" (24x134x1224)

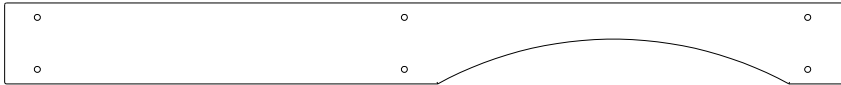

G10 ARCHED RAIL - W4L20391
(x1) 1"x5 1/4"x54 7/8" (24x134x1394)



G12 WALL RAIL - W4L20393
(x1) 1"x5 1/4"x31" (24x134x788)



G13 ARCHED RAIL - W4L20394
(x1) 1"x5 1/4"x75 3/8" (24x134x1913)



G50 GROUND BOARD - W4L20395
(x1) 1"x5 1/4"x86 3/4" (24x134x2205)



H01 HANDRAIL - W4L20396
(x1) 1"x3 3/8"x88 3/4" (24x86x2255)



H02 FLOOR SUPPORT - W4L20397
(x1) 1"x3 3/8"x76 3/4" (24x86x1948)



H03 FLOOR SUPPORT - W4L20398
(x1) 1"x3 3/8"x76 3/4" (24x86x1948)

OWNER'S MANUAL - PARTS IDENTIFICATION

Wood Components (Not to Scale)



H04 FLOOR SUPPORT - W4L20399
(x1) 1"x3 3/8"x74 7/8" (24x86x1901)



H05 SAFETY RAIL - W4L20400
(x1) 1"x3 3/8"x68 5/8" (24x86x1742)



H07 WALL RAIL - W4L20402
(x2) 1"x3 3/8"x54 1/2" (24x86x1384)



H08 FLOOR SUPPORT - W4L20403
(x1) 1"x3 3/8"x54 3/8" (24x86x1382)



H09 FLOOR RAIL - W4L20404
(x1) 1"x3 3/8"x48 1/4" (24x86x1224)



H10 WALL RAIL - W4L20405
(x2) 1"x3 3/8"x54 3/8" (24x86x1382)



H11 FLOOR RAIL - W4L20406
(x1) 1"x3 3/8"x65 5/8" (24x86x1667)



H12 FLOOR RAIL - W4L20407
(x1) 1"x3 3/8"x31" (24x86x788)



H13 FLOOR SUPPORT - W4L20408
(x1) 1"x3 3/8"x52 1/2" (24x86x1334)



H14 FLOOR SUPPORT - W4L20409
(x2) 1"x2 3/4"x2 3/8" (24x60x70)

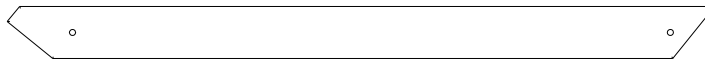

H15 HANDRAIL - W4L20410
(x1) 1"x3 3/8"x46" (24x86x1170)



H16 SWING RAIL SUPPORT - W4L06341
(x2) 1"x3 3/8"x9 1/8" (24x86x232)

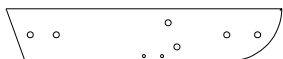

H17 SIDE BACK RAIL - W4L06343
(x2) 1"x3 3/8"x18" (24x86x456)

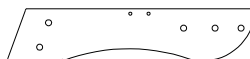

H18 SIDE SEAT SUPPORT - W4L06344
(x2) 1"x3 3/8"x16 1/8" (24x86x410)

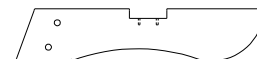

H19 CENTER SEAT SUPPORT - W4L06345
(x1) 1"x3 3/8"x16 1/8" (24x86x410)

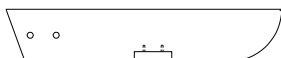

H20 CENTER BACK RAIL - W4L06346
(x1) 1"x3 3/8"x18" (24x86x456)



H21 LEFT ARM REST - W4L06347
(x1) 1"x3 3/8"x19 3/8" (24x86x492)

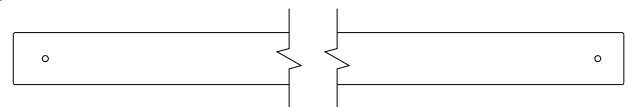

H22 WALL BOARD - W4L20417
(x1) 1"x3 3/8"x61 1/4" (24x86x1557)



H23 WALL RAIL - W4L20418
(x2) 1"x3 3/8"x16" (24x86x406)

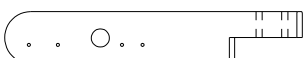

H24 RIGHT ARM REST - W4L06348
(x1) 1"x3 3/8"x19 3/8" (24x86x492)



H25 WALL RAIL - W4L20420
(x1) 1"x3 3/8"x26 1/4" (24x86x666)

OWNER'S MANUAL - PARTS IDENTIFICATION

Wood Components (Not to Scale)



H26 WALL RAIL - W4L20421
(x1) 1"x3 3/8"x27 1/4" (24x86x692)



H27 WALL RAIL - W4L20422
(x1) 1"x3 3/8"x25 1/4" (24x86x642)



H28 WALL RAIL - W4L20423
(x1) 1"x3 3/8"x5 3/4" (24x86x146)



H29 WALL SPACER - W4L20411
(x1) 1"x3 3/8"x3 3/8" (24x86x86)



H30 ATTACHMENT BOARD - W4L20412
(x1) 1"x3 3/8"x31" (24x86x786)



H32 WALL RAIL - W4L20414
(x1) 1"x3 3/8"x54 1/2" (24x86x1384)



H31 SAFETY RAIL - W4L20413
(x1) 1"x3 3/8"x73 1/16" (24x86x1856)

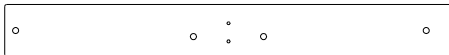

H33 FLOOR SUPPORT - W4L20415
(x1) 1"x3 3/8"x29 1/8" (24x86x740)

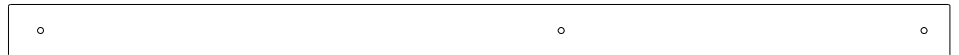

H34 WALL BOARD - W4L20416
(x3) 1"x3 3/8"x61 1/4" (24x86x1557)



H35 WALL RAIL - W4L20419
(x1) 1"x3 3/8"x3 3/8" (24x86x86)



H76 LADDER RUNG - W4L20424
(x5) 1"x3 3/8"x18 1/8" (24x86x460)



H77 ATTACHMENT BOARD - W4L20425
(x1) 1"x3 3/8"x20 1/8" (24x86x512)



H80 SLIDE BRACE WIDE - W4L15715
(x1) 1"x3 3/8"x18 3/8" (24x86x466)



H81 SLIDE BRACE UPRIGHT - W4L13301
(x2) 1"x3 3/8"x22 7/8" (24x86x580)

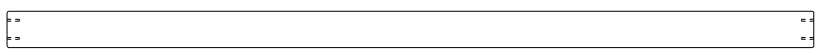

J01 FLOOR JOIST - W4L20426
(x2) 1"x2 3/8"x52 1/2" (24x60x1334)

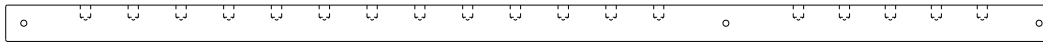

J02 WALL RAIL - W4L20427
(x2) 1"x2 3/8"x68" (24x60x1727)

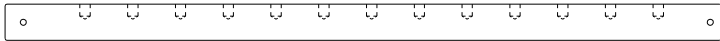

J03 WALL RAIL - W4L20428
(x2) 1"x2 3/8"x46 5/8" (24x60x1184)

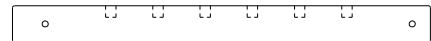

J04 WALL RAIL - W4L20429
(x2) 1"x2 3/8"x27 1/4" (24x60x691)



J05 OUTER CURTAIN ROD HOLDER - W4L20430
(x2) 1"x2 3/8"x2 3/8" (24x60x60)



J06 INNER CURTAIN ROD HOLDER - W4L20431
(x1) 1"x2 3/8"x2 3/8" (24x60x60)

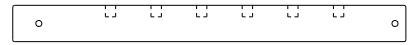

J07 WALL RAIL - W4L20432
(x4) 1"x2 3/8"x25 5/8" (24x60x650)



J08 FLOOR JOIST - W4L20433
(x1) 1"x2 3/8"x20 3/8" (24x60x519)



J09 SUPPORT BOARD - W4L20434
(x5) 1"x2 3/8"x2 3/4" (24x60x70)

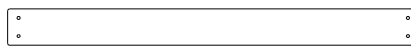

J10 PICKET - W4L20435
(x1) 1"x2 3/8"x26 3/4" (24x60x680)



J11 PICKET - W4L20436
(x1) 1"x2 3/8"x19 3/8" (24x60x492)



J12 SWING RAIL SUPPORT - W4L06342
(x2) 1"x2 3/8"x9 1/8" (24x60x232)



J13 PICKET - W4L20438
(x1) 1"x2 3/8"x12" (24x60x304)

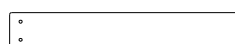

J14 PICKET - W4L20439
(x1) 1"x2 3/8"x15 1/4" (24x60x386)

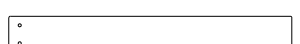

J15 PICKET - W4L20440
(x1) 1"x2 3/8"x18 3/8" (24x60x468)

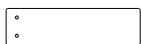

J16 PICKET - W4L20437
(x1) 1"x2 3/8"x8 3/4" (24x60x222)

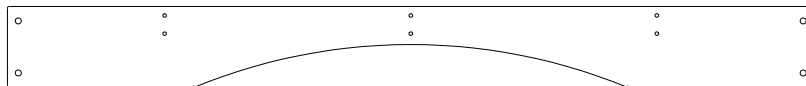

K01 ARCHED RAIL - W4L20441
(x1) 5/8"x5 1/4"x52 1/2" (16x134x1334)



K02 STEP BOARD - W4L20442
(x8) 5/8"x4 3/4"x19" (16x120x483)



K03 GABLE BOARD - W4L20443
(x2) 5/8"x5 1/4"x12 5/8" (16x134x320)

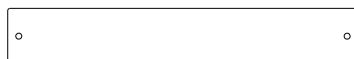

L01 SUPPORT BOARD - W4L20444
(x1) 5/8"x3 5/8"x22 3/4" (16x92x579)



L02 SUPPORT BOARD - W4L20445
(x1) 5/8"x4 3/8"x15 5/8" (16x112x397)

OWNER'S MANUAL - PARTS IDENTIFICATION

Wood Components (Not to Scale)

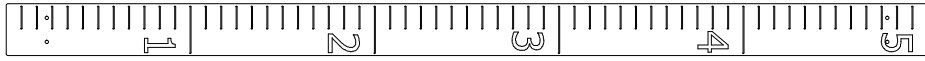

M01 GROWTH BOARD - W4L20446
(x1) 5/8"x3 3/8"x60 1/4" (16x86x1530)

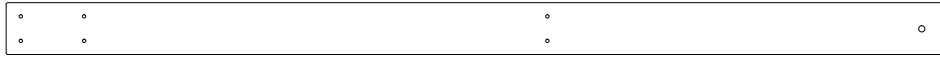

M02 WALL BOARD - W4L20447
(x1) 5/8"x3 3/8"x61 1/4" (16x86x1557)



M03 STEP BOARD - W4L20448
(x24) 5/8"x3 1/4"x19" (16x82x483)



M04 WALL BOARD - W4L20449
(x2) 5/8"x3 3/8"x61 1/4" (16x86x1557)



M05 FLOOR BOARD - W4L20450
(x8) 5/8"x3 3/8"x29" (16x86x738)



M06 WALL BOARD - W4L20451
(x1) 5/8"x3 3/8"x61 1/4" (16x86x1557)



M07 FLOOR BOARD - W4L20452
(x1) 5/8"x3 3/8"x29" (16x86x738)



M08 FLOOR BOARD - W4L20453
(x14) 5/8"x3 3/8"x54 1/2" (16x86x1384)



M09 FLOOR BOARD - W4L20454
(x13) 5/8"x3 3/8"x21 1/4" (16x86x540)



M10 ARCHED RAIL - W4L20455
(x1) 5/8"x3 3/8"x54 1/2" (16x86x1384)

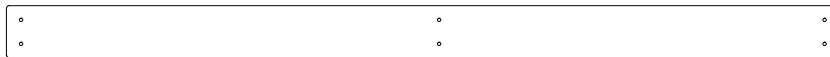

M11 WALL BOARD - W4L20456
(x2) 5/8"x3 3/8"x54 1/4" (16x86x1377)

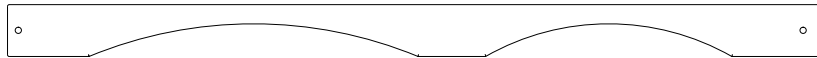

M12 ARCHED RAIL - W4L20457
(x1) 5/8"x3 3/8"x53 1/8" (16x86x1350)



M13 TOP BOARD - W4L20458
(x1) 5/8"x3 1/4"x31" (16x82x786)



M14 ROOF RAFTER - W4L20459
(x4) 5/8"x3 3/8"x36 1/8" (16x86x918)



M15 ROCK WALL BOARD - W4L20460
(x4) 5/8"x3 3/8"x28 1/8" (16x86x714)



M16 FLOOR BOARD - W4L20461
(x1) 5/8"x3 3/8"x21 1/4" (16x86x540)



M17 ROCK WALL BOARD - W4L20462
(x4) 5/8"x3 3/8"x28 1/8" (16x86x714)



M18 WALL BOARD - W4L20463
(x25) 5/8"x3 3/8"x26 3/4" (16x86x680)



M19 ROCK WALL BOARD - W4L20464
(x10) 5/8"x3 3/8"x28 1/8" (16x86x714)



M20 WALL BOARD - W4L20465
(x2) 5/8"x3 3/8"x27" (16x86x686)



M21 FLOOR BOARD - W4L20466
(x5) 5/8"x3 3/8"x29 1/8" (16x86x740)

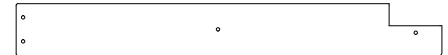

M22 FLOOR BOARD - W4L20467
(x1) 5/8"x3 3/8"x27 3/4" (16x86x704)



M23 FLOOR BOARD - W4L21731
(x4) 5/8"x3 3/8"x29" (16x86x738)

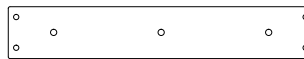

M70 SLIDE BED SUPPORT - W100935
(x1) 5/8"x3 3/8"x19 7/8" (16x86x505)



M73 REAR SUPPORT - W4L20468
(x1) 5/8"x3 3/8"x20 1/8" (16x86x512)

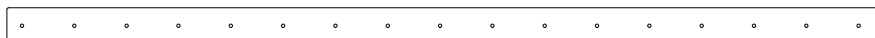

N01 CLEAT - W4L20469
(x1) 5/8"x2 3/8"x57 1/8" (16x60x1452)



N02 FLOOR BOARD - W4L20470
(x2) 5/8"x2 3/8"x54 1/2" (16x60x1384)

OWNER'S MANUAL - PARTS IDENTIFICATION

Wood Components (Not to Scale)



N03 GABLE BOARD - W4L20471
(x2) 5/8"x2 3/8"x14 3/4" (16x60x375)



N04 FLOOR BOARD - W4L20472
(x2) 5/8"x2 3/8"x19 1/2" (16x60x496)



N05 GABLE BOARD - W4L20473
(x4) 5/8"x2 3/8"x13 1/4" (16x60x335)

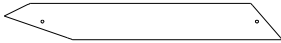

N06 GABLE BOARD - W4L20474
(x4) 5/8"x2 3/8"x18 1/8" (16x60x460)

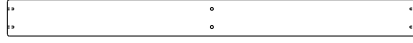

N07 SWING BACK SUPPORT - W4L06349
(x1) 5/8"x2 3/8"x26 5/8" (16x60x676)

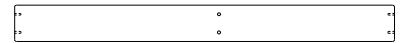

N08 SWING SEAT SUPPORT - W4L06350
(x1) 5/8"x2 3/8"x24 3/4" (16x60x628)



N09 PICKET - W4L20477
(x12) 5/8"x2 3/8"x31 1/4" (16x60x795)

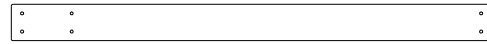

N10 PICKET - W4L20478
(x9) 5/8"x2 3/8"x31 1/4" (16x60x795)



N11 FILLER BOARD - W4L20475
(x1) 5/8"x1 3/4"x28 1/8" (16x44x714)



N12 GABLE BOARD - W4L20476
(x4) 5/8"x2 3/8"x11 1/2" (16x60x293)

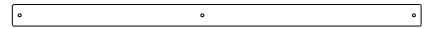

O2 SWING SEAT BOARD - W4L06339
(x7) 5/8"x1 3/8"x26 5/8" (16x36x676)



O3 SWING SEAT BOARD - W4L06340
(x7) 5/8"x1 3/8"x28 1/2" (16x36x724)

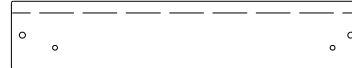

Q01 SUPPORT BOARD - W4L20480
(x1) 1"x4 3/8"x22 3/4" (24x112x579)



SP50 SWING BEAM SUPPORT - W4L20481
(x1) 3 3/8"x3 3/8"x49 3/8" (86x86x1254)

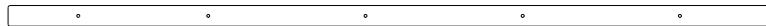

T01 SUPPORT BOARD - W4L20482
(x1) 1"x1 3/8"x50" (24x34x1270)

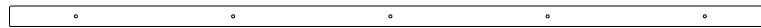

T02 SUPPORT BOARD - W4L20483
(x2) 1"x1 3/8"x49 5/8" (24x34x1260)

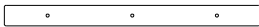

T03 SUPPORT BOARD - W4L20484
(x2) 1"x1 3/8"x16 5/8" (24x34x423)

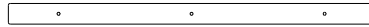

T04 SUPPORT BOARD - W4L20485
(x1) 1"x1 3/8"x23 7/8" (24x34x606)

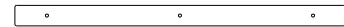

T05 SUPPORT BOARD - W4L20486
(x1) 1"x1 3/8"x21 1/2" (24x34x546)



T06 SUPPORT BOARD - W4L20487
(x2) 1"x1 3/8"x41 7/16" (24x34x1052)

OWNER'S MANUAL - PARTS IDENTIFICATION

Wood Components (Not to Scale)

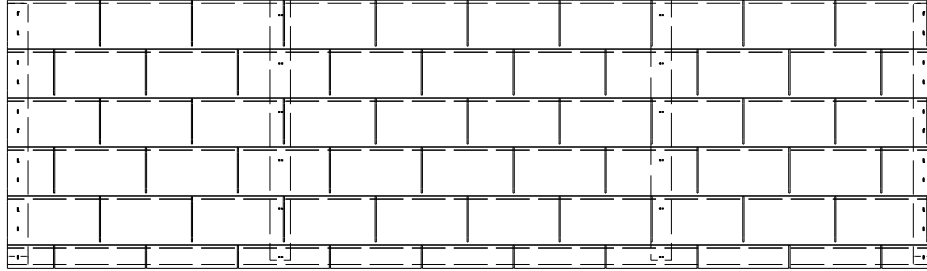

RP1 ROOF PANEL - W2A04391
(x2) 1 3/8"x17 1/2"x60 3/8" (35x444x1532)

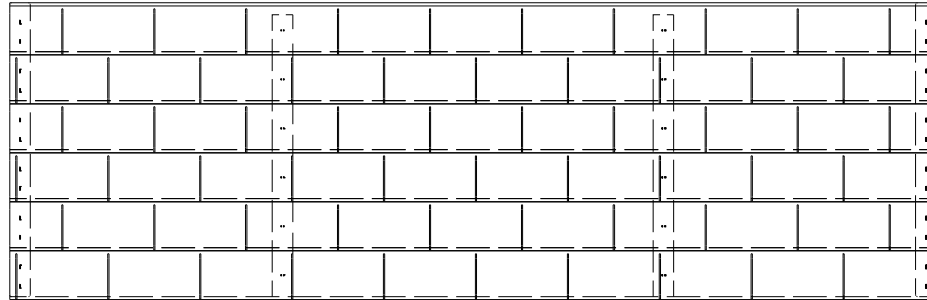

RP2 ROOF PANEL - W2A04392
(x2) 1 3/8"x19 3/8"x60 3/8" (35x491x1532)

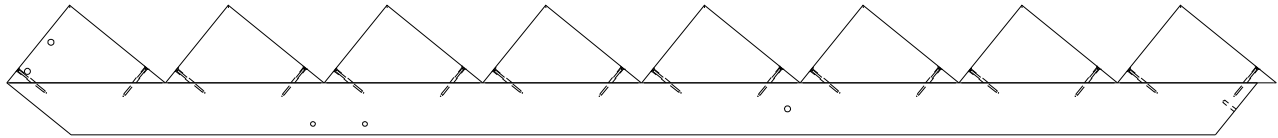

SR1 STAIR RAIL - W2A04393
(x1) 1"x8 3/8"x82 5/8" (24x214x2099)

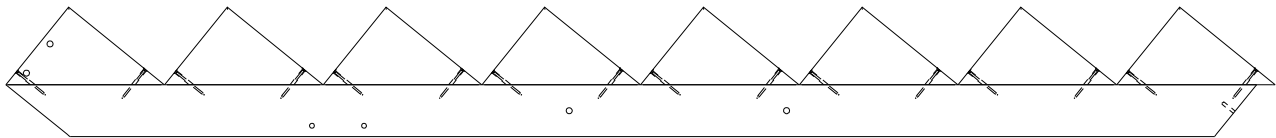

SR2 STAIR RAIL - W2A04394
(x1) 1"x8 3/8"x82 5/8" (24x214x2099)



E20 UPRIGHT - W2A04395
(x1) 1 3/8"x3 3/8"x57 3/8" (36x86x1457)

OWNER'S MANUAL - PARTS IDENTIFICATION

Hardware Components

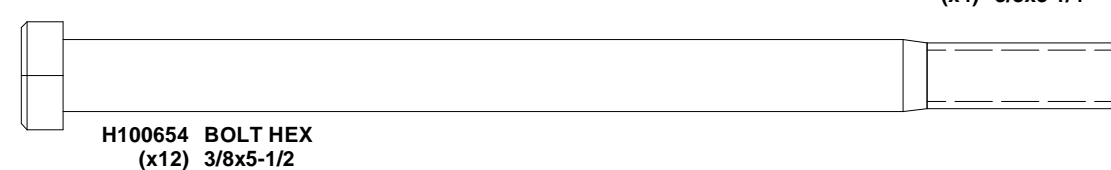
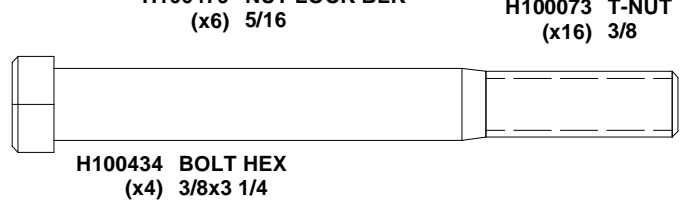
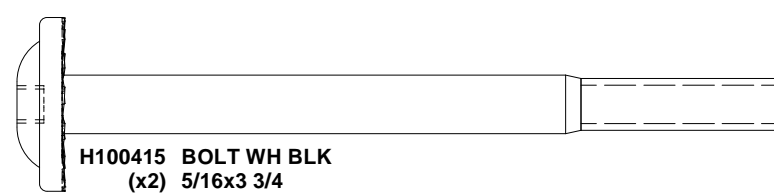
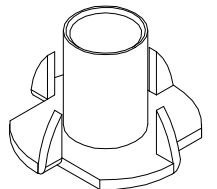
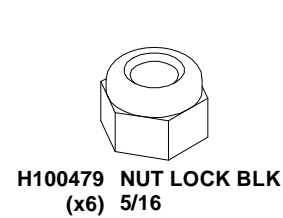
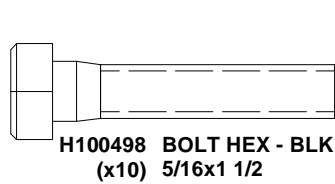
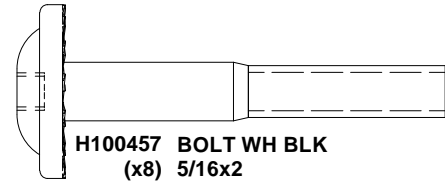
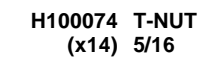
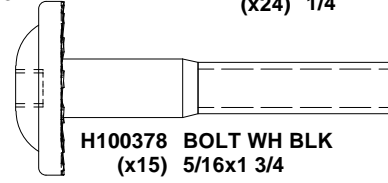
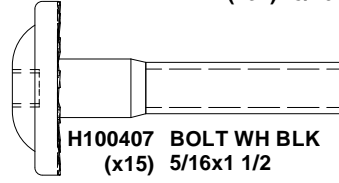
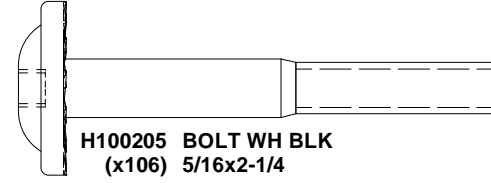
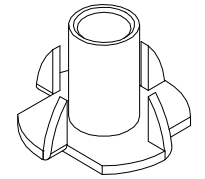
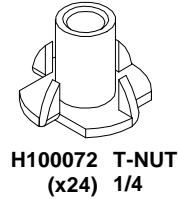
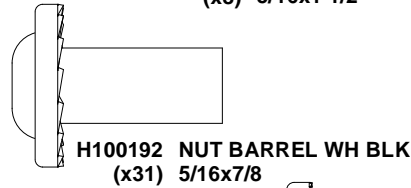
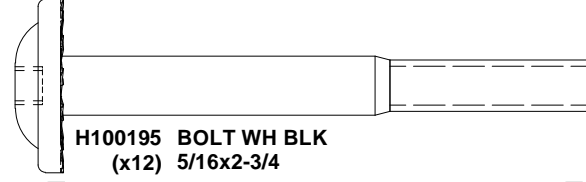
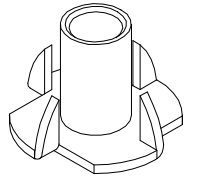
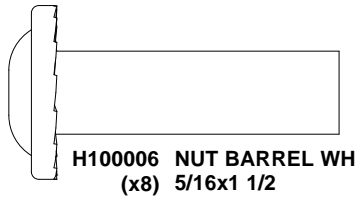
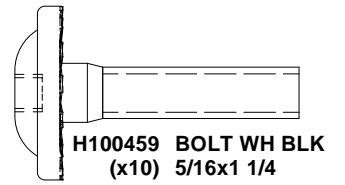
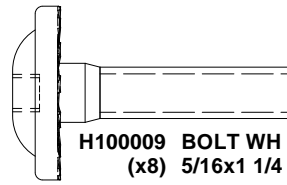
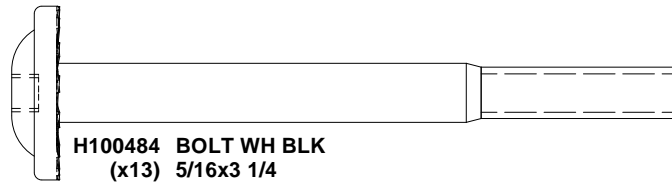
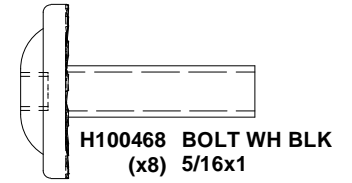
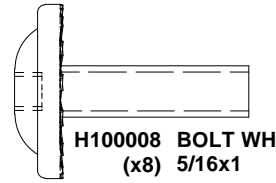
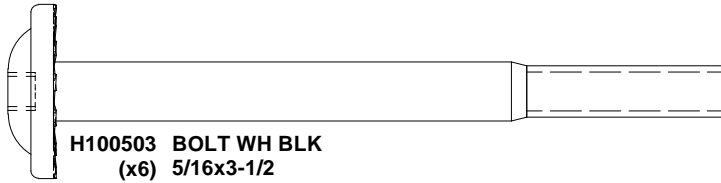
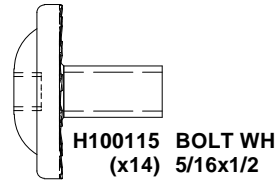
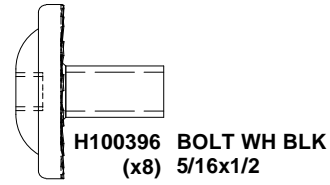
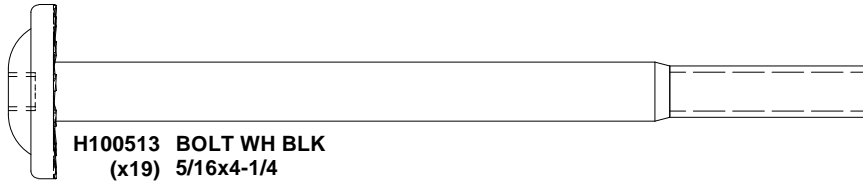
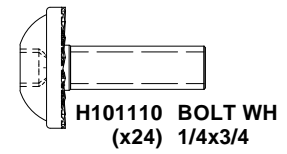
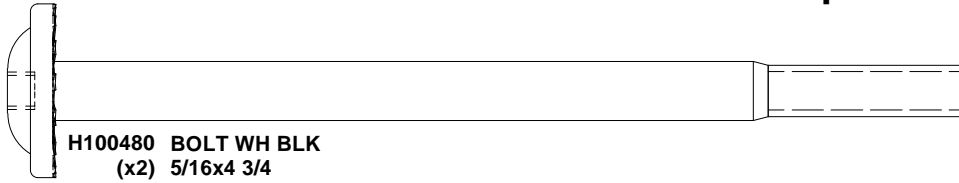

OWNER'S MANUAL - PARTS IDENTIFICATION

Hardware Components

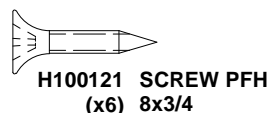
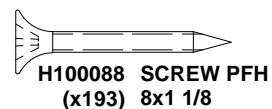
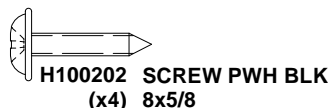
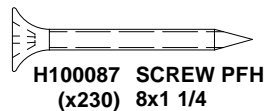
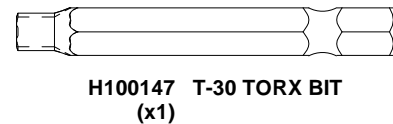
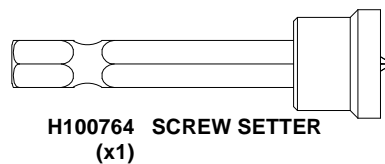
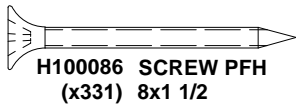
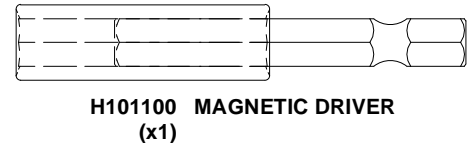
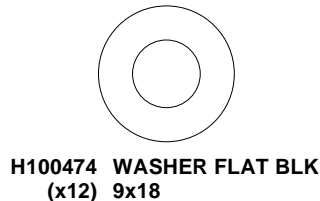
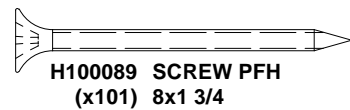
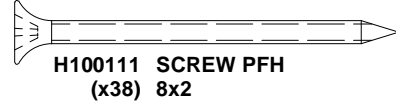
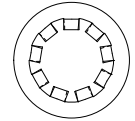
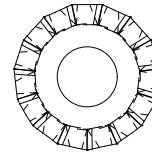
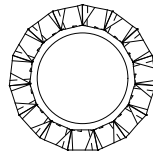
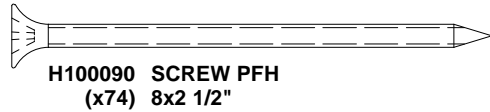
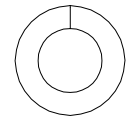
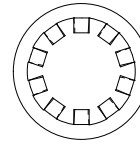
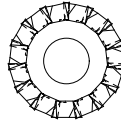
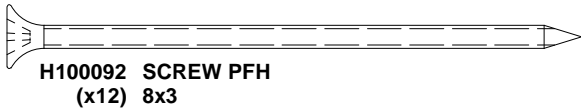
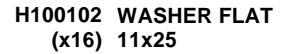
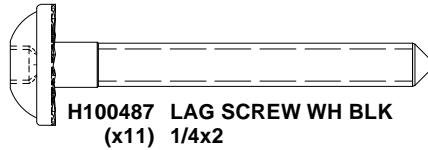
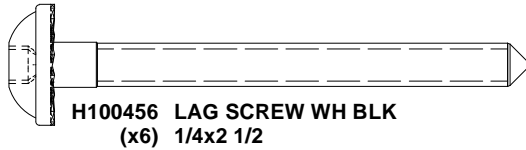
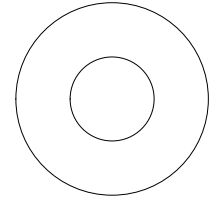
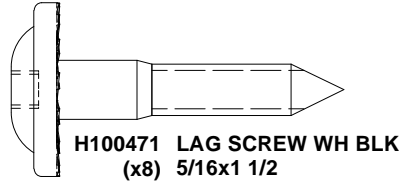
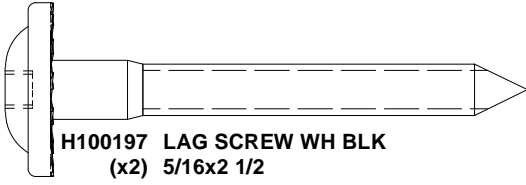
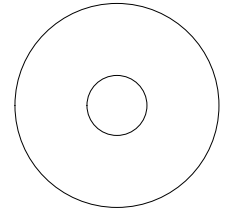
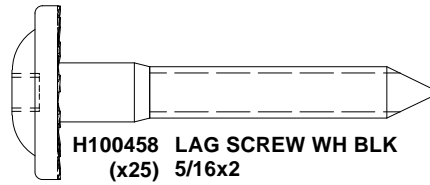
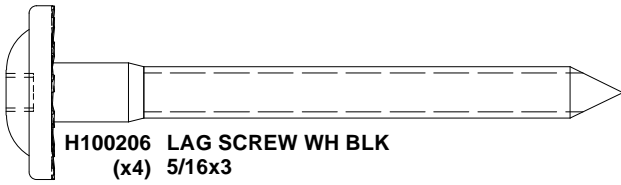

OWNER'S MANUAL - PARTS IDENTIFICATION

Accessory Components (Not to Scale)



A100047 CHAIN GREEN 57"
(x4)



A100177 CHAIN GREEN 31"
(x2)

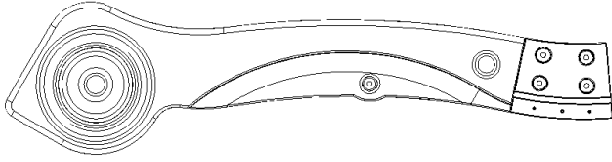

A6P00484 SLIDE RAIL 10' BOTTOM RIGHT GREEN
(x1)

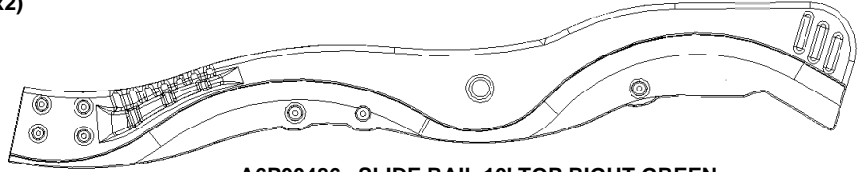

A6P00486 SLIDE RAIL 10' TOP RIGHT GREEN
(x1)

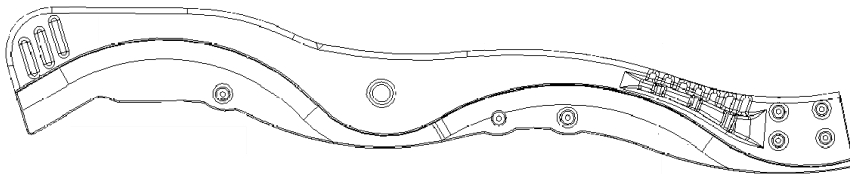

A6P00485 SLIDE RAIL 10' TOP LEFT GREEN
(x1)

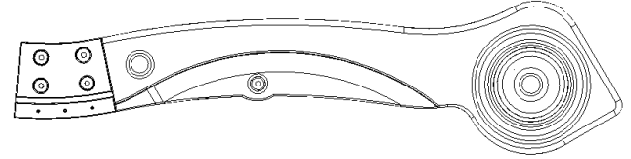

A6P00483 SLIDE RAIL 10' BOTTOM LEFT GREEN
(x1)

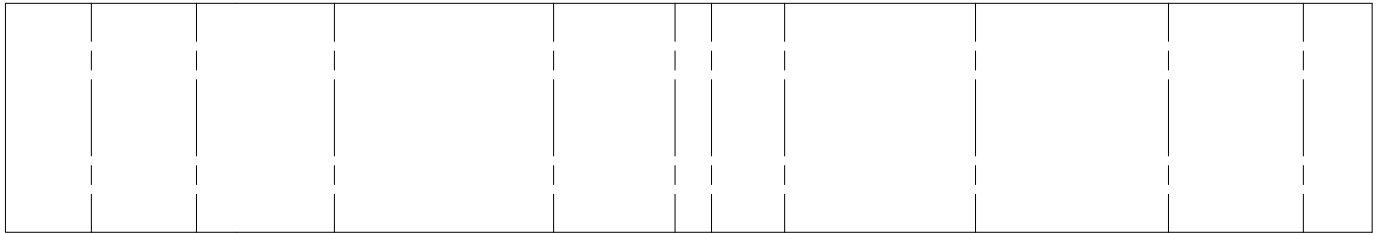

A6P00385 SLIDE BED 10' DARK GREEN
(x1)

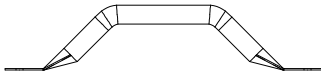

A4M00613 HAND GRIP METAL
(x4) BLACK 381 c/c



A4M03403 BYD ID TAG LARGE
(x1)

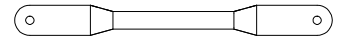

A4M00630 METAL DECK BRACE 380 C/C
(x2)



A6P00054 SWING SEAT GREEN 22"
(x2)

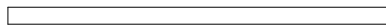

A6P00487 SLIDE TUBE SUPPORT
(x4)

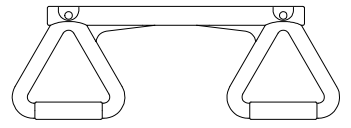

A6P00034 TRAPEZE YELLOW
(x1)

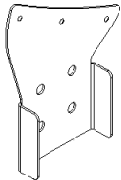

A4M01091 60" SLIDE BRACE
(x1) (RIGHT)

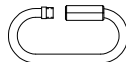

A100069 QUICK LINK
(x10)

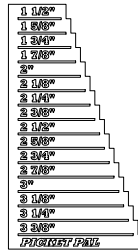

A6P00410 PICKET PAL
(x1)



A4M01047 L BRACKET
(x4) 2.5x38x55x55

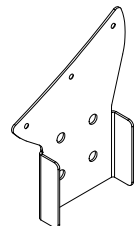

A4M01092 60" SLIDE BRACE
(x1) (LEFT)

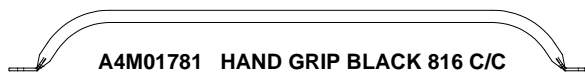

A4M01781 HAND GRIP BLACK 816 C/C
(x2)

OWNER'S MANUAL - PARTS IDENTIFICATION

Accessory Components (Not to Scale)

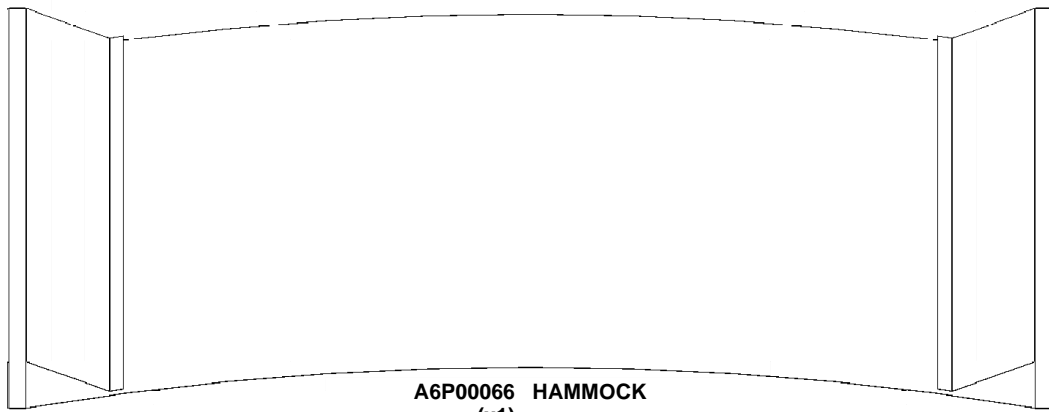

A6P00066 HAMMOCK
(x1)

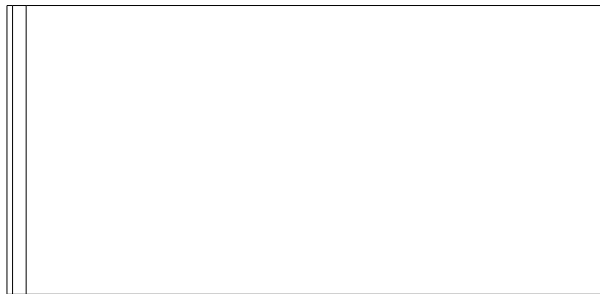

A6P00089 CURTAIN
(x2)

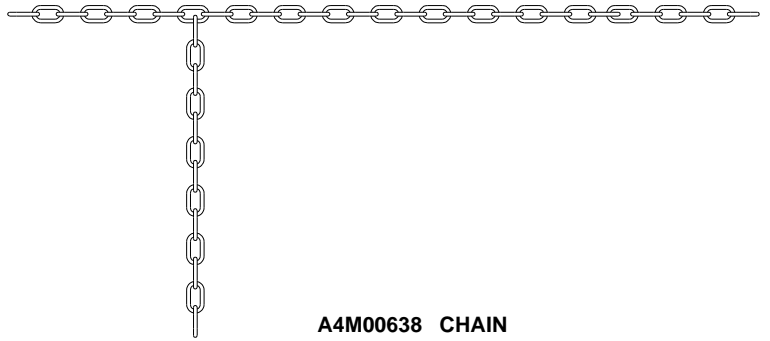

A4M00638 CHAIN
(x2)



A6P00090 PLASTIC CURTAIN ROD
(x1)

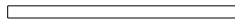

A4M00597 METAL TUBE
(x49)

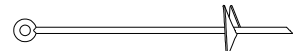

A4M02252 AUGER GROUND STAKE
(x9)

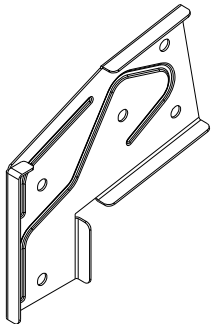

**A4M00617 SWING BEAM
EXTENSION
BRACKET-LEFT**
(x1)

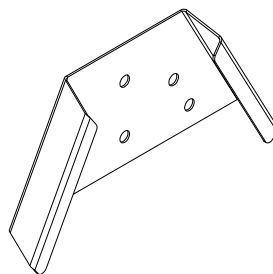

A4M01782 A-FRAME BRACKET
(x1)

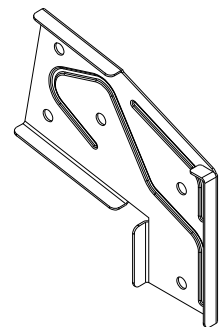

**A4M00618 SWING BEAM
EXTENSION
BRACKET-RIGHT**
(x1)

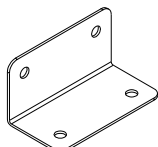

A4M00619 L BRACKET
(x2) 66x66x127 - BLK

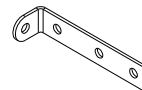

**A4M00632 CHAIN SUPPORT
BRACKET BLK**
(x2)

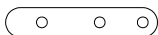

A4M00631 TIE STRAP PLATE BLK
(x2)

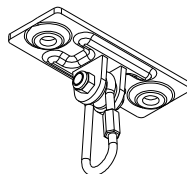

A4M00505 SWING HANGER
(x8)

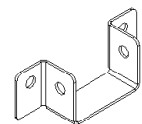

A4M01878 JOIST HANGER 90°
(x2)

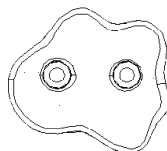

A6P00036 GREEN HC ROCK #1
(x6)

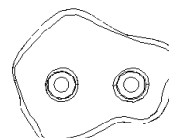

A6P00037 GREEN HC ROCK #2
(x6)

PRE-ASSEMBLY STEP 1 - SORTING PARTS

It is critical for ease of assembly that you take the time to sort and organize the wood and hardware.

WOOD PARTS:

- Organize wood parts by the three-digit, alpha-numeric number stamped on each board (ex. P01).
- If there are multiple boards with the same stamped number, stack those pieces together.
- Stamps can be found on the flat surface of the boards or on the end of the boards.
- Allow yourself plenty of room - the wood pieces can take up a significant amount of space.

NOTE: CARTONS ARE NOT ORGANIZED BY BOARD NUMBER.

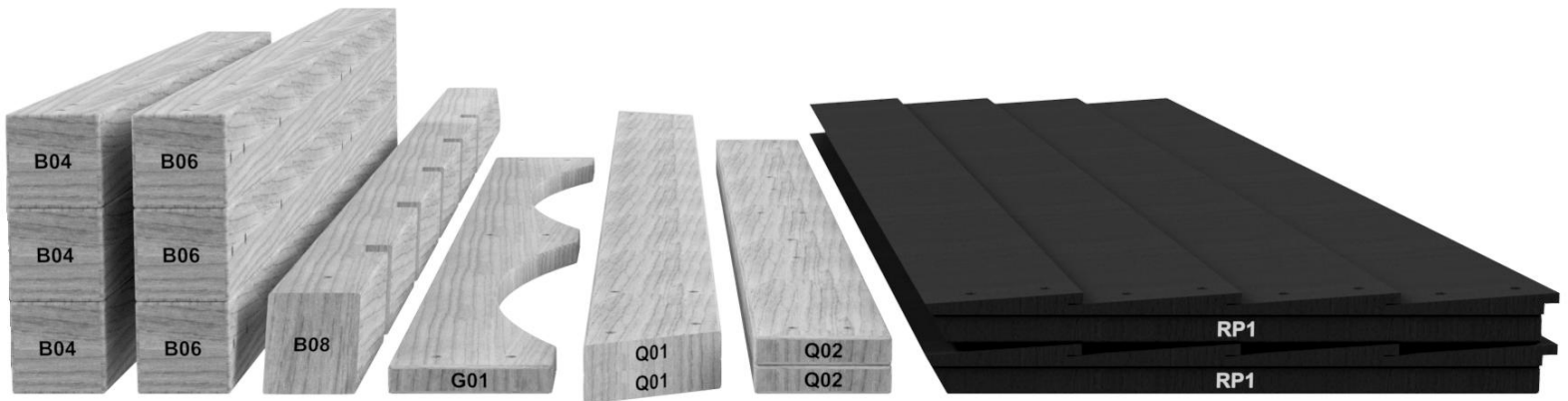

HARDWARE PARTS:

- We recommend that you have a separate table to organize the hardware.
- Hardware bags are printed with a seven-digit, alpha-numeric part number.
- You can organize your hardware by part number or group by hardware type (i.e. bolts, nuts, etc.).
- During assembly you only need to reference the last four digits of the number.



PRE-ASSEMBLY STEP 2 - TOOLS REQUIRED



Cordless Drill or
Electric Drill



Drill Attachments:
Phillips Head



1/8", 3/16", 3/8" & 7/16"
Drill Bits



Phillips Screw Driver



Open End Wrenches 1/2" & 9/16"



3/8" Drive Ratchet, 1/2" &
9/16" STD Sockets 1/2" & 9/16" Deep
Sockets



Claw Hammer



Rubber Mallet - Optional



Tape Measure

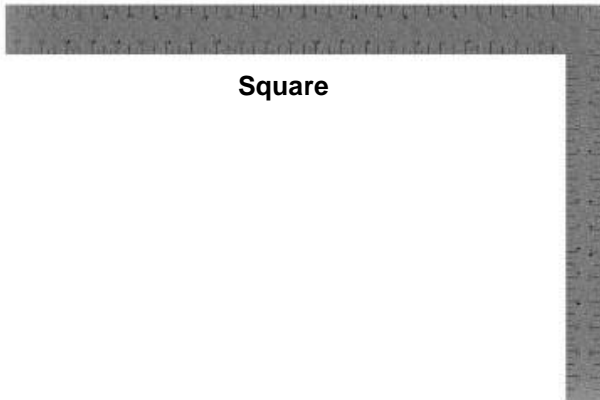

Square





Level 24"

PRE-ASSEMBLY STEP 3 - CHOOSE YOUR ASSEMBLY METHOD



There are several types of assembly instructions available to you.

1. Printed Assembly Manual included with your set
2. BILT APP - 3D interactive instructions
3. Combination of the Printed Manual and BILT APP (Note: Step numbers can differ between the two methods)

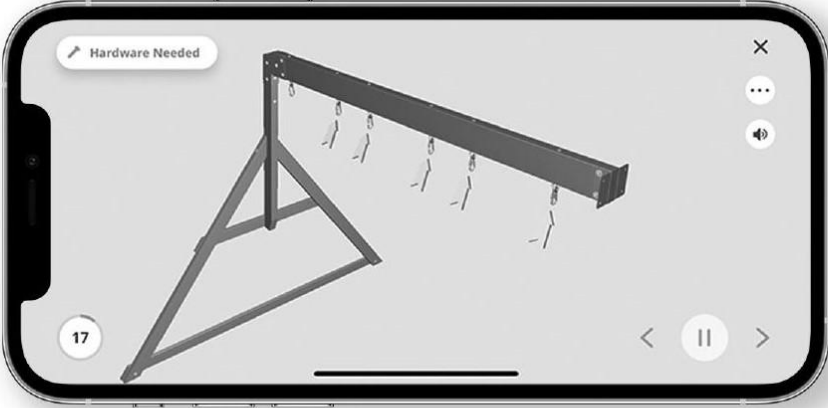

Scan for easy 3D instructions

Download the BILT app
before you begin



The image shows a smartphone screen displaying the BILT app interface. The screen features a 3D assembly diagram of a metal frame structure. At the top left of the app interface, there is a button labeled "Hardware Needed". In the bottom left corner, the number "17" is displayed, indicating the current step. In the bottom right corner, there are navigation controls including a back arrow, a pause button, and a forward arrow. The app interface is overlaid on a dark background.

STEP 1 - LADDER ASSEMBLY

QTY	PART NUMBER	DESCRIPTION
10	H100111	SCREW PFH 8x2

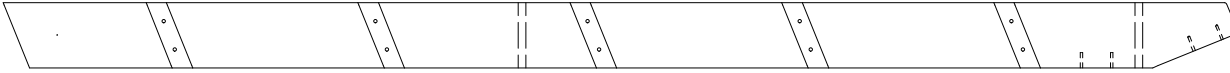

E77 LEFT UPRIGHT - W4L20374
(x1) 1 3/8"x3 3/8"x64 3/8" (36x86x1634)



H76 LADDER RUNG - W4L20424
(x5) 1"x3 3/8"x18 1/8" (24x86x460)

- ALIGN PILOT HOLES

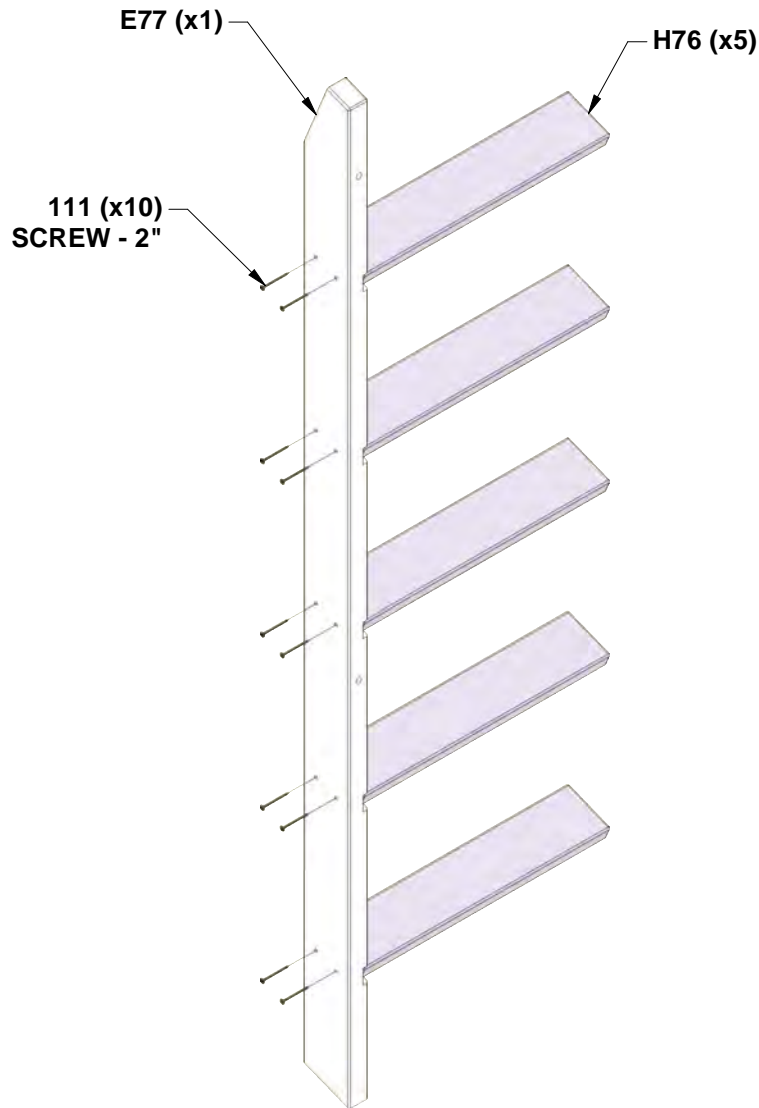

STEP 2 - LADDER ASSEMBLY

QTY	PART NUMBER	DESCRIPTION
10	H100111	SCREW PFH 8x2

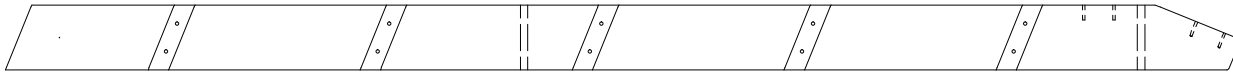

E78 RIGHT UPRIGHT - W4L20375
(x1) 1 3/8"x3 3/8"x64 3/8" (36x86x1634)

- ALIGN PILOT HOLES

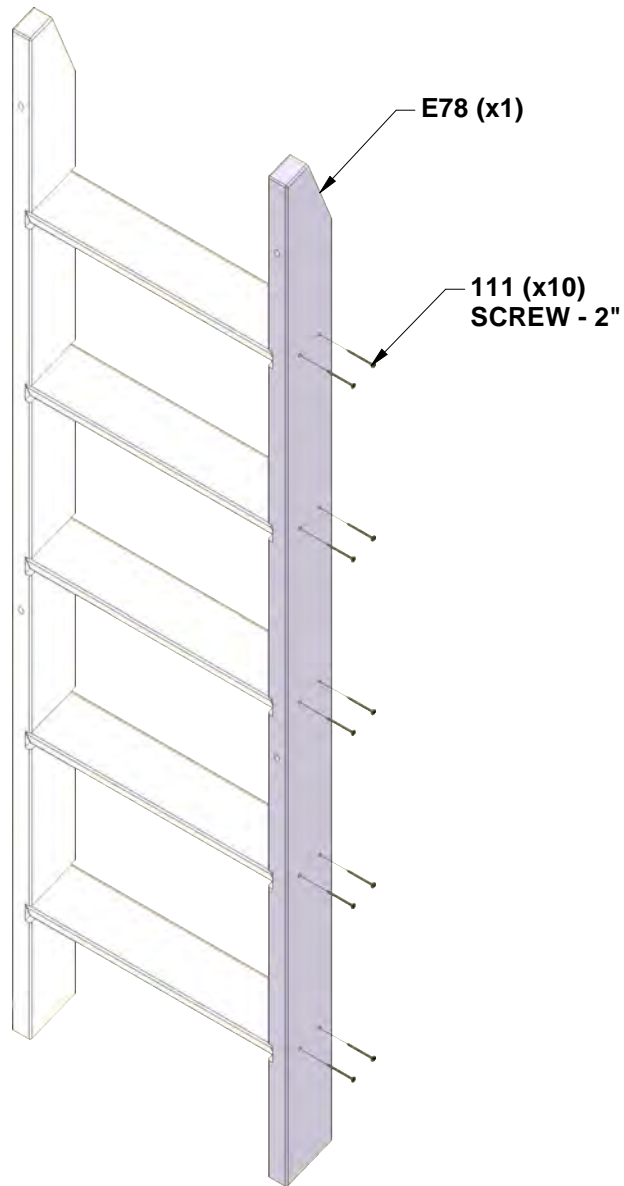

STEP 3 - LADDER ASSEMBLY

QTY	PART NUMBER	DESCRIPTION
8	H100111	SCREW PFH 8x2

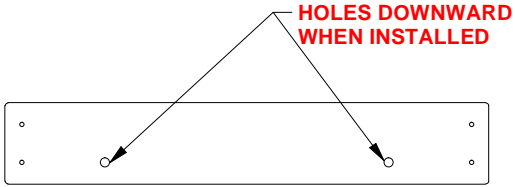

H77 ATTACHMENT BOARD - W4L20425
(x1) 1"x3 3/8"x20 1/8" (24x86x512)



M73 REAR SUPPORT - W4L20468
(x1) 5/8"x3 3/8"x20 1/8" (16x86x512)

- ALIGN PILOT HOLES

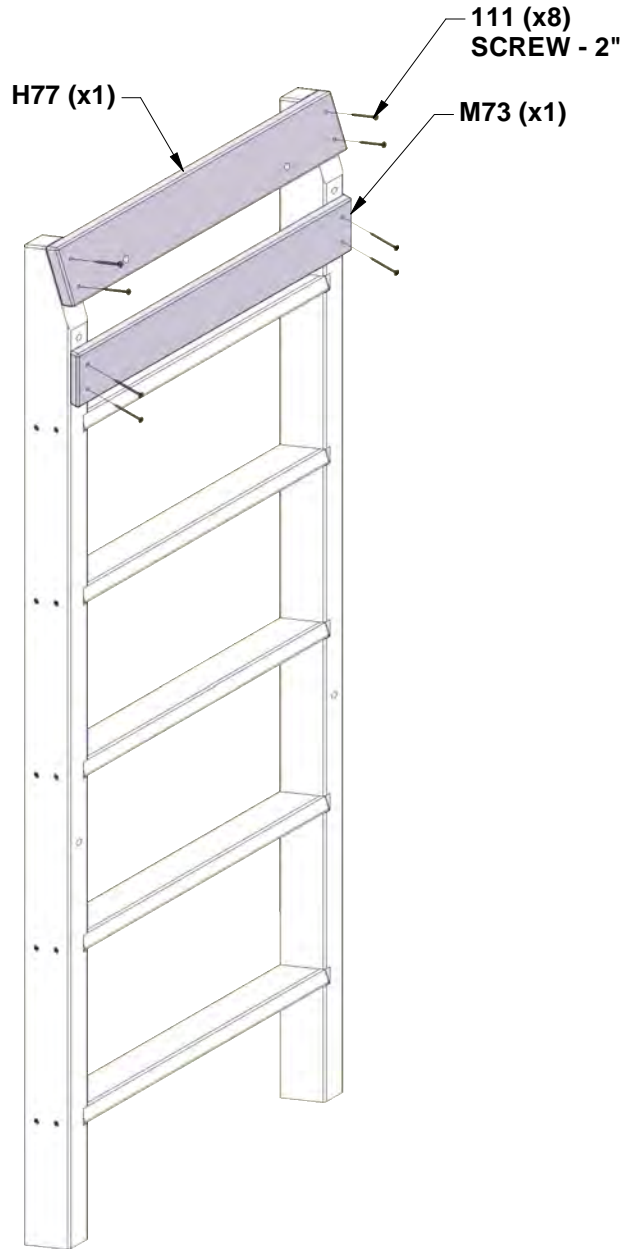

STEP 4 - LADDER ASSEMBLY

QTY	PART NUMBER	DESCRIPTION
4	H100503	BOLT WH 5/16x3-1/2 BLK
4	H100379	T-NUT 5/16 BLK

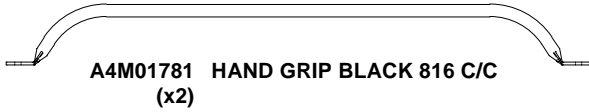

- INSTALL T-NUTS IN WOOD FIRST

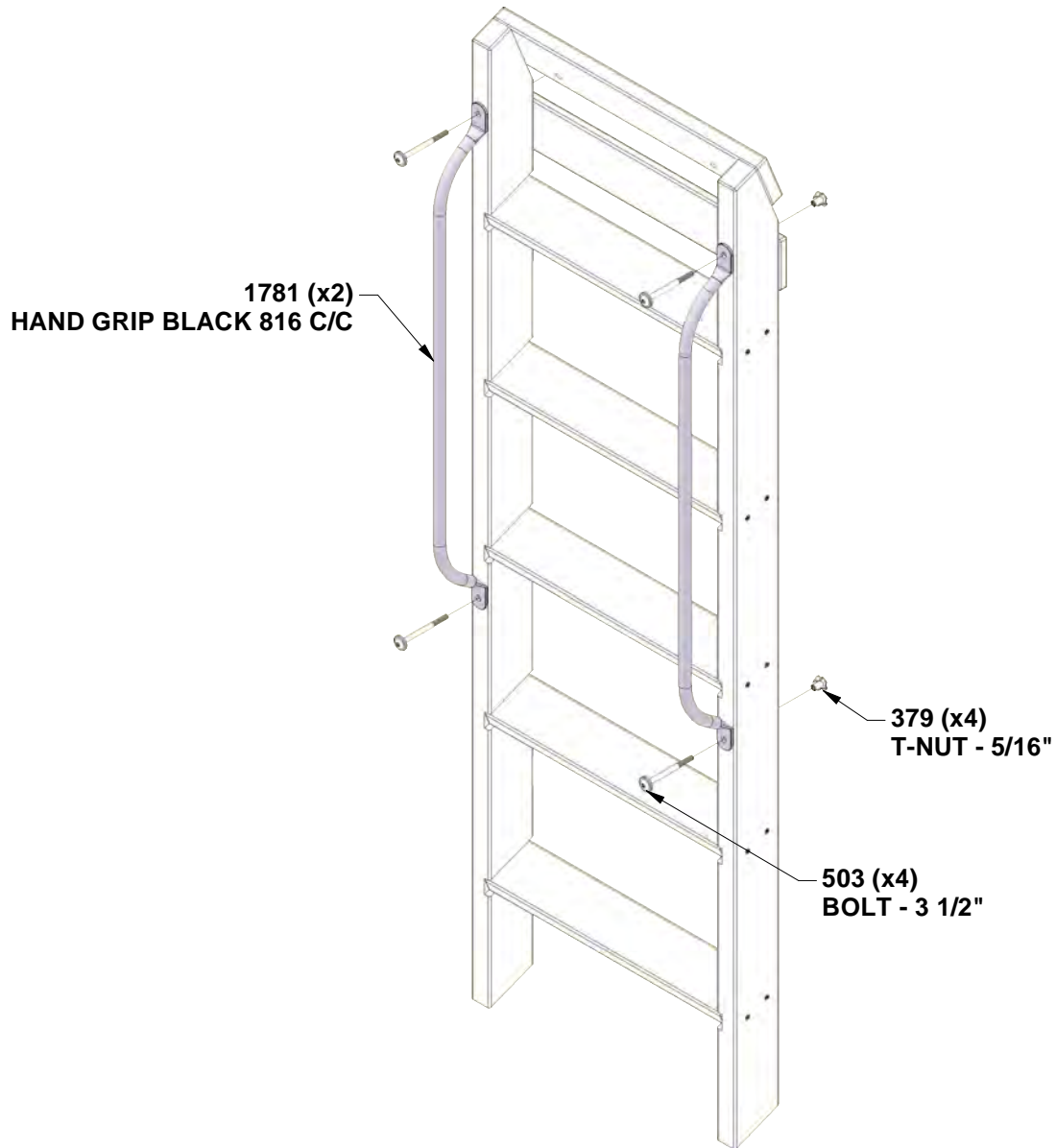

STEP 1 - SWING BEAM



A4M00619 L BRACKET
(x2) 66x66x127 - BLK

QTY	PART NUMBER	DESCRIPTION
5	H100192	NUT BARREL WH 5/16x7/8 BLK
5	H100416	BOLT WH 5/16x3 BLK

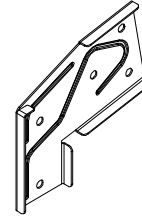

A4M00617 SWING BEAM
(x1) EXTENSION
BRACKET-LEFT

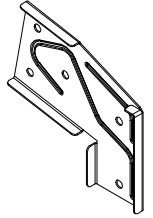

A4M00618 SWING BEAM
(x1) EXTENSION
BRACKET-RIGHT



A50 SWING BEAM - W4L20352
(x1) 3 3/8"x5 1/4"x89 1/2" (86x134x2274)

- ALIGN HOLES

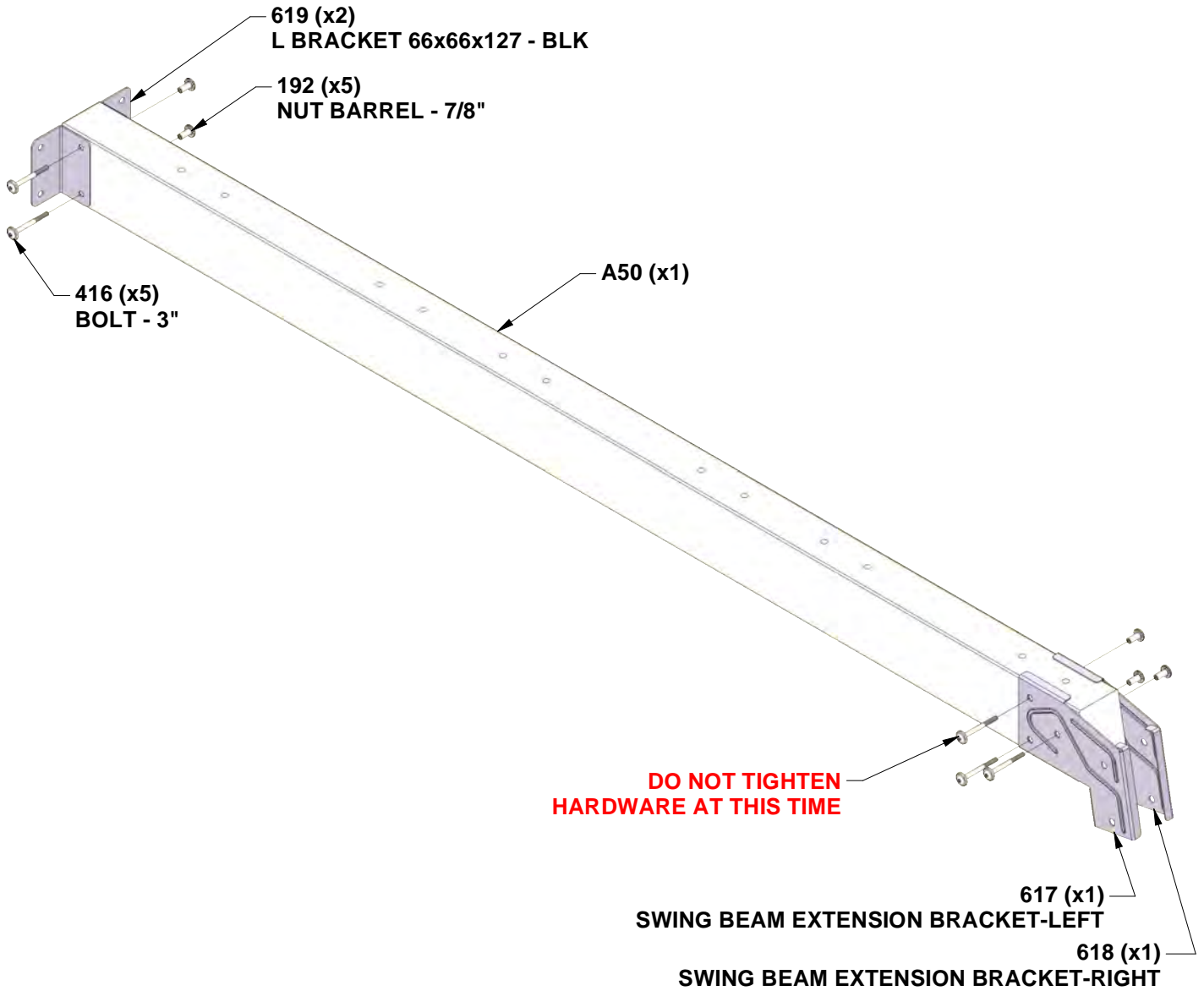

STEP 2 - SWING BEAM

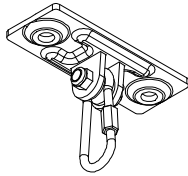

**A4M00505 SWING HANGER
(x6)**

QTY	PART NUMBER	DESCRIPTION
12	H100073	T-NUT 3/8
12	H100102	WASHER FLAT 11x25
12	H100107	WASHER LOCK INT 10x18
12	H100654	BOLT HEX 3/8x5-1/2

- INSTALL T-NUTS IN WOOD FIRST

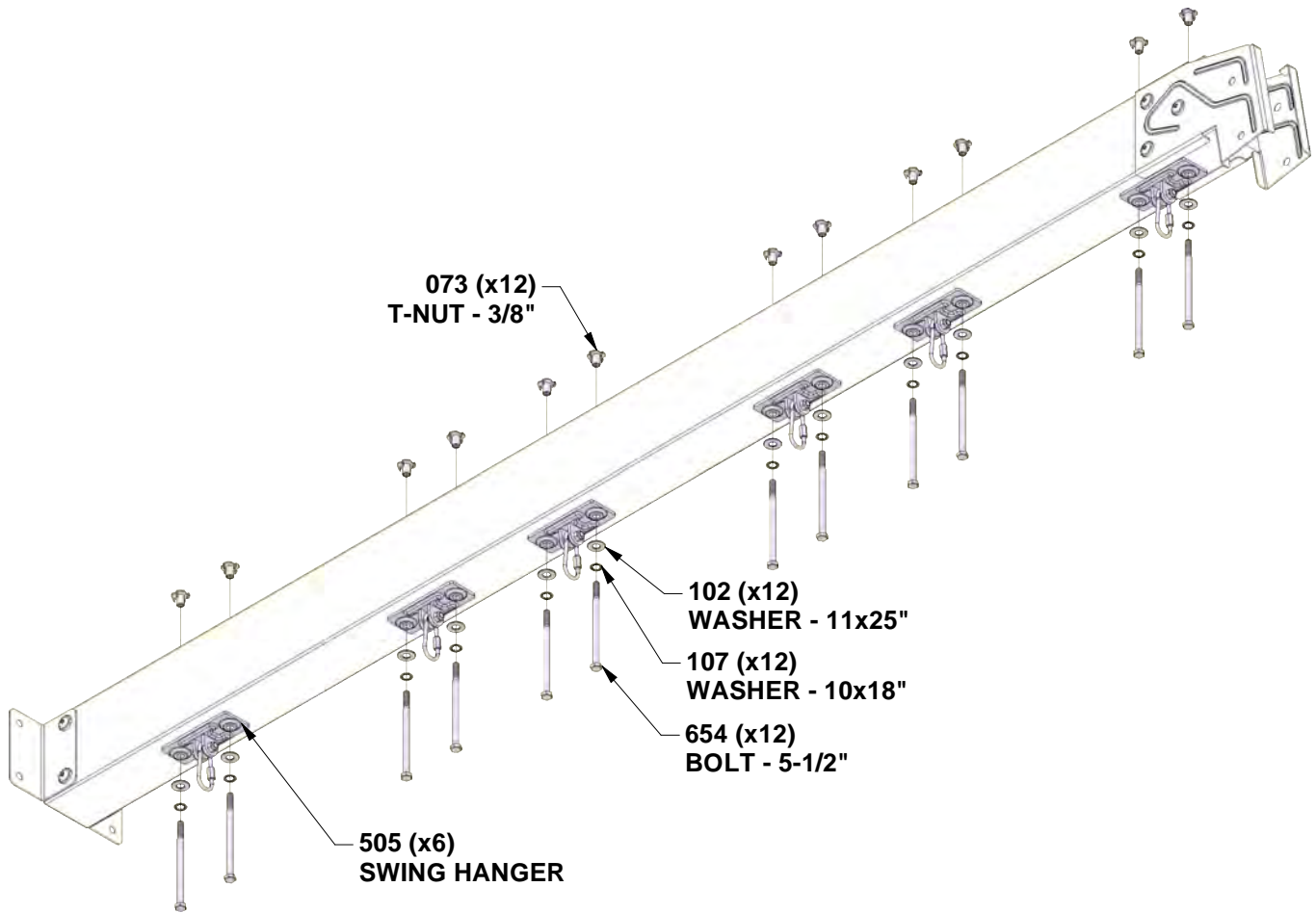

STEP 3 - SWING BEAM



SP50 SWING BEAM SUPPORT - W4L20481
 (x1) 3 3/8" x 3 3/8" x 49 3/8" (86x86x1254)

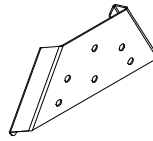

A4M01782 A-FRAME BRACKET
 (x1)

QTY	PART NUMBER	DESCRIPTION
6	H100379	T-NUT 5/16 BLK
4	H100407	BOLT WH 5/16x1 1/2 BLK
2	H100503	BOLT WH 5/16x3-1/2 BLK



E51 ANGLE BRACE - W4L20373
 (x2) 1 3/8" x 3 3/8" x 87 1/4" (36x86x2217)

- INSTALL T-NUTS IN WOOD FIRST

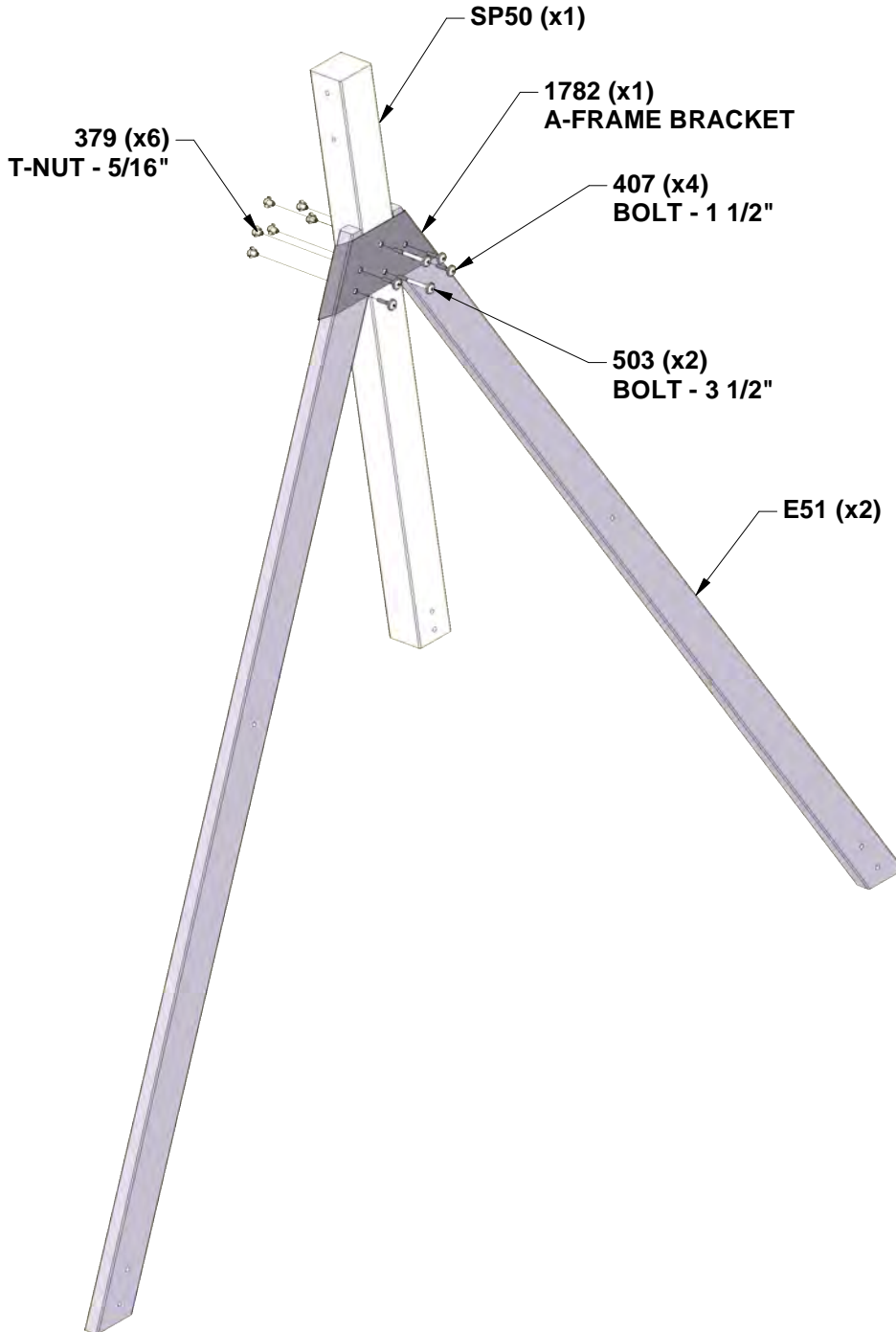

STEP 4 - SWING BEAM

QTY	PART NUMBER	DESCRIPTION
2	H100195	BOLT WH 5/16x2-3/4 BLK
8	H100198	WASHER LOCK EXT 8x19 BLK
4	H100205	BOLT WH 5/16x2-1/4 BLK
8	H100379	T-NUT 5/16 BLK
2	H100480	BOLT WH 5/16x4 3/4 BLK

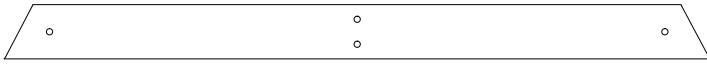

E50 END SUPPORT - W4L20372
 (x1) 1 3/8"x3 3/8"x44 1/8" (36x86x1120)



G50 GROUND BOARD - W4L20395
 (x1) 1"x5 1/4"x86 3/4" (24x134x2205)

- INSTALL T-NUTS IN WOOD FIRST

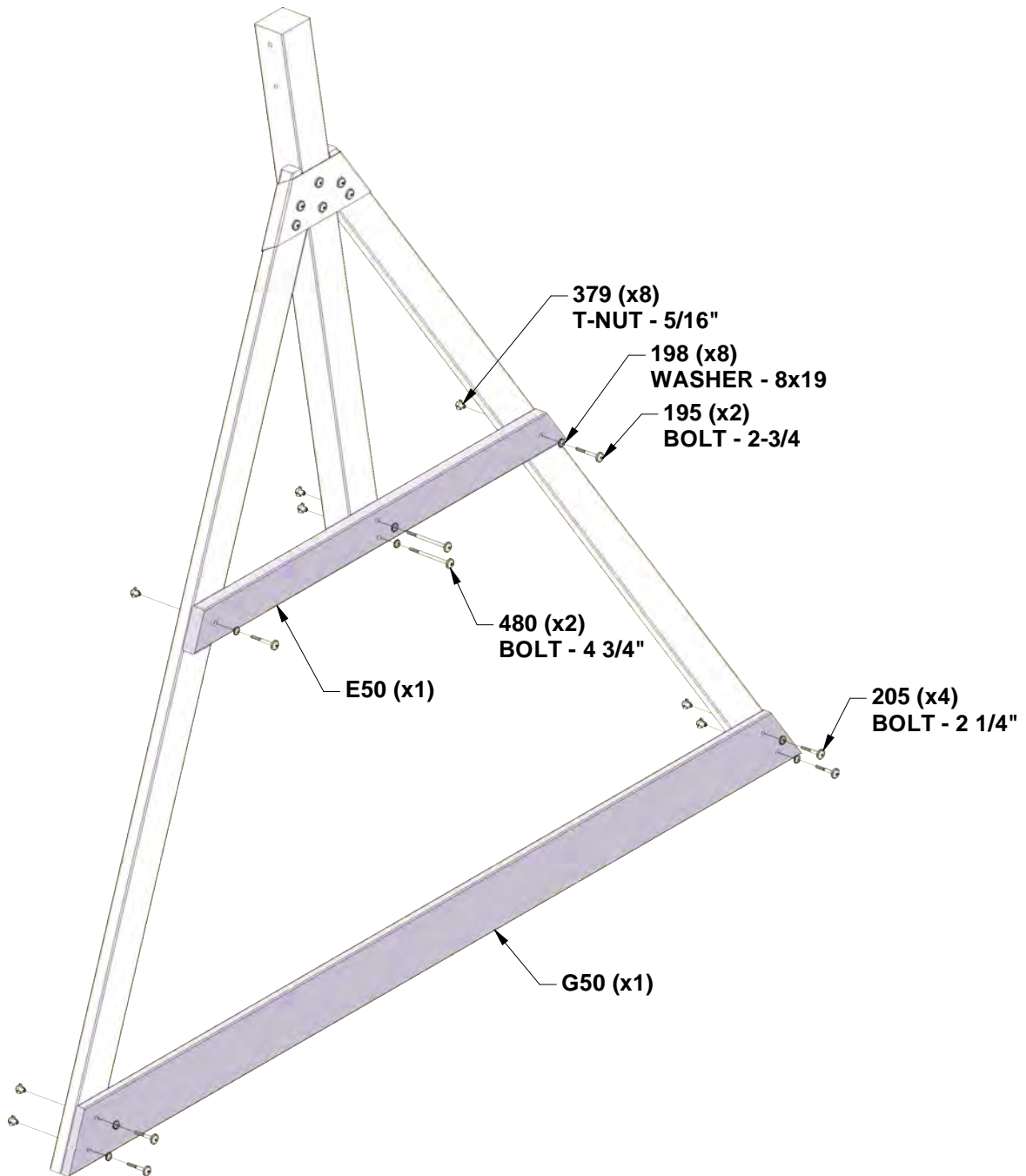

STEP 5 - SWING BEAM

QTY	PART NUMBER	DESCRIPTION
2	H100192	NUT BARREL WH 5/16x7/8 BLK
2	H100416	BOLT WH 5/16x3 BLK

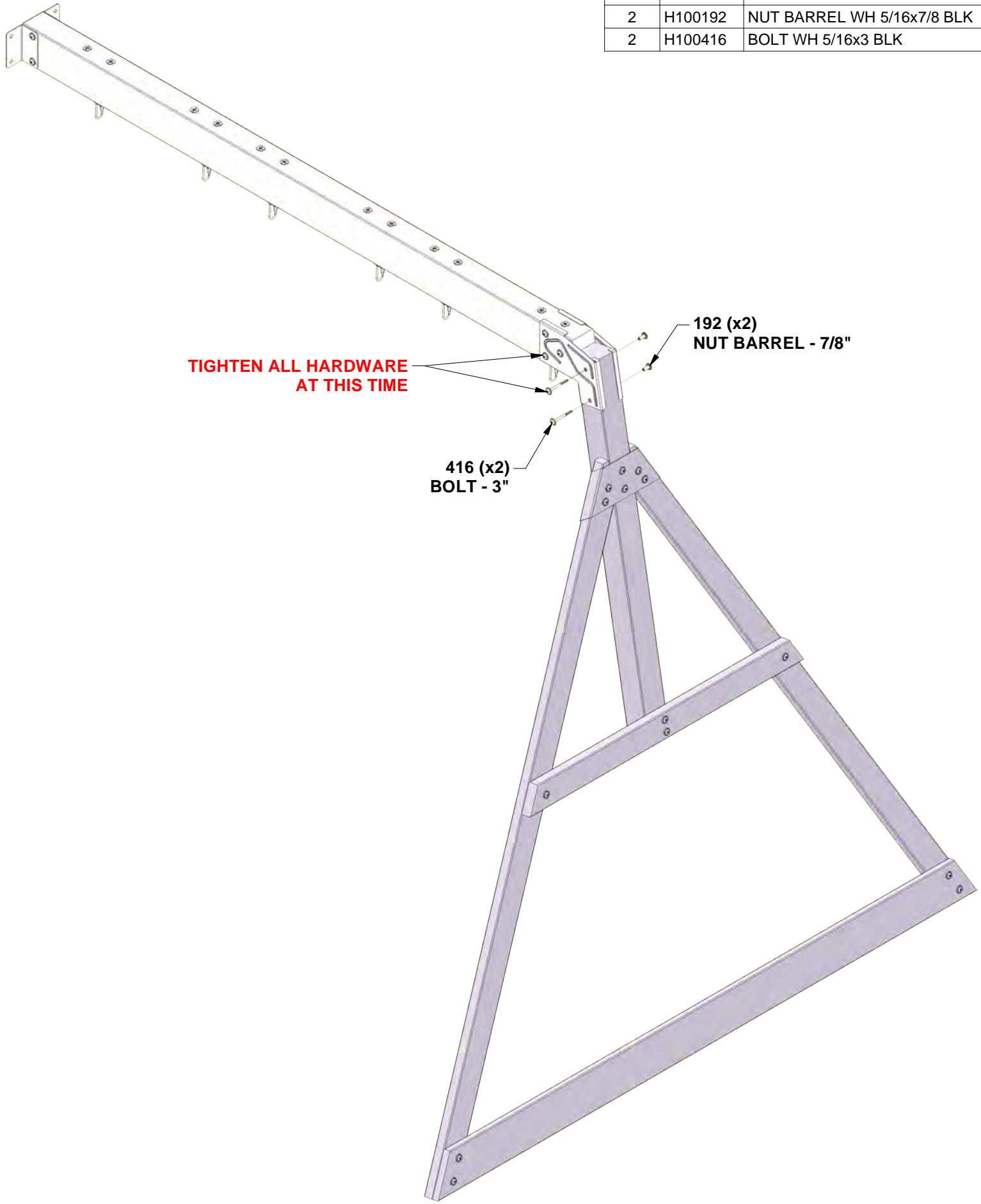

STEP 1 - ROCK WALL ASSEMBLY

QTY	PART NUMBER	DESCRIPTION
24	H100072	T-NUT 1/4
24	H100108	WASHER LOCK INT 8x15
24	H101110	BOLT WH 1/4x3/4



M15 ROCK WALL BOARD - W4L20460
(x4) 5/8"x3 3/8"x28 1/8" (16x86x714)



M17 ROCK WALL BOARD - W4L20462
(x4) 5/8"x3 3/8"x28 1/8" (16x86x714)

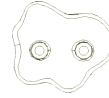

A6P00036 GREEN HC ROCK #1
(x6)



A6P00037 GREEN HC ROCK #2
(x6)

- INSTALL T-NUTS IN WOOD FIRST
- PLACE ROCKS RANDOMLY

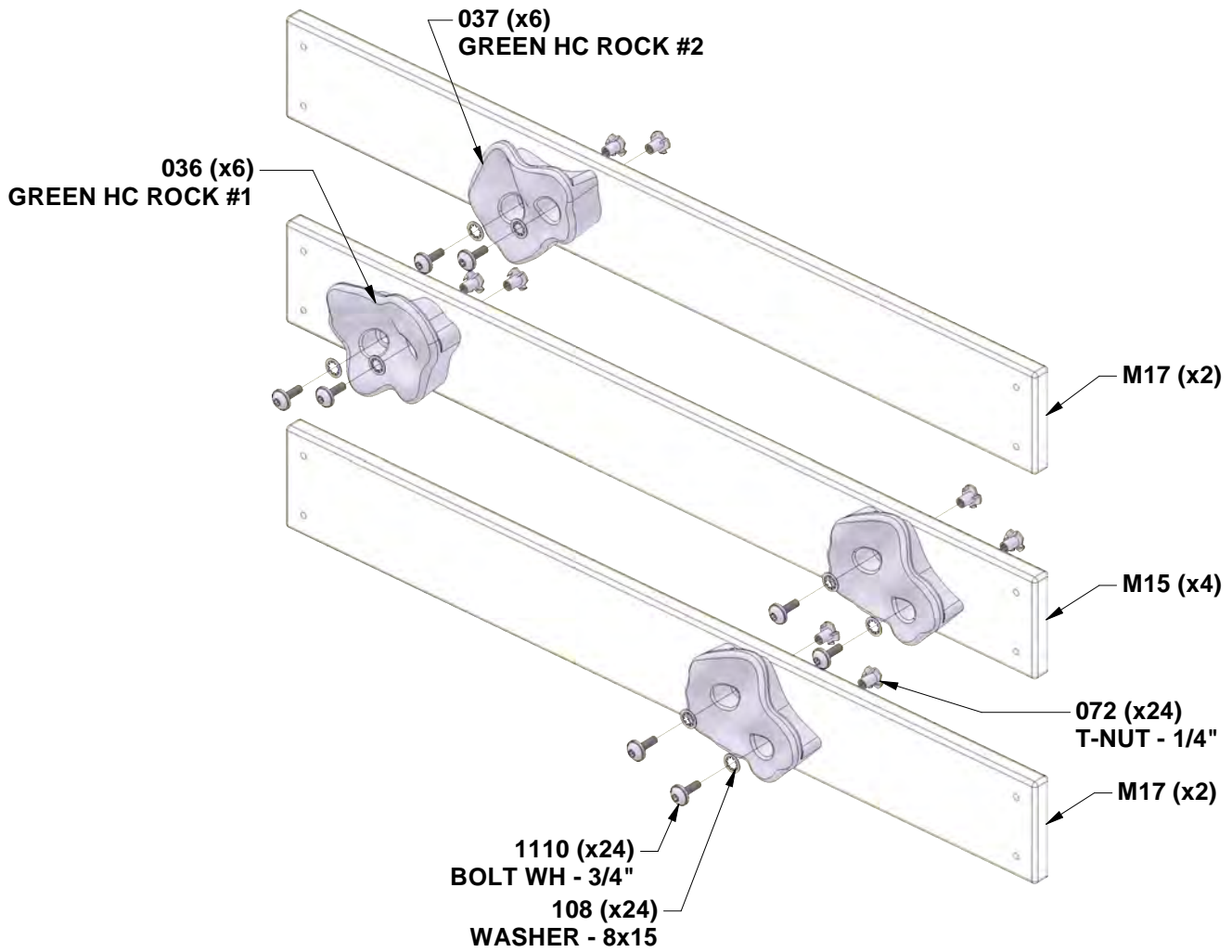
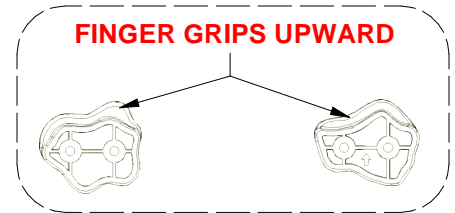

STEP 2 - ROCK WALL ASSEMBLY

QTY	PART NUMBER	DESCRIPTION
74	H100086	SCREW PFH 8x1-1/2"

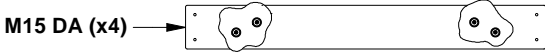

F06 SUPPORT RAIL - W4L20381
(x2) 1 3/8"x2 3/8"x63 1/2" (36x60x1613)

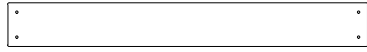

M19 ROCK WALL BOARD - W4L20464
(x10) 5/8"x3 3/8"x28 1/8" (16x86x714)



N11 FILLER BOARD - W4L20475
(x1) 5/8"x1 3/4"x28 1/8" (16x44x714)

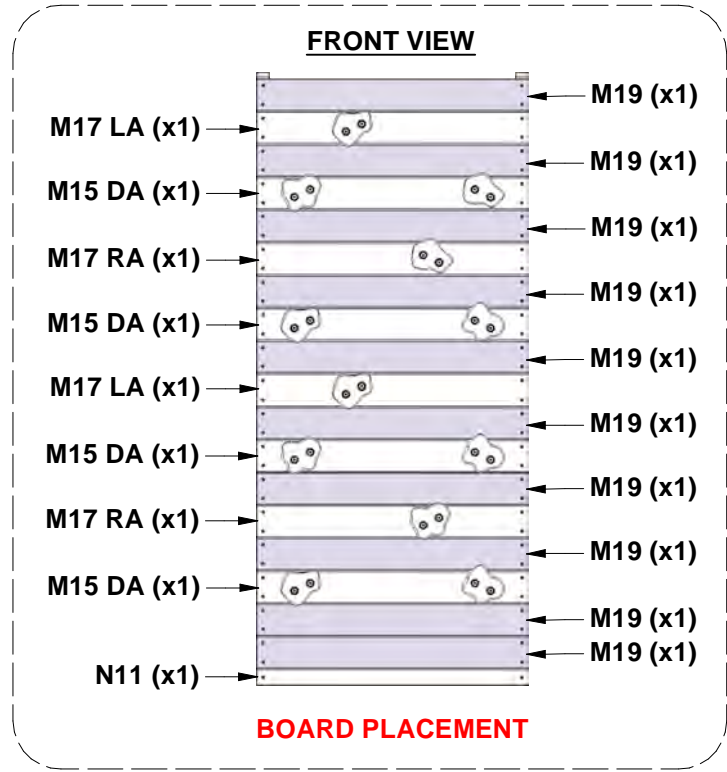
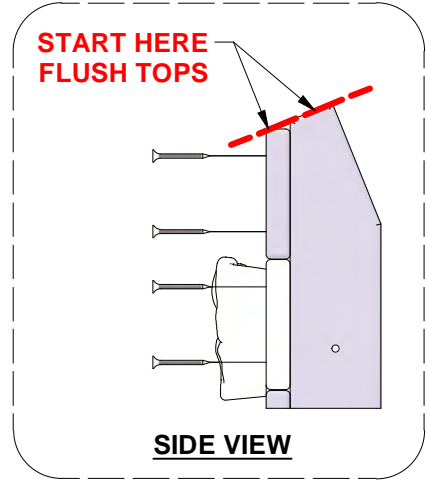
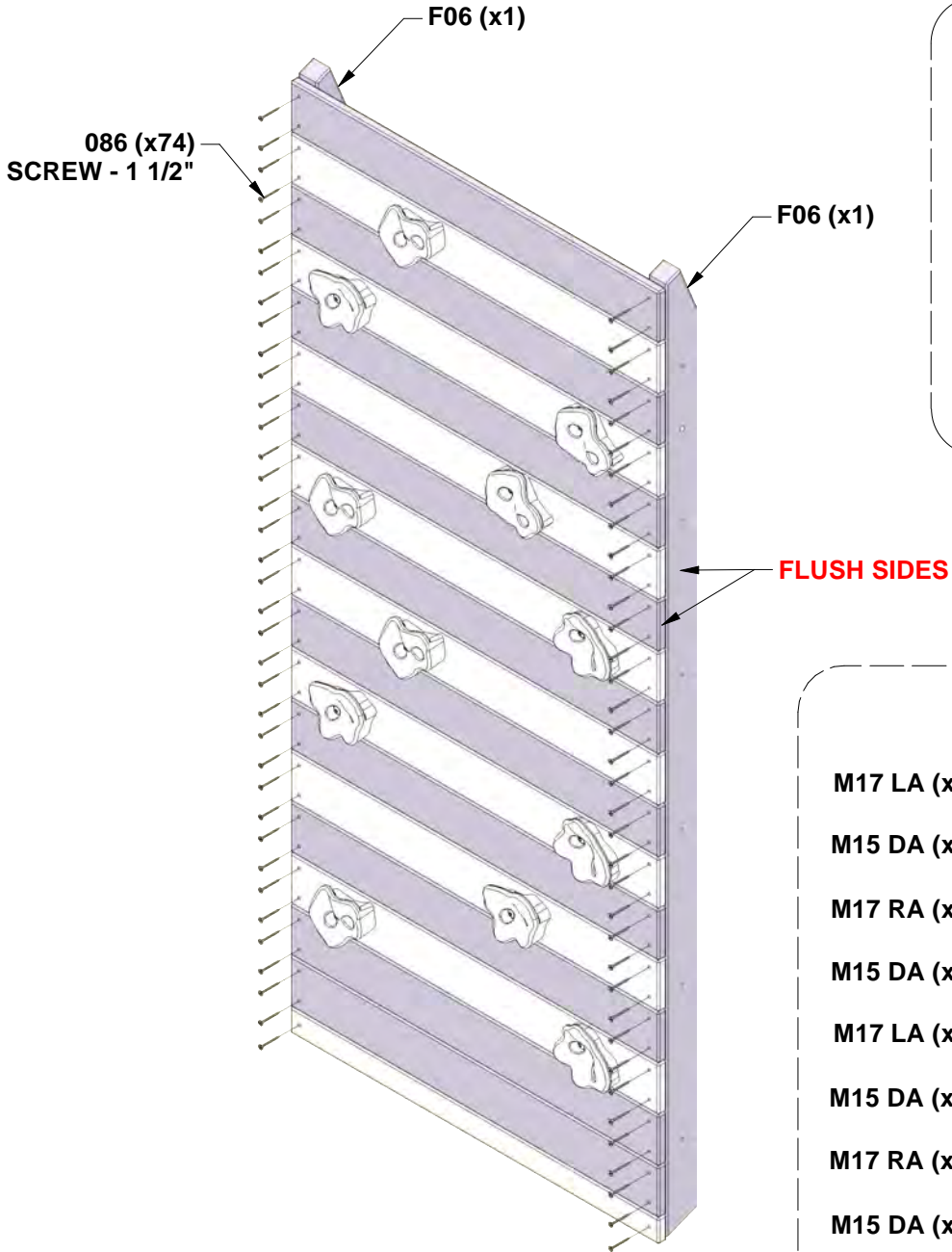

STEP 3 - ROCK WALL ASSEMBLY

QTY	PART NUMBER	DESCRIPTION
12	H100090	SCREW PFH 8x2 1/2

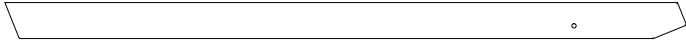

E06 RIGHT RAIL - W4L20360
 (x1) 1 3/8"x3 3/8"x63 7/8" (36x86x1623)



E08 LEFT RAIL - W4L20362
 (x1) 1 3/8"x3 3/8"x63 7/8" (36x86x1623)

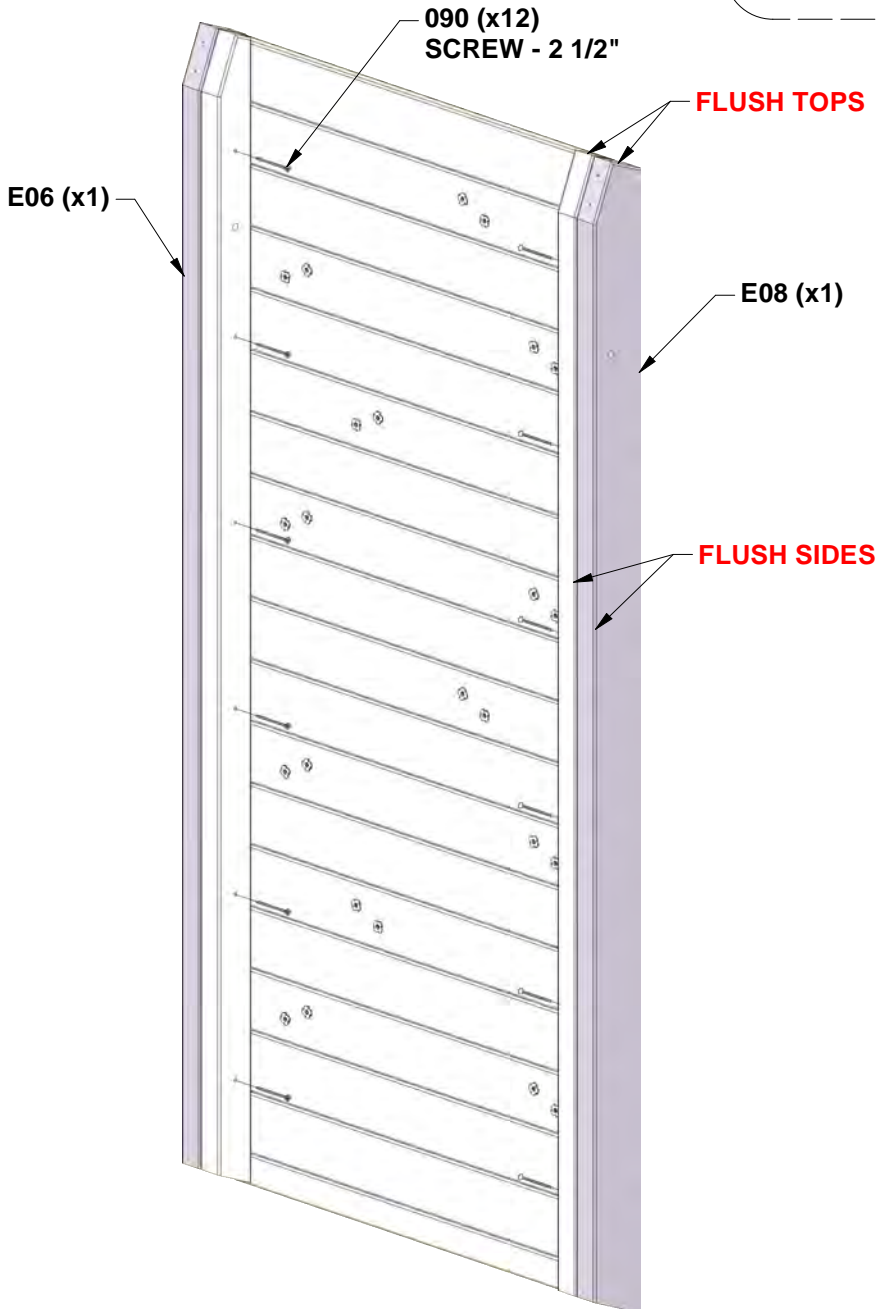
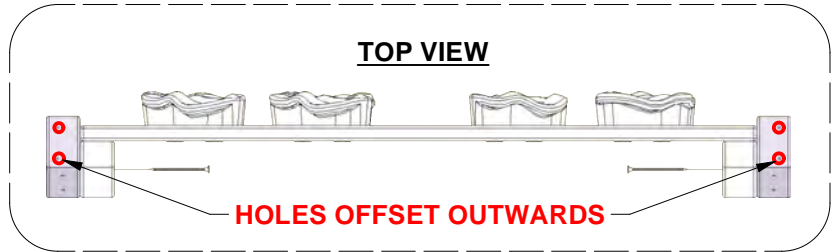

STEP 4 - ROCK WALL ASSEMBLY

QTY	PART NUMBER	DESCRIPTION
17	H100088	SCREW PFH 8x1-1/8"



N01 CLEAT - W4L20469
 (x1) 5/8"x2 3/8"x57 1/8" (16x60x1452)

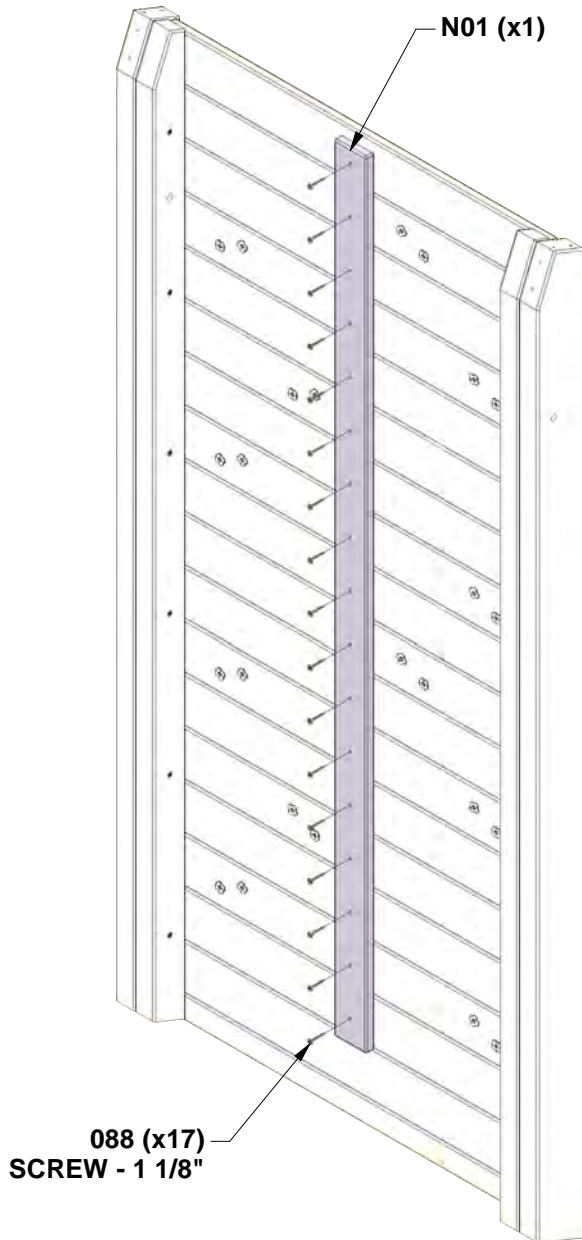
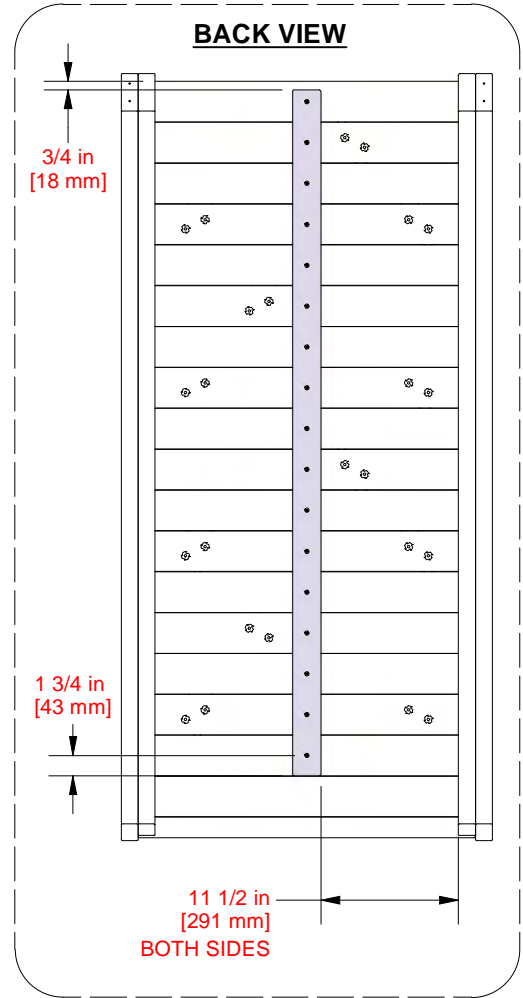

STEP 5 - ROCK WALL ASSEMBLY

QTY	PART NUMBER	DESCRIPTION
4	H100086	SCREW PFH 8x1-1/2"

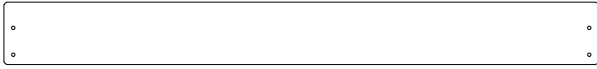

M13 TOP BOARD - W4L20458
(x1) 5/8"x3 1/4"x31" (16x82x786)

- ALIGN PILOT HOLES

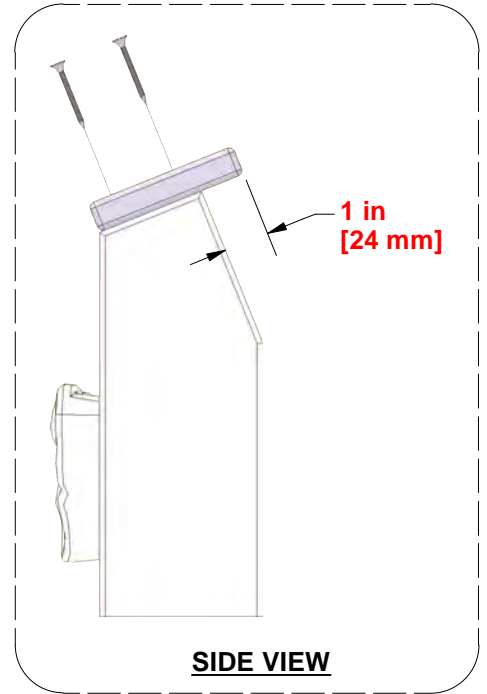
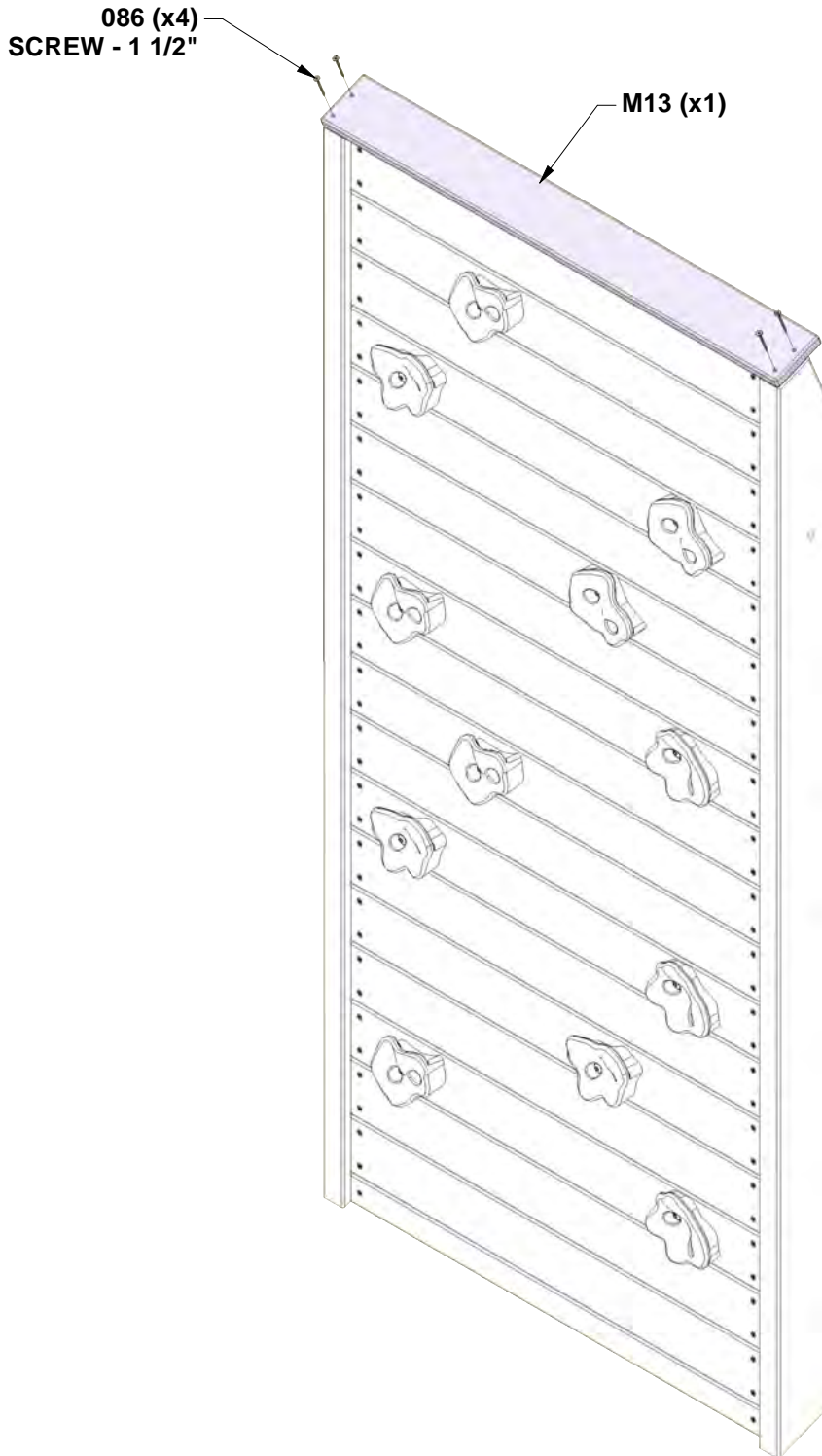

STEP 6 - ROCK WALL ASSEMBLY

QTY	PART NUMBER	DESCRIPTION
8	H100090	SCREW PFH 8x2 1/2
2	H100379	T-NUT 5/16 BLK



H30 ATTACHMENT BOARD - W4L20412
 (x1) 1"x3 3/8"x31" (24x86x786)

- INSTALL T-NUTS IN WOOD FIRST
- ALIGN PILOT HOLES

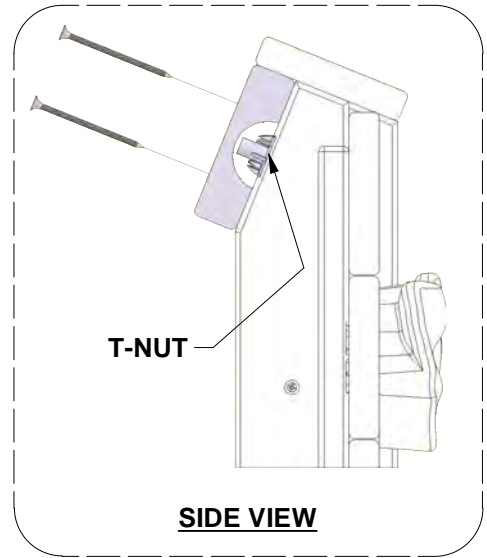
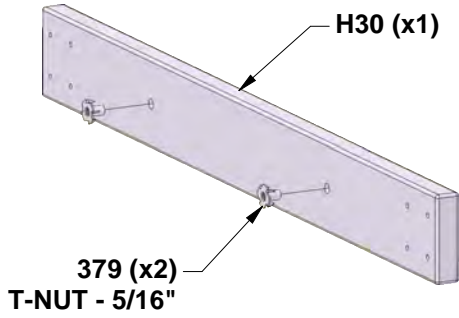

STEP 1 - SWING ASSEMBLY

QTY	PART NUMBER	DESCRIPTION
6	H100089	SCREW PFH 8x1-3/4"
8	H100474	WASHER FLAT 9x18 BLK
4	H100479	NUT LOCK 5/16 BLK
4	H100498	BOLT HEX 5/16x1-1/2 - BLK



N7 SWING BACK SUPPORT - W4L06349
(x1) 5/8"x2 3/8"x26 5/8" (16x60x676)

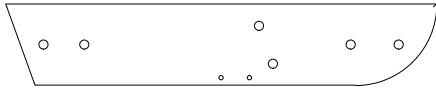

H17 SIDE BACK RAIL - W4L06343
(x2) 1"x3 3/8"x18" (24x86x456)

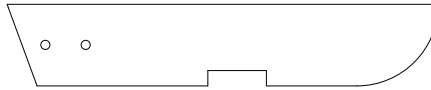

H20 CENTER BACK RAIL - W4L06346
(x1) 1"x3 3/8"x18" (24x86x456)



A4M00631 TIE STRAP PLATE BLK
(x2)

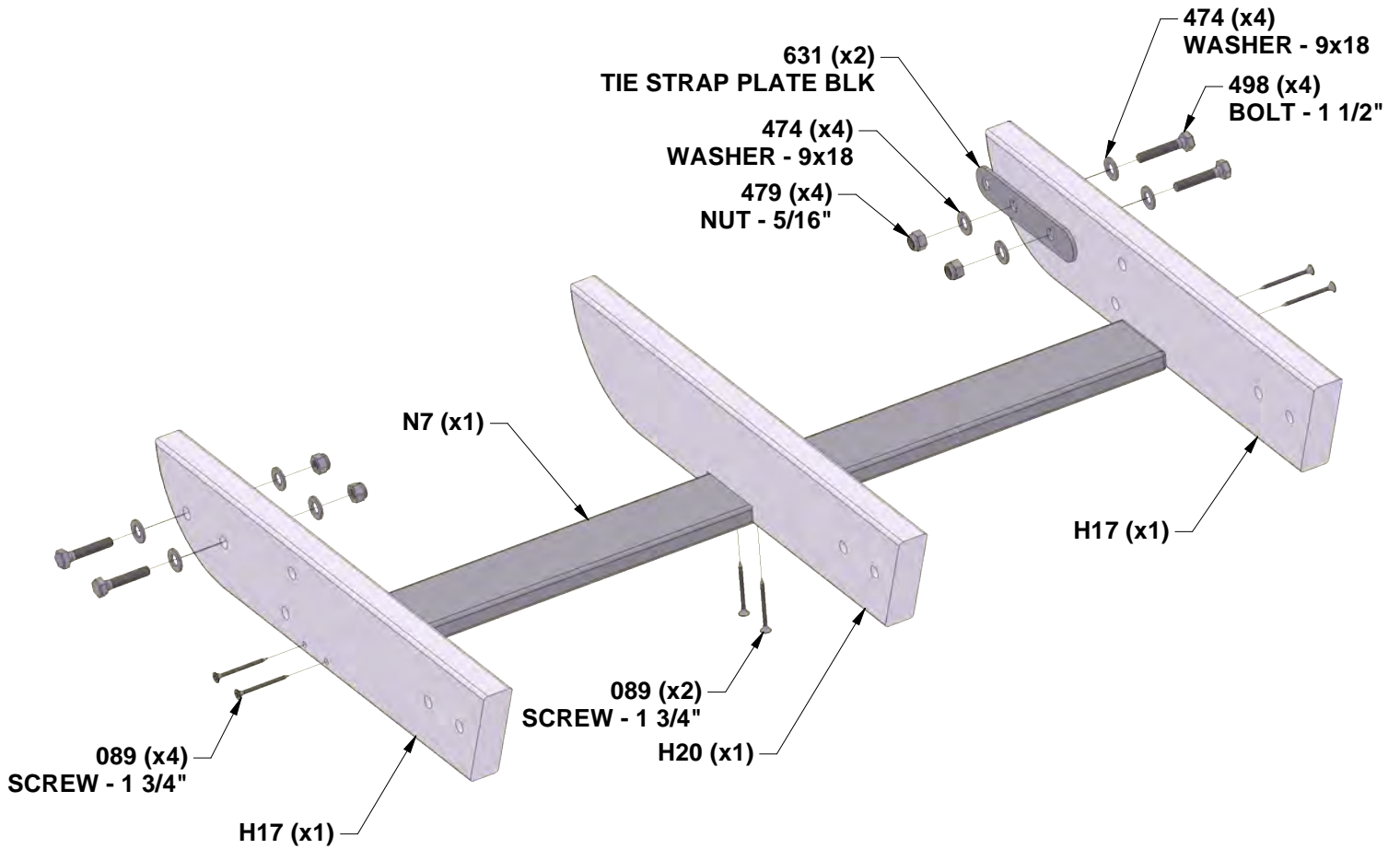

STEP 2 - SWING ASSEMBLY

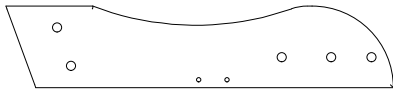

H18 SIDE SEAT SUPPORT - W4L06344
(x2) 1"x3 3/8"x16 1/8" (24x86x410)

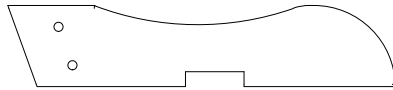

H19 CENTER SEAT SUPPORT - W4L06345
(x1) 1"x3 3/8"x16 1/8" (24x86x410)



N8 SWING SEAT SUPPORT - W4L06350
(x1) 5/8"x2 3/8"x24 3/4" (16x60x628)

QTY	PART NUMBER	DESCRIPTION
6	H100089	SCREW PFH 8x1-3/4"
6	H100192	NUT BARREL WH 5/16x7/8 BLK
6	H100198	WASHER LOCK EXT 8x19 BLK
6	H100199	WASHER LOCK EXT 12x19 BLK
6	H100407	BOLT WH 5/16x1 1/2 BLK

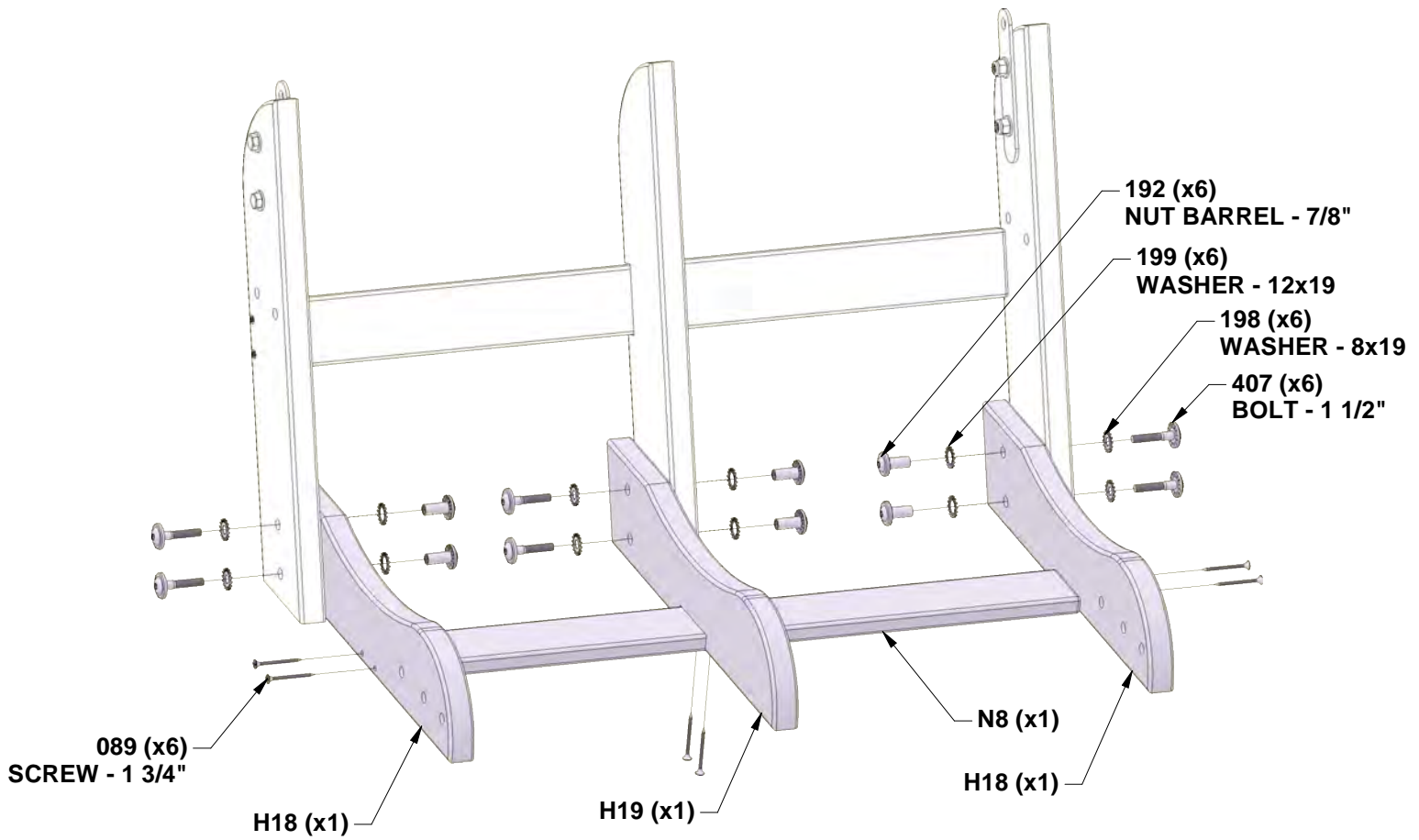

STEP 3 - SWING ASSEMBLY

QTY	PART NUMBER	DESCRIPTION
21	H100087	SCREW PFH 8x1-1/4"



O2 SWING SEAT BOARD - W4L06339
(x7) 5/8"x1 3/8"x26 5/8" (16x36x676)

**USING AN 1/8" [3mm] DRILL BIT,
USE 'O2' BOARDS AS A GUIDE
TO DRILL PILOT HOLES.**

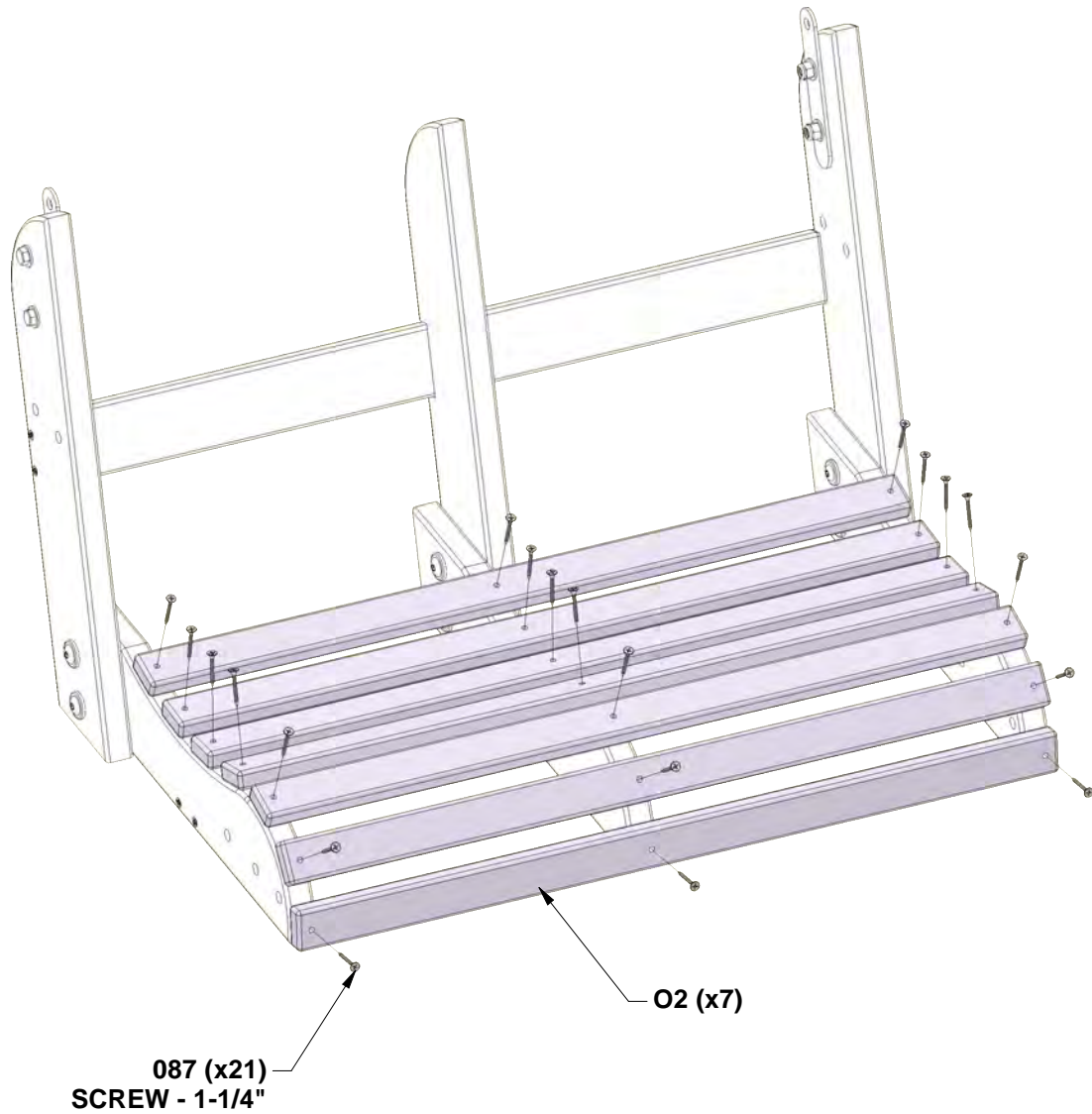
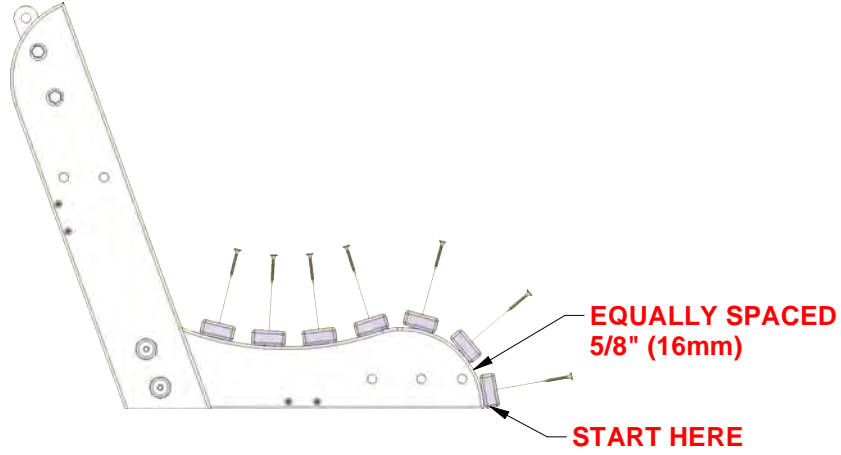

STEP 4 - SWING ASSEMBLY

QTY	PART NUMBER	DESCRIPTION
21	H100087	SCREW PFH 8x1-1/4"

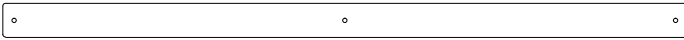

O3 SWING SEAT BOARD - W4L06340
(x7) 5/8"x1 3/8"x28 1/2" (16x36x724)

**USING AN 1/8" [3mm] DRILL BIT,
USE 'O3' BOARDS AS A GUIDE
TO DRILL PILOT HOLES.**

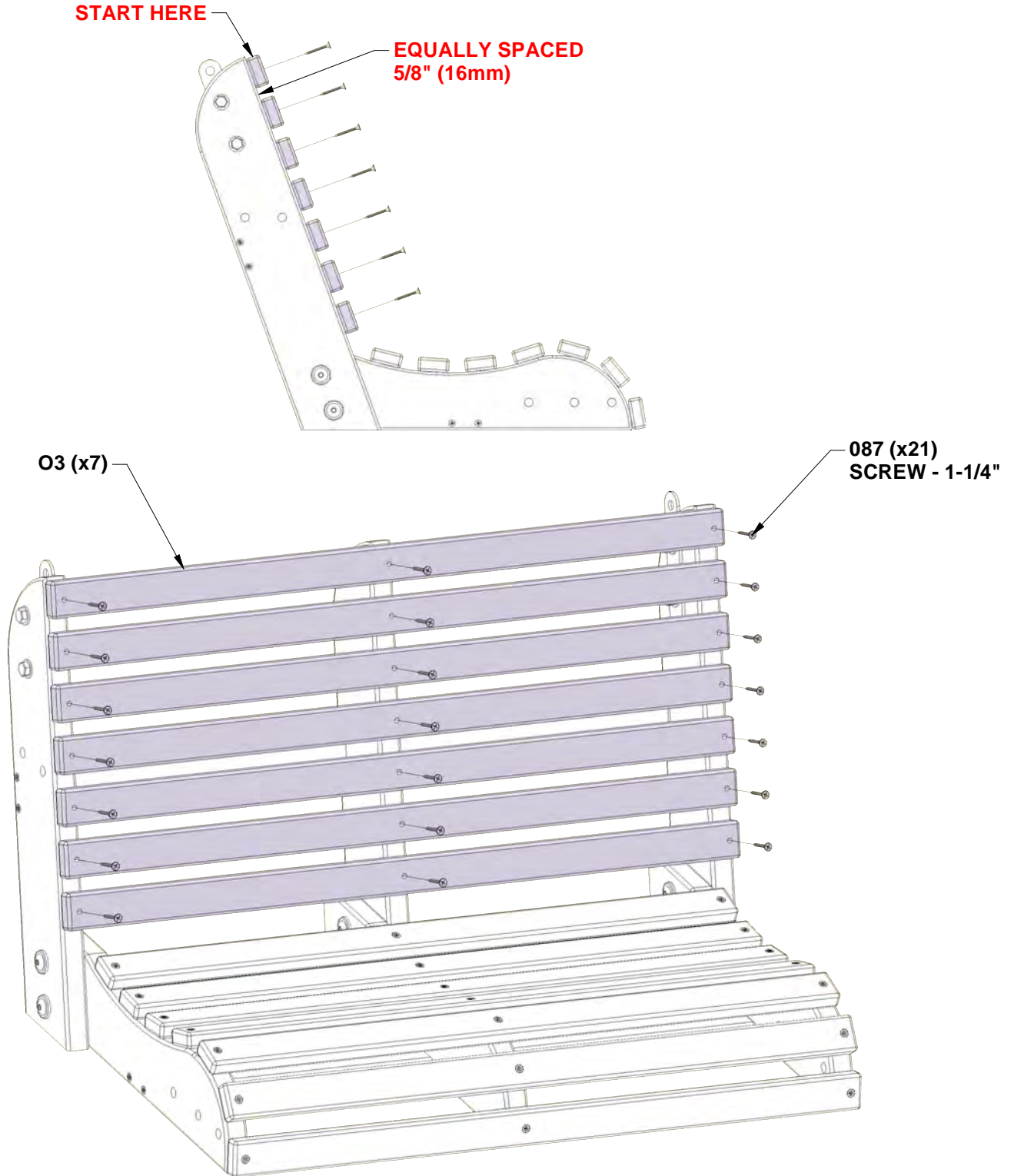

STEP 5 - SWING ASSEMBLY



H16 SWING RAIL SUPPORT - W4L06341
(x2) 1"x3 3/8"x9 1/8" (24x86x232)

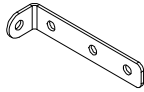

A4M00632 CHAIN SUPPORT BRACKET BLK
(x2)

QTY	PART NUMBER	DESCRIPTION
4	H100192	NUT BARREL WH 5/16x7/8 BLK
4	H100198	WASHER LOCK EXT 8x19 BLK
4	H100199	WASHER LOCK EXT 12x19 BLK
4	H100407	BOLT WH 5/16x1 1/2 BLK
4	H100474	WASHER FLAT 9x18 BLK
2	H100479	NUT LOCK 5/16 BLK
2	H100498	BOLT HEX 5/16x1-1/2 - BLK

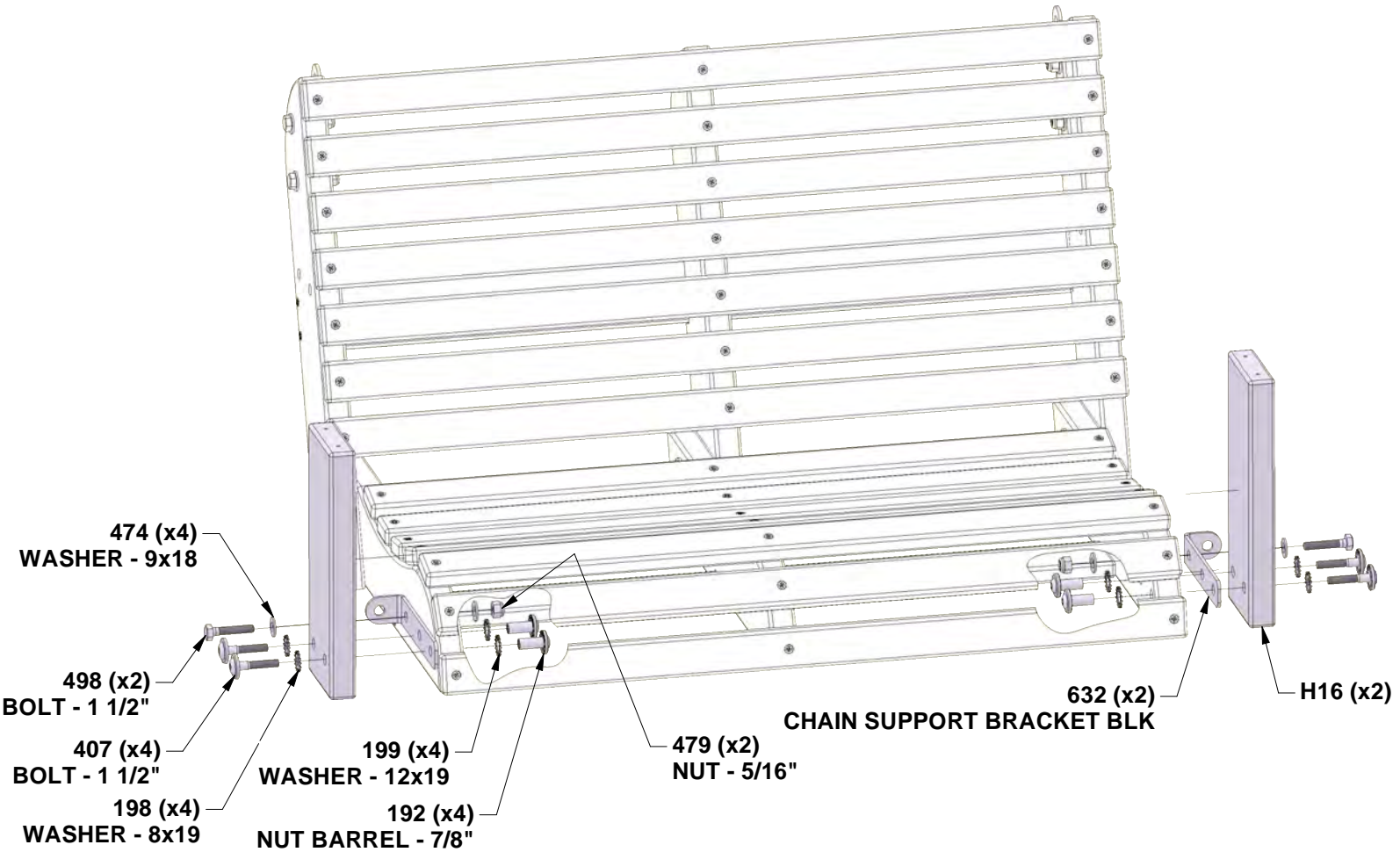

STEP 6 - SWING ASSEMBLY

QTY	PART NUMBER	DESCRIPTION
4	H100090	SCREW PFH 8x2 1/2
4	H100192	NUT BARREL WH 5/16x7/8 BLK
4	H100198	WASHER LOCK EXT 8x19 BLK
4	H100199	WASHER LOCK EXT 12x19 BLK
4	H100205	BOLT WH 5/16x2-1/4 BLK

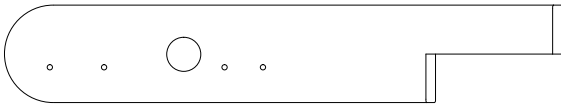

H24 RIGHT ARM REST - W4L06348
 (x1) 1"x3 3/8"x19 3/8" (24x86x492)

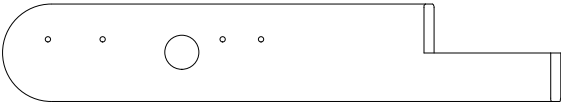

H21 LEFT ARM REST - W4L06347
 (x1) 1"x3 3/8"x19 3/8" (24x86x492)

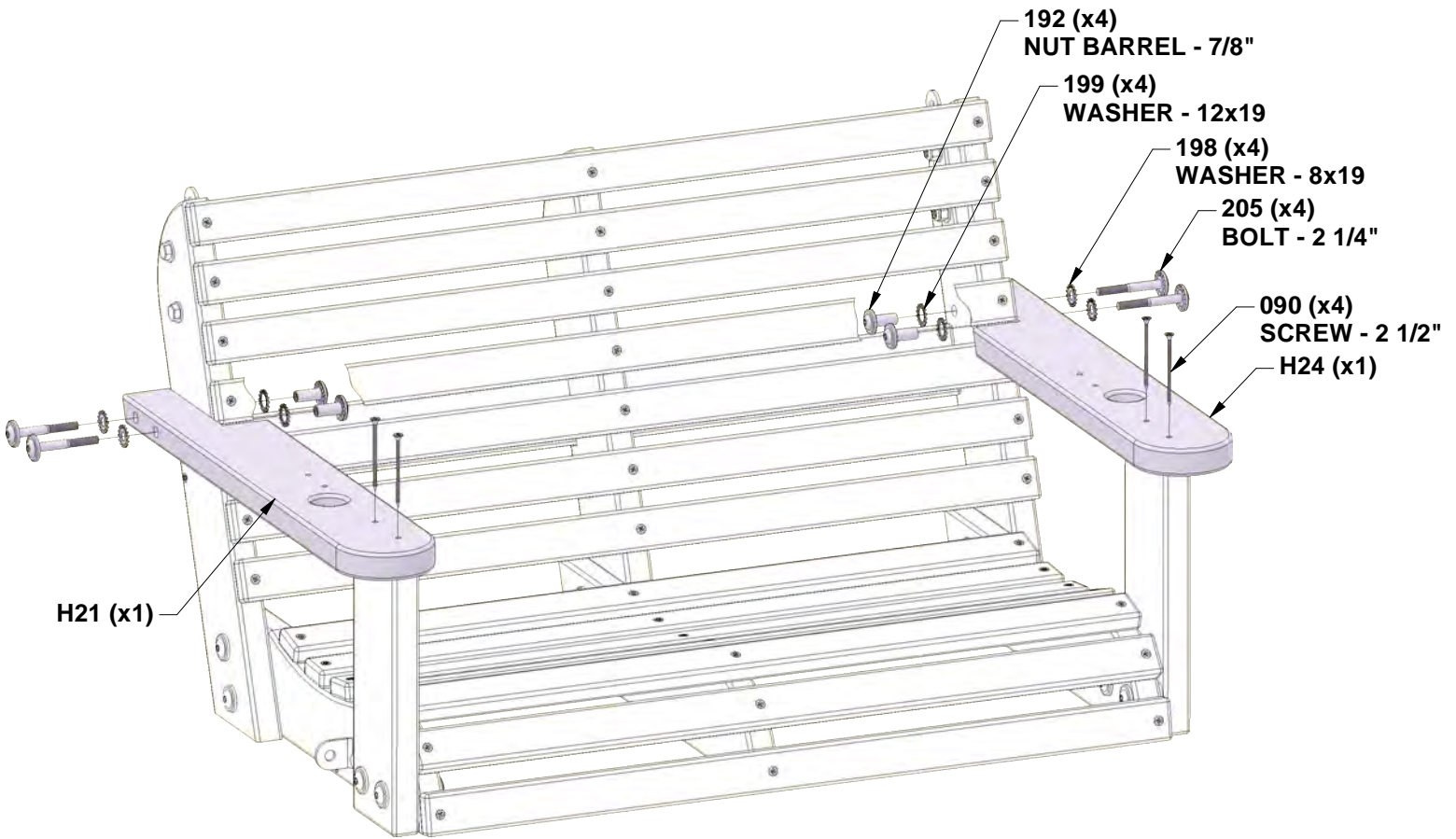

STEP 7 - SWING ASSEMBLY

QTY	PART NUMBER	DESCRIPTION
4	H100089	SCREW PFH 8x1-3/4"
4	H100090	SCREW PFH 8x2 1/2"



J12 SWING RAIL SUPPORT - W4L06342
(x2) 1"x2 3/8"x9 1/8" (24x60x232)

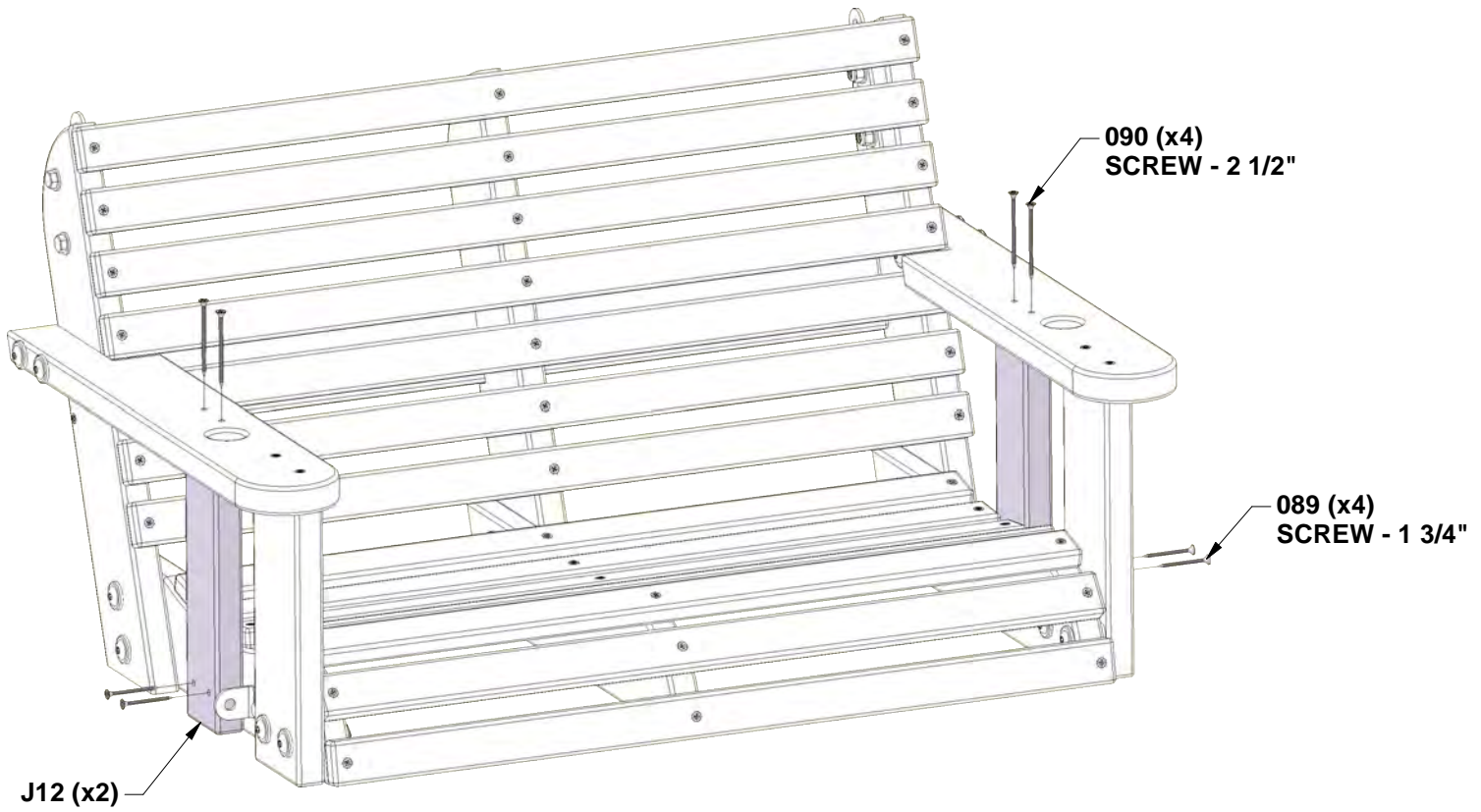

STEP 8 - SWING ASSEMBLY

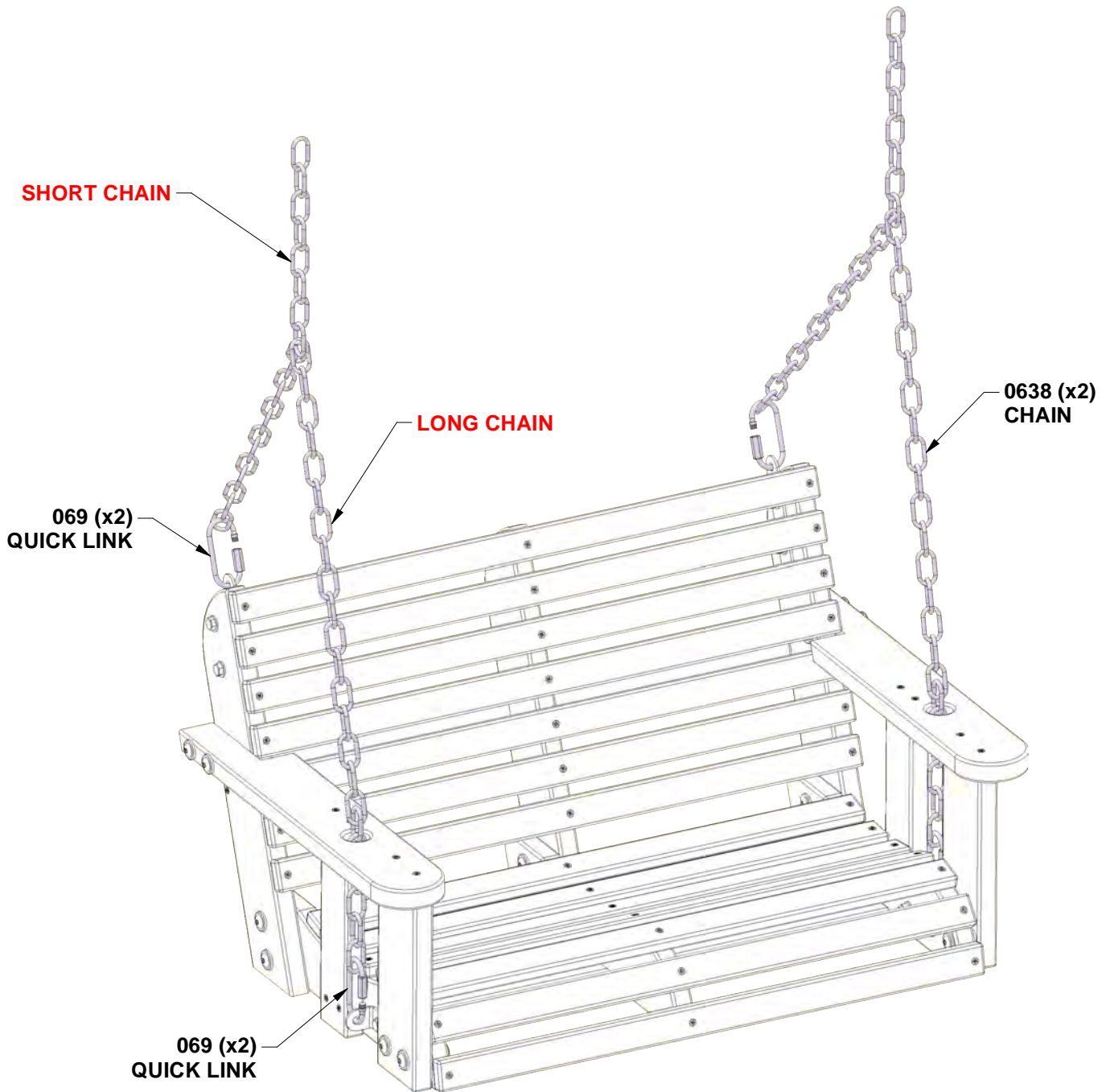
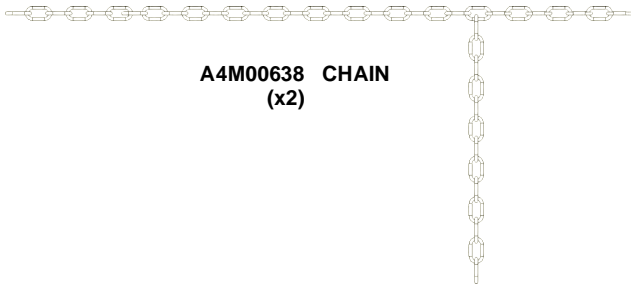

STEP 1 - SLIDE ASSEMBLY

QTY	PART NUMBER	DESCRIPTION
3	H100074	T-NUT 5/16
3	H100115	BOLT WH 5/16x1/2



A6P00385 | SLIDE BED 10' DARK GREEN
(x1)



M70 | SLIDE BED SUPPORT - W100935
(x1) | 5/8"x3 3/8"x19 7/8" (16x86x505)

NOTE:

TAKE NOTE OF SLIDE BED SURFACE FINISH, THE DULL SIDE WILL BE TOWARDS THE GROUND. PLACE SLIDE BRACE CENTERED ON THE BOTTOM (DULL SIDE) AND 1/2" FROM THE EDGE. USE M70 BOARD AS A TEMPLATE FOR DRILLING BOTTOM HOLE PATTERN IN SLIDE BED. USE A 5/16" DRILL BIT.

TOP

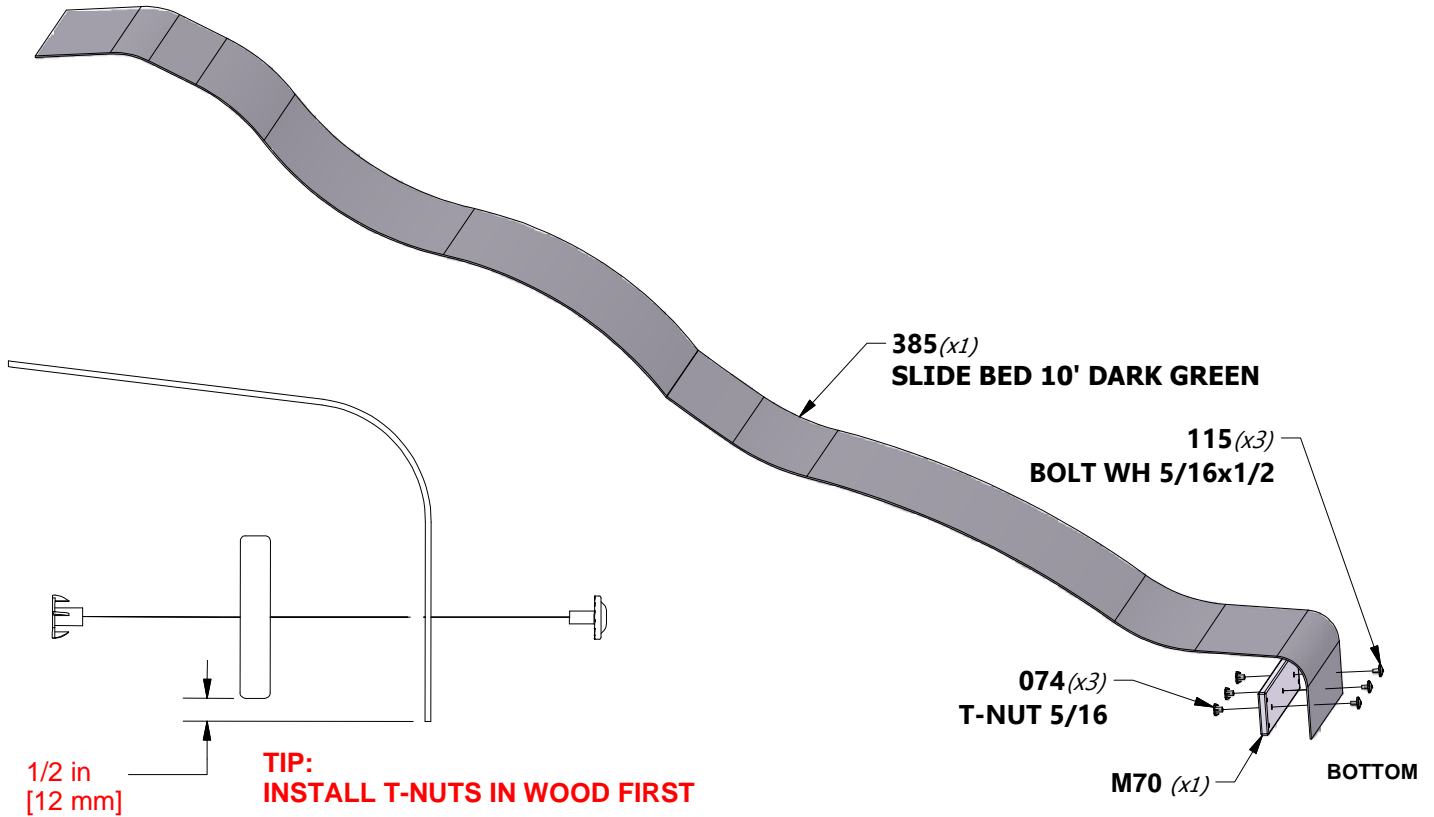

TIP:

PRE-BENDING THE ENDS WILL EASE ASSEMBLY. PLACING THE SLIDE BED OUT IN THE SUN MAKES IT EASIER TO BEND.

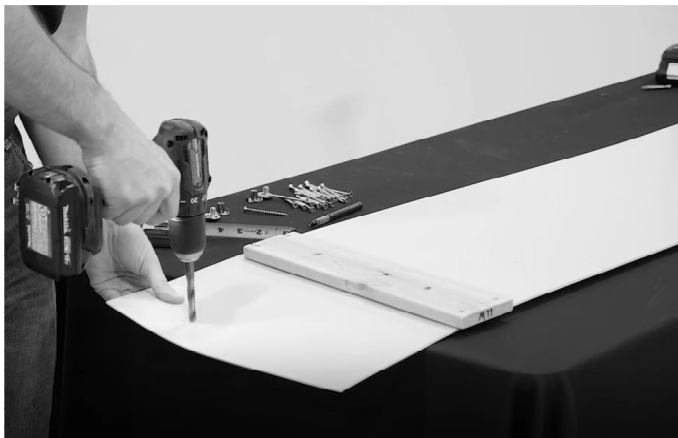

STEP 2 - SLIDE ASSEMBLY

QTY	PART NUMBER	DESCRIPTION
8	H100006	NUT BARREL WH 5/16x1 1/2
8	H100115	BOLT WH 5/16x1/2
6	H100121	SCREW 8x3/4

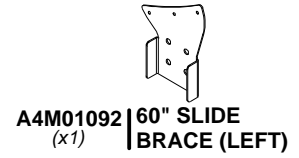
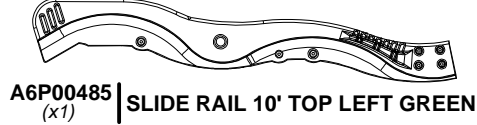
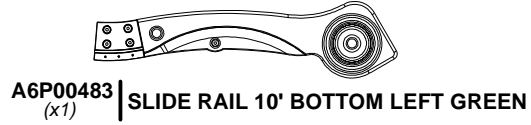
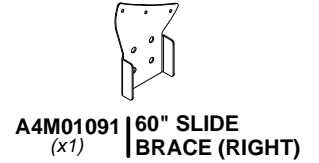
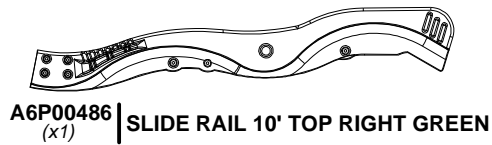

NOTE:
REPEAT ON OTHER SIDE, MAKING
A LEFT AND RIGHT ASSEMBLY.

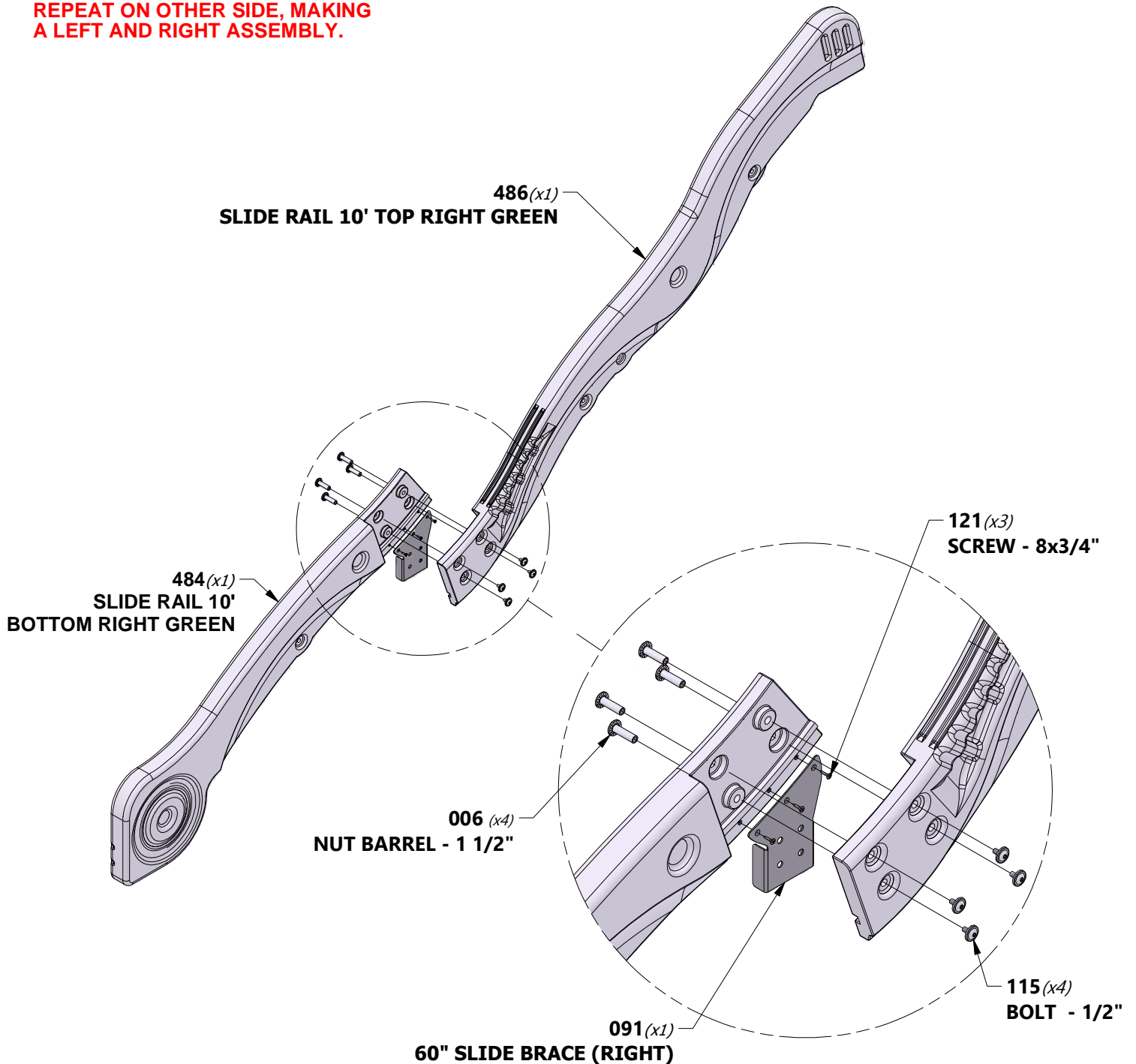

STEP 3 - SLIDE ASSEMBLY

QTY	PART NUMBER	DESCRIPTION
4	H100009	BOLT WH 5/16x1 1/4



A6P00487
(x4) | SLIDE TUBE SUPPORT

NOTE:
INSERT THE (4) SLIDE SUPPORT TUBES INTO THEIR RESPECTIVE PILOT LOCATIONS (FIGURE 1).

PLACE (1) SLIDE RAIL ASSEMBLY ON A FLAT SURFACE AND BEGIN INSERTING SLIDE BED AT THE BOTTOM OF THE SLIDE RAIL (FIGURE 2). HAVE A HELPER BEND THE SLIDE BED TOWARDS THE TOP OF THE SLIDE AND INSERT THE BED INTO THE SLIDE CAVITY. MAKE SURE SLIDE BED IS INSERTED WITHIN 1/8" (3mm) OF GROOVE BOTTOM.

TIP:
A HELPER IS RECOMMENDED FOR THESE FOLLOWING STEPS.

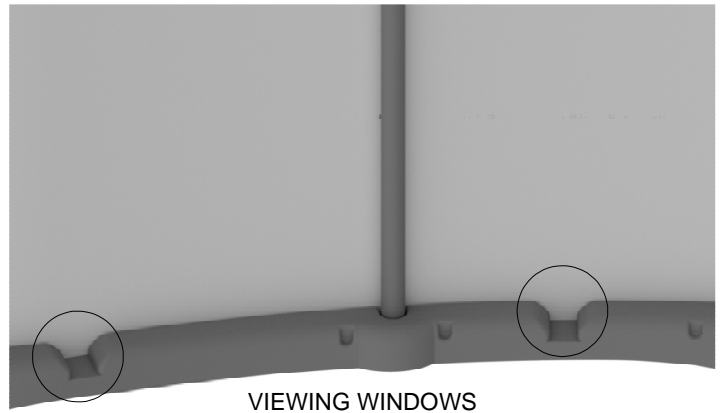
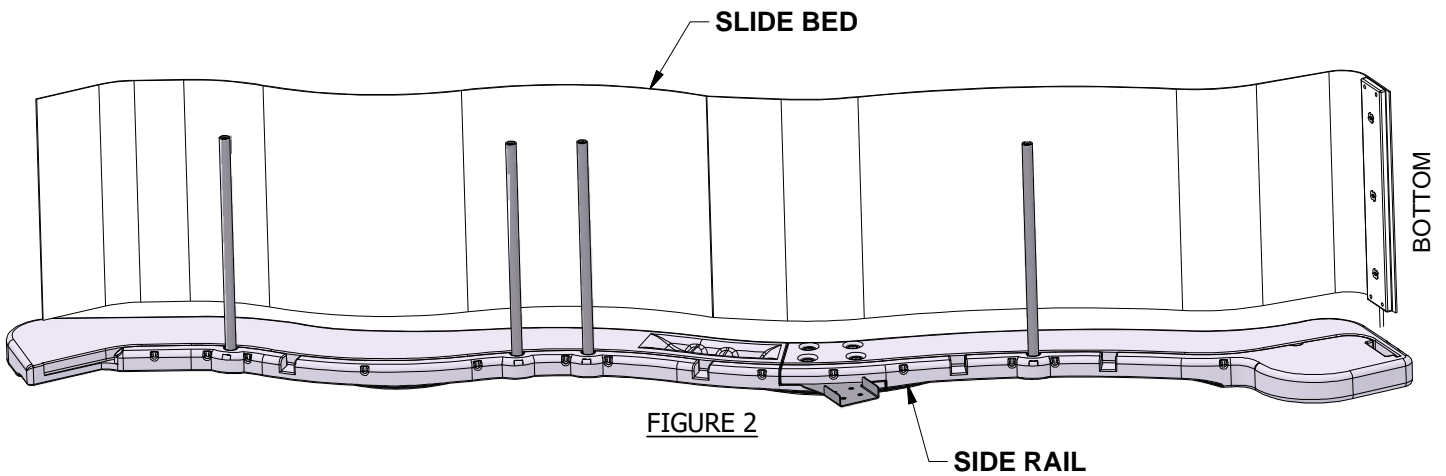
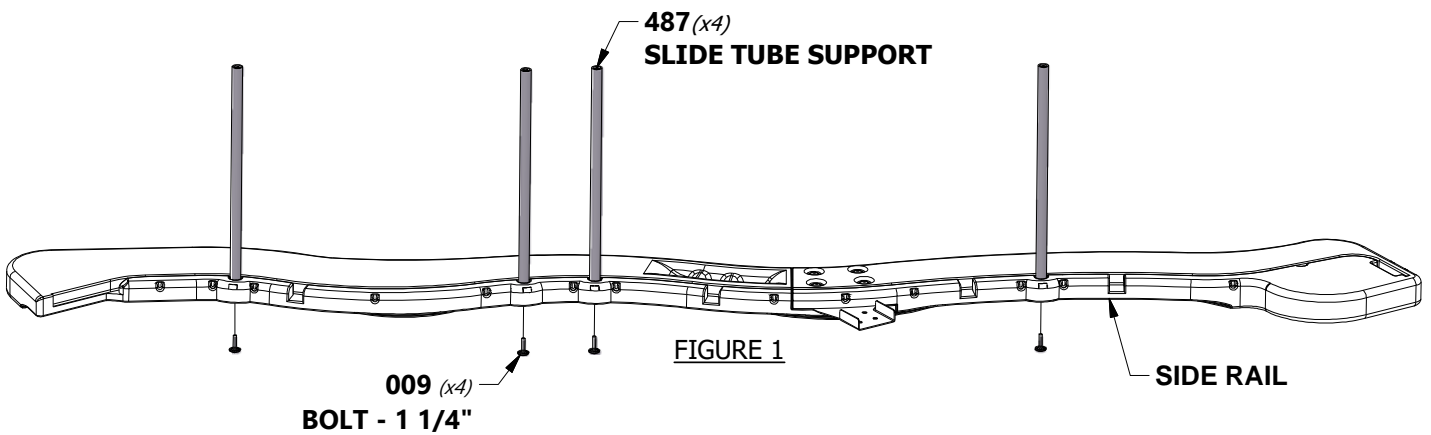

VIEWING WINDOWS

STEP 4 - SLIDE ASSEMBLY

NOTE:
PLACE SECOND SLIDE RAIL ASSEMBLY OVER THE TOP OF THE SLIDE BED AND SLIDE SUPPORT TUBES. INSERT THE SLIDE BED AND SLIDE SUPPORT TUBES INTO THE SLIDE CAVITY. MAKE SURE SLIDE BED IS INSERTED WITHIN 1/8" (3mm) OF GROOVE BOTTOM.



FAILURE TO INSERT SLIDE BED PROPERLY MAY RESULT IN INJURY OR AMPUTATION. EXPOSED SLIDE EDGES CAN BE SHARP AND BECOME A LACERATION HAZARD IF THE SLIDE IS NOT PROPERLY ASSEMBLED.

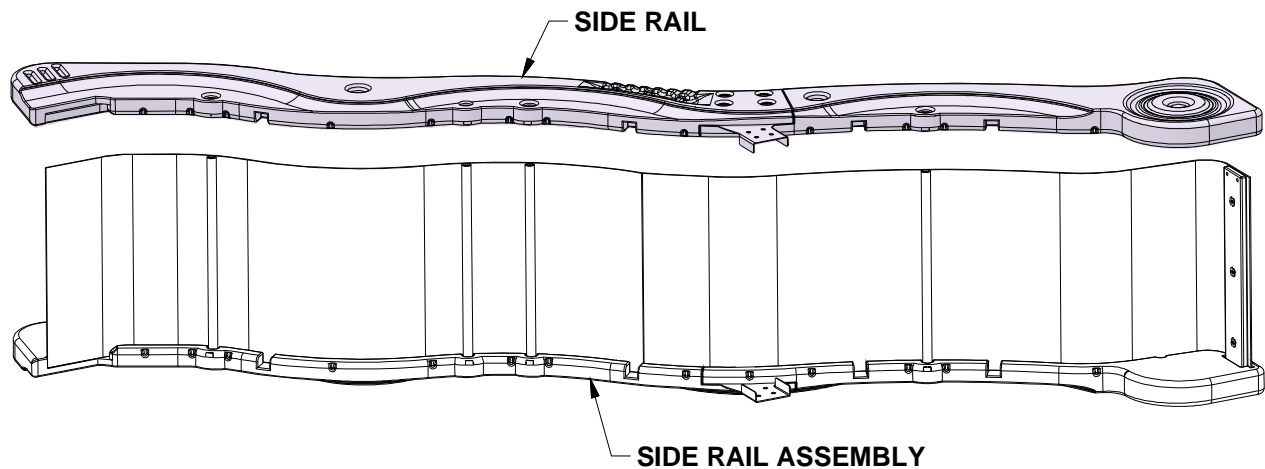

TIP:
USE A RUBBER Mallet TO FULLY SEAT THE SLIDE BED INTO THE SLIDE CAVITY.

STEP 5 - SLIDE ASSEMBLY

QTY	PART NUMBER	DESCRIPTION
4	H100009	BOLT WH 5/16x1 1/4

NOTE:
USE 1 1/4" BOLTS TO FASTEN EACH
SIDE OF THE SLIDE SUPPORT TUBES.

TIP:
HAVING A HELPER HOLD THE SLIDE
ASSEMBLY TOGETHER WHILE YOU FASTEN
WILL MAKE IT EASIER TO ASSEMBLE.

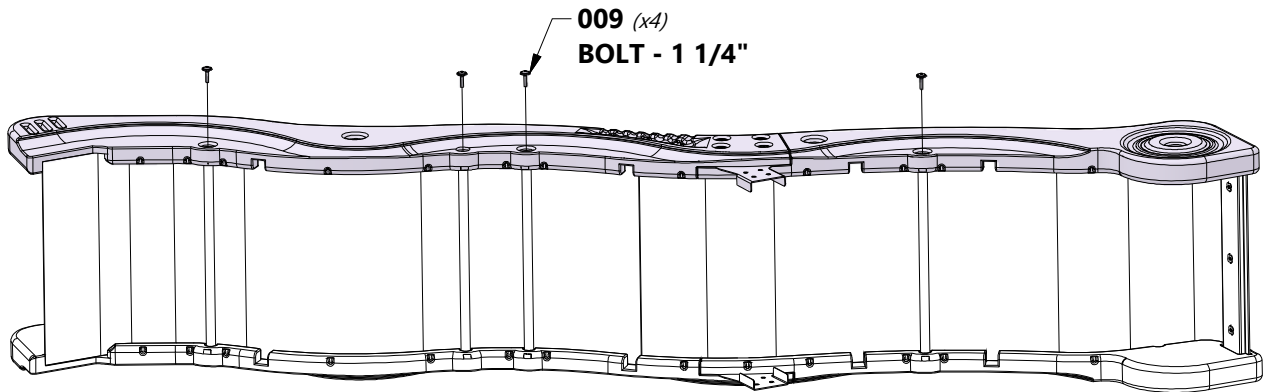

STEP 6 - SLIDE ASSEMBLY

QTY	PART NUMBER	DESCRIPTION
30	H100090	SCREW PFH 8x2 1/2

NOTE:
USING AN 1/8" DRILL BIT, DRILL PILOT HOLES IN EACH INDENTATION ALONG EACH SIDE RAIL. THERE SHOULD BE 15 INDENTATIONS ON EACH RAIL. BE SURE TO DRILL THROUGH THE SLIDE RAIL AND THE SLIDE BED. THEN SECURE WITH THE PROVIDED HARDWARE.

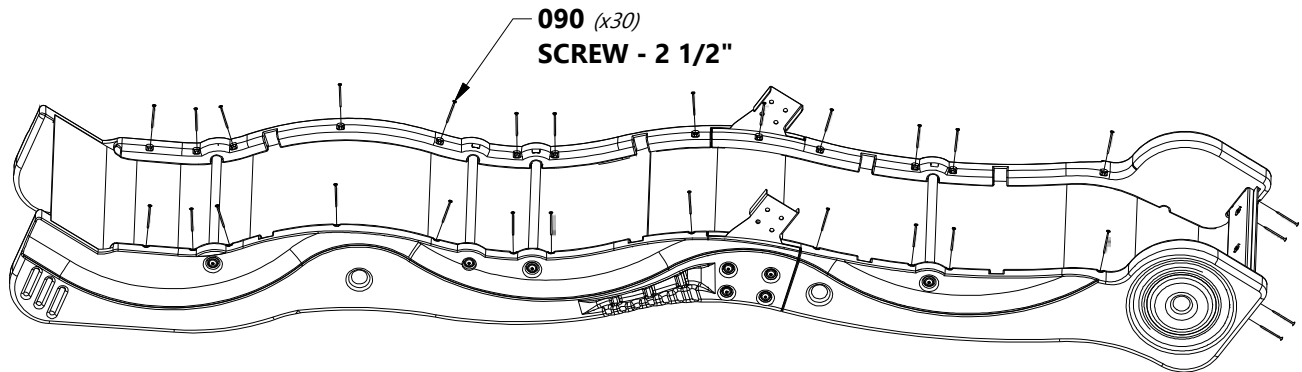

STEP 7 - SLIDE ASSEMBLY

QTY	PART NUMBER	DESCRIPTION
8	H100008	BOLT WH 5/16x1
8	H100074	T-NUT 5/16
4	H100111	SCREW PFH 8x2



H80 | SLIDE BRACE WIDE - W4L15715
(x1) | 1"x3 3/8"x18 3/8" (24x86x466)



H81 | SLIDE BRACE UPRIGHT - W4L13301
(x2) | 1"x3 3/8"x22 7/8" (24x86x580)

TIP:
INSTALL T-NUTS IN WOOD FIRST

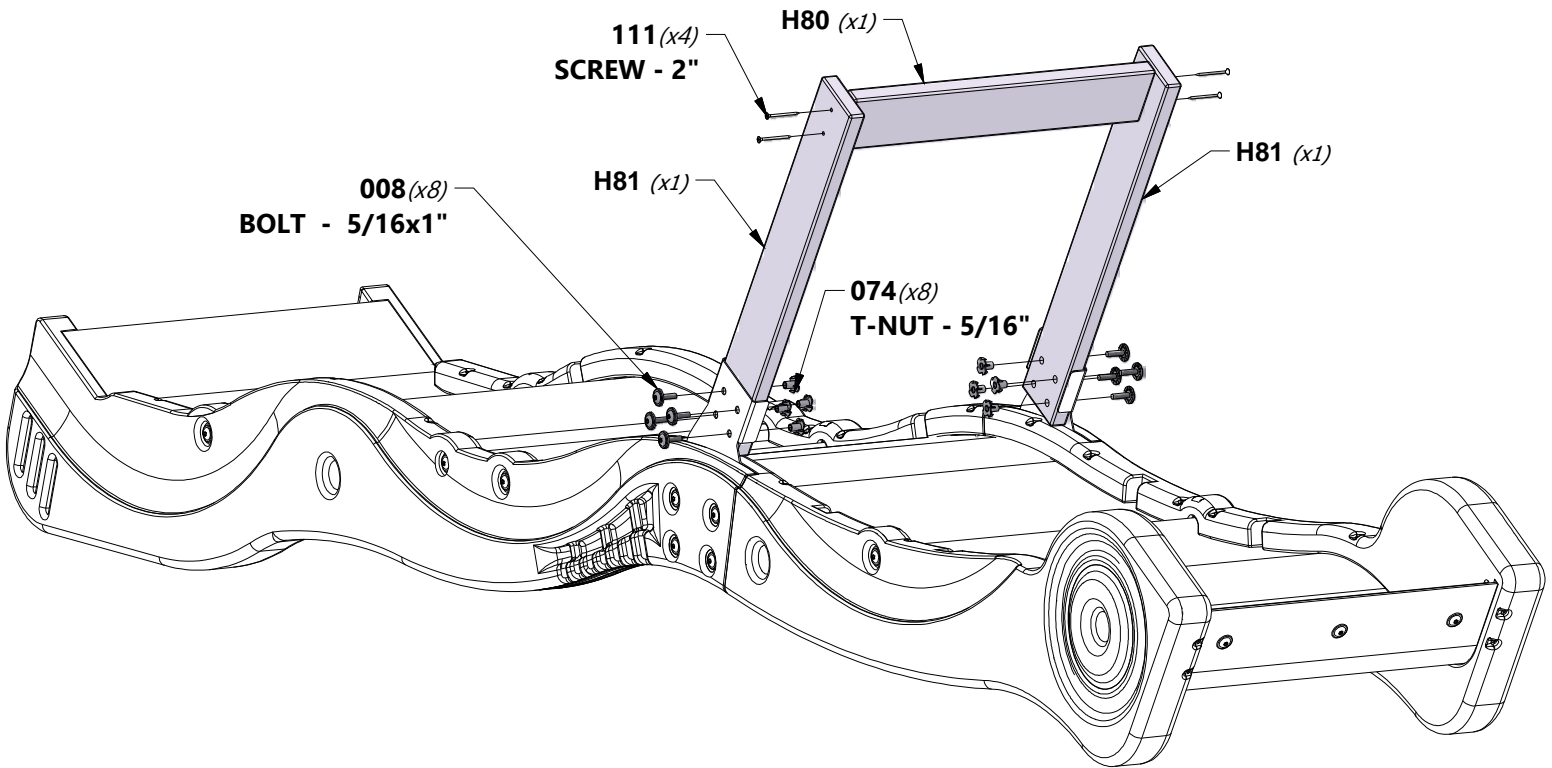

STEP 1 - FORT ASSEMBLY

QTY	PART NUMBER	DESCRIPTION
6	H100198	WASHER LOCK EXT 8x19 BLK
6	H100205	BOLT WH 5/16x2-1/4 BLK
6	H100379	T-NUT 5/16 BLK

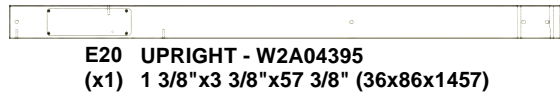
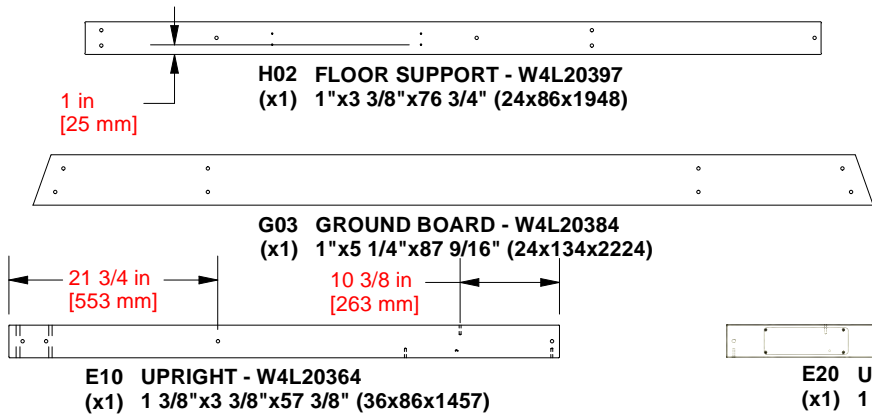

INSTALL T-NUTS IN WOOD FIRST

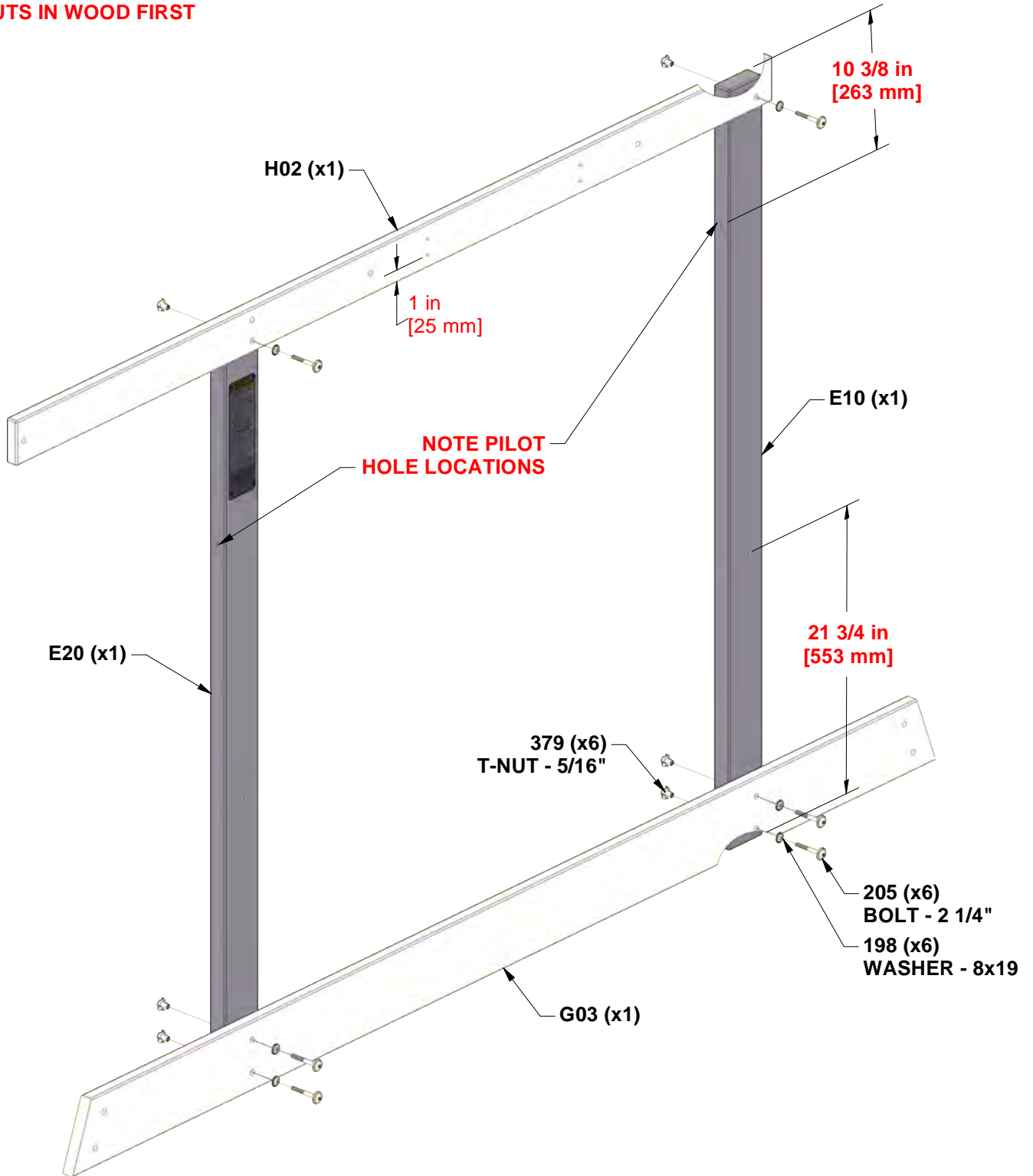

STEP 2 - FORT ASSEMBLY

QTY	PART NUMBER	DESCRIPTION
2	H100198	WASHER LOCK EXT 8x19 BLK
2	H100205	BOLT WH 5/16x2-1/4 BLK
2	H100379	T-NUT 5/16 BLK
2	H100405	WASHER LOCK EXT 6x15 BLK
2	H100487	LAG SCREW WH 1/4x2 BLK



E16 DECK BRACE - W4L20369
 (x2) 1 3/8"x3 3/8"x18 3/8" (36x86x466)

INSTALL T-NUTS IN WOOD FIRST

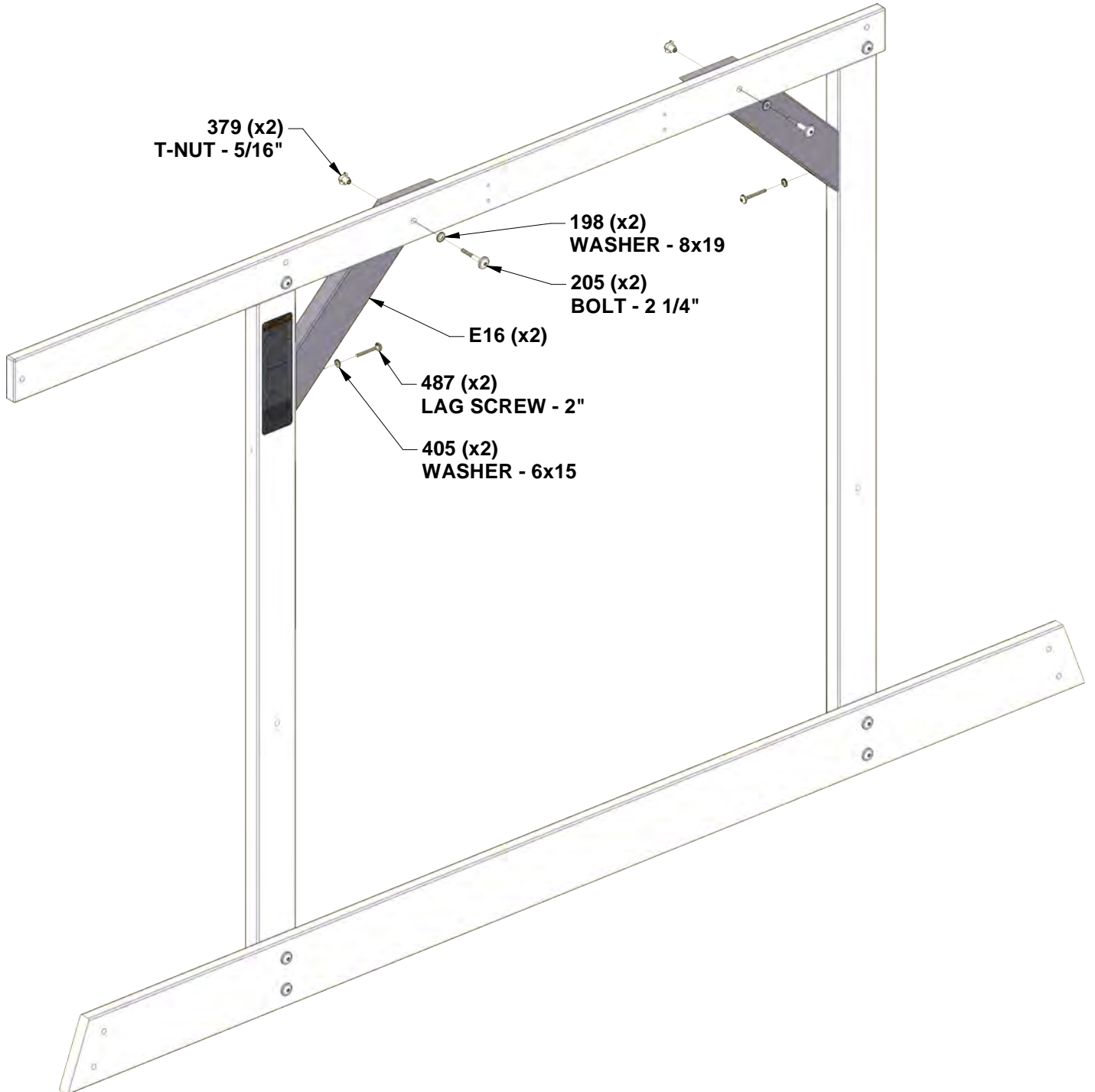

STEP 3 - FORT ASSEMBLY

QTY	PART NUMBER	DESCRIPTION
4	H100198	WASHER LOCK EXT 8x19 BLK
4	H100379	T-NUT 5/16 BLK
4	H100513	BOLT WH 5/16x4 1/4 BLK

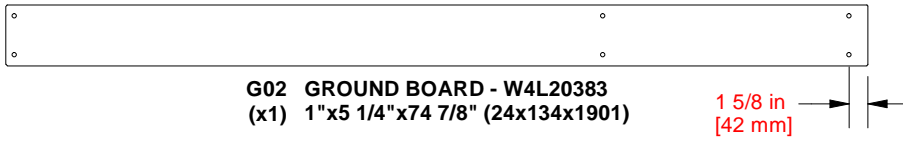
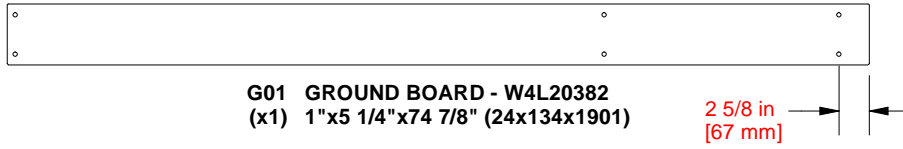

INSTALL T-NUTS IN WOOD FIRST

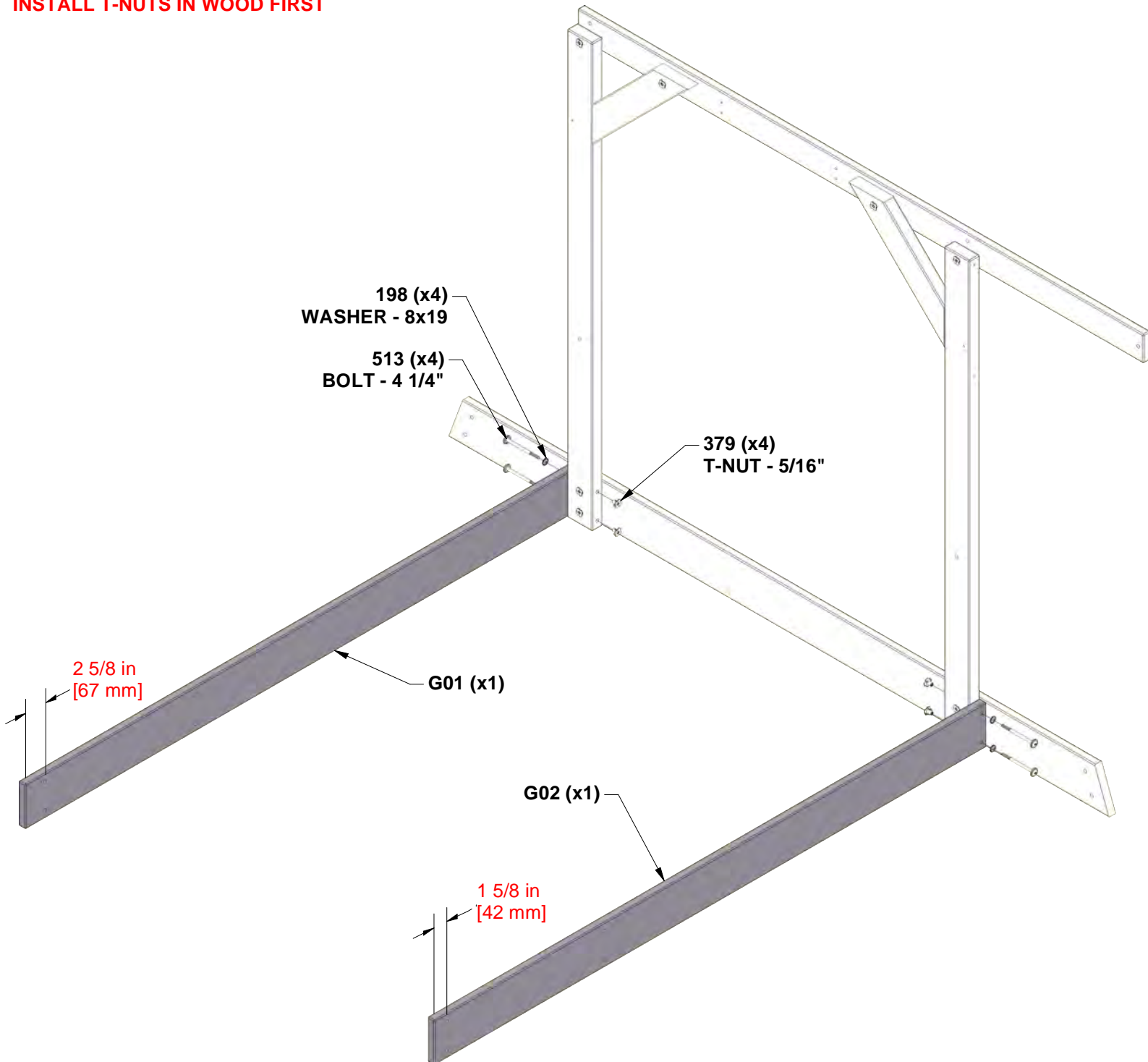

STEP 4 - FORT ASSEMBLY

QTY	PART NUMBER	DESCRIPTION
8	H100198	WASHER LOCK EXT 8x19 BLK
4	H100205	BOLT WH 5/16x2-1/4 BLK
8	H100379	T-NUT 5/16 BLK
4	H100513	BOLT WH 5/16x4 1/4 BLK

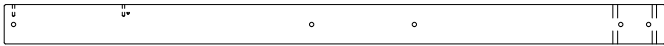

E11 UPRIGHT - W4L20365
(x1) 1 3/8"x3 3/8"x57 3/8" (36x86x1457)

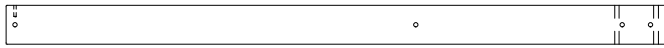

E12 UPRIGHT - W4L20366
(x1) 1 3/8"x3 3/8"x57 3/8" (36x86x1457)



G04 GROUND BOARD - W4L20385
(x1) 1"x5 1/4"x54 1/2" (24x134x1384)

INSTALL T-NUTS IN WOOD FIRST

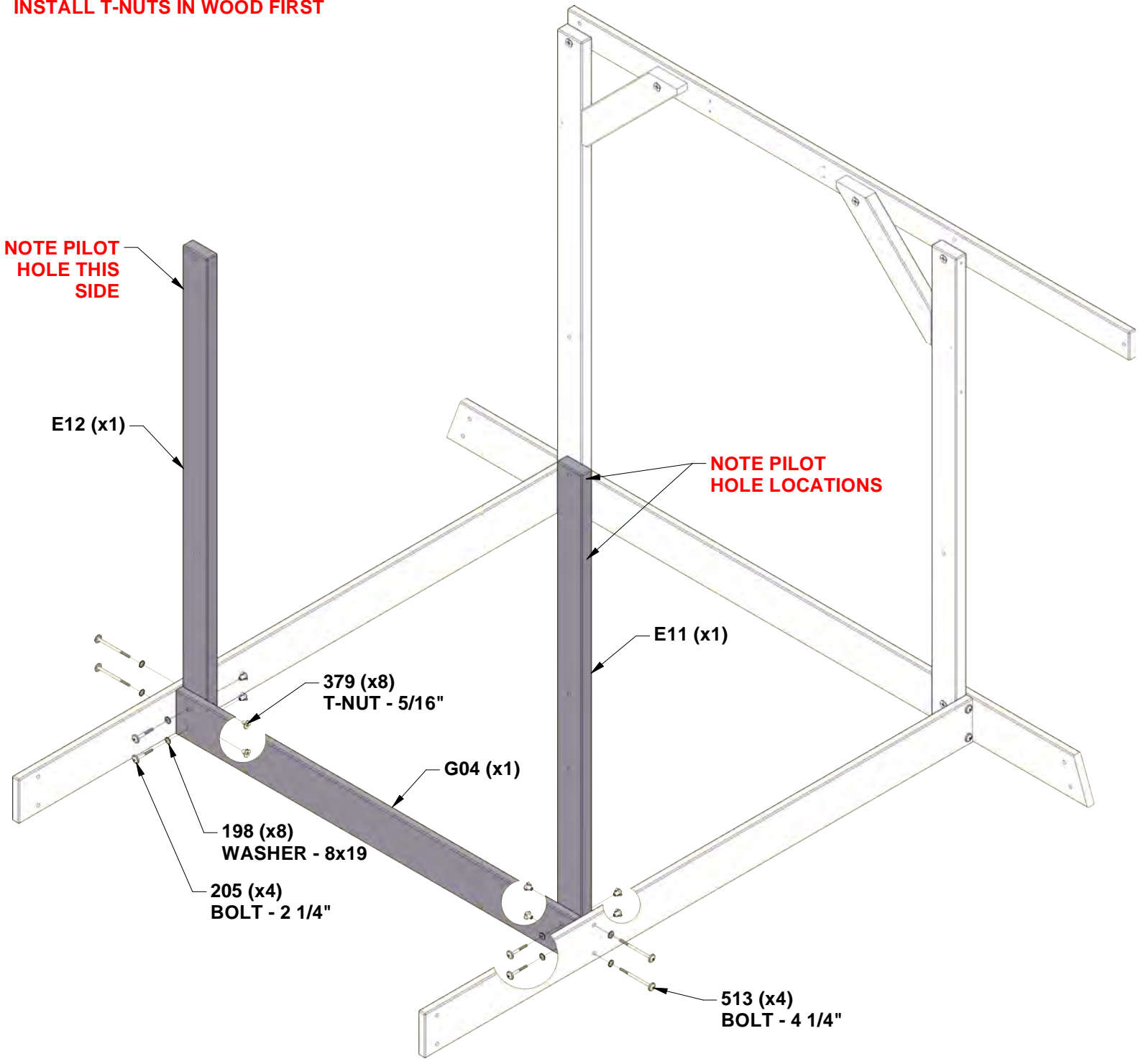

STEP 5 - FORT ASSEMBLY

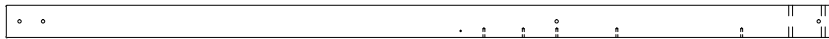

E01 UPRIGHT - W4L20355
(x1) 1 3/8"x3 3/8"x86 1/8" (36x86x2186)

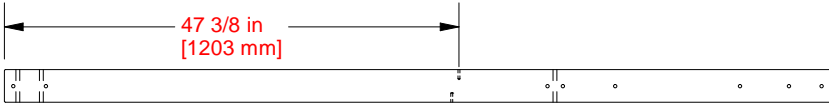

E03 UPRIGHT - W4L20357
(x1) 1 3/8"x3 3/8"x86 1/8" (36x86x2186)



E13 UPRIGHT - W4L20367
(x1) 1 3/8"x3 3/8"x67 13/16" (36x86x1723)

QTY	PART NUMBER	DESCRIPTION
10	H100198	WASHER LOCK EXT 8x19 BLK
6	H100205	BOLT WH 5/16x2-1/4 BLK
10	H100379	T-NUT 5/16 BLK
4	H100513	BOLT WH 5/16x4 1/4 BLK



G05 GROUND BOARD - W4L20386
(x1) 1"x5 1/4"x54 1/2" (24x134x1384)

INSTALL T-NUTS IN WOOD FIRST

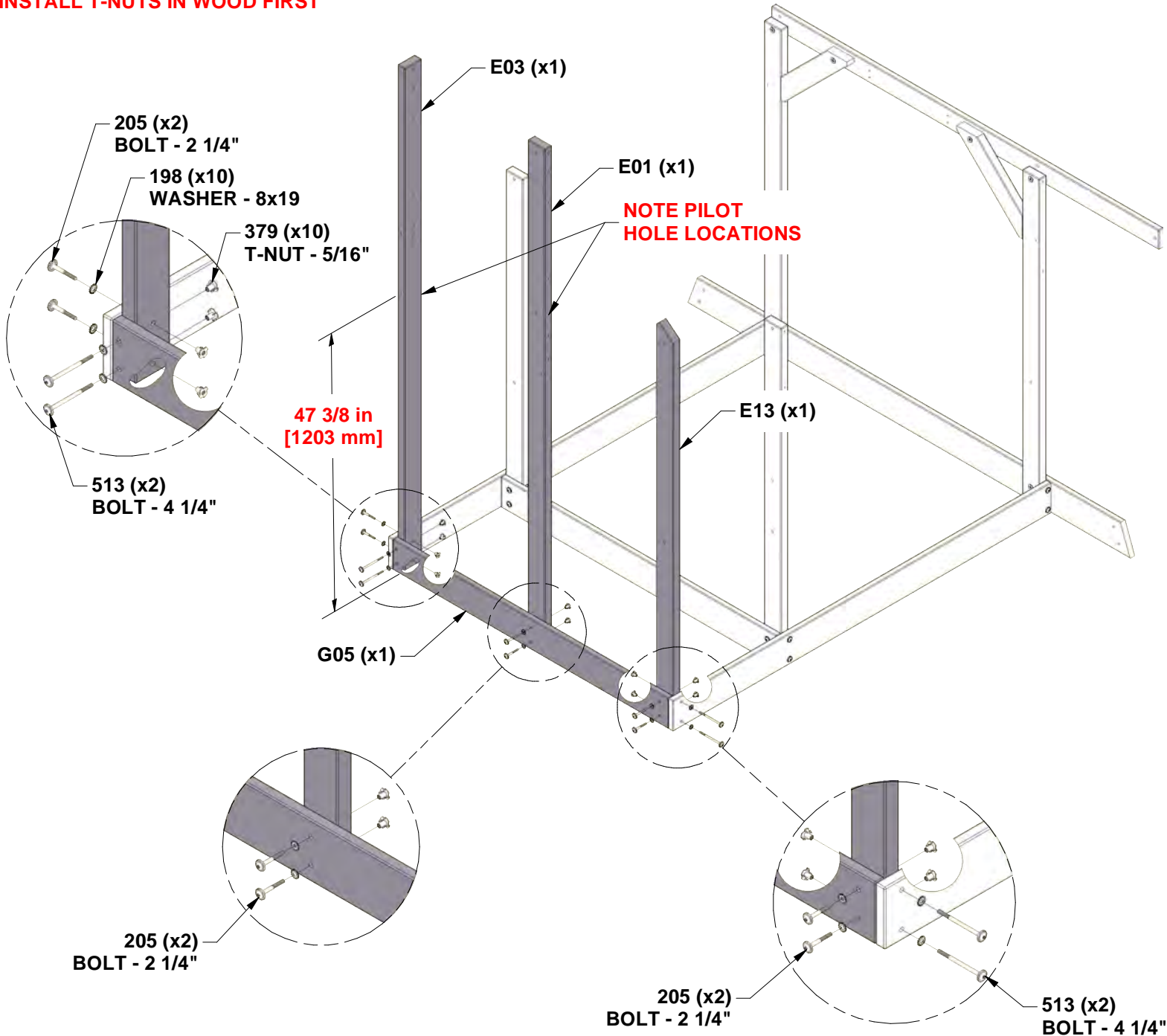

STEP 6 - FORT ASSEMBLY



H03 FLOOR SUPPORT - W4L20398
(x1) 1"x3 3/8"x76 3/4" (24x86x1948)

QTY	PART NUMBER	DESCRIPTION
2	H100198	WASHER LOCK EXT 8x19 BLK
2	H100205	BOLT WH 5/16x2-1/4 BLK
2	H100379	T-NUT 5/16 BLK

INSTALL T-NUTS IN WOOD FIRST

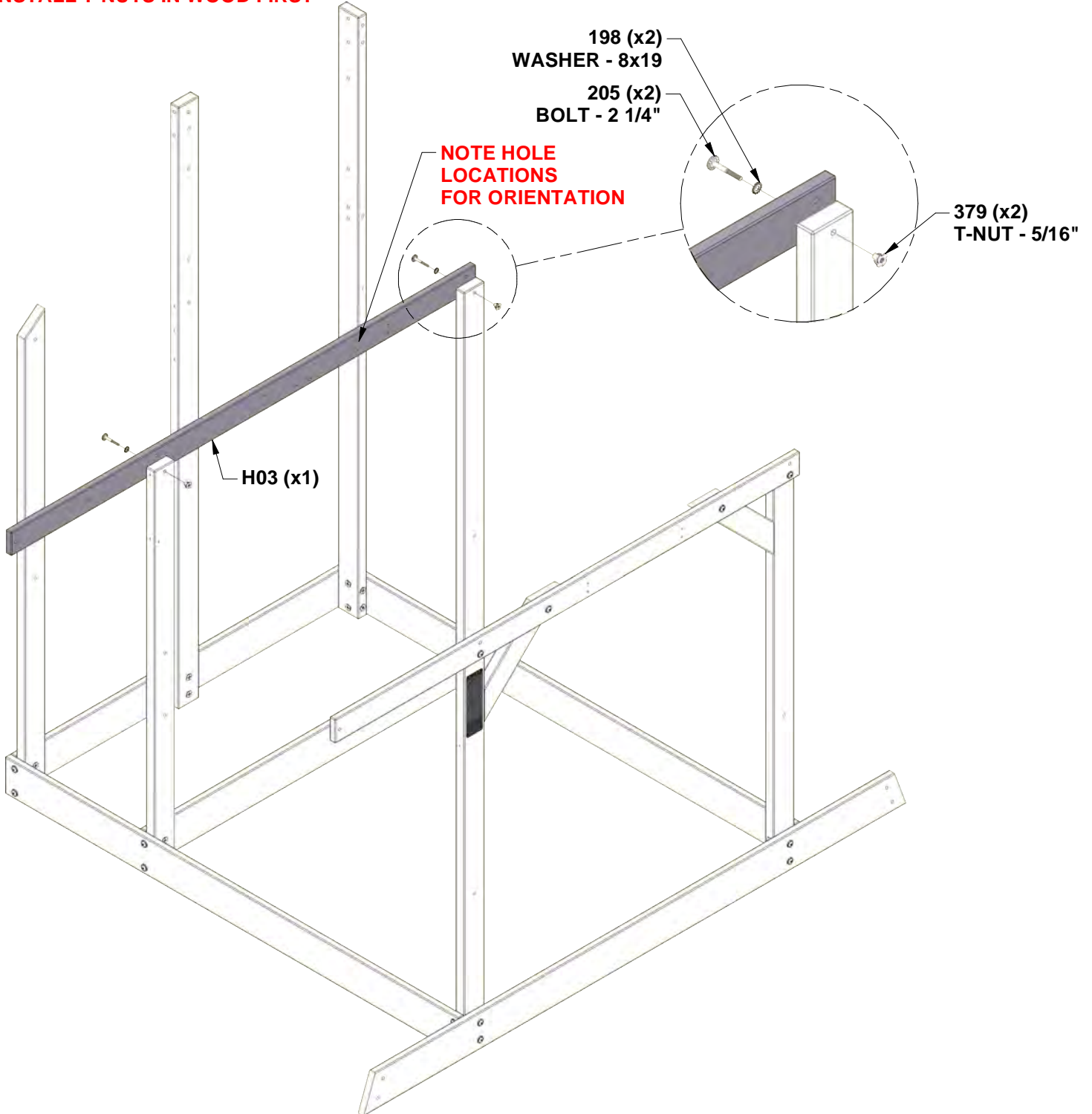

STEP 7 - FORT ASSEMBLY

QTY	PART NUMBER	DESCRIPTION
4	H100198	WASHER LOCK EXT 8x19 BLK
2	H100205	BOLT WH 5/16x2-1/4 BLK
2	H100379	T-NUT 5/16 BLK
2	H100405	WASHER LOCK EXT 6x15 BLK
2	H100458	LAG SCREW WH 5/16x2 BLK
2	H100487	LAG SCREW WH 1/4x2 BLK

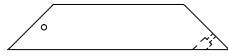

E17 DECK BRACE - W4L20370
 (x2) 1 3/8"x3 3/8"x16 1/2" (36x86x418)

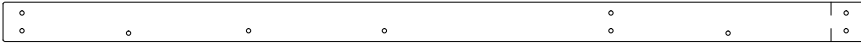

H04 FLOOR SUPPORT - W4L20399
 (x1) 1"x3 3/8"x74 7/8" (24x86x1901)

INSTALL T-NUTS IN WOOD FIRST

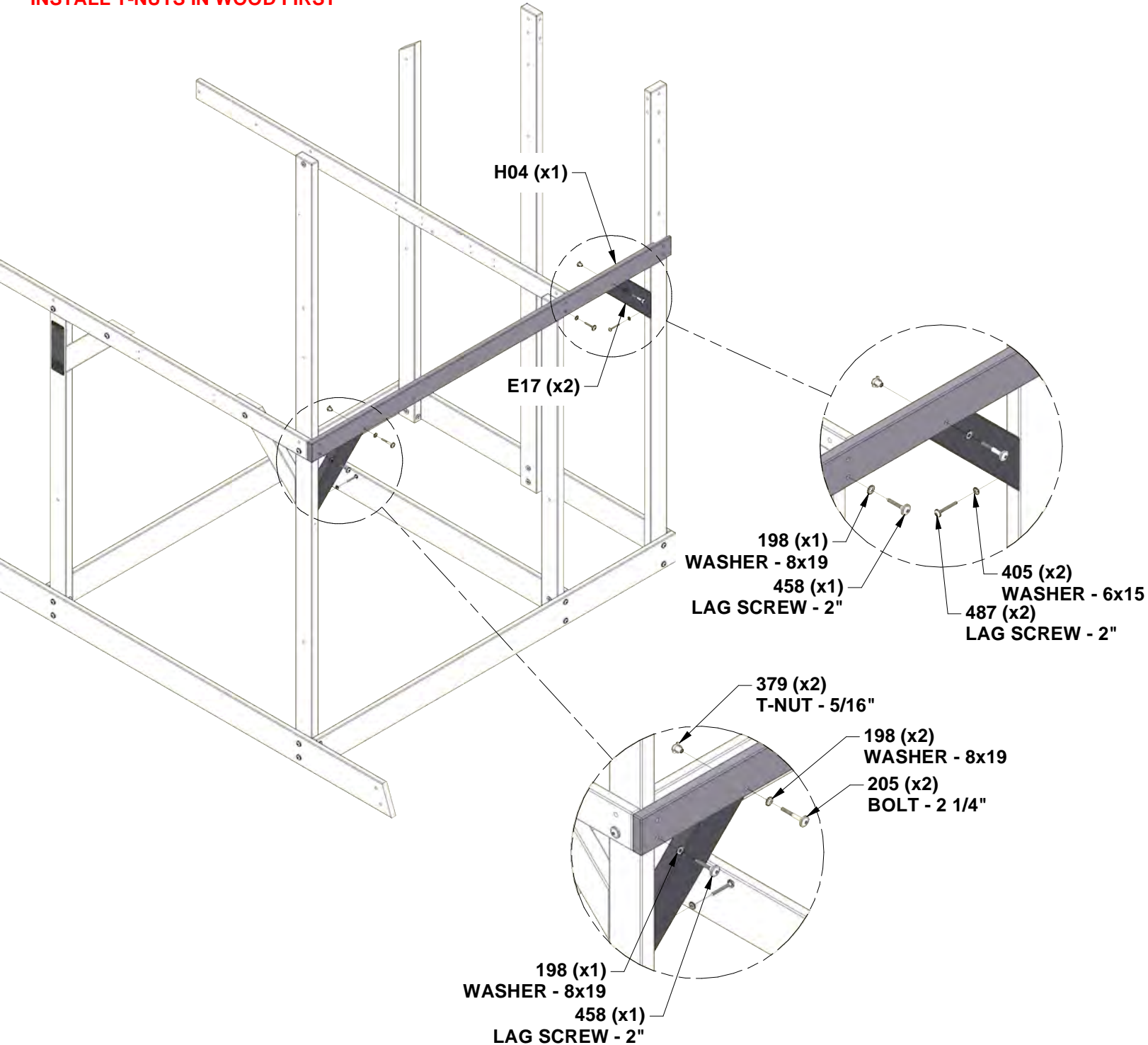

STEP 8 - FORT ASSEMBLY

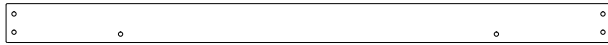

H13 FLOOR SUPPORT - W4L20408
(x1) 1"x3 3/8"x52 1/2" (24x86x1334)



E17 DECK BRACE - W4L20370
(x2) 1 3/8"x3 3/8"x16 1/2" (36x86x418)

QTY	PART NUMBER	DESCRIPTION
4	H100198	WASHER LOCK EXT 8x19 BLK
2	H100205	BOLT WH 5/16x2-1/4 BLK
2	H100379	T-NUT 5/16 BLK
2	H100405	WASHER LOCK EXT 6x15 BLK
2	H100458	LAG SCREW WH 5/16x2 BLK
2	H100487	LAG SCREW WH 1/4x2 BLK

INSTALL T-NUTS IN WOOD FIRST

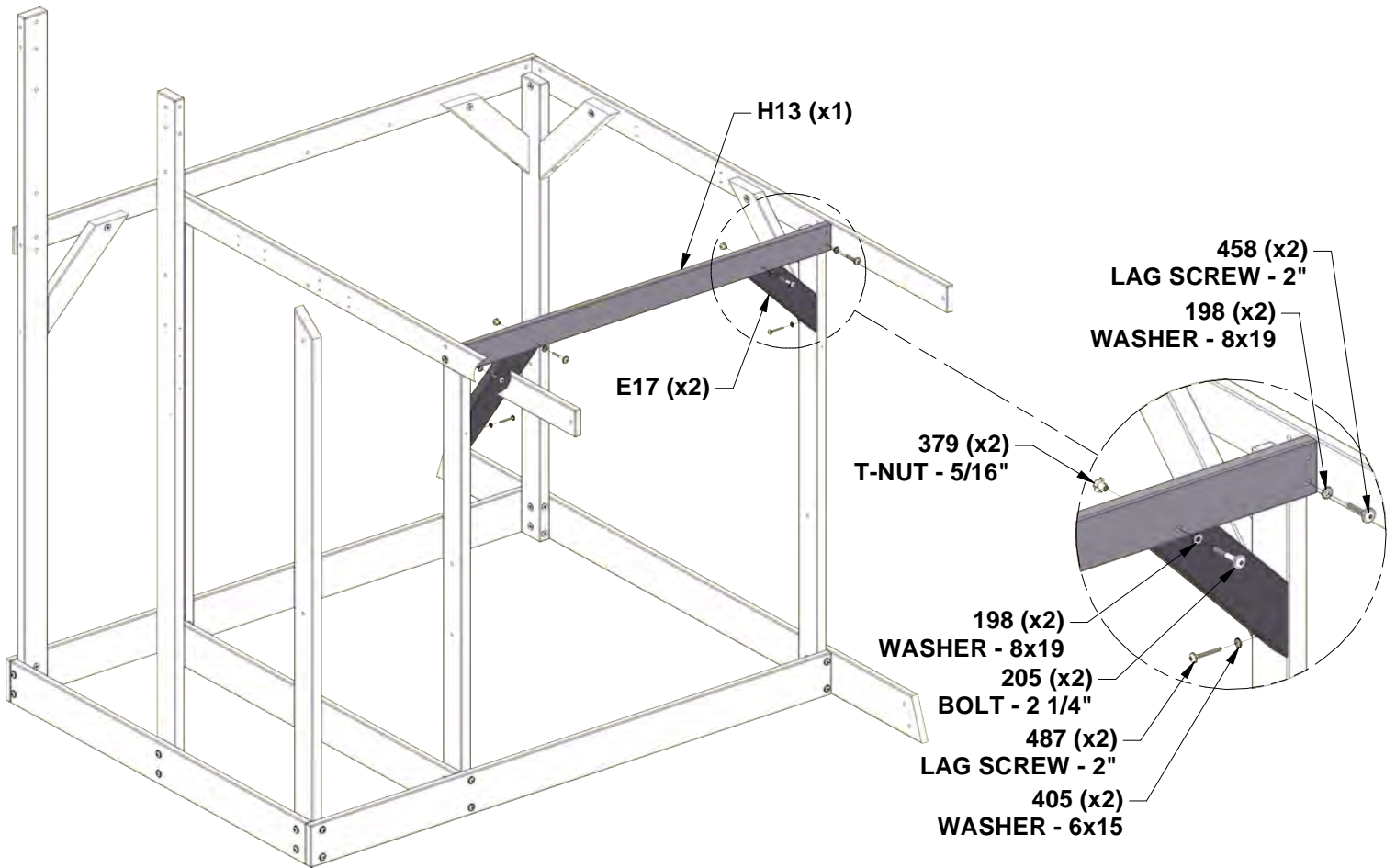

STEP 9 - FORT ASSEMBLY

QTY	PART NUMBER	DESCRIPTION
2	H100198	WASHER LOCK EXT 8x19 BLK
1	H100205	BOLT WH 5/16x2-1/4 BLK
2	H100379	T-NUT 5/16 BLK
1	H100513	BOLT WH 5/16x4 1/4 BLK

Holes downward when installed

1 3/4 in [43 mm]

H33 FLOOR SUPPORT - W4L20415
 (x1) 1"x3 3/8"x29 1/8" (24x86x740)

INSTALL T-NUTS IN WOOD FIRST

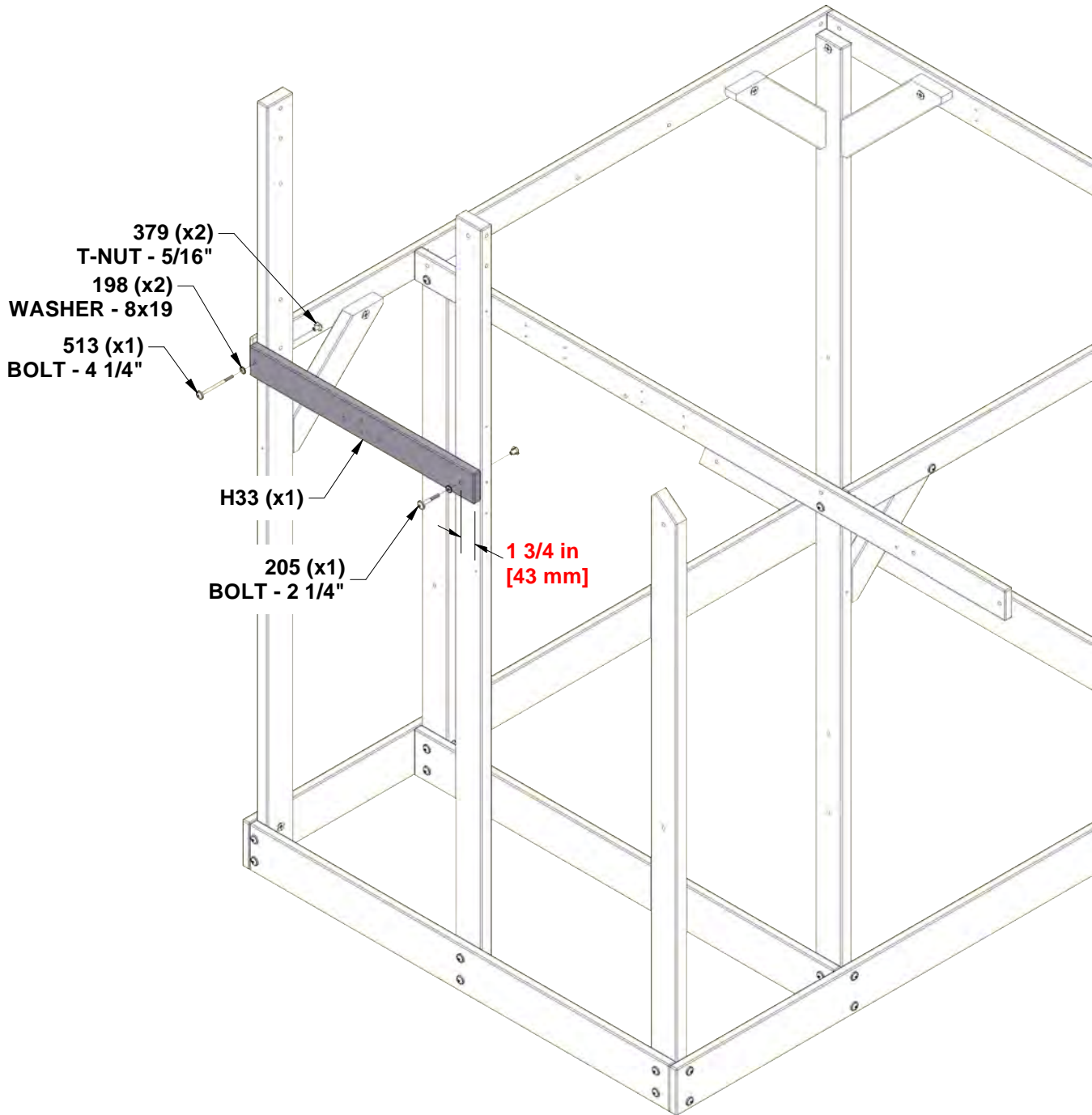

STEP 10 - FORT ASSEMBLY

QTY	PART NUMBER	DESCRIPTION
12	H100090	SCREW PFH 8x2 1/2



J01 FLOOR JOIST - W4L20426
 (x2) 1"x2 3/8"x52 1/2" (24x60x1334)



J08 FLOOR JOIST - W4L20433
 (x1) 1"x2 3/8"x20 3/8" (24x60x519)

ALIGN PILOT HOLES

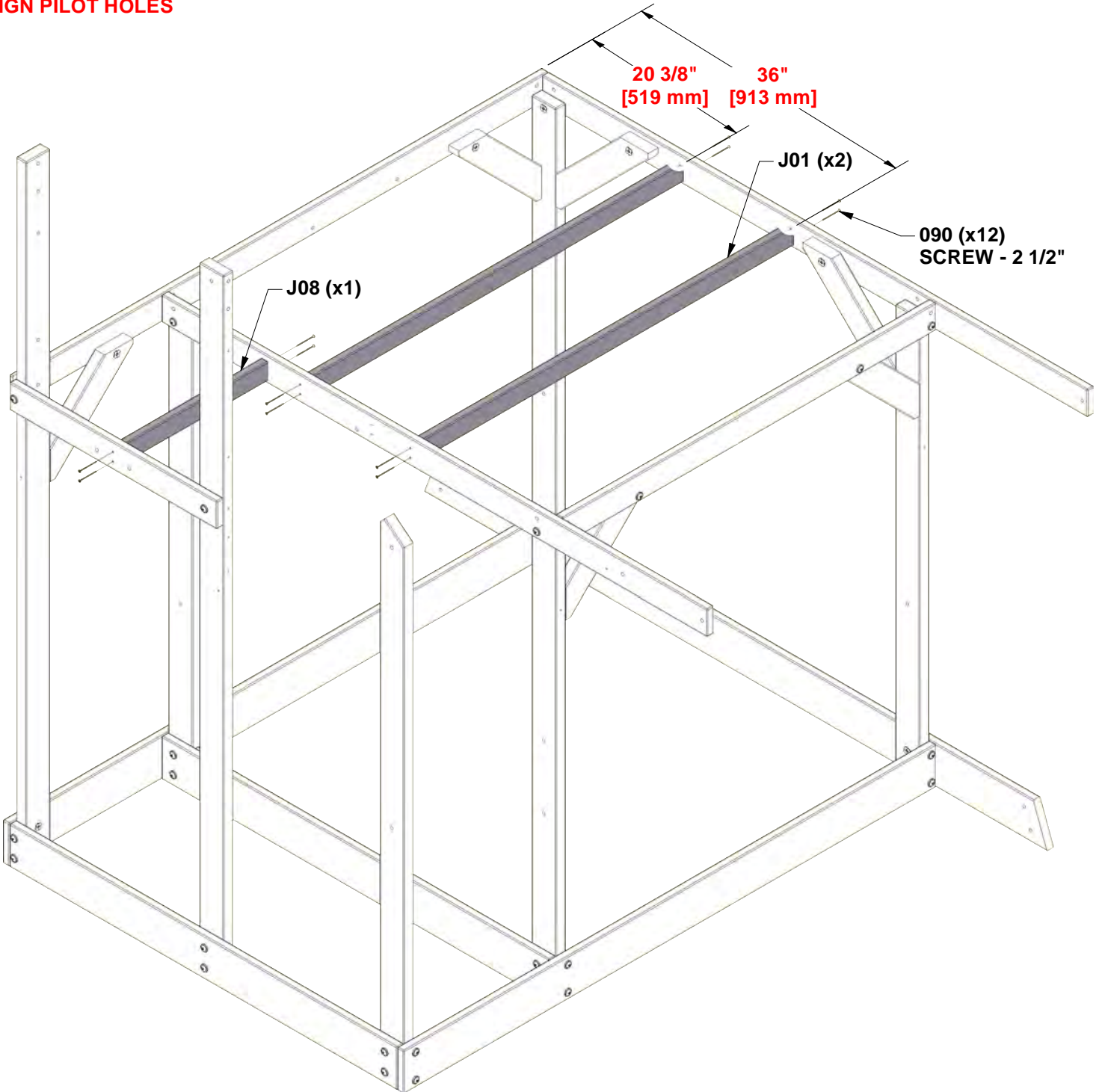

STEP 11 - FORT ASSEMBLY

QTY	PART NUMBER	DESCRIPTION
8	H100198	WASHER LOCK EXT 8x19 BLK
4	H100205	BOLT WH 5/16x2-1/4 BLK
4	H100379	T-NUT 5/16 BLK
4	H100458	LAG SCREW WH 5/16x2 BLK

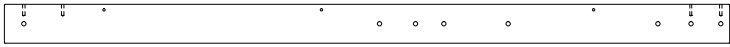

E04 UPRIGHT - W4L20358
(x1) 1 3/8"x3 3/8"x63" (36x86x1600)



E05 UPRIGHT - W4L20359
(x1) 1 3/8"x3 3/8"x63" (36x86x1600)



E07 UPRIGHT - W4L20361
(x1) 1 3/8"x3 3/8"x63" (36x86x1600)

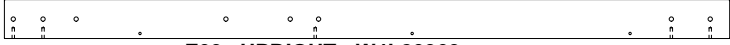

E09 UPRIGHT - W4L20363
(x1) 1 3/8"x3 3/8"x63" (36x86x1600)

INSTALL T-NUTS IN WOOD FIRST

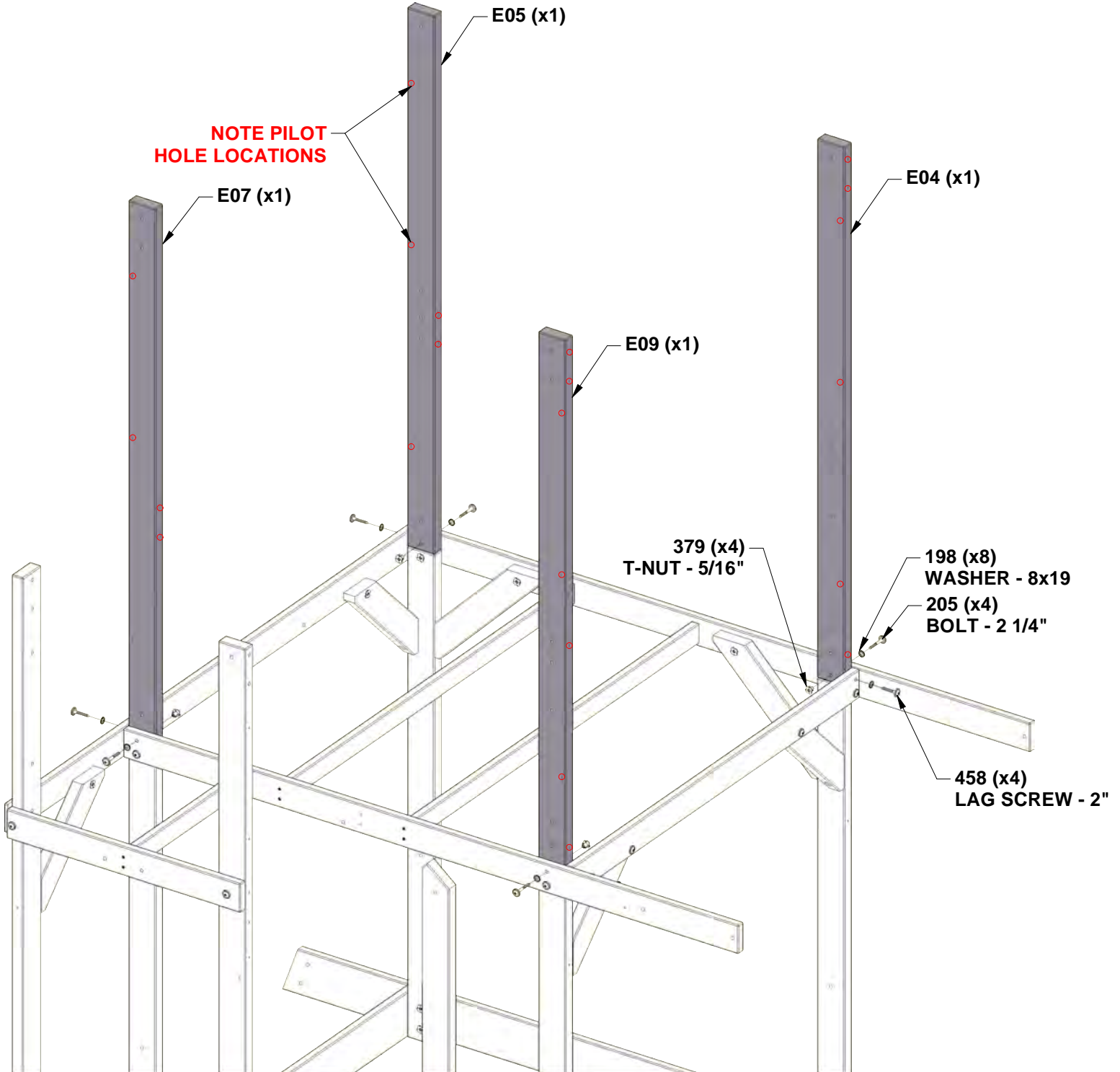

STEP 12 - FORT ASSEMBLY

QTY	PART NUMBER	DESCRIPTION
5	H100089	SCREW PFH 8x1-3/4"



T02 SUPPORT BOARD - W4L20483
 (x1) 1"x1 3/8"x49 5/8" (24x34x1260)

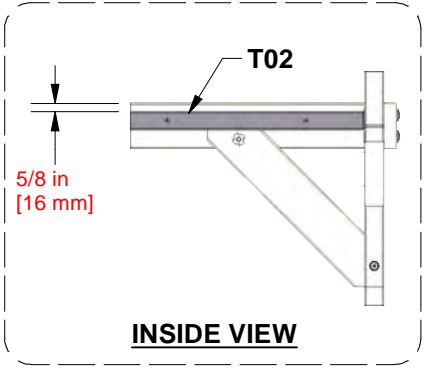
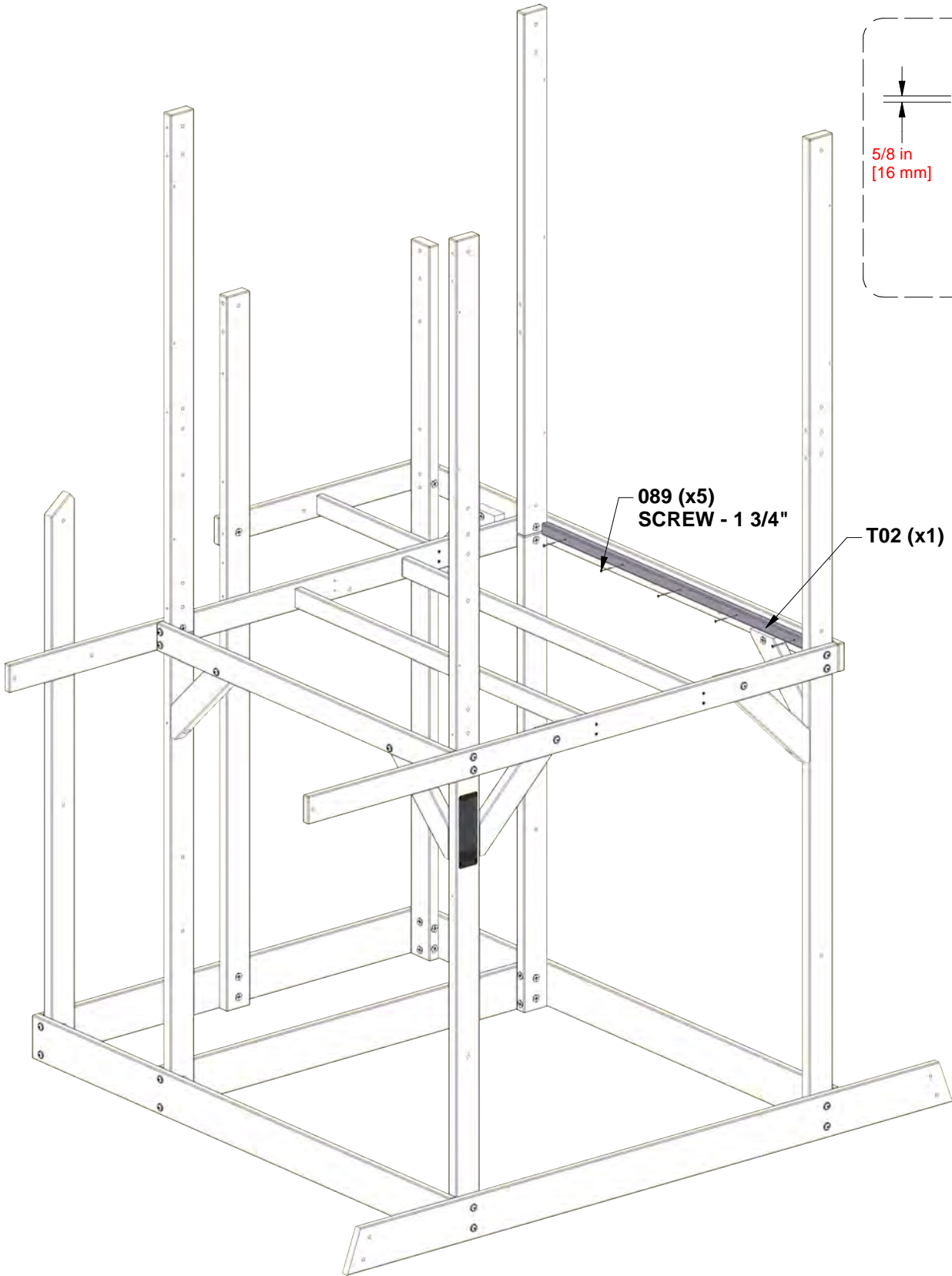

STEP 13 - FORT ASSEMBLY

QTY	PART NUMBER	DESCRIPTION
5	H100089	SCREW PFH 8x1-3/4"

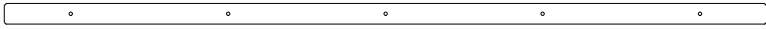

T02 SUPPORT BOARD - W4L20483
(x1) 1"x1 3/8"x49 5/8" (24x34x1260)

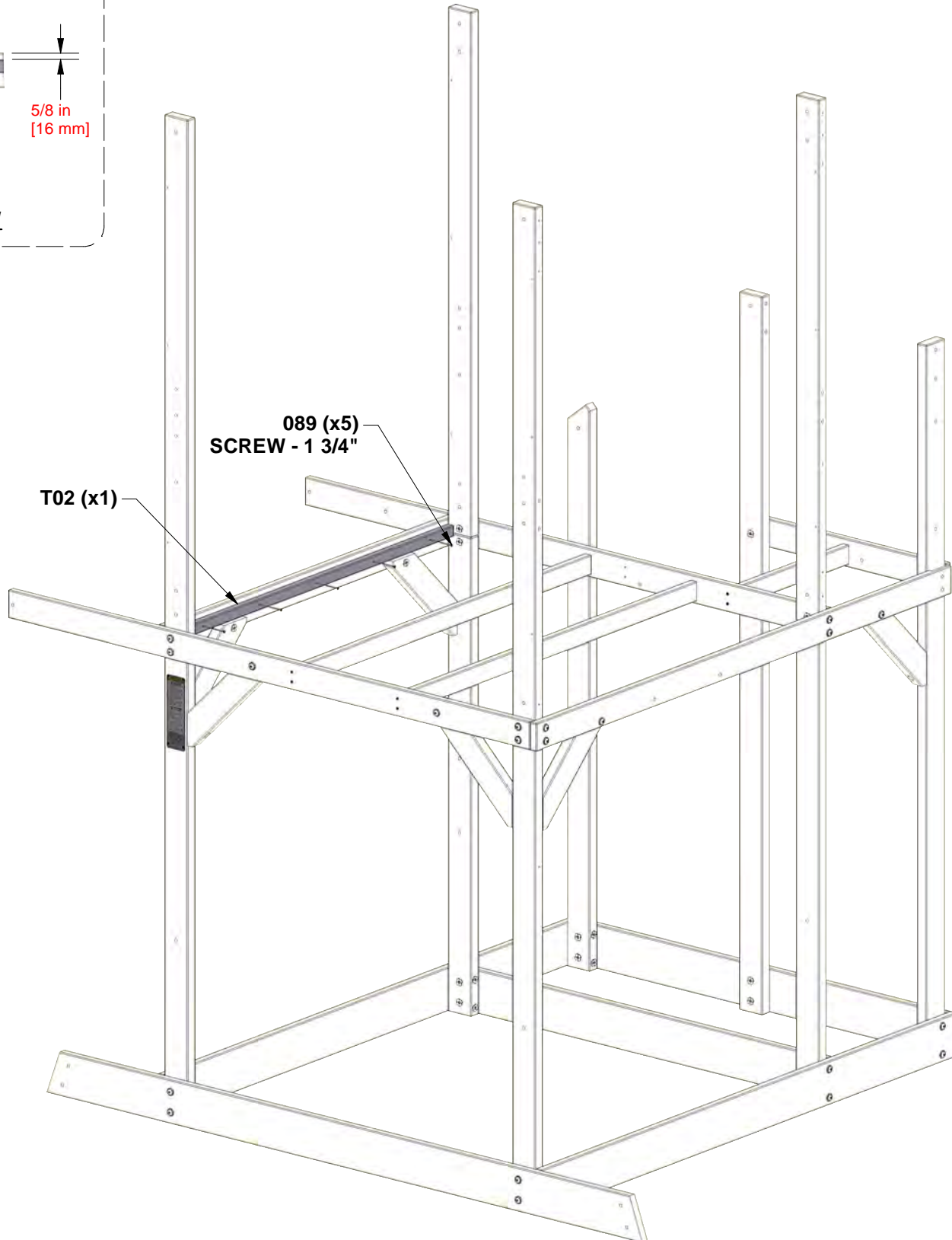
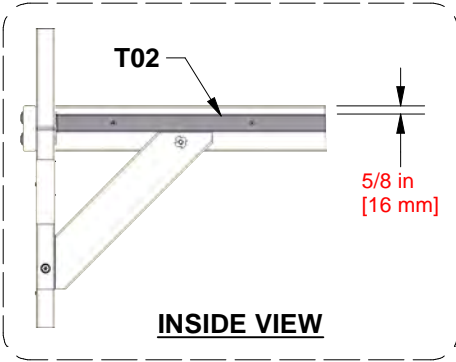

STEP 14 - FORT ASSEMBLY

QTY	PART NUMBER	DESCRIPTION
5	H100089	SCREW PFH 8x1-3/4"

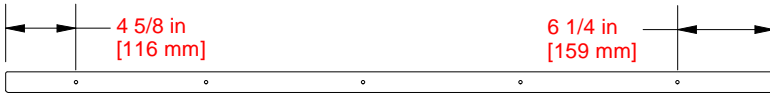

T01 SUPPORT BOARD - W4L20482
 (x1) 1"x1 3/8"x50" (24x34x1270)

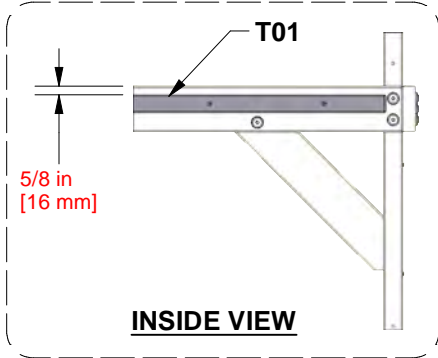

CENTER T01 IN OPENING

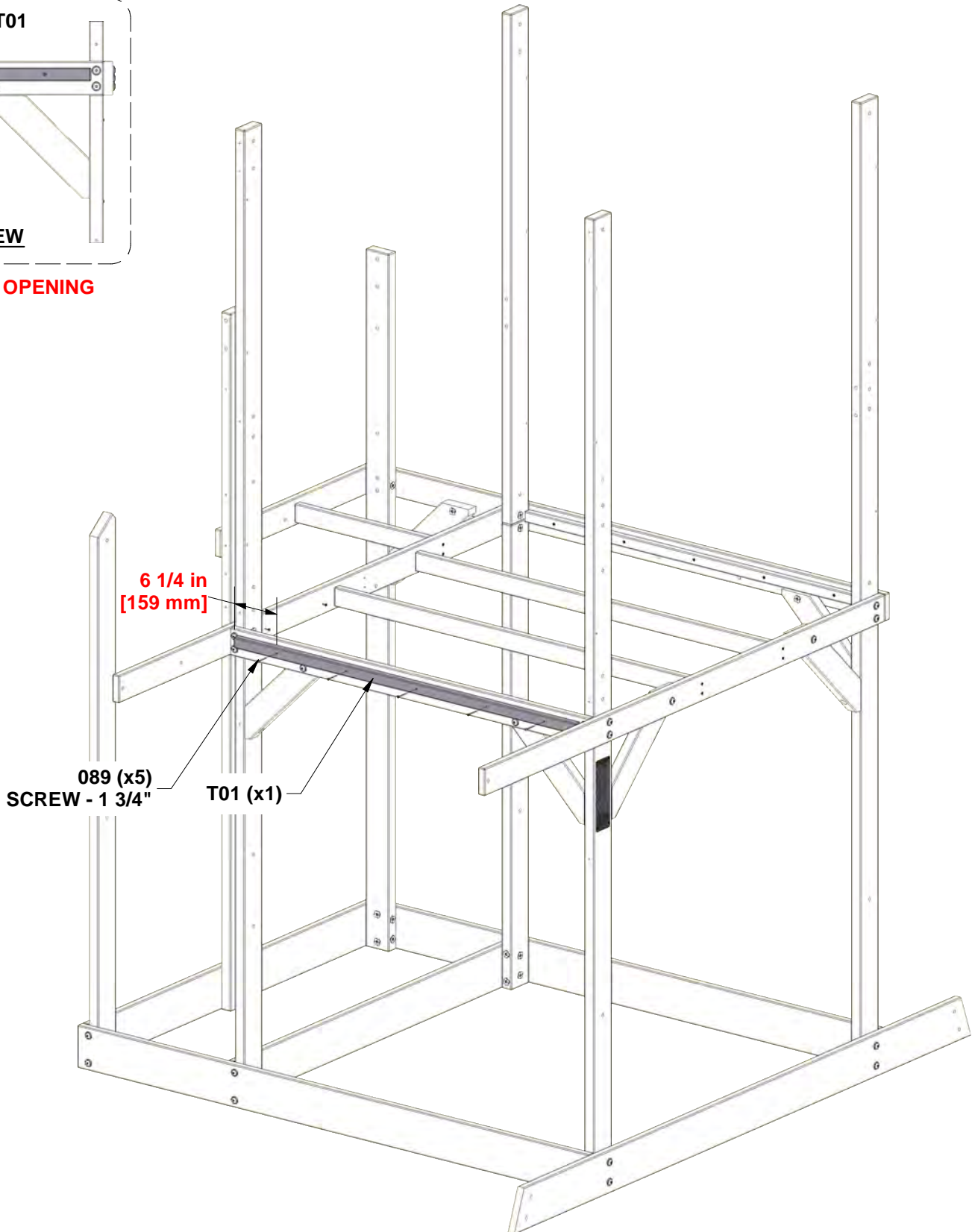

STEP 15 - FORT ASSEMBLY

QTY	PART NUMBER	DESCRIPTION
6	H100198	WASHER LOCK EXT 8x19 BLK
4	H100205	BOLT WH 5/16x2-1/4 BLK
6	H100379	T-NUT 5/16 BLK
2	H100484	BOLT WH 5/16x3 1/4 BLK



F04 POST - W4L20379
 (x1) 1 3/8"x2 3/8"x30 3/8" (36x60x772)



F02 POST - W4L20377
 (x1) 1 3/8"x2 3/8"x30 3/8" (36x60x772)



H08 FLOOR SUPPORT - W4L20403
 (x1) 1"x3 3/8"x54 3/8" (24x86x1382)

INSTALL T-NUTS IN WOOD FIRST

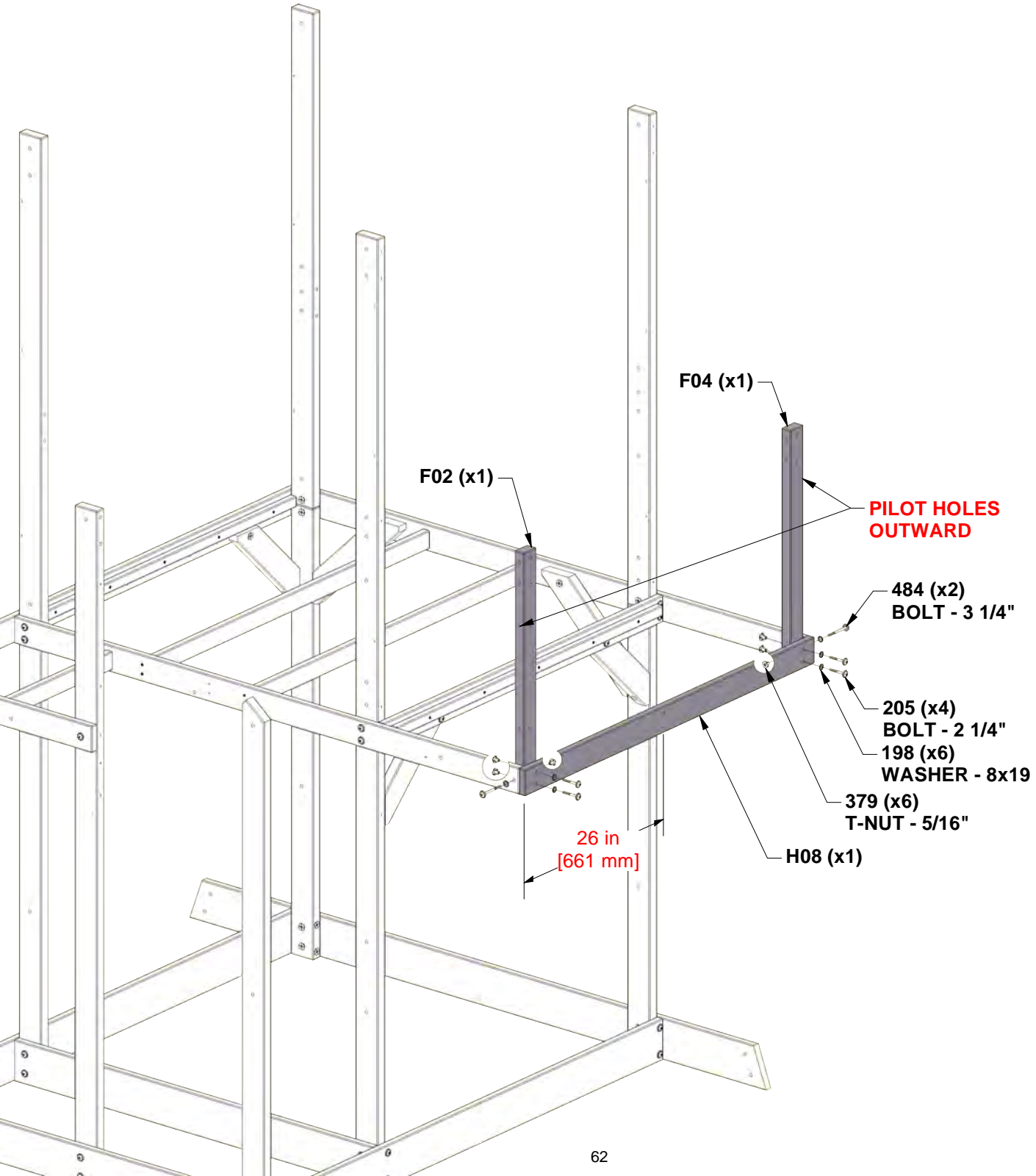

STEP 16 - FORT ASSEMBLY



F03 POST - W4L20378
 (x1) 1 3/8"x2 3/8"x30 3/8" (36x60x772)

QTY	PART NUMBER	DESCRIPTION
2	H100198	WASHER LOCK EXT 8x19 BLK
2	H100205	BOLT WH 5/16x2-1/4 BLK
2	H100379	T-NUT 5/16 BLK

INSTALL T-NUTS IN WOOD FIRST

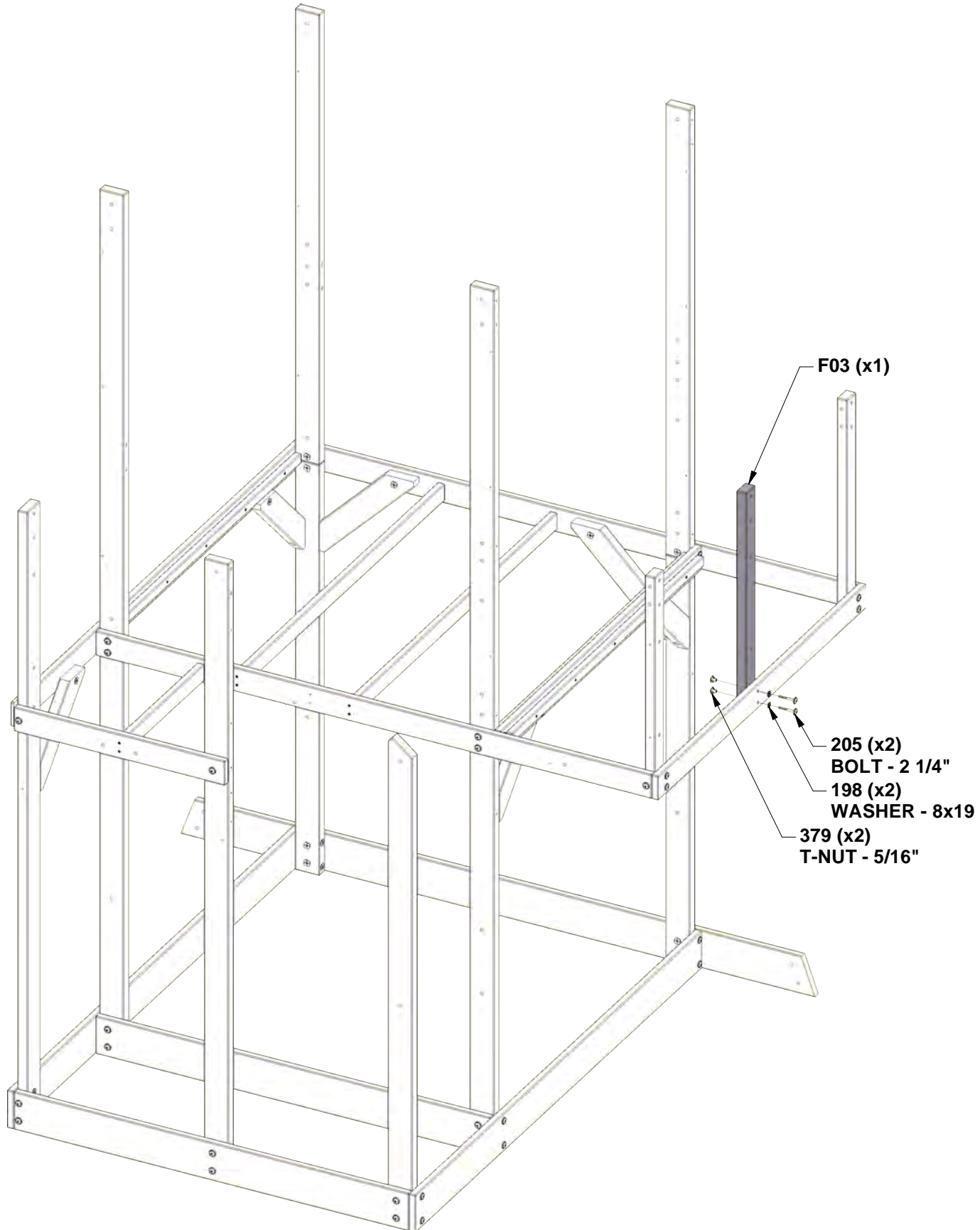

STEP 17 - FORT ASSEMBLY

QTY	PART NUMBER	DESCRIPTION
10	H100089	SCREW PFH 8x1-3/4"
2	H100111	SCREW PFH 8x2"



J09 SUPPORT BOARD - W4L20434
 (x3) 1"x2 3/8"x2 3/4" (24x60x70)

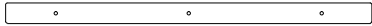

T04 SUPPORT BOARD - W4L20485
 (x1) 1"x1 3/8"x23 7/8" (24x34x606)



T05 SUPPORT BOARD - W4L20486
 (x1) 1"x1 3/8"x21 1/2" (24x34x546)

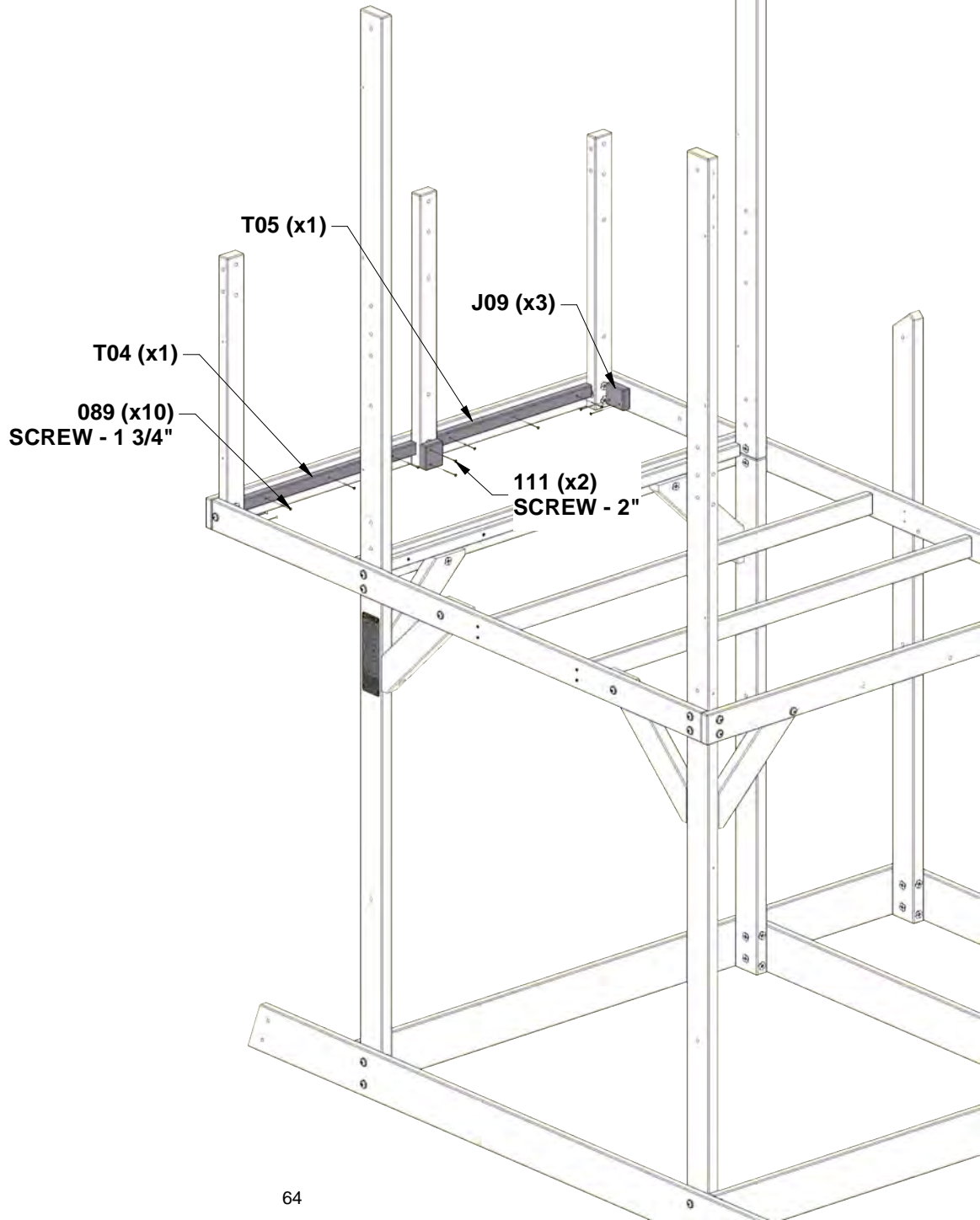
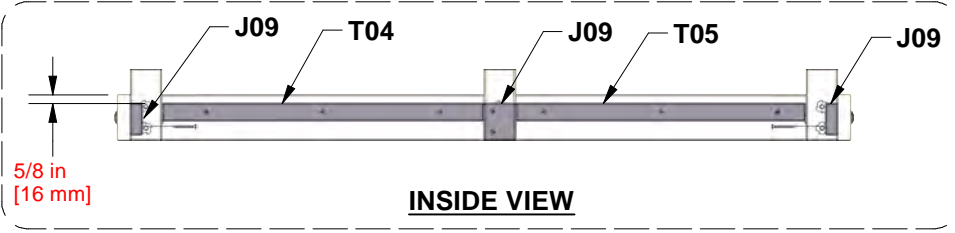

STEP 18 - FORT ASSEMBLY

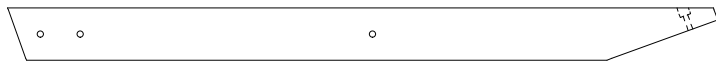

E18 ANGLE BRACE - W4L20371
(x2) 1 3/8"x3 3/8"x46 1/4" (36x86x1174)

QTY	PART NUMBER	DESCRIPTION
4	H100198	WASHER LOCK EXT 8x19 BLK
4	H100205	BOLT WH 5/16x2-1/4 BLK
4	H100379	T-NUT 5/16 BLK
2	H100405	WASHER LOCK EXT 6x15 BLK
2	H100487	LAG SCREW WH 1/4x2 BLK

INSTALL T-NUTS IN WOOD FIRST
NOTE HOLE LOCATIONS

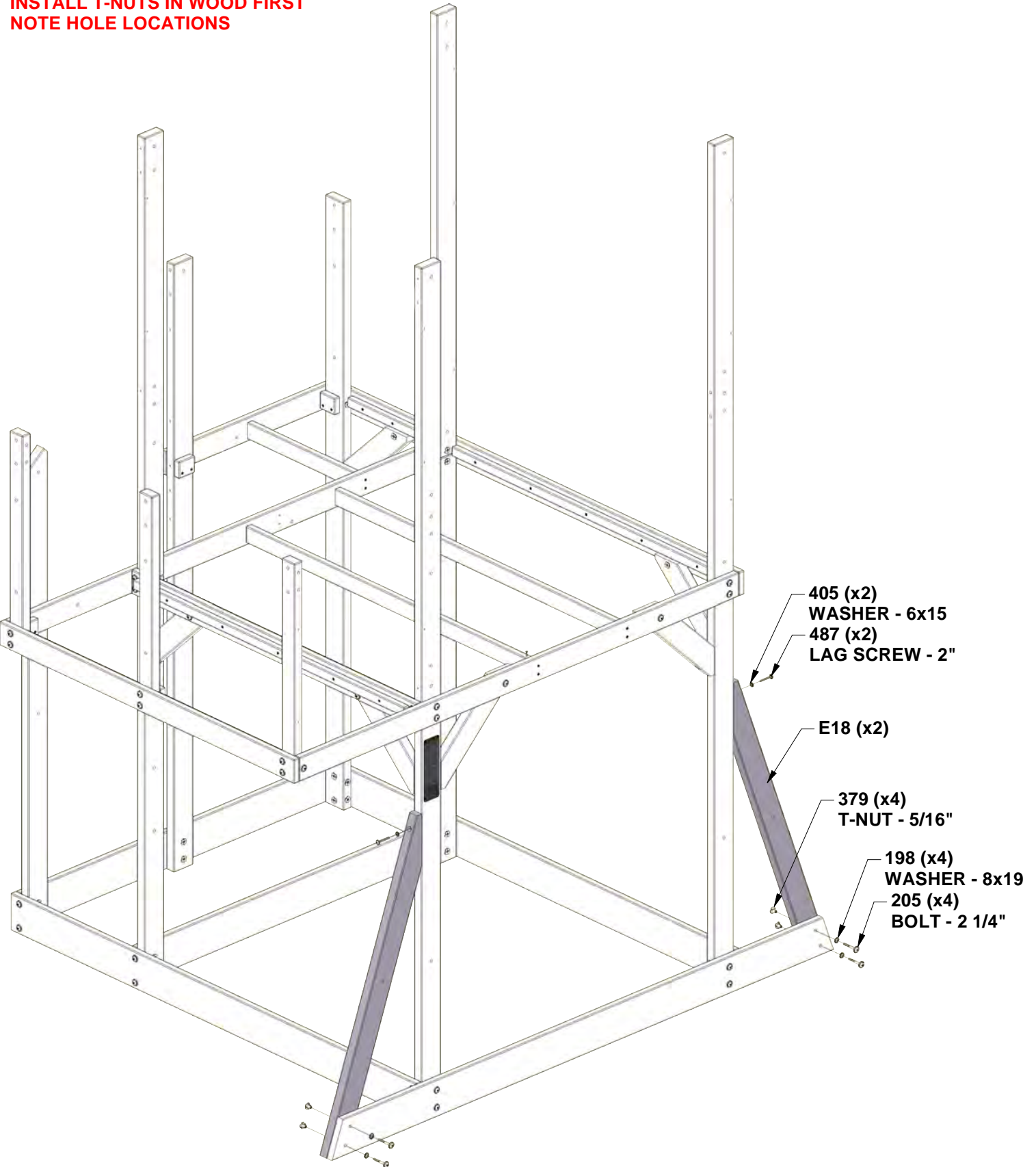

STEP 19 - FORT ASSEMBLY



H09 FLOOR RAIL - W4L20404
 (x1) 1"x3 3/8"x48 1/4" (24x86x1224)



E02 DECK BRACE - W4L20356
 (x1) 1 3/8"x3 3/8"x16 7/16" (36x86x418)

QTY	PART NUMBER	DESCRIPTION
3	H100198	WASHER LOCK EXT 8x19 BLK
3	H100205	BOLT WH 5/16x2-1/4 BLK
3	H100379	T-NUT 5/16 BLK
1	H100405	WASHER LOCK EXT 6x15 BLK
1	H100487	LAG SCREW WH 1/4x2 BLK

INSTALL T-NUTS IN WOOD FIRST

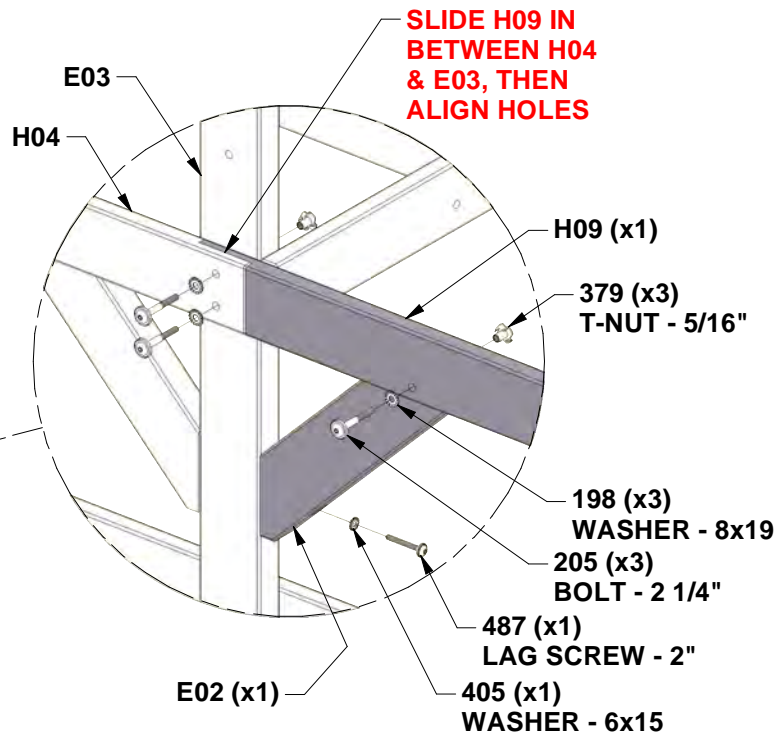
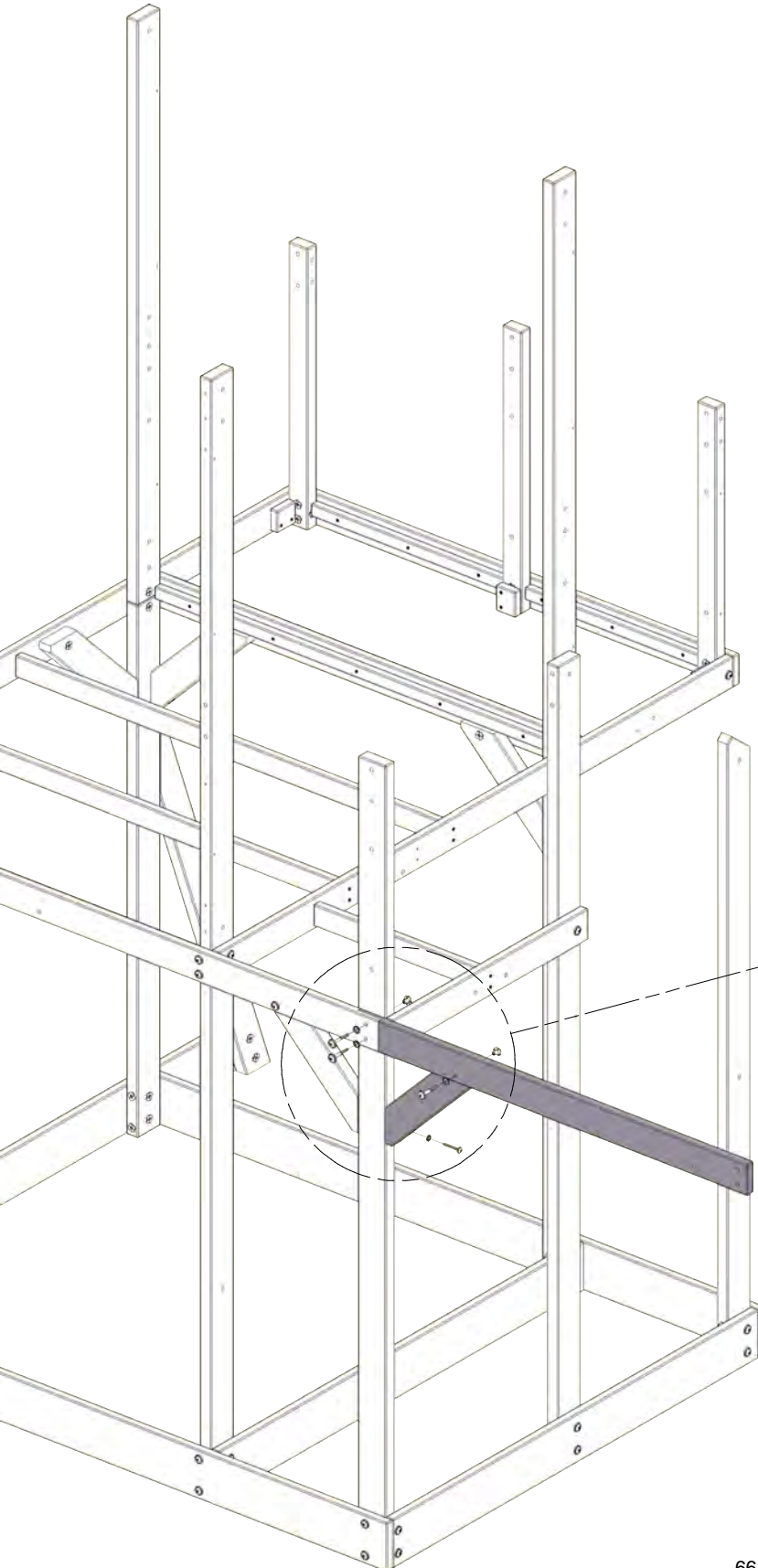

STEP 20 - FORT ASSEMBLY



H11 FLOOR RAIL - W4L20406
(x1) 1"x3 3/8"x65 5/8" (24x86x1667)



E02 DECK BRACE - W4L20356
(x1) 1 3/8"x3 3/8"x16 7/16" (36x86x418)

QTY	PART NUMBER	DESCRIPTION
2	H100198	WASHER LOCK EXT 8x19 BLK
2	H100090	SCREW PFH 8x2 1/2
1	H100205	BOLT WH 5/16x2-1/4 BLK
1	H100379	T-NUT 5/16 BLK
1	H100405	WASHER LOCK EXT 6x15 BLK
1	H100458	LAG SCREW WH 5/16x2 BLK
1	H100487	LAG SCREW WH 1/4x2 BLK

INSTALL T-NUTS IN WOOD FIRST

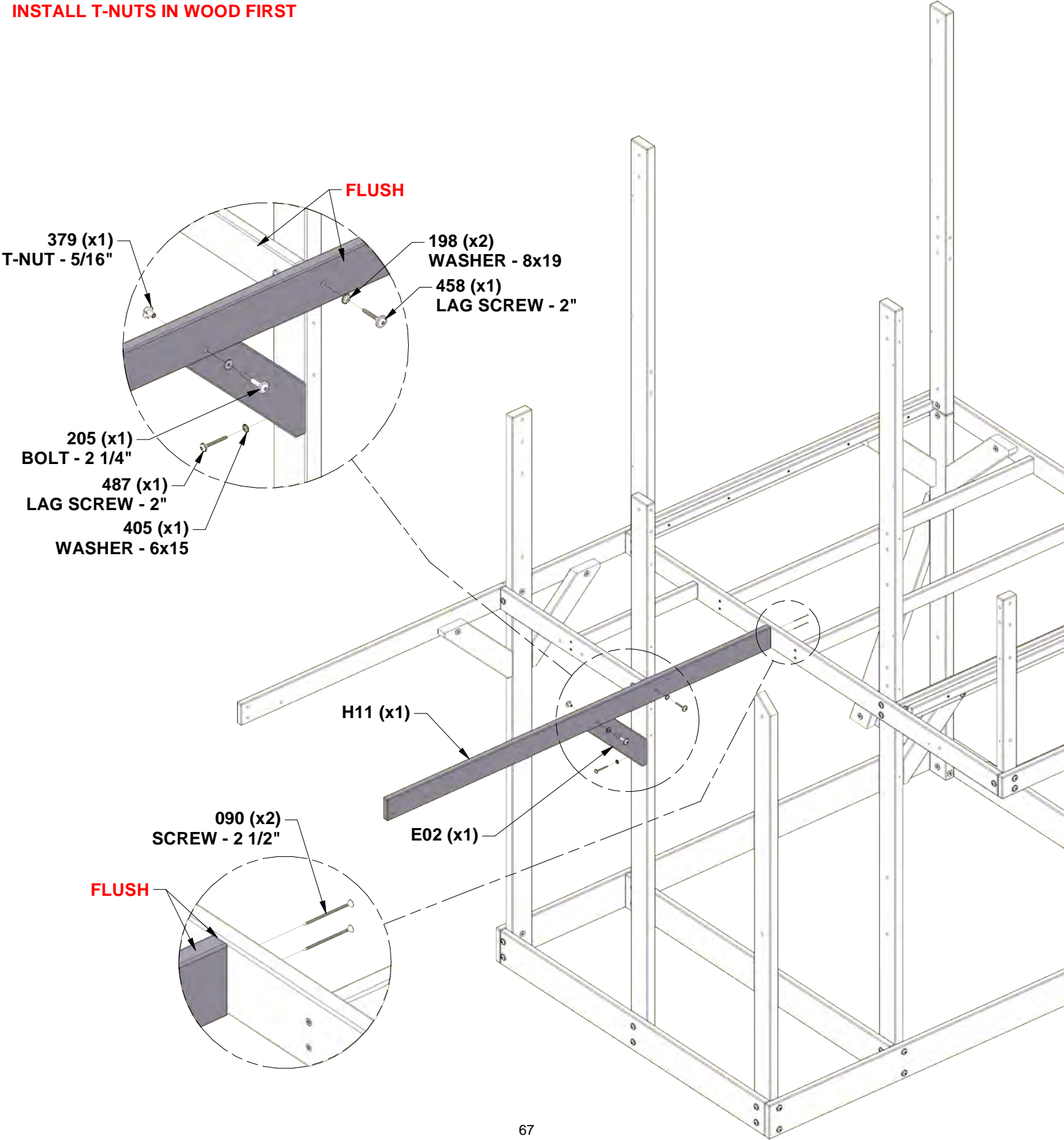

STEP 21 - FORT ASSEMBLY

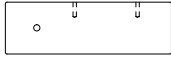

E14 UPRIGHT - W4L20368
 (x1) 1 3/8"x3 3/8"x10 7/8" (36x86x275)

QTY	PART NUMBER	DESCRIPTION
1	H100198	WASHER LOCK EXT 8x19 BLK
1	H100205	BOLT WH 5/16x2-1/4 BLK
1	H100379	T-NUT 5/16 BLK

INSTALL T-NUTS IN WOOD FIRST

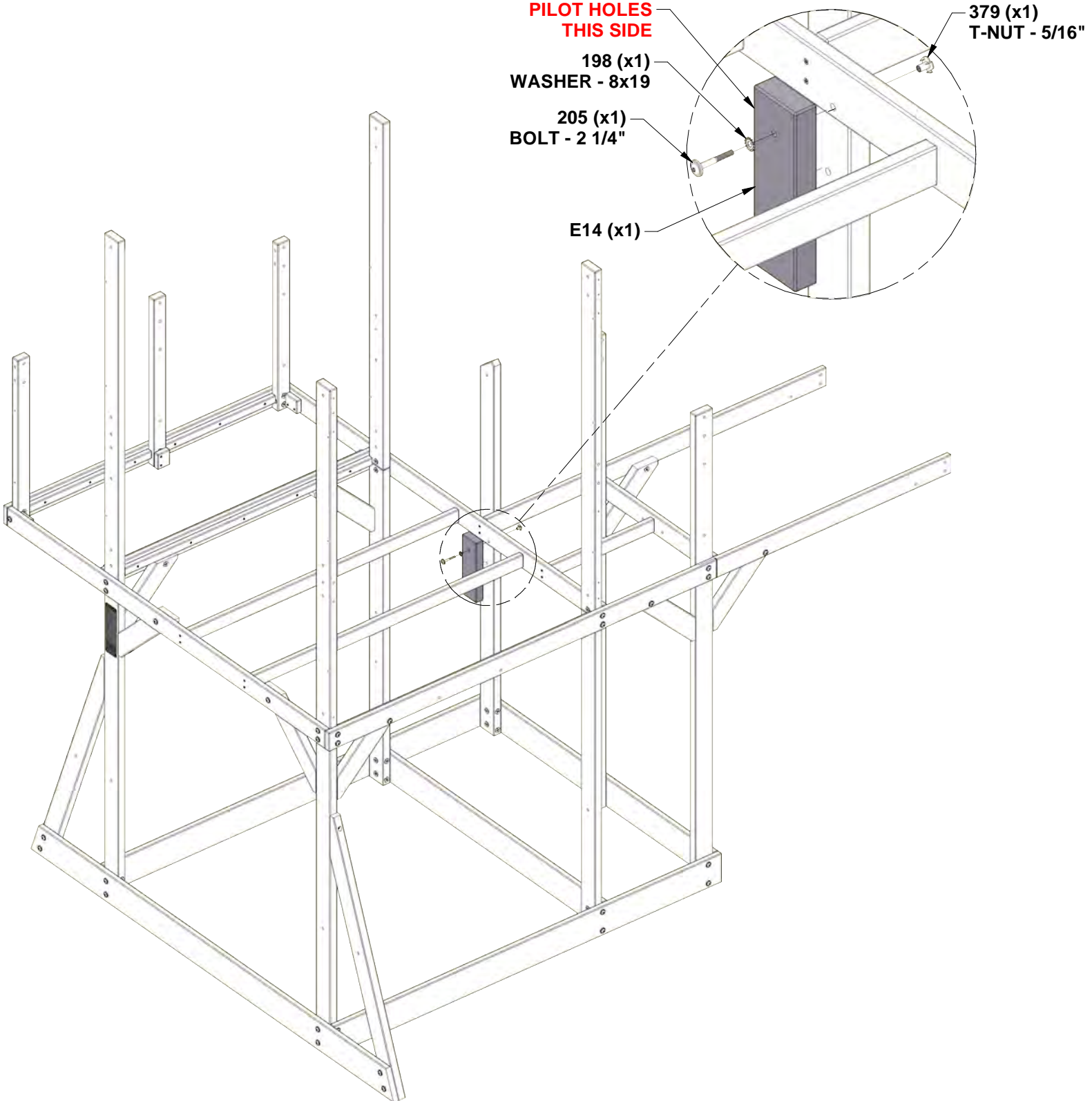

STEP 22 - FORT ASSEMBLY

QTY	PART NUMBER	DESCRIPTION
4	H100198	WASHER LOCK EXT 8x19 BLK
2	H100458	LAG SCREW WH 5/16x2 BLK
2	H100471	LAG SCREW WH 5/16x1-1/2 BLK



L01 SUPPORT BOARD - W4L20444
(x1) 5/8"x3 5/8"x22 3/4" (16x92x579)



Q01 SUPPORT BOARD - W4L20480
(x1) 1"x4 3/8"x22 3/4" (24x112x579)

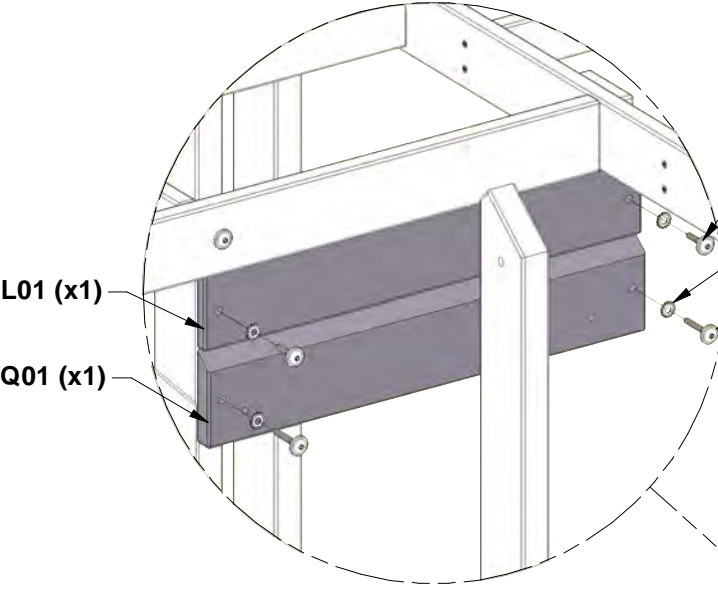

- 471 (x2)
LAG SCREW - 1 1/2"
- 198 (x4)
WASHER - 8x19
- 458 (x2)
LAG SCREW - 2"

L01 (x1)
Q01 (x1)

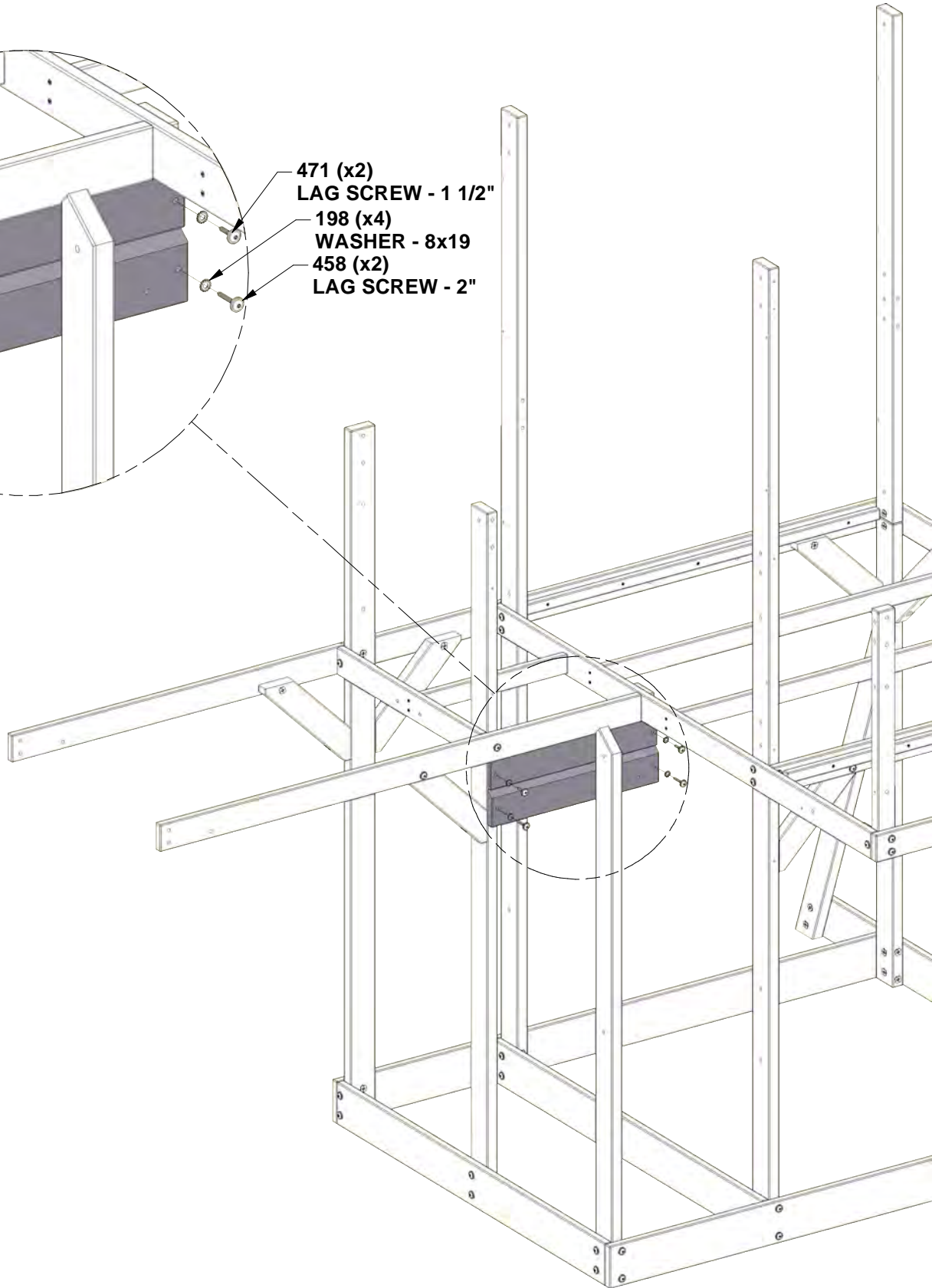

STEP 23 - FORT ASSEMBLY

QTY	PART NUMBER	DESCRIPTION
6	H100198	WASHER LOCK EXT 8x19 BLK
2	H100205	BOLT WH 5/16x2-1/4 BLK
6	H100379	T-NUT 5/16 BLK
4	H100484	BOLT WH 5/16x3 1/4 BLK



F05 UPRIGHT - W4L20380
 (x2) 1 3/8"x2 3/8"x30 3/8" (36x60x772)



H12 FLOOR RAIL - W4L20407
 (x1) 1"x3 3/8"x31" (24x86x788)



H14 FLOOR SUPPORT - W4L20409
 (x2) 1"x2 3/4"x2 3/8" (24x60x70)

INSTALL T-NUTS IN WOOD FIRST

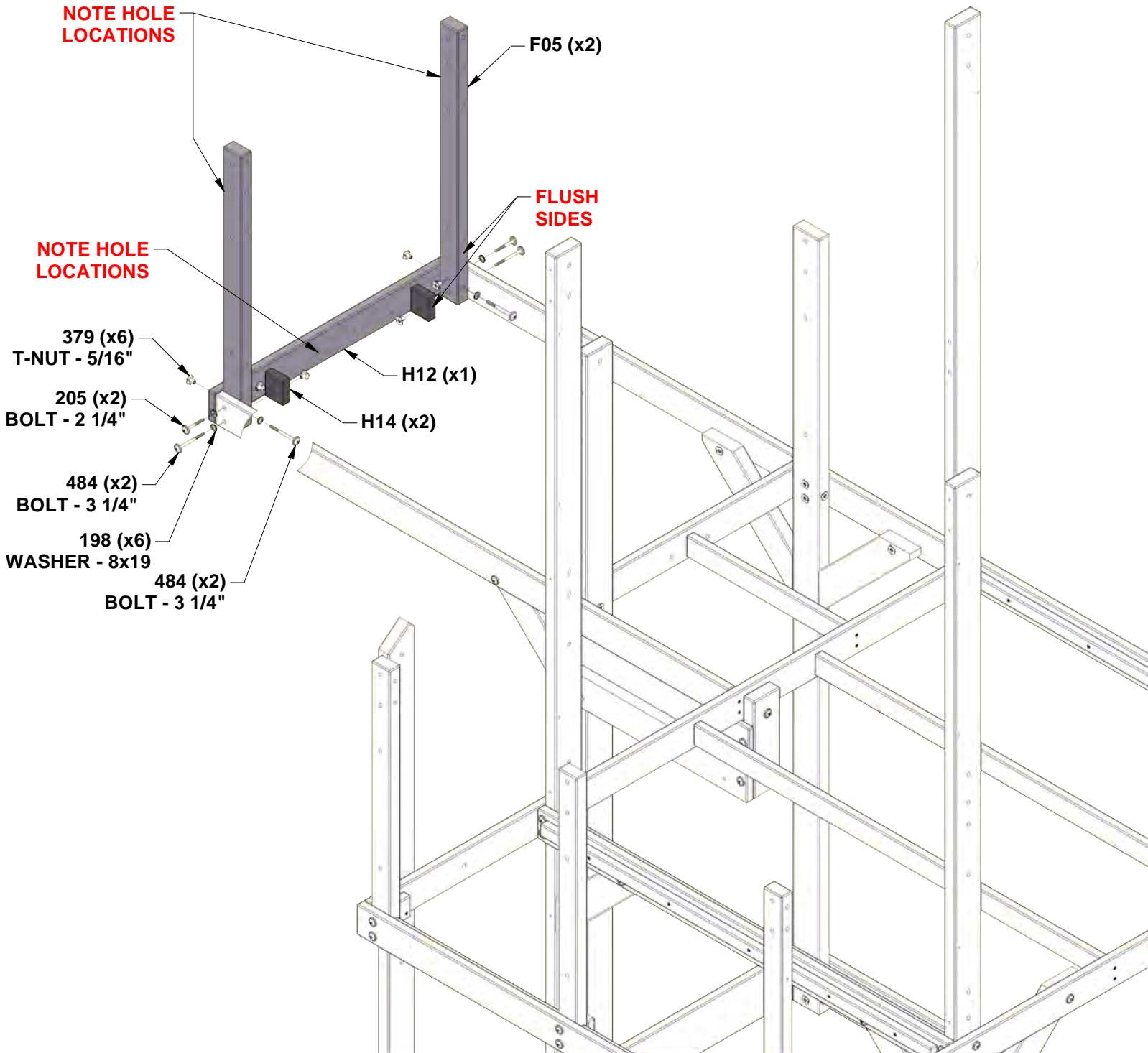

STEP 24 - FORT ASSEMBLY



B09 SWING SUPPORT - W4L20353
(x1) 2 7/8"x3"x44 1/8" (72x76x1122)

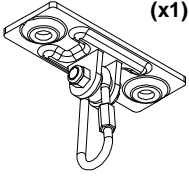

A4M00505 SWING HANGER
(x2)

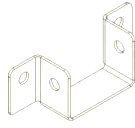

A4M01878 JOIST HANGER 90°
(x2)

QTY	PART NUMBER	DESCRIPTION
2	H100192	NUT BARREL WH 5/16x7/8 BLK
2	H100195	BOLT WH 5/16x2-3/4 BLK
4	H100379	T-NUT 5/16 BLK
4	H100468	BOLT WH 5/16x1 BLK
4	H100073	T-NUT 3/8
4	H100102	WASHER FLAT 11x25
4	H100107	WASHER LOCK INT 10x18
4	H100434	BOLT HEX 3/8x3 1/4

INSTALL T-NUTS IN WOOD FIRST

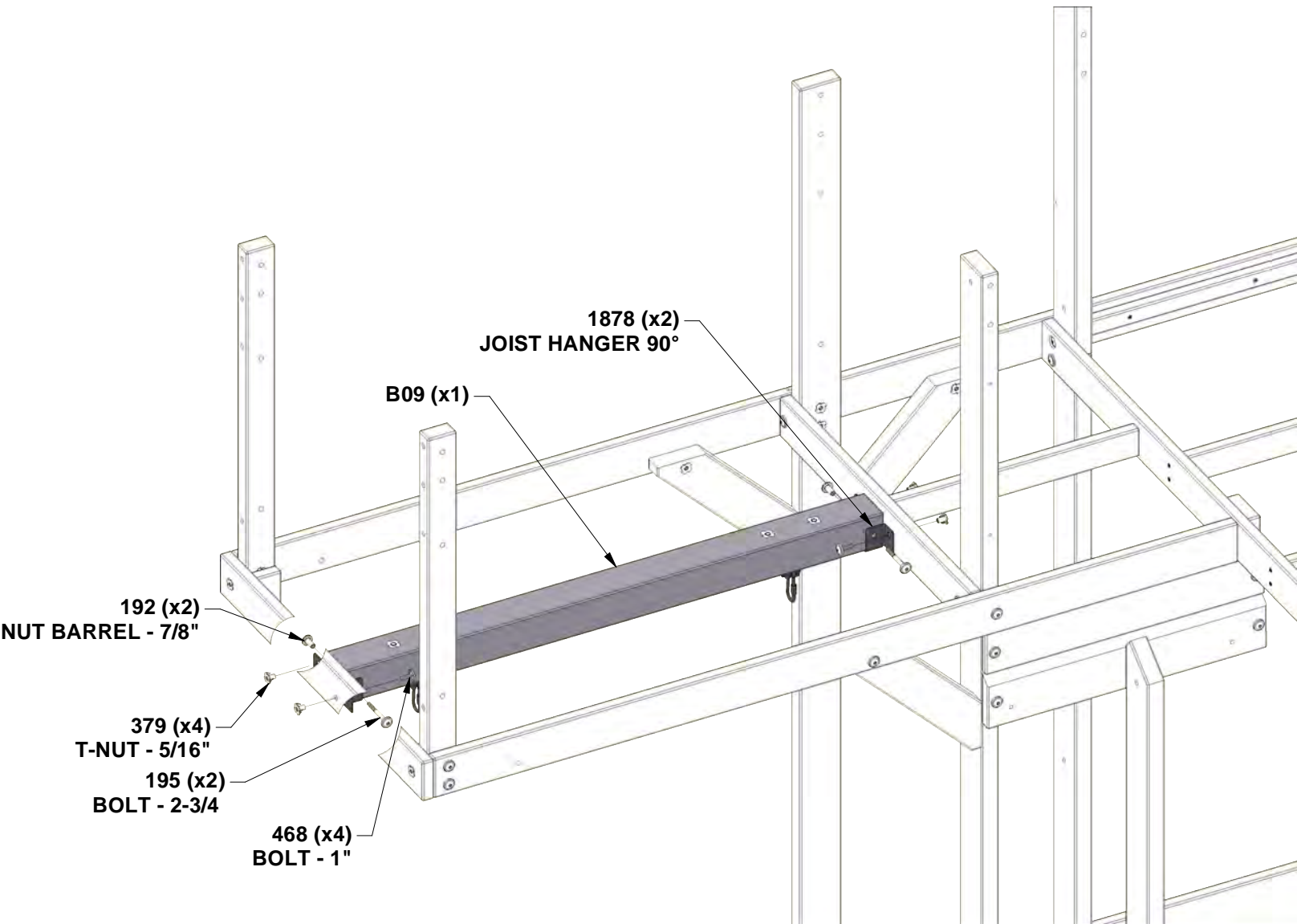
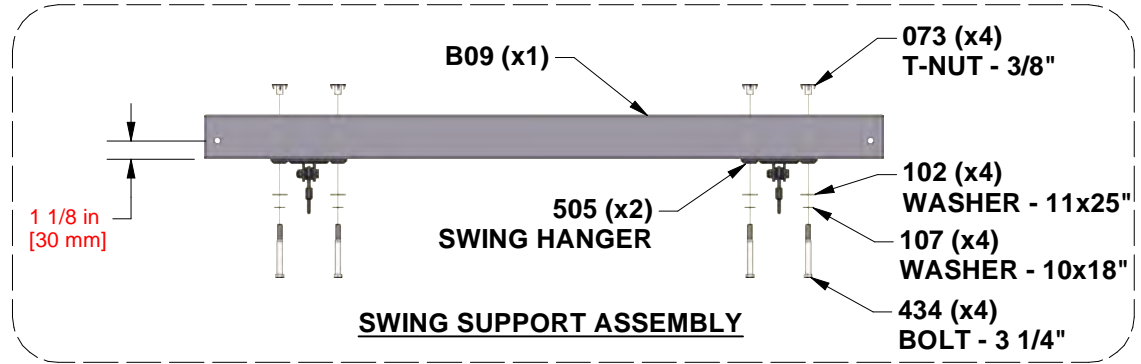

STEP 25 - FORT ASSEMBLY

QTY	PART NUMBER	DESCRIPTION
6	H100089	SCREW PFH 8x1-3/4"
4	H100111	SCREW PFH 8x2"

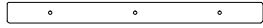

T03 SUPPORT BOARD - W4L20484
(x2) 1"x1 3/8"x16 5/8" (24x34x423)



J09 SUPPORT BOARD - W4L20434
(x2) 1"x2 3/8"x2 3/4" (24x60x70)

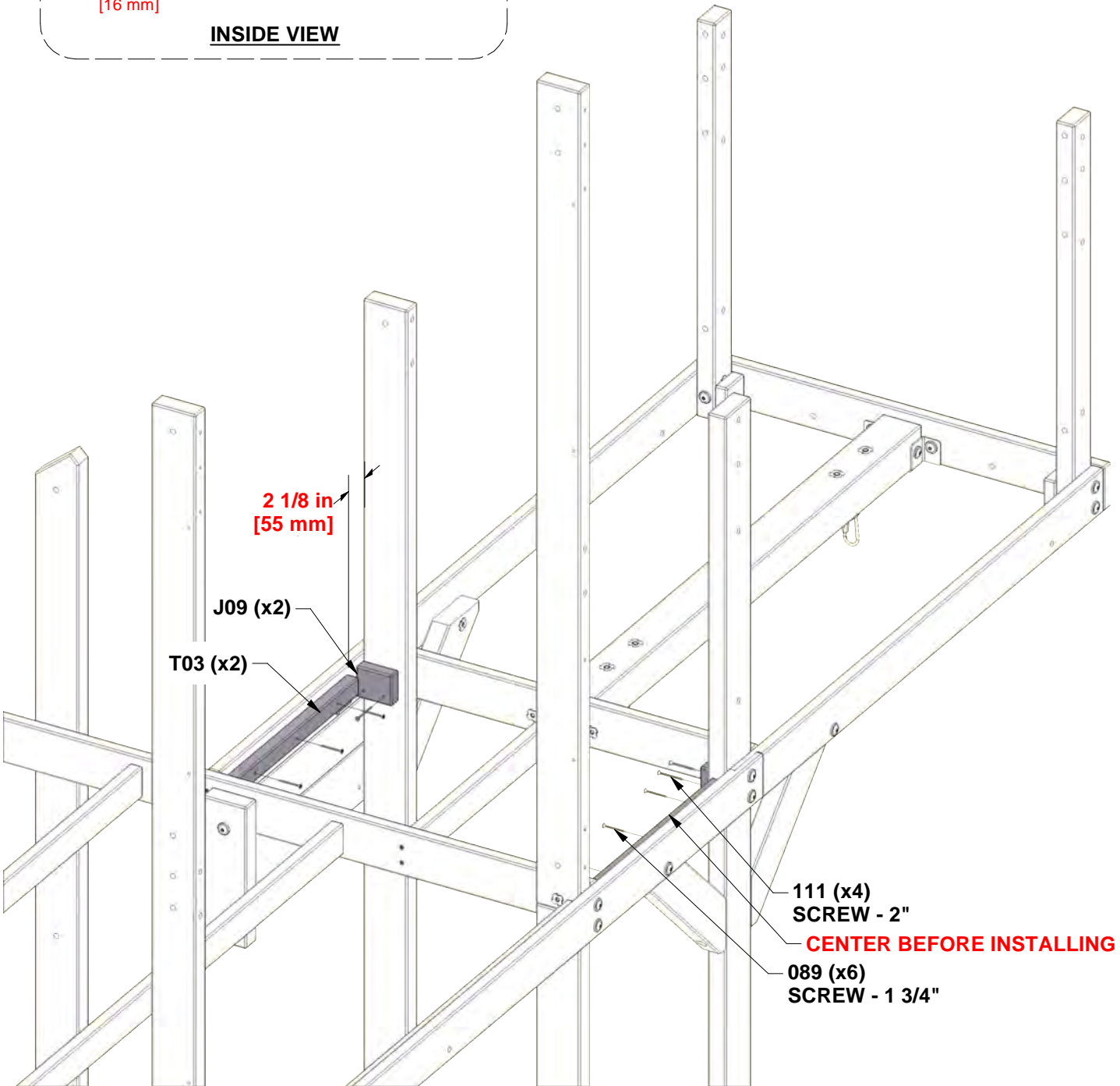
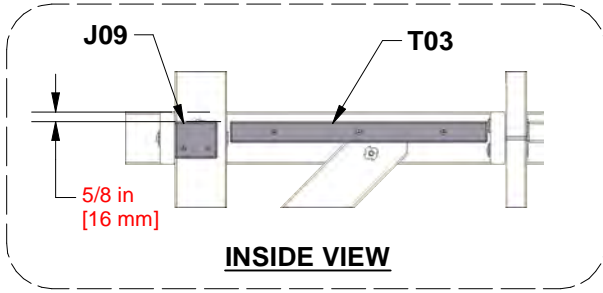

STEP 26 - FORT ASSEMBLY

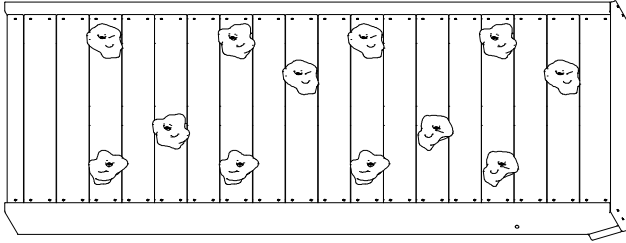

ROCK WALL ASSEMBLY

QTY	PART NUMBER	DESCRIPTION
2	H100195	BOLT WH 5/16x2-3/4 BLK
2	H100198	WASHER LOCK EXT 8x19 BLK
4	H100379	T-NUT 5/16 BLK
2	H100457	BOLT WH 5/16x2 BLK
2	H100468	BOLT WH 5/16x1 BLK

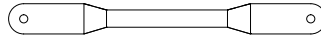

A4M00630 METAL DECK BRACE 380 C/C (x2)

INSTALL T-NUTS IN WOOD FIRST

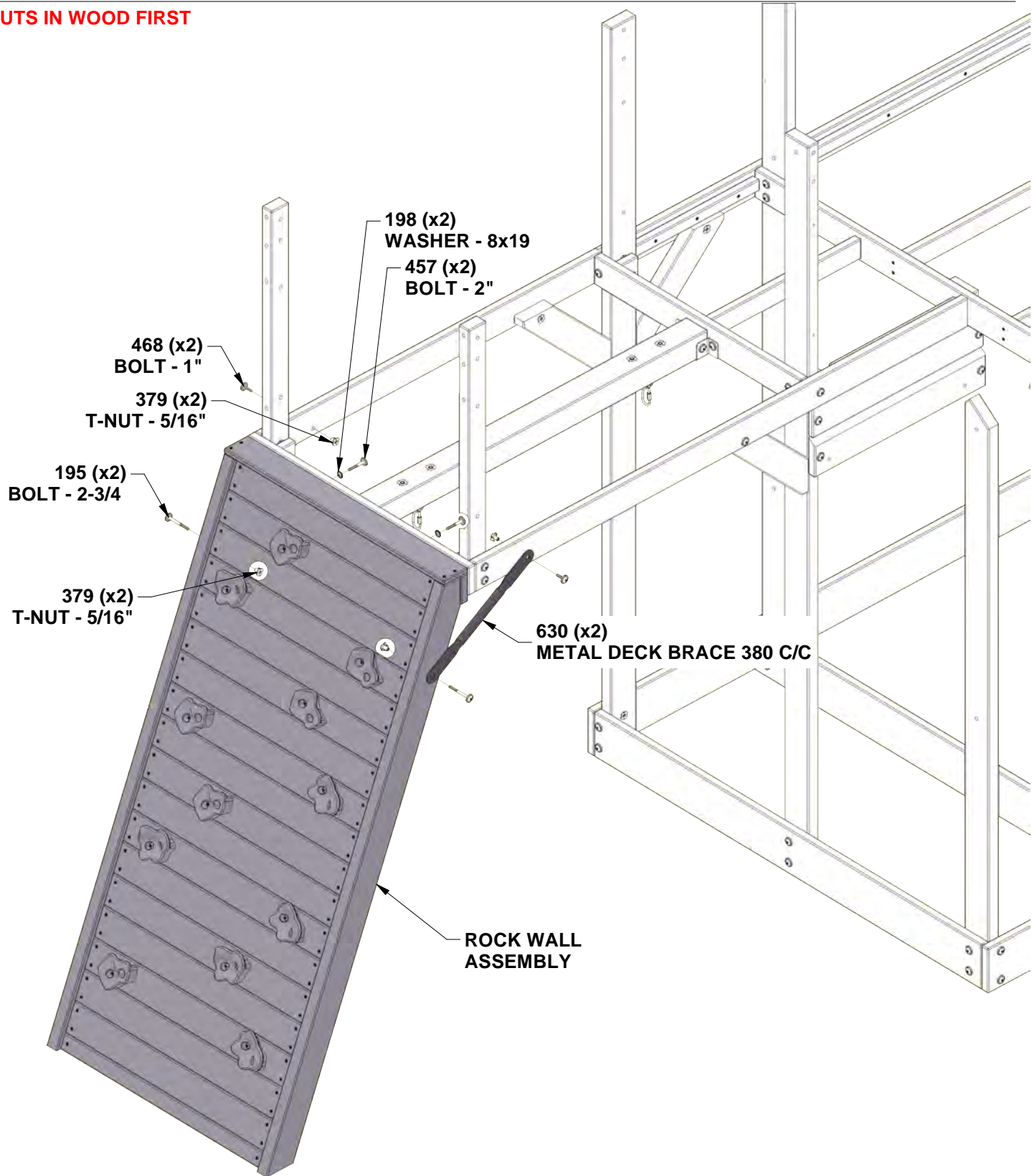

STEP 27 - FORT ASSEMBLY

QTY	PART NUMBER	DESCRIPTION
12	H100089	SCREW PFH 8x1-3/4"

T06 SUPPORT BOARD - W4L20487
(x2) 1"x1 3/8"x41 7/16" (24x34x1052)

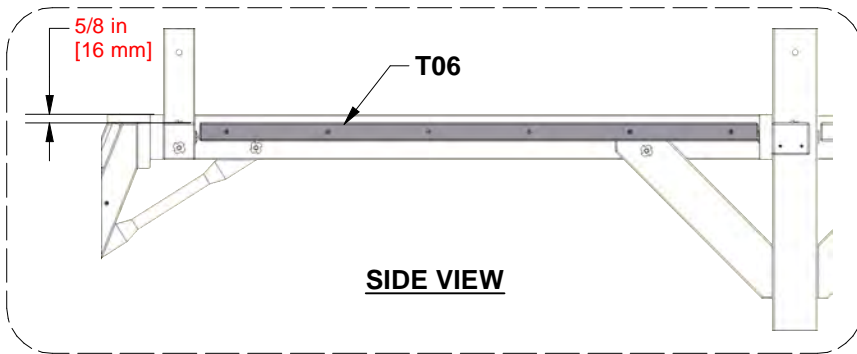

T06 (x2)

089 (x12)
SCREW - 1 3/4"

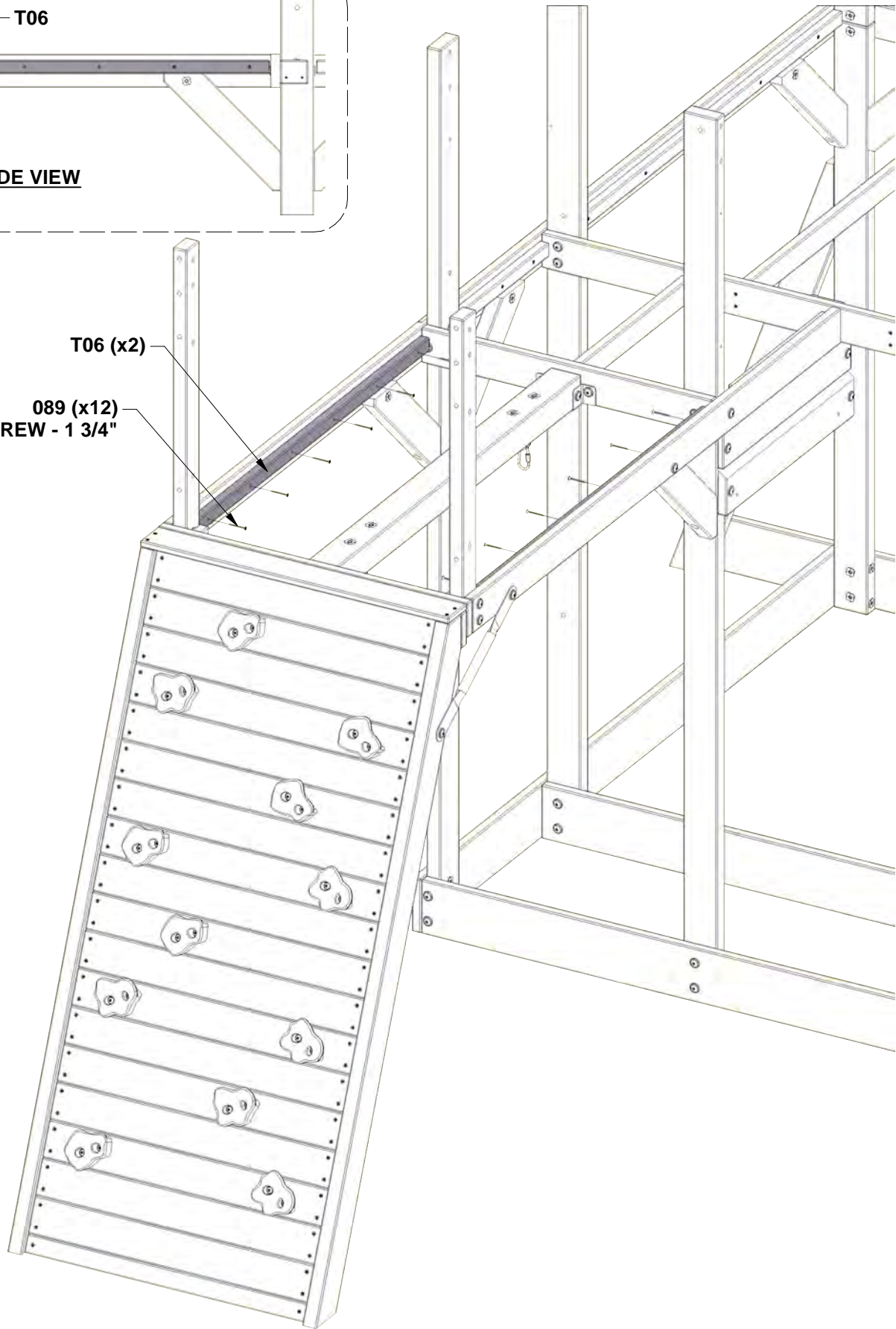

STEP 28 - FORT ASSEMBLY

QTY	PART NUMBER	DESCRIPTION
2	H100198	WASHER LOCK EXT 8x19 BLK
2	H100378	BOLT WH 5/16x1 3/4 BLK
2	H100379	T-NUT 5/16 BLK

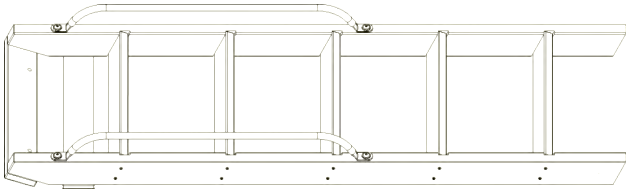

LADDER ASSEMBLY

INSTALL T-NUTS IN WOOD FIRST

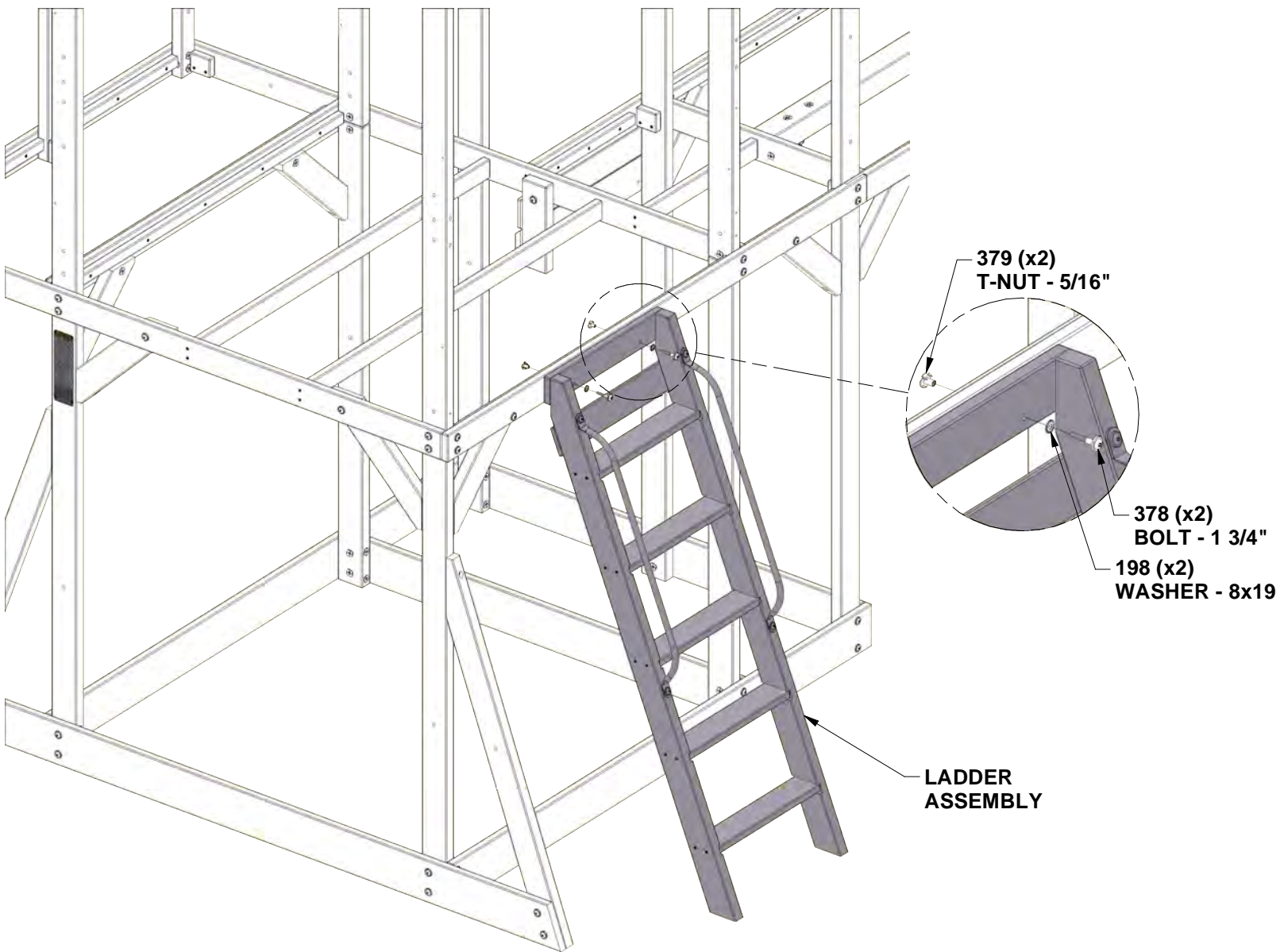

STEP 29 - FORT ASSEMBLY

QTY	PART NUMBER	DESCRIPTION
88	H100086	SCREW PFH 8x1-1/2"
4	H100088	SCREW PFH 8x1-1/8"

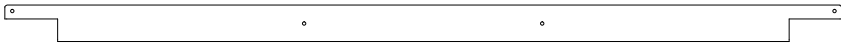

N02 FLOOR BOARD - W4L20470
(x2) 5/8"x2 3/8"x54 1/2" (16x60x1384)



M08 FLOOR BOARD - W4L20453
(x14) 5/8"x3 3/8"x54 1/2" (16x86x1384)

EVENLY SPACE FLOOR BOARDS

**USING AN 1/8" [3mm] DRILL BIT,
USE FLOOR BOARDS AS A GUIDE
TO DRILL PILOT HOLES.**

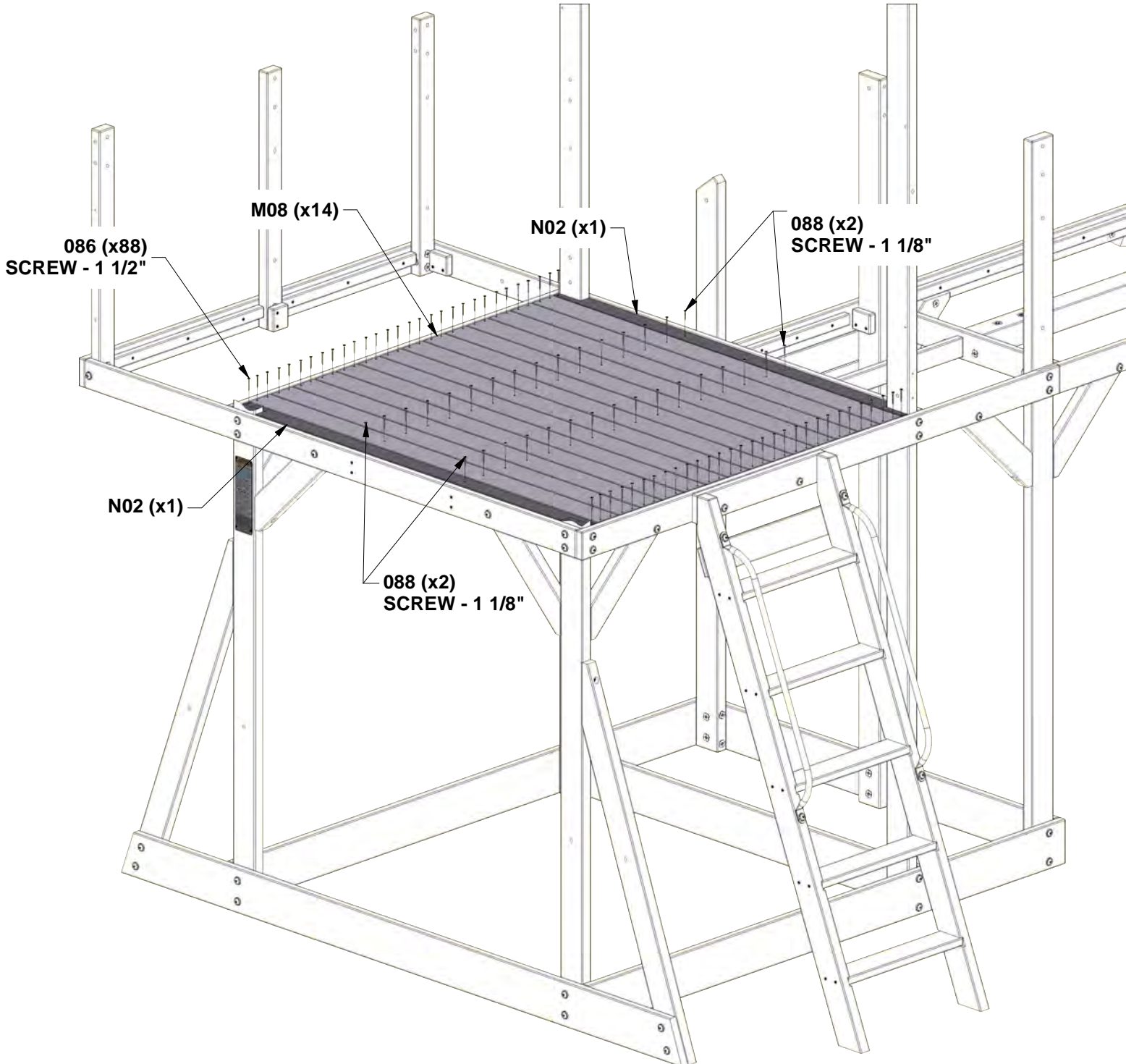

STEP 30 - FORT ASSEMBLY

QTY	PART NUMBER	DESCRIPTION
59	H100086	SCREW PFH 8x1-1/2"



N04 FLOOR BOARD - W4L20472
 (x2) 5/8"x2 3/8"x19 1/2" (16x60x496)



M09 FLOOR BOARD - W4L20454
 (x13) 5/8"x3 3/8"x21 1/4" (16x86x540)



M16 FLOOR BOARD - W4L20461
 (x1) 5/8"x3 3/8"x21 1/4" (16x86x540)

EVENLY SPACE FLOOR BOARDS

USING AN 1/8" [3mm] DRILL BIT, USE FLOOR BOARDS AS A GUIDE TO DRILL PILOT HOLES.

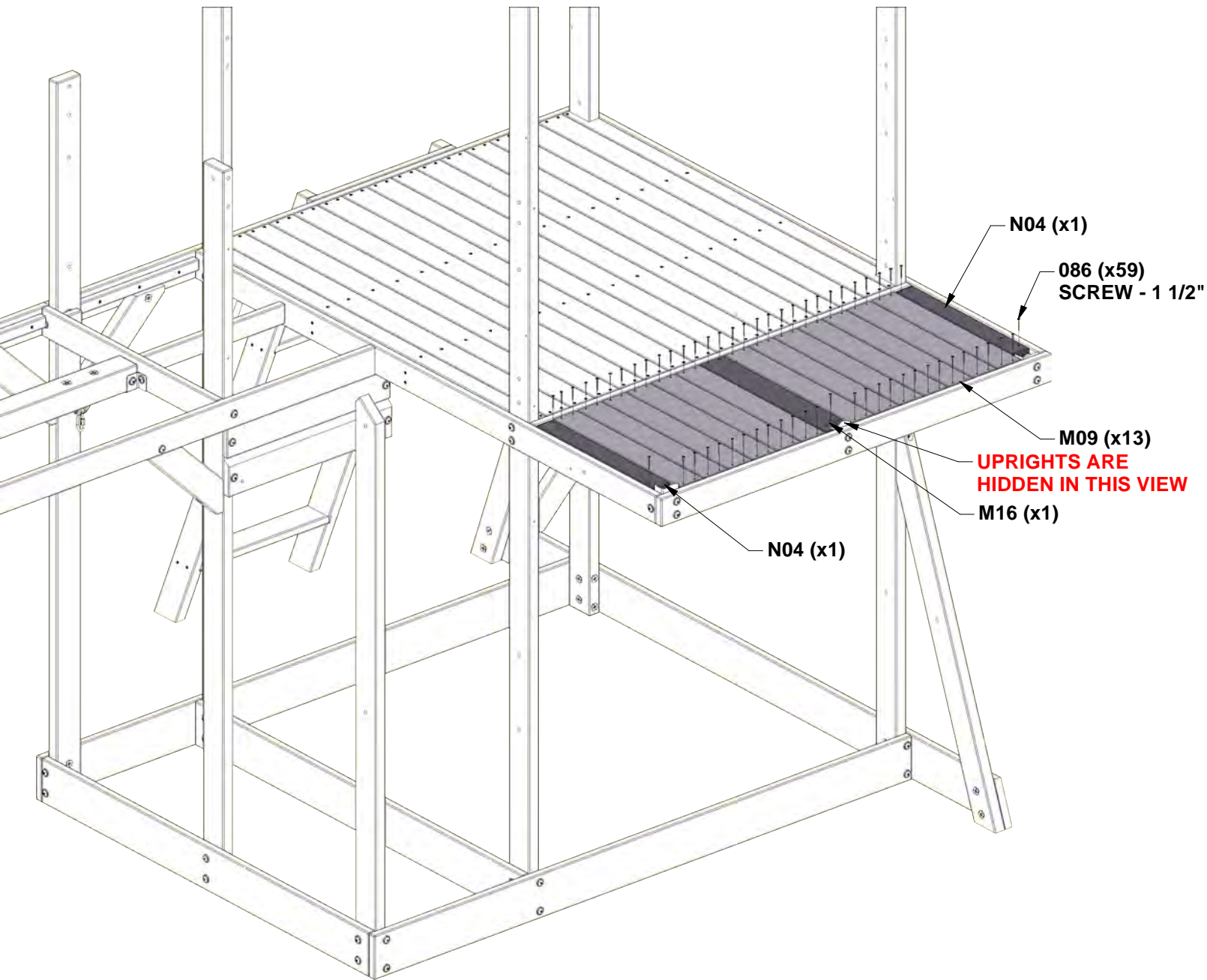
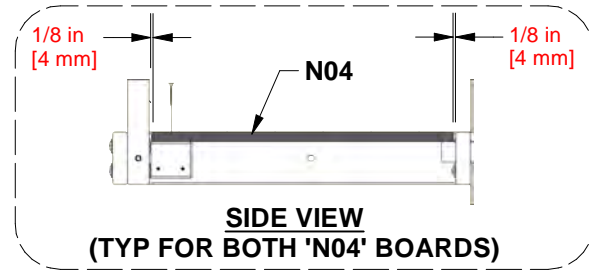

STEP 31 - FORT ASSEMBLY

QTY	PART NUMBER	DESCRIPTION
29	H100086	SCREW PFH 8x1-1/2"



M21 FLOOR BOARD - W4L20466
(x5) 5/8"x3 3/8"x29 1/8" (16x86x740)



M22 FLOOR BOARD - W4L20467
(x1) 5/8"x3 3/8"x27 3/4" (16x86x704)

EVENLY SPACE FLOOR BOARDS
USING AN 1/8" [3mm] DRILL BIT,
USE FLOOR BOARDS AS A GUIDE
TO DRILL PILOT HOLES.

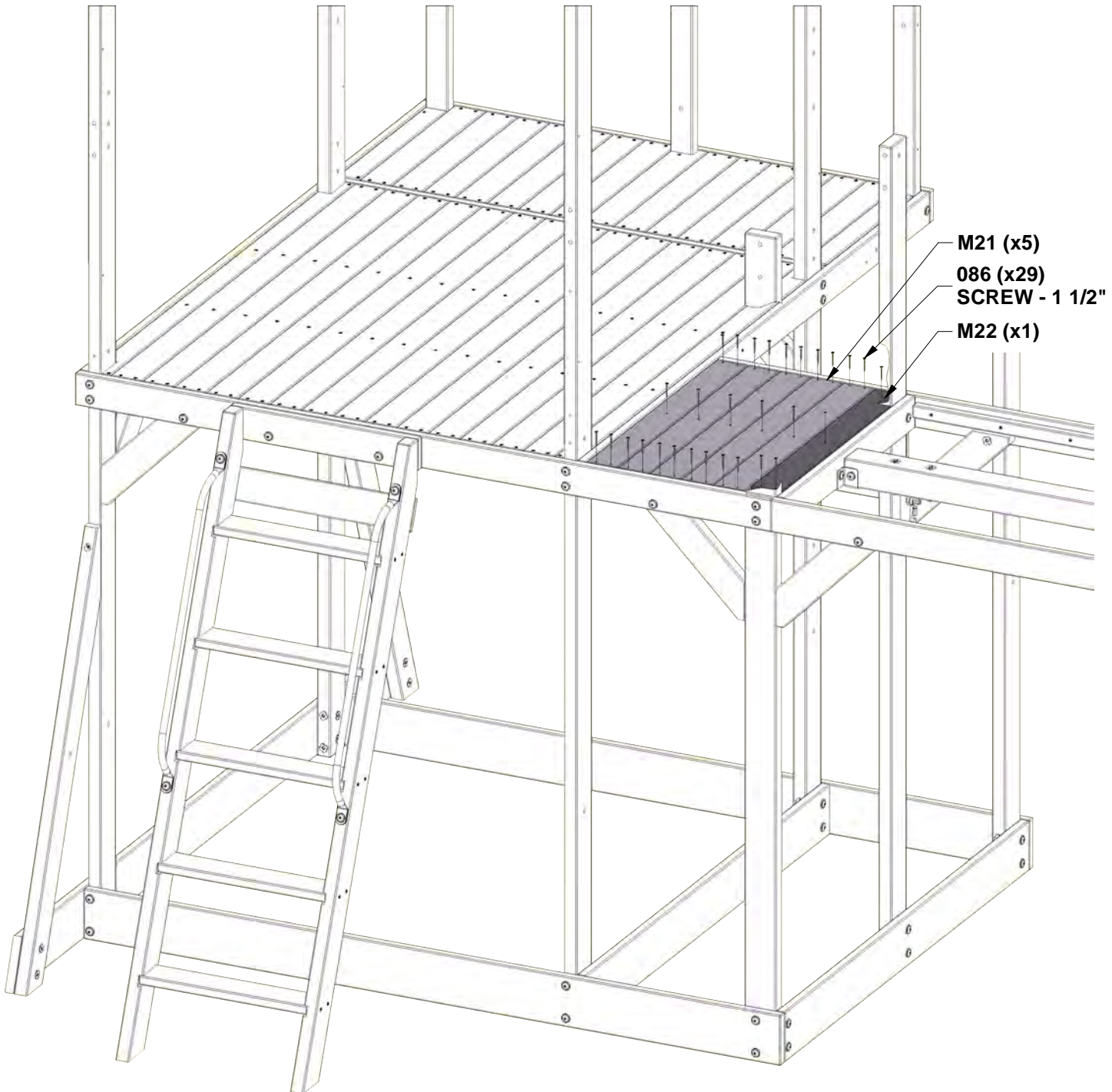

STEP 32 - FORT ASSEMBLY

QTY	PART NUMBER	DESCRIPTION
69	H100086	SCREW PFH 8x1-1/2"



M05 FLOOR BOARD - W4L20450
(x8) 5/8"x3 3/8"x29" (16x86x738)

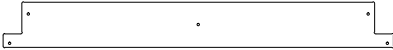

M07 FLOOR BOARD - W4L20452
(x1) 5/8"x3 3/8"x29" (16x86x738)

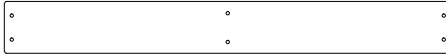

M23 FLOOR BOARD - W4L21731
(x4) 5/8"x3 3/8"x29" (16x86x738)

EVENLY SPACE FLOOR BOARDS

**USING AN 1/8" [3mm] DRILL BIT,
USE FLOOR BOARDS AS A GUIDE
TO DRILL PILOT HOLES.**

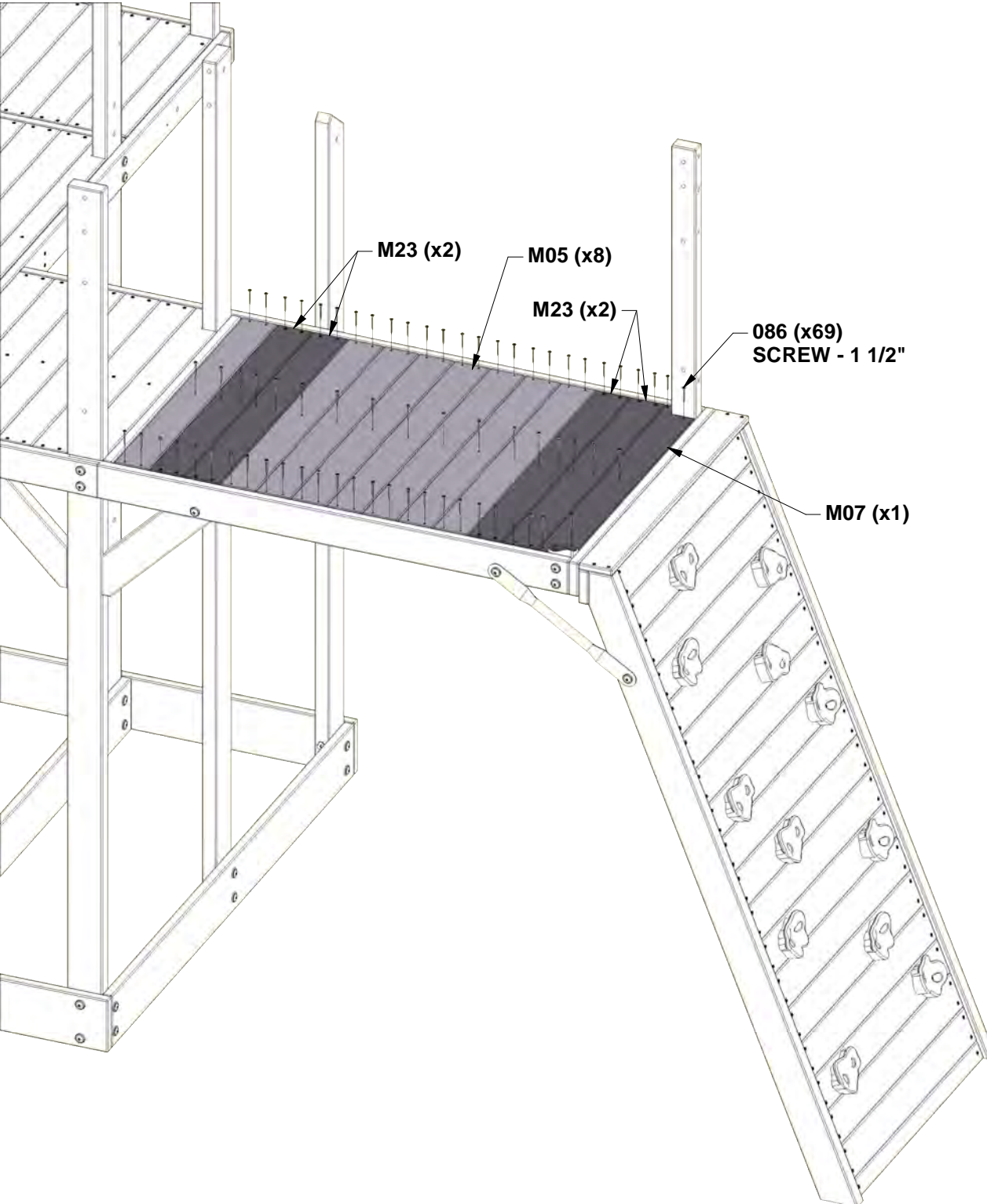

STEP 33 - FORT ASSEMBLY

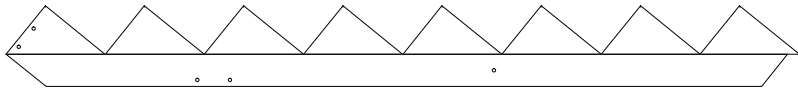

SR1 STAIR RAIL - W2A04393
(x1) 1"x8 3/8"x82 5/8" (24x214x2099)

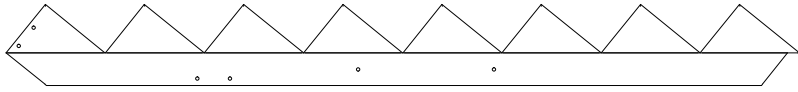

SR2 STAIR RAIL - W2A04394
(x1) 1"x8 3/8"x82 5/8" (24x214x2099)

QTY	PART NUMBER	DESCRIPTION
2	H100198	WASHER LOCK EXT 8x19 BLK
1	H100205	BOLT WH 5/16x2-1/4 BLK
2	H100379	T-NUT 5/16 BLK
6	H100405	WASHER LOCK EXT 6x15 BLK
6	H100456	LAG SCREW WH 1/4x2-1/2 BLK
1	H100484	BOLT WH 5/16x3 1/4 BLK



D01 STAIR SUPPORT - W4L20354 **H29 WALL SPACER - W4L20411**
(x1) 1 3/8"x5 1/4"x17 1/8" (36x134x435) (x1) 1"x3 3/8"x3 3/8" (24x86x86)

INSTALL T-NUTS IN WOOD FIRST

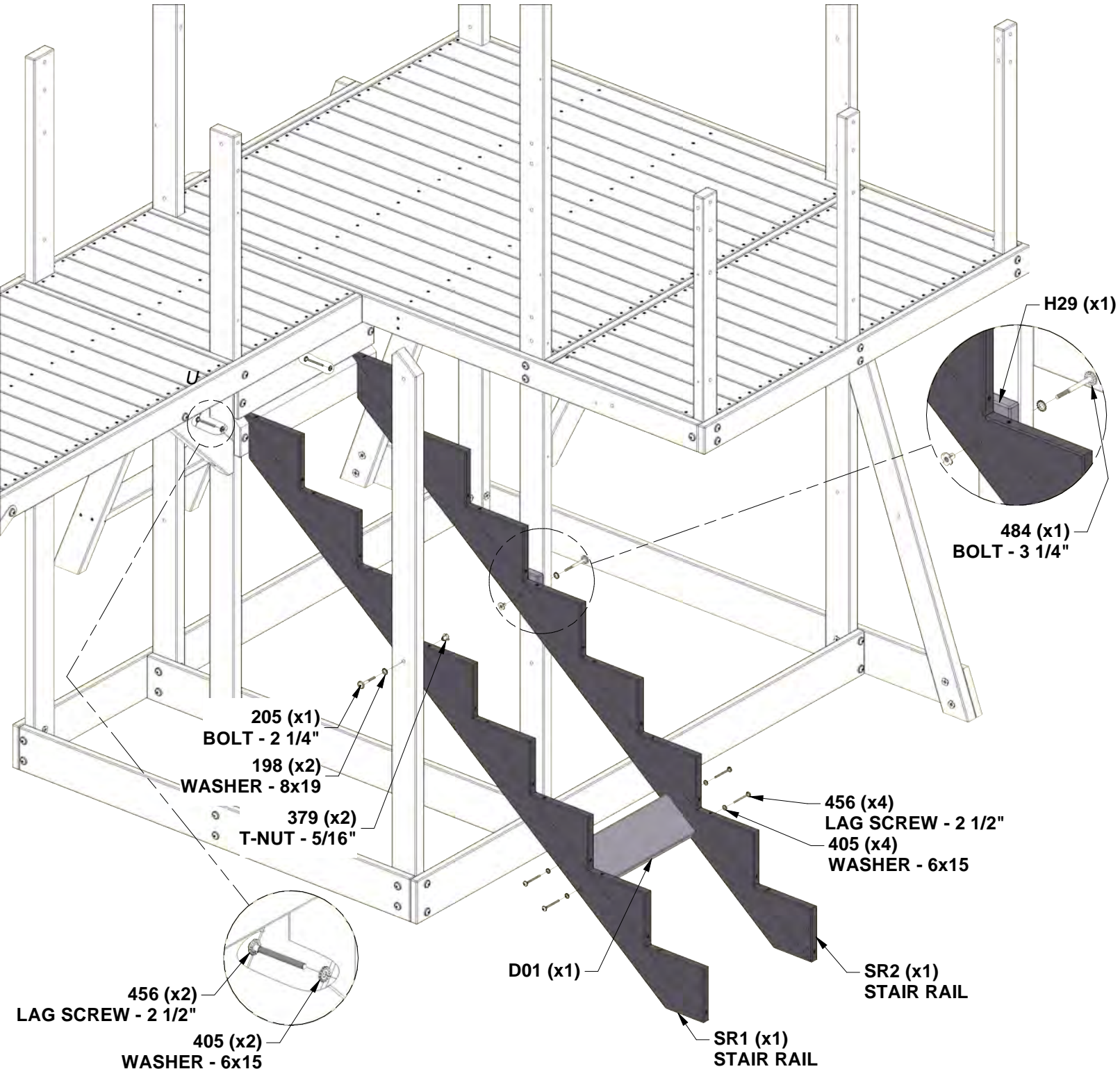

STEP 34 - FORT ASSEMBLY

QTY	PART NUMBER	DESCRIPTION
4	H100192	NUT BARREL WH 5/16x7/8 BLK
4	H100198	WASHER LOCK EXT 8x19 BLK
4	H100199	WASHER LOCK EXT 12x19 BLK
4	H100457	BOLT WH 5/16x2 BLK

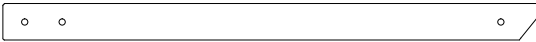

F01 UPRIGHT - W4L20376
(x2) 1 3/8" x 2 3/8" x 34 7/8" (36x60x887)

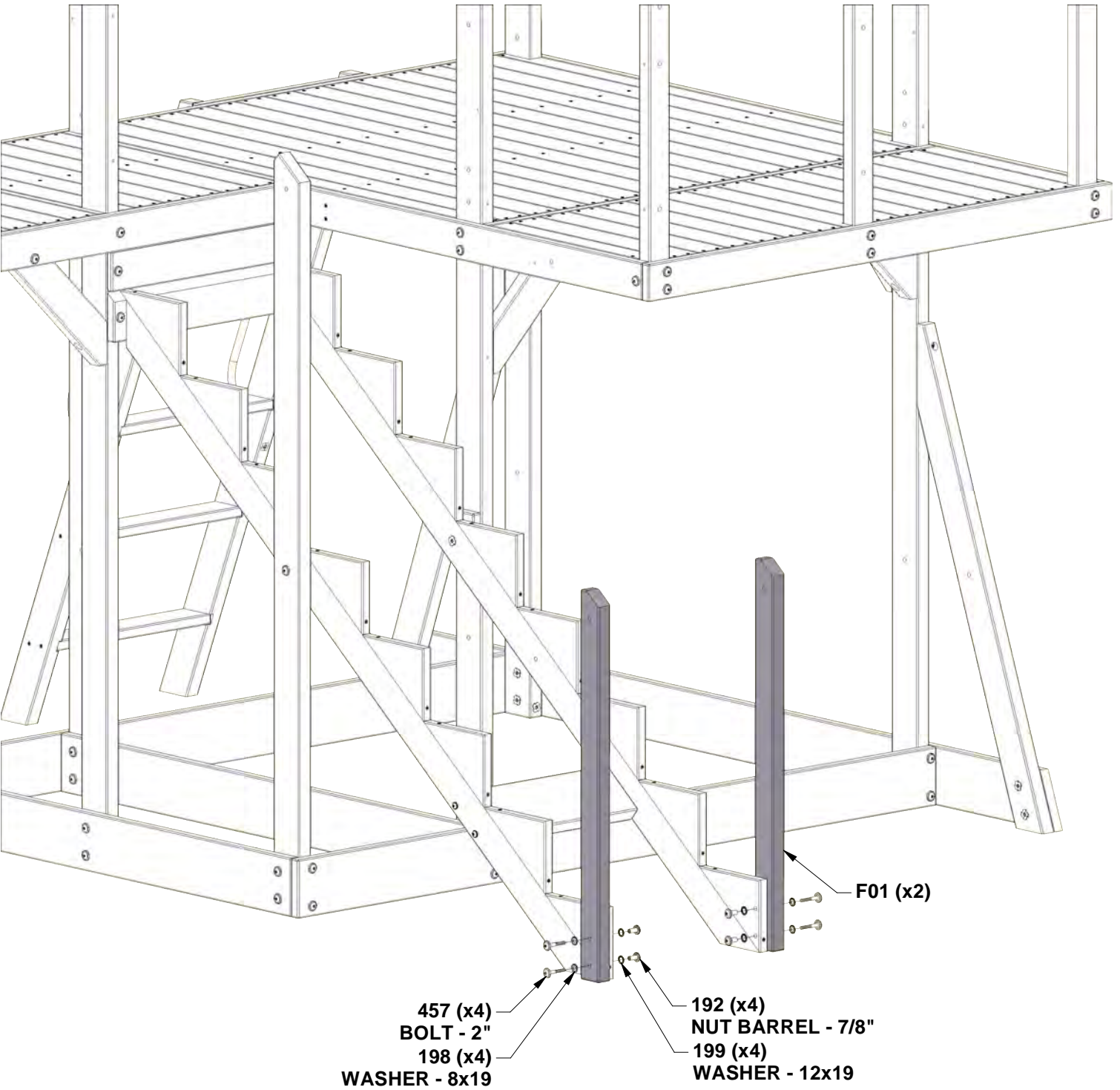

STEP 35 - FORT ASSEMBLY

QTY	PART NUMBER	DESCRIPTION
3	H100198	WASHER LOCK EXT 8x19 BLK
3	H100205	BOLT WH 5/16x2-1/4 BLK
3	H100379	T-NUT 5/16 BLK

H01 HANDRAIL - W4L20396
 (x1) 1"x3 3/8"x88 3/4" (24x86x2255)

INSTALL T-NUTS IN WOOD FIRST

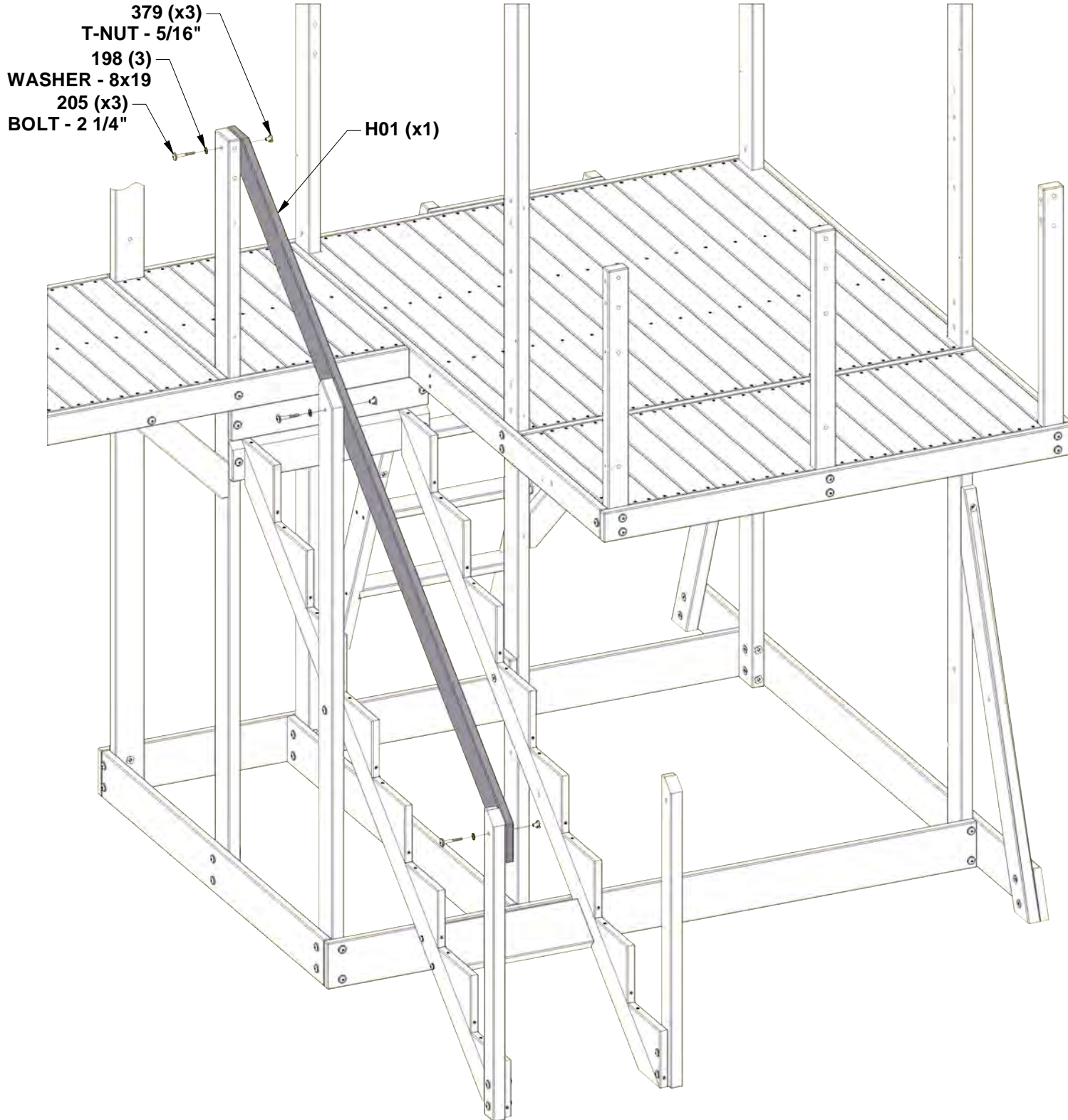

STEP 36 - FORT ASSEMBLY

QTY	PART NUMBER	DESCRIPTION
2	H100198	WASHER LOCK EXT 8x19 BLK
1	H100205	BOLT WH 5/16x2-1/4 BLK
2	H100379	T-NUT 5/16 BLK
1	H100458	LAG SCREW WH 5/16x2 BLK



H15 HANDRAIL - W4L20410
(x1) 1"x3 3/8"x46" (24x86x1170)

INSTALL T-NUTS IN WOOD FIRST

379 (x1)
T-NUT - 5/16"

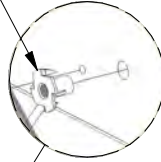

458 (x1)
LAG SCREW - 2"

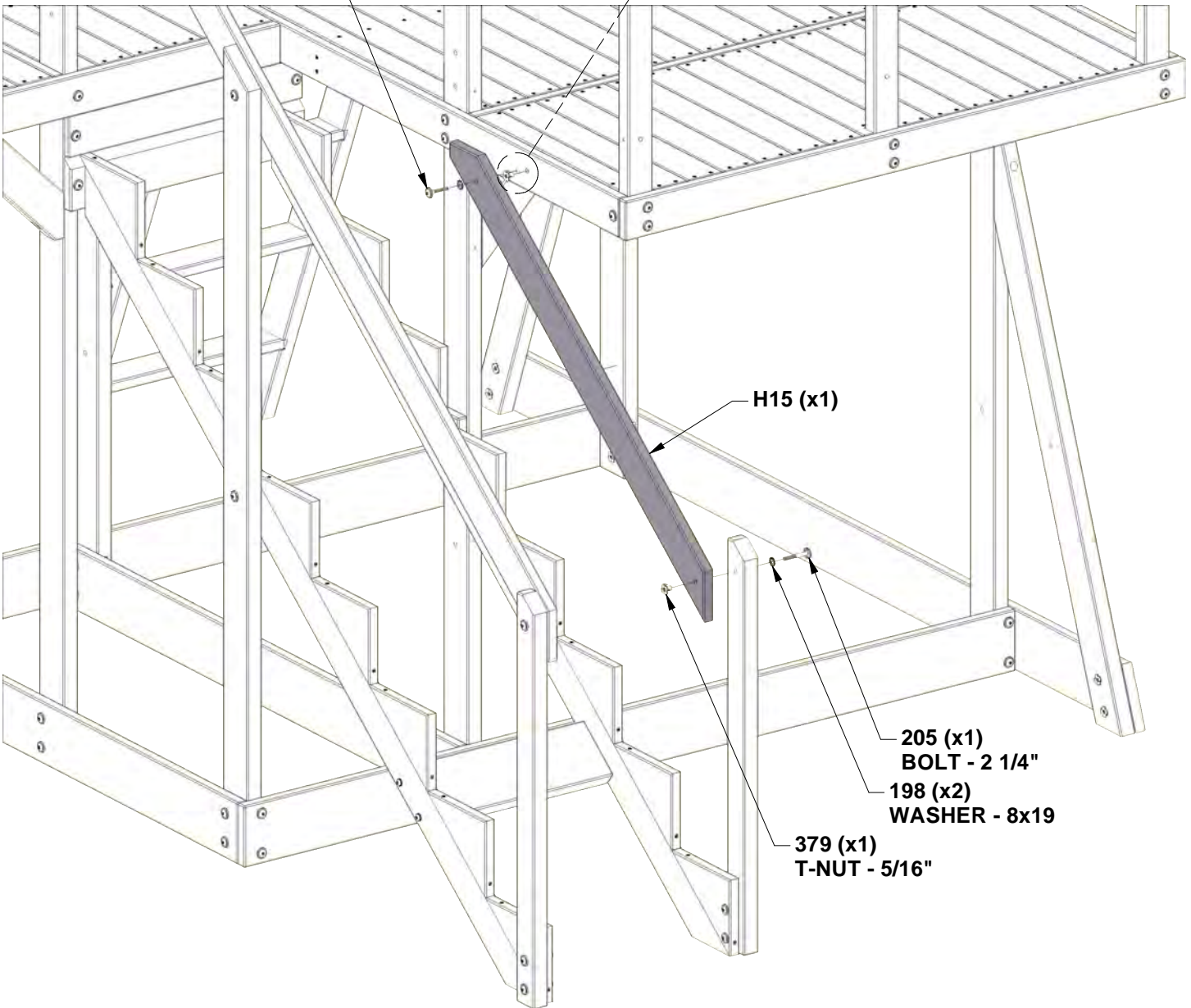

H15 (x1)

205 (x1)
BOLT - 2 1/4"

198 (x2)
WASHER - 8x19

379 (x1)
T-NUT - 5/16"

STEP 37 - FORT ASSEMBLY

QTY	PART NUMBER	DESCRIPTION
10	H100087	SCREW PFH 8x1-1/4"



K02 STEP BOARD - W4L20442
 (x1) 5/8"x4 3/4"x19" (16x120x483)



M03 STEP BOARD - W4L20448
 (x3) 5/8"x3 1/4"x19" (16x82x483)

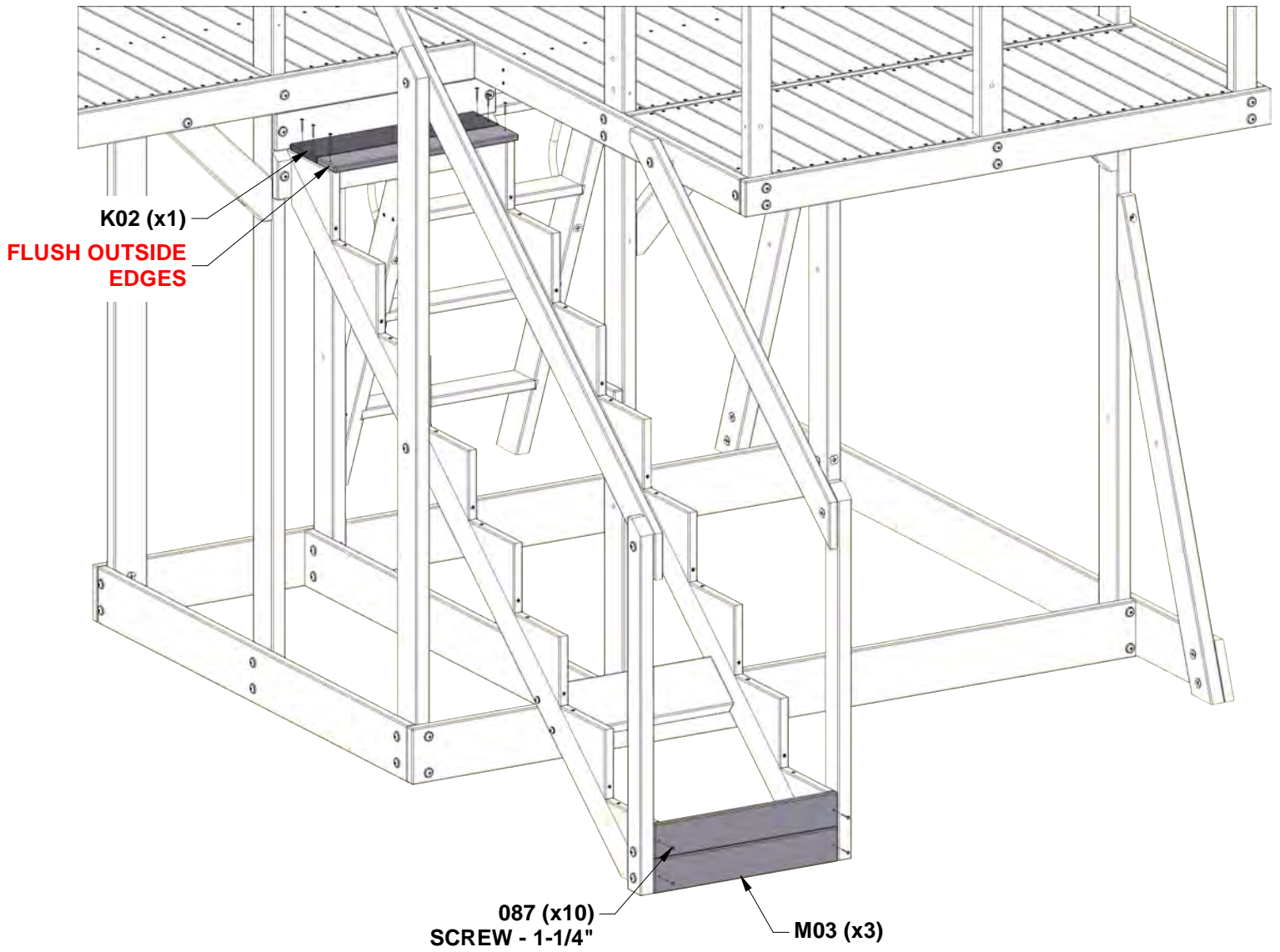

STEP 38 - FORT ASSEMBLY

QTY	PART NUMBER	DESCRIPTION
4	H100087	SCREW PFH 8x1-1/4"



M03 STEP BOARD - W4L20448
(x2) 5/8"x3 1/4"x19" (16x82x483)

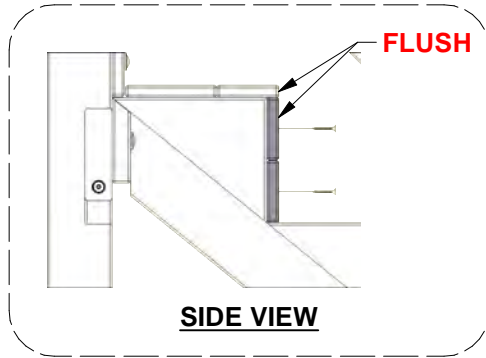

FLUSH OUTSIDE EDGES

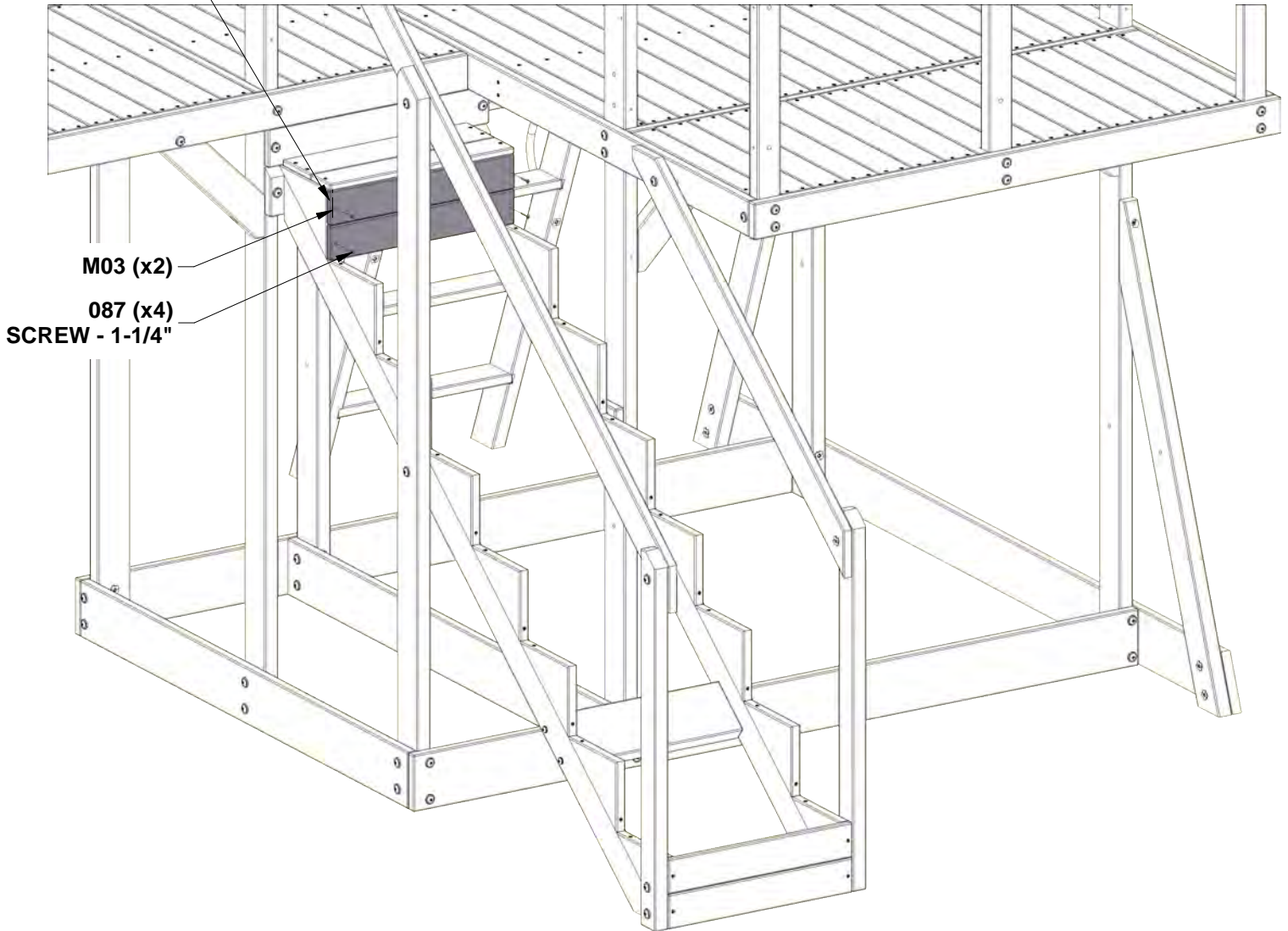

STEP 39 - FORT ASSEMBLY

QTY	PART NUMBER	DESCRIPTION
66	H100087	SCREW PFH 8x1-1/4"



K02 STEP BOARD - W4L20442
 (x7) 5/8"x4 3/4"x19" (16x120x483)



M03 STEP BOARD - W4L20448
 (x19) 5/8"x3 1/4"x19" (16x82x483)

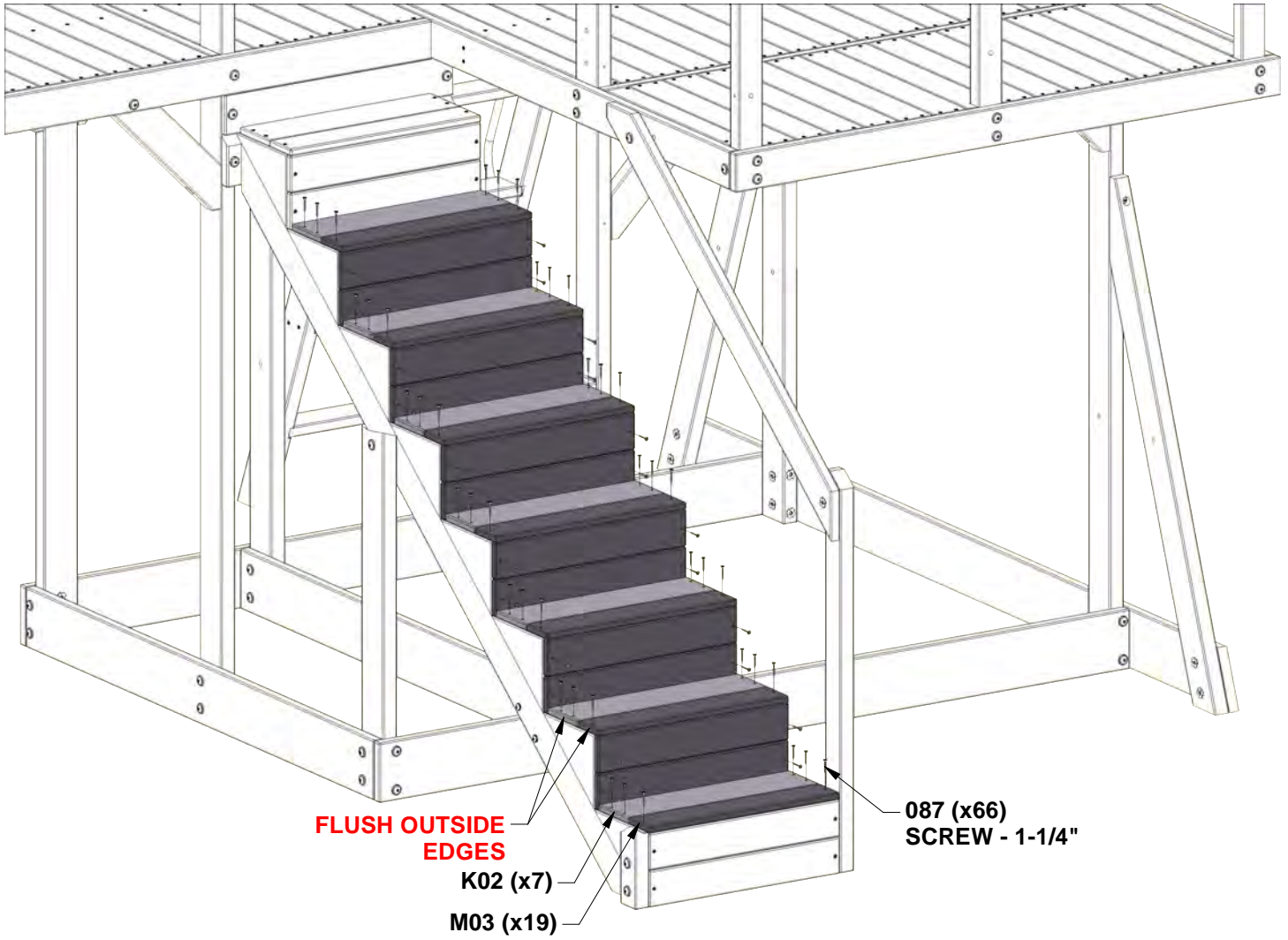

STEP 40 - FORT ASSEMBLY

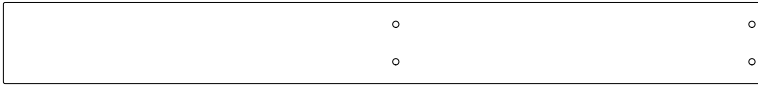

G09 WALL RAIL - W4L20390
 (x1) 1"x5 1/4"x49 1/2" (24x134x1256)

QTY	PART NUMBER	DESCRIPTION
4	H100198	WASHER LOCK EXT 8x19 BLK
2	H100205	BOLT WH 5/16x2-1/4 BLK
4	H100379	T-NUT 5/16 BLK
2	H100484	BOLT WH 5/16x3 1/4 BLK

INSTALL T-NUTS IN WOOD FIRST

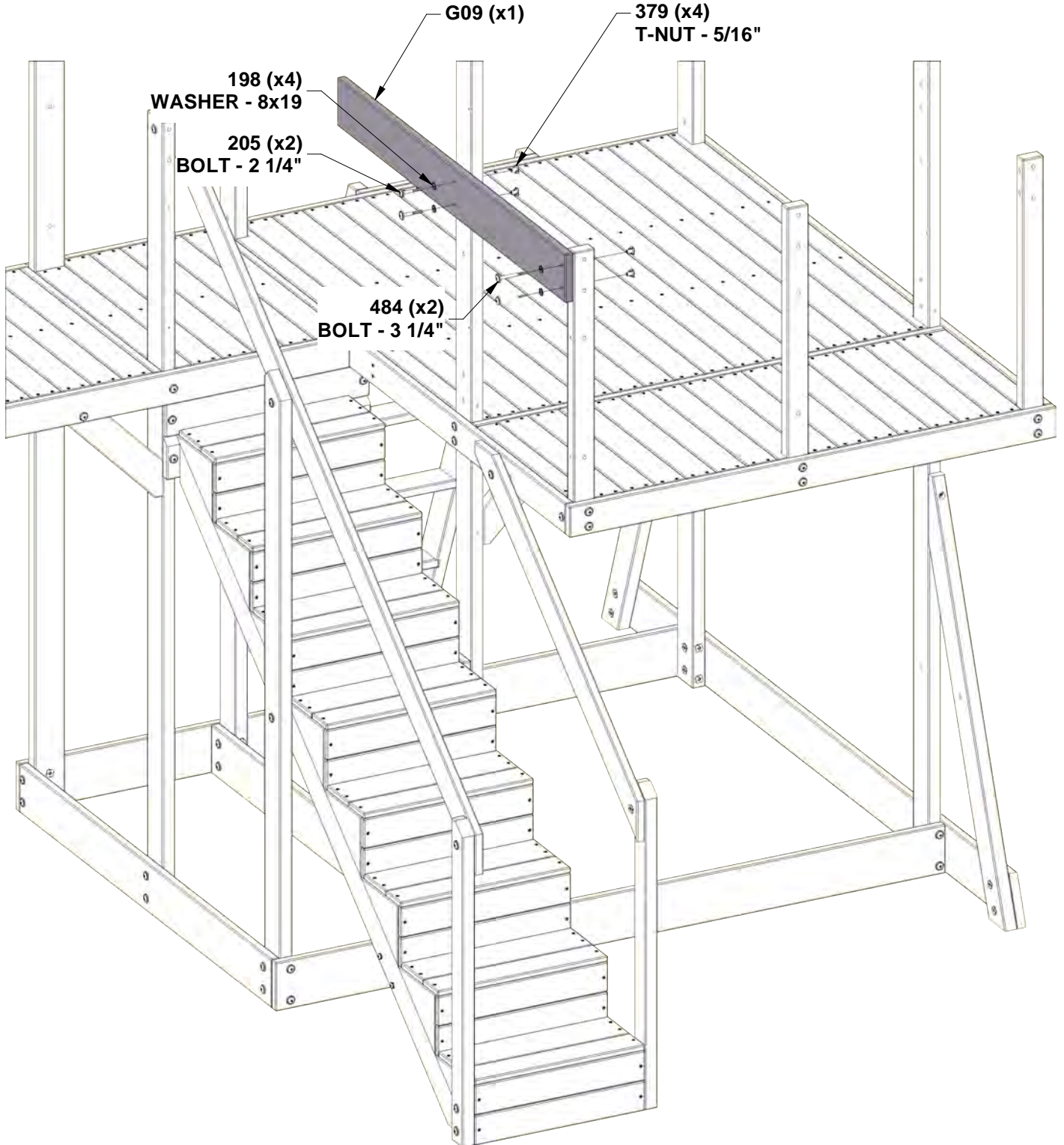

STEP 41 - FORT ASSEMBLY

QTY	PART NUMBER	DESCRIPTION
6	H100198	WASHER LOCK EXT 8x19 BLK
6	H100205	BOLT WH 5/16x2-1/4 BLK
6	H100379	T-NUT 5/16 BLK

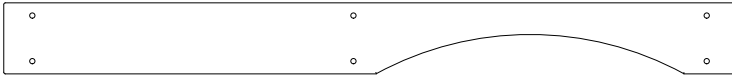

G10 ARCHED RAIL - W4L20391
(x1) 1"x5 1/4"x54 7/8" (24x134x1394)

INSTALL T-NUTS IN WOOD FIRST

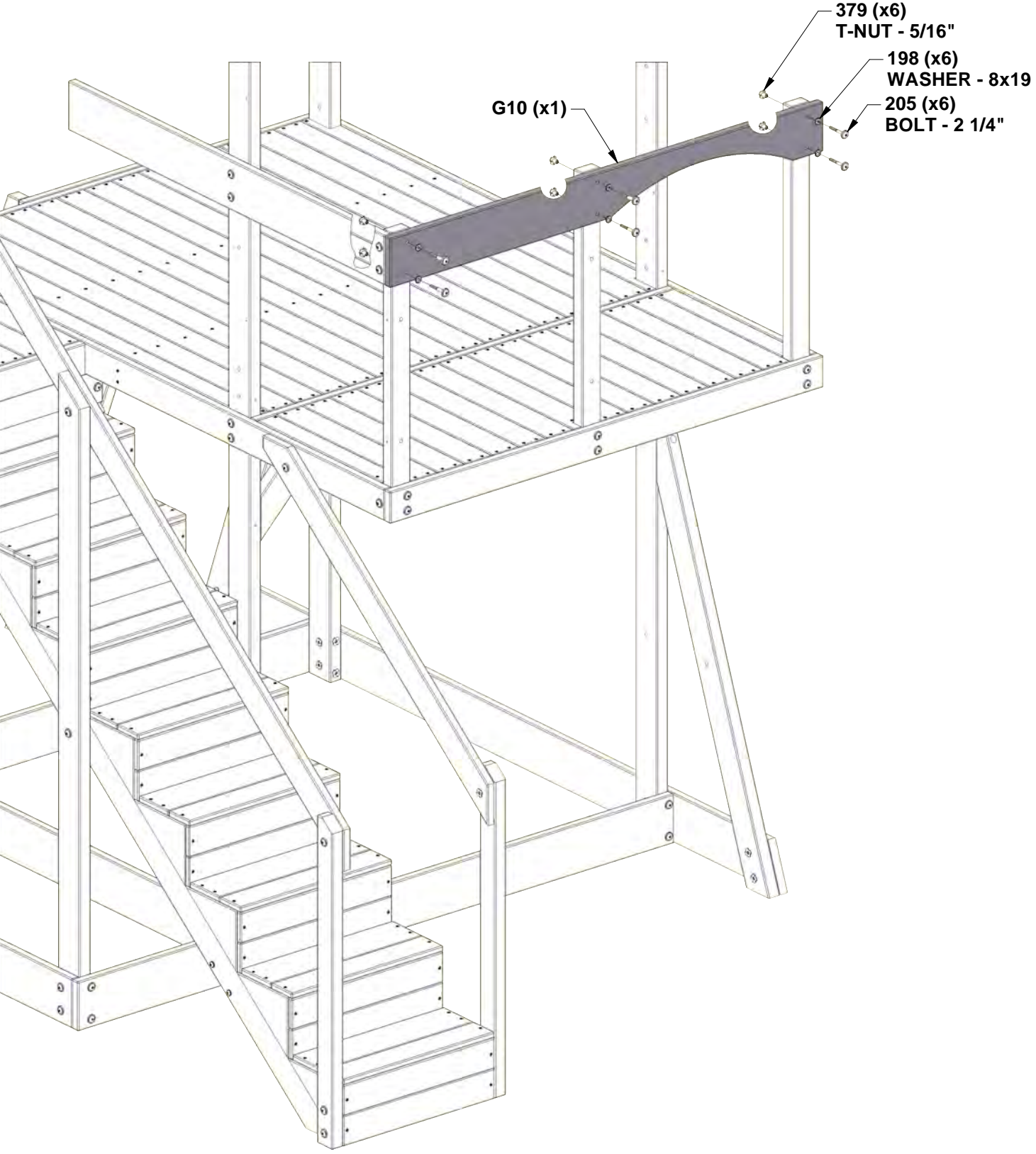

STEP 42 - FORT ASSEMBLY

**HOLES UPWARD
WHEN INSTALLED**



D02 WALL RAIL - W4L20387
(x1) 1 7/16"x5 1/4"x76 3/4" (36x134x1948)

QTY	PART NUMBER	DESCRIPTION
4	H100195	BOLT WH 5/16x2-3/4 BLK
6	H100198	WASHER LOCK EXT 8x19 BLK
8	H100379	T-NUT 5/16 BLK
2	H100415	BOLT WH 5/16x3 3/4 BLK

INSTALL T-NUTS IN WOOD FIRST

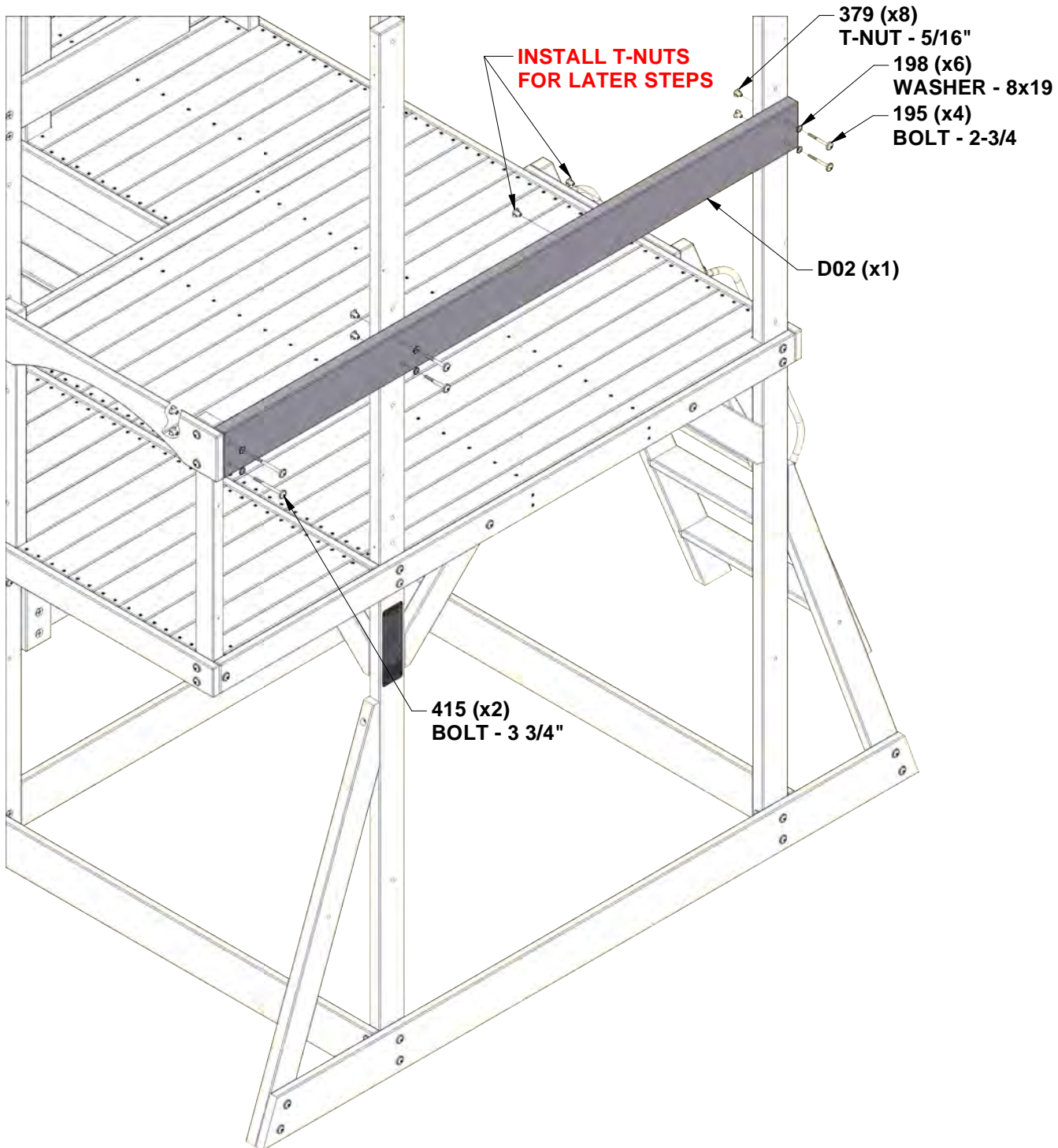

STEP 43 - FORT ASSEMBLY

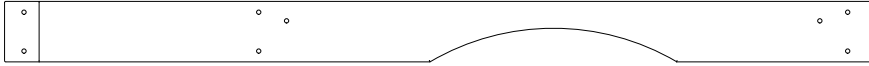

G13 ARCHED RAIL - W4L20394
 (x1) 1"x5 1/4"x75 3/8" (24x134x1913)

QTY	PART NUMBER	DESCRIPTION
4	H100198	WASHER LOCK EXT 8x19 BLK
4	H100379	T-NUT 5/16 BLK
4	H100513	BOLT WH 5/16x4 1/4 BLK

INSTALL T-NUTS IN WOOD FIRST

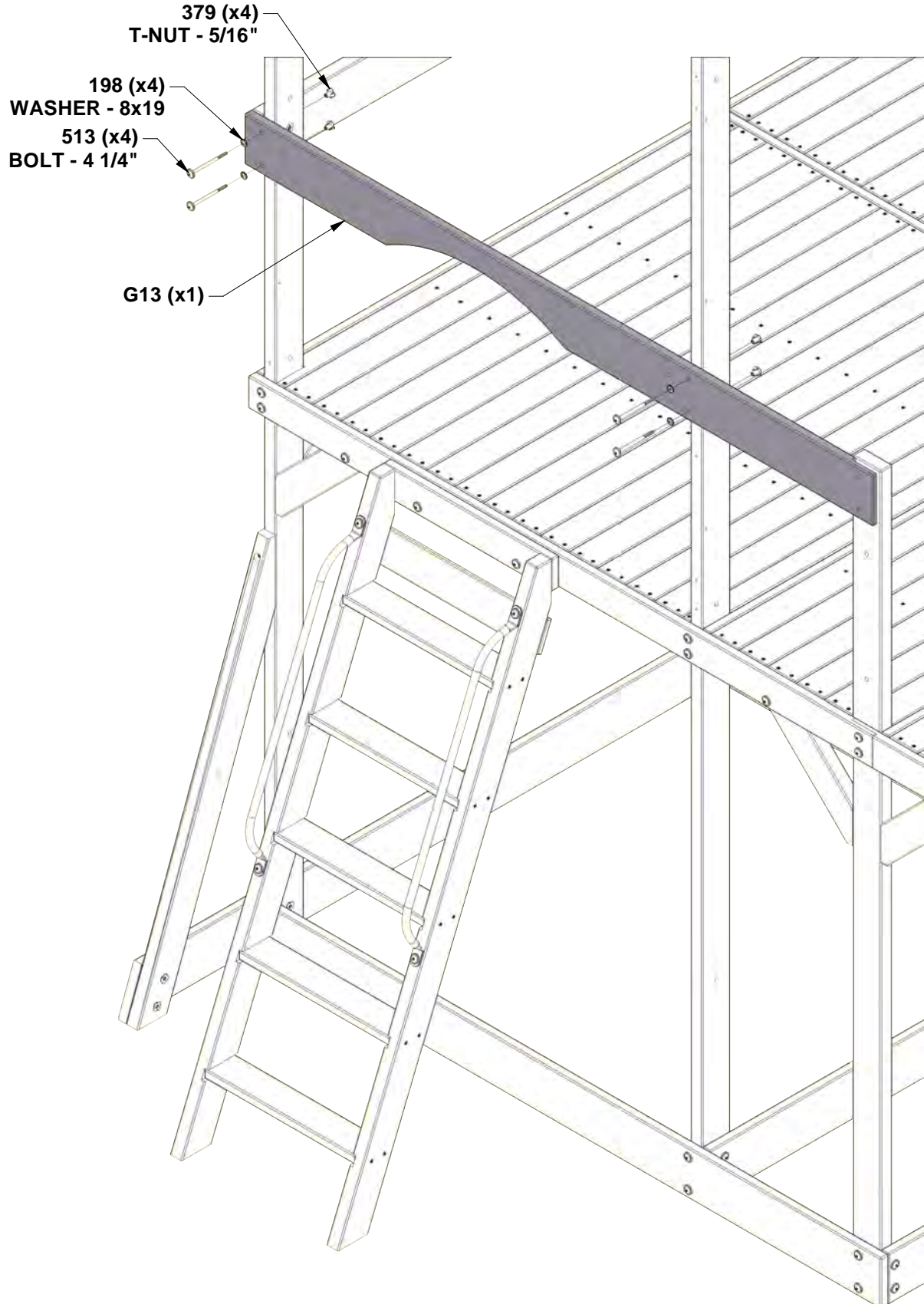

STEP 44 - FORT ASSEMBLY

QTY	PART NUMBER	DESCRIPTION
4	H100198	WASHER LOCK EXT 8x19 BLK
4	H100205	BOLT WH 5/16x2-1/4 BLK
4	H100379	T-NUT 5/16 BLK



G11 WALL RAIL - W4L20392
 (x1) 1"x5 1/4"x48 1/4" (24x134x1224)

INSTALL T-NUTS IN WOOD FIRST

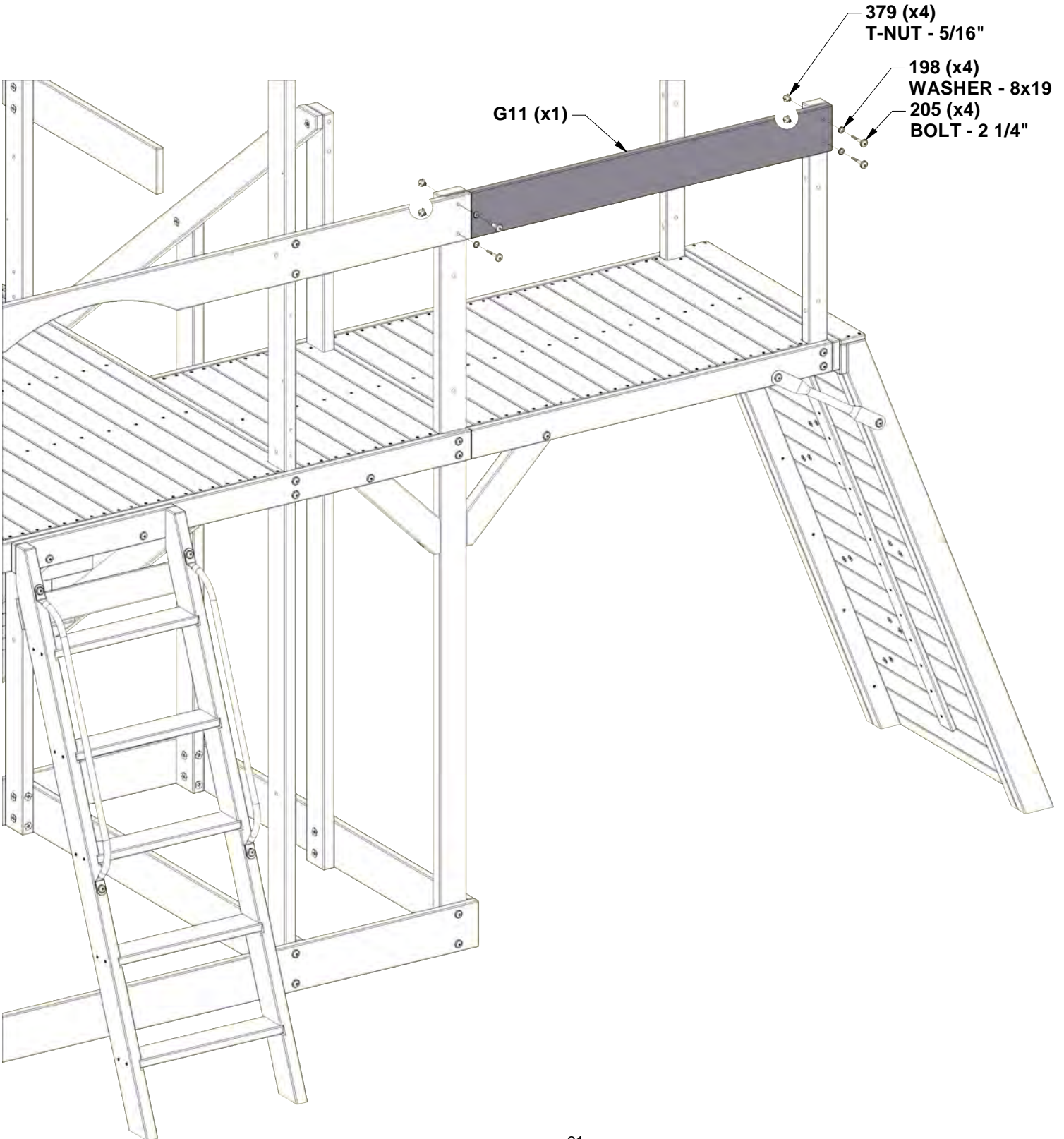

STEP 45 - FORT ASSEMBLY

QTY	PART NUMBER	DESCRIPTION
4	H100198	WASHER LOCK EXT 8x19 BLK
4	H100379	T-NUT 5/16 BLK
4	H100484	BOLT WH 5/16x3 1/4 BLK



G12 WALL RAIL - W4L20393
(x1) 1"x5 1/4"x31" (24x134x788)

INSTALL T-NUTS IN WOOD FIRST

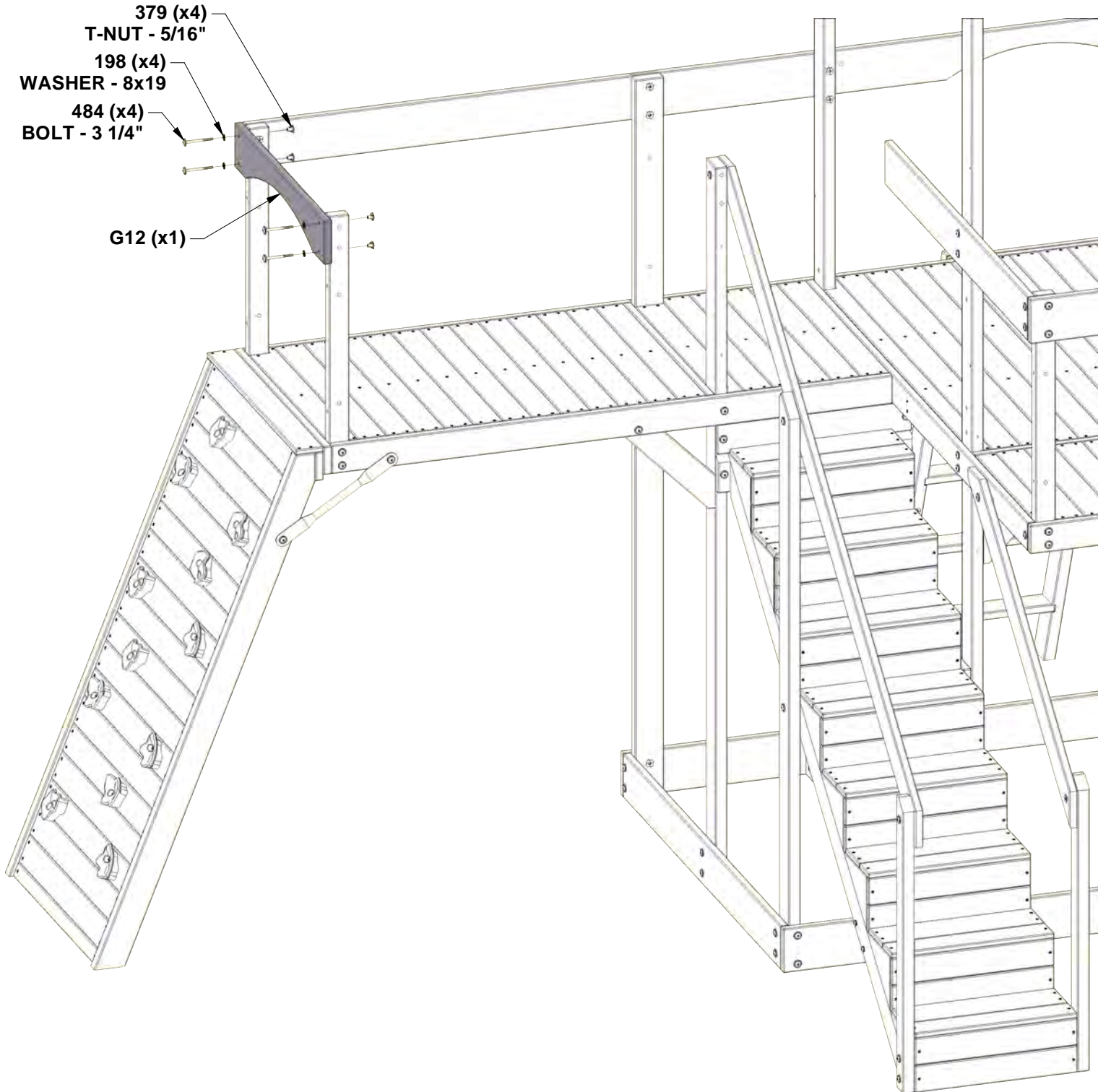

STEP 46 - FORT ASSEMBLY



G08 WALL RAIL - W4L20389
 (x1) 1"x5 1/4"x46 5/8" (24x134x1184)

QTY	PART NUMBER	DESCRIPTION
4	H100198	WASHER LOCK EXT 8x19 BLK
2	H100205	BOLT WH 5/16x2-1/4 BLK
4	H100379	T-NUT 5/16 BLK
2	H100513	BOLT WH 5/16x4 1/4 BLK

INSTALL T-NUTS IN WOOD FIRST

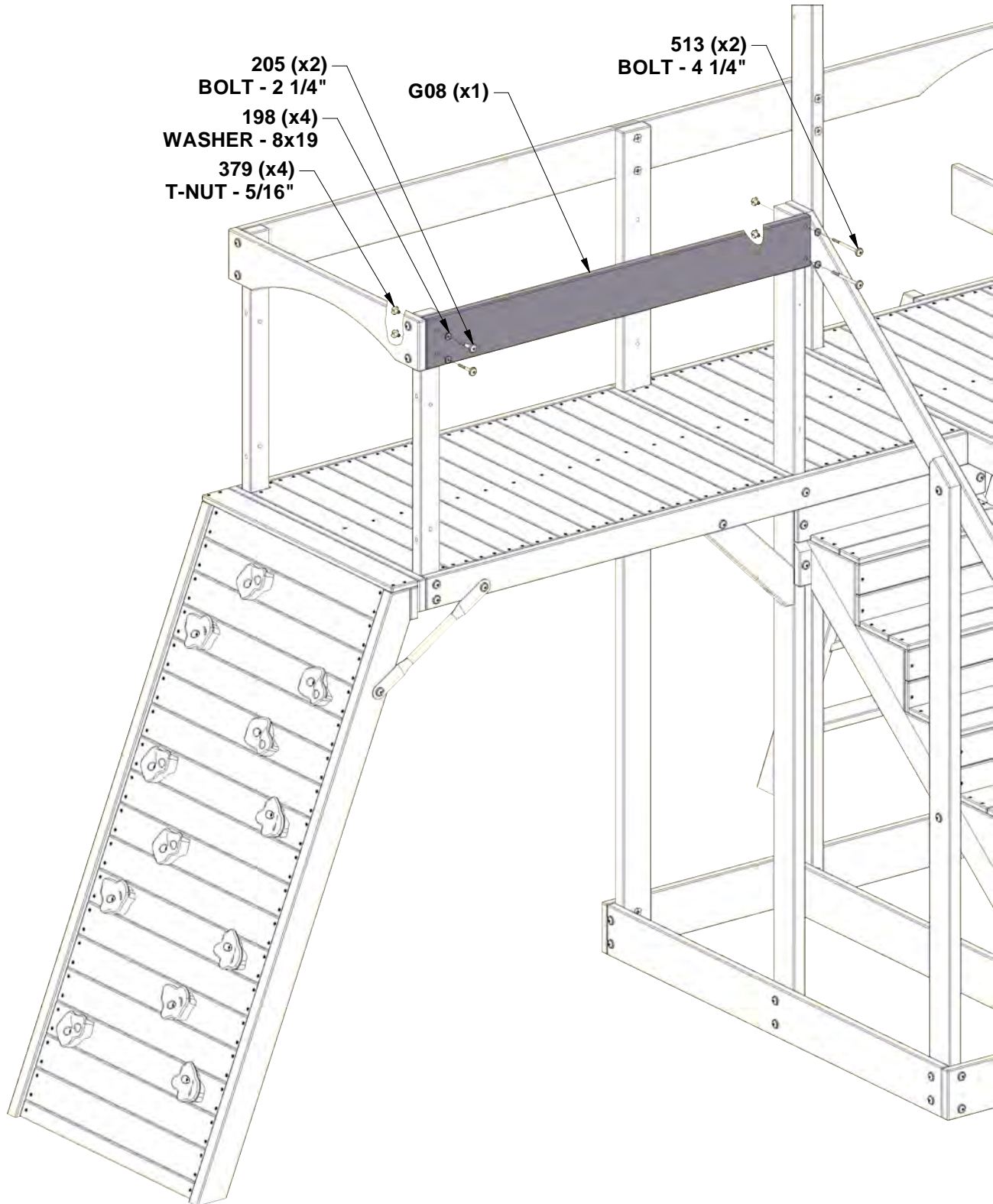

STEP 47 - FORT ASSEMBLY

QTY	PART NUMBER	DESCRIPTION
4	H100198	WASHER LOCK EXT 8x19 BLK
2	H100205	BOLT WH 5/16x2-1/4 BLK
4	H100379	T-NUT 5/16 BLK
2	H100457	BOLT WH 5/16x2 BLK

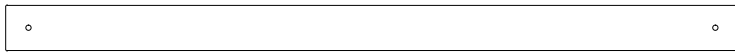

H07 WALL RAIL - W4L20402
(x1) 1"x3 3/8"x54 1/2" (24x86x1384)



M10 ARCHED RAIL - W4L20455
(x1) 5/8"x3 3/8"x54 1/2" (16x86x1384)

6 7/8 in
[175 mm]

3 1/2 in
[89 mm]

INSTALL T-NUTS IN WOOD FIRST

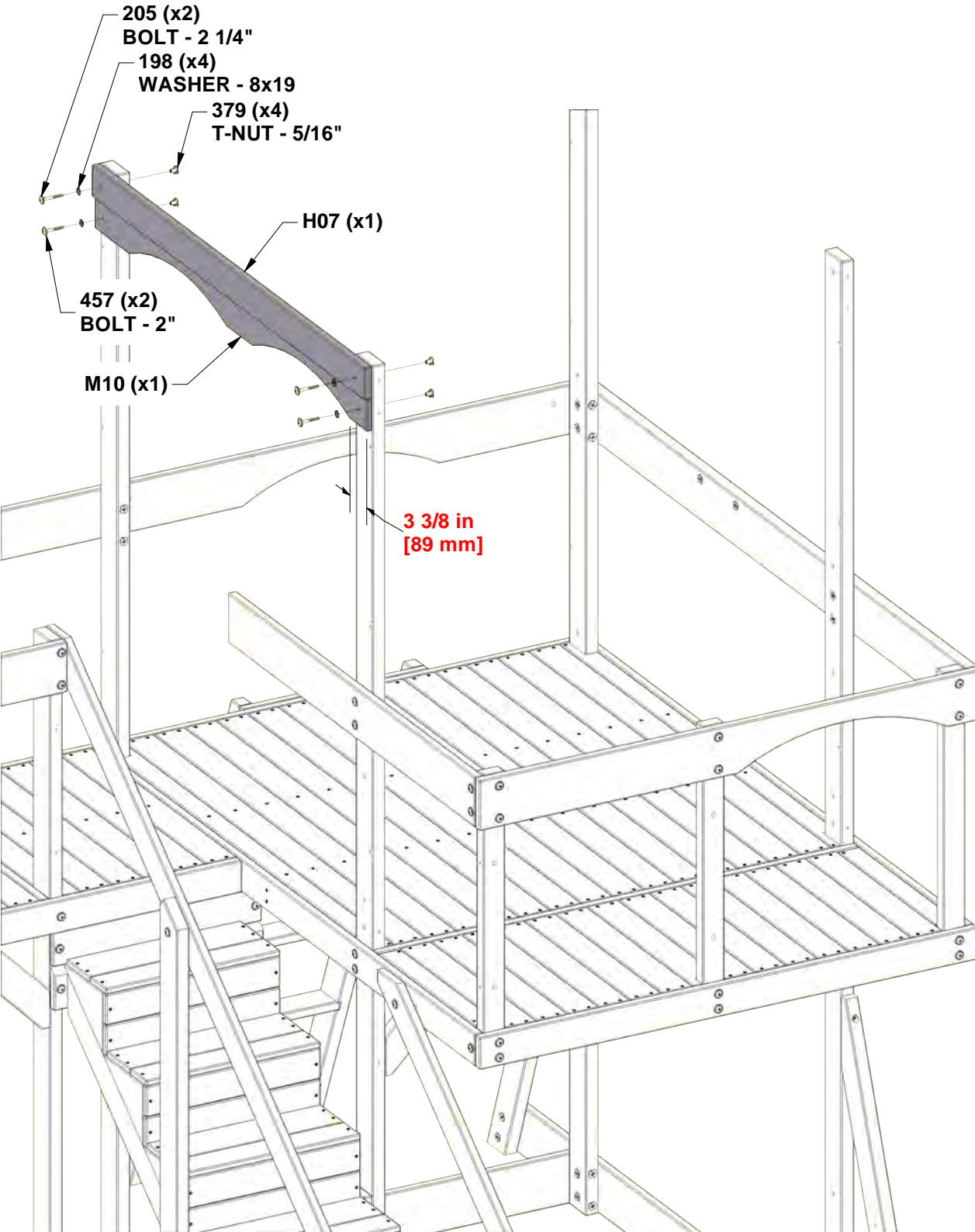

STEP 48 - FORT ASSEMBLY



H07 WALL RAIL - W4L20402
 (x1) 1"x3 3/8"x54 1/2" (24x86x1384)

QTY	PART NUMBER	DESCRIPTION
2	H100198	WASHER LOCK EXT 8x19 BLK
2	H100205	BOLT WH 5/16x2-1/4 BLK
2	H100379	T-NUT 5/16 BLK

INSTALL T-NUTS IN WOOD FIRST

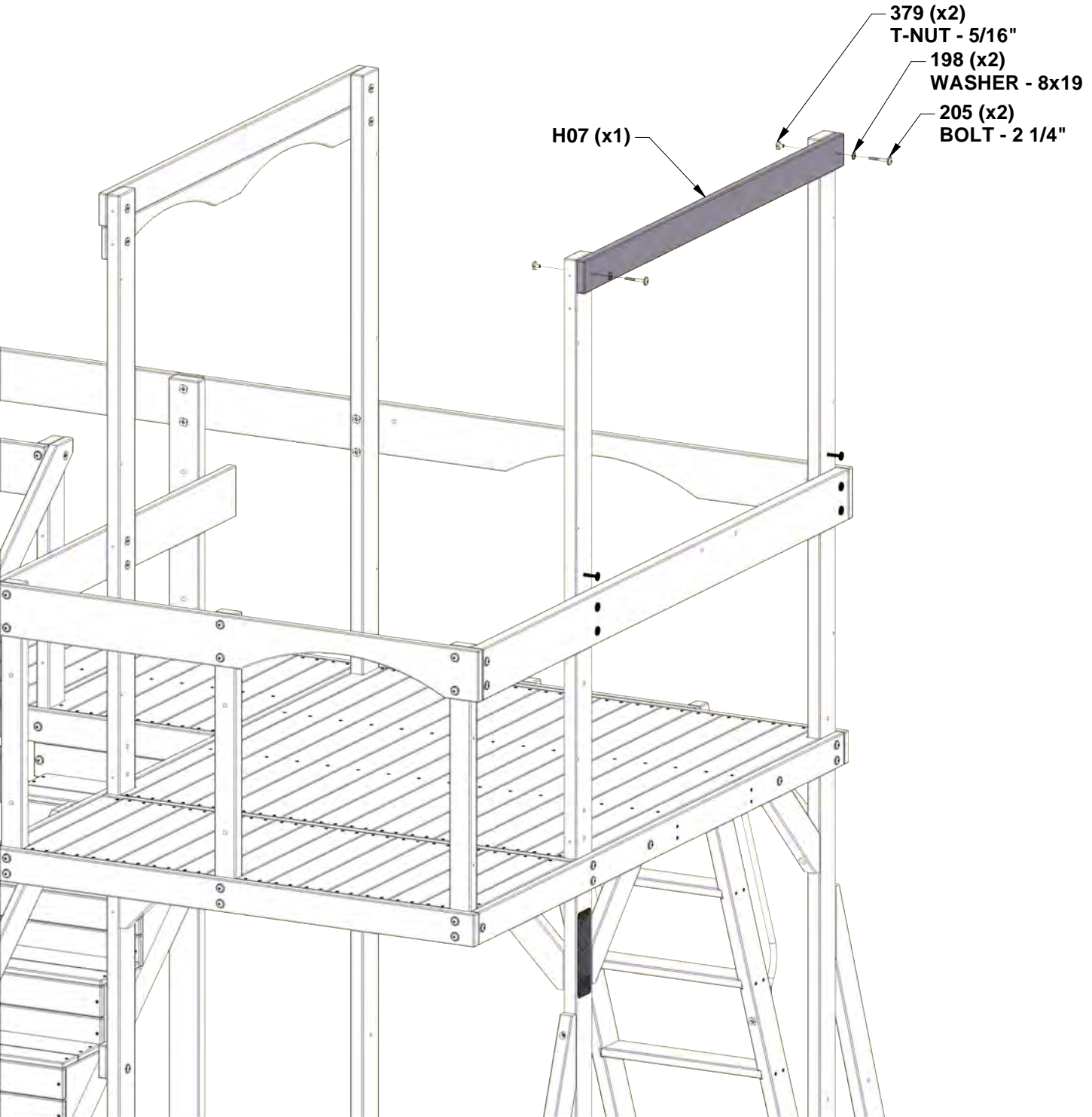

STEP 49 - FORT ASSEMBLY

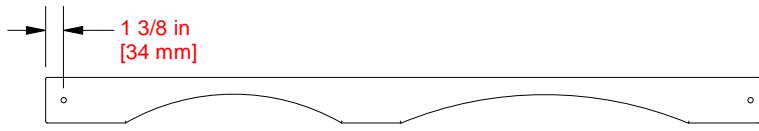

M12 ARCHED RAIL - W4L20457
(x1) 5/8"x3 3/8"x53 1/8" (16x86x1350)

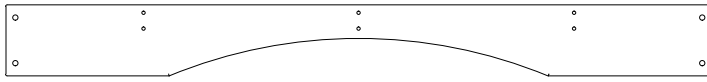

K01 ARCHED RAIL - W4L20441
(x1) 5/8"x5 1/4"x52 1/2" (16x134x1334)

QTY	PART NUMBER	DESCRIPTION
6	H100198	WASHER LOCK EXT 8x19 BLK
6	H100471	LAG SCREW WH 5/16x1-1/2 BLK

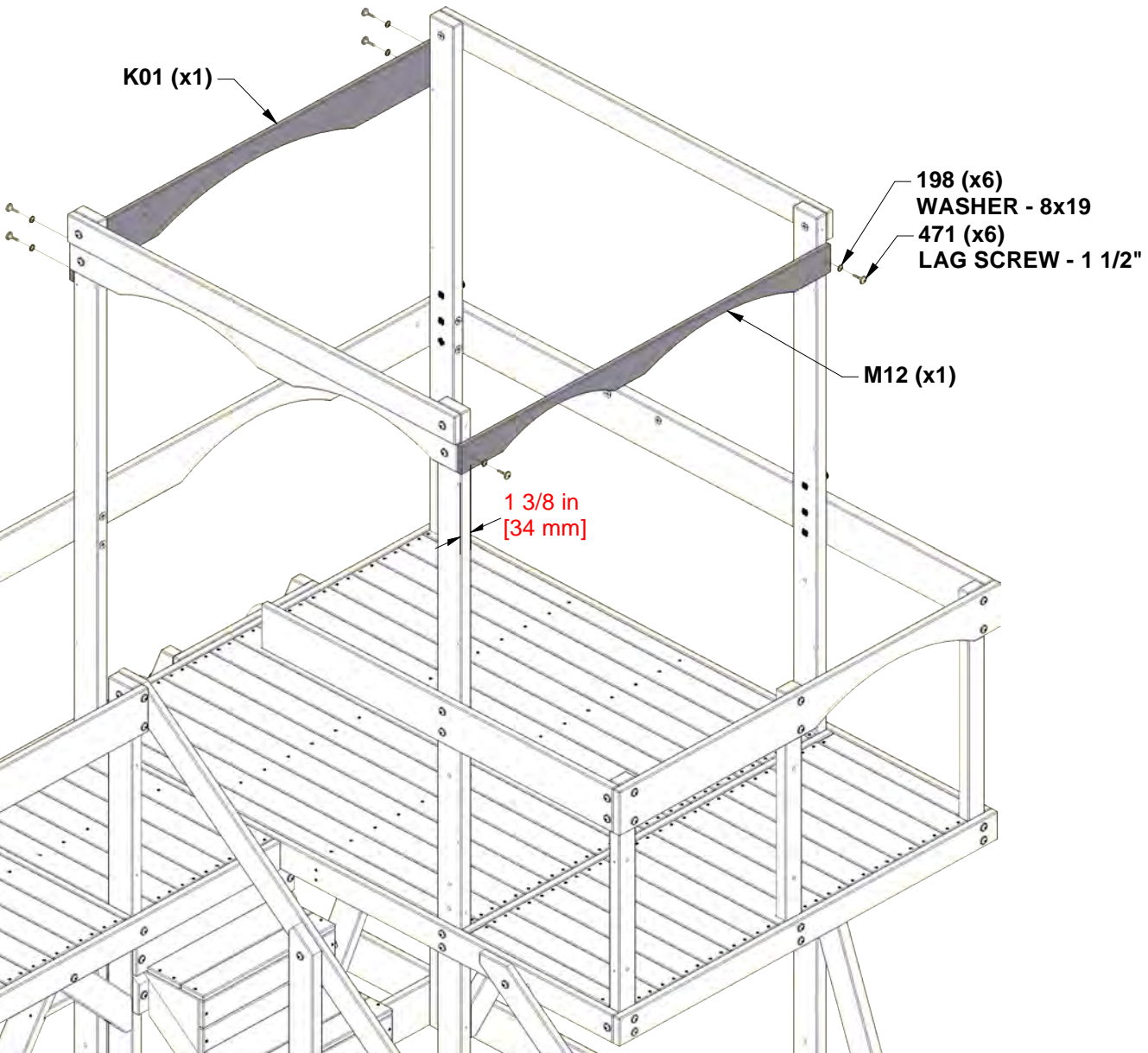

STEP 50 - FORT ASSEMBLY

QTY	PART NUMBER	DESCRIPTION
2	H100090	SCREW PFH 8x2 1/2
4	H100198	WASHER LOCK EXT 8x19 BLK
4	H100206	LAG SCREW WH 5/16x3 BLK



H10 WALL RAIL - W4L20405
(x2) 1"x3 3/8"x54 3/8" (24x86x1382)



M14 ROOF RAFTER - W4L20459
(x4) 5/8"x3 3/8"x36 1/8" (16x86x918)

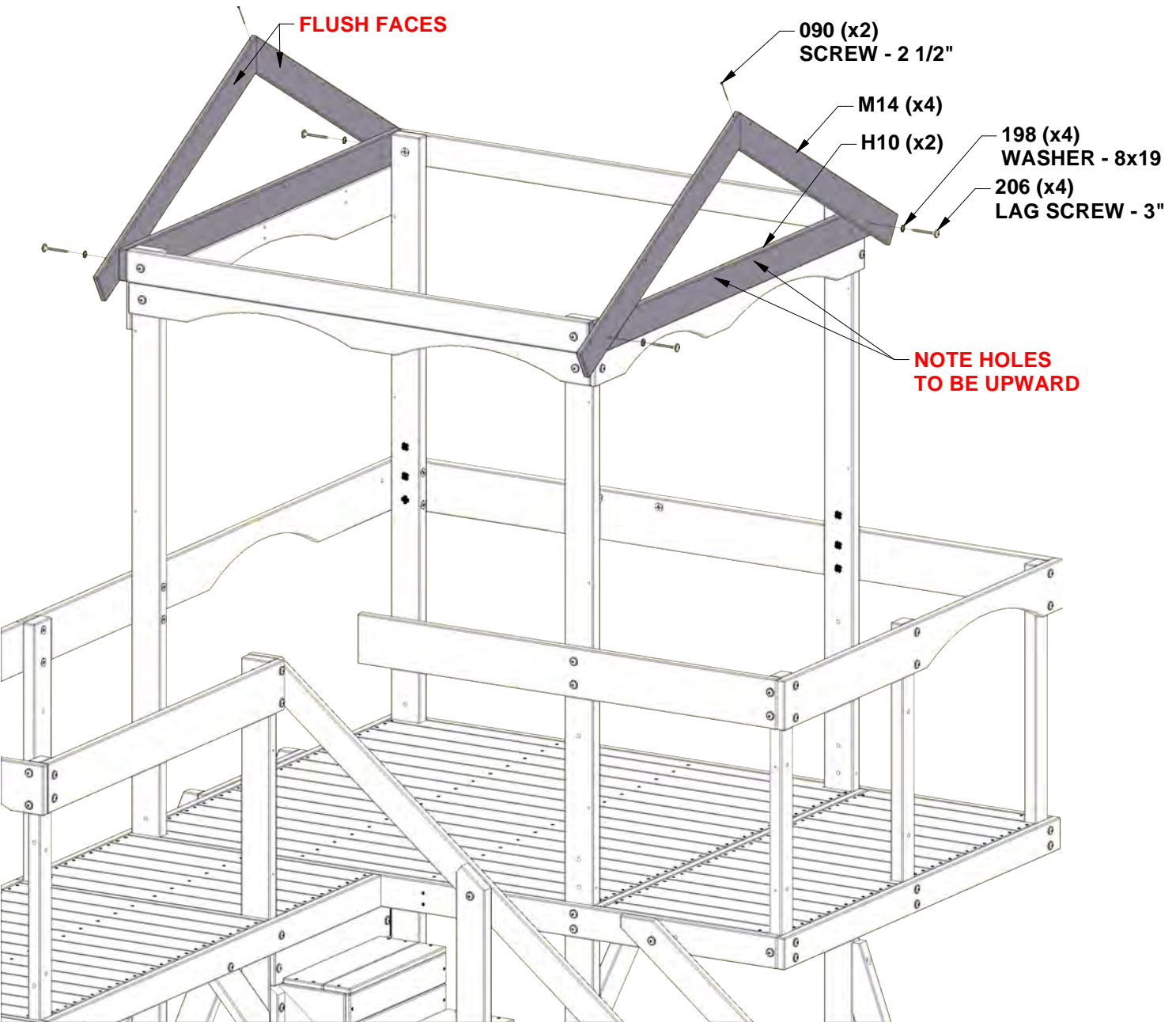

STEP 51 - FORT ASSEMBLY

QTY	PART NUMBER	DESCRIPTION
12	H100089	SCREW PFH 8x1-3/4"

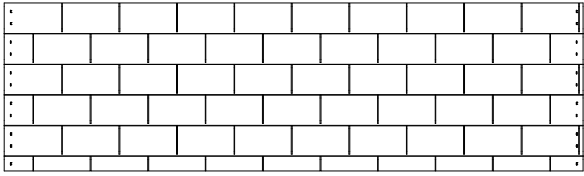

RP1 ROOF PANEL - W2A04391
 (x1) 1 3/8"x17 1/2"x60 3/8" (35x444x1532)

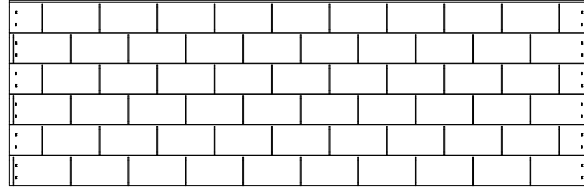

RP2 ROOF PANEL - W2A04392
 (x1) 1 3/8"x19 3/8"x60 3/8" (35x491x1532)

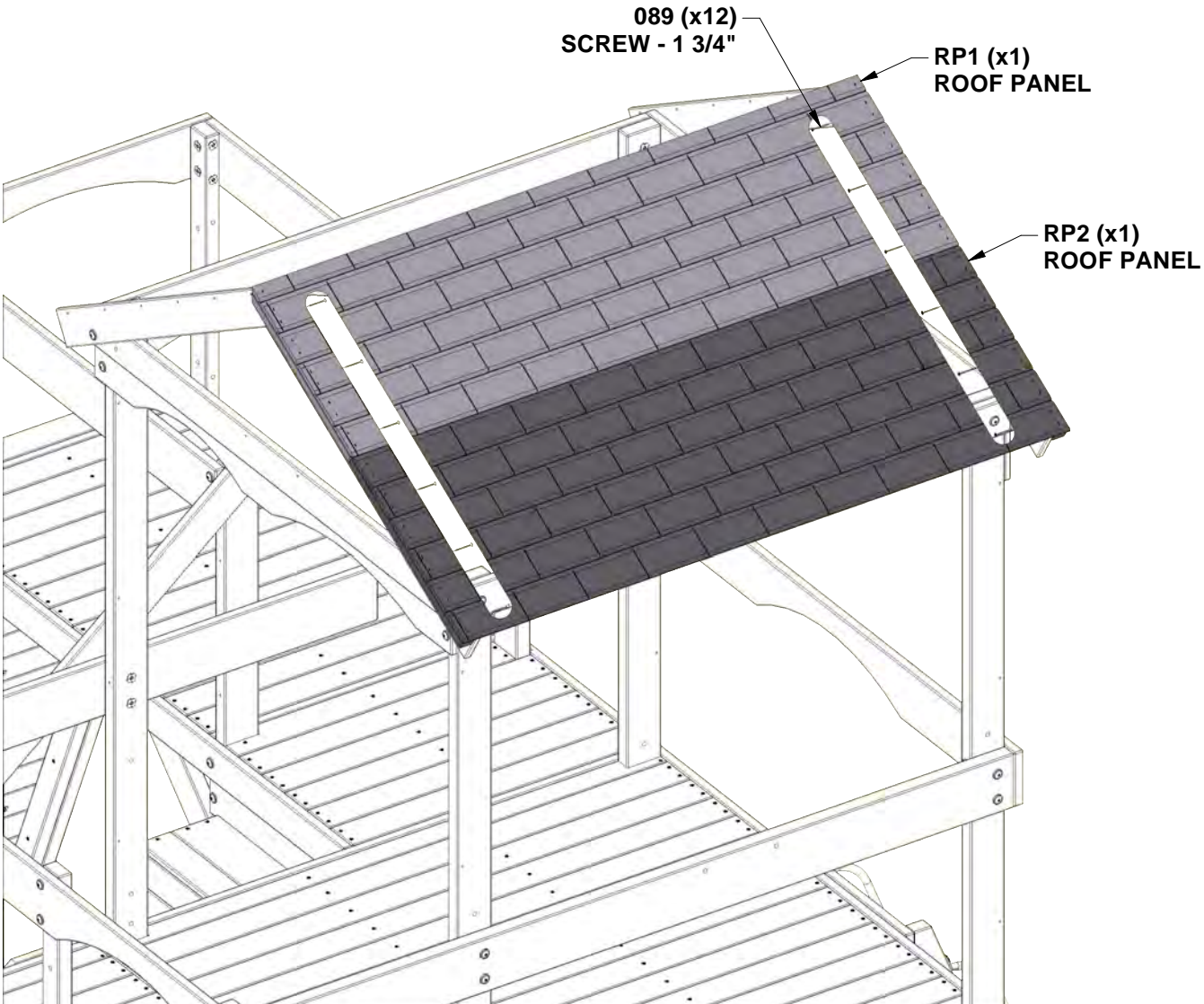
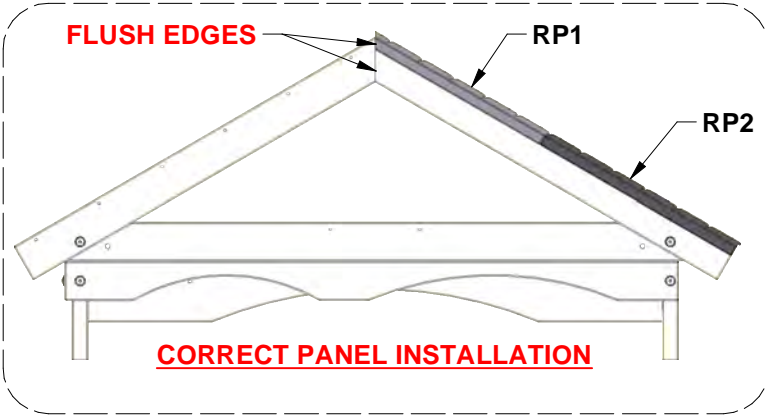

STEP 52 - FORT ASSEMBLY

QTY	PART NUMBER	DESCRIPTION
12	H100089	SCREW PFH 8x1-3/4"

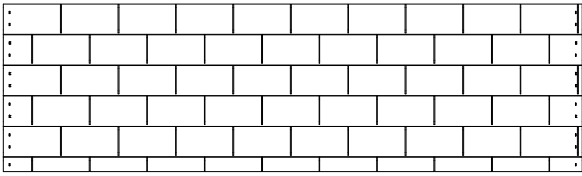

RP1 ROOF PANEL - W2A04391
 (x1) 1 3/8"x17 1/2"x60 3/8" (35x444x1532)

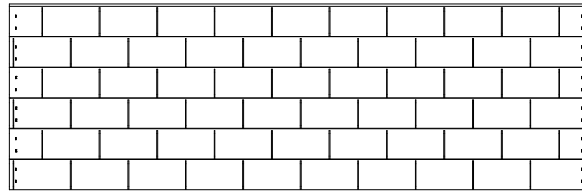

RP2 ROOF PANEL - W2A04392
 (x1) 1 3/8"x19 3/8"x60 3/8" (35x491x1532)

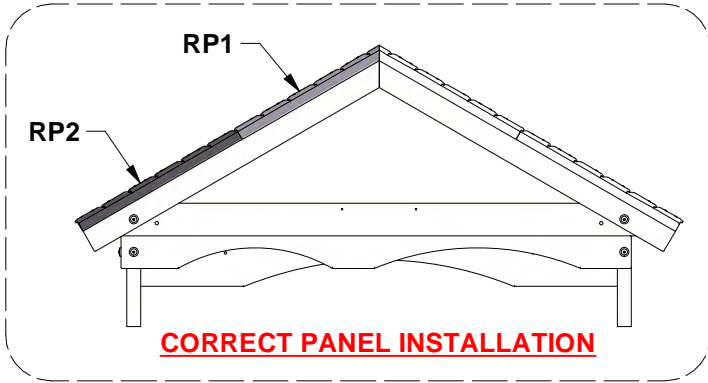

STEP 53 - FORT ASSEMBLY

QTY	PART NUMBER	DESCRIPTION
4	H100086	SCREW PFH 8x1-1/2"
32	H100088	SCREW PFH 8x1-1/8"

- N03 GABLE BOARD - W4L20471
(x2) 5/8"x2 3/8"x14 3/4" (16x60x375)
- N05 GABLE BOARD - W4L20473
(x4) 5/8"x2 3/8"x13 1/4" (16x60x335)
- N06 GABLE BOARD - W4L20474
(x4) 5/8"x2 3/8"x18 1/8" (16x60x460)
- N12 GABLE BOARD - W4L20476
(x4) 5/8"x2 3/8"x11 1/2" (16x60x293)
- K03 GABLE BOARD - W4L20443
(x2) 5/8"x5 1/4"x12 5/8" (16x134x320)

REPEAT STEP ON OPPOSITE SIDE

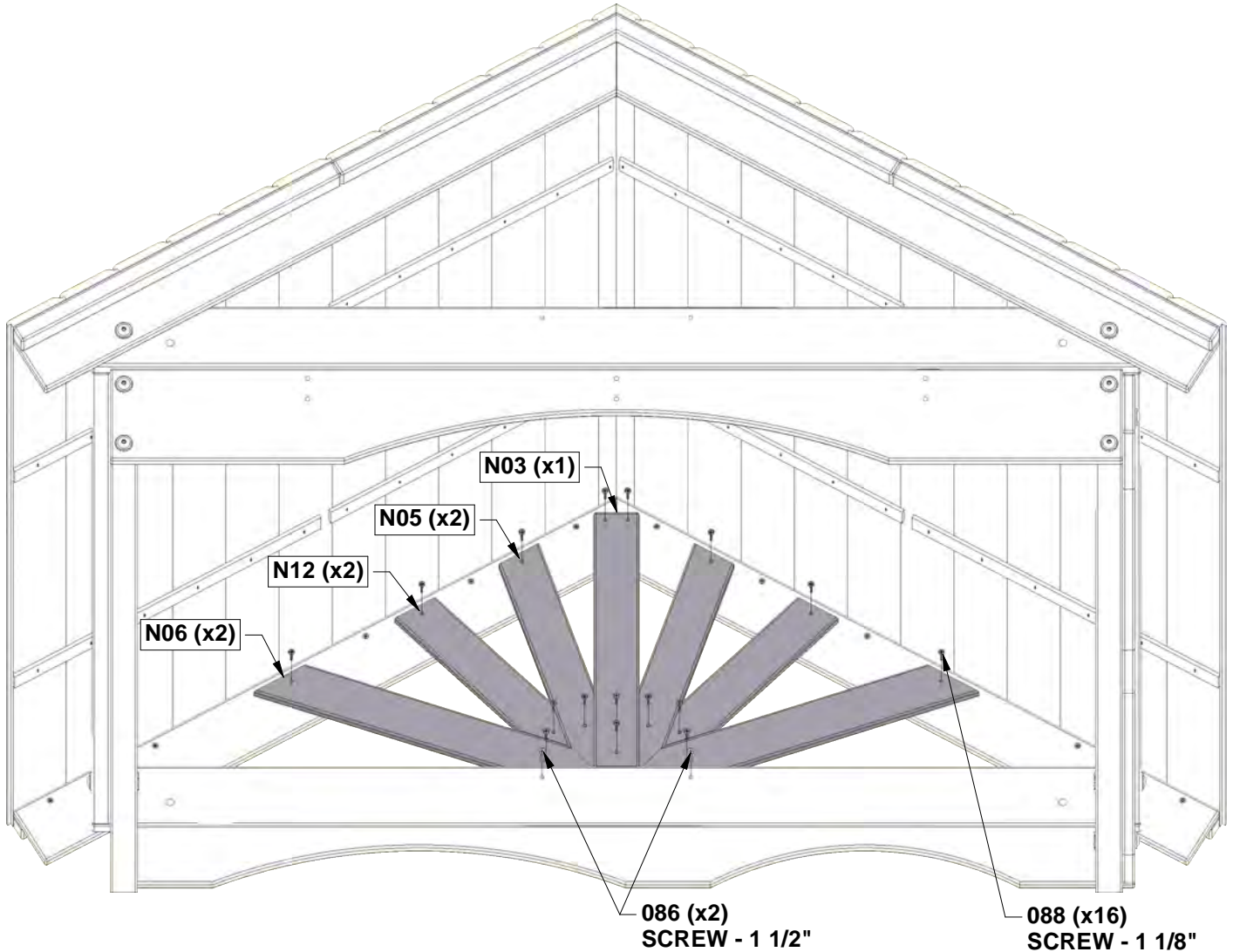
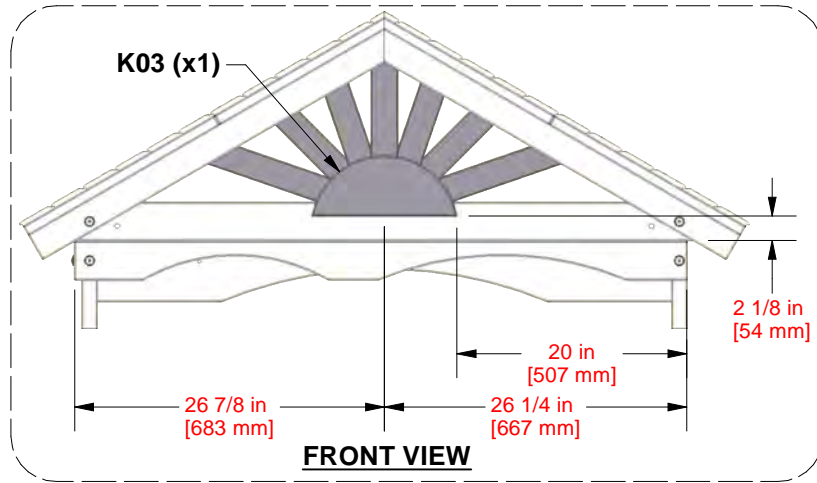
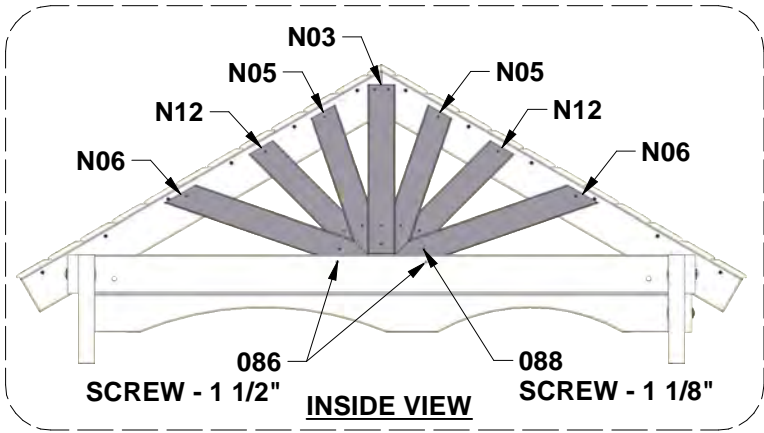

STEP 54 - FORT ASSEMBLY

QTY	PART NUMBER	DESCRIPTION
6	H100088	SCREW PFH 8x1-1/8"
1	H100192	NUT BARREL WH 5/16x7/8 BLK
1	H100198	WASHER LOCK EXT 8x19 BLK
1	H100199	WASHER LOCK EXT 12x19 BLK
1	H100205	BOLT WH 5/16x2-1/4 BLK
2	H100379	T-NUT 5/16 BLK
1	H100396	BOLT WH 5/16x1/2 BLK
1	H100459	BOLT WH 5/16x1 1/4 BLK



M02 WALL BOARD - W4L20447
(x1) 5/8"x3 3/8"x61 1/4" (16x86x1557)



H26 WALL RAIL - W4L20421
(x1) 1"x3 3/8"x27 1/4" (24x86x692)



A4M01047 L BRACKET
(x1) 2.5x38x55x55

**INSTALL T-NUTS IN WOOD FIRST
USING BRACKET AS A GUIDE,
DRILL (1) 3/8" [10mm] HOLE
THRU DECK FOR HARDWARE**

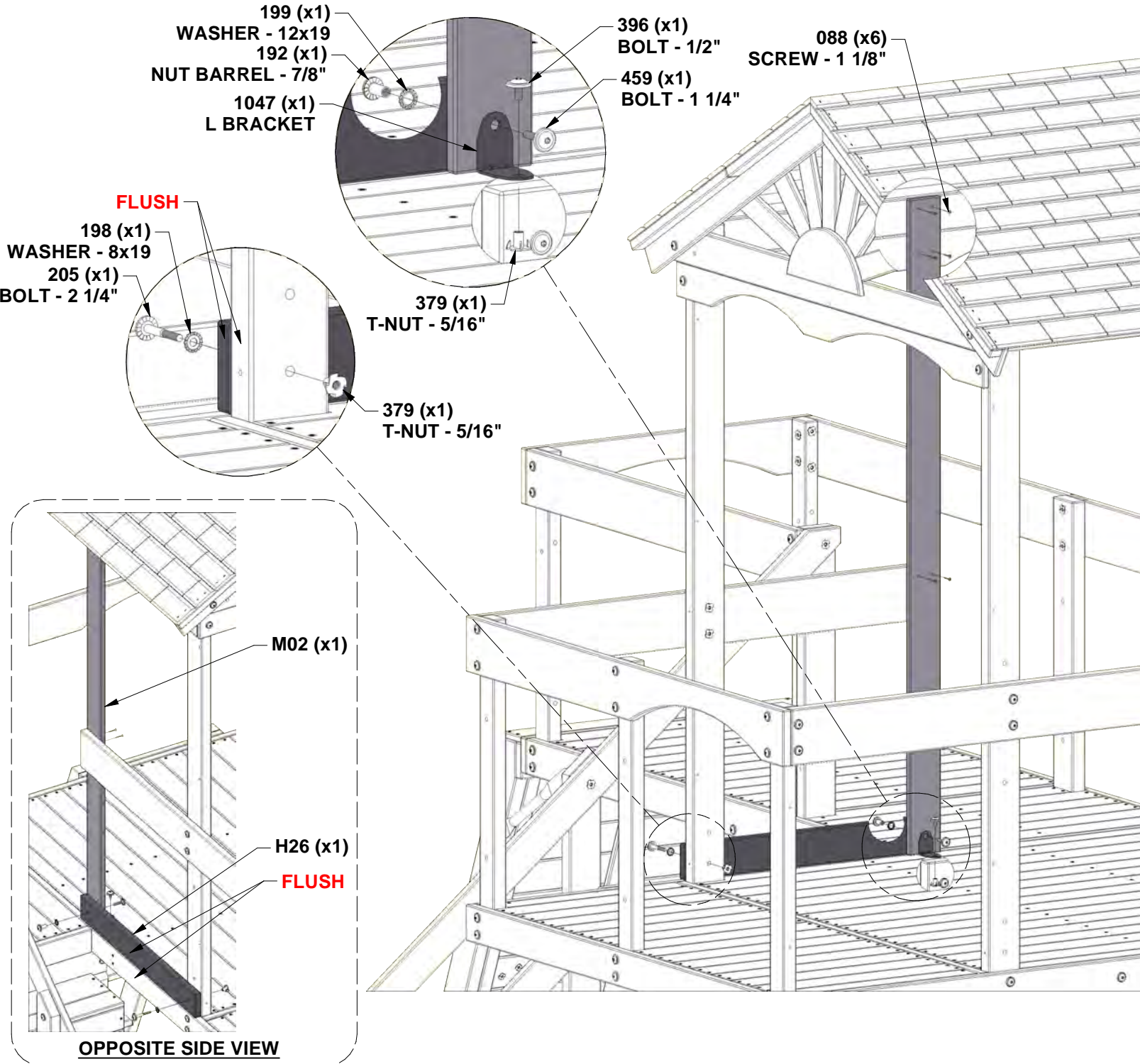

STEP 55 - FORT ASSEMBLY

QTY	PART NUMBER	DESCRIPTION
4	H100198	WASHER LOCK EXT 8x19 BLK
2	H100205	BOLT WH 5/16x2-1/4 BLK
2	H100379	T-NUT 5/16 BLK
2	H100458	LAG SCREW WH 5/16x2 BLK

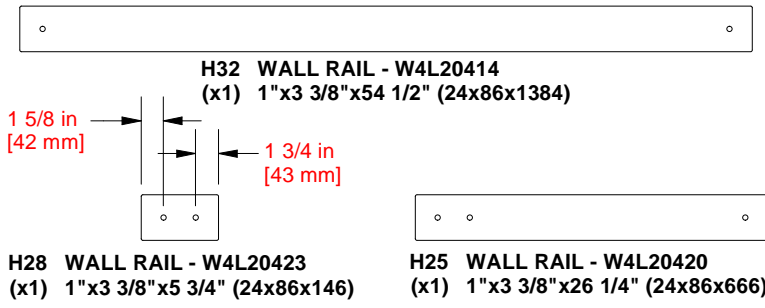

INSTALL T-NUTS IN WOOD FIRST

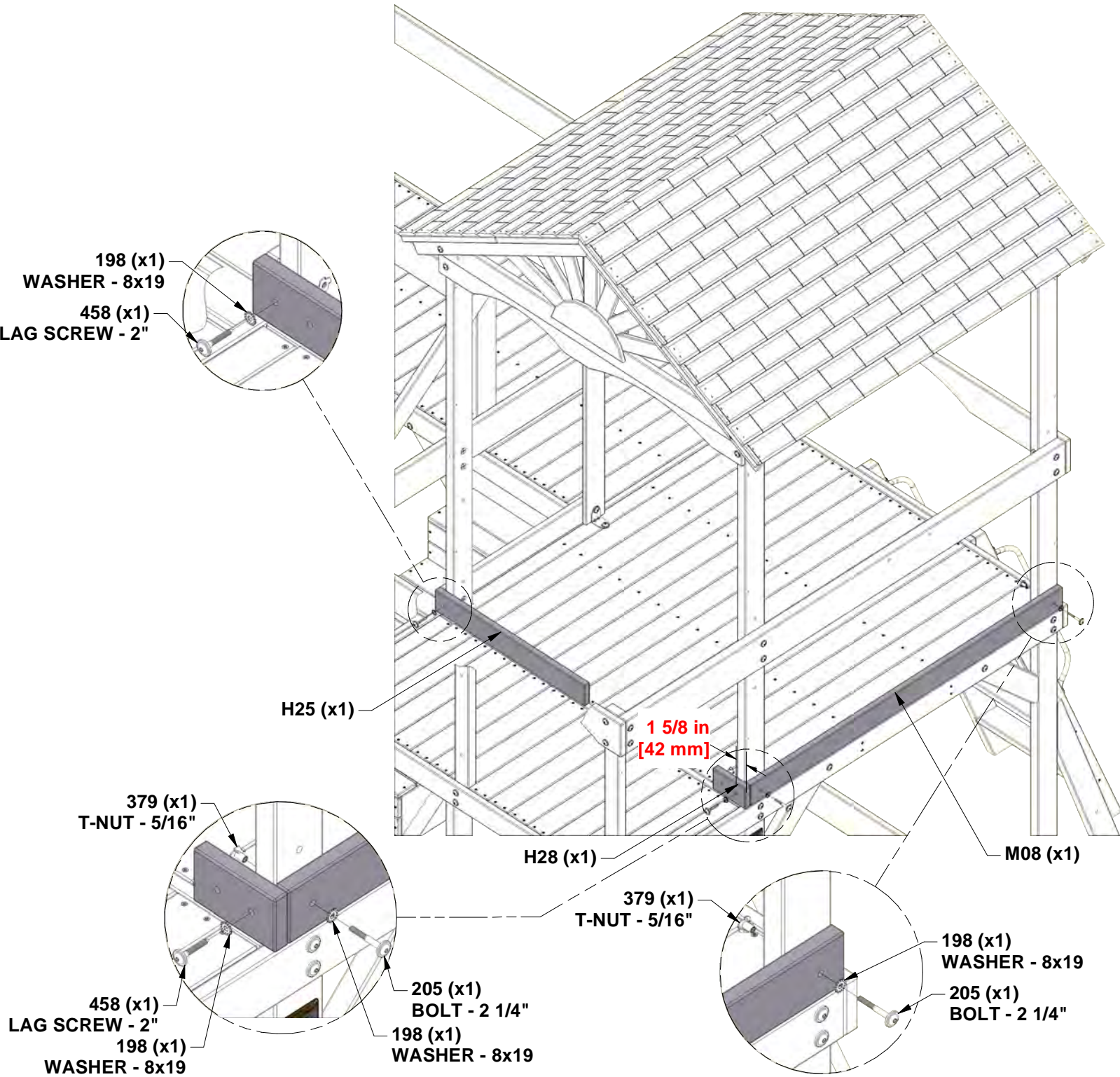

STEP 56 - FORT ASSEMBLY

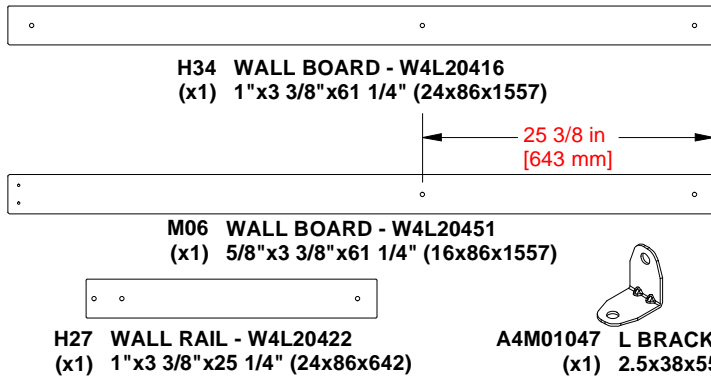

QTY	PART NUMBER	DESCRIPTION
2	H100088	SCREW PFH 8x1-1/8"
3	H100092	SCREW PFH 8x3
1	H100192	NUT BARREL WH 5/16x7/8 BLK
5	H100198	WASHER LOCK EXT 8x19 BLK
1	H100199	WASHER LOCK EXT 12x19 BLK
3	H100378	BOLT WH 5/16x1 3/4 BLK
5	H100379	T-NUT 5/16 BLK
1	H100396	BOLT WH 5/16x1/2 BLK
1	H100407	BOLT WH 5/16x1 1/2 BLK
1	H100458	LAG SCREW WH 5/16x2 BLK
1	H100459	BOLT WH 5/16x1 1/4 BLK

INSTALL T-NUTS IN WOOD FIRST
USING BRACKET AS A GUIDE,
DRILL (1) 3/8" [10mm] HOLE
THRU DECK FOR HARDWARE.

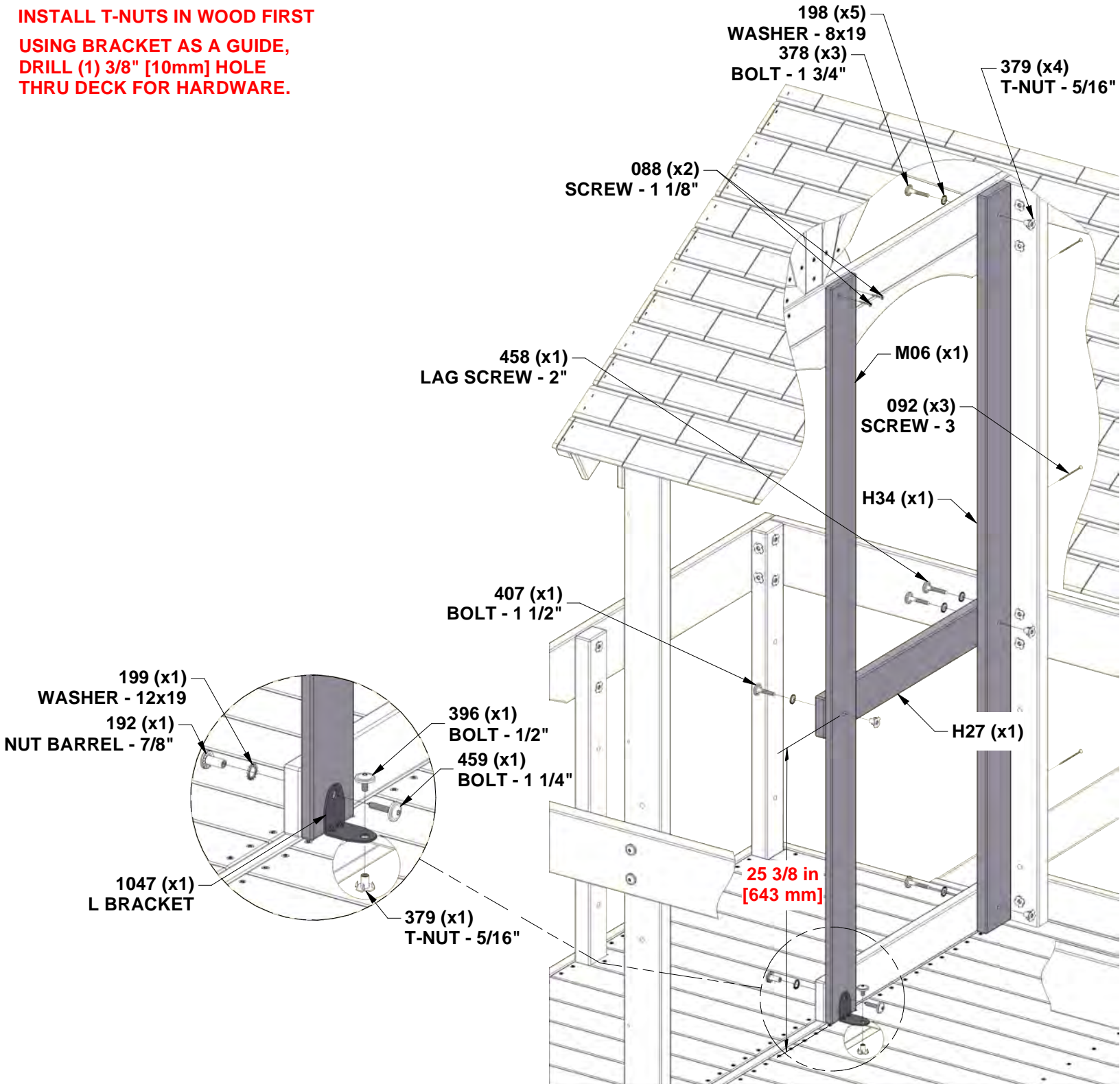

STEP 57 - FORT ASSEMBLY

QTY	PART NUMBER	DESCRIPTION
3	H100198	WASHER LOCK EXT 8x19 BLK
1	H100205	BOLT WH 5/16x2-1/4 BLK
1	H100379	T-NUT 5/16 BLK
2	H100458	LAG SCREW WH 5/16x2 BLK



H23 WALL RAIL - W4L20418
(x2) 1"x3 3/8"x16" (24x86x406)



H35 WALL RAIL - W4L20419
(x1) 1"x3 3/8"x3 3/8" (24x86x86)

INSTALL T-NUTS IN WOOD FIRST

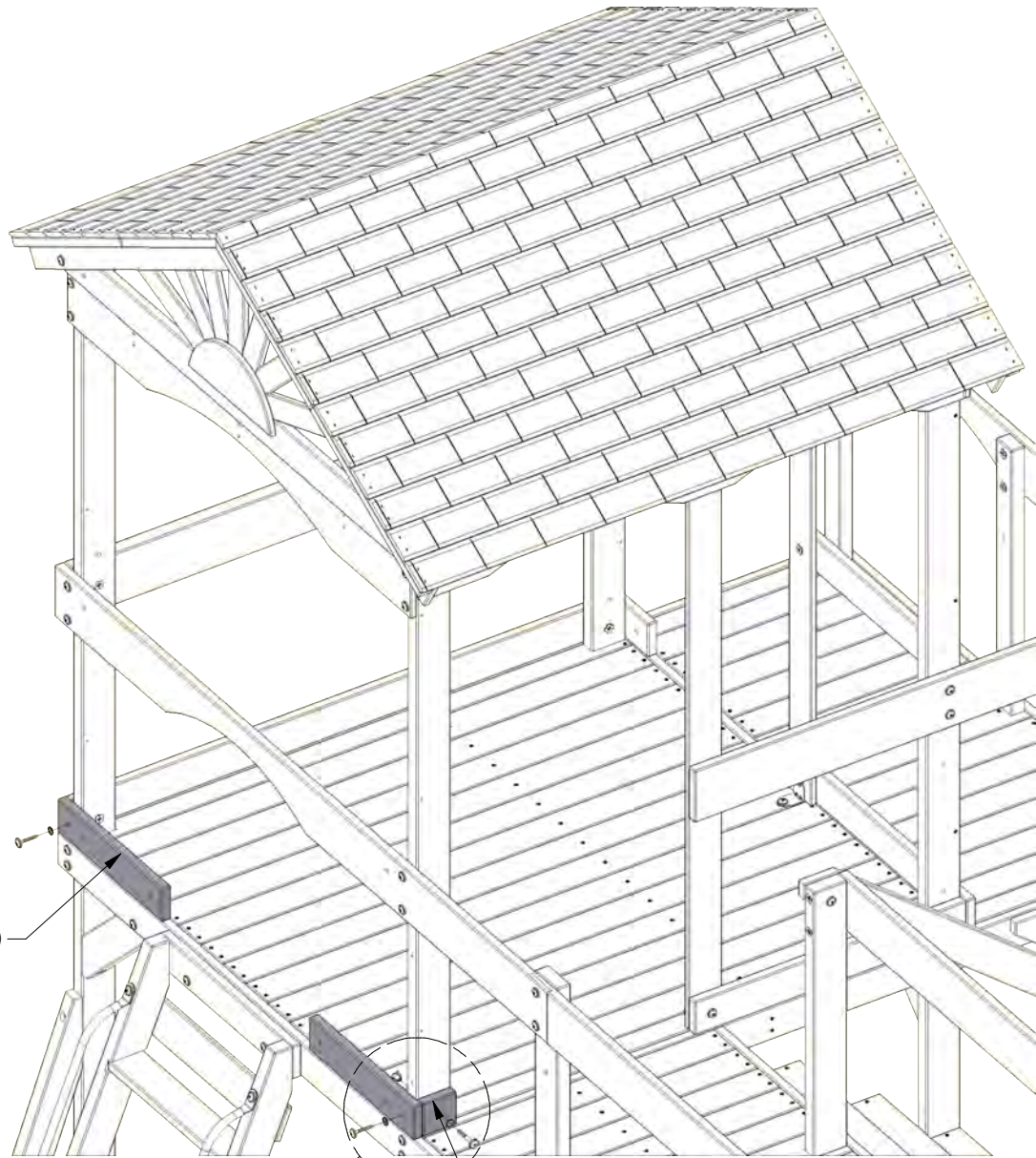

H23 (x2)

H35 (x1)

379 (x1)
T-NUT - 5/16"

458 (x2)
LAG SCREW - 2"

198 (x3)
WASHER - 8x19

205 (x1)
BOLT - 2 1/4"

STEP 58 - FORT ASSEMBLY

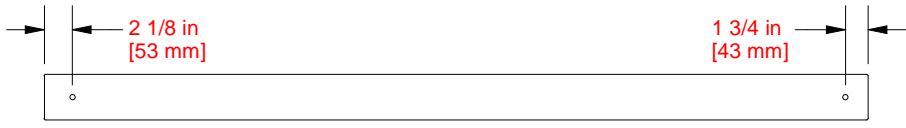

H22 WALL BOARD - W4L20417
(x1) 1"x3 3/8"x61 1/4" (24x86x1557)

QTY	PART NUMBER	DESCRIPTION
3	H100092	SCREW PFH 8x3
2	H100198	WASHER LOCK EXT 8x19 BLK
2	H100378	BOLT WH 5/16x1 3/4 BLK
2	H100379	T-NUT 5/16 BLK

INSTALL T-NUTS IN WOOD FIRST

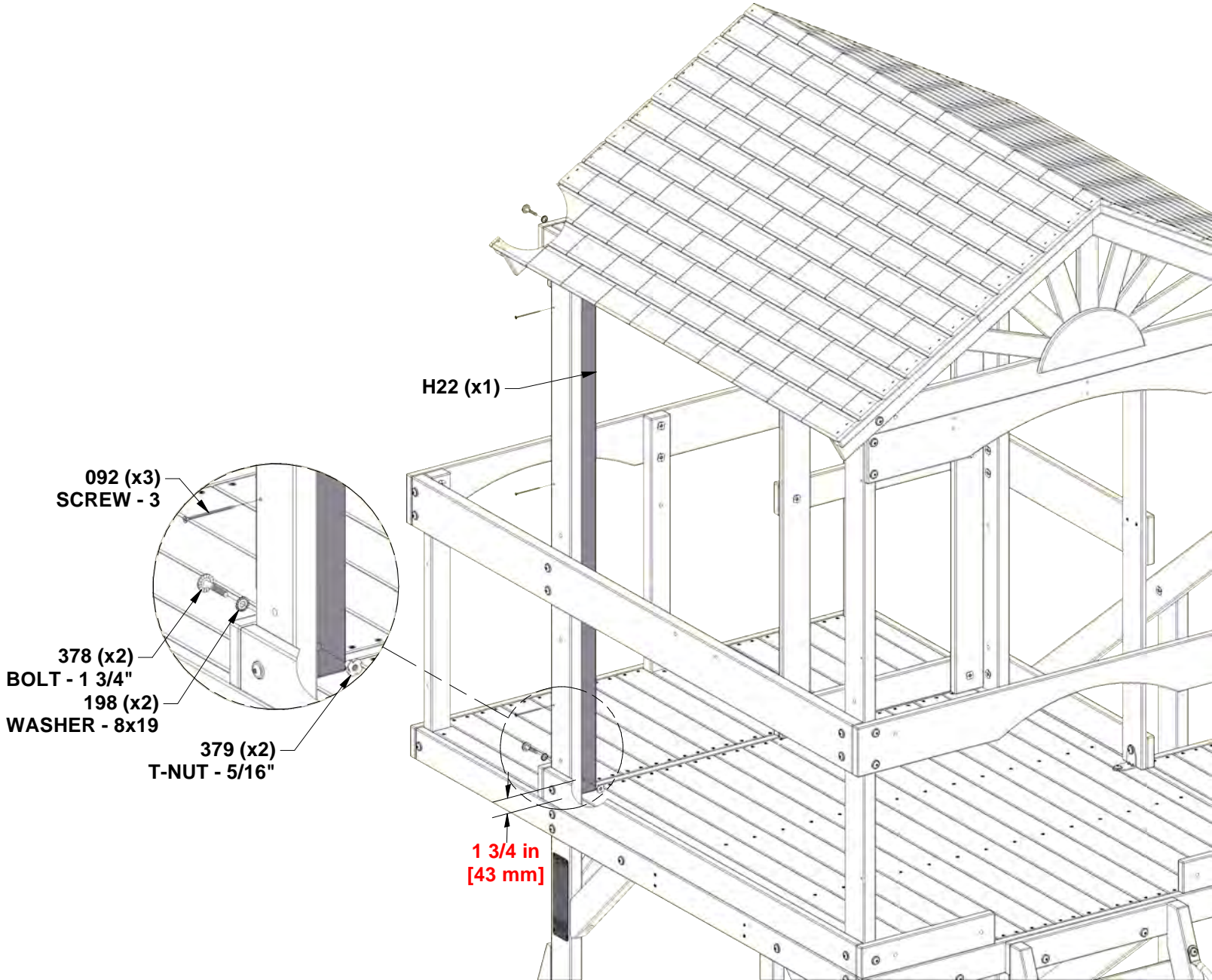

STEP 59 - FORT ASSEMBLY



M20 WALL BOARD - W4L20465
(x2) 5/8"x3 3/8"x27" (16x86x686)

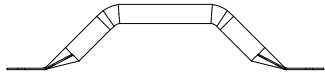

A4M00613 HAND GRIP METAL
(x2) BLACK 381 c/c



A4M01047 L BRACKET
(x2) 2.5x38x55x55

QTY	PART NUMBER	DESCRIPTION
4	H100088	SCREW PFH 8x1-1/8"
2	H100192	NUT BARREL WH 5/16x7/8 BLK
2	H100199	WASHER LOCK EXT 12x19 BLK
6	H100379	T-NUT 5/16 BLK
6	H100396	BOLT WH 5/16x1/2 BLK
2	H100459	BOLT WH 5/16x1 1/4 BLK

INSTALL T-NUTS IN WOOD FIRST

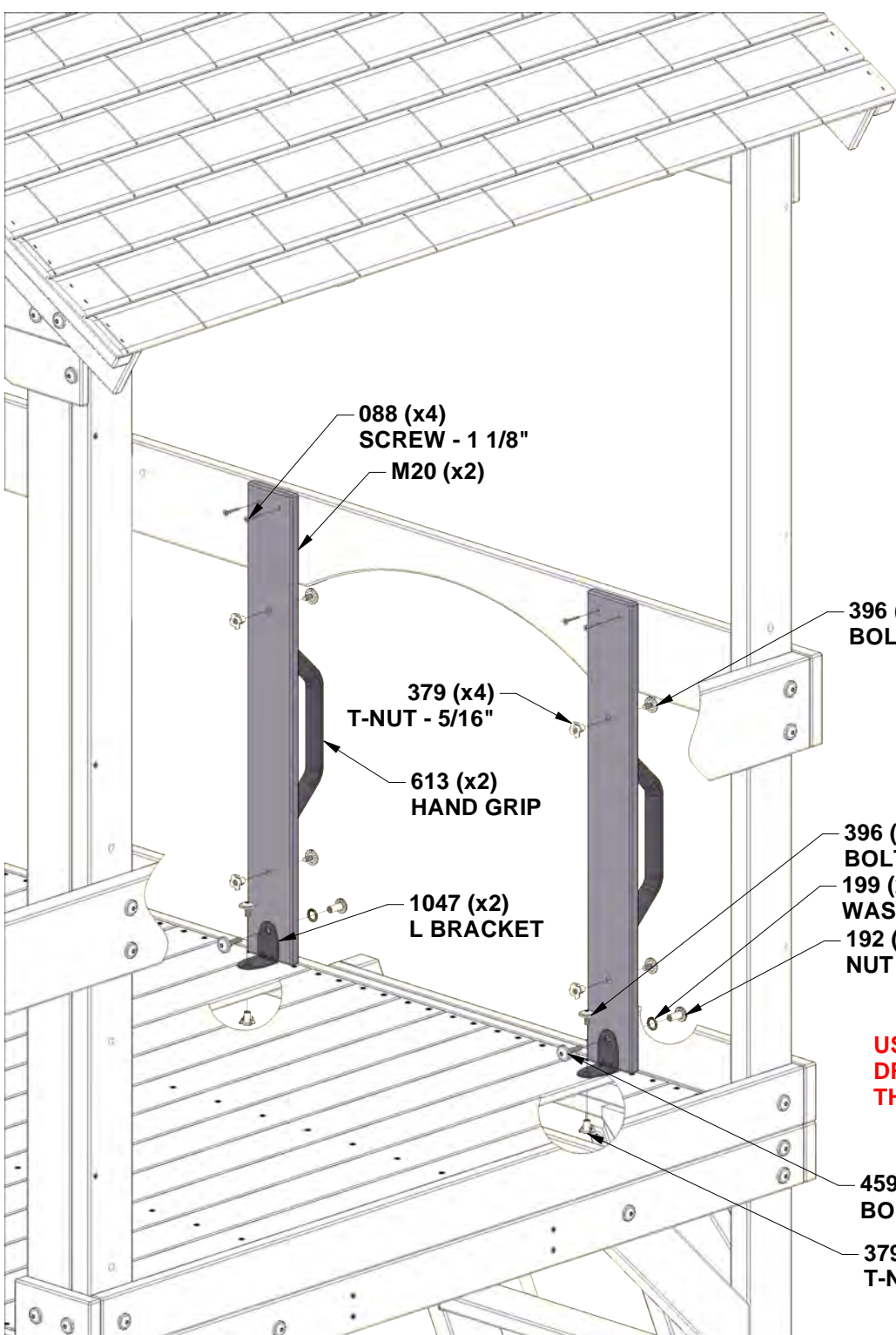

088 (x4)
SCREW - 1 1/8"
M20 (x2)

379 (x4)
T-NUT - 5/16"

613 (x2)
HAND GRIP

1047 (x2)
L BRACKET

396 (x4)
BOLT - 1/2"

396 (x2)
BOLT - 1/2"
199 (x2)
WASHER - 12x19
192 (x2)
NUT BARREL - 7/8"

**USING BRACKET AS A GUIDE,
DRILL (1) 3/8" [10mm] HOLE
THRU DECK FOR HARDWARE.**

459 (x2)
BOLT - 1 1/4"

379 (x2)
T-NUT - 5/16"

STEP 60 - FORT ASSEMBLY

QTY	PART NUMBER	DESCRIPTION
12	H100088	SCREW PFH 8x1-1/8"

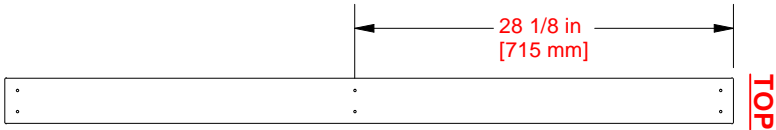

M11 WALL BOARD - W4L20456
(x2) 5/8"x3 3/8"x54 1/4" (16x86x1377)

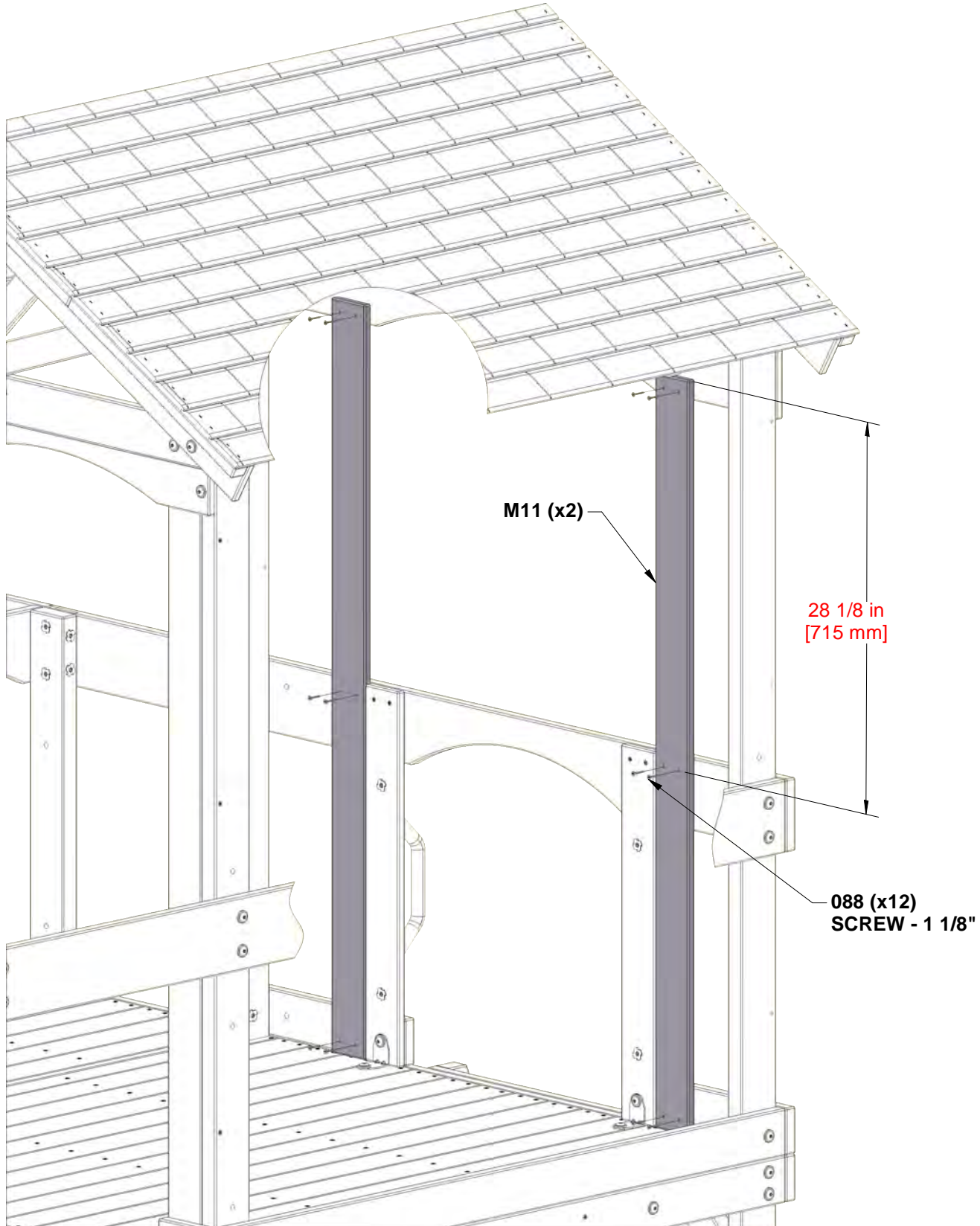

STEP 61 - FORT ASSEMBLY

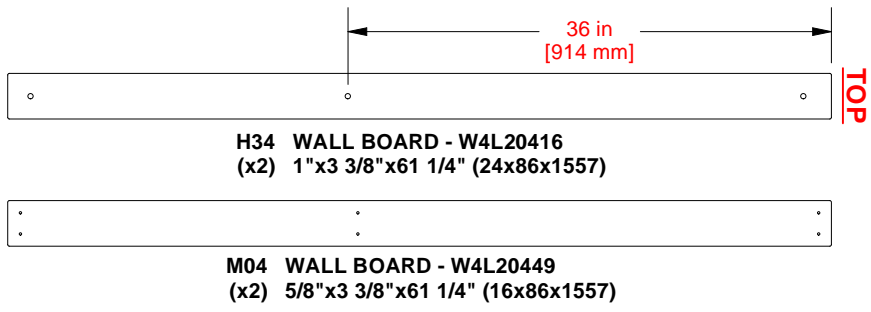

QTY	PART NUMBER	DESCRIPTION
12	H100088	SCREW PFH 8x1-1/8"
6	H100092	SCREW PFH 8x3
6	H100198	WASHER LOCK EXT 8x19 BLK
6	H100378	BOLT WH 5/16x1 3/4 BLK
6	H100379	T-NUT 5/16 BLK

INSTALL T-NUTS IN WOOD FIRST

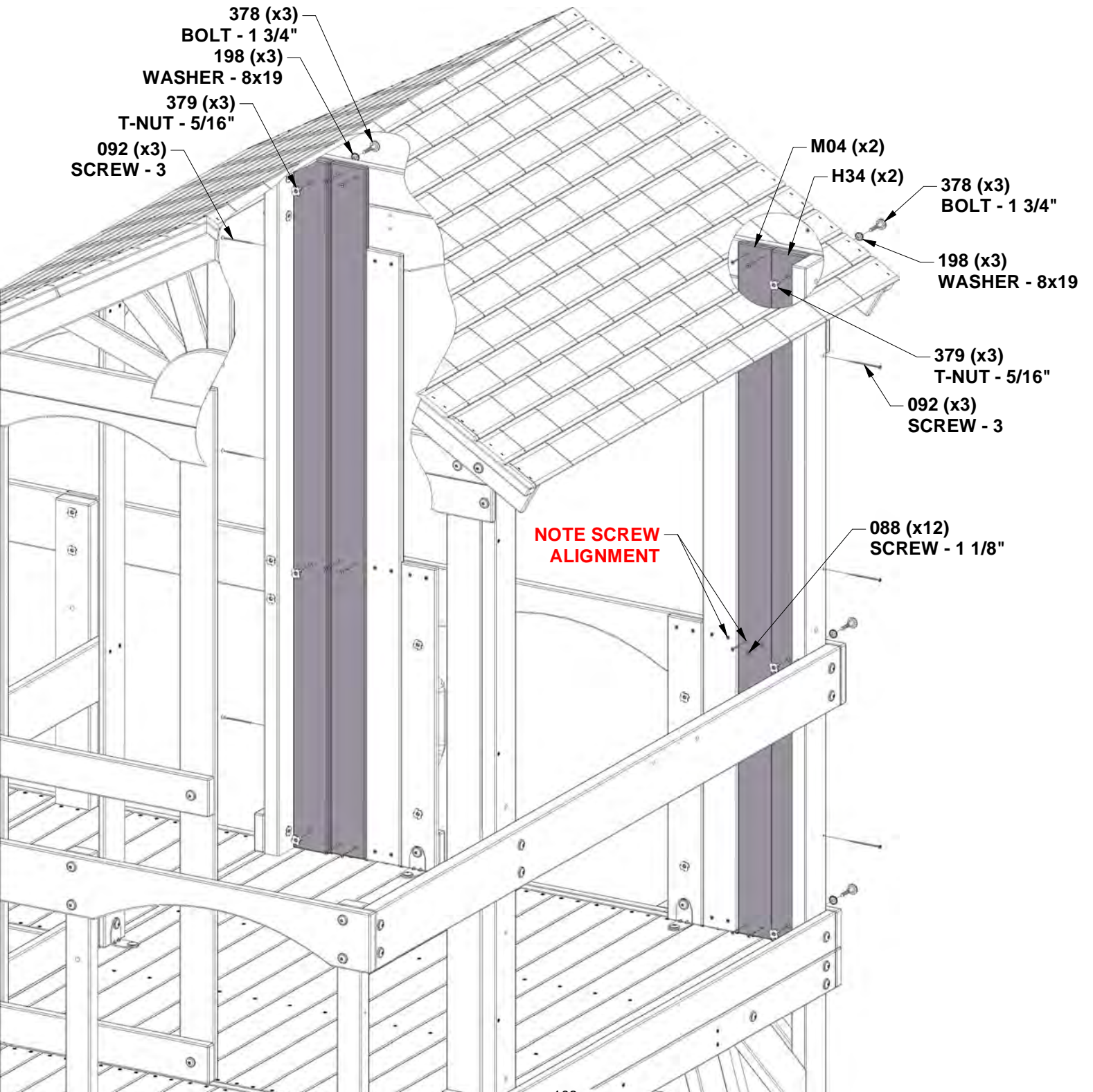

STEP 62 - FORT ASSEMBLY

QTY	PART NUMBER	DESCRIPTION
20	H100088	SCREW PFH 8x1-1/8"



M18 WALL BOARD - W4L20463
(x5) 5/8"x3 3/8"x26 3/4" (16x86x680)

EVENLY SPACE WALL BOARDS

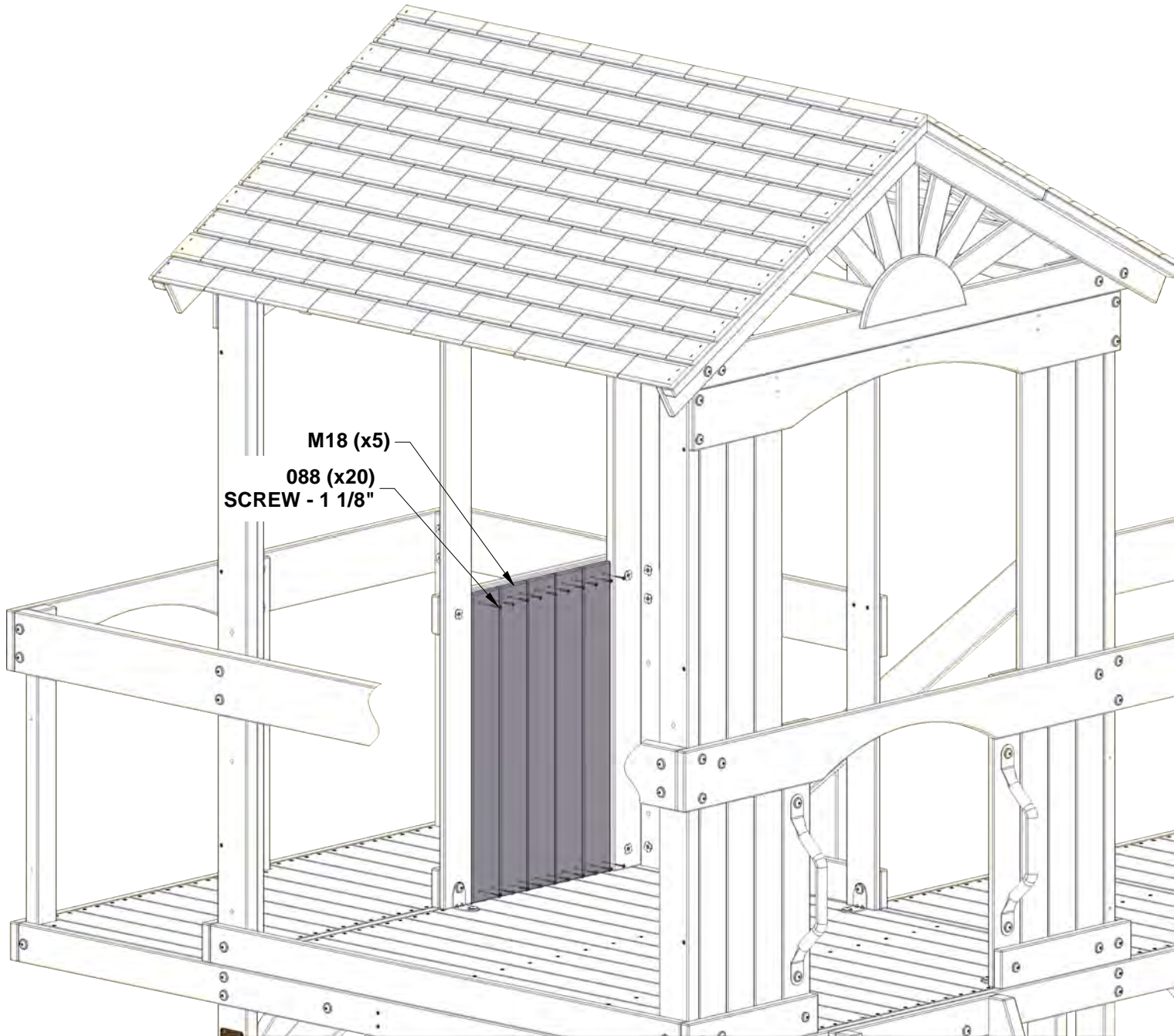

STEP 63 - FORT ASSEMBLY

QTY	PART NUMBER	DESCRIPTION
56	H100088	SCREW PFH 8x1-1/8"



M18 WALL BOARD - W4L20463
(x14) 5/8"x3 3/8"x26 3/4" (16x86x680)

EVENLY SPACE WALL BOARDS

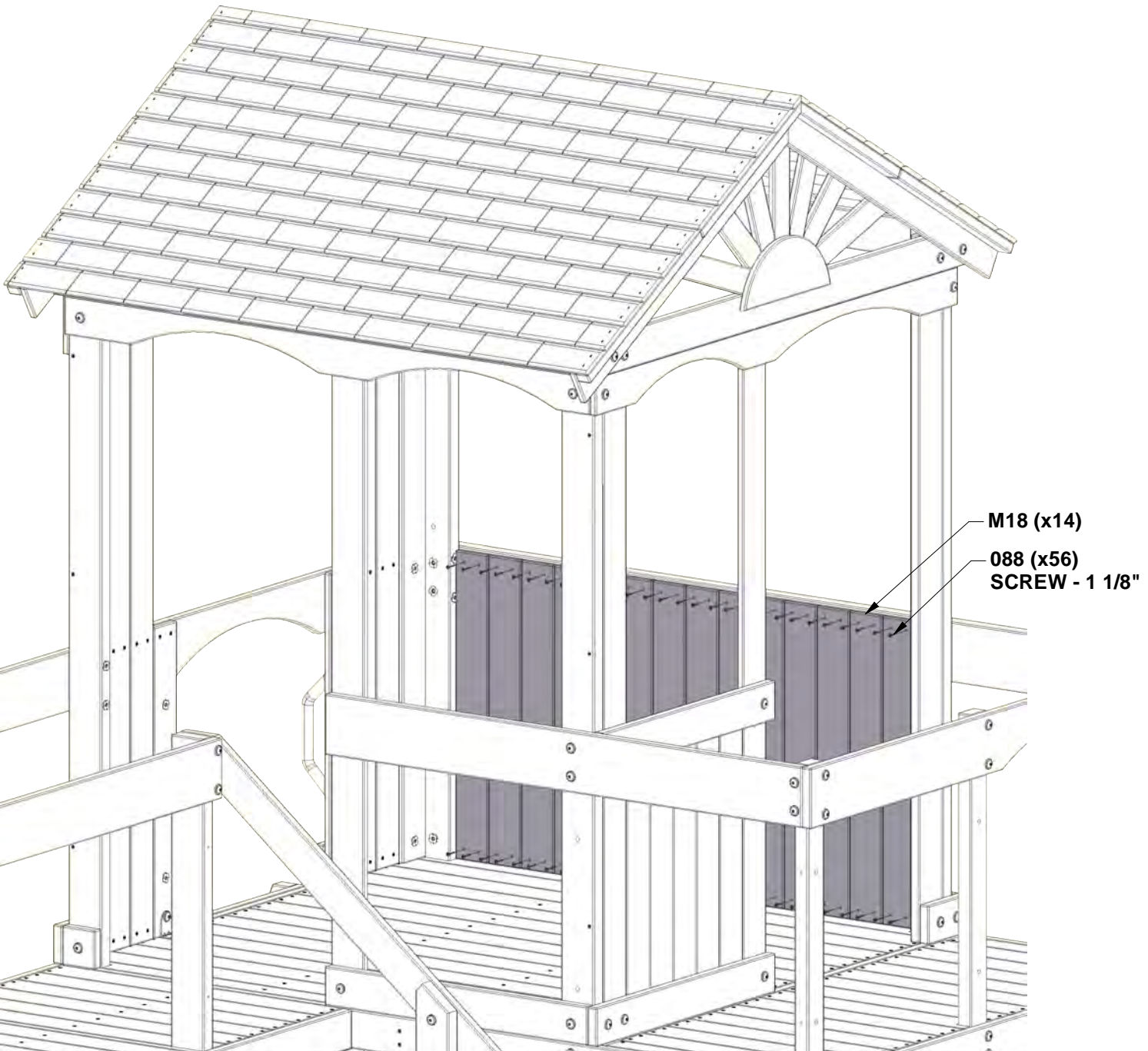

STEP 64 - FORT ASSEMBLY

QTY	PART NUMBER	DESCRIPTION
24	H100088	SCREW PFH 8x1-1/8"



M18 WALL BOARD - W4L20463
(x6) 5/8"x3 3/8"x26 3/4" (16x86x680)

EVENLY SPACE WALL BOARDS

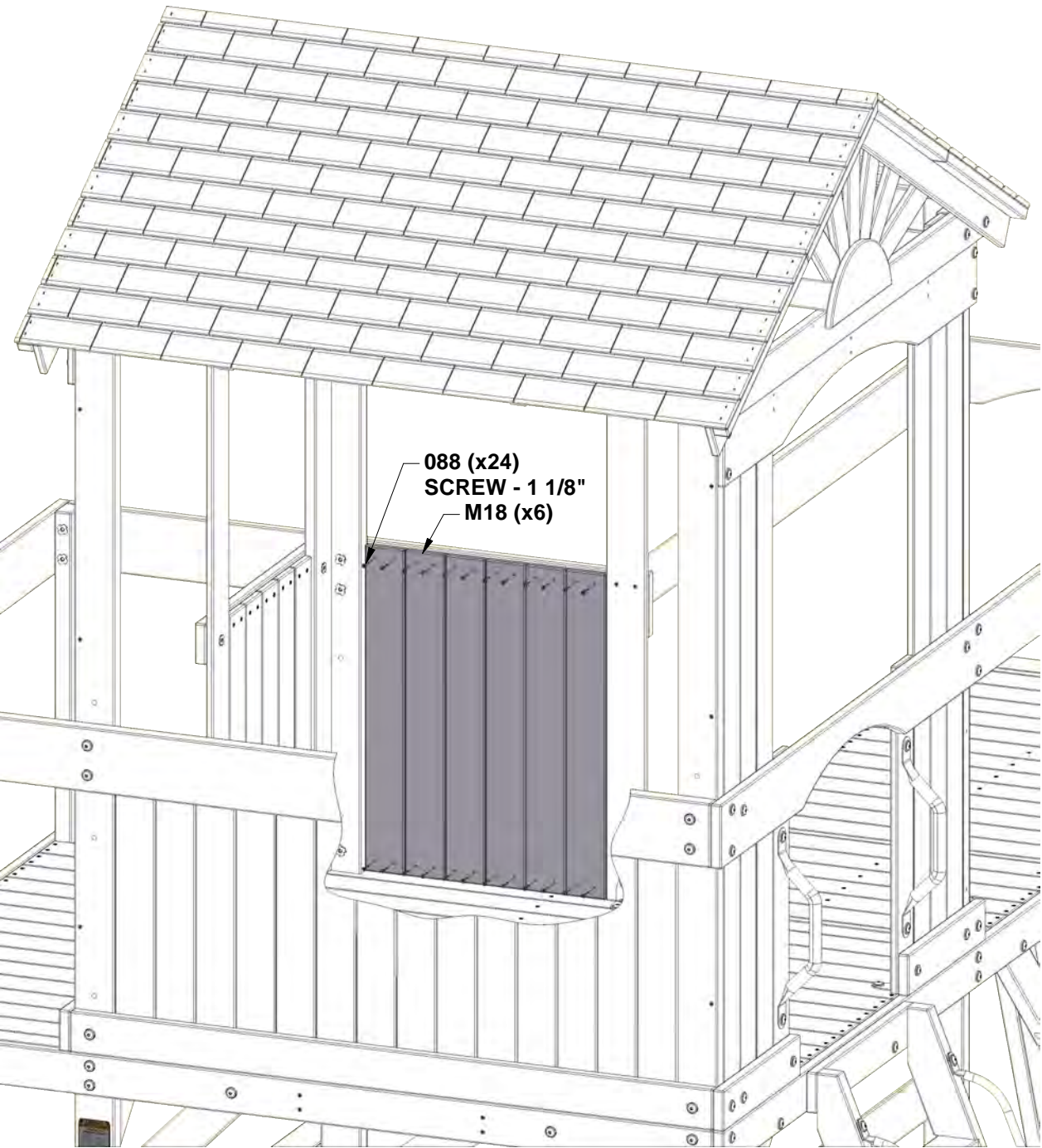

STEP 65A - FORT ASSEMBLY

QTY	PART NUMBER	DESCRIPTION
6	H100198	WASHER LOCK EXT 8x19 BLK
4	H100205	BOLT WH 5/16x2-1/4 BLK
4	H100379	T-NUT 5/16 BLK
2	H100458	LAG SCREW WH 5/16x2 BLK

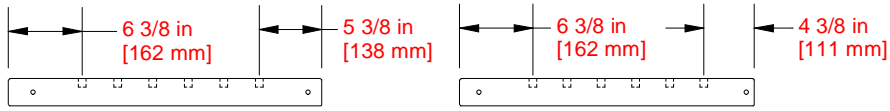

J04 WALL RAIL - W4L20429
 (x1) 1"x2 3/8"x27 1/4" (24x60x691)

J07 WALL RAIL - W4L20432
 (x2) 1"x2 3/8"x25 5/8" (24x60x650)

INSTALL T-NUTS IN WOOD FIRST

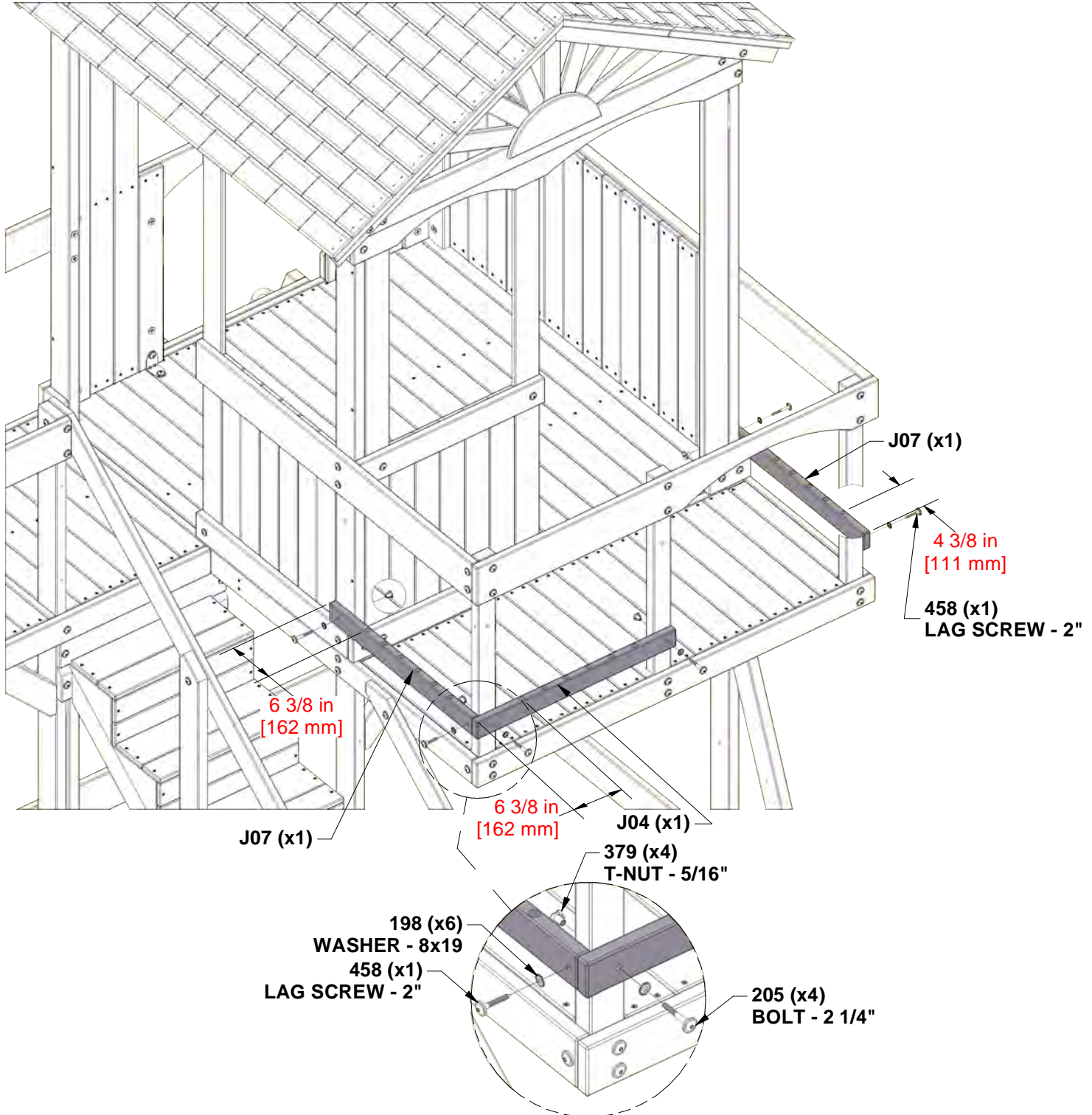

STEP 65B - FORT ASSEMBLY

QTY	PART NUMBER	DESCRIPTION
5	H100198	WASHER LOCK EXT 8x19 BLK
3	H100205	BOLT WH 5/16x2-1/4 BLK
3	H100379	T-NUT 5/16 BLK
2	H100458	LAG SCREW WH 5/16x2 BLK

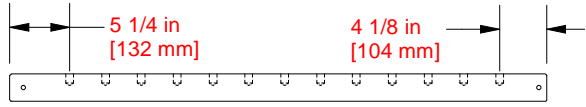

J03 WALL RAIL - W4L20428
(x1) 1"x2 3/8"x46 5/8" (24x60x1184)

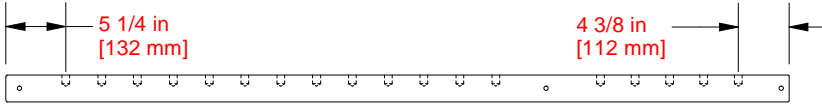

J02 WALL RAIL - W4L20427
(x1) 1"x2 3/8"x68" (24x60x1727)

INSTALL T-NUTS IN WOOD FIRST

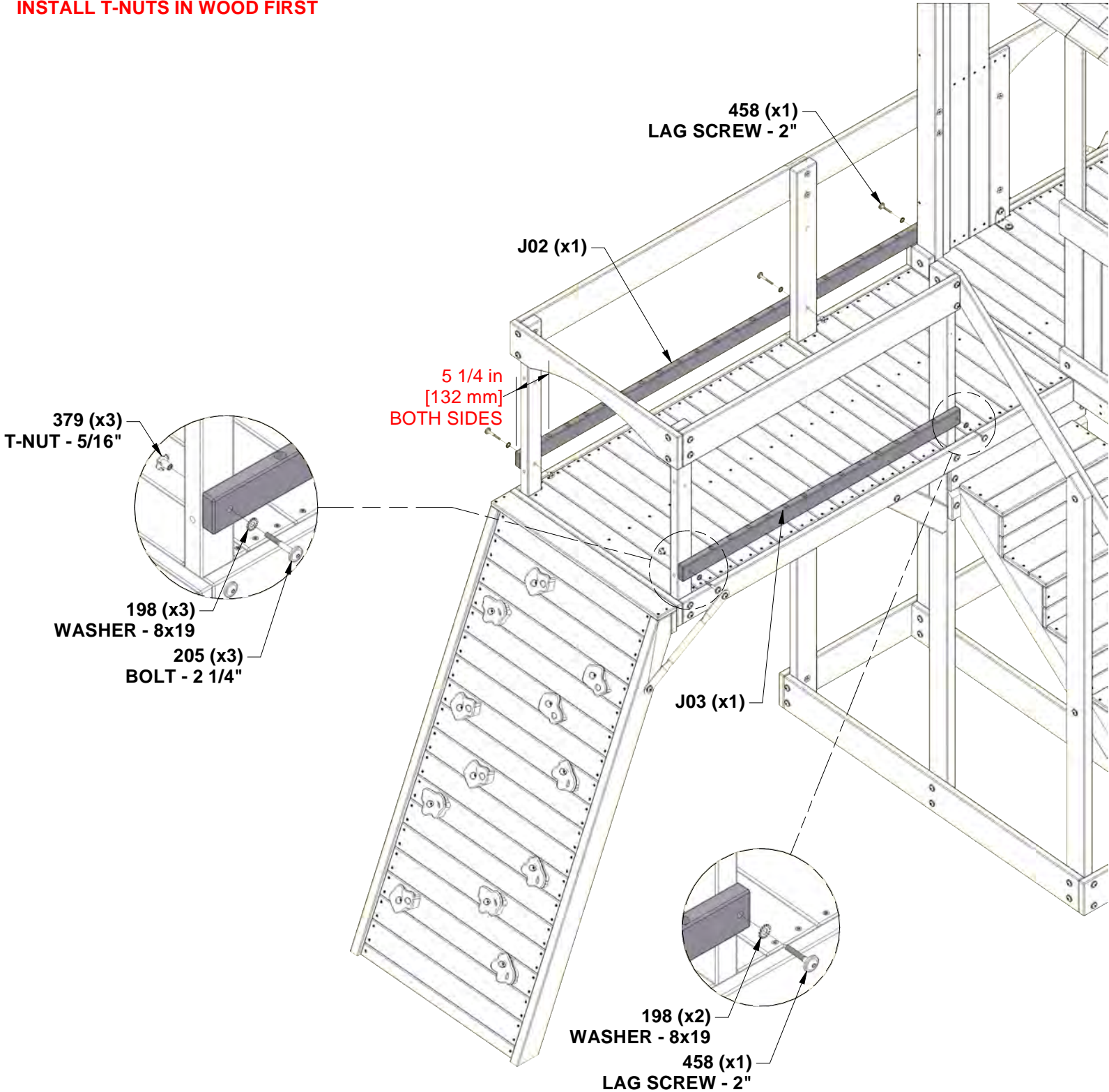

STEP 66 - FORT ASSEMBLY



A4M00597 METAL TUBE
(x49)

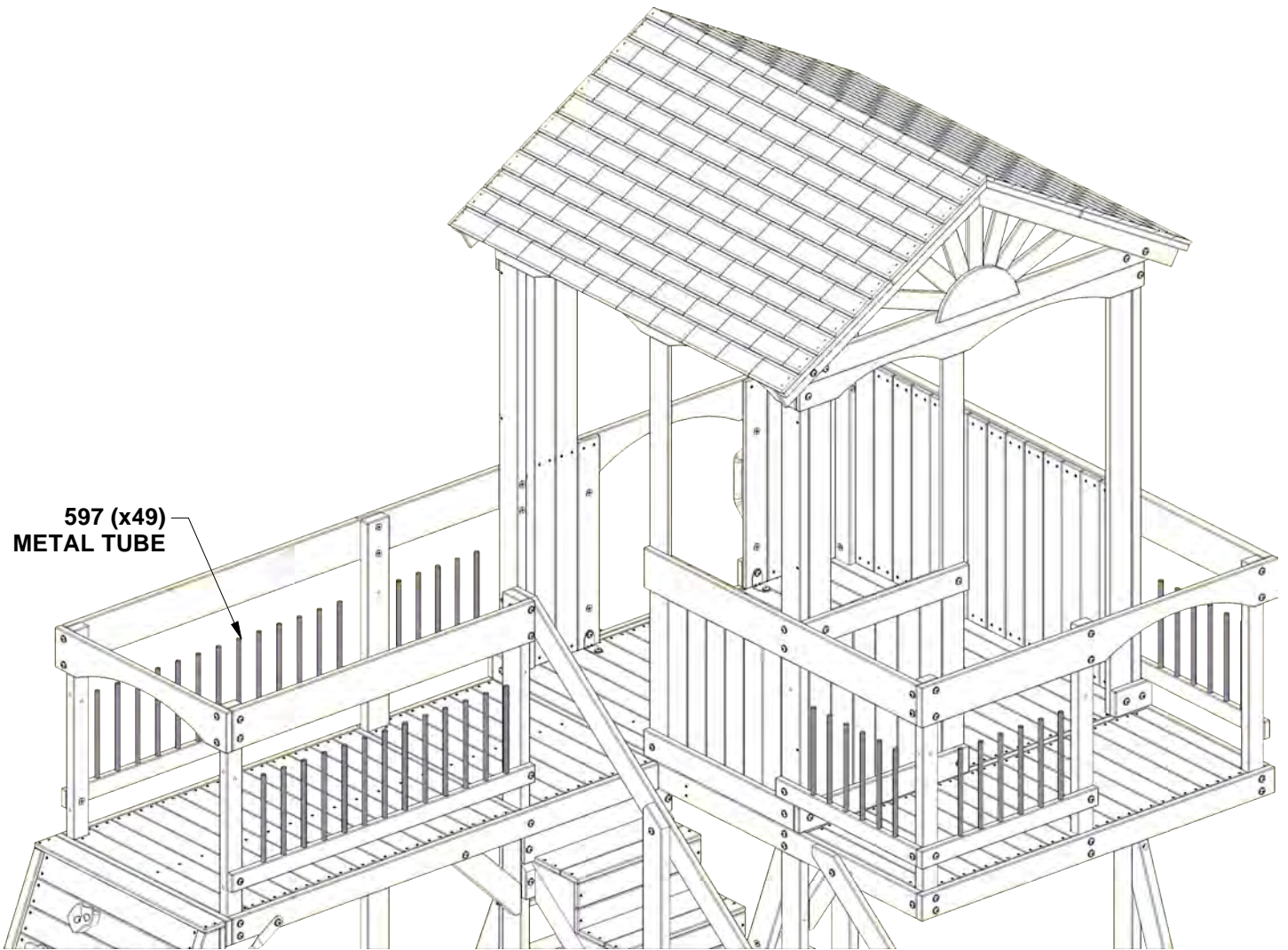

STEP 67A - FORT ASSEMBLY

QTY	PART NUMBER	DESCRIPTION
6	H100198	WASHER LOCK EXT 8x19 BLK
4	H100205	BOLT WH 5/16x2-1/4 BLK
4	H100379	T-NUT 5/16 BLK
2	H100458	LAG SCREW WH 5/16x2 BLK

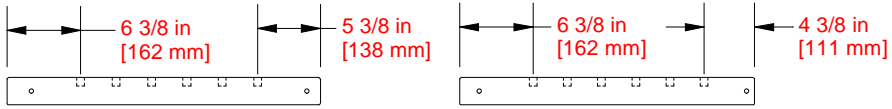

J04 WALL RAIL - W4L20429
 (x1) 1"x2 3/8"x27 1/4" (24x60x691)

J07 WALL RAIL - W4L20432
 (x2) 1"x2 3/8"x25 5/8" (24x60x650)

INSTALL T-NUTS IN WOOD FIRST

INSTALL J-BOARDS USING
 THE SAME DIMENSIONS AS
 SHOWN ON STEP 65

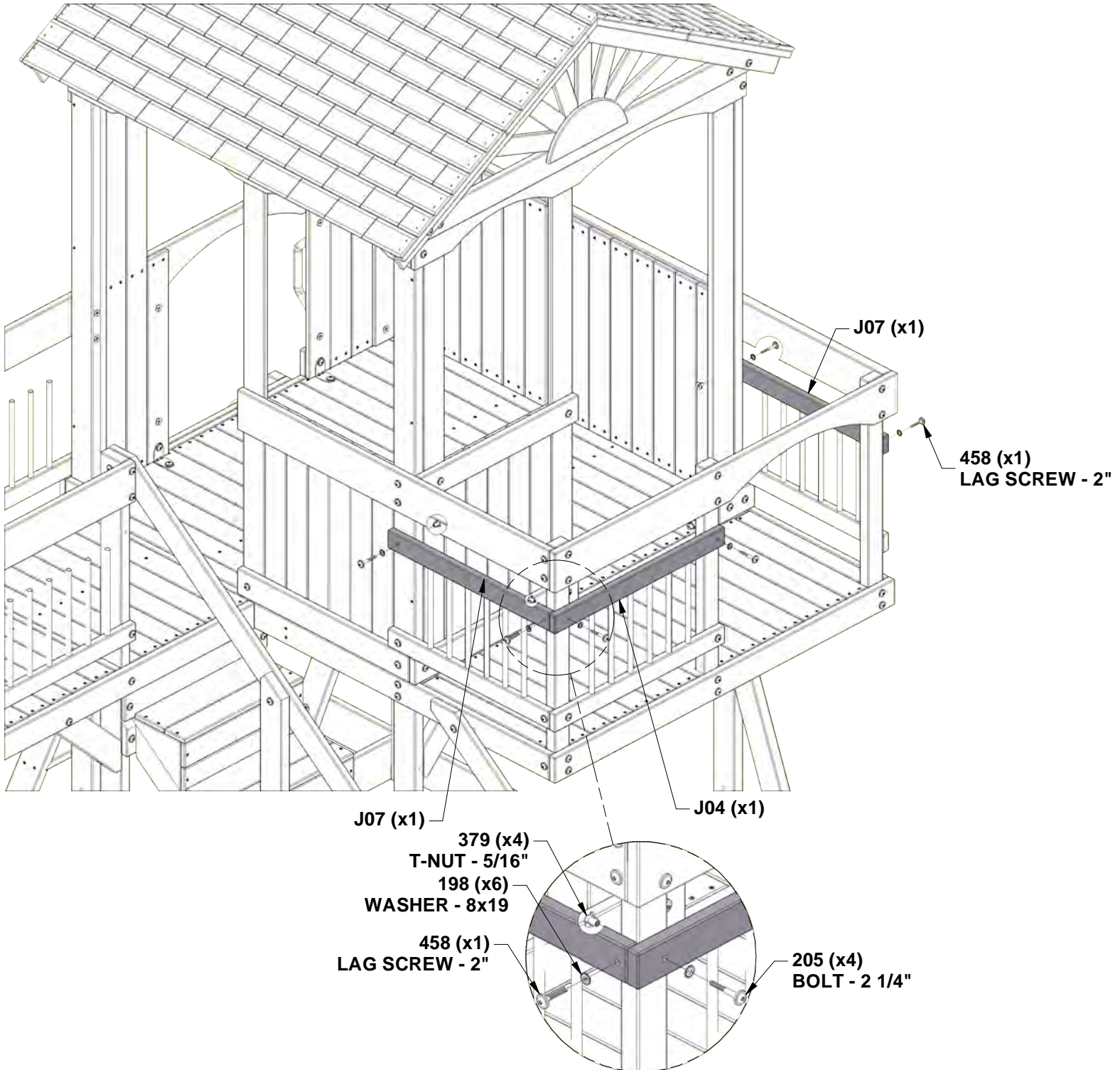

STEP 67B - FORT ASSEMBLY

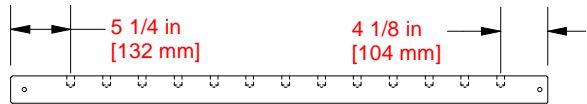

J03 WALL RAIL - W4L20428
(x1) 1"x2 3/8"x46 5/8" (24x60x1184)

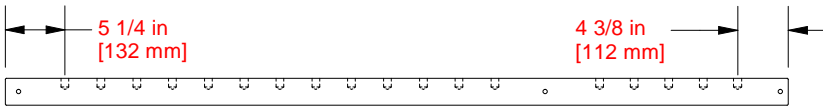

J02 WALL RAIL - W4L20427
(x1) 1"x2 3/8"x68" (24x60x1727)

QTY	PART NUMBER	DESCRIPTION
5	H100198	WASHER LOCK EXT 8x19 BLK
3	H100205	BOLT WH 5/16x2-1/4 BLK
3	H100379	T-NUT 5/16 BLK
2	H100458	LAG SCREW WH 5/16x2 BLK

INSTALL T-NUTS IN WOOD FIRST

INSTALL J-BOARDS USING THE SAME DIMENSIONS AS SHOWN ON STEP 65

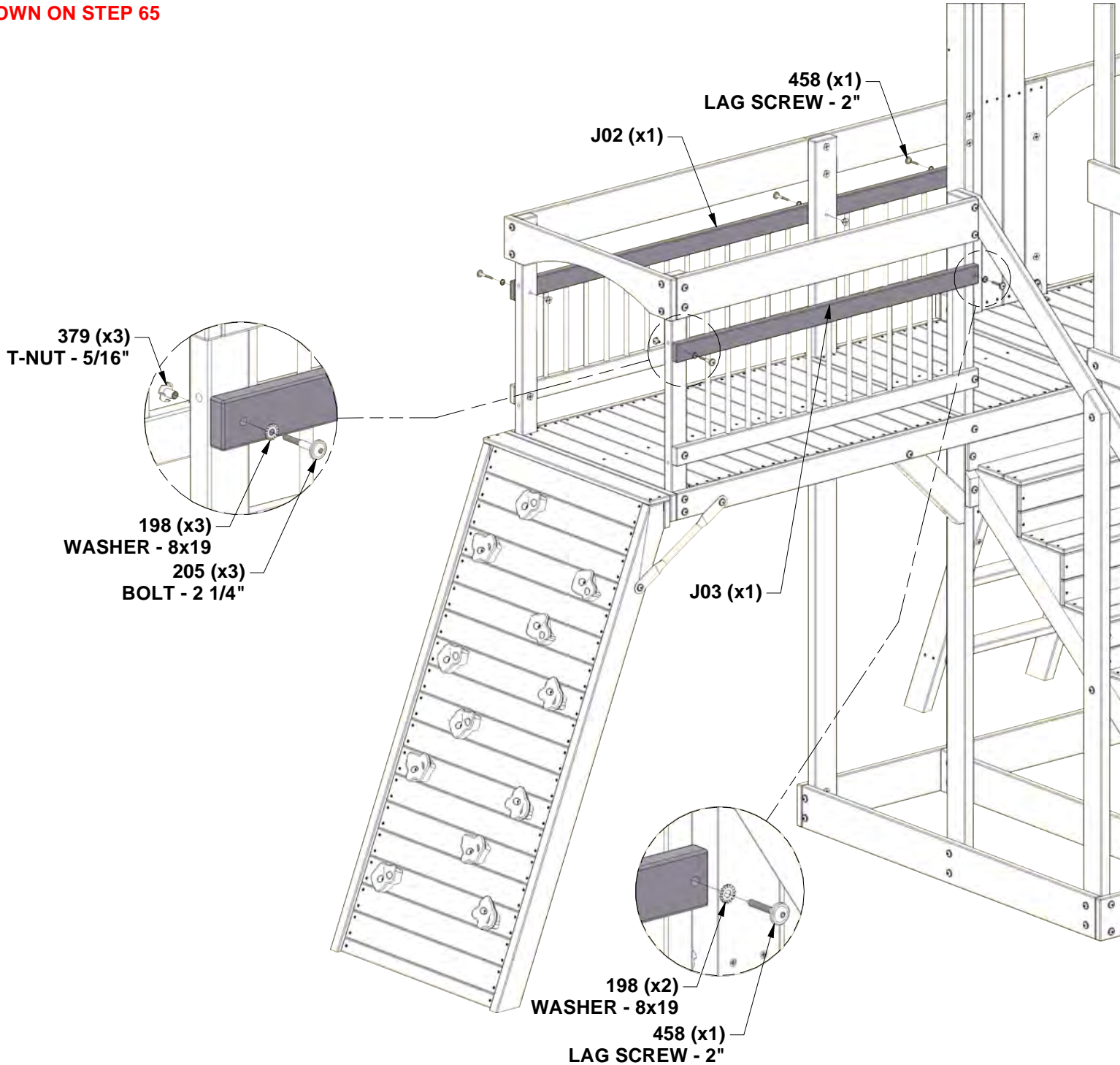

STEP 68 - FORT ASSEMBLY



E19 WALL RAIL - W4L20401
 (x1) 1 7/16"x3 3/8"x54 1/2" (36x86x1384)

QTY	PART NUMBER	DESCRIPTION
2	H100195	BOLT WH 5/16x2-3/4 BLK
2	H100198	WASHER LOCK EXT 8x19 BLK
4	H100379	T-NUT 5/16 BLK

INSTALL T-NUTS IN WOOD FIRST

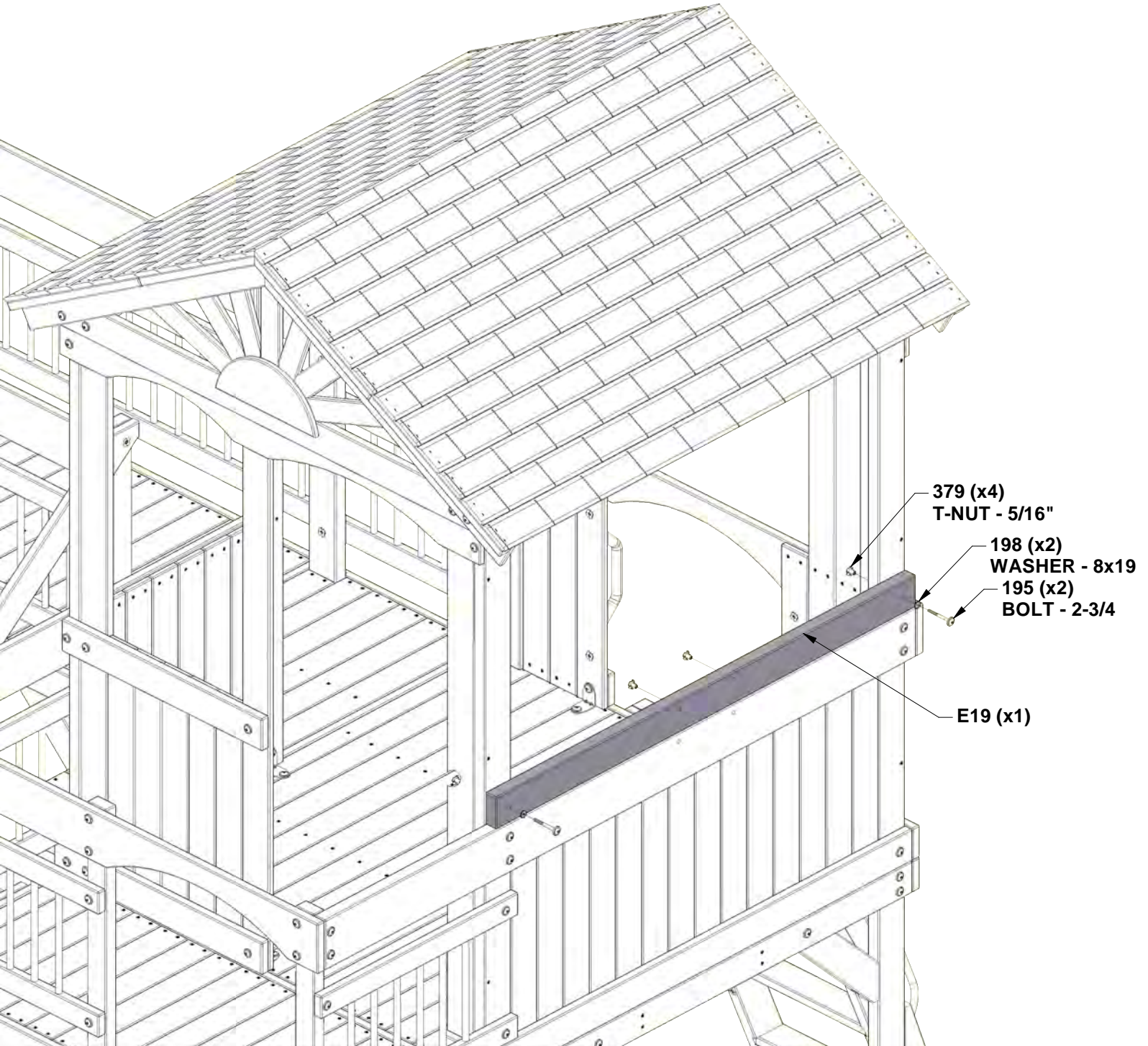

STEP 69 - FORT ASSEMBLY

QTY	PART NUMBER	DESCRIPTION
4	H100205	BOLT WH 5/16x2-1/4 BLK
4	H100379	T-NUT 5/16 BLK



A4M00613 HAND GRIP METAL
(x2) BLACK 381 c/c

INSTALL T-NUTS IN WOOD FIRST

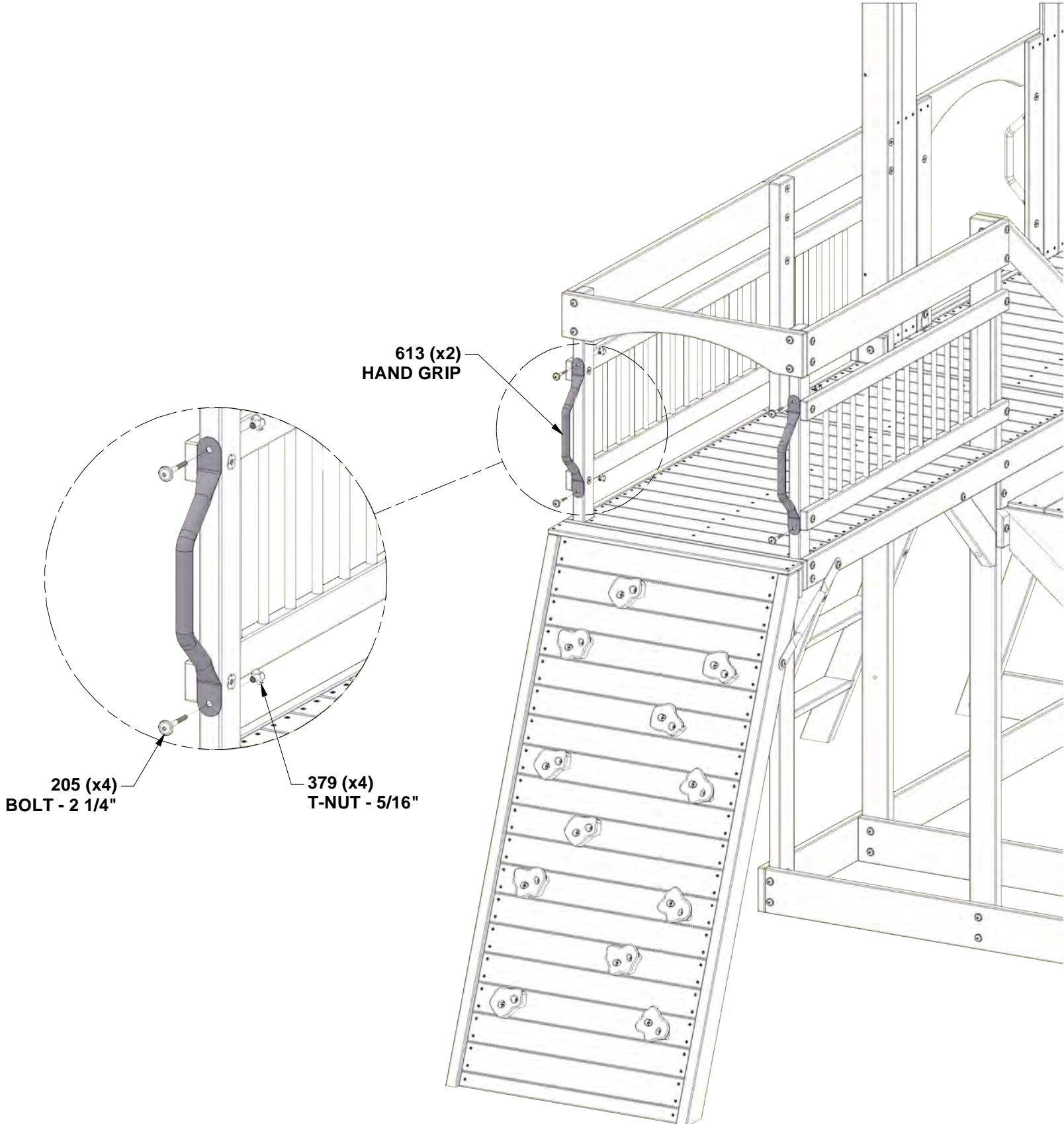

STEP 70 - FORT ASSEMBLY

QTY	PART NUMBER	DESCRIPTION
68	H100087	SCREW PFH 8x1-1/4"

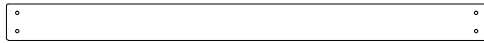

N09 PICKET - W4L20477
 (x8) 5/8"x2 3/8"x31 1/4" (16x60x795)

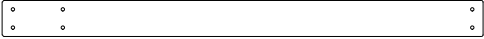

N10 PICKET - W4L20478
 (x6) 5/8"x2 3/8"x31 1/4" (16x60x795)

USE A6P00410 PICKET PAL FOR ALL REMAINING PICKETS.

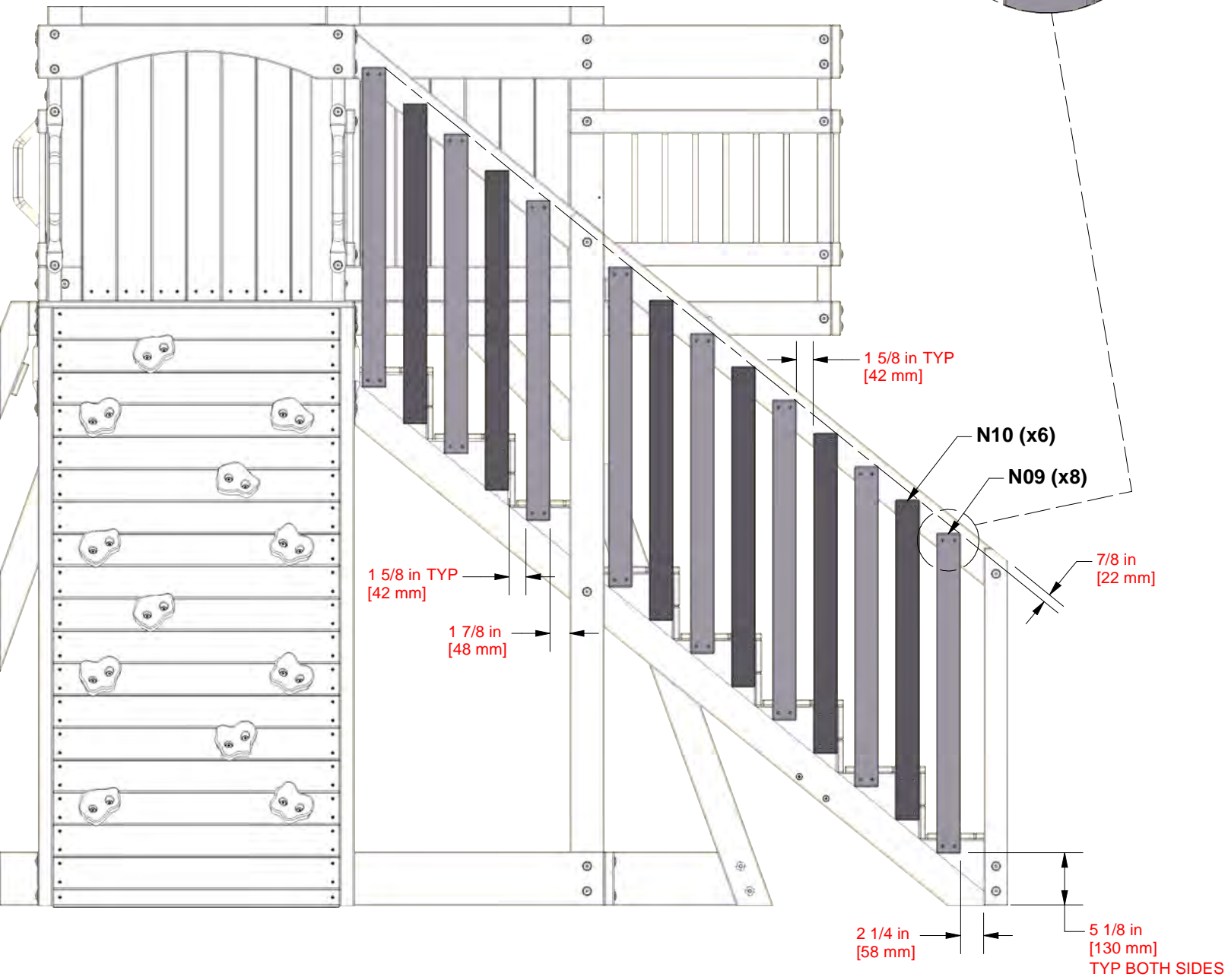
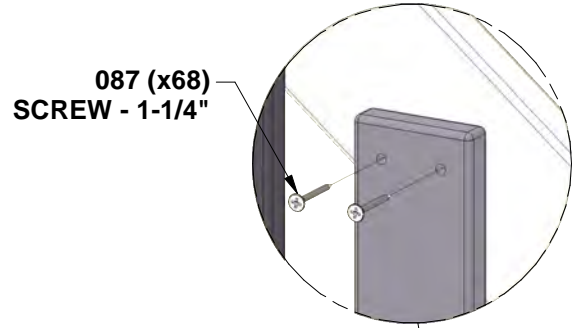

STEP 71 - FORT ASSEMBLY

QTY	PART NUMBER	DESCRIPTION
34	H100087	SCREW PFH 8x1-1/4"
1	H100198	WASHER LOCK EXT 8x19 BLK
1	H100205	BOLT WH 5/16x2-1/4 BLK
1	H100405	WASHER LOCK EXT 6x15 BLK
1	H100487	LAG SCREW WH 1/4x2 BLK



N09 PICKET - W4L20477
(x4) 5/8"x2 3/8"x31 1/4" (16x60x795)



N10 PICKET - W4L20478
(x3) 5/8"x2 3/8"x31 1/4" (16x60x795)



E16 DECK BRACE - W4L20369
(x1) 1 3/8"x3 3/8"x18 3/8" (36x86x466)

INSTALL N-BOARDS USING THE SAME DIMENSIONS AS SHOWN ON STEP 70.

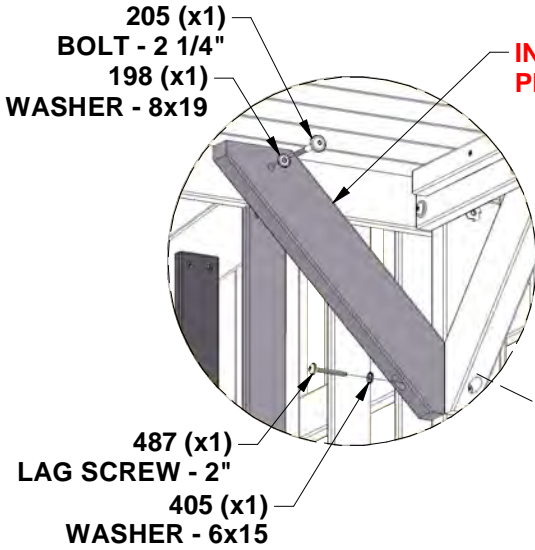

INSTALL E16 AFTER PICKETS ARE INSTALLED

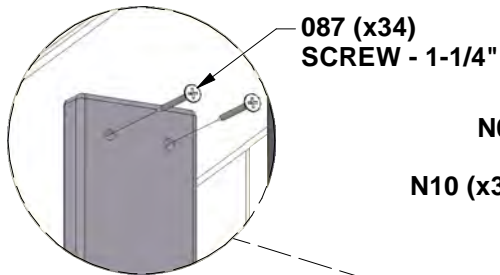

N09 (x4)
N10 (x3)

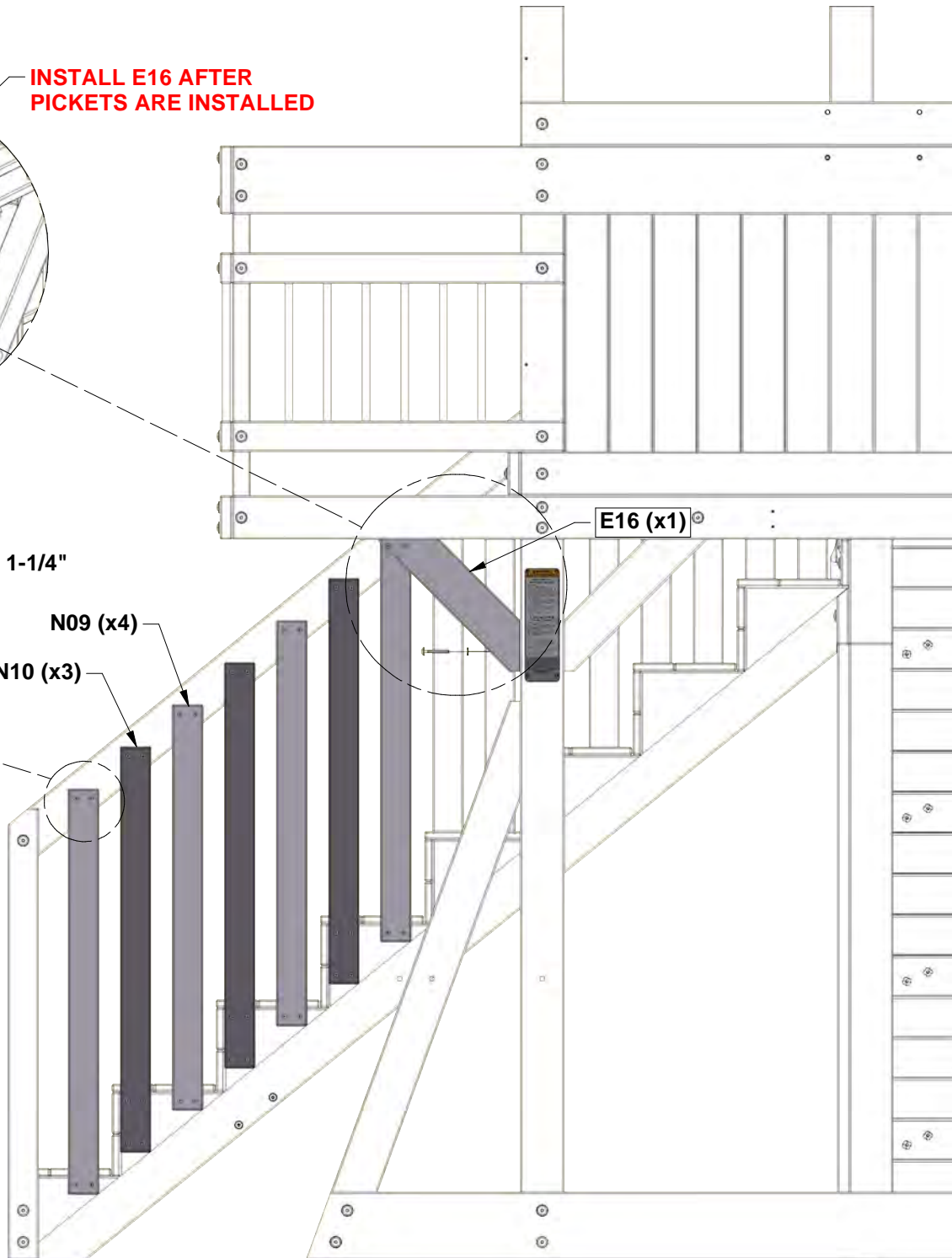

STEP 72 - FORT ASSEMBLY

QTY	PART NUMBER	DESCRIPTION
4	H100086	SCREW PFH 8x1-1/2"
4	H100089	SCREW PFH 8x1-3/4"



J10 PICKET - W4L20435
 (x1) 1"x2 3/8"x26 3/4" (24x60x680)



J11 PICKET - W4L20436
 (x1) 1"x2 3/8"x19 3/8" (24x60x492)

INSTALL J-BOARDS USING THE SAME DIMENSIONS AS SHOWN ON STEP 70.

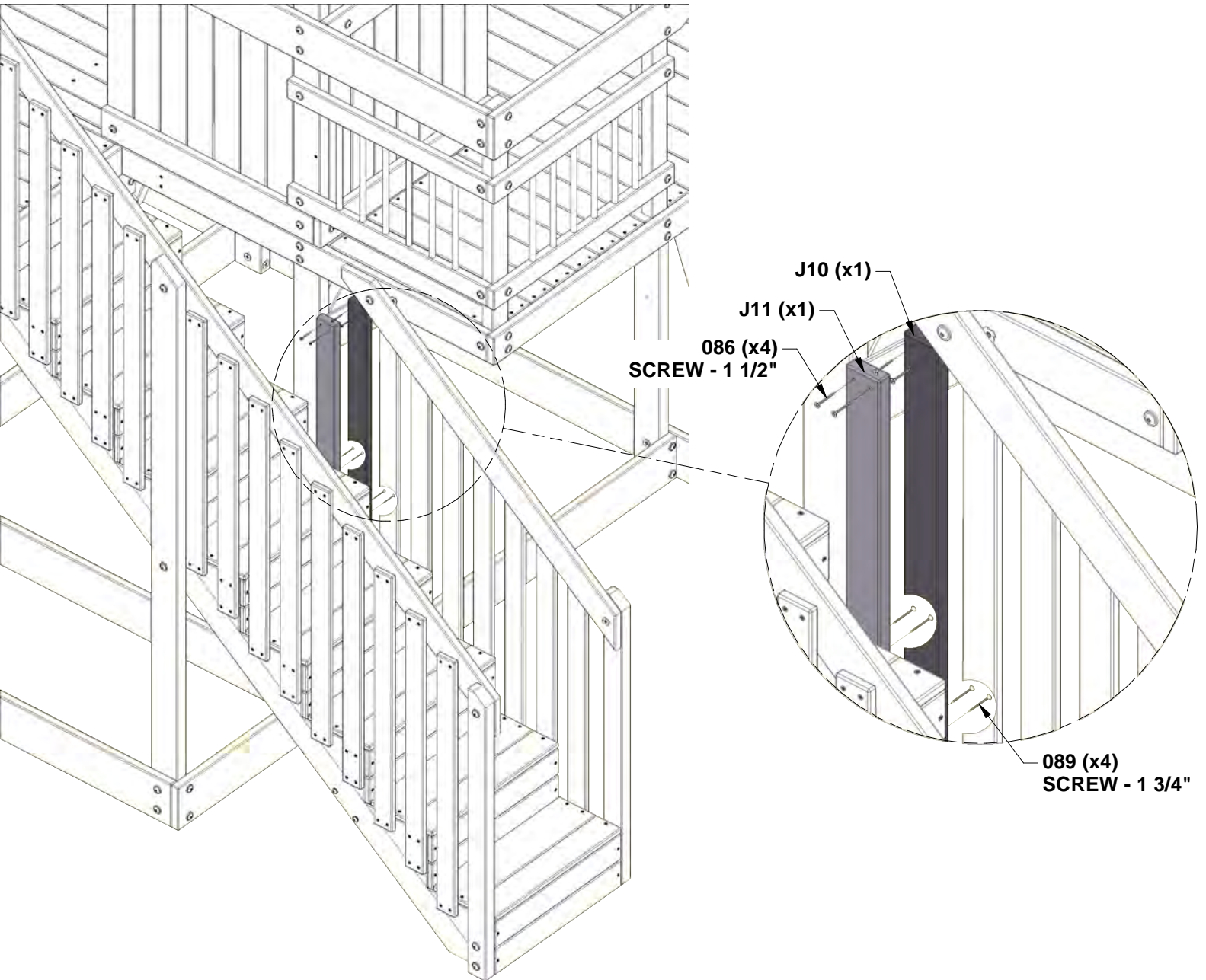

STEP 73 - FORT ASSEMBLY

QTY	PART NUMBER	DESCRIPTION
6	H100087	SCREW PFH 8x1-1/4"
8	H100089	SCREW PFH 8x1-3/4"

J13 PICKET - W4L20438
 (x1) 1"x2 3/8"x12" (24x60x304)

J14 PICKET - W4L20439
 (x1) 1"x2 3/8"x15 1/4" (24x60x386)

J15 PICKET - W4L20440
 (x1) 1"x2 3/8"x18 3/8" (24x60x468)

J16 PICKET - W4L20437
 (x1) 1"x2 3/8"x8 3/4" (24x60x222)

L02 SUPPORT BOARD - W4L20445
 (x1) 5/8"x4 3/8"x15 5/8" (16x112x397)

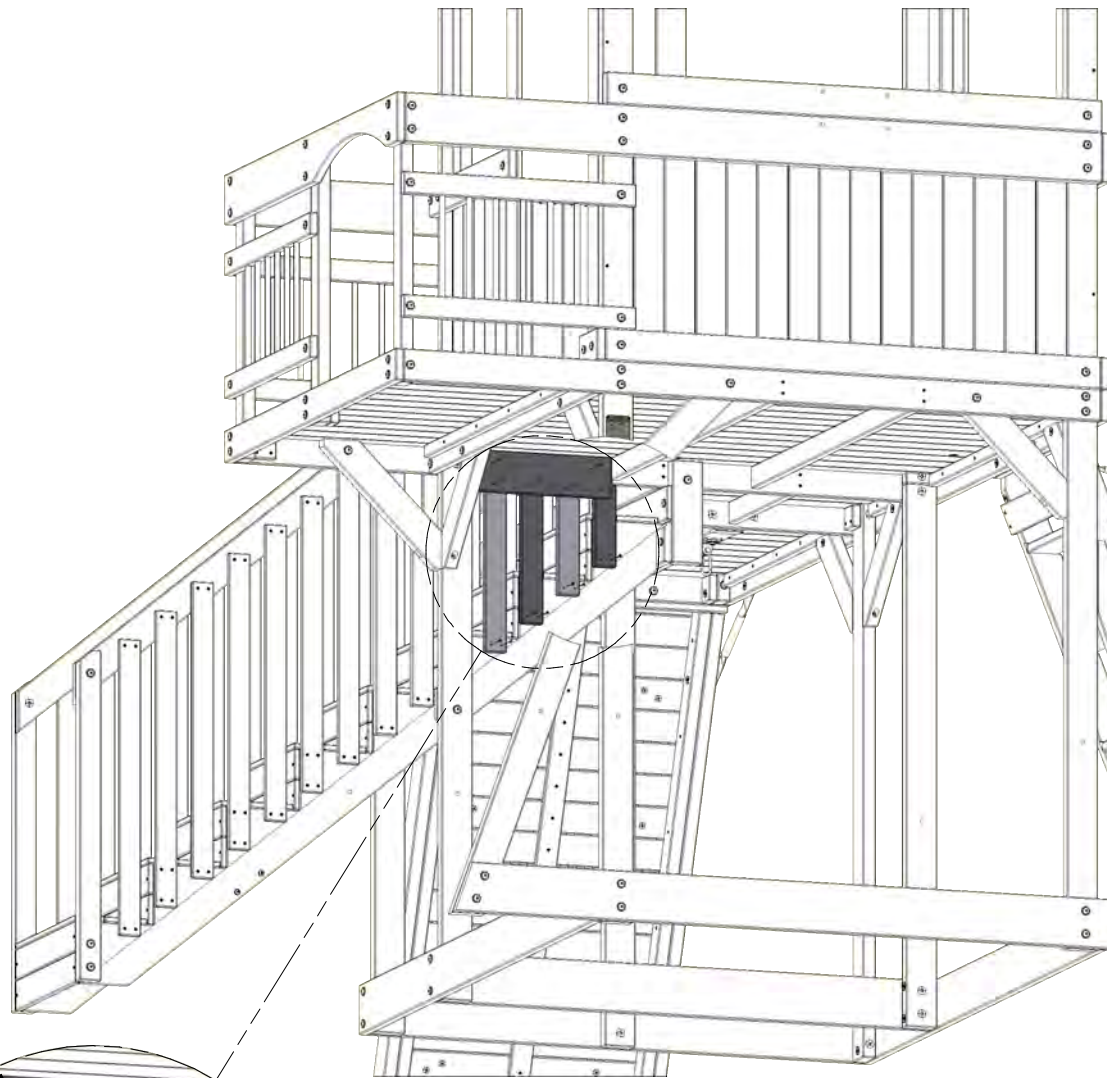
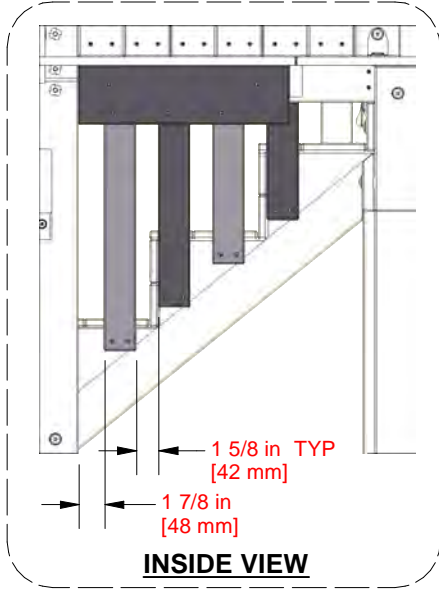

087 (x6)
SCREW - 1-1/4"

L02 (x1)

089 (x8)
SCREW - 1 3/4"

J16 (x1)

J13 (x1)

J14 (x1)

J15 (x1)

STEP 74 - FORT ASSEMBLY

QTY	PART NUMBER	DESCRIPTION
4	H100088	SCREW PFH 8x1-1/8"



M01 GROWTH BOARD - W4L20446
(x1) 5/8"x3 3/8"x60 1/4" (16x86x1530)

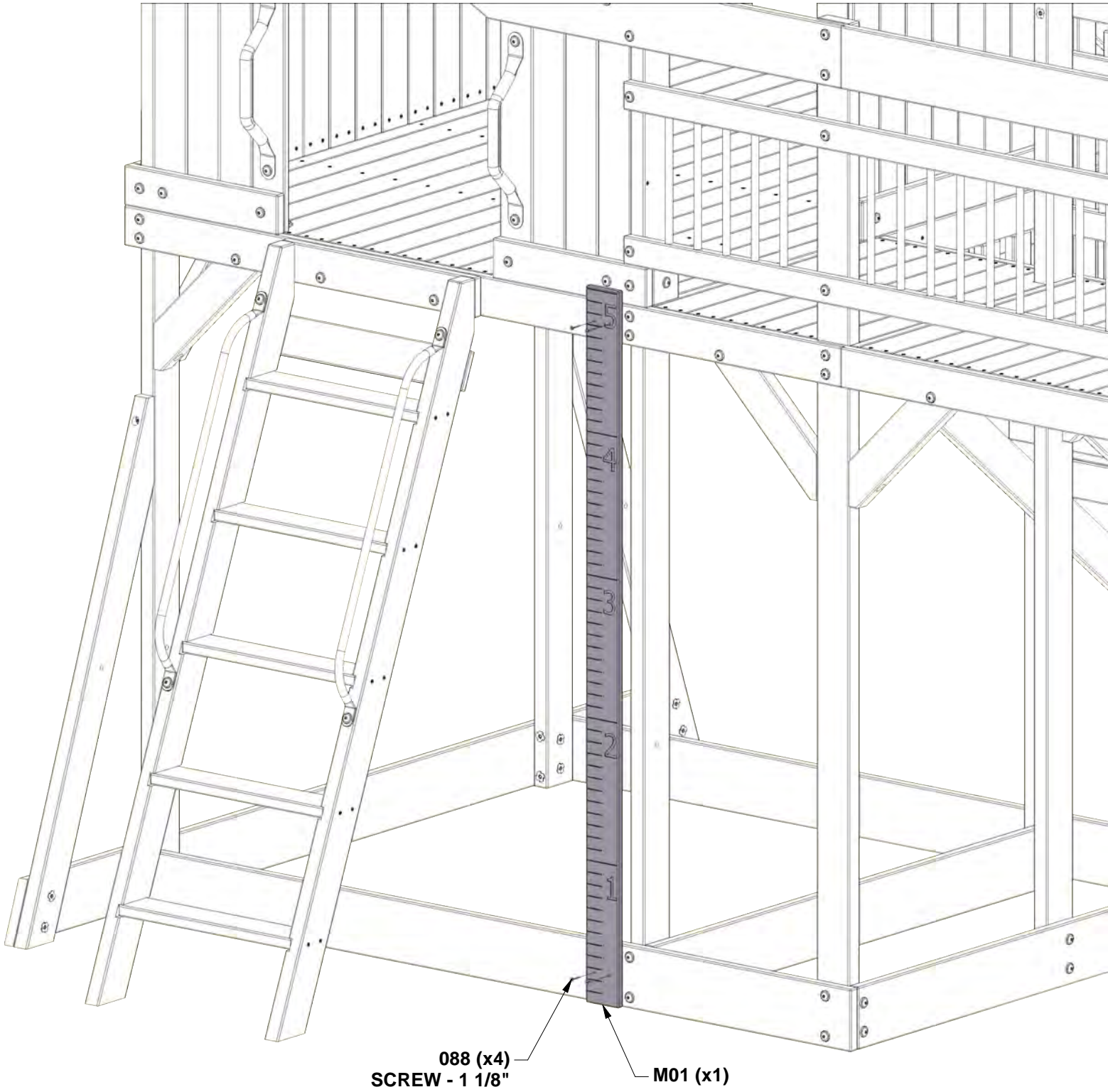

STEP 75 - FORT ASSEMBLY

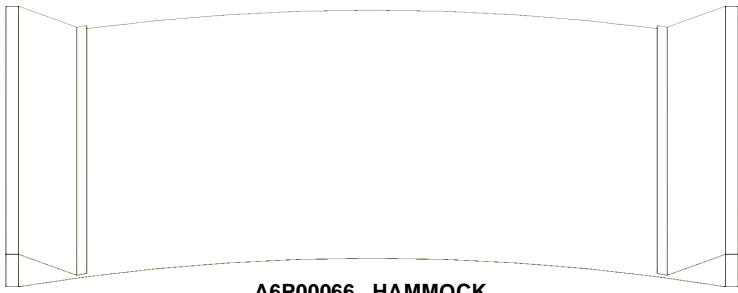

A6P00066 HAMMOCK
(x1)



H05 SAFETY RAIL - W4L20400
(x1) 1"x3 3/8"x68 5/8" (24x86x1742)

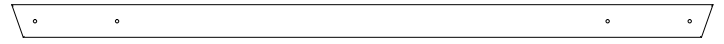

H31 SAFETY RAIL - W4L20413
(x1) 1"x3 3/8"x73 1/16" (24x86x1856)

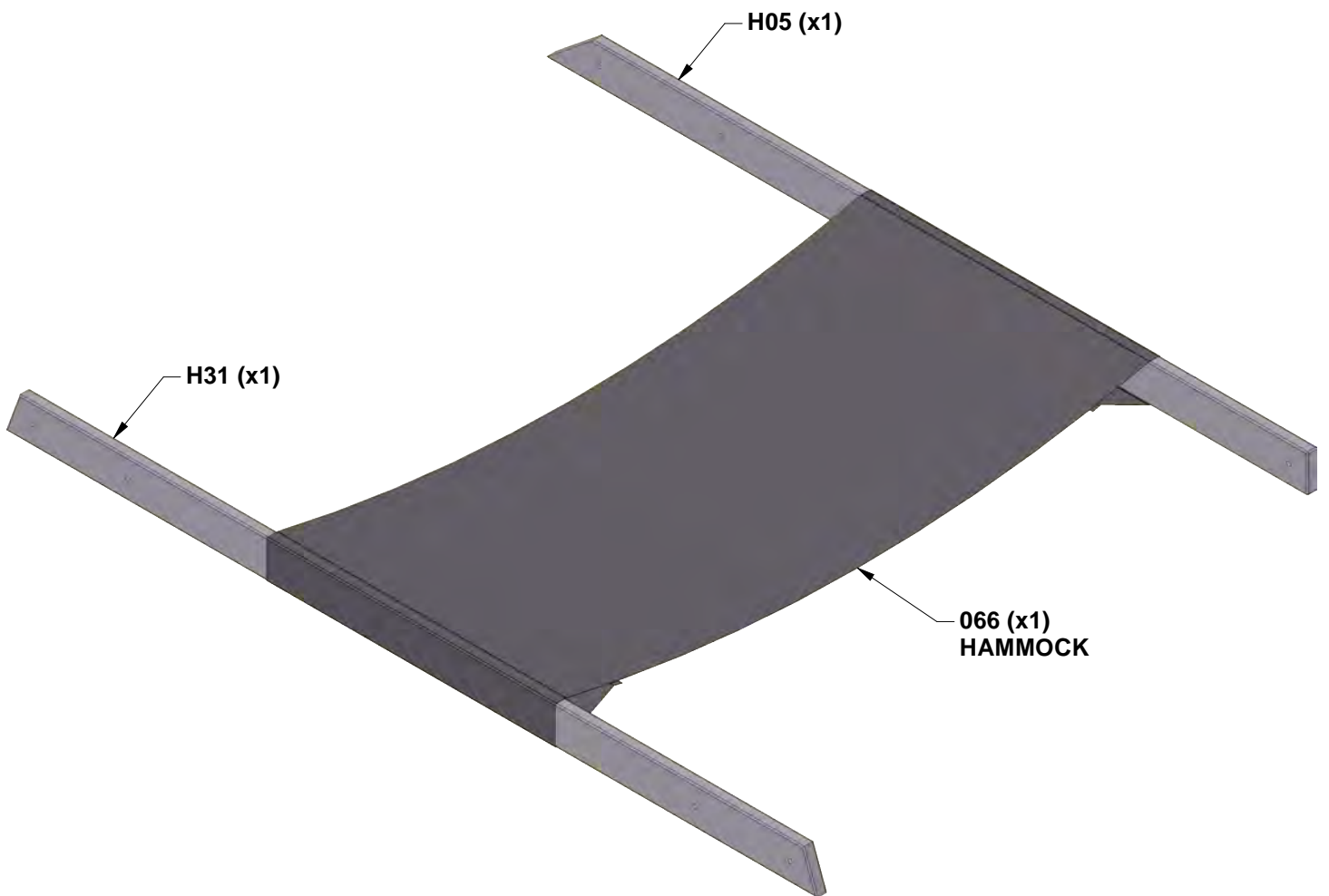

STEP 76 - FORT ASSEMBLY

QTY	PART NUMBER	DESCRIPTION
7	H100198	WASHER LOCK EXT 8x19 BLK
6	H100205	BOLT WH 5/16x2-1/4 BLK
1	H100378	BOLT WH 5/16x1 3/4 BLK
7	H100379	T-NUT 5/16 BLK

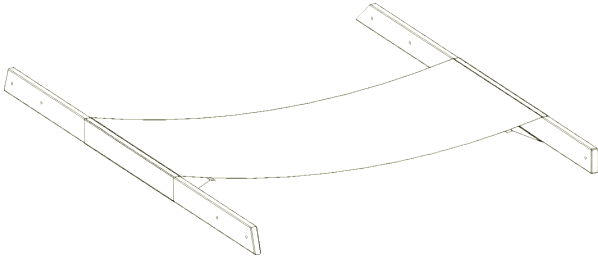

HAMMOCK ASSEMBLY

INSTALL T-NUTS IN WOOD FIRST

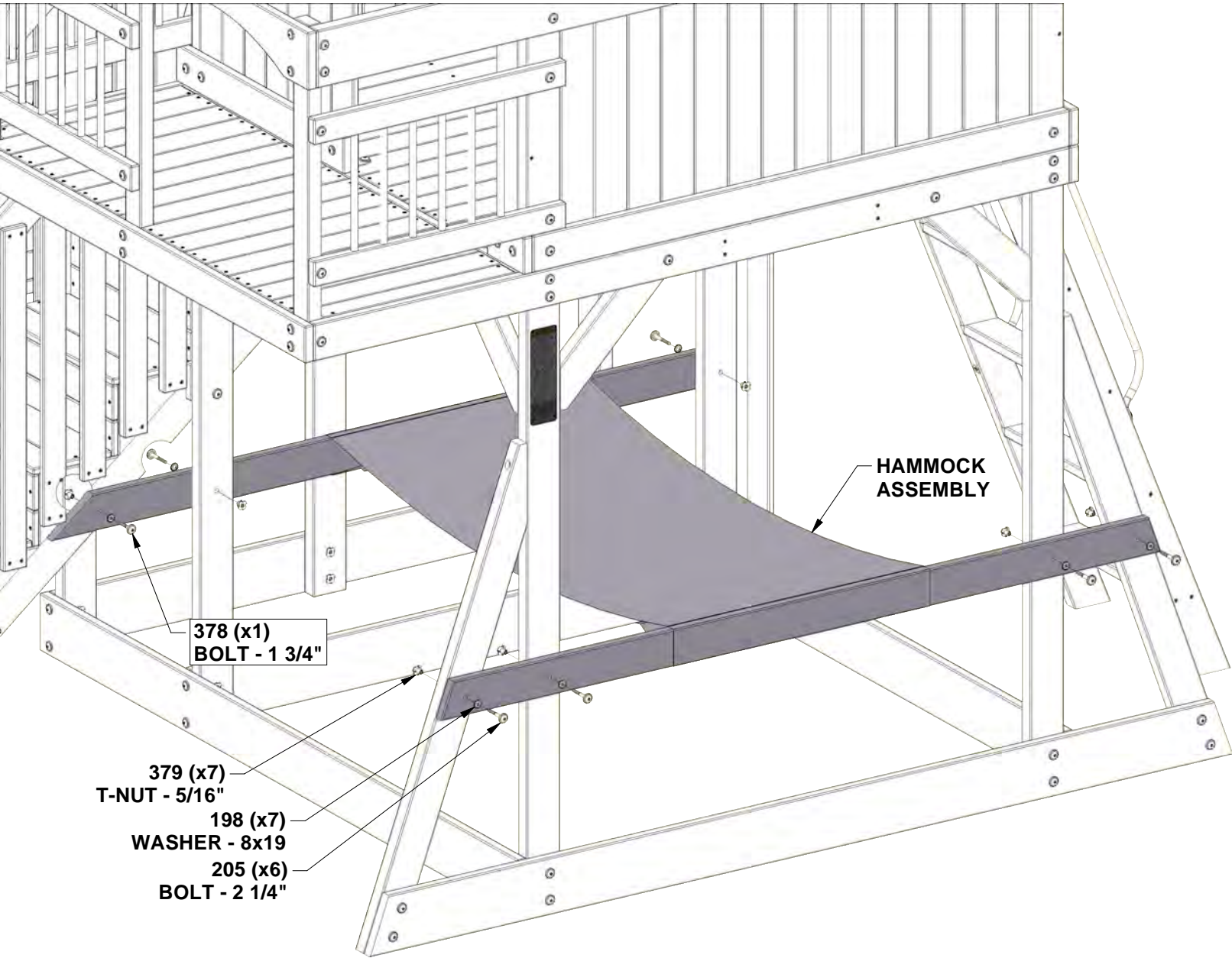

STEP 77 - FORT ASSEMBLY

QTY	PART NUMBER	DESCRIPTION
2	H100089	SCREW PFH 8x1-3/4"



J05 OUTER CURTAIN ROD HOLDER - W4L20430
(x1) 1"x2 3/8"x2 3/8" (24x60x60)

ALIGN PILOT HOLES



STEP 78 - FORT ASSEMBLY

QTY	PART NUMBER	DESCRIPTION
2	H100089	SCREW PFH 8x1-3/4"



A6P00089 CURTAIN
(x1)



A6P00090 PLASTIC CURTAIN ROD
(x1)



J06 INNER CURTAIN ROD HOLDER - W4L20431
(x1) 1"x2 3/8"x2 3/8" (24x60x60)

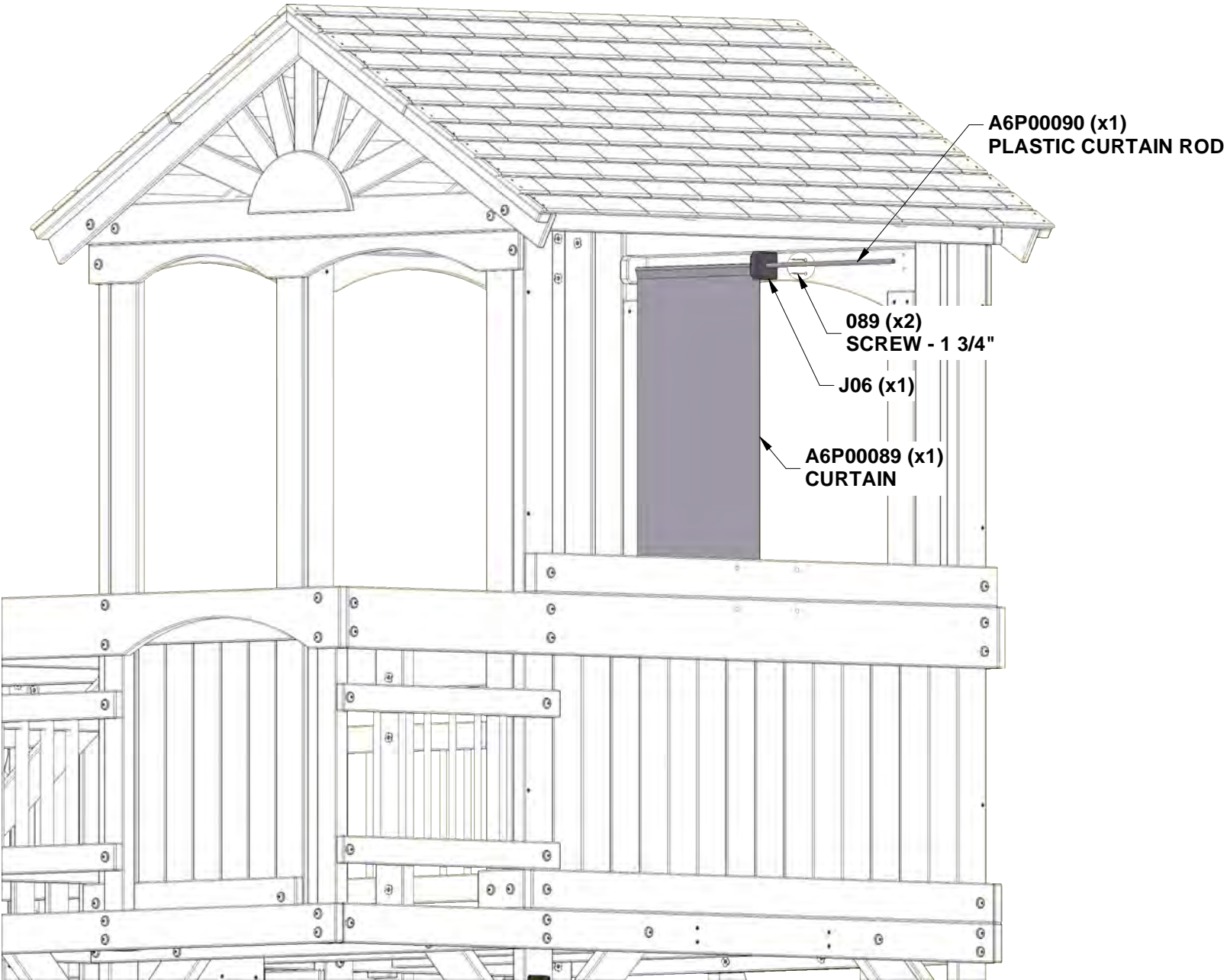

STEP 79 - FORT ASSEMBLY

QTY	PART NUMBER	DESCRIPTION
2	H100089	SCREW PFH 8x1-3/4"

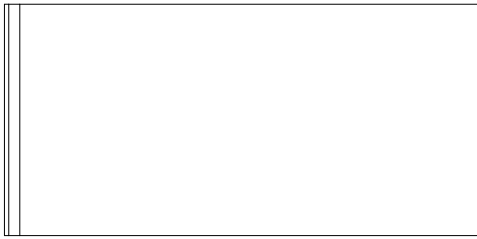

A6P00089 CURTAIN
(x1)



J05 OUTER CURTAIN ROD HOLDER - W4L20430
(x1) 1"x2 3/8"x2 3/8" (24x60x60)

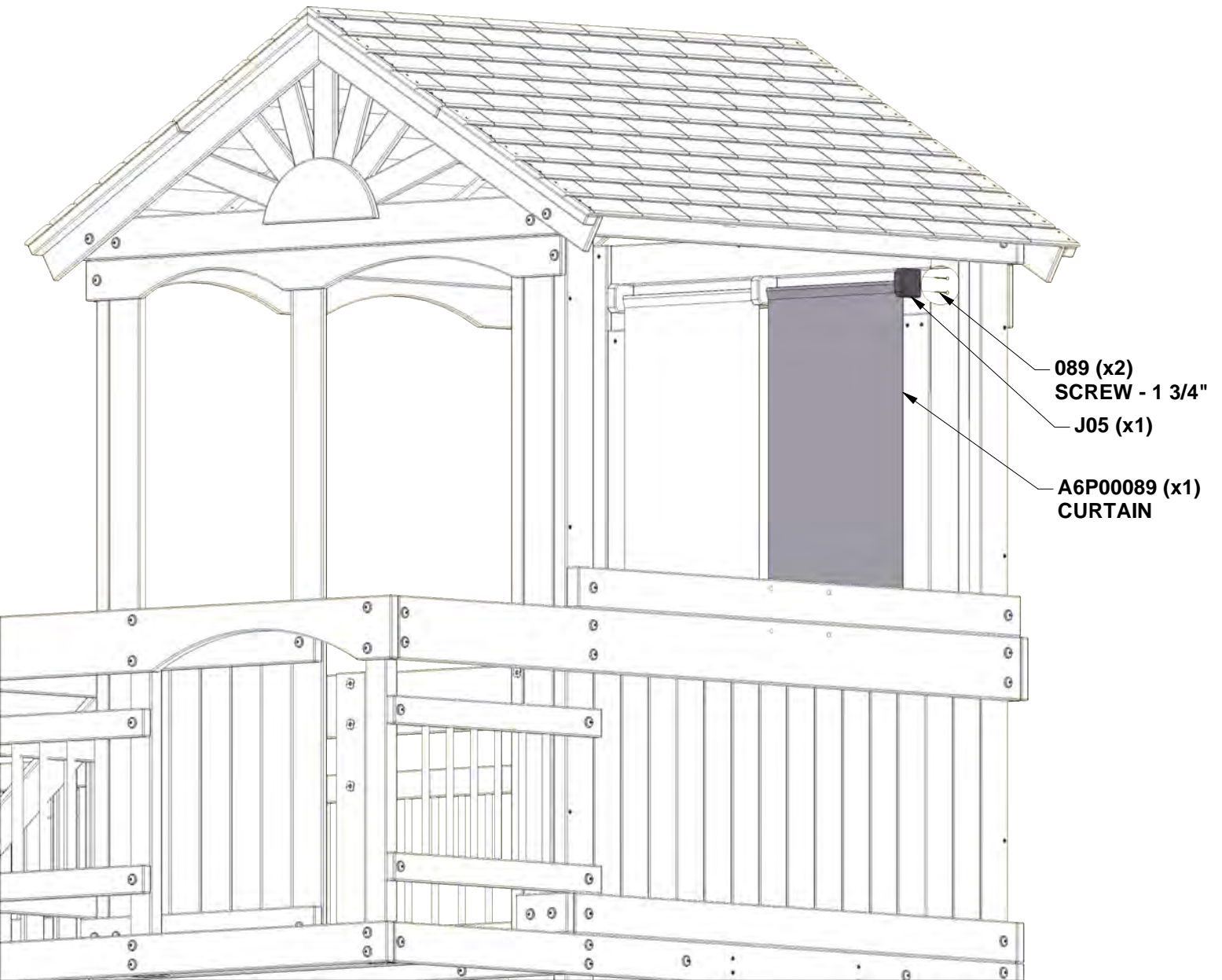

STEP 80 - FORT ASSEMBLY



SWING ASSEMBLY

WHEN HANGING YOUR SWINGS IT IS RECOMMENDED THAT THE BOTTOM OF THE SWING SEAT, WHEN SITTING ON IT, IS LOCATED NO LOWER THAN (20 cm) 7 7/8 INCHES FROM THE GROUND.

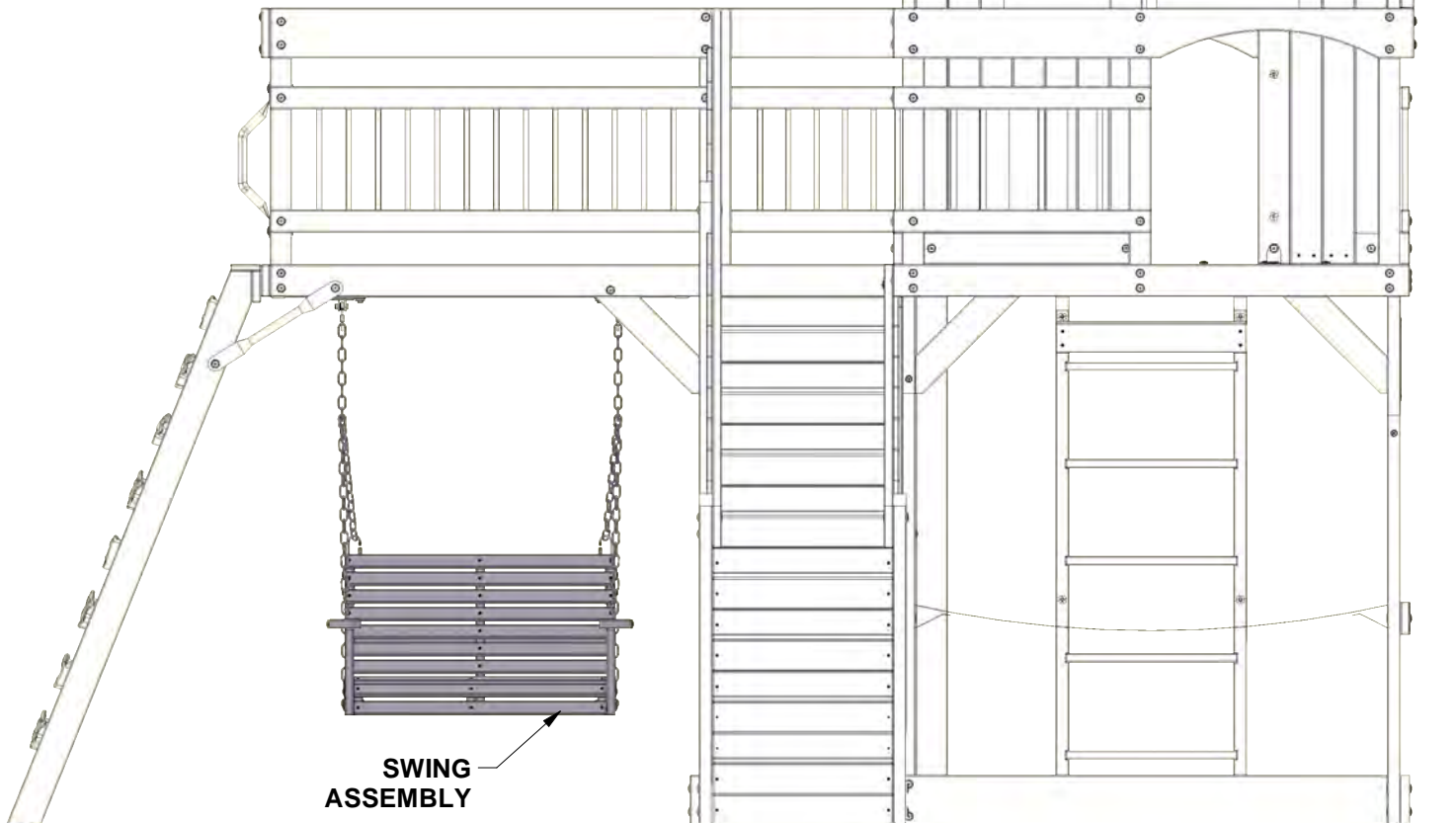
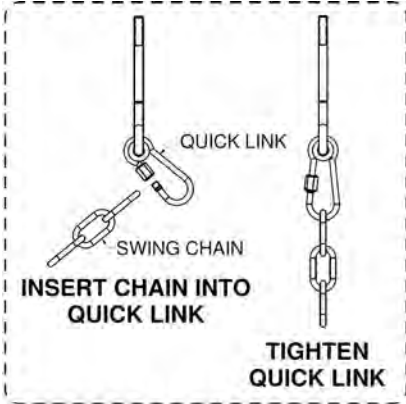

STEP 81 - FORT ASSEMBLY

QTY	PART NUMBER	DESCRIPTION
4	H100477	WASHER SPLIT 5/16 BLK
4	H100478	WASHER FLAT 8x27 BLK
4	H100498	BOLT HEX 5/16x1-1/2 - BLK

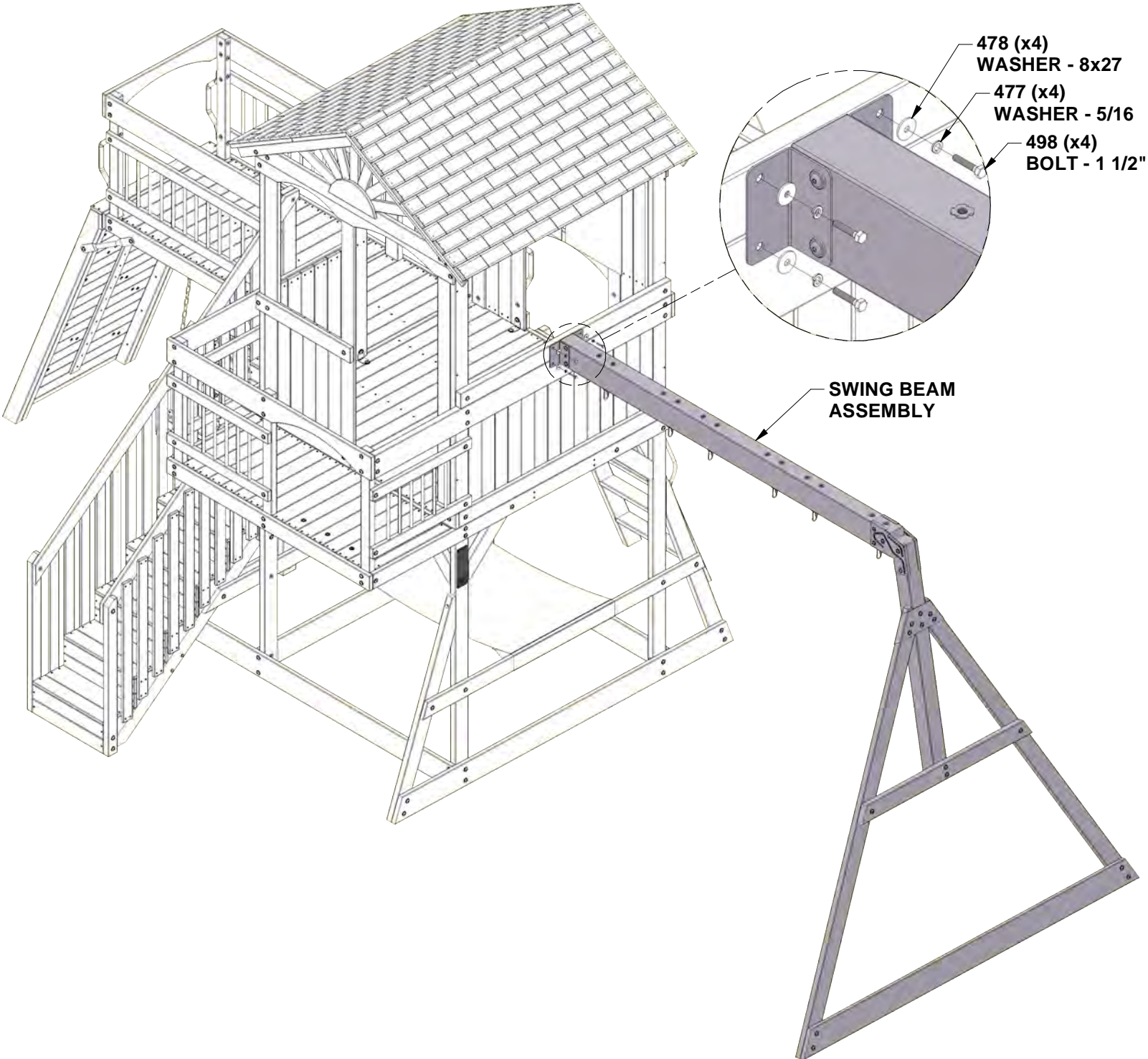
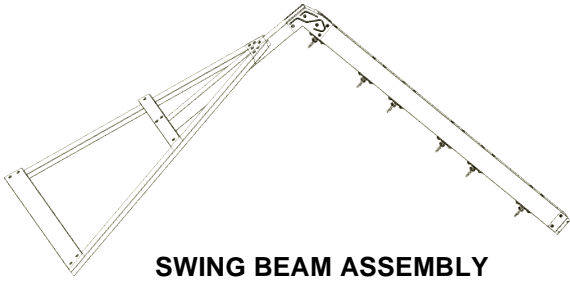

STEP 82 - FORT ASSEMBLY



A100047 CHAIN GREEN 57"
(x4)

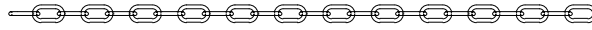

A100177 CHAIN GREEN 31"
(x2)

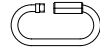

A100069 QUICK LINK
(x6)

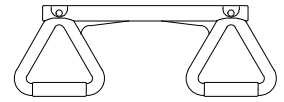

A6P00034 TRAPEZE YELLOW
(x1)



A6P00054 SWING SEAT GREEN 22"
(x2)

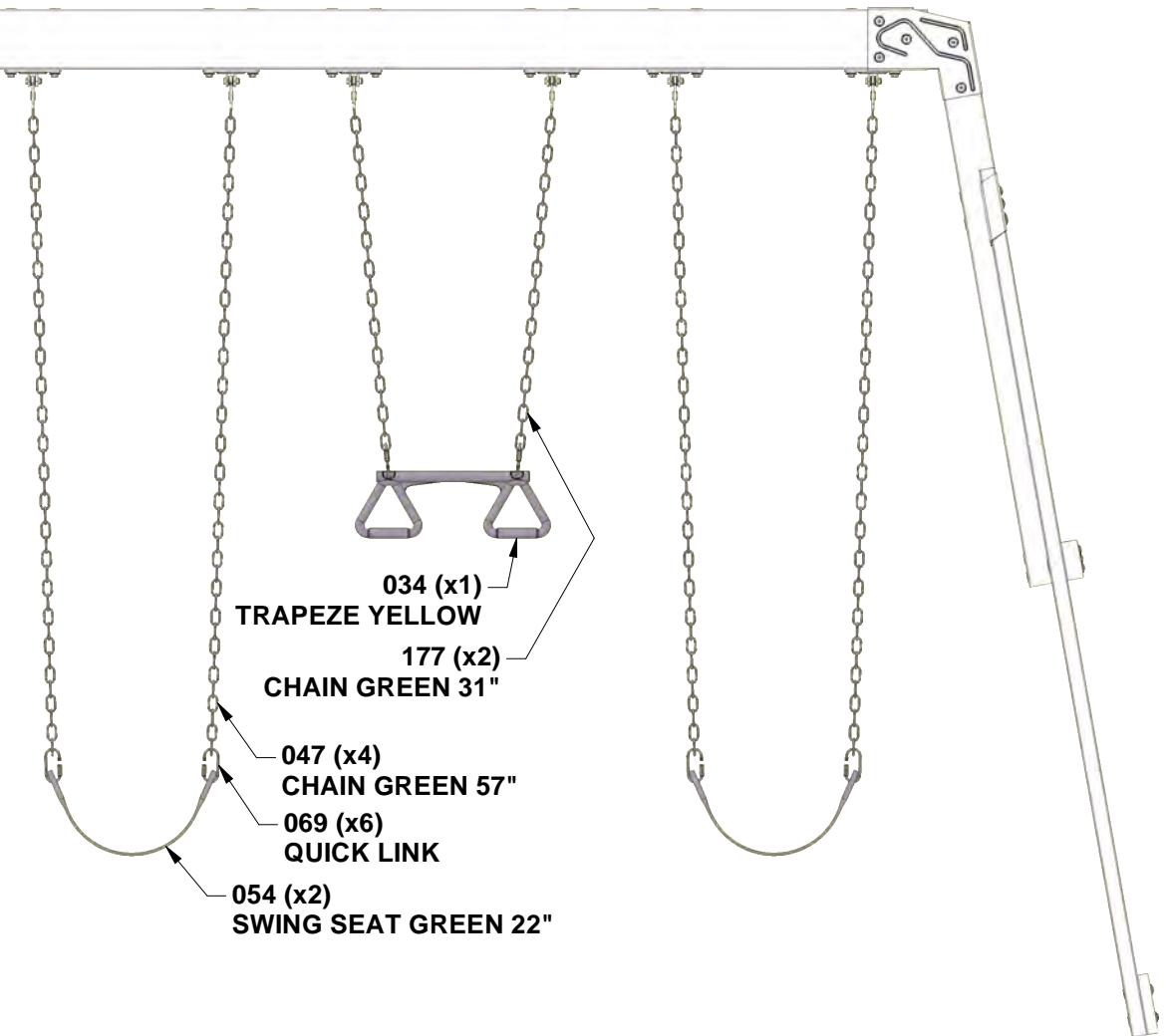
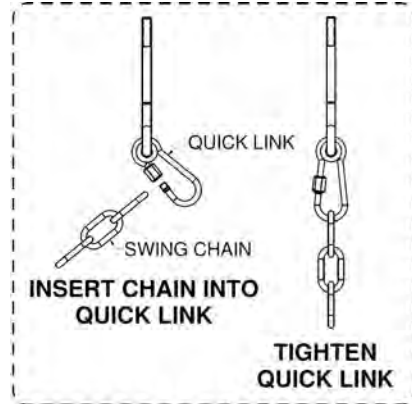
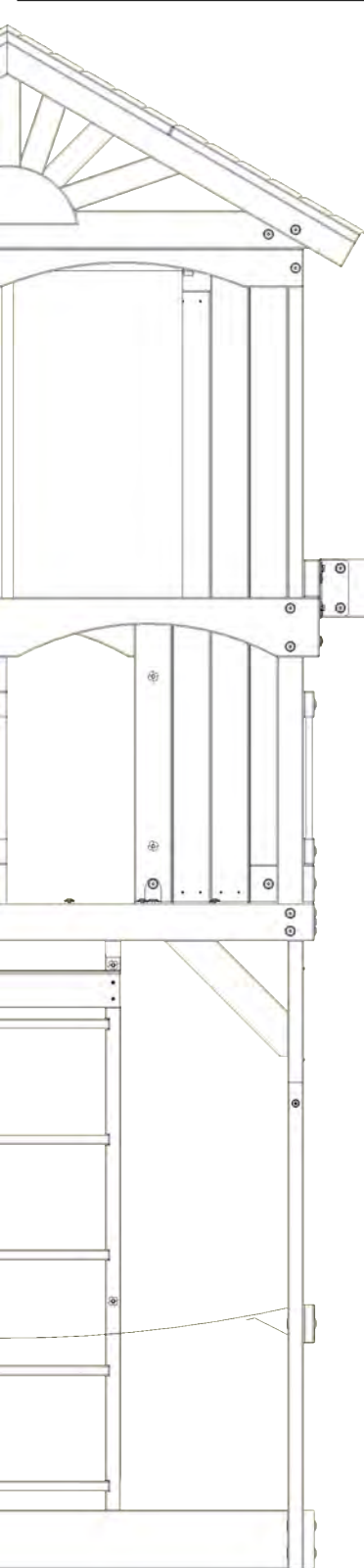

034 (x1)
TRAPEZE YELLOW

177 (x2)
CHAIN GREEN 31"

047 (x4)
CHAIN GREEN 57"

069 (x6)
QUICK LINK

054 (x2)
SWING SEAT GREEN 22"

STEP 83 - FORT ASSEMBLY

QTY	PART NUMBER	DESCRIPTION
3	H100074	T-NUT 5/16
3	H100115	BOLT WH 5/16x1/2

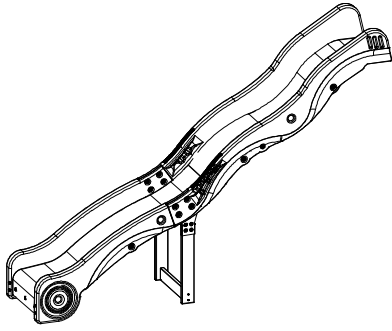

SLIDE ASSEMBLY

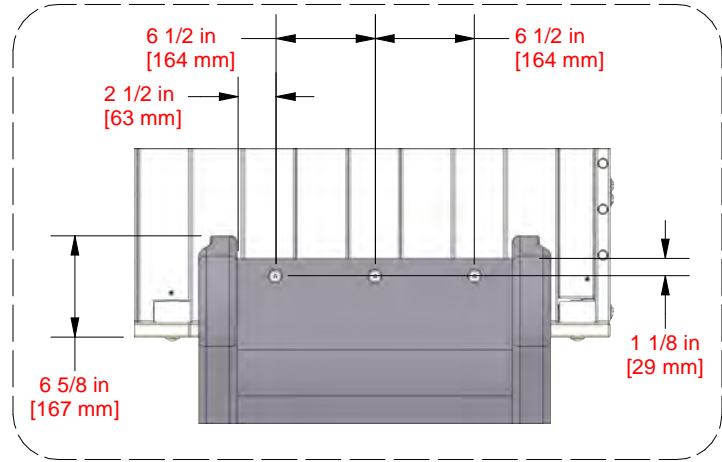

CENTER SLIDE IN OPENING USING DIMENSIONS SHOWN. USING DIMENSIONS AS A TEMPLATE, DRILL (3) 3/8" [10mm] HOLES THRU SLIDE & DECK FOR HARDWARE.

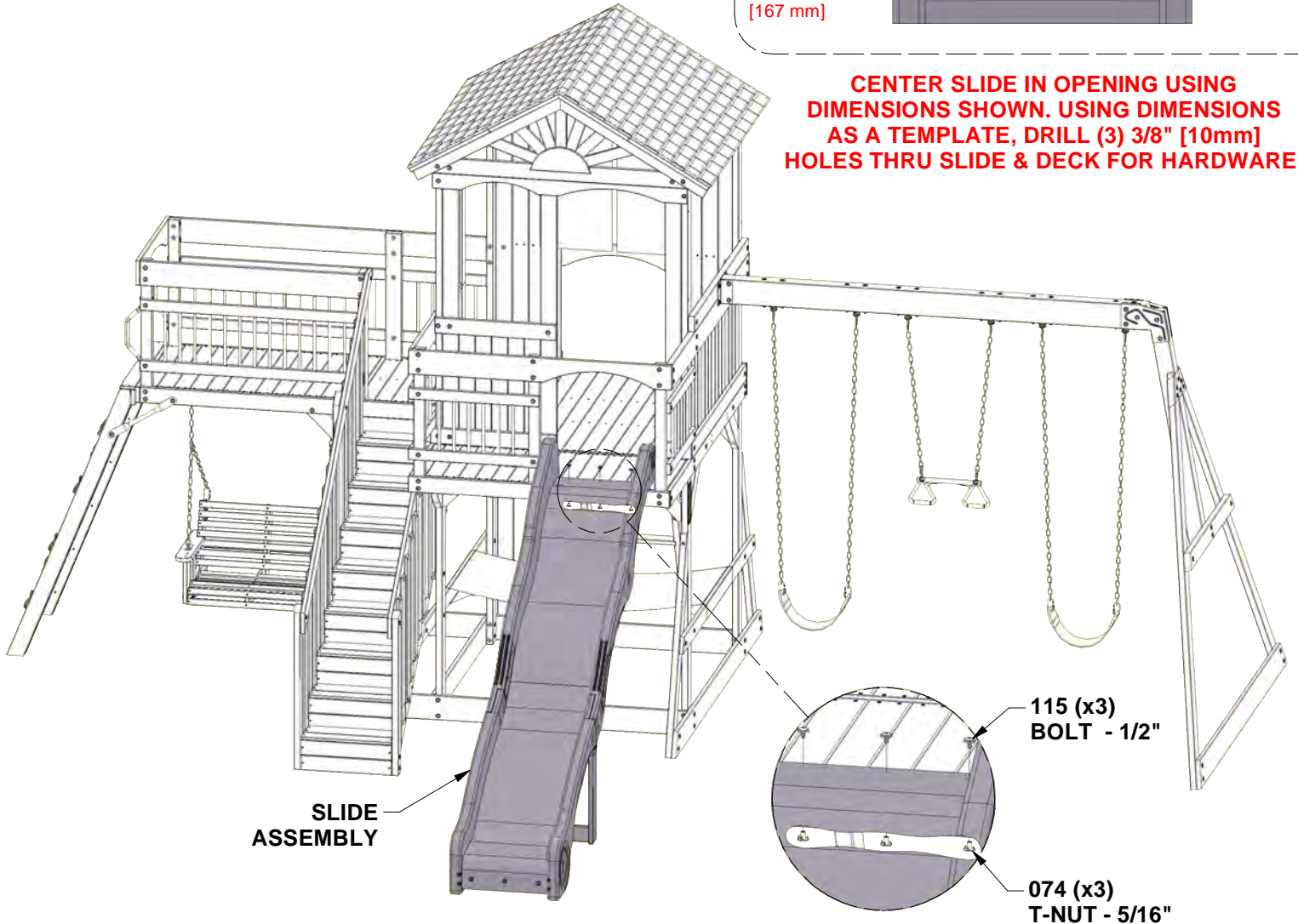

SLIDE ASSEMBLY

**115 (x3)
BOLT - 1/2"**

**074 (x3)
T-NUT - 5/16"**

STEP 84 - FORT ASSEMBLY

QTY	PART NUMBER	DESCRIPTION
4	H100202	SCREW PWH 8x5/8 BLK



A4M03403 BYD ID TAG LARGE
(x1)

