



# Mt. McKinley Wooden Swing Set

Model # 1705012 Owner's Manual & Assembly Instructions

MANUFACTURED BY:  
Backyard Discovery  
3305 Airport Drive  
Pittsburg, KS 66762  
800-856-4445



average 2 person assembly time



assembly time may vary based on skill level

Before you begin

FOR QUICK & EASY ASSEMBLY  
FIND 3D INSTRUCTIONS FOR THIS PRODUCT IN

**BILT.**

DOWNLOAD THE FREE APP

GET IT ON Google Play

Download on the App Store

For the most up to date assembly manual, to register your set, or to order replacement parts please visit [www.backyarddiscovery.com](http://www.backyarddiscovery.com)

**SAVE THIS ASSEMBLY MANUAL FOR FUTURE REFERENCE IN THE EVENT THAT YOU NEED TO ORDER REPLACEMENT PARTS.**

Para obtener instrucciones en español, visite [www.backyarddiscovery.com](http://www.backyarddiscovery.com). Pour des instructions en français, visitez [www.backyarddiscovery.com](http://www.backyarddiscovery.com).

# Basic Setup Dimensions

Place the set on level ground, not less than 6 ft [2 m] from any structure or obstruction such as a fence, garage, house, overhanging branches, laundry lines, or electrical wires.

## **General Information:**

Your set has been designed and engineered for children only and for residential use only. A maximum of 150 lbs. per child is recommended for play activities designed for individual use.

A maximum of 120 lbs. per child is recommended for play activities designed for multiple child use.

A maximum of 9 children is recommended for this swing set.

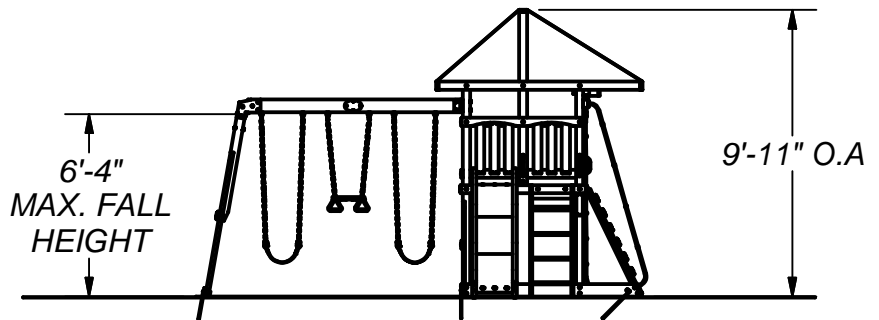
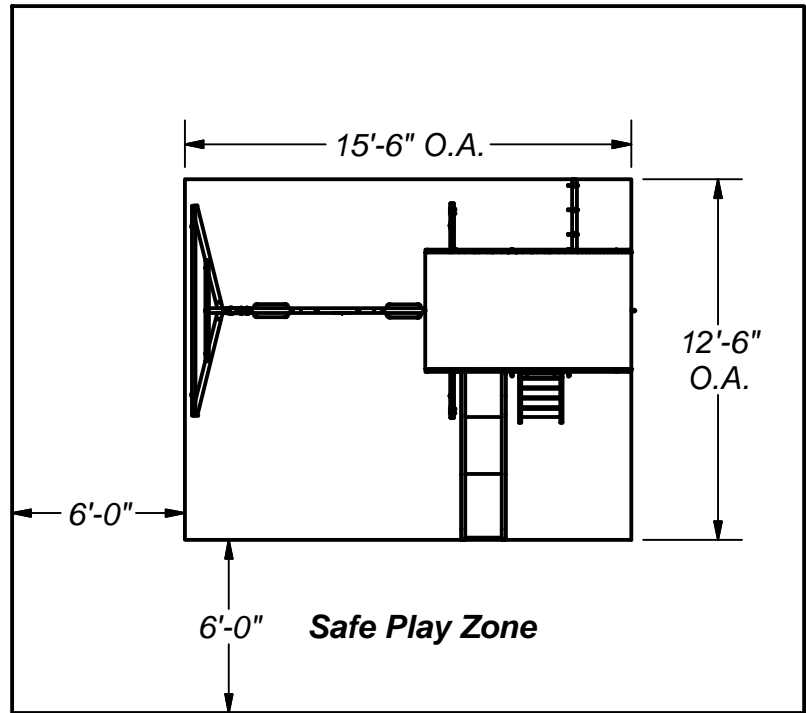

Safe play height: 15'-11" [4.8 m]  
Maximum fall height: 6'-4 1/2" [1.9 m]

## Important Assembly Notes

- 1) While assembling unit, take time before and after each phase to make sure fort is level. If fort is not level, assembly will be difficult and improper assembly may result. Extra care must be taken to ensure the fort is square.
- 2) Tighten bolts securely, tighten nuts on bolts flush to the tube or member.
- 3) Pay close attention to the ITEMS NEEDED FOR EACH PHASE. They can be a valuable aid when sorting your wood and hardware. Assembly will be made easier if items are sorted by phase.
- 4) Pay close attention to make sure you are using the correct hardware in the correct phases. Using incorrect hardware may result in improper assembly.
- 5) Whenever a T-nut is used, follow these directions. Place T-nut in pre-drilled hole. Tap in with hammer. Place bolt with washers in the opposite side. Hand tighten to make sure the bolt is in the T-nut. DO NOT over tighten.
- 6) Read the steps of each phase thoroughly. The written steps may include important information not shown in the illustrations.

# Parts Identification

## Wood Components

(NOT TO SCALE)



(1) **B1 - UPRIGHT POST - W2A02004**  
3"x3"x89 1/2" (76x76x2274)



(1) **B2 - UPRIGHT POST - W4L07119**  
3"x3"x89 1/2" (76x76x2274)



(1) **B3 - UPRIGHT POST - W4L07120**  
3"x3"x89 1/2" (76x76x2274)



(1) **B4 - UPRIGHT POST - W4L07121**  
3"x3"x89 1/2" (76x76x2274)



(1) **E1 - RAIL - W4L07132**  
1 3/8"x3"x51 7/8" (36x76x1318)



(1) **E2 - RAIL - W4L07133**  
1 3/8"x3"x51 7/8" (36x76x1318)



(1) **E3 - RAIL - W4L07134**  
1 3/8"x3"x51 7/8" (36x76x1318)

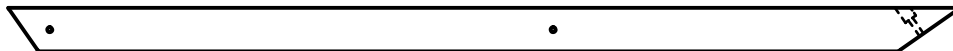

(2) **E77 - ANGLE BRACE - W4L07154**  
1 3/8"x3 3/8"x74 3/8" (36x86x1890)



(1) **G1 - GROUND BOARD - W4L07126**  
1"x5 1/4"x79 1/8" (24x134x2010)

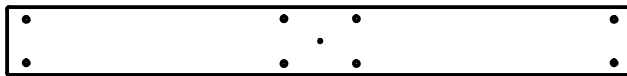

(1) **G2 - WALL RAIL - W4L07153**  
1"x5 1/4"x48 7/8" (24x134x1243)



(2) **H1 - ANGLE BRACE - W4L07127**  
1"x3 3/8"x46 1/8" (24x86x1173)

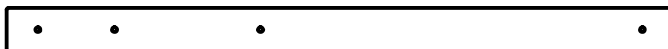

(1) **H2 - FLOOR SUPPORT - W4L07128**  
1"x3 3/8"x52 1/8" (24x86x1324)



(1) **H3 - FLOOR SUPPORT - W4L07129**  
1"x3 3/8"x52 1/8" (24x86x1324)

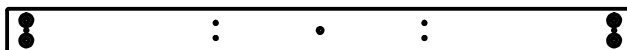

(1) **H4 - FLOOR SUPPORT - W4L07130**  
1"x3 3/8"x48 7/8" (24x86x1243)

# Parts Identification

## Wood Components

(NOT TO SCALE)



- (1) **H5 - FLOOR SUPPORT - W4L07131**  
1"x3 3/8"x48 7/8" (24x86x1243)



- (1) **H6 - UPRIGHT - W4L07147**  
1"x3 3/8"x72" (24x86x1828)



- (1) **H7 - UPRIGHT - W4L07148**  
1"x3 3/8"x72" (24x86x1828)

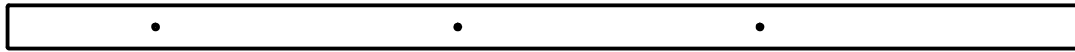

- (2) **H8 - ROOF RAIL - W4L07149**  
1"x3 3/8"x83 7/8" (24x86x2132)



- (2) **H9 - ROOF RAIL - W4L07150**  
1"x3 3/8"x50 7/8" (24x86x1291)



- (1) **H10 - ROOF RAIL - W4L07151**  
1"x3 3/8"x48 7/8" (24x86x1243)



- (2) **H11 - DECK BRACE - W4L07296**  
1"x3 3/8"x17 3/4" (24x86x450)



- (1) **H74 - LEFT UPRIGHT - W4L06930**  
1"x3 3/8"x50 3/4" (24x86x1290)

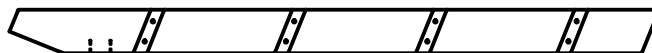

- (1) **H75 - RIGHT UPRIGHT - W4L06931**  
1"x3 3/8"x50 3/4" (24x86x1290)

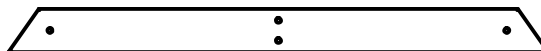

- (1) **H79 - END SUPPORT - W4L06923**  
1"x3 1/2"x42" (24x86x1072)



- (1) **H80 - GROUND BOARD - W4L07155**  
1"x3 3/8"x87 3/8" (24x86x2218)



- (4) **H81 - LADDER RUNG - W4L06933**  
1"x3 3/8"x17 1/8" (24x86x434)



- (2) **J1 - FLOOR JOIST - W4L07139**  
1"x2 3/8"x50 1/4" (24x60x1275)



- (4) **J2 - FLOOR SUPPORT - W4L06710**  
1"x2 3/8"x3" (24x60x76)

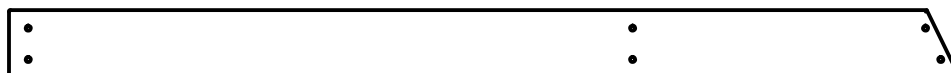

- (1) **K1 - GROUND BOARD - W4L07122**  
5/8"x5 1/4"x74 1/4" (16x134x1888)



# Parts Identification

## Wood Components

(NOT TO SCALE)



- (1) **K2 - GROUND BOARD - W4L07123**  
5/8"x5 1/4"x89 3/8" (16x134x2270)



- (1) **K3 - GROUND BOARD - W4L07124**  
5/8"x5 1/4"x50 1/8" (16x134x1274)



- (1) **K4 - GROUND BOARD - W4L07125**  
5/8"x5 1/4"x23 1/8" (16x134x588)



- (1) **K5 - GROUND BOARD - W4L07135**  
5/8"x5 1/4"x50 1/4" (16x134x1277)



- (6) **M1 - ROCK WALL BOARD - W4L07136**  
5/8"x3 3/8"x49" (16x86x1245)



- (3) **M2 - ROCK WALL BOARD - W4L07137**  
5/8"x3 3/8"x49" (16x86x1245)

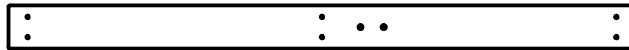

- (3) **M3 - ROCK WALL BOARD - W4L07138**  
5/8"x3 3/8"x49" (16x86x1245)



- (2) **M4 - FLOOR BOARD - W4L07141**  
5/8"x3"x42 7/8" (16x76x1090)



- (1) **M5 - FLOOR BOARD - W4L07142**  
5/8"x3 3/8"x48 7/8" (16x86x1242)



- (1) **M6 - SAFETY RAIL - W4L07143**  
5/8"x3 3/8"x48 7/8" (16x86x1243)



- (1) **M7 - ARCHED RAIL - W4L07144**  
5/8"x3 3/8"x50 7/8" (16x86x1292)



- (2) **M8 - WALL RAIL - W4L07145**  
5/8"x3 3/8"x50 7/8" (16x86x1292)



- (2) **M9 - WALL RAIL - W4L07146**  
5/8"x3 3/8"x48 7/8" (16x86x1243)

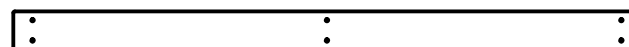

- (1) **M10 - ROCK WALL BOARD - W4L07360**  
5/8"x3"x49" (16x76x1245)



- (13) **M44 - PICKET - W4L07152**  
5/8"x3 3/8"x21 3/8" (16x86x542)

# Parts Identification

## Wood Components

(NOT TO SCALE)

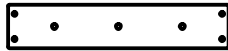

- (1) **M77 - SLIDE BRACE - W100544**  
5/8"x3 3/8"x17 1/4" (16x86x438)



- (2) **M78 - CENTER SLIDE BRACE - W100545**  
5/8"x3 3/8"x17 1/4" (16x86x438)



- (1) **M102 - ATTACHMENT BOARD - W4L06934**  
5/8"x3 3/8"x18 1/4" (16x86x462)



- (1) **M103 - REAR SUPPORT - W4L06932**  
5/8"x3 3/8"x18 1/4" (16x86x462)

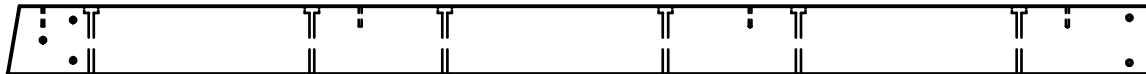

- (1) **SB74 - SWING BEAM EXTENDED - W4L06961**  
2"x5 1/4"x89 1/2" (50x134x2274)



- (2) **T1 - SUPPORT BOARD - W4L07140**  
1"x1 3/8"x44 1/8" (24x34x1122)



- (1) **W1 - SUPPORT BOARD - W4L07156**  
2"x3 3/8"x78 7/8" (50x86x2005)

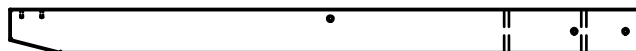

- (1) **W71 - SWING BEAM SUPPORT - W4L06963**  
2"x3 3/8"x49 5/8" (50x86x1260)

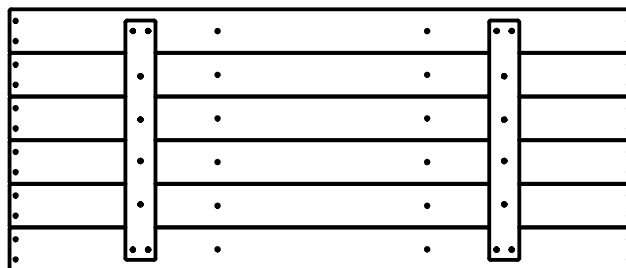

- (2) **FP1 - FLOOR PANEL - W2A02005**  
1 1/4"x20 3/8"x48 5/8" (32x519x1242)

# Parts Identification

## Hardware

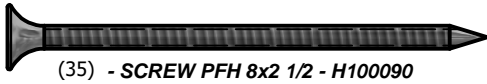

(35) - SCREW PFH 8x2 1/2 - H100090



(13) - SCREW PFH 8x2 1/4 - H100091



(17) - SCREW PFH 8x2 - H100111



(19) - SCREW PFH 8x1-3/4" - H100089



(98) - SCREW PFH 8x1-1/2" - H100086

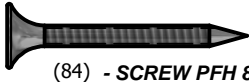

(84) - SCREW PFH 8x1-1/4" - H100087

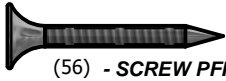

(56) - SCREW PFH 8x1-1/8" - H100088

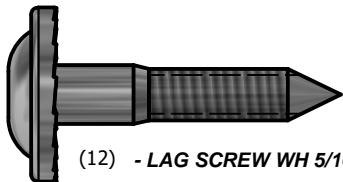

(12) - LAG SCREW WH 5/16x1 1/2 - H100026

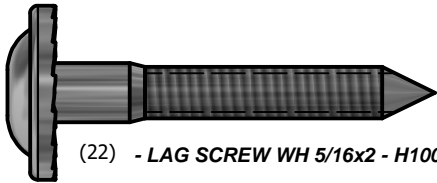

(22) - LAG SCREW WH 5/16x2 - H100027

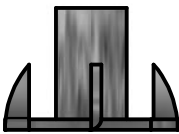

(63) - T-NUT 5/16 - H100074



(22) - T-NUT 1/4 - H100072



(12) - NUT LOCK 5/16 - H100110

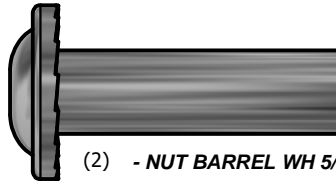

(2) - NUT BARREL WH 5/16x1 1/2 - H100006

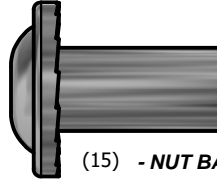

(15) - NUT BARREL WH 5/16x7/8 - H100005

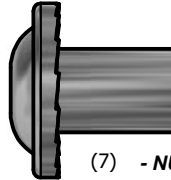

(7) - NUT BARREL WH 5/16x5/8 - H100004

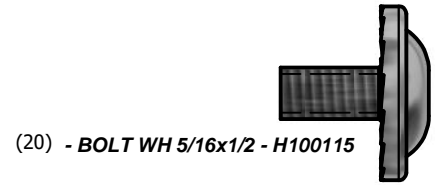

(20) - BOLT WH 5/16x1/2 - H100115

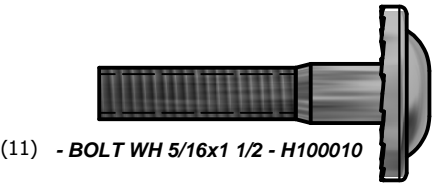

(11) - BOLT WH 5/16x1 1/2 - H100010

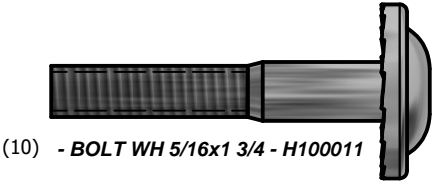

(10) - BOLT WH 5/16x1 3/4 - H100011

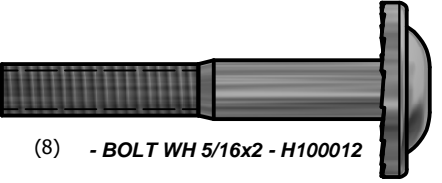

(8) - BOLT WH 5/16x2 - H100012

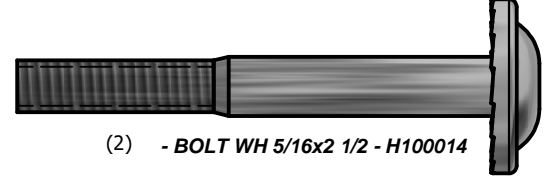

(2) - BOLT WH 5/16x2 1/2 - H100014

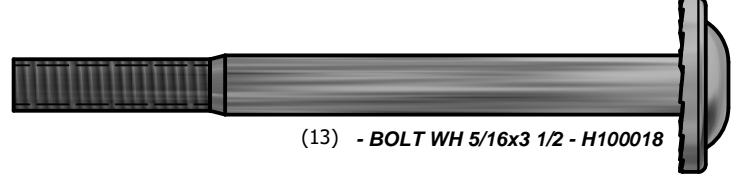

(13) - BOLT WH 5/16x3 1/2 - H100018

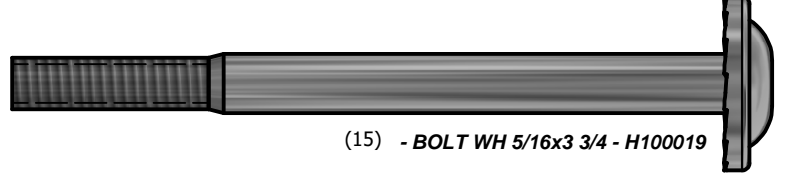

(15) - BOLT WH 5/16x3 3/4 - H100019

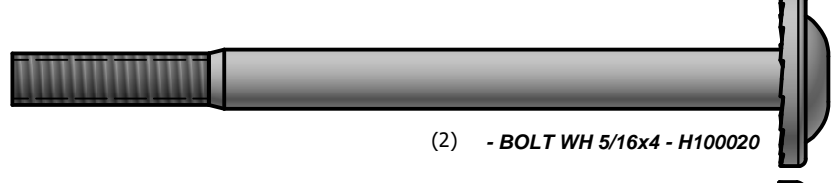

(2) - BOLT WH 5/16x4 - H100020

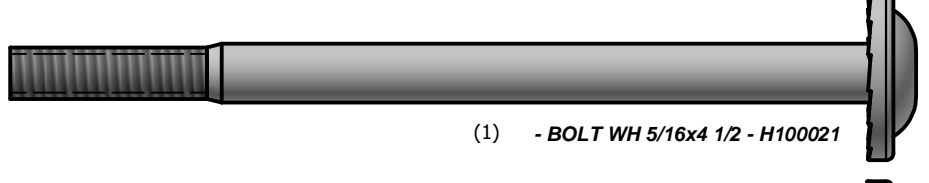

(1) - BOLT WH 5/16x4 1/2 - H100021

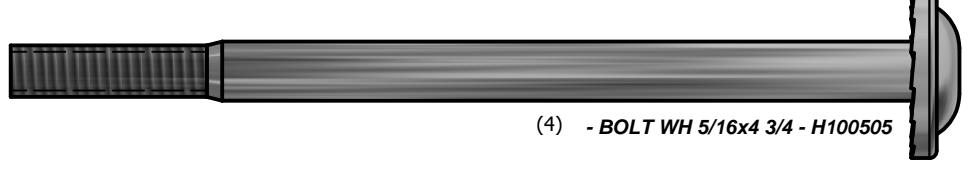

(4) - BOLT WH 5/16x4 3/4 - H100505

# Parts Identification

## Hardware

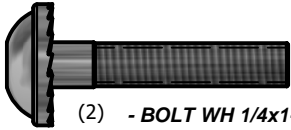

(2) - BOLT WH 1/4x1-1/4 - H100142



(4) - LAG SCREW WH 1/4x2 - H100146

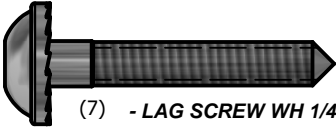

(7) - LAG SCREW WH 1/4x1-1/2 - H100145



(2) - BOLT HEX 5/16x2-3/4 - H100047



(4) - BOLT HEX 5/16x1 1/4 - H100042

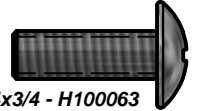

(20) - BOLT PTH 1/4x3/4 - H100063



(15) - SCREW PWH 8x3/4 - H100070



(7) - SCREW PWH 8x5/8 - H100128

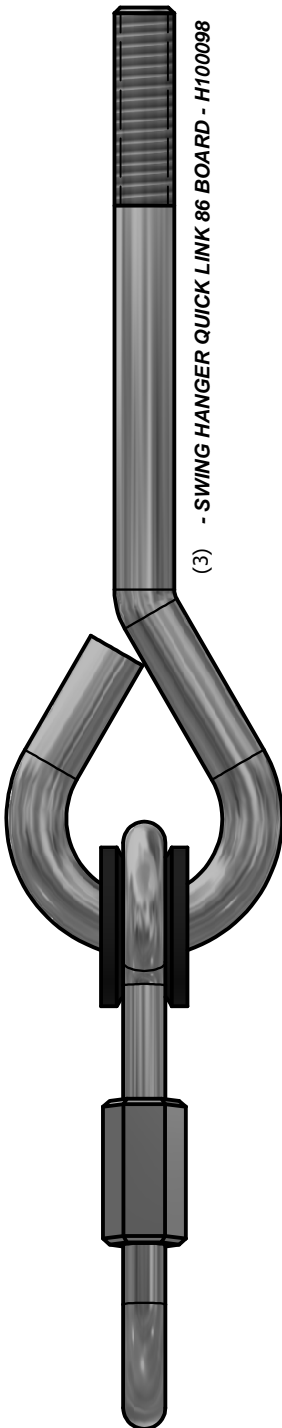

(3) - SWING HANGER QUICK LINK 86 BOARD - H100098

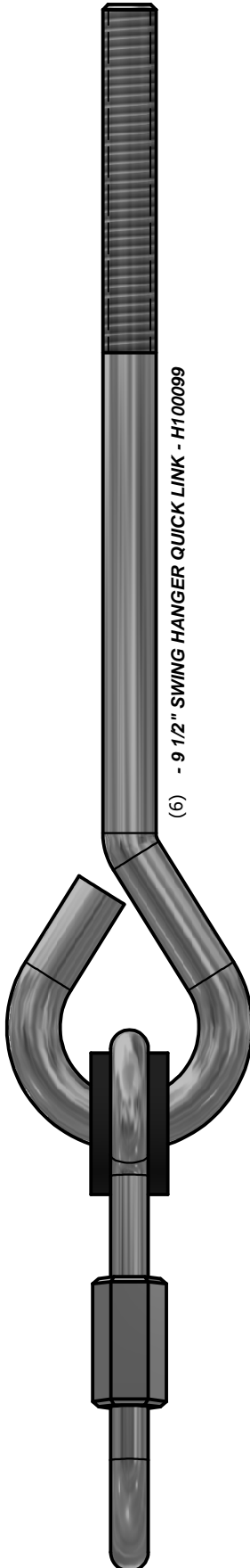

(6) - 9 1/2" SWING HANGER QUICK LINK - H100099

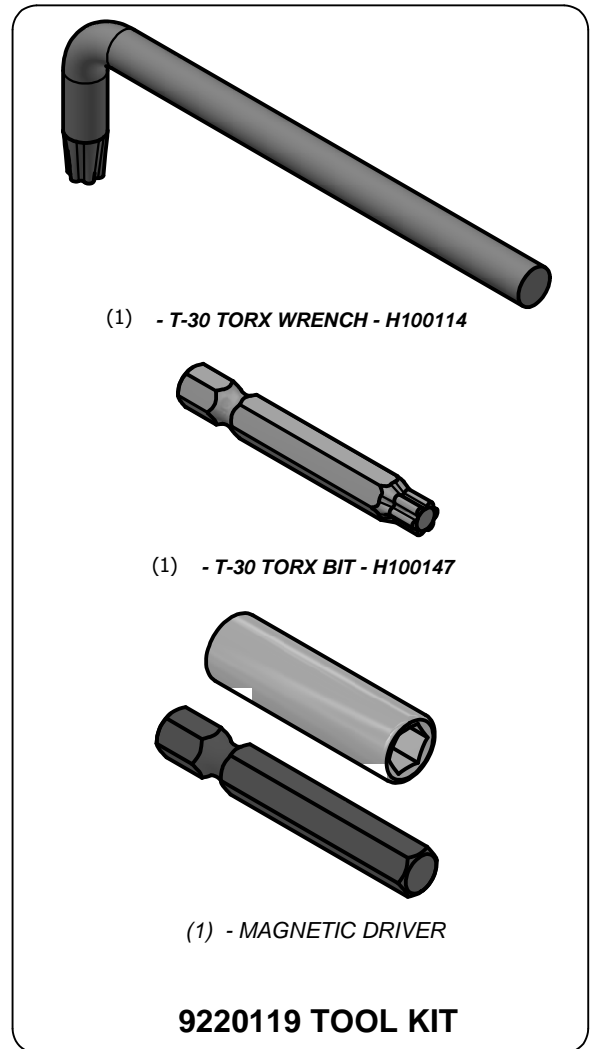

(1) - T-30 TORX WRENCH - H100114

(1) - T-30 TORX BIT - H100147

(1) - MAGNETIC DRIVER

**9220119 TOOL KIT**



(1) - SCREW SETTER - H100764

# Parts Identification

## Hardware

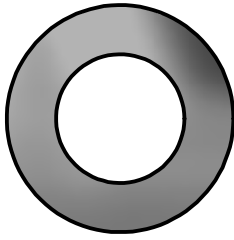

(10) - *WASHER SAFETY 17x30 - H100103*

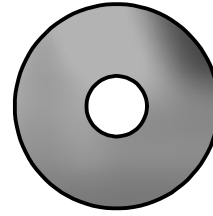

(19) - *WASHER FLAT 8x27 - H100105*

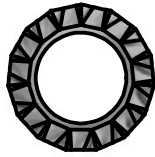

(18) - *WASHER LOCK EXT 12x19 - H100031*

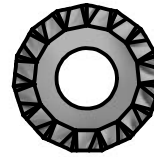

(88) - *WASHER LOCK EXT 8x19 - H100030*



(13) - *WASHER LOCK EXT 6x15 - H100138*

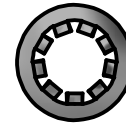

(19) - *WASHER LOCK INT 8x15 - H100108*

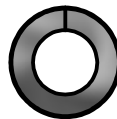

(4) - *WASHER SPLIT 5/16 - H100095*

# Parts Identification

## Accessories (NOT TO SCALE)

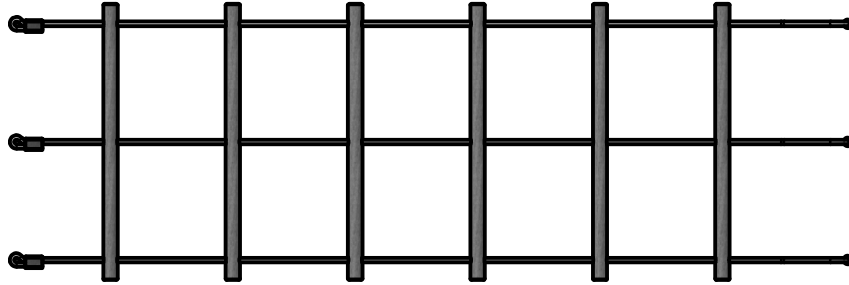

(1) - ROPE LADDER - A6P00161



(1) - CLIMBING ROPE - A6P00120



(2) - CHAIN GREEN 31" - A100177



(4) - CHAIN GREEN 51.25" - A100068



(1) - SLIDE RAIL 8' GREEN RIGHT - A100054



(1) - SLIDE RAIL 8' GREEN LEFT - A100055



(1) - SLIDE BED 8' YELLOW - A100056

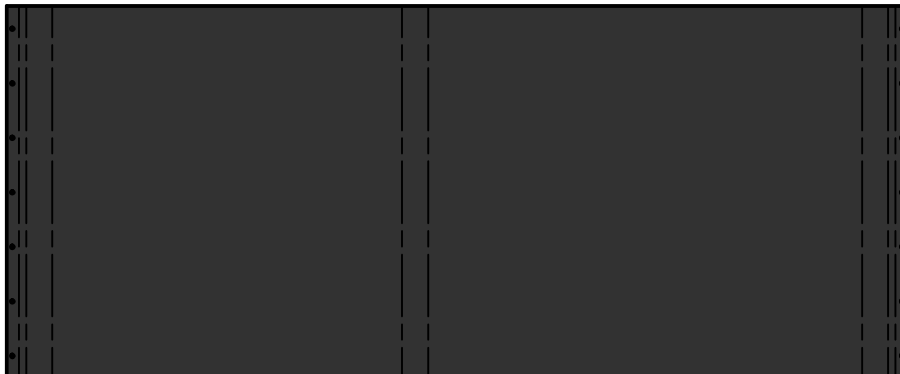

(1) - TARP - A6P00157

# Parts Identification

## Accessories (NOT TO SCALE)



(1) - L-BRACKET 2.5x66x127 - A4M00695



(2) - L BRACKET 66x66x127 - A100140



(3) - GREEN HC ROCK #2 - A6P00037

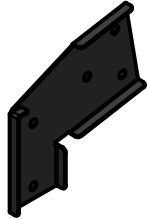

(1) - SWING BEAM EXTENSION BRACKET-LEFT - A100325



(2) - L BRACKET 2.5x38x50x55 - A100340



(2) - RED HC ROCK #2 - A6P00039

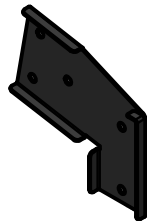

(1) - SWING BEAM EXTENSION BRACKET-RIGHT - A100326



(6) - QUICK LINK - A100069



(1) - "A" REVISION TAG - A100314

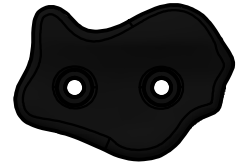

(2) - BLUE HC ROCK #2 - A6P00041



(1) - BYD ID TAG (LARGE) AGES 3-10 - A100164



(1) LP - STEERING WHEEL - A100105

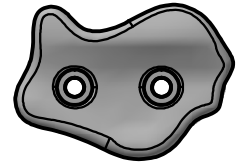

(2) - YELLOW HC ROCK #2 - A6P00043

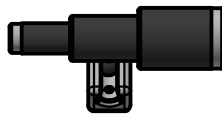

(1) - Telescope Tube - A6P00096-1



(2) - SWING SEAT GREEN 22" - A6P00054

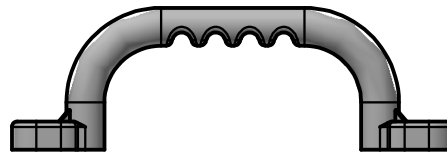

(4) - HAND GRIP YELLOW - A6P00303



(6) - GROUND STAKE REBAR - A4M00527

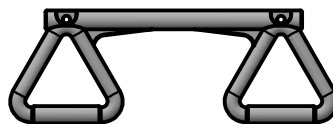

(1) - TRAPEZE YELLOW - A6P00034

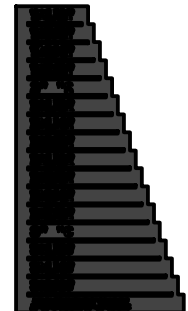

(1) - PICKET PAL - A6P00410

# PRE-ASSEMBLY STEP 1 - SORTING PARTS

It is critical for ease of assembly that you take the time to sort and organize the wood and hardware.

---

## WOOD PARTS:

- Organize wood parts by the three-digit, alpha-numeric number stamped on each board (ex. P01).
- If there are multiple boards with the same stamped number, stack those pieces together.
- Stamps can be found on the flat surface of the boards or on the end of the boards.
- Allow yourself plenty of room - the wood pieces can take up a significant amount of space.

**NOTE: CARTONS ARE NOT ORGANIZED BY BOARD NUMBER.**

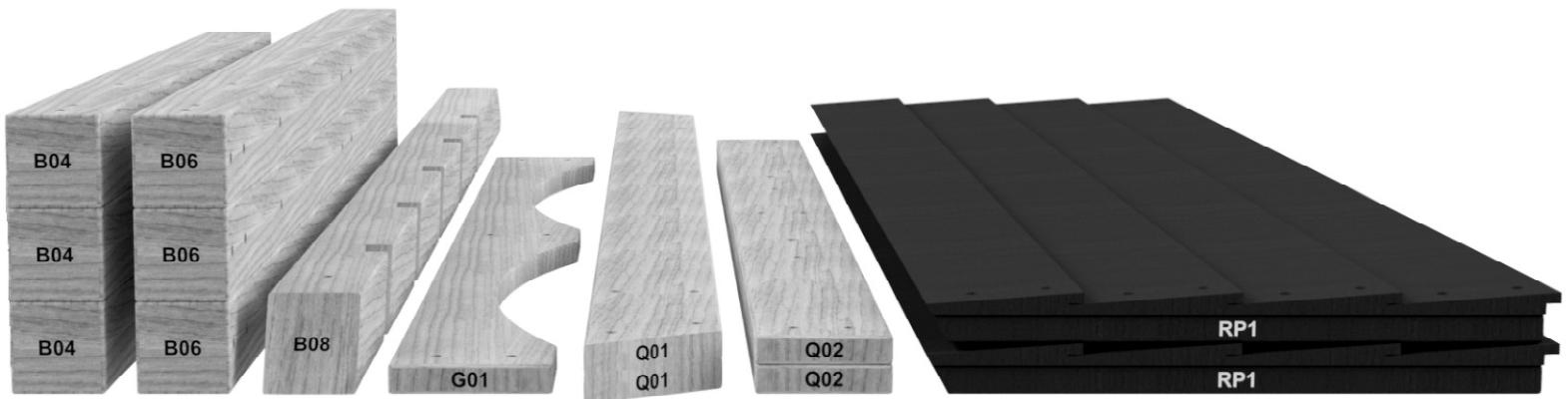

---

## HARDWARE PARTS:

- We recommend that you have a separate table to organize the hardware.
- Hardware bags are printed with a seven-digit, alpha-numeric part number.
- You can organize your hardware by part number or group by hardware type (i.e. bolts, nuts, etc.).
- During assembly you only need to reference the last four digits of the number.

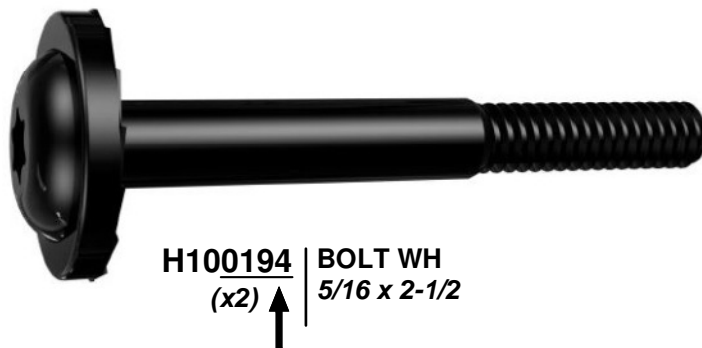



# PRE-ASSEMBLY STEP 2 - TOOLS REQUIRED



Cordless Drill or Electric Drill



Drill Attachments:  
Phillips Head



1/8", 3/16", 3/8" & 7/16"  
Drill Bits



Phillips Screw Driver



Open End Wrenches 1/2" & 9/16"



3/8" Drive Ratchet, 1/2" &  
9/16" STD Sockets 1/2" & 9/16" Deep  
Sockets



Claw Hammer



Rubber Mallet - Optional



Tape Measure

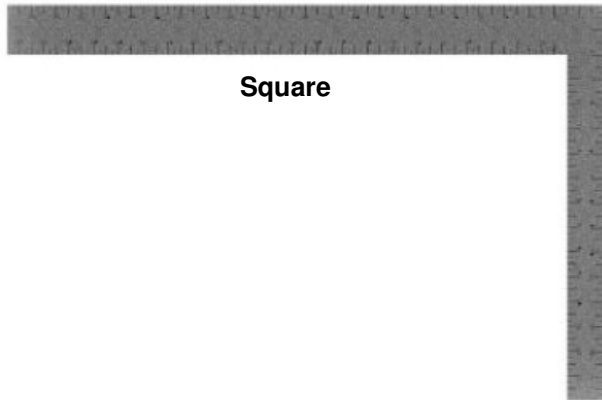

Square



Level 24"

# PRE-ASSEMBLY STEP 3 - CHOOSE YOUR ASSEMBLY METHOD

There are several types of assembly instructions available to you.

1. Printed Assembly Manual included with your set
2. BILT APP - 3D interactive instructions
3. Combination of the Printed Manual and BILT APP (Note: Step numbers can differ between the two methods)



**BILT.**<sup>®</sup>



**Scan for easy  
3D instructions**

Download the BILT app  
before you begin

Download on the  
**App Store**

GET IT ON  
**Google Play**

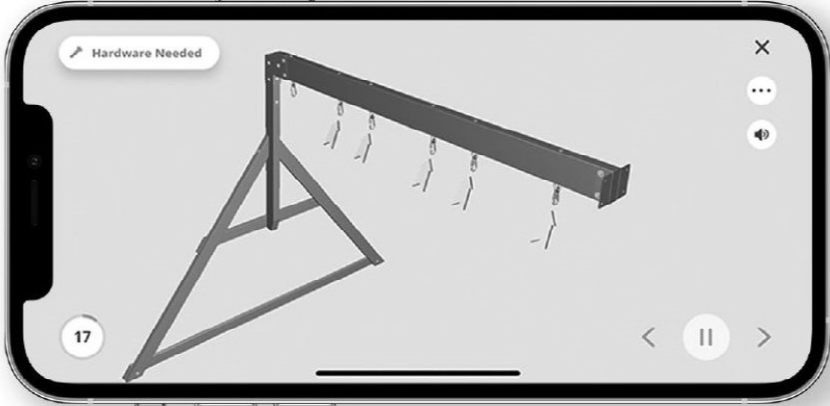



(1) H74 - LEFT UPRIGHT - W4L06930  
1"x3 3/8"x50 3/4" (24x86x1290)



(1) H75 - RIGHT UPRIGHT - W4L06931  
1"x3 3/8"x50 3/4" (24x86x1290)



(4) H81 - LADDER RUNG - W4L06933  
1"x3 3/8"x17 1/8" (24x86x434)

### LADDER ASSEMBLY STEP 1

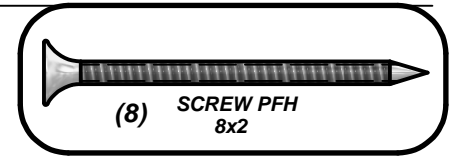
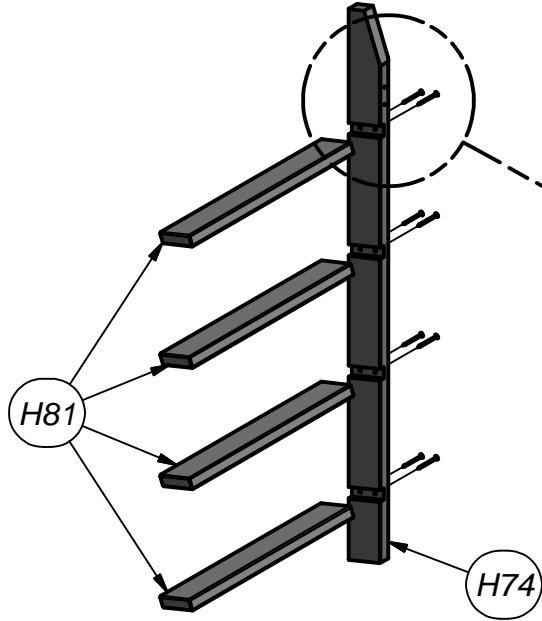

(8) SCREW PFH  
8x2

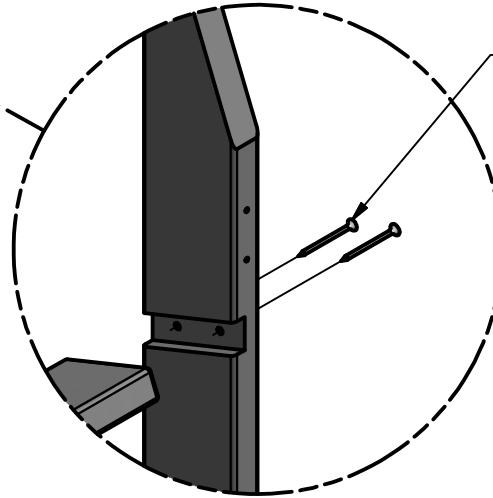

SCREW PFH 8x2  
(8 PLCS)

### LADDER ASSEMBLY STEP 2

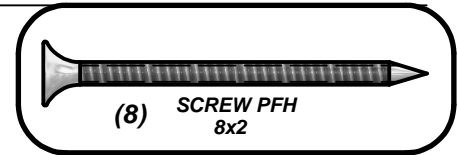
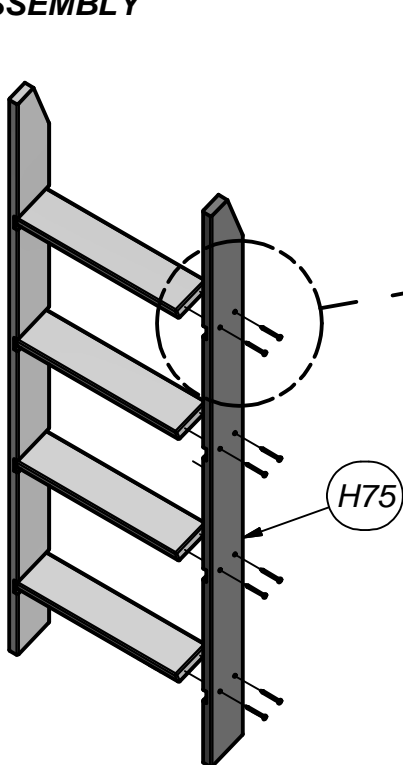

(8) SCREW PFH  
8x2

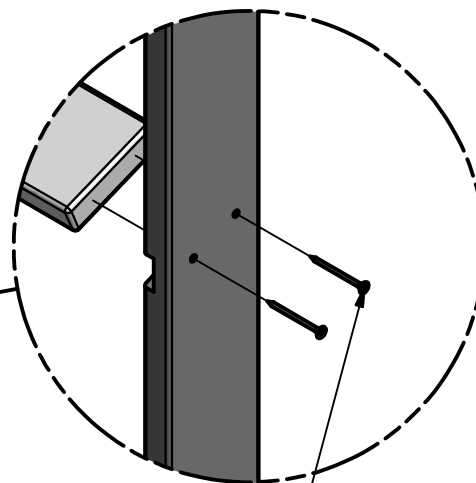

SCREW PFH 8x2  
(8 PLCS)



(1) M102 - ATTACHMENT BOARD - W4L06934  
5/8"x3 3/8"x18 1/4" (16x86x462)

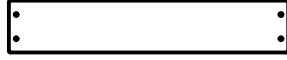

(1) M103 - REAR SUPPORT - W4L06932  
5/8"x3 3/8"x18 1/4" (16x86x462)

**LADDER ASSEMBLY  
STEP 3**

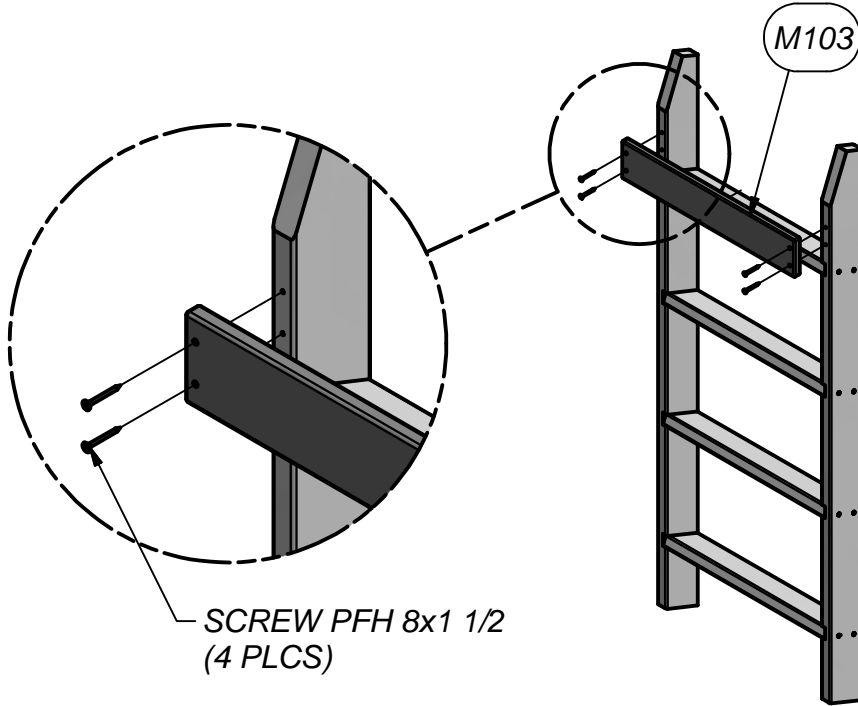
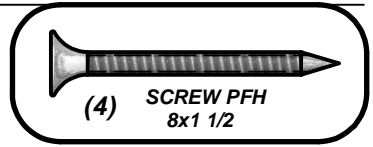

**LADDER ASSEMBLY  
STEP 4**

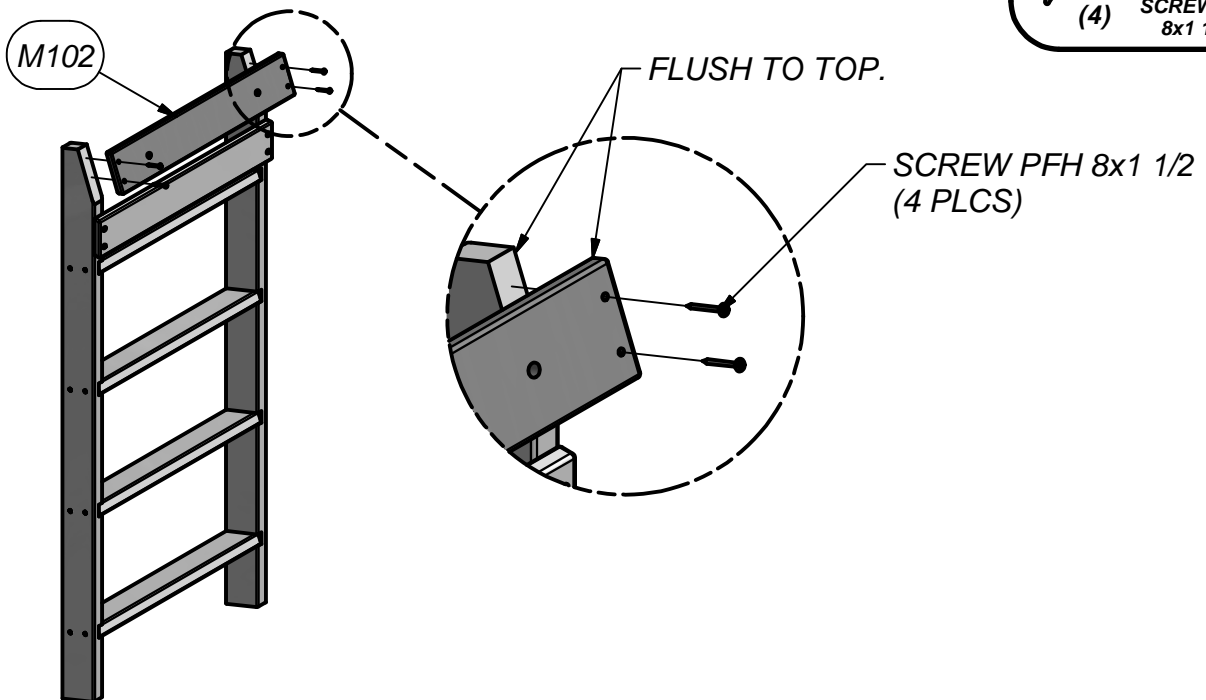
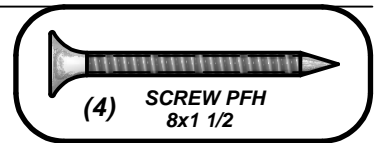

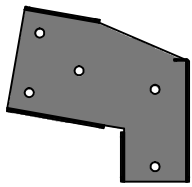

(1) TC - SWING BEAM EXTENSION BRACKET-RIGHT - A100326

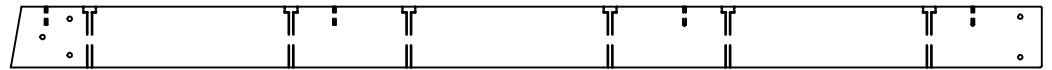

(1) SB74 - SWING BEAM EXTENDED - W4L06961  
2"x5 1/4"x89 1/2" (50x134x2274)

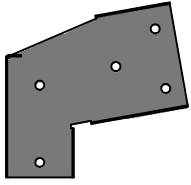

(1) TB - SWING BEAM EXTENSION BRACKET-LEFT - A100325

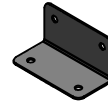

(2) GD - L BRACKET 66x66x127 - A100140

## SWING BEAM ASSEMBLY STEP 1

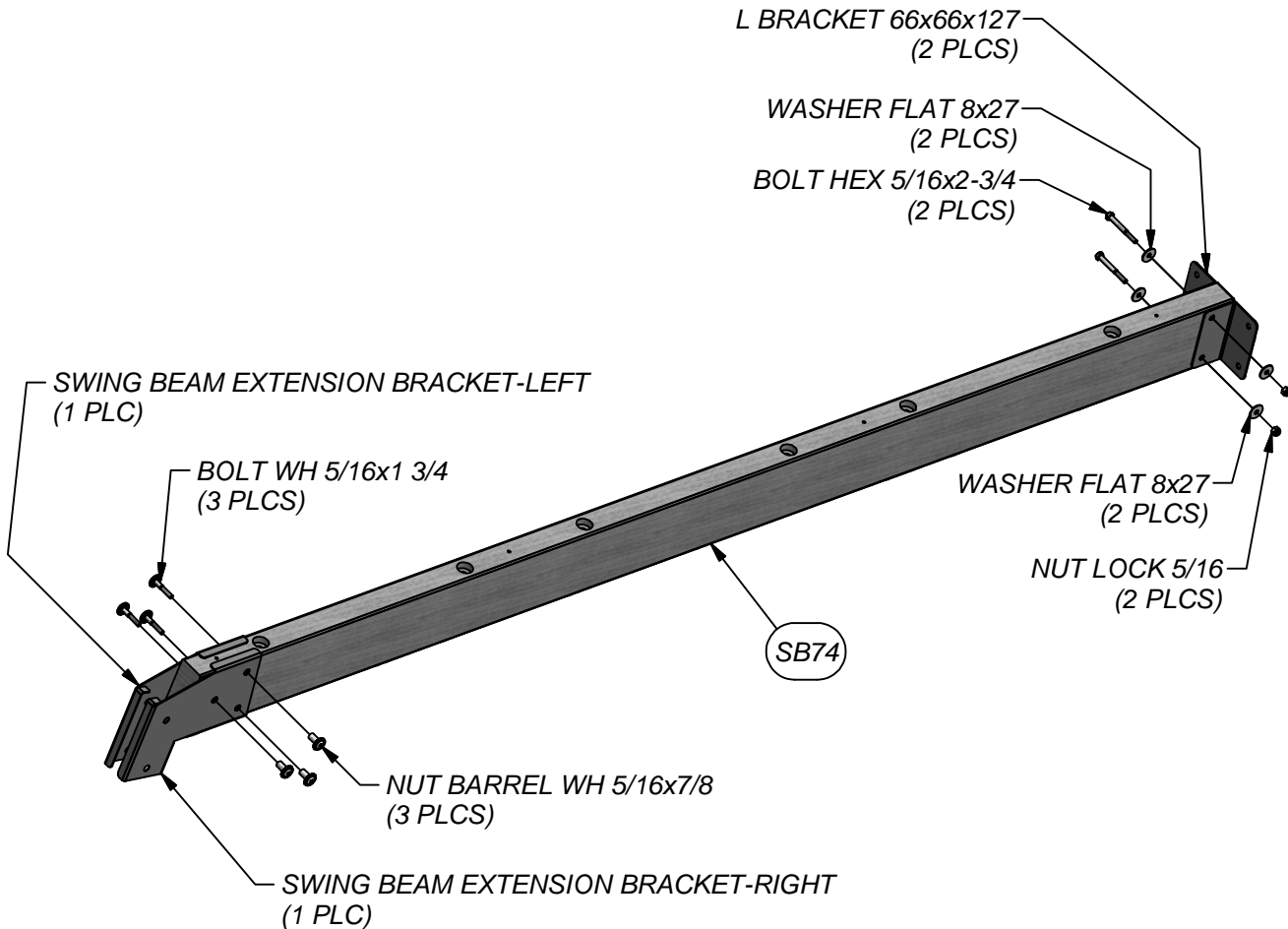
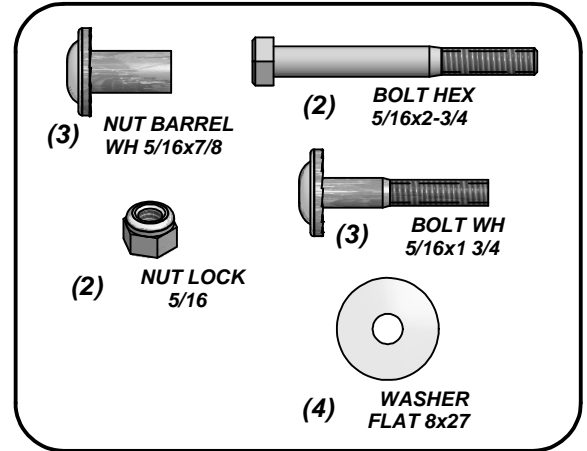

(1) H80 - GROUND BOARD - W4L07155  
1"x3 3/8"x87 3/8" (24x86x2218)

(1) H79 - END SUPPORT - W4L06923  
1"x3 1/2"x42" (24x86x1072)

(2) E77 - ANGLE BRACE - W4L07154  
1 3/8"x3 3/8"x74 3/8" (36x86x1890)

(1) W71 - SWING BEAM SUPPORT - W4L06963  
2"x3 3/8"x49 5/8" (50x86x1260)

**SWING BEAM ASSEMBLY  
STEP 2**

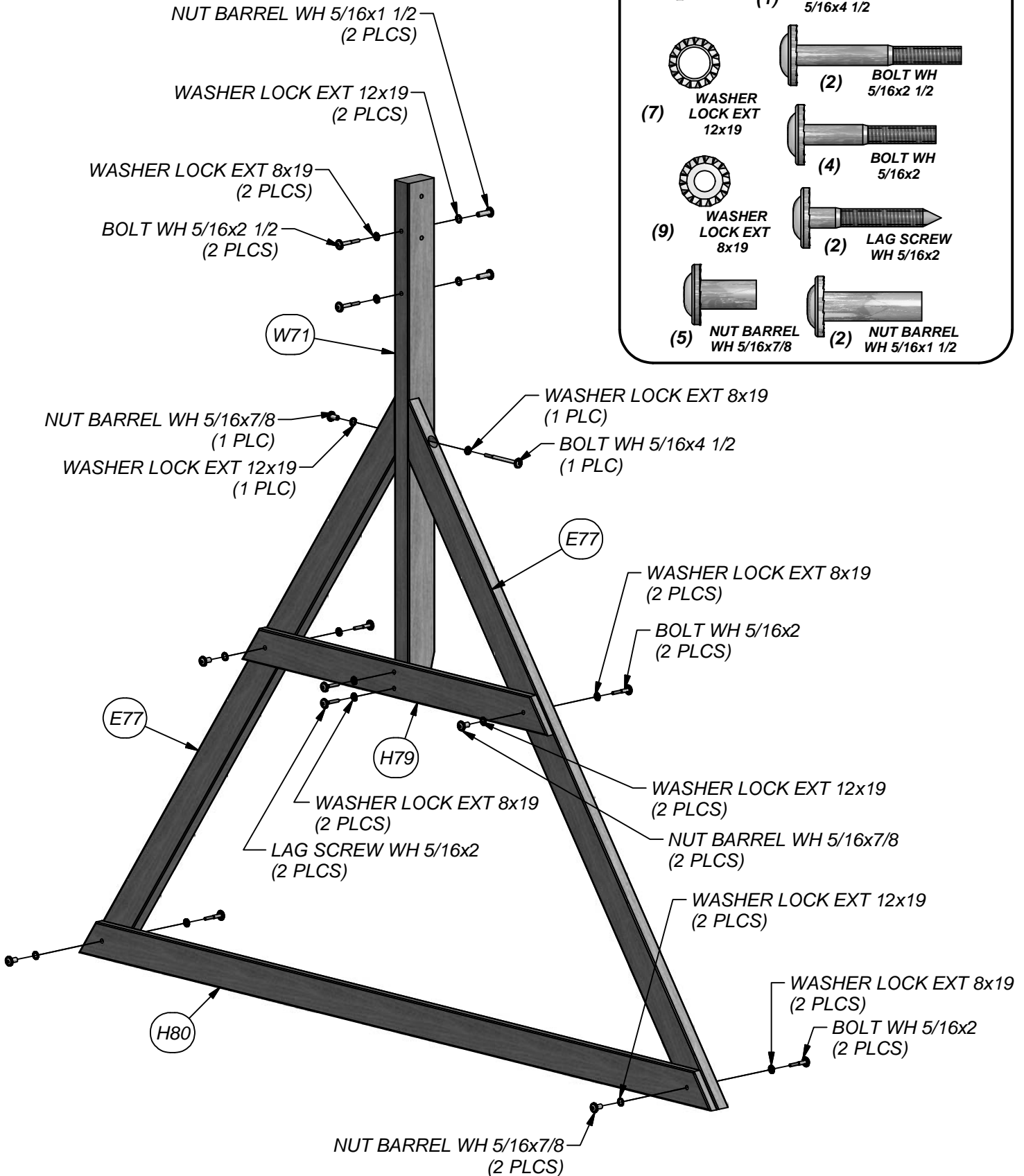

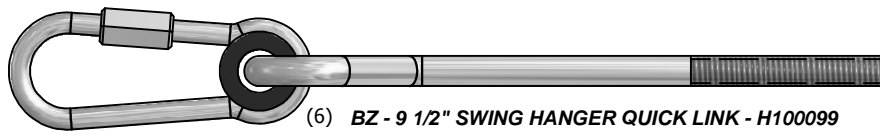

(6) BZ - 9 1/2" SWING HANGER QUICK LINK - H100099

**SWING BEAM ASSEMBLY  
STEP 3**

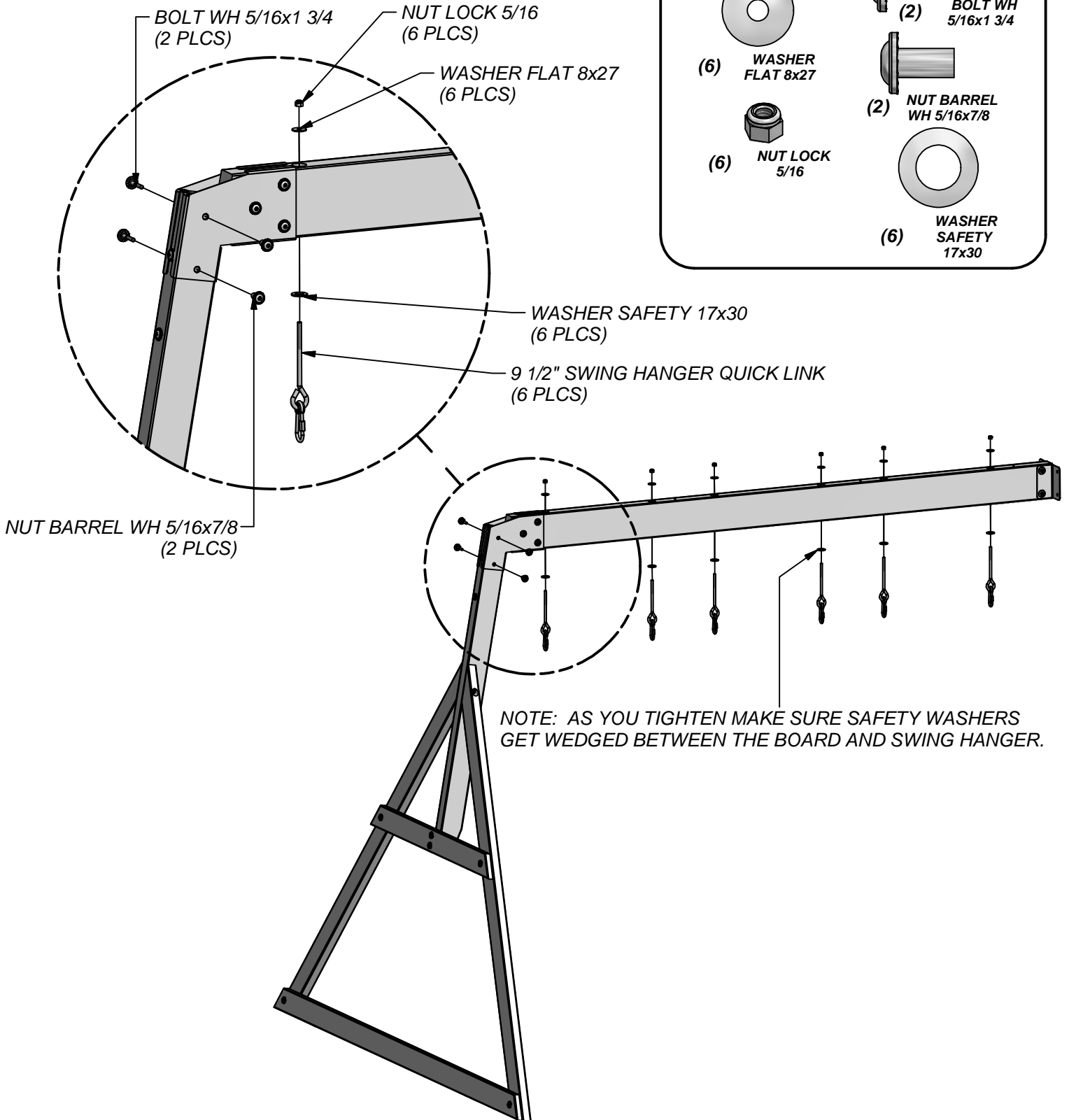

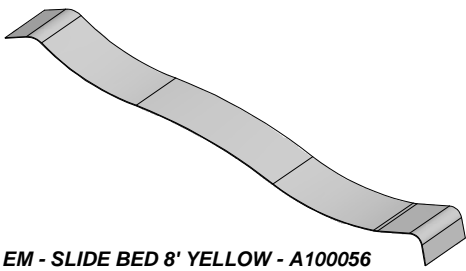

(1) EM - SLIDE BED 8' YELLOW - A100056



(1) M77 - SLIDE BRACE - W100544  
5/8"x3 3/8"x17 1/4" (16x86x438)

### SLIDE ASSEMBLY STEP 1

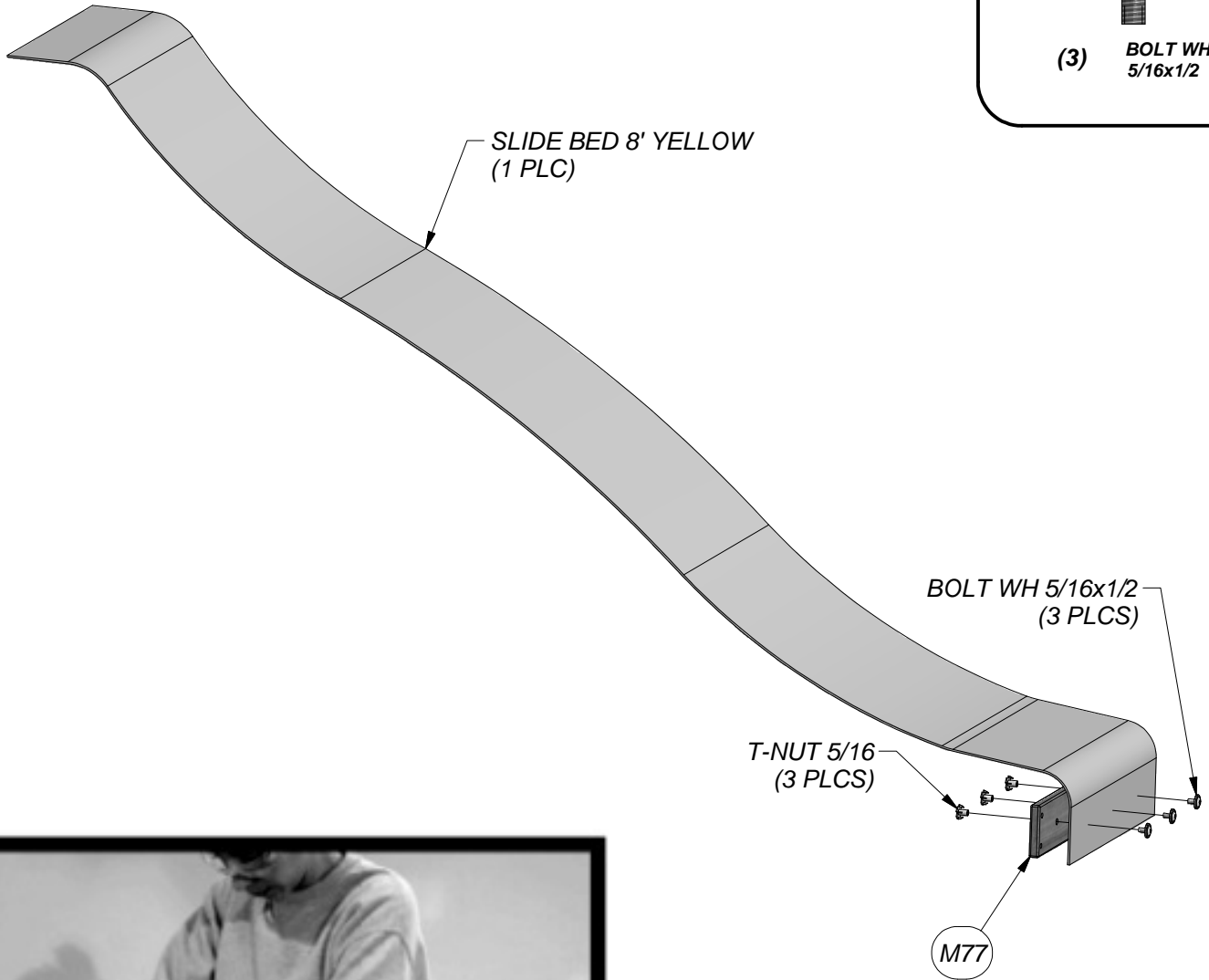
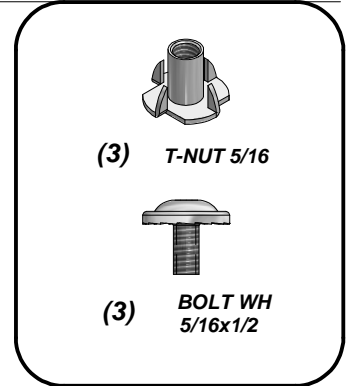

**USE 'M77' SLIDE BRACE AS A TEMPLATE AND USE A 3/8" DRILL BIT FOR DRILLING BOTTOM HOLE PATTERN IN SLIDE BED. BE SURE TO PLACE SLIDE BRACE UP 1/4" FROM BOTTOM EDGE OF SLIDE BED BEFORE MARKING HOLE PATTERN.**

TIP: PREBENDING THE ENDS WILL EASE ASSEMBLY.



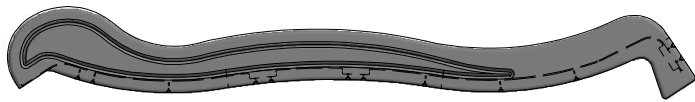

(1) EK - SLIDE RAIL 8' GREEN RIGHT - A100054



(1) EL - SLIDE RAIL 8' GREEN LEFT - A100055



(2) M78 - CENTER SLIDE BRACE - W100545  
5/8"x3 3/8"x17 1/4" (16x86x438)

### SLIDE ASSEMBLY STEP 2

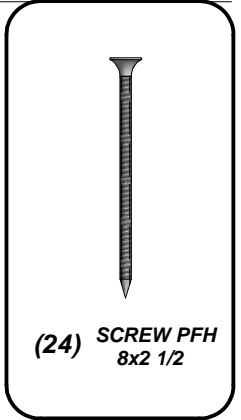
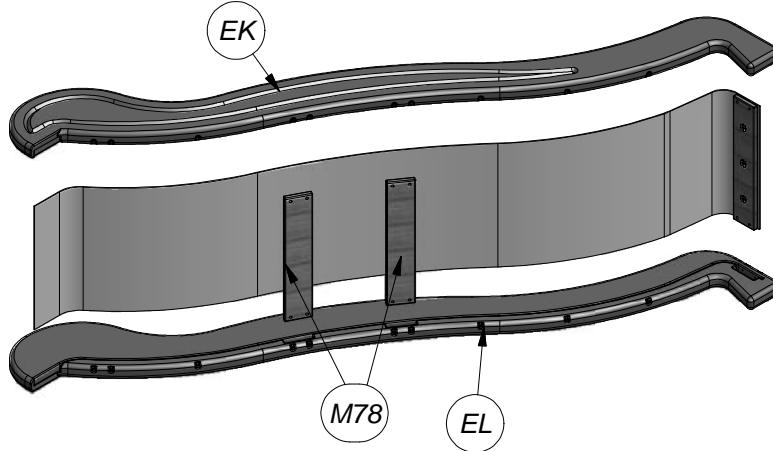

**NOTE:**

**MAKE CERTAIN  
SUPPORTS AND SLIDE  
BED ARE FULLY  
ENGAGED WITHIN  
CHANNEL OF SLIDE  
RAILS.**

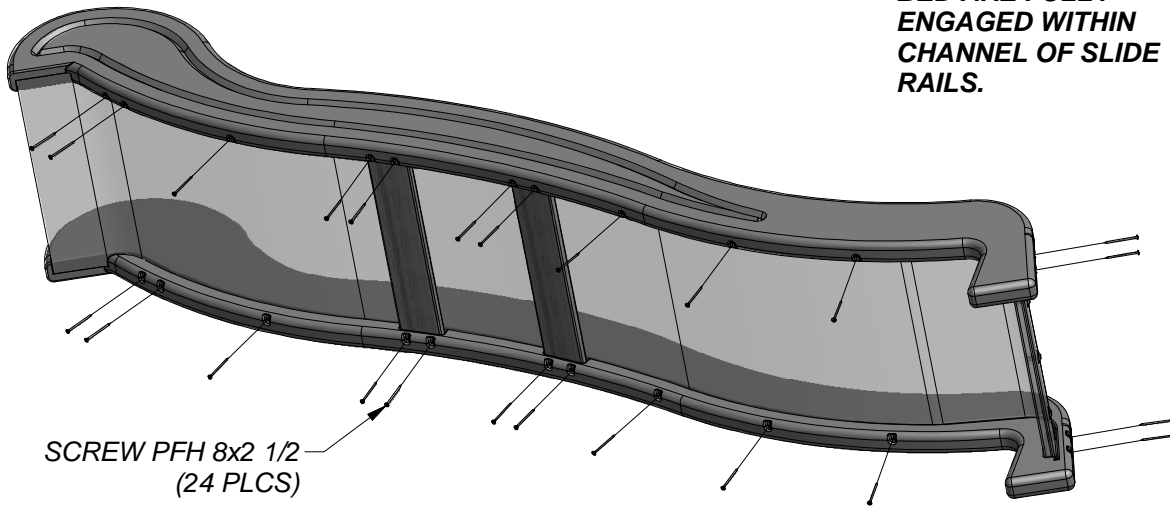

SCREW PFH 8x2 1/2  
(24 PLCS)



**TIP: A HELPER IS REQUIRED FOR THIS STEP.**



(1) **B1 - UPRIGHT POST - W2A02004**  
3"x3"x89 1/2" (76x76x2274)



(1) **B4 - UPRIGHT POST - W4L07121**  
3"x3"x89 1/2" (76x76x2274)

**STEP 1**

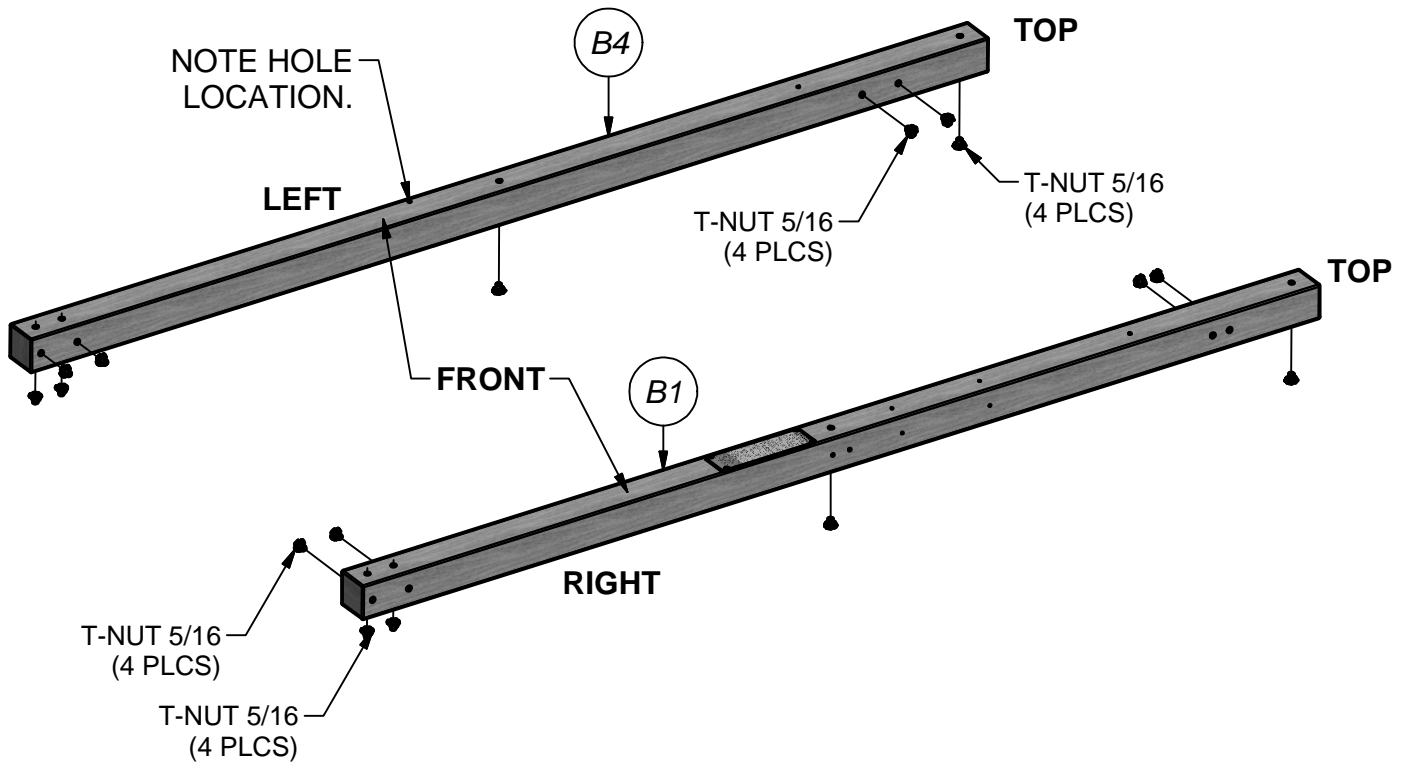
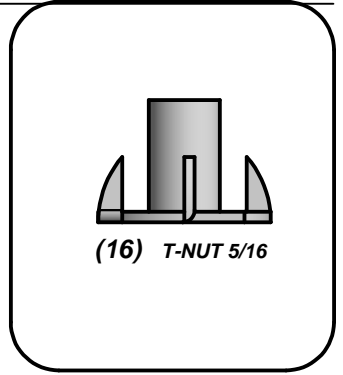



(1) H2 - FLOOR SUPPORT - W4L07128  
1"x3 3/8"x52 1/8" (24x86x1324)

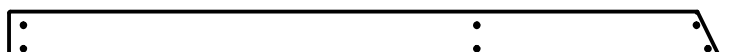

(1) K1 - GROUND BOARD - W4L07122  
5/8"x5 1/4"x74 1/4" (16x134x1888)

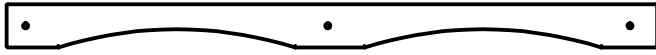

(1) M7 - ARCHED RAIL - W4L07144  
5/8"x3 3/8"x50 7/8" (16x86x1292)

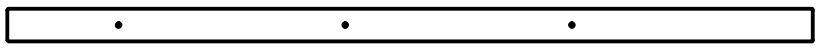

(1) H8 - ROOF RAIL - W4L07149  
1"x3 3/8"x83 7/8" (24x86x2132)

## STEP 2

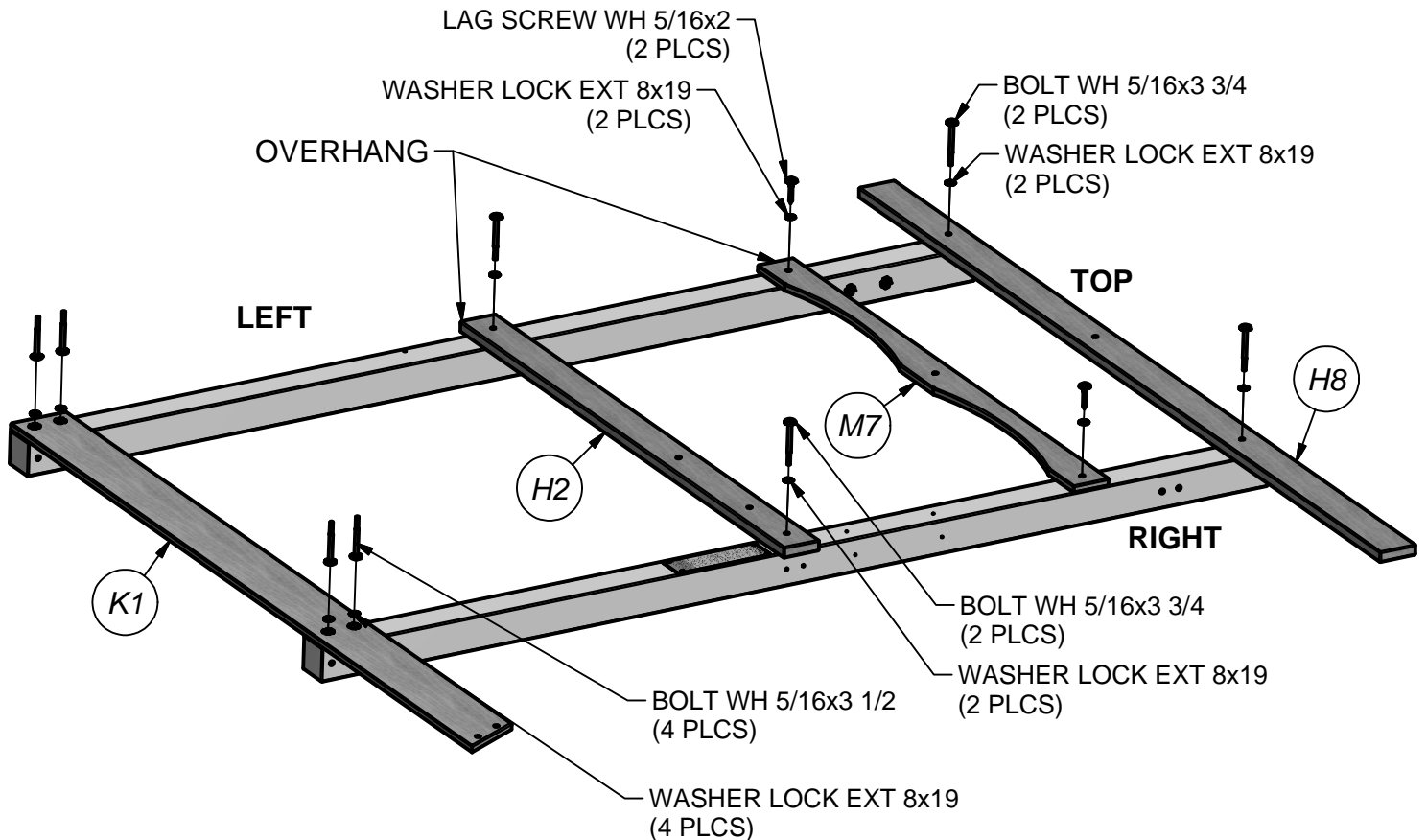
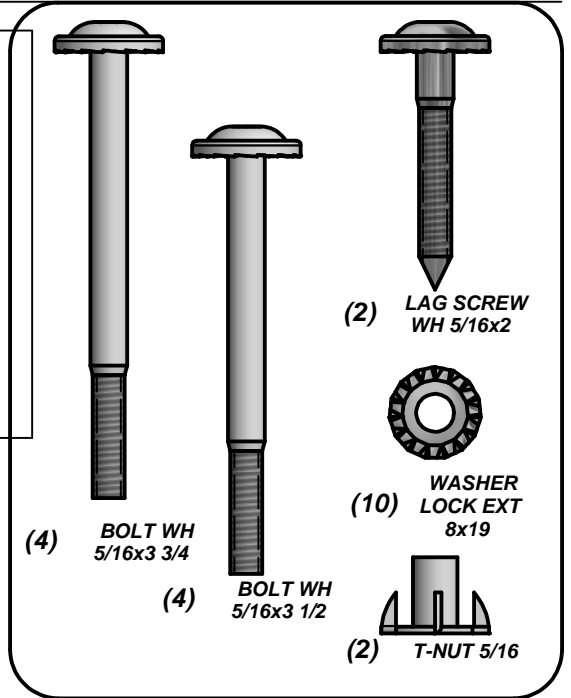
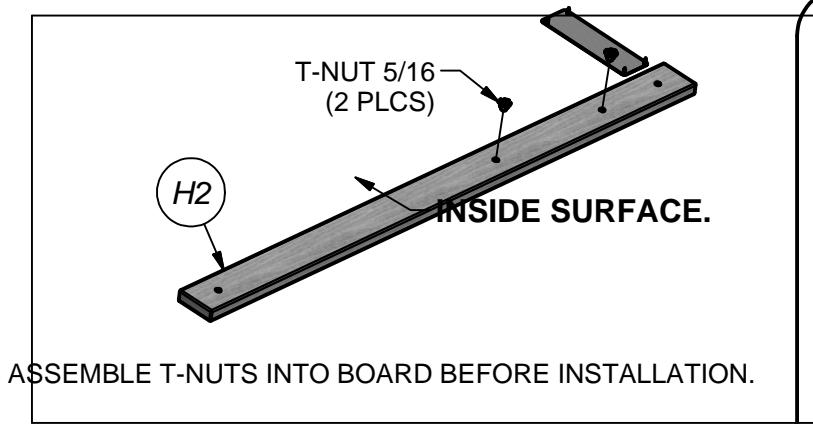



(1) **B2 - UPRIGHT POST - W4L07119**  
3"x3"x89 1/2" (76x76x2274)



(1) **B3 - UPRIGHT POST - W4L07120**  
3"x3"x89 1/2" (76x76x2274)

**STEP 3**

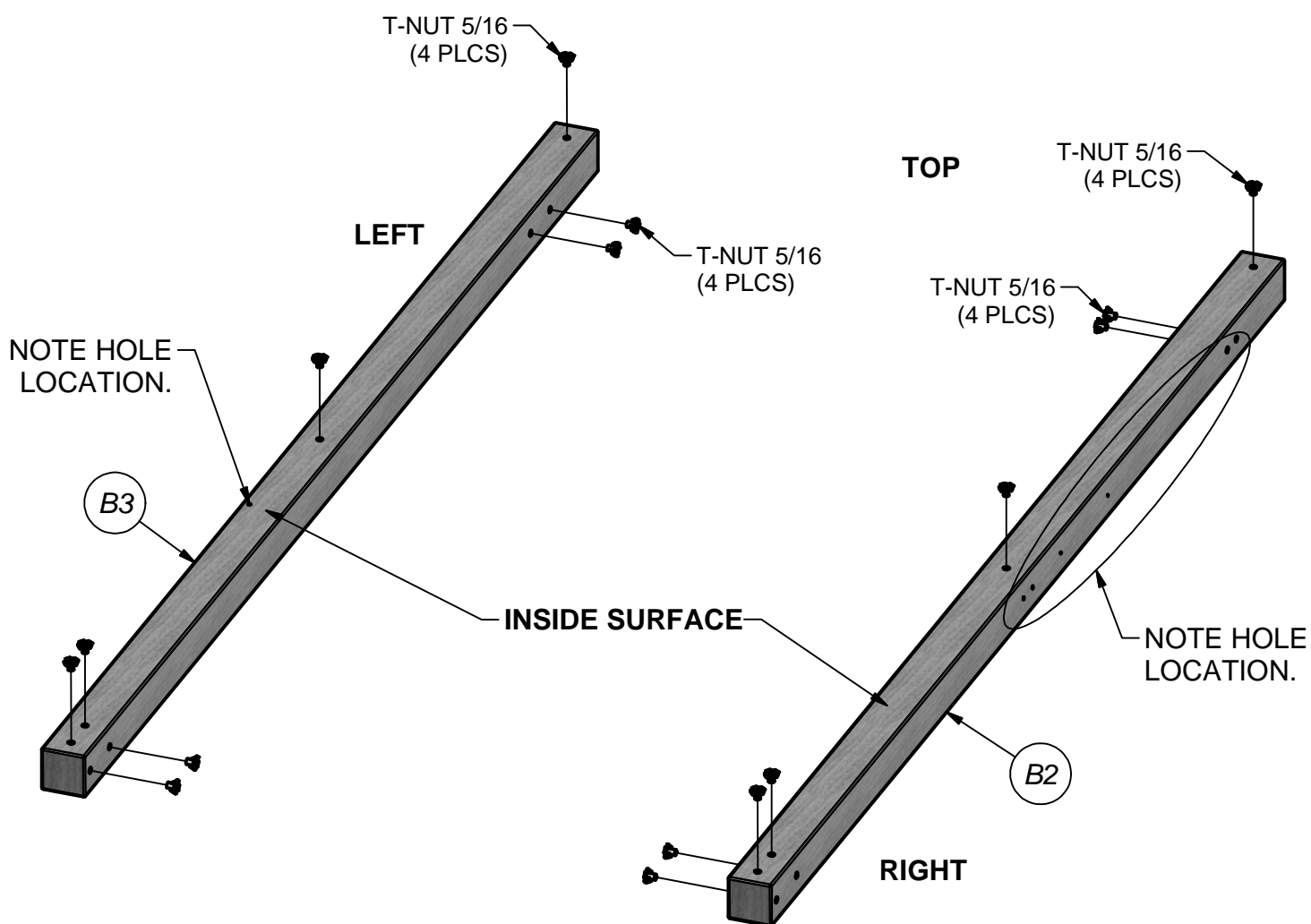
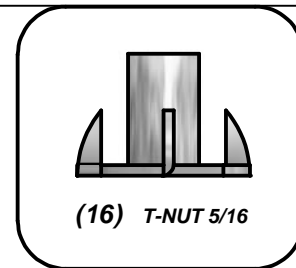



(1) H3 - FLOOR SUPPORT - W4L07129  
1"x3 3/8"x52 1/8" (24x86x1324)



(1) K3 - GROUND BOARD - W4L07124  
5/8"x5 1/4"x50 1/8" (16x134x1274)

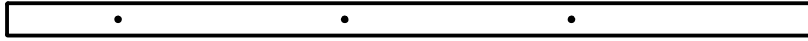

(1) H8 - ROOF RAIL - W4L07149  
1"x3 3/8"x83 7/8" (24x86x2132)



(2) M8 - WALL RAIL - W4L07145  
5/8"x3 3/8"x50 7/8" (16x86x1292)

### STEP 4

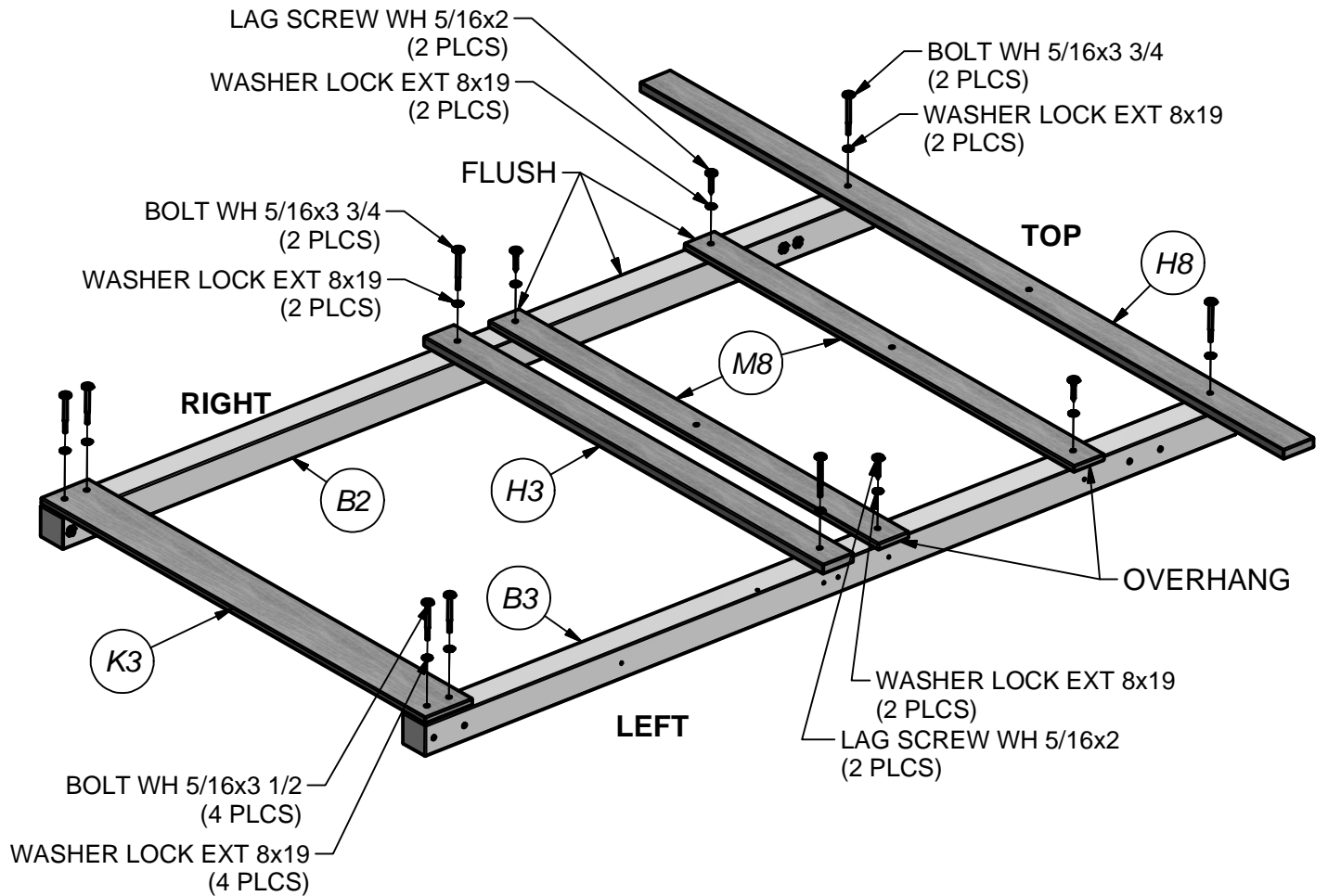
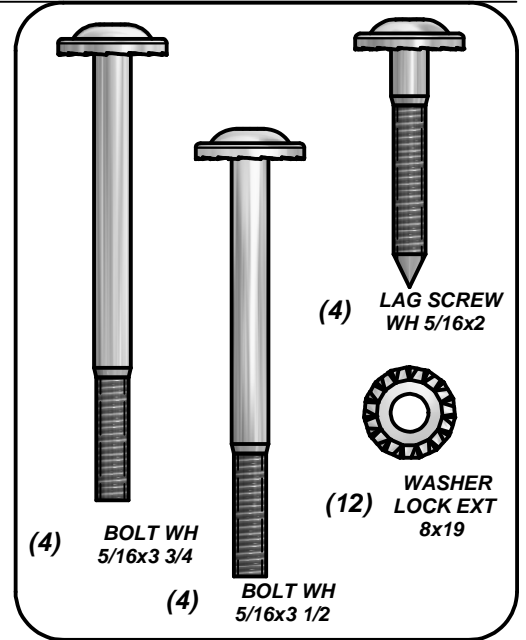

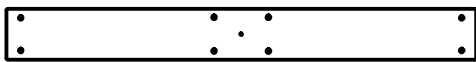

(1) G2 - WALL RAIL - W4L07153  
1"x5 1/4"x48 7/8" (24x134x1243)

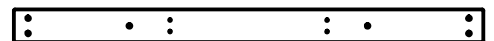

(1) H5 - FLOOR SUPPORT - W4L07131  
1"x3 3/8"x48 7/8" (24x86x1243)



(1) M6 - SAFETY RAIL - W4L07143  
5/8"x3 3/8"x48 7/8" (16x86x1243)



(2) M9 - WALL RAIL - W4L07146  
5/8"x3 3/8"x48 7/8" (16x86x1243)



(1) K2 - GROUND BOARD - W4L07123  
5/8"x5 1/4"x89 3/8" (16x134x2270)

### STEP 5

INSIDE SURFACE.

ASSEMBLE T-NUTS INTO BOARD BEFORE INSTALLATION.

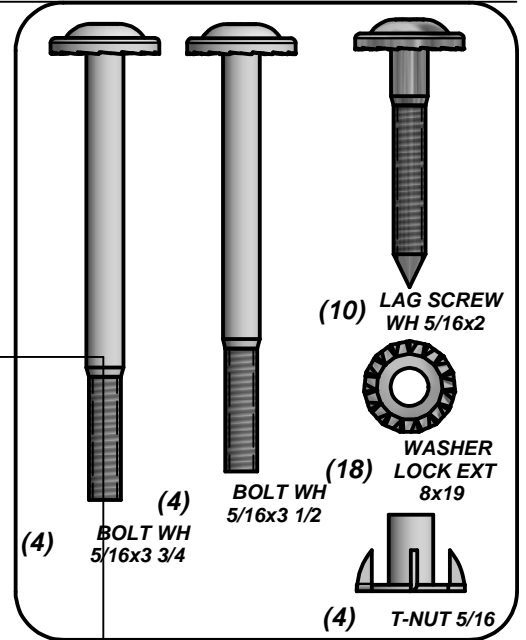
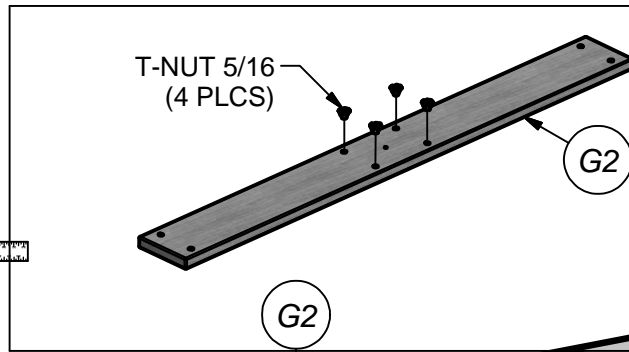

WASHER LOCK EXT 8x19  
(4 PLCS)

BOLT WH 5/16x3 3/4  
(4 PLCS)

LAG SCREW WH 5/16x2  
(2 PLCS)

WASHER LOCK EXT 8x19  
(2 PLCS)

WASHER LOCK EXT 8x19  
(2 PLCS)

LAG SCREW WH 5/16x2  
(2 PLCS)

LAG SCREW WH 5/16x2  
(4 PLCS)

WASHER LOCK EXT 8x19  
(4 PLCS)

WASHER LOCK EXT 8x19  
(2 PLCS)

LAG SCREW WH 5/16x2  
(2 PLCS)

BOLT WH 5/16x3 1/2  
(4 PLCS)

WASHER LOCK EXT 8x19  
(4 PLCS)

RIGHT

LEFT



(1) **G1 - GROUND BOARD - W4L07126**  
1"x5 1/4"x79 1/8" (24x134x2010)

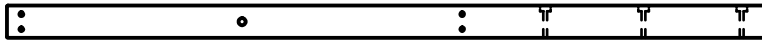

(1) **W1 - SUPPORT BOARD - W4L07156**  
2"x3 3/8"x78 7/8" (50x86x2005)



(1) **H4 - FLOOR SUPPORT - W4L07130**  
1"x3 3/8"x48 7/8" (24x86x1243)

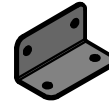

(1) **- L-BRACKET 2.5x66x127 - A4M00695**

### STEP 6

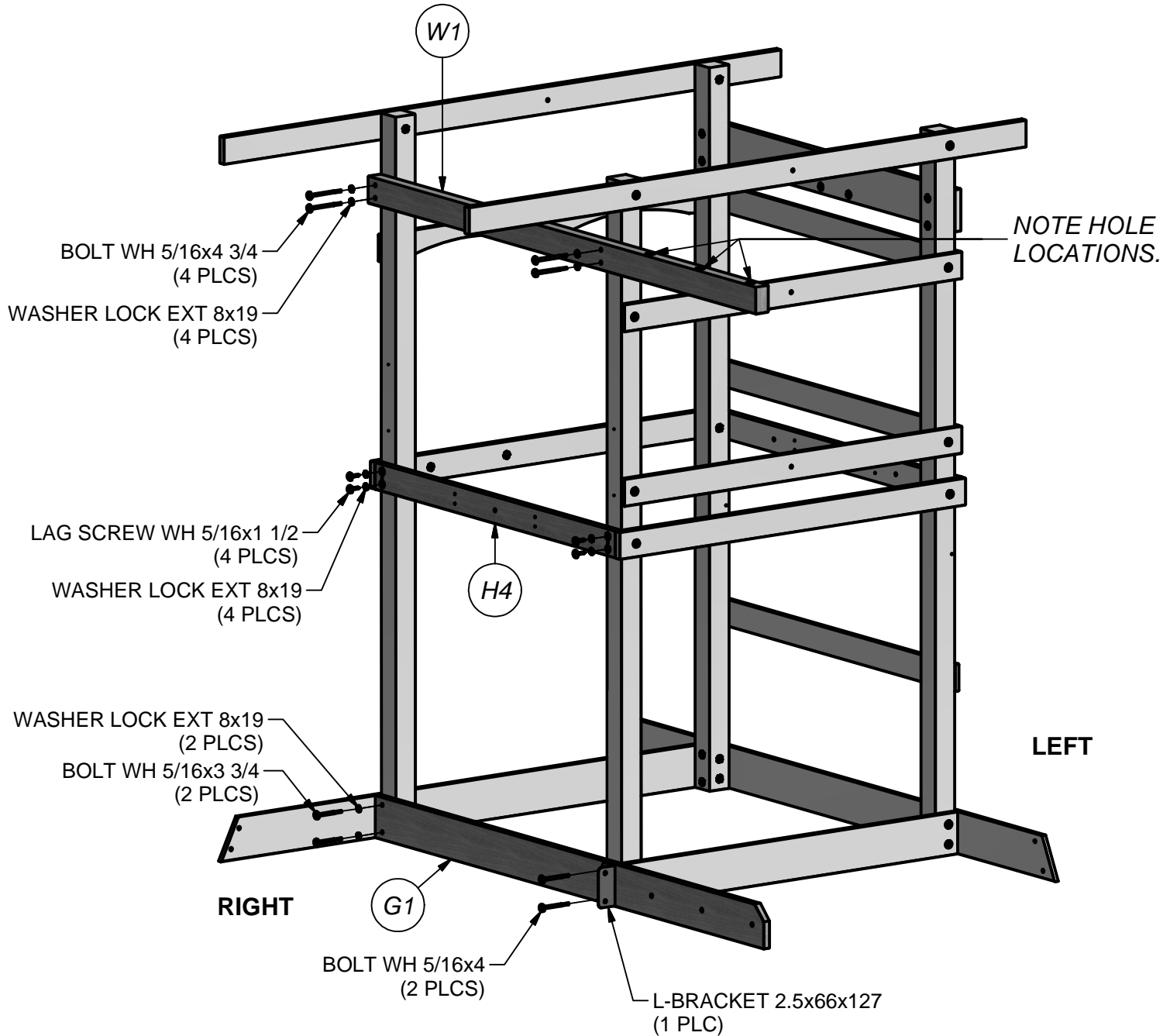
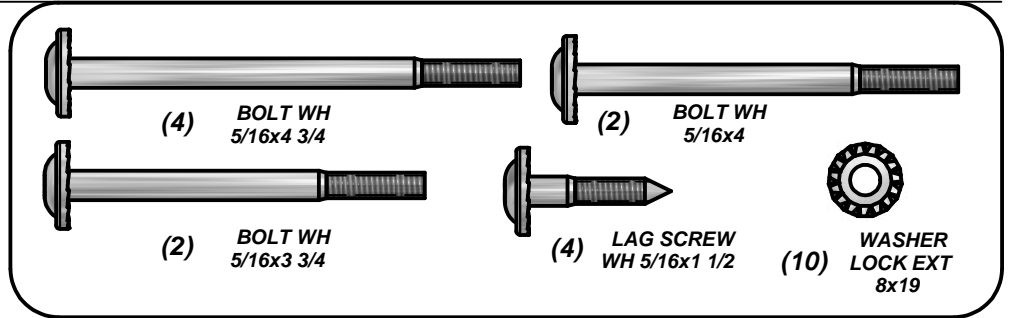



(1) **K4 - GROUND BOARD - W4L07125**  
5/8"x5 1/4"x23 1/8" (16x134x587.5)

**STEP 7**

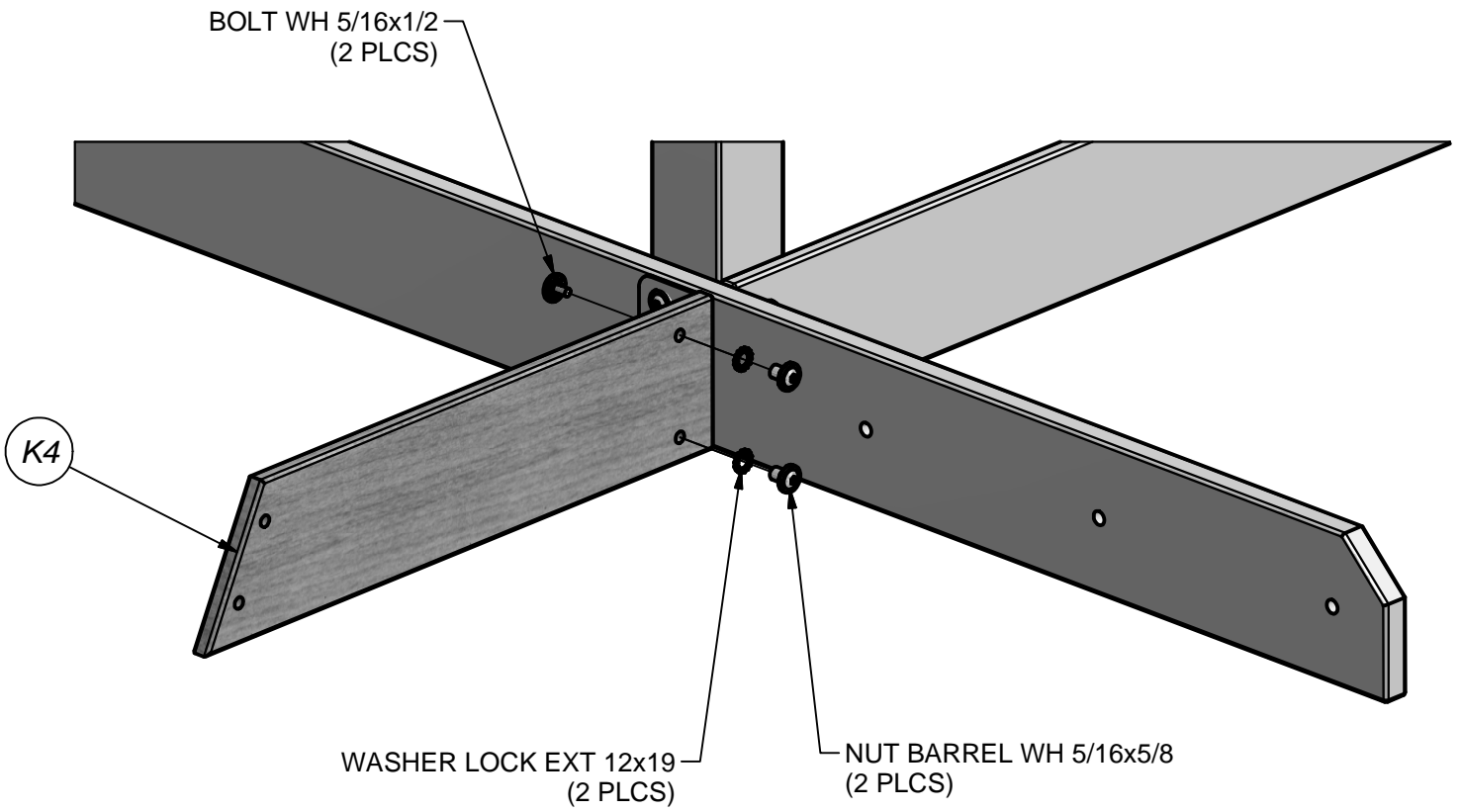
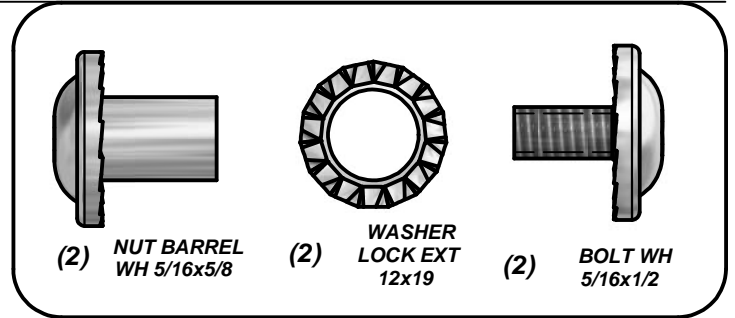





(2) H1 - ANGLE BRACE - W4L07127  
1"x3 3/8"x46 1/8" (24x86x1173)

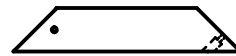

(2) H11 - DECK BRACE - W4L07296  
1"x3 3/8"x17 3/4" (24x86x450)

**STEP 8**

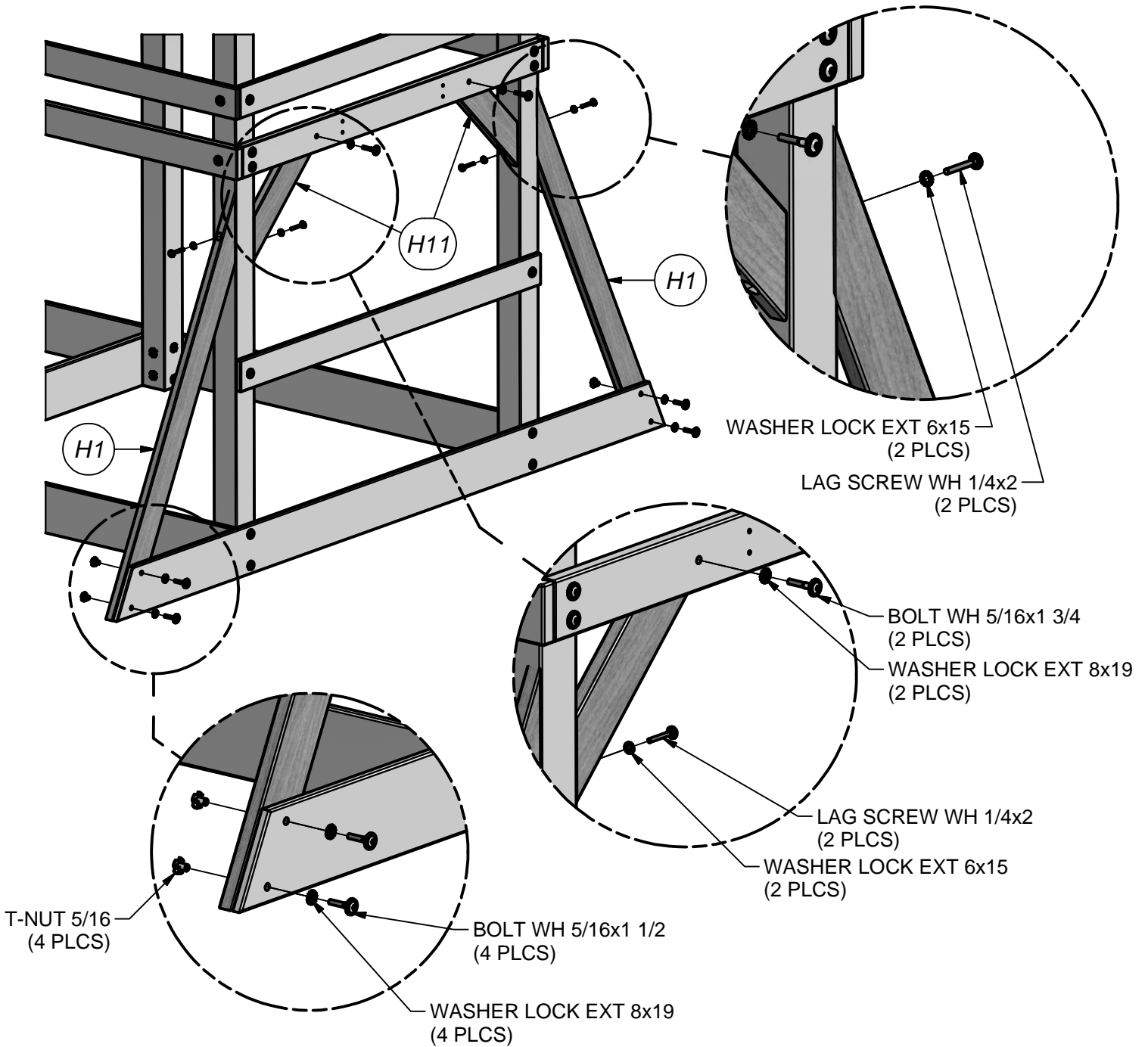
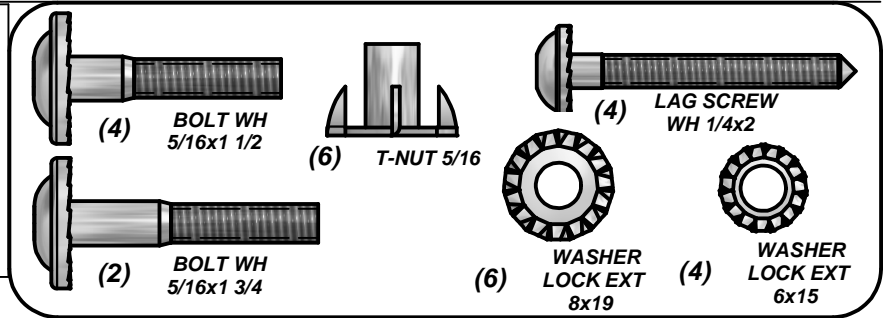
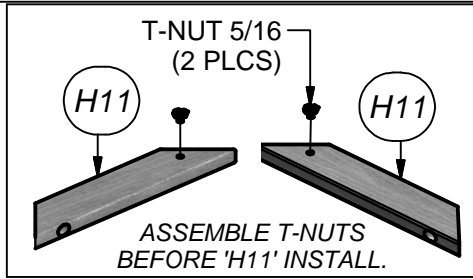



(1) **E1 - RAIL - W4L07132**  
1 3/8"x3"x51 7/8" (36x76x1318)

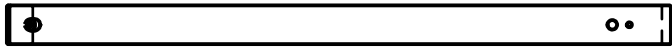

(1) **E2 - RAIL - W4L07133**  
1 3/8"x3"x51 7/8" (36x76x1318)

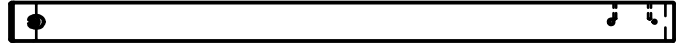

(1) **E3 - RAIL - W4L07134**  
1 3/8"x3"x51 7/8" (36x76x1318)

**STEP 9**

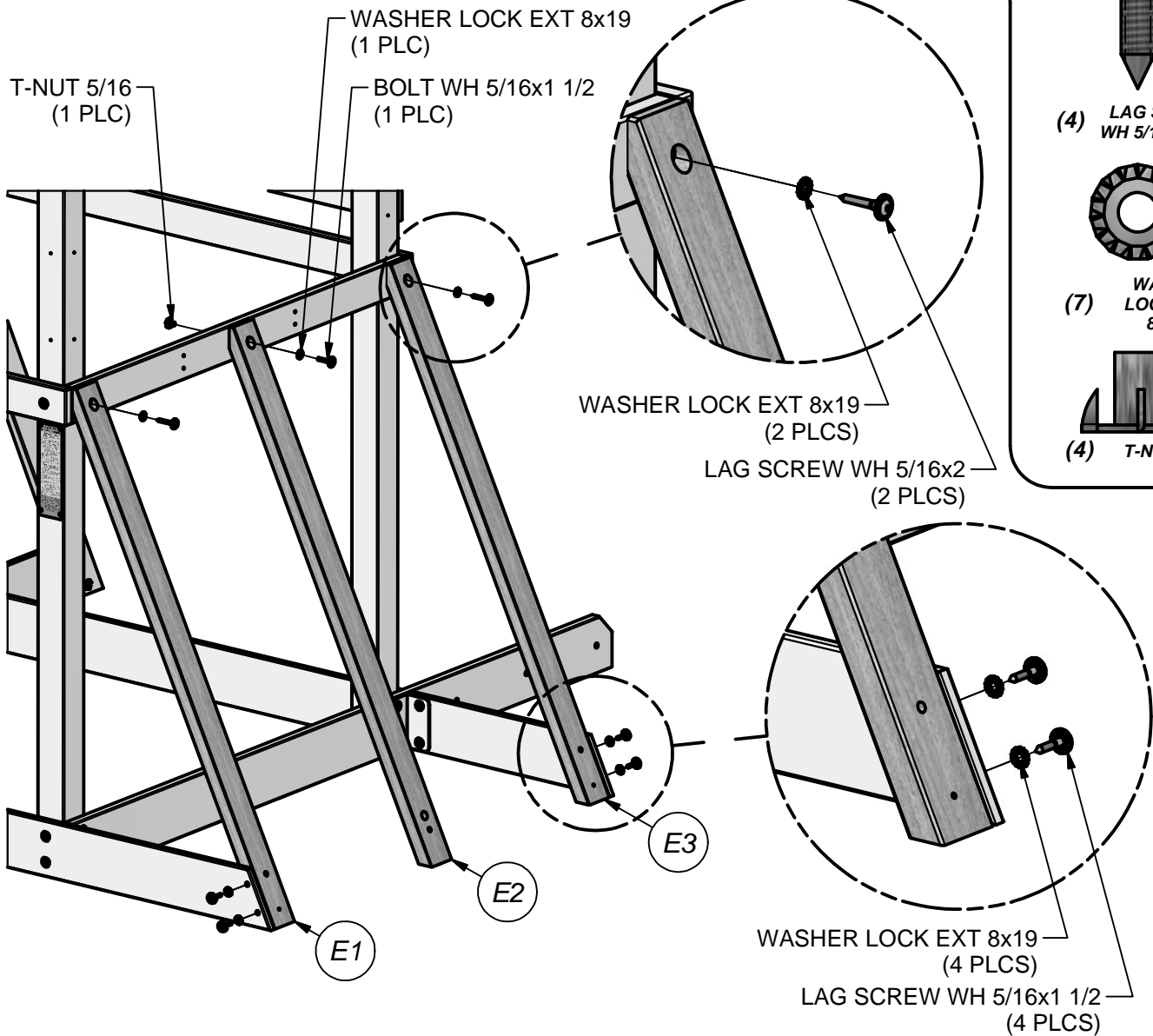
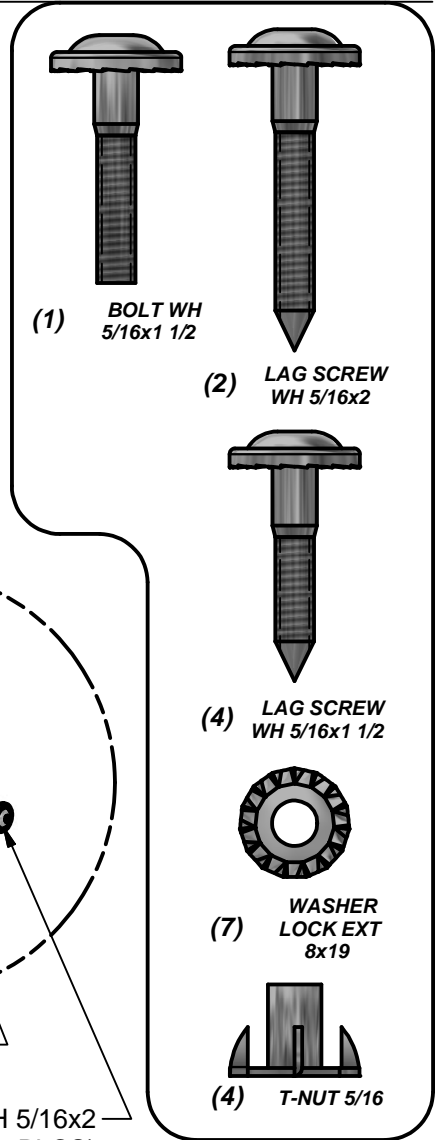
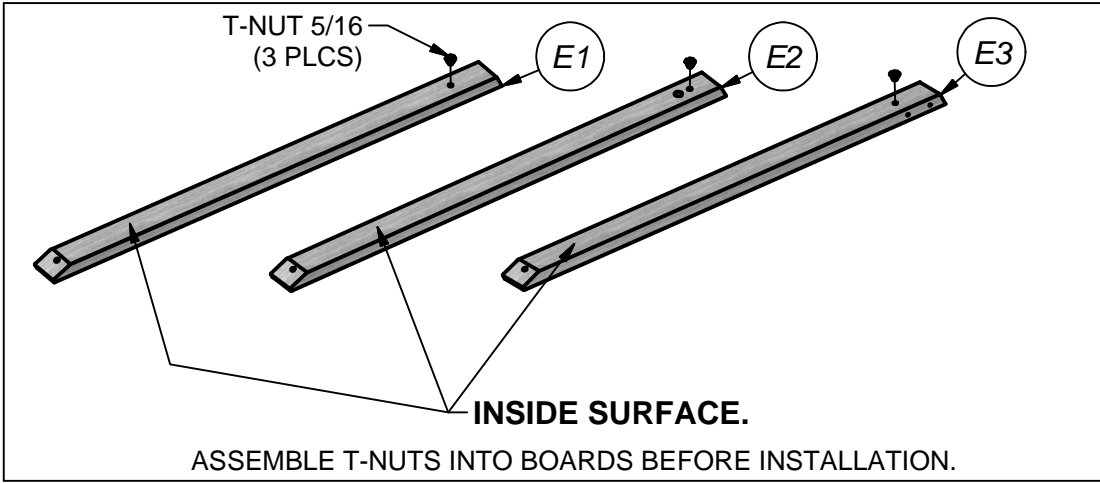

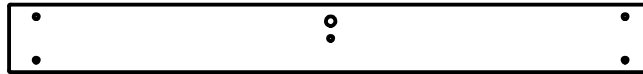

(1) **K5 - GROUND BOARD - W4L07135**  
 5/8"x5 1/4"x50 1/4" (16x134x1277)

**STEP 10**

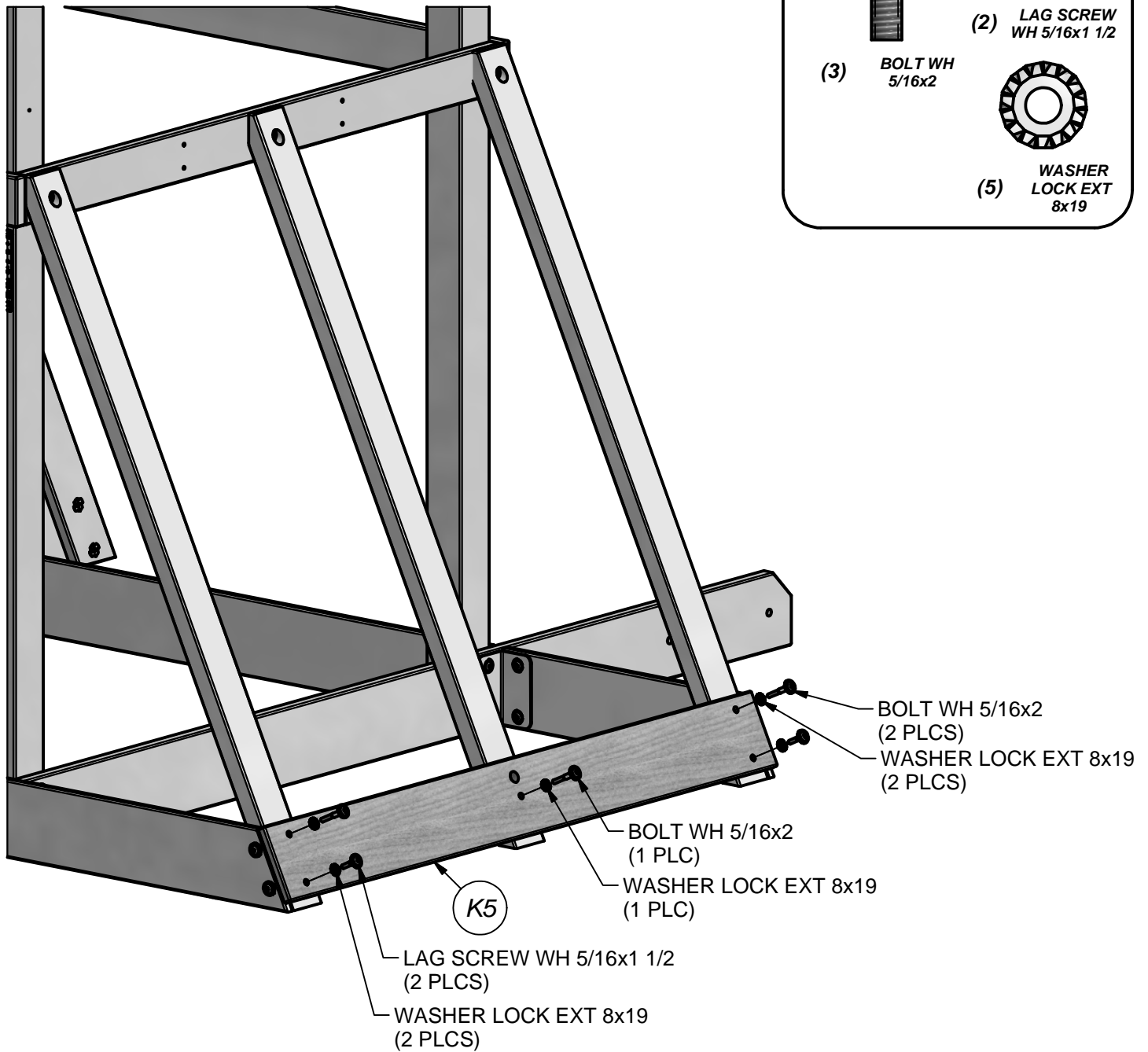
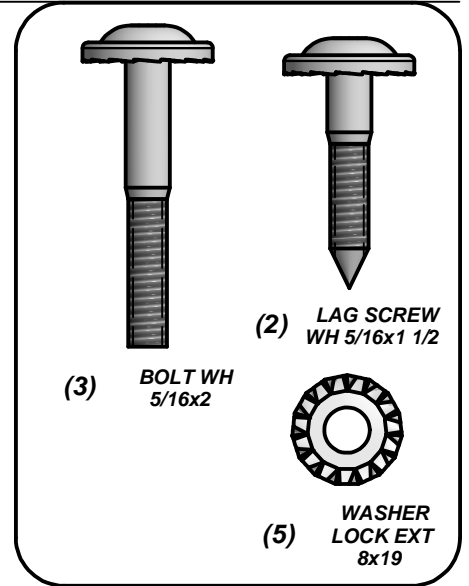



(2) **J1 - FLOOR JOIST - W4L07139**  
1"x2 3/8"x50 1/4" (24x60x1275)

**STEP 11**

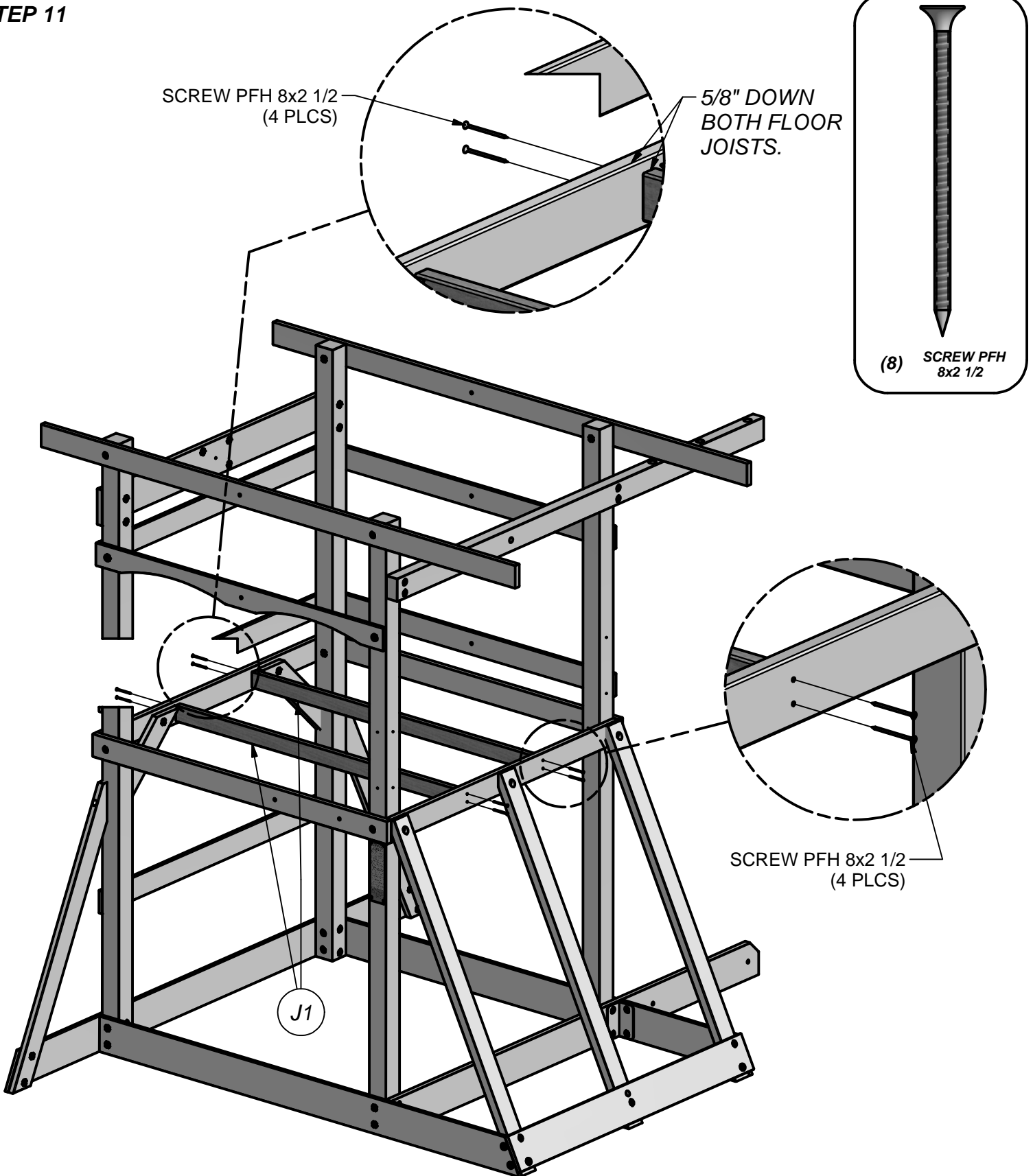

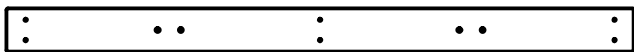

(3) **M2 - ROCK WALL BOARD - W4L07137**  
5/8"x3 3/8"x49" (16x86x1245)



(3) **M3 - ROCK WALL BOARD - W4L07138**  
5/8"x3 3/8"x49" (16x86x1245)



(3) - **GREEN HC ROCK #2 - A6P00037**



(2) - **YELLOW HC ROCK #2 - A6P00043**



(2) - **BLUE HC ROCK #1 - A6P00041**



(2) - **RED HC ROCK #2 - A6P00039**

## STEP 12

ASSEMBLE T-NUTS INTO BOARDS BEFORE ROCK INSTALLATION.

ROCK COLOR PLACEMENT IS  
CONSUMER CHOICE.

BOLT PTH 1/4x3/4  
(4 PLCS)  
WASHER LOCK INT 8x15  
(4 PLCS)

**QTY. 3**

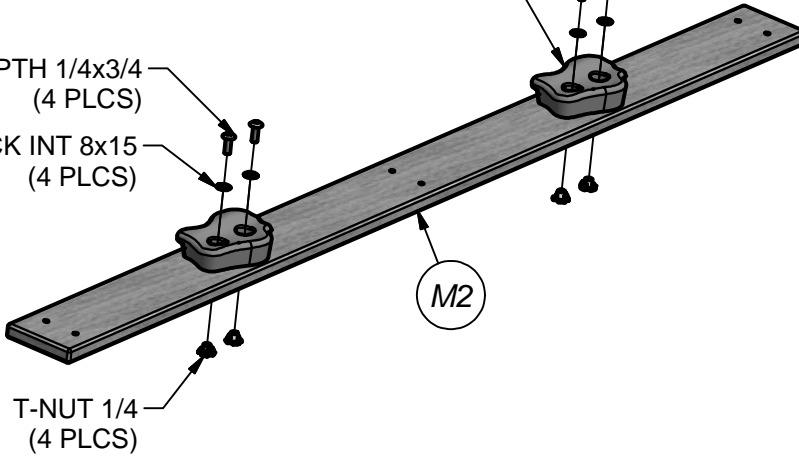

BOLT PTH 1/4x3/4  
(2 PLCS)  
WASHER LOCK INT 8x15  
(2 PLCS)

**QTY. 2**

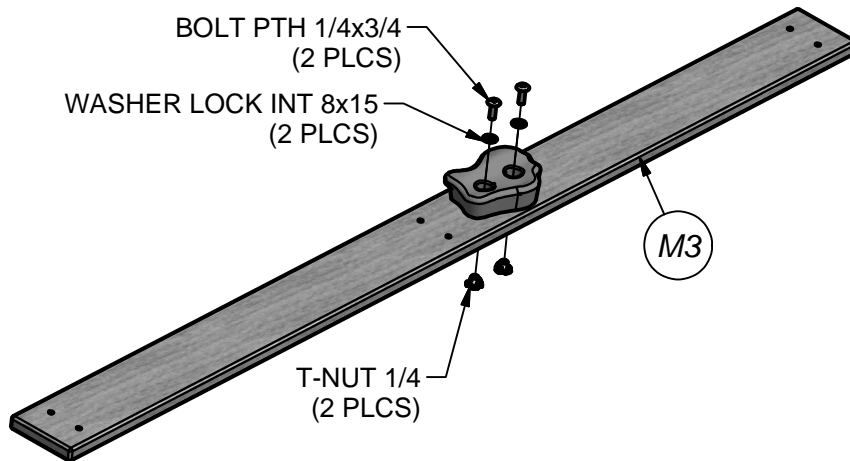

BOLT PTH 1/4x3/4  
(2 PLCS)  
WASHER LOCK INT 8x15  
(2 PLCS)

**QTY. 1**

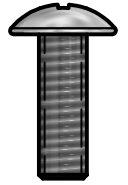
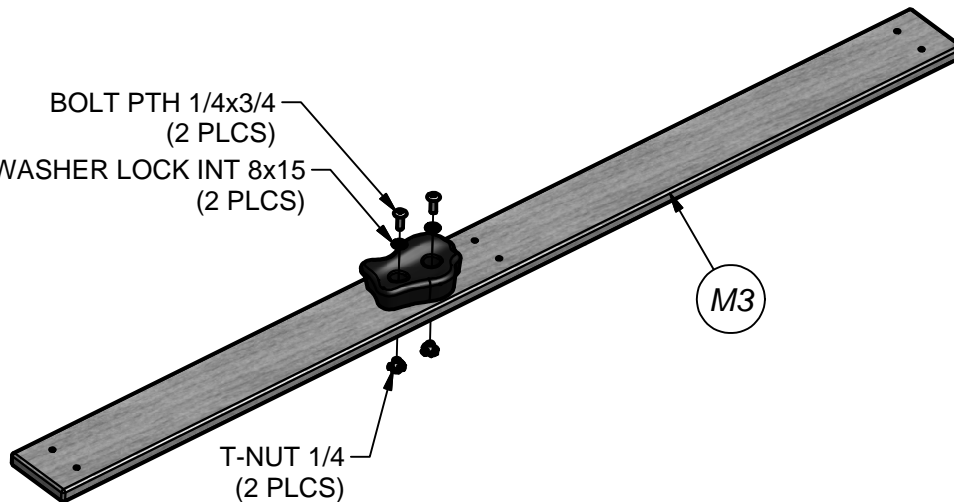

(18) **BOLT PTH**  
1/4x3/4



(18) **WASHER**  
LOCK INT  
8x15



(18) **T-NUT 1/4**

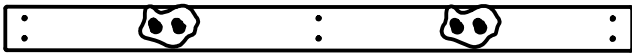

(3) M2 - ROCK WALL BOARD - W4L07137  
5/8"x3 3/8"x49" (16x86x1245)



(6) M1 - ROCK WALL BOARD - W4L07136  
5/8"x3 3/8"x49" (16x86x1245)



(3) M3 - ROCK WALL BOARD - W4L07138  
5/8"x3 3/8"x49" (16x86x1245)

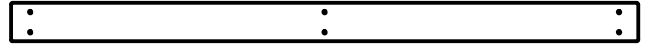

(1) M10 - ROCK WALL BOARD - W4L07360  
5/8"x3"x49" (16x76x1245)

### STEP 13

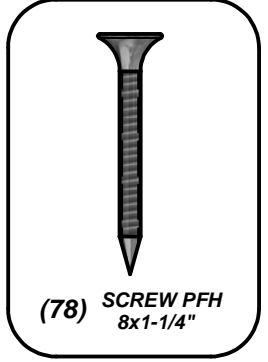

(78) SCREW PFH  
8x1-1/4"

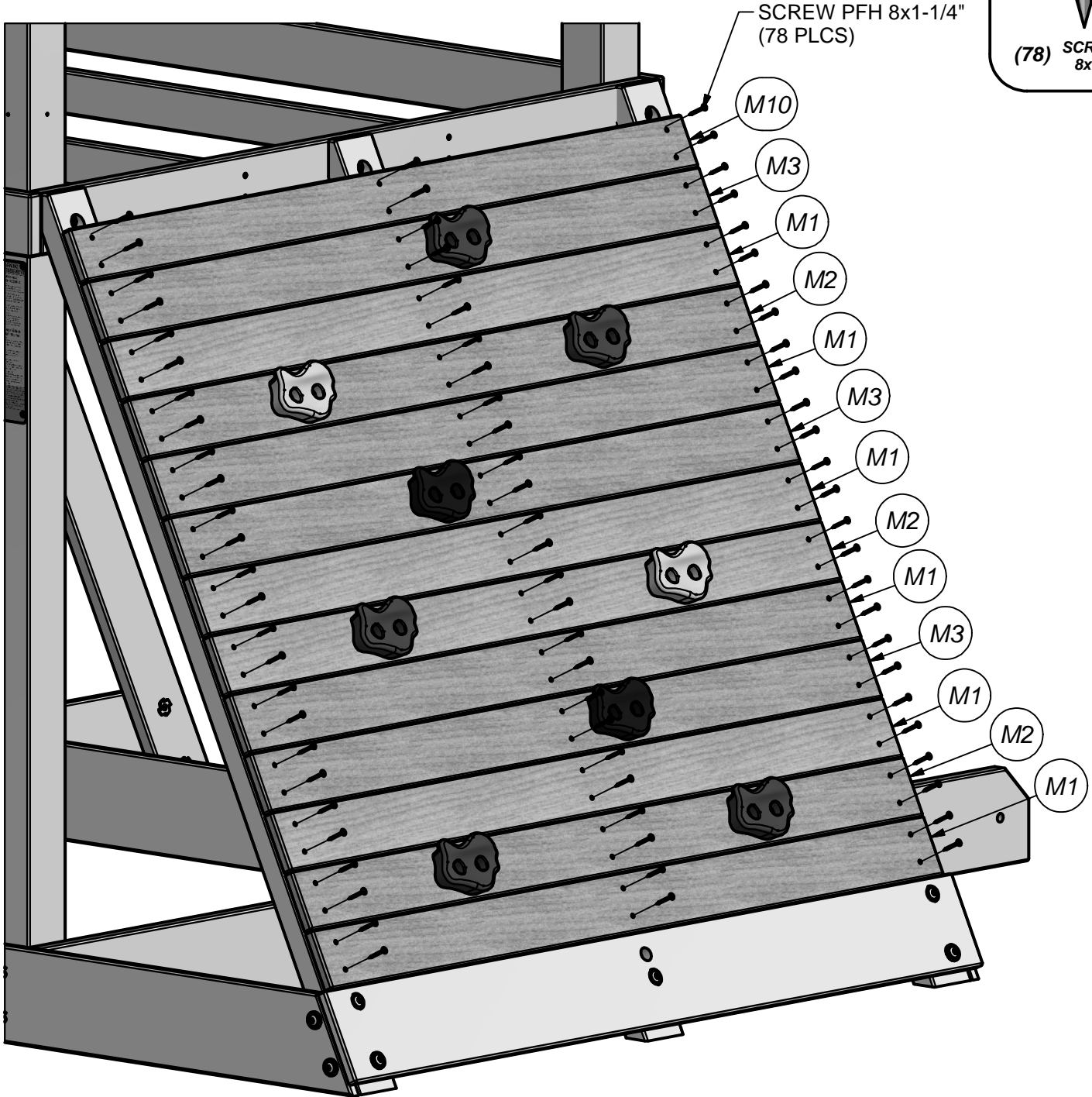

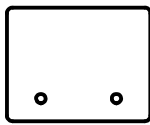

(4) J2 - FLOOR SUPPORT - W4L06710  
1"x2 3/8"x3" (24x60x76)

**STEP 14**

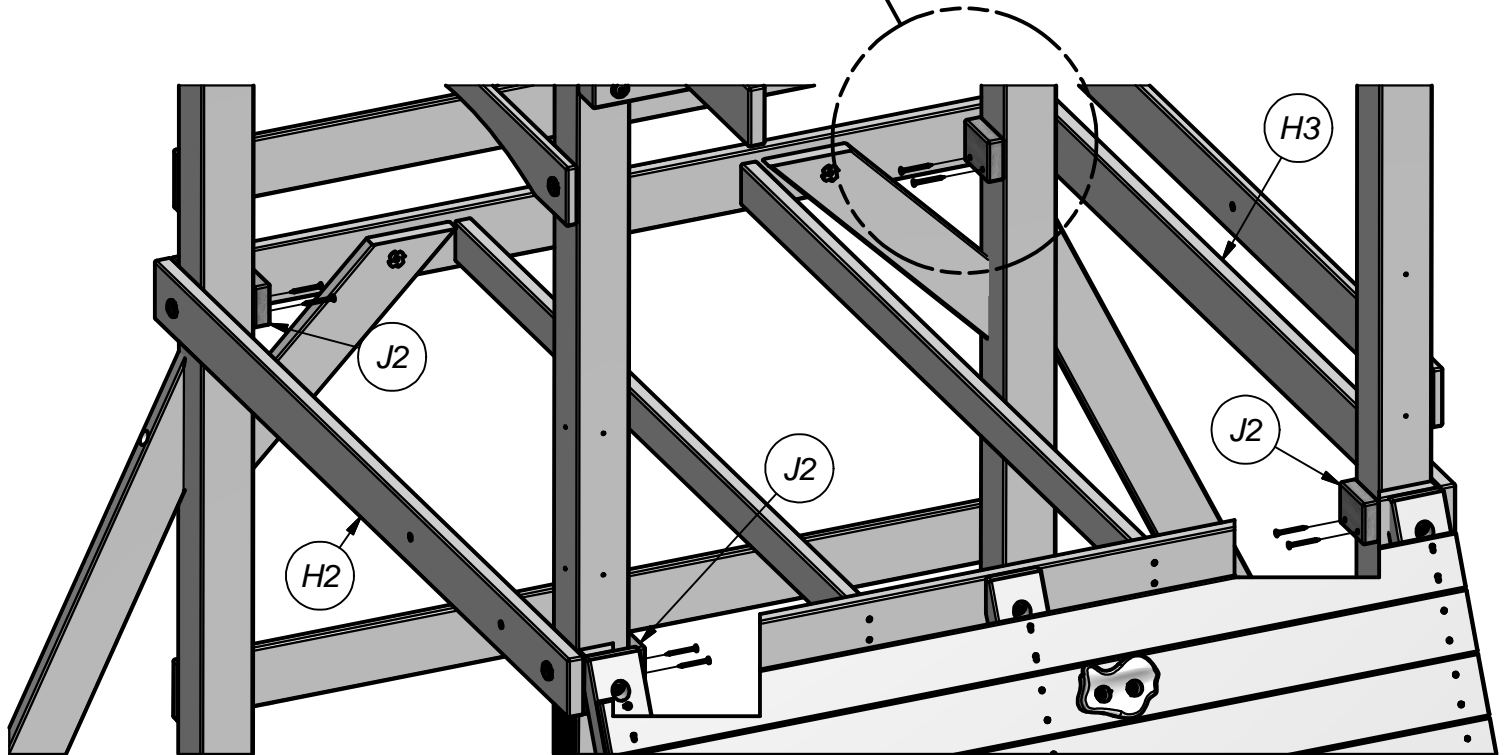
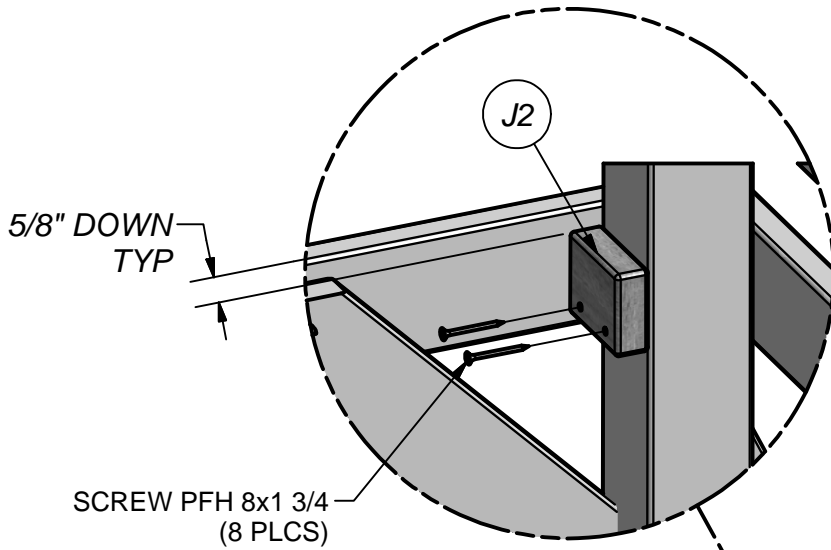
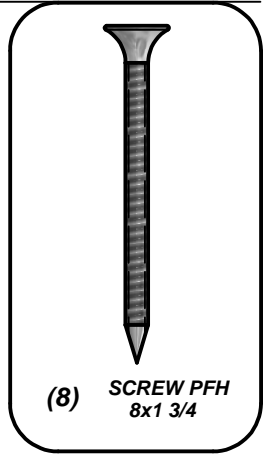



(2) T1 - SUPPORT BOARD - W4L07140  
1"x1 3/8"x44 1/8" (24x34x1122)

**STEP 15**

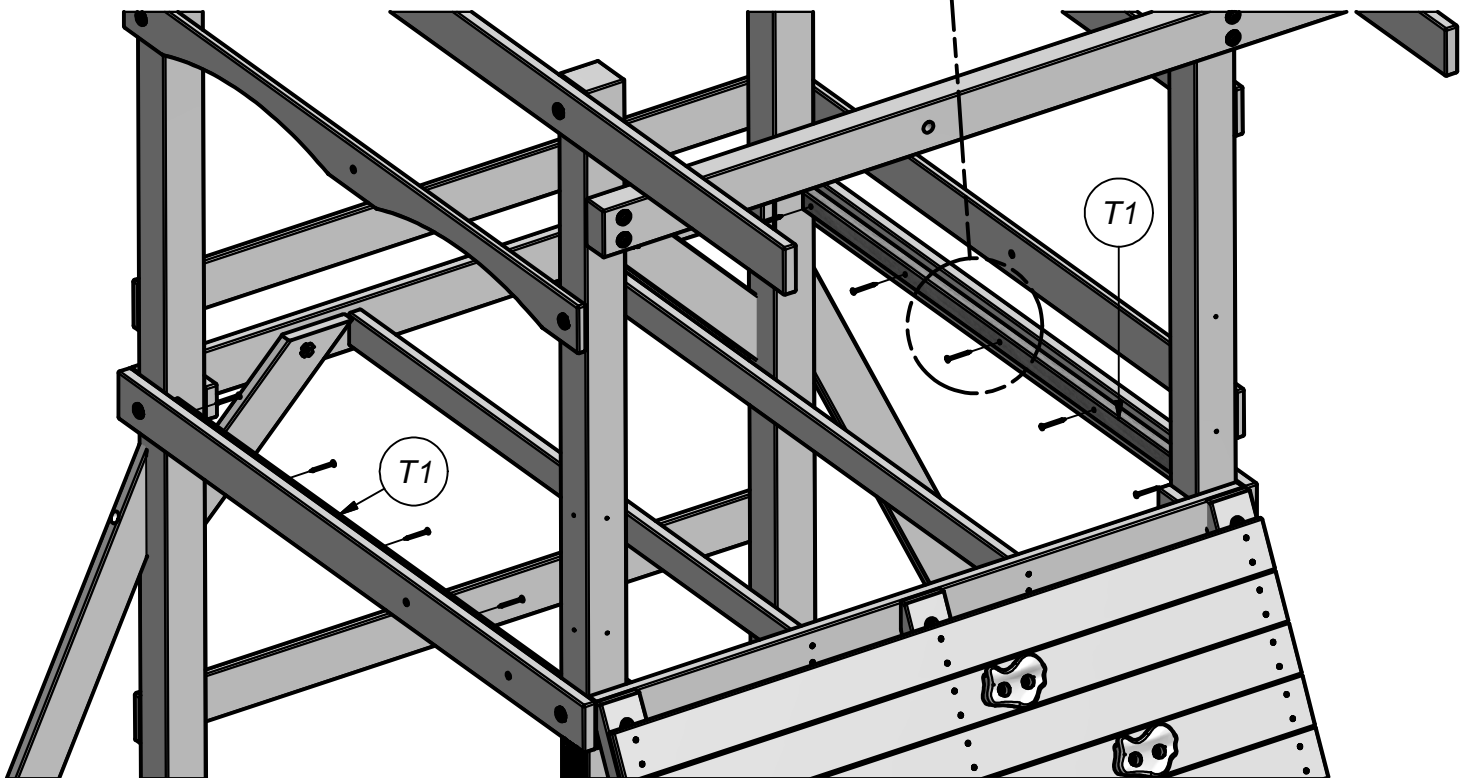
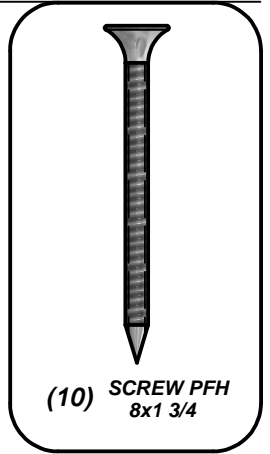
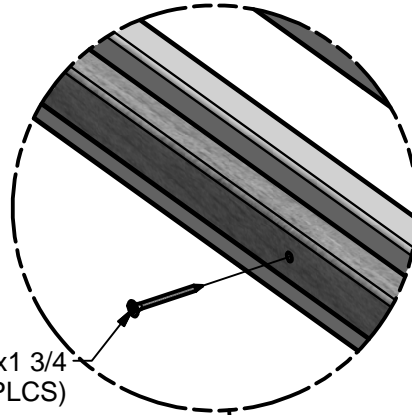
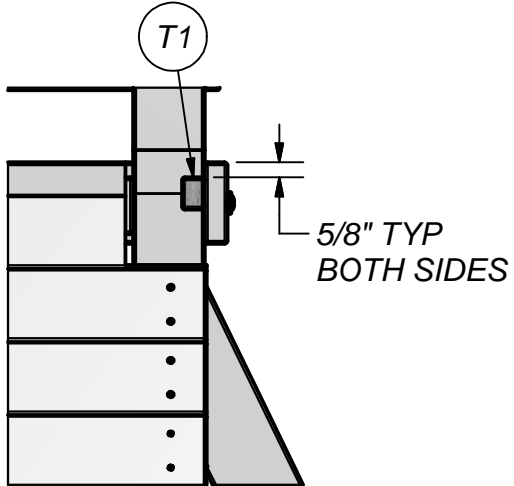



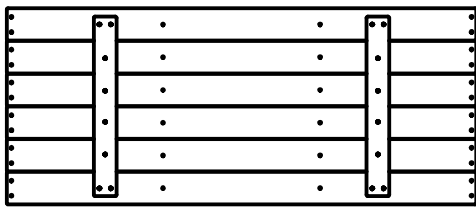

(2) **FP1 - FLOOR PANEL - W2A02005**  
1 1/4"x20 3/8"x48 5/8" (32x519x1242)

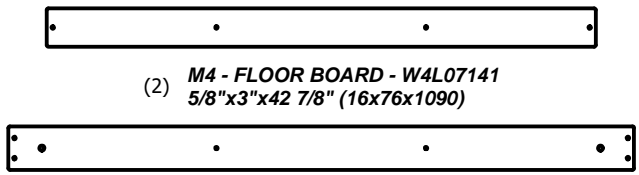

(2) **M4 - FLOOR BOARD - W4L07141**  
5/8"x3"x42 7/8" (16x76x1090)



(1) **M5 - FLOOR BOARD - W4L07142**  
5/8"x3 3/8"x48 7/8" (16x86x1242)

**STEP 16**

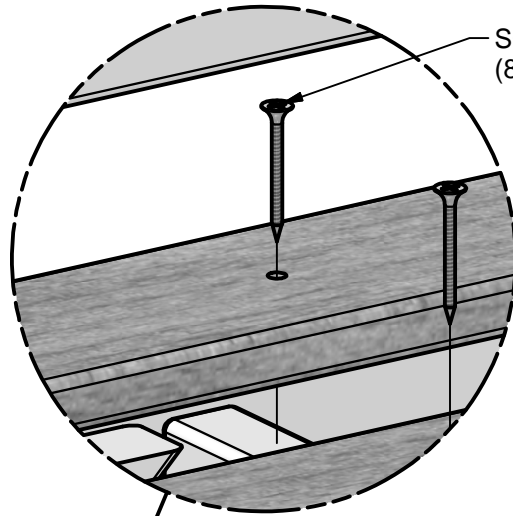

**SCREW PFH 8x1-1/2"**  
(86 PLCS)

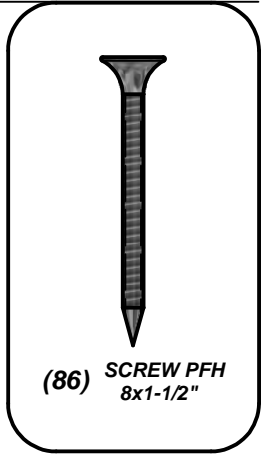

(86) **SCREW PFH**  
8x1-1/2"

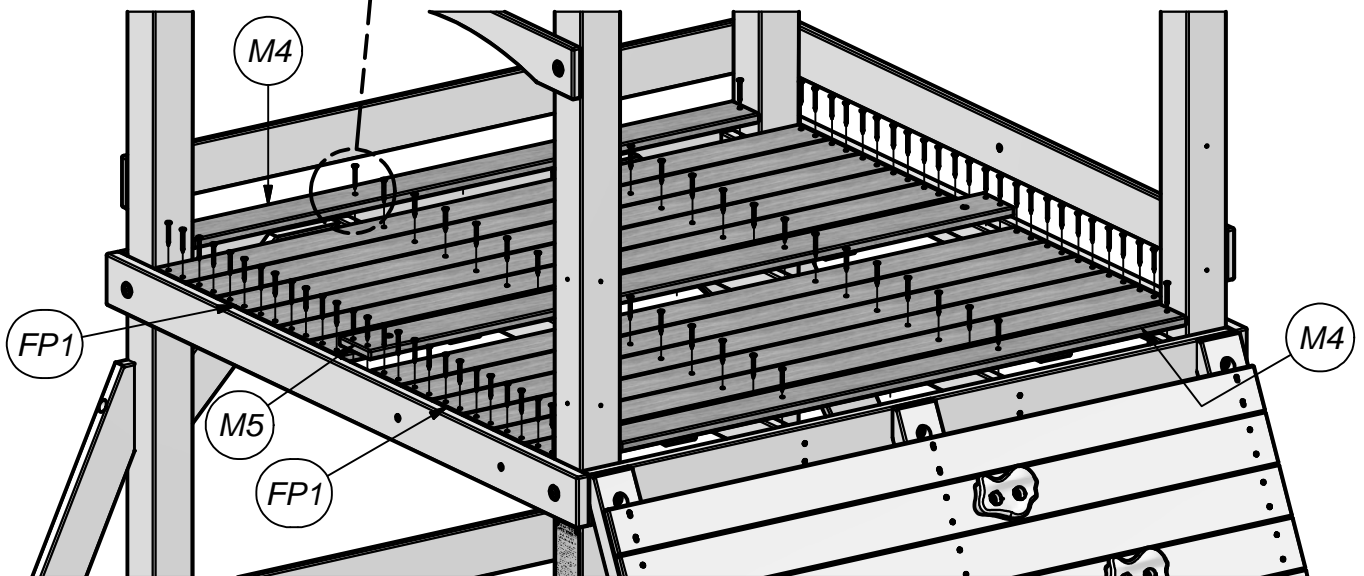



(1) H6 - UPRIGHT - W4L07147  
1"x3 3/8"x72" (24x86x1828)

### STEP 17

ASSEMBLE T-NUTS INTO BOARDS BEFORE INSTALLATION.

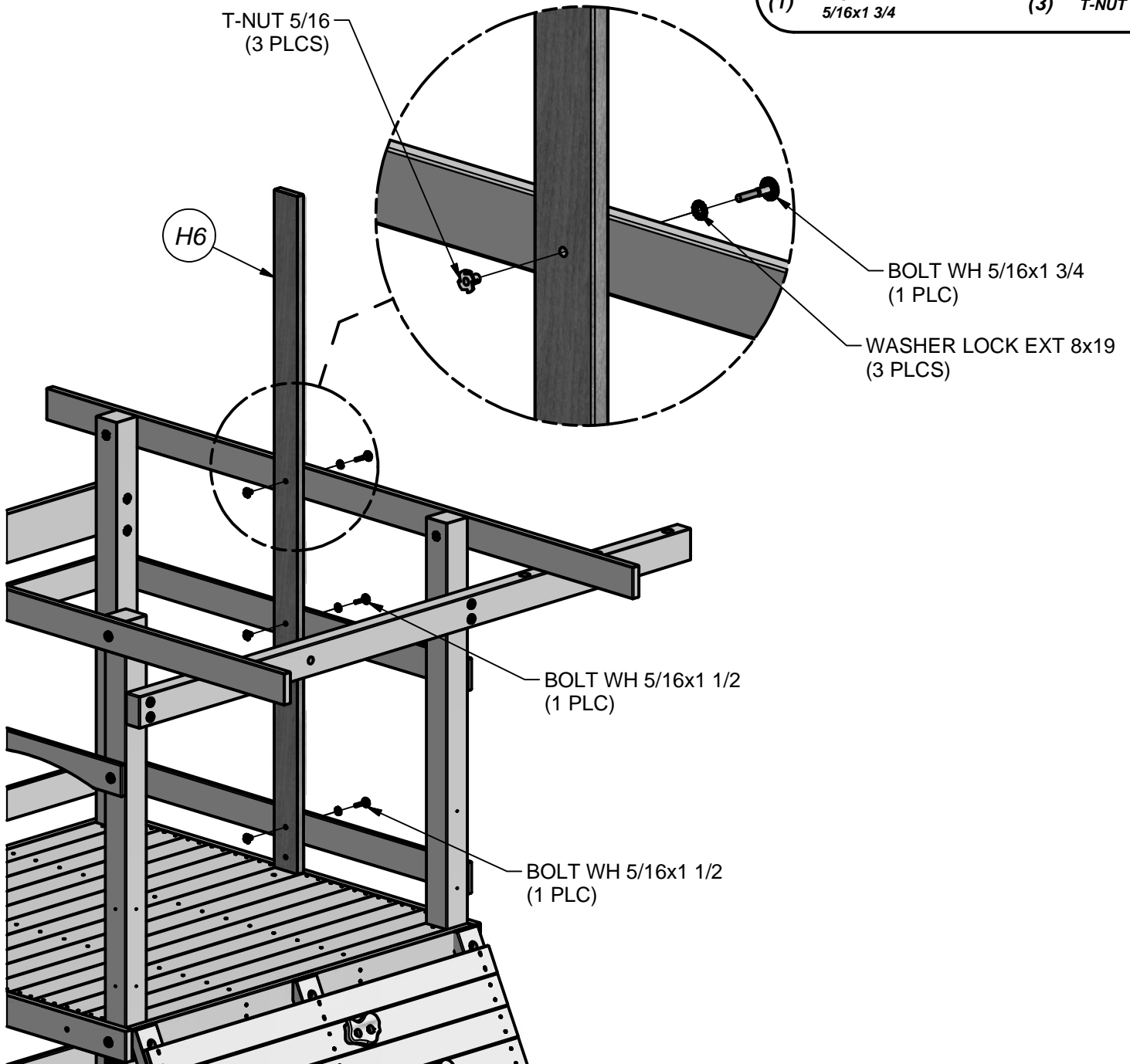
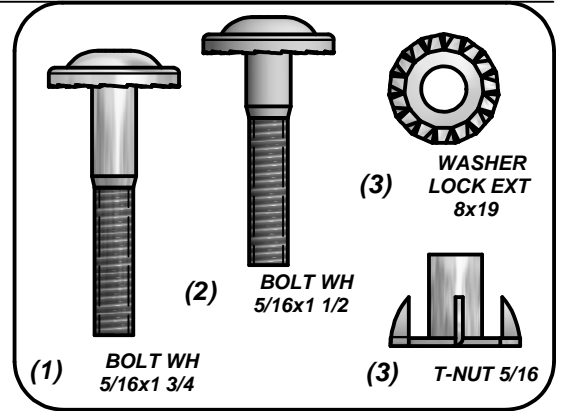



(1) **H7 - UPRIGHT - W4L07148**  
1"x3 3/8"x72" (24x86x1828)

**STEP 18**

ASSEMBLE T-NUTS INTO BOARDS BEFORE INSTALLATION.

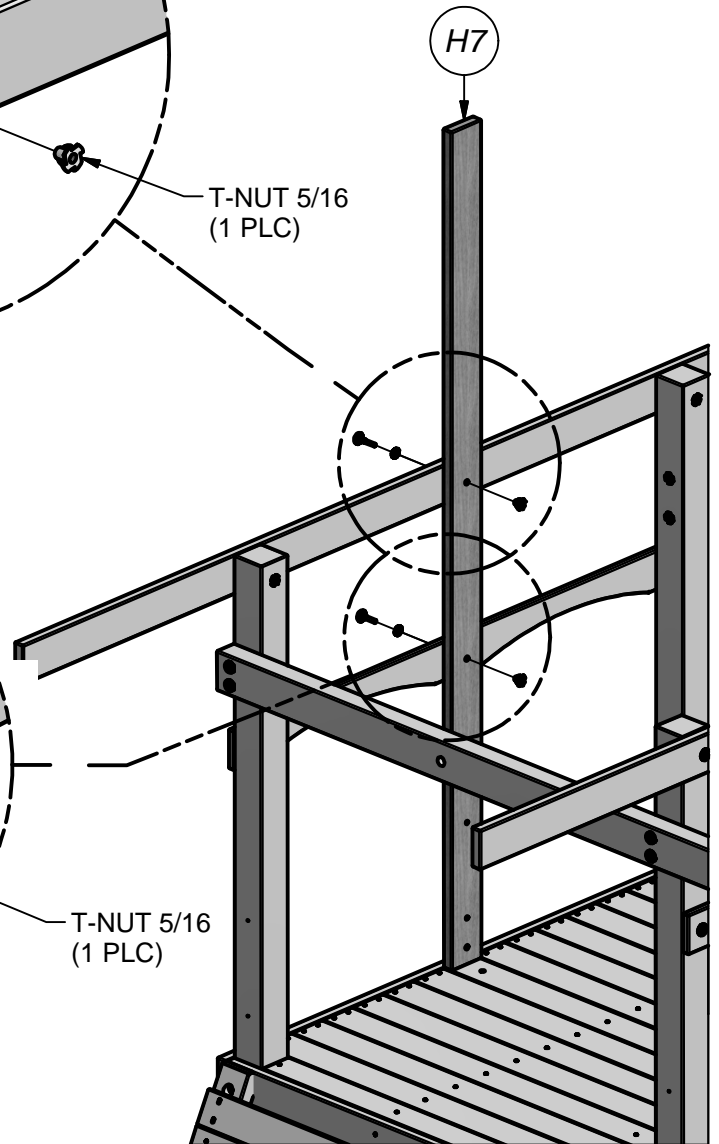
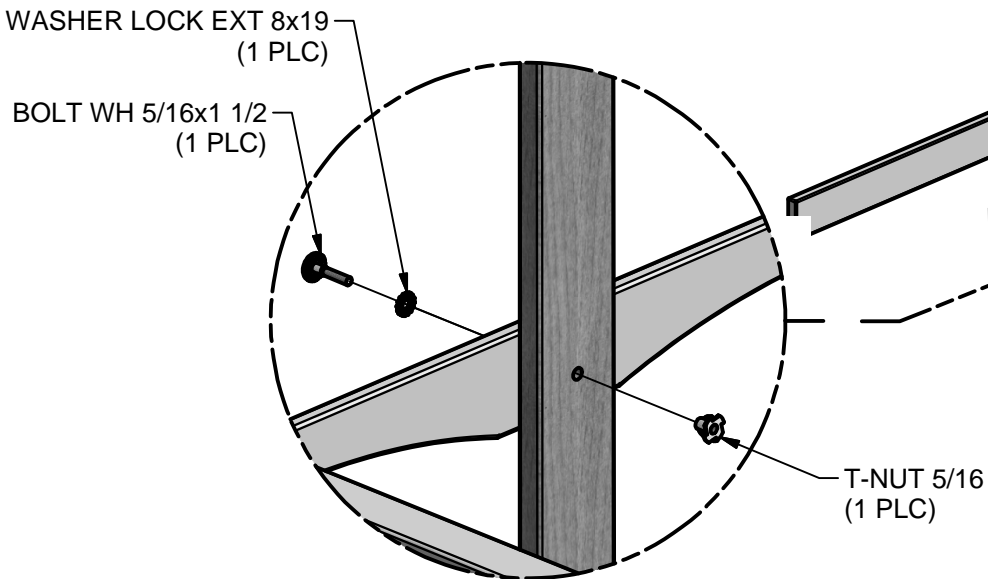
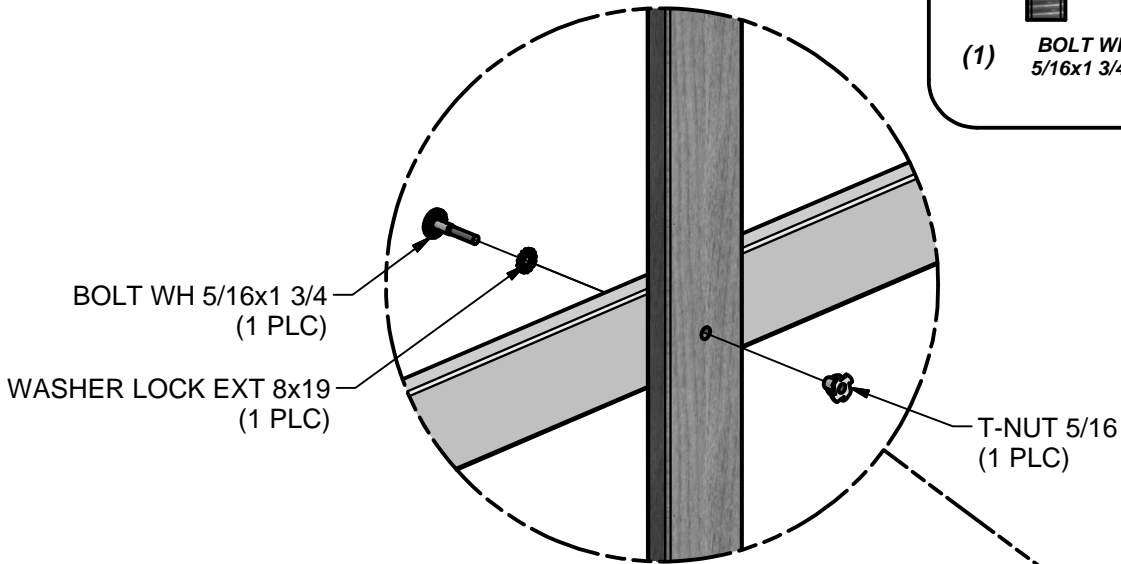
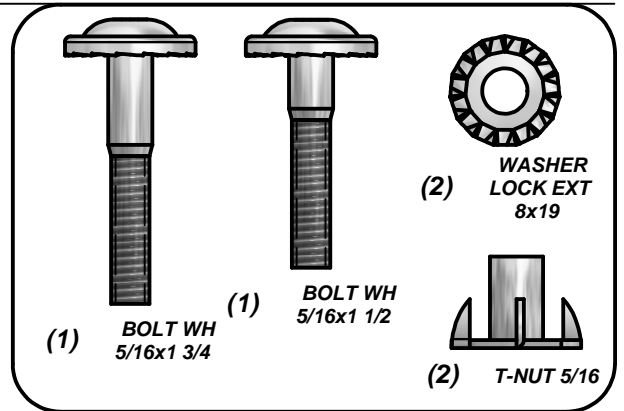



(2) TZ - L BRACKET 2.5x38x50x55 - A100340

**STEP 19**

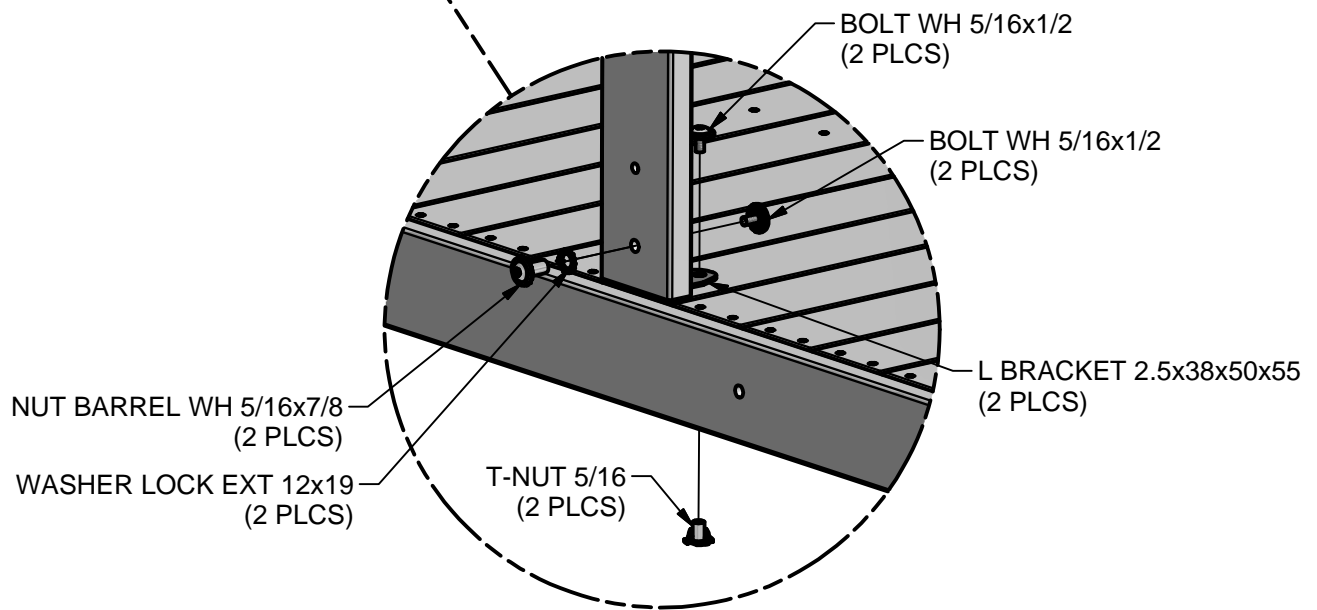
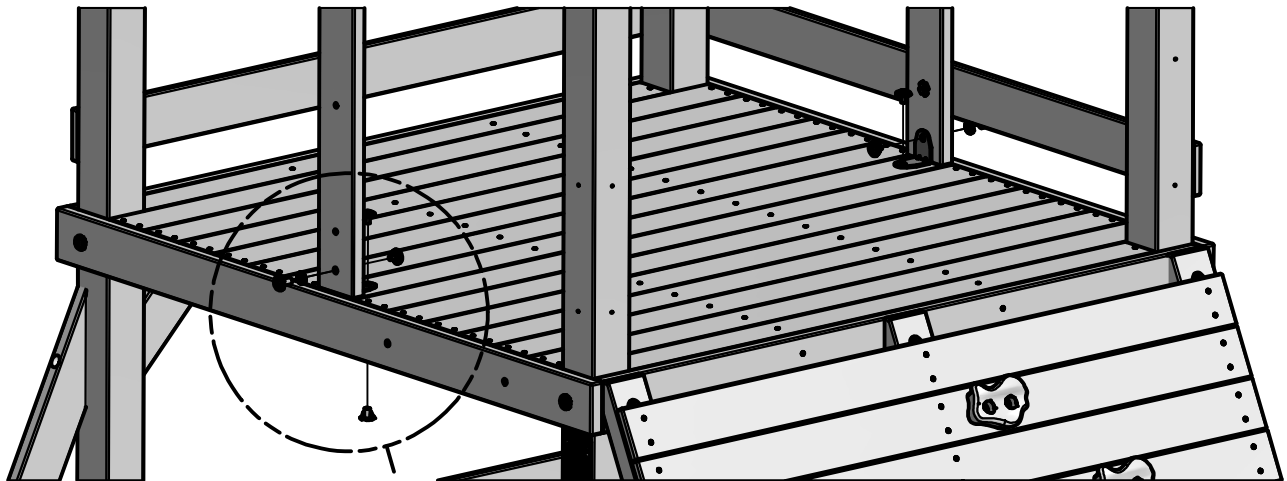
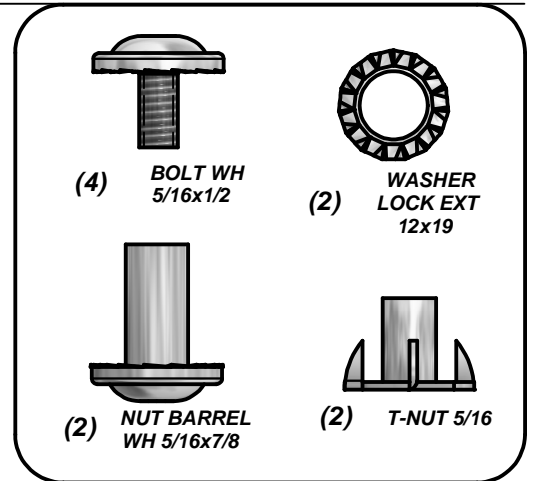
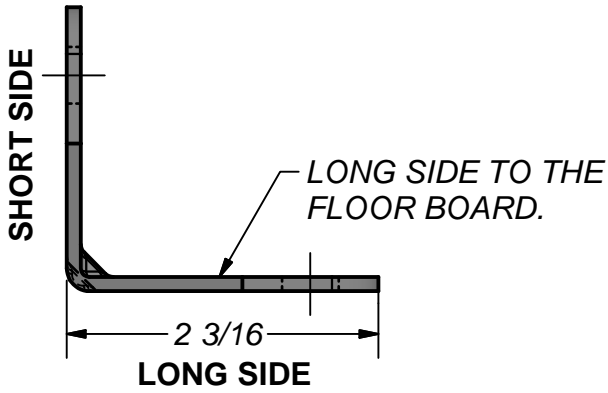



(6) M44 - PICKET - 42 - W4L07152  
5/8"x3 3/8"x21 3/8" (16x86x542)

**STEP 20**

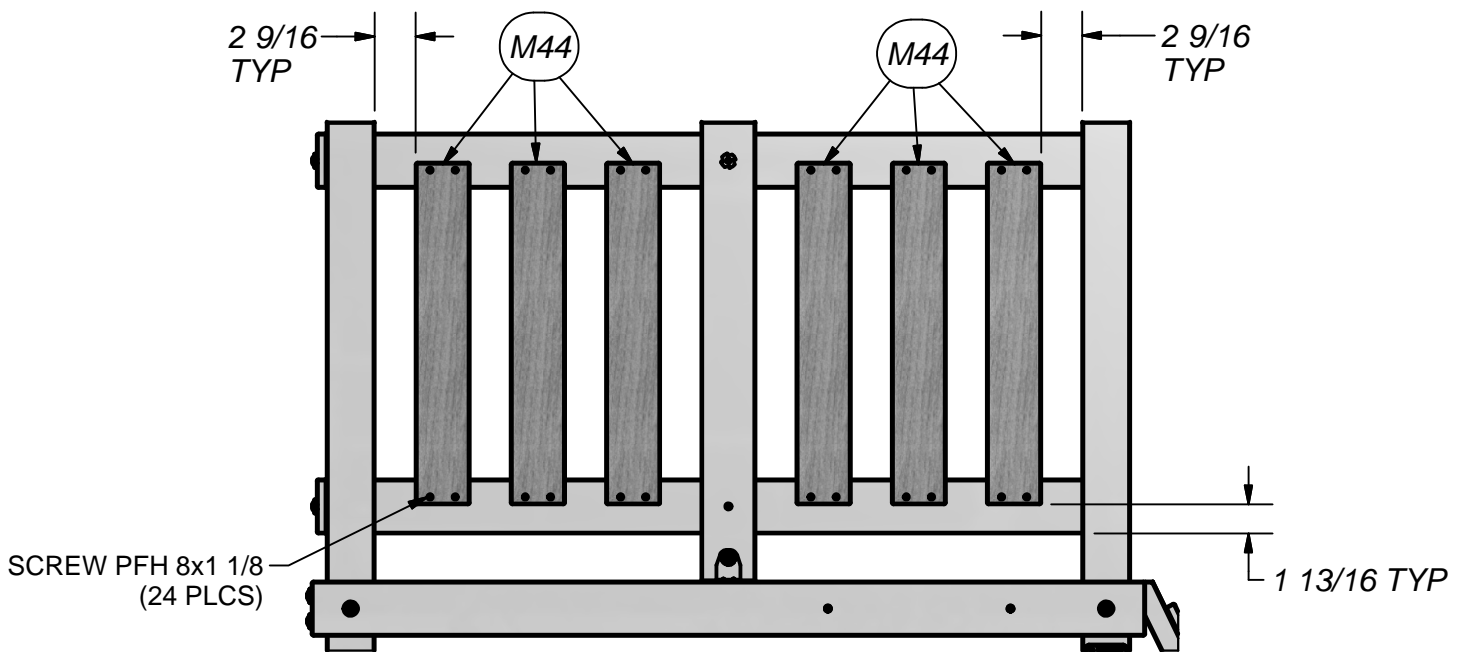
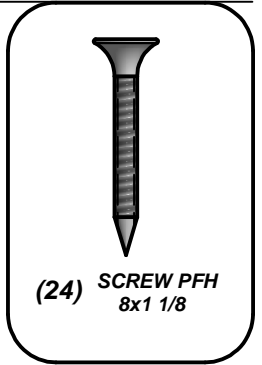
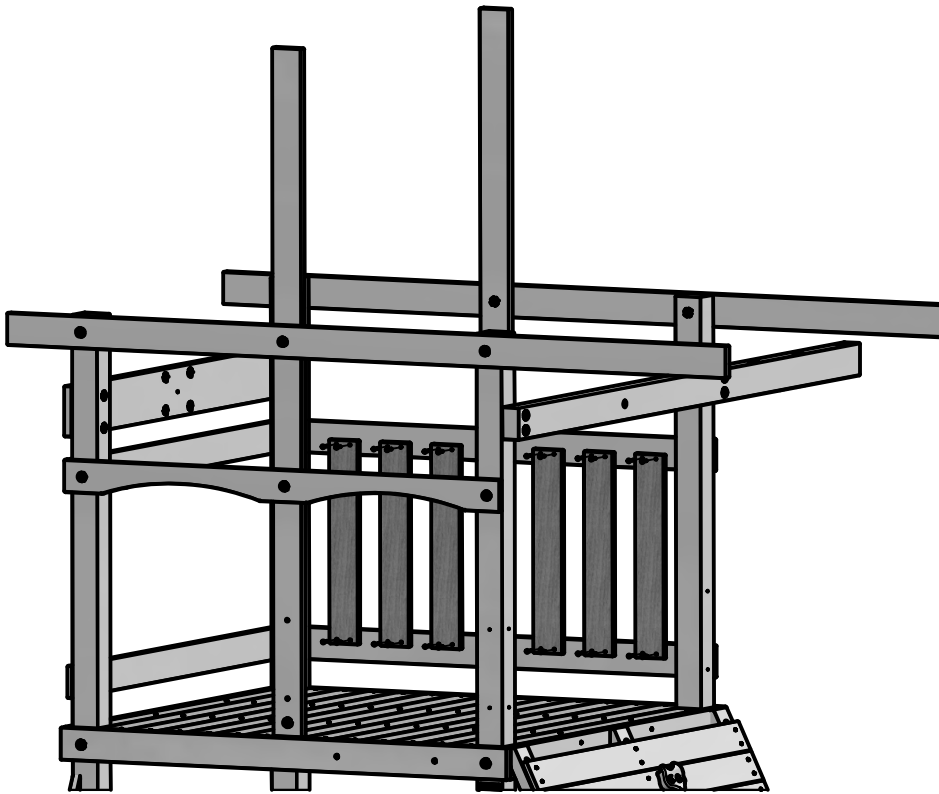



(7) M44 - PICKET - 42 - W4L07152  
5/8"x3 3/8"x21 3/8" (16x86x542)

**STEP 21**

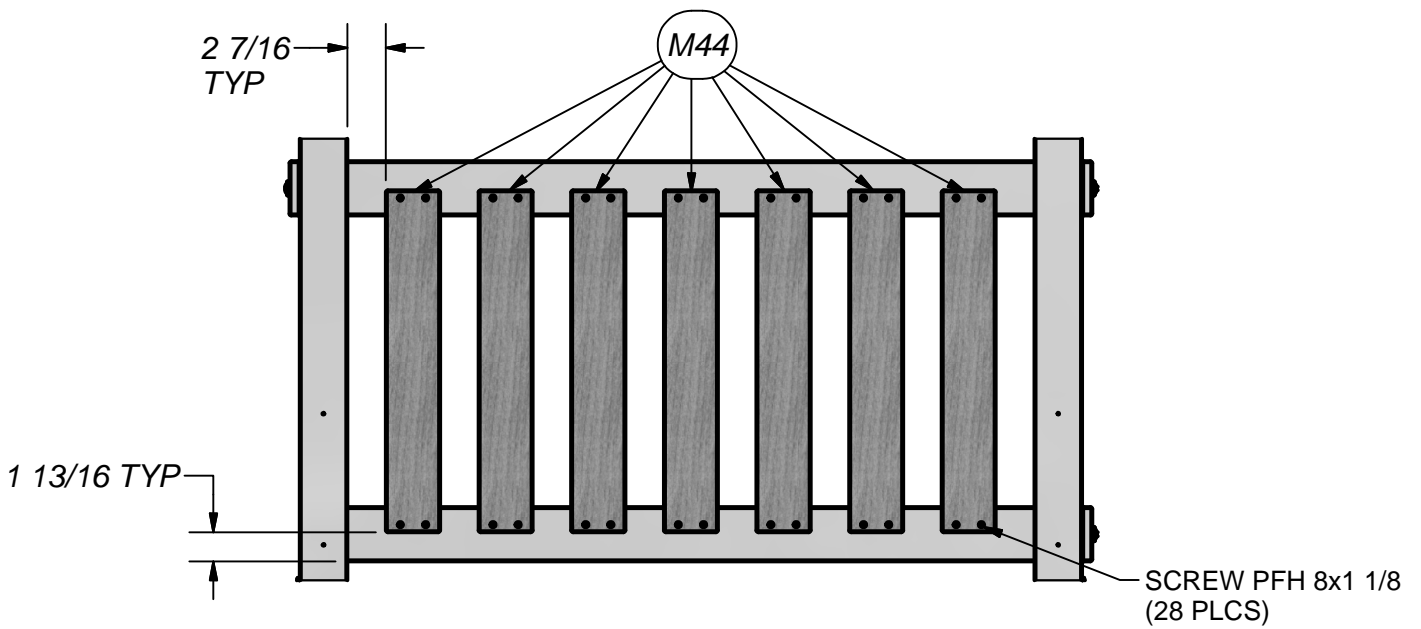
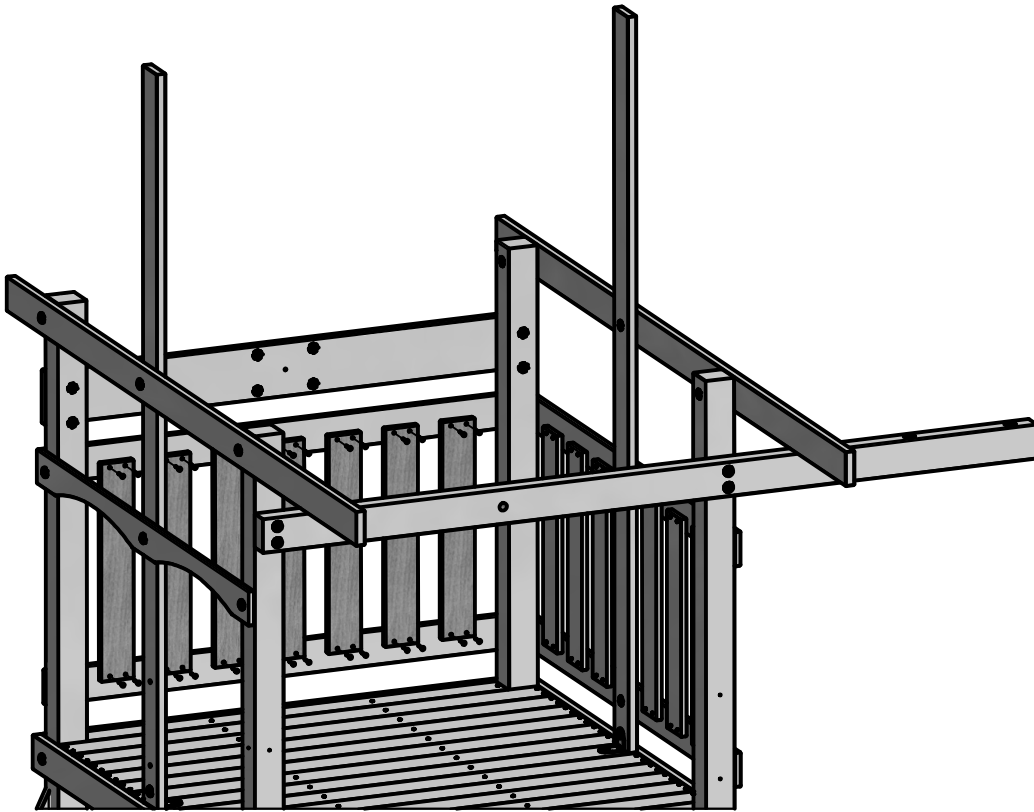
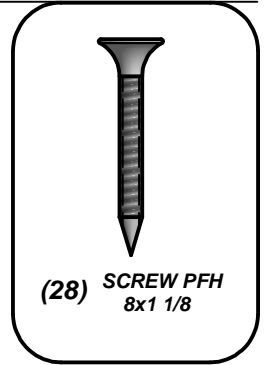



(2) H9 - ROOF RAIL - W4L07150  
1"x3 3/8"x50 7/8" (24x86x1291)



(1) H10 - ROOF RAIL - W4L07151  
1"x3 3/8"x48 7/8" (24x86x1243)

**STEP 22**

SCREW PFH 8x2 1/4  
(12 PLCS)

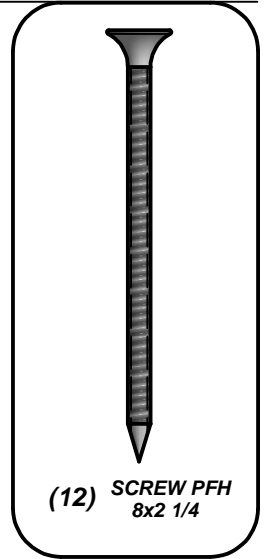
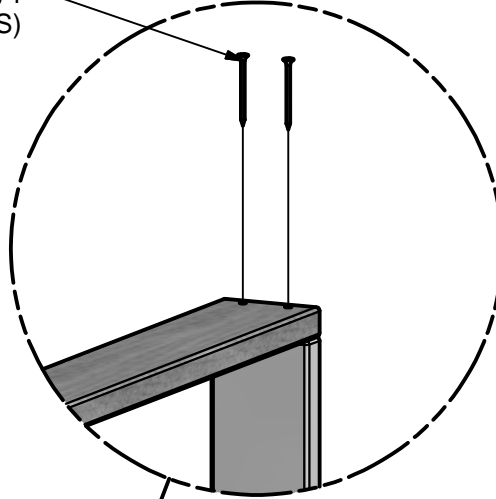

(12) SCREW PFH  
8x2 1/4

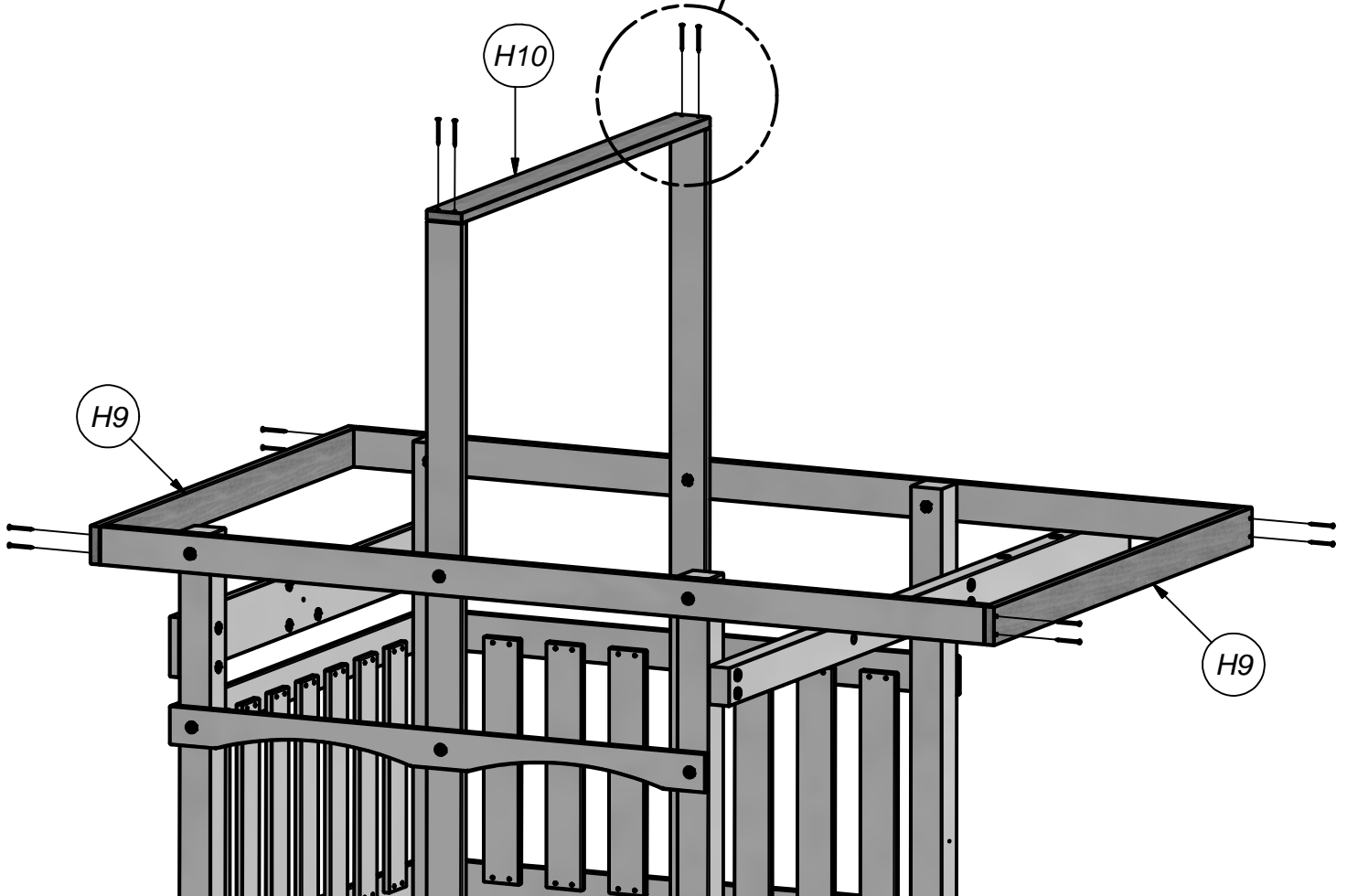

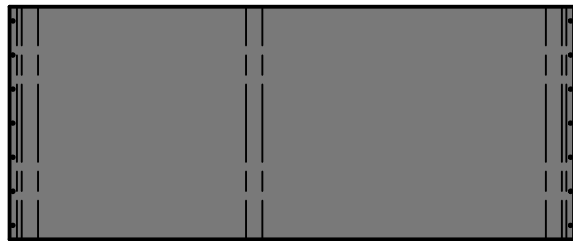

(1) - TARP - A6P00157

**STEP 23**

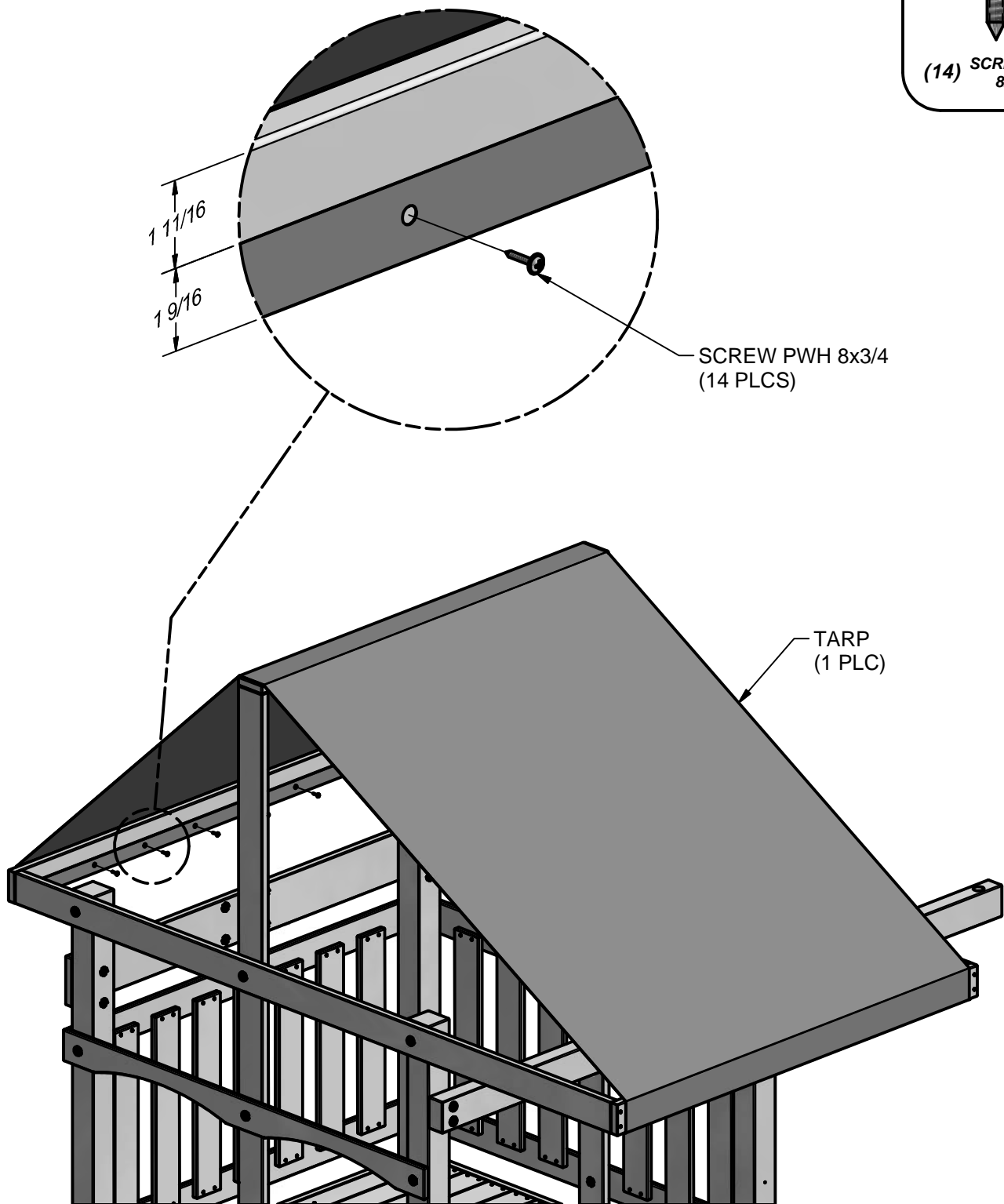
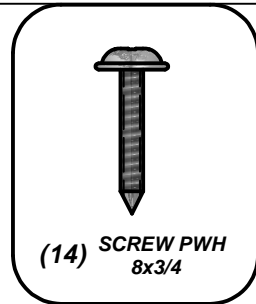



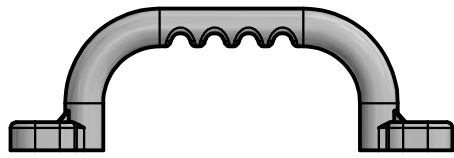

(2) - HAND GRIP YELLOW PLASTIC - A6P00303

**STEP 24**

WASHER LOCK EXT 6x15  
(2 PLCS)

BOLT WH 1/4x1-1/4  
(2 PLCS)

HAND GRIP YELLOW PLASTIC  
(1 PLC)

T-NUT 1/4  
(2 PLCS)

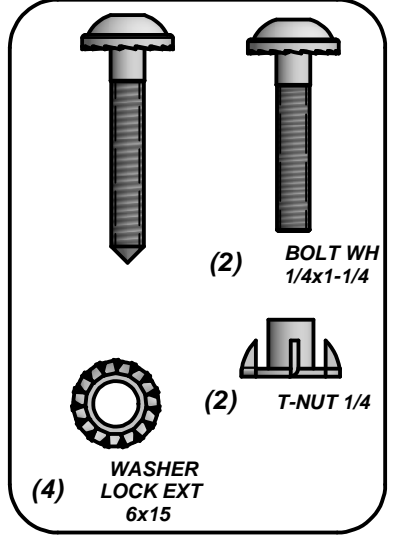
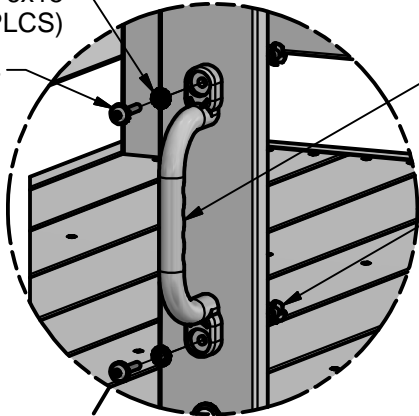

(2) BOLT WH 1/4x1-1/4

(2) T-NUT 1/4

(4) WASHER LOCK EXT 6x15

WASHER LOCK EXT 6x15  
(2 PLCS)

LAG SCREW WH 1/4x1-1/2  
(2 PLCS)

HAND GRIP YELLOW PLASTIC  
(1 PLC)

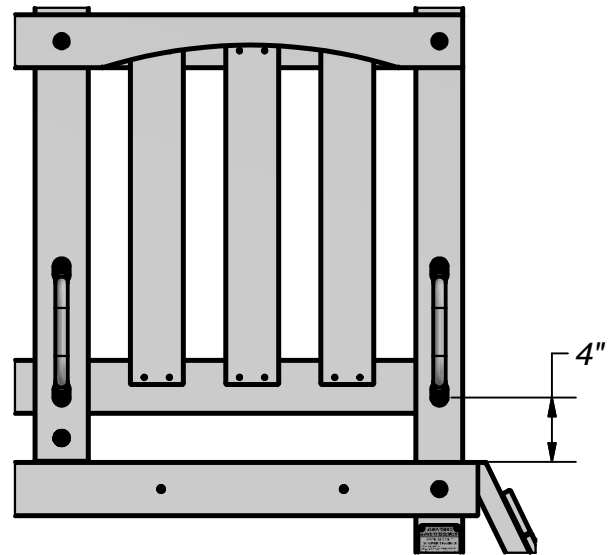
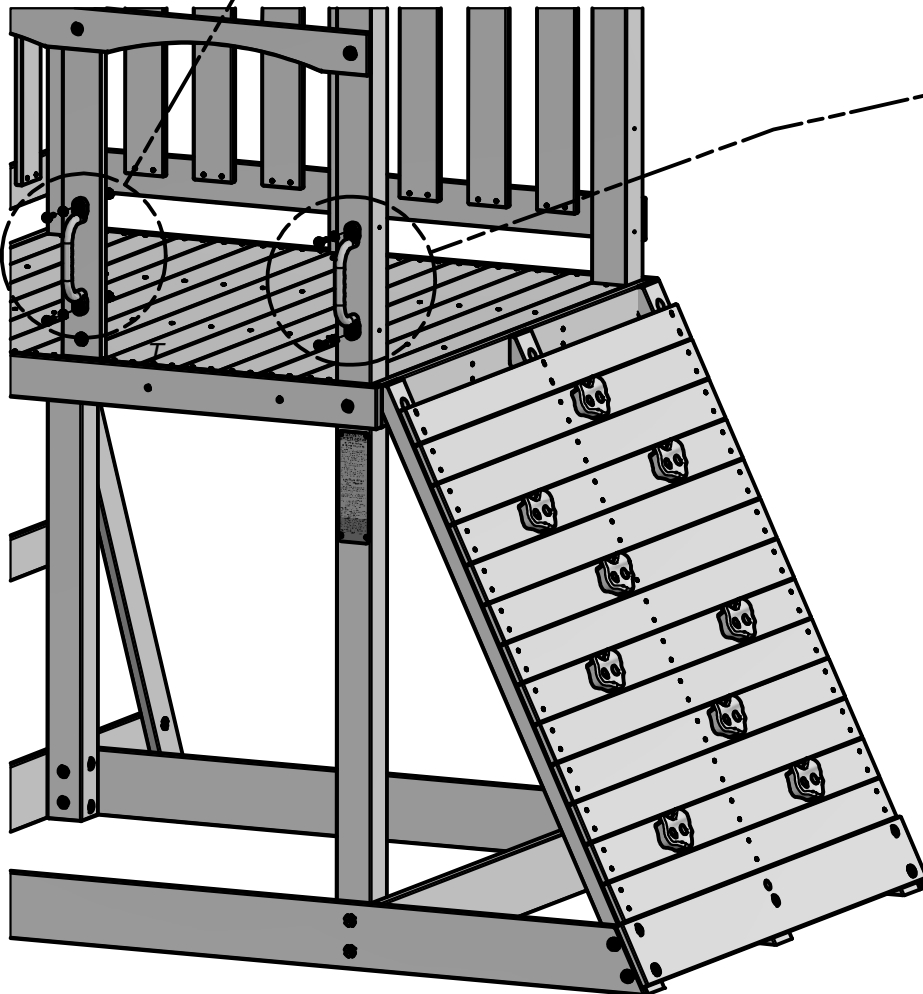
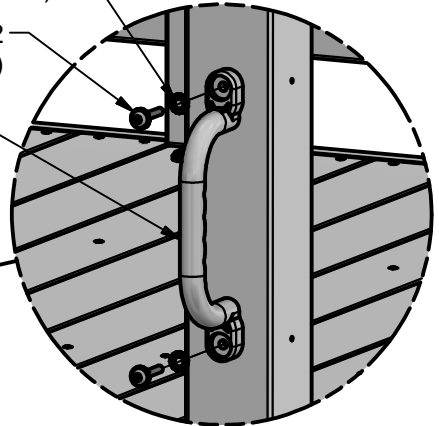

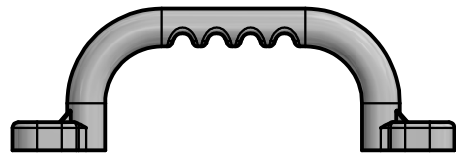

(2) - HAND GRIP YELLOW PLASTIC - A6P00303

**STEP 25**

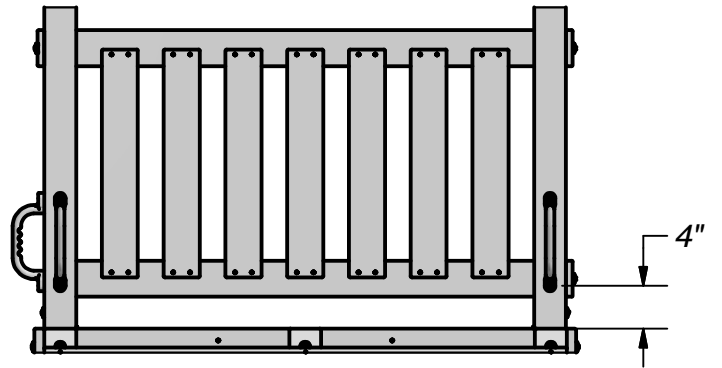
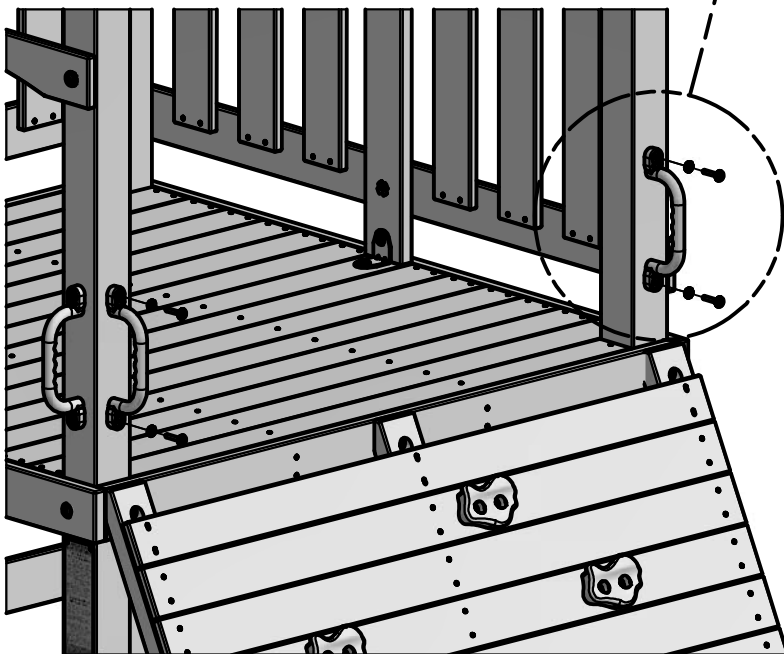
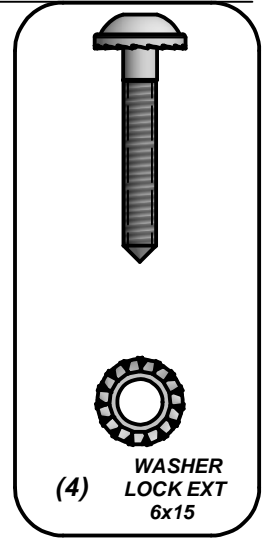
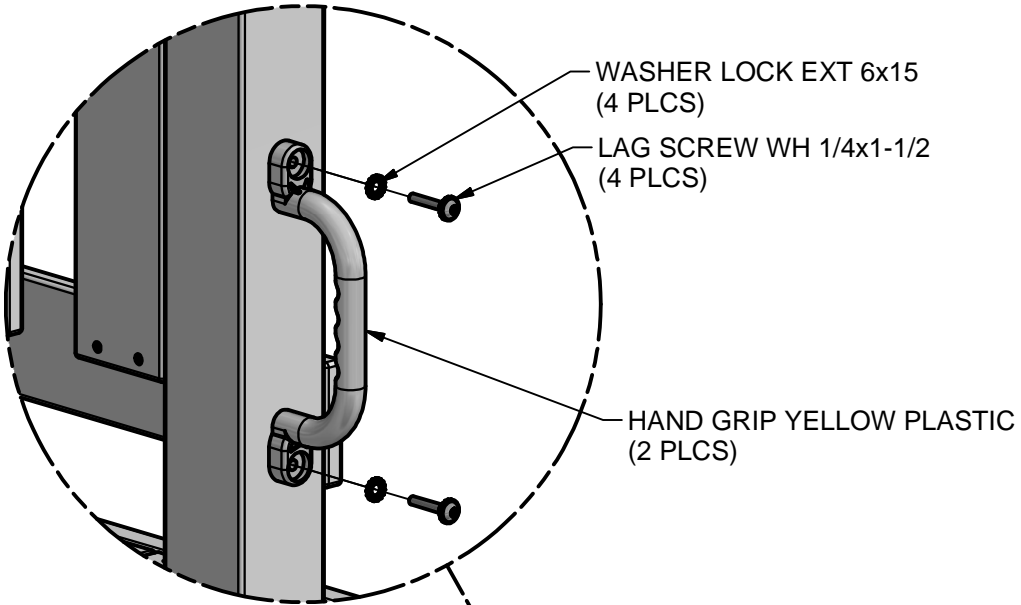

**STEP 26**

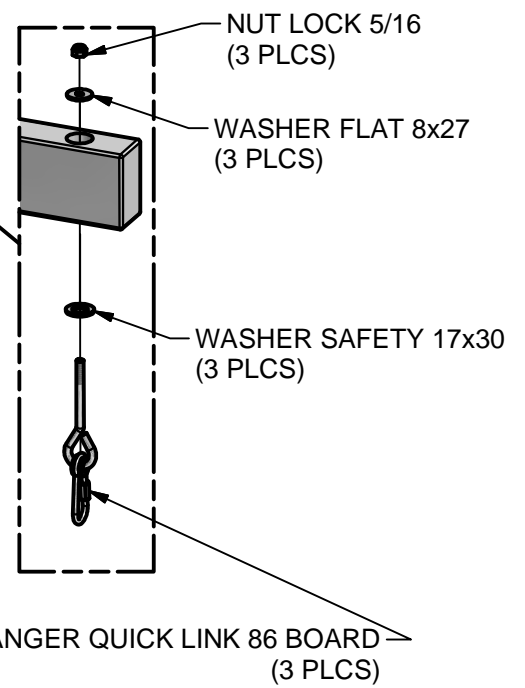
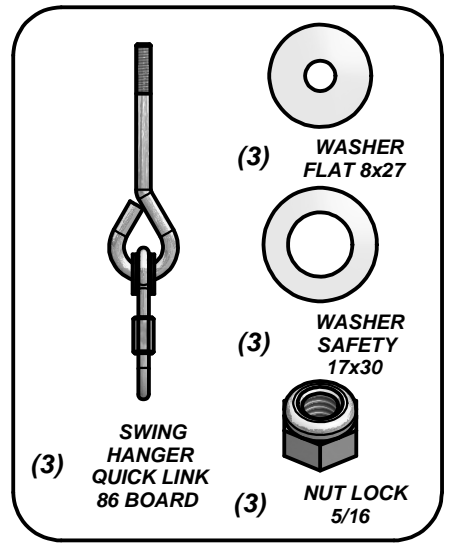
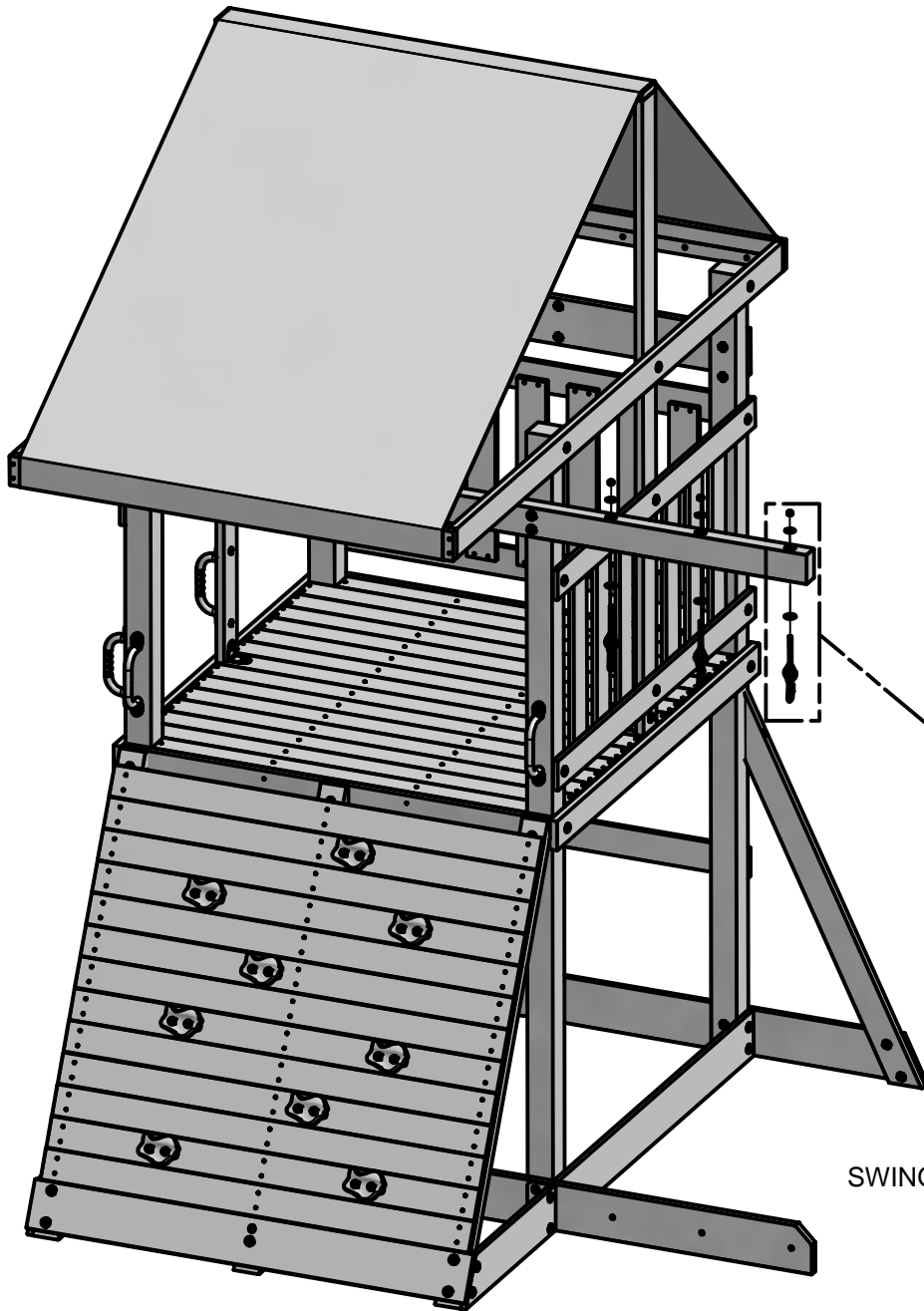

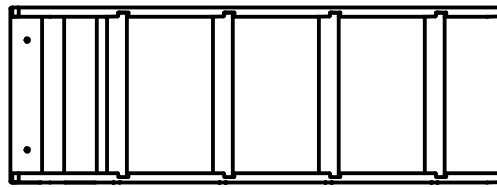

(1) LADDER ASSEMBLY

STEP 27

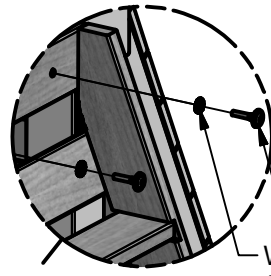
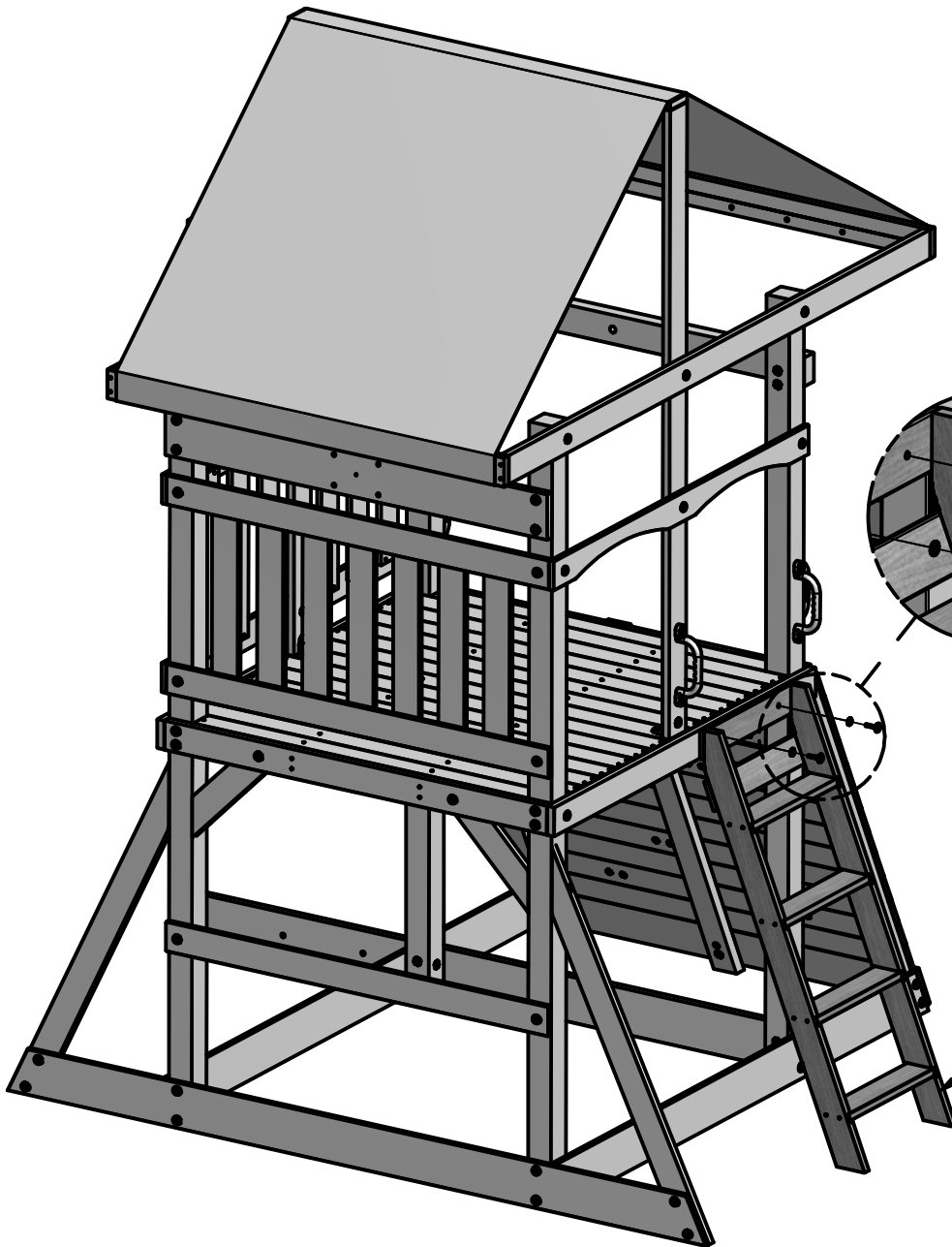
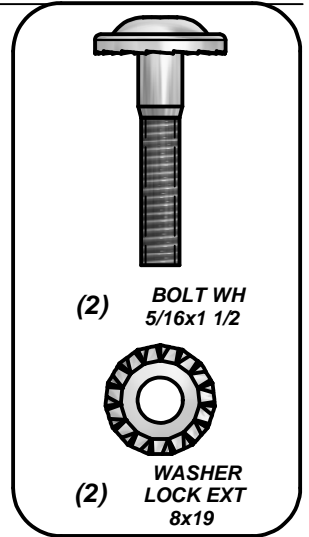

BOLT WH 5/16x1 1/2  
(2 PLCS)  
WASHER LOCK EXT 8x19  
(2 PLCS)

LADDER ASSEMBLY

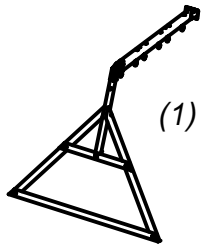

(1) SWING BEAM ASSEMBLY

STEP 28

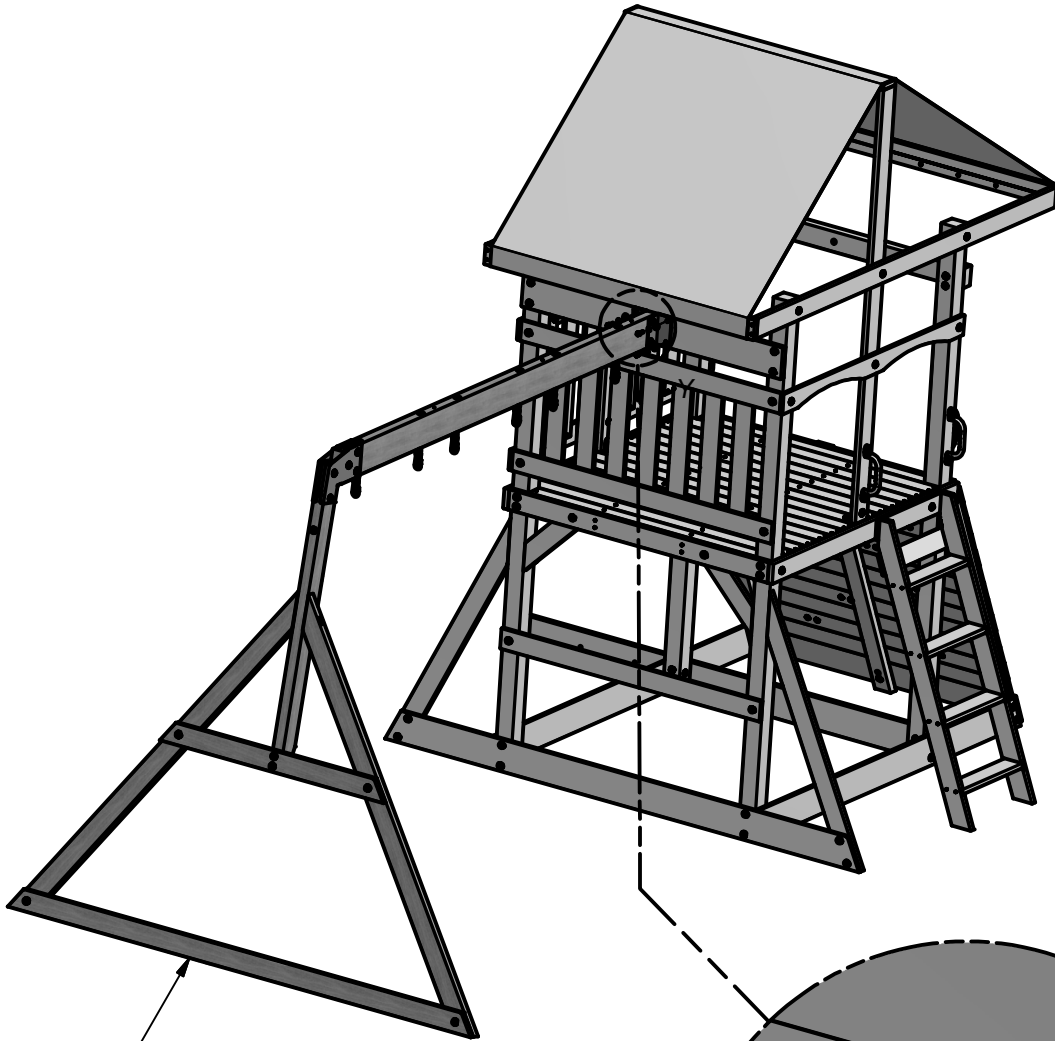

SWING BEAM ASSEMBLY

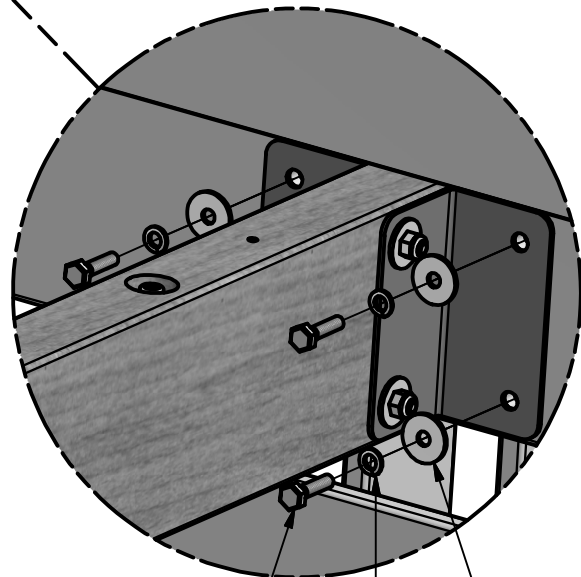
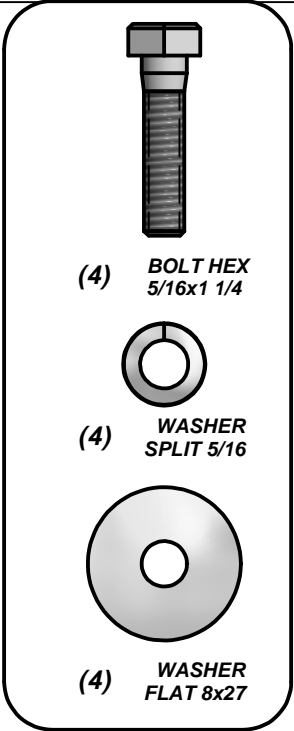

BOLT HEX 5/16x1 1/4 (4 PLCS)

WASHER SPLIT 5/16 (4 PLCS)

WASHER FLAT 8x27 (4 PLCS)



(2) - SWING SEAT GREEN - A6P00054



(4) FA - QUICK LINK - A100069



(4) EZ - CHAIN GREEN 51.25" - A100068

**STEP 29**

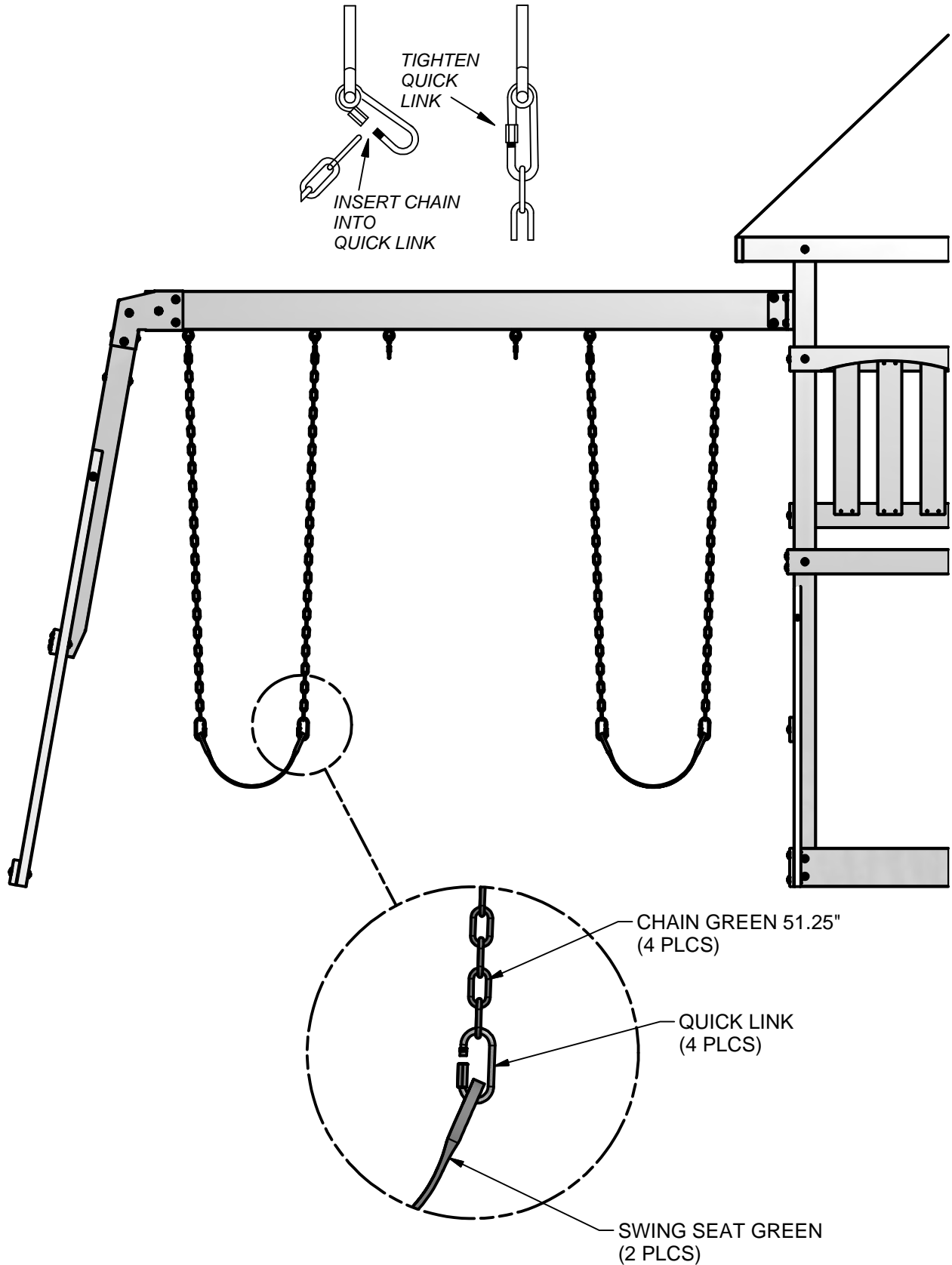



(2) KN - CHAIN GREEN 31" - A100177



(1) - TRAPEZE - A6P00034

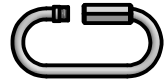

(2) FA - QUICK LINK - A100069

**STEP 30**

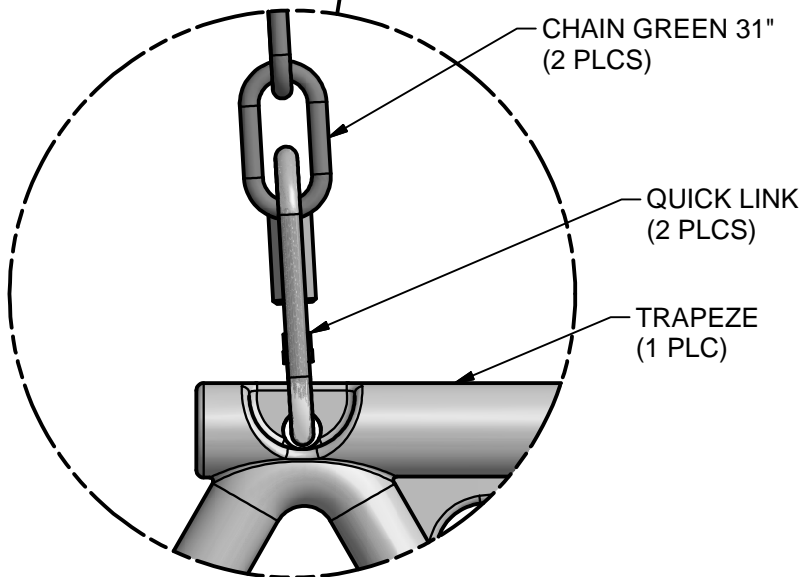
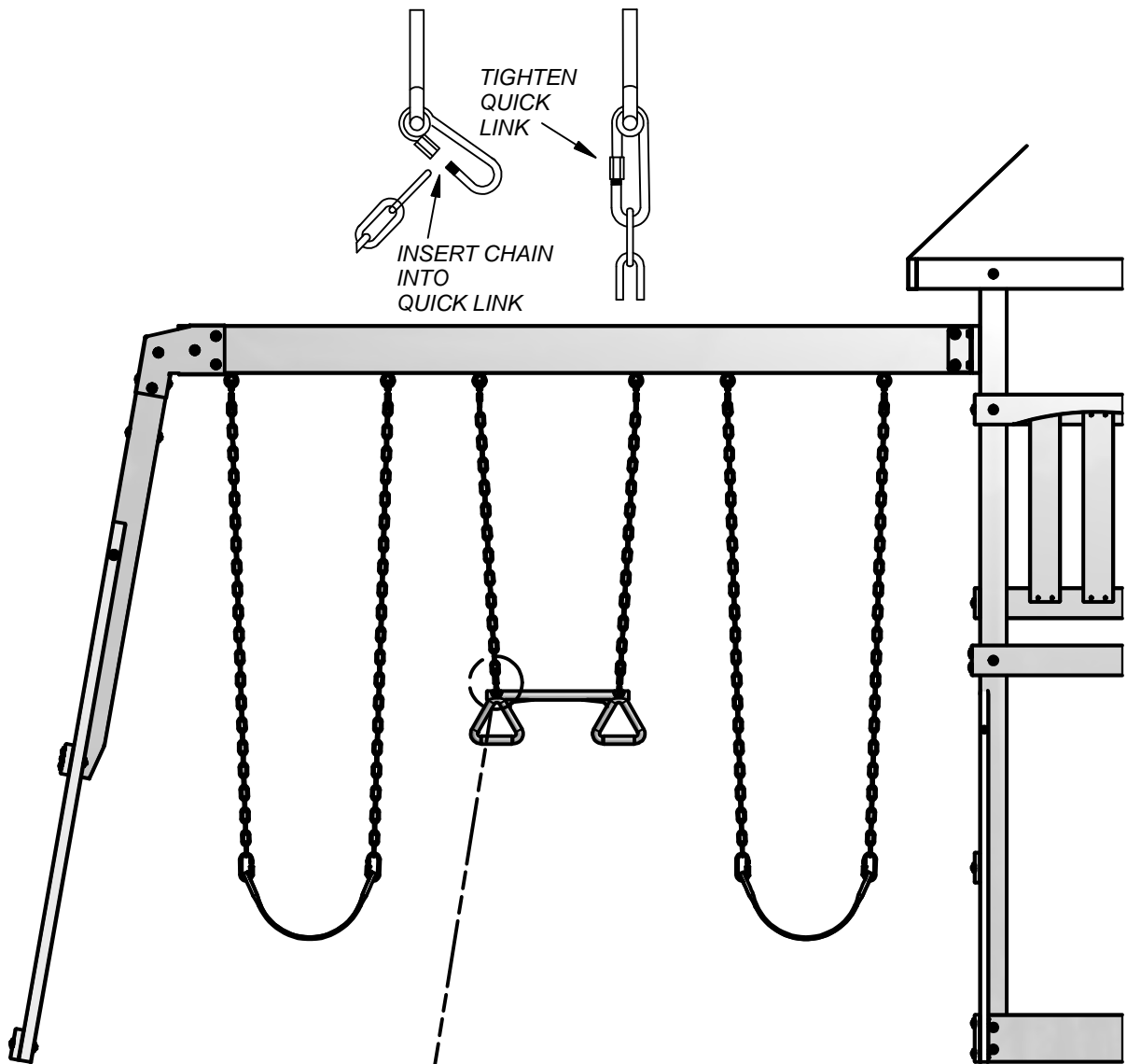



(1) HC - BYD ID TAG (LARGE) 2011 WITH AGES - A100164

**STEP 31**

BYD ID TAG (LARGE) 2011 WITH AGES  
(1 PLC)

SCREW PWH 8x5/8  
(4 PLCS)

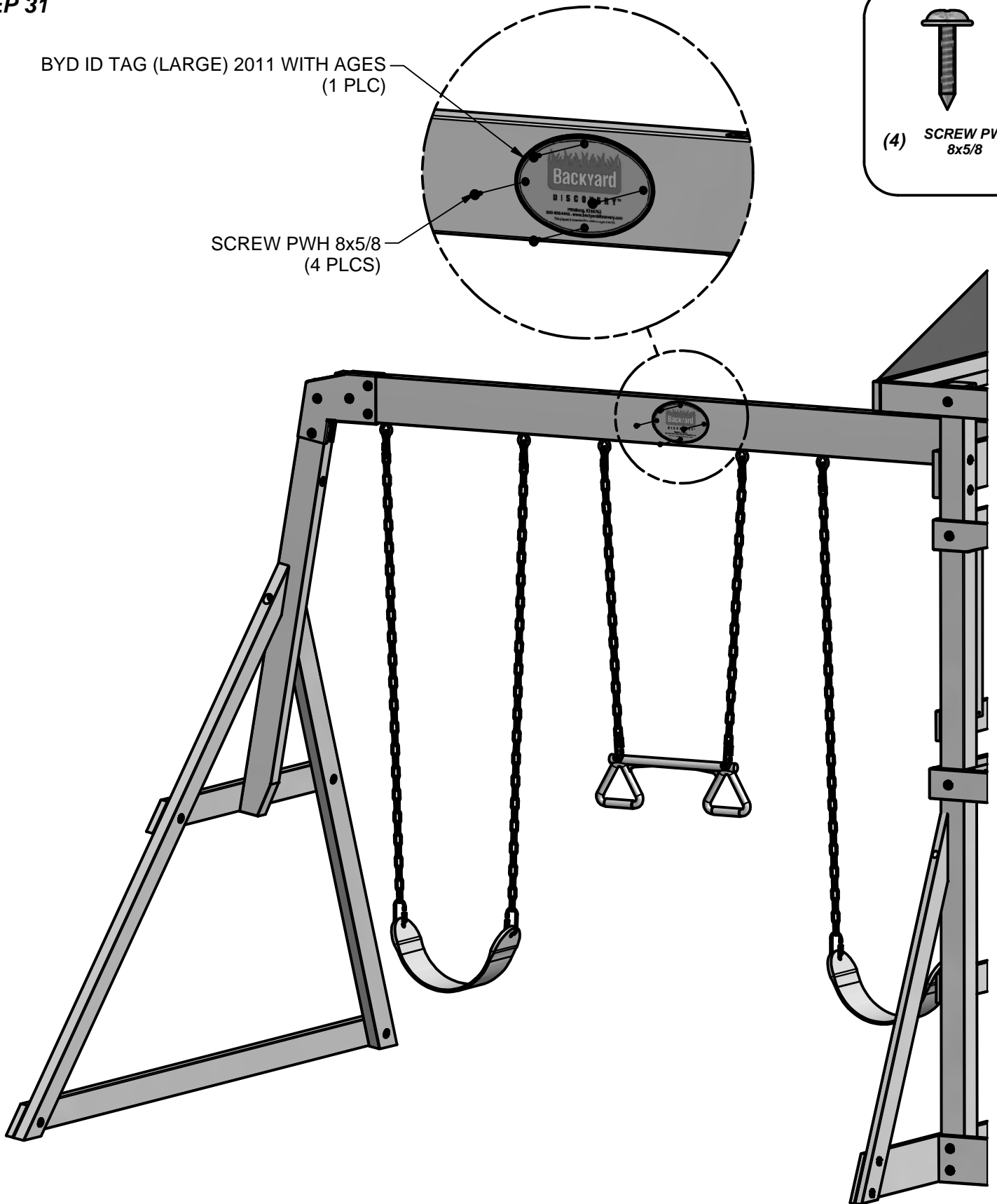
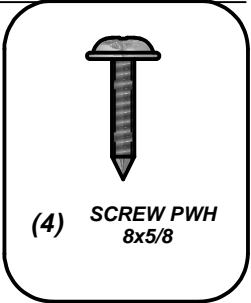



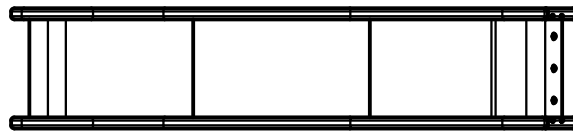

(1) SLIDE ASSEMBLY

STEP 32

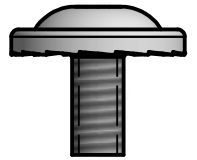
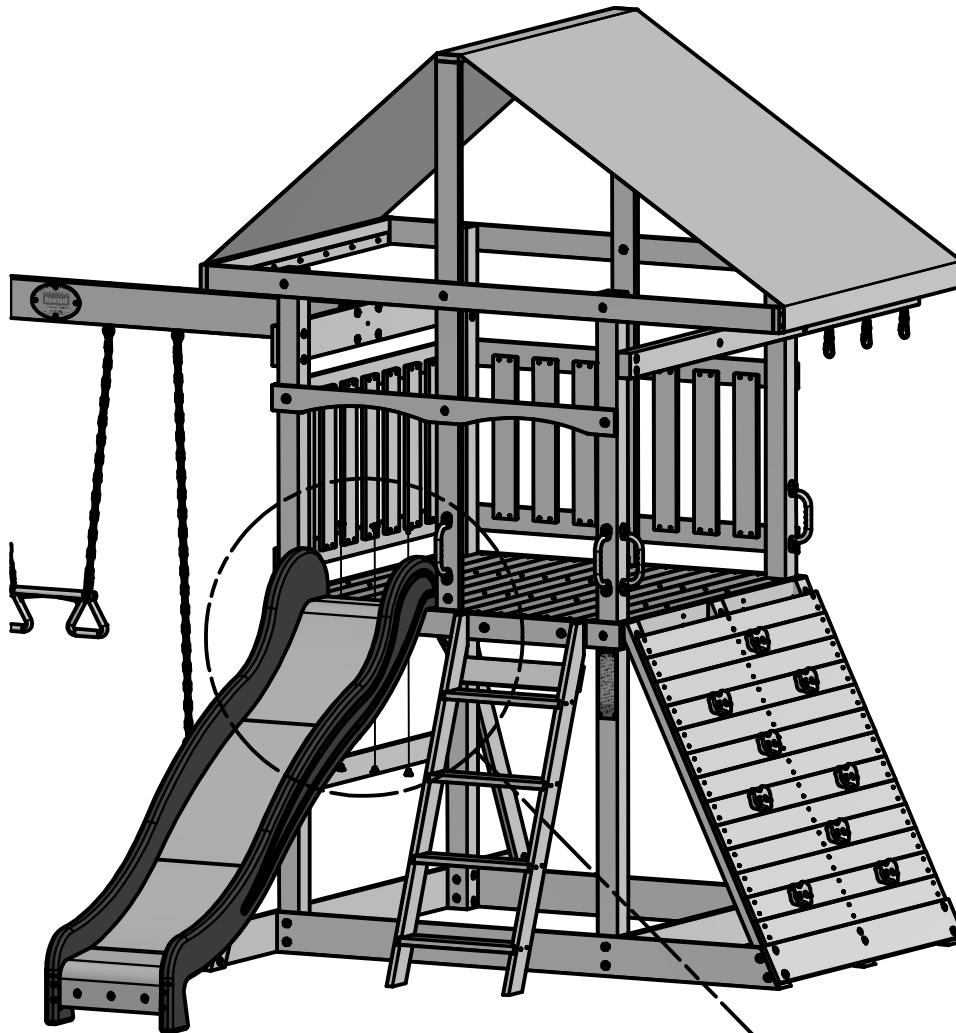

(3) BOLT WH 5/16x1/2

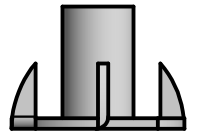

(3) T-NUT 5/16

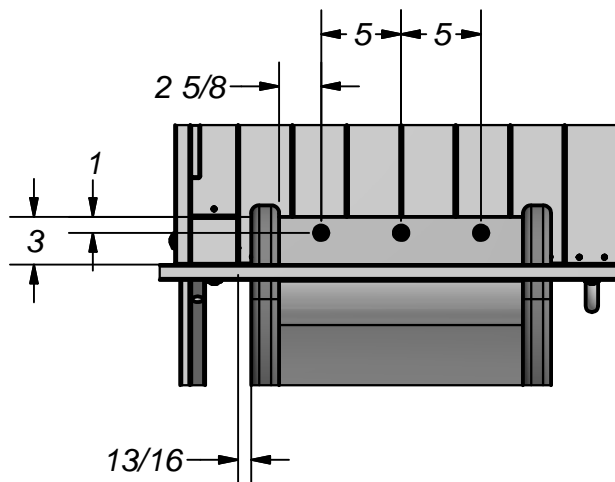

7/16" DRILLING PATTERN

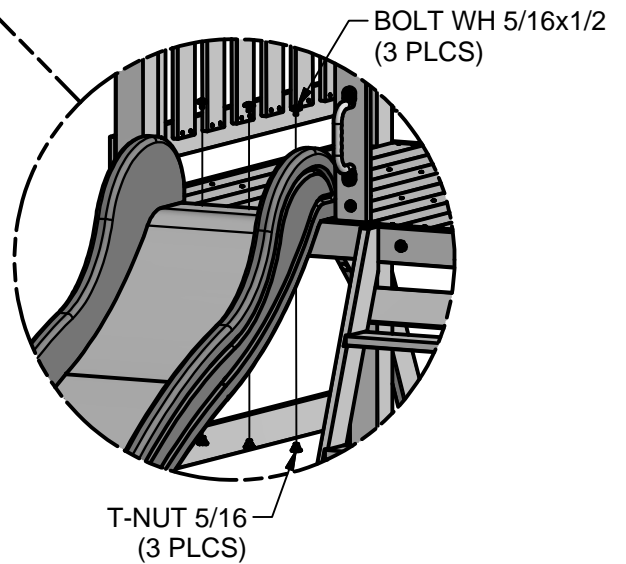

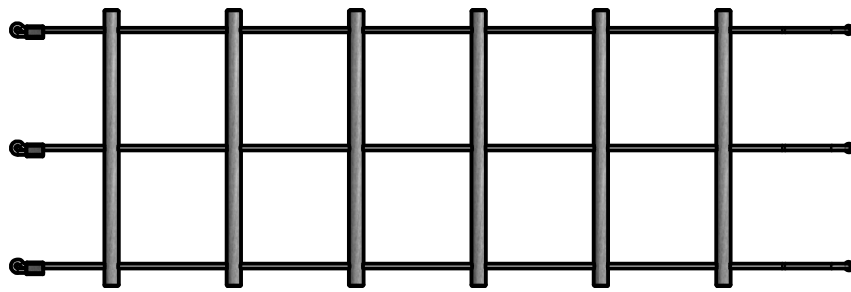

(1) - ROPE LADDER - A6P00161

**STEP 33**

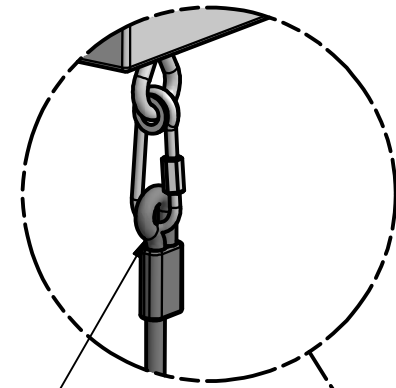

INSERT ROPE  
INTO QUICK LINK.  
(3 PLCS)

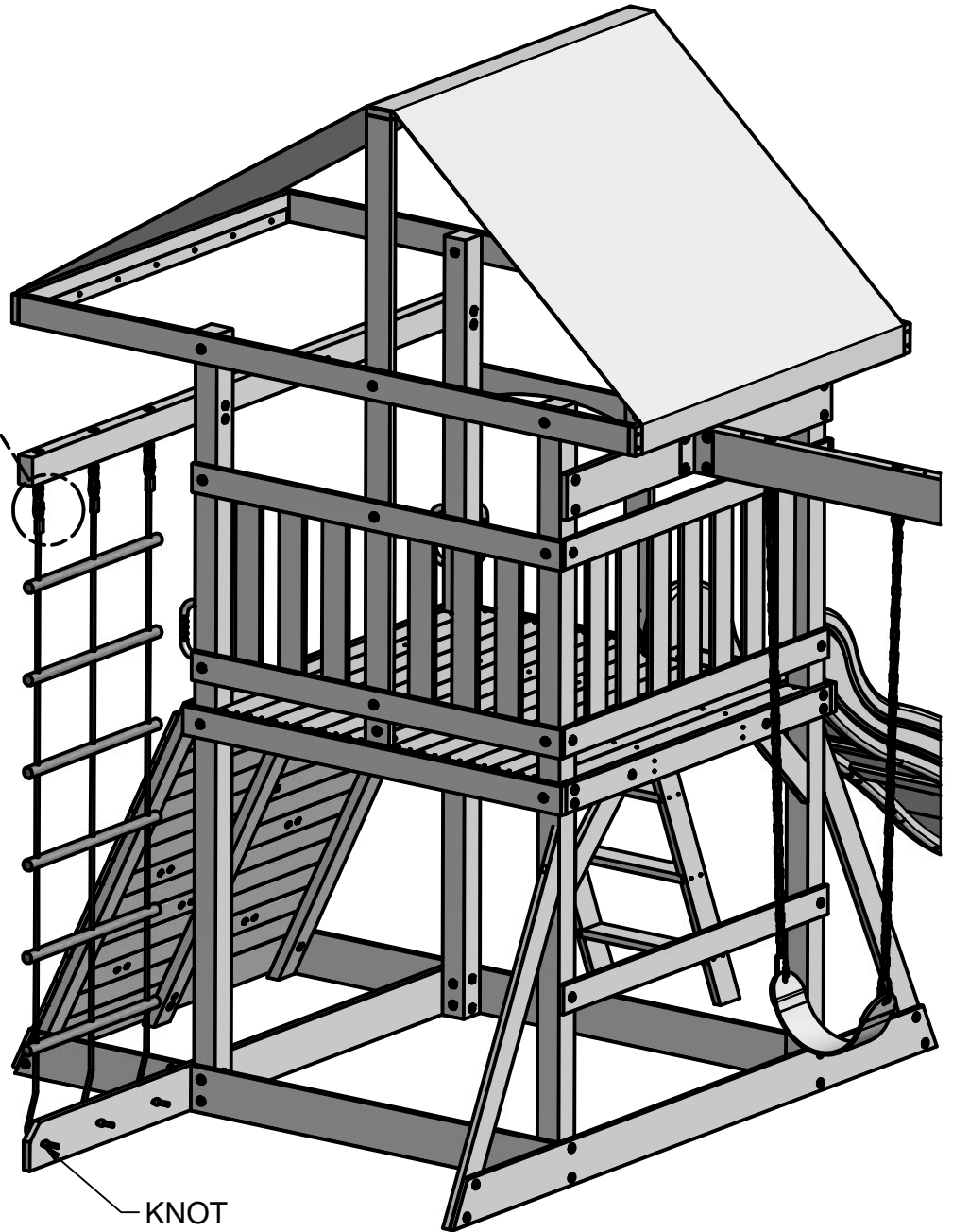

KNOT  
(3 PLCS)

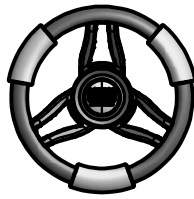

(1) LP - STEERING WHEEL - A100105

**STEP 34**

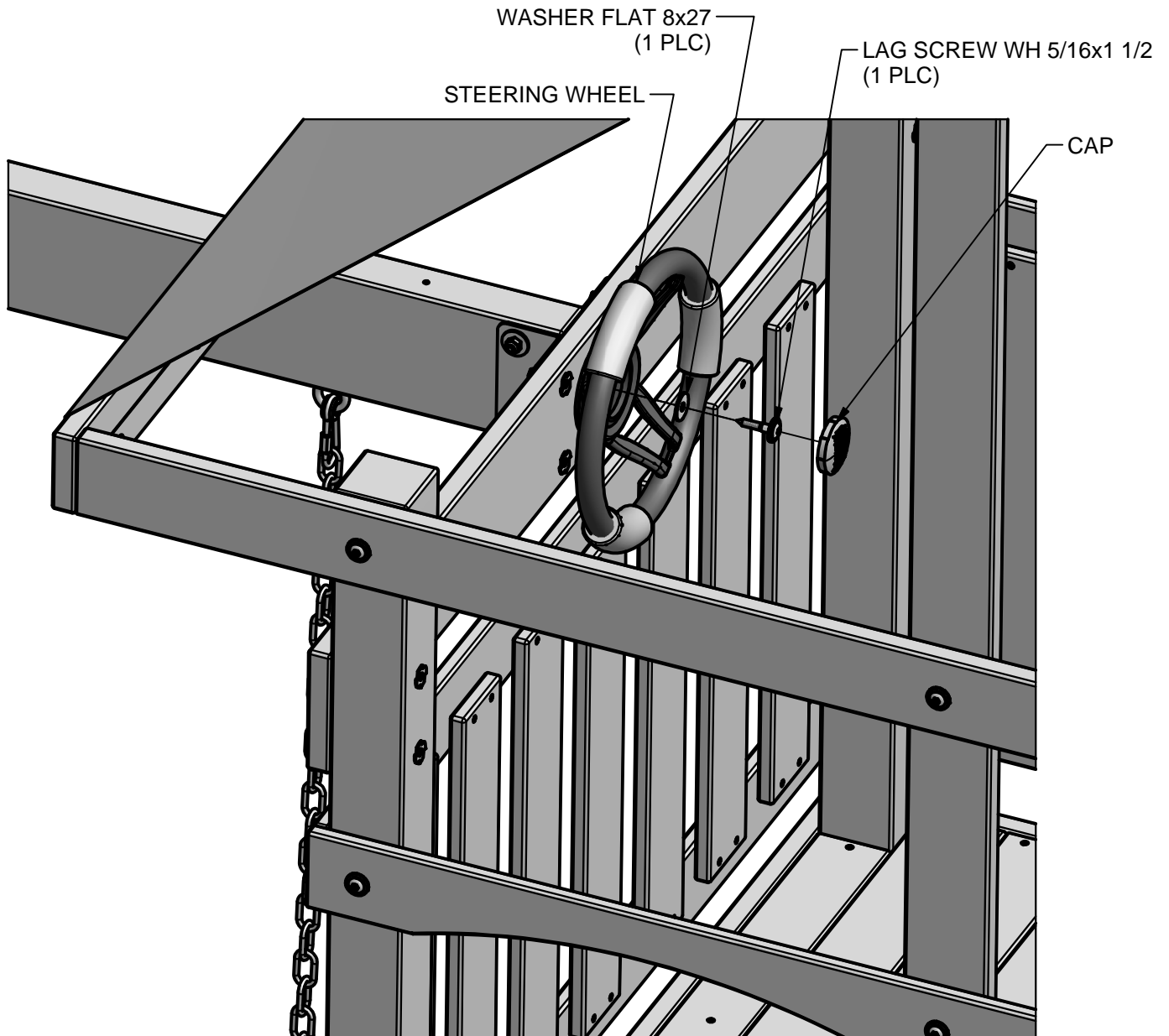
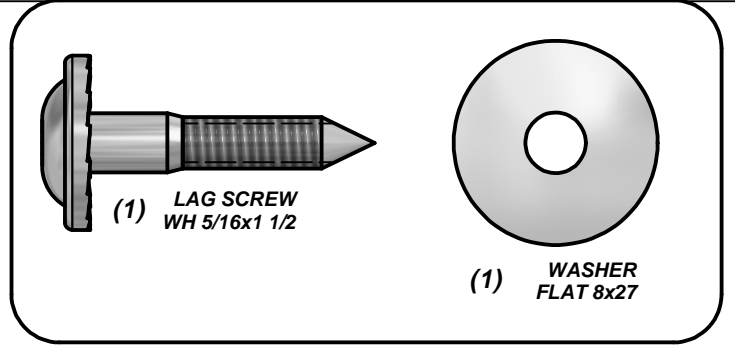

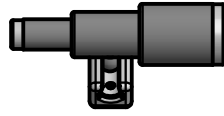

(1) - TELESCOPE - A6P00096

**STEP 35**

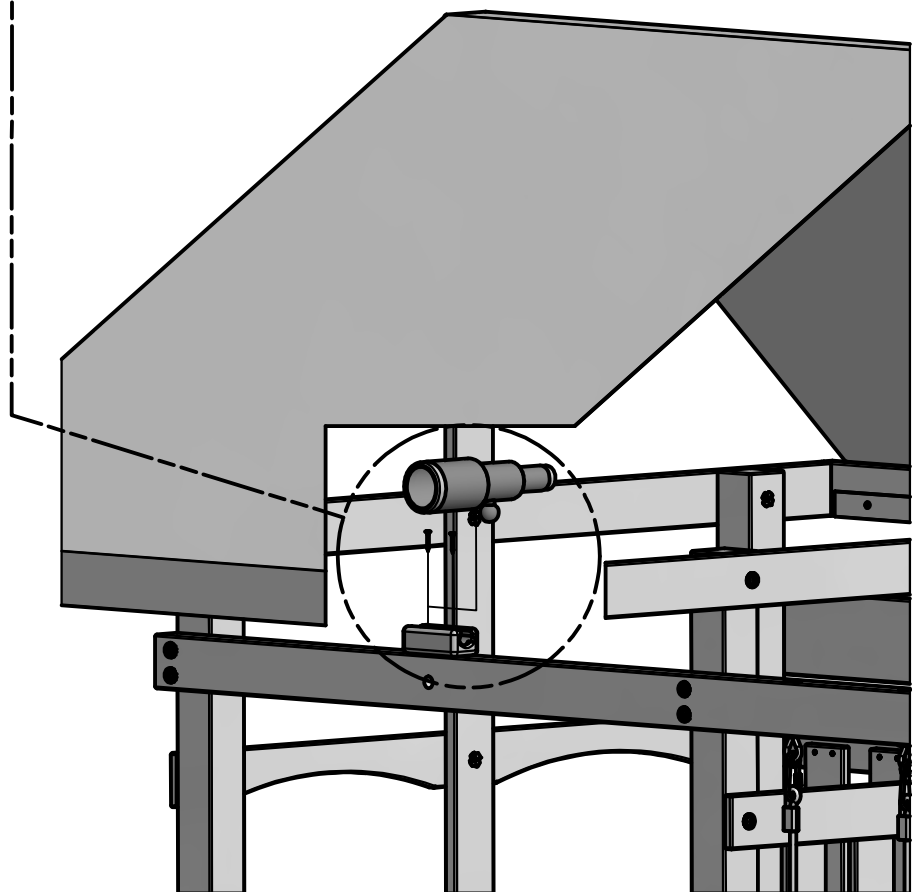
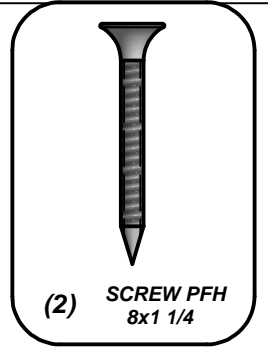
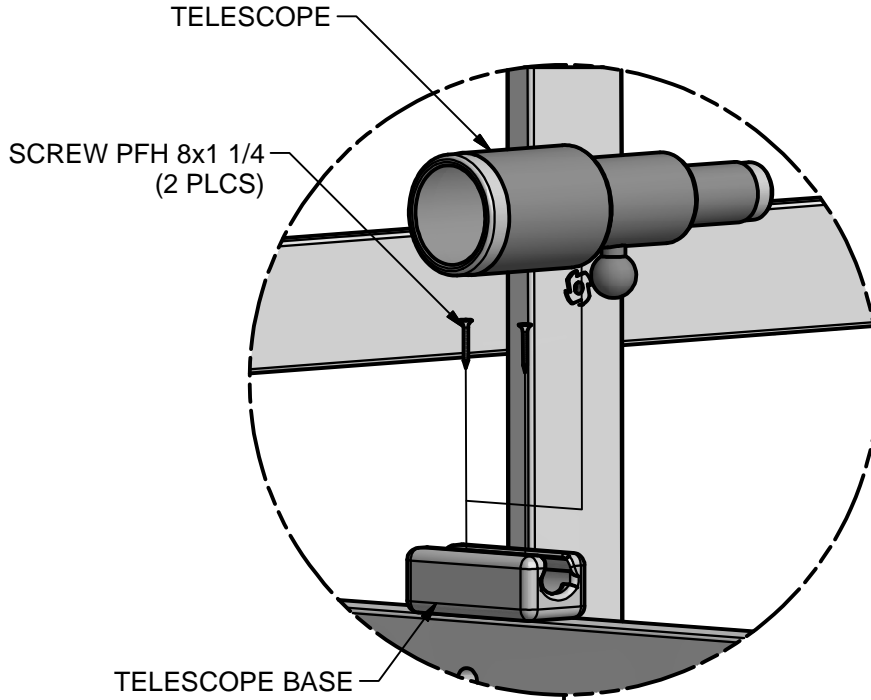



(1) - CLIMBING ROPE - A6P00120

**STEP 36**

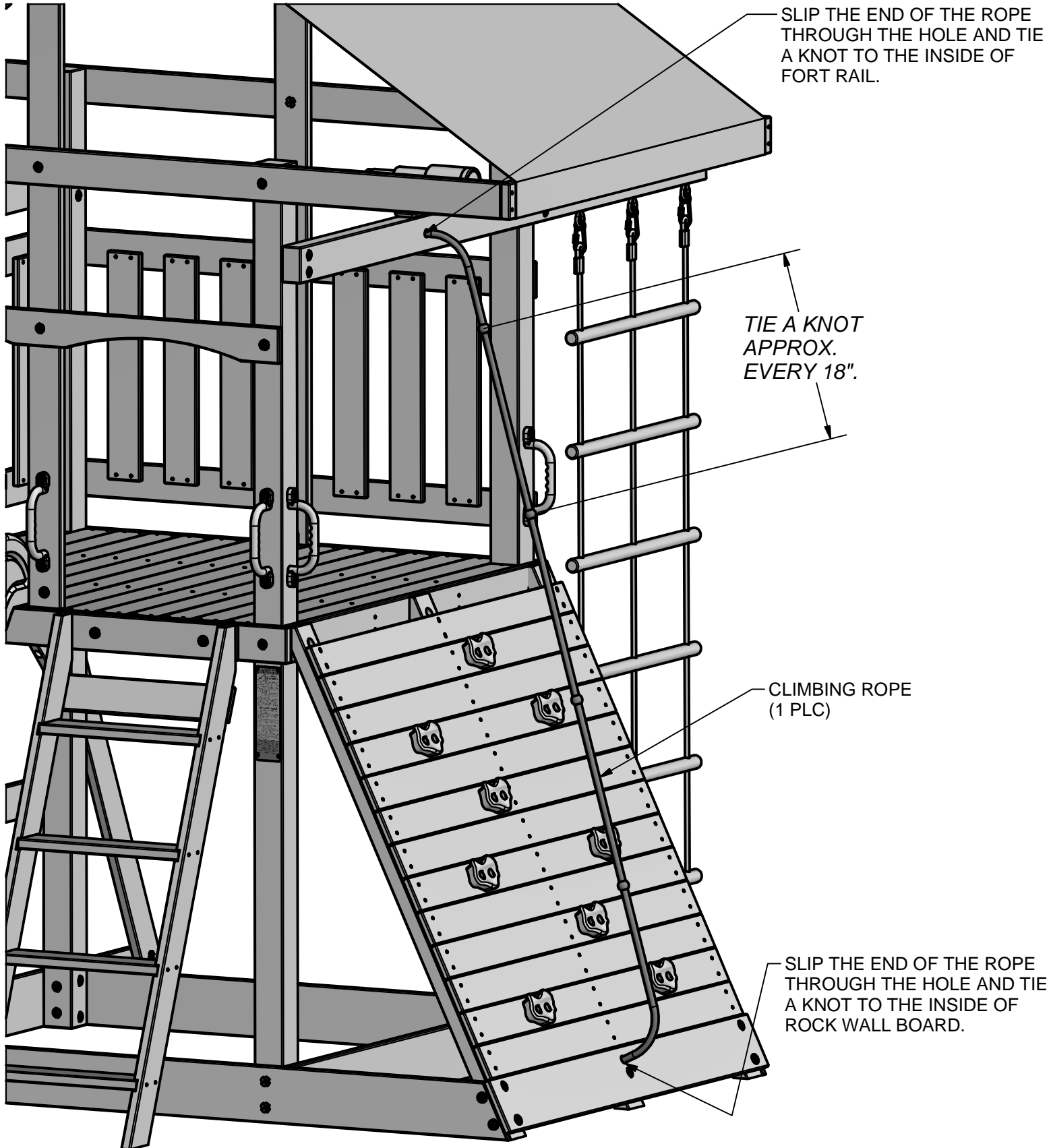



(1) SQ - "A" REVISION TAG - A100314

**STEP 37**

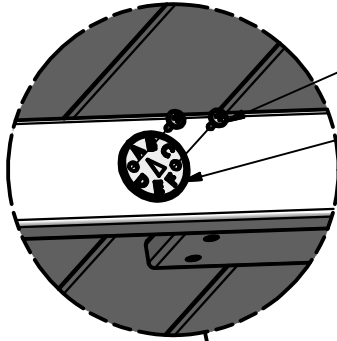

SCREW PWH 8x5/8  
(2 PLCS)

"A" REVISION TAG  
(1 PLC)

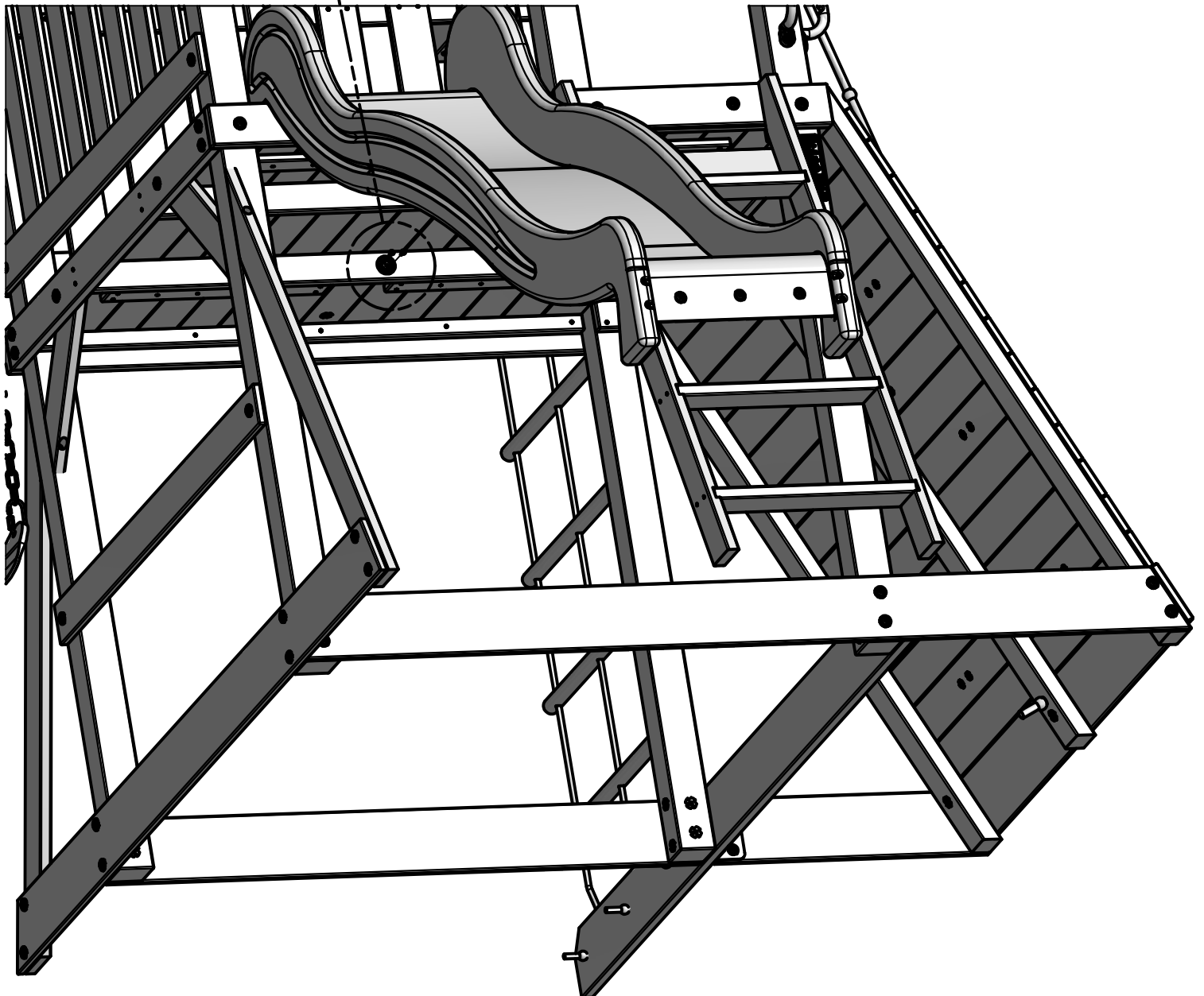
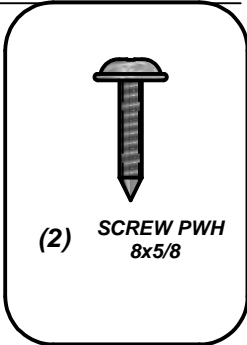

**STEP 38**

# Anchoring Instructions

**TAP IN GROUND STAKES AT AN APPROXIMATE 45° ANGLE AT THE LOCATIONS SHOWN. USING GROUND STAKES AS A GUIDE, DRILL 7/16" DIA HOLES.**

**NOTE:  
FAILURE TO USE GROUND STAKES CAN VOID WARRANTY & CAUSE INJURY!**

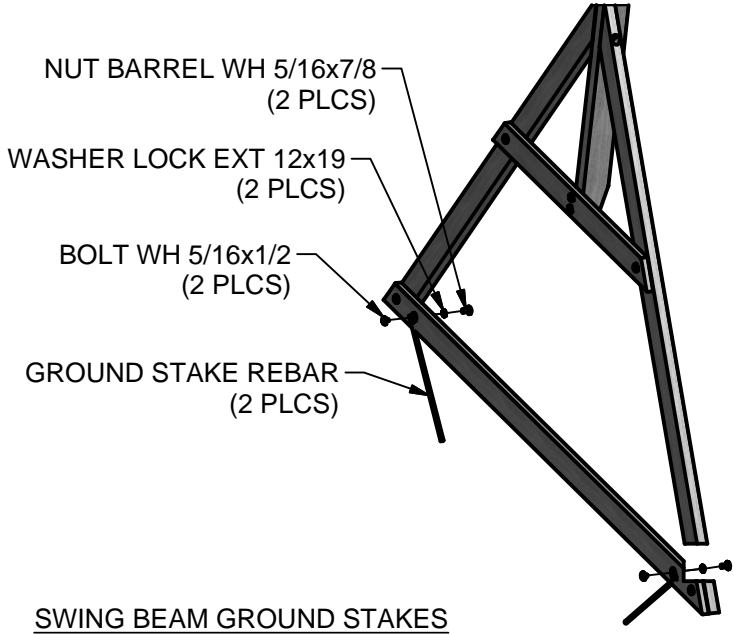

SWING BEAM GROUND STAKES

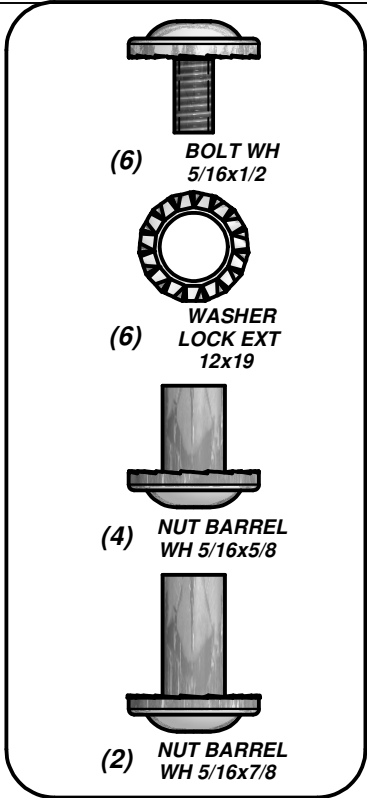

**STEP 39**

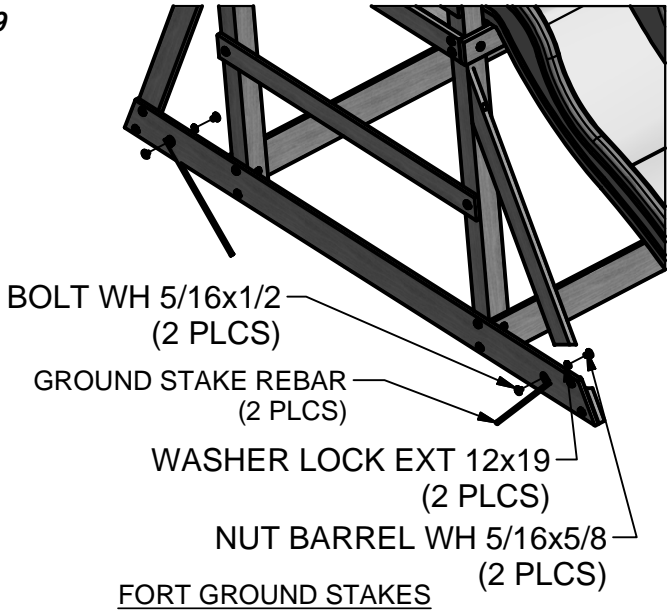

FORT GROUND STAKES

**STEP 40**

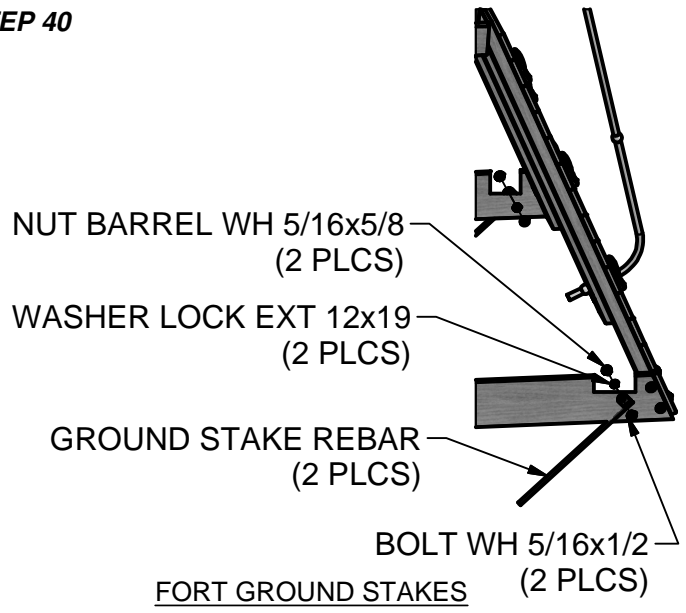

FORT GROUND STAKES

**FINAL STEP**

**DOUBLE CHECK EVERY BOLT, SCREW AND NUT FOR TIGHTNESS. MAKE SURE EVERY BOARD IS SECURE AND MAKE SURE THE PLAY SET IS LEVEL.**

**ENJOY YOUR NEW PLAY SET!**