



MANUFACTURED BY:
Backyard Discovery
3305 Airport Drive, Pittsburg, KS 66762
800-856-4445

Basepoint Business Centre: Rivermead Drive, Westlea, Swindon SN5 7EX Phone: 0800-118-2476
J.P. Coenstraat 7, The Bridge, The Hague, 2595 WP, Netherlands Phone: 0800-567-8990

HILLCREST

Swing Set

Model # 1808058B



WARNING

Adult Assembly Required.

Not suitable for children under 36 months due to small parts.

FOR DOMESTIC USE ONLY. INTENDED FOR OUTDOOR USE.



Please visit www.backyarddiscovery.com

For the most up to date assembly manual, to register your set, or to order replacement parts

Para obtener instrucciones en español, visite www.backyarddiscovery.com



EASY STEP-BY-STEP
3D INTERACTIVE INSTRUCTIONS

DOWNLOAD THE FREE APP



Made in China

INS-1808058B-A-HILLCREST-ENG 01-25-24

Owner's Manual - Basic Setup Dimensions & Assembly Notes

Place the set on level ground, not less than 6'-7" [2 m] from any structure or obstruction such as a fence, garage, house, overhanging branches, laundry lines, or electrical wires.

- While assembling unit, take time before and after each phase to make sure fort is level. If fort is not level, assembly will be difficult and improper assembly may result. Extra care must be taken to insure the fort is square.
- The safe play area refers to a zone extending 6'-7" (2 m) beyond the play product on all sides, including the space above the play product.

SAFE PLAY AREA DIAGRAM

Ground Dimensions

18'-3 3/4" [5.6 m] x 13'-5 1/2" [4.1 m]

Safe Play Area

31'-5 3/4" [9.6 m] x 26'-7 1/2" [8.1 m] x 16'-1 1/4" [4.9 m]

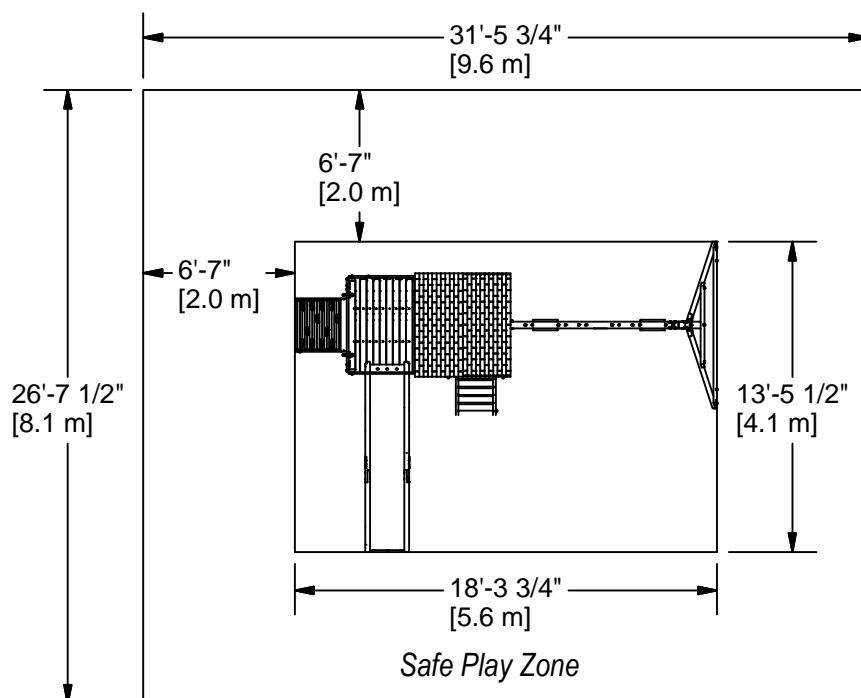

SAFE PLAY HEIGHT: 16'-1 1/4" [4.9 m]
MAXIMUM FALL HEIGHT: 6'-11 1/4" [2.1 m]

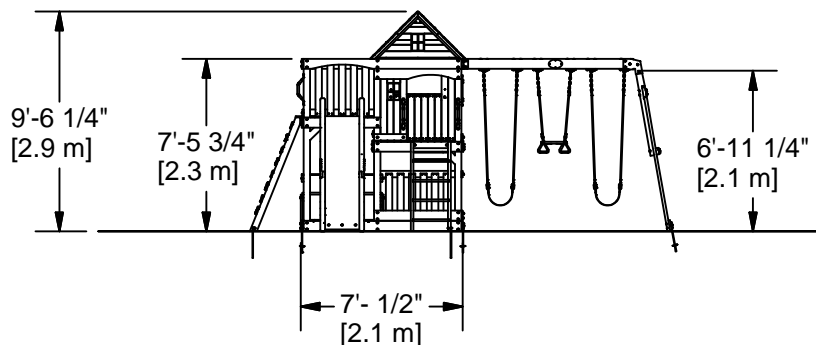

General Information:

Your set has been designed and engineered for children only and for residential use only.
A maximum of 150 lbs. per child is recommended for play activities designed for individual use.
A maximum of 120 lbs. per child is recommended for play activities designed for multiple child use.
A maximum of 9 children is recommended for this swing set.

Owner's Manual - Parts Identification

Wood Components (Not to Scale)

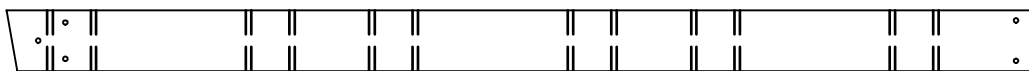

A50 | SWING BEAM - W4L15998
(x1) | 3 3/8"x5 1/4"x89 1/2" (86x134x2274)

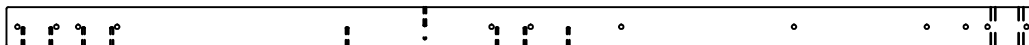

E01 | RIGHT FRONT TOWER LEG - W4L15999
(x1) | 1 3/8"x3 3/8"x89 1/2" (36x86x2274)

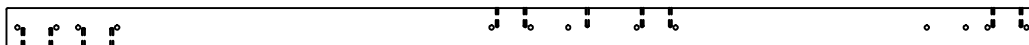

E02 | CENTER FRONT TOWER LEG - W4L16000
(x1) | 1 3/8"x3 3/8"x89 1/2" (36x86x2274)

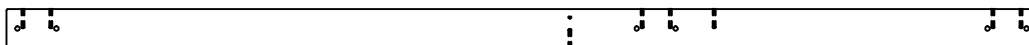

E03 | LEFT FRONT TOWER LEG - W4L16001
(x1) | 1 3/8"x3 3/8"x89 1/2" (36x86x2274)



E04 | DECK BRACE - W4L16002
(x8) | 1 3/8"x3 3/8"x15 1/2" (36x86x394)

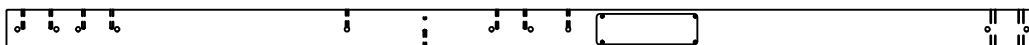

E05 | RIGHT REAR TOWER LEG - W2A03283
(x1) | 1 3/8"x3 3/8"x89 1/2" (36x86x2274)

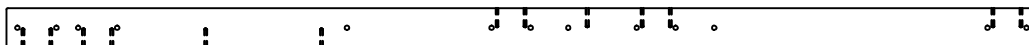

E06 | CENTER REAR TOWER LEG - W4L16005
(x1) | 1 3/8"x3 3/8"x89 1/2" (36x86x2274)

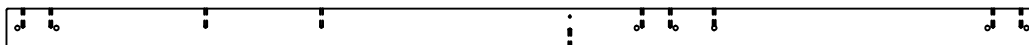

E07 | LEFT REAR TOWER LEG - W4L16006
(x1) | 1 3/8"x3 3/8"x89 1/2" (36x86x2274)

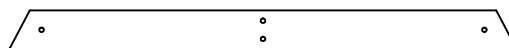

E50 | END SUPPORT - W4L16003
(x1) | 1 3/8"x3 3/8"x44 1/8" (36x86x1120)

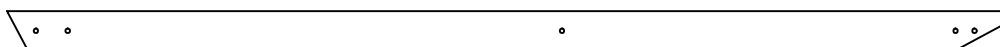

E51 | ANGLE BRACE - W4L16004
(x2) | 1 7/16"x3 3/8"x87 3/16" (36x86x2214)

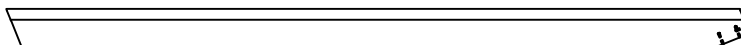

E72 | LEFT RAIL - W4L16007
(x1) | 1 3/8"x3 3/8"x64 1/2" (36x86x1640)

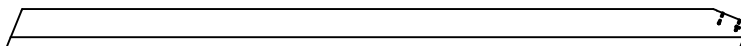

E73 | RIGHT RAIL - W4L16008
(x1) | 1 3/8"x3 3/8"x64 1/2" (36x86x1640)

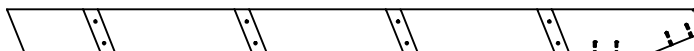

E74 | LEFT UPRIGHT - W4L16028
(x1) | 1 3/8"x3 3/8"x50 3/4" (36x86x1290)



E75 | RIGHT UPRIGHT - W4L16029
(x1) | 1 3/8"x3 3/8"x50 3/4" (36x86x1290)

Owner's Manual - Parts Identification

Wood Components (Not to Scale)

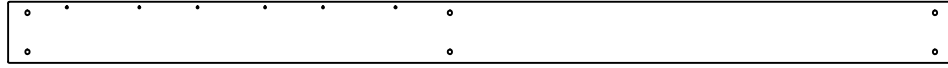

G01 | BASE BOARD - W4L16009
(x2) | 5/8"x5 1/4"x82 1/4" (16x134x2088)

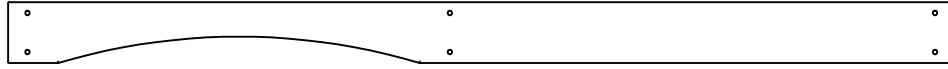

G02 | WALL RAIL - W4L16015
(x1) | 1"x5 1/4"x82 1/4" (24x134x2088)

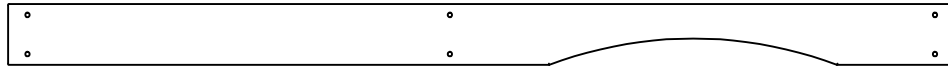

G03 | WALL RAIL - W4L16016
(x1) | 1"x5 1/4"x82 1/4" (24x134x2088)



G04 | FLOOR RAIL - W4L16017
(x2) | 5/8"x5 1/4"x49" (16x134x1244)

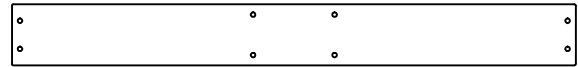

G05 | WALL RAIL/SWING MOUNT - W4L16018
(x1) | 1"x5 1/4"x49" (24x134x1244)

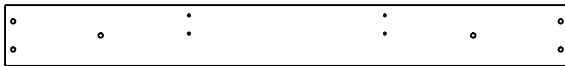

G06 | FLOOR RAIL - W4L16020
(x1) | 1"x5 1/4"x49" (24x134x1244)

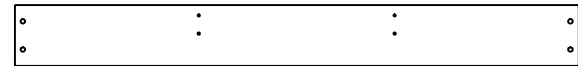

G07 | FLOOR RAIL - W4L16021
(x2) | 1"x5 1/4"x49" (24x134x1244)



G08 | WALL RAIL - W4L16022
(x2) | 1"x5 1/4"x49" (24x134x1244)

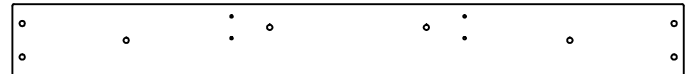

G09 | FLOOR RAIL - W4L16036
(x1) | 1"x5 1/4"x49" (24x134x1244)



G10 | FLOOR RAIL - W4L16010
(x1) | 1"x5 1/4"x45 1/2" (24x134x1156)



G11 | PICNIC TABLE TOP - W4L16011
(x2) | 5/8"x5 1/4"x42" (16x134x1066)

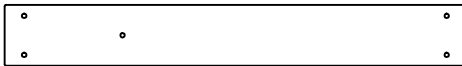

G12 | FLOOR RAIL - W4L16012
(x2) | 1"x5 1/4"x40 1/8" (24x134x1018)

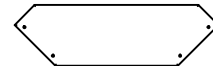

G13 | SAND BOX SEAT - W4L16013
(x2) | 1"x5 1/4"x17 3/4" (24x134x450)

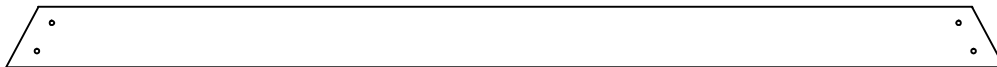

G14 | GROUND BOARD - W4L16019
(x1) | 15/16"x5 1/4"x86 11/16" (24x134x2202)

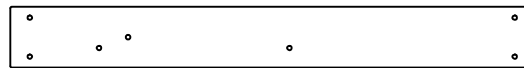

G15 | FLOOR RAIL - W4L16014
(x1) | 1"x5 1/4"x45 1/2" (24x134x1156)



H01 | FLOOR JOIST - W4L16023
(x2) | 1"x3 3/8"x45 1/2" (24x86x1156)

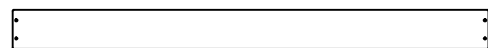

H02 | PICNIC TABLE SEAT - W4L16025
(x2) | 1"x3 3/8"x41 3/8" (24x86x1050)



H03 | FLOOR JOIST - W4L16026
(x2) | 1"x3 3/8"x40 1/8" (24x86x1018)

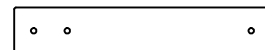

H04 | SEAT UPRIGHT - W4L16027
(x2) | 1"x3 3/8"x19" (24x86x482)

Owner's Manual - Parts Identification

Wood Components (Not to Scale)



H05 | BOTTOM FLOOR BOARD SUPPORT - W4L16024
(x10) | 1"x3 3/8"x5 1/4" (24x86x134)

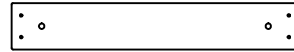

H06 | LADDER MOUNT - W4L16088
(x1) | 1"x3 3/8"x21" (24x86x532)

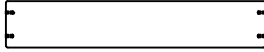

H07 | LADDER RUNG - W4L16030
(x4) | 15/16"x3 3/8"x18 7/8" (24x86x480)

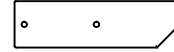

H08 | TABLE SUPPORT - W4L16031
(x2) | 1"x3 3/8"x12" (24x86x306)

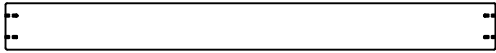

H09 | FLOOR JOIST - W4L16032
(x2) | 1"x3 3/8"x35 3/4" (24x86x908)



H10 | ATTACHMENT BOARD - W4L16045
(x1) | 1"x3 3/8"x27 7/8" (24x86x707)

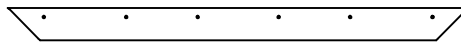

J01 | ROOF RAFTER - W4L16033
(x4) | 1"x2 3/8"x33 5/8" (24x60x854)

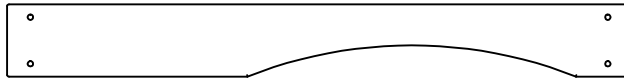

K01 | WALL RAIL - W4L16034
(x1) | 5/8"x5 1/4"x45 1/2" (16x134x1156)

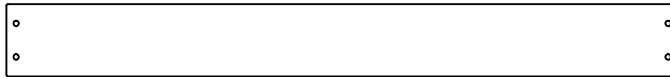

K02 | BASE/SAND BOX BOARD - W4L16035
(x3) | 5/8"x5 1/4"x49" (16x134x1244)



K03 | GROUND BOARD - W4L16038
(x2) | 5/8"x5 1/4"x45 1/2" (16x134x1156)

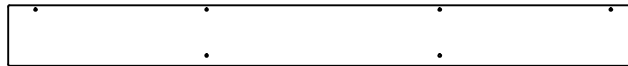

L01 | OUTSIDE FILLER FLOOR BOARD - W4L16039
(x3) | 5/8"x4 3/8"x46" (16x112x1168)



L02 | WALL BOARD - W4L16040
(x4) | 5/8"x4 3/8"x18" (16x112x456)

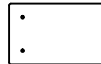

L03 | WALL BOARD - W4L16041
(x4) | 5/8"x4 3/8"x7" (16x112x178)

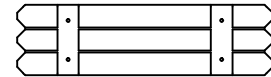

L04 | WINDOW SHUTTER - W4L16042
(x3) | 5/8"x4 3/8"x16" (16x112x406)

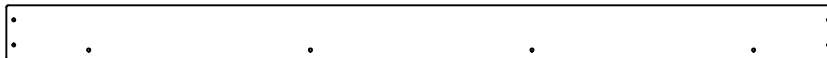

M01 | ROOF CAP - W4L16043
(x2) | 5/8"x3 3/8"x51 7/8" (16x86x1318)

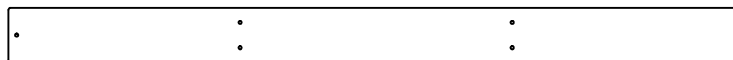

M02 | FLOOR BOARD - W4L16055
(x1) | 5/8"x3 3/8"x46" (16x86x1168)

Owner's Manual - Parts Identification

Wood Components (Not to Scale)



M03 | FLOOR BOARD - W4L16063
(x2) | 5/8"x3 3/8"x50 7/8" (16x86x1292)

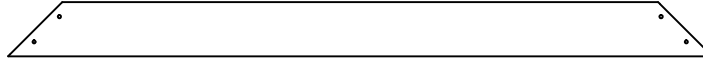

M04 | GABLE BOARD - W4L16065
(x2) | 5/8"x3 3/8"x44" (16x86x1118)

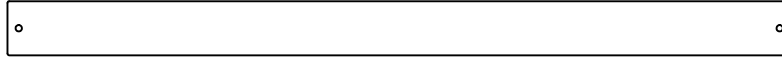

M05 | WALL RAIL - W4L16066
(x3) | 5/8"x3 3/8"x49" (16x86x1244)

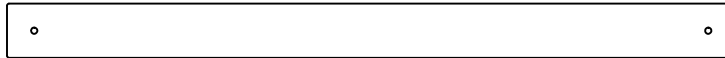

M06 | WALL RAIL - W4L16067
(x2) | 5/8"x3 3/8"x45 1/2" (16x86x1156)

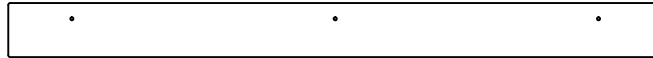

M07 | WALL CAP - W4L16068
(x2) | 5/8"x3 3/8"x40 7/8" (16x86x1038)

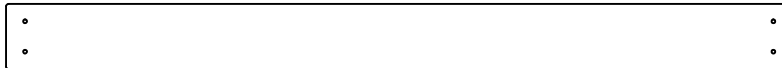

M08 | WALL BOARD - W4L16074
(x9) | 5/8"x3 3/8"x41" (16x86x1040)

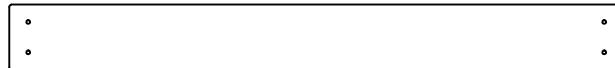

M09 | WALL BOARD - W4L16075
(x6) | 5/8"x3 3/8"x32" (16x86x812)



M10 | WALL BOARD - W4L16044
(x1) | 5/8"x3 3/8"x35" (16x86x888)



M11 | WALL RAIL - W4L16047
(x1) | 5/8"x3 3/8"x40 1/8" (16x86x1018)

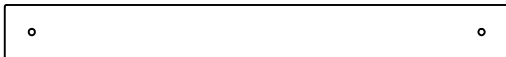

M12 | WINDOW TRIM - W4L16048
(x1) | 5/8"x3 3/8"x31 1/2" (16x86x800)

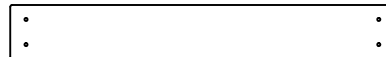

M13 | WALL BOARD - W4L16049
(x7) | 5/8"x3 3/8"x24" (16x86x610)

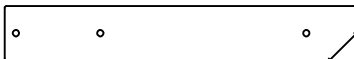

M14 | PICNIC SEAT SUPPORT - W4L16050
(x2) | 5/8"x3 3/8"x22" (16x86x558)

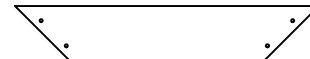

M15 | GABLE BOARD - W4L16051
(x2) | 5/8"x3 3/8"x19" (16x86x482)

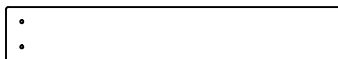

M16 | WALL BOARD - W4L16052
(x2) | 5/8"x3 3/8"x21" (16x86x532)

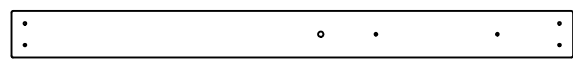

M17 | WALL BOARD - W4L16090
(x2) | 5/8"x3 3/8"x41" (16x86x1040)

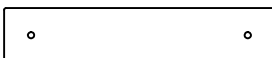

M18 | WALL RAIL - W4L16053
(x1) | 5/8"x3 3/8"x16 7/8" (16x86x430)

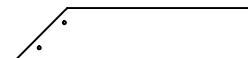

M19 | GABLE BOARD - W4L16054
(x4) | 5/8"x3 3/8"x15 1/4" (16x86x387)

Owner's Manual - Parts Identification

Wood Components (Not to Scale)

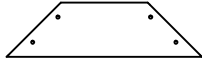

M20 | GABLE BOARD - W4L16056
(x2) | 5/8"x3 3/8"x12 1/4" (16x86x310)

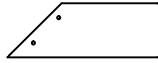

M22 | GABLE BOARD - W4L16058
(x4) | 5/8"x3 3/8"x9 1/2" (16x86x241)

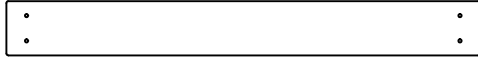

M24 | WALL BOARD - W4L16061
(x7) | 5/8"x3 3/8"x29 5/8" (16x86x752)



M26 | WALL BOARD - W4L16091
(x2) | 5/8"x3 3/8"x29 5/8" (16x86x752)



M28 | WALL BOARD - W4L16064
(x1) | 5/8"x3 3/8"x35" (16x86x888)

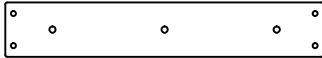

M70 | SLIDE BED SUPPORT - W100935
(x1) | 5/8"x3 3/8"x19 7/8" (16x86x505)

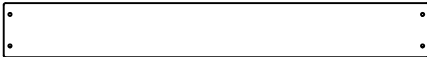

M74 | ROCK WALL BOARD - W4L16071
(x10) | 5/8"x3 3/8"x26 5/8" (16x86x675)

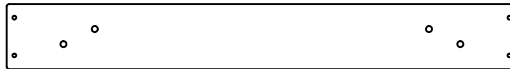

M76 | ROCK WALL BOARD - W4L16073
(x4) | 5/8"x3 3/8"x26 5/8" (16x86x675)

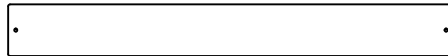

M108 | TOP BOARD - W4L16046
(x1) | 5/8"x3 1/4"x27 7/8" (16x82x707)



N01 | FLOOR BOARD - W4L16076
(x1) | 5/8"x2 3/8"x50 7/8" (16x60x1292)

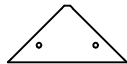

N02 | MENDING PLATE - W4L16077
(x2) | 5/8"x2 3/8"x5" (16x60x126)



N04 | GABLE BOARD - W4L16079
(x4) | 5/8"x2 3/8"x11 7/8" (16x60x301)

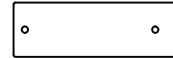

M21 | WALL RAIL - W4L16057
(x2) | 5/8"x3 3/8"x10 1/2" (16x86x268)

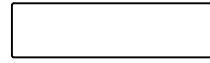

M23 | WINDOW TRIM - W4L16059
(x2) | 5/8"x3 3/8"x12 7/8" (16x86x328)

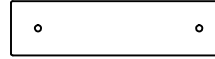

M25 | TABLE SUPPORT - W4L16037
(x2) | 5/8"x3 3/8"x13 1/2" (16x86x342)

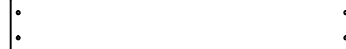

M27 | BOTTOM WALL BOARD - W4L16062
(x13) | 5/8"x3 3/8"x21 3/8" (16x86x544)



M29 | WALL BOARD - W4L16060
(x2) | 5/8"x3 3/8"x5" (16x86x126)

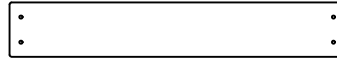

M73 | REAR SUPPORT - W4L16070
(x1) | 5/8"x3 3/8"x21" (16x86x532)



M75 | ROCK WALL BOARD - W4L16072
(x4) | 5/8"x3 3/8"x26 5/8" (16x86x675)

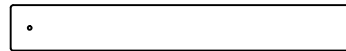

N03 | WALL BOARD - W4L16078
(x2) | 5/8"x2 3/8"x18" (16x60x456)



N05 | WALL BOARD - W4L16080
(x2) | 5/8"x2 3/8"x7" (16x60x178)

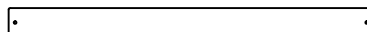

N06 | FILLER BOARD - W4L16089
(x1) | 5/8"x2 1/8"x26 5/8" (16x54x675)

Owner's Manual - Parts Identification

Wood Components (Not to Scale)



O01 | WALL SUPPORT - W4L16081
(x6) | 5/8"x1 3/8"x13" (16x34x330)

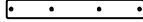

O02 | WALL SUPPORT - W4L16082
(x1) | 5/8"x1 3/8"x10" (16x34x254)



O03 | SAFETY RAIL - W4L16083
(x1) | 5/8"x1 3/8"x20 1/2" (16x34x520)



O04 | WINDOW SHUTTER SLAT - W4L16084
(x6) | 5/8"x1 3/8"x5 3/8" (16x34x136)

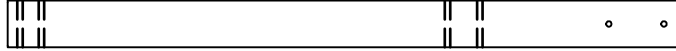

SP50 | SWING BEAM SUPPORT - W4L16085
(x1) | 3 3/8"x3 3/8"x49 3/8" (86x86x1254)



T01 | SEAT SUPPORT - W4L16086
(x4) | 1"x1 3/8"x4 3/8" (24x34x128)

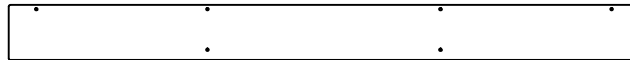

Y01 | OUTSIDE FILLER FLOOR BOARD - W4L16087
(x1) | 5/8"x4"x46" (16x102x1168)

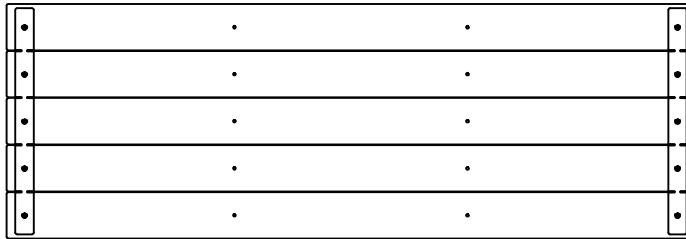

FP1 | FLOOR PANEL - W2A03281
(x1) | 1 5/8"x17 1/8"x50 1/4" (40x434x1276)

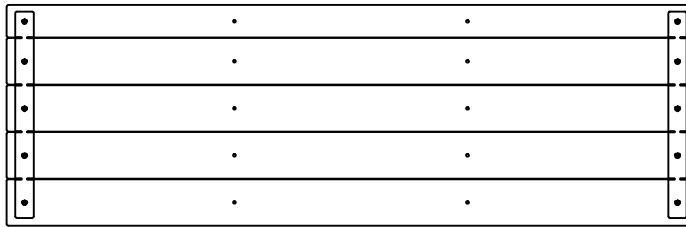

FP2 | FLOOR PANEL - W2A03282
(x1) | 1 5/8"x16 1/8"x50 1/4" (40x408x1276)

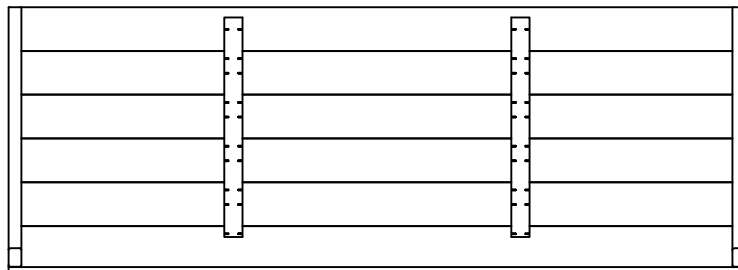

RP1 | ROOF PANEL - W2A03279
(x2) | 1 3/4"x19 1/4"x53 3/4" (45x490x1366)

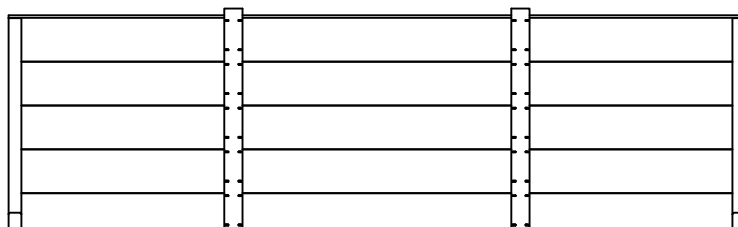

RP2 | ROOF PANEL - W2A03280
(x2) | 1 3/4"x16 1/4"x53 3/4" (45x417x1366)

Owner's Manual - Parts Identification

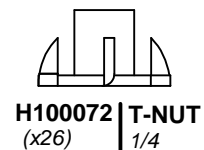
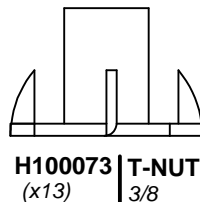
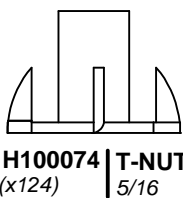
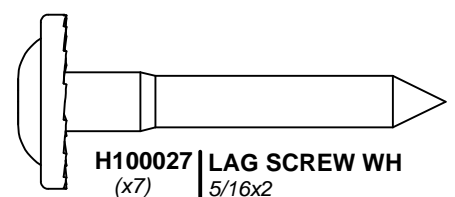
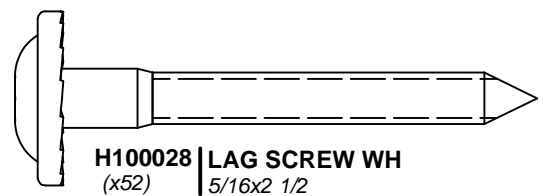
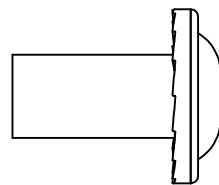
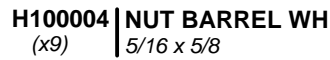
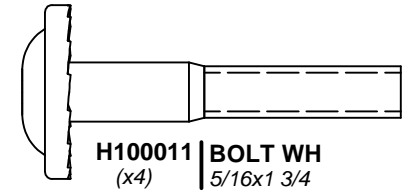
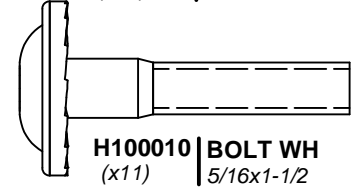
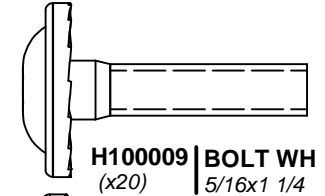
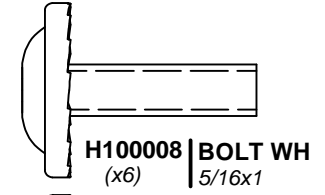
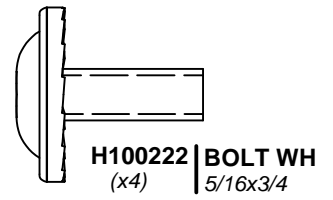
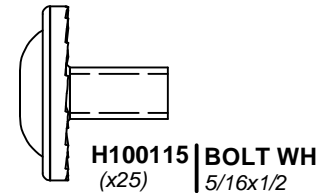
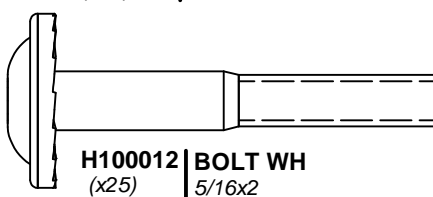
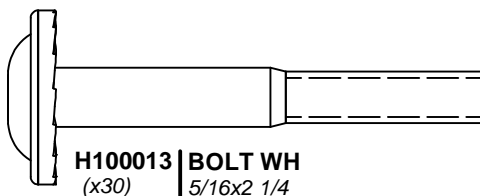
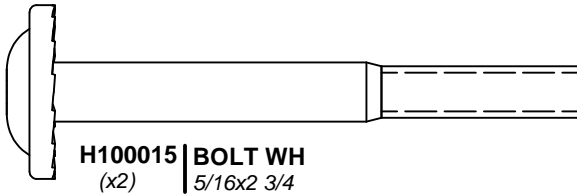
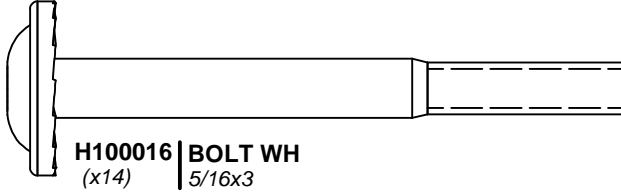
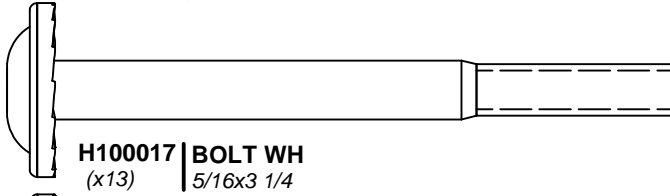
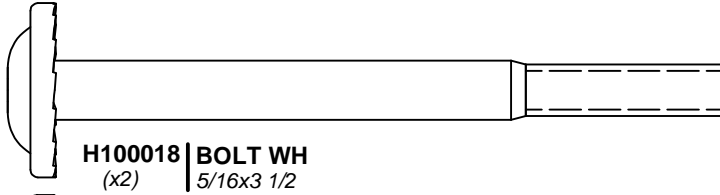
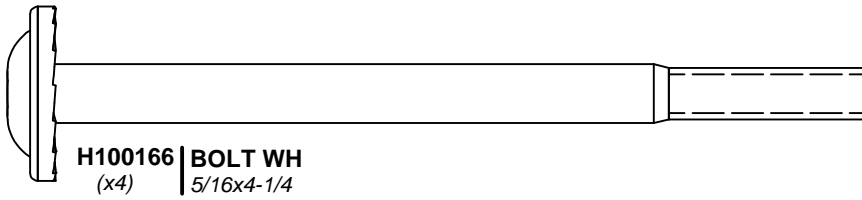
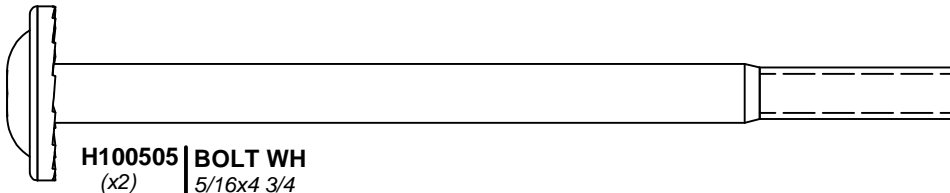

Owner's Manual - Parts Identification

Hardware Components

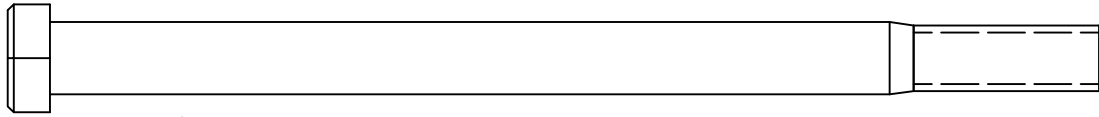

H100654 | BOLT HEX
(x13) | 3/8x5-1/2

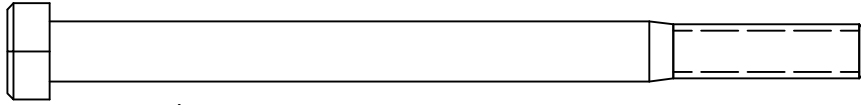

H100054 | BOLT HEX
(x2) | 5/16x4 1/4

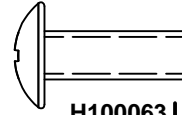

H100063 | BOLT PTH
(x26) | 1/4x3/4

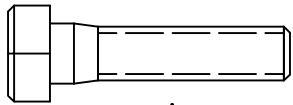

H100042 | BOLT HEX
(x4) | 5/16x1 1/4

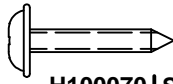

H100070 | SCREW PWH
(x22) | 8x3/4

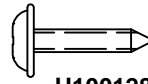

H100128 | SCREW PWH
(x2) | 8x5/8

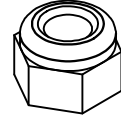

H100110 | NUT LOCK
(x2) | 5/16

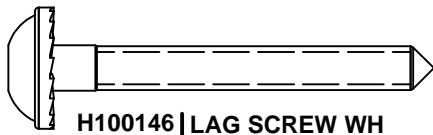

H100146 | LAG SCREW WH
(x9) | 1/4x2

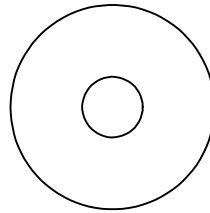

H100105 | WASHER FLAT
(x9) | 8x27

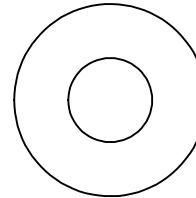

H100102 | WASHER FLAT
(x13) | 11x25

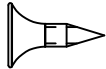

H100124 | SCREW PFH
(x4) | 8 x 1/2

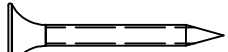

H100088 | SCREW PFH
(x305) | 8x1 1/8

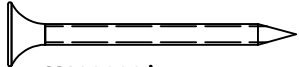

H100086 | SCREW PFH
(x282) | 8x1 1/2

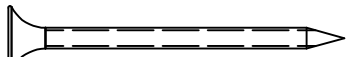

H100089 | SCREW PFH
(x65) | 8x1 3/4

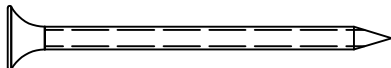

H100111 | SCREW PFH
(x7) | 8x2

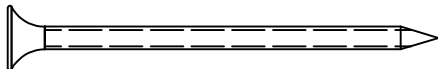

H100091 | SCREW PFH
(x26) | 8x2 1/4

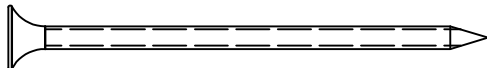

H100090 | SCREW PFH
(x73) | 8x2 1/2"

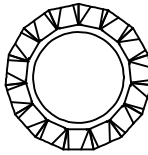

H100031 | WASHER LOCK EXT
(x12) | 12x19

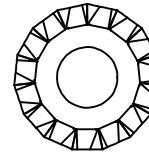

H100030 | WASHER LOCK EXT
(x155) | 8x19

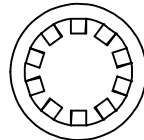

H100107 | WASHER LOCK INT
(x13) | 10x18

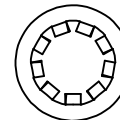

H100108 | WASHER LOCK INT
(x26) | 8x15

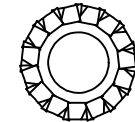

H100138 | WASHER LOCK EXT
(x9) | 6x15

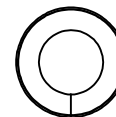

H100095 | WASHER SPLIT
(x4) | 5/16

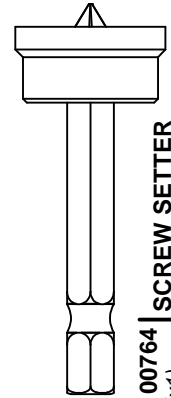

H100764 | SCREW SETTER
(x1)

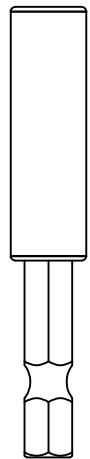

H101100 | MAGNETIC DRIVER
(x1)

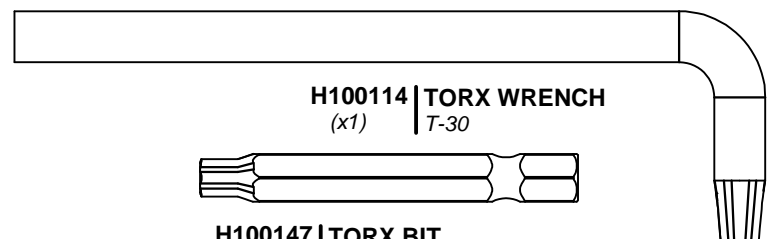

H100114 | TORX WRENCH
(x1) | T-30

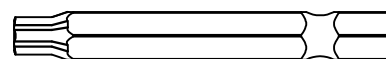

H100147 | TORX BIT
(x1) | T-30

Owner's Manual - Parts Identification

Accessory Components (Not to Scale)



A100035 | SLIDE BED 10' LIGHT GREEN
(x1)

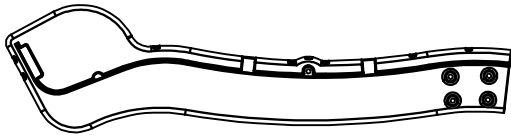

A6P00484 | SLIDE RAIL 10'
BOTTOM RIGHT GREEN
(x1)

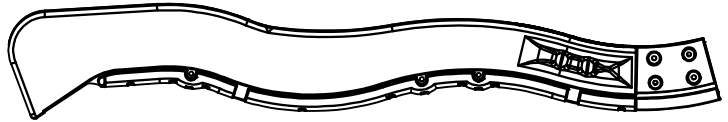

A6P00486 | SLIDE RAIL 10'
TOP RIGHT GREEN
(x1)

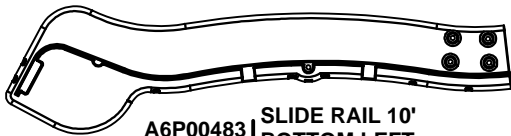

A6P00483 | SLIDE RAIL 10'
BOTTOM LEFT GREEN
(x1)

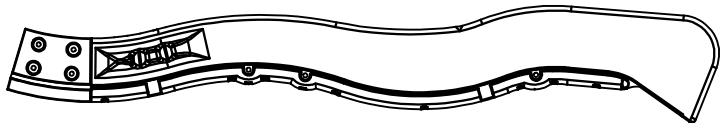

A6P00485 | SLIDE RAIL 10'
TOP LEFT GREEN
(x1)

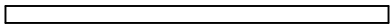

A6P00487 | SLIDE TUBE SUPPORT
(x4)

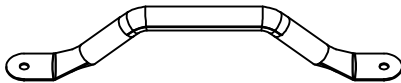

A100118 | HAND GRIP
METAL GREEN
381 c/c
(x4)

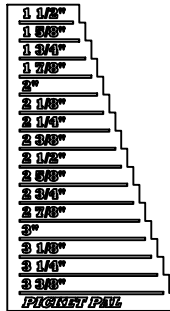

A6P00410 | PICKET PAL
(x1)

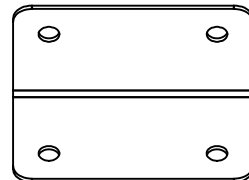

A100140 | L BRACKET
(x2) | 66x66x127



A4M01046 | L BRACKET
(x3) | 2.5x38x55x55

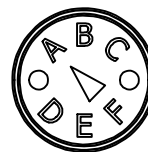

A100314 | "A" REVISION
(x1) TAG

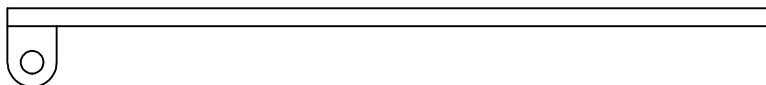

A4M00527 | GROUND STAKE
(x2) REBAR



A100178 | AUGER GROUND
(x6) STAKE

Owner's Manual - Parts Identification

Accessory Components (Not to Scale)

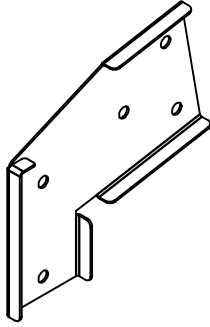

A100325 | SWING BEAM
(x1) | EXTENSION
BRACKET-LEFT

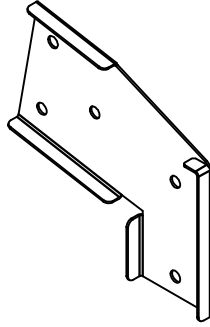

A100326 | SWING BEAM
(x1) | EXTENSION
BRACKET-RIGHT

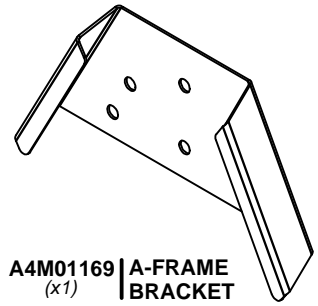

A4M01169 | A-FRAME
(x1) | BRACKET



A100027 | SWING SEAT GREEN 26"
(x2)

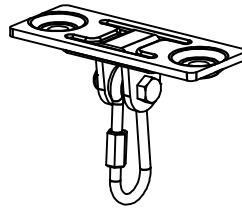

A4M00505 | SWING HANGER
(x6)

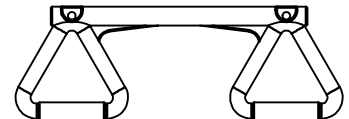

A6P00034 | TRAPEZE
(x1) | YELLOW

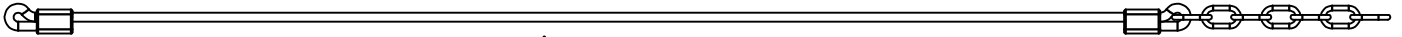

A100183 | ROPE-CHAIN GREEN 57"
(x4)

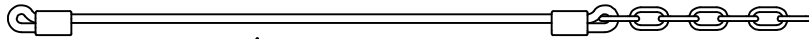

A100083 | ROPE-CHAIN GREEN 33"
(x2)

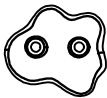

A6P00036 | GREEN HC ROCK #1
(x6)

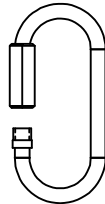

A100069 | QUICK LINK
(x6)

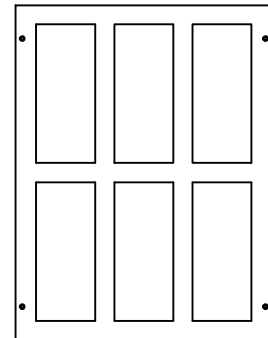

A100010 | PLASTIC WINDOW BYD GREEN 343x444.5
(x2)



A6P00037 | GREEN HC ROCK #2
(x6)



A100164 | BYD ID TAG
(x1)

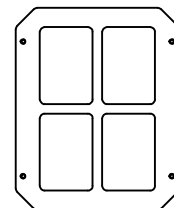

A100146 | WINDOW
(x3) | 216x267 GREEN

PRE-ASSEMBLY STEP 1 - SORTING PARTS

It is critical for ease of assembly that you take the time to sort and organize the wood and hardware.

WOOD PARTS:

- Organize wood parts by the three-digit, alpha-numeric number stamped on each board (ex. P01).
- If there are multiple boards with the same stamped number, stack those pieces together.
- Stamps can be found on the flat surface of the boards or on the end of the boards.
- Allow yourself plenty of room - the wood pieces can take up a significant amount of space.

NOTE: CARTONS ARE NOT ORGANIZED BY BOARD NUMBER.

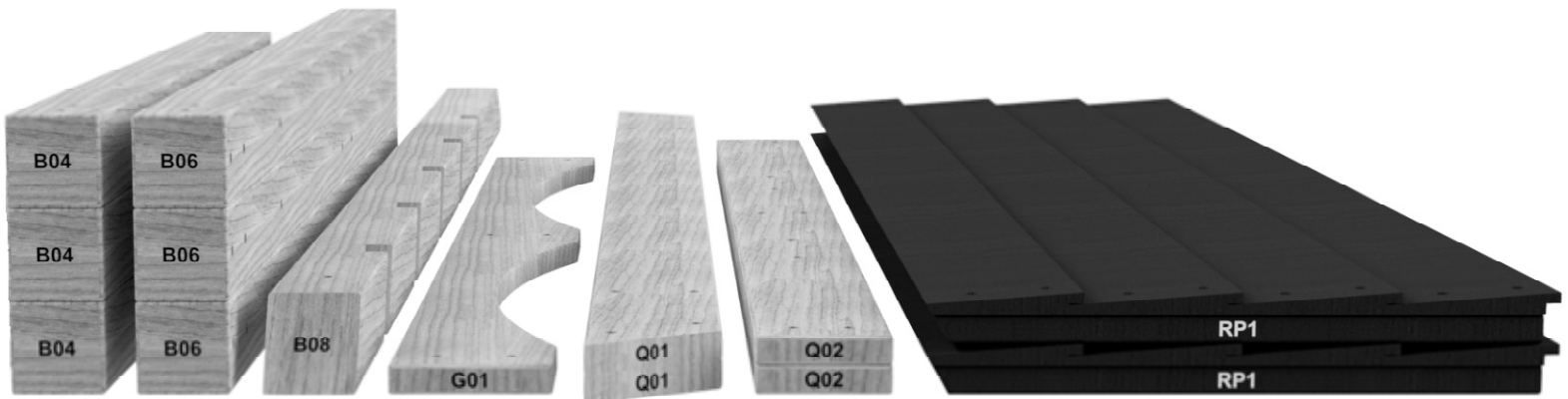

HARDWARE PARTS:

- We recommend that you have a separate table to organize the hardware.
- Hardware bags are printed with a seven-digit, alpha-numeric part number.
- You can organize your hardware by part number or group by hardware type (i.e. bolts, nuts, etc.).
- During assembly you only need to reference the last four digits of the number.

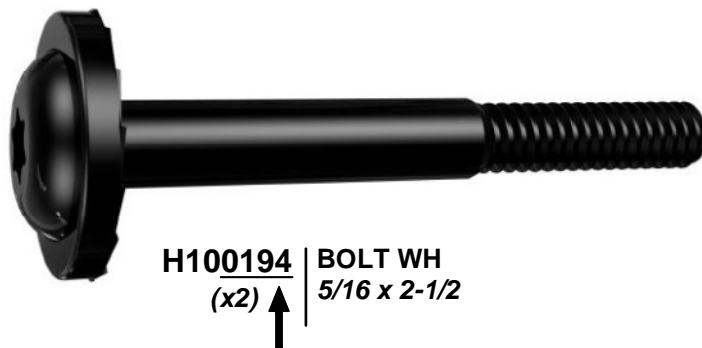

H100194 | BOLT WH
(x2) ↑ | 5/16 x 2-1/2

PRE-ASSEMBLY STEP 2 - TOOLS REQUIRED



*Cordless Drill or
Electric Drill*



*Drill Attachments:
Phillips Head*



*1/8", 3/16", 3/8" & 7/16"
Drill Bits*



Phillips Screw Driver



Open End Wrenches 1/2" & 9/16"



*3/8" Drive Ratchet, 1/2" &
9/16" STD Sockets 1/2" & 9/16"
Deep Sockets*



Claw Hammer



Rubber Mallet - Optional



Tape Measure

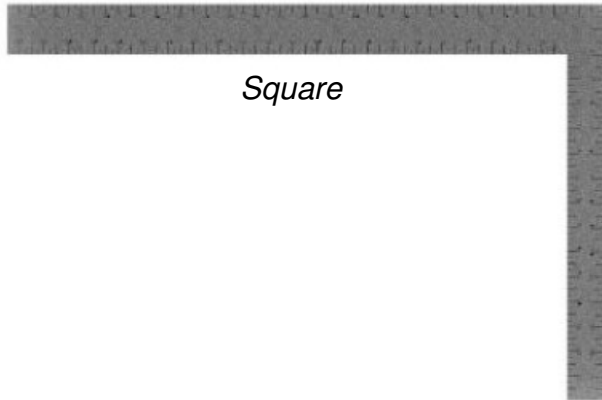

Square



Level 24"

PRE-ASSEMBLY STEP 3 - CHOOSE YOUR ASSEMBLY METHOD

There are several types of assembly instructions available to you.

1. *Printed Assembly Manual included with your set*
2. *BILT APP - 3D interactive instructions*
3. *Combination of the Printed Manual and BILT APP (Note: Step numbers can differ between the two methods)*

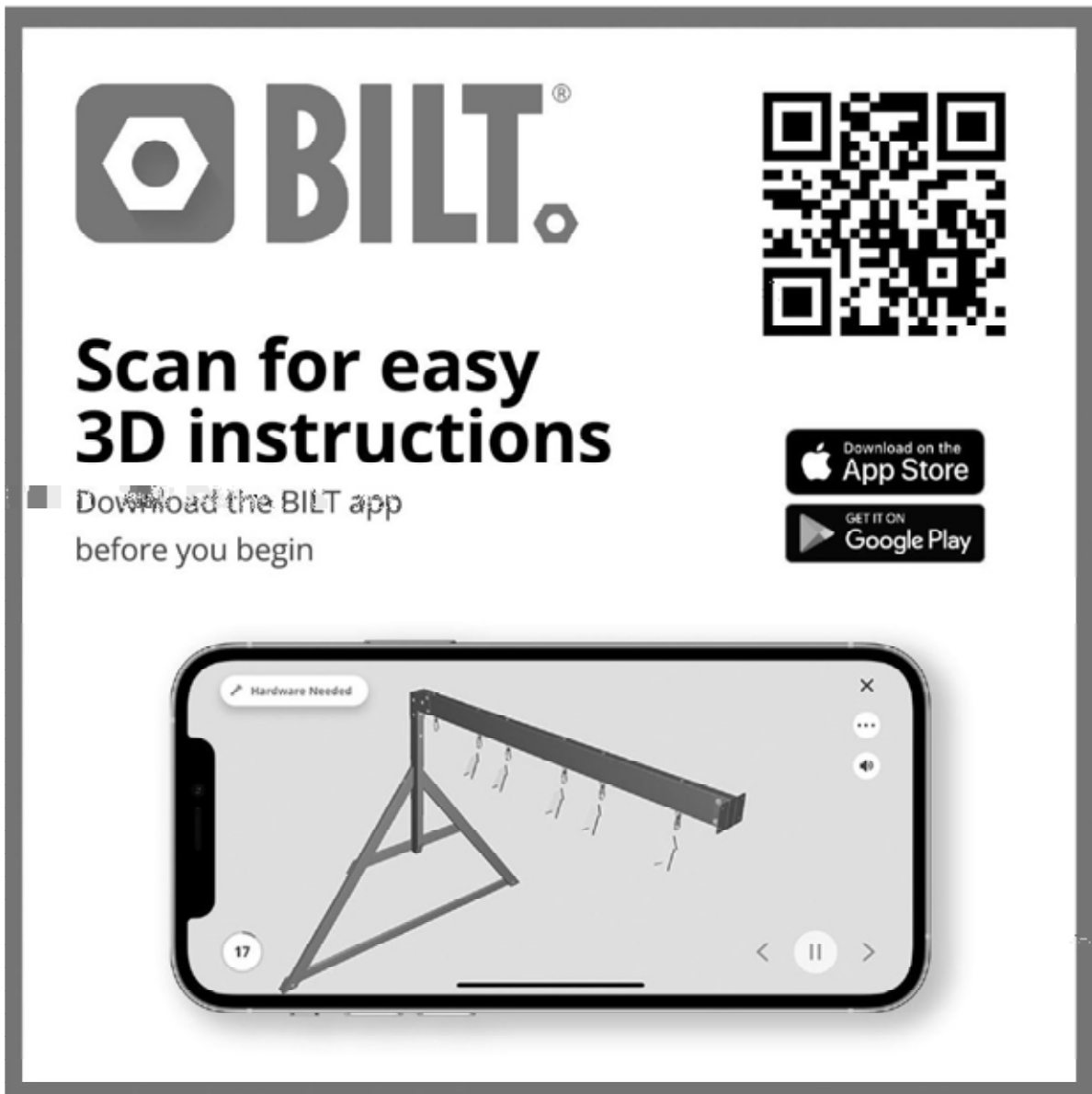

The graphic features the BILT logo (a hexagon with a dot) and the text "BILT.®" in a large, bold, sans-serif font. To the right is a large QR code. Below the logo, the text "Scan for easy 3D instructions" is written in a bold, sans-serif font. Underneath this, it says "Download the BILT app before you begin". To the right of the text are two buttons: "Download on the App Store" and "GET IT ON Google Play". At the bottom, a smartphone screen displays a 3D assembly instruction for a step labeled "17". The screen shows a 3D model of a metal frame with a horizontal bar being attached. The interface includes a "Hardware Needed" button at the top left, a close button (X) at the top right, a menu button (three dots) and a volume icon below it, and navigation arrows and a pause button at the bottom.

STEP 1 - LADDER

QTY	PART NUMBER	DESCRIPTION
8	H100091	SCREW PFH 8x2 1/4



E74 | LEFT UPRIGHT - W4L16028
(x1) | 1 3/8"x3 3/8"x50 3/4" (36x86x1290)

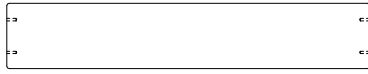

H07 | LADDER RUNG - W4L16030
(x4) | 15/16"x3 3/8"x18 7/8" (24x86x480)

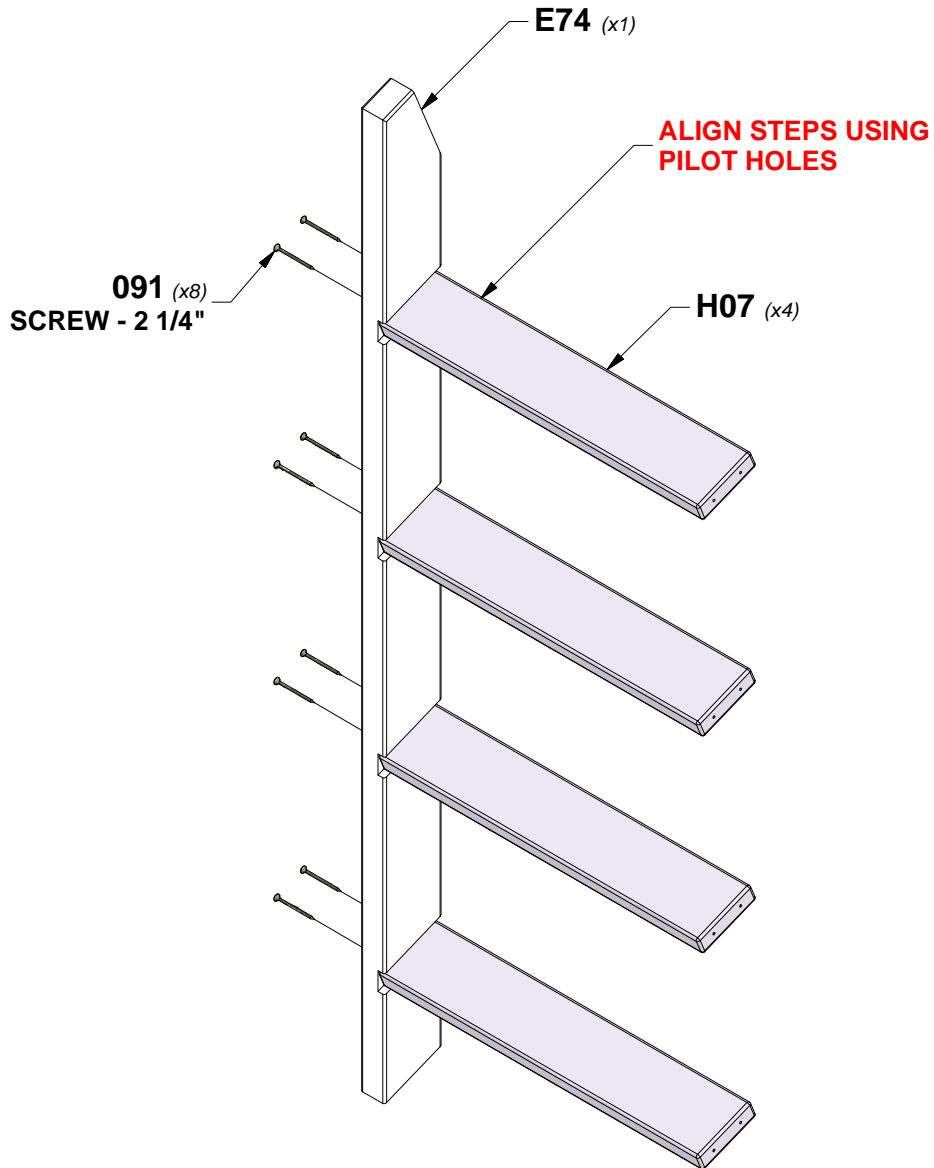

STEP 2 - LADDER

QTY	PART NUMBER	DESCRIPTION
8	H100091	SCREW PFH 8x2 1/4



E75 | RIGHT UPRIGHT - W4L16029
(x1) | 1 3/8"x3 3/8"x50 3/4" (36x86x1290)

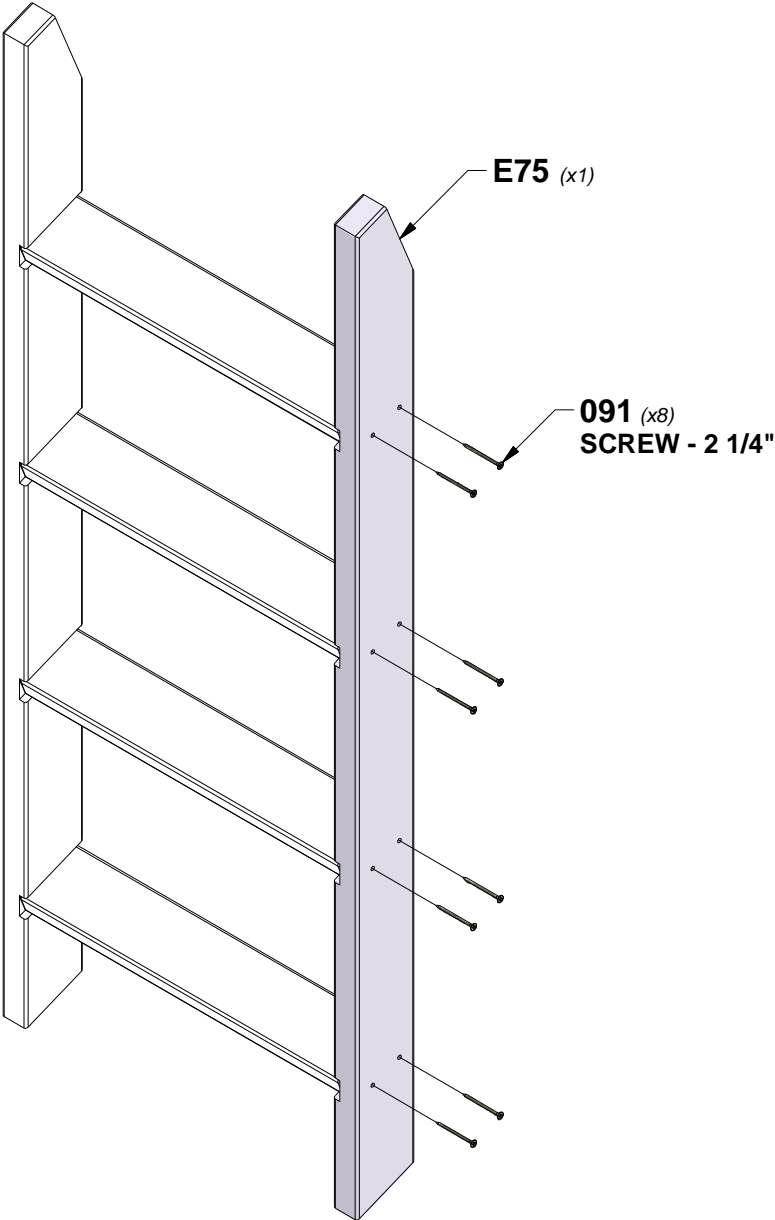

STEP 3 - LADDER

QTY	PART NUMBER	DESCRIPTION
4	H100091	SCREW PFH 8x2 1/4



M73 REAR SUPPORT - W4L16070
(x1) 5/8"x3 3/8"x21" (16x86x532)

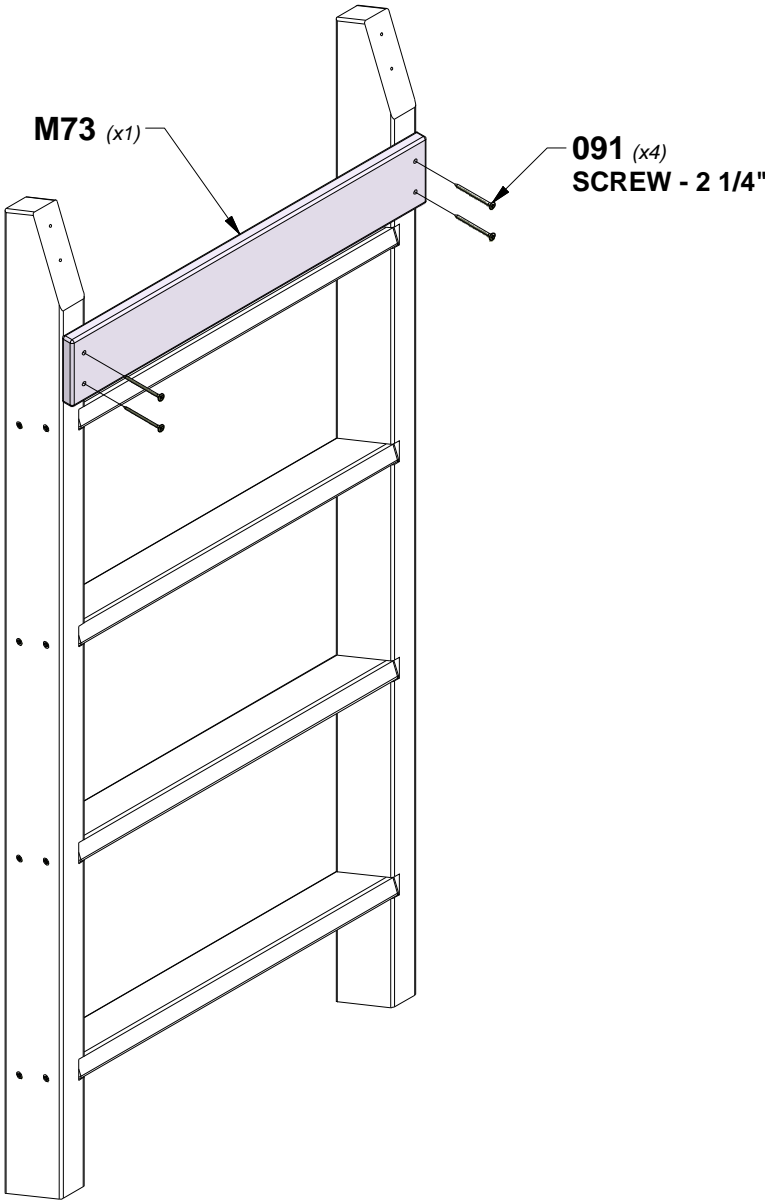

STEP 4 - LADDER

QTY	PART NUMBER	DESCRIPTION
4	H100091	SCREW PFH 8x2 1/4



H06 | LADDER MOUNT - W4L16088
(x1) | 1"x3 3/8"x21" (24x86x532)

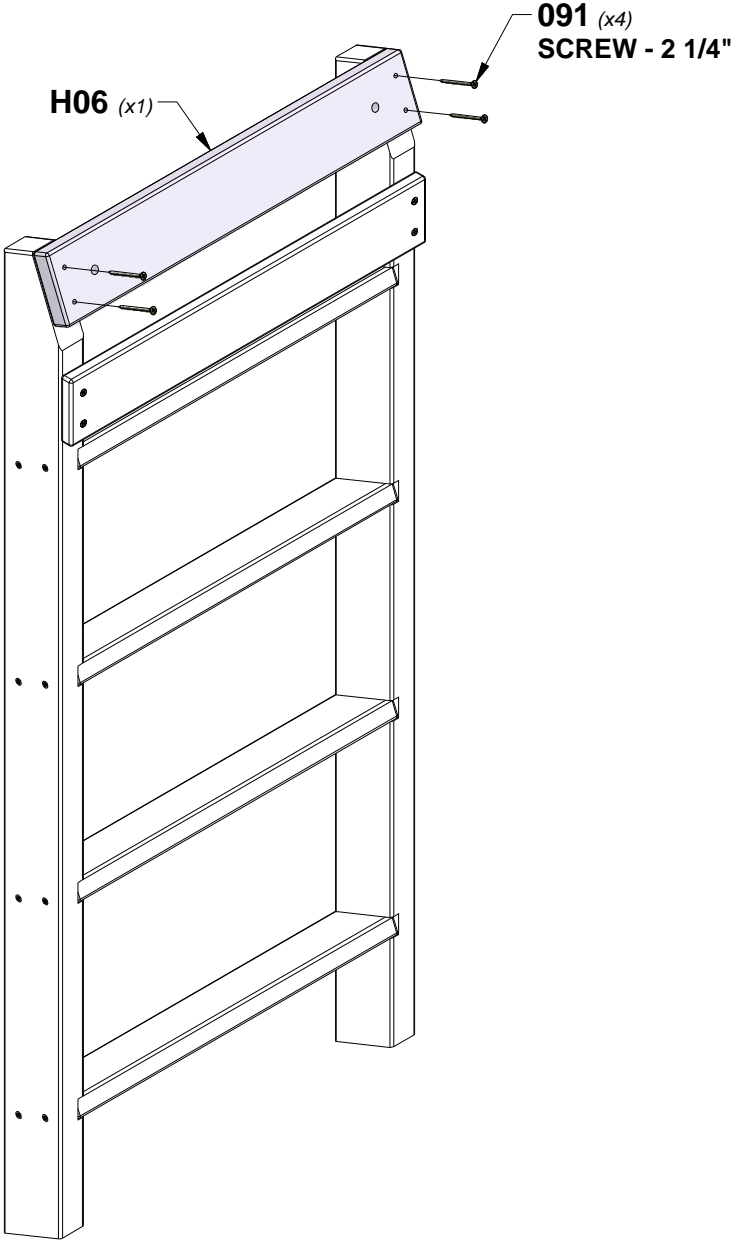

STEP 1 - ROCK WALL

QTY	PART NUMBER	DESCRIPTION
24	H100063	BOLT PTH 1/4x3/4
24	H100072	T-NUT 1/4
24	H100108	WASHER LOCK INT 8x15



M75 | ROCK WALL BOARD - W4L16072
(x4) 5/8"x3 3/8"x26 5/8" (16x86x675)

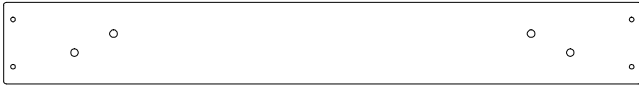

M76 | ROCK WALL BOARD - W4L16073
(x4) 5/8"x3 3/8"x26 5/8" (16x86x675)

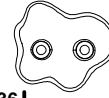

A6P00036 | GREEN HC ROCK #1
(x6)



A6P00037 | GREEN HC ROCK #2
(x6)

TIP:
INSTALL T-NUTS IN WOOD FIRST

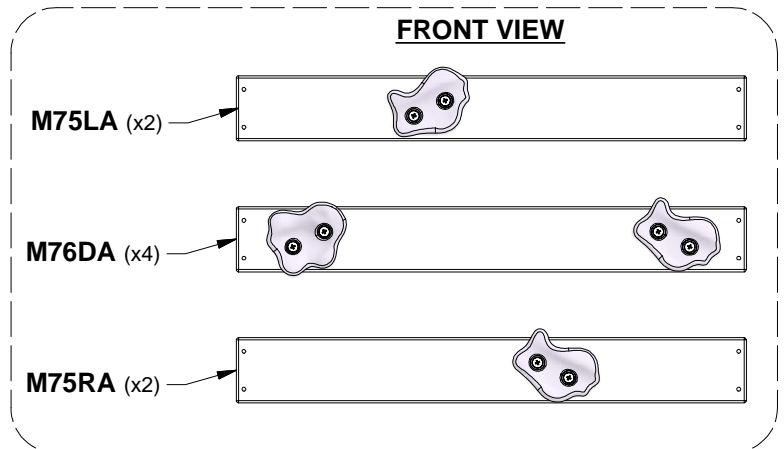
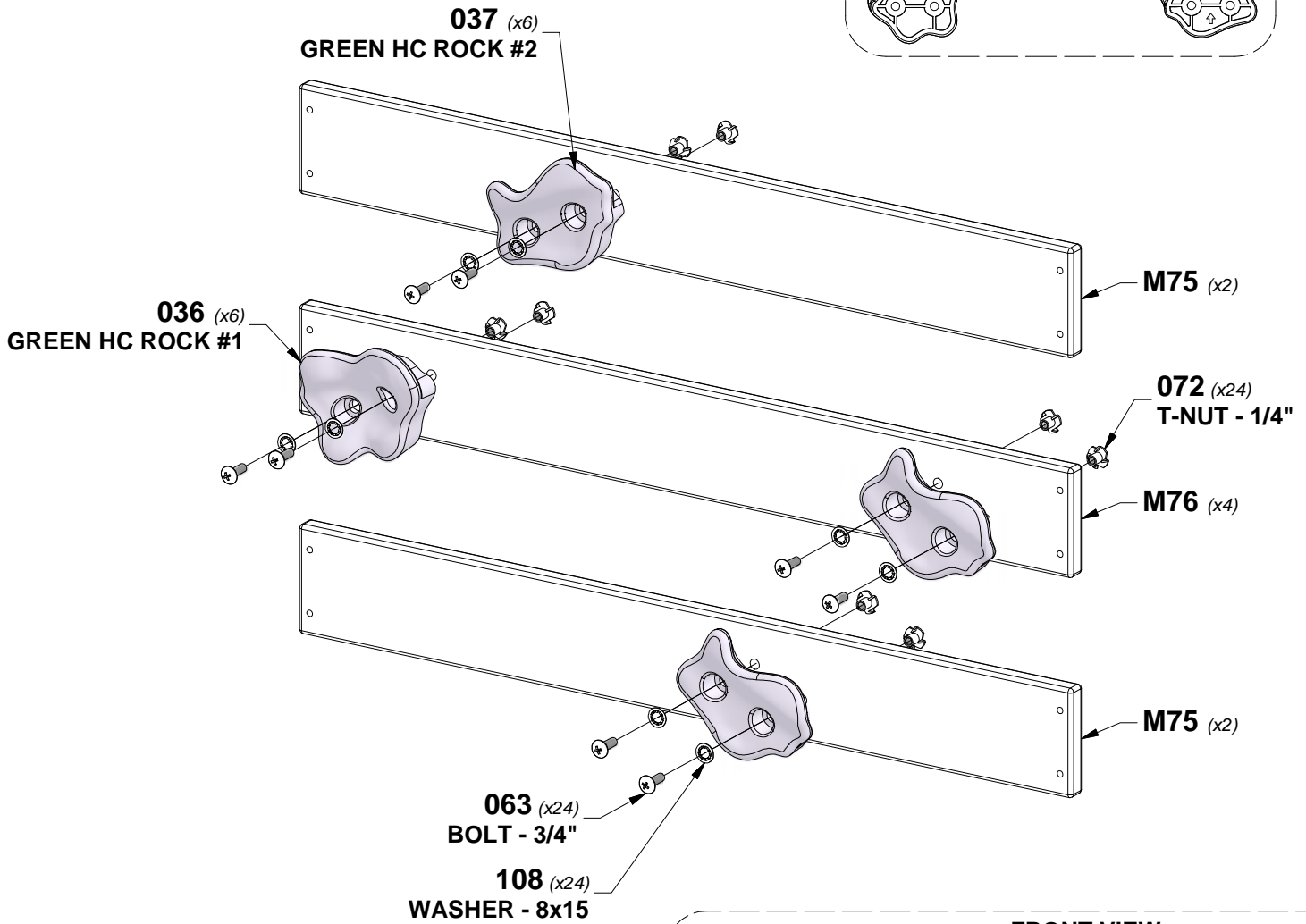
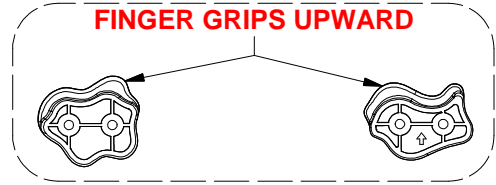

STEP 2 - ROCK WALL

QTY	PART NUMBER	DESCRIPTION
74	H100086	SCREW PFH 8x1-1/2"

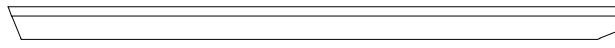
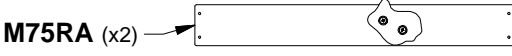
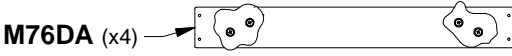

E72 | LEFT RAIL - W4L16007
(x1) | 1 3/8"x3 3/8"x64 1/2" (36x86x1640)

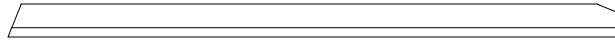

E73 | RIGHT RAIL - W4L16008
(x1) | 1 3/8"x3 3/8"x64 1/2" (36x86x1640)



M74 | ROCK WALL BOARD - W4L16071
(x10) | 5/8"x3 3/8"x26 5/8" (16x86x675)

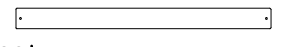

N06 | FILLER BOARD - W4L16089
(x1) | 5/8"x2 1/8"x26 5/8" (16x54x675)

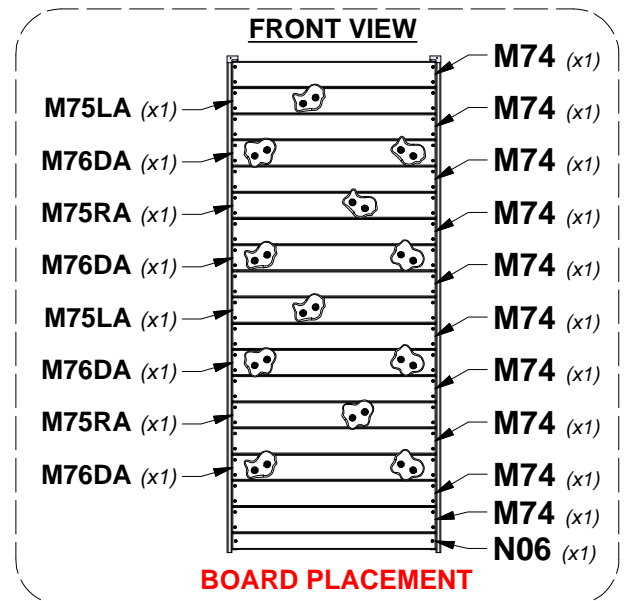
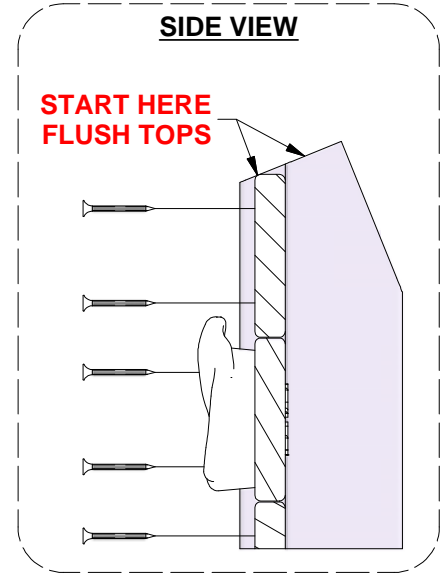
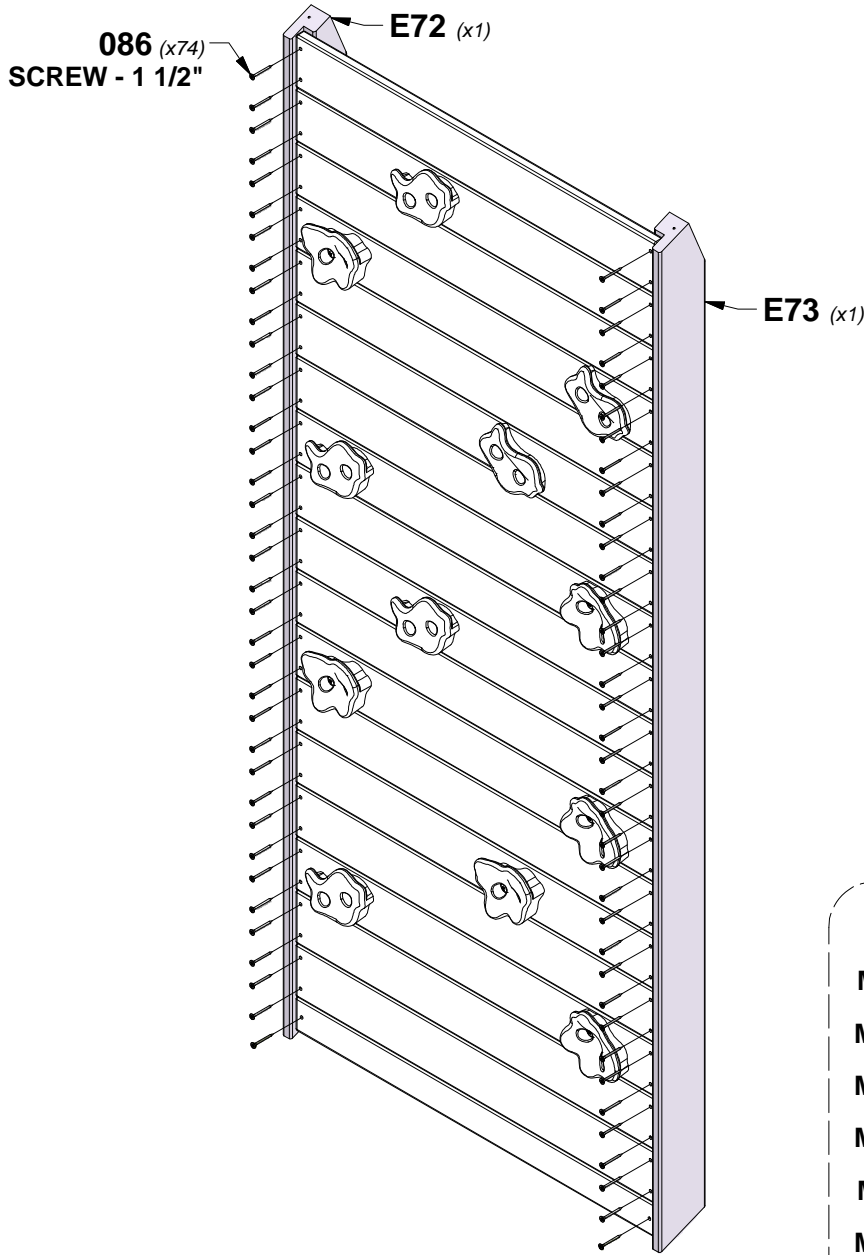

STEP 3 - ROCK WALL

QTY	PART NUMBER	DESCRIPTION
2	H100086	SCREW PFH 8x1-1/2"



M108 | TOP BOARD - W4L16046
(x1) | 5/8"x3 1/4"x27 7/8" (16x82x707)

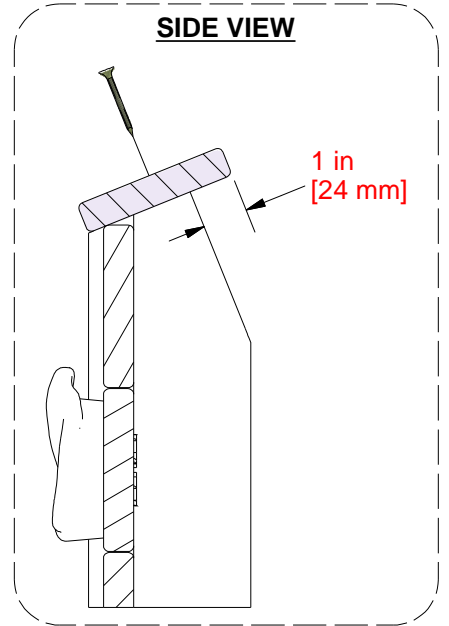
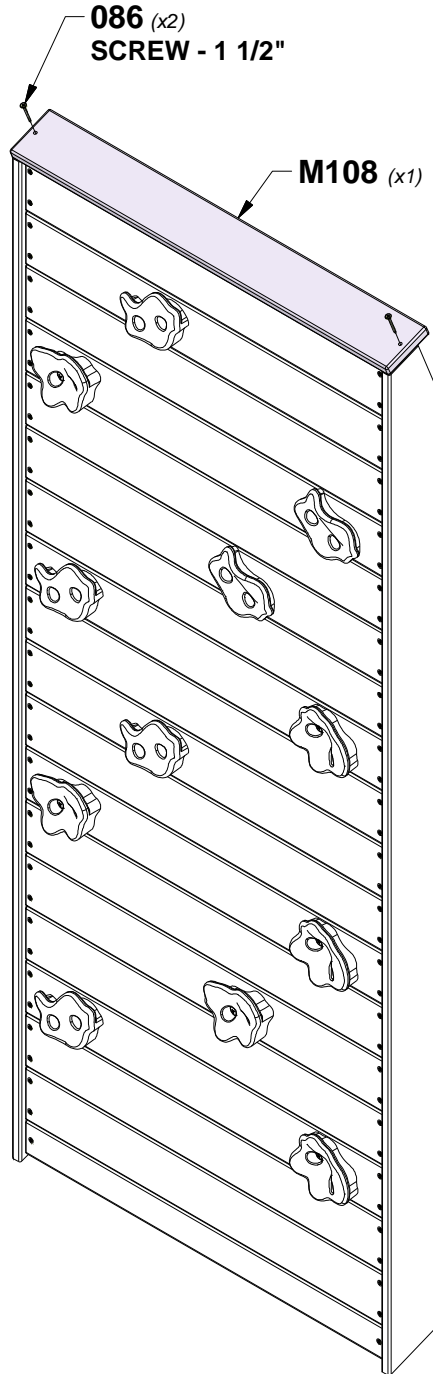

STEP 4 - ROCK WALL

QTY	PART NUMBER	DESCRIPTION
2	H100074	T-NUT 5/16
4	H100111	SCREW PFH 8x2"

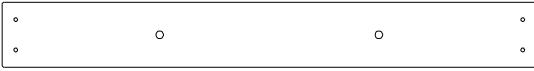

H10 | ATTACHMENT BOARD - W4L16045
 (x1) | 1"x3 3/8"x27 7/8" (24x86x707)

TIP:
INSTALL T-NUTS IN WOOD FIRST

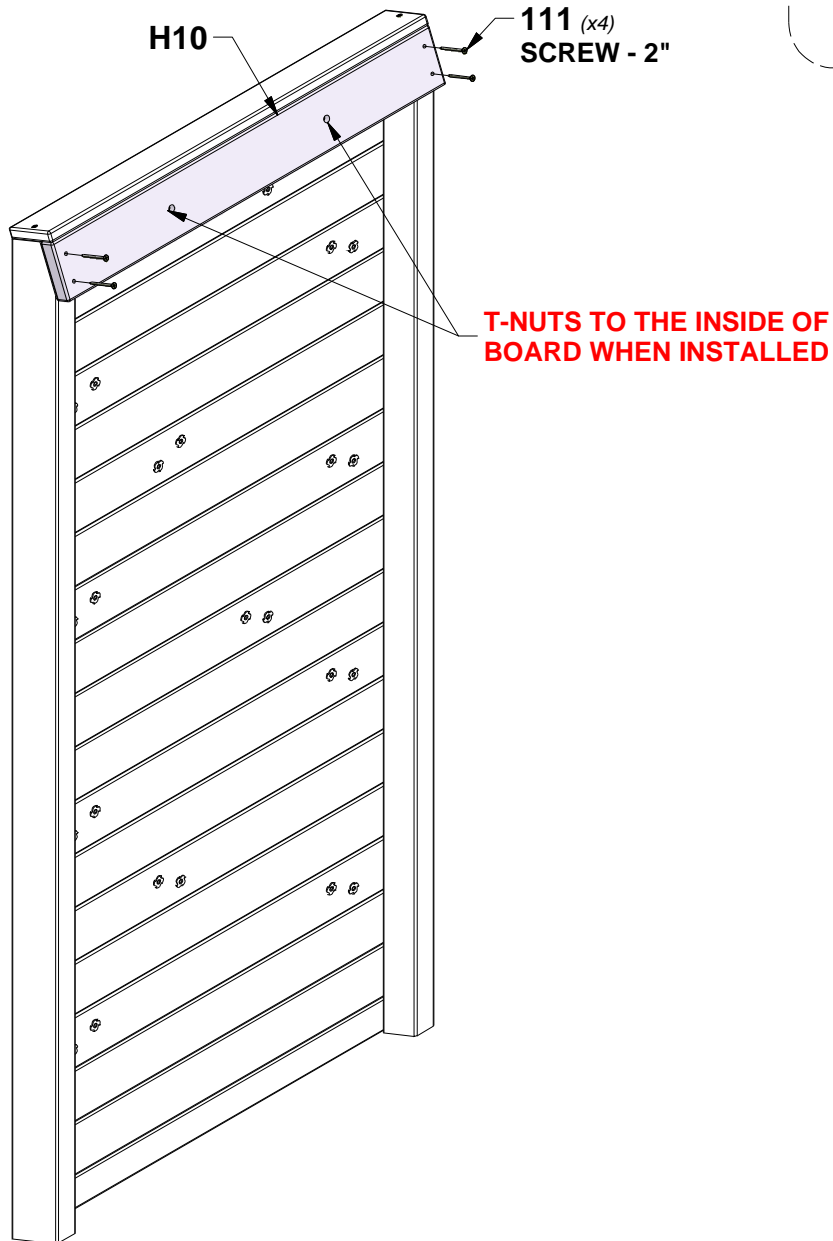
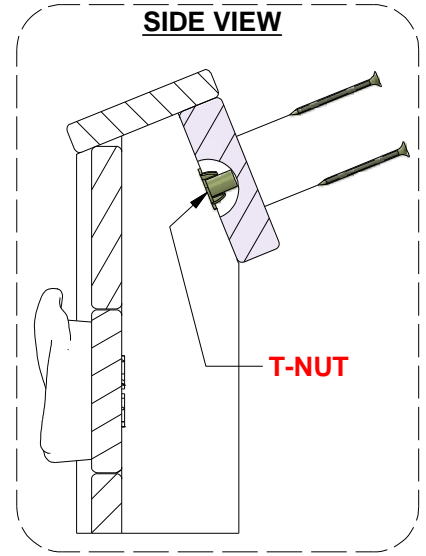
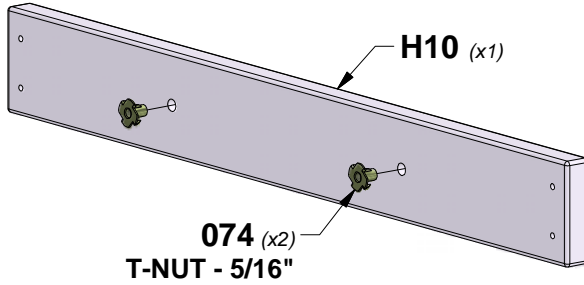

STEP 1 - SWING BEAM

QTY	PART NUMBER	DESCRIPTION
3	H100005	NUT BARREL WH 5/16x7/8
3	H100016	BOLT WH 5/16x3
2	H100054	BOLT HEX 5/16x4 1/4
4	H100105	WASHER FLAT 8x27
2	H100110	NUT LOCK 5/16

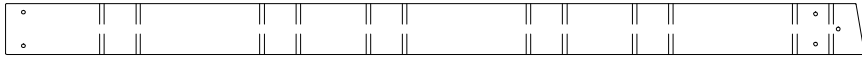

A50 SWING BEAM - W4L15998
(x1) 3 3/8"x5 1/4"x89 1/2" (86x134x2274)

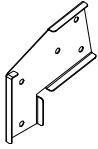

A100325 SWING BEAM EXTENSION BRACKET-LEFT
(x1)

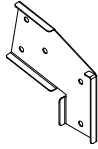

A100326 SWING BEAM EXTENSION BRACKET-RIGHT
(x1)



A100140 L BRACKET
(x2) 66x66x127

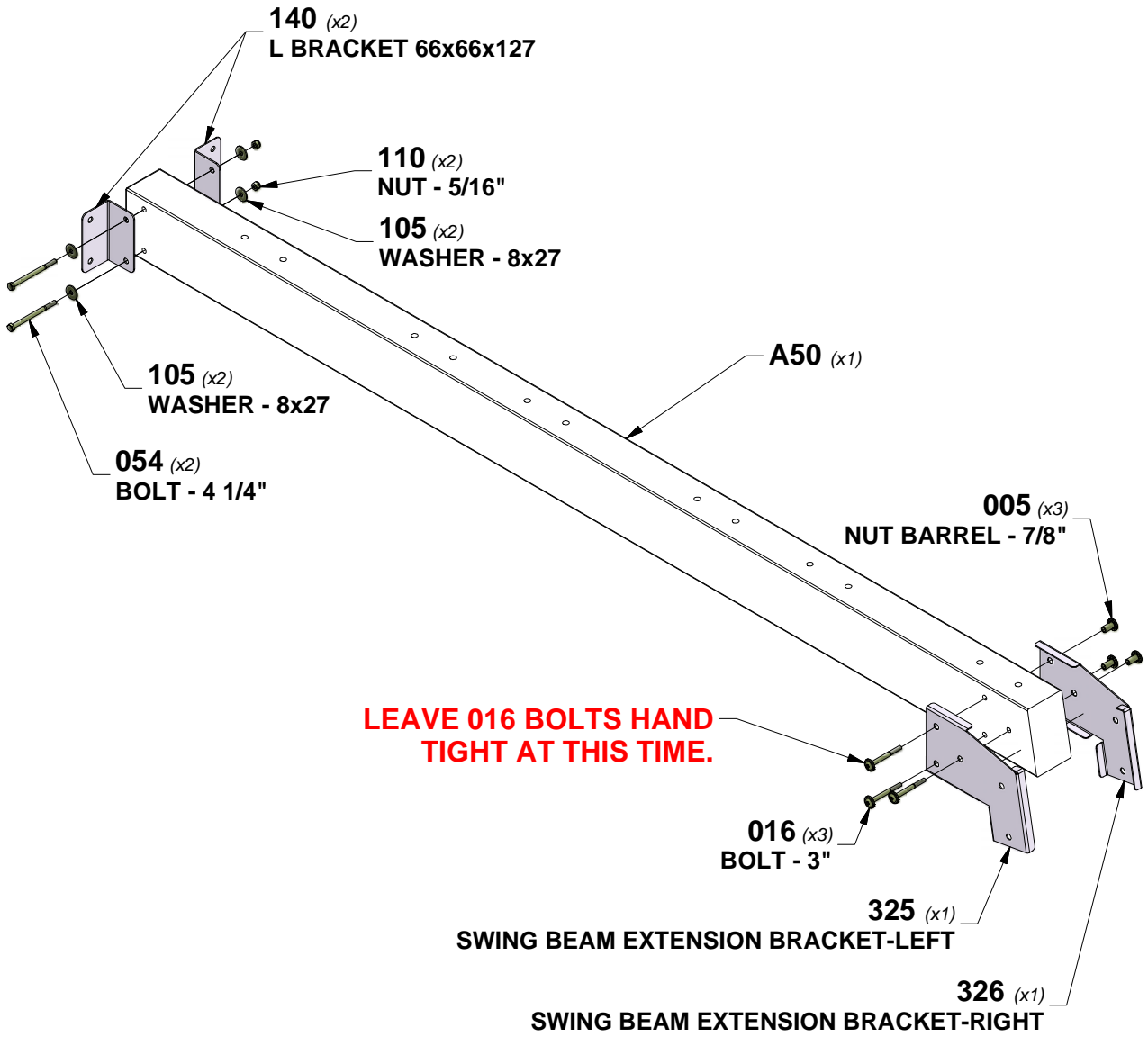

STEP 2 - SWING BEAM

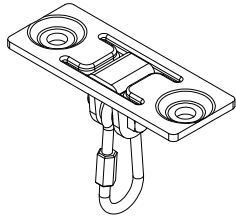

A4M00505 | SWING HANGER
(x6)

QTY	PART NUMBER	DESCRIPTION
12	H100073	T-NUT 3/8
12	H100102	WASHER FLAT 11x25
12	H100107	WASHER LOCK INT 10x18
12	H100654	BOLT HEX 3/8x5-1/2

TIP:
INSTALL T-NUTS IN WOOD FIRST

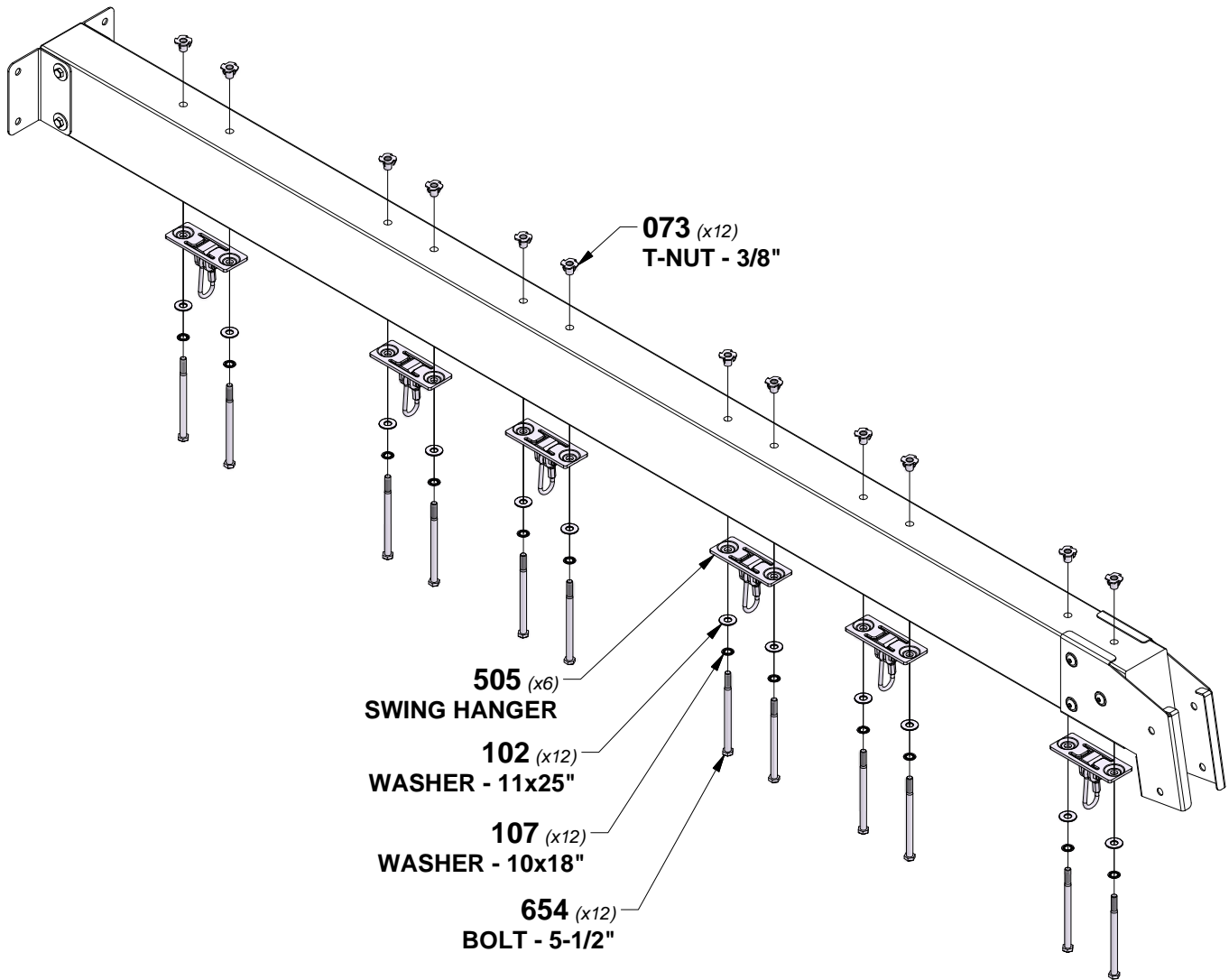

STEP 3 - SWING BEAM

QTY	PART NUMBER	DESCRIPTION
4	H100124	SCREW PFH 8x1/2



A100164
(x1) | BYD ID TAG
(LARGE) AGES
3-10

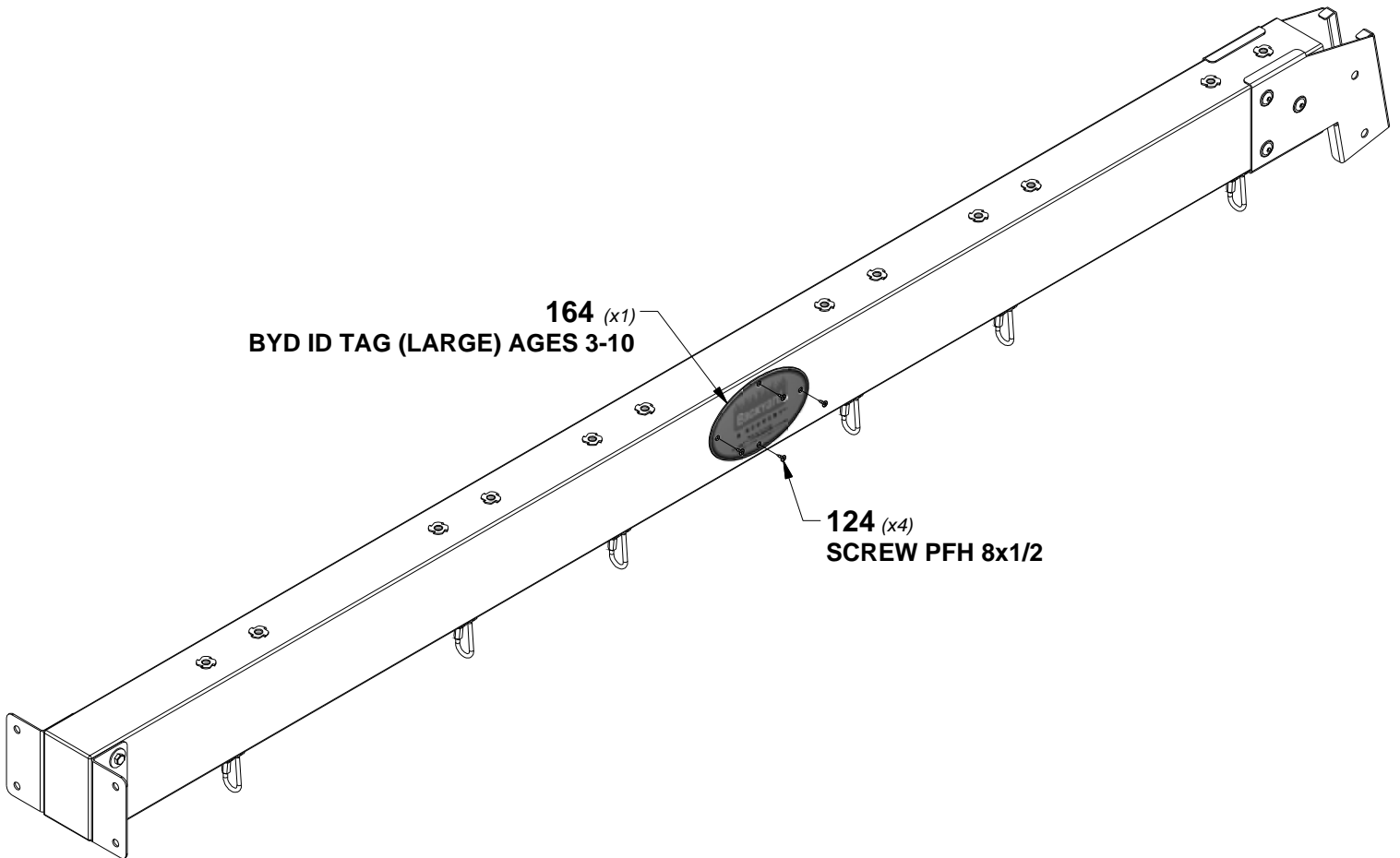

164 (x1)
BYD ID TAG (LARGE) AGES 3-10

124 (x4)
SCREW PFH 8x1/2

STEP 4 - SWING BEAM

QTY	PART NUMBER	DESCRIPTION
4	H100009	BOLT WH 5/16x1 1/4
2	H100018	BOLT WH 5/16x3 1/2
6	H100074	T-NUT 5/16



SP50 | SWING BEAM SUPPORT - W4L16085
(x1) | 3 3/8"x3 3/8"x49 3/8" (86x86x1254)

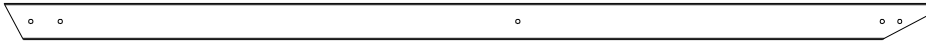

E51 | ANGLE BRACE - W4L16004
(x2) | 1 7/16"x3 3/8"x87 3/16" (36x86x2214)

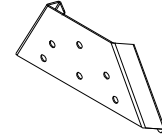

A4M01169 | A-FRAME BRACKET
(x1)

TIP:
INSTALL T-NUTS IN WOOD FIRST

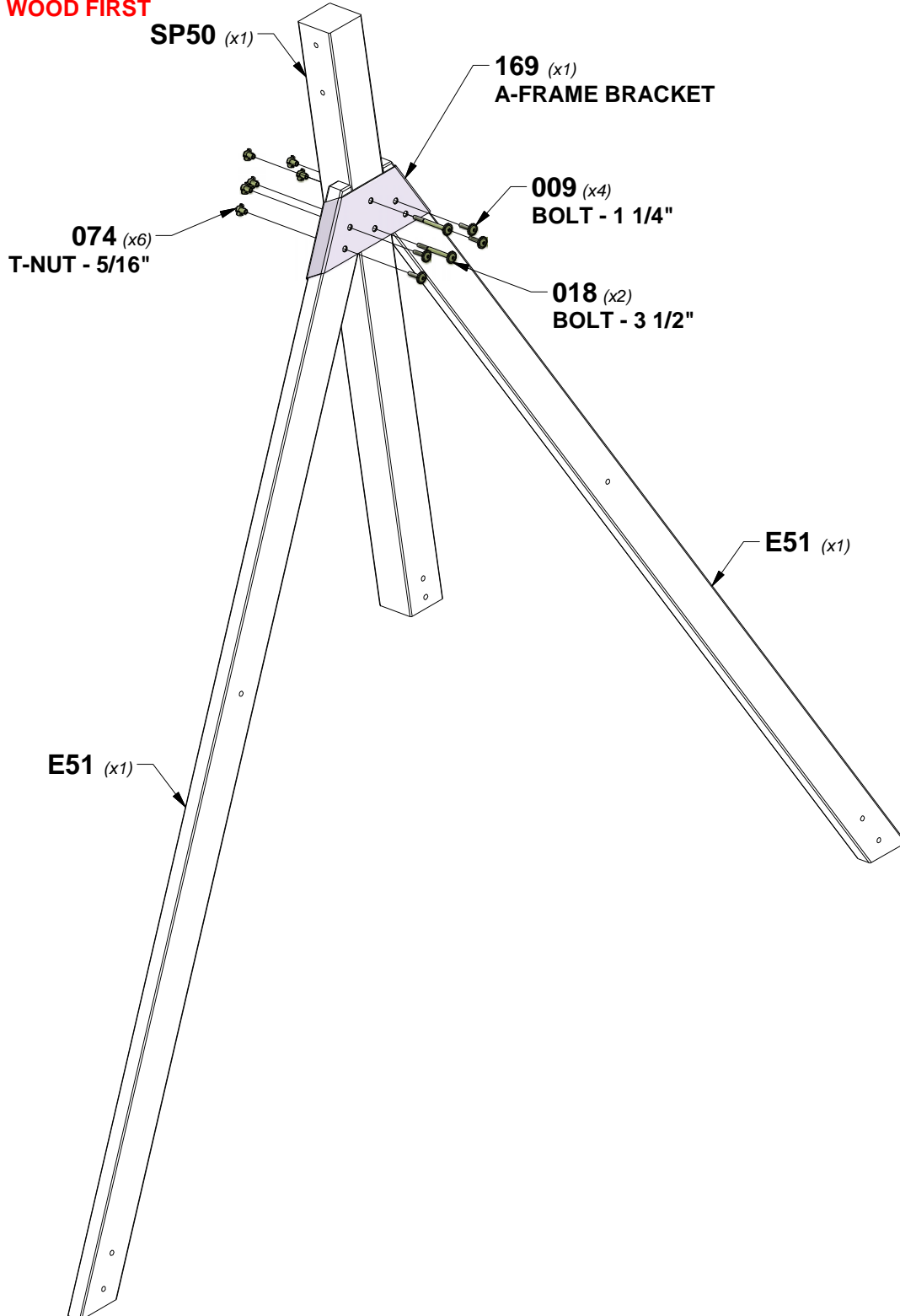

STEP 5 - SWING BEAM

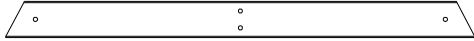

E50 | END SUPPORT - W4L16003
(x1) | 1 3/8"x3 3/8"x44 1/8" (36x86x1120)

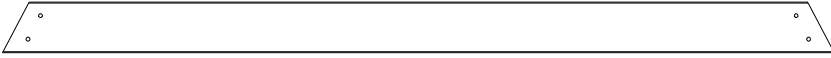

G14 | GROUND BOARD - W4L16019
(x1) | 15/16"x5 1/4"x86 11/16" (24x134x2202)

QTY	PART NUMBER	DESCRIPTION
4	H100013	BOLT WH 5/16x2 1/4
2	H100015	BOLT WH 5/16x2 3/4
8	H100030	WASHER LOCK EXT 8x19
8	H100074	T-NUT 5/16
2	H100505	BOLT WH 5/16x4 3/4

TIP:
INSTALL T-NUTS IN WOOD FIRST

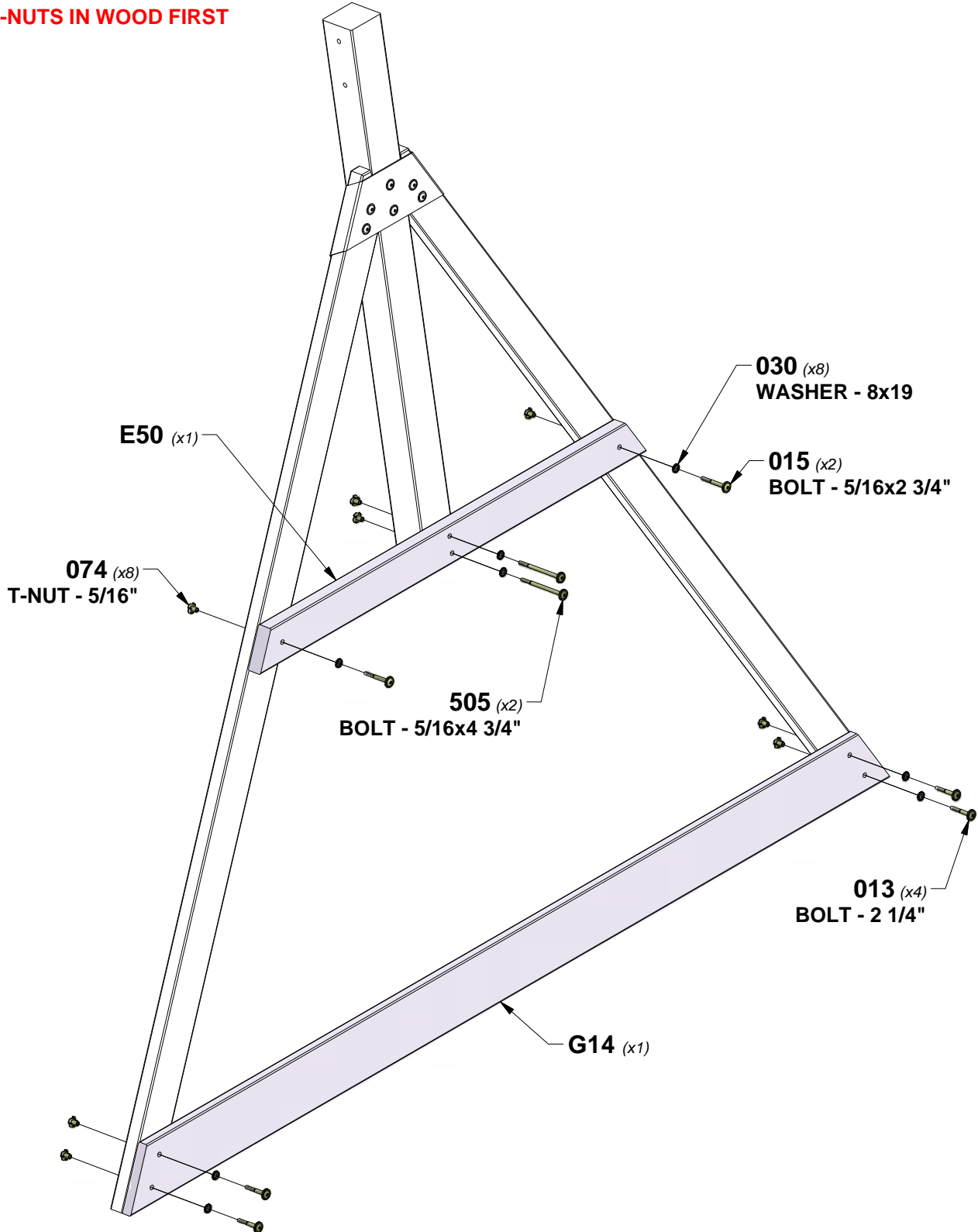

STEP 6 - SWING BEAM

QTY	PART NUMBER	DESCRIPTION
2	H100005	NUT BARREL WH 5/16x7/8
2	H100016	BOLT WH 5/16x3

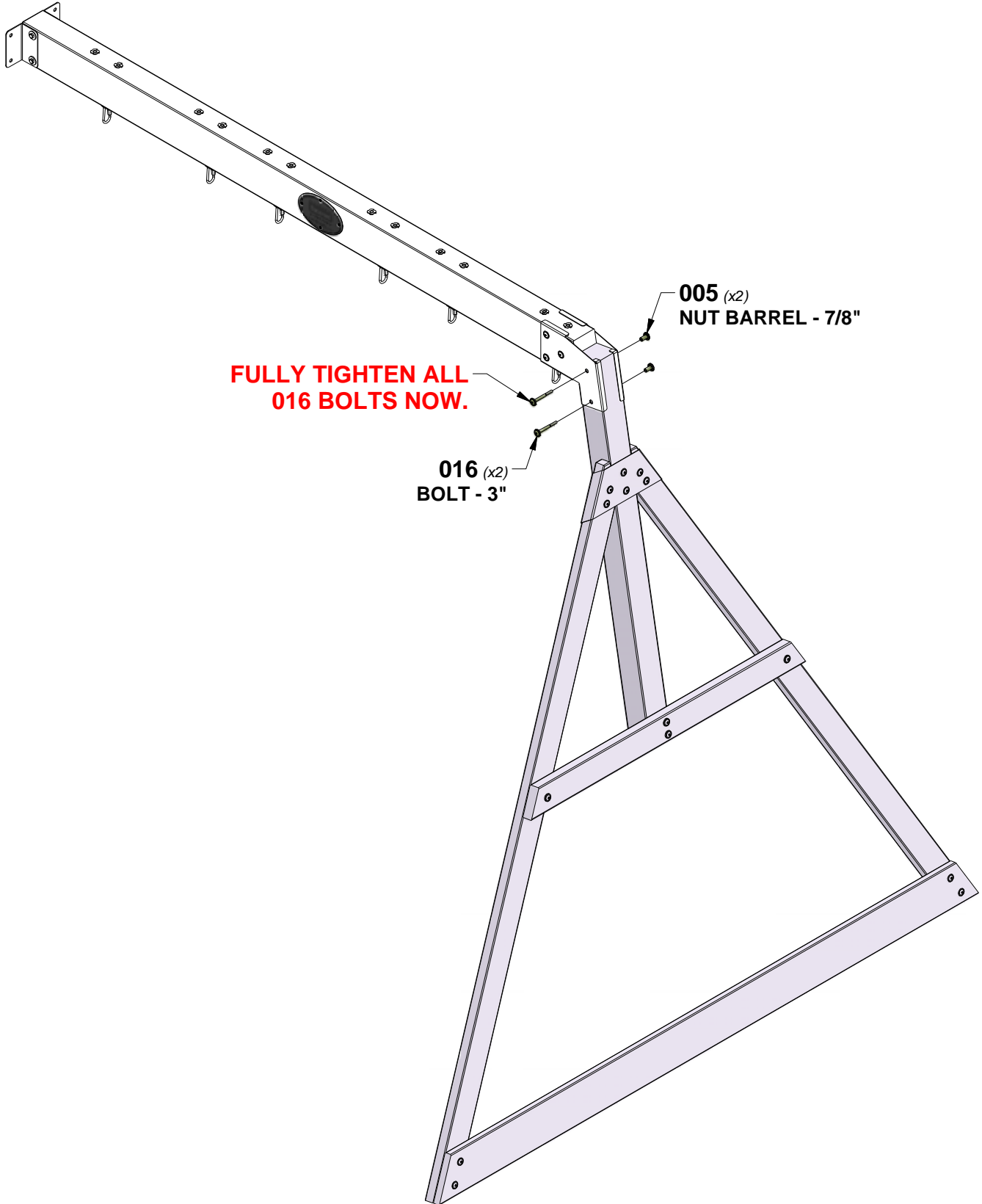

STEP 1 - FORT ASSEMBLY

QTY	PART NUMBER	DESCRIPTION
2	H100013	BOLT WH 5/16x2 1/4
12	H100028	LAG SCREW WH 5/16x2 1/2
14	H100030	WASHER LOCK EXT 8x19
2	H100074	T-NUT 5/16
2	H100138	WASHER LOCK EXT 6x15
2	H100146	LAG SCREW WH 1/4x2

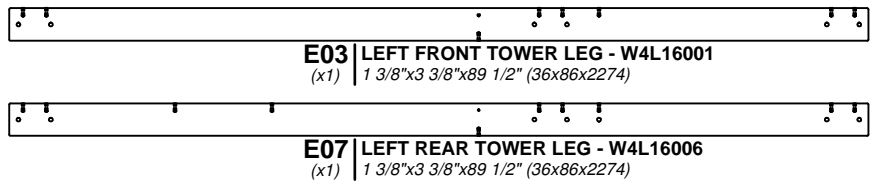
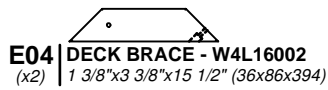
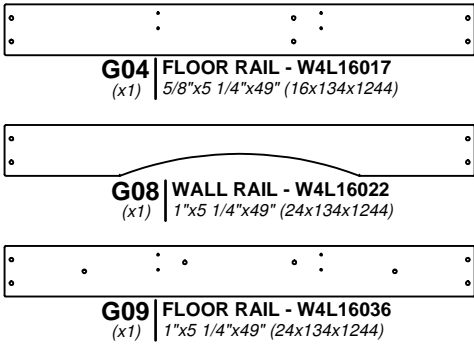

TIP:
INSTALL T-NUTS IN WOOD FIRST

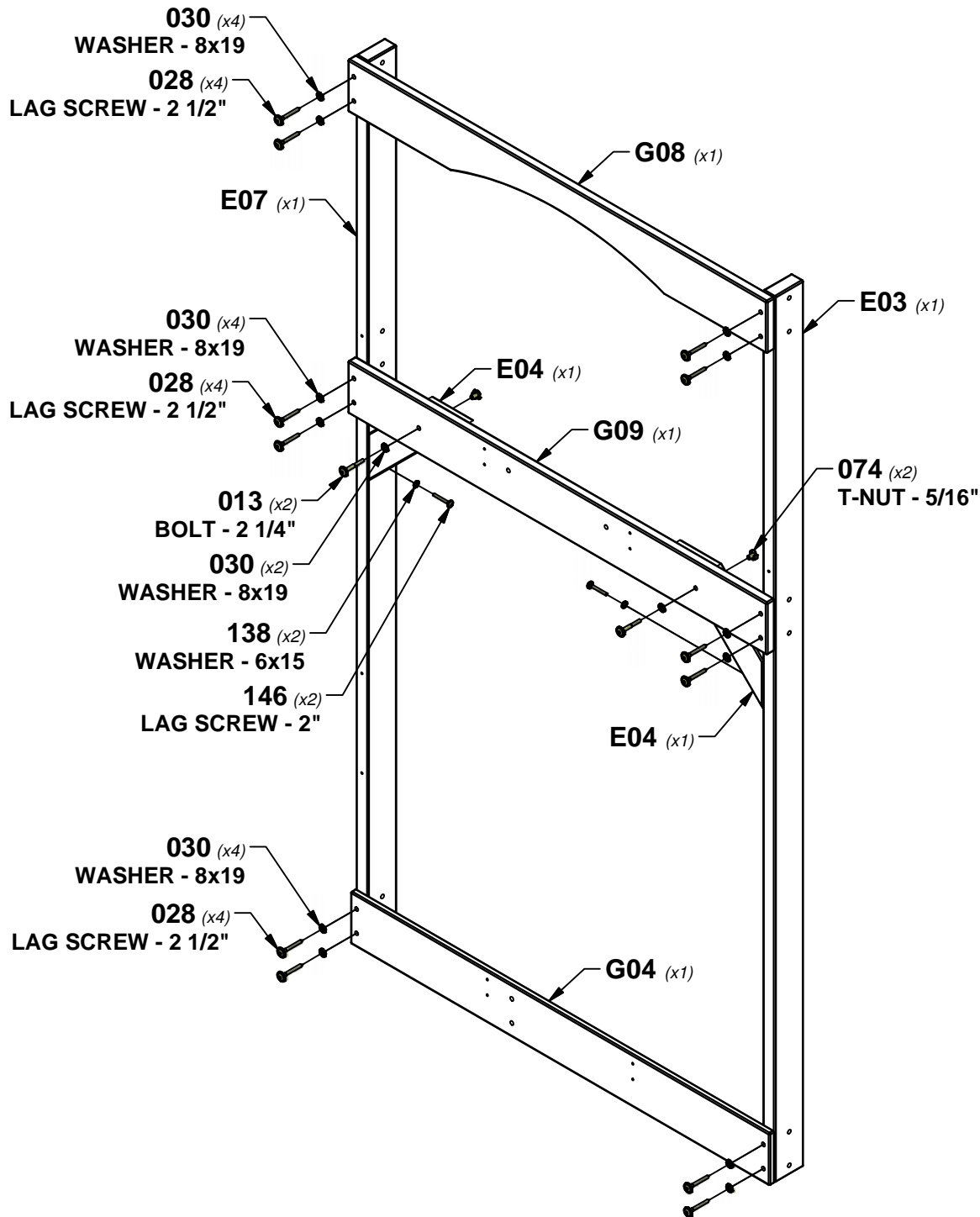

STEP 2 - FORT ASSEMBLY

QTY	PART NUMBER	DESCRIPTION
20	H100028	LAG SCREW WH 5/16x2 1/2
20	H100030	WASHER LOCK EXT 8x19

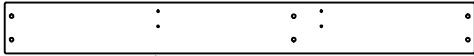

G04 FLOOR RAIL - W4L16017
(x1) 5/8"x5 1/4"x49" (16x134x1244)

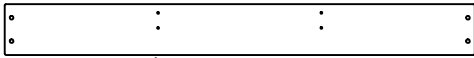

G07 FLOOR RAIL - W4L16021
(x2) 1"x5 1/4"x49" (24x134x1244)

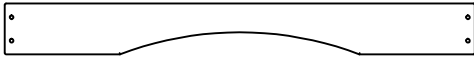

G08 WALL RAIL - W4L16022
(x1) 1"x5 1/4"x49" (24x134x1244)

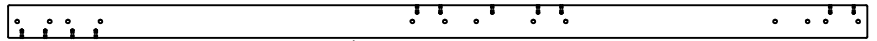

E02 CENTER FRONT TOWER LEG - W4L16000
(x1) 1 3/8"x3 3/8"x89 1/2" (36x86x2274)

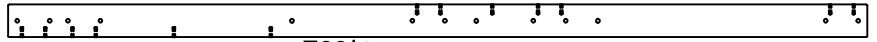

E06 CENTER REAR TOWER LEG - W4L16005
(x1) 1 3/8"x3 3/8"x89 1/2" (36x86x2274)

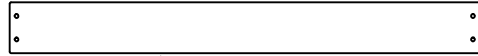

K02 BASE/SAND BOX BOARD - W4L16035
(x1) 5/8"x5 1/4"x49" (16x134x1244)

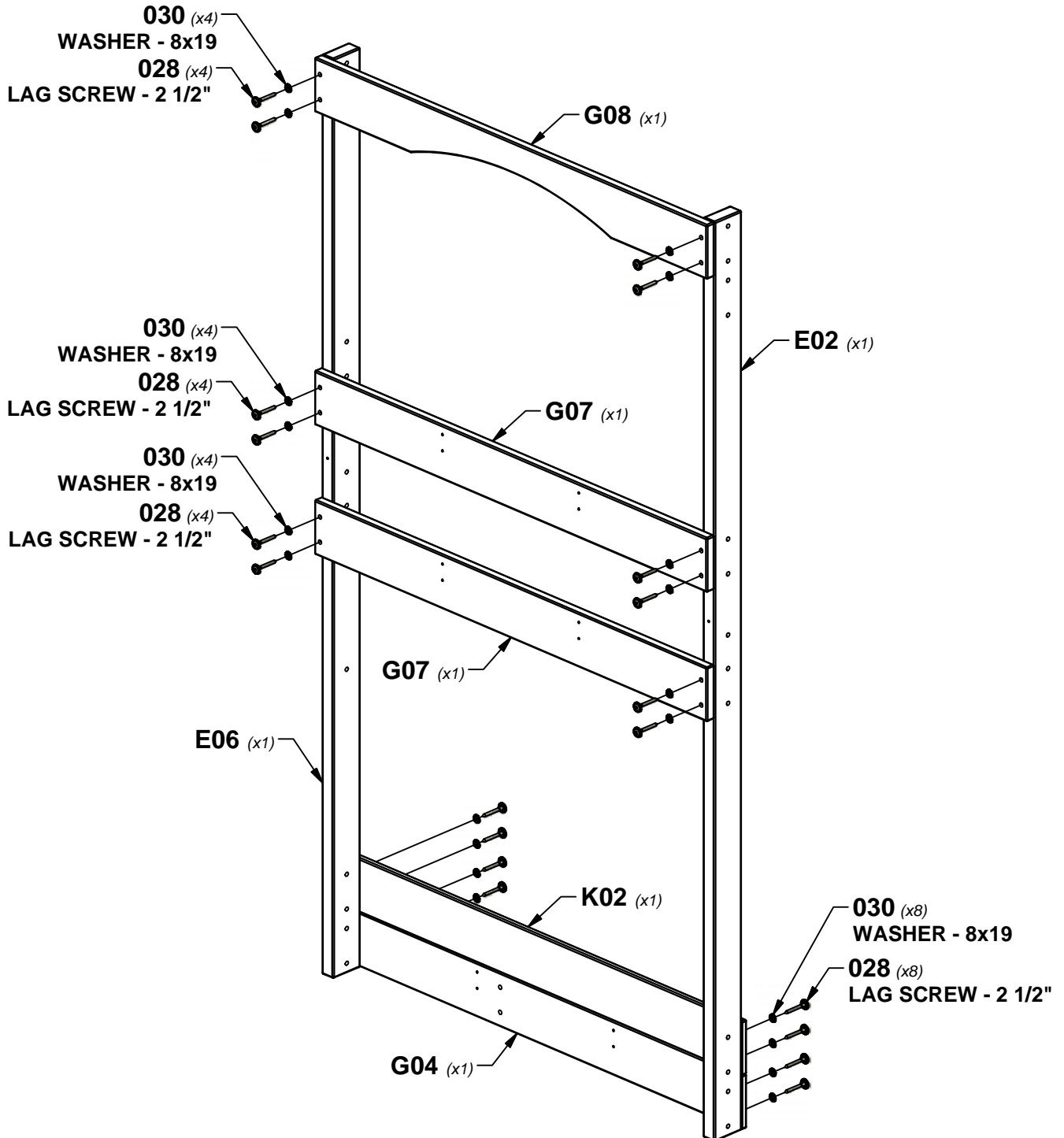

STEP 3 - FORT ASSEMBLY

QTY	PART NUMBER	DESCRIPTION
2	H100013	BOLT WH 5/16x2 1/4
2	H100027	LAG SCREW WH 5/16x2
12	H100028	LAG SCREW WH 5/16x2 1/2
20	H100030	WASHER LOCK EXT 8x19
10	H100074	T-NUT 5/16
2	H100138	WASHER LOCK EXT 6x15
2	H100146	LAG SCREW WH 1/4x2
4	H100166	BOLT WH 5/16x4 1/4

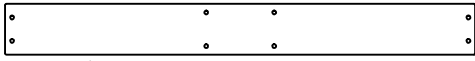

G05 | WALL RAIL/SWING MOUNT - W4L16018
(x1) | 1"x5 1/4"x49" (24x134x1244)

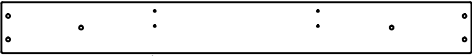

G06 | FLOOR RAIL - W4L16020
(x1) | 1"x5 1/4"x49" (24x134x1244)



K02 | BASE/SAND BOX BOARD - W4L16035
(x2) | 5/8"x5 1/4"x49" (16x134x1244)

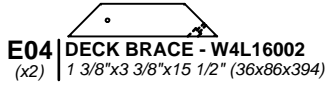

E04 | DECK BRACE - W4L16002
(x2) | 1 3/8"x3 3/8"x15 1/2" (36x86x394)

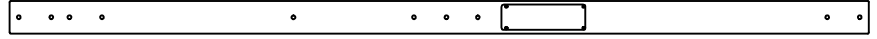

E05 | RIGHT REAR TOWER LEG - W2A03283
(x1) | 1 3/8"x3 3/8"x89 1/2" (36x86x2274)

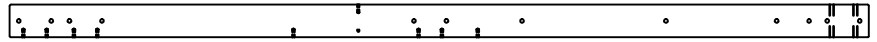

E01 | RIGHT FRONT TOWER LEG - W4L15999
(x1) | 1 3/8"x3 3/8"x89 1/2" (36x86x2274)

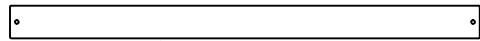

M05 | WALL RAIL - W4L16066
(x1) | 5/8"x3 3/8"x49" (16x86x1244)

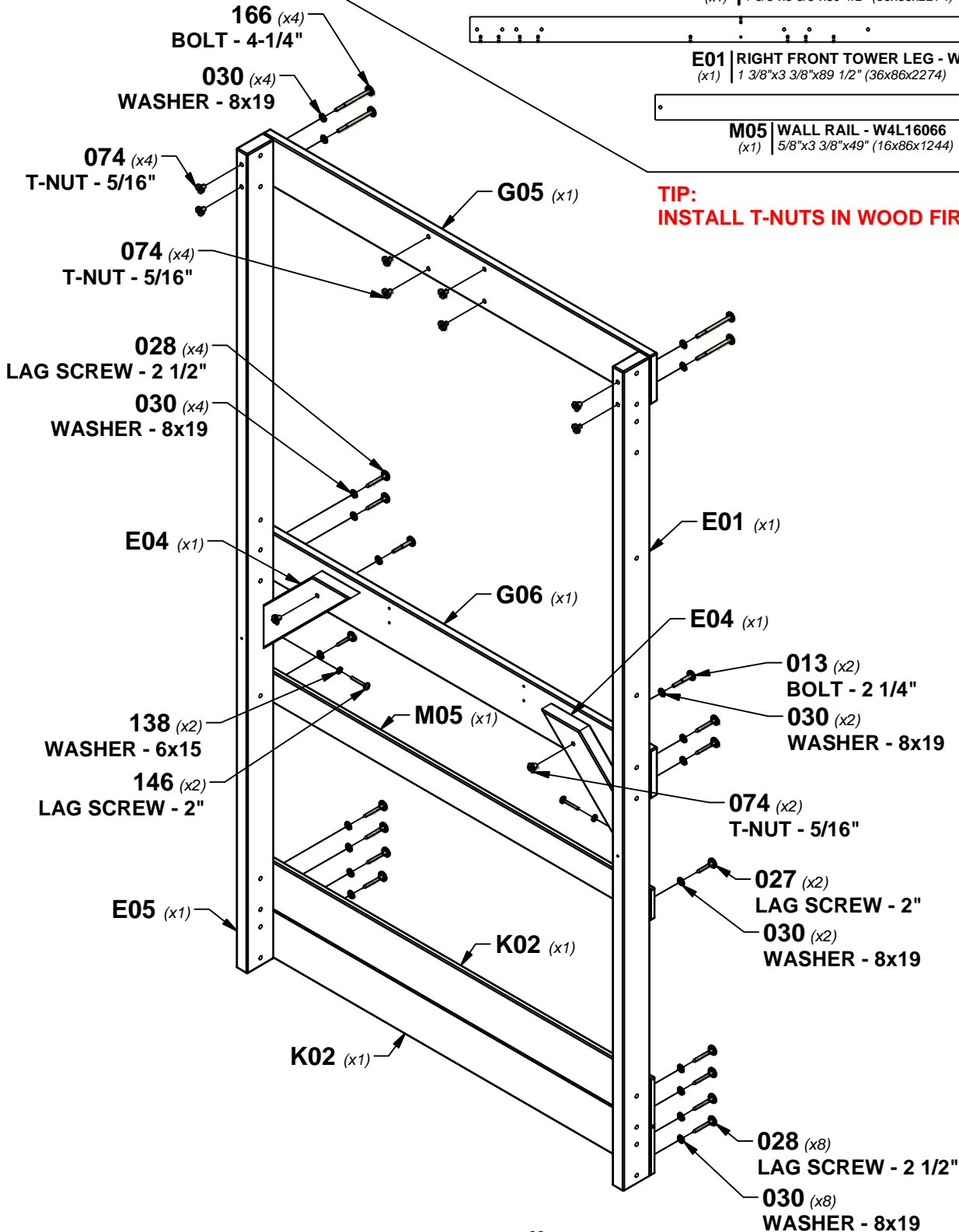

STEP 4 - FORT ASSEMBLY

QTY	PART NUMBER	DESCRIPTION
12	H100012	BOLT WH 5/16x2
8	H100016	BOLT WH 5/16x3
20	H100030	WASHER LOCK EXT 8x19
20	H100074	T-NUT 5/16



G01 | BASE BOARD - W4L16009
(x2) | 5/8"x5 1/4"x82 1/4" (16x134x2088)

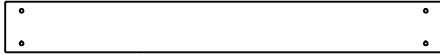

K03 | GROUND BOARD - W4L16038
(x2) | 5/8"x5 1/4"x45 1/2" (16x134x1156)



H05 | BOTTOM FLOOR BOARD SUPPORT - W4L16024
(x4) | 1"x3 3/8"x5 1/4" (24x86x134)

TIP:
INSTALL T-NUTS IN WOOD FIRST

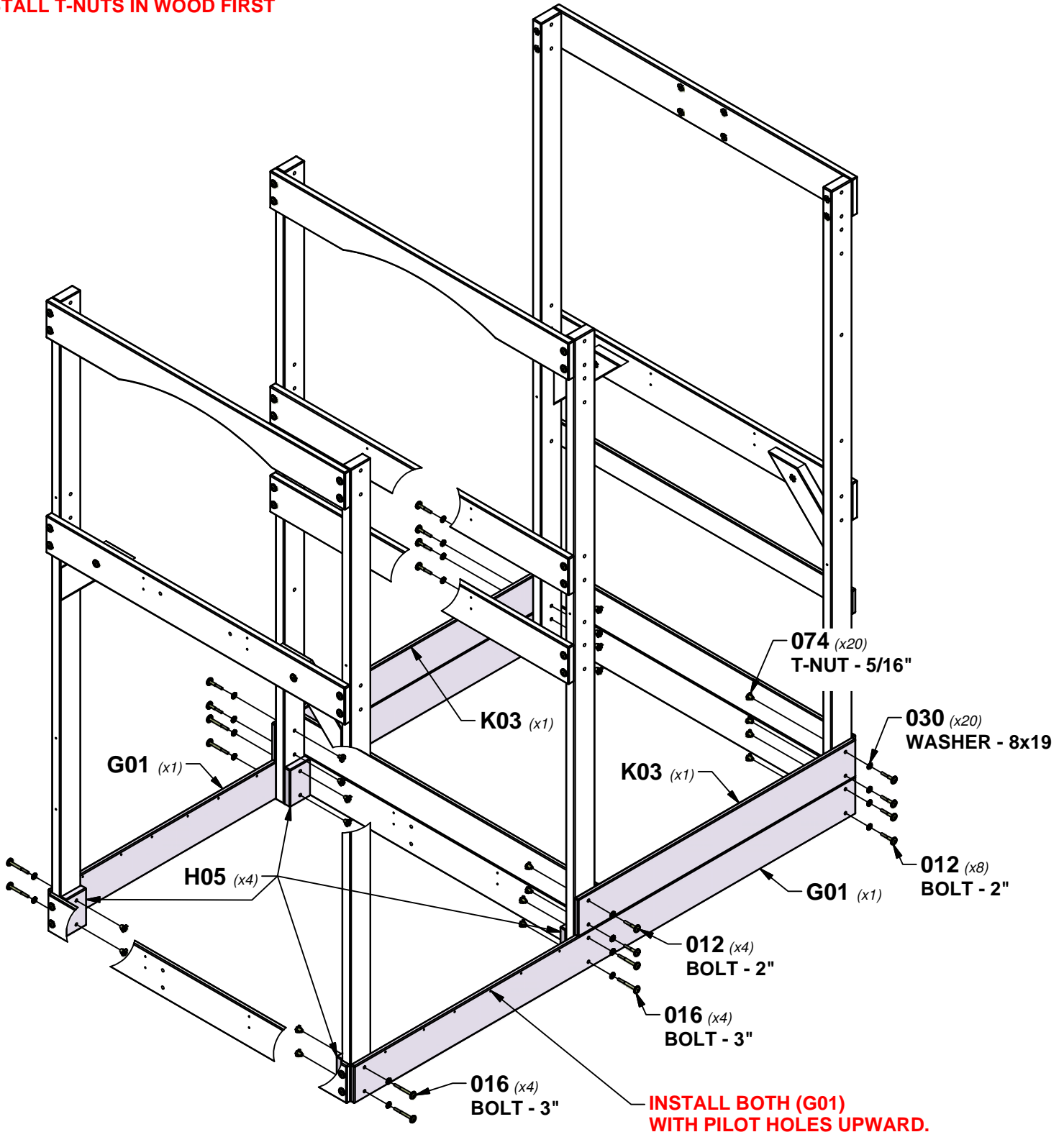

STEP 5 - FORT ASSEMBLY

QTY	PART NUMBER	DESCRIPTION
4	H100013	BOLT WH 5/16x2 1/4
12	H100017	BOLT WH 5/16x3 1/4
16	H100030	WASHER LOCK EXT 8x19
16	H100074	T-NUT 5/16

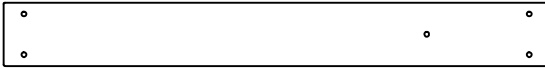

G10 | FLOOR RAIL - W4L16010
(x1) | 1"x5 1/4"x45 1/2" (24x134x1156)

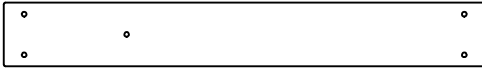

G12 | FLOOR RAIL - W4L16012
(x2) | 1"x5 1/4"x40 1/8" (24x134x1018)



H05 | BOTTOM FLOOR BOARD SUPPORT - W4L16024
(x6) | 1"x3 3/8"x5 1/4" (24x86x134)

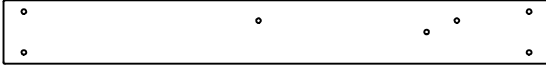

G15 | FLOOR RAIL - W4L16014
(x1) | 1"x5 1/4"x45 1/2" (24x134x1156)

TIP:
INSTALL T-NUTS IN WOOD FIRST

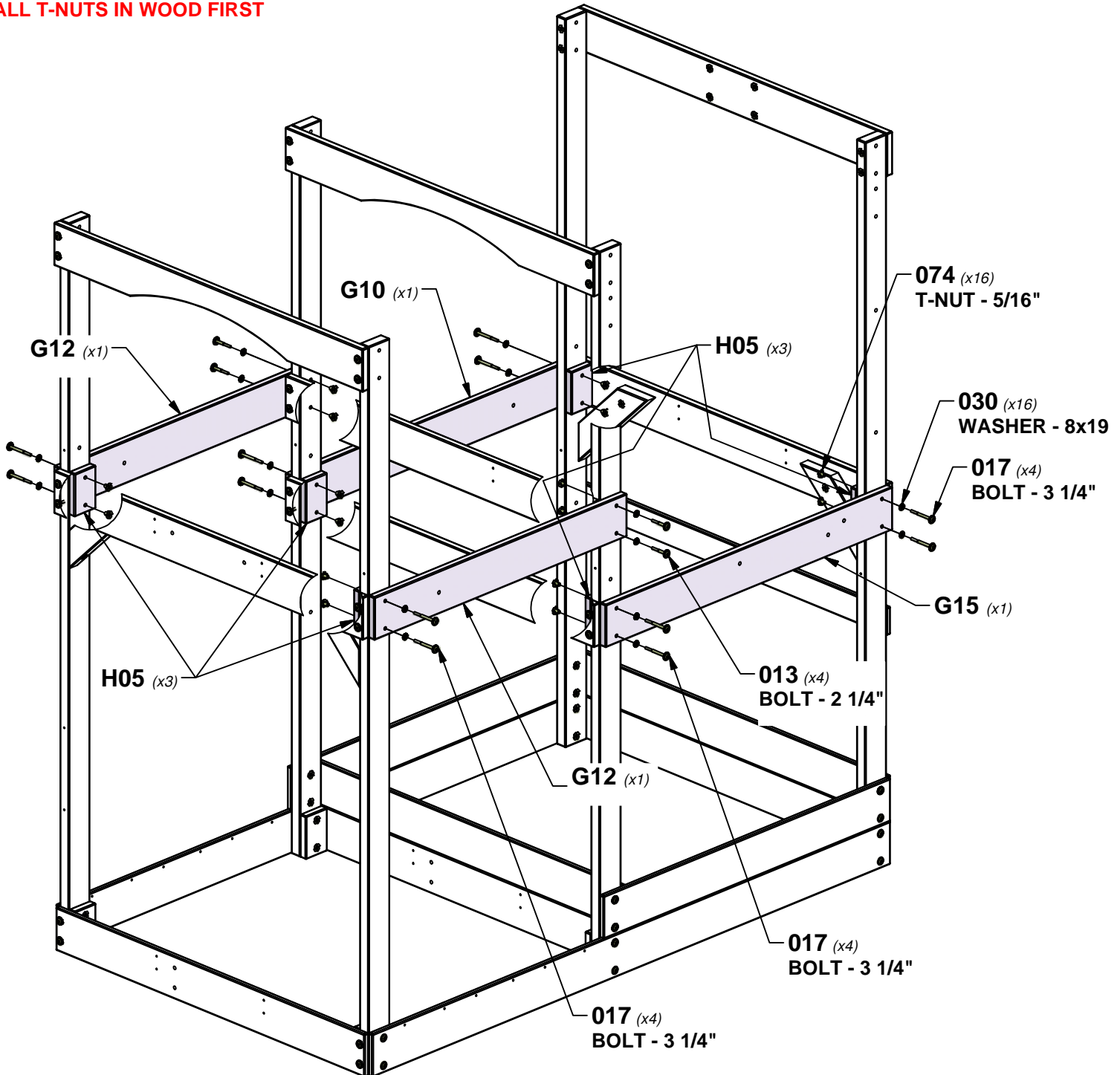

STEP 6 - FORT ASSEMBLY

QTY	PART NUMBER	DESCRIPTION
12	H100013	BOLT WH 5/16x2 1/4
16	H100030	WASHER LOCK EXT 8x19
16	H100074	T-NUT 5/16
4	H100012	BOLT WH 5/16x2

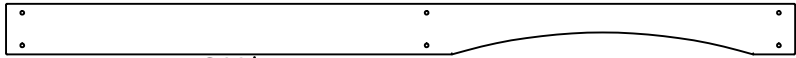

G02 | WALL RAIL - W4L16015
(x1) | 1"x5 1/4"x82 1/4" (24x134x2088)



G03 | WALL RAIL - W4L16016
(x1) | 1"x5 1/4"x82 1/4" (24x134x2088)

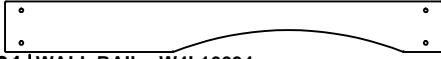

K01 | WALL RAIL - W4L16034
(x1) | 5/8"x5 1/4"x45 1/2" (16x134x1156)

TIP:
INSTALL T-NUTS IN WOOD FIRST

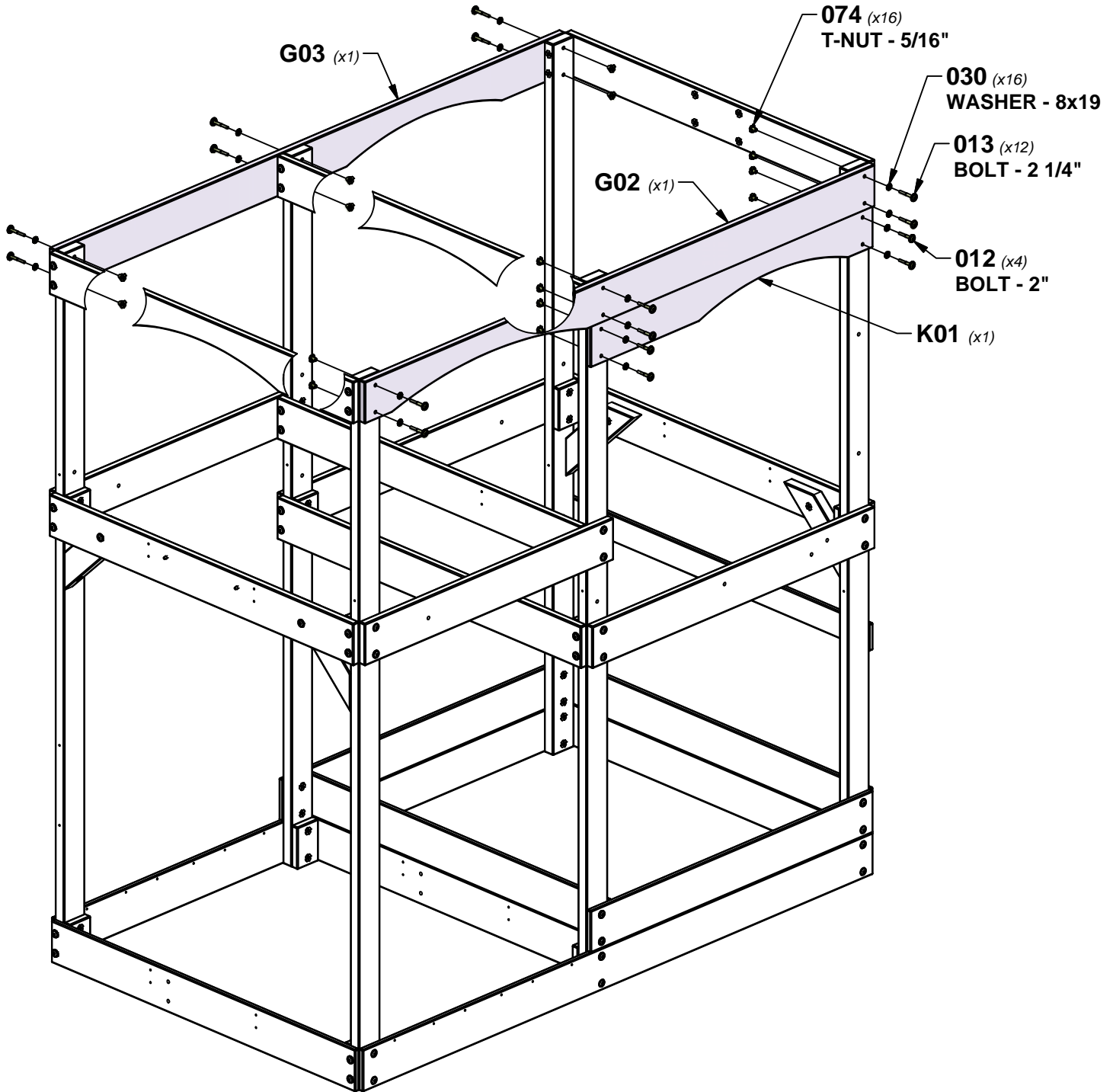

STEP 7 - FORT ASSEMBLY

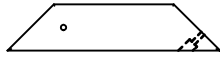

E04 | DECK BRACE - W4L16002
(x4) | 1 3/8"x3 3/8"x15 1/2" (36x86x394)

QTY	PART NUMBER	DESCRIPTION
4	H100013	BOLT WH 5/16x2 1/4
4	H100030	WASHER LOCK EXT 8x19
4	H100074	T-NUT 5/16
4	H100138	WASHER LOCK EXT 6x15
4	H100146	LAG SCREW WH 1/4x2

TIP:
INSTALL T-NUTS IN WOOD FIRST

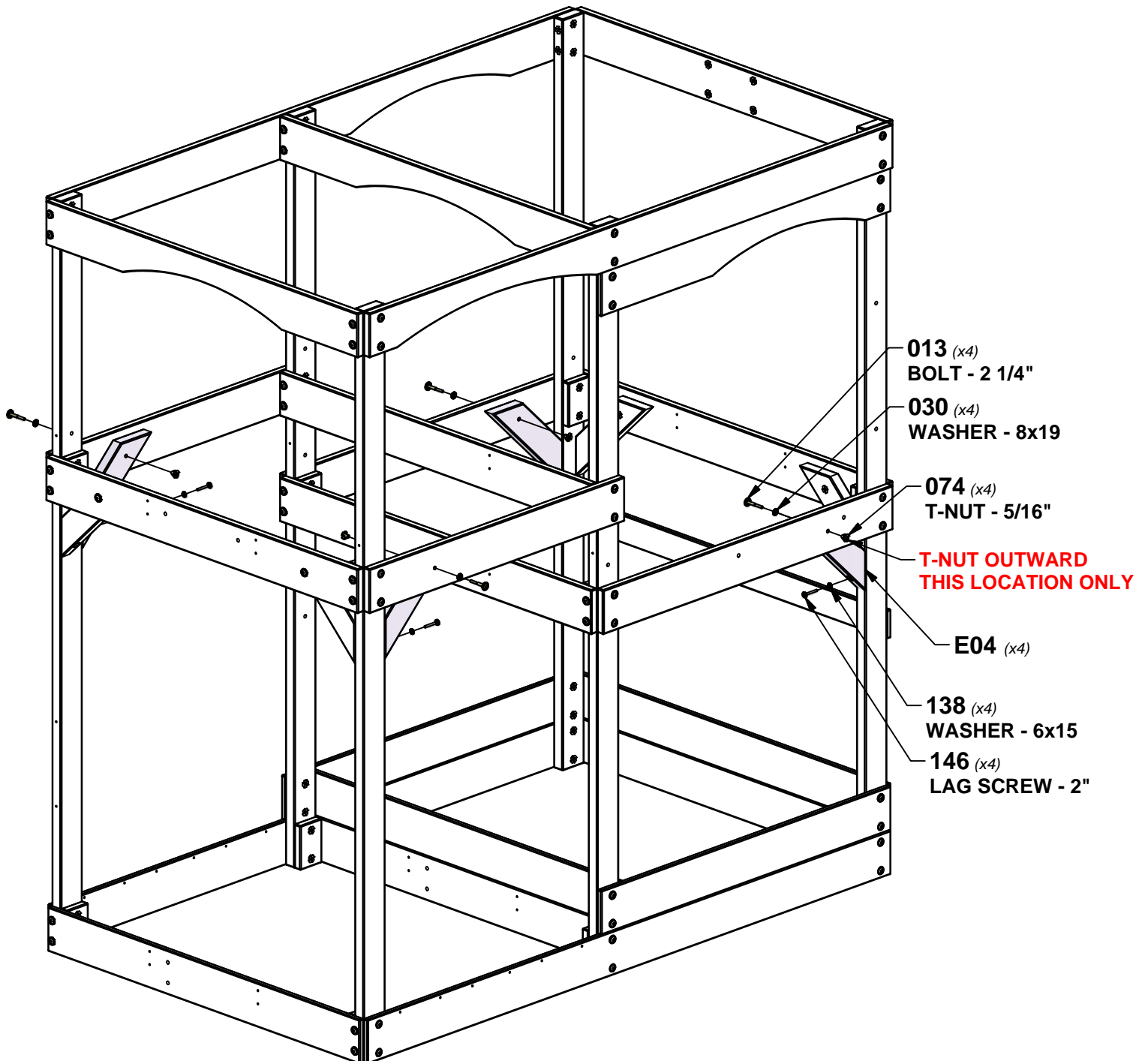

STEP 8 - FORT ASSEMBLY

QTY	PART NUMBER	DESCRIPTION
24	H100090	SCREW PFH 8x2 1/2
2	H100128	SCREW PWH 8x5/8

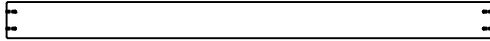

H01 | FLOOR JOIST - W4L16023
(x2) | 1"x3 3/8"x45 1/2" (24x86x1156)

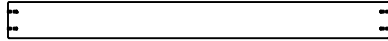

H09 | FLOOR JOIST - W4L16032
(x2) | 1"x3 3/8"x35 3/4" (24x86x908)

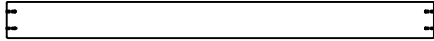

H03 | FLOOR JOIST - W4L16026
(x2) | 1"x3 3/8"x40 1/8" (24x86x1018)



A100314 | "A" REVISION TAG
(x1)

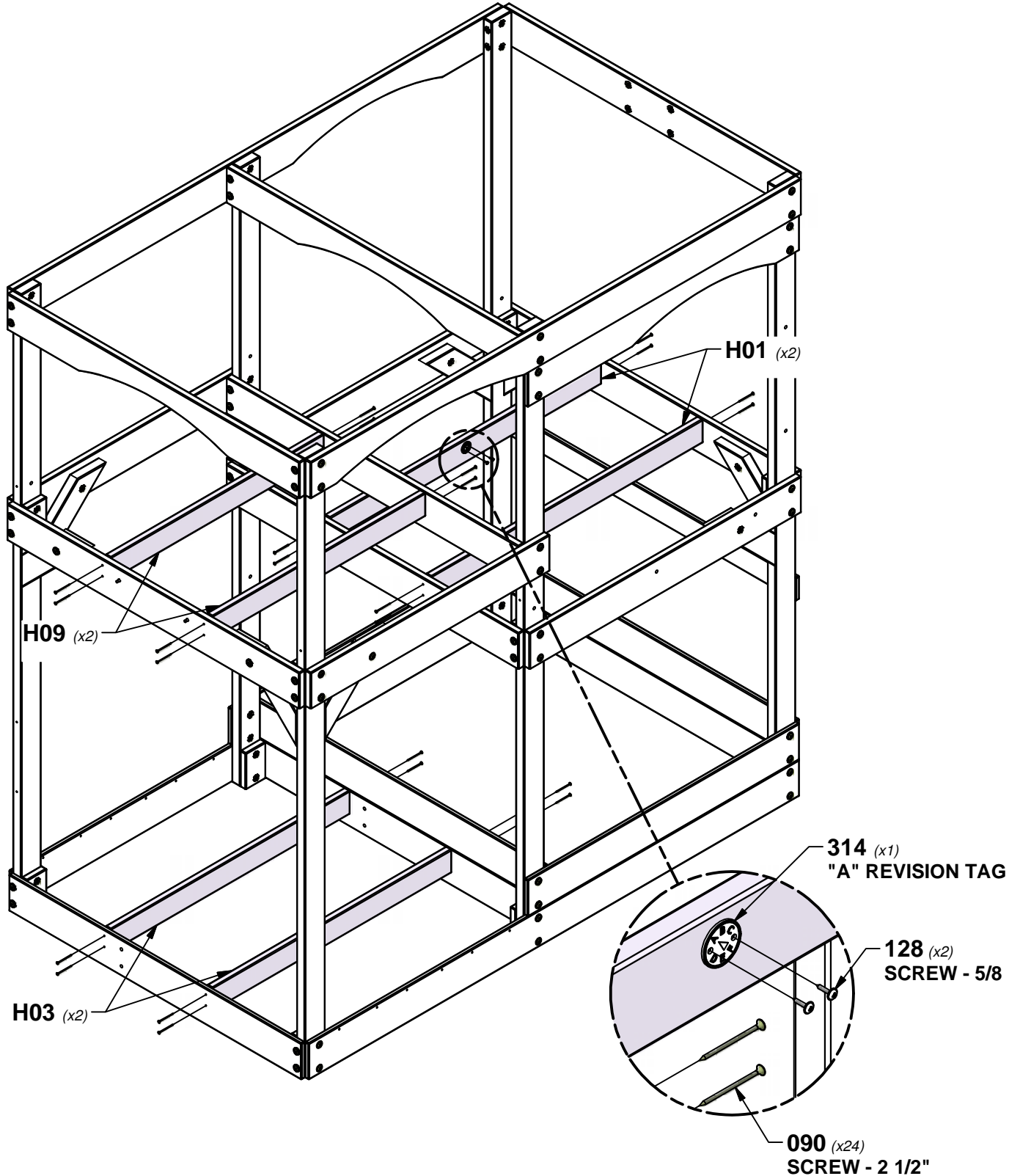

STEP 9 - FORT ASSEMBLY



H04 SEAT UPRIGHT - W4L16027
(x2) 1"x3 3/8"x19" (24x86x482)

QTY	PART NUMBER	DESCRIPTION
4	H100010	BOLT WH 5/16x1 1/2
4	H100030	WASHER LOCK EXT 8x19
4	H100074	T-NUT 5/16

TIP:
INSTALL T-NUTS IN WOOD FIRST

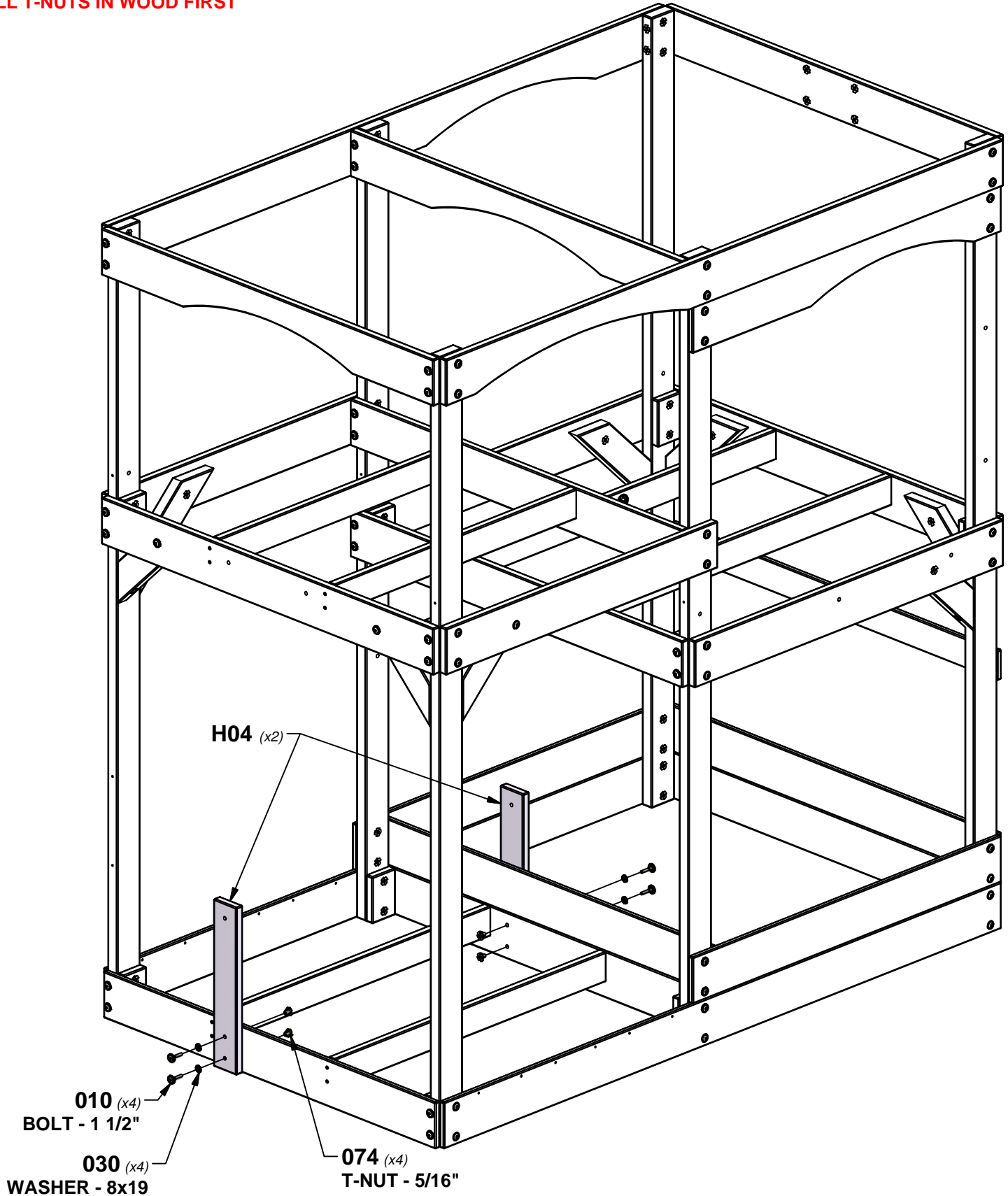

STEP 10 - FORT ASSEMBLY

QTY	PART NUMBER	DESCRIPTION
26	H100086	SCREW PFH 8x1-1/2"
12	H100089	SCREW PFH 8x1-3/4"

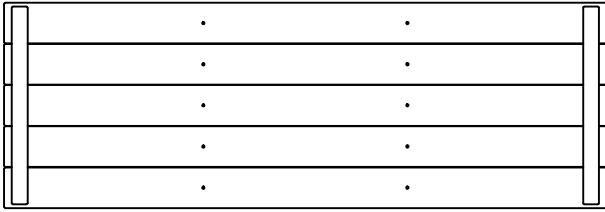

FP1 | FLOOR PANEL - W2A03281
(x1) | 1 5/8"x17 1/8"x50 1/4" (40x434x1276)

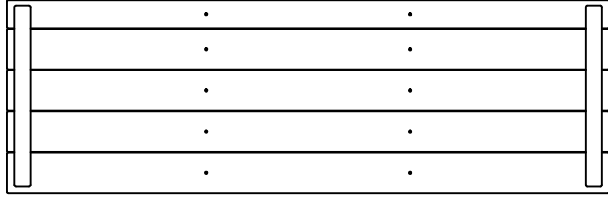

FP2 | FLOOR PANEL - W2A03282
(x1) | 1 5/8"x16 1/8"x50 1/4" (40x408x1276)



M02 | FLOOR BOARD - W4L16055
(x1) | 5/8"x3 3/8"x46" (16x86x1168)

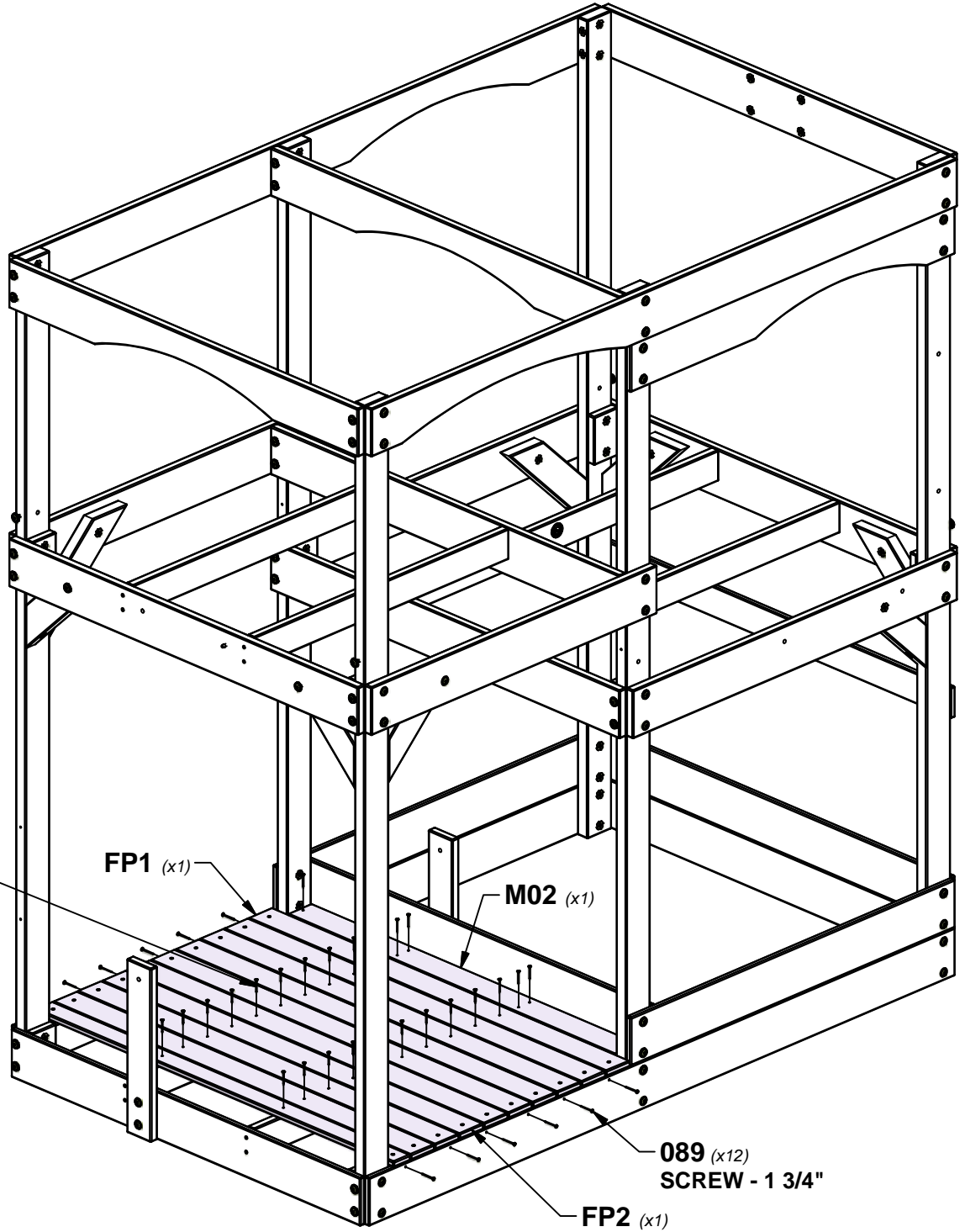

STEP 11 - FORT ASSEMBLY

QTY	PART NUMBER	DESCRIPTION
78	H100086	SCREW PFH 8x1-1/2"

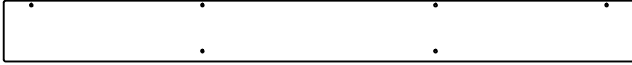

L01 | OUTSIDE FILLER FLOOR BOARD - W4L16039
(x2) | 5/8"x4 3/8"x46" (16x112x1168)

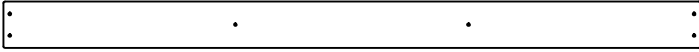

M03 | FLOOR BOARD - W4L16063
(x11) | 5/8"x3 3/8"x50 7/8" (16x86x1292)

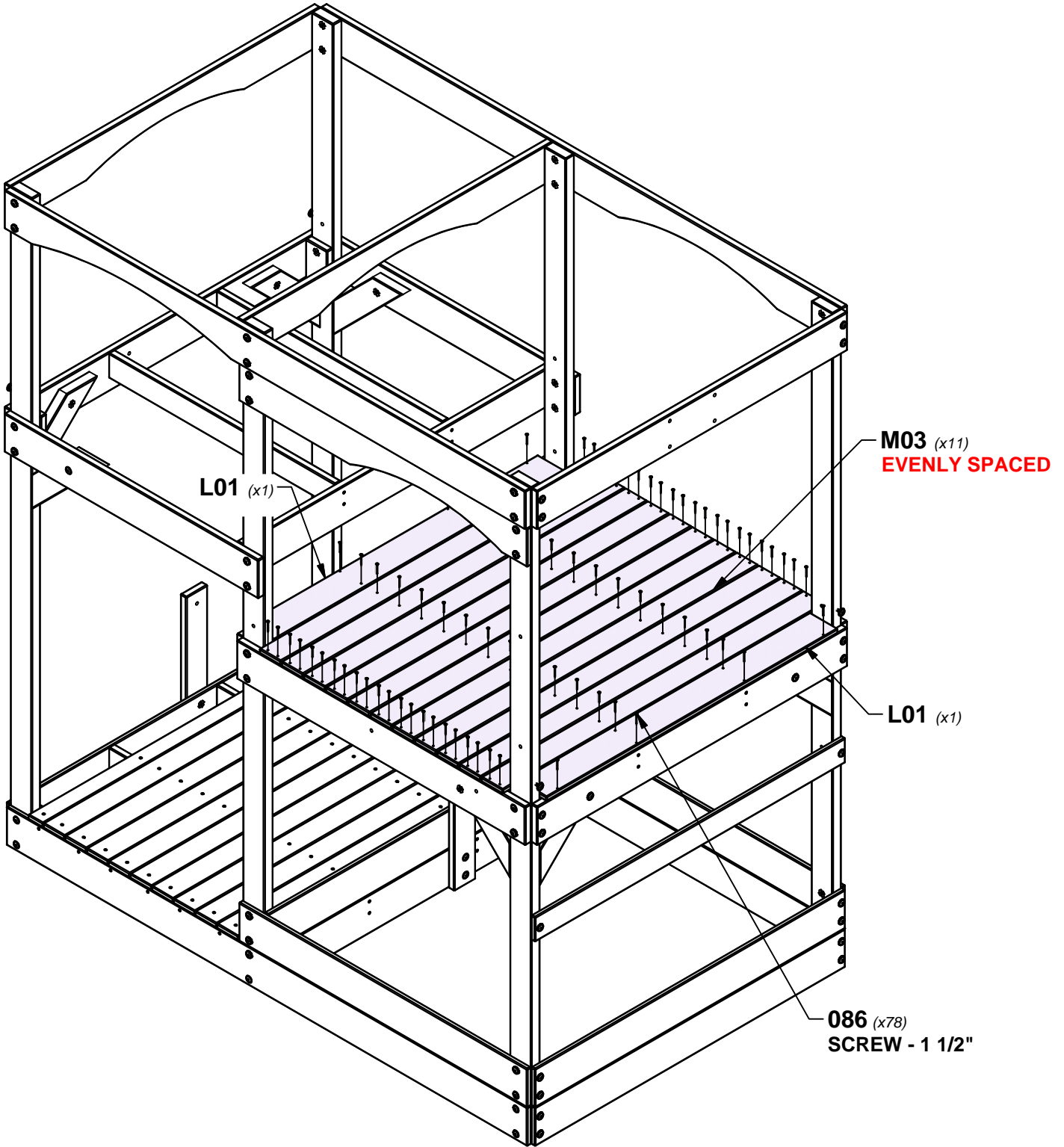

STEP 12 - FORT ASSEMBLY

QTY	PART NUMBER	DESCRIPTION
2	H100011	BOLT WH 5/16x1 3/4
2	H100030	WASHER LOCK EXT 8x19
2	H100074	T-NUT 5/16

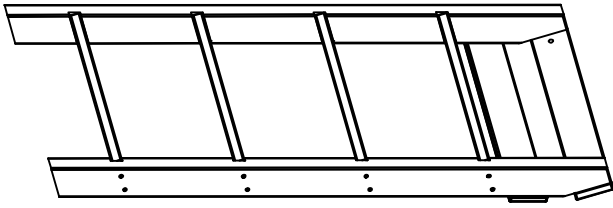

LADDER ASSEMBLY

TIP:
INSTALL T-NUTS IN WOOD FIRST

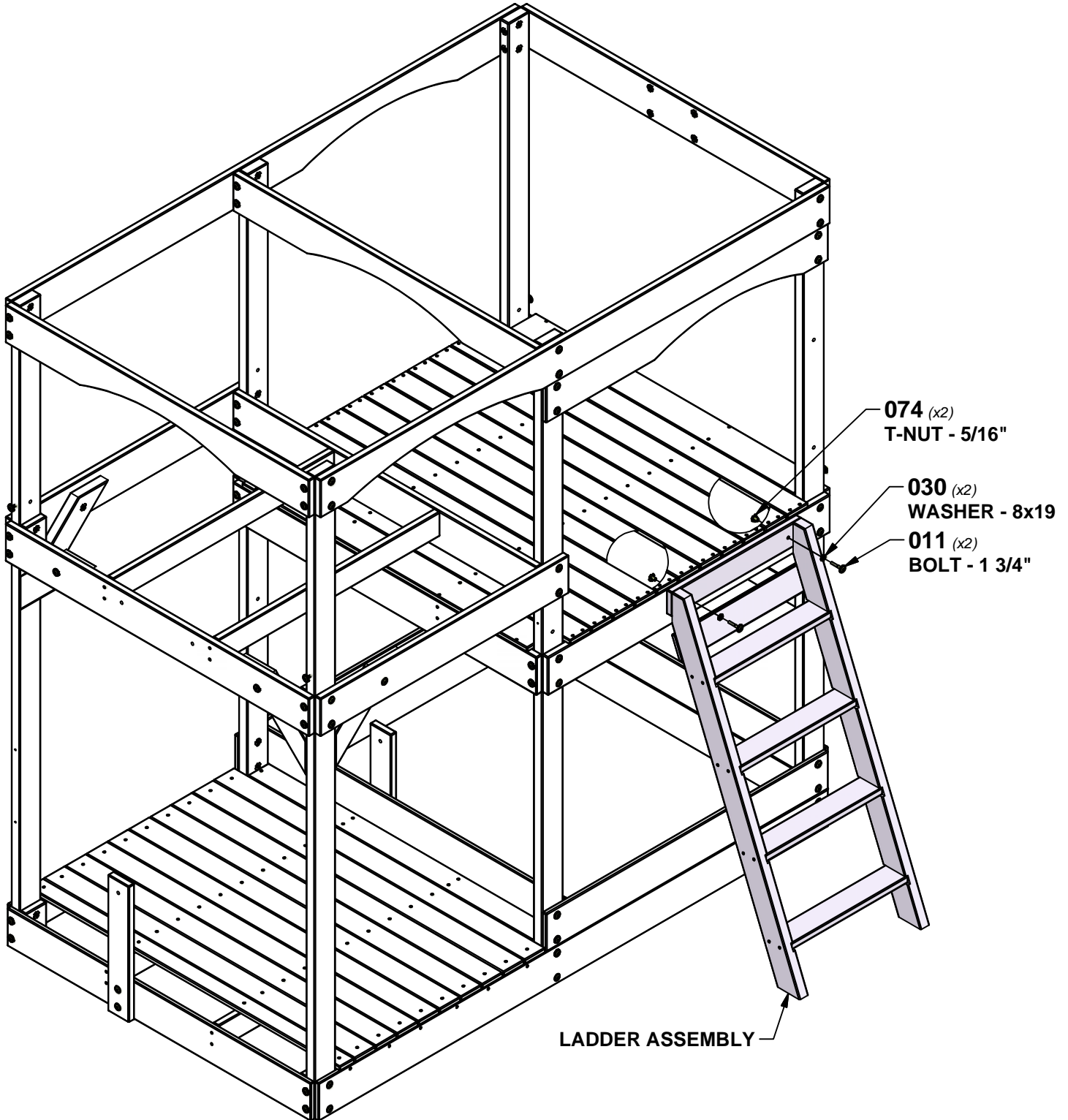

LADDER ASSEMBLY

STEP 13 - FORT ASSEMBLY

QTY	PART NUMBER	DESCRIPTION
64	H100086	SCREW PFH 8x1-1/2"

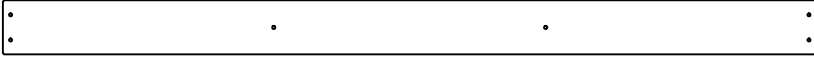

M03 | FLOOR BOARD - W4L16063
(x9) 5/8"x3 3/8"x50 7/8" (16x86x1292)

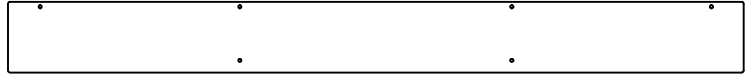

L01 | OUTSIDE FILLER FLOOR BOARD - W4L16039
(x1) 5/8"x4 3/8"x46" (16x112x1168)

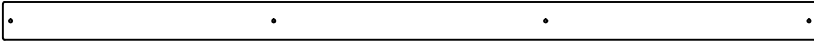

N01 | FLOOR BOARD - W4L16076
(x1) 5/8"x2 3/8"x50 7/8" (16x60x1292)

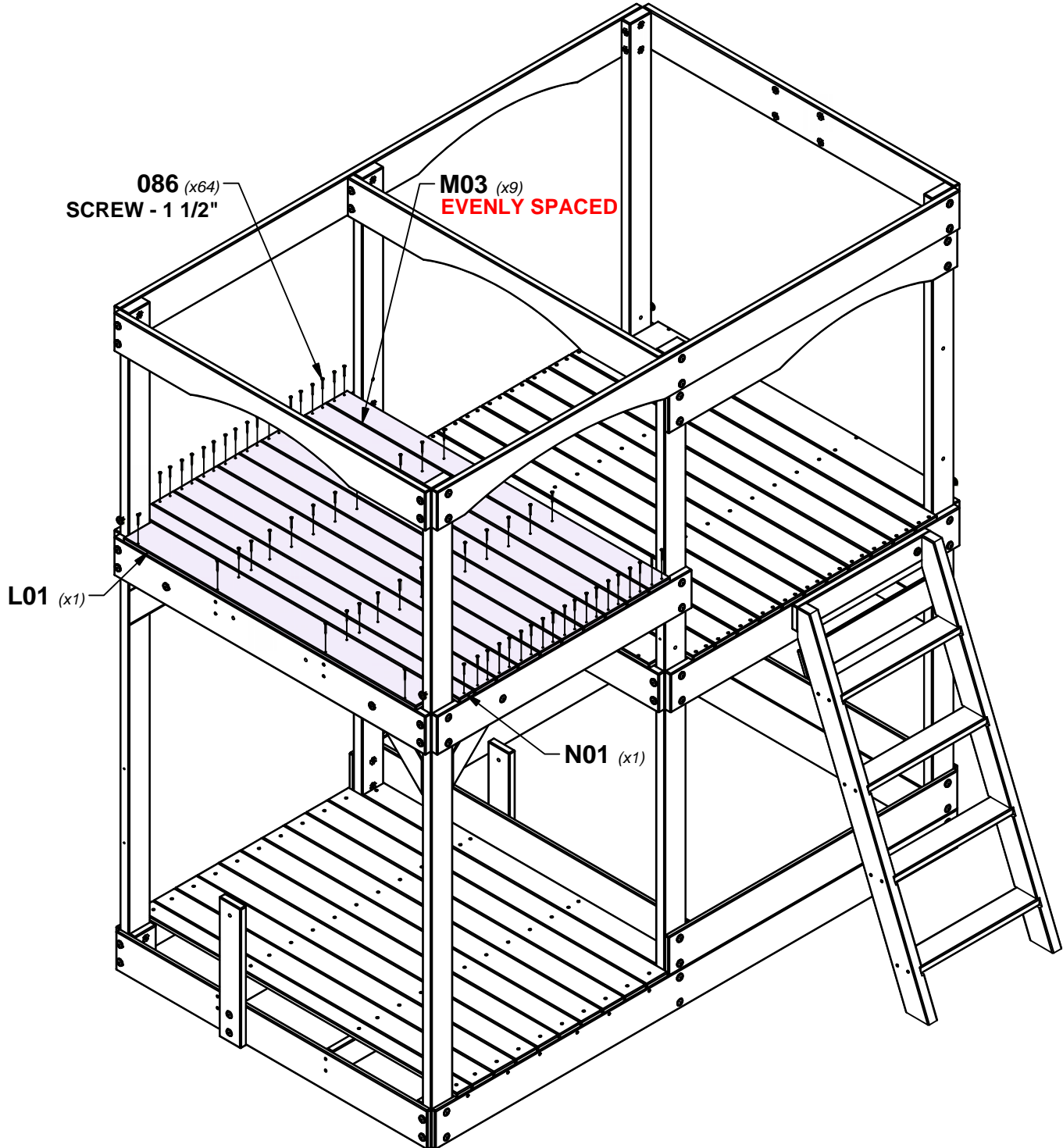

STEP 14 - FORT ASSEMBLY

QTY	PART NUMBER	DESCRIPTION
6	H100012	BOLT WH 5/16x2
6	H100030	WASHER LOCK EXT 8x19
6	H100074	T-NUT 5/16



M06 | WALL RAIL - W4L16067
(x2) | 5/8"x3 3/8"x45 1/2" (16x86x1156)

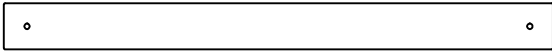

M11 | WALL RAIL - W4L16047
(x1) | 5/8"x3 3/8"x40 1/8" (16x86x1018)

TIP:
INSTALL T-NUTS IN WOOD FIRST

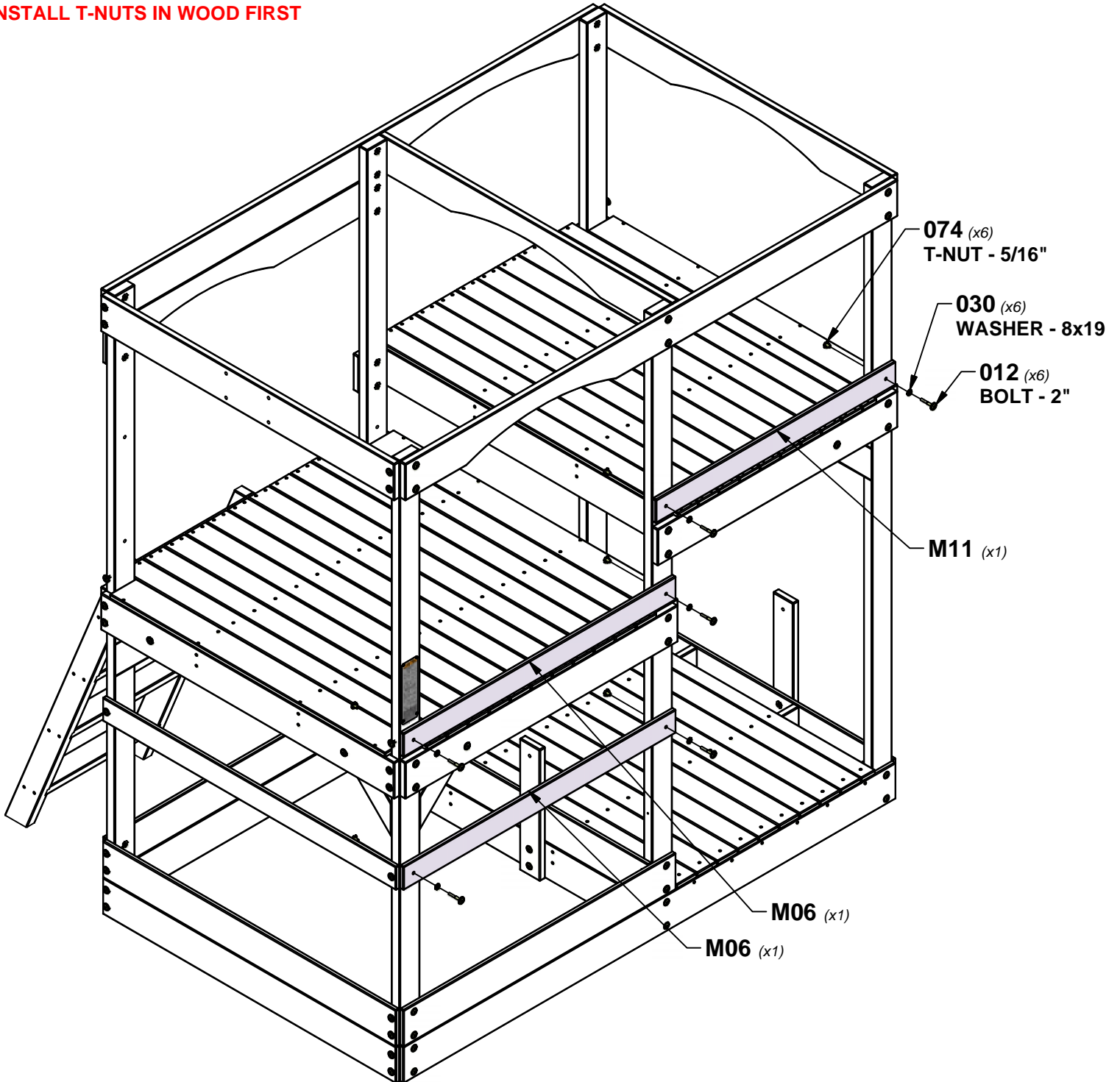

STEP 15 - FORT ASSEMBLY

QTY	PART NUMBER	DESCRIPTION
1	H100012	BOLT WH 5/16x2
2	H100027	LAG SCREW WH 5/16x2
3	H100030	WASHER LOCK EXT 8x19
1	H100074	T-NUT 5/16



M05 | WALL RAIL - W4L16066
(x1) | 5/8"x3 3/8"x49" (16x86x1244)



M18 | WALL RAIL - W4L16053
(x1) | 5/8"x3 3/8"x16 7/8" (16x86x430)

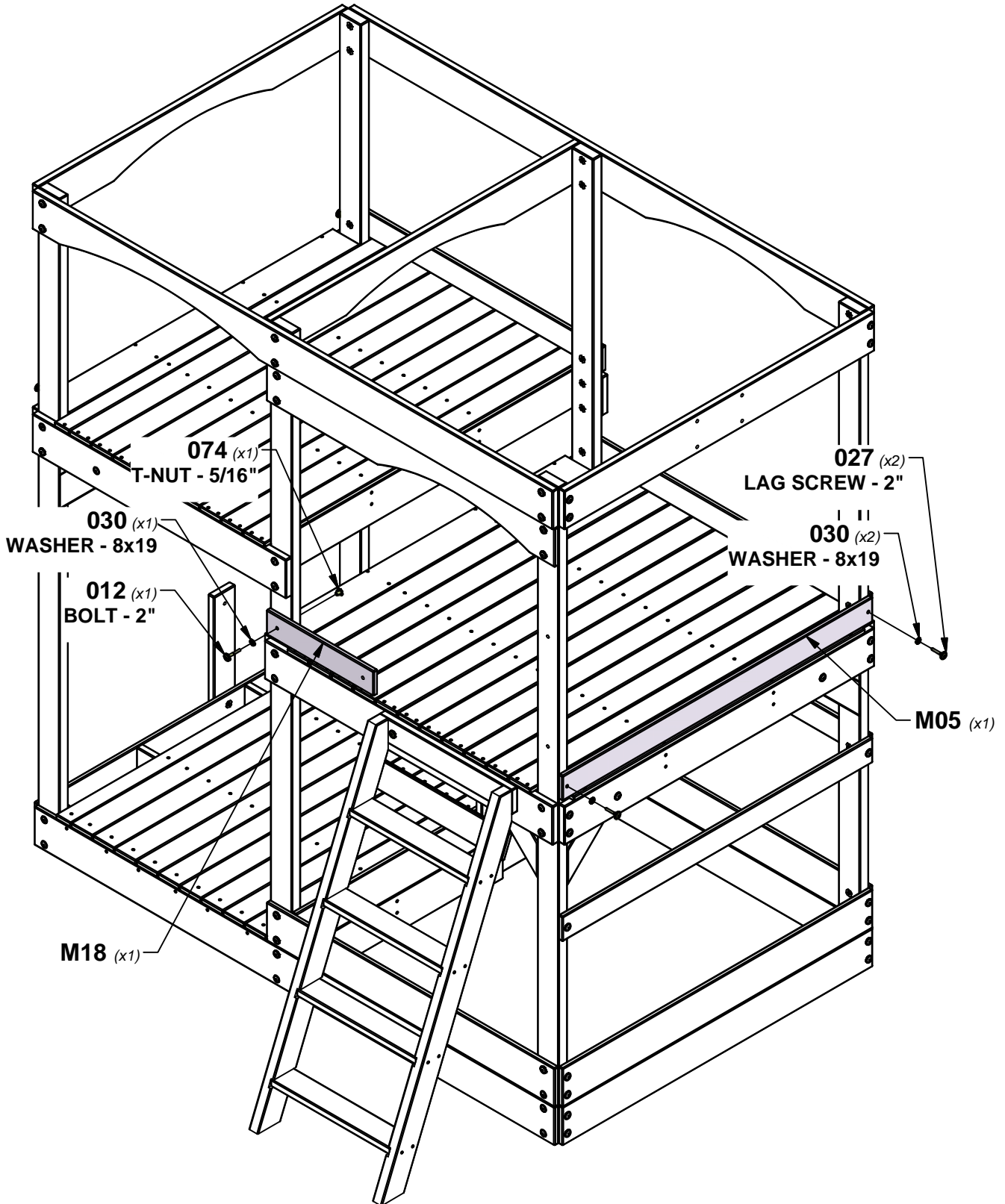

STEP 16 - FORT ASSEMBLY

QTY	PART NUMBER	DESCRIPTION
2	H100027	LAG SCREW WH 5/16x2
2	H100028	LAG SCREW WH 5/16x2 1/2
4	H100030	WASHER LOCK EXT 8x19

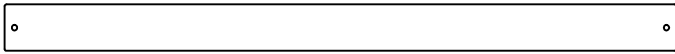

M05 | WALL RAIL - W4L16066
(x1) | 5/8"x3 3/8"x49" (16x86x1244)

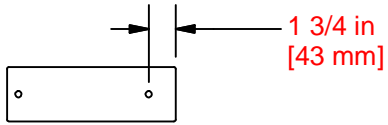

M21 | WALL RAIL - W4L16057
(x2) | 5/8"x3 3/8"x10 1/2" (16x86x268)

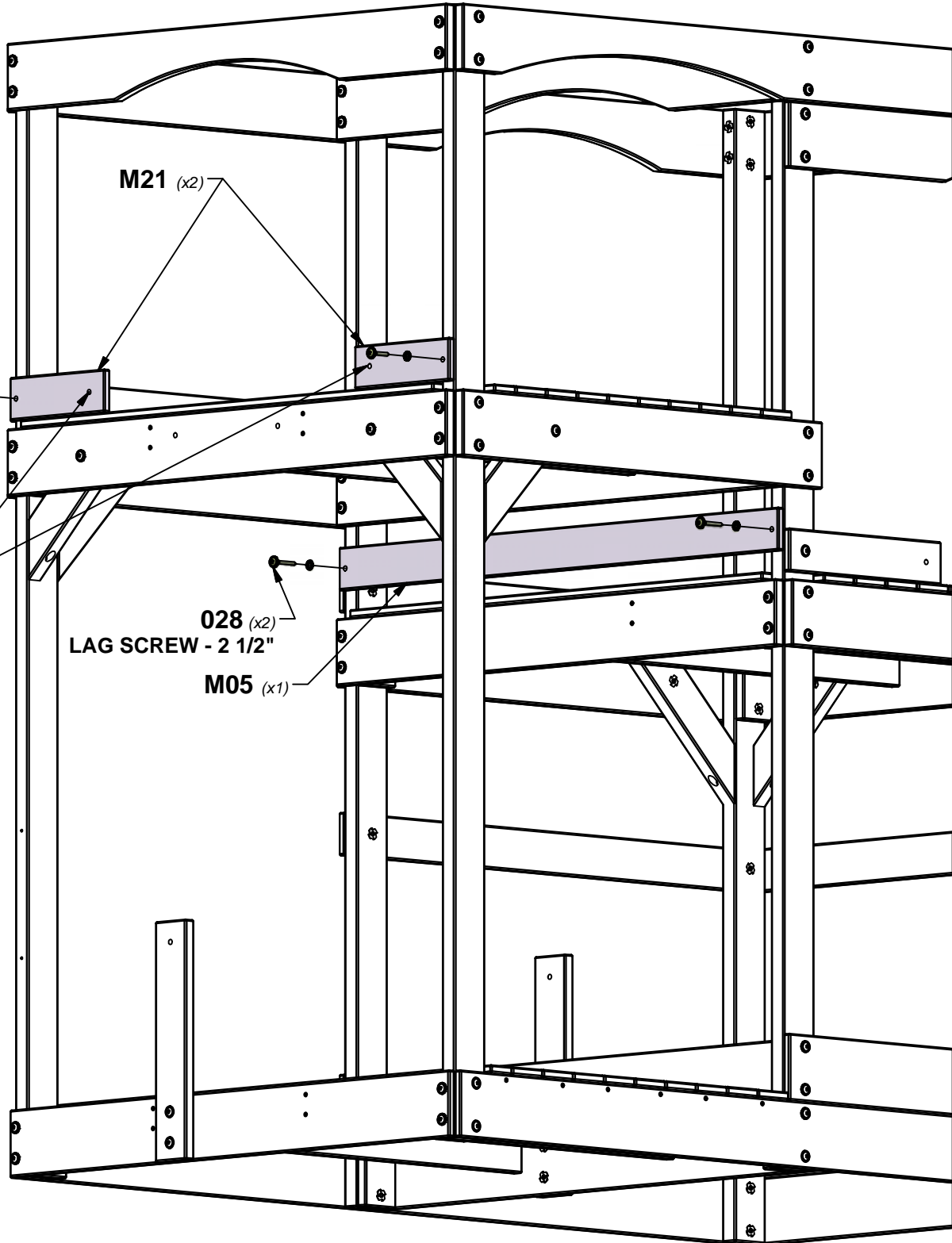

030 (x4)
WASHER - 8x19

027 (x2)
LAG SCREW - 2"

1 3/4 in
[43mm]
HOLES TO INSIDE

028 (x2)
LAG SCREW - 2 1/2"

M05 (x1)

STEP 17 - FORT ASSEMBLY

QTY	PART NUMBER	DESCRIPTION
24	H100088	SCREW PFH 8x1-1/8"



M09 | WALL BOARD - W4L16075
 (x6) | 5/8"x3 3/8"x32" (16x86x812)

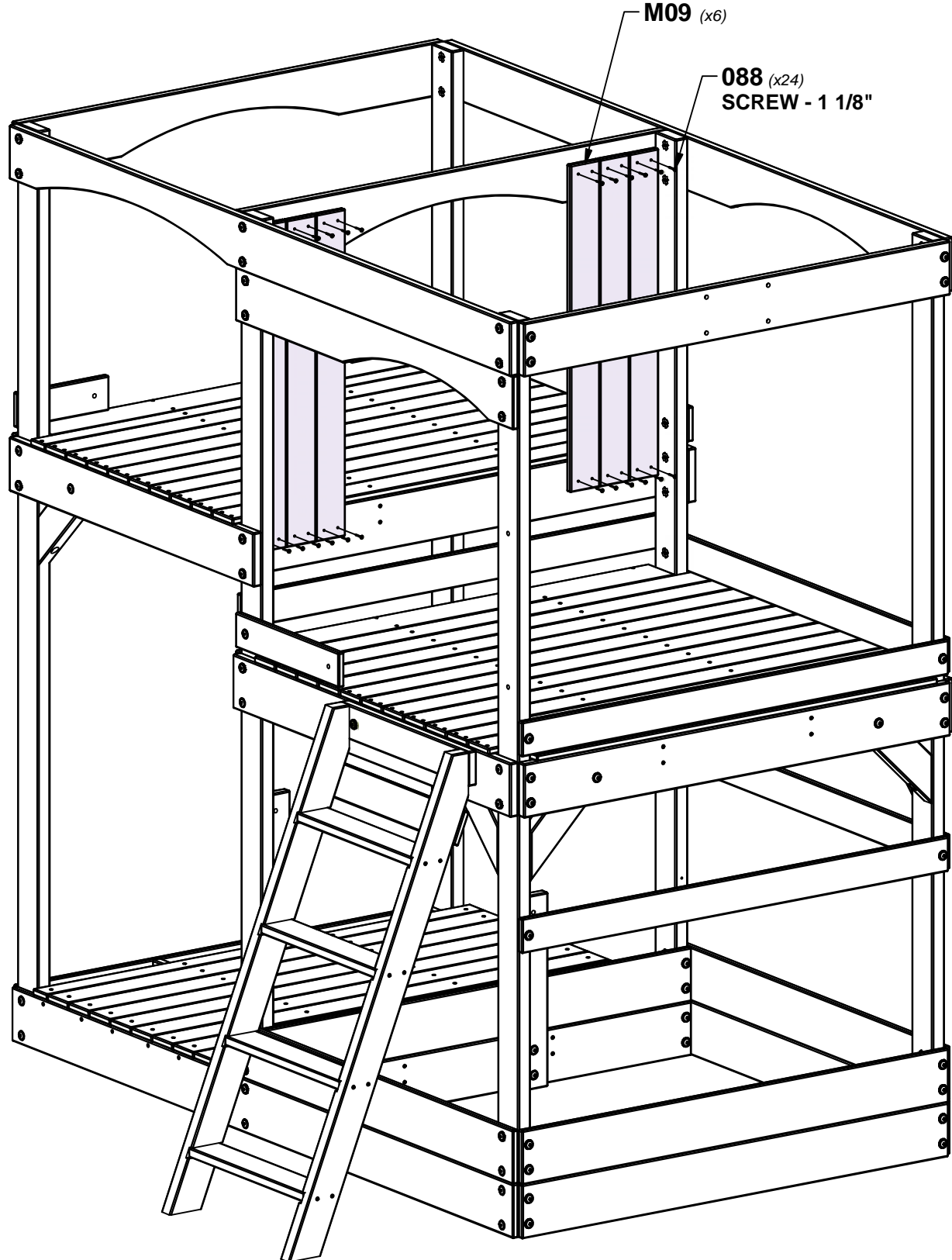
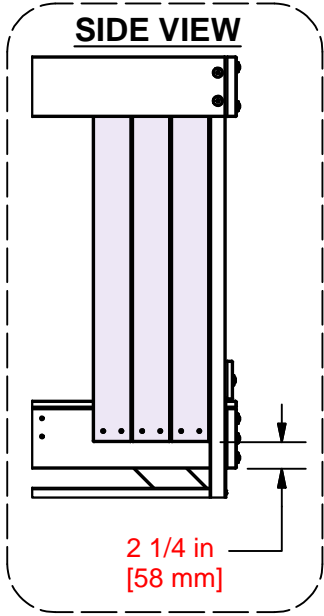

STEP 18 - FORT ASSEMBLY



M24 WALL BOARD - W4L16061
(x2) 5/8"x3 3/8"x29 5/8" (16x86x752)

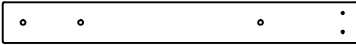

M26 WALL BOARD - W4L16091
(x2) 5/8"x3 3/8"x29 5/8" (16x86x752)



A4M01046 L BRACKET
(x2) 2.5x38x55x55

TOP

QTY	PART NUMBER	DESCRIPTION
2	H100005	NUT BARREL WH 5/16x7/8
2	H100008	BOLT WH 5/16x1
2	H100031	WASHER LOCK EXT 12x19
2	H100074	T-NUT 5/16
12	H100088	SCREW PFH 8x1-1/8"
2	H100115	BOLT WH 5/16x1/2

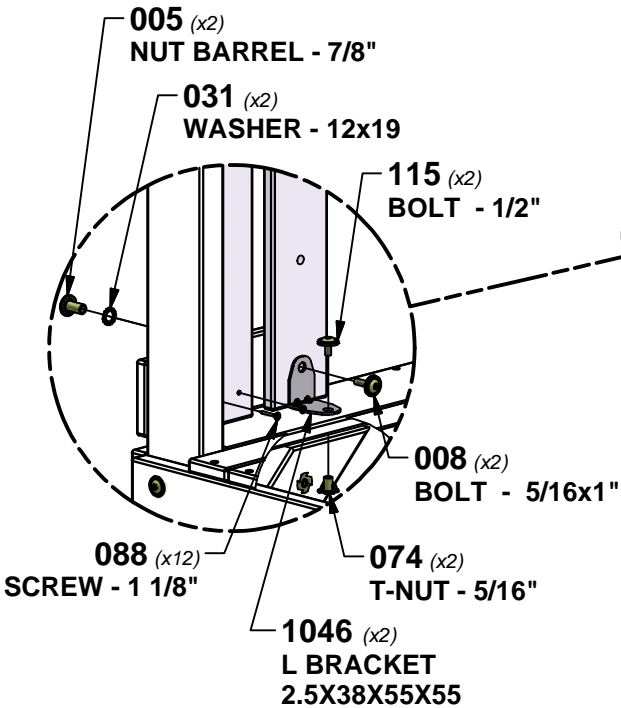
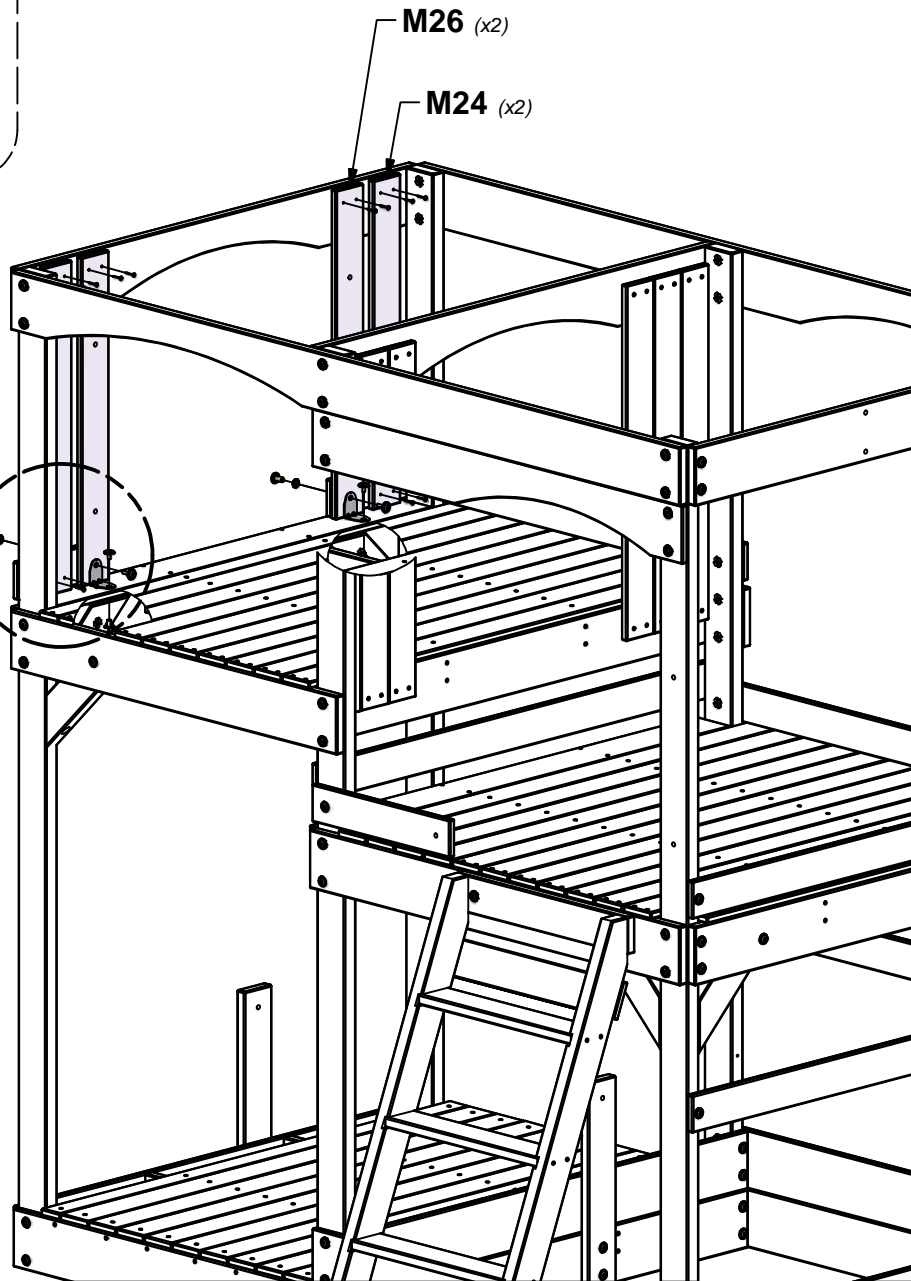
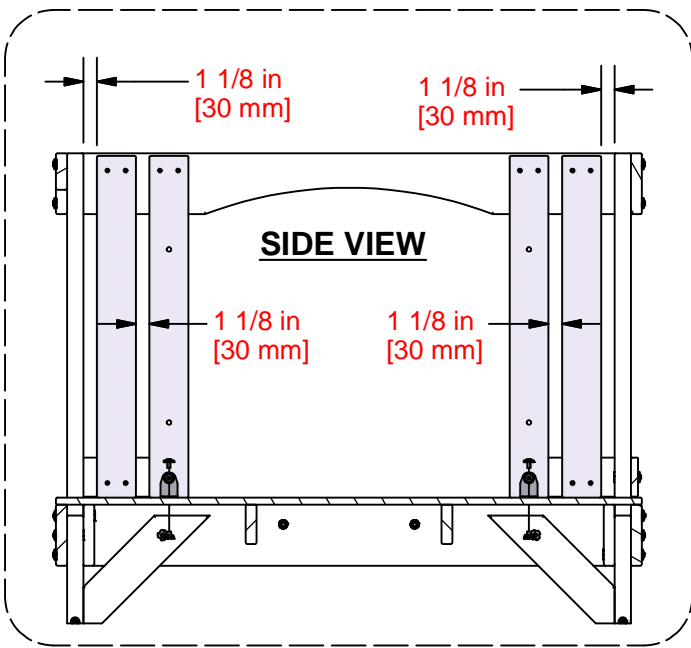

USING L BRACKET AS A GUIDE, DRILL (2) 3/8 in [10 mm] HOLES THRU FLOOR FOR HARDWARE

STEP 19 - FORT ASSEMBLY

QTY	PART NUMBER	DESCRIPTION
20	H100088	SCREW PFH 8x1-1/8"



M24 | WALL BOARD - W4L16061
(x5) 5/8"x3 3/8"x29 5/8" (16x86x752)

SIDE VIEW

2 3/4 in TYPICAL SPACING
[69 mm]

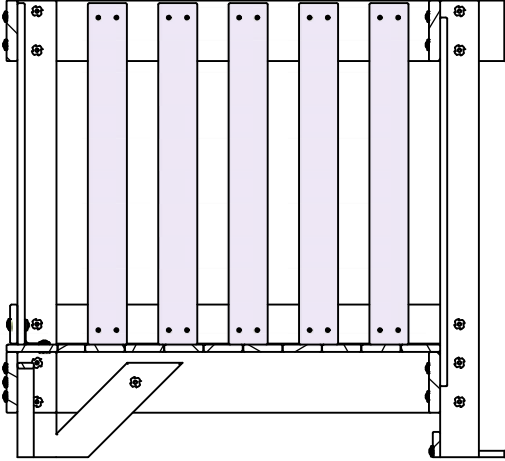

USE A6P00410 PICKET PAL FOR SPACING

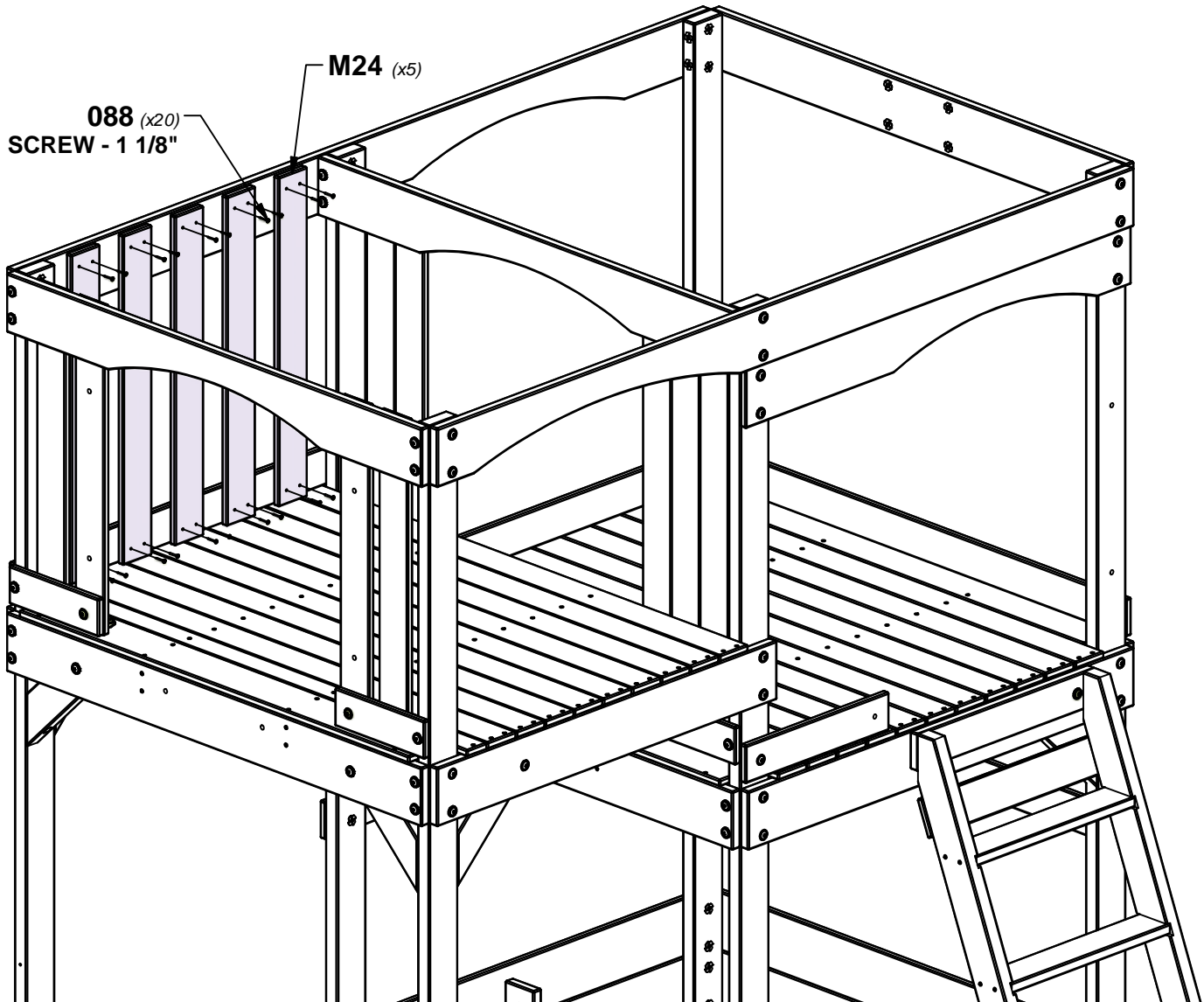

STEP 20 - FORT ASSEMBLY

QTY	PART NUMBER	DESCRIPTION
16	H100088	SCREW PFH 8x1-1/8"



M08 | WALL BOARD - W4L16074
(x2) | 5/8"x3 3/8"x41" (16x86x1040)

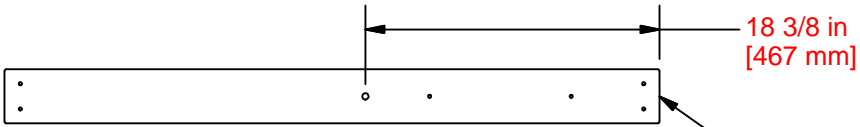

M17 | WALL BOARD - W4L16090
(x2) | 5/8"x3 3/8"x41" (16x86x1040)

TOP

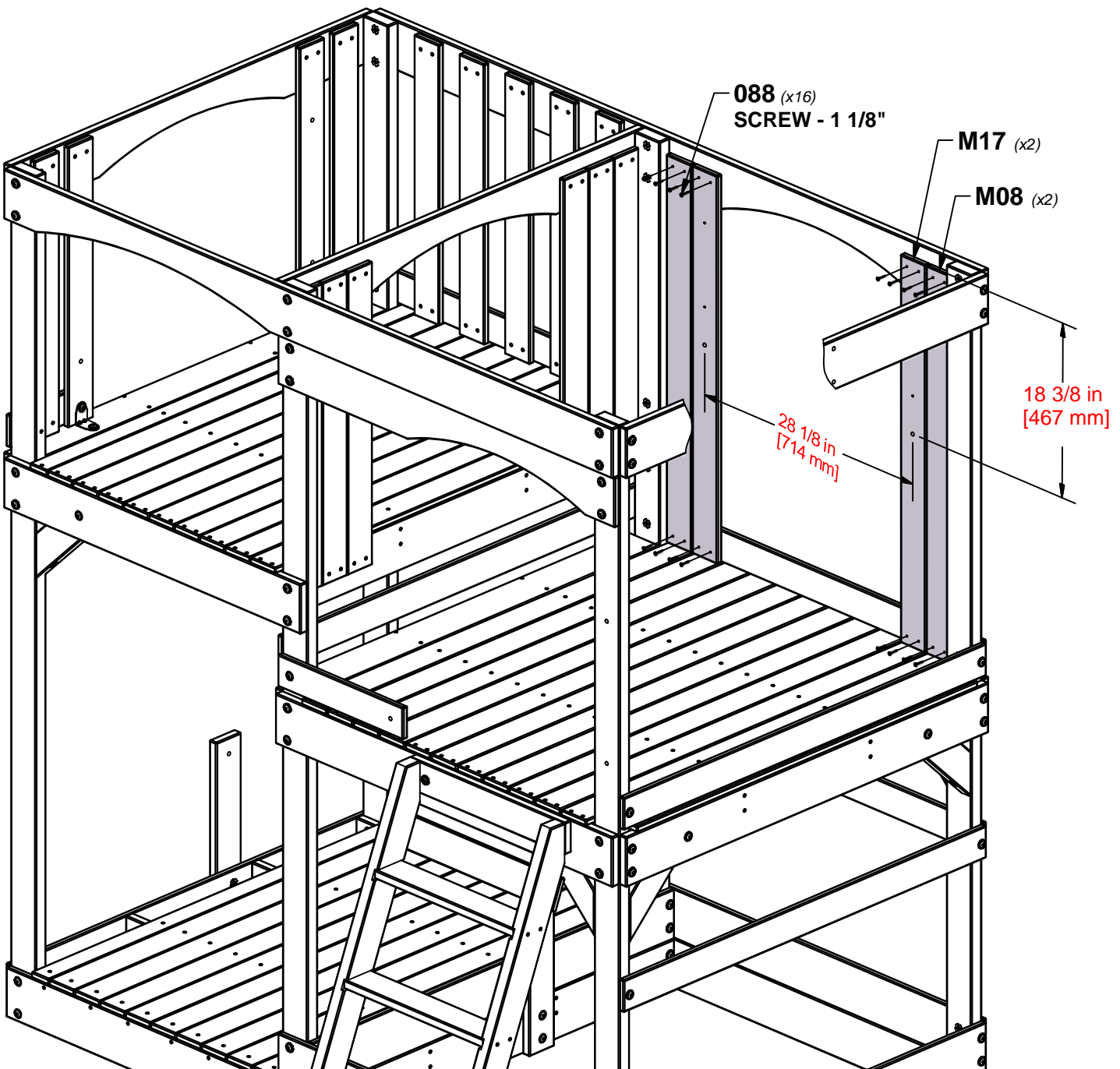

STEP 21 - FORT ASSEMBLY

QTY	PART NUMBER	DESCRIPTION
2	H100009	BOLT WH 5/16x1 1/4
2	H100030	WASHER LOCK EXT 8x19
2	H100074	T-NUT 5/16
28	H100088	SCREW PFH 8x1-1/8"



M12 WINDOW TRIM - W4L16048
(x1) 5/8"x3 3/8"x31 1/2" (16x86x800)



M13 WALL BOARD - W4L16049
(x7) 5/8"x3 3/8"x24" (16x86x610)

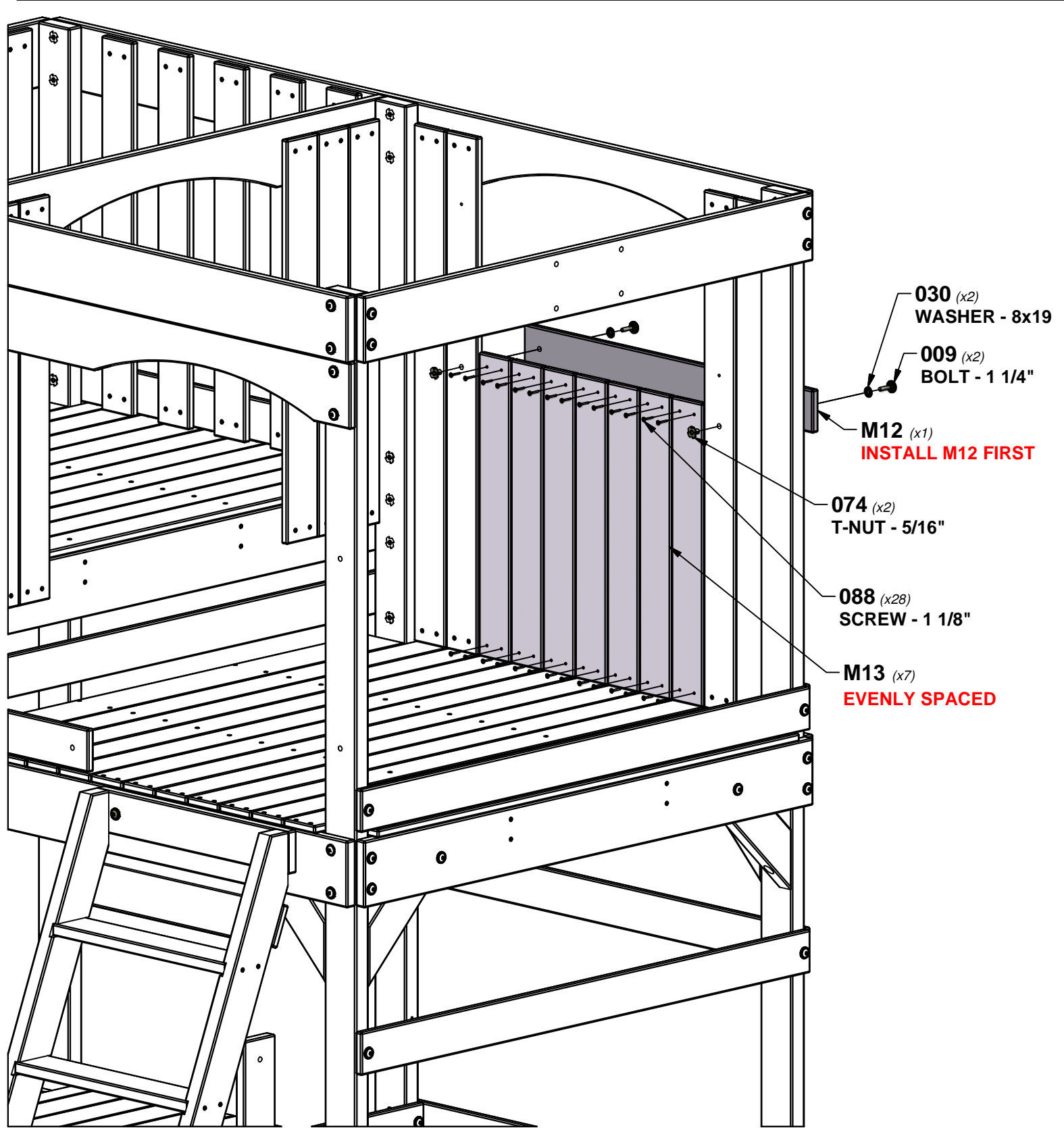

STEP 22 - FORT ASSEMBLY

QTY	PART NUMBER	DESCRIPTION
4	H100088	SCREW PFH 8x1-1/8"

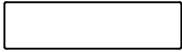

M23 | WINDOW TRIM - W4L16059
(x2) | 5/8"x3 3/8"x12 7/8" (16x86x328)

SIDE VIEW

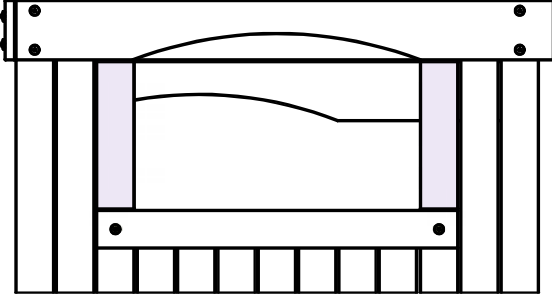

CORRECT BOARD ASSEMBLY

088 (x4)
SCREW - 1 1/8"

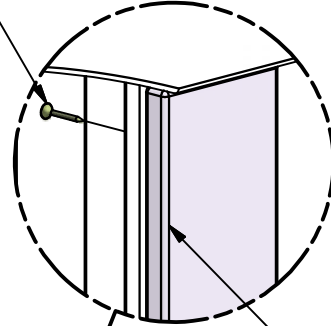

M23 (x2)

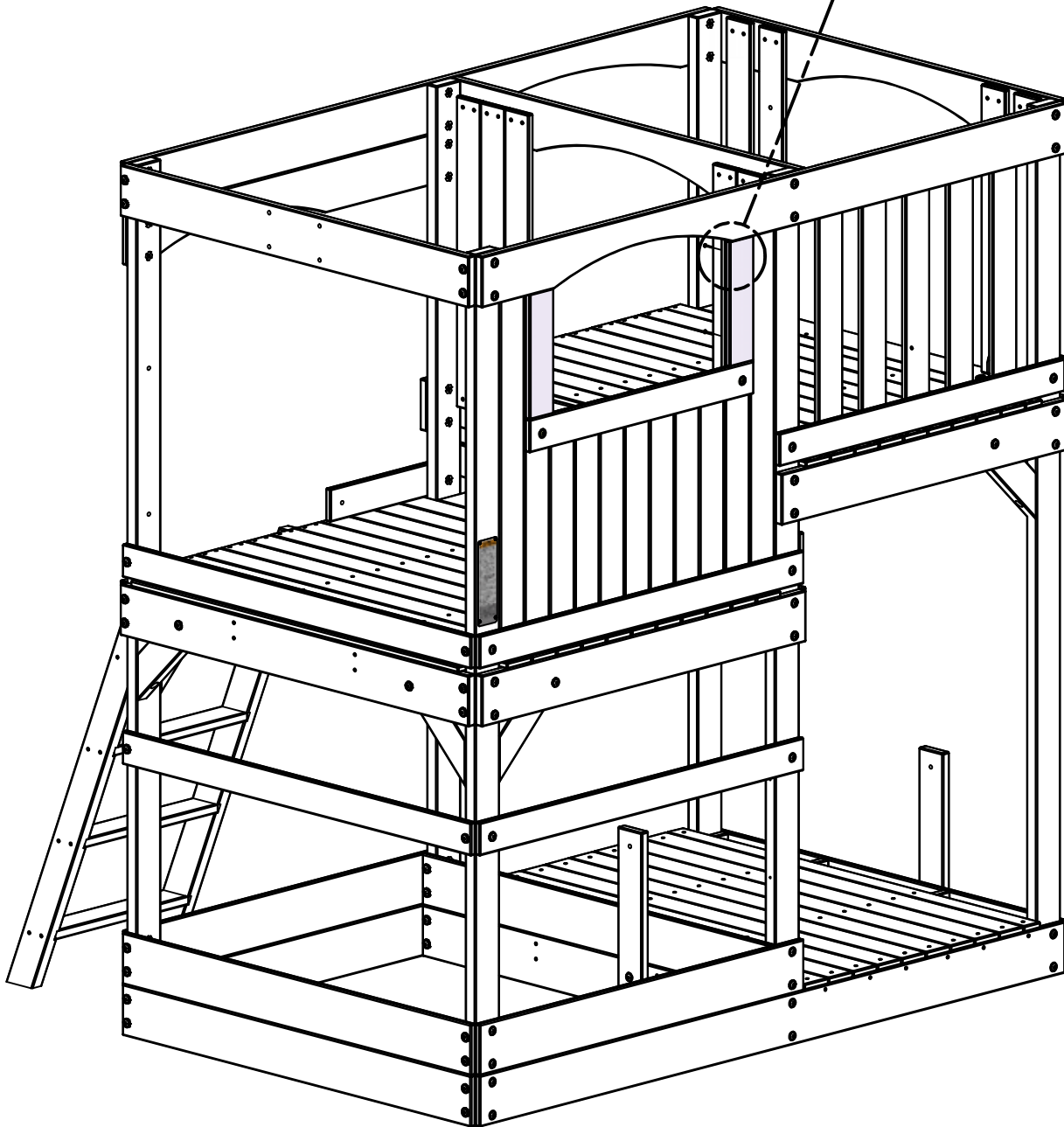

STEP 23 - FORT ASSEMBLY

QTY	PART NUMBER	DESCRIPTION
48	H100088	SCREW PFH 8x1-1/8"



M08 | WALL BOARD - W4L16074
(x7) | 5/8"x3 3/8"x41" (16x86x1040)

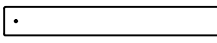

N03 | WALL BOARD - W4L16078
(x2) | 5/8"x2 3/8"x18" (16x60x456)



N05 | WALL BOARD - W4L16080
(x2) | 5/8"x2 3/8"x7" (16x60x178)

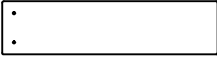

L02 | WALL BOARD - W4L16040
(x4) | 5/8"x4 3/8"x18" (16x112x456)



L03 | WALL BOARD - W4L16041
(x4) | 5/8"x4 3/8"x7" (16x112x178)

**FLUSH TOPS OF L03 & N05 BOARDS
WITH TOP OF M08 BOARDS**

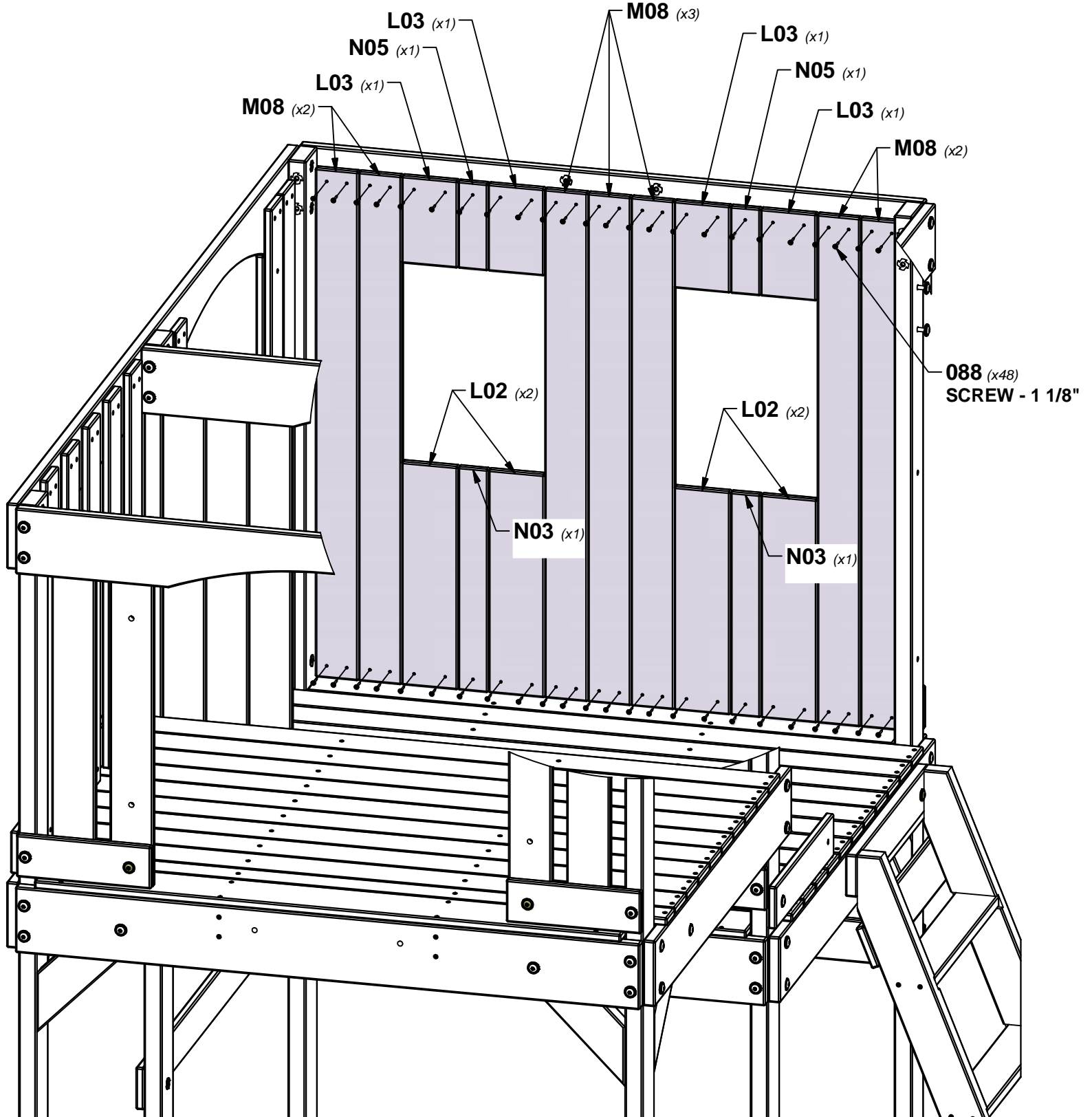

STEP 24 - FORT ASSEMBLY

QTY	PART NUMBER	DESCRIPTION
8	H100070	SCREW PWH 8x3/4
10	H100088	SCREW PFH 8x1-1/8"

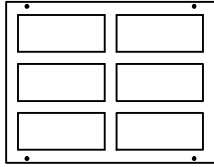

PLASTIC
A100010 WINDOW BYD
(x2) GREEN
343x444.5



O01 WALL SUPPORT - W4L16081
(x2) 5/8"x1 3/8"x13" (16x34x330)

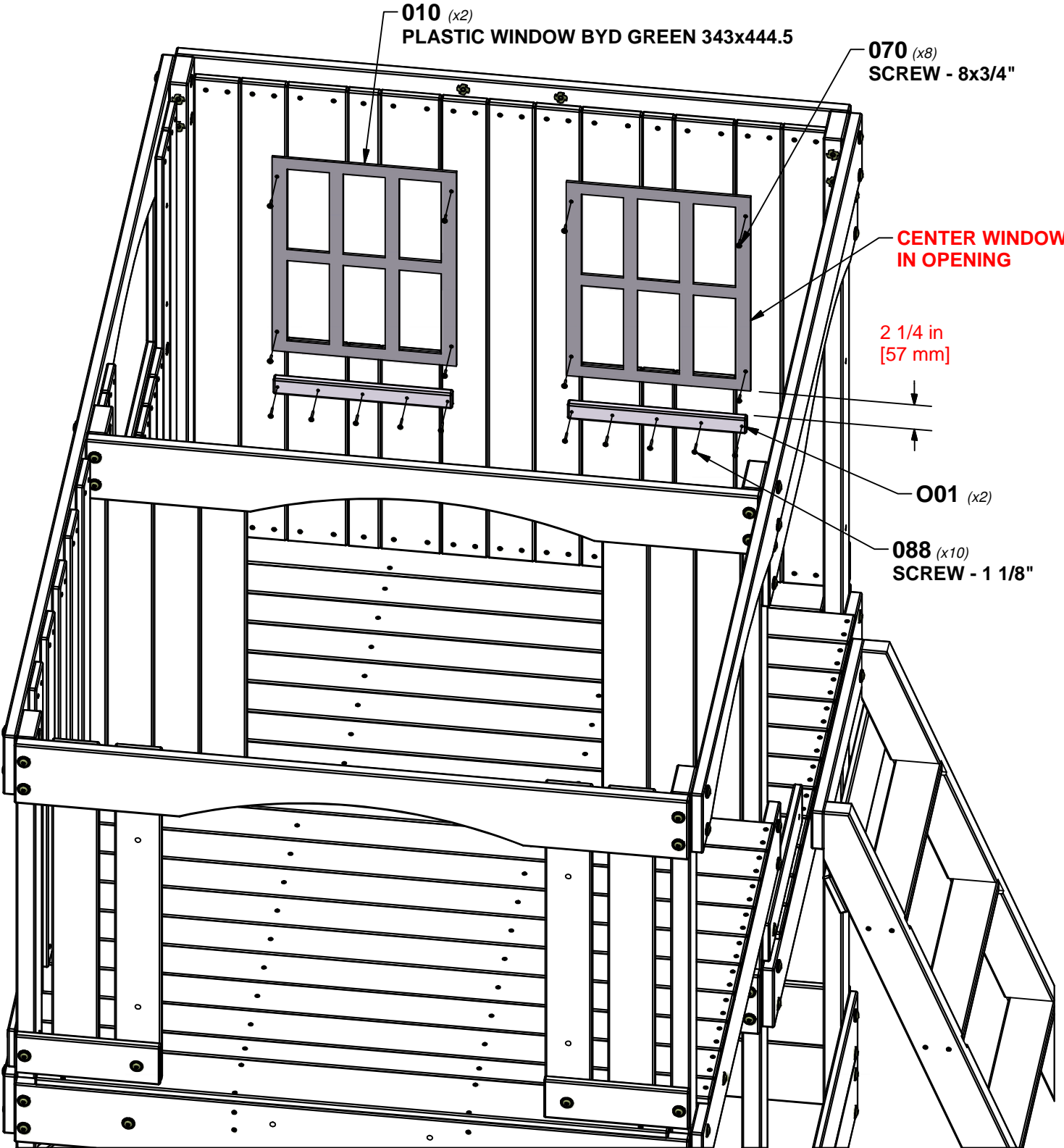

STEP 25 - FORT ASSEMBLY

QTY	PART NUMBER	DESCRIPTION
12	H100086	SCREW PFH 8x1-1/2"

O04 WINDOW SHUTTER SLAT - W4L16084
 (x6) 5/8"x1 3/8"x5 3/8" (16x34x136)

L04 WINDOW SHUTTER - W4L16042
 (x3) 5/8"x4 3/8"x16" (16x112x406)

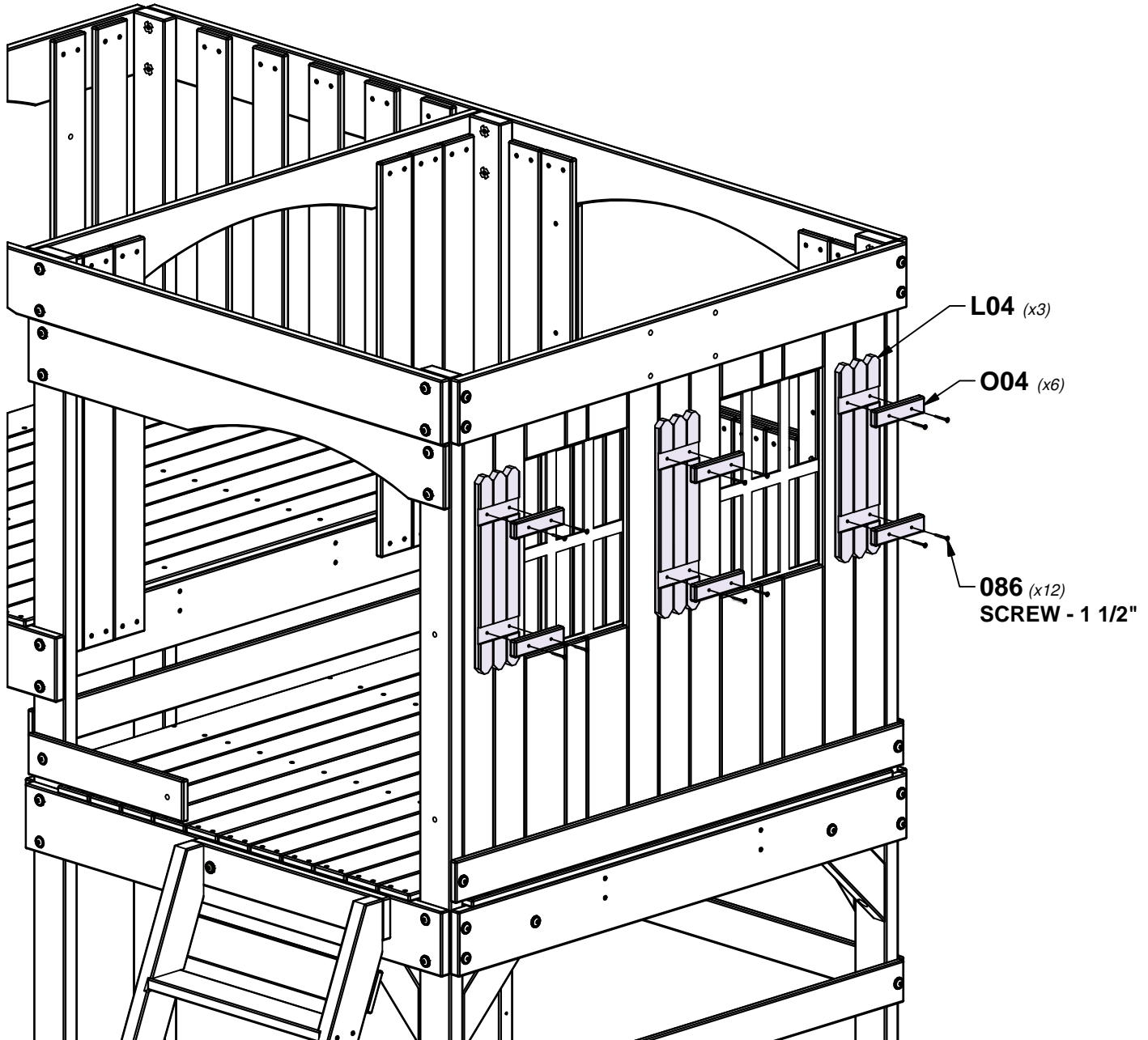
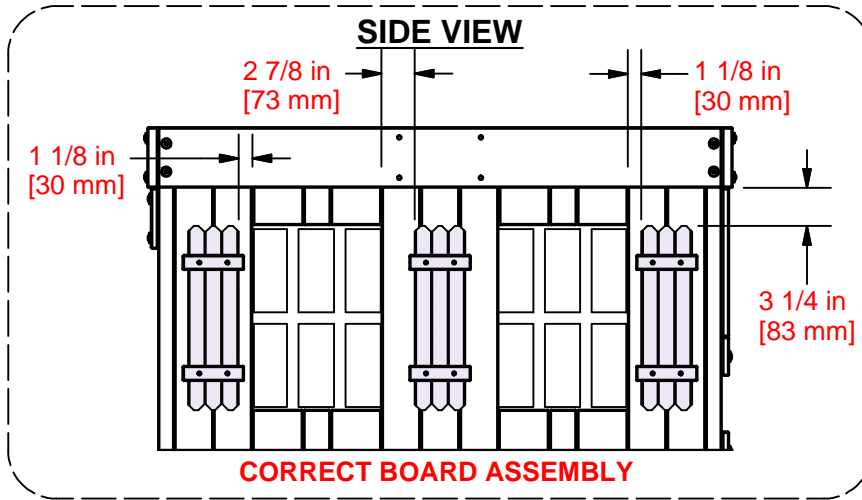

STEP 26 - FORT ASSEMBLY

QTY	PART NUMBER	DESCRIPTION
1	H100005	NUT BARREL WH 5/16x7/8
1	H100008	BOLT WH 5/16x1
1	H100031	WASHER LOCK EXT 12x19
1	H100074	T-NUT 5/16
14	H100088	SCREW PFH 8x1-1/8"
1	H100115	BOLT WH 5/16x1/2



M10 | WALL BOARD - W4L16044
(x1) | 5/8"x3 3/8"x35" (16x86x888)



M28 | WALL BOARD - W4L16064
(x1) | 5/8"x3 3/8"x35" (16x86x888)



A4M01046 | L BRACKET
(x1) | 2.5x38x55x55

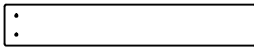

M16 | WALL BOARD - W4L16052
(x2) | 5/8"x3 3/8"x21" (16x86x532)



M29 | WALL BOARD - W4L16060
(x2) | 5/8"x3 3/8"x5" (16x86x126)

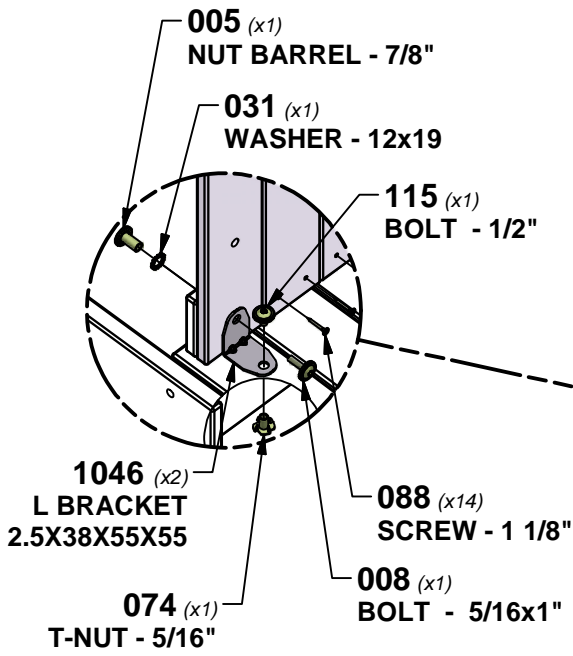

**USING L BRACKET AS A GUIDE,
DRILL (1) 3/8 in [10 mm] HOLES
THRU FLOOR FOR HARDWARE**

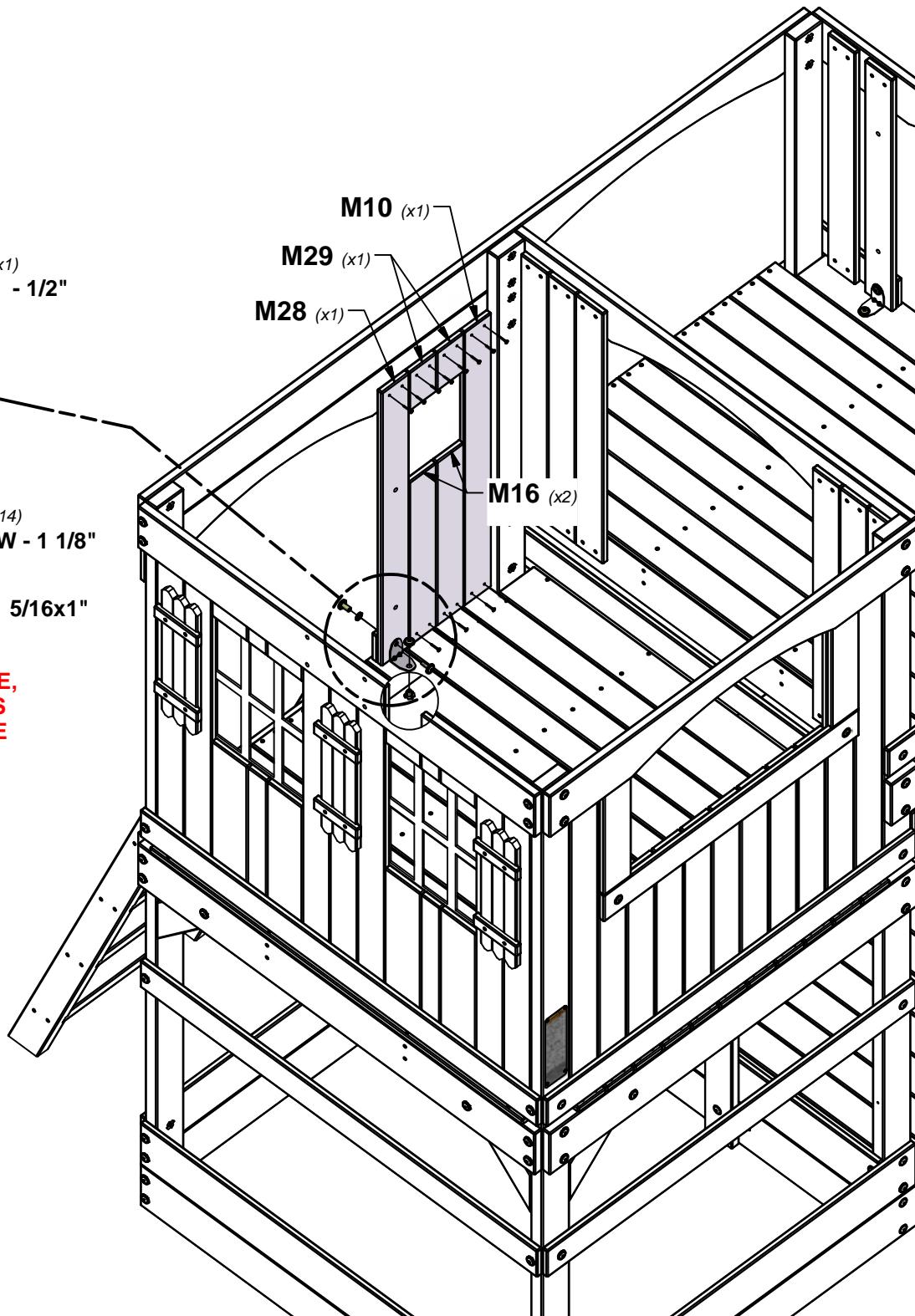

STEP 27 - FORT ASSEMBLY

QTY	PART NUMBER	DESCRIPTION
4	H100070	SCREW PWH 8x3/4
4	H100088	SCREW PFH 8x1-1/8"

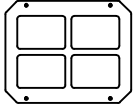

A100146 | WINDOW
(x1) | 216x267 GREEN

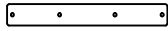

O02 | WALL SUPPORT - W4L16082
(x1) | 5/8"x1 3/8"x10" (16x34x254)

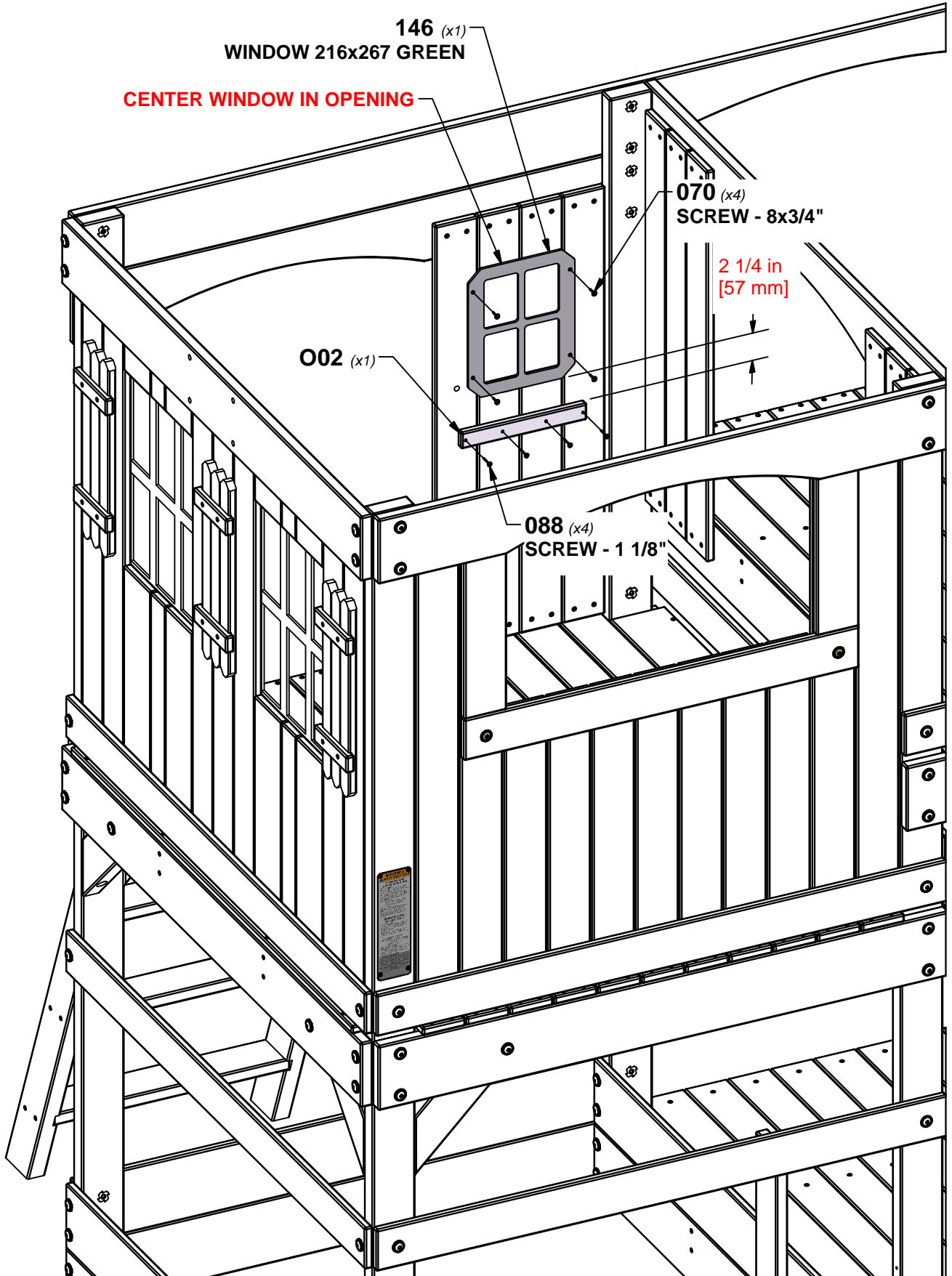

STEP 28 - FORT ASSEMBLY

QTY	PART NUMBER	DESCRIPTION
8	H100086	SCREW PFH 8x1-1/2"
2	H100111	SCREW PFH 8x2"

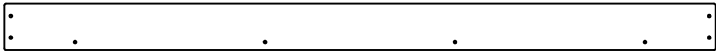

M01 | ROOF CAP - W4L16043
(x2) | 5/8"x3 3/8"x51 7/8" (16x86x1318)

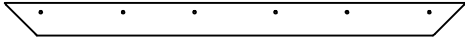

J01 | ROOF RAFTER - W4L16033
(x4) | 1"x2 3/8"x33 5/8" (24x60x854)

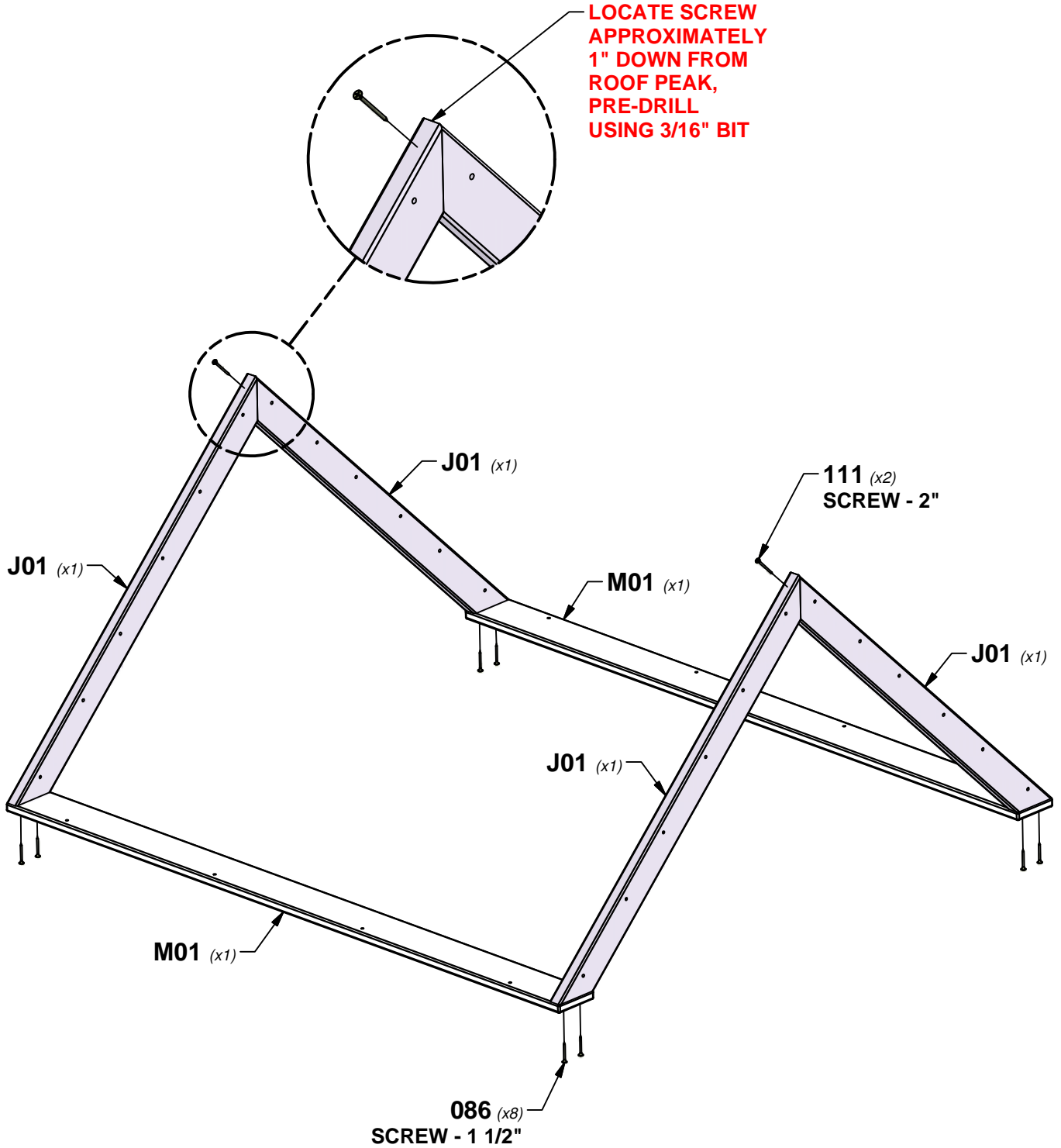

STEP 29 - FORT ASSEMBLY

QTY	PART NUMBER	DESCRIPTION
8	H100090	SCREW PFH 8x2 1/2



ROOF BASE ASSEMBLY

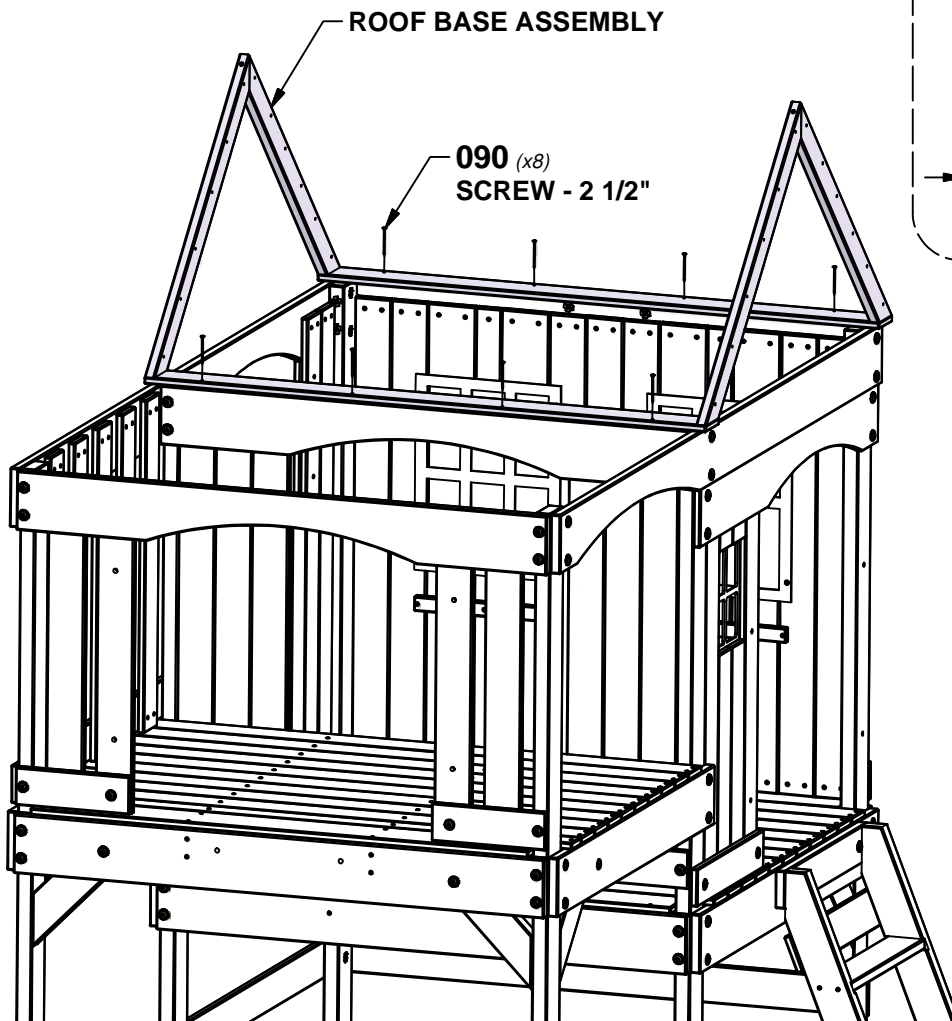
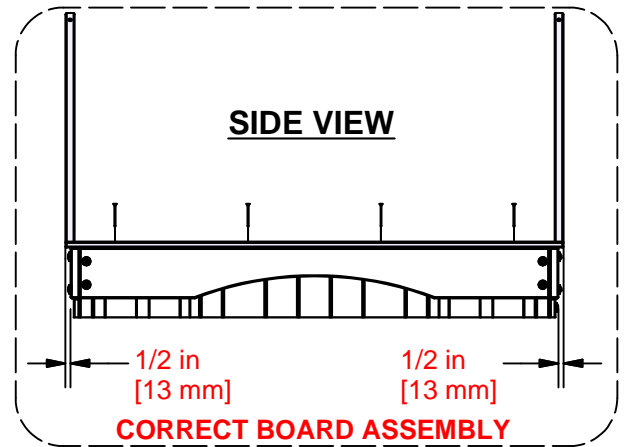
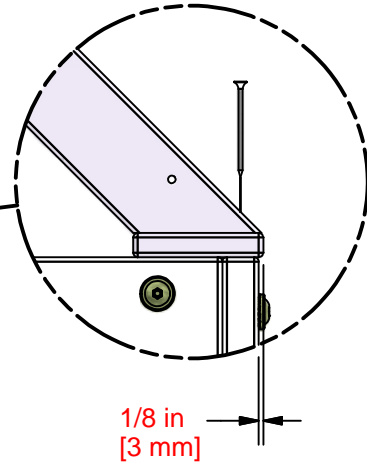
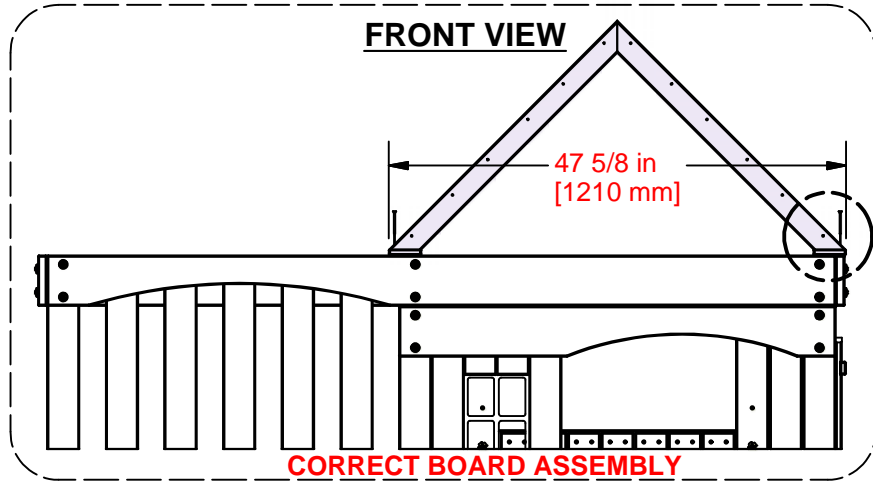

STEP 30 - FORT ASSEMBLY

QTY	PART NUMBER	DESCRIPTION
6	H100090	SCREW PFH 8x2 1/2

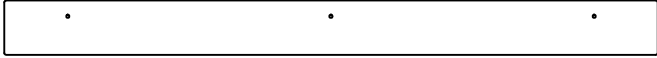

M07 | WALL CAP - W4L16068
 (x2) | 5/8"x3 3/8"x40 7/8" (16x86x1038)

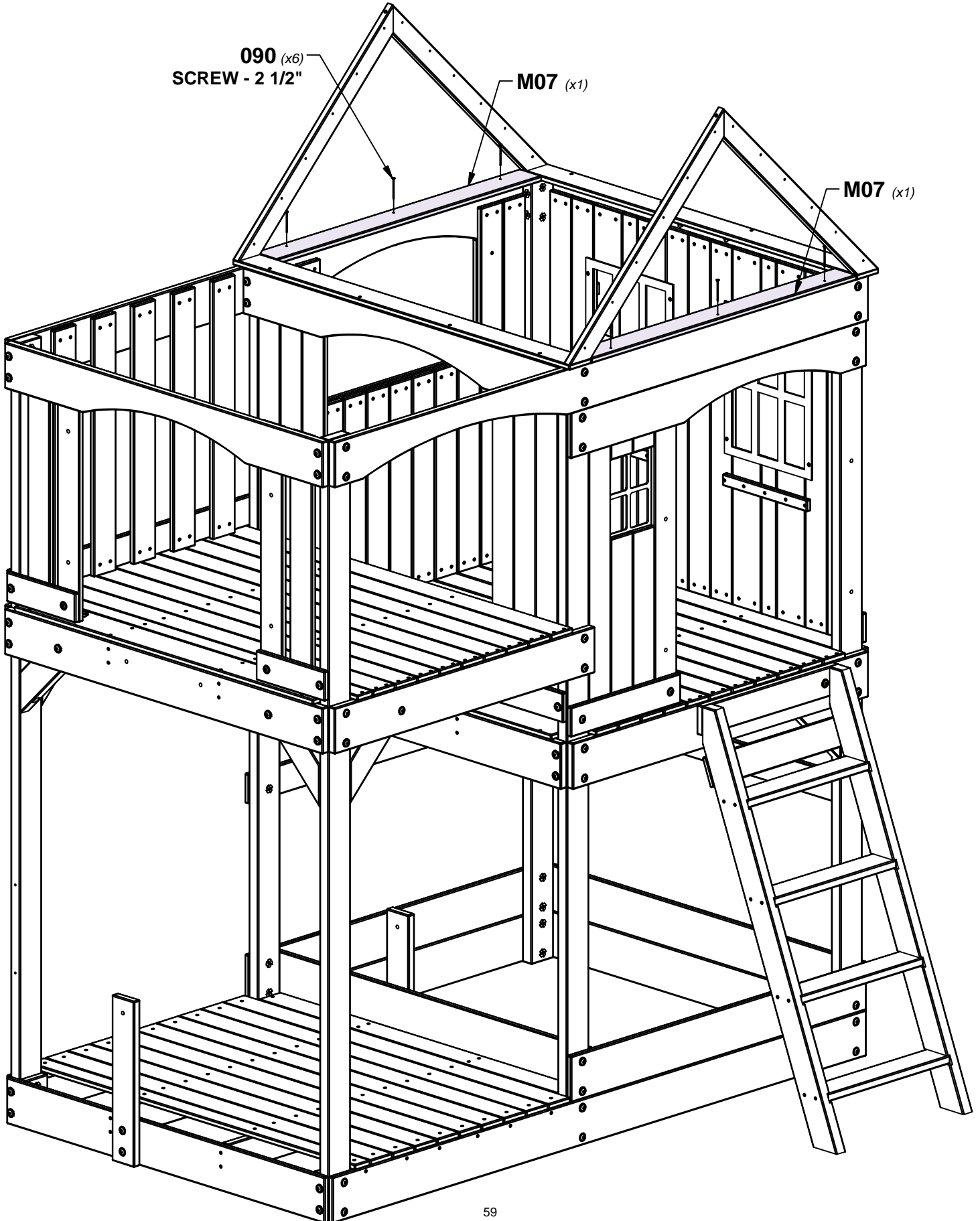

STEP 31 - FORT ASSEMBLY

QTY	PART NUMBER	DESCRIPTION
44	H100088	SCREW PFH 8x1-1/8"

M19 | GABLE BOARD - W4L16054
(x4) | 5/8"x3 3/8"x15 1/4" (16x86x387)

M22 | GABLE BOARD - W4L16058
(x4) | 5/8"x3 3/8"x9 1/2" (16x86x241)

N04 | GABLE BOARD - W4L16079
(x4) | 5/8"x2 3/8"x11 7/8" (16x60x301)

M04 | GABLE BOARD - W4L16065
(x2) | 5/8"x3 3/8"x44" (16x86x1118)

M20 | GABLE BOARD - W4L16056
(x2) | 5/8"x3 3/8"x12 1/4" (16x86x310)

M15 | GABLE BOARD - W4L16051
(x2) | 5/8"x3 3/8"x19" (16x86x482)

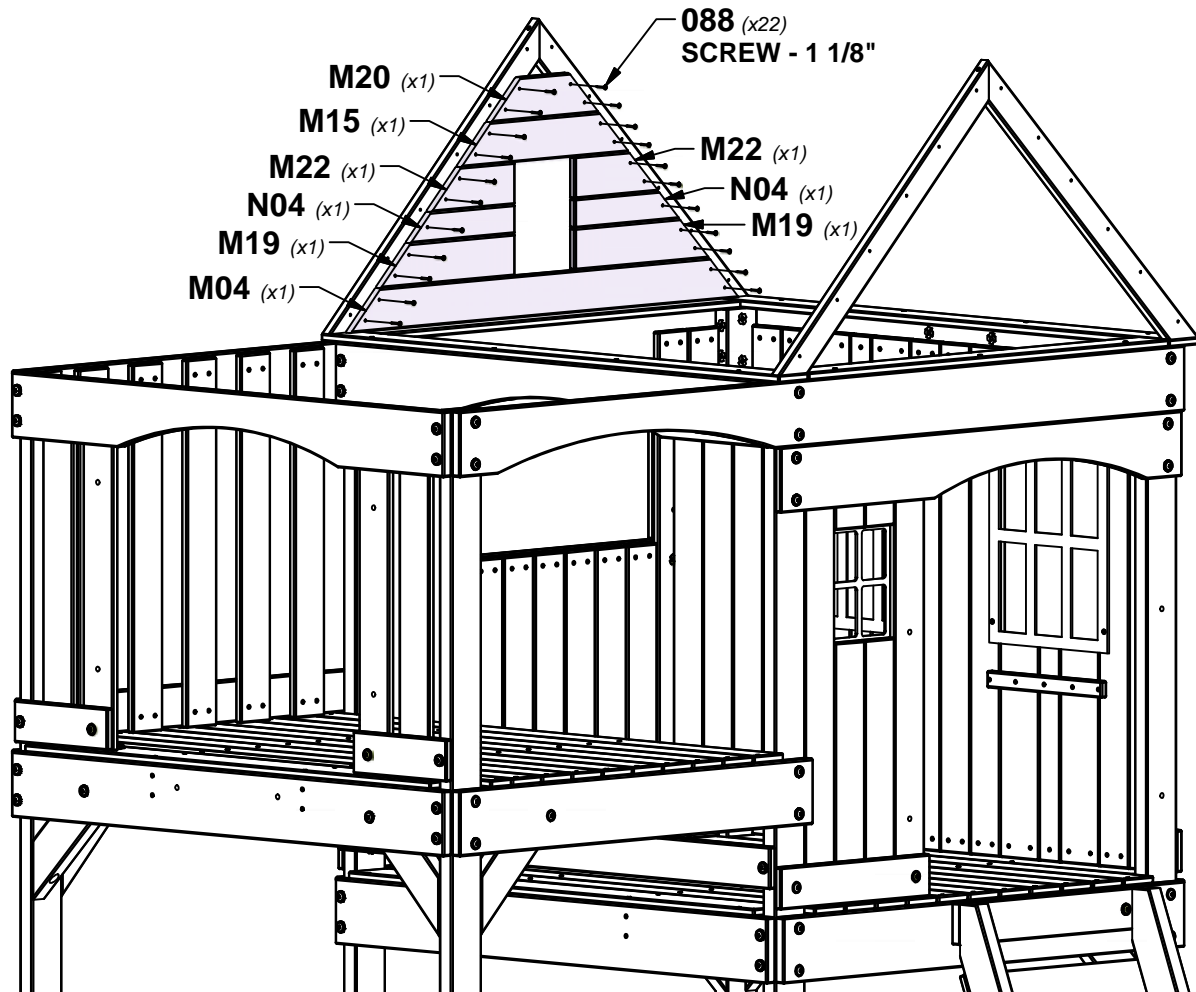
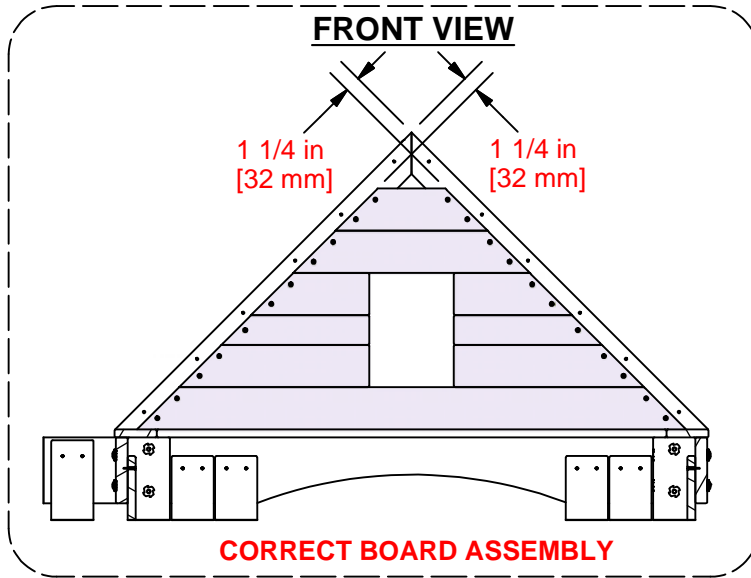

STEP 32 - FORT ASSEMBLY

QTY	PART NUMBER	DESCRIPTION
8	H100070	SCREW PWH 8x3/4
20	H100088	SCREW PFH 8x1-1/8"

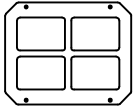

A100146 WINDOW
(x2) 216x267 GREEN



O01 WALL SUPPORT - W4L16081
(x4) 5/8"x1 3/8"x13" (16x34x330)

FRONT VIEW

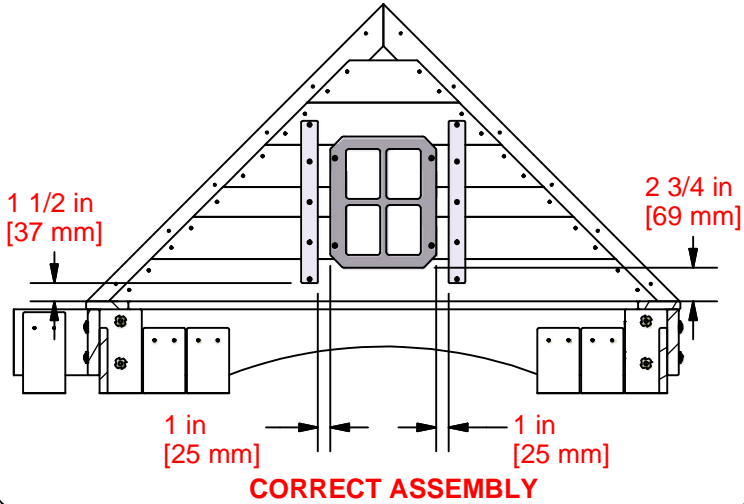

REPEAT STEPS 31 & 32 ON THE OPPOSITE SIDE.

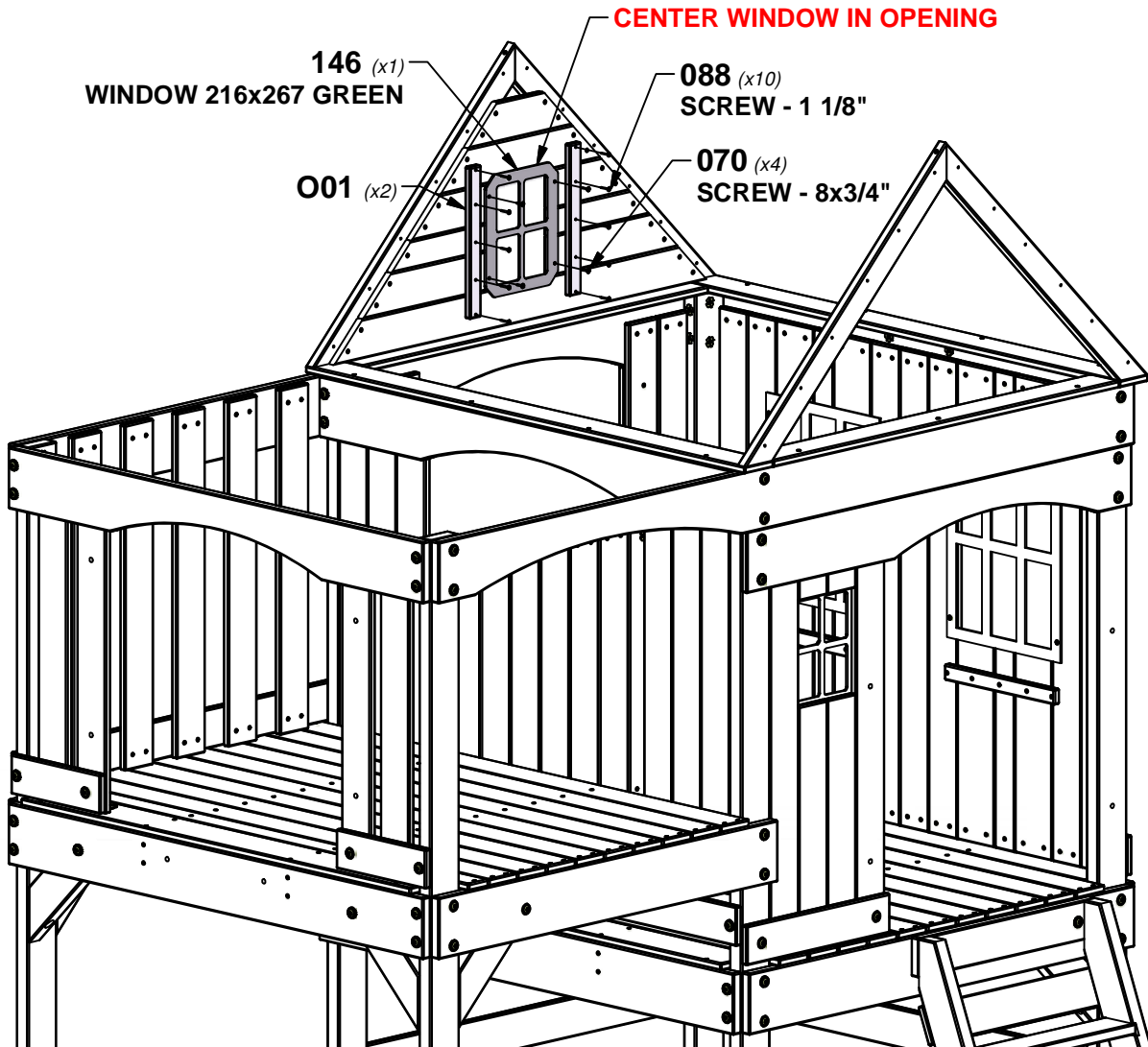

STEP 33 - FORT ASSEMBLY

QTY	PART NUMBER	DESCRIPTION
24	H100089	SCREW PFH 8x1-3/4"



RP1 | ROOF PANEL - W2A03279
(x2) | 1 3/4"x19 1/4"x53 3/4" (45x490x1366)

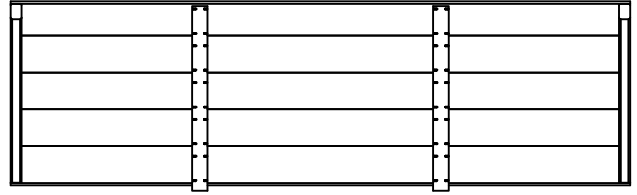

RP2 | ROOF PANEL - W2A03280
(x2) | 1 3/4"x16 1/4"x53 3/4" (45x417x1366)

REPEAT THIS STEP FOR THE OPPOSITE SIDE.

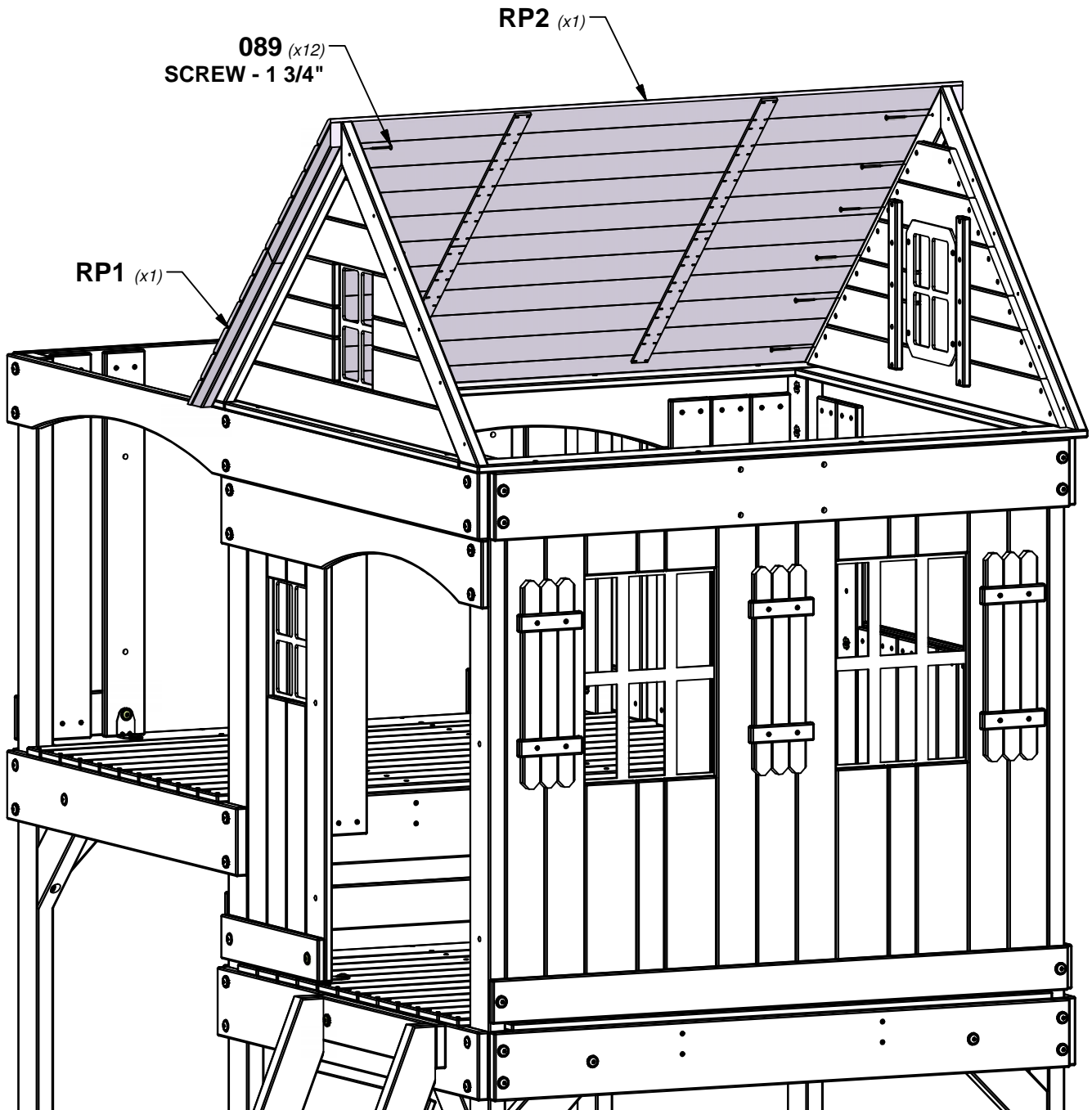

STEP 34 - FORT ASSEMBLY

QTY	PART NUMBER	DESCRIPTION
4	H100088	SCREW PFH 8x1-1/8"

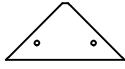

N02 | MENDING PLATE - W4L16077
(x2) | 5/8"x2 3/8"x5" (16x60x126)

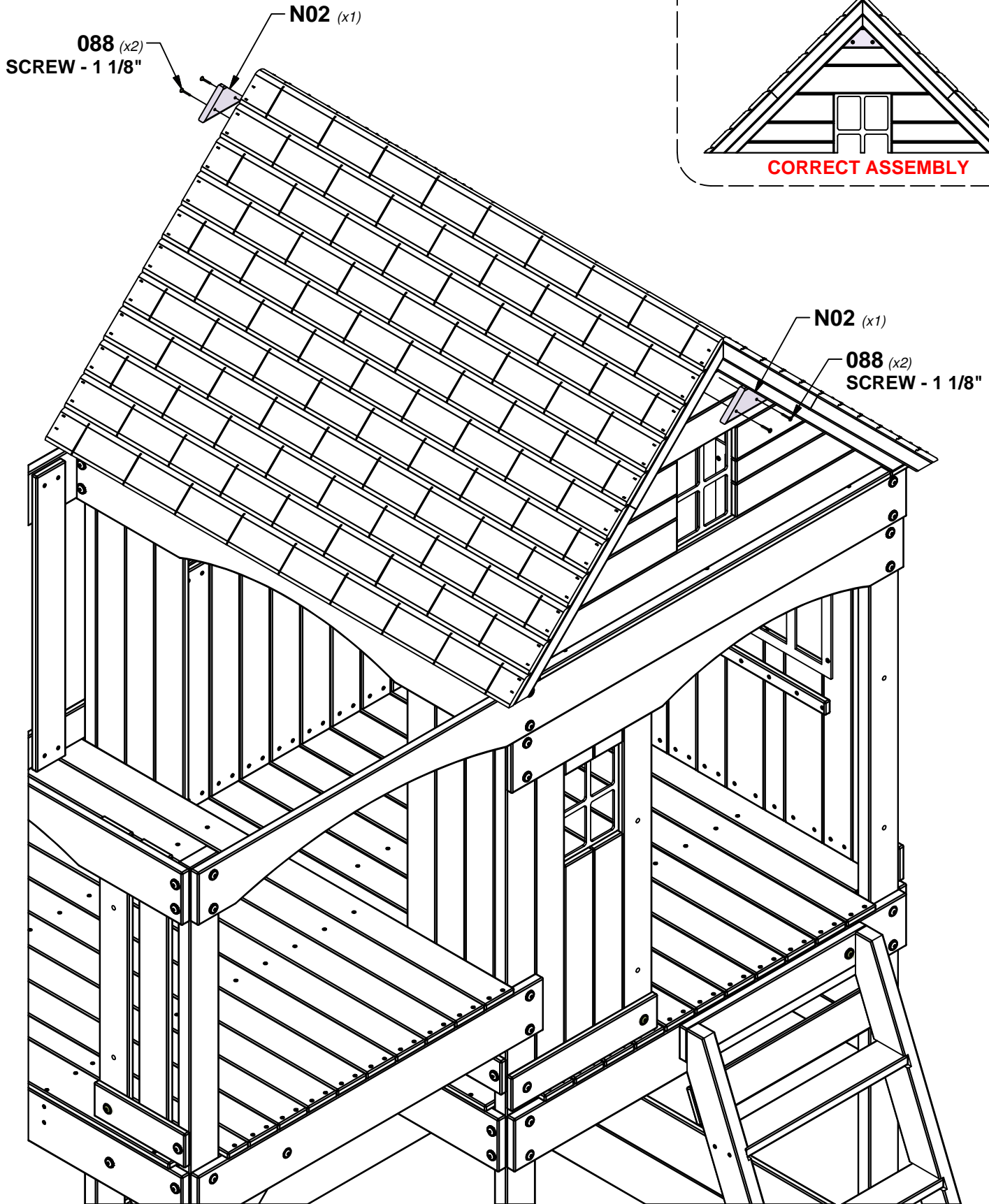

STEP 35 - FORT ASSEMBLY

QTY	PART NUMBER	DESCRIPTION
2	H100010	BOLT WH 5/16x1 1/2
8	H100074	T-NUT 5/16
6	H100115	BOLT WH 5/16x1/2



A100118 | **HAND GRIP**
 (x4) | **METAL GREEN**
 381 c/c

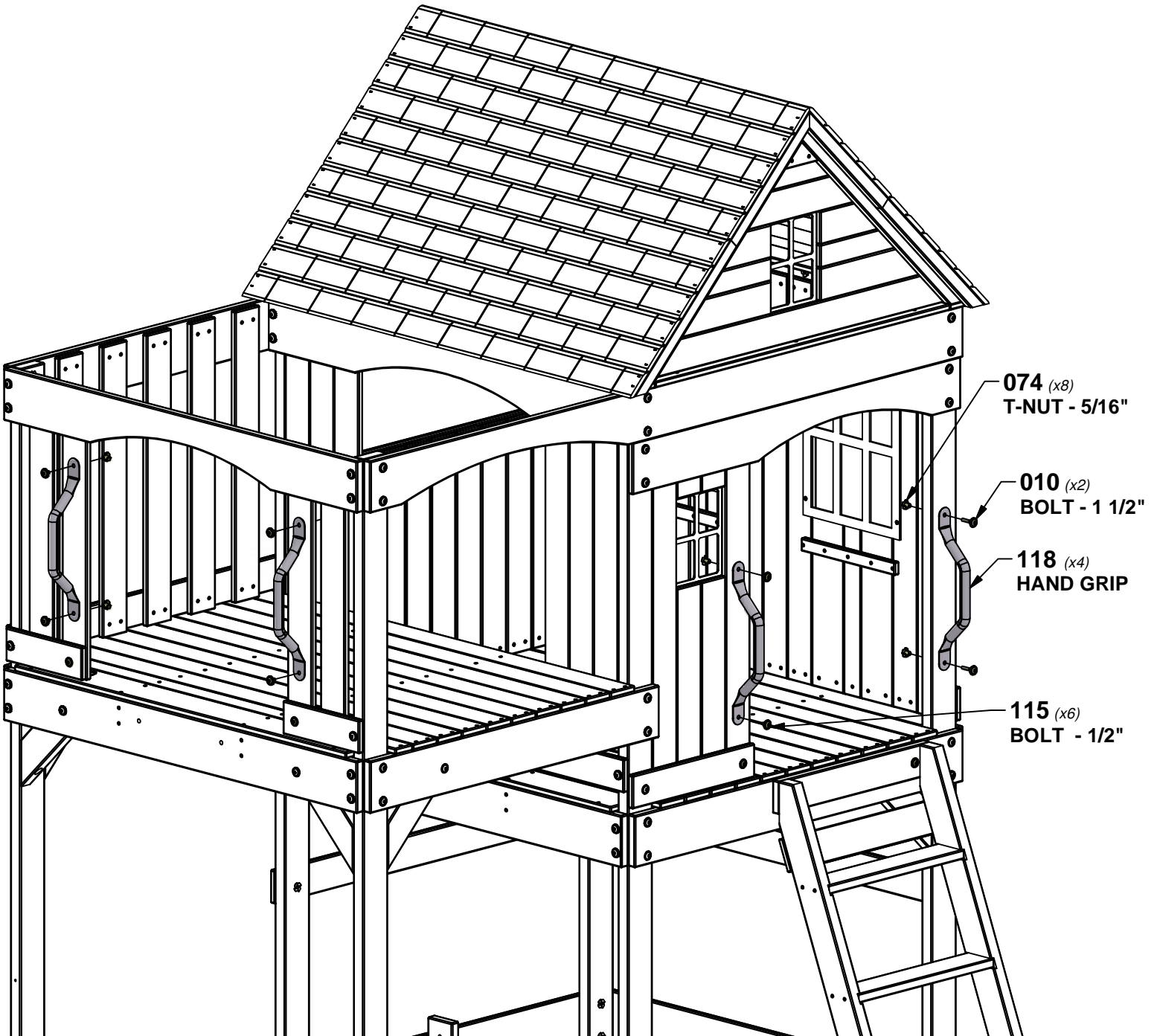

STEP 36 - FORT ASSEMBLY

QTY	PART NUMBER	DESCRIPTION
8	H100086	SCREW PFH 8x1-1/2"

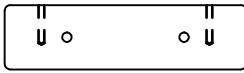

T01 SEAT SUPPORT - W4L16086
(x4) 1"x1 3/8"x5" (24x34x128)

PLACEMENT VIEWS

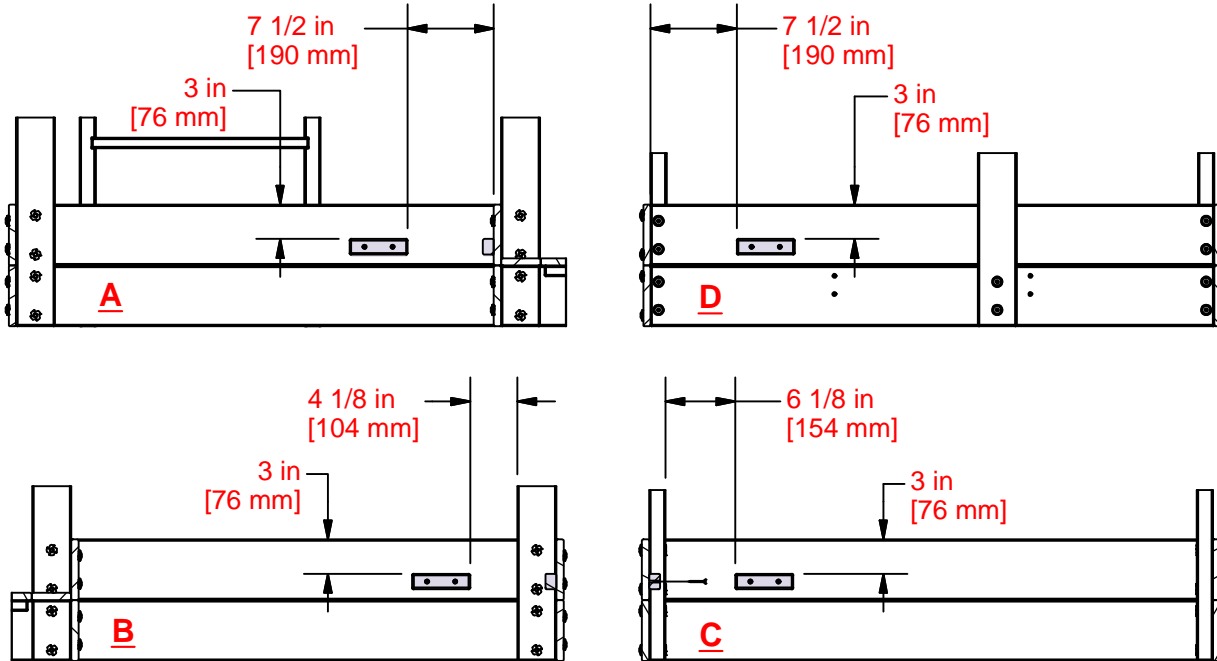

SEE LOCATIONS BELOW (A, B, C, & D)

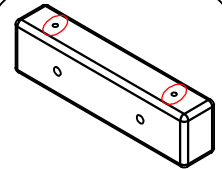

INSTALL T01
WITH SMALL
PILOT HOLES
UPWARD

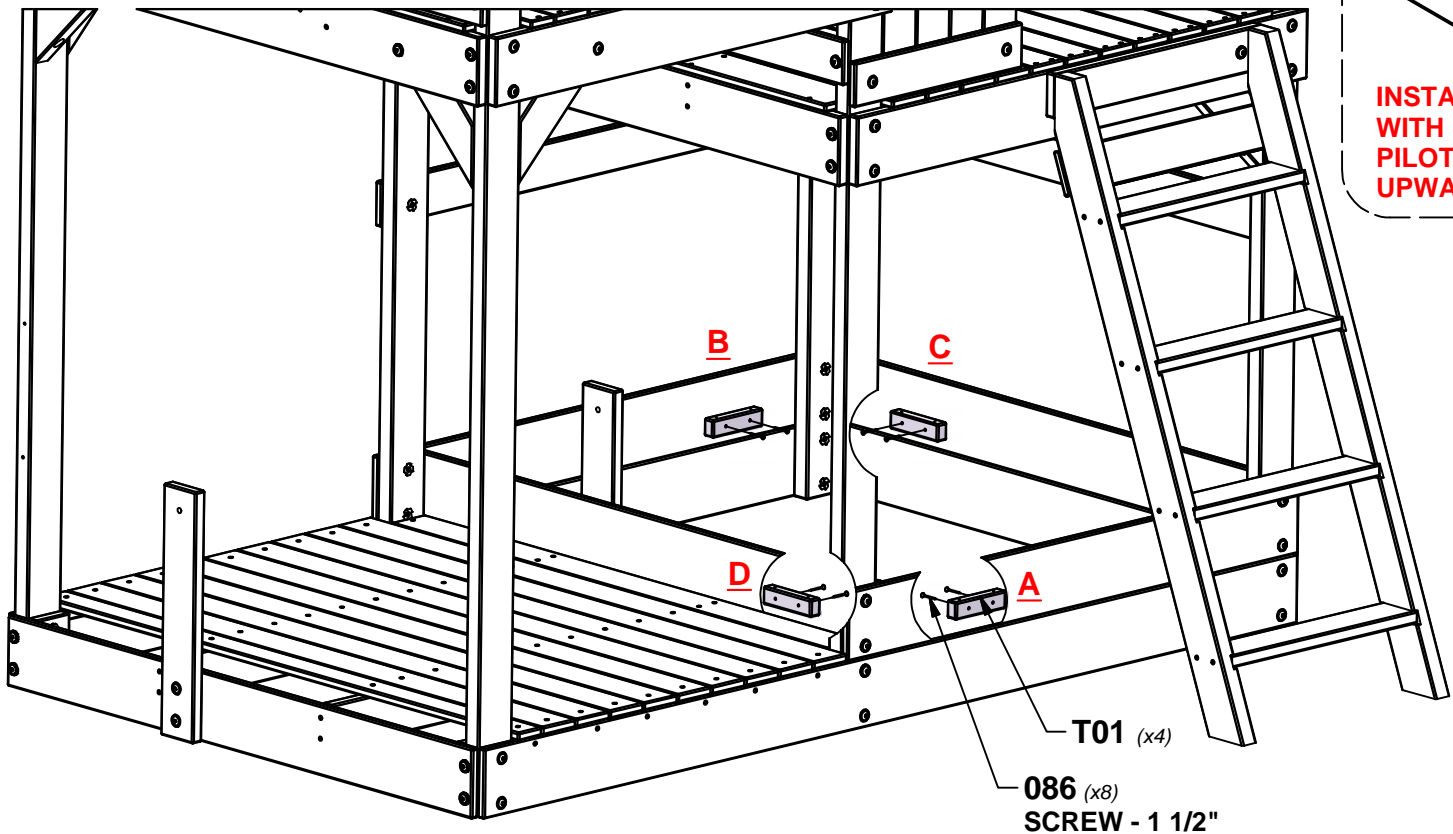

T01 (x4)

086 (x8)
SCREW - 1 1/2"

STEP 37 - FORT ASSEMBLY

QTY	PART NUMBER	DESCRIPTION
8	H100089	SCREW PFH 8x1-3/4"



G13 SAND BOX SEAT - W4L16013
(x2) | 1"x5 1/4"x17 3/4" (24x134x450)

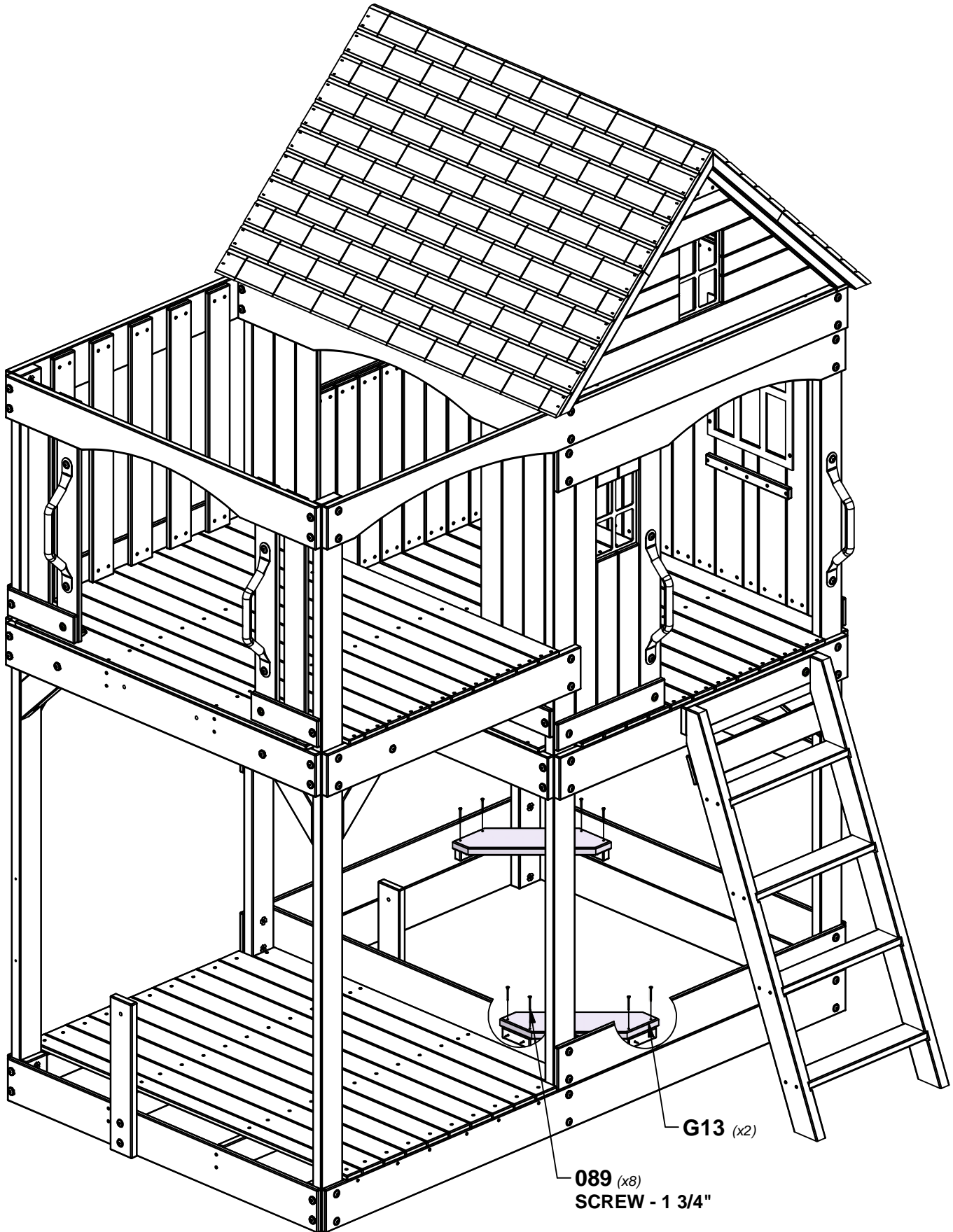

STEP 38 - FORT ASSEMBLY

QTY	PART NUMBER	DESCRIPTION
24	H100088	SCREW PFH 8x1-1/8"



M27 | BOTTOM WALL BOARD - W4L16062
 (x6) | 5/8" x 3 3/8" x 21 3/8" (16x86x544)

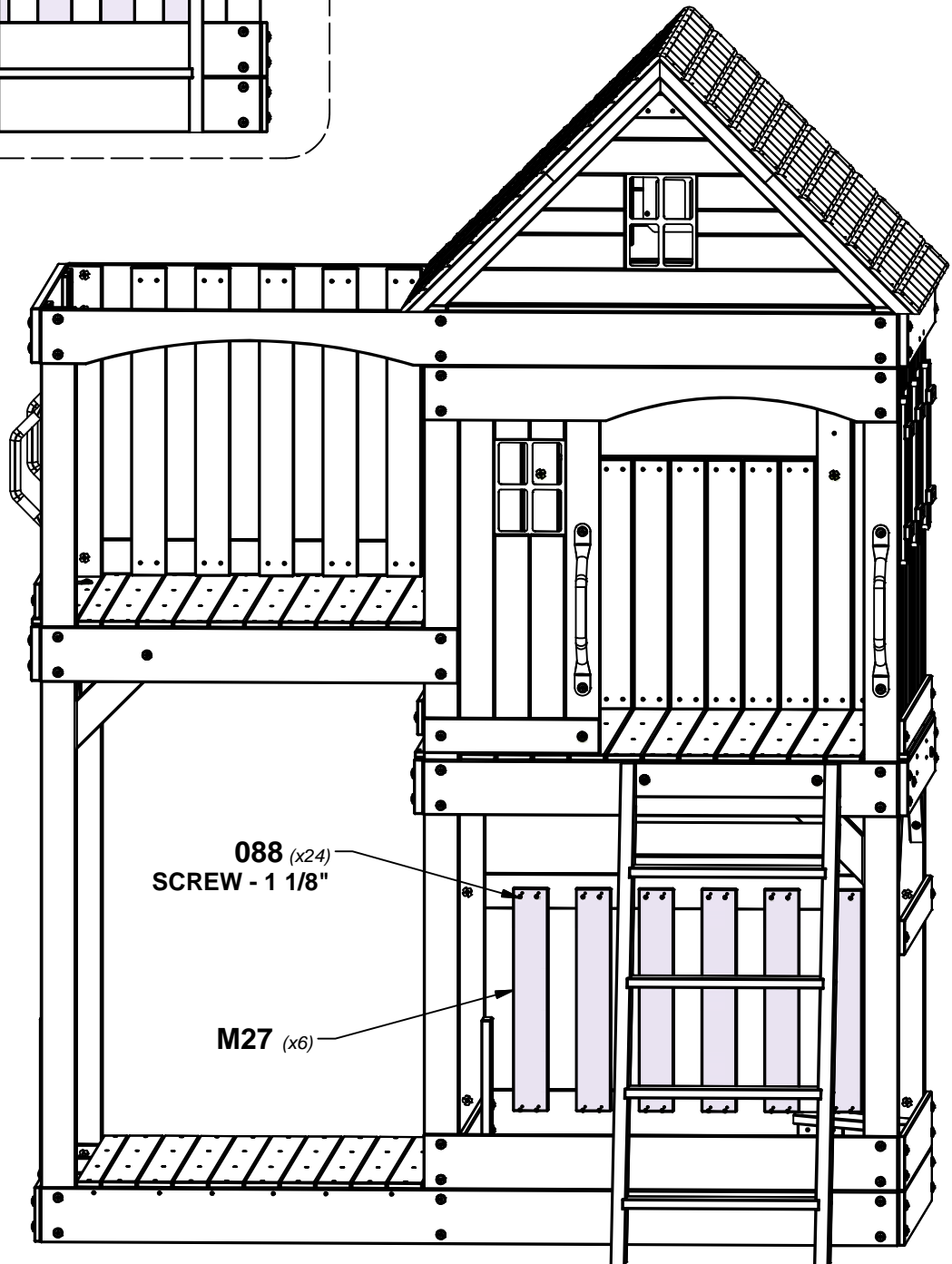
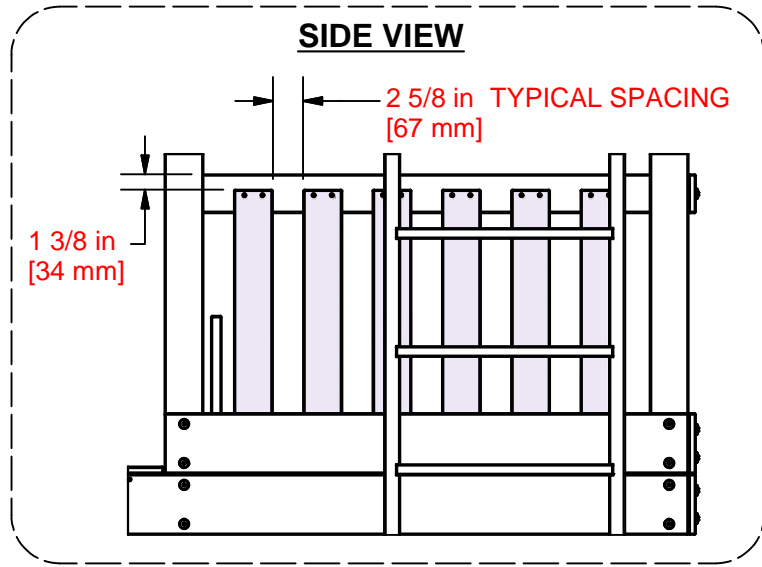

STEP 39 - FORT ASSEMBLY

QTY	PART NUMBER	DESCRIPTION
28	H100088	SCREW PFH 8x1-1/8"



M27 | BOTTOM WALL BOARD - W4L16062
(x7) 5/8"x3 3/8"x21 3/8" (16x86x544)

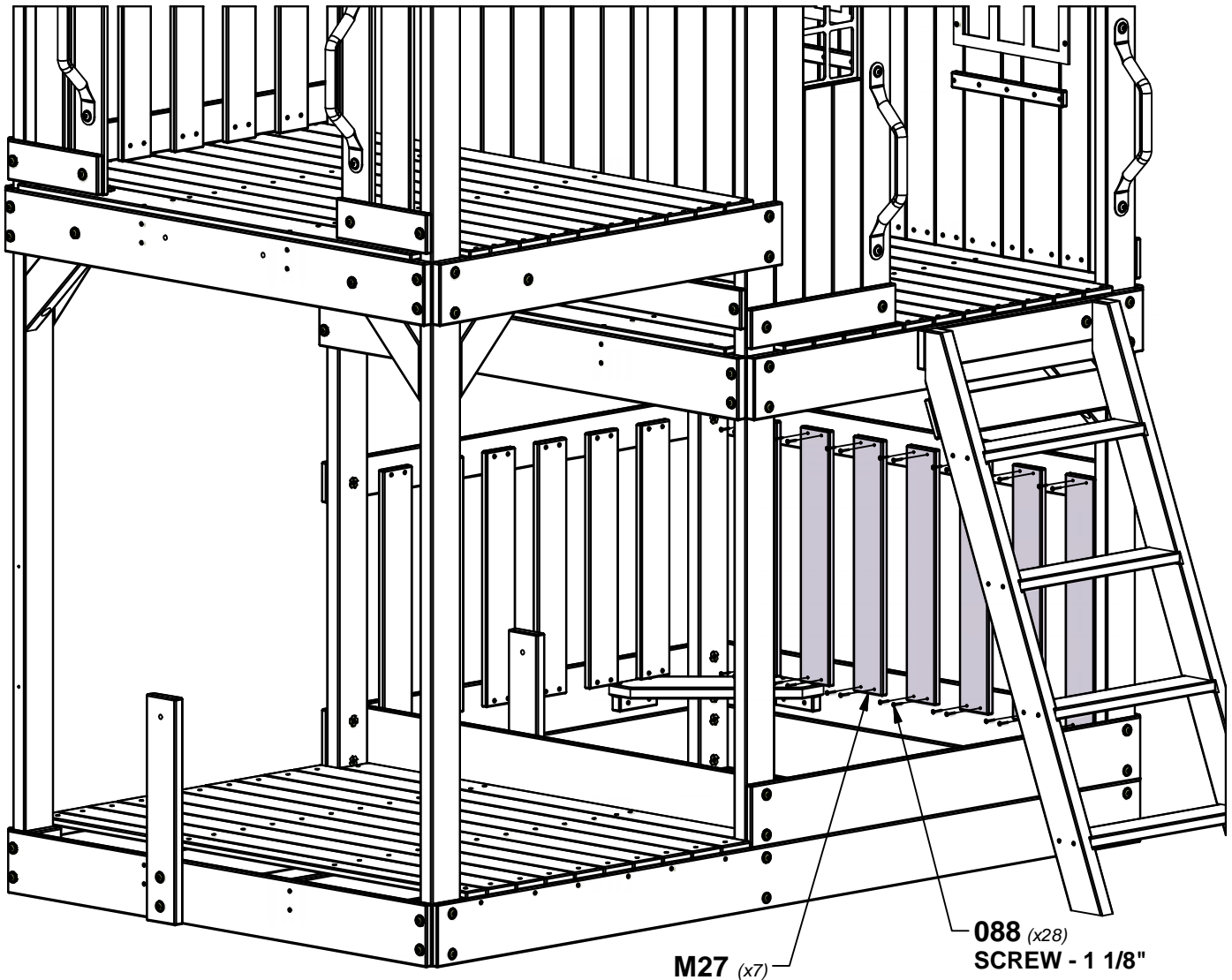
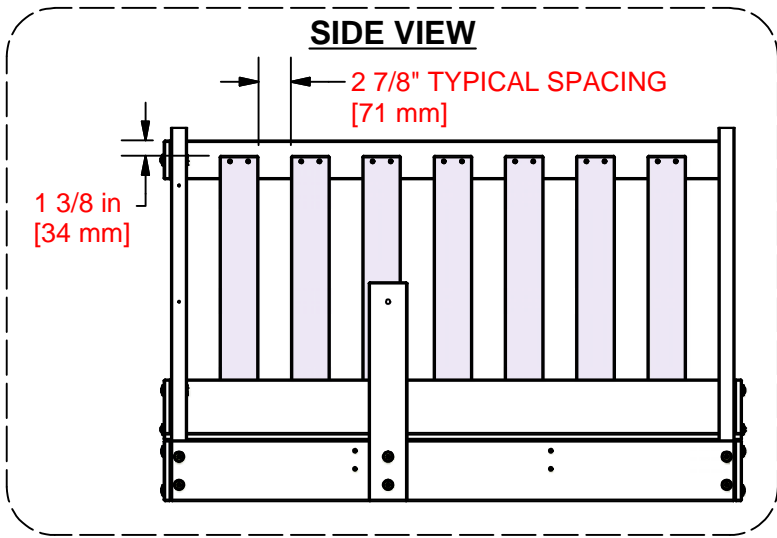

STEP 40 - FORT ASSEMBLY

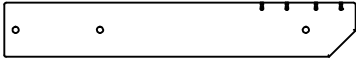

M14 | PICNIC SEAT SUPPORT - W4L16050
(x2) | 5/8"x3 3/8"x22" (16x86x558)

QTY	PART NUMBER	DESCRIPTION
2	H100010	BOLT WH 5/16x1 1/2
2	H100028	LAG SCREW WH 5/16x2 1/2
4	H100030	WASHER LOCK EXT 8x19
2	H100074	T-NUT 5/16

**REMOVE PICKET
UNTIL AFTER
STEP 41**

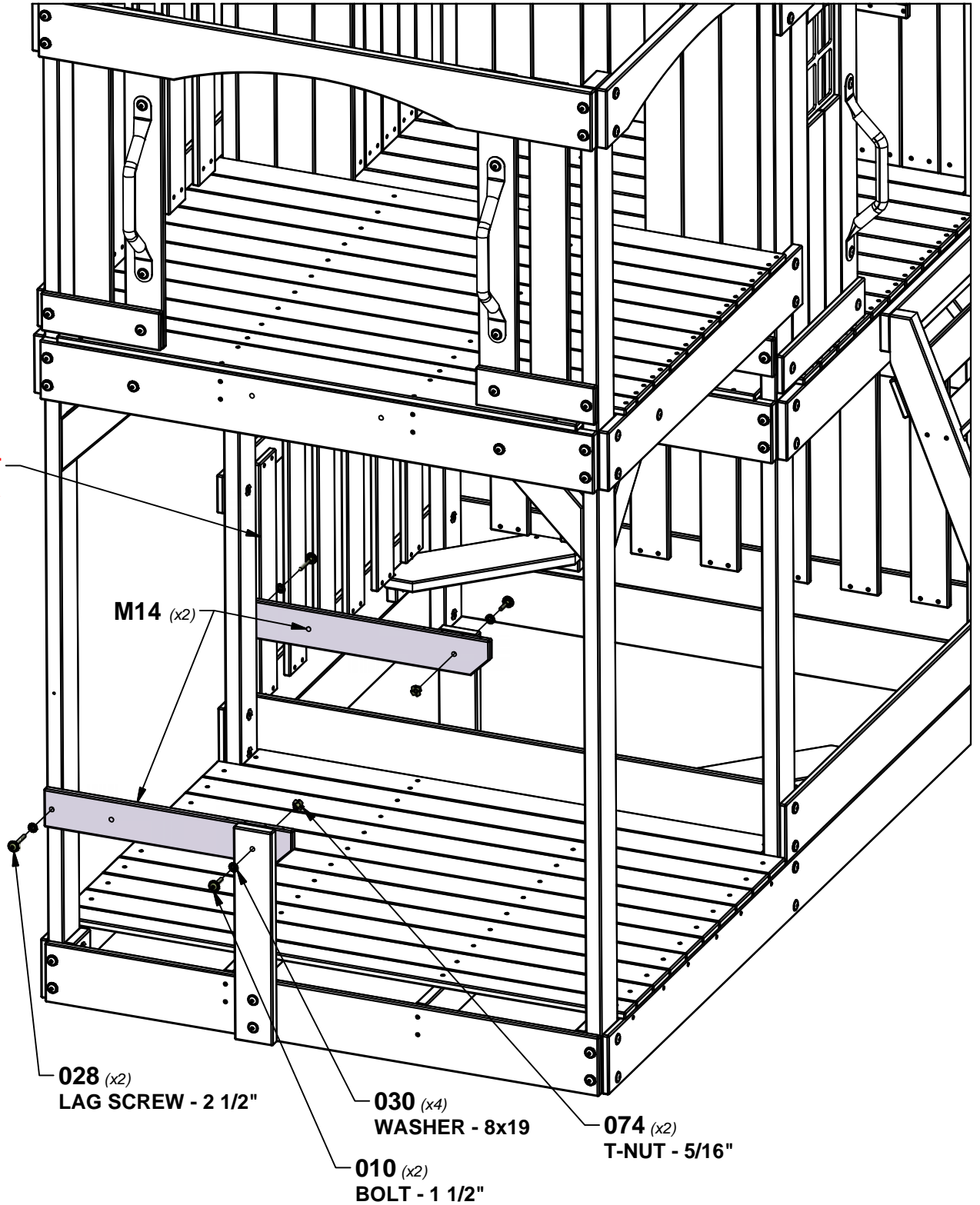

STEP 41 - FORT ASSEMBLY

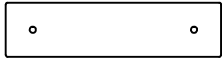

M25 TABLE SUPPORT - W4L16037
(x2) 5/8"x3 3/8"x13 1/2" (16x86x342)

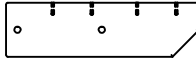

H08 TABLE SUPPORT - W4L16031
(x2) 1"x3 3/8"x12" (24x86x306)

QTY	PART NUMBER	DESCRIPTION
2	H100009	BOLT WH 5/16x1 1/4
2	H100010	BOLT WH 5/16x1 1/2
2	H100028	LAG SCREW WH 5/16x2 1/2
6	H100030	WASHER LOCK EXT 8x19
4	H100074	T-NUT 5/16

TIP:
INSTALL T-NUTS IN WOOD FIRST

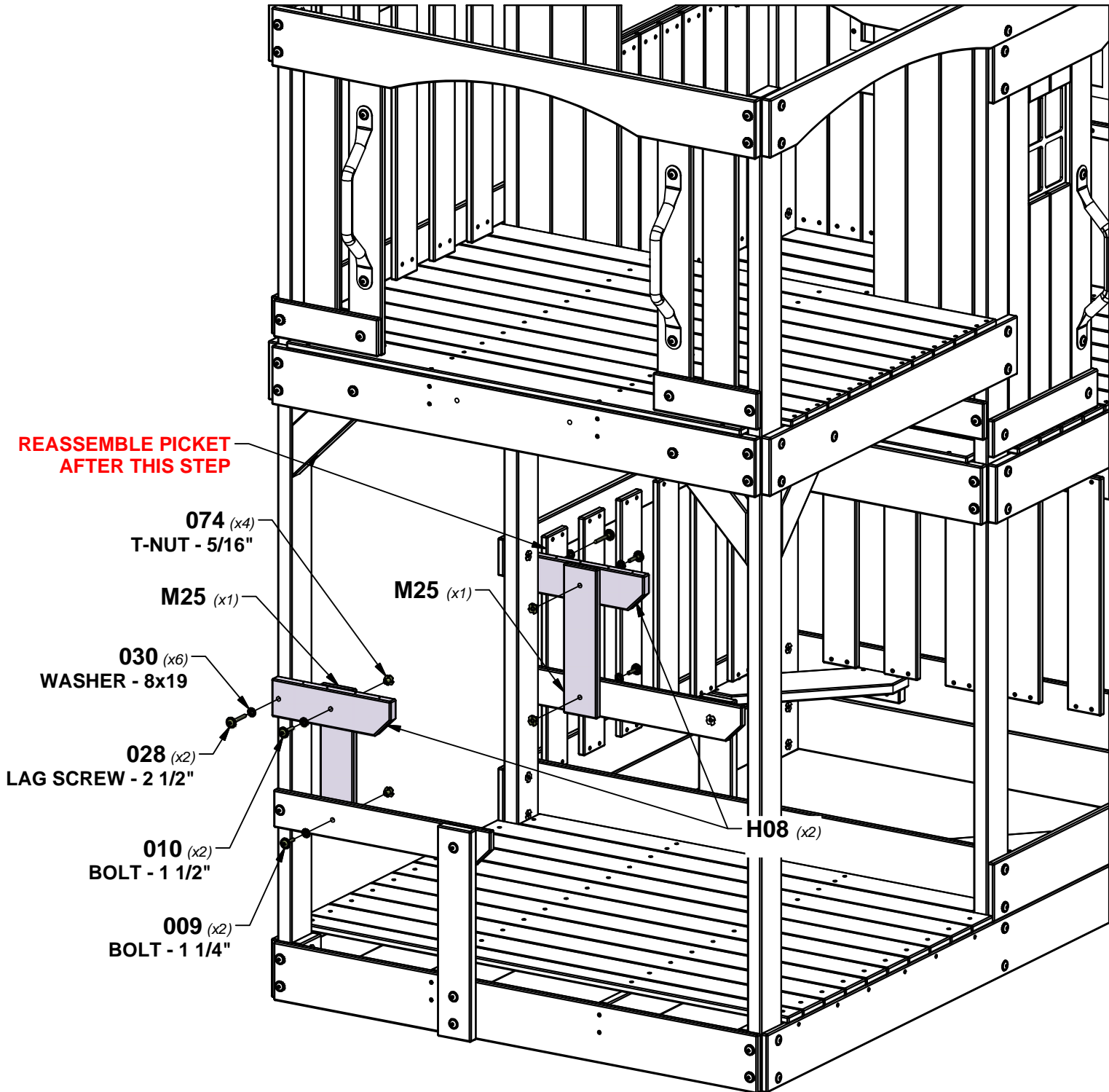

STEP 42 - FORT ASSEMBLY

QTY	PART NUMBER	DESCRIPTION
1	H100088	SCREW PFH 8x1-1/8"
1	H100089	SCREW PFH 8x1-3/4"

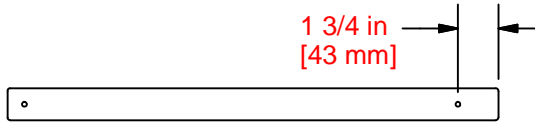

O03 SAFETY RAIL - W4L16083
(x1) 5/8"x1 3/8"x20 1/2" (16x34x520)

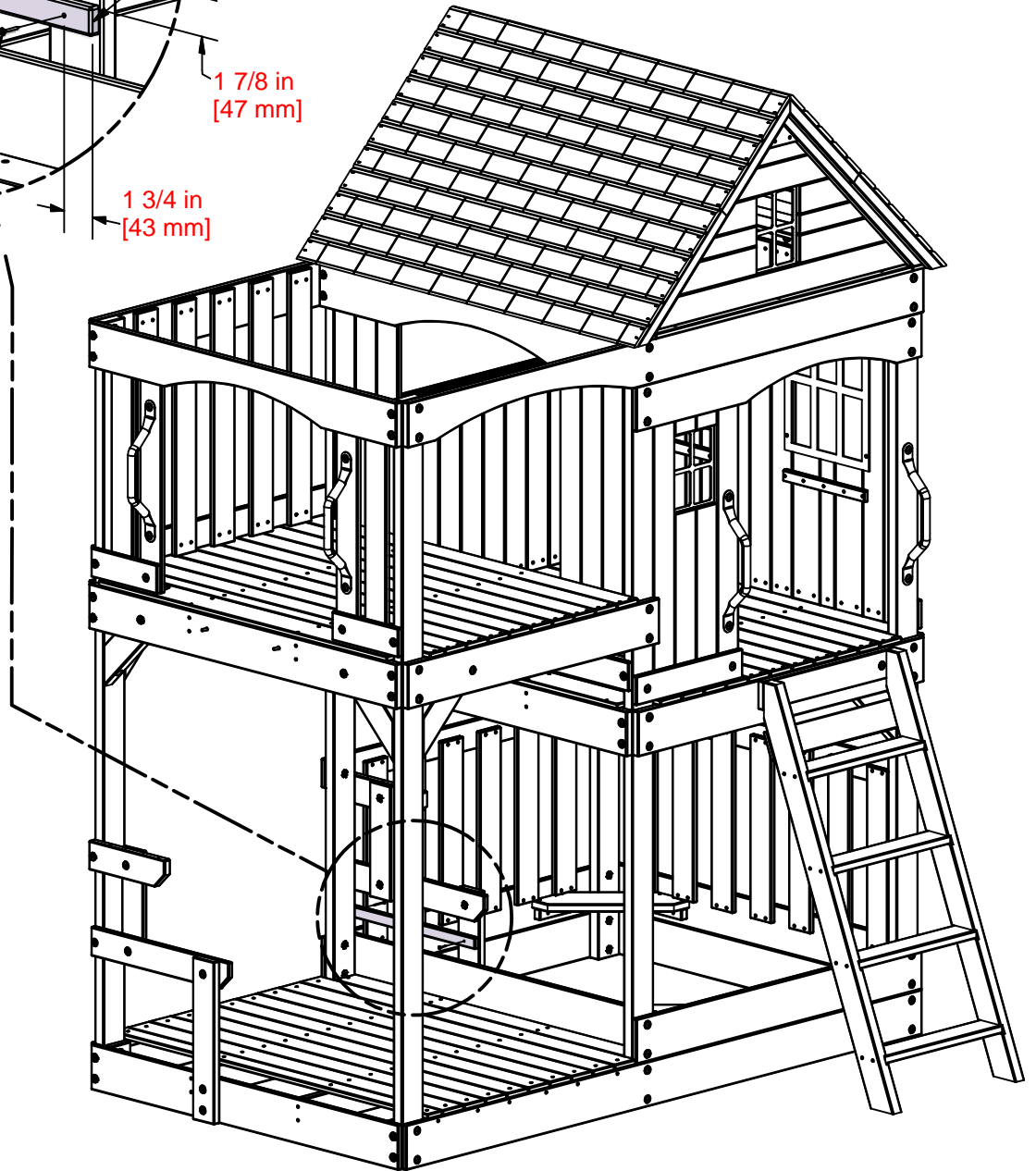
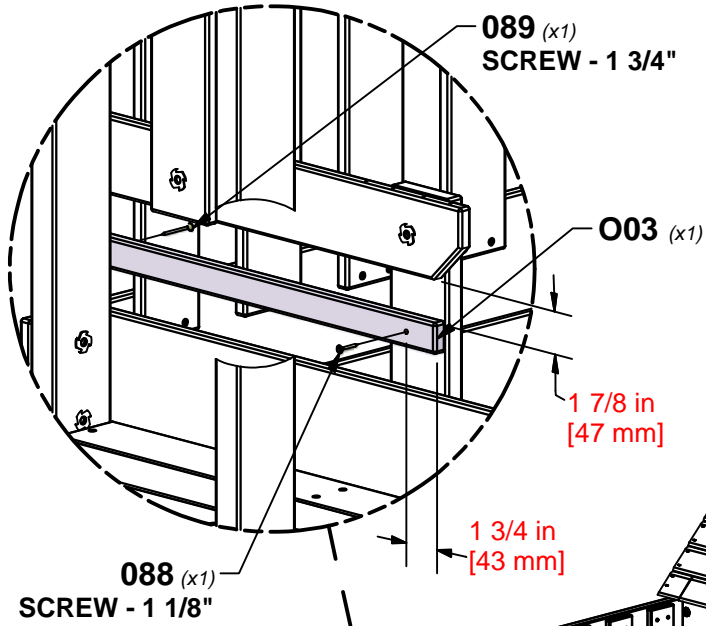

STEP 43 - FORT ASSEMBLY

QTY	PART NUMBER	DESCRIPTION
16	H100089	SCREW PFH 8x1-3/4"



H02 | PICNIC TABLE SEAT - W4L16025
(x2) | 1"x3 3/8"x41 3/8" (24x86x1050)



G11 | PICNIC TABLE TOP - W4L16011
(x2) | 5/8"x5 1/4"x42" (16x134x1066)

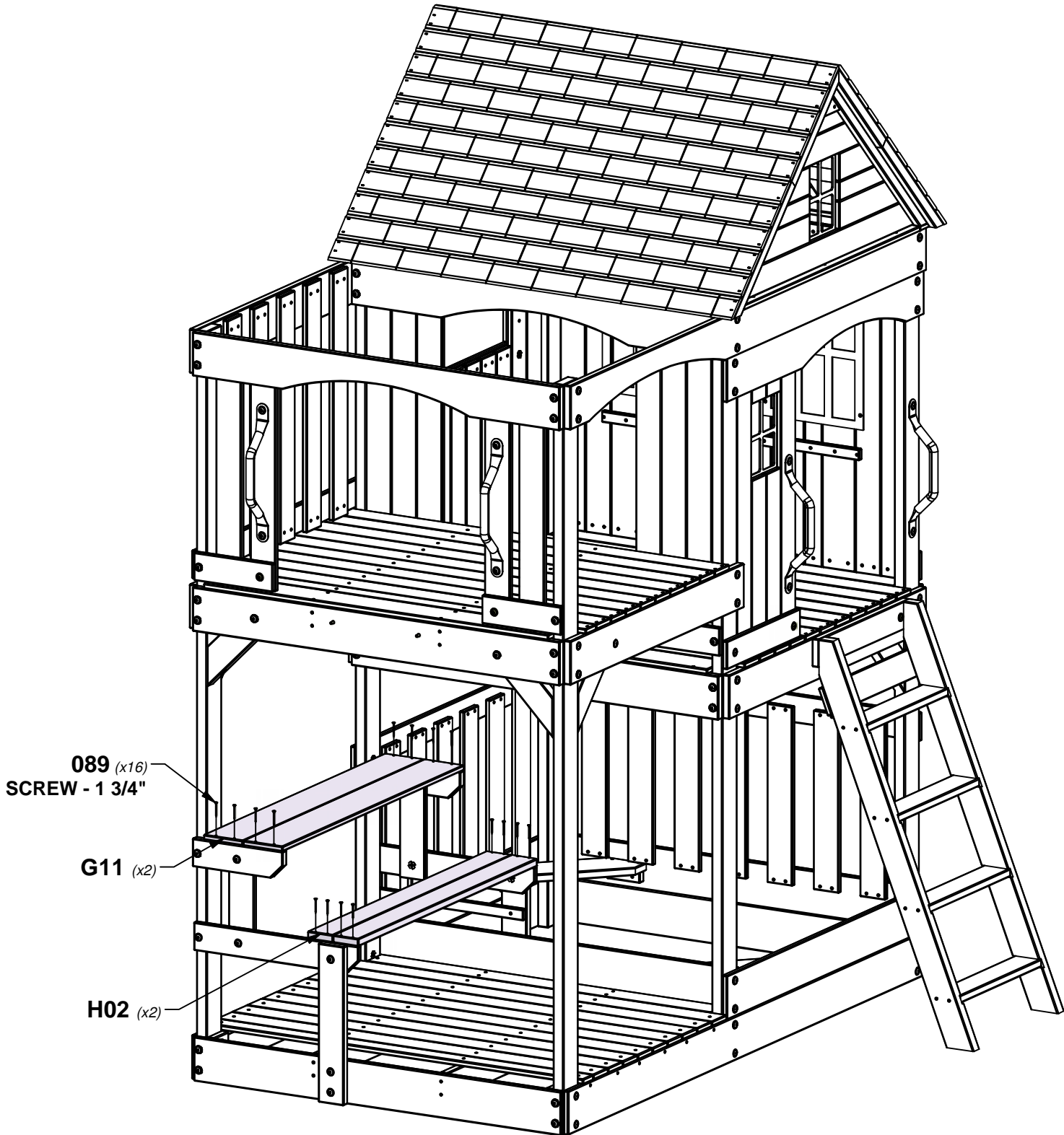

STEP 44 - FORT ASSEMBLY

QTY	PART NUMBER	DESCRIPTION
2	H100011	BOLT WH 5/16x1 3/4
2	H100030	WASHER LOCK EXT 8x19

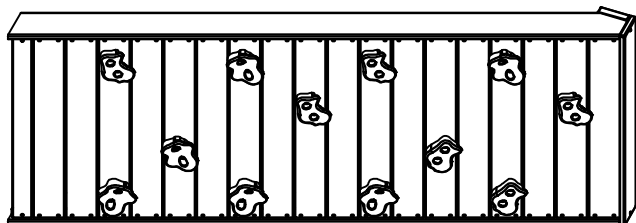

ROCKWALL ASSEMBLY

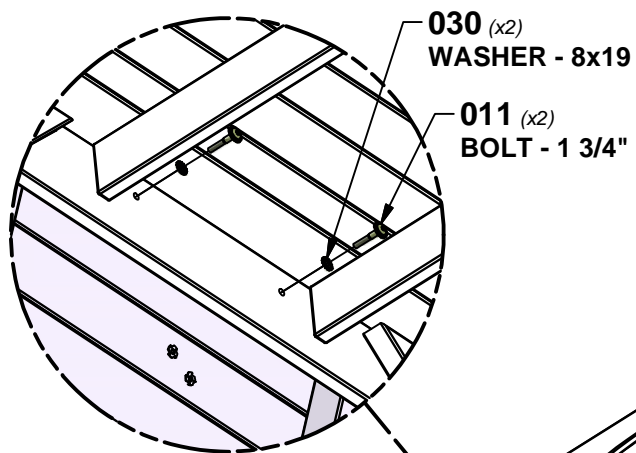

030 (x2)
WASHER - 8x19

011 (x2)
BOLT - 1 3/4"

ROCKWALL ASSEMBLY

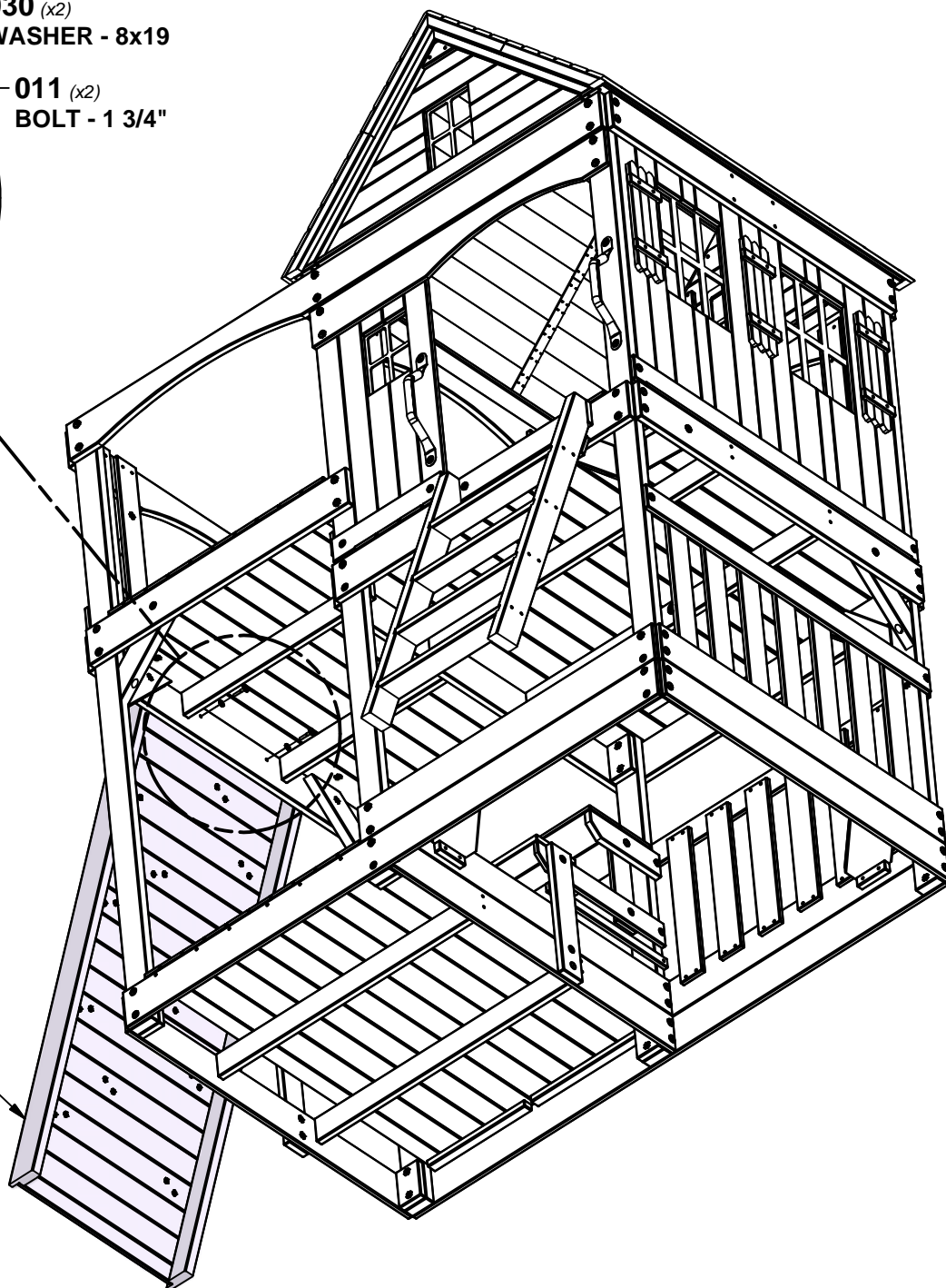

STEP 45 - FORT ASSEMBLY

QTY	PART NUMBER	DESCRIPTION
4	H100042	BOLT HEX 5/16x1 1/4
4	H100095	WASHER SPLIT 5/16
4	H100105	WASHER FLAT 8x27

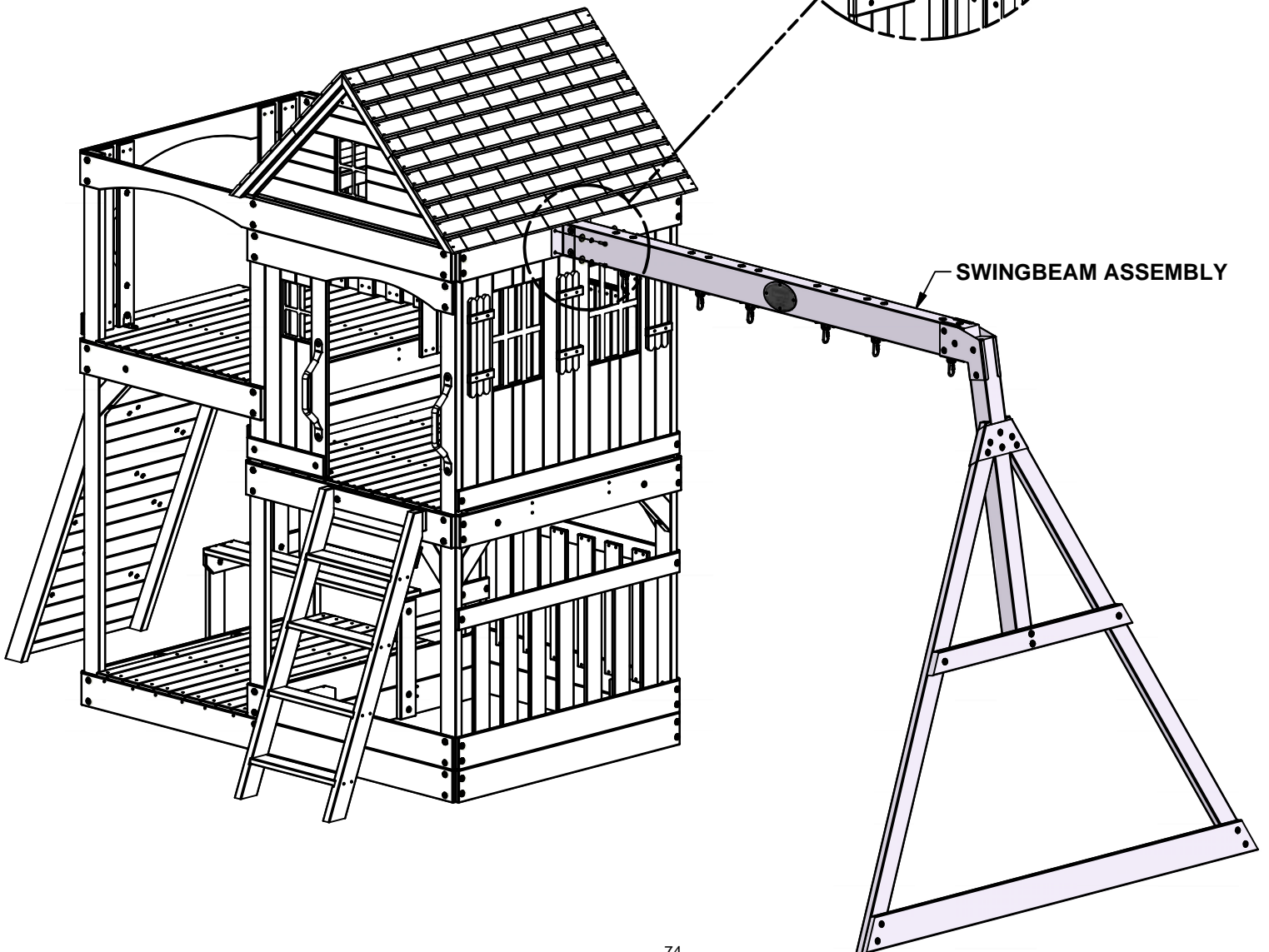
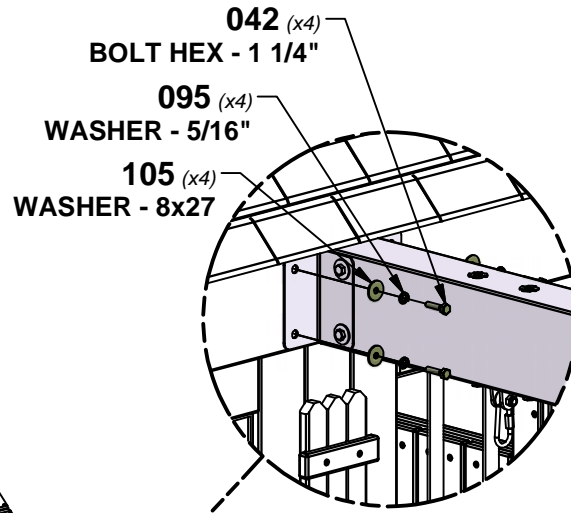
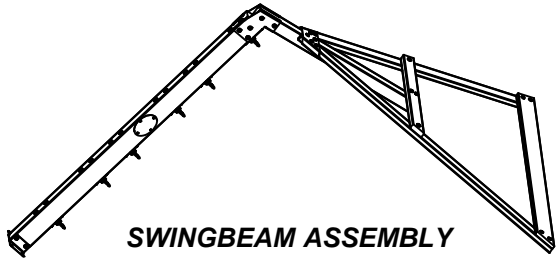

STEP 46 - FORT ASSEMBLY

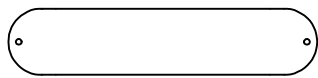

A100027 (x2) | SWING SEAT GREEN 26"

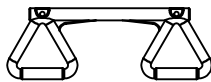

A6P00034 (x1) | TRAPEZE YELLOW

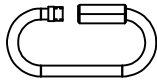

A100069 (x6) | QUICK LINK



A100183 (x4) | ROPE-CHAIN GREEN 57"



A100083 (x2) | ROPE-CHAIN GREEN 33"

NOTE:
 WHEN HANGING YOUR SWINGS, IT IS
 REQUIRED TO ONLY TRIM AROUND THE
 SPECIFIC CHAIN LOOP THAT ALLOWS THE
 BOTTOM OF THE SWING SEAT, (WHEN
 SITTING ON IT) TO BE NO LOWER THAN
 (35CM) 13 7/8 INCHES FROM THE GROUND.

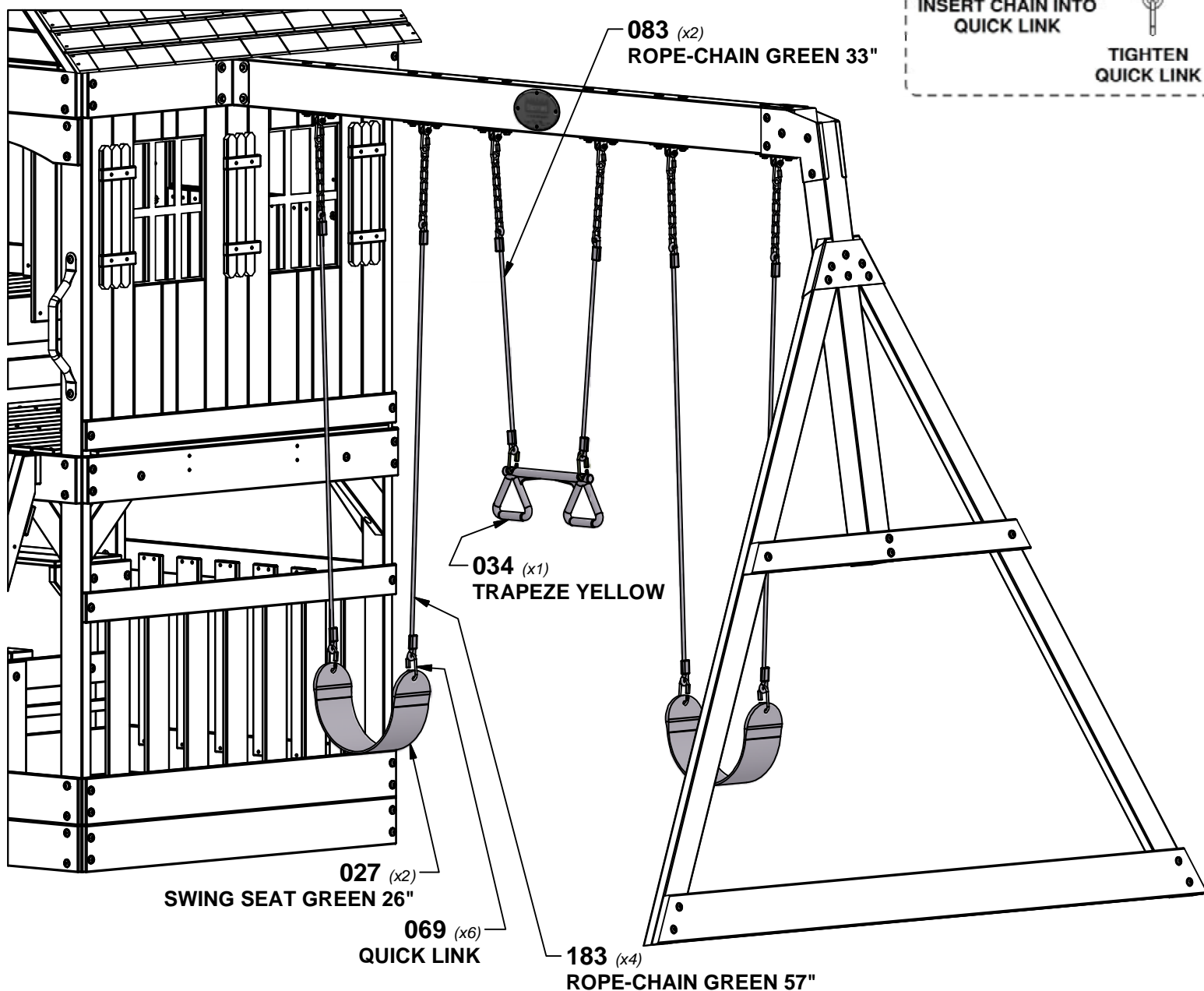
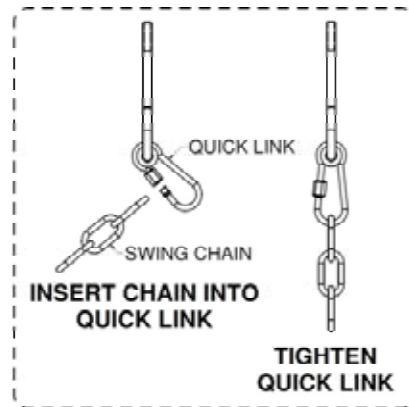

STEP 1 - SLIDE

QTY	PART NUMBER	DESCRIPTION
3	H100074	T-NUT 5/16
3	H100115	BOLT WH 5/16x1/2



A100035
(x1) | **SLIDE BED 10' LIGHT GREEN**

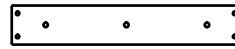

M70
(x1) | **SLIDE SUPPORT BOARD - W100935**
5/8"x3 3/8"x19 7/8" (16x86x505)

NOTE:

TAKE NOTE OF SLIDE BED SURFACE FINISH, THE DULL SIDE WILL BE TOWARDS THE GROUND. PLACE SLIDE BRACE CENTERED ON THE BOTTOM (DULL SIDE) AND 1/2" FROM THE EDGE. USE **M70** BOARD AS A TEMPLATE FOR DRILLING BOTTOM HOLE PATTERN IN SLIDE BED. USE A 5/16" DRILL BIT.

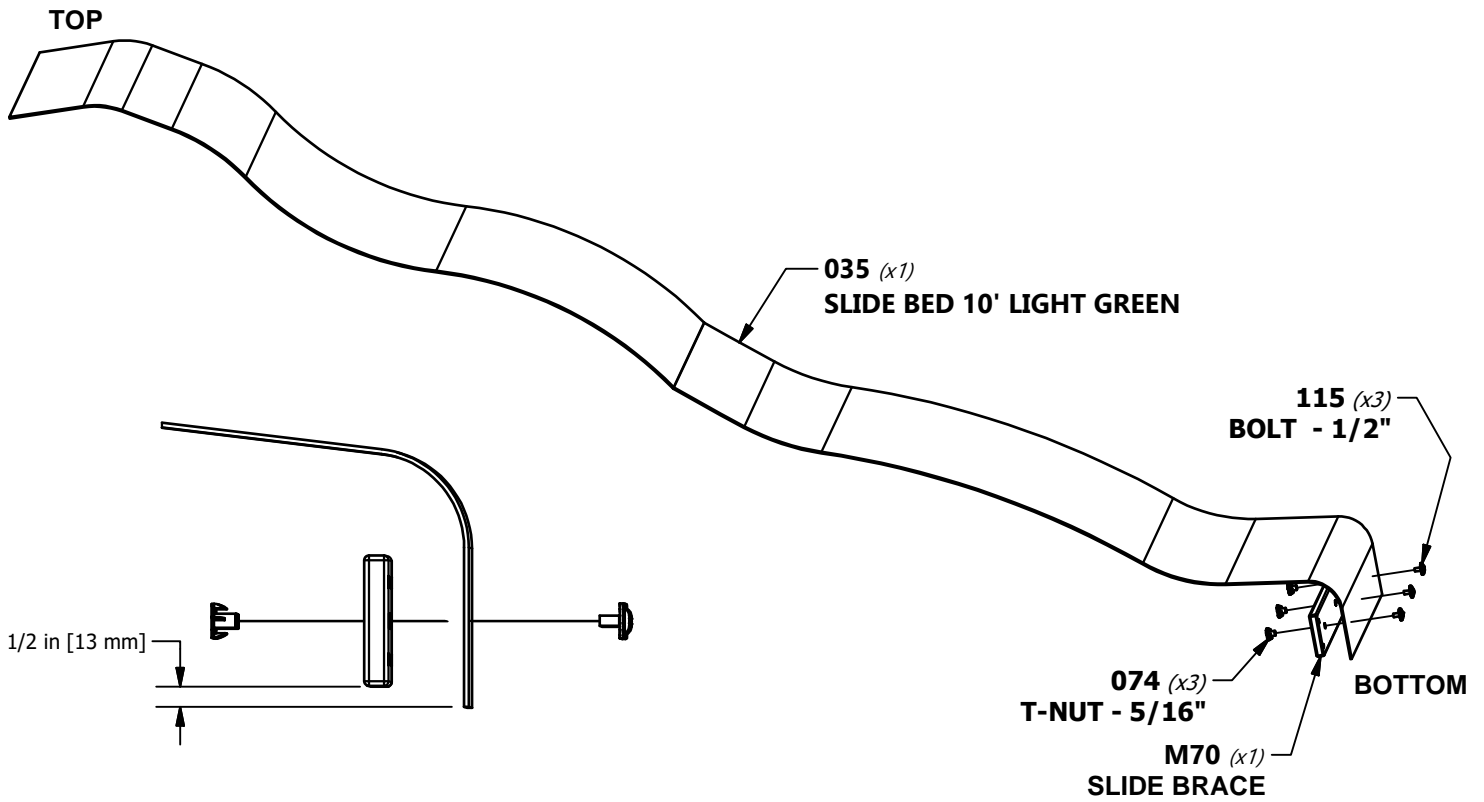

TIP:

PRE-BENDING THE ENDS WILL EASE ASSEMBLY. PLACING THE SLIDE BED OUT IN THE SUN MAKES IT EASIER TO BEND.

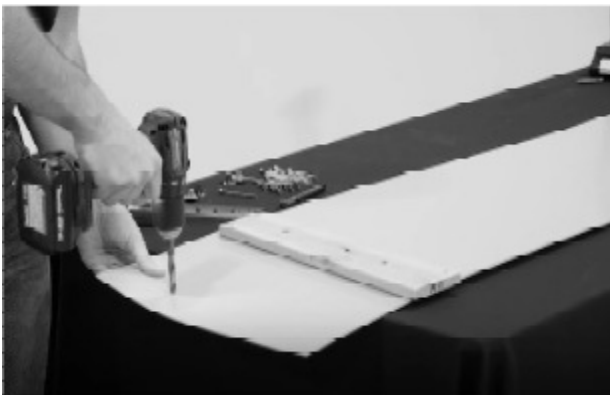

STEP 2 - SLIDE

QTY	PART NUMBER	DESCRIPTION
8	H100006	NUT BARREL WH 5/16x1 1/2
8	H100115	BOLT WH 5/16x1/2

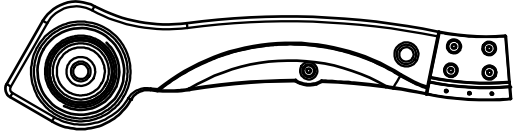

A6P00484 | SLIDE RAIL 10' BOTTOM RIGHT GREEN
(x1)

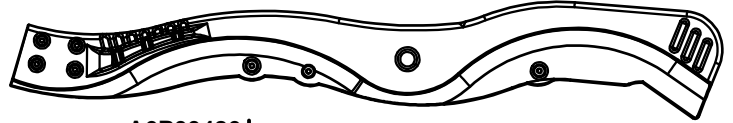

A6P00486 | SLIDE RAIL 10' TOP RIGHT GREEN
(x1)

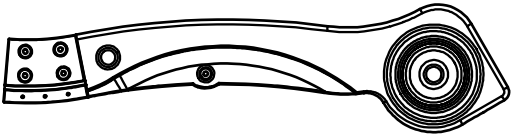

A6P00483 | SLIDE RAIL 10' BOTTOM LEFT GREEN
(x1)

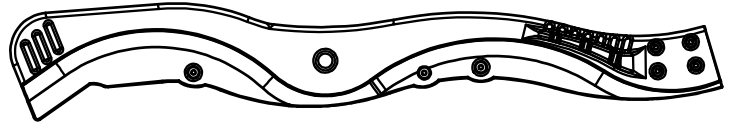

A6P00485 | SLIDE RAIL 10' TOP LEFT GREEN
(x1)

NOTE:
REPEAT ON OTHER SIDE, MAKING
A LEFT AND RIGHT ASSEMBLY.

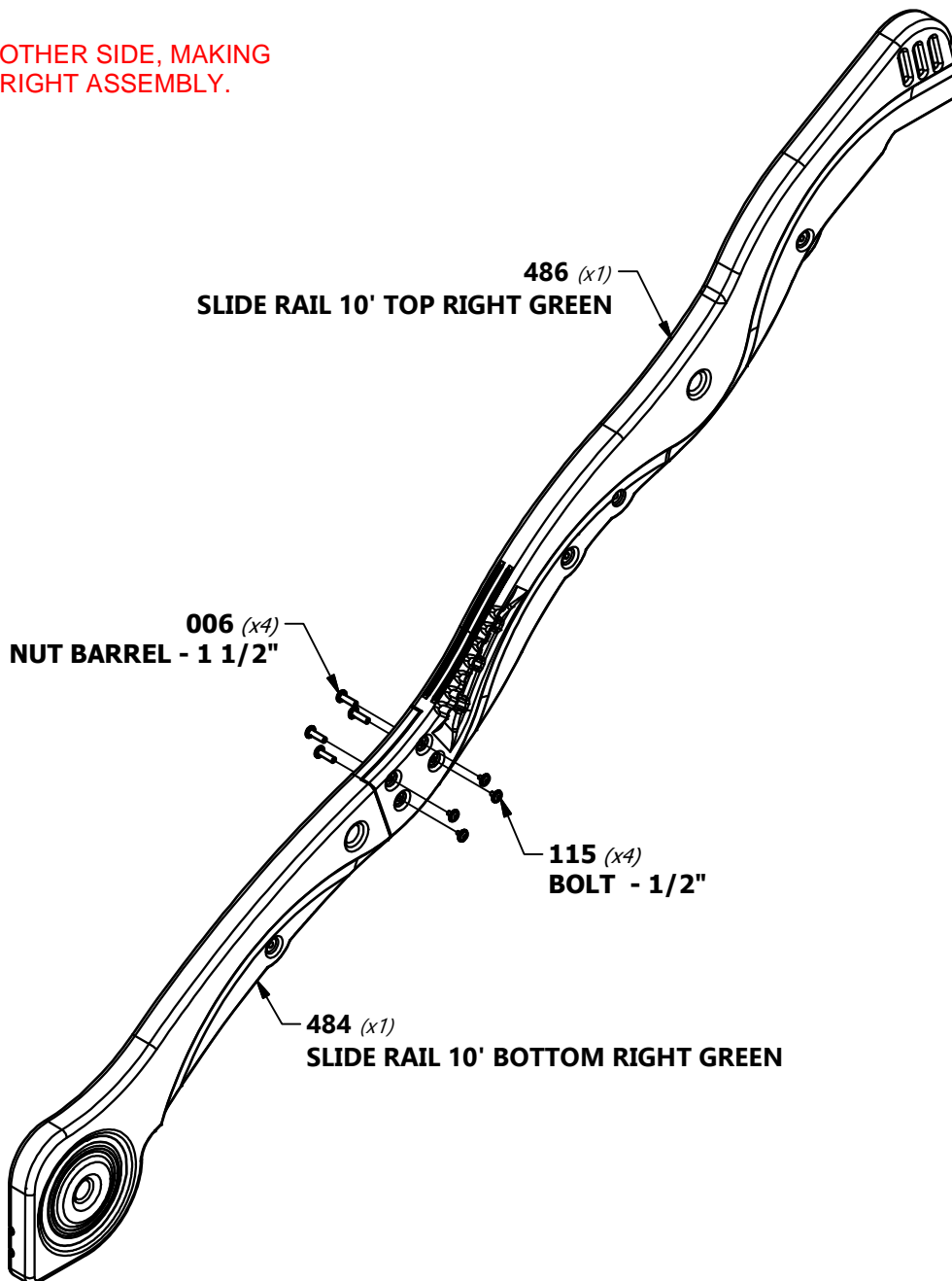

STEP 3 - SLIDE

QTY	PART NUMBER	DESCRIPTION
4	H100009	BOLT WH 5/16x1 1/4

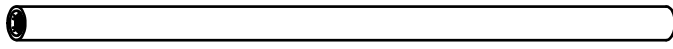

A6P00487
(x4) | **SLIDE TUBE SUPPORT**

NOTE:
INSERT THE (4) SLIDE SUPPORT TUBES INTO THEIR RESPECTIVE PILOT LOCATIONS (FIGURE 1).

PLACE (1) SLIDE RAIL ASSEMBLY ON A FLAT SURFACE AND BEGIN INSERTING SLIDE BED AT THE BOTTOM OF THE SLIDE RAIL (FIGURE 2). HAVE A HELPER BEND THE SLIDE BED TOWARDS THE TOP OF THE SLIDE AND INSERT THE BED INTO THE SLIDE CAVITY. MAKE SURE SLIDE BED IS INSERTED WITHIN 1/8" (3mm) OF GROOVE BOTTOM.

TIP:
A HELPER IS RECOMMENDED FOR THESE FOLLOWING STEPS.

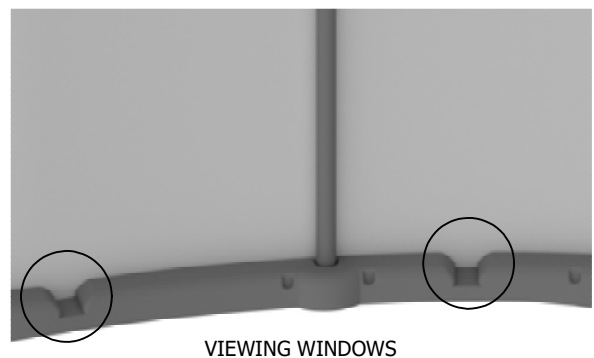
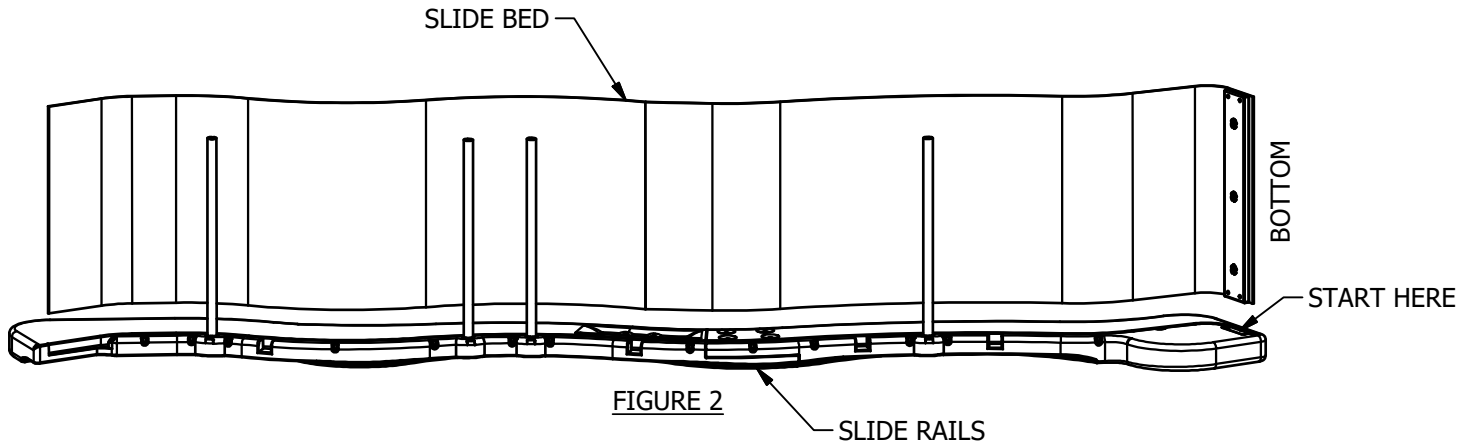
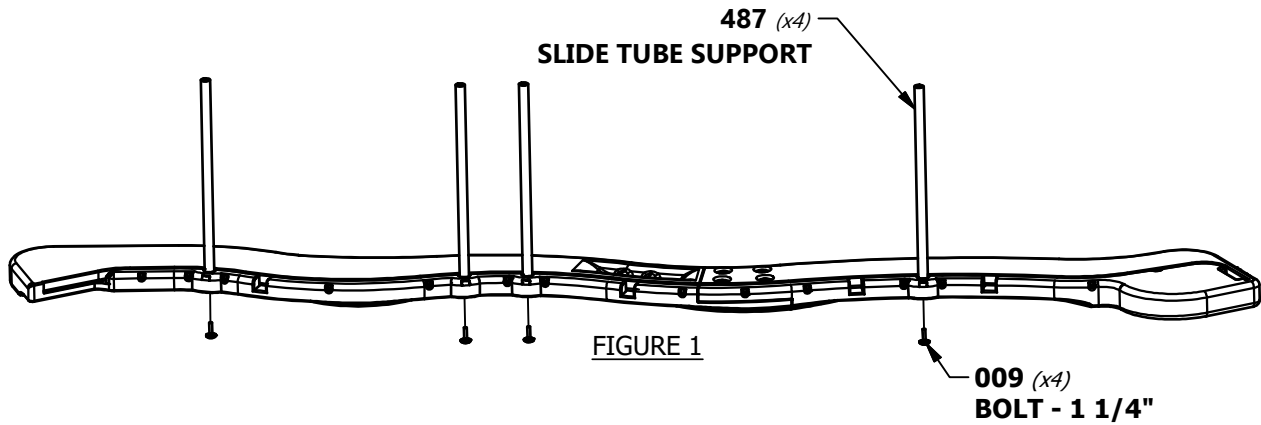

STEP 4 - SLIDE

NOTE:

PLACE SECOND SLIDE RAIL ASSEMBLY OVER THE TOP OF THE SLIDE BED AND SLIDE SUPPORT TUBES. INSERT THE SLIDE BED AND SLIDE SUPPORT TUBES INTO THE SLIDE CAVITY. MAKE SURE SLIDE BED IS INSERTED WITHIN 1/8" (3mm) OF GROOVE BOTTOM.



FAILURE TO INSERT SLIDE BED PROPERLY MAY RESULT IN INJURY OR AMPUTATION. EXPOSED SLIDE EDGES CAN BE SHARP AND BECOME A LACERATION HAZARD IF THE SLIDE IS NOT PROPERLY ASSEMBLED.

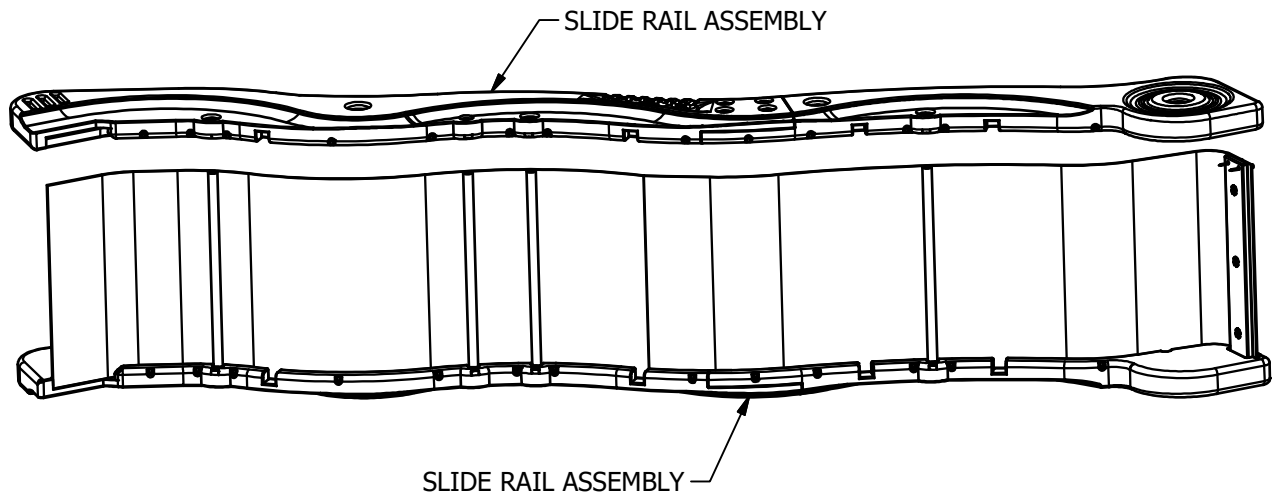

TIP:
USE A RUBBER Mallet TO FULLY SEAT
THE SLIDE BED INTO THE SLIDE CAVITY.

STEP 5 - SLIDE

QTY	PART NUMBER	DESCRIPTION
4	H100009	BOLT WH 5/16x1 1/4

NOTE:
USE 1 1/4" BOLTS TO FASTEN EACH
SIDE OF THE SLIDE SUPPORT TUBES.

TIP:
HAVING A HELPER HOLD THE SLIDE
ASSEMBLY TOGETHER WHILE YOU FASTEN
WILL MAKE IT EASIER TO ASSEMBLE.

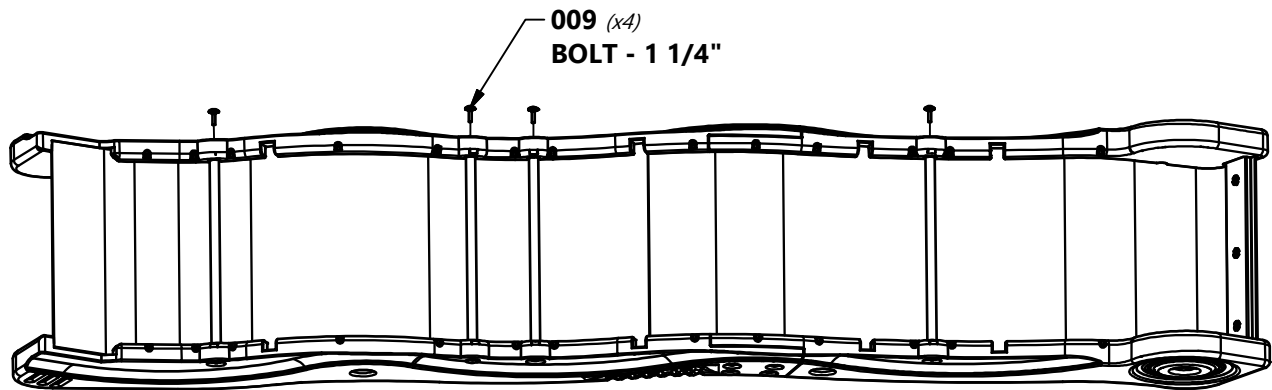

STEP 6 - SLIDE

QTY	PART NUMBER	DESCRIPTION
30	H100090	SCREW PFH 8x2 1/2

NOTE:
USING AN 1/8" DRILL BIT, DRILL PILOT HOLES IN EACH INDENTATION
ALONG EACH SIDE RAIL. THERE SHOULD BE 15 INDENTATIONS ON
EACH RAIL. BE SURE TO DRILL THROUGH THE SLIDE RAIL AND THE
SLIDE BED. THEN SECURE WITH THE PROVIDED HARDWARE.

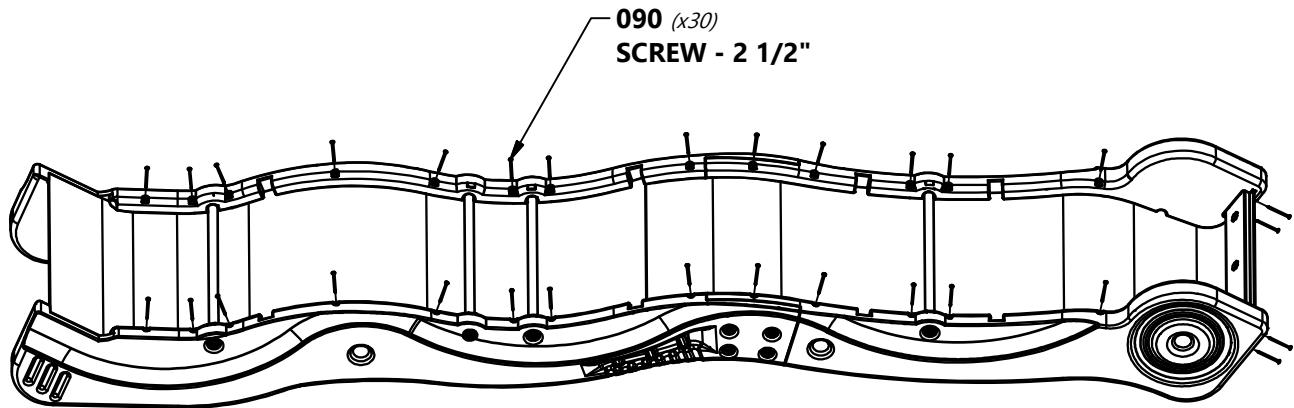

STEP 47 - FORT ASSEMBLY

QTY	PART NUMBER	DESCRIPTION
3	H100074	T-NUT 5/16
3	H100115	BOLT WH 5/16x1/2

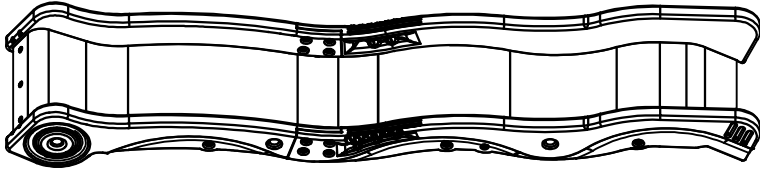

SLIDE ASSEMBLY

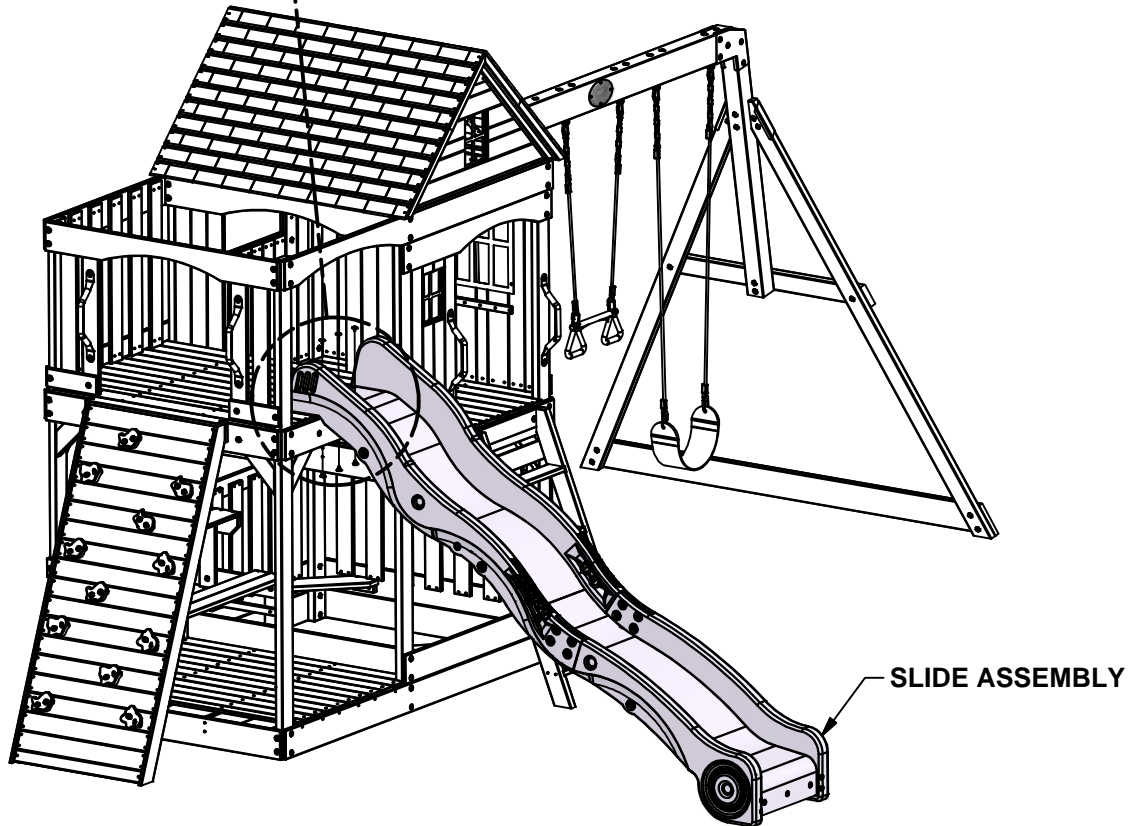
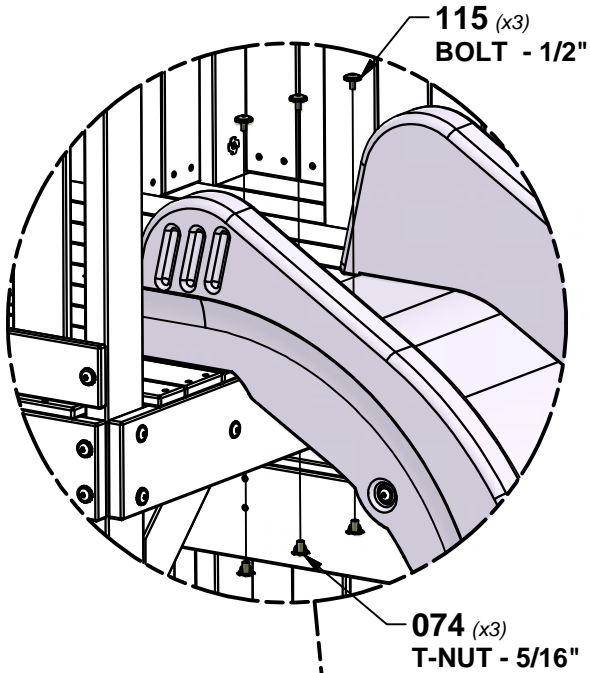
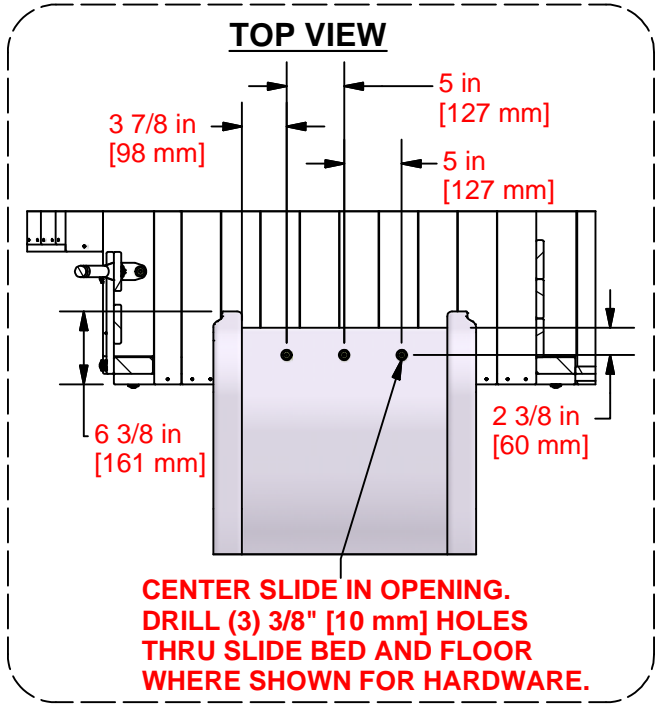

STEP 48 - FORT ASSEMBLY

QTY	PART NUMBER	DESCRIPTION
8	H100004	NUT BARREL WH 5/16x5/8
8	H100031	WASHER LOCK EXT 12x19
2	H100008	BOLT WH 5/16x1
2	H100009	BOLT WH 5/16x1 1/4
4	H100222	BOLT WH 5/16x3/4

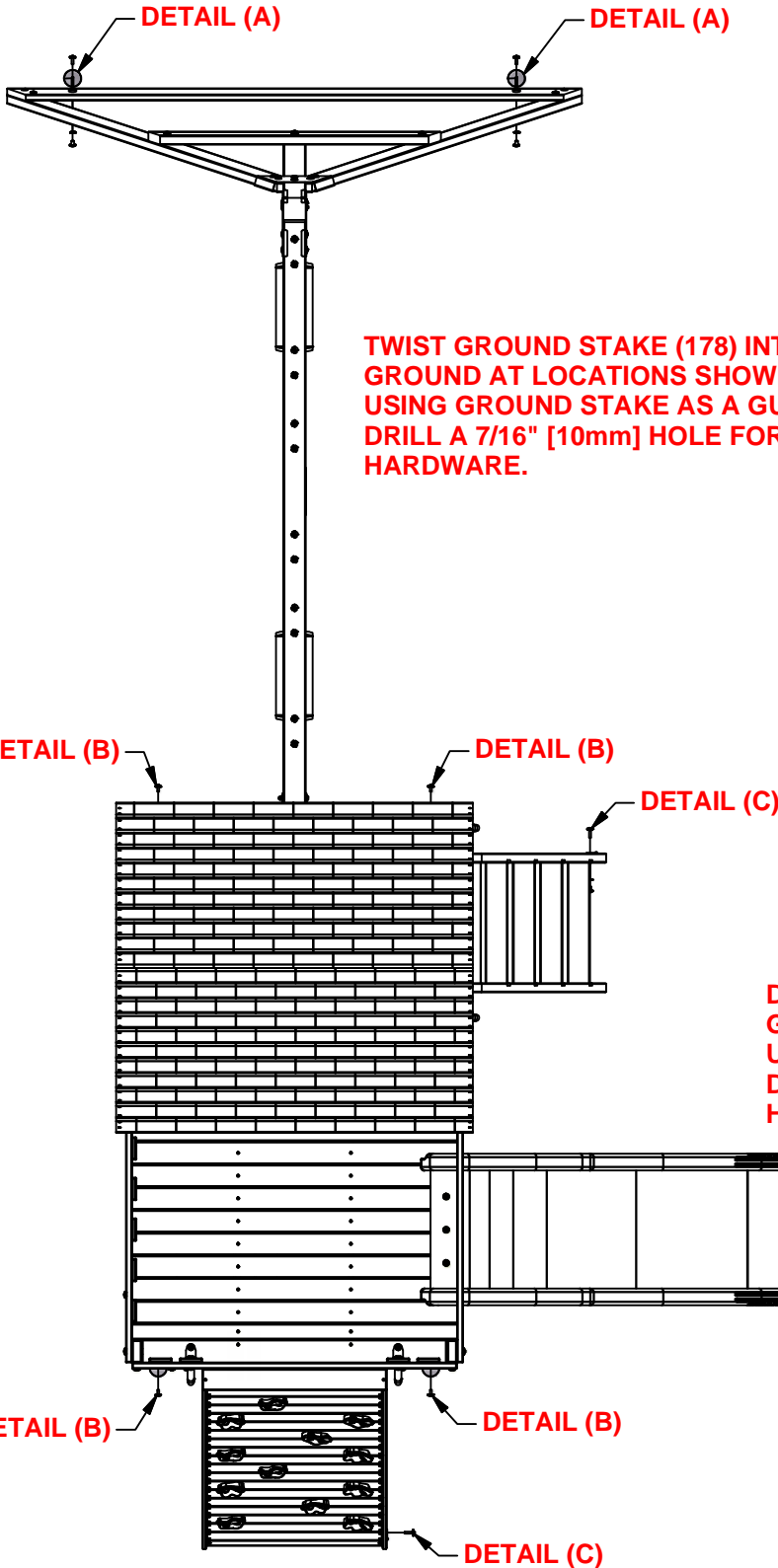

TWIST GROUND STAKE (178) INTO GROUND AT LOCATIONS SHOWN. USING GROUND STAKE AS A GUIDE, DRILL A 7/16" [10mm] HOLE FOR HARDWARE.

DRIVE GROUND STAKE (527) INTO GROUND AT LOCATIONS SHOWN. USING GROUND STAKE AS A GUIDE, DRILL A 7/16" [10mm] HOLE FOR HARDWARE.

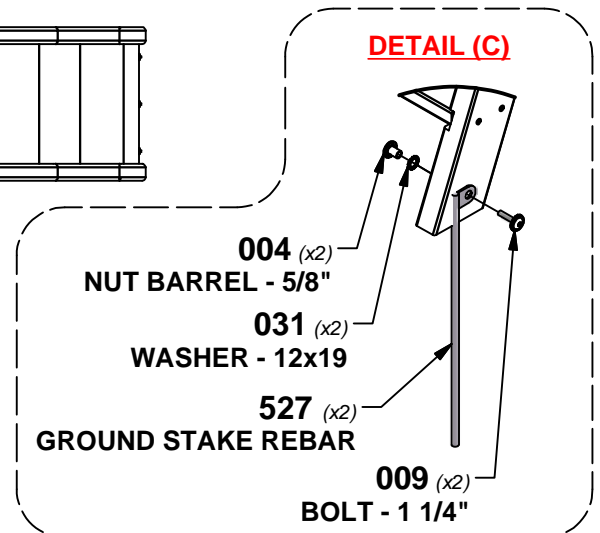
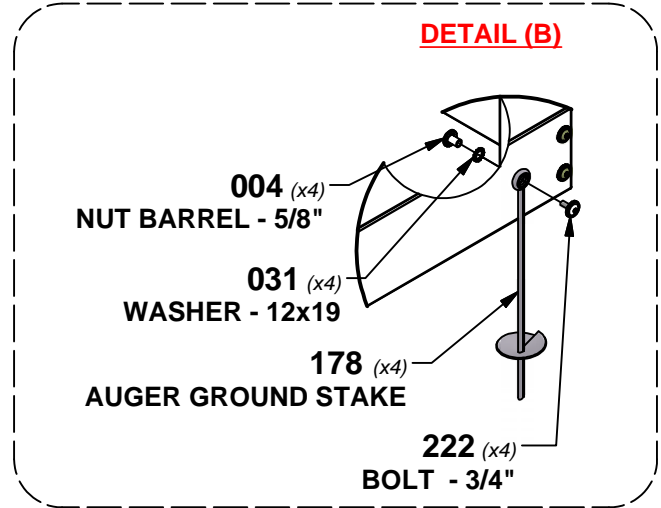
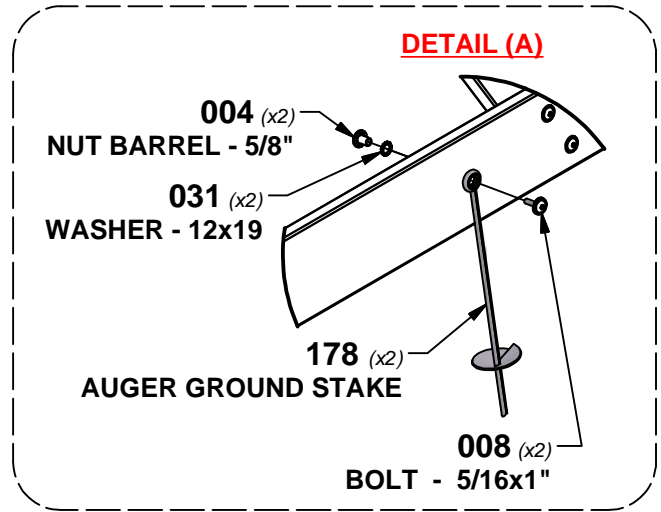

STEP 49 - FORT ASSEMBLY

QTY	PART NUMBER	DESCRIPTION
6	H100086	SCREW PFH 8x1-1/2"



Y01 | OUTSIDE FILLER FLOOR BOARD - W4L16087
(x1) | 5/8"x4"x46" (16x102x1168)

