



MANUFACTURED BY:
Backyard Discovery
3305 Airport Drive, Pittsburg, KS 66762
800-856-4445

Basepoint Business Centre: Rivermead Drive, Westlea, Swindon SN5 7EX Phone: 0800-118-2476
J.P. Coenstraat 7, The Hague, 2595 WP, Netherlands Phone: 0800-567-8990

EAGLES NEST ELITE

Swing Set

Model # 1902329B, 2300163, & 2300309

The assembly manual must be retained
since it contains important information



WARNING

Adult Assembly Required.

Not suitable for children under 36 months due to small parts.
FOR DOMESTIC USE ONLY. INTENDED FOR OUTDOOR USE.



Please visit www.backyarddiscovery.com

For the most up to date assembly manual, to register your set, or to order replacement parts
Para obtener instrucciones en español, visite www.backyarddiscovery.com



EASY STEP-BY-STEP
3D INTERACTIVE INSTRUCTIONS
DOWNLOAD THE FREE APP



Made in China

INS-1902329B, 2300163, & 2300309-A-EAGLES NEST ELITE-ENG 08/30/23

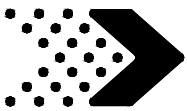

Place the set on level ground, not less than 6'-7" [2 m] from any structure or obstruction such as a fence, garage, house, overhanging branches, laundry lines, or electrical wires.

- While assembling unit, take time before and after each phase to make sure fort is level. If fort is not level, assembly will be difficult and improper assembly may result. Extra care must be taken to insure the fort is square.
- The safe play area refers to a zone extending 6'-7" [2 m] beyond the play product on all slides, including the space above the play product.

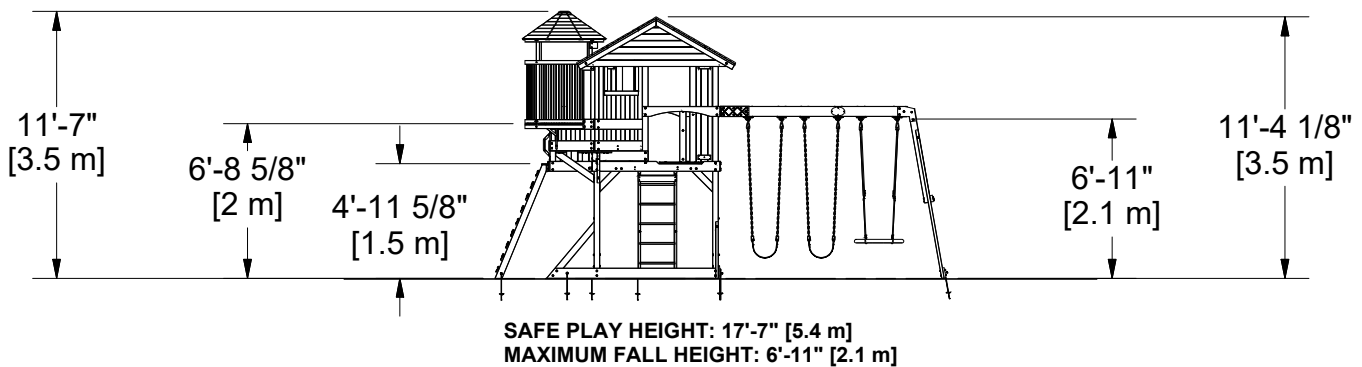
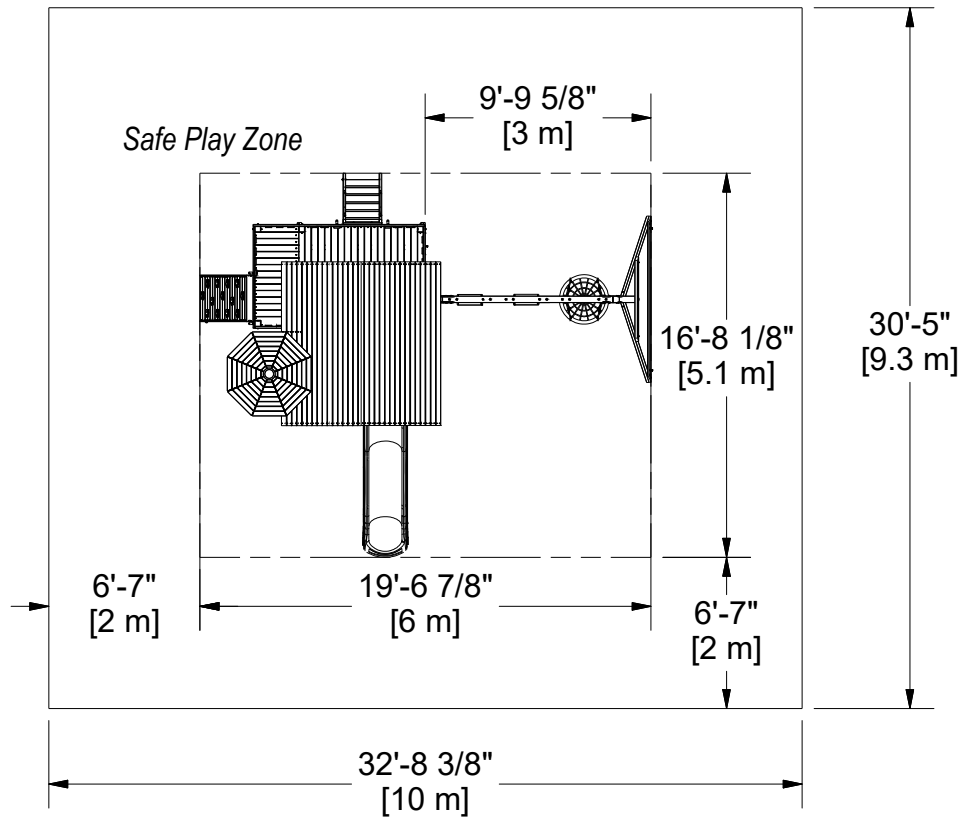

General Information:

Your set has been designed and engineered for children only and for residential use only.
 A maximum of 150 lbs. per child is recommended for play activities designed for individual use.
 A maximum of 120 lbs. per child is recommended for play activities designed for multiple child use.
 A maximum of 9 children is recommended for this swing set.

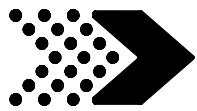

STEP 1

PRE-ASSEMBLY - SORTING PARTS

It is critical for ease of assembly that you take the time to sort and organize the wood and hardware.

WOOD PARTS:

- Organize wood parts by the three-digit, alpha-numeric number stamped on each board (ex. P01).
- If there are multiple boards with the same stamped number, stack those pieces together.
- Stamps can be found on the flat surface of the boards or on the end of the boards.
- Allow yourself plenty of room - the wood pieces can take up a significant amount of space.

NOTE: CARTONS ARE NOT ORGANIZED BY BOARD NUMBER.

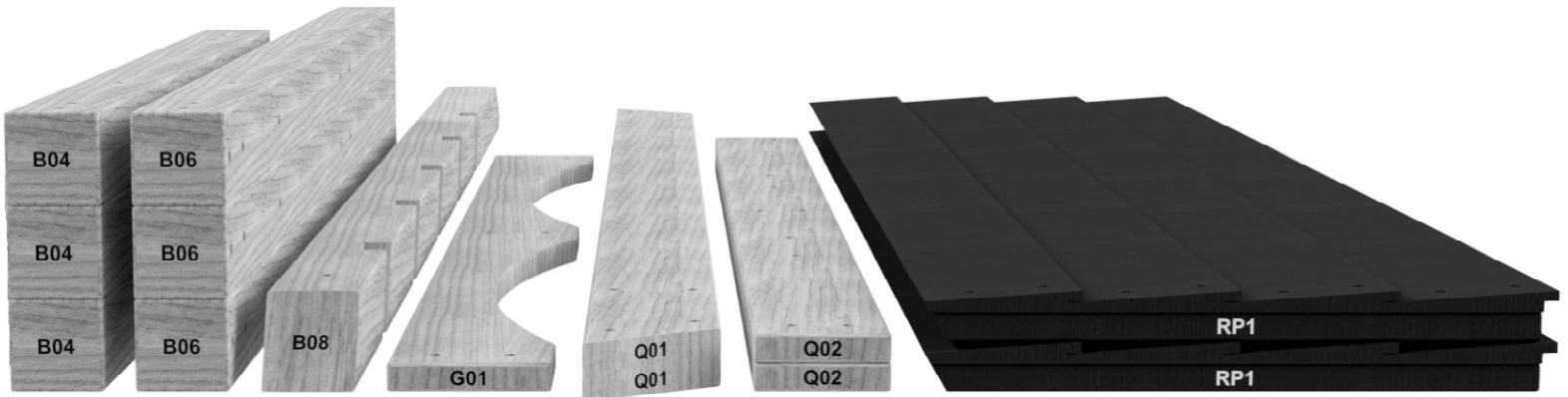

HARDWARE PARTS:

- We recommend that you have a separate table to organize the hardware.
- Hardware bags are printed with a seven-digit, alpha-numeric part number.
- You can organize your hardware by part number or group by hardware type (i.e. bolts, nuts, etc.).
- During assembly you only need to reference the last four digits of the number.



H100194 | BOLT WH
(x2) ↑ 5/16 x 2-1/2

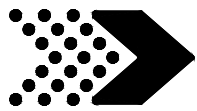

STEP 2

PRE-ASSEMBLY - TOOLS REQUIRED



Cordless Drill or
Electric Drill



Drill Attachments:
Phillips Head



1/8", 3/16", 3/8" & 7/16"
Drill Bits



Open End Wrenches 1/2" & 9/16"



3/8" Drive Ratchet, 1/2" &
9/16" STD Sockets 1/2" & 9/16" Deep
Sockets



Phillips Screw Driver



Claw Hammer



Rubber Mallet - Optional



Tape Measure

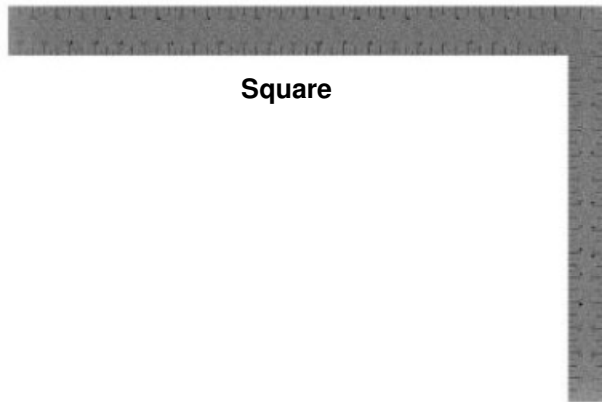

Square



Level 24"



STEP 3

PRE-ASSEMBLY - CHOOSE YOUR ASSEMBLY METHOD

There are several types of assembly instructions available to you.

1. Printed Assembly Manual included with your set
2. BILT APP - 3D interactive instructions
3. Combination of the Printed Manual and BILT APP (Note: Step numbers can differ between the two methods)

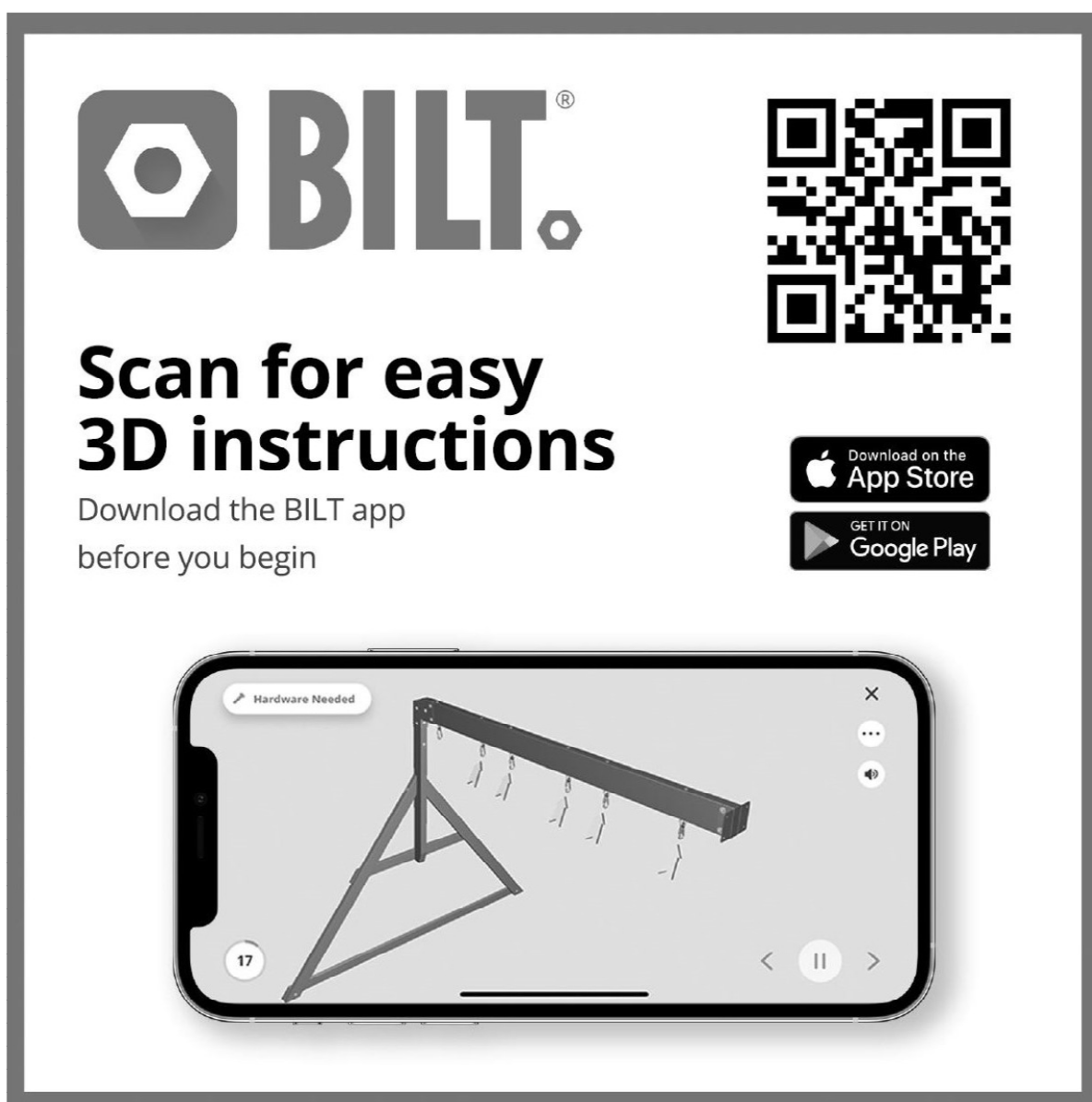

The advertisement features the BILT logo (a hexagon with a dot) and the text "BILT.®". To the right is a large QR code. Below the logo, the text reads "Scan for easy 3D instructions" and "Download the BILT app before you begin". There are two buttons: "Download on the App Store" and "GET IT ON Google Play". At the bottom, a smartphone screen displays a 3D assembly diagram of a metal frame with a horizontal bar and hanging weights. The screen includes a "Hardware Needed" label, a close button (X), a menu button (three dots), a volume icon, a page number "17", and navigation arrows.

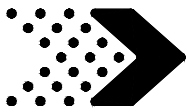

A1 | SWING BEAM - W4L12838
(x1) | 3 3/8"x5 1/4"x89 1/2" (86x134x2274)



A2 | SB 9" BLOCK - W4L08962
(x1) | 3 3/8"x5 1/4"x9" (86x134x228)

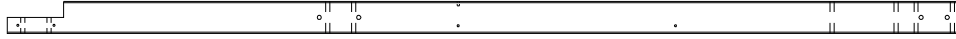

B1 | POST - W4L12809
(x1) | 3"x3"x89 5/8" (76x76x2275)



B4 | POST - W4L12811
(x1) | 3"x3"x59" (76x76x1500)



B8 | POST - W4L08475
(x1) | 3"x3"x53 7/8" (76x76x1370)



B5 | POST - W4L12812
(x1) | 3"x3"x69 3/4" (76x76x1771)

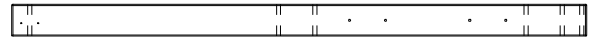

B9 | POST - W4L08476
(x1) | 3"x3"x53 7/8" (76x76x1370)



B10 | POST - W4L08484
(x1) | 3"x3"x47 1/4" (76x76x1201)



B12 | POST - W4L08487
(x1) | 3"x3"x13 5/8" (76x76x345)



B14 | POST - W4L12826
(x1) | 3"x3"x53 7/8" (76x76x1370)



B15 | POST - W4L12810
(x2) | 3"x3"x29 3/8" (76x76x746)



B16 | POST - W4L08553
(x1) | 3"x3"x53 7/8" (76x76x1370)



B17 | POST - W4L08696
(x2) | 3"x3"x33 7/8" (76x76x860)



B19 | POST - W4L12828
(x1) | 3"x3"x33 7/8" (76x76x860)



B21 | POST - W4L08746
(x1) | 3"x3"x33 7/8" (76x76x860)

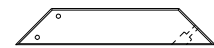

E1 | ANGLE SUPPORT - W4L08458
(x6) | 1 3/8"x3 3/8"x18 3/4" (36x86x475)

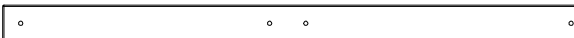

E2 | POST - W4L08522
(x2) | 3 3/8"x1 3/8"x53 7/8" (86x36x1370)

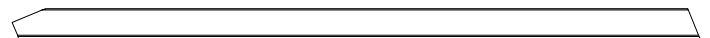

E3 | LEFT RAIL - W4L12830
(x1) | 1 3/8"x3 3/8"x64 3/4" (36x86x1645)



E4 | RIGHT RAIL - W4L12831
(x1) | 1 3/8"x3 3/8"x64 3/4" (36x86x1645)



E6 | FLOOR SUPPORT - W4L12807
(x2) | 1 3/8"x3 3/8"x54 3/8" (36x86x1382)



E7 | ANGLE BRACE - W4L08494
(x4) | 1 3/8"x3 3/8"x38 1/2" (36x86x978)



E8 | ANGLE SUPPORT BRACE - W4L12935
(x2) | 1 3/8"x3 3/8"x25 3/8" (36x86x643)



E50 | END SUPPORT - W4L11379
(x1) | 1 3/8"x3 3/8"x44 1/8" (36x86x1120)

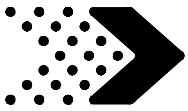

E51 | ANGLE BRACE - W4L11378
(x2) | 1 3/8"x3 3/8"x88 3/4" (36x86x2254)

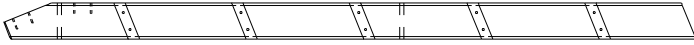

E77 | LEFT UPRIGHT - W4L12840
(x1) | 1 3/8"x3 3/8"x64 7/8" (36x86x1649)

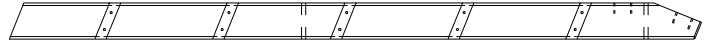

E78 | RIGHT UPRIGHT - W4L12841
(x1) | 1 3/8"x3 3/8"x64 7/8" (36x86x1649)



F1 | POST - W4L08495
(x2) | 1 3/8"x2 3/8"x54 5/8" (36x60x1389)



F2 | POST - W4L08503
(x1) | 1 3/8"x2 3/8"x47 1/4" (36x60x1200)



F3 | POST - W4L08504
(x1) | 1 3/8"x2 3/8"x47 1/4" (36x60x1200)

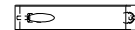

F4 | WALL SUPPORT - W4L13101
(x1) | 1 3/8"x2 3/8"x11 3/4" (36x60x300)



G1 | WALL SUPPORT - W4L12822
(x1) | 1"x5 1/4"x77 3/8" (24x134x1964)



G2 | WALL SUPPORT - W4L12824
(x1) | 1"x5 1/4"x66 5/8" (24x134x1692)

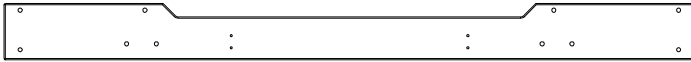

G3 | WALL SUPPORT - W4L12801
(x1) | 1"x5 1/4"x64 3/4" (24x134x1645)

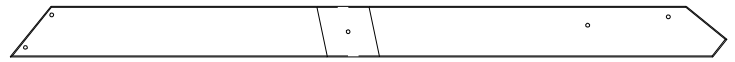

G4 | CROSS BRACE - W4L12821
(x4) | 1"x5 1/4"x74 3/4" (24x134x1898)



G5 | CROSS BRACE - W4L12915
(x2) | 1"x5 1/4"x17 3/4" (24x134x450)



G6 | WALL SUPPORT - W4L12804
(x1) | 1"x5 1/4"x77 3/8" (24x134x1964)

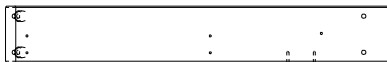

G7 | WALL SUPPORT - W4L12842
(x1) | 1"x5 1/4"x32" (24x134x915)



G9 | BASE BOARD - W4L12885
(x1) | 1"x5 1/4"x79 1/4" (24x134x2014)



G8 | WALL SUPPORT - W4L12843
(x1) | 1"x5 1/4"x32" (24x134x813)

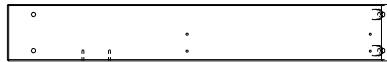

G10 | WALL SUPPORT - W4L08481
(x1) | 1"x5 1/4"x36" (24x134x915)



G11 | WALL SUPPORT - W4L08486
(x1) | 1"x5 1/4"x7 1/2" (24x134x192)



G12 | WALL SUPPORT - W4L08490
(x1) | 1"x5 1/4"x29 1/8" (24x134x741)



G13 | WALL SUPPORT - W4L08491
(x1) | 1"x5 1/4"x28 1/4" (24x134x716)



G14 | WALL SUPPORT - W4L08492
(x1) | 1"x5 1/4"x10 5/8" (24x134x269)

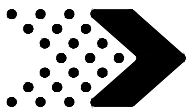

Parts Identification

Wood Components (Not to Scale)



G15 | WALL SUPPORT - W4L08545
(x1) | 1"x5 1/4"x30 1/4" (24x134x768)



G16 | WALL SUPPORT - W4L08546
(x1) | 1"x5 1/4"x14 7/8" (24x134x378)



G18 | BASE BOARD - W4L12820
(x2) | 1"x5 1/4"x56" (24x134x1422)



G17 | WALL SUPPORT - W4L12825
(x1) | 1"x5 1/4"x14 7/8" (24x134x378)

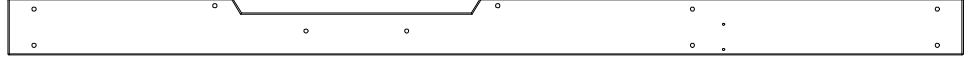

G20 | DECK BOARD - W4L12803
(x1) | 1"x5 1/4"x89 5/8" (24x134x2276)



G19 | WALL SUPPORT - W4L08560
(x1) | 1"x5 1/4"x8 5/8" (24x134x218)



G21 | WALL SUPPORT - W4L12815
(x1) | 1"x5 1/4"x77 3/8" (24x134x1964)



G22 | DECK RAIL - W4L12816
(x1) | 1"x5 1/4"x53 1/8" (24x134x1349)



G23 | DECK BOARD - W4L08698
(x1) | 1"x5 1/4"x22" (24x134x560)



G24 | DECK BOARD - W4L12805
(x1) | 1"x5 1/4"x25 3/8" (24x134x645)



G25 | ENTRY BOARD - W4L12817
(x1) | 1"x5 1/4"x53 1/8" (24x134x1349)



G27 | BASE BOARD - W4L12819
(x1) | 1"x5 1/4"x64 3/4" (24x134x1645)



G26 | WALL SUPPORT - W4L08485
(x1) | 1"x5 1/4"x36" (24x134x915)



G28 | DECK BOARD - W4L12818
(x1) | 1"x5 1/4"x89 5/8" (24x134x2276)



G29 | BASE BOARD - W4L12827
(x1) | 1"x5 1/4"x89 5/8" (24x134x2275)



G30 | SLIDE ARCH BOARD - W4L12813
(x1) | 1"x5 1/4"x40 1/2" (24x134x1028)

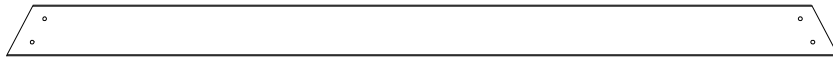

G50 | GROUND BOARD - W4L11380
(x1) | 1"x5 1/4"x86 3/4" (24x134x2202)



H1 | WALL PICKET - W4L12829
(x3) | 1"x3 3/8"x29 3/4" (24x86x756)



H5 | FLOOR SUPPORT - W4L08479
(x1) | 1"x3 3/8"x32" (24x86x813)



H6 | FLOOR SUPPORT - W4L08482
(x1) | 1"x3 3/8"x32" (24x86x813)



H7 | FLOOR SUPPORT - W4L08483
(x1) | 1"x3 3/8"x26" (24x86x661)



H10 | ROOF SUPPORT - W4L08513
(x1) | 1"x3 3/8"x76 3/4" (24x86x1949)



H11 | ROOF SUPPORT - W4L08518
(x1) | 1"x3 3/8"x76 3/4" (24x86x1949)

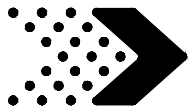

H12 | ROOF SUPPORT - W4L08519
(x1) | 1"x3 3/8"x39 1/2" (24x86x1004)



H13 | ROOF SUPPORT - W4L08520
(x1) | 1"x3 3/8"x74 3/4" (24x86x1900)

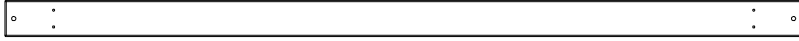

H14 | ROOF SUPPORT - W4L08521
(x1) | 1"x3 3/8"x74 3/4" (24x86x1900)

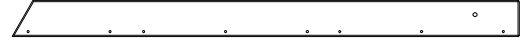

H15 | RAFTER - W4L08526
(x4) | 1"x3 3/8"x47 5/8" (24x86x1209)

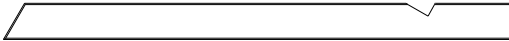

H16 | RAFTER - W4L08527
(x2) | 1"x3 3/8"x47 5/8" (24x86x1209)

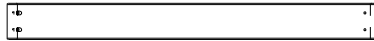

H17 | WALL SUPPORT - W4L08533
(x1) | 1"x3 3/8"x35" (24x86x889)

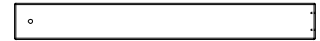

H18 | ROOF SUPPORT - W4L08541
(x1) | 1"x3 3/8"x28 1/4" (24x86x717)



H20 | FLOOR SUPPORT - W4L08562
(x9) | 1"x2 3/4"x3" (24x70x76)



H21 | BASE BOARD - W4L08563
(x1) | 1"x3 3/8"x35" (24x86x889)



H23 | FLOOR SUPPORT - W4L12800
(x1) | 1"x3 3/8"x64 3/4" (24x86x1645)



H24 | FLOOR SUPPORT - W4L12888
(x1) | 1"x3 3/8"x58 3/4" (24x86x1493)



H26 | FLOOR SUPPORT - W4L08700
(x1) | 1"x3 3/8"x46 1/8" (24x86x1172)

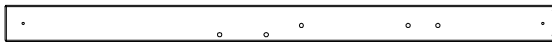

H28 | FLOOR SUPPORT - W4L12823
(x1) | 1"x3 3/8"x52 1/8" (24x86x1324)

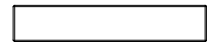

H76 | LADDER RUNG - W4L06609
(x5) | 1"x3 3/8"x18 1/8" (24x86x460)



H110 | ATTACHMENT BOARD - W4L12839
(x1) | 1"x3 3/8"x20 1/8" (24x86x512)



J1 | WALL SUPPORT - W4L08496
(x2) | 1"x2 3/8"x27 1/8" (24x60x688)



J2 | FLOOR SUPPORT - W4L12844
(x1) | 1"x2 3/8"x23 3/8" (24x60x594)



J3 | FLOOR SUPPORT - W4L12845
(x1) | 1"x2 3/8"x24 3/8" (24x60x619)



J31 | ATTACHMENT BOARD - W4L12836
(x1) | 1"x3 3/8"x24 1/4" (24x86x615)



K4 | FLOOR BOARD - W4L12808
(x1) | 5/8"x5"x64 3/4" (16x128x1644)



K6 | WALL PICKET - W4L08561
(x1) | 5/8"x5 1/4"x43 1/4" (16x132x1099)

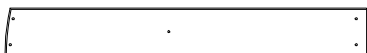

L1 | FLOOR BOARD - W4L12916
(x2) | 5/8"x4 3/8"x34" (16x112x865)

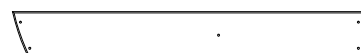

L4 | FLOOR BOARD - W4L12917
(x2) | 5/8"x4 3/8"x33 1/2" (16x112x852)



L5 | FLOOR BOARD - W4L12918
(x2) | 5/8"x4 3/8"x31 7/8" (16x112x811)



L6 | FLOOR BOARD - W4L12919
(x2) | 5/8"x4 3/8"x27" (16x112x687)

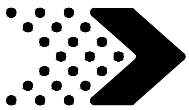

L8 | WALL PICKET - W4L08046
(x4) | 5/8"x4 3/8"x9 5/8" (16x112x244)

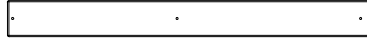

M1 | FLOOR BOARD - W4L08489
(x1) | 5/8"x3 3/8"x34 1/4" (16x86x869)



M7 | FLOOR BOARD - W4L08038
(x2) | 5/8"x2 1/2"x19 3/8" (16x62x493)

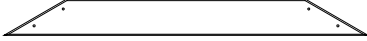

M16 | WALL BOARD - W4L08530
(x2) | 5/8"x3 3/8"x34 1/8" (16x86x867)

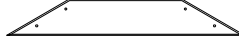

M17 | WALL BOARD - W4L08531
(x2) | 5/8"x3 3/8"x22 3/8" (16x86x567)



M18 | WALL BOARD - W4L08532
(x2) | 5/8"x3"x10 1/2" (16x77x268)



M20 | WALL BOARD - W4L08536
(x1) | 5/8"x3 3/8"x20 1/2" (16x86x521)



M23 | WALL PICKET - W4L08544
(x16) | 5/8"x3 3/8"x29 7/8" (16x86x759)



M26 | ROCK WALL BOARD - W4L12832
(x9) | 5/8"x3 3/8"x23 1/4" (16x86x590)



M28 | ROCK WALL BOARD - W4L12833
(x4) | 5/8"x3 3/8"x23 1/4" (16x86x590)

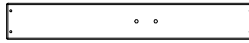

M29 | ROCK WALL BOARD - W4L12834
(x5) | 5/8"x3 3/8"x23 1/4" (16x86x590)

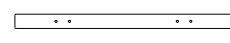

O70 | SLIDE MOUNTING BOARD - W4L09040
(x1) | 5/8"x1 3/8"x20 3/8" (16x34x517)



M30 | ROCK WALL END BOARD - W4L12835
(x1) | 5/8"x3 3/8"x24 1/4" (16x86x615)



M31 | ROCK WALL BOARD - W4L12837
(x1) | 5/8"x2 3/4"x23 1/4" (16x69x590)



M38 | TURRET FILLER BOARD - W4L11445
(x2) | 5/8"x3 3/8"x5 3/4" (16x86x146)



M39 | FLOOR BOARD - W4L11558
(x1) | 5/8"x3"x18 7/8" (16x76x480)



M73 | REAR SUPPORT - W4L11417
(x1) | 5/8"x3 3/8"x20 1/8" (16x86x512)

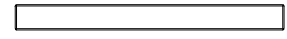

N2 | WINDOW BOTTOM - W4L08538
(x1) | 5/8"x2 3/8"x25 1/4" (16x60x640)



N3 | WINDOW SIDE - W4L08539
(x2) | 5/8"x2 3/8"x12 5/8" (16x60x321)



N4 | ROCK WALL CLEAT - W4L12847
(x1) | 5/8"x2 3/8"x61 3/4" (16x60x1568)



N6 | RAFTER CLEAT - W4L11446
(x1) | 5/8"x2 3/8"x3 1/8" (16x60x80)



O1 | WALL PICKET - W4L08506
(x60) | 5/8"x1 3/8"x32 7/8" (16x34x835)



O2 | WALL PICKET - W4L08047
(x2) | 5/8"x3"x9 5/8" (16x75x244)



O3 | WALL PICKET - W4L08512
(x1) | 5/8"x1 3/8"x39 7/8" (16x34x1013)



SP50 | SWING BEAM SUPPORT - W4L11377
(x1) | 3 3/8"x3 3/8"x49 3/8" (86x86x1254)



T1 | FLOOR SUPPORT - W4L08466
(x2) | 1"x1 3/8"x48 3/8" (24x34x1230)



T2 | WALL BOARD - W4L12846
(x2) | 1"x1 3/8"x5 7/8" (24x34x150)

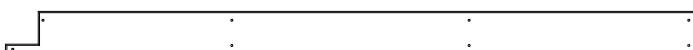

Y1 | FLOOR BOARD - W4L12806
(x1) | 5/8"x4"x64 3/4" (16x102x1644)



Y2 | FLOOR BOARD - W4L12814
(x1) | 5/8"x4"x64 3/4" (16x102x1644)

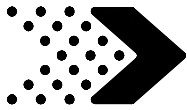

B2 | POST - W2A02902
(x1) | 3"x3"x89 5/8" (76x76x2275)

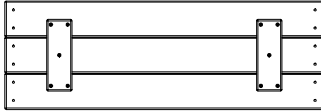

WP1 | RIGHT WALL PANEL - W2A02903
(x2) | 1 1/4"x10 3/16"x29 7/8" (32x258x759)

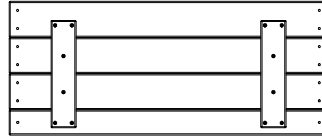

WP2 | RIGHT WALL PANEL - W2A02904
(x2) | 1 1/4"x12 1/2"x29 7/8" (32x318x759)

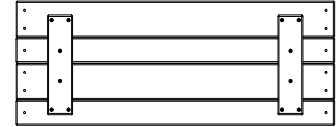

WP4 | WALL PANEL - W2A02906
(x2) | 1 1/4"x11 5/8"x29 7/8" (32x295x759)



WP3 | REAR FORT WALL - W2A02905
(x2) | 1 1/4"x8 1/8"x53 15/16" (32x212x1370)

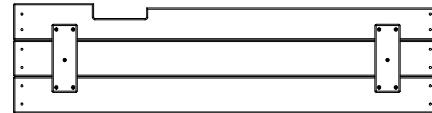

WP5 | WALL PANEL - W2A02907
(x1) | 1 1/4"x9 13/16"x39 7/8" (32x250x1013)

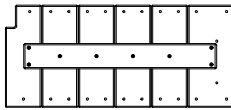

WP7 | WALL PANEL - W2A02909
(x1) | 1/16"x1/16"x1/16" (32x547x243)

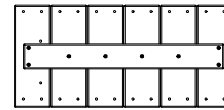

WP6 | WALL PANEL - W2A02908
(x1) | 1/16"x1/16"x1/16" (32x243x521)

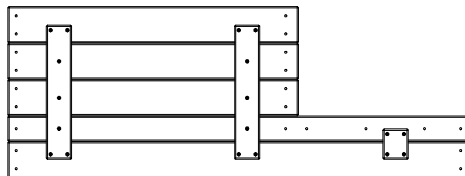

WP8 | LEFT WINDOW WALL PANEL - W2A02910
(x1) | 1 1/4"x16"x43 1/4" (32x407x1099)

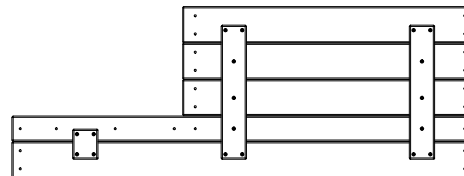

WP9 | RIGHT WINDOW WALL PANEL - W2A02911
(x1) | 1 1/4"x15 7/8"x43 1/4" (32x404x1099)

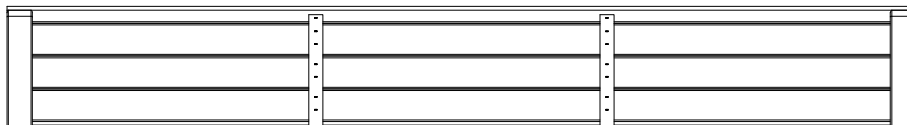

RP01 | ROOF PANEL - W2A02182
(x2) | 1/16"x1/16"x1/16" (40x287x2165)

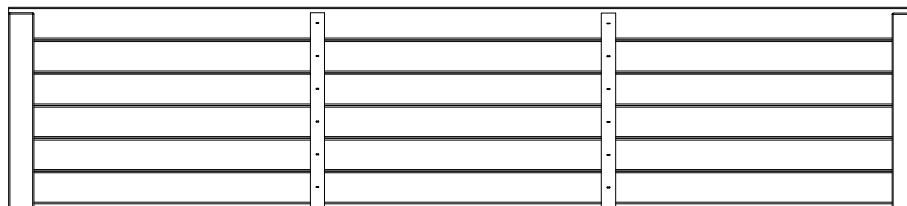

RP02 | ROOF PANEL - W2A020184
(x2) | 1 9/16"x19 1/4"x85 3/16" (40x488x2165)

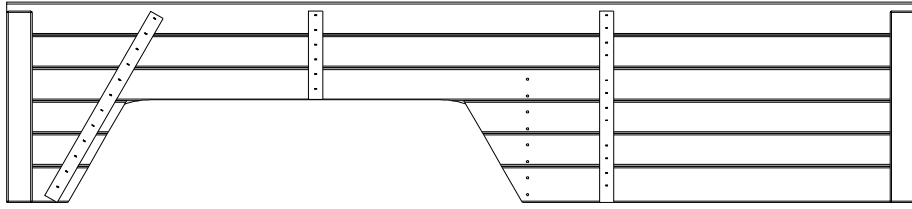
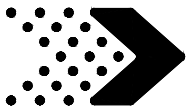

RP03 | ROOF PANEL - W2A02185
(x1) | 1 9/16"x18 3/4"x85 3/16" (40x476x2165)

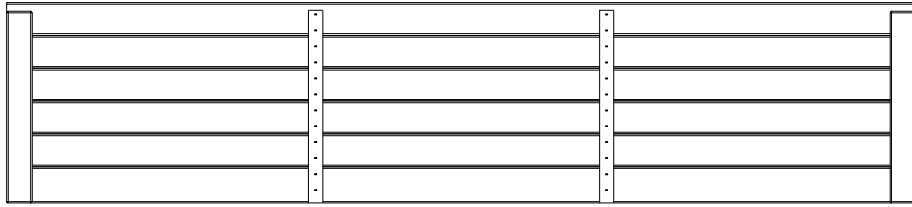

RP04 | ROOF PANEL - W2A02186
(x1) | 1 9/16"x18 3/4"x85 1/4" (40x476x2165)

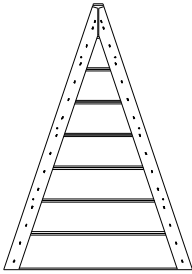

RP07 | ROOF PANEL - W2A02189
(x8) | 13/16"x24 7/8"x17 11/16" (21x632x450)

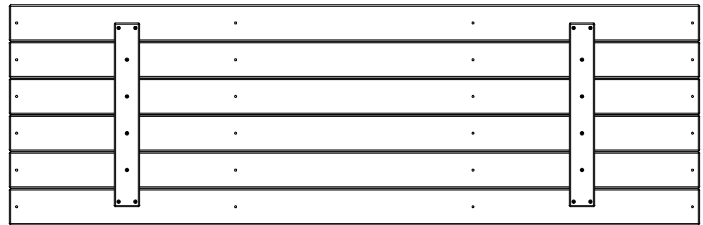

FP1 | FLOOR PANEL - W2A02900
(x2) | 1 1/4"x20 9/16"x65 11/16" (32x523x1644)

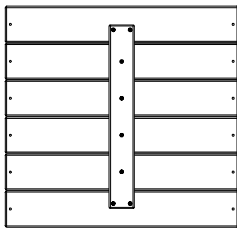

FP3 | FLOOR PANEL - W2A02227
(x2) | 1 1/4"x22 1/16"x20 11/16" (32x555x525)

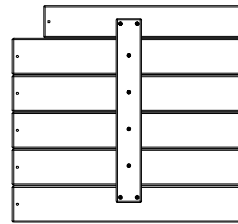

FP4 | FLOOR PANEL - W2A02228
(x1) | 1 1/4"x20 1/4"x22" (32x515x555)

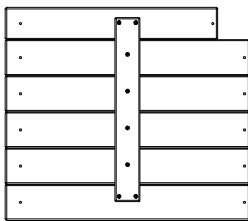

FP5 | FLOOR PANEL - W2A02229
(x1) | 1 1/4"x19 15/16"x22 15/16" (32x506x582)

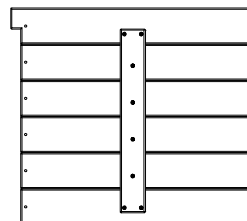

FP6 | FLOOR PANEL - W2A02230
(x1) | 1 1/4"x20 5/16"x22 15/16" (32x516x582)

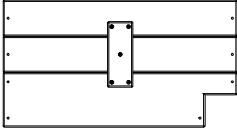
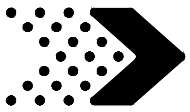

FP7 | FLOOR PANEL - W2A02248
(x1) | 1 1/4"x12 1/16"x22 1/16" (32x302x558)

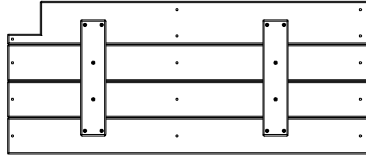

FP8 | FLOOR PANEL - W2A02912
(x1) | 1 1/4"x14 5/16"x34 3/16" (32x363x869)

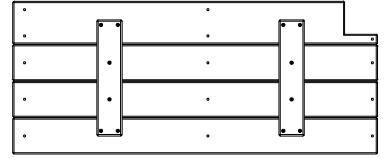

FP9 | FLOOR PANEL - W2A02913
(x1) | 1 1/4"x14 5/16"x34 3/16" (32x363x869)

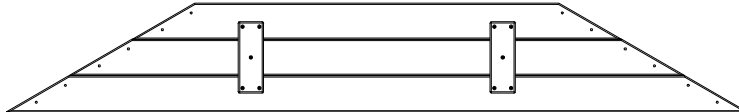

GP1 | GABLE PANEL - W2A02914
(x2) | 1 1/4"x69 1/2"x10 3/16" (32x1766x259)

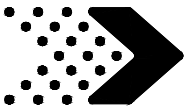

H100396 | BOLT WH BLK
(x7) | 5/16x1/2

H100363 | BOLT WH BLK
(x1) | 5/16x6



H100468 | BOLT WH BLK
(x20) | 5/16x1

H100480 | BOLT WH BLK
(x3) | 5/16x4 3/4



H100534 | BOLT WH BLK
(x1) | 5/16x4 1/2



H100378 | BOLT WH BLK
(x18) | 5/16x1 3/4

H100415 | BOLT WH BLK
(x103) | 5/16x3 3/4



H100457 | BOLT WH BLK
(x4) | 5/16x2

H100503 | BOLT WH BLK
(x4) | 5/16x3-1/2



H100205 | BOLT WH BLK
(x26) | 5/16x2-1/4

H100484 | BOLT WH BLK
(x9) | 5/16x3 1/4



H100195 | BOLT WH BLK
(x7) | 5/16x2-3/4

H100416 | BOLT WH BLK
(x22) | 5/16x3



H100192 | NUT BARREL WH BLK
(x26) | 5/16x7/8



H100193 | NUT BARREL WH BLK
(x2) | 5/16x1-1/2

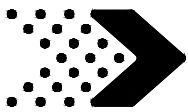

Parts Identification

Hardware Components



H100171 | BOLT WH BLK
(x12) | 1/4x1

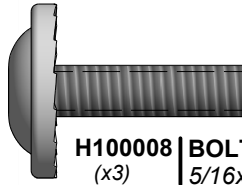

H100008 | BOLT WH
(x3) | 5/16x1

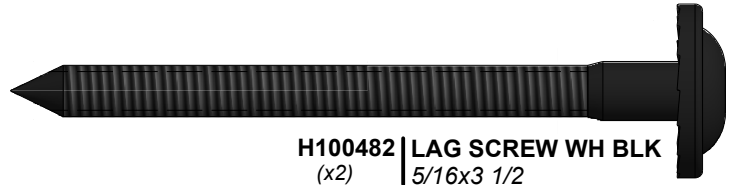

H100482 | LAG SCREW WH BLK
(x2) | 5/16x3 1/2

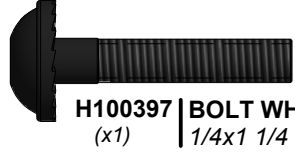

H100397 | BOLT WH BLK
(x1) | 1/4x1 1/4

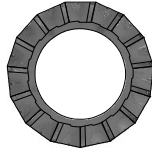

H100031 | WASHER LOCK EXT
(x3) | 12x19



H100197 | LAG SCREW WH BLK
(x25) | 5/16x2 1/2

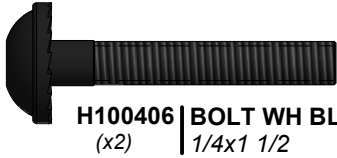

H100406 | BOLT WH BLK
(x2) | 1/4x1 1/2



H100004 | NUT BARREL WH
(x3) | 5/16 x 5/8



H100458 | LAG SCREW WH BLK
(x9) | 5/16x2



H100488 | BOLT WH BLK
(x4) | 1/4x2



H100567 | BOLT WH BLK
(x22) | 1/4x2 1/4



H100088 | SCREW PFH
(x4) | 8x1 1/8



H100471 | LAG SCREW WH BLK
(x3) | 5/16x1 1/2



H100800 | BOLT WH BLK
(x2) | 1/4x3



H100487 | LAG SCREW WH BLK
(x9) | 1/4x2

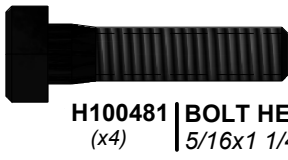

H100481 | BOLT HEX BLK
(x4) | 5/16x1 1/4

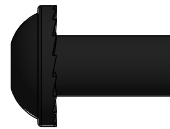

H100404 | NUT BARREL WH BLK
(x10) | 1/4x5/8



H100460 | LAG SCREW WH BLK
(x4) | 1/4x1



H100665 | BOLT HEX SD
(x13) | 3/8x5 3/4

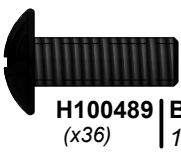

H100489 | BOLT PTH BLK
(x36) | 1/4x3/4

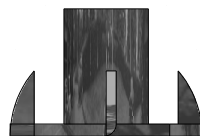

H100700 | T-NUT SD
(x13) | 3/8



H100379 | T-NUT BLK
(x192) | 5/16



H100398 | T-NUT BLK
(x59) | 1/4

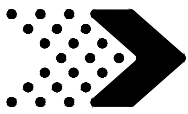

Parts Identification

Hardware Components



H100203 | SCREW PFH BLK
(x4) | 8x1/2



H100380 | SCREW PFH BLK
(x35) | 8x1 1/8



H100387 | SCREW PFH BLK
(x336) | 8x1-1/4



H100200 | SCREW PFH BLK
(x299) | 8x1 1/2



H100382 | SCREW PFH BLK
(x14) | 8x1 3/4



H100391 | SCREW PFH BLK
(x116) | 8x2



H100362 | SCREW PFH BLK
(x9) | 8x3

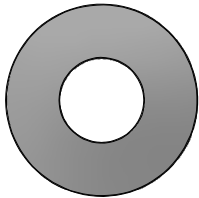

H100703 | WASHER FLAT SD
(x13) | 11x25

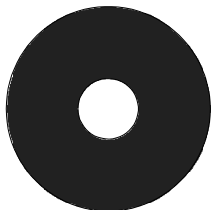

H100478 | WASHER FLAT BLK
(x4) | 8x27



H100630 | WASHER FLAT BLK
(x11) | 8x19

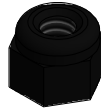

H100653 | NUT LOCK BLK
(x11) | 1/4

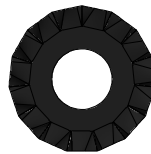

H100198 | WASHER LOCK EXT BLK
(x206) | 8x19



H100474 | WASHER FLAT BLK
(x9) | 9x18



H100477 | WASHER SPLIT BLK
(x4) | 5/16



H100400 | WASHER LOCK EXT BLK
(x10) | 8x15



H100746 | SCREW PWH SD
(x150) | 10x1 1/4



H100736 | SCREW PWH SD
(x1) | 8x1 5/8



H100408 | SCREW PWH BLK
(x2) | 8x1/2



H100392 | SCREW PWH BLK
(x76) | 8x3/4

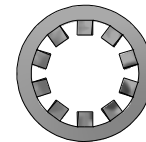

H100708 | WASHER LOCK INT SD
(x13) | 10x18

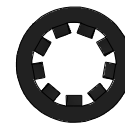

H100473 | WASHER LOCK INT BLK
(x28) | 8x15



H100199 | WASHER LOCK EXT BLK
(x15) | 12x19

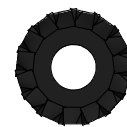

H100405 | WASHER LOCK EXT BLK
(x14) | 6x15

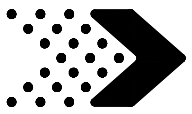

H100114 | TORX WRENCH
(x1) | T-30



H100147 | TORX BIT
(x1) | T-30



H100764 | SCREW SETTER
(x1)

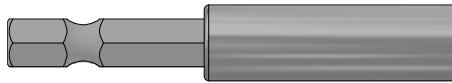

H101100 | MAGNETIC DRIVER
(x1)

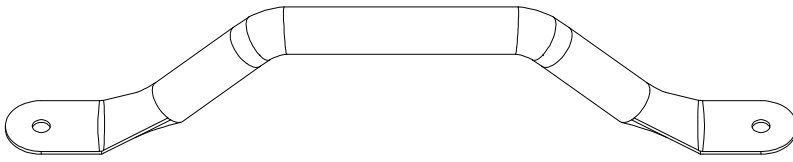
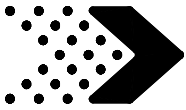

A100118 | **HAND GRIP METAL GREEN 381 c/c**
(x4)



A100164 | **BYD ID TAG (LARGE) AGES 3-10**
(x1)



A100134 | **HAND GRIP GREEN 816 C/C**
(x2)



A100178 | **AUGER GROUND STAKE**
(x8)

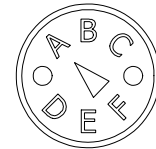

A100314 | **"A" REVISION TAG**
(x1)

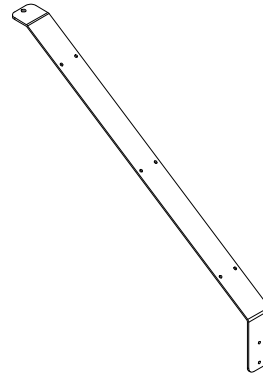

A4M00842 | **METAL ROOF FULL RIB**
(x8)

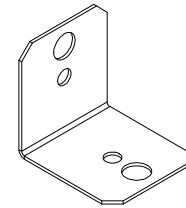

A4M00555 | **90° L-BRACKET - BLK**
(x4)

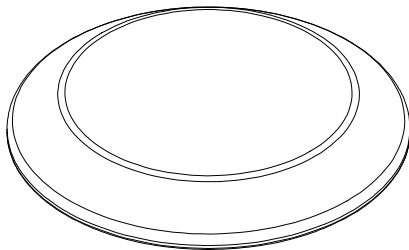

A6P00239 | **ROUND ROOF PLASTIC CAP**
(x1)

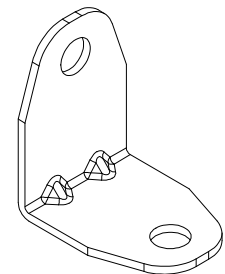

A4M00615 | **L BRACKET BLK**
(x3)

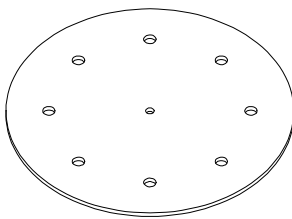

A4M00844 | **ROUND ROOF RIB CONNECTOR PLATE**
(x1)

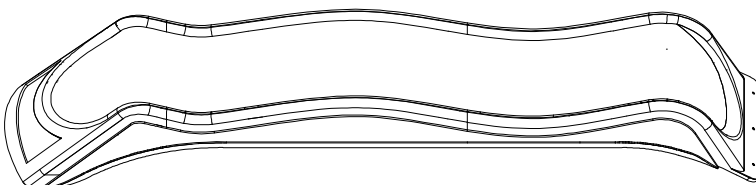

(x1) **SLIDE VF 10 FT**

10 FT VACUUM FORMED SLIDES		
PART NUMBER	COLOR	MODEL NUMBER
A100287	GREEN	1902329B
A6P00540	YELLOW	2300309
A6P00539	GREY	2300163

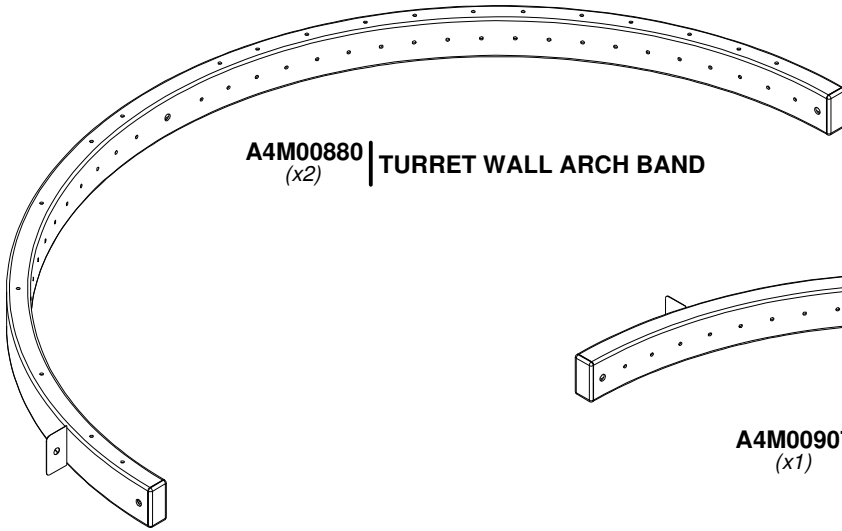
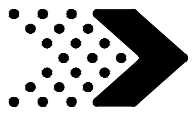

A4M00880 | TURRET WALL ARCH BAND
(x2)

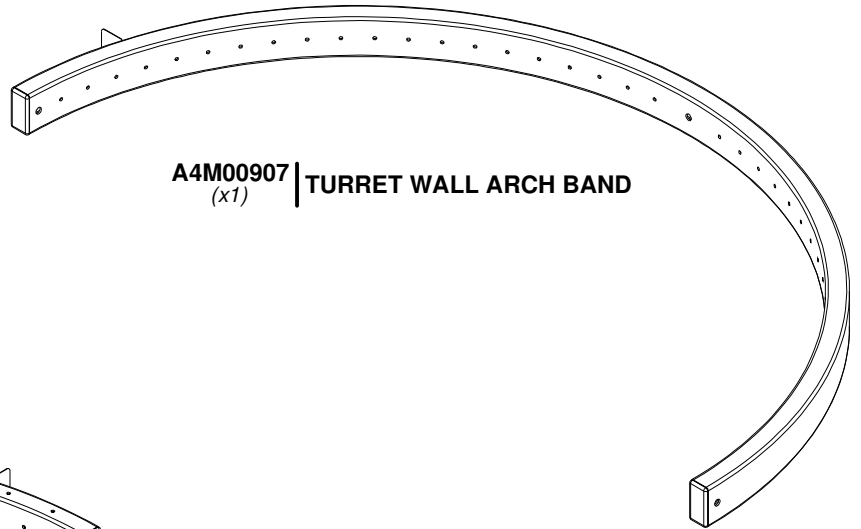

A4M00907 | TURRET WALL ARCH BAND
(x1)

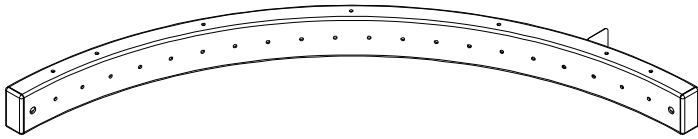

A4M00881 | QUARTER ROUND TURRET FLOOR SUPPORT
(x2)

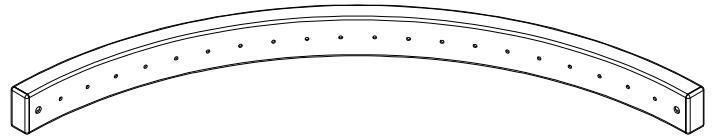

A4M00883 | QUARTER ROUND TURRET FLOOR SUPPORT
(x1)

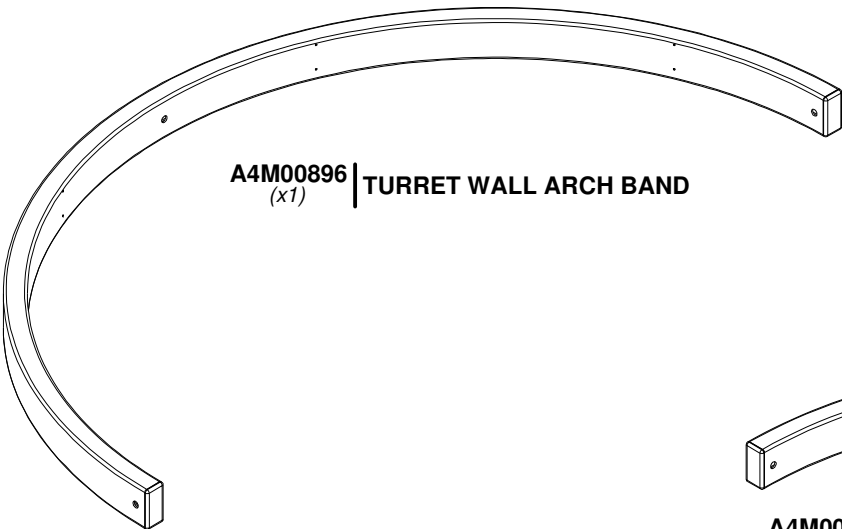

A4M00896 | TURRET WALL ARCH BAND
(x1)



A4M00897 | QUARTER ROUND TURRET FLOOR SUPPORT
(x2)

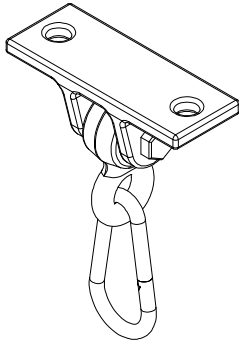
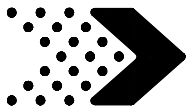

A4M00926 | SINGLE DUCTILE HANGER SD
(x6)

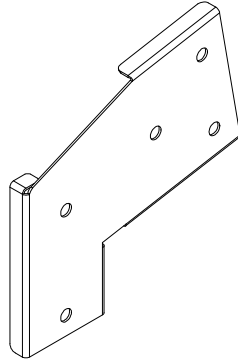

A100326 | SWING BEAM EXTENSION BRACKET-RIGHT
(x1)

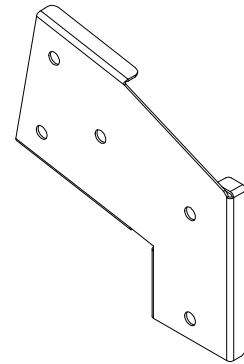

A100325 | SWING BEAM EXTENSION BRACKET-LEFT
(x1)

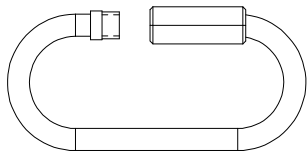

A4M00927 | QUICK LINK SD
(x4)

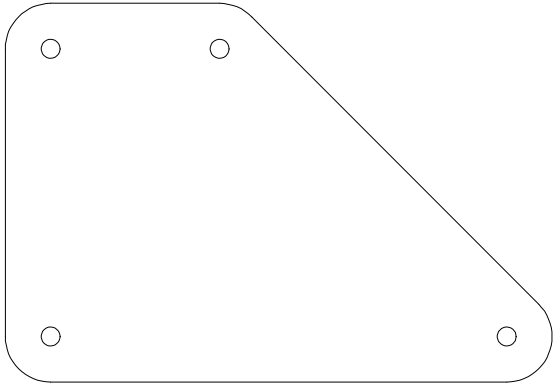

A4M00827 | TRIANGLE BRACE - BLK
(x4)

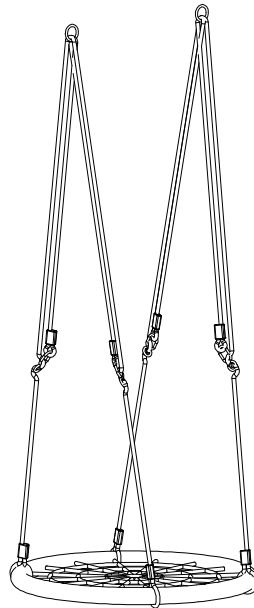

A6P00253 | 26" WEB SWING SEAT
(x1)

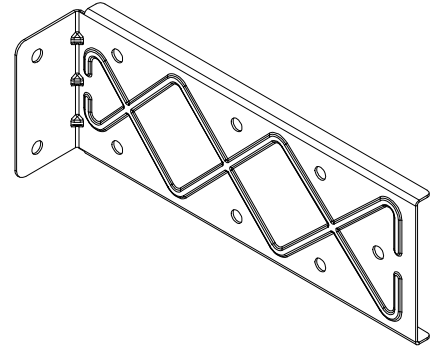

A4M00993 | EXTENDED SWING BEAM BRACKET
(x2)

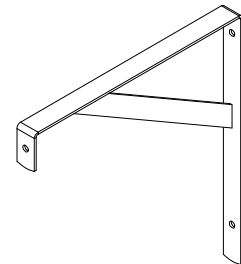

A4M01012 | METAL ANGLE BRACE
(x2)

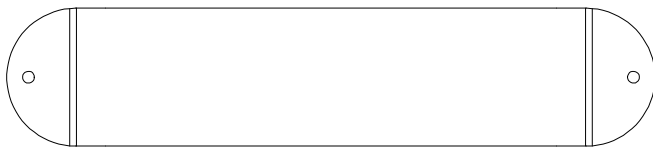

A6P00362 | 26" HD BELT SWING
(x2)

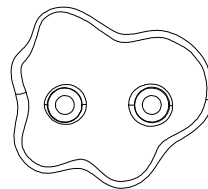

A6P00036 | GREEN HC ROCK #1
(x6)

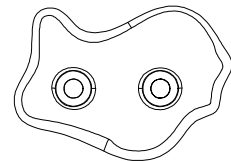

A6P00037 | GREEN HC ROCK #2
(x7)

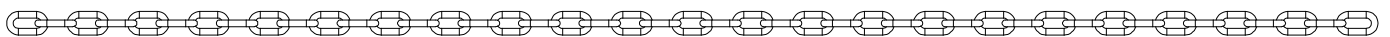

A4M01005 | CHAIN GREEN 7mm X 57in
(x4)

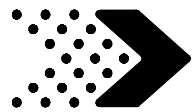

Phase 1

STEP 1

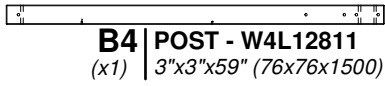

B4 | POST - W4L12811
(x1) | 3"x3"x59" (76x76x1500)

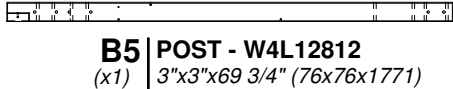

B5 | POST - W4L12812
(x1) | 3"x3"x69 3/4" (76x76x1771)

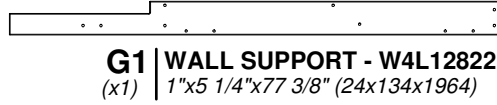

G1 | WALL SUPPORT - W4L12822
(x1) | 1"x5 1/4"x77 3/8" (24x134x1964)

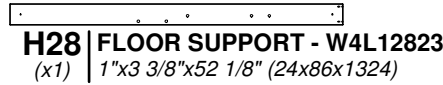

H28 | FLOOR SUPPORT - W4L12823
(x1) | 1"x3 3/8"x52 1/8" (24x86x1324)

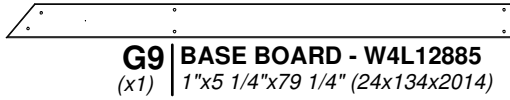

G9 | BASE BOARD - W4L12885
(x1) | 1"x5 1/4"x79 1/4" (24x134x2014)



A4M00827 | TRIANGLE BRACE - BLK
(x2)



H100480 | BOLT WH BLK
(x1) | 5/16x4 3/4



H100415 | BOLT WH BLK
(x6) | 5/16x3 3/4



H100416 | BOLT WH BLK
(x4) | 5/16x3



H100382 | SCREW PFH BLK
(x2) | 8x1 3/4



H100379 | T-NUT BLK
(x11) | 5/16



H100198 | WASHER LOCK EXT BLK
(x7) | 8x19



NOTE:
ASSEMBLE THE SUB ASSEMBLY FIRST.



TIP:
1. FOR EASE OF ASSEMBLY WE RECOMMEND USING SAW HORSES TO ASSEMBLE FORT.
2. WE RECOMMEND INSTALLING T-NUTS INTO BOARDS BEFORE ASSEMBLY.

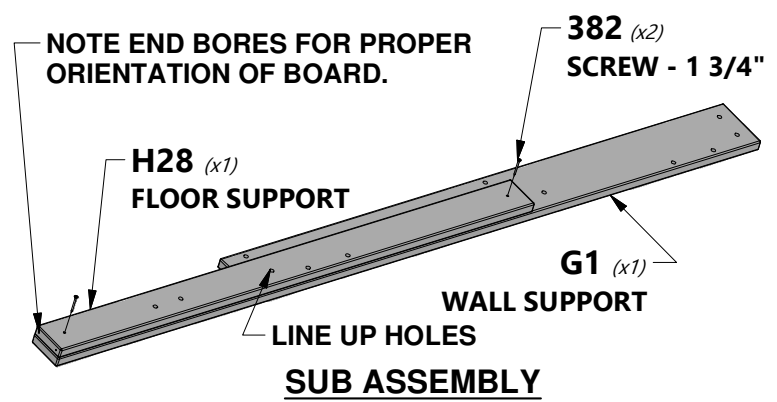

NOTE PILOT HOLE LOCATION FOR PROPER ORIENTATION OF THE POST.

480 (x1)
BOLT - 4 3/4"

SUB ASSEMBLY (x1)
(SEE ABOVE)

379 (x11)
T-NUT - 5/16"

827 (x2)
TRIANGLE BRACE - BLK

415 (x2)
BOLT - 3 3/4"

198 (x7)
WASHER - 8x19

415 (x4)
BOLT - 3 3/4"

B4 (x1)
POST

B5 (x1)
POST

G9 (x1)
BASE BOARD

416 (x4)
BOLT - 3"

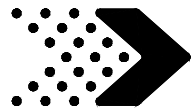

Phase 1

STEP 2

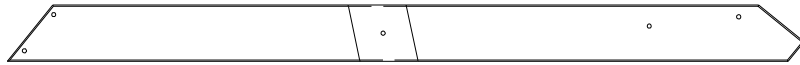

G4 | CROSS BRACE - W4L12821
(x2) | 1"x5 1/4"x74 3/4" (24x134x1898)



H100468 | BOLT WH BLK
(x5) | 5/16x1



H100378 | BOLT WH BLK
(x2) | 5/16x1 3/4



H100195 | BOLT WH BLK
(x2) | 5/16x2-3/4



H100198 | WASHER LOCK EXT BLK
(x5) | 8x19



H100379 | T-NUT BLK
(x9) | 5/16



TIP:

1. FOR EASE OF ASSEMBLY WE RECOMMEND USING SAW HORSES TO ASSEMBLE FORT.
2. WE RECOMMEND INSTALLING T-NUTS INTO BOARDS BEFORE ASSEMBLY.

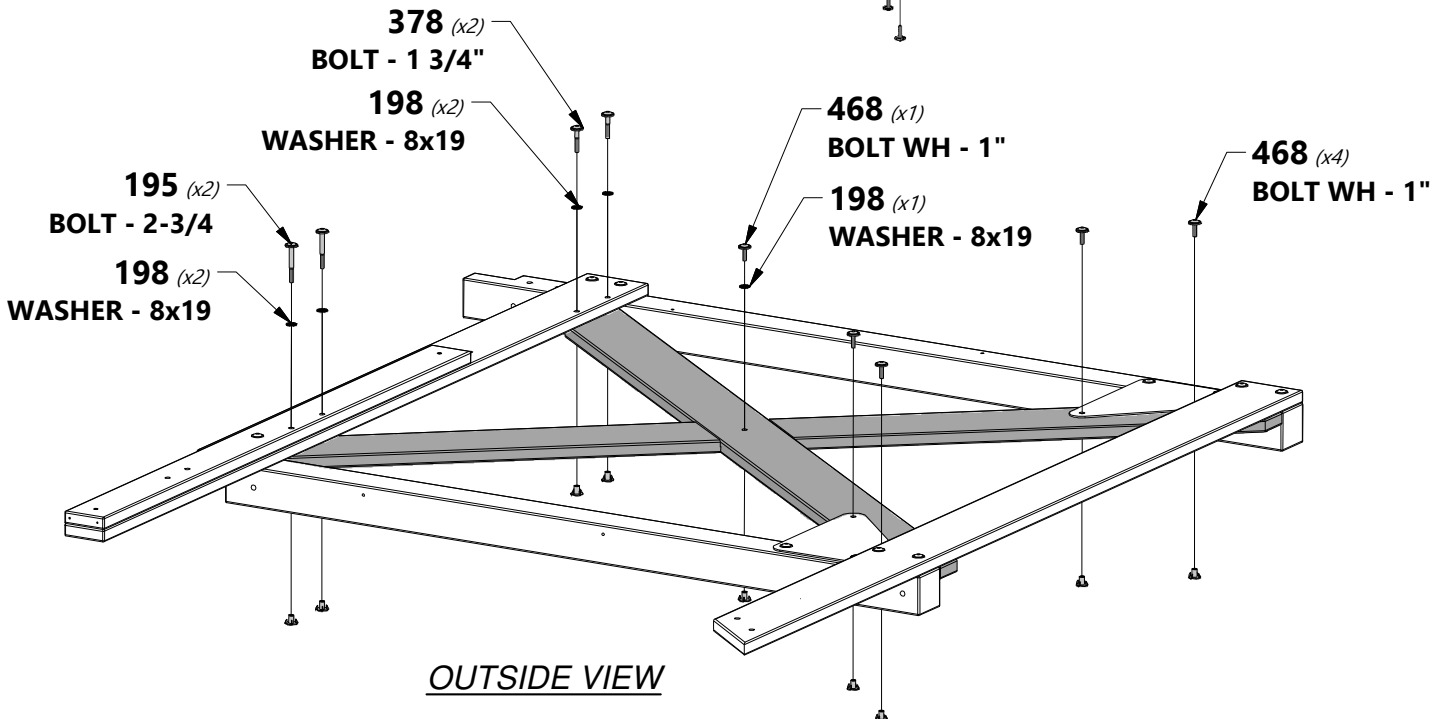
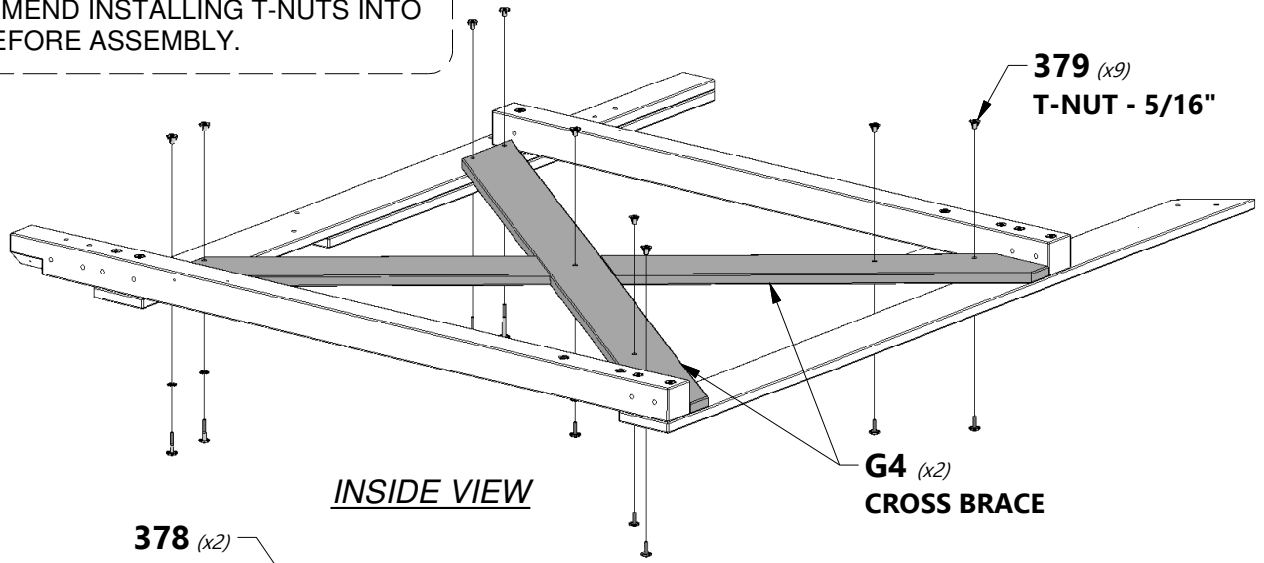

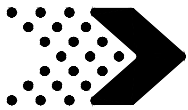

Phase 1

STEP 3

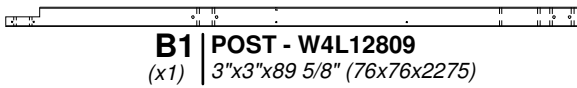

B1 | POST - W4L12809
(x1) | 3"x3"x89 5/8" (76x76x2275)

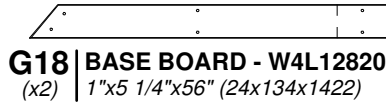

G18 | BASE BOARD - W4L12820
(x2) | 1"x5 1/4"x56" (24x134x1422)

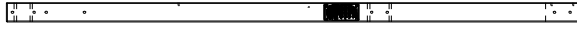

B2 | POST - W2A02902
(x1) | 3"x3"x89 5/8" (76x76x2275)

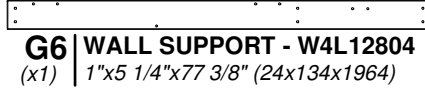

G6 | WALL SUPPORT - W4L12804
(x1) | 1"x5 1/4"x77 3/8" (24x134x1964)



A4M00827 | TRIANGLE BRACE - BLK
(x2)



H100468 | BOLT WH BLK
(x2) | 5/16x1



H100198 | WASHER LOCK EXT BLK
(x10) | 8x19



H100416 | BOLT WH BLK
(x4) | 5/16x3



H100379 | T-NUT BLK
(x14) | 5/16



H100415 | BOLT WH BLK
(x8) | 5/16x3 3/4



NOTE:
ASSEMBLE THE SUB ASSEMBLY FIRST.



TIP:
1. FOR EASE OF ASSEMBLY WE RECOMMEND USING SAW HORSES TO ASSEMBLE FORT.
2. WE RECOMMEND INSTALLING T-NUTS INTO BOARDS BEFORE ASSEMBLY.

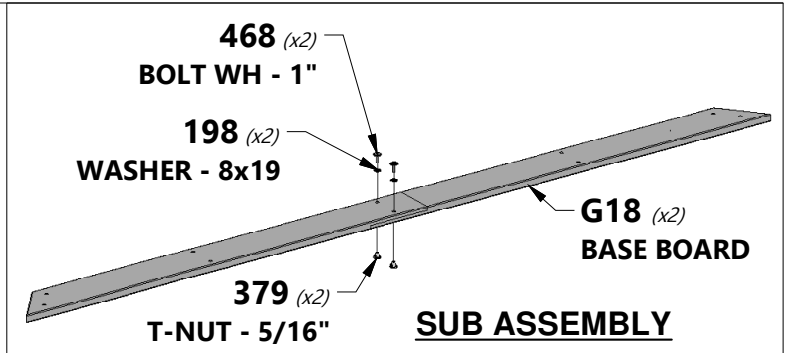

NOTE HOLE LOCATED AT THE TOP OF THE BOARD.

NOTE HOLES LOCATED AT THE BOTTOM OF THE BOARD.

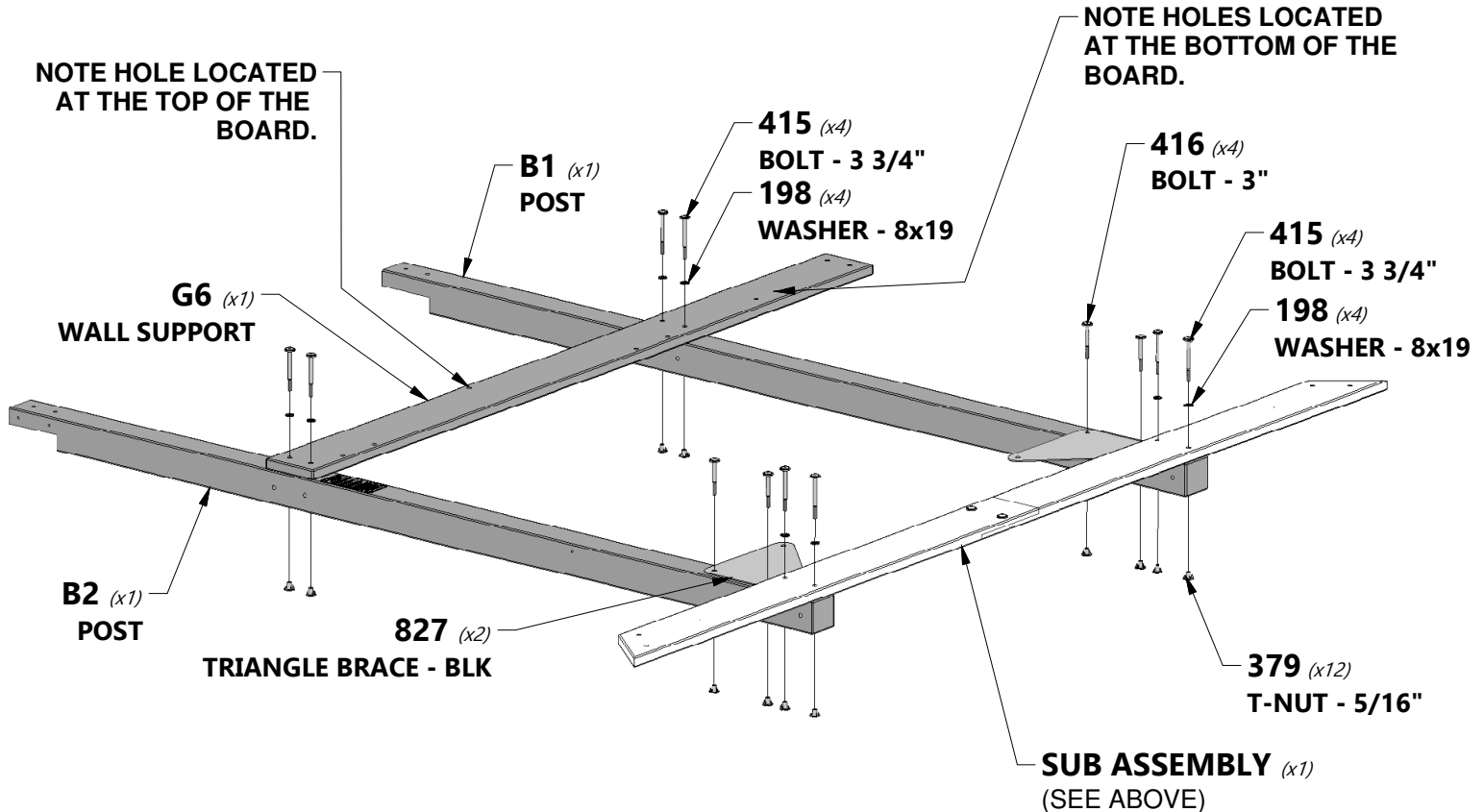

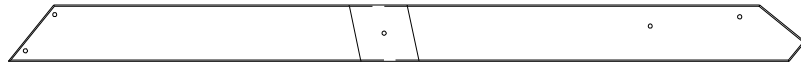
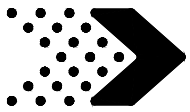

G4 | CROSS BRACE - W4L12821
(x2) | 1"x5 1/4"x74 3/4" (24x134x1898)



H100468 | BOLT WH BLK
(x5) | 5/16x1



H100378 | BOLT WH BLK
(x4) | 5/16x1 3/4



H100198 | WASHER LOCK EXT BLK
(x5) | 8x19



H100379 | T-NUT BLK
(x9) | 5/16



TIP:

1. FOR EASE OF ASSEMBLY WE RECOMMEND USING SAW HORSES TO ASSEMBLE FORT.
2. WE RECOMMEND INSTALLING T-NUTS INTO BOARDS BEFORE ASSEMBLY.

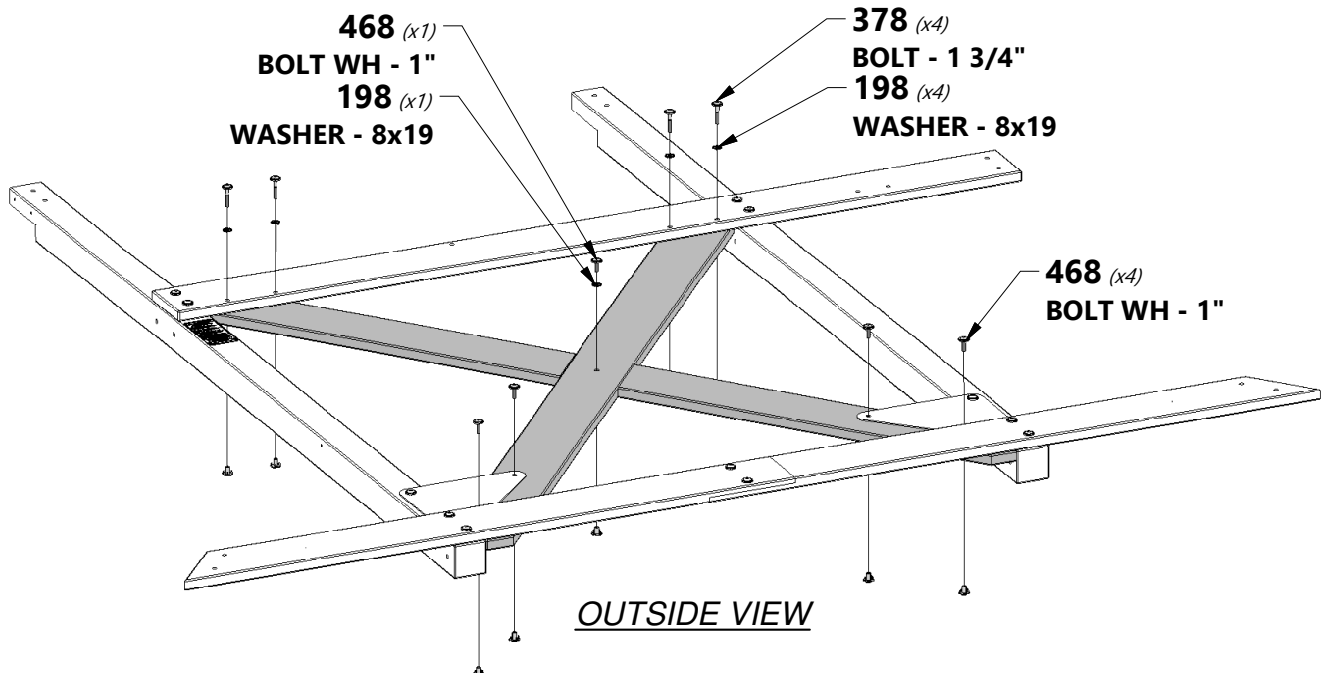
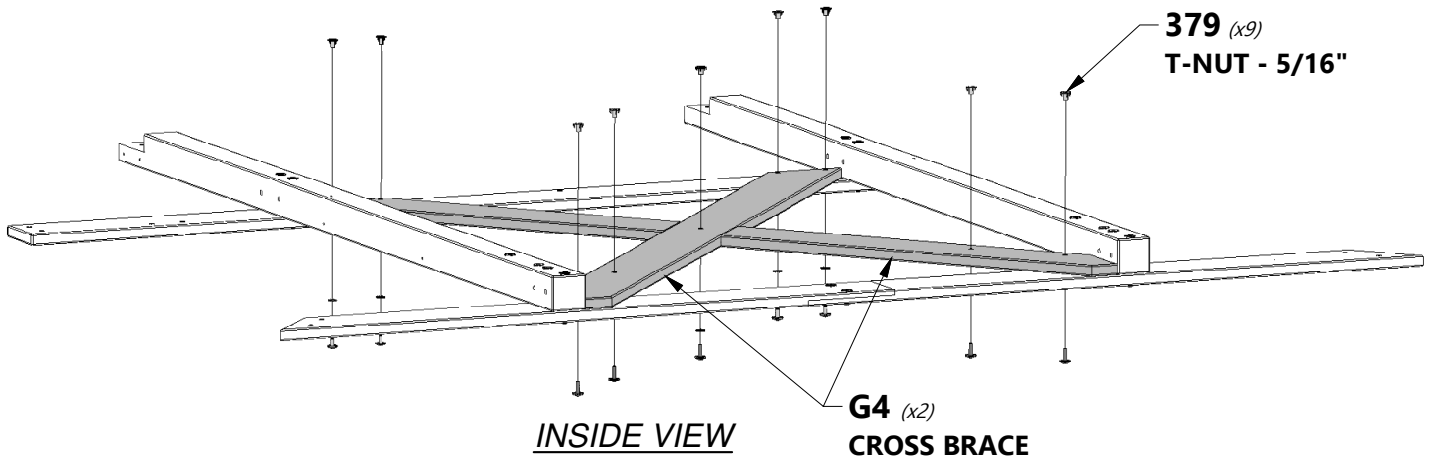

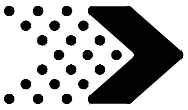

Phase 1

STEP 5

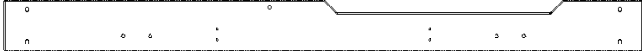

G2 | WALL SUPPORT - W4L12824
(x1) | 1"x5 1/4"x66 5/8" (24x134x1692)



G29 | BASE BOARD - W4L12827
(x1) | 1"x5 1/4"x89 5/8" (24x134x2275)



H100415 | BOLT WH BLK
(x8) | 5/16x3 3/4



H100198 | WASHER LOCK EXT BLK
(x8) | 8x19



H100379 | T-NUT BLK
(x8) | 5/16



TIP:

1. WE RECOMMEND INSTALLING T-NUTS INTO BOARDS BEFORE ASSEMBLY.

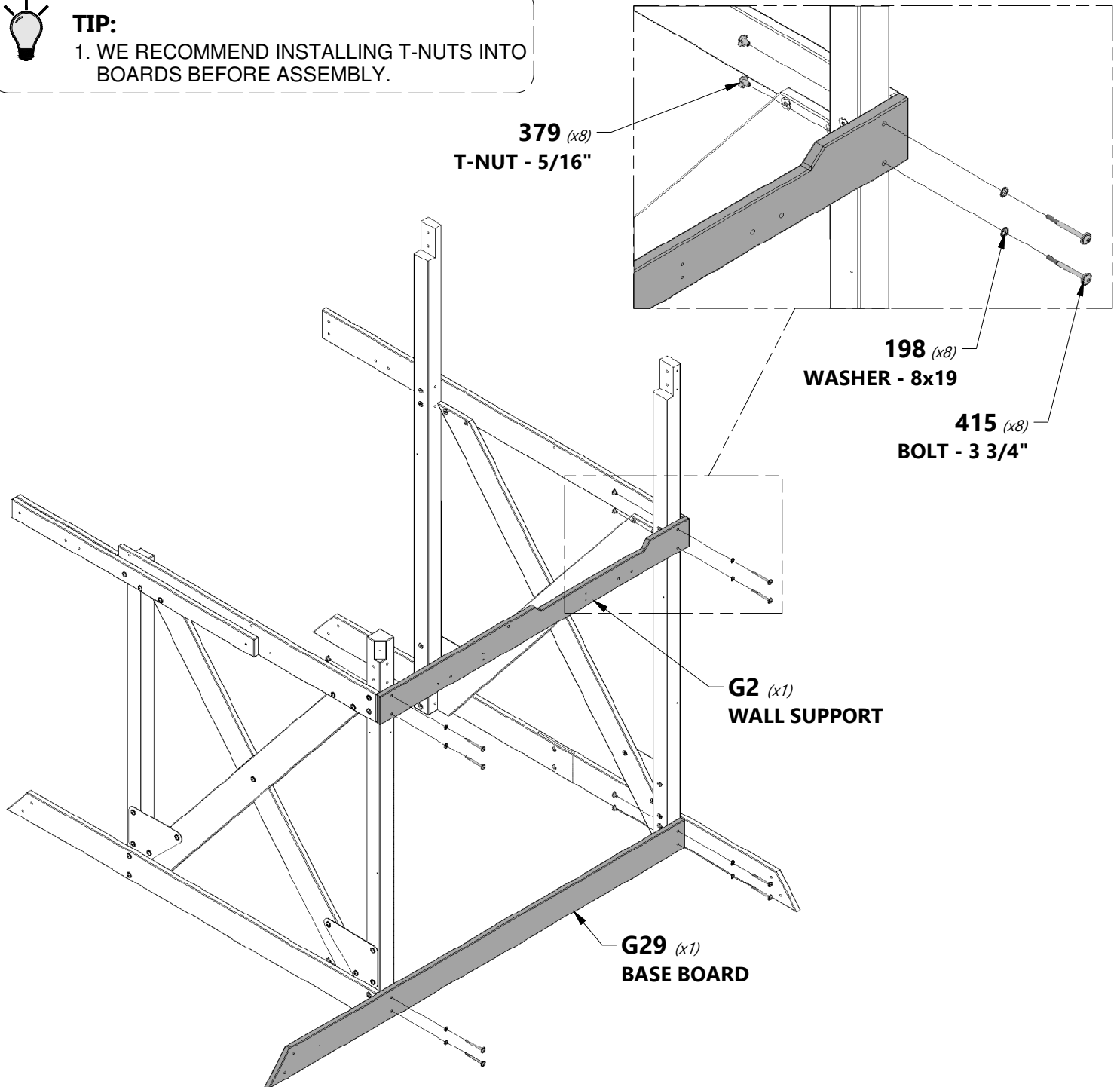

379 (x8)
T-NUT - 5/16"

198 (x8)
WASHER - 8x19

415 (x8)
BOLT - 3 3/4"

G2 (x1)
WALL SUPPORT

G29 (x1)
BASE BOARD

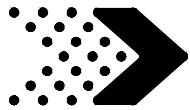

Phase 1

STEP 6

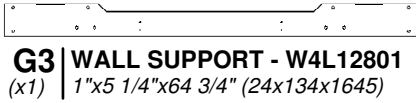

G3 | WALL SUPPORT - W4L12801
(x1) | 1"x5 1/4"x64 3/4" (24x134x1645)



G27 | BASE BOARD - W4L12819
(x1) | 1"x5 1/4"x64 3/4" (24x134x1645)

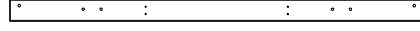

H23 | FLOOR SUPPORT - W4L12800
(x1) | 1"x3 3/8"x64 3/4" (24x86x1645)

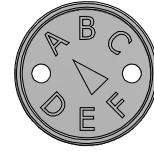

A100314 | "A" REVISION TAG
(x1)



H100480 | BOLT WH BLK
(x2) | 5/16x4 3/4



H100392 | SCREW PWH BLK
(x2) | 8x3/4



H100379 | T-NUT BLK
(x7) | 5/16



H100415 | BOLT WH BLK
(x5) | 5/16x3 3/4



H100198 | WASHER LOCK EXT BLK
(x7) | 8x19



TIP:

WE RECOMMEND INSTALLING T-NUTS INTO BOARDS BEFORE ASSEMBLY.

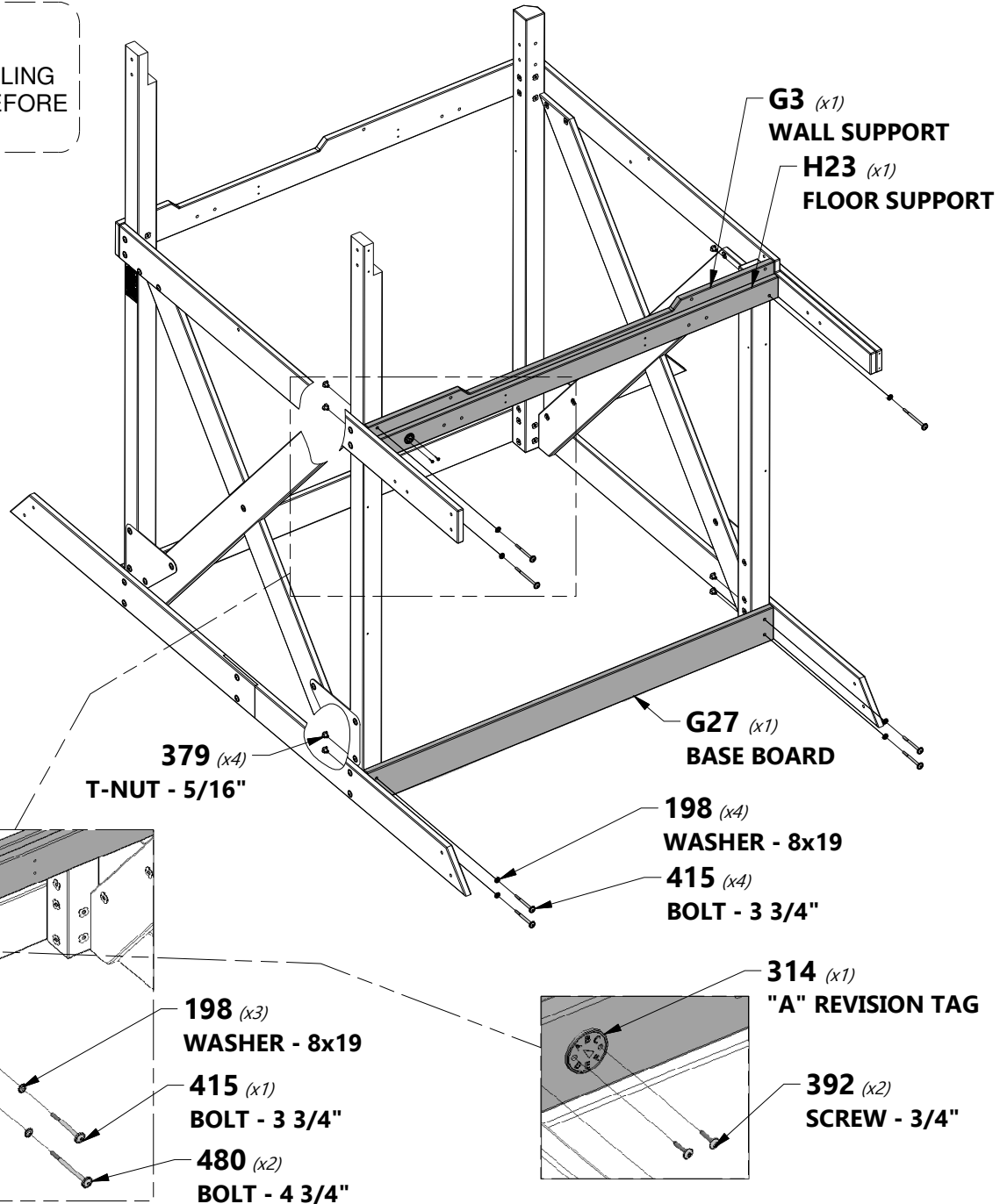

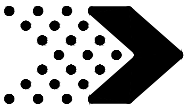

Phase 1

STEP 7

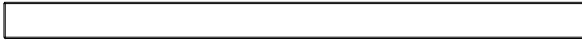

E6 | FLOOR SUPPORT - W4L12807
(x2) | 1 3/8"x3 3/8"x54 3/8" (36x86x1382)



H100362 | SCREW PFH BLK
(x8) | 8x3

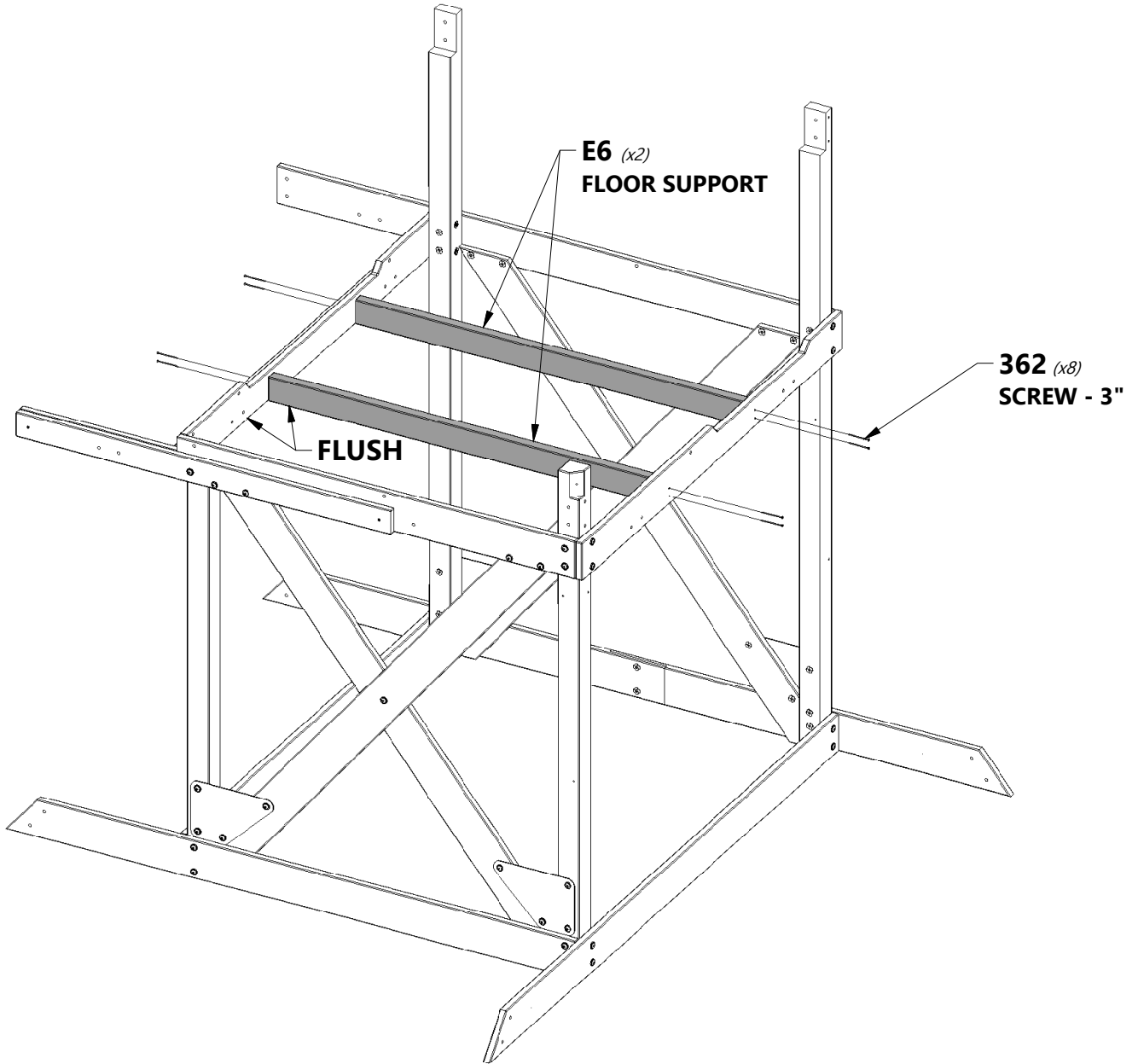

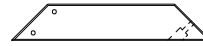
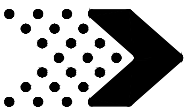

E1 | ANGLE SUPPORT - W4L08458
(x6) | 1 3/8"x3 3/8"x18 3/4" (36x86x475)



H100484 | BOLT WH BLK
(x6) | 5/16x3 1/4



H100198 | WASHER LOCK EXT BLK
(x18) | 8x19



H100205 | BOLT WH BLK
(x6) | 5/16x2-1/4



H100379 | T-NUT BLK
(x12) | 5/16



H100197 | LAG SCREW WH BLK
(x6) | 5/16x2 1/2



TIP:
WE RECOMMEND INSTALLING T-NUTS INTO
BOARDS BEFORE ASSEMBLY.
(THE SIDE OF THE SUPPORT THAT
ACCEPTS THE T-NUTS VARIES).

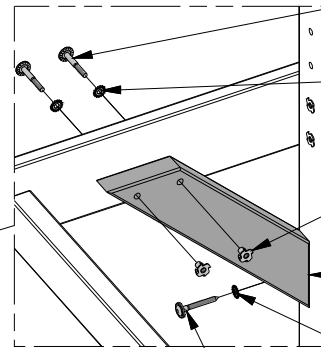

205 (x4)
BOLT - 2 1/4"

198 (x4)
WASHER - 8x19

379 (x4)
T-NUT - 5/16"

E1 (x6)
ANGLE SUPPORT

198 (x2)
WASHER - 8x19

197 (x2)
LAG SCREW - 2 1/2"

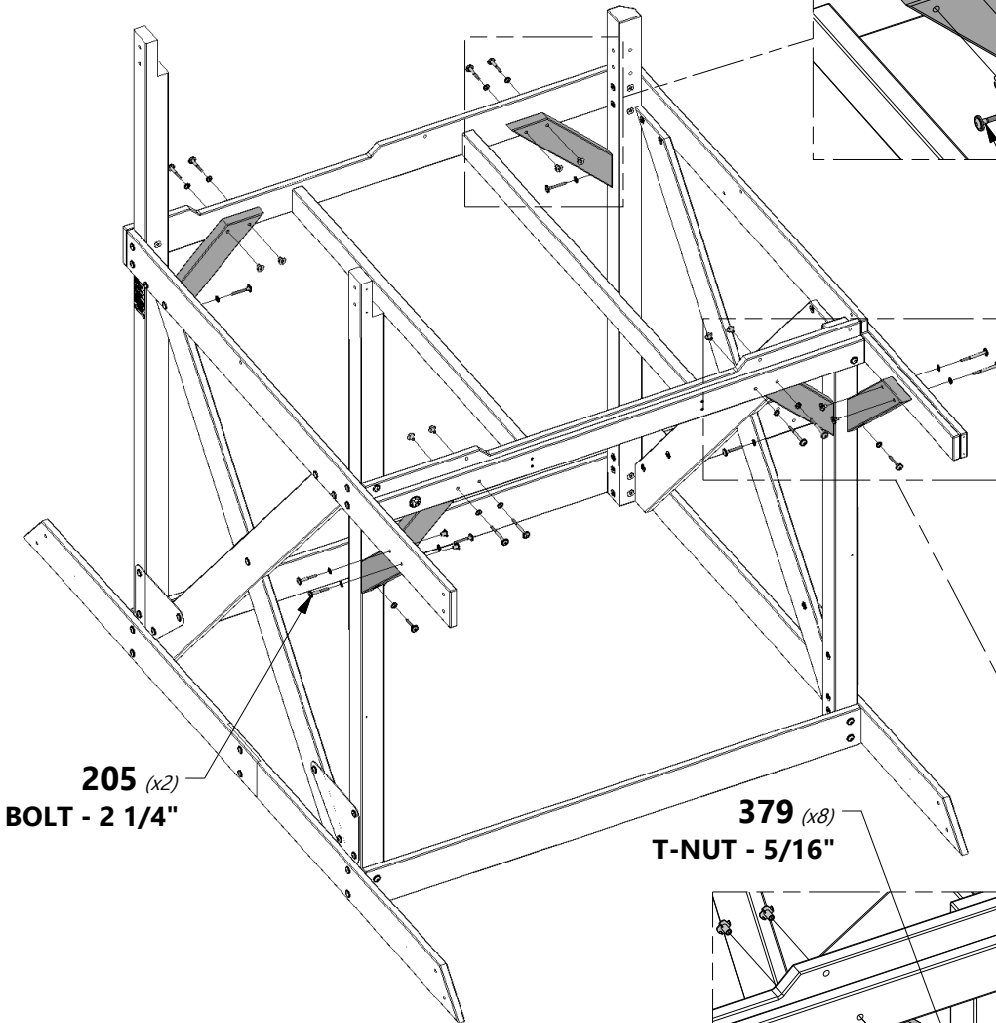

205 (x2)
BOLT - 2 1/4"

379 (x8)
T-NUT - 5/16"

484 (x4)
BOLT - 3 1/4"

198 (x8)
WASHER - 8x19

484 (x2)
BOLT - 3 1/4"

198 (x4)
WASHER - 8x19

197 (x4)
LAG SCREW - 2 1/2"

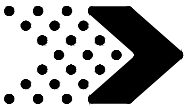

Phase 1

STEP 9



E7 | **ANGLE BRACE - W4L08494**
(x4) | 1 3/8"x3 3/8"x38 1/2" (36x86x978)



H100205 | **BOLT WH BLK**
(x8) | 5/16x2-1/4



H100197 | **LAG SCREW WH BLK**
(x4) | 5/16x2 1/2



H100198 | **WASHER LOCK EXT BLK**
(x12) | 8x19



H100379 | **T-NUT BLK**
(x8) | 5/16



TIP:
WE RECOMMEND INSTALLING T-NUTS INTO
BOARDS BEFORE ASSEMBLY.

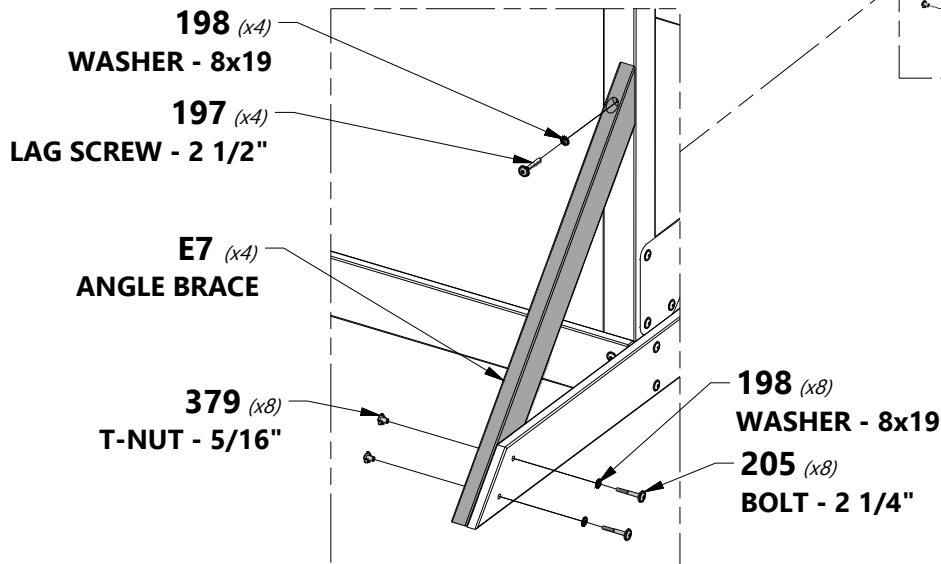
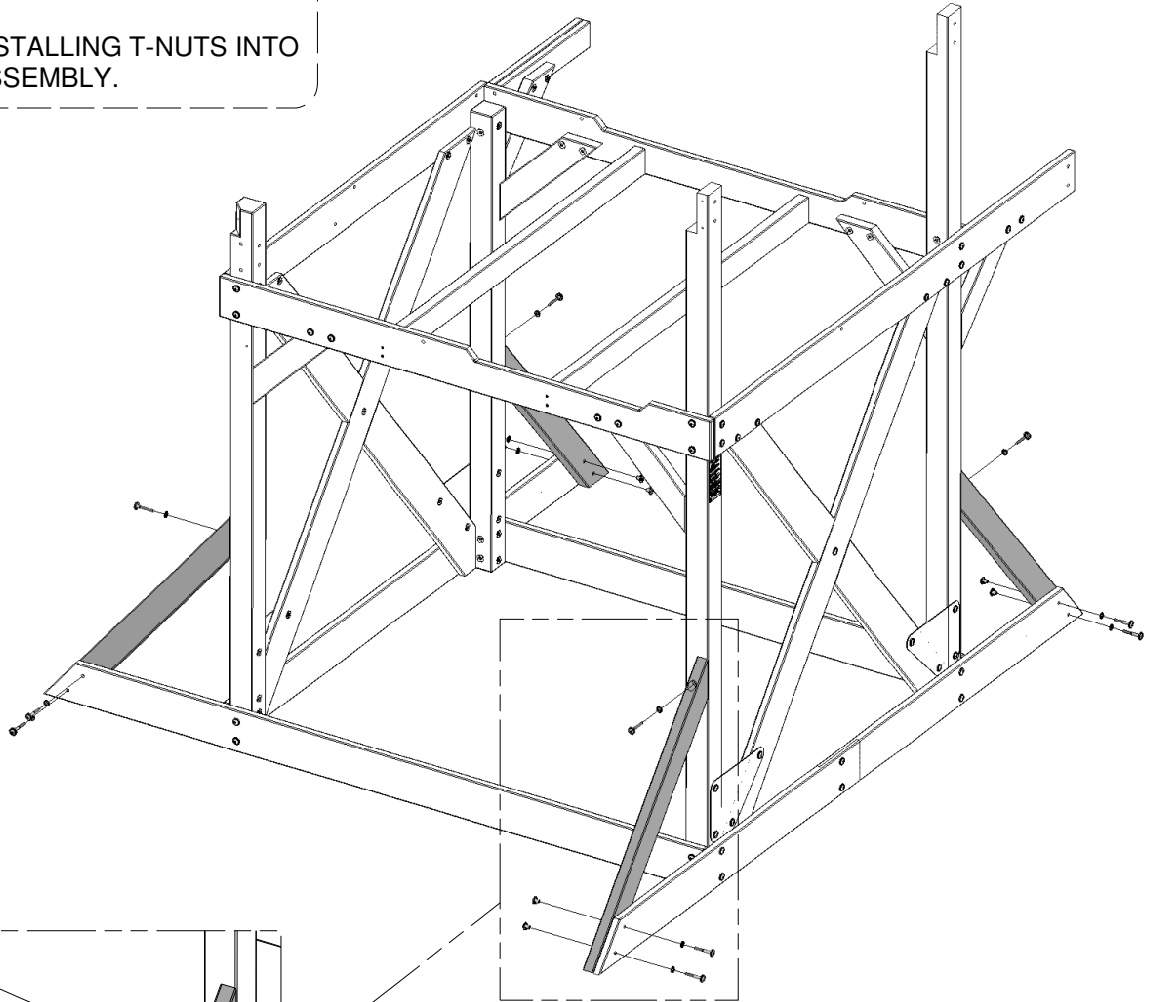

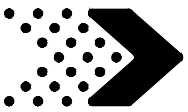

Phase 1

STEP 10

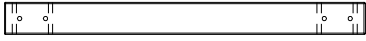

B17 | POST - W4L08696
(x1) | 3"x3"x33 7/8" (76x76x860)



H100415 | BOLT WH BLK
(x2) | 5/16x3 3/4



H100198 | WASHER LOCK EXT BLK
(x2) | 8x19



H100379 | T-NUT BLK
(x2) | 5/16



TIP:
WE RECOMMEND INSTALLING T-NUTS
INTO BOARDS BEFORE ASSEMBLY.

NOTE HOLE ORIENTATION.

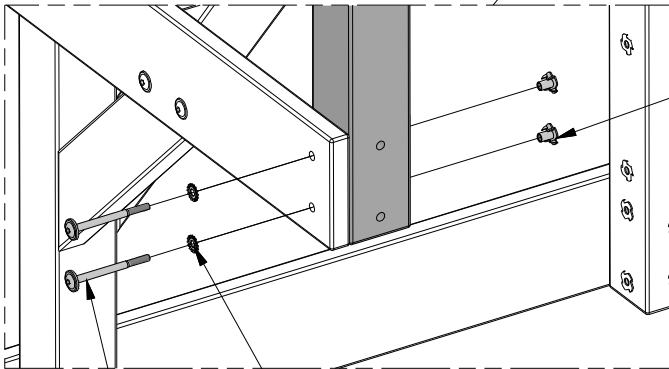
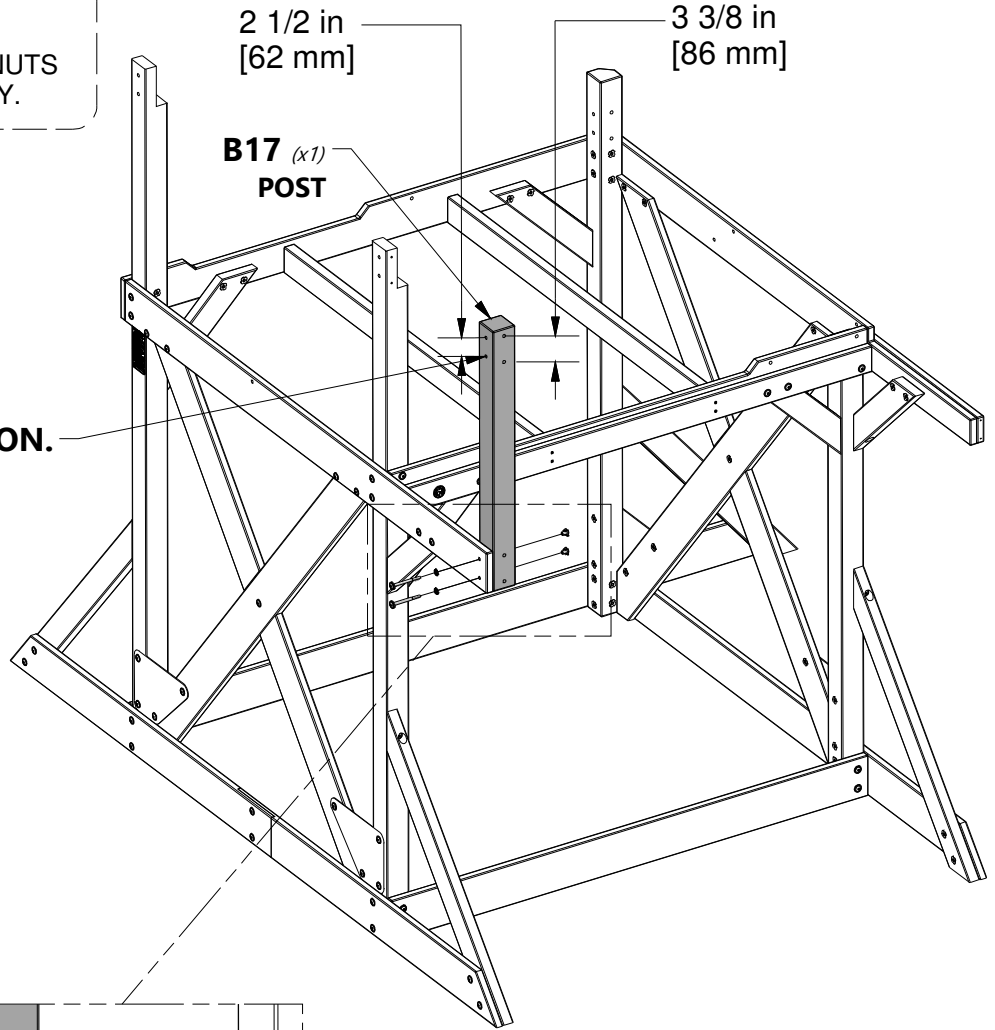

379 (x2)
T-NUT - 5/16"

198 (x2)
WASHER - 8x19
415 (x2)
BOLT - 3 3/4"

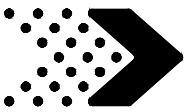

Phase 1

STEP 11

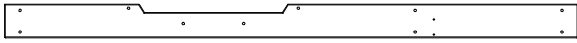

G20 | DECK BOARD - W4L12803
(x1) | 1"x5 1/4"x89 5/8" (24x134x2276)



H100391 | SCREW PFH BLK
(x2) | 8x2



H100415 | BOLT WH BLK
(x2) | 5/16x3 3/4



H100198 | WASHER LOCK EXT BLK
(x2) | 8x19



H100379 | T-NUT BLK
(x2) | 5/16



TIP:

WE RECOMMEND INSTALLING T-NUTS INTO BOARDS BEFORE ASSEMBLY.

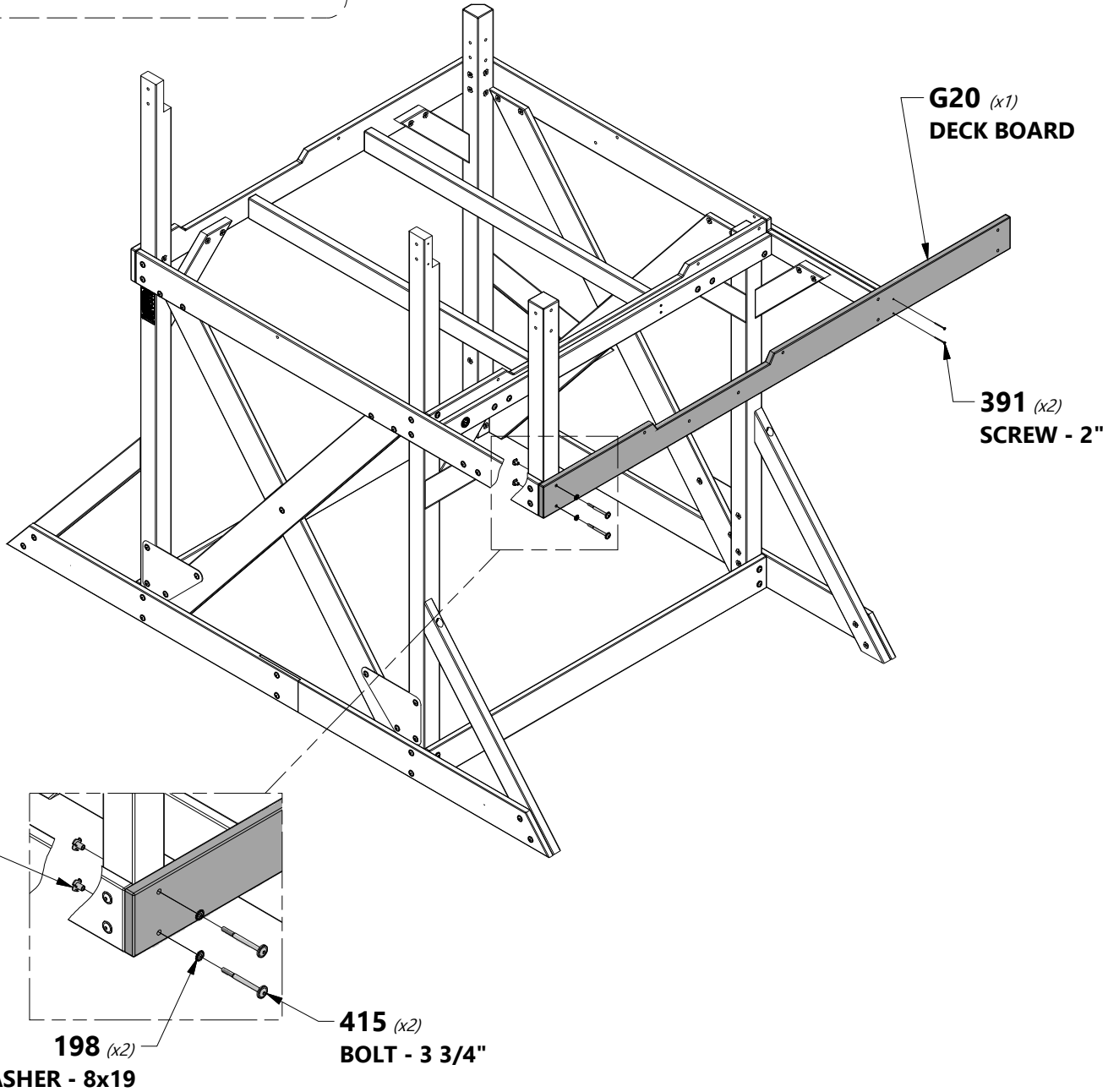

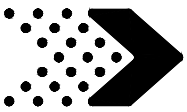

Phase 1

STEP 12



B17 | POST - W4L08696
(x1) | 3"x3"x33 7/8" (76x76x860)



B19 | POST - W4L12828
(x1) | 3"x3"x33 7/8" (76x76x860)



H100415 | BOLT WH BLK
(x4) | 5/16x3 3/4



H100198 | WASHER LOCK EXT BLK
(x4) | 8x19



H100379 | T-NUT BLK
(x4) | 5/16



TIP:
WE RECOMMEND INSTALLING T-NUTS INTO BOARDS BEFORE ASSEMBLY.

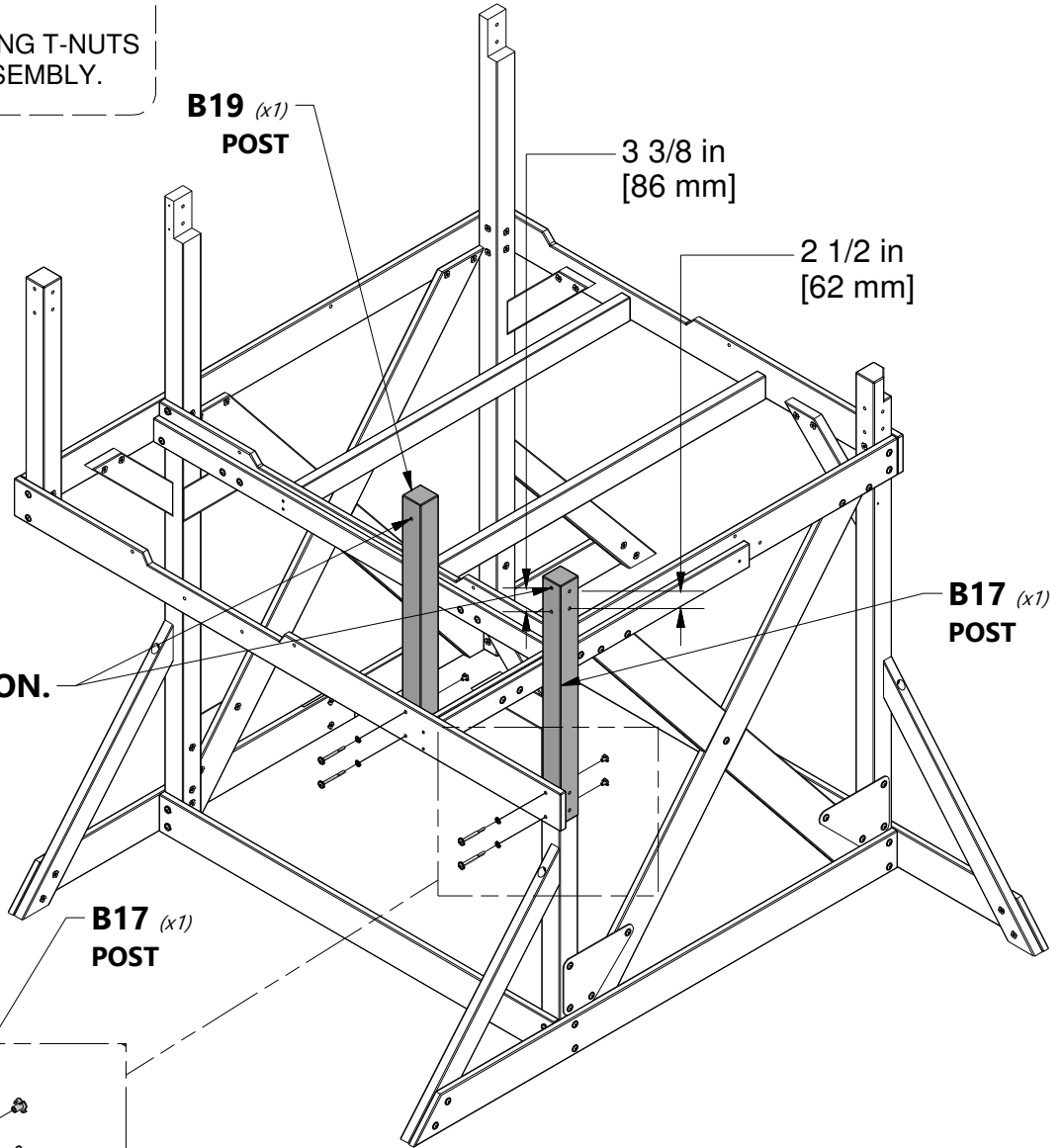

NOTE HOLE ORIENTATION.

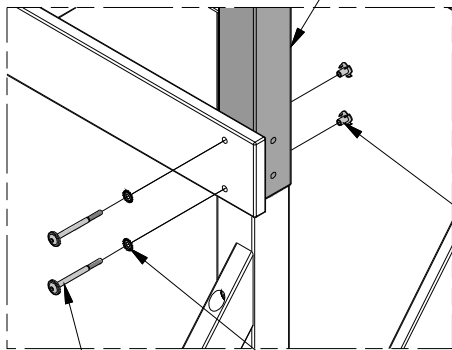

415 (x4)
BOLT - 3 3/4"

198 (x4)
WASHER - 8x19

379 (x4)
T-NUT - 5/16"

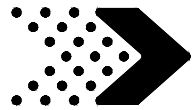

Phase 1

STEP 13

G23 | DECK BOARD - W4L08698
(x1) | 1"x5 1/4"x22" (24x134x560)

2 1/8 in
[55 mm]
A4M00615 | L BRACKET BLK
(x1)
2 in
[50 mm]

H100396 | BOLT WH BLK
(x2) | 5/16x1/2

H100192 | NUT BARREL WH BLK
(x2) | 5/16x7/8

H100199 | WASHER LOCK EXT BLK
(x2) | 12x19



NOTE:
ASSEMBLE THE SUB ASSEMBLY FIRST.



TIP:
WE RECOMMEND INSTALLING T-NUTS INTO BOARDS BEFORE ASSEMBLY.

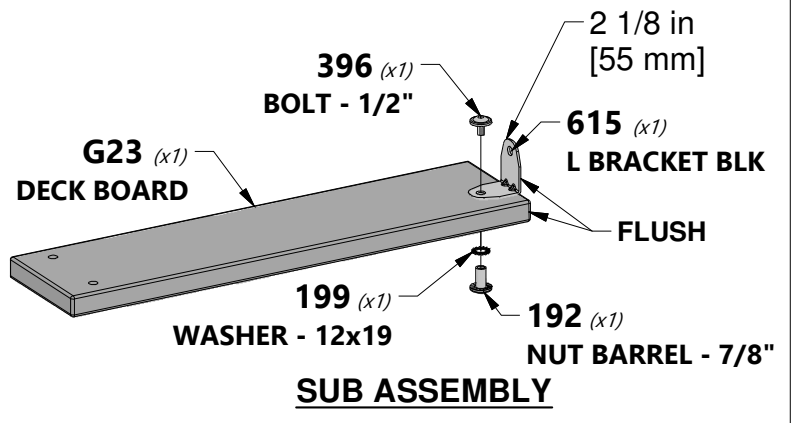

192 (x1)
NUT BARREL - 7/8"

199 (x1)
WASHER - 12x19

396 (x1)
BOLT - 1/2"

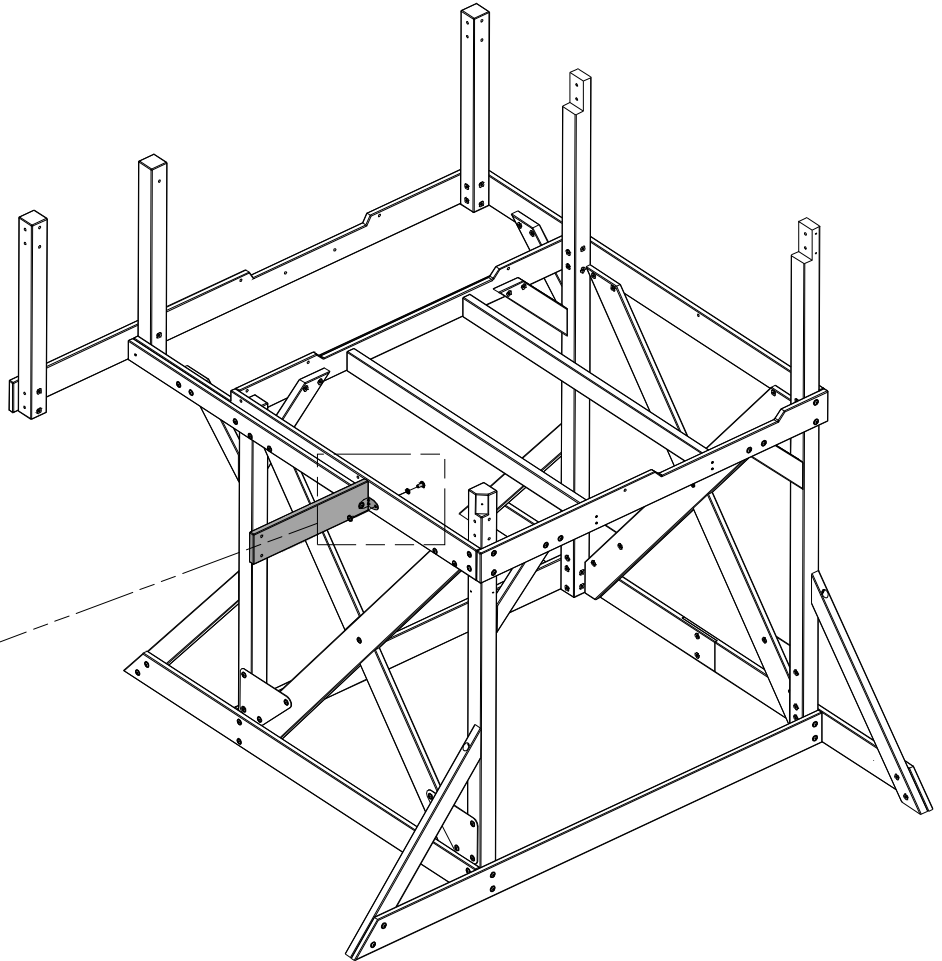

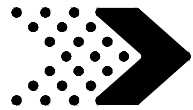

Phase 1

STEP 14



B21 | POST - W4L08746
(x1) | 3"x3"x33 7/8" (76x76x860)



H100415 | BOLT WH BLK
(x2) | 5/16x3 3/4



H100198 | WASHER LOCK EXT BLK
(x2) | 8x19



H100379 | T-NUT BLK
(x2) | 5/16



TIP:
WE RECOMMEND INSTALLING T-NUTS INTO BOARDS BEFORE ASSEMBLY.

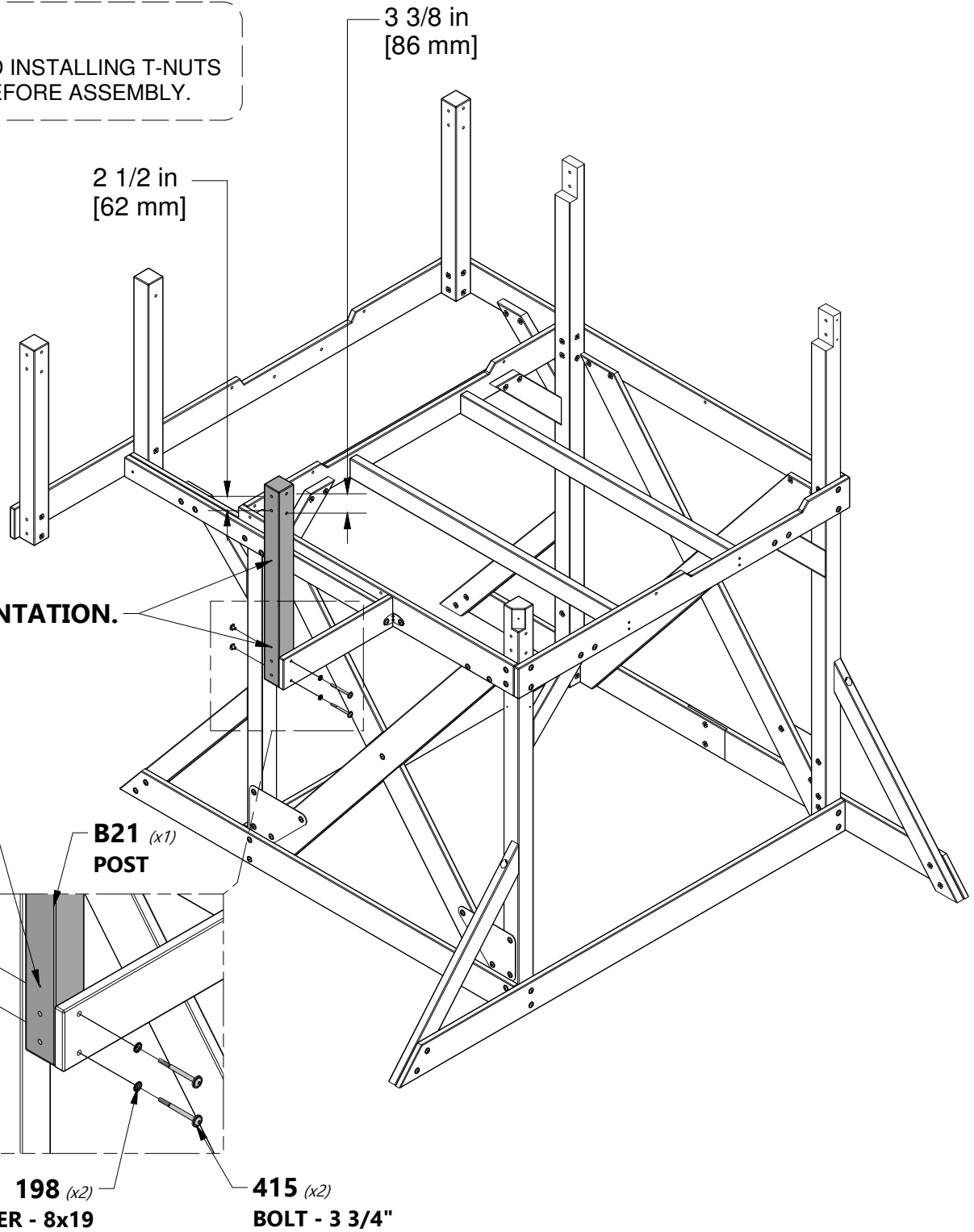

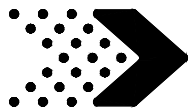

Phase 1

STEP 15

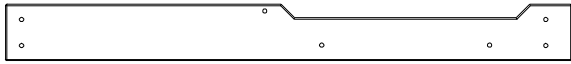

G22 | DECK RAIL - W4L12816
(x1) | 1"x5 1/4"x53 1/8" (24x134x1349)



H100415 | BOLT WH BLK
(x4) | 5/16x3 3/4



H100198 | WASHER LOCK EXT BLK
(x4) | 8x19



H100379 | T-NUT BLK
(x4) | 5/16



TIP:

WE RECOMMEND INSTALLING T-NUTS INTO BOARDS BEFORE ASSEMBLY.

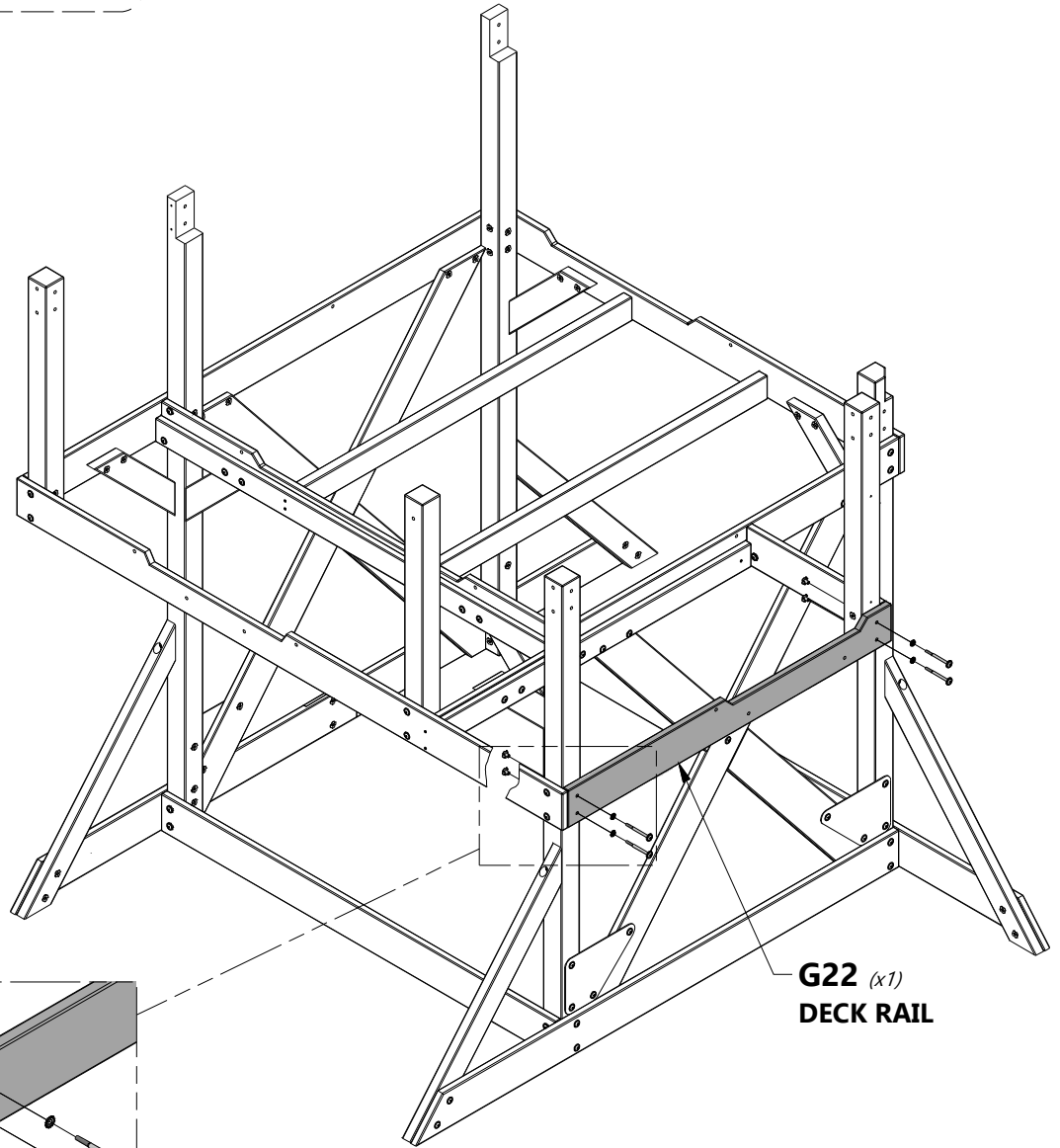

G22 (x1)
DECK RAIL

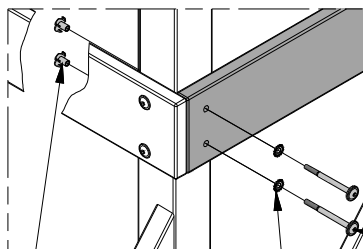

379 (x4)
T-NUT - 5/16"

198 (x4)
WASHER - 8x19

415 (x4)
BOLT - 3 3/4"

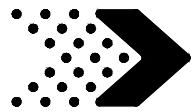

Phase 1

STEP 16



H26 | FLOOR SUPPORT - W4L08700
(x1) | 1"x3 3/8"x46 1/8" (24x86x1172)



H100382 | SCREW PFH BLK
(x4) | 8x1 3/4

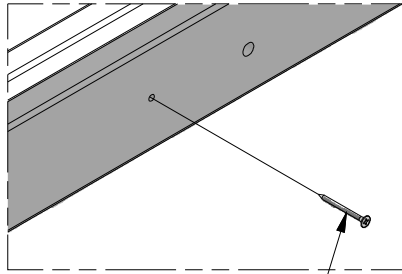

382 (x4)
SCREW - 1 3/4"

LINE UP HOLES.

H26 (x1)
FLOOR SUPPORT

1 7/8 in
[48 mm]
OR FLUSH AT
BOTTOM

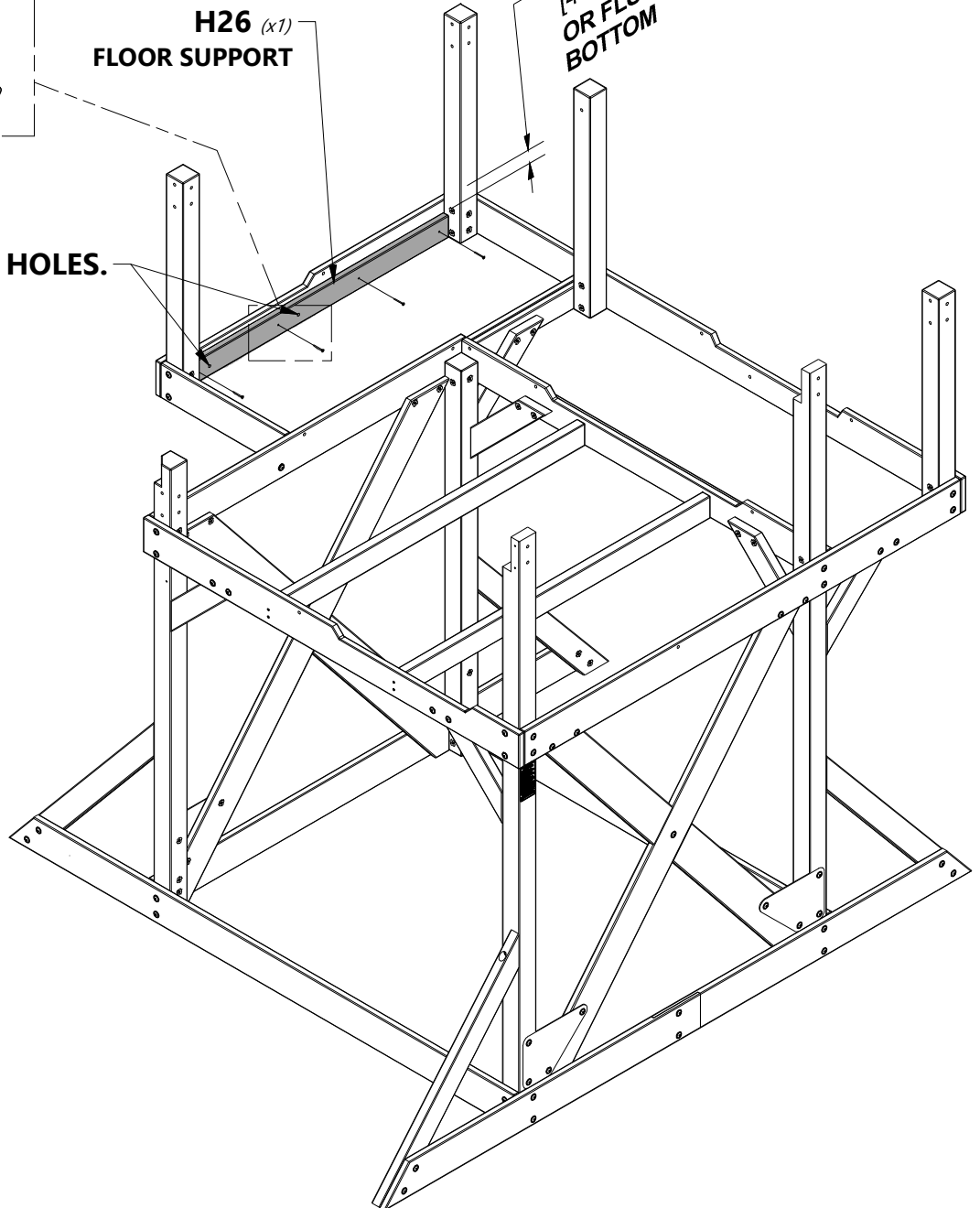

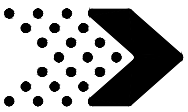

H24 | FLOOR SUPPORT - W4L12888
(x1) | 1"x3 3/8"x58 3/4" (24x86x1493)



H100382 | SCREW PFH BLK
(x4) | 8x1 3/4

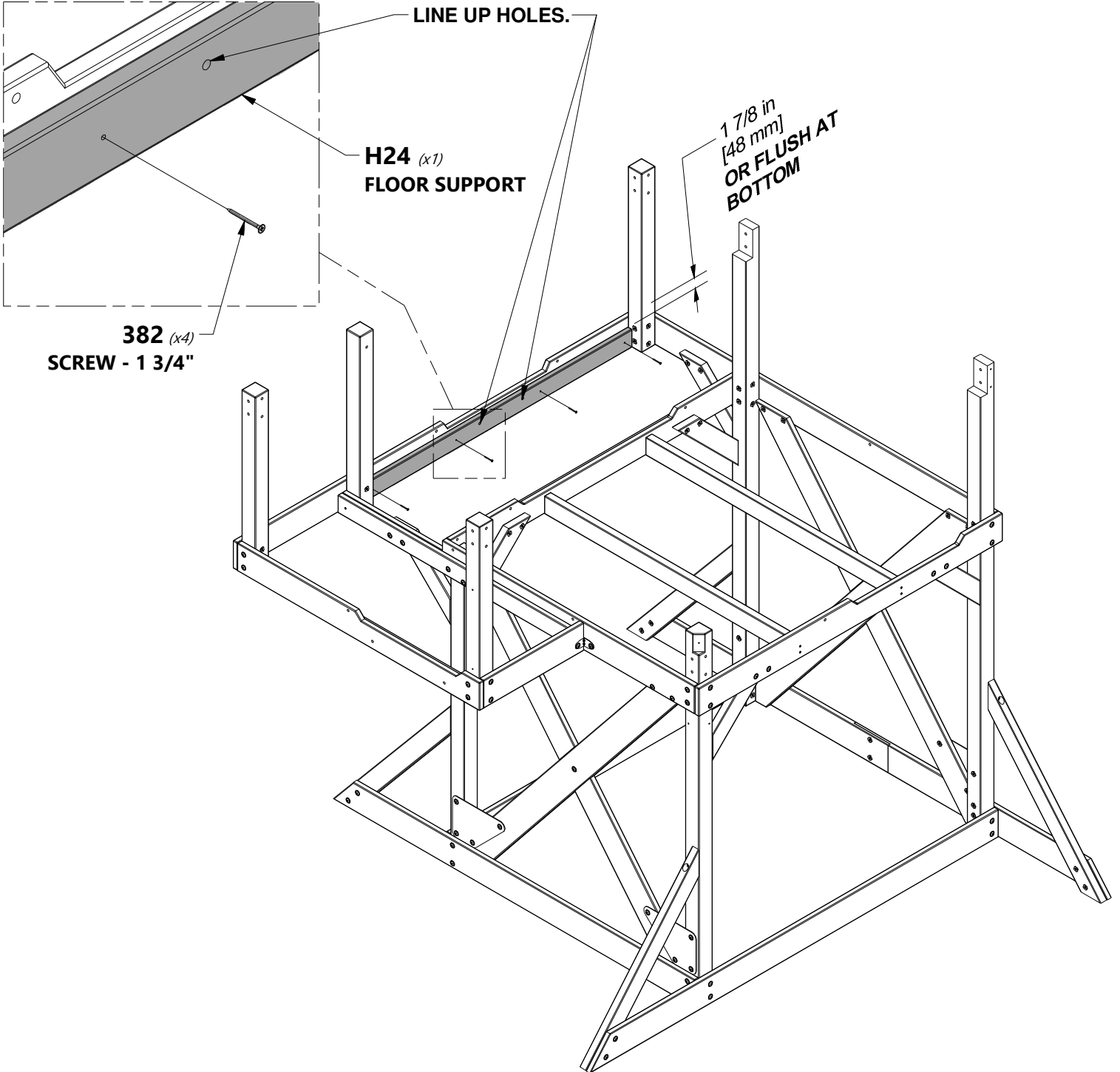

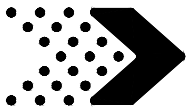

H20 | FLOOR SUPPORT - W4L08562
(x7) | 1"x2 3/4"x3" (24x70x76)



H100391 | SCREW PFH BLK
(x14) | 8x2

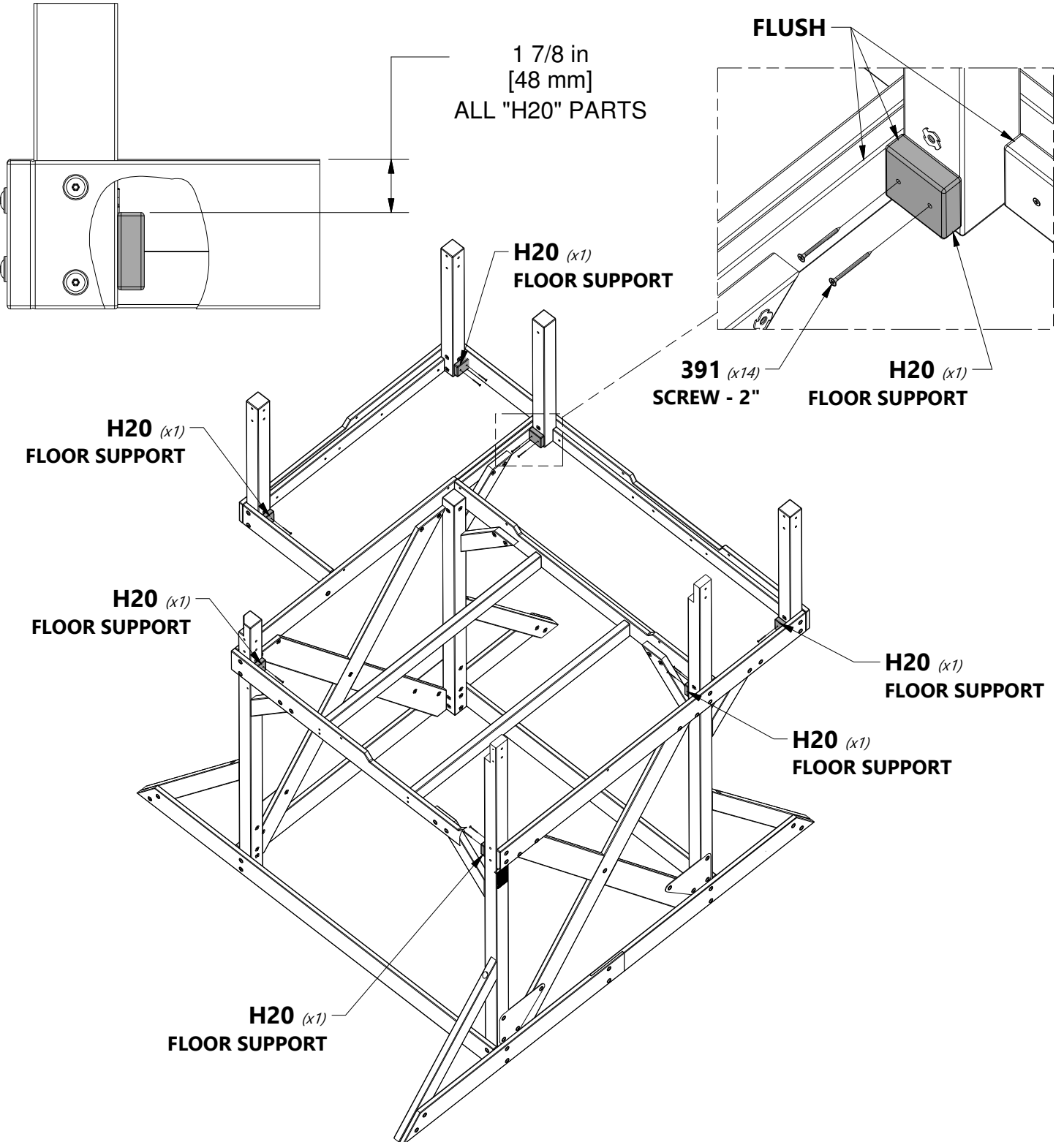

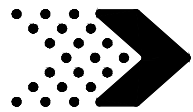

T1 | FLOOR SUPPORT - W4L08466
(x2) | 1"x1 3/8"x48 3/8" (24x34x1230)



H100391 | SCREW PFH BLK
(x8) | 8x2

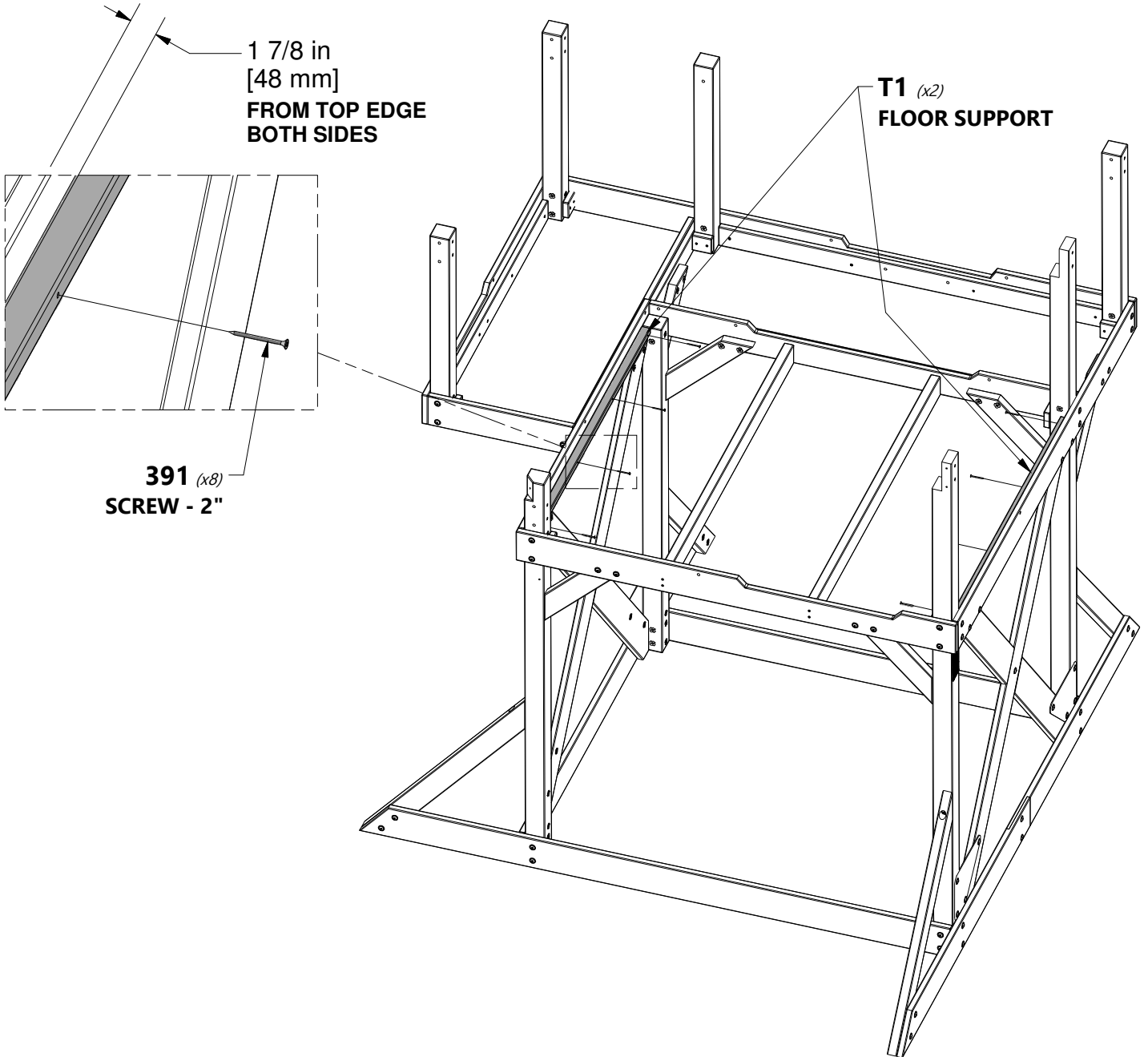

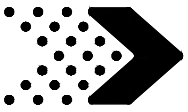

Phase 1

STEP 20

K4 | FLOOR BOARD - W4L12808
(x1) | 5/8"x5"x64 3/4" (16x128x1644)

Y1 | FLOOR BOARD - W4L12806
(x1) | 5/8"x4"x64 3/4" (16x102x1644)

Y2 | FLOOR BOARD - W4L12814
(x1) | 5/8"x4"x64 3/4" (16x102x1644)

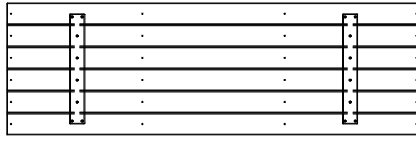

FP1 | FLOOR PANEL - W2A02900
(x2) | 1 1/4"x20 9/16"x65 11/16" (32x523x1644)



H100200 | SCREW PFH BLK
(x72) | 8x1 1/2

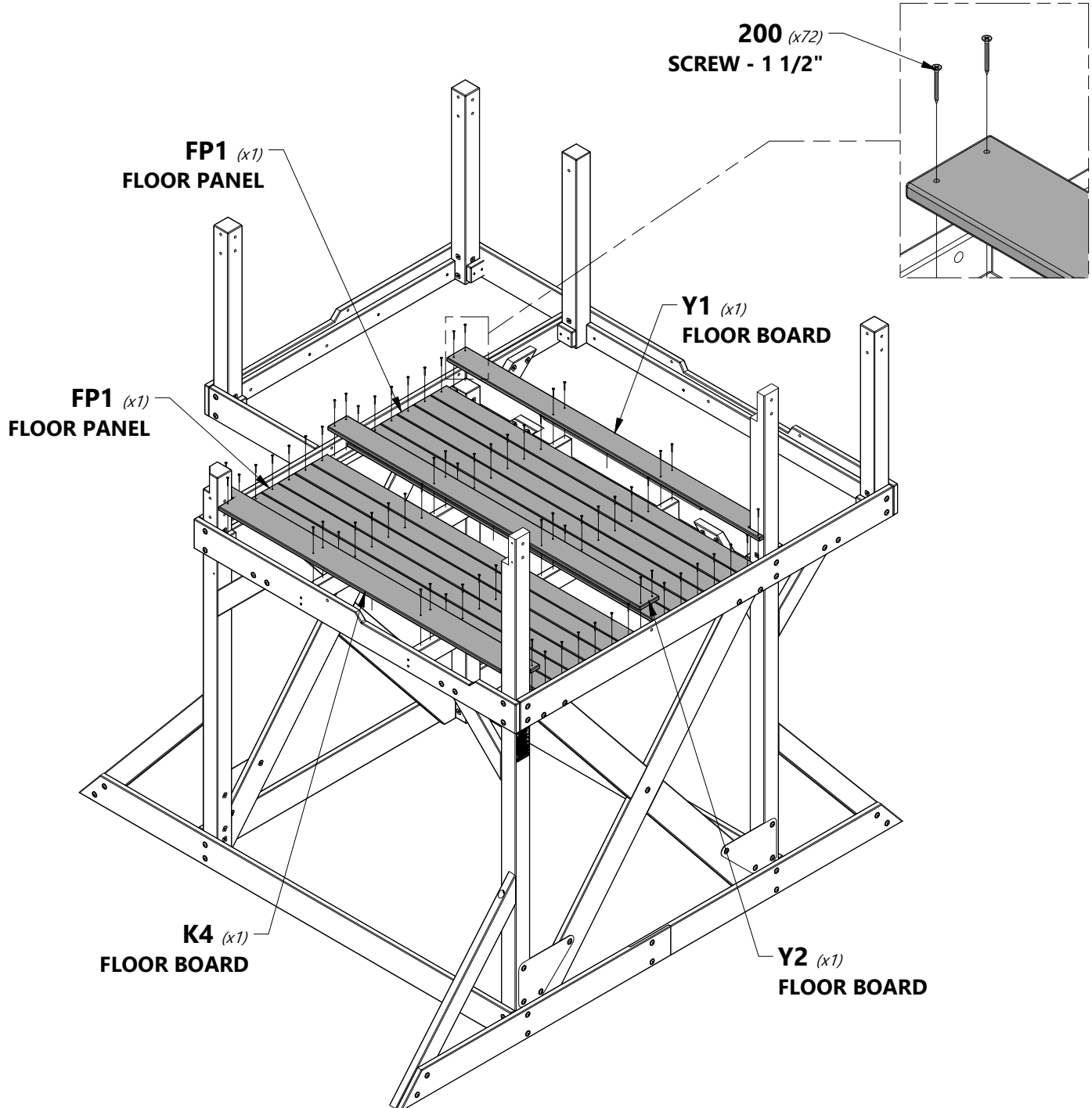

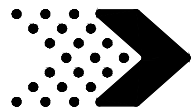

Phase 1

STEP 21



M39 | FLOOR BOARD - W4L11558
(x1) | 5/8"x3"x18 7/8" (16x76x480)

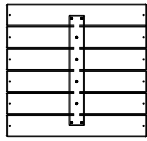

FP3 | FLOOR PANEL - W2A02227
(x2) | 1 1/4"x22 1/16"x20 11/16" (32x555x525)

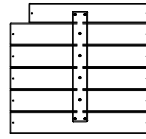

FP4 | FLOOR PANEL - W2A02228
(x1) | 1 1/4"x20 1/4"x22" (32x515x555)



H100200 | SCREW PFH BLK
(x38) | 8x1 1/2

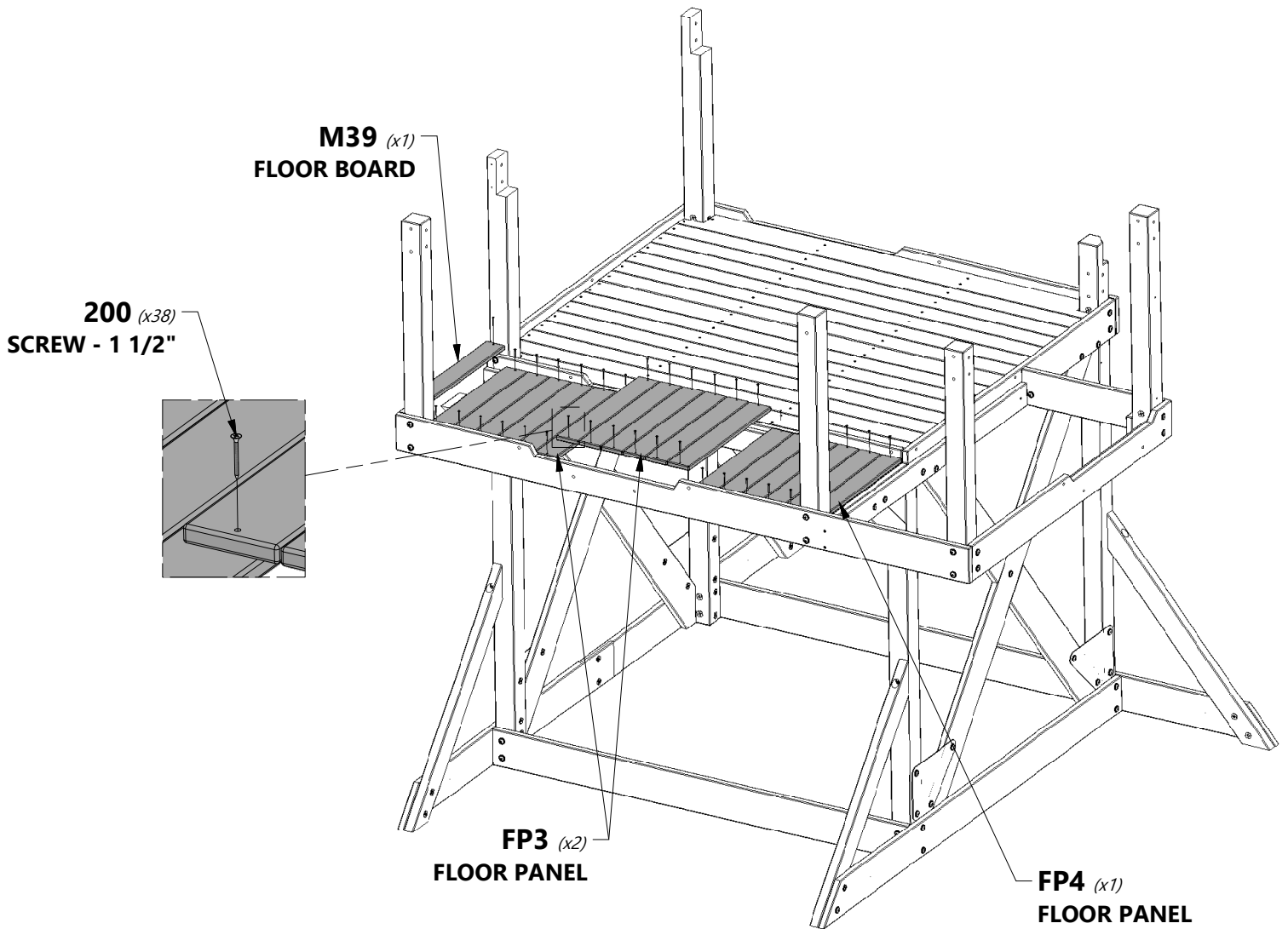

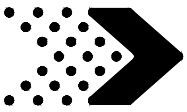

Phase 1

STEP 22

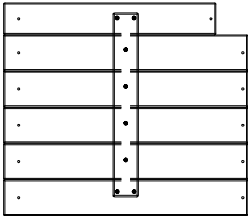

FP5 | FLOOR PANEL - W2A02229
(x1) | 1 1/4"x19 15/16"x22 15/16" (32x506x582)

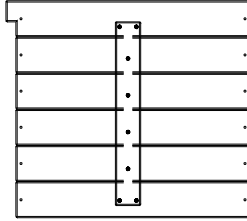

FP6 | FLOOR PANEL - W2A02230
(x1) | 1 1/4"x20 5/16"x22 15/16" (32x516x582)

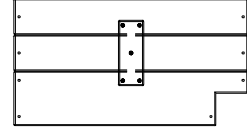

FP7 | FLOOR PANEL - W2A02248
(x1) | 1 1/4"x12 1/16"x22 1/16" (32x302x558)



H100200 | SCREW PFH BLK
(x32) | 8x1 1/2



NOTE:

DO NOT PUT WEIGHT OR WALK ON BALCONY SURFACES UNTIL AFTER PHASE 7 COMPLETION.

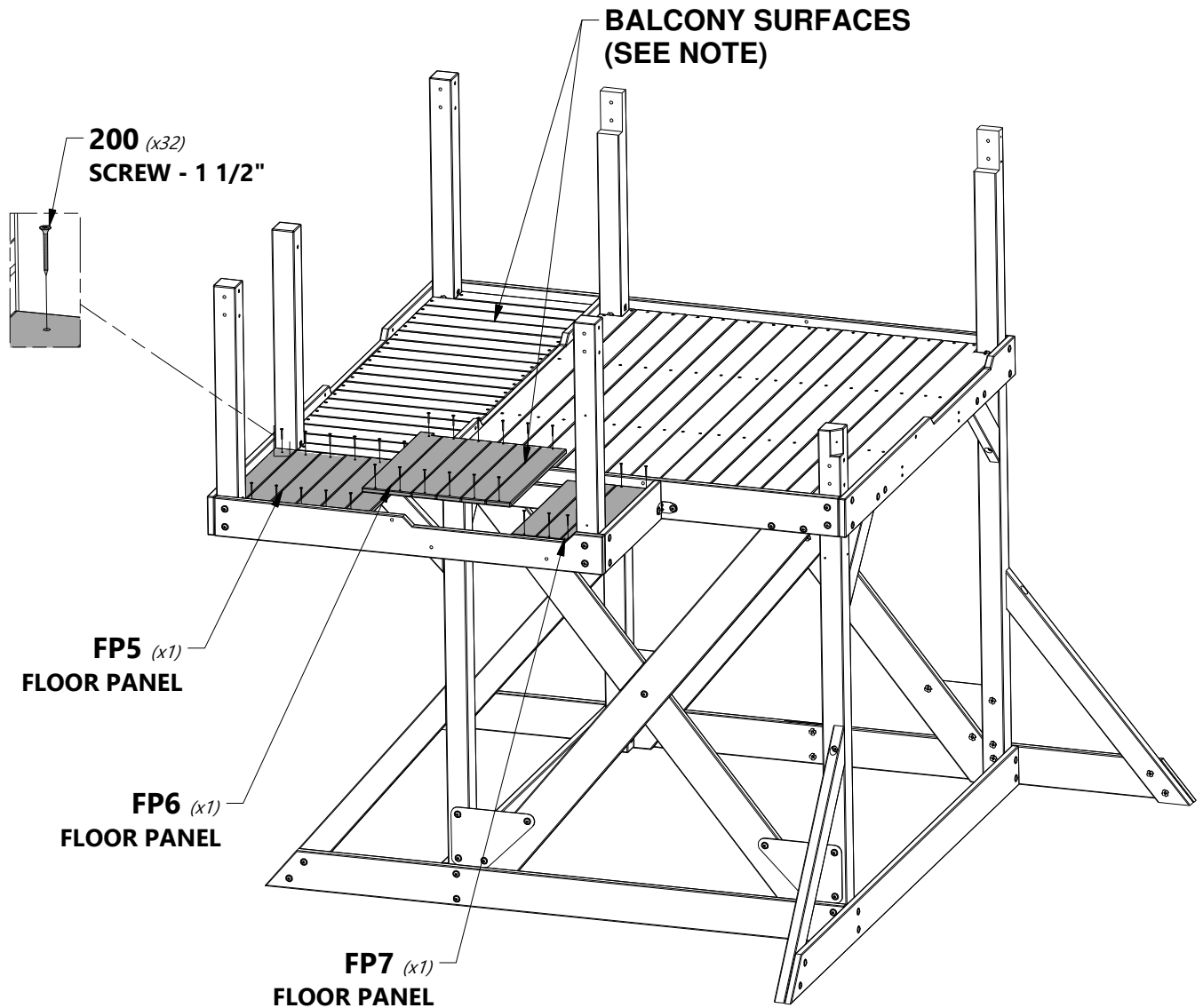

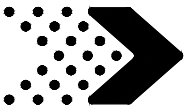

A100178 (x4) METAL GROUND STAKE BROWN



H100171 (x4) BOLT WH BLK 1/4x1



H100404 (x4) NUT BARREL WH BLK 1/4x5/8



H100474 (x4) WASHER FLAT BLK 9x18



H100400 (x4) WASHER LOCK EXT BLK 8x15

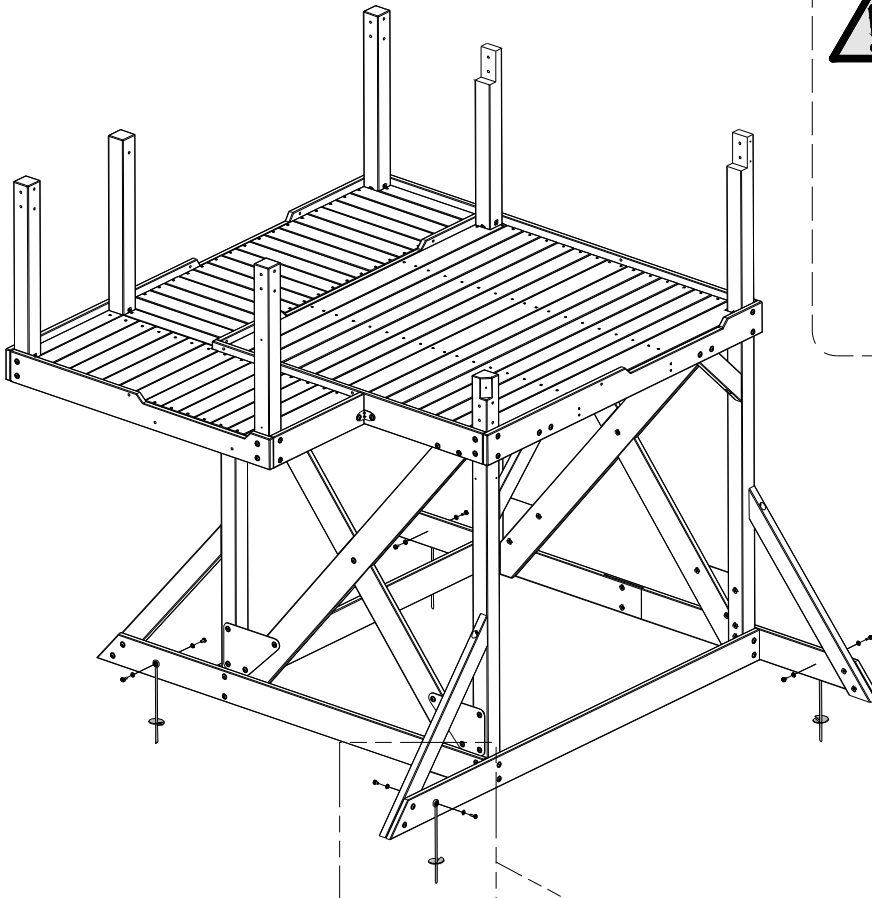

NOTE:

1. SCREW THE AUGER INTO THE GROUND NEXT TO THE GROUND BOARD.
2. USING THE EYELET OF THE AUGER AS A TEMPLATE, DRILL A 5/16" [8 mm] HOLE THROUGH THE GROUND BOARD.
3. USE HARDWARE PROVIDED TO SECURE AUGERS TO GROUND BOARDS.



NOTE:

FAILURE TO USE GROUND STAKES CAN VOID WARRANTY AND CAUSE INJURY!

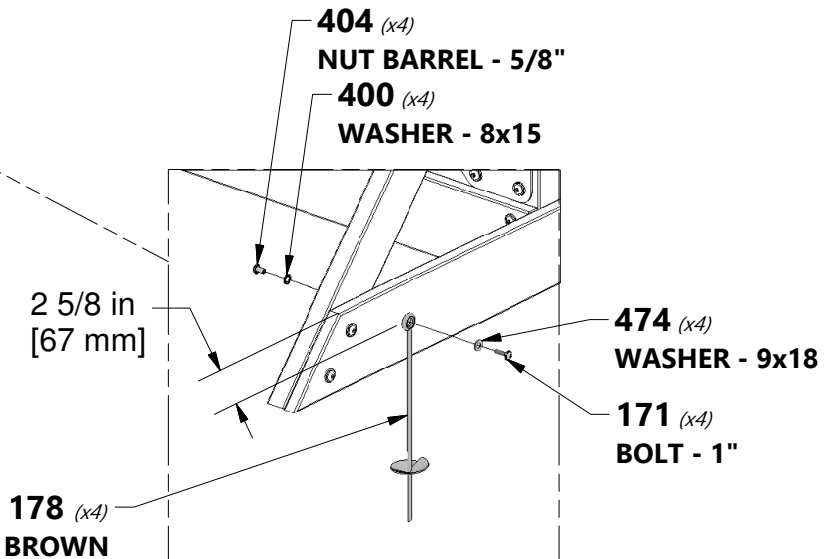

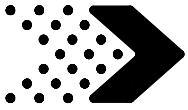

Phase 2

STEP 1

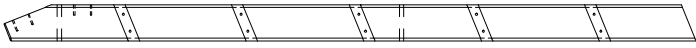

E77 | LEFT UPRIGHT - W4L12840
(x1) | 1 3/8"x3 3/8"x64 7/8" (36x86x1649)



H76 | LADDER RUNG - W4L06609
(x5) | 1"x3 3/8"x18 1/8" (24x86x460)



H100391 | SCREW PFH BLK
(x10) | 8x2

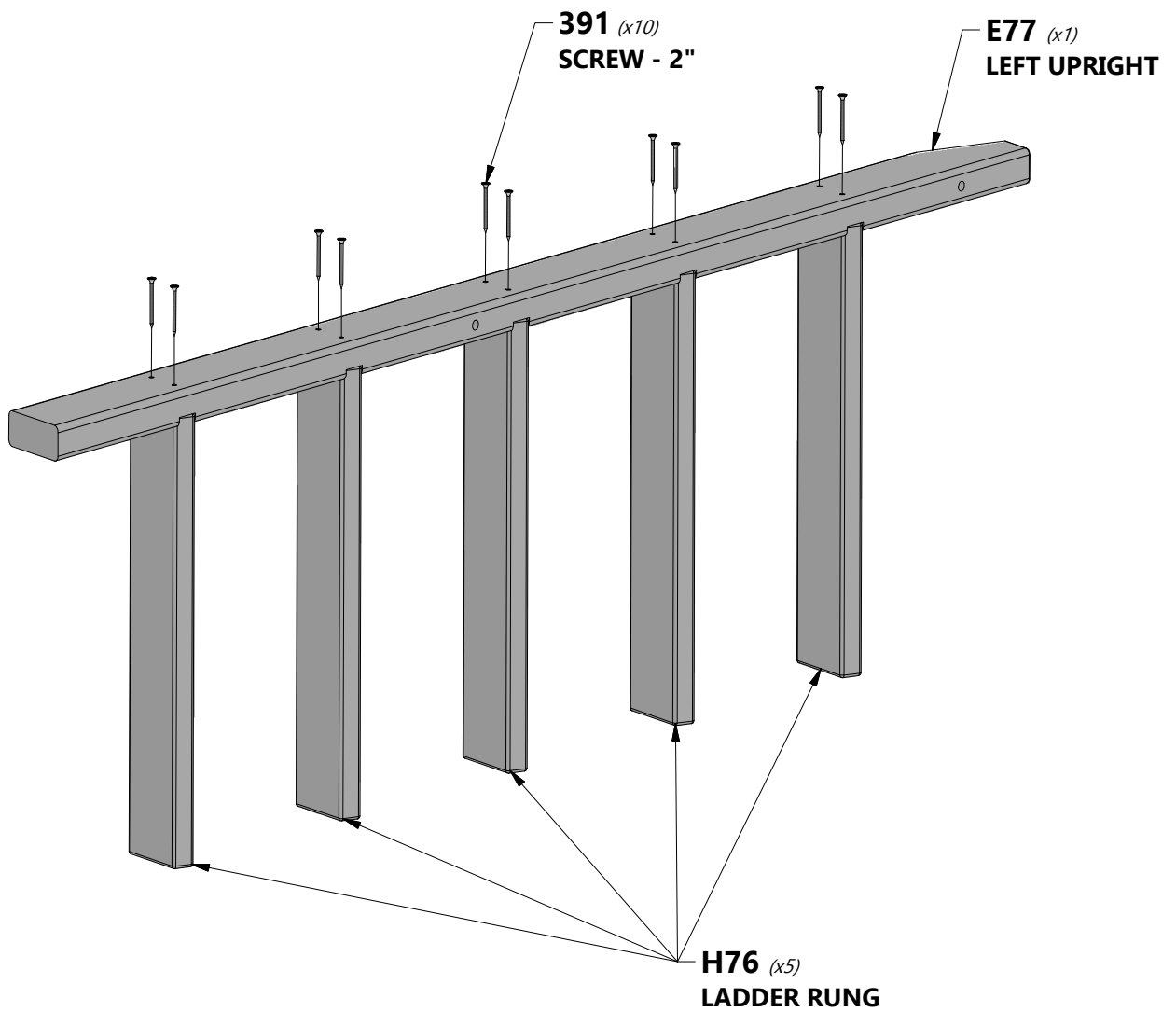

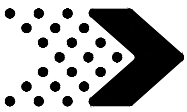

Phase 2

STEP 2

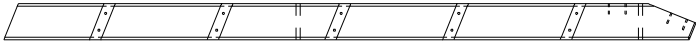

E78 | RIGHT UPRIGHT - W4L12841
(x1) | 1 3/8"x3 3/8"x64 7/8" (36x86x1649)



H100391 | SCREW PFH BLK
(x10) | 8x2

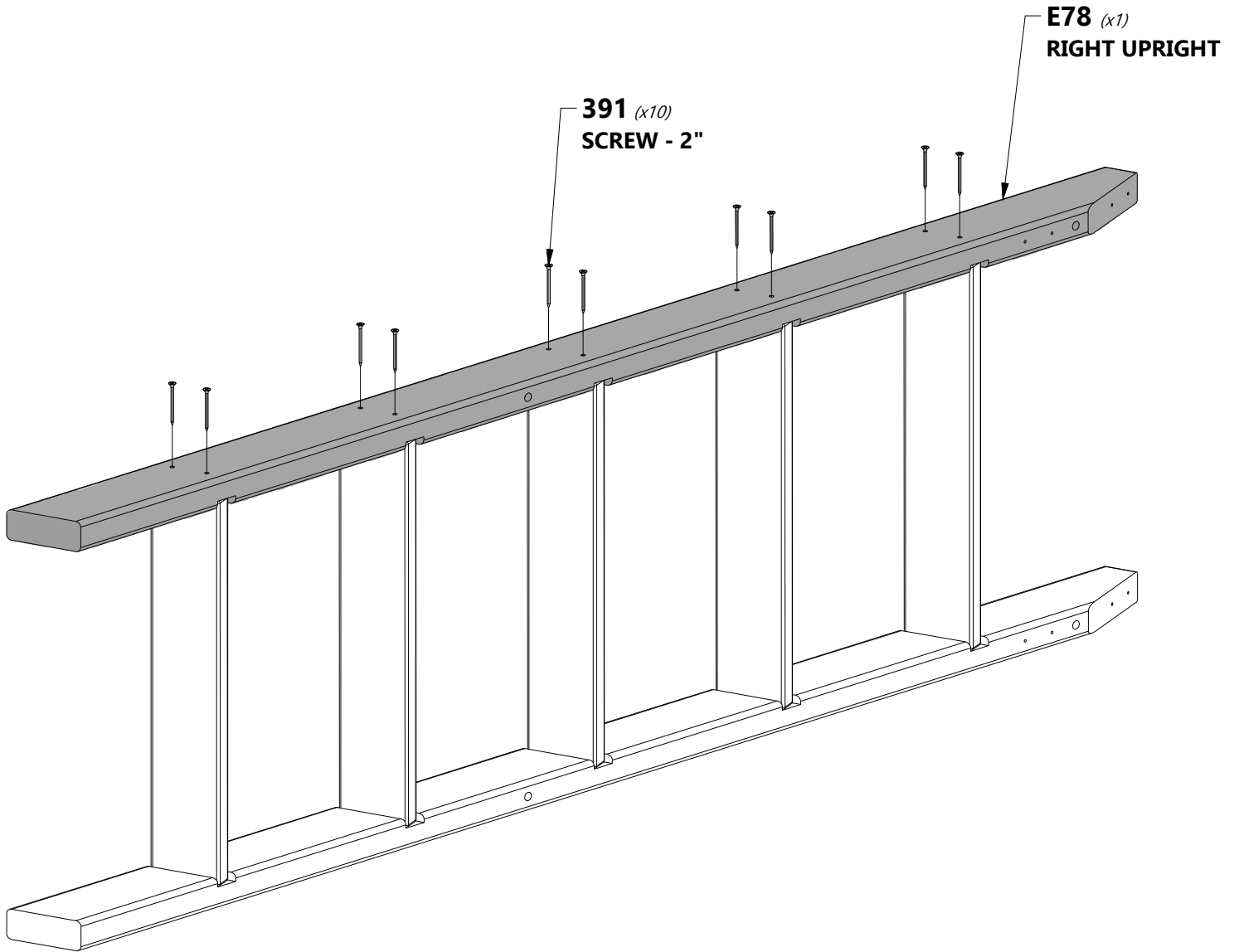

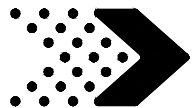

Phase 2

STEP 3



A100134
(x2) | **HAND GRIP GREEN 816 C/C**



H100503 | **BOLT WH BLK**
(x4) | **5/16x3-1/2**



H100379 | **T-NUT BLK**
(x4) | **5/16**



TIP:

WE RECOMMEND INSTALLING T-NUTS INTO BOARDS BEFORE ASSEMBLY.

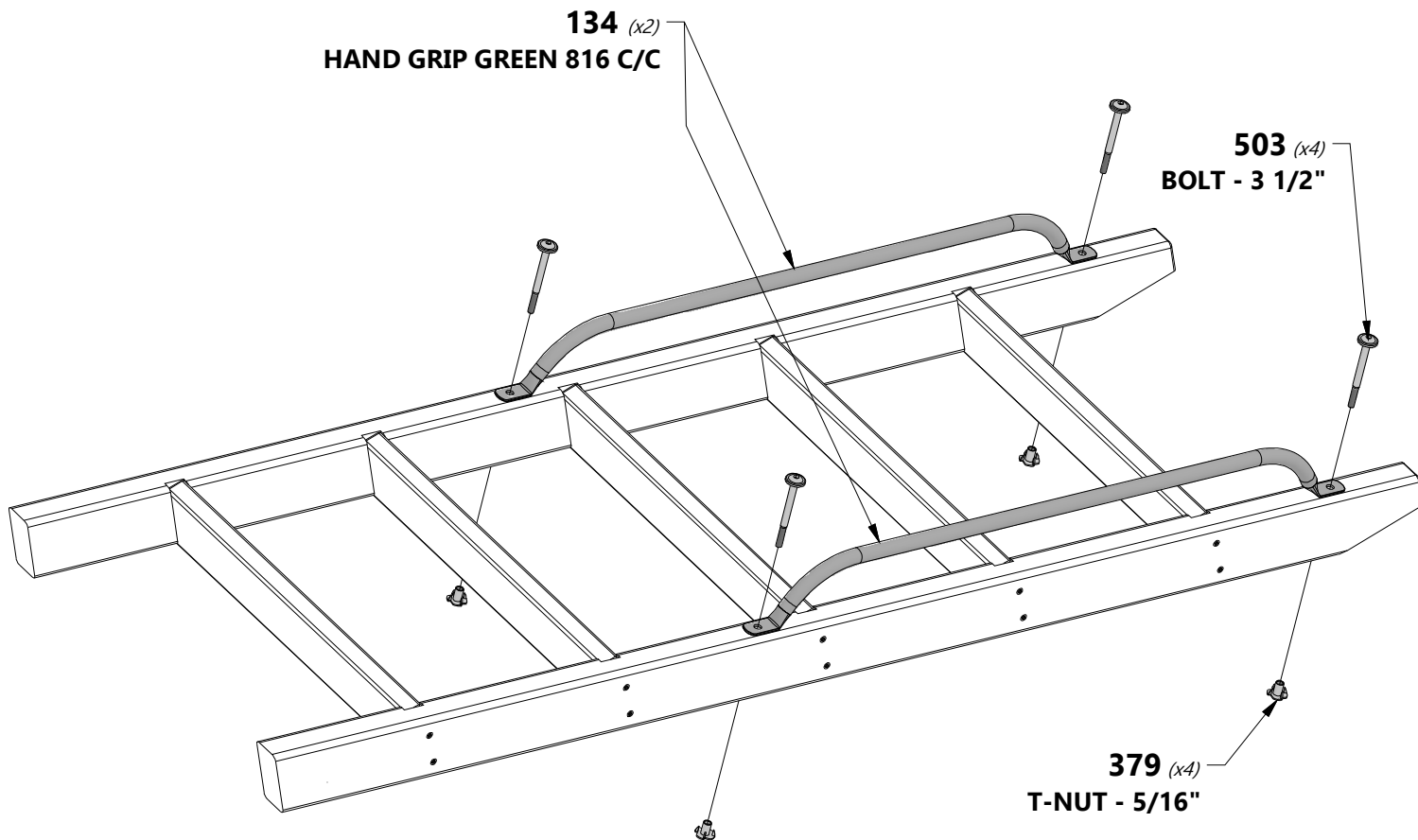

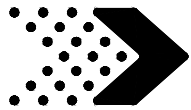

Phase 2

STEP 4



H110 | ATTACHMENT BOARD - W4L12839
(x1) | 1"x3 3/8"x20 1/8" (24x86x512)

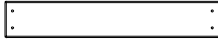

M73 | REAR SUPPORT - W4L11417
(x1) | 5/8"x3 3/8"x20 1/8" (16x86x512)



H100391 | SCREW PFH BLK
(x8) | 8x2

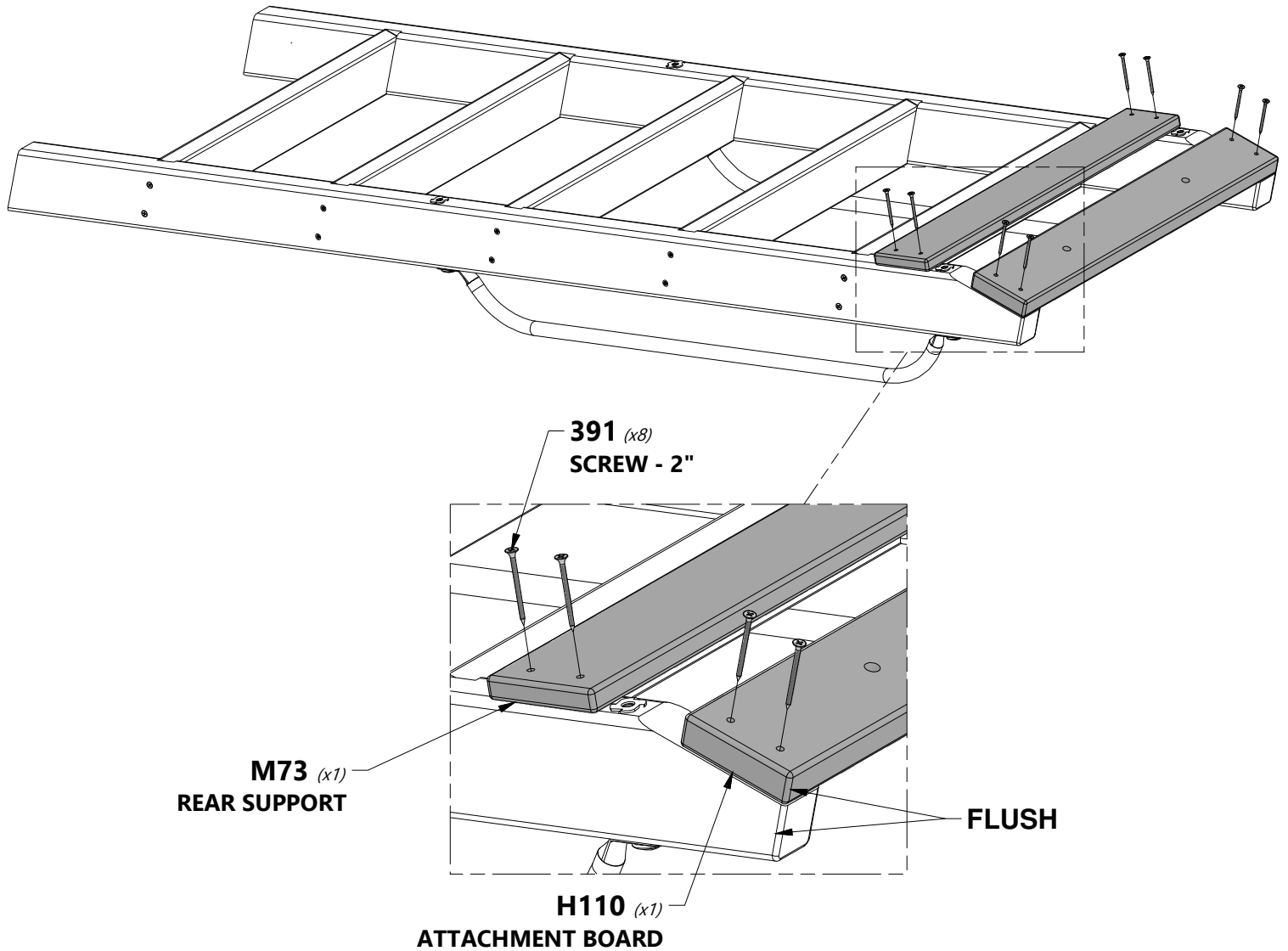

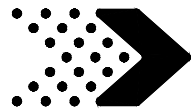

Phase 2

STEP 5

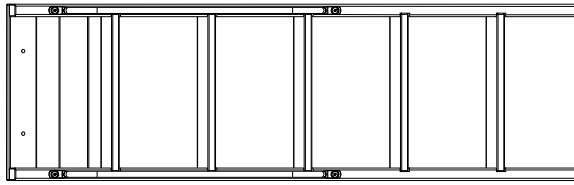

(x1) LADDER SUB ASSEMBLY
(FROM PREVIOUS STEP).



H100195 | BOLT WH BLK
(x2) | 5/16x2-3/4



H100198 | WASHER LOCK EXT BLK
(x2) | 8x19



H100379 | T-NUT BLK
(x2) | 5/16



TIP:

WE RECOMMEND INSTALLING T-NUTS INTO BOARDS BEFORE ASSEMBLY.

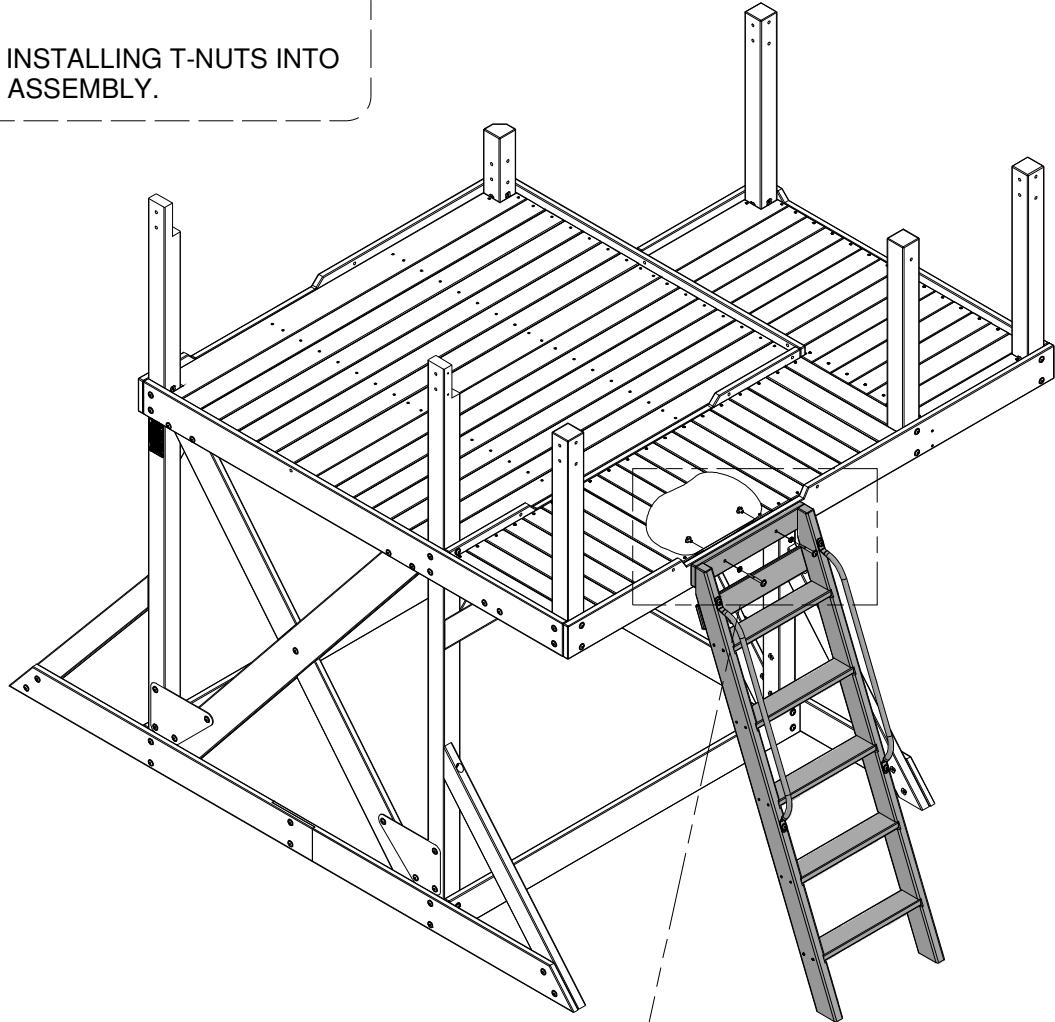

379 (x2)
T-NUT - 5/16"

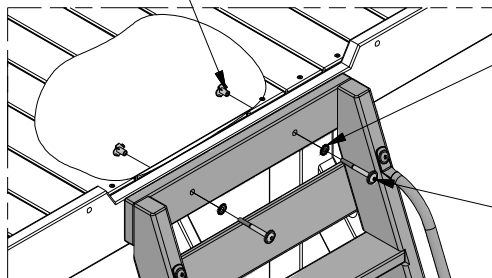

198 (x2)
WASHER - 8x19

195 (x2)
BOLT - 2-3/4

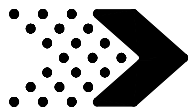

Phase 3

STEP 1



FRONT

G21 | WALL SUPPORT - W4L12815
(x1) | 1"x5 1/4"x77 3/8" (24x134x1964)



B15 | POST - W4L12810
(x2) | 3"x3"x29 3/8" (76x76x746)



NOTE:

ASSEMBLE THE SUB ASSEMBLY FIRST.



TIP:

WE RECOMMEND INSTALLING T-NUTS INTO BOARDS BEFORE ASSEMBLY.



H100415 | BOLT WH BLK
(x6) | 5/16x3 3/4



H100198 | WASHER LOCK EXT BLK
(x6) | 8x19



H100379 | T-NUT BLK
(x10) | 5/16

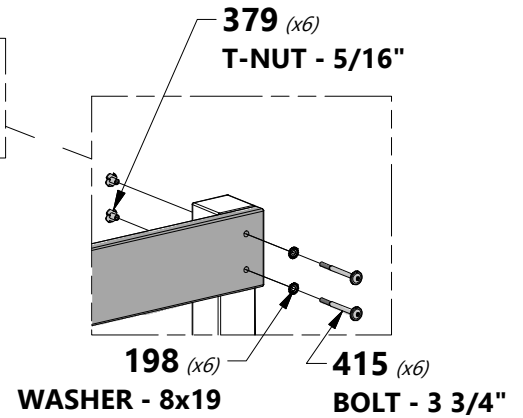
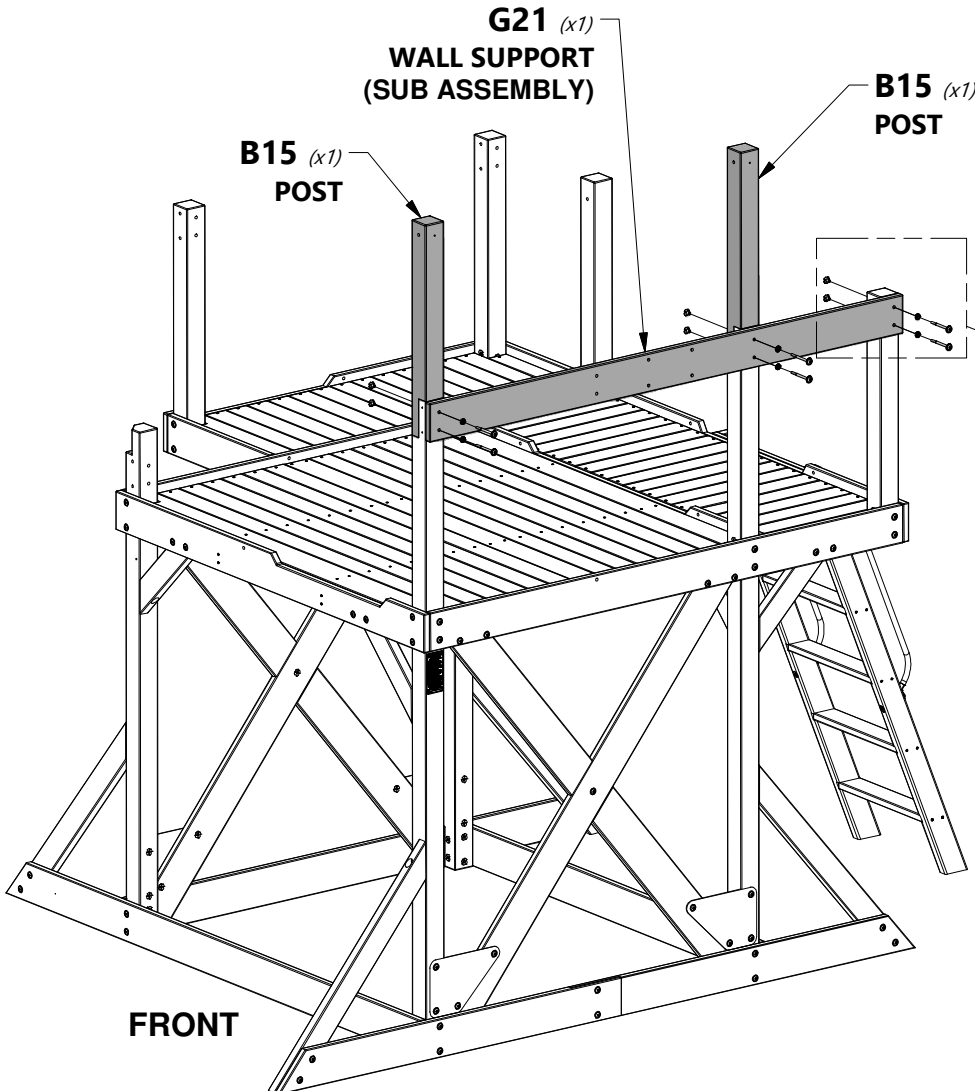
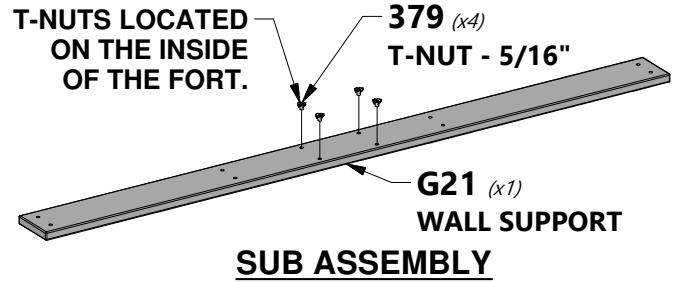

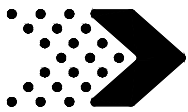

Phase 3

STEP 2



B14 | POST - W4L12826
(x1) | 3"x3"x53 7/8" (76x76x1370)



H100415 | BOLT WH BLK
(x3) | 5/16x3 3/4



H100198 | WASHER LOCK EXT BLK
(x3) | 8x19



H100379 | T-NUT BLK
(x3) | 5/16



TIP:

WE RECOMMEND INSTALLING T-NUTS INTO BOARDS BEFORE ASSEMBLY.

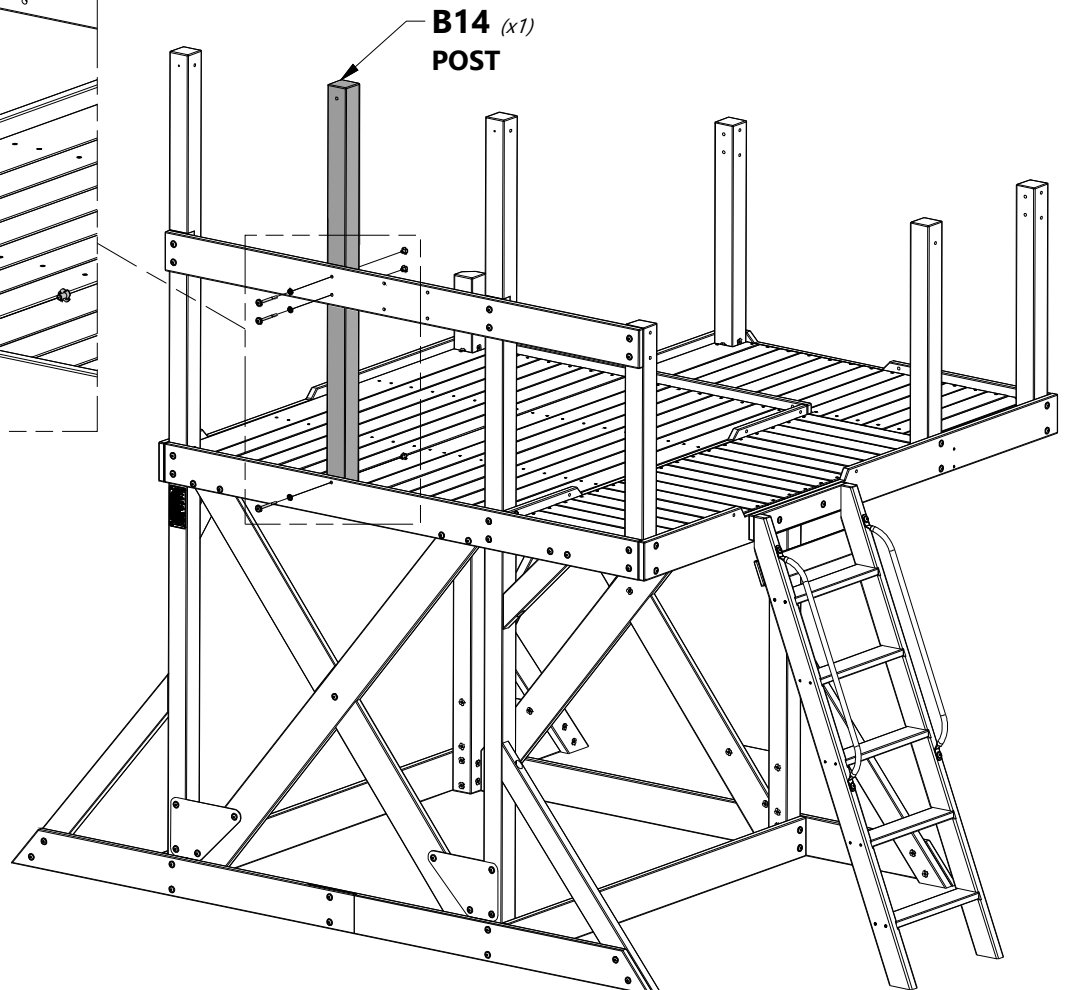
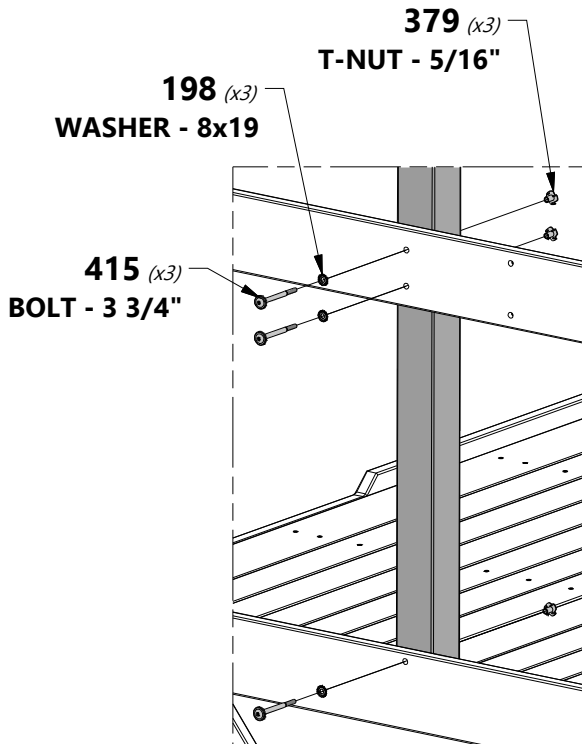

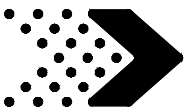

Phase 3

STEP 3

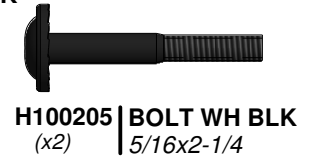
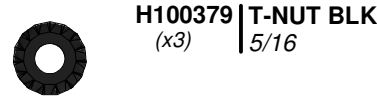
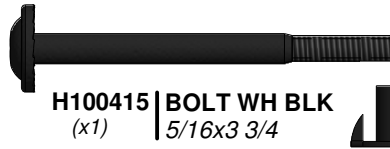
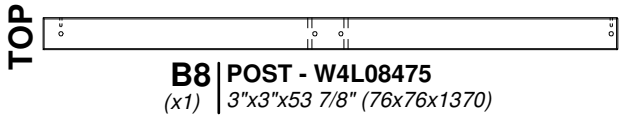
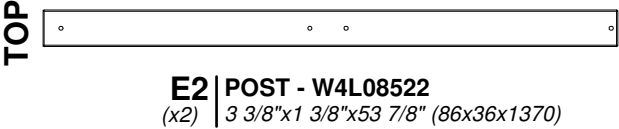

TIP:
WE RECOMMEND INSTALLING T-NUTS INTO BOARDS BEFORE ASSEMBLY.

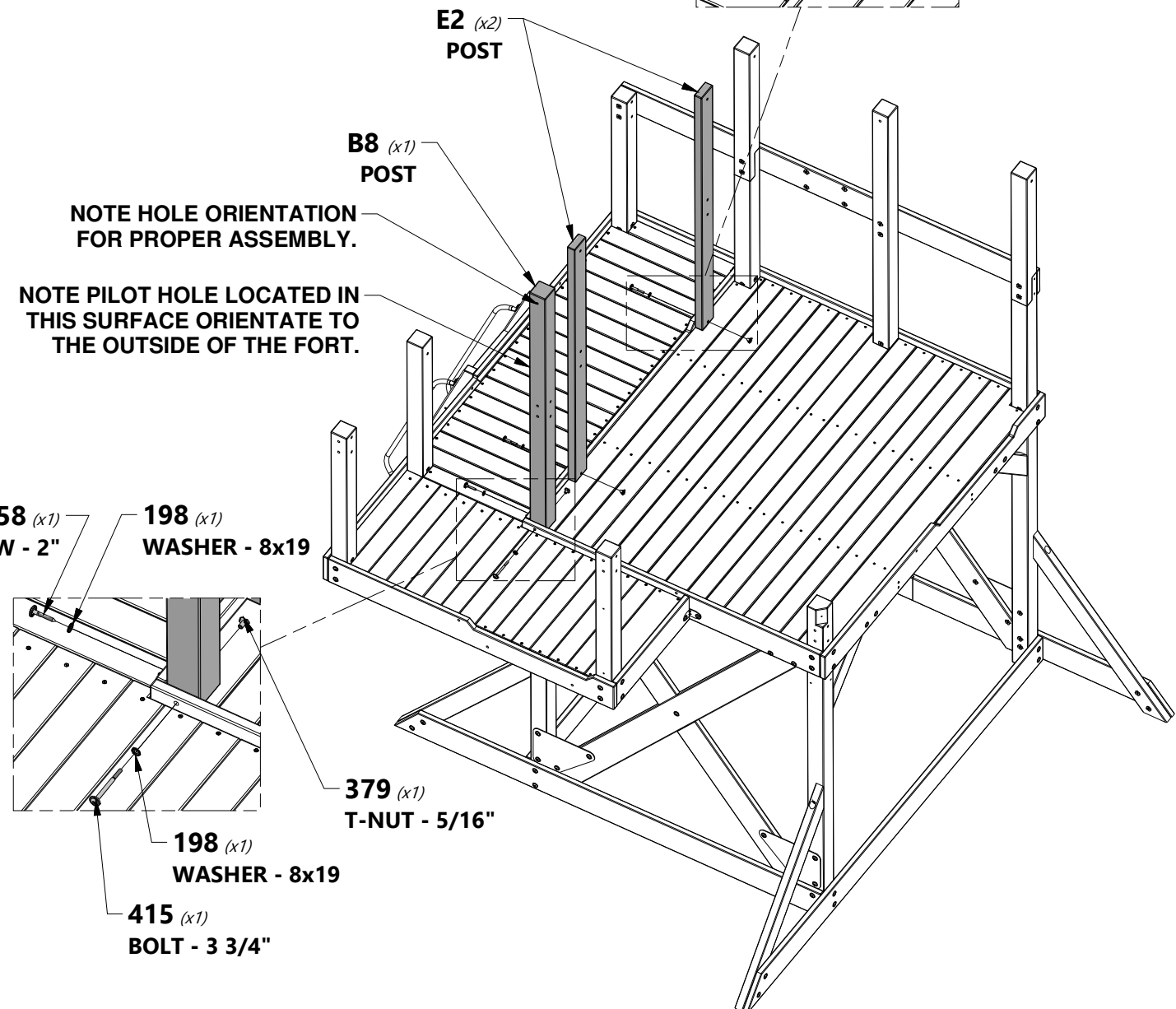
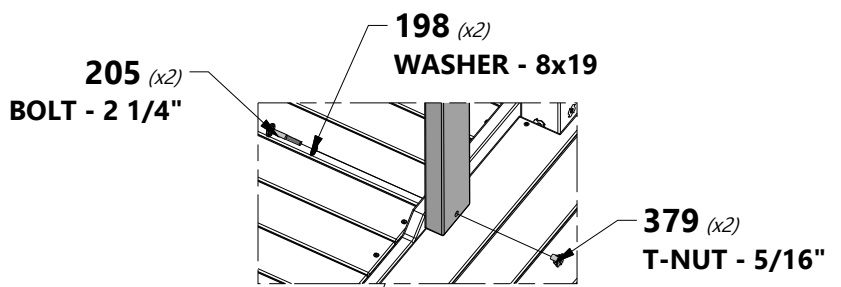

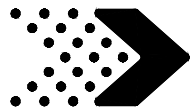

Phase 3

STEP 4

1 3/4 in
[43 mm]

G16 | WALL SUPPORT - W4L08546
(x1) | 1"x5 1/4"x14 7/8" (24x134x378)

1 3/4 in
[43 mm]

G17 | WALL SUPPORT - W4L12825
(x1) | 1"x5 1/4"x14 7/8" (24x134x378)

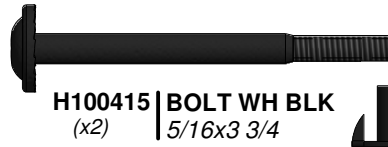

H100415 | BOLT WH BLK
(x2) | 5/16x3 3/4



H100458 | LAG SCREW WH BLK
(x2) | 5/16x2



H100379 | T-NUT BLK
(x6) | 5/16



H100198 | WASHER LOCK EXT BLK
(x8) | 8x19



H100205 | BOLT WH BLK
(x4) | 5/16x2-1/4



TIP:
WE RECOMMEND INSTALLING T-NUTS
INTO BOARDS BEFORE ASSEMBLY.

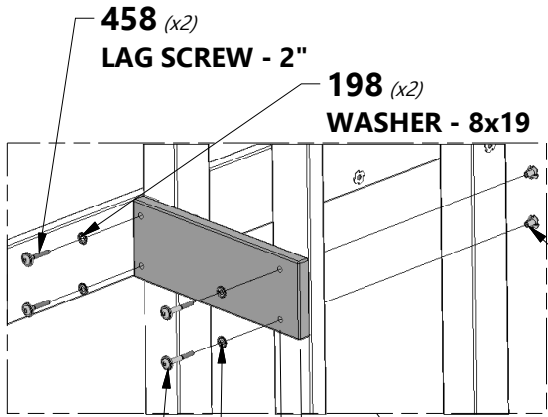

458 (x2)
LAG SCREW - 2"

198 (x2)
WASHER - 8x19

198 (x2)
WASHER - 8x19

205 (x2)
BOLT - 2 1/4"

379 (x2)
T-NUT - 5/16"

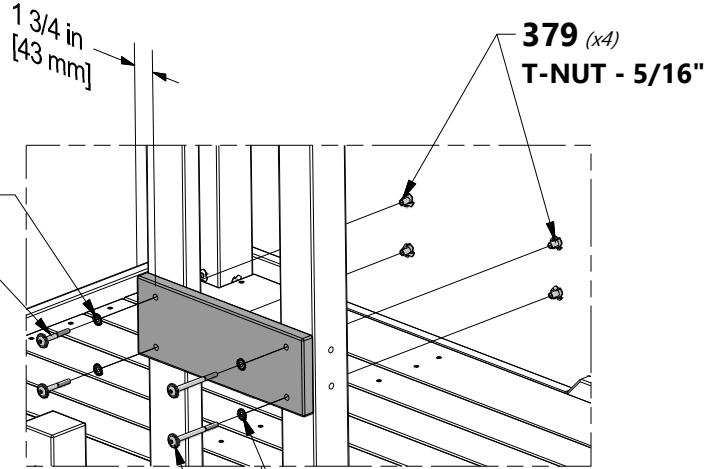

379 (x4)
T-NUT - 5/16"

415 (x2)
BOLT - 3 3/4"

198 (x2)
WASHER - 8x19

205 (x2)
BOLT - 2 1/4"

198 (x2)
WASHER - 8x19

1 3/4 in
[43 mm]

G17 (x1)
WALL SUPPORT

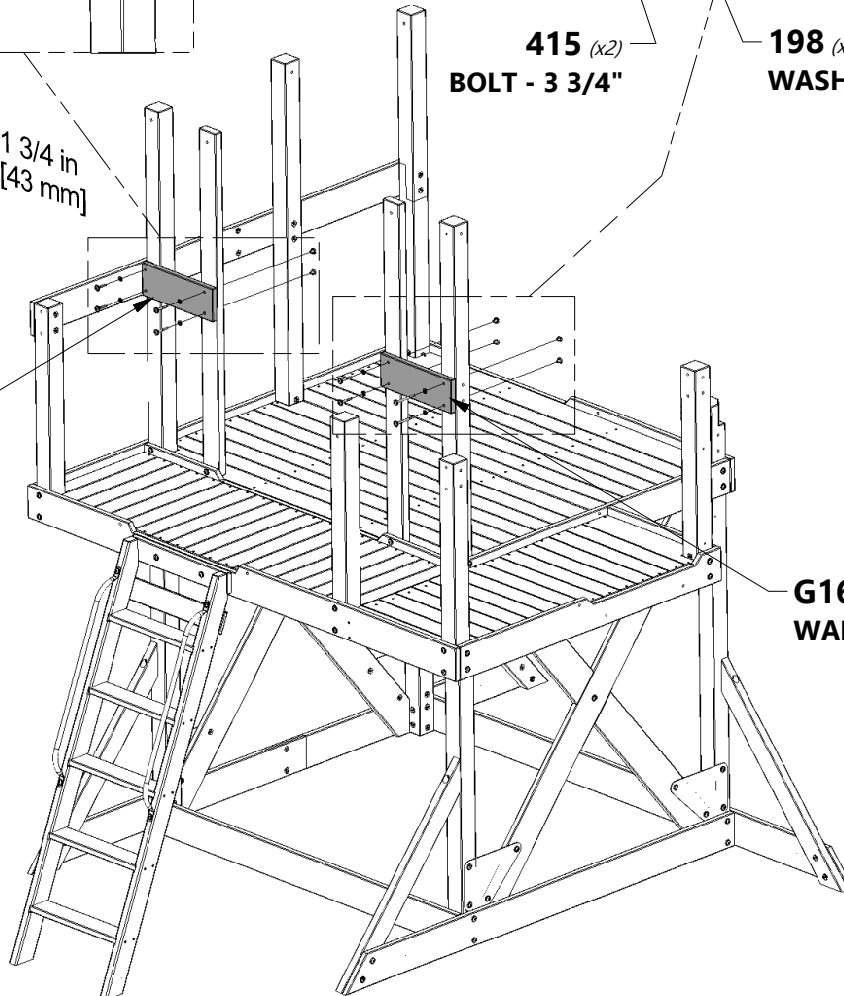

G16 (x1)
WALL SUPPORT

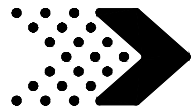

Phase 3

STEP 5

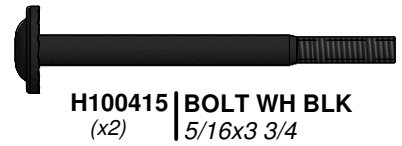
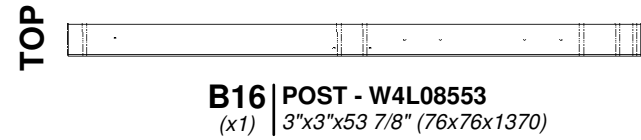
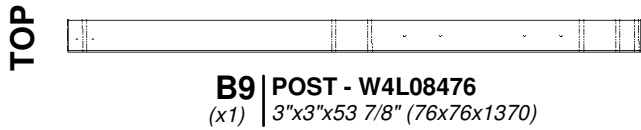

TIP:

WE RECOMMEND INSTALLING T-NUTS INTO BOARDS BEFORE ASSEMBLY.

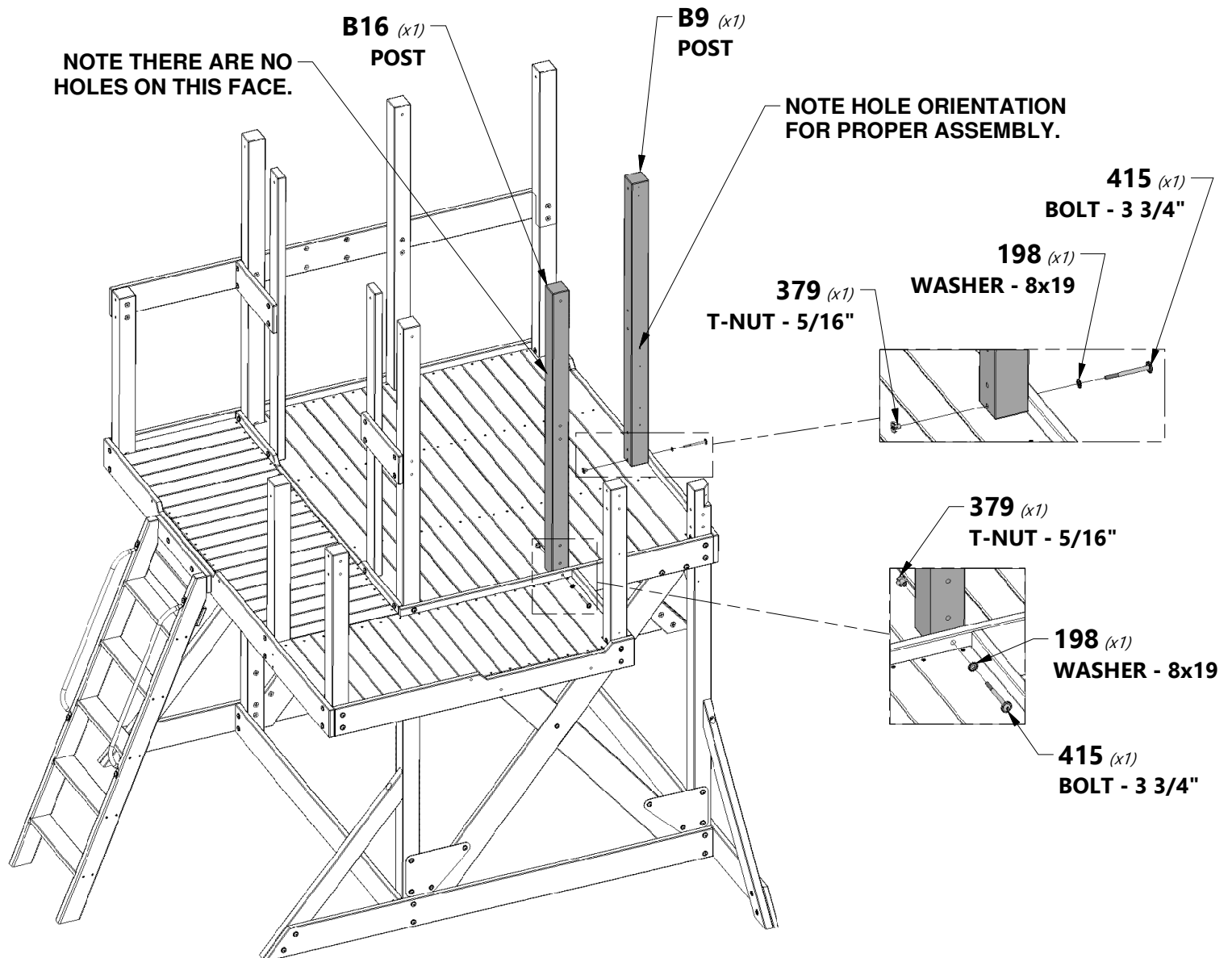

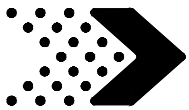

Phase 3

STEP 6



G13 | WALL SUPPORT - W4L08491
(x1) | 1"x5 1/4"x28 1/4" (24x134x716)

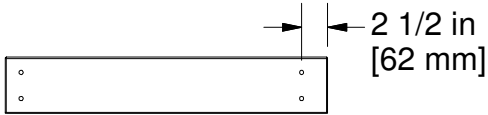

G15 | WALL SUPPORT - W4L08545
(x1) | 1"x5 1/4"x30 1/4" (24x134x768)



H100415 | BOLT WH BLK
(x8) | 5/16x3 3/4



H100198 | WASHER LOCK EXT BLK
(x8) | 8x19



H100379 | T-NUT BLK
(x8) | 5/16



TIP:
WE RECOMMEND INSTALLING T-NUTS
INTO BOARDS BEFORE ASSEMBLY.

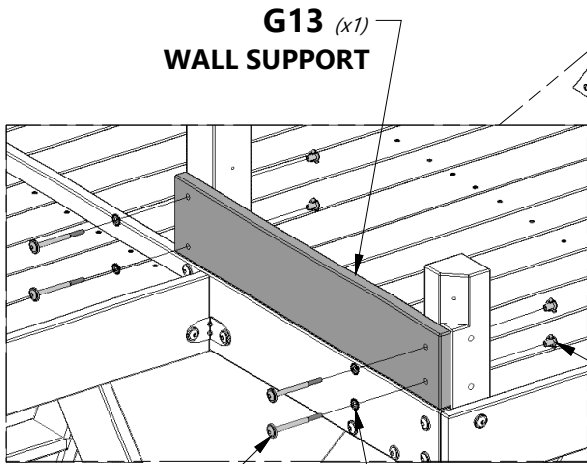
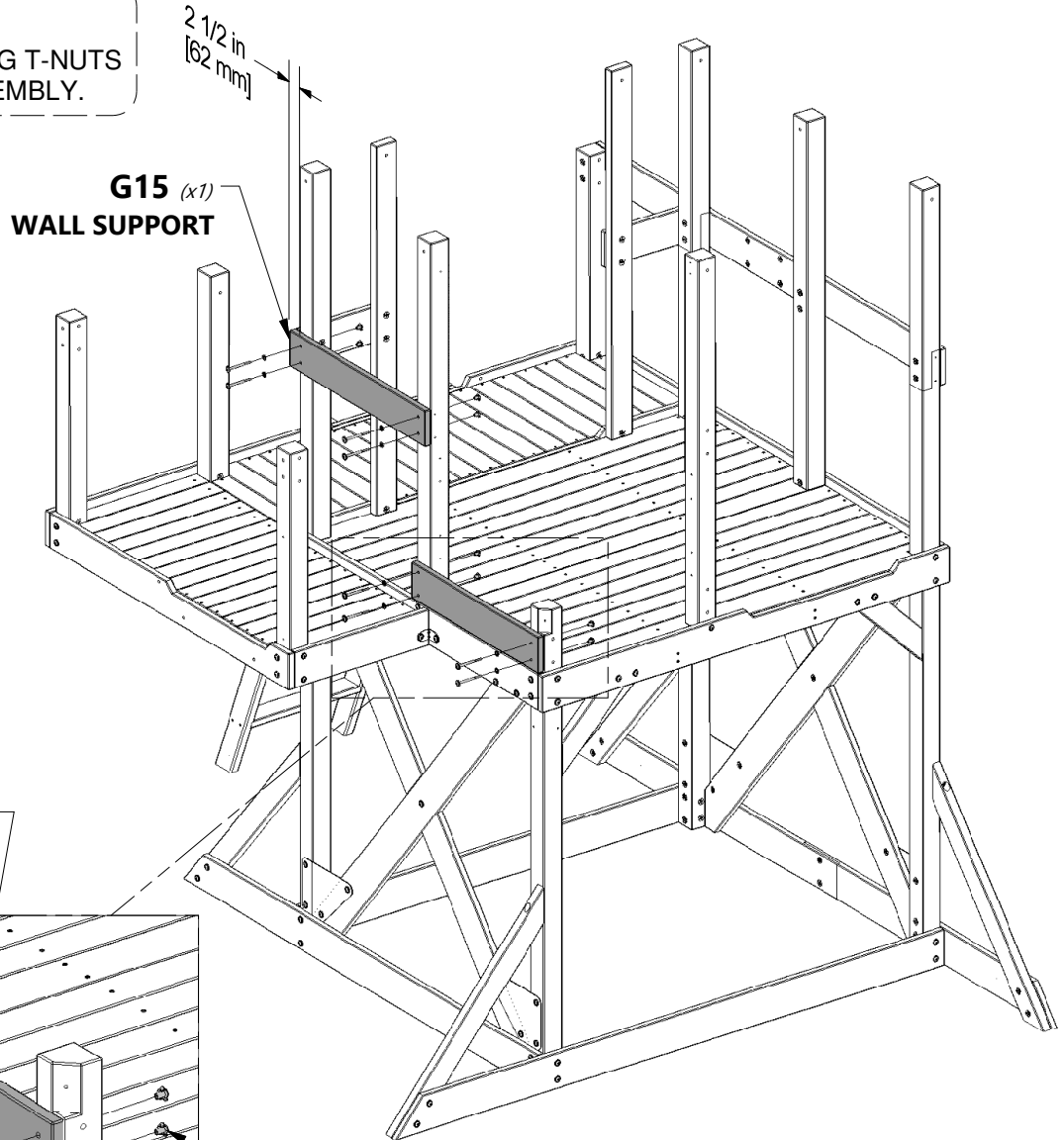

415 (x8)
BOLT - 3 3/4"

198 (x8)
WASHER - 8x19

379 (x8)
T-NUT - 5/16"

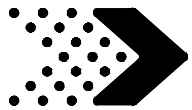

Phase 3

STEP 7

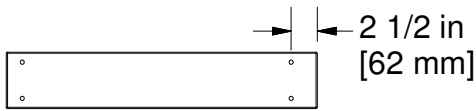

G12 | WALL SUPPORT - W4L08490
(x1) | 1"x5 1/4"x29 1/8" (24x134x741)



G30 | SLIDE ARCH BOARD - W4L12813
(x1) | 1"x5 1/4"x40 1/2" (24x134x1028)



H100415 | BOLT WH BLK
(x6) | 5/16x3 3/4



H100197 | LAG SCREW WH BLK
(x2) | 5/16x2 1/2



H100198 | WASHER LOCK EXT BLK
(x8) | 8x19



H100379 | T-NUT BLK
(x6) | 5/16

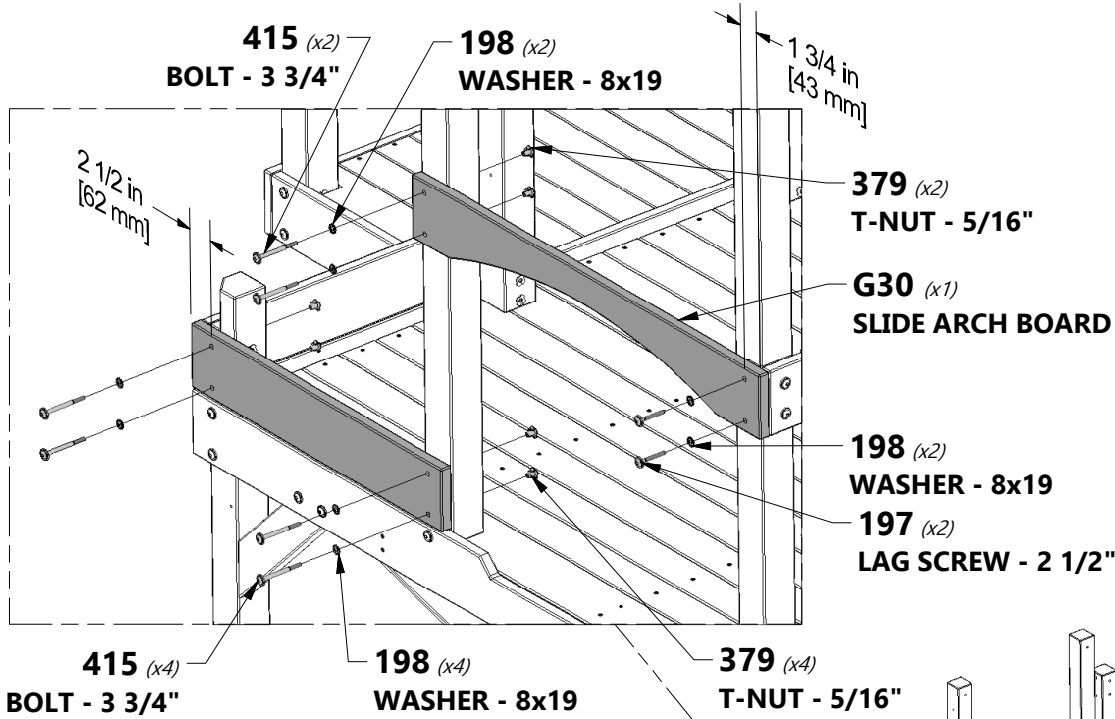

 **TIP:**
WE RECOMMEND INSTALLING T-NUTS INTO BOARDS BEFORE ASSEMBLY.

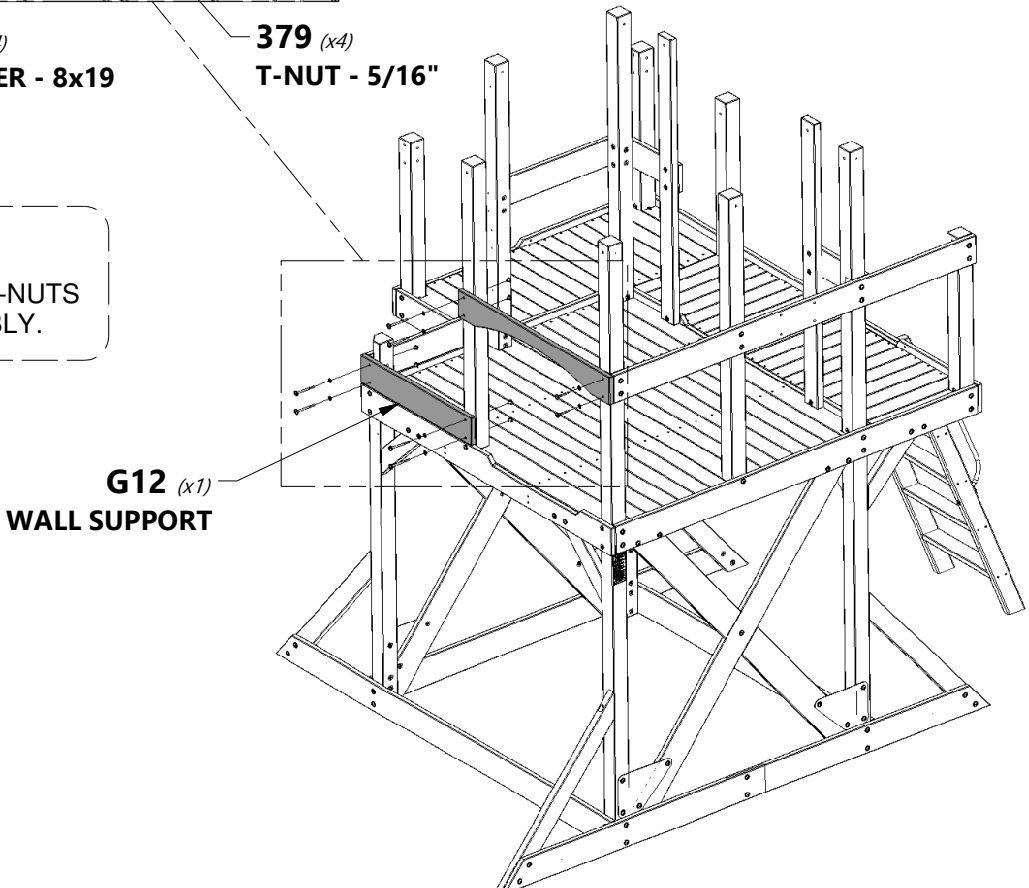

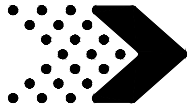

Phase 3

STEP 8



G24 | DECK BOARD - W4L12805
(x1) | 1"x5 1/4"x25 3/8" (24x134x645)



G25 | ENTRY BOARD - W4L12817
(x1) | 1"x5 1/4"x53 1/8" (24x134x1349)



H100415 | BOLT WH BLK
(x6) | 5/16x3 3/4



H100197 | LAG SCREW WH BLK
(x2) | 5/16x2 1/2



H100198 | WASHER LOCK EXT BLK
(x8) | 8x19



H100379 | T-NUT BLK
(x6) | 5/16

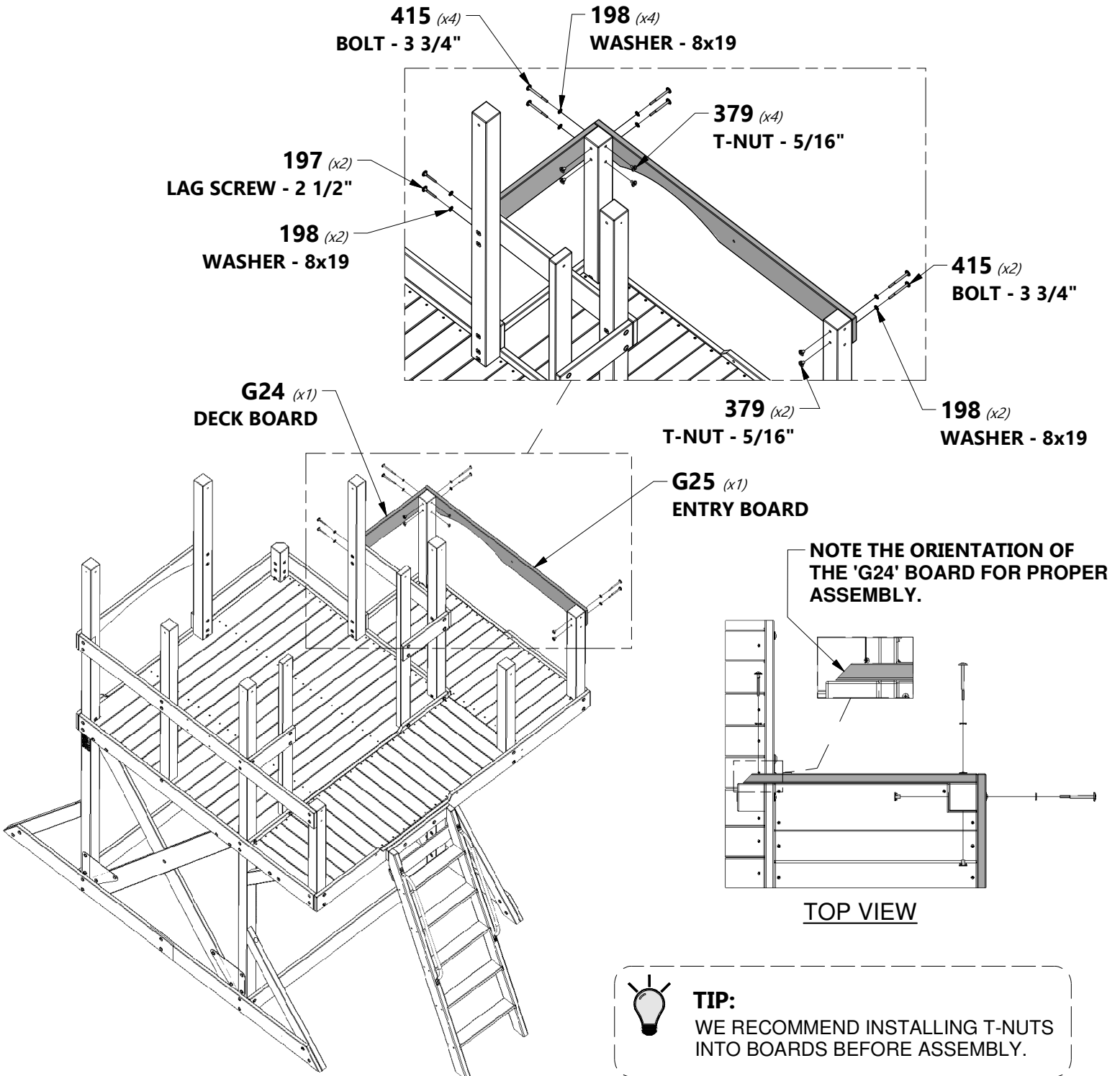

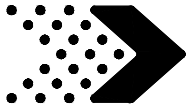

Phase 3

STEP 9

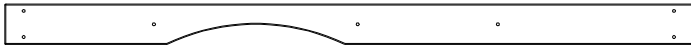

G28 | DECK BOARD - W4L12818
(x1) | 1"x5 1/4"x89 5/8" (24x134x2276)



H100415 | BOLT WH BLK
(x5) | 5/16x3 3/4



H100198 | WASHER LOCK EXT BLK
(x5) | 8x19



H100379 | T-NUT BLK
(x5) | 5/16



TIP:
WE RECOMMEND INSTALLING T-NUTS
INTO BOARDS BEFORE ASSEMBLY.

379 (x5)
T-NUT - 5/16"

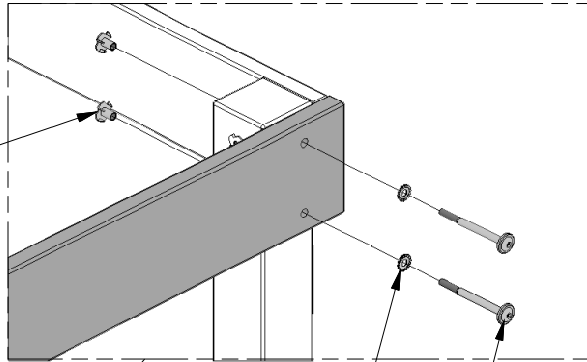

198 (x5)
WASHER - 8x19

415 (x5)
BOLT - 3 3/4"

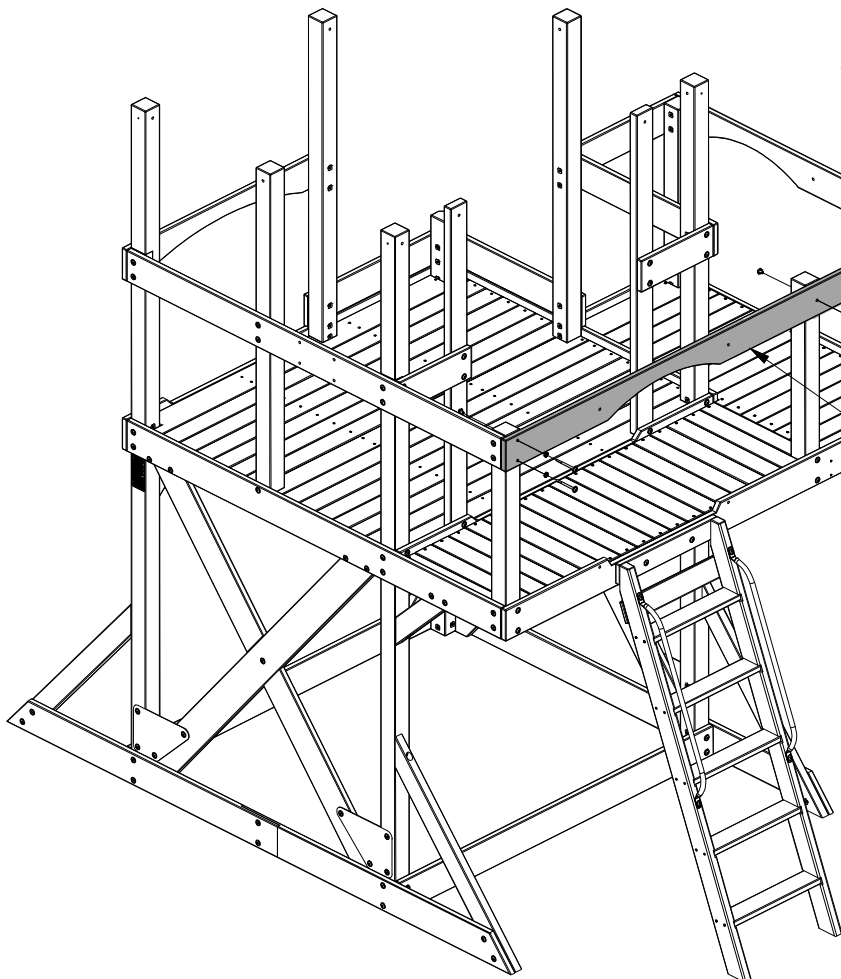

G28 (x1)
DECK BOARD

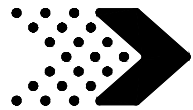

Phase 3

STEP 10



H11 | ROOF SUPPORT - W4L08518
(x1) | 1"x3 3/8"x76 3/4" (24x86x1949)



H100415 | BOLT WH BLK
(x1) | 5/16x3 3/4



H100458 | LAG SCREW WH BLK
(x2) | 5/16x2



H100198 | WASHER LOCK EXT BLK
(x3) | 8x19



H100379 | T-NUT BLK
(x1) | 5/16



TIP:
WE RECOMMEND INSTALLING T-NUTS INTO BOARDS BEFORE ASSEMBLY.

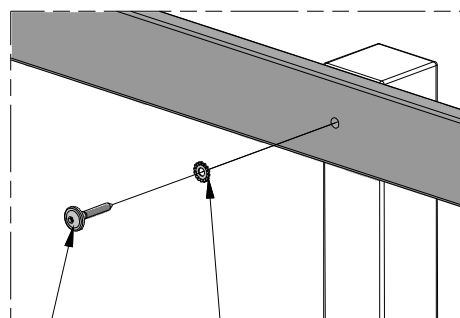

458 (x2)
LAG SCREW - 2"

198 (x2)
WASHER - 8x19

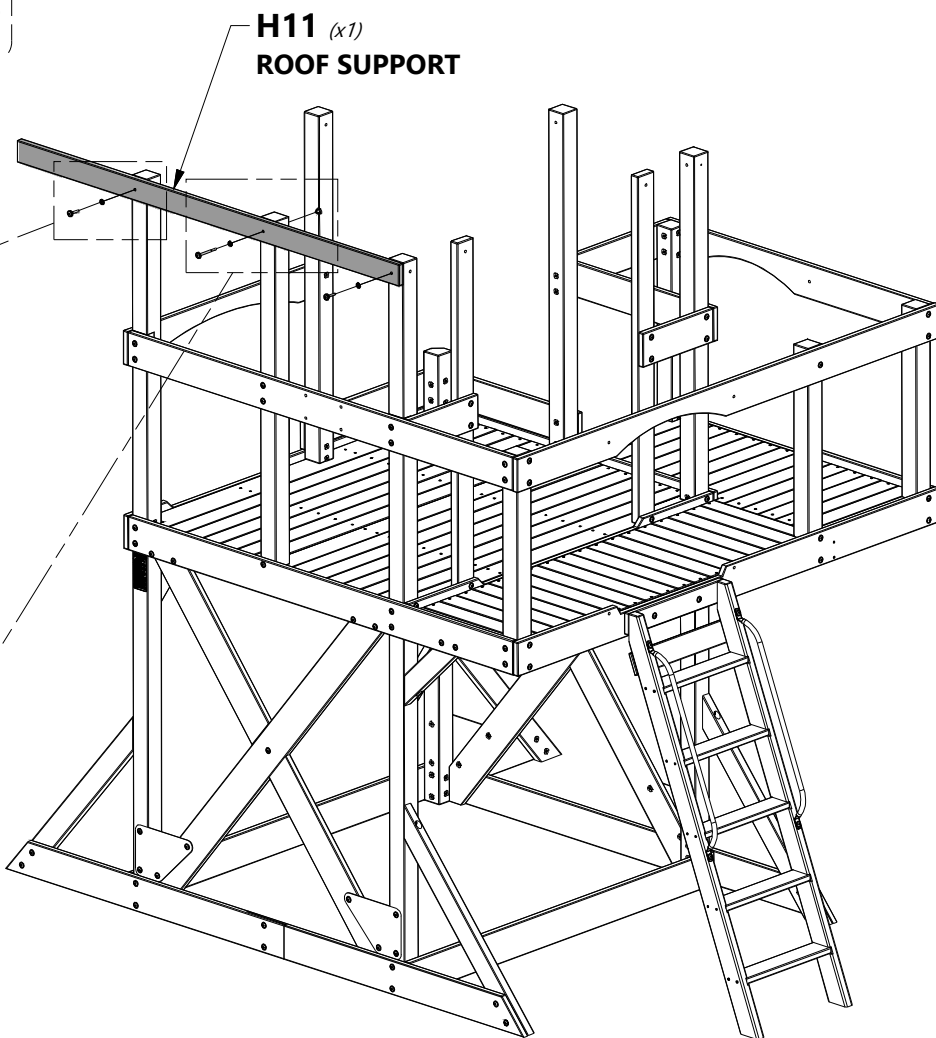

H11 (x1)
ROOF SUPPORT

379 (x1)
T-NUT - 5/16"

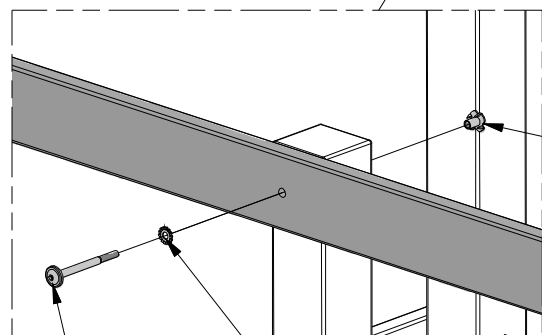

415 (x1)
BOLT - 3 3/4"

198 (x1)
WASHER - 8x19

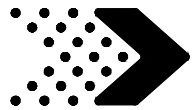

Phase 3

STEP 11

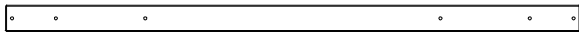

H13 | ROOF SUPPORT - W4L08520
(x1) | 1"x3 3/8"x74 3/4" (24x86x1900)



H100415 | BOLT WH BLK
(x1) | 5/16x3 3/4



H100458 | LAG SCREW WH BLK
(x1) | 5/16x2



H100379 | T-NUT BLK
(x3) | 5/16



H100198 | WASHER LOCK EXT BLK
(x4) | 8x19



H100205 | BOLT WH BLK
(x2) | 5/16x2-1/4



TIP:
WE RECOMMEND INSTALLING T-NUTS
INTO BOARDS BEFORE ASSEMBLY.

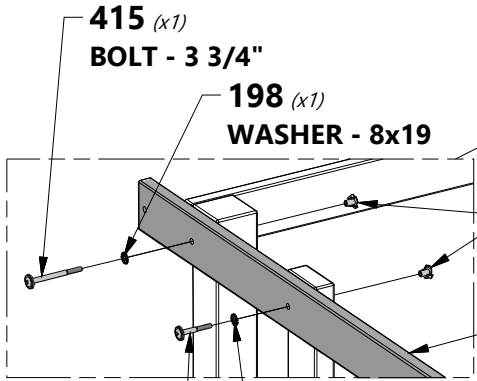
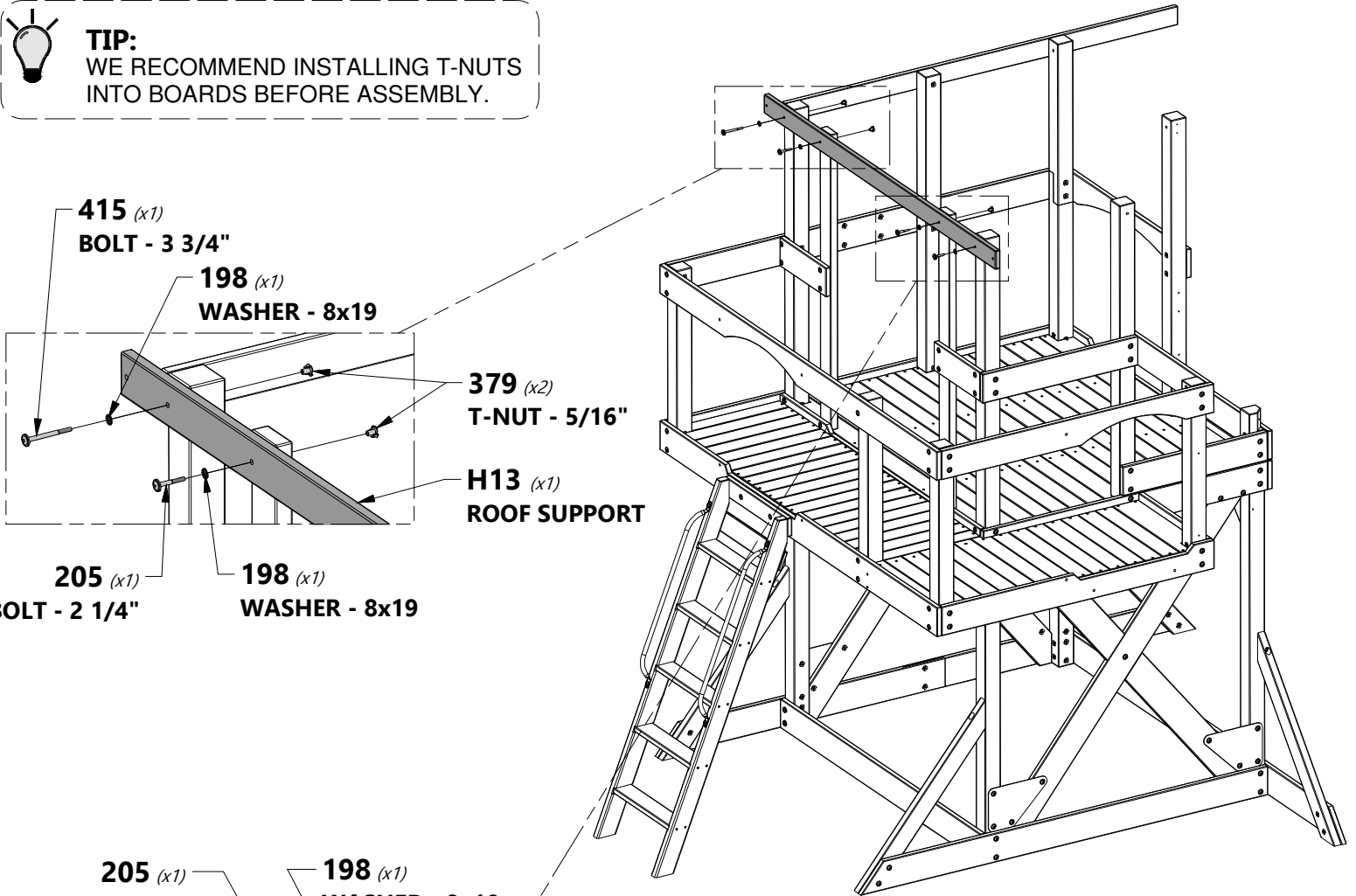

415 (x1)
BOLT - 3 3/4"

198 (x1)
WASHER - 8x19

379 (x2)
T-NUT - 5/16"

H13 (x1)
ROOF SUPPORT

205 (x1)
BOLT - 2 1/4"

198 (x1)
WASHER - 8x19

205 (x1)
BOLT - 2 1/4"

198 (x1)
WASHER - 8x19

379 (x1)
T-NUT - 5/16"

458 (x1)
LAG SCREW - 2"

198 (x1)
WASHER - 8x19

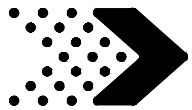

Phase 3

STEP 12

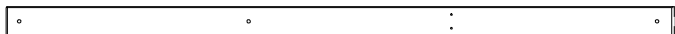

H10 | ROOF SUPPORT - W4L08513
(x1) | 1"x3 3/8"x76 3/4" (24x86x1949)



H100415 | BOLT WH BLK
(x2) | 5/16x3 3/4



H100198 | WASHER LOCK EXT BLK
(x2) | 8x19



H100379 | T-NUT BLK
(x2) | 5/16

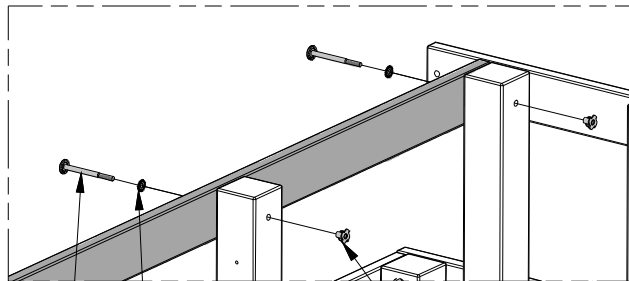

415 (x2) | BOLT - 3 3/4"
198 (x2) | WASHER - 8x19
379 (x2) | T-NUT - 5/16"



TIP:
WE RECOMMEND INSTALLING T-NUTS INTO BOARDS BEFORE ASSEMBLY.

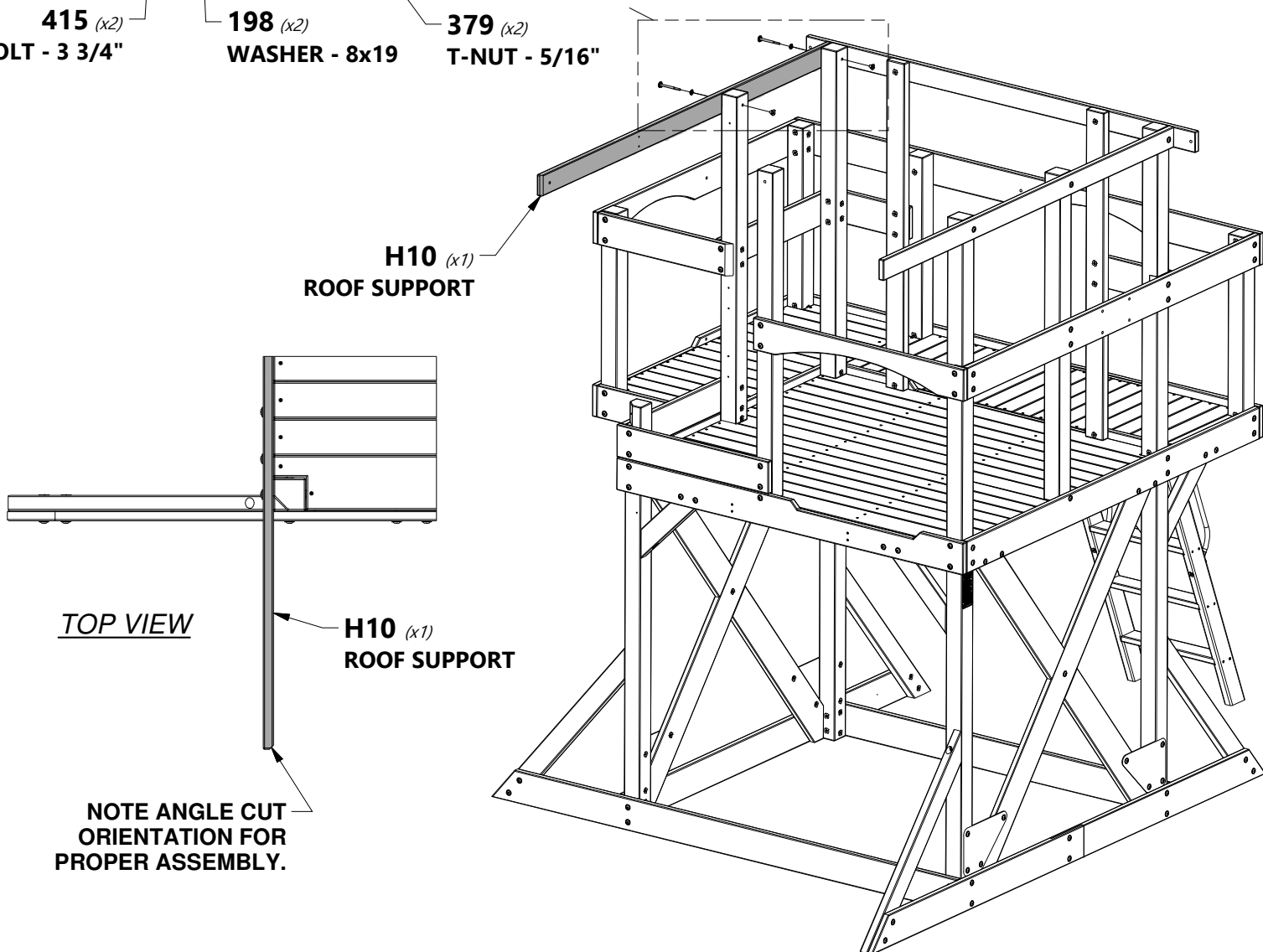

H10 (x1) | ROOF SUPPORT

H10 (x1) | ROOF SUPPORT

TOP VIEW

NOTE ANGLE CUT ORIENTATION FOR PROPER ASSEMBLY.

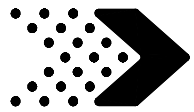

Phase 3

STEP 13

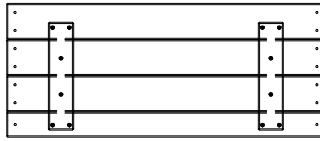
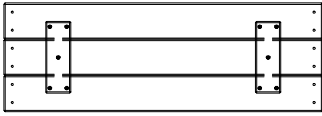

WP1 | RIGHT WALL PANEL - W2A02903
(x2) | 1 1/4"x10 3/16"x29 7/8" (32x258x759)

WP2 | RIGHT WALL PANEL - W2A02904
(x2) | 1 1/4"x12 1/2"x29 7/8" (32x318x759)



H100387 | SCREW PFH BLK
(x52) | 8x1-1/4

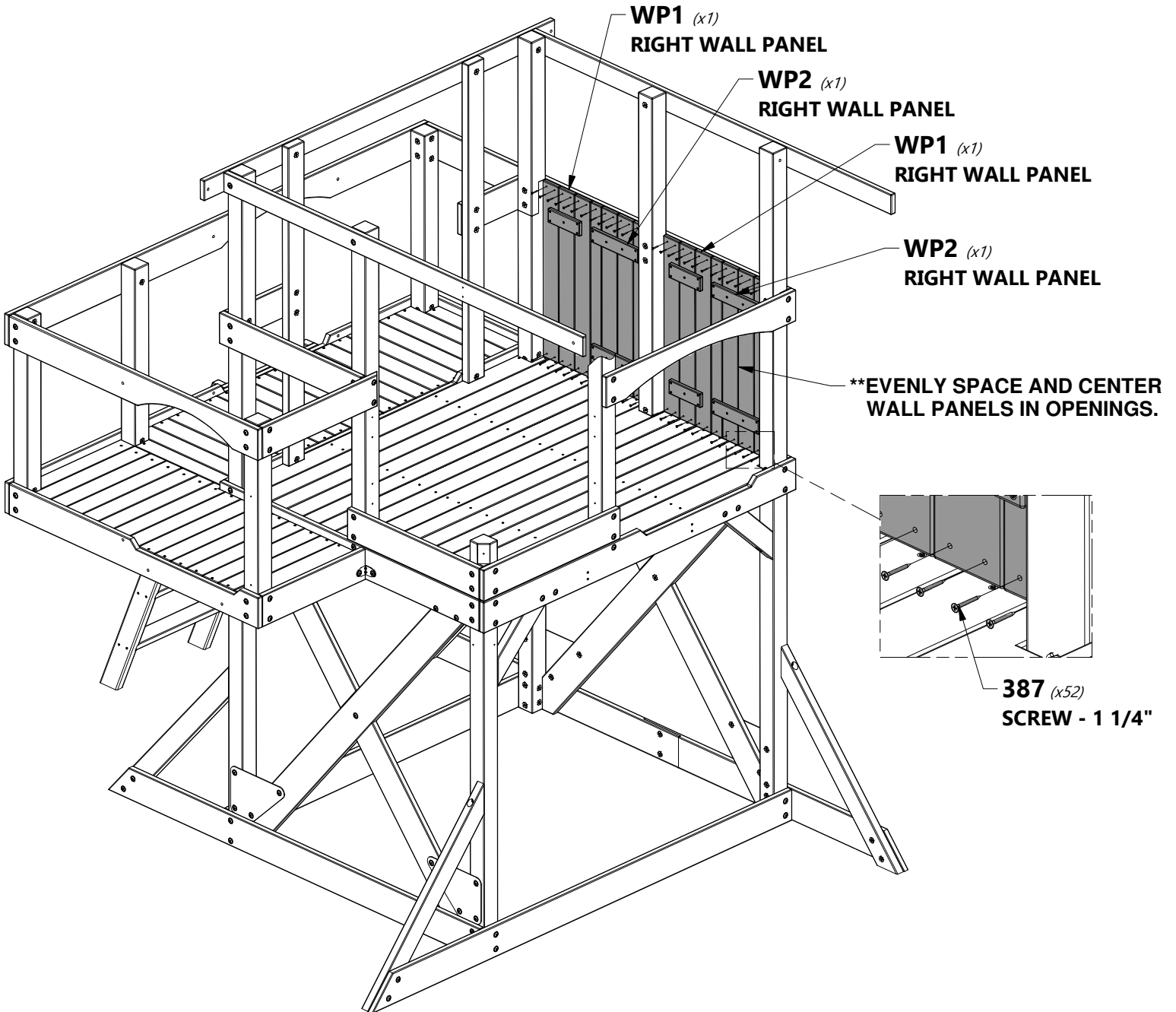

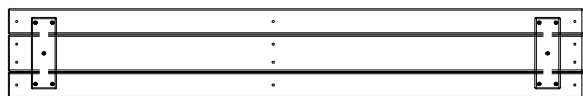
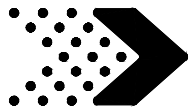

WP3 | REAR FORT WALL - W2A02905
(x2) | 1 1/4"x8 1/8"x53 15/16" (32x212x1370)



H100387 | SCREW PFH BLK
(x24) | 8x1-1/4

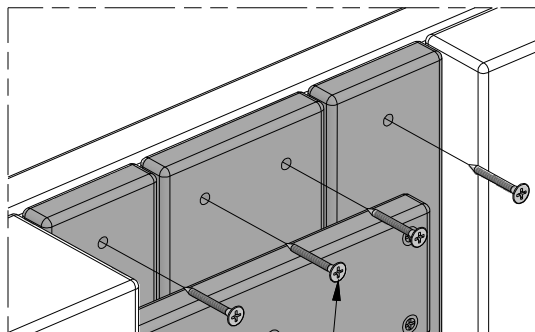

387 (x24)
SCREW - 1 1/4"

****CENTER WALL PANELS IN OPENINGS.**

WP3 (x2)
REAR FORT WALL

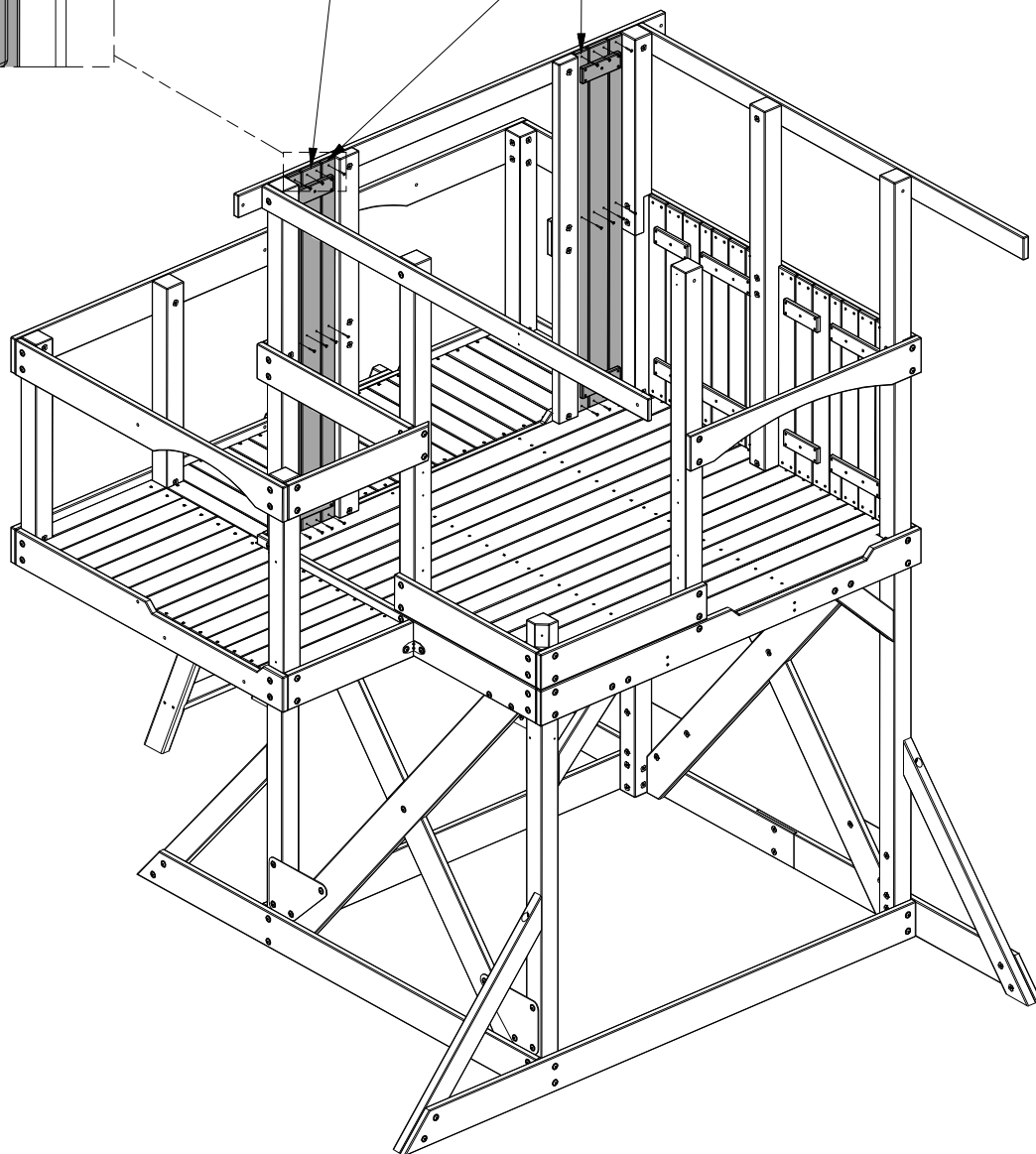

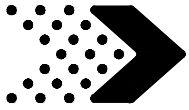

Phase 3

STEP 15

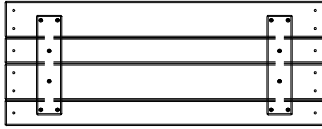

WP4 | WALL PANEL - W2A02906
(x2) | 1 1/4"x11 5/8"x29 7/8" (32x295x759)



H100387 | SCREW PFH BLK
(x24) | 8x1-1/4

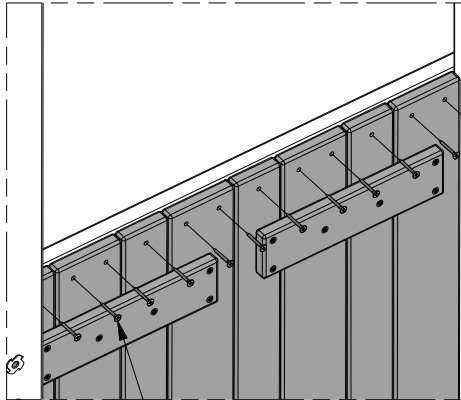

387 (x24)
SCREW - 1 1/4"

****EVENLY SPACE AND CENTER
WALL PANELS IN OPENINGS.**

WP4 (x2)
WALL PANEL

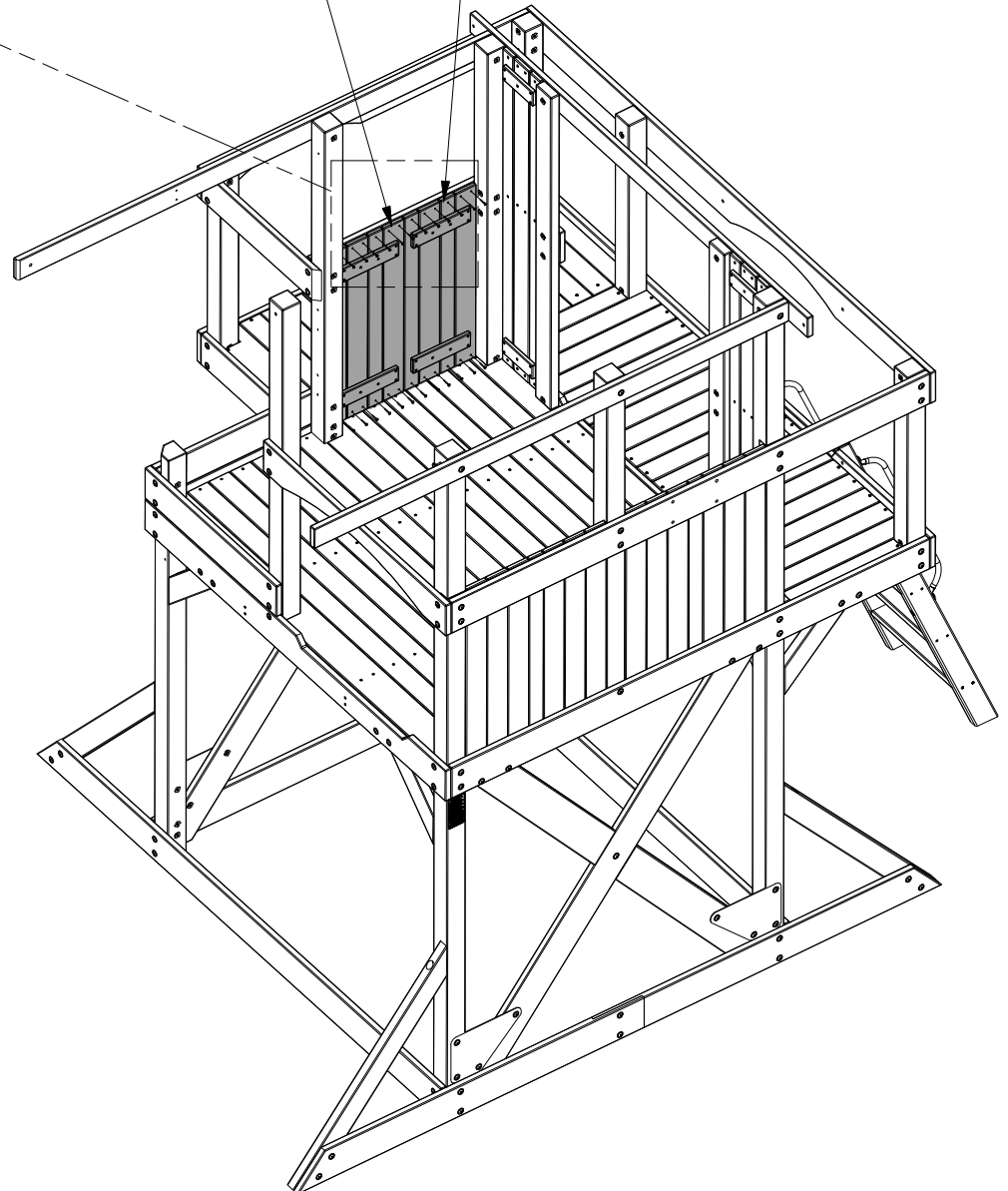

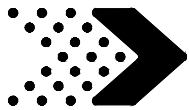

Phase 3

STEP 16

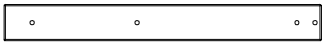

H1 | WALL PICKET - W4L12829
(x2) | 1"x3 3/8"x29 3/4" (24x86x756)



A100118 | HAND GRIP METAL GREEN 381 c/c
(x2)



H100378 | BOLT WH BLK
(x4) | 5/16x1 3/4



H100468 | BOLT WH BLK
(x4) | 5/16x1



H100198 | WASHER LOCK EXT BLK
(x4) | 8x19



H100379 | T-NUT BLK
(x8) | 5/16



NOTE:

ASSEMBLE THE (2) SUB ASSEMBLIES FIRST.



TIP:

WE RECOMMEND INSTALLING T-NUTS INTO BOARDS BEFORE ASSEMBLY.

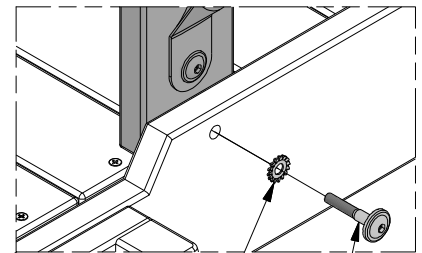
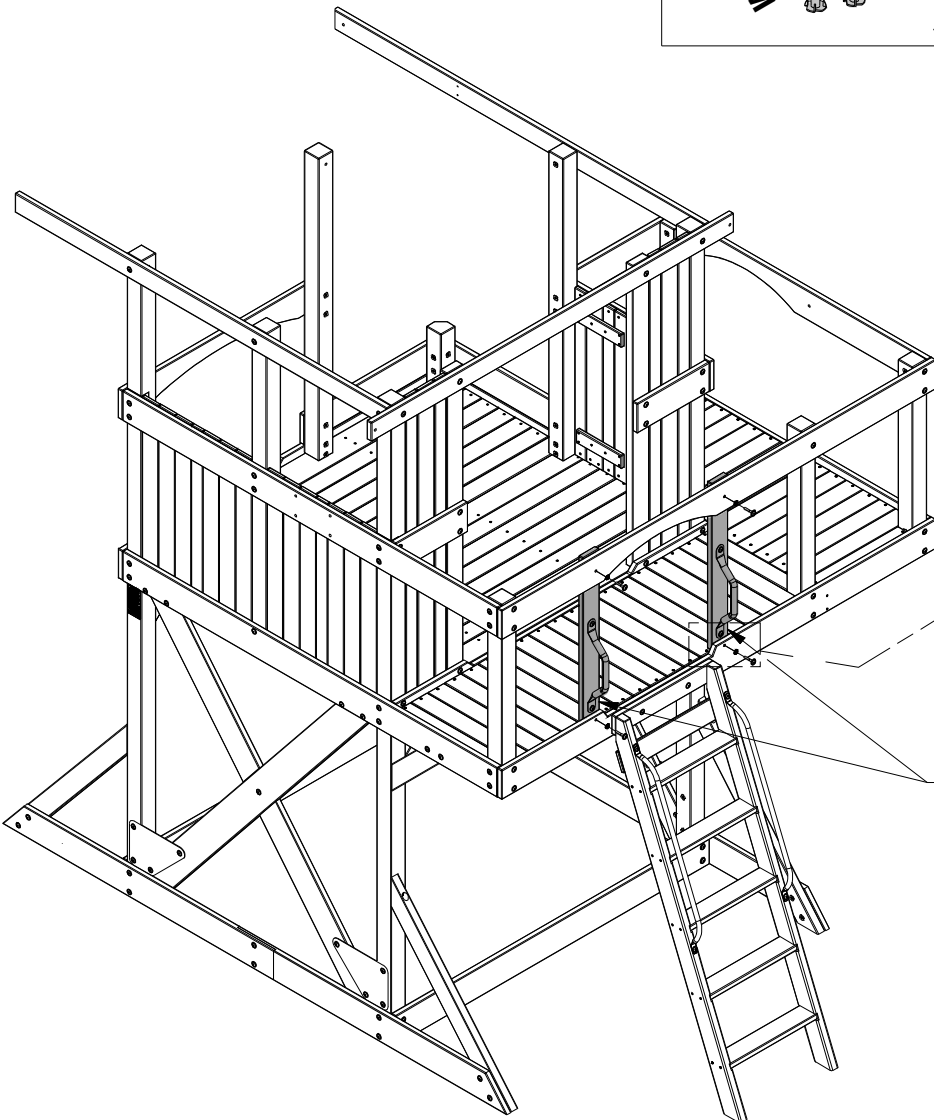
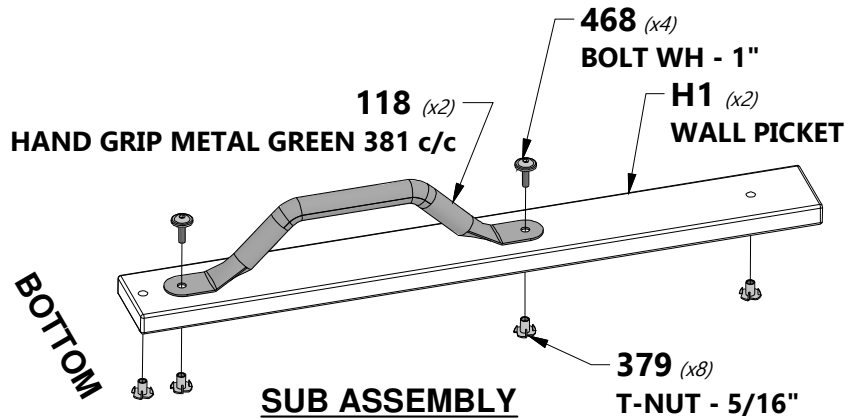

**GRAB HANDLE
SUB ASSEMBLY**

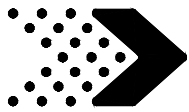

Phase 3

STEP 17

TOP



H1 | WALL PICKET - W4L12829
(x1) | 1"x3 3/8"x29 3/4" (24x86x756)



H100378 | BOLT WH BLK
(x2) | 5/16x1 3/4



H100198 | WASHER LOCK EXT BLK
(x2) | 8x19



H100379 | T-NUT BLK
(x2) | 5/16



NOTE:

1. DO NOT PUT ANY WEIGHT ON SHORT THE BALCONY UNTIL AFTER COMPLETION OF PHASE 7.
2. USE A LADDER TO ASSEMBLE ANY PICKETS LOCATED ON THE SHORT BALCONY RAILS.



TIP:

WE RECOMMEND INSTALLING T-NUTS INTO BOARDS BEFORE ASSEMBLY.

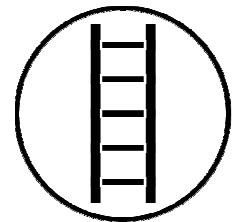
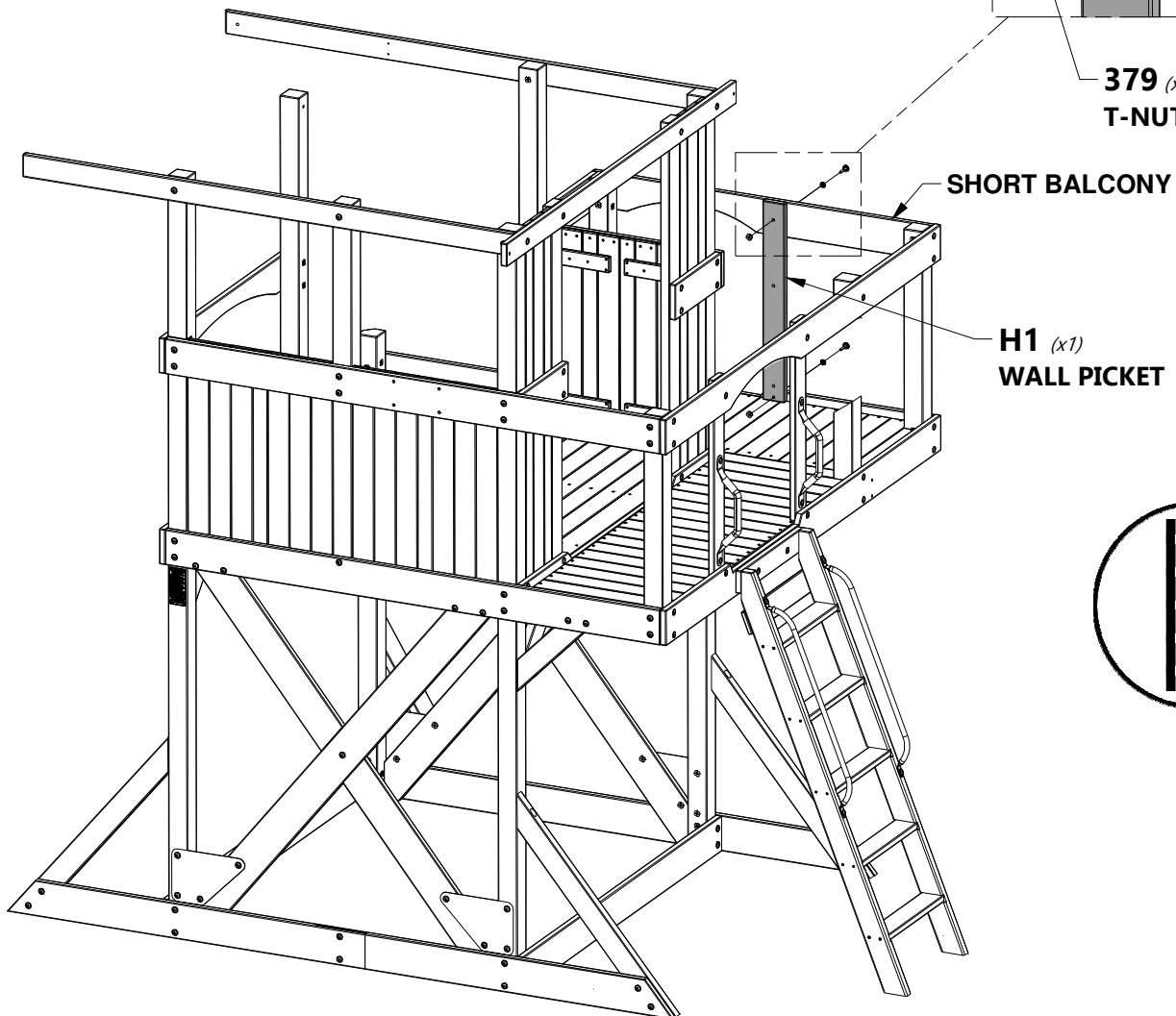
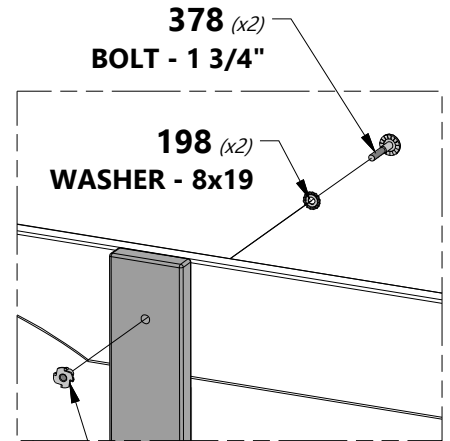

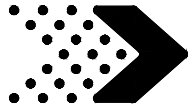

M23 | WALL PICKET - W4L08544
(x3) | 5/8"x3 3/8"x29 7/8" (16x86x759)



H100387 | SCREW PFH BLK
(x12) | 8x1-1/4



NOTE:

1. DO NOT PUT ANY WEIGHT ON SHORT THE BALCONY UNTIL AFTER COMPLETION OF PHASE 7.
2. USE A LADDER TO ASSEMBLE ANY PICKETS LOCATED ON THE SHORT BALCONY RAILS.

START HERE →

2 3/8 in
[60 mm]
(3 SPCS)

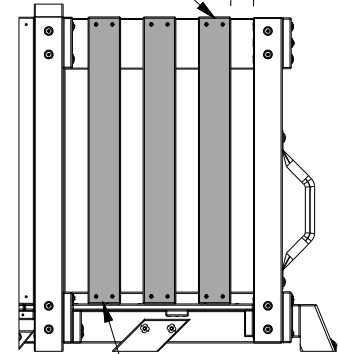

M23 (x3)
WALL PICKET

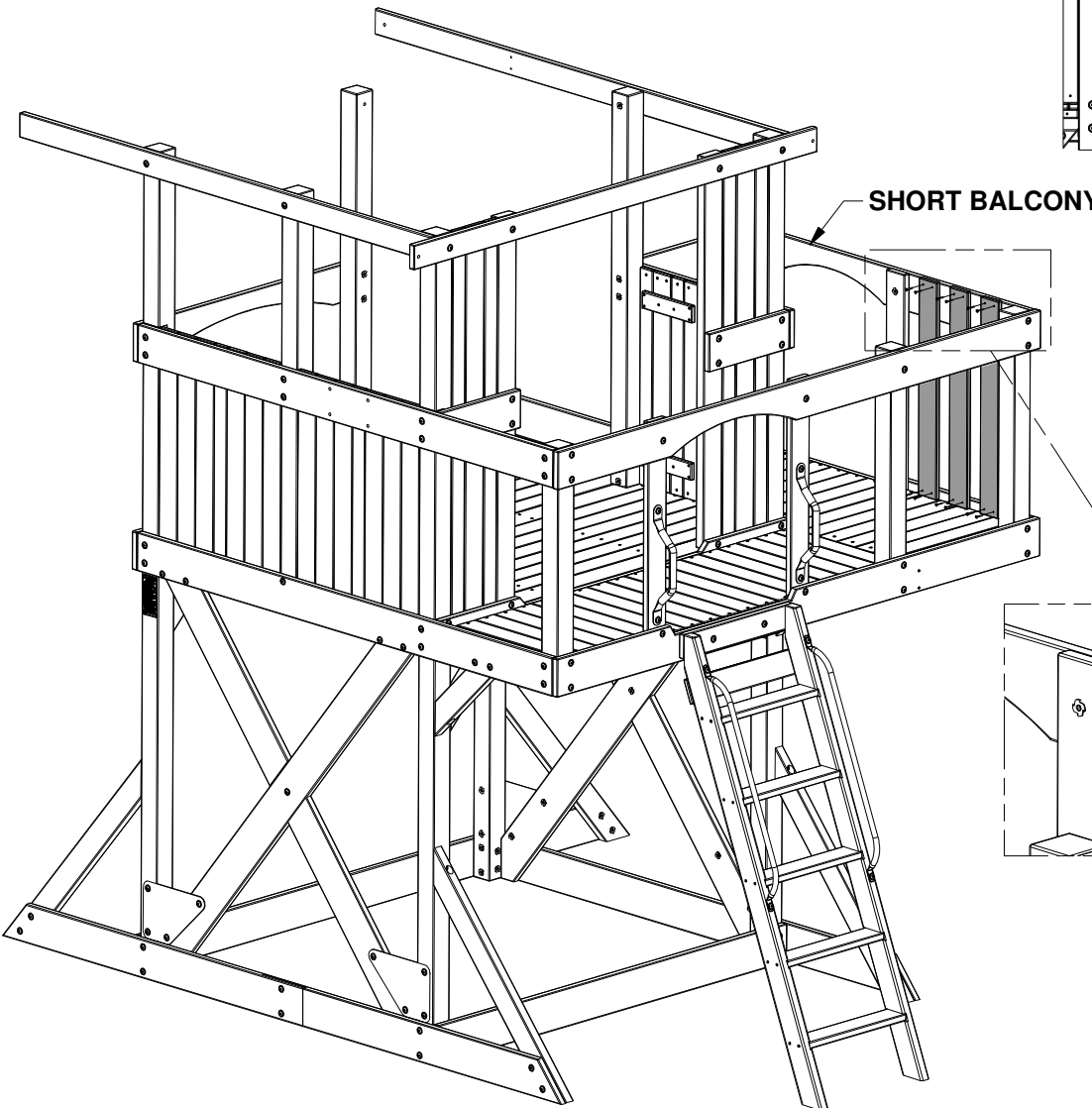
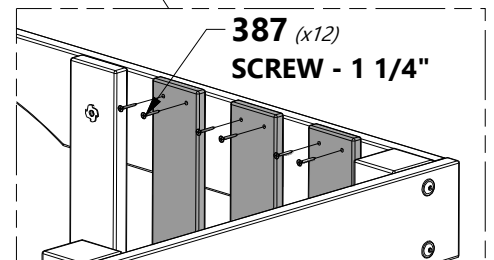
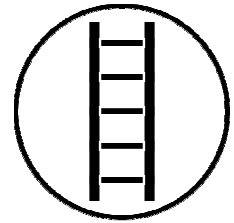

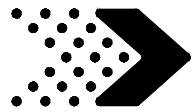

Phase 3

STEP 19



M23 | WALL PICKET - W4L08544
(x3) | 5/8"x3 3/8"x29 7/8" (16x86x759)



H100387 | SCREW PFH BLK
(x12) | 8x1-1/4

2 1/2 in
[62 mm]
(3 SPCS)

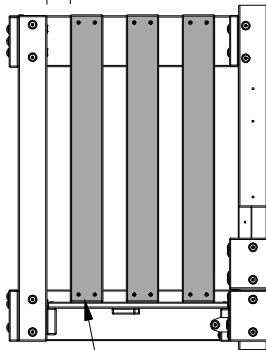

M23 (x3)
WALL PICKET

SHORT BALCONY



NOTE:

1. DO NOT PUT ANY WEIGHT ON SHORT THE BALCONY UNTIL AFTER COMPLETION OF PHASE 7.
2. USE A LADDER TO ASSEMBLE ANY PICKETS LOCATED ON THE SHORT BALCONY RAILS.

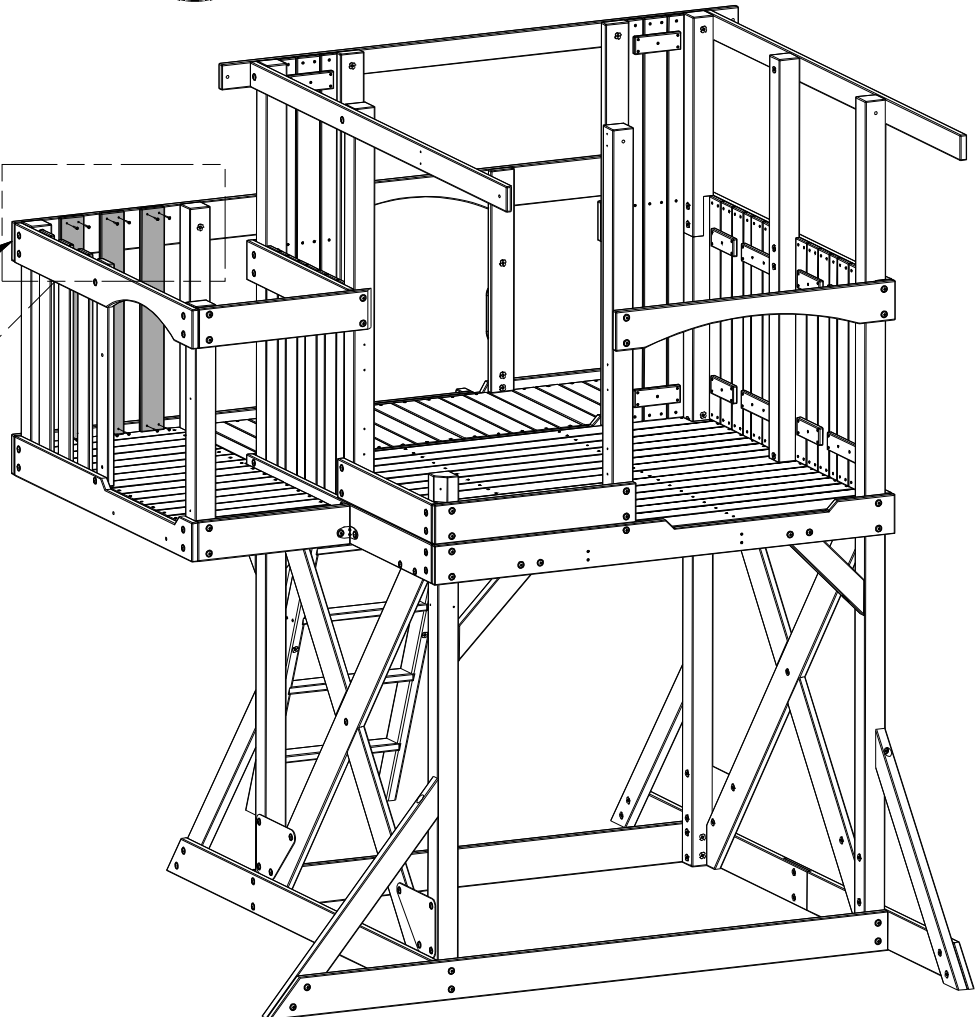
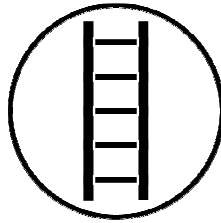

387 (x12)
SCREW - 1 1/4"

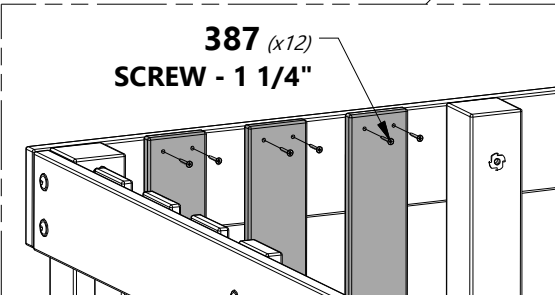

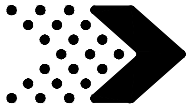

Phase 3

STEP 20



M23 | WALL PICKET - W4L08544
(x2) | 5/8"x3 3/8"x29 7/8" (16x86x759)



H100387 | SCREW PFH BLK
(x8) | 8x1-1/4

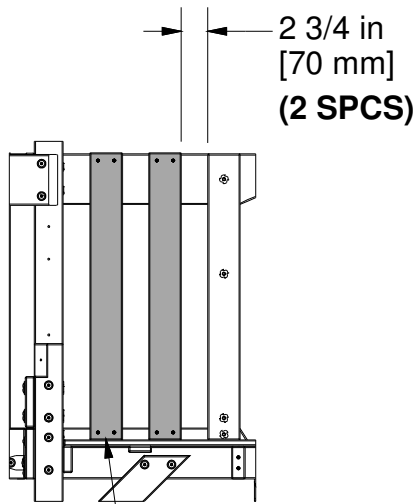

M23 (x2)
WALL PICKET

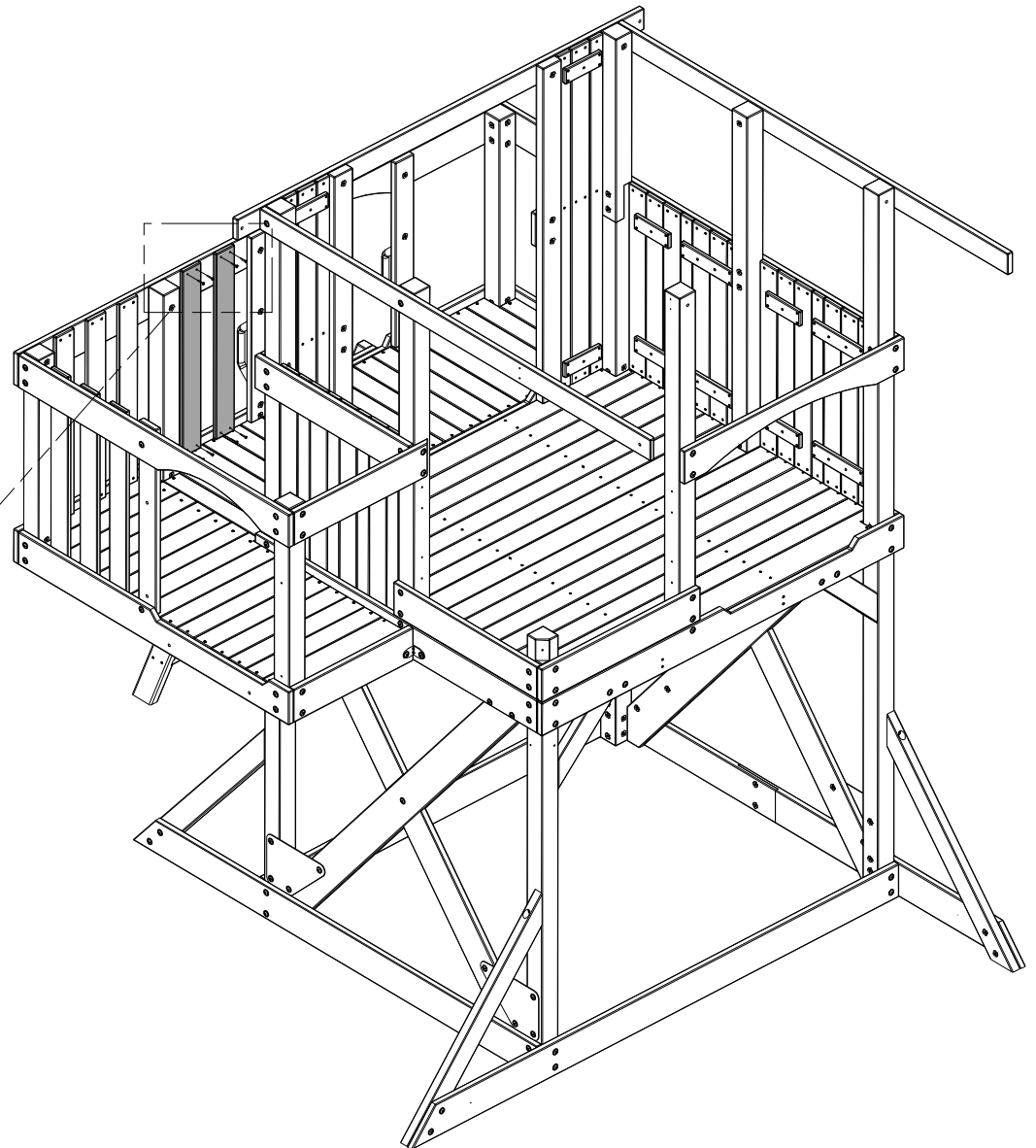

387 (x8)
SCREW - 1 1/4"

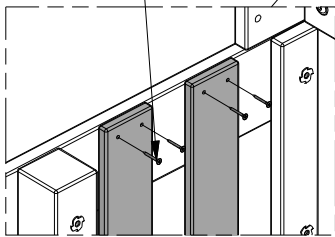

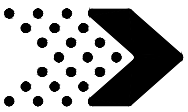

Phase 3

STEP 21



M23 | WALL PICKET - W4L08544
(x2) | 5/8"x3 3/8"x29 7/8" (16x86x759)



H100387 | SCREW PFH BLK
(x8) | 8x1-1/4

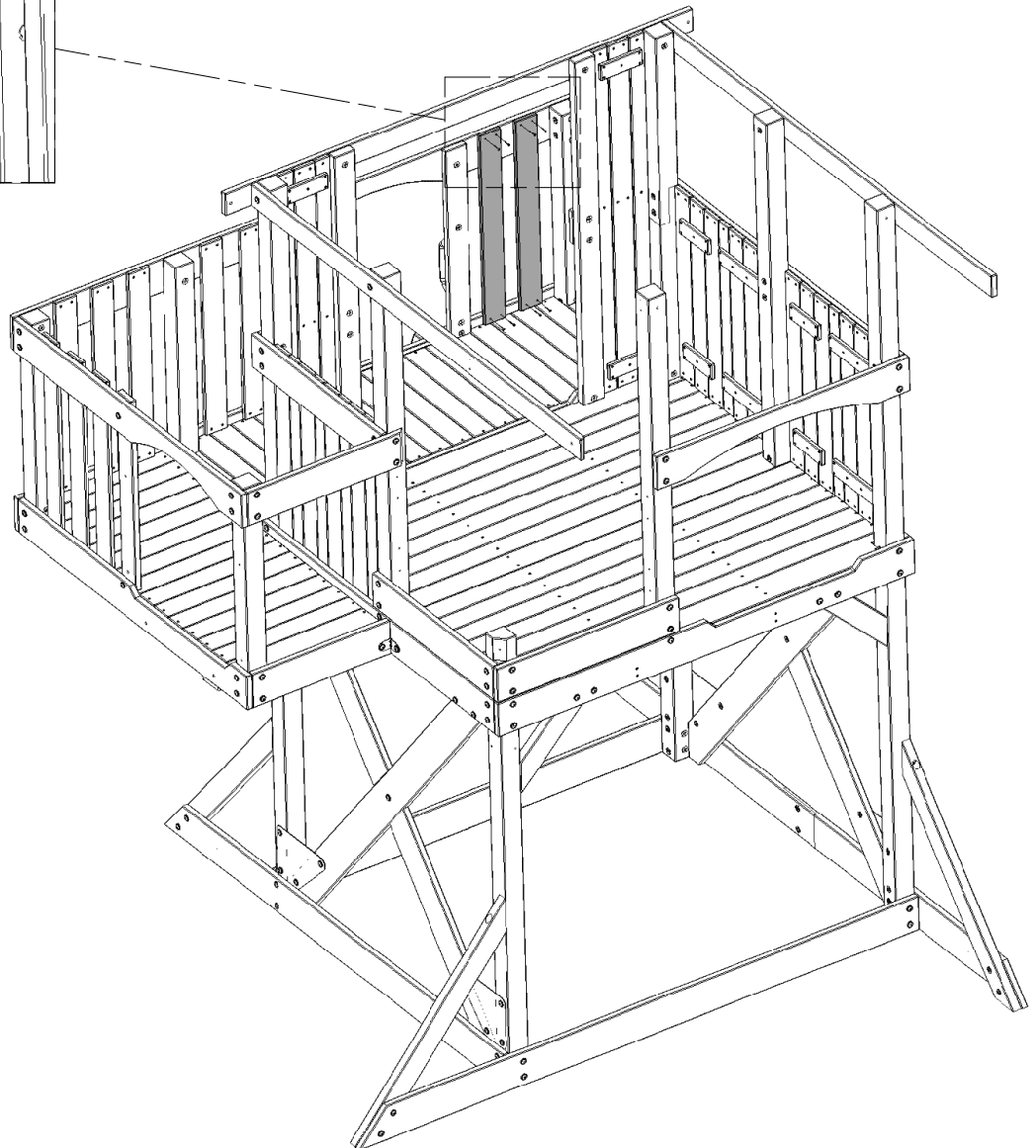
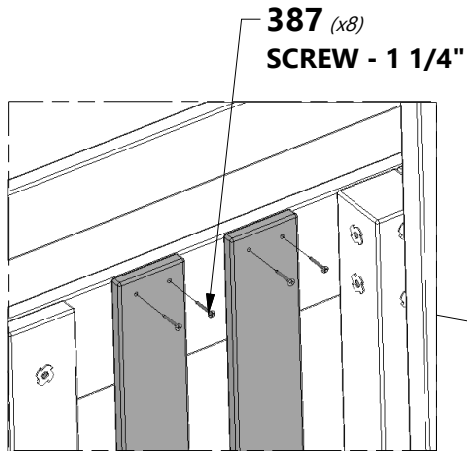

2 3/8 in
[60 mm]
(2 SPCS)

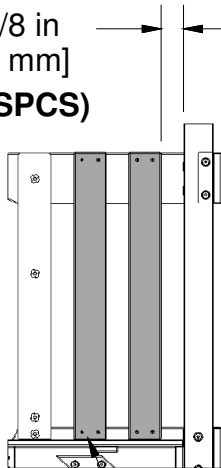

M23 (x2)
WALL PICKET

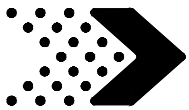

Phase 3

STEP 22



M23 | WALL PICKET - W4L08544
(x3) | 5/8"x3 3/8"x29 7/8" (16x86x759)



H100387 | SCREW PFH BLK
(x12) | 8x1-1/4

2 3/8 in
[60 mm]
(3 SPCS)

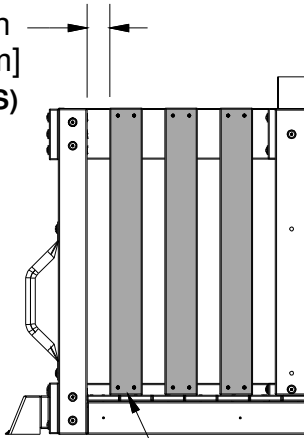

M23 (x3)
WALL PICKET

387 (x12)
SCREW - 1 1/4"

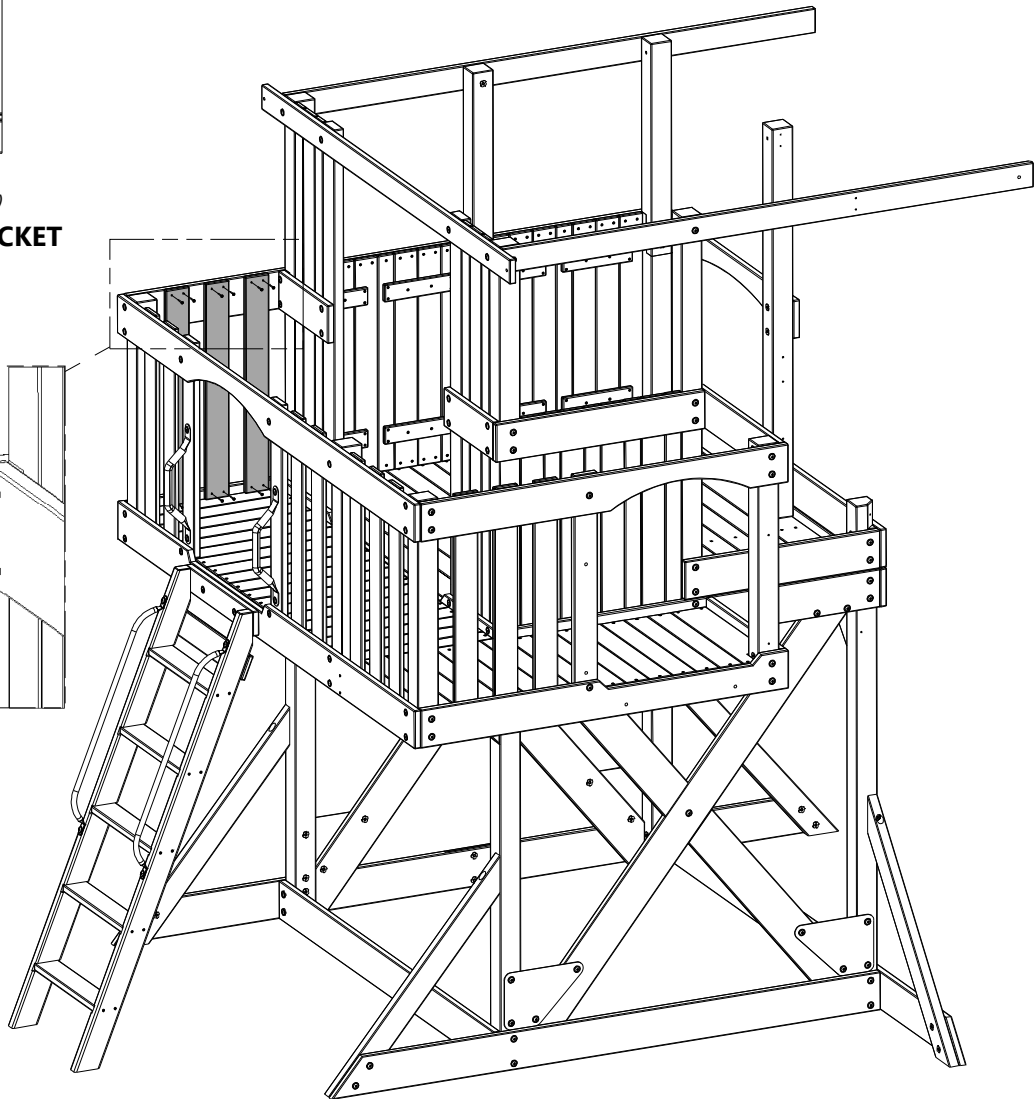

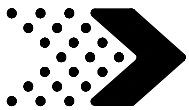

Phase 4

STEP 1



H5 | FLOOR SUPPORT - W4L08479
(x1) | 1"x3 3/8"x32" (24x86x813)



H21 | BASE BOARD - W4L08563
(x1) | 1"x3 3/8"x35" (24x86x889)

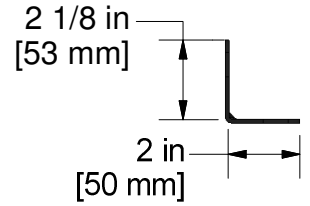

A4M00615 | L BRACKET BLK
(x2)



H100197 | LAG SCREW WH BLK
(x1) | 5/16x2 1/2



H100198 | WASHER LOCK EXT BLK
(x1) | 8x19



H100396 | BOLT WH BLK
(x4) | 5/16x1/2



H100199 | WASHER LOCK EXT BLK
(x2) | 12x19



H100192 | NUT BARREL WH BLK
(x2) | 5/16x7/8



H100379 | T-NUT BLK
(x2) | 5/16



NOTE:

1. ASSEMBLE THE SUB ASSEMBLY FIRST.
2. PRESS SUB ASSEMBLY AGAINST CORNER RAILS AND MARK 'L' BRACKET HOLES.
3. DRILL THROUGH MARKED FLOOR BOARDS USING A 3/8" (10 MM) DRILL BIT.
4. ATTACH SUB ASSEMBLY TO FORT FLOOR USING HARDWARE SHOWN BELOW.
5. INSTALL T-NUTS INTO FLOOR BOARDS BEFORE ASSEMBLY.

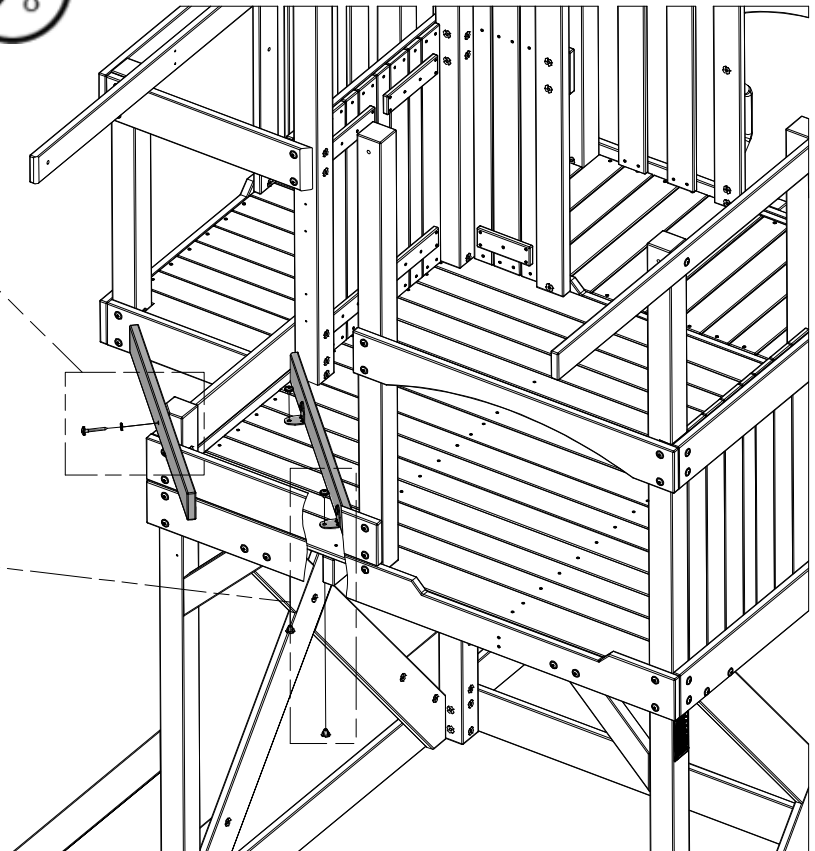
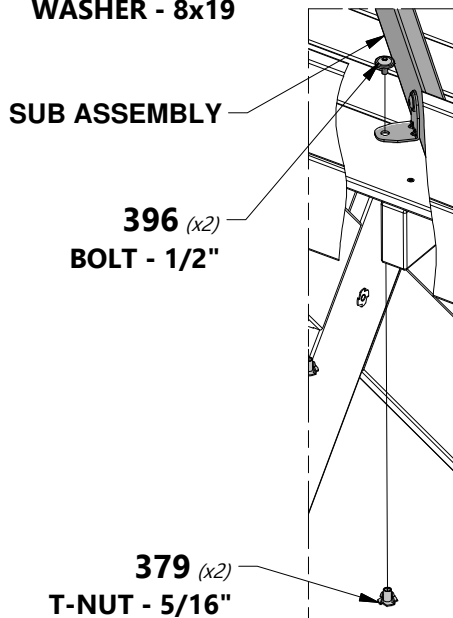
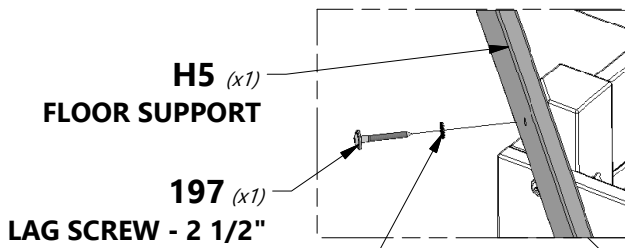
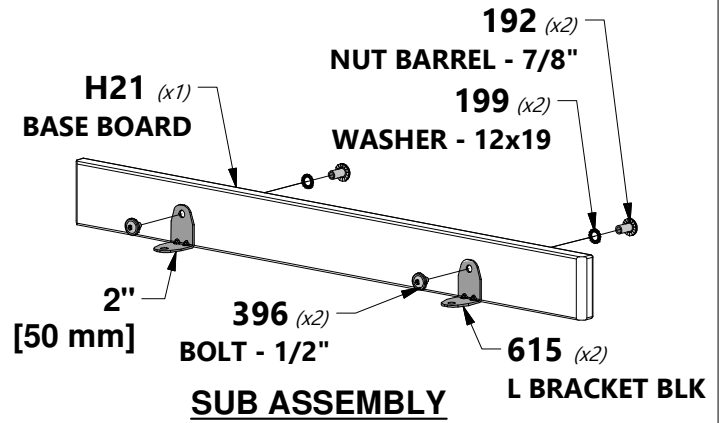

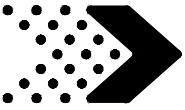

Phase 4

STEP 2

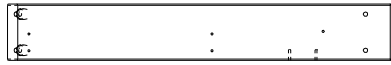

G7 | WALL SUPPORT - W4L12842
(x1) | 1"x5 1/4"x36" (24x134x915)

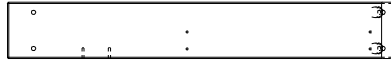

G10 | WALL SUPPORT - W4L08481
(x1) | 1"x5 1/4"x36" (24x134x915)



H100197 | LAG SCREW WH BLK
(x4) | 5/16x2 1/2



H100198 | WASHER LOCK EXT BLK
(x4) | 8x19



H100391 | SCREW PFH BLK
(x4) | 8x2

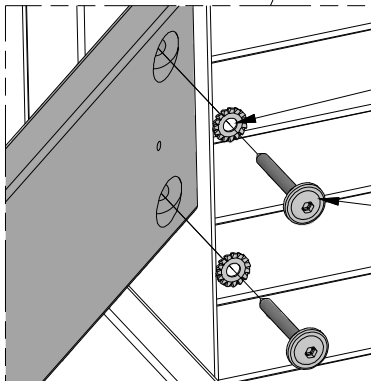
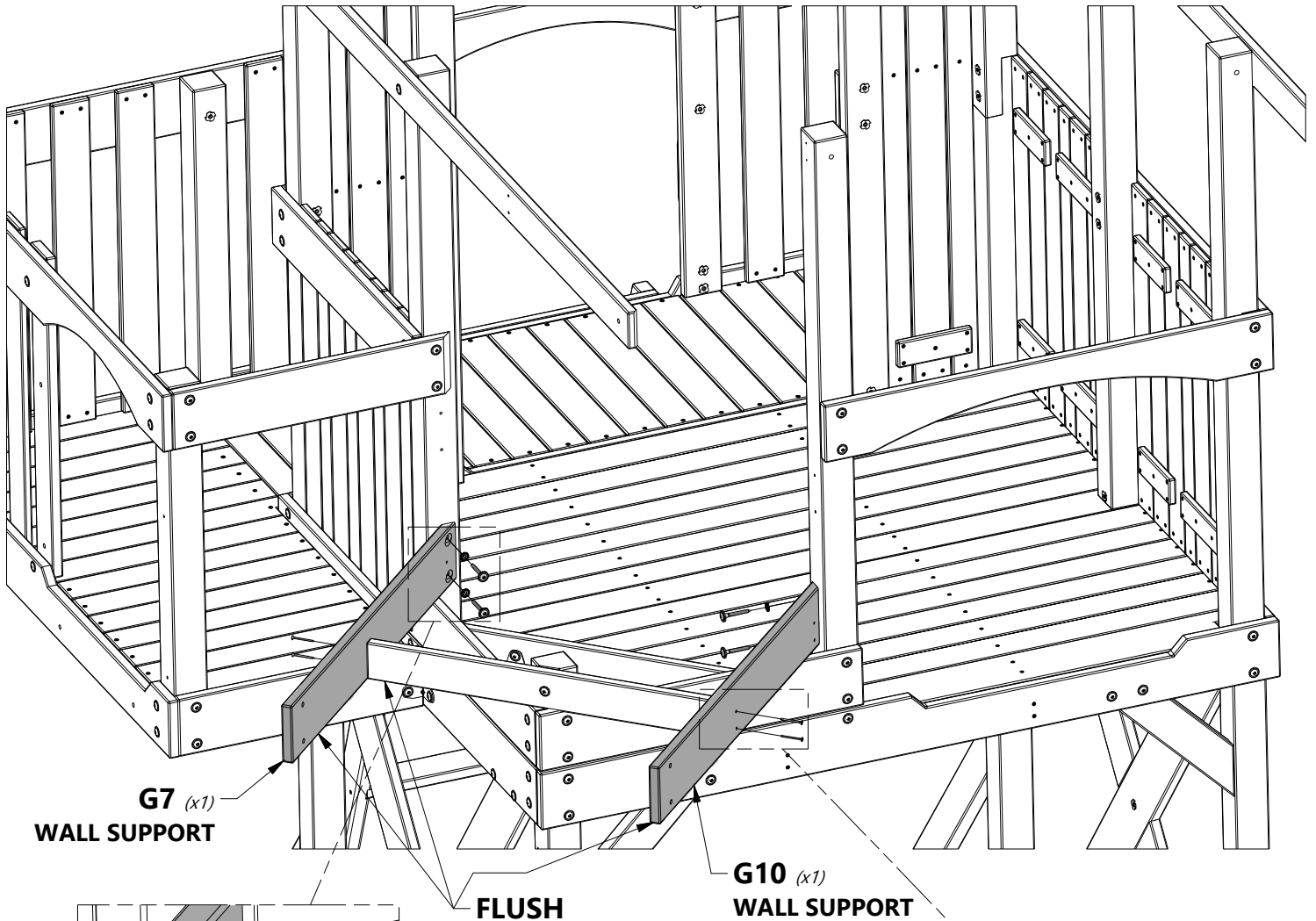

198 (x4)
WASHER - 8x19

197 (x4)
LAG SCREW - 2 1/2"

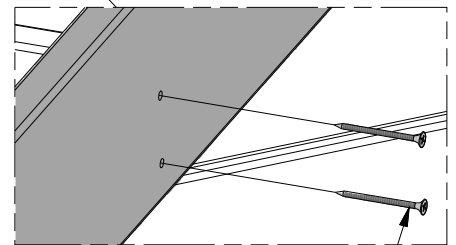

391 (x4)
SCREW - 2"

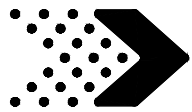

Phase 4

STEP 3

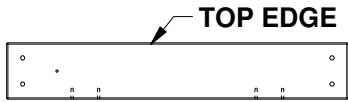

G8 | WALL SUPPORT - W4L12843
(x1) | 1"x5 1/4"x32" (24x134x813)



B10 | POST - W4L08484
(x1) | 3"x3"x47 1/4" (76x76x1201)

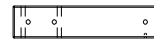

B12 | POST - W4L08487
(x1) | 3"x3"x13 5/8" (76x76x345)



H100415 | BOLT WH BLK
(x8) | 5/16x3 3/4



H100458 | LAG SCREW WH BLK
(x1) | 5/16x2



H100379 | T-NUT BLK
(x8) | 5/16



H100198 | WASHER LOCK EXT BLK
(x9) | 8x19



TIP:
WE RECOMMEND INSTALLING T-NUTS INTO
BOARDS BEFORE ASSEMBLY.

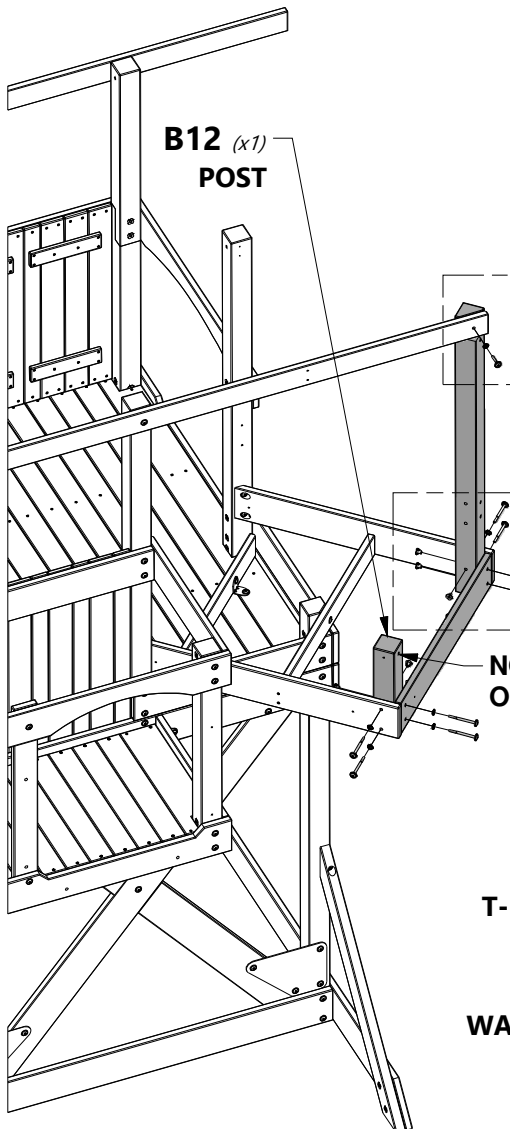

B12 (x1)
POST

NOTE HOLE
ORIENTATION.

379 (x8)
T-NUT - 5/16"

G8 (x1)
WALL SUPPORT

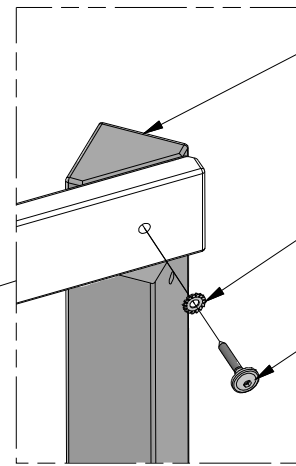

B10 (x1)
POST

198 (x1)
WASHER - 8x19

458 (x1)
LAG SCREW - 2"

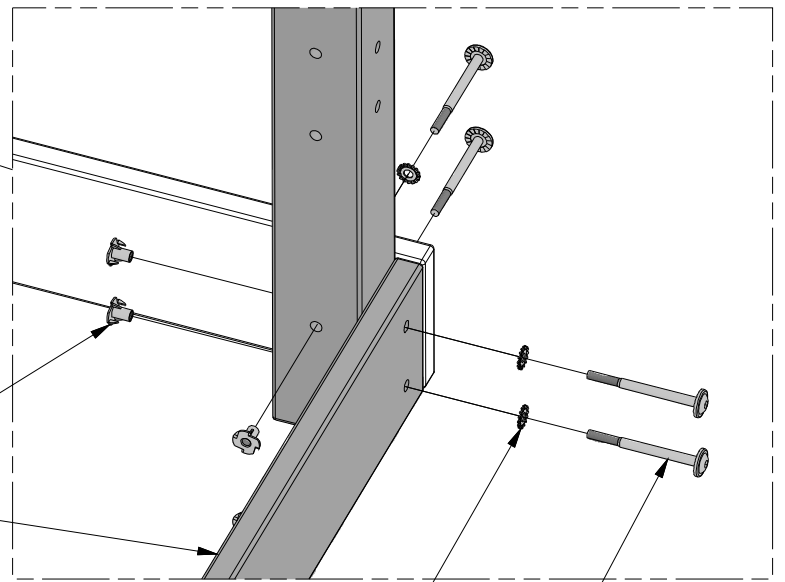

198 (x8)
WASHER - 8x19

415 (x8)
BOLT - 3 3/4"

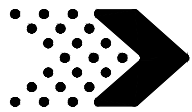

Phase 4

STEP 4

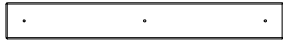

H7 | FLOOR SUPPORT - W4L08483
(x1) | 1"x3 3/8"x26" (24x86x661)



H6 | FLOOR SUPPORT - W4L08482
(x1) | 1"x3 3/8"x32" (24x86x813)



H20 | FLOOR SUPPORT - W4L08562
(x2) | 1"x2 3/4"x3" (24x70x76)



H100382 | SCREW PFH BLK
(x3) | 8x1 3/4



H100391 | SCREW PFH BLK
(x8) | 8x2

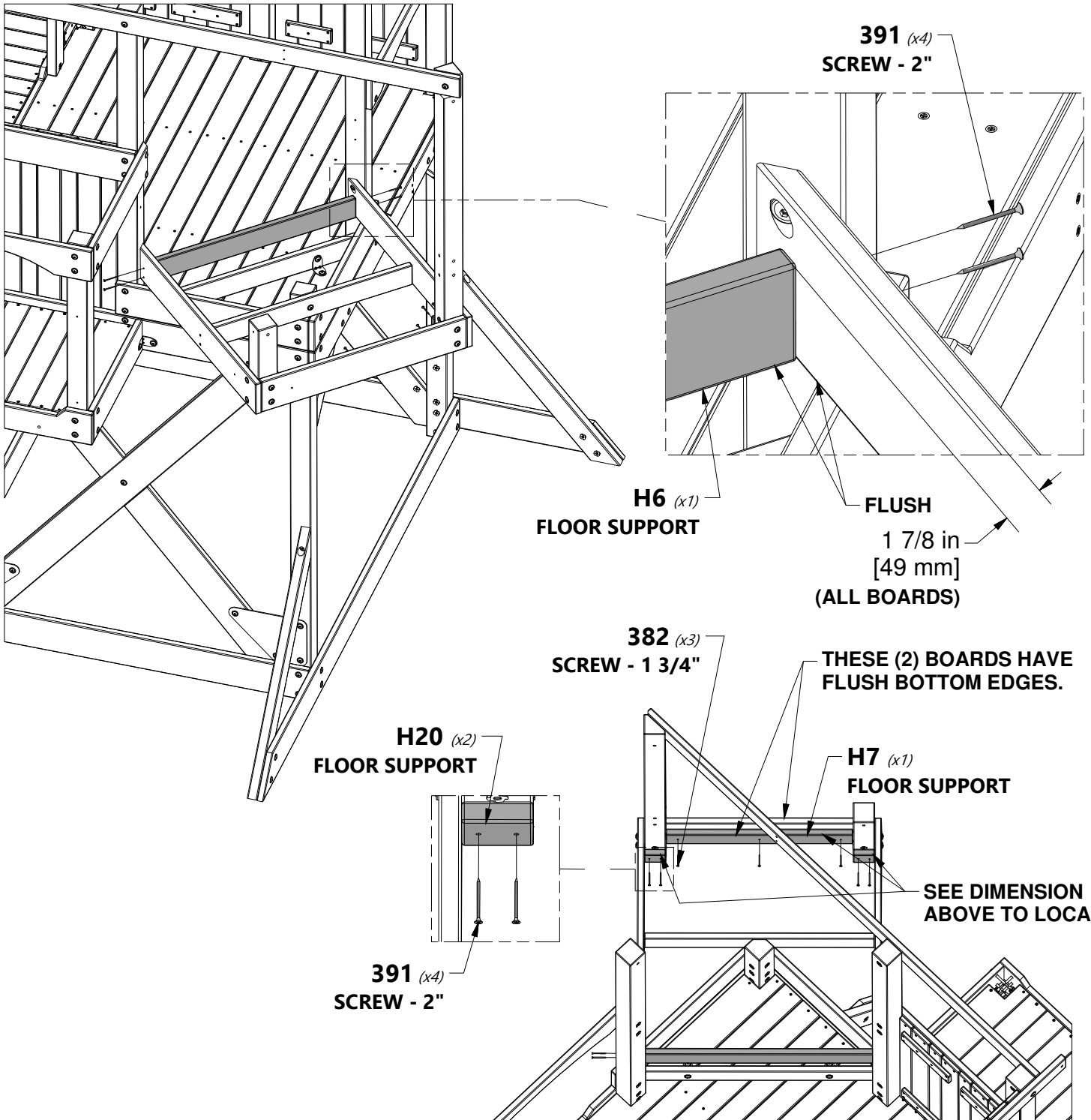

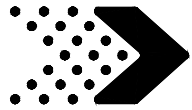

Phase 4

STEP 5



E8 | ANGLE SUPPORT BRACE - W4L12935
(x2) | 1 3/8"x3 3/8"x25 3/8" (36x86x643)



G5 | CROSS BRACE - W4L12915
(x2) | 1"x5 1/4"x17 3/4" (24x134x450)



H100484 | BOLT WH BLK
(x2) | 5/16x3 1/4



H100482 | LAG SCREW WH BLK
(x2) | 5/16x3 1/2



H100198 | WASHER LOCK EXT BLK
(x4) | 8x19



H100487 | LAG SCREW WH BLK
(x8) | 1/4x2

H100379 | T-NUT BLK
(x2) | 5/16



H100405 | WASHER LOCK EXT BLK
(x8) | 6x15



NOTE:

1. ASSEMBLE THE SUB ASSEMBLIES FIRST. (NOTE: THERE IS A LEFT & RIGHT ASSEMBLY).
2. ATTACH SUB ASSEMBLIES TO TURRET DECK FLOOR USING HARDWARE SHOWN BELOW.



TIP:

WE RECOMMEND INSTALLING T-NUTS INTO BOARDS BEFORE ASSEMBLY.

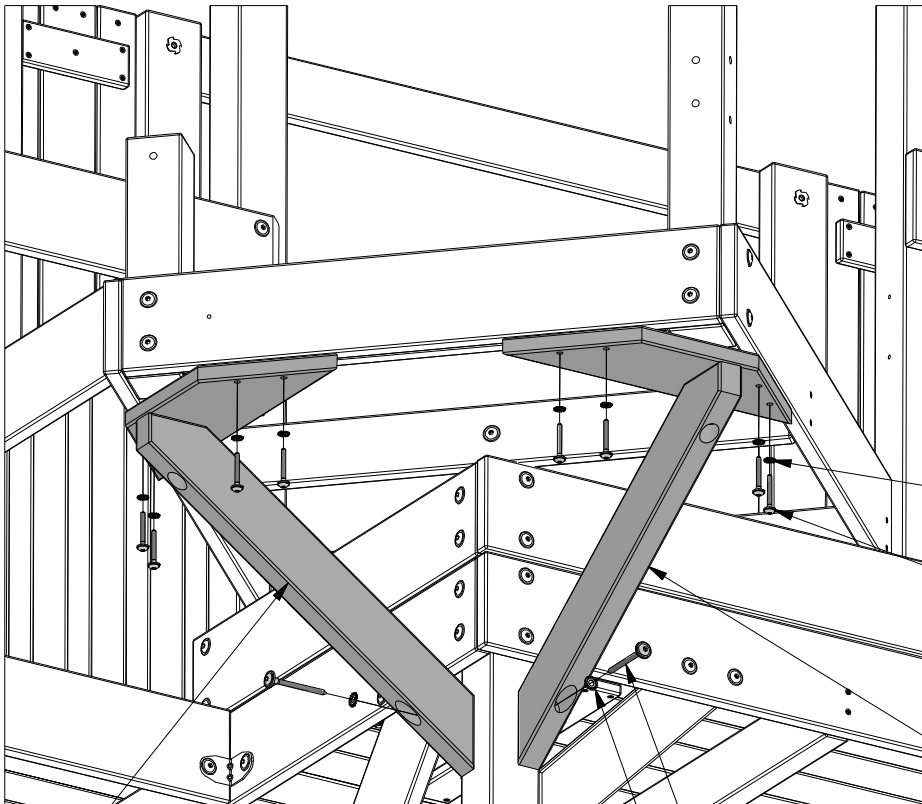
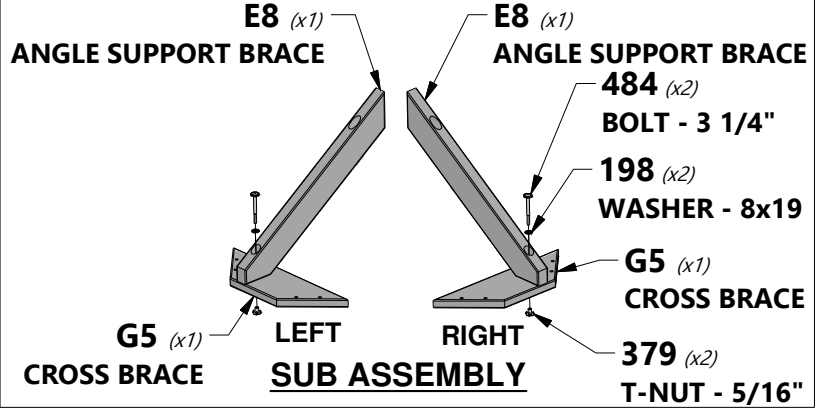

405 (x8) WASHER - 6x15

487 (x8) LAG SCREW - 2"

LEFT SUB ASSEMBLY

RIGHT SUB ASSEMBLY

198 (x2) WASHER - 8x19

482 (x2) LAG SCREW - 3 1/2"

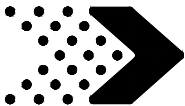

Phase 4

STEP 6

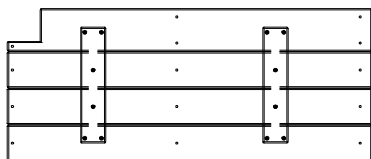

FP8 | FLOOR PANEL - W2A02912
(x1) | 1 1/4"x14 5/16"x34 3/16" (32x363x869)

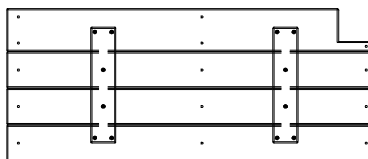

FP9 | FLOOR PANEL - W2A02913
(x1) | 1 1/4"x14 5/16"x34 3/16" (32x363x869)

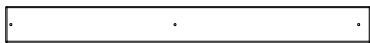

M1 | FLOOR BOARD - W4L08489
(x1) | 5/8"x3 3/8"x34 1/4" (16x86x869)



H100200 | SCREW PFH BLK
(x31) | 8x1 1/2

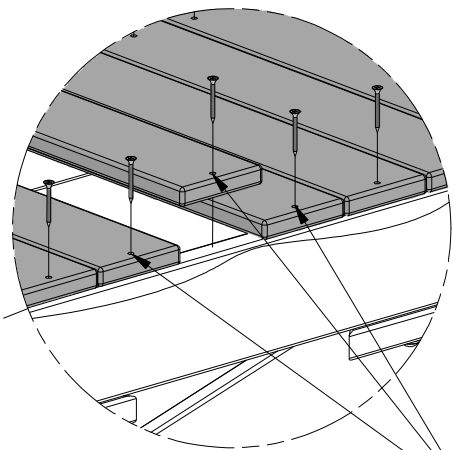
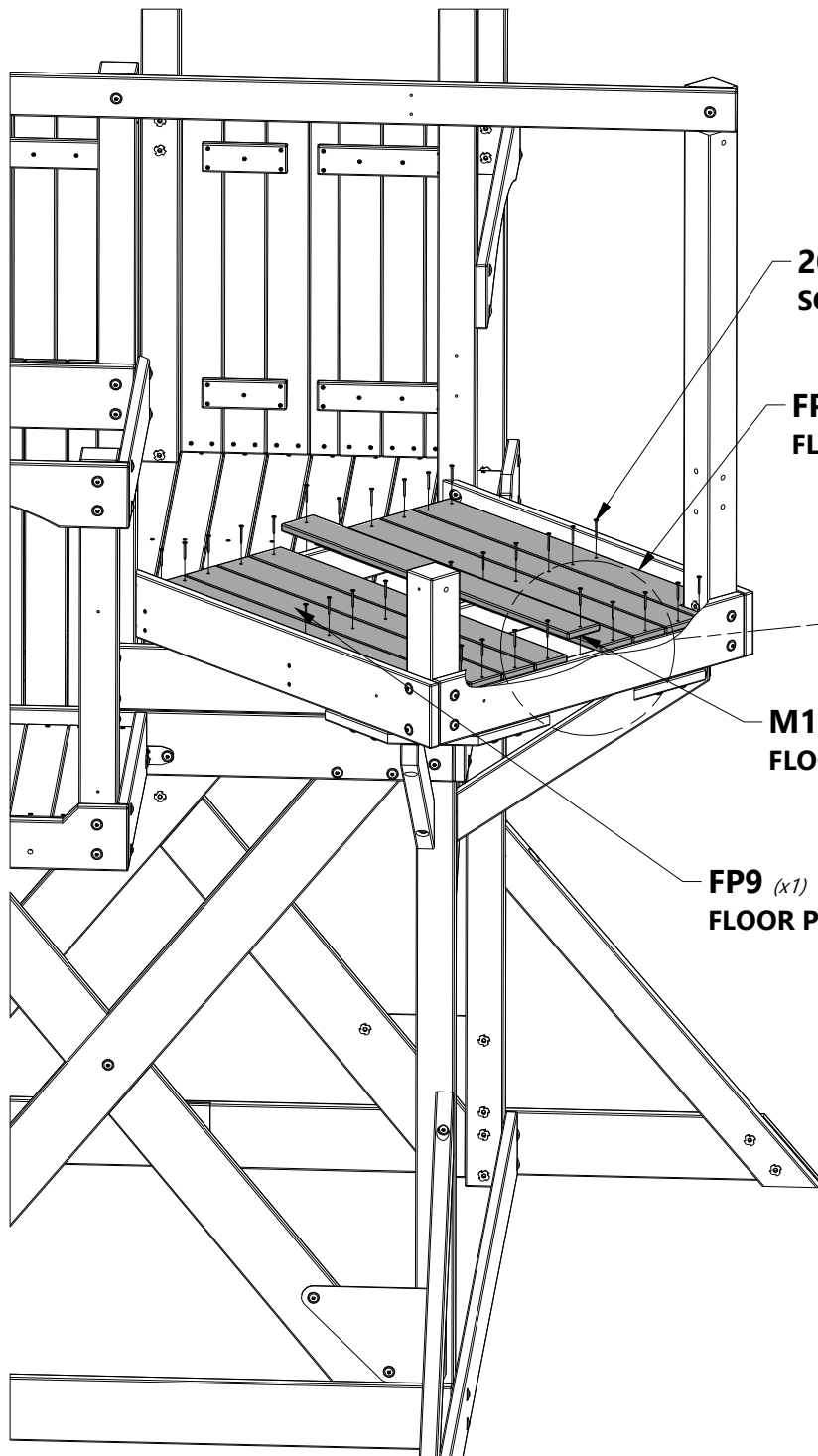

NOTE HOLE PLACEMENT FOR PROPER ASSEMBLY.

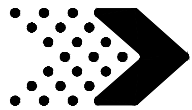

Phase 4

STEP 7



G11 | WALL SUPPORT - W4L08486
(x1) | 1"x5 1/4"x7 1/2" (24x134x192)



G14 | WALL SUPPORT - W4L08492
(x1) | 1"x5 1/4"x10 5/8" (24x134x269)



G26 | WALL SUPPORT - W4L08485
(x1) | 1"x5 1/4"x36" (24x134x915)



H100197 | LAG SCREW WH BLK
(x4) | 5/16x2 1/2



H100379 | T-NUT BLK
(x8) | 5/16



H100415 | BOLT WH BLK
(x4) | 5/16x3 3/4



H100198 | WASHER LOCK EXT BLK
(x8) | 8x19



TIP:

WE RECOMMEND INSTALLING T-NUTS INTO BOARDS BEFORE ASSEMBLY.

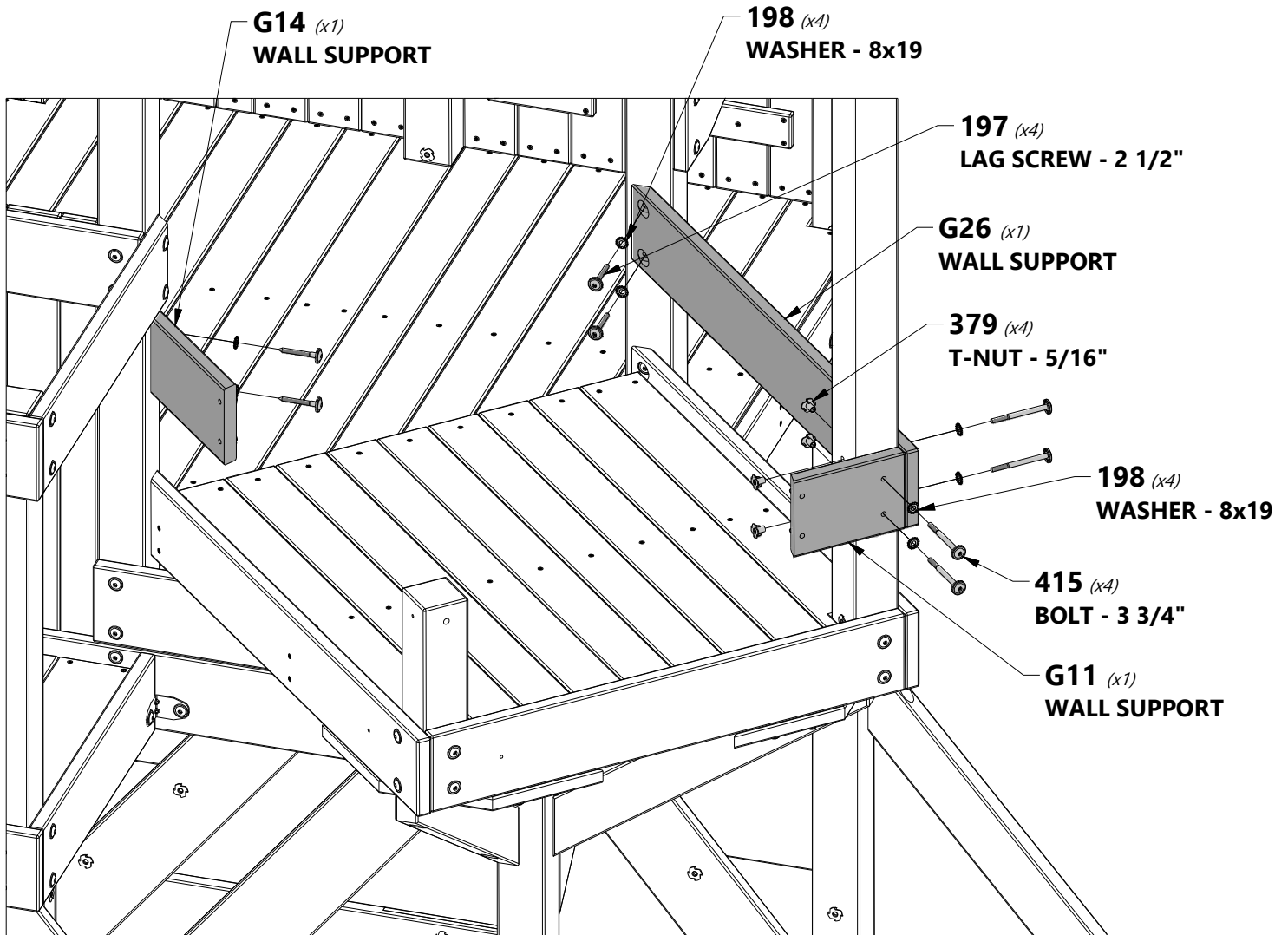

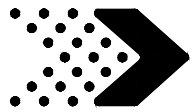

Phase 4

STEP 8



J2 | FLOOR SUPPORT - W4L12844
(x1) | 1"x2 3/8"x23 3/8" (24x60x594)



J3 | FLOOR SUPPORT - W4L12845
(x1) | 1"x2 3/8"x24 3/8" (24x60x619)



H100415 | BOLT WH BLK
(x1) | 5/16x3 3/4



H100458 | LAG SCREW WH BLK
(x1) | 5/16x2



H100379 | T-NUT BLK
(x1) | 5/16



H100198 | WASHER LOCK EXT BLK
(x2) | 8x19



TIP:
WE RECOMMEND INSTALLING T-NUTS INTO BOARDS BEFORE ASSEMBLY.

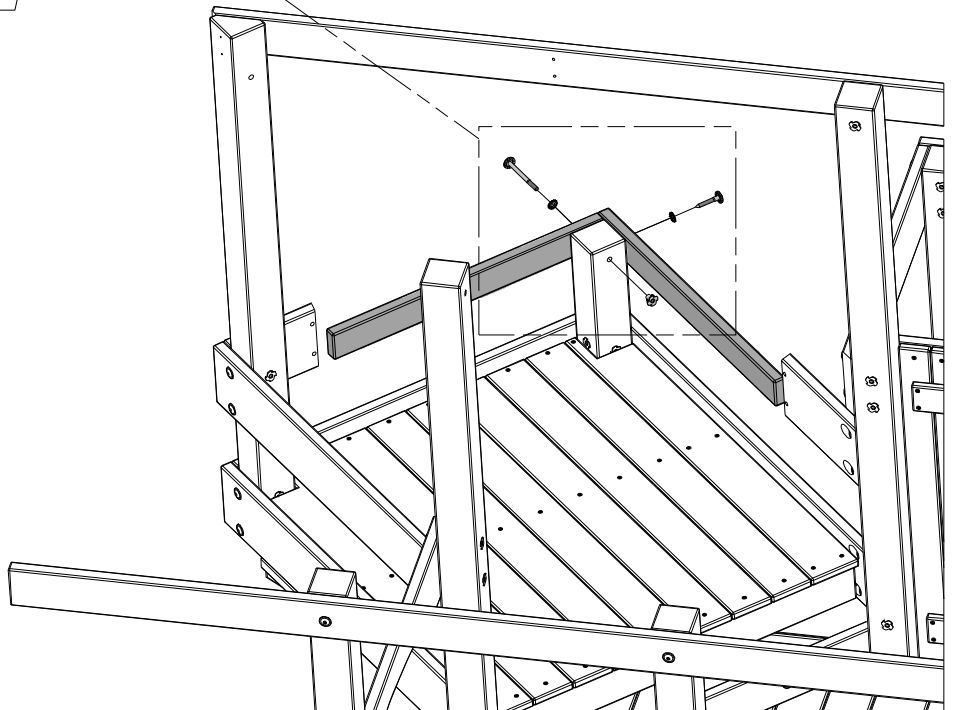
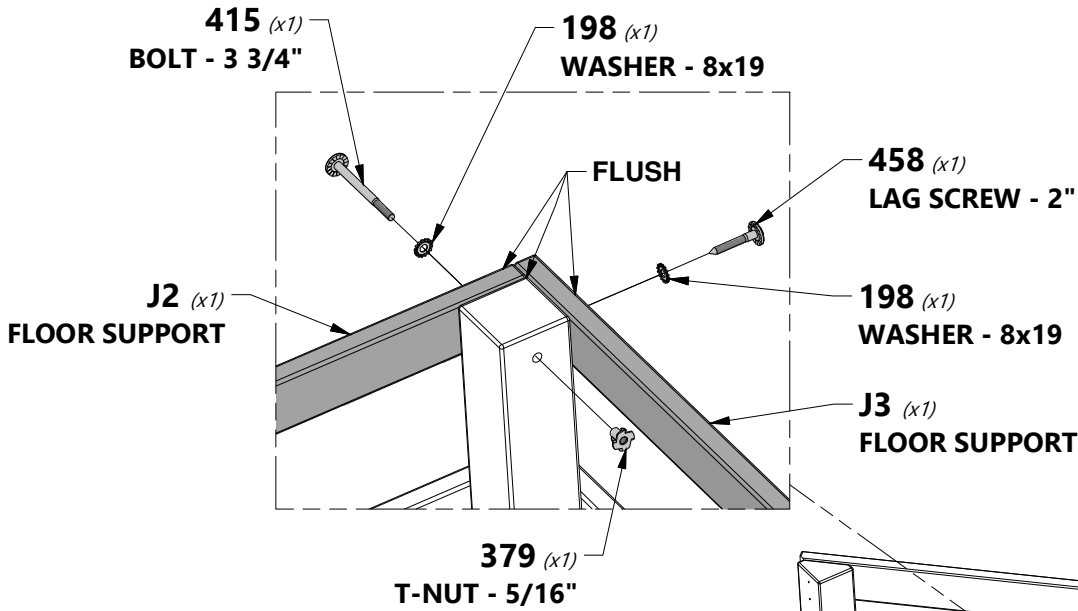

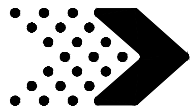

Phase 4

STEP 9

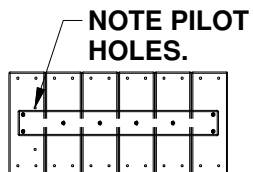

WP6 | WALL PANEL - W2A02908
(x1) | 1/16"x1/16"x1/16" (32x243x521)

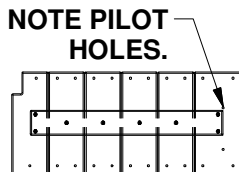

WP7 | WALL PANEL - W2A02909
(x1) | 1/16"x1/16"x1/16" (32x547x243)



H100387 | SCREW PFH BLK
(x46) | 8x1-1/4

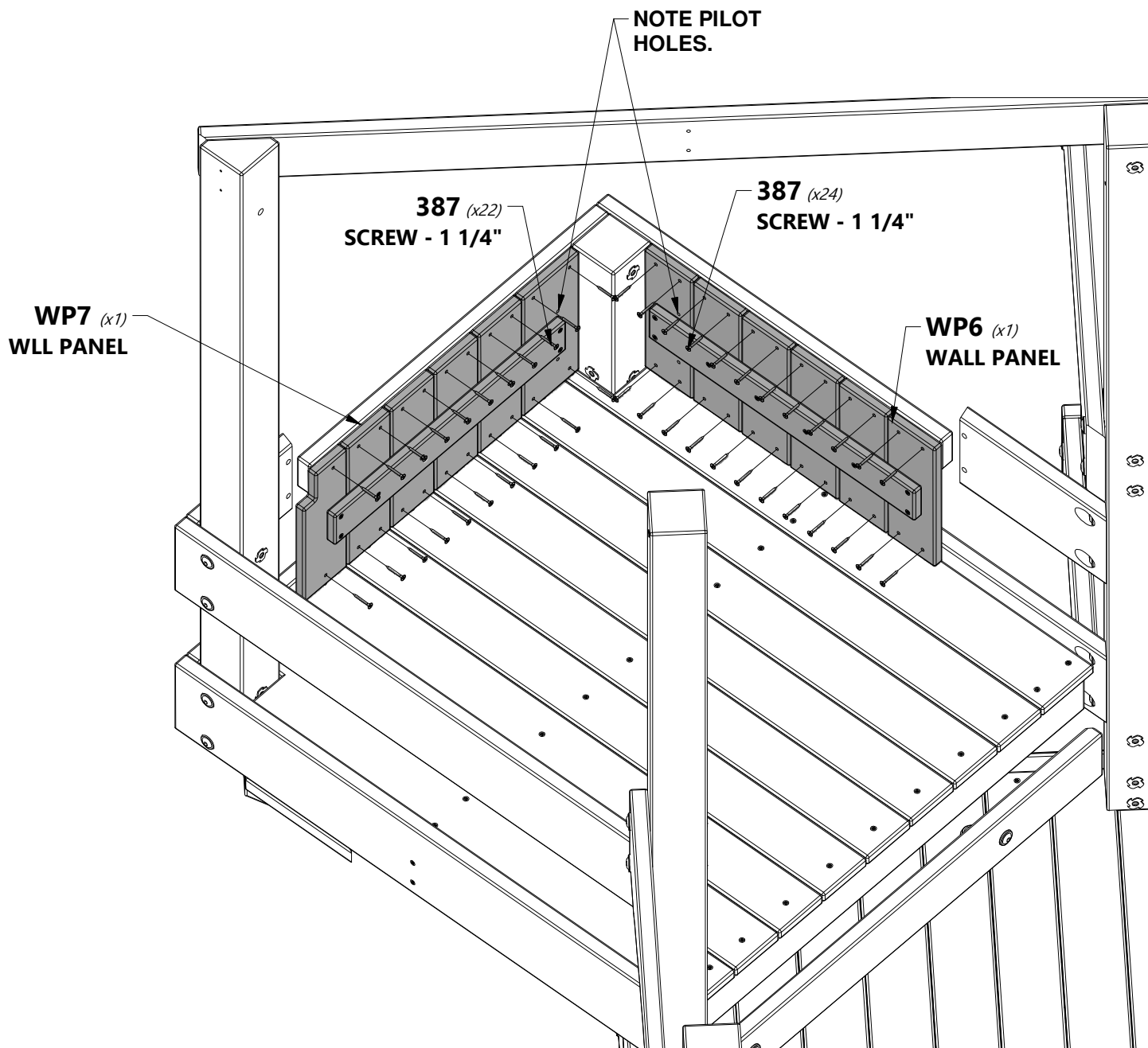

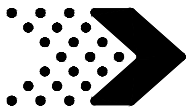

H17 | WALL SUPPORT - W4L08533
(x1) 1"x3 3/8"x35" (24x86x889)



H100391 | SCREW PFH BLK
(x4) 8x2

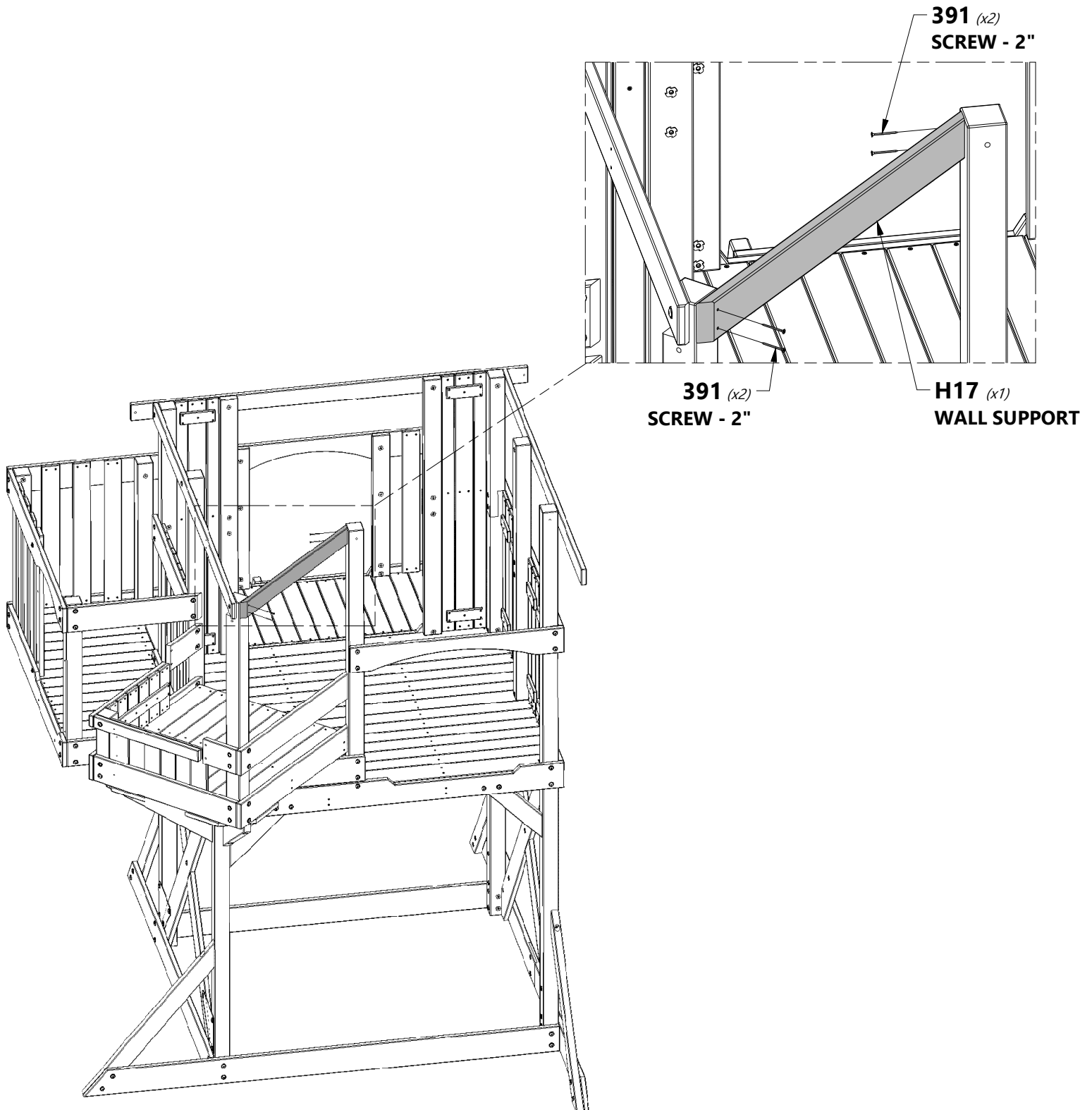

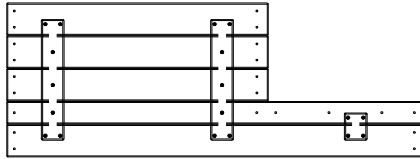
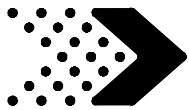

WP8 | LEFT WINDOW WALL PANEL - W2A02910
(x1) | 1 1/4"x16"x43 1/4" (32x407x1099)

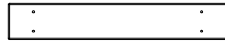

M20 | WALL BOARD - W4L08536
(x1) | 5/8"x3 3/8"x20 1/2" (16x86x521)

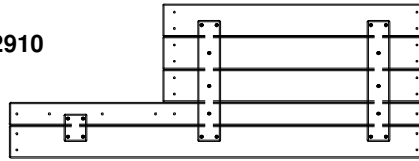

WP9 | RIGHT WINDOW WALL PANEL - W2A02911
(x1) | 1 1/4"x15 7/8"x43 1/4" (32x404x1099)



H100387 | SCREW PFH BLK
(x28) | 8x1-1/4



NOTE:

INSTALL 'WP8' AND 'WP9' PANELS BEFORE INSTALLING 'M20' BOARD.

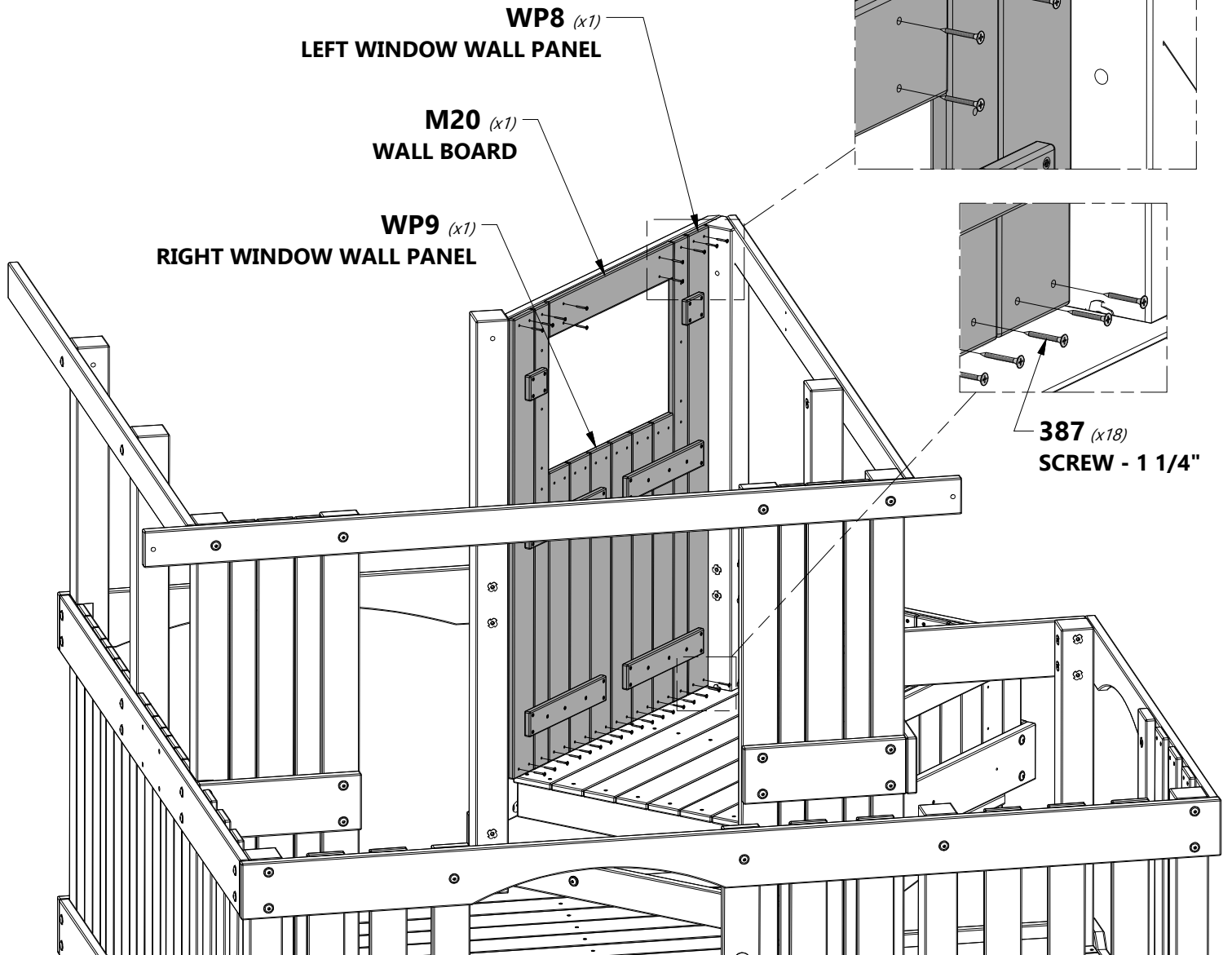

387 (x10)
SCREW - 1 1/4"

WP8 (x1)
LEFT WINDOW WALL PANEL

M20 (x1)
WALL BOARD

WP9 (x1)
RIGHT WINDOW WALL PANEL

387 (x18)
SCREW - 1 1/4"

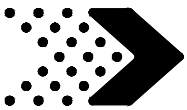

Phase 4

STEP 12



N2 | WINDOW BOTTOM - W4L08538
(x1) | 5/8"x2 3/8"x25 1/4" (16x60x640)



N3 | WINDOW SIDE - W4L08539
(x2) | 5/8"x2 3/8"x12 5/8" (16x60x321)



H100380 | SCREW PFH BLK
(x20) | 8x1 1/8"

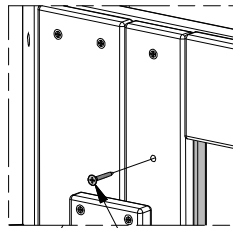

380 (x20)
SCREW - 1 1/8"

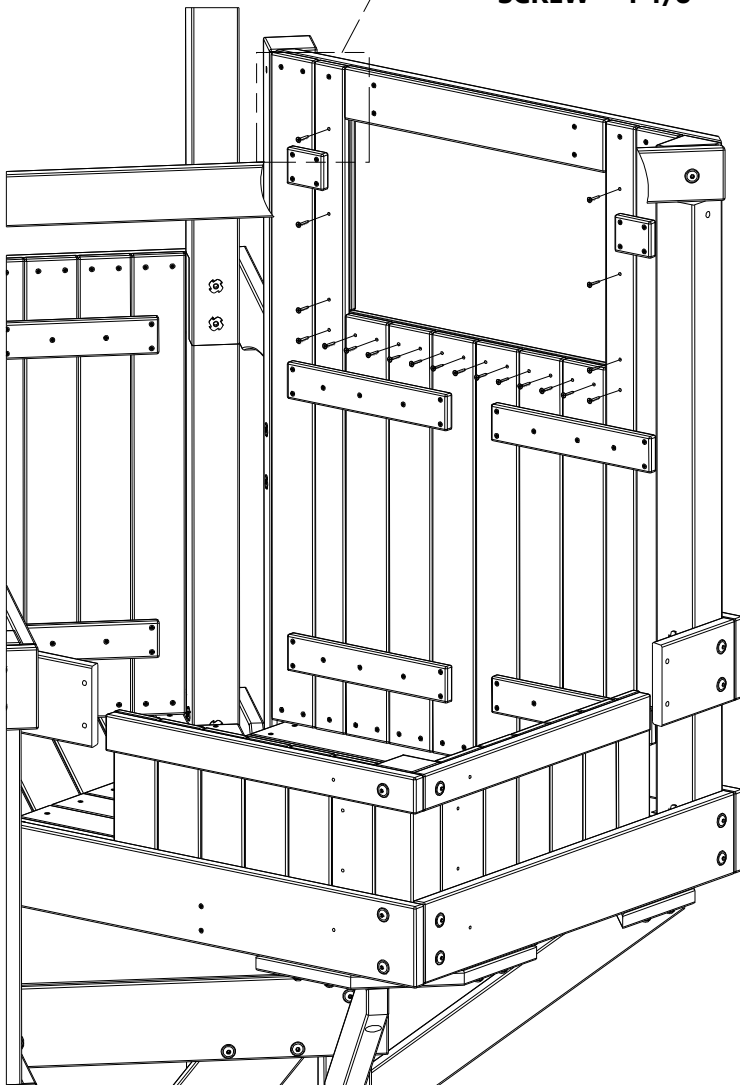

INSIDE VIEW

N3 (x2)
WINDOW SIDE

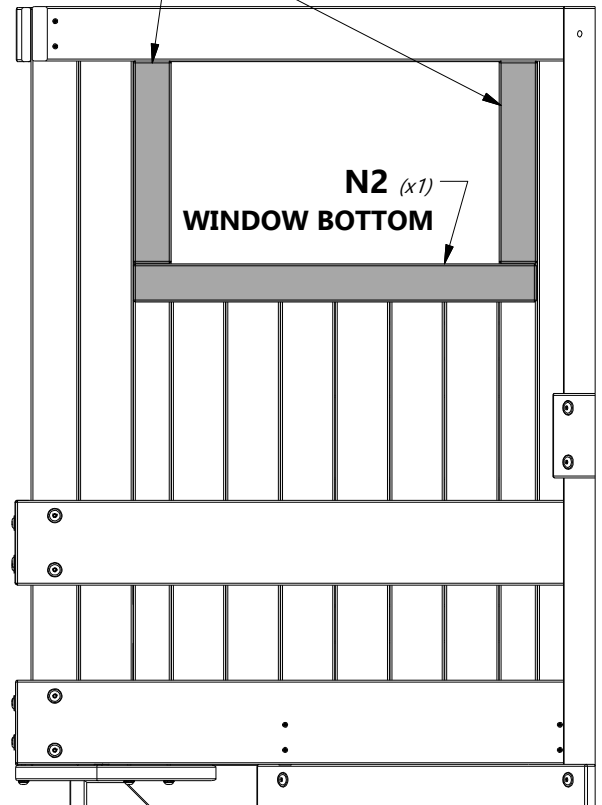

N2 (x1)
WINDOW BOTTOM

OUTSIDE VIEW

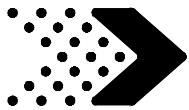

Phase 4

STEP 13



H12 | ROOF SUPPORT - W4L08519
(x1) | 1"x3 3/8"x39 1/2" (24x86x1004)



H18 | ROOF SUPPORT - W4L08541
(x1) | 1"x3 3/8"x28 1/4" (24x86x717)



H100415 | BOLT WH BLK
(x1) | 5/16x3 3/4



H100534 | BOLT WH BLK
(x1) | 5/16x4 1/2



H100379 | T-NUT BLK
(x1) | 5/16



H100198 | WASHER LOCK EXT BLK
(x2) | 8x19



H100199 | WASHER LOCK EXT BLK
(x1) | 12x19



H100192 | NUT BARREL WH BLK
(x1) | 5/16x7/8



H100391 | SCREW PFH BLK
(x2) | 8x2



TIP:

WE RECOMMEND INSTALLING T-NUTS INTO BOARDS BEFORE ASSEMBLY.

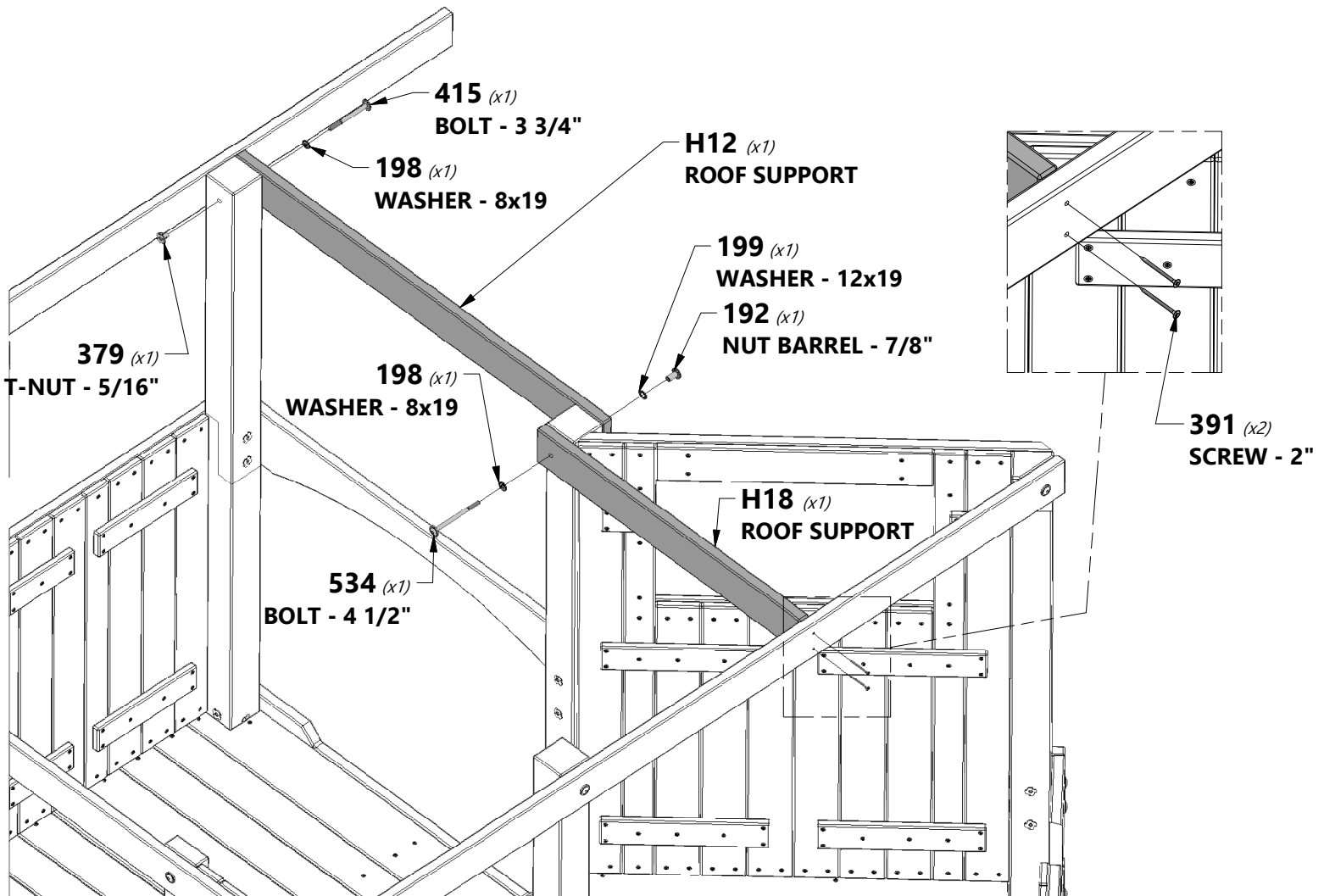

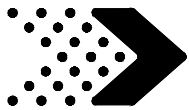

Phase 4

STEP 14



H14 | ROOF SUPPORT - W4L08521
(x1) | 1"x3 3/8"x74 3/4" (24x86x1900)



H100391 | SCREW PFH BLK
(x4) | 8x2

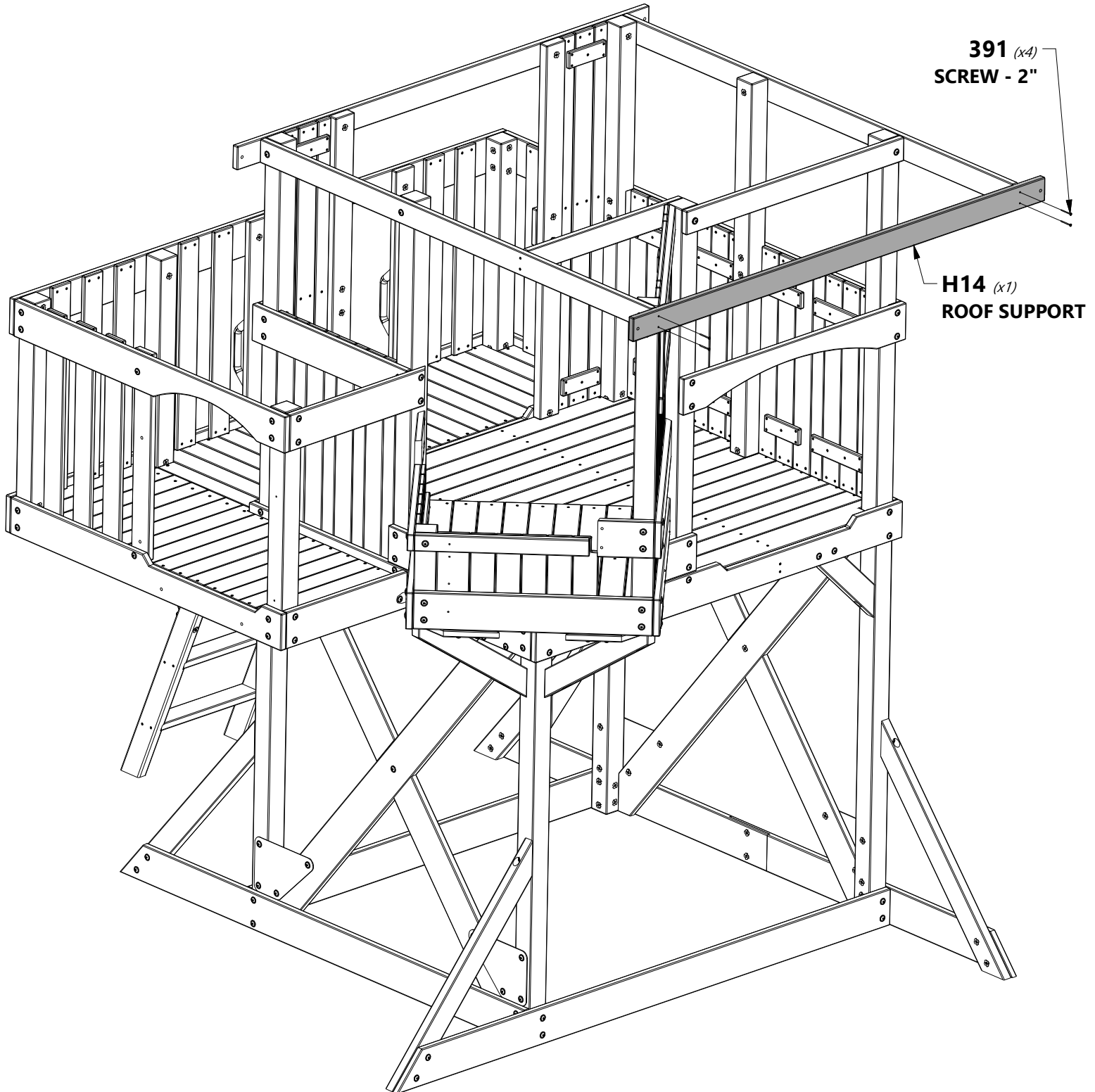

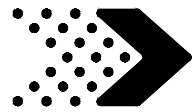

Phase 4

STEP 15



T2 | WALL BOARD - W4L12846
(x2) | 1"x1 3/8"x5 7/8" (24x34x150)



H100200 | SCREW PFH BLK
(x4) | 8x1 1/2

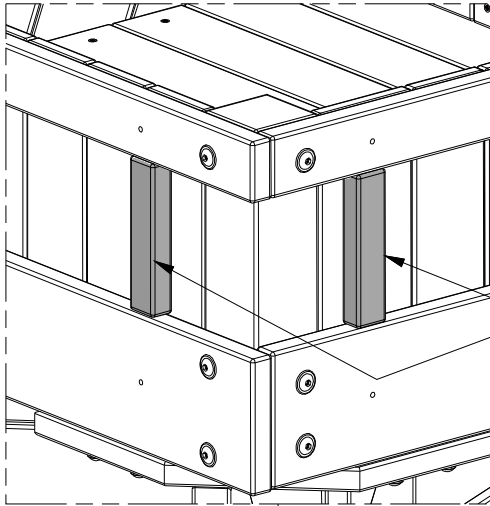

T2 (x2)
WALL BOARD

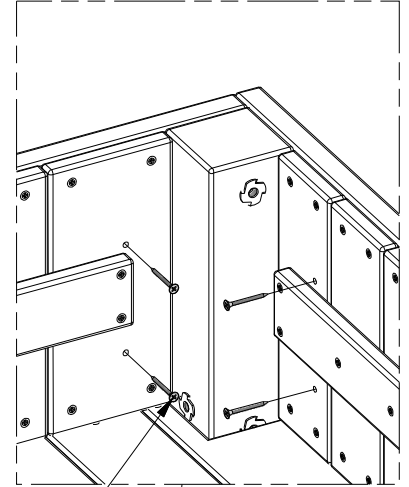

200 (x4)
SCREW - 1 1/2"

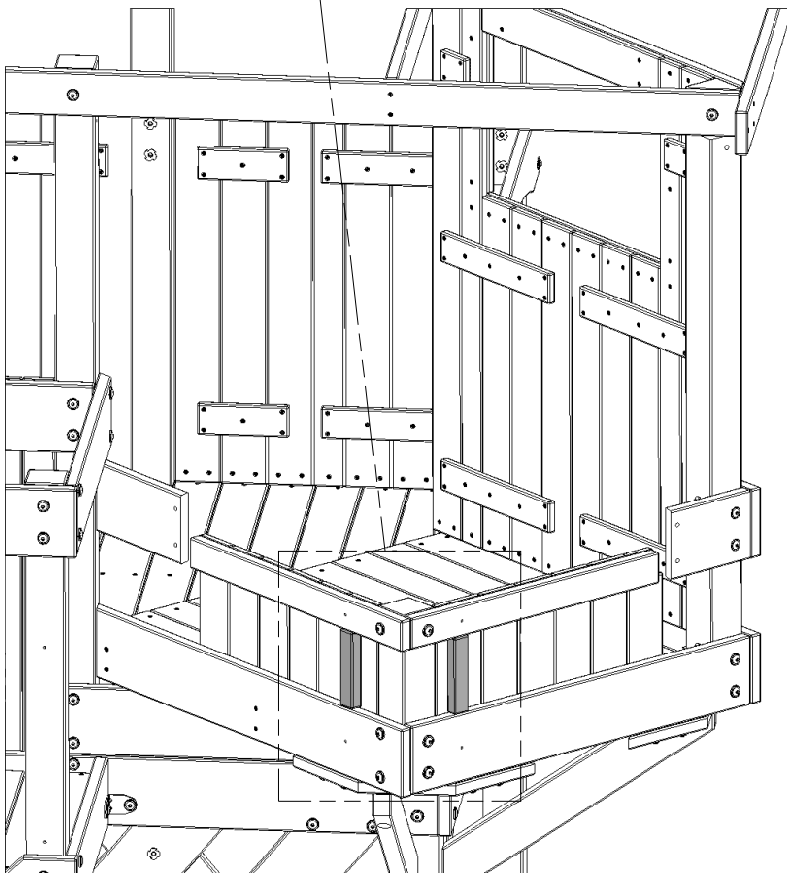

OUTSIDE VIEW

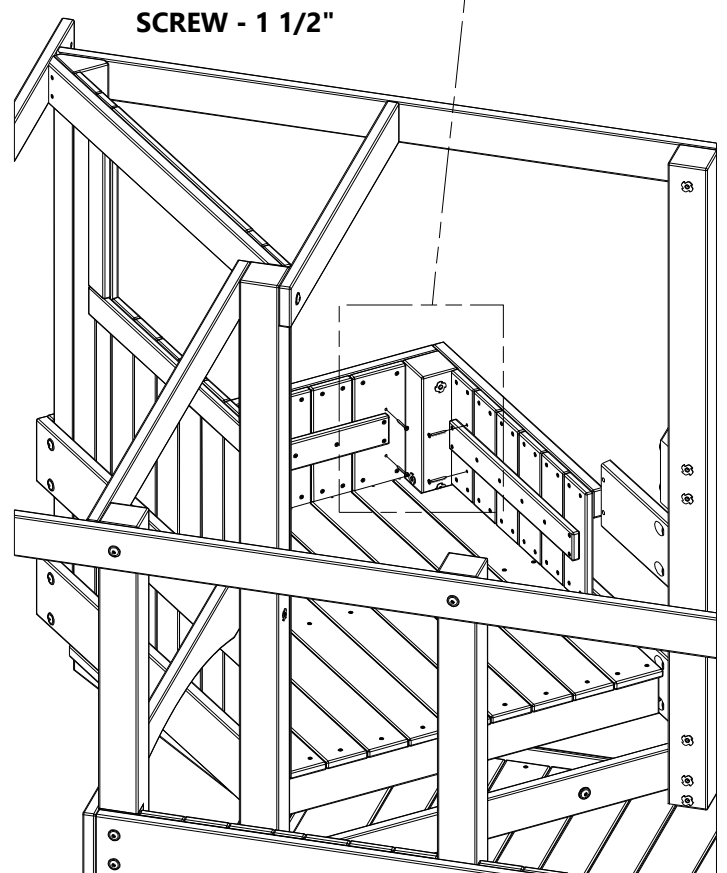

INSIDE VIEW

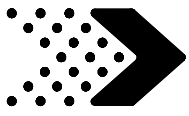

Phase 5

STEP 1



F1 | **POST - W4L08495**
(x2) | 1 3/8"x2 3/8"x54 5/8" (36x60x1389)



J1 | **WALL SUPPORT - W4L08496**
(x1) | 1"x2 3/8"x27 1/8" (24x60x688)

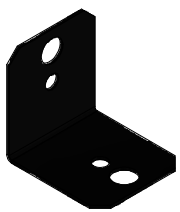

A4M00555 | **90° L-BRACKET - BLK**
(x2)



H100200 | **SCREW PFH BLK**
(x4) | 8x1 1/2



H100392 | **SCREW PWH BLK**
(x2) | 8x3/4

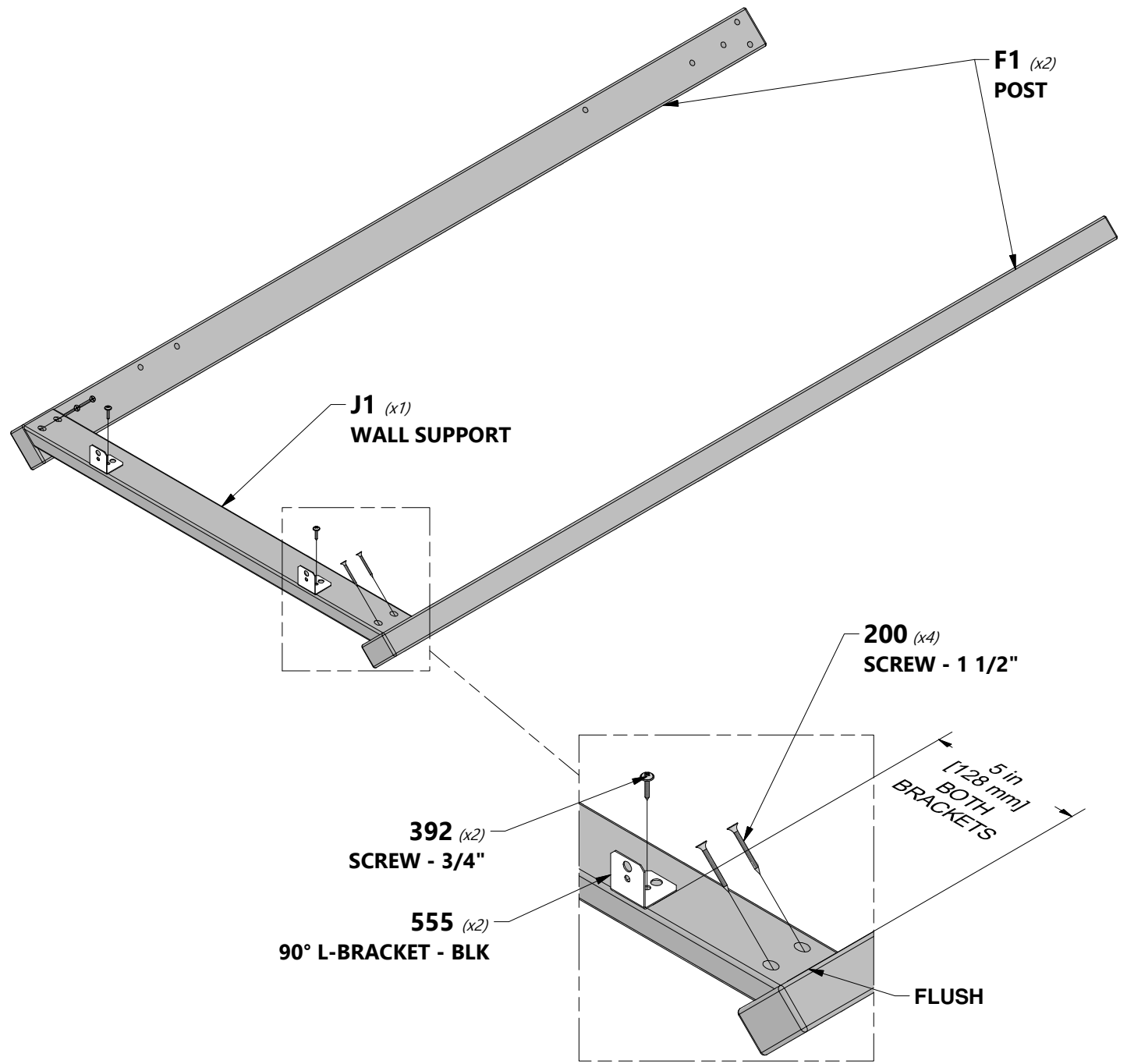

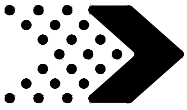

Phase 5

STEP 2



F2 | POST - W4L08503
(x1) | 1 3/8"x2 3/8"x47 1/4" (36x60x1200)

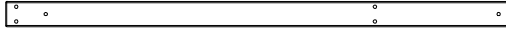

F3 | POST - W4L08504
(x1) | 1 3/8"x2 3/8"x47 1/4" (36x60x1200)

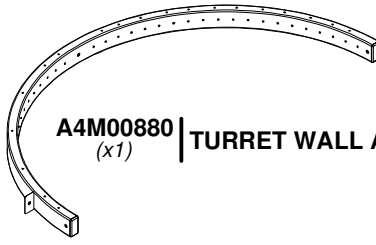

A4M00880 | TURRET WALL ARCH BAND
(x1)



A4M00881 | QUARTER ROUND TURRET FLOOR SUPPORT
(x1)



H100800 | BOLT WH BLK
(x2) | 1/4x3



H100567 | BOLT WH BLK
(x3) | 1/4x2 1/4



H100398 | T-NUT BLK
(x5) | 1/4



TIP:
WE RECOMMEND INSTALLING T-NUTS INTO
BOARDS BEFORE ASSEMBLY.

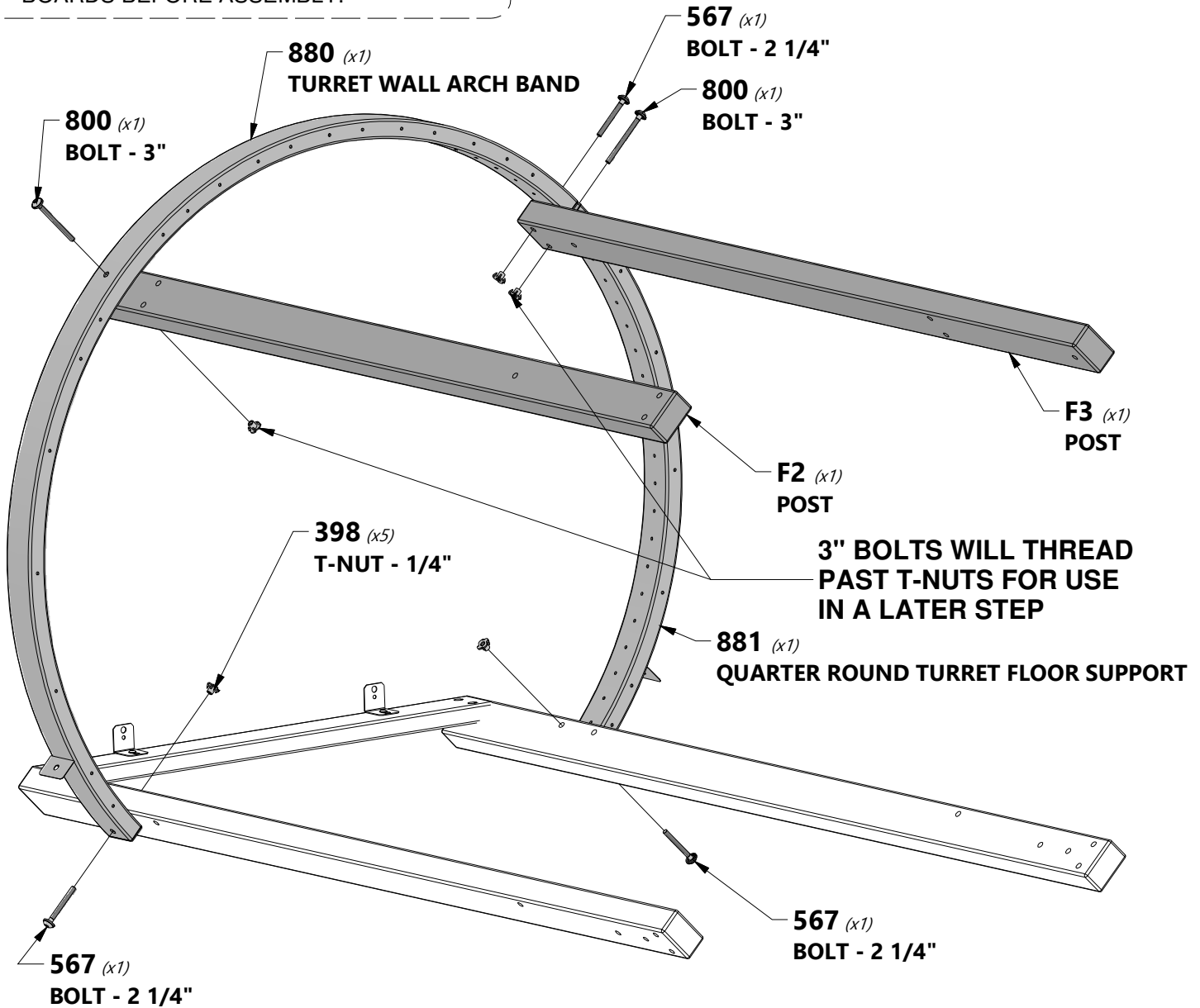

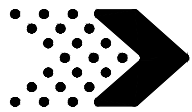

Phase 5

STEP 3

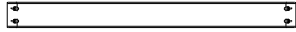

J1 | WALL SUPPORT - W4L08496
(x1) | 1"x2 3/8"x27 1/8" (24x60x688)



H100200 | SCREW PFH BLK
(x4) | 8x1 1/2

200 (x4)
SCREW - 1 1/2"

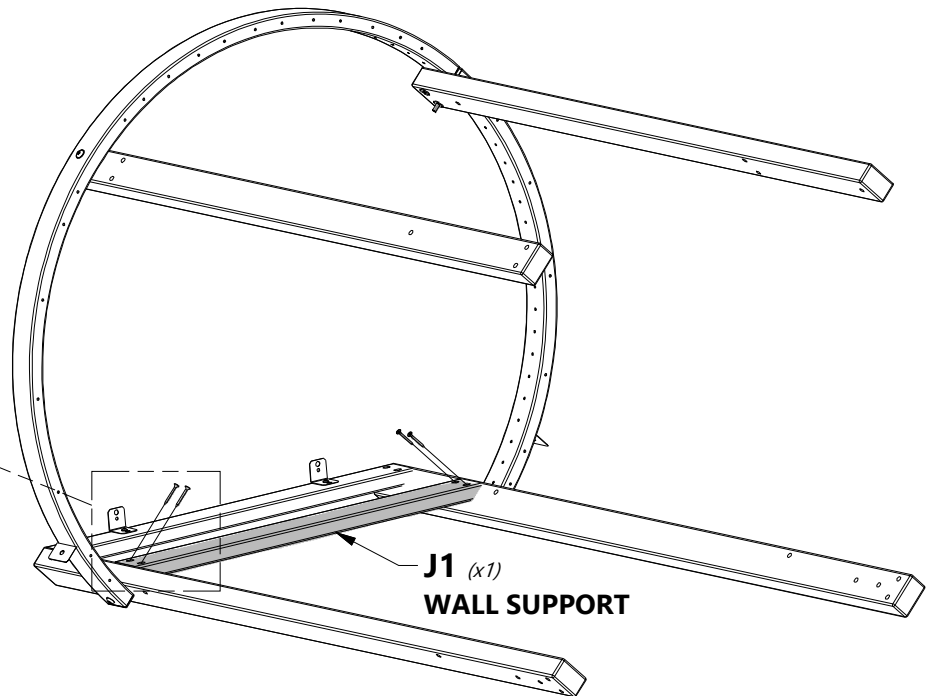
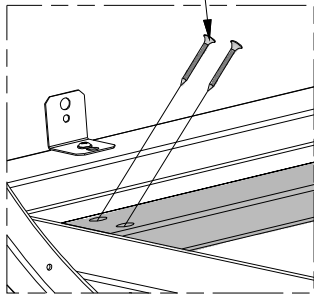

5 in
[124 mm]

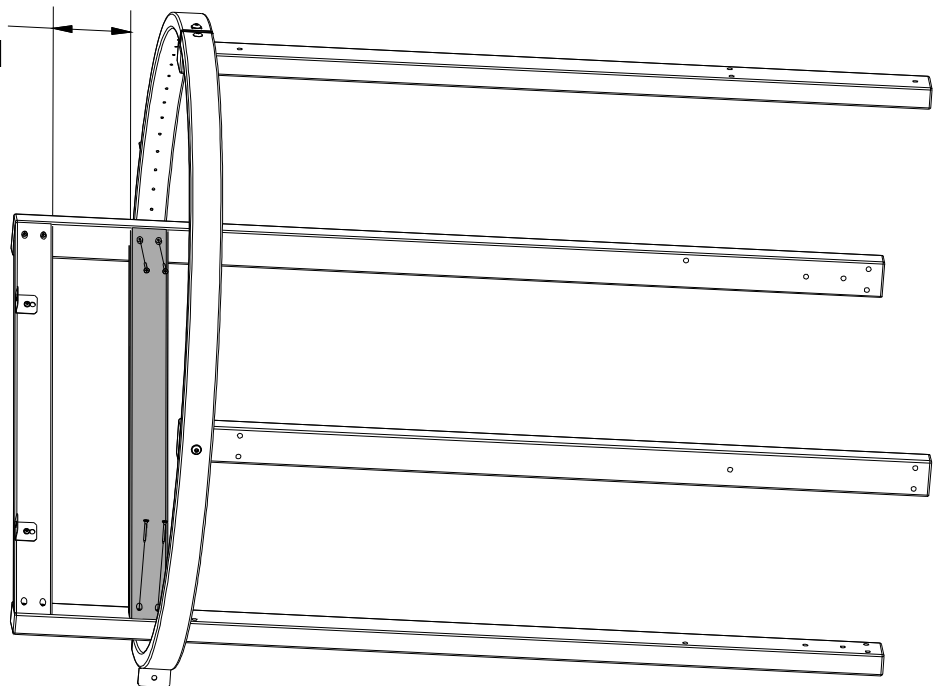

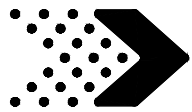

Phase 5

STEP 4

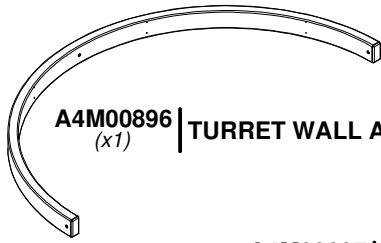

A4M00896 | TURRET WALL ARCH BAND
(x1)



A4M00897 | QUARTER ROUND TURRET FLOOR SUPPORT
(x2)



H100567 | BOLT WH BLK
(x7) | 1/4x2 1/4



H100398 | T-NUT BLK
(x7) | 1/4



TIP:

WE RECOMMEND INSTALLING T-NUTS INTO BOARDS BEFORE ASSEMBLY.

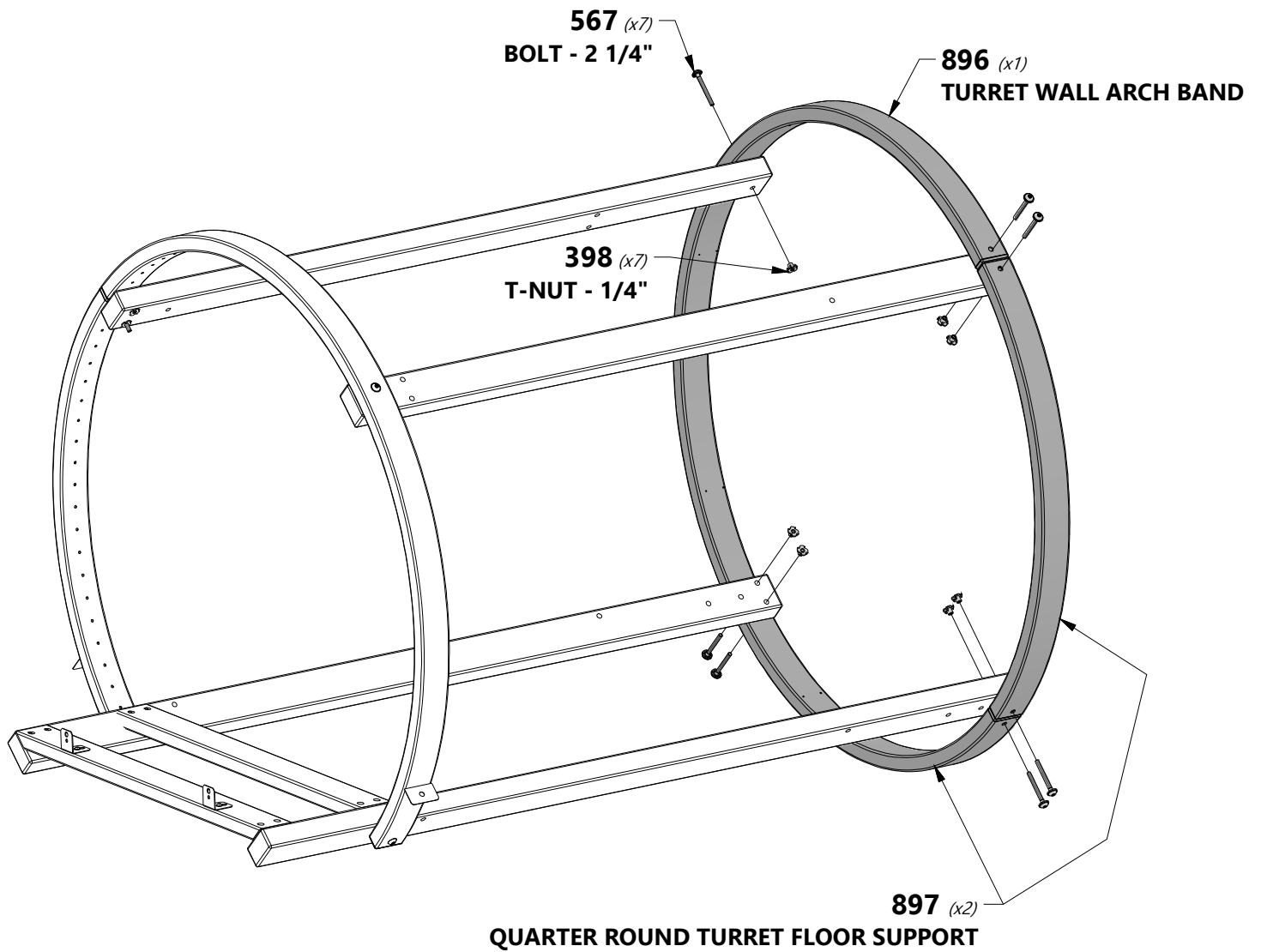

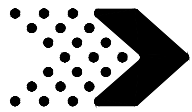

Phase 5

STEP 5

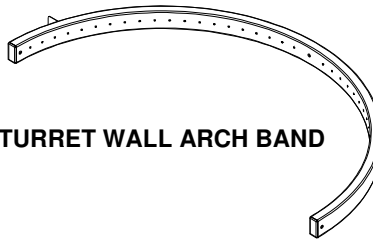

A4M00907 | TURRET WALL ARCH BAND
(x1)



A4M00883 | QUARTER ROUND TURRET FLOOR SUPPORT
(x1)



H100567 | BOLT WH BLK
(x5) | 1/4x2 1/4



H100398 | T-NUT BLK
(x5) | 1/4



TIP:
WE RECOMMEND INSTALLING T-NUTS
INTO BOARDS BEFORE ASSEMBLY.

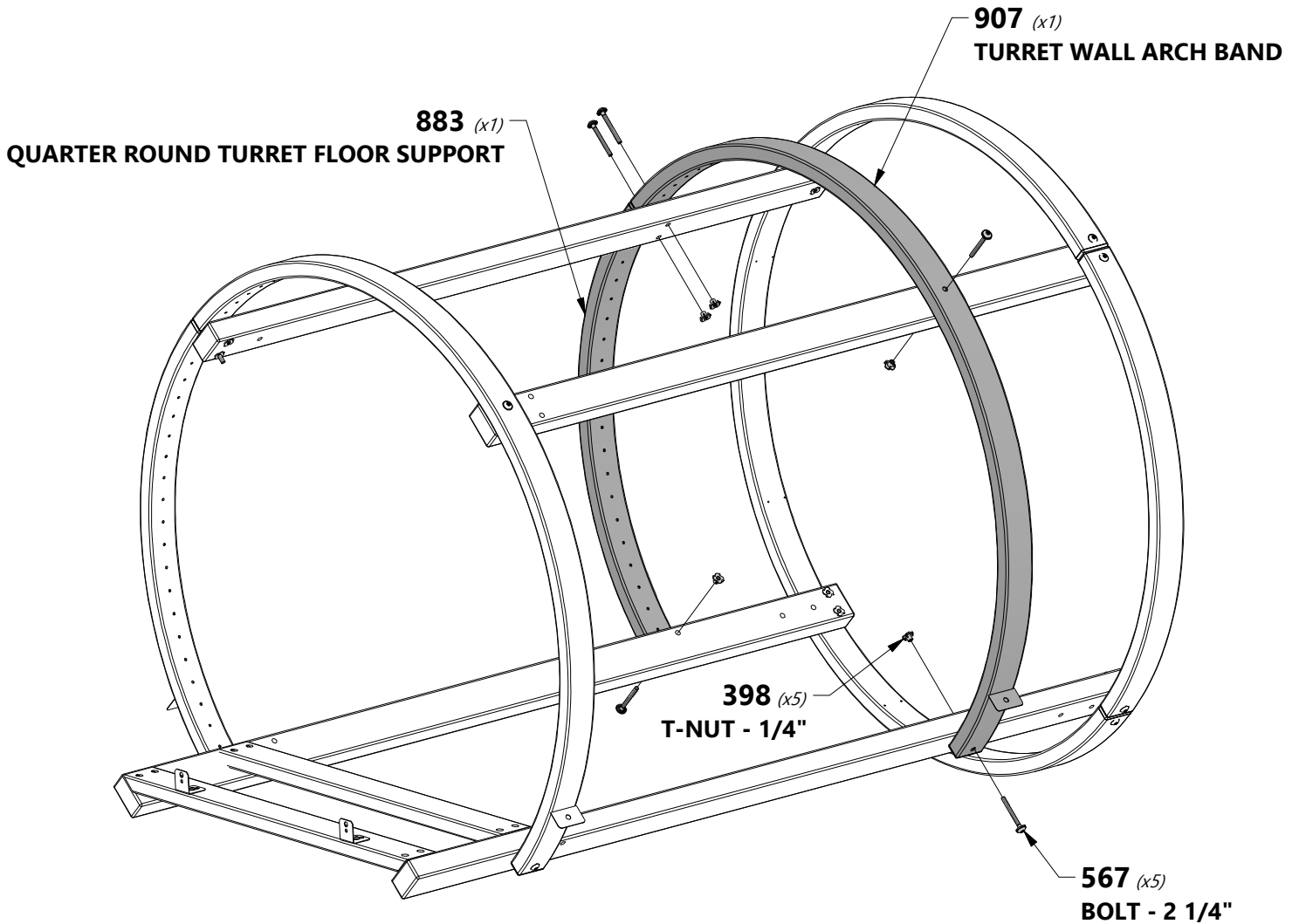

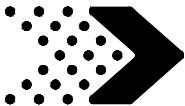

Phase 5

STEP 6

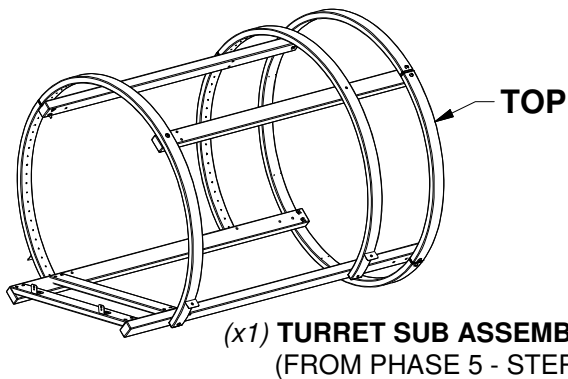

H100171 | BOLT WH BLK
(x2) | 1/4x1

H100398 | T-NUT BLK
(x2) | 1/4

H100408 | SCREW PWH BLK
(x2) | 8x1/2



TIP:
WE RECOMMEND INSTALLING T-NUTS INTO BOARDS BEFORE ASSEMBLY.

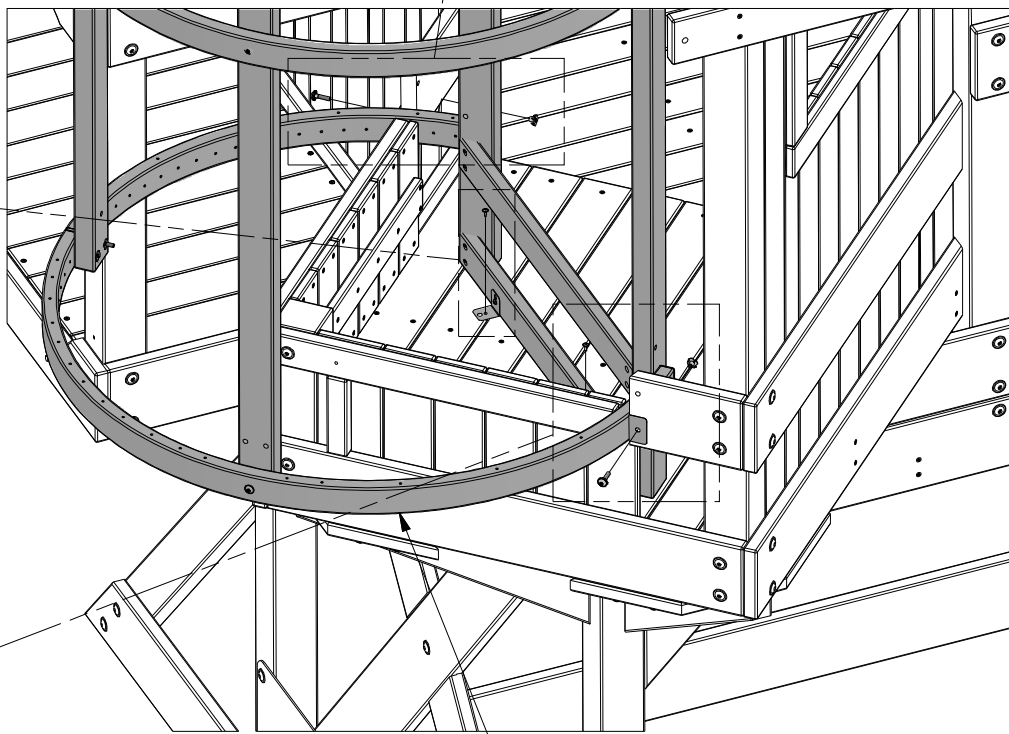
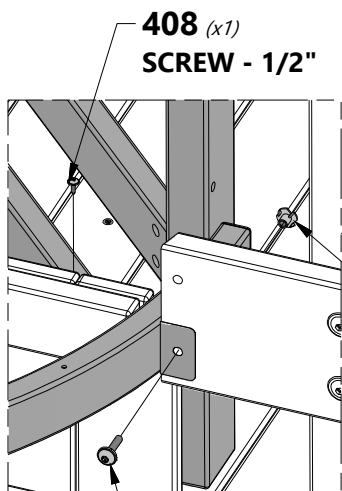
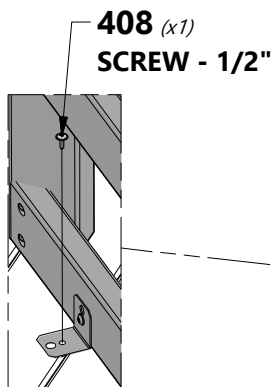
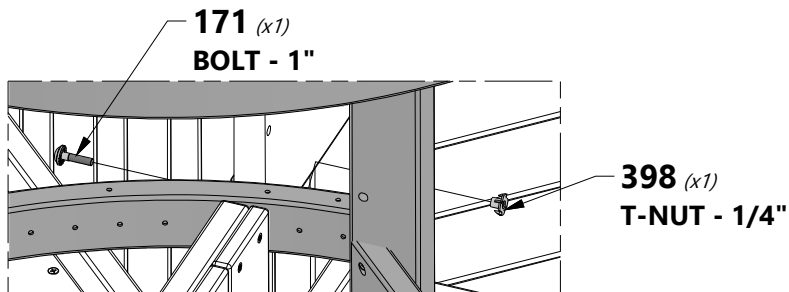

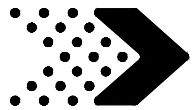

Phase 5

STEP 7



A4M01012 | METAL ANGLE BRACE
(x2)



H100460 | LAG SCREW WH BLK
(x4) | 1/4x1



H100630 | WASHER FLAT BLK
(x2) | 8x19



H100653 | NUT LOCK BLK
(x2) | 1/4

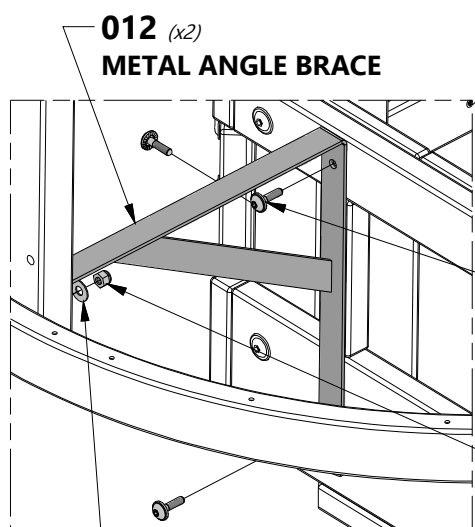
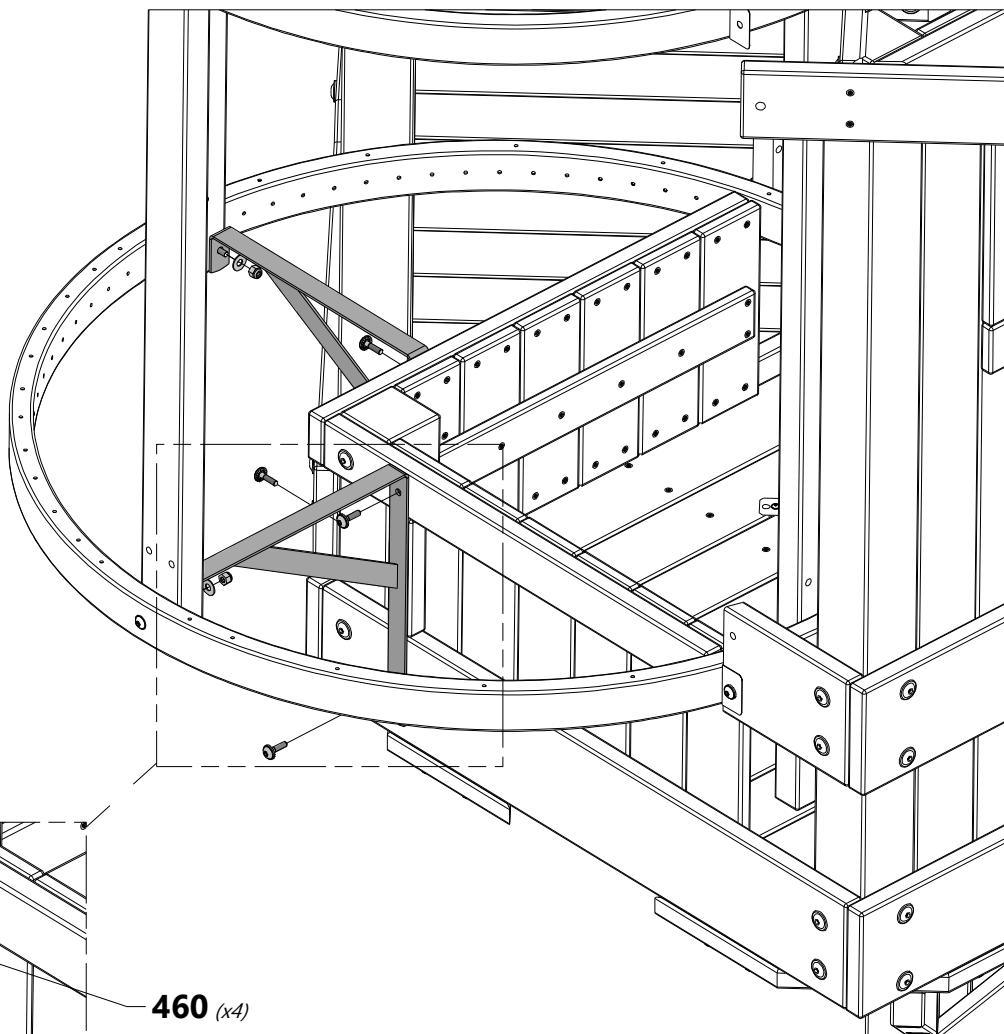

012 (x2)
METAL ANGLE BRACE

460 (x4)
LAG SCREW - 1"

653 (x2)
NUT - 1/4"

630 (x2)
WASHER - 8x19

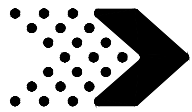

Phase 5

STEP 8



L8 | WALL PICKET - W4L08046
(x4) | 5/8"x4 3/8"x9 5/8" (16x112x244)



O2 | WALL PICKET - W4L08047
(x2) | 5/8"x3"x9 5/8" (16x75x244)



H100387 | SCREW PFH BLK
(x24) | 8x1-1/4

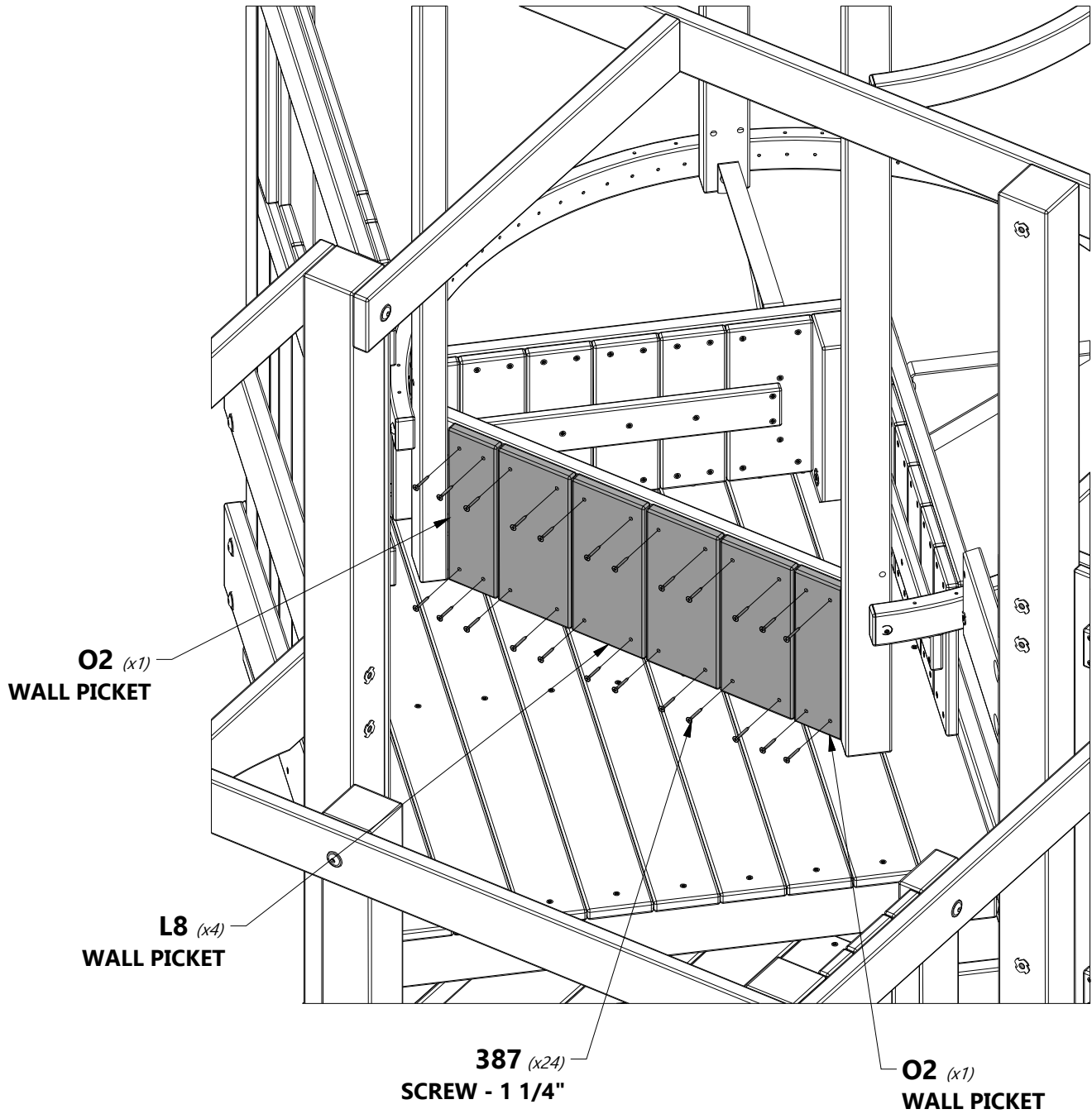

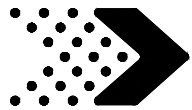

Phase 5

STEP 9

M7 | FLOOR BOARD - W4L08038
(x2) 5/8"x2 1/2"x19 3/8" (16x62x493)

L4 | FLOOR BOARD - W4L12917
(x2) 5/8"x4 3/8"x33 1/2" (16x112x852)

H100200 | SCREW PFH BLK
(x20) 8x1 1/2"

L5 | FLOOR BOARD - W4L12918
(x2) 5/8"x4 3/8"x31 7/8" (16x112x811)

H100746 | SCREW PWH SD
(x26) 10x1 1/4"

L1 | FLOOR BOARD - W4L12916
(x2) 5/8"x4 3/8"x34" (16x112x865)

L6 | FLOOR BOARD - W4L12919
(x2) 5/8"x4 3/8"x27" (16x112x687)

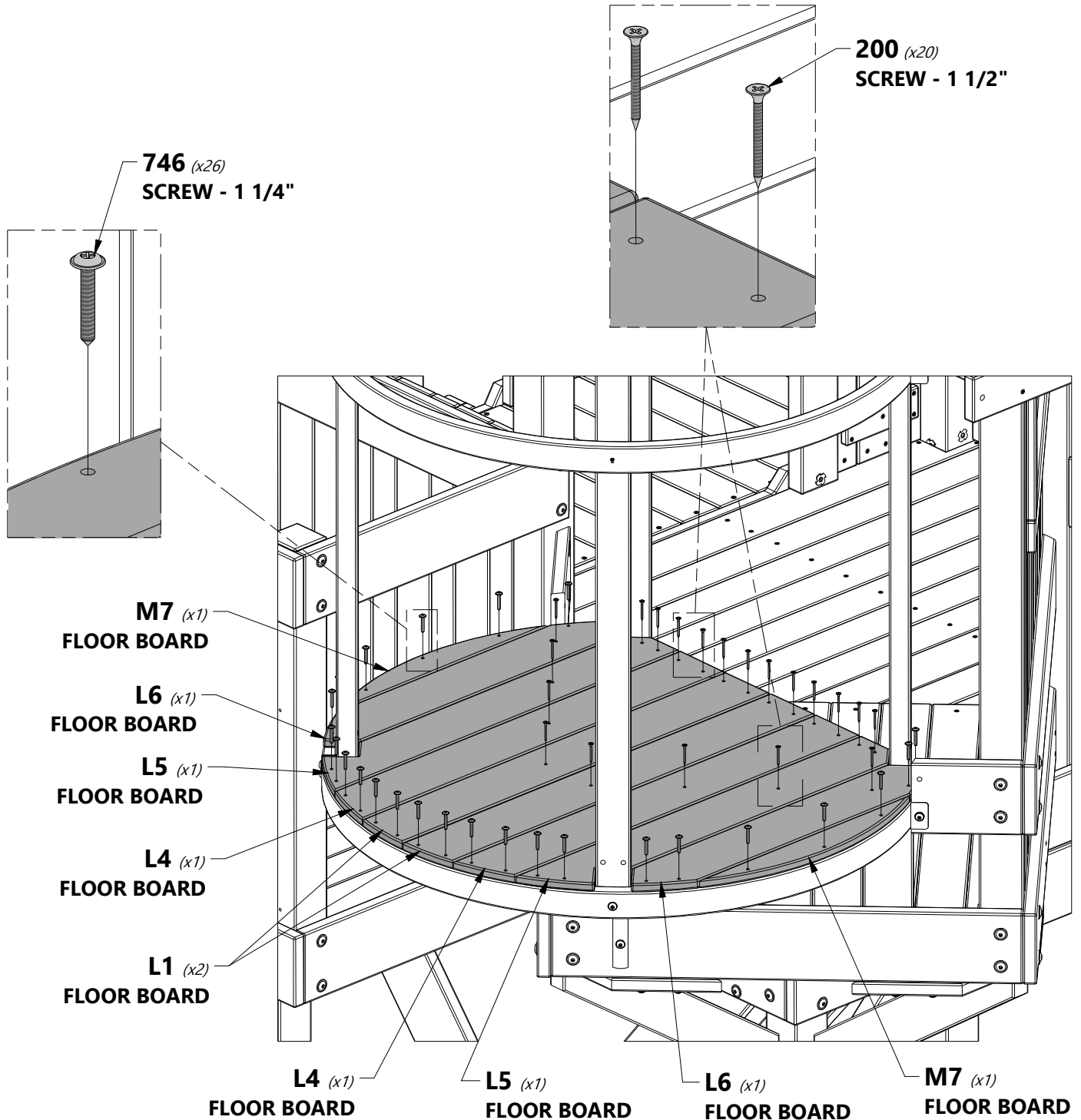

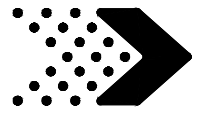

Phase 5

STEP 10

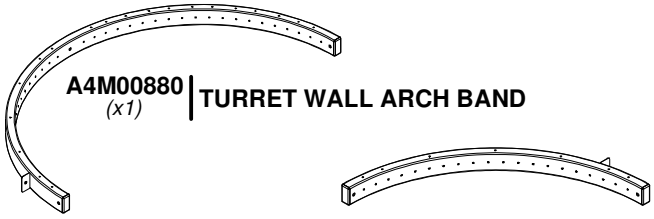

A4M00880 | TURRET WALL ARCH BAND
(x1)

A4M00881 | QUARTER ROUND TURRET FLOOR SUPPORT
(x1)

H100567 | BOLT WH BLK
(x5) | 1/4x2 1/4

H100398 | T-NUT BLK
(x5) | 1/4

H100171 | BOLT WH BLK
(x2) | 1/4x1



TIP:
WE RECOMMEND INSTALLING T-NUTS INTO BOARDS BEFORE ASSEMBLY.

567 (x3)
BOLT - 2 1/4"

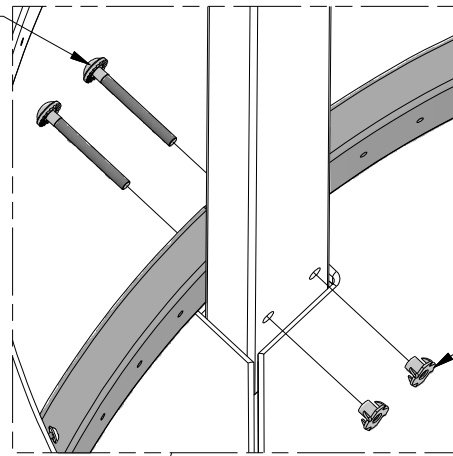

398 (x3)
T-NUT - 1/4"

880 (x1)
TURRET WALL ARCH BAND

881 (x1)
QUARTER ROUND TURRET FLOOR SUPPORT

171 (x2)
BOLT - 1"

398 (x2)
T-NUT - 1/4"

398 (x2)
T-NUT - 1/4"

567 (x2)
BOLT - 2 1/4"

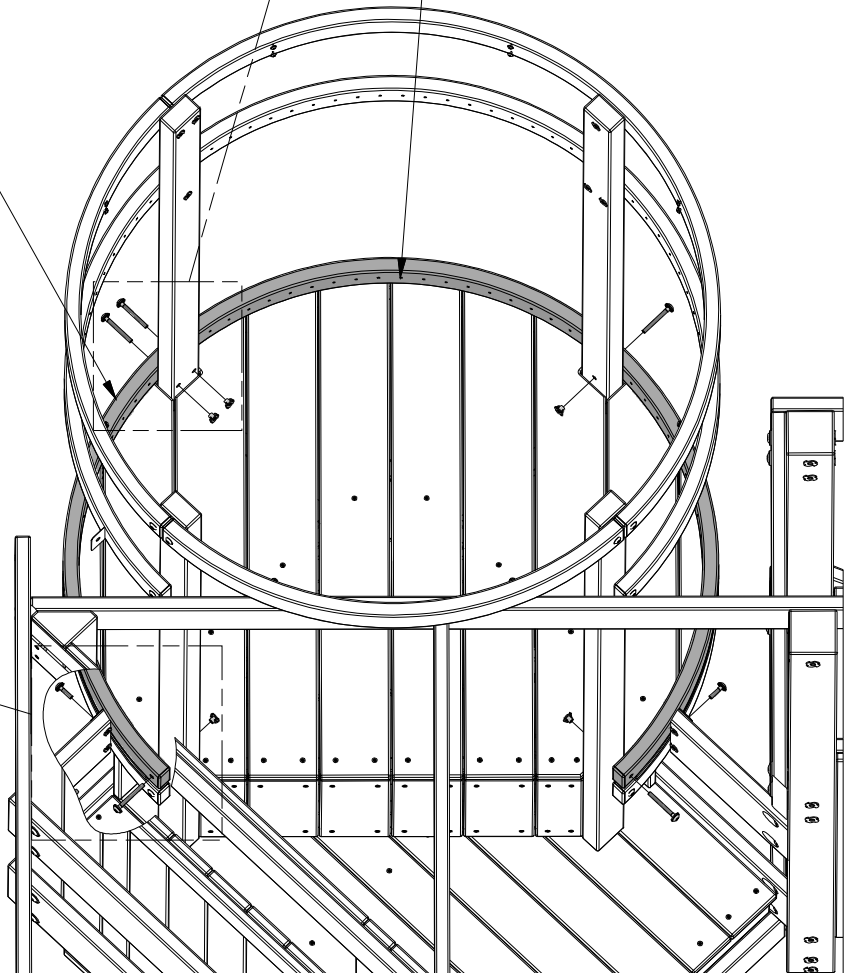

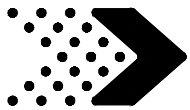

O1 | WALL PICKET - W4L08506
(x60) | 5/8"x1 3/8"x32 7/8" (16x34x835)



H100746 | SCREW PWH SD
(x120) | 10x1 1/4

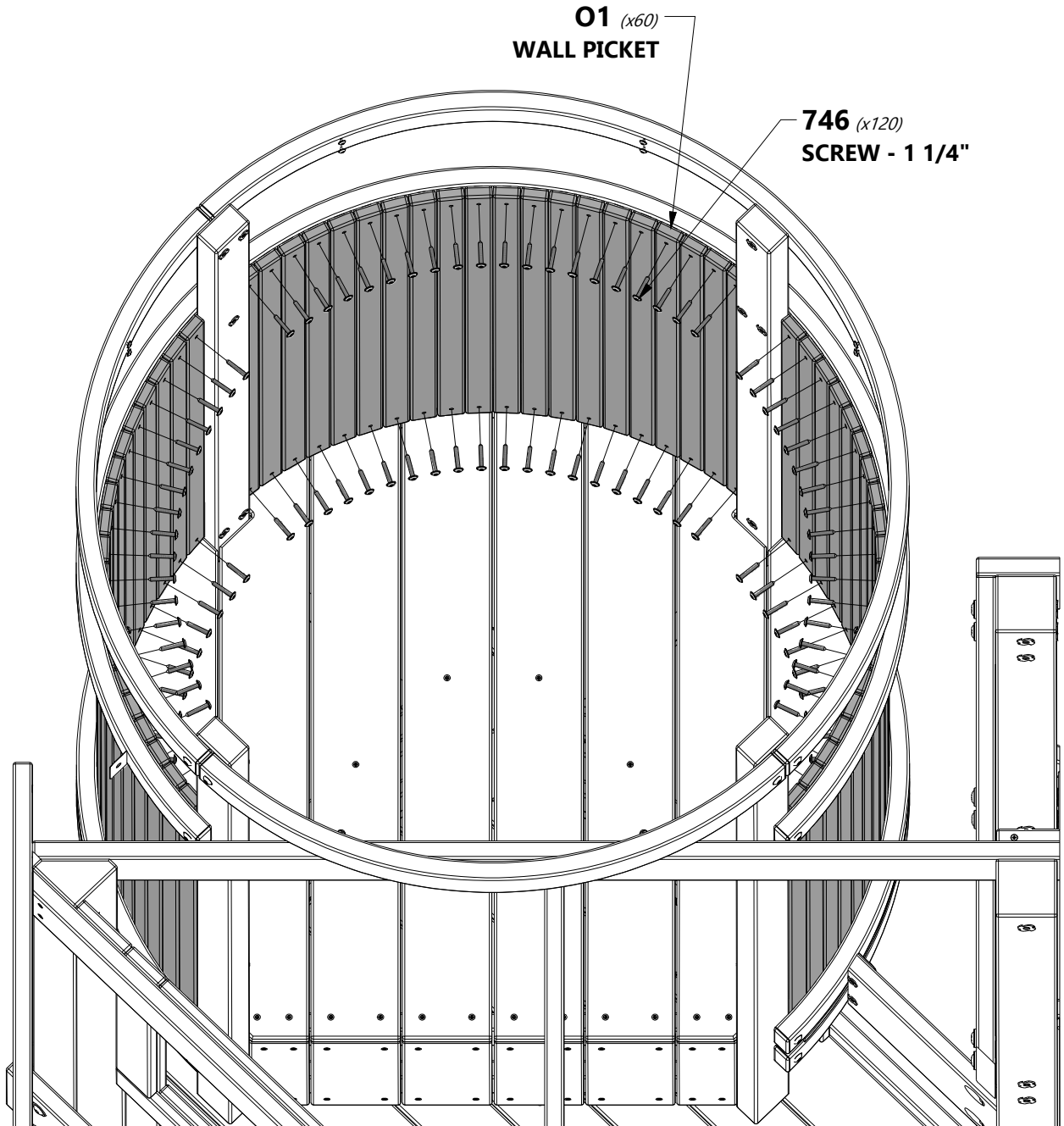

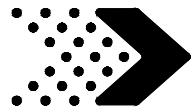

Phase 5

STEP 12



G19 | WALL SUPPORT - W4L08560
(x1) | 1"x5 1/4"x8 5/8" (24x134x218)



H100415 | BOLT WH BLK
(x1) | 5/16x3 3/4



H100379 | T-NUT BLK
(x1) | 5/16



H100387 | SCREW PFH BLK
(x4) | 8x1-1/4



K6 | WALL PICKET - W4L08561
(x1) | 5/8"x5 1/4"x43 1/4" (16x132x1099)



H100171 | BOLT WH BLK
(x1) | 1/4x1



H100398 | T-NUT BLK
(x1) | 1/4



H100198 | WASHER LOCK EXT BLK
(x1) | 8x19



NOTE:

1. ASSEMBLE THE SUB ASSEMBLY FIRST.
2. INSTALL THE T-NUT INTO 'G19' BOARD AND THEN ASSEMBLE 'K6' TO 'G19' BOARD.



TIP:

WE RECOMMEND INSTALLING T-NUTS INTO BOARDS BEFORE ASSEMBLY.

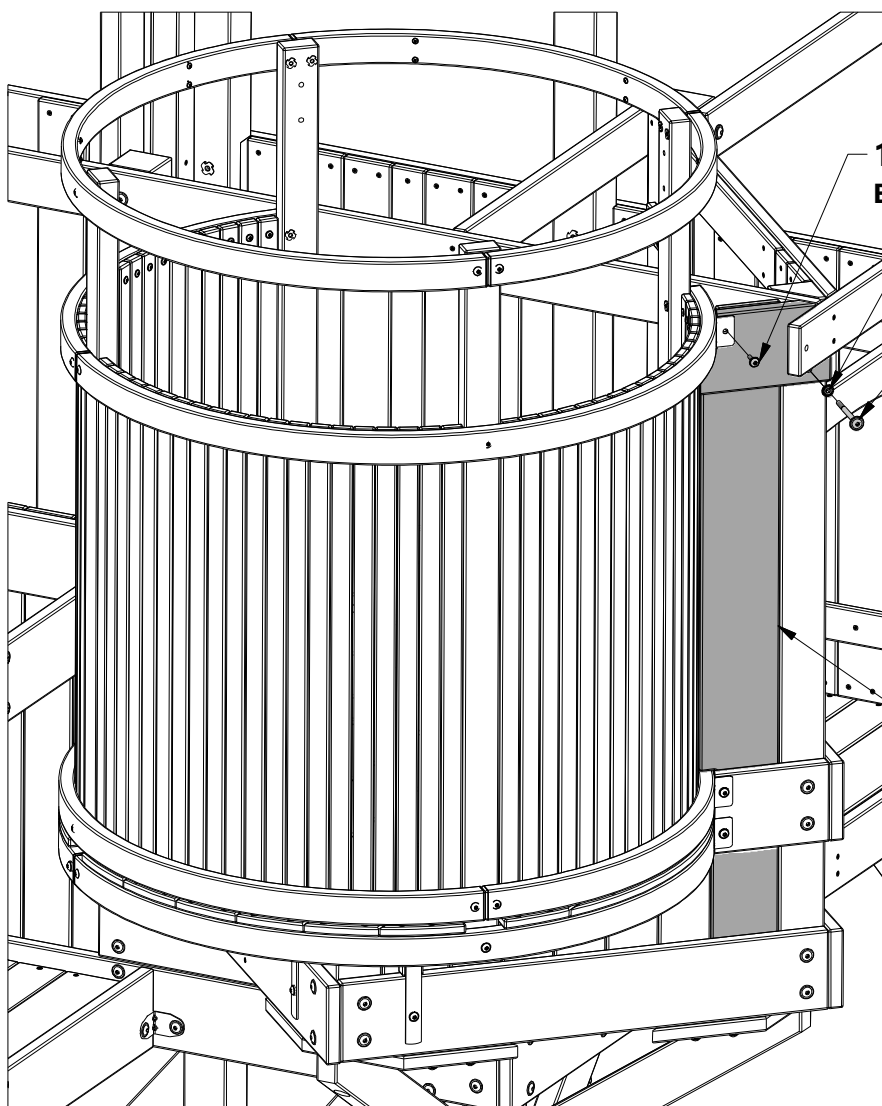
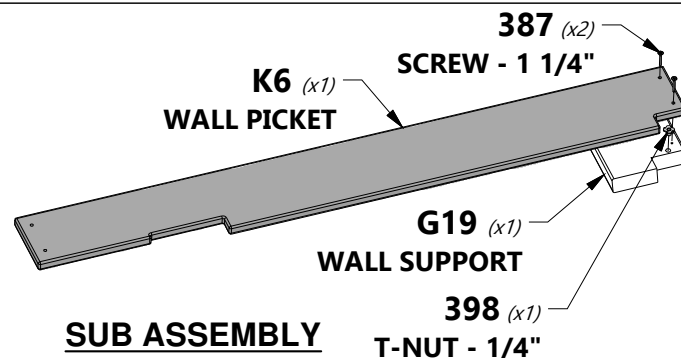

OUTSIDE VIEW

- 171 (x1) BOLT - 1"
- 198 (x1) WASHER - 8x19
- 415 (x1) BOLT - 3 3/4"
- 379 (x1) T-NUT - 5/16"

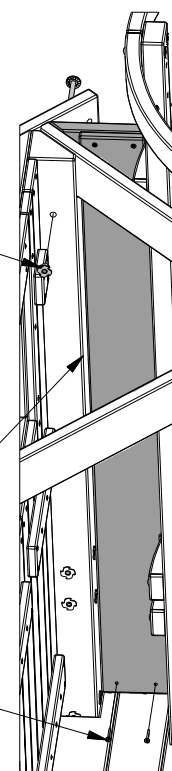

INSIDE VIEW

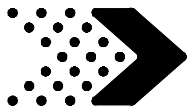

Phase 5

STEP 13

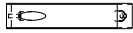

F4 | WALL SUPPORT - W4L13101
(x1) | 1 3/8"x2 3/8"x11 3/4" (36x60x300)

H100397 | BOLT WH BLK
(x1) | 1/4x1 1/4

H100405 | WASHER LOCK EXT BLK
(x1) | 6x15

H100198 | WASHER LOCK EXT BLK
(x1) | 8x19

H100400 | WASHER LOCK EXT BLK
(x1) | 8x15

H100471 | LAG SCREW WH BLK
(x1) | 5/16x1 1/2

H100404 | NUT BARREL WH BLK
(x1) | 1/4x5/8

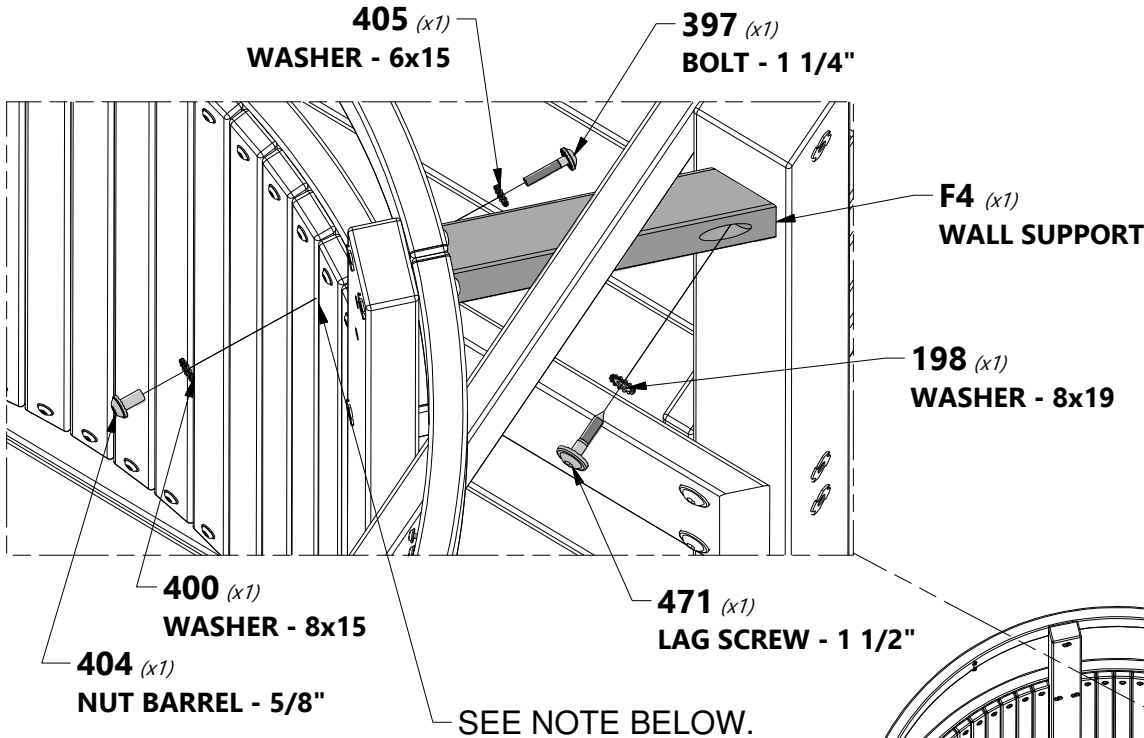

NOTE:

1. USE THE 'J4' SUPPORT HOLE AS A TEMPLATE AND MARK WHERE THE SUPPORT MEETS THE TURRET.
2. USING A 5/16" OR 8 MM DRILL BIT, DRILL A THROUGH HOLE INTO THE TURRET.
3. ATTACH THE 'J4' SUPPORT TO THE TURRET USING HARDWARE SHOWN.

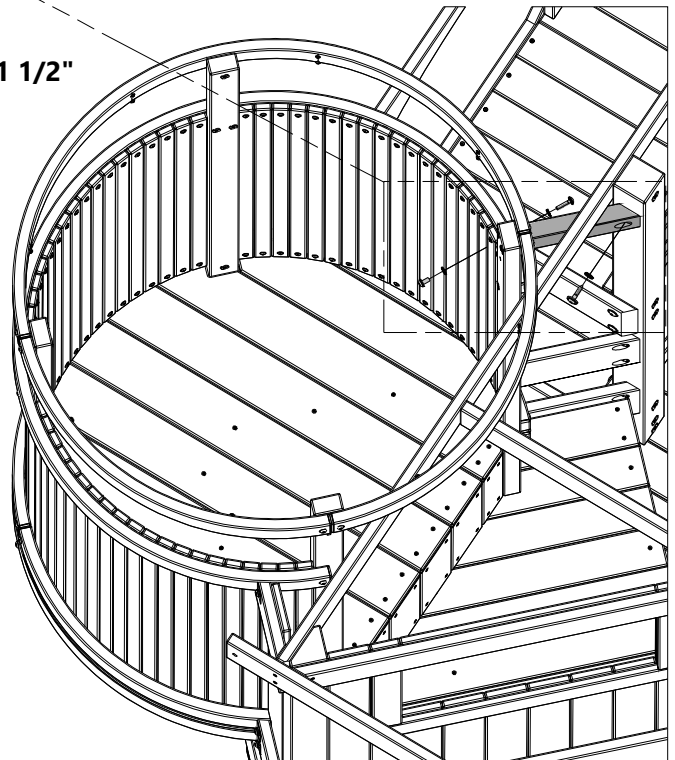

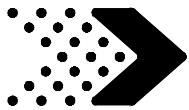

Phase 5

STEP 14

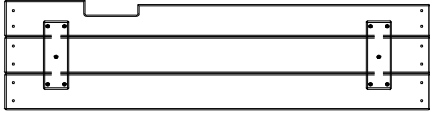

WP5 | WALL PANEL - W2A02907
(x1) | 1 1/4"x9 13/16"x39 7/8" (32x250x1013)



O3 | WALL PICKET - W4L08512
(x1) | 5/8"x1 3/8"x39 7/8" (16x34x1013)



H100387 | SCREW PFH BLK
(x14) | 8x1-1/4

WP5 (x1)
WALL PANEL

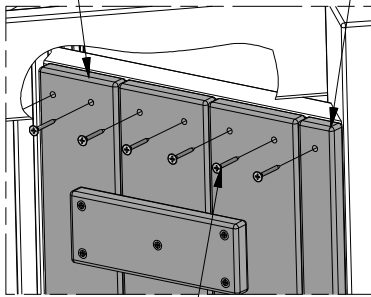

387 (x14)
SCREW - 1 1/4"

O3 (x1)
WALL PICKET

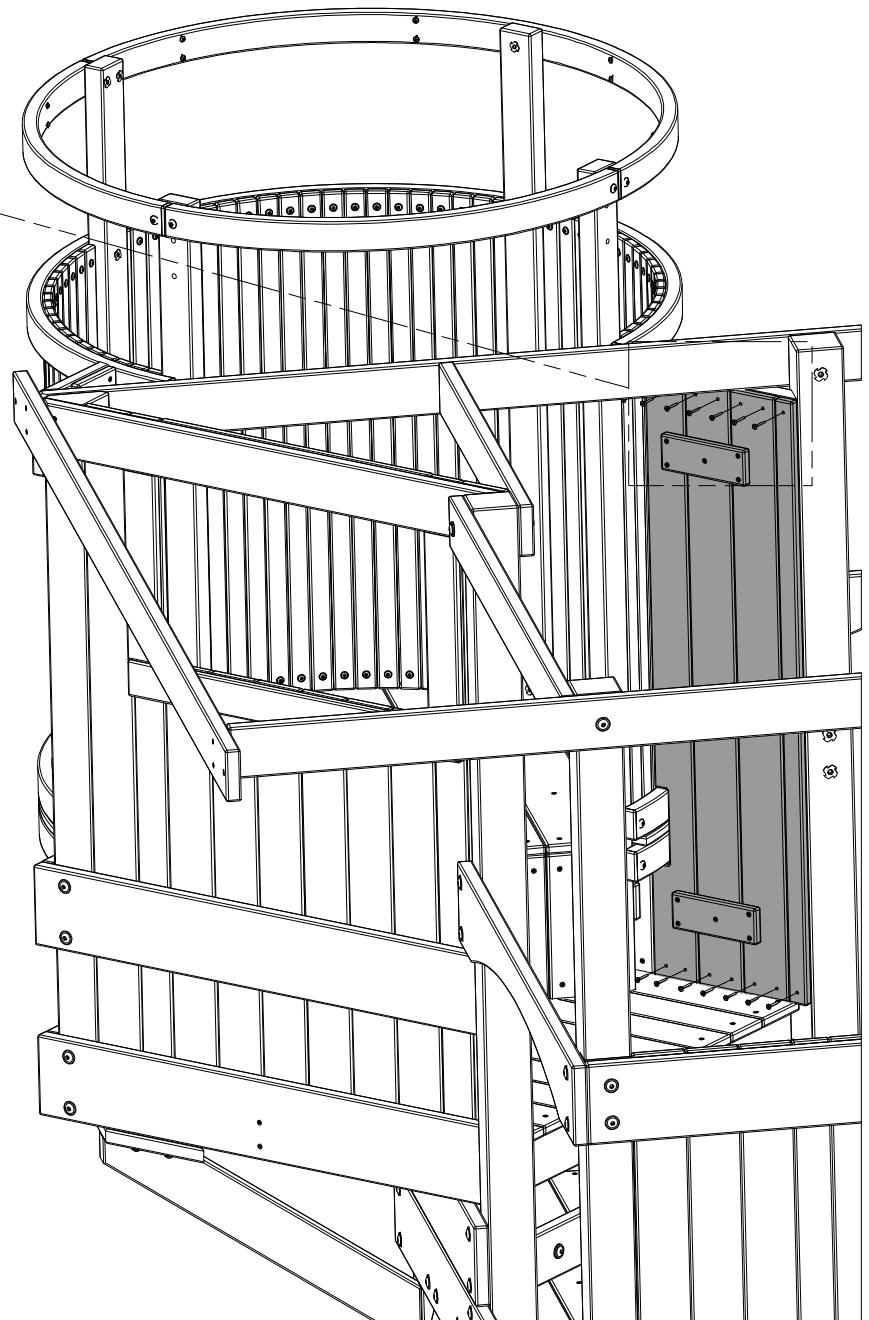

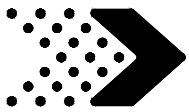

Phase 5

STEP 15



M38 | TURRET FILLER BOARD - W4L11445
(x2) | 5/8"x3 3/8"x5 3/4" (16x86x146)



H100488 | BOLT WH BLK
(x4) | 1/4x2



H100405 | WASHER LOCK EXT BLK
(x4) | 6x15



H100398 | T-NUT BLK
(x4) | 1/4



TIP:

WE RECOMMEND INSTALLING T-NUTS INTO BOARDS BEFORE ASSEMBLY.

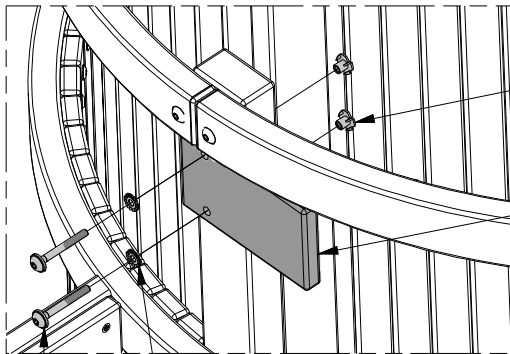

398 (x4)
T-NUT - 1/4"

M38 (x2)
TURRET FILLER BOARD

488 (x4)
BOLT - 2"

405 (x4)
WASHER - 6x15

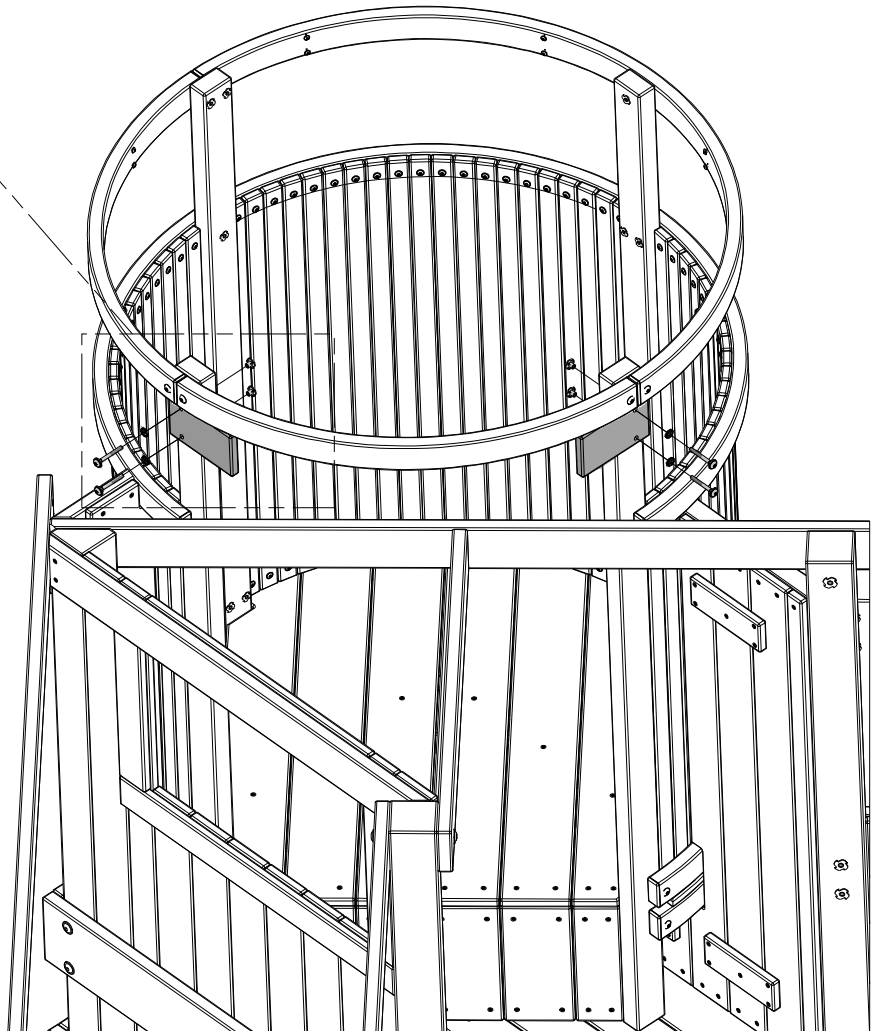

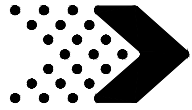

Phase 5

STEP 16

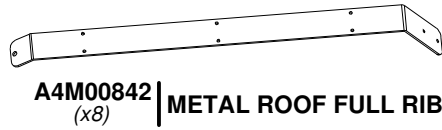

A4M00842 (x8) | METAL ROOF FULL RIB

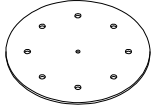

A4M00844 (x1) | ROUND ROOF RIB CONNECTOR PLATE



H100489 (x8) | BOLT PTH BLK
1/4x3/4



H100630 (x8) | WASHER FLAT BLK
8x19



H100653 (x8) | NUT LOCK BLK
1/4



H100392 (x16) | SCREW PWH BLK
8x3/4



NOTE:
ASSEMBLE THE SUB ASSEMBLY FIRST.

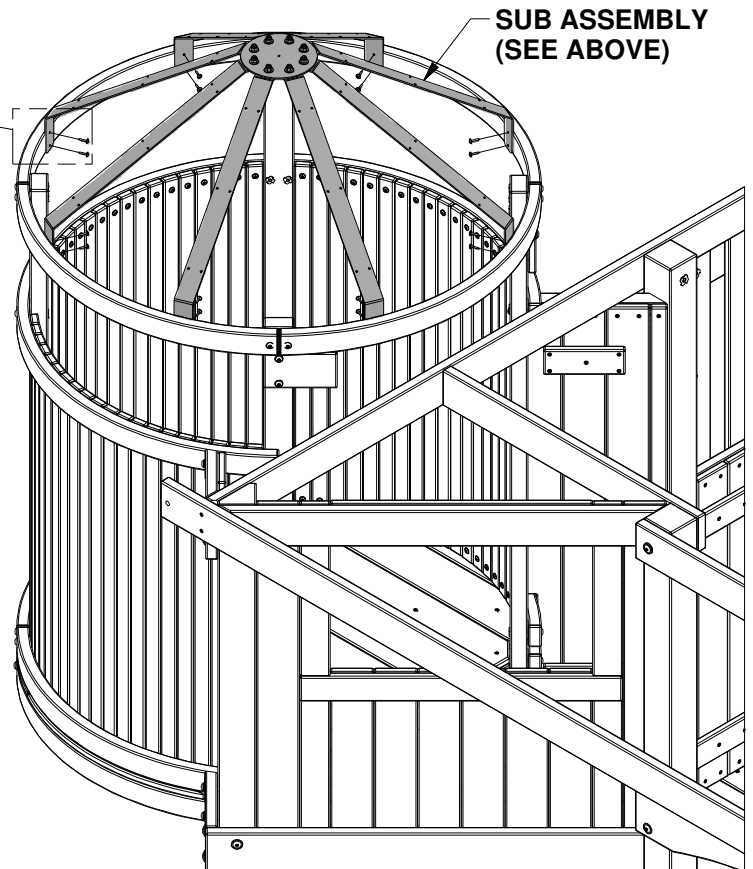
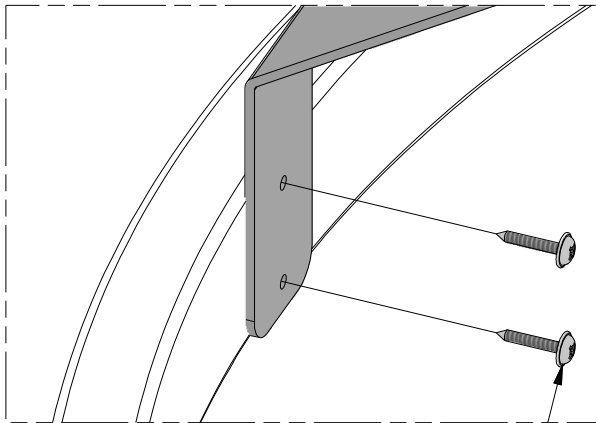
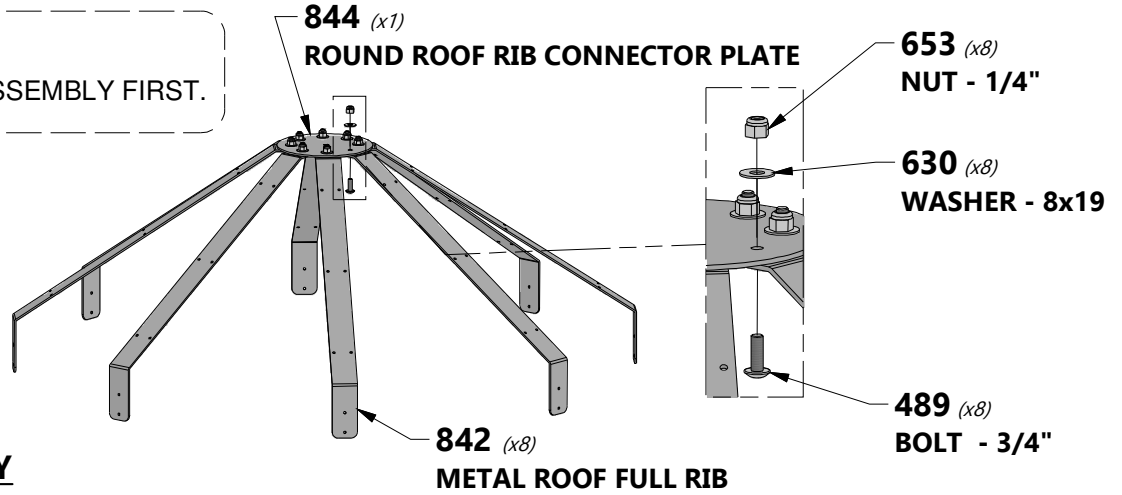

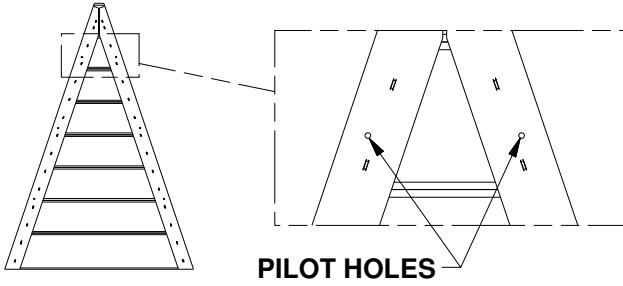

H100392 | SCREW PWH BLK
(x48) | 8x3/4

RP07 | ROOF PANEL - W2A02189
(x8) | 13/16"x24 7/8"x17 11/16" (21x632x450)

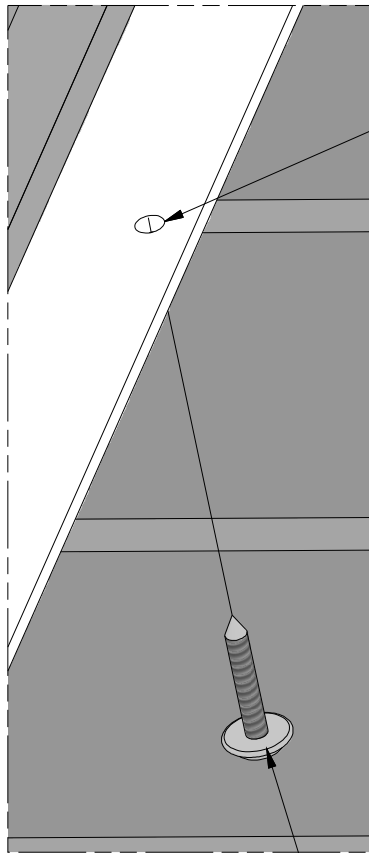

SCREW INTO
PILOT HOLES
LOCATED IN
ROOF PANELS.

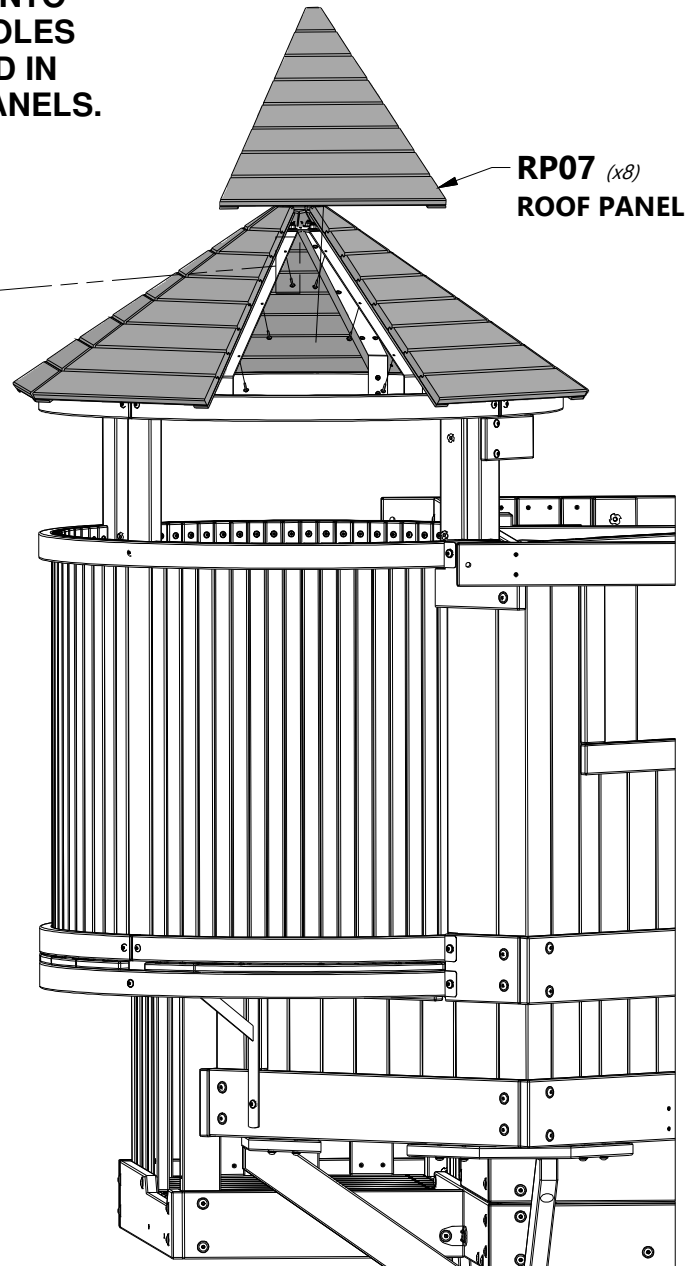

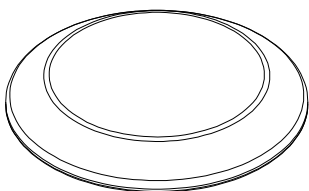
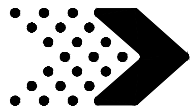

A6P00239 (x1) ROUND ROOF PLASTIC CAP



H100736 SCREW PWH SD (x1) 8x1 5/8



NOTE: DO NOT OVER-TIGHTEN SCREW.



2 PEOPLE REQUIRED

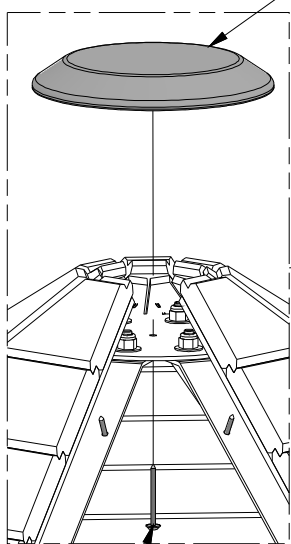

239 (x1) ROUND ROOF PLASTIC CAP

736 (x1) SCREW - 1 5/8"

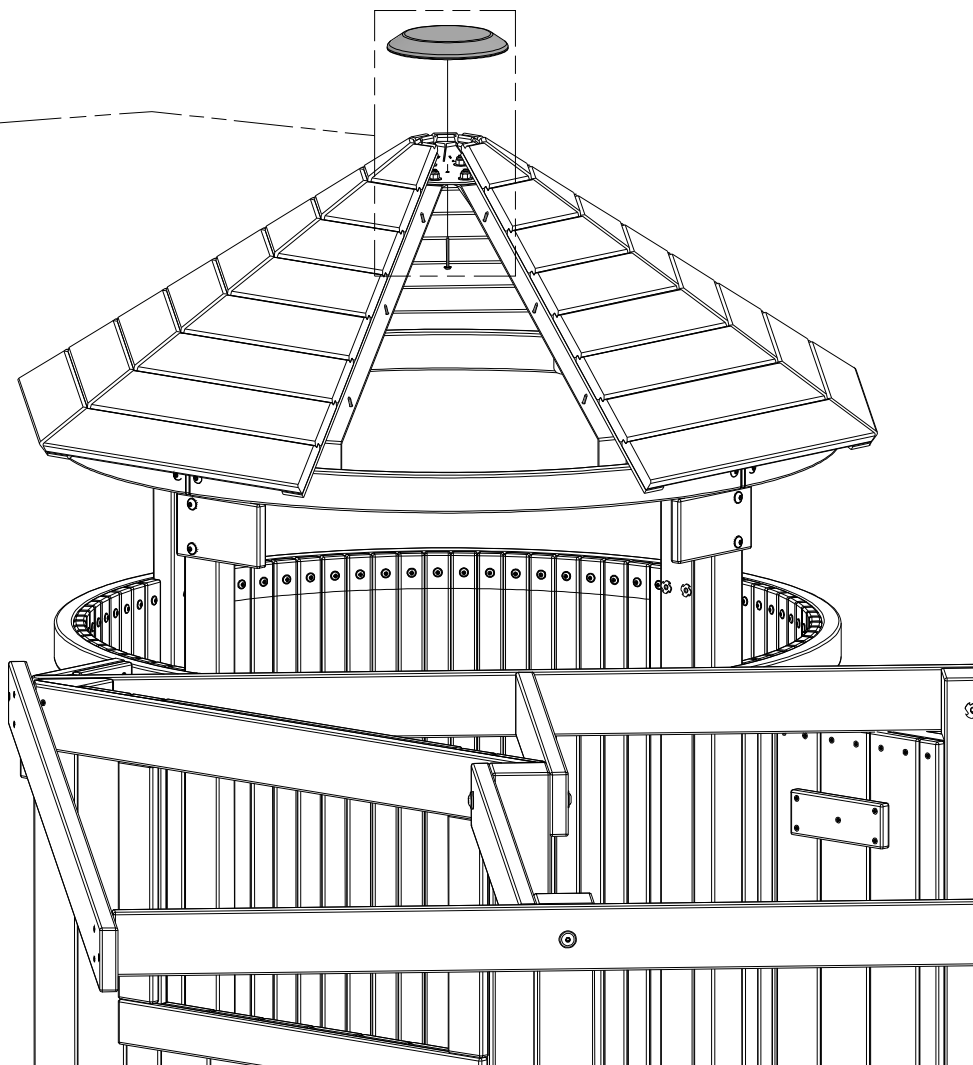

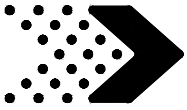

M23 | WALL PICKET - W4L08544
(x3) | 5/8"x3 3/8"x29 7/8" (16x86x759)



H100387 | SCREW PFH BLK
(x12) | 8x1-1/4



NOTE:

1. DO NOT PUT ANY WEIGHT ON SHORT THE BALCONY UNTIL AFTER COMPLETION OF PHASE 7.
2. USE A LADDER TO ASSEMBLE ANY PICKETS LOCATED ON THE SHORT BALCONY RAILS.

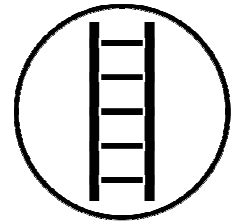
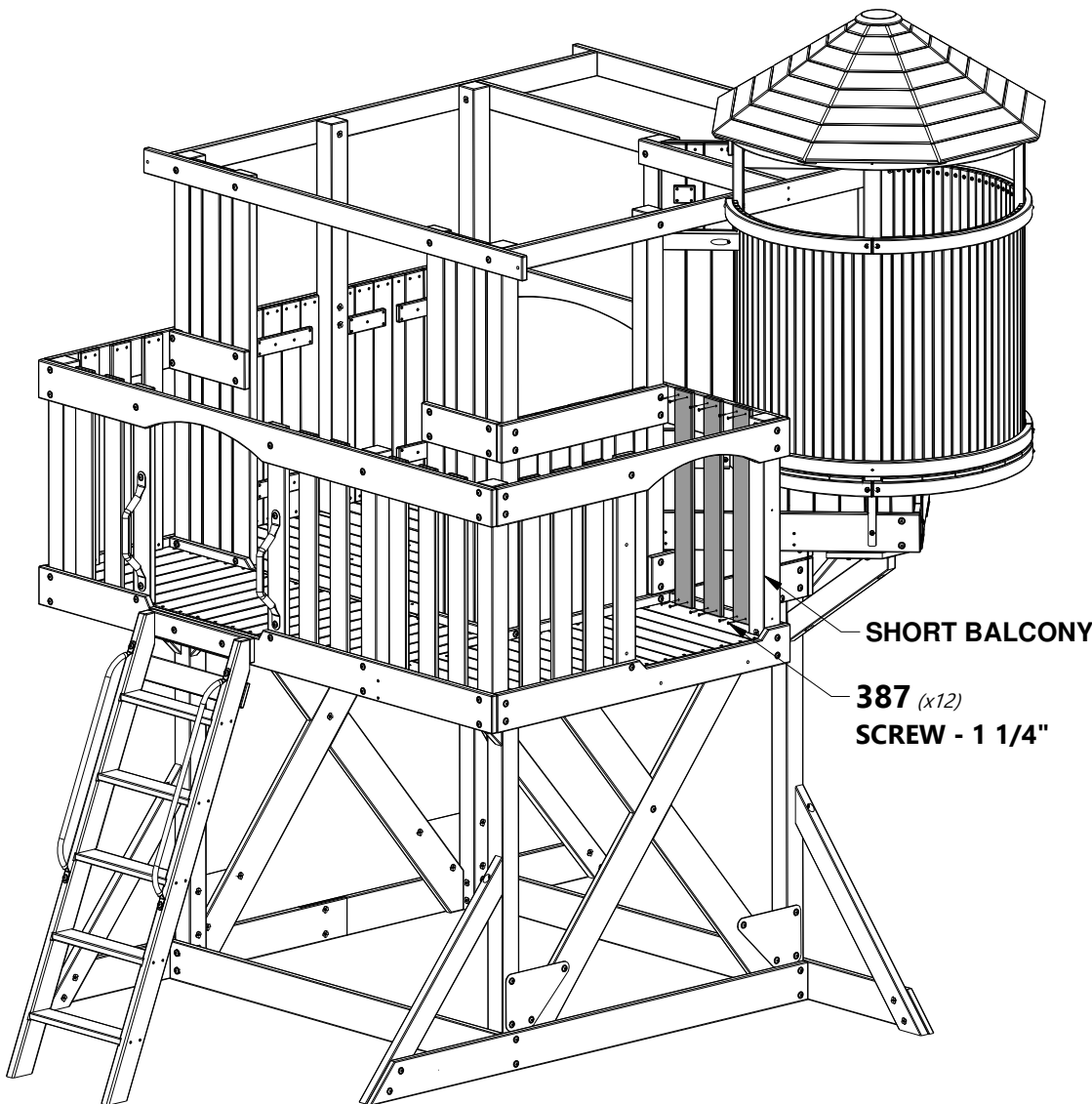

2 3/8 in
[60 mm]
(3 SPCS)

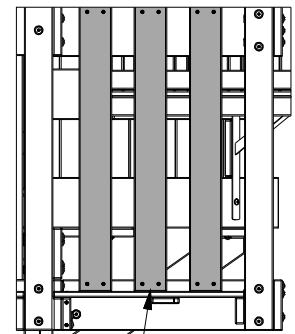

M23 (x3)
WALL PICKET

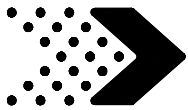

Phase 6

STEP 1

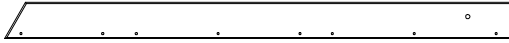

H15 | RAFTER - W4L08526
(x2) | 1"x3 3/8"x47 5/8" (24x86x1209)



H100378 | BOLT WH BLK
(x2) | 5/16x1 3/4



H100379 | T-NUT BLK
(x2) | 5/16



H100198 | WASHER LOCK EXT BLK
(x2) | 8x19



TIP:

WE RECOMMEND INSTALLING T-NUTS INTO BOARDS BEFORE ASSEMBLY.

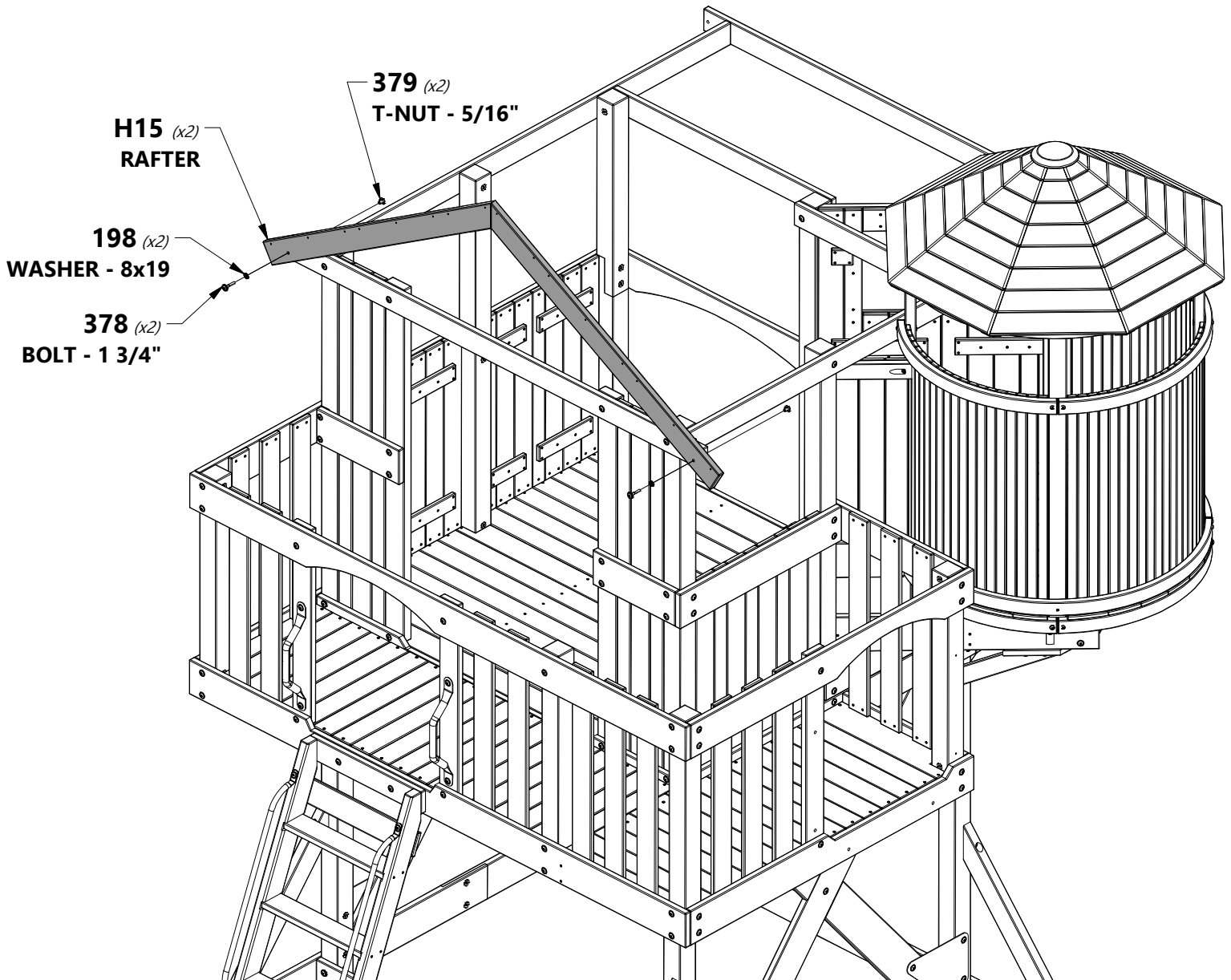

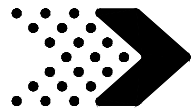

Phase 6

STEP 2

M16 | WALL BOARD - W4L08530
(x1) 5/8"x3 3/8"x34 1/8" (16x86x867)

M17 | WALL BOARD - W4L08531
(x1) 5/8"x3 3/8"x22 3/8" (16x86x567)

M18 | WALL BOARD - W4L08532
(x1) 5/8"x3"x10 1/2" (16x77x268)

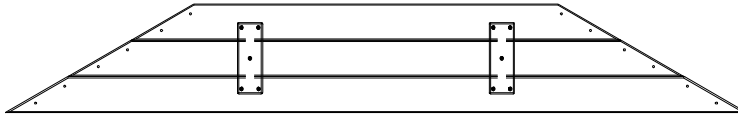

GP1 | GABLE PANEL - W2A02914
(x1) 1 1/4"x69 1/2"x10 3/16" (32x1766x259)



H100387 | SCREW PFH BLK
(x24) 8x1-1/4

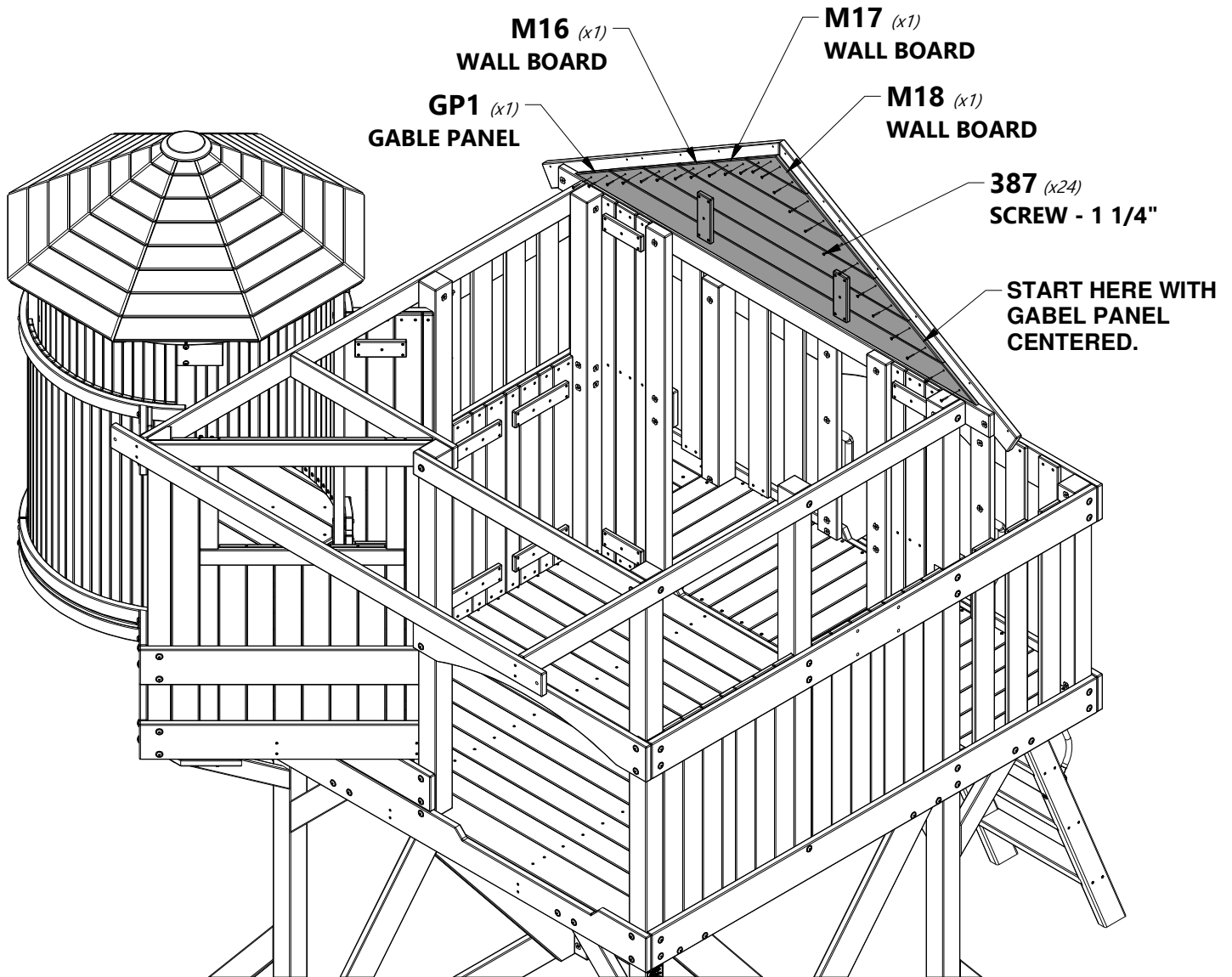

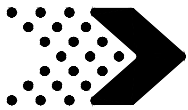

Phase 6

STEP 3

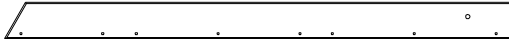

H15 | RAFTER - W4L08526
(x2) | 1"x3 3/8"x47 5/8" (24x86x1209)



H100378 | BOLT WH BLK
(x2) | 5/16x1 3/4



H100379 | T-NUT BLK
(x2) | 5/16



H100198 | WASHER LOCK EXT BLK
(x2) | 8x19



TIP:
WE RECOMMEND INSTALLING T-NUTS INTO
BOARDS BEFORE ASSEMBLY.

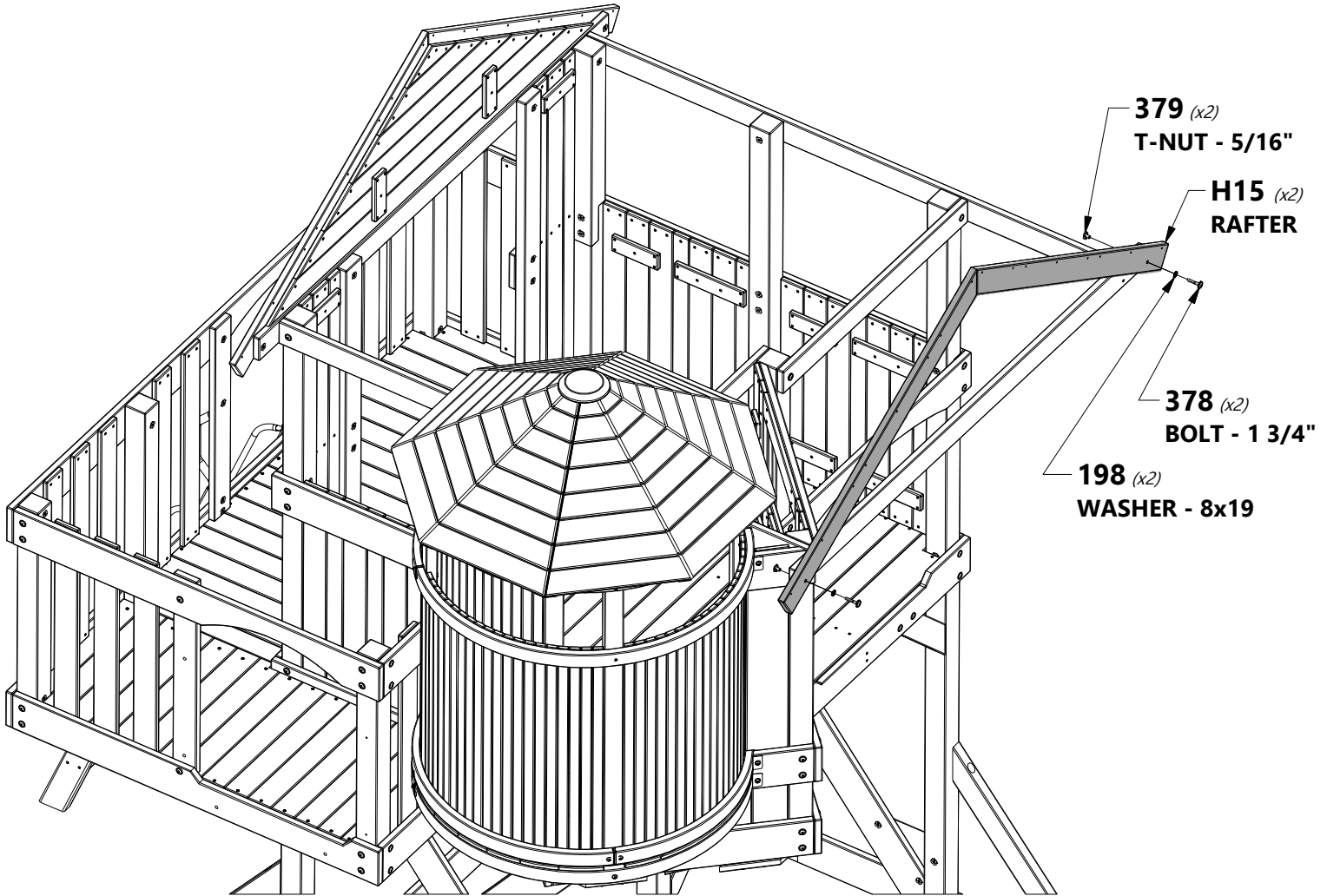



Phase 6

STEP 4

M16 | WALL BOARD - W4L08530
 (x1) | 5/8"x3 3/8"x34 1/8" (16x86x867)

M17 | WALL BOARD - W4L08531
 (x1) | 5/8"x3 3/8"x22 3/8" (16x86x567)

M18 | WALL BOARD - W4L08532
 (x1) | 5/8"x3"x10 1/2" (16x77x268)

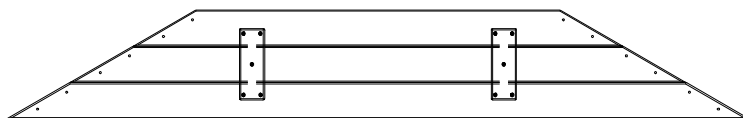

GP1 | GABLE PANEL - W2A02914
 (x1) | 1 1/4"x69 1/2"x10 3/16" (32x1766x259)



H100387 | SCREW PFH BLK
 (x24) | 8x1-1/4

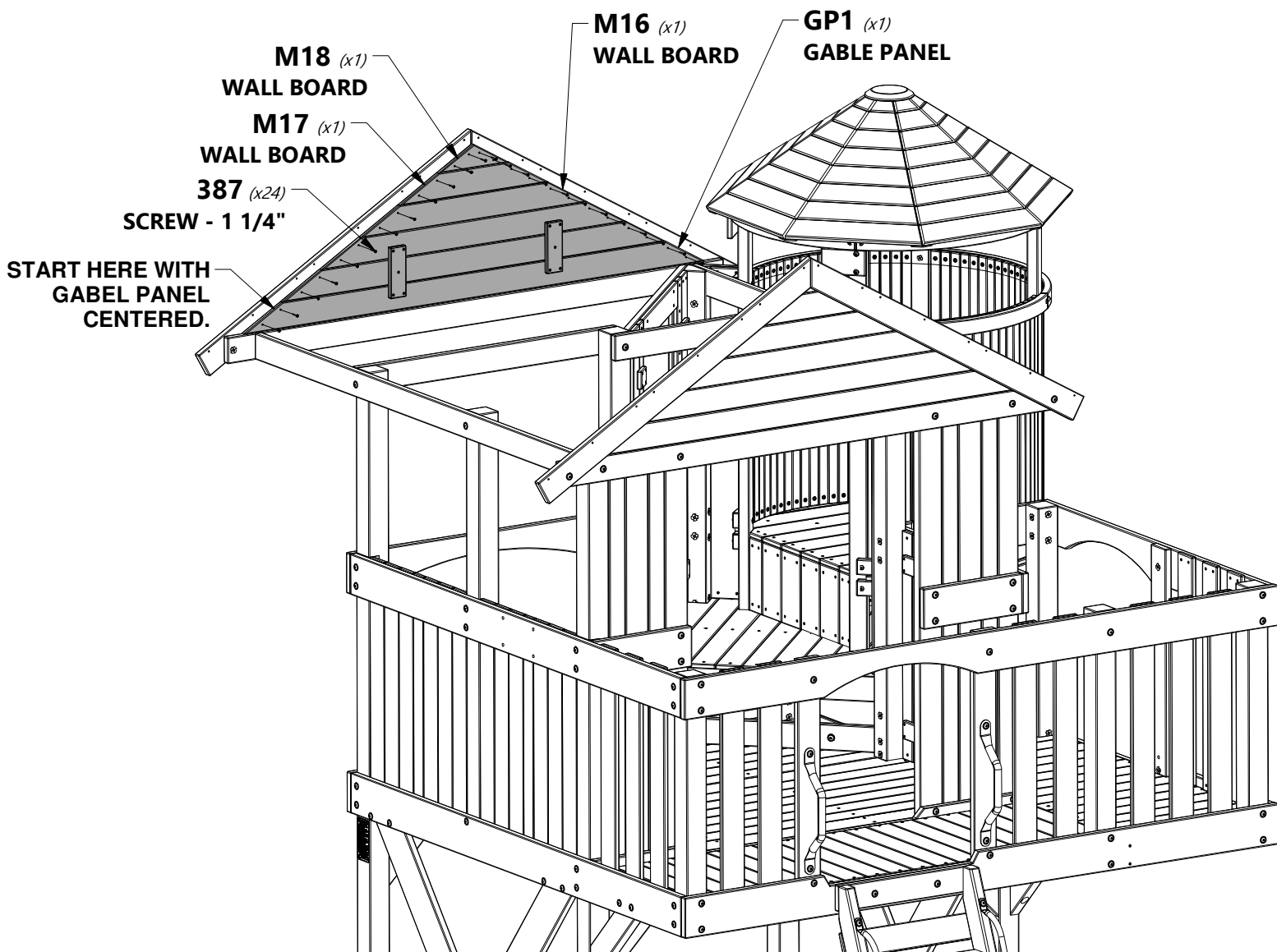

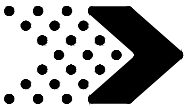

Phase 6

STEP 5

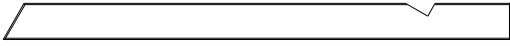

H16 | RAFTER - W4L08527
(x2) | 1"x3 3/8"x47 5/8" (24x86x1209)



N6 | RAFTER CLEAT - W4L11446
(x1) | 5/8"x2 3/8"x3 1/8" (16x60x80)

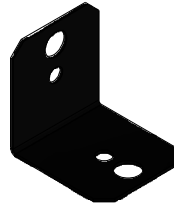

A4M00555 | 90° L-BRACKET - BLK
(x2)



H100392 | SCREW PWH BLK
(x4) | 8x3/4



H100387 | SCREW PFH BLK
(x4) | 8x1-1/4

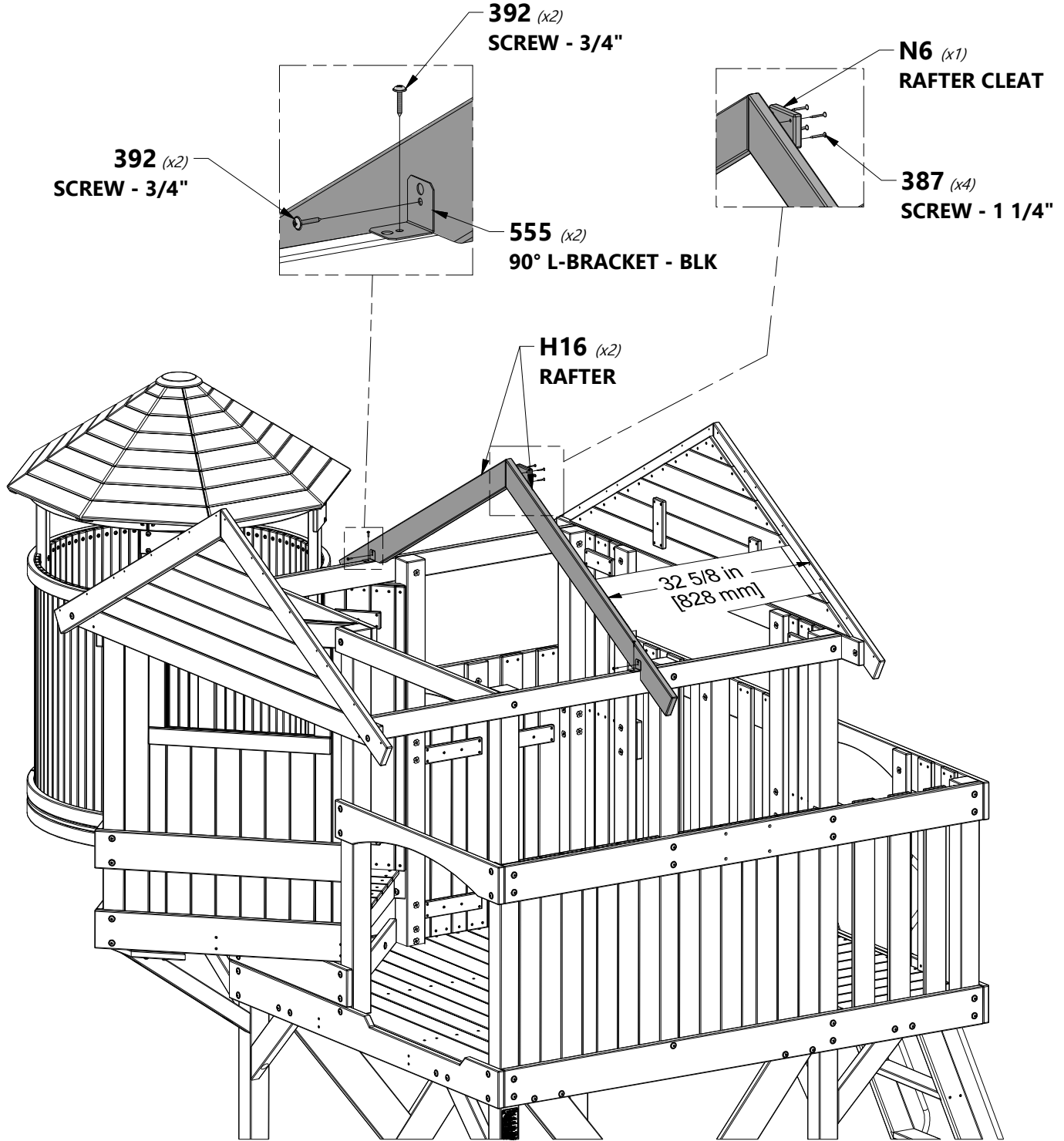

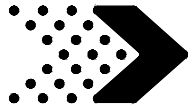

Phase 6

STEP 6

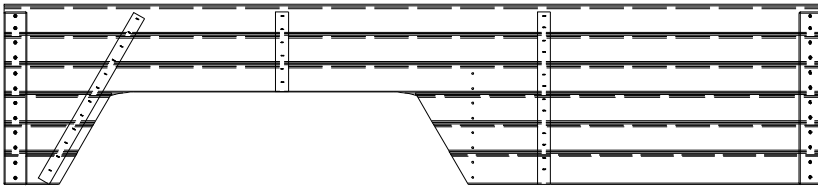

RP03 | ROOF PANEL - W2A02185
(x1) 1 9/16"x18 3/4"x85 3/16" (40x476x2165)



H100200 | SCREW PFH BLK
(x8) 8x1-1/2



H100391 | SCREW PFH BLK
(x6) 8x2

391 (x6)
SCREW - 2"
BOTH ENDS



TIP:
WE RECOMMEND INSTALLING THE ROOF FASTENERS ON THE RIGHT SIDE USING A SMALL HAND OPERATED PHILLIPS SCREW DRIVER.

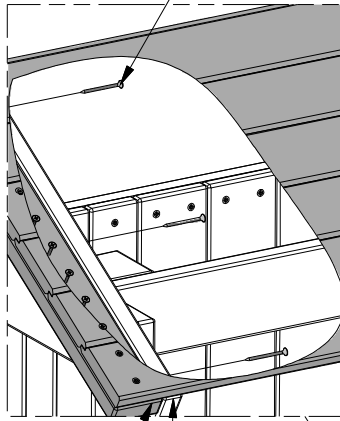

FLUSH

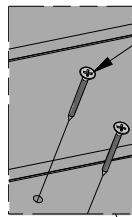

200 (x8)
SCREW - 1 1/2"

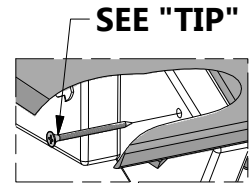

SEE "TIP" ABOVE.

RP03 (x1)
ROOF PANEL

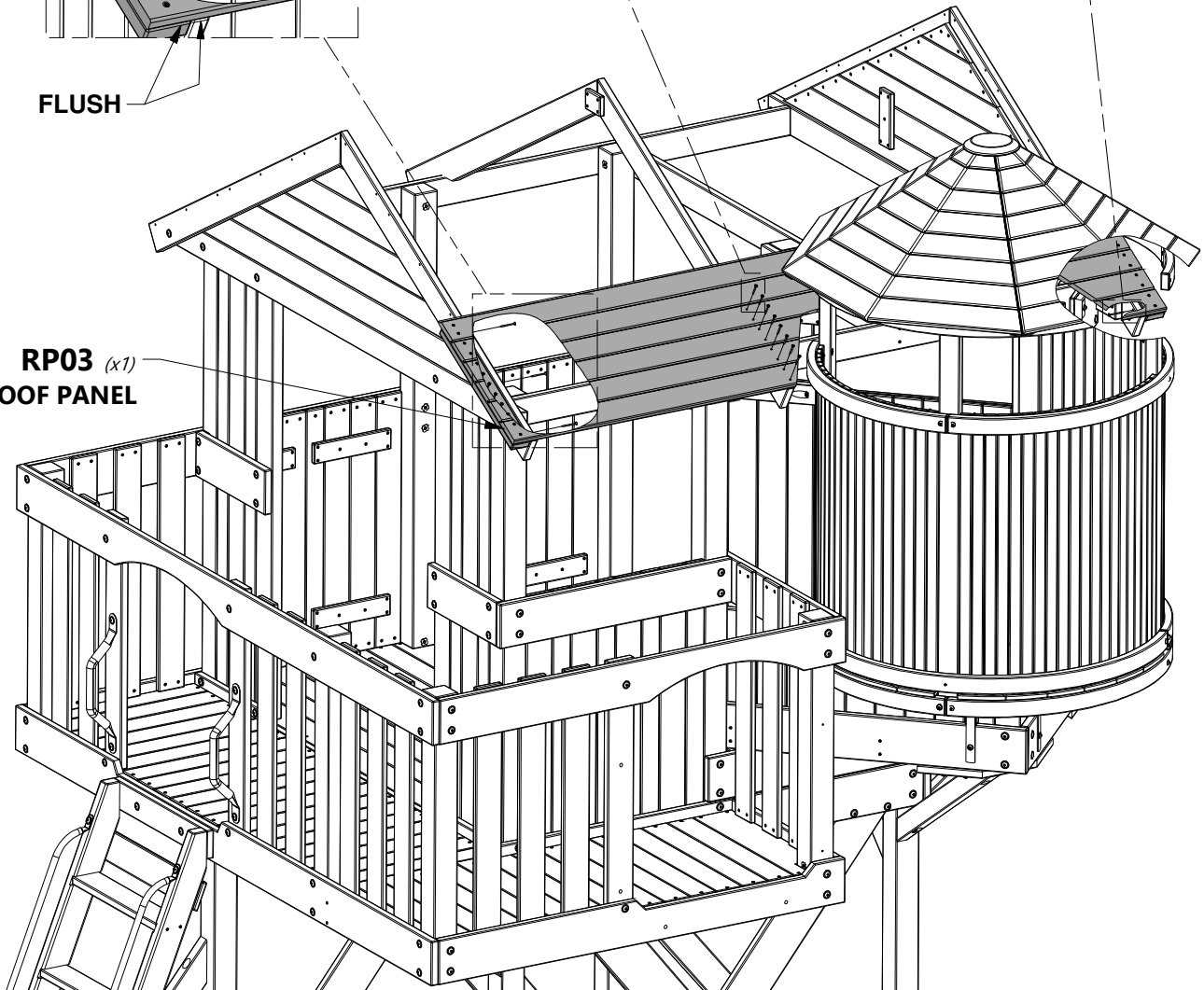

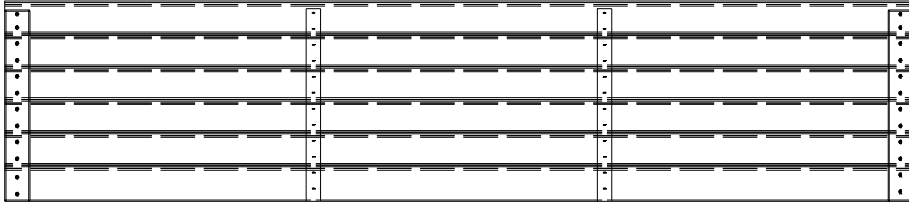
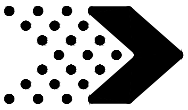

RP04 | ROOF PANEL - W2A02186
(x1) 1 9/16"x18 3/4"x85 1/4" (40x476x2165)



H100391 | SCREW PFH BLK
(x6) 8x2

391 (x6)
SCREW - 2"
BOTH ENDS

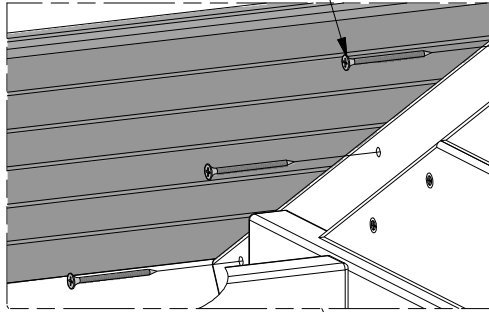

RP04 (x1)
ROOF PANEL

FLUSH

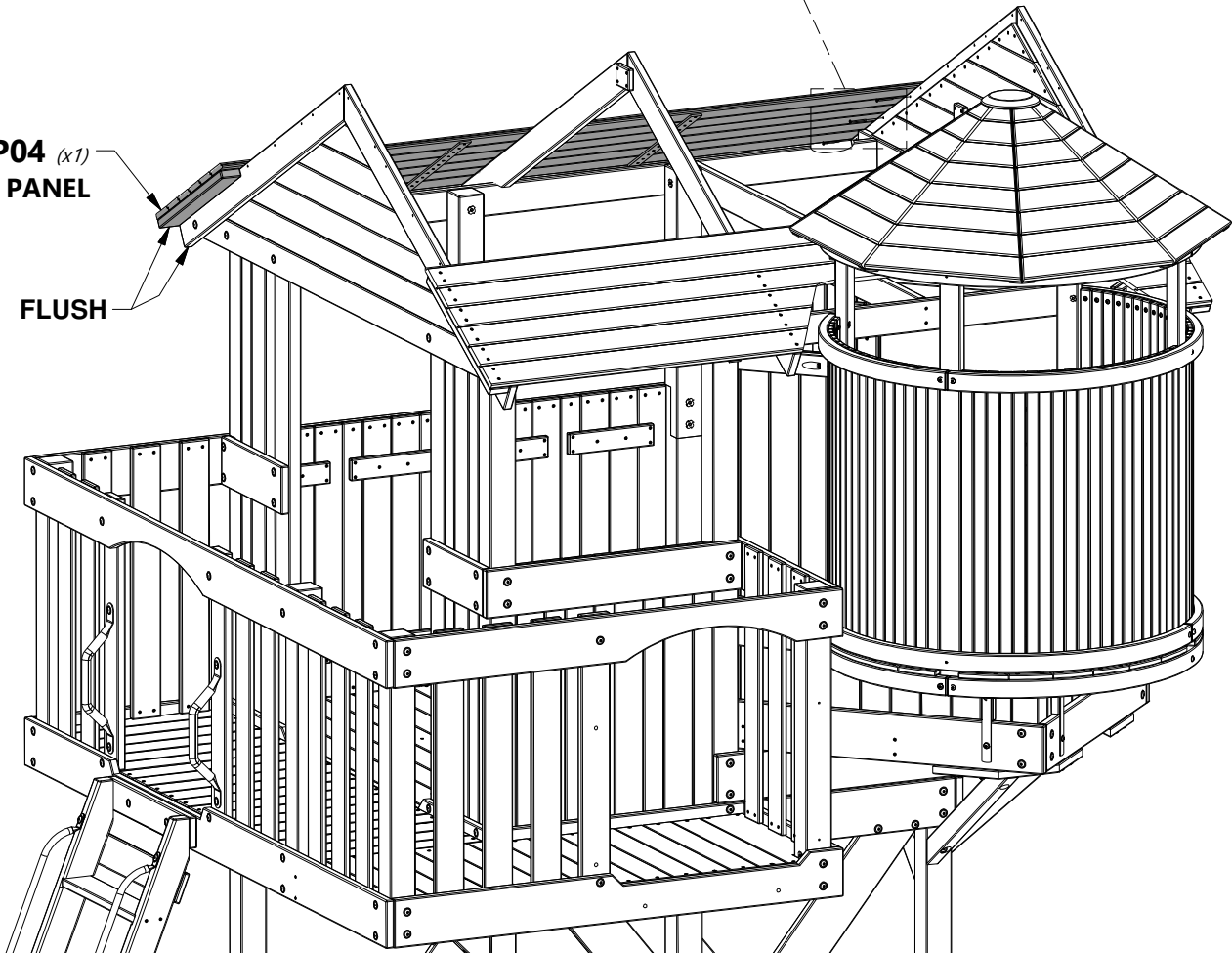

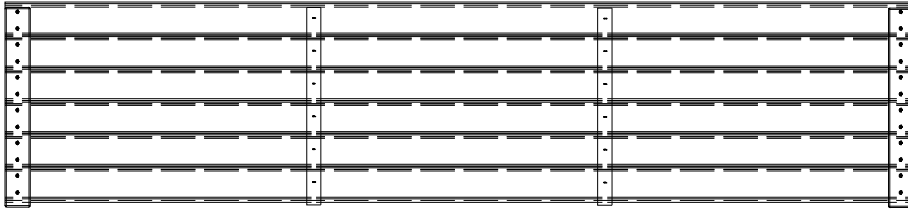
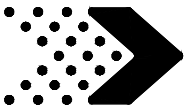

RP02 | ROOF PANEL - W2A020184
(x1) | 1 9/16"x19 1/4"x85 3/16" (40x488x2165)



H100391 | SCREW PFH BLK
(x6) | 8x2

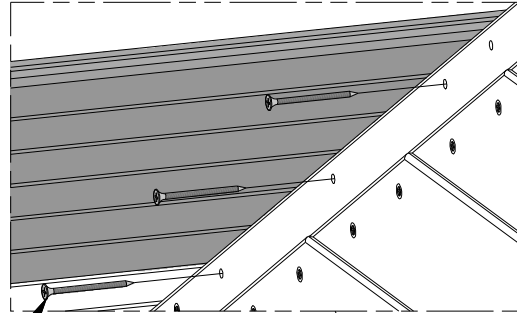

391 (x6)
SCREW - 2"
BOTH ENDS

RP02 (x1)
ROOF PANEL

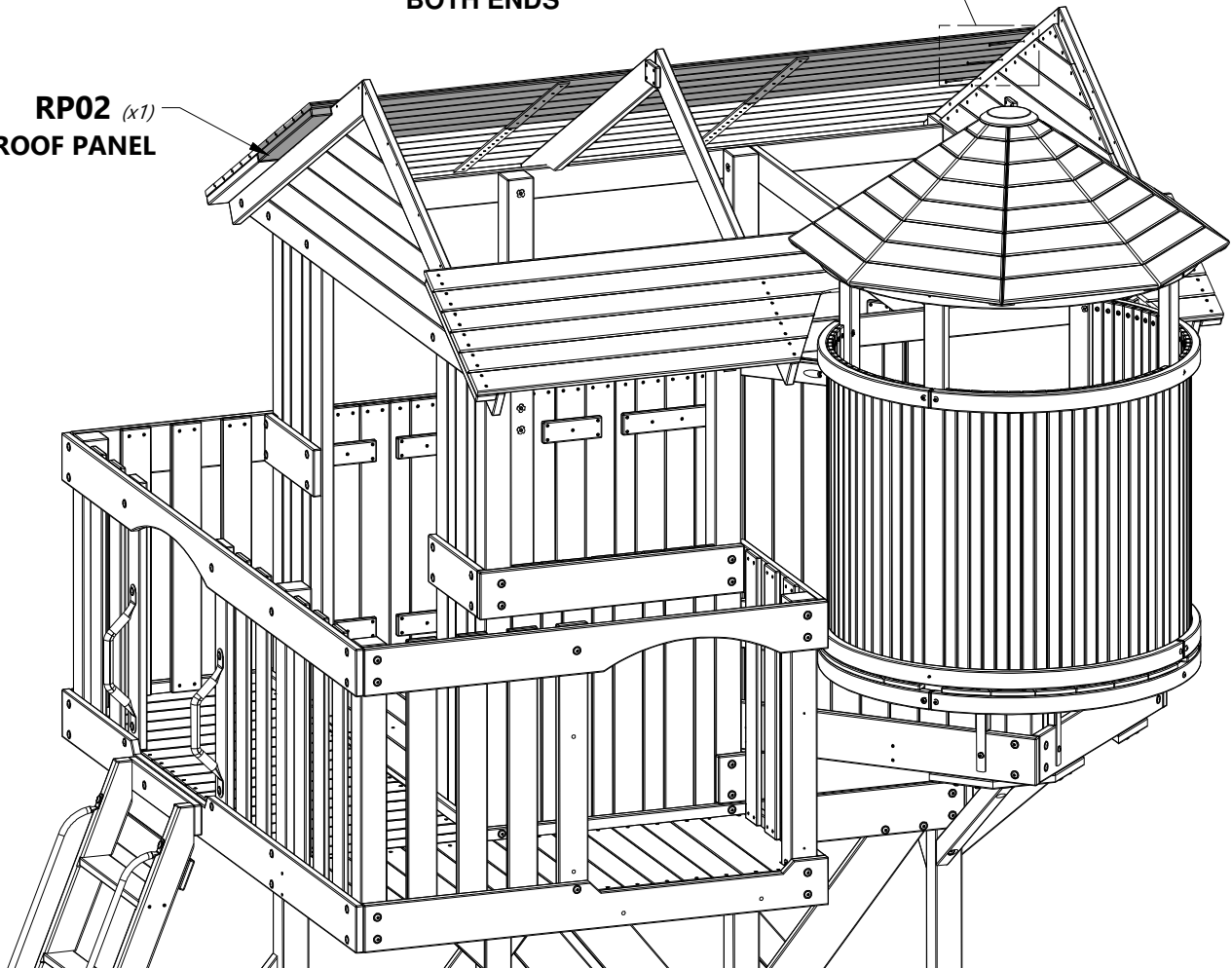

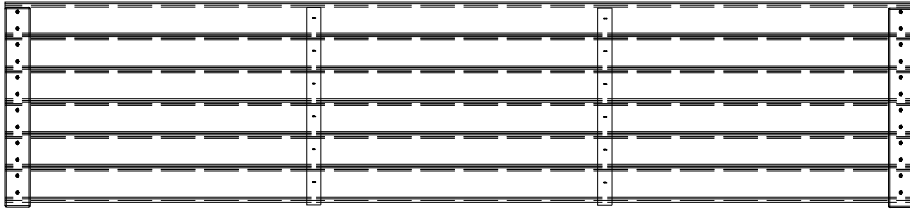
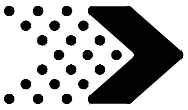

RP02 | ROOF PANEL - W2A020184
(x1) | 1 9/16"x19 1/4"x85 3/16" (40x488x2165)



H100391 | SCREW PFH BLK
(x6) | 8x2

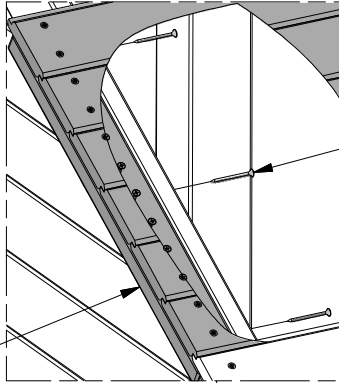

391 (x6)
SCREW - 2"
BOTH ENDS

RP02 (x1)
ROOF PANEL

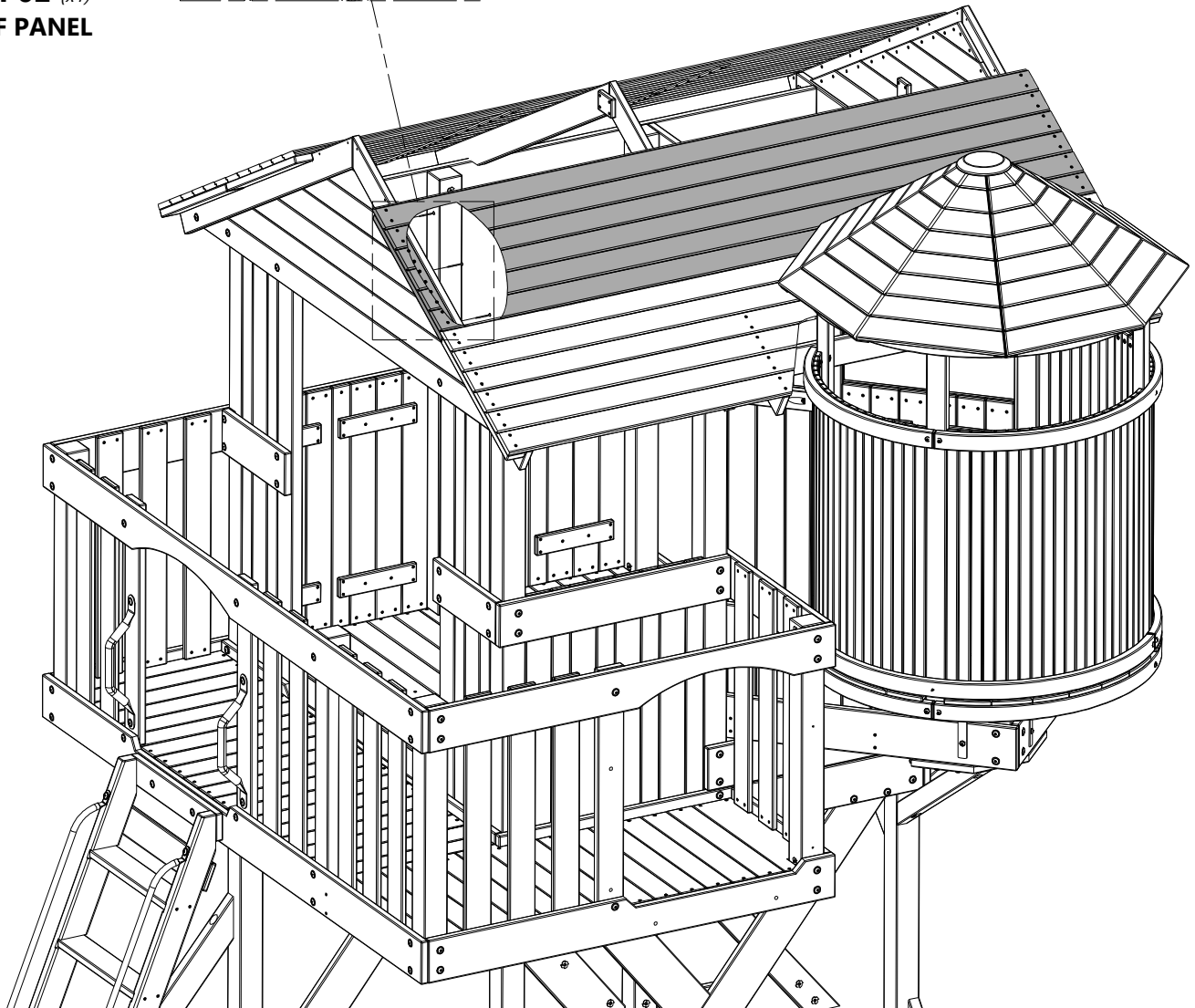

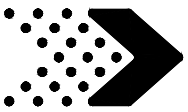

RP01 | ROOF PANEL - W2A02182
(x1) | 1/16"x1/16"x1/16" (40x287x2165)



H100391 | SCREW PFH BLK
(x4) | 8x2

RP01 (x1)
ROOF PANEL

391 (x4)
SCREW - 2"

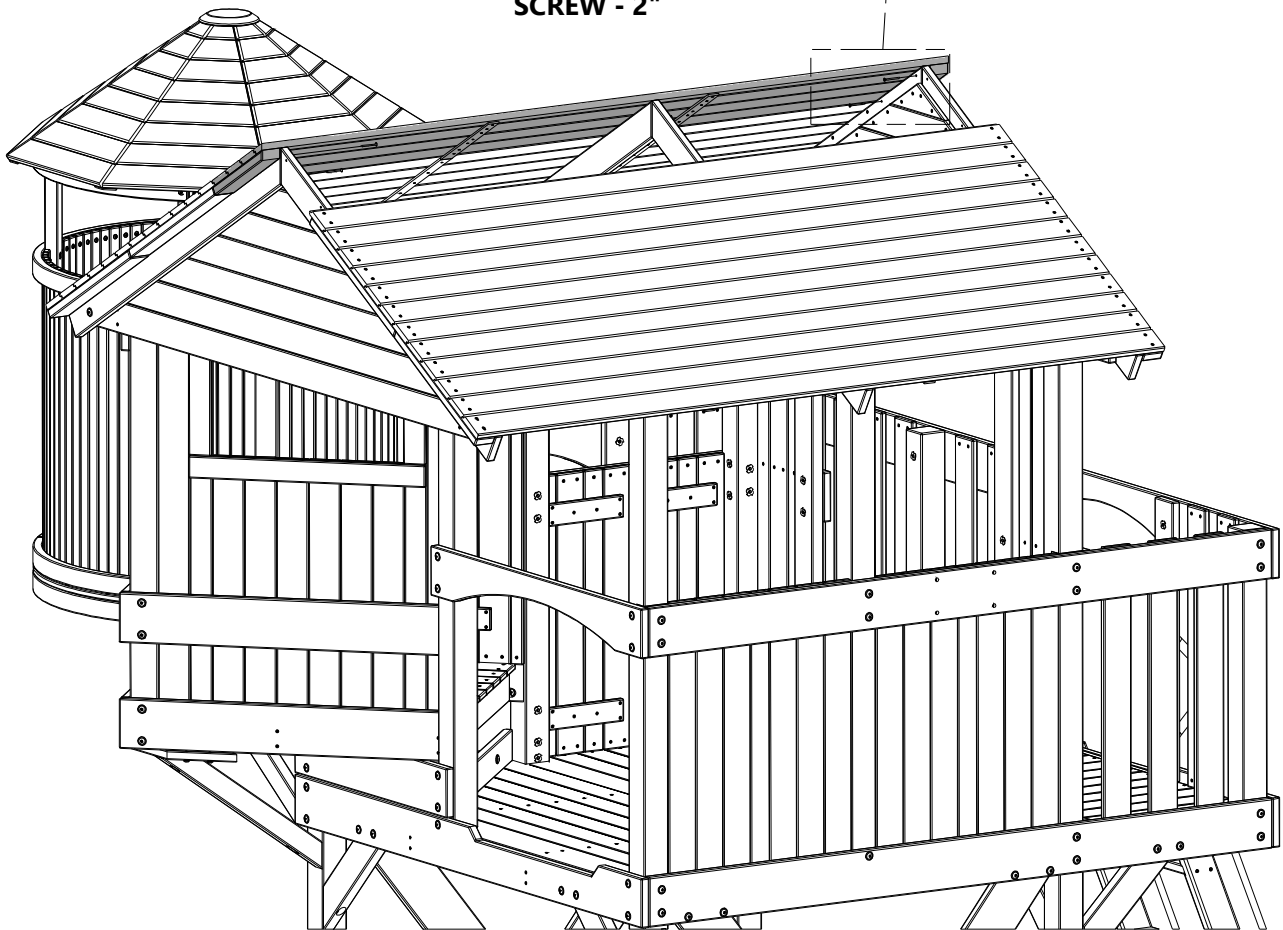
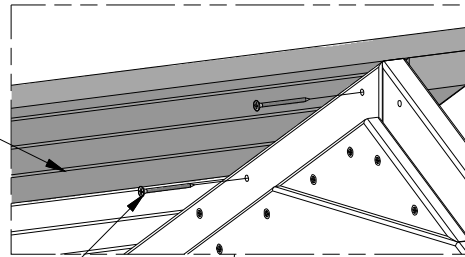

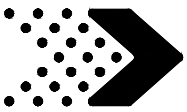

RP01 | ROOF PANEL - W2A02182
(x1) | 1/16"x1/16"x1/16" (40x287x2165)



H100391 | SCREW PFH BLK
(x4) | 8x2

ROOF EDGES SHOULD MEET WITH NO GAP SHOWING.

391 (x4)
SCREW - 2"

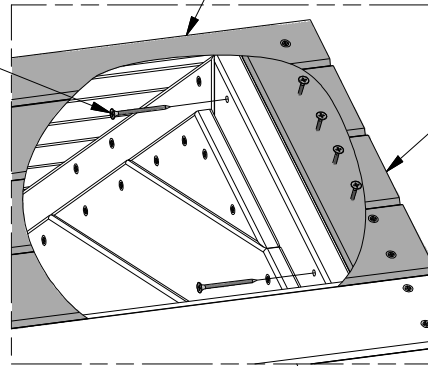

RP01 (x1)
ROOF PANEL

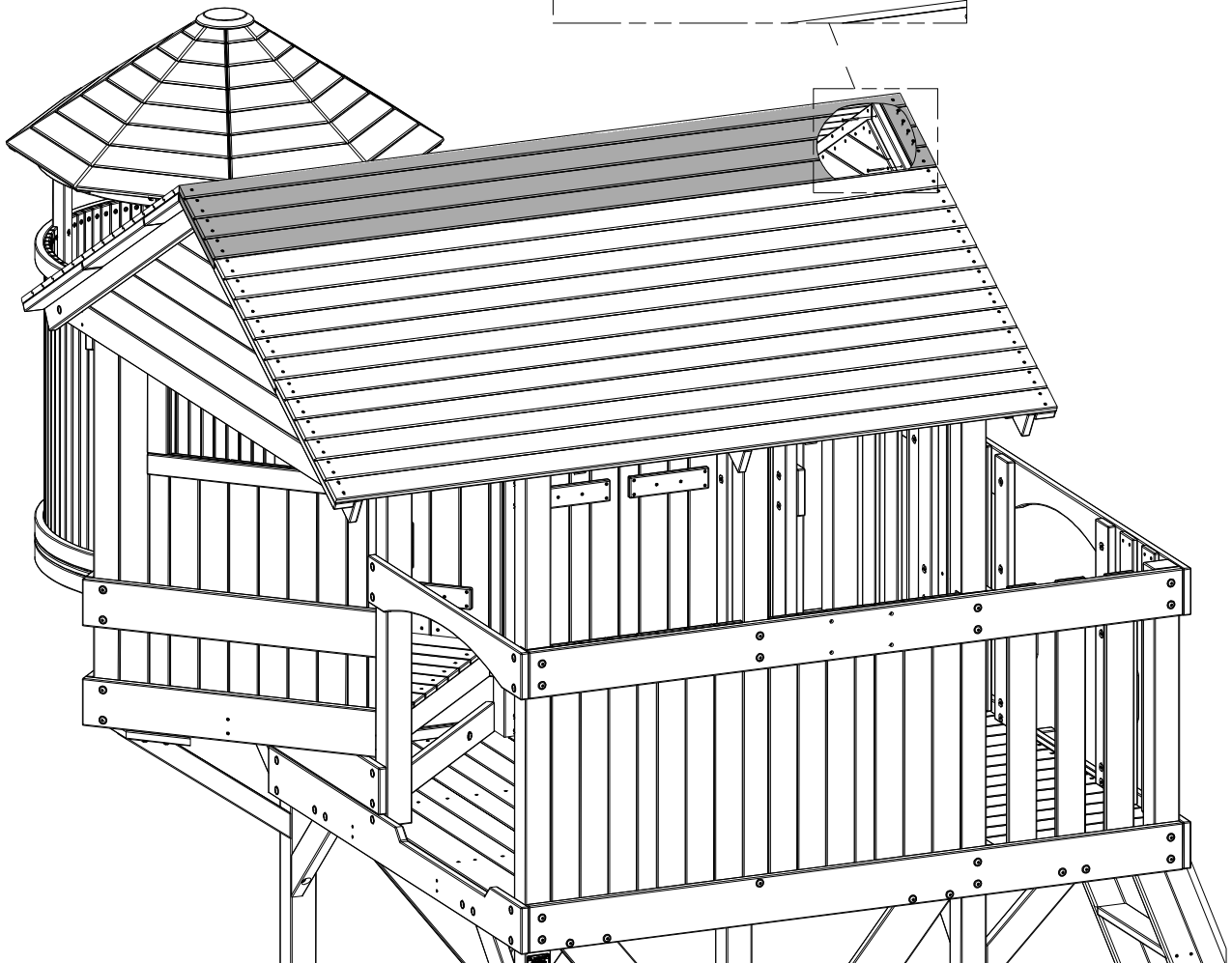

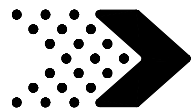

Phase 7

STEP 1

M28 | ROCK WALL BOARD - W4L12833
(x4) | 5/8"x3 3/8"x23 1/4" (16x86x590)

M29 | ROCK WALL BOARD - W4L12834
(x5) | 5/8"x3 3/8"x23 1/4" (16x86x590)

A6P00036 | GREEN HC ROCK #1
(x6)

A6P00037 | GREEN HC ROCK #2
(x7)

H100489 | BOLT PTH BLK
(x26) | 1/4x3/4

H100473 | WASHER LOCK INT BLK
(x26) | 8x15

H100398 | T-NUT BLK
(x26) | 1/4



TIP:

WE RECOMMEND INSTALLING T-NUTS INTO BOARDS BEFORE ASSEMBLY.



NOTE:

ASSEMBLE THE ROCK WALL BOARD SUB ASSEMBLIES AS FOLLOWS:
1. LEFT ROCK - SUB ASSEMBLY - x3
2. DOUBLE ROCK - SUB ASSEMBLY - x4
3. RIGHT ROCK - SUB ASSEMBLY - x2

****PLACE ROCKS AS DESIRED!**

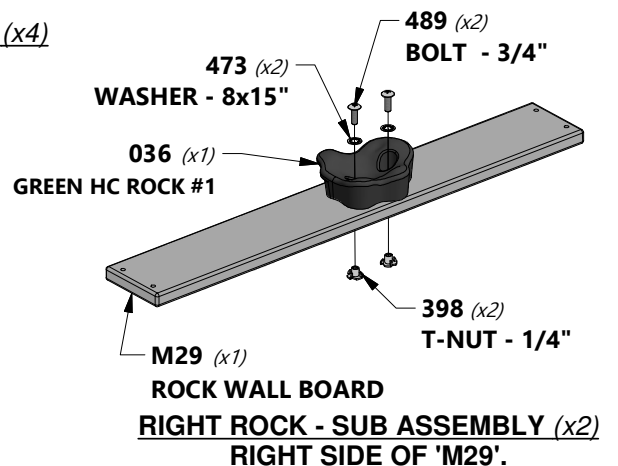
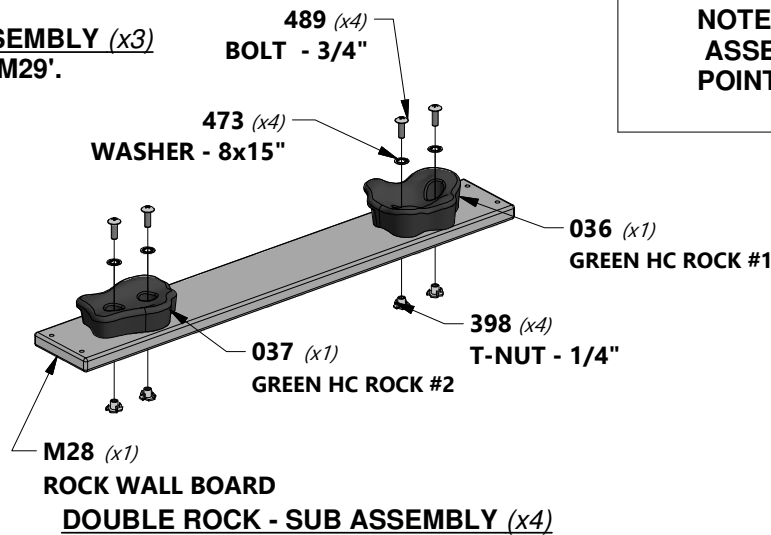
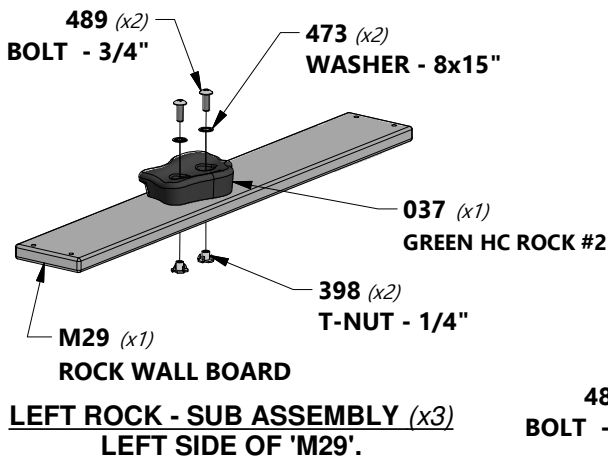

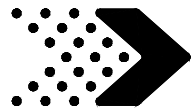

Phase 7

STEP 2



E3 | LEFT RAIL - W4L12830
(x1) | 1 3/8"x3 3/8"x64 3/4" (36x86x1645)



E4 | RIGHT RAIL - W4L12831
(x1) | 1 3/8"x3 3/8"x64 3/4" (36x86x1645)



M26 | ROCK WALL BOARD - W4L12832
(x9) | 5/8"x3 3/8"x23 1/4" (16x86x590)



M31 | ROCK WALL BOARD - W4L12837
(x1) | 5/8"x2 3/4"x23 1/4" (16x69x590)

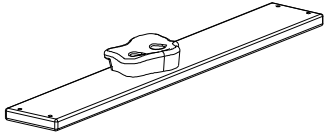

LEFT ROCK - SUB ASSEMBLY (x3)
(FROM PHASE 7 - STEP 1).

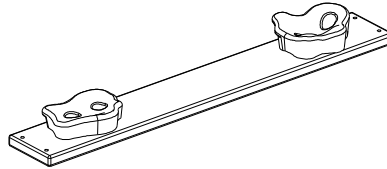

DOUBLE ROCK - SUB ASSEMBLY (x4)
(FROM PHASE 7 - STEP 1).

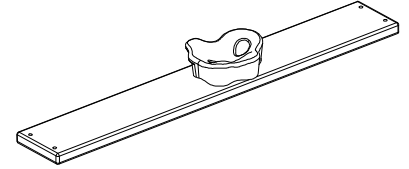

RIGHT ROCK - SUB ASSEMBLY (x2)
(FROM PHASE 7 - STEP 1).



H100200 | SCREW PFH BLK
(x76) | 8x1 1/2

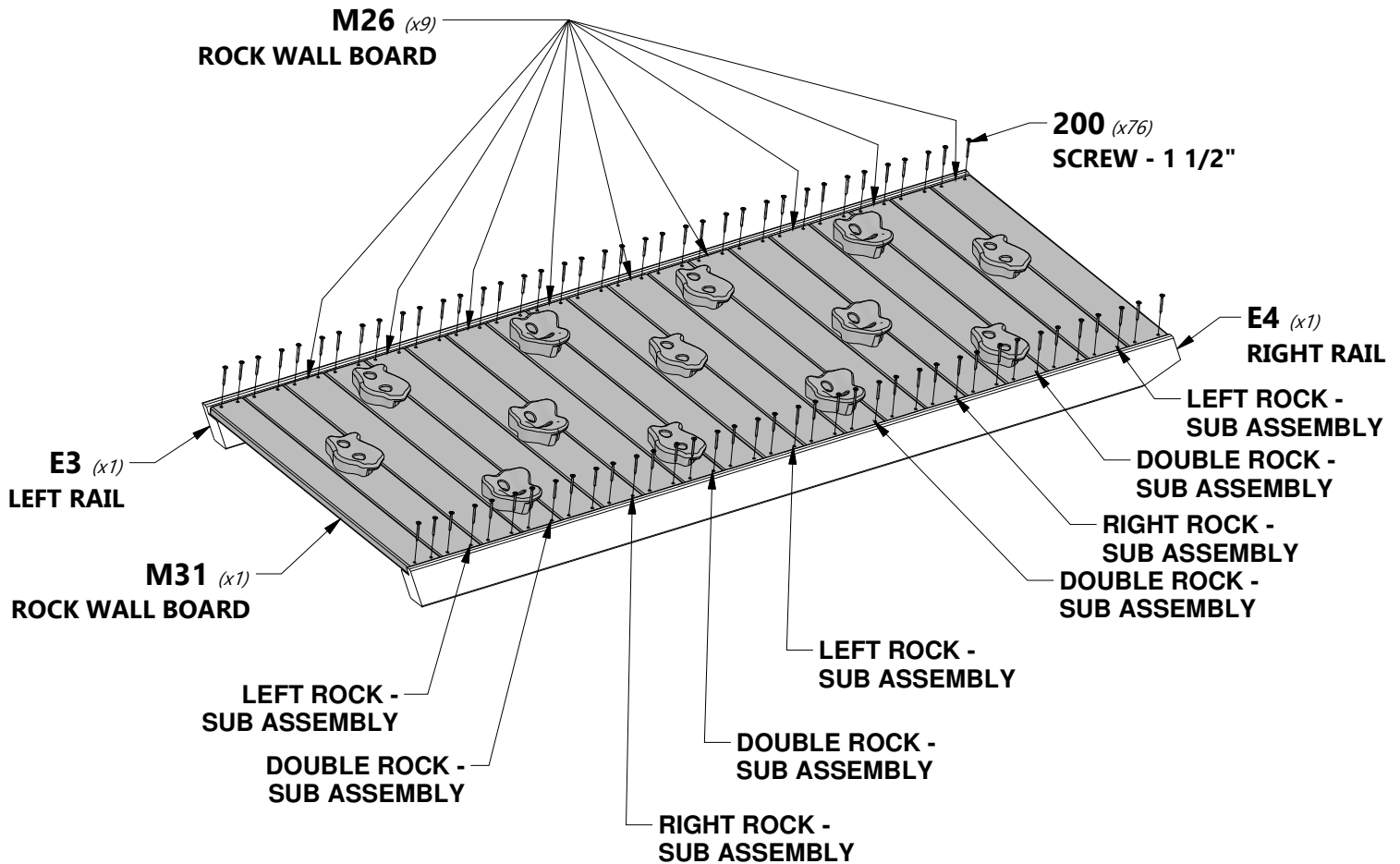

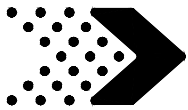

Phase 7

STEP 3



N4 | **ROCK WALL CLEAT - W4L12847**
(x1) | 5/8"x2 3/8"x61 3/4" (16x60x1568)



H100380 | **SCREW PFH BLK**
(x12) | 8x1 1/8

9 1/2 in
[241 mm]

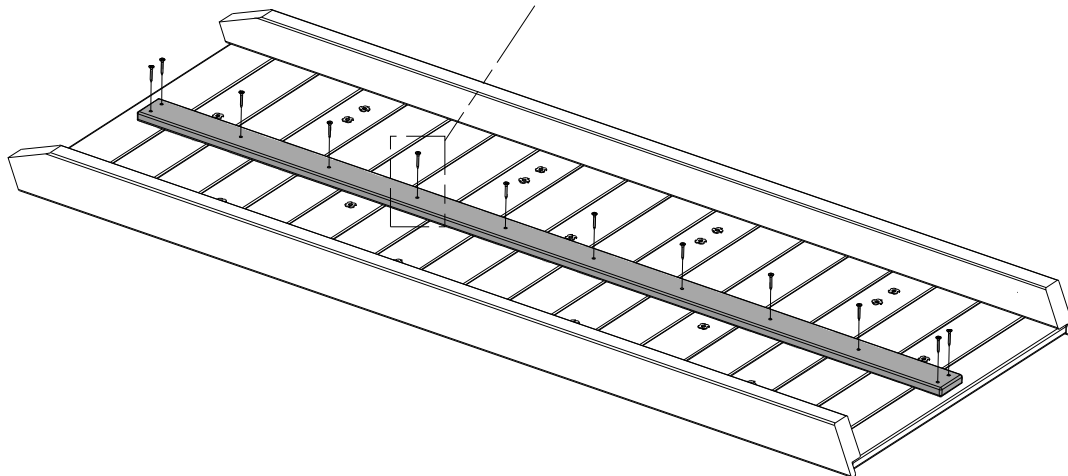
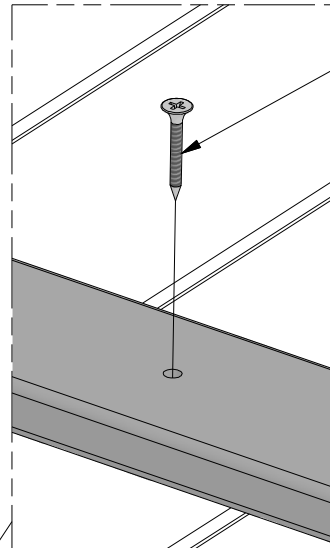
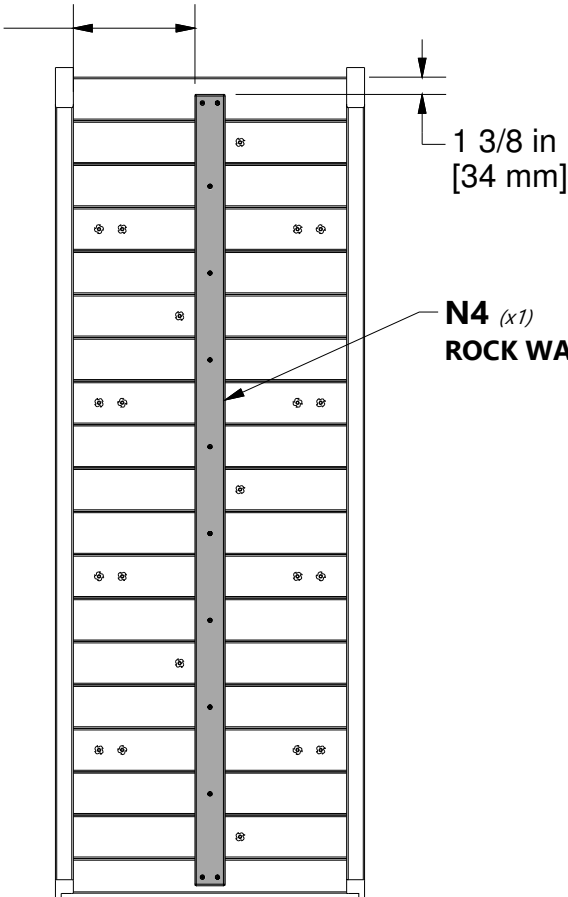



Phase 7

STEP 4

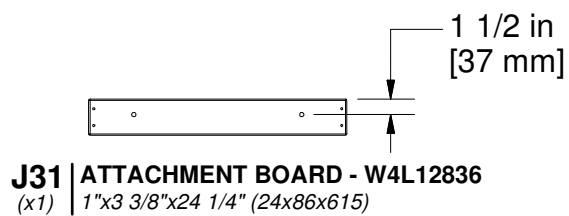

H100391 | SCREW PFH BLK
(x4) | 8x2



H100379 | T-NUT BLK
(x2) | 5/16

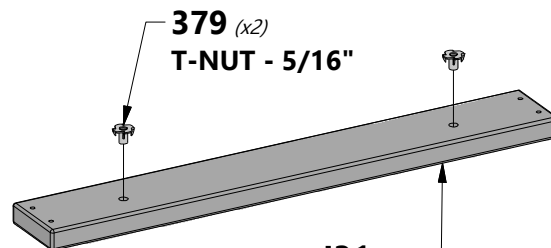

ATTACHMENT BOARD

SUB ASSEMBLY

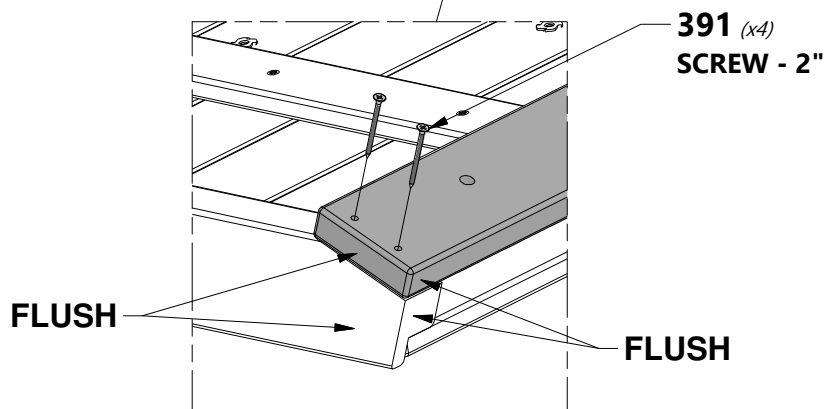
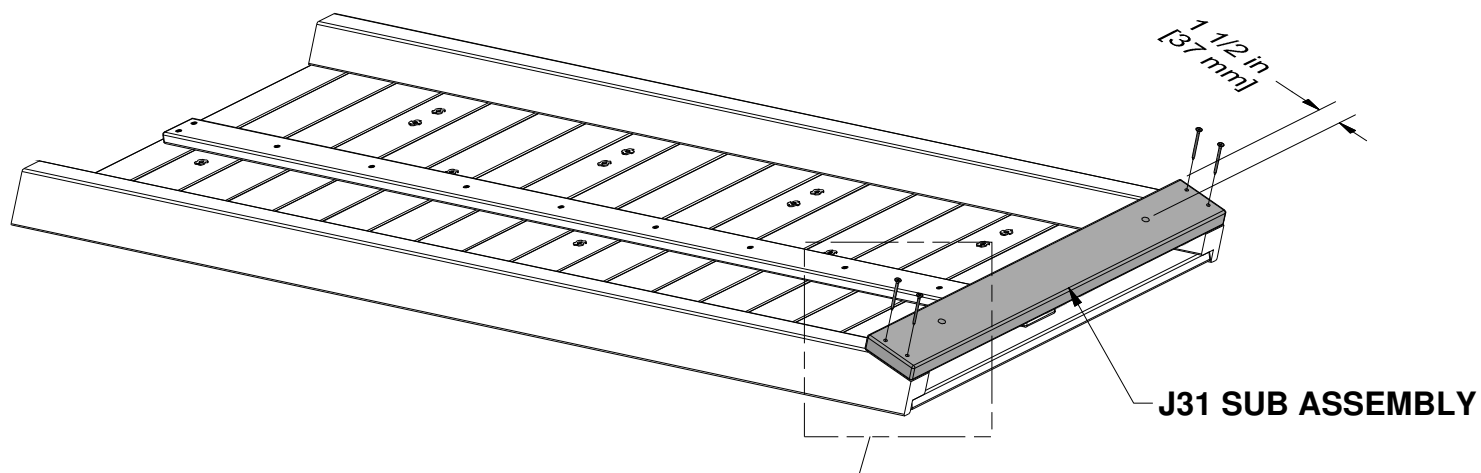

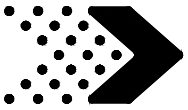

Phase 7

STEP 5



M30 | **ROCK WALL END BOARD - W4L12835**
(x1) | 5/8"x3 3/8"x24 1/4" (16x86x615)



H100200 | **SCREW PFH BLK**
(x4) | 8x1 1/2

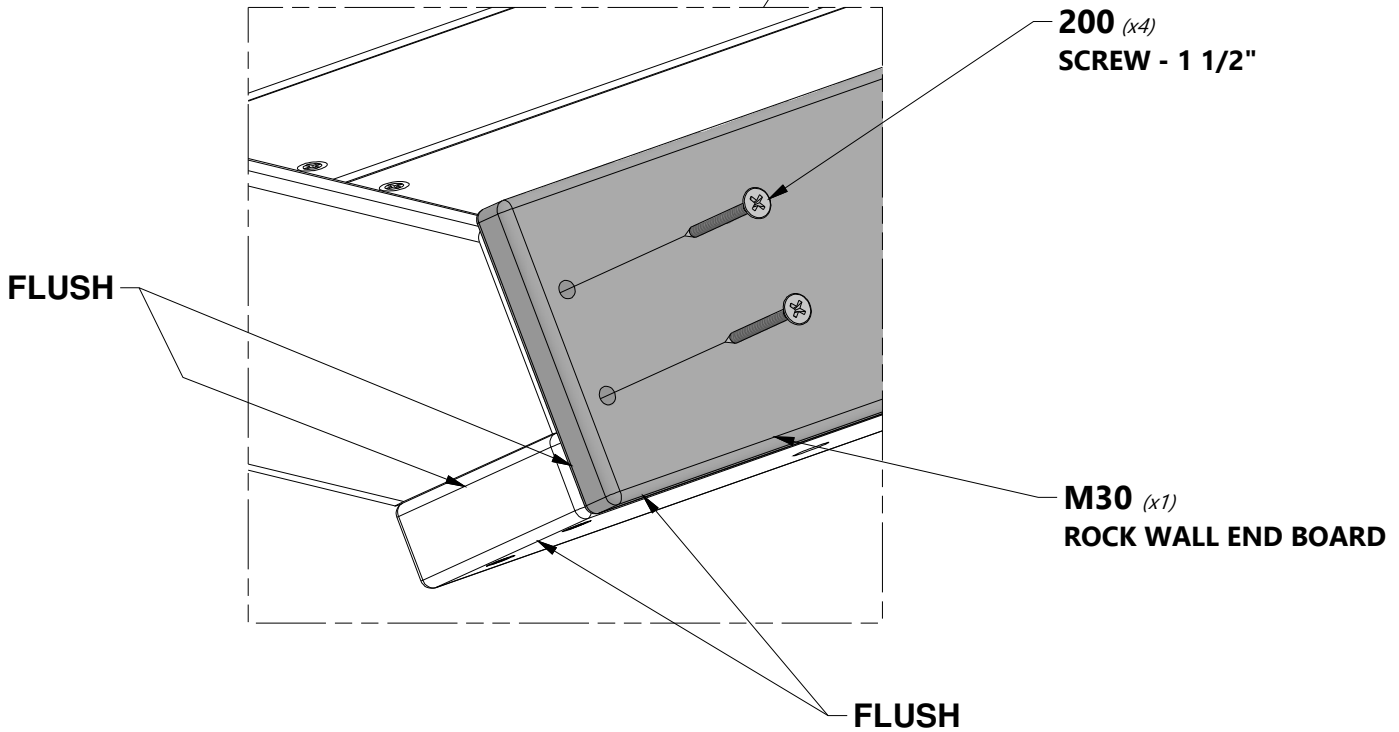
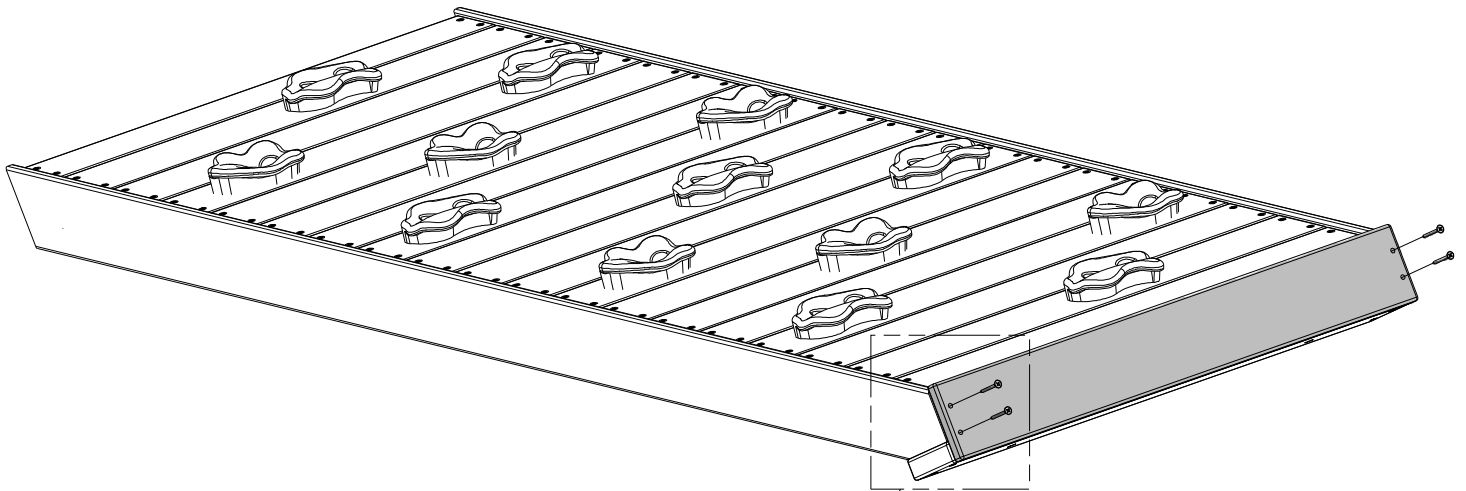

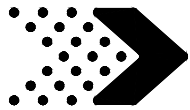

Phase 7

STEP 6

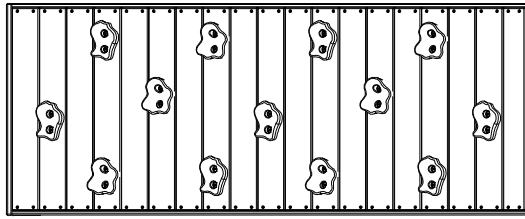

(1) **ROCK WALL ASSEMBLY**
(FROM PREVIOUS STEP).



H100195 | BOLT WH BLK
(x2) | 5/16x2-3/4



H100198 | WASHER LOCK EXT BLK
(x2) | 8x19

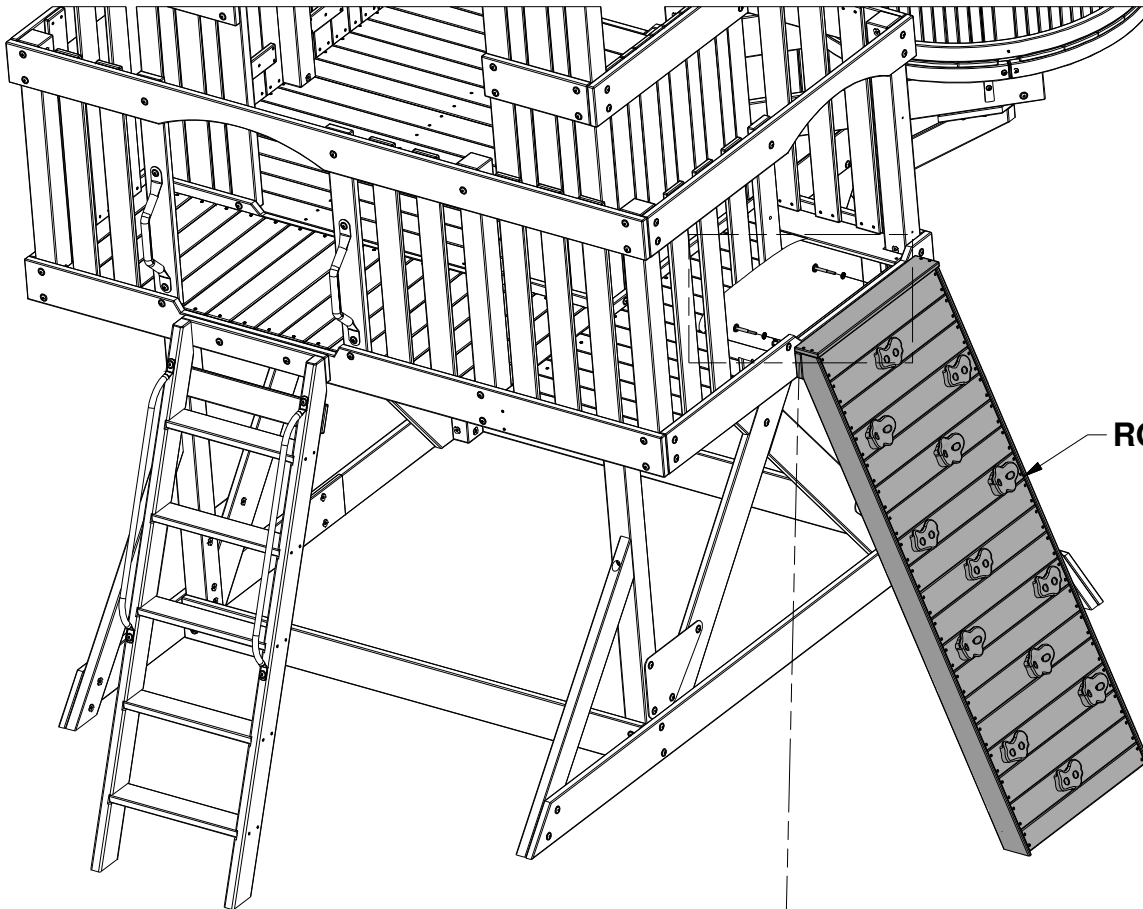

ROCK WALL ASSEMBLY

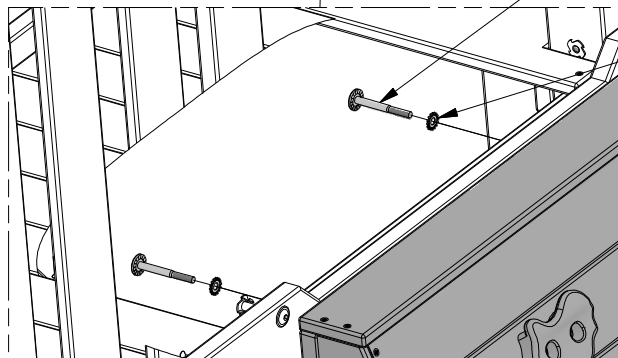

195 (x2)
BOLT - 2-3/4

198 (x2)
WASHER - 8x19

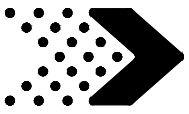

Phase 7

STEP 7



A100118 | HAND GRIP METAL GREEN 381 c/c
(x2)



H100471 | LAG SCREW WH BLK
(x2) | 5/16x1 1/2



H100468 | BOLT WH BLK
(x2) | 5/16x1



H100379 | T-NUT BLK
(x2) | 5/16



TIP:

WE RECOMMEND INSTALLING T-NUTS INTO BOARDS BEFORE ASSEMBLY.

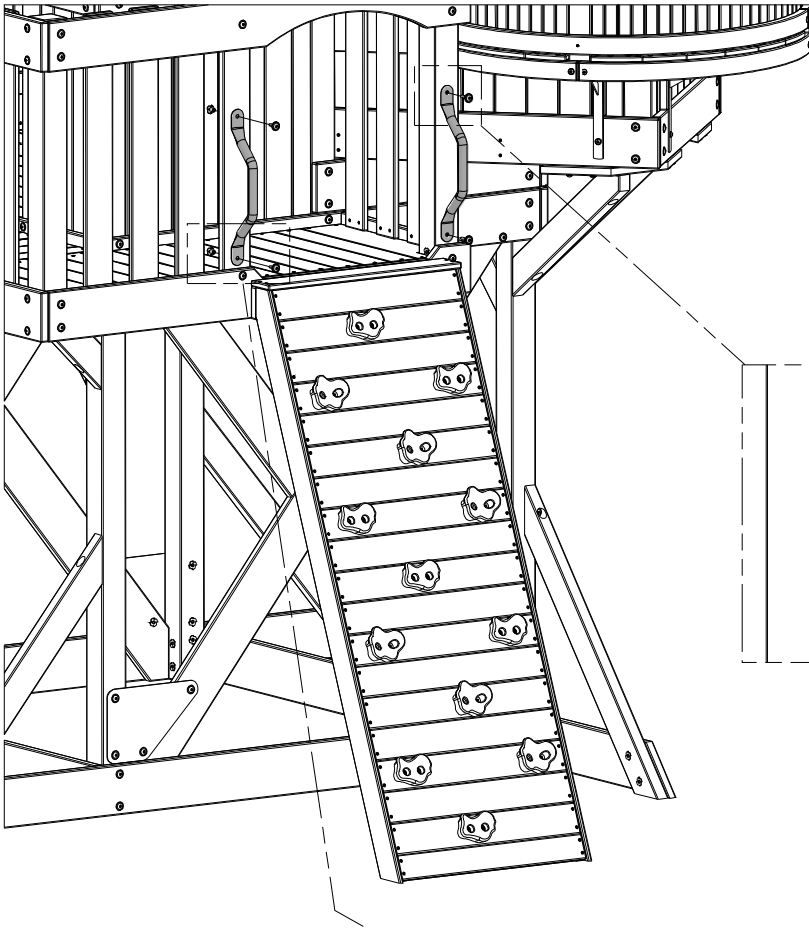

118 (x2)

HAND GRIP METAL GREEN 381 c/c

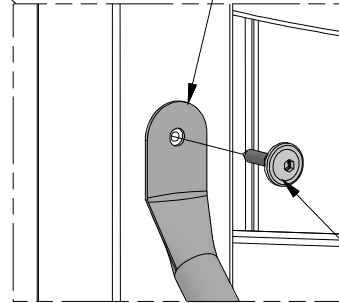

471 (x2)

LAG SCREW - 1 1/2"

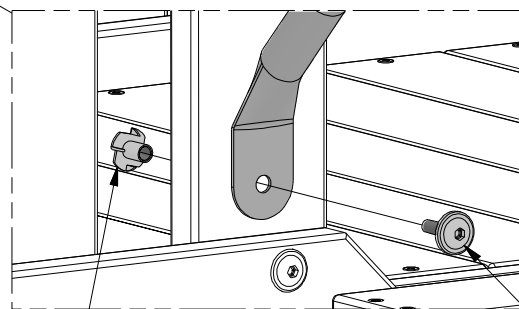

379 (x2)

T-NUT - 5/16"

468 (x2)

BOLT WH - 1"



Phase 8

STEP 1

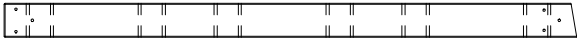

A1 | SWING BEAM - W4L12838
(x1) | 3 3/8"x5 1/4"x89 1/2" (86x134x2274)



A2 | SB 9" BLOCK - W4L08962
(x1) | 3 3/8"x5 1/4"x9" (86x134x228)

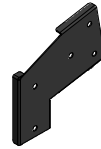

A100326 | SWING BEAM EXTENSION BRACKET-RIGHT
(x1)

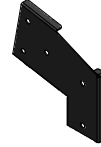

A100325 | SWING BEAM EXTENSION BRACKET-LEFT
(x1)

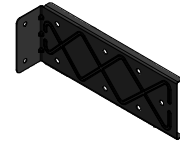

A4M00993 | EXTENDED SWING BEAM BRACKET
(x2)



H100416 | BOLT WH BLK
(x10) | 5/16x3



H100192 | NUT BARREL WH BLK
(x10) | 5/16x7/8

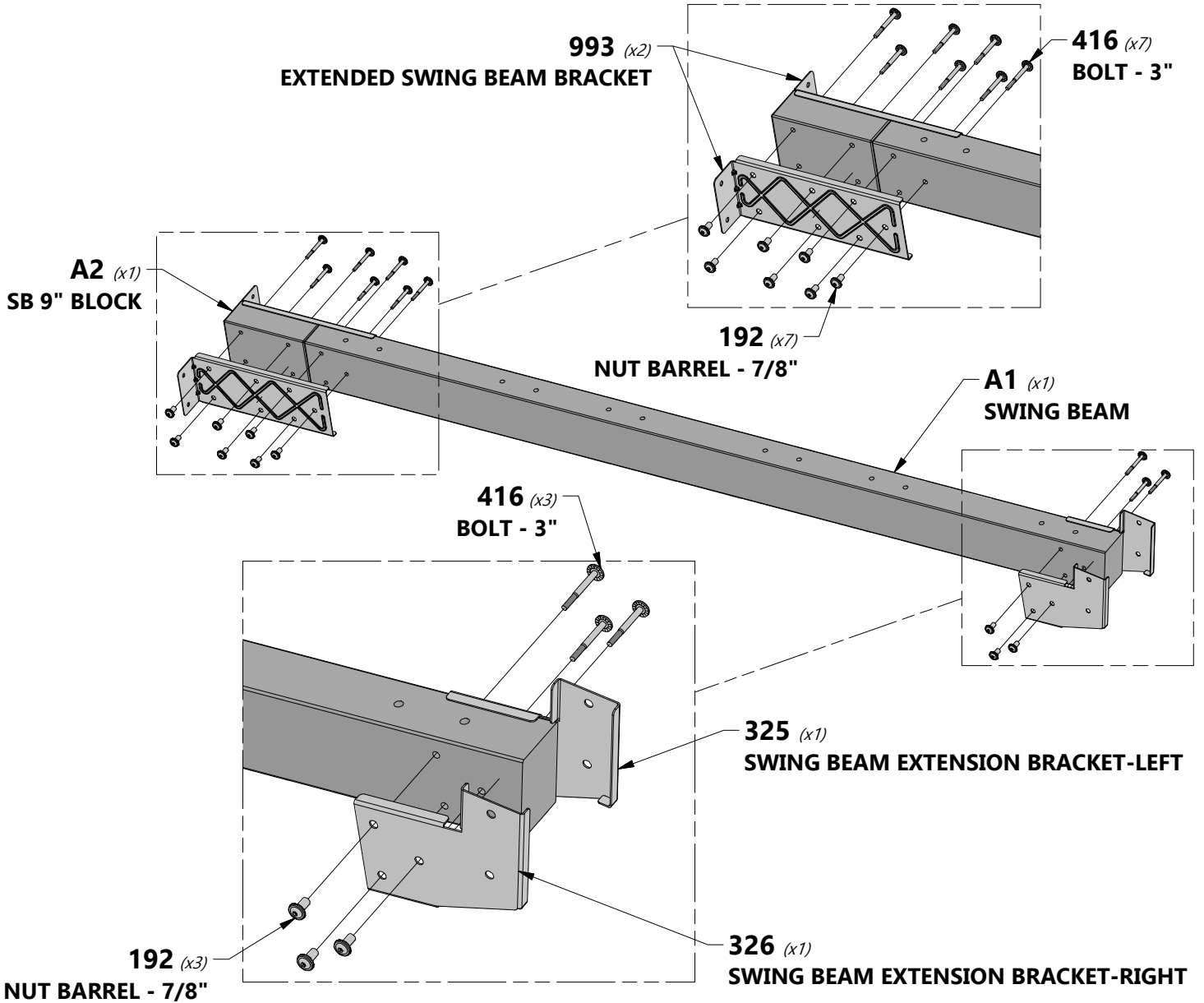

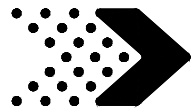

Phase 8

STEP 2



A100164 | BYD ID TAG (LARGE) AGES 3-10
(x1)

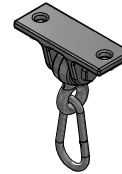

A4M00926 | SINGLE DUCTILE HANGER SD
(x6)



H100665 | BOLT HEX SD
(x12) | 3/8x5 3/4



H100708 | WASHER LOCK INT SD
(x12) | 10x18



H100703 | WASHER FLAT SD
(x12) | 11x25

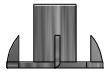

H100700 | T-NUT SD
(x12) | 3/8



H100203 | SCREW PFH BLK
(x4) | 8x1/2



TIP:
WE RECOMMEND INSTALLING T-NUTS INTO
BOARDS BEFORE ASSEMBLY.

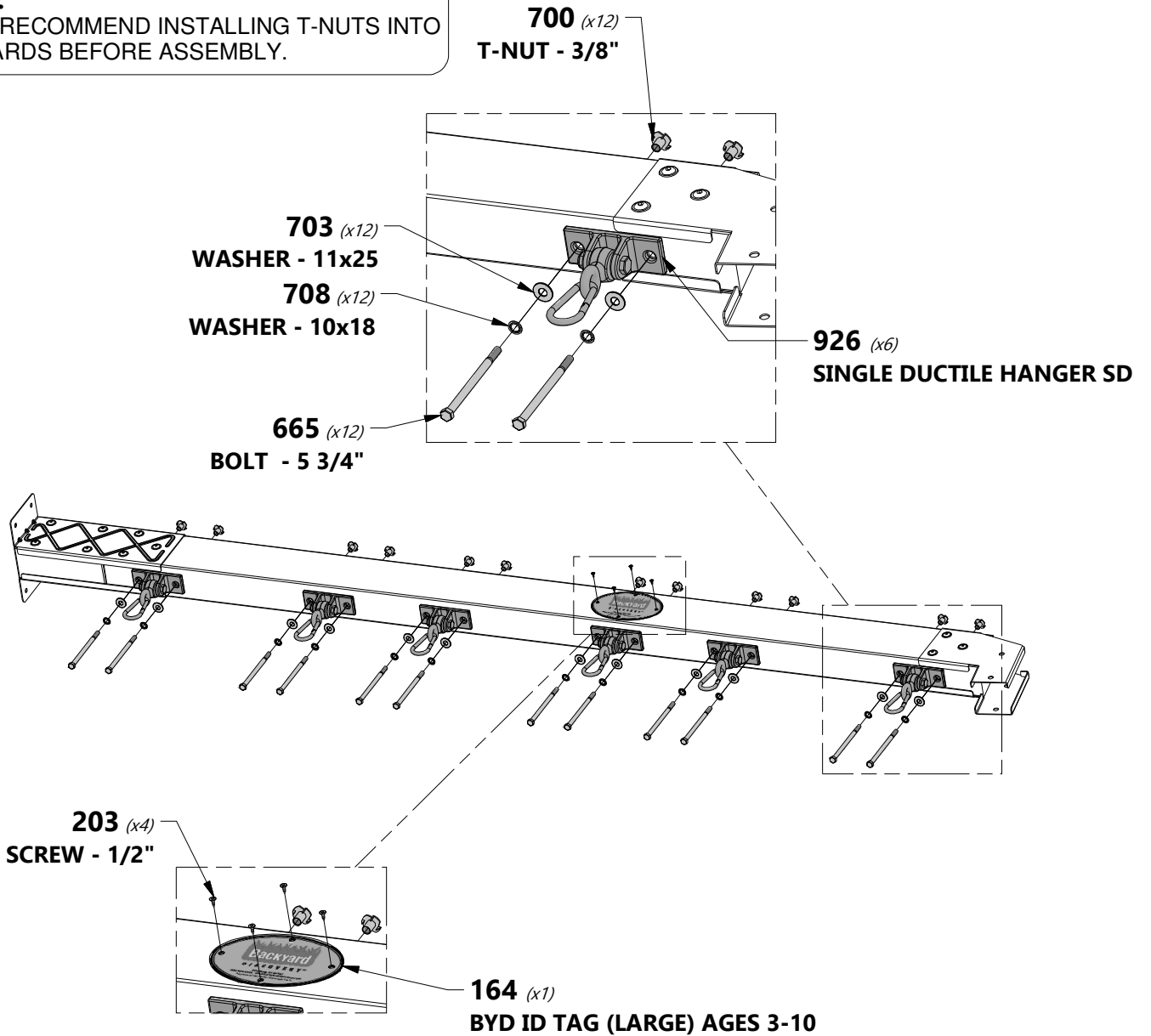

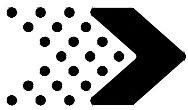

Phase 8

STEP 3

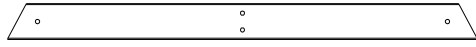

E50 | END SUPPORT - W4L11379
(x1) | 1 3/8"x3 3/8"x44 1/8" (36x86x1120)



E51 | ANGLE BRACE - W4L11378
(x2) | 1 3/8"x3 3/8"x88 3/4" (36x86x2254)

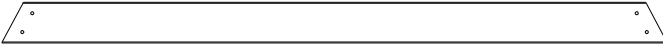

G50 | GROUND BOARD - W4L11380
(x1) | 1"x5 1/4"x86 3/4" (24x134x2202)



SP50 | SWING BEAM SUPPORT - W4L11377
(x1) | 3 3/8"x3 3/8"x49 3/8" (86x86x1254)



H100363 | BOLT WH BLK
(x1) | 5/16X6



H100415 | BOLT WH BLK
(x2) | 5/16x3 3/4



H100205 | BOLT WH BLK
(x2) | 5/16x2-1/4



H100457 | BOLT WH BLK
(x4) | 5/16x2



H100193 | NUT BARREL WH BLK
(x2) | 5/16x1-1/2



H100192 | NUT BARREL WH BLK
(x7) | 5/16x7/8



H100198 | WASHER LOCK EXT BLK
(x9) | 8x19



H100199 | WASHER LOCK EXT BLK
(x9) | 12x19

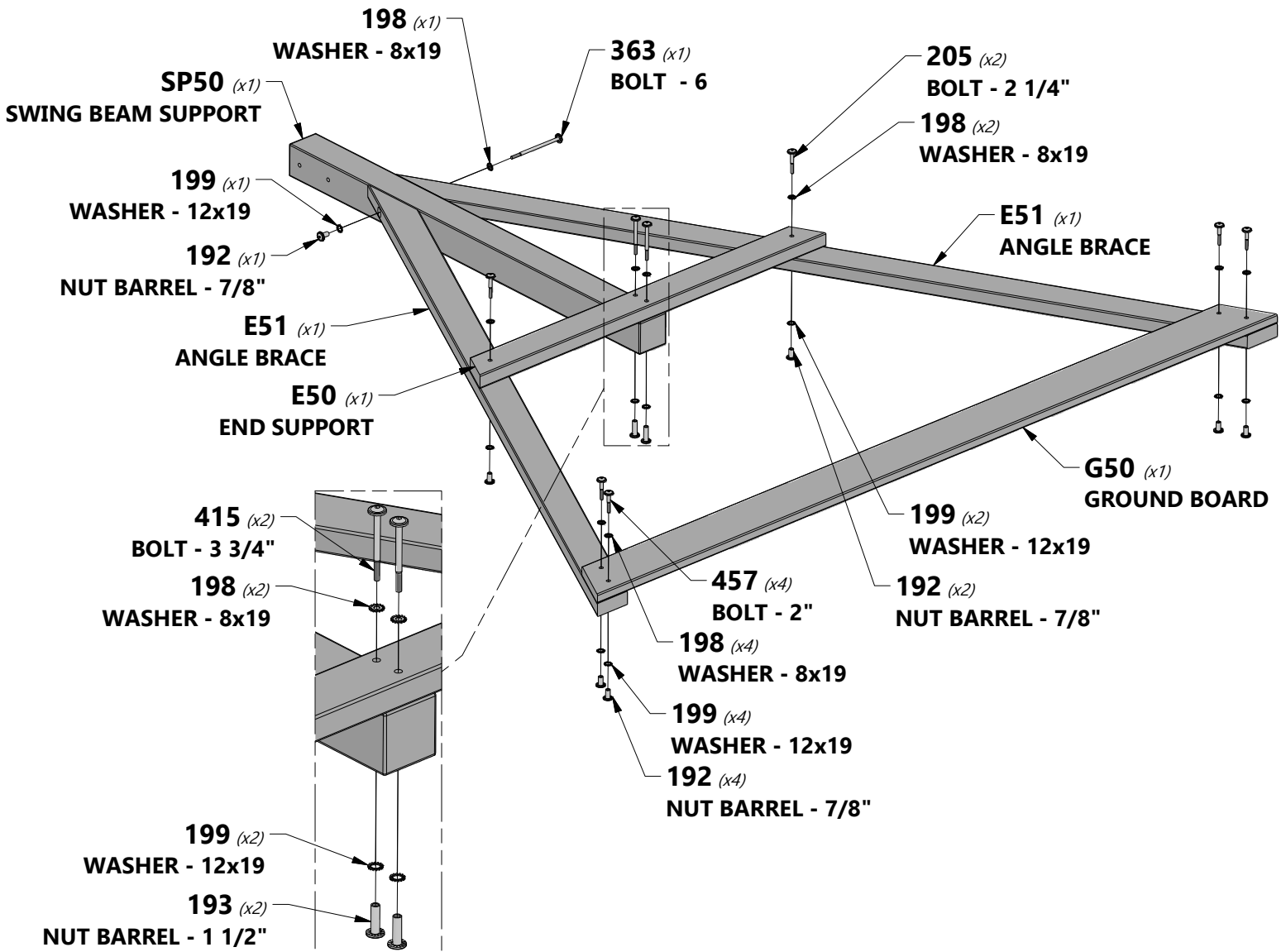

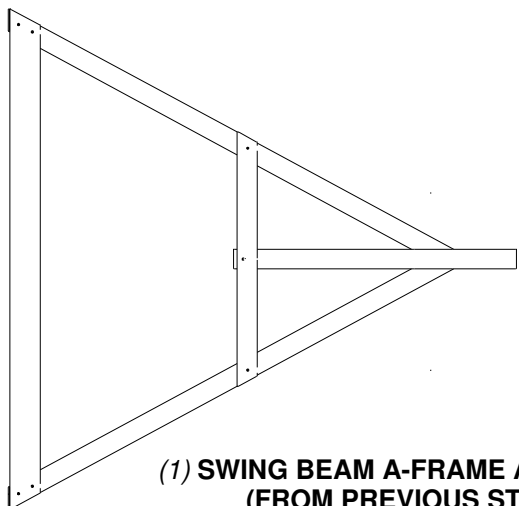
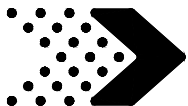

(1) SWING BEAM A-FRAME ASSEMBLY
(FROM PREVIOUS STEP).



H100416 | BOLT WH BLK
(x2) | 5/16x3



H100192 | NUT BARREL WH BLK
(x2) | 5/16x7/8

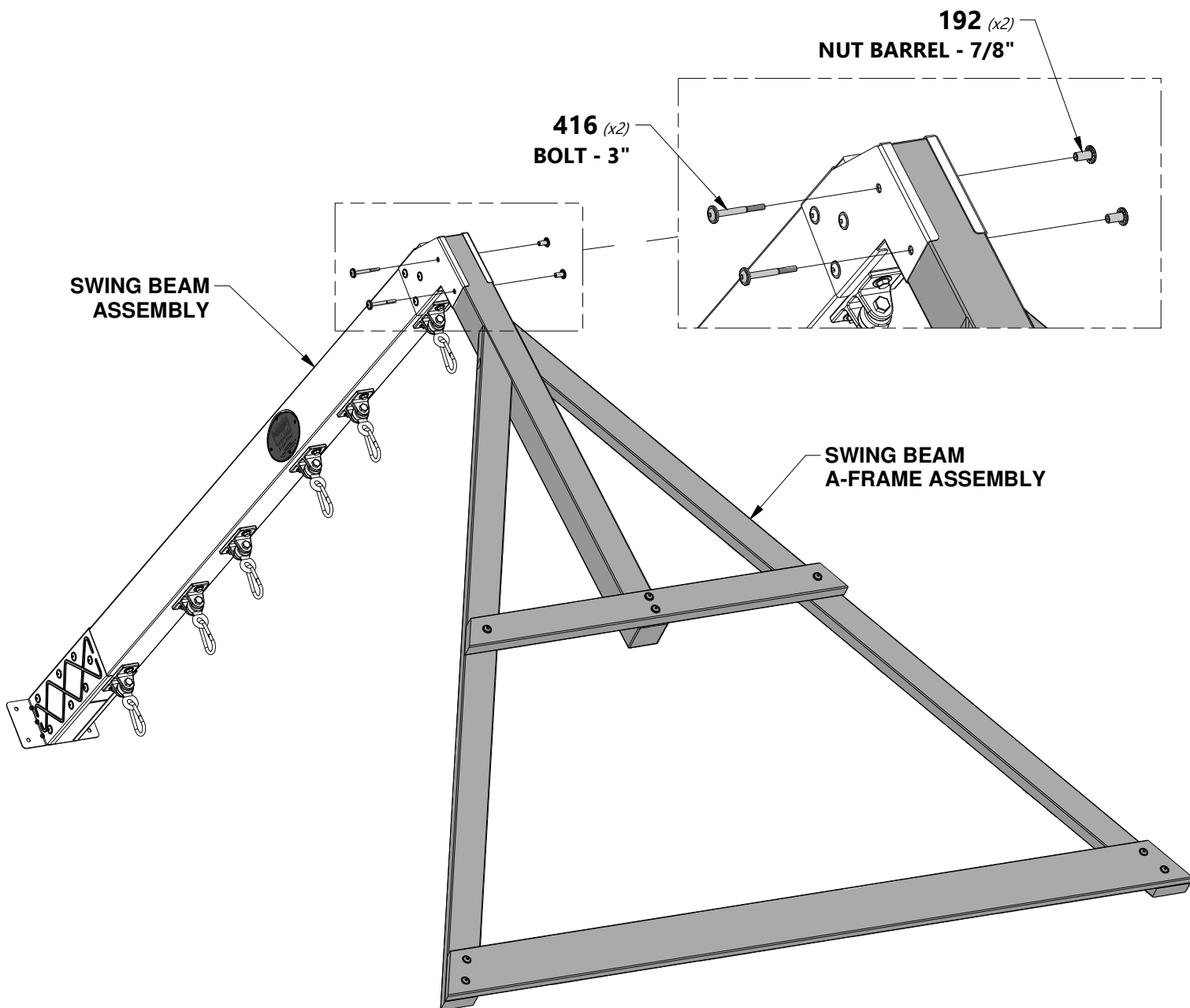

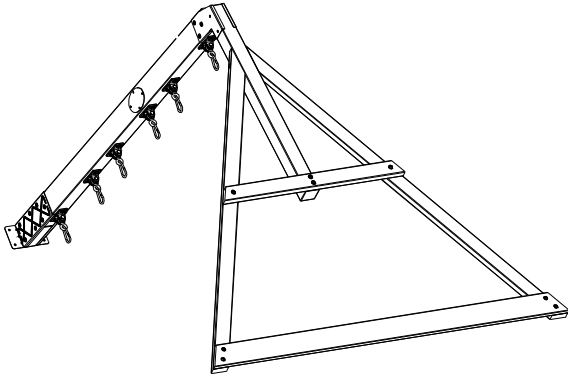
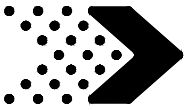

(1) SWING BEAM ASSEMBLY
(FROM PREVIOUS STEP).



H100481 | BOLT HEX BLK
(x4) | 5/16x1 1/4



H100477 | WASHER SPLIT BLK
(x4) | 5/16



H100478 | WASHER FLAT BLK
(x4) | 8x27

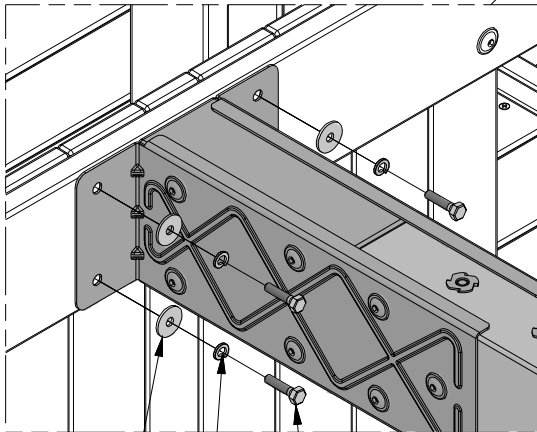
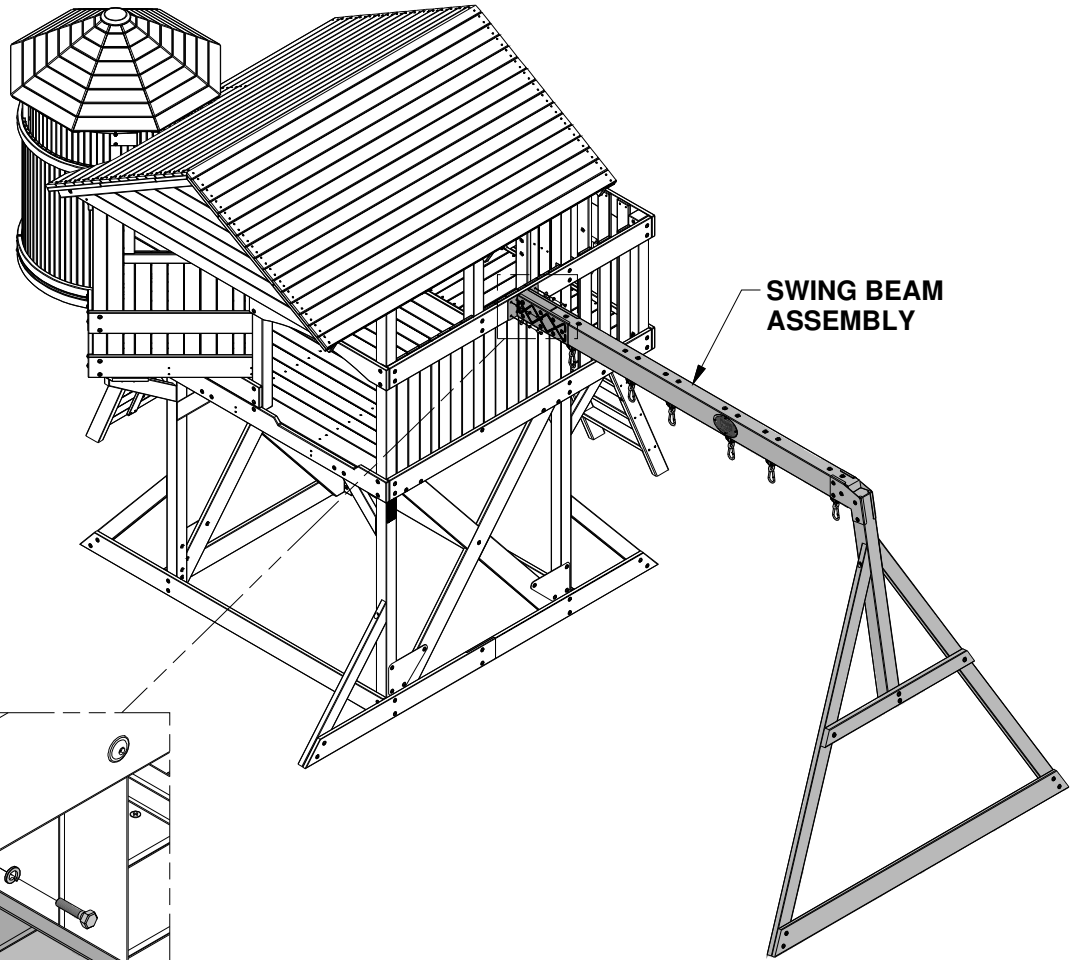

478 (x4)
WASHER - 8x27

481 (x4)
BOLT - 1 1/4"

477 (x4)
WASHER - 5/16

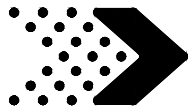

Phase 8

STEP 6



A6P00362 | 26" HD BELT SWING
(x2)

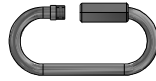

A4M00927 | QUICK LINK SD
(x4)

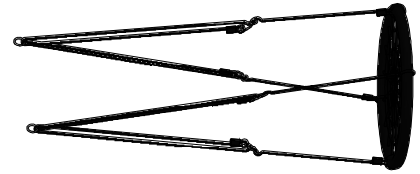

A6P00253 | 26" WEB SWING SEAT
(x1)



A4M01005 | CHAIN GREEN 7mm x 1452mm (57in)
(x4)



NOTE:
SEE WEB SWING SETUP INSTRUCTIONS, ON
THE NEXT PAGE, FOR PROPER INSTALLATION.

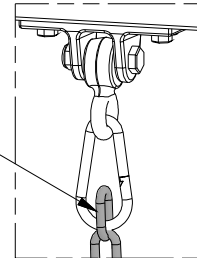

005 *(x4)*

CHAIN GREEN 7mm x 1452mm (57in)

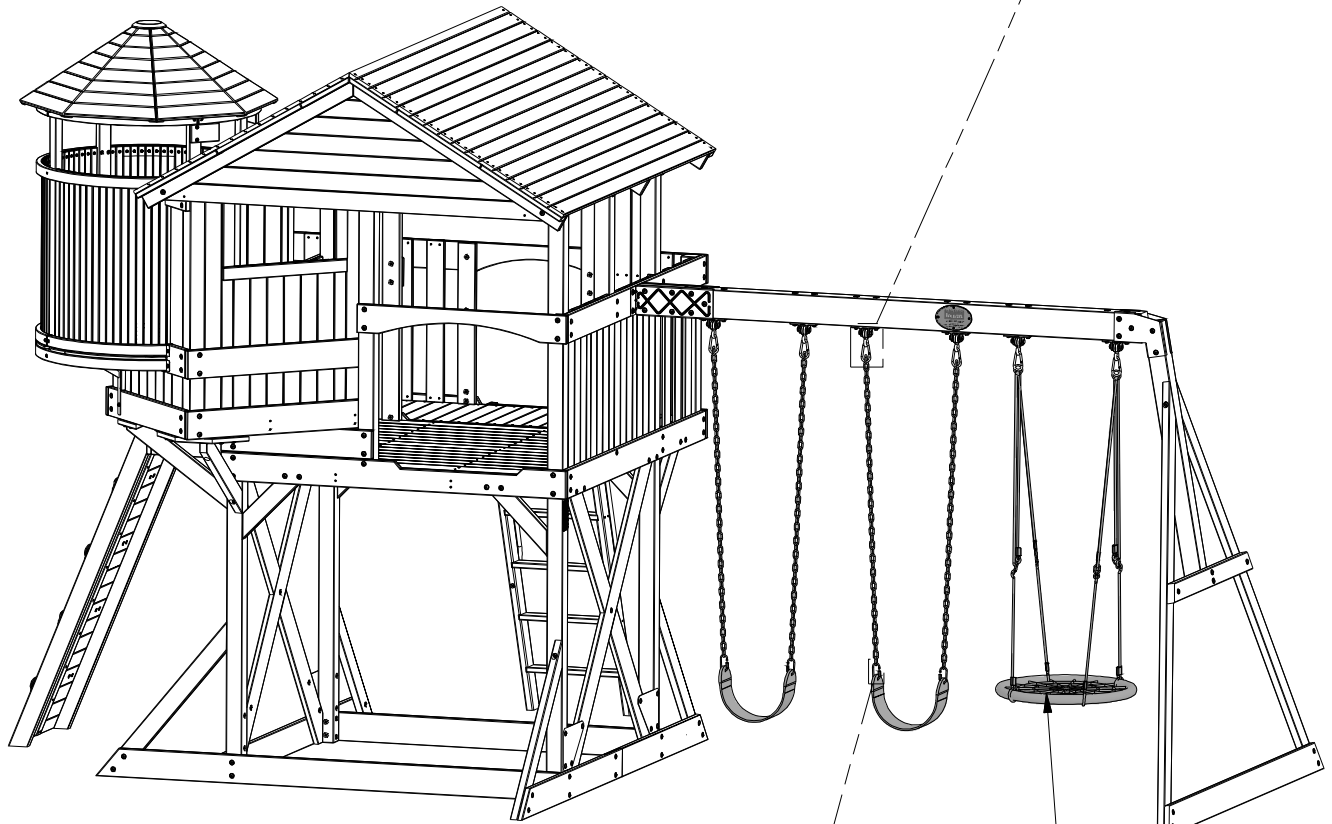

927 *(x4)*
QUICK LINK SD

362 *(x2)*
26" HD BELT SWING

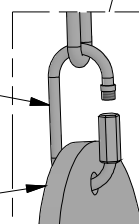

253 *(x1)*
26" WEB SWING SEAT

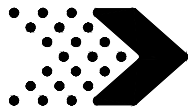

WEB SWING SETUP INSTRUCTIONS:

FOLLOW INSTRUCTIONS BELOW BEFORE USING THE WEB SWING.



IMPORTANT:

SWING MUST BE SET AT A MINIMUM OF 8 INCHES OFF THE GROUND WHEN INSTALLED.



IMPORTANT:

TO ENSURE STRAIGHT SWINGING MOTION, ADJUST ALL (4) "S" BRACKETS UNTIL WEB SEAT IS LEVEL.



Note: It is important that the web swing hang level.



IMPORTANT:

MAKE SURE THE (4) LOOPS ARE IN A SYMMETRICAL PATTERN BEFORE SWINGING. (SEE BELOW).

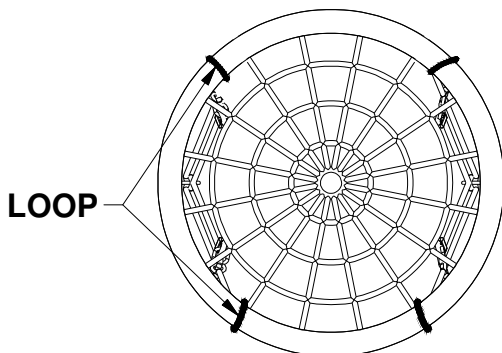
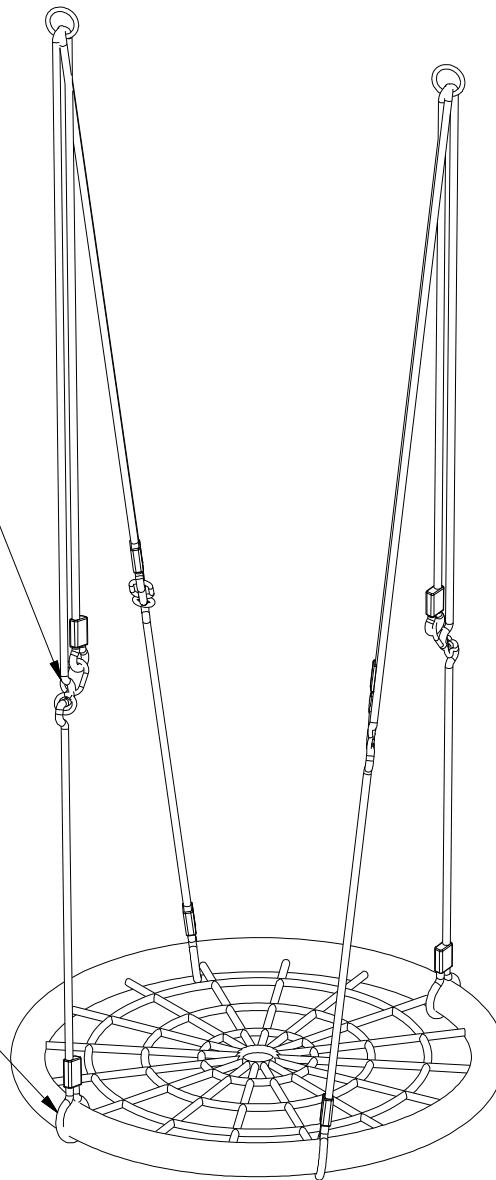
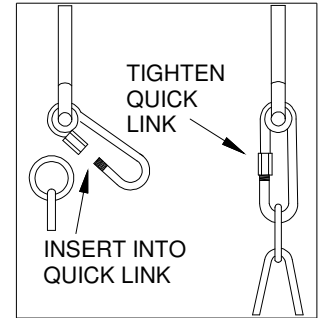

INCORRECT LOOP LOCATIONS (NON-SYMMETRICAL PATTERN)

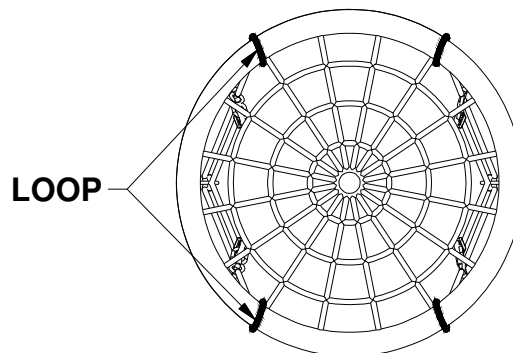

CORRECT LOOP LOCATIONS (SYMMETRICAL PATTERN)

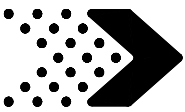

Phase 9

STEP 1



O70 | SLIDE MOUNTING BOARD - W4L09040
(x1) | 5/8"x1 3/8"x20 3/8" (16x34x517)

10 FT VACUUM FORMED SLIDE

PART NUMBER	COLOR	MODEL NUMBER
A100287	GREEN	1902329B
A6P00540	YELLOW	2300309
A6P00539	GREY	2300163



H100004 | NUT BARREL WH
(x3) | 5/16 x 5/8

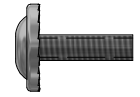

H100008 | BOLT WH
(x3) | 5/16x1



H100031 | WASHER LOCK EXT
(x3) | 12x19



H100088 | SCREW PFH
(x4) | 8x1 1/8

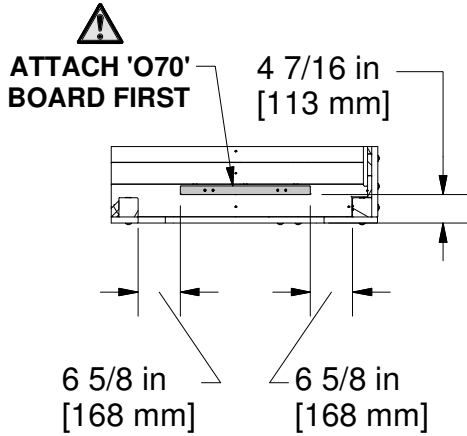

ASSEMBLY NOTE:

1. INSTALL 'O70' BOARD FIRST. NO DRILLING REQUIRED TO ATTACH 'O70' BOARD.
2. USING DIMENSIONS SHOWN DRILL (3) 3/8" (10mm) HOLES THROUGH THE FLOOR. ATTACHED SLIDE USING SUPPLIED HARDWARE.

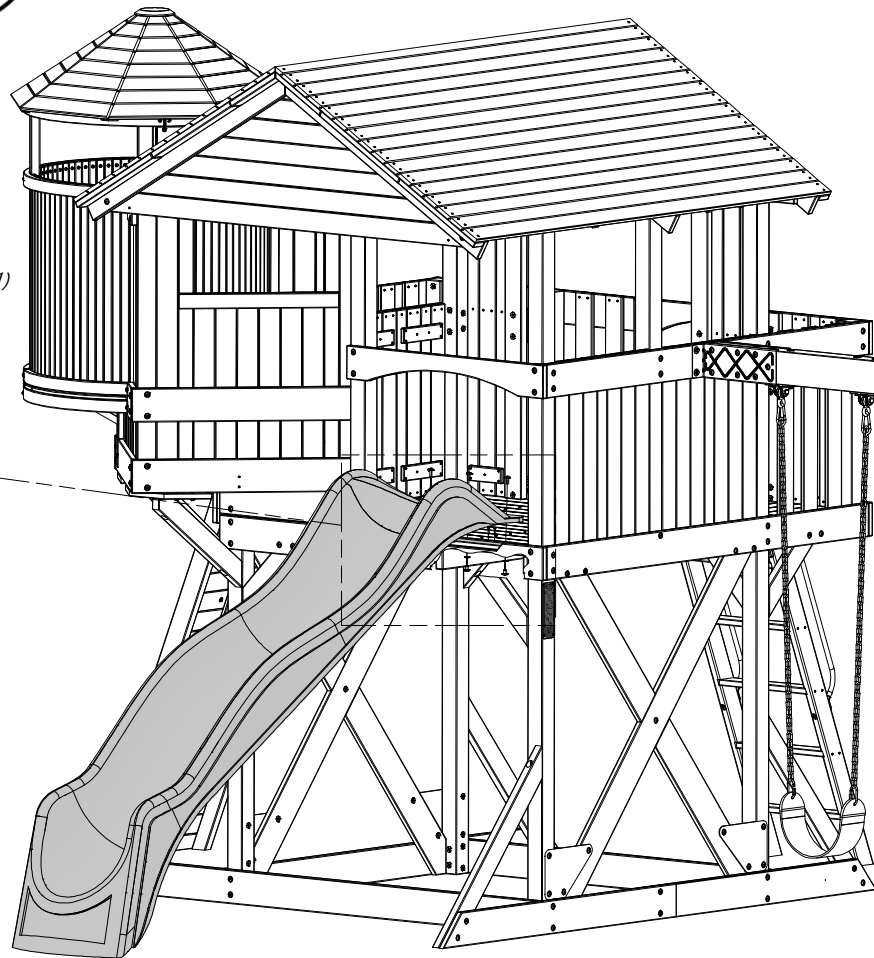
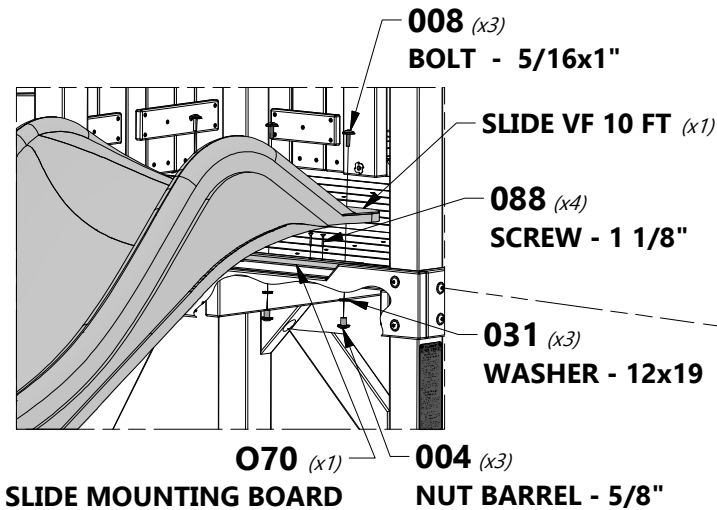
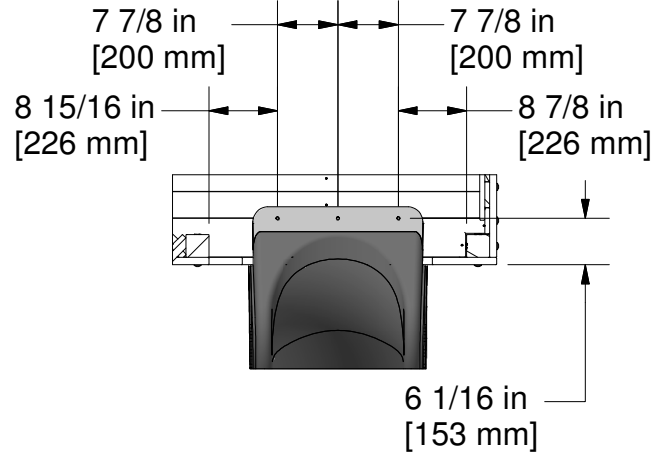
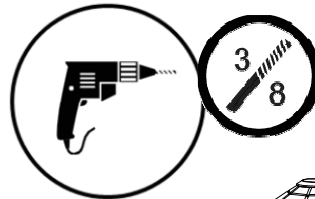

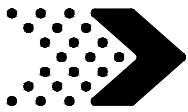

A100178 | AUGER GROUND STAKE
(x4)



H100406 | BOLT WH BLK
(x2) 1/4x1 1/2



H100171 | BOLT WH BLK
(x2) 1/4x1



H100404 | NUT BARREL WH BLK
(x4) 1/4x5/8



H100474 | WASHER FLAT BLK
(x4) 9x18



H100400 | WASHER LOCK EXT BLK
(x4) 8x15



NOTE:

FAILURE TO USE GROUND STAKES CAN VOID WARRANTY AND CAUSE INJURY!



NOTE:

1. SCREW THE AUGER INTO THE GROUND NEXT TO THE GROUND BOARD.
2. USING THE EYELET OF THE AUGER AS A TEMPLATE, DRILL A 5/16" [8 mm] HOLE THROUGH THE GROUND BOARD.
3. USE HARDWARE PROVIDED TO SECURE AUGERS TO GROUND BOARDS.

