



Model #
 2002517, 2002524,
 2002531, 2002548,
 2002555, 2002562,
 2002579, 2002586

CABANA

Owner's Manual & Assembly Instructions

MANUFACTURED BY:
 Backyard Discovery
 3305 Airport Drive
 Pittsburg, KS 66762
 800-856-4445

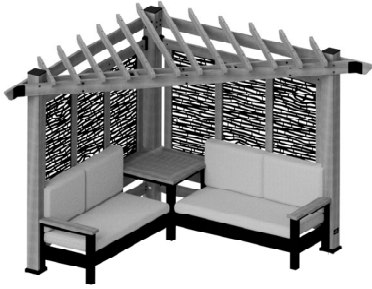

2002517 TUSCANY CABANA
 (BAMBOO - CAST PUMICE)

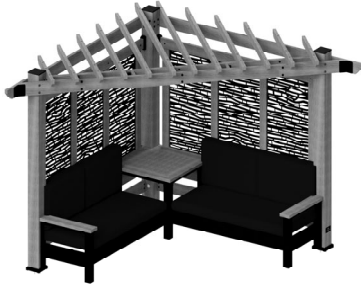

2002524 TUSCANY CABANA
 (BAMBOO - SPECTRUM INDIGO)

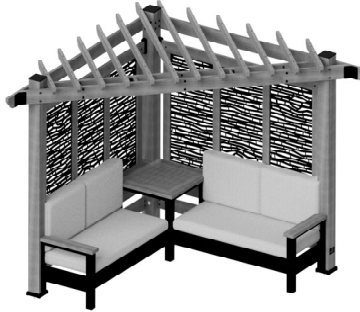

2002531 TUSCANY CABANA
 (BAMBOO - CAST SLATE)

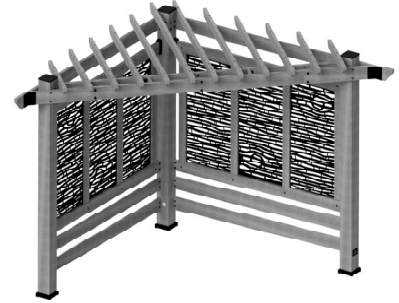

2002548 SIENA CABANA PERGOLA
 (BAMBOO PATTERN)

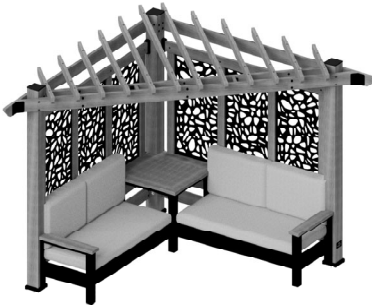

2002555 TUSCANY CABANA
 (PEBBLE - CAST PUMICE)

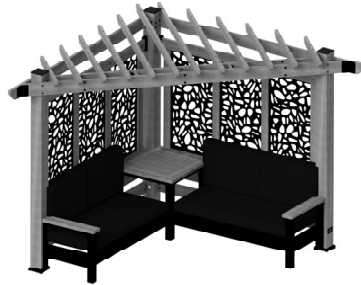

2002562 TUSCANY CABANA
 (PEBBLE - SPECTRUM INDIGO)

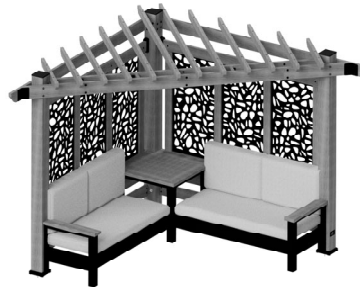

2002579 TUSCANY CABANA
 (PEBBLE - CAST SLATE)

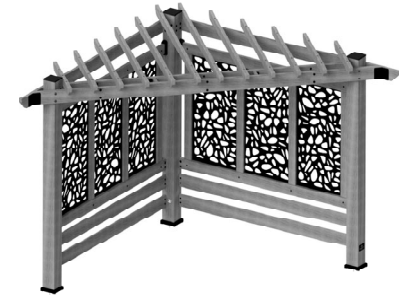

2002586 VERONA CABANA PERGOLA
 (PEBBLE PATTERN)



**INSTALLATION
 SERVICES
 AVAILABLE!***

Need a helping hand?

Let our team of professionals handle the installation for you!

GOCONFIGURE
 888-888-5424

*Installation services are only available to U.S. customers.

average 2 person assembly time



assembly time may vary based on skill level

Before you begin

**FOR QUICK &
 EASY ASSEMBLY**

FIND 3D INSTRUCTIONS
 FOR THIS PRODUCT IN

BILT.

DOWNLOAD THE FREE APP



For the most up to date assembly manual,
 to register your set, or to order replacement parts please visit
www.backyarddiscovery.com

**SAVE THIS ASSEMBLY MANUAL FOR FUTURE REFERENCE IN THE EVENT THAT
 YOU NEED TO ORDER REPLACEMENT PARTS.**

Para obtener instrucciones en español, visite www.backyarddiscovery.com



GOCONFIGURE
Putting it all together for you

INSTALLATION SERVICES AVAILABLE!*

Need a helping hand?

Let our team of professionals handle the installation for you!

GOCONFIGURE
888-888-5424

**Installation services are only available
to U.S. customers.*

With Go Configure, we bring you 18 years of experience right to your doorstep. We service a wide array of indoor and outdoor recreation products that most consumers don't have the time or ability to deliver & install themselves.

We do the heavy lifting, so you don't have to!

- 18+ Years of Experience Servicing Big Box Retailers and Direct Consumers
- Highly Skilled, Specialized, Courteous, Professional Service Technicians
- Over 140,000 Installations Annually
- White Glove Service

- Satisfaction Guarantee
- Flexible Appointments, including weekends
- Coverage across the nation

Visit www.goconfigure.com for more info!

**Installation services are only available to U.S. customers.*



The store where you made your purchase does not stock parts for this item. If you have assembly questions or you are missing or have damaged parts, please call

1-800-856-4445

you can also visit www.backyarddiscovery.com
or e-mail customerservice@backyarddiscovery.com

Please have the following information ready when you make your call:

- Model Number of the product located on the front of the assembly manual
 - The item description and number from the parts list from the manual that was included in your box
-
- Read entire assembly manual, paying special attention to the important tips and safety information.
 - To ensure there are no missing pieces do a complete inventory by first separating and identifying all parts.
 - Make sure to check packing material for small parts that may have fallen out during shipment.
 - Structures are not intended for public use. The Company does not warranty any of its residential structures subjected to commercial use.
 - This manual contains helpful information concerning assembly preparation, installation procedure and required maintenance.
 - Always keep safety in mind as your structure is being built.
 - Keep these instructions for future reference.



THE MANUFACTURER RESERVES THE RIGHT TO MAKE SUBSTITUTIONS TO WARRANTY CLAIMS IF PARTS ARE UNAVAILABLE OR OBSOLETE

This Limited Warranty by Backyard Discovery applies to products manufactured under the Backyard Discovery brand or its other brands, including but not limited to, Adventure Playsets and Leisure Time Products.

Backyard Discovery Wood Patio Structure

Backyard Discovery warrants this wood patio product to be free from defects in materials and workmanship for a period of two (2) years from the original date of purchase. All wood carries a five (5) year warranty against rot and decay from the original purchase date. LIMITED WARRANTY

OUTDOOR PATIO ITEMS

THE MANUFACTURER RESERVES THE RIGHT TO MAKE SUBSTITUTIONS TO WARRANTY CLAIMS IF PARTS ARE UNAVAILABLE OR OBSOLETE

This Limited Warranty by Backyard Discovery applies to products manufactured under the Backyard Discovery brand or its other brands, including but not limited to, Adventure Playsets and Leisure Time Products.

Backyard Discovery Wood Patio Structure

Backyard Discovery warrants this wood patio product to be free from defects in materials and workmanship for a period of two (2) years from the original date of purchase. All wood carries a five (5) year warranty against rot and decay from the original purchase date.

Backyard Discovery Metal Patio Structure

Backyard Discovery warrants this metal patio product to be free from defect in materials and workmanship for a period of five (5) years from the original date of purchase.

General Warranty Information

This warranty applies to the original owner and registrant and is non-transferable. Regular maintenance is required to ensure maximum life and performance of this product. Failure by the owner to maintain the product according to the maintenance requirements may void this warranty. Maintenance guidelines are provided in the Owner's Manual.

This Limited Warranty does not cover:

Backyard Discovery Metal Patio Structure

Backyard Discovery warrants this metal patio product to be free from defect in materials and workmanship for a period of five (5) years from the original date of purchase.

General Warranty Information

This warranty applies to the original owner and registrant and is non-transferable. Regular maintenance is required to ensure maximum life and performance of this product. Failure by the owner to maintain the product according to the maintenance requirements may void this warranty. Maintenance guidelines are provided in the Owner's Manual.

This Limited Warranty does not cover:

- Natural occurring properties of wood such as twisting, warping, checking, peeling or any other natural occurring properties of wood that do not affect performance or integrity.
- Installation – the warranty is null and void if installation is not in accordance with the Assembly Instructions.
- Labor for any inspection
- Labor for replacement of any defective item(s)
- Incidental or consequential damages
- Cosmetic defects, including rusting, color fading, minor cracks, corrosion, which do not affect performance or integrity of a part or the entire product.
- Vandalism, improper use, failure due to loading or use beyond the capacities stated in the applicable Assembly Manual.
- Acts of nature including but not limited to wind, storms, hail, floods, excessive water exposure.
- Improper installation including but not limited to installation on uneven, unlevel, or soft ground.

Backyard Discovery products have been designed for safety and quality. Any modifications made to the original product could damage the structural integrity of the unit leading to failure and possible injury. Modification voids any-and-all warranties and Backyard Discovery assumes no liability for the modified products or consequences resulting from failure of a modified product. Backyard Discovery disclaims all other representations and warranties of any kind, express or implied.

USA and Canada: To make a warranty or replacement part claim please visit backyarddiscovery.com or call Backyard Discovery customer service at **800-856-4445**. Backyard Discovery will, at its sole discretion, replace any part within the stated warranty period that is defective in workmanship or materials. At Backyard Discovery's discretion, photographs of the defective part, physical return of the defective part to Backyard Discovery, or proof of purchase may be required for verification.

Outside of the USA and Canada: Contact place of purchase or distributor for warranty service.

This Warranty gives you specific legal rights. You may have other rights as well which vary from state to state, province to province or country to country, where you bought the product. This warranty excludes all consequential damages however, some states do not allow the limitation or exclusion of consequential damages and therefore this limitation may not apply to you.

Please read entire booklet completely before beginning the assembly process

Please retain these instructions and your receipt for future reference. Keep them in a safe place where you can refer to them as needed. In order to provide you with the most efficient service, it is required that you provide us with the part numbers when ordering parts.

For Your Records:

Please take time and fill out the information below. This information will be needed for warranty issues.

Where Purchased: _____
 Date of Purchase: _____
 Installation Date: _____
 Installed by: _____
 Tracking Number: _____



Product Number Plate

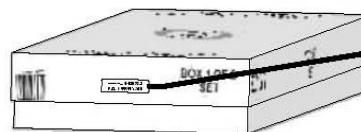

Tracking Number Reference Label

Tracking ID number on the carton and on the product number plate are included for tracking purposes associated with warranty claims.



WARNING

IT IS IMPORTANT TO CHECK AND TIGHTEN ALL HARDWARE AT THE BEGINNING AND DURING THE SEASON AS THEY MAY LOOSEN DUE TO WOOD EXPANSION AND CONTRACTION.

- **DO NOT climb or walk on the roof for any reason**
- **Requires two or more people to assemble safely**
- **Check for underground utilities before digging or driving stakes into the ground.**
- **Check carefully for overhead lines and ensure there is at least 6ft (2m) clearance from any overhead electrical wires.**
- **Permanent structures may require a building permit. As the purchaser and or installer of this product you are advised to consult local planning, zoning and building inspection departments for guidance on applicable building codes and/or zoning requirements.**
- Wood is NOT flame retardant and will burn. Grills, fire pits and chimineas are a fire hazard if place too close to your structure.
- Wear gloves to avoid injury during installation.
- During installation, follow all safety warnings provided with your tools and use safety glasses.
- Check all nuts and bolts twice monthly during the usage season and tighten as required.(But not so tight that you crack the wood) It is particularly important that this procedure be followed at the beginning of each season.
- Oil all metallic moving parts monthly during the usage period.
- Check all coverings for bolts and sharp edges twice monthly during usage season to be certain they are in place. Replace when necessary. It is especially important to do this at the beginning of each new season.
- For rusted areas on metallic members such as hinges, brackets, etc. sand and repaint, using a non lead-based paint meeting the requirements of Title 16 CRF Part 1303.
- Inspect wood parts monthly. The grain of the wood sometimes will lift in the dry season causing splinters to appear. Light sanding may be necessary to maintain a safe environment. Treating your Product with protection (sealant) after sanding will help prevent severe checking/splitting and other weather damage.
- We have applied a waterborne translucent stain to your unit. This is done for color only. Once or twice a year, depending on your climate conditions, you must apply some type of protection (sealant) to the wood of your unit. Prior to the application of sealant, lightly sand any "rough" spots on your set. Please note this is a requirement of your warranty.

OWNERS SHALL BE RESPONSIBLE FOR MAINTAINING THE LEGIBILITY OF THE WARNING LABELS



Your Backyard Discovery structure is designed and constructed of quality materials. As with all outdoor products it will weather and wear. To maximize the enjoyment, safety and life of your structure it is important that you properly maintain it.

About Our Wood

Backyard Discovery takes great care in selecting the best quality lumber available, wood is still a product of nature and susceptible to weathering which can change the appearance of your set.

What causes weathering? Does it affect the strength of my product?

One of the main reasons for weathering is the effects of water (moisture); the moisture content of the wood at the surface is different than the interior of the wood. As the climate changes, moisture moves in or out of the wood, causing tension which can result in checking and or warping. You can expect the following due to weathering. These changes will not affect the strength of the product:

1. Checking is surface cracks in the wood along the grain. A post (4" x 4") will experience more checking than a board (1" x 4") because the surface and interior moisture content will vary more widely than in thinner wood.

2. Warping results from any distortion (twisting, cupping) from the original plane of the board and often happens from rapid wetting and drying of the wood.

3. Fading happens as a natural change in the wood color as it is exposed to sun-light and will turn grey over time.

How can I reduce the amount of weathering to wood product?

1. Your wood product is coated with a water-based stain. Sunlight will break down the coating, so we recommend applying a water repellent or stain on a yearly basis (see your local stain and paint supplier for a recommended product). You must apply some type of protection (sealant) to the wood of your product. **Please note this is a requirement of your warranty.** Most weathering is just the normal result of nature and will not affect safety. However if you are concerned that a part has experienced a severe weathering problem please call our customer service department for further assistance.

2. Inspect wood parts monthly. The grain of the wood sometimes will lift in the dry season causing splinters to appear. Light sanding may be necessary to maintain a safe environment. Treating your Product with protection (sealant) after sanding will help prevent severe checking/ splitting and other weather damage.



Protrusion Hazard

Incorrect

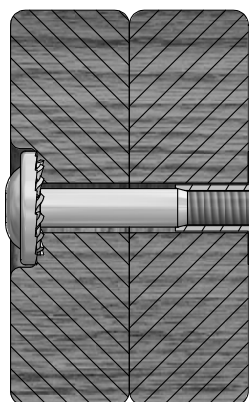

If you see exposed threads and your bolt protrudes beyond the T-Nut you may have over tightened the bolt. To eliminate this, remove the bolt and add washers to eliminate the problem.

Correct

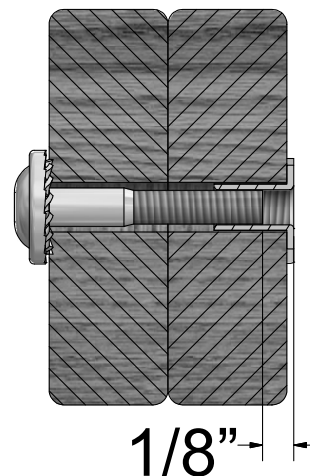

Proper Hardware Assembly

Bolt and T-Nut Assembly

Tap T-nut into the provided hole. Insert your bolt through the lock washer and insert into the provided hole opposite from the T-Nut. Turn clockwise to thread into T-nut. Do not completely tighten until instructed.

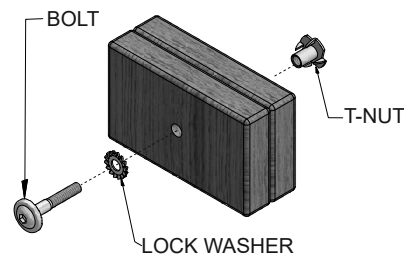

Bolt and Barrel Nut Assembly

Insert barrel nut through the lock washer and press the pair through the provided hole. Insert your bolt through the second lock washer and insert the pair into the provided hole opposite from the barrel nut. Turn clockwise to thread into the barrel nut. Do not completely tighten until instructed.

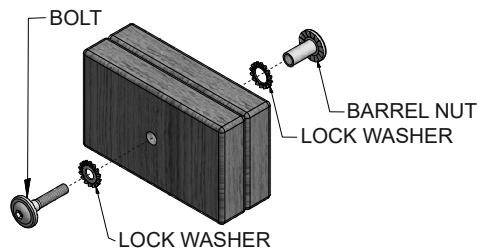

Lag Assembly

Normally there will be a pre-drilled pilot hole on assemblies that require a Lag Screw. If there is no pilot hole, line up the two boards as they are to be attached and use the factory drilled hole as a guide to drill another pilot hole into the adjoining board. This will keep the wood from splitting. Only a lock washer is required for steps with Lag Screws.

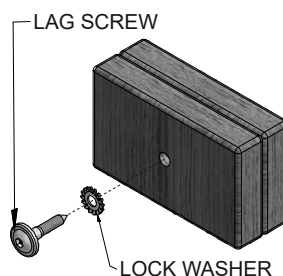



ASSEMBLY TIP:

Keep an eye out for these boxes which will contain helpful pictures and information making the assembly process as quick and painless as possible.

Sorting Wood

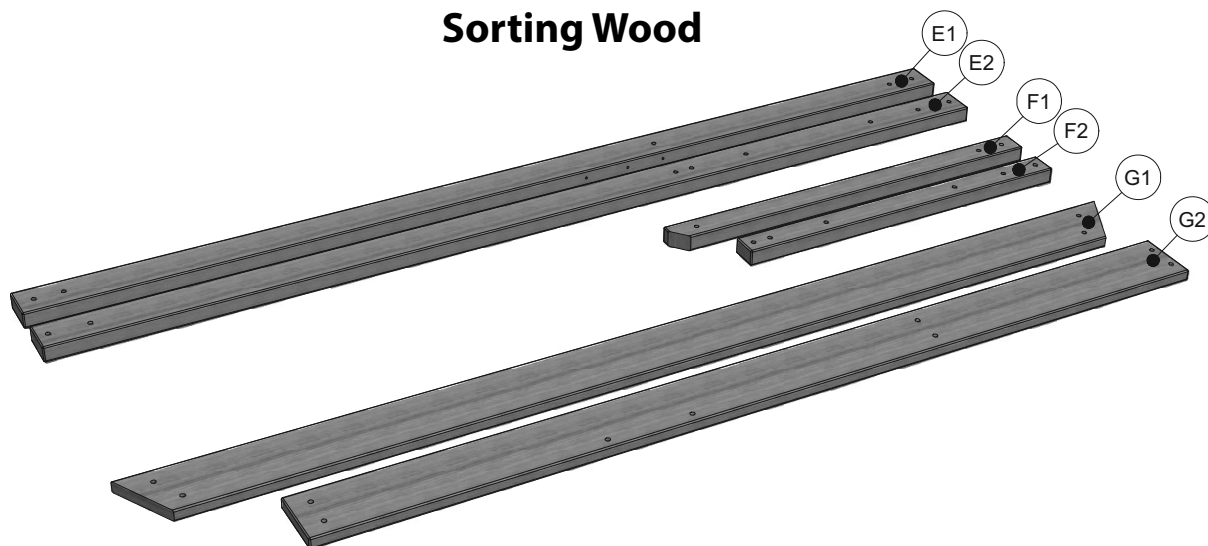

When removing the wood from the boxes we recommend arranging them by part number before you begin assembly. This will allow for faster assembly and easily identify any parts that may be missing or damaged.

Sorting Hardware

NUT BARREL
H100545



SCREW
H100695

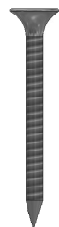

T-NUT
H100699

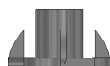

WASHER FLAT
H100706



BOLT HEX
H100716

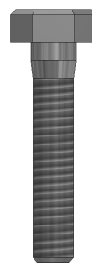

BOLT
H100718

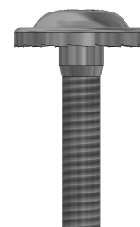

SCREW PWH
H100742

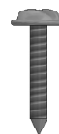

To help with assembly we recommend sorting your hardware bags with the seven digit alpha-numeric number printed on the bags or by hardware type (i.e. bolts, nuts, etc.). Organizing your hardware will make assembly easier.

Hardware Identification

Hardware bags are printed with a seven digit alpha-numeric part number. During assembly you only need to reference the last three digits of the part number as noted in each step. This will make finding the correct hardware easier.

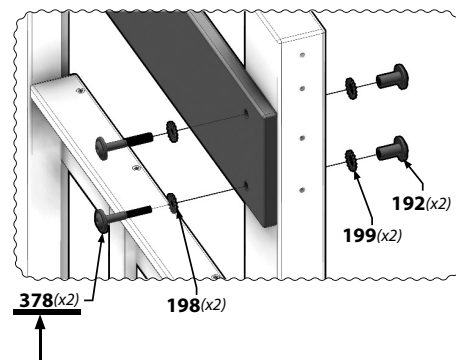
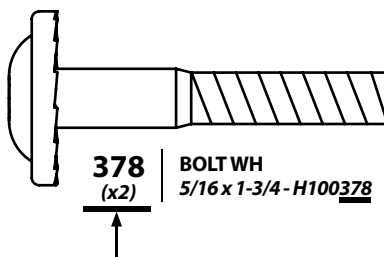

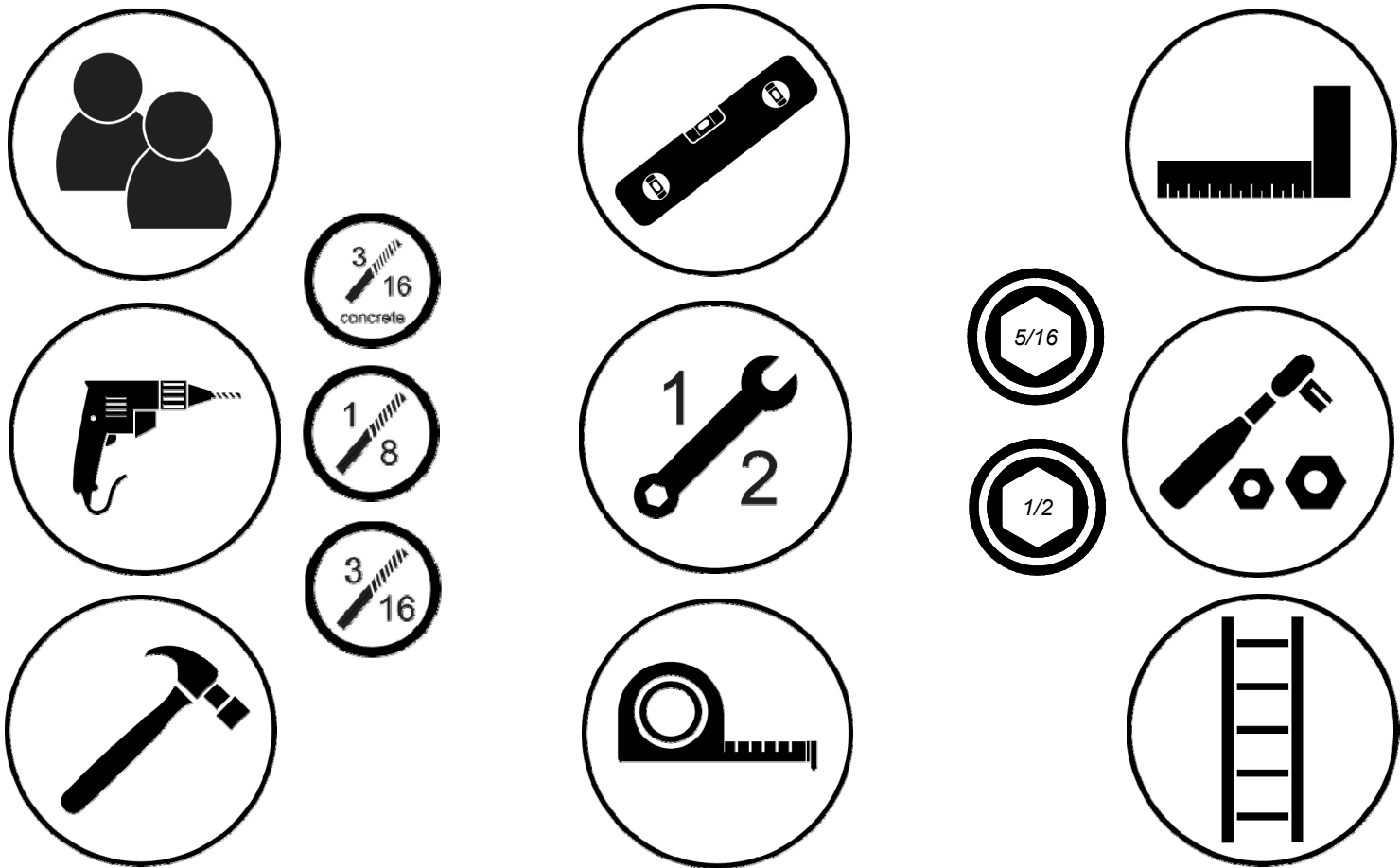

Icons and their uses you will see throughout this manual



You will need to make sure that your assembly is square before tightening your bolts.



When you see this icon you will need a socket wrench. The icons below show the size of attachments needed for assembly 1/2.



For proper assembly you will need to ensure that your structure is level before proceeding to the next step.

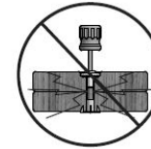

This icon warns you to not over tighten your bolts. This is to prevent structural damage and also splintering your wood.



Some steps in the assembly process will require an extra set of hands. Make sure you have a helper available.



A ladder will be needed for assembly. Do NOT stand on the set when it is incomplete, unstable, and not anchored. Failure to do so may result in injury.



This icon shows the size of an open ended wrench. Using the wrench as the fraction bar.



This icon will show you what drill attachments are needed. For this example you will need a Phillips head attachment and 3/8 drill bit.

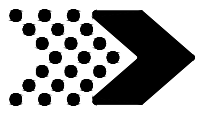

It is critically important that you start with square and level footings, concrete pad or deck to attach your structure





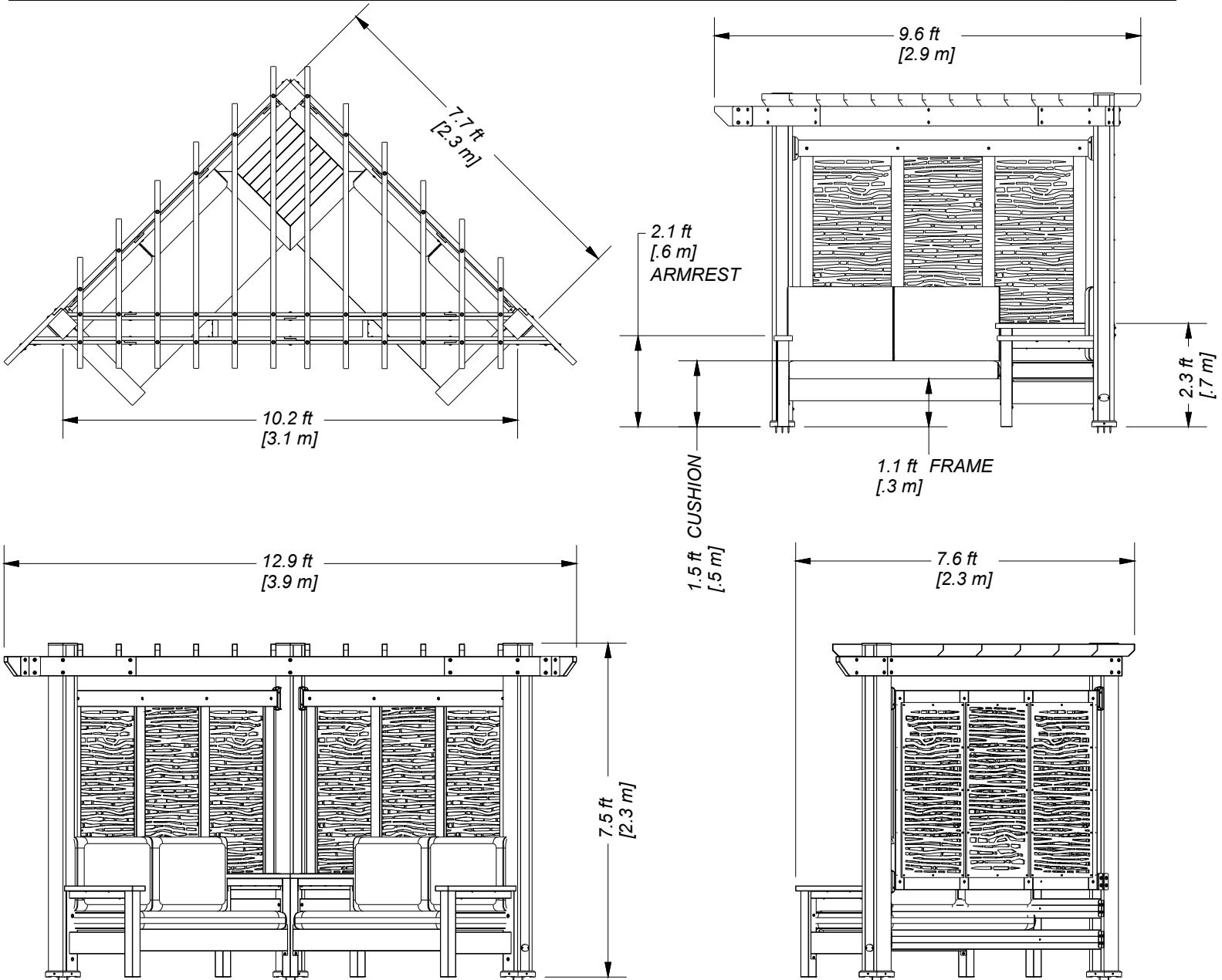

- Pay close attention to the items needed for each step. Make sure you are using the correct hardware for each step. Using incorrect hardware may result in improper assembly
- Remember to double check for underground utilities and overhead electrical lines

Post mounts are provided with your structure which allows you to permanently install your structure to a pre-existing or new wood or concrete surface.

- The hardware to attach the post mounts to the structure is included.
- The hardware to mount the structure permanently to a concrete surface is included.
- The hardware to mount the structure permanently to a wood deck is NOT included and will need to be purchased separately. You must ensure there is ample structural support under the deck before permanently attaching.

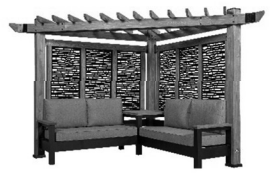

BEFORE YOU BEGIN THE ASSEMBLY OF YOUR BACKYARD DISCOVERY CABANA PERGOLA PLEASE USE THE TABLE BELOW TO ENSURE YOU RECEIVED ALL COMPONENTS NEEDED FOR THE ITEM # YOU PURCHASED. IF YOU ARE MISSING ANY CARTONS PLEASE CONTACT OUR CUSTOMER SERVICE TEAM AT 1-800-856-5424.

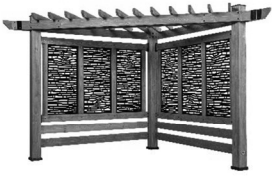
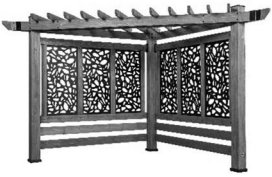
ITEM # ORDERED	NAME	IMAGE	COMPONENT LIST FOR FG	TOTAL # OF CARTONS
2002517	Tuscany Cabana Lounger		9205376-1 - Cedar frame Box 1 9205376-2 - Cedar frame Box 2 9205017-1 - Steel seating frame Box 1 9205017-2 - Steel seating frame Box 2 9205239 - Meranti table top & armrests 9205352 - Composite Panels - bamboo pattern 9205123 - Cushions (Pumice)	7 total cartons
2002524	Tuscany Cabana Lounger		9205376-1 - Cedar frame Box 1 9205376-2 - Cedar frame Box 2 9205017-1 - Steel seating frame Box 1 9205017-2 - Steel seating frame Box 2 9205239 - Meranti table top & armrests 9205352 - Composite Panels - bamboo pattern 9205116 - Cushions (Blue)	7 total cartons
2002531	Tuscany Cabana Lounger		9205376-1 - Cedar frame Box 1 9205376-2 - Cedar frame Box 2 9205017-1 - Steel seating frame Box 1 9205017-2 - Steel seating frame Box 2 9205239 - Meranti table top & armrests 9205352 - Composite Panels - bamboo pattern 9205109 - Cushions (Gray)	7 total cartons
2002555	Tuscany Cabana Lounger		9205376-1 - Cedar frame Box 1 9205376-2 - Cedar frame Box 2 9205017-1 - Steel seating frame Box 1 9205017-2 - Steel seating frame Box 2 9205239 - Meranti table top & armrests 9205369 - Composite panels - pebble pattern 9205123 - Cushions (Pumice)	7 total cartons
2002562	Tuscany Cabana Lounger		9205376-1 - Cedar frame Box 1 9205376-2 - Cedar frame Box 2 9205017-1 - Steel seating frame Box 1 9205017-2 - Steel seating frame Box 2 9205239 - Meranti table top & armrests 9205369 - Composite panels - pebble pattern 9205116 - Cushions (Blue)	7 total cartons
2002579	Tuscany Cabana Lounger		9205376-1 - Cedar frame Box 1 9205376-2 - Cedar frame Box 2 9205017-1 - Steel seating frame Box 1 9205017-2 - Steel seating frame Box 2 9205239 - Meranti table top & armrests 9205369 - Composite panels - pebble pattern 9205109 - Cushions (Gray)	7 total cartons
2002548	Verona Cabana Pergola		9205376-1 - Cedar frame Box 1 9205376-2 - Cedar frame Box 2 9205352 - Composite Panels - bamboo pattern	3 total cartons
2002586	Verona Cabana Pergola		9205376-1 - Cedar frame Box 1 9205376-2 - Cedar frame Box 2 9205369 - Composite panels - pebble pattern	3 total cartons



Wood Components (Not to Scale)

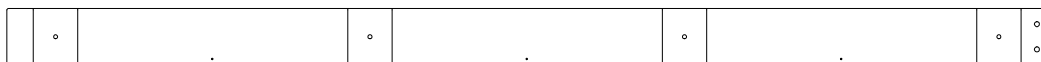

AN1 | LOWER SUPPORT - W4L13810
(1) | 1 3/8"x4 3/8"x81 1/4" (36x112x2064)

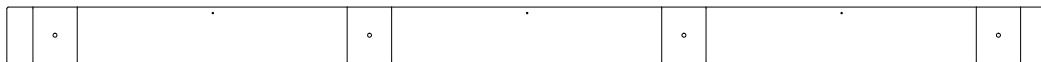

AN2 | TOP SUPPORT - W4L13809
(2) | 1 3/8"x4 3/8"x81 1/4" (36x112x2064)

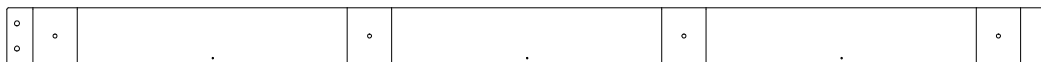

AN3 | LOWER SUPPORT - W4L13835
(1) | 1 3/8"x4 3/8"x81 1/4" (36x112x2064)



D1 | JOIST - W4L13812
(1) | 1 3/8"x5 1/4"x89 1/2" (36x134x2274)



D2 | JOIST - W4L13813
(1) | 1 3/8"x5 1/4"x89 1/2" (36x134x2274)



D3 | JOIST END - W4L13814
(1) | 1 3/8"x5 1/4"x18 3/4" (36x134x477)



D4 | JOIST END - W4L13815
(1) | 1 3/8"x5 1/4"x18 3/4" (36x134x477)



D5 | SUPPORT BRACE - W4L13823
(2) | 1 3/8"x5 1/4"x4 5/8" (36x134x116)



E1 | TOP JOIST - W4L13824
(2) | 1 3/8"x3 3/8"x81 1/2" (36x86x2070)



E2 | TOP JOIST - W4L13825
(2) | 1 3/8"x3 3/8"x71 1/2" (36x86x1817)



E3 | TOP JOIST - W4L13826
(2) | 1 3/8"x3 3/8"x61 1/8" (36x86x1553)



E4 | TOP JOIST - W4L13827
(2) | 1 3/8"x3 3/8"x50 3/4" (36x86x1289)



E5 | TOP JOIST - W4L13828
(2) | 1 3/8"x3 3/8"x40 3/8" (36x86x1025)



E6 | TOP JOIST - W4L13829
(2) | 1 3/8"x3 3/8"x30" (36x86x761)



Wood Components (Not to Scale)

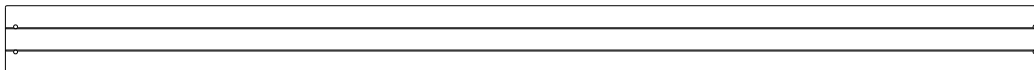

G3 | TOP RAIL - W4L13832
(4) | 1"x5 1/4"x81 1/4" (24x134x2063)



G7 | BEAM END - W4L13816
(1) | 1"x5 1/4"x29" (24x134x736)

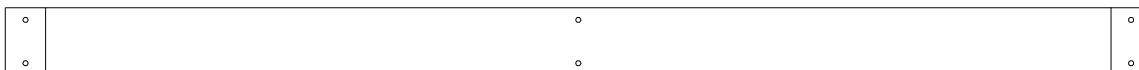

G8 | BEAM - W4L13817
(2) | 1"x5 1/4"x89 1/2" (24x134x2274)



G9 | BEAM - W4L13818
(1) | 1"x5 1/4"x71 1/8" (24x134x1807)



G10 | BEAM - W4L13819
(1) | 1"x5 1/4"x71 1/8" (24x134x1807)



G11 | BEAM END - W4L13820
(1) | 1"x5 1/4"x19" (24x134x484)



G12 | BEAM - W4L13821
(1) | 1"x5 1/4"x61 1/4" (24x134x1555)



G13 | BEAM - W4L13822
(1) | 1"x5 1/4"x61 1/4" (24x134x1555)



Wood Components (Not to Scale)



G14 | BEAM END - W4L13830
(1) | 1"x5 1/4"x29" (24x134x736)



G15 | BEAM END - W4L13831
(1) | 1"x5 1/4"x19" (24x134x484)



H1 | VERTICAL SUPPORT - W4L13808
(8) | 1"x3 3/8"x53 7/8" (24x86x1368)



WP1 | W2A02859
(1) | 5 1/2"x5 1/2"x89 5/8" (140x140x2274)



WP2 | W2A02860
(1) | 5 1/2"x5 1/2"x89 5/8" (140x140x2274)



WP3 | W2A02861
(1) | 5 1/2"x5 1/2"x89 5/8" (140x140x2274)

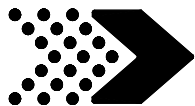

Wood Components (Not to Scale)

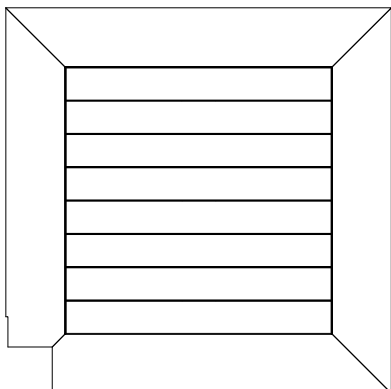

TT1 | W2A02868
(1) | 1 5/16"x30 1/8"x30 1/8" (34x765x765)

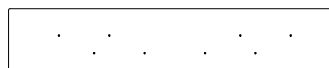

D7 | ARM REST - W4L14844
(2) | 1 3/8"x4 5/8"x26" (34x118x660)



Hardware Components



H100363 | BOLT WH BLK
(18) | 5/16X6



H100407 | BOLT WH BLK
(18) | 5/16x1 1/2



H100468 | BOLT WH BLK
(4) | 5/16x1



H100193 | NUT BARREL
(18) | WH BLK
5/16x1-1/2



H100825 | LAG SCREW
(38) | 5/16x4 BLK



H100192 | NUT BARREL
(18) | WH BLK
5/16x7/8



H100206 | LAG SCREW WH BLK
(4) | 5/16x3

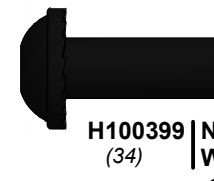

H100399 | NUT BARREL
(34) | WH BLK
1/4x7/8



H100197 | LAG SCREW WH BLK
(4) | 5/16x2 1/2



H100379 | T-NUT BLK
(4) | 5/16



H100471 | LAG SCREW WH BLK
(9) | 5/16x1 1/2



H100403 | LAG SCREW WH BLK
(18) | 1/4x1 1/2

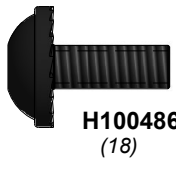

H100486 | BOLT WH BLK
(18) | 1/4x5/8

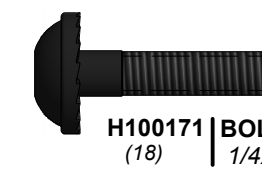

H100171 | BOLT WH BLK
(18) | 1/4x1



Hardware Components



H100391 | SCREW PFH BLK
(13) | 8x2



H100200 | SCREW PFH BLK
(13) | 8x1 1/2



H100385 | SCREW PFH BLK
(13) | 8x1



H100120 | SCREW
CONCRETE
ANCHOR
(13) | 1/4x2



H100797 | SCREW PWH BLK
(76) | 8x1



H100392 | SCREW PWH BLK
(2) | 8x3/4



H100202 | SCREW PWH BLK
(17) | 8x5/8



H100199 | WASHER LOCK
(35) | EXT BLK
12x19



H100400 | WASHER LOCK
(35) | EXT BLK
8x15



H100405 | WASHER LOCK
(17) | EXT BLK
6x15



H100198 | WASHER LOCK
(76) | EXT BLK
8x19



H100764 | SCREW SETTER
(1)



A100042 | TORX BIT
(2) | T-40



H100147 | TORX BIT
(2) | T-30

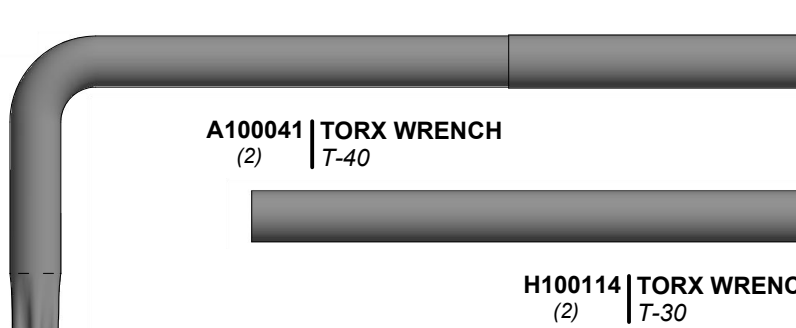

A100041 | TORX WRENCH
(2) | T-40

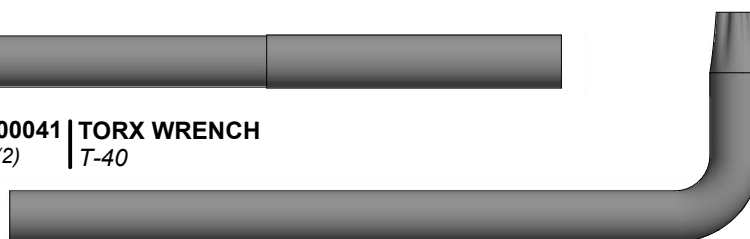

H100114 | TORX WRENCH
(2) | T-30

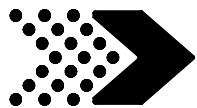

Accessory Components (Not to Scale)

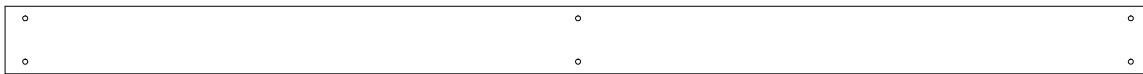

A4M01111 | METAL BEAM
(2)

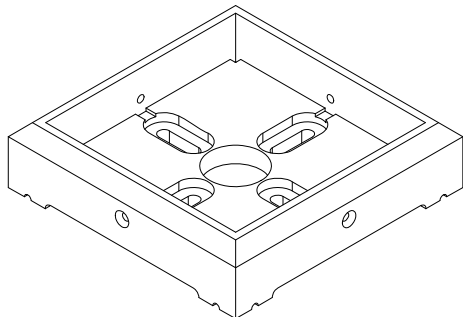

A100029 | FOOT 142
(3) | SQUARE POST



A100241 | BYD ID TAG
(1) | (SMALL)
WITHOUT AGES

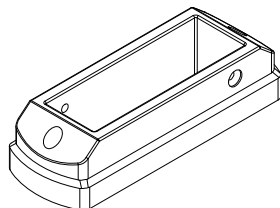

A6P00442 | MOUNTING
(6) | BRACKET

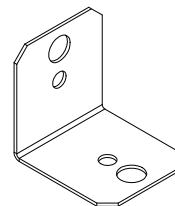

A4M00555 | 90° L-BRACKET -
(8) | BLK

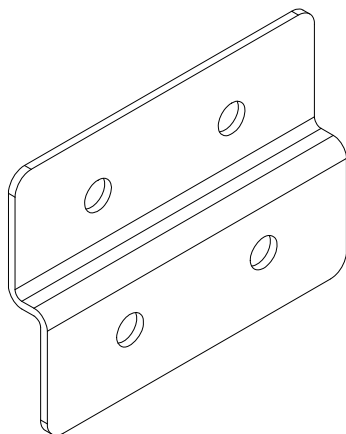

A4M01166 | L BRACKET
(2) | 40x40x112 - BLK

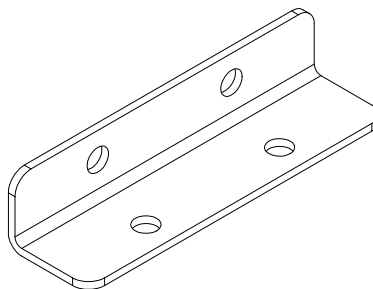

A4M01108 | L BRACKET
(8) | 24x30x112 - BLK

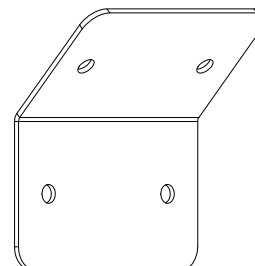

A4M01097 | BRACKET 135°
(2) | BLK



Accessory Components (Not to Scale)

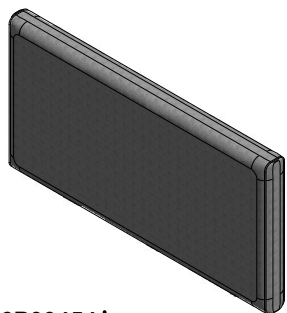

A6P00454
(2) SEAT CUSHION

9205123
CAST PUMICE

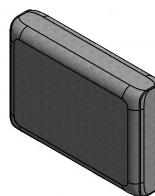

A6P00455
(4) BACK CUSHION

OR

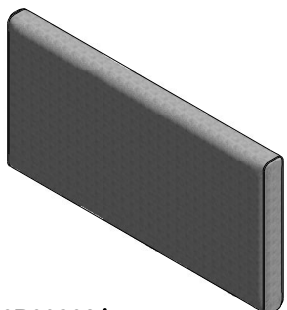

A6P00392
(2) SEAT CUSHION

9205109
CAST SLATE

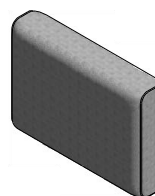

A6P00393
(4) BACK CUSHION

OR



A6P00394
(2) SEAT CUSHION

9205116
SPECTRUM INDIGO



A6P00395
(4) BACK CUSHION

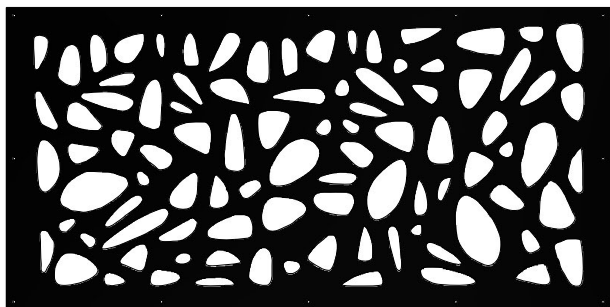

A6P00441
(6) DECORATIVE BACK PANEL

OR

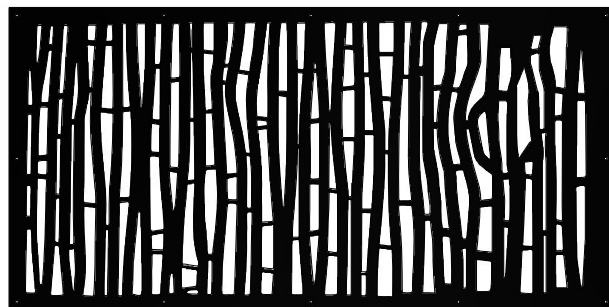

A6P00440
(6) DECORATIVE BACK PANEL

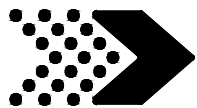

Accessory Components (Not to Scale)

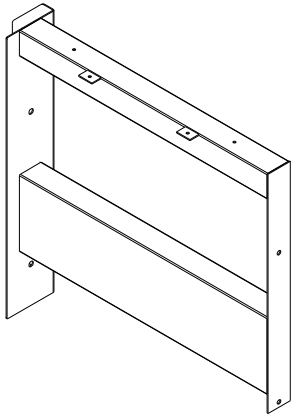

A4M01060 (1) | FRAME RAIL - RIGHT

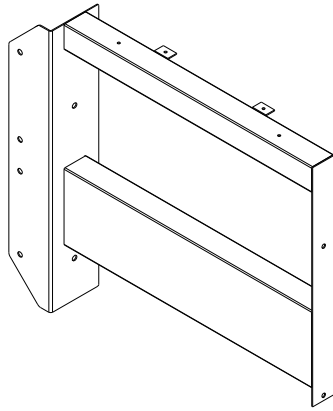

A4M01066 (1) | FRAME END - RIGHT



A4M01063 (1) | POST



A4M01069 (1) | POST



A4M01070 (1) | POST



A4M01105 (1) | ARM POST - LEFT



A4M01106 (1) | ARM POST - RIGHT

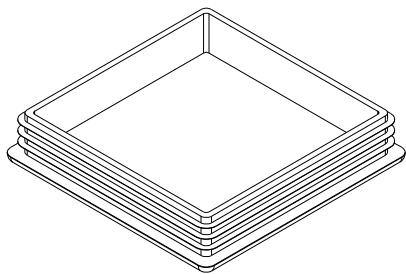

A6P00377 (5) | SNAP-IN SQUARE PLUG

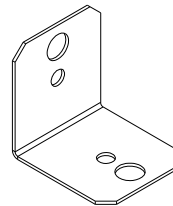

A4M00555 (2) | 90° L-BRACKET - BLK

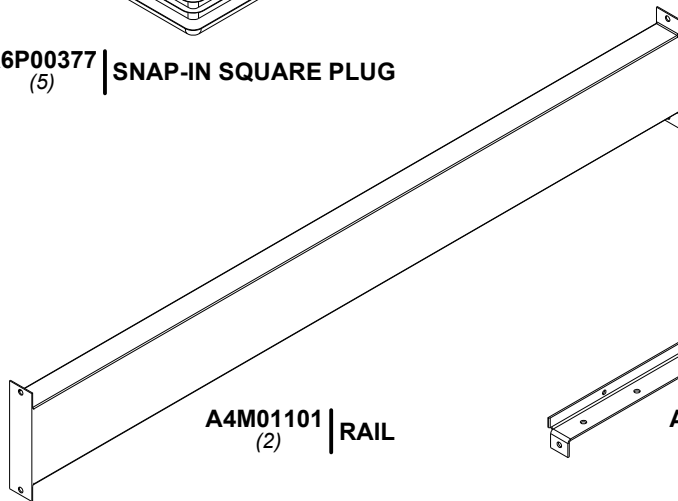

A4M01101 (2) | RAIL

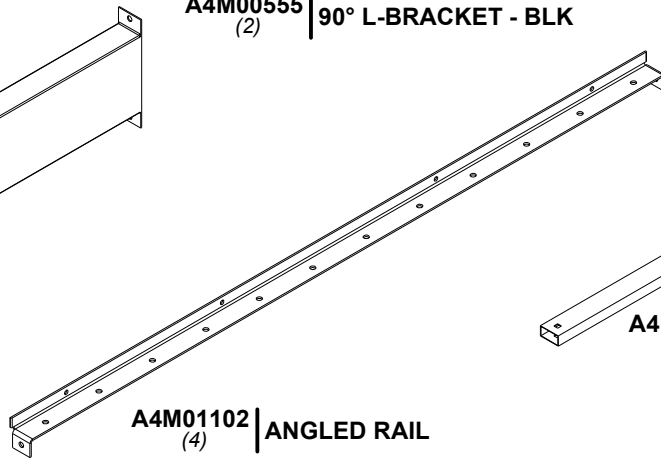

A4M01102 (4) | ANGLED RAIL

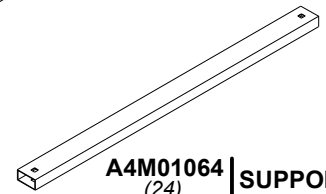

A4M01064 (24) | SUPPORT

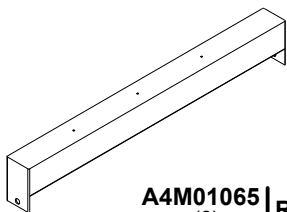

A4M01065 (2) | RAIL

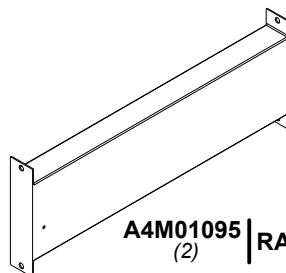

A4M01095 (2) | RAIL

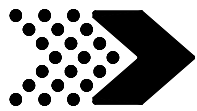

Accessory Components (Not to Scale)



H100471 | LAG SCREW WH BLK
(11) | 5/16x1 1/2



H100171 | BOLT WH BLK
(38) | 1/4x1



H100460 | LAG SCREW WH BLK
(11) | 1/4x1

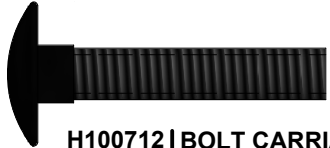

H100712 | BOLT CARRIAGE BLK
(50) | 5/16x1 1/2



H100824 | SCREW PWH BLK
(11) | 8x3



H100391 | SCREW PFH BLK
(7) | 8x2



H100392 | SCREW PWH BLK
(4) | 8x3/4



H100202 | SCREW PWH BLK
(4) | 8x5/8

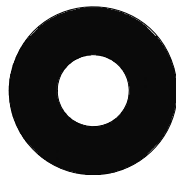

H100770 | WASHER FLAT
(52) | BLK
5/16

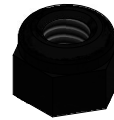

H100479 | NUT LOCK BLK
(50) | 5/16



H100856 | DRILL BIT
(1) | 1/4" (6mm)

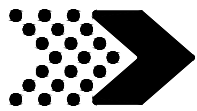

CABANA ASSEMBLY

STEP 1

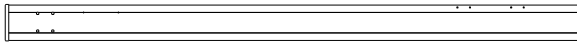

WP1 | W2A02859
(1) | 5 1/2"x5 1/2"x89 5/8" (140x140x2274)

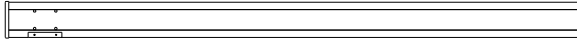

WP3 | W2A02861
(1) | 5 1/2"x5 1/2"x89 5/8" (140x140x2274)



D2 | JOIST - W4L13813
(1) | 1 3/8"x5 1/4"x89 1/2" (36x134x2274)

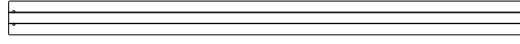

G3 | TOP RAIL - W4L13832
(2) | 1"x5 1/4"x81 1/4" (24x134x2063)



D4 | JOIST END - W4L13815
(1) | 1 3/8"x5 1/4"x18 3/4" (36x134x477)

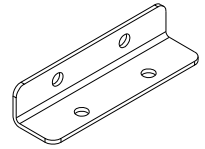

A4M01108 | L BRACKET
(4) | 24x30x112 - BLK



H100363 | BOLT WH BLK
(8) | 5/16x6



H100193 | NUT BARREL WH BLK
(8) | 5/16x1-1/2



H100486 | BOLT WH BLK
(8) | 1/4x5/8



H100399 | NUT BARREL WH BLK
(8) | 1/4x7/8



H100403 | LAG SCREW WH BLK
(8) | 1/4x1 1/2



H100400 | WASHER LOCK EXT BLK
(8) | 8x15



H100198 | WASHER LOCK EXT BLK
(8) | 8x19



H100199 | WASHER LOCK EXT BLK
(8) | 12x19

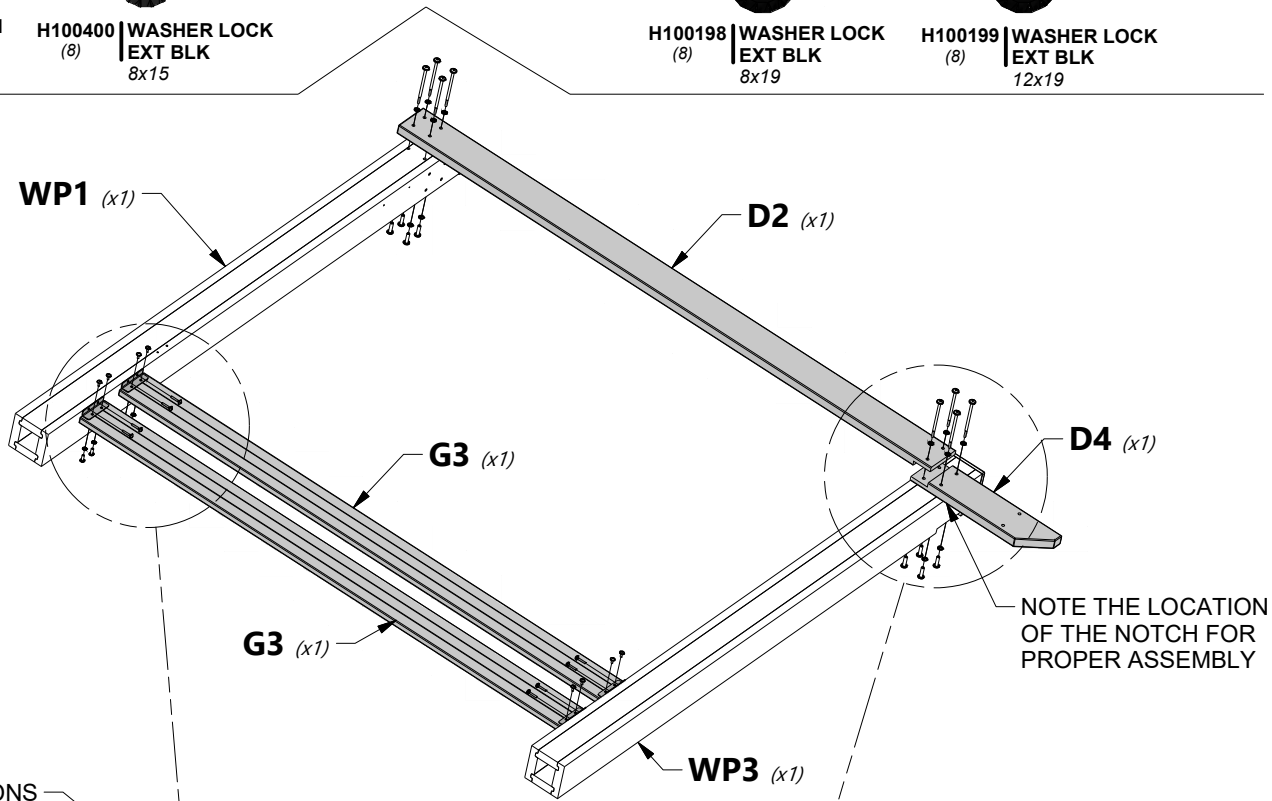

NOTE HOLE LOCATIONS FOR PROPER ASSEMBLY

486 (x8)
BOLT - 5/8"

108 (x4)
L BRACKET

363 (x8)
BOLT - 6"

198 (x8)
WASHER - 8x19

400 (x8)
WASHER - 8x15

199 (x8)
WASHER - 12x19

399 (x8)
NUT BARREL - 7/8

193 (x8)
NUT BARREL - 1 1/2"

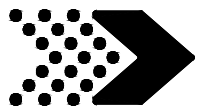

CABANA ASSEMBLY

STEP 2

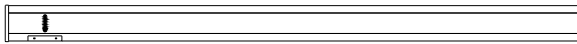

WP2 | W2A02860
(1) | 5 1/2"x5 1/2"x89 5/8" (140x140x2274)

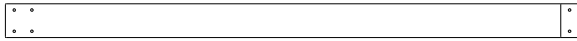

D1 | JOIST - W4L13812
(1) | 1 3/8"x5 1/4"x89 1/2" (36x134x2274)

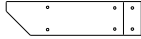

D3 | JOIST END - W4L13814
(1) | 1 3/8"x5 1/4"x18 3/4" (36x134x477)

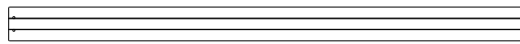

G3 | TOP RAIL - W4L13832
(2) | 1"x5 1/4"x81 1/4" (24x134x2063)

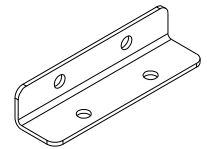

A4M01108 | L BRACKET
(4) | 24x30x112 - BLK



H100363 | BOLT WH BLK
(8) | 5/16x6



H100193 | NUT BARREL WH BLK
(8) | 5/16x1-1/2



H100486 | BOLT WH BLK
(8) | 1/4x5/8



H100399 | NUT BARREL WH BLK
(8) | 1/4x7/8



H100403 | LAG SCREW WH BLK
(8) | 1/4x1 1/2



H100400 | WASHER LOCK EXT BLK
(8) | 8x15



H100198 | WASHER LOCK EXT BLK
(8) | 8x19



H100199 | WASHER LOCK EXT BLK
(8) | 12x19

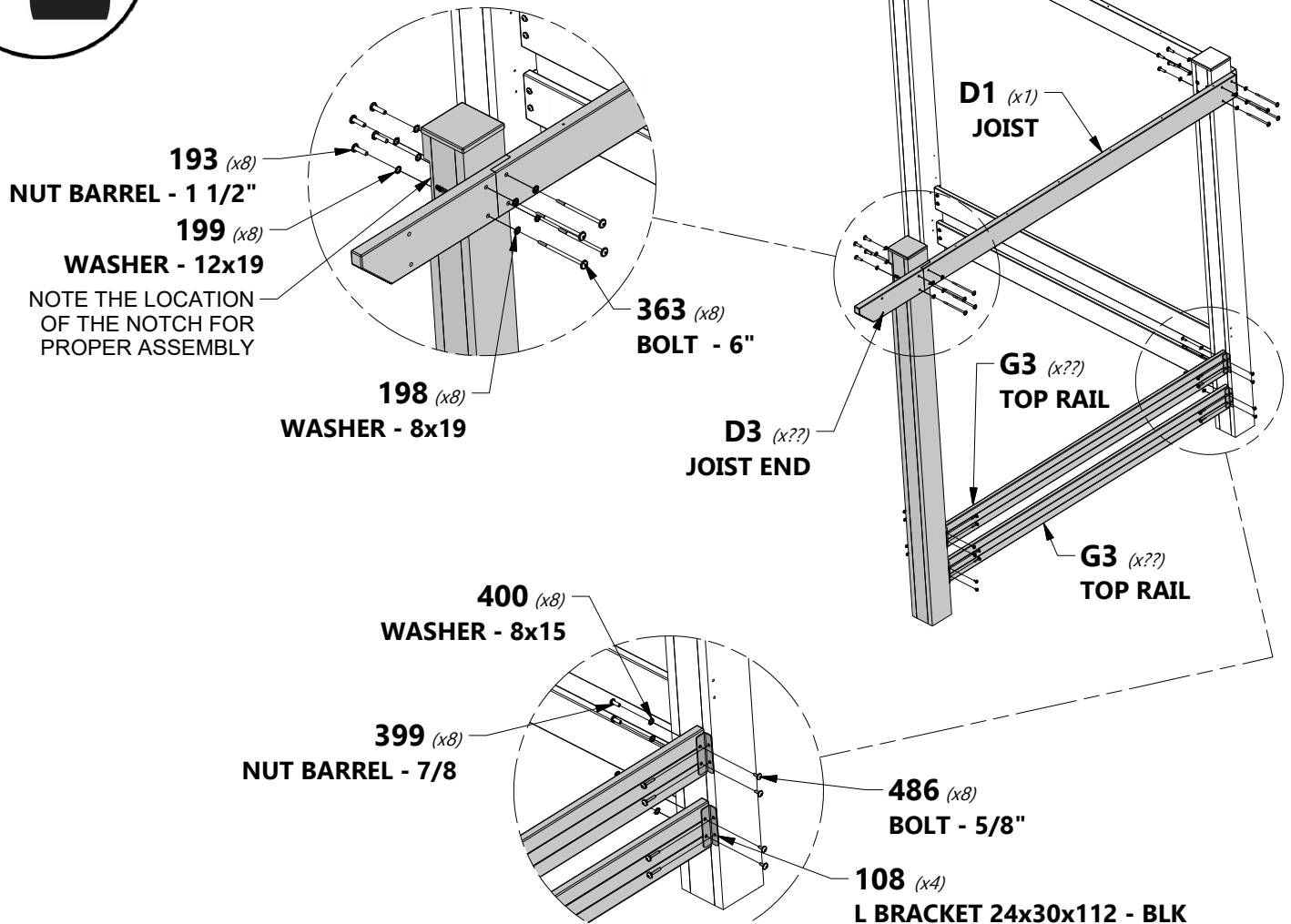

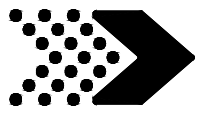

CABANA ASSEMBLY

STEP 3



H100391 | SCREW PFH BLK
(8) | 8x2

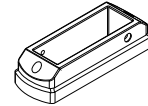

A6P00442 | MOUNTING
(4) | BRACKET

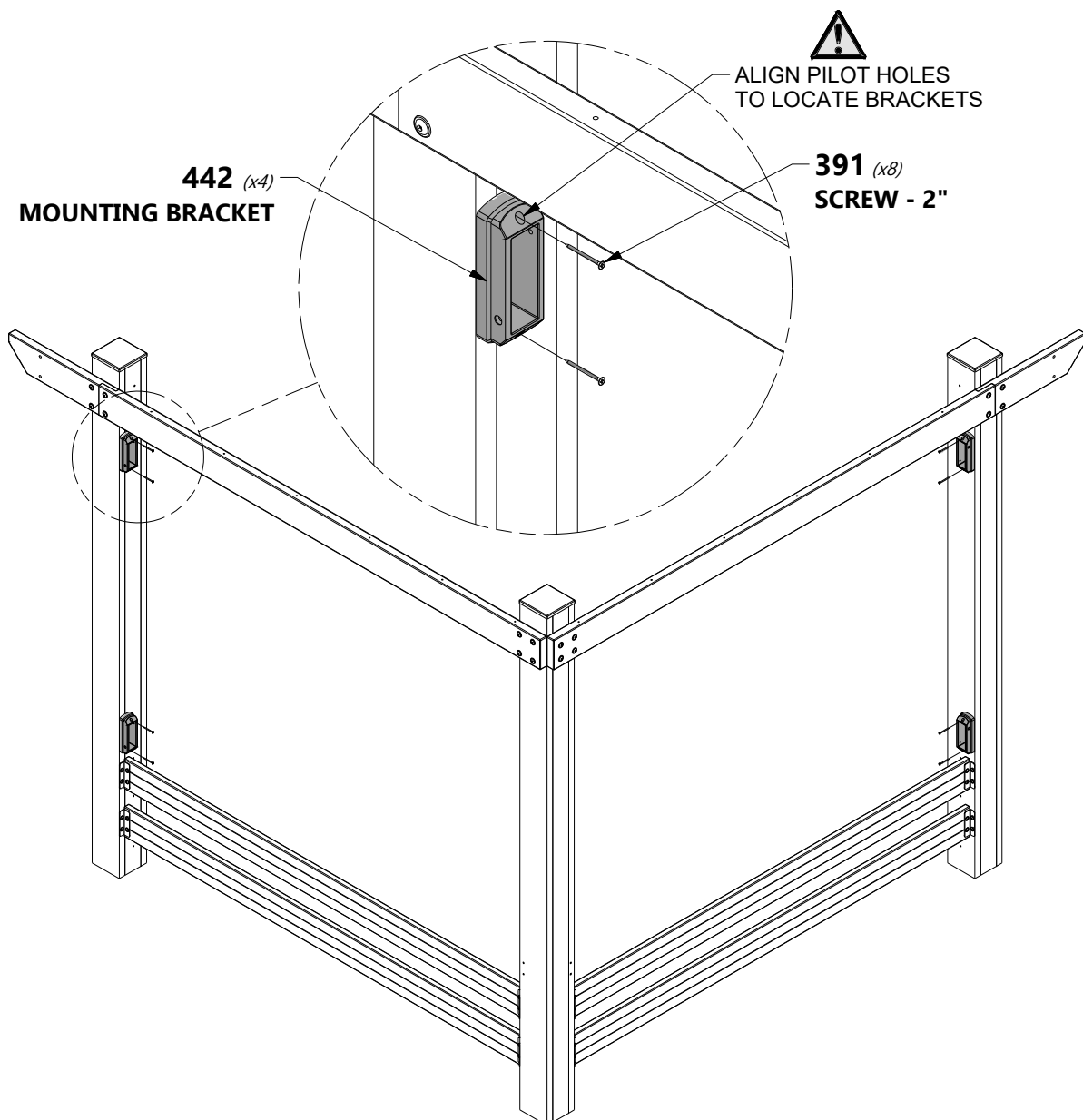

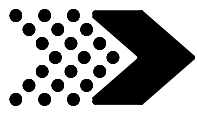

CABANA ASSEMBLY

STEP 4 PREPARATION

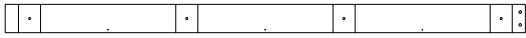

AN1 | LOWER SUPPORT - W4L13810
(1) | 1 3/8"x4 3/8"x81 1/4" (36x112x2064)

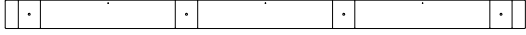

AN2 | TOP SUPPORT - W4L13809
(2) | 1 3/8"x4 3/8"x81 1/4" (36x112x2064)

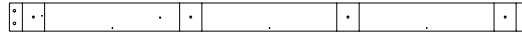

AN3 | LOWER SUPPORT - W4L13835
(1) | 1 3/8"x4 3/8"x81 1/4" (36x112x2064)

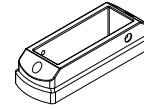

A6P00442 | MOUNTING BRACKET
(2)

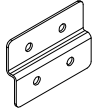

A4M01166 | L BRACKET
(2) | 40x40x112 - BLK



H100407 | BOLT WH BLK
(4) | 5/16x1 1/2



H100379 | T-NUT BLK
(4) | 5/16



H100385 | SCREW PFH BLK
(4) | 8x1

PREPARATION LEFT SUPPORTS

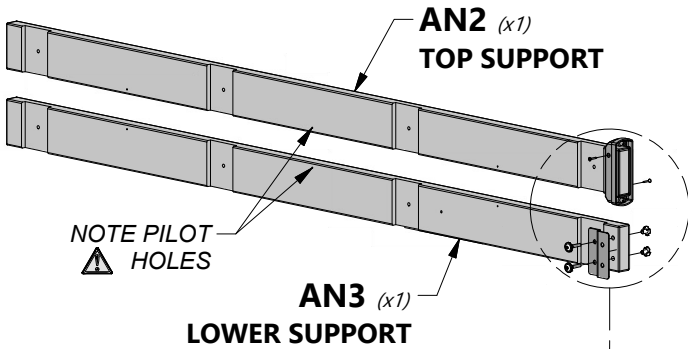

PREPARATION RIGHT SUPPORTS

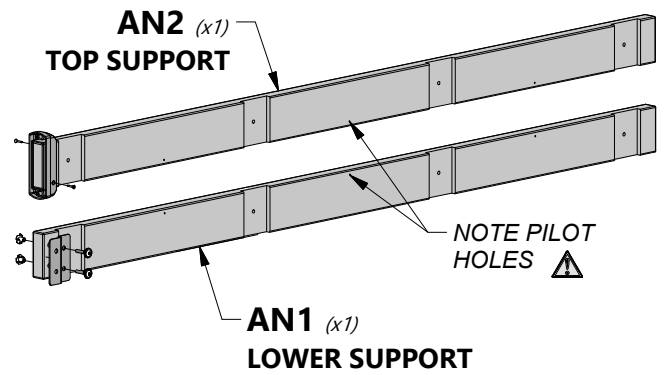

REPEAT STEPS SHOWN FOR RIGHT & LEFT SUPPORTS

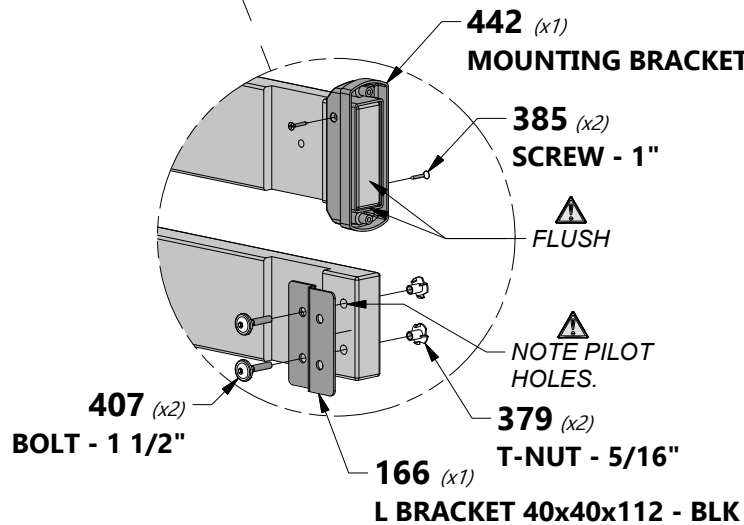

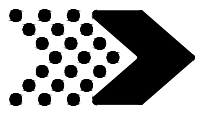

CABANA ASSEMBLY

STEP 4



LEFT SUPPORTS FROM PREVIOUS STEP

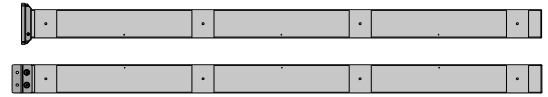

RIGHT SUPPORTS FROM PREVIOUS STEP



H100471 | LAG SCREW WH
(4) | BLK
5/16x1 1/2



H100391 | SCREW PFH BLK
(4) | 8x2



H100385 | SCREW PFH BLK
(8) | 8x1

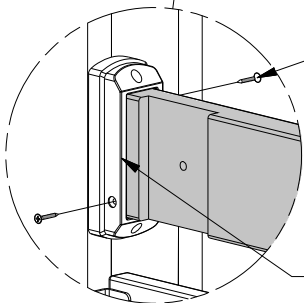
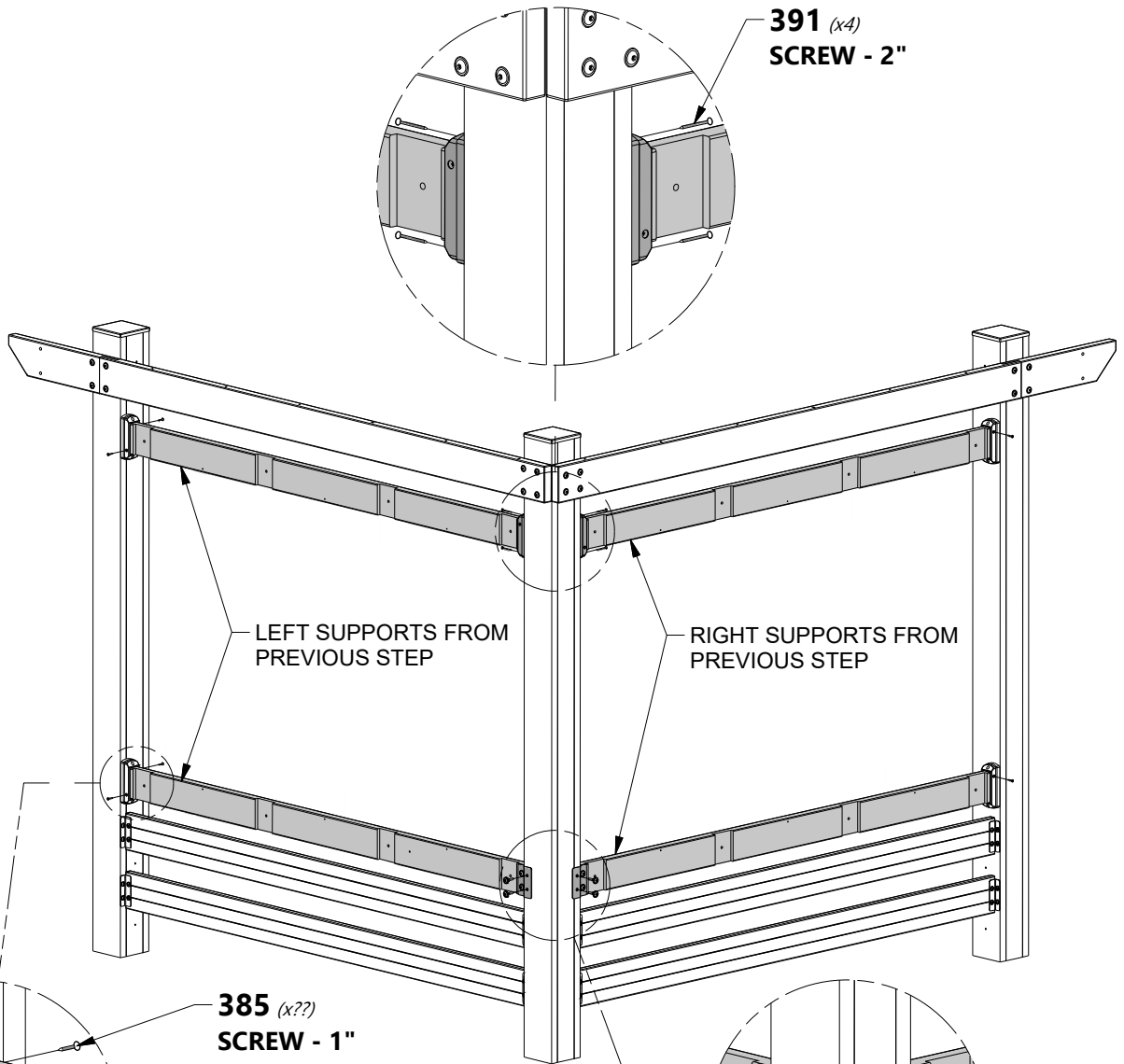

385 (x??)
SCREW - 1"

INSERT LEFT & RIGHT SUPPORT ASSEMBLIES INTO PREVIOUSLY ATTACHED MOUNTING BRACKETS ON CABANA AND SECURE AS SHOWN.

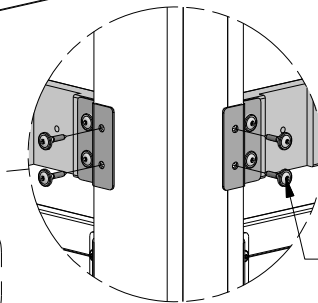

471 (x4)
LAG SCREW - 1 1/2"

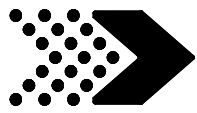

CABANA ASSEMBLY

STEP 5

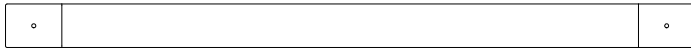

H1 | VERTICAL SUPPORT - W4L13808
(8) | 1"x3 3/8"x53 7/8" (24x86x1368)



H100400 | WASHER LOCK
(16) | EXT BLK
8x15



H100405 | WASHER LOCK
(16) | EXT BLK
6x15



H100171 | BOLT WH BLK
(16) | 1/4x1



H100399 | NUT BARREL
(16) | WH BLK
1/4x7/8

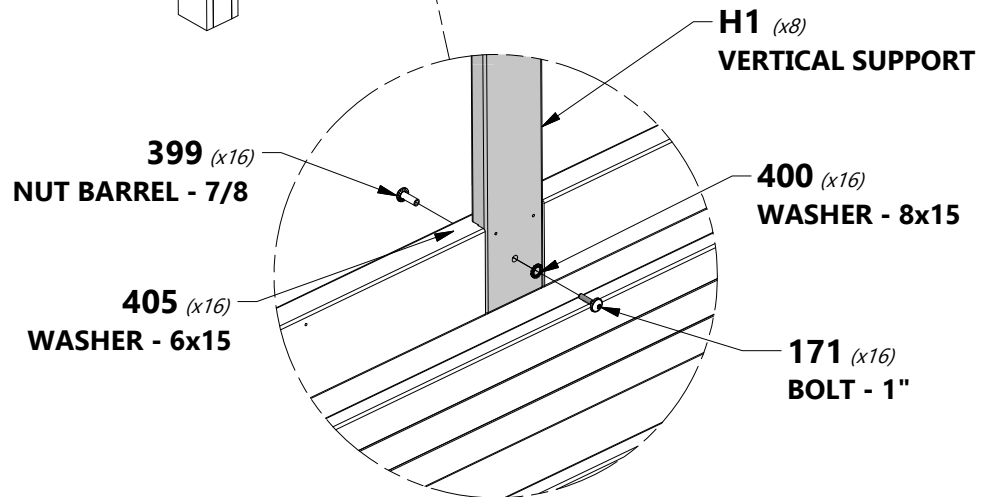
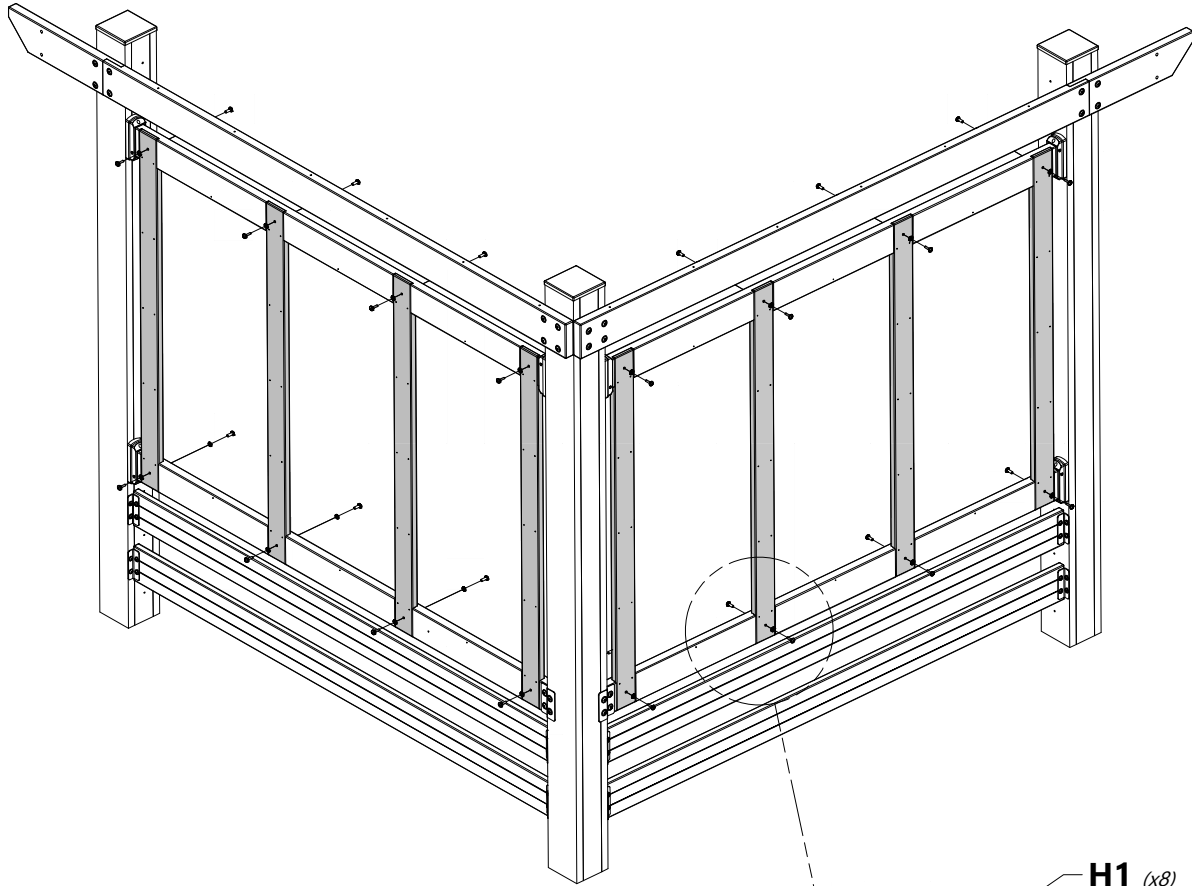

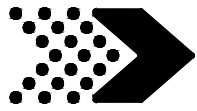

CABANA ASSEMBLY

STEP 6



G8 | BEAM - W4L13817
(1) | 1"x5 1/4"x89 1/2" (24x134x2274)

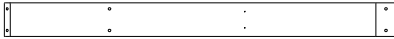

G12 | BEAM - W4L13821
(1) | 1"x5 1/4"x61 1/4" (24x134x1555)

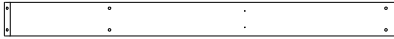

G13 | BEAM - W4L13822
(1) | 1"x5 1/4"x61 1/4" (24x134x1555)

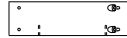

G11 | BEAM END - W4L13820
(1) | 1"x5 1/4"x19" (24x134x484)



G15 | BEAM END - W4L13831
(1) | 1"x5 1/4"x19" (24x134x484)

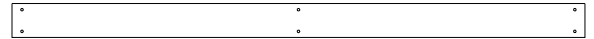

A4M01111 | METAL BEAM
(1)



H100407 | BOLT WH BLK
(6) | 5/16x1 1/2



H100192 | NUT BARREL
(6) | WH BLK
5/16x7/8



H100199 | WASHER LOCK
(6) | EXT BLK
12x19



H100198 | WASHER LOCK
(6) | EXT BLK
8x19

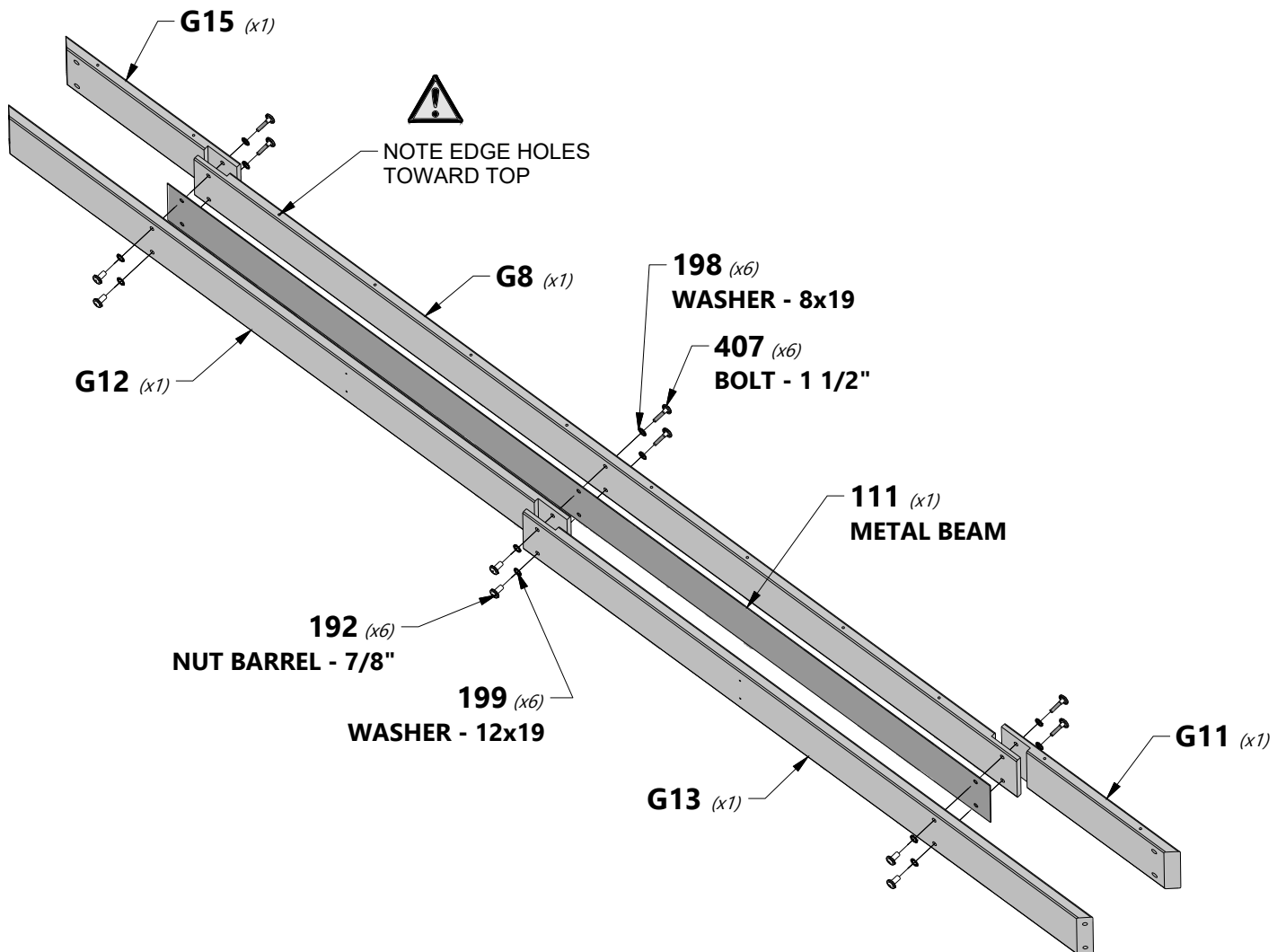

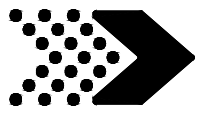

CABANA ASSEMBLY

STEP 7

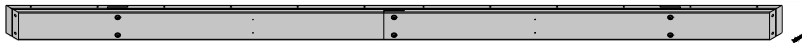

(1) REAR BEAM SUBASSEMBLY



H100197 | LAG SCREW WH BLK
(4) | 5/16x2 1/2



H100198 | WASHER LOCK
(4) | EXT BLK
8x19

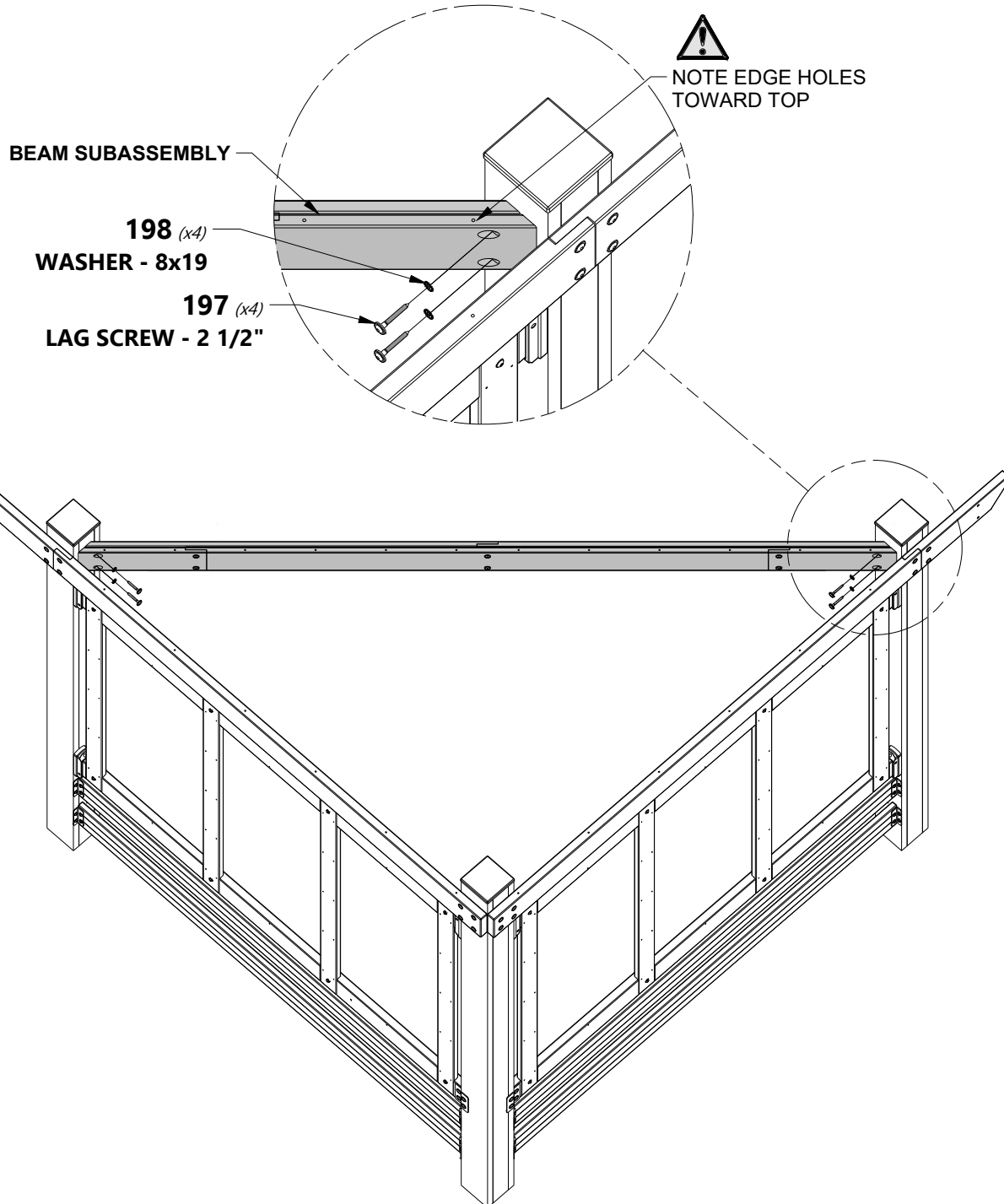

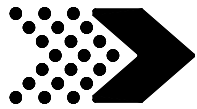

CABANA ASSEMBLY

STEP 8

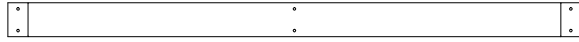

G8 | BEAM - W4L13817
(1) | 1"x5 1/4"x89 1/2" (24x134x2274)



G9 | BEAM - W4L13818
(1) | 1"x5 1/4"x71 1/8" (24x134x1807)



G10 | BEAM - W4L13819
(1) | 1"x5 1/4"x71 1/8" (24x134x1807)

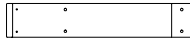

G7 | BEAM END - W4L13816
(1) | 1"x5 1/4"x29" (24x134x736)



G14 | BEAM END - W4L13830
(1) | 1"x5 1/4"x29" (24x134x736)

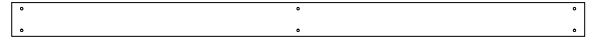

A4M01111 | METAL BEAM
(1)

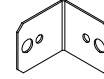

A4M00555 | 90° L-BRACKET - BLK
(4)



H100407 | BOLT WH BLK
(6) | 5/16x1 1/2



H100192 | NUT BARREL
WH BLK
(6) | 5/16x7/8



H100199 | WASHER LOCK
EXT BLK
(6) | 12x19



H100198 | WASHER LOCK
EXT BLK
(6) | 8x19



H100202 | SCREW PWH BLK
(4) | 8x5/8

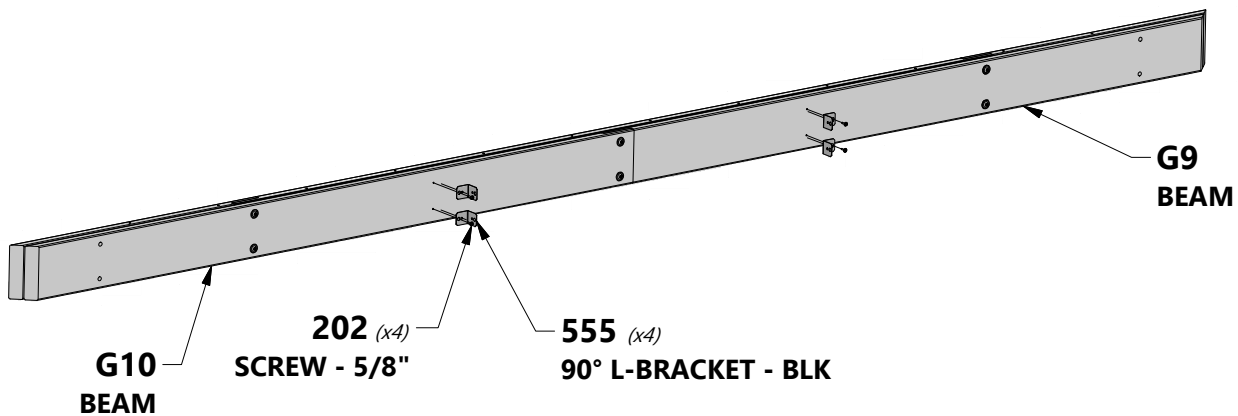
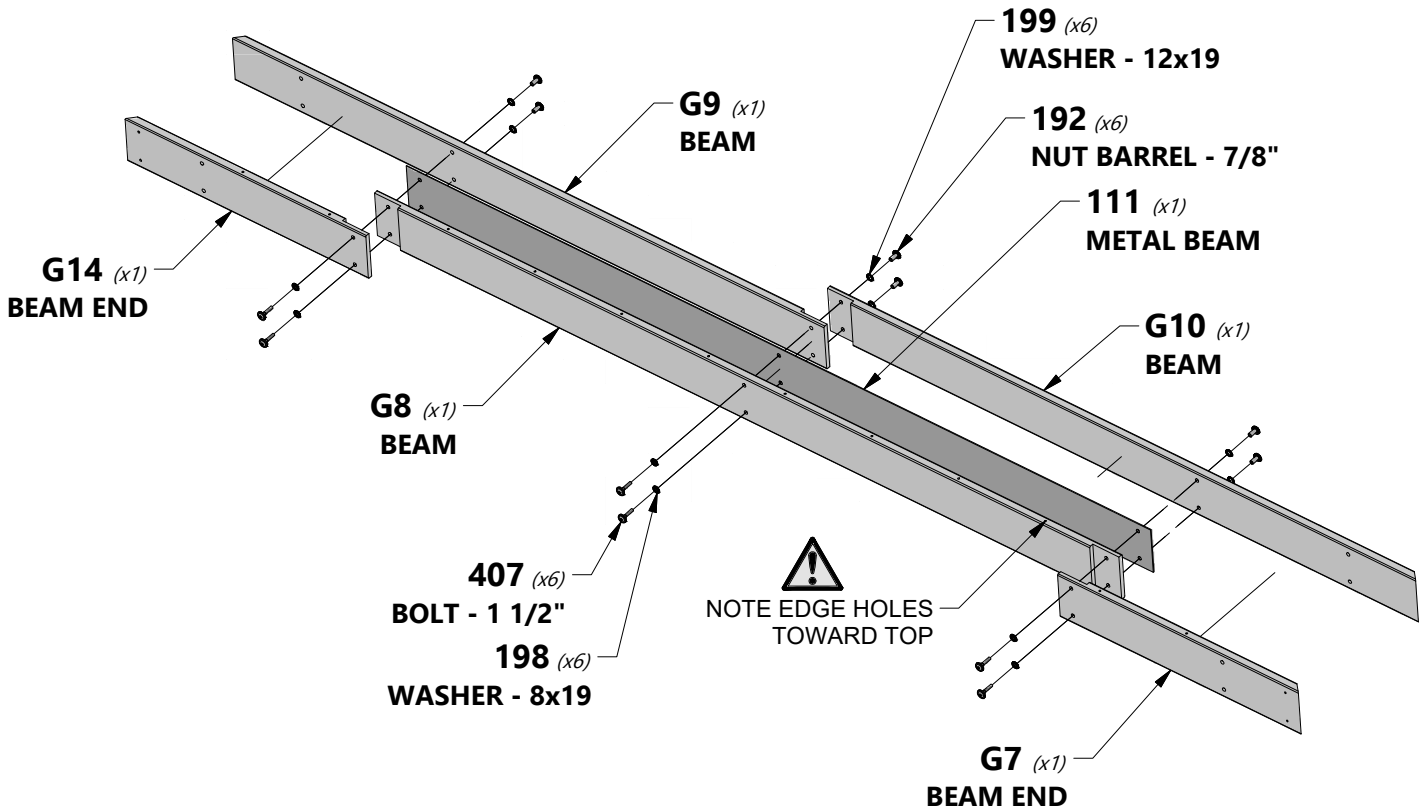

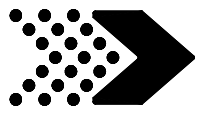

CABANA ASSEMBLY

STEP 9



D5 | SUPPORT BRACE - W4L13823
(2) | 1 3/8"x5 1/4"x4 5/8" (36x134x116)



H100202 | SCREW PWH BLK
(8) | 8x5/8

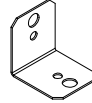

A4M00555 | 90° L-BRACKET - BLK
(4) | BLK

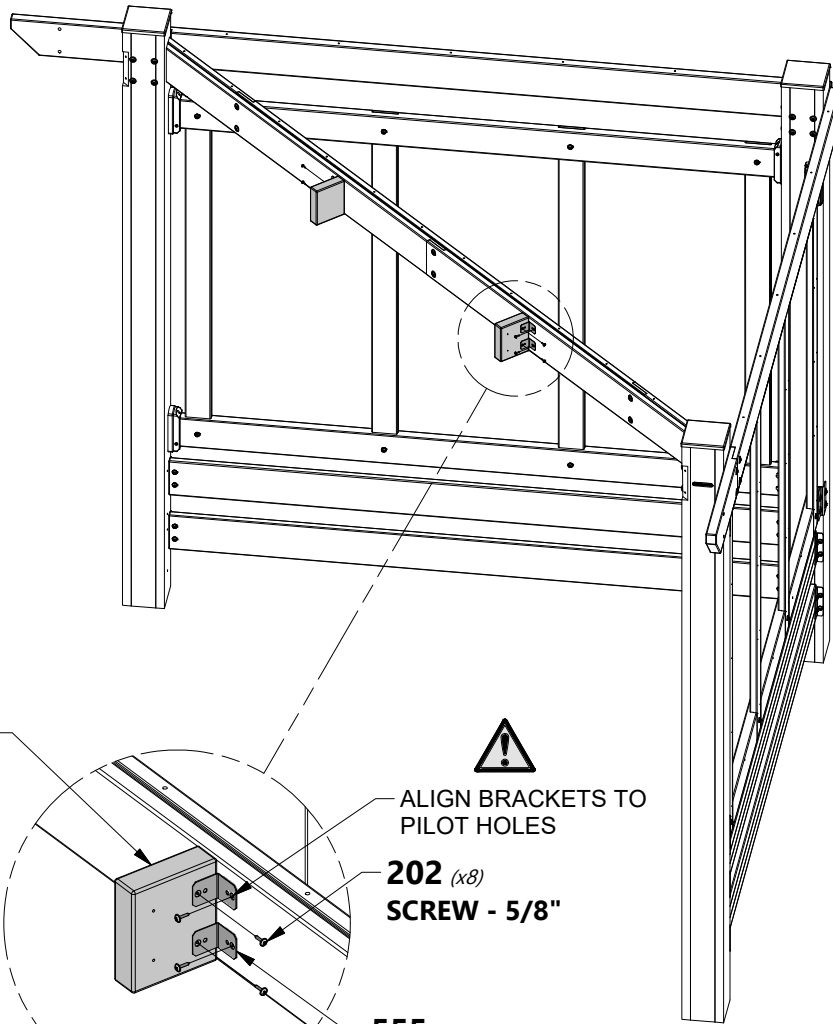

D5 (x2)
SUPPORT BRACE



ALIGN BRACKETS TO
PILOT HOLES

202 (x8)
SCREW - 5/8"

555 (x4)
90° L-BRACKET - BLK

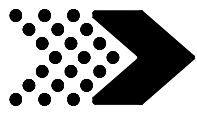

CABANA ASSEMBLY

STEP 10



(1) FRONT BEAM SUBASSEMBLY



H100202 | SCREW PWH BLK
(4) | 8x5/8

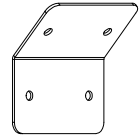

A4M01097 | BRACKET 135°
(2) | BLK



H100206 | LAG SCREW WH BLK
(4) | 5/16x3



H100471 | LAG SCREW WH BLK
(4) | 5/16x1 1/2



H100468 | BOLT WH BLK
(4) | 5/16x1



H100192 | NUT BARREL
(4) | WH BLK
5/16x7/8



H100199 | WASHER LOCK
(4) | EXT BLK
12x19



H100198 | WASHER LOCK
(4) | EXT BLK
8x19

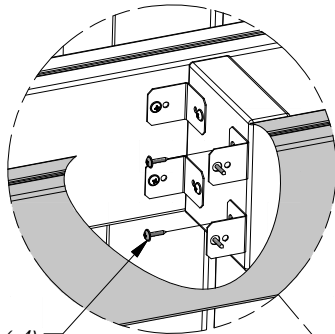

202 (x4)
SCREW - 5/8"

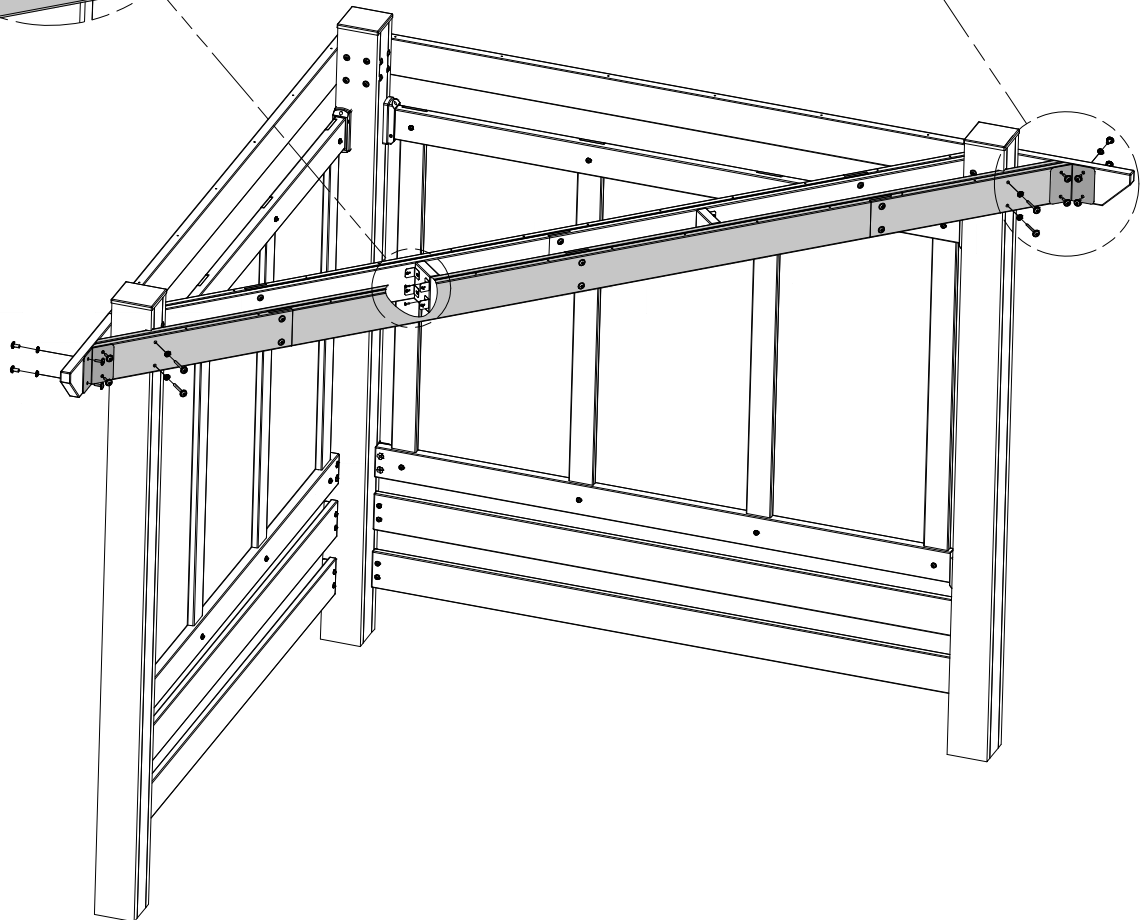
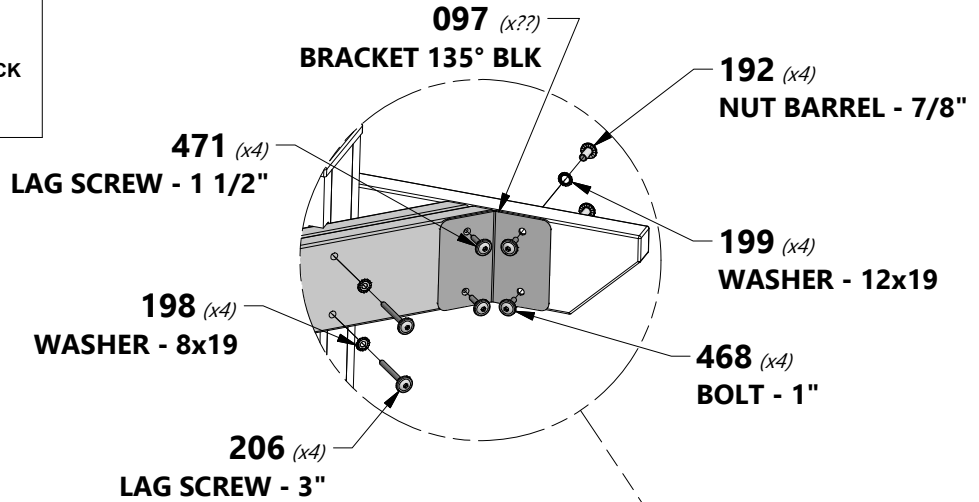

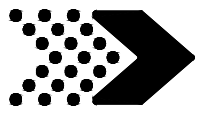

CABANA ASSEMBLY

STEP 11

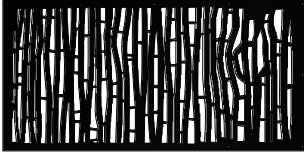

A6P00440
(6) | DECORATIVE BACK PANEL

OR



A6P00441
(6) | DECORATIVE BACK PANEL



H100797 | SCREW PWH BLK
(72) | 8x1



1. ALTERNATE TOP AND BOTTOM AS SHOWN BELOW.
2. TEXTURED SIDE OF PANEL FACES INWARD.

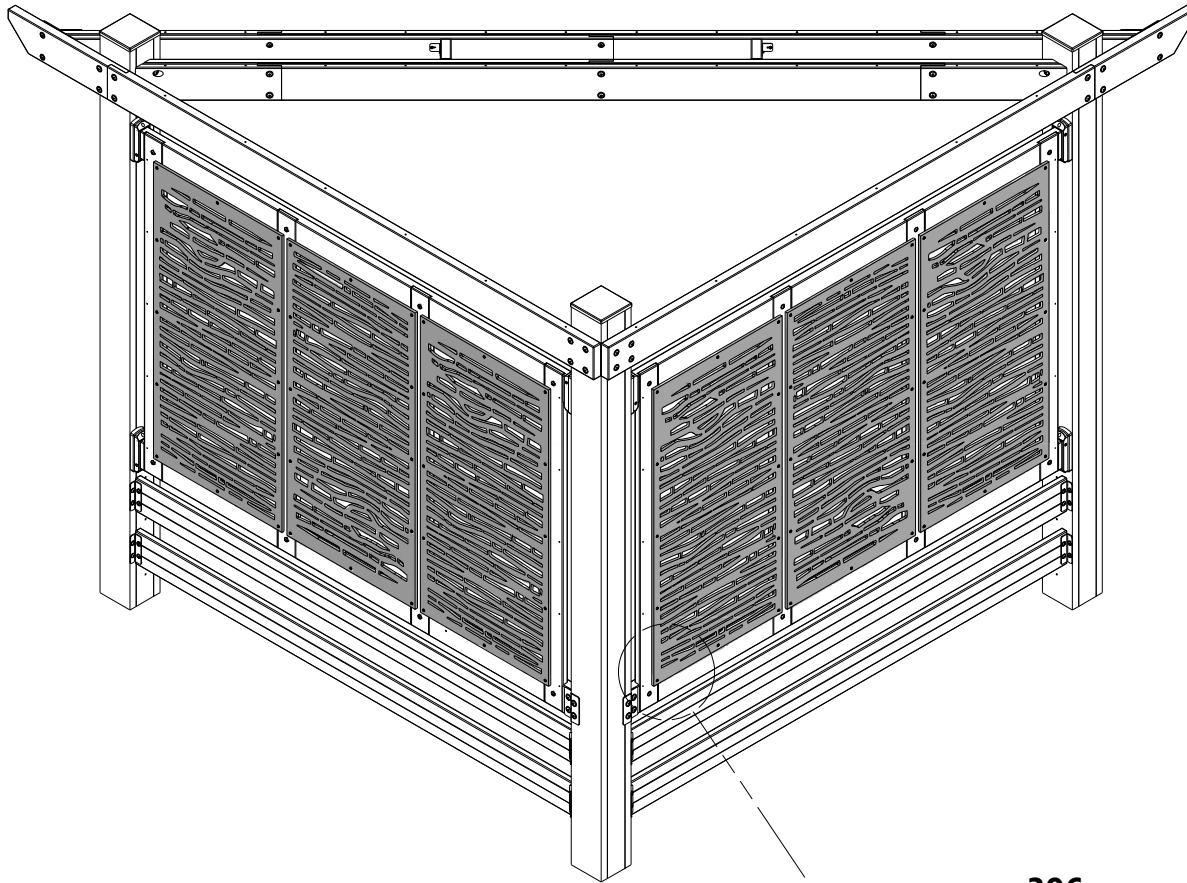

396 (x6)
DECORATIVE BACK PANEL

TOP

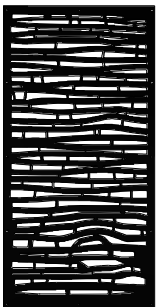

OR

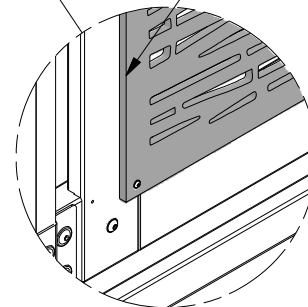
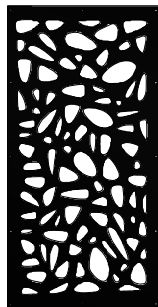

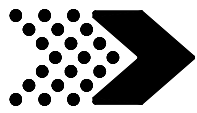

CABANA ASSEMBLY

STEP 12

E1 | TOP JOIST - W4L13824
(2) | 1 3/8"x3 3/8"x81 1/2" (36x86x2070)

E2 | TOP JOIST - W4L13825
(2) | 1 3/8"x3 3/8"x71 1/2" (36x86x1817)

E3 | TOP JOIST - W4L13826
(2) | 1 3/8"x3 3/8"x61 1/8" (36x86x1553)

E6 | TOP JOIST - W4L13829
(2) | 1 3/8"x3 3/8"x30" (36x86x761)

E5 | TOP JOIST - W4L13828
(2) | 1 3/8"x3 3/8"x40 3/8" (36x86x1025)

E4 | TOP JOIST - W4L13827
(2) | 1 3/8"x3 3/8"x50 3/4" (36x86x1289)



H100825 | LAG SCREW
(36) | 5/16x4 BLK



H100198 | WASHER LOCK
(36) | EXT BLK
8x19

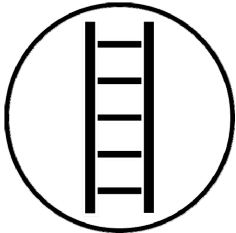

825 (x36)
LAG 5/16x4 BLK

198 (x36)
WASHER - 8x19

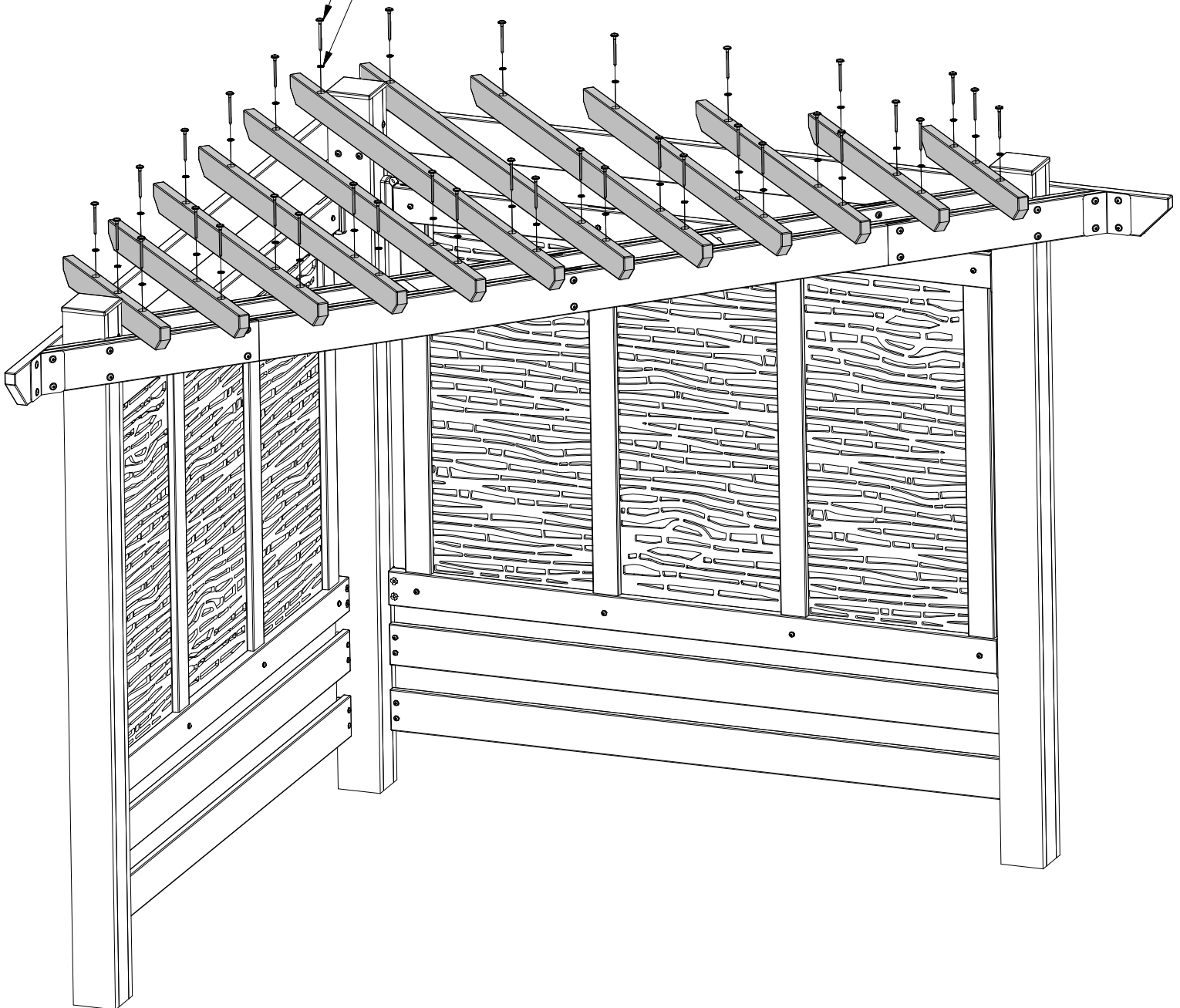
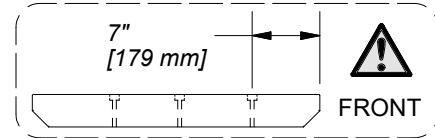

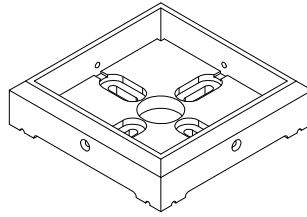
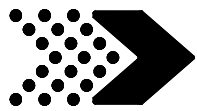

A100029 | FOOT 142
(3) SQUARE POST



1. DECIDE WHERE TO PLACE THE PERGOLA. NOTE THIS MOUNTING PROCEDURE IS MEANT TO BE USED ON CONCRETE ONLY.

2. PLACE THE PERGOLA EXACTLY WHERE IT WILL BE ANCHORED WHEN COMPLETED AND SLIDE A FOOT UNDER EACH POST.

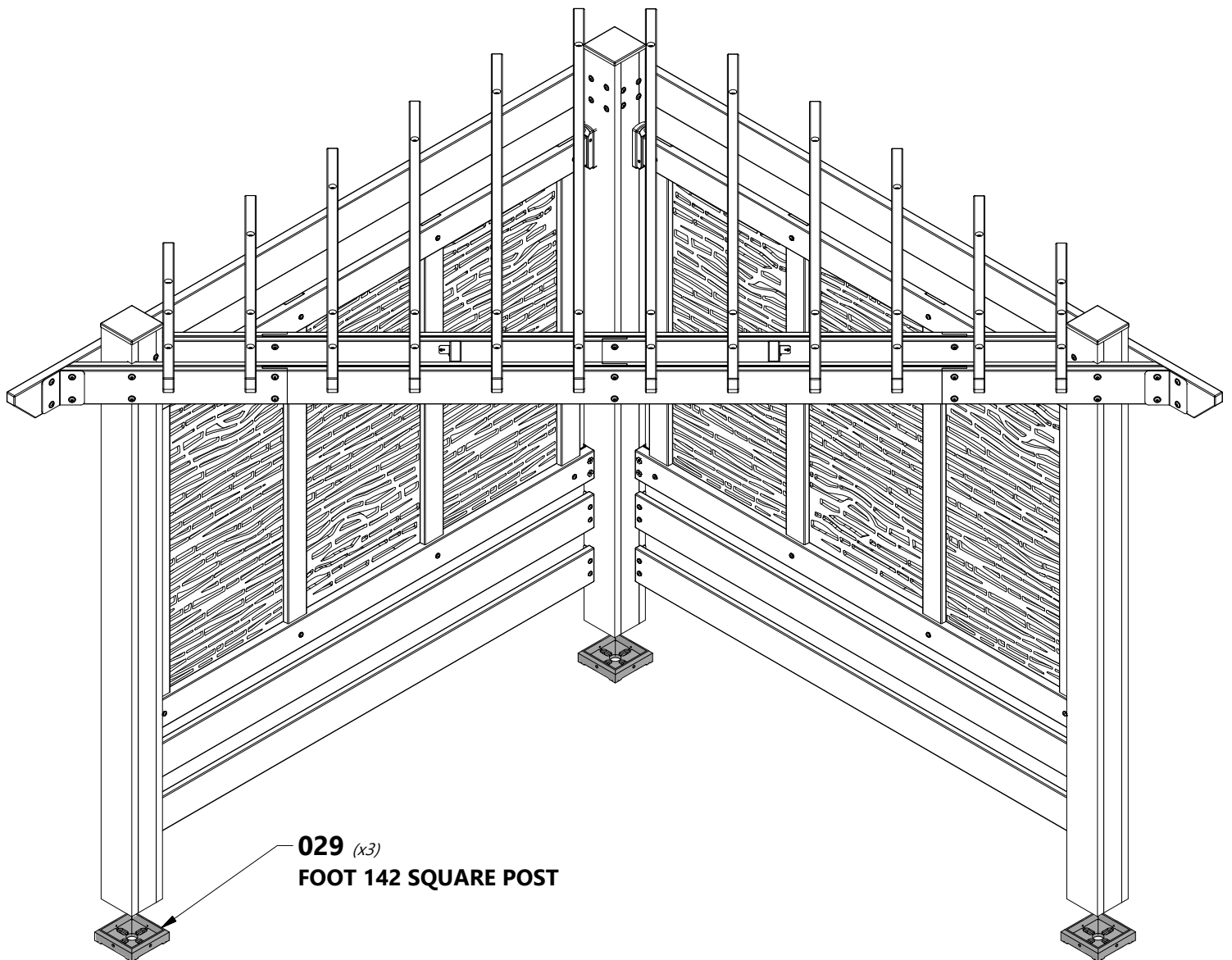

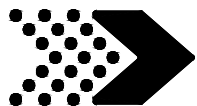

H100120 | SCREW CONCRETE ANCHOR
(12) | 1/4x2



USE CHALK TO TRACE AROUND THE EDGES OF EACH FOOT.

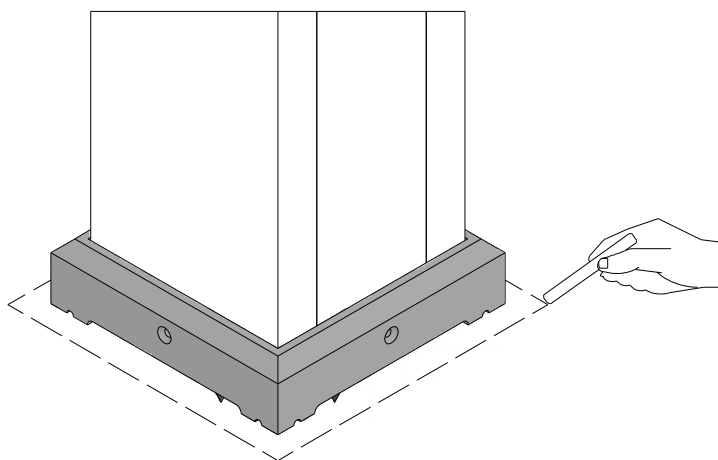

1. MOVE THE PERGOLA ASIDE. PLACE EACH FOOT INSIDE OF THE LINES DRAWN IN THE PREVIOUS STEP. USING A 3/16" CONCRETE DRILL BIT, PILOT DRILL ATTACHMENT HOLES INTO THE CONCRETE PAD.

2. USE THE 1/4"x2" CONCRETE ANCHORS TO ATTACH EACH FOOT TO THE CONCRETE SURFACE.

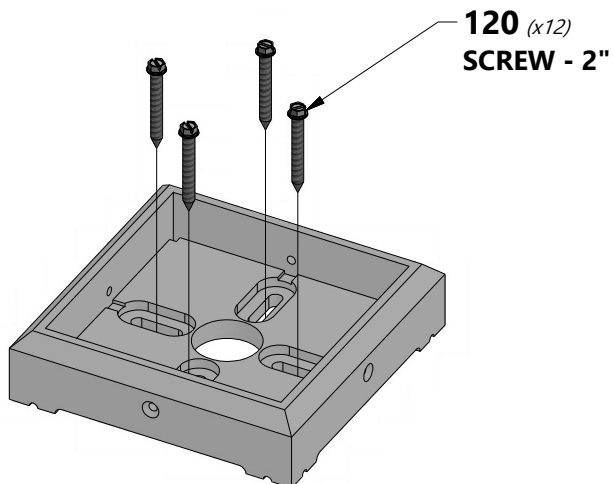

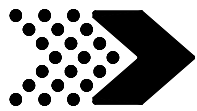

ANCHORING

STEP 15



A100241 | **BYD ID TAG**
(1) | **(SMALL)**
| **WITHOUT AGES**



H100200 | **SCREW PFH BLK**
(12) | **8x1 1/2**



H100392 | **SCREW PWH BLK**
(2) | **8x3/4**



MOVE THE PERGOLA BACK IN TO PLACE, SETTING EACH POST INSIDE A FOOT AND MOUNT.

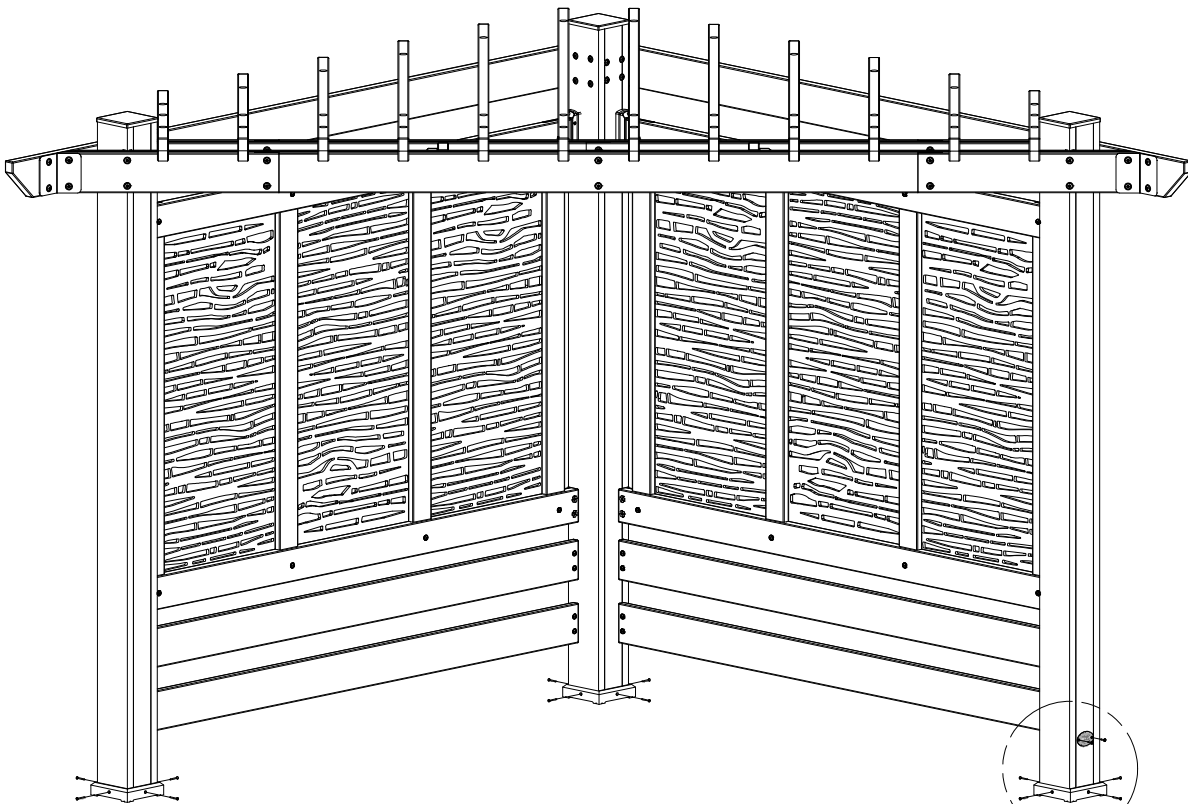

241 *(x1)*
BYD ID TAG

392 *(x2)*
SCREW - 3/4"

200 *(x12)*
SCREW - 1 1/2"

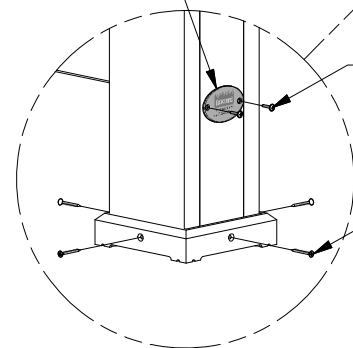



PRODUCT IS FINISHED

FOR CUSTOMERS ASSEMBLING MODELS:

**2002517, 2002524, 2002531, 2202555, 2202562,
2002579, OR 2002586 CONTINUE ON TO NEXT STEP.**

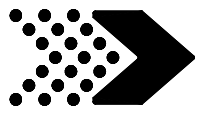

SEATING ASSEMBLY

STEP 16

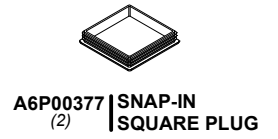
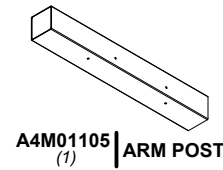
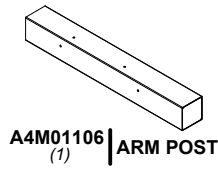
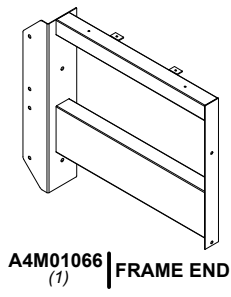
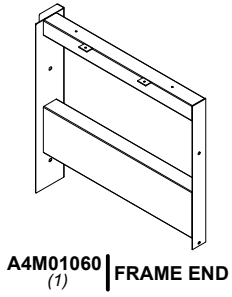

H100171 | BOLT WH BLK
(4) | 1/4x1

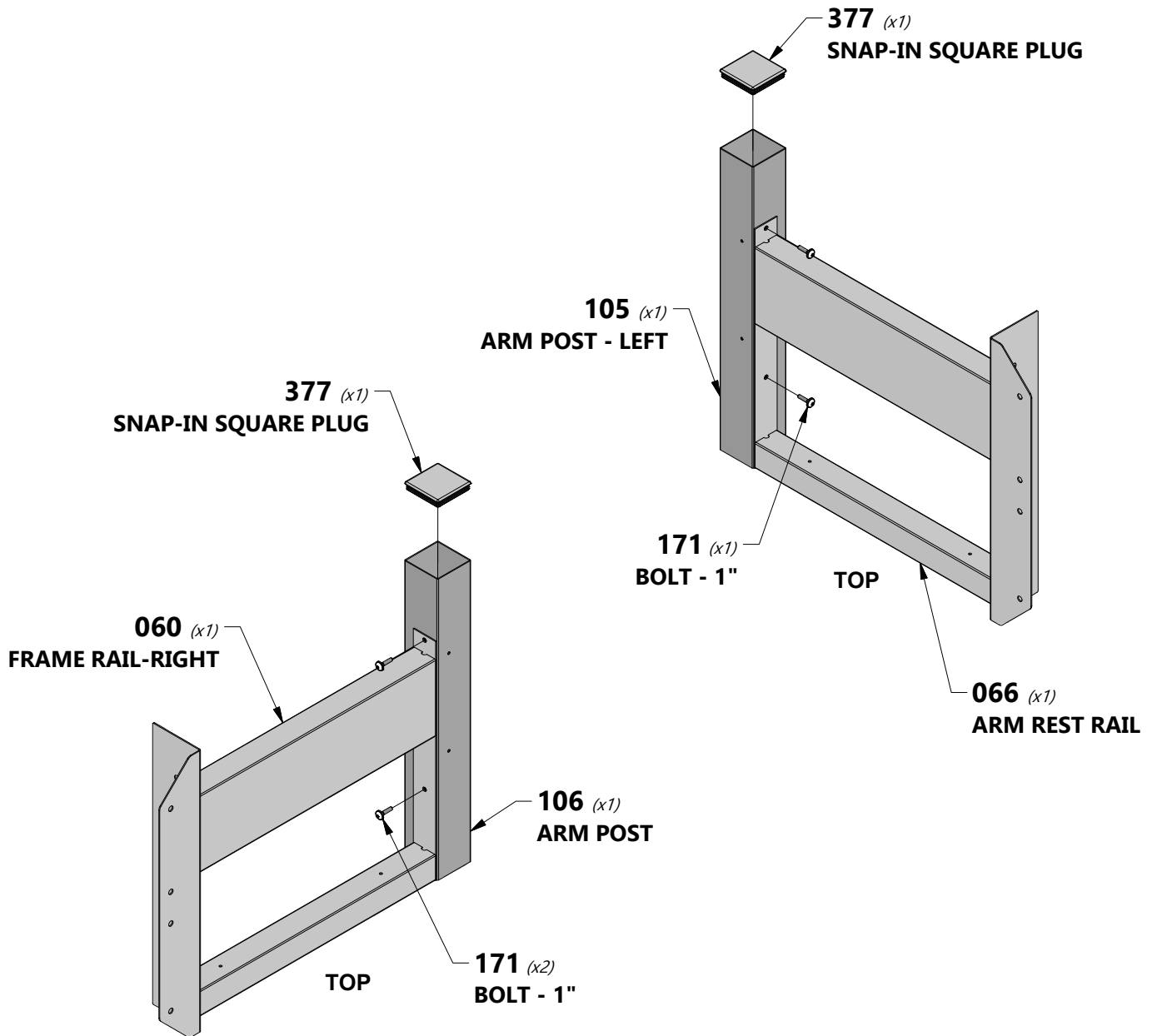

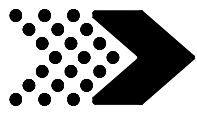

SEATING ASSEMBLY

STEP 17

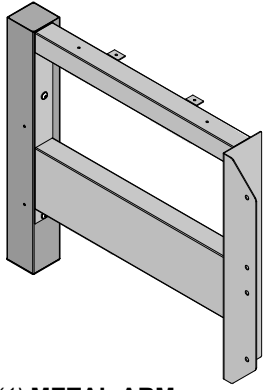

(1) METAL ARM SUBASSEMBLY - LEFT

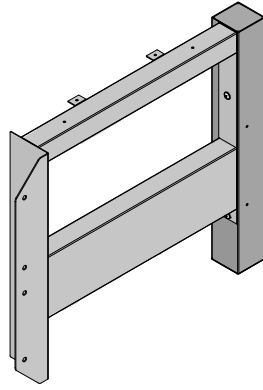

(1) METAL ARM SUBASSEMBLY - RIGHT



H100471 | LAG SCREW WH BLK
(10) | 5/16x1 1/2



NOTE:

LOCATE AND USE ARMREST ASSEMBLY HOLES AS A TEMPLATE. MARK AND DRILL HOLES SECURING METAL ARMRESTS TO POST. USE THE 6mm DRILL BIT PROVIDED IN HARDWARE KIT TO DRILL 3/8" [10mm] DEEP HOLES. USE HARDWARE PROVIDED.

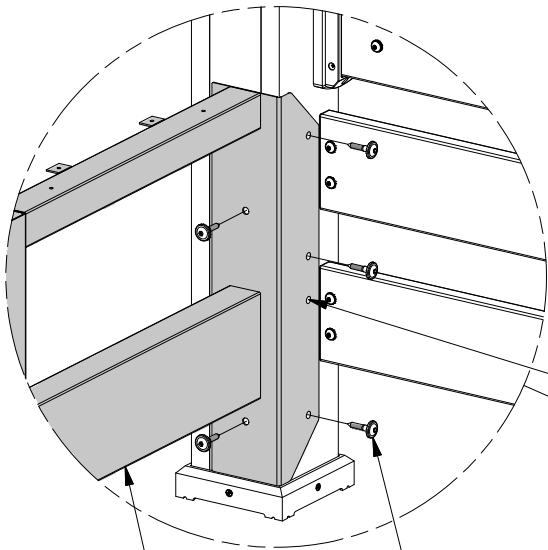

(1) METAL ARM SUBASSEMBLY - LEFT

471 (x10)
LAG SCREW - 1 1/2"



DO NOT DRILL THIS HOLE

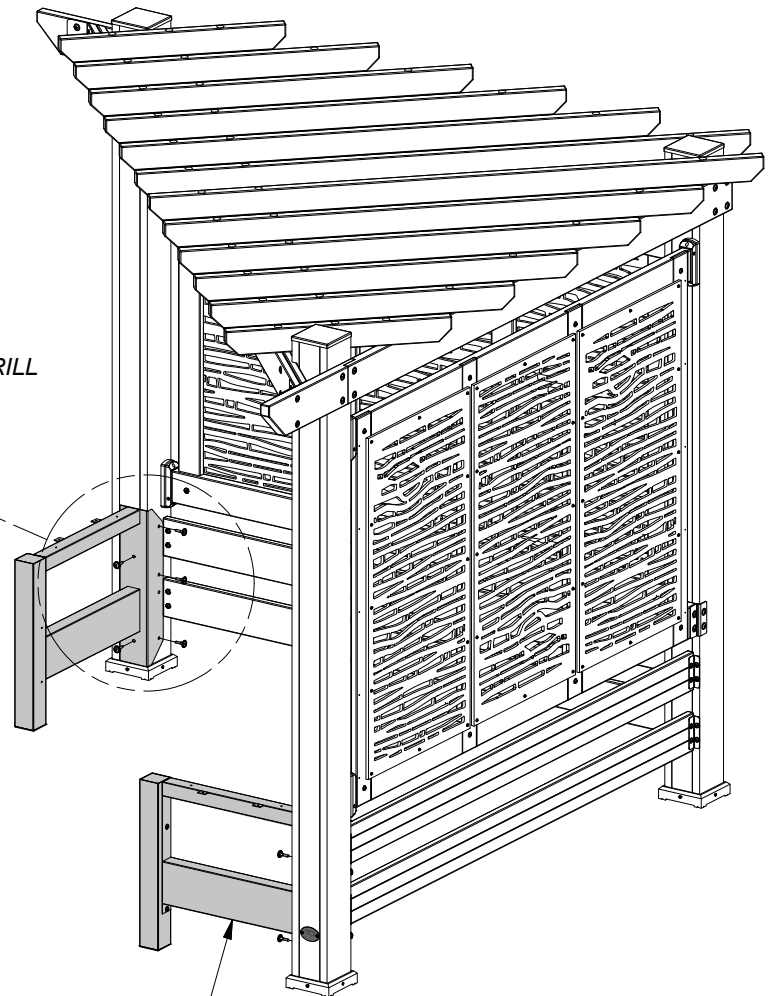

(1) METAL ARM SUBASSEMBLY - RIGHT

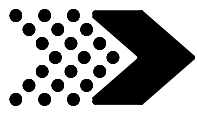

SEATING ASSEMBLY

STEP 18

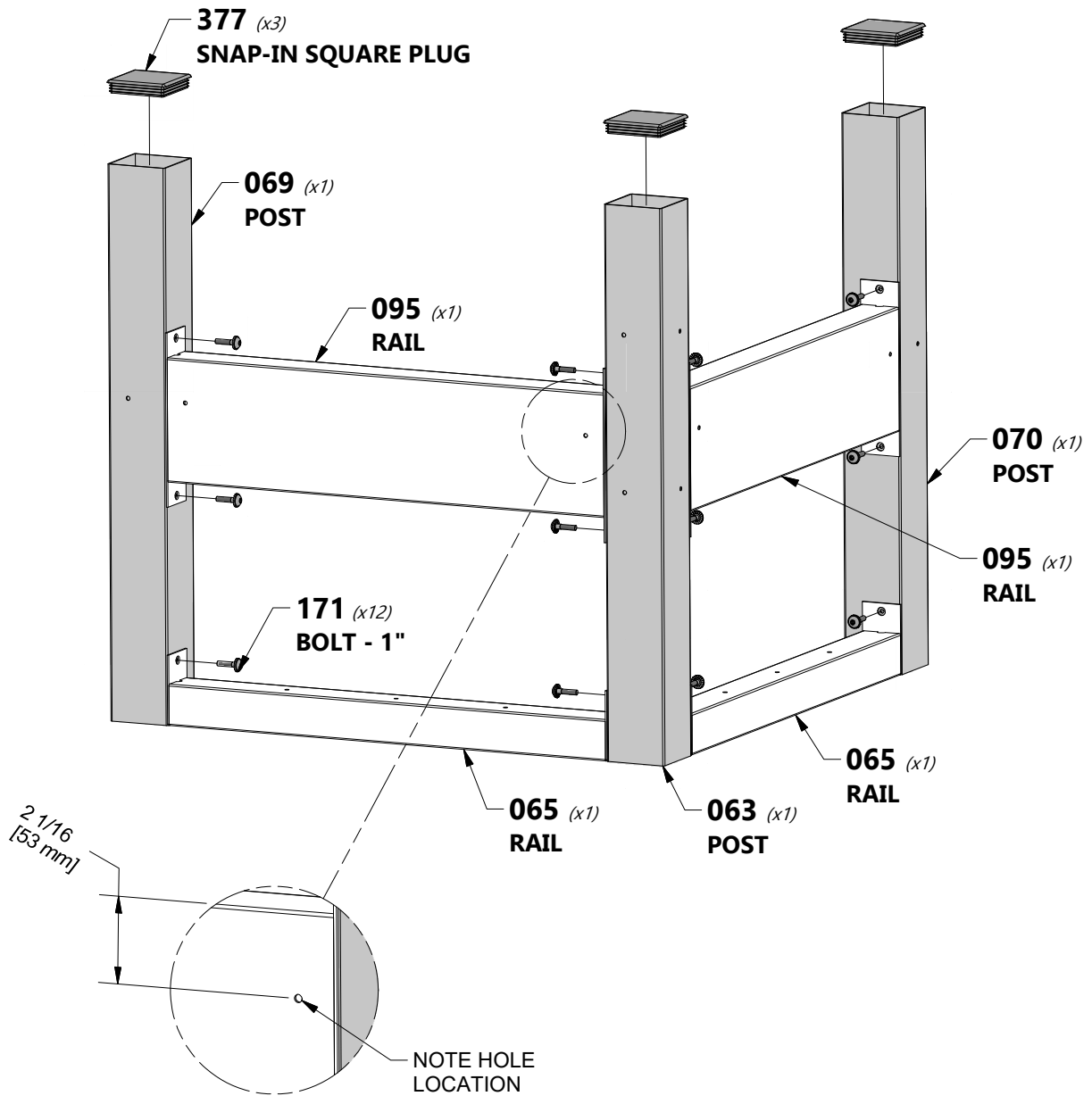
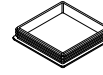
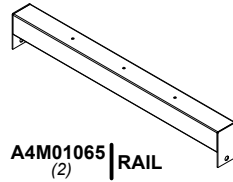
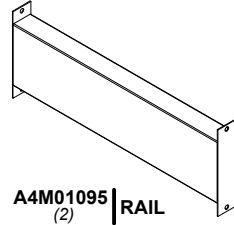
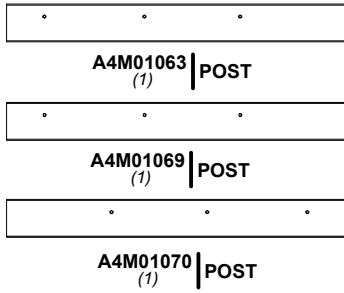

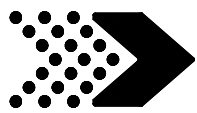

SEATING ASSEMBLY

STEP 19

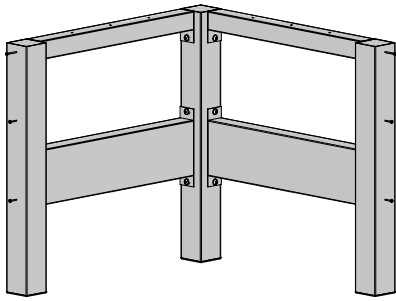

(1) METAL TABLE BASE SUBASSEMBLY



H100391 | SCREW PFH BLK
(6) | 8x2

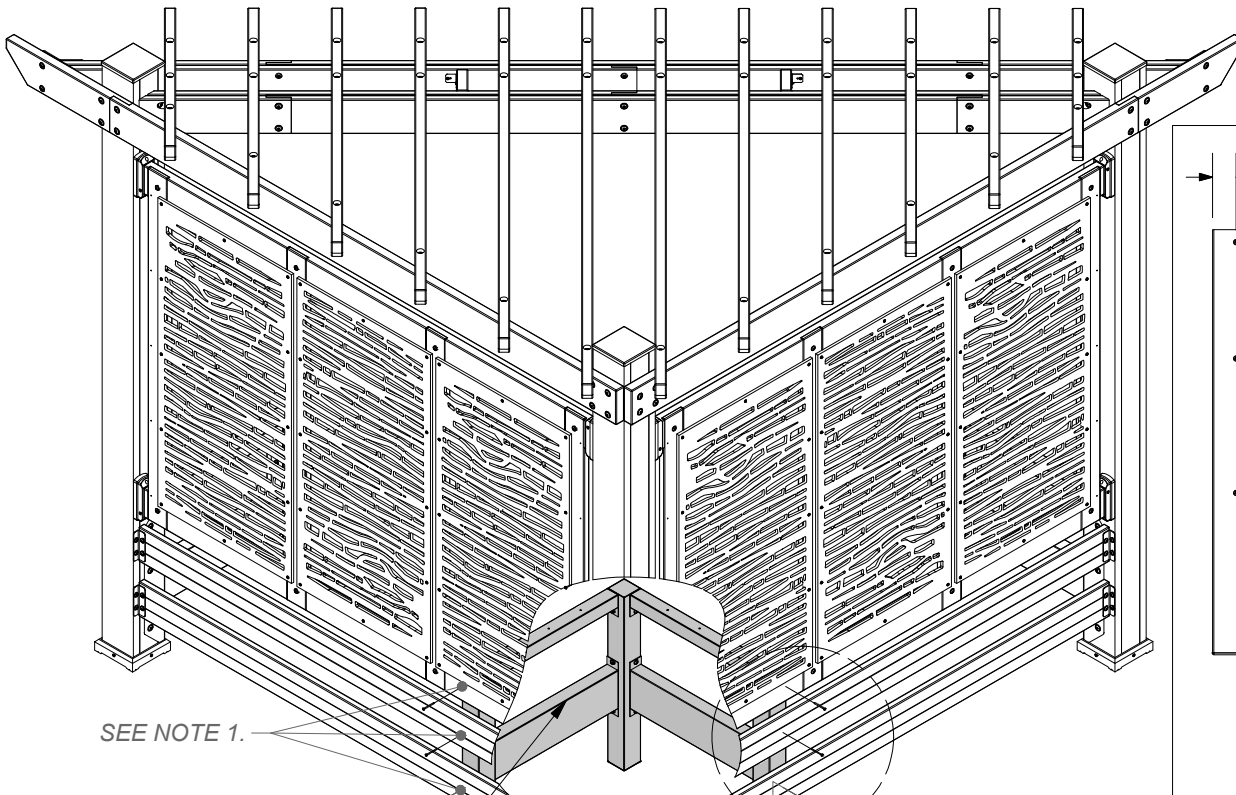

DRILLING LOCATIONS

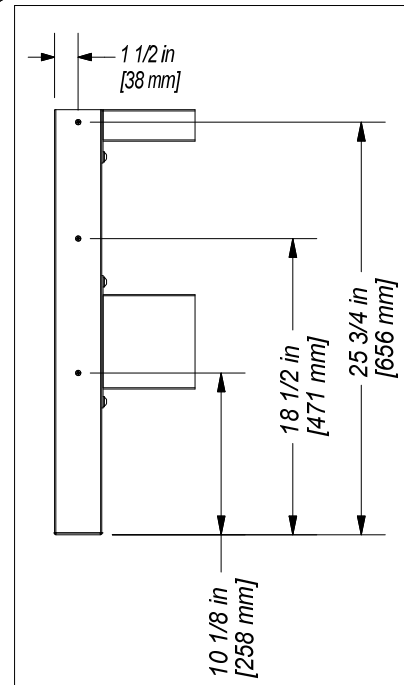

SEE NOTE 1.

METAL ARM TABLE BASE SUBASSEMBLY (FROM STEP 18)

23 1/2 in [598 mm]

23 1/2 in [598 mm]

NOTE: DIMS TAKEN FROM INSIDE OF LEG TO C/L OF SCREWS.

SEE NOTE 1.

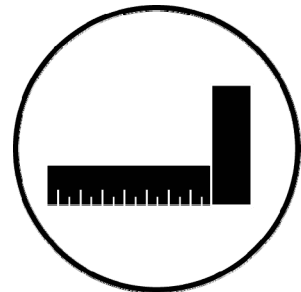
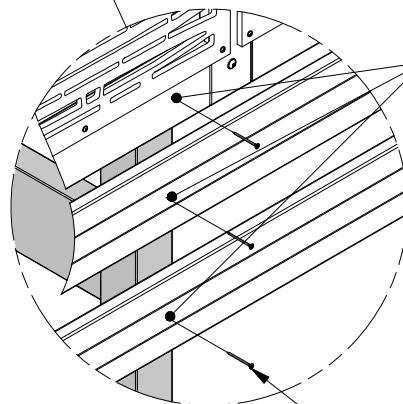

391 (x6)
SCREW - 2"



NOTE:

1. MARK & DRILL A 3/16" [5mm] THROUGH HOLE IN DRILLING LOCATIONS.
2. USE HARDWARE SHOWN TO ATTACH METAL TABLE FRAME TO CABANA.

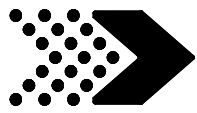

SEATING ASSEMBLY

STEP 20

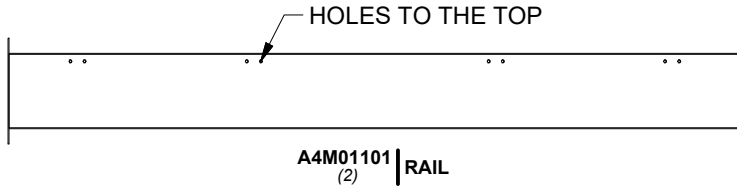

H100171 | BOLT WH BLK
(8) | 1/4x1

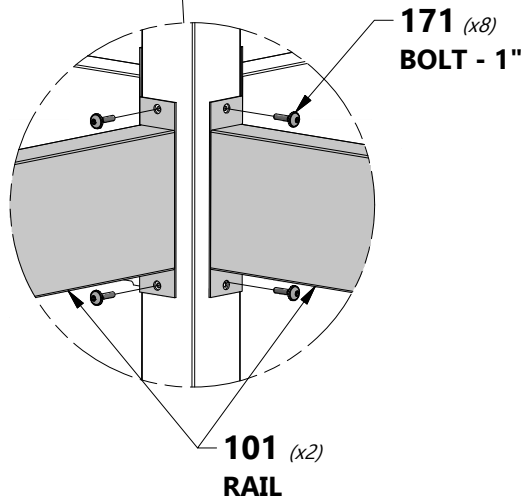
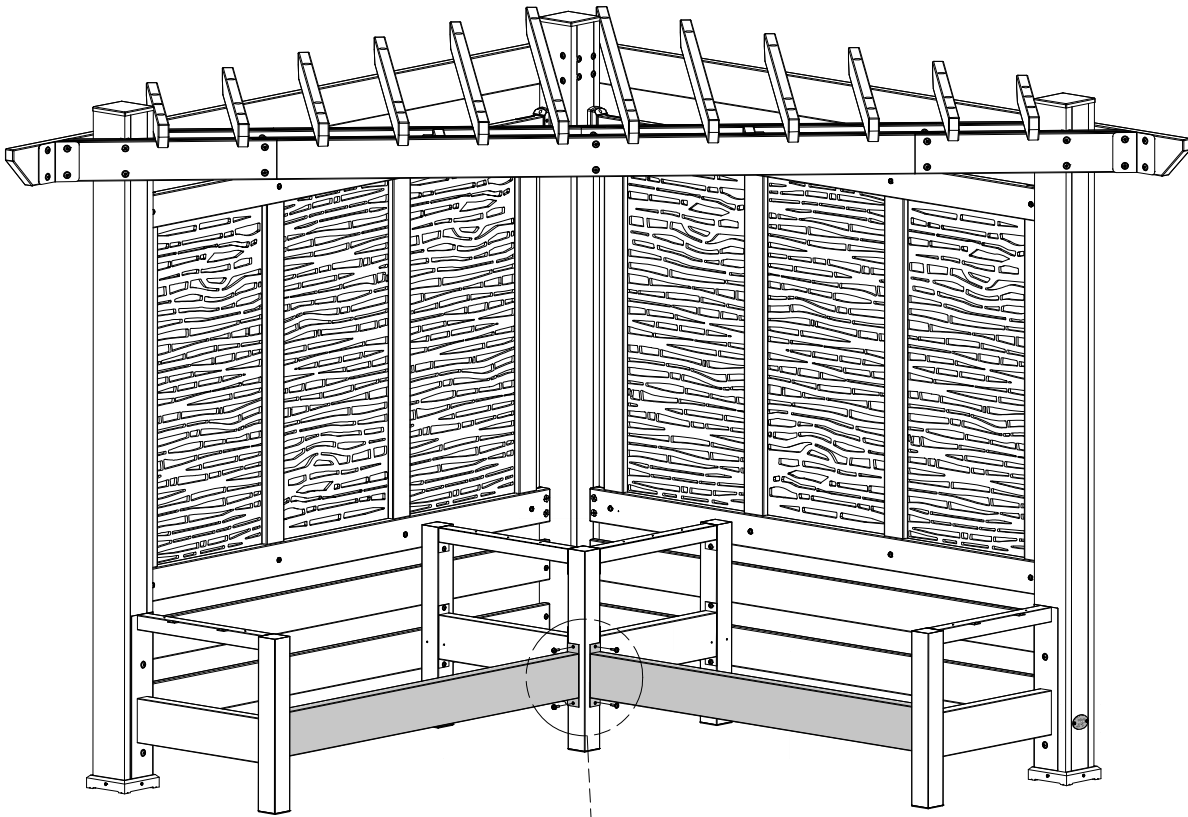

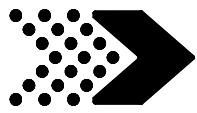

SEATING ASSEMBLY

STEP 21

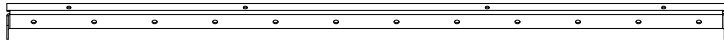

A4M01102 | ANGLED RAIL
(4)

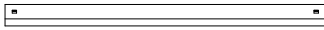

A4M01064 | SUPPORT
(24)



H100712 | BOLT CARRIAGE BLK
(48) | 5/16x1 1/2



H100479 | NUT LOCK BLK
(48) | 5/16



H100770 | WASHER FLAT
(48) | BLK
5/16

 LOOSELY TIGHTEN SEAT SUPPORT FRAME FOR EASIER ATTACHMENT TO METAL FRAME AND CABANA RAILS!

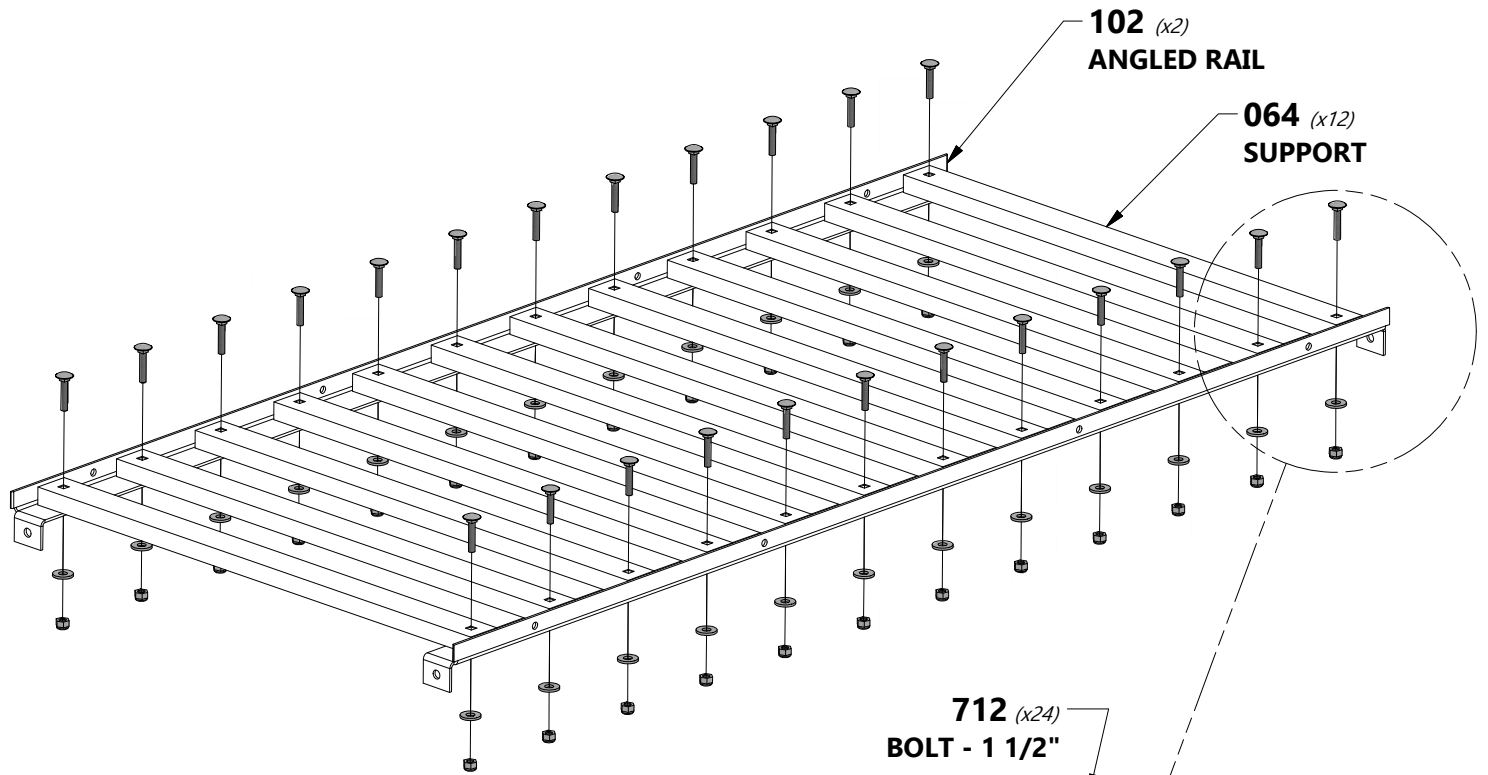

COMPLETE THIS STEP TWICE

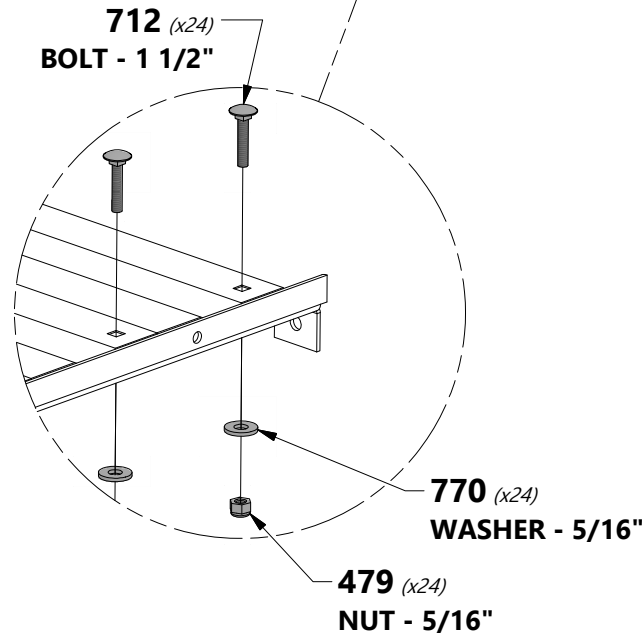

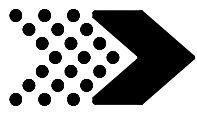

SEATING ASSEMBLY

STEP 22

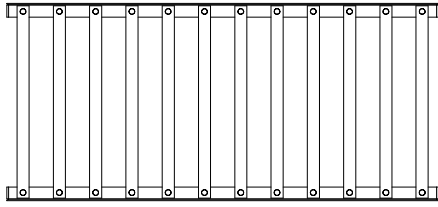

(2) SEAT SUPPORT SUBASSEMBLY



H100171 | BOLT WH BLK
(12) | 1/4x1



H100460 | LAG SCREW WH BLK
(10) | 1/4x1



1. PILOT DRILL WOOD RAILS, USING A 1/8" DRILL BIT, BEFORE INSTALL HARDWARE TO AVOID SPLITTING.

2. AFTER SEAT SUPPORT SUBASSEMBLIES ARE INSTALLED, FINISH TIGHTENING ALL THE BOLTS AND SCREWS FROM PREVIOUS STEP.

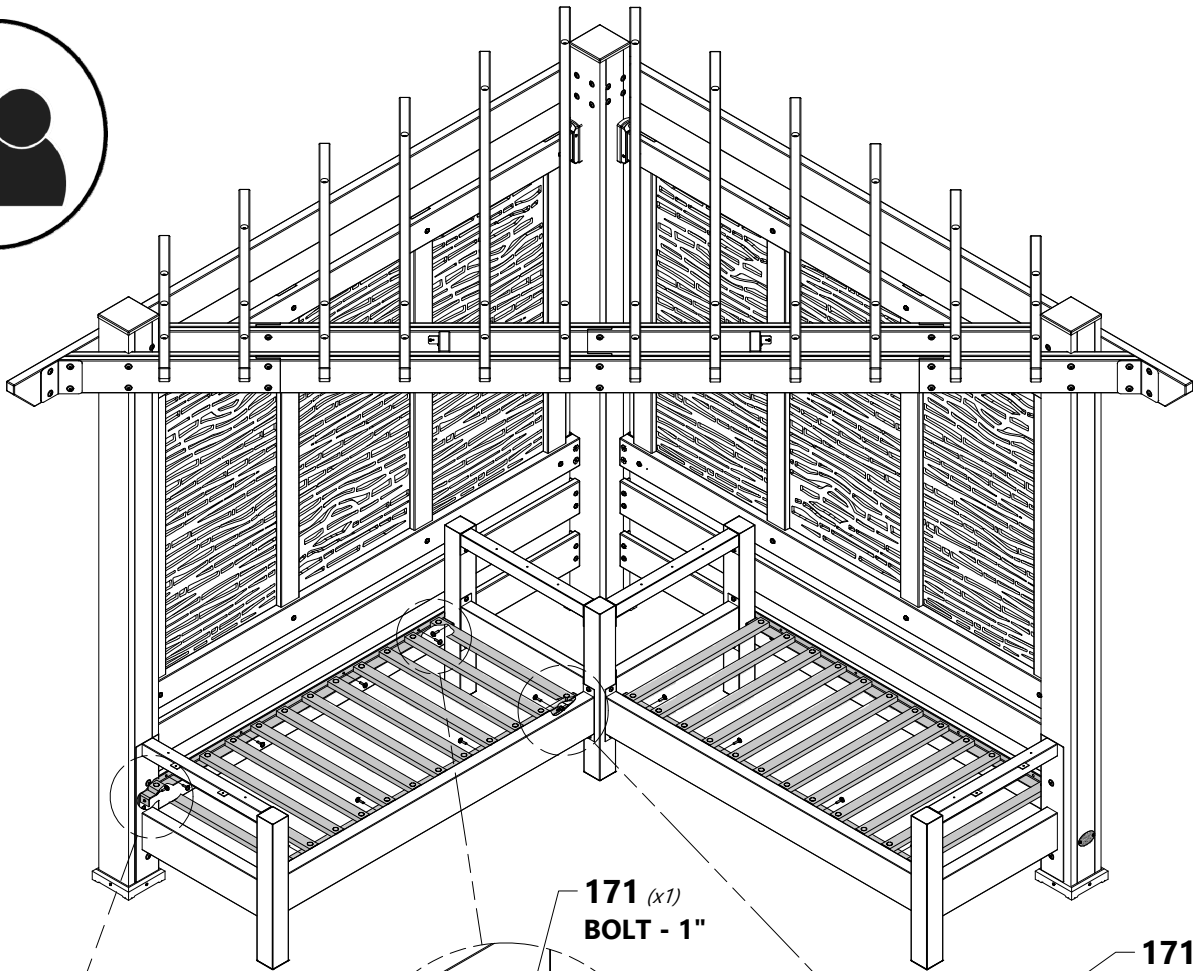

171 (x1)
BOLT - 1"

171 (x4)
BOLT - 1"
(FRONT L-BRACKET)

460 (x1)
LAG SCREW - 1"
(CORNER POST)

460 (x4)
LAG SCREW - 1"
(BACK L-BRACKET)

171 (x1)
BOLT - 1"

REPEAT FOR BOTH SEAT SUBASSEMBLIES

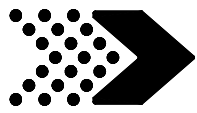

SEATING ASSEMBLY

STEP 23

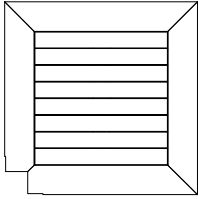

TT1 | TABLE TOP - W2A02868
(1) | 1 5/16" x 30 1/8" x 30 1/8" (34x765x765)

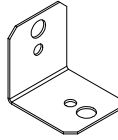

A4M00555 | 90° L-BRACKET - BLK
(2)

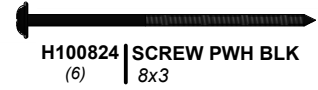

H100824 | SCREW PWH BLK
(6) | 8x3



H100202 | SCREW PWH BLK
(4) | 8x5/8

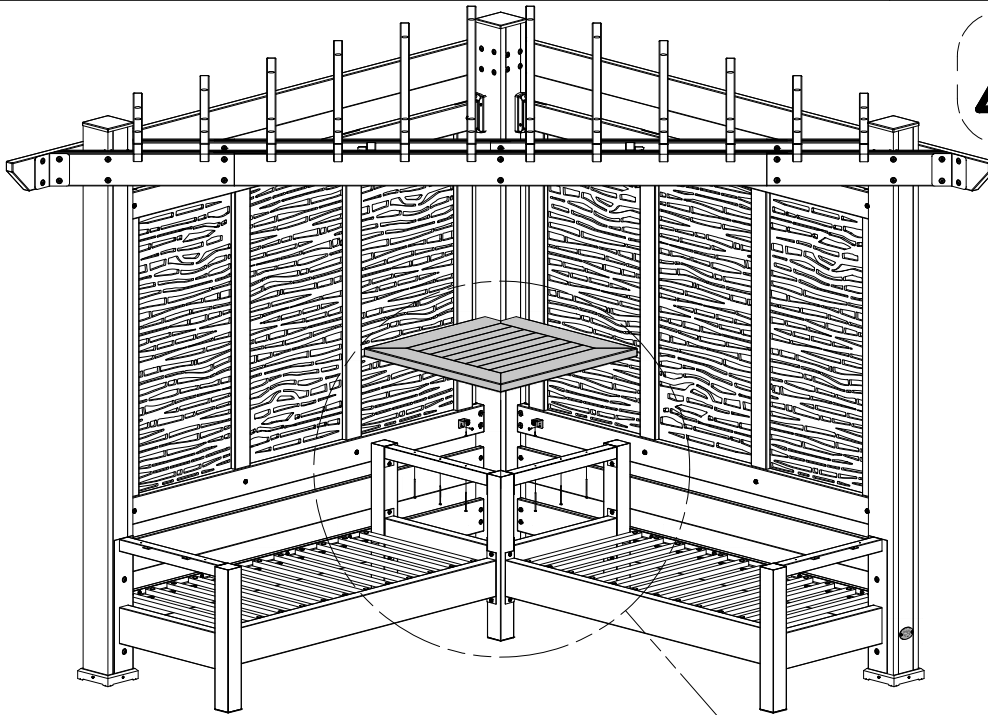

NOTE:
ATTACH REAR CORNER L-BRACKETS FIRST

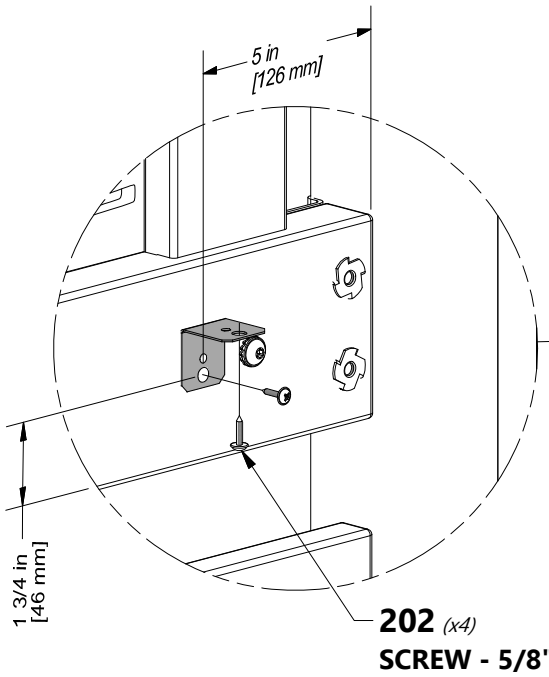

202 (x4)
SCREW - 5/8"

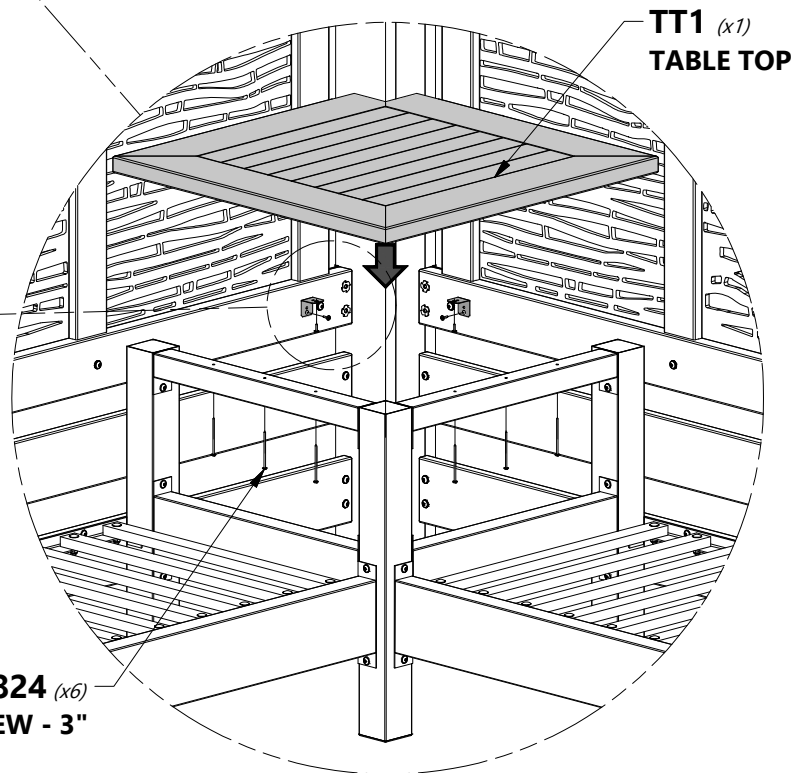

824 (x6)
SCREW - 3"

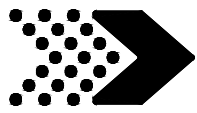

SEATING ASSEMBLY

STEP 24

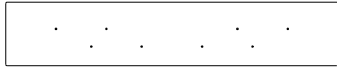

D7 | **ARM REST - W4L14844**
(2) | 1 3/8"x4 5/8"x26" (34x118x660)

 **H100824** | **SCREW PWH BLK**
(4) | 8x3

 **H100392** | **SCREW PWH BLK**
(4) | 8x3/4

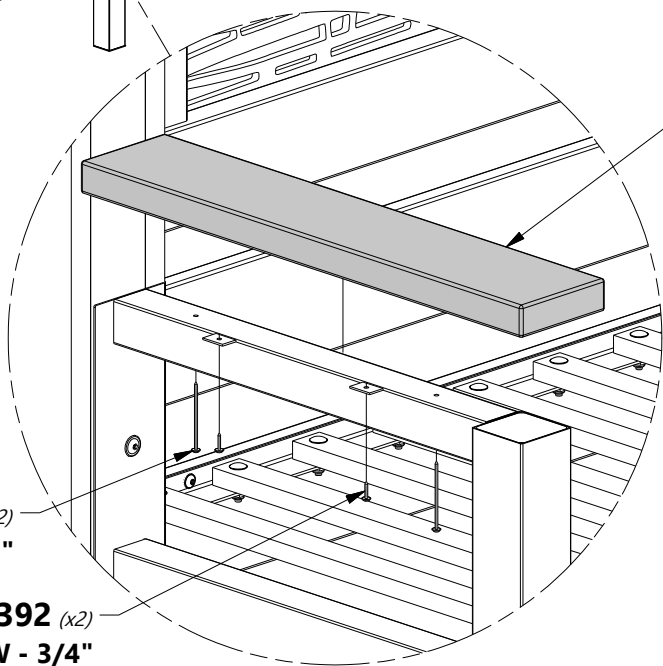
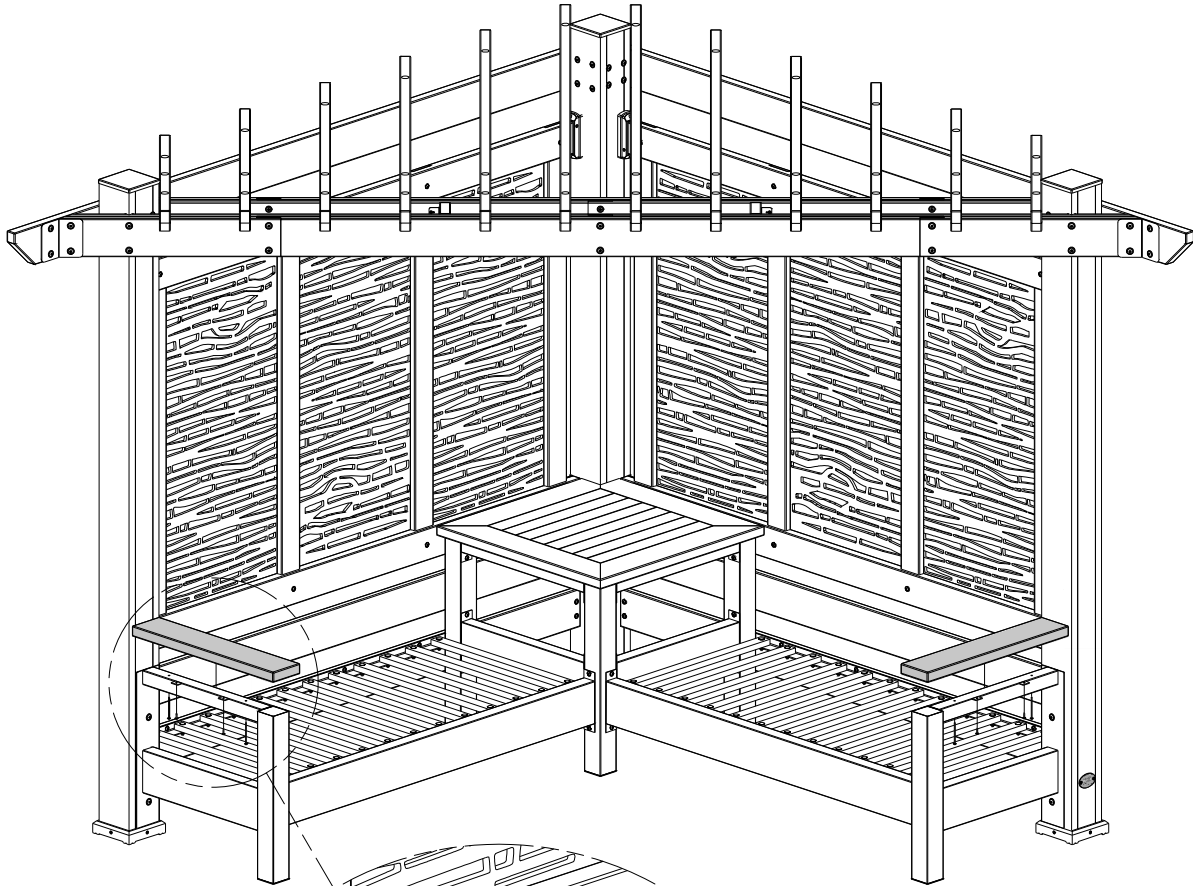

D7 (x1)
ARM REST

REPEAT FOR BOTH ARM RESTS

824 (x2)
SCREW - 3"

392 (x2)
SCREW - 3/4"

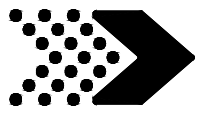

SEATING ASSEMBLY

STEP 25

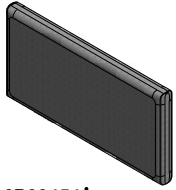

A6P00454 (2) SEAT CUSHION

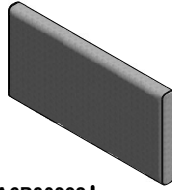

A6P00392 (2) SEAT CUSHION



A6P00394 (2) SEAT CUSHION

OR

OR

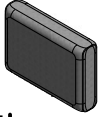

A6P00455 (4) BACK CUSHION

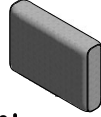

A6P00393 (4) BACK CUSHION

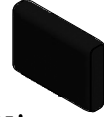

A6P00395 (4) BACK CUSHION

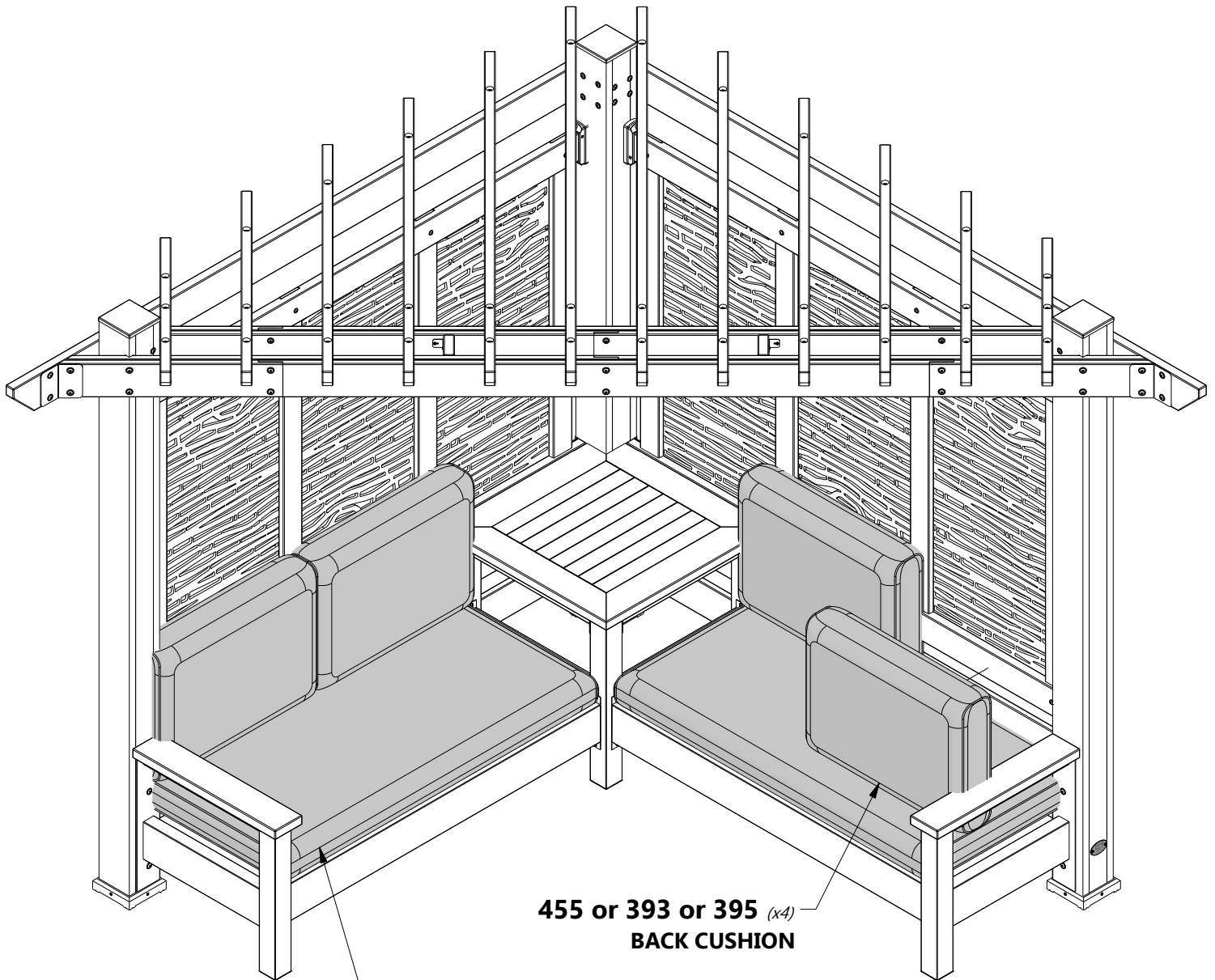

455 or 393 or 395 (x4)
BACK CUSHION

454 or 392 or 394 (x2)
SEAT CUSHION