



Manufactured by:
Backyard Discovery
3305 Airport Drive, Pittsburg, KS 66762
800-856-4445

Basepoint Business Centre: Rivermead Drive, Westlea, Swindon SN5 7EX Phone: 0800-118-2476
J.P. Coenstraat 7, The Bridge, The Hague, 2595 WP, Netherlands Phone: 08005678990

SAXONY GRILL GAZEBO

MODEL # : 2104617B



Please visit www.backyarddiscovery.com
For the most up to date assembly manual, to register your product, or to order
replacement parts *Para obtener instrucciones en español, visite*
www.backyarddiscovery.com



EASY STEP-BY-STEP
3D INTERACTIVE INSTRUCTIONS
DOWNLOAD THE FREE APP



INSTALLATION
SERVICES
AVAILABLE!
See inside for details

OWNER'S MANUAL - BASIC SETUP DIMENSIONS & ASSEMBLY NOTES

It is critically important that you start with square and level footings, concrete pad or deck to attach your structure

- Pay close attention to the items needed for each step. Make sure you are using the correct hardware for each step. Using incorrect hardware may result in improper assembly
- Remember to double check for underground utilities and overhead electrical lines

Post mounts are provided with your structure which allows you to permanently install your structure to a pre-existing or new wood or concrete surface. See Anchor Instructions for further details and recommendations.

- The hardware to attach the post mounts to the structure is included.
- The hardware to mount the structure permanently to a concrete surface is included.
- The hardware to mount the structure permanently to a wood deck is NOT included and will need to be purchased separately. You must ensure there is ample structural support under the deck before permanently attaching.

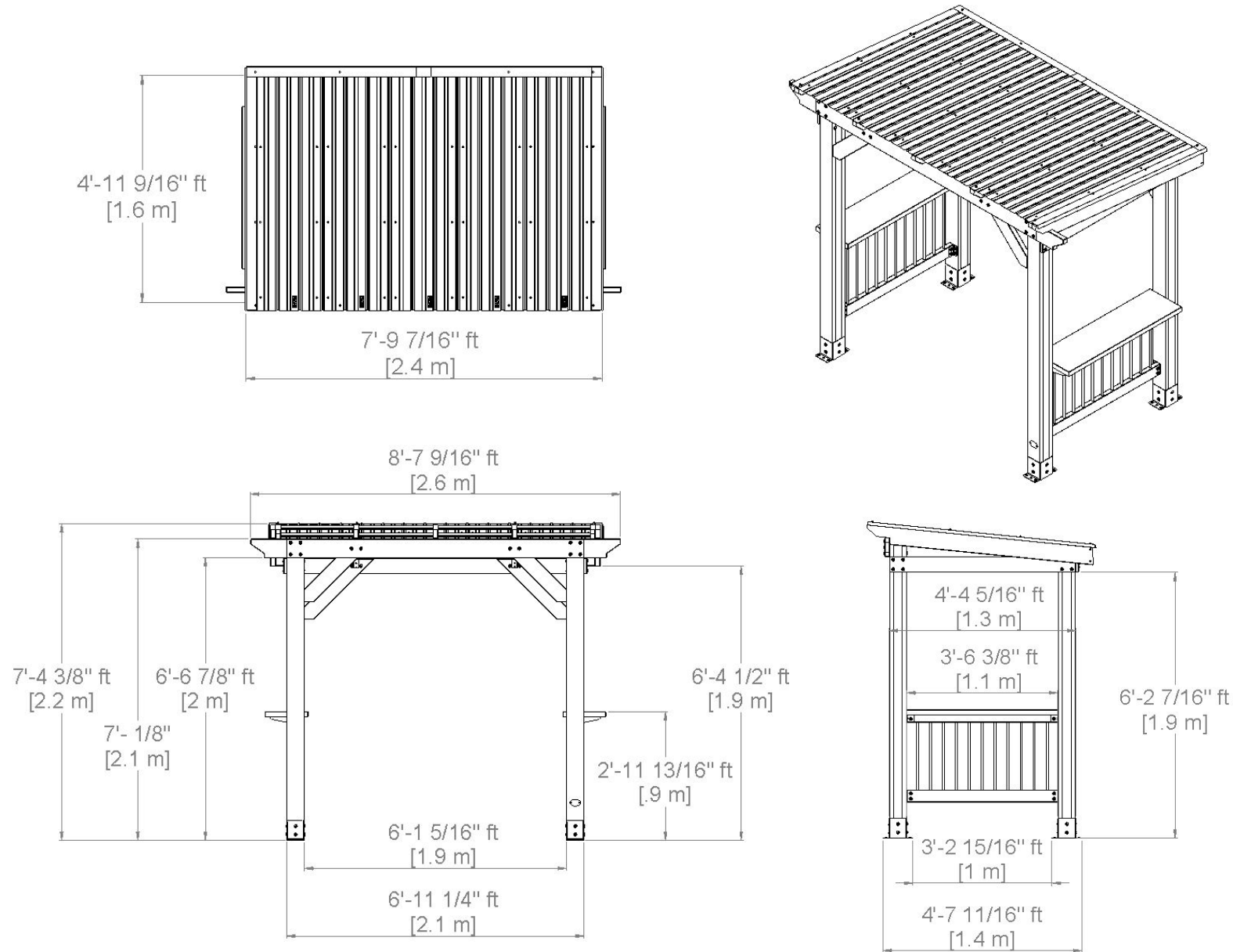

OWNER'S MANUAL - ANCHORING LAYOUT

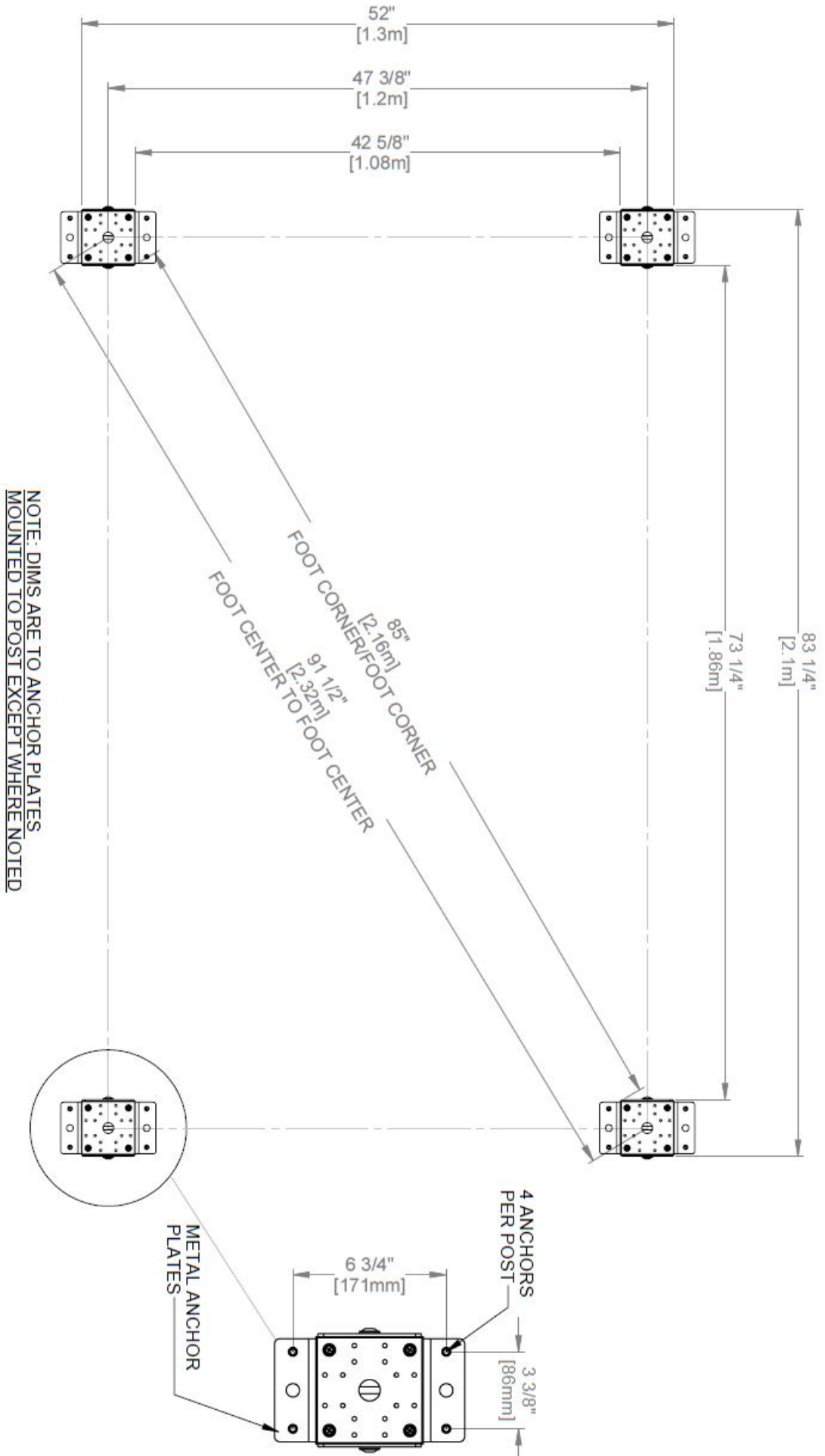

OWNER'S MANUAL - PARTS IDENTIFICATION

Wood Components (Not to Scale)

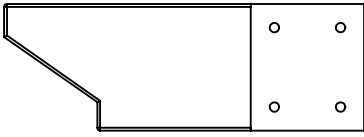

D1 | JOIST END-W4L14097
(1) | 1 7/16"x5 1/4"x15" (36x134x381)

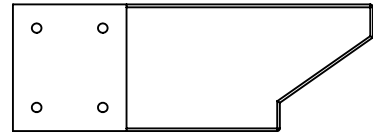

D2 | JOIST END-W4L14098
(1) | 1 7/16"x5 1/4"x15" (36x134x381)



D3 | JOIST-W4L14099
(1) | 1 7/16"x5 1/4"x83" (36x134x2108)



D4 | CORBEL-W4L16376
(2) | 1 7/16"x4 7/16"x26 1/2" (36x112x673)



D5 | CORBEL-W4L16377
(1) | 1 7/16"x4 7/16"x25 7/8" (36x112x657)



D6 | BEAM-W4L14107
(1) | 1 7/16"x5 1/4"x64" (36x134x1626)

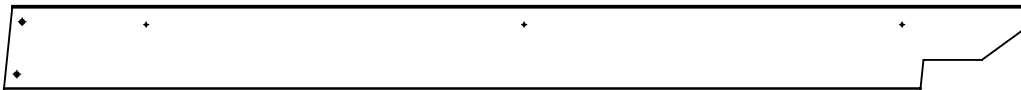

D8 | BEAM-W4L14345
(1) | 1 7/16"x5 1/4"x64" (36x134x1626)

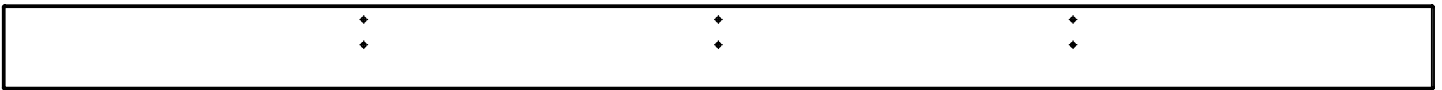

D7 | BEAM-W4L14110
(1) | 1 7/16"x5 1/4"x89 7/16" (36x134x2272)



E1 | RAFTER-W4L14111
(2) | 1 7/16"x3 3/8"x62 3/8" (36x86x1585)



E2 | RAIL-W4L14317
(4) | 1 7/16"x3 3/8"x42 3/8" (36x86x1076)



E3 | RAFTER-W4L14971
(1) | 1 7/16"x3 3/8"x62 3/8" (36x86x1585)

OWNER'S MANUAL - PARTS IDENTIFICATION

Wood Components (Not to Scale)



F1 | RAFTER-W4L14108
(2) | 1 7/16"x2 3/8"x62 1/4" (36x60x1582)



H2 | PURLIN-W4L14109
(3) | 15/16"x3 3/8"x89 7/16" (24x86x2272)



Q1 | RAIL-W4L14101
(2) | 15/16"x4 7/16"x52 1/16" (24x112x1322)



Q2 | RAIL-W4L14102
(1) | 15/16"x4 7/16"x84 7/8" (24x112x2156)

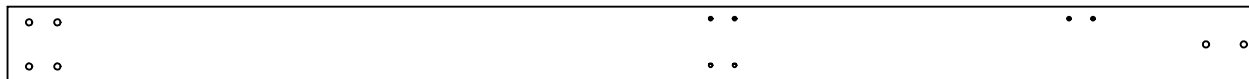

P1 | POST-W2A03401
(1) | 4 3/4"x4 3/4"x78 1/4" (120x120x1987)



P2 | POST-W2A03402
(1) | 4 3/4"x4 3/4"x83 1/2" (120x120x2121)



P3 | POST-W2A03403
(1) | 4 3/4"x4 3/4"x78 1/4" (120x120x1987)



P4 | POST-W2A03404
(1) | 4 3/4"x4 3/4"x83 1/2" (120x120x2121)



D9 | CORBEL W/ ID TAG-W2A03462
(1) | 1 7/16"x4 7/16"x25 7/8" (36x112x657)

OWNER'S MANUAL - PARTS IDENTIFICATION

Hardware Components (Not to Scale)

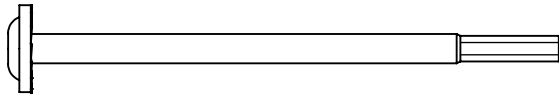

H100964 | BOLT WH BLK
(9) | 5/16 x 5-1/2



H100653 | NUT LOCK BLK
(4) | 1/4



H100201 | SCREW PFH BLK
(7) | 8 x 2-1/2

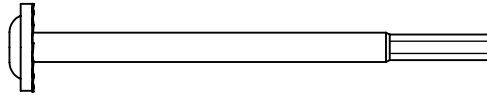

H100480 | BOLT WH BLK
(34) | 5/16 x 4-3/4



H100630 | WASHER FLAT BLK
(22) | 8 x 19



H100382 | SCREW PFH BLK
(16) | 8 x 1-3/4

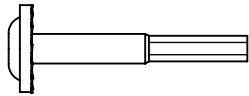

H100205 | BOLT WH BLK
(4) | 5/16 x 2-1/4



H100469 | NUT BARREL WH BLK
(26) | 5/16 x 5/8



H100200 | SCREW PFH BLK
(17) | 8 x 1-1/2

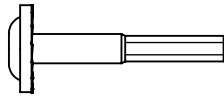

H100457 | BOLT WH BLK
(4) | 5/16 x 2



H100192 | NUT BARREL WH BLK
(9) | 5/16 x 7/8



H100536 | SCREW PWH BLK
(9) | 8 x 1-1/4

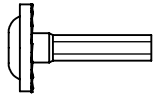

H100459 | BOLT WH BLK
(18) | 5/16 x 1-1/4

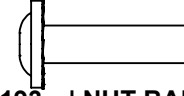

H100193 | NUT BARREL WH BLK
(34) | 5/16 x 1-1/2



H100392 | SCREW PWH BLK
(2) | 8 x 3/4

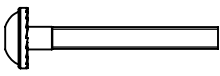

H100488 | BOLT WH BLK
(4) | 1/4 x 2



H100405 | WASHER LOCK EXT BLK
(4) | 6 x 15

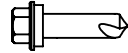

H100759 | SCREW TAPPING
(15) | 1/4 x 3/4

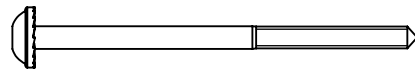

H100564 | LAG SCREW WH BLK
(4) | 1/4 x 4



H100198 | WASHER LOCK EXT BLK
(44) | 8 x 19



H101008 | SCREW CONFIRMAT BLK
(11) | 7 x 3

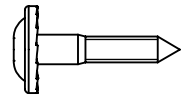

H100471 | LAG SCREW WH BLK
(42) | 5/16 x 1-1/2



H100199 | WASHER LOCK EXT BLK
(52) | 12 x 19

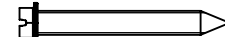

H100120 | CONCRETE ANCHOR 1/4"x2"
(18)

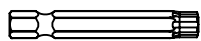

A100042 | T-40 TORX BIT
(x1)

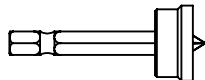

H100764 | SCREW SETTER
(x1)



H101100 | MAGNETIC DRIVER
(x1)

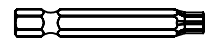

H100147 | T-30 TORX BIT
(x1)

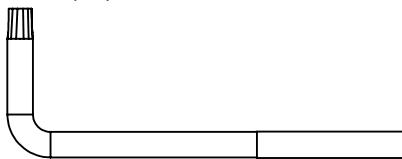

A100041 | TORX WRENCH
(x1) | T-40

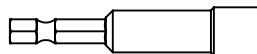

H101106 | HEX DRIVER
(x1) | 5/16



H100114 | TORX WRENCH
(x1) | T-30

OWNER'S MANUAL - PARTS IDENTIFICATION

Accessory Components (Not to Scale)



A4M01162 | ROOF EDGE TRIM
(2)

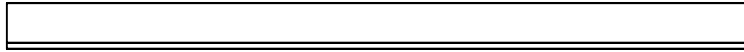

A4M01160 | ROOF EDGE TRIM
(4)

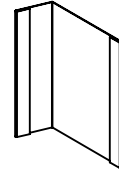

A4M00983 | ROOF EDGE TRIM SPLICE
(2)

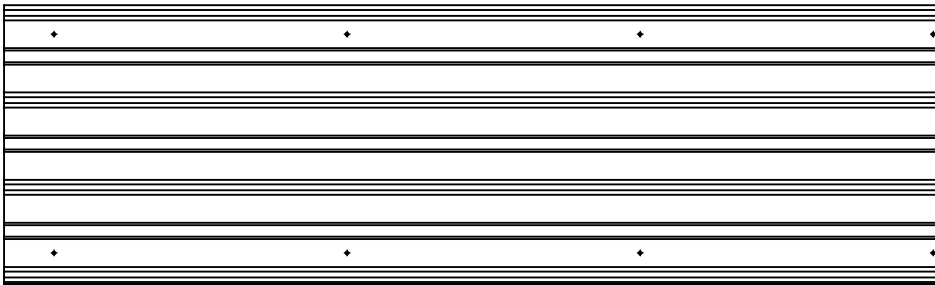

A4M01227 | 29 GA STEEL SHEETING
(5)

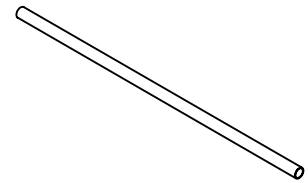

A4M01225 | METAL TUBE
(22)

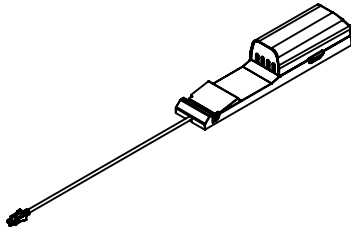

9205413 | ELECTRICAL ENCLOSURE
(1)

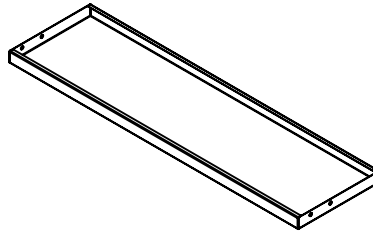

A4M01210 | TABLE
(2)

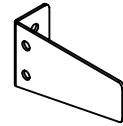

A4M01224 | L BRACKET
(2)

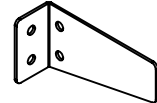

A4M01223 | L BRACKET
(2)



A100241 | BYD ID TAG
(1)

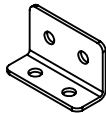

A4M00855 | L BRACKET 51x32x82x3.175
(8)



A4M01477 | POST PLATE
(8)



A4M01228 | RAFTER BRACKET
(4)

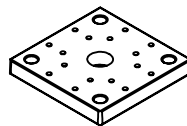

A6P00500 | PLASTIC POST FOOT
(4)

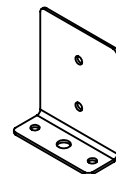

A4M01478 | POST ANCHORING PLATE
(8)

PRE-ASSEMBLY STEP 1 - TOOLS REQUIRED



Cordless Drill or
Electric Drill



Drill Attachments:
Phillips Head

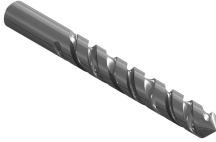

1/8", 3/16", 3/8" &
7/16" Drill Bits

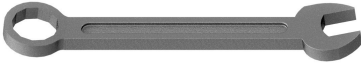

Open End
Wrenches 1/2" &
7/16"



3/8" Drive Ratchet, 1/2" &
7/16" STD Sockets, 1/2" &
7/16" Deep Sockets



Tape Measure



Claw Hammer



Phillips Screw Driver

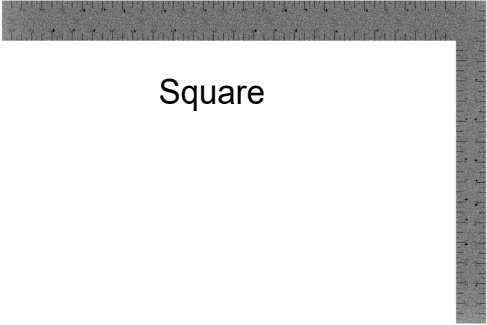

Square



Level 24"

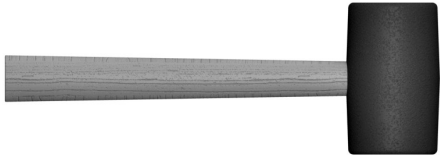

Rubber Mallet -
Optional

PRE-ASSEMBLY STEP 2 - SORTING PARTS

It is critical for ease of assembly that you take the time to sort and organize the wood and hardware.

WOOD PARTS:

- Organize wood parts by the three-digit, alpha-numeric number stamped on each board (ex. P01).
- If there are multiple boards with the same stamped number, stack those pieces together.
- Stamps can be found on the flat surface of the boards or on the end of the boards.
- Allow yourself plenty of room - the wood pieces can take up a significant amount of space.

NOTE: CARTONS ARE NOT ORGANIZED BY BOARD NUMBER.



HARDWARE PARTS:

- We recommend that you have a separate table to organize the hardware.
- Hardware bags are printed with a seven-digit, alpha-numeric part number.
- You can organize your hardware by part number or group by hardware type (i.e. bolts, nuts, etc.).
- During assembly you only need to reference the last four digits of the number.

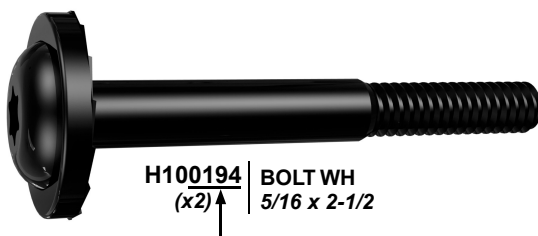

PRE-ASSEMBLY STEP 3 - CHOOSE YOUR ASSEMBLY METHOD

There are several types of assembly instructions available to you.

1. Printed Assembly Manual included with your set
2. BILT APP - 3D interactive instructions
3. Combination of the Printed Manual and BILT APP (Note: Step numbers can differ between the two methods)



The graphic is a rectangular advertisement for the BILT app. At the top left is the BILT logo, which consists of a stylized hexagonal bolt head icon followed by the word "BILT." in a bold, sans-serif font. To the right of the logo is a large QR code. Below the logo and QR code, the text "Scan for easy 3D instructions" is written in a large, bold, black font. Underneath this, in a smaller font, it says "Download the BILT app before you begin". To the right of this text are two buttons: "Download on the App Store" with the Apple logo and "GET IT ON Google Play" with the Google Play logo. At the bottom of the graphic is a smartphone displaying the BILT app interface. The screen shows a 3D model of a metal truss structure with a horizontal beam and several hanging components. The app interface includes a "Hardware Needed" button at the top left, a close button (X) at the top right, a menu button (three dots) below the close button, a back button (left arrow) at the bottom left, a play/pause button (two vertical bars) at the bottom center, and a forward button (right arrow) at the bottom right. A small circle with the number "17" is visible in the bottom left corner of the phone screen.

STEP 4 - GAZEBO FRAME ASSEMBLY



P1 | POST-W2A03401
 (1) | 4 3/4"x4 3/4"x78 1/4" (120x120x1987)

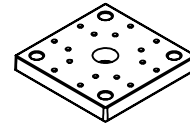

A6P00500
 (4) | **PLASTIC POST FOOT**



P2 | POST-W2A03402
 (1) | 4 3/4"x4 3/4"x83 1/2" (120x120x2121)



P3 | POST-W2A03403
 (1) | 4 3/4"x4 3/4"x78 1/4" (120x120x1987)

QTY.	PART NUMBER	DESCRIPTION
16	H100200	SCREW PFH 8 X 1 1/2 BLK



P4 | POST-W2A03404
 (1) | 4 3/4"x4 3/4"x83 1/2" (120x120x2121)

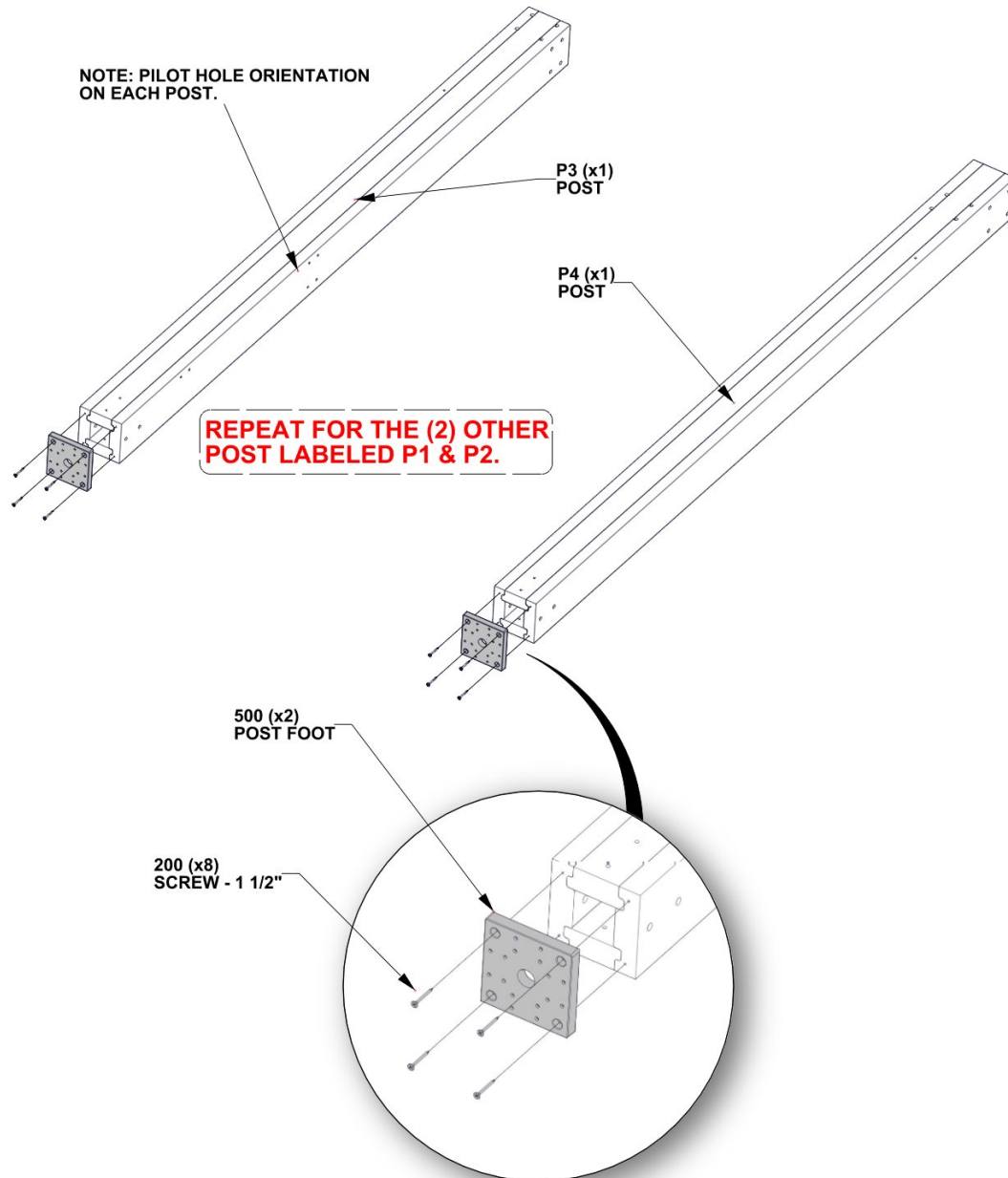

STEP 5 - GAZEBO FRAME ASSEMBLY



Q1 | RAIL-W4L14101
 (1) | 15/16"x4 7/16"x52 1/16" (24x112x1322)

QTY.	PART NUMBER	DESCRIPTION
8	H100480	BOLT WH 5/16 X 4 3/4 BLK
8	H100199	WASHER LOCK EXT 12X18 BLK
8	H100193	NUT BARREL WH 5/16 X 1 1/2 BLK
8	H100198	WASHER LOCK EXT 8X19 BLK

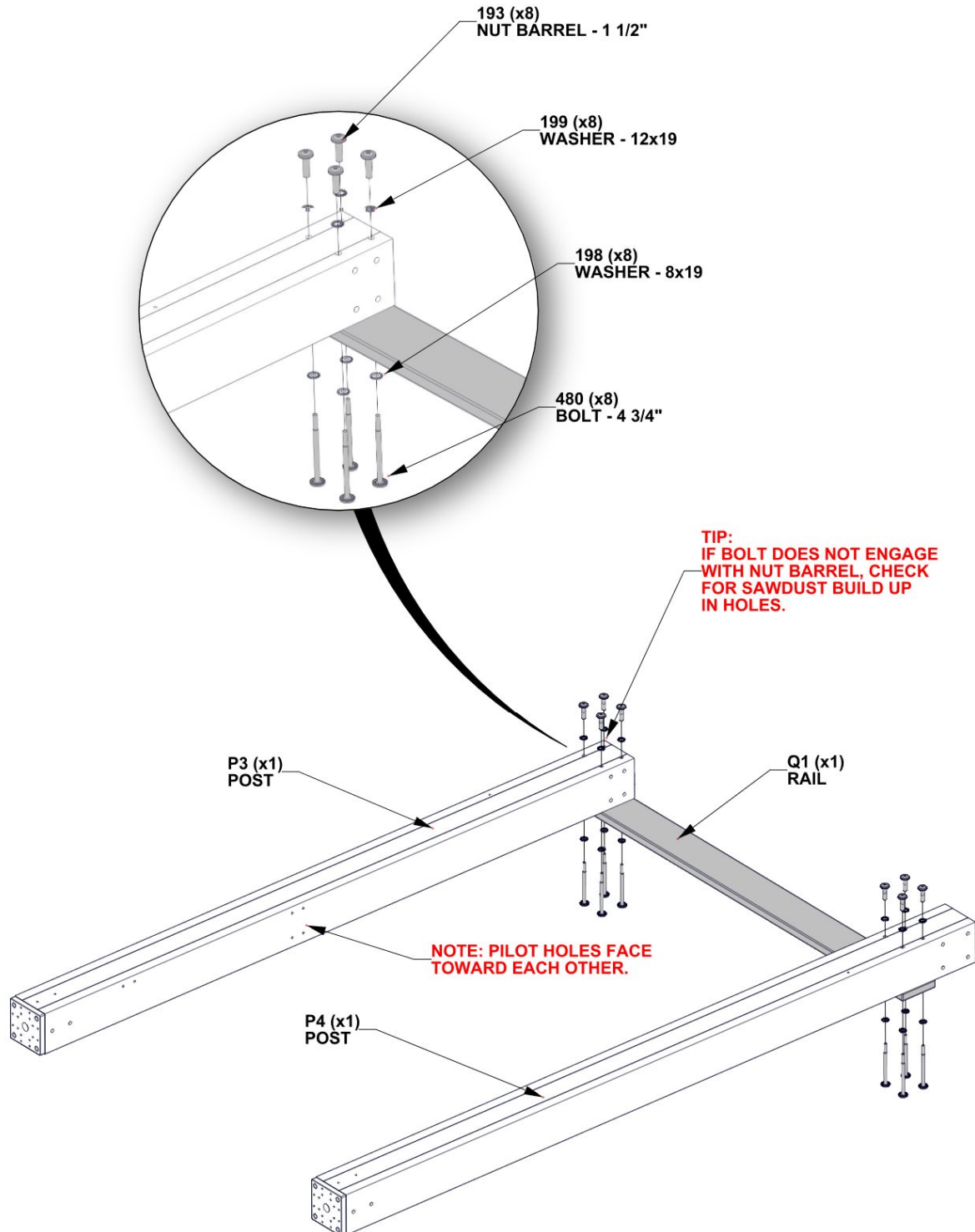

STEP 6 - GAZEBO FRAME ASSEMBLY

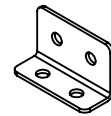

A4M00855 (2) | L BRACKET 51x32x82x3.175



E2 | RAIL-W4L14317
(1) | 1 7/16"x3 3/8"x42 3/8" (36x86x1076)

QTY.	PART NUMBER	DESCRIPTION
4	H100469	NUT BARREL WH 5/16 X 5/8 BLK
4	H100471	LAG SCREW WH 5/16 X 1 1/2 BLK
4	H100459	BOLT WH 5/16 X 1 1/4 BLK
4	H100199	WASHER LOCK EXT 12X19 BLK

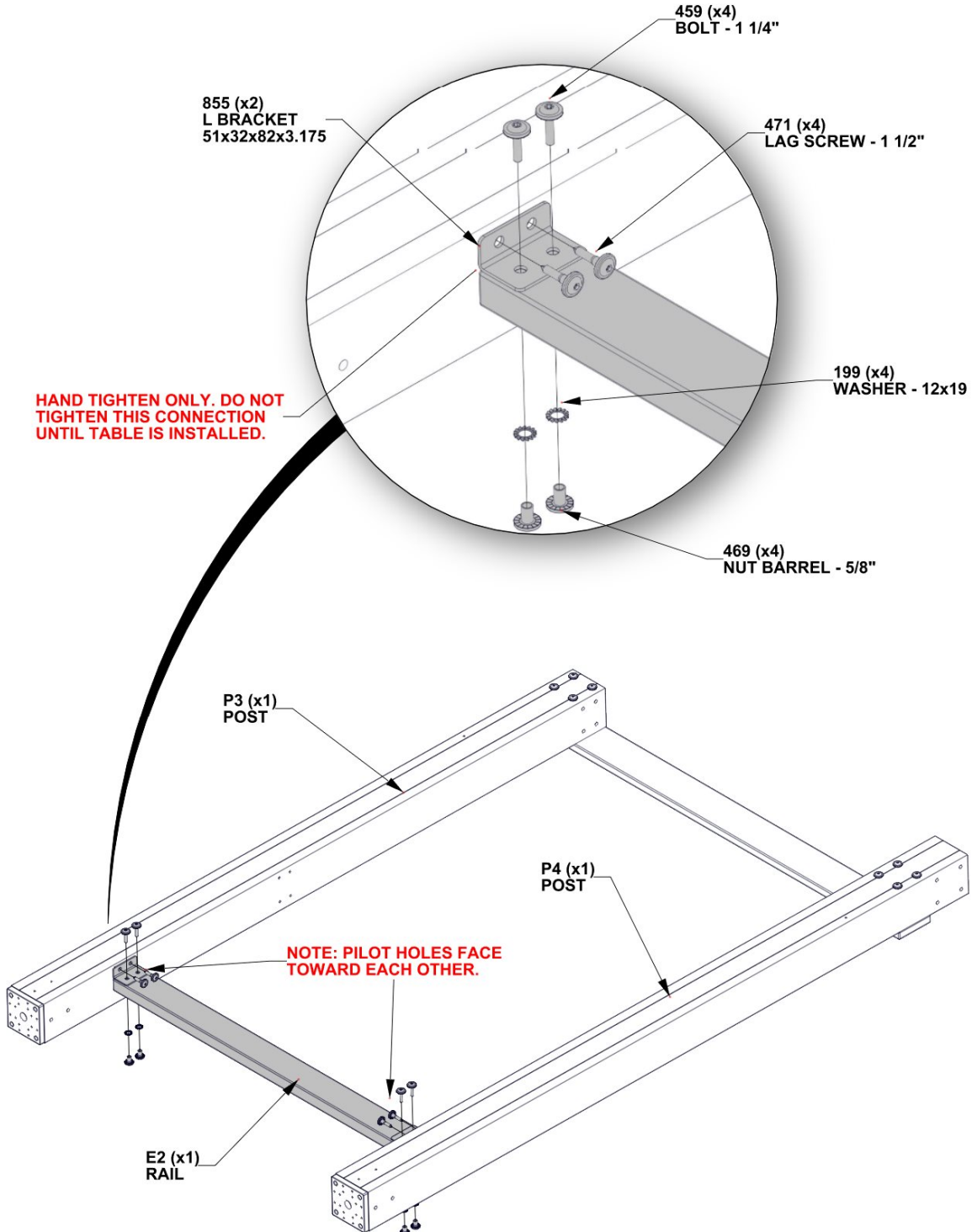

STEP 7 - GAZEBO FRAME ASSEMBLY



Q1 | RAIL-W4L14101
 (1) | 15/16"x4 7/16"x52 1/16" (24x112x1322)

QTY.	PART NUMBER	DESCRIPTION
8	H100480	BOLT WH 5/16 X 4 3/4 BLK
8	H100199	WASHER LOCK EXT 12X18 BLK
8	H100193	NUT BARREL WH 5/16 X 1 1/2 BLK
8	H100198	WASHER LOCK EXT 8X19 BLK

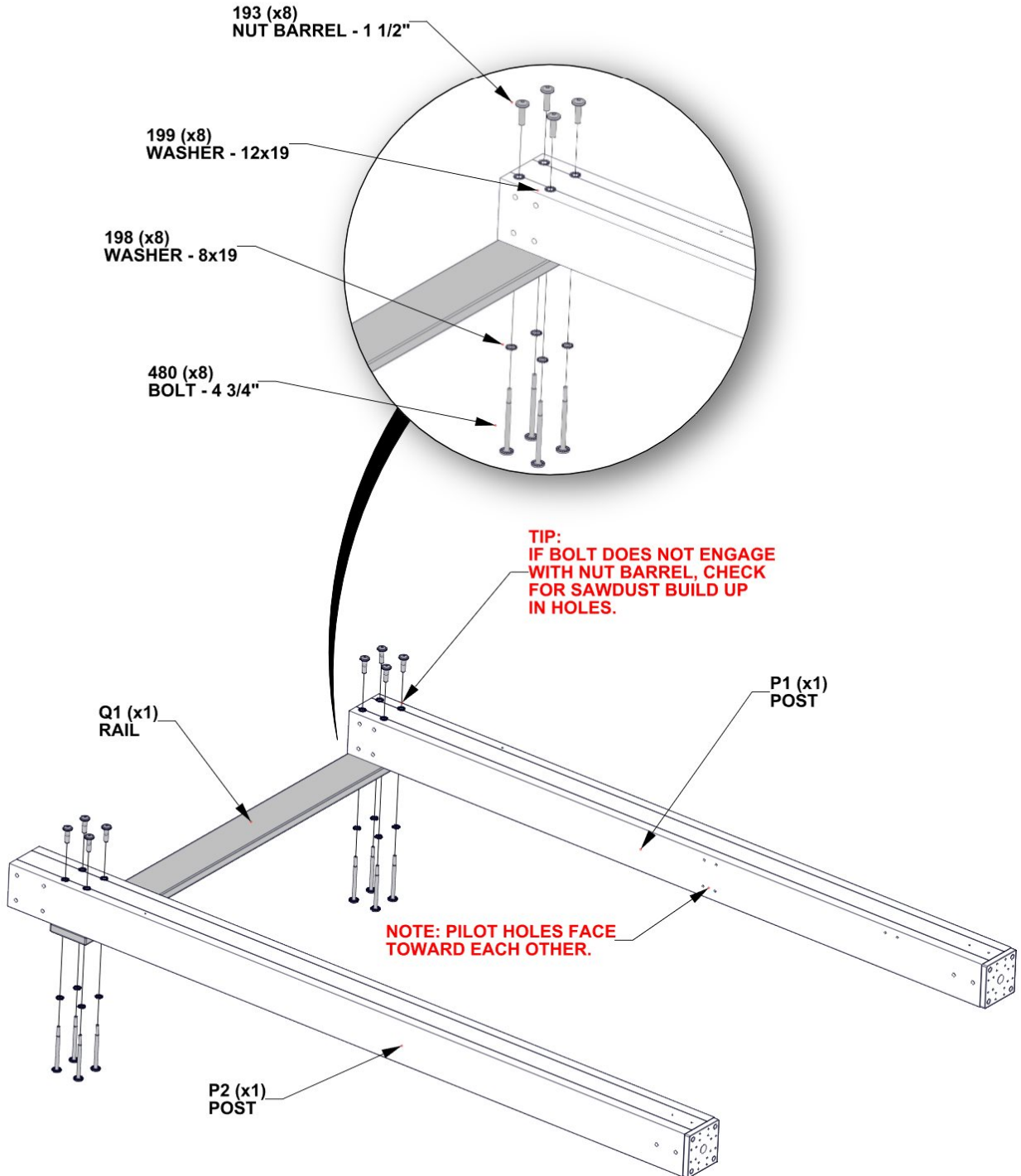

STEP 8 - GAZEBO FRAME ASSEMBLY

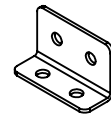

A4M00855 | L BRACKET 51x32x82x3.175
(2)



E2 | RAIL-W4L14317
(1) | 1 7/16"x3 3/8"x42 3/8" (36x86x1076)

QTY.	PART NUMBER	DESCRIPTION
4	H100469	NUT BARREL WH 5/16 X 5/8 BLK
4	H100471	LAG SCREW WH 5/16 X 1 1/2 BLK
4	H100459	BOLT WH 5/16 X 1 1/4 BLK
4	H100199	WASHER LOCK EXT 12X19 BLK

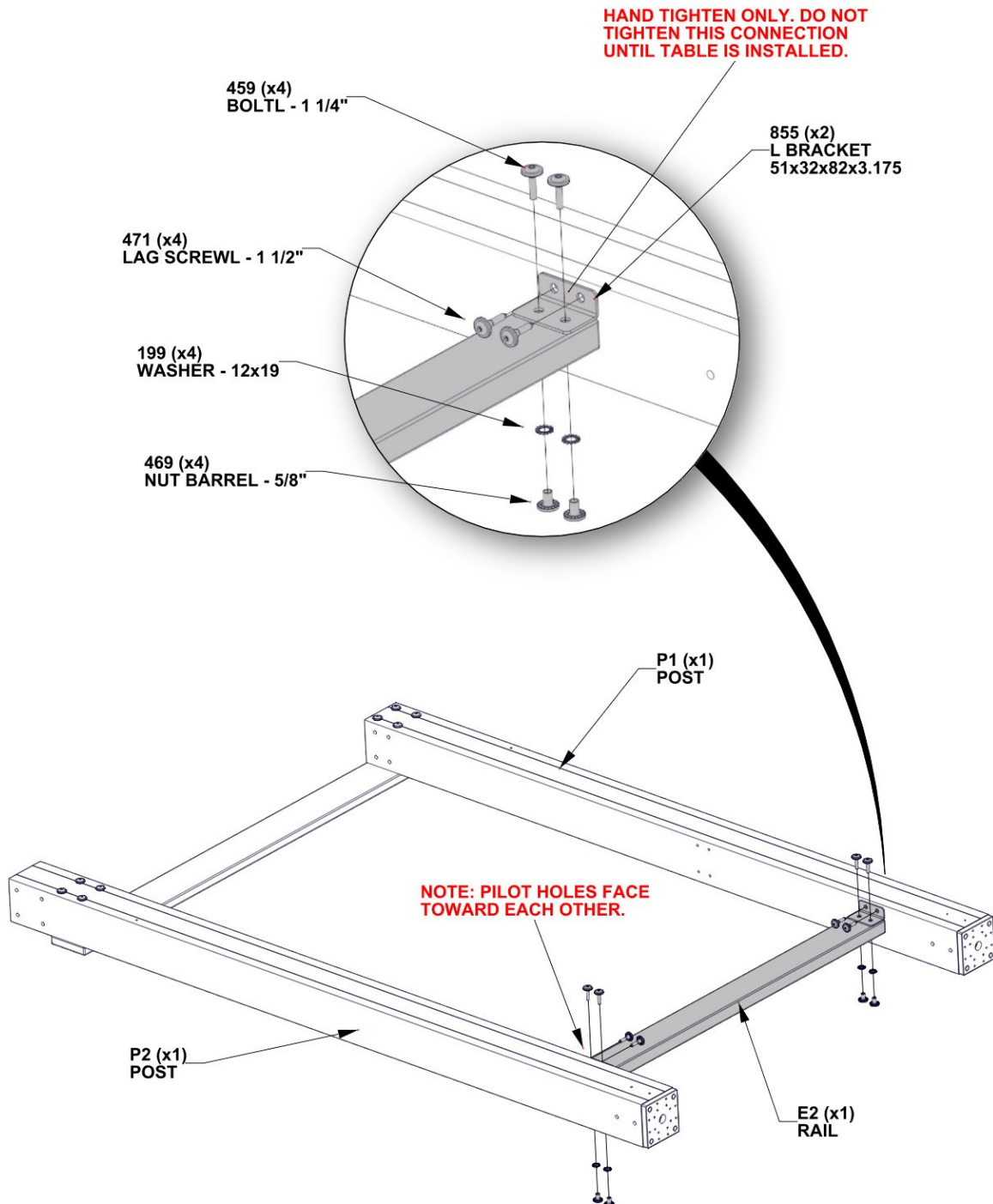

STEP 9 - GAZEBO FRAME ASSEMBLY

QTY.	PART NUMBER	DESCRIPTION
8	H100199	WASHER LOCK EXT 12X19 BLK
8	H100193	NUT BARREL WH 5/16 X 1 1/2 BLK
8	H100198	WASHER LOCK EXT 8X19 BLK
8	H100964	BOLT WH 5/16 X 5 1/2 BLK



D1 | JOIST END-W4L14097
 (1) | 1 7/16"x5 1/4"x15" (36x134x381)



D2 | JOIST END-W4L14098
 (1) | 1 7/16"x5 1/4"x15" (36x134x381)

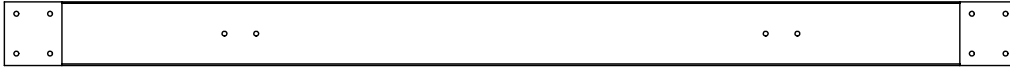

D3 | JOIST-W4L14099
 (1) | 1 7/16"x5 1/4"x83" (36x134x2108)

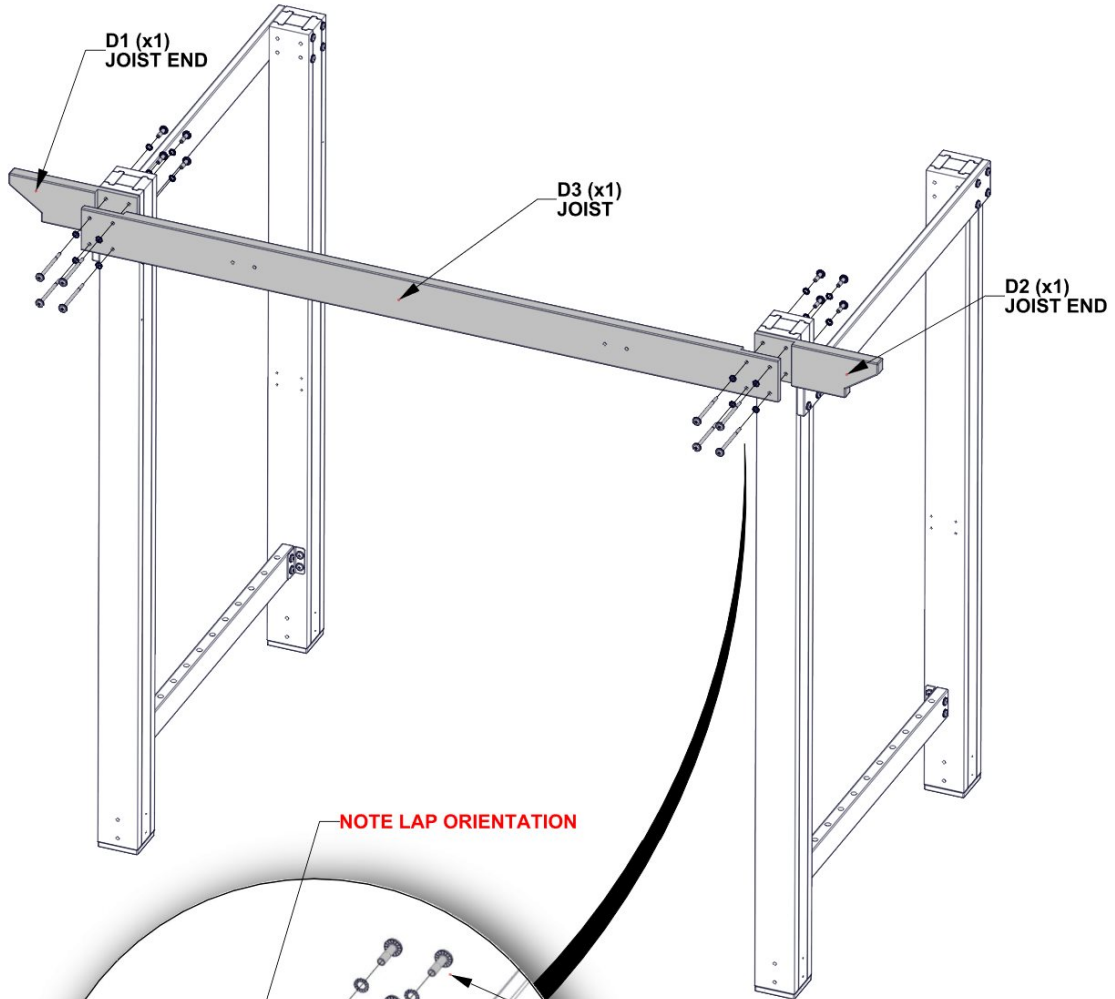

NOTE LAP ORIENTATION

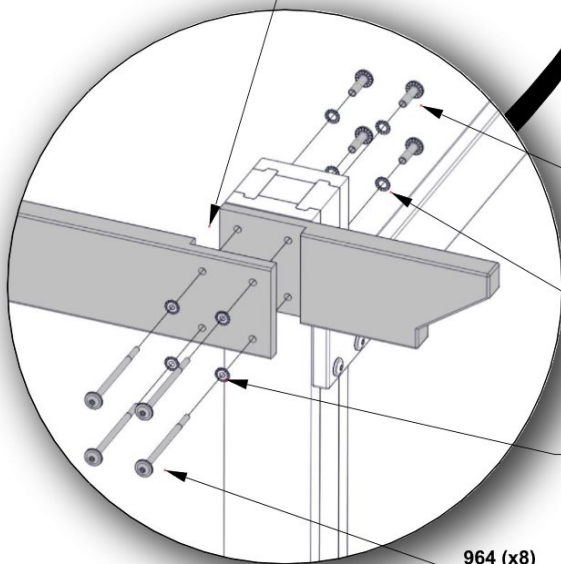

**193 (x8)
NUT BARREL - 1 1/2"**

**199 (x8)
WASHER - 12x19**

**198 (x8)
WASHER - 8x19**

**964 (x8)
BOLT - 5 1/2"**

STEP 10 - GAZEBO FRAME ASSEMBLY



D4 | CORBEL-W4L16376
 (2) | 1 7/16"x4 7/16"x26 1/2" (36x112x673)

QTY.	PART NUMBER	DESCRIPTION
2	H100405	WASHER LOCK EXT 6X15 BLK
2	H100564	LAG SCREW WH 1/4 X 4 BLK
4	H100199	WASHER LOCK EXT 12X19 BLK
4	H100198	WASHER LOCK EXT 8X19 BLK
4	H100205	BOLT WH 5/16 X 2 1/4 BLK
4	H100192	NUT BARREL WH 5/16 X 7/8 BLK

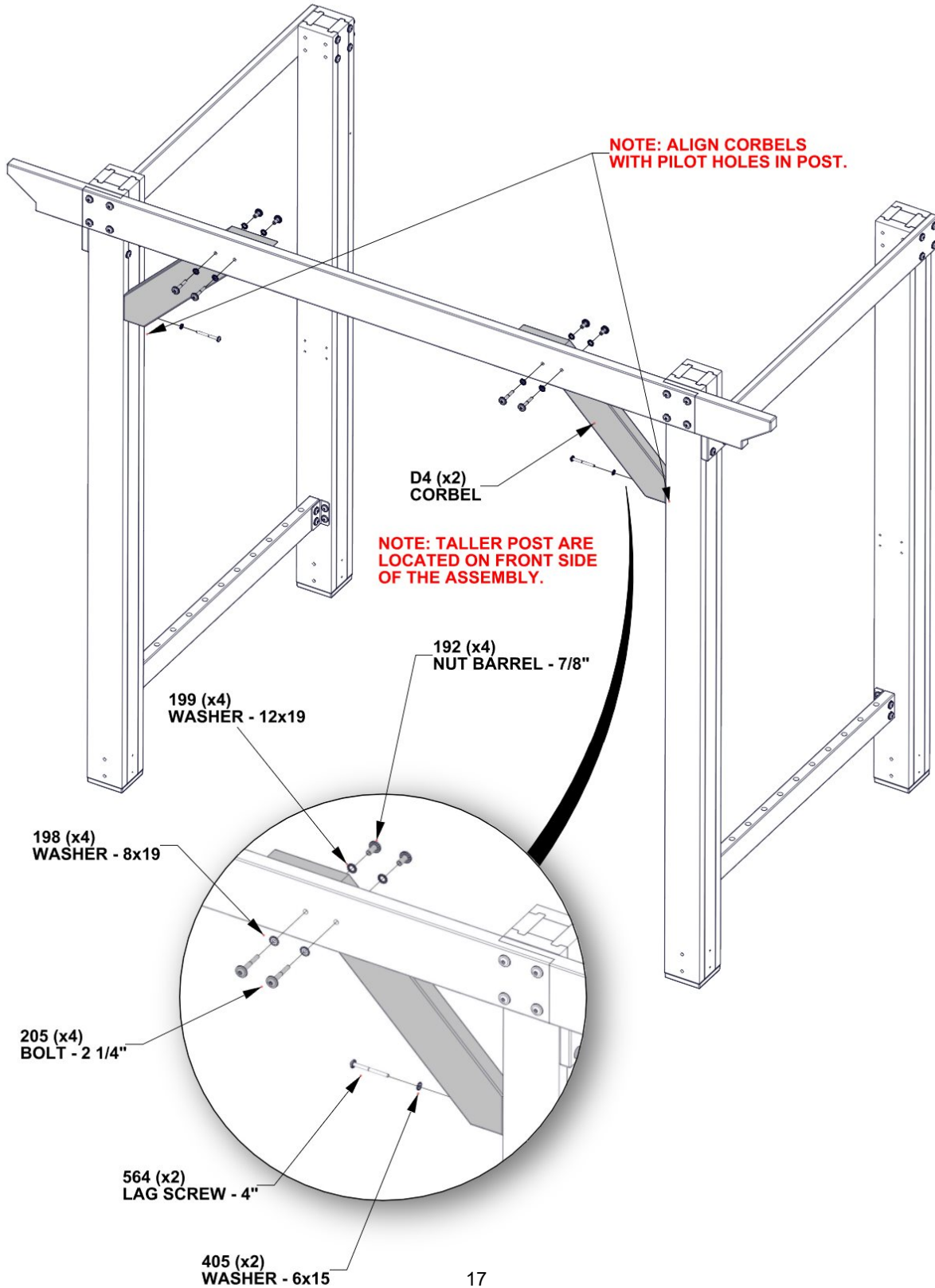

STEP 11 - GAZEBO FRAME ASSEMBLY

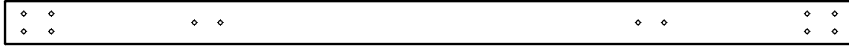

Q2 | RAIL-W4L14102
 (1) | 15/16"x4 7/16"x84 7/8" (24x112x2156)

QTY.	PART NUMBER	DESCRIPTION
8	H100480	BOLT WH 5/16 X 4 3/4 BLK
8	H100199	WASHER LOCK EXT 12X19 BLK
8	H100193	NUT BARREL WH 5/16 X 1 1/2 BLK
8	H100198	WASHER LOCK EXT 8X19 BLK

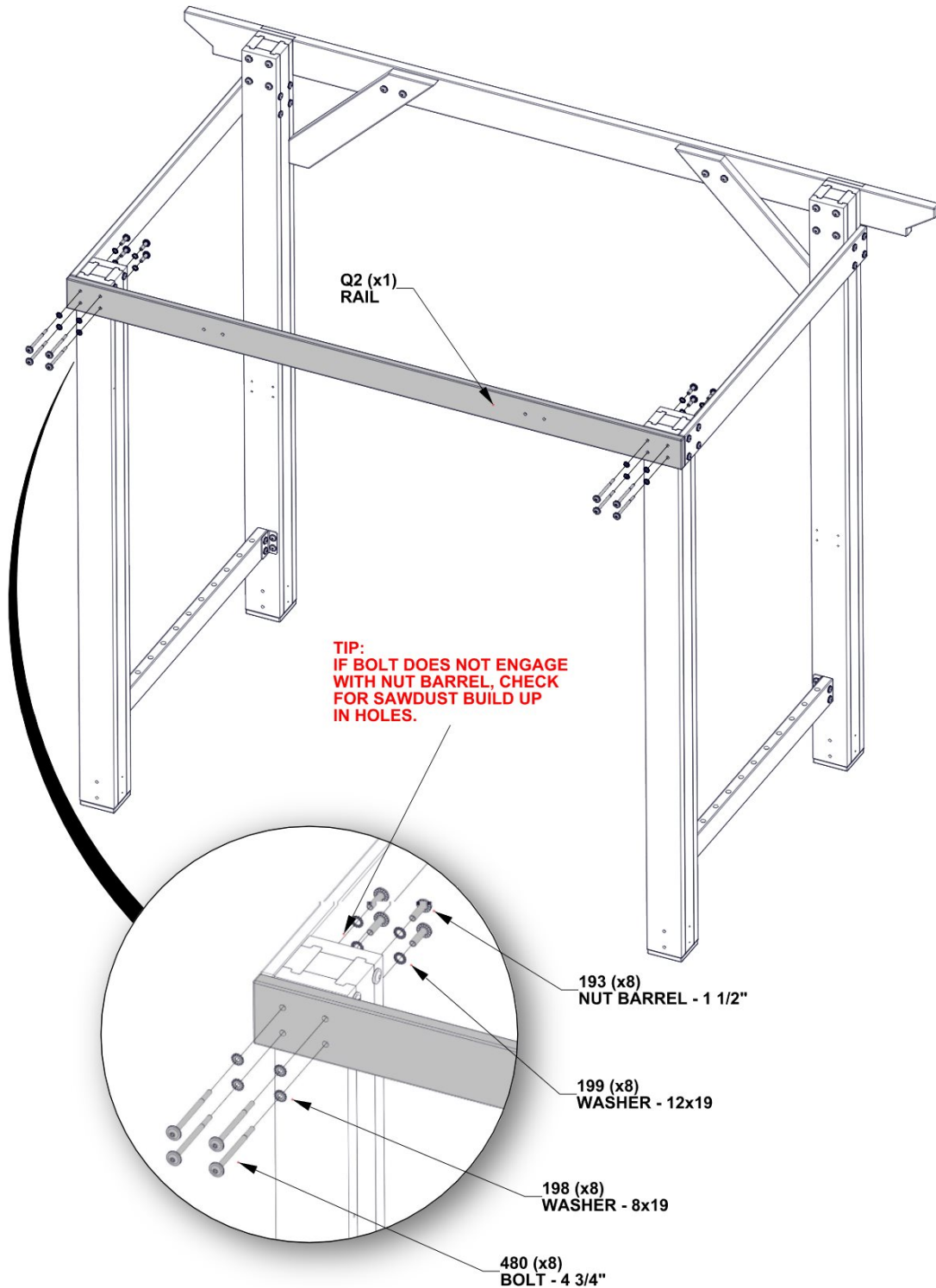

STEP 12 - GAZEBO FRAME ASSEMBLY



D5 | **CORBEL-W4L16377**
 (1) | 1 7/16"x4 7/16"x25 7/8" (36x112x657)



D9 | **CORBEL W/ ID TAG-W2A03462**
 (1) | 1 7/16"x4 7/16"x25 7/8" (36x112x657)

QTY.	PART NUMBER	DESCRIPTION
2	H100405	WASHER LOCK EXT 6X15 BLK
2	H100564	LAG SCREW WH 1/4 X 4 BLK
4	H100199	WASHER LOCK EXT 12X18 BLK
4	H100198	WASHER LOCK EXT 8X19 BLK
4	H100192	NUT BARREL WH 5/16 X 7/8 BLK
4	H100457	BOLT WH 5/16 X 2 BLK

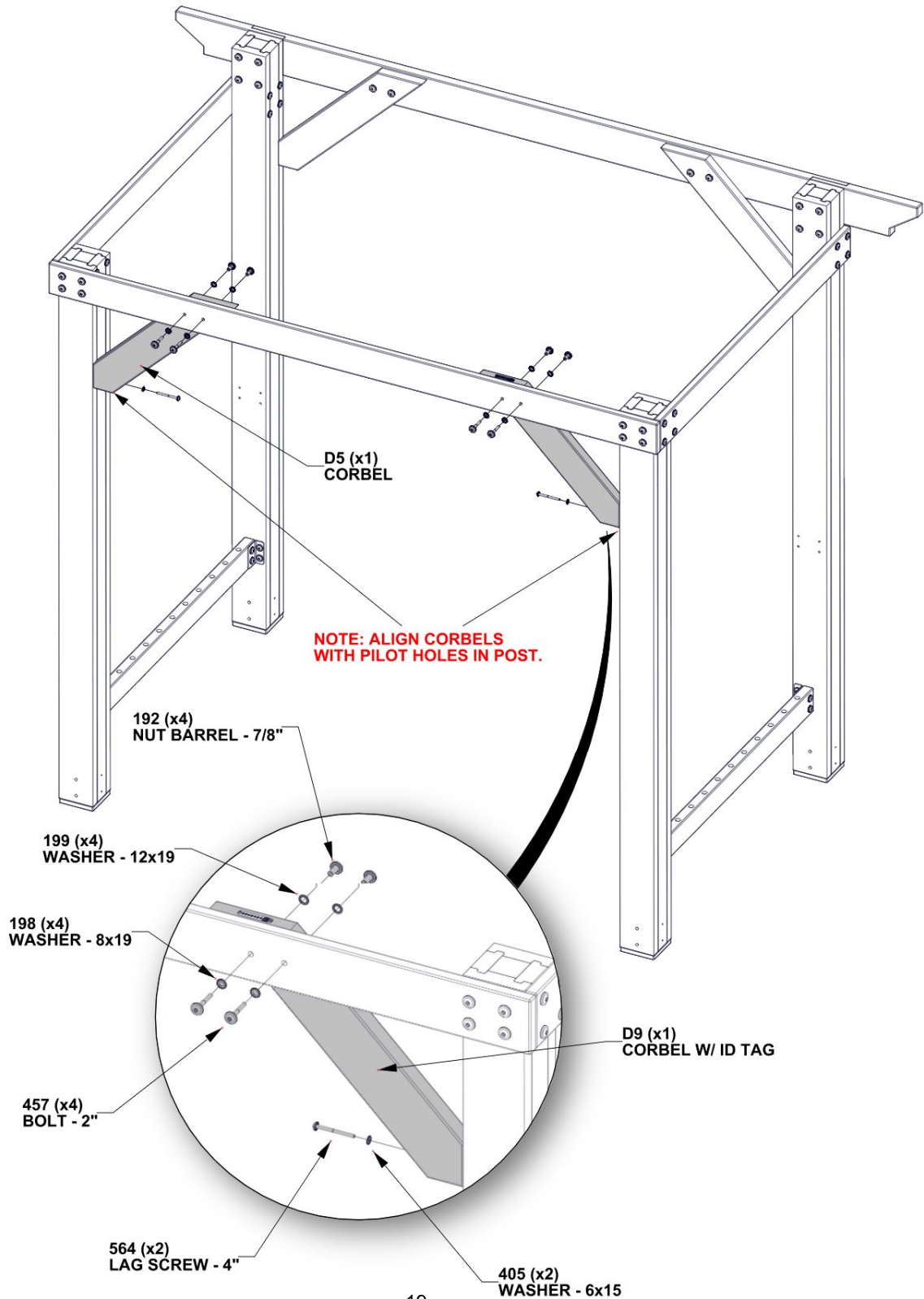

STEP 13 - RAIL ASSEMBLY

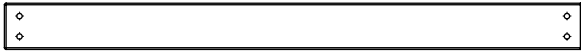

E2 | RAIL-W4L14317
(2) | 1 7/16"x3 3/8"x42 3/8" (36x86x1076)

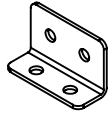

A4M00855 | L BRACKET 51x32x82x3.175
(4)

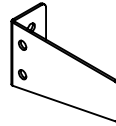

A4M01224 | L BRACKET
(2)

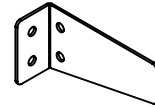

A4M01223 | L BRACKET
(2)

QTY.	PART NUMBER	DESCRIPTION
8	H100469	NUT BARREL WH 5/16 X 5/8 BLK
8	H100459	BOLT WH 5/16 X 1 1/4 BLK

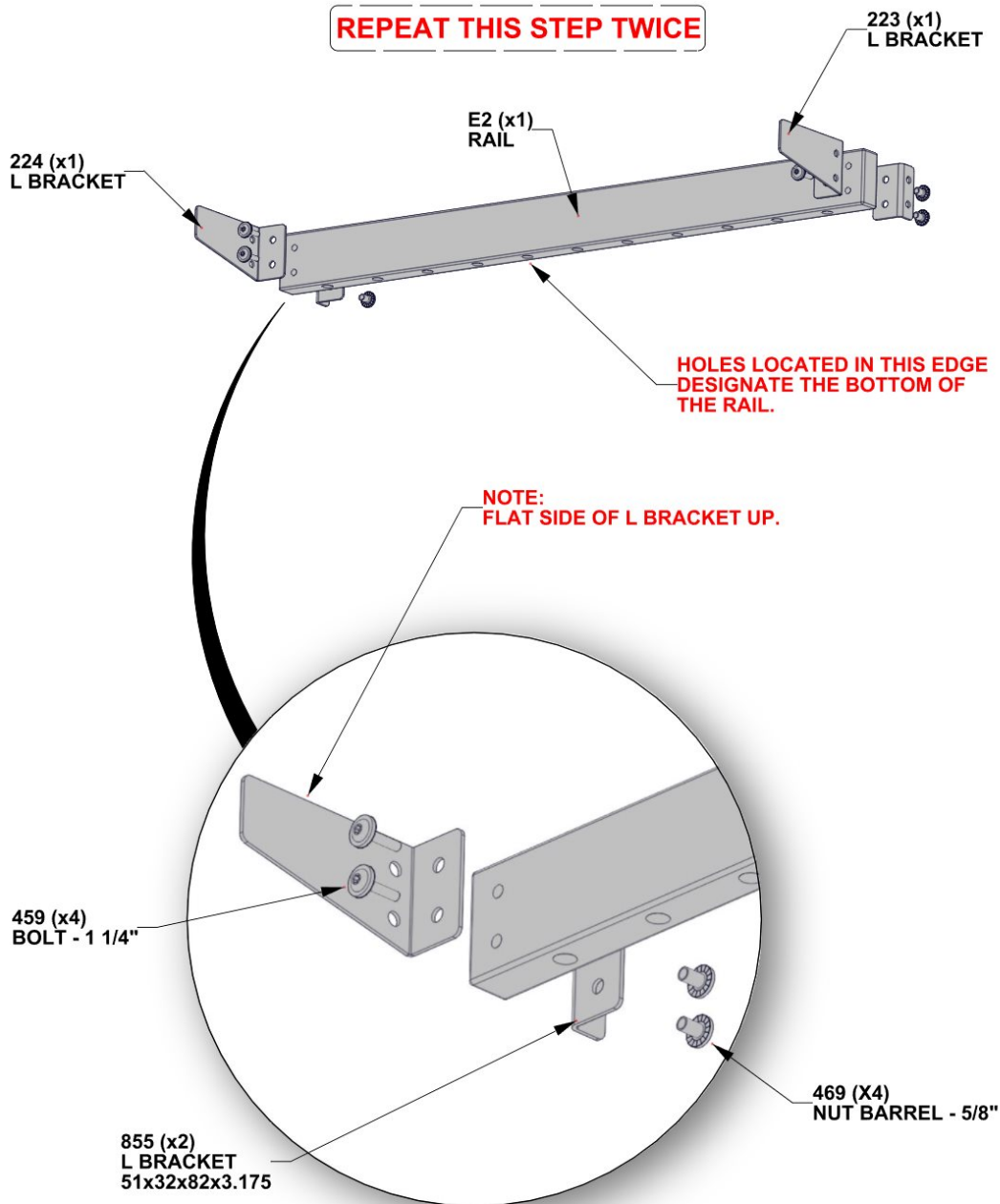

STEP 14 - RAIL ASSEMBLY

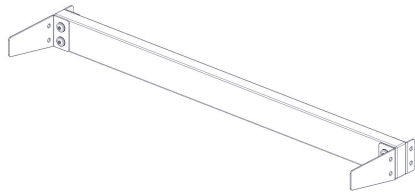

(2) RAIL ASSEMBLY

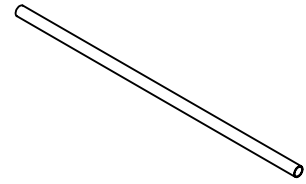

A4M01225 | METAL TUBE
(22)

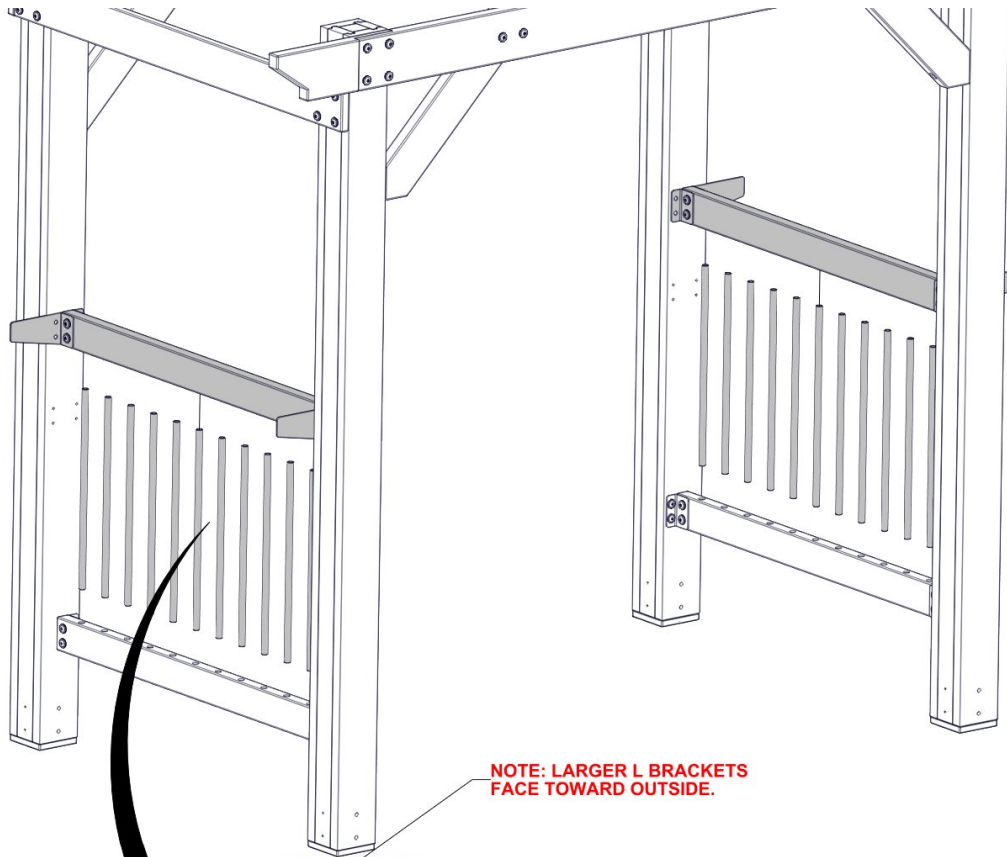

**NOTE: LARGER L BRACKETS
FACE TOWARD OUTSIDE.**

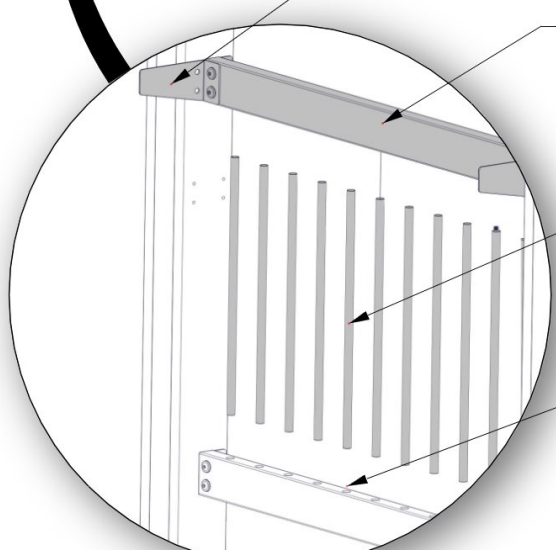

RAIL ASSEMBLY FROM
PREVIOUS STEP

225 (x22)
METAL TUBE

**PLACE RODS INTO BOTTOM
BOARD ON UPRIGHT. PLACE RAIL
ASSEMBLY ON TOP. SECURE
BETWEEN BOTH BOARDS.**

STEP 15- SHELF ASSEMBLY

QTY.	PART NUMBER	DESCRIPTION
8	H100471	LAG SCREW WH 5/16 X 1 1/2 BLK

REPEAT STEP FOR OPPOSITE SIDE

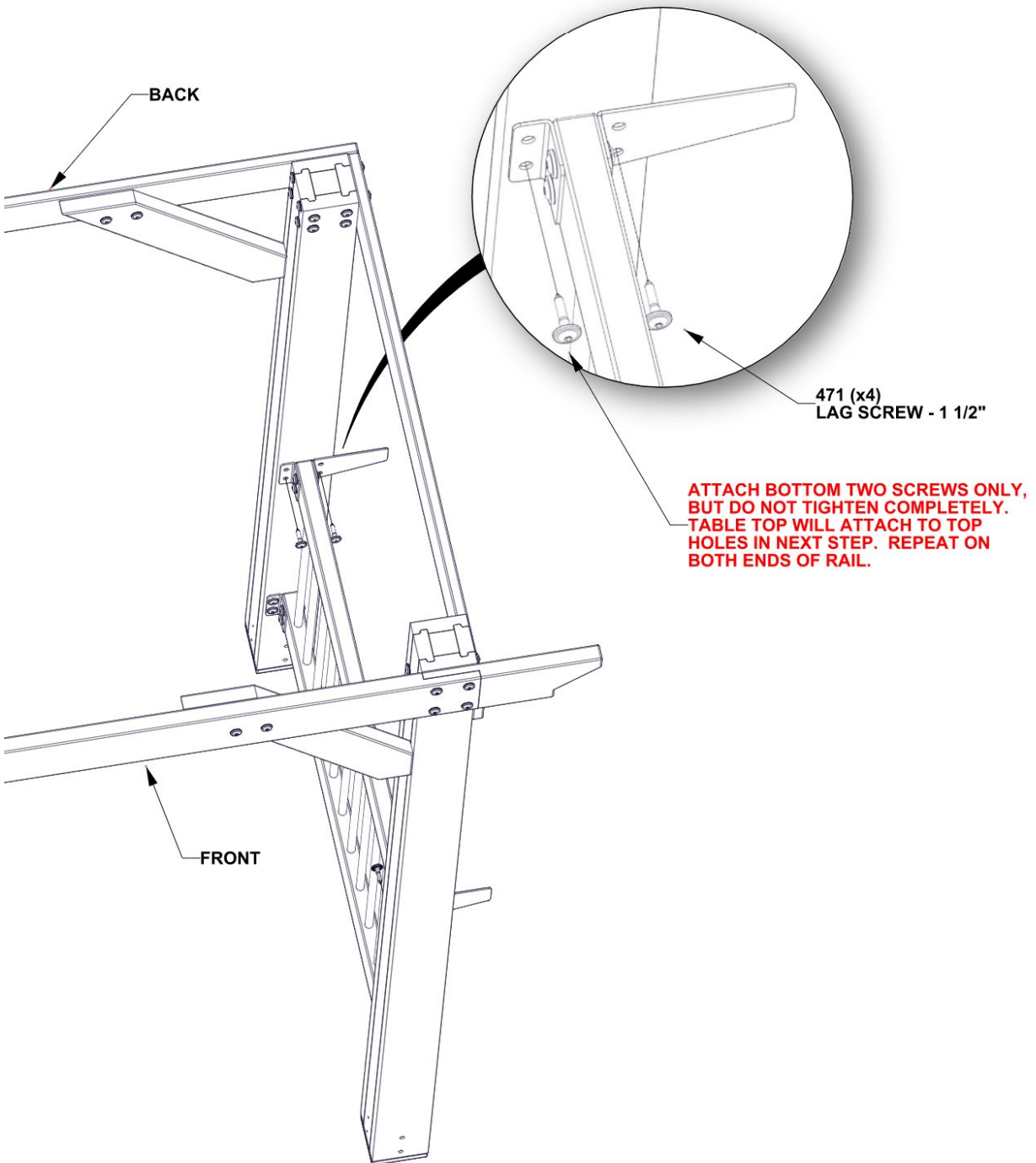

STEP 16 - SHELF ASSEMBLY

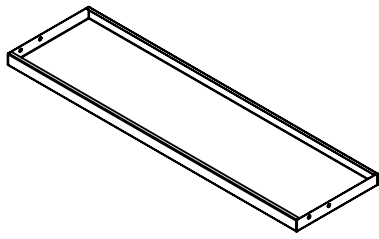

A4M01210 | TABLE
(2)

QTY.	PART NUMBER	DESCRIPTION
8	H100471	LAG SCREW WH 5/16 X 1 1/2 BLK

REPEAT STEP FOR OPPOSITE SIDE

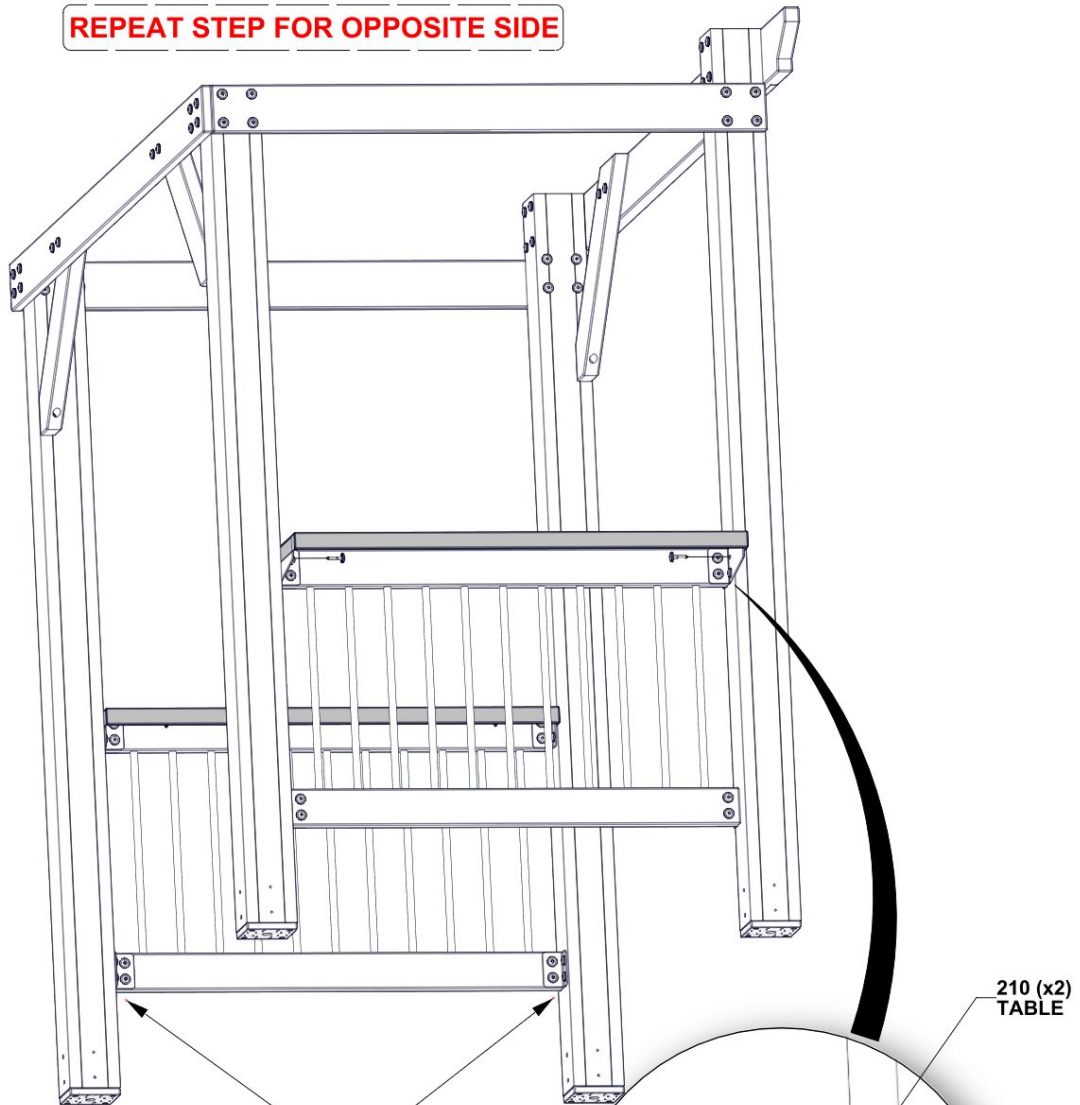

**AFTER TABLE IS INSTALLED,
TIGHTEN ALL CONNECTIONS.**

471 (x8)
LAG SCREW - 1 1/2"

**AFTER TABLE IS ATTACHED,
TIGHTEN THE BOTTOM SCREWS
ON ALL SIDES AS REQUIRED.**

STEP 17 - GAZEBO ROOF ASSEMBLY

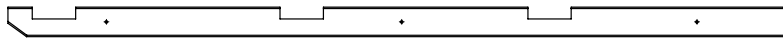

F1 | RAFTER-W4L14108
 (2) | 1 7/16"x2 3/8"x62 1/4" (36x60x1582)

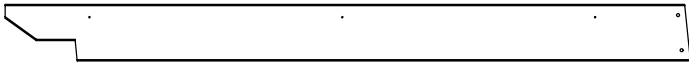

D6 | BEAM-W4L14107
 (1) | 1 7/16"x5 1/4"x64" (36x134x1626)

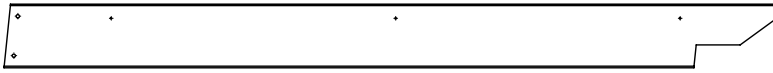

D8 | BEAM-W4L14345
 (1) | 1 7/16"x5 1/4"x64" (36x134x1626)

QTY.	PART NUMBER	DESCRIPTION
6	H100201	SCREW PFH 8 X 2 1/2 BLK

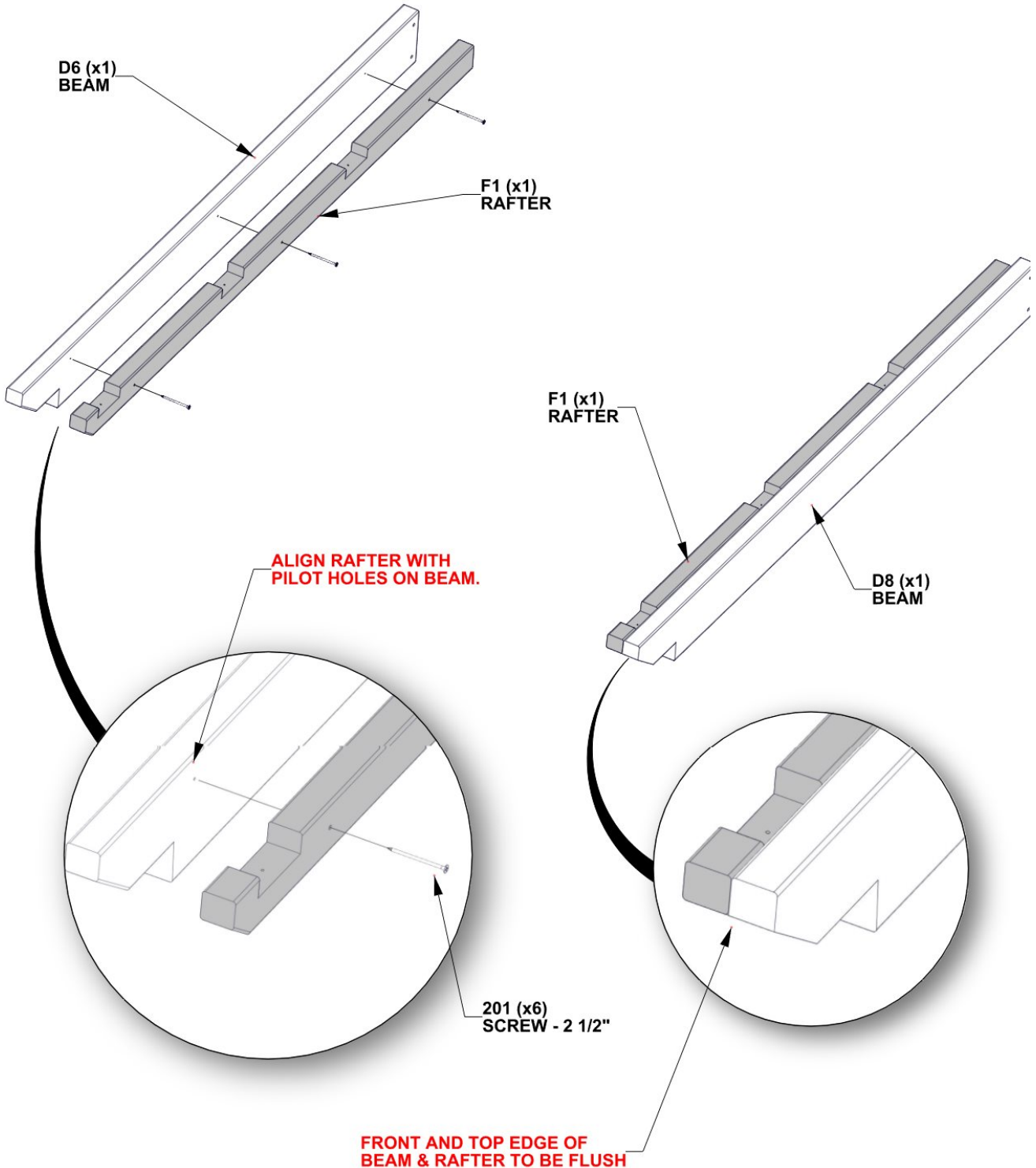

STEP 18 - GAZEBO ROOF ASSEMBLY

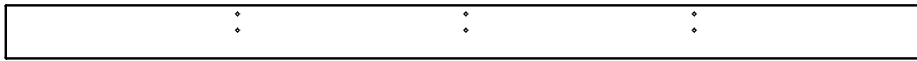

D7 | BEAM-W4L14110
(1) | 1 7/16"x5 1/4"x89 7/16" (36x134x2272)

QTY.	PART NUMBER	DESCRIPTION
4	H101008	SCREW CONFIRMAT 7 X 3 BLK

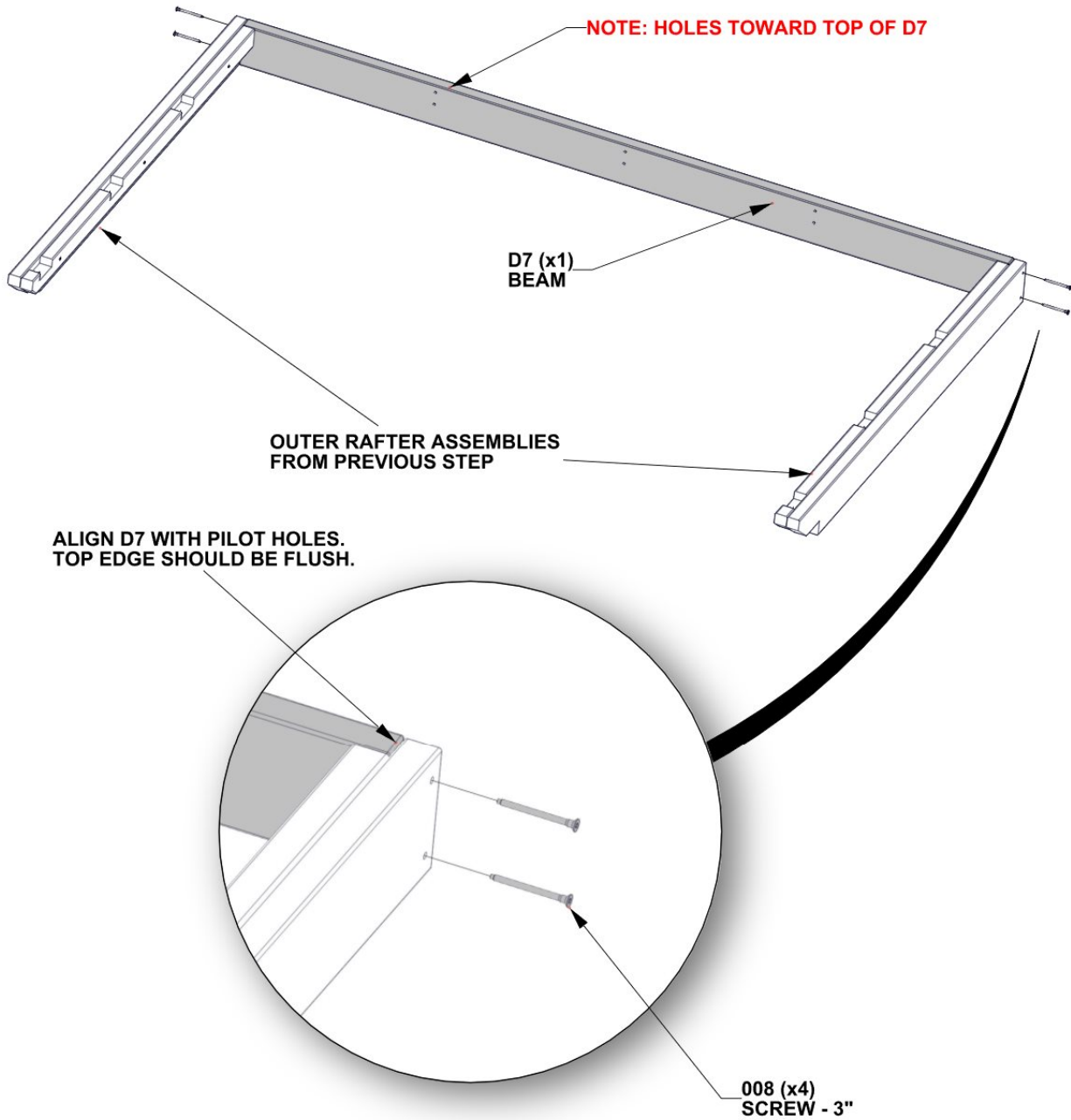

STEP 19 - GAZEBO ROOF ASSEMBLY

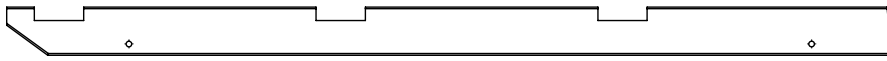

E1 | RAFTER-W4L14111
 (2) | 1 7/16"x3 3/8"x62 3/8" (36x86x1585)

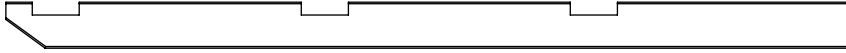

E3 | RAFTER-W4L14971
 (1) | 1 7/16"x3 3/8"x62 3/8" (36x86x1585)

QTY.	PART NUMBER	DESCRIPTION
6	H101008	SCREW CONFIRMAT 7 X 3 BLK

**FLIP ASSEMBLY FROM PREVIOUS STEP OVER.
 LAY RAFTERS FLAT, ALIGNING PILOT HOLES
 WITH HOLES IN D7.**

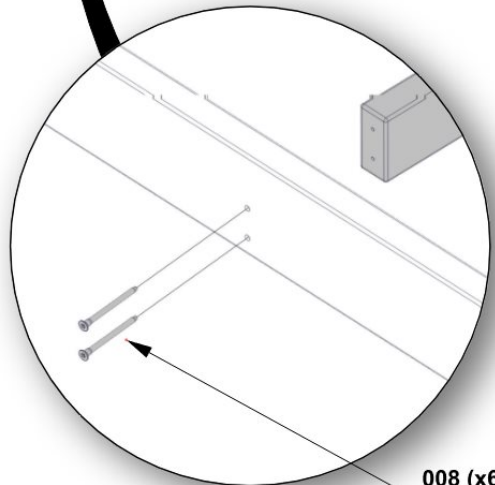
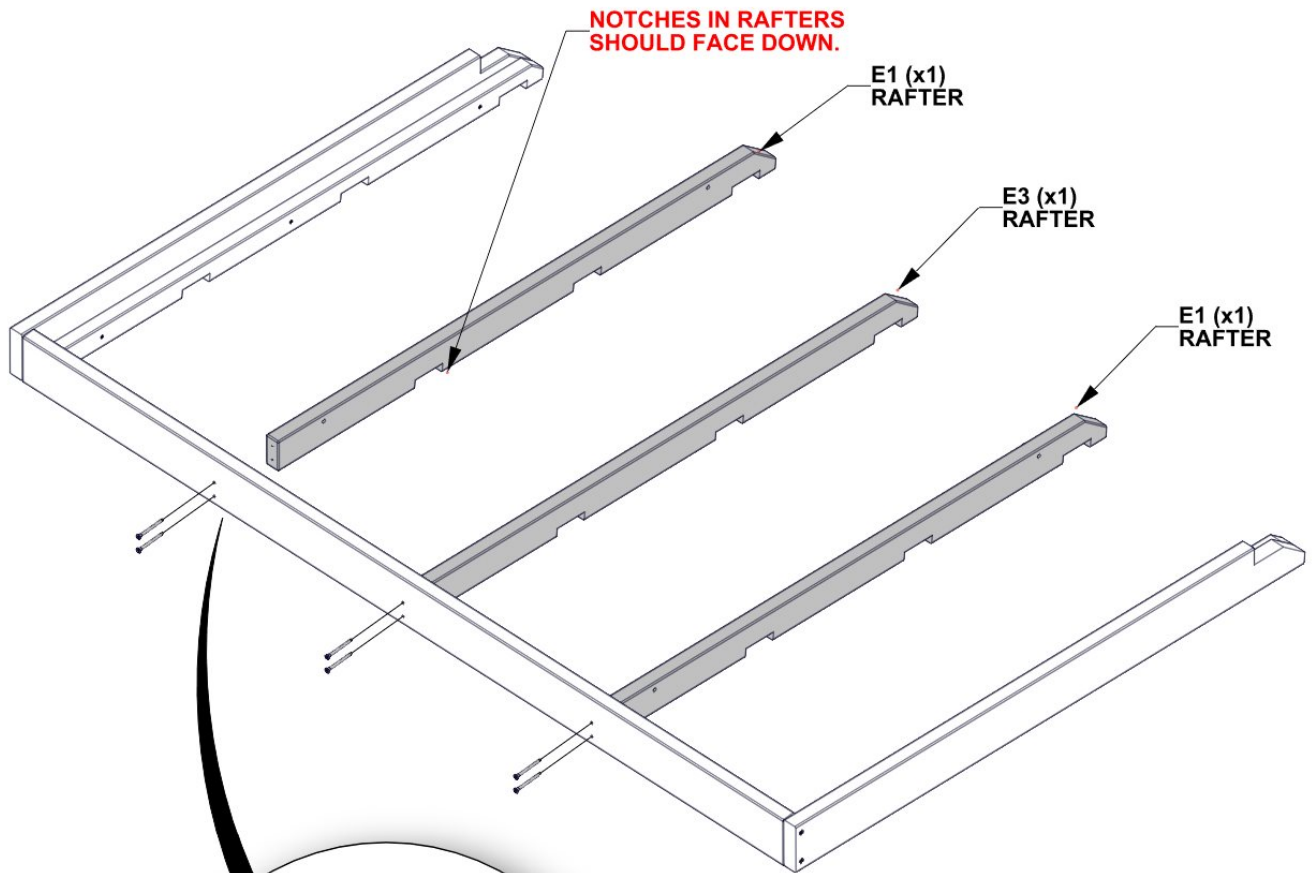

**008 (x6)
 SCREW - 3"**

STEP 20 - GAZEBO ROOF ASSEMBLY

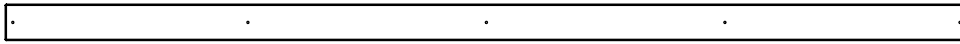

H2 | PURLIN-W4L14109
 (1) | 15/16"x3 3/8"x89 7/16" (24x86x2272)

QTY.	PART NUMBER	DESCRIPTION
5	H100382	SCREW PFH 8 X 1 3/4 BLK

FLIP ASSEMBLY FROM PREVIOUS STEP OVER. POSITION H2 PURLIN IN PLACE. MEASURE DIAGONALLY AND SQUARE AS NEEDED. MEASUREMENT SHOULD BE 112 inches [2845 mm]

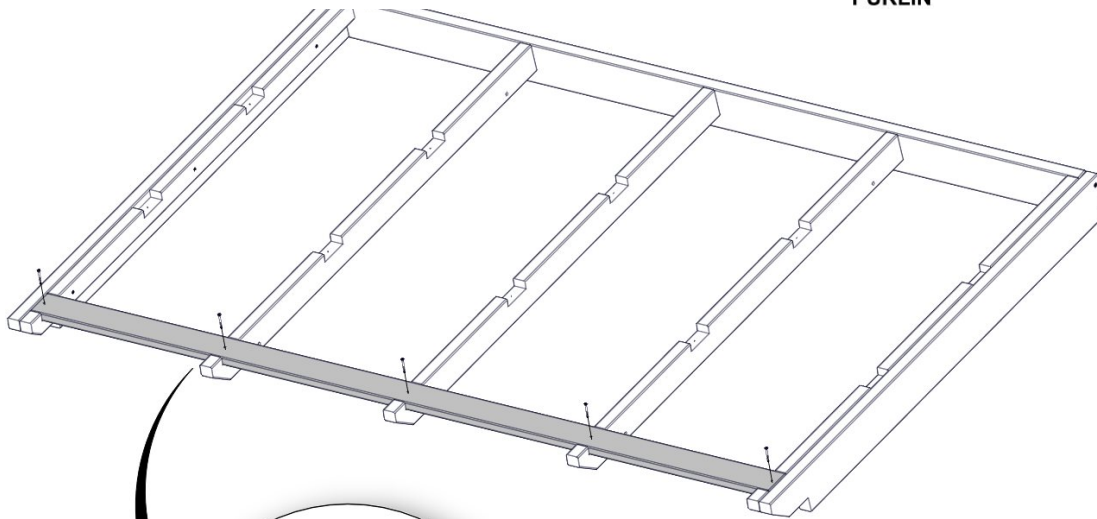
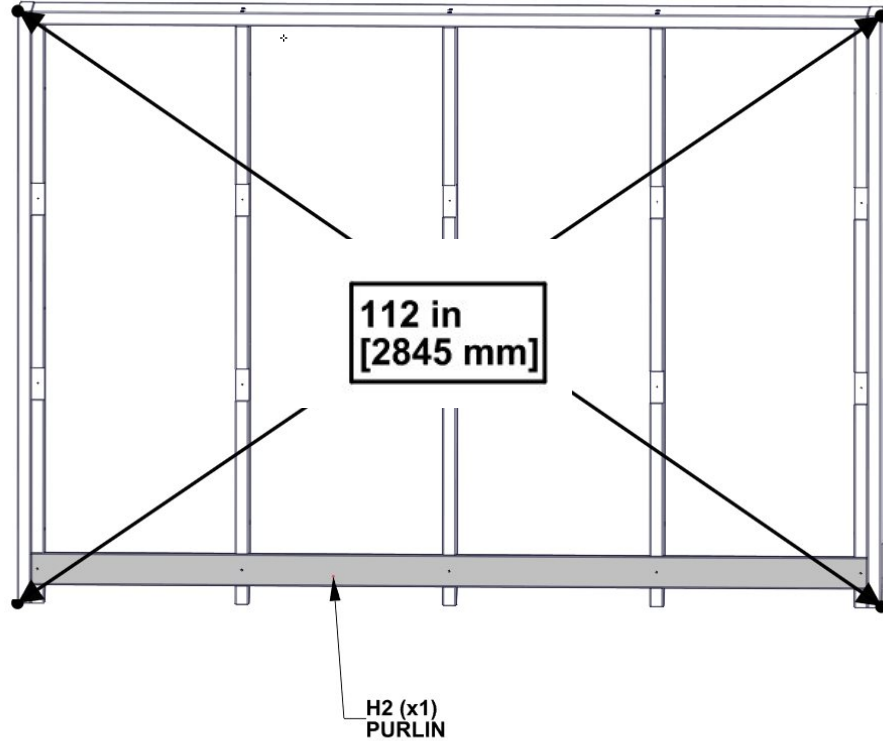

ONCE SQUARE, INSERT SCREWS. RE-MEASURE CORNER TO CORNER.

382 (x5)
SCREW - 1 3/4"

STEP 21 - GAZEBO ROOF ASSEMBLY

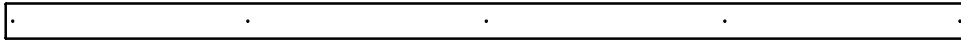

H2 | PURLIN-W4L14109
(2) | 15/16"x3 3/8"x89 7/16" (24x86x2272)

QTY.	PART NUMBER	DESCRIPTION
10	H100382	SCREW PFH 8 X 1 3/4 BLK

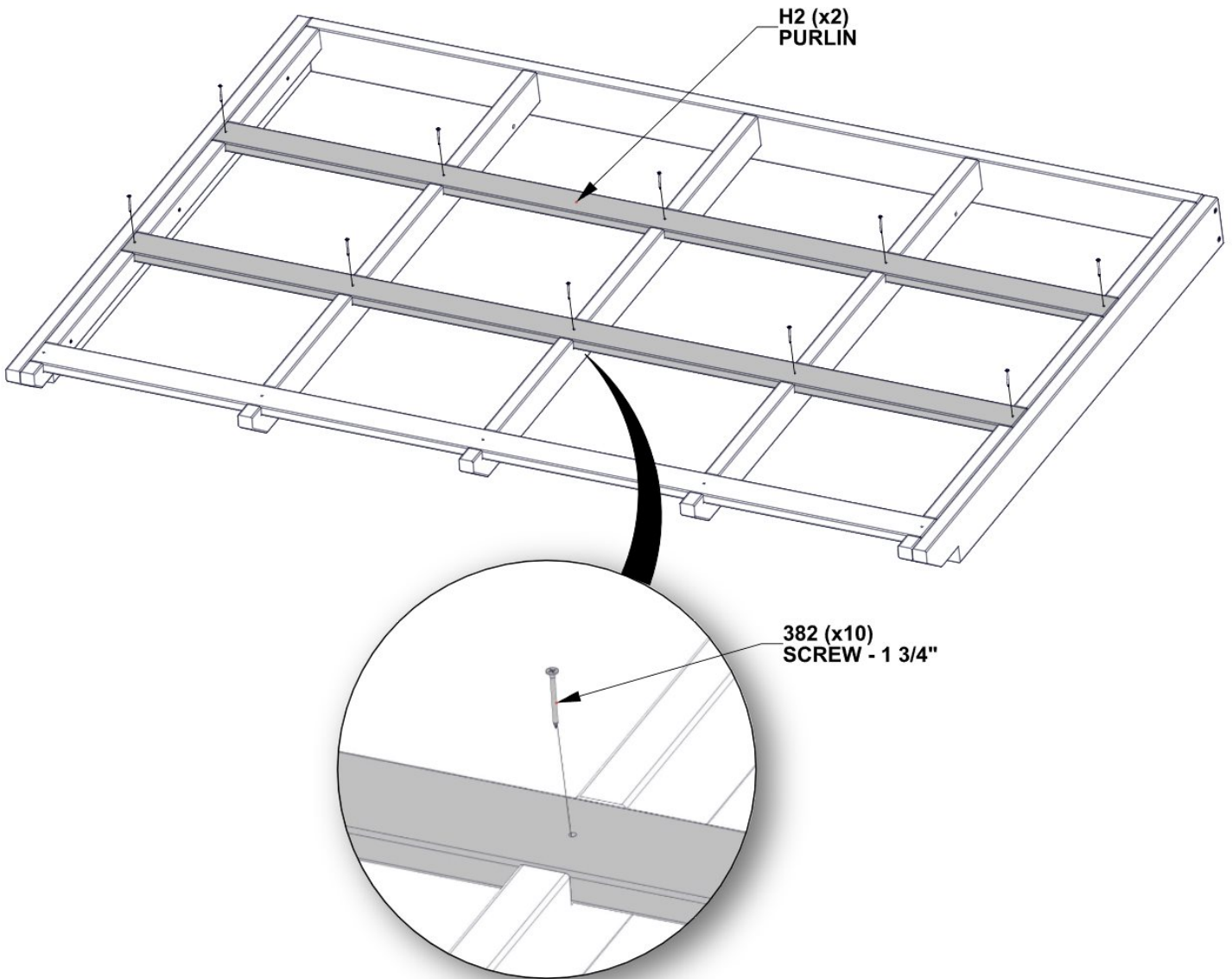

STEP 22 - GAZEBO ROOF ASSEMBLY

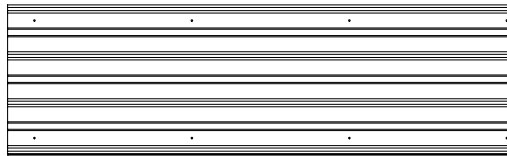

A4M01227 | 29 GA STEEL SHEETING
(5)

QTY.	PART NUMBER	DESCRIPTION
40	H100833	SCREW WOODGRIP 10-16x3/4"

NOTE:
WARNING:
GLOVES SHOULD BE WORN WHEN HANDLING ROOF PANELS;
EDGES ARE SHARP. REMOVE BLUE FILM FROM EACH SHEET.

1. LOOKING AT THE FRONT OF THE UNIT AS PICTURED BELOW, PLACE TIN SHEETS DOWN.
2. STARTING AT THE LEFT SIDE AND WORKING TOWARD THE RIGHT SIDE OVER LAPPING BY ONE RIB.
3. CENTER SHEETS ON ROOF AND LEAVE EQUAL GAPS ON BOTH LEFT AND RIGHT SIDES. SCREW IN PLACE.

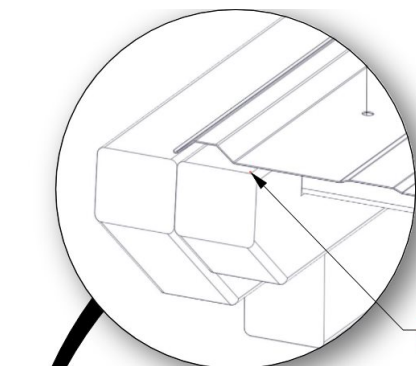
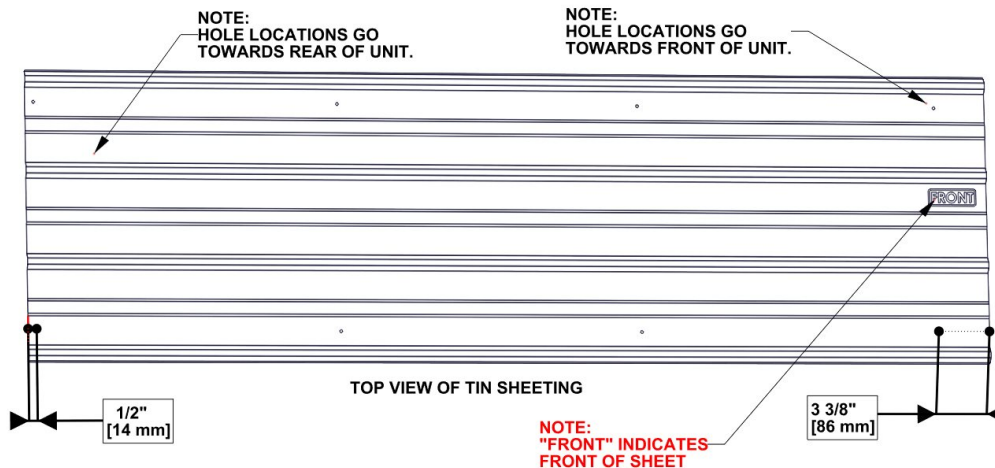

FLUSH EDGE OF SHEET WITH END OF RAFTER

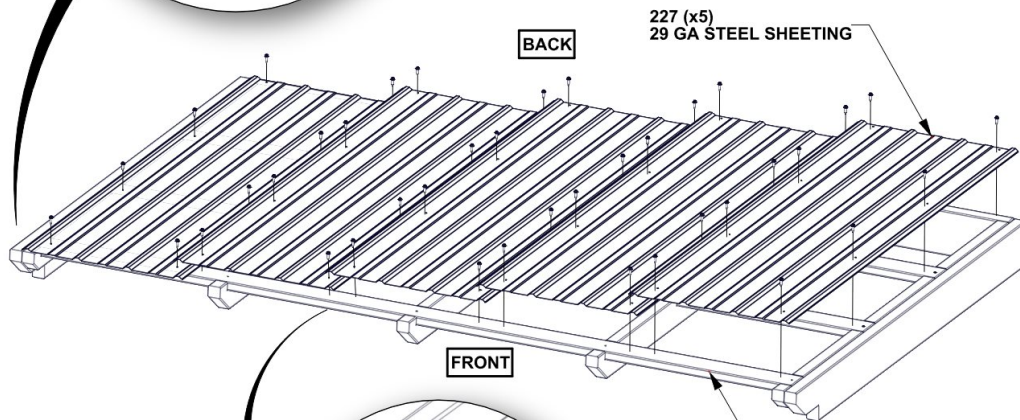

NOTE: SHEETS OVERLAP BY (1) RIB

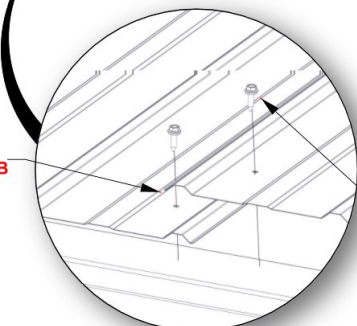

833 (x40)
SCREW - 3/4"

STEP 23 - GAZEBO ROOF ASSEMBLY

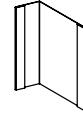

A4M01162 | ROOF EDGE TRIM
(2)

A4M00983 | ROOF EDGE TRIM SPLICE
(2)

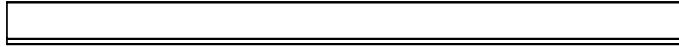

A4M01160 | ROOF EDGE TRIM
(4)

QTY.	PART NUMBER	DESCRIPTION
14	H100759	SCREW SELF TAPPING 1/4x3/4

NOTE: SCREWS GO THROUGH EDGE TRIM INTO THE TOP OF THE RIBS IN THE APPROXIMATE LOCATIONS SHOWN.

NOTE: DO NOT OVERTIGHTEN SCREWS. OVERTIGHTENING MAY CAUSE DAMAGE TO THE TRIM PIECE.

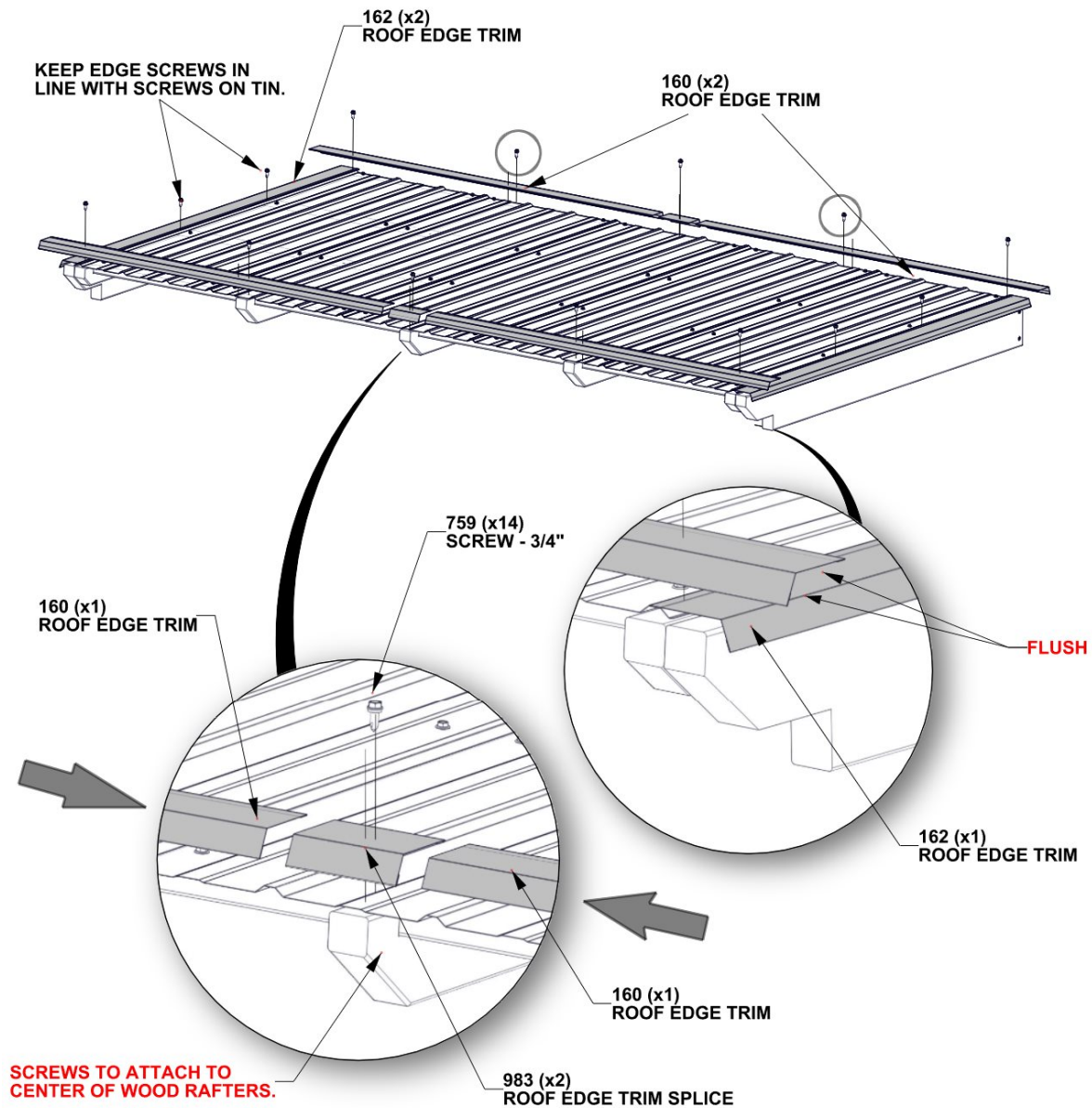

NOTE:
SLIDE ROOF EDGE TRIM 160 INTO EACH SIDE OF EDGE TRIM SPLICE 983. PUSH TOGETHER UNTIL ROOF EDGE TRIM 160 IS FLUSH WITH ROOF EDGE TRIM 162 ON EACH SIDE OF THE UNIT. INSTALL SCREWS.

STEP 24 - GAZEBO ROOF ASSEMBLY



A4M01228
(4) | **RAFTER BRACKET**

QTY.	PART NUMBER	DESCRIPTION
4	H100488	BOLT WH 1/4 X 2 BLK
4	H100630	WASHER FLAT 8x19 BLK
4	H100653	NUT LOCK 1/4 BLK
8	H100536	SCREW PWH 8 X 1 1/4 BLK

**SLIDE ROOF PANEL
ON FROM BACKSIDE
UNTIL OUTSIDE RAFTERS
MEET FRONT BEAM**

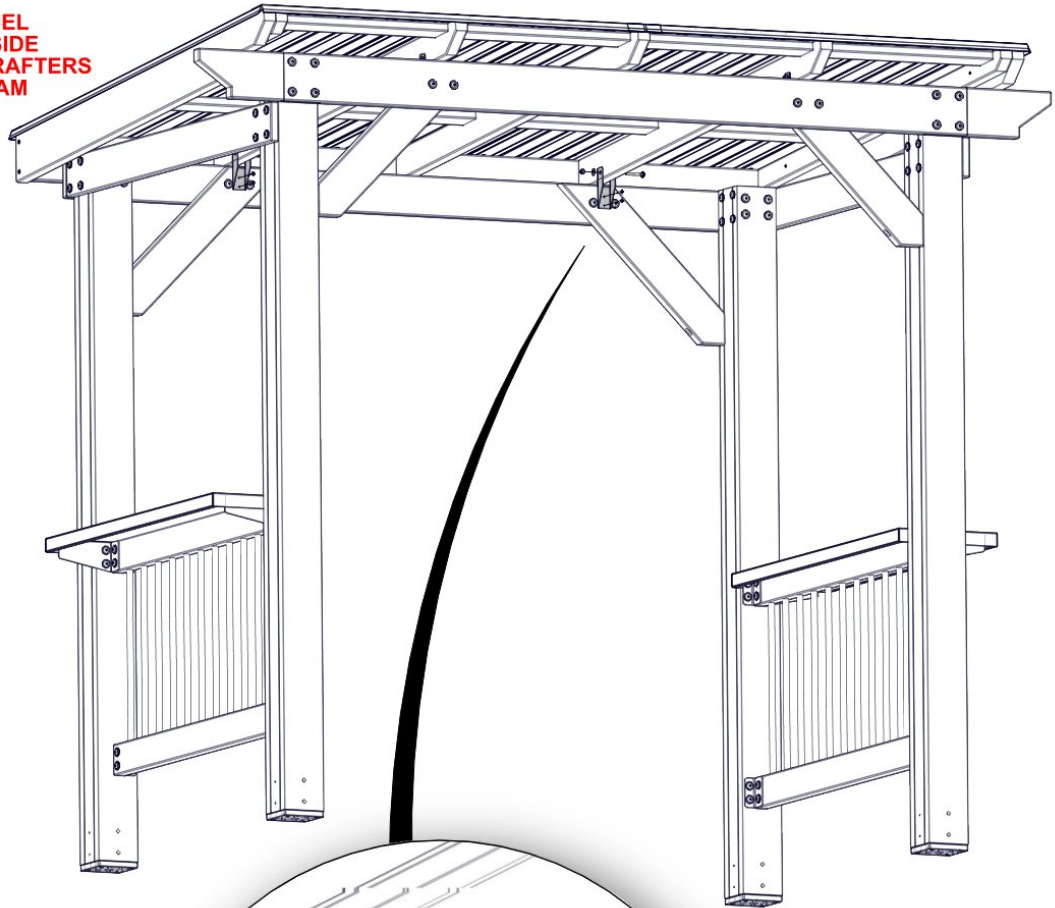

653 (x4)
NUT - 1/4"

630 (x4)
WASHER - 8x19

228 (x4)
RAFTER BRACKET

488 (x4)
BOLT - 2"

536 (x8)
SCREW - 1 1/4"

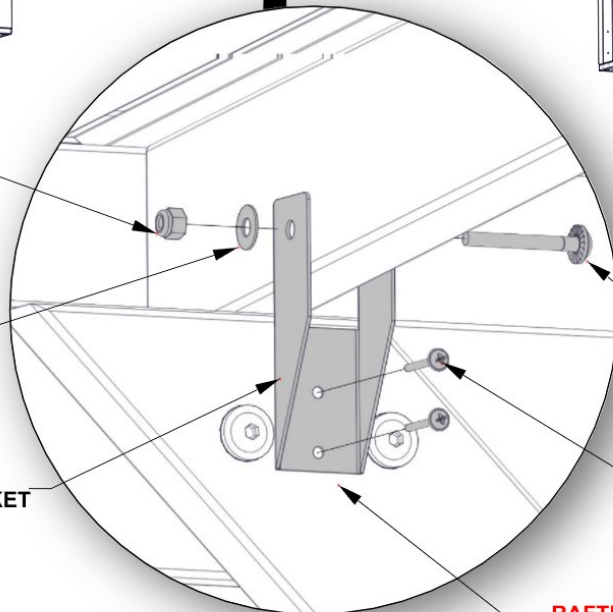

**REPEAT STEP TO FASTEN
OTHER (3) RAFTER BRACKETS**

**RAFTER BRACKET WILL
BE POSITIONED BETWEEN
CORBEL BOLTS.**

STEP 25 - GAZEBO ASSEMBLY



A4M01477 (8) | POST PLATE

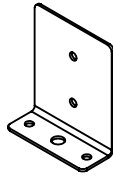

A4M01478 (8) | POST ANCHORING PLATE

QTY.	PART NUMBER	DESCRIPTION
8	H100480	BOLT WH 5/16 X 4 3/4 BLK
8	H100469	NUT BARREL WH 5/16 X 5/8 BLK
16	H100471	LAG SCREW WH 5/16 X 1 1/2 BLK

NOTES:
 477 POST PLATES MOUNT ON LEFT AND RIGHT SIDE OF POST.
 478 POST ANCHORING PLATES MOUNT ON FRONT AND BACK OF POST.

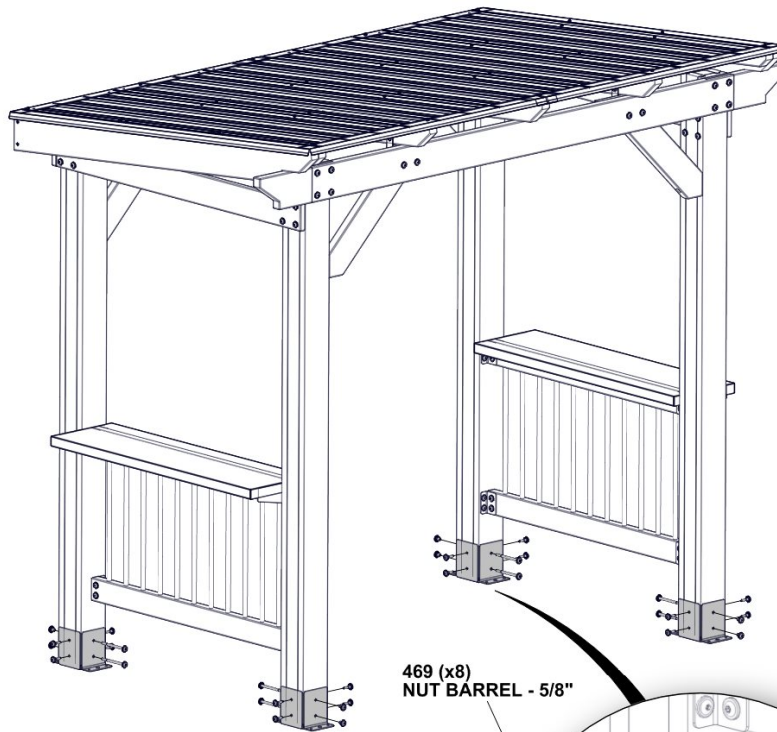

469 (x8)
NUT BARREL - 5/8"

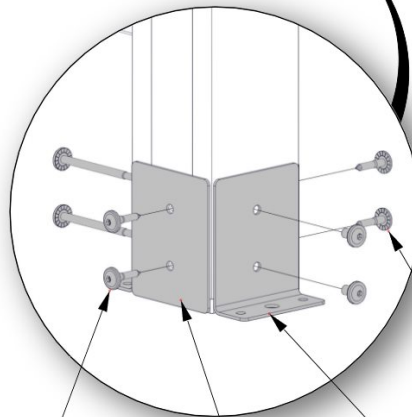

471 (x8)
LAG SCREW - 1 1/2"

477 (x8)
POST PLATE

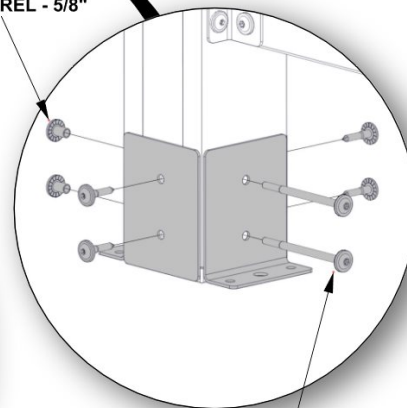

480 (x8)
BOLT - 4 3/4"

471 (x8)
LAG SCREW - 1 1/2"

478 (x8)
POST ANCHORING PLATE

STEP 26 - GAZEBO ASSEMBLY



A100241 | BYD ID TAG
(1)

QTY.	PART NUMBER	DESCRIPTION
2	H100392	SCREW PWH 8 X 3/4 BLK

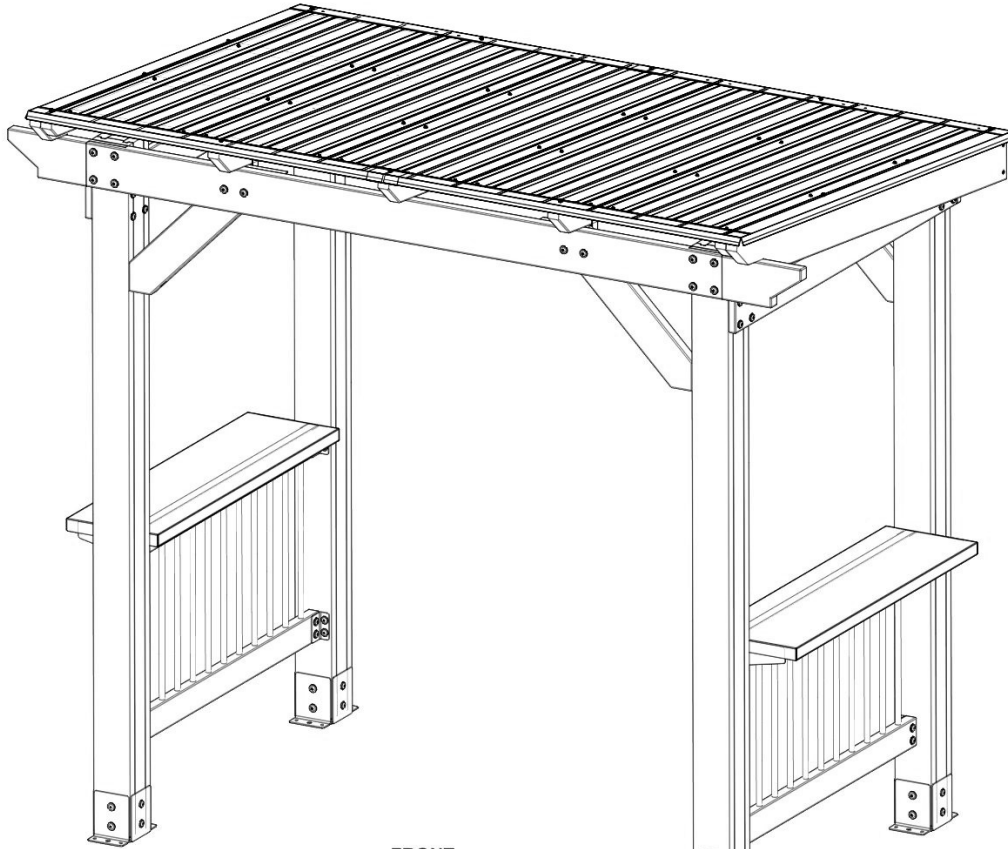

FRONT

241 (x1)
BYD ID TAG (SMALL) WITHOUT AGES

392 (x2)
SCREW - 3/4"

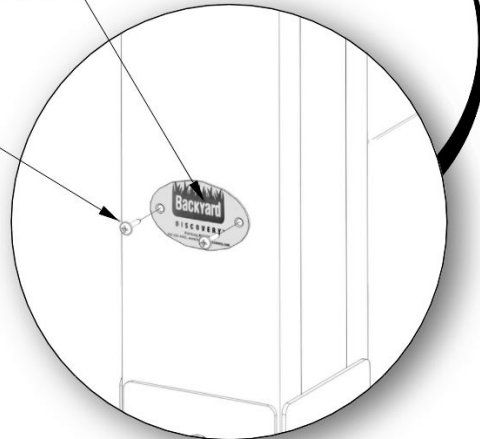

STEP 27 - GAZEBO ASSEMBLY

QTY.	PART NUMBER	DESCRIPTION
16	H100630	WASHER FLAT 8x19 BLK
16	H100120	CONCRETE ANCHOR 1/4"x2"

NOTES:
MANUFACTURER RECOMMENDS INSTALLATION ON CONCRETE SURFACE OR CONCRETE POST PADS. SEE BELOW
FOR INSTALLATION ON WOOD DECK, YOU MUST ENSURE THERE IS AMPLE STRUCTURAL SUPPORT UNDER DECK.

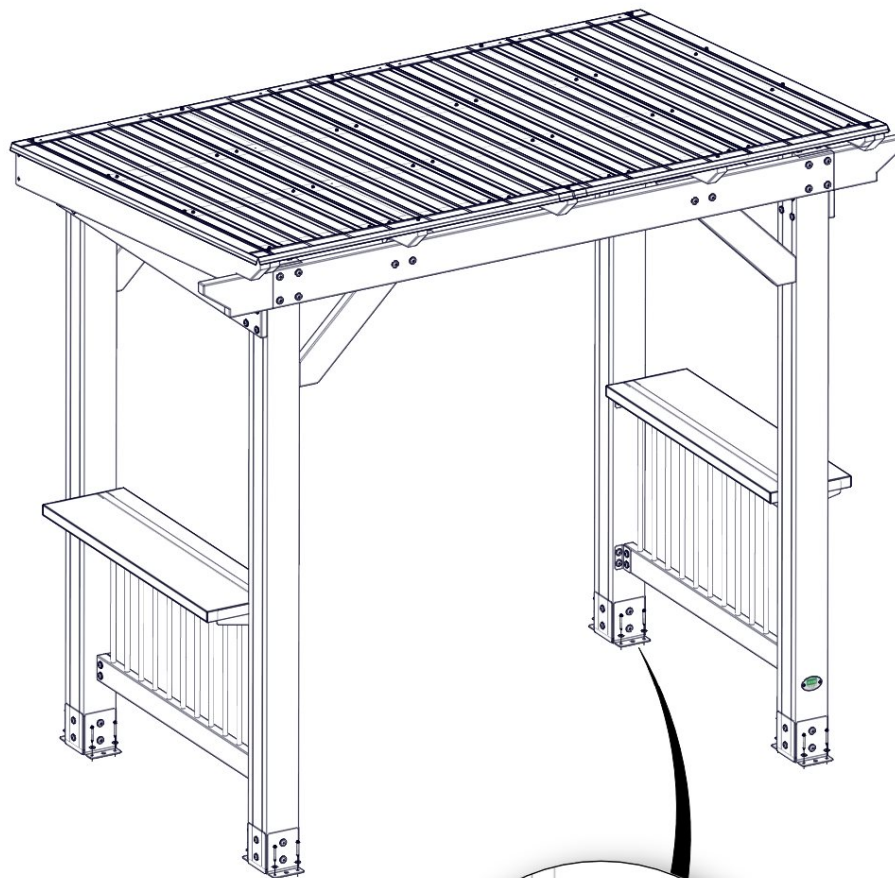

120 (x16)
SCREW - 2"

630 (x16)
WASHER - 8x19

NOTES:
PRE-DRILL HOLES FOR CONCRETE ANCHORS
USING A 3/16" CONCRETE DRILL BIT.

ELECTRICAL ENCLOSURE

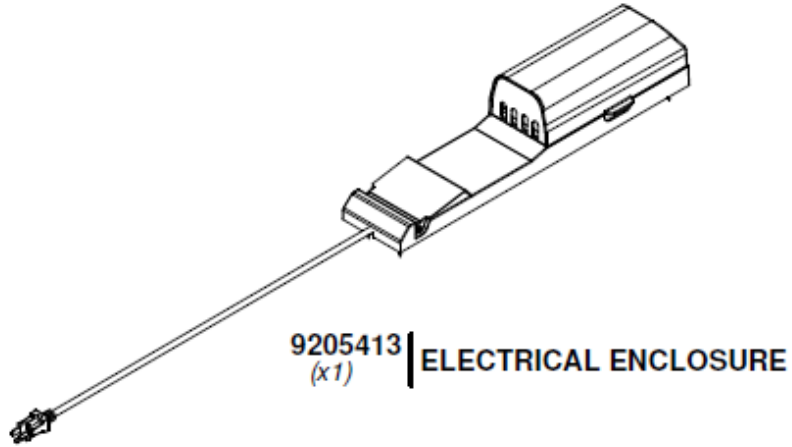

FOR ELECTRICAL ENCLOSURE INSTALLATION REFER TO ASSEMBLY INSTRUCTIONS THAT COMES PACKAGED WITH THE ELECTRICAL ENCLOSURE KIT. INSTALL ON ANY POST THAT IS DESIRED. FOLLOW DIRECTIONS FOR PROPER INSTALLATION.



PowerPort™

Model # 9205413
Wood Post Mounting Instructions



PowerPort.

MANUFACTURED BY:
Backyard Discovery
3305 Airport Drive
Pittsburg, KS 66762
800-856-4445

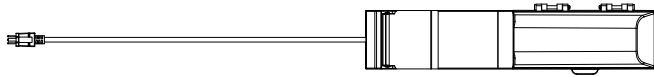

9205413 | ELECTRICAL ENCLOSURE
(x1)



H100966 | SCREW RAISED HEAD
(x4) | 8x1 1/2

WARNING: Cancer and Reproductive Harm - www.P65Warnings.ca.gov

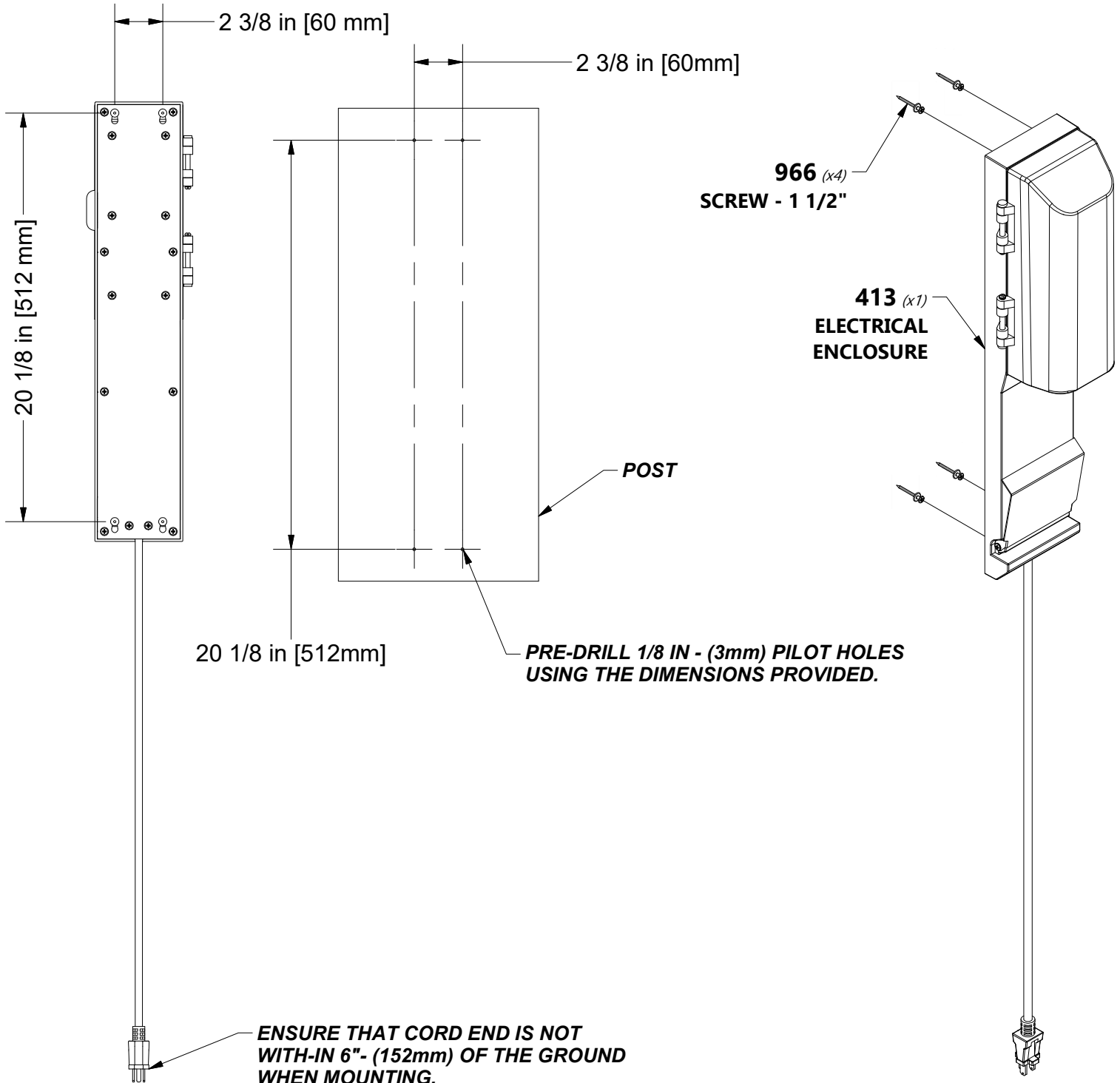



PowerPort

Model # 9205413
Metal Post Mounting Instructions



MANUFACTURED BY:
Backyard Discovery
3305 Airport Drive
Pittsburg, KS 66762
800-856-4445



A4M01292 | MOUNTING BRACKET
(x2)

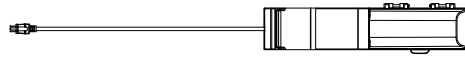

9205413 | ELECTRICAL ENCLOSURE
(x1)



H100746 | SCREW TAPPING
(x4) 10x1 1/4"

WARNING: Cancer and Reproductive Harm - www.P65Warnings.ca.gov

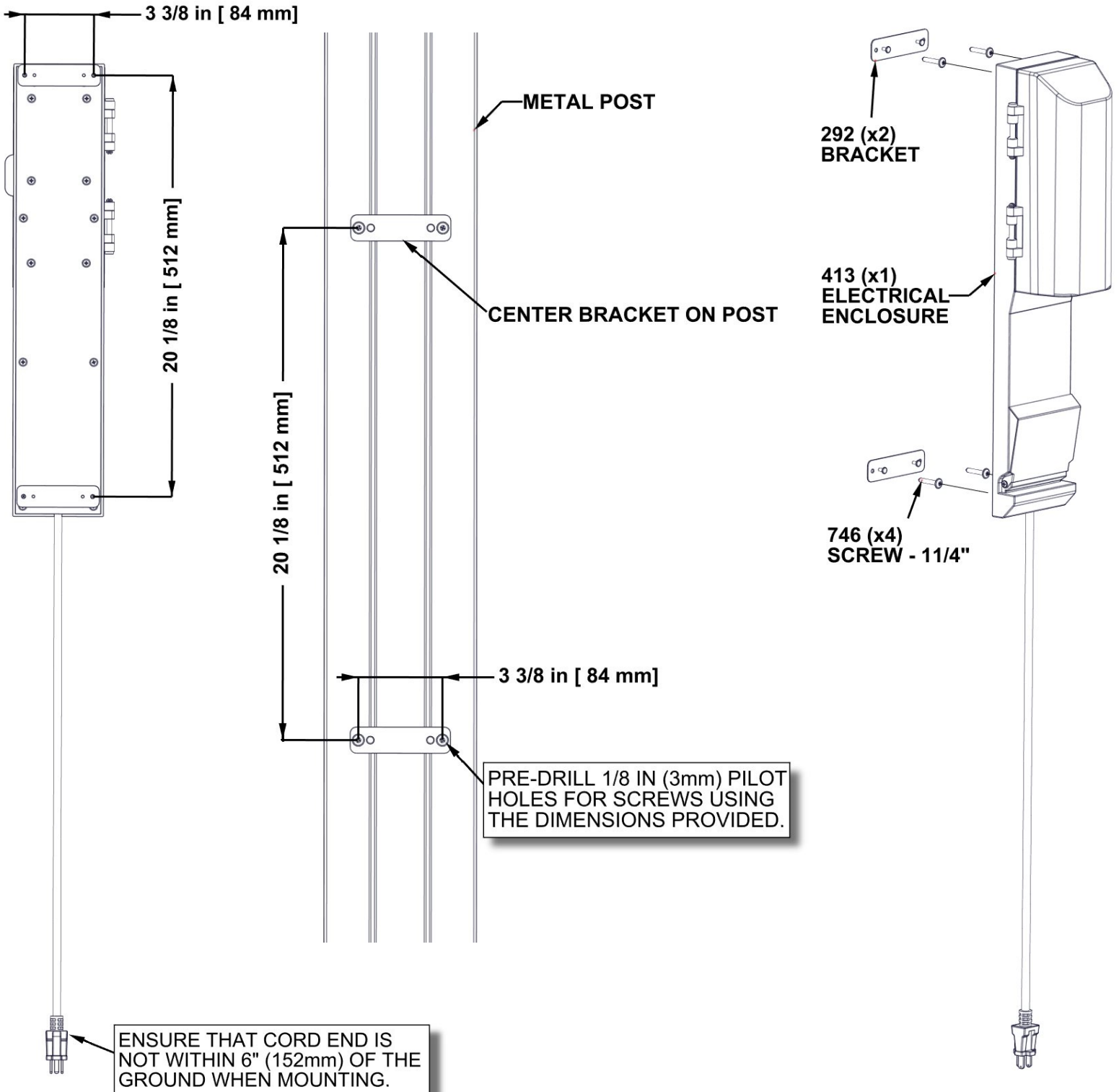

FCC MARKING:

This device complies with part 15 of the FCC Rules. Operation is subject to the following two conditions: (1) This device may not cause harmful interference, and (2) this device must accept any interference received, including interference that may cause undesired operation.

FCC INSTRUCTIONS:

CAUTION: Changes or modifications not expressly approved by the party responsible for compliance could void the user's authority to operate the equipment.

For a Class B digital device or peripheral, the instructions furnished the user shall include the following or similar statement, placed in a prominent location in the text of the manual:

Note: This equipment has been tested and found to comply with the limits for a Class B digital device, pursuant to part 15 of the FCC Rules. These limits are designed to provide reasonable protection against harmful interference in a residential installation. This equipment generates, uses and can radiate radio frequency energy and, if not installed and used in accordance with the instructions, may cause harmful interference to radio communications. However, there is no guarantee that interference will not occur in a particular installation. If this equipment does cause harmful interference to radio or television reception, which can be determined by turning the equipment off and on, the user is encouraged to try to correct the interference by one or more of the following measures:

- Reorient or relocate the receiving antenna.
- Increase the separation between the equipment and receiver.
- Connect the equipment into an outlet on a circuit different from that to which the receiver is connected.
- Consult the dealer or an experienced radio/TV technician for help.