



# 12x14 RAYVEN GAZEBO

Model # 2105324

Owner's Manual & Assembly Instructions

MANUFACTURED BY:  
Backyard Discovery  
3305 Airport Drive  
Pittsburg, KS 66762  
800-856-4445



  
GOCONFIGURE  
Putting it all together for you

**INSTALLATION SERVICES AVAILABLE!\***

*Need a helping hand?*  
Let our team of professionals handle the installation for you!

**GOCONFIGURE**  
888-888-5424

\*Installation services are only available to U.S. customers.

average 2 person assembly time

**INTERMEDIATE**

**12**

**HOURS**

assembly time may vary based on skill level

Before you begin >>>

**FOR QUICK & EASY ASSEMBLY**

FIND 3D INSTRUCTIONS FOR THIS PRODUCT IN

**BILT.**

DOWNLOAD THE FREE APP

 GET IT ON Google Play

 Download on the App Store

For the most up to date assembly manual, to register your set, or to order replacement parts please visit [www.backyarddiscovery.com](http://www.backyarddiscovery.com)

**SAVE THIS ASSEMBLY MANUAL FOR FUTURE REFERENCE IN THE EVENT THAT YOU NEED TO ORDER REPLACEMENT PARTS.**

Para obtener instrucciones en español, visite [www.backyarddiscovery.com](http://www.backyarddiscovery.com)



**GOCONFIGURE**  
*Putting it all together for you*

# **INSTALLATION SERVICES AVAILABLE!\***

*Need a helping hand?*

Let our team of professionals handle the installation for you!

**GOCONFIGURE**  
**888-888-5424**

*\*Installation services are only available  
to U.S. customers.*

With Go Configure, we bring you 18 years of experience right to your doorstep. We service a wide array of indoor and outdoor recreation products that most consumers don't have the time or ability to deliver & install themselves.

**We do the heavy lifting, so you don't have to!**

- 
- 18+ Years of Experience Servicing Big Box Retailers and Direct Consumers
  - Highly Skilled, Specialized, Courteous, Professional Service Technicians
  - Over 140,000 Installations Annually
  - White Glove Service

- Satisfaction Guarantee
  - Flexible Appointments, including weekends
  - Coverage across the nation
- Visit [www.goconfigure.com](http://www.goconfigure.com) for more info!**
- 

*\*Installation services are only available to U.S. customers.*



The store where you made your purchase does not stock parts for this item. If you have assembly questions or you are missing or have damaged parts, please call

**1-800-856-4445**

you can also visit [www.backyarddiscovery.com](http://www.backyarddiscovery.com)  
or e-mail [customerservice@backyarddiscovery.com](mailto:customerservice@backyarddiscovery.com)

**Please have the following information ready when you make your call:**

- Model Number of the product located on the front of the assembly manual
  - The item description and number from the parts list from the manual that was included in your box
- 
- Read entire assembly manual, paying special attention to the important tips and safety information.
  - To ensure there are no missing pieces do a complete inventory by first separating and identifying all parts.
  - Make sure to check packing material for small parts that may have fallen out during shipment.
  - Structures are not intended for public use. The Company does not warranty any of its residential structures subjected to commercial use.
  - This manual contains helpful information concerning assembly preparation, installation procedure and required maintenance.
  - Always keep safety in mind as your structure is being built.
  - Keep these instructions for future reference.



**Please read entire booklet completely before beginning the assembly process**

**Please retain these instructions and your receipt for future reference. Keep them in a safe place where you can refer to them as needed. In order to provide you with the most efficient service, it is required that you provide us with the part numbers when ordering parts.**

### For Your Records:

Please take time and fill out the information below. This information will be needed for warranty issues.

Where Purchased: \_\_\_\_\_  
 Date of Purchase: \_\_\_\_\_  
 Installation Date: \_\_\_\_\_  
 Installed by: \_\_\_\_\_  
 Tracking Number: \_\_\_\_\_

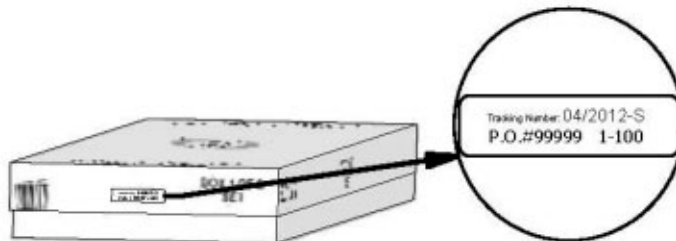

### Tracking Number Reference Label

Tracking ID number on the carton and on the bottom of the vertical ID plate are included for tracking purposes associated with warranty claims.

This Limited Warranty by Backyard Discovery applies to products manufactured under the Backyard Discovery brand or its other brands including but not limited to Backyard Botanical, Adventure Playsets, and Leisure Time Products.

Backyard Discovery warrants that this product is free from defect in materials and workmanship for a period of one (1) year from the original date of purchase. This one (1) year warranty covers all parts including wood, hardware, and accessories. All wood carries a five (5) year pro-rated warranty against rot and decay. Refer to the schedule below for charges associated with replacement of parts under this Limited Warranty. In addition, Backyard Discovery will replace any parts within the first 30 days from date of purchase found to be missing from or damaged in the original packaging.

This warranty applies to the original owner and registrant and is non-transferable. Regular maintenance is required to assure maximum life and performance of this product. Failure by the owner to maintain the product according to the maintenance requirements may void this warranty. Maintenance guidelines are provided in the Owner's Manual.

This Limited Warranty does not cover:

- Labor for any inspection
- Labor for replacement of any defective item(s)
- Incidental or consequential damages
- Cosmetic defects which do not affect performance or integrity of a part or the entire product
- Vandalism, improper use, failure due to loading or use beyond the capacities stated in the applicable Assembly Manual.
- Acts of nature including but not limited to wind, storms, hail, floods, excessive water exposure
- Improper installation including but not limited to installation on uneven, unlevel, or soft ground
- Minor twisting, warping, checking, or any other natural occurring properties of wood that do not affect performance or integrity

Backyard Discovery products have been designed for safety and quality. Any modifications made to the original product could damage the structural integrity of the unit leading to failure and possible injury. Modification voids any and all warranties and Backyard Discovery assumes no liability for any modified products or consequences resulting from failure of a modified product.

This product is warranted for RESIDENTIAL USE ONLY. Under no circumstance should a Backyard Discovery product be used in public settings. Such use may lead to product failure and potential injury. Any and all public use will void this warranty. Backyard Discovery disclaims all other representations and warranties of any kind, express or implied.

### **Pro Rated Part Replacement Schedule**

<b><u>Product Age</u></b>	<b><u>Customer Pays</u></b>
<b>All Parts</b>	
0-30 days from date of purchase	\$0 and free shipping
31 days to 1 year	\$0 + S&H
<b>Wood Rot and Decay Only</b>	
1 year	\$0 and free shipping
2 year	20% + S&H
3 year	40% + S&H
4 year	60% + S&H
5 year	80% + S&H
Over 5 years	100% + S&H



# WARNING

**IT IS IMPORTANT TO CHECK AND TIGHTEN ALL HARDWARE AT THE BEGINNING AND DURING THE SEASON AS THEY MAY LOOSEN DUE TO WOOD EXPANSION AND CONTRACTION.**

- **DO NOT climb or walk on the roof for any reason**
- **Requires two or more people to assemble safely**
- **Check for underground utilities before digging or driving stakes into the ground.**
- **Check carefully for overhead lines and ensure there is at least 6ft (2m) clearance from any overhead electrical wires.**
- **Permanent structures may require a building permit. As the purchaser and or installer of this product you are advised to consult local planning, zoning and building inspection departments for guidance on applicable building codes and/or zoning requirements.**
- Wood is NOT flame retardant and will burn. Grills, fire pits and chimineas are a fire hazard if place too close to your structure.
- Wear gloves to avoid injury during installation.
- During installation, follow all safety warnings provided with your tools and use safety glasses.
- Check all nuts and bolts twice monthly during the usage season and tighten as required.(But not so tight that you crack the wood) It is particularly important that this procedure be followed at the beginning of each season.
- Oil all metallic moving parts monthly during the usage period.
- Check all coverings for bolts and sharp edges twice monthly during usage season to be certain they are in place. Replace when necessary. It is especially important to do this at the beginning of each new season.
- For rusted areas on metallic members such as hinges, brackets, etc. sand and repaint, using a non lead-based paint meeting the requirements of Title 16 CRF Part 1303.
- Inspect wood parts monthly. The grain of the wood sometimes will lift in the dry season causing splinters to appear. Light sanding may be necessary to maintain a safe environment. Treating your Product with protection (sealant) after sanding will help prevent severe checking/splitting and other weather damage.
- We have applied a waterborne translucent stain to your unit. This is done for color only. Once or twice a year, depending on your climate conditions, you must apply some type of protection (sealant) to the wood of your unit. Prior to the application of sealant, lightly sand any "rough" spots on your set. Please note this is a requirement of your warranty.

**OWNERS SHALL BE RESPONSIBLE FOR MAINTAINING THE LEGIBILITY OF THE WARNING LABELS**



***Your Backyard Discovery structure is designed and constructed of quality materials. As with all outdoor products it will weather and wear. To maximize the enjoyment, safety and life of your structure it is important that you properly maintain it.***

---

### About Our Wood

Backyard Discovery uses 100% Nordic Spruce wood. Although we take great care in selecting the best quality lumber available, wood is still a product of nature and susceptible to weathering which can change the appearance of your set.

#### **What causes weathering? Does it affect the strength of my product?**

One of the main reasons for weathering is the effects of water (moisture); the moisture content of the wood at the surface is different than the interior of the wood. As the climate changes, moisture moves in or out of the wood, causing tension which can result in checking and or warping. You can expect the following due to weathering. These changes will not affect the strength of the product:

**1. Checking** is surface cracks in the wood along the grain. A post (4" x 4") will experience more checking than a board (1" x 4") because the surface and interior moisture content will vary more widely than in thinner wood.

**2. Warping** results from any distortion (twisting, cupping) from the original plane of the board and often happens from rapid wetting and drying of the wood.

**3. Fading** happens as a natural change in the wood color as it is exposed to sun-light and will turn grey over time.

#### **How can I reduce the amount of weathering to wood product?**

**1.** Your wood product is coated with a water-based stain. Sunlight will break down the coating, so we recommend applying a water repellent or stain on a yearly basis (see your local stain and paint supplier for a recommended product). You must apply some type of protection (sealant) to the wood of your product. **Please note this is a requirement of your warranty.** Most weathering is just the normal result of nature and will not affect safety. However if you are concerned that a part has experienced a severe weathering problem please call our customer service department for further assistance.

**2.** Inspect wood parts monthly. The grain of the wood sometimes will lift in the dry season causing splinters to appear. Light sanding may be necessary to maintain a safe environment. Treating your Product with protection (sealant) after sanding will help prevent severe checking/ splitting and other weather damage.



### Protrusion Hazard

### Incorrect

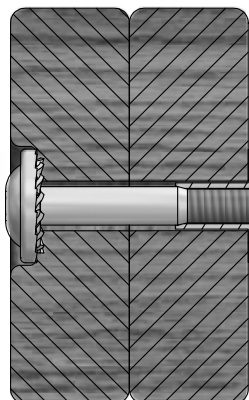

If you see exposed threads and your bolt protrudes beyond the T-Nut you may have over tightened the bolt or used incorrect hardware. If you've overtightened, remove the bolt and add washers to eliminate the protrusion.

### Correct

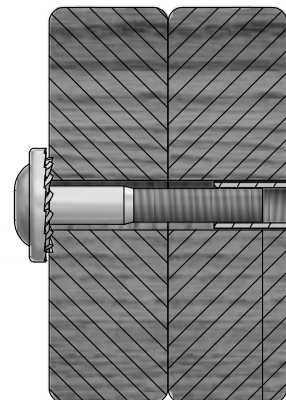

1/8"

## Proper Hardware Assembly

### Bolt and T-Nut Assembly

Tap T-nut into the provided hole. Insert your bolt through the lock washer and insert into the provided hole opposite from the T-Nut. Turn clockwise to thread into T-nut. Do not completely tighten until instructed.

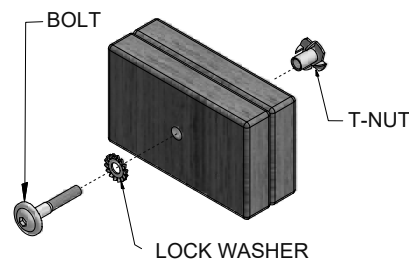

### Bolt and Barrel Nut Assembly

Insert barrel nut through the lock washer and press the pair through the provided hole. Insert your bolt through the second lock washer and insert the pair into the provided hole opposite from the barrel nut. Turn clockwise to thread into the barrel nut. Do not completely tighten until instructed.

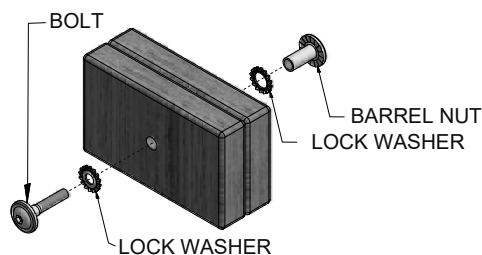

### Lag Assembly

Normally there will be a pre-drilled pilot hole on assemblies that require a Lag Screw. If there is no pilot hole, line up the two boards as they are to be attached and use the factory drilled hole as a guide to drill another pilot hole into the adjoining board. This will keep the wood from splitting. Only a lock washer is required for steps with Lag Screws.

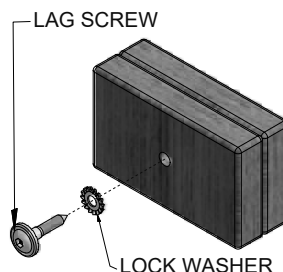



### ASSEMBLY TIP:

Keep an eye out for these boxes which will contain helpful pictures and information making the assembly process as quick and painless as possible.

## Sorting Wood

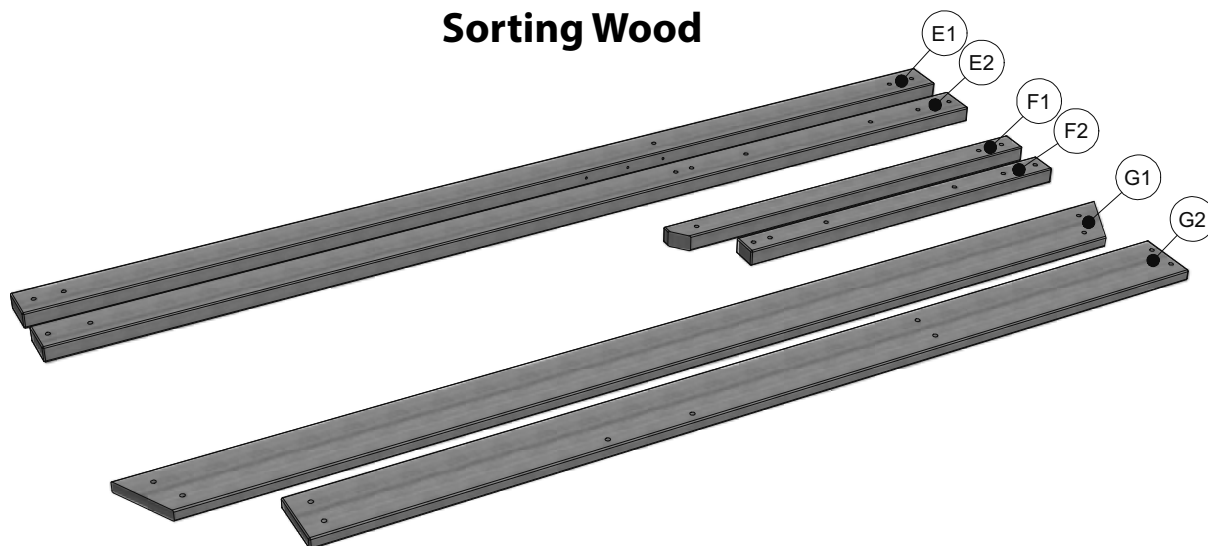

When removing the wood from the boxes we recommend arranging them by part number before you begin assembly. This will allow for faster assembly and easily identify any parts that may be missing or damaged.

## Sorting Hardware

**NUT BARREL**  
H100545



**SCREW**  
H100695



**T-NUT**  
H100699

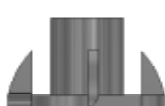

**WASHER FLAT**  
H100706



**BOLT HEX**  
H100716

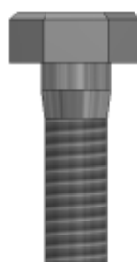

**BOLT**  
H100718



**SCREW PWH**  
H100742

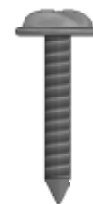

To help with assembly we recommend sorting your hardware bags with the seven digit alpha-numeric number printed on the bags or by hardware type (i.e. bolts, nuts, etc.). Organizing your hardware will make assembly easier.

## Hardware Identification

Hardware bags are printed with a seven digit alpha-numeric part number. During assembly you only need to reference the last three digits of the part number as noted in each step. This will make finding the correct hardware easier.

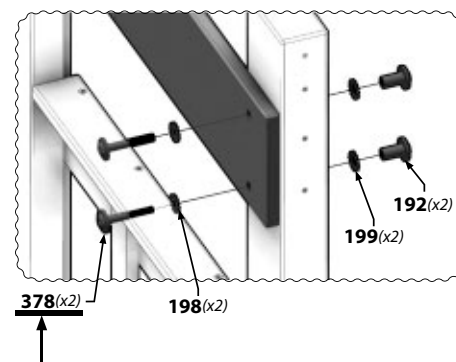
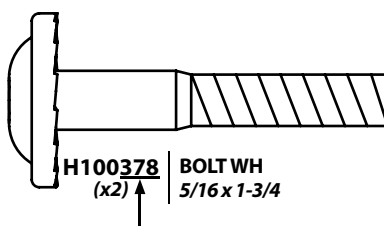



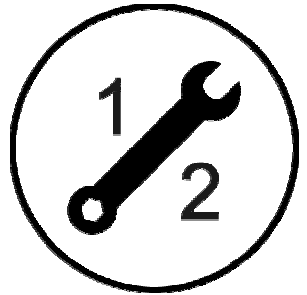
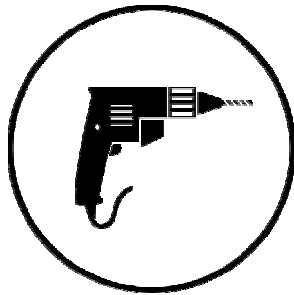
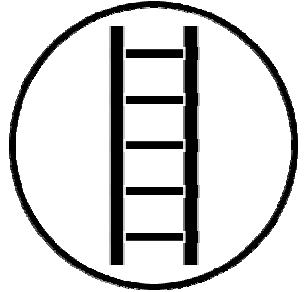
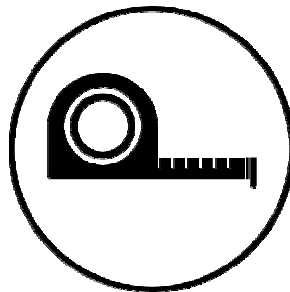
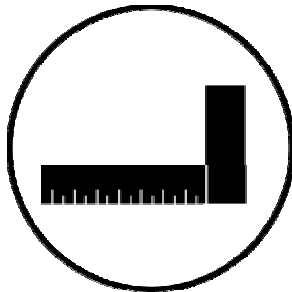
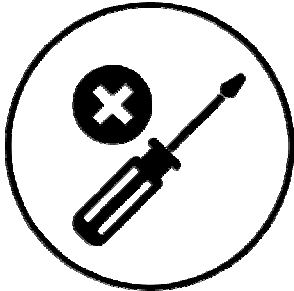
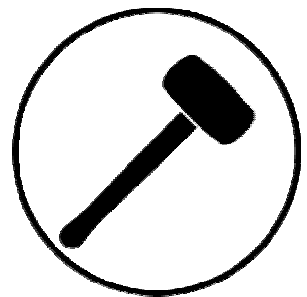
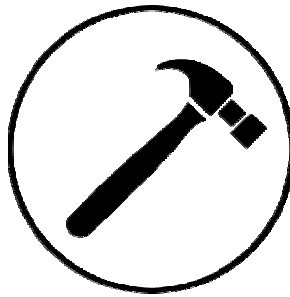
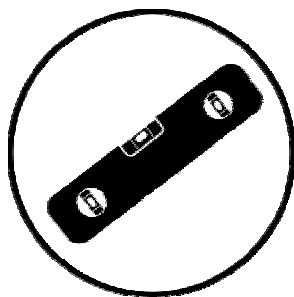
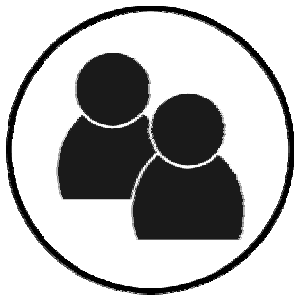
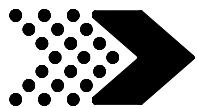

## Icons and their uses you will see throughout this manual



You will need to make sure that your assembly is square before tightening your bolts.



When you see this icon you will need a socket wrench. The icons below show the size of attachments needed for assembly 1/2.



For proper assembly you will need to ensure that your structure is level before proceeding to the next step.

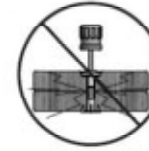

This icon warns you to not over tighten your bolts. This is to prevent structural damage and also splintering your wood.



Some steps in the assembly process will require an extra set of hands. Make sure you have a helper available.



A ladder will be needed for assembly. Do NOT stand on the set when it is incomplete, unstable, and not anchored. Failure to do so may result in injury.



This icon shows the size of an open ended wrench. Using the wrench as the fraction bar.



This icon will show you what drill attachments are needed. For this example you will need a Phillips head attachment and 3/8 drill bit.





**It is critically important that you start with square and level footings, concrete pad or deck to attach your structure**

- Pay close attention to the items needed for each step. Make sure you are using the correct hardware for each step. Using incorrect hardware may result in improper assembly
- Remember to double check for underground utilities and overhead electrical lines

**Post mounts are provided with your structure which allows you to permanently install your structure to a pre-existing or new wood or concrete surface.**

- The hardware to attach the post mounts to the structure is included.
- The hardware to mount the structure permanently to a concrete surface is included.
- The hardware to mount the structure permanently to a wood deck is NOT included and will need to be purchased separately. You must ensure there is ample structural support under the deck before permanently attaching.

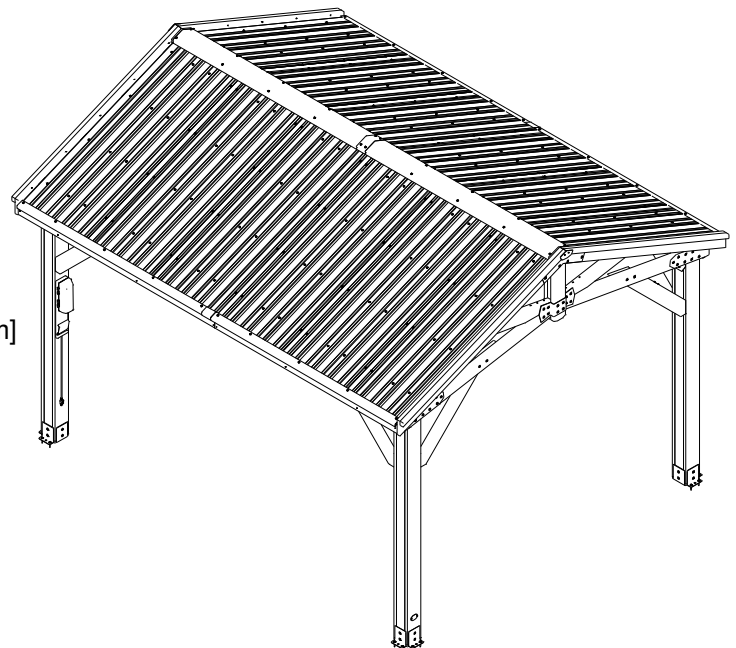
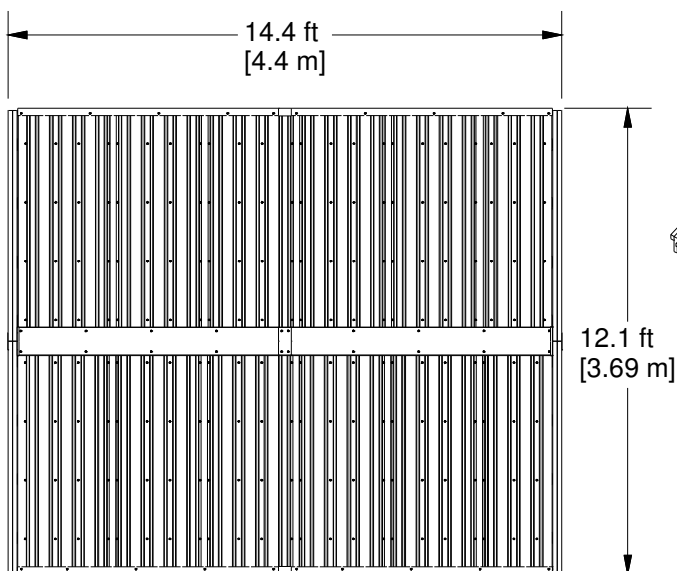
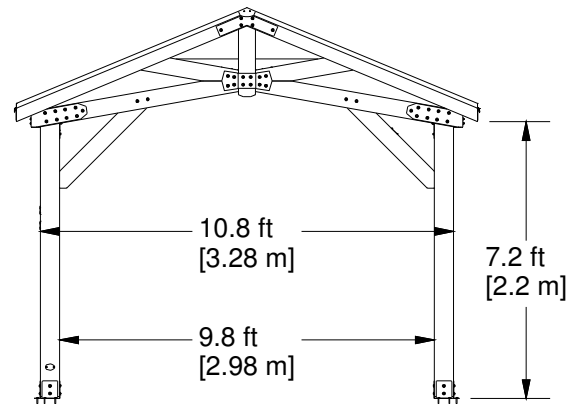
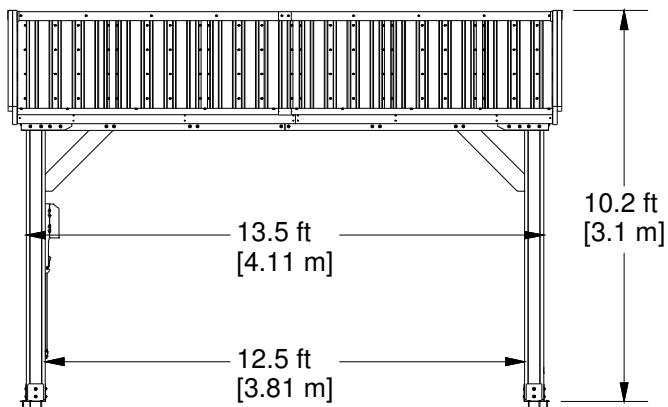



## Wood Components (Not to Scale)



**D01 | GABLE BOARD - W4L14992**  
(x4) | 1 3/8"x5 1/4"x24 1/4" (36x134x615)



**D02 | TOP RAIL - W4L14998**  
(x4) | 1 3/8"x5 1/4"x53 3/4" (36x134x1366)



**D03 | TOP RAIL - W4L14994**  
(x2) | 1 3/8"x5 1/4"x57" (36x134x1448)



**D04 | CORBEL - W4L14997**  
(x4) | 1 3/8"x5 1/4"x35 7/8" (36x134x910)



**D05 | GABLE BOARD - W4L14995**  
(x2) | 1 3/8"x1 1/2"x5 1/4" (36x38x134)

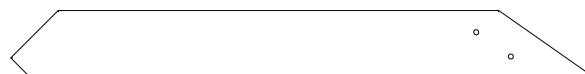

**D06 | CORBEL - W4L14996**  
(x3) | 1 3/8"x5 1/4"x45 5/8" (36x134x1160)



**D07 | TOP RAIL - W4L15038**  
(x4) | 1 3/8"x5 1/4"x82 1/4" (36x134x2091)



**E01 | RAFTER - W4L14988**  
(x8) | 1 3/8"x3 3/8"x76 3/8" (36x86x1941)

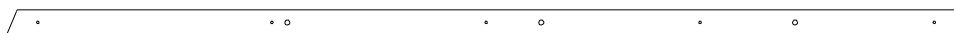

**E02 | TRUSS - W4L15001**  
(x4) | 1 7/16"x1 15/16"x74 15/16" (36x50x1903)



**E03 | SHEATHING BOARD - W4L14989**  
(x8) | 1 3/8"x3 3/8"x80 3/8" (36x86x2040)

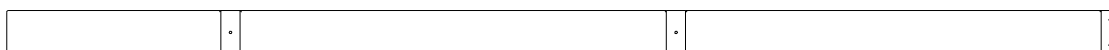

**E04 | SHEATHING BOARD - W4L14990**  
(x8) | 1 3/8"x3 3/8"x87" (36x86x2209)



**E05 | RAFTER - W4L15004**  
(x4) | 1 3/8"x3 3/8"x76 3/8" (36x86x1941)



**E06 | ACCESSORY TRUSS - W4L14991**  
(x2) | 1 3/8"x3 3/8"x73 13/16" (36x86x1875)



**H02 | FASCIA - W4L14987**  
(x2) | 1"x3 3/8"x80 3/8" (24x86x2040)



**H03 | FASCIA - W4L14993**  
(x2) | 1"x3 3/8"x87" (24x86x2209)



**H04 | RAFTER - W4L14999**  
(x2) | 1"x3 3/8"x89 1/4" (24x86x2267)



Wood Components (Not to Scale)



**H05** | RAFTER - W4L15000  
(x2) | 1"x3 3/8"x69 1/2" (24x86x1766)



**H06** | FASCIA - W4L15005  
(x2) | 1"x3 3/8"x63 1/2" (24x86x1614)



**H07** | FASCIA - W4L15006  
(x2) | 1"x3 3/8"x70 1/8" (24x86x1783)



**J09** | RIDGE CAP STIFFENER - W4L15002  
(x2) | 1"x2 3/8"x77 5/8" (24x60x1973)

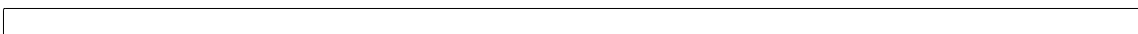

**J10** | RIDGE CAP STIFFENER - W4L15003  
(x2) | 1"x2 3/8"x89 1/2" (24x60x2273)

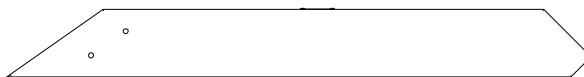

**CA01** | CORBEL - W2A02879  
(x1) | 1 7/16"x5 3/8"x46 1/16" (36x136x1160)

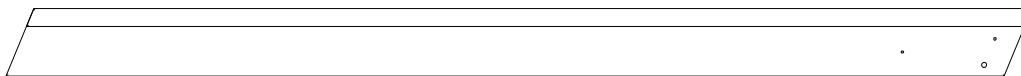

**GP1** | GABLE PANEL - W2A02871  
(x2) | 2 13/16"x5 1/4"x80 3/16" (72x134x2037)



**GP2** | GABLE PANEL - W2A02872  
(x2) | 2 13/16"x5 1/4"x80 3/16" (72x134x2037)



**P01** | POST - W2A02873  
(x2) | 6"x6"x89 1/2" (152x152x2274)



**P02** | POST - W2A02874  
(x2) | 6"x6"x89 1/2" (152x152x2274)

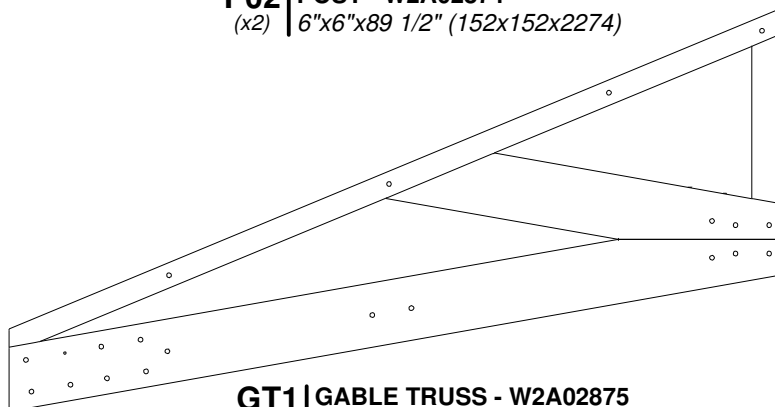

**GT1** | GABLE TRUSS - W2A02875  
(x4) | 1 7/16"x33 5/8"x64 9/16" (36x854x1640)

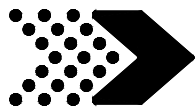

Hardware Components

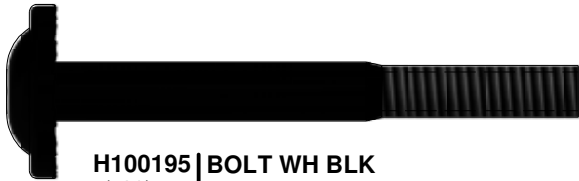

H100195 | BOLT WH BLK  
(x36) | 5/16x2-3/4



H100205 | BOLT WH BLK  
(x38) | 5/16x2-1/4



H100378 | BOLT WH BLK  
(x9) | 5/16x1 3/4



H100416 | BOLT WH BLK  
(x22) | 5/16x3



H100459 | BOLT WH BLK  
(x9) | 5/16x1 1/4



H100471 | LAG SCREW  
(x46) | WH BLK  
5/16x1 1/2



H100503 | BOLT WH BLK  
(x7) | 5/16x3-1/2



H100564 | LAG SCREW WH BLK  
(x13) | 1/4x4



H100513 | BOLT WH BLK  
(x18) | 5/16x4-1/4

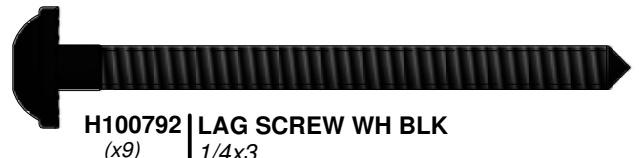

H100792 | LAG SCREW WH BLK  
(x9) | 1/4x3



H100881 | BOLT WH BLK  
(x9) | 5/16x5



H100488 | BOLT WH BLK  
(x9) | 1/4x2



H100976 | BOLT WH BLK  
(x2) | 5/16x6 1/4



H100379 | T-NUT BLK  
(x98) | 5/16



H100354 | BOLT WH BLK  
(x4) | 5/16x6 1/2



H101046 | BOLT WH BLK  
(x13) | 5/16x7 1/2

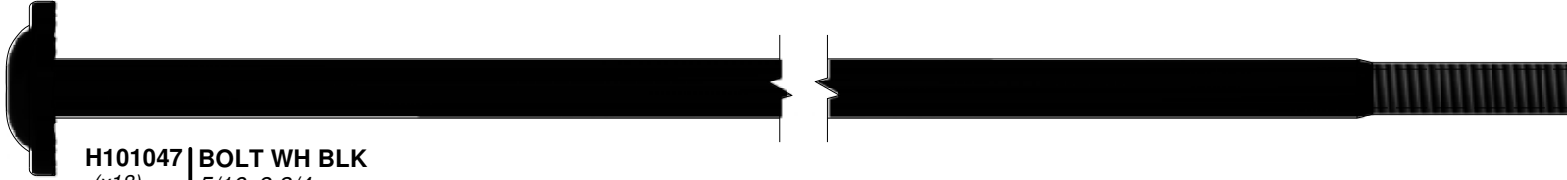

H101047 | BOLT WH BLK  
(x18) | 5/16x9 3/4

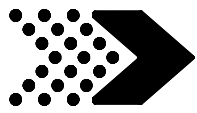

Hardware Components



H100201 | SCREW PFH BLK  
(x39) | 8x2-1/2



H100483 | SCREW PFH BLK  
(x4) | 8x2 1/4



H100391 | SCREW PFH BLK  
(x120) | 8x2



H100382 | SCREW PFH BLK  
(x11) | 8x1 3/4



H100200 | SCREW PFH BLK  
(x24) | 8x1 1/2



H100392 | SCREW PWH BLK  
(x24) | 8x3/4



H100760 | SCREW WOODGRIP  
(x188) | 10x1 1/4



H100833 | SCREW WOODGRIP  
(x22) | 10x3/4



H100759 | SCREW TAPPING  
(x22) | 1/4x3/4



H100823 | SCREW PWH BLK  
(x17) | 8x1-1/2

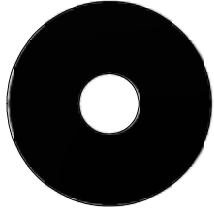

H100478 | WASHER FLAT BLK  
(x82) | 8x27



H100198 | WASHER LOCK EXT BLK  
(x68) | 8x19

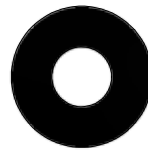

H100630 | WASHER FLAT BLK  
(x26) | 8x19



H100405 | WASHER LOCK EXT BLK  
(x22) | 6x15



H100120 | SCREW CONCRETE ANCHOR  
(x18) | 1/4x2

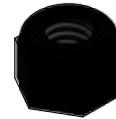

H100479 | NUT LOCK BLK  
(x76) | 5/16



H100653 | NUT LOCK BLK  
(x9) | 1/4



H100764 | SCREW SETTER  
(x1)



H100659 | LAG SCREW BLK  
(x4) | 5/16x1 1/2

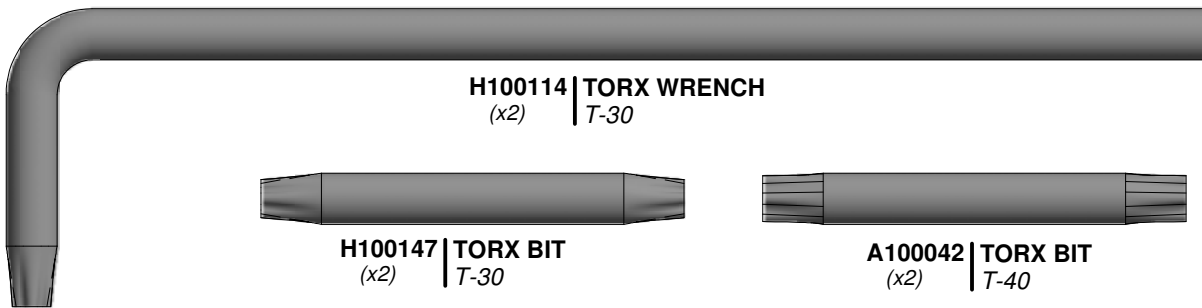

H100114 | TORX WRENCH  
(x2) | T-30



H100147 | TORX BIT  
(x2) | T-30



A100042 | TORX BIT  
(x2) | T-40

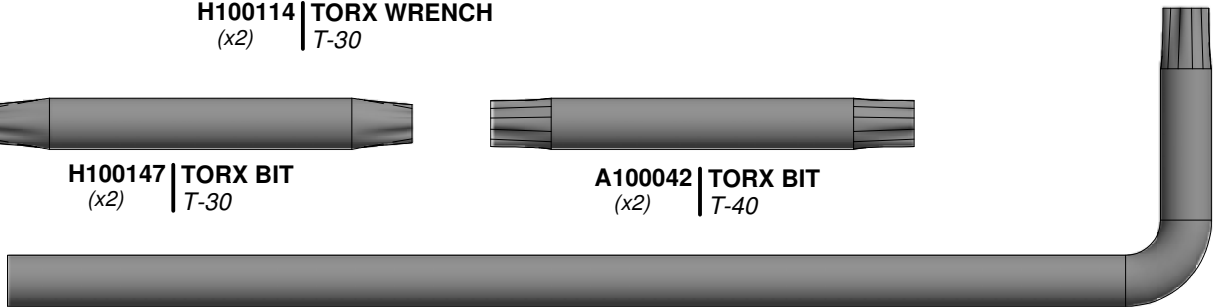

A100041 | TORX WRENCH  
(x2) | T-40

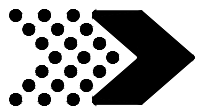

Accessory Components (Not to Scale)

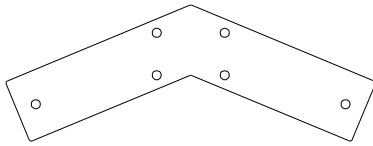

A4M01130 | GABLE BRACKET  
(x2)

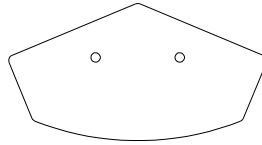

A4M01147 | PEAK SEAM BRACKET  
(x2)

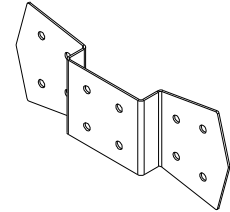

A4M01129 | GABLE BRACKET  
(x4)



A4M00978 | POST PLATE  
(x8)

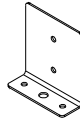

A4M00977 | POST ANCHORING PLATE  
(x8)

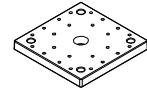

A6P00308 | 6x6 POST FOOT  
(x4)

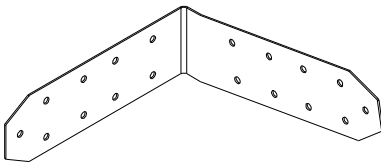

A4M01301 | RIGHT OUTSIDE BRACKET  
(x2)

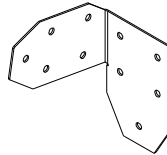

A4M01232 | LEFT ANGLE BRACKET  
(x2)

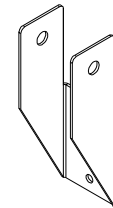

A4M01228 | RAFTER BRACKET  
(x8)

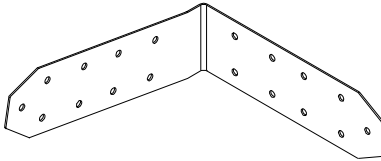

A4M01302 | LEFT OUTSIDE BRACKET  
(x2)

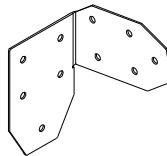

A4M01233 | RIGHT ANGLE BRACKET  
(x2)

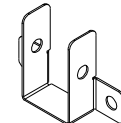

A4M01148 | TRUSS BRACKET  
(x2)



A100241 | BYD ID TAG  
(SMALL)  
WITHOUT AGES  
(x1)

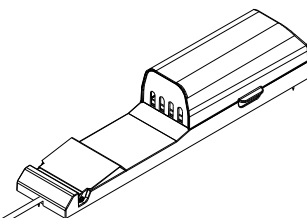

9205413 | ELECTRICAL ENCLOSURE  
(x1)

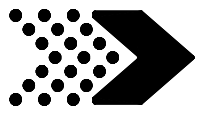

Accessory Components (Not to Scale)

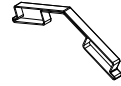
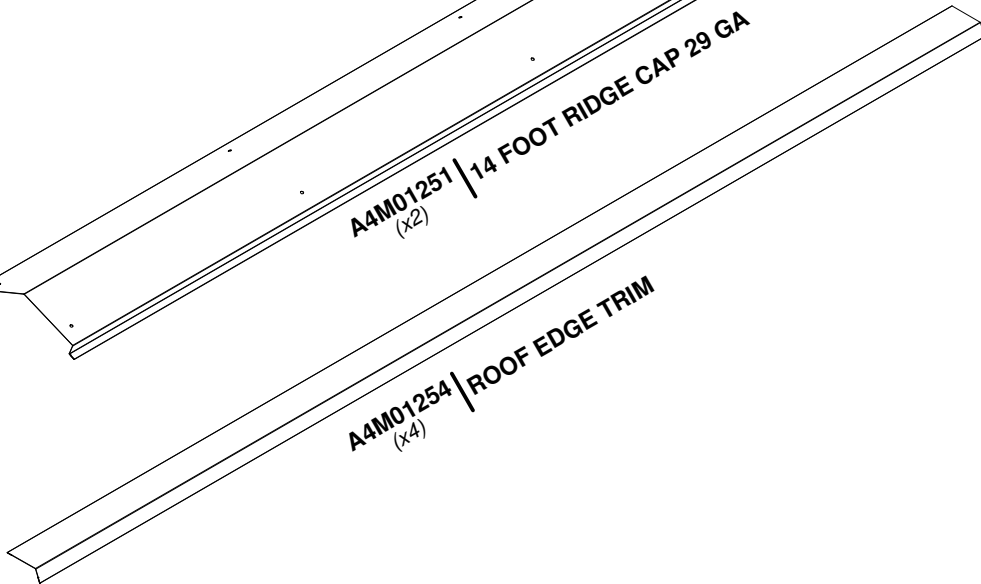
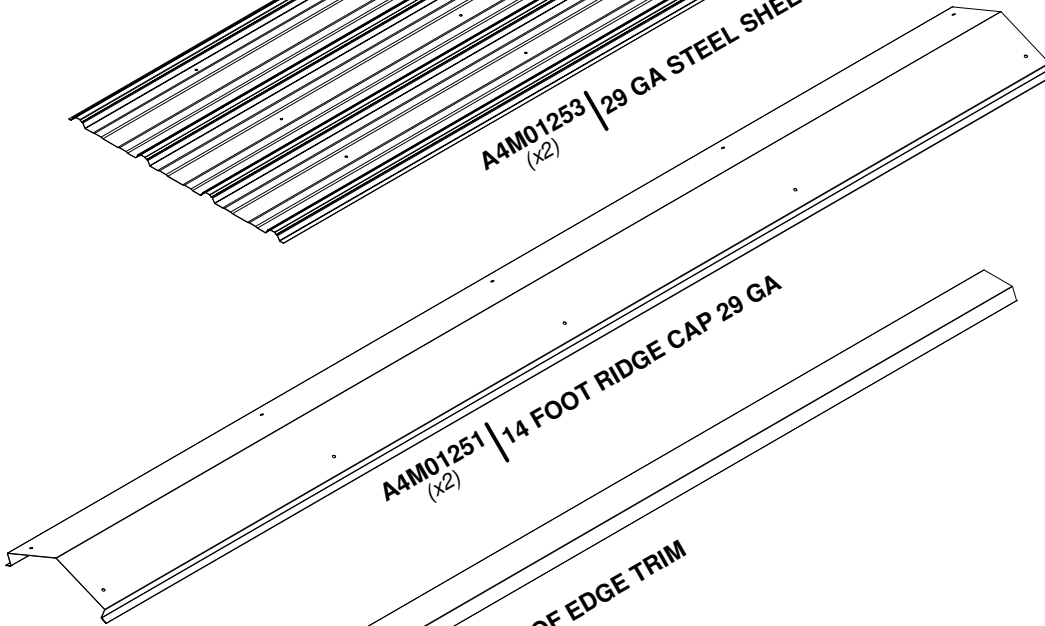
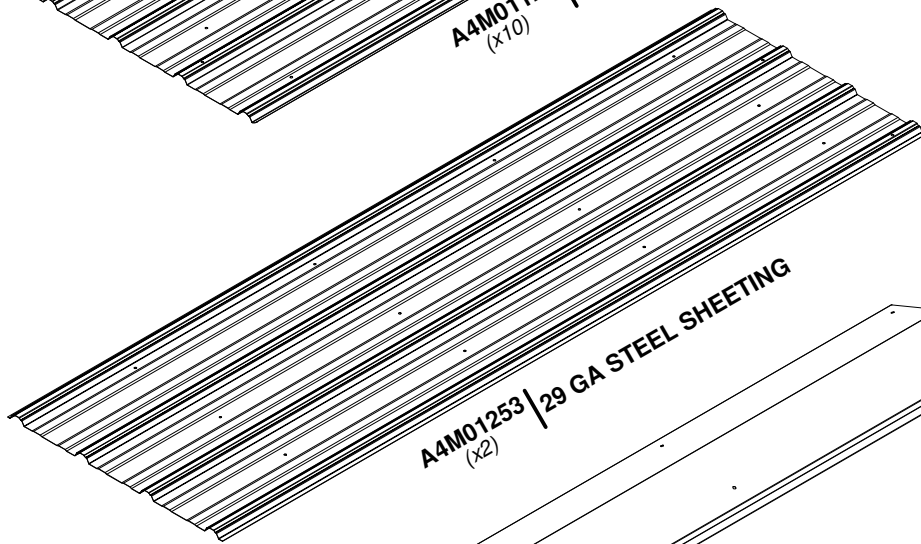
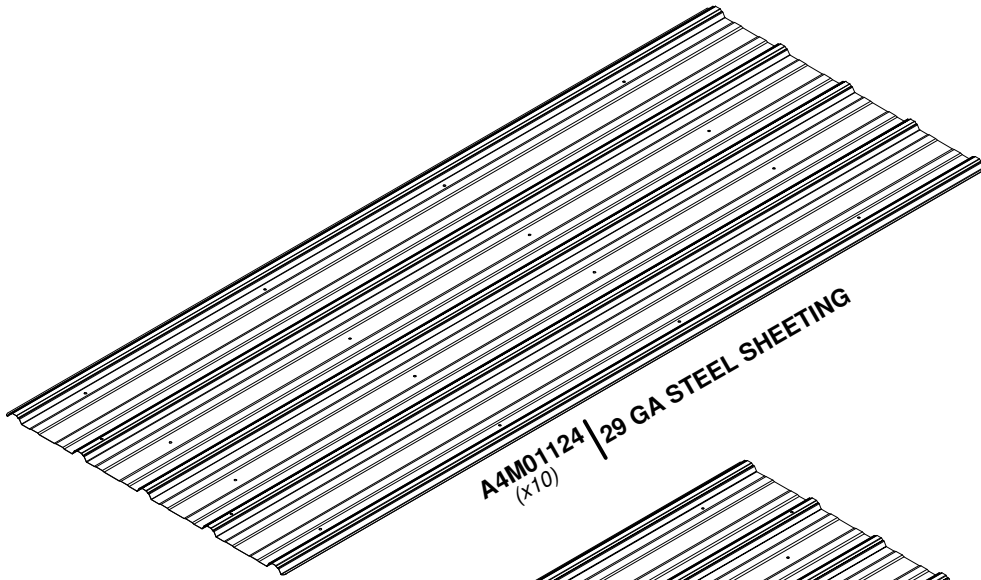

A6P00398 | RIDGE CAP PROTECTOR  
(x2)

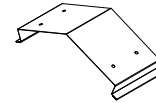

A4M01127 | RIDGE CAP SPLICE  
(x1)



A4M00983 | ROOF EDGE TRIM SPLICE  
(x2)



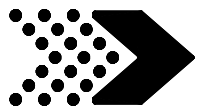

# STEP 1



**P01** | POST - W2A02873  
(x2) | 6"x6"x89 1/2" (152x152x2274)



**P02** | POST - W2A02874  
(x2) | 6"x6"x89 1/2" (152x152x2274)

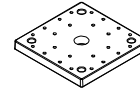

**A6P00308** | 6x6 POST FOOT  
(x4)



**H100200** | SCREW PFH BLK  
(x16) | 8x1 1/2

**COMPLETE THIS STEP TWICE**



**TIP:**

FOR EASE OF ASSEMBLY WE RECOMMEND USING SAW HORSES FOR STEPS 1 THRU 6.

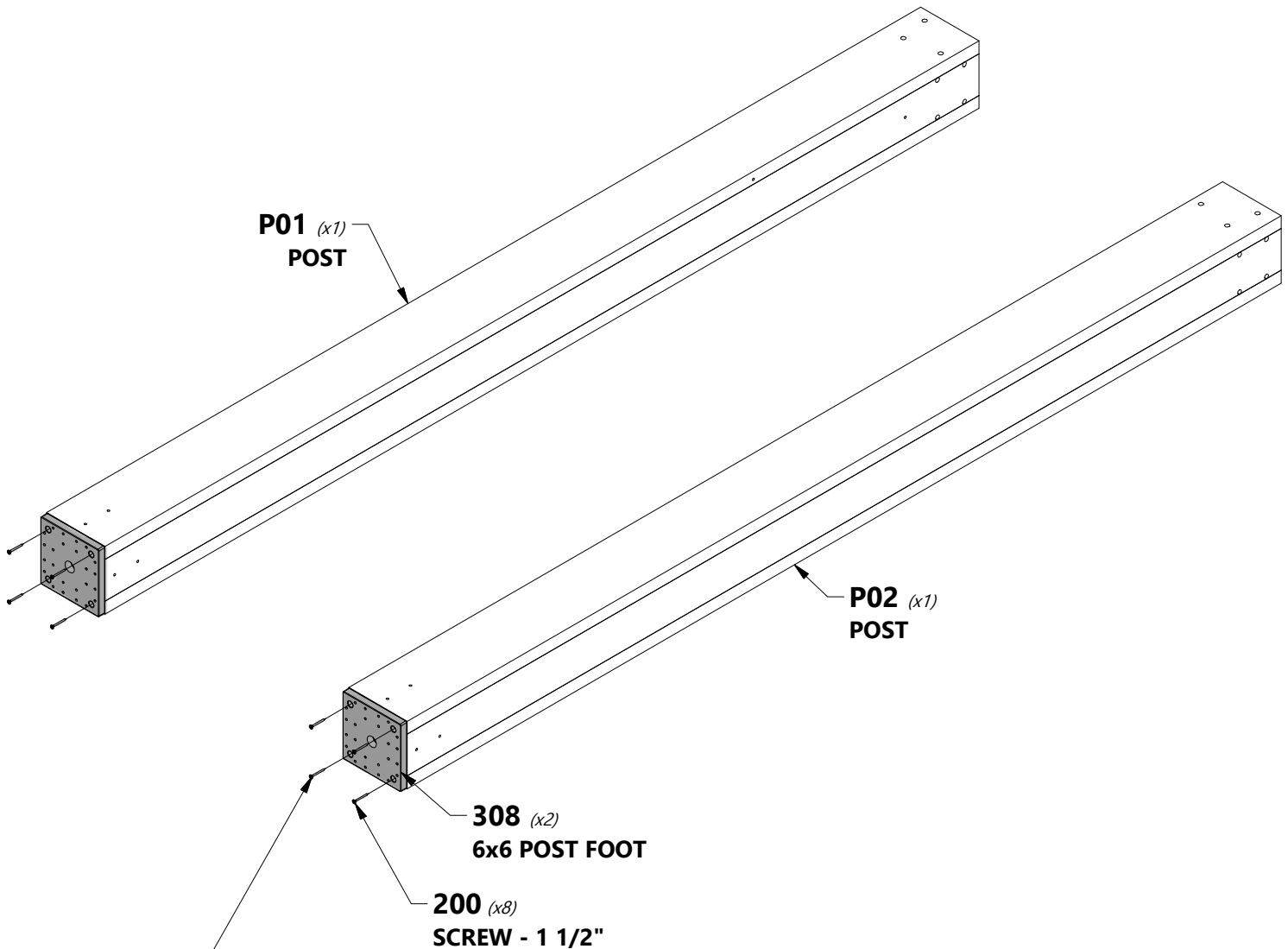

**NOTE:**  
ALIGN POST FOOT & DRILL  
1/8" PILOT HOLES FOR THE  
ATTACHMENT HARDWARE.

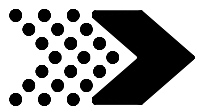

# STEP 2

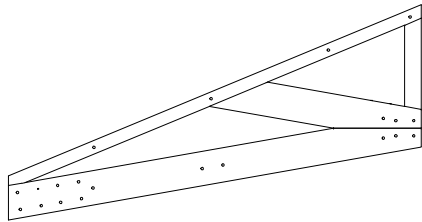

**GT1 | GABLE TRUSS**  
(x4) | 1 7/16"x33 5/8"x64 9/16" (36x854x1640)



**D01 | GABLE BOARD - W4L14992**  
(x4) | 1 3/8"x5 1/4"x24 1/4" (36x134x615)



**D05 | GABLE BOARD - W4L14995**  
(x2) | 1 3/8"x1 1/2"x5 1/4" (36x38x134)

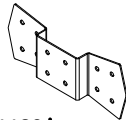

**A4M01129 | GABLE BRACKET**  
(x4)



**H100881 | BOLT WH BLK**  
(x8) | 5/16x5



**H100205 | BOLT WH BLK**  
(x16) | 5/16x2-1/4



**H100479 | NUT LOCK BLK**  
(x24) | 5/16



**H100483 | SCREW PFH BLK**  
(x4) | 8x2 1/4



**H100478 | WASHER FLAT BLK**  
(x24) | 8x27

**COMPLETE THIS STEP TWICE**



**NOTE:**  
IF NEEDED FOR EASE OF ASSEMBLY, USE METAL BRACKET AS A GUIDE AND DRILL THRU USING A 7/16" - (10mm) DRILL BIT, THEN ASSEMBLE.

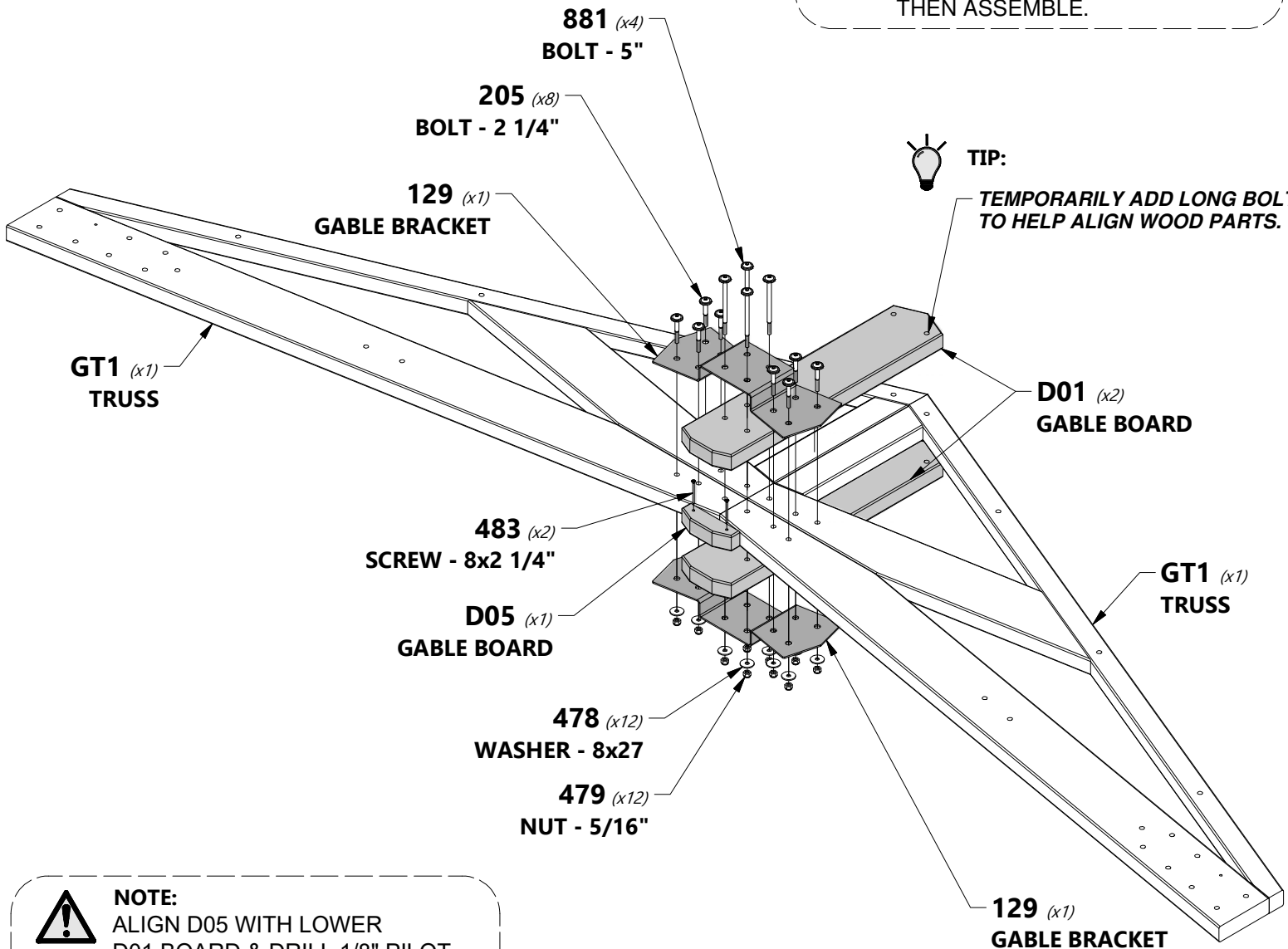

**TIP:**

TEMPORARILY ADD LONG BOLTS TO HELP ALIGN WOOD PARTS.



**NOTE:**  
ALIGN D05 WITH LOWER D01 BOARD & DRILL 1/8" PILOT HOLES FOR ATTACHMENT HARDWARE.

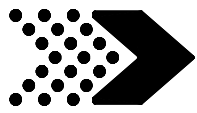

# STEP 3A

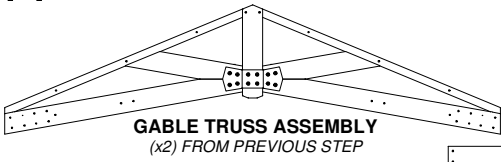

**D02 | TOP RAIL - W4L14998**  
(x4) | 1 3/8"x5 1/4"x53 3/4" (36x134x1366)

**D07 | TOP RAIL - W4L15038**  
(x4) | 1 3/8"x5 1/4"x82 1/4" (36x134x2091)

**P01 | POST - W2A02873**  
(x2) | 6"x6"x89 1/2" (152x152x2274)

**P02 | POST - W2A02874**  
(x2) | 6"x6"x89 1/2" (152x152x2274)

**A4M01301 | RIGHT OUTSIDE BRACKET**  
(x2)

**A4M01232 | LEFT ANGLE BRACKET**  
(x2)

**A4M01302 | LEFT OUTSIDE BRACKET**  
(x2)

**A4M01233 | RIGHT ANGLE BRACKET**  
(x2)

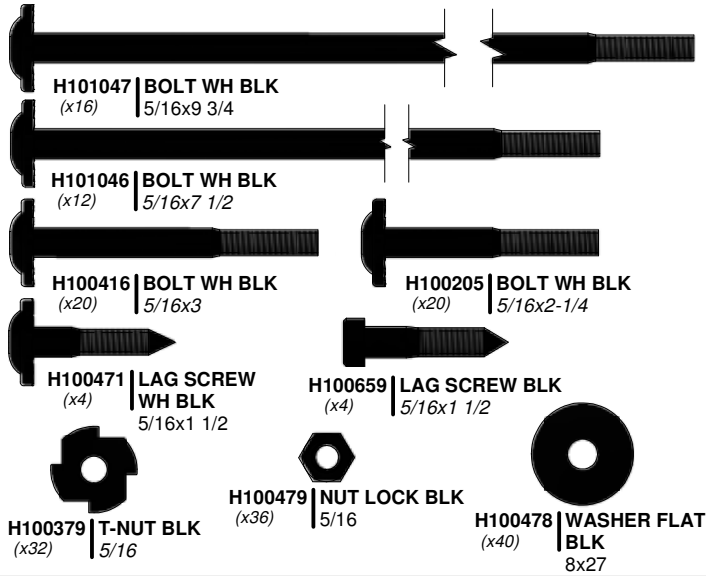

## COMPLETE THIS STEP TWICE

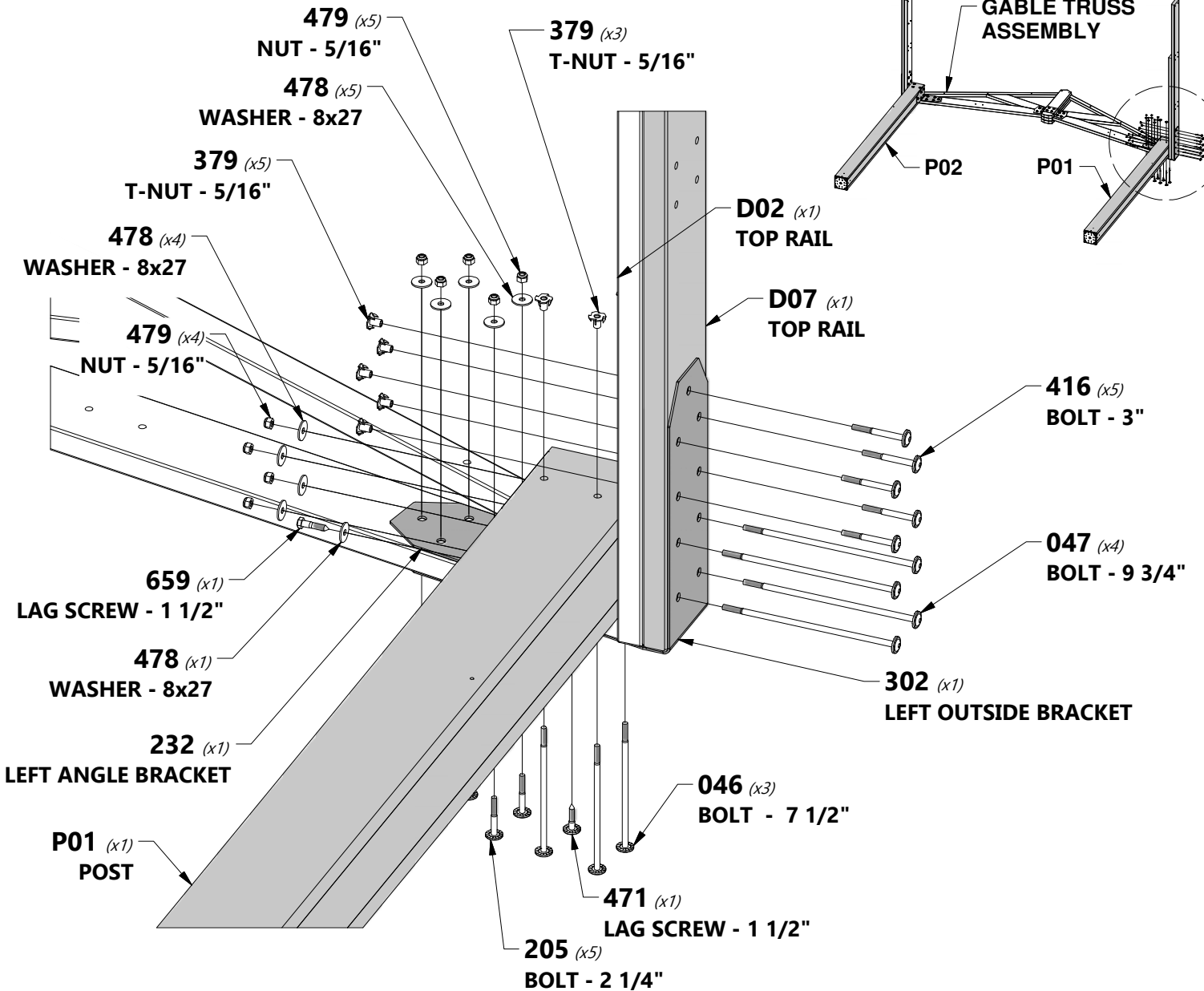

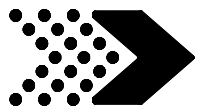

# STEP 3B

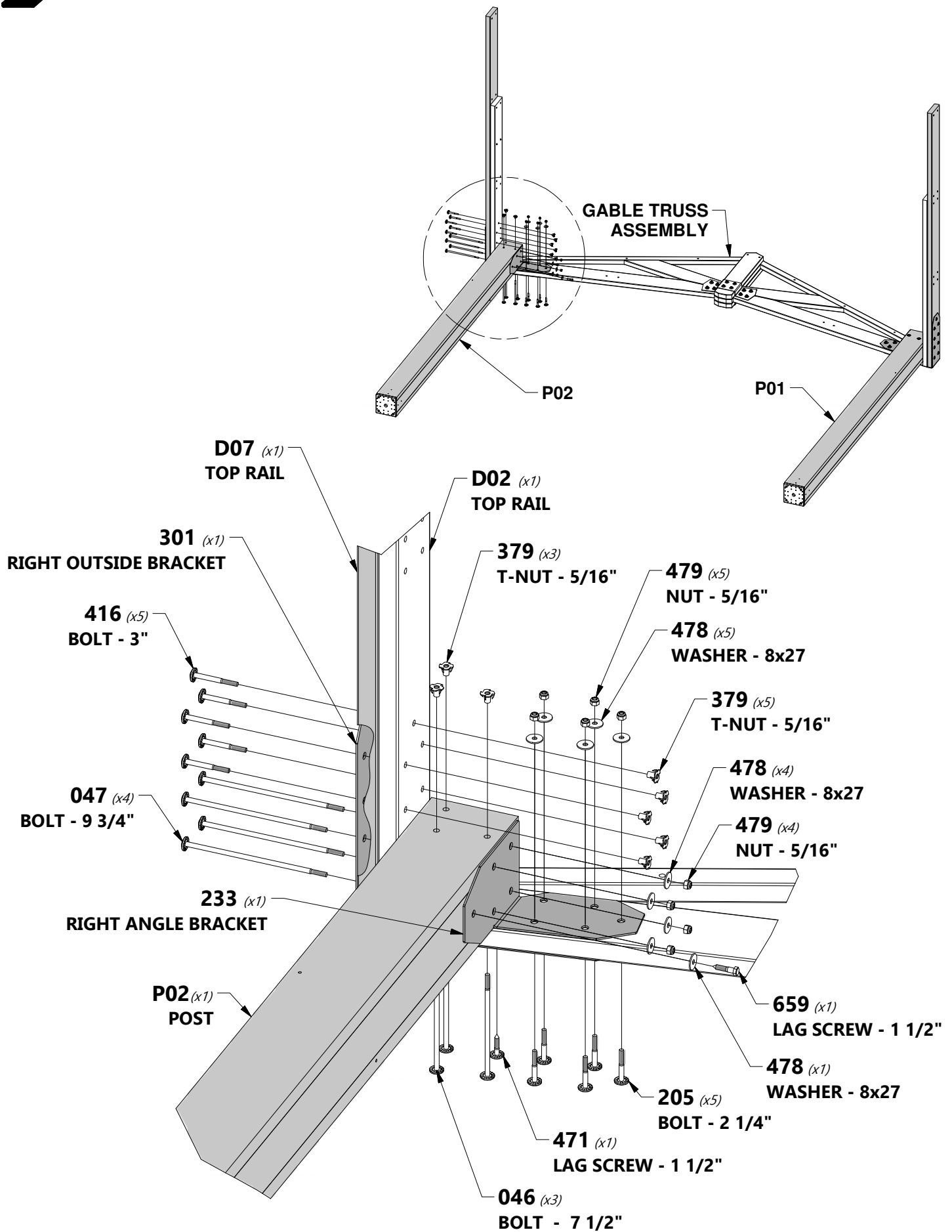

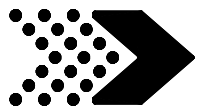

# STEP 4

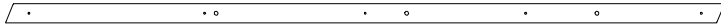

**E02** | TRUSS - W4L15001  
(x4) | 1 7/16"x1 15/16"x74 15/16" (36x50x1903)



**H100201** | SCREW PFH BLK  
(16) | 8x2-1/2

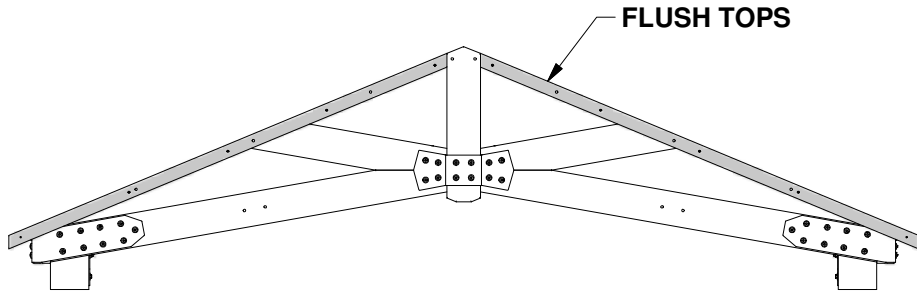

**COMPLETE THIS STEP TWICE**

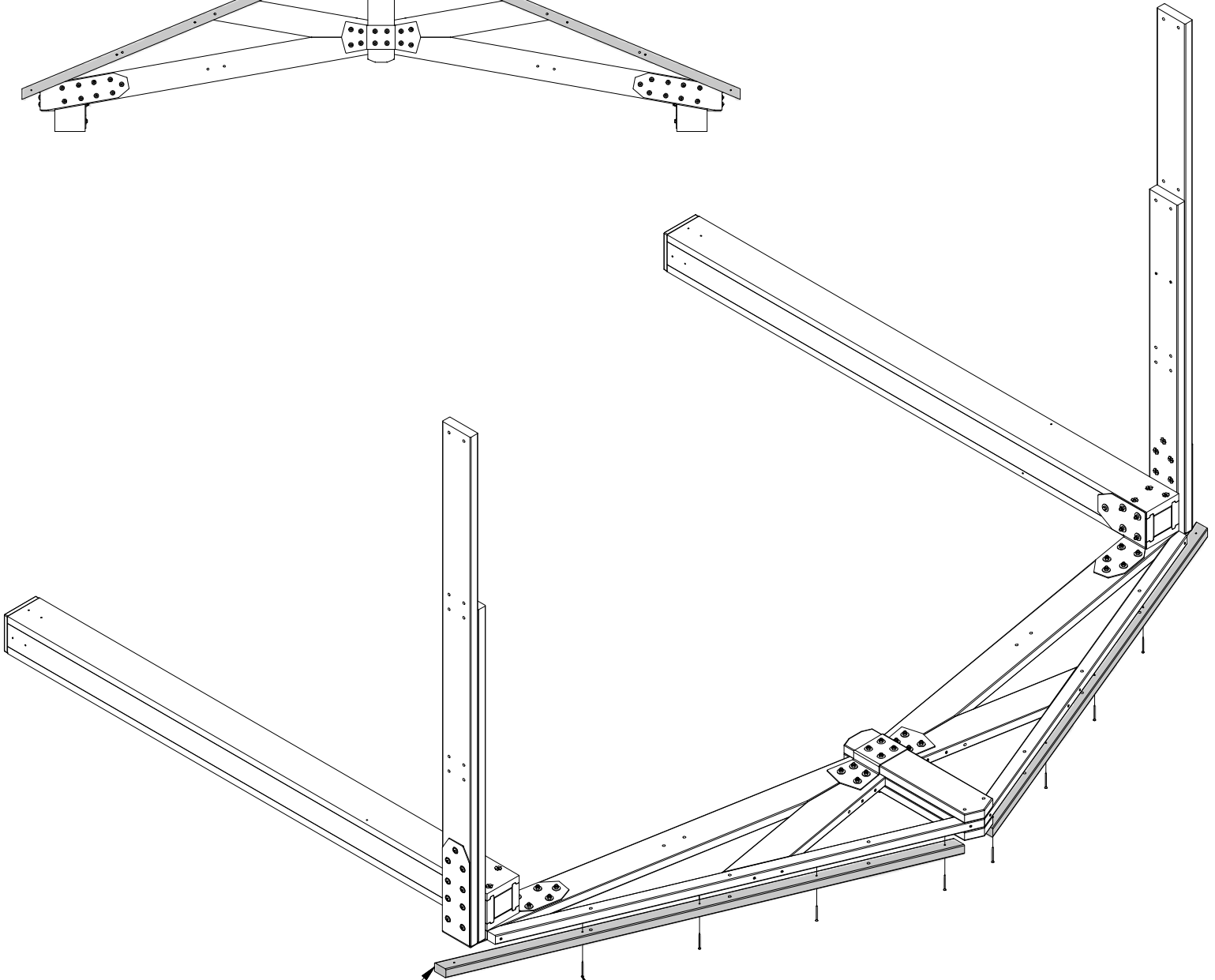

**E02** (x2)  
TRUSS

**201** (x8)  
SCREW - 2 1/2"

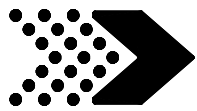

# STEP 5



**D06 | CORBEL - W4L14996**  
(x3) | 1 3/8"x5 1/4"x45 5/8" (36x134x1160)



**CA01 | CORBEL - W2A02879**  
(x1) | 1 7/16"x5 3/8"x46 1/16" (36x136x1170)

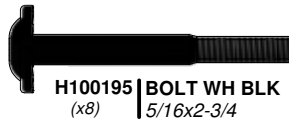

**H100195 | BOLT WH BLK**  
(x8) | 5/16x2-3/4

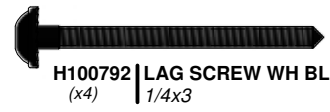

**H100792 | LAG SCREW WH BLK**  
(x4) | 1/4x3



**H100379 | T-NUT BLK**  
(x8) | 5/16



**H100198 | WASHER LOCK  
EXT BLK**  
(x8) | 8x19



**H100405 | WASHER LOCK  
EXT BLK**  
(x4) | 6x15

## COMPLETE THIS STEP TWICE

2 D06 BOARDS WILL BE USED FOR THE OTHER SIDE.

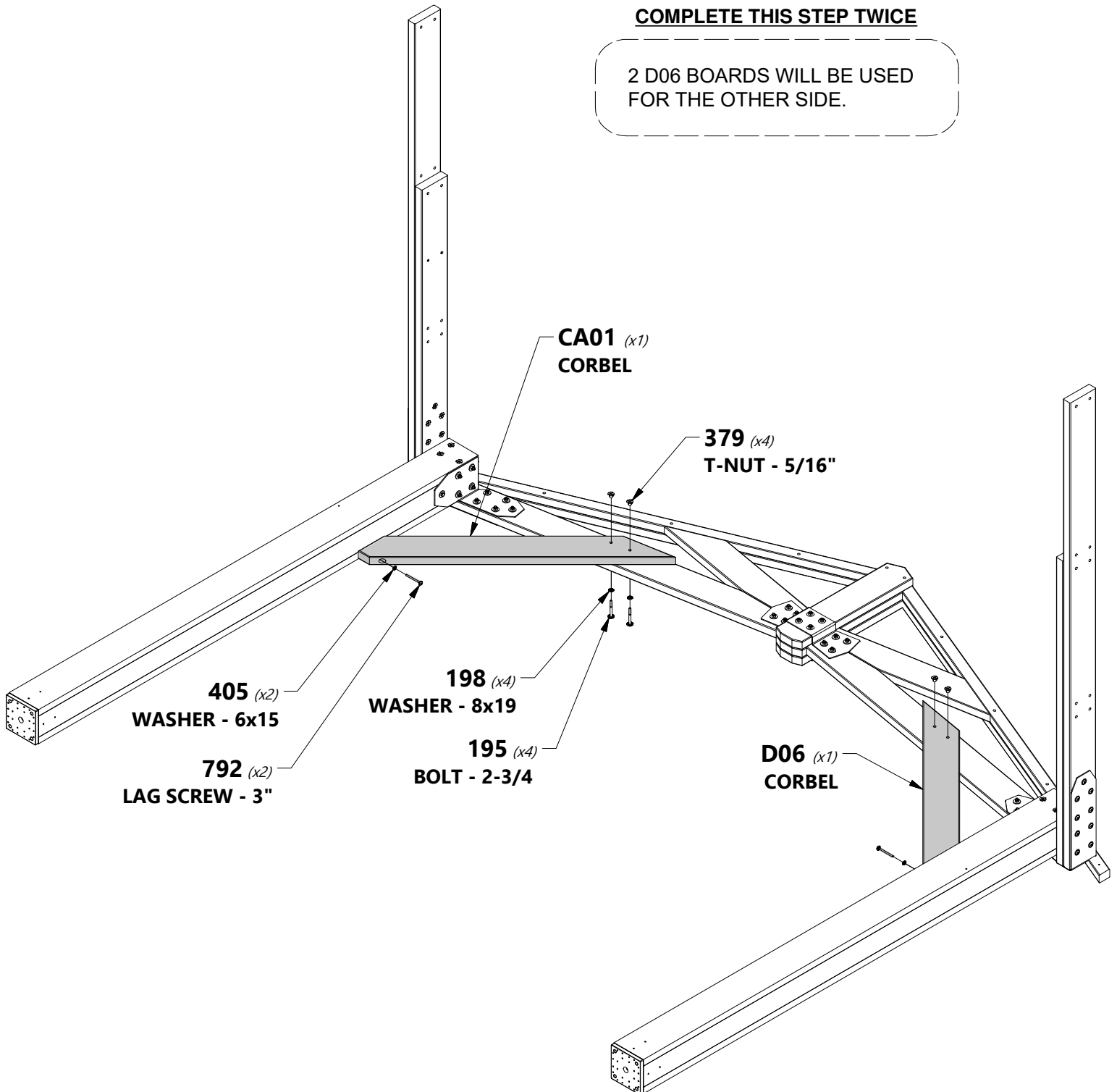

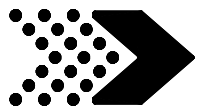

# STEP 6

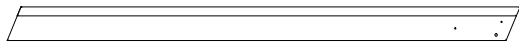

**GP1** | GABLE PANEL - W2A02871  
(x2) | 2 13/16"x5 1/4"x80 3/16" (72x134x2037)

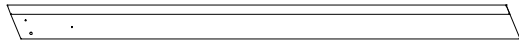

**GP2** | GABLE PANEL - W2A02872  
(x2) | 2 13/16"x5 1/4"x80 3/16" (72x134x2037)



**A4M01147** | PEAK SEAM BRACKET  
(x2)

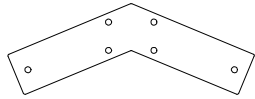

**A4M01130** | GABLE BRACKET  
(x2)



**H100564** | LAG SCREW WH BLK  
(x12) | 1/4x4



**H100405** | WASHER LOCK  
(x12) | EXT BLK  
6x15



**H100471** | LAG SCREW  
(x8) | WH BLK  
5/16x1 1/2



**H100200** | SCREW PFH BLK  
(x4) | 8x1 1/2



**H100201** | SCREW PFH BLK  
(x4) | 8x2-1/2

## COMPLETE THIS STEP TWICE

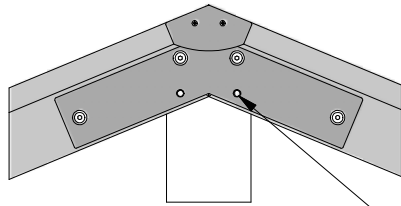

FRONT VIEW



**TIP:**  
TEMPORARILY ADD LONG BOLTS  
TO HELP ALIGN WOOD PARTS.

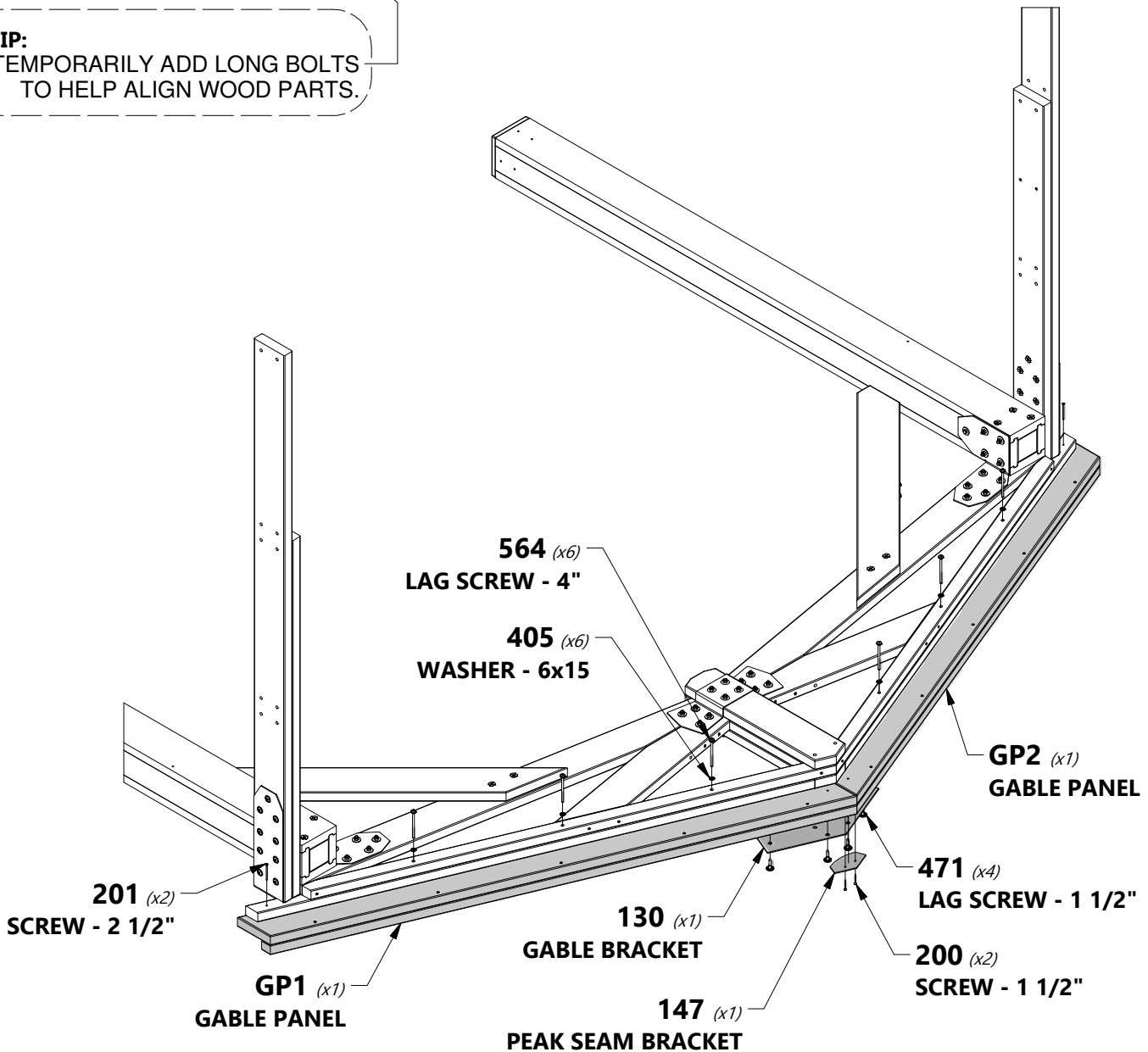

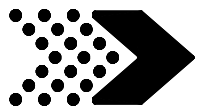

# STEP 7

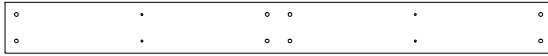

**D03 | TOP RAIL - W4L14994**  
(x2) | 1 3/8"x5 1/4"x57" (36x134x1448)

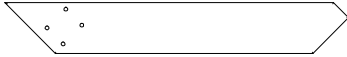

**D04 | CORBEL - W4L14997**  
(x2) | 1 3/8"x5 1/4"x35 7/8" (36x134x910)



**H100513 | BOLT WH BLK**  
(x8) | 5/16x4-1/4



**H100195 | BOLT WH BLK**  
(x12) | 5/16x2-3/4



**H100379 | T-NUT BLK**  
(x20) | 5/16



**H100198 | WASHER LOCK  
EXT BLK**  
(x20) | 8x19



**H100792 | LAG SCREW WH BLK**  
(x2) | 1/4x3



**H100405 | WASHER LOCK  
EXT BLK**  
(x2) | 6x15

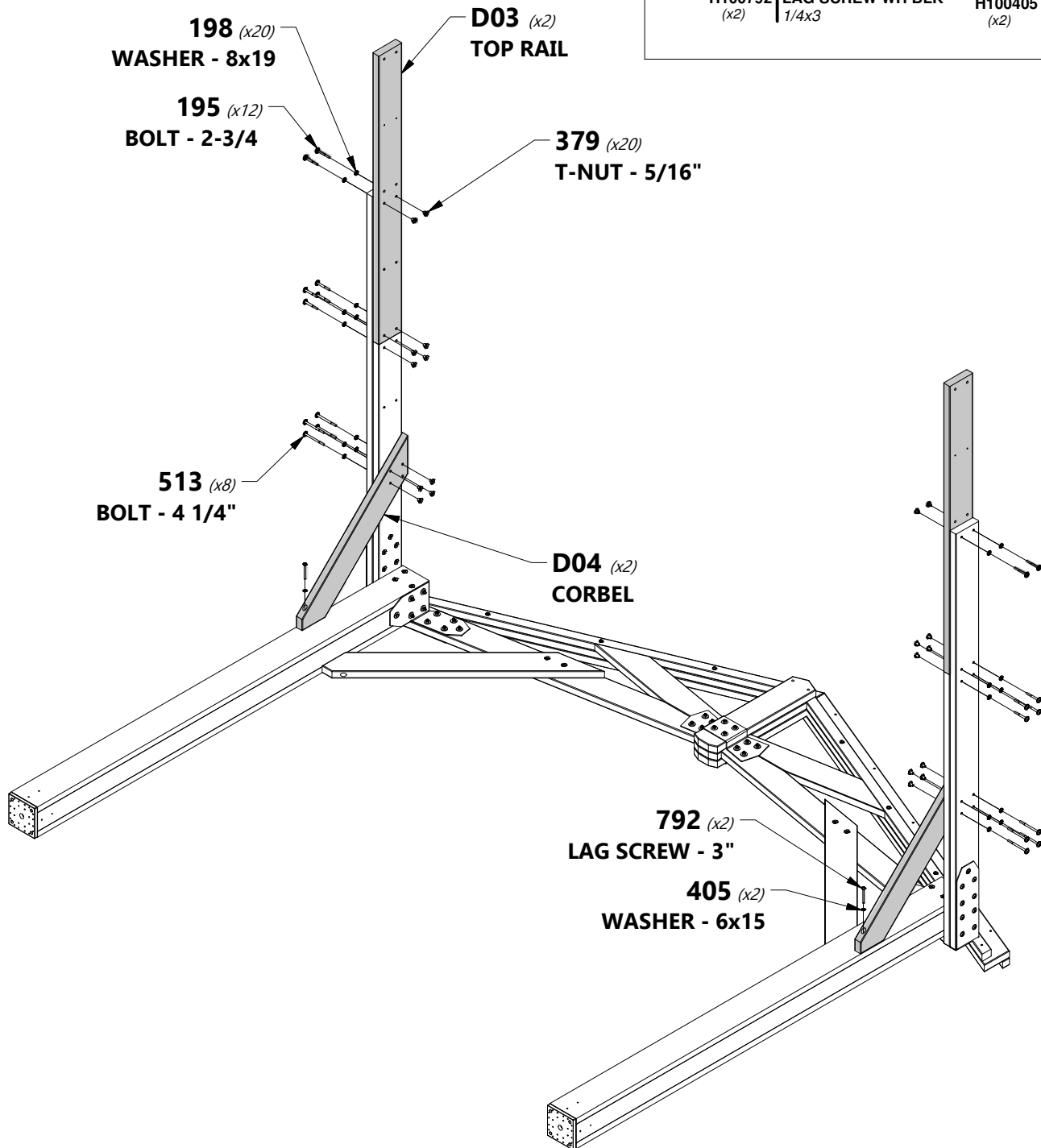



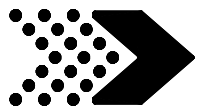

# STEP 8

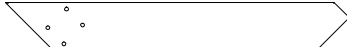

**D04 | CORBEL - W4L14997**  
(x2) | 1 3/8"x5 1/4"x35 7/8" (36x134x910)



**H100513 | BOLT WH BLK**  
(x8) | 5/16x4-1/4



**H100195 | BOLT WH BLK**  
(x12) | 5/16x2-3/4



**H100201 | SCREW PFH BLK**  
(16) | 8x2-1/2



**H100379 | T-NUT BLK**  
(x20) | 5/16



**H100198 | WASHER LOCK**  
(x20) | EXT BLK  
8x19



**H100792 | LAG SCREW WH BLK**  
(x2) | 1/4x3



**H100405 | WASHER LOCK**  
(x2) | EXT BLK  
6x15

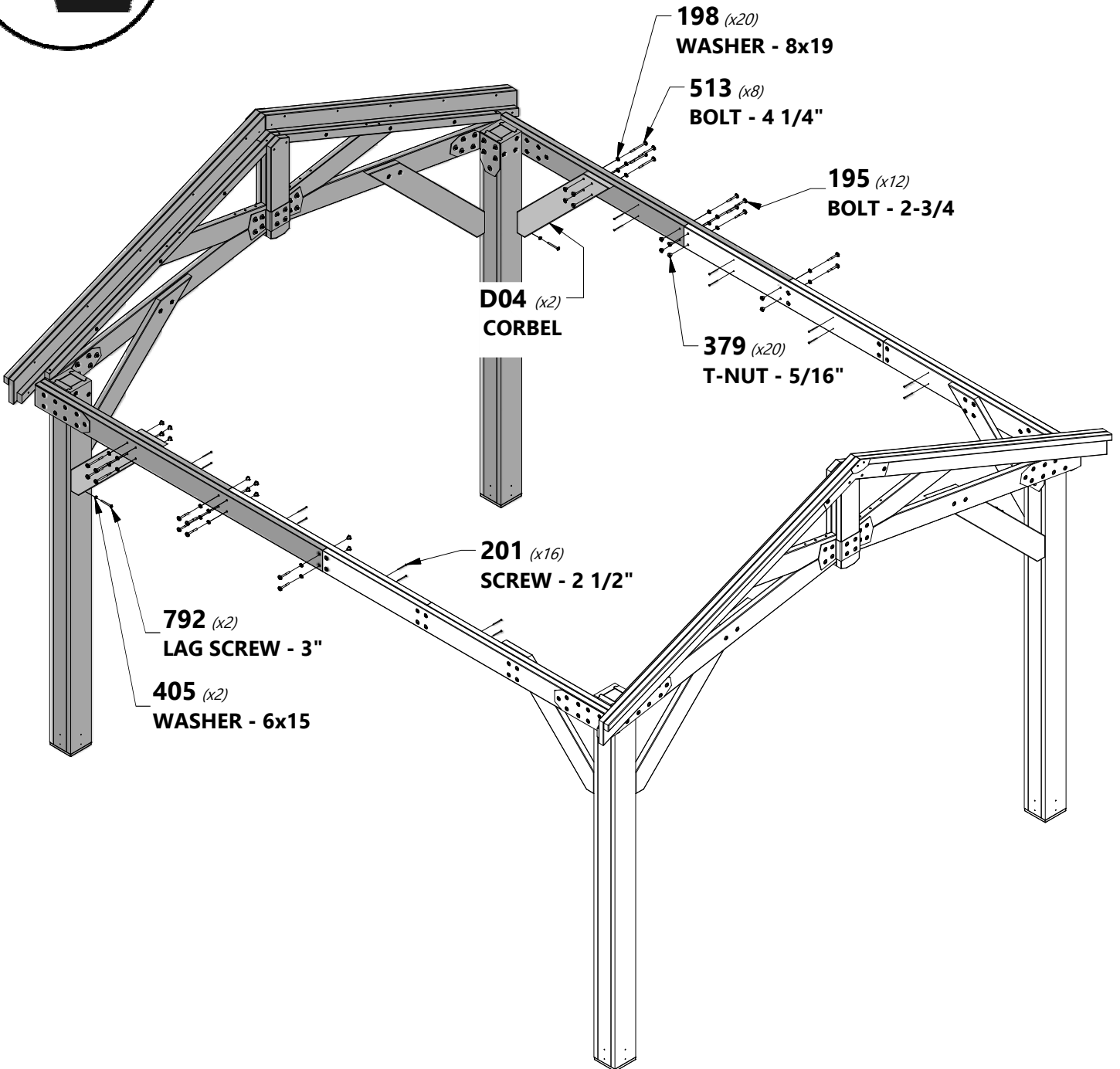
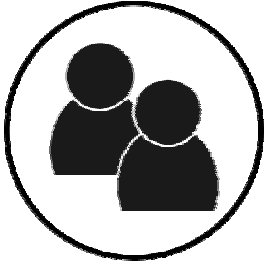

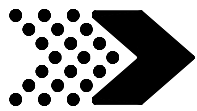

# STEP 9

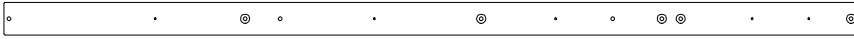

**H04 | RAFTER - W4L14999**  
(x2) | 1"x3 3/8"x89 1/4" (24x86x2267)

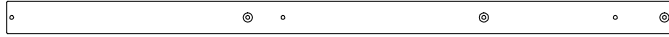

**H05 | RAFTER - W4L15000**  
(x2) | 1"x3 3/8"x69 1/2" (24x86x1766)



**H100459 | BOLT WH BLK**  
(x8) | 5/16x1 1/4



**H100379 | T-NUT BLK**  
(x16) | 5/16



**H100382 | SCREW PFH BLK**  
(x10) | 8x1 3/4



**H100198 | WASHER LOCK**  
(x8) | EXT BLK  
8x19

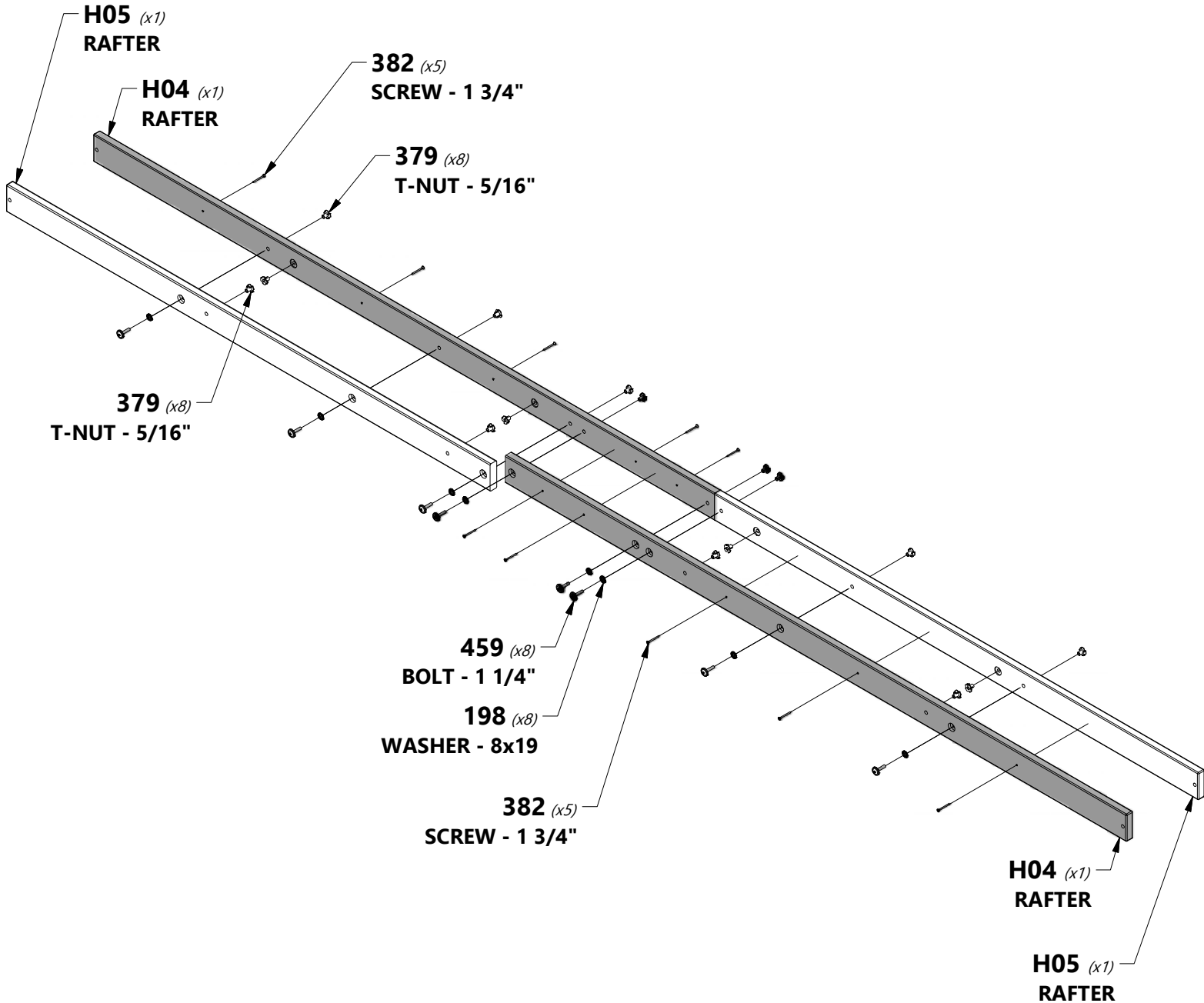

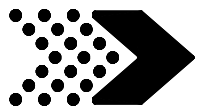

# STEP 10

**RAFTER ASSEMBLY FROM PREVIOUS STEP**

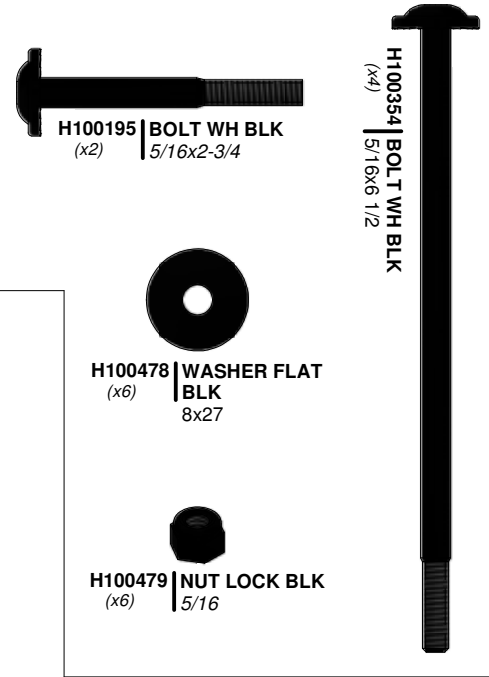
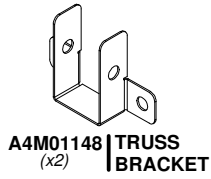

**354 (x4)**  
BOLT - 6 1/2"

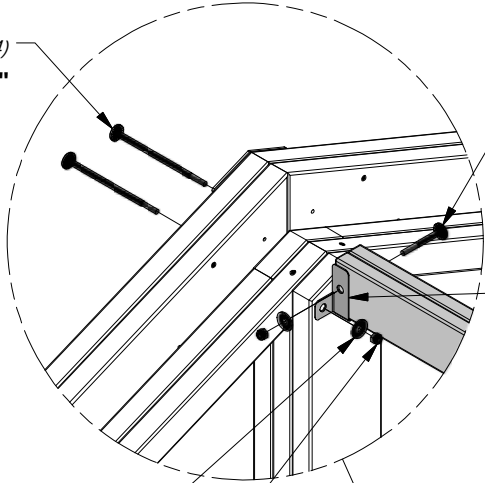

**195 (x2)**  
BOLT - 2-3/4"

**148 (x2)**  
TRUSS BRACKET

**478 (x6)**  
WASHER - 8x27

**479 (x6)**  
NUT - 5/16"

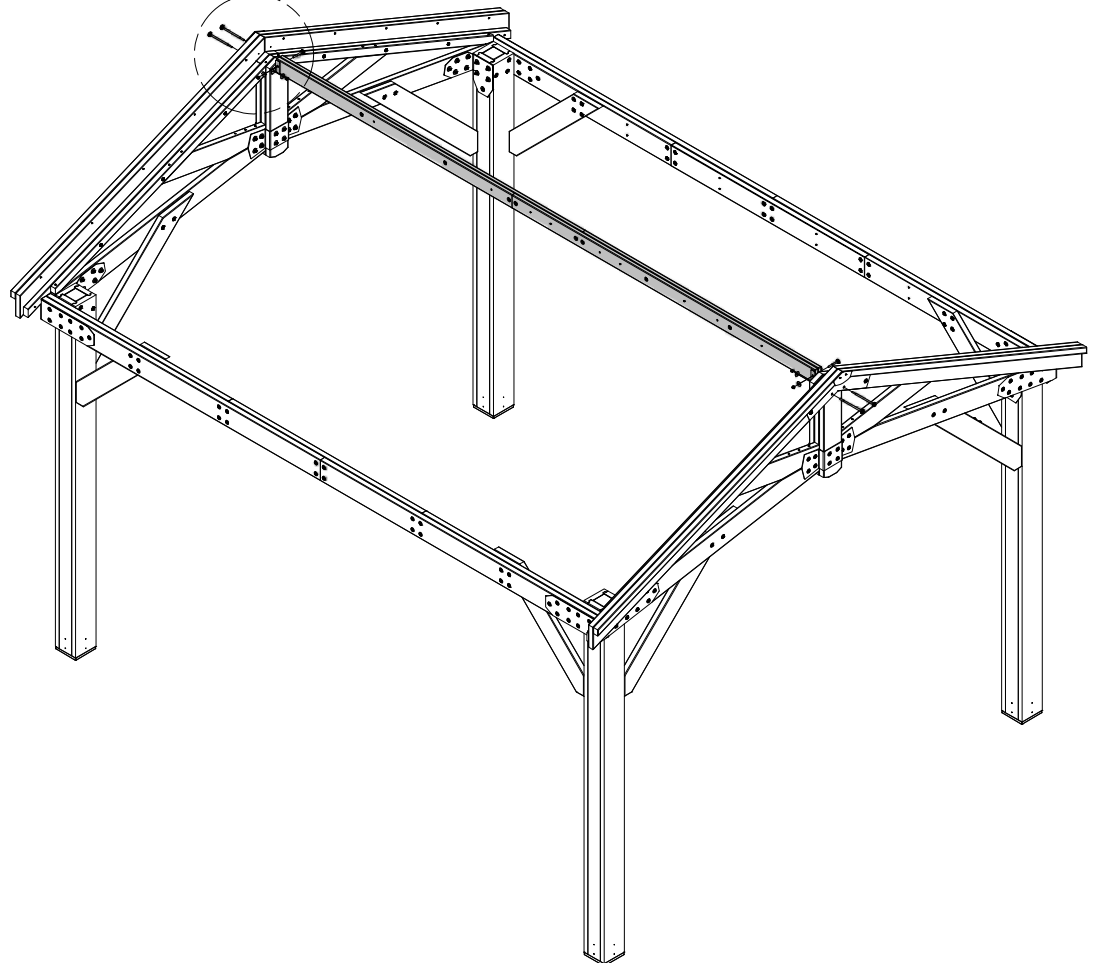

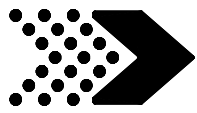

# STEP 11

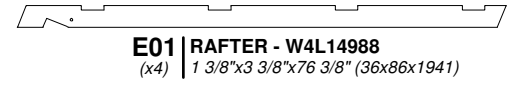

**E01** | RAFTER - W4L14988  
(x4) | 1 3/8"x3 3/8"x76 3/8" (36x86x1941)

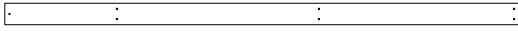

**H02** | FASCIA - W4L14987  
(x1) | 1"x3 3/8"x80 3/8" (24x86x2040)

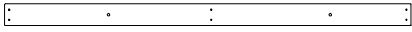

**H06** | FASCIA - W4L15005  
(x1) | 1"x3 3/8"x63 1/2" (24x86x1614)

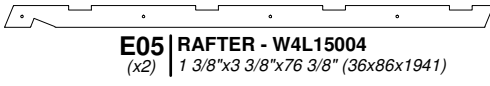

**E05** | RAFTER - W4L15004  
(x2) | 1 3/8"x3 3/8"x76 3/8" (36x86x1941)

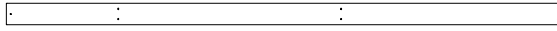

**H03** | FASCIA - W4L14993  
(x1) | 1"x3 3/8"x87" (24x86x2209)

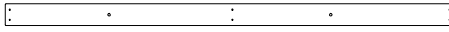

**H07** | FASCIA - W4L15006  
(x1) | 1"x3 3/8"x70 1/8" (24x86x1783)



**H100391** | SCREW PFH BLK  
(x24) | 8x2



**H100503** | BOLT WH BLK  
(x3) | 5/16x3-1/2



**H100478** | WASHER FLAT  
(x3) | BLK  
8x27



**H100479** | NUT LOCK BLK  
(x3) | 5/16

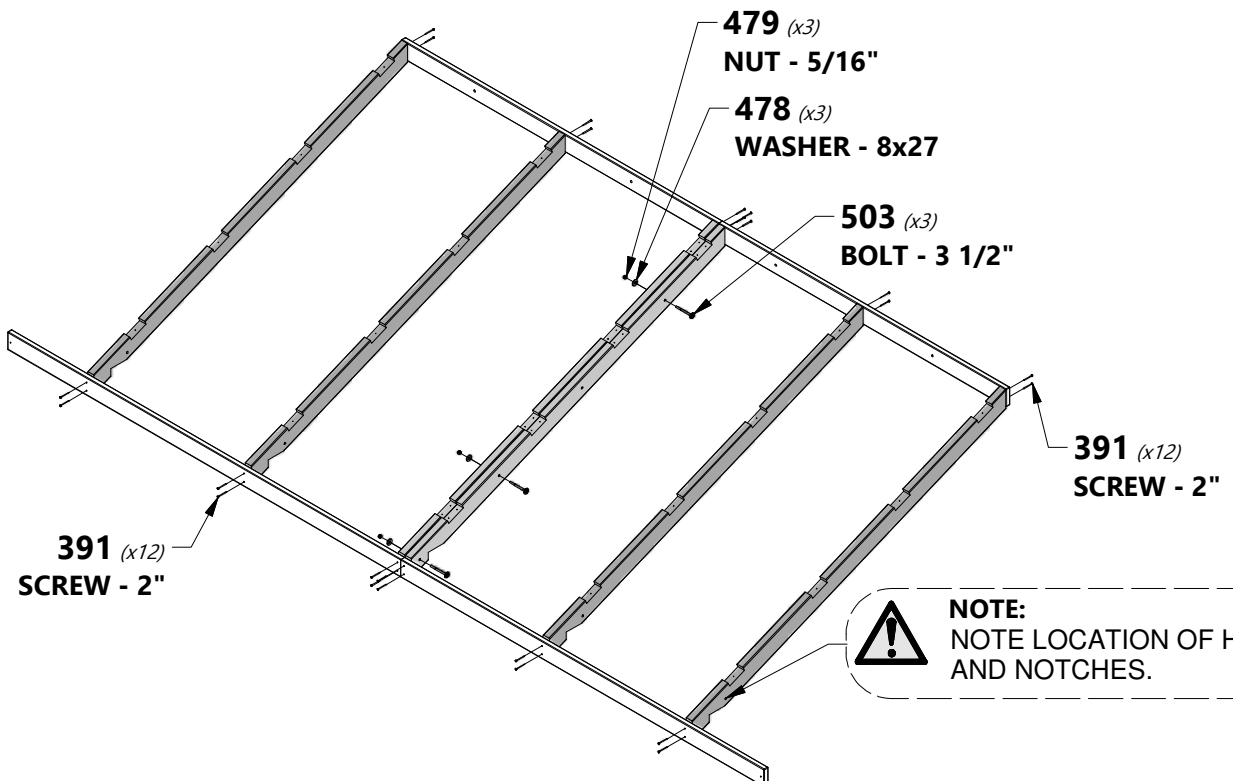
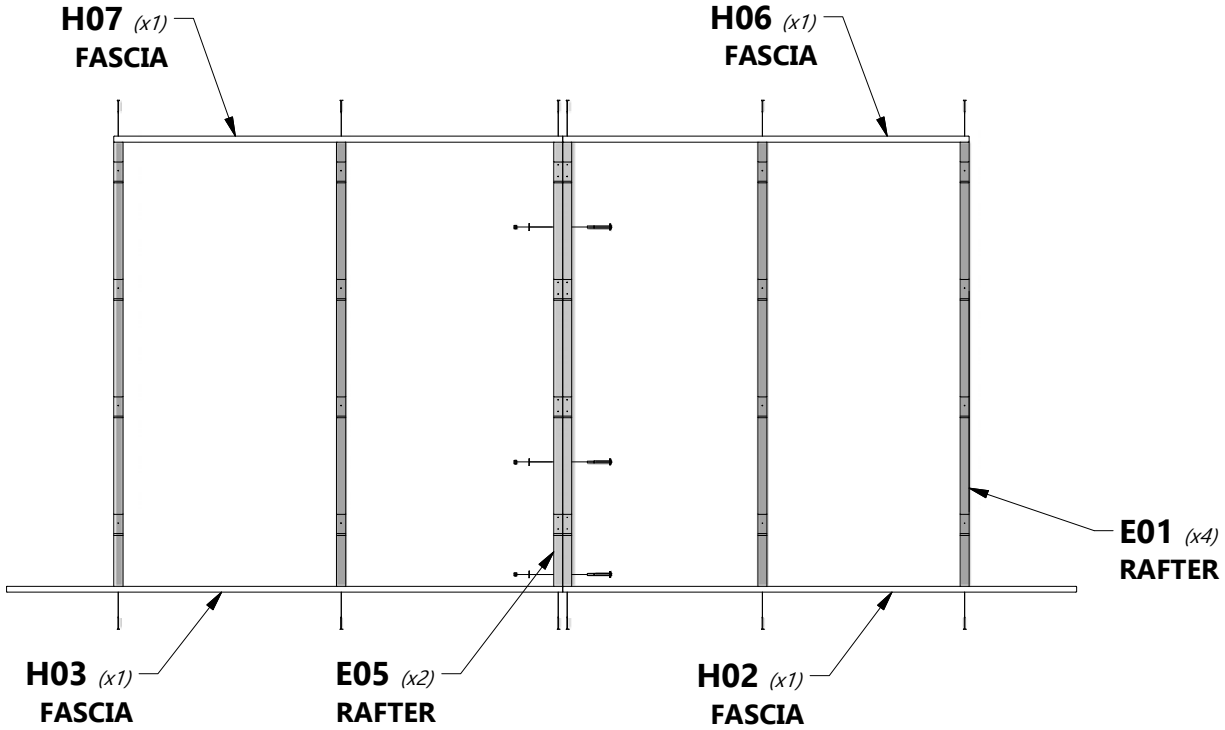

**NOTE:**  
NOTE LOCATION OF HOLES  
AND NOTCHES.

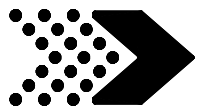

# STEP 12



**E03** | SHEATHING BOARD - W4L14989  
(x4) | 1 3/8"x3 3/8"x80 3/8" (36x86x2040)



**E04** | SHEATHING BOARD - W4L14990  
(x4) | 1 3/8"x3 3/8"x87" (36x86x2209)



**H100391** | SCREW PFH BLK  
(x32) | 8x2

14'-1"  
[4.29m]

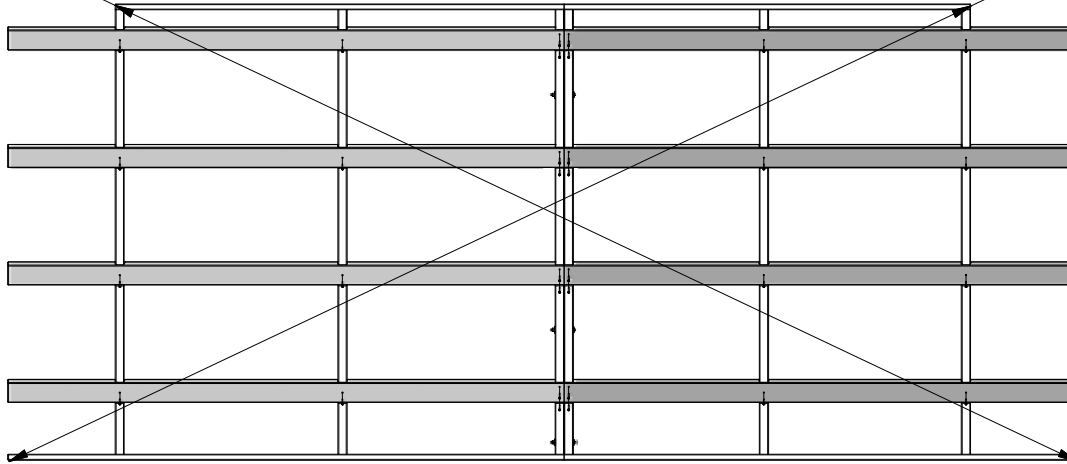

14'-1"  
[4.29m]

**E04** (x4)  
SHEATHING BOARD

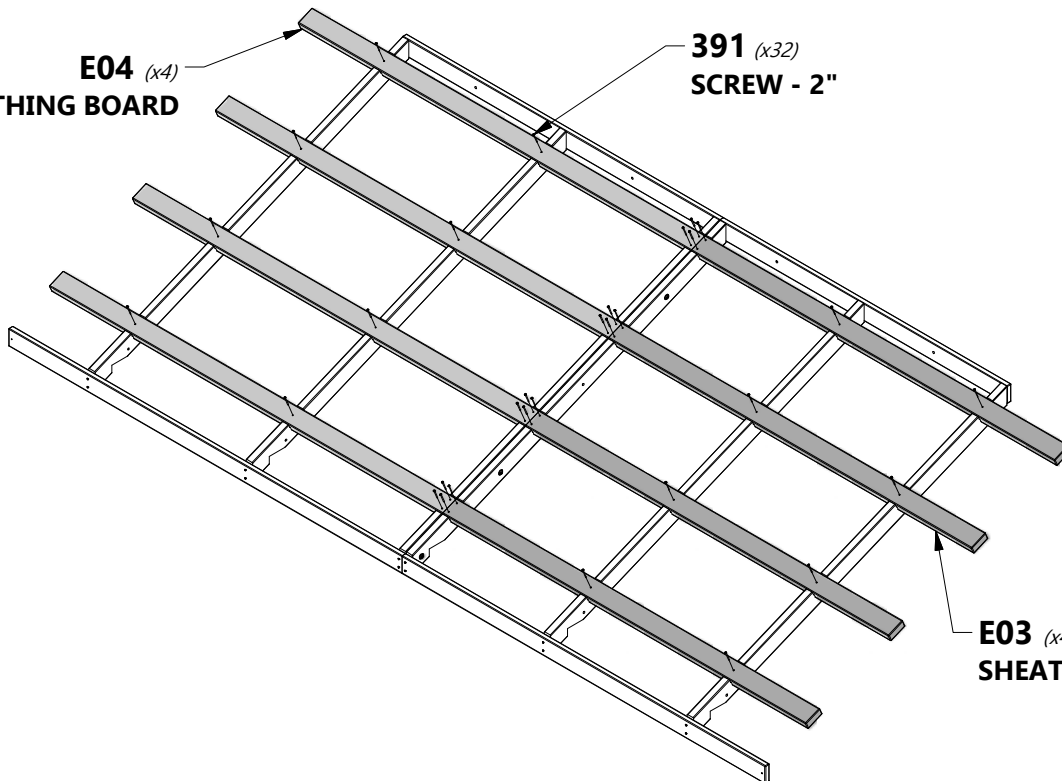

**391** (x32)  
SCREW - 2"

**E03** (x4)  
SHEATHING BOARD

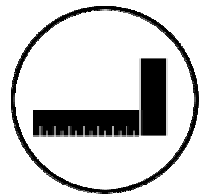

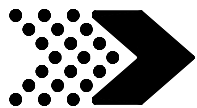

# STEP 13

**NOTE:**

USE THIS PAGE TO FAMILIARIZE YOURSELF WITH THE ROOF PANEL & ASSIST YOU IN THE COMING STEPS.

**WARNING:**

GLOVES SHOULD BE WORN WHEN HANDLING ROOF PANELS; EDGES ARE SHARP.

- Note the pre-drilled holes on the top end of each sheet shown below. These holes will always go towards the ridge of the roof and will be used to install the ridge cap in a later step. Assemble each roof panel by starting as shown below and working toward the left as shown.

POSITION YOUR ROOF PANELS ON THE GROUND SO THEY MIRROR EACH OTHER AS SHOWN.  
REMOVE PROTECTIVE BLUE FILM FROM PANELS.

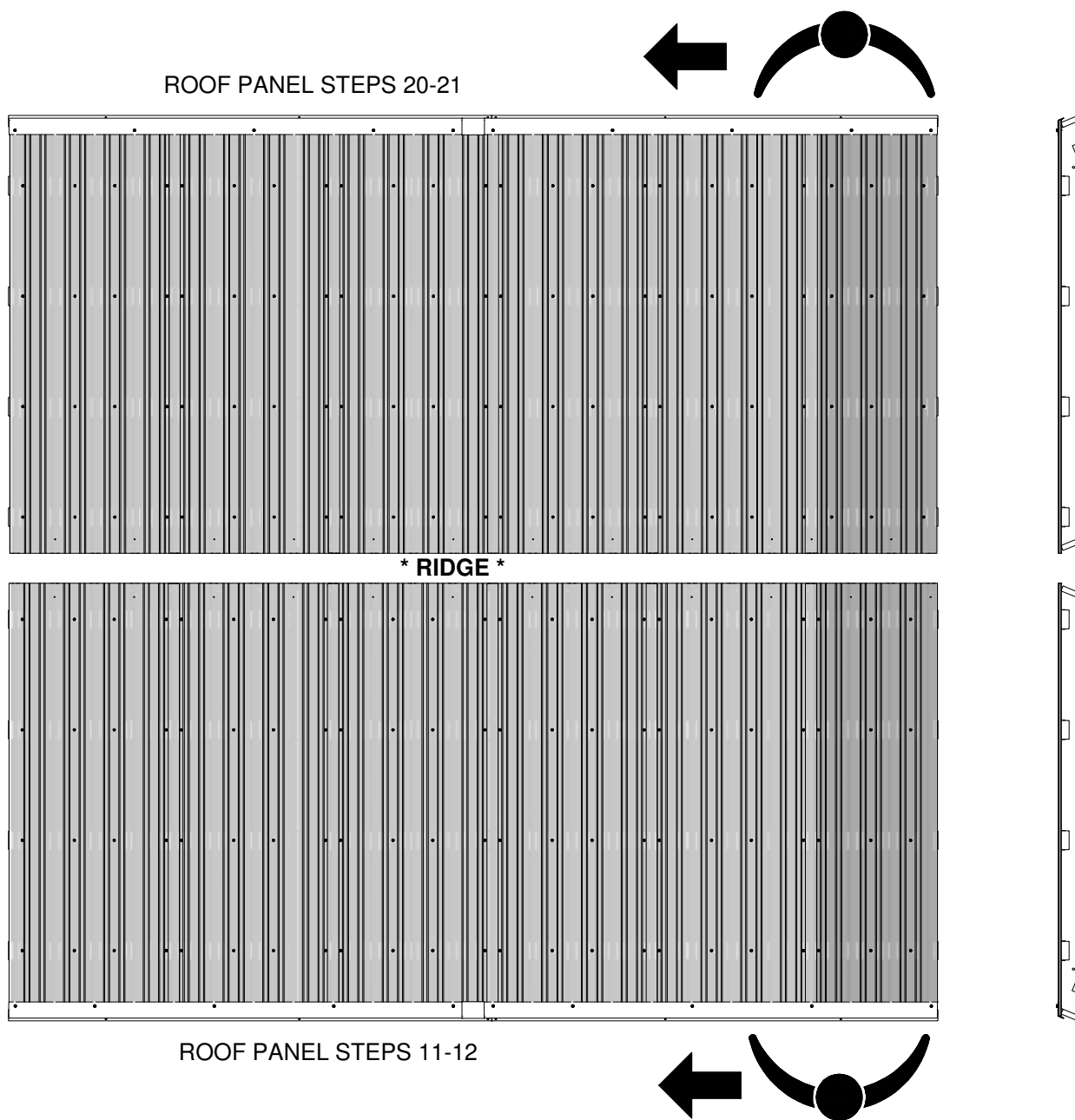

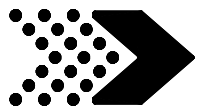

# STEP 14

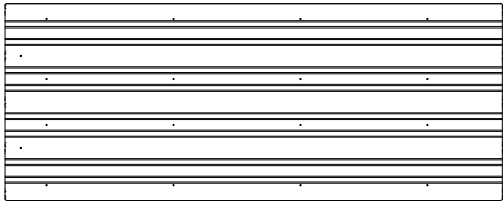

**A4M01124** | 29 GA STEEL SHEETING  
(x2)

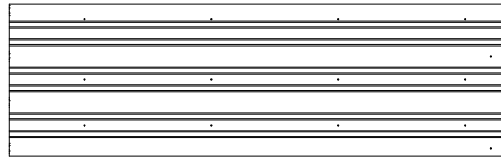

**A4M01253** | 29 GA STEEL SHEETING  
(x1)



**H100760** | SCREW WOODGRIP  
(x12) | 10x1 1/4

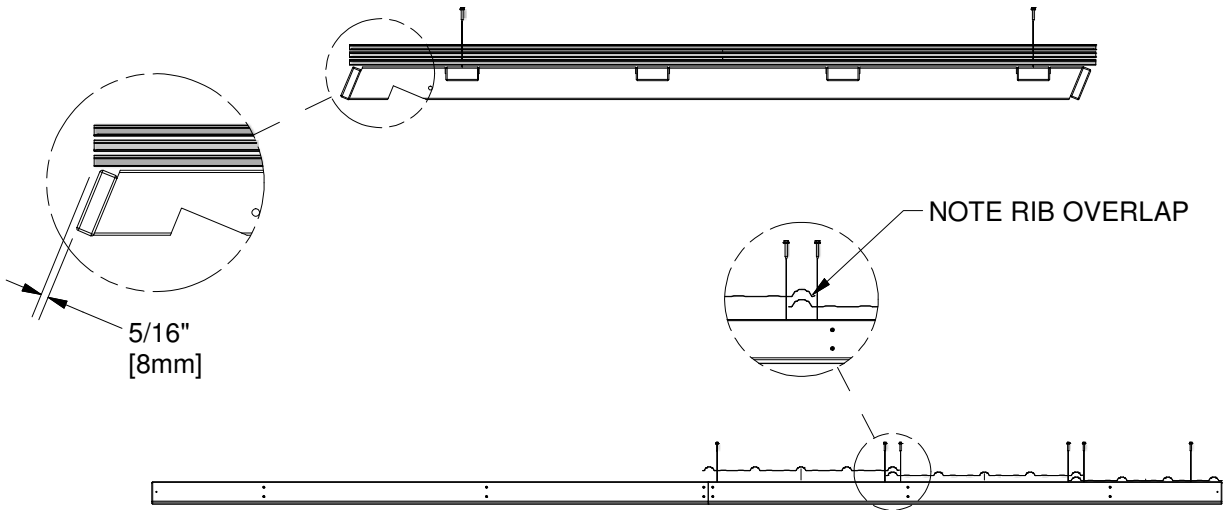
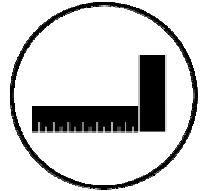

**NOTE:**  
MAKE SURE YOUR ROOF PANEL IS SQUARE BEFORE MOVING ON.

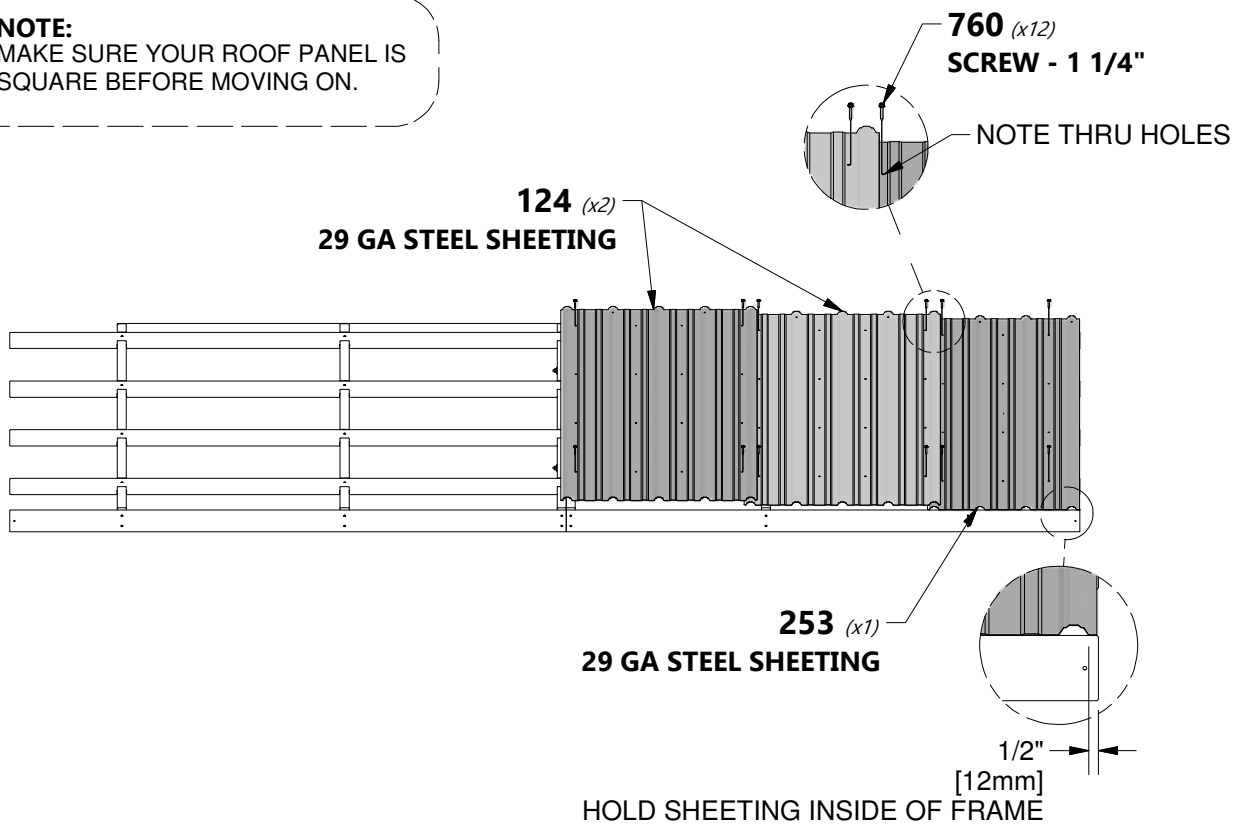

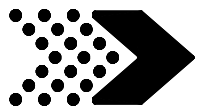

# STEP 15



**H100760 | SCREW WOODGRIP**  
(x32) | 10x1 1/4

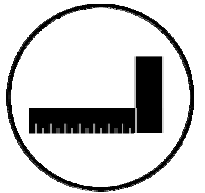

**760 (x32)**  
**SCREW - 1 1/4"**

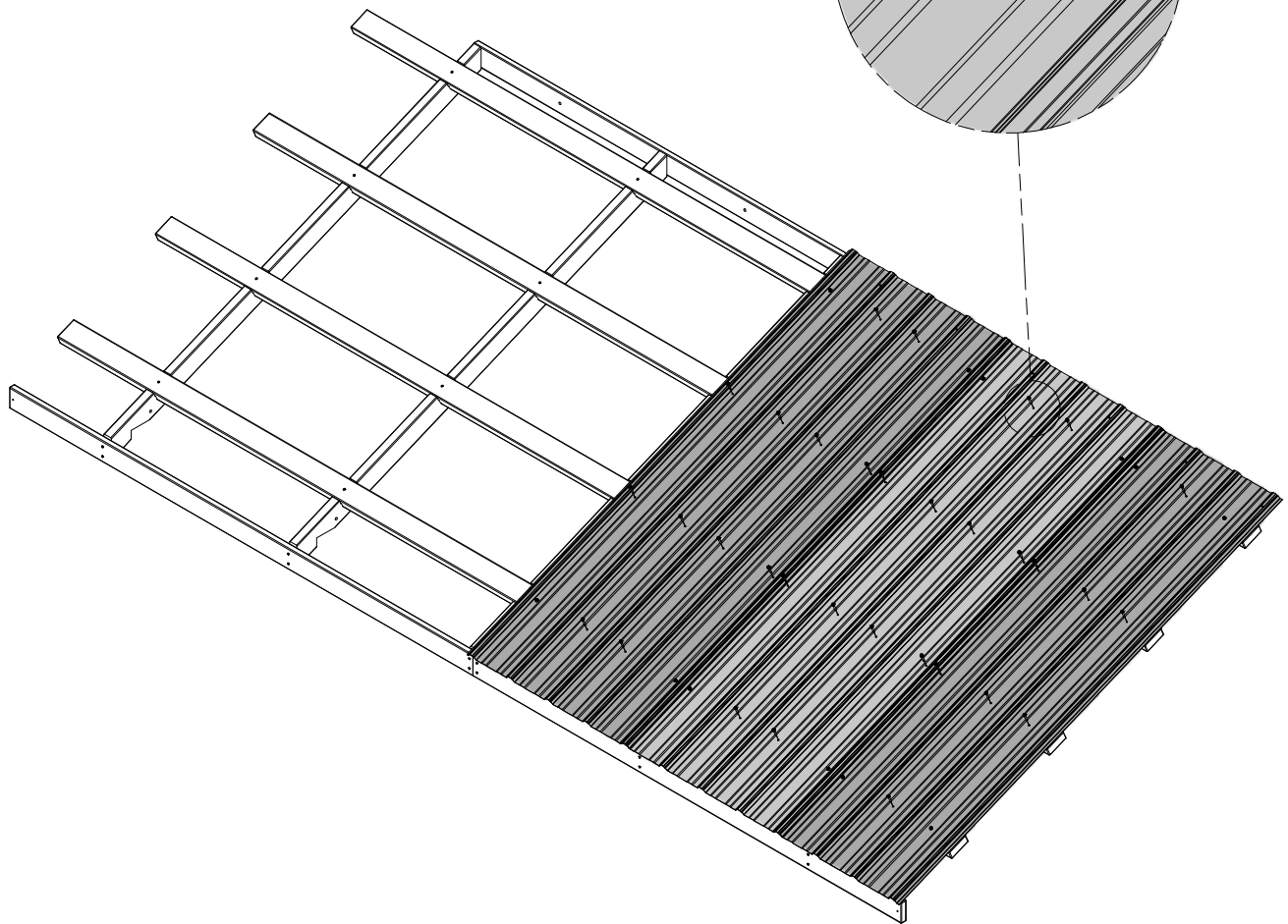
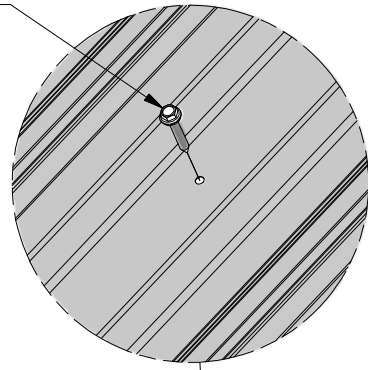



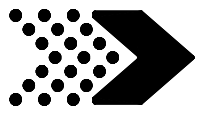

# STEP 16

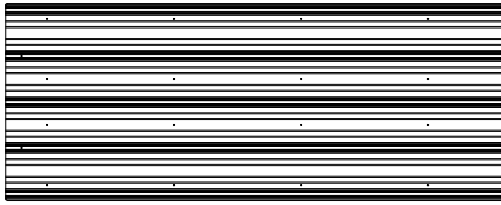

**A4M01124**  
(x3) | **29 GA STEEL SHEETING**



**H100760** | **SCREW WOODGRIP**  
(x48) | 10x1 1/4

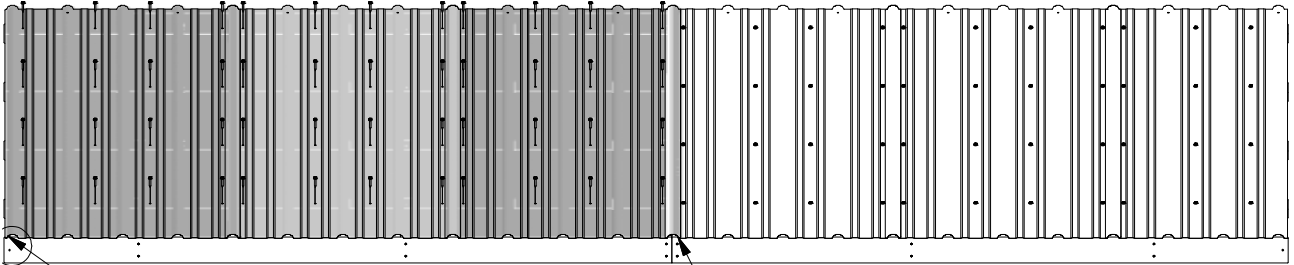

HOLD SHEETING INSIDE OF ROOF FRAME

NOTE RIB OVERLAPS ALL PLACES

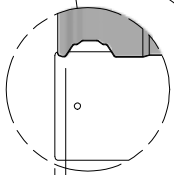

3/8"  
[10mm]

NOTE THRU HOLES

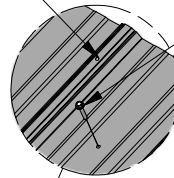

**760** (x48)  
**SCREW - 1 1/4"**

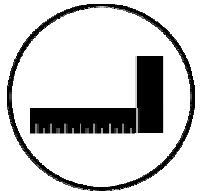

**124** (x3)  
**29 GA STEEL SHEETING**

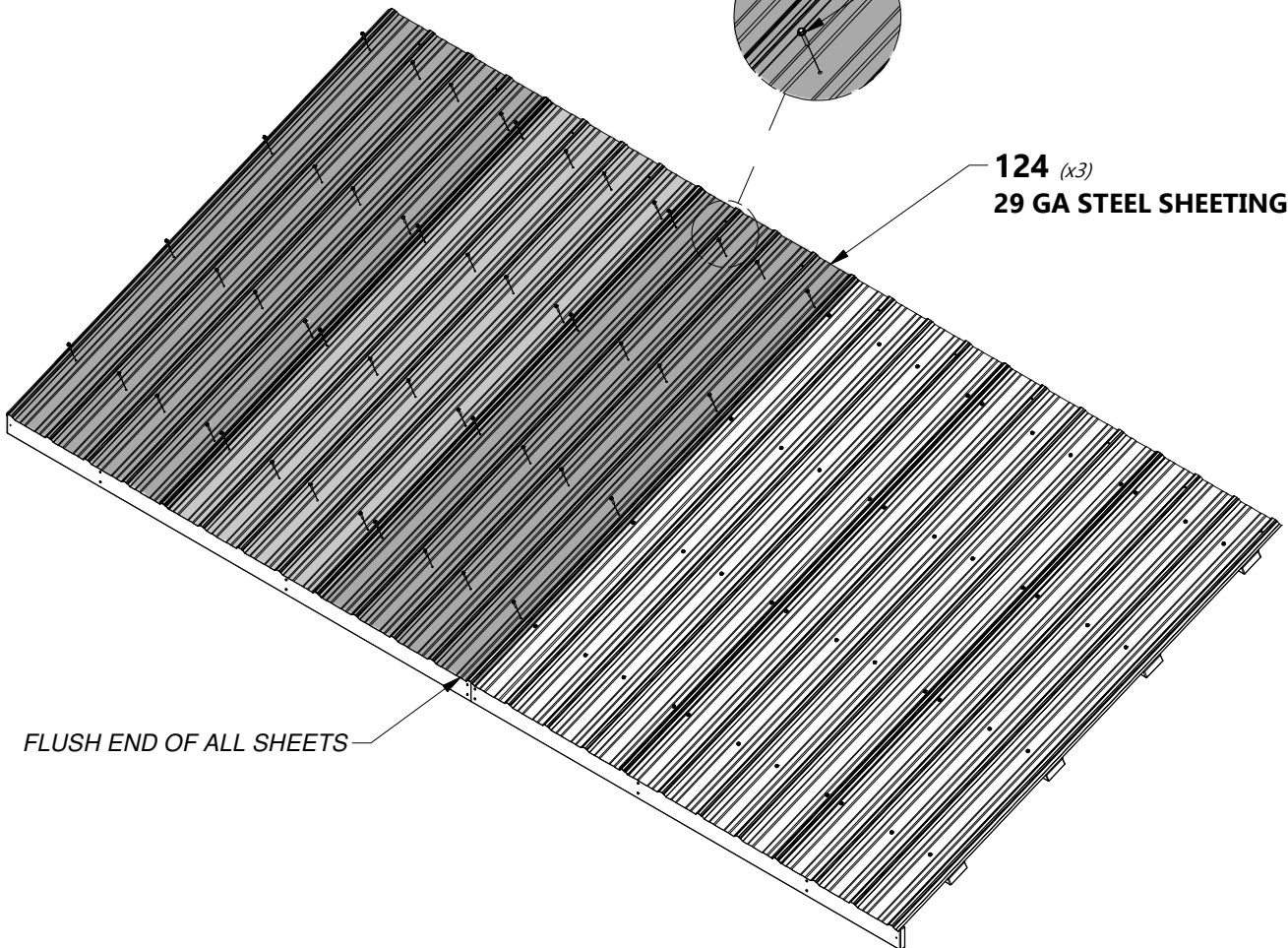

FLUSH END OF ALL SHEETS

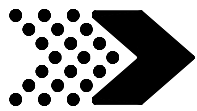

# STEP 17

**SEPARATE THE ROOF PANELS AT THIS TIME FOR EASE OF INSTALLING**

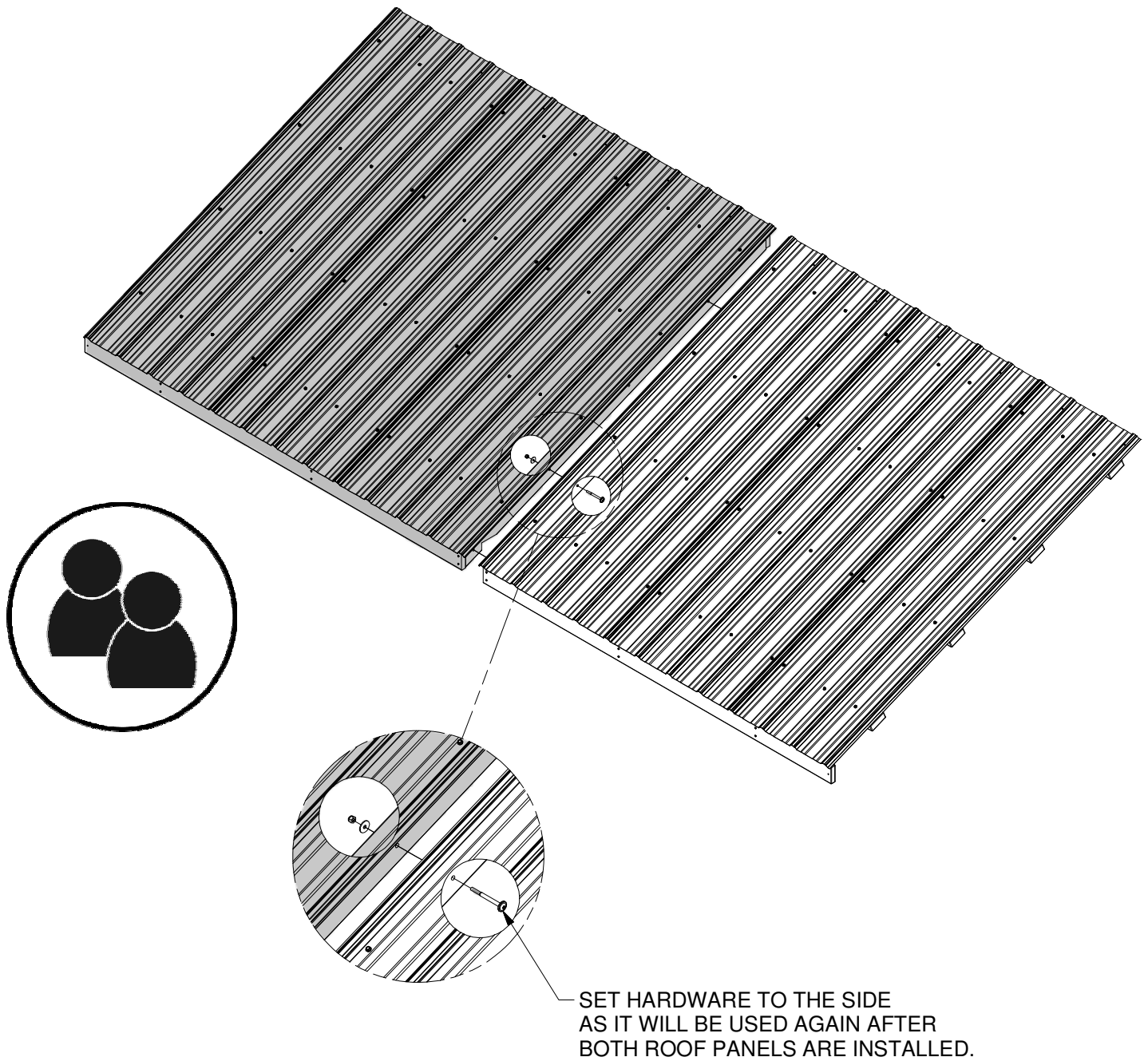

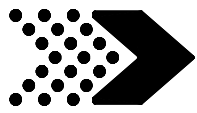

# STEP 18



**NOTE:**  
 WITH AT LEAST TWO PEOPLE LIFT ASSEMBLED ROOF  
 PANEL AND SLIDE IT INTO THE TRACKS ON THE  
 RAFTERS. ONCE IN PLACE, INSTALL ATTACHMENT  
 HARDWARE AS SHOWN.

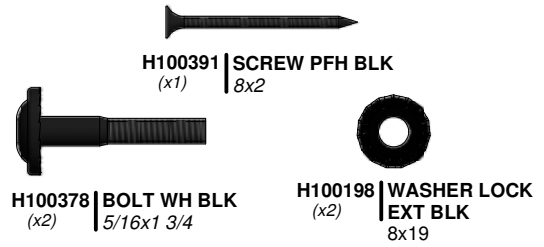

198 (x2)  
 WASHER - 8x19

378 (x2)  
 BOLT - 1 3/4"

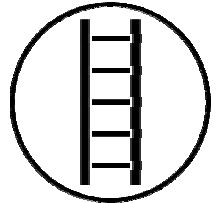
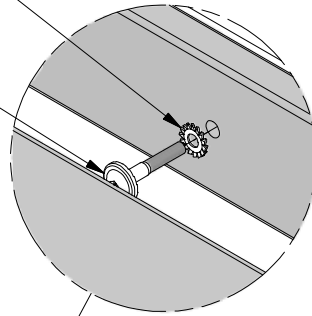

SLIDE ROOF  
 PANEL UPWARD.  
 THEN INSTALL  
 HARDWARE.

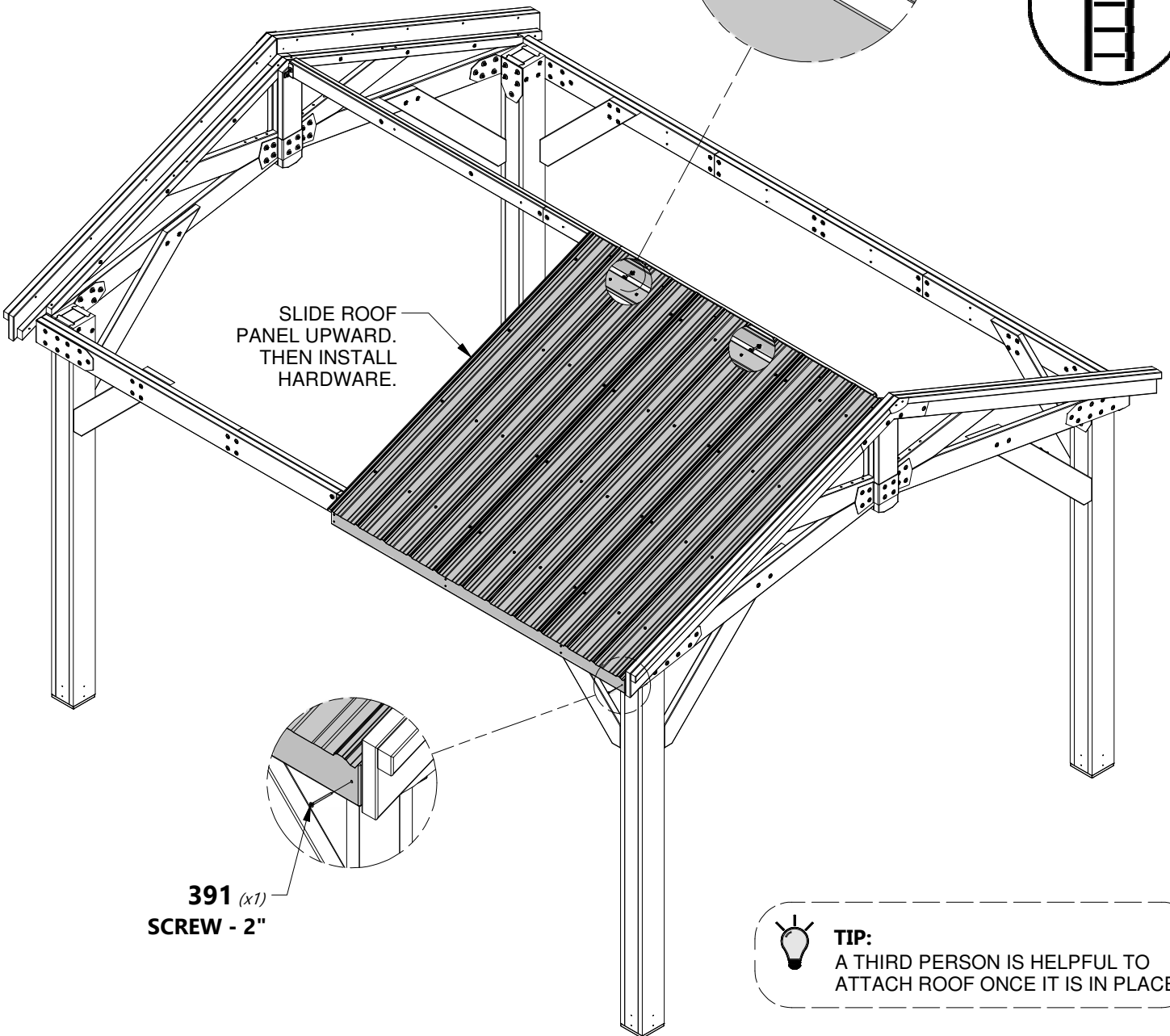

391 (x1)  
 SCREW - 2"

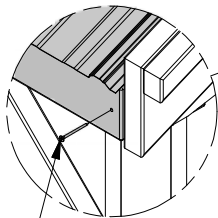

**TIP:**  
 A THIRD PERSON IS HELPFUL TO  
 ATTACH ROOF ONCE IT IS IN PLACE.

# STEP 19



**NOTE:**  
WITH AT LEAST TWO PEOPLE LIFT ASSEMBLED ROOF PANEL AND SLIDE IT INTO THE TRACKS ON THE RAFTERS. ONCE IN PLACE, INSTALL ATTACHMENT HARDWARE AS SHOWN.



**TIP:**  
A THIRD PERSON IS HELPFUL TO ATTACH ROOF ONCE IT IS IN PLACE.

**198 (x2)**  
**WASHER - 8x19**

**378 (x2)**  
**BOLT - 1 3/4"**

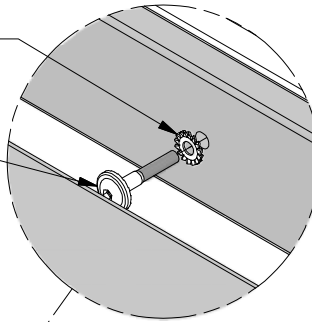

**H100391** | **SCREW PFH BLK**  
(x1) | 8x2



**H100378** | **BOLT WH BLK**  
(x2) | 5/16x1 3/4

**H100198** | **WASHER LOCK**  
(x2) | **EXT BLK**  
8x19

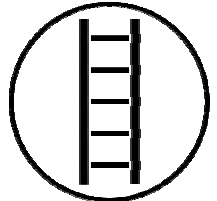
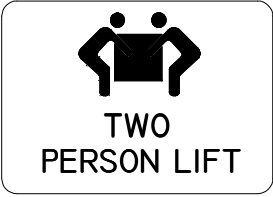

SLIDE ROOF  
PANEL UPWARD.  
THEN INSTALL  
HARDWARE.

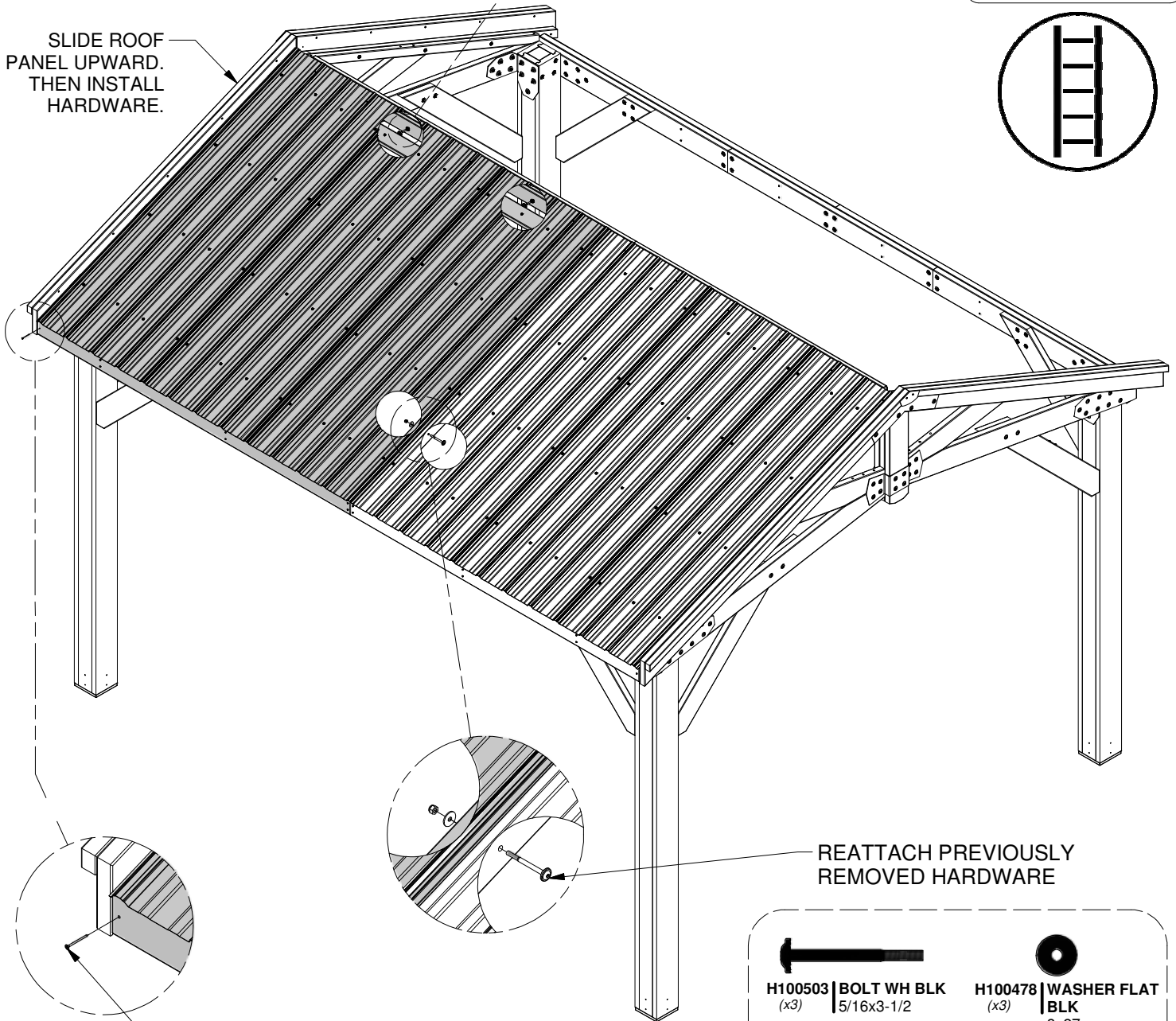

REATTACH PREVIOUSLY  
REMOVED HARDWARE

**391 (x1)**  
**SCREW - 2"**

**H100503** | **BOLT WH BLK**  
(x3) | 5/16x3-1/2

**H100478** | **WASHER FLAT**  
(x3) | **BLK**  
8x27

**H100479** | **NUT LOCK BLK**  
(x3) | 5/16



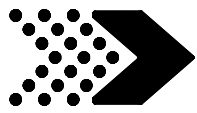

# STEP 20

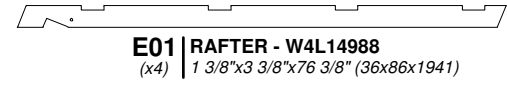

**E01** | RAFTER - W4L14988  
(x4) | 1 3/8"x3 3/8"x76 3/8" (36x86x1941)

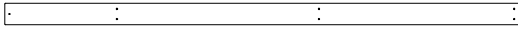

**H02** | FASCIA - W4L14987  
(x1) | 1"x3 3/8"x80 3/8" (24x86x2040)

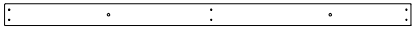

**H06** | FASCIA - W4L15005  
(x1) | 1"x3 3/8"x63 1/2" (24x86x1614)

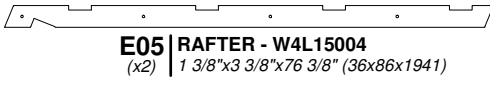

**E05** | RAFTER - W4L15004  
(x2) | 1 3/8"x3 3/8"x76 3/8" (36x86x1941)

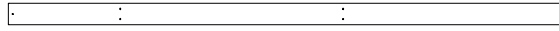

**H03** | FASCIA - W4L14993  
(x1) | 1"x3 3/8"x87" (24x86x2209)

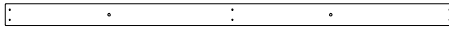

**H07** | FASCIA - W4L15006  
(x1) | 1"x3 3/8"x70 1/8" (24x86x1783)



**H100391** | SCREW PFH BLK  
(x24) | 8x2



**H100503** | BOLT WH BLK  
(x3) | 5/16x3-1/2



**H100478** | WASHER FLAT  
(x3) | BLK  
8x27



**H100479** | NUT LOCK BLK  
(x3) | 5/16

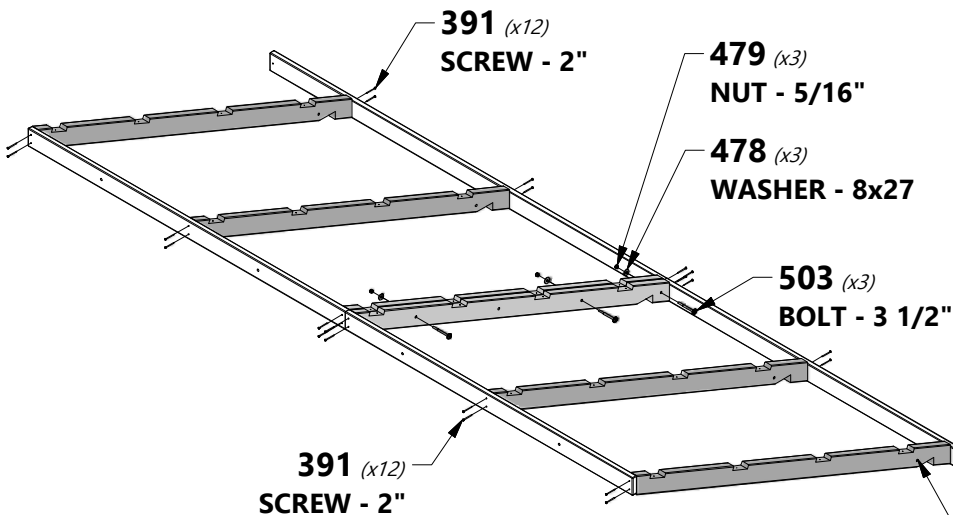
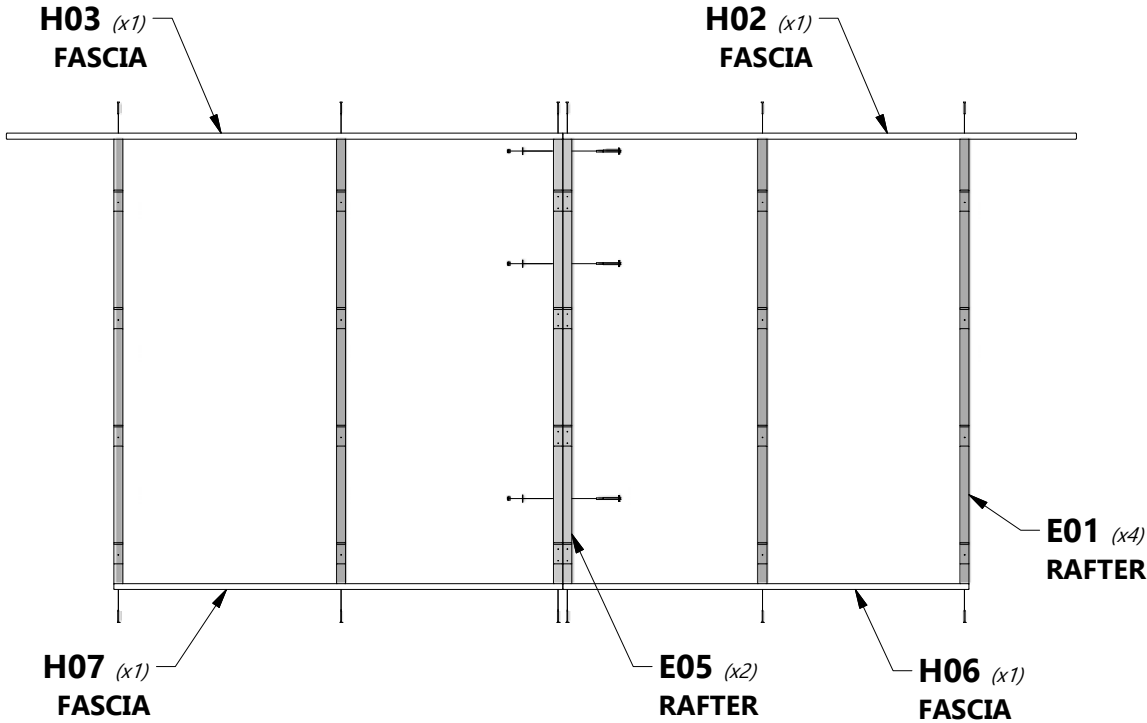

NOTE LOCATION OF HOLES AND NOTCHES.

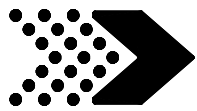

# STEP 21

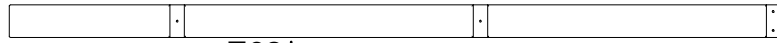

**E03** | SHEATHING BOARD - W4L14989  
(x4) | 1 3/8"x3 3/8"x80 3/8" (36x86x2040)



**E04** | SHEATHING BOARD - W4L14990  
(x4) | 1 3/8"x3 3/8"x87" (36x86x2209)



**H100391** | SCREW PFH BLK  
(x32) | 8x2

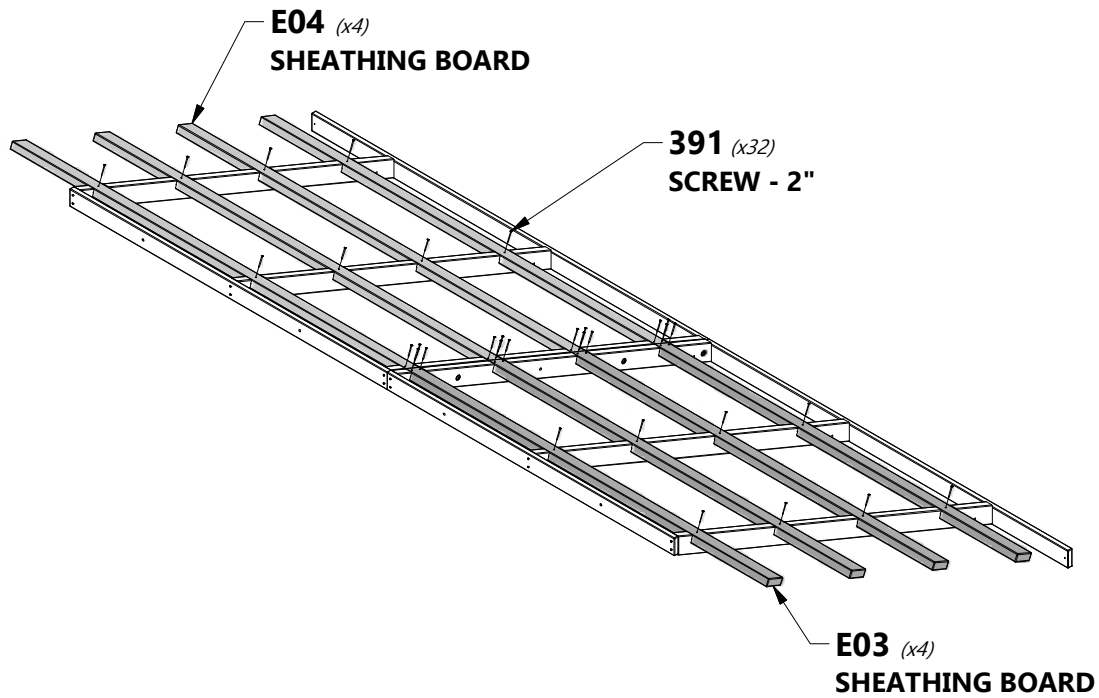
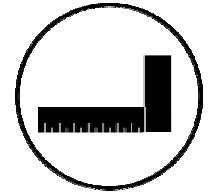
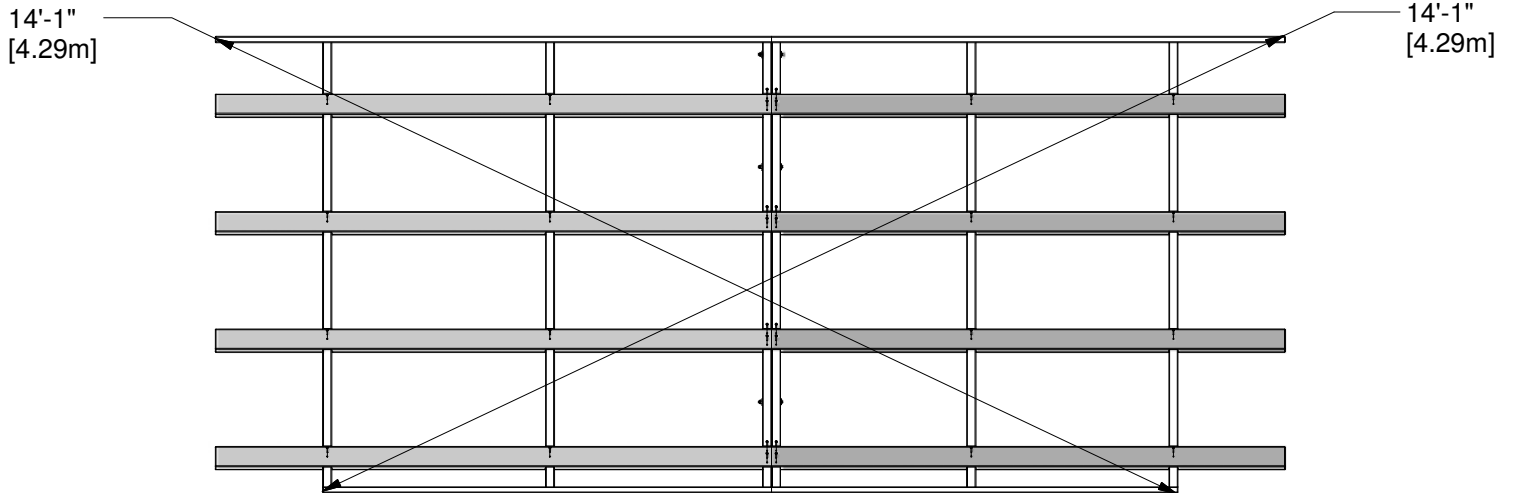

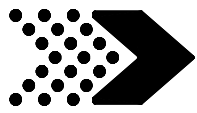

# STEP 22

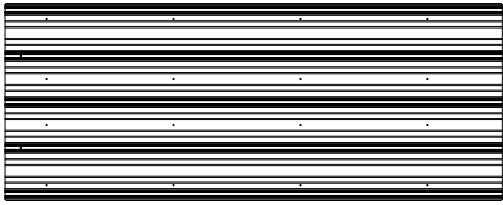

**A4M01124** | 29 GA STEEL SHEETING  
(x2)

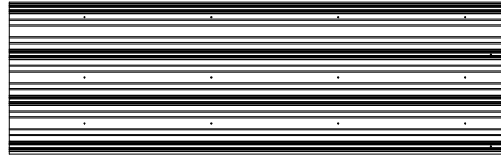

**A4M01253** | 29 GA STEEL SHEETING  
(x1)



**H100760** | SCREW WOODGRIP  
(x12) | 10x1 1/4

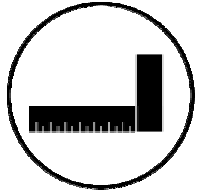
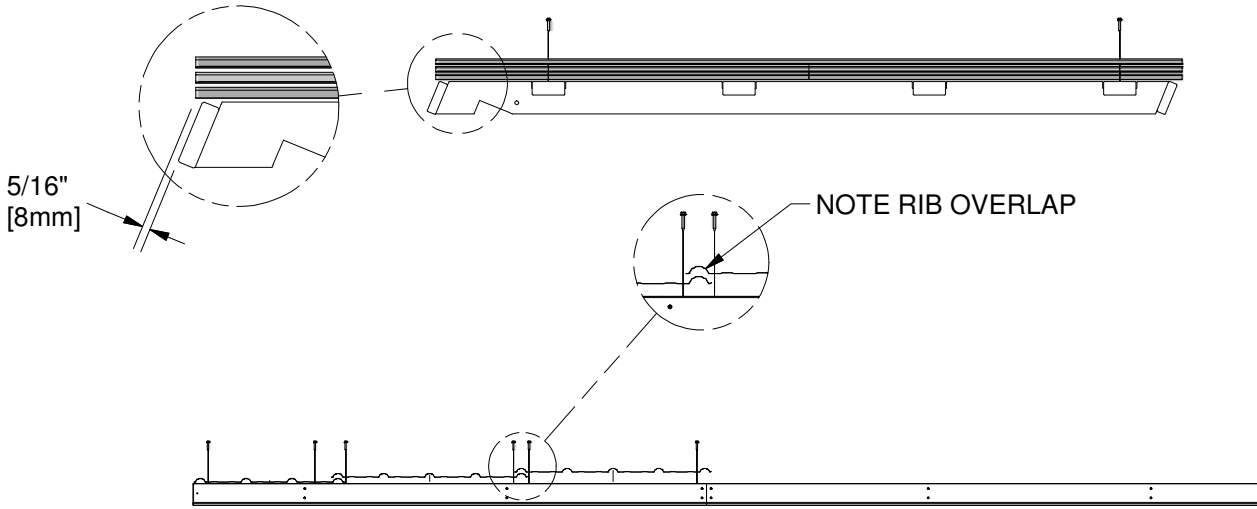

**NOTE:**  
MAKE SURE YOUR ROOF PANEL IS SQUARE BEFORE MOVING ON.

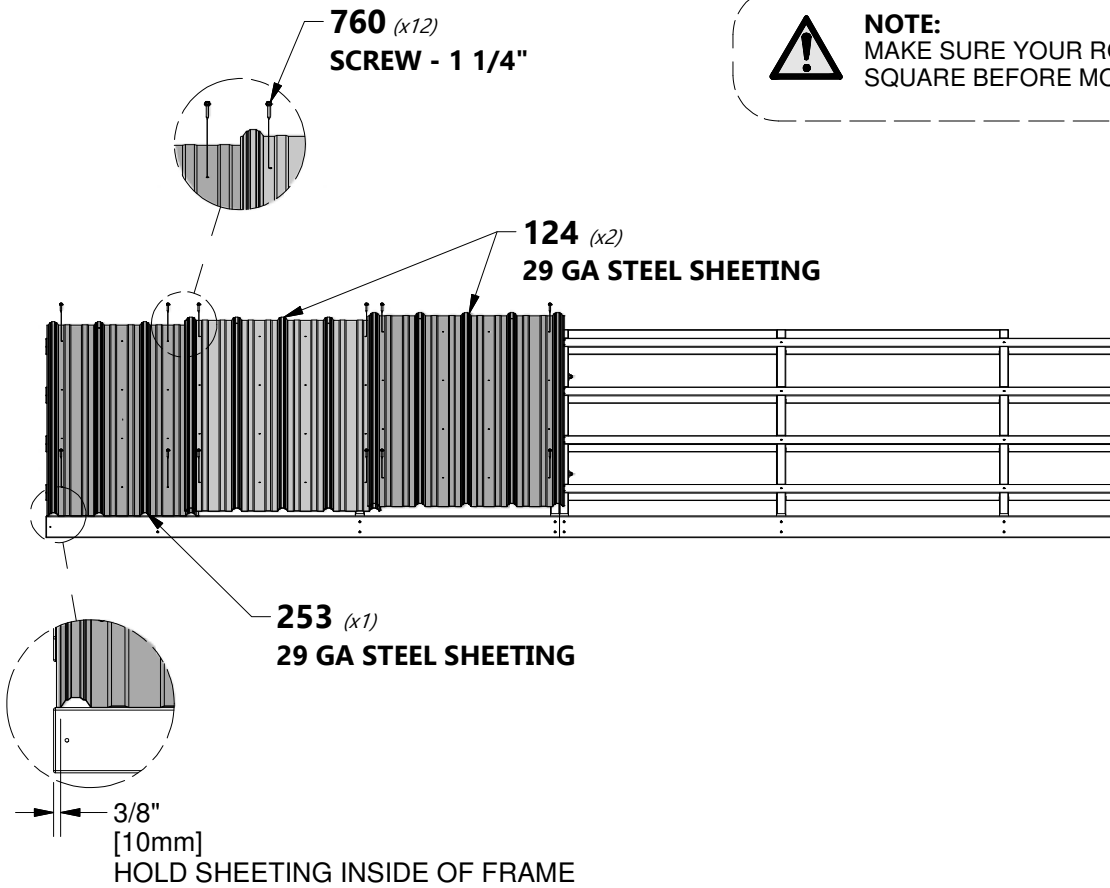

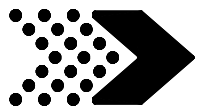

# STEP 23



H100760 | SCREW WOODGRIP  
(x32) | 10x1 1/4

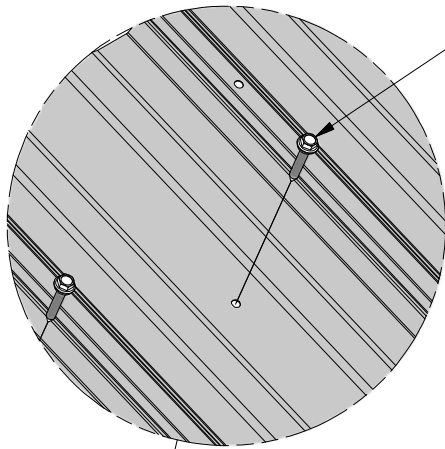
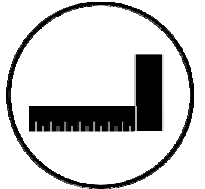

760 (x32)  
SCREW - 1 1/4"

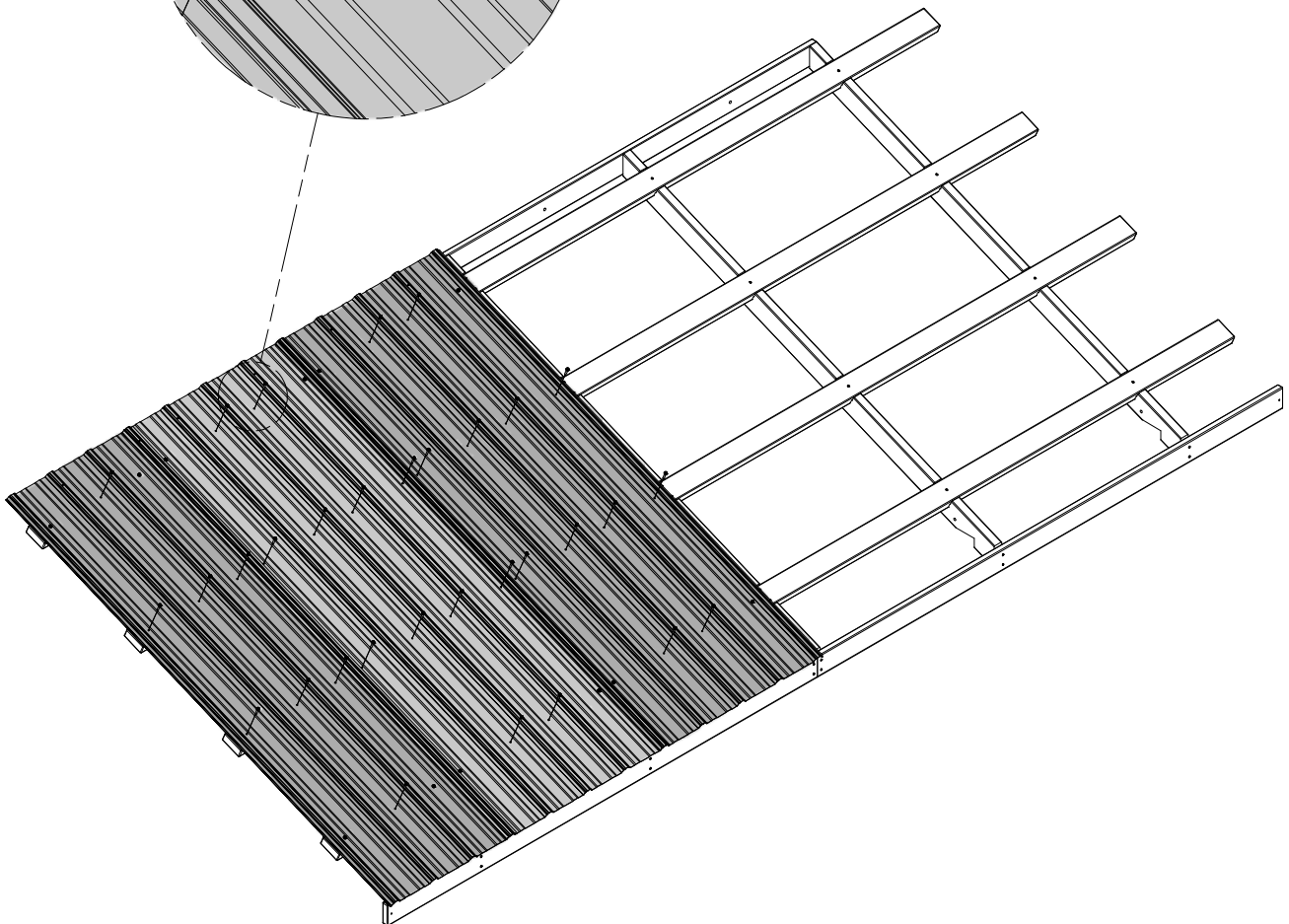



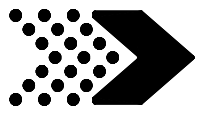

# STEP 24

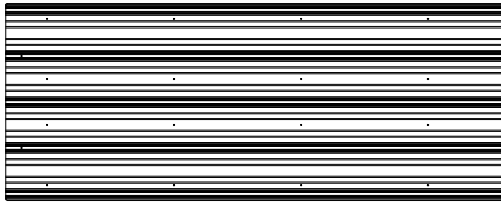

**A4M01124**  
(x3) | **29 GA STEEL SHEETING**



**H100760** | **SCREW WOODGRIP**  
(x48) | **10x1 1/4**

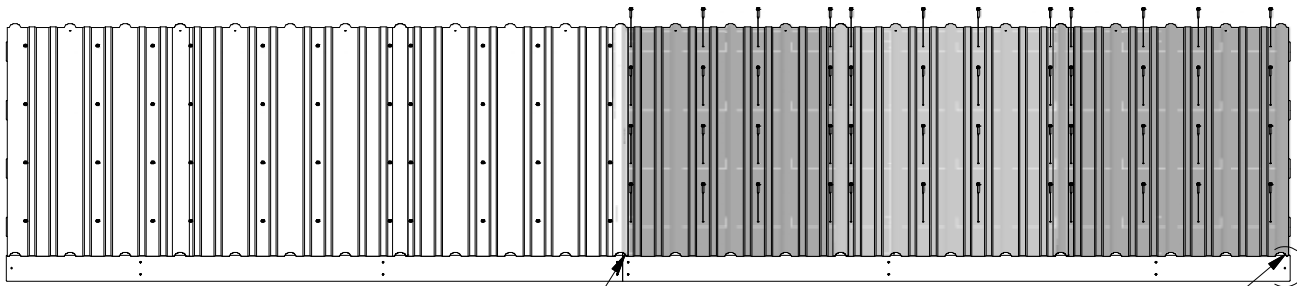

NOTE RIB OVERLAPS  
ALL PLACES

HOLD SHEETING INSIDE  
OF ROOF FRAME

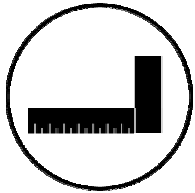

NOTE THRU HOLES

**760** (x48)  
**SCREW - 1 1/4"**

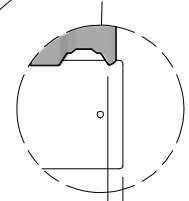

1/2"  
[12mm]

**124** (x3)  
**29 GA STEEL SHEETING**

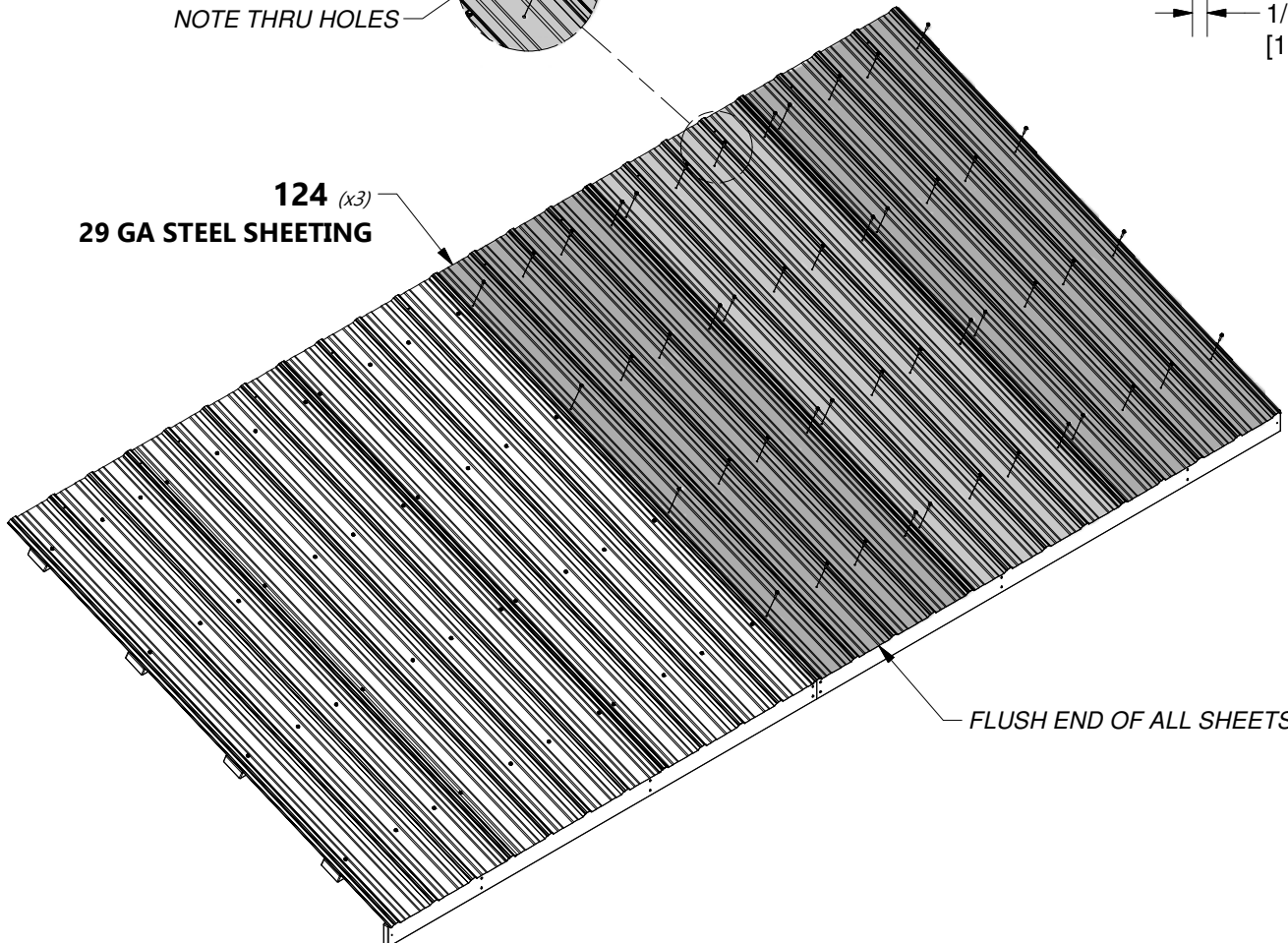

FLUSH END OF ALL SHEETS



# STEP 25

**SEPARATE THE ROOF PANELS AT THIS TIME FOR EASE OF INSTALLING**

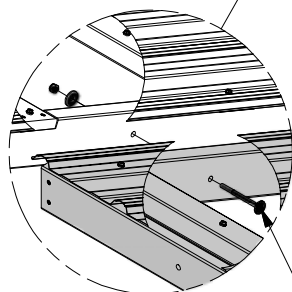
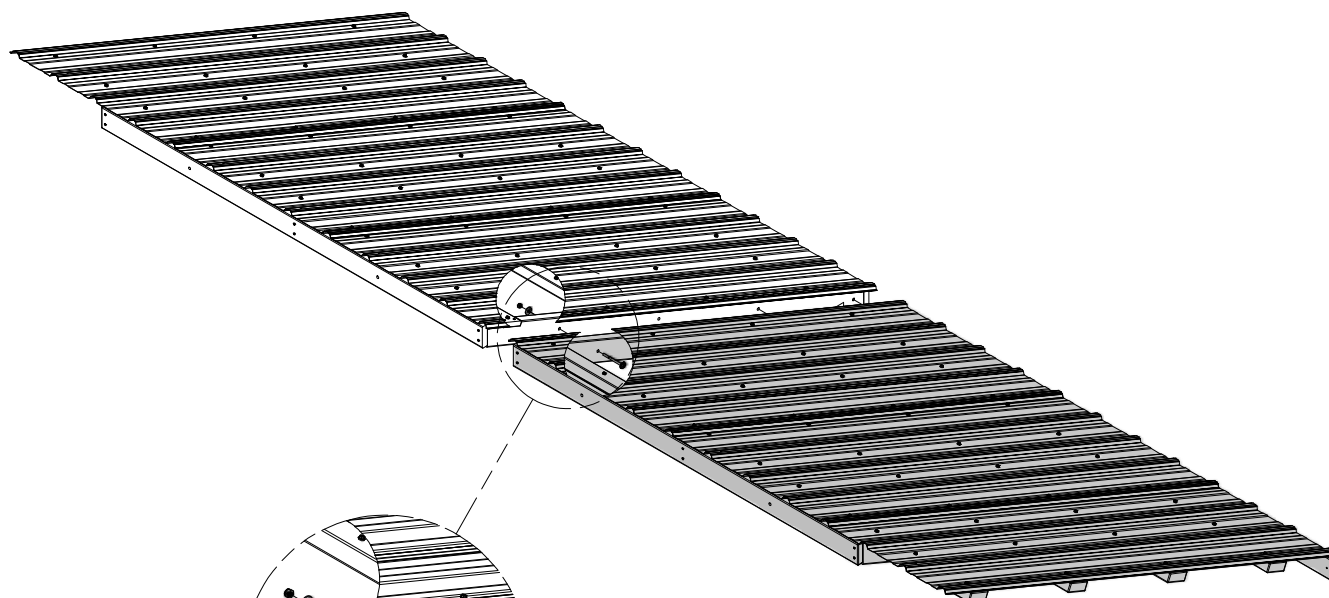

SET HARDWARE TO THE SIDE  
AS IT WILL BE USED AGAIN AFTER  
BOTH ROOF PANELS ARE INSTALLED.

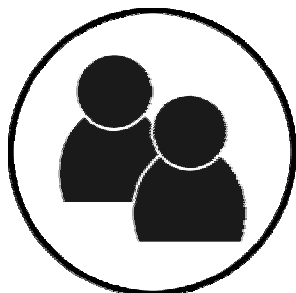

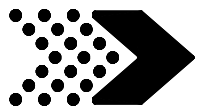



# STEP 26

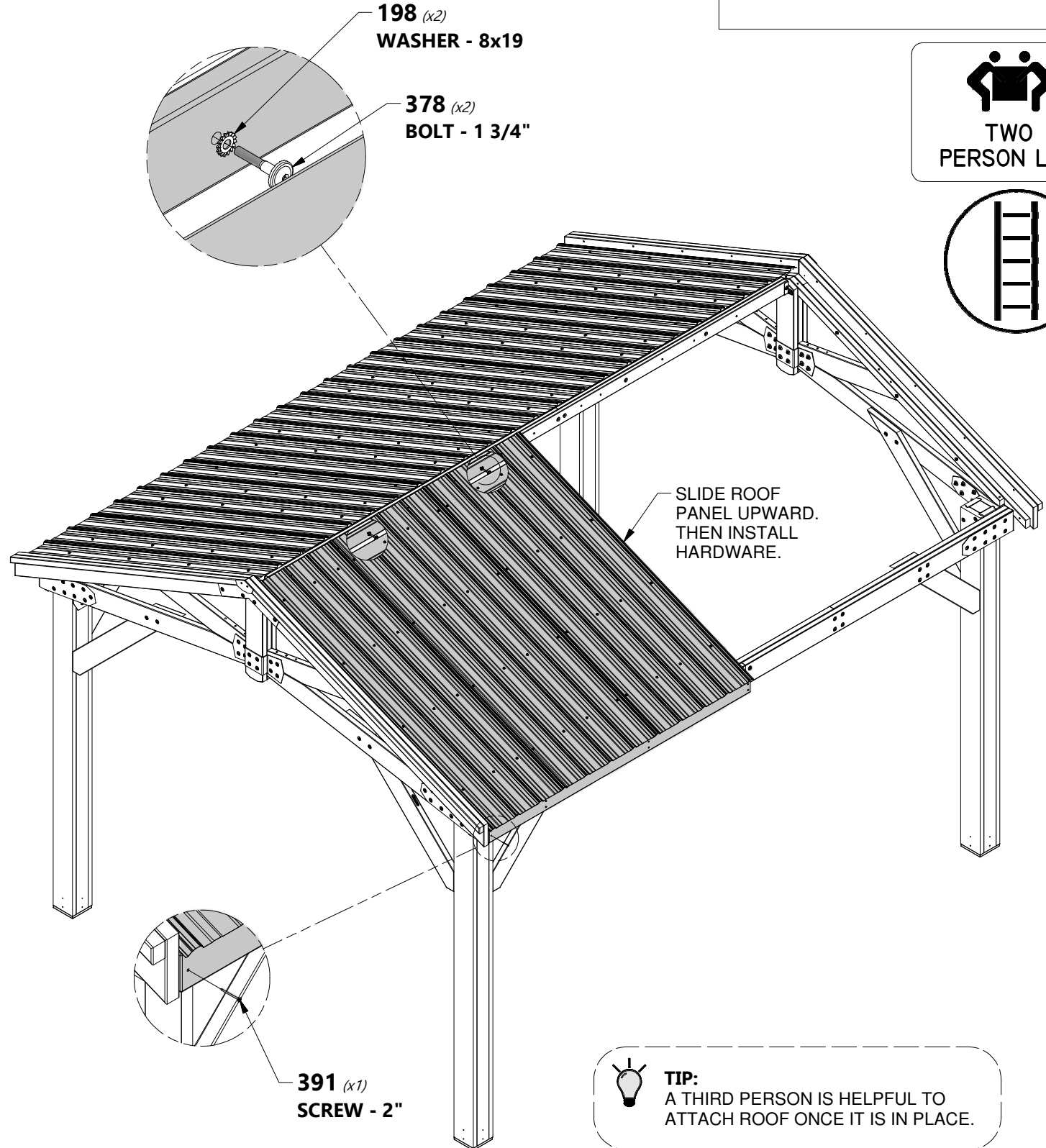
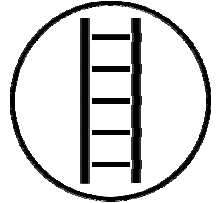
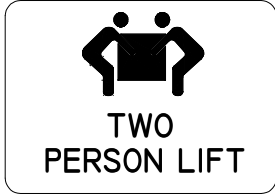
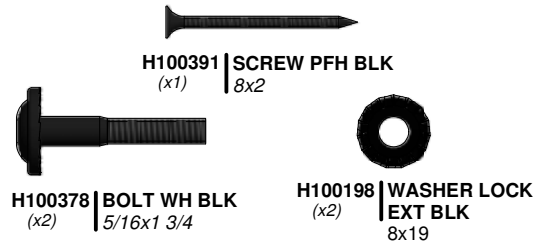

**NOTE:**  
WITH AT LEAST TWO PEOPLE LIFT ASSEMBLED ROOF PANEL AND SLIDE IT INTO THE TRACKS ON THE RAFTERS. ONCE IN PLACE, INSTALL ATTACHMENT HARDWARE AS SHOWN.



 **TIP:**  
A THIRD PERSON IS HELPFUL TO ATTACH ROOF ONCE IT IS IN PLACE.

# STEP 27



**NOTE:**  
WITH AT LEAST TWO PEOPLE LIFT ASSEMBLED ROOF PANEL AND SLIDE IT INTO THE TRACKS ON THE RAFTERS. ONCE IN PLACE, INSTALL ATTACHMENT HARDWARE AS SHOWN.



**TIP:**  
A THIRD PERSON IS HELPFUL TO ATTACH ROOF ONCE IT IS IN PLACE.



**TWO PERSON LIFT**

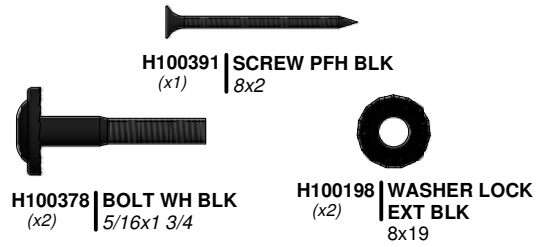
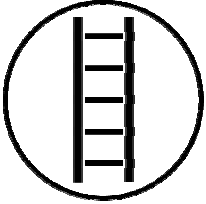

198 (x2)  
WASHER - 8x19

378 (x2)  
BOLT - 1 3/4"

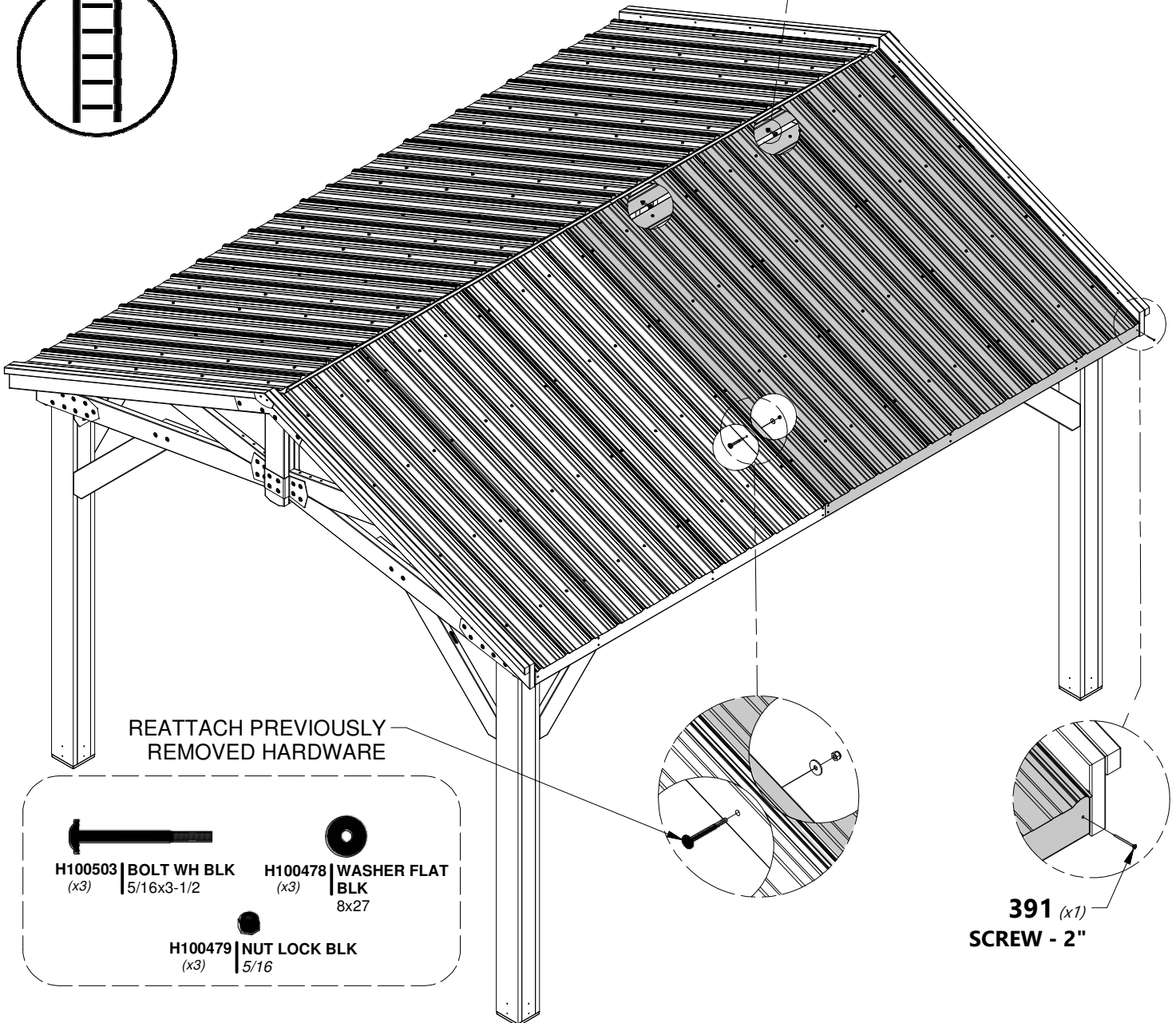

REATTACH PREVIOUSLY REMOVED HARDWARE



391 (x1)  
SCREW - 2"

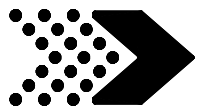

# STEP 28

A4M01254 (x4) ROOF EDGE TRIM

A4M00983 (x2) ROOF EDGE TRIM SPLICE



H100759 (x20) SCREW TAPPING 1/4x3/4

## COMPLETE ON BOTH SIDES



### TIP:

DUE TO MULTIPLE LAYERS OF METAL ON THE EDGE TRIM, IT IS RECOMMENDED THAT A 1/8" DRILL BIT IS USED TO CREATE STARTER HOLES.



### NOTE:

SCREWS GO THROUGH EDGE TRIM INTO THE TOP OF THE RIBS IN THE APPROXIMATE LOCATIONS SHOWN.

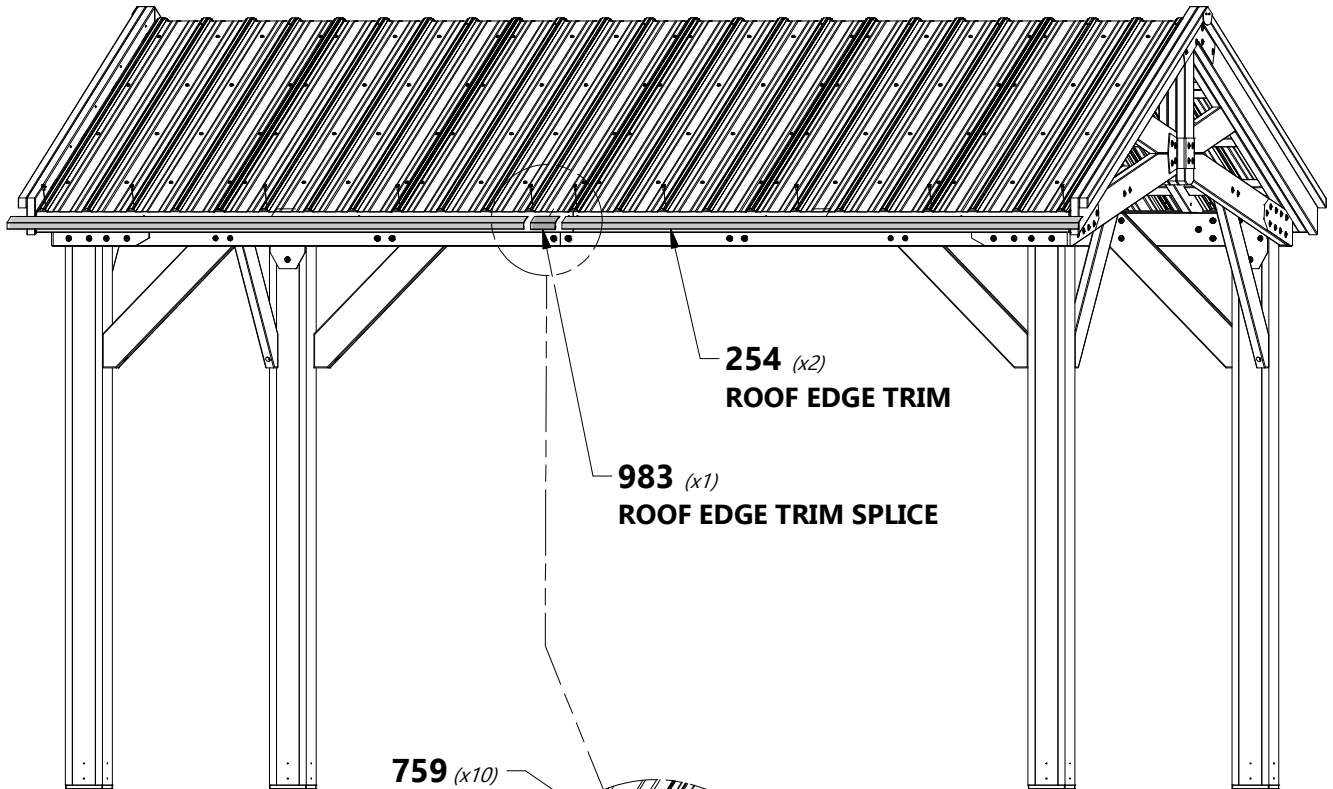
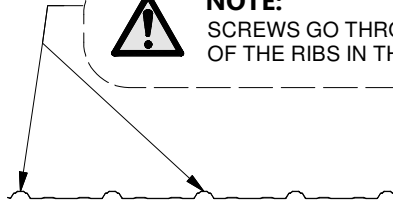

### NOTE:

SLIDE EDGE TRIM INTO SPLICE. ENSURE THAT BOTH ENDS ARE FLUSH WITH EDGE OF ROOF PANELS.

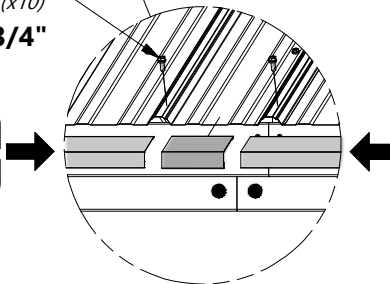

### SIDE VIEW

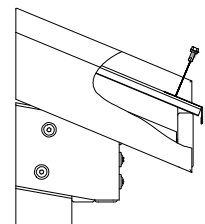

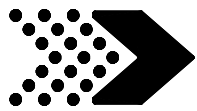

# STEP 29

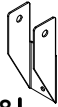

**A4M01228** | RAFTER BRACKET  
(x8)



**E06** | ACCESSORY TRUSS - W4L14991  
(x2) | 1 3/8"x3 3/8"x73 13/16" (36x86x1875)



**H100488** | BOLT WH BLK  
(x8) | 1/4x2



**H100630** | WASHER FLAT BLK  
(x8) | 8x19



**H100653** | NUT LOCK BLK  
(x8) | 1/4



**H100976** | BOLT WH BLK  
(x2) | 5/16x6 1/4



**H100823** | SCREW PWH BLK  
(x16) | 8x1-1/2



**H100478** | WASHER FLAT  
BLK  
(x2) | 8x27



**H100479** | NUT LOCK BLK  
(x2) | 5/16

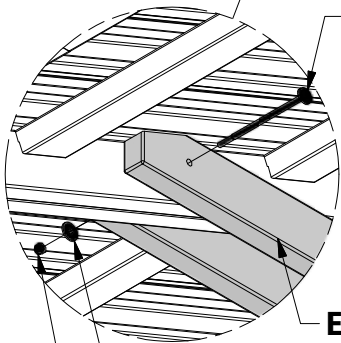
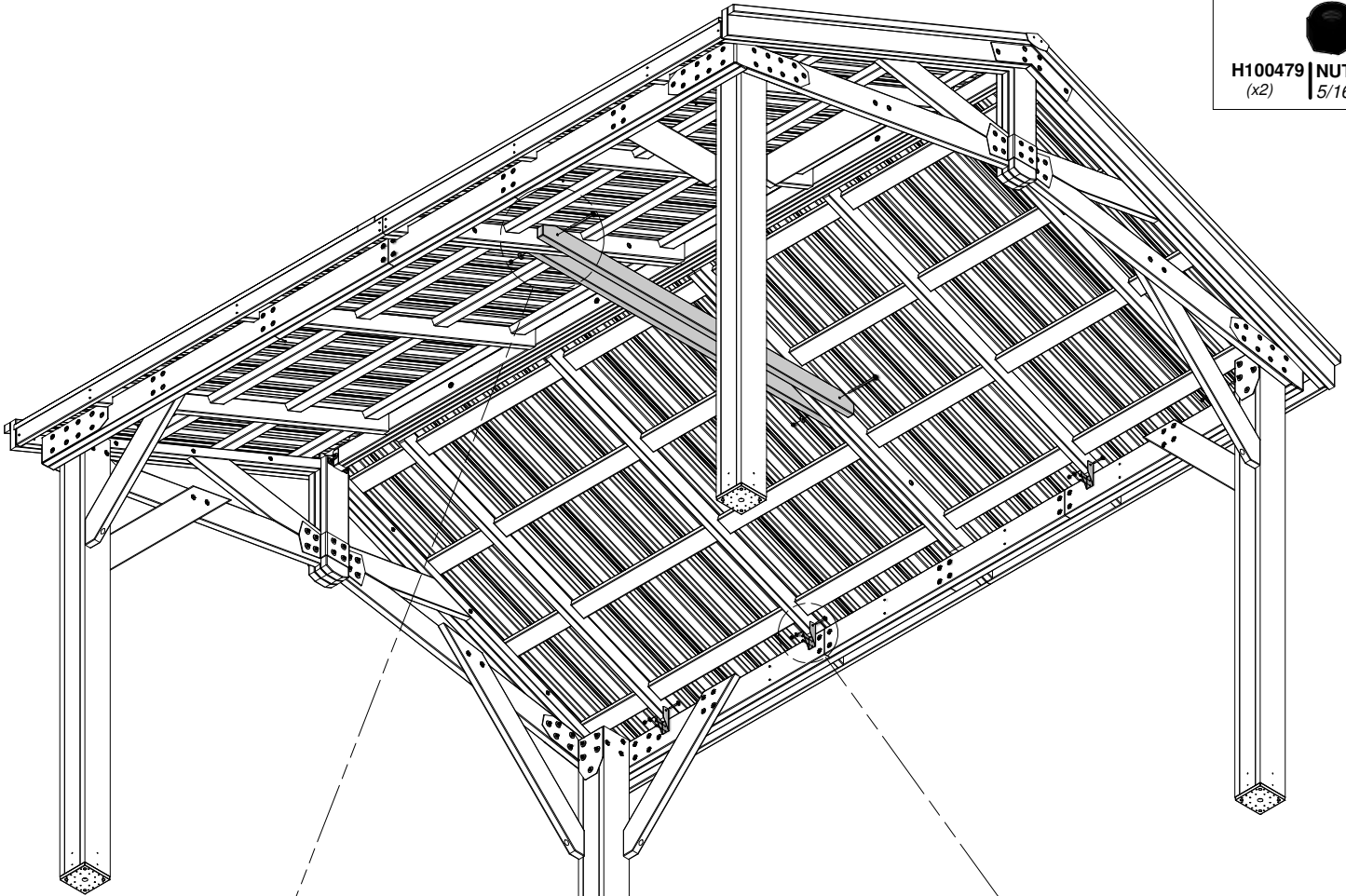

**976** (x2)  
BOLT - 6 1/4"

**E06** (x2)  
ACCESSORY TRUSS

**478** (x2)  
WASHER - 8x27

**479** (x2)  
NUT - 5/16"

**630** (x1)  
WASHER - 8x19

**653** (x1)  
NUT - 1/4"

**823** (x2)  
SCREW - 1 1/2"

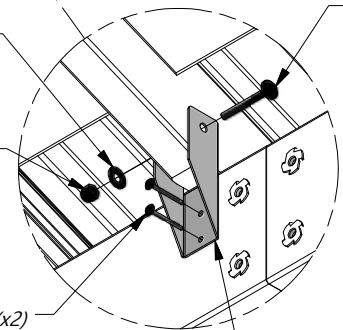

**488** (x1)  
BOLT - 2"

**228** (x1)  
RAFTER BRACKET



**NOTE:**  
INSTALL ON EACH OF  
THE (8) RAFTER ENDS.

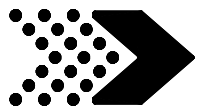

# STEP 30

  
A4M01127 (x1) | RIDGE CAP SPLICE

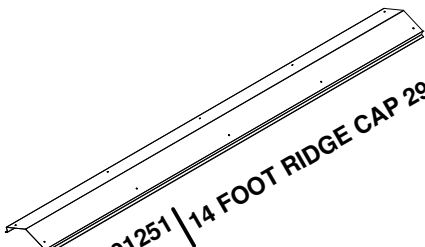
  
A4M01251 (x2) | 14 FOOT RIDGE CAP 29 GA

## RIDGE CAP ASSEMBLY PREPARATION



**NOTE:**  
INSTALL THE PROVIDED RIDGE CAP SPLICE BY SLIDING EACH RIDGE CAP INTO THE SPLICE AS SHOWN UNTIL CENTERED.

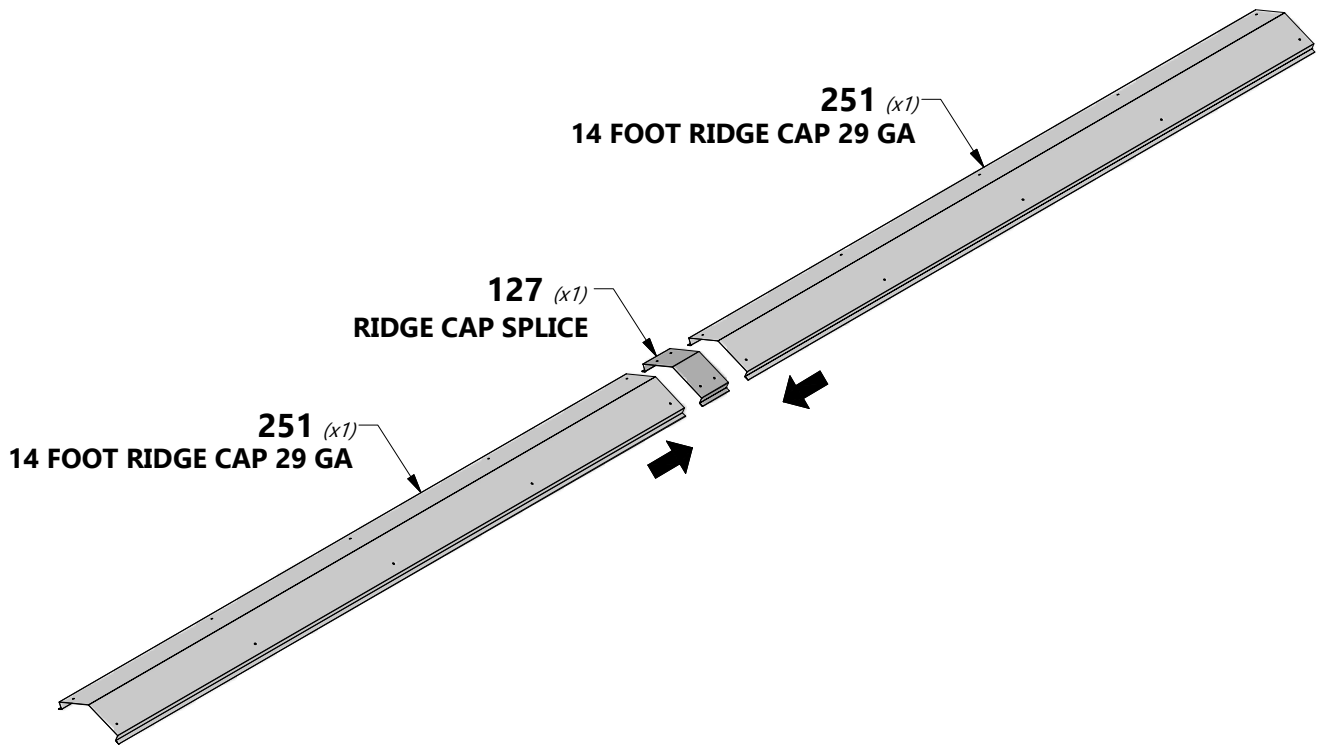

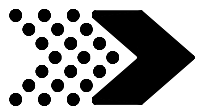

# STEP 31

**A6P00398**  
(x2) | **RIDGE CAP PROTECTOR**

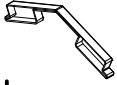

**J09** | **RIDGE CAP STIFFENER - W4L15002**  
(x2) | 1"x2 3/8"x77 5/8" (24x60x1973)



**J10** | **RIDGE CAP STIFFENER - W4L15003**  
(x2) | 1"x2 3/8"x89 1/2" (24x60x2273)

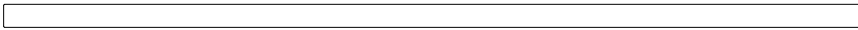

**H100833** | **SCREW WOODGRIP**  
(x20) | 10x3/4

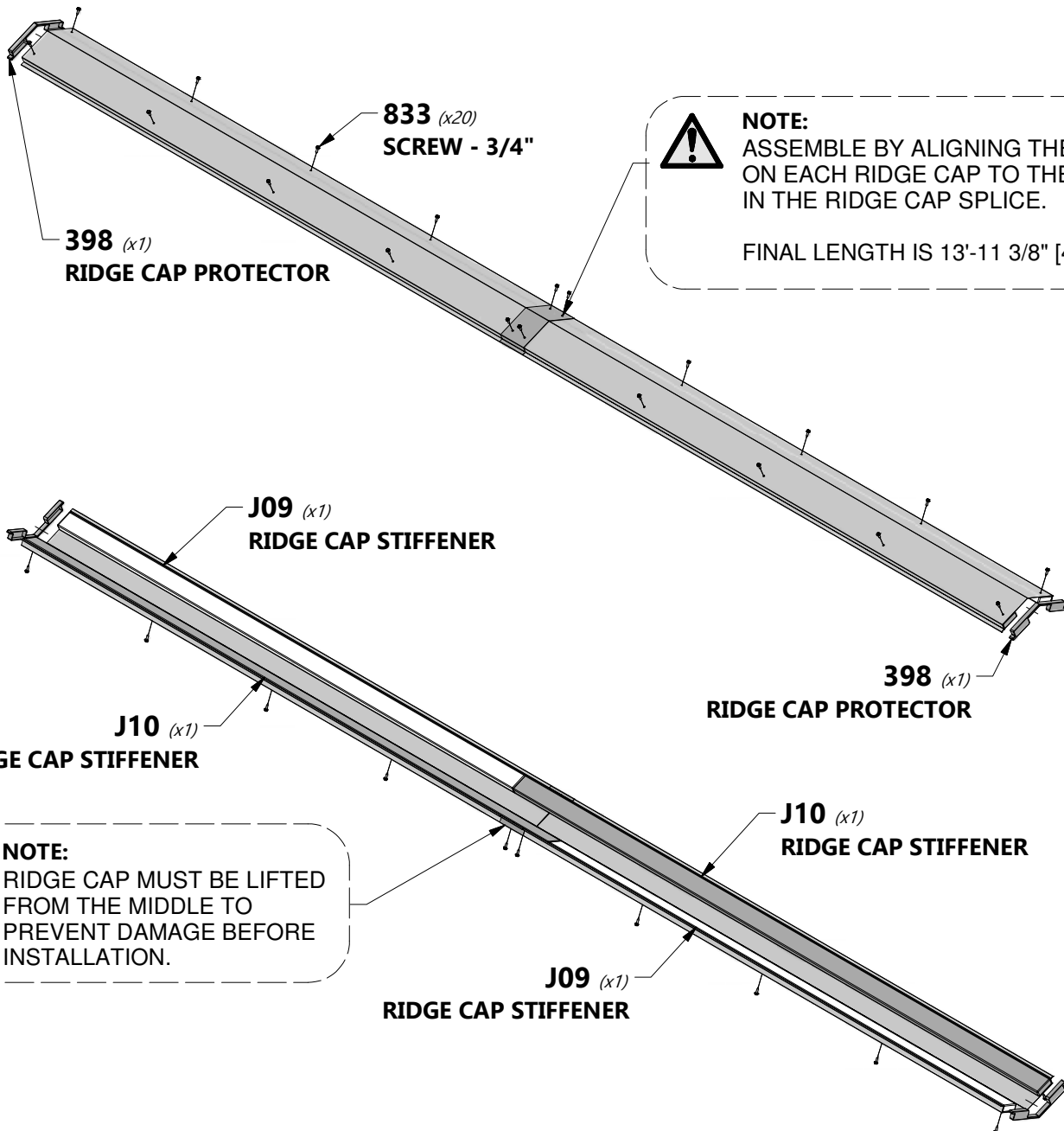

**NOTE:**  
ASSEMBLE BY ALIGNING THE HOLES ON EACH RIDGE CAP TO THE HOLES IN THE RIDGE CAP SPLICE.  
  
FINAL LENGTH IS 13'-11 3/8" [4250mm]

**NOTE:**  
RIDGE CAP MUST BE LIFTED FROM THE MIDDLE TO PREVENT DAMAGE BEFORE INSTALLATION.



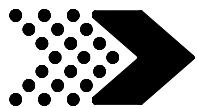

# STEP 32



RIDGE CAP ASSEMBLY FROM PREVIOUS STEP



H100392 | SCREW PWH BLK  
(x22) | 8x3/4

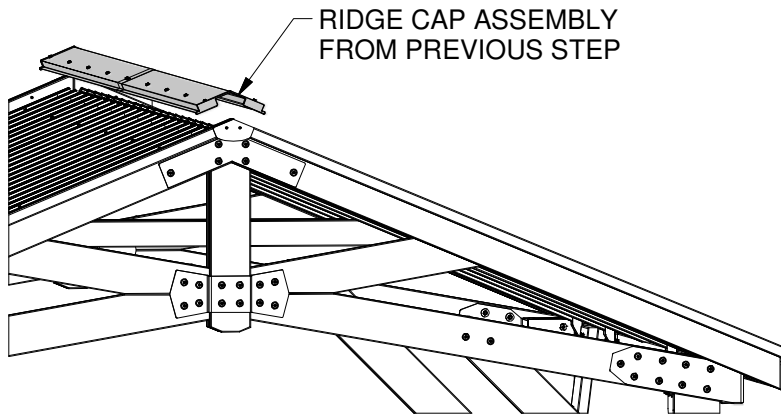

RIDGE CAP ASSEMBLY FROM PREVIOUS STEP

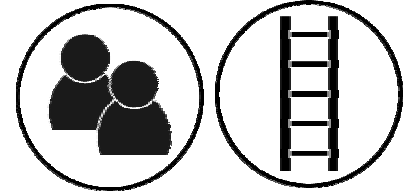

**NOTE:** USING AN ADULT HELPER, SLIDE RIDGE CAP ASSEMBLY CAREFULLY ACROSS THE ROOF RIDGE UNTIL BOTH ENDS SIT INSIDE RAFTERS AS SHOWN.



**NOTE:** RIDGE CAP ASSEMBLY HAS BEEN DESIGNED FOR SAFE INSTALLATION FROM A LADDER AND NO ROOF ACCESS IS REQUIRED NOR RECOMMENDED.

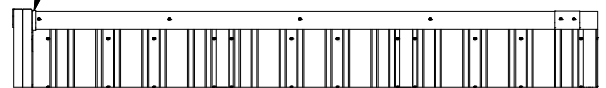

**TIP:**

FOR PROPER INSTALLATION, USE AN ADULT HELPER TO KEEP DOWNWARD PRESSURE ON THE RIDGE CAP DURING SCREW INSTALLATION.

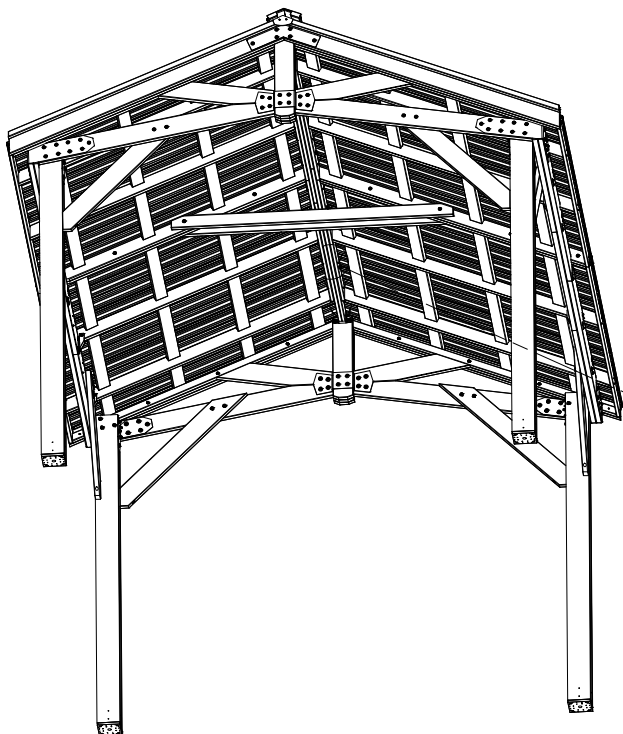

INSTALL SCREWS THRU PILOT HOLES IN ROOF PANELS INTO RIDGE CAP STIFFENER BOARDS.

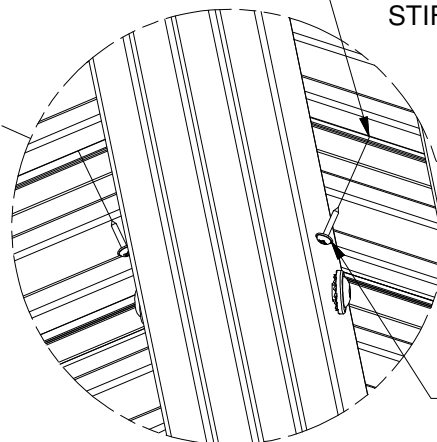

392 (x22)  
SCREW - 3/4"

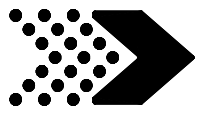

# STEP 33

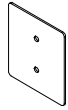

**A4M00978** | POST PLATE  
*(x8)*

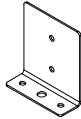

**A4M00977** | POST ANCHORING PLATE  
*(x8)*



**H100471** | LAG SCREW  
*(x32)* | WH BLK  
5/16x1 1/2

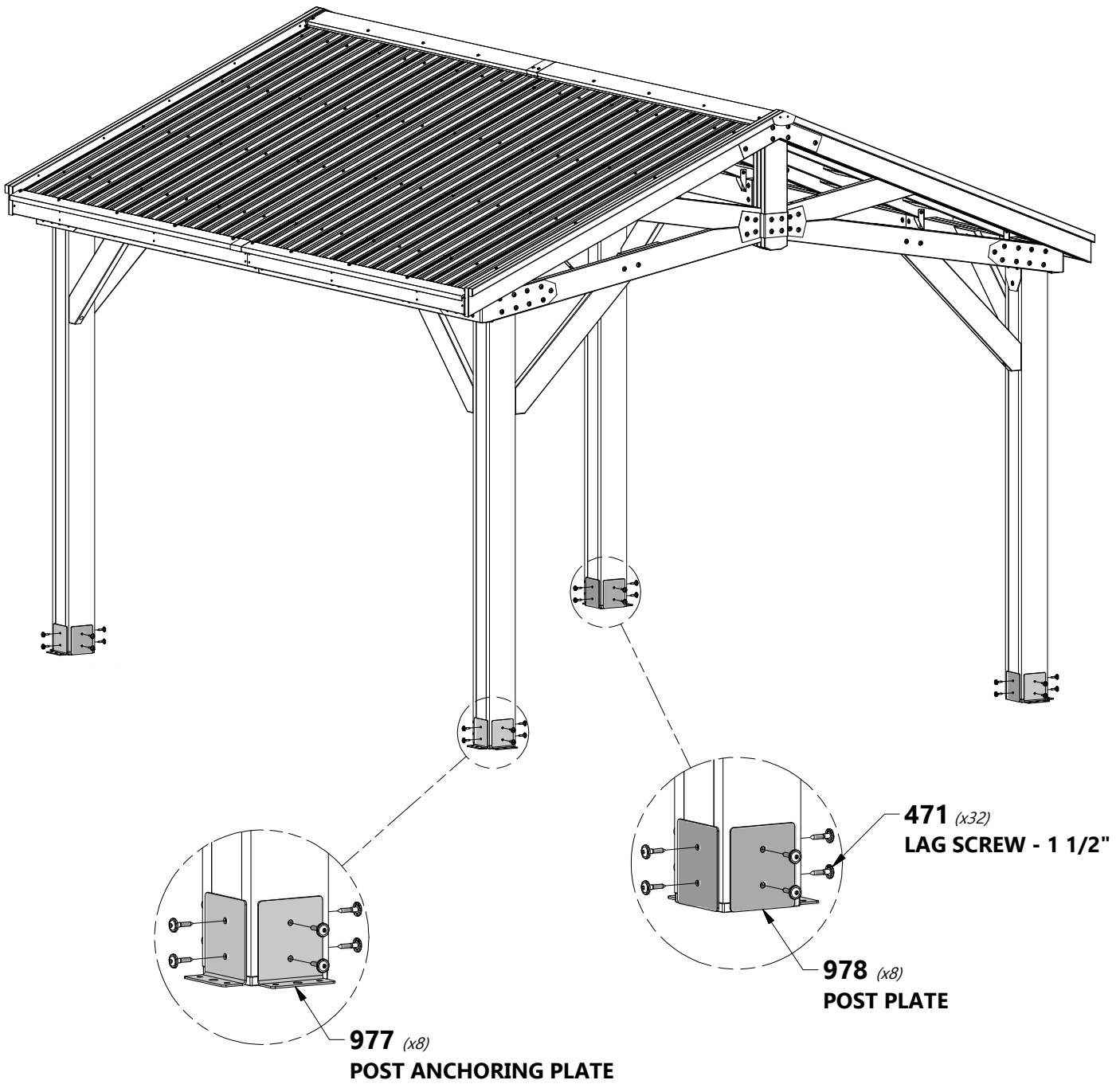

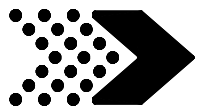

# STEP 34



A100241 (x1) BYD ID TAG (SMALL) WITHOUT AGES



H100200 (x2) SCREW PFH BLK 8x1 1/2

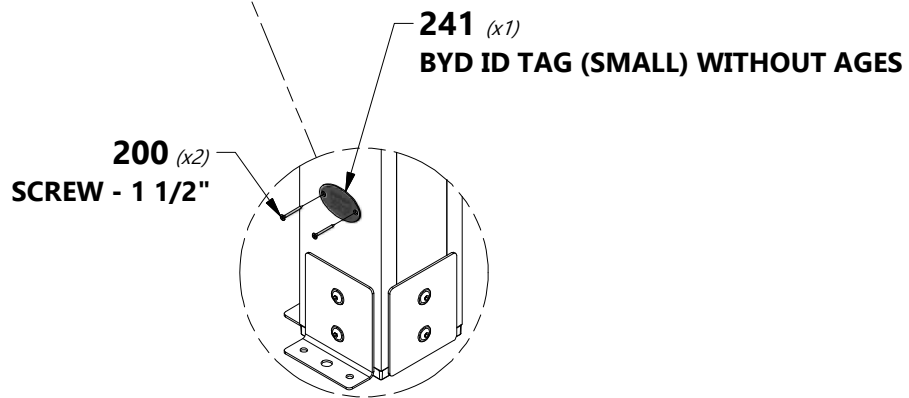
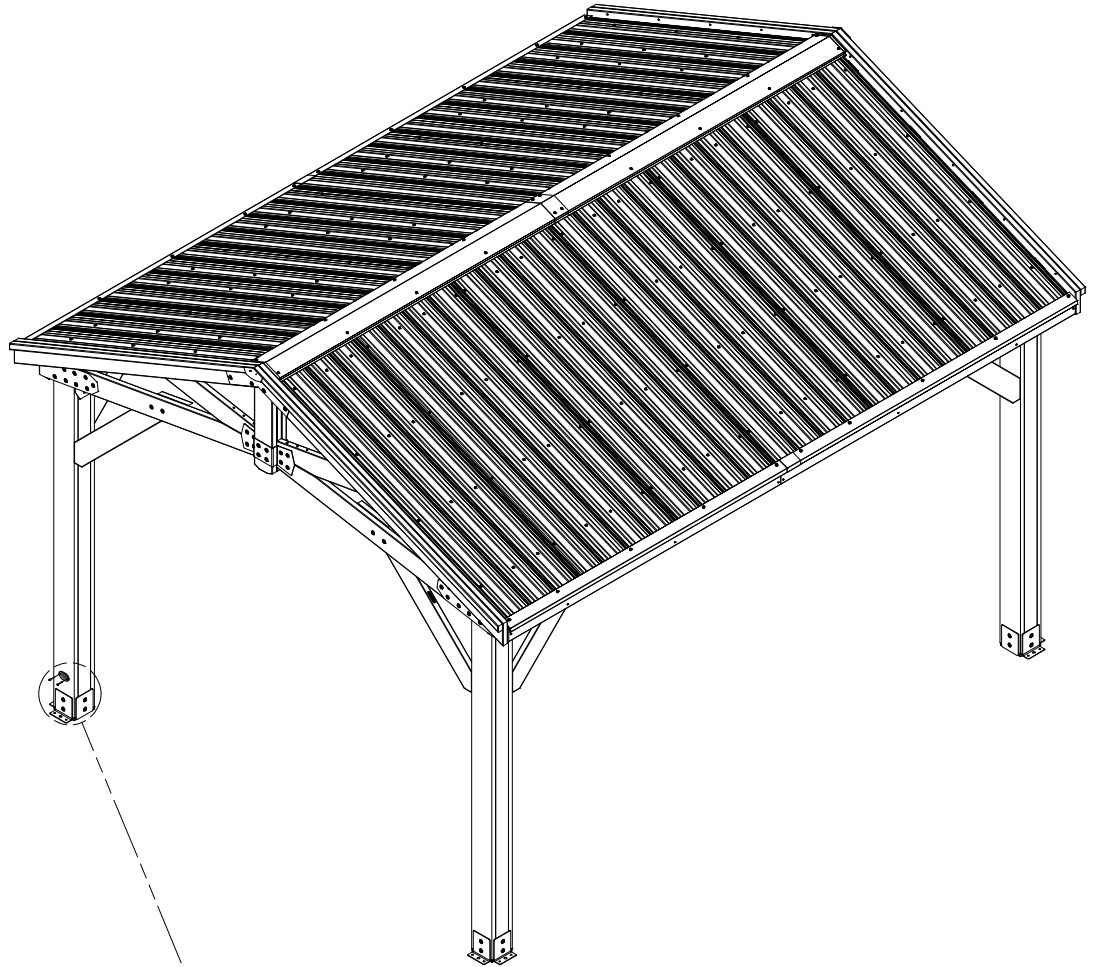

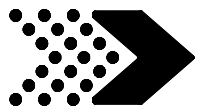

# STEP 35



**H100120** | SCREW CONCRETE ANCHOR  
(x16) | 1/4x2



**H100630** | WASHER FLAT BLK  
(x16) | 8x19



**NOTE:** MANUFACTURER RECOMMENDS INSTALLATION ON CONCRETE SURFACE OR CONCRETE POST PADS. SEE BELOW.

FOR INSTALLATION ON WOOD DECK, YOU MUST ENSURE THERE IS AMPLE STRUCTURAL SUPPORT UNDER DECK. HARDWARE NOT INCLUDED.

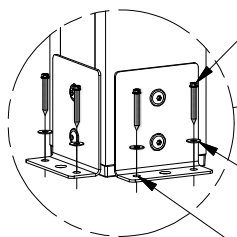
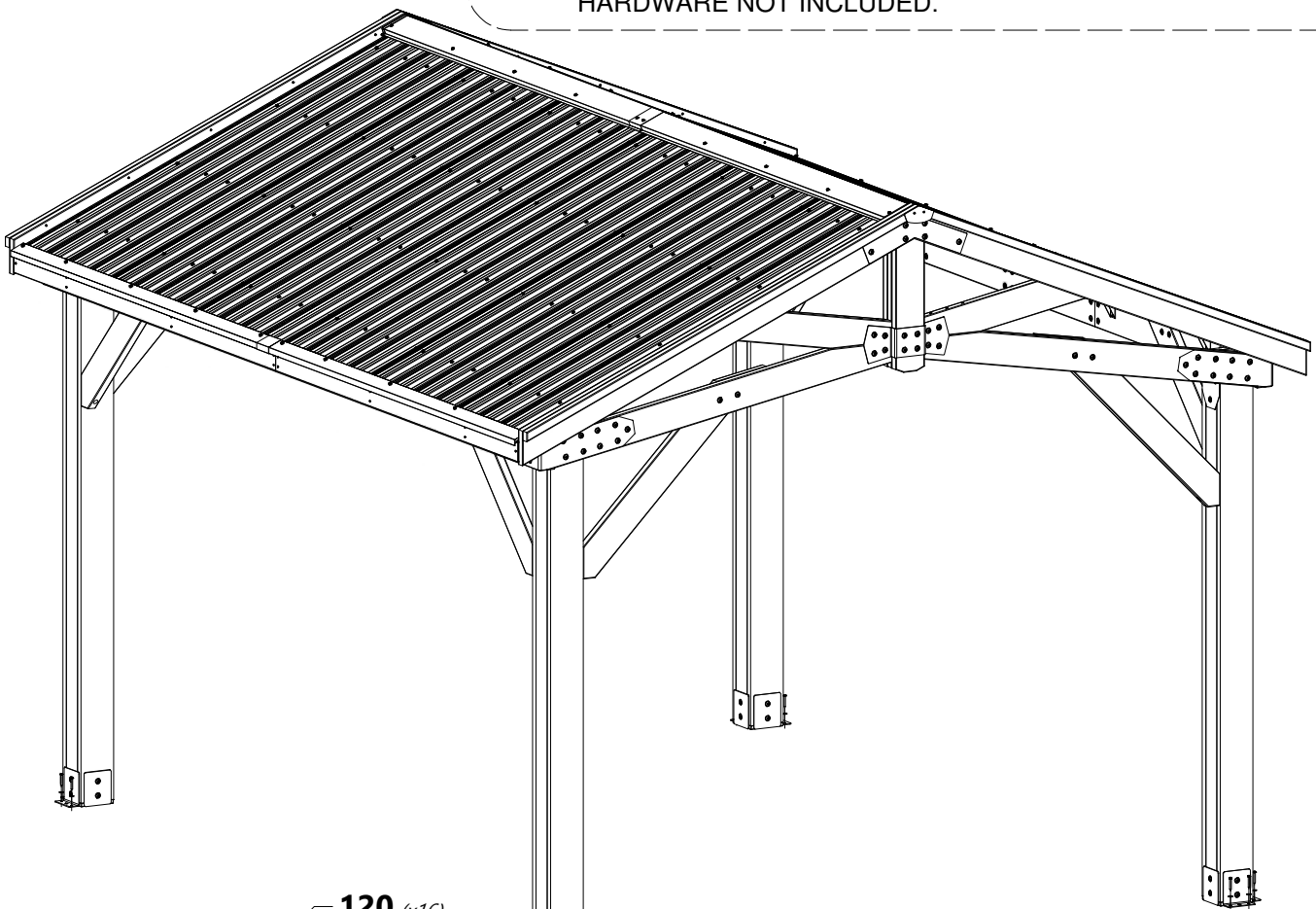

**120** (x16)  
**SCREW - 2"**

**630** (x16)  
**WASHER - 8x19**



**NOTE:** PRE-DRILL HOLES FOR CONCRETE ANCHORS USING A 3/16" CONCRETE DRILL BIT.

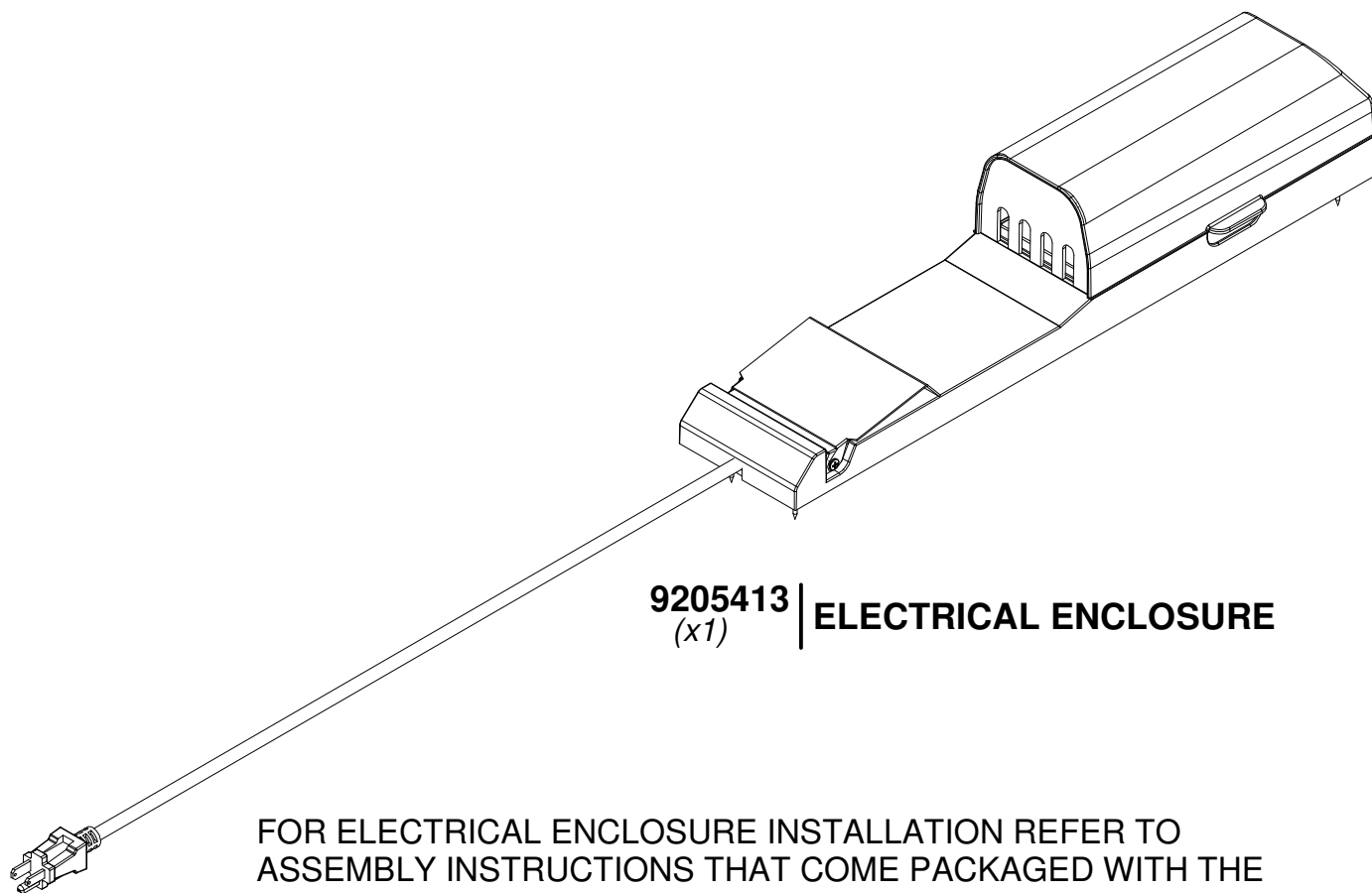

**9205413** | **ELECTRICAL ENCLOSURE**  
*(x1)*

FOR ELECTRICAL ENCLOSURE INSTALLATION REFER TO ASSEMBLY INSTRUCTIONS THAT COME PACKAGED WITH THE ELECTRICAL ENCLOSURE KIT. INSTALL ON ANY POST THAT IS DESIRED. FOLLOW DIRECTIONS FOR PROPER INSTALLATION.