



Manufactured by:
 Backyard Discovery
 3305 Airport Drive, Pittsburg, KS 66762
 800-856-4445

Basepoint Business Centre: Rivermead Drive, Westlea, Swindon SN5 7EX Phone: 0800-118-2476 J.P. Coenstraat 7, The Bridge, The Hague, 2595 WP, Netherlands Phone: 08005678990

14x10 TRENTON, WINDHAM PERGOLA

MODEL #'s : 2105126, 2105157, 2105423B, 2105454B



2105157, 2105454B AU
 WINDHAM (WHITE)



2105126, 2105423B AU
 TRENTON (BLACK)



Please visit www.backyarddiscovery.com
 For the most up to date assembly manual, to register your product, or to order
 replacement parts *Para obtener instrucciones en español, visite*
www.backyarddiscovery.com



EASY STEP-BY-STEP
 3D INTERACTIVE INSTRUCTIONS
 DOWNLOAD THE FREE APP
 



INSTALLATION
 SERVICES
 AVAILABLE!
See inside for details

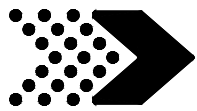

It is critically important that you start with square and level footings, concrete pad or deck to attach your structure

- Pay close attention to the items needed for each step. Make sure you are using the correct hardware for each step. Using incorrect hardware may result in improper assembly
- Remember to double check for underground utilities and overhead electrical lines

Post mounts are provided with your structure which allows you to permanently install your structure to a pre-existing or new wood or concrete surface.

- The hardware to attach the post mounts to the structure is included.
- The hardware to mount the structure permanently to a concrete surface is NOT included.
- The hardware to mount the structure permanently to a wood deck is NOT included and will need to be purchased separately. **You must ensure there is ample structural support under the deck before permanently attaching.**

Metal Roof Assembly

Remove plastic covering from metal roof panels before installing each piece. Place roofing materials on a nonabrasive, flat surface before and after assembly as it could bend, dent or scratch

Overall Dimensions

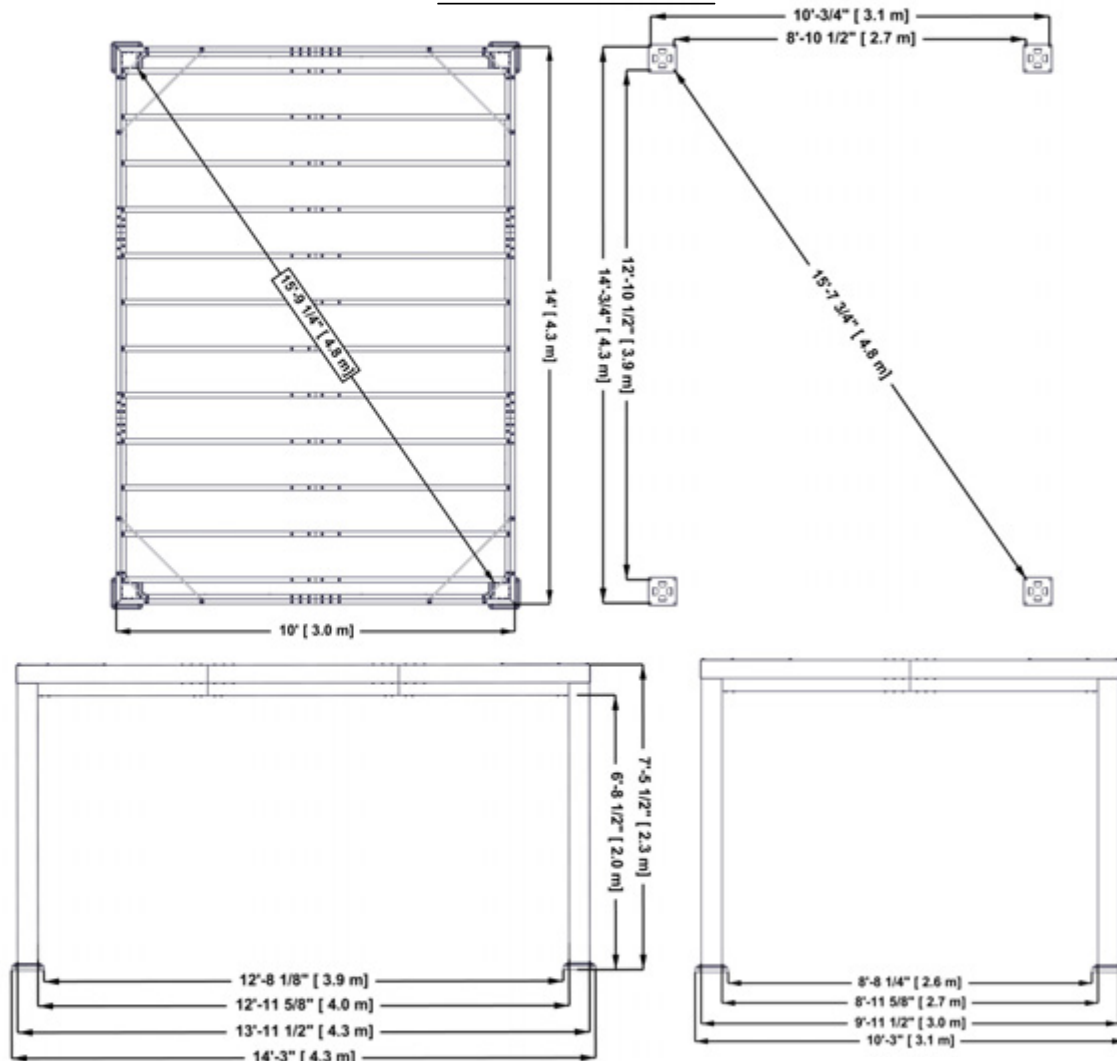

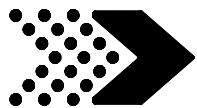

Metal Components (Not to Scale)



A | **POST-A4M01436**
(x4) | 6"X6"X89" (152x152x2261)



B1 | **JOIST END-A4M01458**
(x2) | 1 3/8"X5 1/4"X55 7/8" (36x134x1420)

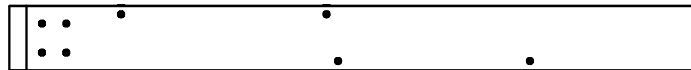

B2 | **JOIST END-A4M01459**
(x2) | 1 3/8"X5 1/4"X55 7/8" (36x134x1420)

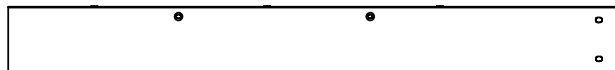

C1 | **JOIST END-A4M01461**
(x2) | 1 3/8"X5 1/4"X49 3/4" (36x134x1264)

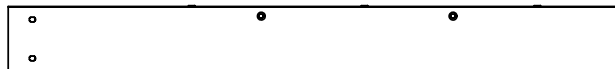

C2 | **JOIST END-A4M01462**
(x2) | 1 3/8"X5 1/4"X49 3/4" (36x134x1264)



D1 | **JOIST END-A4M01464**
(x2) | 1 3/8"X5 1/4"X59 7/8" (36x134x1521)



D2 | **JOIST END-A4M01465**
(x2) | 1 3/8"X5 1/4"X59 7/8" (36x134x1521)

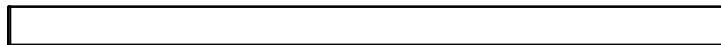

F | **JOIST END-A4M01466**
(x24) | 1 5/8"X3 1/8"X58 1/2" (41x81x1485)

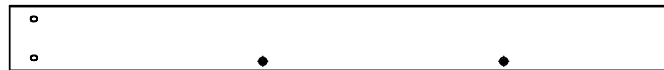

E1 | **JOIST END-A4M01467**
(x2) | 1 3/8"X5 1/4"X53 3/4" (36x134x1365)



E2 | **JOIST END-A4M01468**
(x2) | 1 3/8"X5 1/4"X53 3/4" (36x134x1365)

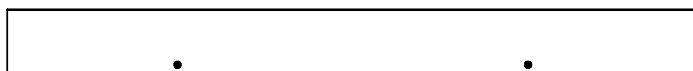

B3 | **JOIST-A4M01460**
(x2) | 1 3/8"X5 1/4"X55 7/8" (36x134x1420)



C3 | **JOIST-A4M01463**
(x2) | 1 3/8"X5 1/4"X55 7/8" (36x134x1420)

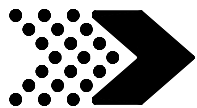

Metal Components (Not to Scale)

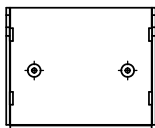

G1 | BRACKET-A4M01452
(x8) | 1 1/4"X4 1/8"X5" (32x104x128)

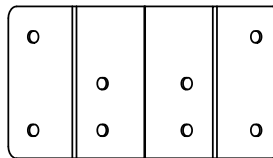

G2 | W BRACKET-A4M01453
(x4) | 3"X5 1/8"X9 1/8" (78x130x233)



H1 | SPLICE BRACKET-A4M01437
(x4) | 1 1/4"X5 1/8"X15 3/4" (33x131x400)



H2 | SPLICE BRACKET-A4M01438
(x12) | 1 1/2"X3"X15 3/4" (37x77x400)



H3 | SPLICE BRACKET-A4M01439
(x4) | 1 1/4"X5 1/8"X19 5/8" (33x131x500)



H4 | SPLICE BRACKET-A4M01440
(x4) | 1 1/4"X5 1/8"X11" (33x130x280)

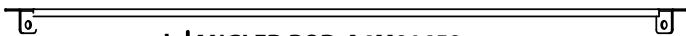

L | ANGLED ROD-A4M01450
(x4) | 1 1/4"X1 1/2"X36 3/8" (33x38x924)



M | ANGLED ROD-A4M01451
(x4) | 1 1/4"X1 1/2"X12 7/8" (33x38x327)

Accessory Components (Not to Scale)

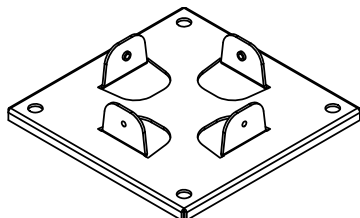

P1 | A4M01454
(x4) | POST FOOT

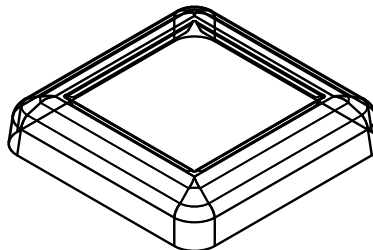

P2 | A4M01455
(x4) | POST FOOT COVER

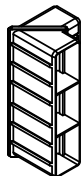

N1 | A6P00493
(x4) | L PLUG

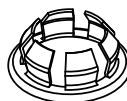

N2 | A4M01352
(x20) | HOLE COVER



9220409 OR
9205413 | ELECTRICAL ENCLOSURE
(x1)



Hardware Components



H101101 | TORX PAN HEAD
(380) | 1/4-20x3/4"



H101053 | STEEL WASHER
(404) | 6x20



H101054 | SEALANT WASHER
(404)

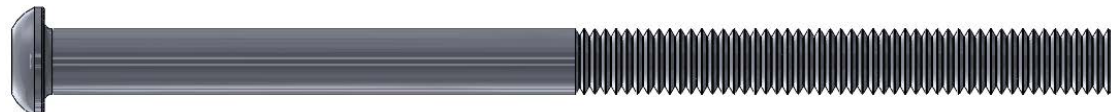

H101102 | TORX PAN HEAD
(24) | 1/4-20x4"



H101103 | TORX SOCKET SCREW
(20) | 1/4-20



H100120 | CONCRETE ANCHOR
(16) | 1/4x2



H100630 | FLAT WASHER
(#()) | BLK *x#+

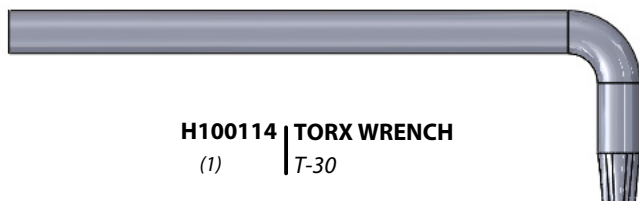

H100114 | TORX WRENCH
(1) | T-30

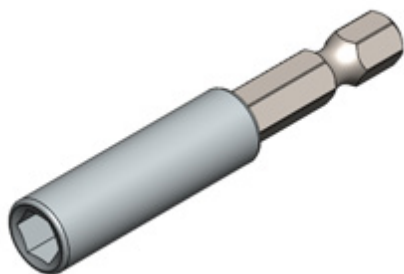

H101100 | BIT EXTENSION
(1)

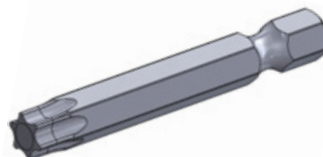

H100147 | TORX BIT
(1) | T-30

PRE-ASSEMBLY STEP 1 - SORTING PARTS

It is critical for ease of assembly that you take the time to sort and organize the parts and hardware.

METAL PARTS:

- Organize metal parts by the three-digit, alpha-numeric number stamped on each part (ex. P01).
- If there are multiple parts with the same stamped number, stack those pieces together.
- Stamps can be found on the flat surface of the parts or on the end of the parts.
- Allow yourself plenty of room - the parts can take up a significant amount of space.

NOTE: CARTONS ARE NOT ORGANIZED BY PART NUMBER.

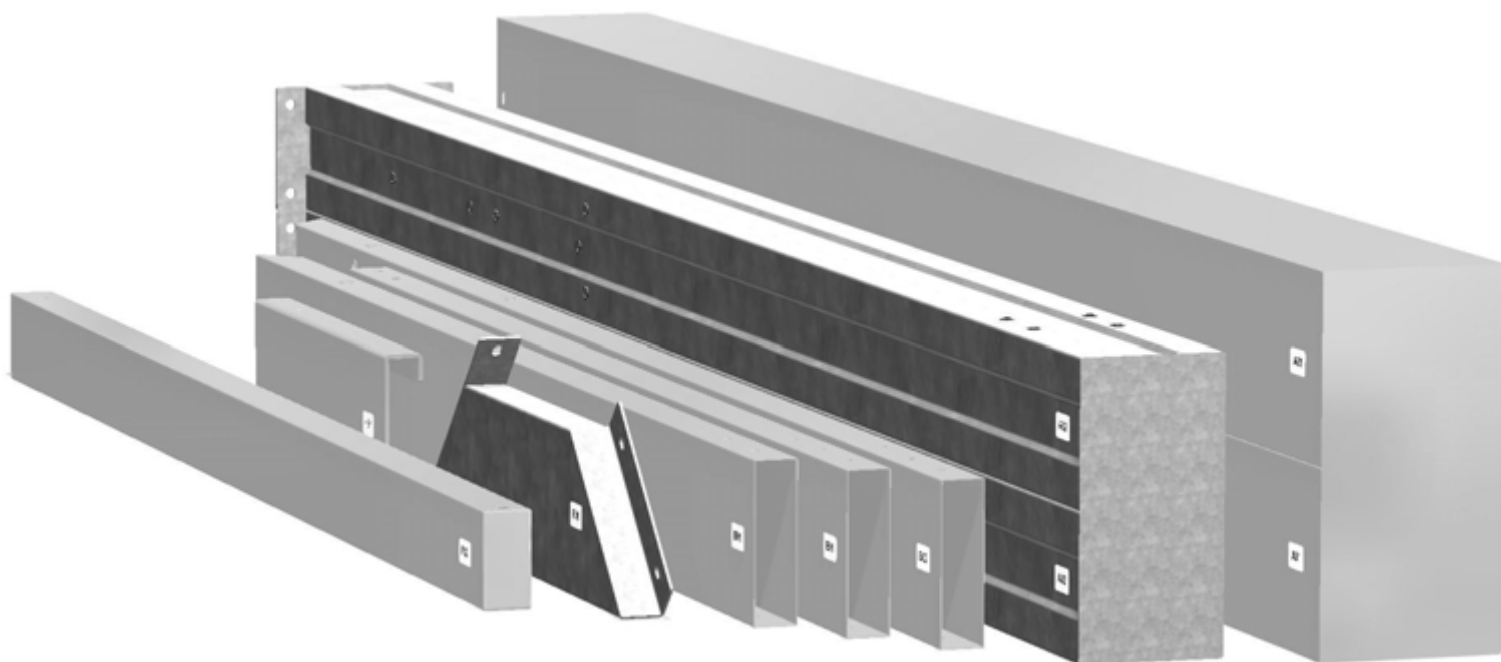

HARDWARE PARTS:

- We recommend that you have a separate table to organize the hardware.
- Hardware bags are printed with a seven-digit, alpha-numeric part number.
- You can organize your hardware by part number or group by hardware type (i.e. bolts, nuts, etc.).
- During assembly you only need to reference the last four digits of the number.

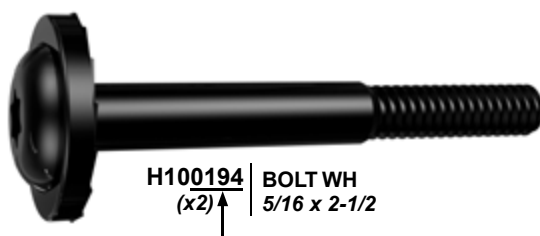

PRE-ASSEMBLY STEP 2 - TOOLS REQUIRED



Cordless Drill or
Electric Drill



Drill Attachments:
Phillips Head



3/16" Concrete
Drill Bit



Phillips Screw Driver

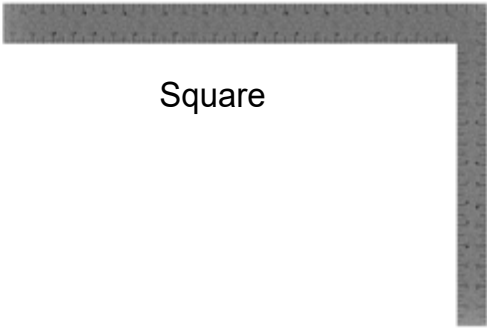

Square



Rubber Mallet -
Optional



Tape Measure



Level 24"

PRE-ASSEMBLY STEP 3 - CHOOSE YOUR ASSEMBLY METHOD

There are several types of assembly instructions available to you.

1. Printed Assembly Manual included with your set
2. BILT APP - 3D interactive instructions
3. Combination of the Printed Manual and BILT APP (Note: Step numbers can differ between the two methods)



The graphic is a rectangular advertisement for the BILT app. At the top left is the BILT logo, which consists of a stylized hexagonal icon with a dot inside, followed by the word "BILT." in a bold, sans-serif font. To the right of the logo is a large QR code. Below the logo and QR code, the text "Scan for easy 3D instructions" is written in a large, bold, black font. Underneath this, in a smaller font, it says "Download the BILT app before you begin". To the right of this text are two buttons: "Download on the App Store" with the Apple logo and "GET IT ON Google Play" with the Google Play logo. At the bottom of the graphic is a smartphone screen displaying a 3D interactive assembly instruction. The screen shows a 3D model of a structure with a horizontal beam and a triangular support. A red arrow points to a specific part of the structure. The screen also has a "Partners Needed" button in the top left, a close button (X) in the top right, and navigation arrows (back, play/pause, forward) at the bottom.

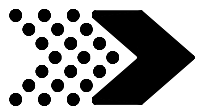

PERGOLA ASSEMBLY

STEP 1

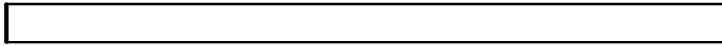

F | JOIST END-A4M01466
(x12) | 1 5/8"X3 1/8"X58 1/2" (41x81x1485)



H2 | SPLICE BRACKET-A4M01438
(x12) | 1 1/2"X3"X15 3/4" (37x77x400)



H101101 | TORX PAN HEAD
(48) | 1/4-20x3/4"



H101053 | STEEL WASHER
(48) | 6x20



H101054 | SEALANT WASHER
(48)

COMPLETE THIS STEP TWELVE TIMES.



DO NOT FULLY TIGHTEN BOLTS AT THIS STEP.

SLIDE H2 INTO F AND LINE UP TWO HOLES TOP AND BOTTOM.

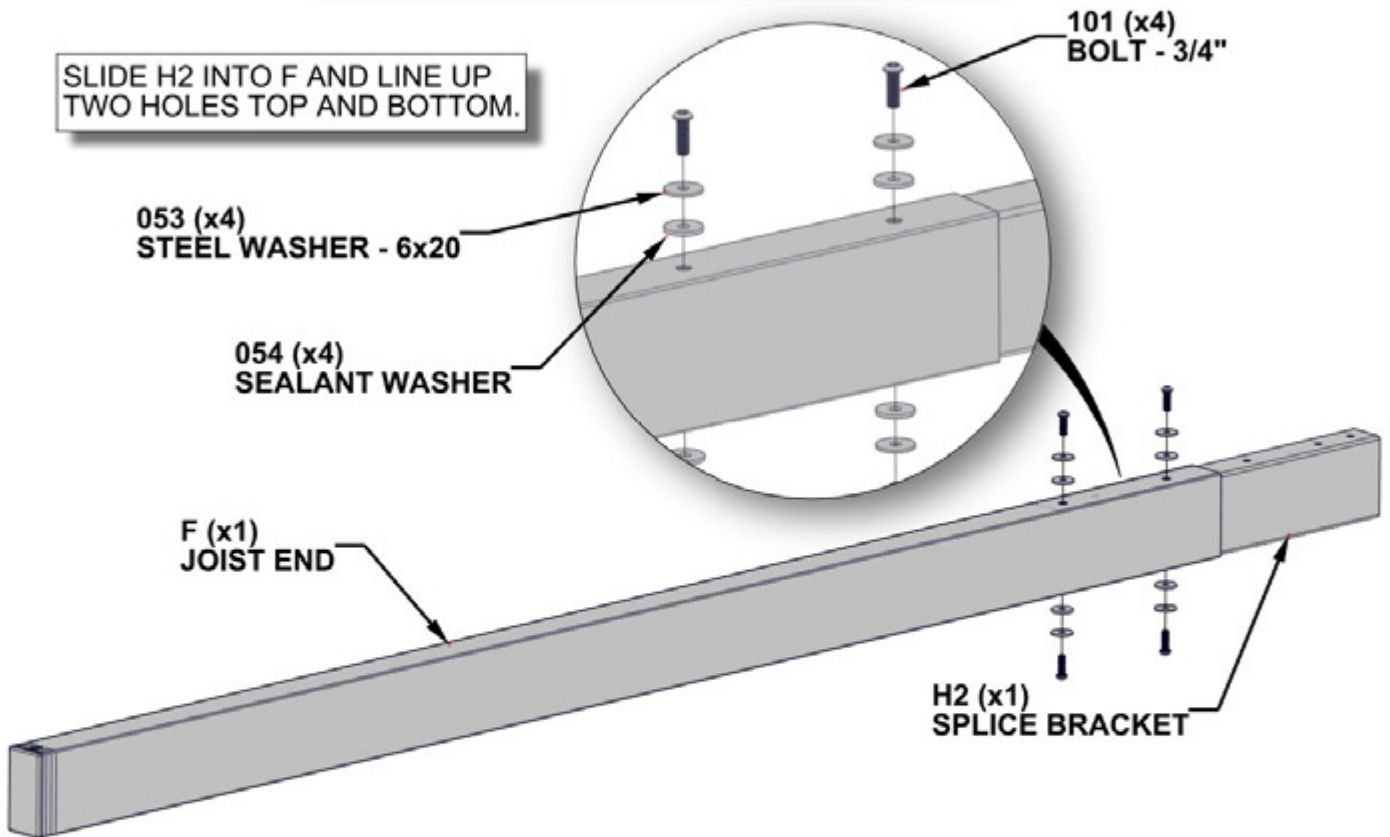

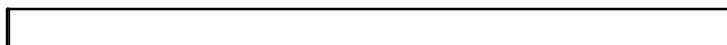

F | JOIST END-A4M01466
(x12) | 1 5/8"X3 1/8"X58 1/2" (41x81x1485)



H101101 | TORX PAN HEAD
(48) | 1/4-20x3/4"



H101053 | STEEL WASHER
(48) | 6x20



H101054 | SEALANT WASHER
(48)

COMPLETE THIS STEP TWELVE TIMES.

SLIDE F ONTO SPLICE BRACKET AND STAND UP ASSEMBLY WITH PACKAGING CARDBOARD UNDERNEATH. GENTLY TAP ASSEMBLY ON CARDBOARD UNTIL GAP CLOSES THEN TIGHTEN ALL BOLTS ON JOIST.

IT IS RECOMMENDED THAT BOLTS ARE FULLY TIGHTENED IN THIS ORDER.

053 (x4) STEEL WASHER - 6x20

054 (x4) SEALANT WASHER

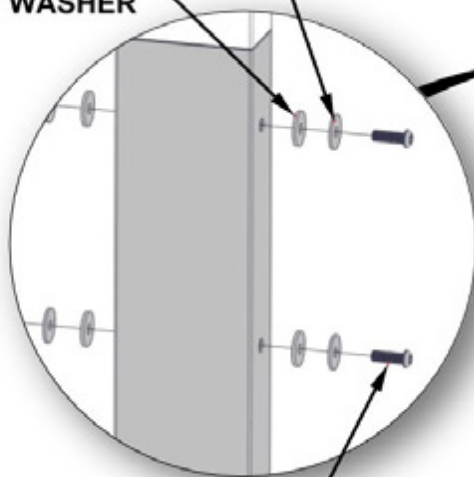

101 (x4) BOLT - 3/4"

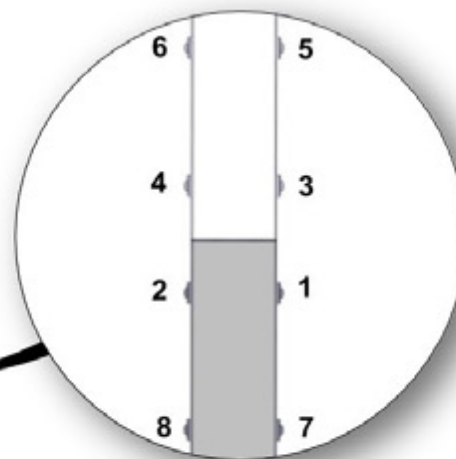

F (x1) JOIST END

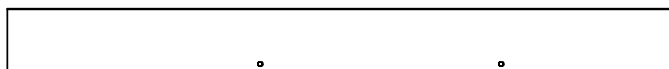

E2 | JOIST END-A4M01468
(x2) | 1 3/8"X5 1/4"X53 3/4" (36x134x1365)



H1 | SPLICE BRACKET-A4M01437
(x2) | 1 1/4"X5 1/8"X15 3/4" (33x131x400)



H101101 | TORX PAN HEAD
(12) | 1/4-20x3/4"



H101053 | STEEL WASHER
(12) | 6x20



H101054 | SEALANT WASHER
(12)

COMPLETE THIS STEP TWICE.



DO NOT FULLY TIGHTEN BOLTS AT THIS STEP.

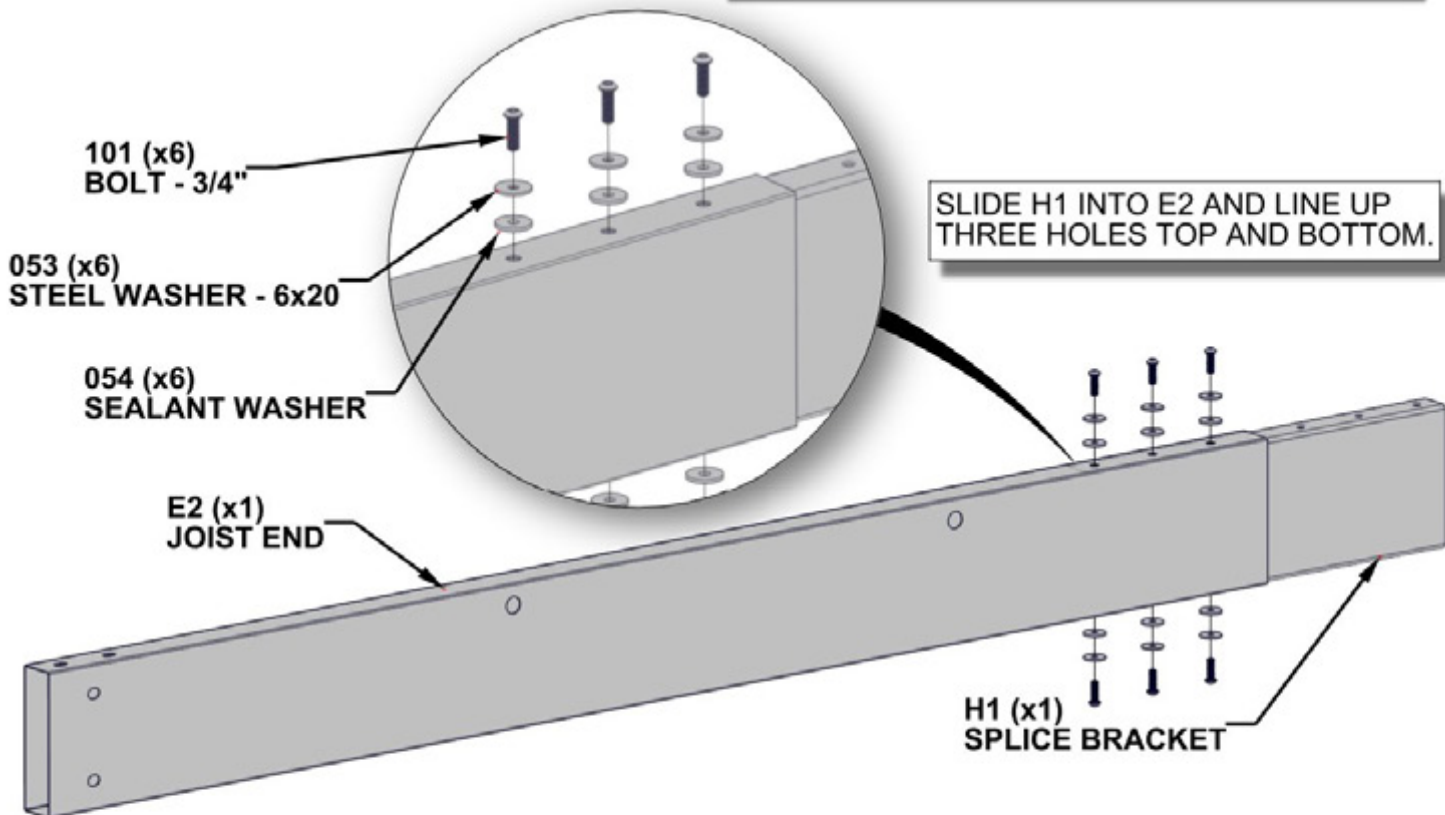



E1 | JOIST END-A4M01467
(x2) | 1 3/8"X5 1/4"X53 3/4" (36x134x1365)

H101101 | TORX PAN HEAD
(12) | 1/4-20x3/4"

H101053 | STEEL WASHER
(12) | 6x20

H101054 | SEALANT WASHER
(12)

COMPLETE THIS STEP TWICE.

SLIDE E1 ONTO SPLICE BRACKET AND STAND UP ASSEMBLY WITH PACKAGING CARDBOARD UNDERNEATH. GENTLY TAP ASSEMBLY ON CARDBOARD UNTIL GAP CLOSSES THEN TIGHTEN ALL BOLTS ON JOIST.

IT IS RECOMMENDED THAT BOLTS ARE FULLY TIGHTENED IN THIS ORDER.

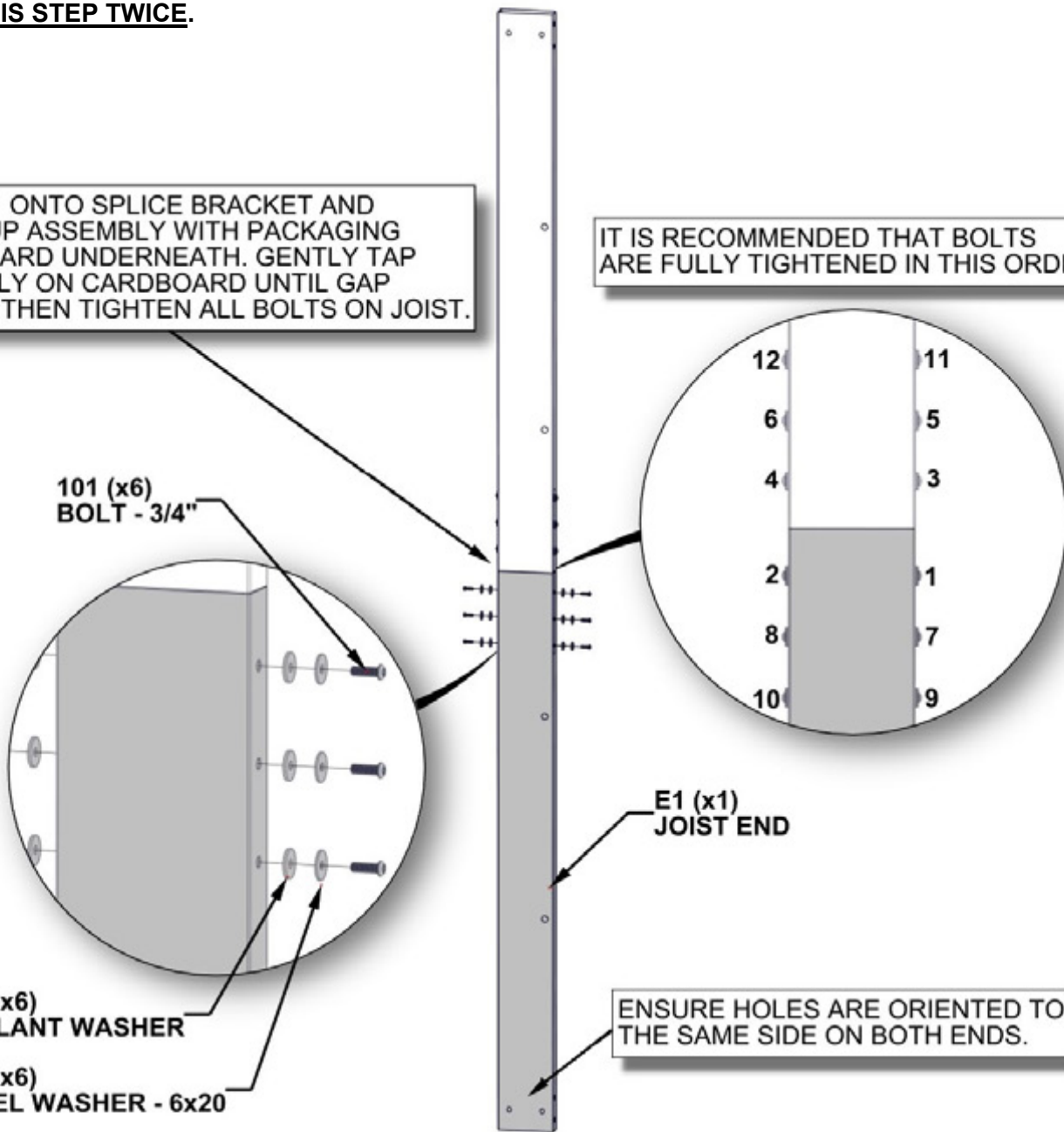

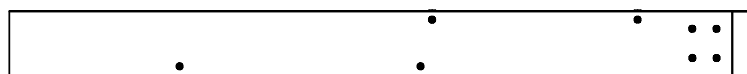

D1 | JOIST END-A4M01464
(x2) | 1 3/8"X5 1/4"X59 7/8" (36x134x1521)



H1 | SPLICE BRACKET-A4M01437
(x2) | 1 1/4"X5 1/8"X15 3/4" (33x131x400)



H101101 | TORX PAN HEAD
(12) | 1/4-20x3/4"



H101053 | STEEL WASHER
(12) | 6x20



H101054 | SEALANT WASHER
(12)

COMPLETE THIS STEP TWICE.



DO NOT FULLY TIGHTEN BOLTS AT THIS STEP.

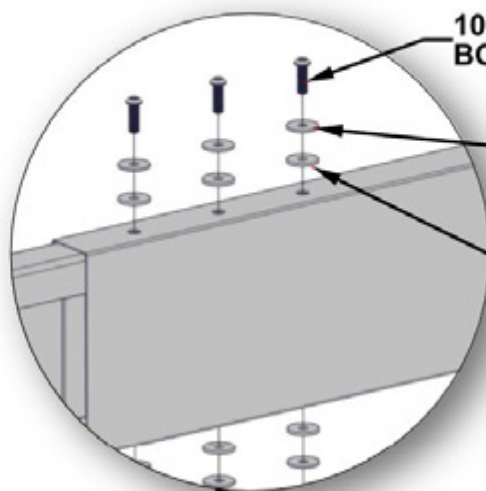

101 (x6) BOLT - 3/4"

053 (x6) STEEL WASHER - 6x20

054 (x6) SEALANT WASHER

SLIDE H1 INTO D1 AND LINE UP THREE HOLES TOP AND BOTTOM.

D1 (x1) JOIST END

H1 (x1) SPLICE BRACKET



PERGOLA ASSEMBLY

STEP 6

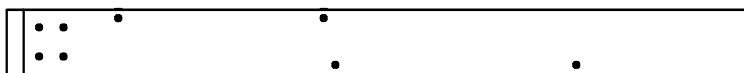

D2 | JOIST END-A4M01465
(x2) | 1 3/8"X5 1/4"X59 7/8" (36x134x1521)

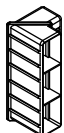

N1 | A6P00493
(x4) | L PLUG



H101101 | TORX PAN HEAD
(12) | 1/4-20x3/4"



H101053 | STEEL WASHER
(12) | 6x20



H101054 | SEALANT WASHER
(12)

COMPLETE THIS STEP TWICE.



SLIDE D2 ONTO SPLICE BRACKET AND STAND UP ASSEMBLY WITH PACKAGING CARDBOARD UNDERNEATH. GENTLY TAP ASSEMBLY ON CARDBOARD UNTIL GAP CLOSSES THEN TIGHTEN ALL BOLTS ON JOIST.

IT IS RECOMMENDED THAT BOLTS ARE FULLY TIGHTENED IN THIS ORDER.

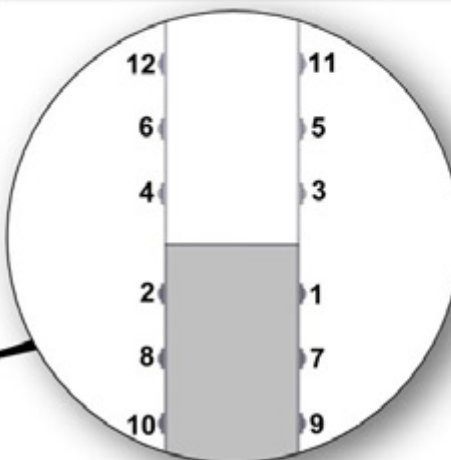

101 (x6)
BOLT - 3/4"

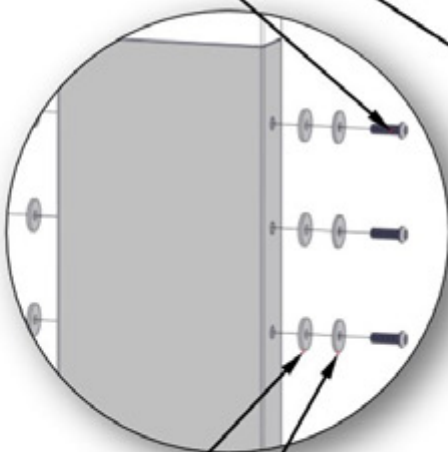

ENSURE THAT HOLES ARE ORIENTED TO THE SAME SIDE.

054 (x6)
SEALANT WASHER

053 (x6)
STEEL WASHER - 6x20

N1 (x2)
L PLUG

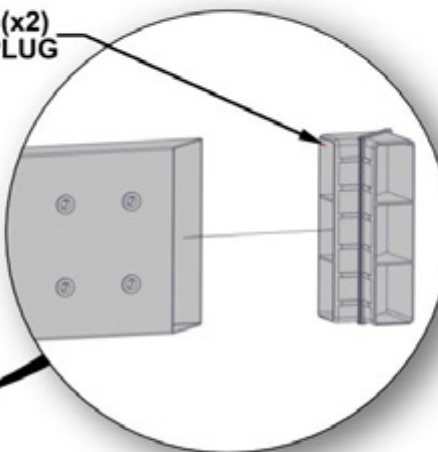

D2 (x1)
JOIST END

ONCE BOLTS ARE FULLY TIGHTENED, LAY THE ASSEMBLY BACK DOWN FLAT. USING A RUBBER Mallet, TAP AN N1 INTO EACH END AS SHOWN.

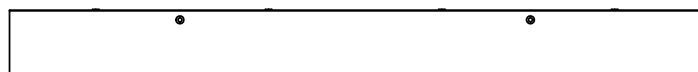

C3 | JOIST-A4M01463
(x2) | 1 3/8"X5 1/4"X55 7/8" (36x134x1420)



H4 | SPLICE BRACKET-A4M01440
(x4) | 1 1/4"X5 1/8"X11" (33x130x280)



H101101 | TORX PAN HEAD
(16) | 1/4-20x3/4"



H101053 | STEEL WASHER
(16) | 6x20



H101054 | SEALANT WASHER
(16)

COMPLETE THIS STEP TWICE.



DO NOT FULLY TIGHTEN BOLTS AT THIS STEP.

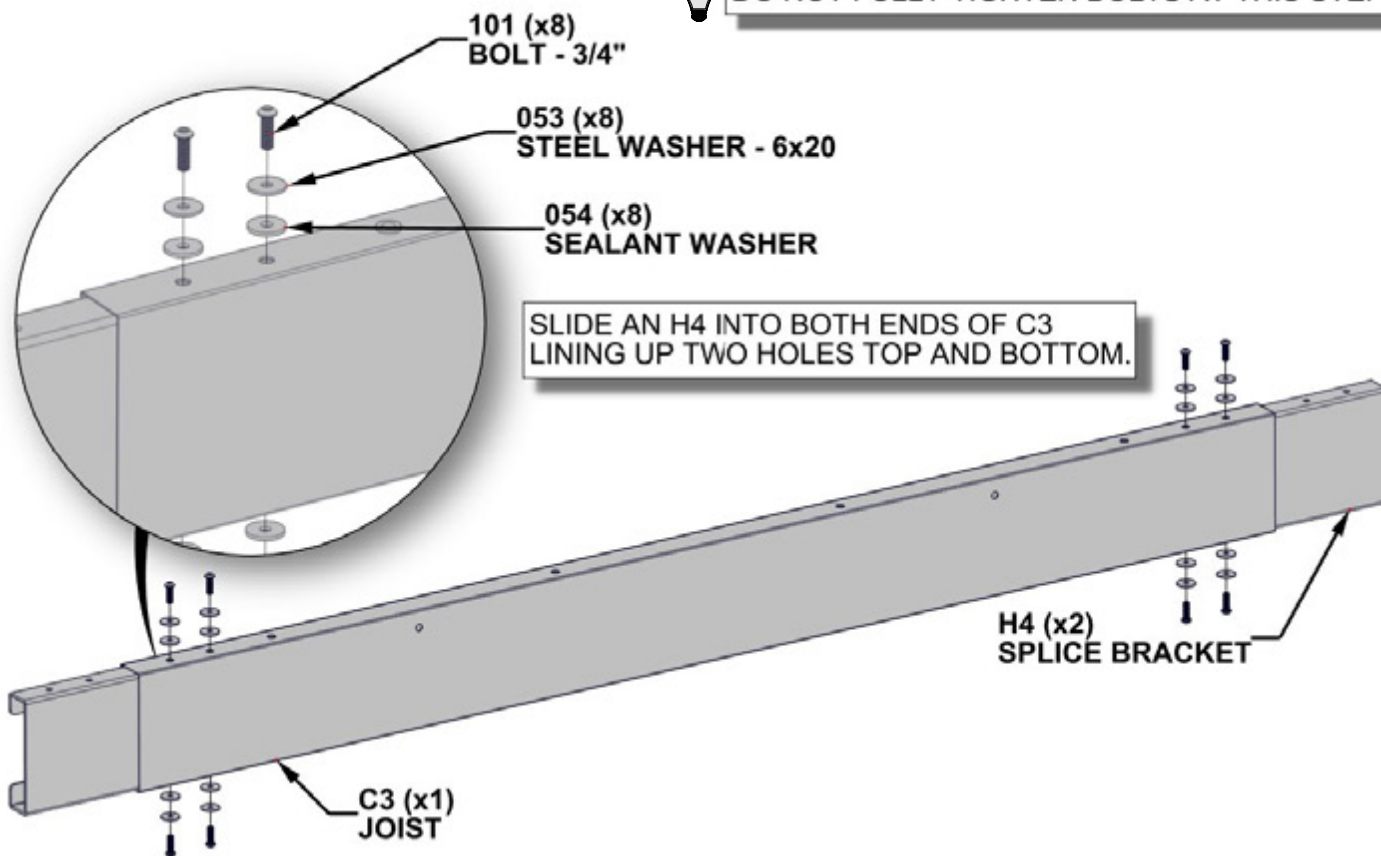



PERGOLA ASSEMBLY

STEP 8



C1 | JOIST END-A4M01461
(x2) | 1 3/8"X5 1/4"X49 3/4" (36x134x1264)



C2 | JOIST END-A4M01462
(x2) | 1 3/8"X5 1/4"X49 3/4" (36x134x1264)

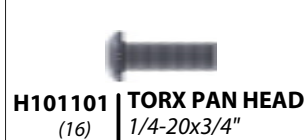

H101101 | TORX PAN HEAD
(16) | 1/4-20x3/4"



H101053 | STEEL WASHER
(16) | 6x20



H101054 | SEALANT WASHER
(16)

COMPLETE THIS STEP TWICE.

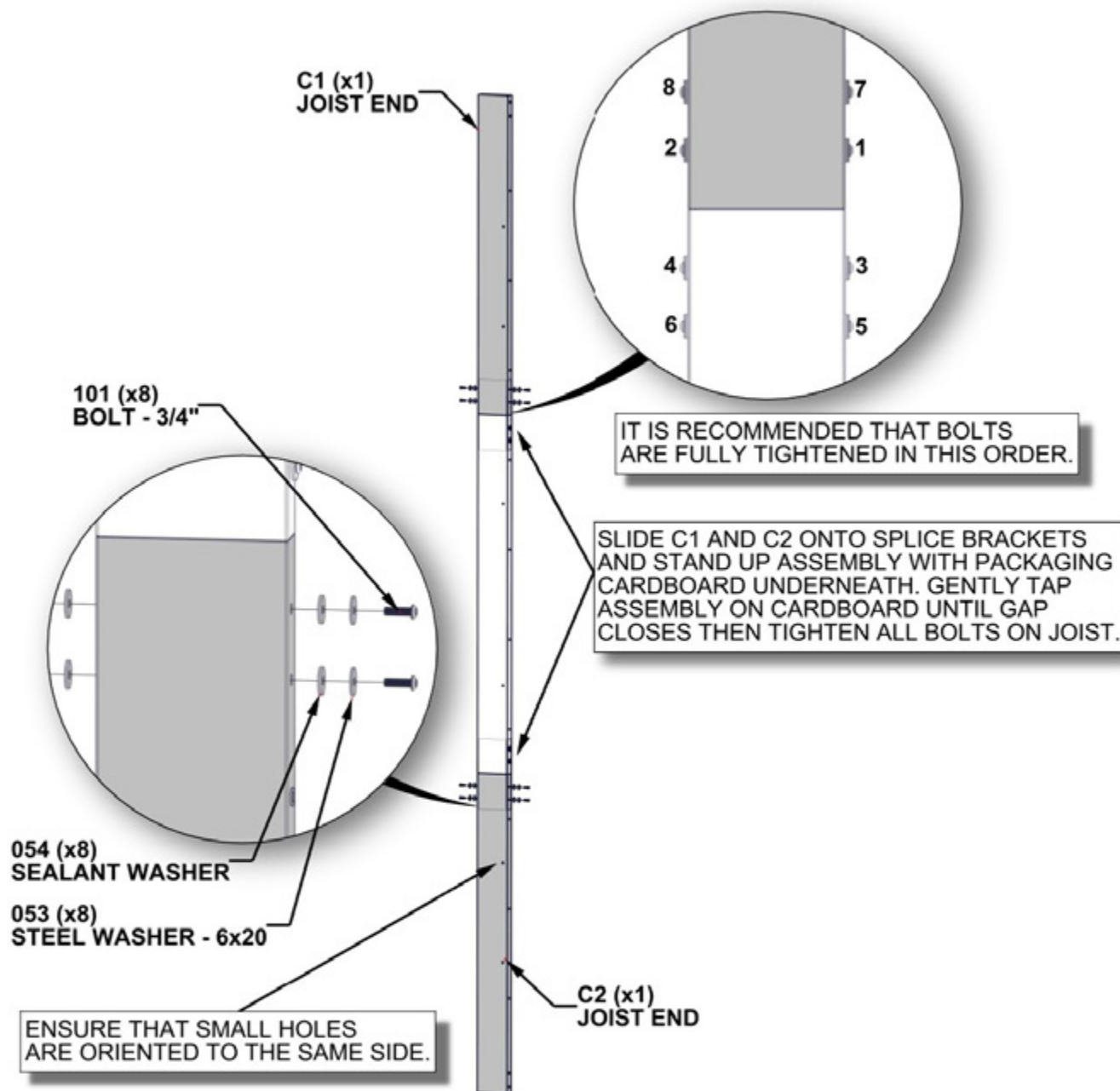



B3 | JOIST-A4M01460
(x2) | 1 3/8"X5 1/4"X5 7/8" (36x134x1420)



H3 | SPLICE BRACKET-A4M01439
(x4) | 1 1/4"X5 1/8"X19 5/8" (33x131x500)



H101101 | TORX PAN HEAD
(24) | 1/4-20x3/4"



H101053 | STEEL WASHER
(24) | 6x20



H101054 | SEALANT WASHER
(24)

COMPLETE THIS STEP TWICE.



DO NOT FULLY TIGHTEN BOLTS AT THIS STEP.

**SLIDE AN H3 INTO BOTH ENDS OF B3
LINING UP THREE HOLES TOP AND BOTTOM.**

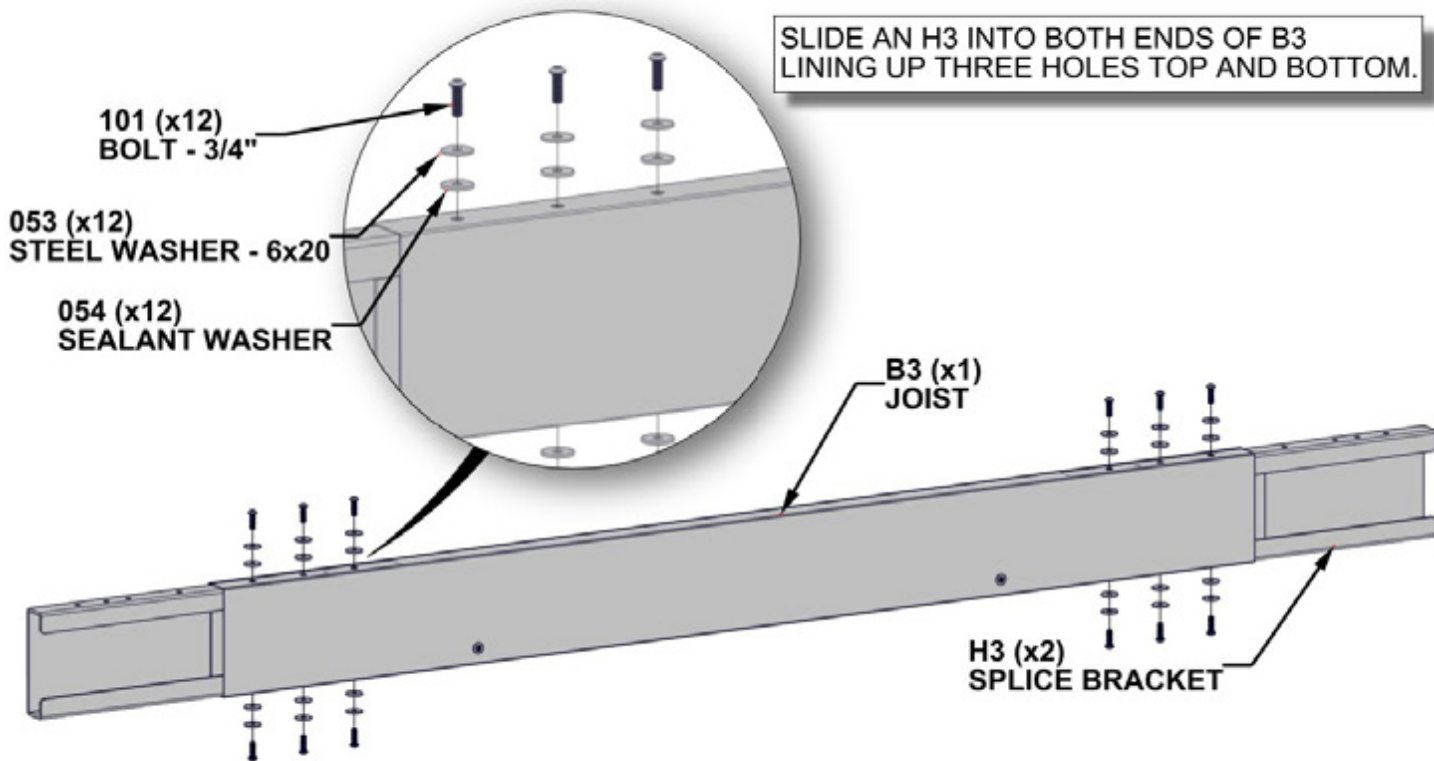

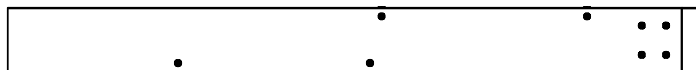

B1 JOIST END-A4M01458
(x2) | 1 3/8"X5 1/4"X55 7/8" (36x134x1420)

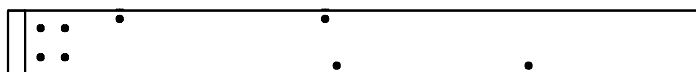

B2 JOIST END-A4M01459
(x2) | 1 3/8"X5 1/4"X55 7/8" (36x134x1420)

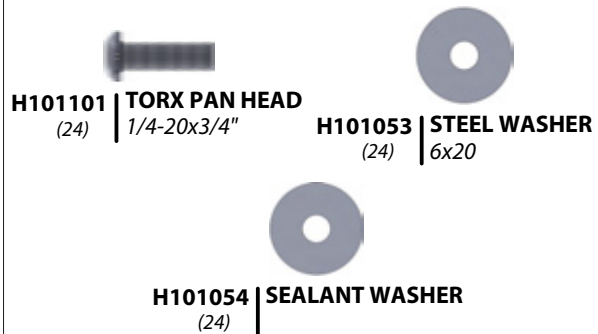

COMPLETE THIS STEP TWICE.

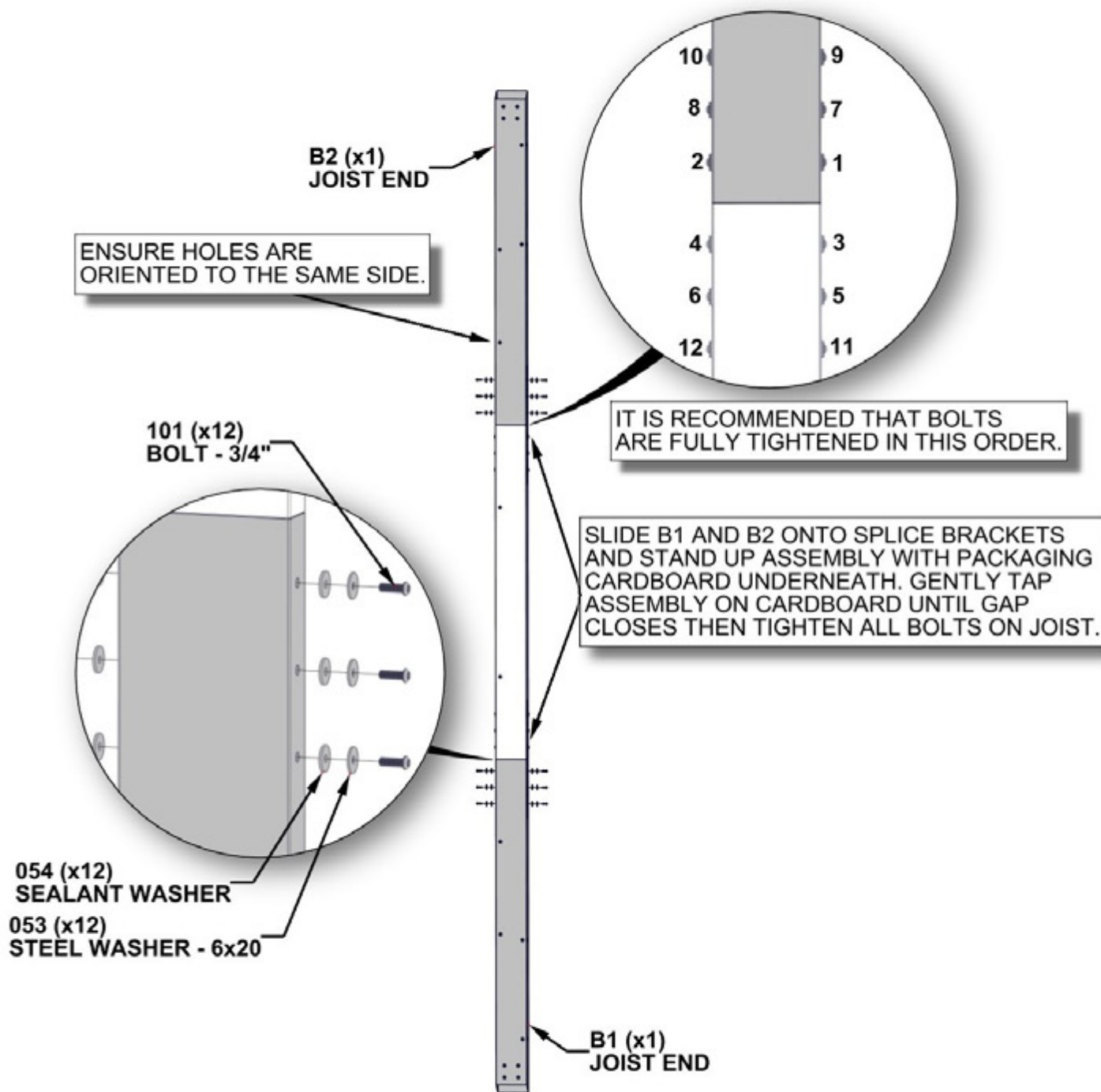



A | **POST-A4M01436**
(x4) | 6"X6"X89" (152x152x2261)

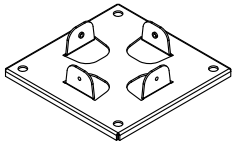

P1 | **A4M01454**
(x4) | **POST FOOT**

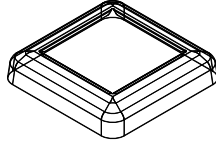

P2 | **A4M01455**
(x4) | **POST FOOT COVER**



H101101 | **TORX PAN HEAD**
(16) | 1/4-20x3/4"



H101053 | **STEEL WASHER**
(16) | 6x20



H101054 | **SEALANT WASHER**
(16)

COMPLETE THIS STEP FOUR TIMES.

SLIDE POST FOOT COVER ON BEFORE BOLTING ON POST FOOT. TABS ON POST FOOT LINE UP WITH HOLES IN POST.

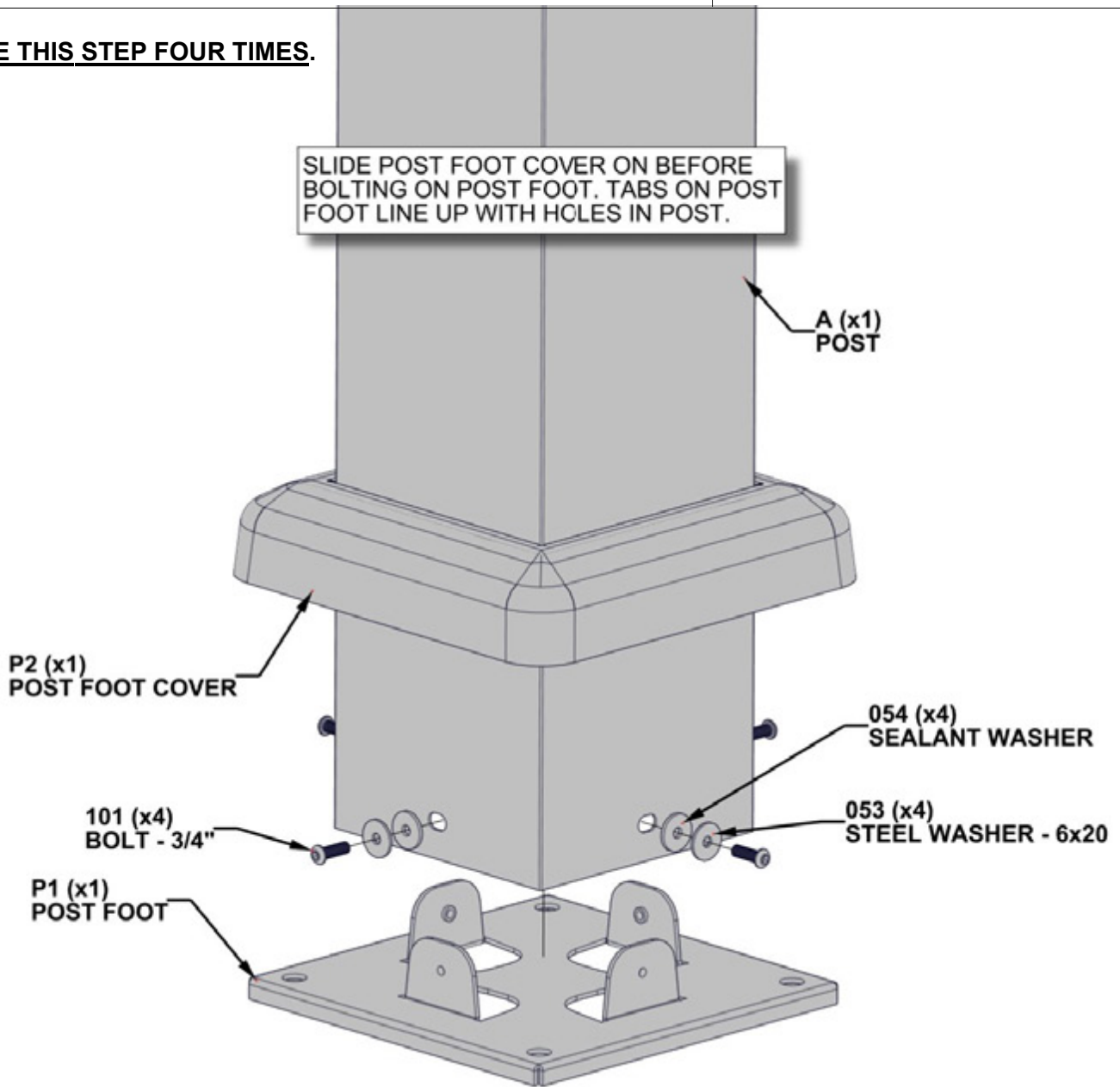

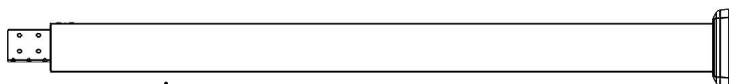

(4) POST ASSEMBLY - FROM STEP 11

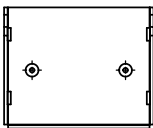

G1 BRACKET-A4M01452
(x8) | 1 1/4"X4 1/8"X5" (32x104x128)



H101101 TORX PAN HEAD
(16) | 1/4-20x3/4"



H101053 STEEL WASHER
(16) | 6x20



H101054 SEALANT WASHER
(16)



CORRECT ORIENTATION AND ATTACHMENT IS CRITICAL FOR LATER STEPS.

COMPLETE THIS STEP FOUR TIMES.

NOTE BRACKET ORIENTATION AND THAT ONLY BOTTOM TWO HOLES ARE BOLTED TO POST. TOP HOLE IS LEFT OPEN.

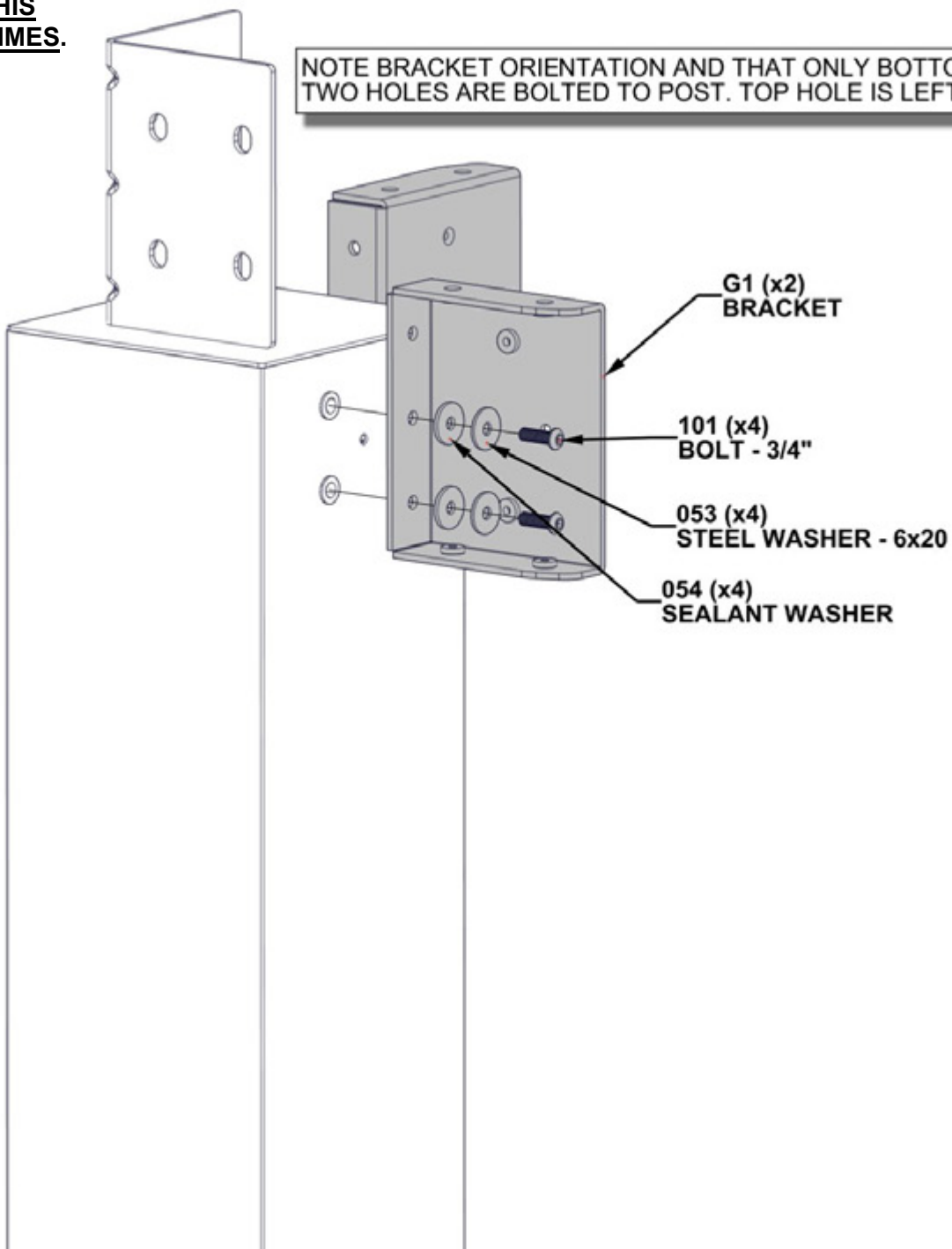

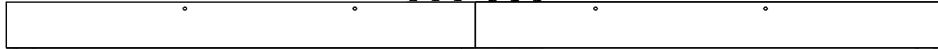
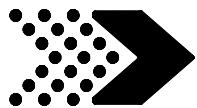

(2) INNER END JOIST ASSEMBLY - FROM STEPS 3 & 4



H101101 TORX PAN HEAD
(16) | 1/4-20x3/4"



H101053 STEEL WASHER
(16) | 6x20



H101054 SEALANT WASHER
(16)

COMPLETE THIS STEP TWICE.



DO NOT FULLY TIGHTEN BOLTS AT THIS STEP.

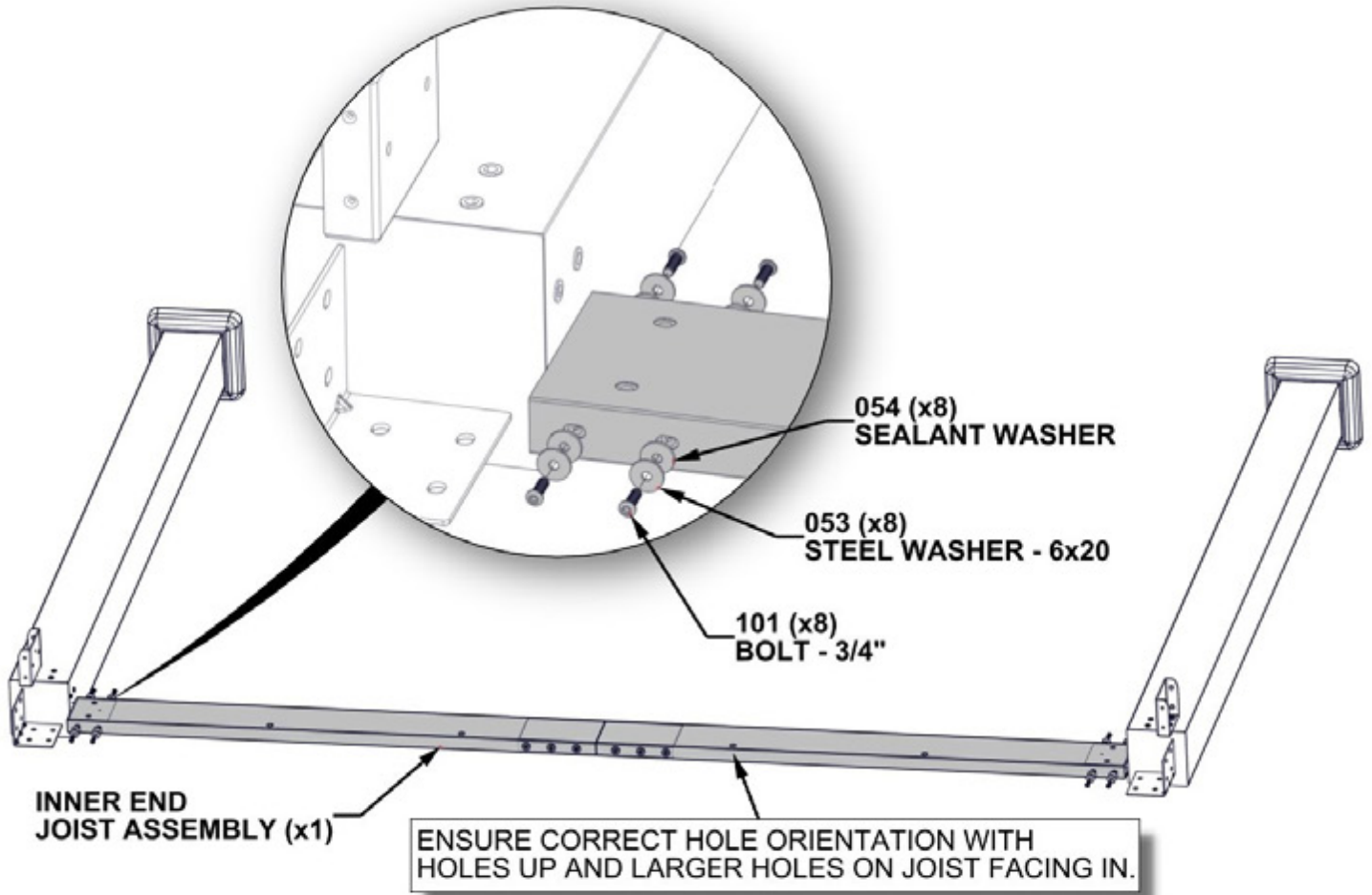

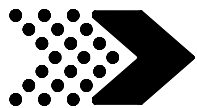

(2) INNER SIDE JOIST ASSEMBLY - FROM STEPS 7 & 8



H101101 TORX PAN HEAD
(12) 1/4-20x3/4"



H101053 STEEL WASHER
(12) 6x20



H101054 SEALANT WASHER
(12)

STAND UP ASSEMBLIES FROM PREVIOUS STEP. SLIDE JOIST ASSEMBLIES ONTO BRACKETS AND BOLT THEM ON. NOTE ORIENTATION AND BOLT PLACEMENT.



LEAVE BOLT HOLE OPEN.

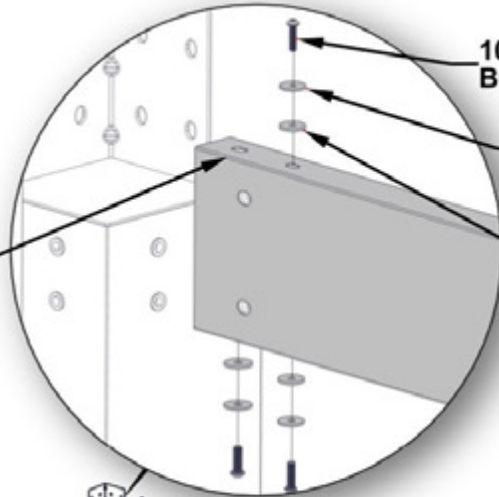

101 (x12)
BOLT - 3/4"

053 (x12)
STEEL WASHER - 6x20

054 (x12)
SEALANT WASHER

ENSURE CORRECT HOLE ORIENTATION WITH HOLES UP AND LARGER HOLES ON JOIST FACING IN.

INNER SIDE JOIST ASSEMBLY (x2)

DO NOT FULLY TIGHTEN BOLTS AT THIS STEP.

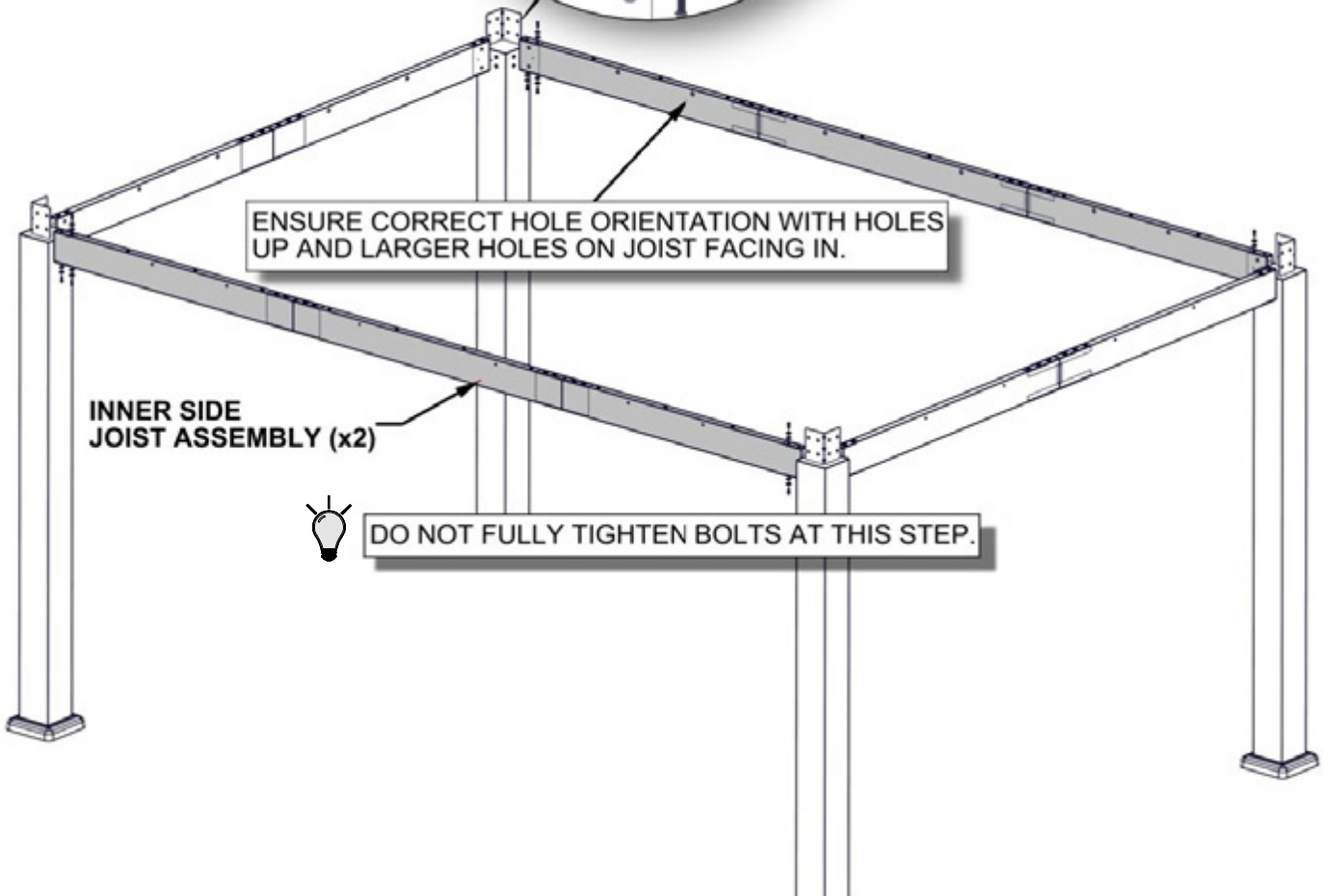

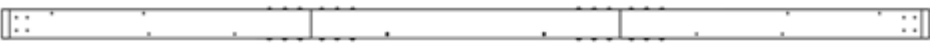

(2) OUTER SIDE JOIST ASSEMBLY - FROM STEPS 9 & 10

H101101 | TORX PAN HEAD
(16) | 1/4-20x3/4"

H101053 | STEEL WASHER
(16) | 6x20

H101103 | TORX SOCKET SCREW
(12) | 1/4-20

H101054 | SEALANT WASHER
(16)

 HAND TIGHTEN BOTTOM BOLTS WITH WRENCH.

WHEN INSERTING 103 BOLTS USE THE ALLEN WRENCH TO GET THEM STARTED. THIS WILL REDUCE THE POTENTIAL OF DROPPING A BOLT INTO THE CHANNEL.



101 (x16)
BOLT - 3/4"

053 (x16)
STEEL WASHER - 6x20

054 (x16)
SEALANT WASHER

103 (x12)
BOLT - 1/4-20

BOLT HOLES FACE UP.

OUTER SIDE
JOIST ASSEMBLY (x2)

BOLT ON ENDS OF JOIST ASSEMBLIES TO POST BRACKETS FIRST, THEN BOLT ON 103 BOLTS.



DO NOT FULLY TIGHTEN BOLTS AT THIS STEP.

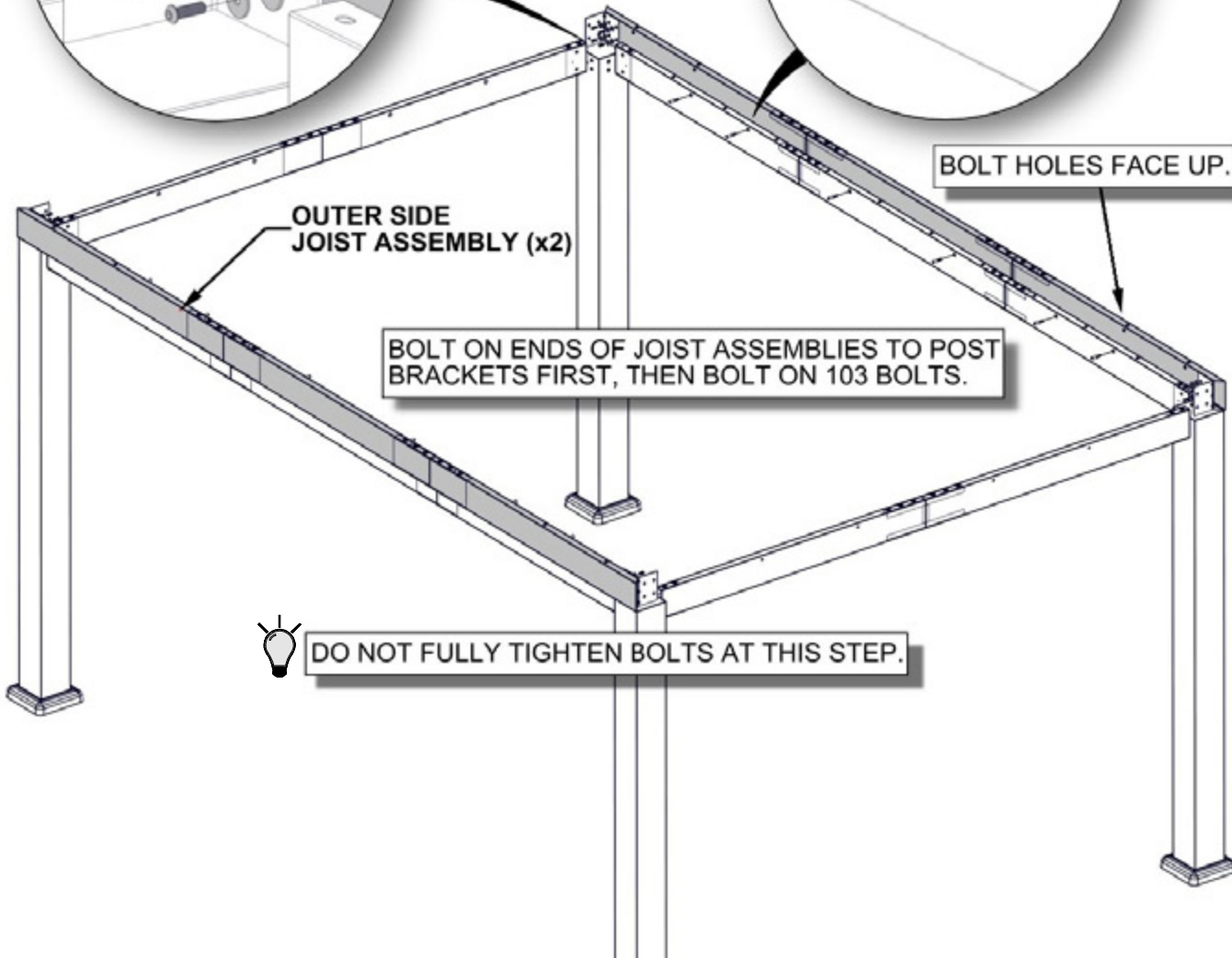

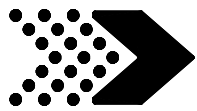

PERGOLA ASSEMBLY

STEP 16



(2) OUTER END JOIST ASSEMBLY - FROM STEPS 5 & 6

H101101 | TORX PAN HEAD
(16) | 1/4-20x3/4"

H101053 | STEEL WASHER
(16) | 6x20

H101103 | TORX SOCKET SCREW
(8) | 1/4-20

H101054 | SEALANT WASHER
(16)

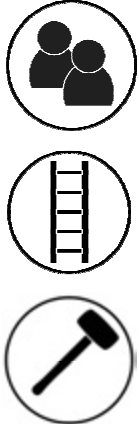

WHEN INSERTING 103 BOLTS USE THE ALLEN WRENCH TO GET THEM STARTED. THIS WILL REDUCE THE POTENTIAL OF DROPPING A BOLT INTO THE CHANNEL.



103 (x8)
BOLT - 1/4-20

054 (x16)
SEALANT WASHER

053 (x16)
STEEL WASHER - 6x20

101 (x16)
BOLT - 3/4"

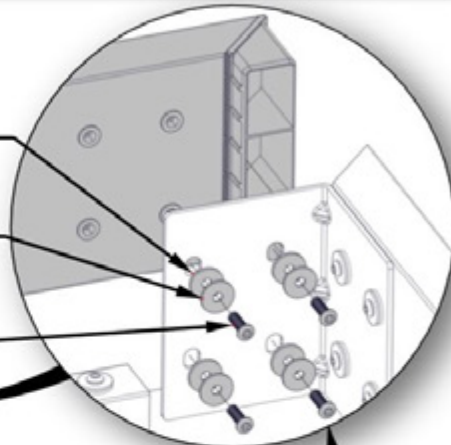

HAND TIGHTEN BOTTOM BOLTS WITH WRENCH.

BOLT HOLES FACE UP.

TAP L PLUG AND JOIST ASSEMBLY INTO PLACE AS SHOWN. BOLT ENDS OF JOIST ASSEMBLY TO POSTS, THEN BOLT ON 103 BOLTS.

OUTER END JOIST ASSEMBLY (x2)



DO NOT FULLY TIGHTEN BOLTS AT THIS STEP.

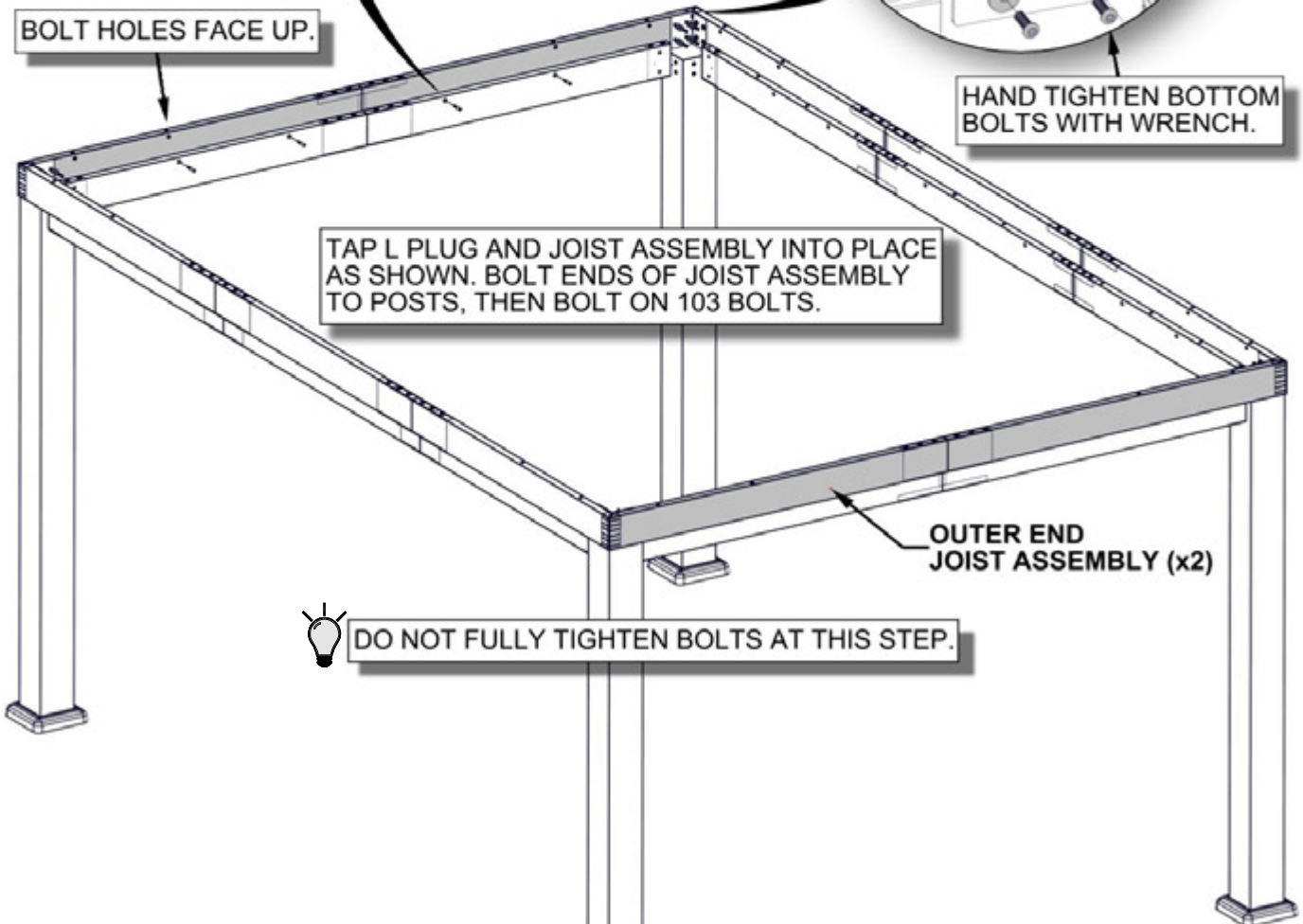

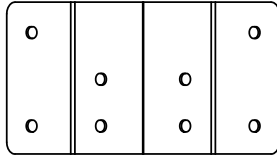
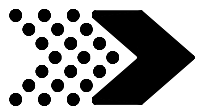

G2 W BRACKET-A4M01453
(x4) | 3"X5 1/8"X9 1/8" (78x130x233)



H101101 TORX PAN HEAD
(32) | 1/4-20x3/4"



H101053 STEEL WASHER
(32) | 6x20



H101054 SEALANT WASHER
(32)

ATTACH AND FULLY TIGHTEN W BRACKET FIRST.

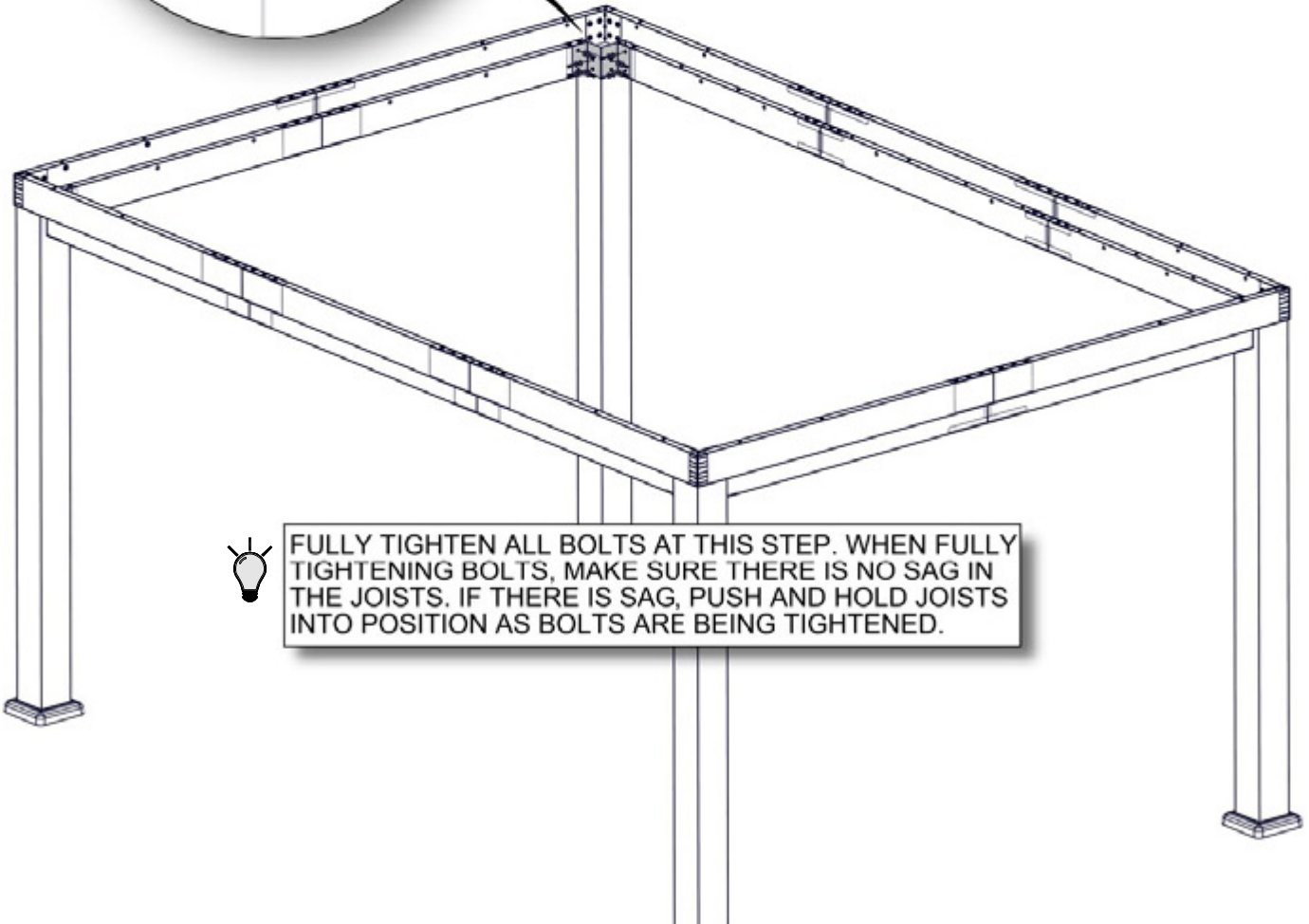
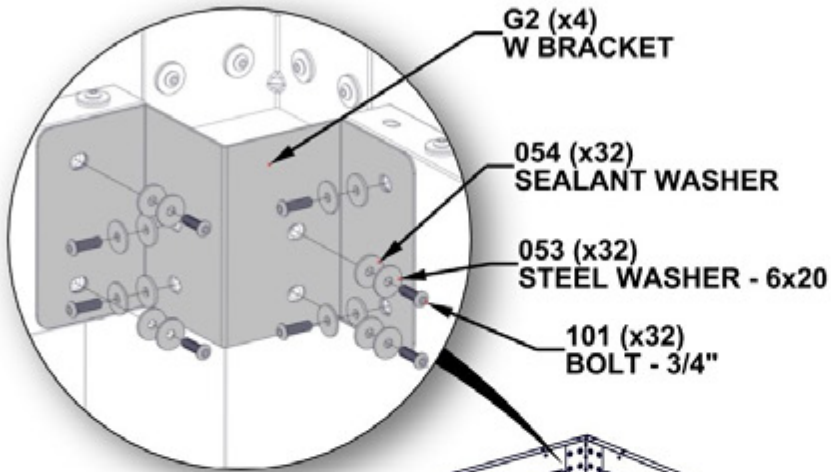

FULLY TIGHTEN ALL BOLTS AT THIS STEP. WHEN FULLY TIGHTENING BOLTS, MAKE SURE THERE IS NO SAG IN THE JOISTS. IF THERE IS SAG, PUSH AND HOLD JOISTS INTO POSITION AS BOLTS ARE BEING TIGHTENED.



(12) JOIST ASSEMBLY - FROM STEPS 1 & 2



H101102 | TORX PAN HEAD
(24) | 1/4-20x4"



H101053 | STEEL WASHER
(24) | 6x20



H101054 | SEALANT WASHER
(24)



102 (x24)
BOLT - 4"

053 (x24)
STEEL WASHER - 6x20

054 (x24)
SEALANT WASHER

JOIST ASSEMBLY (x12)

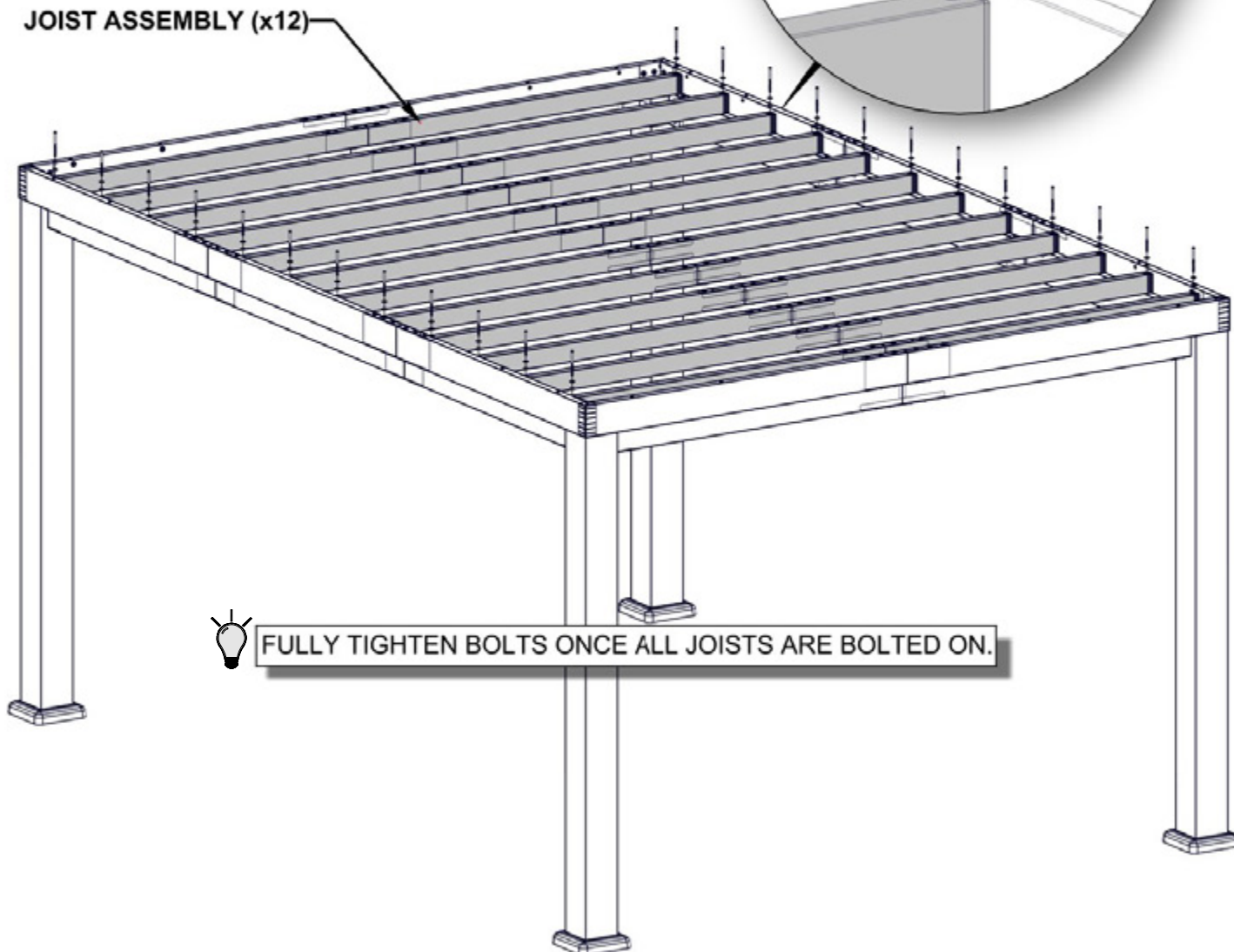
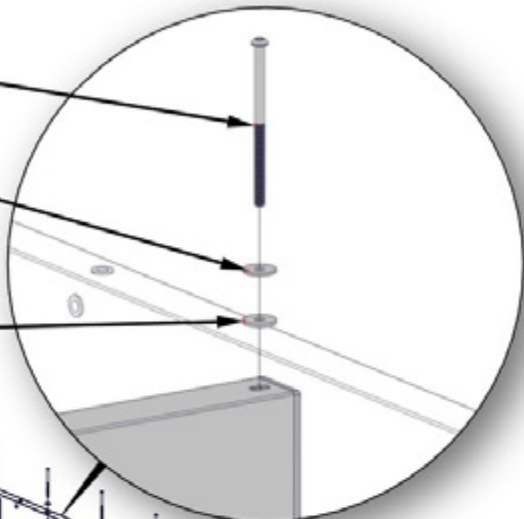

FULLY TIGHTEN BOLTS ONCE ALL JOISTS ARE BOLTED ON.

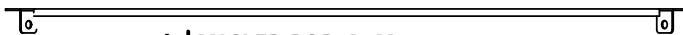

L | ANGLED ROD-A4M01450
(x4) | 1 1/4"X1 1/2"X36 3/8" (33x38x924)

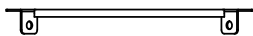

M | ANGLED ROD-A4M01451
(x4) | 1 1/4"X1 1/2"X12 7/8" (33x38x327)



H101101 | TORX PAN HEAD
(32) | 1/4-20x3/4"



H101053 | STEEL WASHER
(32) | 6x20



H101054 | SEALANT WASHER
(32)

TO GET ANGLED RODS TO LINE UP DIAGONAL MEASUREMENTS MAY NEED TO BE TAKEN FROM POST TO POST. ADJUSTMENTS TO SQUARE UP ASSEMBLY MAY NEED TO BE MADE.



COMPLETE THIS STEP FOUR TIMES.

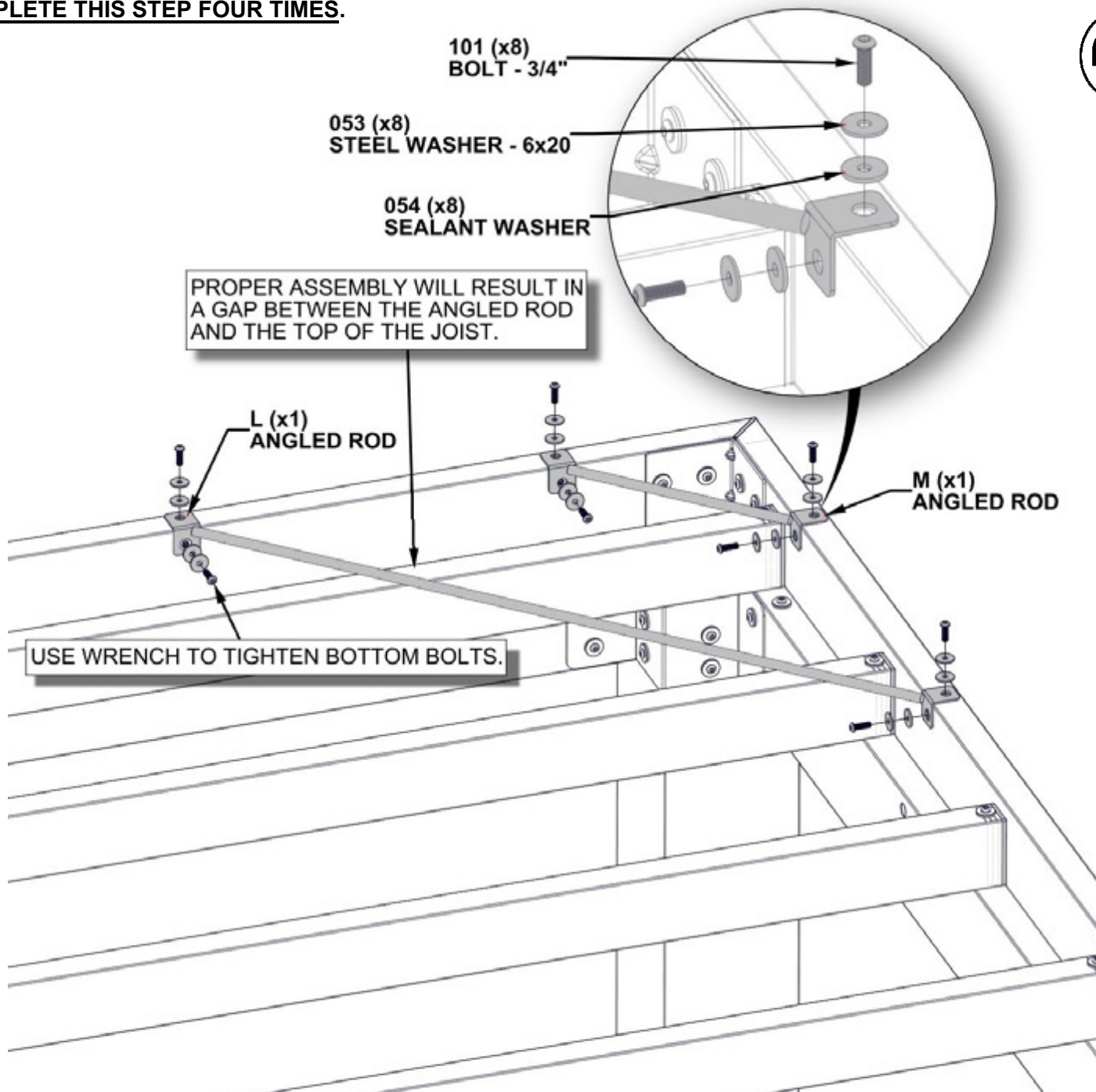

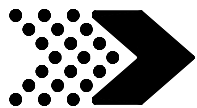

H100120 | CONCRETE ANCHOR
(16) | 1/4x2



H100630 | FLAT WASHER
(16) | BLK 8x19

NOTE: MANUFACTURER RECOMMENDS INSTALLATION ON CONCRETE SURFACE OR CONCRETE POST PADS. SEE BELOW.

FOR INSTALLATION ON A WOOD DECK, YOU MUST ENSURE THERE IS AMPLE STRUCTURAL SUPPORT UNDER THE DECK. SCREWS ARE NOT PROVIDED TO ATTACH TO DECK.

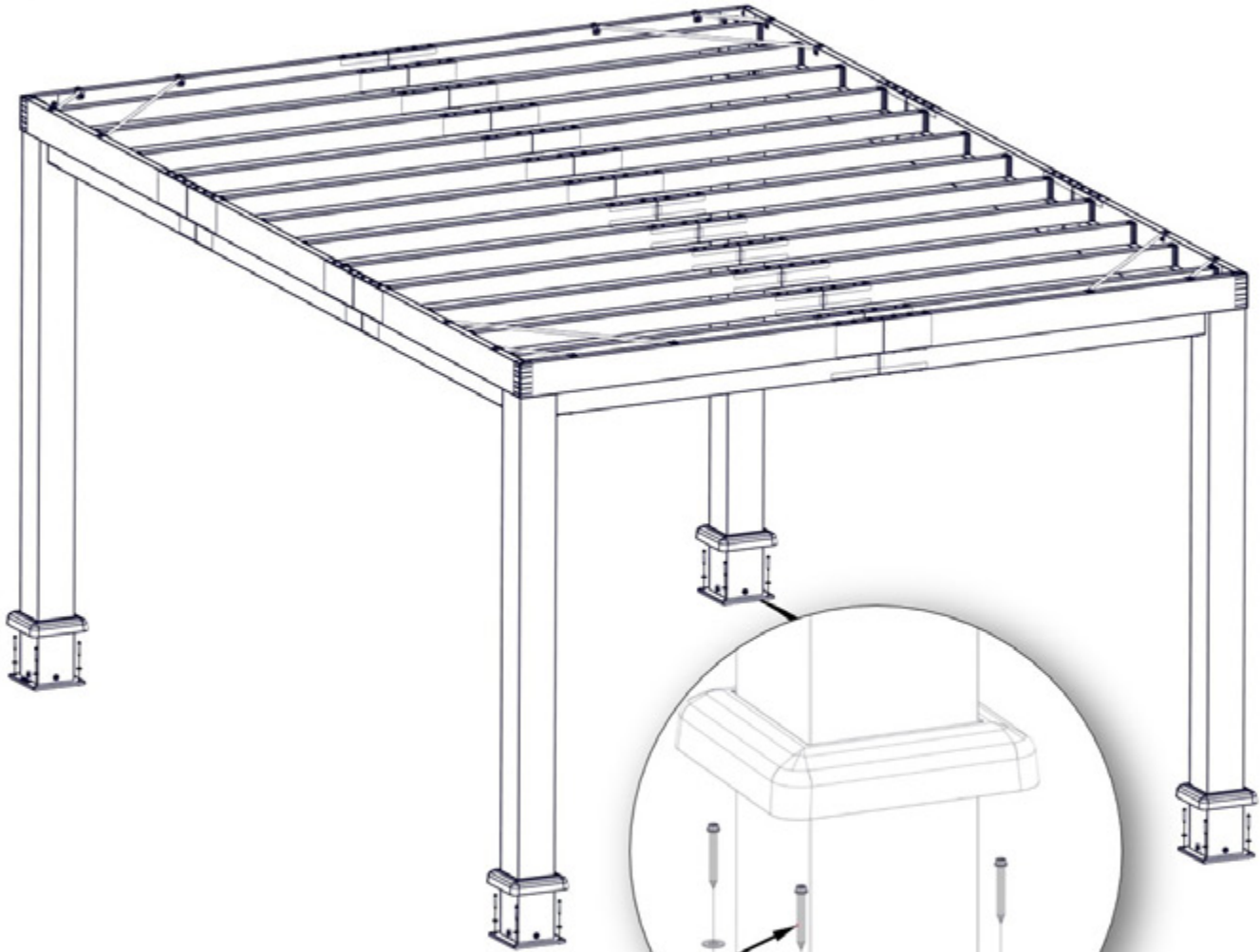
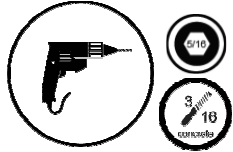

120 (x16)
SCREW - 2"

630 (x16)
WASHER 8x19

ONCE PERGOLA IS PLACED IN THE DESIRED LOCATION, PRE-DRILL HOLES FOR CONCRETE ANCHORS USING A 3/16" CONCRETE DRILL BIT.

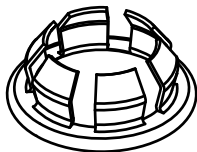

N2 | A4M01352
(x20) HOLE COVER



BEFORE HOLE COVERS ARE INSTALLED, ENSURE ALL JOISTS ARE WITHOUT SAG. ADJUST AND TIGHTEN BOLTS AS NEEDED TO ELIMINATE ANY SAG.



USE A SMALL PIECE OF WOOD TO TAP HOLE COVERS IN WITH A RUBBER Mallet.

N2 (x20)
HOLE COVER

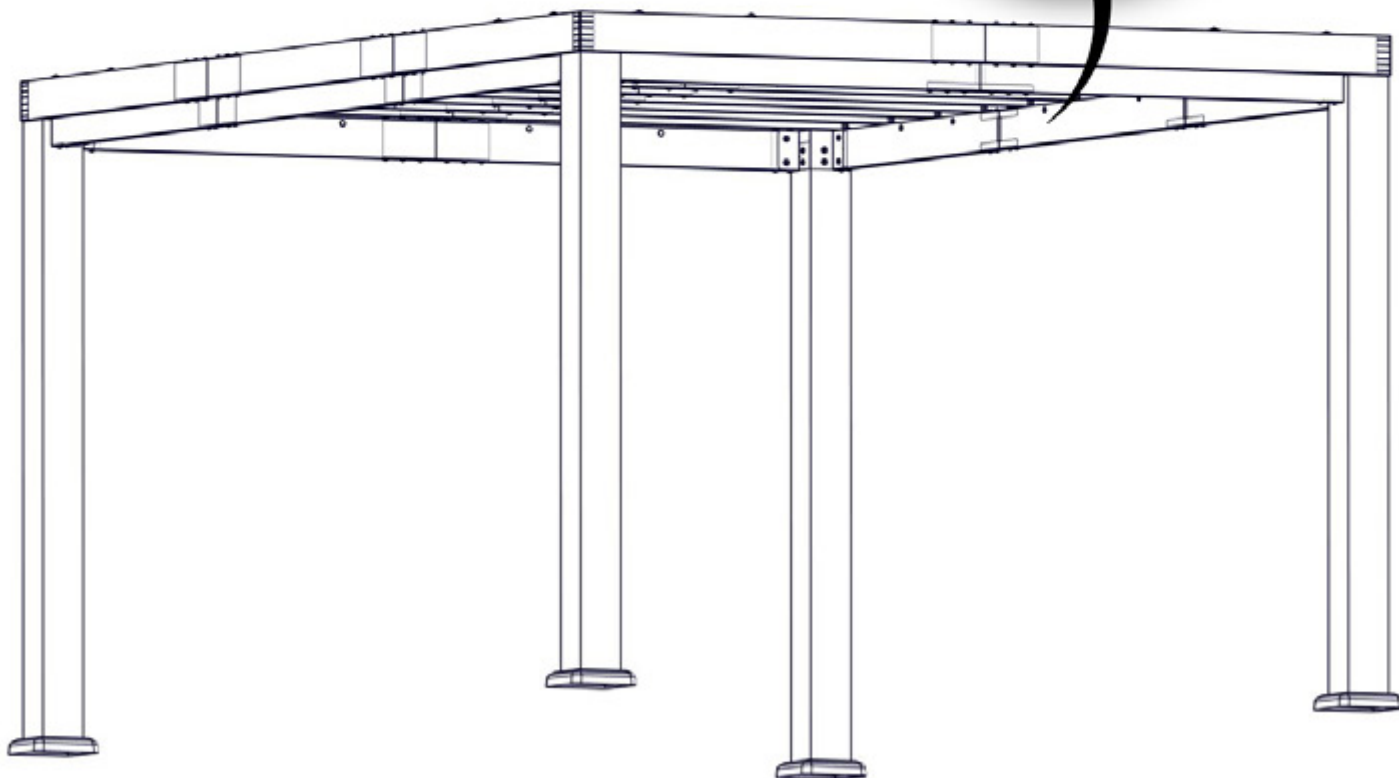
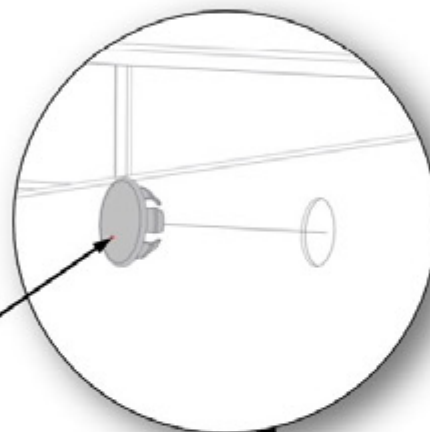

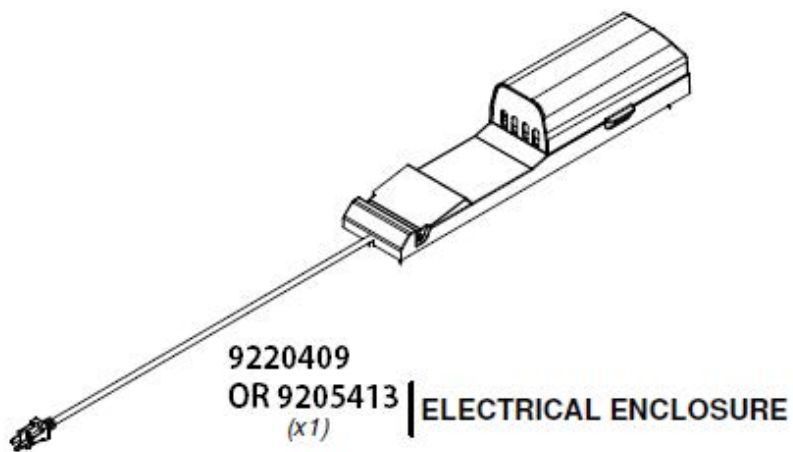

FOR ELECTRICAL ENCLOSURE INSTALLATION REFER TO ASSEMBLY INSTRUCTIONS THAT COMES PACKAGED WITH THE ELECTRICAL ENCLOSURE KIT. INSTALL ON ANY POST THAT IS DESIRED. FOLLOW DIRECTIONS FOR PROPER INSTALLATION.