



Manufactured by:
Backyard Discovery
3305 Airport Drive, Pittsburg, KS 66762
800-856-4445

Basepoint Business Centre: Rivermead Drive, Westlea, Swindon SN5 7EX Phone: 0800-118-2476
J.P. Coenstraat 7, The Bridge, The Hague, 2595 WP, Netherlands Phone: 08005678990

14x10 Cordova / Barrington Gazebo

MODEL # : 2106536F / 2306042B

THE ASSEMBLY MANUAL MUST BE RETAINED SINCE IT CONTAINS IMPORTANT INFORMATION



Please visit www.backyarddiscovery.com
For the most up to date assembly manual, to register your product, or to order
replacement parts *Para obtener instrucciones en español, visite*
www.backyarddiscovery.com



EASY STEP-BY-STEP
3D INTERACTIVE INSTRUCTIONS
DOWNLOAD THE FREE APP



OWNER'S MANUAL - BASIC SETUP DIMENSIONS & ASSEMBLY NOTES

It is critically important that you start with square and level footings, concrete pad or deck to attach your structure

- Pay close attention to the items needed for each step. Make sure you are using the correct hardware for each step. Using incorrect hardware may result in improper assembly
- Remember to double check for underground utilities and overhead electrical lines

Post mounts are provided with your structure which allows you to permanently install your structure to a pre-existing or new wood or concrete surface. See Anchor Instructions for further details and recommendations.

- The hardware to attach the post mounts to the structure is included.
- The hardware to mount the structure permanently to a concrete surface is included.
- The hardware to mount the structure permanently to a wood deck is NOT included and will need to be purchased separately. You must ensure there is ample structural support under the deck before permanently attaching.

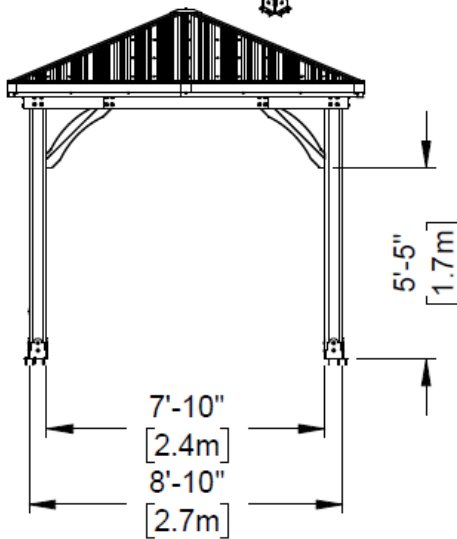
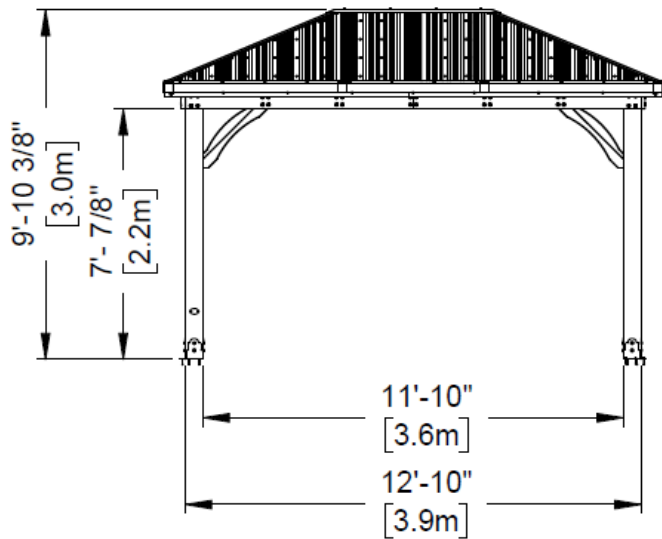
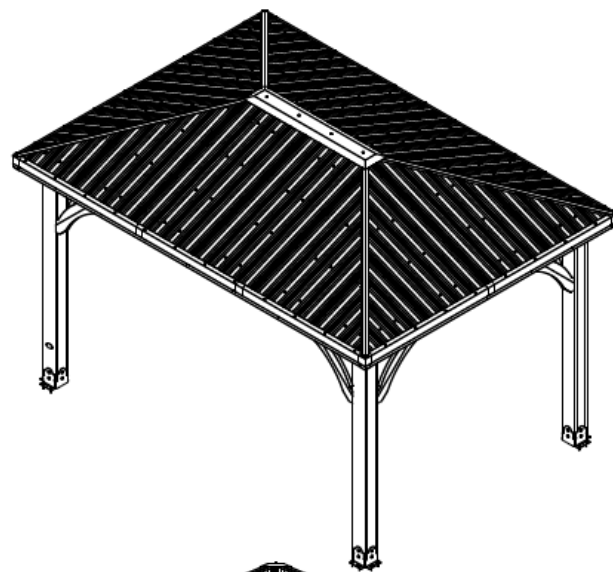
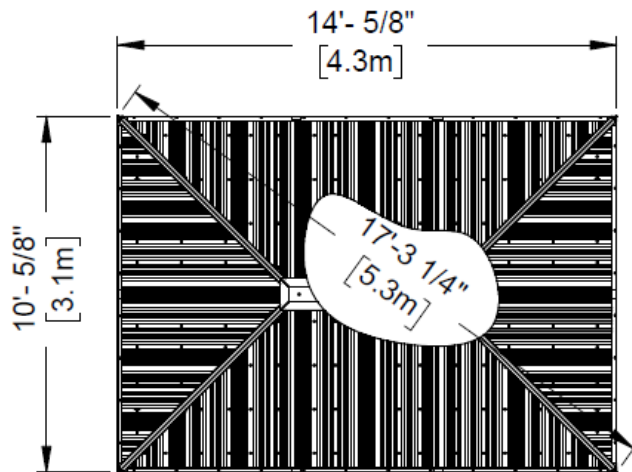

OWNER'S MANUAL - ANCHORING LAYOUT

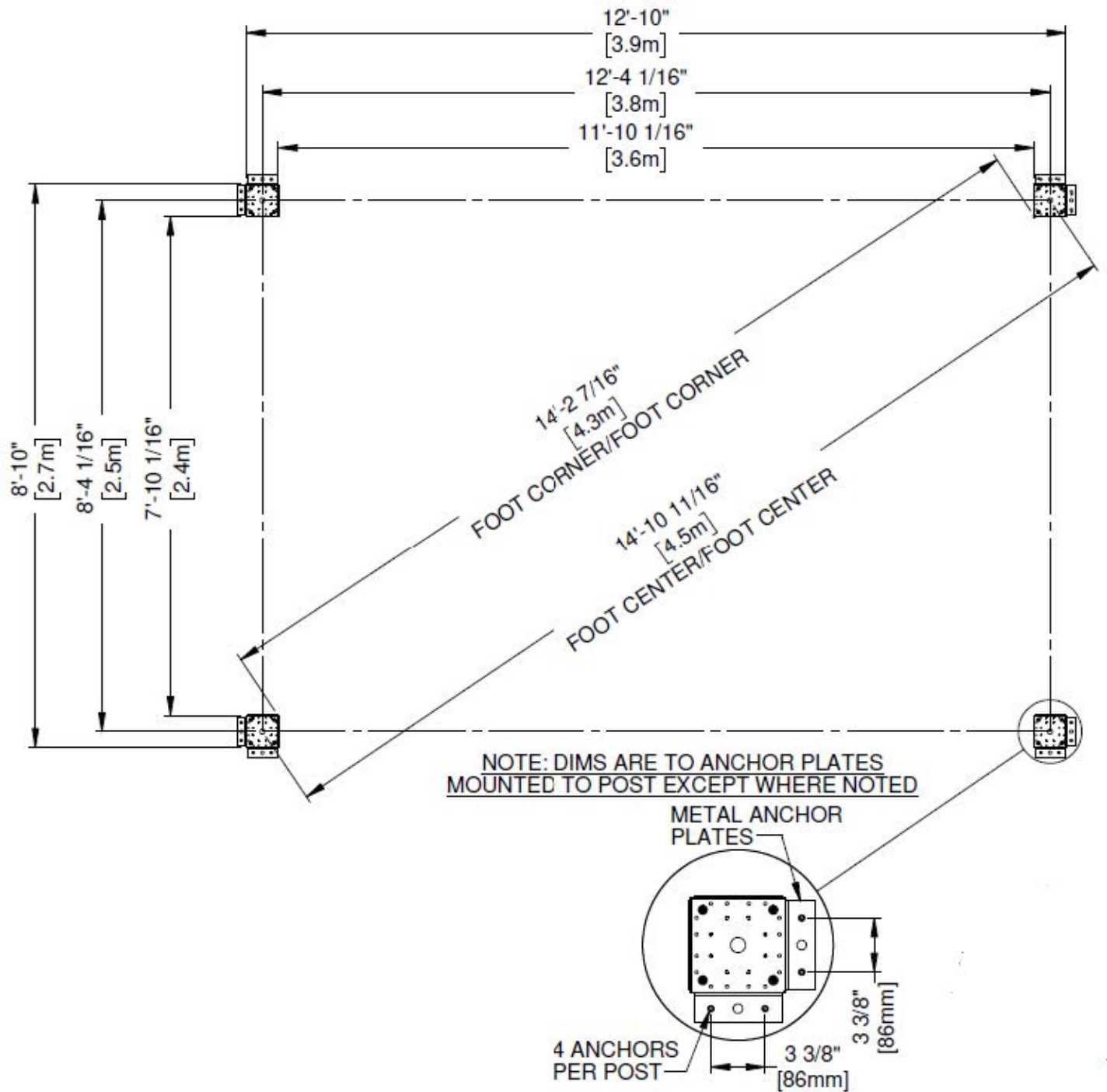

OWNER'S MANUAL - PARTS IDENTIFICATION

Wood Components (Not to Scale)



H01 | ROOF JOIST-W4L16295
(2) | 1"x3 3/8"x88 3/16" (24x86x2240)



H02 | ROOF JOIST- W4L16283
(2) | 1"x3 3/8"x46 3/4" (24x86x1188)

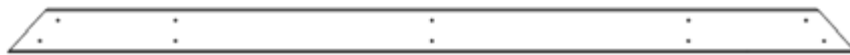

H03 | PURLIN - W4L16281
(2) | 1"x3 3/8"x68 3/8" (24x86x1736)



H04 | PURLIN - W4L16921
(4) | 1"x3 3/8"x29 5/8" (24x86x752)



H05 | PURLIN-W4L16291
(4) | 1"x3 3/8"x65 1/2" (24x86x1664)



H07 | PURLIN-W4L16292
(4) | 1"x3 3/8"x59 7/16" (24x86x1509)

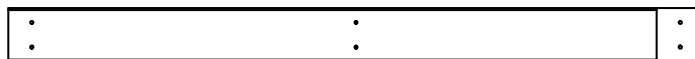

H08 | PURLIN-W4L16293
(4) | 1"x3 3/8"x 43 11/16" (24x86x1110)



H09 | ROOF JOIST-W4L16296
(2) | 1"x3 3/8"x88 1/8" (24x86x2240)

OWNER'S MANUAL - PARTS IDENTIFICATION

Wood Components (Not to Scale)



H10 | ROOF JOIST-W4L16309
(2) 1"x3 3/8"x76 7/8" (24x86x1952)



H11 | ROOF JOIST- W4L16297
(2) 1"x3 3/8"x15 15/16" (24x86x404)



H13 | PURLIN - W4L16303
(2) 1"x3 3/8"x20 1/4" (24x86x514)



H12 | ROOF JOIST-W4L16308
(2) 1"x3 3/8"x76 7/8" (24x86x1952)

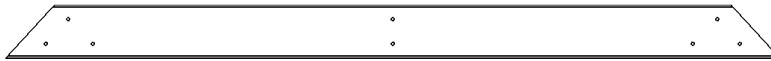

H14 | PURLIN - W4L16304
(2) 1"x3 3/8"x50 1/16" (24x86x1272)

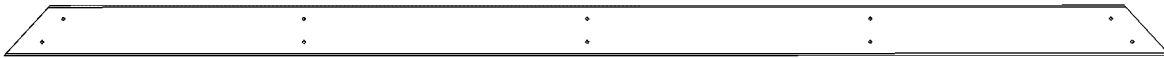

H15 | PURLIN - W4L16305
(2) 1"x3 3/8"x79 15/16" (24x86x2030)



H16 | PURLIN - W4L16922
(4) 1"x3 3/8"x56" (24x86x1423)

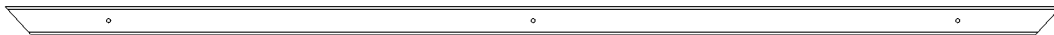

H17 | PURLIN - W4L16289
(2) 1"x1 3/8"x51 3/8" (24x34x1306)



H18 | ROOF SUPPORT- W4L16315
(1) 1"x3 3/8"x48" (24x86x1219)



H19 | ROOF SUPPORT-W4L16928
(4) 1"x3 3/8"x75 3/16" (24x86x1909)

OWNER'S MANUAL - PARTS IDENTIFICATION

Wood Components (Not to Scale)



E01 | RAFTER- W4L16284
(2) | 1 3/8"x3 3/8"x44" (36x86x1117)



E02 | RAFTER- W4L16288
(4) | 1 3/8"x3 3/8"x63 7/8" (36x86x1622)



E03 | RAFTER- W4L16286
(2) | 1 3/8"x3 3/8"x20 7/16" (36x86x519)



E06 | RAFTER - W4L16287
(2) | 1 3/8"x3 3/8"x20 7/16" (36x86x519)



E04 | RAFTER- W4L16285
(2) | 1 3/8"x3 3/8"x44" (36x86x1117)

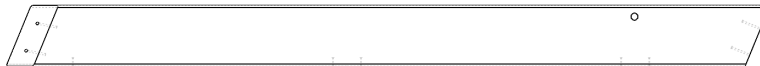

E05 | RAFTER - W4L17402
(2) | 1 3/8"x3 3/8"x42 7/8" (36x86x1087)



E07 | RAFTER- W4L17401
(2) | 1 3/8"x3 3/8"x42 7/8" (36x86x1087)



E12 | RAFTER - W4L16302
(2) | 1 3/8"x3 3/8"x21 3/4" (36x86x553)



E10 | RAFTER- W4L16300
(2) | 1 3/8"x3 3/8"x21 3/4" (36x86x553)



E09 | RAFTER- W4L16298
(2) | 1 3/8"x3 3/8"x55 13/16" (36x86x1417)



E11 | RAFTER W4L16290
(2) | 1 3/8"x3 3/8"x63 7/8" (36x86x1622)



D01 | BEAM- W4L16926
(4) | 1 3/8"x5 1/4"x30 15/16" (36x134x786)



D02 | BEAM- W4L16927
(2) | 1 3/8"x5 1/4"x55 3/4" (36x134x1416)

OWNER'S MANUAL - PARTS IDENTIFICATION

Wood Components (Not to Scale)



C01 | CORBEL-W2A03393
(7) | 1 3/8"x6 7/16"x35 1/8" (36x163x893)



C02 | CORBEL W/TAG-W2A03394
(1) | 1 3/8"x6 7/16"x35 1/8" (36x163x893)



G01 | BEAM - W4L16923
(4) | 1"x5 1/4"x53 3/16" (24x134x1351)

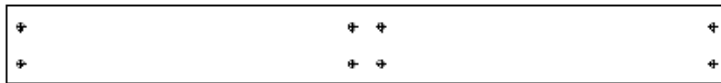

G02 | MID BRACE BEAM - W4L16924
(2) | 1"x5 1/4"x47 5/8" (24x134x1210)



G03 | BEAM - W4L16925
(4) | 1"x5 1/4"x77" (24x134x1956)

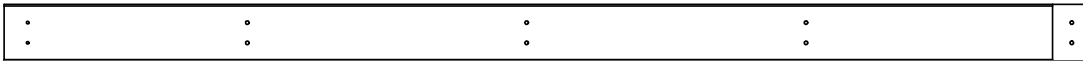

Q01 | ROOF JOIST-W4L16294
(4) | 1"x4 7/16"x84 9/16" (24x112x2148)

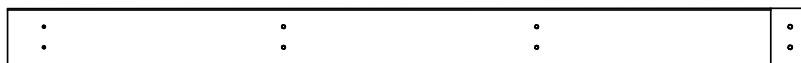

Q02 | ROOF JOIST-W4L16307
(4) | 1"x4 3/8"x61 1/2" (24x112x1562)

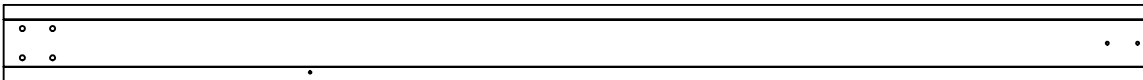

P01 | POST-W2A03571
(x2) | 6"x6"x89 1/2" (152x152x2274)

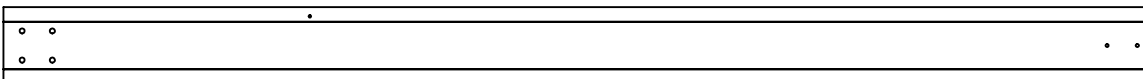

P02 | POST-W2A03572
(x2) | 6"x6"x89 1/2" (152x152x2274)

OWNER'S MANUAL - PARTS IDENTIFICATION

Hardware Components (Not to Scale)

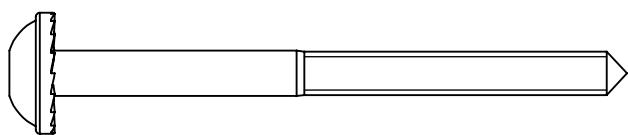

H100792 | LAG SCREW WH BLK
(12) | 1/4x3

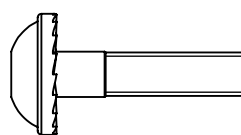

H100171 | BOLT WH BLK
(32) | 1/4x1

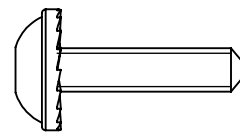

H100460 | LAG SCREW WH BLK
(16) | 1/4x1

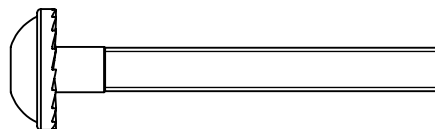

H100488 | BOLT WH BLK
(18) | 1/4x2

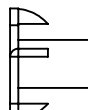

H100379 | T-NUT BLK
(94) | 5/16

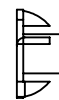

H100398 | T-NUT BLK
(32) | 1/4

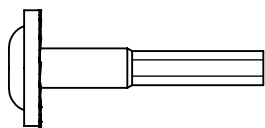

H100378 | BOLT WH BLK
(30) | 5/16x1-3/4

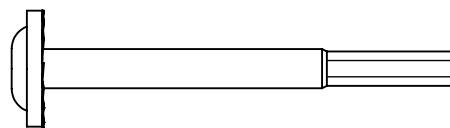

H100484 | BOLT WH BLK
(16) | 5/16x3-1/4

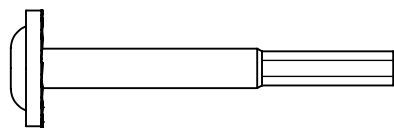

H100195 | BOLT WH BLK
(16) | 5/16x2-3/4

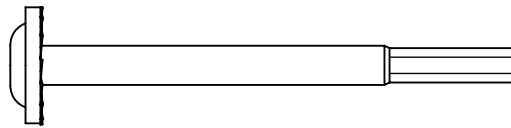

H100415 | BOLT WH BLK
(16) | 5/16x3-3/4

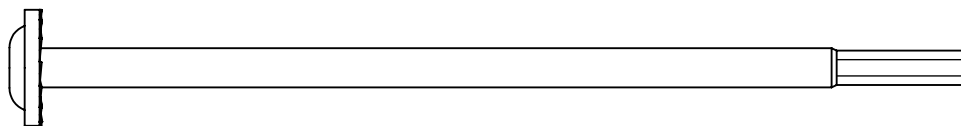

H100196 | BOLT WH BLK
(16) | 5/16x7-1/4

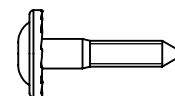

H100471 | LAG SCREW WH BLK
(32) | 5/16x1-1/2

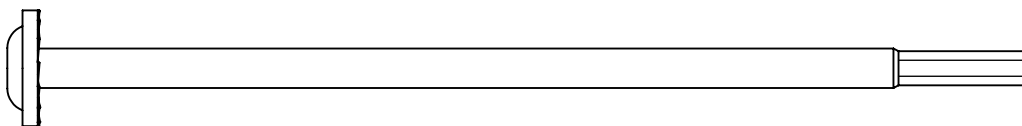

H100963 | BOLT WH BLK
(16) | 5/16x7-3/4

OWNER'S MANUAL - PARTS IDENTIFICATION

Hardware Components



H100385 | SCREW PFH BLK
(36) | 8x1

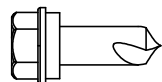

H100759 | SCREW TAPPING
(48) | 1/4x3/4

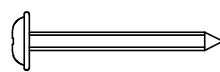

H100536 | SCREW PWH BLK
(40) | 8x1 1/4

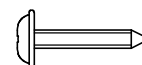

H100392 | SCREW PWH BLK
(16) | 8x3/4



H100200 | SCREW PFH BLK
(22) | 8x1 1/2

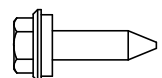

H100833 | SCREW WOODGRIP
(220) | 10x3/4



H101030 | SCREW CONFIRMAT BLK
(96) | 7x2

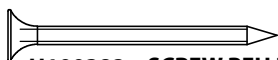

H100382 | SCREW PFH BLK
(20) | 8x1 3/4

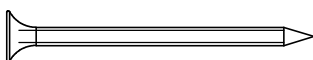

H100391 | SCREW PFH BLK
(188) | 8x2

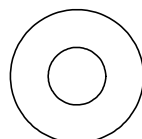

H100770 | WASHER FLAT BLK 5/16
(16)



H101034 | WEATHER PROOF WASHER
(4)



H100479 | NUT LOCK BLK 5/16
(16)

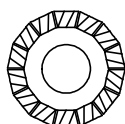

H100198 | WASHER LOCK EXT BLK 8x19
(110)

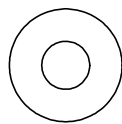

H100630 | WASHER FLAT BLK 8x19
(34)

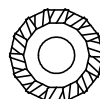

H100405 | WASHER LOCK EXT BLK 6x15
(8)



H100653 | NUT LOCK BLK 1/4
(18)

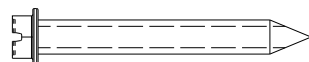

H100120 | SCREW CONCRETE ANCHOR
(16) | 1/4x2

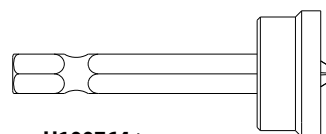

H100764 | SCREW SETTER
(1)

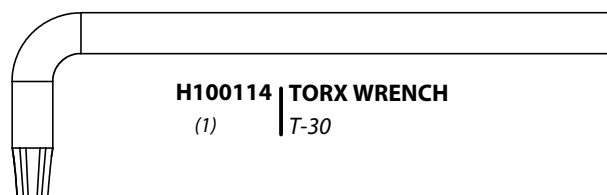

H100114 | TORX WRENCH
(1) | T-30

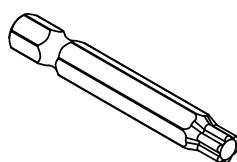

H100147 | T-30 TORX BIT
(1)

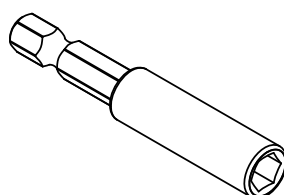

H101100 | BIT ADAPTOR
(1)

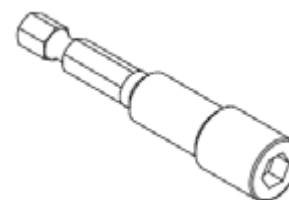

H101106 | SOCKET DRIVER
(1)

OWNER'S MANUAL - PARTS IDENTIFICATION

Accessory Components (Not to Scale)

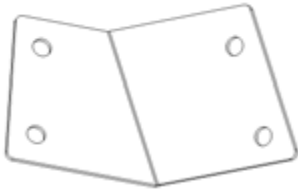

A4M01191 | PANEL BRACKET
(2)

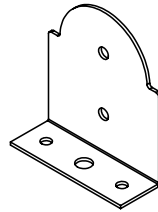

A4M01793 | POST ANCHOR PLATE
(x8)

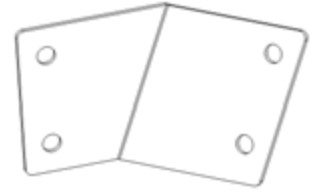

A4M01192 | PANEL BRACKET
(2)

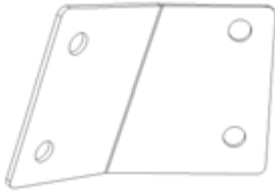

A4M01194 | PANEL BRACKET
(2)

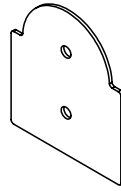

A4M01794 | POST PLATE
(x8)

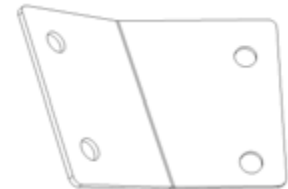

A4M01193 | PANEL BRACKET
(2)

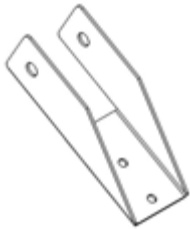

A4M01228 | RAFTER CLIP
(18)

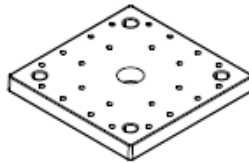

A6P00308 | 6X6 POST FOOT
(4)

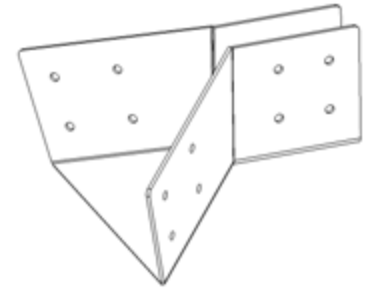

A4M01184 | PANEL SUPPORT BRACKET
(2)

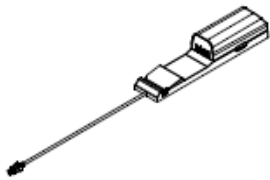

9205413 | ELECTRICAL ENCLOSURE
(1)



A4M01185 | CORNER BRACKET
(4)

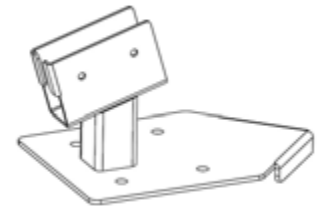

A4M01234 | POST CLIP
(4)

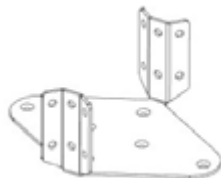

A4M02501 | FAN MOUNT BRACKET
(1)



A4M02158 | BYD ID TAG (SMALL) WITHOUT AGES
(1)

OWNER'S MANUAL - PARTS IDENTIFICATION

Accessory Components (Not to Scale)



A4M02885 | EDGE TRIM LONG
(8)



A4M02869 | EDGE TRIM SHORT
(2)

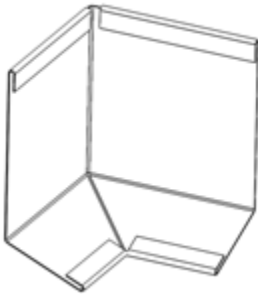

A4M02825 | EDGE TRIM CORNER SPLICE
(4)



A4M01205 | METAL SPACER
(4)

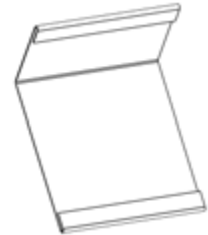

A4M02822 | EDGE TRIM SPLICE
(6)

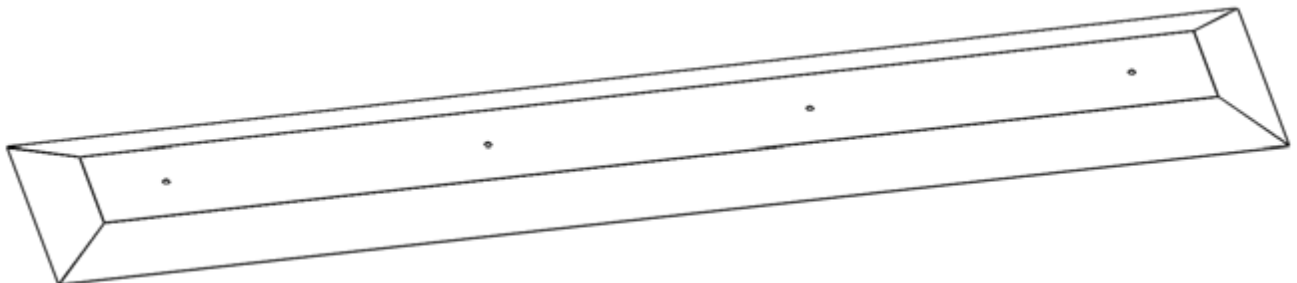

A4M02870 | RIDGE PEAK CAP
(1)

OWNER'S MANUAL - PARTS IDENTIFICATION

Accessory Components (Not to Scale)

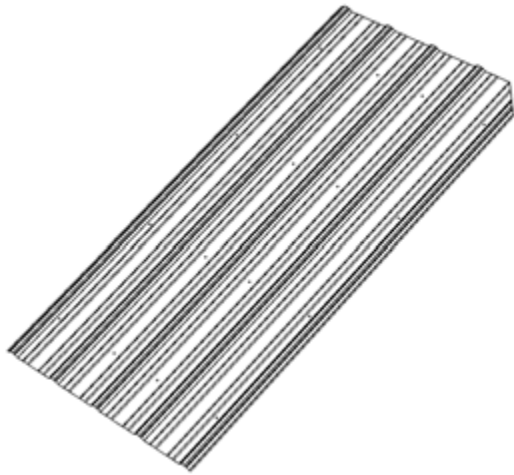

A4M02916 | 29 GA STEEL SHEETING
(2)

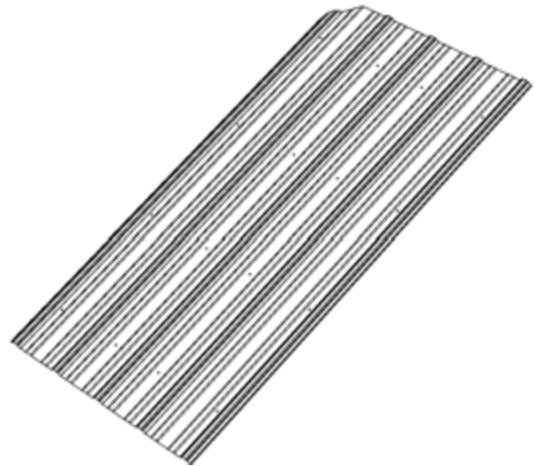

A4M02917 | 29 GA STEEL SHEETING
(2)

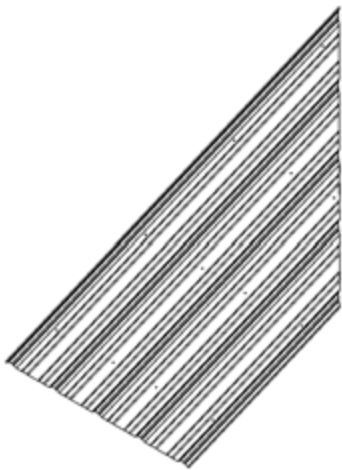

A4M02918-1 | 29 GA STEEL SHEETING
(2)

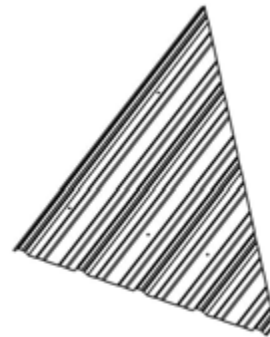

A4M02918-2 | 29 GA STEEL SHEETING
(2)

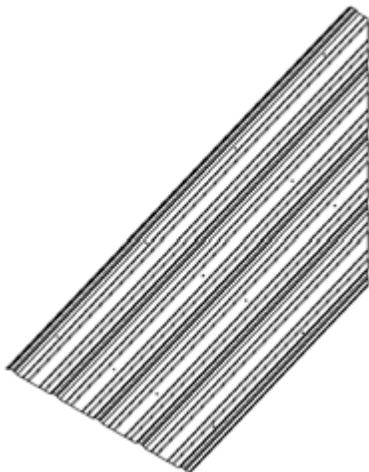

A4M02919-2 | 29 GA STEEL SHEETING
(2)



A4M02919-1 | 29 GA STEEL SHEETING
(2)

OWNER'S MANUAL - PARTS IDENTIFICATION

Accessory Components (Not to Scale)

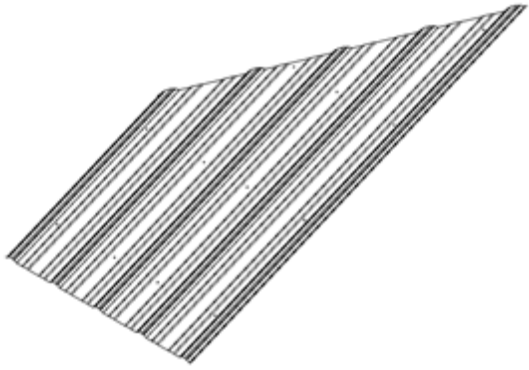

A4M02920-1 | 29 GA STEEL SHEETING
(2)

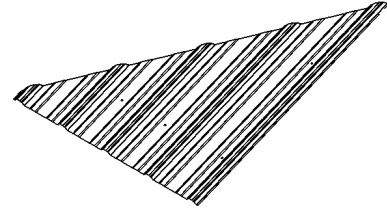

A4M02920-2 | 29 GA STEEL SHEETING
(2)

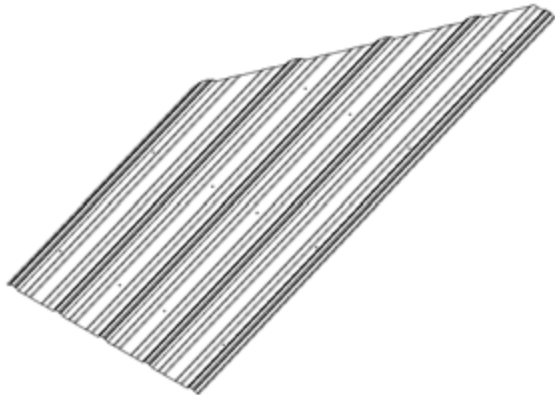

A4M02921-2 | 29 GA STEEL SHEETING
(2)

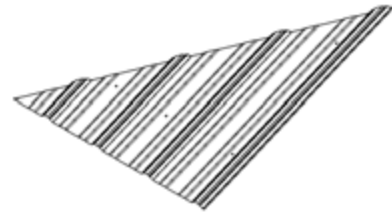

A4M02921-1 | 29 GA STEEL SHEETING
(2)

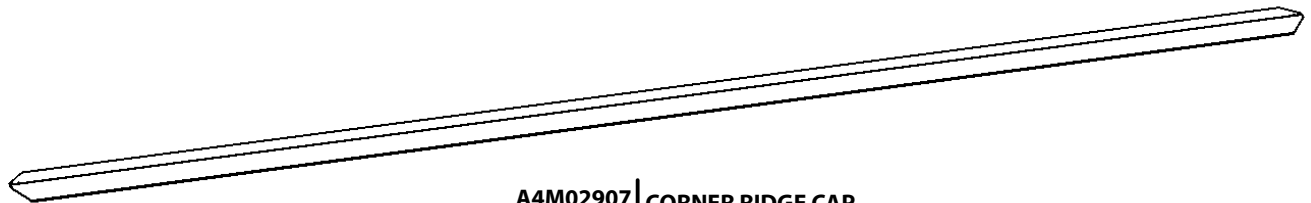

A4M02907 | CORNER RIDGE CAP
(4)



A4M02906 | RIDGE CAP CHANNEL
(8)

PRE-ASSEMBLY STEP 1 - SORTING PARTS

It is critical for ease of assembly that you take the time to sort and organize the wood and hardware.

WOOD PARTS:

- Organize wood parts by the three-digit, alpha-numeric number stamped on each board (ex. P01).
- If there are multiple boards with the same stamped number, stack those pieces together.
- Stamps can be found on the flat surface of the boards or on the end of the boards.
- Allow yourself plenty of room - the wood pieces can take up a significant amount of space.

NOTE: CARTONS ARE NOT ORGANIZED BY BOARD NUMBER.



HARDWARE PARTS:

- We recommend that you have a separate table to organize the hardware.
- Hardware bags are printed with a seven-digit, alpha-numeric part number.
- You can organize your hardware by part number or group by hardware type (i.e. bolts, nuts, etc.).
- During assembly you only need to reference the last four digits of the number.

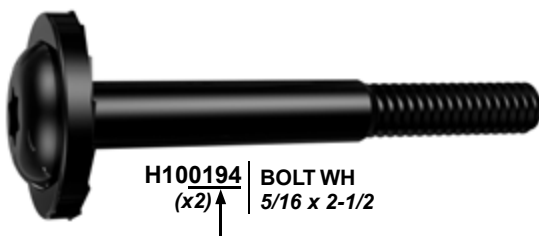

H100194 | BOLT WH
(x2) ↑ 5/16 x 2-1/2

PRE-ASSEMBLY STEP 2 - TOOLS REQUIRED



Cordless Drill or Electric Drill



Drill Attachments:
Phillips Head



1/8", 3/16", 3/8" &
7/16" Drill Bits



Phillips Screw Driver



Open End
Wrenches 1/2" &
7/16"



3/8" Drive Ratchet, 1/2" &
7/16" STD Sockets, 1/2" &
7/16" Deep Sockets



Tape Measure



Claw Hammer

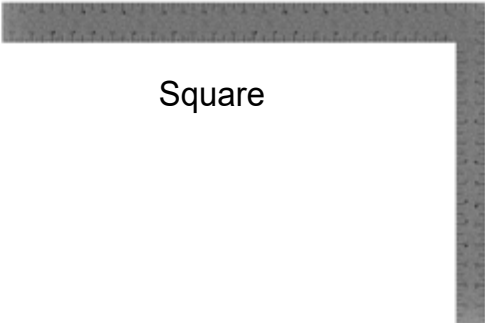

Square



Level 24"



Rubber Mallet -
Optional



A6P00460 | QUICK RELEASE
(2) BAR CLAMP

PRE-ASSEMBLY STEP 3 - CHOOSE YOUR ASSEMBLY METHOD

There are several types of assembly instructions available to you.

1. Printed Assembly Manual included with your set
2. BILT APP - 3D interactive instructions
3. Combination of the Printed Manual and BILT APP (Note: Step numbers can differ between the two methods)



STEP 1 - 10FT POST ASSEMBLY

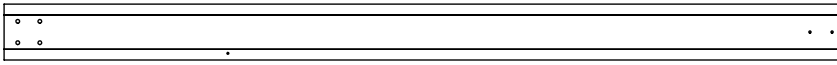

P01 | POST-W2A03571
 (x1) | 6"x6"x89 1/2" (152x152x2274)

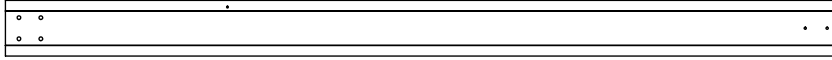

P02 | POST-W2A03572
 (x1) | 6"x6"x89 1/2" (152x152x2274)

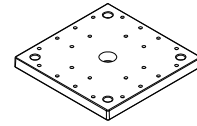

A6P00308 | 6x6 POST FOOT
 (2)

QTY	PART NUMBER	DESCRIPTION
8	H100200	SCREW PFH 8x1 1/2 BLK

TIP:

- FOR EASE OF ASSEMBLY, SAW HORSES ARE RECOMMENDED FOR STEPS 1 THROUGH 3

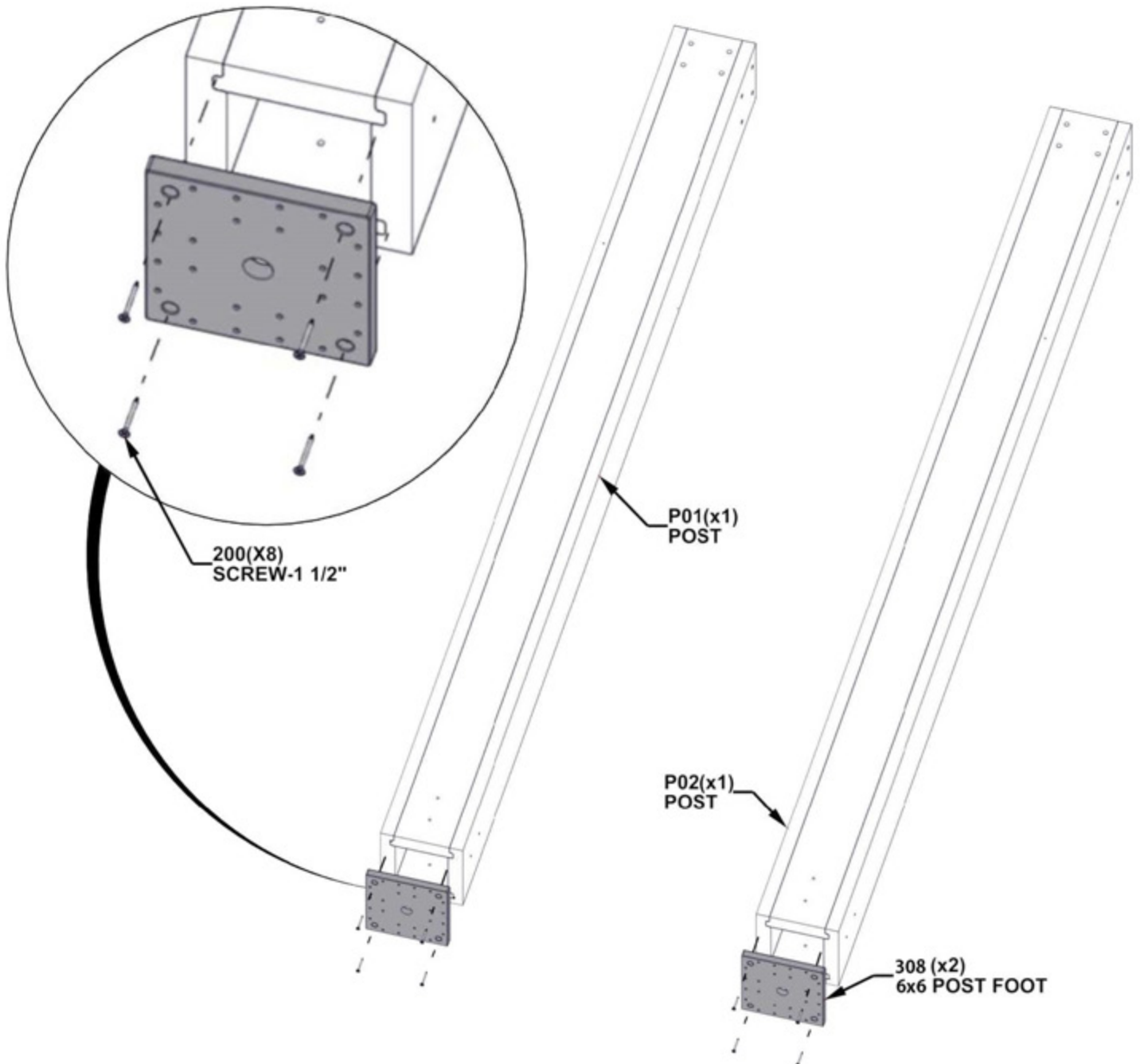

STEP 2 - 10FT POST ASSEMBLY

Qty	PART NUMBER	DESCRIPTION
8	H100198	WASHER LOCK EXT 8X19 BLK
8	H100195	BOLT WH 5/16 X 2 3/4 BLK
8	H100379	T-NUT 5/16 BLK



D02 | BEAM-W4L16927
 (1) | 1 7/16"x5 1/4"x55 3/4" (36x134x1416)



D01 | BEAM-W4L16926
 (2) | 1 7/16"x5 1/4"x30 15/16" (36x134x786)



C01 | CORBEL-W2A03393
 (2) | 1 3/8"x6 7/16"x35 1/8" (36x163x893)

HAND TIGHTEN BOLTS UNTIL STEP 3

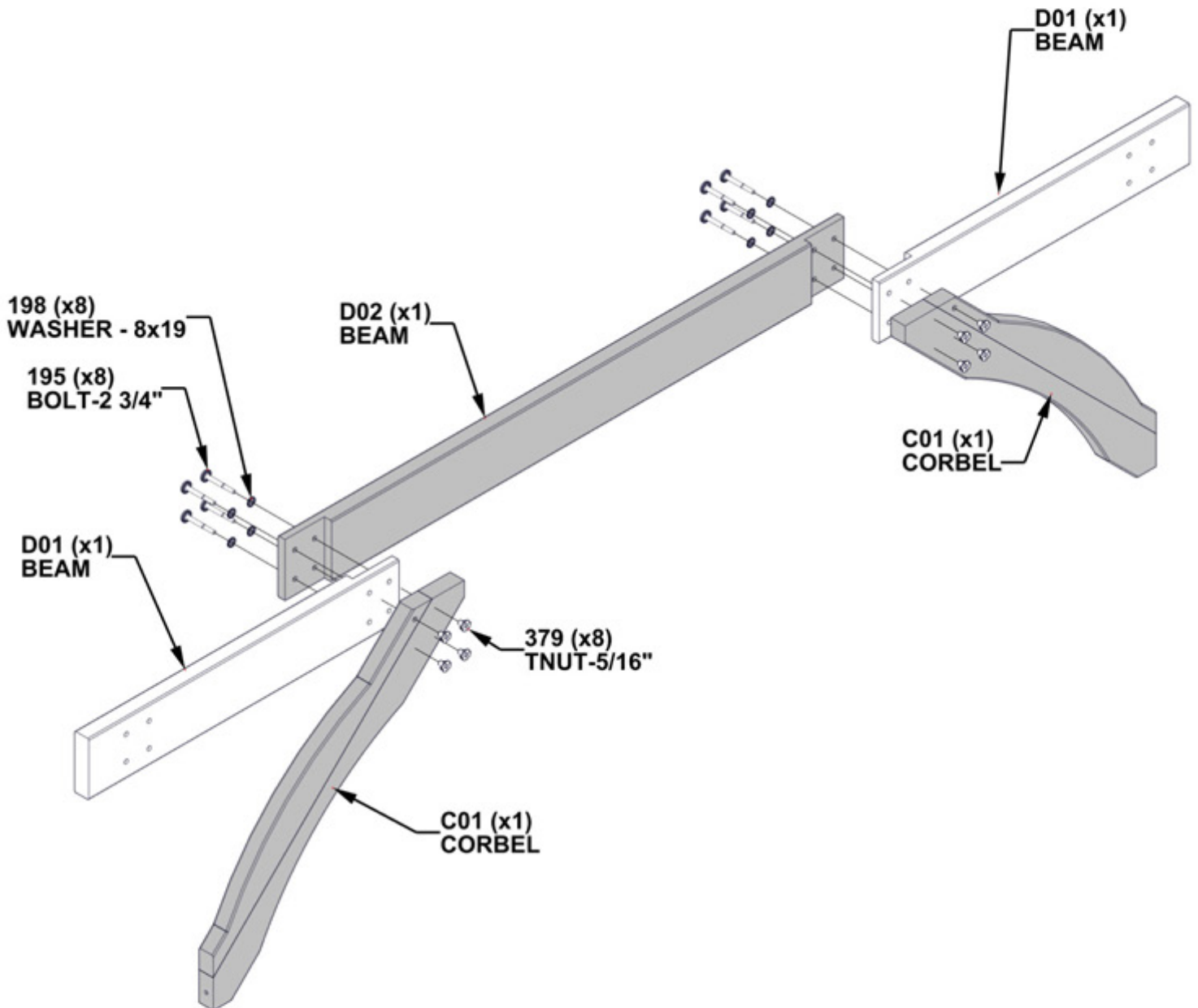

STEP 3 - 10FT POST ASSEMBLY

Qty	PART NUMBER	DESCRIPTION
8	H100198	WASHER LOCK EXT 8X19 BLK
8	H100196	BOLT WH 5/16 X 7 1/4 BLK
8	H100379	T-NUT 5/16 BLK
2	H100405	WASHER LOCK EXT 6X15 BLK
2	H100792	LAG SCREW WH 1/4 X 3 BLK



- TIPS:**
- INSERT BOLTS FIRST FOLLOW BY LAG SCREWS
 - TO AVOID WOOD SPLITTING, MAKE SURE LAG SCREWS GO INTO PILOT HOLES

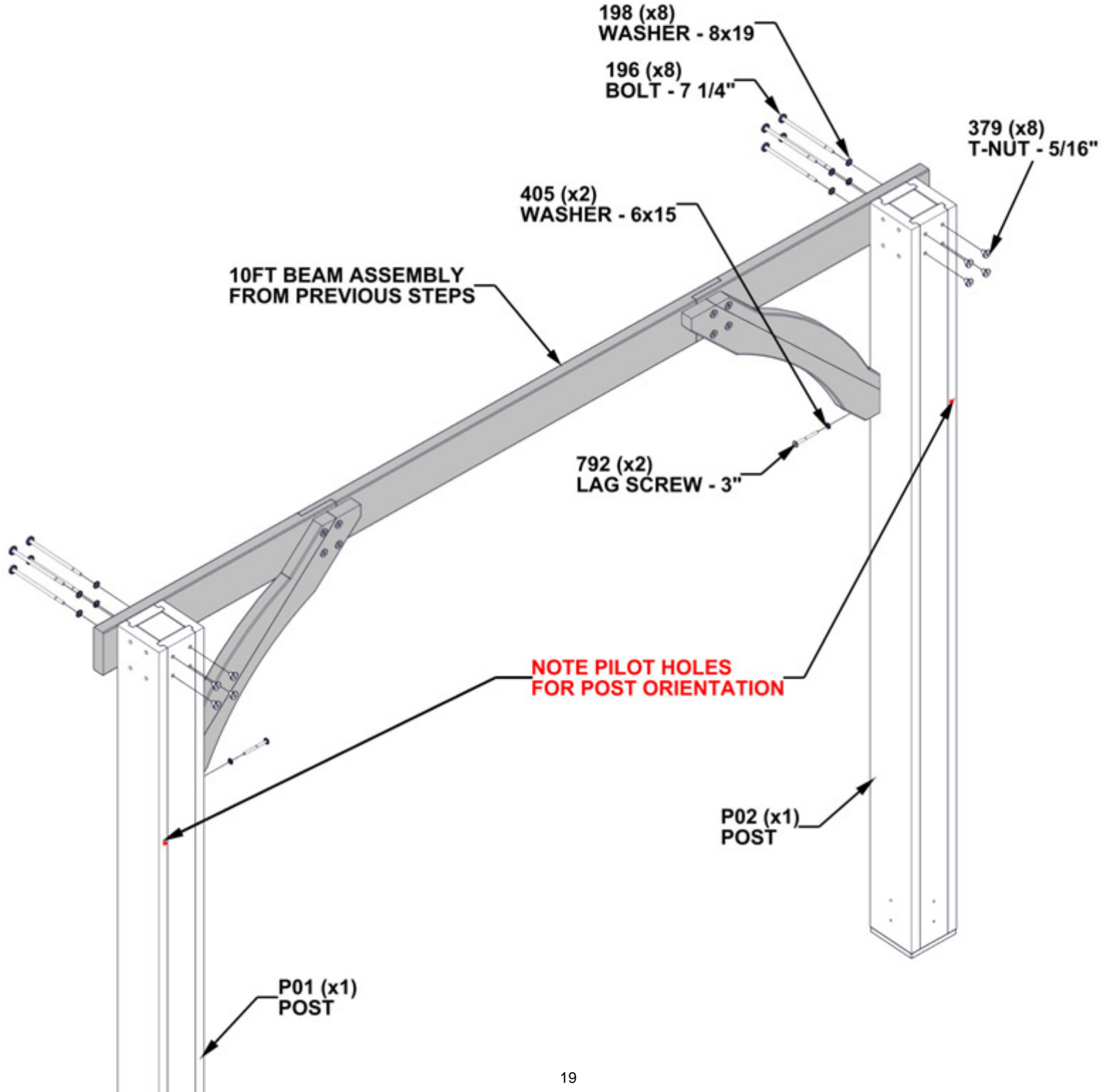

**SET 10FT ASSEMBLY TO THE SIDE
AND REPEAT STEPS 1 THROUGH 3.**

STEP 4 - 14FT BEAM ASSEMBLY

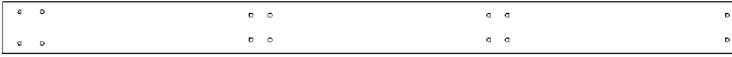

Qty	PART NUMBER	DESCRIPTION
8	H100198	WASHER LOCK EXT 8X19 BLK
8	H100378	BOLT WH 5/16 X 1 3/4 BLK
8	H100379	T-NUT 5/16 BLK

G03 | BEAM - W4L16925

(2) | 15/16"x5 1/4"x77" (24x134x1956)



G02 | MID BRACE BEAM - W4L16924

(1) | 15/16"x5 1/4"x47 5/8" (24x134x1210)

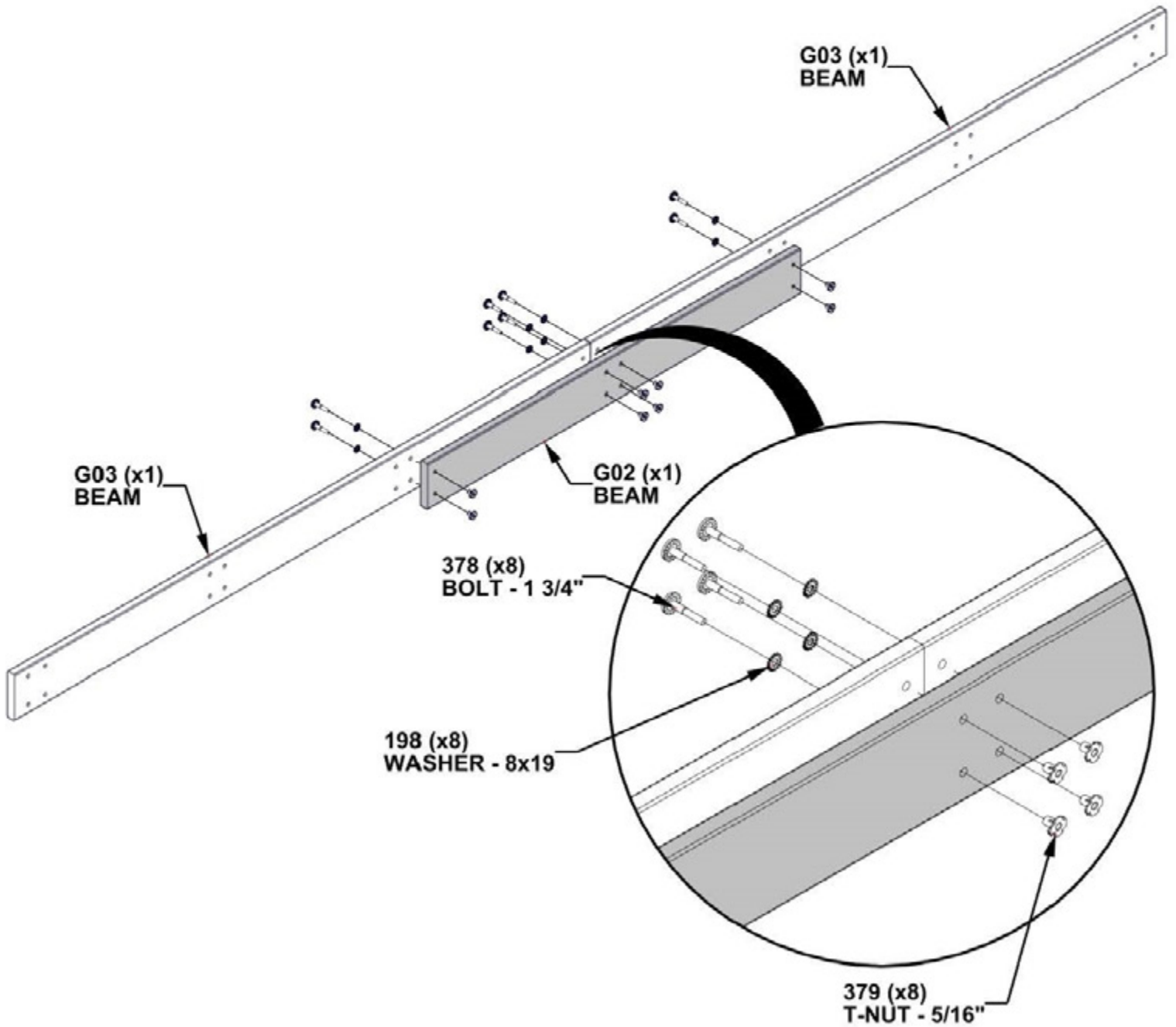

STEP 5 - 14FT BEAM ASSEMBLY

Qty	PART NUMBER	DESCRIPTION
4	H100198	WASHER LOCK EXT 8X19 BLK
4	H100378	BOLT WH 5/16 X 1 3/4 BLK
4	H100379	T-NUT 5/16 BLK



G01 | BEAM - W4L16923
 (2) | 15/16"x5 1/4"x53 3/16" (24x134x1351)

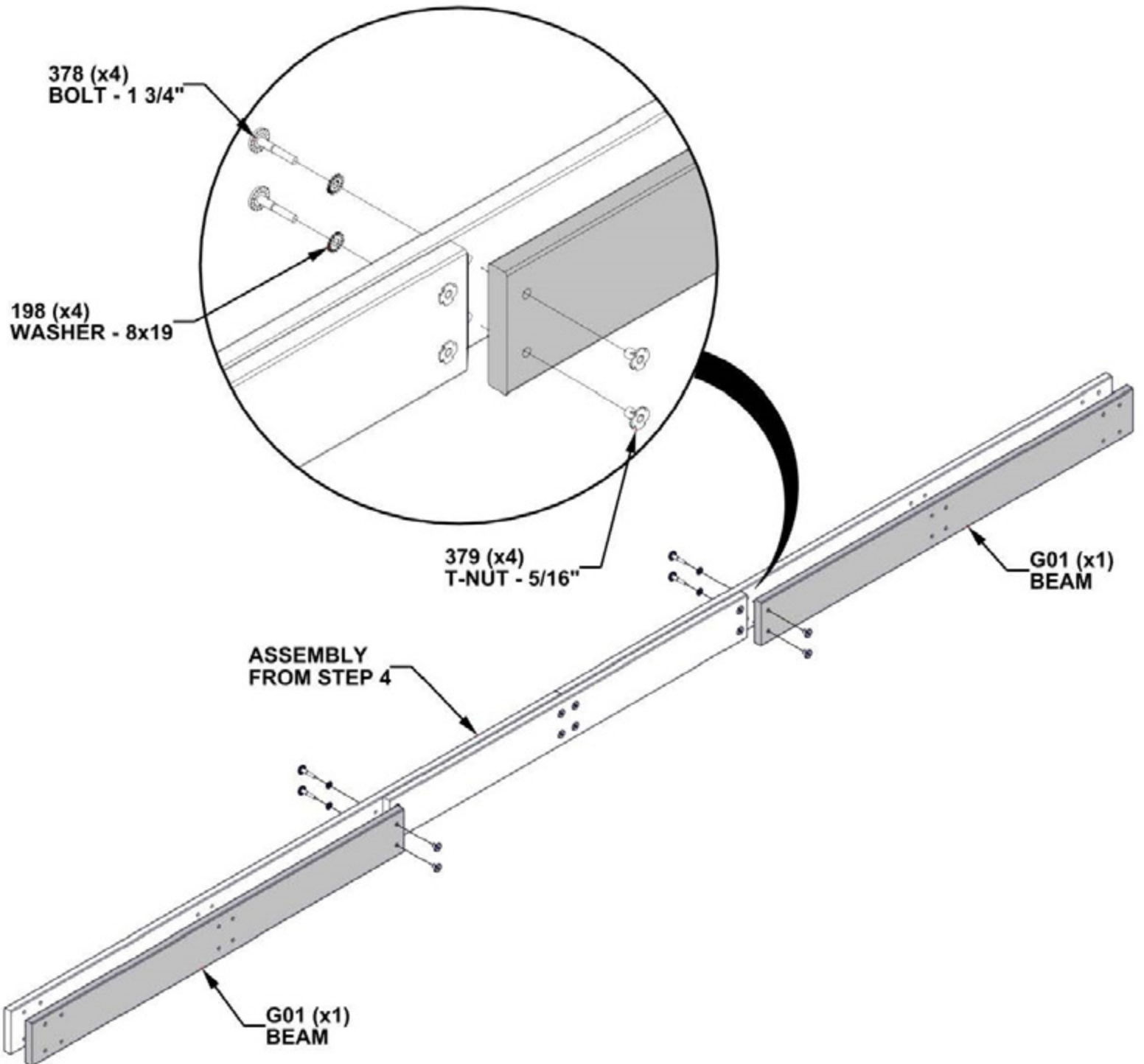

STEP 6 - 14FT BEAM ASSEMBLY

Qty	PART NUMBER	DESCRIPTION
8	H100198	WASHER LOCK EXT 8X19 BLK
8	H100484	BOLT WH 5/16 X 3 1/4 BLK
8	H100379	T-NUT 5/16 BLK



C01 | CORBEL-W2A03393
(1) 1 3/8"x6 7/16"x35 1/8" (36x163x893)



C02 | CORBEL W/TAG-W2A03394
(1) 1 3/8"x6 7/16"x35 1/8" (36x163x893)

TIP:
TWO "C01" PARTS WILL BE USED ON OTHER SIDE

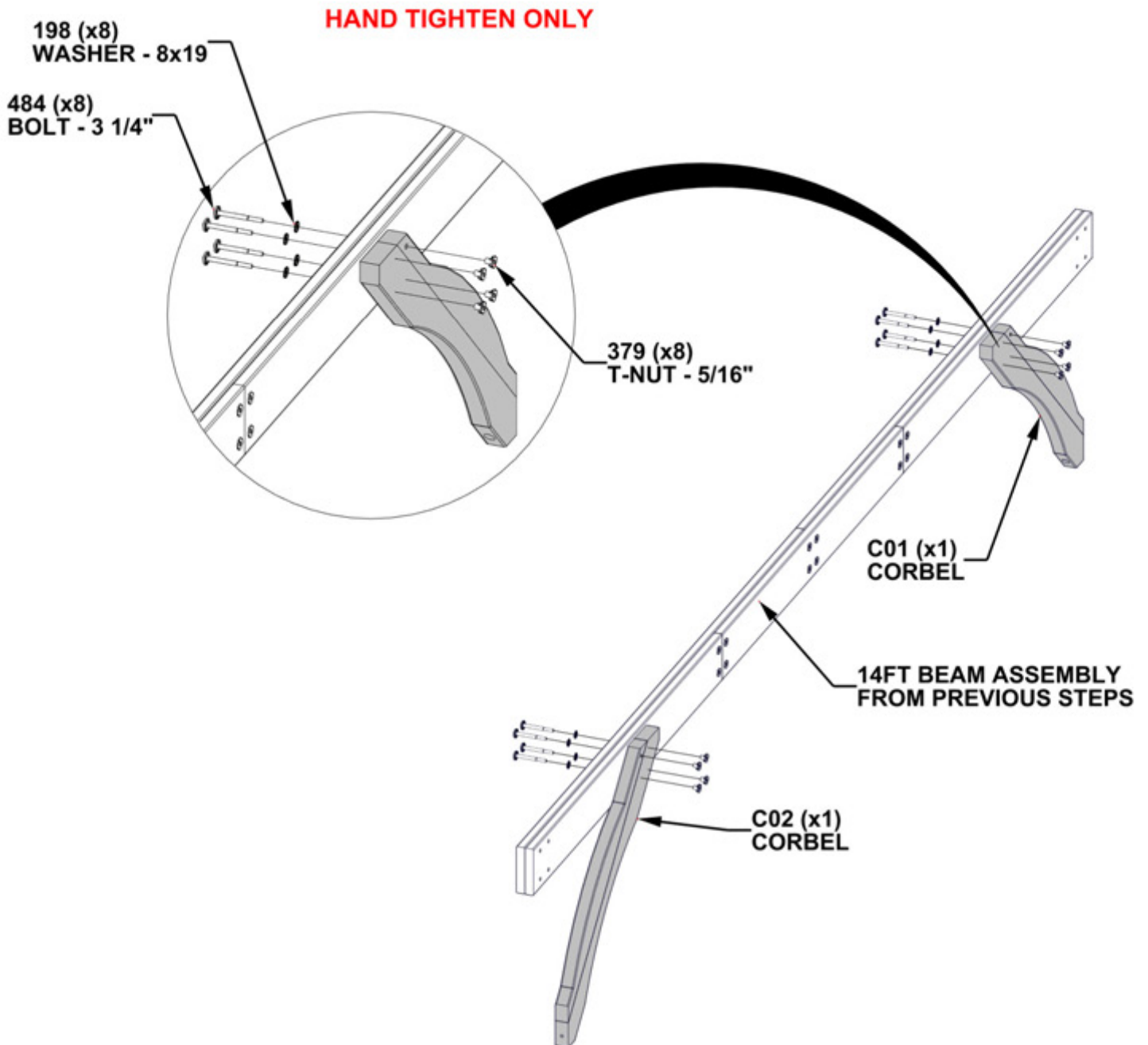

STEP 7 - 14FT BEAM ASSEMBLY

Qty	PART NUMBER	DESCRIPTION
8	H100198	WASHER LOCK EXT 8X19 BLK
8	H100963	BOLT WH 5/16 X 7 3/4
8	H100379	T-NUT 5/16 BLK
2	H100405	WASHER LOCK EXT 6X15 BLK
2	H100792	LAG SCREW WH 1/4 X 3 BLK

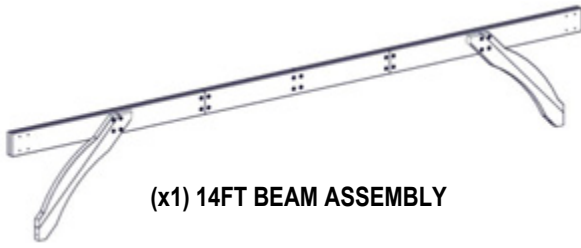

TIPS:

- THREE PEOPLE ARE HELPFUL FOR THIS STEP.
- MOVE THE 10FT POST ASSEMBLIES TO THEIR FINAL LOCATION WITH SOMEONE HOLDING EACH ASSEMBLY UPRIGHT.
- USING A THIRD PERSON, CONNECT THE 14FT BEAM ASSEMBLY TO THE POSTS TO MAKE THE GAZEBO FRAME.
- INSERT BOLTS FIRST, FOLLOWED BY LAG SCREWS
- TO AVOID WOOD SPLITTING, MAKE SURE LAG SCREWS GO INTO PILOT HOLES

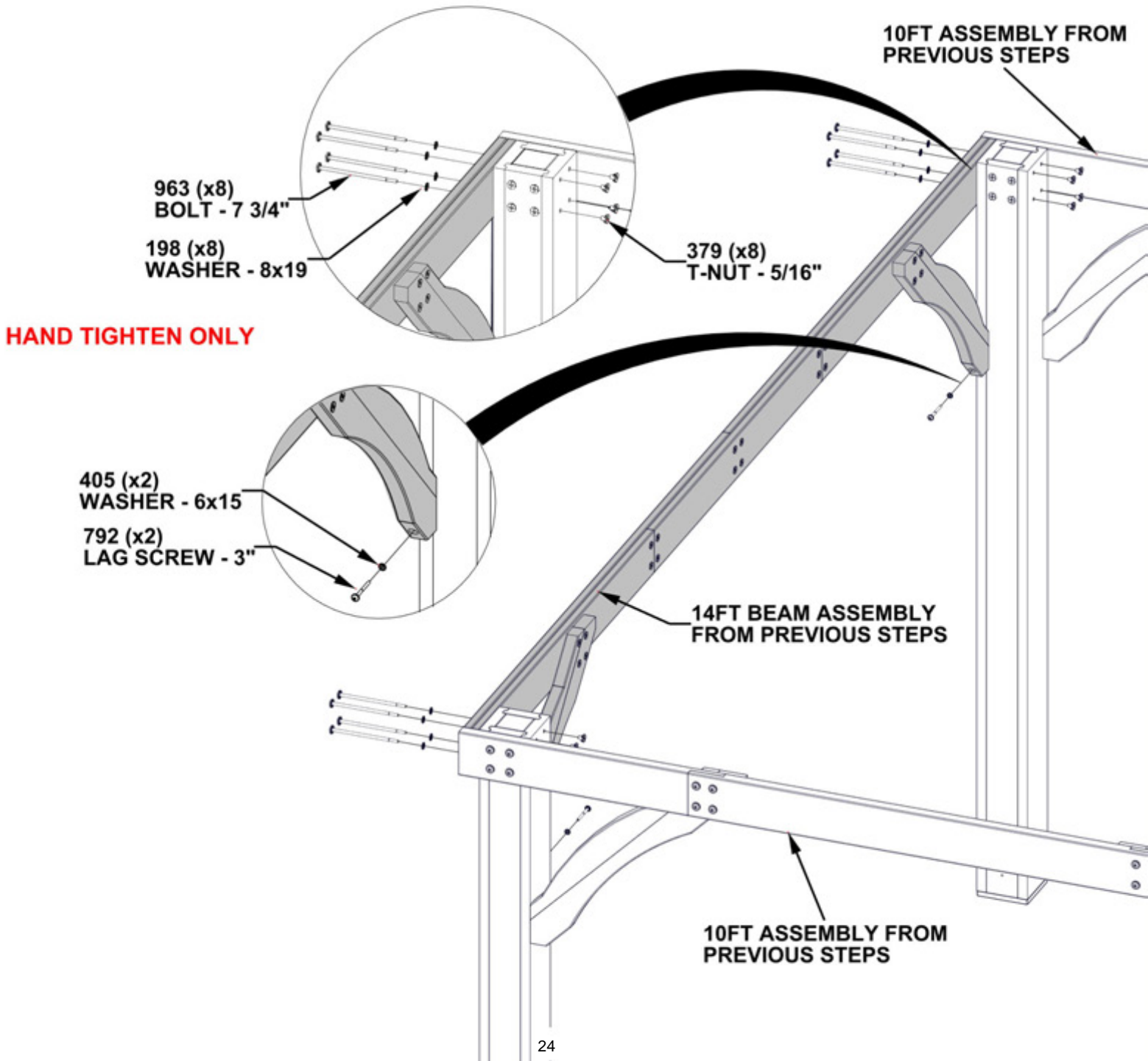

**SET 14FT UPRIGHT ASSEMBLY TO THE
SIDE AND REPEAT STEPS 4 THROUGH 7.**

STEP 8A: SQUARE STRUCTURE

**CRITICAL: SQUARE UNIT BEFORE PROCEEDING TO NEXT STEPS.
ONCE SQUARE, TIGHTEN ALL HARDWARE.**

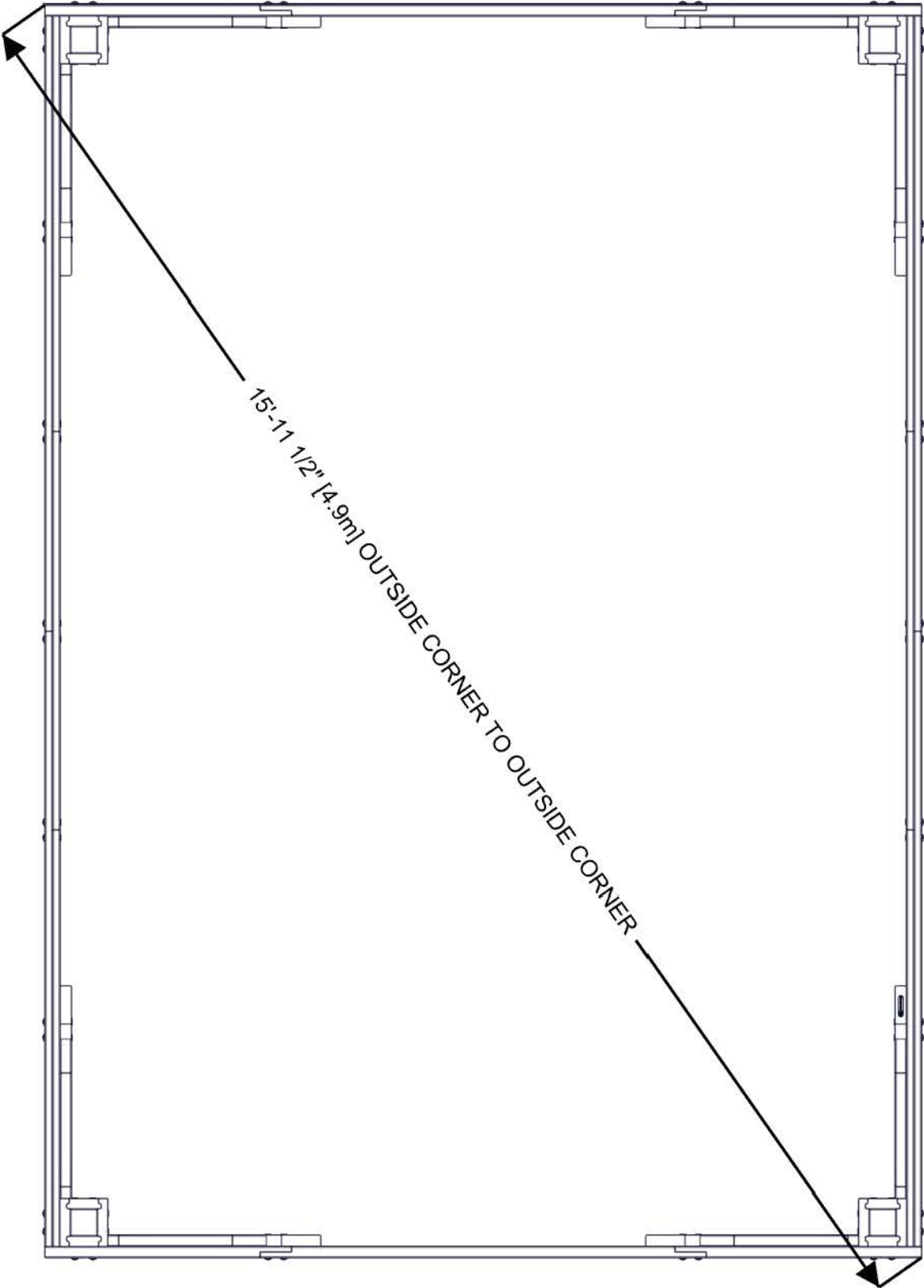

TOP VIEW

STEP 8B - ROOF SUPPORT ASSEMBLY

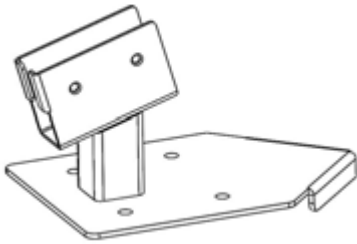

A4M01234
(4) POST CLIP

QTY	PART NUMBER	DESCRIPTION
16	H100460	LAG SCREW WH 1/4x1 BLK

DO NOT OVERTIGHTEN

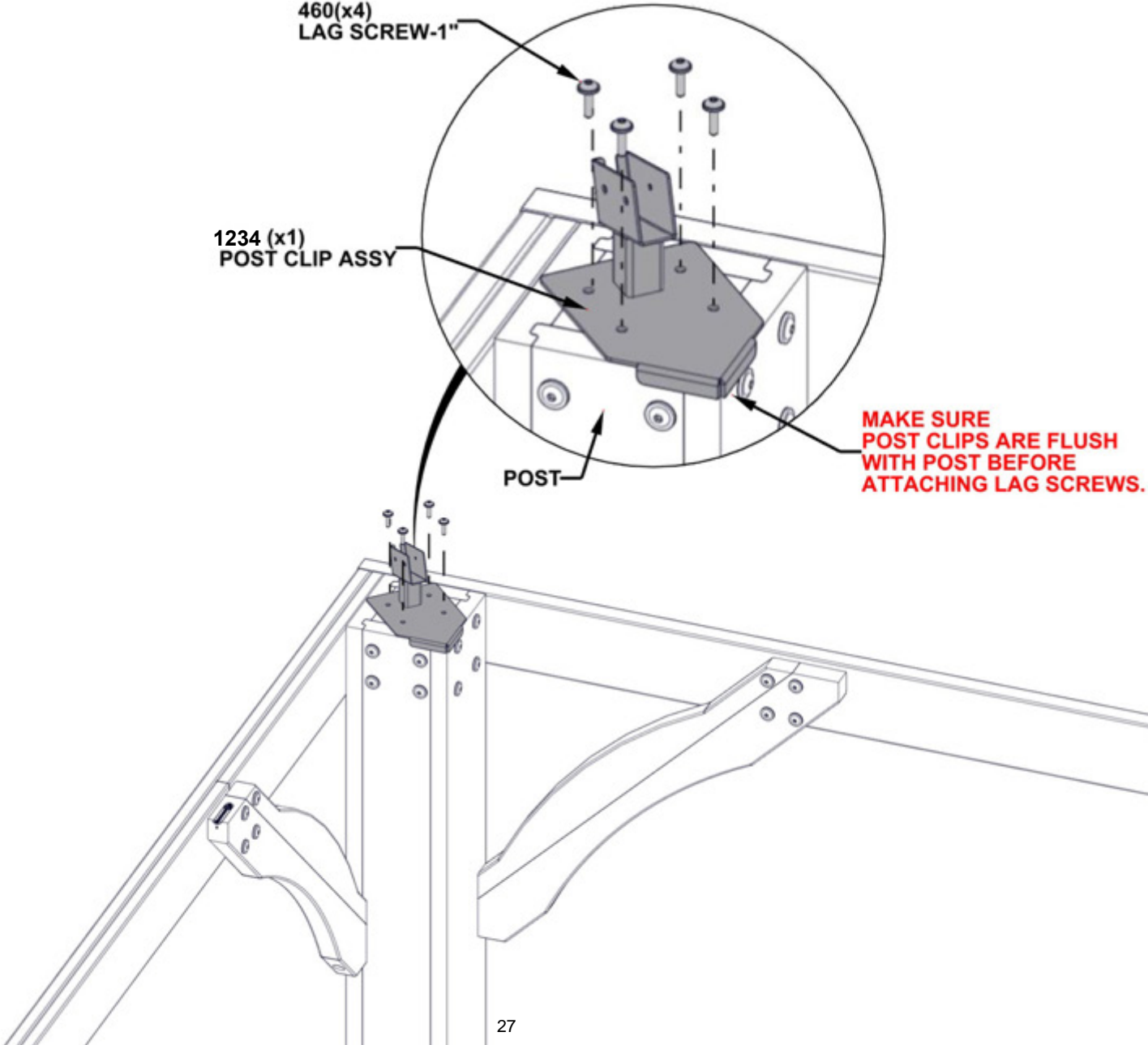

STEP 9 - ROOF SUPPORT ASSEMBLY

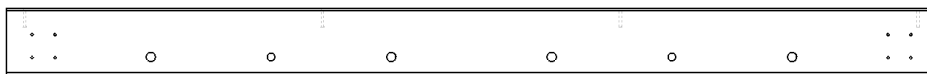

QTY	PART NUMBER	DESCRIPTION
2	H100379	T-NUT 5/16 BLK
8	H100385	SCREW PFH 8x1 BLK

H18 | ROOF SUPPORT- W4L16315
 (1) 1"x3 3/8"x48" (24x86x1220)

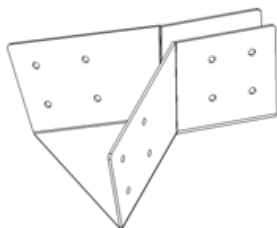

A4M01184 | PANEL SUPPORT BRACKET
 (2)

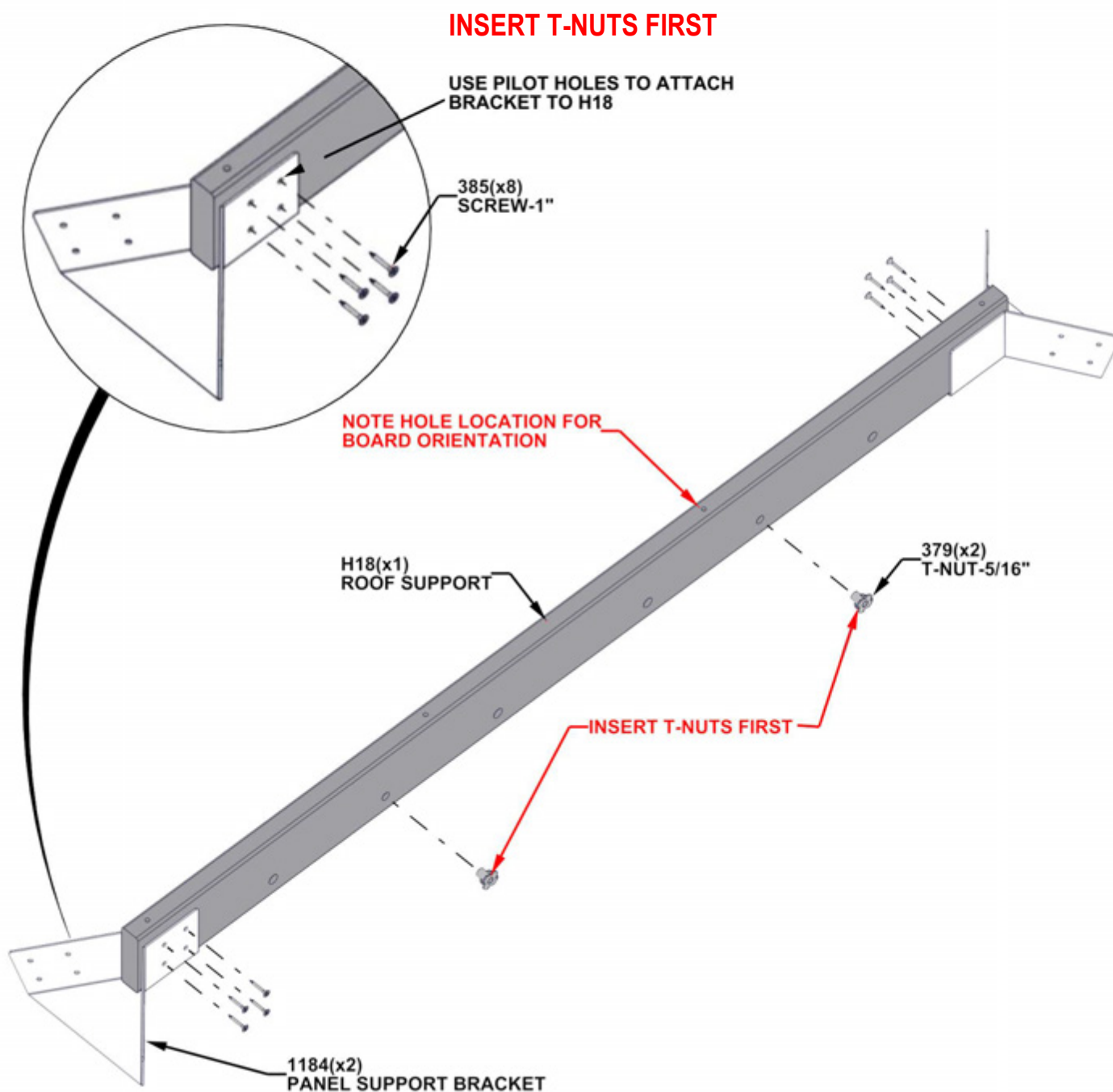

STEP 10 - ROOF SUPPORT ASSEMBLY



H19 | ROOF SUPPORT-W4L16928
 (4) 1"x3 3/8"x75 3/16" (24x86x1909)

QTY	PART NUMBER	DESCRIPTION
4	H100379	T-NUT 5/16 BLK
16	H100385	SCREW PFH 8x1 BLK

REPEAT ON ON OPPOSITE END OF ROOF SUPPORT BOARD

INSERT T-NUTS FIRST

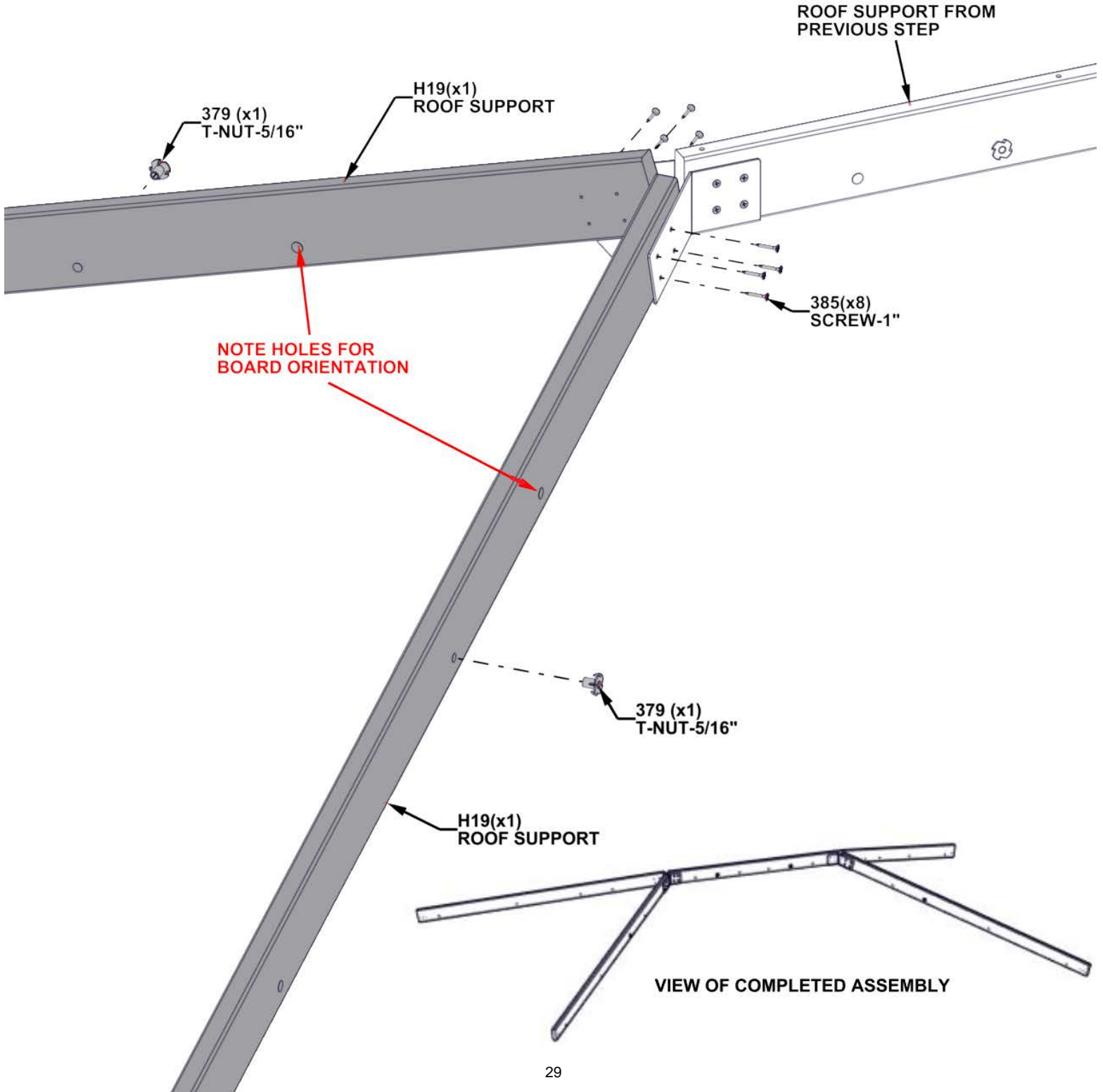

STEP 11 - ROOF SUPPORT ASSEMBLY

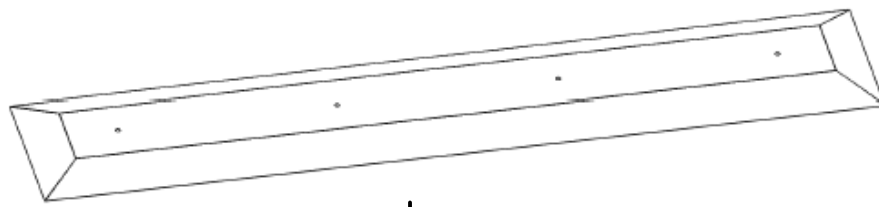

A4M02870 | RIDGE PEAK CAP
(1)



A4M01205 | METAL SPACER
(4)

QTY	PART NUMBER	DESCRIPTION
4	H101034	WEATHER PROOFING WASHER
4	H100792	LAG SCREW WH 1/4x3 BLK

- TIPS:
- REMOVE PROTECTIVE BLUE FILM BEFORE ASSEMBLY
 - ALIGN RIDGE PEAK CAP AND METAL SPACER WITH PILOT HOLES BEFORE INSERTING LAG SCREWS

WARNING: GLOVES ARE RECOMMENDED WHEN HANDLING STEEL ROOF PIECES

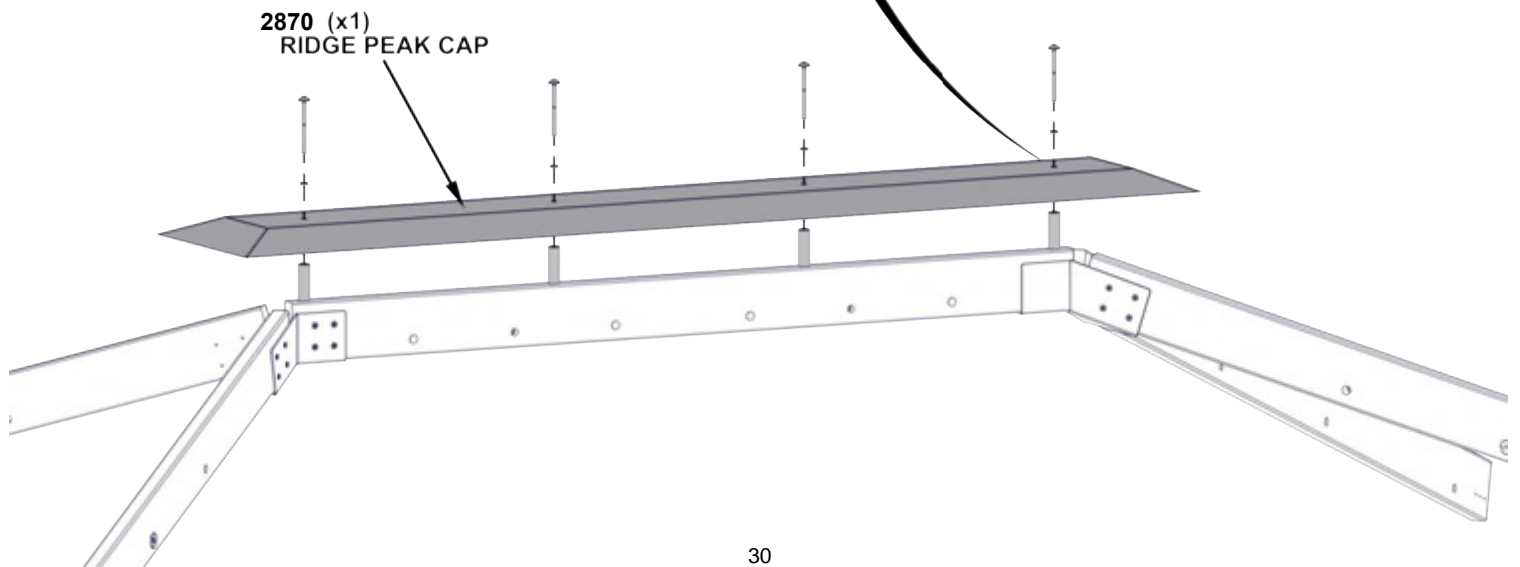
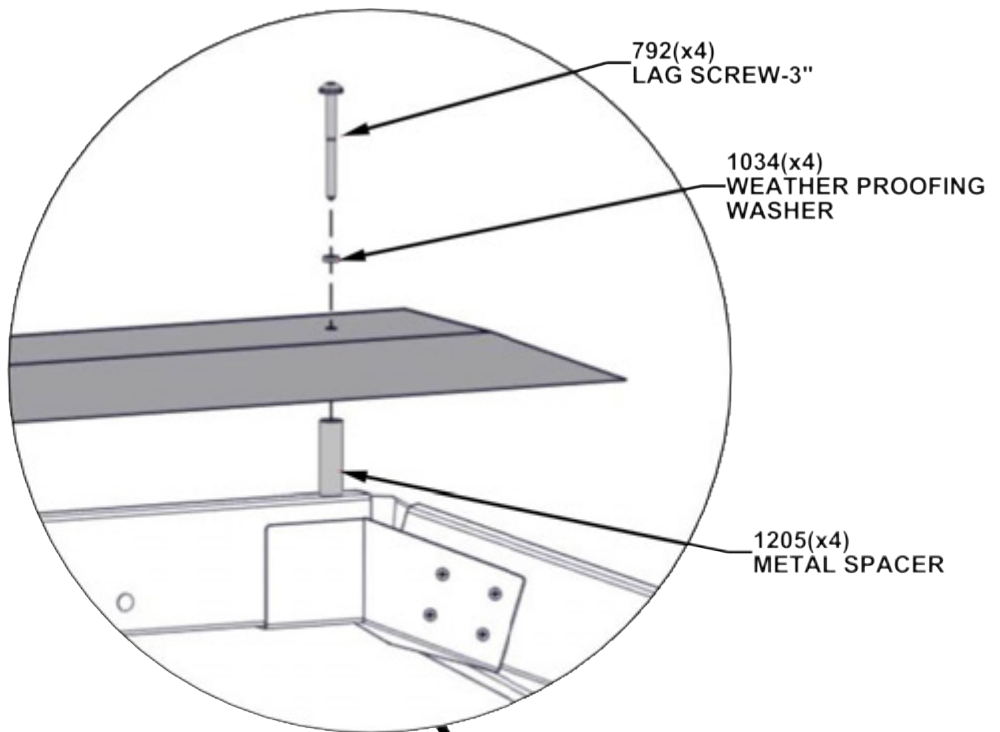

STEP 12 SUPPORT ASSEMBLY

- THREE PEOPLE ARE HELPFUL FOR THIS STEP.
- POSITION A PERSON ON A LADDER IN THE CENTER OF THE BASE.
- LIFT ROOF SUPPORT UP AND OVER THE 14FT SIDE AND INSERT INTO CORNER POST CLIPS.

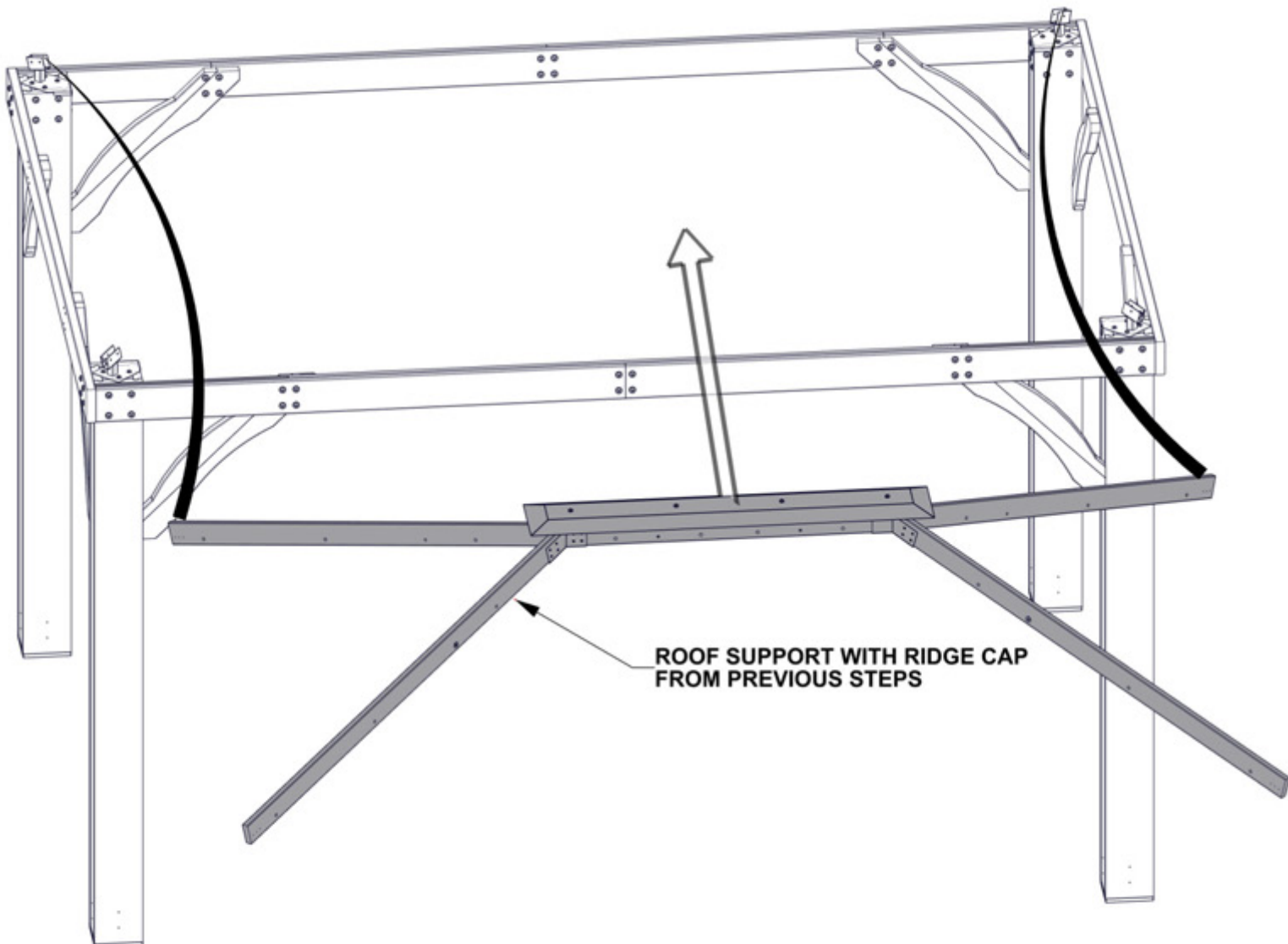

STEP 13 ROOF SUPPORT ASSEMBLY

QTY	PART NUMBER	DESCRIPTION
12	H100385	SCREW PFH 8x1 BLK

REPEAT ON ALL POSTS

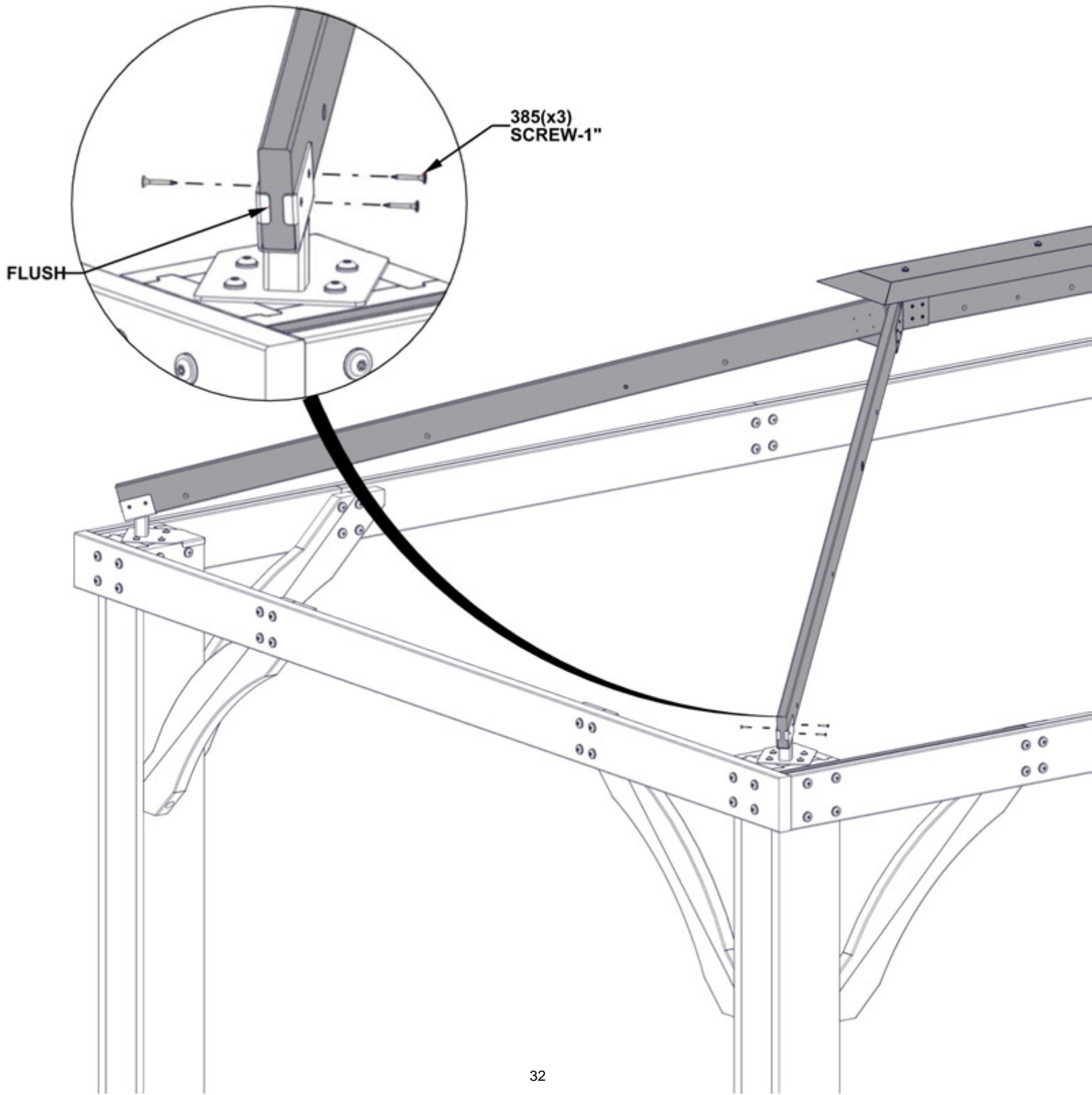

STEP 14 - 14FT ROOF PANEL ASSEMBLY



H02 | ROOF JOIST- W4L16283
(1) 1"x3 3/8"x46 3/4" (24x86x1188)

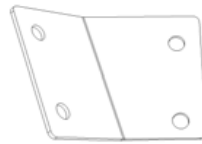

A4M01193 | PANEL BRACKET
(1)

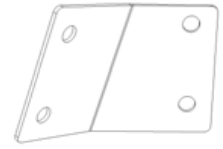

A4M01191 | PANEL BRACKET
(1)

QTY	PART NUMBER	DESCRIPTION
4	H100398	T-NUT 1/4 BLK
4	H100171	BOLT WH 1/4x1 BLK

**INSERT T-NUTS FIRST
HAND TIGHTEN ONLY**

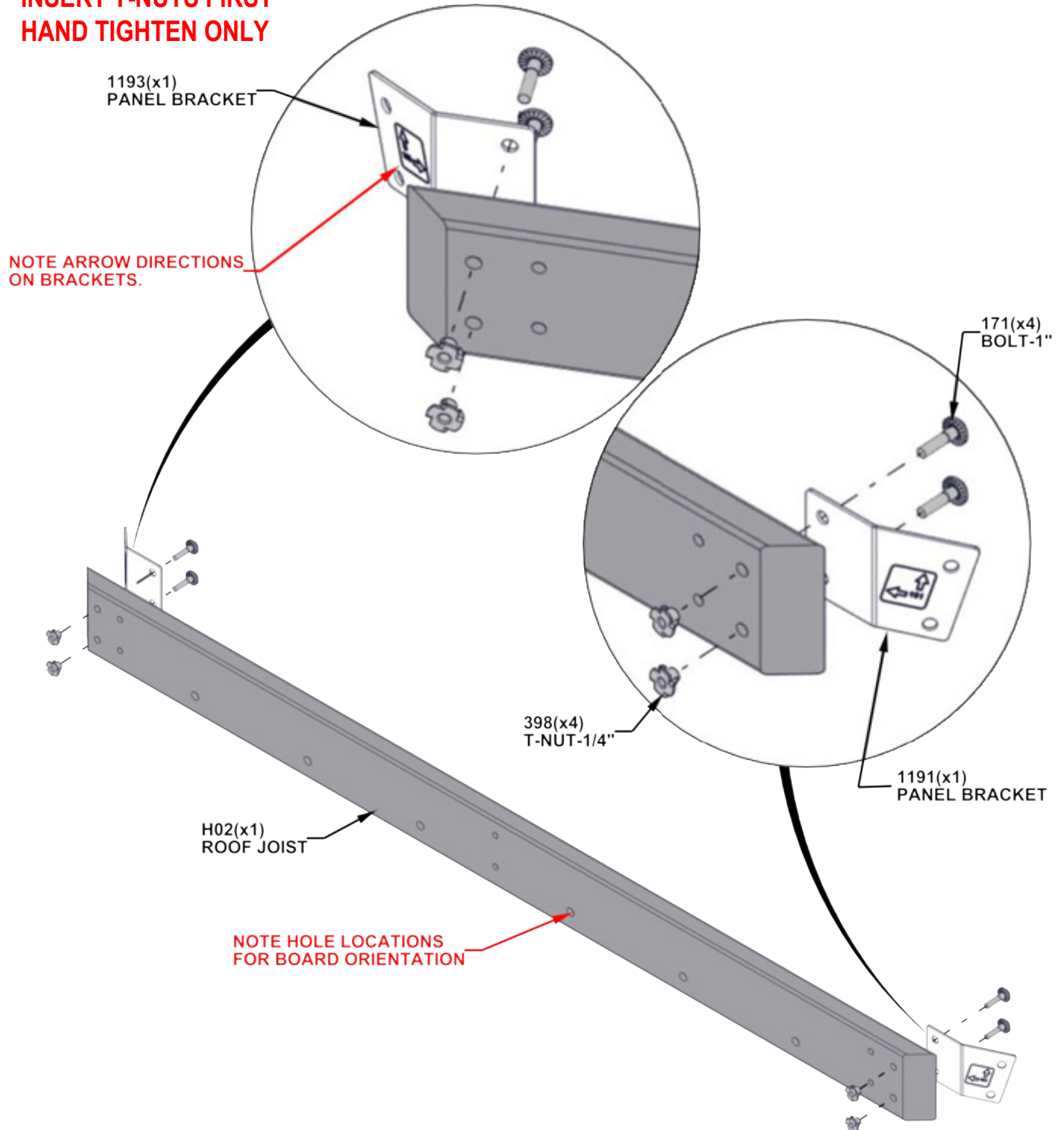

STEP 15 - 14FT ROOF PANEL ASSEMBLY



H01 | ROOF JOIST-W4L16295

(1) 1"X3 3/8"X88 3/16" (24x86x2240)

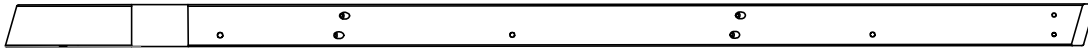

H09 | ROOF JOIST-W4L16296

(1) 1"X3 3/8"X88 1/8" (24x86x2240)

QTY	PART NUMBER	DESCRIPTION
4	H100398	T-NUT 1/4 BLK
4	H100171	BOLT WH 1/4x1 BLK

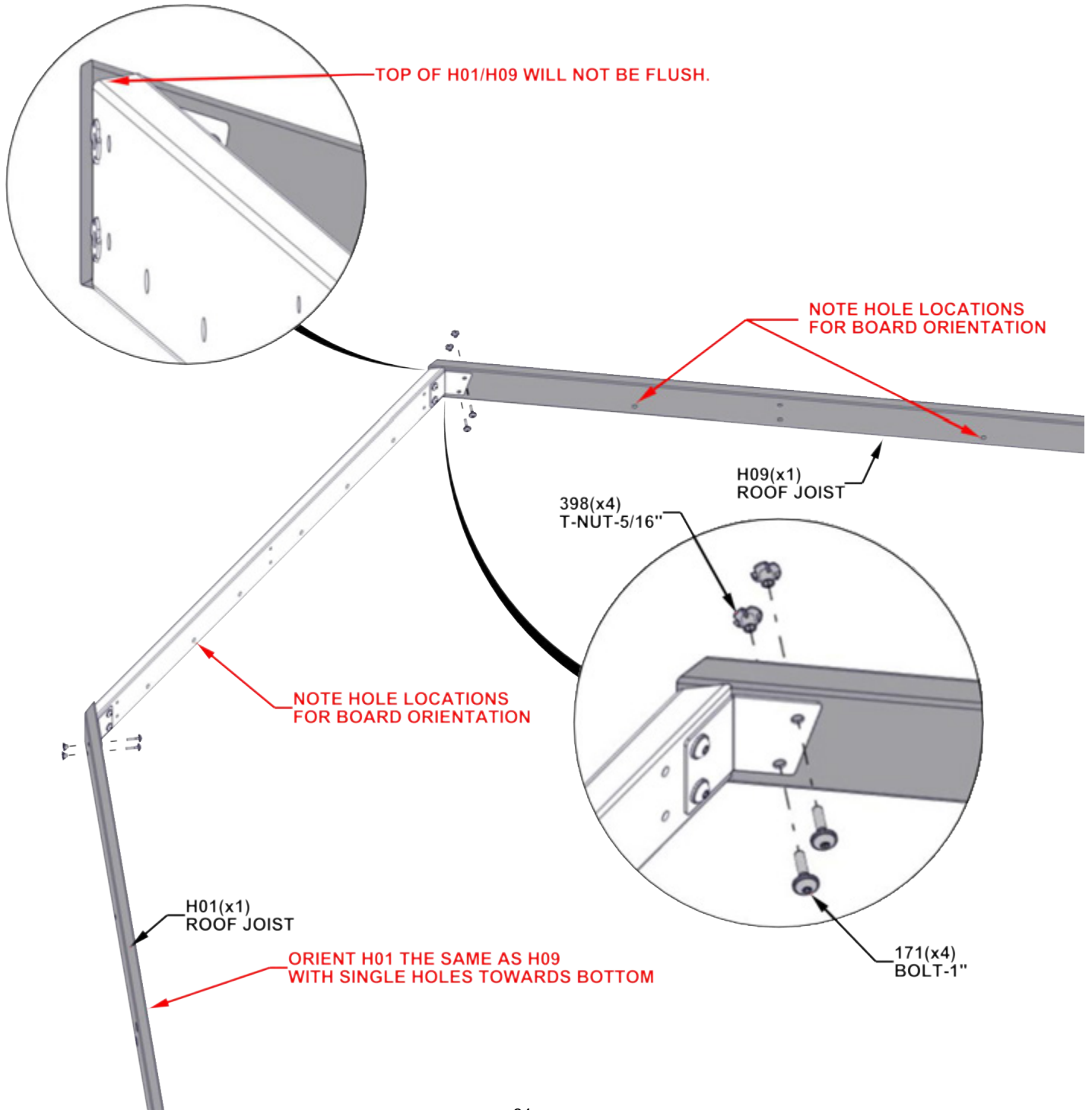

STEP 16 - 14FT ROOF PANEL ASSEMBLY

E02 | RAFTER- W4L16288
(2) 1 3/8"x3 3/8"x63 7/8" (36x86x1622)

E11 | RAFTER- W4L16290
(1) 1 3/8"x3 3/8"x63 7/8" (36x86x1622)

E03 | RAFTER- W4L16286
(1) 1 3/8"x3 3/8"x20 7/16" (36x86x519)

E06 | RAFTER - W4L16287
(1) 1 3/8"x3 3/8"x20 7/16" (36x86x519)

E01 | RAFTER- W4L16284
(1) 1 3/8"x3 3/8"x44" (36x86x1117)

E04 | RAFTER- W4L16285
(1) 1 3/8"x3 3/8"x44" (36x86x1117)

QTY	PART NUMBER	DESCRIPTION
14	H101030	SCREW 2" CONFIRMAT BLK

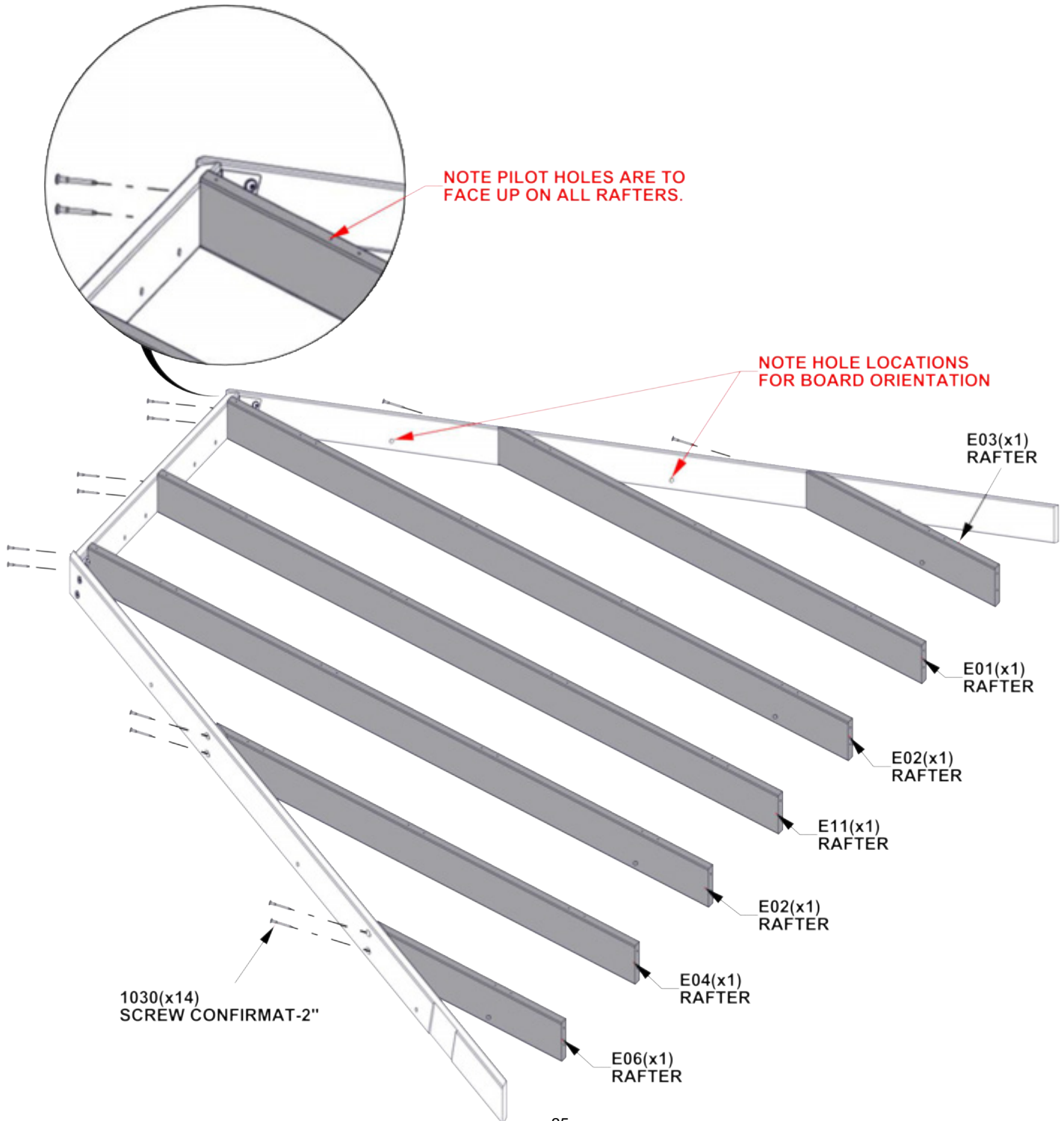

STEP 17A - 14FT ROOF PANEL ASSEMBLY

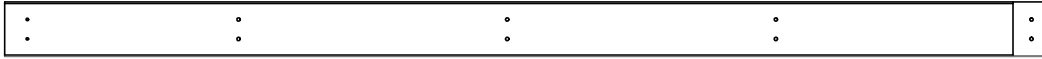

Q01 ROOFJOIST-W4L16294
 (2) 1"x4 7/16"x84 9/16" (24x112x2148)

QTY	PART NUMBER	DESCRIPTION
4	H100382	SCREW PFH 8x1 3/4 BLK
14	H101030	SCREW 2" CONFIRMAT BLK

TIP:

- RAFTERS MAY NEED TO BE LOOSENED TO ATTACH Q01 TO H01/H09

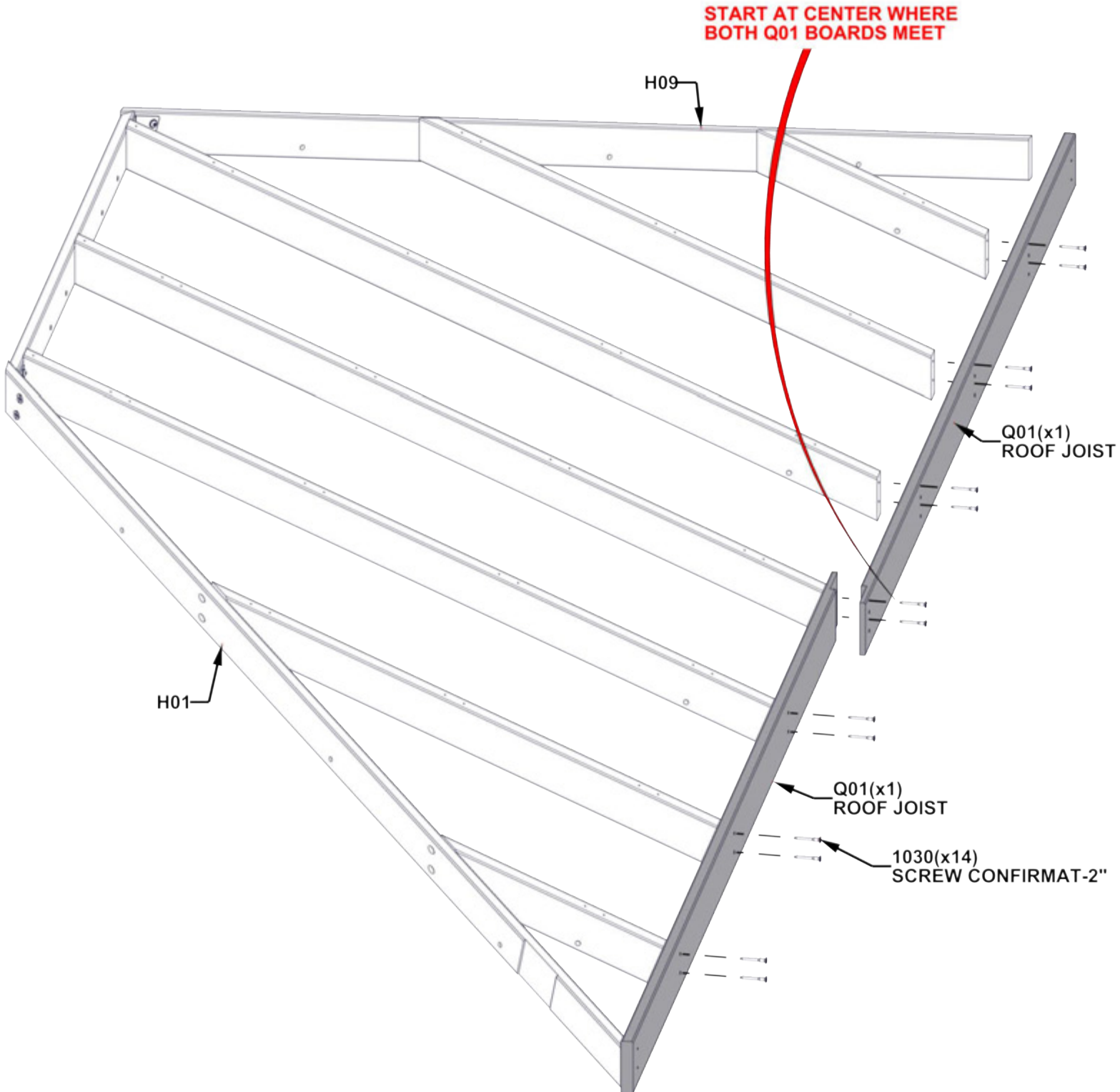

STEP 17B - 14FT ROOF PANEL ASSEMBLY

- TIPS:
- USING THE Q01 BOARD AS A GUIDE AND A 1/8" DRILL BIT, DRILL PILOT HOLES INTO THE H01 BOARD USING THE DIMENSION BELOW.
 - REPEAT ON OPPOSITE END WITH H09 BOARD.

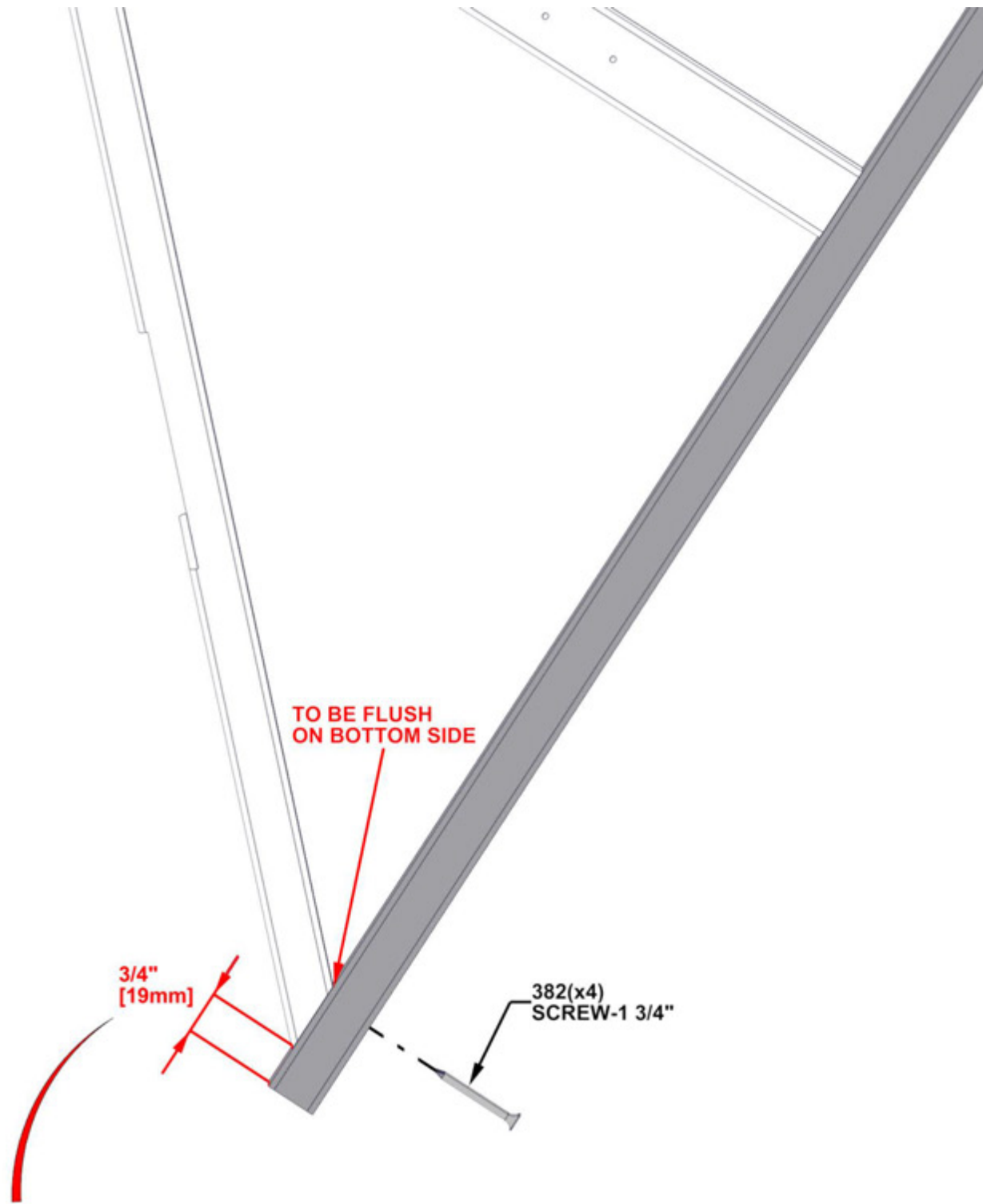

THIS DIMENSION IS CRITICAL TO THE PANEL ASSEMBLY

STEP 17C - 14FT ROOF PANEL ASSEMBLY

TIP:

- LOOSEN HARDWARE TO ADJUST FOR SQUARING IF NEEDED

CRITICAL:

- SQUARE UNIT BEFORE PROCEEDING TO NEXT STEPS.
- THE BELOW DIMENSIONS ARE CRITICAL TO THE FINAL ROOF ASSEMBLY.
- MEASUREMENTS SHOULD BE WITHIN +/- 1/4".
- MEASUREMENTS OUTSIDE OF TOLERANCE WILL LEAD TO THE INABILITY TO ASSEMBLE THE ROOF.

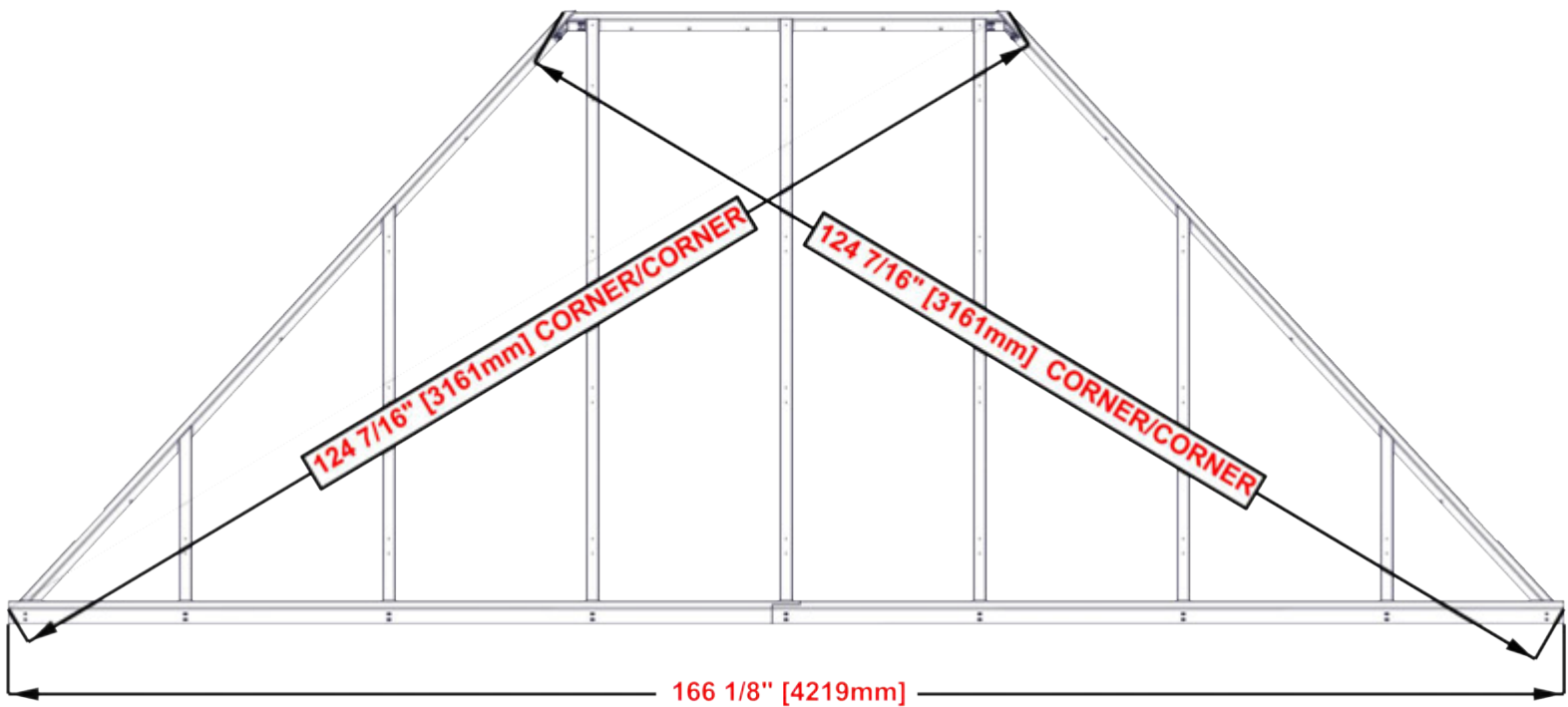

STEP 18 - 14FT ROOF PANEL ASSEMBLY

H07 | PURLIN-W4L16292
(2) | 1"x3 3/8"x59 7/16" (24x86x1509)

H05 | PURLIN-W4L16291
(2) | 1"x3 3/8"x65 1/2" (24x86x1664)

H08 | PURLIN-W4L16293
(2) | 1"x3 3/8"x 43 11/16" (24x86x1110)

H04 | PURLIN - W4L16921
(2) | 1"x3 3/8"x29 5/8" (24x86x752)

H03 | PURLIN - W4L16281
(1) | 1"x3 3/8"x68 3/8" (24x86x1736)

H17 | PURLIN - W4L16289
(1) | 1"x1 3/8"x51 3/8" (24x34x1306)

Qty	PART NUMBER	DESCRIPTION
56	H100391	SCREW PFH 8 X 2 BLK
3	H100200	SCREW PFH 8 X 1 1/2 BLK

- TIPS:**
- ALIGN PURLIN PILOT HOLES WITH RAFTER PILOT HOLES
 - ATTACH SCREWS FROM THE CENTER AND WORK OUTWARD
 - H01 AND H09 BOARDS DO NOT HAVE PILOT HOLES FOR OUTSIDE EDGE SCREWS.
 - USING THE PURLINS AS A GUIDE AND A 1/8" DRILL BIT, DRILL PILOT HOLES INTO H01/H09 BOARDS.

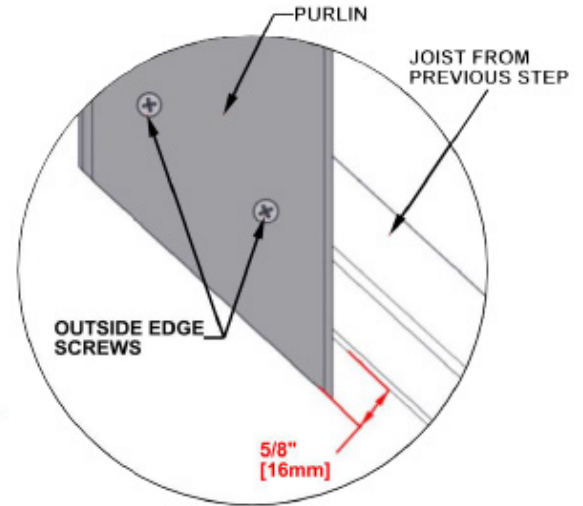

H17 PURLIN WILL NOT OVERHANG

IF PURLINS OVERHANG MORE THAN 5/8", CUT DOWN TO 5/8"

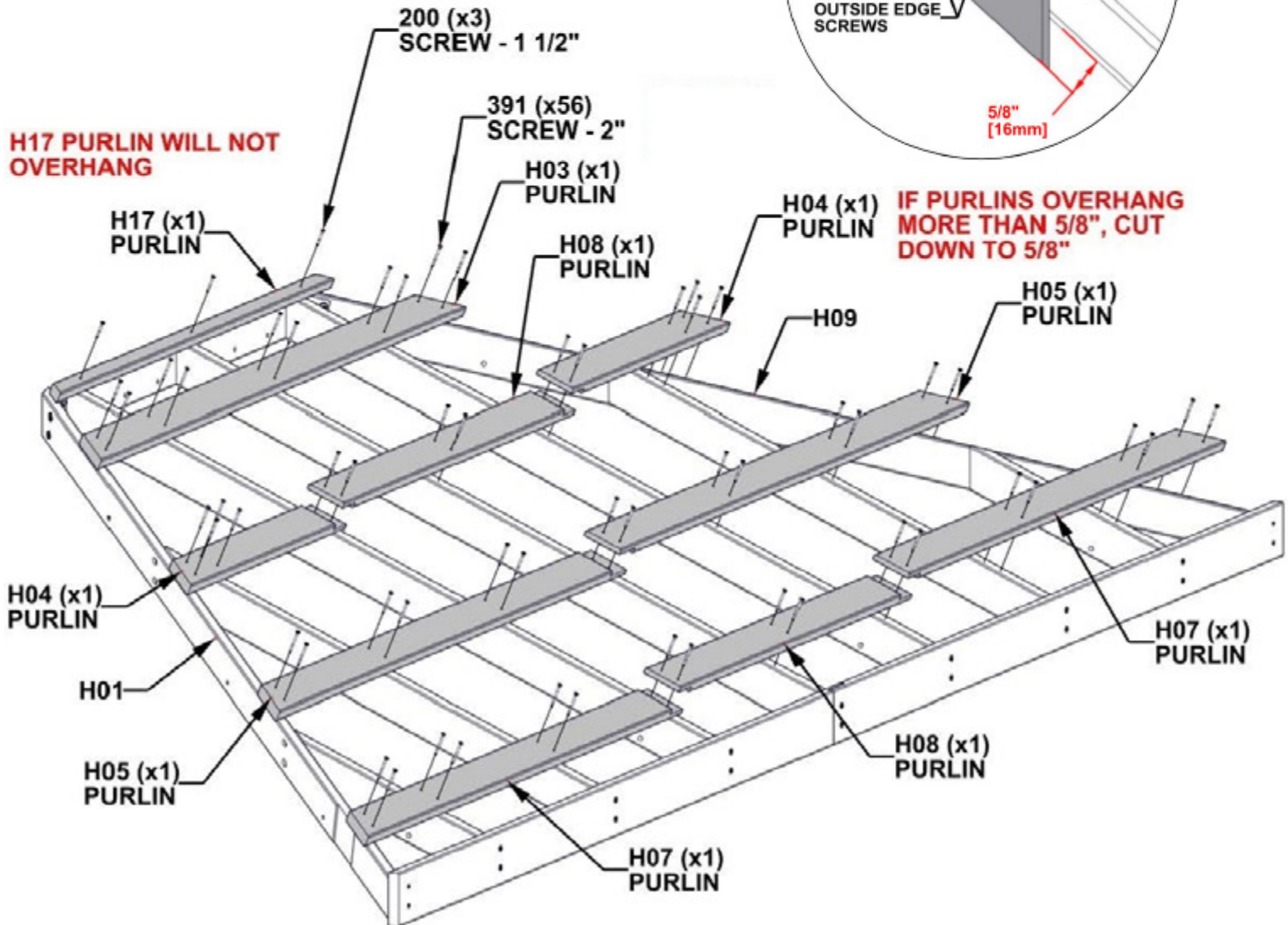

STEP 19 - 14FT ROOF PANEL ASSEMBLY

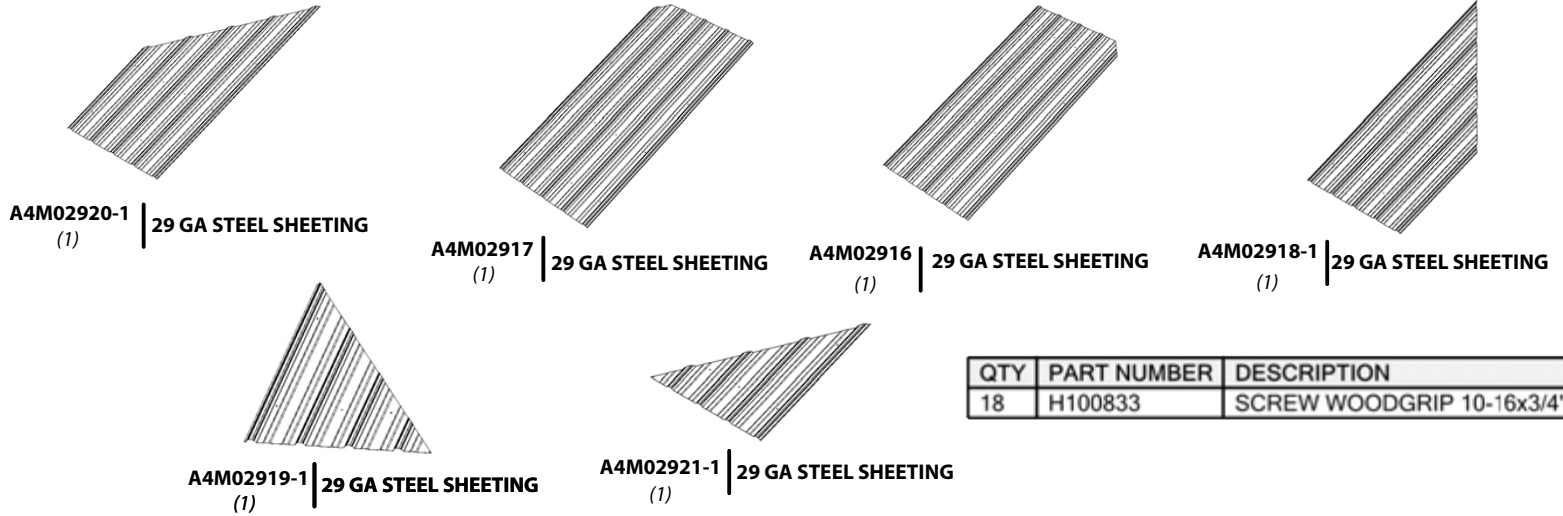

TIPS:

- REMOVE PROTECTIVE BLUE FILM
- STARTING IN THE CENTER, PLACE PANELS AS SHOWN BELOW.
- OVERLAP PANELS BY ONE RIDGE.
- PANELS SHOULD BE FLUSH WITH PURLIN ENDS AND Q01 ROOF JOIST.
- ONCE SHEETING IS IN PLACE, IT IS RECOMMENDED TO ADD H100833 SCREWS IN THE MIDDLE OF SHEETS TO HOLD SHEETING FOR THE NEXT STEP.

WARNING: GLOVES ARE RECOMMENDED WHEN HANDLING STEEL ROOF PIECES

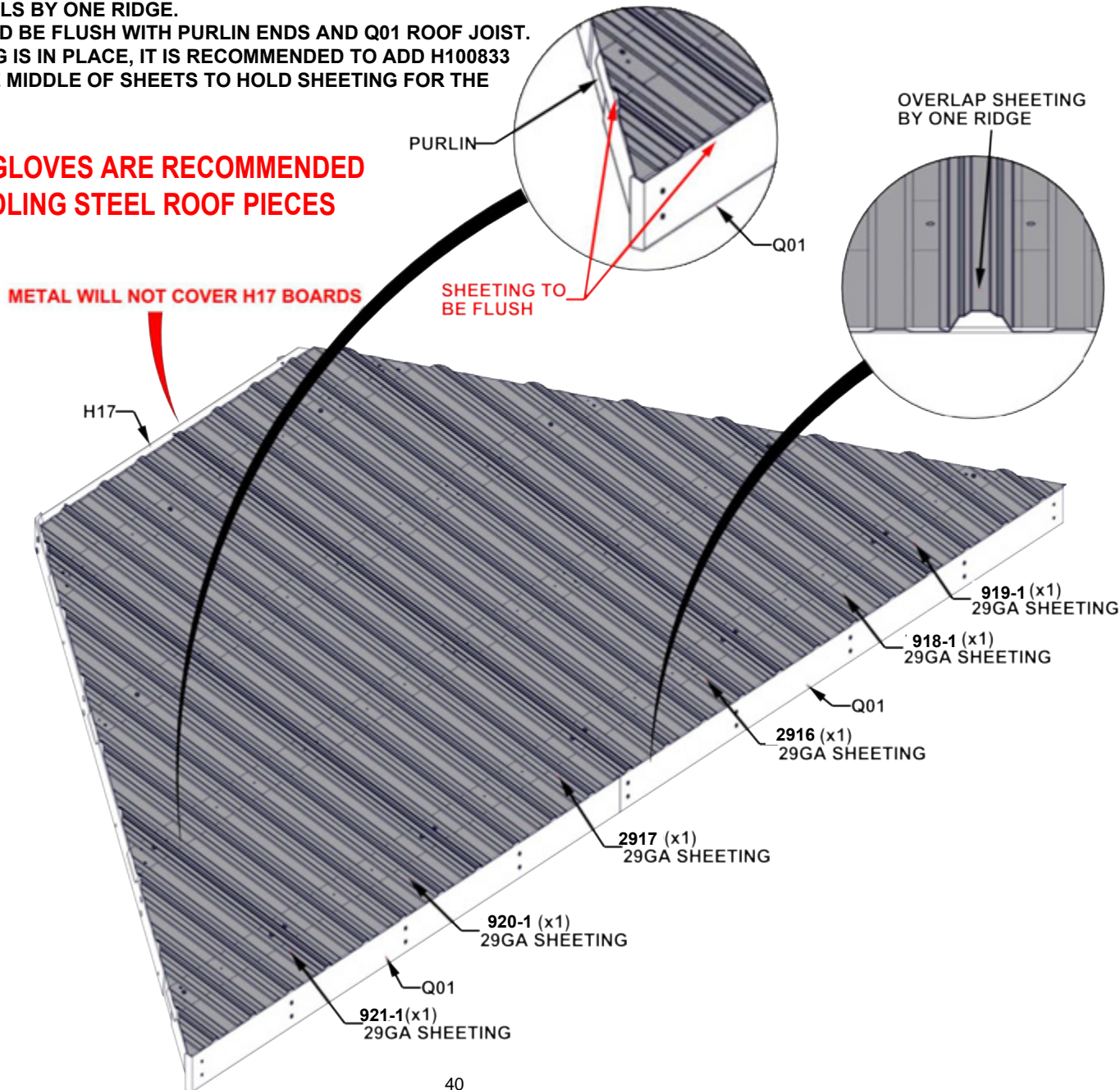

STEP 20 - 14FT ROOF PANEL ASSEMBLY

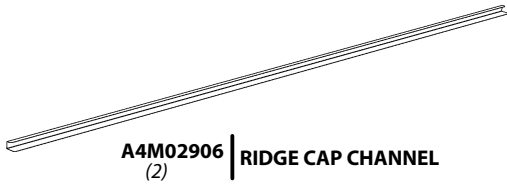

QTY	PART NUMBER	DESCRIPTION
8	H100833	SCREW WOODGRIP 10-16x3/4"

TIPS:

- POSITION THE RIDGE CAP CHANNEL OVER THE EDGE OF THE ROOF PANELS WITH THE WIDER SIDE OF THE CHANNEL ON THE BOTTOM.
- MAKE SURE THE PANELS ARE FULLY SEATED INTO THE CHANNEL.
- FLUSH THE TOP OF THE CHANNEL WITH THE TOP OF THE METAL PANELS.

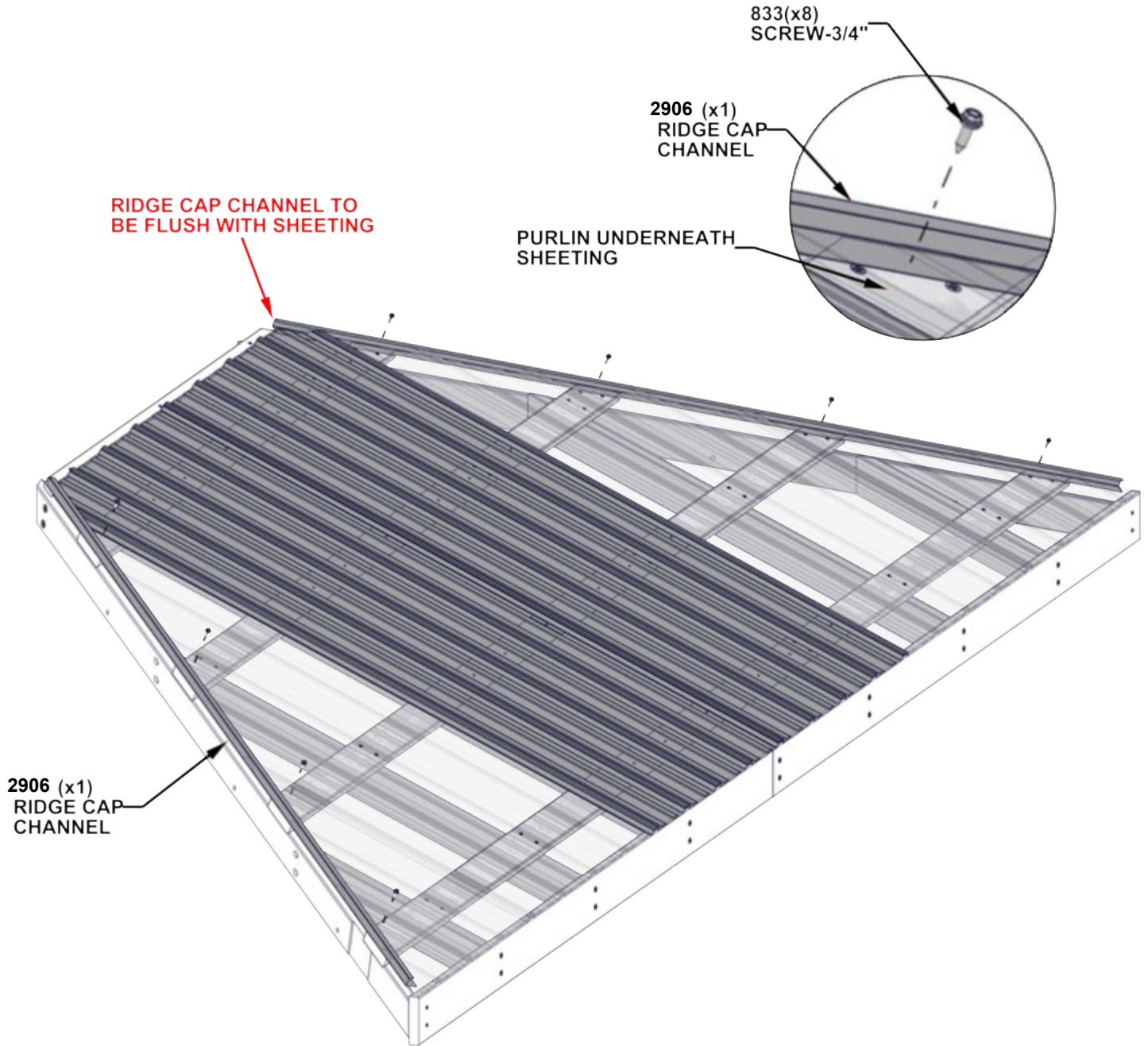

STEP 21 - 14FT ROOF PANEL ASSEMBLY

QTY	PART NUMBER	DESCRIPTION
44	H100833	SCREW WOODGRIP 10-16x3/4"

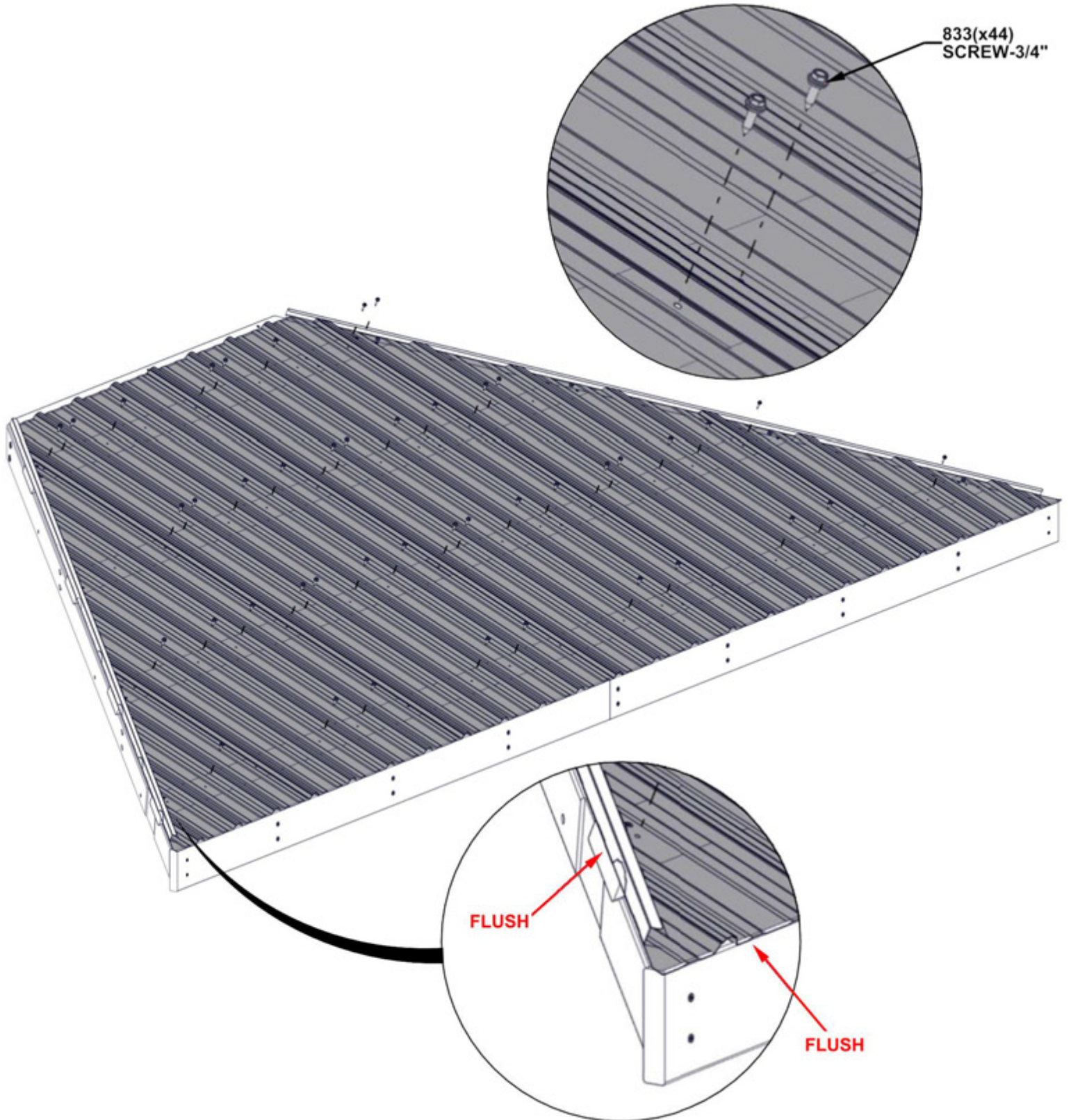

**REPEAT 14FT ROOF PANEL
ASSEMBLY STEPS 14 THROUGH 21**

STEP 22 - 10FT ROOF PANEL ASSEMBLY



A4M01192 | PANEL BRACKET
(1)

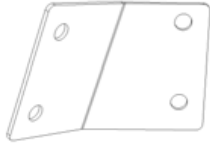

A4M01194 | PANEL BRACKET
(1)

QTY	PART NUMBER	DESCRIPTION
4	H100398	T-NUT 1/4 BLK
4	H100171	BOLT WH 1/4x1 BLK



H11 | ROOF JOIST-W4L16297
(1) 1"x3 3/8"x15 15/16" (24x86x404)

**INSERT T-NUTS FIRST
HAND TIGHTEN ONLY**

**NOTE ARROW DIRECTIONS
ON BRACKETS**

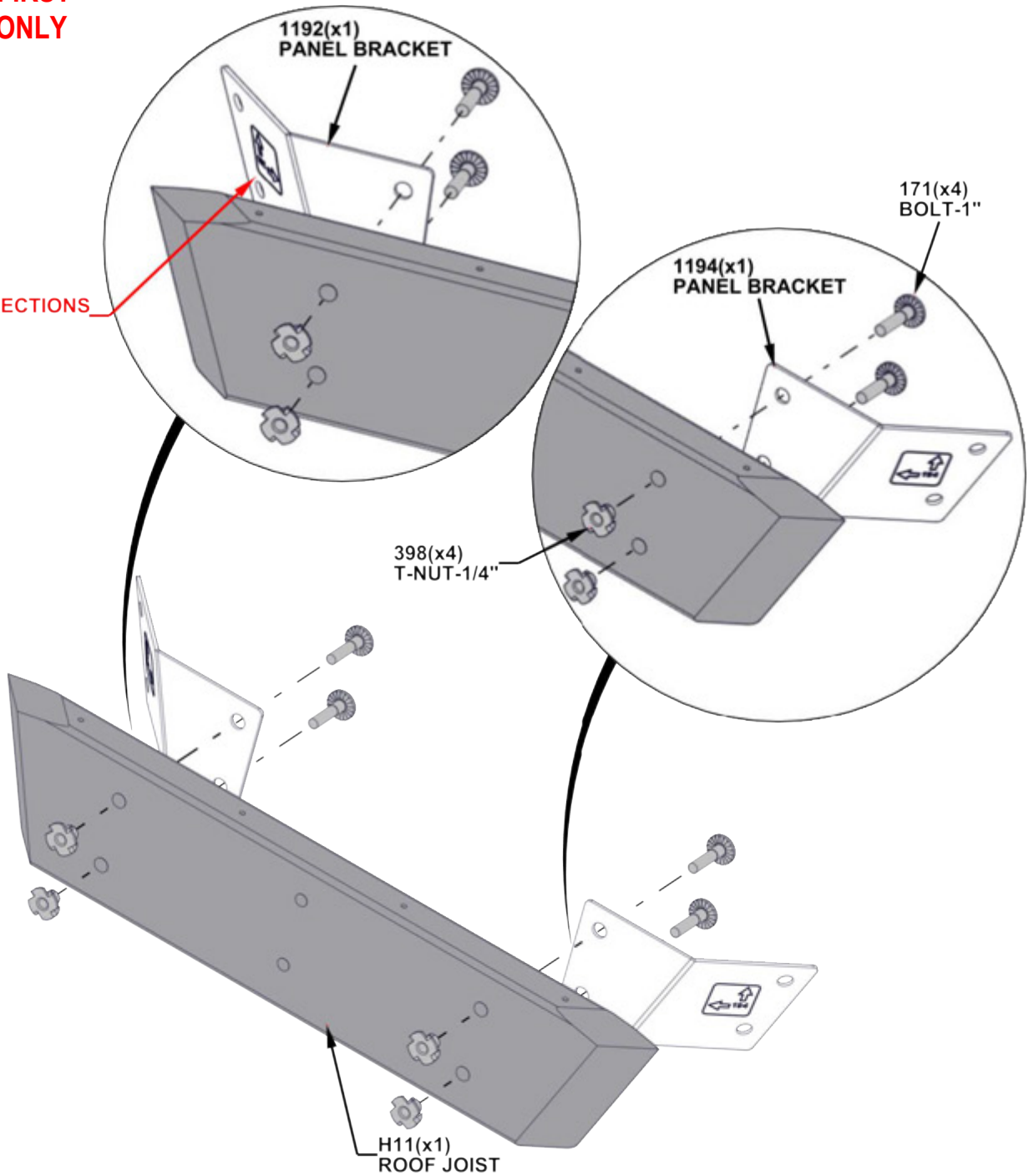

STEP 23 - 10FT ROOF PANEL ASSEMBLY

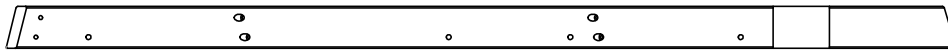

H12 | ROOF JOIST-W4L16308
(1) 1"x3 3/8"x76 3/4" (24x86x1952)



H10 | ROOF JOIST-W4L16309
(1) 1"x3 3/8"x76 7/8" (24x86x1952)

QTY	PART NUMBER	DESCRIPTION
4	H100398	T-NUT 1/4 BLK
4	H100171	BOLT WH 1/4x1 BLK

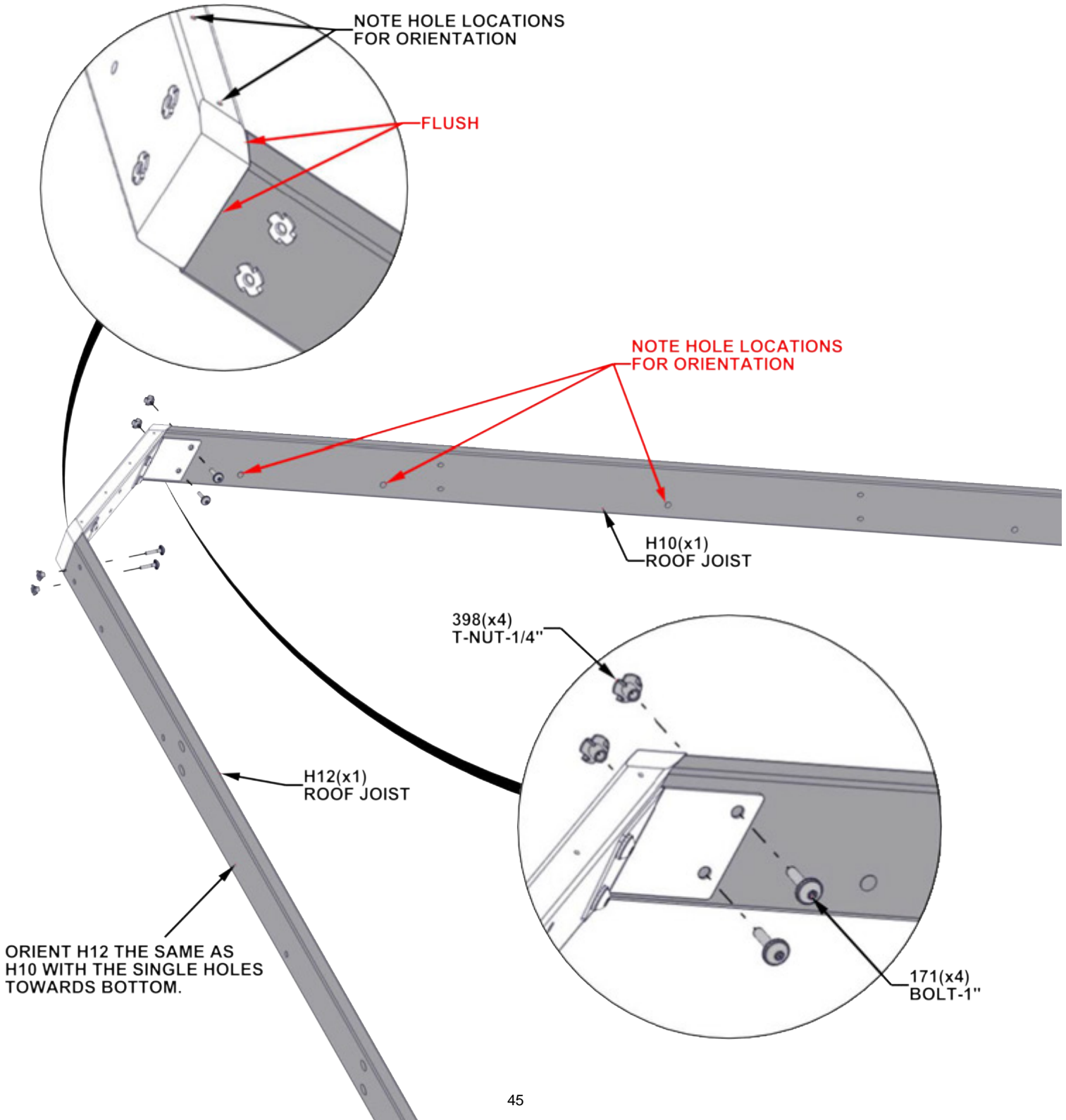

STEP 24 - 10FT ROOF PANEL ASSEMBLY



E09 | RAFTER- W4L16298
(1) | 1 3/8"x3 3/8"x55 13/16" (36x86x1417)



E07 | RAFTER- W4L17401
(1) | 1 3/8"x3 3/8"x42 7/8" (36x86x1087)



E12 | RAFTER - W4L16302
(1) | 1 3/8"x3 3/8"x21 3/4" (36x86x553)



E05 | RAFTER - W4L17402
(1) | 1 3/8"x3 3/8"x42 7/8" (36x86x1087)

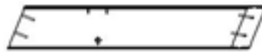

E10 | RAFTER- W4L16300
(1) | 1 3/8"x3 3/8"x21 3/4" (36x86x553)

QTY	PART NUMBER	DESCRIPTION
10	H101030	SCREW 2" CONFIRMAT BLK

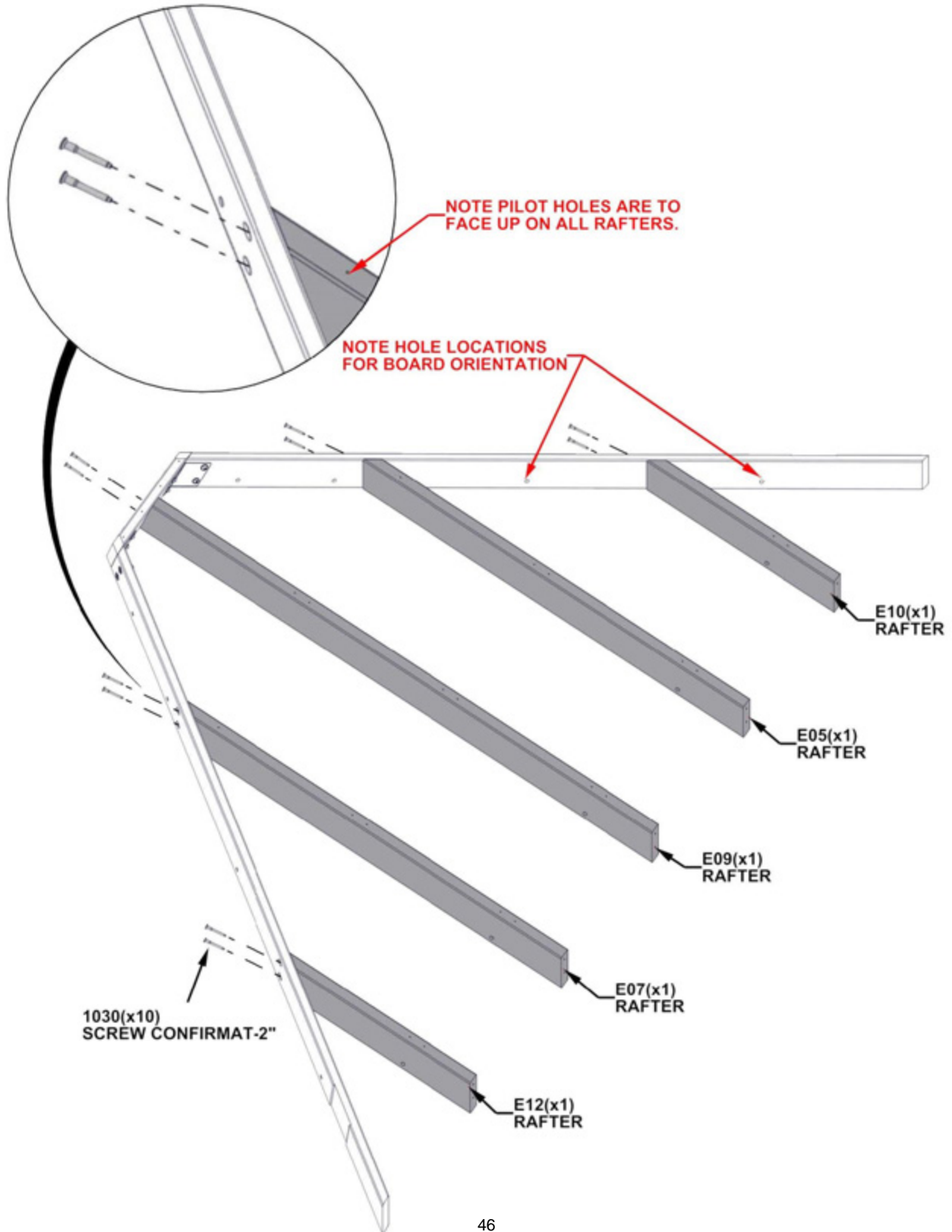

STEP 25A - 10FT ROOF PANEL ASSEMBLY

:	:	:	:
---	---	---	---

Q02 | ROOF JOIST-W4L16307
(2) | 1"x4 7/16"x61 1/2" (24x112x1562)

QTY	PART NUMBER	DESCRIPTION
4	H100382	SCREW PFH 8x1 3/4 BLK
10	H101030	SCREW 2" CONFIRMAT BLK

TIP:

- RAFTERS MAY NEED TO BE LOOSENED TO ATTACH Q02 TO H12/H10

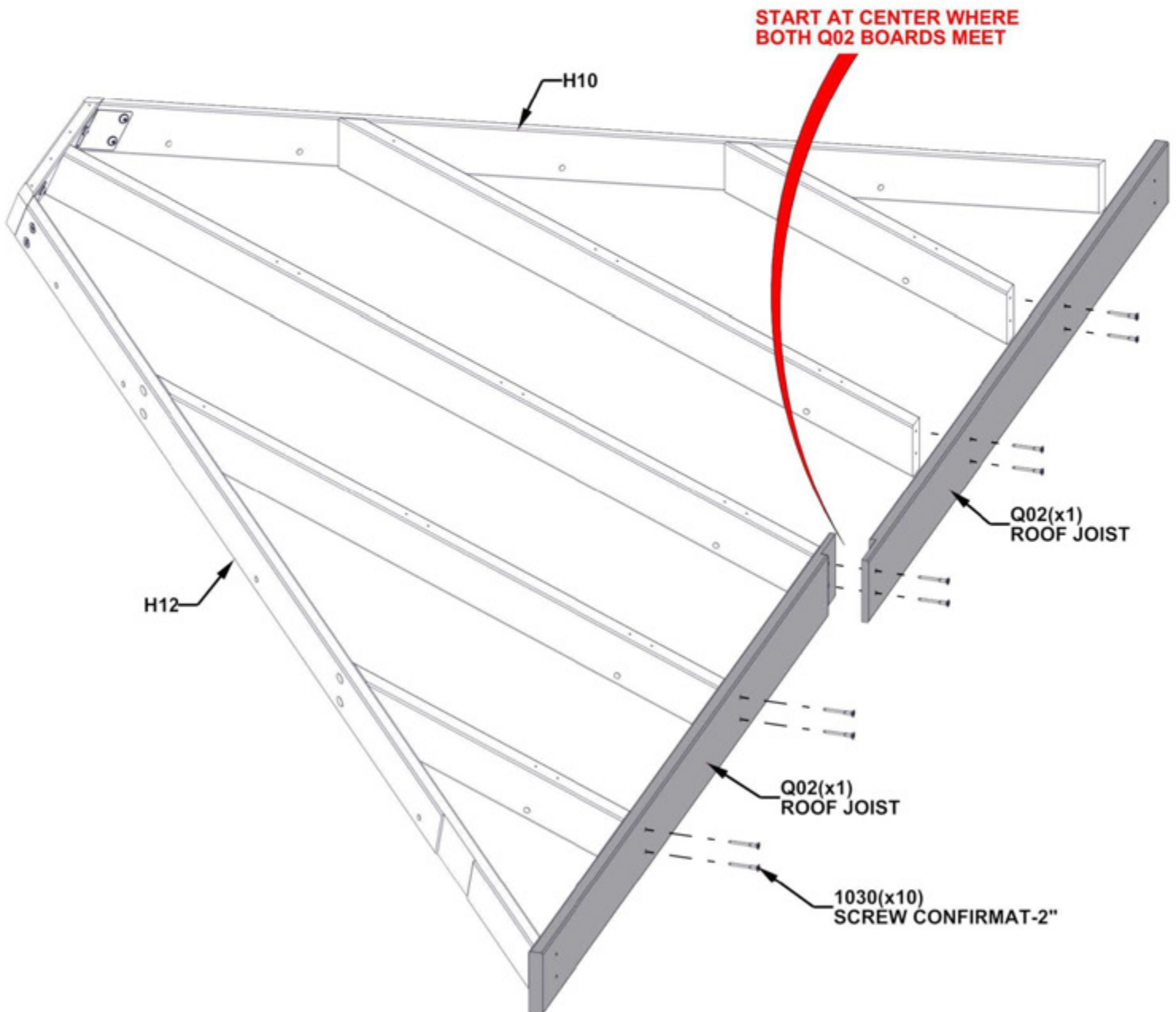

STEP 25B - 10FT ROOF PANEL ASSEMBLY

- USING THE Q02 BOARD AS A GUIDE AND A 1/8" DRILL BIT, DRILL PILOT HOLES INTO THE H12 BOARD USING THE DIMENSION BELOW.
- REPEAT ON OPPOSITE END WITH H10 BOARD.

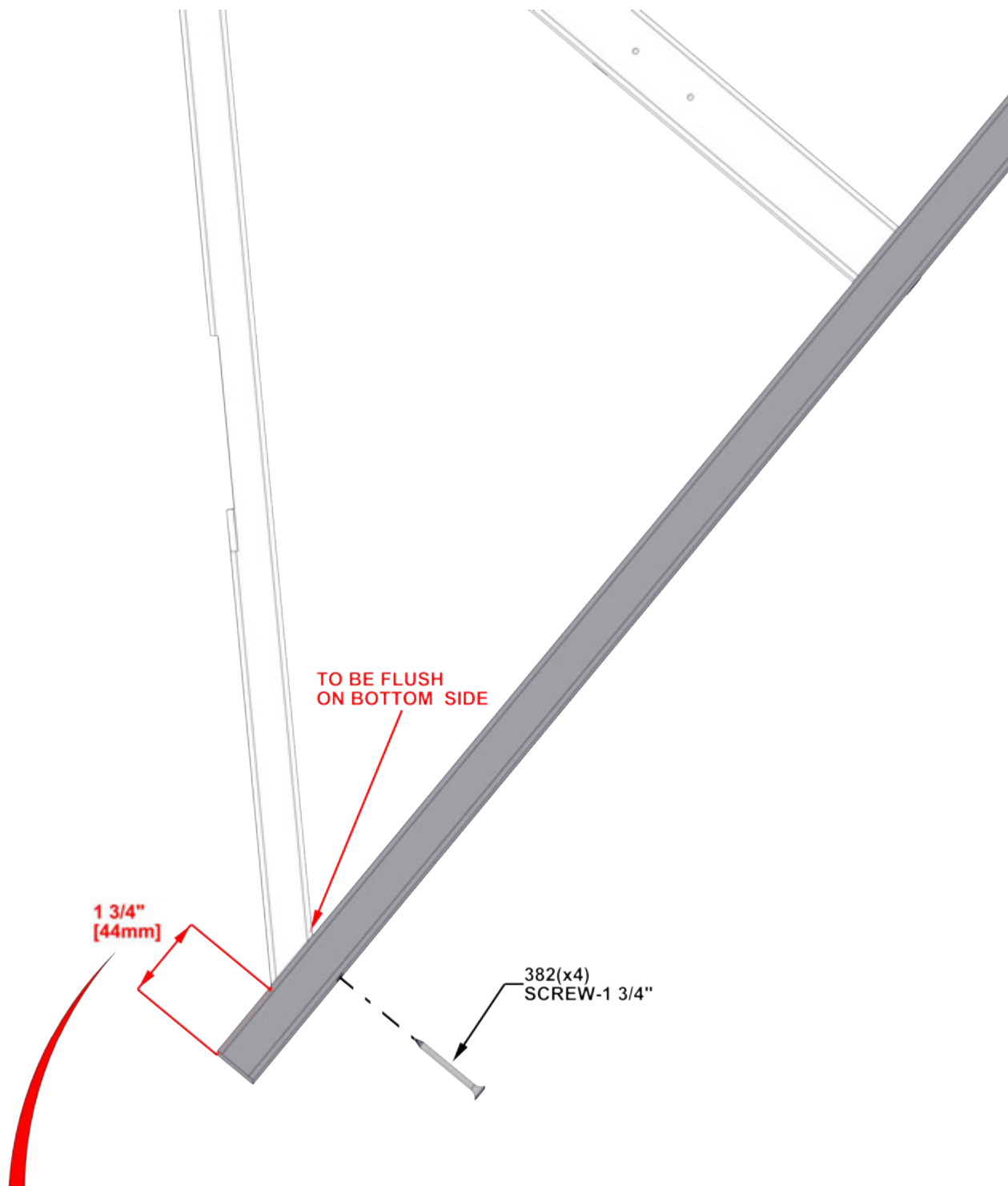

THIS DIMENSION IS CRITICAL TO THE PANEL ASSEMBLY

STEP 25C - 10FT ROOF PANEL ASSEMBLY

TIP:

- LOOSEN HARDWARE TO ADJUST FOR SQUARING IF NEEDED

CRITICAL:

- SQUARE UNIT BEFORE PROCEEDING TO NEXT STEPS.
- THE BELOW DIMENSIONS ARE CRITICAL TO THE FINAL ROOF ASSEMBLY.
- MEASUREMENTS SHOULD BE WITHIN +/- 1/4".
- MEASUREMENTS OUTSIDE OF TOLERANCE WILL LEAD TO THE INABILITY TO ASSEMBLE THE ROOF.

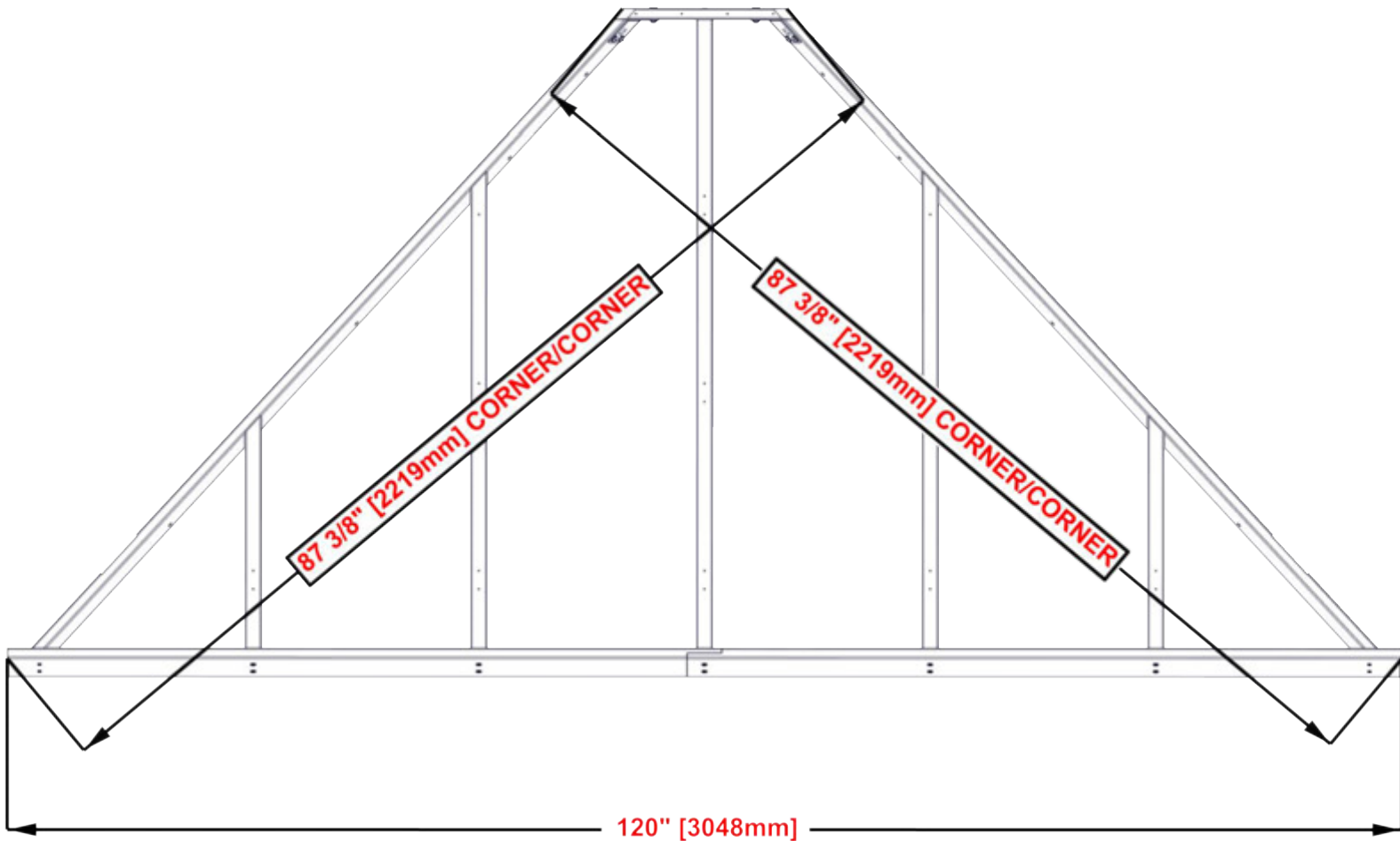

STEP 26 - 10FT ROOF PANEL ASSEMBLY

H13 | ROOF JOIST - W4L16303
(1) | 1"x3 3/8"x20 1/4" (24x86x514)

H14 | PURLIN - W4L16304
(1) | 1"x3 3/8"x50 1/16" (24x86x1272)

H15 | PURLIN - W4L16305
(1) | 1"x3 3/8"x79 7/8" (24x86x2030)



H16 | PURLIN - W4L16922
(2) | 1"x3 3/8"x56" (24x86x1423)

Qty	PART NUMBER	DESCRIPTION
38	H100391	SCREW PFH 8 X 2 BLK

- TIPS:**
- ALIGN PURLIN PILOT HOLES WITH RAFTER PILOT HOLES
 - ATTACH SCREWS FROM THE CENTER AND WORK OUTWARD
 - H12 AND H10 BOARDS DO NOT HAVE PILOT HOLES FOR OUTSIDE EDGE SCREWS.
 - USING THE PURLINS AS A GUIDE AND A 1/8" DRILL BIT, DRILL PILOT HOLES INTO H12/H10 BOARDS.

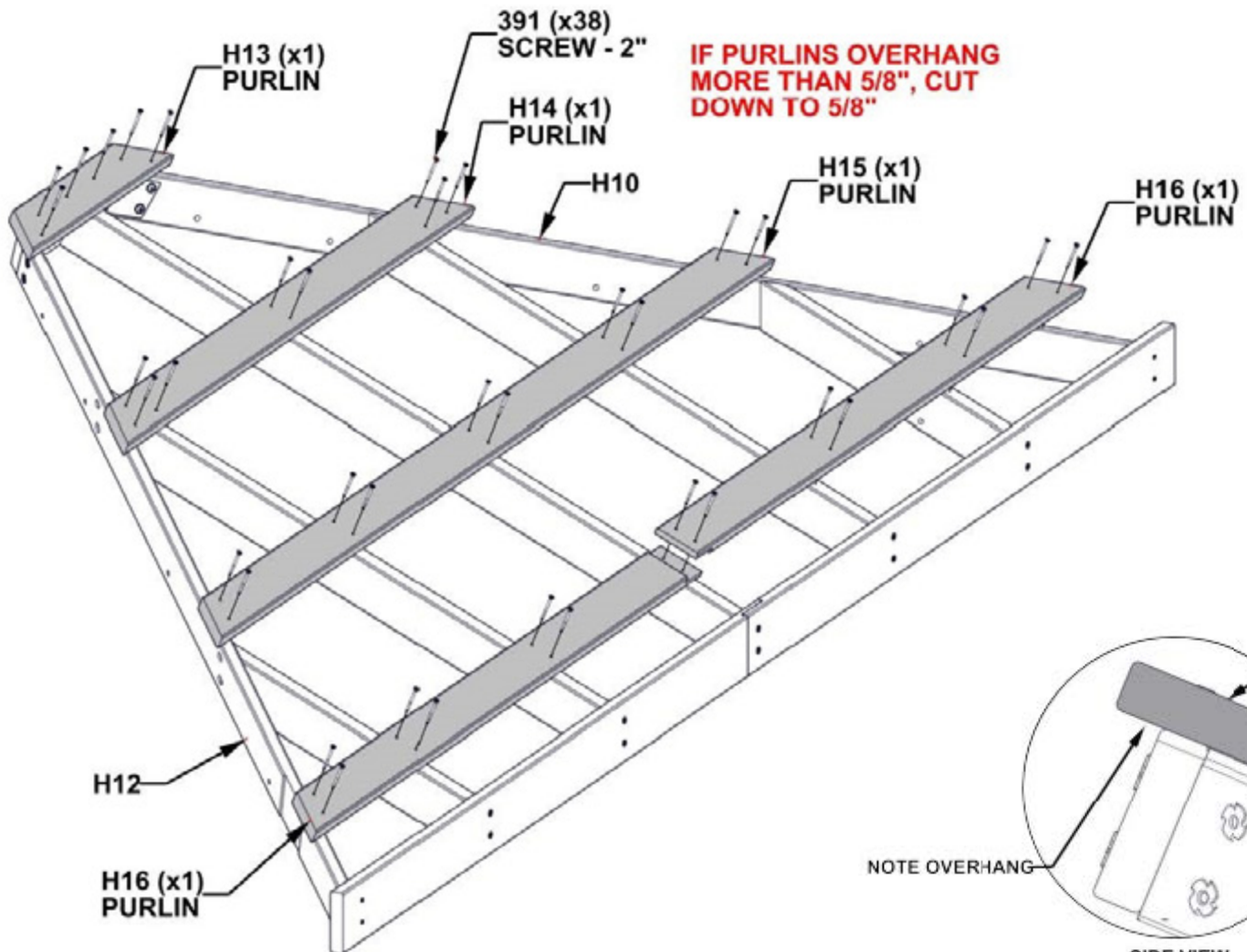
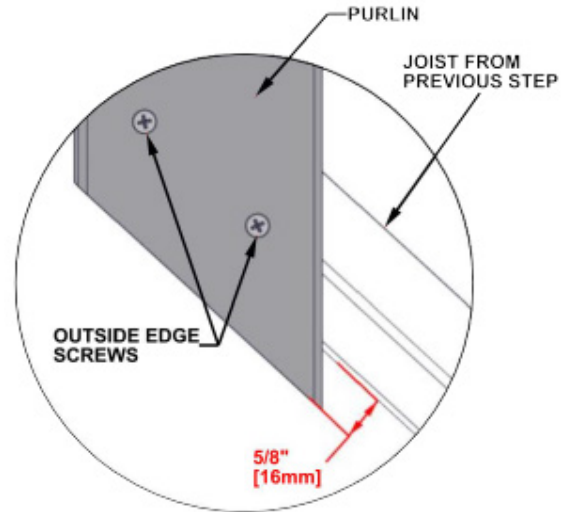

STEP 27 - 10FT ROOF PANEL ASSEMBLY

QTY	PART NUMBER	DESCRIPTION
12	H100833	SCREW WOODGRIP 10-16x3/4"

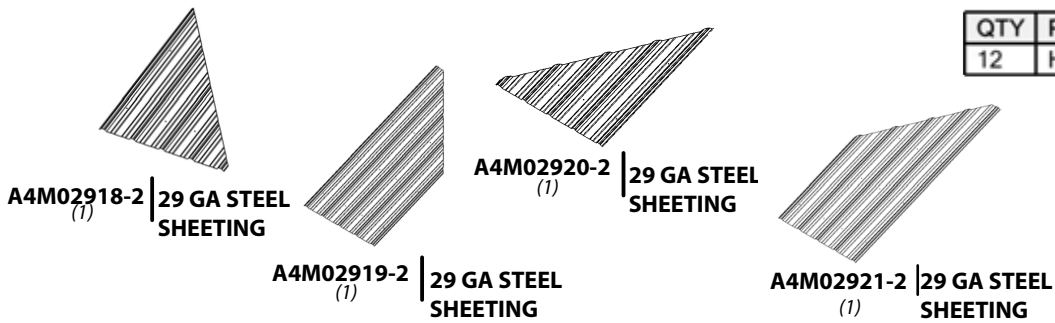

TIPS:

- REMOVE PROTECTIVE BLUE FILM
- STARTING IN THE CENTER, PLACE PANELS AS SHOWN BELOW.
- OVERLAP PANELS BY ONE RIDGE.
- PANELS SHOULD BE FLUSH WITH PURLIN ENDS AND Q02 ROOF JOIST.
- ONCE SHEETING IS IN PLACE, IT IS RECOMMENDED TO ADD H100833 SCREWS IN THE MIDDLE TO HOLD SHEETING FOR THE NEXT STEP.

WARNING: GLOVES ARE RECOMMENDED WHEN HANDLING STEEL ROOF PIECES

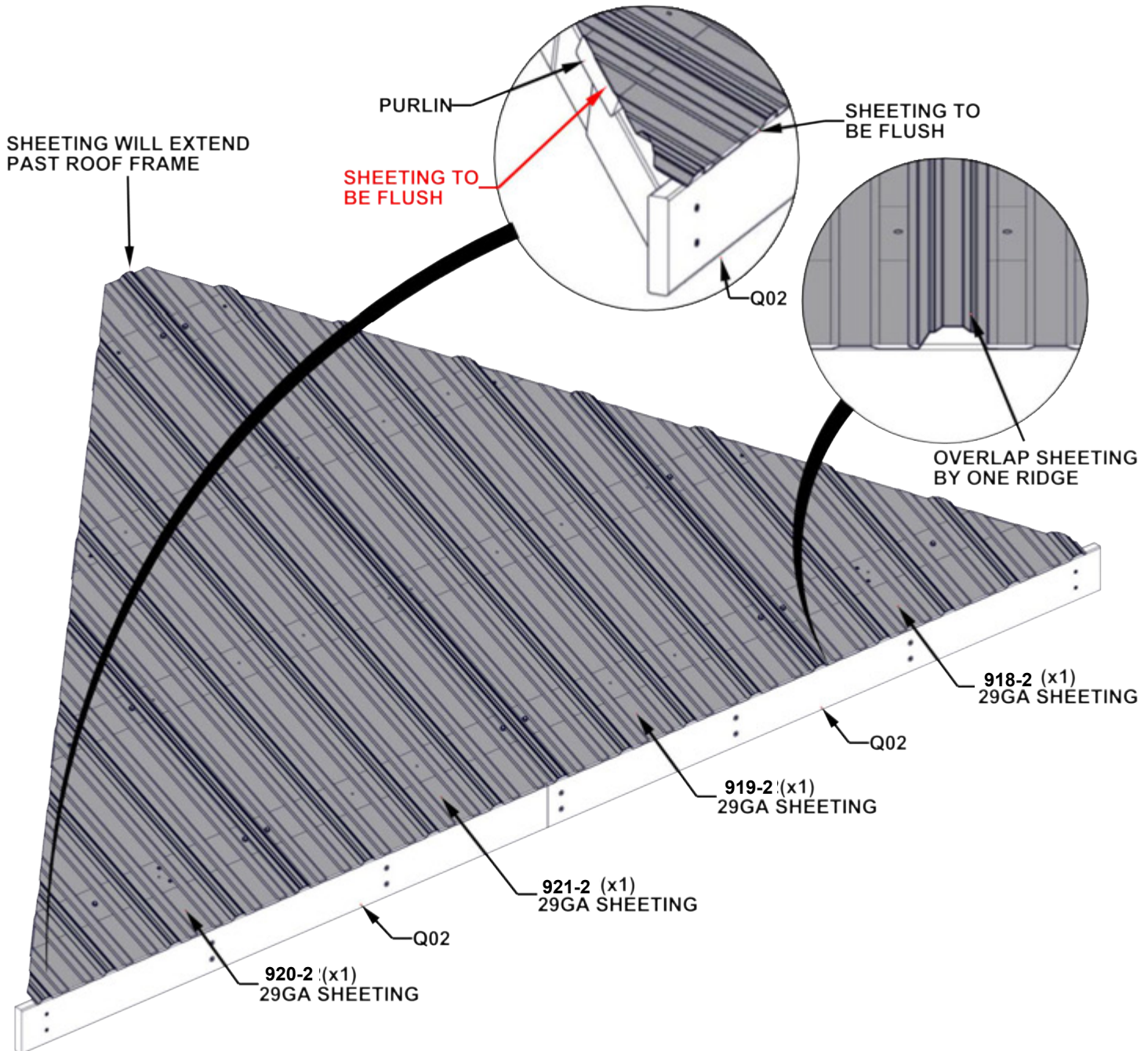

STEP 28 - 10FT ROOF PANEL ASSEMBLY

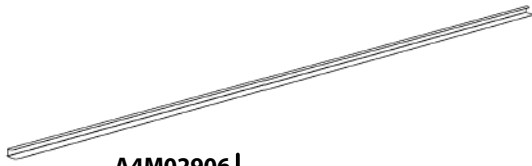

A4M02906 | RIDGE CAP CHANNEL
(2)

QTY	PART NUMBER	DESCRIPTION
8	H100833	SCREW WOODGRIP 10-16x3/4"

TIPS:

- POSITION THE RIDGE CAP CHANNEL OVER THE EDGE OF THE ROOF PANELS WITH THE WIDER SIDE OF THE CHANNEL ON THE BOTTOM.
- MAKE SURE THE PANELS ARE FULLY SEATED INTO THE CHANNEL.
- FLUSH THE TOP OF THE CHANNEL WITH THE TOP OF THE METAL PANELS.

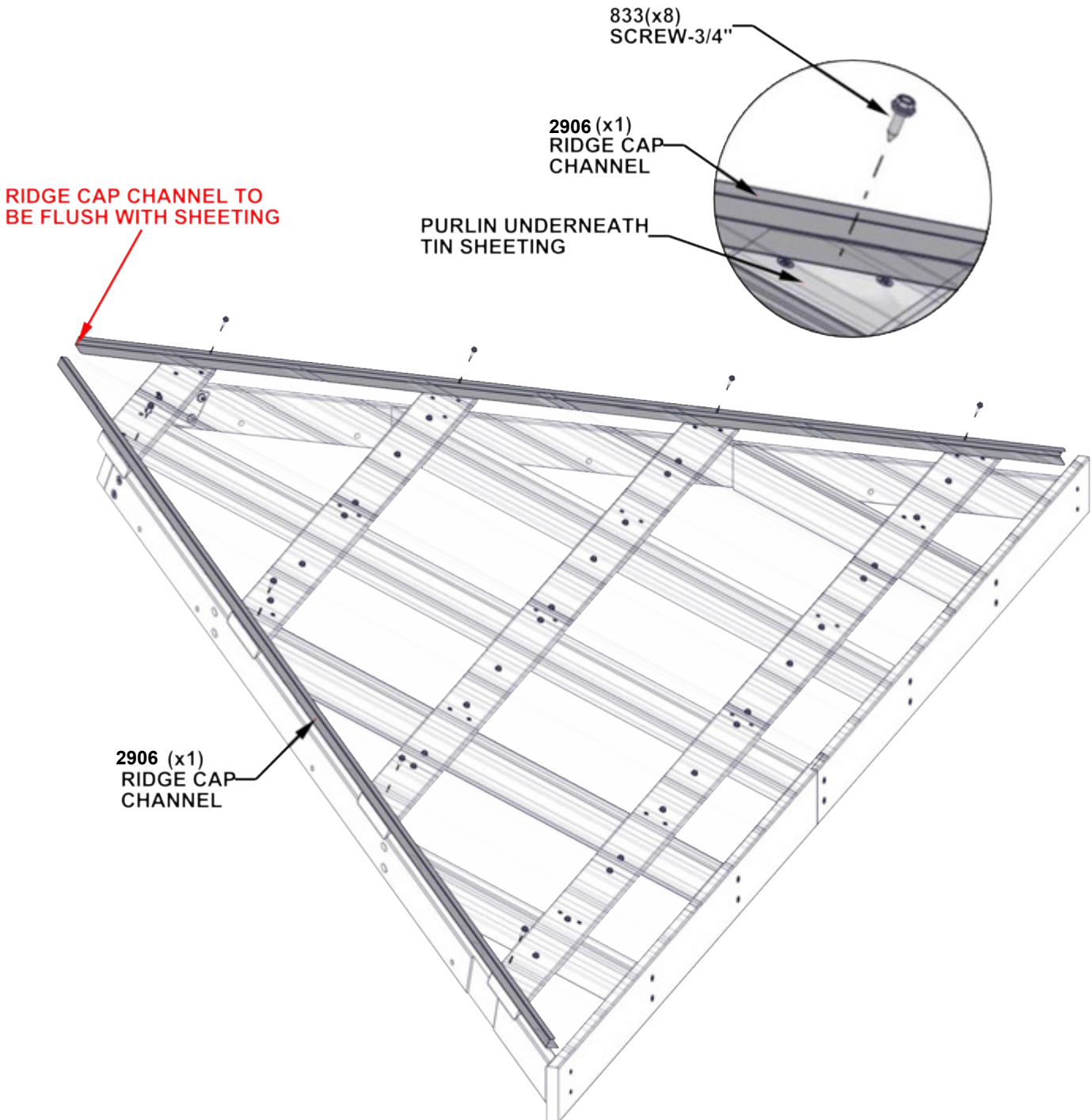

STEP 29 - 10FT ROOF PANEL ASSEMBLY

QTY	PART NUMBER	DESCRIPTION
20	H100833	SCREW WOODGRIP 10-16x3/4"

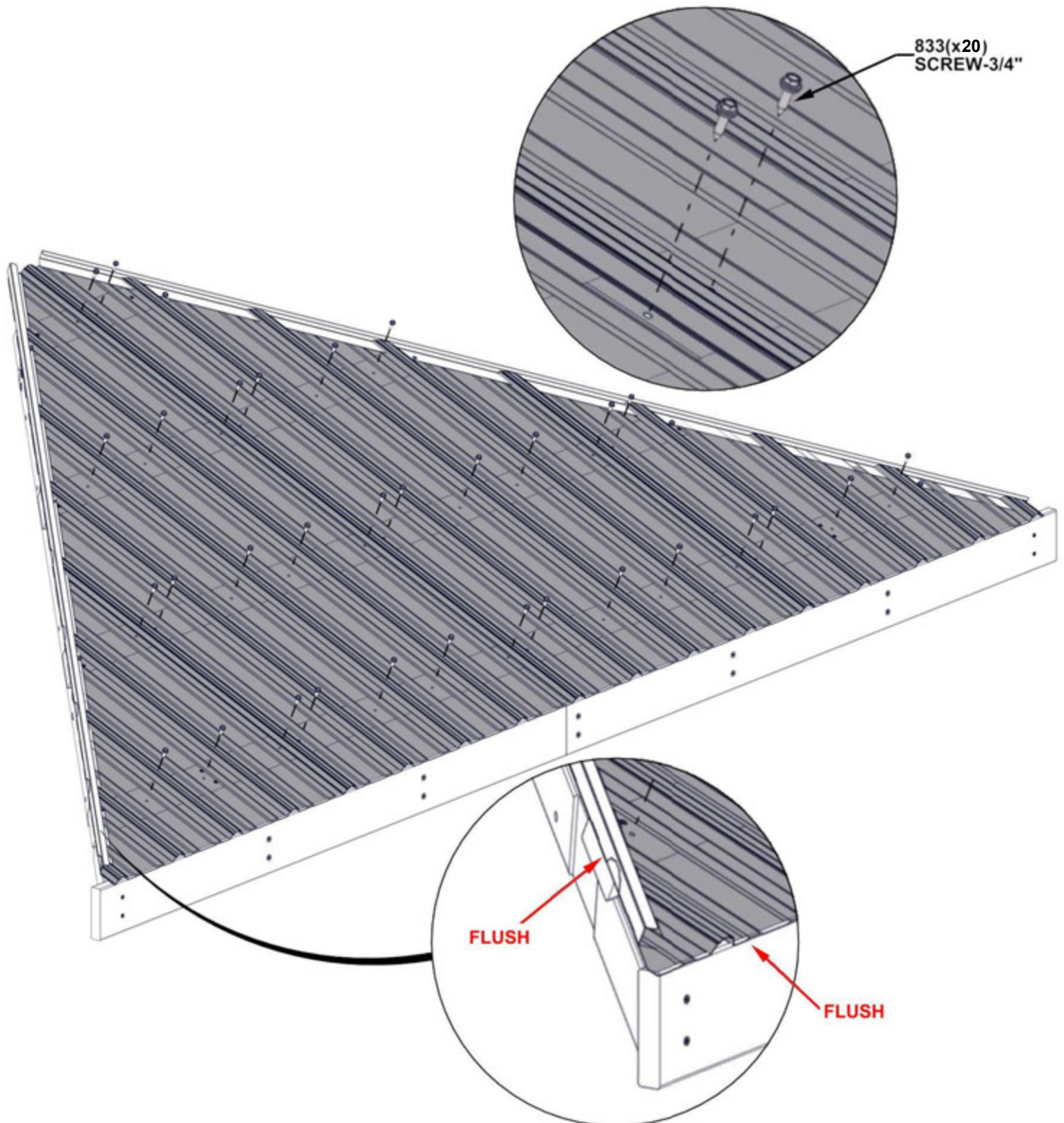

**REPEAT 10FT ROOF PANEL
ASSEMBLY STEPS 22 THROUGH 29**

STEP 30 - 10FT ROOF PANEL ATTACHMENT

TIPS:

- THREE PEOPLE ARE HELPFUL FOR THIS STEP.
- POSITION A PERSON ON A LADDER IN THE CENTER OF THE GAZEBO TO HELP SUPPORT THE ROOF PANEL.
- WITH TWO PEOPLE, WORK THE PANEL UP WITHOUT SLIDING OR DRAGGING, UNTIL IT MEETS THE ROOF SUPPORT FRAME.
- MAKE SURE THE ROOF PANEL SLIDES UNDERNEATH THE RIDGE CAP.

WARNING: GLOVES ARE RECOMMENDED WHEN HANDLING STEEL ROOF PIECES

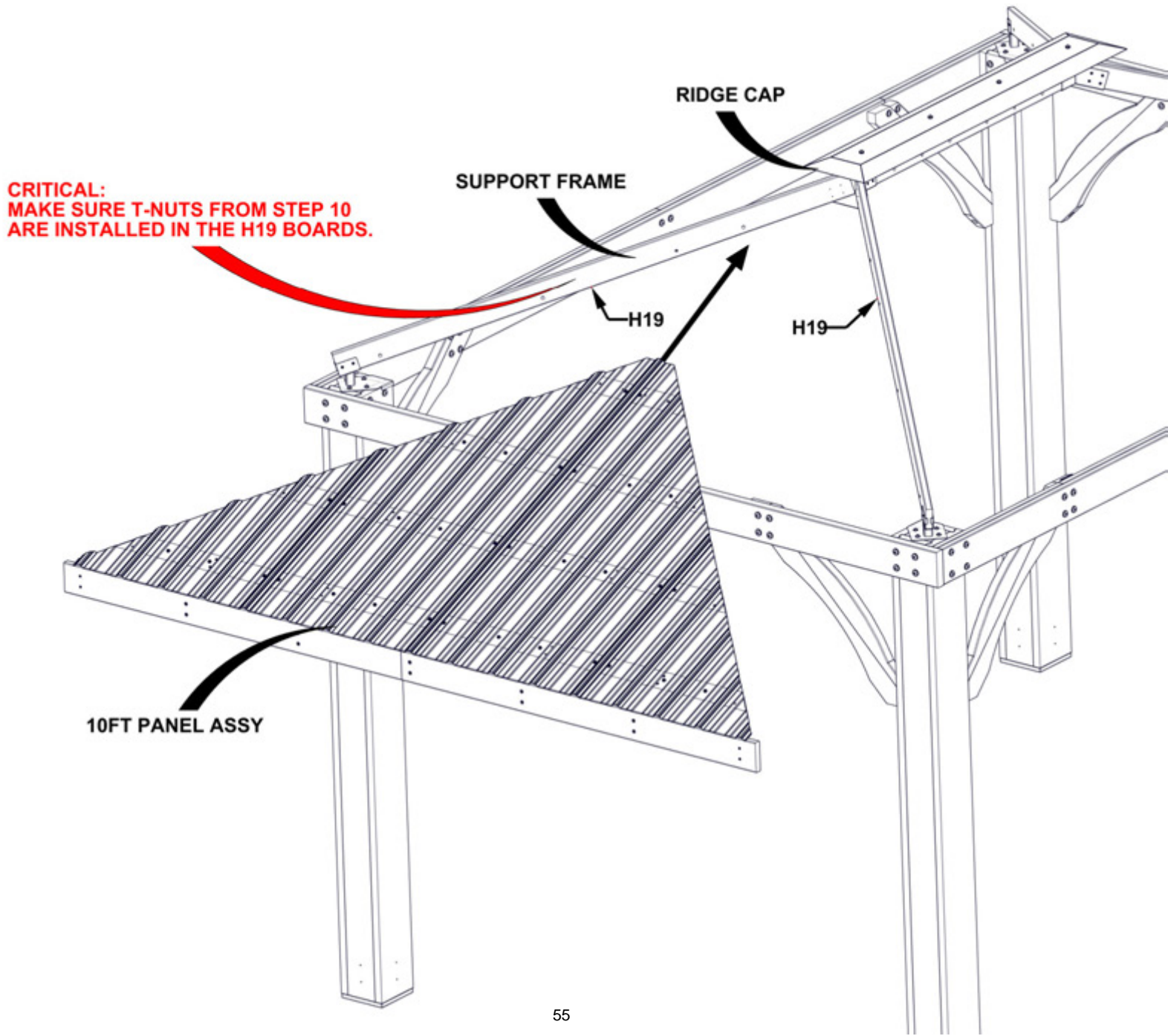

STEP 31 - 10FT ROOF PANEL ATTACHMENT

QTY	PART NUMBER	DESCRIPTION
2	H100198	WASHER LOCK EXT 8X19 BLK
2	H100378	BOLT WH 5/16x1 3/4 BLK

- TIPS:**
- IF NECESSARY, USE A LONG SCREWDRIVER OR CLAMPS TO HOLD PANELS IN PLACE.
 - INSERT BOLTS INTO THE SECOND HOLE FROM THE TOP OF THE H10 & H12 BOARDS.

HAND TIGHTEN ONLY

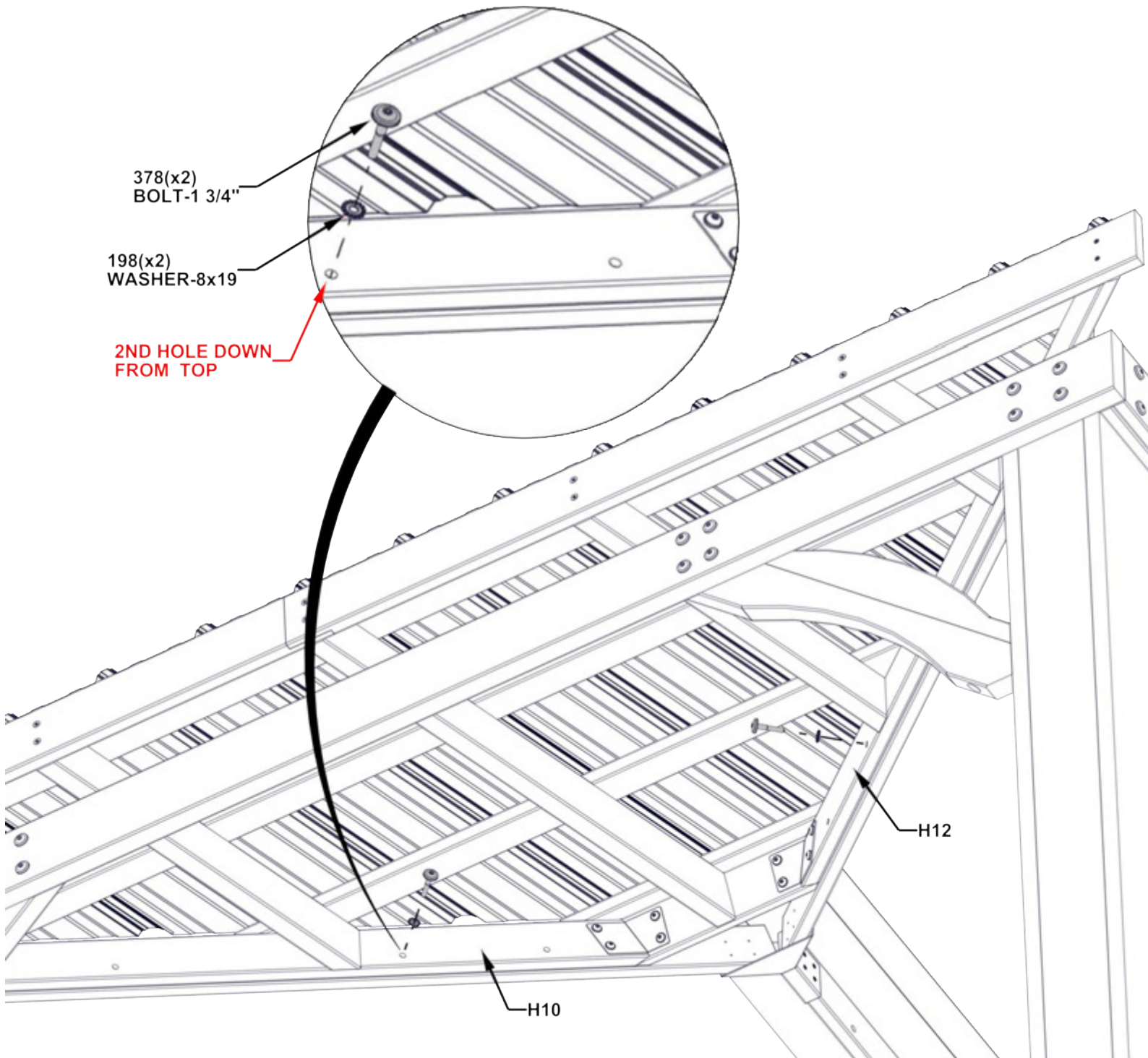

**REPEAT 10FT ROOF PANEL INSTALLATION
STEPS 30 & 31**

STEP 32 - 14FT ROOF PANEL ATTACHMENT

TIPS:

- THREE PEOPLE ARE HELPFUL FOR THIS STEP.
- POSITION A PERSON ON A LADDER IN THE CENTER OF THE GAZEBO TO HELP SUPPORT THE ROOF PANEL.
- WITH TWO PEOPLE, WORK THE PANEL UP, WITHOUT SLIDING OR DRAGGING, UNTIL IT MEETS THE ROOF SUPPORT FRAME.
- MAKE SURE THE ROOF PANEL SLIDES UNDERNEATH THE RIDGE CAP.

WARNING: GLOVES ARE RECOMMENDED WHEN HANDLING STEEL ROOF PIECES

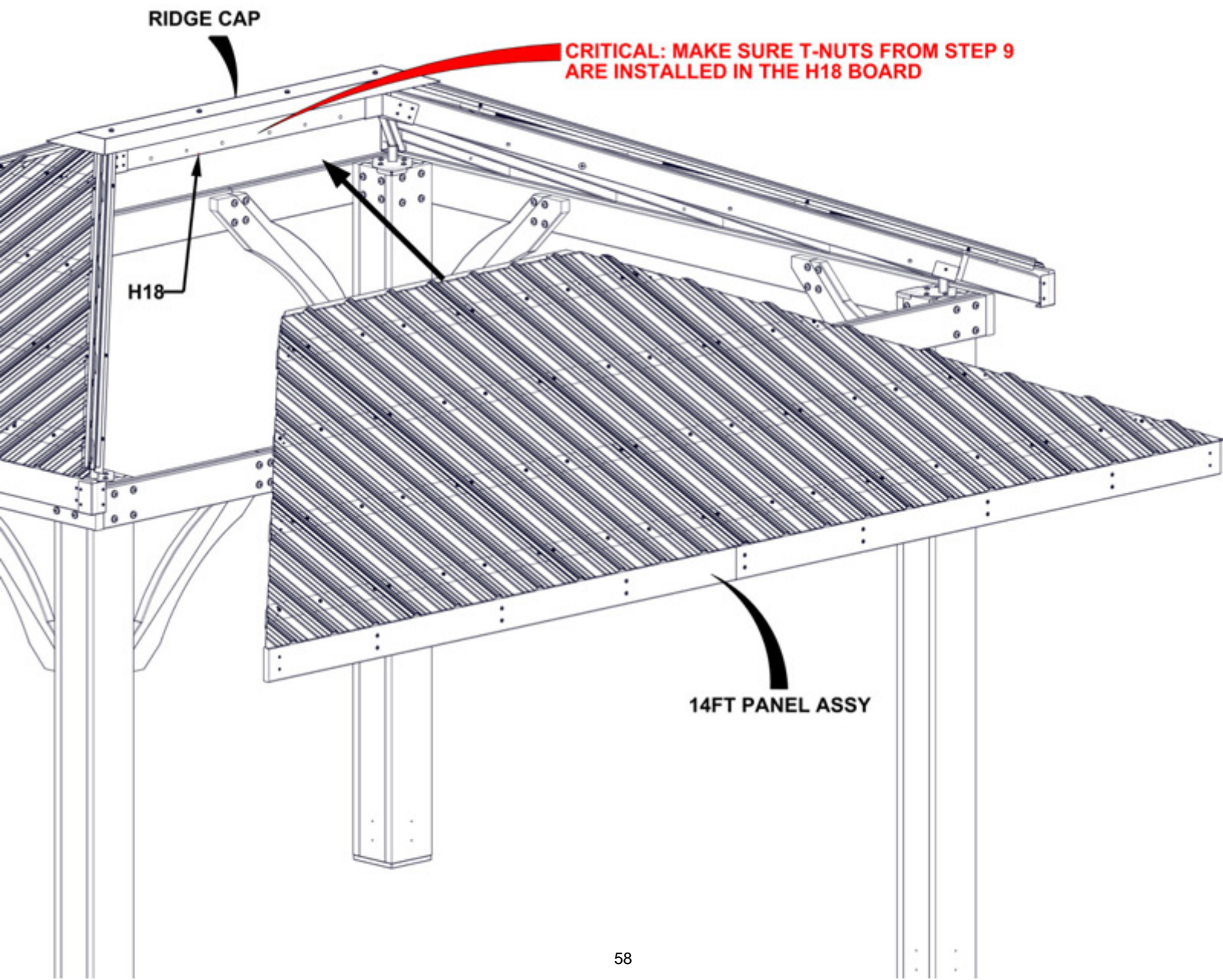

STEP 33 - 14FT ROOF PANEL ATTACHMENT

QTY	PART NUMBER	DESCRIPTION
2	H100198	WASHER LOCK EXT 8x19
2	H100378	BOLT WH 5/16x1 3/4 BLK

- TIPS:
- IF NECESSARY, USE A LONG SCREWDRIVER OR CLAMPS TO HOLD PANELS IN PLACE.

HAND TIGHTEN ONLY

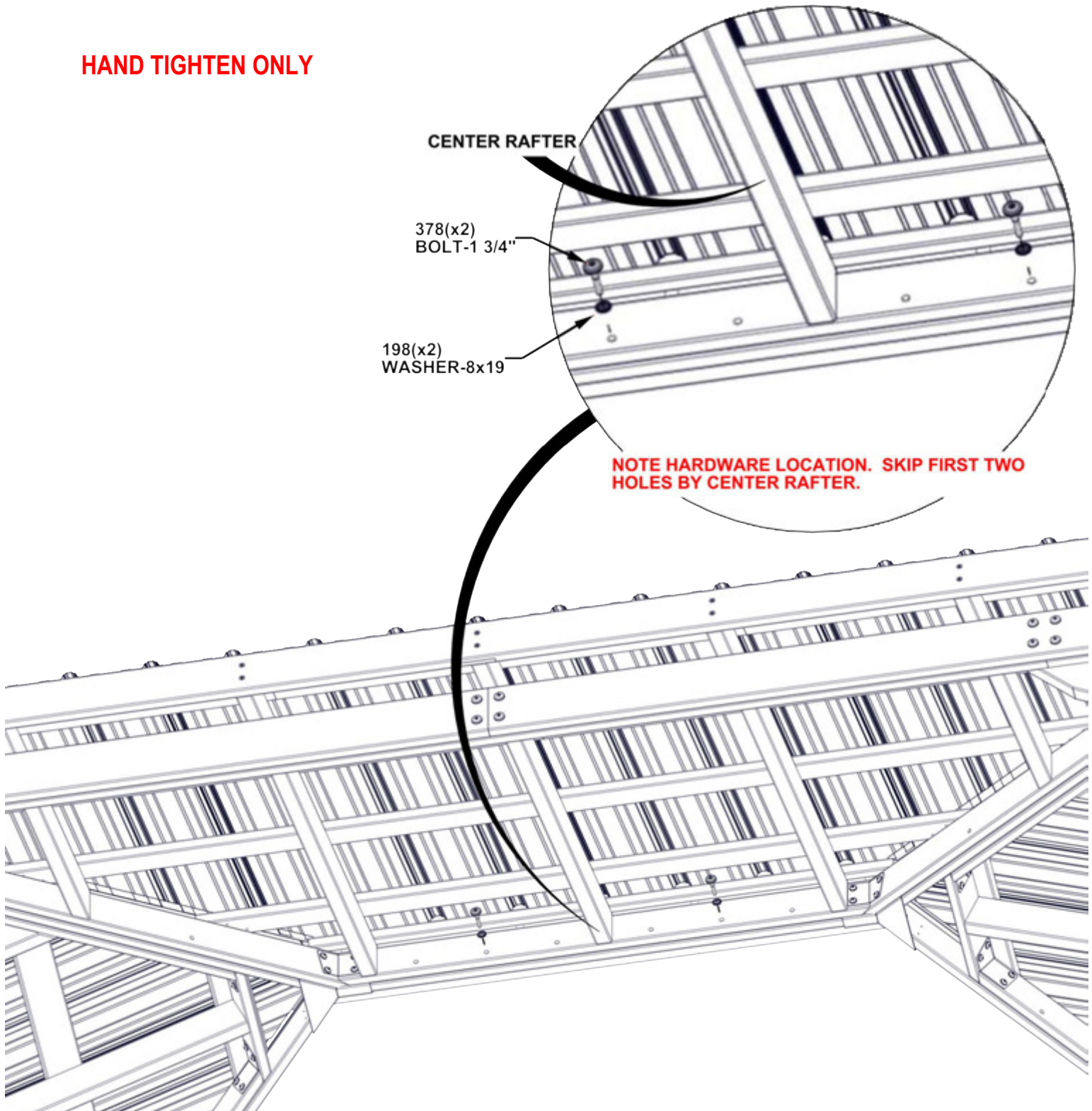

STEP 34A - ROOF PANEL ATTACHMENT

QTY	PART NUMBER	DESCRIPTION
4	H100198	WASHER LOCK EXT 8X19 BLK
4	H100770	WASHER FLAT 5/16 BLK
4	H100479	NUT LOCK 5/16 BLK
4	H100415	BOLT WH 5/16X3 3/4 BLK

TIPS:

- REPEAT STEPS 32 FOR SECOND 14FT ROOF PANEL.
- IF NECESSARY USE A LONG SCREWDRIVER OR CLAMPS TO HOLD PANEL IN PLACE.

HAND TIGHTEN ONLY

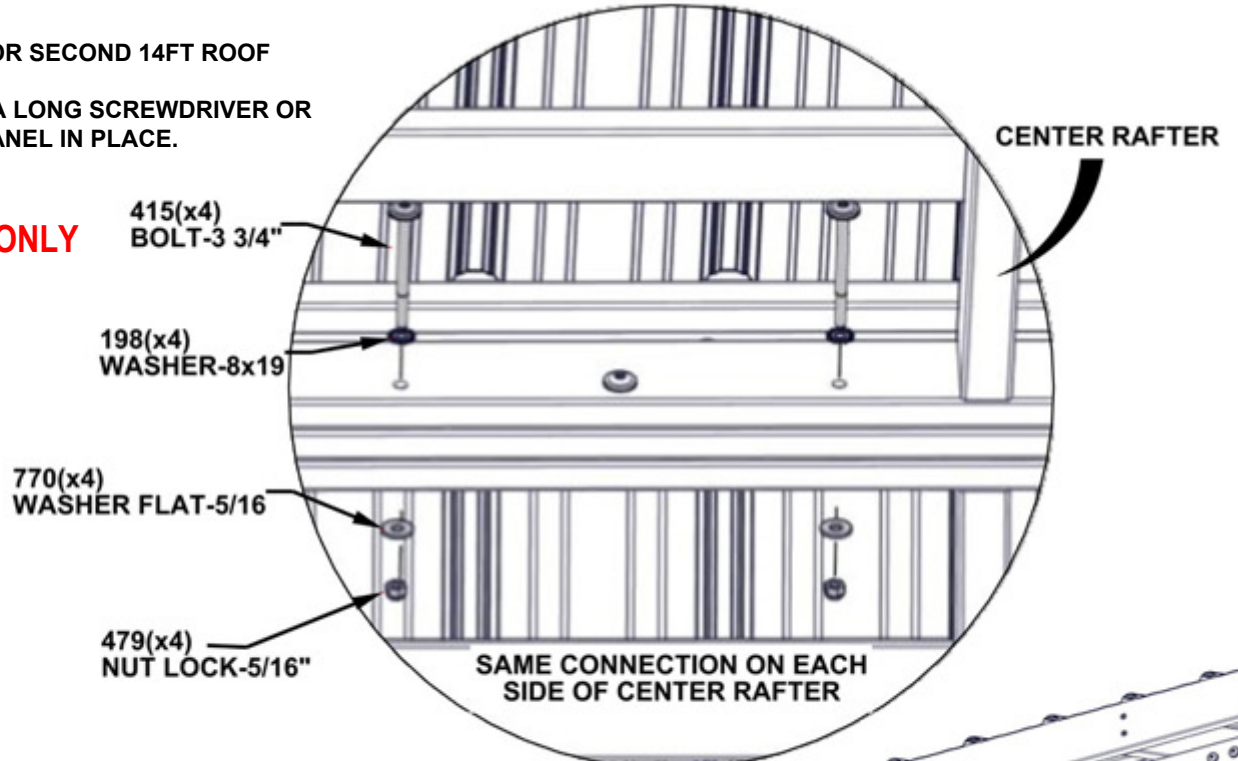

STEP 34B - ROOF PANEL ATTACHMENT

QTY	PART NUMBER	DESCRIPTION
12	H100198	WASHER LOCK EXT 8X19 BLK
12	H100770	WASHER FLAT 5/16 BLK
12	H100479	NUT LOCK 5/16 BLK
12	H100415	BOLT WH 5/16x3 3/4 BLK

HAND TIGHTEN ONLY

IF THE HOLES ARE SLIGHTLY UNALIGNED, DRIVE THE BOLT THROUGH THE (3) BOARDS USING A DRILL. THIS WILL ENABLE THE BOLTS TO SCREW INTO THE HOLES.

770(x3)
WASHER FLAT-5/16"

479(x3)
NUT LOCK-5/16"

198(x3)
WASHER-8x19

415(x3)
BOLT-3 3/4"

REPEAT ON ALL FOUR
DIAGONAL ROOF JOISTS

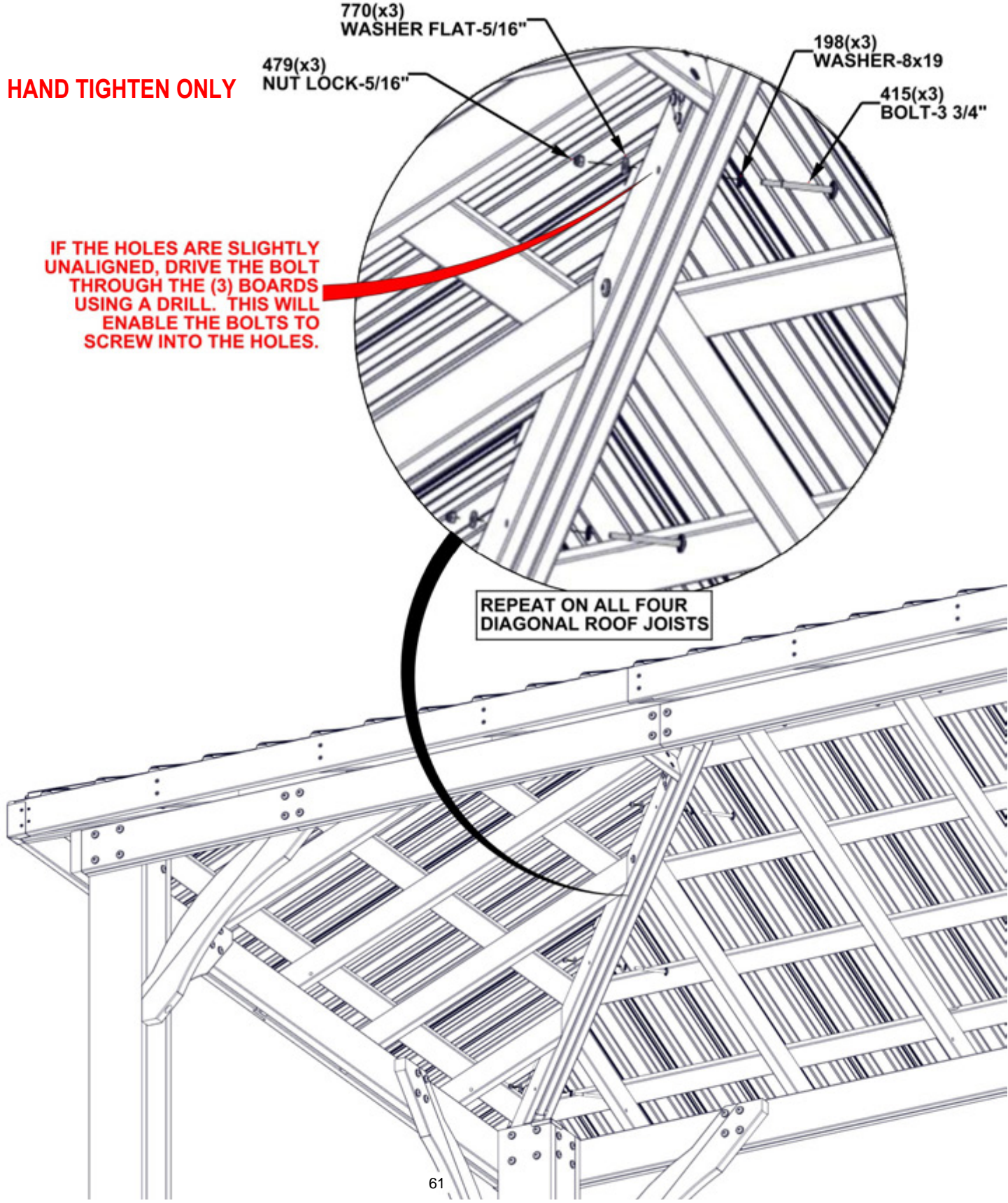

STEP 35 - ROOF PANEL ATTACHMENT

**TIGHTEN ALL THE HARDWARE IN THE ORDER SHOWN BELOW.
START AT THE TOP AND WORK YOUR WAY DOWN.**

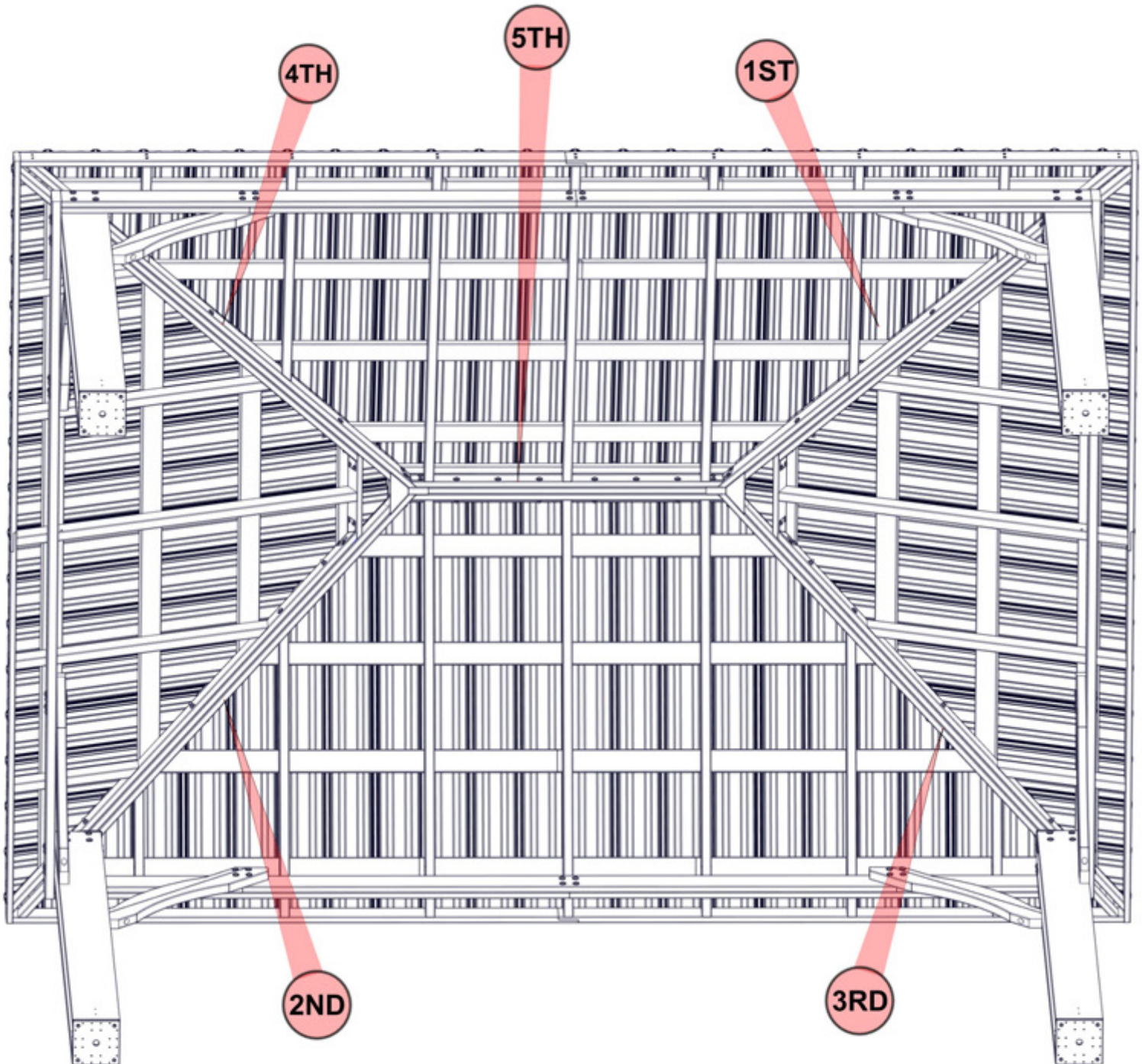

STEP 36 - ROOF ASSEMBLY

QTY	PART NUMBER	DESCRIPTION
18	H100630	WASHER FLAT 8x19 BLK
36	H100536	SCREW PWH 8x1 1/4 BLK
18	H100653	NUT LOCK 1/4 BLK
18	H100488	BOLT WH 1/4x2 BLK

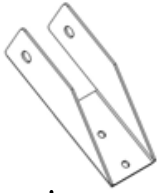

A4M01228 | RAFTER CLIP
(18)

TIPS:

- ATTACH RAFTER CLIPS FIRST WITH 2" BOLTS.
- USING THE BRACKET AS A TEMPLATE AND A 1/8" DRILL BIT, DRILL PILOT HOLES FOR THE H100536 SCREWS.
- DRILL PILOT HOLES APPROXIMATELY 1/2" DEEP.

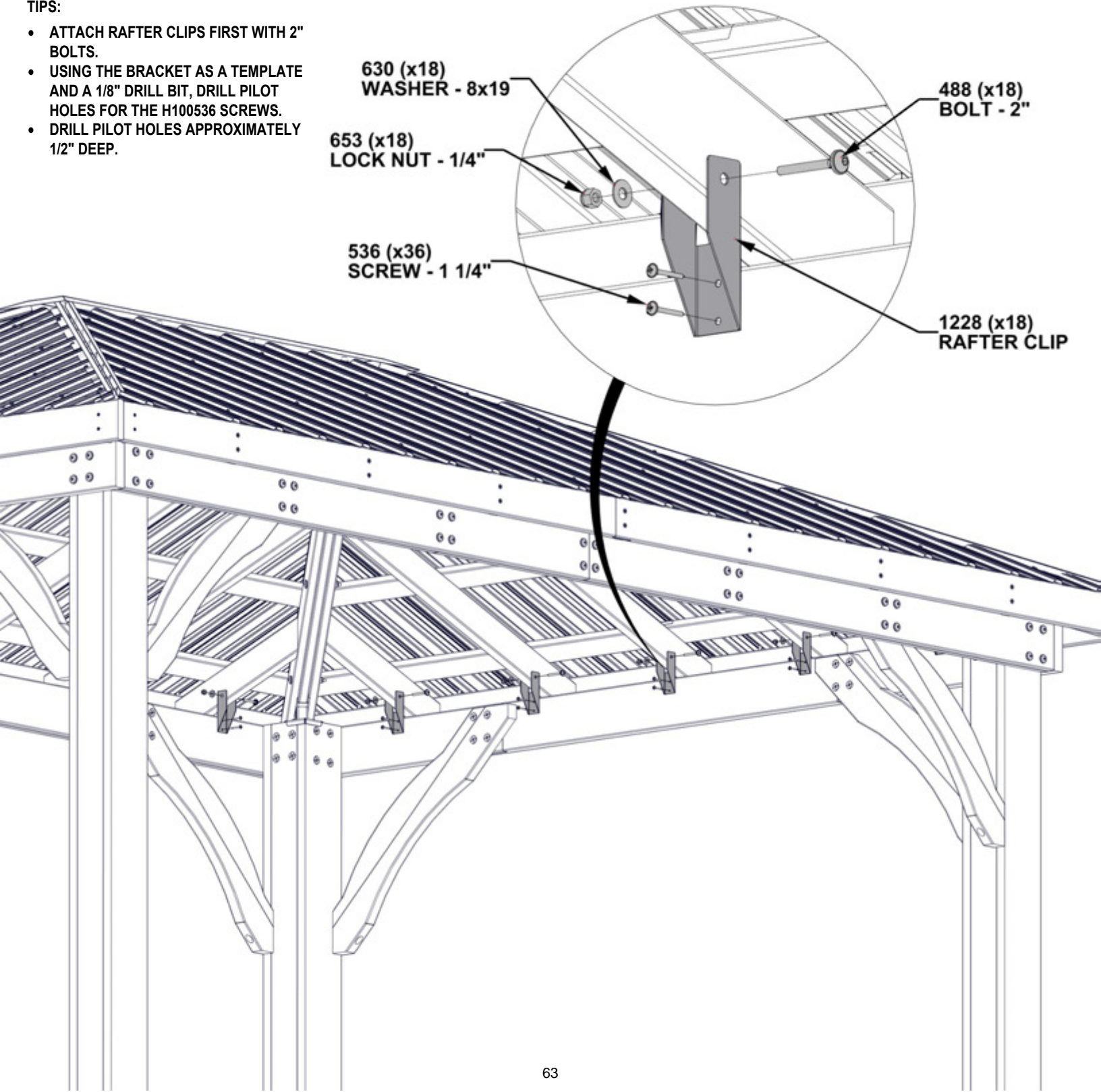

STEP 37 - ROOF ASSEMBLY



QTY	PART NUMBER	DESCRIPTION
16	H100392	SCREW PWH 8x3/4 BLK

A4M01185
(4) CORNER BRACKET

REPEAT ON EACH CORNER

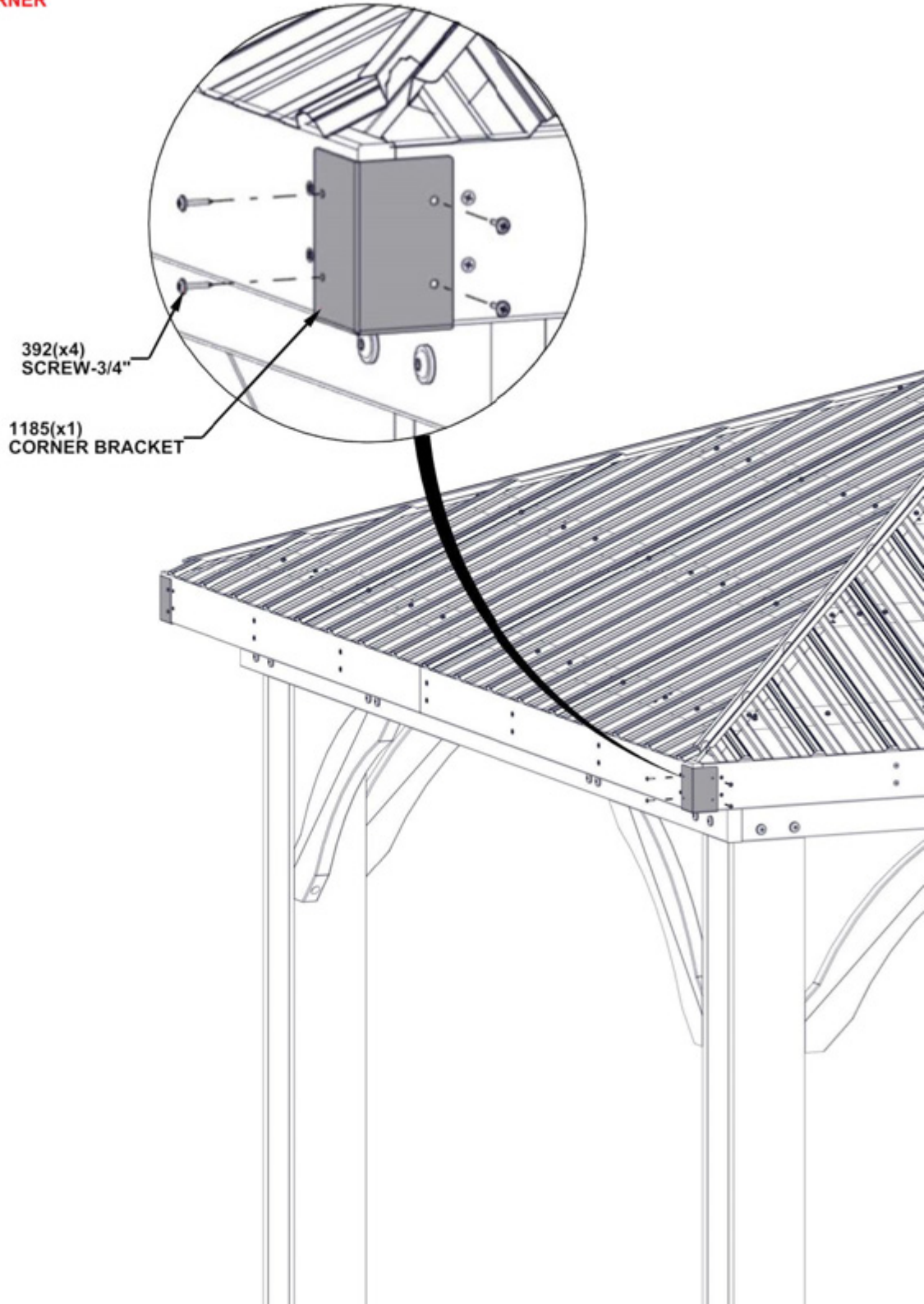

STEP 38 - 14FT ROOF TRIM



A4M02885 (4) | EDGE TRIM LONG

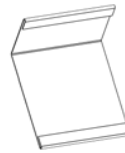

A4M02822 (4) | EDGE TRIM SPLICE

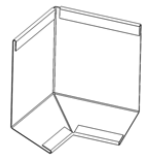

A4M02825 (4) | EDGE TRIM CORNER SPLICE



A4M02869 (2) | EDGE TRIM SHORT

QTY	PART NUMBER	DESCRIPTION
24	H100759	SCREW SELF TAPPING 1/4x3/4

TIPS:

- START ON THE LEFT SIDE OF A 14FT PANEL.
- SLIDE EDGE TRIM PIECES TOGETHER AS SHOWN BELOW.
- MAKE SURE ALL PANELS ARE COVERED BEFORE INSTALLING SCREWS.
- INSTALL H100759 AS SHOWN

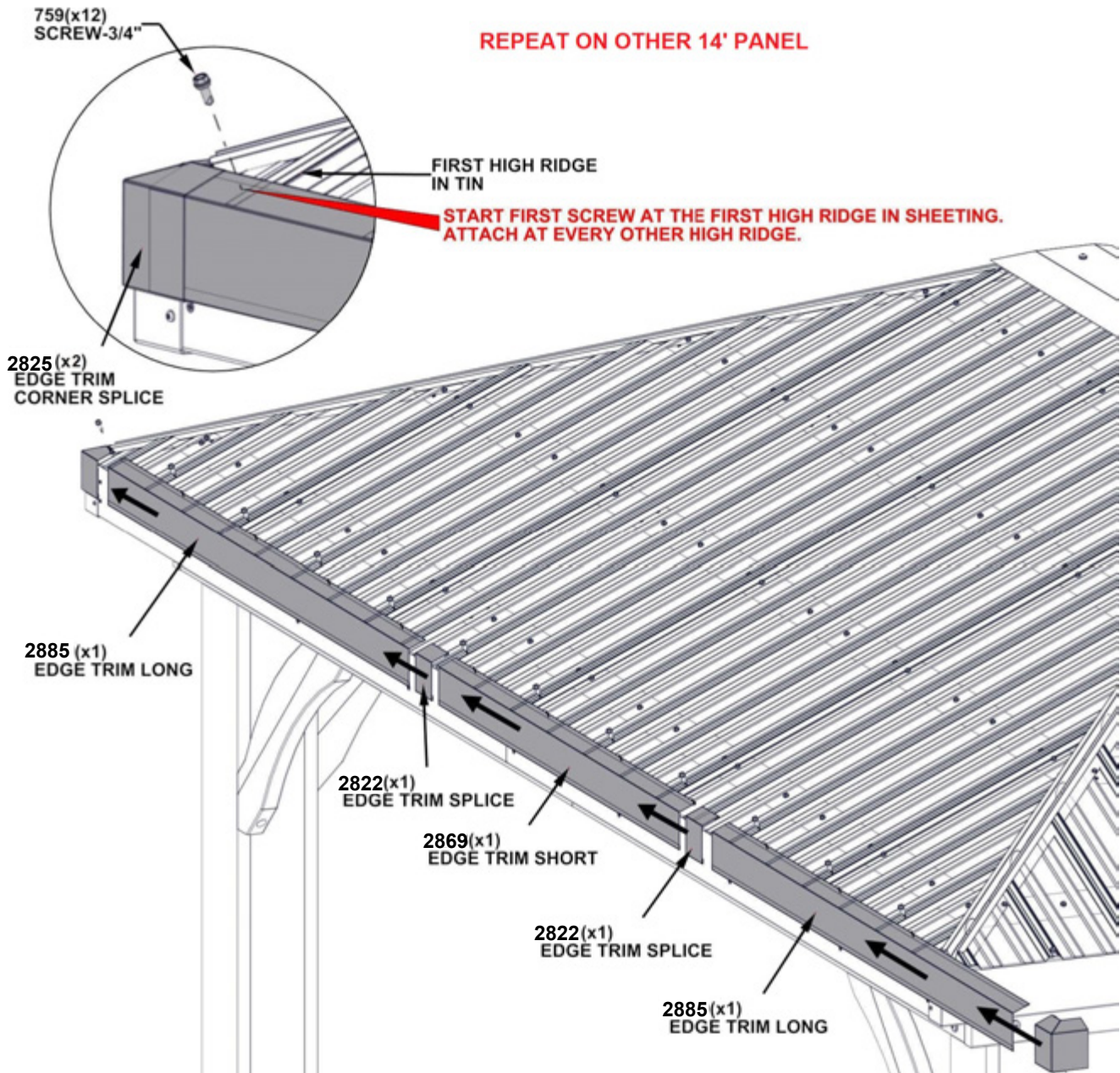

NOTE: EDGE TRIM"2869"IS ONLY USED ON 14FT SIDES IN THE MIDDLE

STEP 39 - 10FT ROOF TRIM

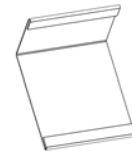

A4M02822 | EDGE TRIM SPLICE
(2)



A4M02885 | EDGE TRIM LONG
(4)

QTY	PART NUMBER	DESCRIPTION
16	H100759	SCREW SELF TAPPING 1/4x3/4

TIPS:

- START ON THE LEFT SIDE OF A 10FT PANEL.
- SLIDE EDGE TRIM PIECES TOGETHER AS SHOWN BELOW.
- MAKE SURE ALL PANELS ARE COVERED BEFORE INSTALLING SCREWS.
- INSTALL H100759 SCREWS AS SHOWN.

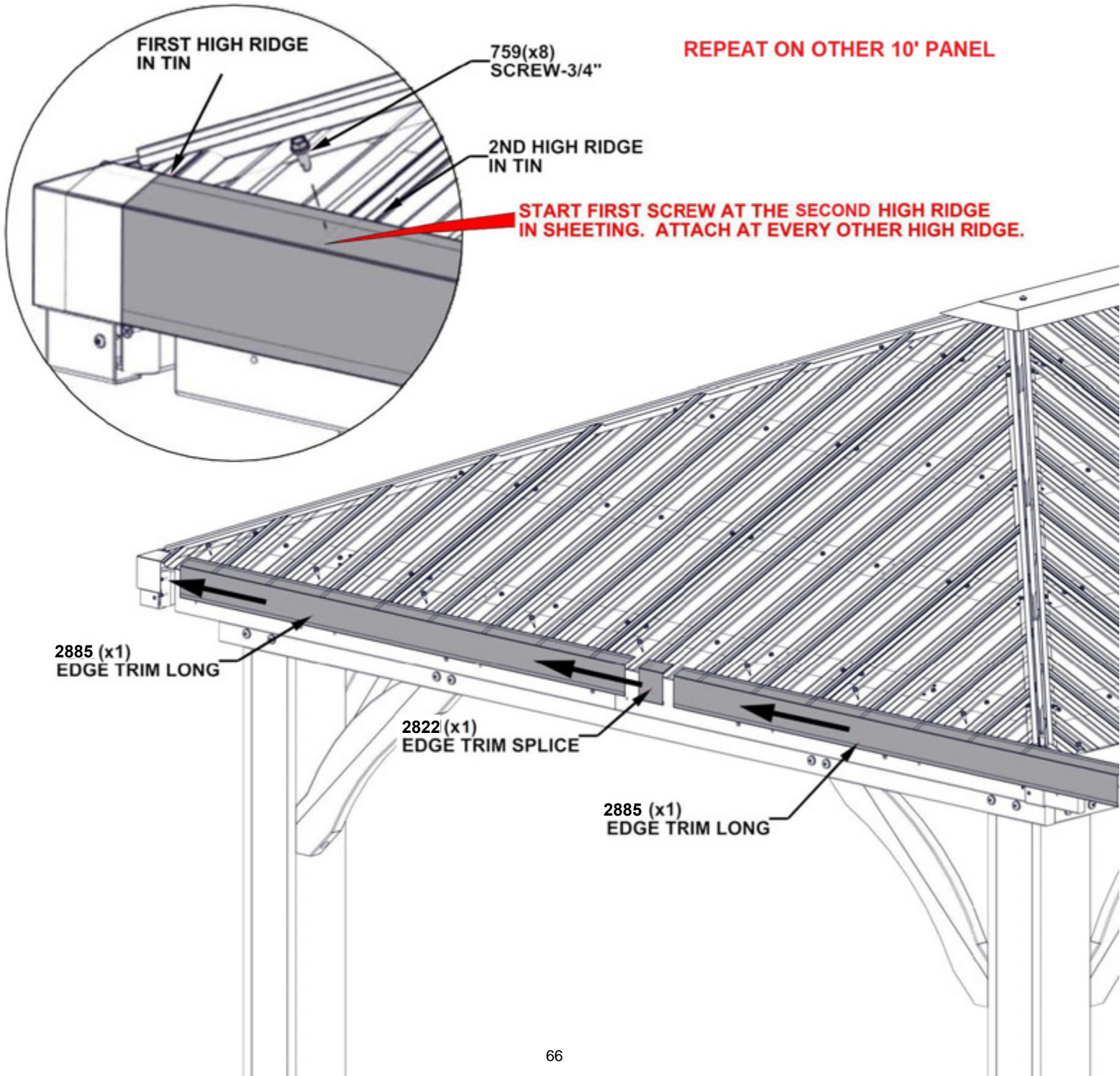

STEP 40 - ROOF ASSEMBLY

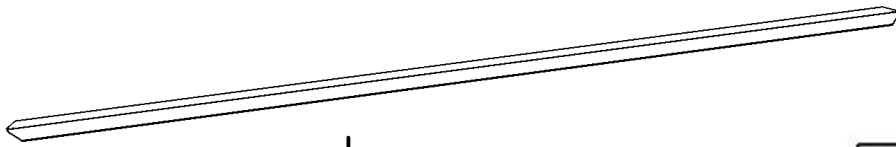

A4M02907 | CORNER RIDGE CAP
(4)

QTY	PART NUMBER	DESCRIPTION
8	H100759	SCREW SELF TAPPING 1/4x3/4

TIPS:

- SLIDE CORNER RIDGE CAP ONTO ROOF RIDGE CAP CHANNEL AS SHOWN.
- DO NOT PUSH ALL THE WAY TO THE TOP. FLUSH WITH CORNER OF GAZEBO AS SHOWN.
- REPEAT ON ALL CORNERS.

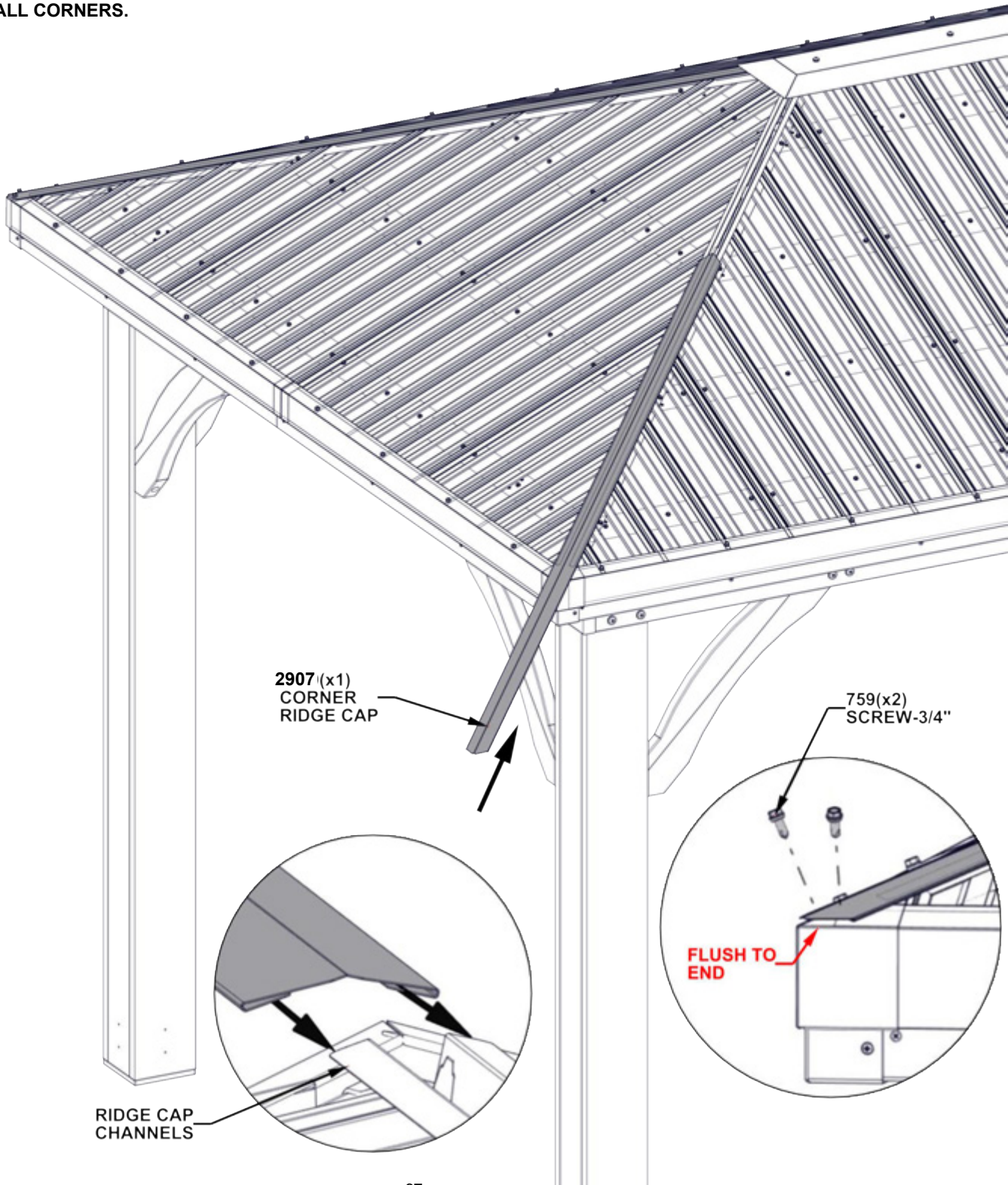

STEP 41 - GAZEBO ASSEMBLY

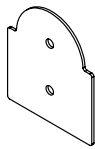
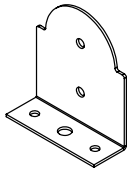

Qty	PART NUMBER	BOM DESCRIPTION (config)
32	H100471	LAG SCREW WH 5/16x1 1/2 BLK

A4M01793 (x8) | POST ANCHOR PLATE

A4M01794 (x8) | POST PLATE

NOTE:

- ALL 794 STEEL POST PLATES GO ON THE INSIDES OF THE POSTS AS SHOWN.
- ALL 793 STEEL POST ANCHORING PLATES GO ON THE OUTSIDES OF THE POSTS AS SHOWN.

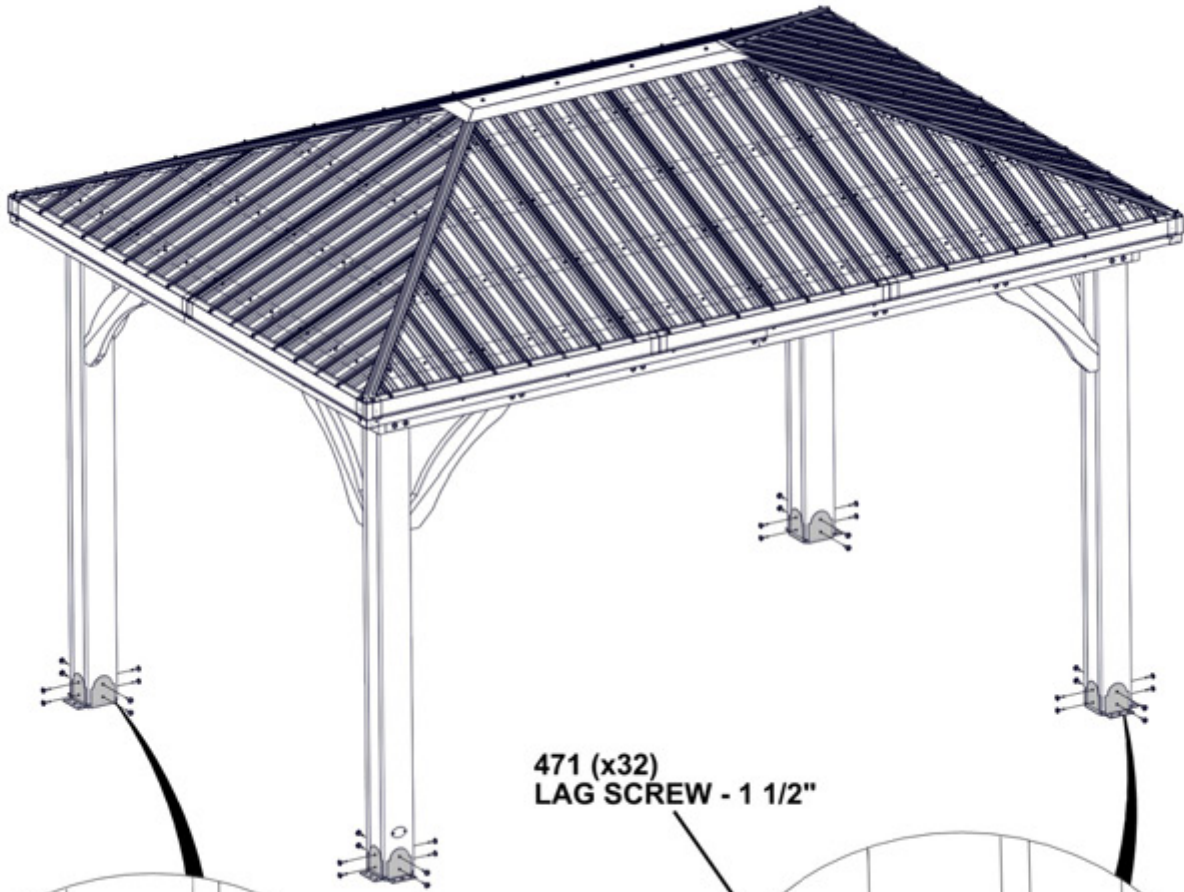

471 (x32)
LAG SCREW - 1 1/2"

794 (x8)
POST PLATE

793 (x8)
POST ANCHORING PLATE

STEP 42 - GAZEBO ASSEMBLY

QTY	PART NUMBER	DESCRIPTION
4	H100536	SCREW PWH 8x1 1/4 BLK



A4M02158
BYD ID TAG PATIO
(x1)

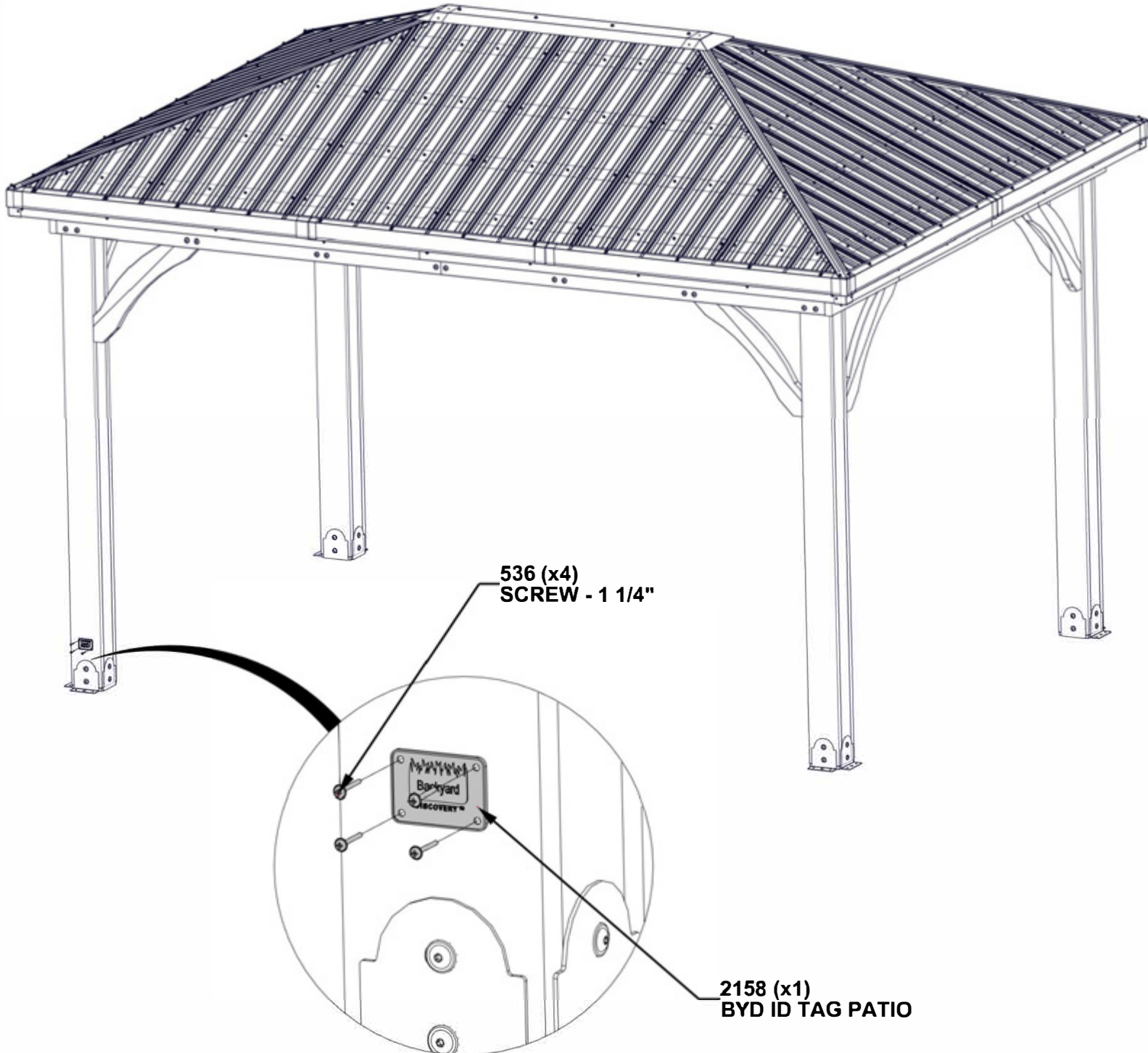

STEP 43 - GAZEBO ASSEMBLY

QTY	PART NUMBER	DESCRIPTION
16	H100120	CONCRETE ANCHOR 1/4"x2"
16	H100630	WASHER FLAT 8x19 BLK

MANUFACTURER RECOMMENDS INSTALLATION ON CONCRETE POST PADS, SEE BELOW. FOR INSTALLATION ON A WOOD DECK, YOU MUST ENSURE THERE IS AMPLE STRUCTURE SUPPORT UNDER DECK. SCEW ARE NOT PROVIDED TO ATTACH TO A DECK.

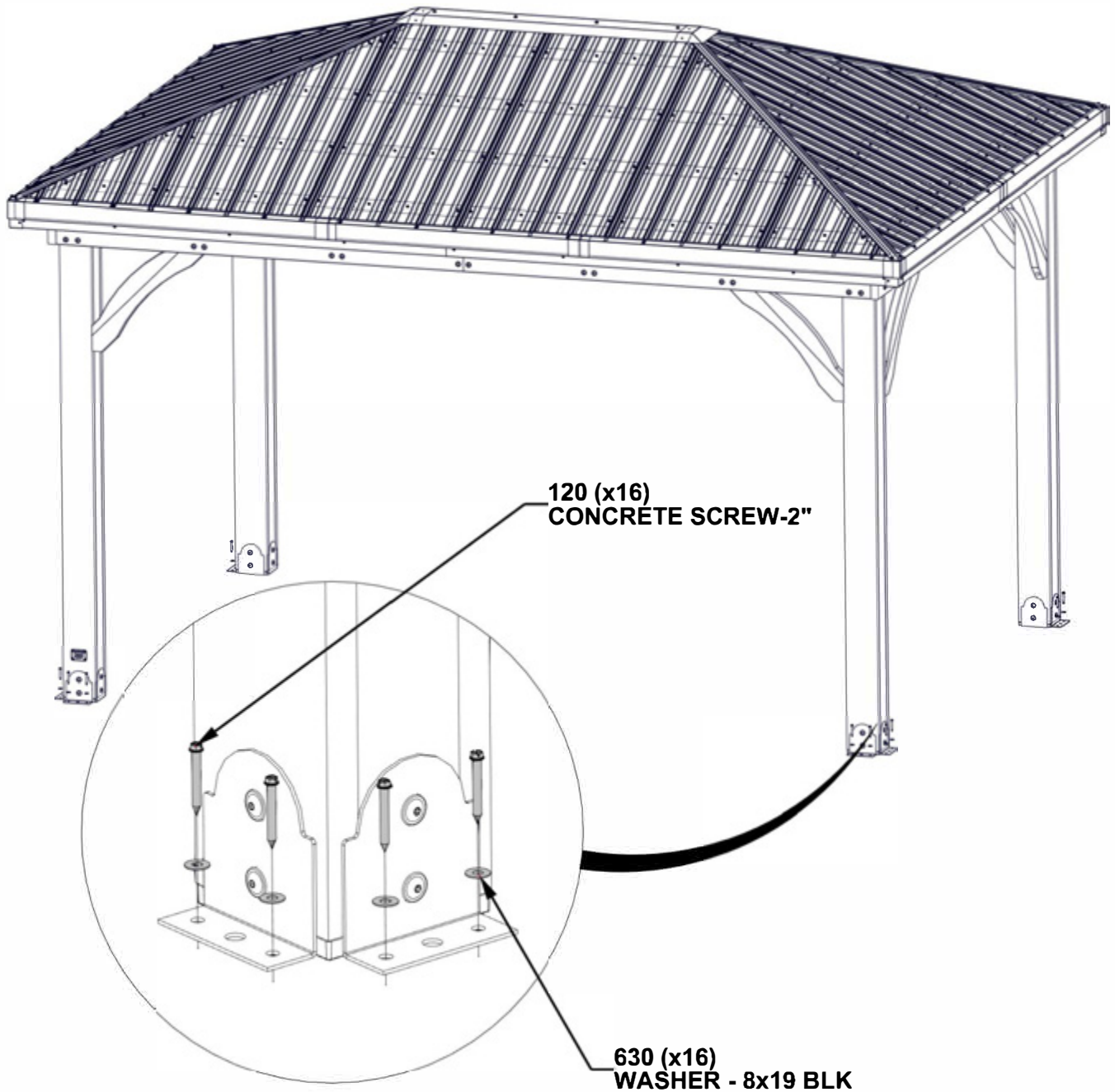

STEP 44 - GAZEBO ASSEMBLY (OPTIONAL)

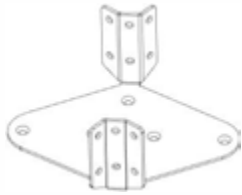

QTY	PART NUMBER	DESCRIPTION
4	H100382	SCREW PFH 8x1 3/4 BLK

A4M02501 FAN MOUNT BRACKET
(x1)

- ATTACH YOUR ELECTRICAL BOX (SOLD SEPERATLY) WITH THE PROVIDED HOLES IN FAN MOUNT BRACKET.
- PLACE FAN MOUNT BRACKET ON RIDGE BEAMS AND MOVE TO DESIRED FAN LOCATION.
- ROTATE BRACKET UNTIL MOUNTING FLANGES ALIGN BEST WITH RIDGE BEAMS.

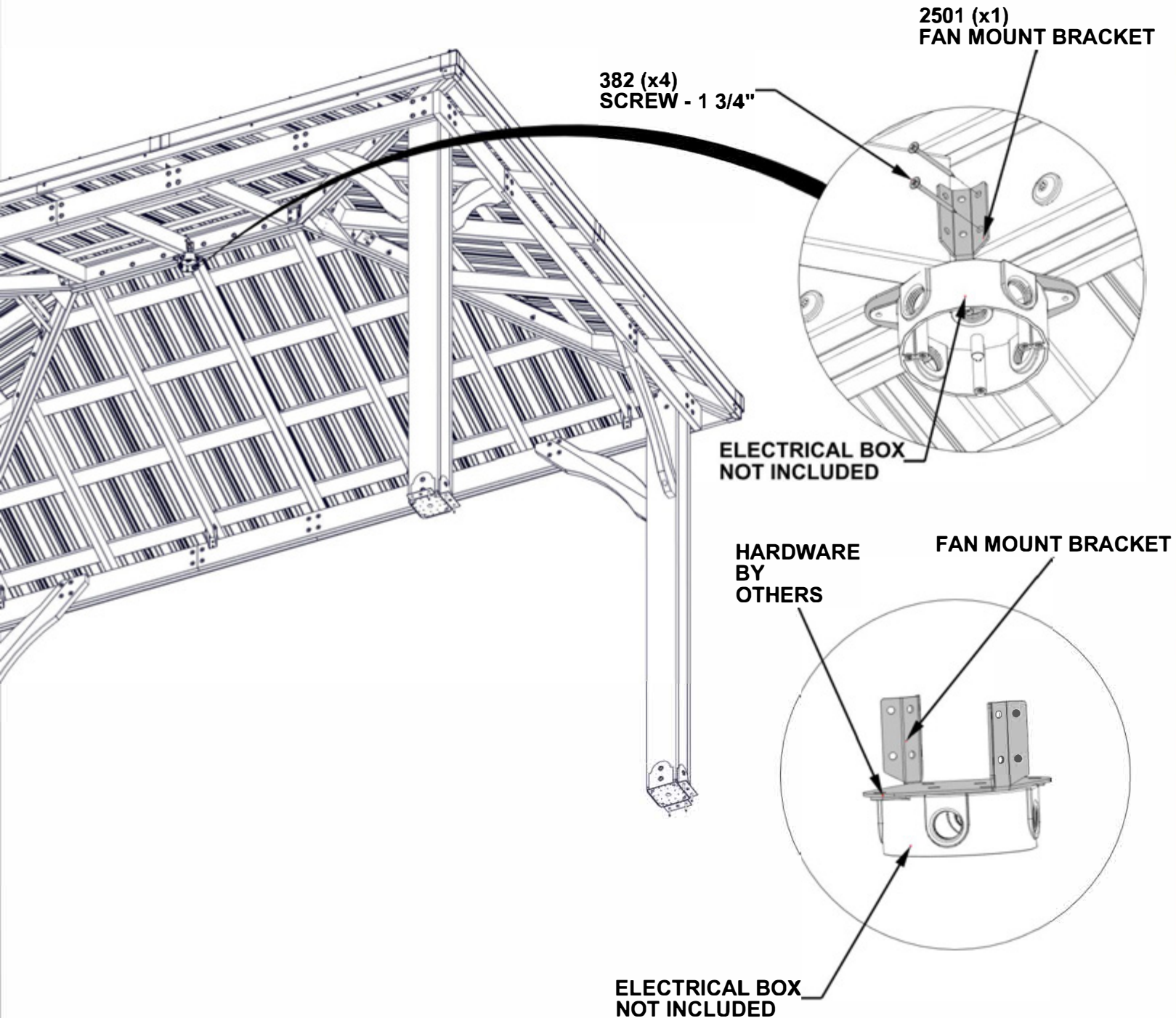

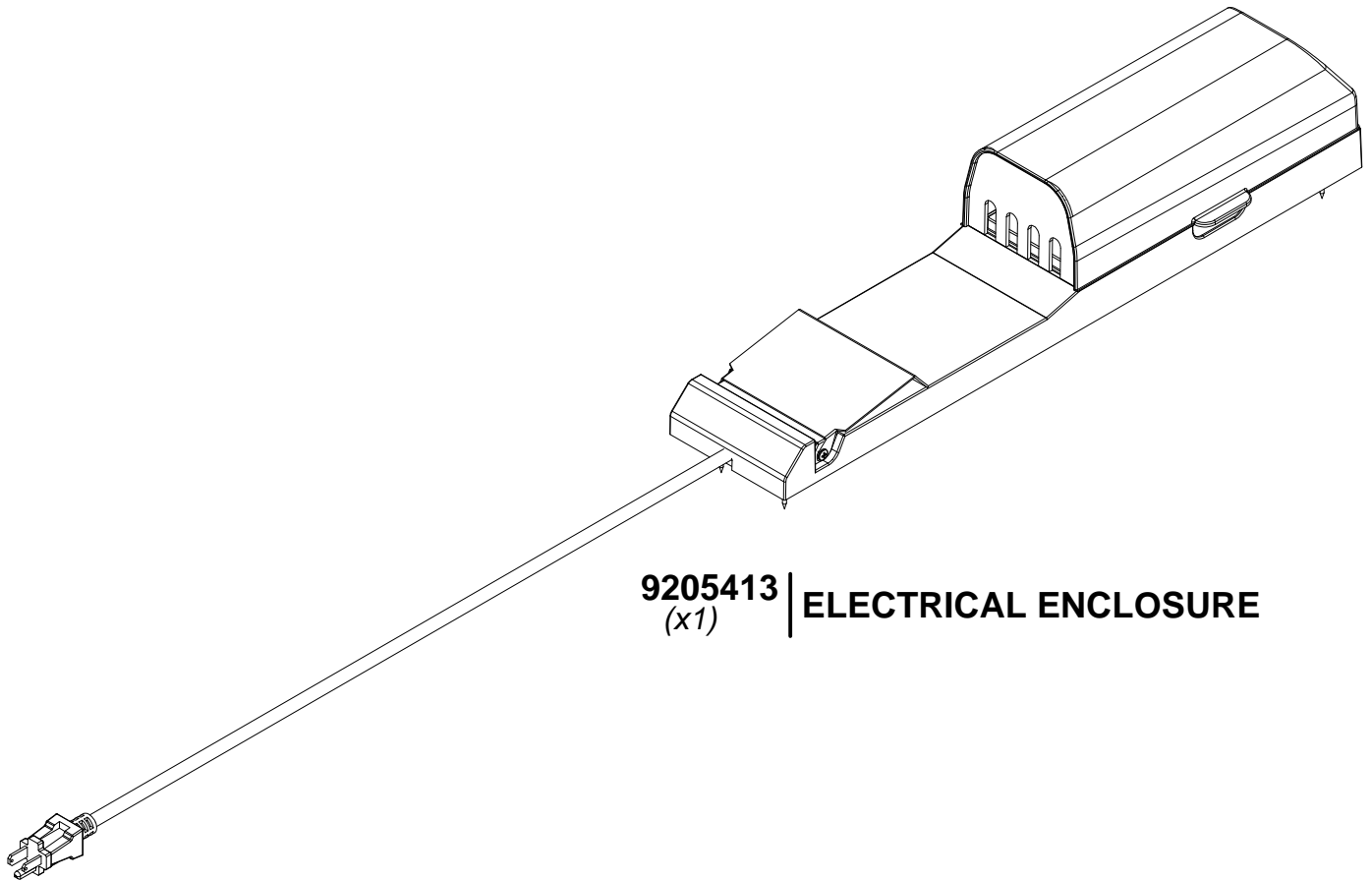

9205413 | **ELECTRICAL ENCLOSURE**
(x1)

FOR POWERPORT INSTALLATION REFER TO ASSEMBLY INSTRUCTIONS THAT COME PACKAGED WITH THE POWERPORT KIT. INSTALL ON ANY POST THAT IS DESIRED. FOLLOW DIRECTIONS FOR PROPER INSTALLATION.