



Manufactured by:
Backyard Discovery
3305 Airport Drive, Pittsburg, KS 66762
800-856-4445

Basepoint Business Centre: Rivermead Drive, Westlea, Swindon SN5 7EX Phone: 0800-118-2476
J.P. Coenstraat 7, The Bridge, The Hague, 2595 WP, Netherlands Phone: 08005678990

ACACIA CONSOLE TABLE

MODEL # : 2204034



Please visit www.backyarddiscovery.com
For the most up to date assembly manual, to register your product, or to order
replacement parts *Para obtener instrucciones en español, visite*
www.backyarddiscovery.com

OWNER'S MANUAL - BASIC SETUP DIMENSIONS & ASSEMBLY NOTES

- Pay close attention to the items needed for each step. Make sure you are using the correct hardware for each step. Using incorrect hardware may result in improper assembly

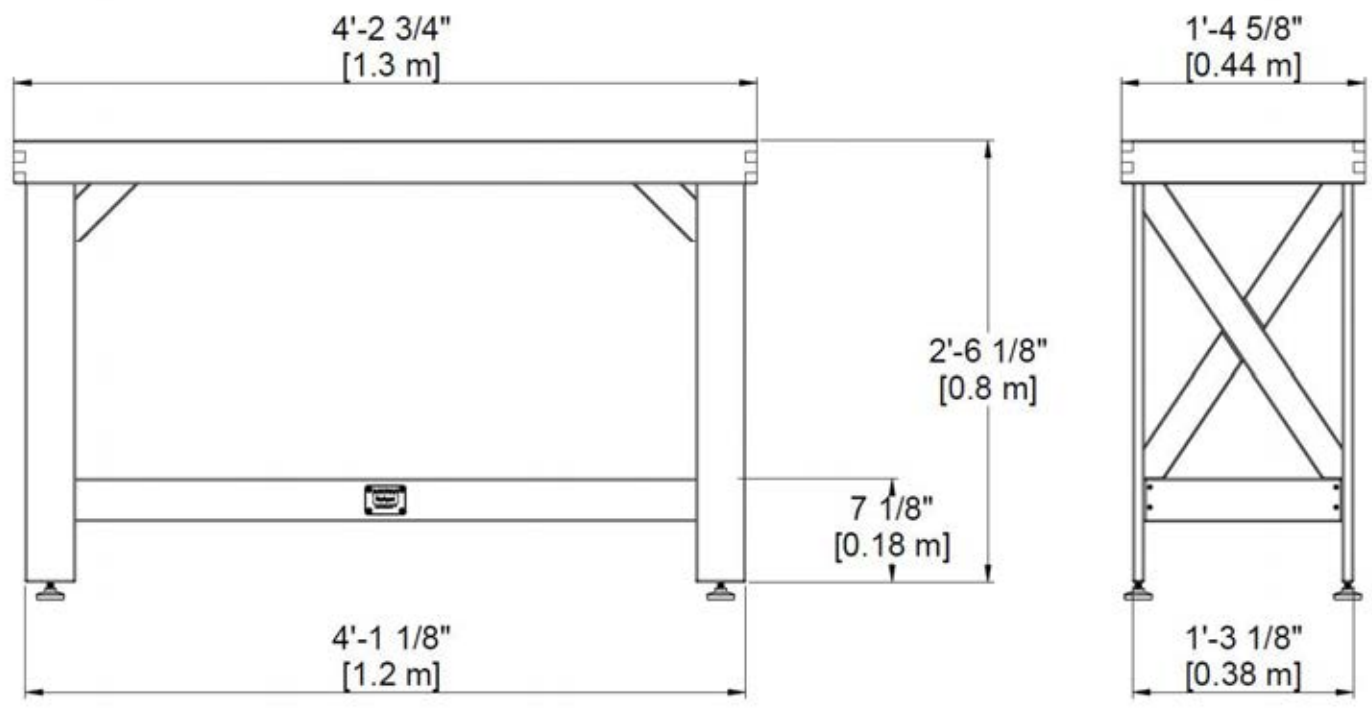

OWNER'S MANUAL - PARTS IDENTIFICATION

WOOD COMPONENTS (NOT TO SCALE)

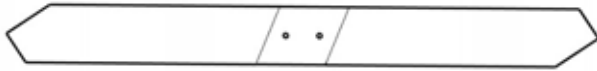

CB1 CROSS BRACE - W4L15961
(x2) 13/16"x2 3/8"x24 1/8" (20x60x613)



CB2 CROSS BRACE - W4L15962
(x2) 13/16"x2 3/8"x24 1/8" (20x60x613)



FL1 FRONT LEG LEFT ASSEMBLY - W2A03350
(x1) 13/16"x3 3/8"x29 1/2" (20x86x750)



FL2 FRONT LEG RIGHT ASSEMBLY - W2A03351
(x1) 13/16"x3 3/8"x29 1/2" (20x86x750)



BL1 BACK LEG LEFT ASSEMBLY - W2A03352
(x1) 13/16"x3 3/8"x29 1/2" (20x86x750)



BL2 BACK LEG RIGHT ASSEMBLY - W2A03353
(x1) 13/16"x3 3/8"x29 1/2" (20x86x750)



CB3 BRACE - W4L15963
(x2) 13/16"x2 3/8"x7 5/16" (20x60x186)



TP1 TOP PANEL ASSEMBLY - W2A03348
(x1) 2 15/16"x16 5/8"x50 11/16" (75x423x1288)

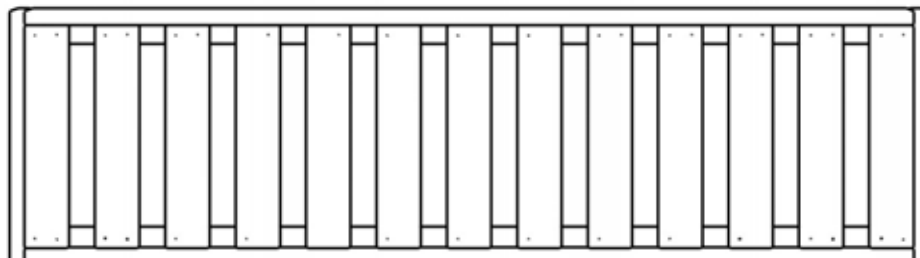

BP1 BOTTOM PANEL ASSEMBLY - W2A03349
(x1) 2 15/16"x13 1/2"x49 1/8" (75x343x1248)

OWNER'S MANUAL - PARTS IDENTIFICATION

ACCESSORY COMPONENTS (NOT TO SCALE)



A4M02158
BYD ID TAG PATIO
(x1)

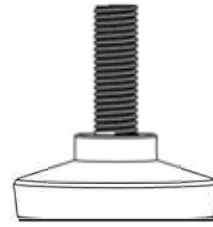

A6P00481
ADJUSTABLE FOOT
(x4)

HARDWARE COMPONENTS (NOT TO SCALE)

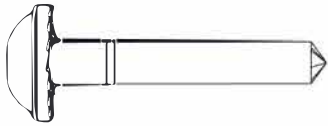

H100403 LAG SCREW WH BLK
(x2) 1/4 X 1 1/2



H101090 SCREW TWH BLK
(x2) 8 X 1 3/4

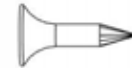

H100883 SCREW TFH BLK
(x4) 8 X 5/8

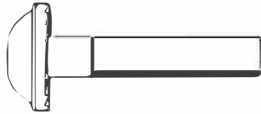

H100397 BOLT WH BLK
(x12) 1/4 X 1 1/4



H101089 SCREW TWH BLK
(x8) 8 X 1 1/2



H100392 SCREW PWH BLK
(x4) 8 X 3/4

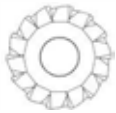

H100405 WASHER LOCK EXT
(x14) 6 X 15

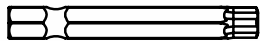

H100147 TORX BIT
(x1) T-30

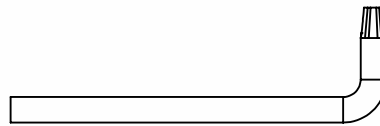

H100114 TORX WRENCH
(x2) T-30

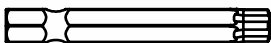

H100879 TORX BIT
(x1) T-20



H101100 MAGNETIC DRIVER
(x1)

PRE-ASSEMBLY STEP 1 - TOOLS REQUIRED



Cordless Drill or
Electric Drill



Drill Attachments:
Phillips Head



Phillips Screw Driver



Tape Measure



Claw Hammer



Rubber Mallet -
Optional

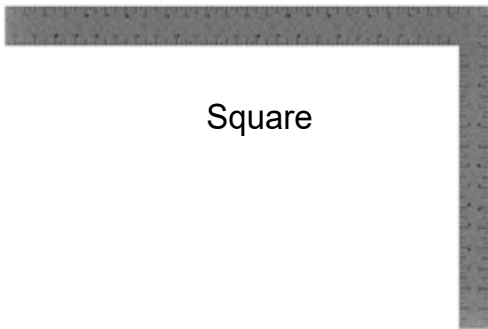

Square



Level 24"

PRE-ASSEMBLY STEP 2 - SORTING PARTS

It is critical for ease of assembly that you take the time to sort and organize the wood and hardware.

WOOD PARTS:

- Organize wood parts by the three-digit, alpha-numeric number stamped on each board (ex. P01).
- If there are multiple boards with the same stamped number, stack those pieces together.
- Stamps can be found on the flat surface of the boards or on the end of the boards.
- Allow yourself plenty of room - the wood pieces can take up a significant amount of space.

NOTE: CARTONS ARE NOT ORGANIZED BY BOARD NUMBER.



HARDWARE PARTS:

- We recommend that you have a separate table to organize the hardware.
- Hardware bags are printed with a seven-digit, alpha-numeric part number.
- You can organize your hardware by part number or group by hardware type (i.e. bolts, nuts, etc.).
- During assembly you only need to reference the last four digits of the number.

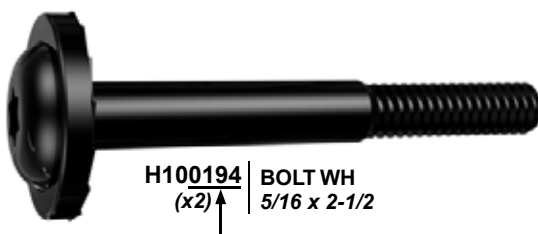

STEP 1 - TABLE ASSEMBLY



BL2 BACK LEG RIGHT ASSEMBLY - W2A03353
(x1) 13/16"x3 3/8"x29 1/2" (20x86x750)



FL2 FRONT RIGHT LEG ASSEMBLY - W2A03351
(x1) 13/16"x3 3/8"x29 1/2" (20x86x750)

QTY	PART NUMBER	DESCRIPTION
2	H101089	SCREW TWH 8x1 1/2 BLK



CB2 CROSS BRACE - W4L15962
(x1) 13/16"x2 3/8"x24 1/8" (20x60x613)

- BE SURE TO MATCH BL2 WITH FL2.
- ALIGN CROSS BRACE WITH PILOT HOLES IN LEGS.
- INSERT SCREWS.
- PLACE LEGS AND CROSS BRACE ON A FLAT SURFACE. TOP AND BOTTOM OF EACH LEG SHOULD ALIGN WITH THE SAME PLANE.

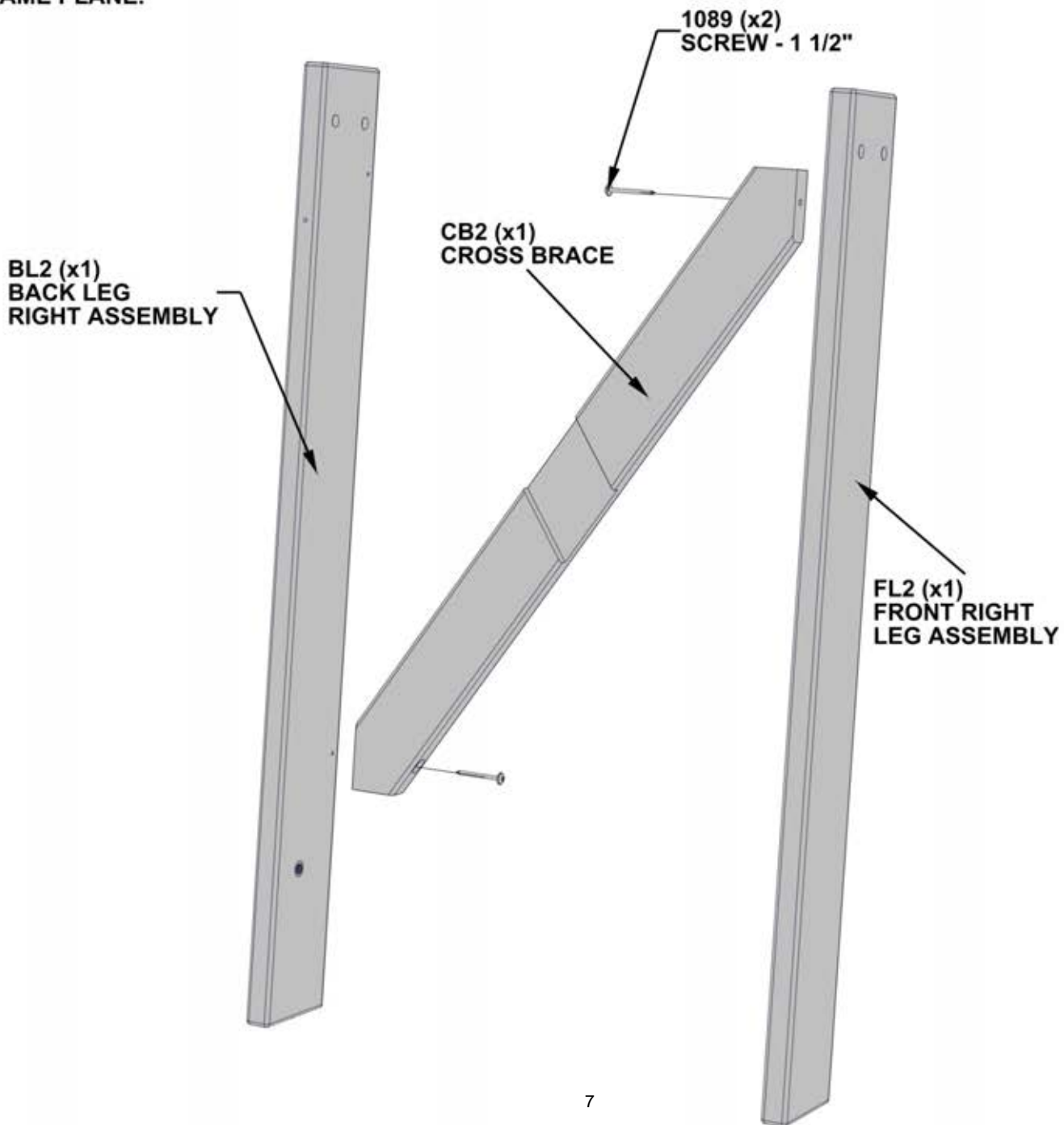

STEP 2 - TABLE ASSEMBLY

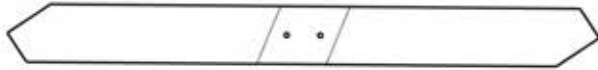

CB1 CROSS BRACE - W4L15961
(x1) 13/16"x2 3/8"x24 1/8" (20x60x613)

QTY	PART NUMBER	DESCRIPTION
2	H100883	SCREW TFH 8X5/8 BLK
2	H101089	SCREW TWH 8x1 1/2 BLK

- BE SURE TO MATCH BL2 WITH FL2.
- ALIGN CB1 WITH PILOT HOLES IN LEGS OF ASSEMBLY FROM STEP 1.
- INSERT SCREWS.
- PLACE LEGS AND CROSS BRACE ON A FLAT SURFACE. TOP AND BOTTOM OF EACH LEG SHOULD BE ALONG THE SAME PLANE.

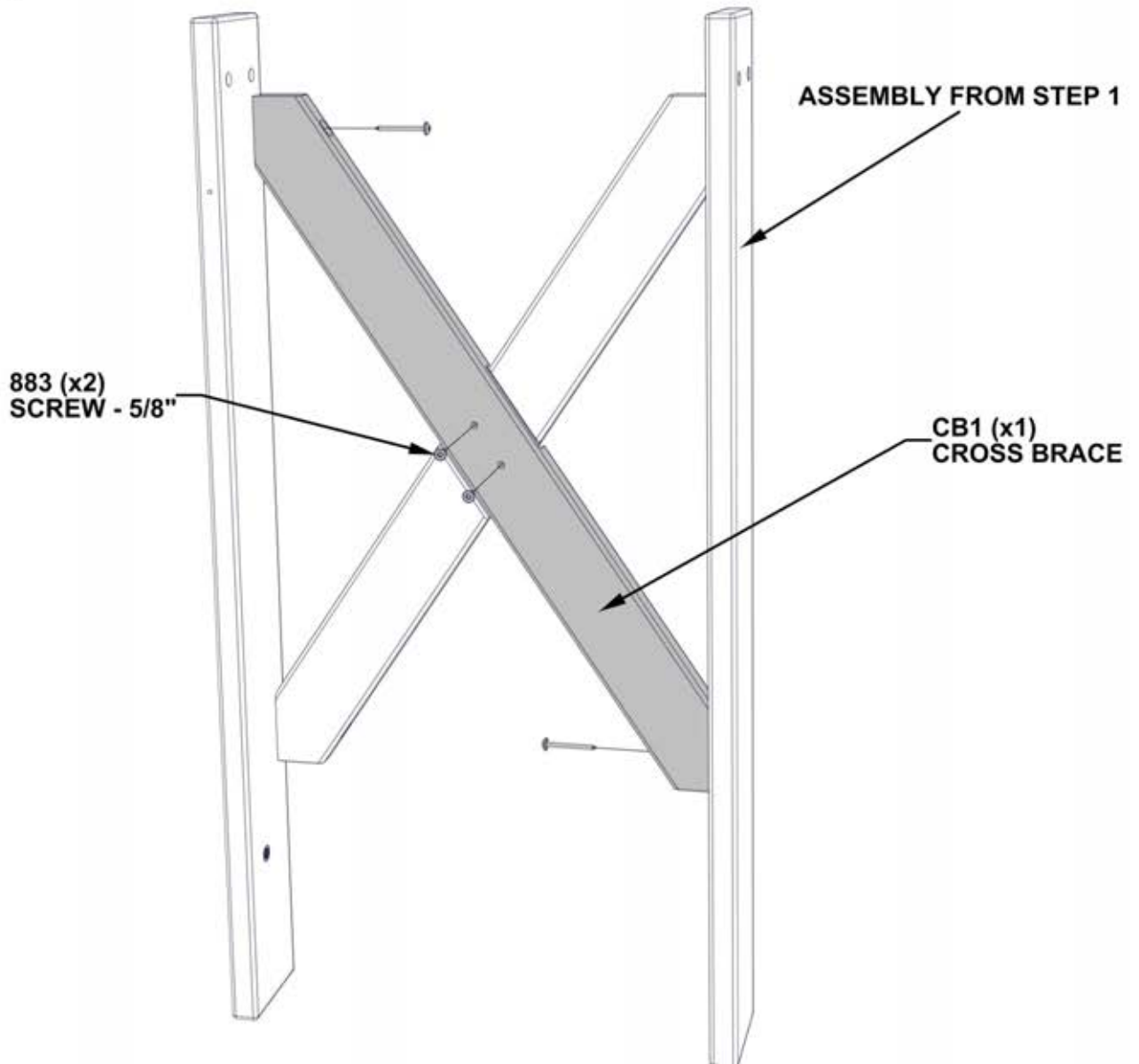

STEP 3 - TABLE ASSEMBLY



FL1 FRONT LEG LEFT ASSEMBLY - W2A03350
(x1) 13/16"x3 3/8"x29 1/2" (20x86x750)

QTY	PART NUMBER	DESCRIPTION
2	H101089	SCREW TWH 8x1 1/2 BLK



CB2 CROSS BRACE - W4L15962
(x1) 13/16"x2 3/8"x24 1/8" (20x60x613)



BL1 BACK LEFT LEG ASSEMBLY - W2A03352
(x1) 13/16"x3 3/8"x29 1/2" (20x86x750)

- BE SURE TO MATCH BL1 WITH FL1.
- ALIGN CB2 WITH PILOT HOLES IN LEGS.
- INSERT SCREWS.
- PLACE LEGS AND CROSS BRACE ON A FLAT SURFACE. TOP AND BOTTOM OF EACH LEG SHOULD ALONG THE SAME PLANE.

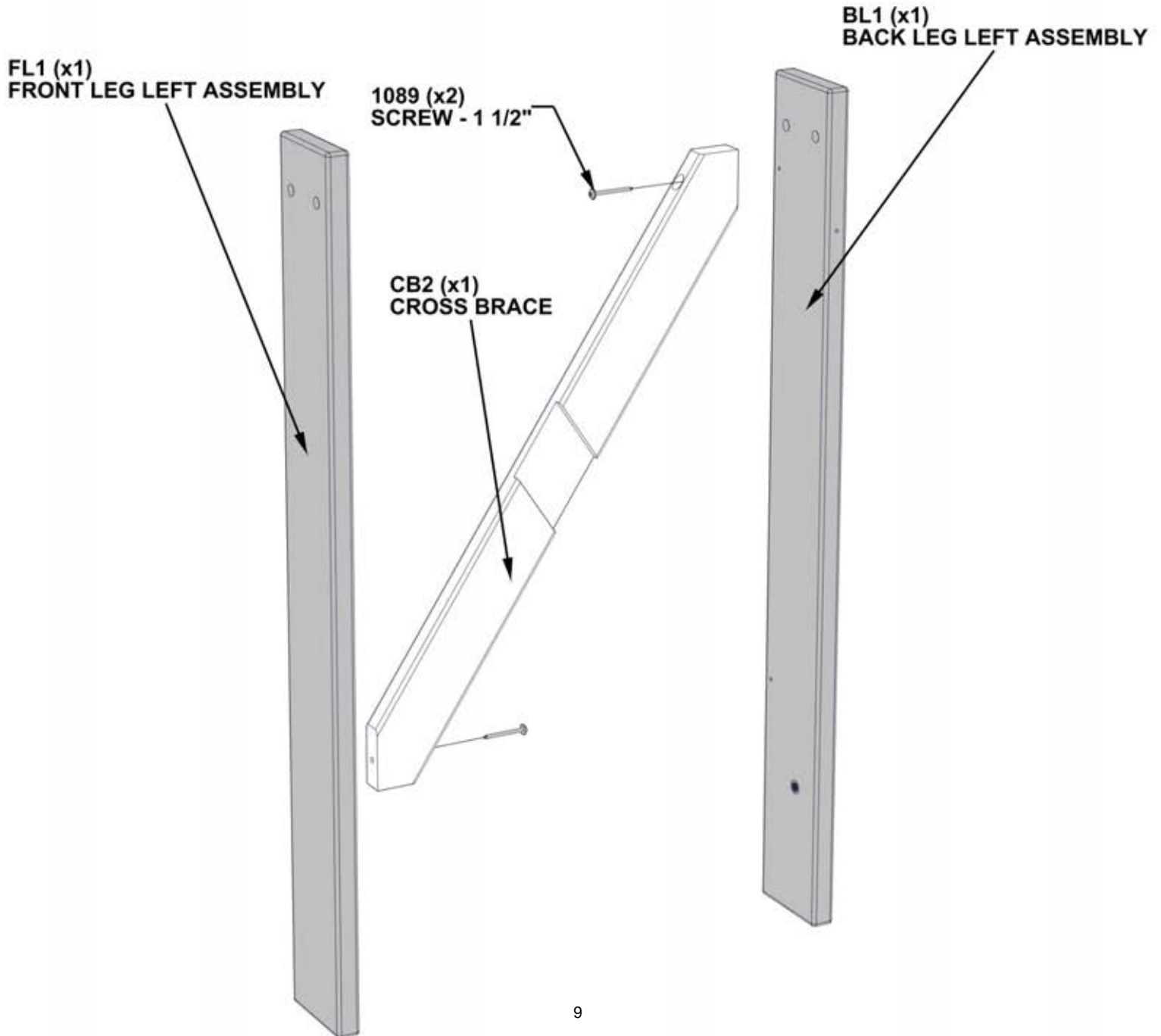

STEP 4 - TABLE ASSEMBLY

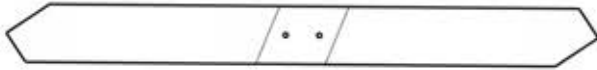

QTY	PART NUMBER	DESCRIPTION
2	H100883	SCREW TFH 8X5/8 BLK
2	H101089	SCREW TWH 8x1 1/2 BLK

CB1 CROSS BRACE - W4L15961
 (x1) 13/16"x2 3/8"x24 1/8" (20x60x613)

- BE SURE TO MATCH BL1 WITH FL1.
- ALIGN CROSS BRACE WITH PILOT HOLES IN LEGS.
- INSERT SCREWS.
- PLACE LEGS AND CROSS BRACE ON A FLAT SURFACE. TOP AND BOTTOM OF EACH LEG SHOULD ALONG THE SAME PLANE.

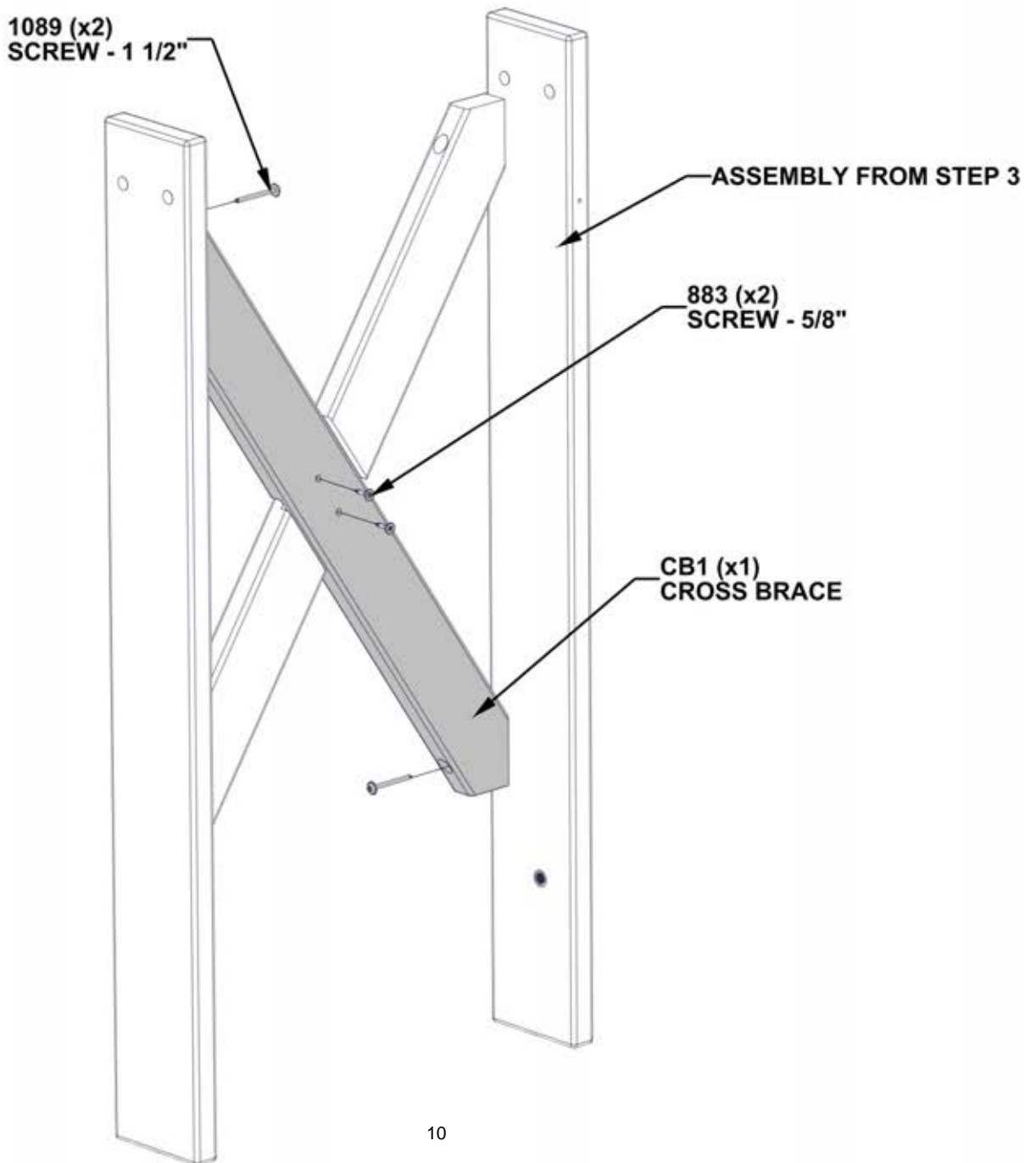

STEP 5 - TABLE ASSEMBLY

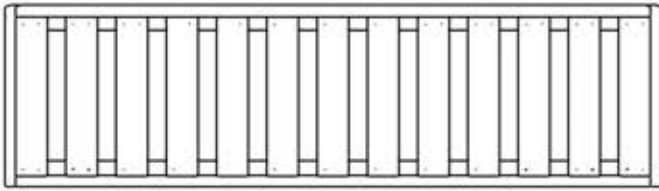

QTY	PART NUMBER	DESCRIPTION
4	H100397	BOLT WH 1/4x1 1/4 BLK
4	H100405	WASHER LOCK EXT 6x15

BP1 BOTTOM PANEL ASSEMBLY - W2A03349
 (x1) 2 15/16"x13 1/2"x49 1/8" (75x343x1248)

SQUARE BOTTOM PANEL ASSEMBLY TO EACH LEG BEFORE TIGHTENING.

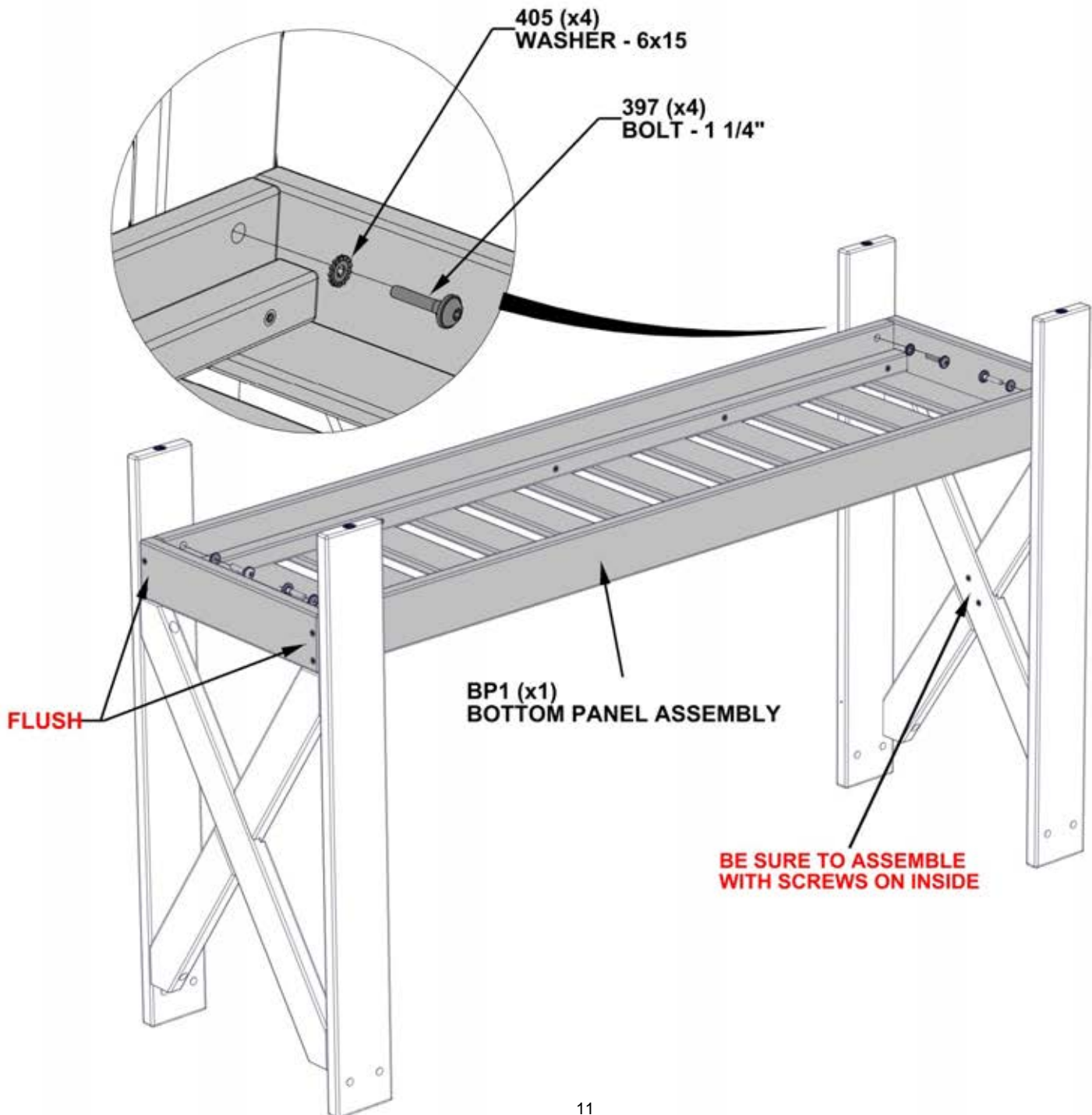

STEP 6 - TABLE ASSEMBLY



A6P00481 | ADJUSTABLE FOOT
(x4)

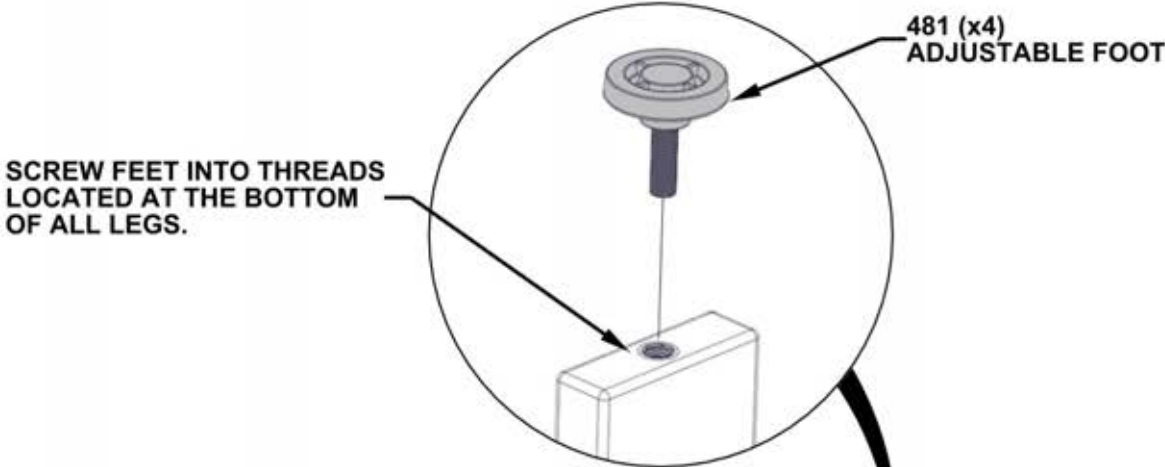

SCREW FEET INTO THREADS
LOCATED AT THE BOTTOM
OF ALL LEGS.

481 (x4)
ADJUSTABLE FOOT

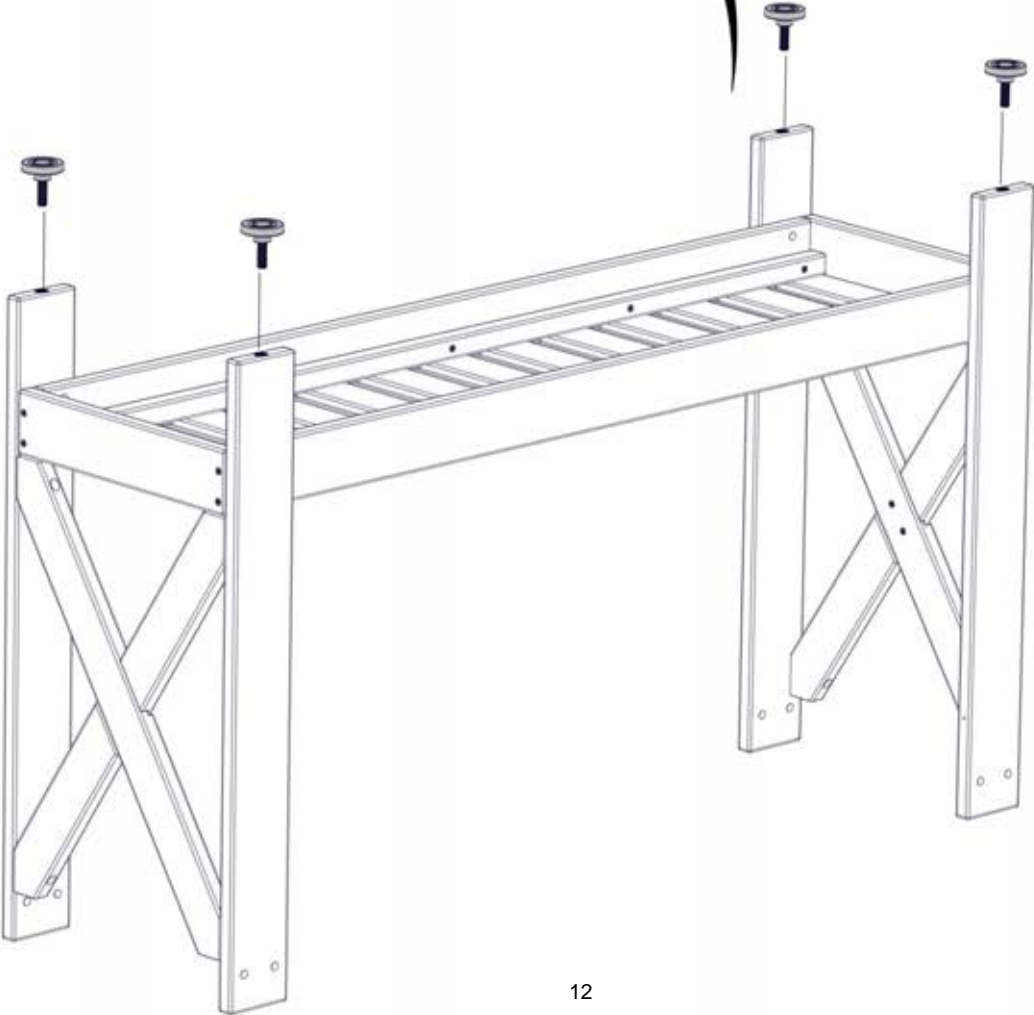

STEP 7 - TABLE ASSEMBLY



QTY	PART NUMBER	DESCRIPTION
8	H100397	BOLT WH 1/4x1 1/4 BLK
8	H100405	WASHER LOCK EXT 6x15

TP1 TOP PANEL ASSEMBLY - W2A03348
(x1) 2 15/16"x16 5/8"x50 11/16" (75x423x1288)

**PILOT HOLES IN TOP PANEL
AND BACK POST ON SAME SIDE.**

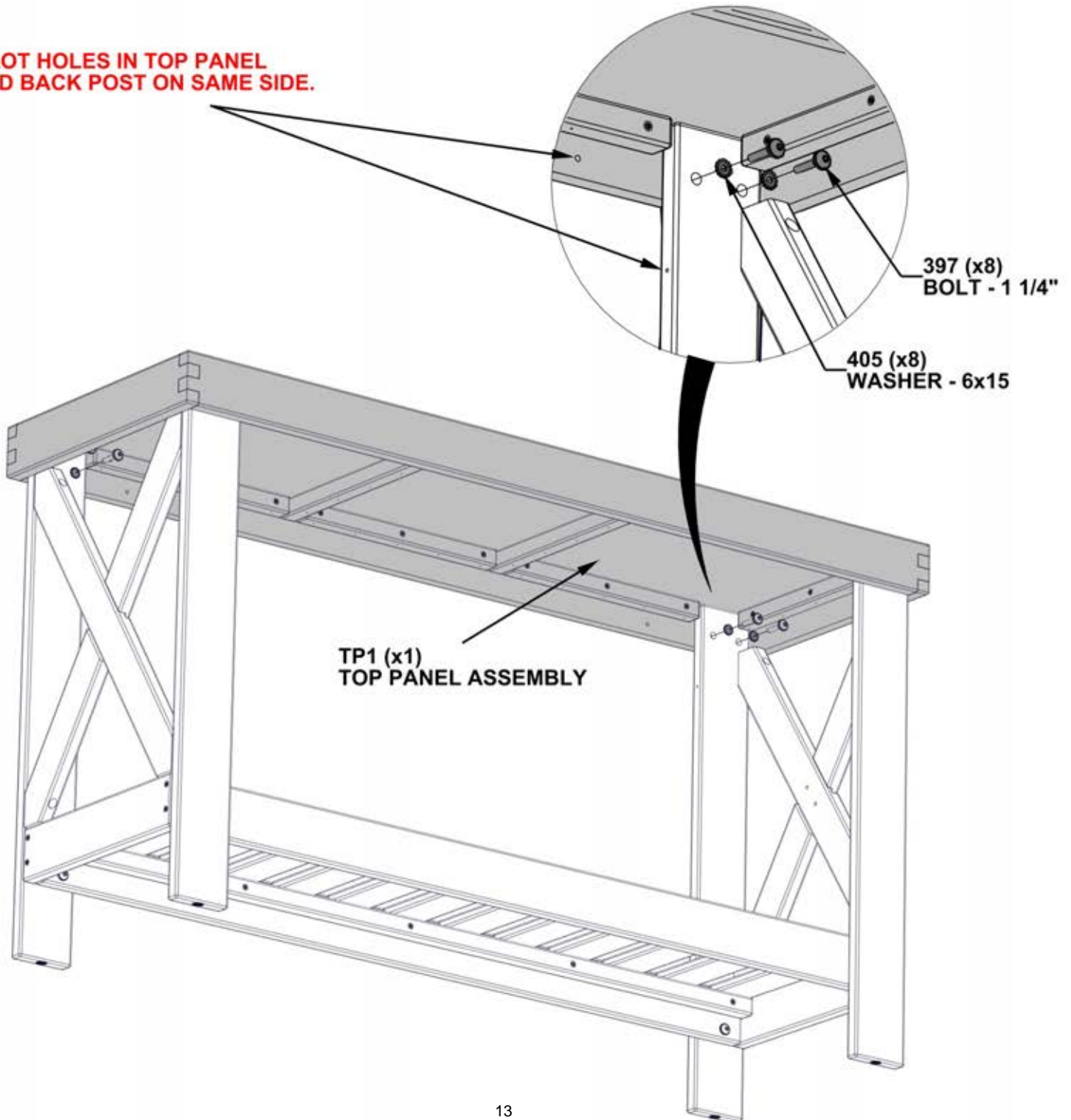

STEP 8 - TABLE ASSEMBLY



CB3 BRACE - W4L15963
(x2) 13/16"x2 3/8"x7 5/16" (20x60x186)

QTY	PART NUMBER	DESCRIPTION
2	H100403	LAG SCREW WH 1/4x1 1/2 BLK
2	H100405	WASHER LOCK EXT 6x15
2	H101090	SCREW TWH 8x1 3/4 BLK

- ALIGN HARDWARE WITH PILOT HOLES NOTED ON PREVIOUS STEP TO AVOID SPLITTING.

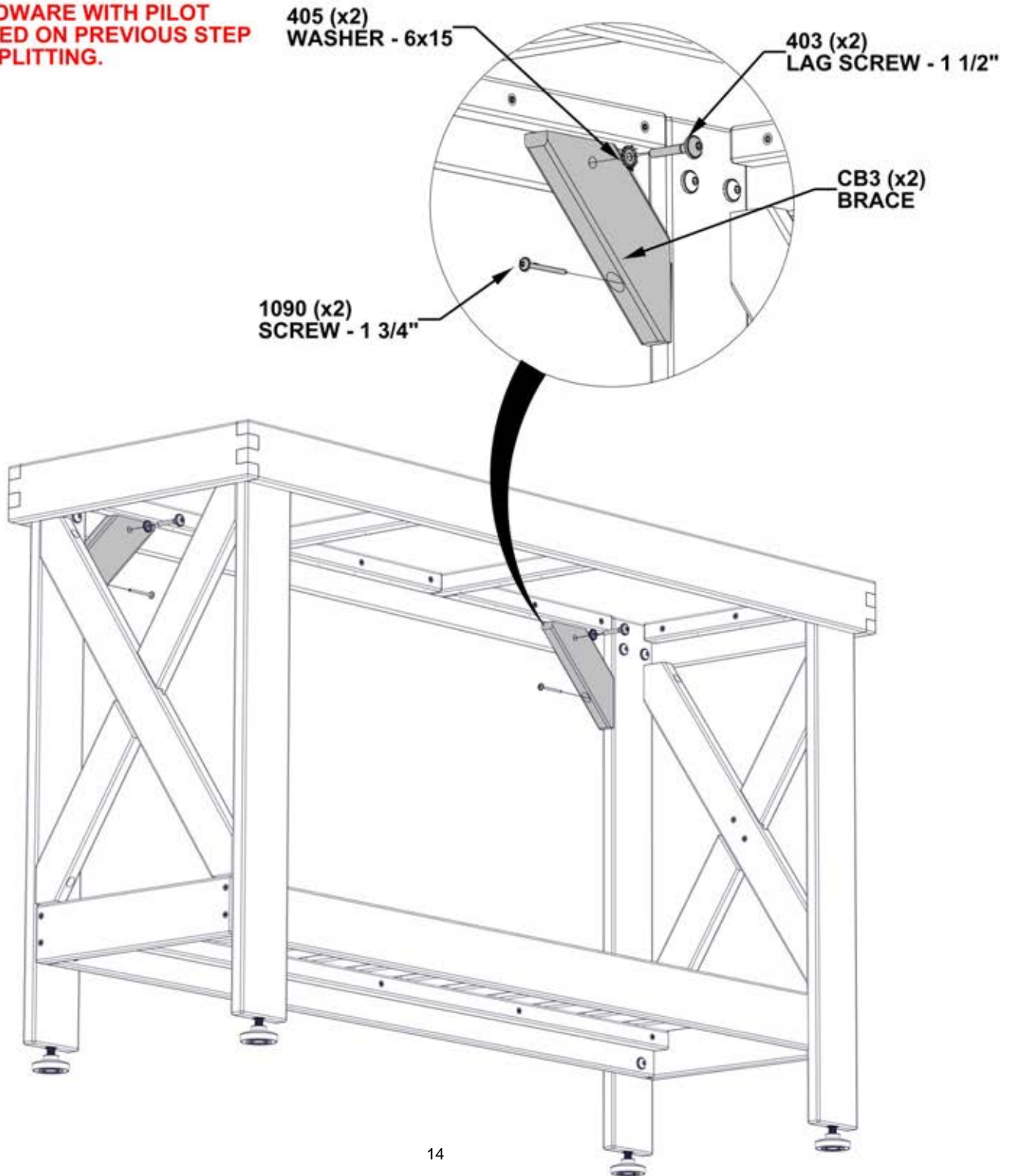

STEP 9 - TABLE ASSEMBLY



A4M02158
BYD ID TAG PATIO
(x1)

QTY	PART NUMBER	DESCRIPTION
4	H100392	SCREW PWH 8x3/4 BLK

CENTER ID TAG ON FRONT OF BOTTOM PANEL AS SHOWN

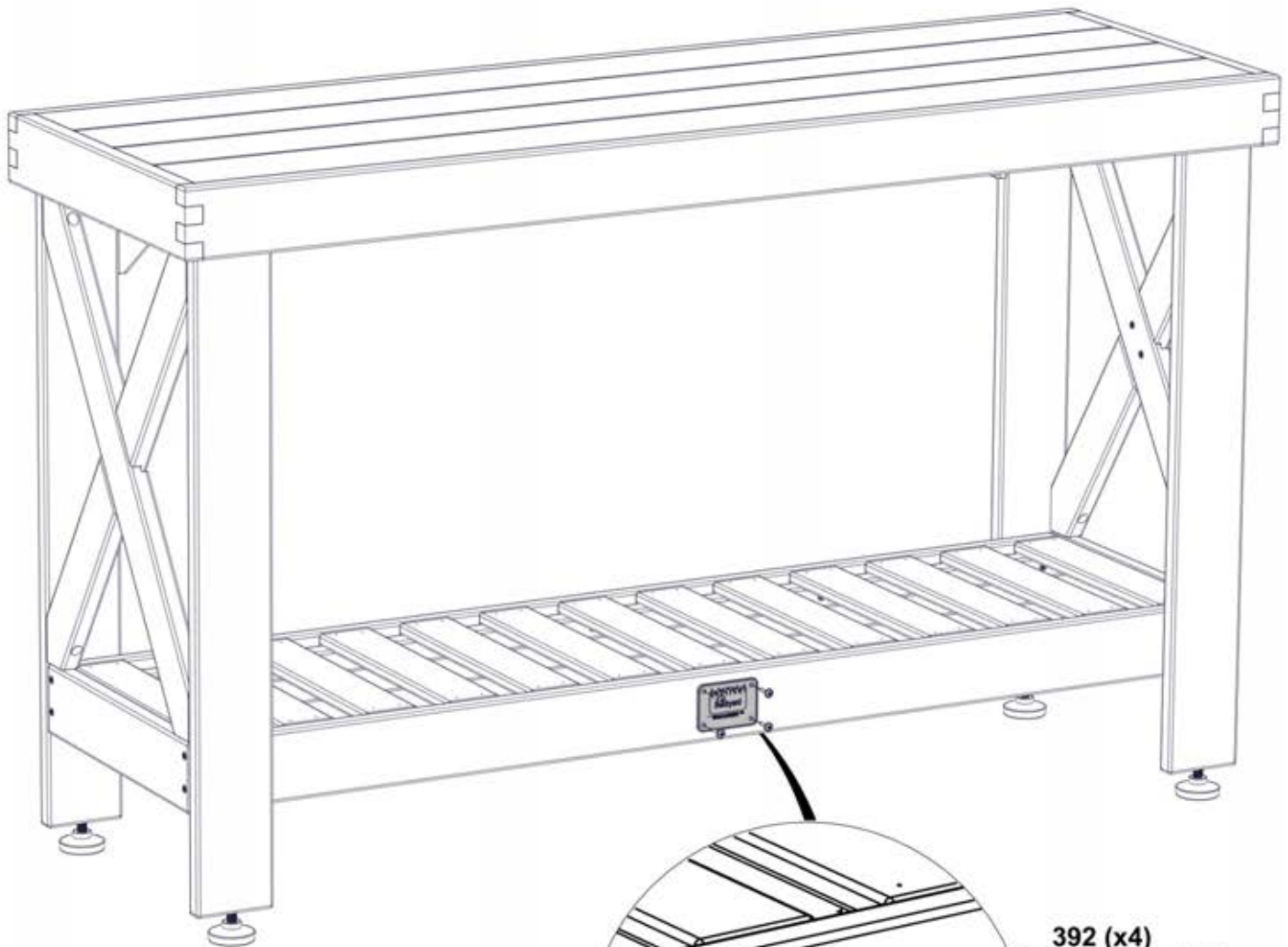

2158 (x1)
BYD ID TAG PATIO

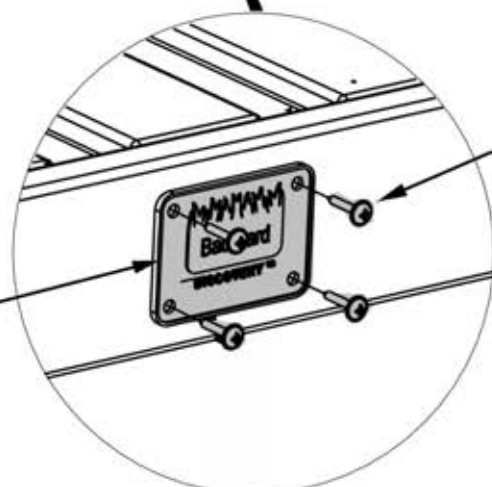

392 (x4)
SCREW - 3/4"