



Manufactured by:
Backyard Discovery
3305 Airport Drive, Pittsburg, KS
66762 800-856-4445

Basepoint Business Centre: Rivermead Drive, Westlea, Swindon SN5 7EX Phone: 0800-118-2476
J.P. Coenstraat 7, The Bridge, The Hague, 2595 WP, Netherlands Phone: 08005678990

14x12 NORWOOD GAZEBO

MODEL # : 2206021B



Please visit www.backyarddiscovery.com
For the most up to date assembly manual, to register your product, or to order replacement parts *Para obtener instrucciones en español, visite* www.backyarddiscovery.com



EASY STEP-BY-STEP
3D INTERACTIVE INSTRUCTIONS
DOWNLOAD THE FREE APP



OWNER'S MANUAL - BASIC SETUP DIMENSIONS & ASSEMBLY NOTES

It is critically important that you start with square and level footings, concrete pad or deck to attach your structure

- Pay close attention to the items needed for each step. Make sure you are using the correct hardware for each step. Using incorrect hardware may result in improper assembly
- Remember to double check for underground utilities and overhead electrical lines

Post mounts are provided with your structure which allows you to permanently install your structure to a pre-existing or new wood or concrete surface. See Anchor Instructions for further details and recommendations.

- The hardware to attach the post mounts to the structure is included.
- The hardware to mount the structure permanently to a concrete surface is included.
- The hardware to mount the structure permanently to a wood deck is NOT included and will need to be purchased separately. You must ensure there is ample structural support under the deck before permanently attaching.

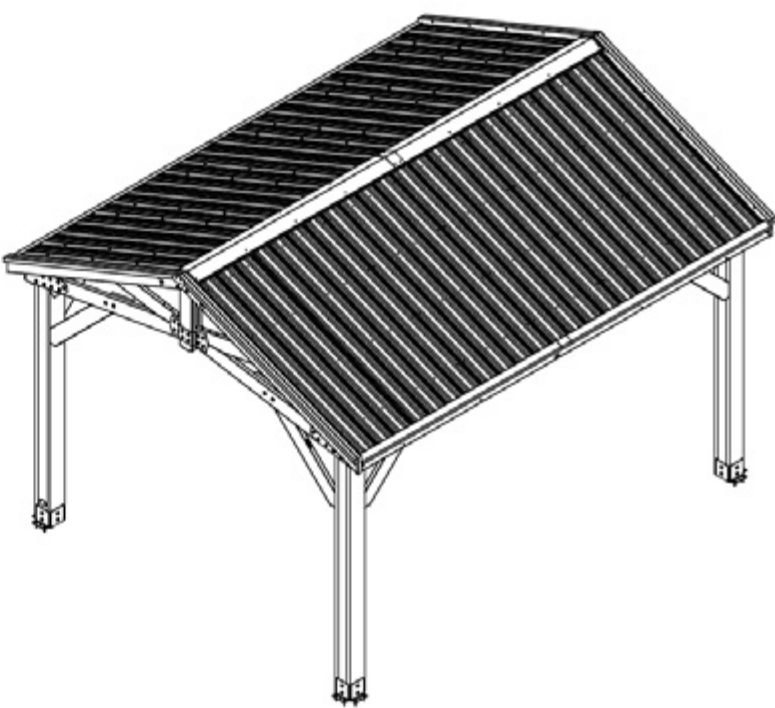
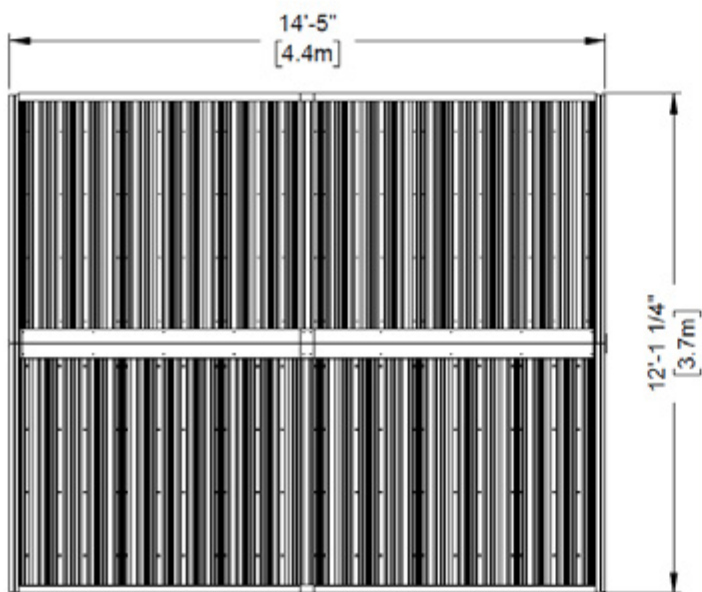
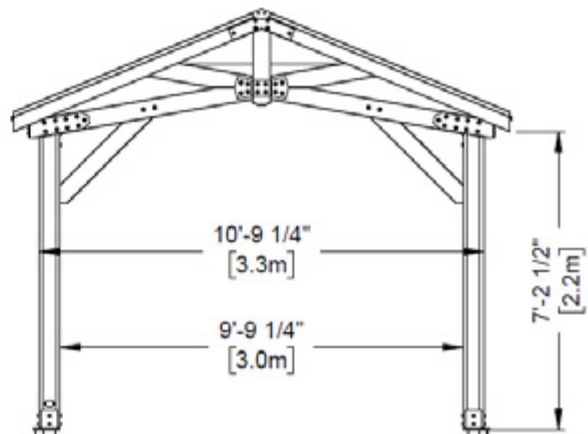
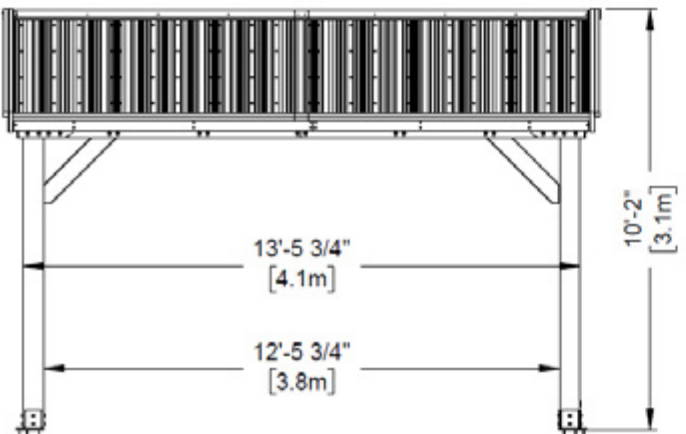

OWNER'S MANUAL - ANCHORING LAYOUT

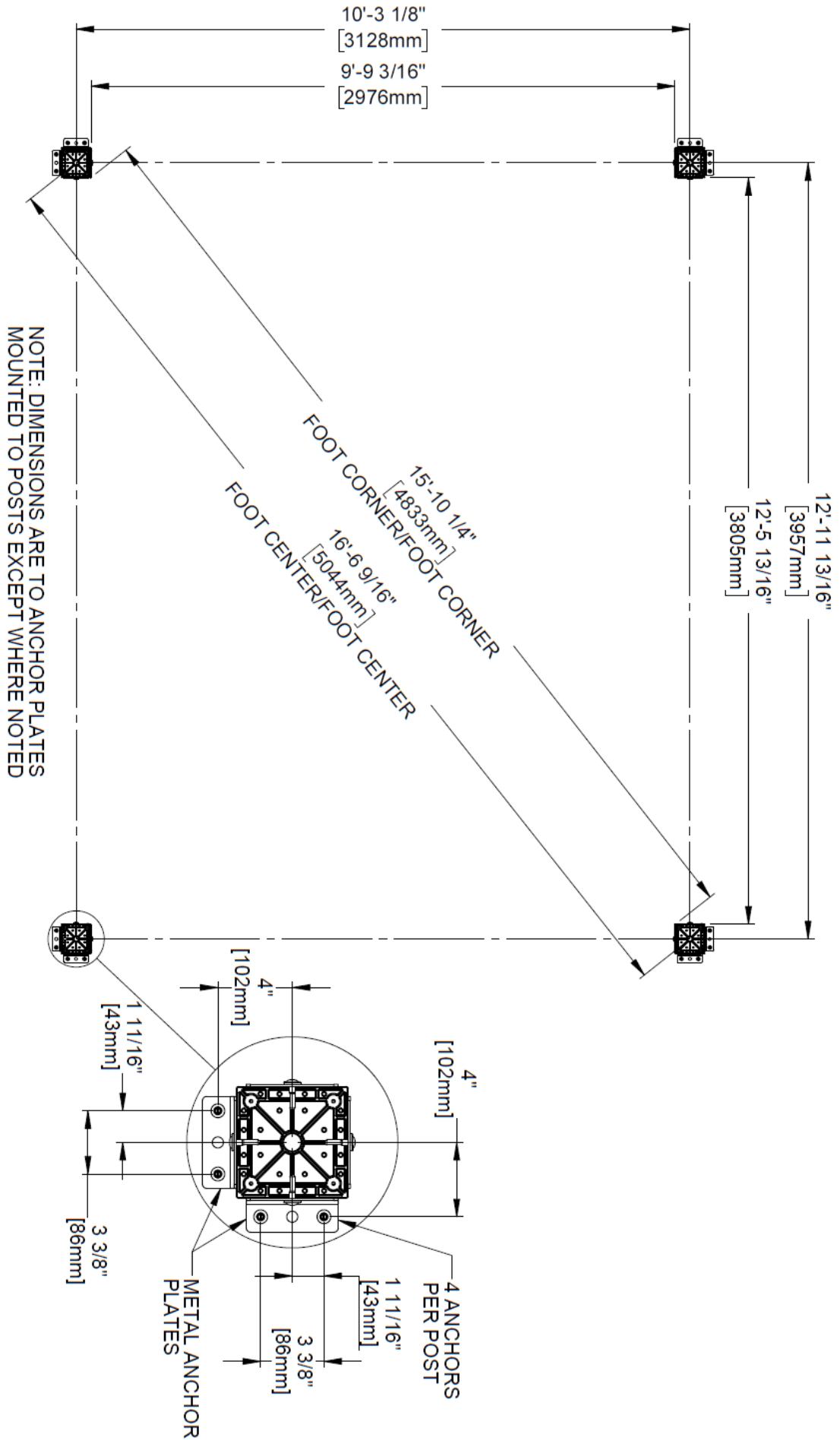

OWNER'S MANUAL - PARTS IDENTIFICATION

Wood Components (Not to Scale)



D01 GABLE BOARD - W4L19640
(x4) 1 3/8"x5 1/4"x24" (36x134x626)

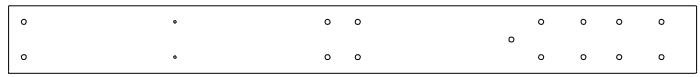

D02 TOP RAIL - W4L16886
(x4) 1 3/8"x5 1/4"x53 3/4" (36x134x1366)



D03 TOP RAIL - W4L16887
(x2) 1 3/8"x5 1/4"x57" (36x134x1448)



D04 CORBEL - W4L16853
(x4) 1 3/8"x5 1/4"x34 7/16" (36x134x875)



D05 GABLE BOARD - W4L16854
(x2) 1 3/8"x1 1/2"x5 1/4" (36x38x134)

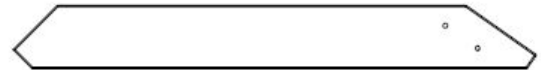

D06 CORBEL - W4L16375
(x3) 1 3/8"x5 1/4"x44 1/16" (36x134x1119)



D07 TOP RAIL - W4L16888
(x4) 1 3/8"x5 1/4"x82 1/4" (36x134x2091)



E01 RAFTER - W4L19638
(x8) 1 3/8"x3 3/8"x76 3/8" (36x86x1941)



E02 TRUSS - W4L19639
(x4) 1 3/8"x2 3/8"x74 15/16" (36x60x1910)



E05 RAFTER - W4L19637
(x4) 1 3/8"x3 3/8"x76 3/8" (36x86x1941)

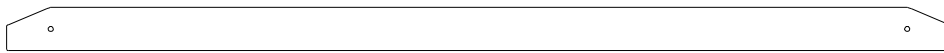

E06 ACCESSORY TRUSS - W4L16863
(x2) 1 3/8"x3 3/8"x73 13/16" (36x86x1875)



H01 SHEATHING BOARD - W4L19635
(x8) 1"x3 3/8"x80 3/8" (24x86x2040)



H02 FASCIA - W4L16891
(x2) 1"x3 3/8"x80 3/8" (24x86x2040)



H03 FASCIA - W4L16892
(x2) 1"x3 3/8"x87" (24x86x2209)



H04 RAFTER - W4L16893
(x2) 1"x3 3/8"x89 1/4" (24x86x2267)



H05 RAFTER - W4L16894
(x2) 1"x3 3/8"x69 1/2" (24x86x1766)

OWNER'S MANUAL - PARTS IDENTIFICATION

Wood Components (Not to Scale)

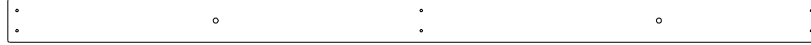

H06 FASCIA - W4L16895
(x2) 1"x3 3/8"x63 1/2" (24x86x1614)

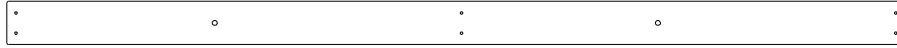

H07 FASCIA - W4L16896
(x2) 1"x3 3/8"x70 1/8" (24x86x1783)



H08 NOTCHED SUPPORT BOARD - W4L16915
(x2) 1"x3 3/8"x89 1/2" (24x86x2274)



H09 SHEATHING BOARD - W4L19636
(x8) 1"x3 3/8"x87" (24x86x2209)



J09 RIDGE CAP STIFFENER - W4L16897
(x2) 1"x2 3/8"x77 5/8" (24x60x1973)



J10 RIDGE CAP STIFFENER - W4L16898
(x2) 1"x2 3/8"x89 1/2" (24x60x2273)

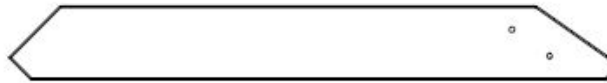

CA01 CORBEL - W2A03461
(x1) 1 3/8"x5 3/8"x44 1/16" (36x136x1119)



GP1 GABLE PANEL - W2A04177
(x2) 2 13/16"x5 1/4"x80 3/16" (72x134x2037)

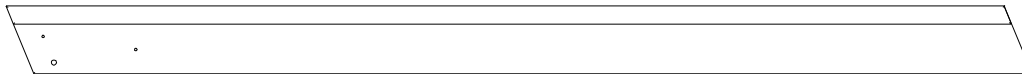

GP2 GABLE PANEL - W2A04178
(x2) 2 13/16"x5 1/4"x80 3/16" (72x134x2037)



P01 POST - W2A03501
(x2) 6"x6"x89 1/2" (152x152x2274)



P02 POST - W2A03502
(x2) 6"x6"x89 1/2" (152x152x2274)

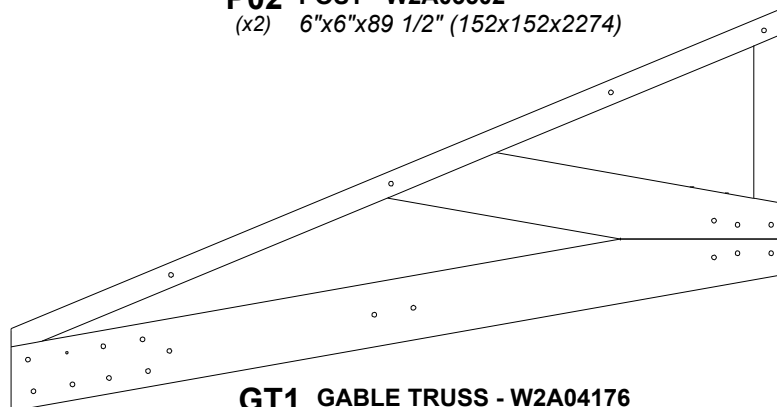

GT1 GABLE TRUSS - W2A04176
(x4) 1 7/16"x33 5/8"x64 9/16" (36x864x1854)

OWNER'S MANUAL - PARTS IDENTIFICATION

Hardware Components

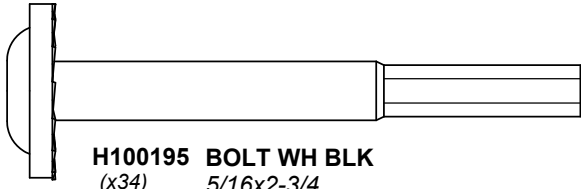

H100195 BOLT WH BLK
(x34) 5/16x2-3/4

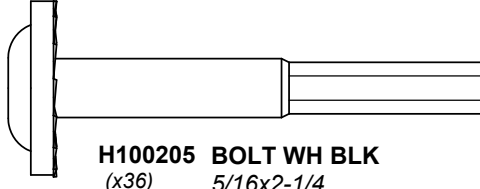

H100205 BOLT WH BLK
(x36) 5/16x2-1/4

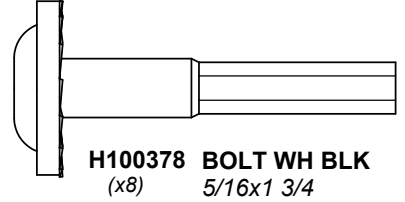

H100378 BOLT WH BLK
(x8) 5/16x1 3/4



H100416 BOLT WH BLK
(x20) 5/16x3

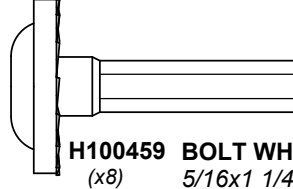

H100459 BOLT WH BLK
(x8) 5/16x1 1/4

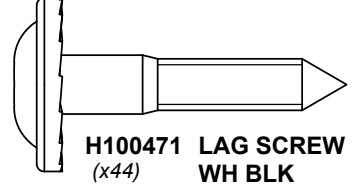

H100471 LAG SCREW WH BLK
(x44) 5/16x1 1/2



H100503 BOLT WH BLK
(x6) 5/16x3-1/2

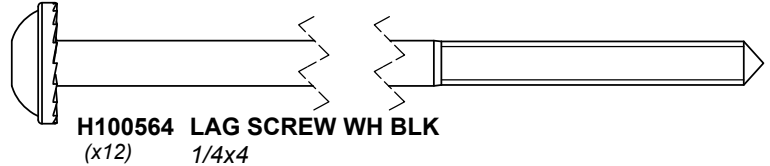

H100564 LAG SCREW WH BLK
(x12) 1/4x4

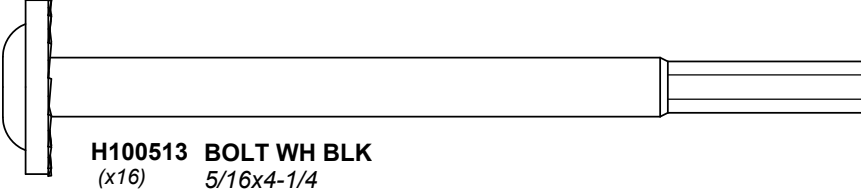

H100513 BOLT WH BLK
(x16) 5/16x4-1/4

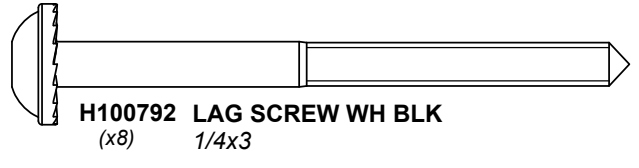

H100792 LAG SCREW WH BLK
(x8) 1/4x3

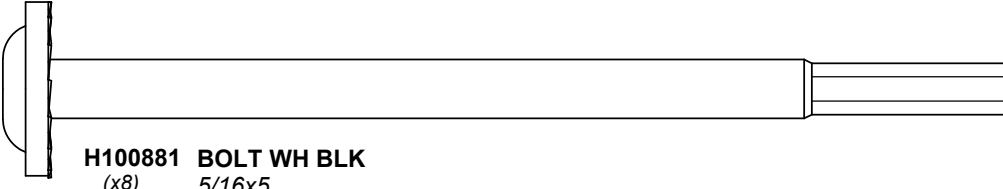

H100881 BOLT WH BLK
(x8) 5/16x5

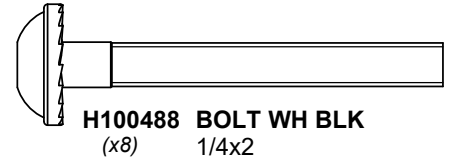

H100488 BOLT WH BLK
(x8) 1/4x2

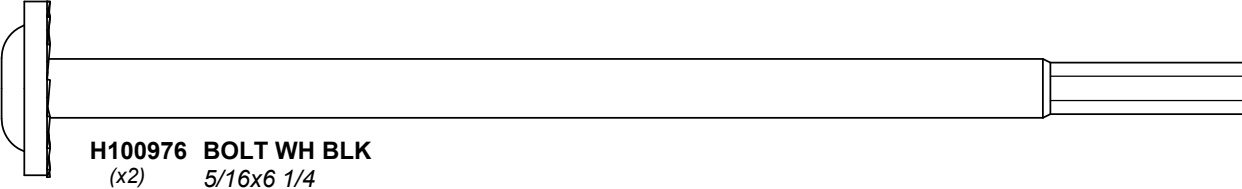

H100976 BOLT WH BLK
(x2) 5/16x6 1/4

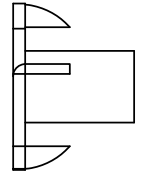

H100379 T-NUT BLK
(x96) 5/16

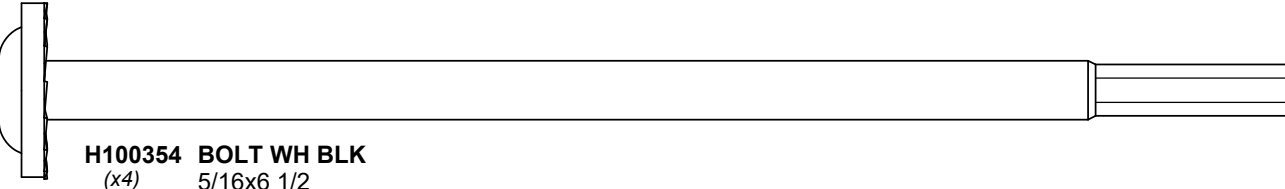

H100354 BOLT WH BLK
(x4) 5/16x6 1/2

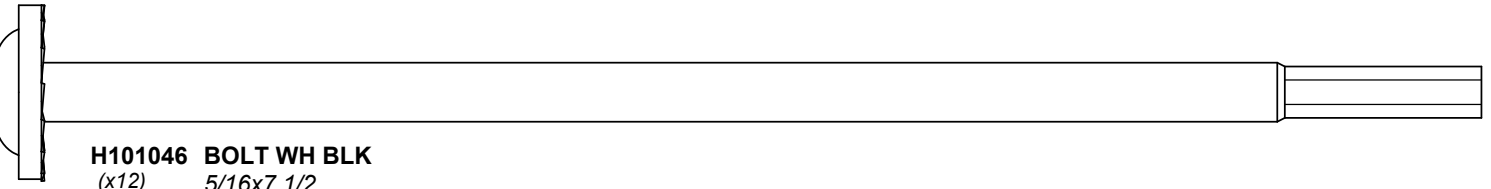

H101046 BOLT WH BLK
(x12) 5/16x7 1/2

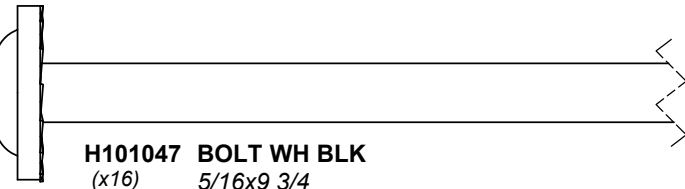

H101047 BOLT WH BLK
(x16) 5/16x9 3/4

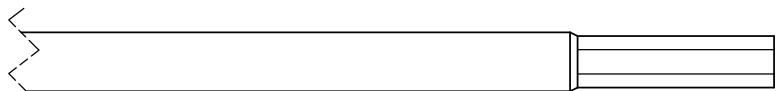

OWNER'S MANUAL - PARTS IDENTIFICATION

Hardware Components



H100201 SCREW PFH BLK
(x36) 8x2-1/2

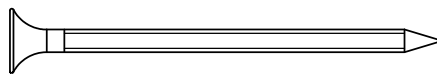

H100483 SCREW PFH BLK
(x4) 8x2 1/4

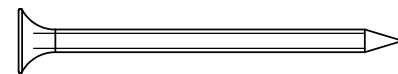

H100391 SCREW PFH BLK
(x148) 8x2

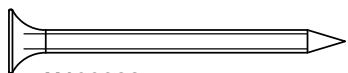

H100382 SCREW PFH BLK
(x14) 8x1 3/4

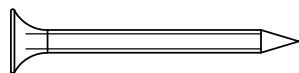

H100200 SCREW PFH BLK
(x20) 8x1 1/2

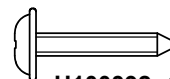

H100392 SCREW PWH BLK
(x22) 8x3/4

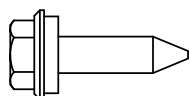

H100833 SCREW WOODGRIP
(x220) 10x3/4

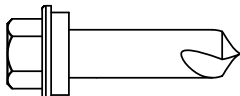

H100759 SCREW TAPPING
(x20) 1/4x1

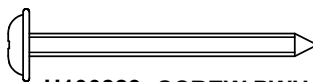

H100823 SCREW PWH BLK
(x16) 8x1-1/2

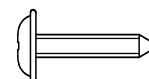

H100202 SCREW PWH BLK
(x4) 8x5/8

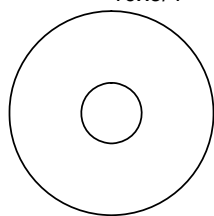

H100478 WASHER FLAT BLK
(x78) 8x27

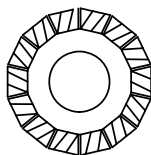

H100198 WASHER LOCK EXT BLK
(x76) 8x19

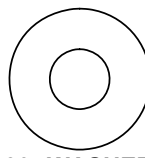

H100630 WASHER FLAT BLK
(x24) 8x19

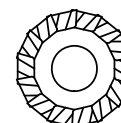

H100405 WASHER LOCK EXT BLK
(x20) 6x15

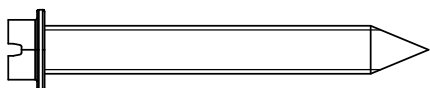

H100120 SCREW CONCRETE ANCHOR
(x16) 1/4x2

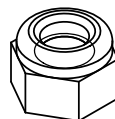

H100479 NUT LOCK BLK
(x74) 5/16



H100653 NUT LOCK BLK
(x8) 1/4

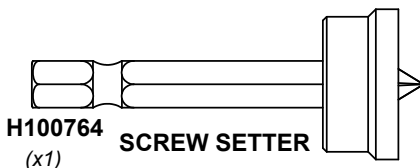

H100764 SCREW SETTER
(x1)

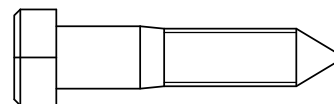

H100659 LAG SCREW BLK
(x4) 5/16x1 1/2

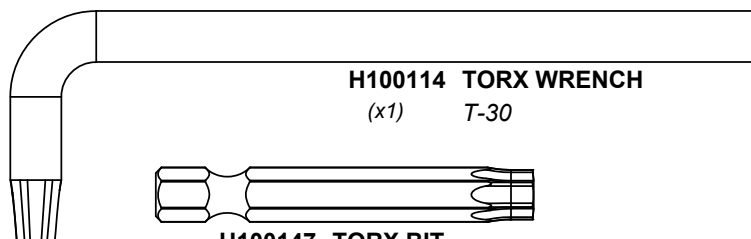

H100114 TORX WRENCH
(x1) T-30

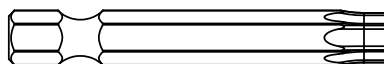

H100147 TORX BIT
(x1) T-30

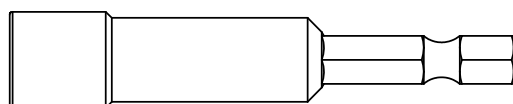

H101106 HEX DRIVER
(x1) 5/16



H101100 MAGNETIC DRIVER
(x1)

OWNER'S MANUAL - PARTS IDENTIFICATION

Accessory Components (Not to Scale)

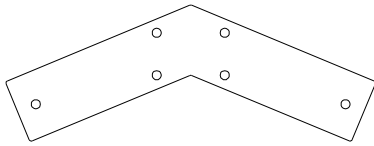

A4M01130
(x2) **GABLE BRACKET**

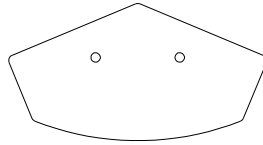

A4M01147
(x2) **PEAK SEAM BRACKET**

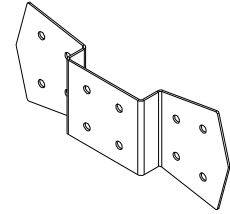

A4M01129
(x4) **GABLE BRACKET**



A4M00978
(x8) **POST PLATE**

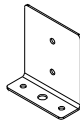

A4M00977
(x8) **POST ANCHORING PLATE**

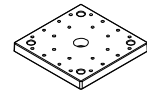

A6P00308
(x4) **6x6 POST FOOT**

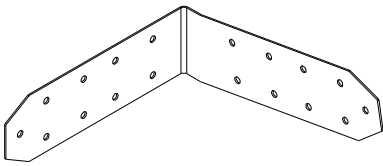

A4M01301
(x2) **RIGHT OUTSIDE BRACKET**

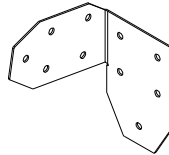

A4M01232
(x2) **LEFT ANGLE BRACKET**

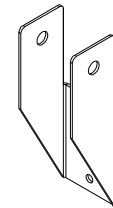

A4M01228
(x8) **RAFTER BRACKET**

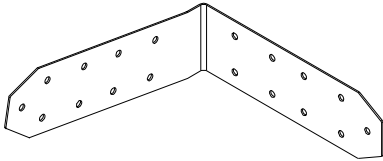

A4M01302
(x2) **LEFT OUTSIDE BRACKET**

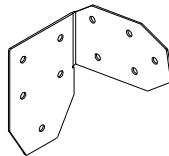

A4M01233
(x2) **RIGHT ANGLE BRACKET**

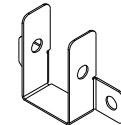

A4M01148
(x2) **TRUSS BRACKET**



A4M02158
(x1) **BYD ID TAG PATIO**

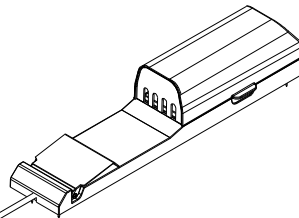

9205413
(x1) **ELECTRICAL ENCLOSURE**

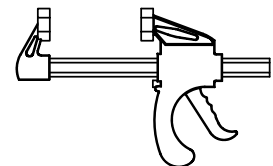

A6P00460
(x2) **6" QUICK RELEASE BAR CLAMP**

OWNER'S MANUAL - PARTS IDENTIFICATION

Accessory Components (Not to Scale)

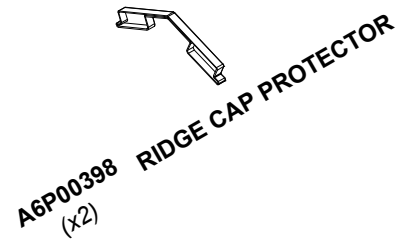
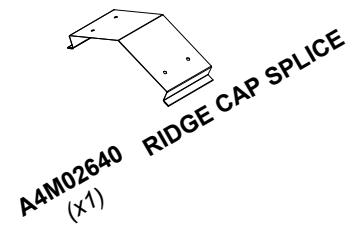
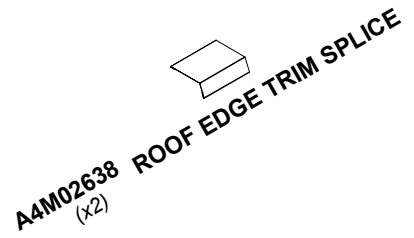
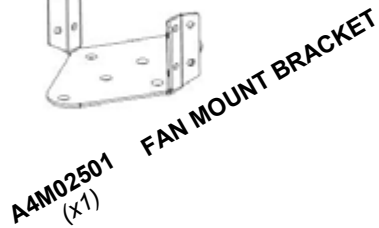
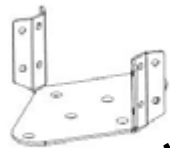
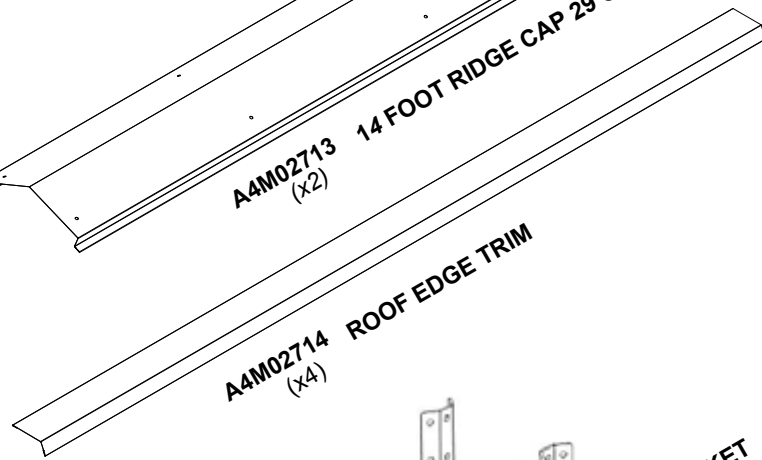
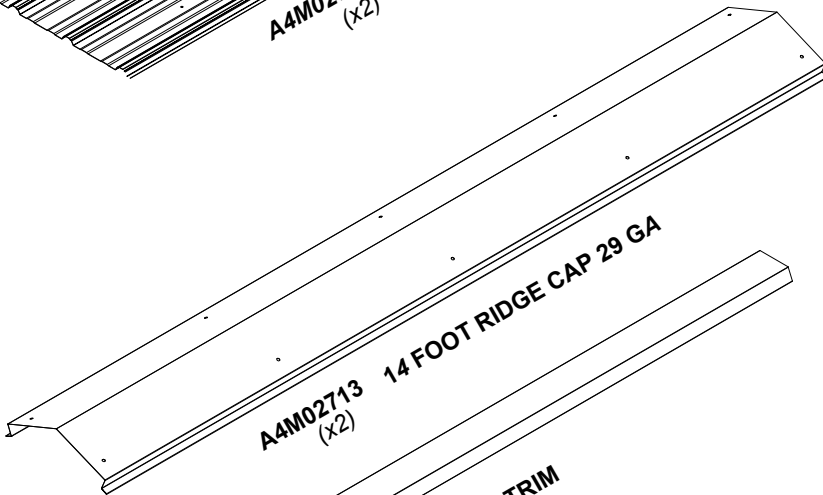
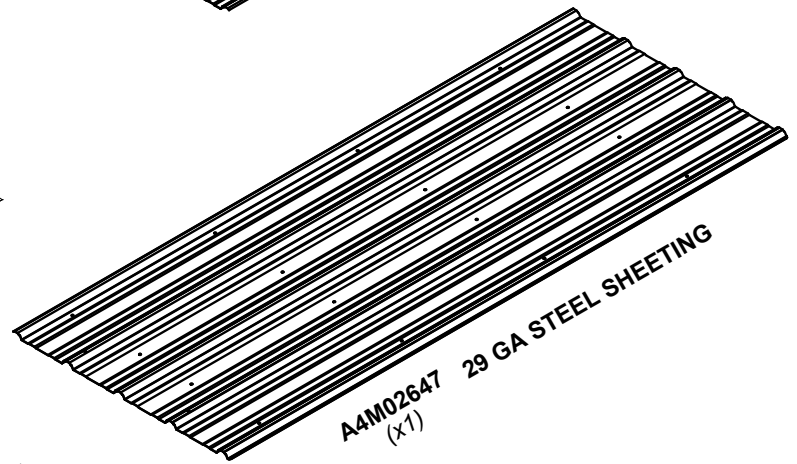
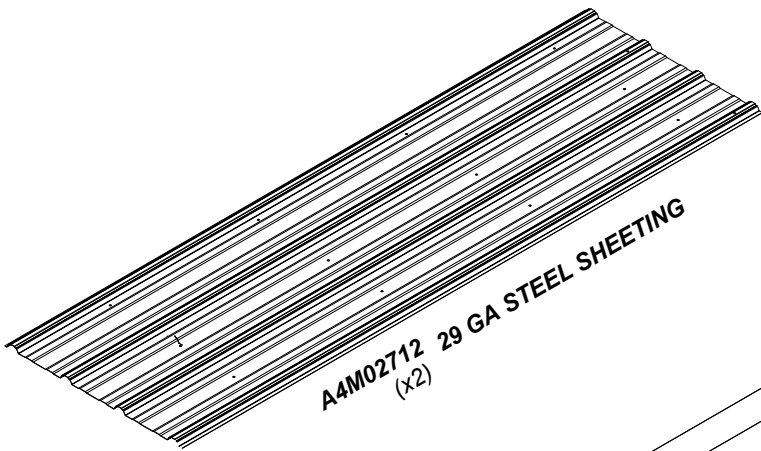
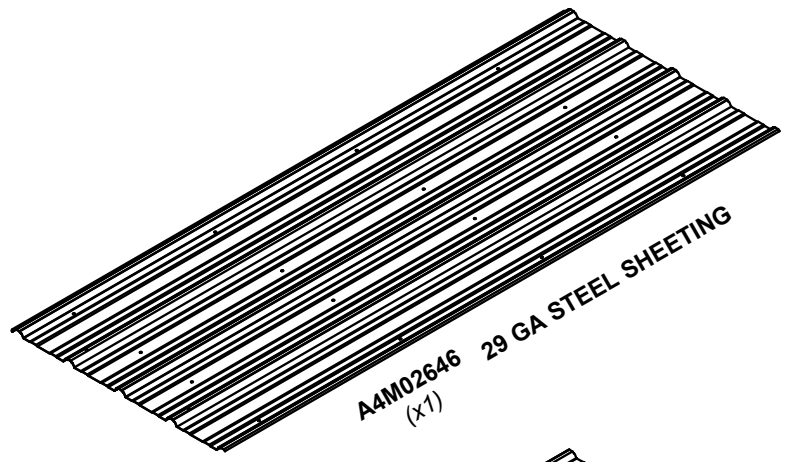
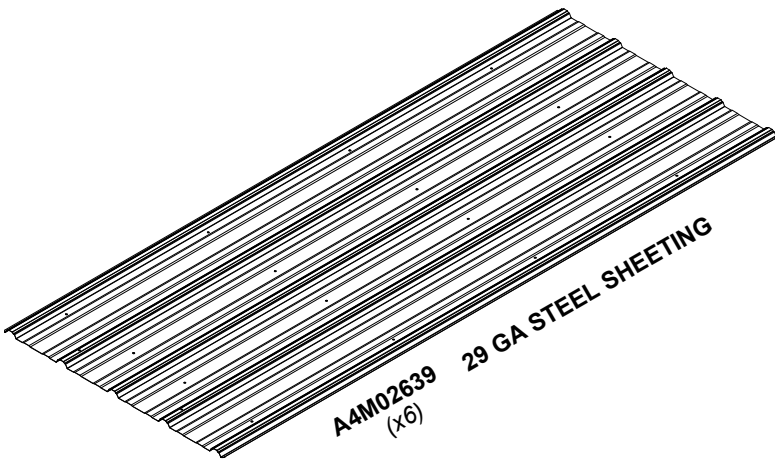

OWNER'S MANUAL - PARTS IDENTIFICATION

Accessory Components (Not to Scale)

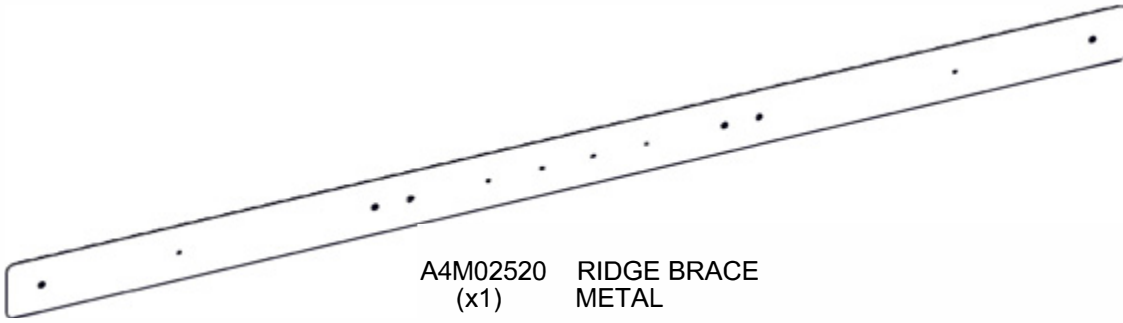

A4M02520 RIDGE BRACE
(x1) METAL



A4M02376 GAZEBO BRACE
(x2) METAL

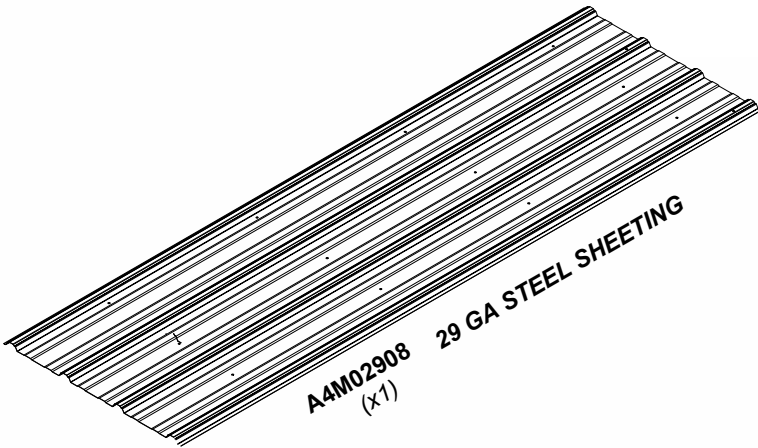

A4M02908 29 GA STEEL SHEETING
(x1)

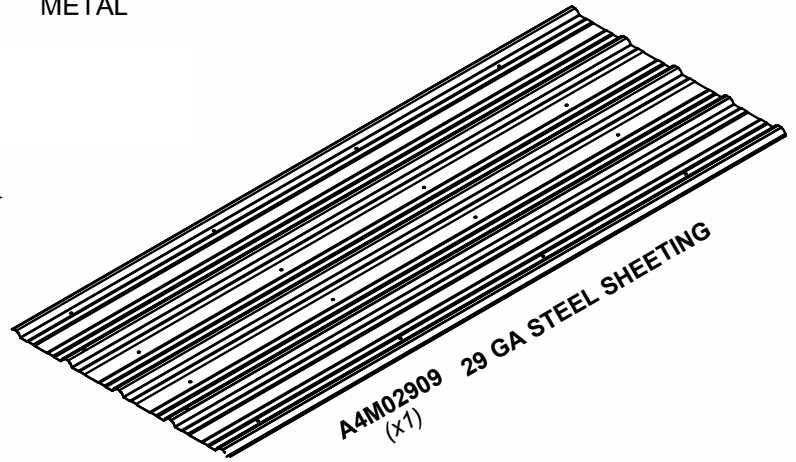

A4M02909 29 GA STEEL SHEETING
(x1)



A4M02679 ROOF END TRIM
(x2)



A4M02680 ROOF END TRIM
(x2)

PRE-ASSEMBLY STEP 1 - SORTING PARTS

It is critical for ease of assembly that you take the time to sort and organize the wood and hardware.

WOOD PARTS:

- Organize wood parts by the three-digit, alpha-numeric number stamped on each board (ex. P01).
- If there are multiple boards with the same stamped number, stack those pieces together.
- Stamps can be found on the flat surface of the boards or on the end of the boards.
- Allow yourself plenty of room - the wood pieces can take up a significant amount of space.

NOTE: CARTONS ARE NOT ORGANIZED BY BOARD NUMBER.



HARDWARE PARTS:

- We recommend that you have a separate table to organize the hardware.
- Hardware bags are printed with a seven-digit, alpha-numeric part number.
- You can organize your hardware by part number or group by hardware type (i.e. bolts, nuts, etc.).
- During assembly you only need to reference the last four digits of the number.

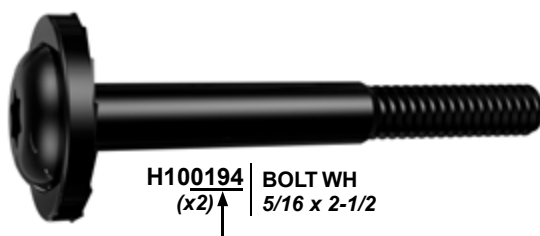

PRE-ASSEMBLY STEP 2 - TOOLS REQUIRED



Cordless Drill
or Electric Drill



Drill
Attachments:
Phillips Head



1/8", 3/16", 3/8" &
7/16" Drill Bits



Phillips Screw Driver



Open End
Wrenches 1/2" &
9/16"



3/8" Drive Ratchet, 1/2" &
7/16" STD Sockets 1/2" & 7/16"
Deep Sockets



Claw Hammer



Rubber Mallet
- Optional

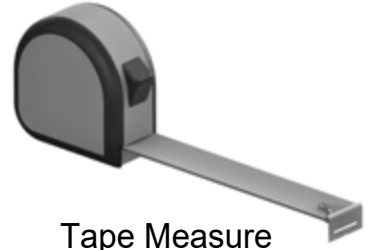

Tape Measure

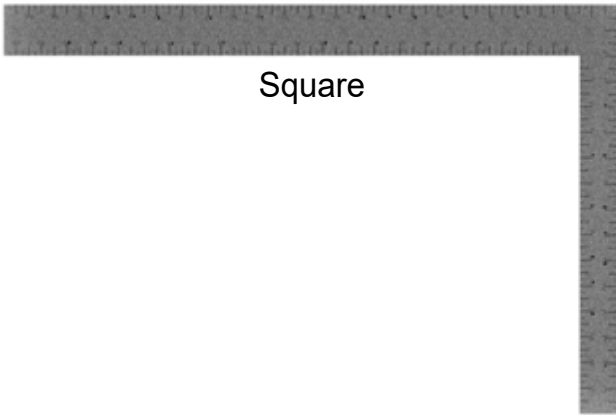

Square



Level 24"

PRE-ASSEMBLY STEP 3 - CHOOSE YOUR ASSEMBLY METHOD

There are several types of assembly instructions available to you.

1. Printed Assembly Manual included with your set
2. BILT APP - 3D interactive instructions
3. Combination of the Printed Manual and BILT APP (Note: Step numbers can differ between the two methods)



The graphic features the BILT logo (a hexagon with a bolt head inside) and the word "BILT." in a bold, sans-serif font. To the right is a large QR code. Below the logo, the text "Scan for easy 3D instructions" is written in a large, bold font. Underneath this, it says "Download the BILT app before you begin". To the right of this text are two buttons: "Download on the App Store" and "GET IT ON Google Play". At the bottom, a smartphone screen displays a 3D assembly instruction for step 17, showing a metal frame with a horizontal bar being attached. The screen includes a "Hardware Needed" list, a close button (X), a menu button (three dots), a volume icon, and navigation arrows.

STEP 4 -POST ASSEMBLY

QTY	PART NUMBER	DESCRIPTION
8	H100200	SCREW PFH 8x1 1/2 BLK



P01 POST - W2A03501
(x1) 6"x6"x89 1/2" (152x152x2274)



P02 POST - W2A03502
(x1) 6"x6"x89 1/2" (152x152x2274)

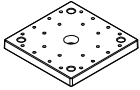

A6P00308 (x2) 6x6 POST FOOT

• FOR EASE OF ASSEMBLY, WE RECOMMEND USING SAW HORSES FOR STEPS 4 - 11.

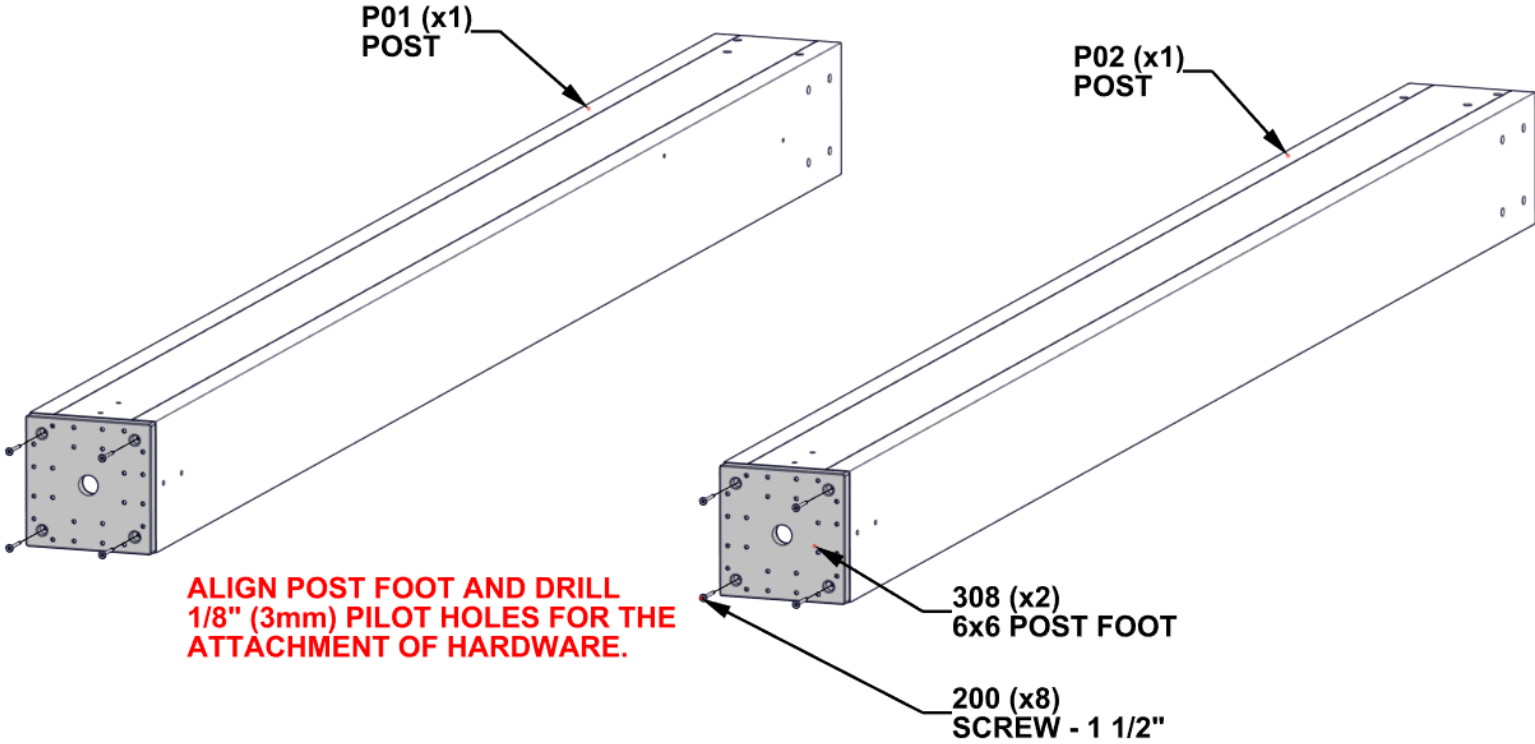

STEP 5 - GABLE ASSEMBLY

QTY	PART NUMBER	DESCRIPTION
2	H100483	SCREW PFH 8x2 1/4 BLK



D01 GABLE BOARD - W4L19640
(x1) 1 3/8"x5 1/4"x24 1/4" (36x134x626)



D05 GABLE BOARD - W4L16854
(x1) 1 3/8"x1 1/2"x5 1/4" (36x38x134)

- ALIGN D05 WITH D01 ENSURING THAT BOTTOM FACES ARE FLUSH.
- DRILL 1/8" (3mm) PILOT HOLES IN D01 USING D05 AS TEMPLATE.

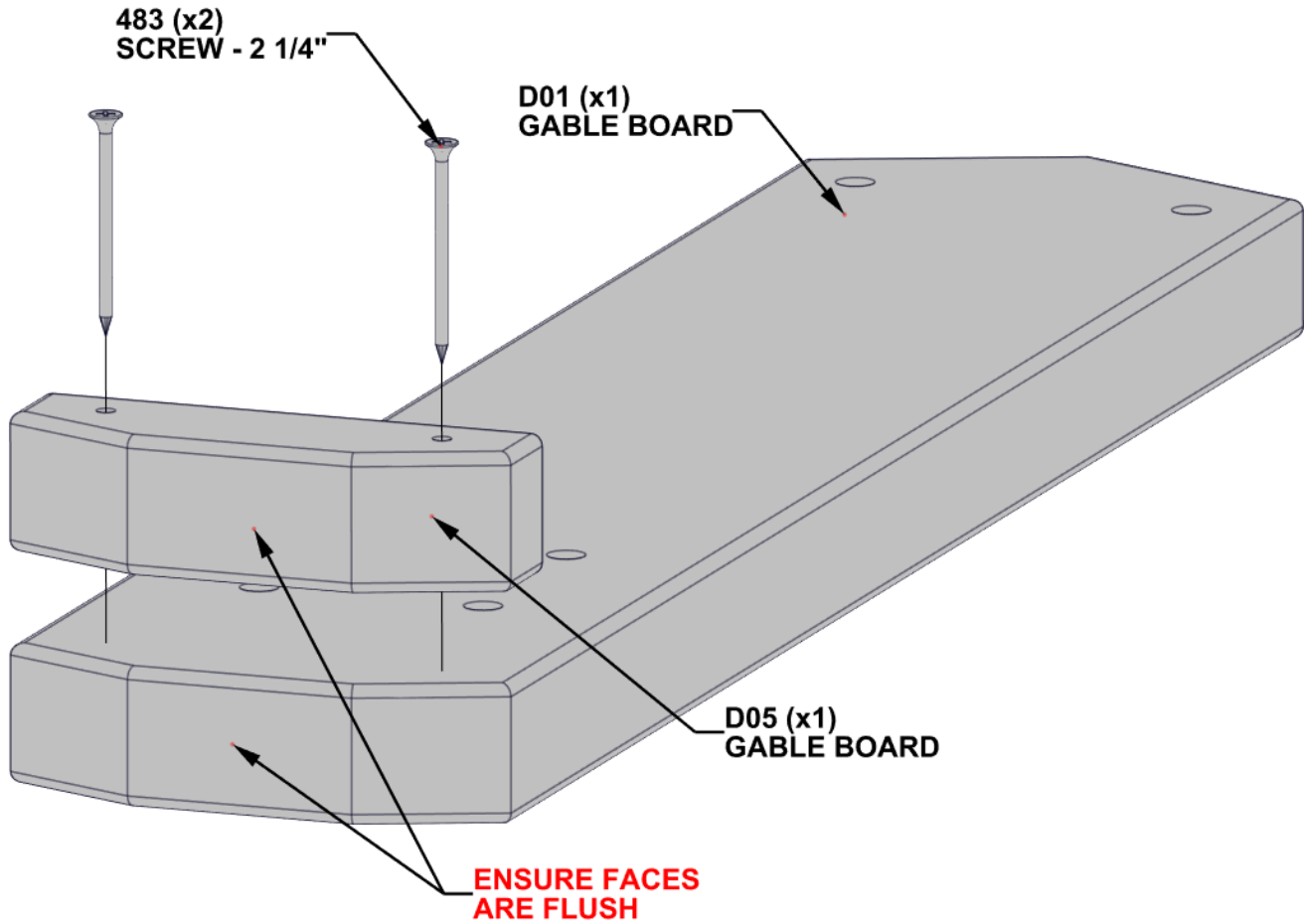

STEP 6 - GABLE ASSEMBLY

QTY	PART NUMBER	DESCRIPTION
4	H100479	NUT LOCK 5/16 BLK
4	H100881	BOLT WH 5/16x5 BLK
4	H100478	WASHER FLAT 8x27 BLK

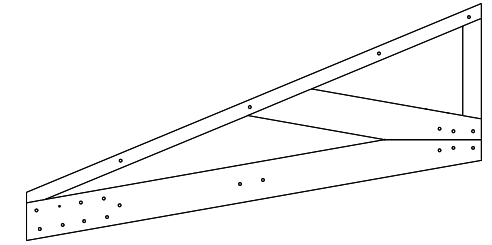

GT1 GABLE TRUSS - W2A04176
(x2) 1 7/16"x33 5/8"x64 9/16" (36x864x1854)



D01 GABLE BOARD - W4L19640
(x1) 1 3/8"x5 1/4"x24 5/8" (36x134x626)

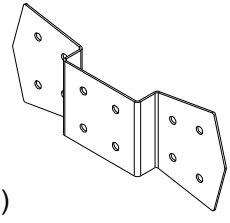

A4M01129 GABLE BRACKET
(x2)

• IF HOLES DO NOT ALIGN, USE THE METAL BRACKET AS A GUIDE AND A 7/16" (10mm) DRILL BIT TO DRILL THROUGH THE BOARDS.

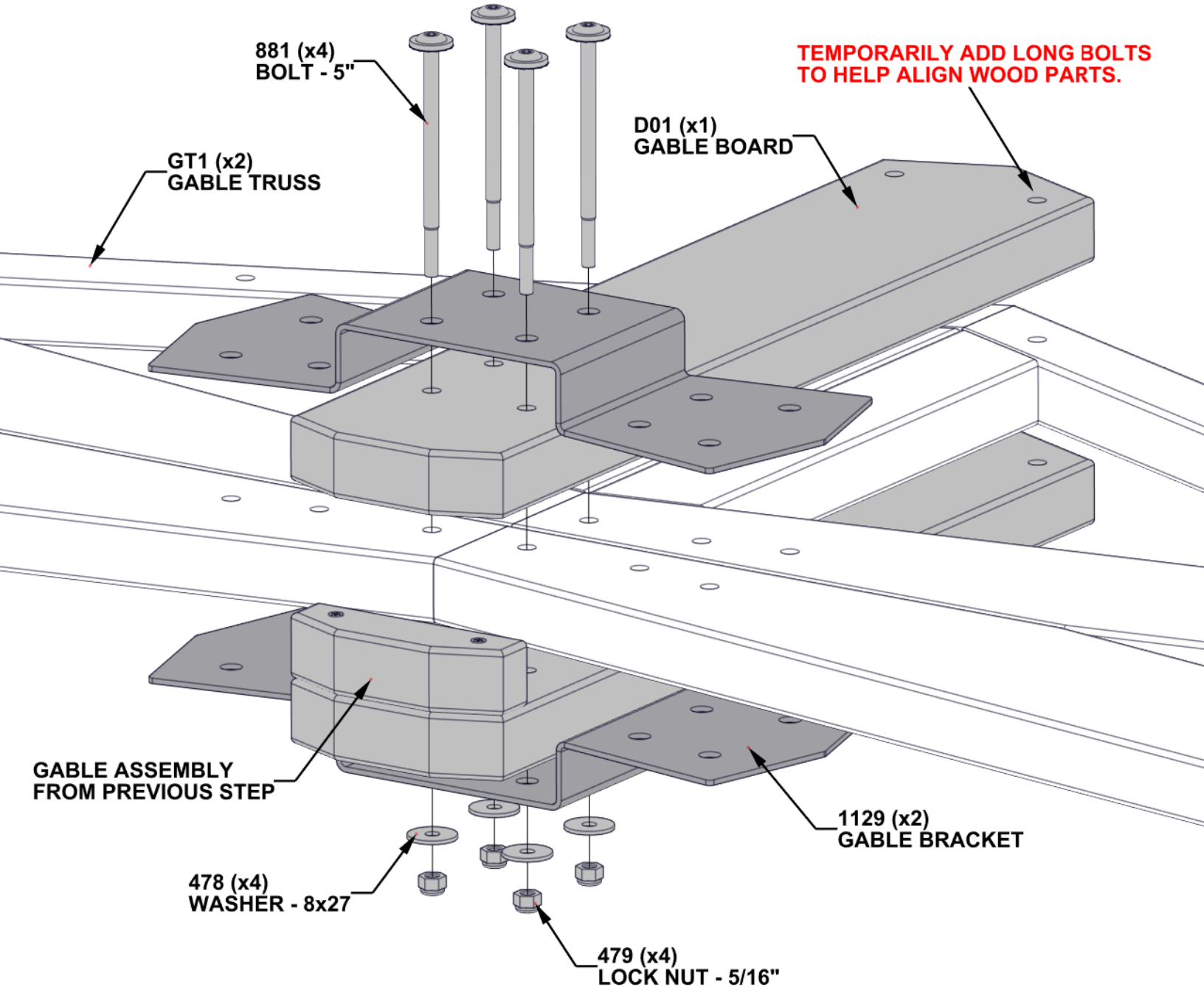

STEP 7 - GABLE ASSEMBLY

QTY	PART NUMBER	DESCRIPTION
8	H100479	NUT LOCK 5/16 BLK
8	H100205	BOLT WH 5/16x2 1/4 BLK
8	H100478	WASHER FLAT 8x27 BLK

• IF HOLES DO NOT ALIGN, USE THE METAL BRACKET AS A GUIDE AND A 7/16" (10mm) DRILL BIT TO DRILL THROUGH THE BOARDS.

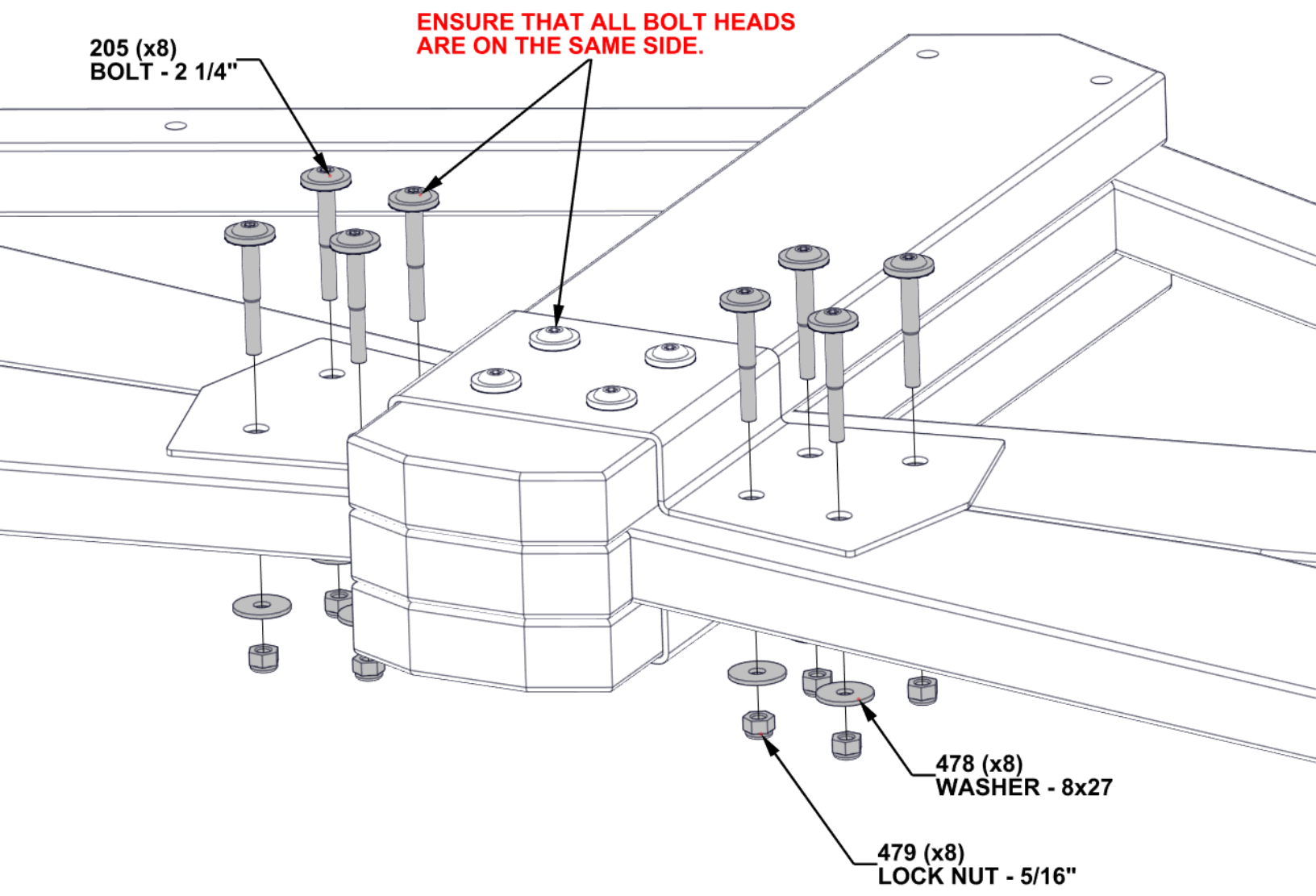

STEP 8A - GABLE ASSEMBLY

QTY	PART NUMBER	DESCRIPTION
10	H100478	WASHER FLAT 8x27 BLK
1	H100659	LAG SCREW HEX 5/16x1 1/2 BLK
9	H100479	NUT LOCK 5/16 BLK
8	H100379	T-NUT 5/16 BLK
4	H101047	BOLT WH 5/16x9 3/4 BLK
5	H100416	BOLT WH 5/16x3 BLK
5	H100205	BOLT WH 5/16x2 1/4 BLK
3	H101046	BOLT WH 5/16x7 1/2 BLK
1	H100471	LAG SCREW WH 5/16x1 1/2 BLK

- P01 POST - W2A03501
(x1) 6"x6"x89 1/2" (152x152x2274)
- D02 TOP RAIL - W4L16886
(x1) 1 3/8"x5 1/4"x53 3/4" (36x134x1366)
- D07 TOP RAIL - W4L16888
(x1) 1 3/8"x5 1/4"x82 1/4" (36x134x2091)

- A4M01232 LEFT ANGLE BRACKET
(x1)
- A4M01302 LEFT OUTSIDE BRACKET
(x1)

• INSERT T-NUTS FIRST

ALIGN HOLES BEFORE TIGHTENING HARDWARE

NOTE PILOT HOLES FOR ORIENTATION

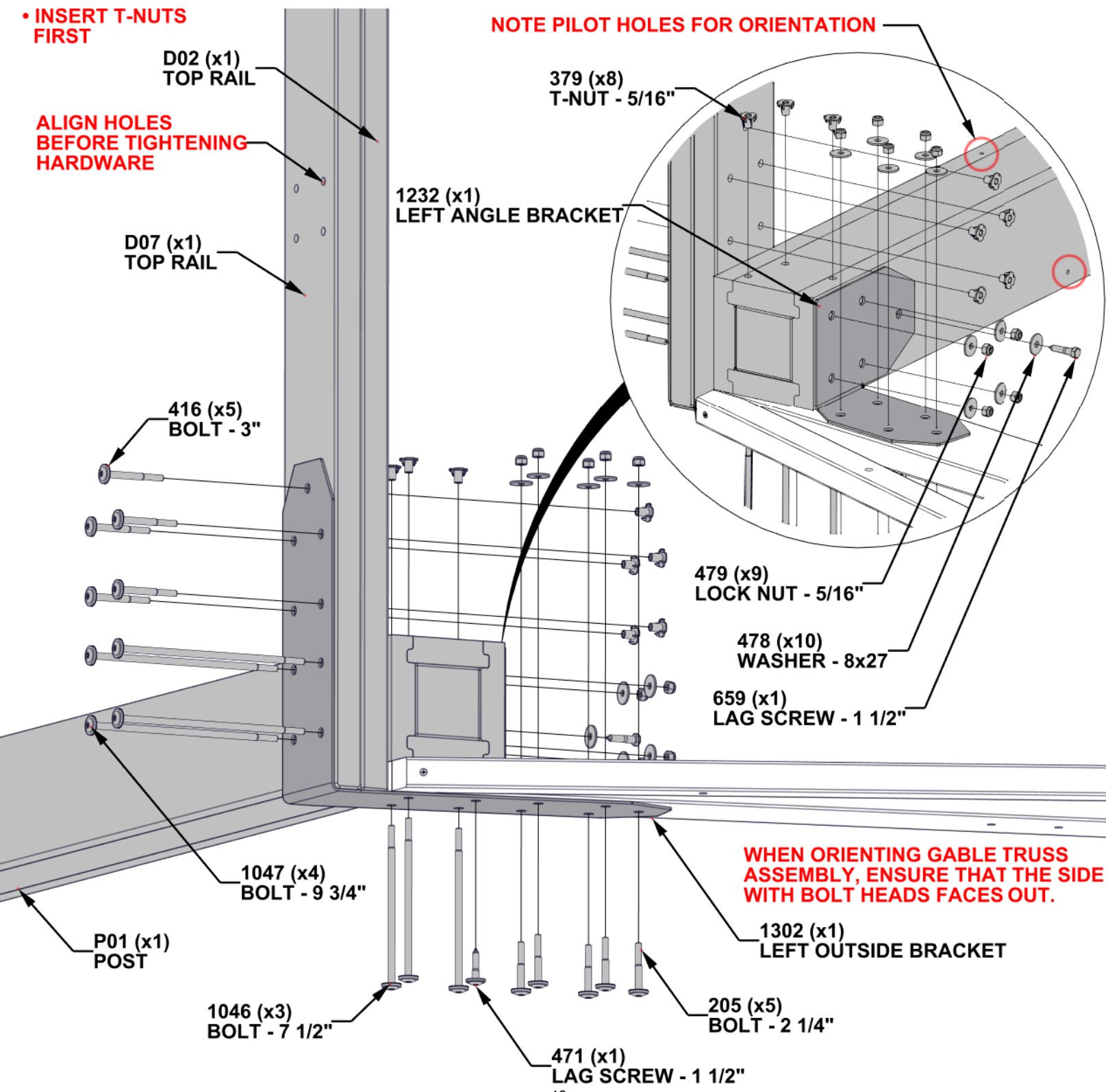

STEP 8B - GABLE ASSEMBLY

QTY	PART NUMBER	DESCRIPTION
10	H100478	WASHER FLAT 8x27 BLK
1	H100659	LAG SCREW HEX 5/16x1 1/2 BLK
9	H100479	NUT LOCK 5/16 BLK
8	H100379	T-NUT 5/16 BLK
3	H101046	BOLT WH 5/16x7 1/2 BLK
4	H101047	BOLT WH 5/16x9 3/4 BLK
5	H100205	BOLT WH 5/16x2 1/4 BLK
5	H100416	BOLT WH 5/16x3 BLK
1	H100471	LAG SCREW WH 5/16x1 1/2 BLK

P02 POST - W2A03502
(x1) 6"x6"x89 1/2" (152x152x2274)

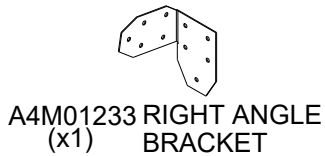

D02 TOP RAIL - W4L16886
(x1) 1 3/8"x5 1/4"x53 3/4" (36x134x1366)

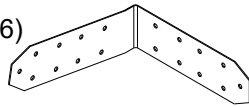

D07 TOP RAIL - W4L16888
(x1) 1 3/8"x5 1/4"x82 1/4" (36x134x2091)

• INSERT T-NUTS FIRST

NOTE PILOT HOLES FOR ORIENTATION

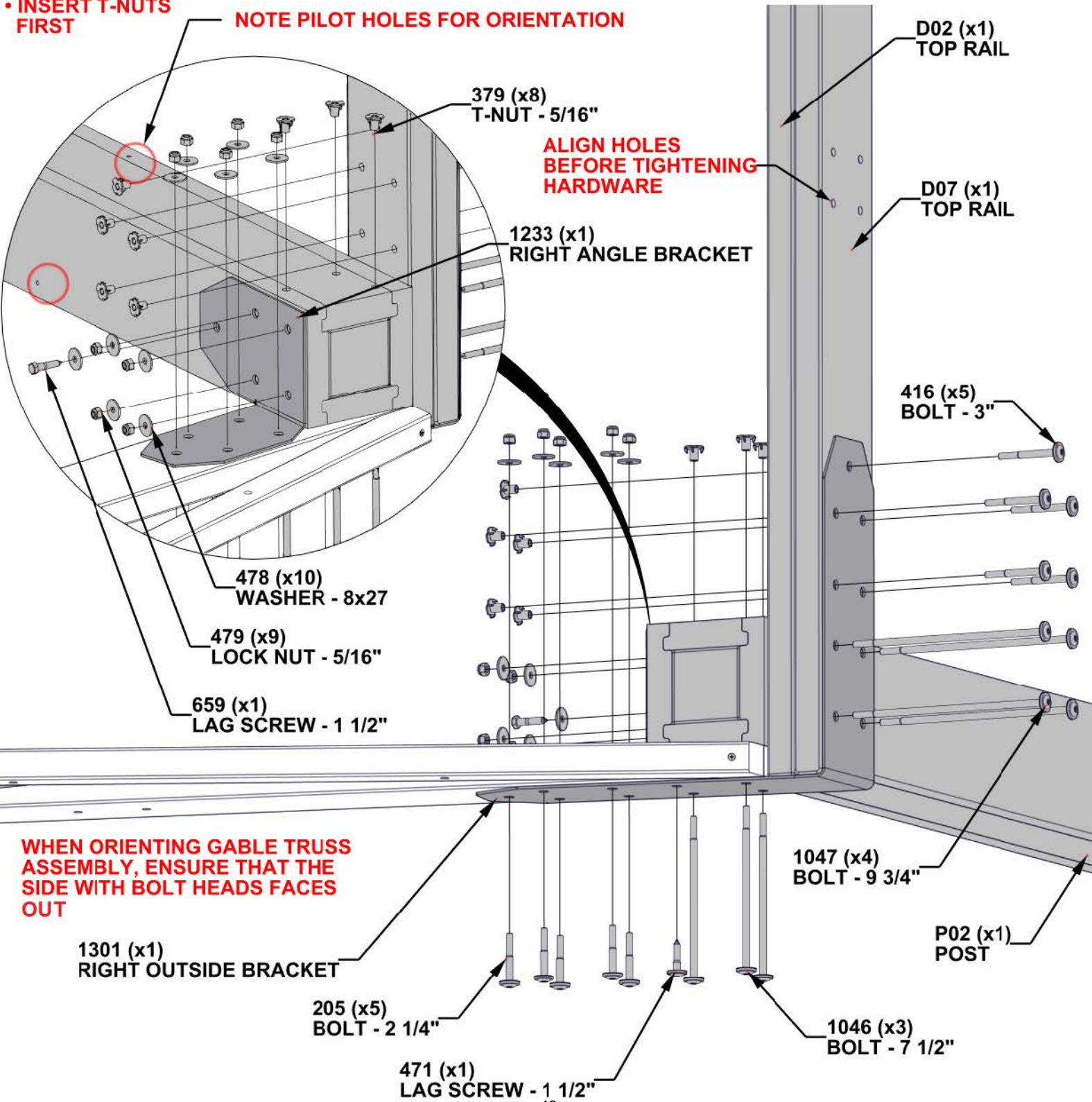

STEP 9 - GABLE ASSEMBLY

Qty	PART NUMBER	DESCRIPTION
4	H100195	BOLT WH 5/16x2 3/4 BLK
4	H100198	WASHER LOCK EXT 8x19
4	H100379	T-NUT 5/16 BLK
2	H100405	WASHER LOCK EXT 6x15
2	H100792	LAG SCREW WH 1/4x3 BLK



D06 CORBEL - W4L16375
(x1) 1 3/8"x5 1/4"x44 1/16" (36x134x1119)



CA01 CORBEL WITH TAG - W2A03461
(x1) 1 3/8"x5 1/4"x44 1/16" (36x134x1119)

- WHEN BUILDING THE SECOND END GABLE, TWO D06 CORBELS WILL BE USED.
- INSERT T-NUTS FIRST.

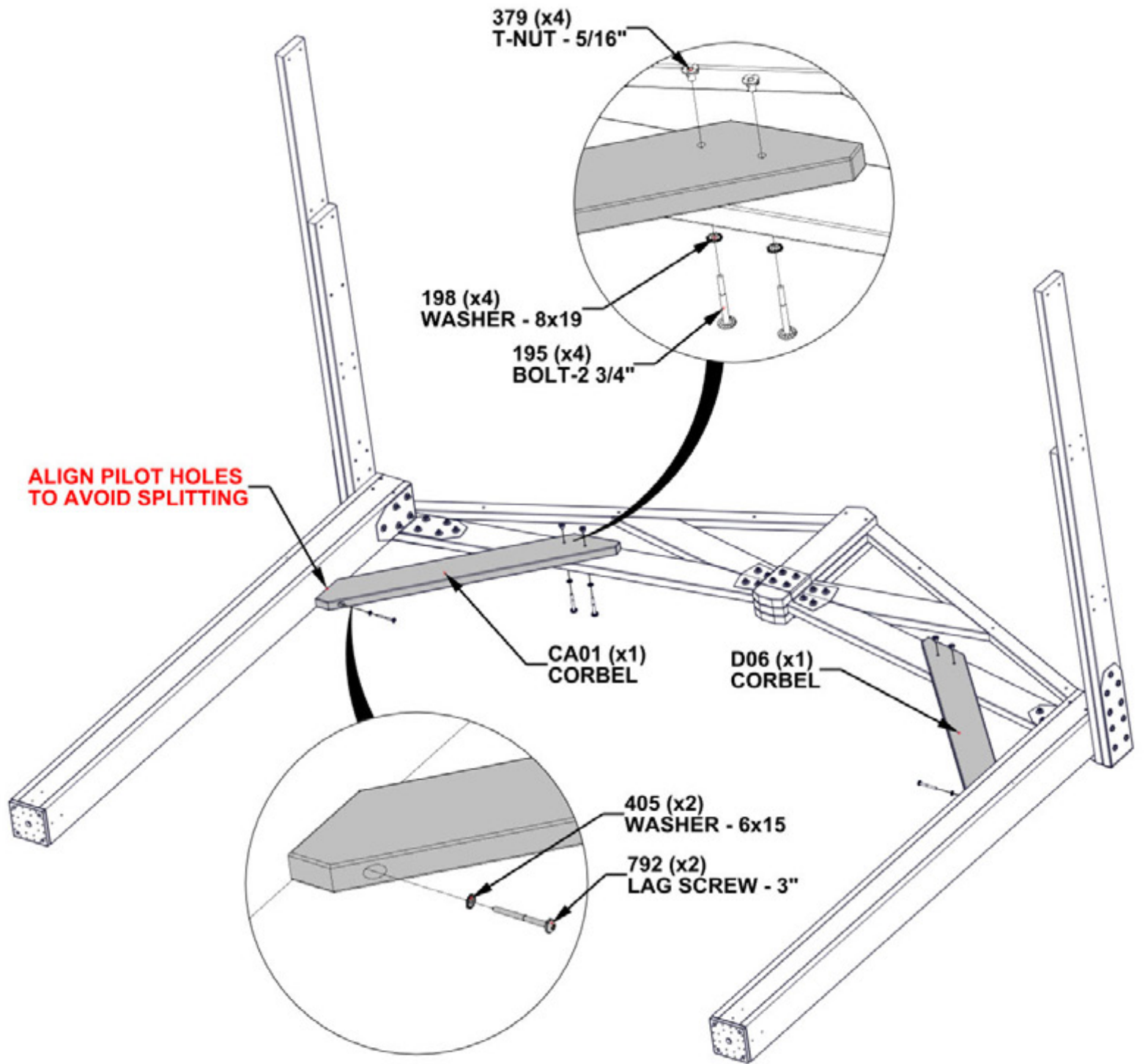

STEP 10 - GAZEBO ASSEMBLY



D04 CORBEL - W4L16853
(x2) 1 3/8"X5 1/4"X35 7/8" (36x134x875)

Qty	PART NUMBER	DESCRIPTION
8	H100198	WASHER LOCK EXT 8x19
8	H100379	T-NUT 5/16 BLK
2	H100405	WASHER LOCK EXT 6x15
8	H100513	BOLT WH 5/16x4 1/4 BLK
2	H100792	LAG SCREW WH 1/4x3 BLK

• INSERT T-NUT FIRST

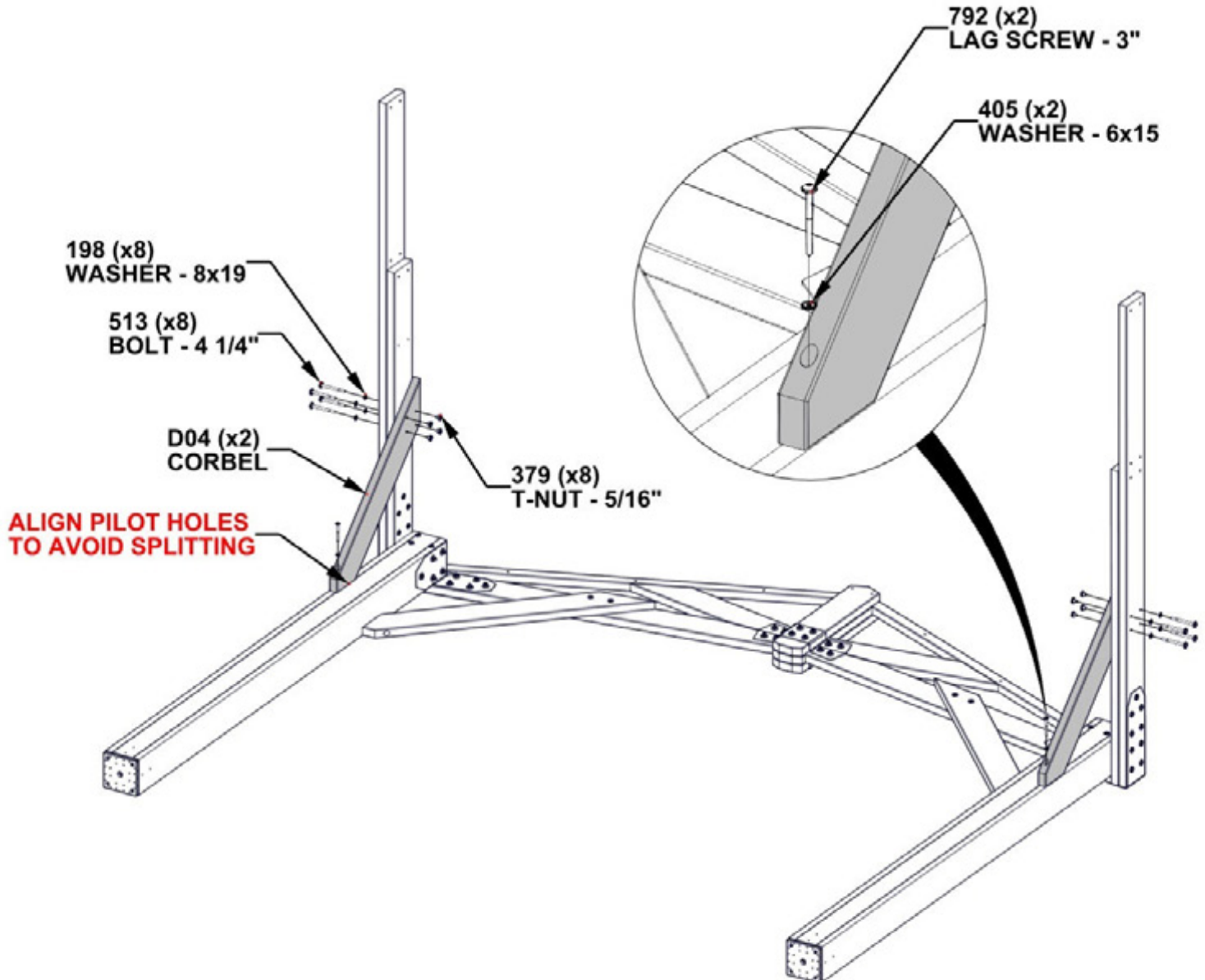

**REPEAT POST AND GABLE ASSEMBLY
STEPS 4 THROUGH 10**

STEP 11A - GAZEBO ASSEMBLY

Qty	PART NUMBER	DESCRIPTION
4	H100195	BOLT WH 5/16x2 3/4 BLK
4	H100198	WASHER LOCK EXT 8x19
4	H100201	SCREW PFH 8x2 1/2 BLK
4	H100379	T-NUT 5/16 BLK



A4M02376 GAZEBO BRACE
(x2) METAL

- ATTACH 2376 BRACE BY SLIDING IT IN BETWEEN BOARDS TO THE FIRST SET OF BOLT HOLES.

• INSERT T-NUTS FIRST

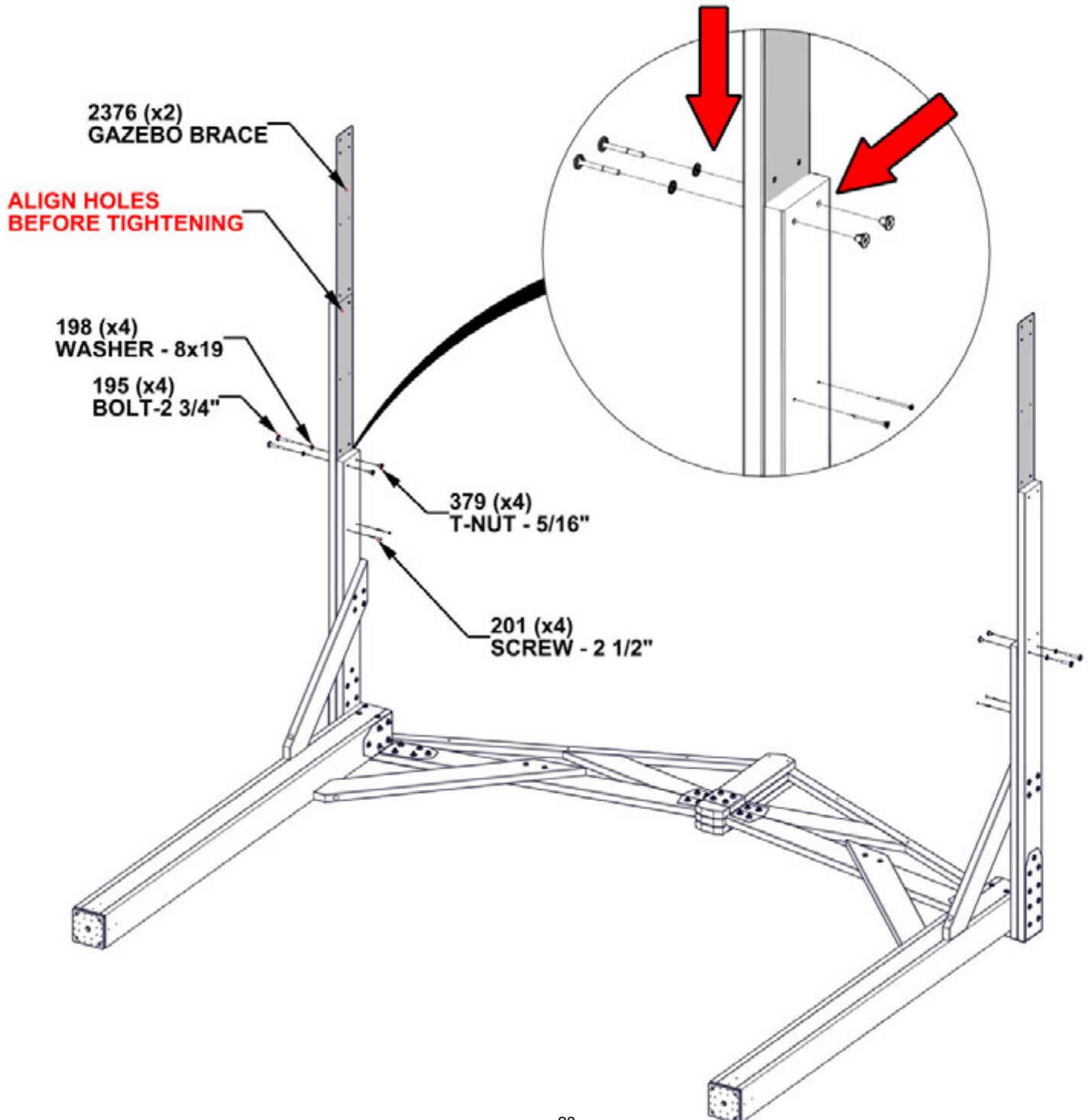

STEP 11B - GAZEBO ASSEMBLY

Qty	PART NUMBER	DESCRIPTION
8	H100195	BOLT WH 5/16x2 3/4 BLK
8	H100198	WASHER LOCK EXT 8x19
4	H100201	SCREW PFH 8x2 1/2 BLK
8	H100379	T-NUT 5/16 BLK

D03 TOP RAIL - W4L16887
 (x2) 1 3/8"X5 1/4"X57" (36x134x1448)

• INSERT T-NUTS FIRST

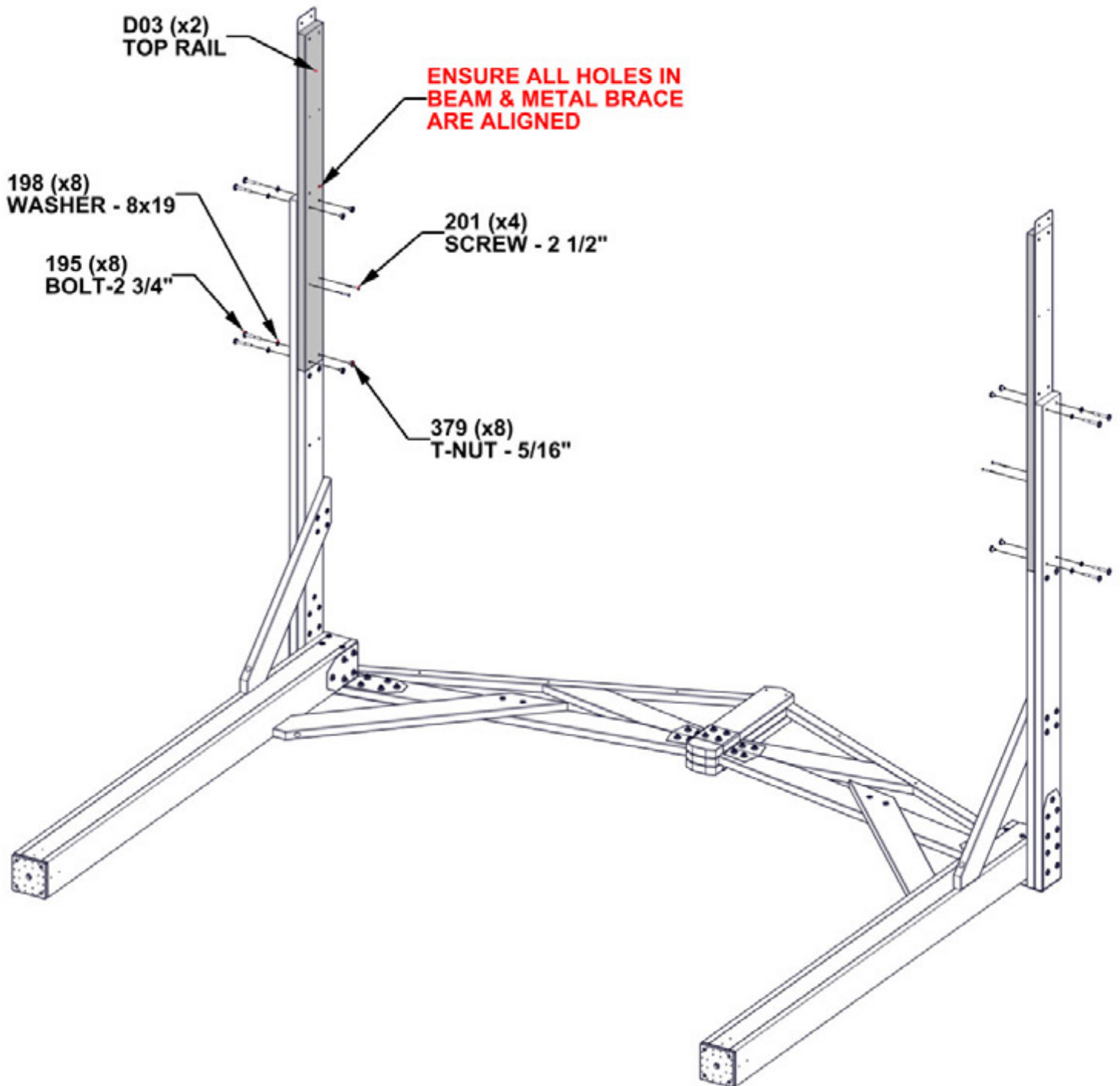

STEP 12 - GAZEBO ASSEMBLY



H08 NOTCHED SUPPORT BOARD - W4L16915
(x2) 1"X3 3/8"X89 1/2" (24x86x2274)

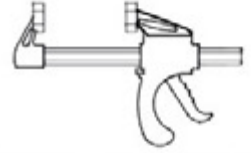

A6P00460 6" QUICK RELEASE
(x2) BAR CLAMP

- ADDITIONAL HELPERS ARE RECOMMENDED FOR THIS STEP.
- USING THE INCLUDED CLAMPS AND H08 BOARDS, STAND UP ONE GABLE END AND SECURELY CLAMP AS SHOWN.

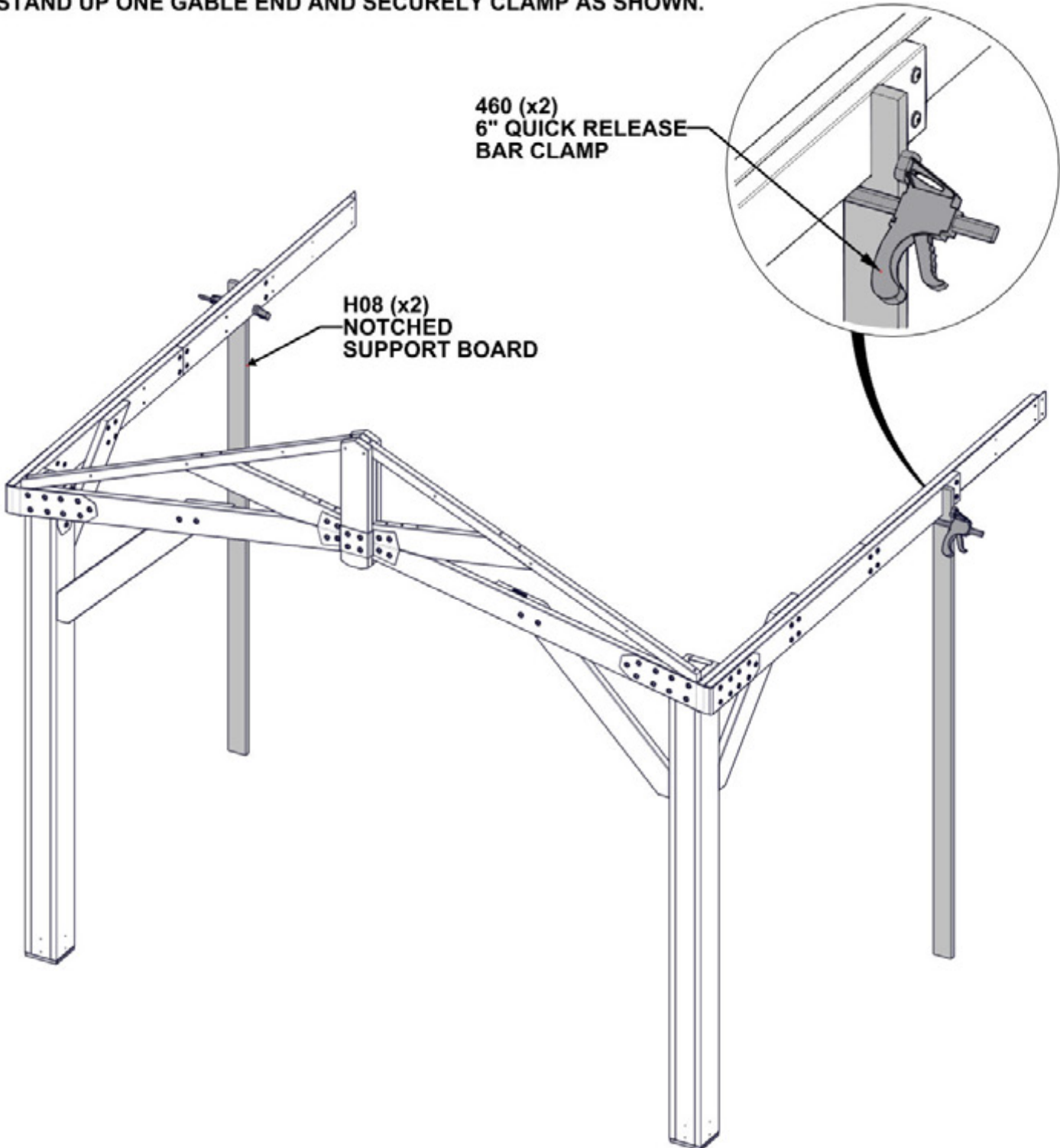

STEP 13 - GAZEBO ASSEMBLY

QTY	PART NUMBER	DESCRIPTION
12	H100379	T-NUT 5/16 BLK
12	H100195	BOLT WH 5/16x2 3/4 BLK
12	H100198	WASHER LOCK EXT 8x19
8	H100201	SCREW PFH 8x2 1/2 BLK

- ADDITIONAL PEOPLE NEEDED FOR THIS STEP.
- STAND UP OTHER GABLE END AND ATTACH HARDWARE AS SHOWN.
- ONCE ALL HARDWARE IS SECURELY ATTACHED, REMOVE CLAMPS AND H08 BOARDS.
- **INSERT T-NUTS FIRST**

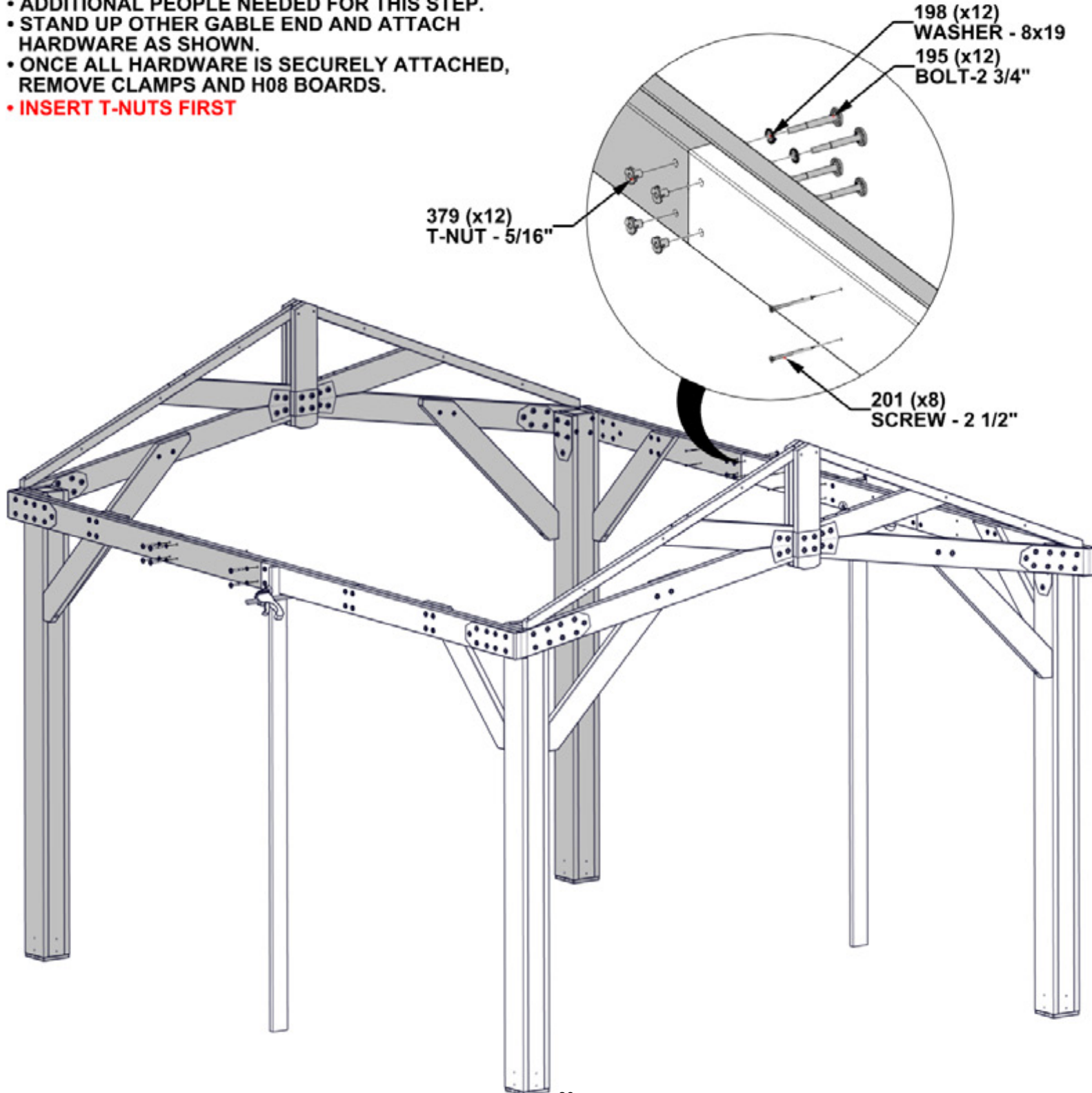

STEP 14 - GAZEBO ASSEMBLY

QTY	PART NUMBER	DESCRIPTION
16	H1100201	SCREW PFH 8x2 1/2 BLK

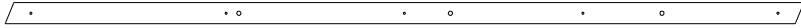

E02 TRUSS - W4L19639
(x4) 1 3/8"x2 3/8"x75 3/16" (36x60x1910)

• REPEAT THIS STEP FOR OPPOSITE SIDE.

ALIGN HOLES FOR
CORRECT ORIENTATION

FLUSH TOPS

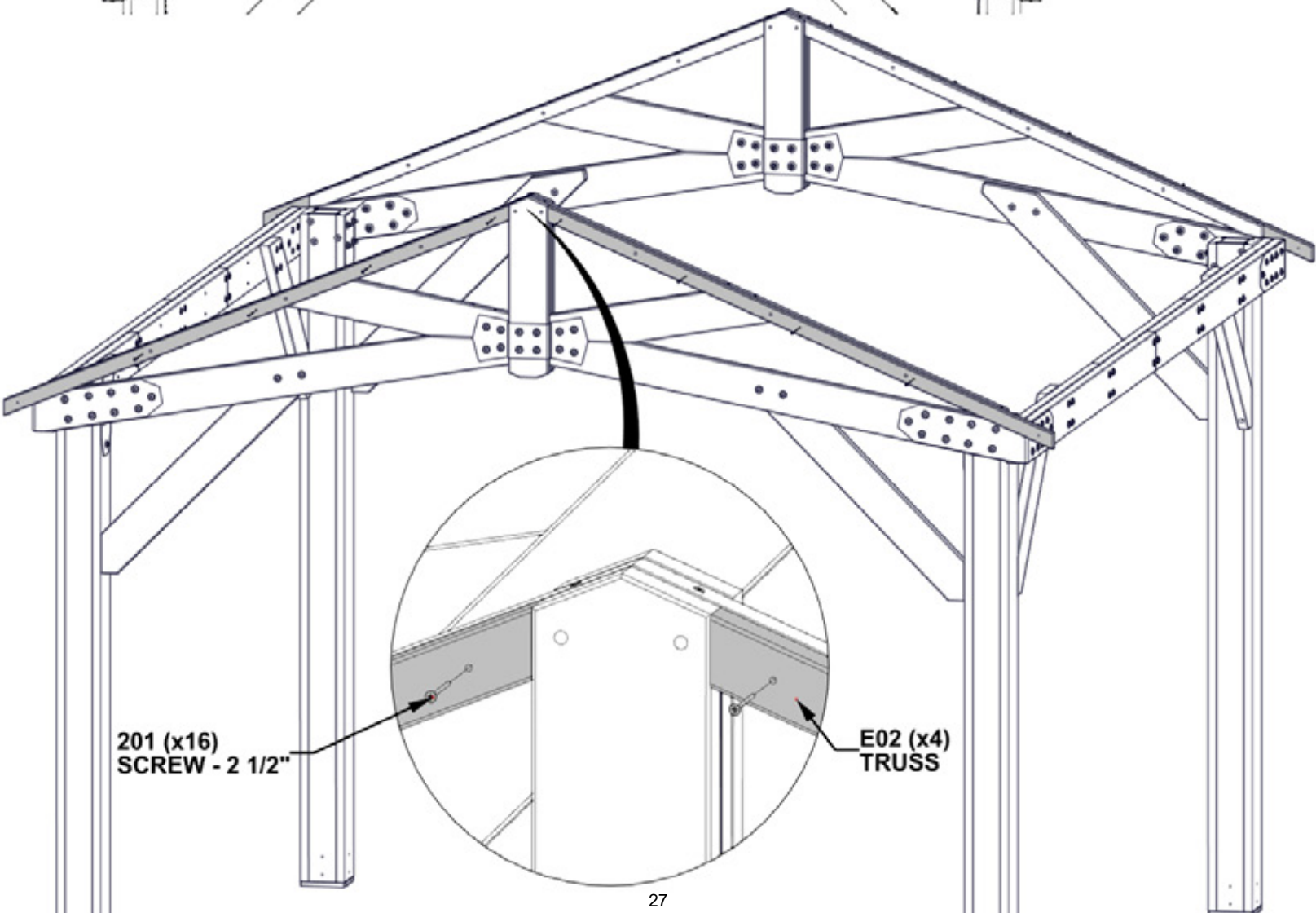
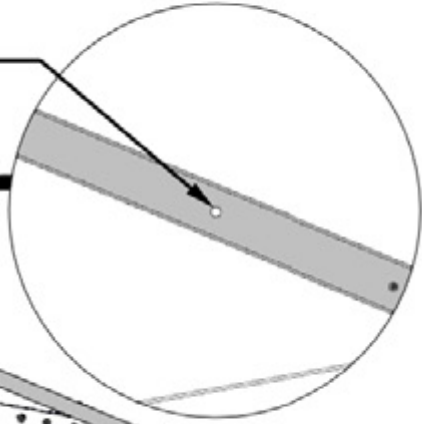

STEP 15 - GAZEBO ASSEMBLY

QTY	PART NUMBER	DESCRIPTION
12	H100564	LAG SCREW WH 1/4x4 BLK
12	H100405	WASHER LOCK EXT 6x15
4	H100201	SCREW PFH 8x2 1/2 BLK

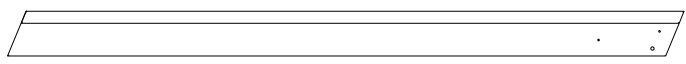

GP1 GABLE PANEL - W2A04177
(x2) 2 13/16"x5 1/4"x80 3/16" (72x134x2037)

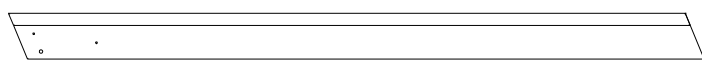

GP2 GABLE PANEL - W2A04178
(x2) 2 13/16"x5 1/4"x80 3/16" (72x134x2037)

• ALIGN LAG SCREWS WITH PILOT HOLES IN GABLE PANELS.

TEMPORARILY INSERT 354 BOLTS TO ALIGN GABLE PANEL WITH GABLE

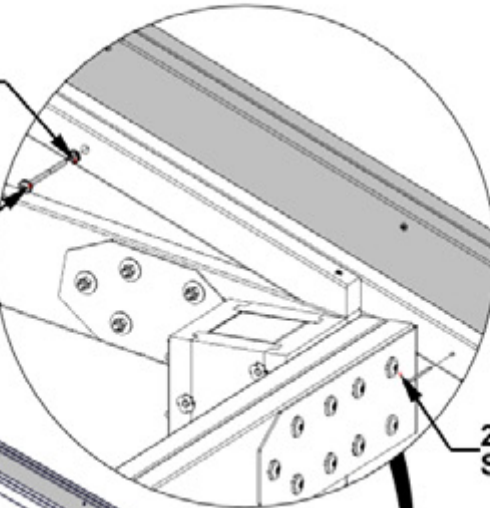
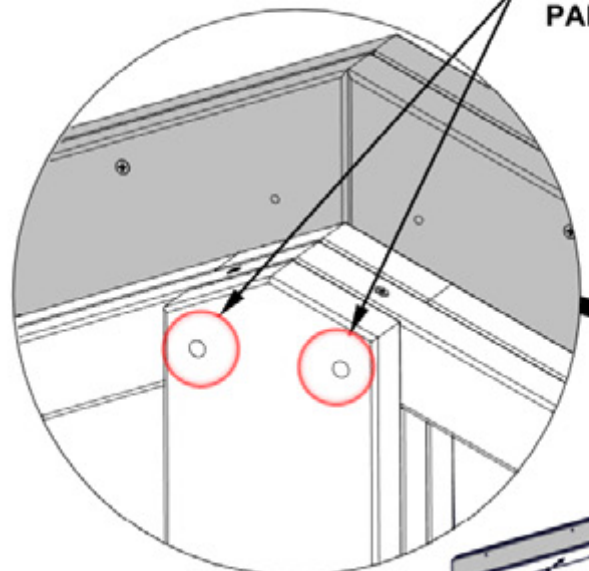

405 (x12)
WASHER - 6x15

564 (x12)
LAG SCREW - 4"

201 (x4)
SCREW - 2 1/2"

GP1 (x2)
GABLE PANEL

GP2 (x2)
GABLE PANEL

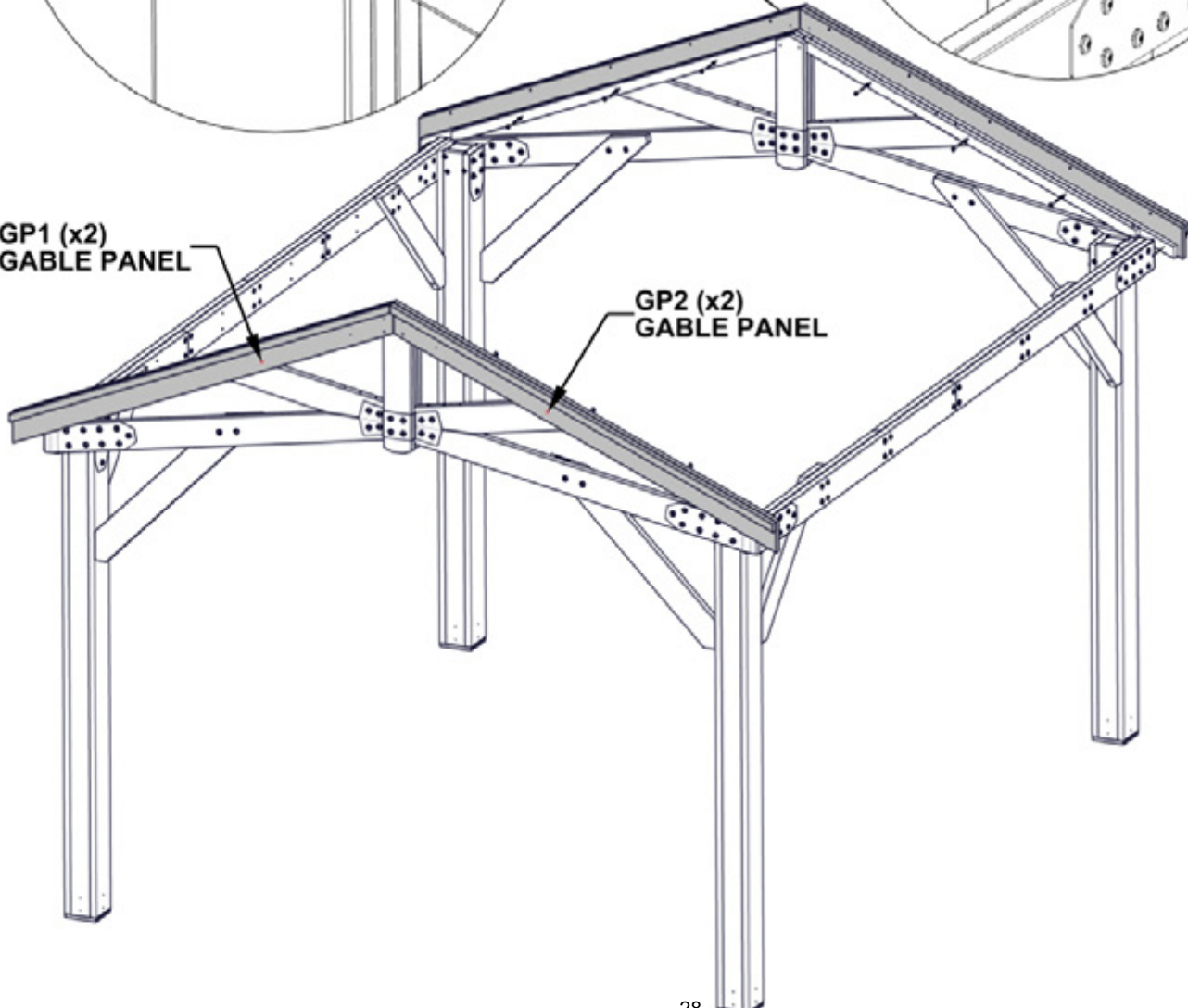

STEP 16 - GAZEBO ASSEMBLY

QTY	PART NUMBER	DESCRIPTION
4	H100479	NUT LOCK 5/16 BLK
4	H100354	BOLT WH 5/16x6 1/2 BLK
8	H100471	LAG SCREW WH 5/16x1 1/2 BLK
4	H100478	WASHER FLAT 8x27 BLK
4	H100200	SCREW PFH 8x1 1/2 BLK

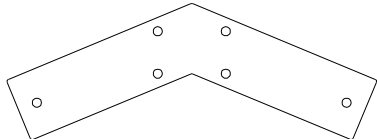

A4M01130
(x2) **GABLE BRACKET**

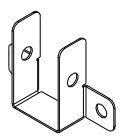

A4M01148
(x2) **TRUSS BRACKET**

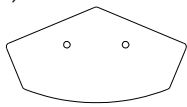

A4M01147
(x2) **PEAK SEAM BRACKET**

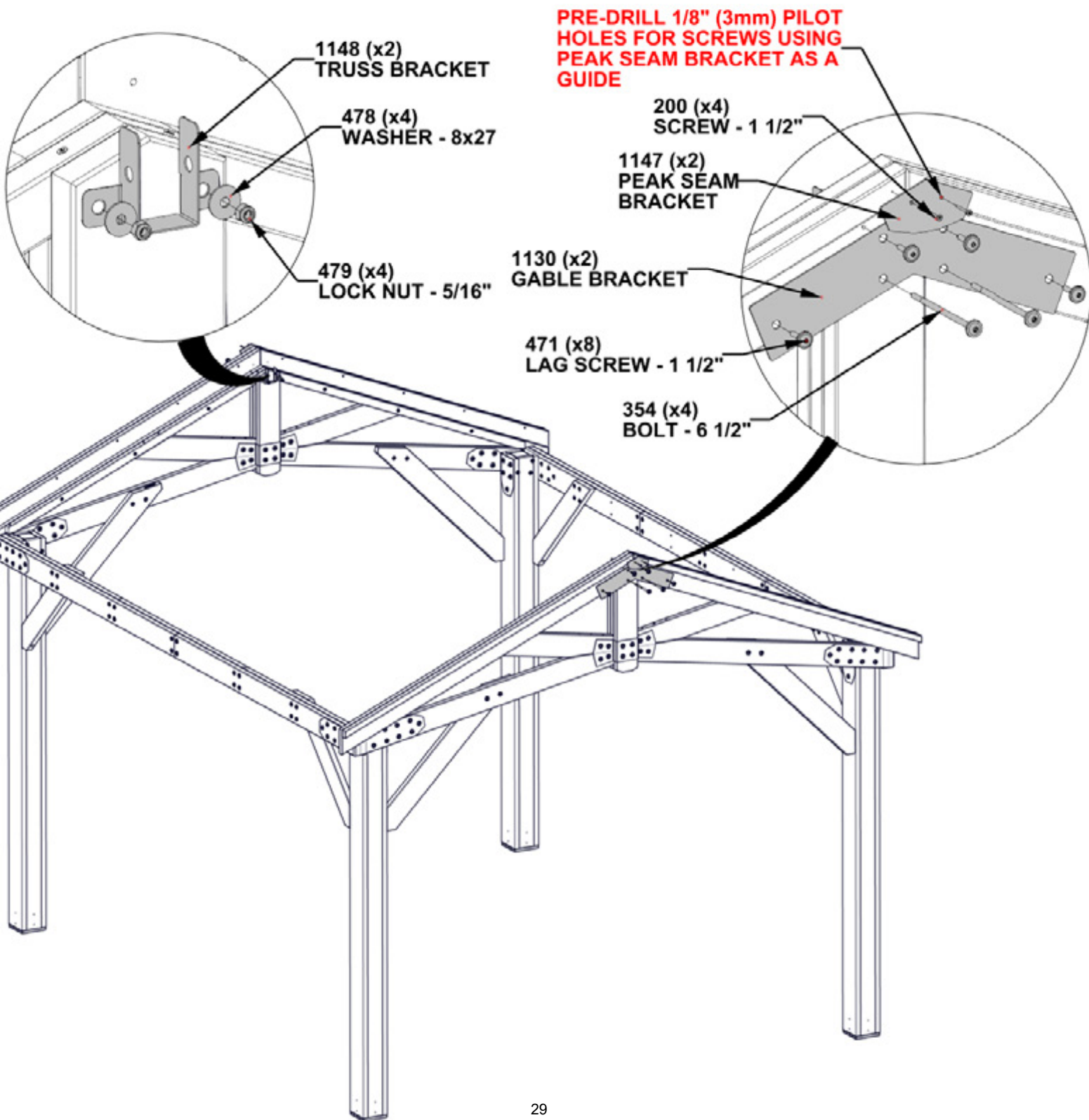

PRE-DRILL 1/8" (3mm) PILOT HOLES FOR SCREWS USING PEAK SEAM BRACKET AS A GUIDE

1148 (x2)
TRUSS BRACKET

478 (x4)
WASHER - 8x27

479 (x4)
LOCK NUT - 5/16"

200 (x4)
SCREW - 1 1/2"

1147 (x2)
PEAK SEAM BRACKET

1130 (x2)
GABLE BRACKET

471 (x8)
LAG SCREW - 1 1/2"

354 (x4)
BOLT - 6 1/2"

STEP 17 - RAFTER ASSEMBLY

Qty	PART NUMBER	DESCRIPTION
8	H100198	WASHER LOCK EXT 8x19
16	H100379	T-NUT 5/16 BLK
10	H100382	SCREW PFH 8x1 3/4 BLK
8	H100459	BOLT WH 5/16x1 1/4 BLK



H05 RAFTER - W4L16894
(x2) 1"X3 3/8"X69 1/2" (24x86x1766)

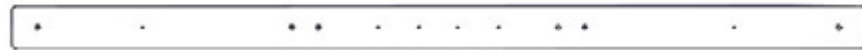

A4M02520 RIDGE BRACE
(x1) METAL



H04 RAFTER - W4L16893
(x2) 1"X3 3/8"X89 1/4" (24x86x2267)

• INSERT T-NUTS FIRST

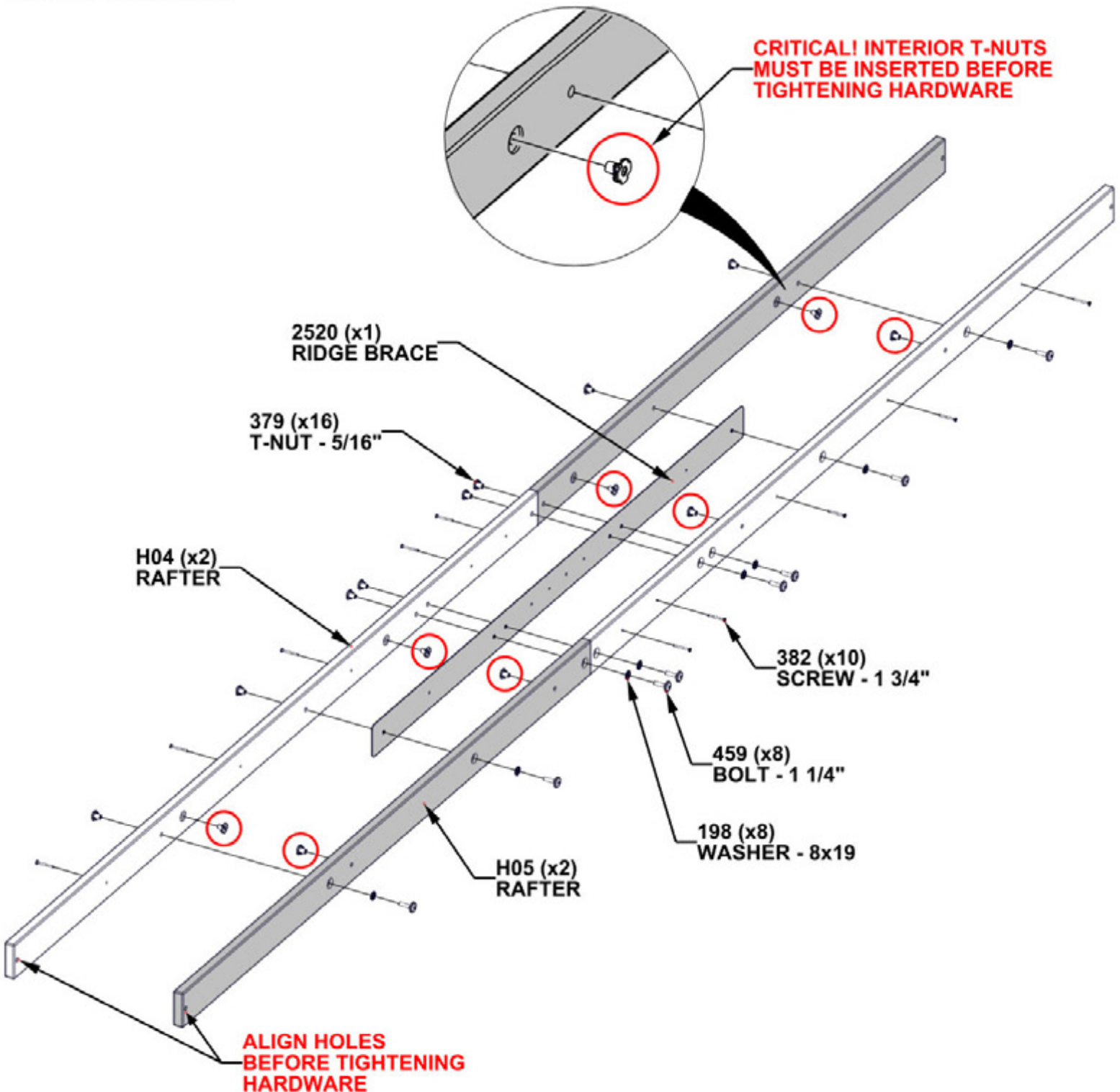

STEP 18 - RAFTER ASSEMBLY

QTY	PART NUMBER	DESCRIPTION
2	H100479	NUT LOCK 5/16 BLK
2	H100195	BOLT WH 5/16x2 3/4 BLK
2	H100478	WASHER FLAT 8x27 BLK

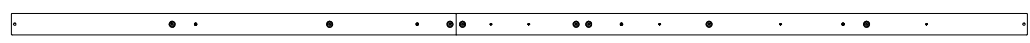

RAFTER ASSEMBLY FROM PREVIOUS STEP

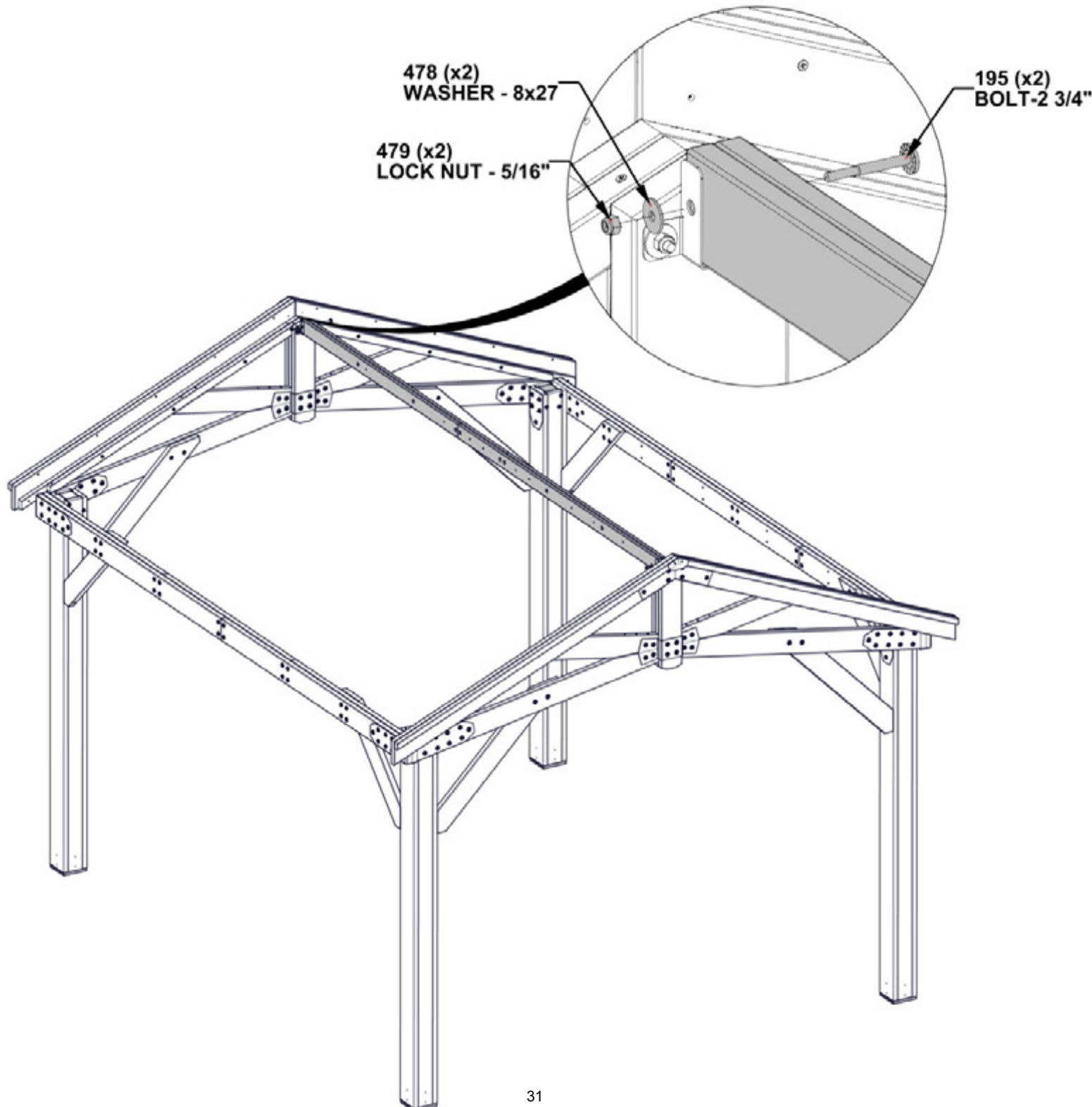

STEP 19 - ROOF PANEL ASSEMBLY

QTY	PART NUMBER	DESCRIPTION
2	H100479	NUT LOCK 5/16 BLK
2	H100503	BOLT WH 5/16x3 1/2 BLK
2	H100478	WASHER FLAT 8x27 BLK
24	H100391	SCREW PFH 8x2 BLK
2	H100198	WASHER LOCK EXT 8x19

- H02 FASCIA - W4L16891
(x1) 1"x3 3/8"x80 3/8" (24x86x2040)
- H03 FASCIA - W4L16892
(x1) 1"x3 3/8"x87" (24x86x2209)
- H06 FASCIA - W4L16895
(x1) 1"x3 3/8"x63 1/2" (24x86x1614)
- H07 FASCIA - W4L16896
(x1) 1"x3 3/8"x70 1/8" (24x86x1783)

- E01 RAFTER - W4L19638
(x4) 1 3/8"x3 3/8"x76 3/8" (36x86x1941)
- E05 RAFTER - W4L19637
(x2) 1 3/8"x3 3/8"x76 3/8" (36x86x1941)

ROOF PANEL A

DO NOT REPEAT THIS STEP FOR SECOND 14FT PANEL. IT IS ASSEMBLED DIFFERENTLY STARTING IN STEP 26.

DIMENSIONS ARE CRITICAL FOR CORRECT ORIENTATION.

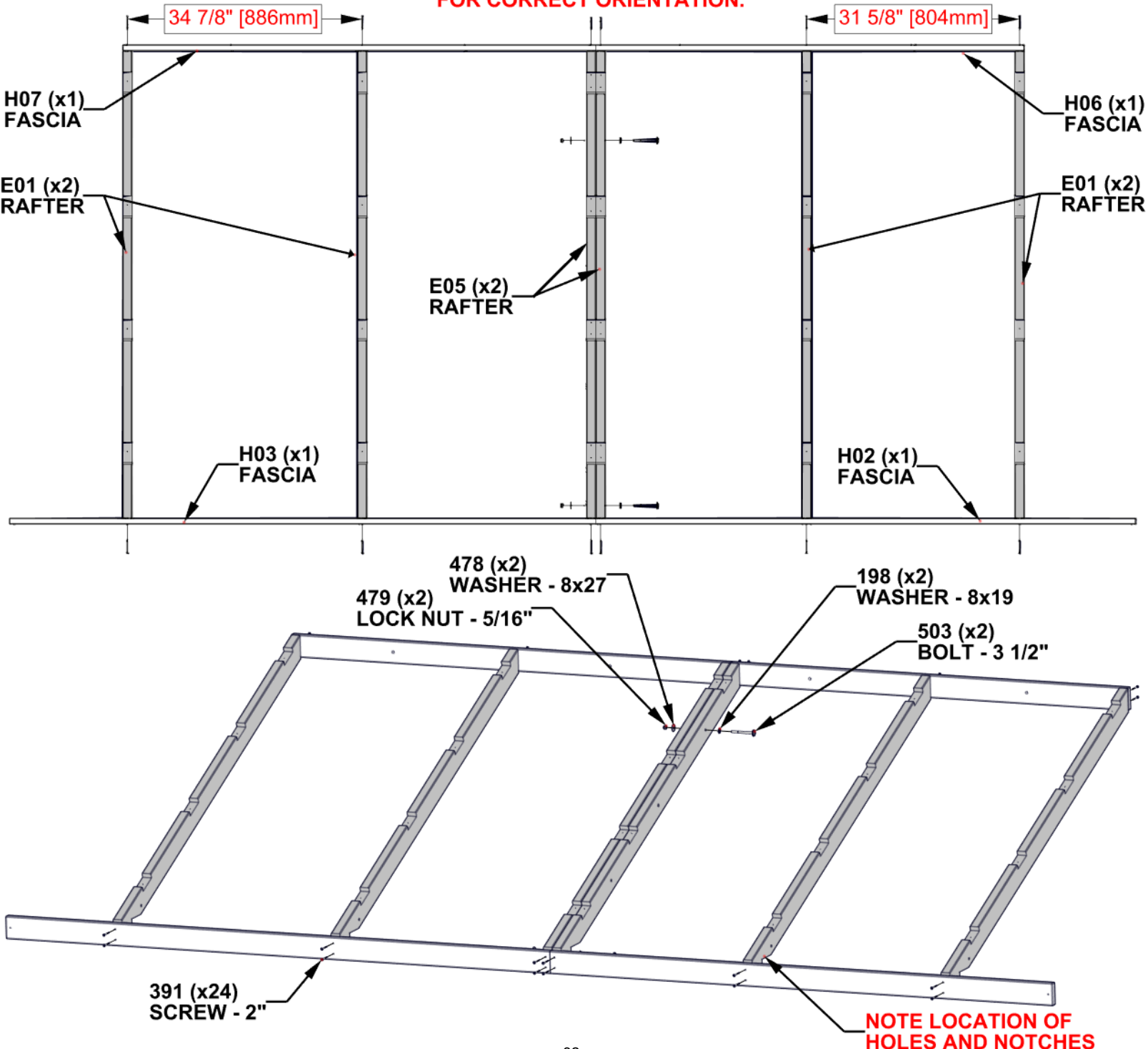

STEP 20A - ROOF PANEL ASSEMBLY

Qty	PART NUMBER	DESCRIPTION
48	H100391	SCREW PFH 8x2 BLK



H01 SHEATHING BOARD - W4L19635
(x4) 15/16"X3 3/8"X80 3/8" (24x86x2040)



H09 SHEATHING BOARD - W4L19636
(x4) 15/16"X3 3/8"X87" (24x86x2209)

ROOF PANEL A

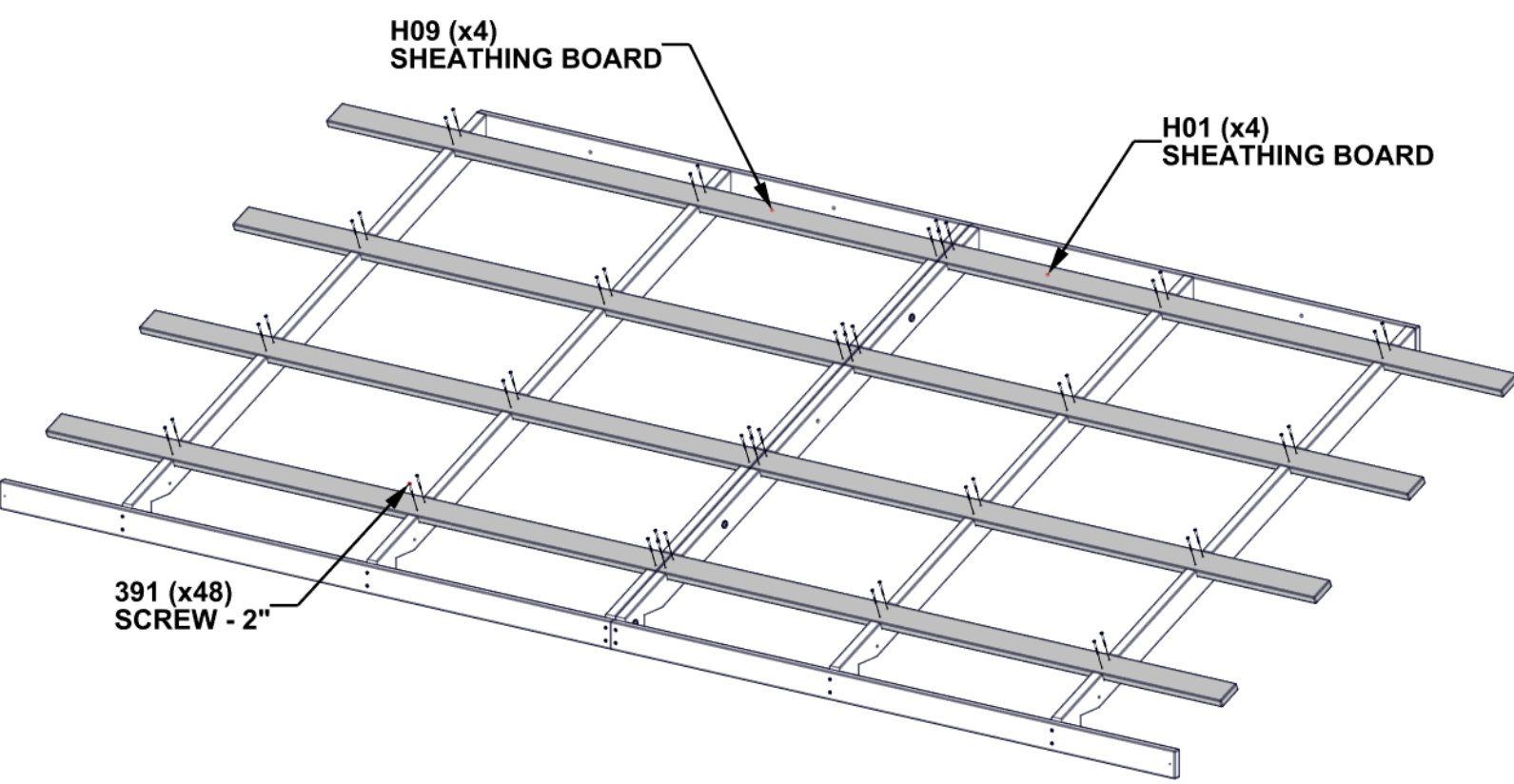

STEP 20B - ROOF PANEL ASSEMBLY

ROOF PANEL A

TIP: LOOSEN HARDWARE TO ADJUST FOR SQUARING IF NEEDED

- CRITICAL:**
- SQUARE UNIT BEFORE PROCEEDING TO NEXT STEPS.
 - THE BELOW DIMENSIONS ARE CRITICAL TO THE FINAL ROOF ASSEMBLY.
 - MEASUREMENTS SHOULD BE HELD WITHIN +/- 1/4".
 - MEASUREMENTS OUTSIDE OF TOLERANCE WILL LEAD TO THE INABILITY TO ASSEMBLY THE ROOF.
 - AFTER PANEL IS SQUARED, FULLY TIGHTEN ALL HARDWARE.

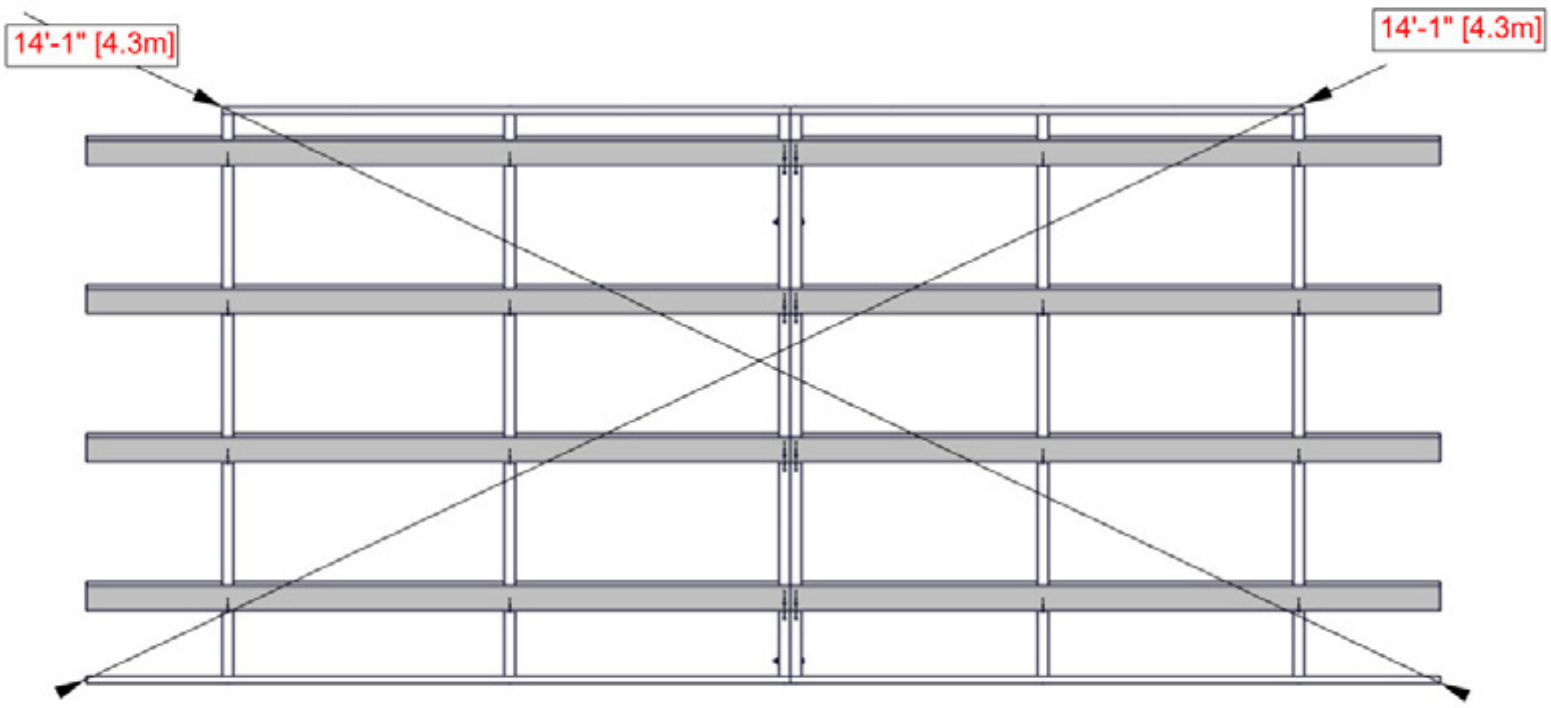

STEP 21 - ROOF PANEL ASSEMBLY

ROOF PANEL A

- USE THIS PAGE TO FAMILIARIZE YOURSELF WITH THE ROOF PANEL AND ASSIST YOU IN STEPS 22-24.
- REMOVE PROTECTIVE BLUE FILM.
- START AT THE END INDICATED AND ASSEMBLE IN THE DIRECTION OF THE ARROW.
- **GLOVES SHOULD BE WORN WHEN HANDLING ROOF PANELS: EDGES ARE SHARP.**

THE PRE-DRILLED HOLES ON EACH PANEL SHOULD ALWAYS BE POSITIONED ON THE RIDGE SIDE.

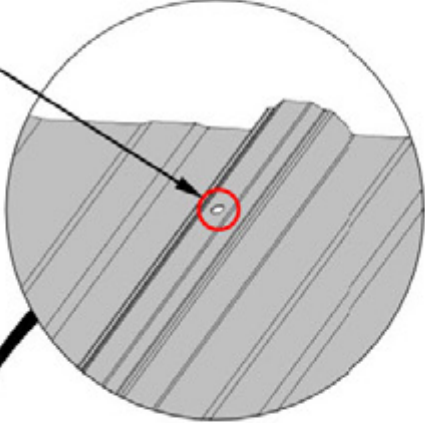

RIDGE

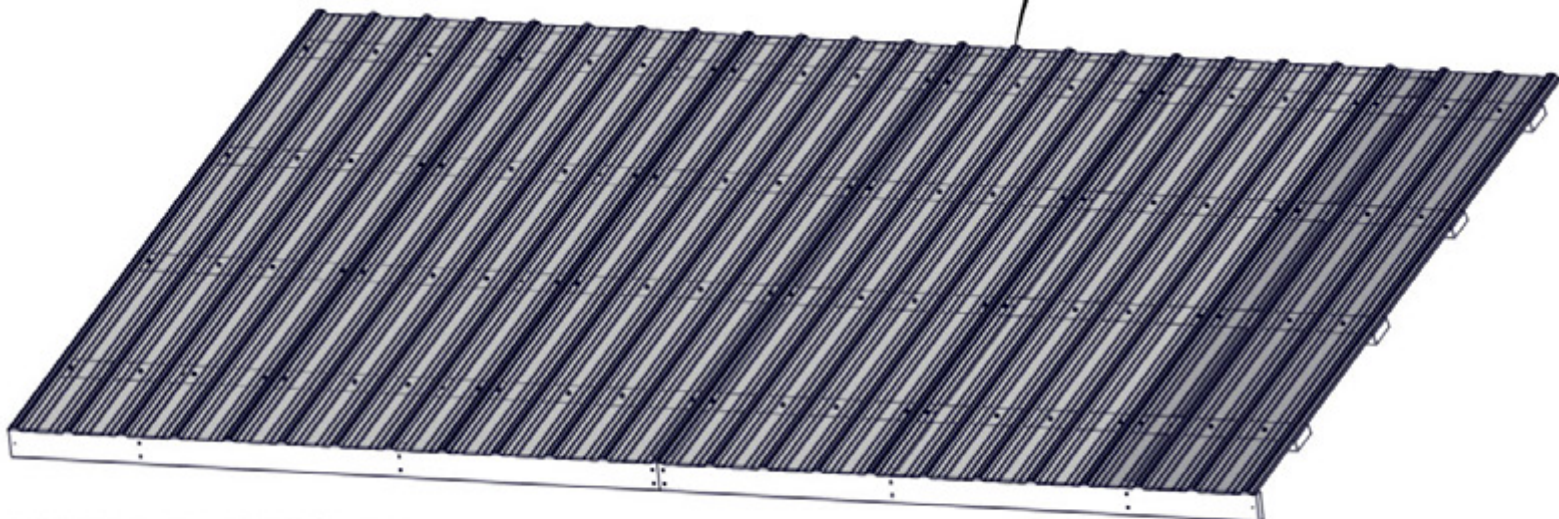

ROOF PANEL STEPS 22-24



STEP 22 - ROOF PANEL ASSEMBLY

QTY	PART NUMBER	DESCRIPTION
28	H100833	SCREW WOODGRIP 10-16x3/4"

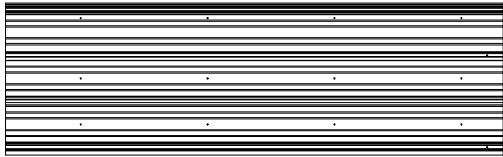

A4M02712 (x1) 29 GA STEEL SHEETING

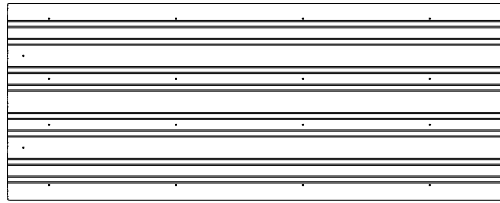

A4M02639 (x1) 29 GA STEEL SHEETING

ROOF PANEL A

• MAKE SURE YOUR ROOF PANEL IS SQUARE BEFORE MOVING ON.

NOTE RIB OVERLAP

833 (x28)
SCREW - 3/4"

3/8" [8mm]

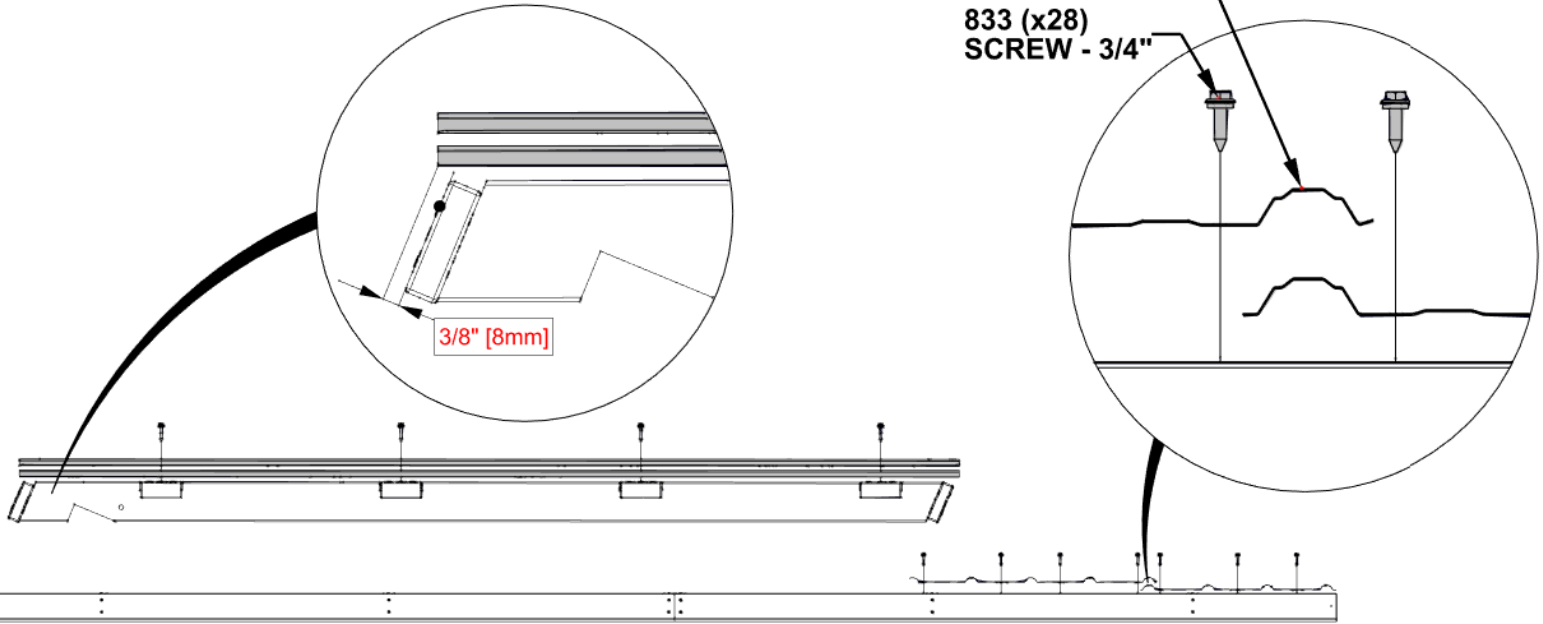

2712 (x1)
29 GA STEEL SHEETING

2639 (x1)
29 GA STEEL SHEETING

FLUSH SHEETING
ENDS

PLACE SHEETING
ON ROOF PANEL,
ALIGNING EDGE OF
RIB 1/2" (12mm) FROM
END OF H BOARD

1/2" [12mm]

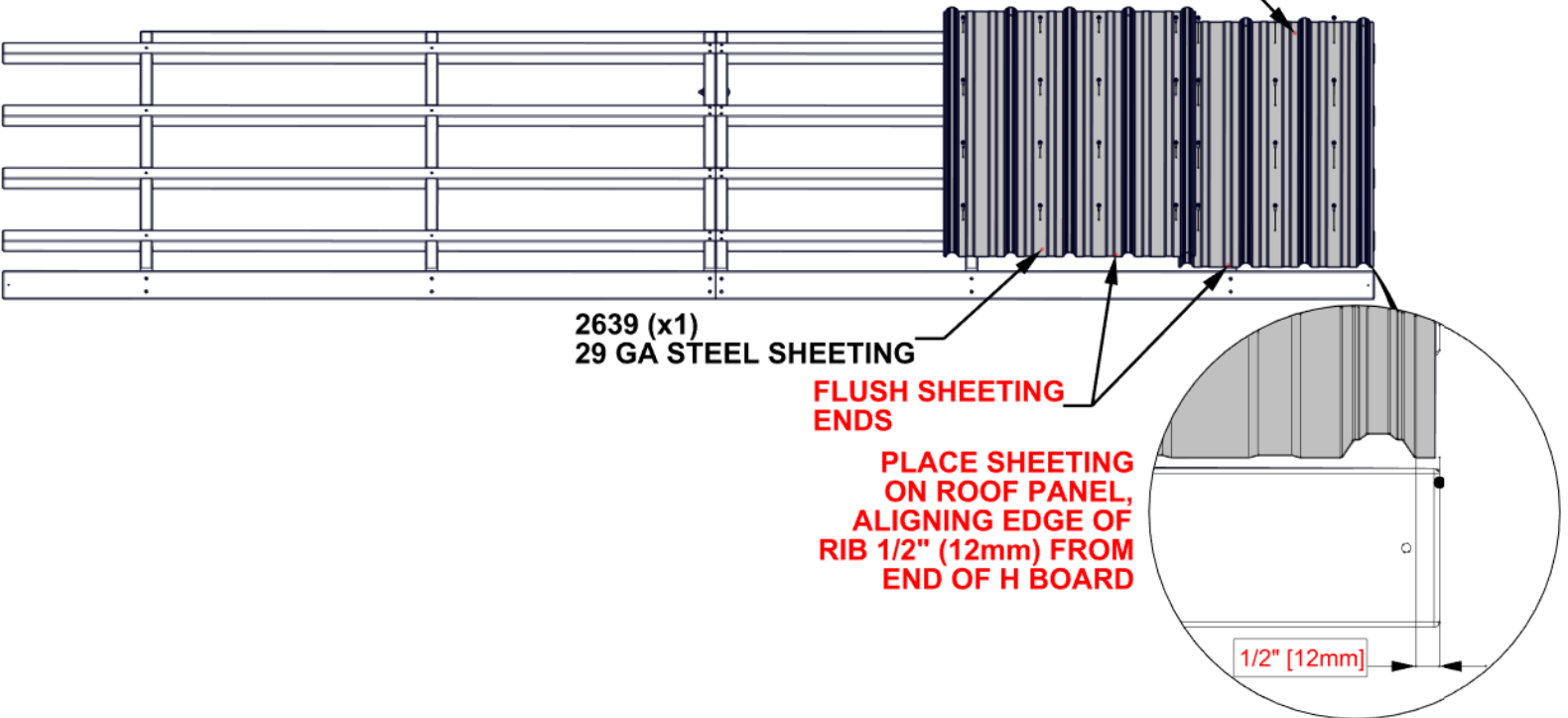

STEP 23 - ROOF PANEL ASSEMBLY

Qty	PART NUMBER	DESCRIPTION
32	H100833	SCREW WOODGRIP 10-16x3/4



A4M02908 29GA STEEL SHEETING
(x1)

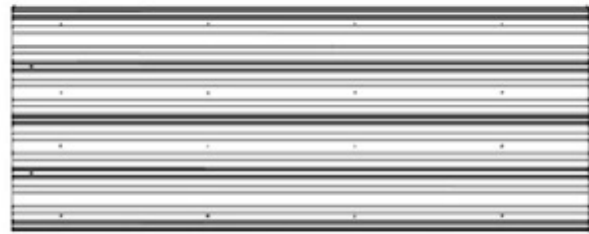

A4M02646 29GA STEEL SHEETING
(x1)

ROOF PANEL A

833 (x32)
SCREW - 3/4"

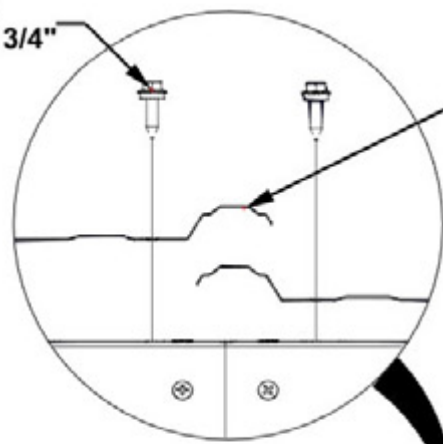

**NOTE RIB
OVERLAP**

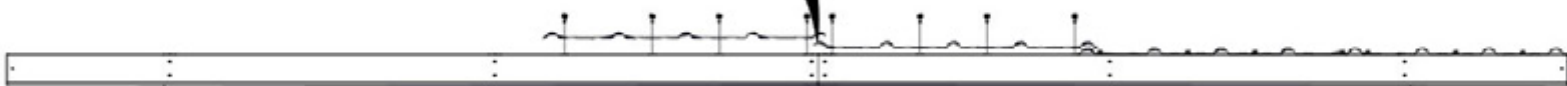

2908 (x1)
29GA STEEL SHEETING

2646 (x1)
29GA STEEL SHEETING

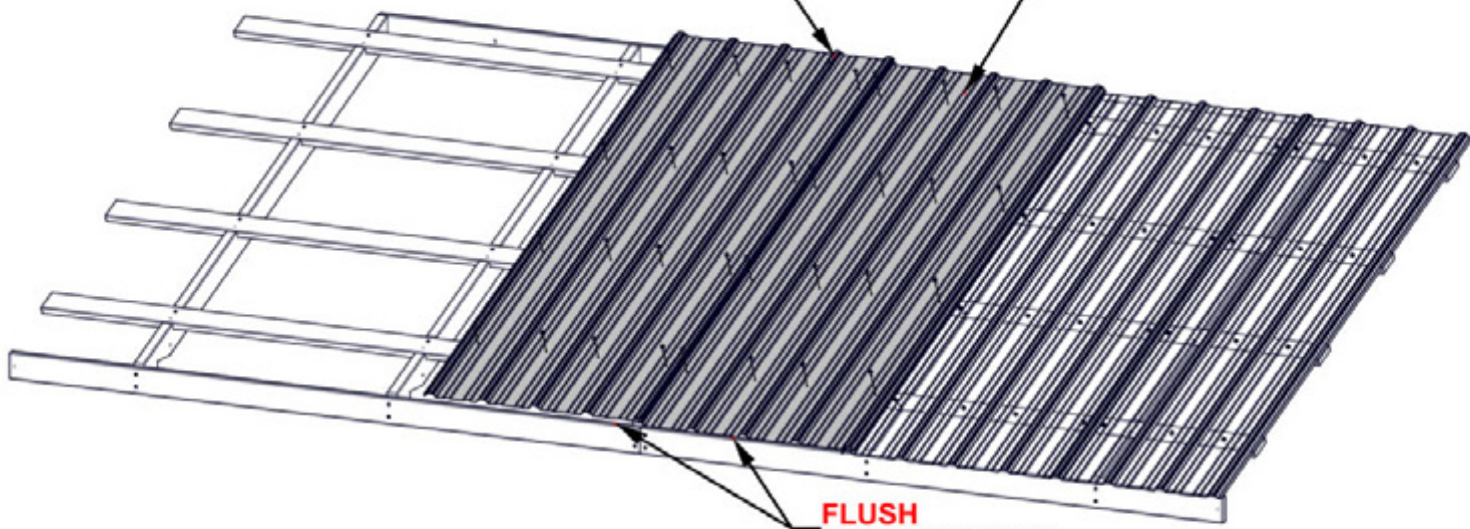

**FLUSH
SHEETING ENDS**

STEP 24 - ROOF PANEL ASSEMBLY

QTY	PART NUMBER	DESCRIPTION
32	H100833	SCREW WOODGRIP 10-16x3/4"



A4M02639 (x2) 29 GA STEEL SHEETING

ROOF PANEL A

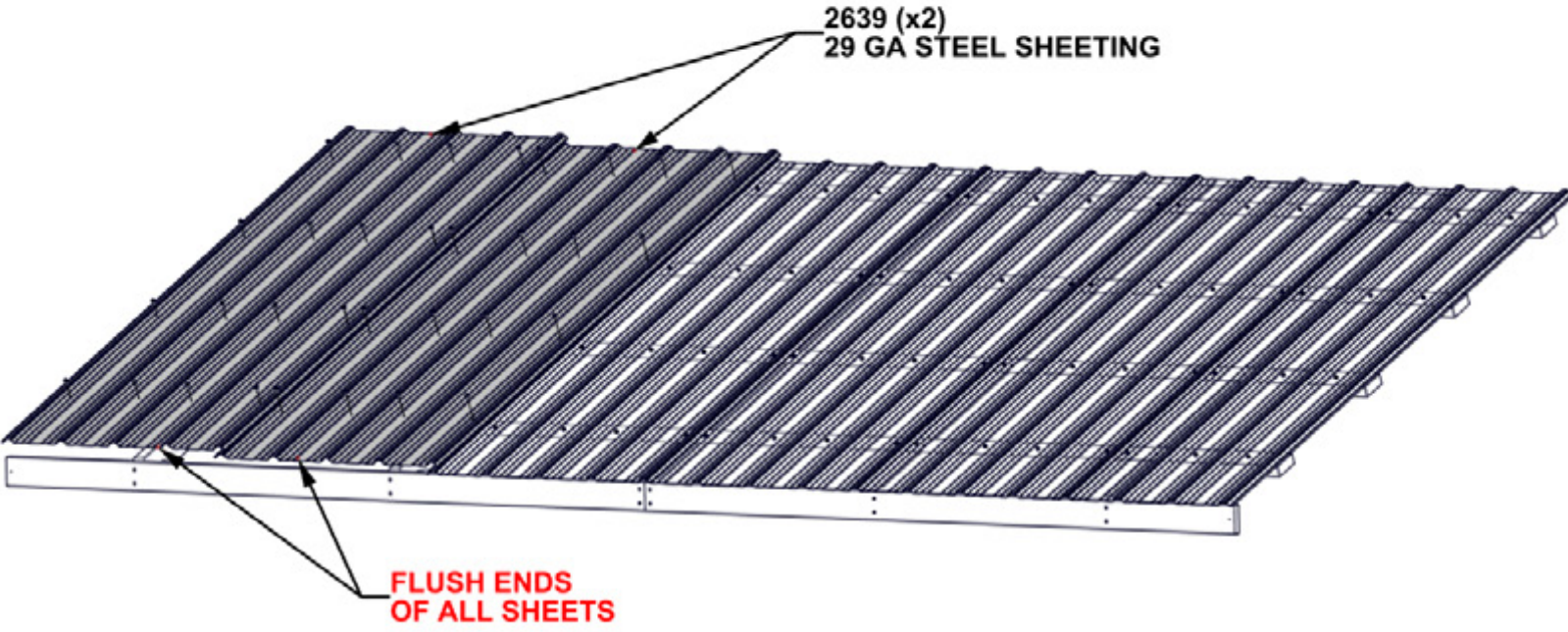
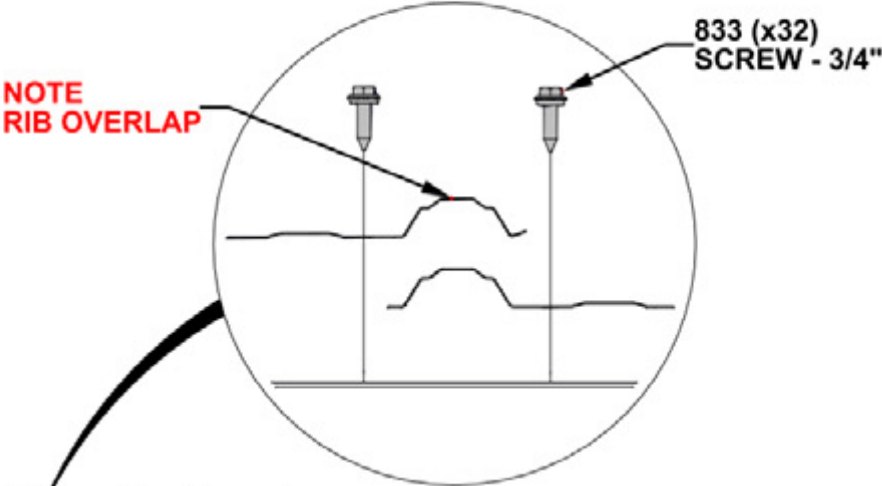

STEP 25 - ROOF PANEL ASSEMBLY

ROOF PANEL A

- SEPARATE ROOF PANEL FOR EASE OF ASSEMBLING.
- REMOVE HARDWARE & SET ASIDE. IT WILL BE USED AGAIN AFTER BOTH SECTIONS ARE INSTALLED.

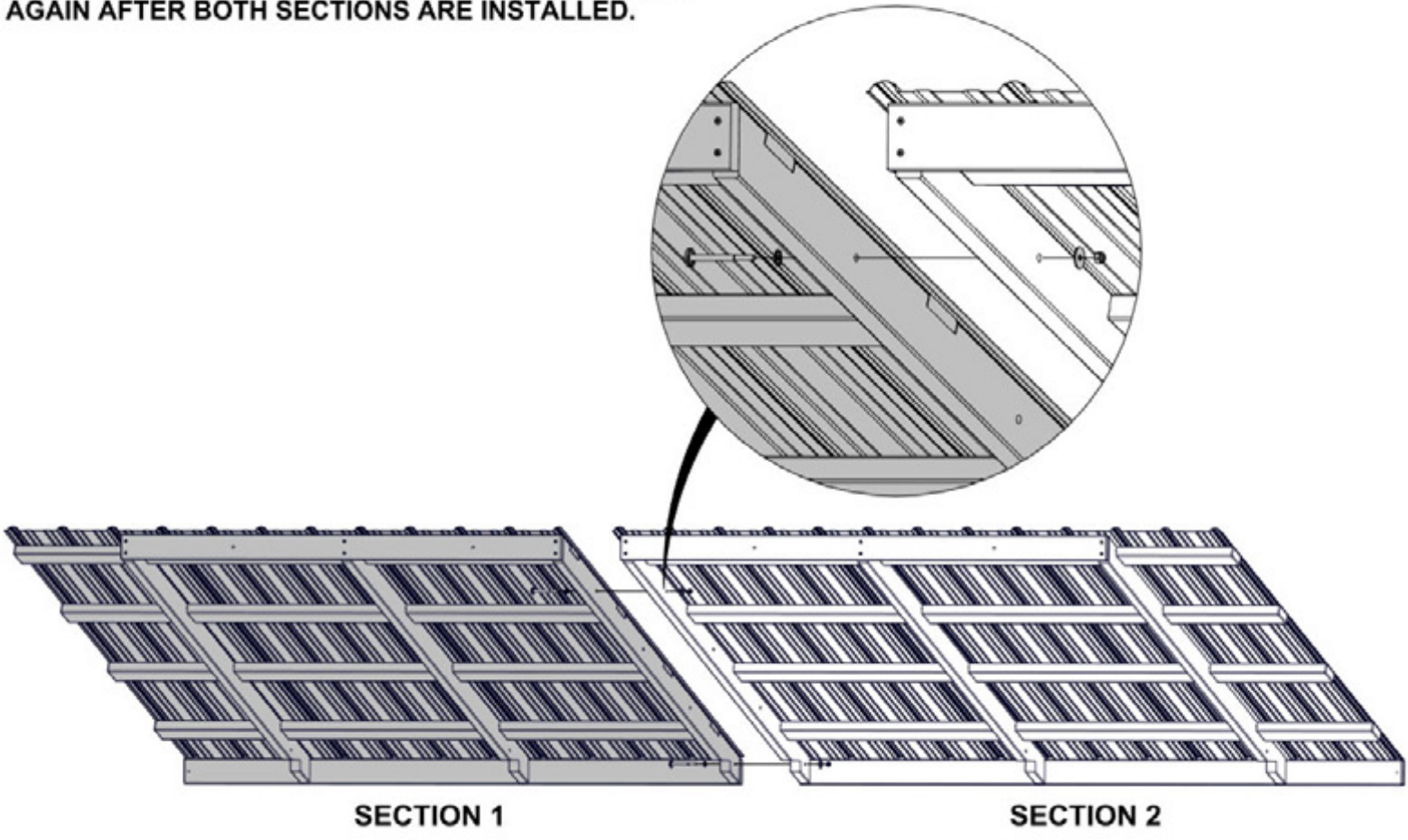

STEP 26 - ROOF PANEL ASSEMBLY

QTY	PART NUMBER	DESCRIPTION
2	H100479	NUT LOCK 5/16 BLK
2	H100503	BOLT WH 5/16x3 1/2 BLK
2	H100478	WASHER FLAT 8x27 BLK
24	H100391	SCREW PFH 8x2 BLK
2	H100198	WASHER LOCK EXT 8x19

H02 FASCIA - W4L16891
(x1) 1"x3 3/8"x80 3/8" (24x86x2040)

H03 FASCIA - W4L16892
(x1) 1"x3 3/8"x87" (24x86x2209)

H06 FASCIA - W4L16895
(x1) 1"x3 3/8"x63 1/2" (24x86x1614)

H07 FASCIA - W4L16896
(x1) 1"x3 3/8"x70 1/8" (24x86x1783)

E01 RAFTER - W4L19638
(x4) 1 3/8"x3 3/8"x76 3/8" (36x86x1941)

E05 RAFTER - W4L19637
(x2) 1 3/8"x3 3/8"x76 3/8" (36x86x1941)

ROOF PANEL B

DIMENSIONS ARE CRITICAL FOR CORRECT ORIENTATION.

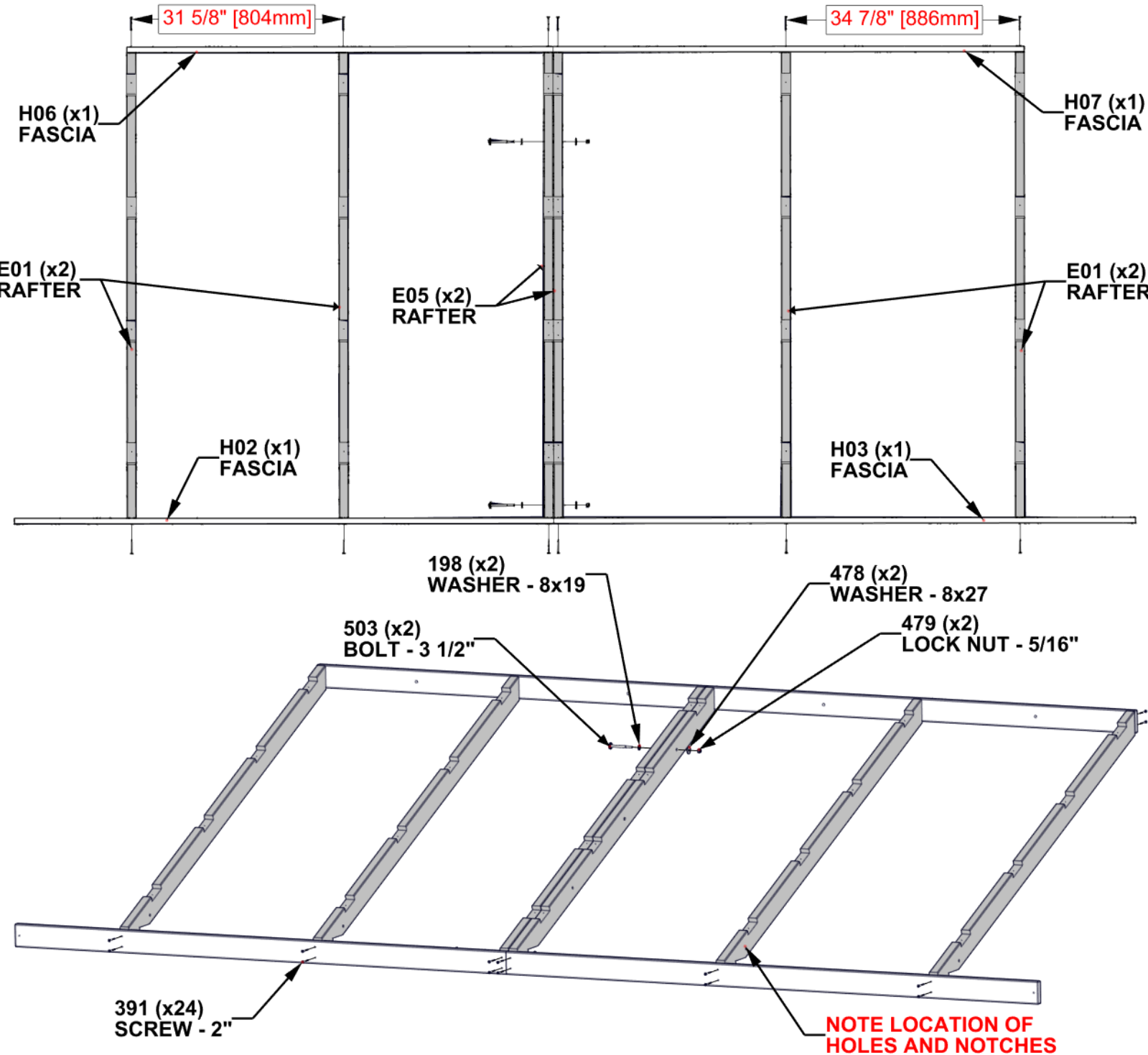

STEP 27A - ROOF PANEL ASSEMBLY

Qty	PART NUMBER	DESCRIPTION
48	H100391	SCREW PFH 8x2 BLK

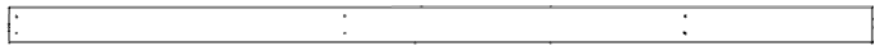

H01 SHEATHING BOARD - W4L19635
(x4) 15/16"X3 3/8"X80 3/8" (24x86x2040)



H09 SHEATHING BOARD - W4L19636
(x4) 15/16"X3 3/8"X87" (24x86x2209)

ROOF PANEL B

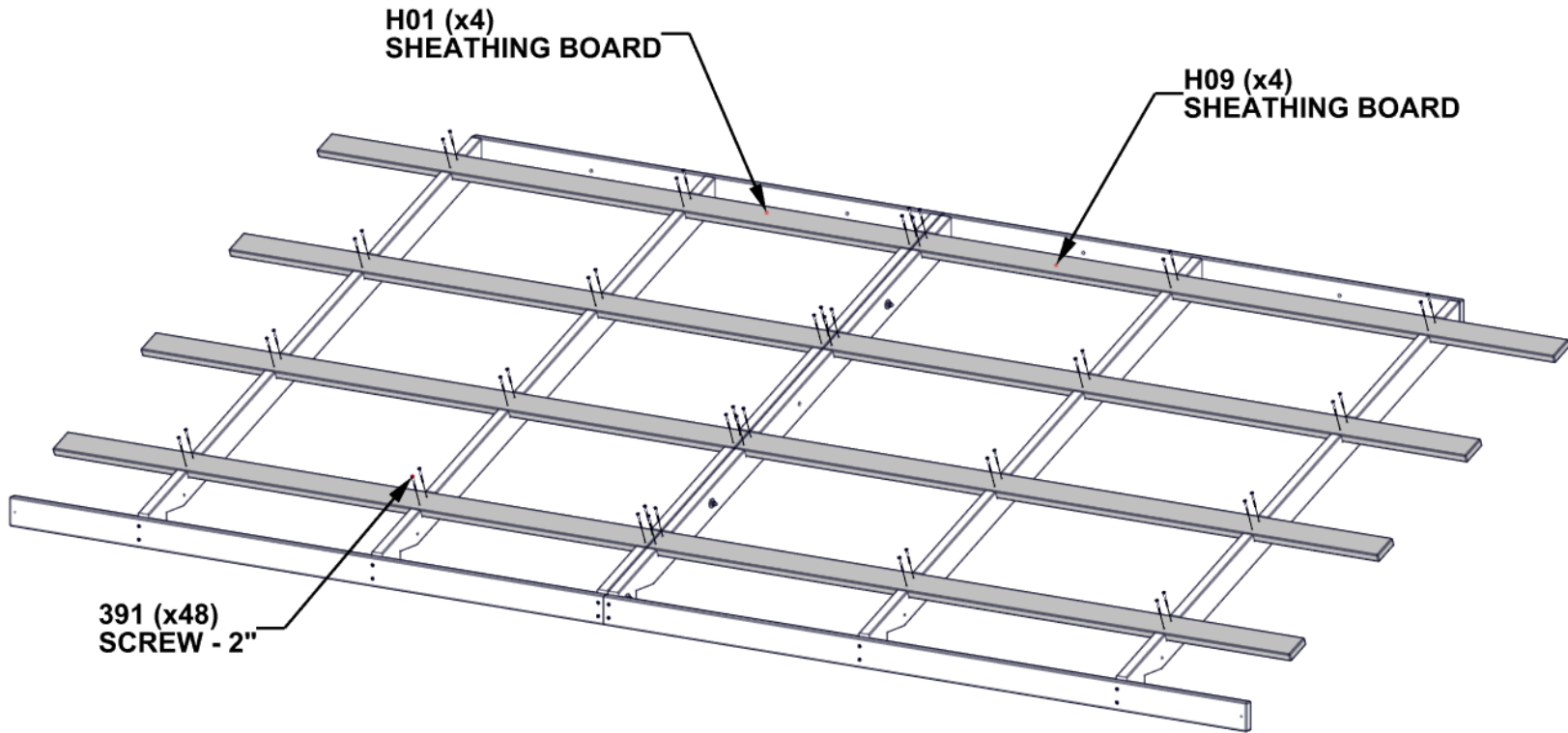

STEP 27B - ROOF PANEL ASSEMBLY

ROOF PANEL B

TIP: LOOSEN HARDWARE TO ADJUST FOR SQUARING IF NEEDED

- CRITICAL:**
- SQUARE UNIT BEFORE PROCEEDING TO NEXT STEPS.
 - THE BELOW DIMENSIONS ARE CRITICAL TO THE FINAL ROOF ASSEMBLY.
 - MEASUREMENTS SHOULD BE HELD WITHIN +/- 1/4".
 - MEASUREMENTS OUTSIDE OF TOLERANCE WILL LEAD TO THE INABILITY TO ASSEMBLY THE ROOF.
 - AFTER PANEL IS SQUARED, FULLY TIGHTEN ALL HARDWARE.

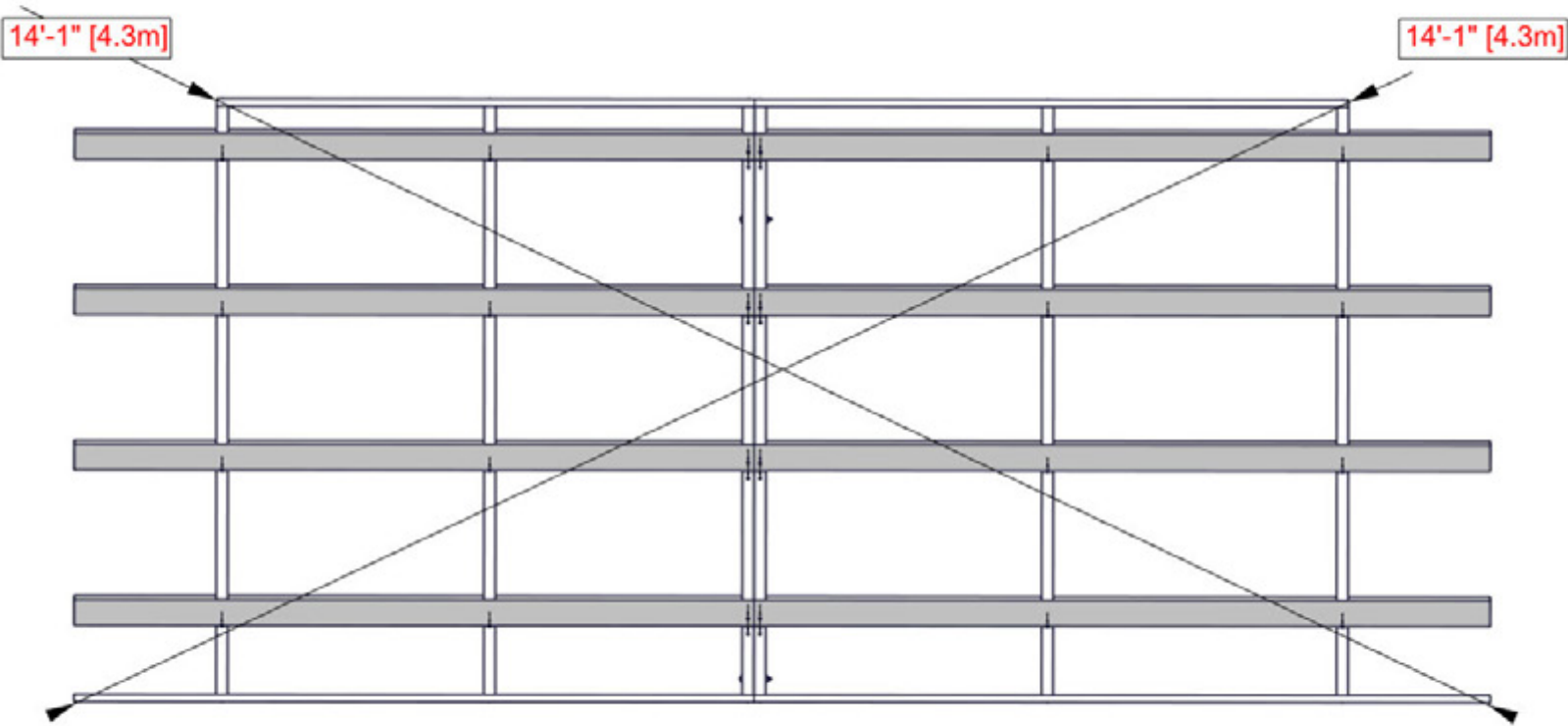

STEP 28 - ROOF PANEL ASSEMBLY

ROOF PANEL B

- USE THIS PAGE TO FAMILIARIZE YOURSELF WITH THE ROOF PANEL AND ASSIST YOU IN STEPS 29-31.
- REMOVE PROTECTIVE BLUE FILM.
- START AT THE END INDICATED AND ASSEMBLE IN THE DIRECTION OF THE ARROW.
- **GLOVES SHOULD BE WORN WHEN HANDLING ROOF PANELS: EDGES ARE SHARP.**

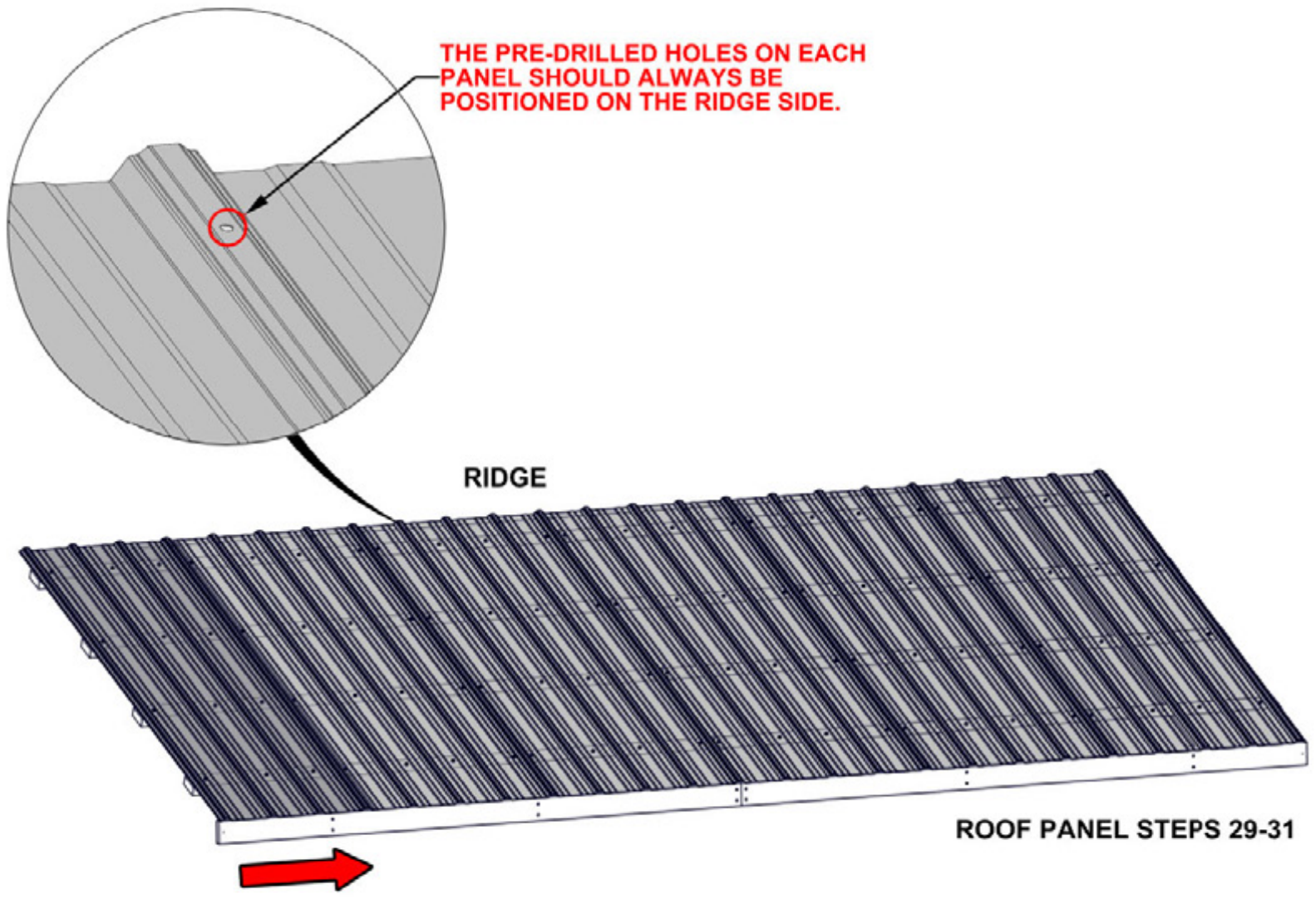

STEP 29 - ROOF PANEL ASSEMBLY

QTY	PART NUMBER	DESCRIPTION
28	H100833	SCREW WOODGRIP 10-16x3/4"

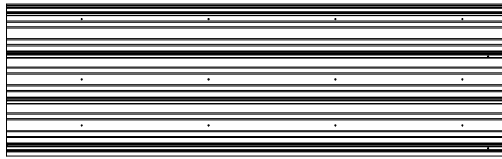

A4M02712 (x1) 29 GA STEEL SHEETING

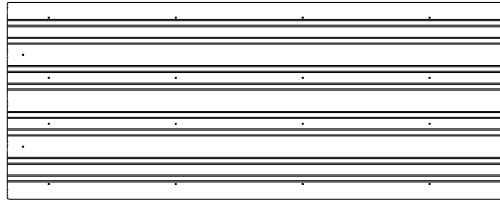

A4M02639 (x1) 29 GA STEEL SHEETING

ROOF PANEL B

• MAKE SURE YOUR ROOF PANEL IS SQUARE BEFORE MOVING ON.

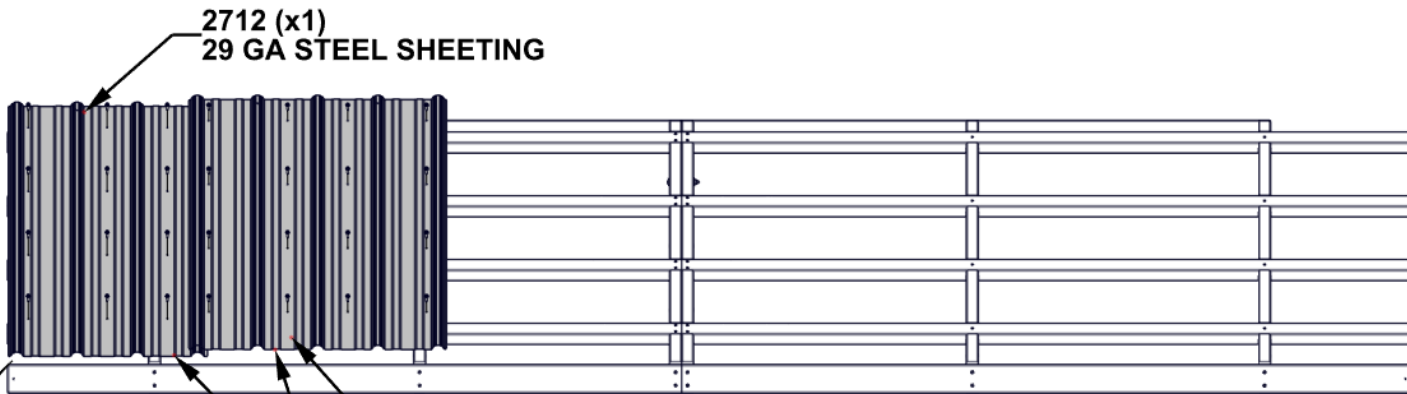
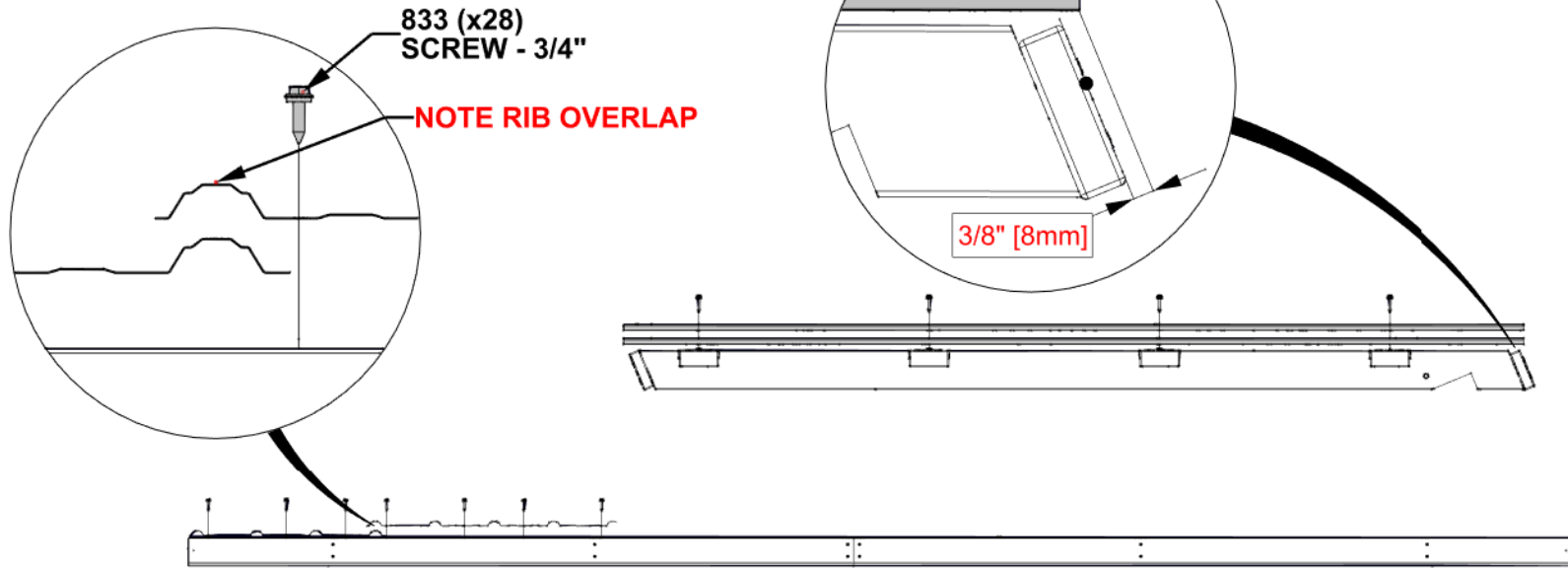

PLACE SHEETING ON ROOF PANEL, ALIGNING EDGE OF RIB 1/2" (12mm) FROM END OF H BOARD

STEP 30 - ROOF PANEL ASSEMBLY

Qty	PART NUMBER	DESCRIPTION
32	H100833	SCREW WOODGRIP 10-16x3/4

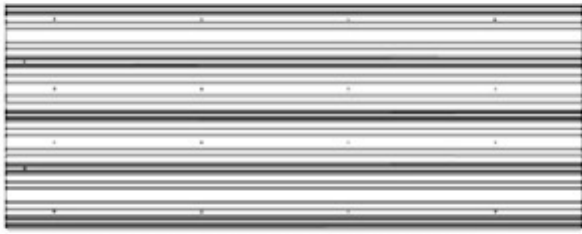

A4M02909 29GA STEEL SHEETING
(x1)

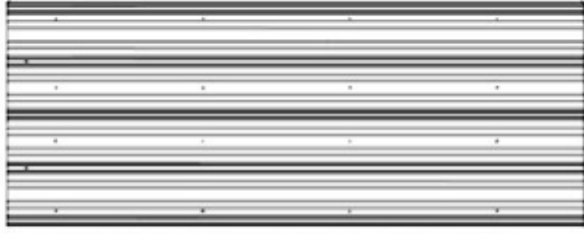

A4M02647 29GA STEEL SHEETING
(x1)

ROOF PANEL B

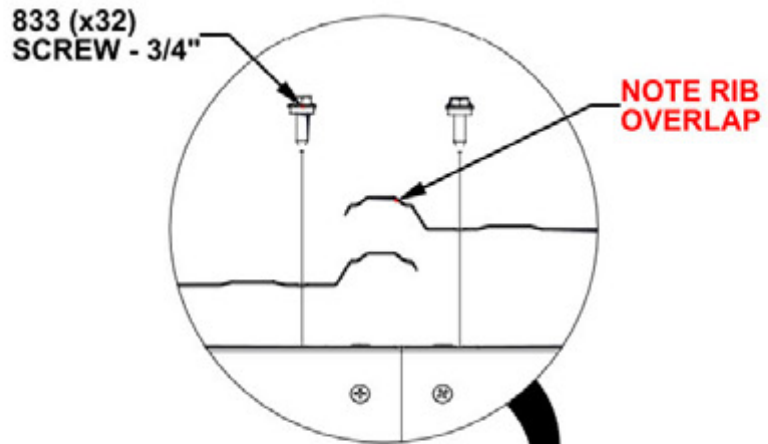

NOTE RIB OVERLAP

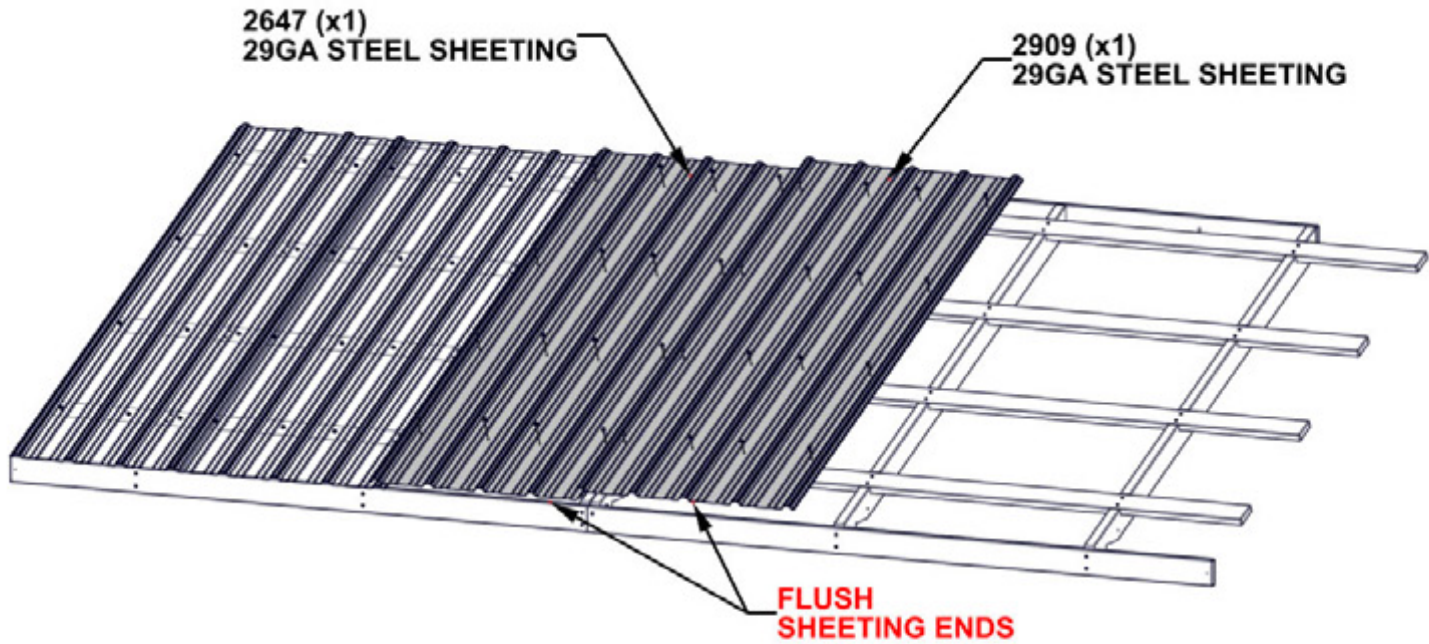
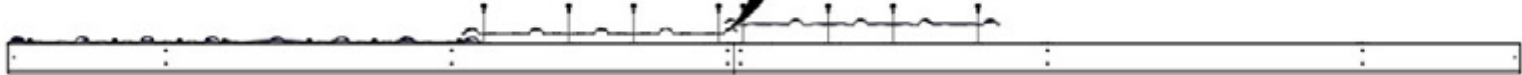

STEP 31 - ROOF PANEL ASSEMBLY

QTY	PART NUMBER	DESCRIPTION
32	H100833	SCREW WOODGRIP 10-16x3/4"

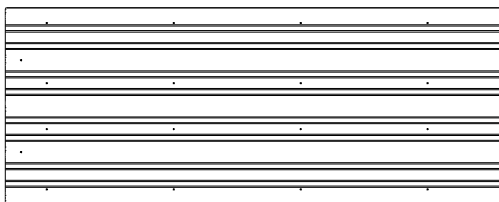

A4M02639
(x2) 29 GA STEEL SHEETING

ROOF PANEL B

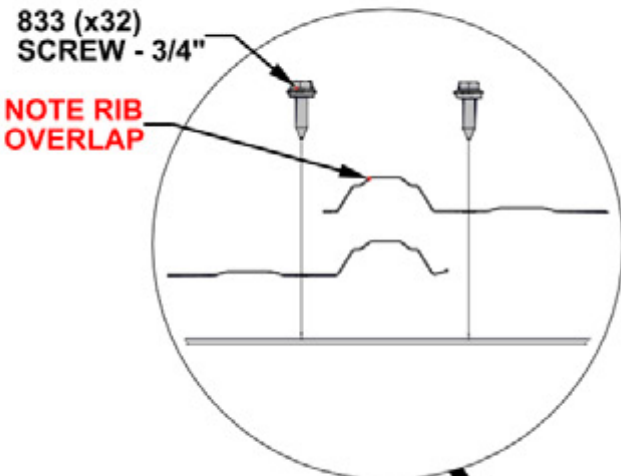

2639 (x2)
29 GA STEEL SHEETING

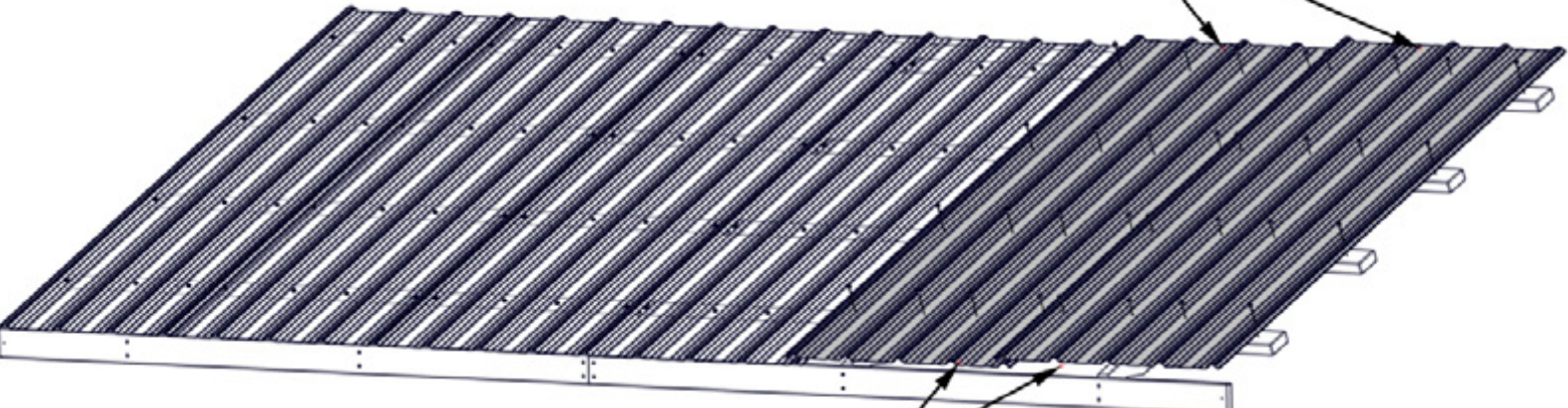

FLUSH ENDS OF ALL SHEETS

STEP 32 - ROOF PANEL ASSEMBLY

ROOF PANEL B

- SEPARATE ROOF PANEL FOR EASE OF ASSEMBLING.
- REMOVE HARDWARE & SET ASIDE. IT WILL BE USED AGAIN AFTER BOTH SECTIONS ARE INSTALLED.

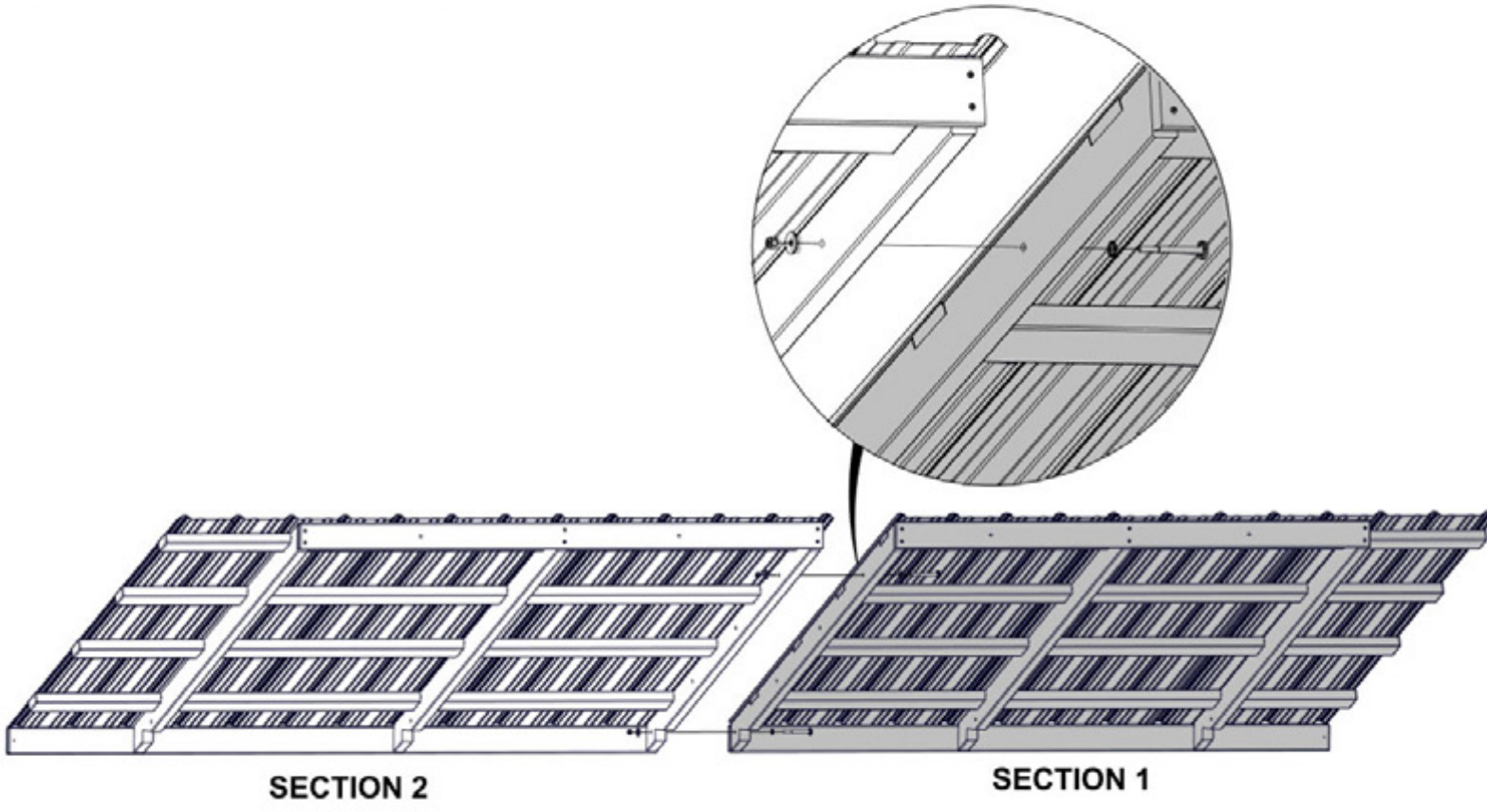

STEP 33 - ROOF ASSEMBLY

QTY	PART NUMBER	DESCRIPTION
2	H100378	BOLT WH 5/16x1 3/4 BLK
2	H100198	WASHER LOCK EXT 8x19
1	H100391	SCREW PFH 8x2 BLK

- ADDITIONAL PEOPLE ARE HELPFUL FOR THIS STEP.
- SLIDE ROOF PANEL ALONG TRACKS ON RAFTERS.
- ONCE IN PLACE, INSTALL BOLTS AND WASHERS.
- INSTALL SCREW LAST.

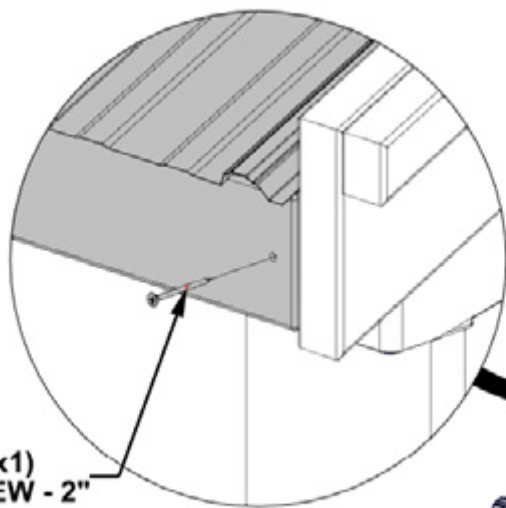
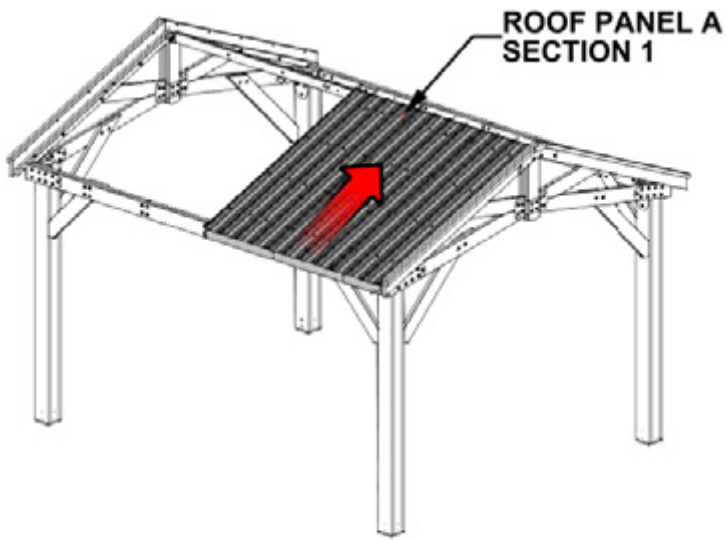

391 (x1)
SCREW - 2"

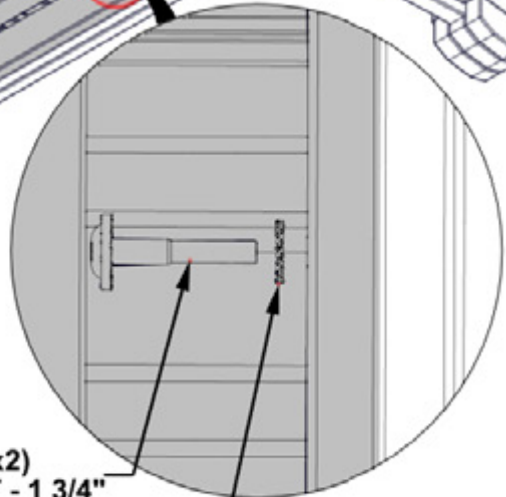
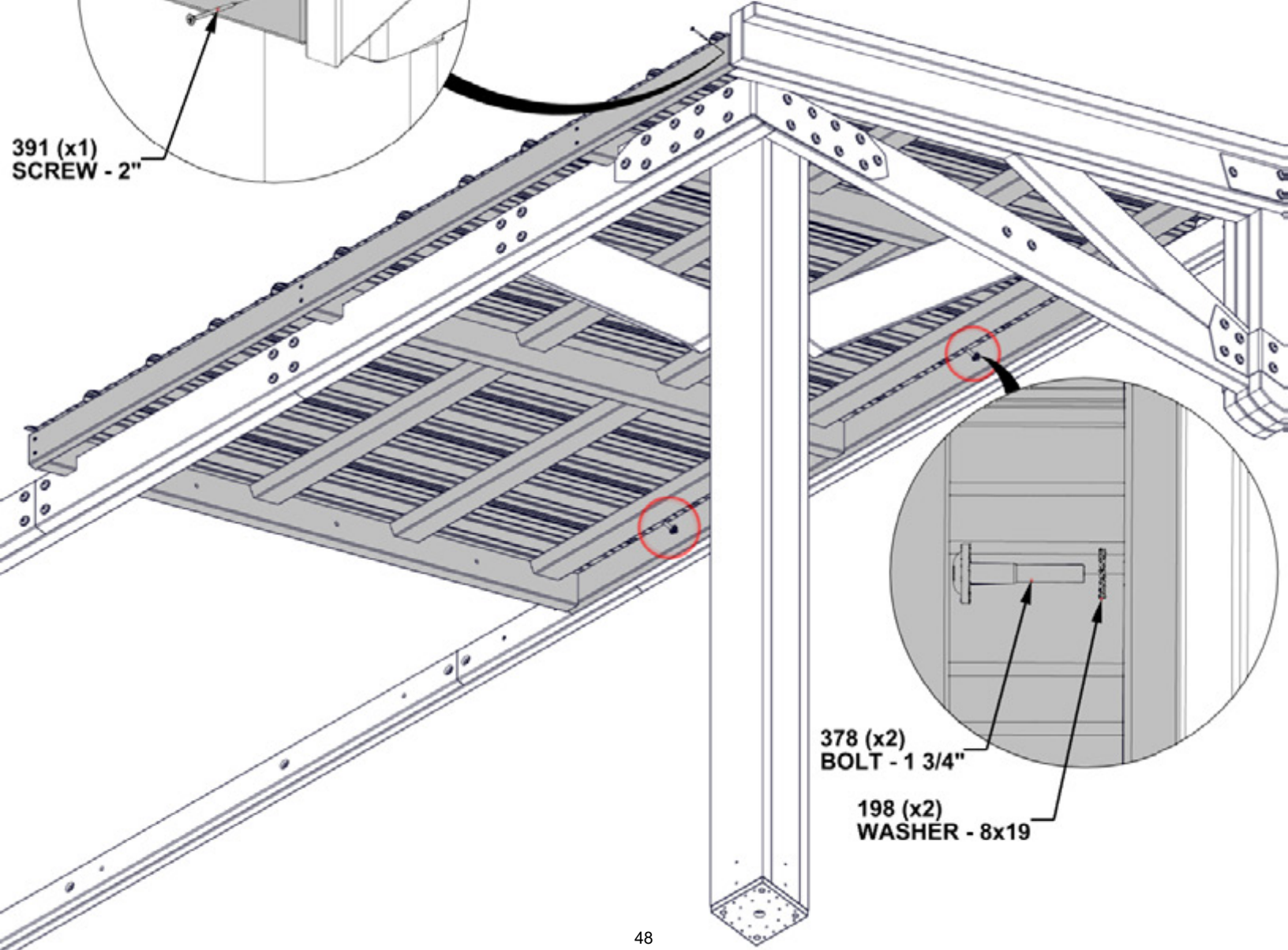

378 (x2)
BOLT - 1 3/4"

198 (x2)
WASHER - 8x19

STEP 34 - ROOF ASSEMBLY

QTY	PART NUMBER	DESCRIPTION
2	H100378	BOLT WH 5/16x1 3/4 BLK
2	H100198	WASHER LOCK EXT 8x19
1	H100391	SCREW PFH 8x2 BLK

- ADDITIONAL PEOPLE ARE HELPFUL FOR THIS STEP.
- SLIDE ROOF PANEL ALONG TRACKS ON RAFTERS.
- ONCE IN PLACE, INSTALL BOLTS AND WASHERS.
- INSTALL SCREW LAST.

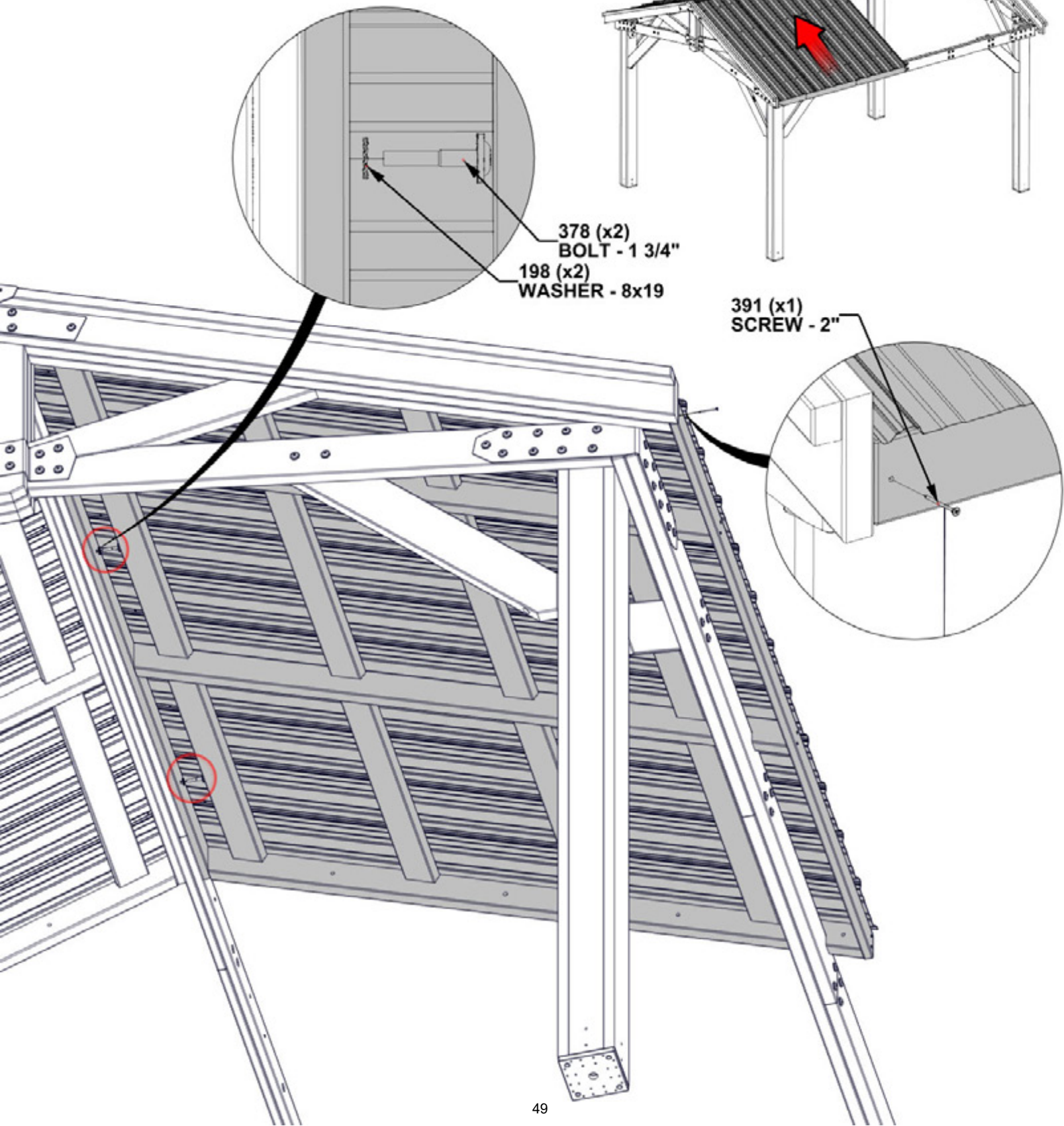
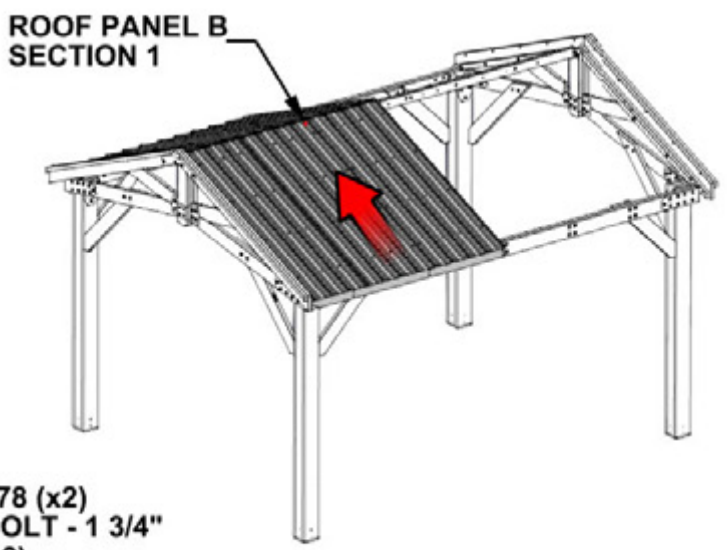

STEP 35 - ROOF ASSEMBLY

QTY	PART NUMBER	DESCRIPTION
3	H100479	NUT LOCK 5/16 BLK
3	H100503	BOLT WH 5/16x3 1/2 BLK
2	H100378	BOLT WH 5/16x1 3/4 BLK
5	H100198	WASHER LOCK EXT 8x19
3	H100478	WASHER FLAT 8x27 BLK
1	H100391	SCREW PFH 8x2 BLK

- ADDITIONAL PEOPLE ARE HELPFUL FOR THIS STEP.
- SLIDE ROOF PANEL ALONG TRACKS ON RAFTERS.
- ONCE IN PLACE, INSTALL BOLTS AND WASHERS.
- INSTALL SCREW LAST.
- THE CORNER OF EXISTING PANEL MAY NEED TO BE LIFTED TO GET THE PANEL STARTED SLIDING UP.

ROOF PANEL A SECTION 2

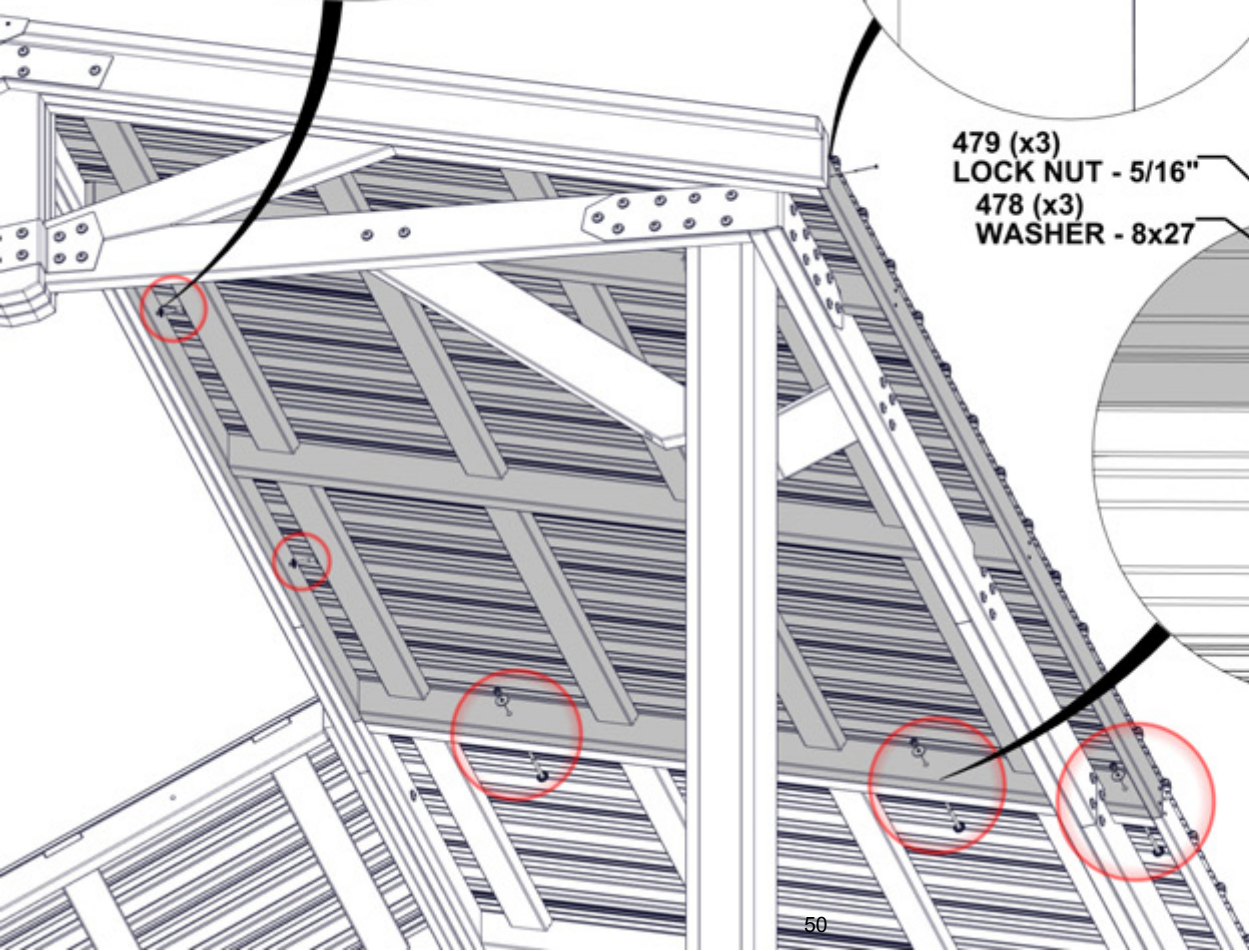
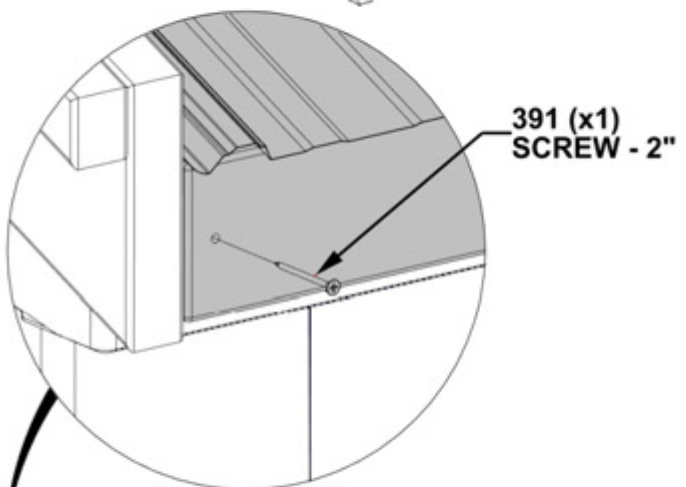
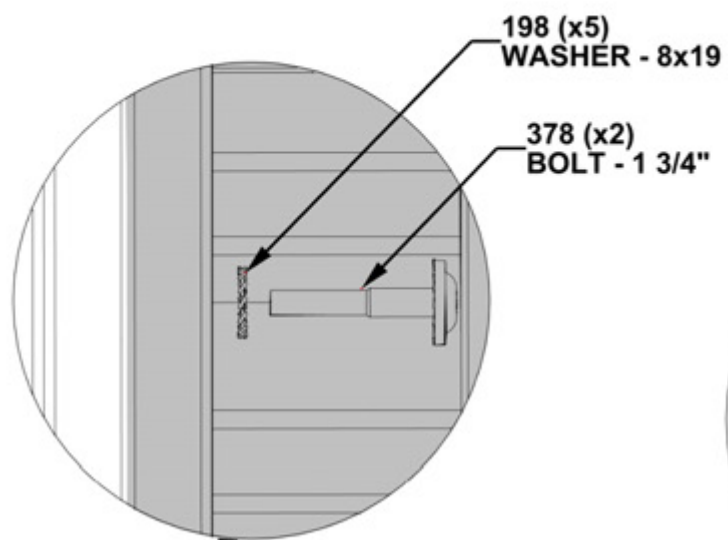
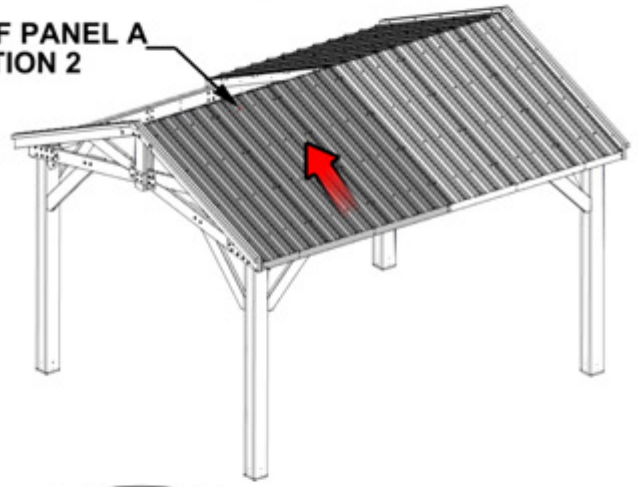

479 (x3)
LOCK NUT - 5/16"

478 (x3)
WASHER - 8x27

**RE-INSTALL REMOVED
HARDWARE**

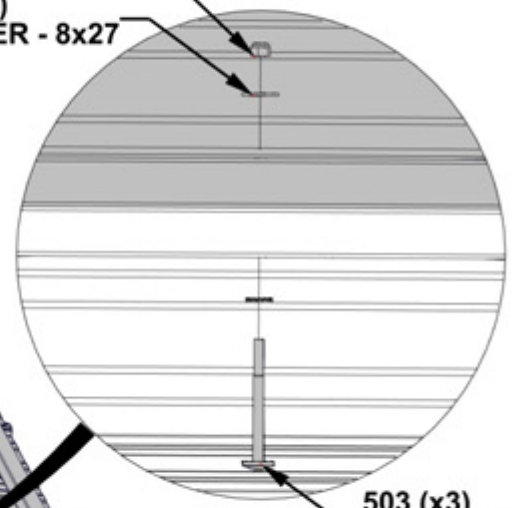

503 (x3)
BOLT - 3 1/2"

STEP 36 - ROOF ASSEMBLY

QTY	PART NUMBER	DESCRIPTION
3	H100479	NUT LOCK 5/16 BLK
2	H100378	BOLT WH 5/16x1 3/4 BLK
3	H100503	BOLT WH 5/16x3 1/2 BLK
5	H100198	WASHER LOCK EXT 8x19
3	H100478	WASHER FLAT 8x27 BLK
1	H100391	SCREW PFH 8x2 BLK

- ADDITIONAL PEOPLE ARE HELPFUL FOR THIS STEP.
- SLIDE ROOF PANEL ALONG TRACKS ON RAFTERS.
- ONCE IN PLACE, INSTALL BOLTS AND WASHERS.
- INSTALL SCREW LAST.
- THE CORNER OF EXISTING PANEL MAY NEED TO BE LIFTED TO GET THE PANEL STARTED SLIDING UP.

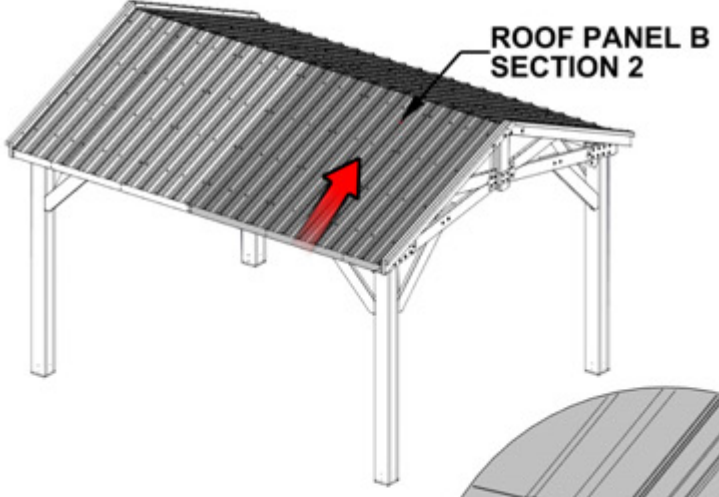

378 (x2)
BOLT - 1 3/4"

198 (x5)
WASHER - 8x19

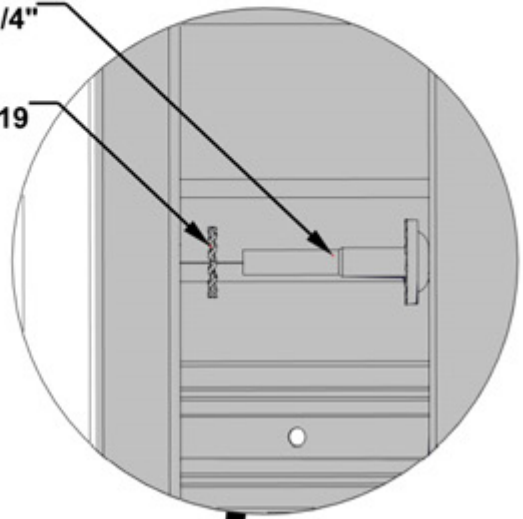

391 (x1)
SCREW - 2"

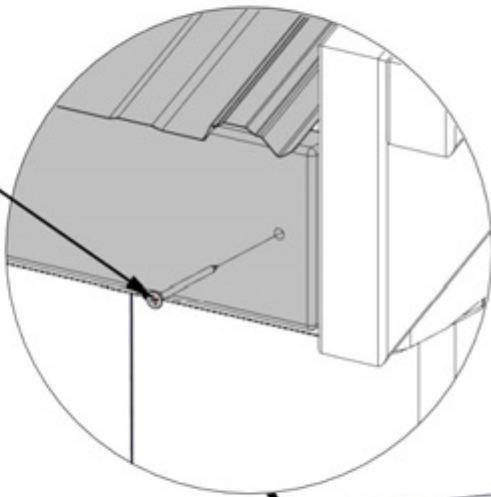

RE-INSTALL REMOVED HARDWARE

479 (x3)
LOCK NUT - 5/16"

478 (x3)
WASHER - 8x27

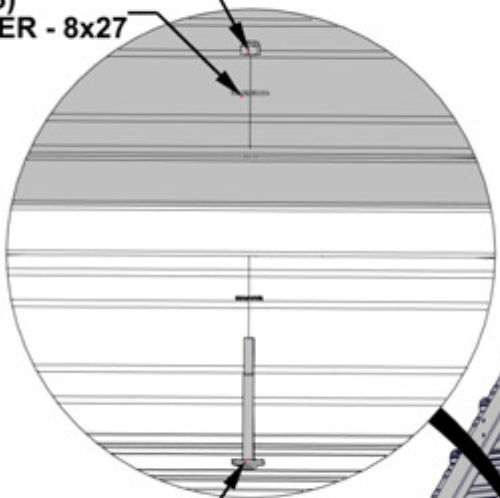

503 (x3)
BOLT - 3 1/2"

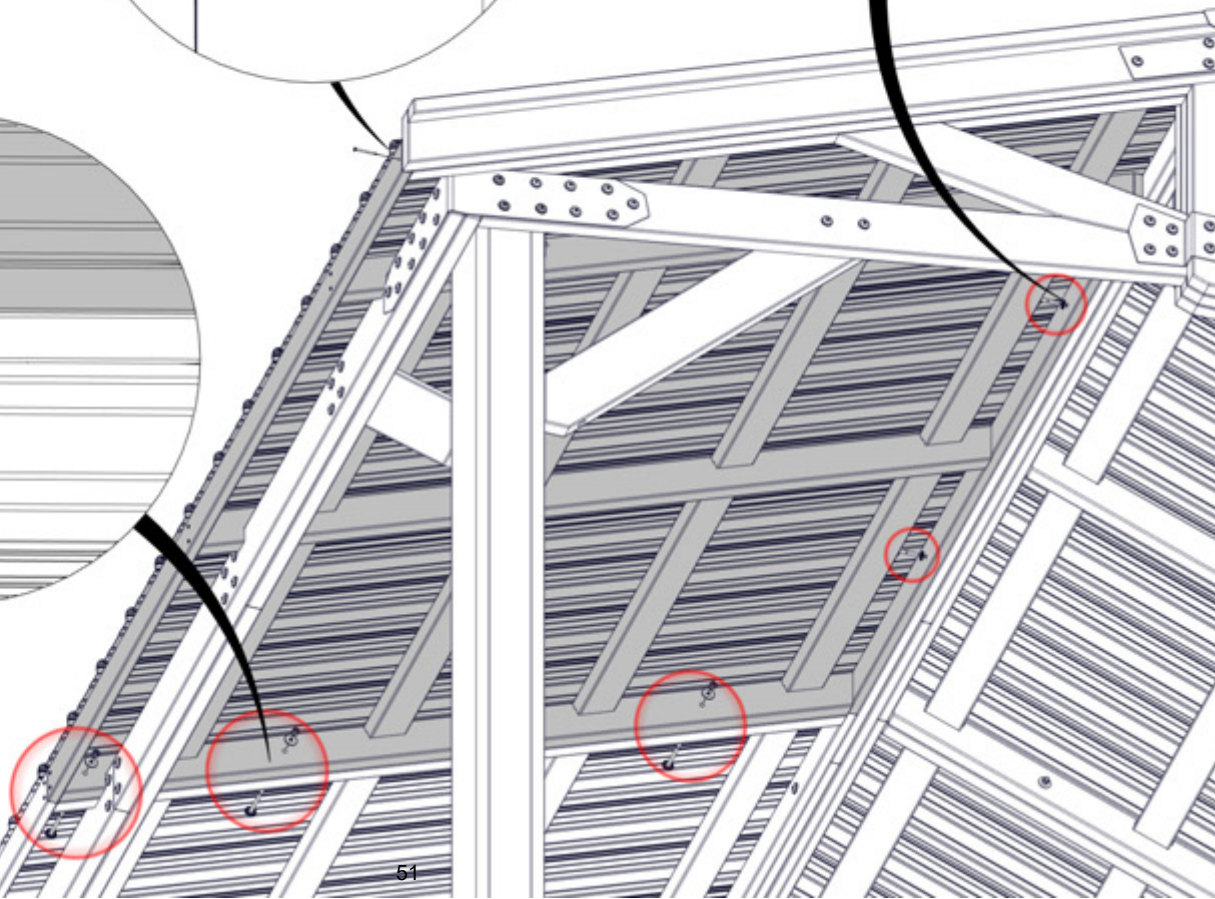

STEP 37 - ROOF ASSEMBLY

QTY	PART NUMBER	DESCRIPTION
2	H100479	NUT LOCK 5/16 BLK
2	H100976	BOLT WH 5/16x6 1/4 BLK
2	H100478	WASHER FLAT 8x27 BLK
2	H100198	WASHER LOCK EXT 8x19



E06 ACCESSORY TRUSS - W4L16863
 (x2) 1 3/8"x3 3/8"x73 13/16" (36x86x1875)

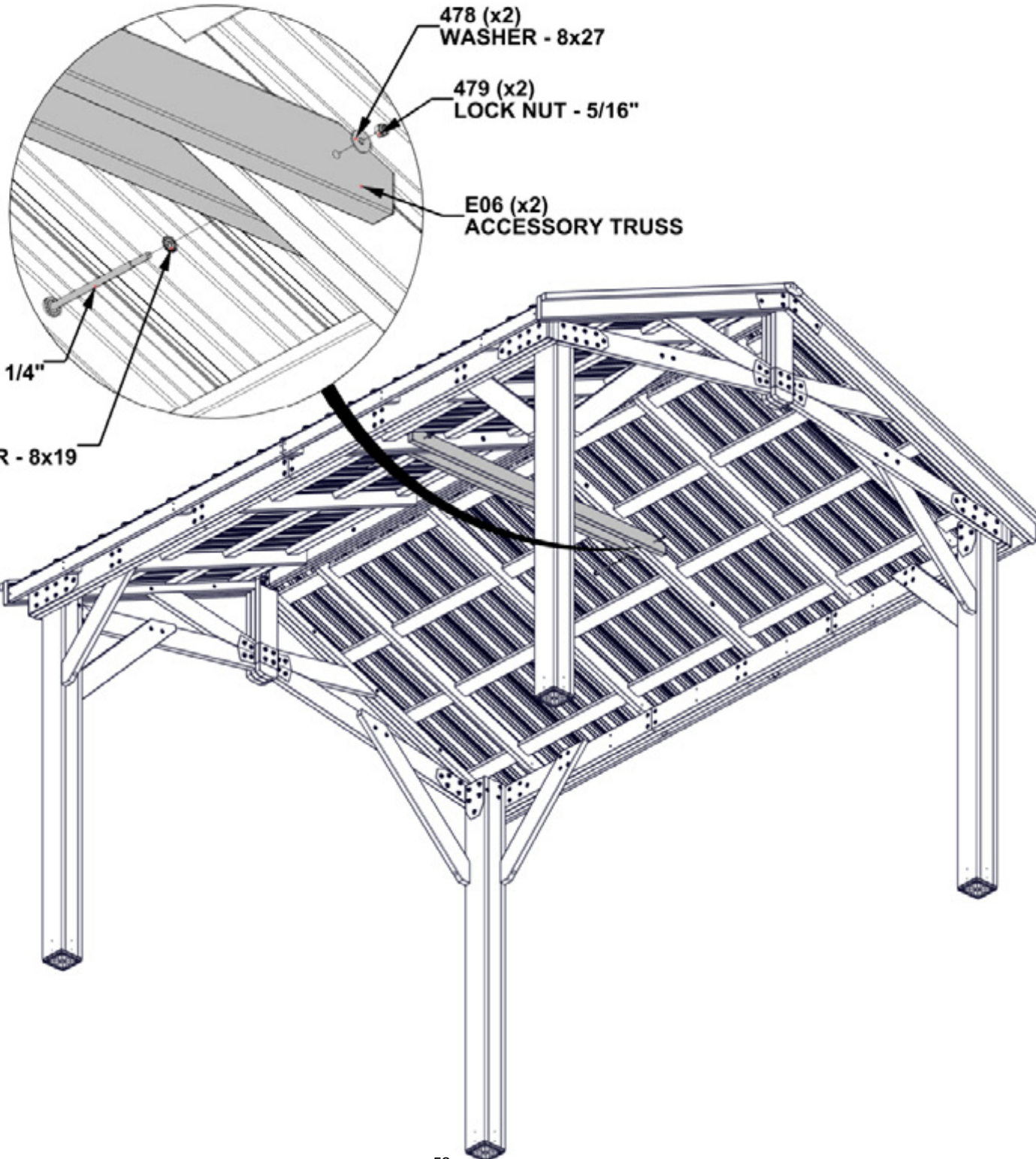

STEP 38 - ROOF ASSEMBLY

QTY	PART NUMBER	DESCRIPTION
8	H100653	NUT LOCK 1/4 BLK
8	H100488	BOLT WH 1/4x2 BLK
8	H100630	WASHER FLAT 8x19 BLK
16	H100823	SCREW PWH 8x1 1/2 BLK

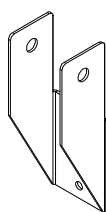

A4M01228 (x8) RAFTER BRACKET

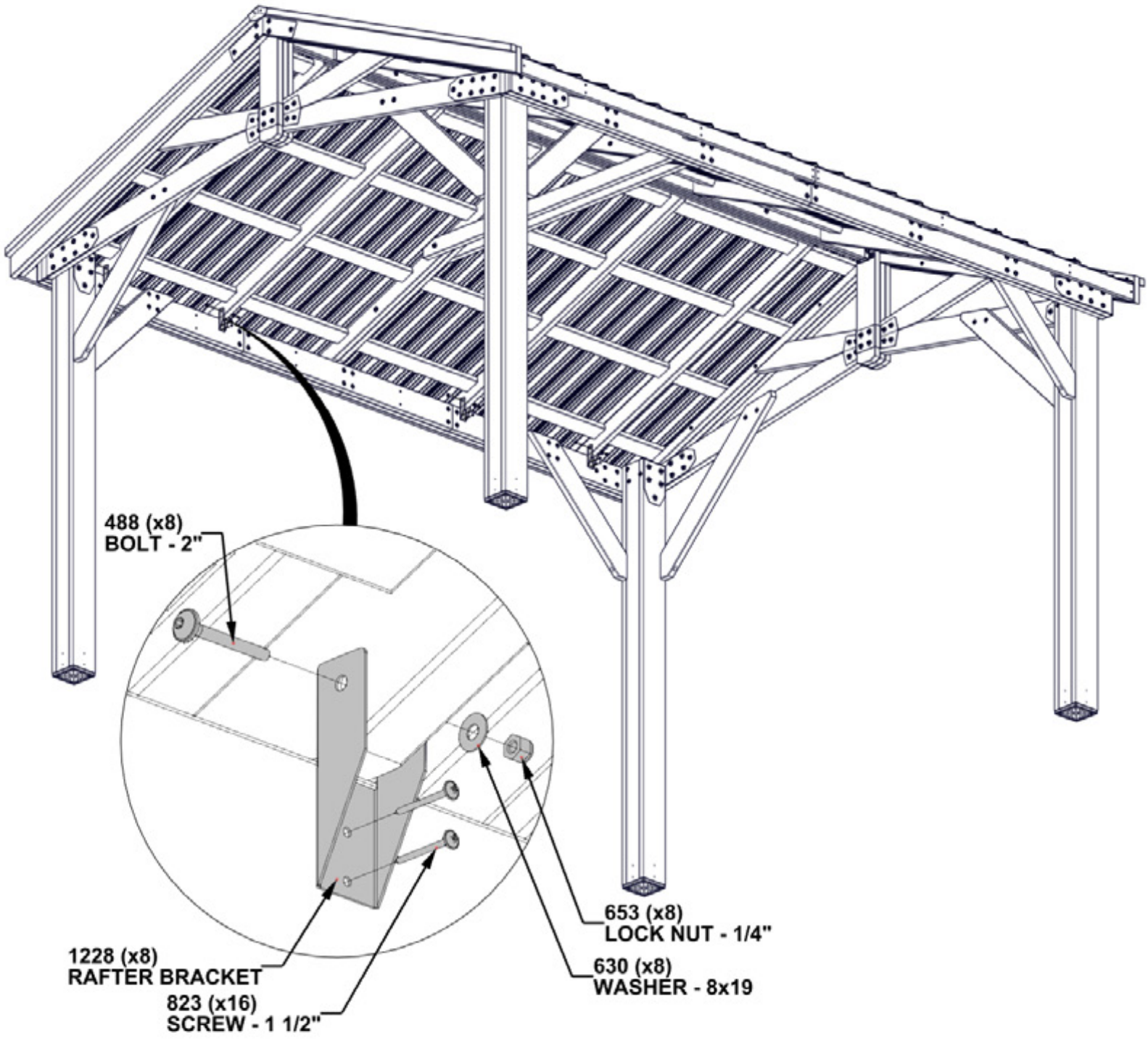

STEP 39 - ROOF ASSEMBLY

Qty	PART NUMBER	DESCRIPTION
16	H100391	SCREW PFH 8x2 BLK

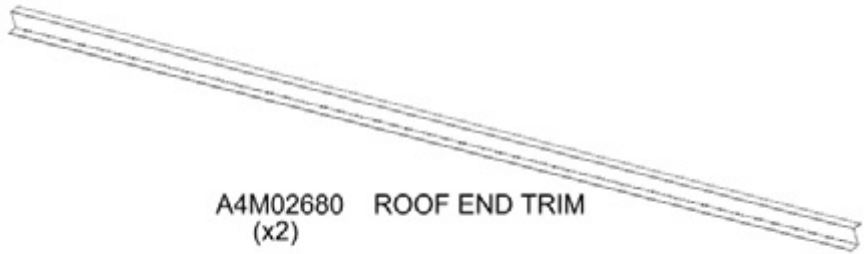
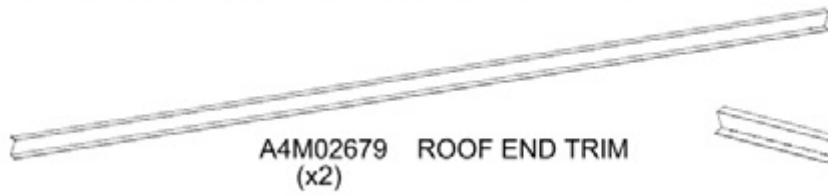

• ATTACH SCREWS IN LINE WITH ROOF PANEL SCREWS.

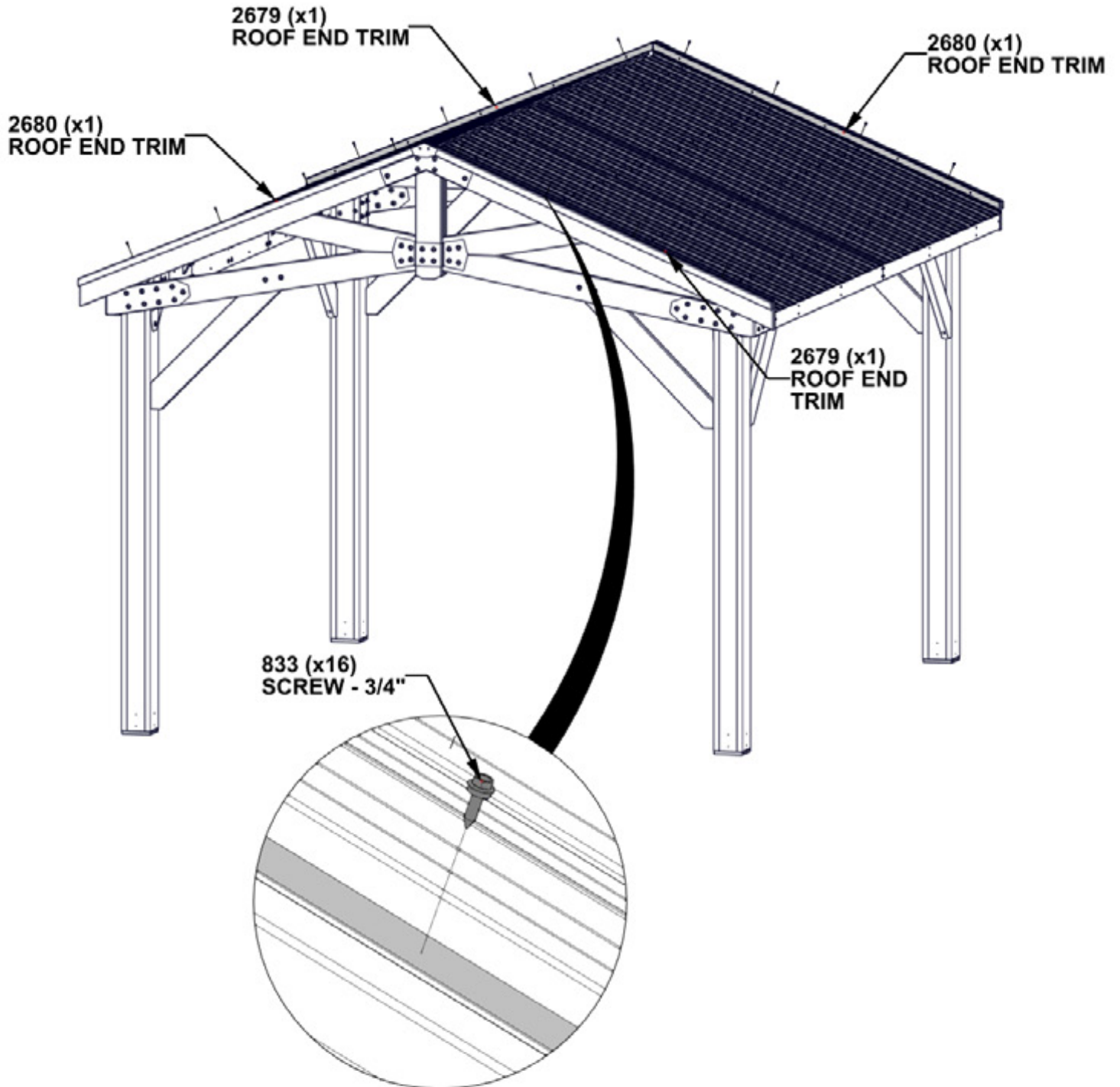

STEP 40 - ROOF ASSEMBLY

QTY	PART NUMBER	DESCRIPTION
20	H100759	SCREW SELF TAPPING 1/4x1

A4M02714 ROOF EDGE TRIM
(x4)

A4M02638 ROOF EDGE TRIM
(x2) SPLICE

- DUE TO MULTIPLE LAYERS OF METAL ON THE EDGE TRIM, IT IS RECOMMENDED TAT AN 1/8" (3mm) DRILL BIT IS USED TO CREATE STARTER HOLES.
- REMOVE PROTECTIVE BLUE FILM.
- GLOVES SHOULD BE WORN WHEN HANDLING ROOF METAL. EDGES ARE SHARP.
- START FIRST SCREW AT THE FIRST RIB FROM END. ATTACH SCREWS ON EVERY OTHER RIB.
- REPEAT THIS STEP ON THE OPPOSITE SIDE.

SCREWS GO THROUGH EDGE TRIM INTO THE TOP OF THE RIBS IN THE APPROXIMATE LOCATIONS SHOWN.

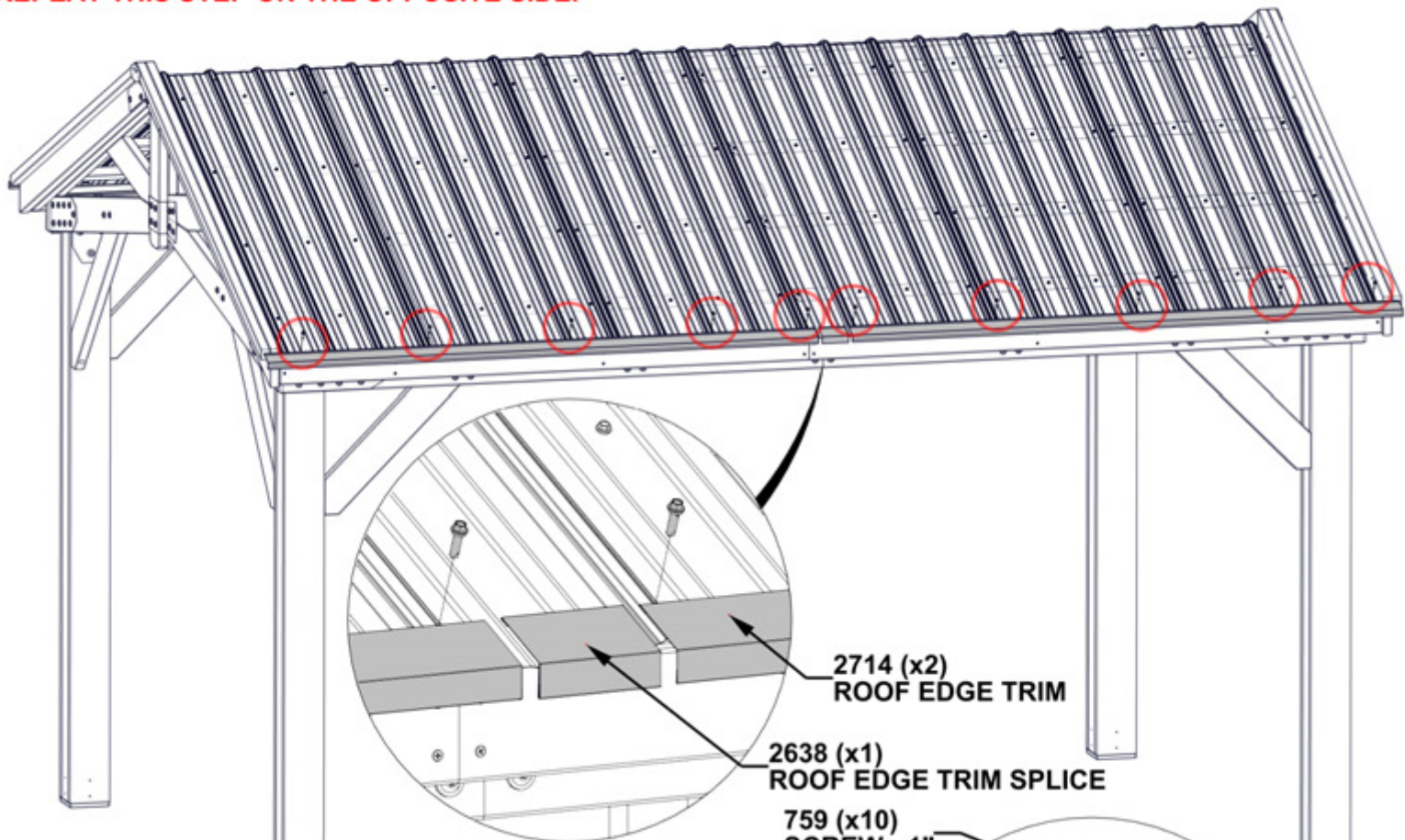

SLIDE TRIM INTO SPLICE ENSURING THAT BOTH ENDS ARE FLUSH WITH THE EDGES OF ROOF PANELS.

2714 (x2)
ROOF EDGE TRIM

2638 (x1)
ROOF EDGE TRIM SPLICE

759 (x10)
SCREW - 1"

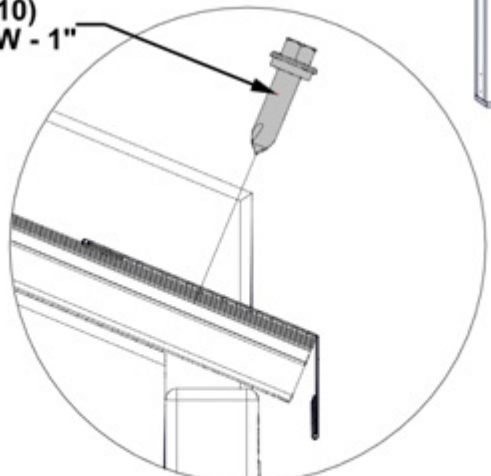

SIDE VIEW

STEP 41 - ROOF ASSEMBLY

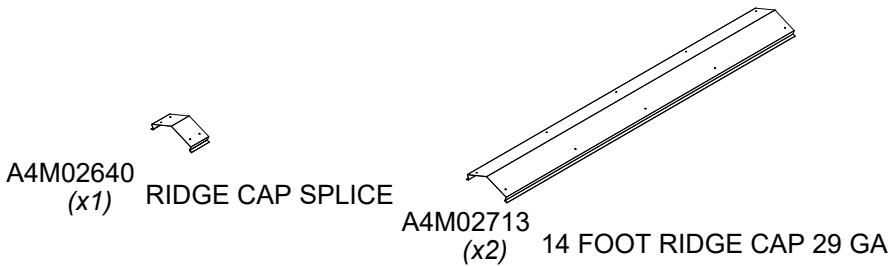

• SLIDE EACH RIDGE CAP INTO THE RIDGE CAP SPLICE UNTIL CENTERED.

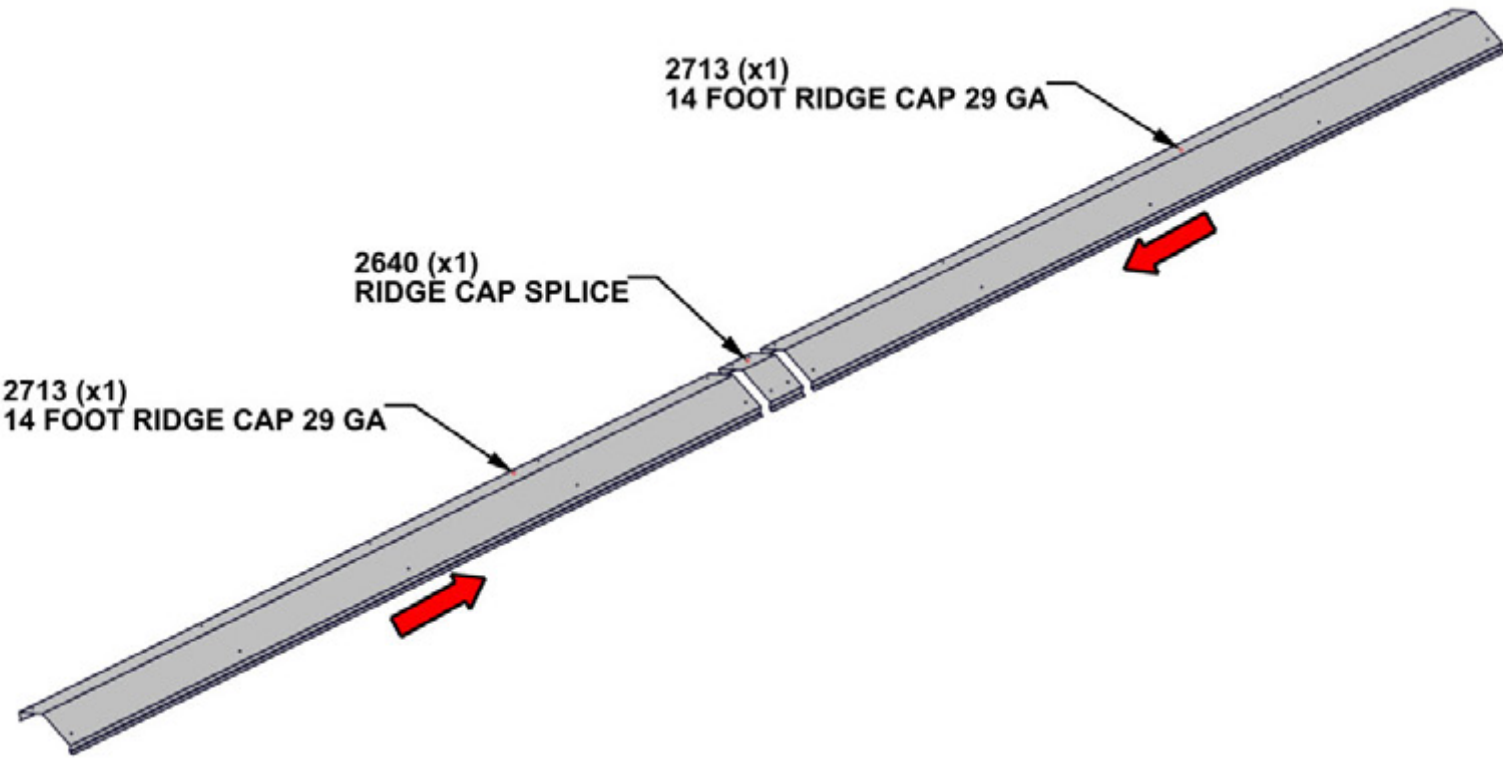

STEP 42 - ROOF ASSEMBLY

QTY	PART NUMBER	DESCRIPTION
20	H100833	SCREW WOODGRIP 10-16x3/4"

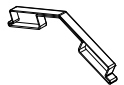

A6P00398
(x2) RIDGE CAP PROTECTOR

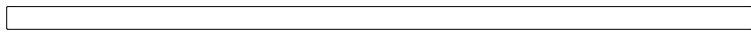

J09 RIDGE CAP STIFFENER - W4L16897
(x2) 1"x2 3/8"x77 5/8" (24x60x1973)



J10 RIDGE CAP STIFFENER - W4L16898
(x2) 1"x2 3/8"x89 1/2" (24x60x2273)

- REMOVE SPACERS FROM RIDGE CAP PROTECTORS BEFORE INSTALLING.
- ALIGN THE HOLES ON EACH RIDGE CAP TO THE HOLES IN THE RIDGE CAP SPLICE BEFORE INSERTING SCREWS.
- **FINAL LENGTH - 13'-11 3/8" [4250mm]**

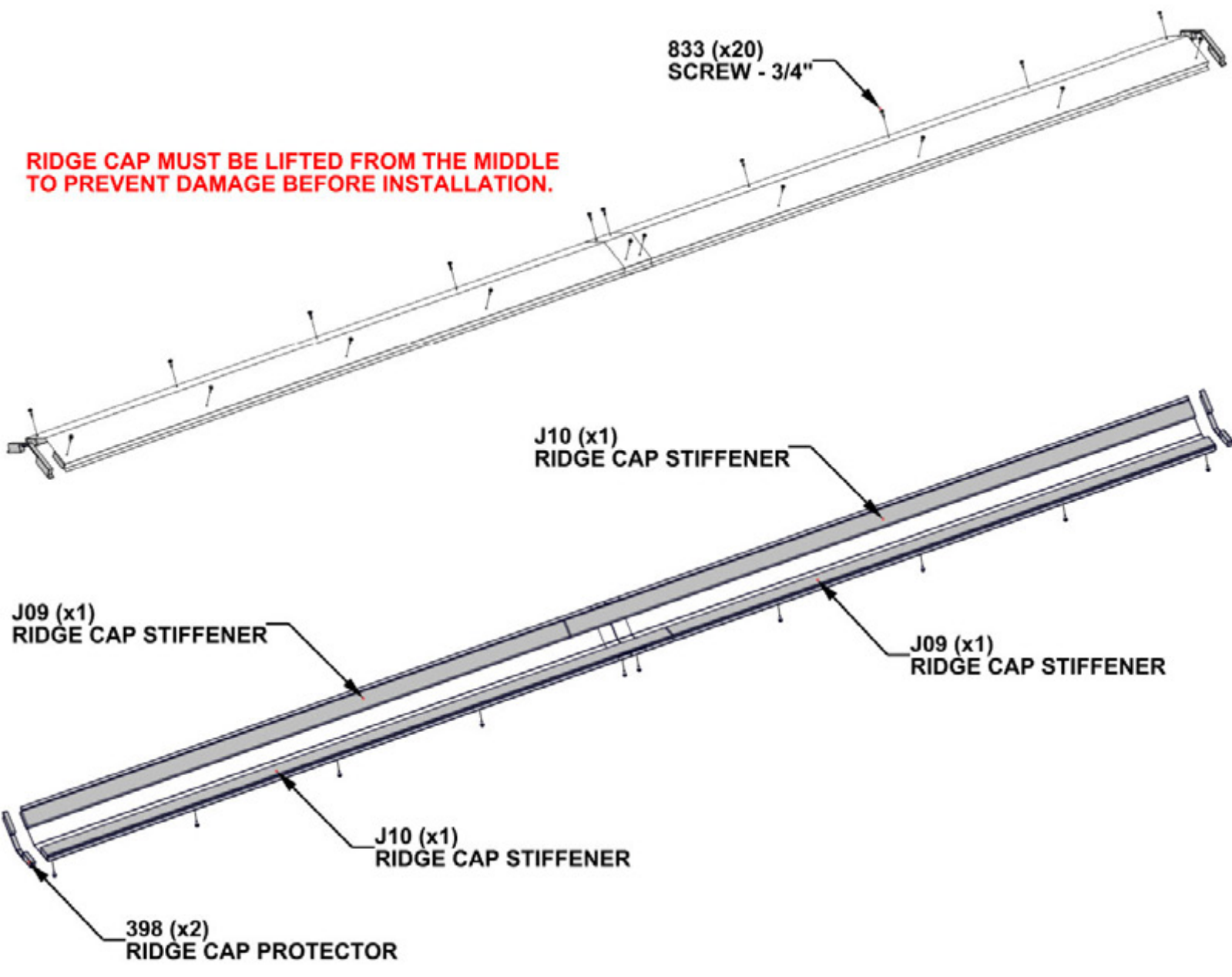

STEP 43 - ROOF ASSEMBLY

QTY	PART NUMBER	DESCRIPTION
22	H100392	SCREW PWH 8x3/4 BLK



RIDGE CAP ASSEMBLY - FROM PREVIOUS STEPS

DO NOT CLIMB ON ROOF TO INSTALL. ROOF CAP HAS BEEN DESIGNED TO INSTALL WITH THE USE OF A LADDER.

- FOR PROPER INSTALLATION, USE AN ADULT HELPER TO KEEP DOWNWARD PRESSURE ON THE RIDGE CAP WHILE SCREWING IN SCREWS.

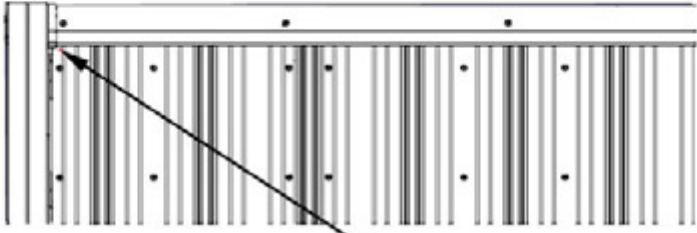
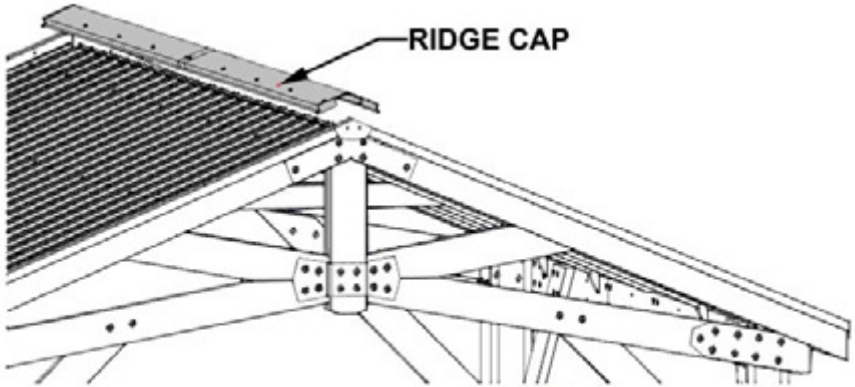

SLIDE RIDGE CAP ASSEMBLY ACROSS THE ROOF RIDGE UNTIL BOTH ENDS SIT INSIDE RAFTERS AS SHOWN.

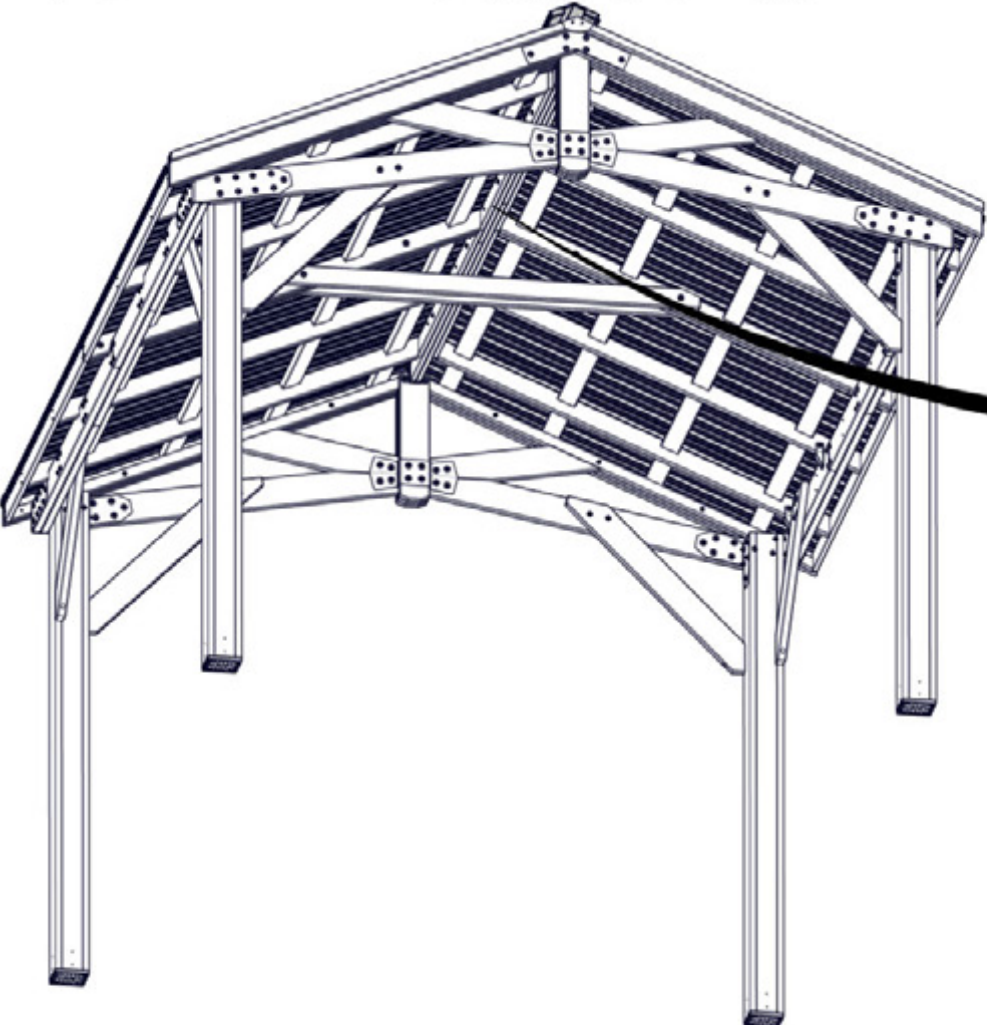

INSTALL SCREWS THROUGH PILOT HOLES IN ROOF PANELS INTO RIDGE CAP STIFFENER BOARDS.

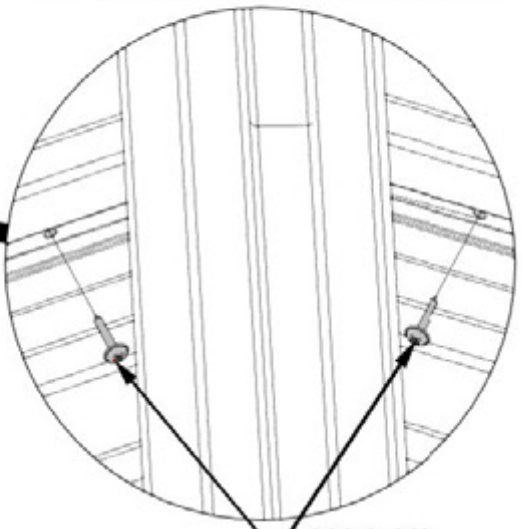

392 (x22)
SCREW - 3/4"

STEP 44 - GAZEBO ASSEMBLY

QTY	PART NUMBER	DESCRIPTION
4	H100382	SCREW PFH 8x1 3/4 BLK

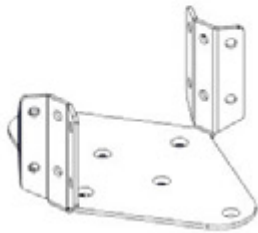

A4M02501 FAN MOUNT BRACKET
(x1)

NOTES:

1. BEFORE MOUNTING, ATTACH YOUR ELECTRICAL BOX (PROVIDED SEPARATELY) USING THE PROVIDED HOLES IN FAN MOUNT BRACKET.
2. PLACE FAN MOUNT BRACKET ON RIDGE BEAMS AND MOVE TO DESIRED FAN LOCATION.
3. ROTATE BRACKET UNTIL MOUNTING FLANGES ALIGN BEST WITH RIDGE BEAMS.
4. USE AN 1/8" DRILL BIT AND DRILL PILOT HOLES AND ATTACH AS SHOWN.
5. IF BRACKET WILL NOT FIT OVER THE RIDGE BEAM, SLIGHTLY FLEX OUT BRACKET EARS TO FIT.

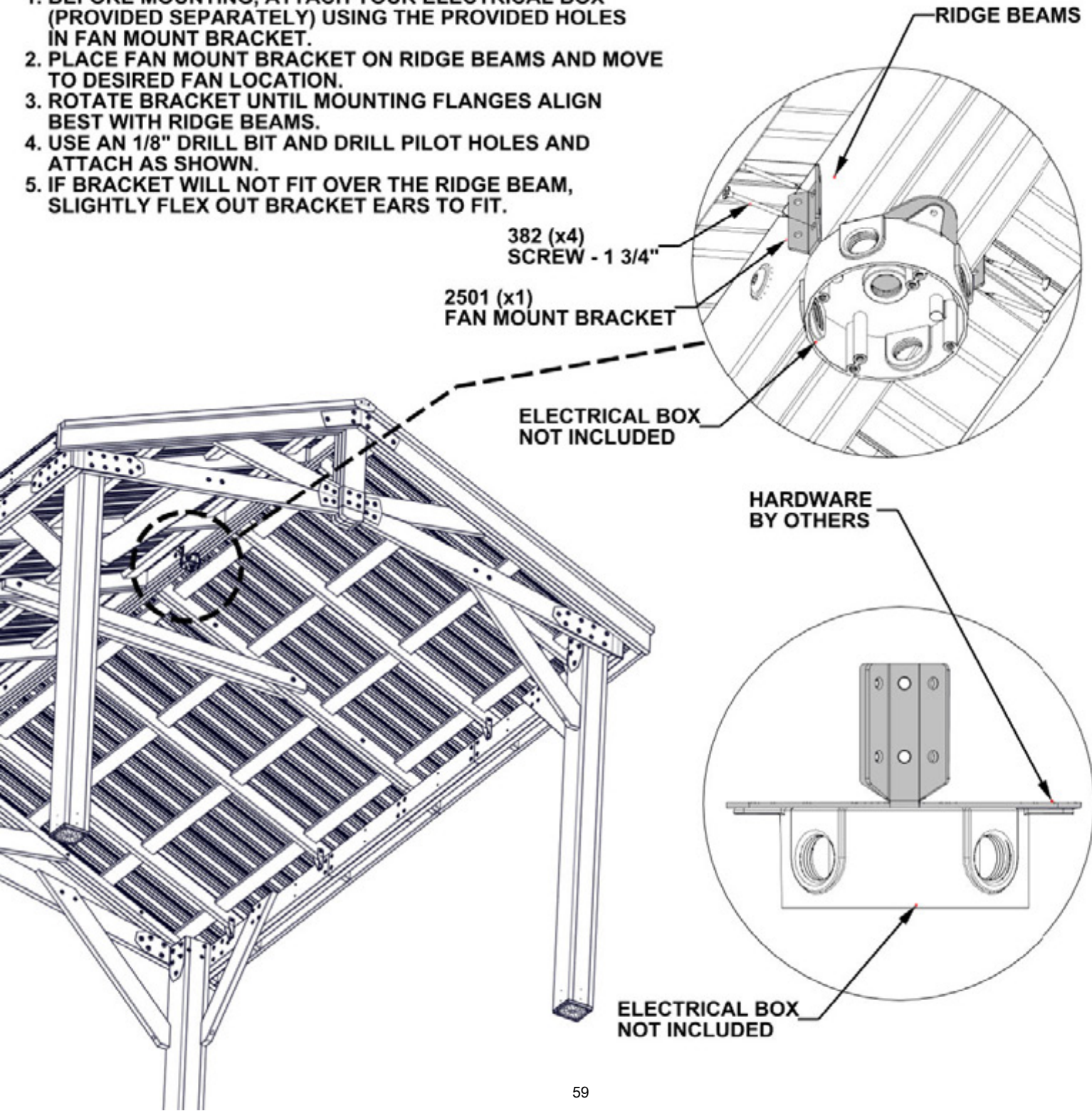

382 (x4)
SCREW - 1 3/4"

2501 (x1)
FAN MOUNT BRACKET

ELECTRICAL BOX
NOT INCLUDED

HARDWARE
BY OTHERS

ELECTRICAL BOX
NOT INCLUDED

STEP 45 - ROOF ASSEMBLY

QTY	PART NUMBER	DESCRIPTION
32	H100471	LAG SCREW WH 5/16x1 1/2 BLK

A4M00978
(x8) POST PLATE

A4M00977
(x8) POST ANCHORING PLATE

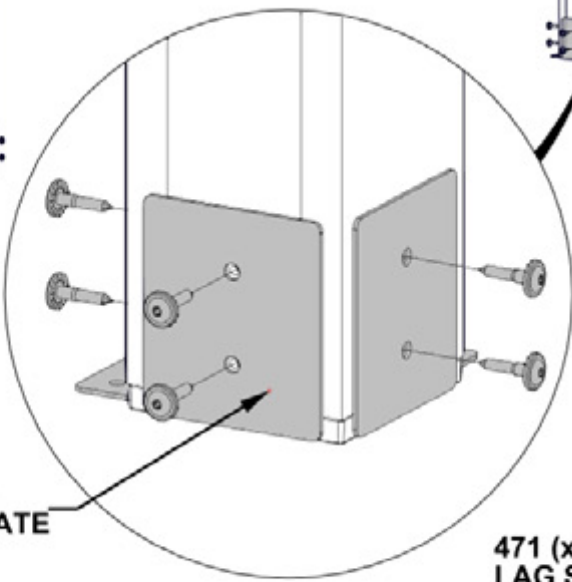
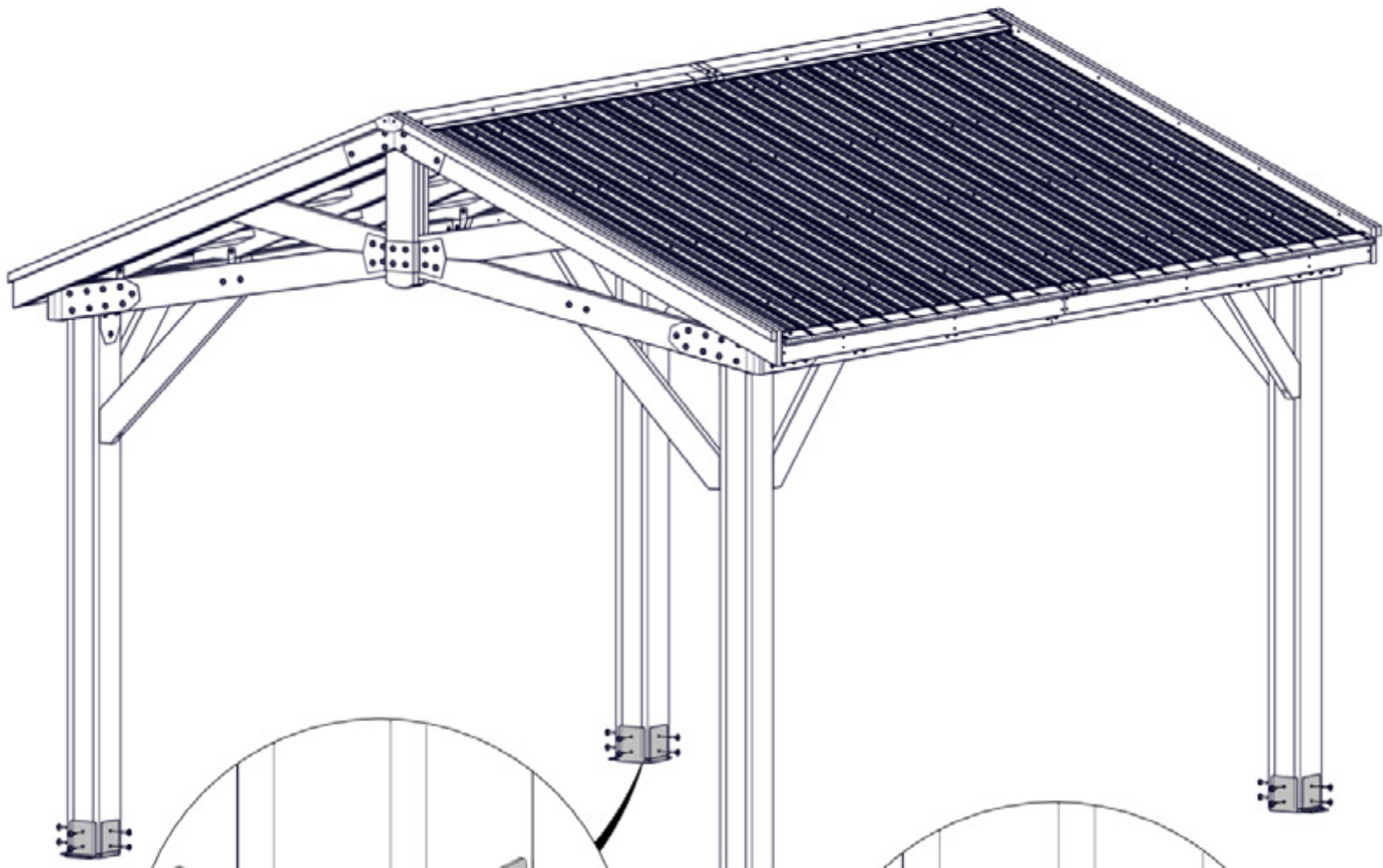

0978 (x8)
POST PLATE

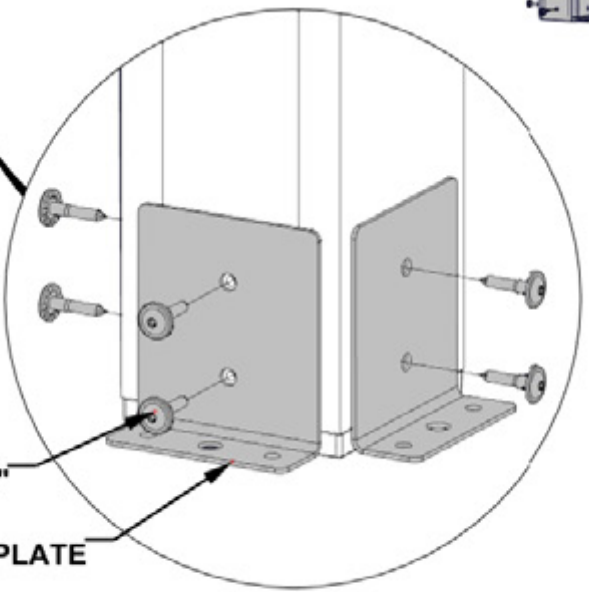

471 (x32)
LAG SCREW - 1 1/2"

0977 (x8)
POST ANCHORING PLATE

STEP 46 - GAZEBO ASSEMBLY

Qty	PART NUMBER	DESCRIPTION
4	H100202	SCREW PWH 8x5/8 BLK



A4M02158 BYD ID TAG PATIO
(x1)

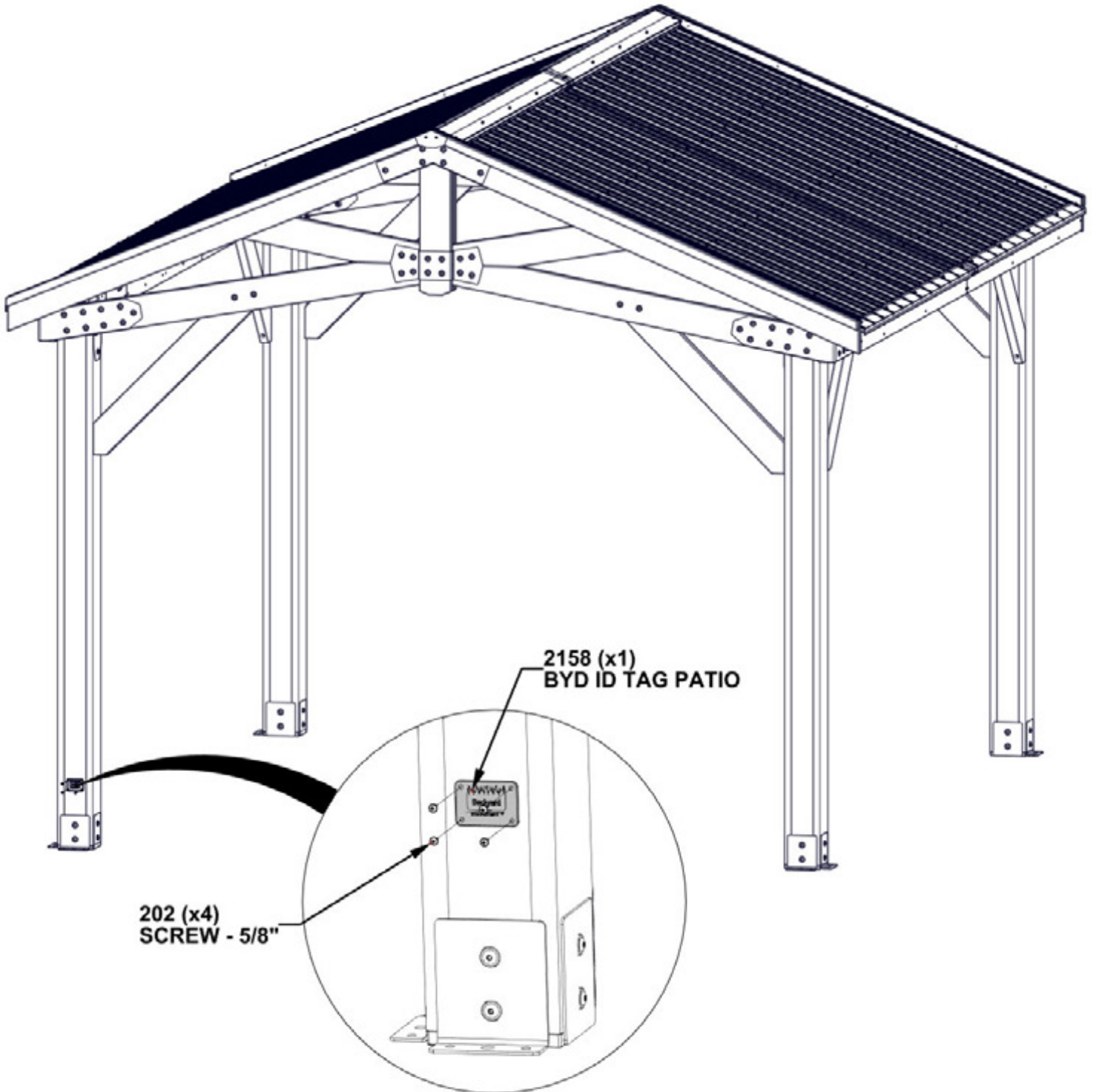

STEP 47 - GAZEBO ASSEMBLY

QTY	PART NUMBER	DESCRIPTION
16	H100630	WASHER FLAT 8x19 BLK
16	H100120	CONCRETE ANCHOR

- MANUFACTURER RECOMMENDS INSTALLATION ON CONCRETE SURFACE OR CONCRETE POST PAD AS SHOWN BELOW.
- FOR INSTALLATION ON WOOD DECK, YOU MUST ENSURE THERE IS AMPLE STRUCTURAL SUPPORT UNDER THE DECK. HARDWARE NOT INCLUDED FOR DECK ATTACHMENT.

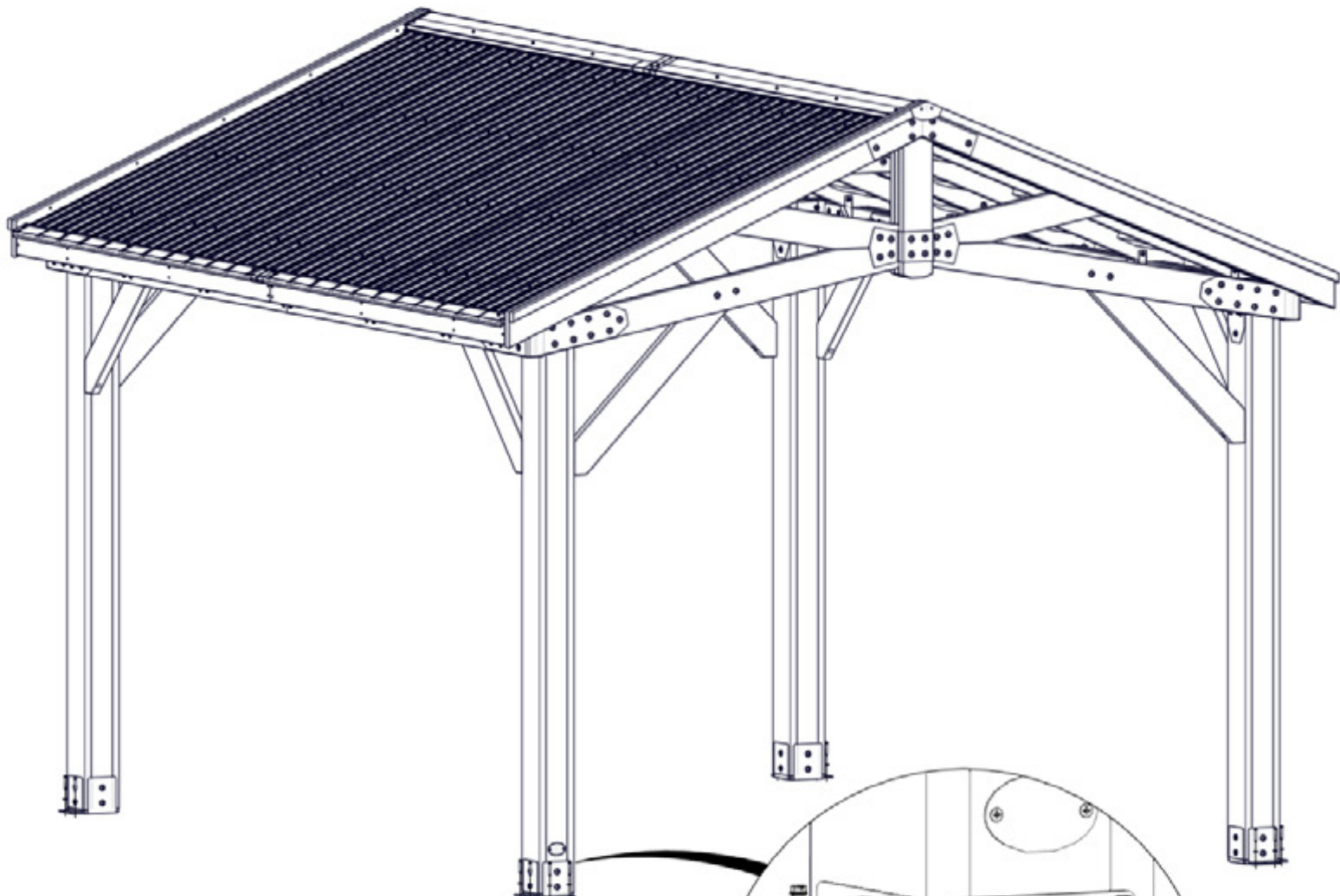

120 (x16)
SCREW - 2"

630 (x16)
WASHER - 8x19

**PRE-DRILL HOLES FOR
CONCRETE ANCHORS USING
A 3/16" CONCRETE DRILL BIT**

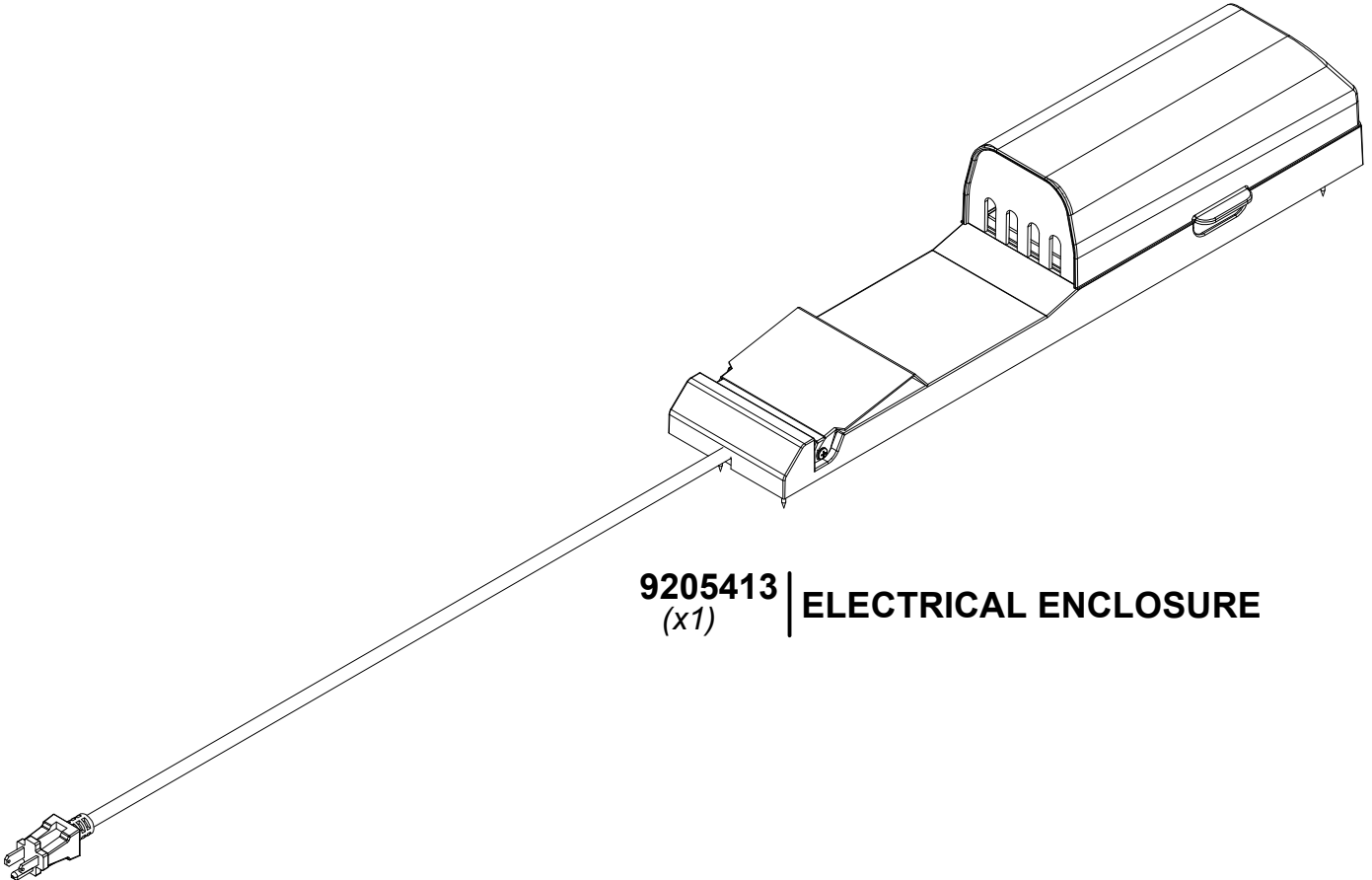

9205413 | **ELECTRICAL ENCLOSURE**
(x1)

FOR POWERPORT INSTALLATION REFER TO ASSEMBLY INSTRUCTIONS THAT COME PACKAGED WITH THE POWERPORT KIT. INSTALL ON ANY POST THAT IS DESIRED. FOLLOW DIRECTIONS FOR PROPER INSTALLATION.