



MANUFACTURED BY:
Backyard Discovery
 3305 Airport Drive, Pittsburg, KS 66762
 800-856-4445

Basepoint Business Centre: Rivermead Drive, Westlea, Swindon SN5 7EX Phone: 0800-118-2476
 J.P. Coenstraat 7, The Bridge, The Hague, 2595 WP, Netherlands Phone: 0800-567-8990

12x10 ARLINGTON GAZEBO

Model # 2206106B

The assembly manual must be retained since it contains important information



Please visit www.backyarddiscovery.com

For the most up to date assembly manual, to register your set, or to order replacement parts
Para obtener instrucciones en español, visite www.backyarddiscovery.com



**EASY STEP-BY-STEP
 3D INTERACTIVE INSTRUCTIONS**
 DOWNLOAD THE FREE APP



Made in China

INS-2206106B-A-12x10 ARLINGTON-ENG 12-1-2023

Owner's Manual - Basic Setup Dimensions & Assembly Notes

It is critically important that you start with square and level footings, concrete pad or deck to attach your structure

- Pay close attention to the items needed for each step. Make sure you are using the correct hardware for each step. Using incorrect hardware may result in improper assembly
- Remember to double check for underground utilities and overhead electrical lines

Post mounts are provided with your structure which allows you to permanently install your structure to a pre-existing or new wood or concrete surface.

- The hardware to attach the post mounts to the structure is included.
- The hardware to mount the structure permanently to a concrete surface is included.
- The hardware to mount the structure permanently to a wood deck is NOT included and will need to be purchased separately. **You must ensure there is ample structural support under the deck before permanently attaching.**

Metal Roof Assembly

Remove plastic covering from metal roof panels before installing each piece. Place roofing materials on a nonabrasive, flat surface before and after assembly as it could bend, dent or scratch

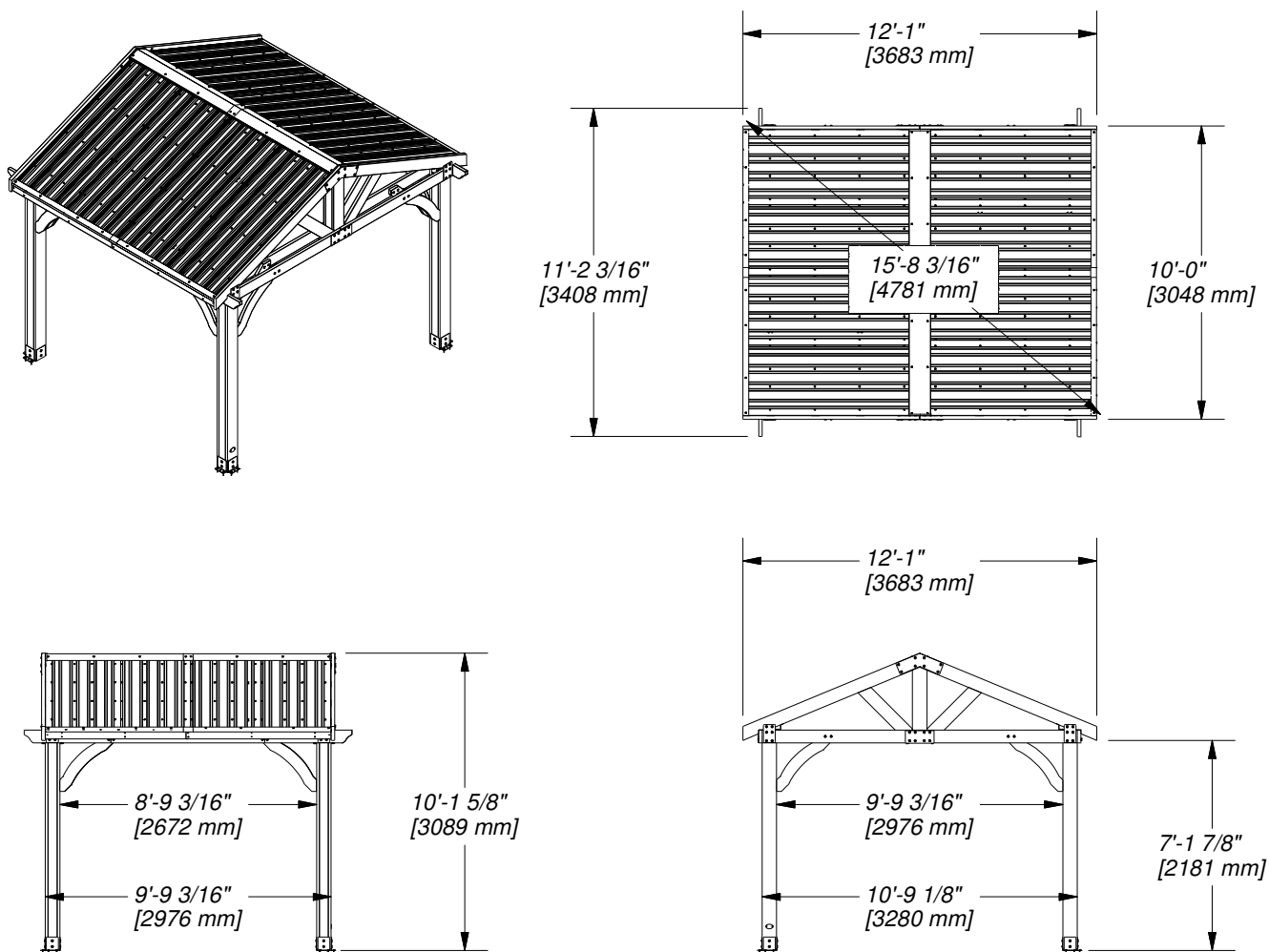

Owner's Manual - Parts Identification

Wood Components (Not to Scale)



D01 BEAM - W4L17995
(x2) 1 3/8"x5 1/4"x63" (36x134x1600)

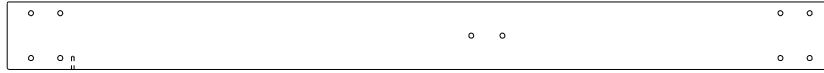

D02 BEAM - W4L18471
(x8) 1 3/8"x5 1/4"x64 5/8" (36x134x1640)



D03 BEAM - W4L17992
(x4) 1 3/8"x5 1/4"x35 5/8" (36x134x904)



D04 BEAM - W4L17994
(x4) 1 3/8"x5 1/4"x53 7/8" (36x134x1370)



D05 ANGLE BRACE - W4L17997
(x4) 1 3/8"x5 1/4"x30 1/4" (36x134x769)

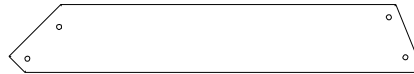

D06 ANGLE BRACE - W4L18472
(x4) 1 3/8"x5 1/4"x32 3/8" (36x134x823)



D07 ANGLE BRACE - W4L18473
(x8) 1 3/8"x6 3/8"x35" (36x163x888)



D08 ANGLE BRACE - W4L18474
(x7) 1 3/8"x6 3/8"x33 7/8" (36x163x860)



D09 ANGLE BRACE W/TAG - W2A04059
(x1) 1 3/8"x6 3/8"x33 7/8" (36x163x860)

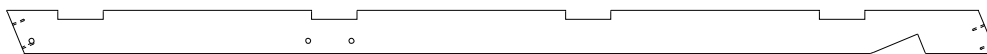

E01 OUTSIDE RAFTER - W4L17999
(x4) 1 3/8"x3 3/8"x77 3/8" (36x86x1965)



E02 RAFTER - W4L17998
(x6) 1 3/8"x3 3/8"x77 3/8" (36x86x1965)

Owner's Manual - Parts Identification

Wood Components (Not to Scale)



E03 SHEATHING BOARD - W4L17993
(x8) 1 3/8"x3 3/8"x83 3/4" (36x86x2126)



E04 SHEATHING BOARD - W4L17996
(x8) 1 3/8"x3 3/8"x35 1/4" (36x86x896)

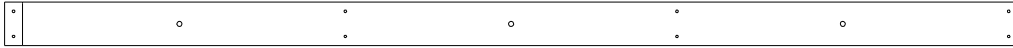

H01 RAFTER - W4L18475
(x2) 1"x3 3/8"x79 3/16" (24x86x2012)



H02 FASCIA - W4L18470
(x4) 1"x3 3/8"x59 3/8" (24x86x1507)

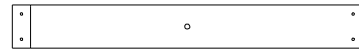

H03 RAFTER - W4L18476
(x2) 1"x3 3/8"x27 5/16" (24x86x695)

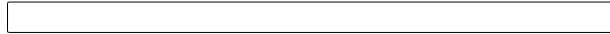

J09 RIDGE CAP STIFFENER - W4L18487
(x2) 1"x2 3/8"x47 5/8" (24x60x1210)

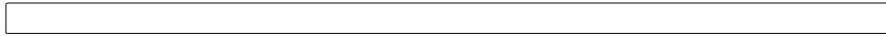

J10 RIDGE CAP STIFFENER - W4L18488
(x2) 1"x2 3/8"x69 1/4" (24x60x1760)

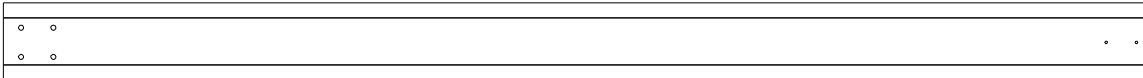

P1 POST - W2A03766
(x2) 6"x6"x89 1/2" (152x152x2274)

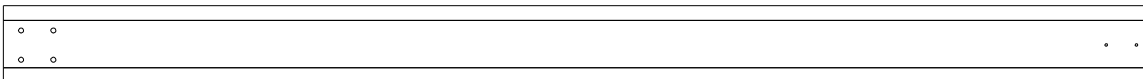

P2 POST - W2A03767
(x2) 6"x6"x89 1/2" (152x152x2274)

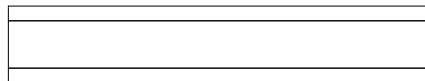

P3 POST - W2A03769
(x2) 6"x6"x33 1/4" (152x152x845)

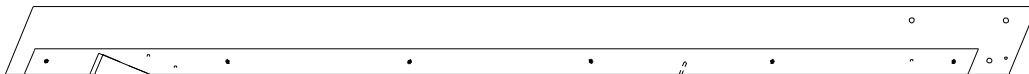

RP1 END RAFTER - W2A03768
(x2) 2 13/16"x5 1/4"x80 5/8" (72x134x2048)

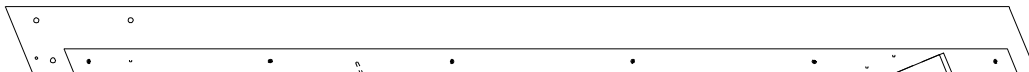

RP2 END RAFTER - W2A03770
(x2) 2 13/16"x5 1/4"x80 5/8" (72x134x2048)

Owner's Manual - Parts Identification

Hardware Components

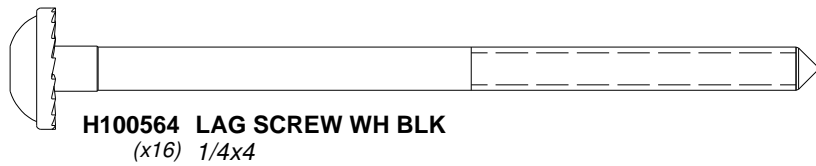
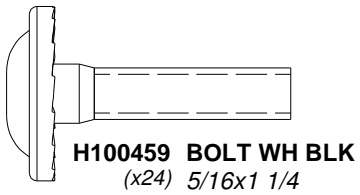
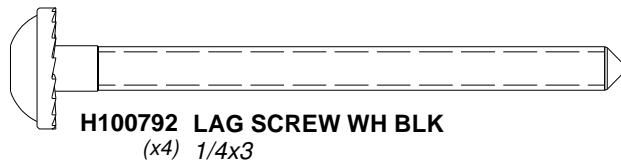
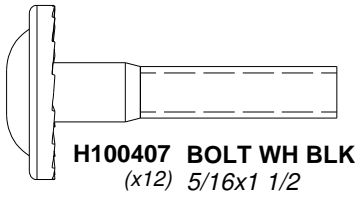
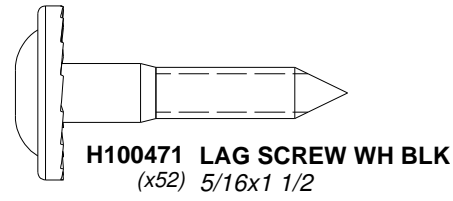
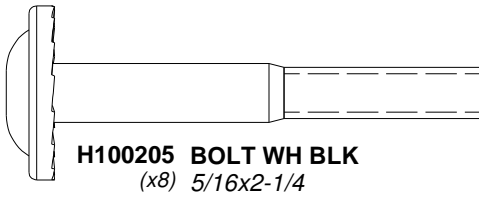
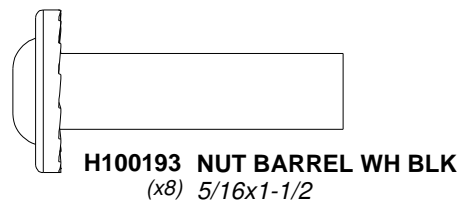
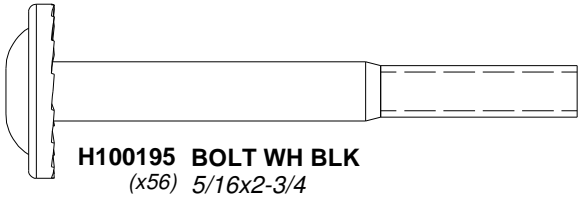
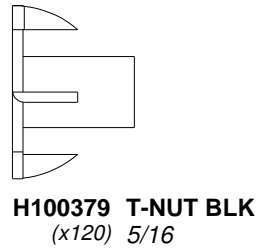
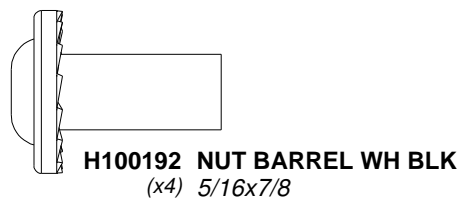
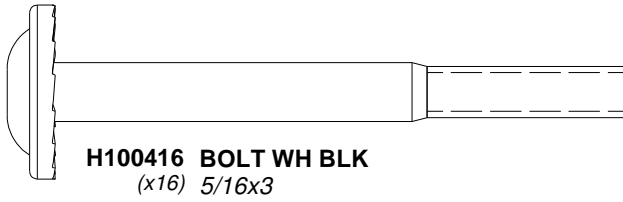
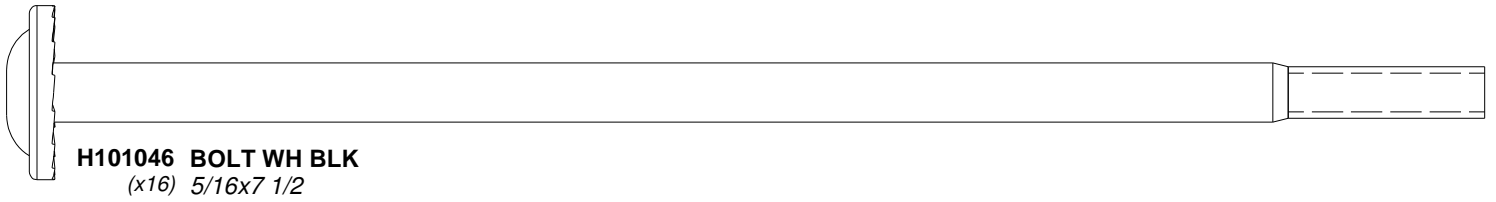
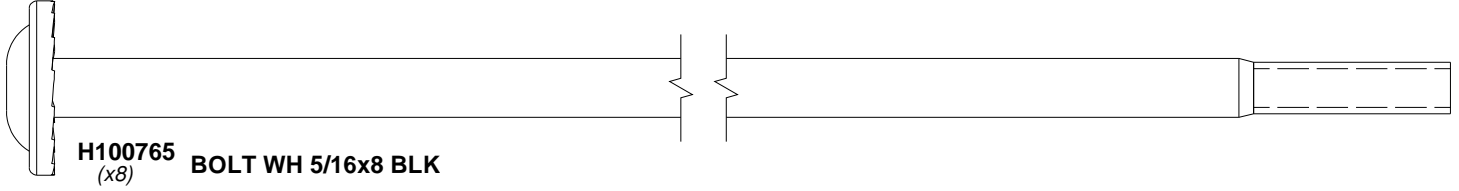
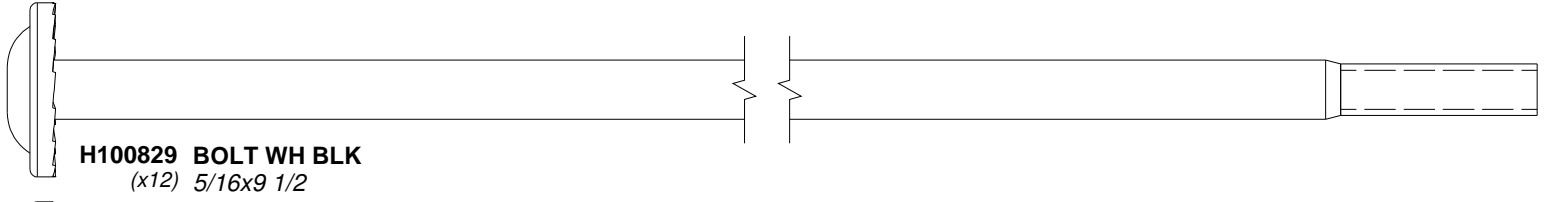
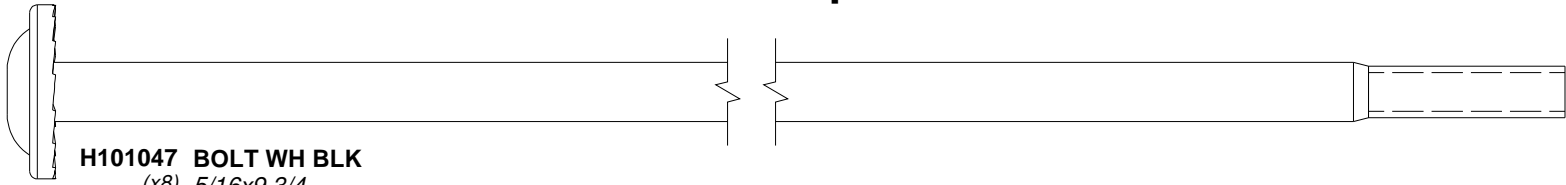

Owner's Manual - Parts Identification

Hardware Components

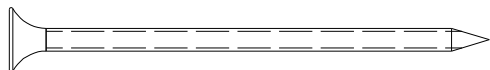

H100201 SCREW PFH BLK
(x4) 8x2-1/2

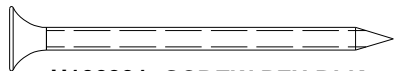

H100391 SCREW PFH BLK
(x74) 8x2



H100382 SCREW PFH BLK
(x4) 8x1 3/4

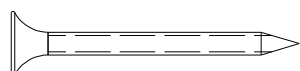

H100200 SCREW PFH BLK
(x28) 8x1 1/2

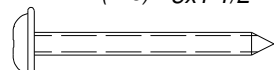

H100536 SCREW PWH BLK
(x30) 8x1 1/4

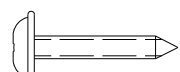

H100392 SCREW PWH BLK
(x16) 8x3/4

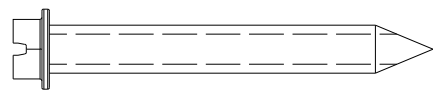

H100120 SCREW CONCRETE ANCHOR
(x16) 1/4x2

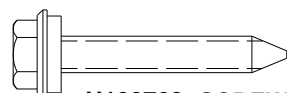

H100760 SCREW WOODGRIP
(x128) 10x1 1/4



H100833 SCREW WOODGRIP
(x16) 10x3/4

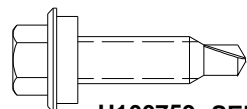

H100759 SELF TAPPING
(x16) 1/4-14

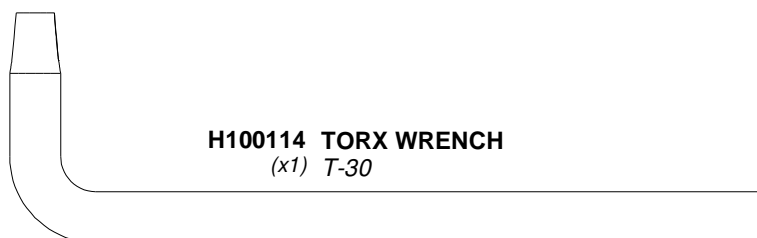

H100114 TORX WRENCH
(x1) T-30

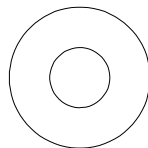

H100630 WASHER FLAT BLK
(x16) 8x19

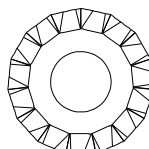

H100198 WASHER LOCK EXT BLK
(x92) 8x19

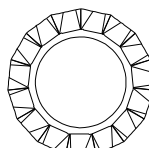

H100199 WASHER LOCK EXT BLK
(x4) 12x19

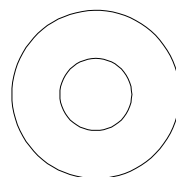

H100770 WASHER FLAT BLK
(x4) 5/16

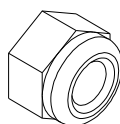

H100479 NUT LOCK BLK
(x28) 5/16

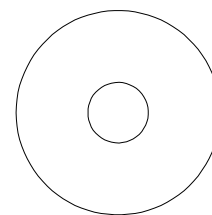

H100478 WASHER FLAT BLK
(x24) 8x27

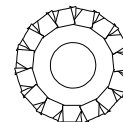

H100405 WASHER LOCK EXT BLK
(x20) 6x15

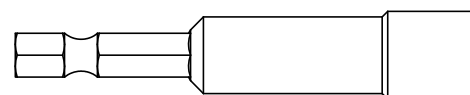

H101106 HEX DRIVER
(x1) 5/16

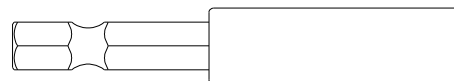

H101100 MAGNETIC DRIVER
(x1)

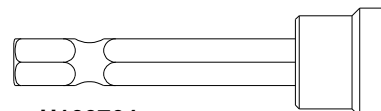

H100764 SCREW SETTER
(x1)

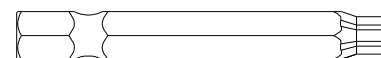

H100147 TORX BIT
(x1) T-30

Owner's Manual - Parts Identification

Accessory Components (Not to Scale)



A100241
(x1) **BYD ID TAG (SMALL) WITHOUT AGES**

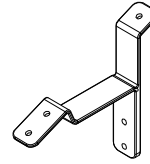

A4M00961
(x6) **ROOF BRACKET**

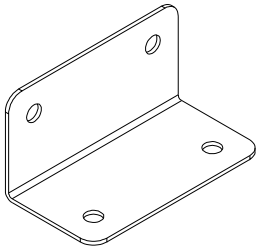

A4M00619
(x4) **L BRACKET 66x66x127 - BLK**

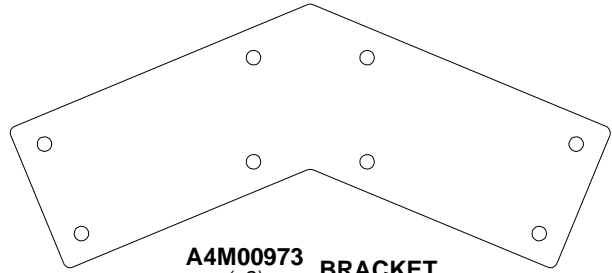

A4M00973
(x2) **BRACKET**

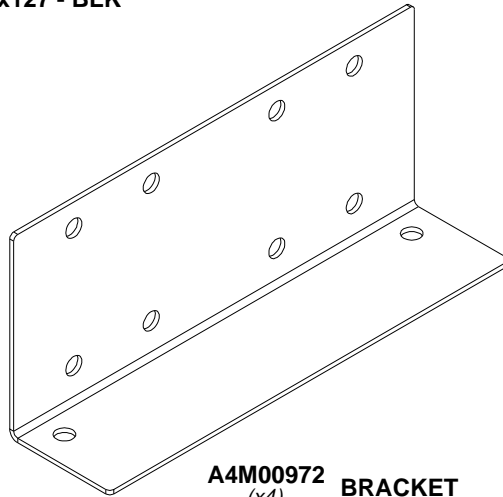

A4M00972
(x4) **BRACKET**

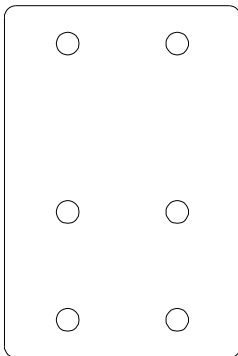

A4M00974
(x4) **BRACKET**

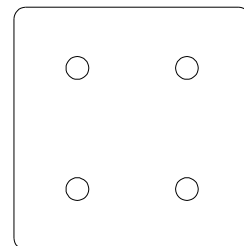

A4M00979
(x4) **BRACKET**

Owner's Manual - Parts Identification

Accessory Components (Not to Scale)

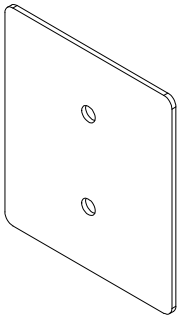

A4M00978
(x8) **POST PLATE**

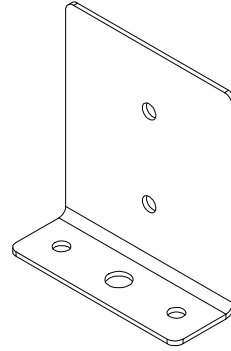

A4M00977
(x8) **POST ANCHORING PLATE**

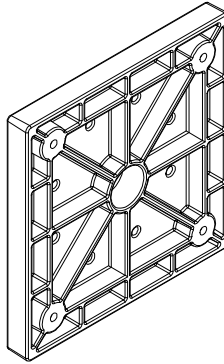

A6P00308
(x4) **6x6 POST FOOT**

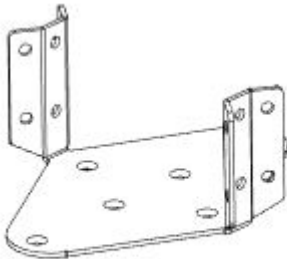

A4M02501
(x1) **FAN MOUNT BRACKET**

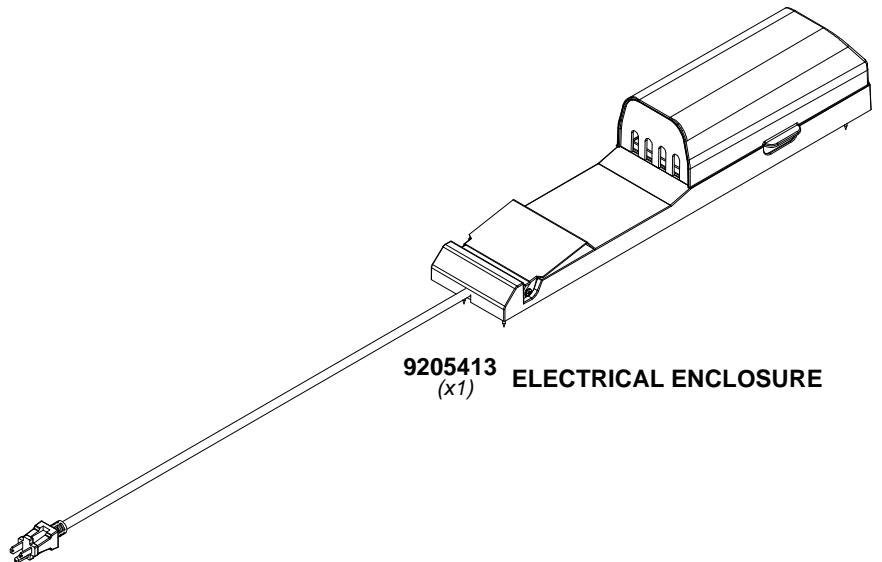

9205413
(x1) **ELECTRICAL ENCLOSURE**

Owner's Manual - Parts Identification

Accessory Components (Not to Scale)



A4M02639
(x8) 29 GA STEEL SHEETING

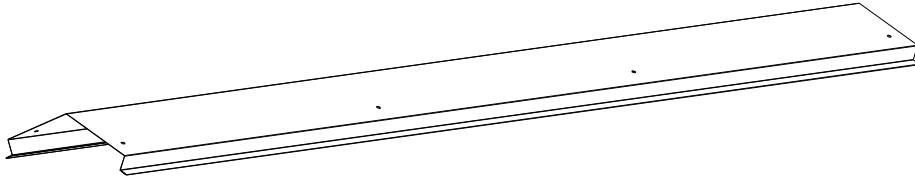

A4M02636
(x2) RIDGE CAP 29 GA

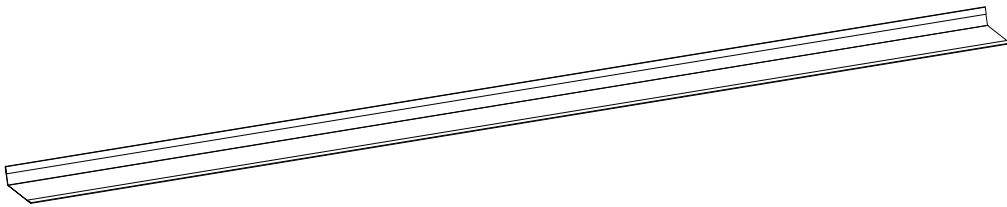

A4M02637
(x4) ROOF EDGE TRIM



A4M02638
(x2) ROOF EDGE TRIM SPLICE

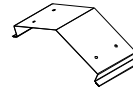

A4M02640
(x1) RIDGE CAP SPLICE

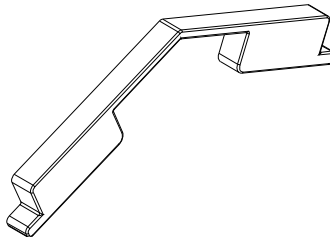

A6P00398
(x2) RIDGE CAP PROTECTOR

PRE-ASSEMBLY STEP 1 - SORTING PARTS

It is critical for ease of assembly that you take the time to sort and organize the wood and hardware.

WOOD PARTS:

- Organize wood parts by the three-digit, alpha-numeric number stamped on each board (ex. P01).
- If there are multiple boards with the same stamped number, stack those pieces together.
- Stamps can be found on the flat surface of the boards or on the end of the boards.
- Allow yourself plenty of room - the wood pieces can take up a significant amount of space.

NOTE: CARTONS ARE NOT ORGANIZED BY BOARD NUMBER.



HARDWARE PARTS:

- We recommend that you have a separate table to organize the hardware.
- Hardware bags are printed with a seven-digit, alpha-numeric part number.
- You can organize your hardware by part number or group by hardware type (i.e. bolts, nuts, etc.).
- During assembly you only need to reference the last four digits of the number.

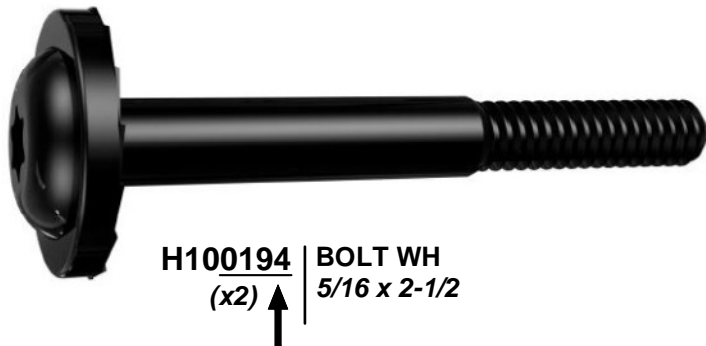

PRE-ASSEMBLY STEP 2 - TOOLS REQUIRED



Cordless Drill or
Electric Drill



Drill Attachments:
Phillips Head



1/8", 3/16", 3/8" & 7/16"
Drill Bits



Phillips Screw Driver



Open End Wrenches 1/2" & 9/16"



3/8" Drive Ratchet, 1/2" &
9/16" STD Sockets 1/2" & 9/16" Deep
Sockets



Claw Hammer



Rubber Mallet - Optional



Tape Measure

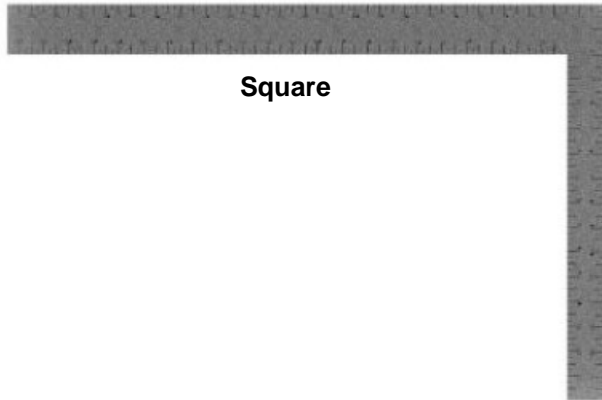

Square



Level 24"

PRE-ASSEMBLY STEP 3 - CHOOSE YOUR ASSEMBLY METHOD

There are several types of assembly instructions available to you.

1. Printed Assembly Manual included with your set
2. BILT APP - 3D interactive instructions
3. Combination of the Printed Manual and BILT APP (Note: Step numbers can differ between the two methods)

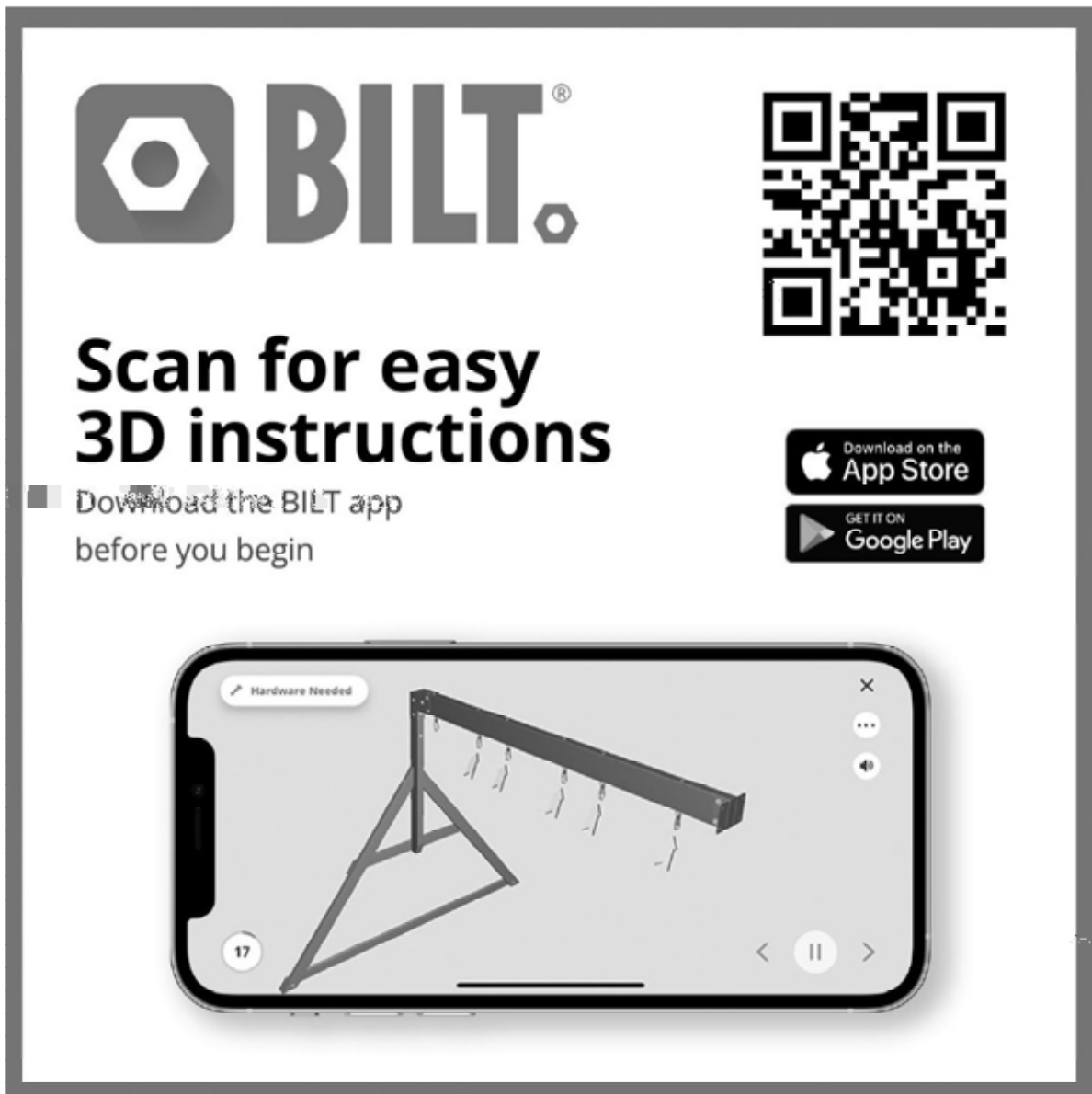

The advertisement features the BILT logo (a hexagon with a dot) and the text "BILT.®" in a large, bold font. To the right is a large QR code. Below the logo, the text "Scan for easy 3D instructions" is displayed in a large, bold font. Underneath this, it says "Download the BILT app before you begin". To the right of the text are two buttons: "Download on the App Store" and "GET IT ON Google Play". At the bottom, a smartphone screen displays a 3D assembly instruction for a step labeled "17". The screen shows a 3D model of a structure with a horizontal beam and a triangular base. A "Hardware Needed" button is visible in the top left corner of the app interface. Navigation icons (back, pause, forward) are at the bottom of the screen.

STEP 1 - GAZEBO ASSEMBLY

QTY	PART NUMBER	DESCRIPTION
16	H100200	SCREW PFH 8x1-1/2 BLK



P1 POST - W2A03766
(x2) 6"x6"x89 1/2" (152x152x2274)

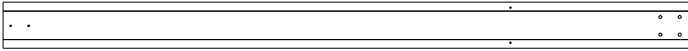

P2 POST - W2A03767
(x2) 6"x6"x89 1/2" (152x152x2274)

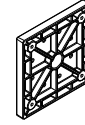

A6P00308
(x4) **6x6 POST FOOT**

COMPLETE THIS STEP TWICE

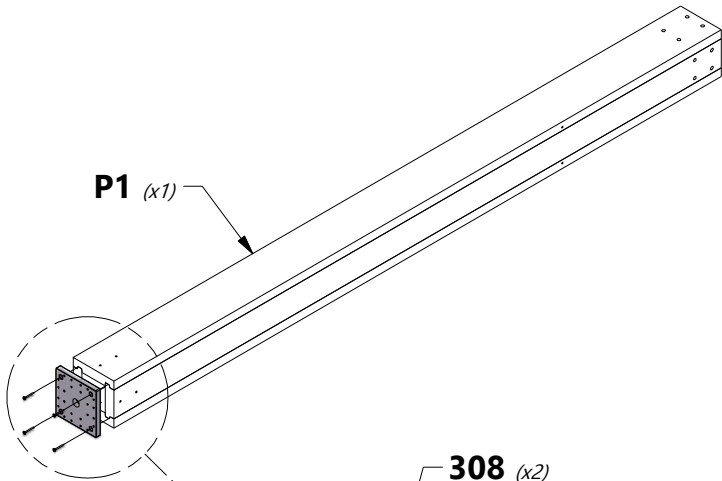

P1 (x1)

308 (x2)
6x6 POST FOOT

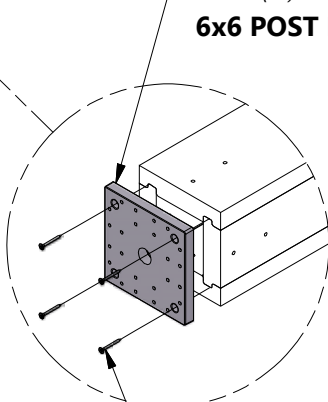

200 (x8)
SCREW - 1 1/2"

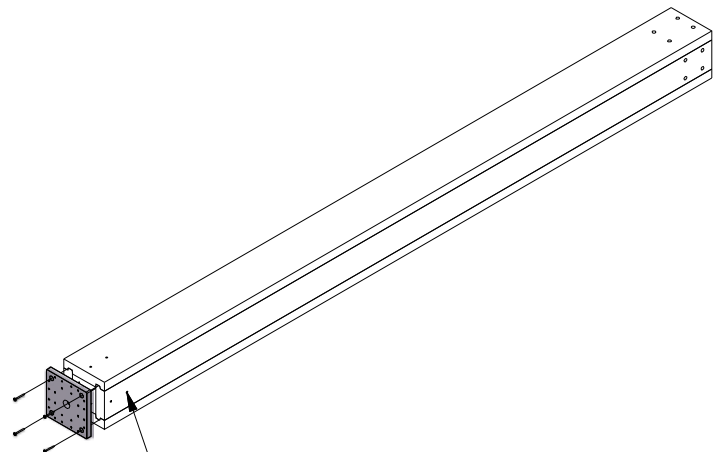

P2 (x1)

STEP 2 - GAZEBO ASSEMBLY

QTY	PART NUMBER	DESCRIPTION
8	H100193	NUT BARREL WH 5/16x1-1/2 BLK
8	H100471	LAG SCREW WH 5/16x1-1/2 BLK
16	H100478	WASHER FLAT 8x27 BLK
16	H100479	NUT LOCK 5/16 BLK
8	H100765	BOLT WH 5/16x8 BLK
8	H100829	BOLT WH 5/16x9 1/2 BLK
8	H101047	BOLT WH 5/16x9 3/4 BLK

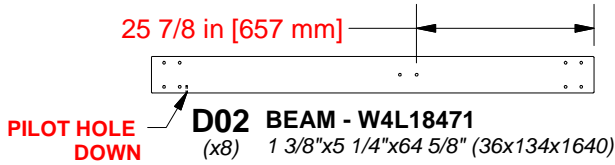

A4M00972 BRACKET
(x4)

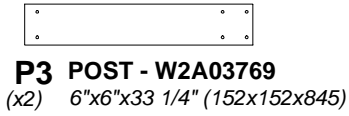

A4M00974 BRACKET
(x4)

A4M00619 L BRACKET 66x66x127 - BLK
(x4)

COMPLETE THIS STEP TWICE

TIP:
SAW DUST CAN BE LEFT BEHIND IN BOLTS HOLES.
IF YOU HAVE TROUBLE WITH BOLT ENGAGING, USE
A LONG SCREW DRIVER TO REMOVE THE DEBRIS.

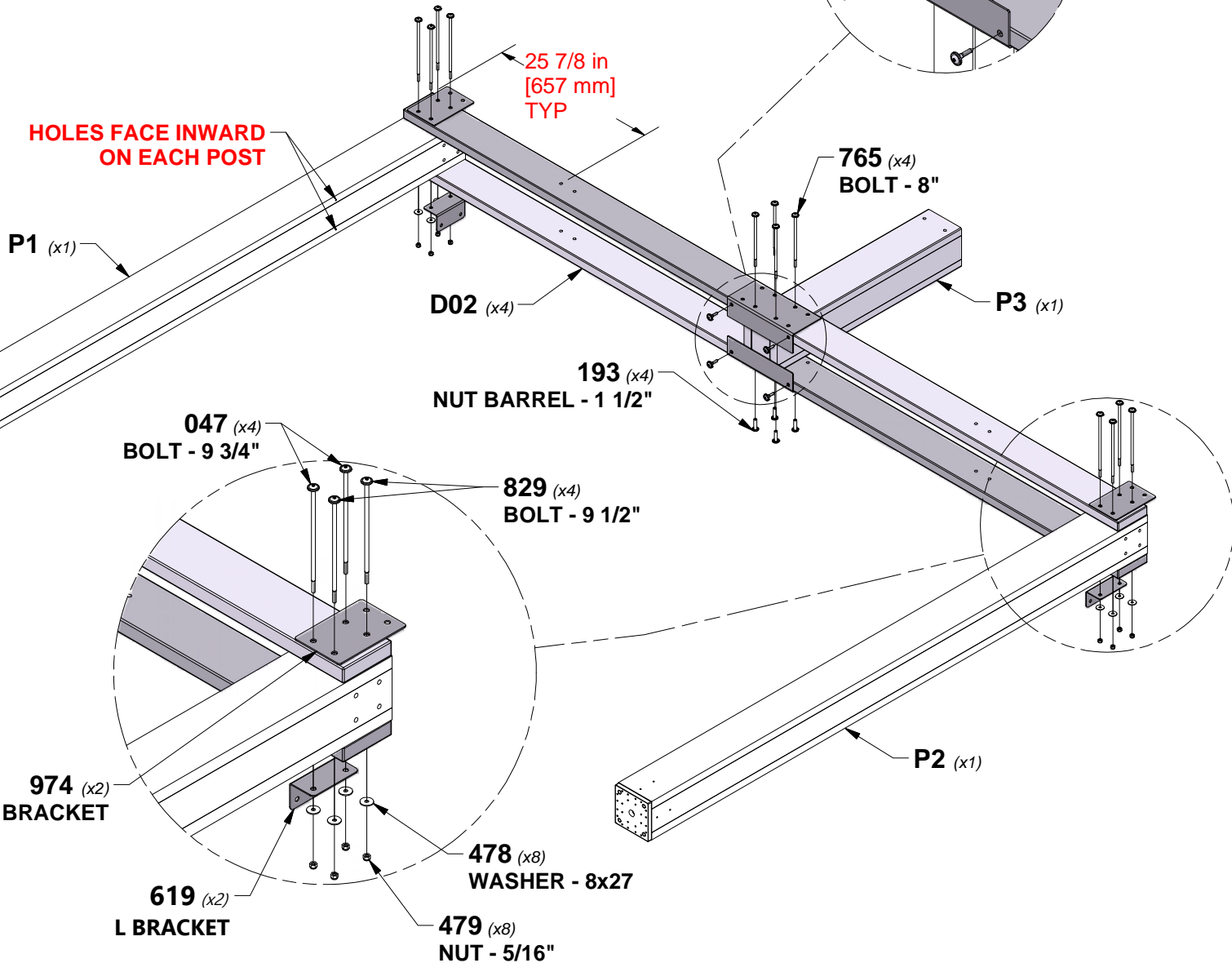
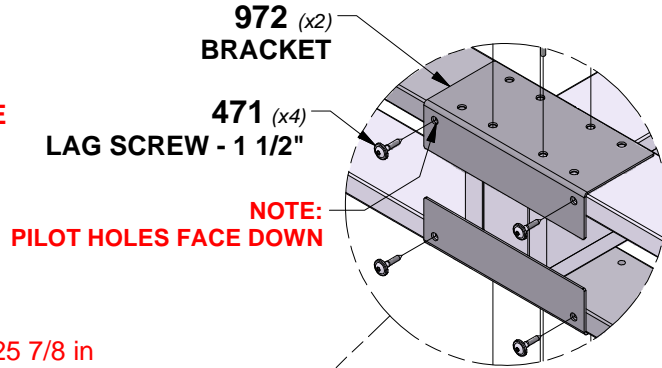

STEP 3 - GAZEBO ASSEMBLY

QTY	PART NUMBER	DESCRIPTION
16	H100195	BOLT WH 5/16x2-3/4 BLK
16	H100198	WASHER LOCK EXT 8x19 BLK
16	H100379	T-NUT 5/16 BLK
8	H100405	WASHER LOCK EXT 6x15 BLK
8	H100564	LAG SCREW WH 1/4x4 BLK



D08 ANGLE BRACE - W4L18474
(x7) 1 3/8"x6 3/8"x33 7/8" (36x163x860)



D09 ANGLE BRACE W/TAG - W2A04059
(x1) 1 3/8"x6 3/8"x33 7/8" (36x163x860)

TIP:
INSTALL T-NUTS IN WOOD FIRST

COMPLETE THIS STEP TWICE
NOTE D09 WILL BE USED ONLY ONCE

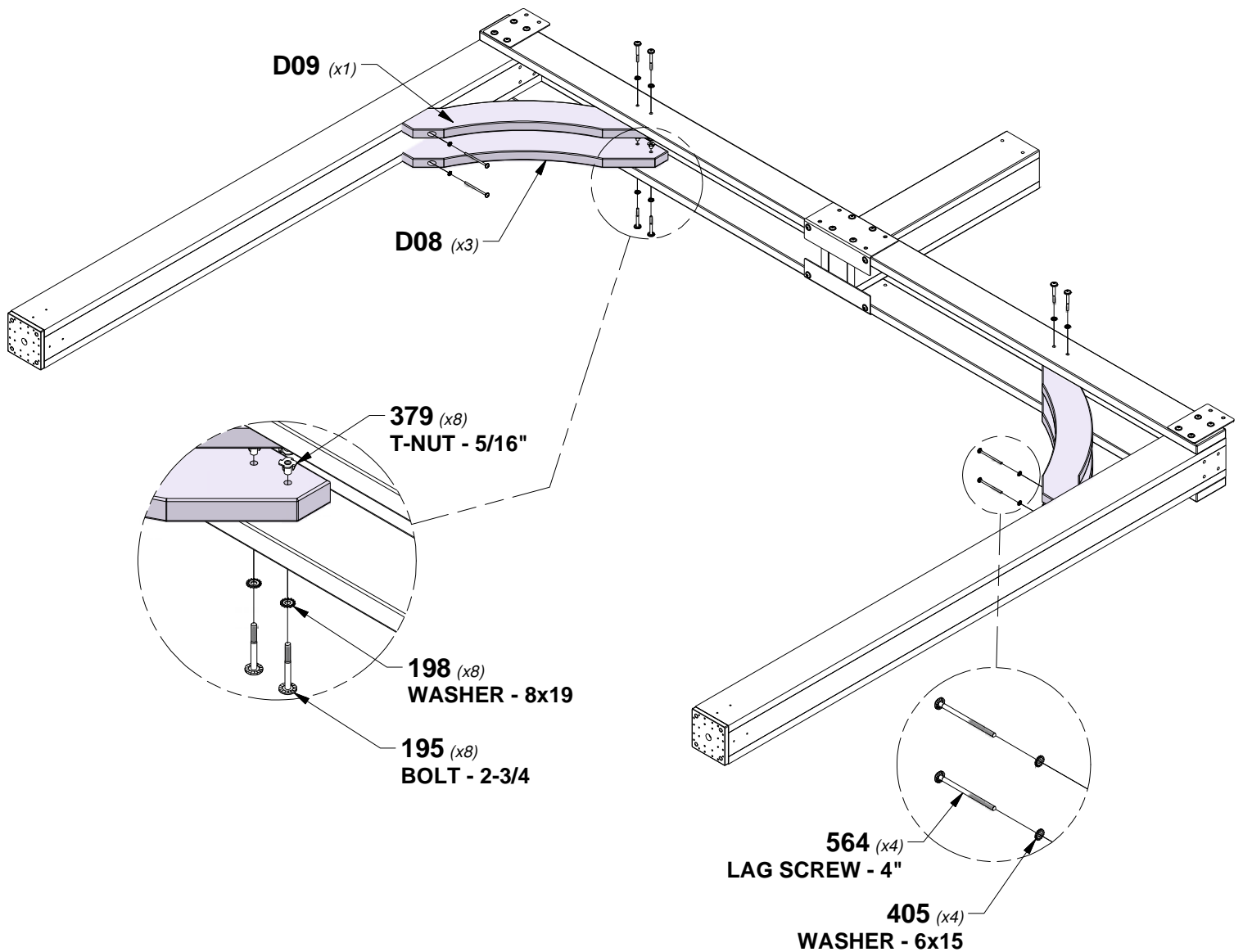

STEP 4A - GAZEBO ASSEMBLY



D04 BEAM - W4L17994
(x4) 1 3/8"x5 1/4"x53 7/8" (36x134x1370)

QTY	PART NUMBER	DESCRIPTION
8	H100198	WASHER LOCK EXT 8x19 BLK
8	H100379	T-NUT 5/16 BLK
8	H100459	BOLT WH 5/16x1 1/4 BLK

TIP:
INSTALL T-NUTS IN WOOD FIRST

COMPLETE THIS STEP TWICE

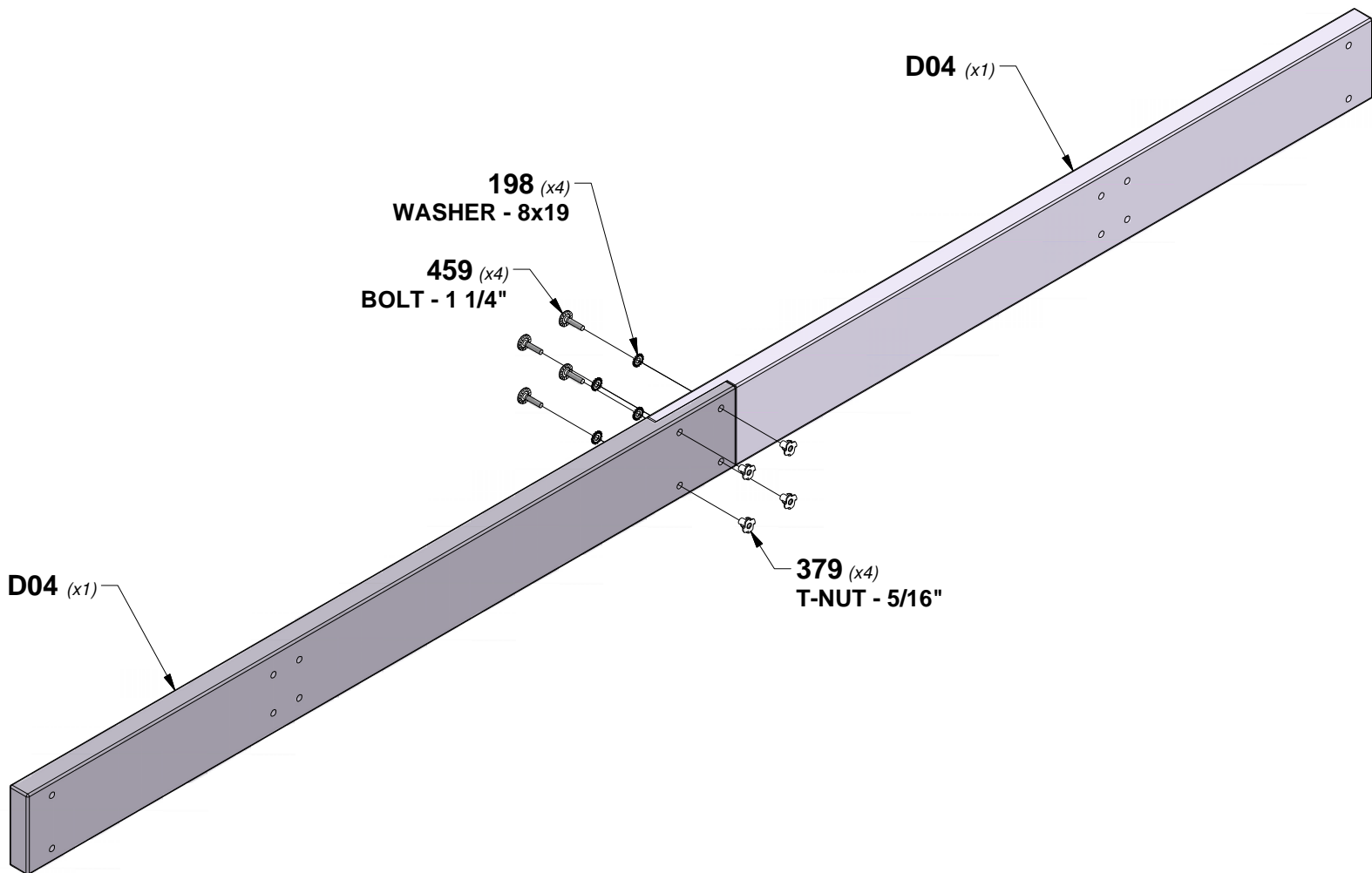

STEP 4B - GAZEBO ASSEMBLY

QTY	PART NUMBER	DESCRIPTION
8	H100198	WASHER LOCK EXT 8x19 BLK
8	H100205	BOLT WH 5/16x2-1/4 BLK
8	H100478	WASHER FLAT 8x27 BLK
8	H100479	NUT LOCK 5/16 BLK

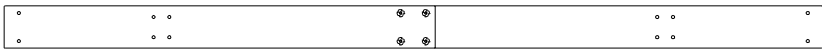

(x2) BEAM ASSEMBLY

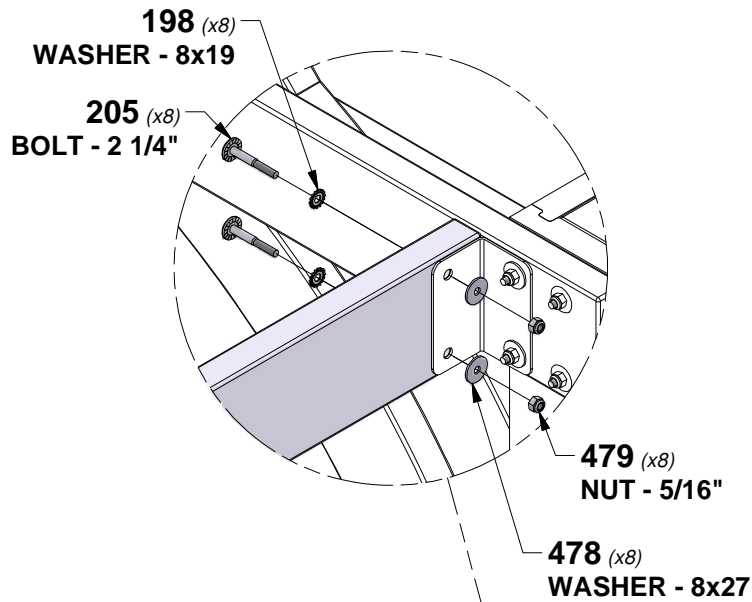

BEAM ASSEMBLY (x2)

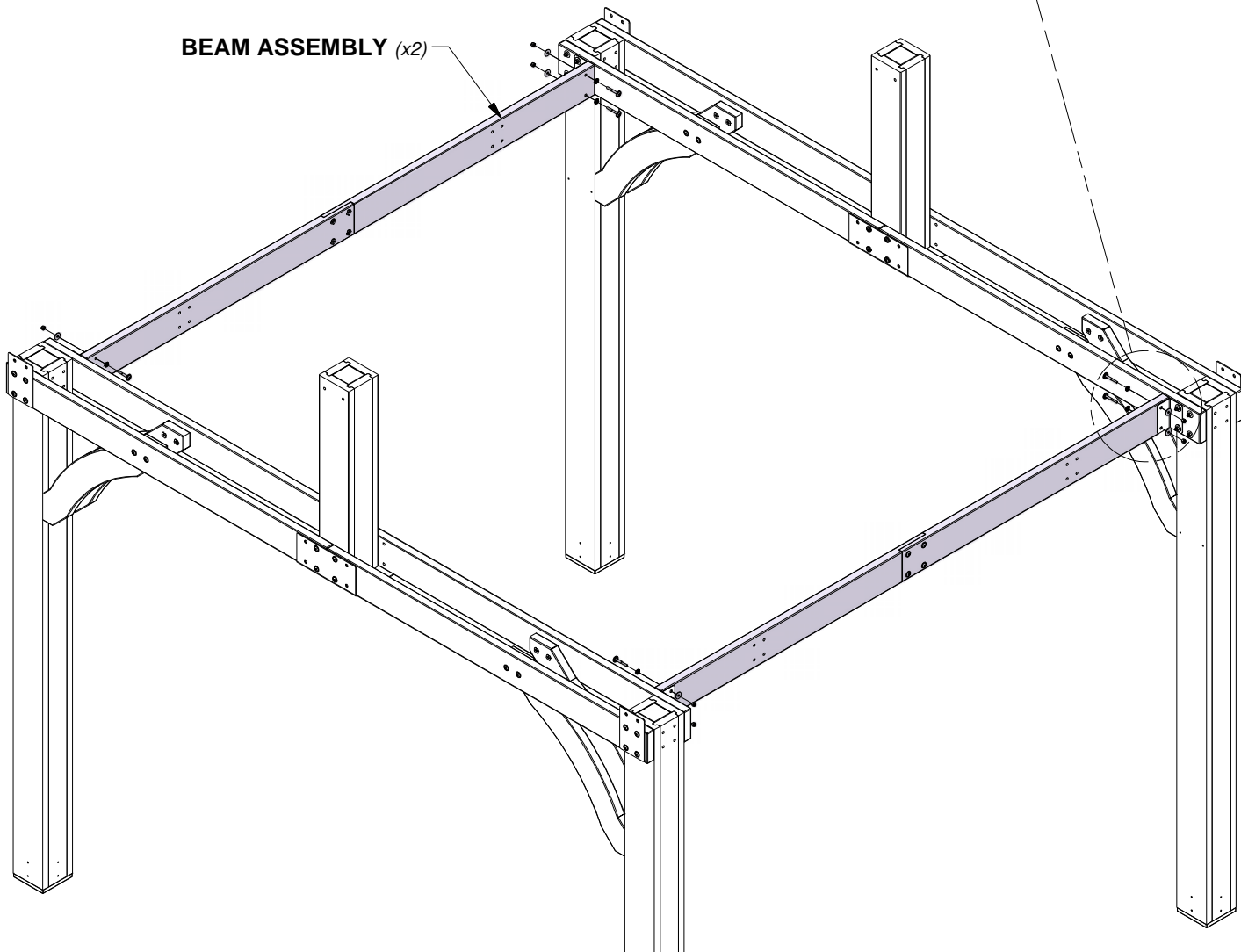

STEP 5A - GAZEBO ASSEMBLY



D01 BEAM - W4L17995
(x2) 1 3/8"x5 1/4"x63" (36x134x1600)



D03 BEAM - W4L17992
(x4) 1 3/8"x5 1/4"x35 5/8" (36x134x904)



D07 ANGLE BRACE - W4L18473
(x4) 1 3/8"x6 3/8"x35" (36x163x888)

QTY	PART NUMBER	DESCRIPTION
16	H100195	BOLT WH 5/16x2-3/4 BLK
16	H100198	WASHER LOCK EXT 8x19 BLK
16	H100379	T-NUT 5/16 BLK

TIP:
INSTALL T-NUTS IN WOOD FIRST

COMPLETE THIS STEP TWICE

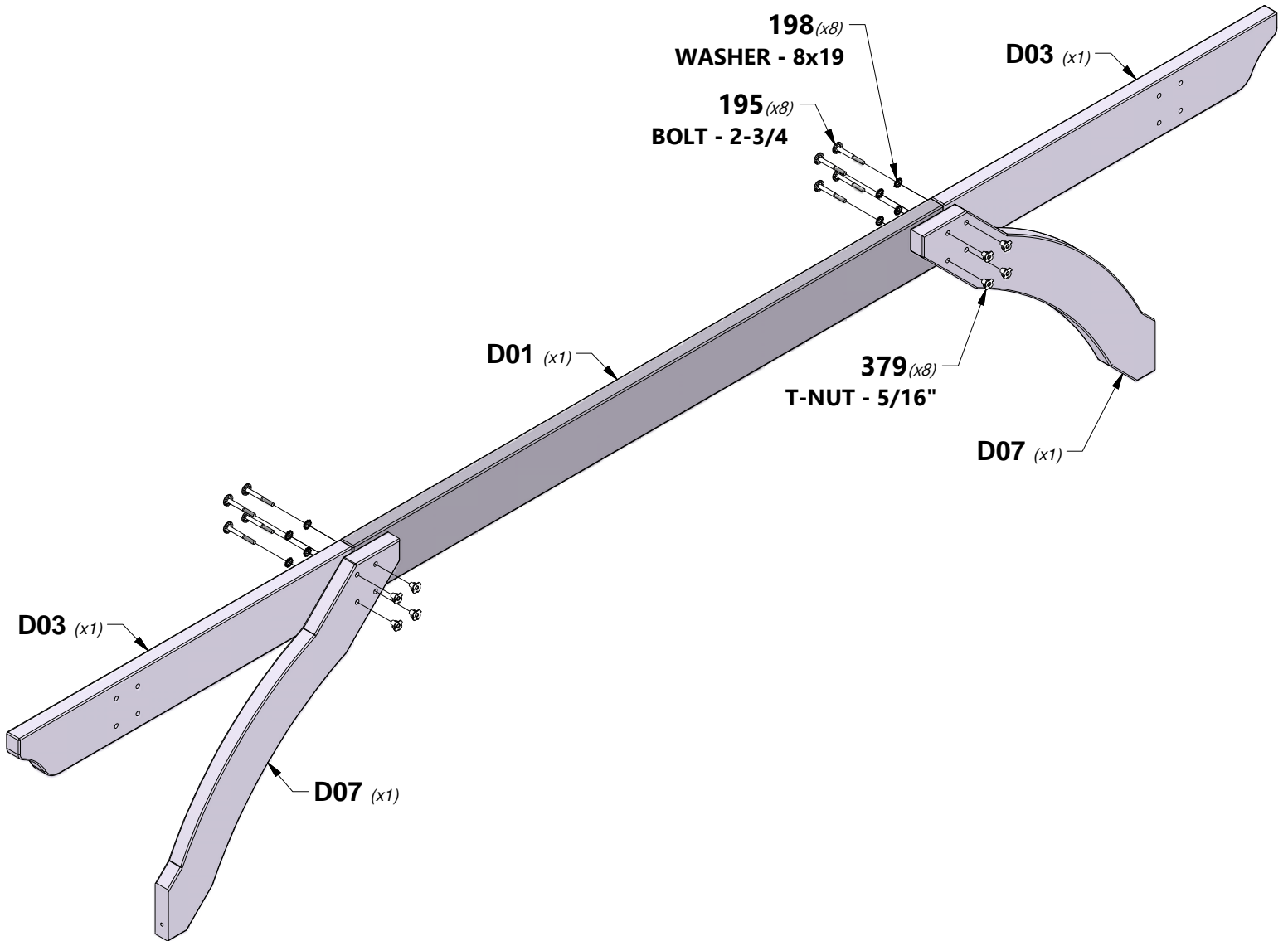

STEP 5B - GAZEBO ASSEMBLY

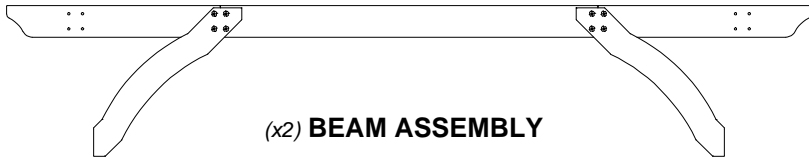

QTY	PART NUMBER	DESCRIPTION
16	H100379	T-NUT 5/16 BLK
4	H100405	WASHER LOCK EXT 6x15 BLK
4	H100564	LAG SCREW WH 1/4x4 BLK
16	H101046	BOLT WH 5/16x7-1/2 BLK

A4M00979
(x4) BRACKET

TIP:
INSTALL T-NUTS IN WOOD FIRST

TIP:
ALIGN HOLES IN PLATE WITH HOLES
IN BEAM ASSEMBLY AND MOUNT.

379 (x16)
T-NUT - 5/16"

979 (x4)
BRACKET

046 (x16)
BOLT - 7 1/2"

BEAM ASSEMBLY (x2)

564 (x4)
LAG SCREW - 4"

405 (x4)
WASHER - 6x15

STEP 6 - GAZEBO ASSEMBLY



D07 ANGLE BRACE - W4L18473
 (x4) 1 3/8"x6 3/8"x35" (36x163x888)

QTY	PART NUMBER	DESCRIPTION
16	H100195	BOLT WH 5/16x2-3/4 BLK
16	H100198	WASHER LOCK EXT 8x19 BLK
16	H100379	T-NUT 5/16 BLK
4	H100405	WASHER LOCK EXT 6x15 BLK
4	H100564	LAG SCREW WH 1/4x4 BLK

TIP:
INSTALL T-NUTS IN WOOD FIRST

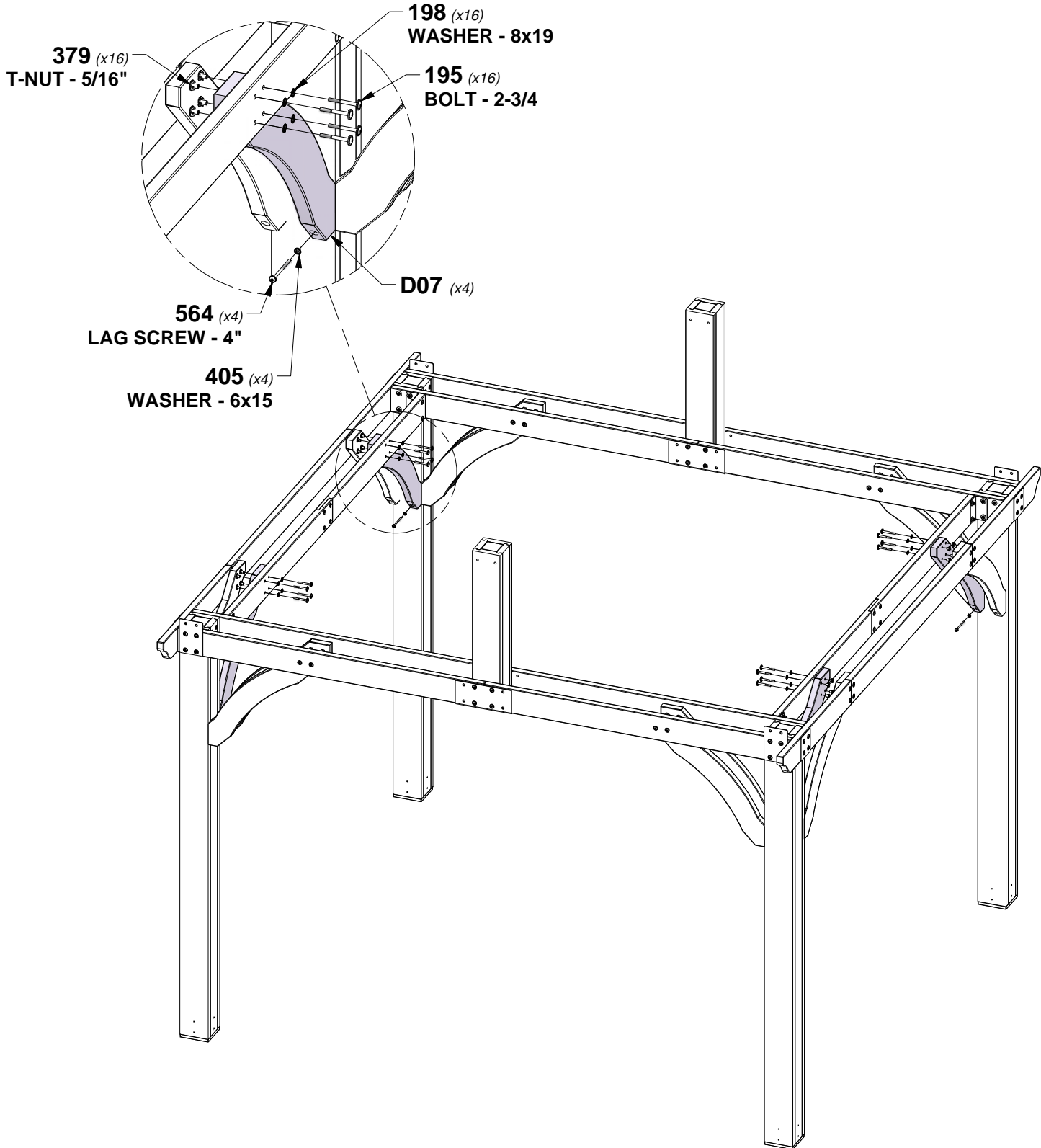

STEP 7A - GAZEBO ASSEMBLY

QTY	PART NUMBER	DESCRIPTION
4	H100201	SCREW PFH 8x2-1/2 BLK
8	H100379	T-NUT 5/16 BLK
4	H100405	WASHER LOCK EXT 6x15 BLK
8	H100416	BOLT WH 5/16x3 BLK
8	H100471	LAG SCREW WH 5/16x1-1/2 BLK
4	H100792	LAG SCREW WH 1/4x3 BLK

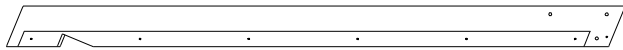

RP1 END RAFTER - W2A03768
(x2) 2 13/16"x5 1/4"x80 5/8" (72x134x2048)

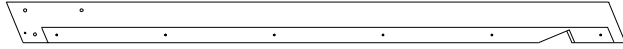

RP2 END RAFTER - W2A03770
(x2) 2 13/16"x5 1/4"x80 5/8" (72x134x2048)

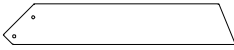

D05 ANGLE BRACE - W4L17997
(x4) 1 3/8"x5 1/4"x30 1/4" (36x134x769)

TIP:
INSTALL T-NUTS IN WOOD FIRST

**ALIGN PILOT HOLES WITH POST HOLES BY
TEMPORARILY INSTALLING THE LONG 9-1/2"
BOLTS H100829 BEFORE INSTALLING SCREWS.**

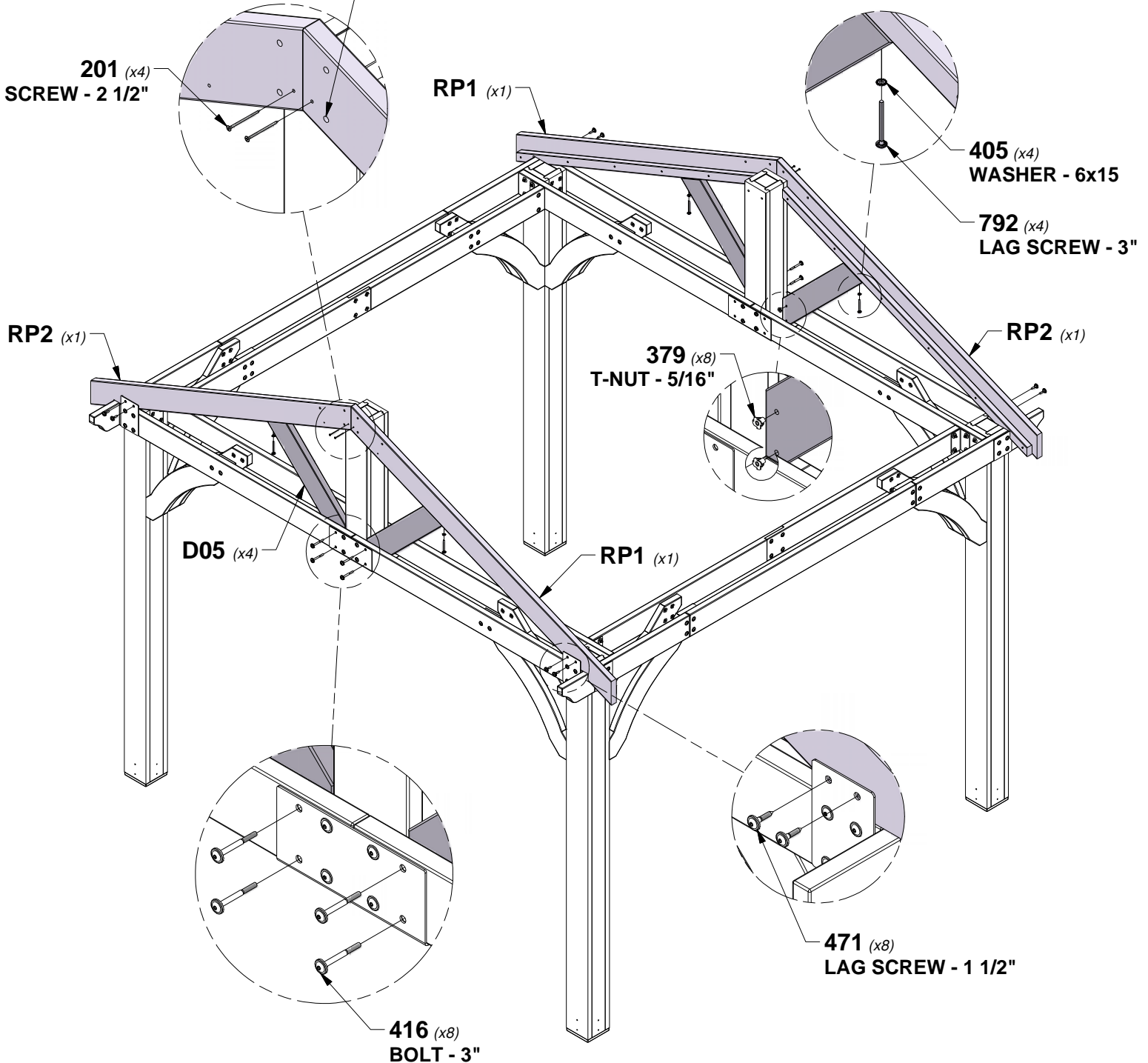

STEP 7B - GAZEBO ASSEMBLY

QTY	PART NUMBER	DESCRIPTION
8	H100379	T-NUT 5/16 BLK
8	H100407	BOLT WH 5/16x1 1/2 BLK
4	H100471	LAG SCREW WH 5/16x1-1/2 BLK

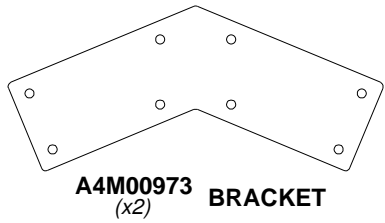

TIP:
INSTALL T-NUTS IN WOOD FIRST

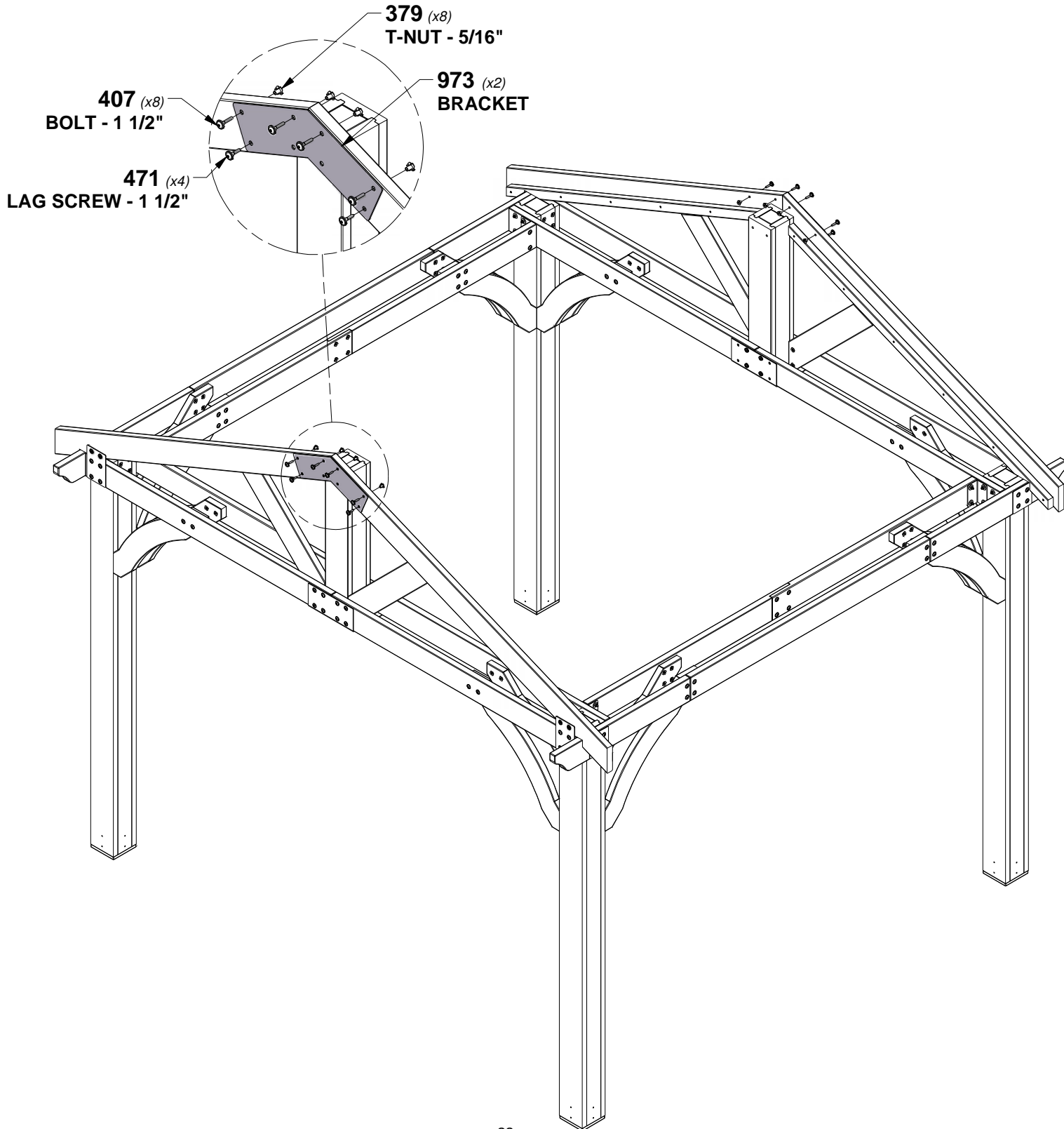

STEP 8 - GAZEBO ASSEMBLY

QTY	PART NUMBER	DESCRIPTION
10	H100200	SCREW PFH 8x1-1/2 BLK
30	H100391	SCREW PFH 8x2 BLK



E01 OUTSIDE RAFTER - W4L17999
(x4) 1 3/8"x3 3/8"x77 3/8" (36x86x1965)

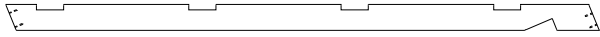

E02 RAFTER - W4L17998
(x6) 1 3/8"x3 3/8"x77 3/8" (36x86x1965)

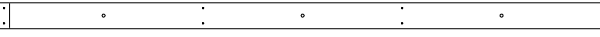

H01 RAFTER - W4L18475
(x2) 1"x3 3/8"x79 3/16" (24x86x2012)

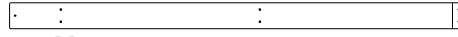

H02 FASCIA - W4L18470
(x4) 1"x3 3/8"x59 3/8" (24x86x1507)

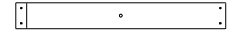

H03 RAFTER - W4L18476
(x2) 1"x3 3/8"x27 5/16" (24x86x695)

COMPLETE THIS STEP TWICE

JOINTS OVERLAP

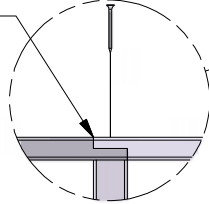

JOINTS OVERLAP

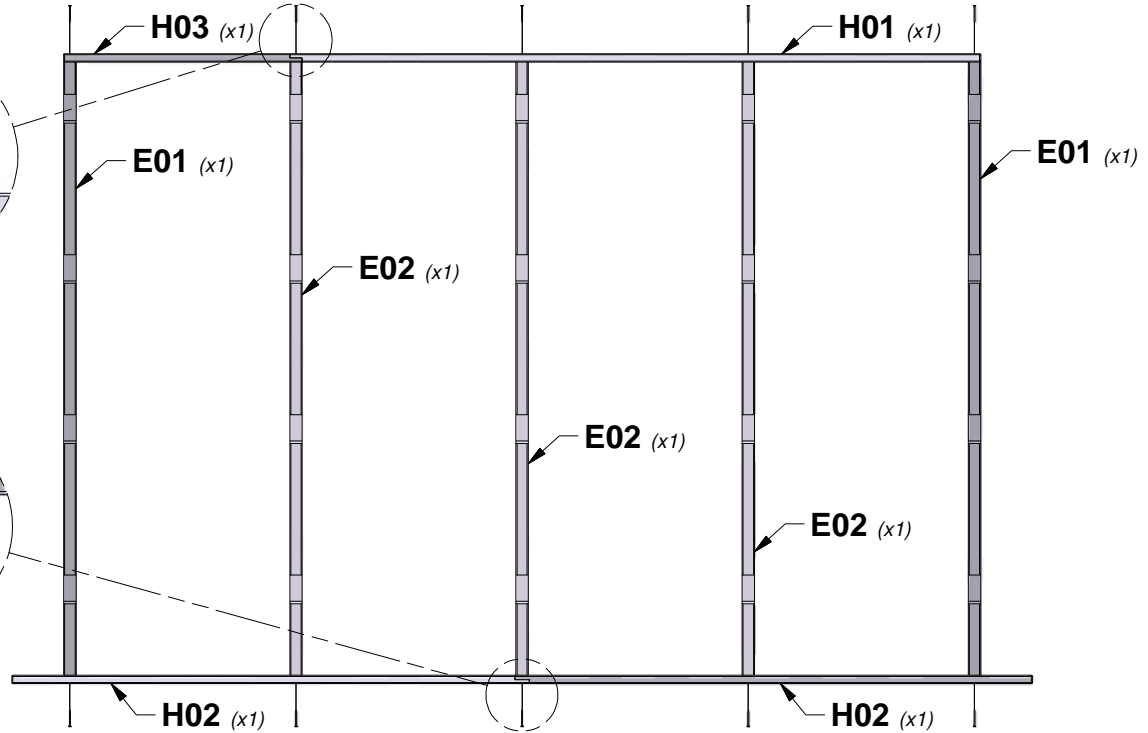
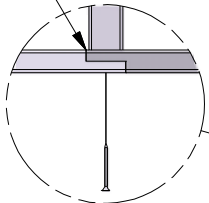

FRONT

ALIGN PILOT HOLES ON BOTH ENDS

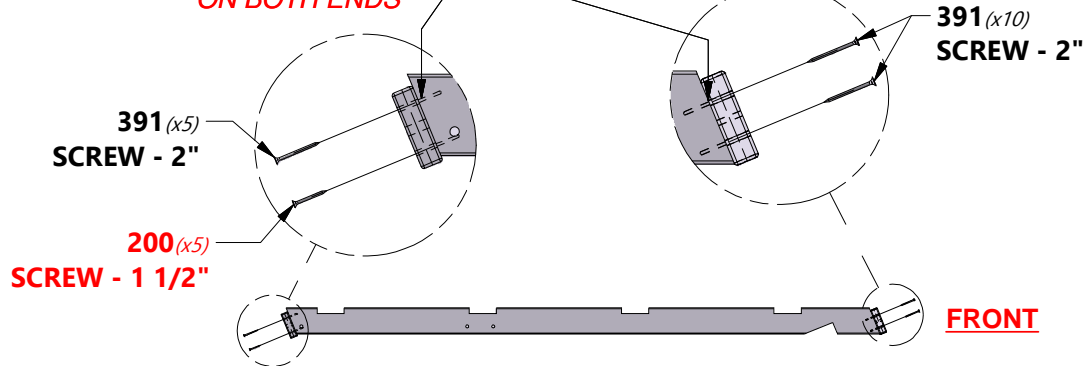

FRONT

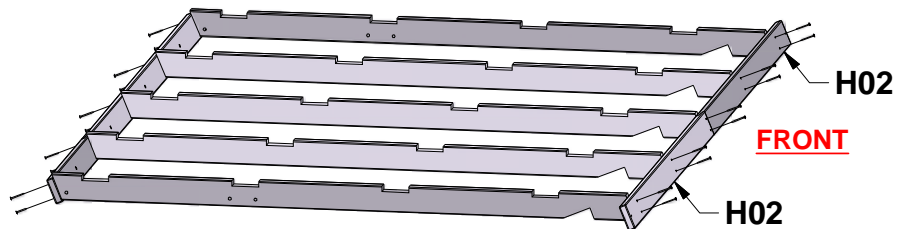

FRONT

STEP 9 - GAZEBO ASSEMBLY

QTY	PART NUMBER	DESCRIPTION
16	H100198	WASHER LOCK EXT 8x19 BLK
16	H100379	T-NUT 5/16 BLK
40	H100391	SCREW PFH 8x2 BLK
16	H100459	BOLT WH 5/16x1 1/4 BLK

E04 SHEATHING BOARD - W4L17996
 (x8) 1 3/8"x3 3/8"x35 1/4" (36x86x896)

E03 SHEATHING BOARD - W4L17993
 (x8) 1 3/8"x3 3/8"x83 3/4" (36x86x2126)

TIP:
INSTALL T-NUTS IN WOOD FIRST
COMPLETE THIS STEP TWICE

SQUARE EACH ROOF PANEL.
MEASURE FROM CORNER TO CORNER AS SHOWN AND ENSURE THE MEASUREMENT IS THE SAME IN EACH DIRECTION. THEN INSTALL THE E3 & E4 BOARDS AS SHOWN.

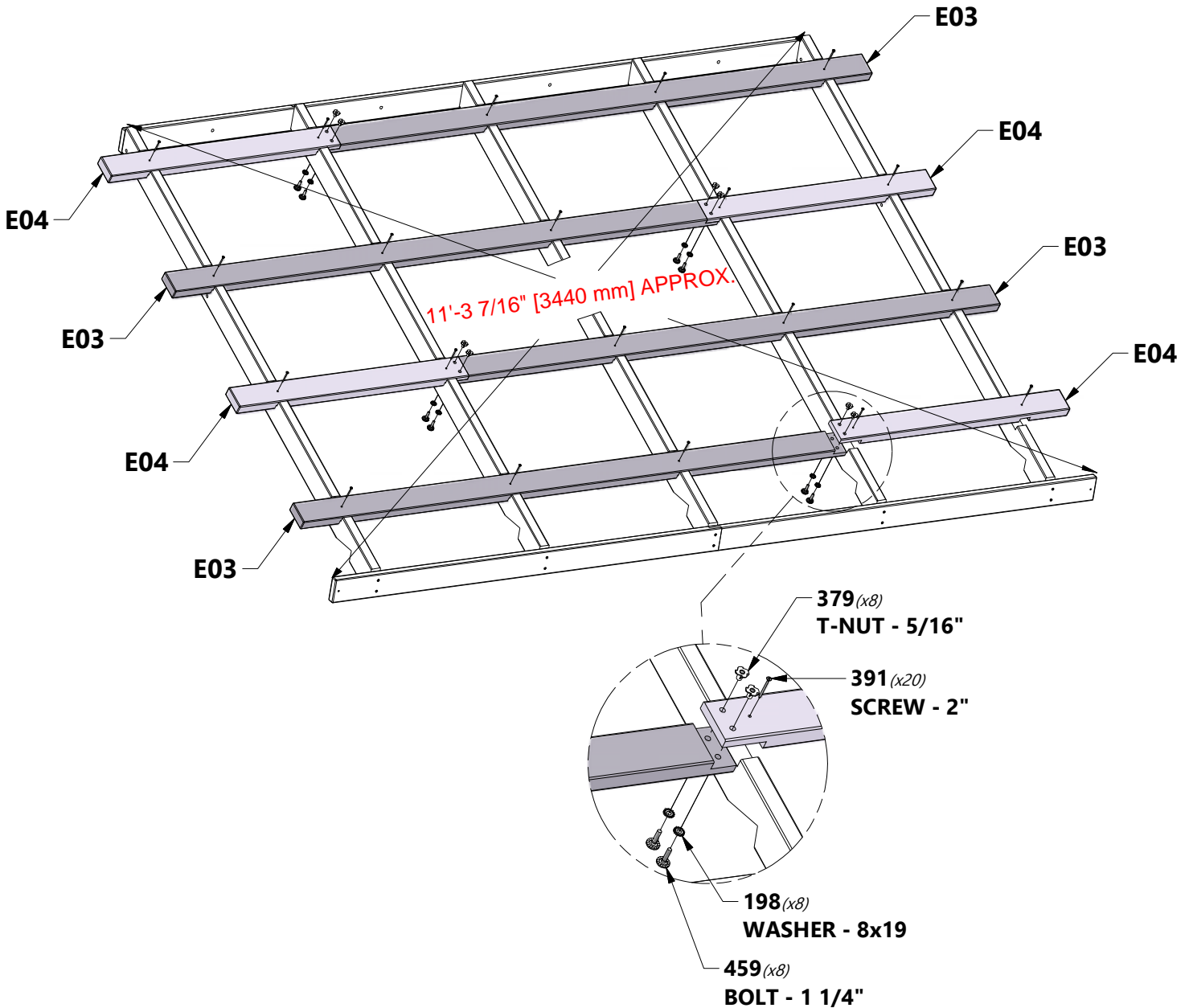

STEP 10 - GAZEBO ASSEMBLY

ROOF PREPARATION

USE THIS PAGE TO FAMILIARIZE YOURSELF WITH THE ROOF PANEL & ASSIST YOU IN THE COMING STEPS.

WARNING: GLOVES SHOULD BE WORN WHEN HANDLING ROOF PANELS; EDGES ARE SHARP.

TIPS:

- Note the pre-drilled holes on the top end of each sheet shown below. These holes will always go towards the ridge of the roof and will be used to install the ridge cap in a later step.
- Assemble each roof panel by starting on the right side and working toward the left as shown.
- Carefully remove protective blue film from panels.
- Position your roof panels on the ground so they mirror each other as shown.

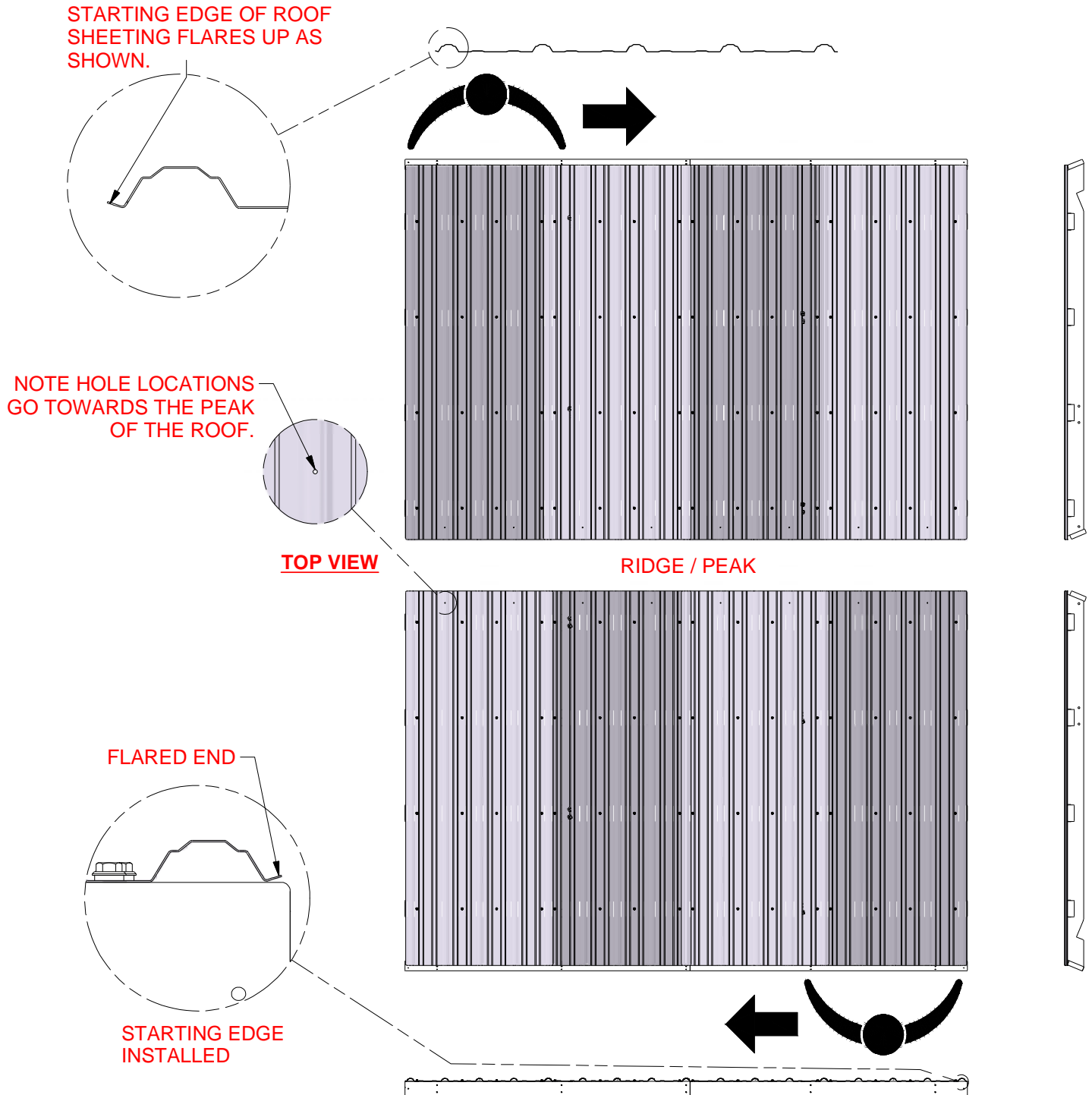

STEP 11 - GAZEBO ASSEMBLY

QTY	PART NUMBER	DESCRIPTION
8	H100760	1-1/4 WOODGRIP SCREW



A4M02639
(x2) **29 GA STEEL SHEETING**

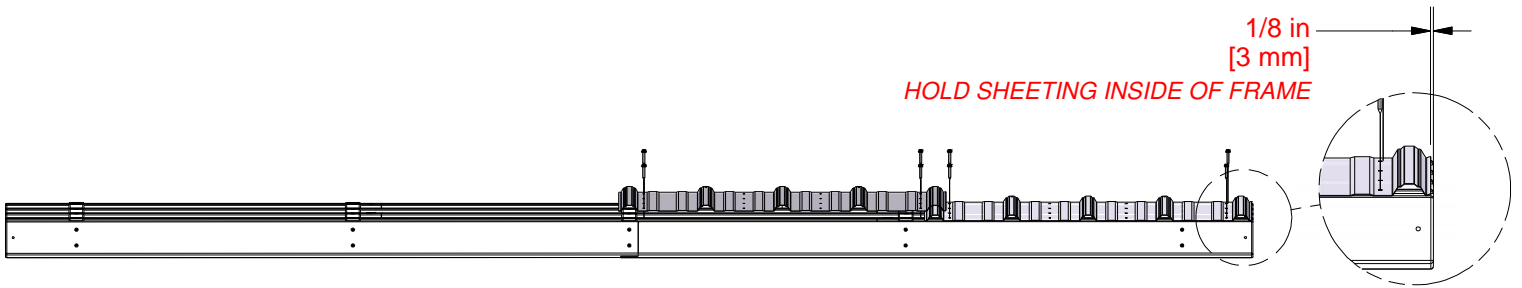
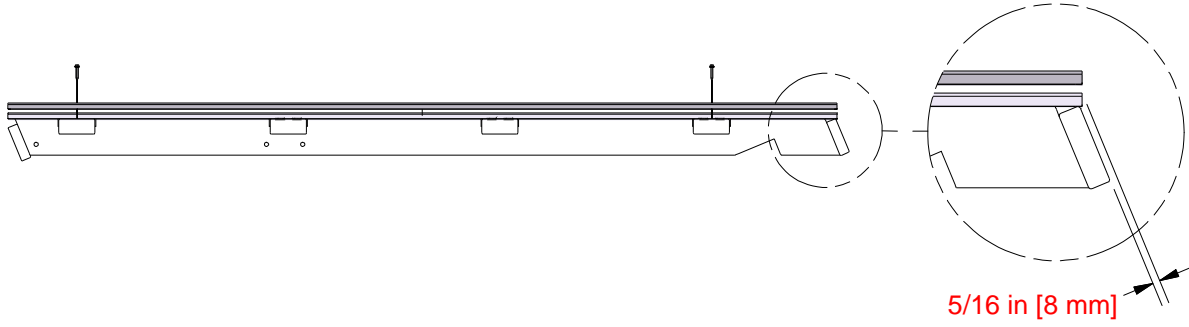

MAKE SURE YOUR ROOF PANEL IS SQUARE BEFORE MOVING ON.

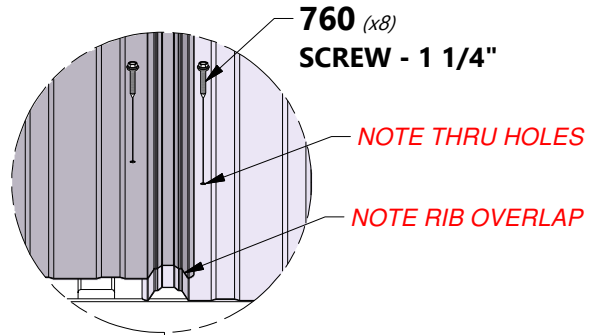

2639 (x2)
29 GA STEEL SHEETING

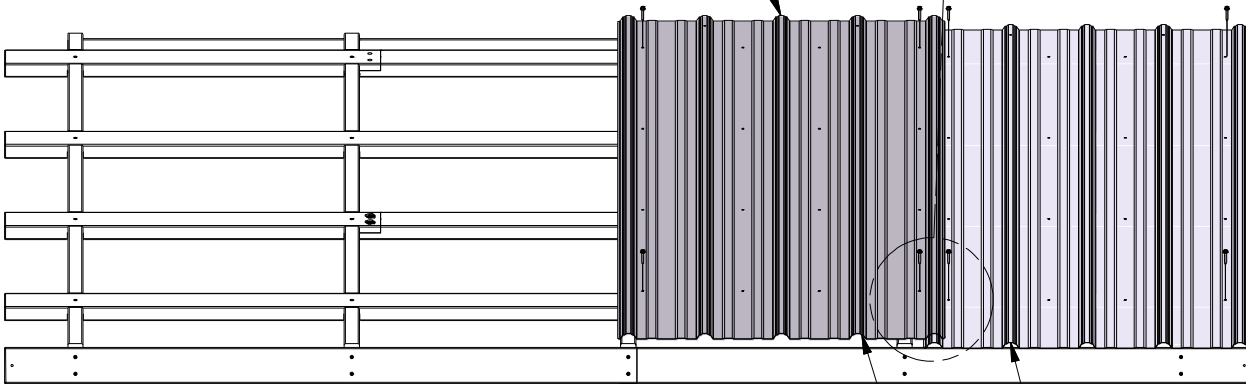

STEP 12 - GAZEBO ASSEMBLY

QTY	PART NUMBER	DESCRIPTION
24	H100760	1-1/4 WOODGRIP SCREW

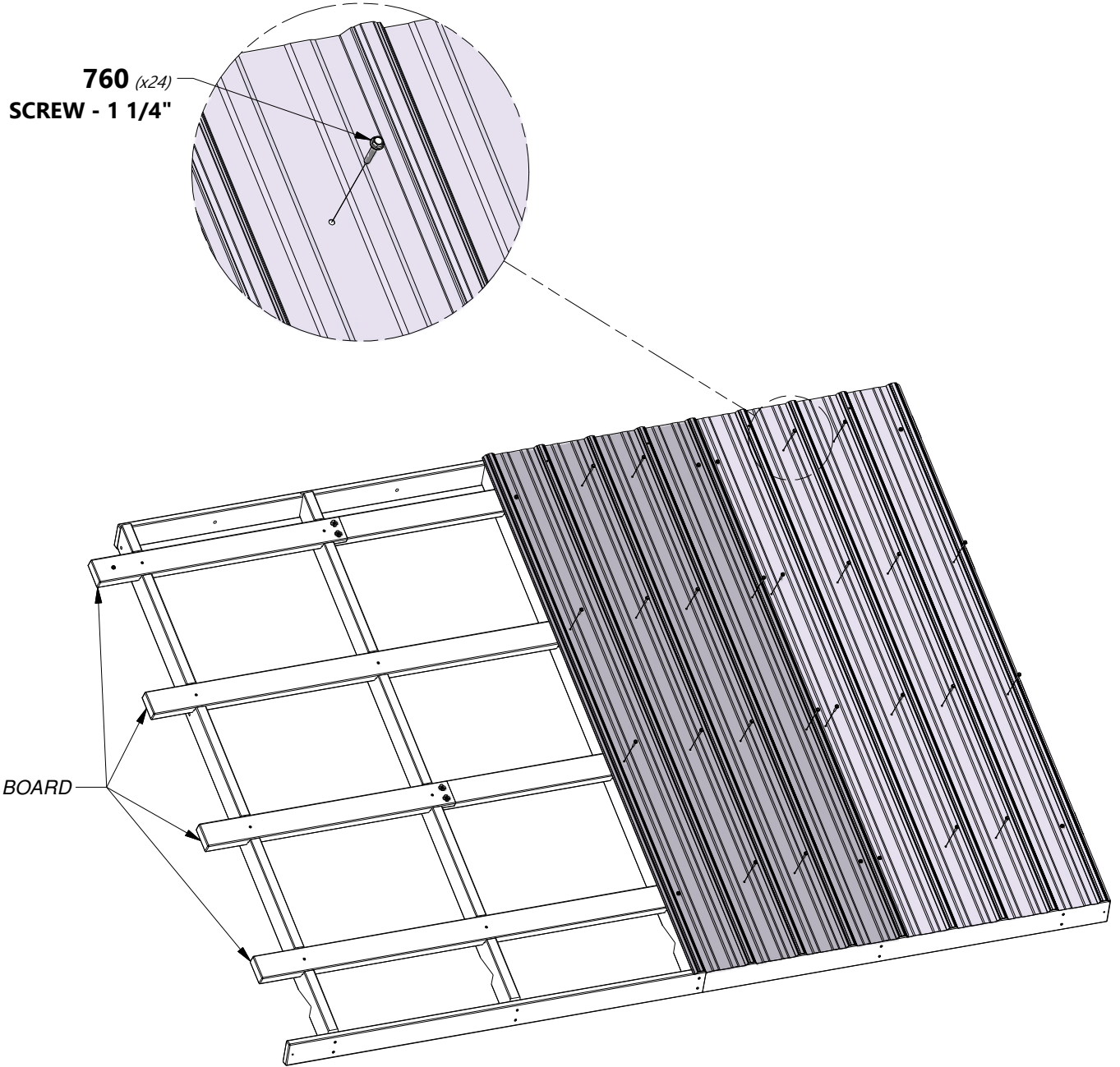

STEP 13 - GAZEBO ASSEMBLY

QTY	PART NUMBER	DESCRIPTION
32	H100760	1-1/4 WOODGRIP SCREW

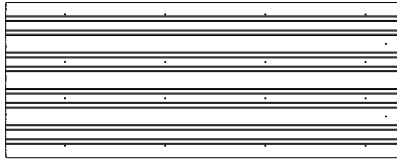

A4M02639
(x2) **29 GA STEEL SHEETING**

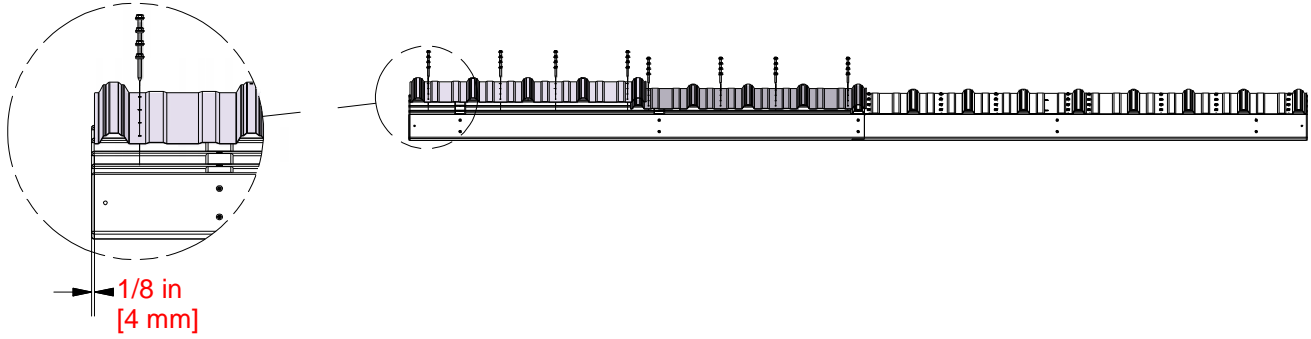

NOTE HOLE LOCATIONS

760 (x32)
SCREW - 1 1/4"

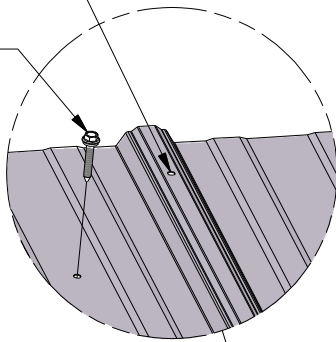

NOTE RIB OVERLAP

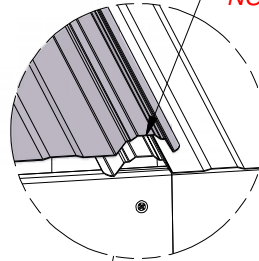

2639 (x2)
29 GA STEEL SHEETING

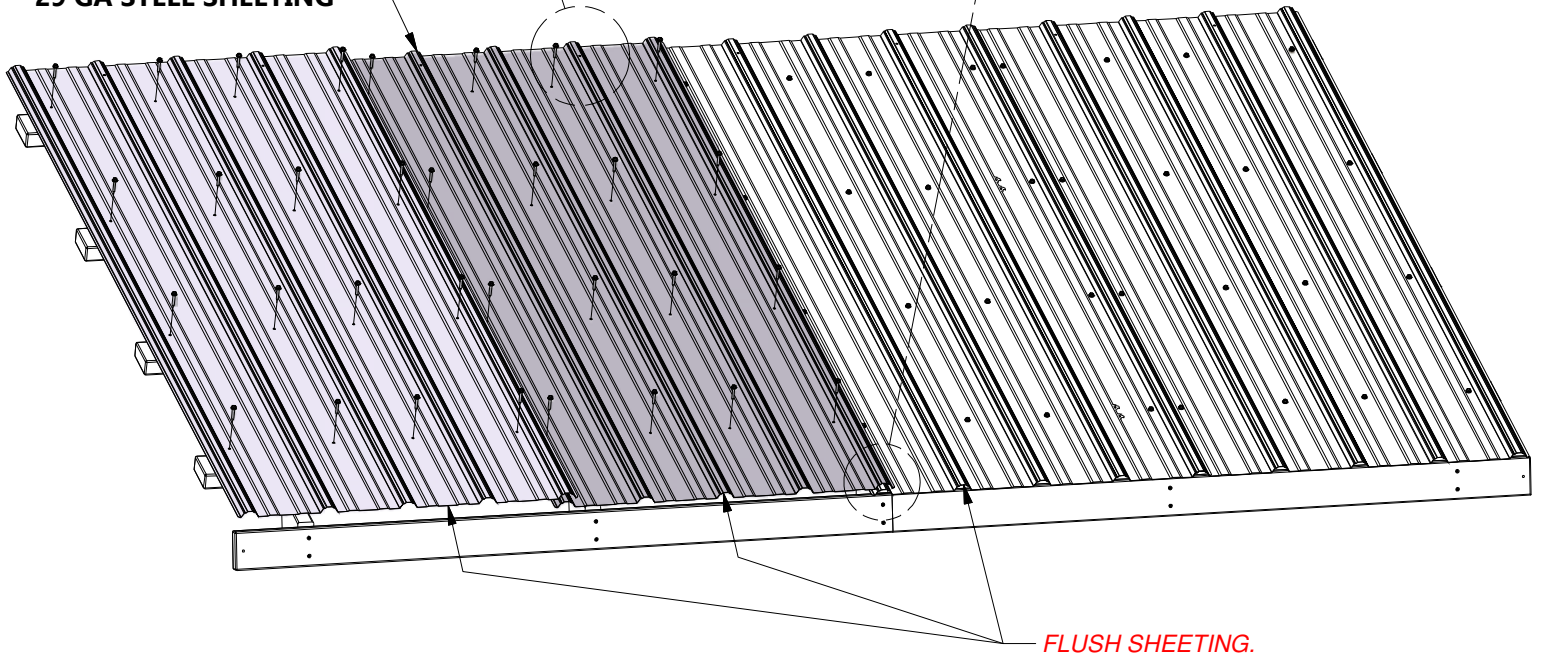

STEP 14 - GAZEBO ASSEMBLY

QTY	PART NUMBER	DESCRIPTION
8	H100760	1-1/4 WOODGRIP SCREW

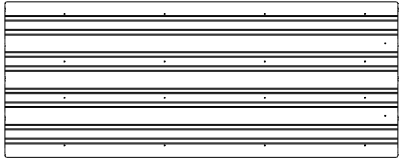

A4M02639
(x2) **29 GA STEEL SHEETING**

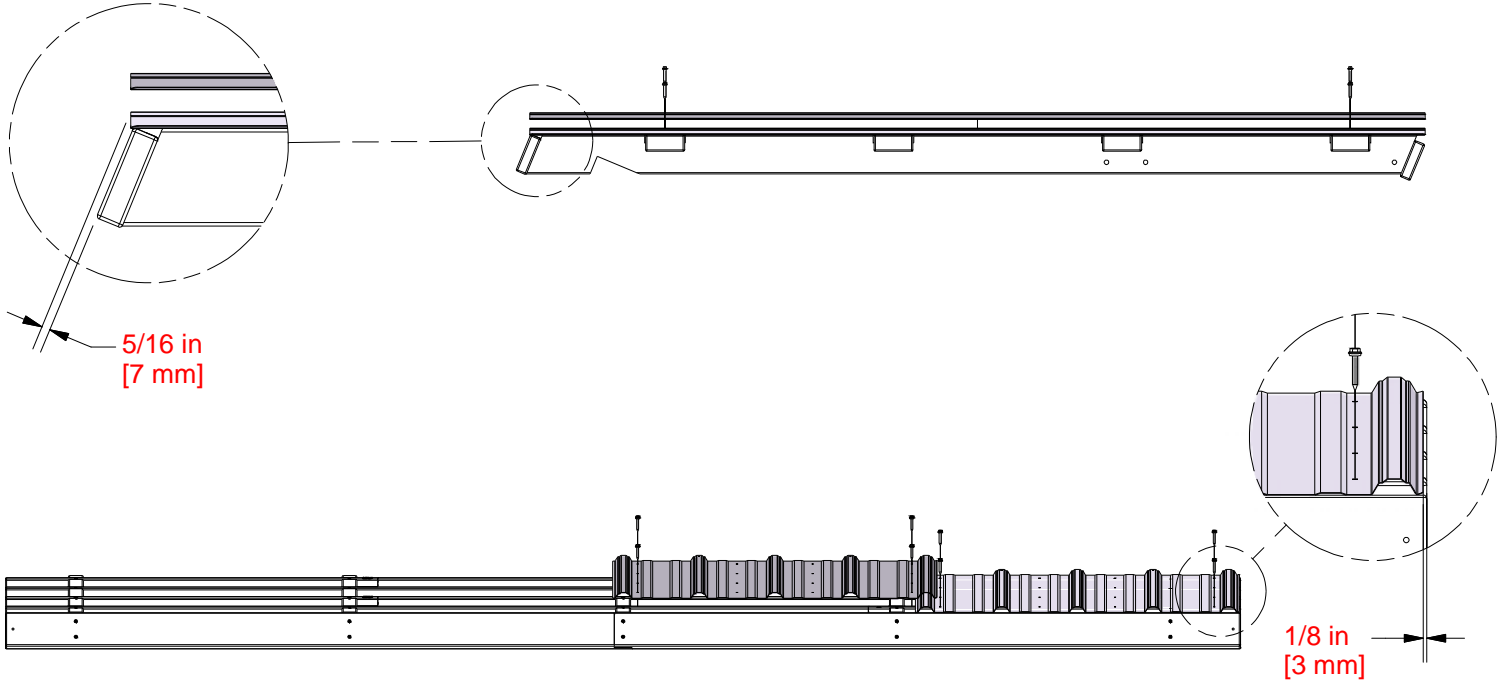

MAKE SURE YOUR ROOF PANEL IS SQUARE BEFORE MOVING ON.

760 (x8)
SCREW - 1 1/4"

NOTE THRU HOLES

NOTE RIB OVERLAP

FLUSH SHEETING.

2639 (x2)
29 GA STEEL SHEETING

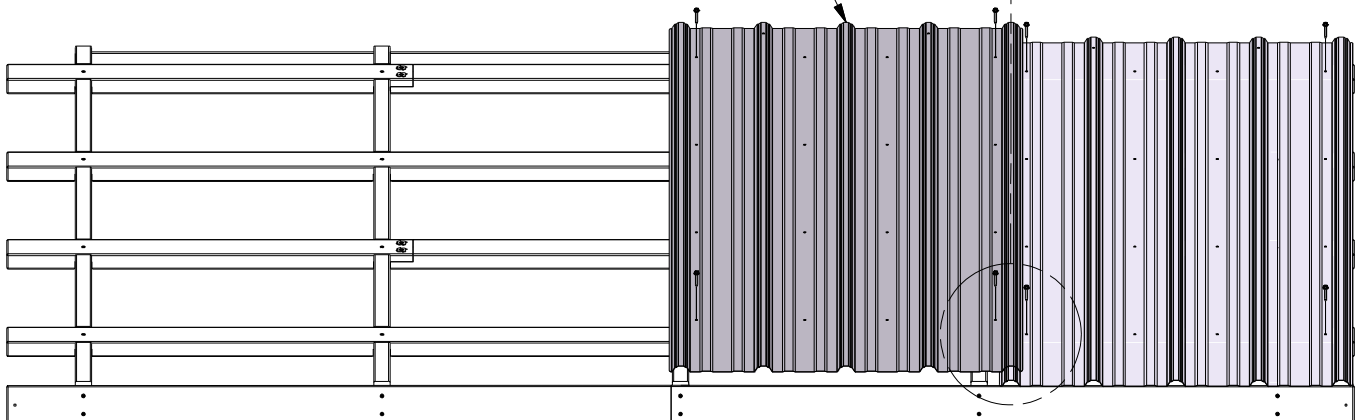

STEP 15 - GAZEBO ASSEMBLY

QTY	PART NUMBER	DESCRIPTION
24	H100760	1-1/4 WOODGRIP SCREW

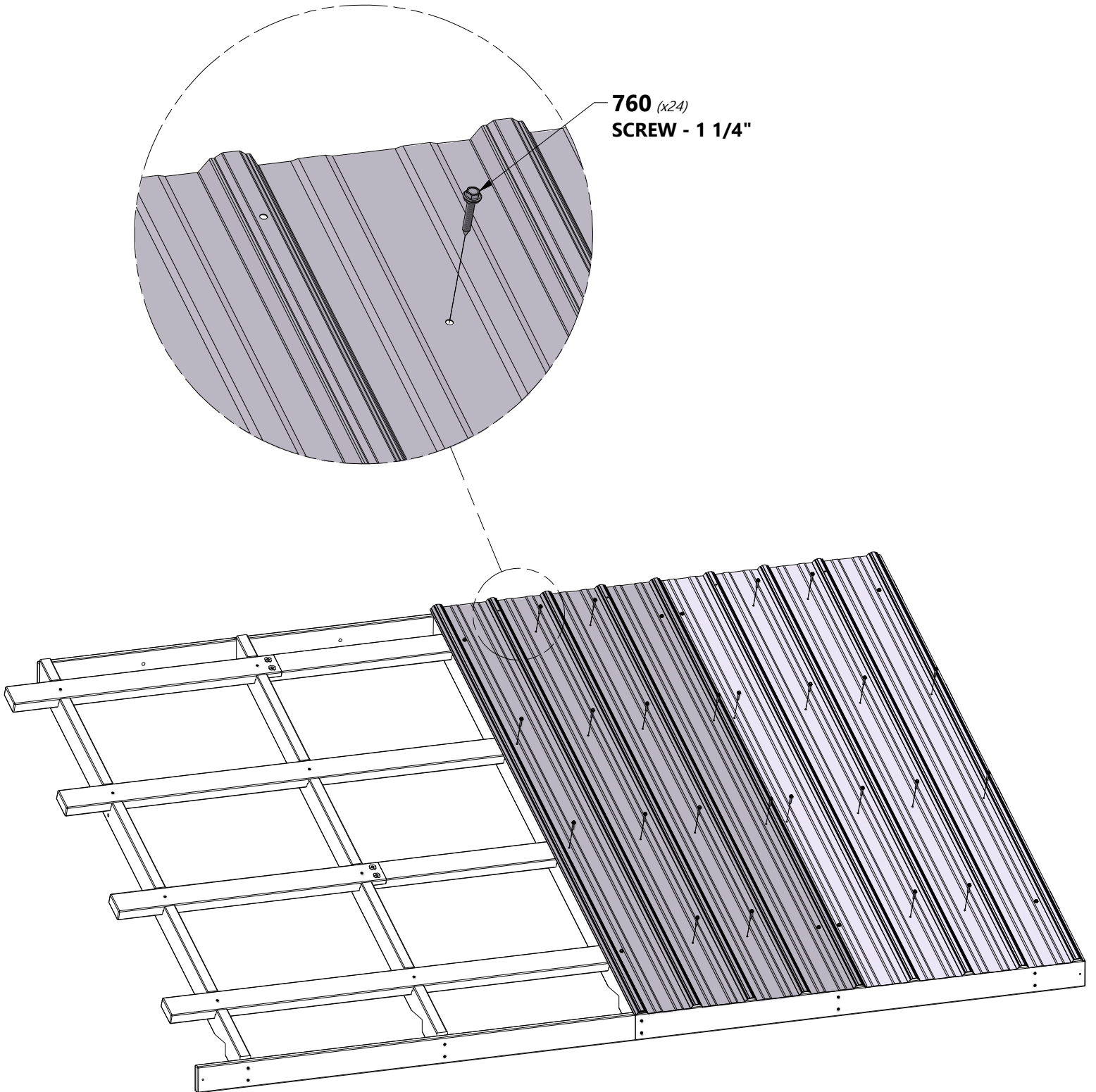

STEP 16 - GAZEBO ASSEMBLY

QTY	PART NUMBER	DESCRIPTION
32	H100760	1-1/4 WOODGRIP SCREW

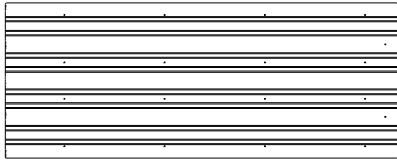

A4M02639
(x2) **29 GA STEEL SHEETING**

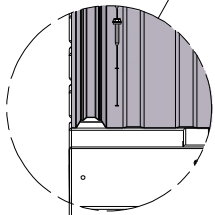
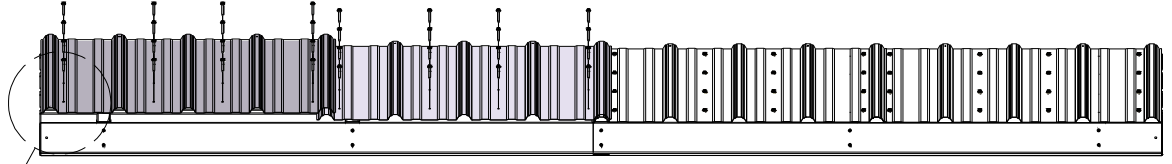

1/8 in [3 mm]
HOLD SHEETING TO INSIDE OF FRAME.

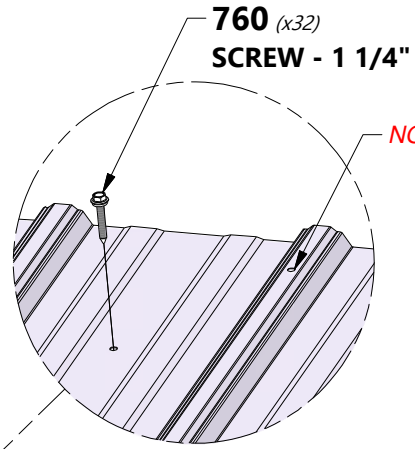

760 (x32)
SCREW - 1 1/4"

NOTE HOLE LOCATIONS

2639 (x2)
29 GA STEEL SHEETING

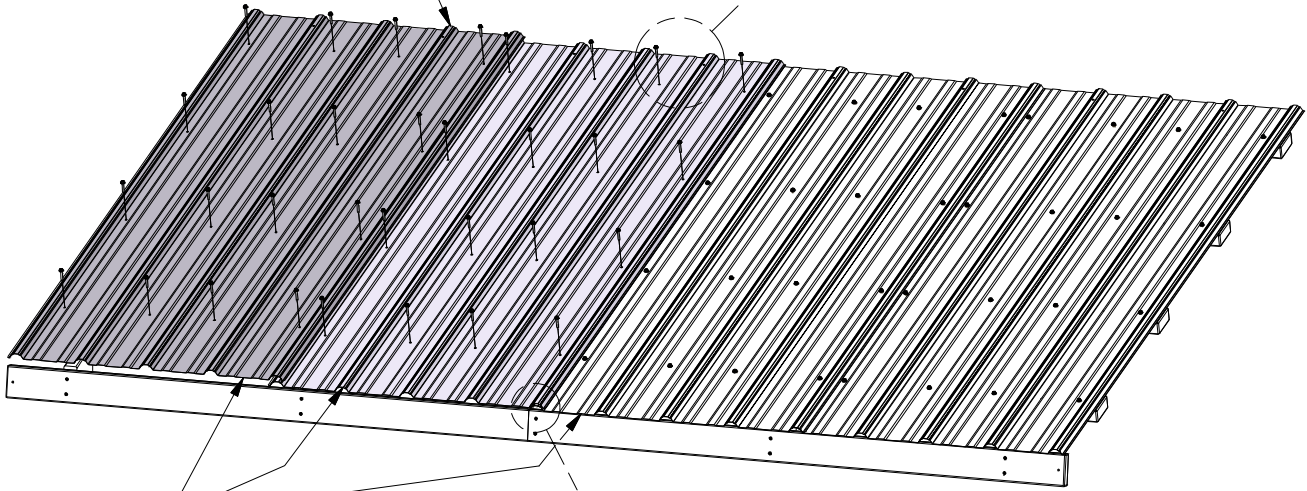

FLUSH SHEETING.

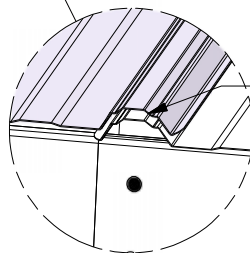

NOTE RIB OVERLAP

STEP 17 - GAZEBO ASSEMBLY

QTY	PART NUMBER	DESCRIPTION
16	H100759	SCREW TAPPING

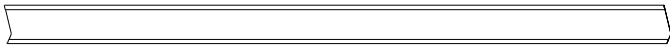

A4M02637
(x4) **ROOF EDGE TRIM**



A4M02638
(x2) **ROOF EDGE TRIM SPLICE**

COMPLETE THIS STEP TWICE

DUE TO MULTIPLE LAYERS OF METAL ON THE EDGE TRIM, IT IS RECOMMENDED THAT A 1/8" DRILL BIT IS USED TO CREATE STARTER HOLES.

SCREWS GO THROUGH EDGE TRIM INTO THE TOP OF THE RIBS IN THE APPROXIMATE LOCATIONS SHOWN.

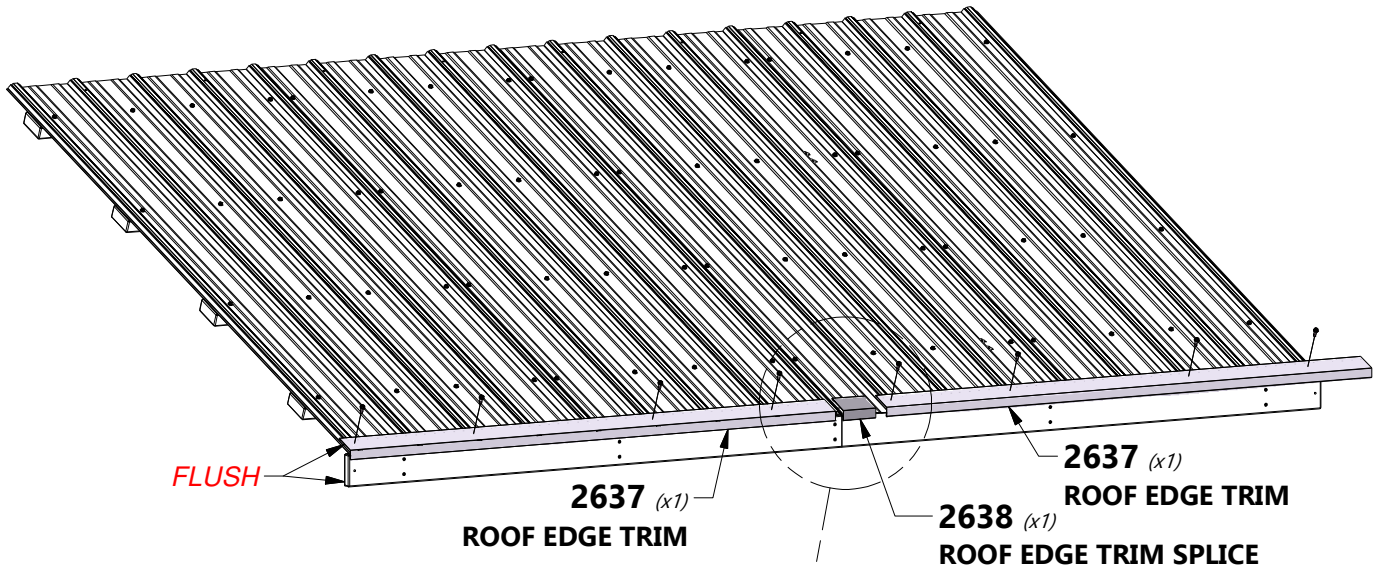

759 (x8)
SCREW - 3/4"

SLIDE EDGE TRIM INTO SPLICE. ENSURE THAT BOTH ENDS ARE FLUSH WITH EDGE OF ROOF PANELS.

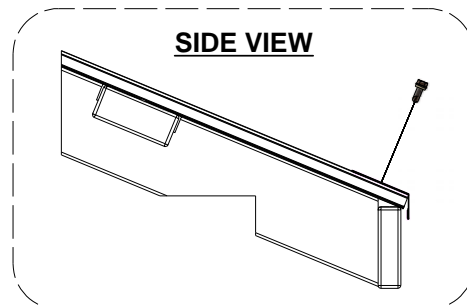
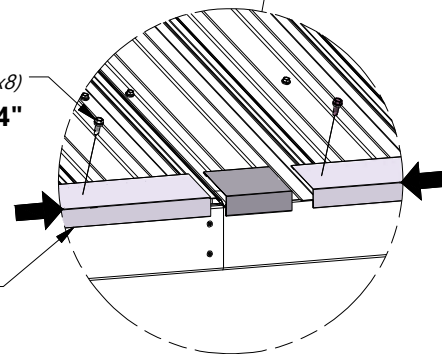

STEP 18 - GAZEBO ASSEMBLY

QTY	PART NUMBER	DESCRIPTION
2	H100391	SCREW PFH 8x2 BLK
2	H100479	NUT LOCK 5/16 BLK
2	H100770	WASHER FLAT 5/16 BLK
2	H100829	BOLT WH 5/16x9 1/2 BLK

TIPS:

- With at least two people lift assembled roof panel and slide it into the tracks on the rafters.
- Once in place, install attachment hardware as shown.
- A third person is helpful to attach roof once it is in place.

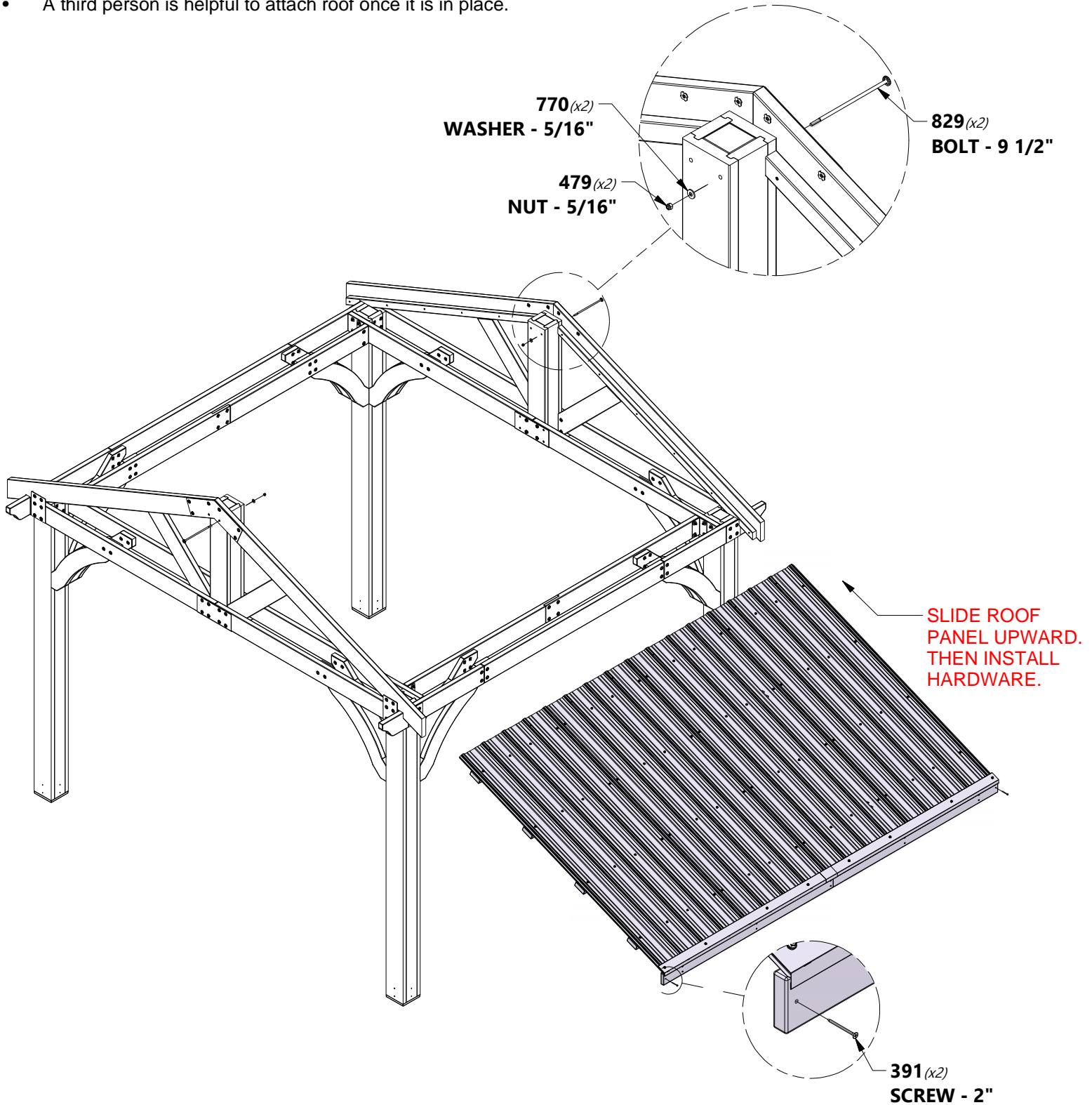

STEP 19 - GAZEBO ASSEMBLY

QTY	PART NUMBER	DESCRIPTION
4	H100192	NUT BARREL WH 5/16x7/8 BLK
4	H100198	WASHER LOCK EXT 8x19 BLK
4	H100199	WASHER LOCK EXT 12x19 BLK
2	H100391	SCREW PFH 8x2 BLK
4	H100407	BOLT WH 5/16x1 1/2 BLK

- TIPS:**
- With at least two people lift assembled roof panel and slide it into the tracks on the rafters.
 - Once in place, install attachment hardware as shown.
 - A third person is helpful to attach roof once it is in place.

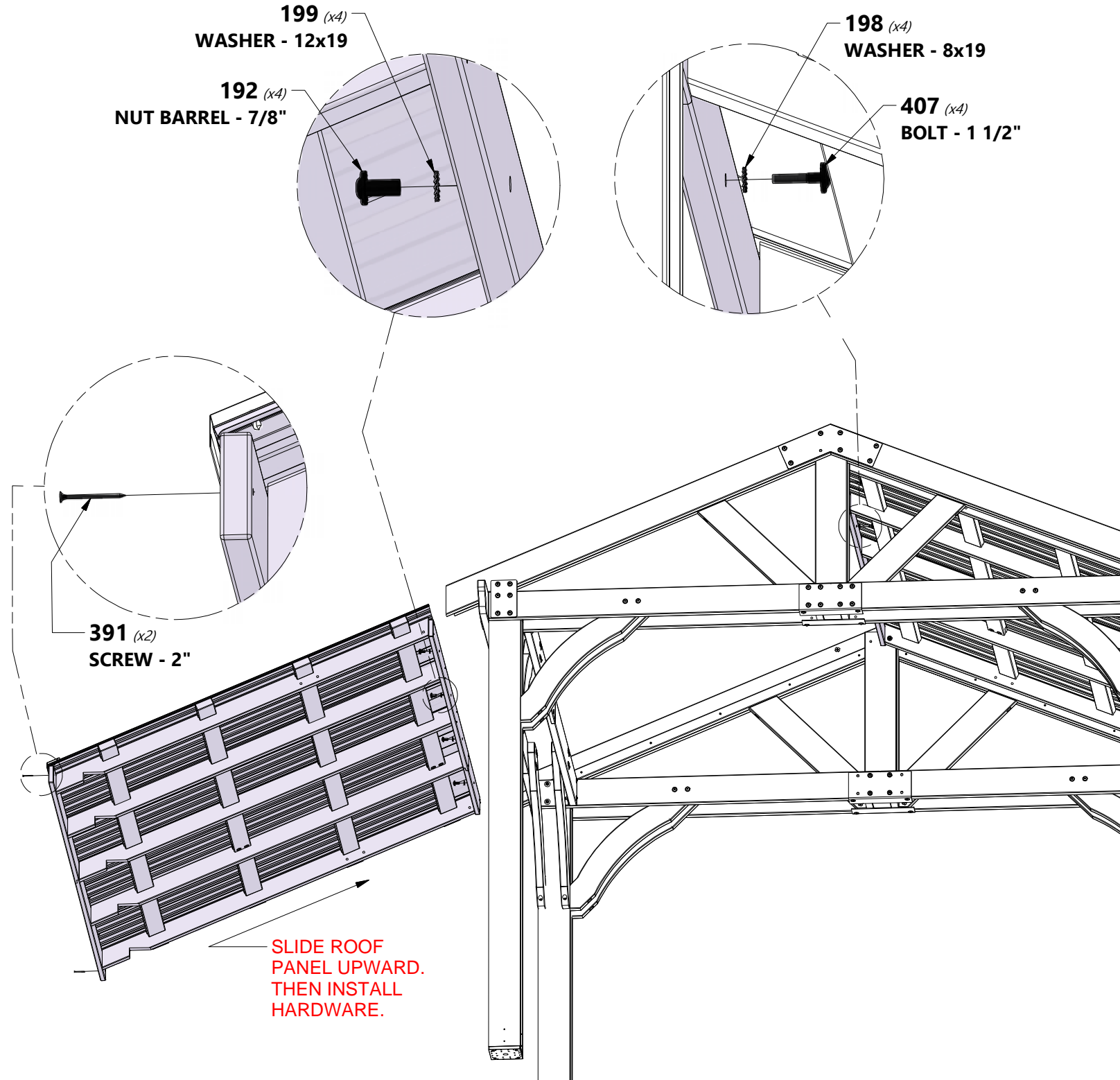

STEP 20 - GAZEBO ASSEMBLY

QTY	PART NUMBER	DESCRIPTION
2	H100479	NUT LOCK 5/16 BLK
2	H100770	WASHER FLAT 5/16 BLK
2	H100829	BOLT WH 5/16x9 1/2 BLK

COMPLETE THIS STEP TWICE

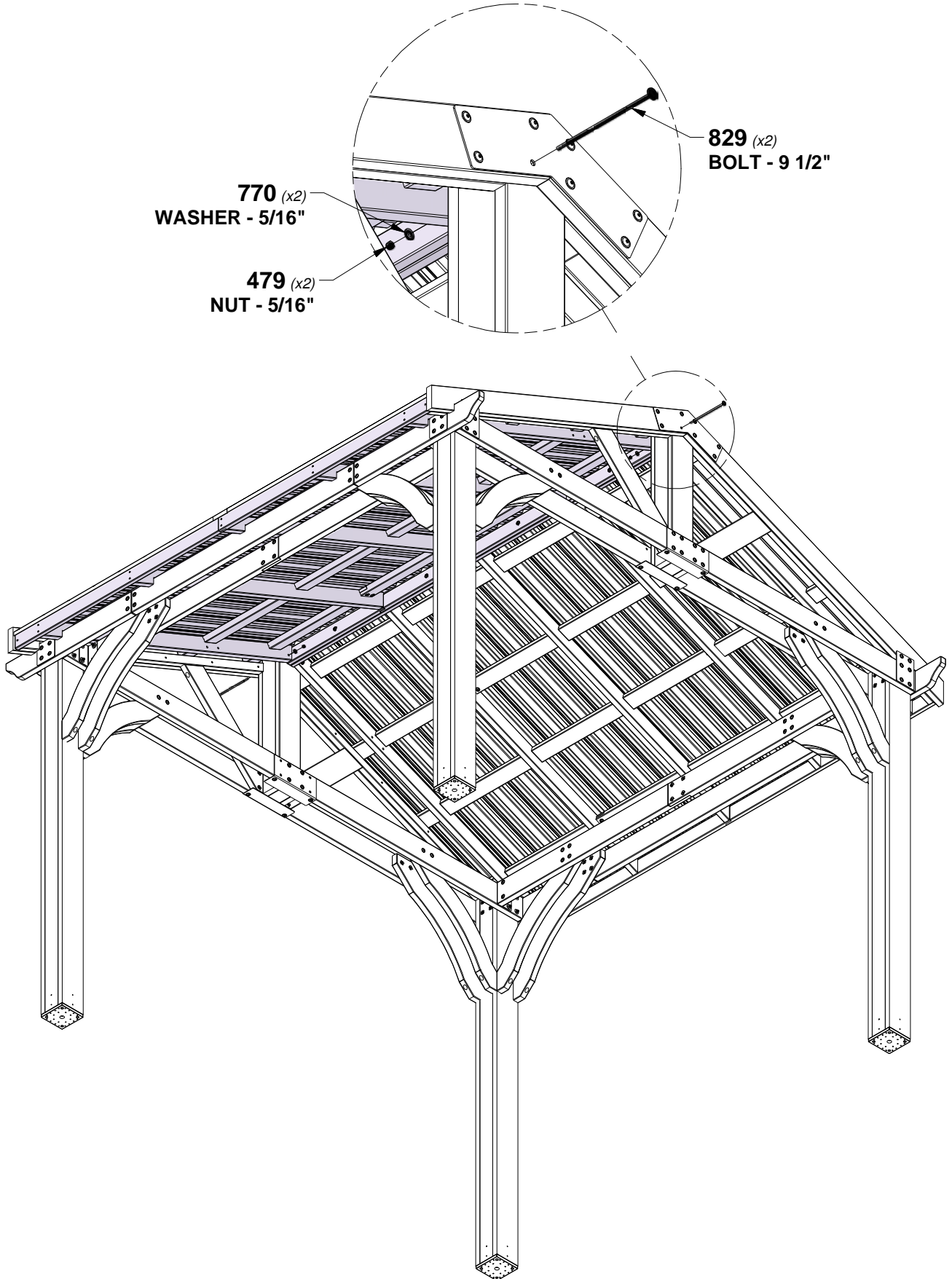

STEP 21 - GAZEBO ASSEMBLY



D06 ANGLE BRACE - W4L18472
 (x4) 1 3/8"x5 1/4"x32 3/8" (36x134x823)

QTY	PART NUMBER	DESCRIPTION
8	H100195	BOLT WH 5/16x2-3/4 BLK
8	H100198	WASHER LOCK EXT 8x19 BLK
16	H100379	T-NUT 5/16 BLK
8	H100416	BOLT WH 5/16x3 BLK

TIP:
INSTALL T-NUTS IN WOOD FIRST

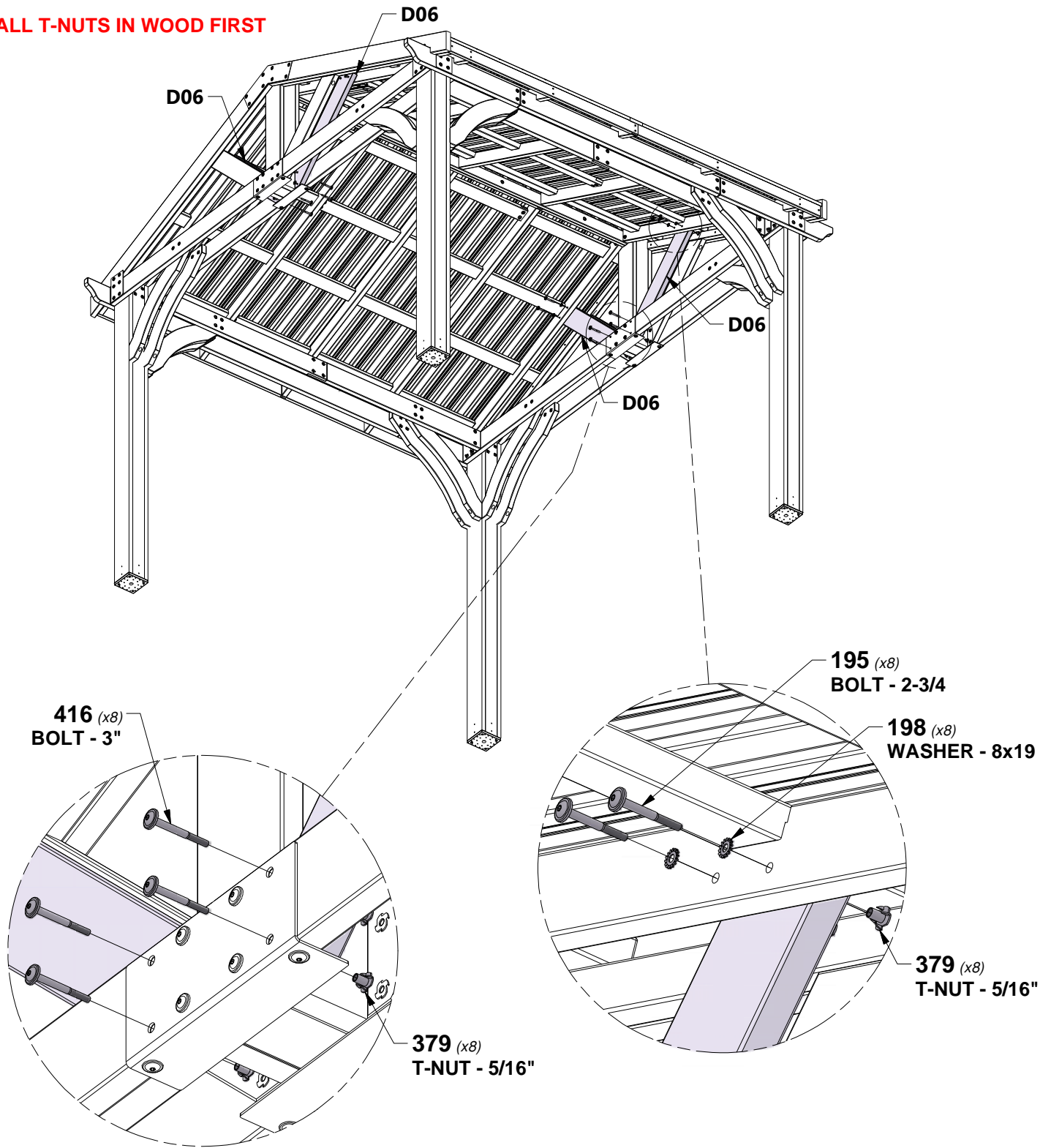

STEP 22 - GAZEBO ASSEMBLY

QTY	PART NUMBER	DESCRIPTION
30	H100536	SCREW PWH 8x1-1/4 BLK

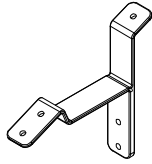

A4M00961
(x6) **ROOF BRACKET**

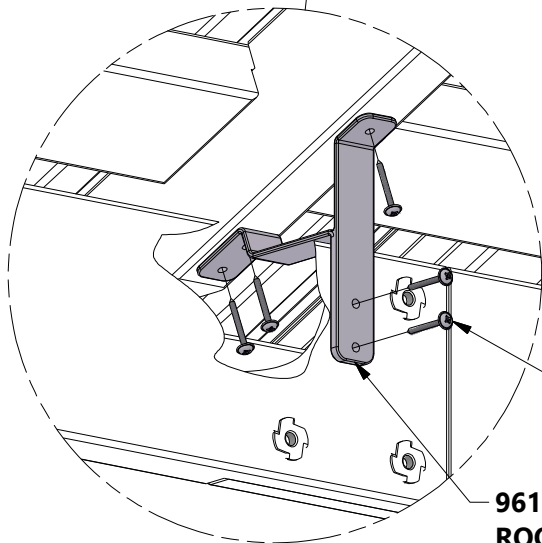
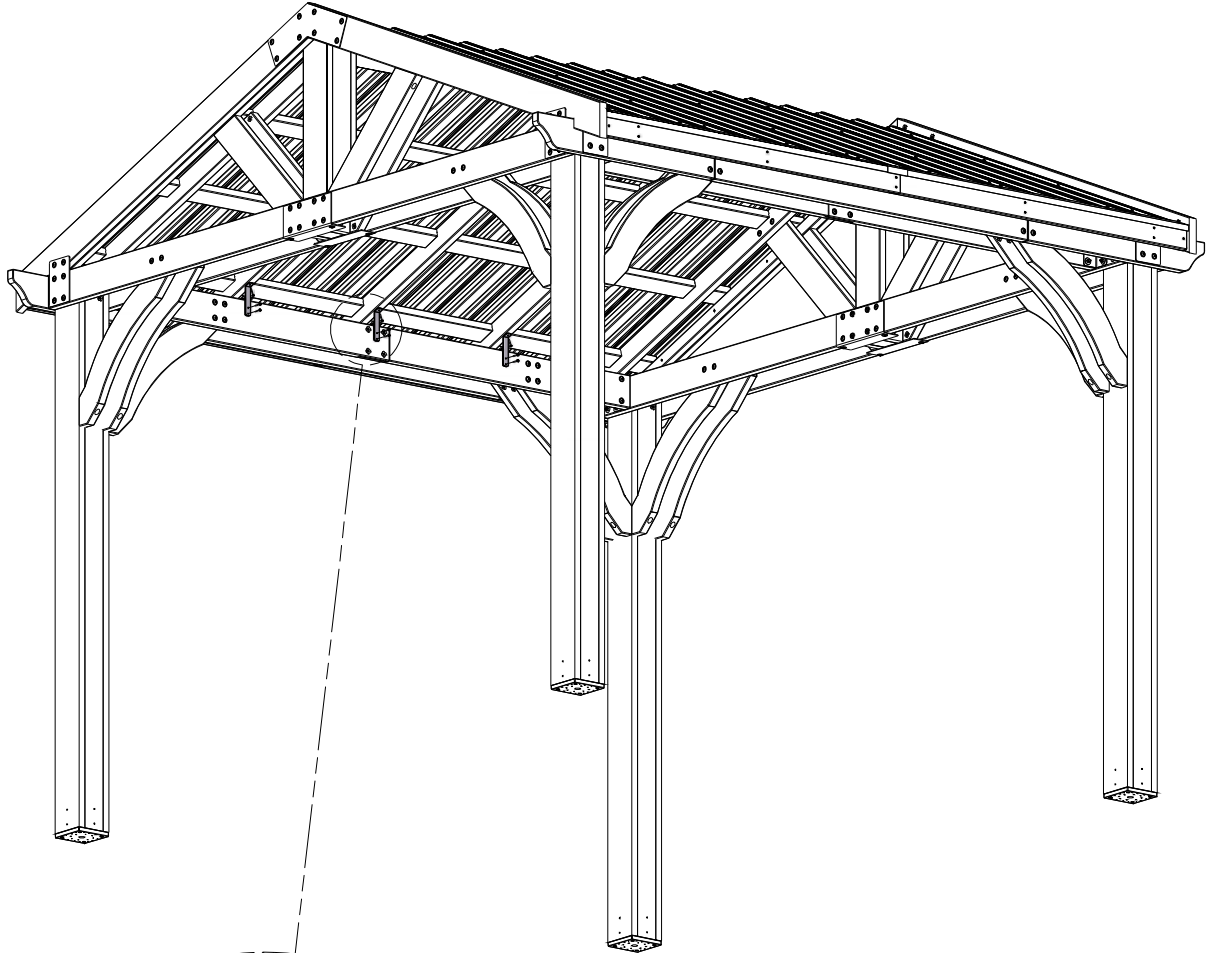

CENTER ROOF BRACKETS ON EACH RAFTER AND ATTACH.

536 (x30)
SCREW - 1/4"

961 (x6)
ROOF BRACKET

STEP 23 - GAZEBO ASSEMBLY

Qty	PART NUMBER	DESCRIPTION
4	H100382	SCREW PFH 8x1 3/4 BLK

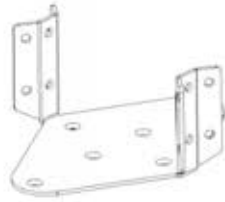

A4M02501 FAN MOUNT BRACKET
(x1)

NOTES:

1. ATTACH YOUR ELECTRICAL BOX (PROVIDED SEPARATELY) WITH THE PROVIDED HOLES IN FAN MOUNT BRACKET.
2. PLACE FAN MOUNT BRACKET ON RIDGE BEAMS AND MOVE TO DESIRED FAN LOCATION.
3. ROTATE BRACKET UNTIL MOUNTING FLANGES ALIGN BEST WITH RIDGE BEAMS.
4. USE AN 1/8" DRILL BIT AND DRILL PILOT HOLES AND ATTACH AS SHOWN.

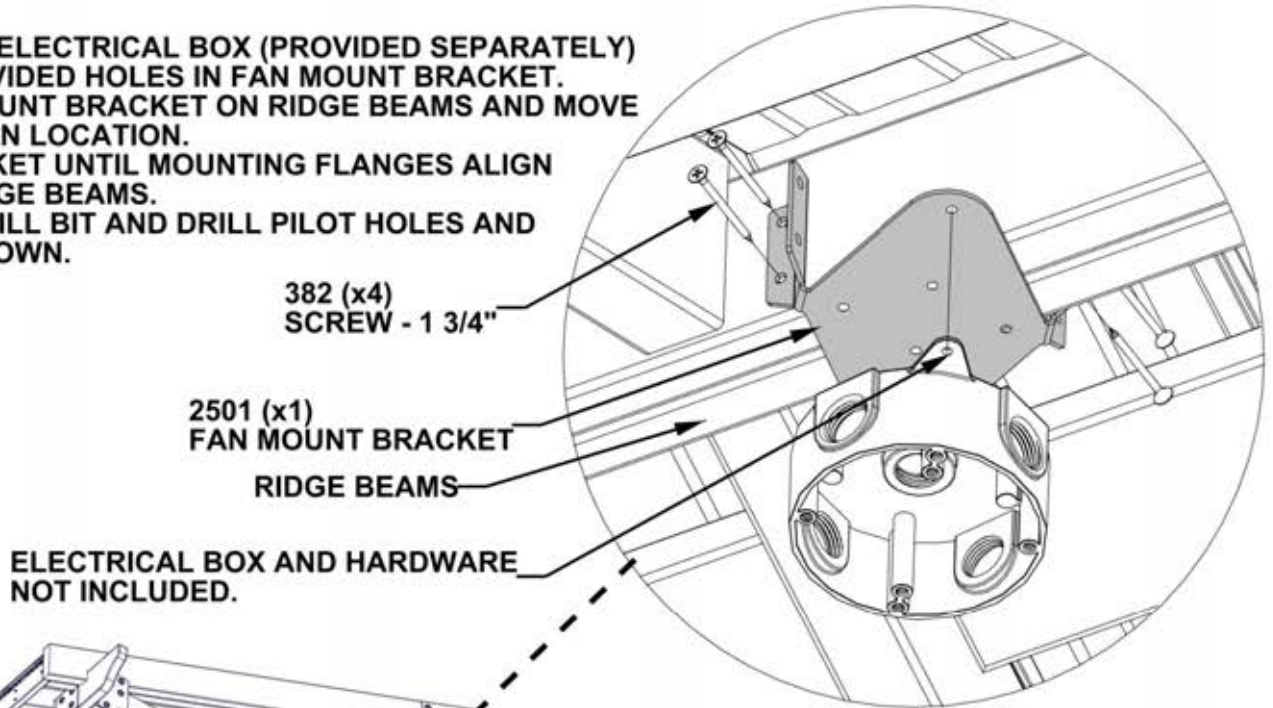

382 (x4)
SCREW - 1 3/4"

2501 (x1)
FAN MOUNT BRACKET

RIDGE BEAMS

ELECTRICAL BOX AND HARDWARE
NOT INCLUDED.

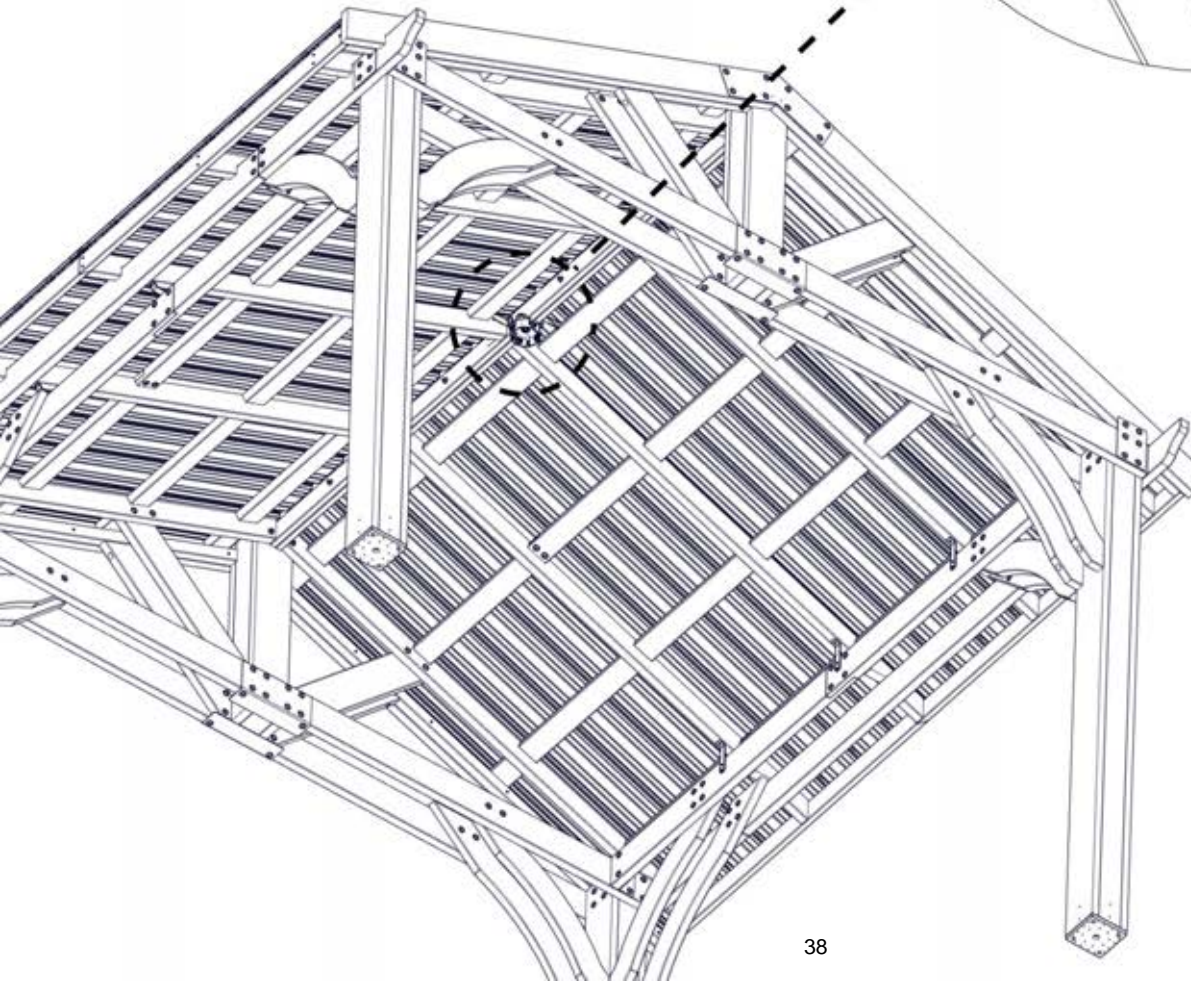

STEP 24 - GAZEBO ASSEMBLY

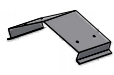

A4M02640 RIDGE CAP SPLICE
(x1)

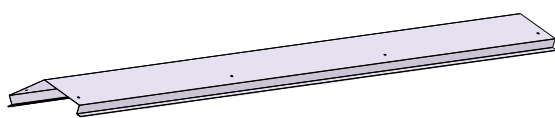

A4M02636 RIDGE CAP 29 GA
(x2)

RIDGE CAP ASSEMBLY PREPARATION

INSTALL THE PROVIDED RIDGE CAP SPLICE BY SLIDING EACH RIDGE CAP INTO THE SPLICE AS SHOWN UNTIL CENTERED.

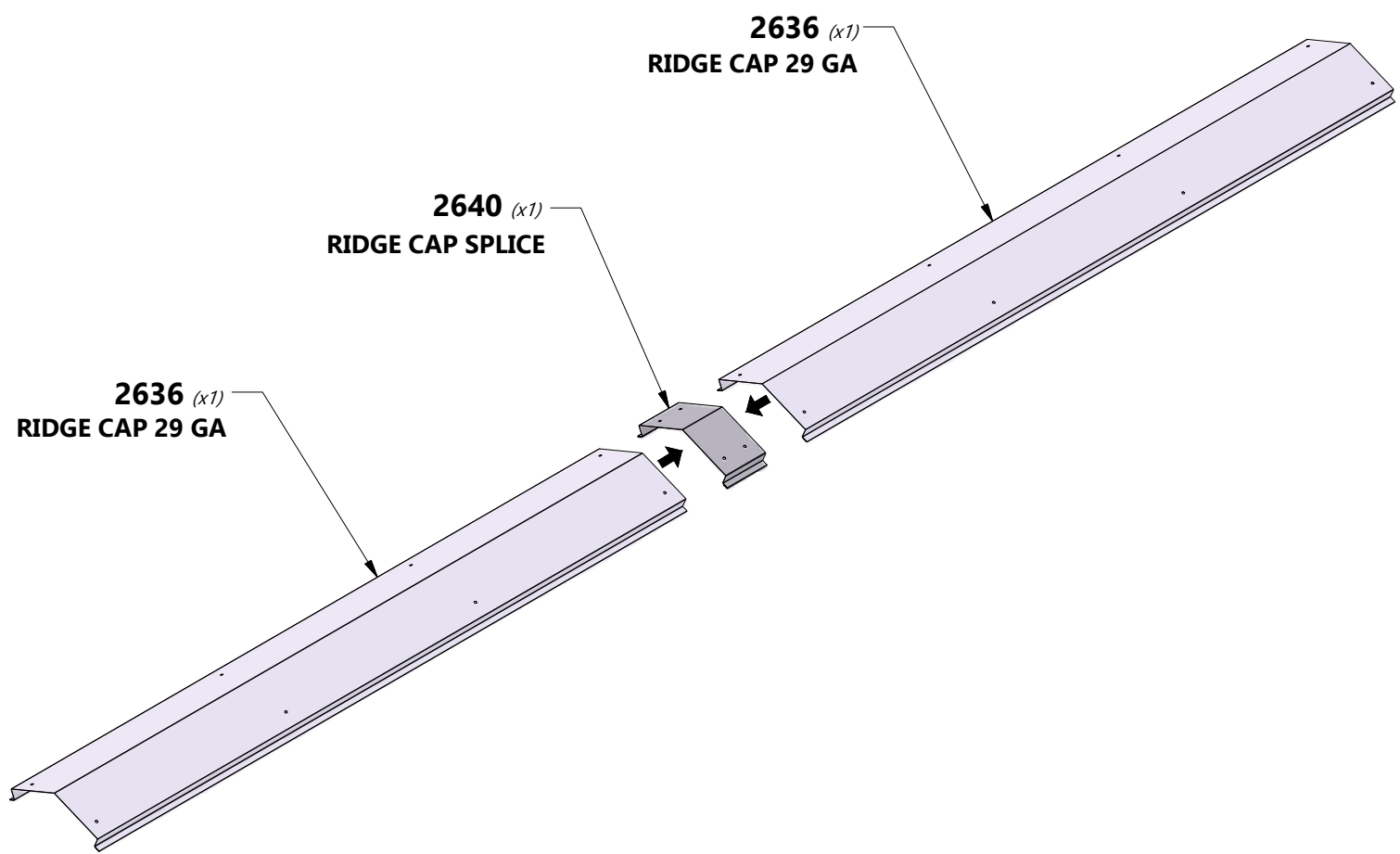

STEP 25 - GAZEBO ASSEMBLY

QTY	PART NUMBER	DESCRIPTION
16	H100833	SCREW WOODGRIP

J10 RIDGE CAP STIFFENER - W4L18488
 (x2) 1"x2 3/8"x69 1/4" (24x60x1760)

J09 RIDGE CAP STIFFENER - W4L18487
 (x2) 1"x2 3/8"x47 5/8" (24x60x1210)

A6P00398 RIDGE CAP PROTECTOR
 (x2)

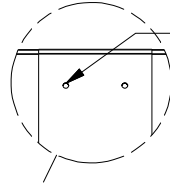
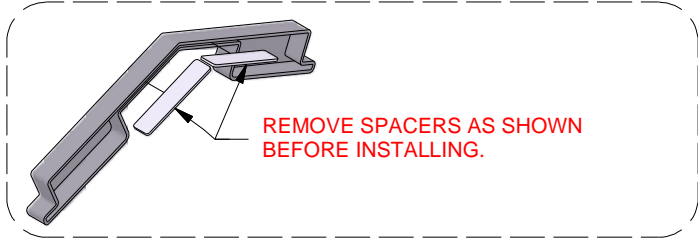
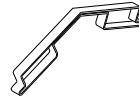

ASSEMBLE BY ALIGNING THE HOLES ON EACH RIDGE CAP TO THE HOLES IN THE RIDGE CAP SPLICE TO ENSURE THAT THE OVERALL LENGTH IS 117 1/16" MAX.

TOP VIEW

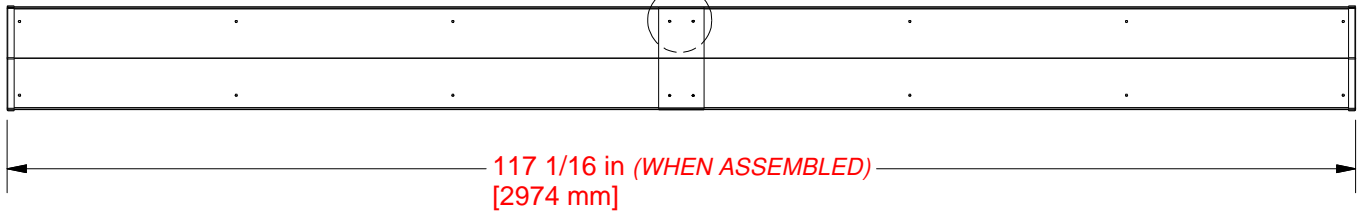

BOTTOM VIEW

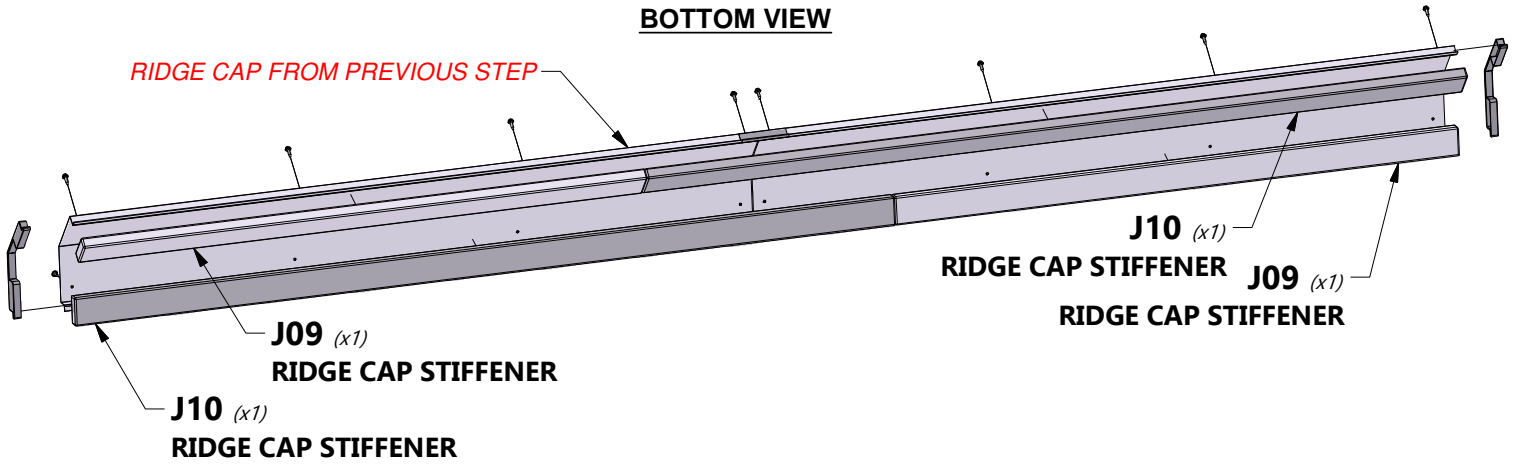

TOP ISO VIEW

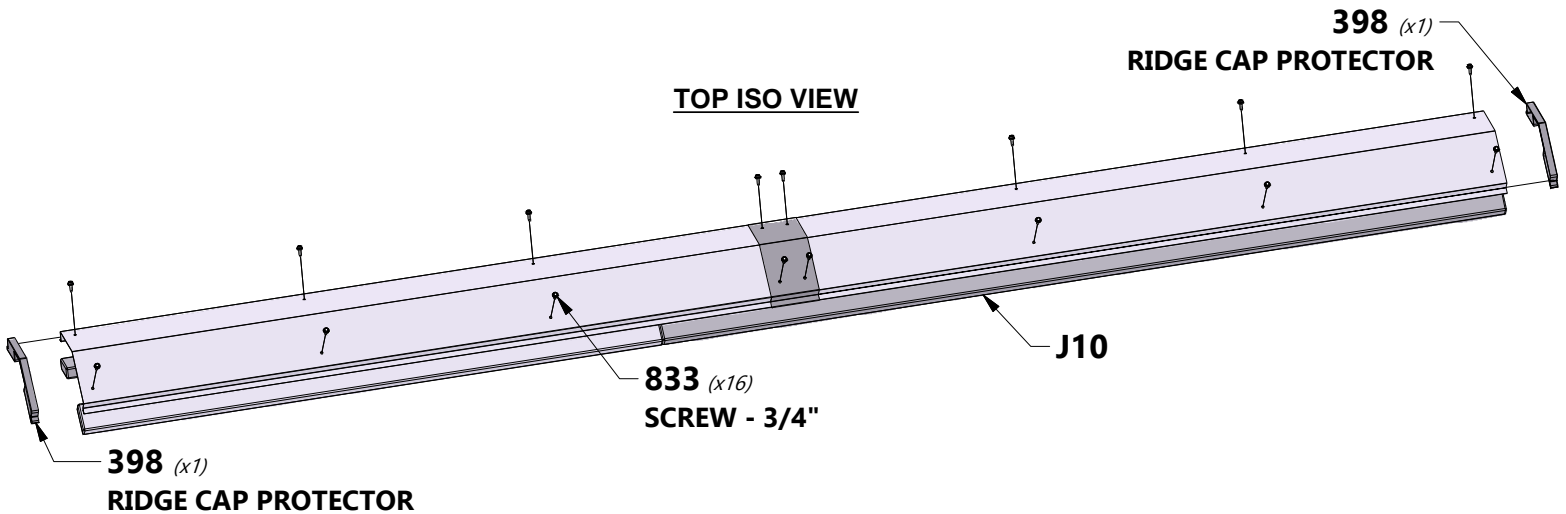

STEP 26 - GAZEBO ASSEMBLY

QTY	PART NUMBER	DESCRIPTION
16	H100392	SCREW PWH 8x3/4 BLK

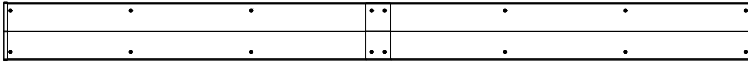

RIDGE CAP ASSEMBLY FROM PREVIOUS STEP

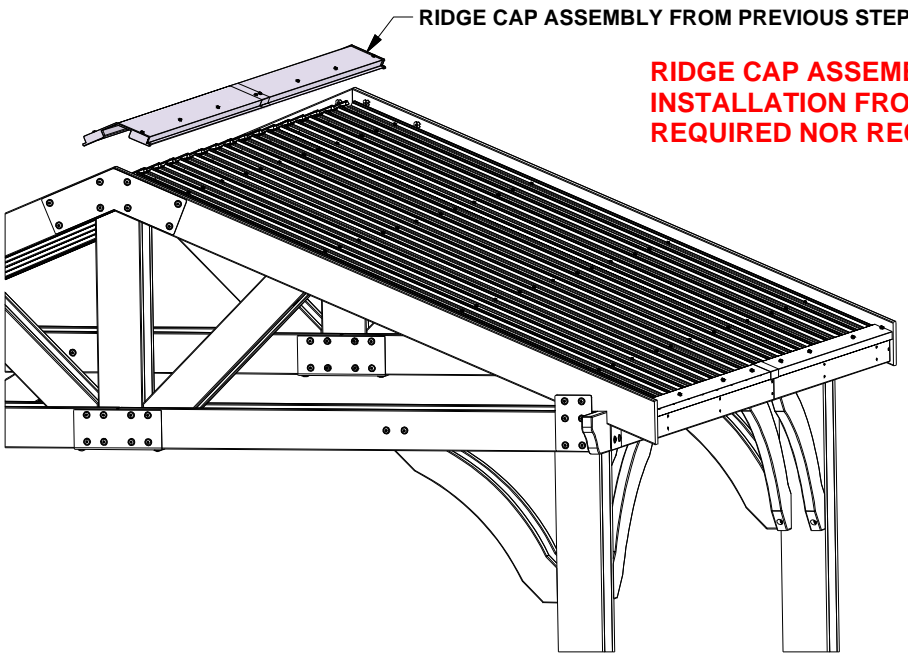

RIDGE CAP ASSEMBLY FROM PREVIOUS STEP

RIDGE CAP ASSEMBLY HAS BEEN DESIGNED FOR SAFE INSTALLATION FROM A LADDER AND NO ROOF ACCESS IS REQUIRED NOR RECOMMENDED.

USING AN ADULT HELPER, SLIDE RIDGE CAP ASSEMBLY CAREFULLY ACROSS THE ROOF RIDGE UNTIL BOTH ENDS SIT INSIDE RAFTERS AS SHOWN.

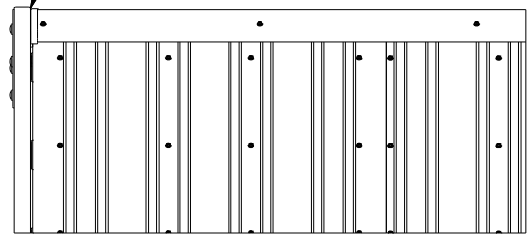

FOR PROPER INSTALLATION, USE AN ADULT HELPER TO KEEP DOWNWARD PRESSURE ON THE RIDGE CAP DURING SCREW INSTALLATION. NOTE ALL SCREWS LAND IN STIFFENER BOARDS.

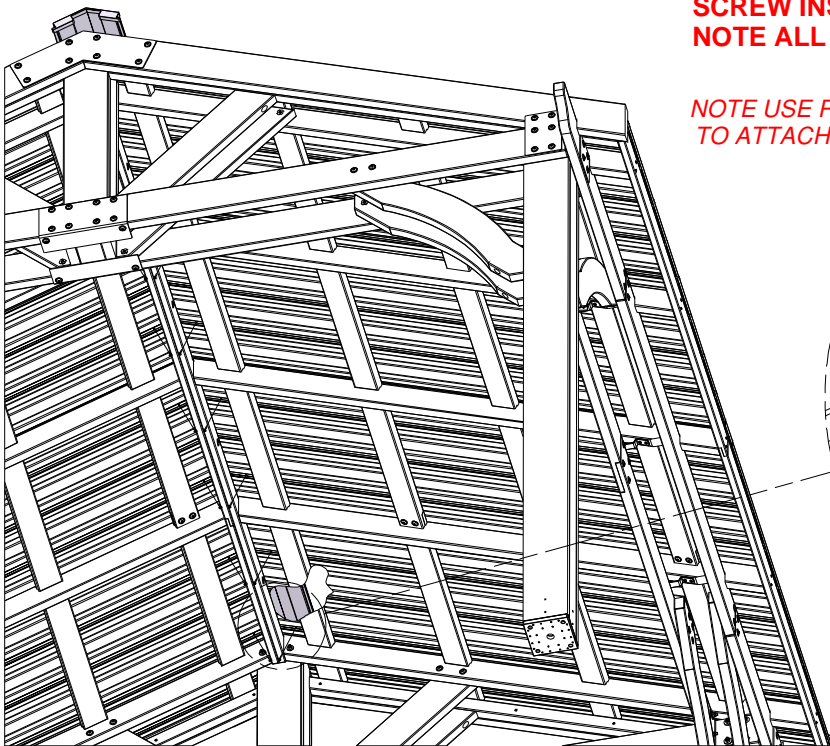

NOTE USE PILOT HOLES TO ATTACH RIDGE CAP.

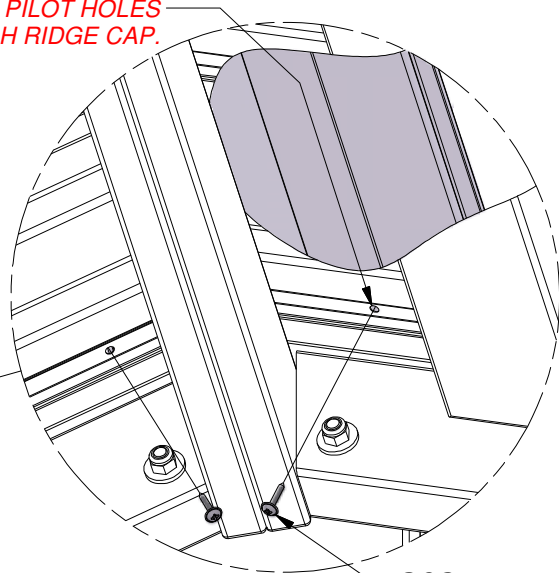

**392 (x16)
SCREW - 3/4"**

STEP 27 - GAZEBO ASSEMBLY

QTY	PART NUMBER	DESCRIPTION
32	H100471	LAG SCREW WH 5/16x1-1/2 BLK

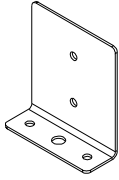

A4M00977
(x8) POST ANCHORING PLATE

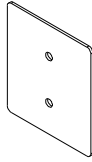

A4M00978
(x8) POST PLATE

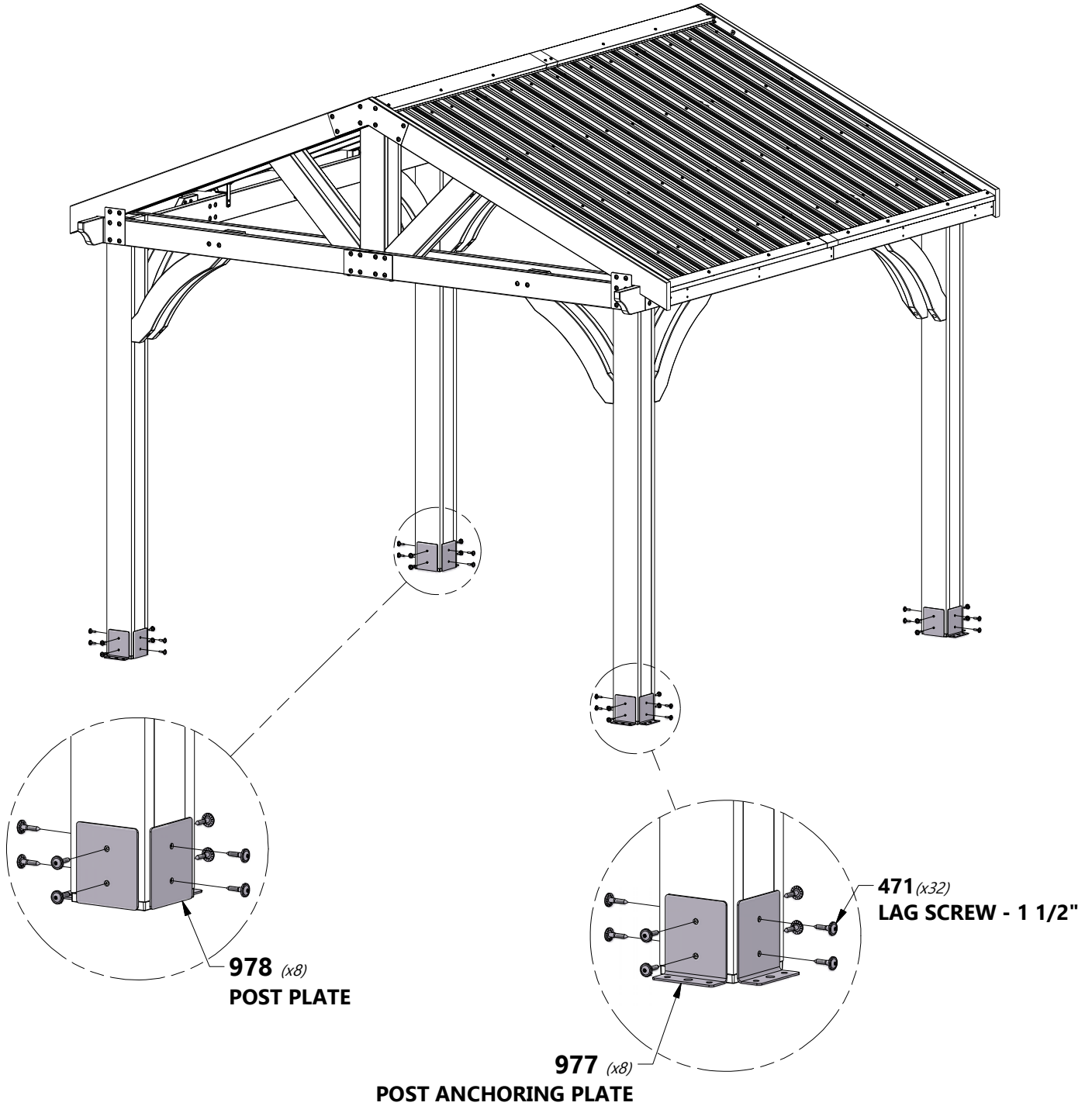

STEP 28 - GAZEBO ASSEMBLY

QTY	PART NUMBER	DESCRIPTION
2	H100200	SCREW PFH 8x1-1/2 BLK



A100241 BYD ID TAG (SMALL) WITHOUT AGES
(x1)

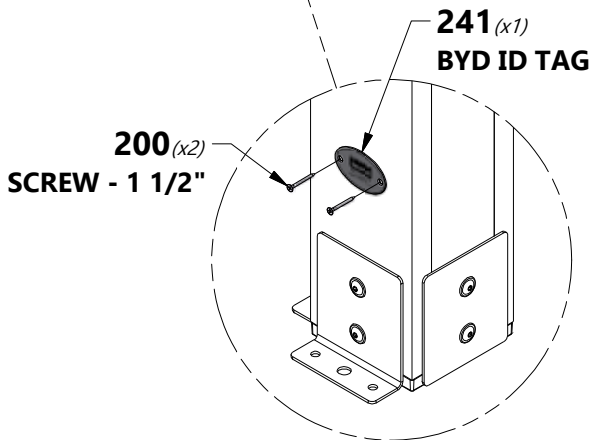
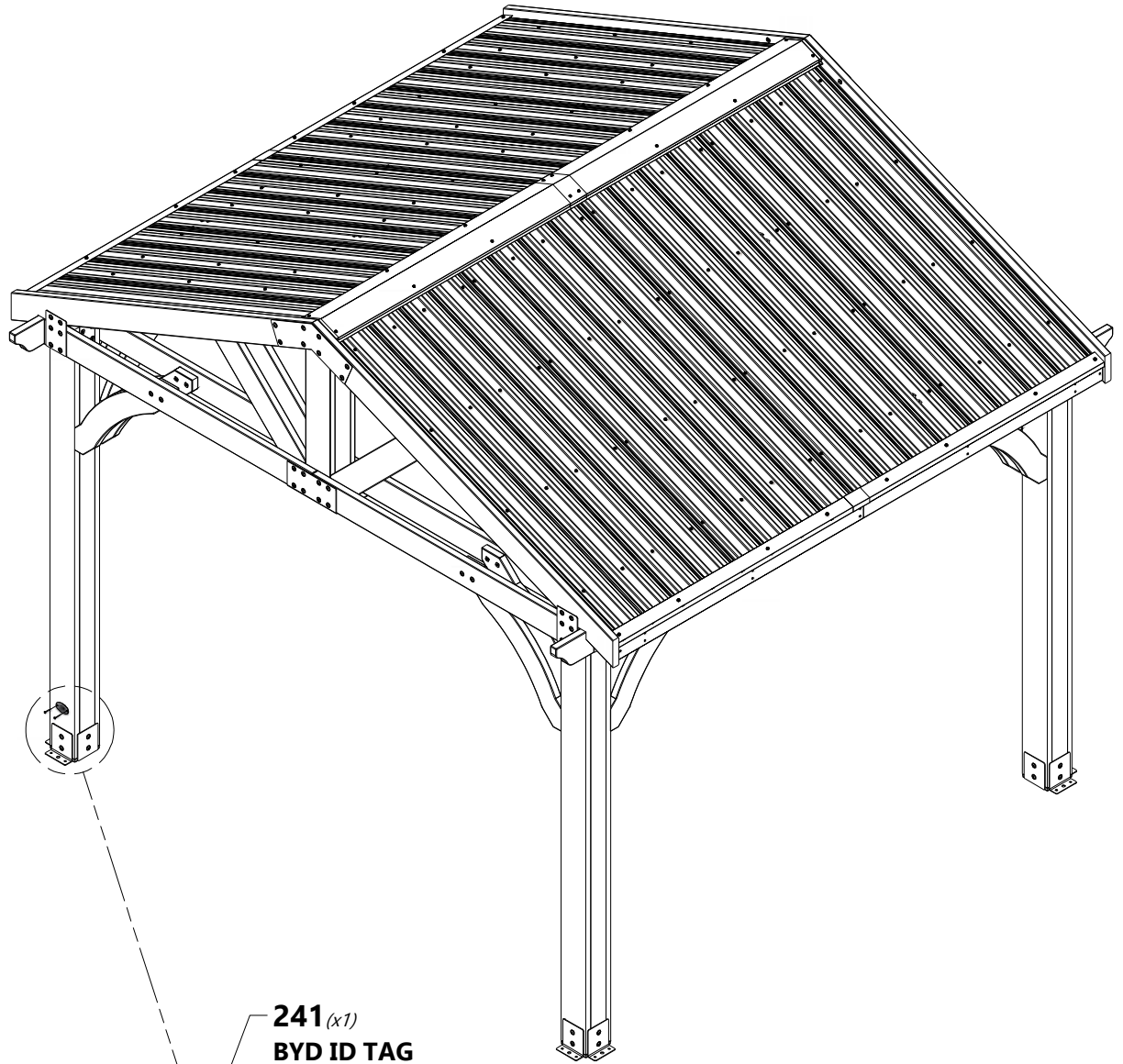

STEP 29 - GAZEBO ASSEMBLY

QTY	PART NUMBER	DESCRIPTION
16	H100120	SCREW CONCRETE ANCHOR
16	H100630	WASHER FLAT 8x19 BLK

MANUFACTURER RECOMMENDS INSTALLATION ON CONCRETE SURFACE OR CONCRETE POST PADS. SEE BELOW.

FOR INSTALLATION ON WOOD DECK, YOU MUST ENSURE THERE IS AMPLE STRUCTURAL SUPPORT UNDER DECK.

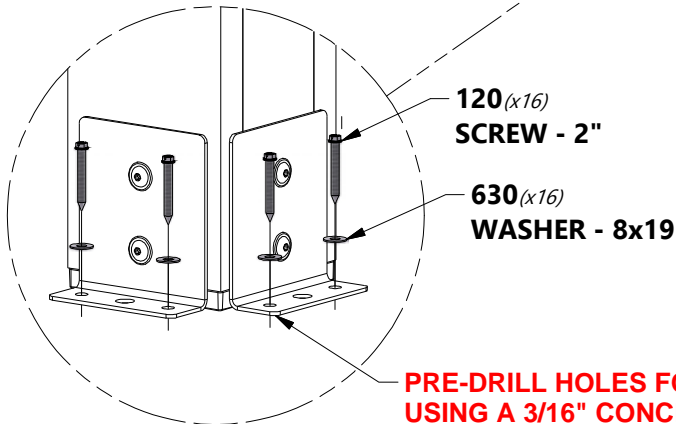
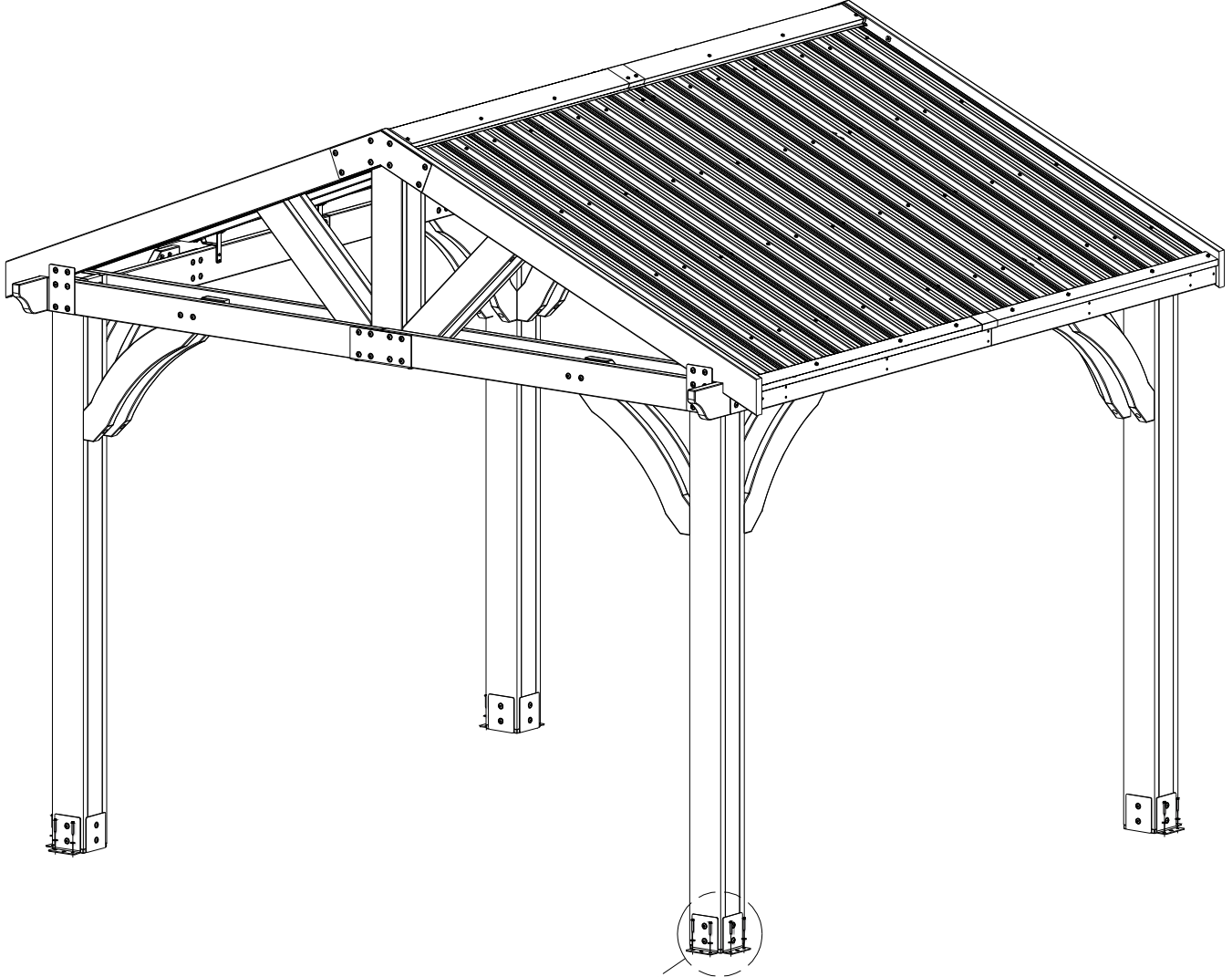

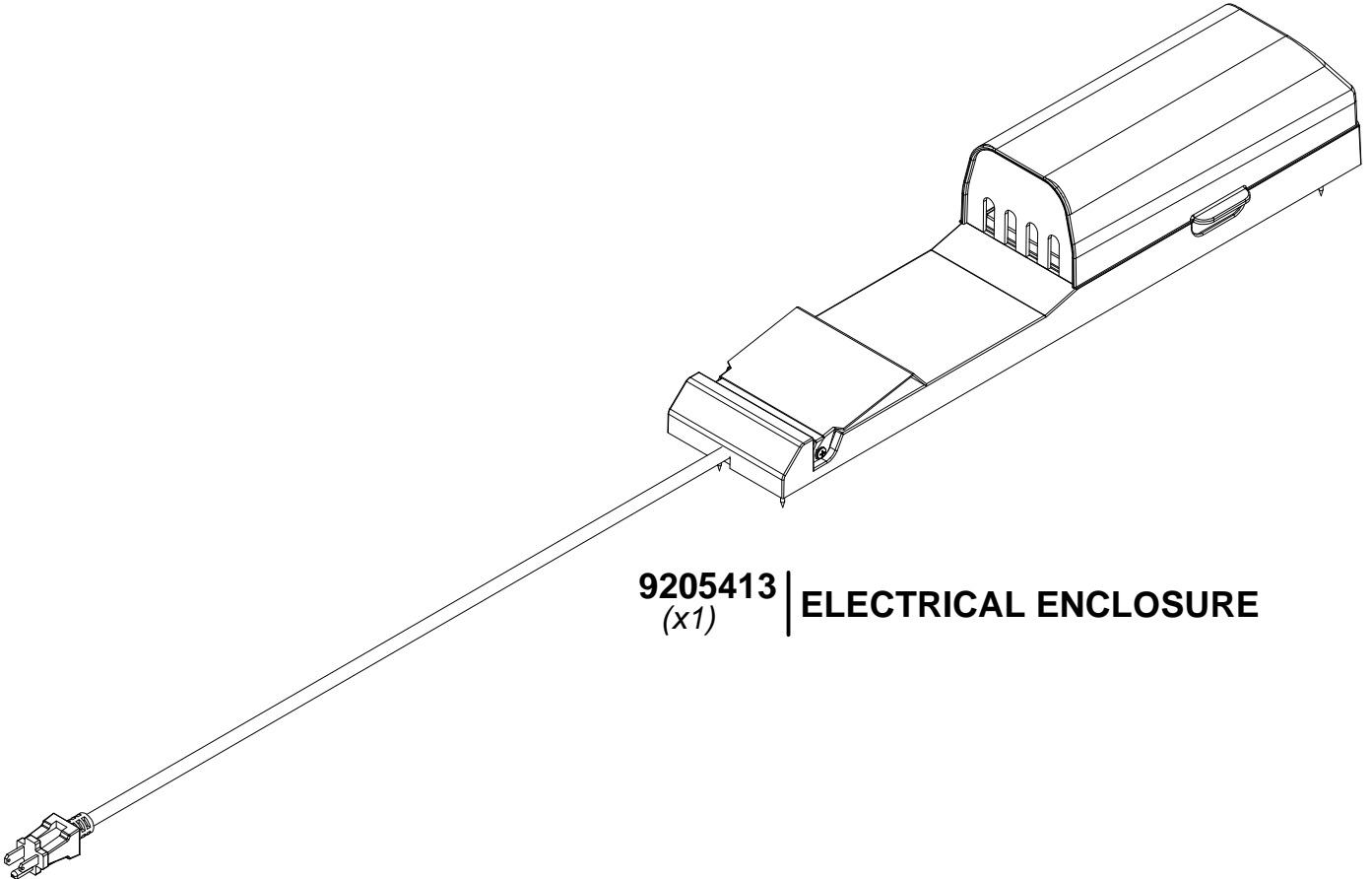

9205413 | **ELECTRICAL ENCLOSURE**
(x1)

FOR POWERPORT INSTALLATION REFER TO ASSEMBLY INSTRUCTIONS THAT COME PACKAGED WITH THE POWERPORT KIT. INSTALL ON ANY POST THAT IS DESIRED. FOLLOW DIRECTIONS FOR PROPER INSTALLATION.