



MANUFACTURED BY:  
Backyard Discovery  
3305 Airport Drive, Pittsburg, KS 66762  
800-856-4445

Basepoint Business Centre: Rivermead Drive, Westlea, Swindon SN5 7EX Phone: 0800-118-2476  
J.P. Coenstraat 7, The Bridge, The Hague, 2595 WP, Netherlands Phone: 0800-567-8990

# CANYON CREEK - WHITE

## Swing Set

### Model # 2300347

The assembly manual must be retained  
since it contains important information



#### WARNING

*Adult Assembly Required.*

Not suitable for children under 36 months due to small parts.  
**FOR DOMESTIC USE ONLY. INTENDED FOR OUTDOOR USE.**



**Please visit [www.backyarddiscovery.com](http://www.backyarddiscovery.com)**

For the most up to date assembly manual, to register your set, or to order replacement parts

*Para obtener instrucciones en español, visite [www.backyarddiscovery.com](http://www.backyarddiscovery.com)*



**EASY STEP-BY-STEP  
3D INTERACTIVE INSTRUCTIONS**  
DOWNLOAD THE FREE APP



Made in China

INS-2300347-A-CANYON CREEK - WHITE-ENG 01-18-24

# Owner's Manual - Basic Setup Dimensions & Assembly Notes

Place the set on level ground, not less than 6'-7" [2 m] from any structure or obstruction such as a fence, garage, house, overhanging branches, laundry lines, or electrical wires.

- While assembling unit, take time before and after each phase to make sure fort is level. If fort is not level, assembly will be difficult and improper assembly may result. Extra care must be taken to insure the fort is square.
- The safe play area refers to a zone extending 6'-7" (2 m) beyond the play product on all sides, including the space above the play product.

## SAFE PLAY AREA DIAGRAM

### Ground Dimensions

13'-4 1/4" [4.1 m] x 16'-4 1/4" [5.0 m]

### Safe Play Area

26'-6 1/4" [8.1 m] x 29'-6 1/4" [9.0 m] x 16'-6 1/4" [5.0 m]

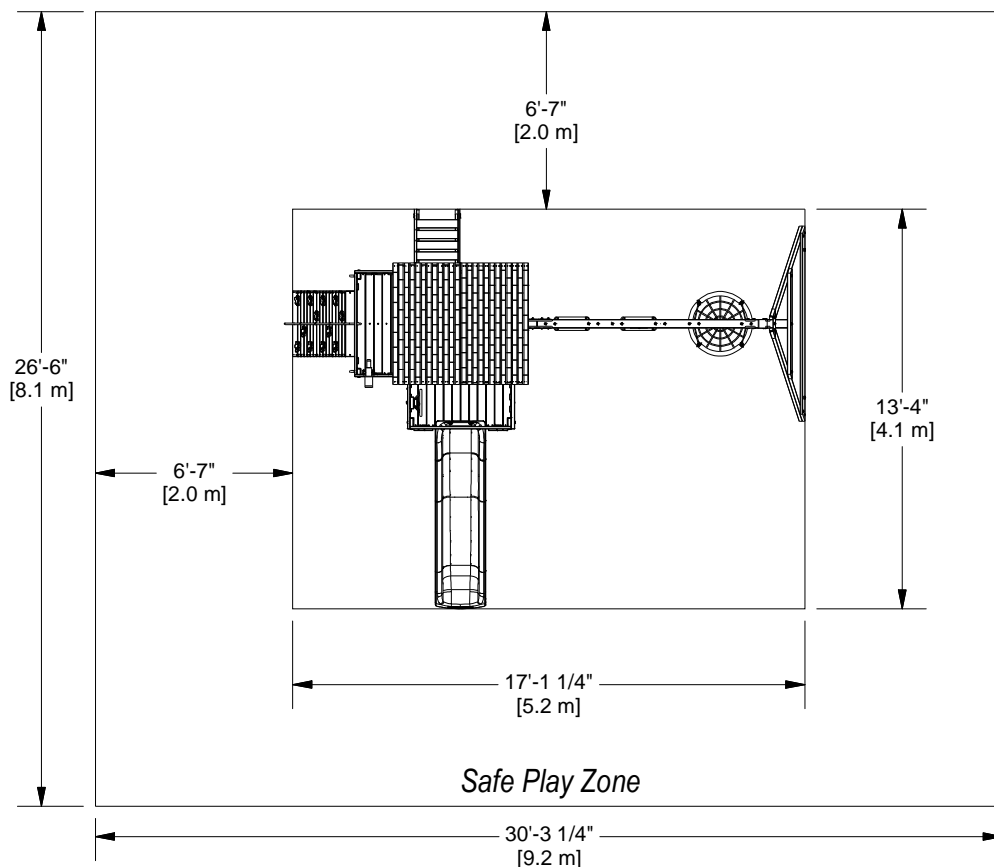

SAFE PLAY HEIGHT: 16'-6 1/4" [5.0 m]  
 MAXIMUM FALL HEIGHT: 6'-4 1/2" [1.9 m]

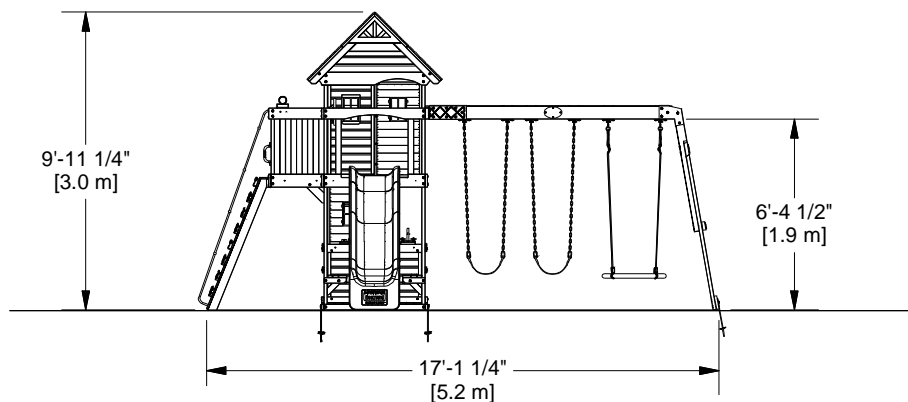

### General Information:

Your set has been designed and engineered for children only and for residential use only.  
 A maximum of 150 lbs. per child is recommended for play activities designed for individual use.  
 A maximum of 120 lbs. per child is recommended for play activities designed for multiple child use.  
 A maximum of 9 children is recommended for this swing set.

# Owner's Manual - Parts Identification

## Wood Components (Not to Scale)



**A1 SWING BEAM EXTENDED - W4L18499**  
(x1) 3 3/8"x5 1/4"x89 1/2" (86x134x2274)



**A2 SB 9" BLOCK - W4L19017**  
(x1) 3 3/8"x5 1/4"x9" (86x134x228)

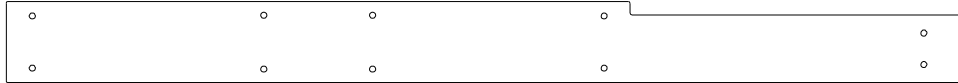

**D1 SWING BEAM MOUNT - W4L19015**  
(x1) 1 3/8"x5 1/4"x62 3/8" (36x134x1585)



**E1 DECK BRACE - W4L17821**  
(x4) 1 3/8"x3 3/8"x12 1/4" (36x86x311)



**E2 LEFT REAR UPRIGHT - W4L17823**  
(x1) 1 3/8"x3 3/8"x51 3/4" (36x86x1314)



**E3 LEFT FRONT UPRIGHT - W4L17824**  
(x1) 1 3/8"x3 3/8"x51 3/4" (36x86x1314)

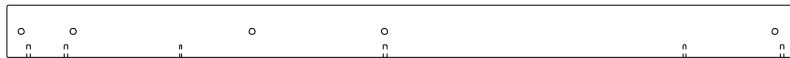

**E4 RIGHT FRONT UPRIGHT - W4L17825**  
(x1) 1 3/8"x3 3/8"x51 3/4" (36x86x1314)

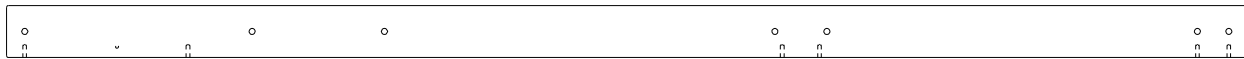

**E5 RIGHT FRONT BALCONY UPRIGHT - W4L17826**  
(x1) 1 3/8"x3 3/8"x80 3/4" (36x86x2052)



**E6 LEFT REAR UPRIGHT - W4L19001**  
(x1) 1 3/8"x3 3/8"x43 1/2" (36x86x1104)



**E7 RIGHT REAR UPRIGHT - W4L17831**  
(x1) 1 3/8"x3 3/8"x43 1/2" (36x86x1104)



**E8 LEFT FRONT UPRIGHT - W4L19002**  
(x1) 1 3/8"x3 3/8"x43 1/2" (36x86x1104)



**E9 RIGHT FRONT UPRIGHT - W4L17833**  
(x1) 1 3/8"x3 3/8"x43 1/2" (36x86x1104)



**E10 MOUNTING BLOCK - W4L17815**  
(x1) 1 3/8"x3"x4 3/4" (36x76x120)



**E11 RIGHT FRONT BALCONY UPRIGHT - W4L17827**  
(x1) 1 3/8"x3 3/8"x80 3/4" (36x86x2052)



**E12 MOUNTING BLOCK - W4L17816**  
(x1) 1 3/8"x3"x4 3/4" (36x76x120)



**E72 RAIL - W4L17808**  
(x2) 1 3/8"x3 3/8"x57 3/8" (36x86x1457)

# Owner's Manual - Parts Identification

## Wood Components (Not to Scale)

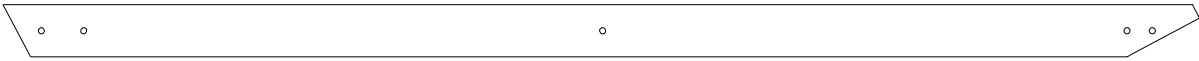

**E77 ANGLE BRACE - W4L18495**  
(x2) 1 3/8"x3 3/8"x78" (36x86x1980)



**E79 END SUPPORT - W4L18496**  
(x1) 1 1/2"x3 1/2"x44" (36x86x1120)

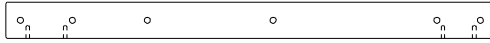

**F1 RIGHT BALCONY UPRIGHT - W4L17806**  
(x1) 1 3/8"x2 3/8"x31 3/4" (36x60x805)

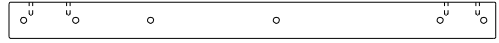

**F2 LEFT BALCONY UPRIGHT - W4L17807**  
(x1) 1 3/8"x2 3/8"x31 3/4" (36x60x805)



**F03 SUPPORT BLOCK - W4L18516**  
(x1) 1 3/8"x2 3/8"x9 1/4" (36x60x234)

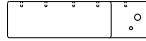

**F04 SUPPORT BLOCK - W4L18517**  
(x1) 1 3/8"x2 3/8"x9 1/4" (36x60x234)

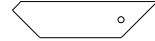

**F5 ANGLE BRACE - W4L17822**  
(x2) 1 3/8"x2 3/8"x9 1/2" (36x60x240)



**F06 FLOOR JOIST - W4L18510**  
(x1) 1 3/8"x2"x40 1/2" (36x50x1030)



**G2 GROUND BOARD - W4L19003**  
(x1) 1"x5 1/4"x42 1/4" (24x134x1072)



**G3 GROUND BOARD - W4L19004**  
(x1) 1"x5 1/4"x42 1/4" (24x134x1072)

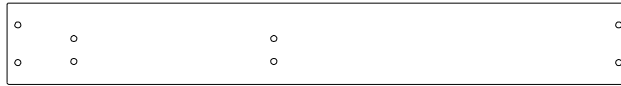

**G4 GROUND BOARD - W4L19005**  
(x1) 1"x5 1/4"x40 1/2" (24x134x1030)



**G5 RIGHT CENTER WALL RAIL - W4L19006**  
(x1) 1"x5 1/4"x63 3/8" (24x134x1609)

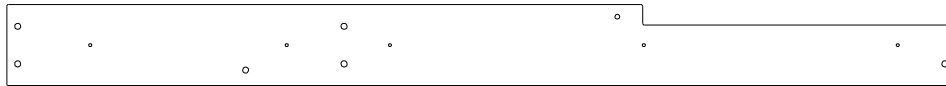

**G6 FRONT CENTER WALL RAIL - W4L19014**  
(x1) 1"x5 1/4"x61 3/4" (24x134x1570)



**G7 REAR CENTER WALL RAIL - W4L19007**  
(x1) 1"x5 1/4"x61 3/4" (24x134x1570)

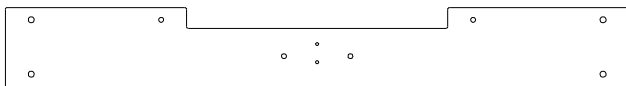

**G8 LEFT CENTER WALL RAIL - W4L19000**  
(x1) 1"x5 1/4"x40 5/8" (24x134x1032)



**G9 LEFT BALCONY WALL RAIL - W4L17648**  
(x1) 1"x5 1/4"x20 3/4" (24x134x528)

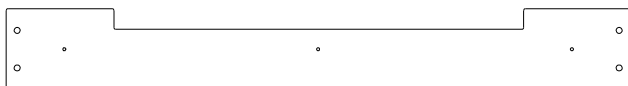

**G10 FRONT BALCONY WALL RAIL - W4L17649**  
(x1) 1"x5 1/4"x40 5/8" (24x134x1032)

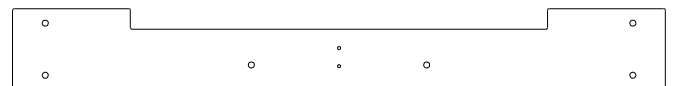

**G11 LEFT SIDE WALL BOARD - W4L19008**  
(x1) 1"x5 1/4"x42 1/2" (24x134x1080)

# Owner's Manual - Parts Identification

## Wood Components (Not to Scale)



**G12 GROUND BOARD - W4L18497**  
(x1) 1"x5 1/4"x78 1/8" (24x134x1984)

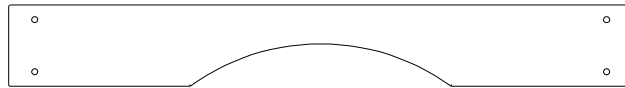

**G13 ARCHED WALL RAIL - W4L19010**  
(x1) 1"x5 1/4"x40 5/8" (24x134x1032)



**G14 ANGLED WALL RAIL - W4L19011**  
(x1) 1"x5 1/4"x45 3/4" (24x134x1162)

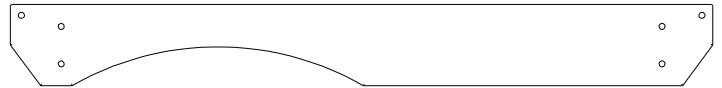

**G15 ANGLED WALL RAIL - W4L19012**  
(x1) 1"x5 1/4"x45 3/4" (24x134x1162)



**H1 TABLE SUPPORT - W4L11147**  
(x1) 1"x3 3/8"x22 3/8" (24x86x567)

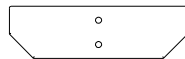

**H2 TABLE SUPPORT - W4L18018**  
(x1) 1"x3 3/8"x11 5/8" (24x86x295)



**H3 TABLE SUPPORT - W4L18021**  
(x1) 1"x3 3/8"x11 5/8" (24x86x295)



**H5 ATTACHMENT BOARD - W4L17639**  
(x1) 1"x3 3/8"x18 1/4" (24x86x465)



**H06 BENCH BOARD - W4L18518**  
(x2) 1"x3 3/8"x23" (24x86x583)

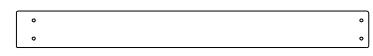

**H07 BENCH BOARD - W4L18519**  
(x2) 1"x2 3/8"x23" (24x60x583)



**H08 BENCH BOARD - W4L18520**  
(x2) 1"x3 3/8"x23" (24x86x583)



**H9 ATTACHMENT BOARD - W4L17814**  
(x1) 1"x3 3/8"x26 1/4" (24x86x667)



**H76 LADDER RUNG - W4L18505**  
(x4) 1"x3 3/8"x17 1/4" (24x86x437)



**H77 LEFT UPRIGHT - W4L11173**  
(x1) 1"x3 3/8"x58" (24x86x1474)



**H78 RIGHT UPRIGHT - W4L11174**  
(x1) 1"x3 3/8"x58" (24x86x1474)



**J1 PORCH GROUND BOARD - W4L11128**  
(x1) 1"x2 3/8"x40 1/2" (24x60x1030)

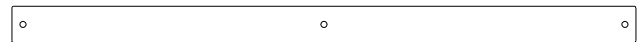

**J2 PORCH GROUND BOARD - W4L11129**  
(x1) 1"x2 3/8"x40 5/8" (24x60x1032)

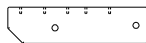

**J3 BENCH SUPPORT - W4L18017**  
(x2) 1"x2 3/8"x9" (24x60x230)



**J5 SUPPORT BLOCK - W4L18022**  
(x2) 1"x2 3/8"x2 7/8" (24x60x72)

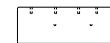

**J6 SUPPORT BLOCK - W4L17817**  
(x1) 1"x2 3/8"x6 1/4" (24x60x160)



**J7 SUPPORT BLOCK - W4L11158**  
(x1) 1"x2 3/8"x3 3/8" (24x60x86)



**J09 FLOOR JOIST - W4L18527**  
(x1) 1"x2 3/8"x20 1/4" (24x60x515)



**J10 PORCH GROUND BOARD - W4L17650**  
(x2) 1"x2 3/8"x21 1/8" (24x60x537)

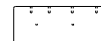

**J11 SUPPORT BLOCK - W4L17818**  
(x1) 1"x2 3/8"x6 1/4" (24x60x160)

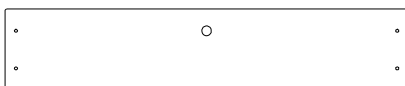

**K01 ROCK WALL BOARD - W4L18503**  
(x1) 5/8"x5 1/4"x26 1/4" (16x134x667)

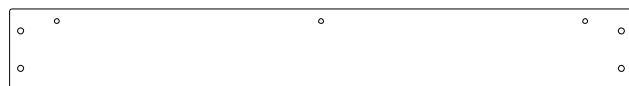

**K4 GROUND BOARD - W4L19009**  
(x1) 5/8"x5 1/4"x40 1/2" (16x134x1030)

# Owner's Manual - Parts Identification

## Wood Components (Not to Scale)



**K12** ARCHED WALL RAIL - W4L11143  
(x1) 5/8"x5 1/4"x40 5/8" (16x134x1032)



**K16** TABLE BOARD - W4L18530  
(x1) 5/8"x5 1/4"x23" (16x134x583)



**K17** FLOOR BOARD - W4L18523  
(x2) 5/8"x5 1/4"x21 1/8" (16x134x537)



**L05** FLOOR BOARD - W4L18524  
(x1) 5/8"x4 1/8"x19 1/4" (16x104x488)



**M1** WALL RAIL - W4L19013  
(x1) 5/8"x3 3/8"x40 1/2" (16x86x1030)



**M03** BENCH BOARD - W4L18529  
(x2) 5/8"x3 3/8"x23" (16x86x583)



**M04** FLOOR BOARD - W4L18506  
(x8) 5/8"x3 3/8"x21 1/8" (16x86x537)



**M06** COUNTER TOP - W4L18511  
(x1) 5/8"x3 3/8"x37 5/8" (16x86x957)



**M07** COUNTER TOP - W4L18512  
(x2) 5/8"x3 3/8"x38 5/8" (16x86x981)

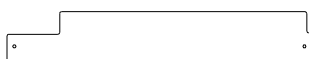

**M08** FLOOR BOARD - W4L18526  
(x1) 5/8"x3 1/4"x19 7/8" (16x82x504)

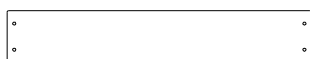

**M09** FLOOR BOARD - W4L18521  
(x10) 5/8"x3 3/8"x19 7/8" (16x86x504)

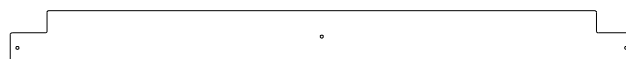

**M10** FLOOR BOARD - W4L18513  
(x1) 5/8"x3 3/8"x40 5/8" (16x86x1031)

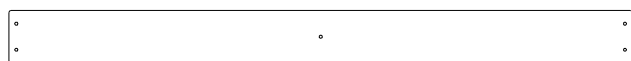

**M11** FLOOR BOARD - W4L18522  
(x15) 5/8"x3 3/8"x40 5/8" (16x86x1031)



**M12** FLOOR BOARD - W4L18528  
(x2) 5/8"x3 1/4"x40 5/8" (16x82x1031)

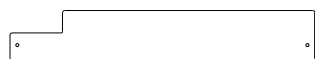

**M13** FLOOR BOARD - W4L18525  
(x1) 5/8"x3 1/4"x19 7/8" (16x82x504)

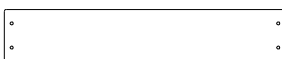

**M73** REAR SUPPORT - W4L18504  
(x1) 5/8"x3 3/8"x18 1/4" (16x86x465)

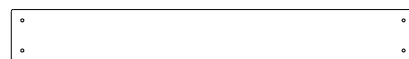

**M74** ROCK WALL BOARD - W4L18500  
(x7) 5/8"x3 3/8"x26 1/4" (16x86x667)



**M75** ROCK WALL BOARD - W4L18501  
(x4) 5/8"x3 3/8"x26 1/4" (16x86x667)



**M76** ROCK WALL BOARD - W4L18502  
(x4) 5/8"x3 3/8"x26 1/4" (16x86x667)

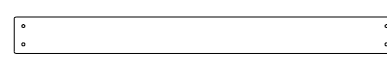

**N02** PICKET - W4L18514  
(x18) 5/8"x2 3/8"x24 3/4" (16x60x628)

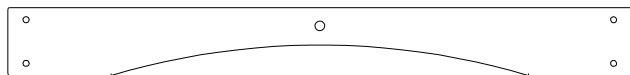

**Q1** ARCHED WALL RAIL - W4L11142  
(x1) 1"x4 3/8"x40 5/8" (24x112x1032)



**Q2** GROUND BOARD - W4L17640  
(x2) 1"x4 3/8"x24 3/8" (24x112x620)



**Q3** ARCHED WALL RAIL - W4L17653  
(x1) 1"x4 3/8"x40 5/8" (24x112x1032)



**Q4** WALL RAIL - W4L17654  
(x1) 1"x4 3/8"x23 5/8" (24x112x600)

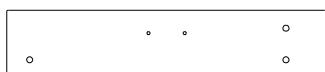

**Q5** WALL RAIL - W4L17655  
(x1) 1"x4 3/8"x20 7/8" (24x112x529)

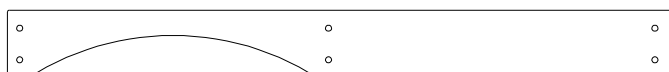

**Q6** ARCHED WALL RAIL - W4L19016  
(x1) 1"x4 3/8"x43 7/8" (24x112x1113)

# Owner's Manual - Parts Identification

## Wood Components (Not to Scale)

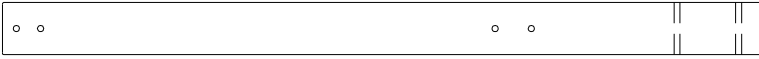

**SP71 SWING BEAM SUPPORT - W4L18498**  
(x1) 3 3/8"x3 3/8"x49 1/2" (86x86x1256)



**T01 SUPPORT BOARD - W4L18507**  
(x3) 1"x1 3/8"x37 5/8" (24x34x957)

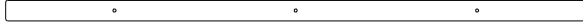

**T02 SUPPORT BOARD - W4L18508**  
(x1) 1"x1 3/8"x37 3/4" (24x34x959)



**T03 SUPPORT BOARD - W4L18509**  
(x2) 1"x1 3/8"x18 3/4" (24x34x477)



**T04 SUPPORT BOARD - W4L18515**  
(x1) 1"x1 3/8"x37 3/4" (24x34x958)



**Y1 TOP BOARD - W4L17809**  
(x1) 5/8"x3 3/4"x26 1/4" (16x94x667)



**E13 RIGHT REAR UPRIGHT ASSEMBLY - W2A03847**  
(x1) 1 3/8"x3 3/8"x51 3/4" (36x86x1314)

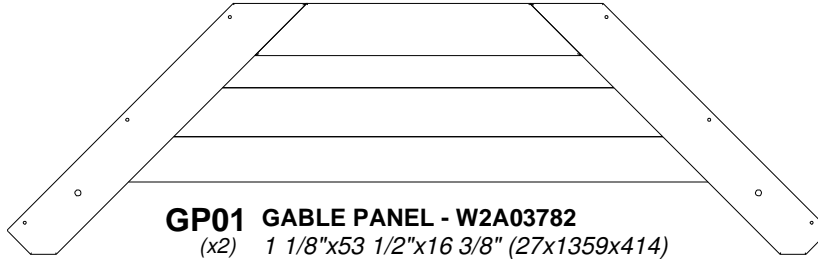

**GP01 GABLE PANEL - W2A03782**  
(x2) 1 1/8"x53 1/2"x16 3/8" (27x1359x414)

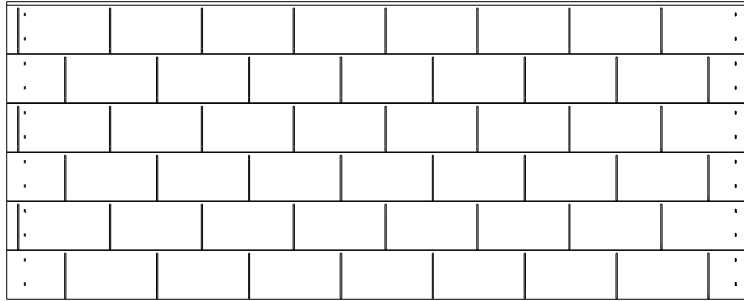

**RP1 LOWER ROOF PANEL - W2A04024**  
(x2) 1 3/8"x19 3/8"x48 5/8" (35x491x1236)

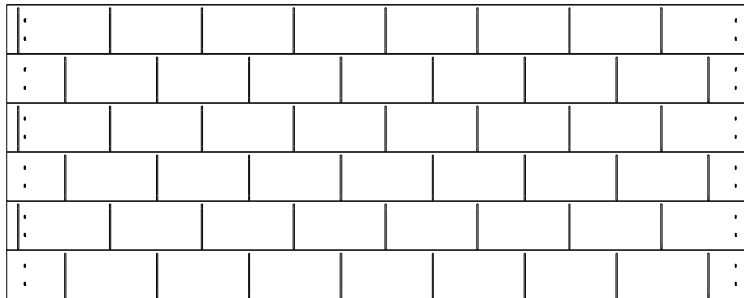

**RP2 TOP ROOF PANEL - W2A04025**  
(x2) 1 3/8"x19 1/8"x48 5/8" (35x486x1236)

# Owner's Manual - Parts Identification

## Wood Components (Not to Scale)

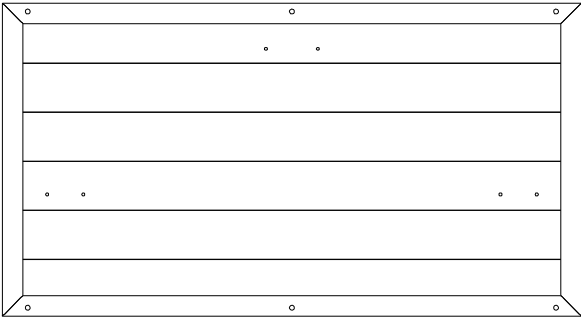

**WP01 WALL PANEL - W2A03778**  
(x1) 1"x20 3/8"x37 3/4" (24x517x958)

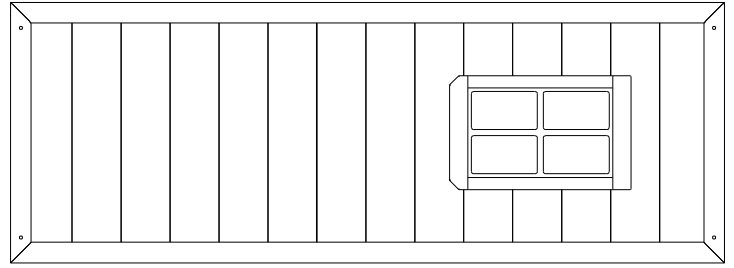

**WP02 WALL PANEL - W2A03779**  
(x1) 1"x16 7/8"x46 1/2" (24x430x1181)

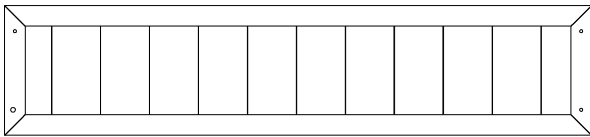

**WP03 WALL PANEL - W2A03786**  
(x1) 1"x18 7/8"x11 3/4" (24x214x971)

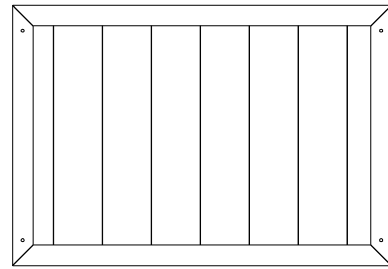

**WP04 WALL PANEL - W2A03784**  
(x2) 1"x16 7/8"x24 5/8" (24x430x627)

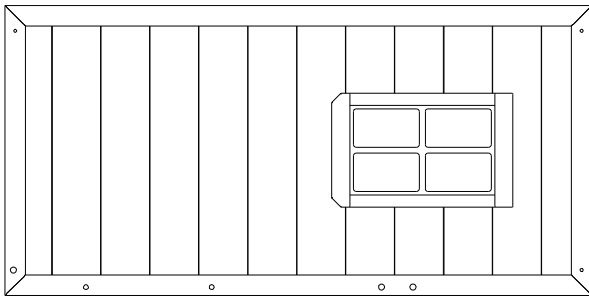

**WP05 WALL PANEL - W2A03785**  
(x1) 1"x16 7/8"x46 1/2" (24x479x971)

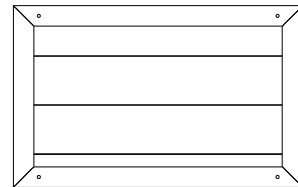

**WP06 WALL PANEL - W2A03780**  
(x1) 1"x18 7/8"x11 3/4" (24x479x300)

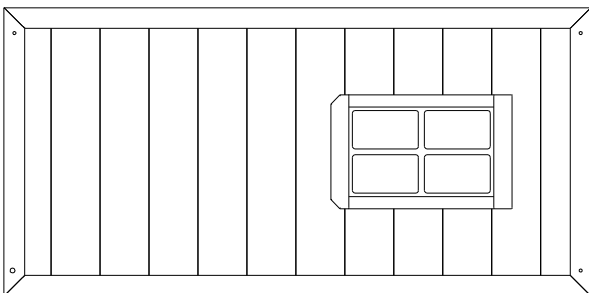

**WP07 WALL PANEL - W2A03783**  
(x1) 1"x16 7/8"x46 1/2" (24x476x971)

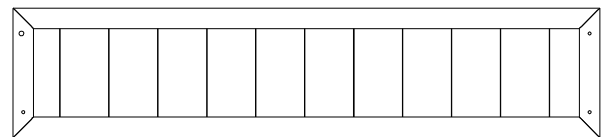

**WP08 WALL PANEL - W2A03787**  
(x1) 1"x18 7/8"x11 3/4" (24x214x971)



# Owner's Manual - Parts Identification

## Wood Components (Not to Scale)

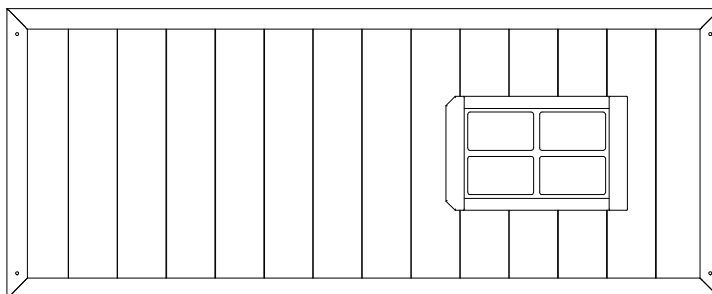

**WP09 WALL PANEL - W2A03781**  
(x1) 1"x16 7/8"x46 1/2" (24x479x1181)

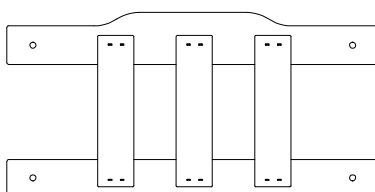

**WP10 BENCH BACK ASSEMBLY - W2A03777**  
(x2) 1 1/8"x11 7/8"x24 1/4" (27x303x615)

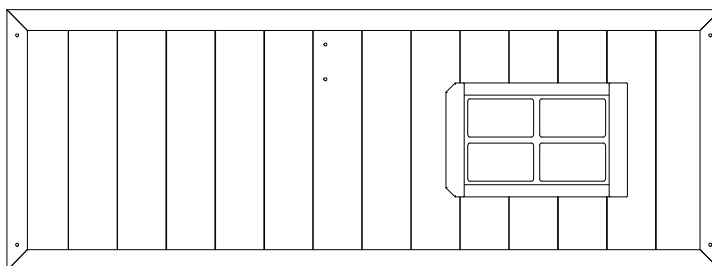

**WP11 WALL PANEL - W2A03788**  
(x1) 1"x16 7/8"x46 1/2" (24x430x1181)

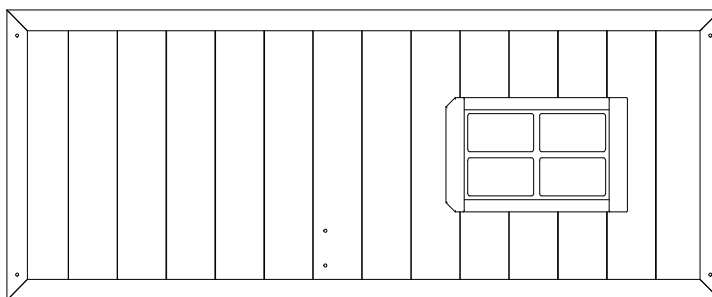

**WP12 WALL PANEL - W2A03789**  
(x1) 1"x16 7/8"x46 1/2" (24x479x1181)

# Owner's Manual - Parts Identification

## Hardware Components



**H101170 BOLT HEX BLK**  
(x12) 3/8x5 3/4



**H100498 BOLT HEX - BLK**  
(x4) 5/16x1 1/2

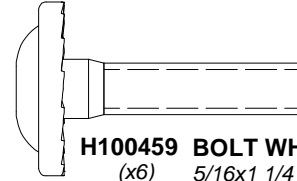

**H100459 BOLT WH BLK**  
(x6) 5/16x1 1/4



**H100480 BOLT WH BLK**  
(x2) 5/16x4 3/4

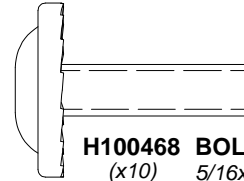

**H100468 BOLT WH BLK**  
(x10) 5/16x1

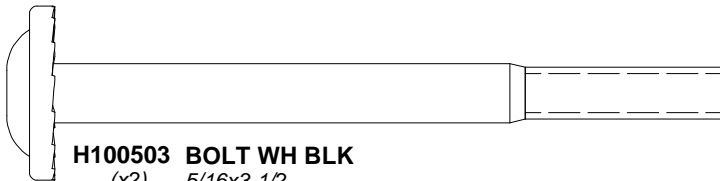

**H100503 BOLT WH BLK**  
(x2) 5/16x3-1/2

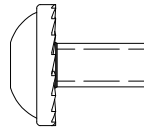

**H100401 BOLT WH BLK**  
(x1) 1/4x1/2

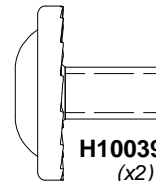

**H100396 BOLT WH BLK**  
(x2) 5/16x1/2

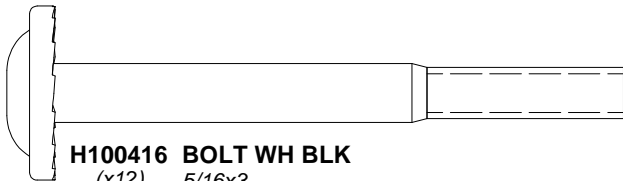

**H100416 BOLT WH BLK**  
(x12) 5/16x3

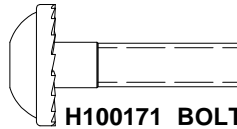

**H100171 BOLT WH BLK**  
(x2) 1/4x1

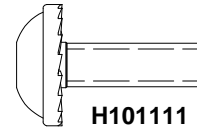

**H101111 BOLT WH BLK**  
(x24) 1/4x3/4

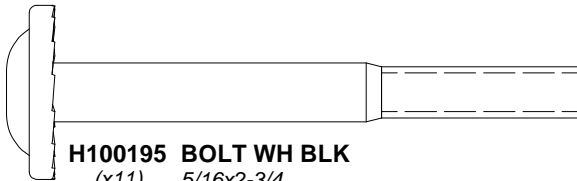

**H100195 BOLT WH BLK**  
(x11) 5/16x2-3/4

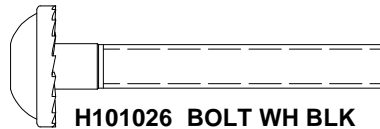

**H101026 BOLT WH BLK**  
(x8) 1/4x1-3/4

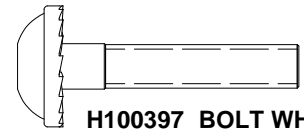

**H100397 BOLT WH BLK**  
(x2) 1/4x1 1/4

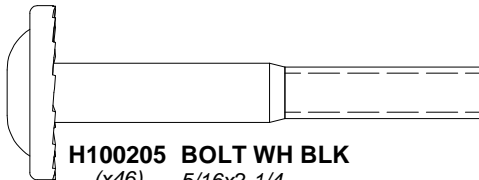

**H100205 BOLT WH BLK**  
(x46) 5/16x2-1/4



**H100831 NUT BARREL PTH BLK**  
(x4) 1/4x3/4

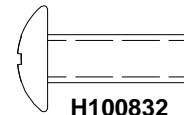

**H100832 BOLT PTH BLK (with LOCTITE)**  
(x4) 1/4x3/4

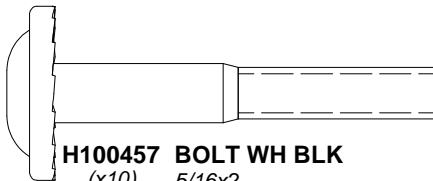

**H100457 BOLT WH BLK**  
(x10) 5/16x2

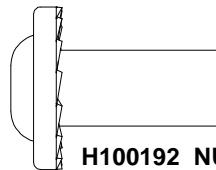

**H100192 NUT BARREL WH BLK**  
(x14) 5/16x7/8

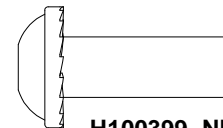

**H100399 NUT BARREL WH BLK**  
(x1) 1/4x7/8

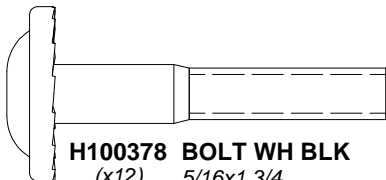

**H100378 BOLT WH BLK**  
(x12) 5/16x1 3/4

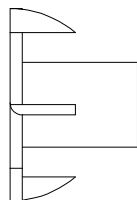

**H101168 T-NUT BLK**  
(x12) 3/8

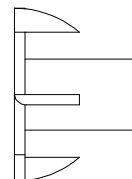

**H100379 T-NUT BLK**  
(x111) 5/16

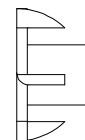

**H100398 T-NUT BLK**  
(x42) 1/4

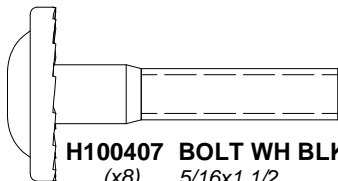

**H100407 BOLT WH BLK**  
(x8) 5/16x1 1/2

# Owner's Manual - Parts Identification

## Hardware Components

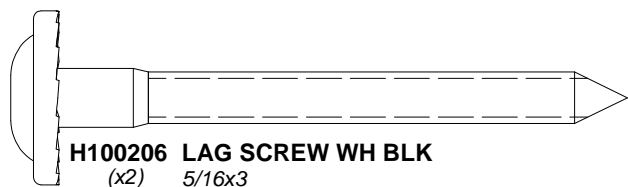

**H100206 LAG SCREW WH BLK**  
(x2) 5/16x3

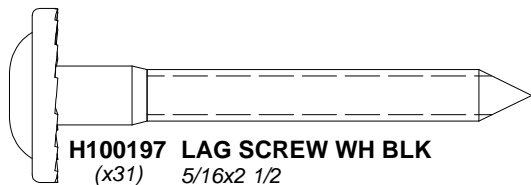

**H100197 LAG SCREW WH BLK**  
(x31) 5/16x2 1/2

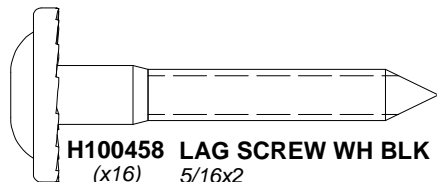

**H100458 LAG SCREW WH BLK**  
(x16) 5/16x2

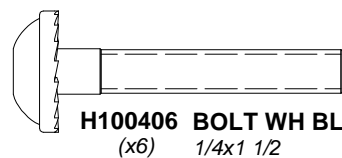

**H100406 BOLT WH BLK**  
(x6) 1/4x1 1/2

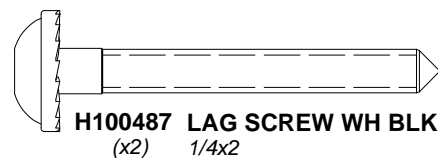

**H100487 LAG SCREW WH BLK**  
(x2) 1/4x2

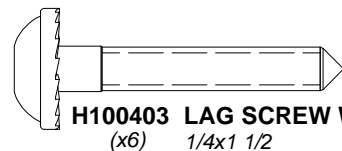

**H100403 LAG SCREW WH BLK**  
(x6) 1/4x1 1/2

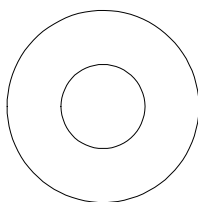

**H101167 WASHER FLAT BLK**  
(x12) 11x25

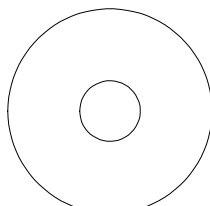

**H100105 WASHER FLAT**  
(x3) 8x27

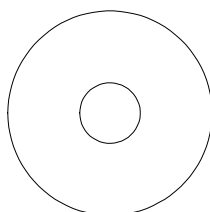

**H100478 WASHER FLAT BLK**  
(x4) 8x27

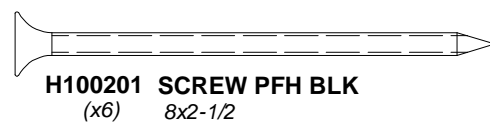

**H100201 SCREW PFH BLK**  
(x6) 8x2-1/2

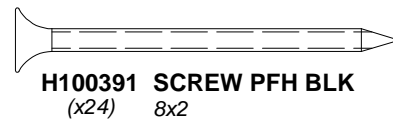

**H100391 SCREW PFH BLK**  
(x24) 8x2

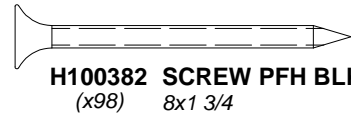

**H100382 SCREW PFH BLK**  
(x98) 8x1 3/4

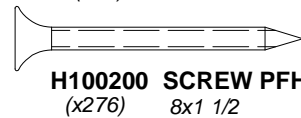

**H100200 SCREW PFH BLK**  
(x276) 8x1 1/2

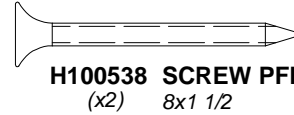

**H100538 SCREW PFH SD**  
(x2) 8x1 1/2

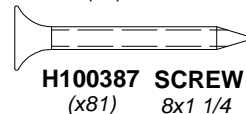

**H100387 SCREW PFH BLK**  
(x81) 8x1 1/4

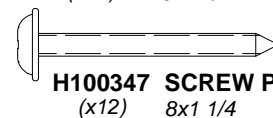

**H100347 SCREW PWH SD**  
(x12) 8x1 1/4

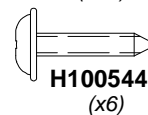

**H100544 SCREW PWH SD**  
(x6) 8x5/8

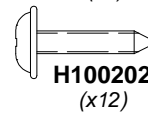

**H100202 SCREW PWH BLK**  
(x12) 8x5/8

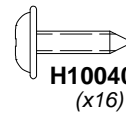

**H100408 SCREW PWH BLK**  
(x16) 8x1/2

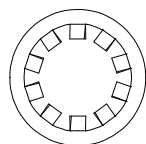

**H101166 WASHER LOCK INT BLK**  
(x12) 10x18

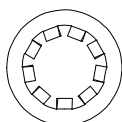

**H100473 WASHER LOCK INT BLK**  
(x24) 8x15

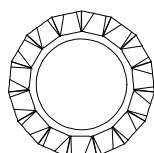

**H100199 WASHER LOCK EXT BLK**  
(x2) 12x19

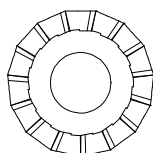

**H100198 WASHER LOCK EXT BLK**  
(x132) 8x19

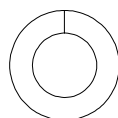

**H100477 WASHER SPLIT BLK**  
(x4) 5/16

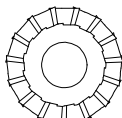

**H100405 WASHER LOCK EXT BLK**  
(x24) 6x15

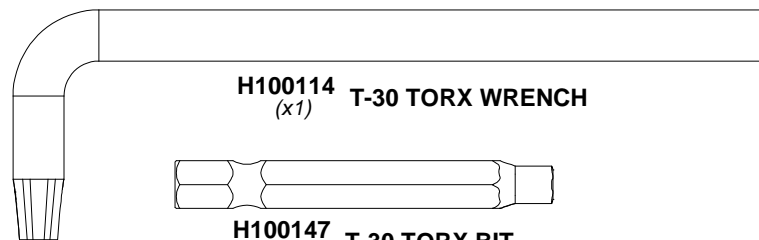

**H100114 T-30 TORX WRENCH**  
(x1)

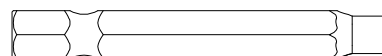

**H100147 T-30 TORX BIT**  
(x1)

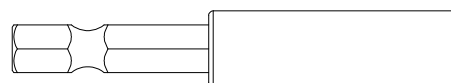

**H101100 MAGNETIC DRIVER**  
(x1)

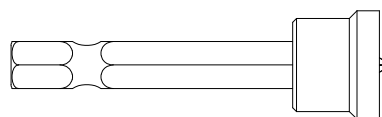

**H100764 SCREW SETTER**  
(x1)

# Owner's Manual - Parts Identification

## Accessory Components (Not to Scale)

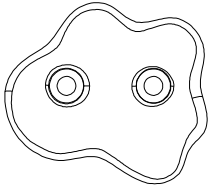

**A6P00592 GREY HC ROCK**  
(x12) #1

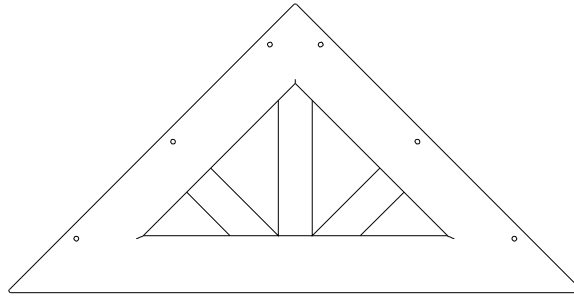

**A6P00836 PLASTIC SUNBURST**  
(x2)

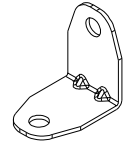

**A4M01047 L BRACKET**  
(x2) 2.5x38x55x55

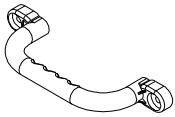

**A6P00654 HAND GRIP**  
(x4) GREY PLASTIC

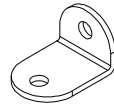

**A4M00710 L BRACKET**  
(x2) BLACK 32x51

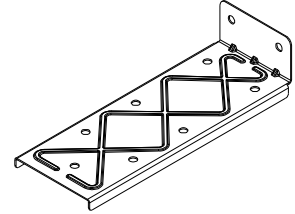

**A4M01679 EXTENDED SWING BEAM BRACKET**  
(x2)

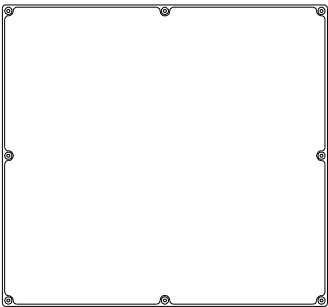

**A6P00324 CHALK BOARD**  
(x1) LARGE

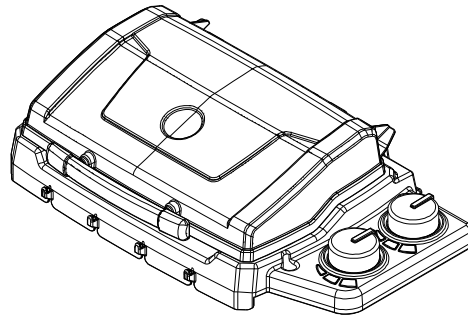

**A6P00282 BBQ GRILL**  
(x1)

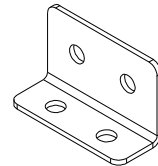

**A4M00855 L BRACKET**  
(x2) 32x51x82

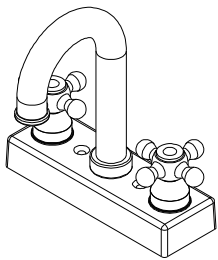

**A6P00024 FAUCET KIT**  
(x1)



**141154 GRILL FOOD SET**  
(x1)

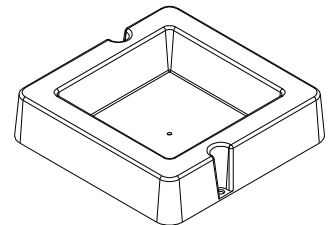

**A6P00032 SURFACE MOUNT BASIN**  
(x1)

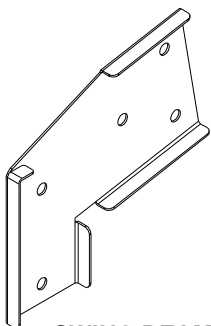

**A4M00617 SWING BEAM EXTENSION BRACKET-LEFT**  
(x1)

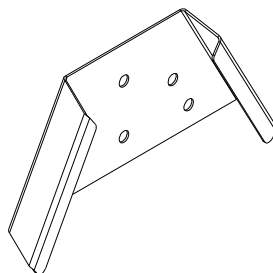

**A4M01782 A-FRAME BRACKET**  
(x1)

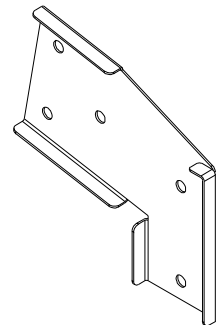

**A4M00618 SWING BEAM EXTENSION BRACKET-RIGHT**  
(x1)

# Owner's Manual - Parts Identification

## Accessory Components (Not to Scale)

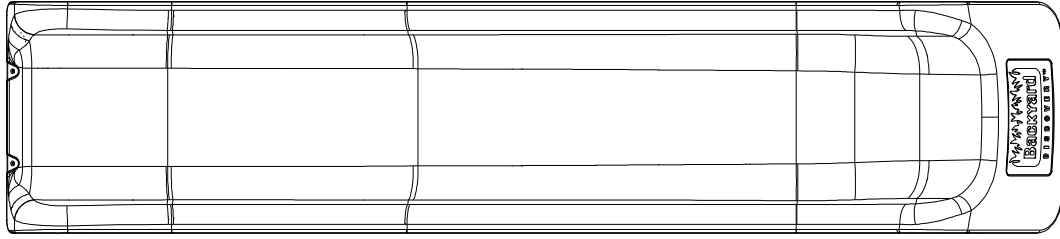

**A6P00554**  
(x1) **8' BLOW MOLDED SLIDE - GREY**

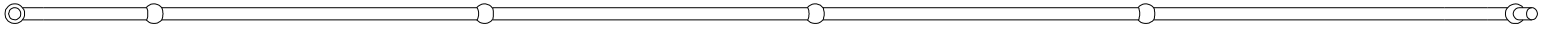

**A6P00537**  
(x1) **CLIMBING ROPE**

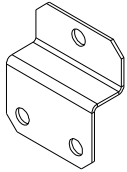

**A4M02676**  
(x4) **BRACKET**

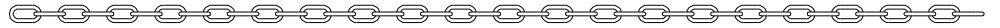

**A4M02256**  
(x4) **CHAIN BLACK 51.25"**

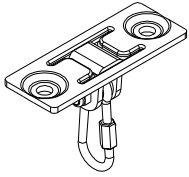

**A4M02171**  
(x6) **SWING HANGER**

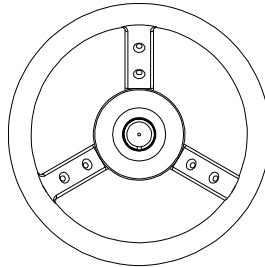

**A6P00618**  
(x1) **STEERING WHEEL**



**A4M01126**  
(x1) **26" WEB SWING**

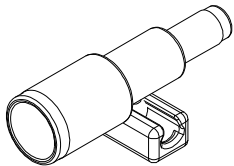

**A6P00596**  
(x1) **TELESCOPE**



**A6P00595**  
(x2) **SWING SEAT GREY 22"**



**A100164**  
(x1) **BYD ID TAG  
(LARGE) AGES  
3-10**

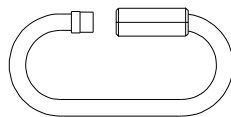

**A4M00633**  
(x4) **QUICK LINK BLK**

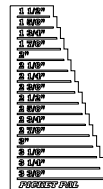

**A6P00410**  
(x1) **PICKET PAL**



**A4M02252**  
(x6) **AUGER GROUND  
STAKE**

# PRE-ASSEMBLY STEP 1 - SORTING PARTS

It is critical for ease of assembly that you take the time to sort and organize the wood and hardware.

---

## WOOD PARTS:

- Organize wood parts by the three-digit, alpha-numeric number stamped on each board (ex. P01).
- If there are multiple boards with the same stamped number, stack those pieces together.
- Stamps can be found on the flat surface of the boards or on the end of the boards.
- Allow yourself plenty of room - the wood pieces can take up a significant amount of space.

**NOTE: CARTONS ARE NOT ORGANIZED BY BOARD NUMBER.**

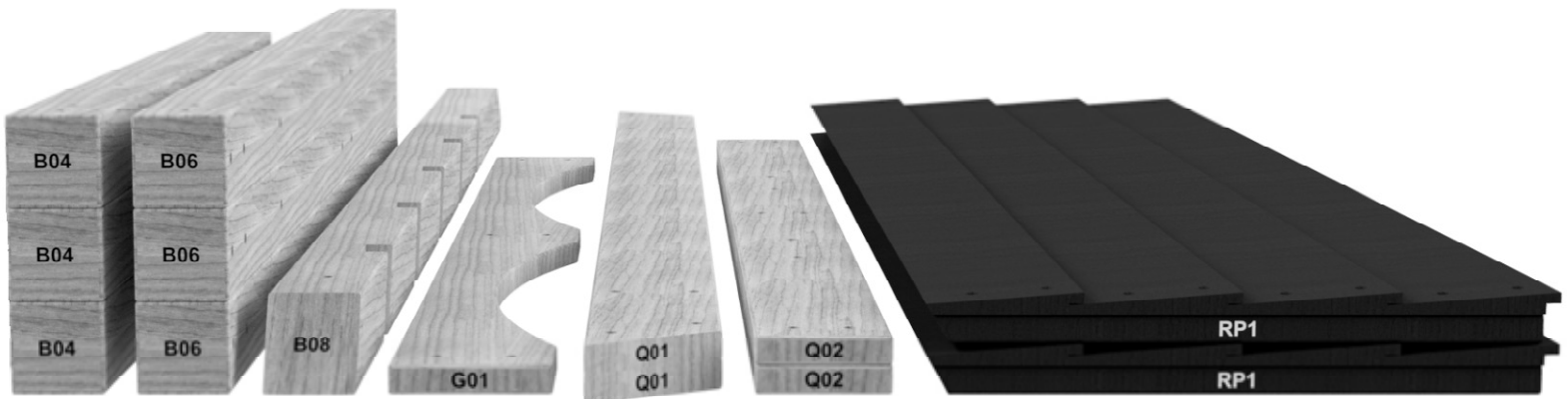

## HARDWARE PARTS:

- We recommend that you have a separate table to organize the hardware.
- Hardware bags are printed with a seven-digit, alpha-numeric part number.
- You can organize your hardware by part number or group by hardware type (i.e. bolts, nuts, etc.).
- During assembly you only need to reference the last four digits of the number.

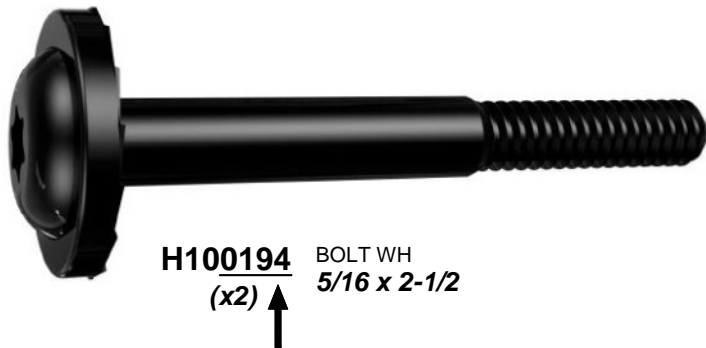

# PRE-ASSEMBLY STEP 2 - TOOLS REQUIRED



Cordless Drill or  
Electric Drill



Drill Attachments:  
Phillips Head



1/8", 3/16", 3/8" & 7/16" Drill Bits



Phillips Screw Driver



Open End Wrenches 1/2" & 9/16"



3/8" Drive Ratchet, 1/2" &  
9/16" STD Sockets 1/2" & 9/16" Deep Sockets



Claw Hammer



Rubber Mallet - Optional

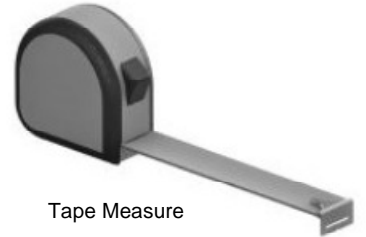

Tape Measure

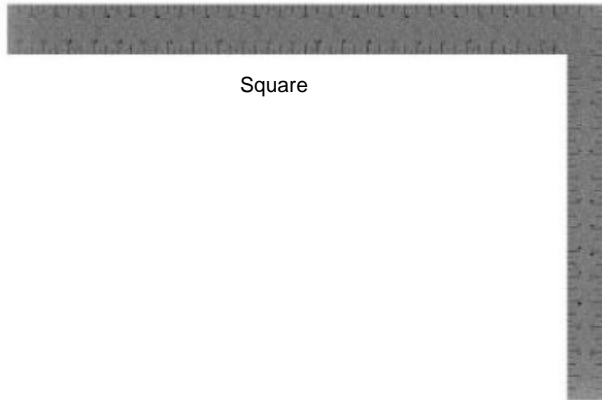

Square





Level 24"

# PRE-ASSEMBLY STEP 3 - CHOOSE YOUR ASSEMBLY METHOD



There are several types of assembly instructions available to you.

1. Printed Assembly Manual included with your set
2. BILT APP - 3D interactive instructions
3. Combination of the Printed Manual and BILT APP (Note: Step numbers can differ between the two methods)

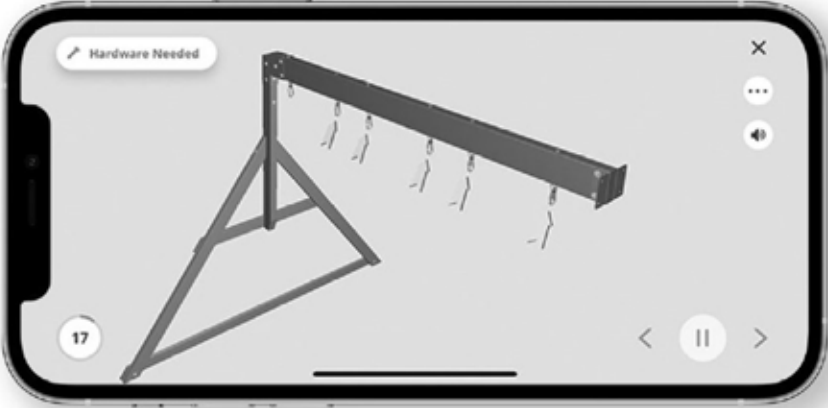

## Scan for easy 3D instructions

Download the BILT app  
before you begin



The image shows a smartphone screen displaying the BILT app interface. The screen features a 3D assembly diagram of a structure with a horizontal beam and a triangular base. The diagram is rendered in a light gray color. In the top left corner of the app interface, there is a button labeled "Hardware Needed". In the bottom left corner, there is a circular icon with the number "17". In the bottom right corner, there are navigation icons: a back arrow, a pause button, and a forward arrow. The smartphone is shown in a dark gray frame.



# STEP 1 - LADDER ASSEMBLY

QTY	PART NUMBER	DESCRIPTION
8	H100391	SCREW PFH 8x2 BLK



**H77 LEFT UPRIGHT - W4L11173**  
(x1) 1"x3 3/8"x58" (24x86x1474)

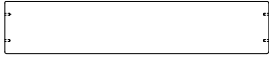

**H76 LADDER RUNG - W4L18505**  
(x4) 1"x3 3/8"x17 1/4" (24x86x437)

**TIP:**  
**ALIGN PILOT HOLES**

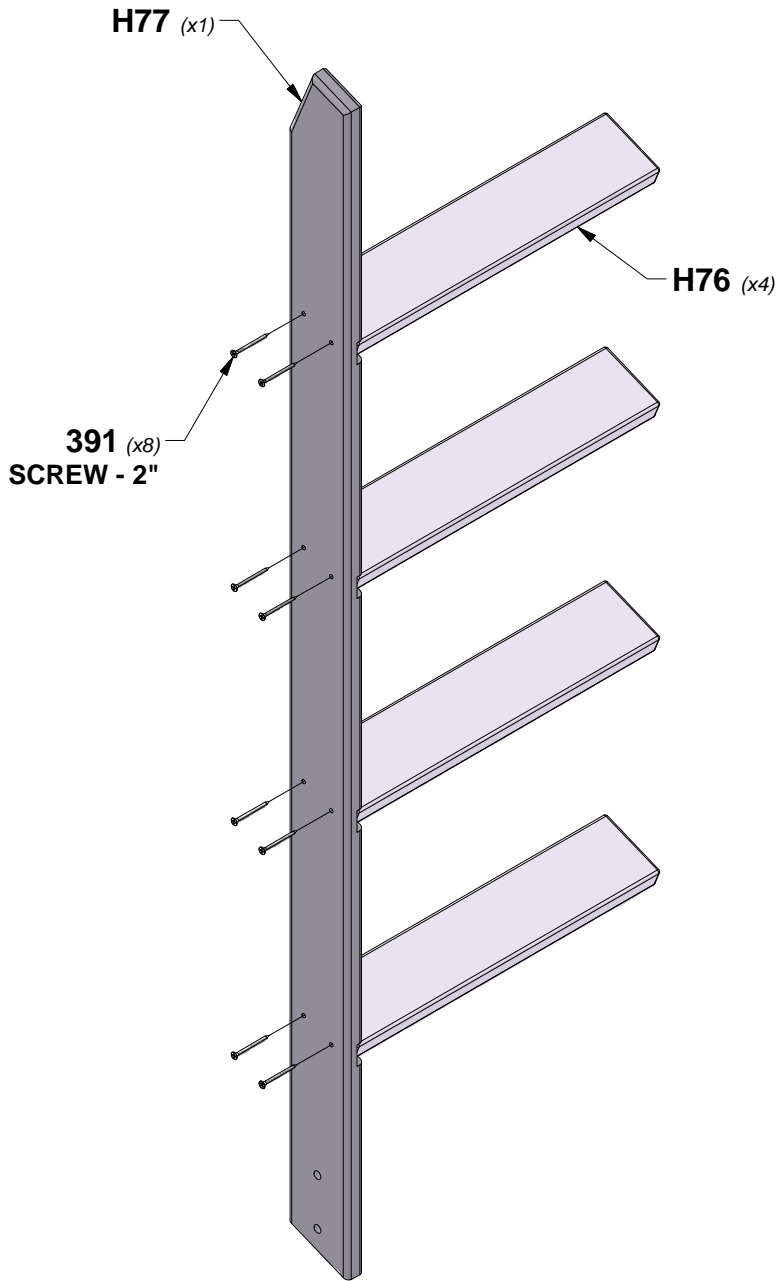

# STEP 2 - LADDER ASSEMBLY

QTY	PART NUMBER	DESCRIPTION
8	H100391	SCREW PFH 8x2 BLK

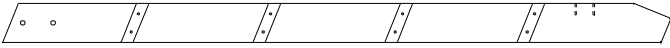

**H78 RIGHT UPRIGHT - W4L11174**  
(x1) 1"x3 3/8"x58" (24x86x1474)

**TIP:**  
**ALIGN PILOT HOLES**

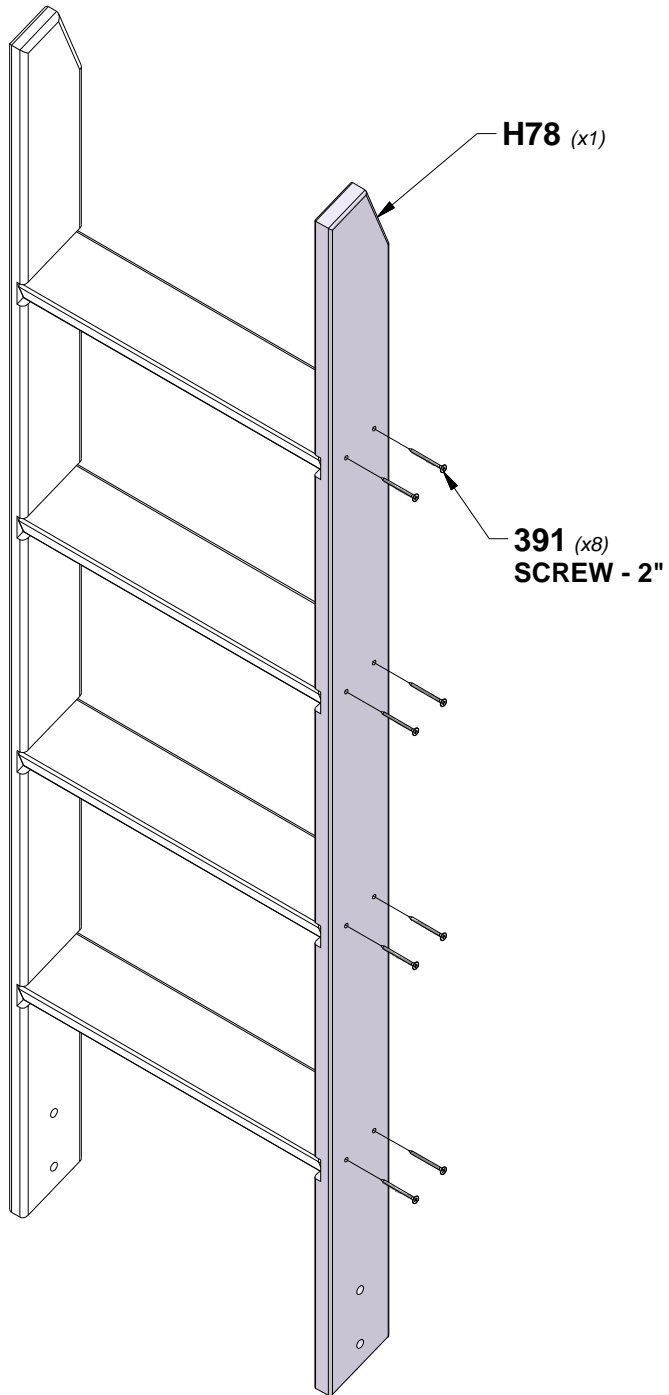

# STEP 3 - LADDER ASSEMBLY

QTY	PART NUMBER	DESCRIPTION
4	H100200	SCREW PFH 8x1-1/2 BLK
4	H100391	SCREW PFH 8x2 BLK



**H5 ATTACHMENT BOARD - W4L17639**  
 (x1) 1"x3 3/8"x18 1/4" (24x86x465)



**M73 REAR SUPPORT - W4L18504**  
 (x1) 5/8"x3 3/8"x18 1/4" (16x86x465)

**TIP:**  
**ALIGN PILOT HOLES**

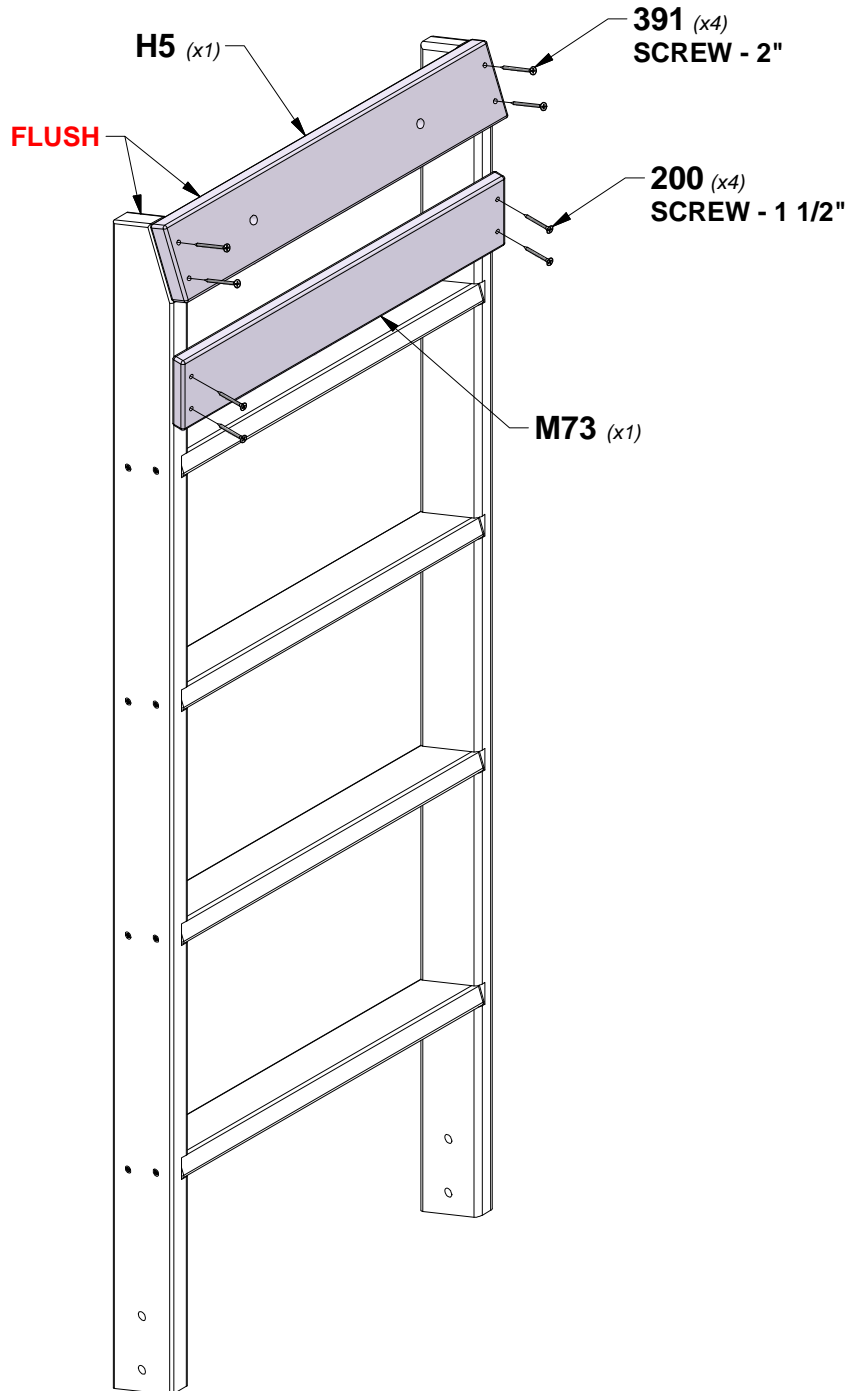

# STEP 1 - ROCK WALL ASSEMBLY

QTY	PART NUMBER	DESCRIPTION
24	H100398	T-NUT 1/4 BLK
24	H100473	WASHER LOCK INT 8x15 BLK
24	H101111	BOLT WH 1/4x3/4 BLK



**M75 ROCK WALL BOARD - W4L18501**  
(x4) 5/8"x3 3/8"x26 1/4" (16x86x667)



**M76 ROCK WALL BOARD - W4L18502**  
(x4) 5/8"x3 3/8"x26 1/4" (16x86x667)

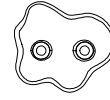

**A6P00592**  
(x12) **GREY HC ROCK #1**

**TIP:**  
**INSTALL T-NUTS IN WOOD FIRST**

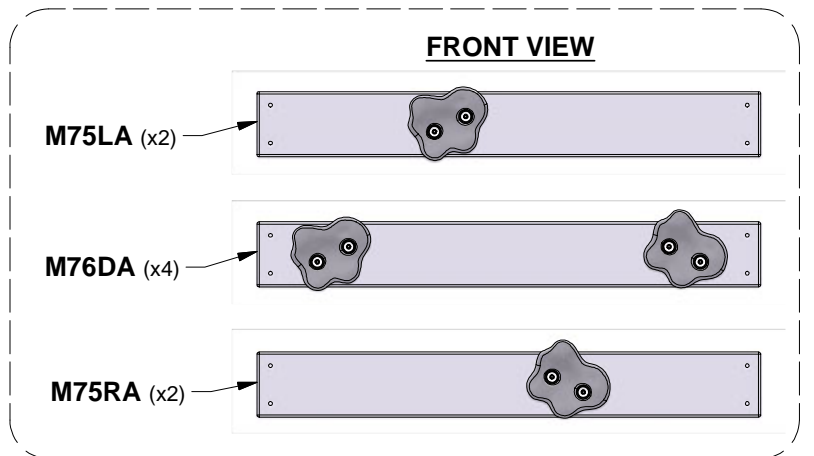
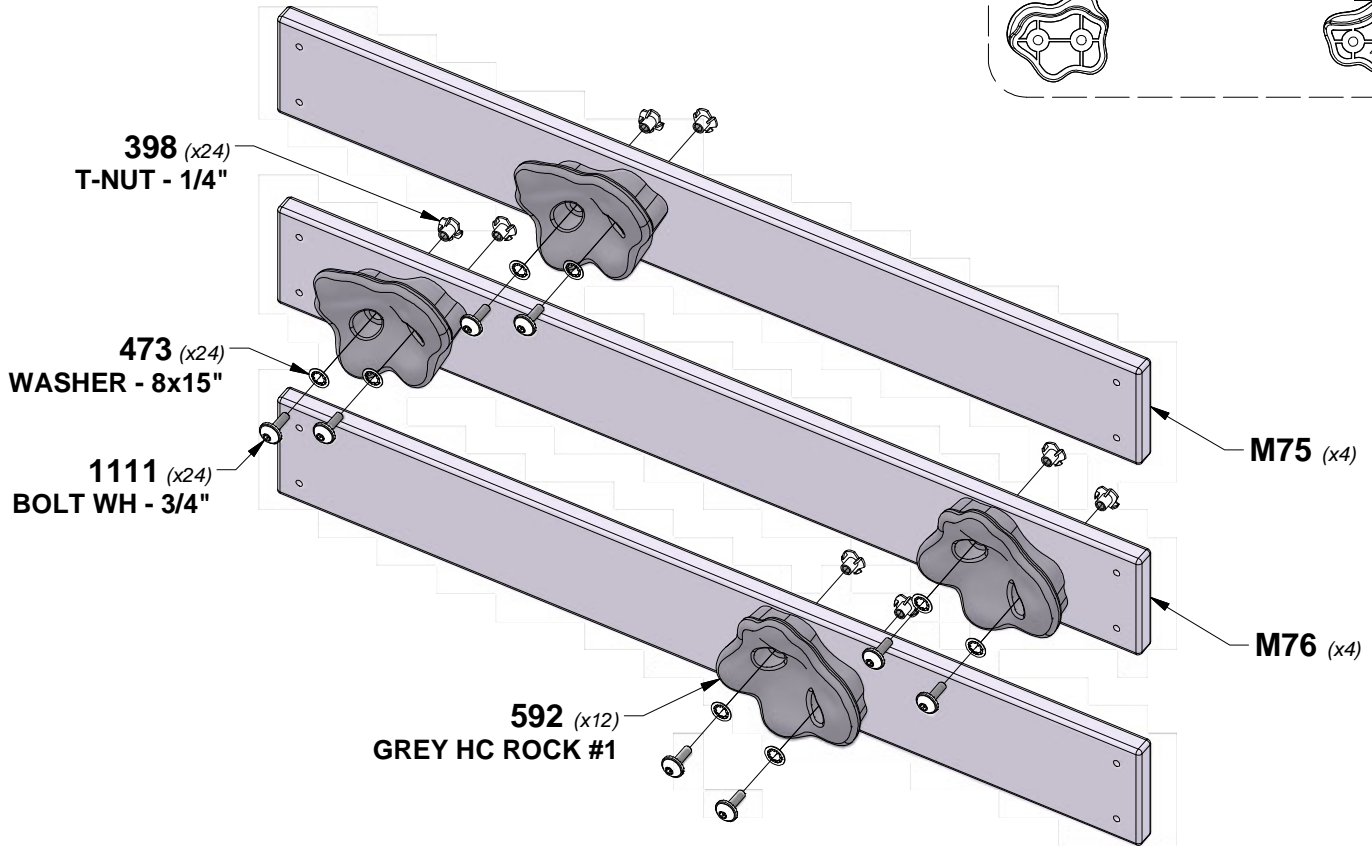
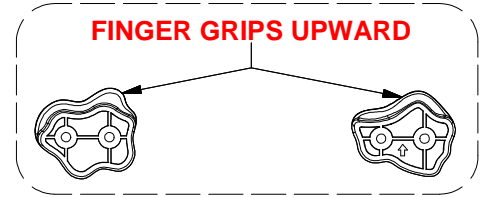

# STEP 2 - ROCK WALL ASSEMBLY

QTY	PART NUMBER	DESCRIPTION
64	H100200	SCREW PFH 8x1-1/2 BLK

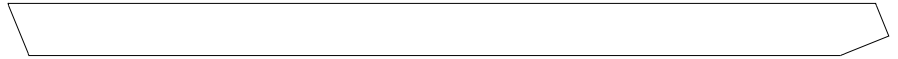
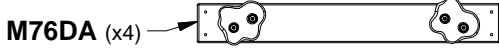
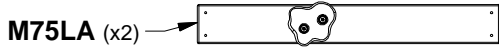

**E72 RAIL - W4L17808**  
(x2) 1 3/8"x3 3/8"x57 3/8" (36x86x1457)



**M74 ROCK WALL BOARD - W4L18500**  
(x7) 5/8"x3 3/8"x26 1/4" (16x86x667)

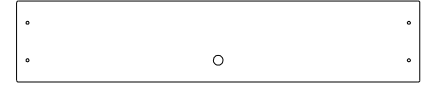

**K01 ROCK WALL BOARD - W4L18503**  
(x1) 5/8"x5 1/4"x26 1/4" (16x134x667)

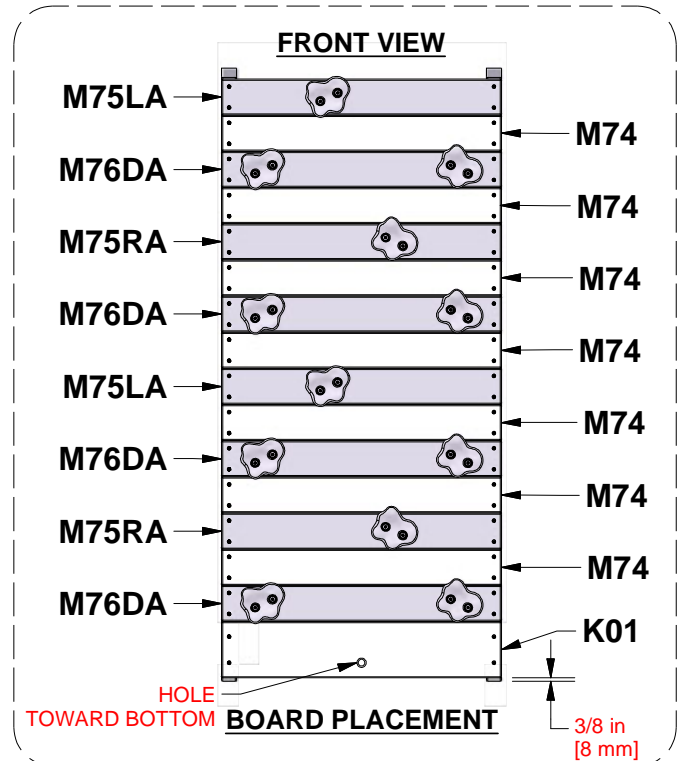
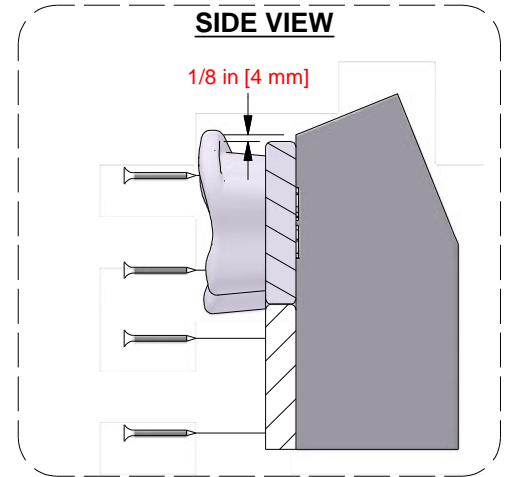
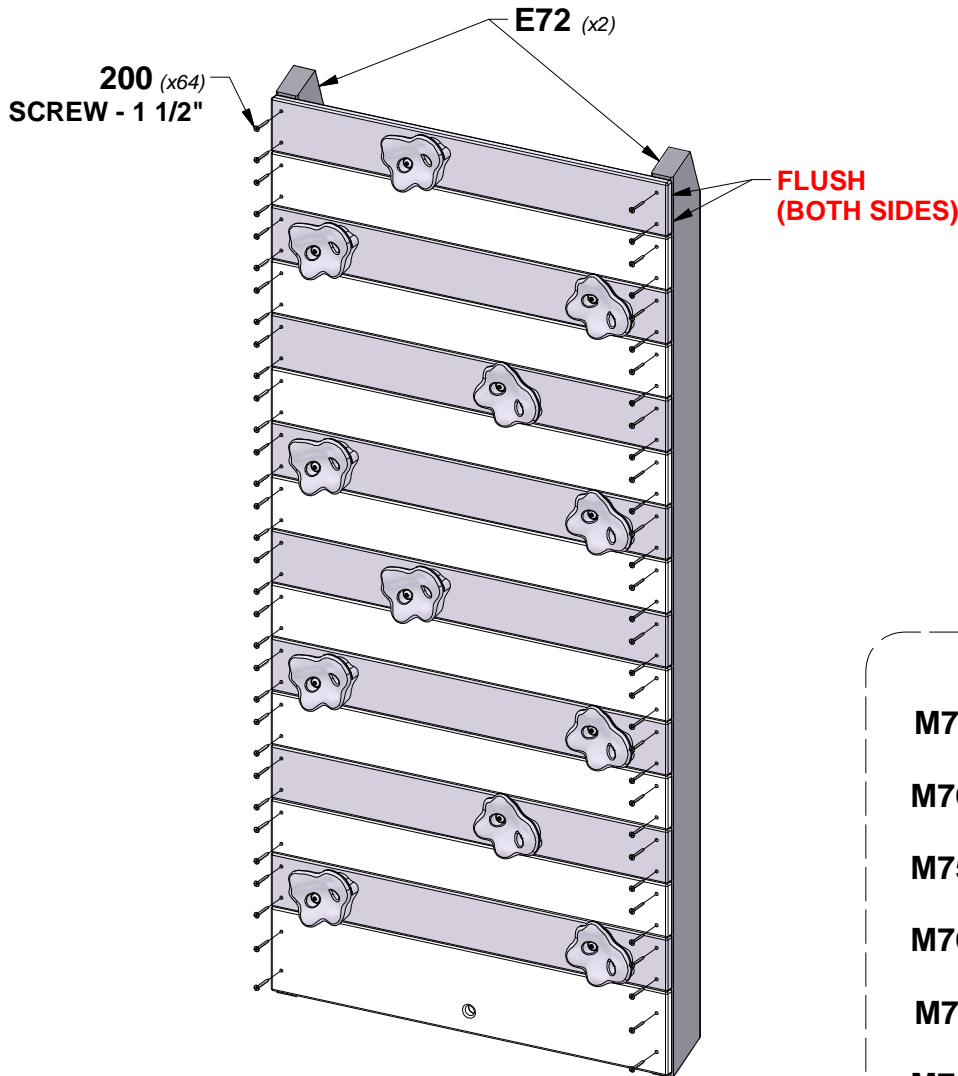

# STEP 3 - ROCK WALL ASSEMBLY

QTY	PART NUMBER	DESCRIPTION
2	H100200	SCREW PFH 8x1-1/2 BLK

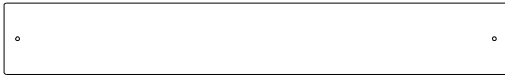

**Y1 TOP BOARD - W4L17809**  
(x1) 5/8"x3 3/4"x26 1/4" (16x94x667)

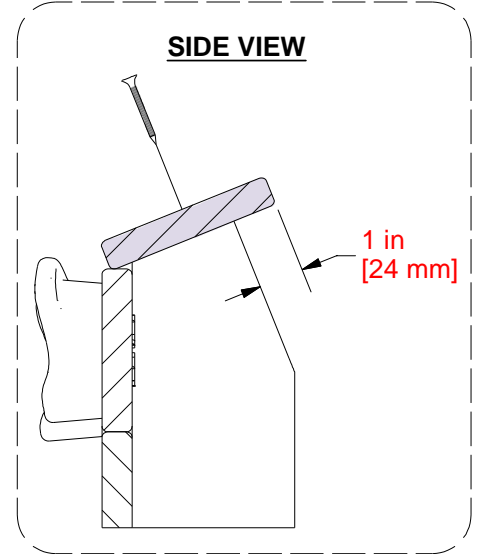
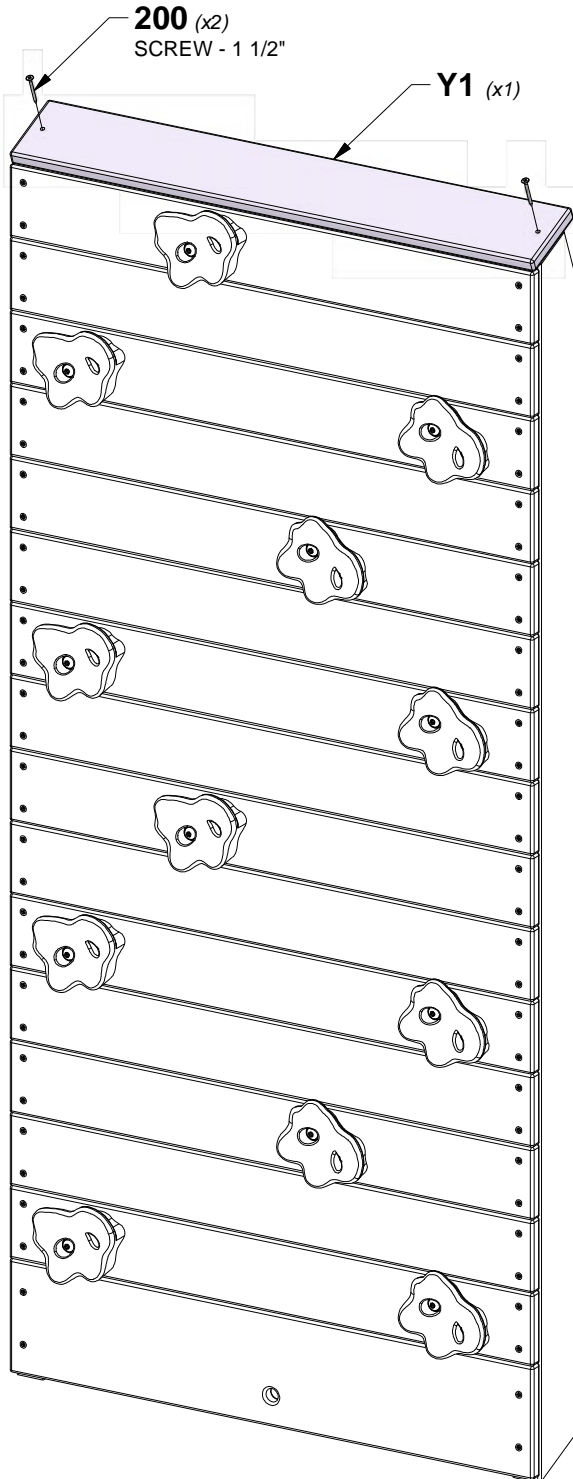

# STEP 4 - ROCK WALL ASSEMBLY

QTY	PART NUMBER	DESCRIPTION
4	H100200	SCREW PFH 8x1-1/2 BLK
2	H100379	T-NUT 5/16 BLK



**H9 ATTACHMENT BOARD - W4L17814**  
 (x1) 1"x3 3/8"x26 1/4" (24x86x667)

**TIP:**  
**INSTALL T-NUTS IN WOOD FIRST**

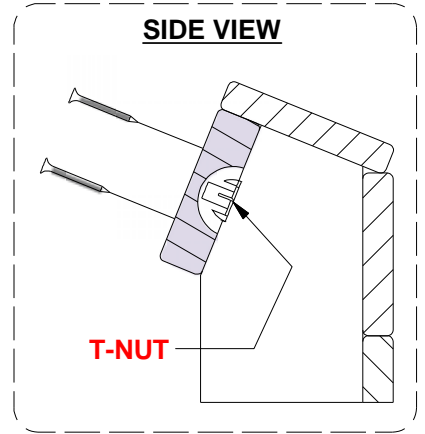
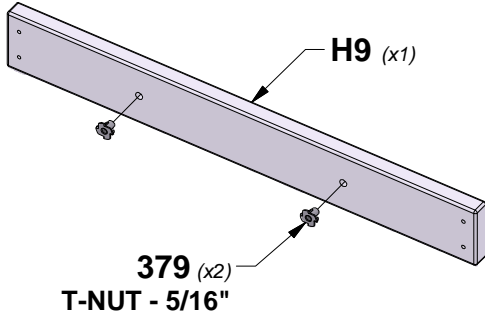

# STEP 1 - SWING BEAM ASSEMBLY

QTY	PART NUMBER	DESCRIPTION
10	H100192	NUT BARREL WH 5/16x7/8 BLK
10	H100416	BOLT WH 5/16x3 BLK



**A1 SWING BEAM EXTENDED - W4L18499**  
(x1) 3 3/8"x5 1/4"x89 1/2" (86x134x2274)



**A2 SB 9" BLOCK - W4L19017**  
(x1) 3 3/8"x5 1/4"x9" (86x134x228)

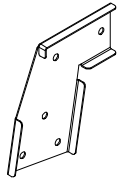

**A4M00618 SWING BEAM EXTENSION BRACKET-RIGHT**  
(x1)

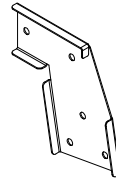

**A4M00617 SWING BEAM EXTENSION BRACKET-LEFT**  
(x1)

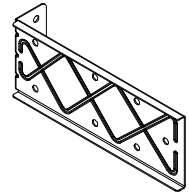

**A4M01679 EXTENDED SWING BEAM BRACKET**  
(x2)

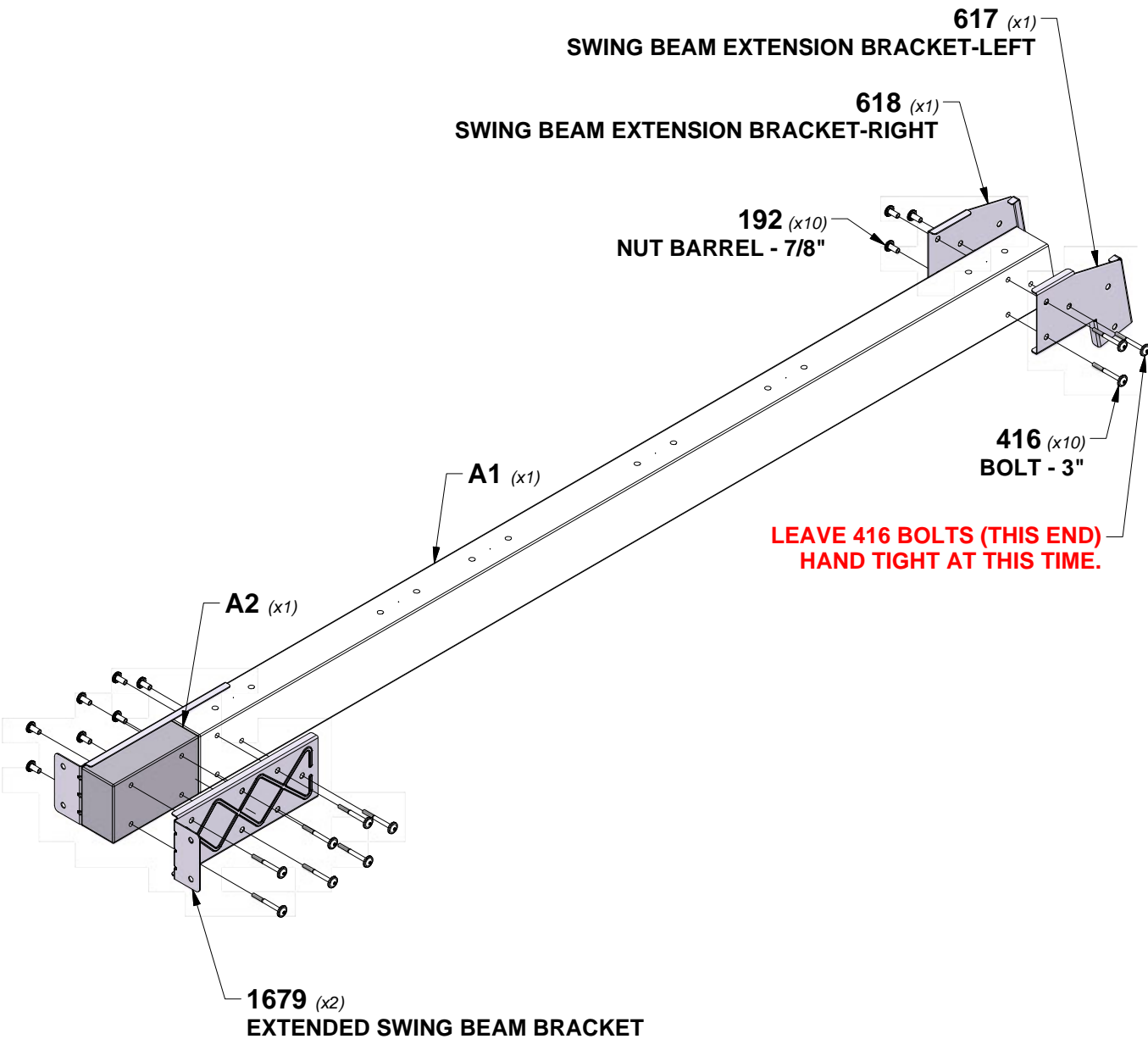



# STEP 2 - SWING BEAM ASSEMBLY

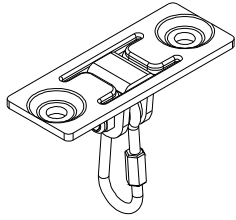

**A4M02171**  
(x6) **SWING HANGER**

QTY	PART NUMBER	DESCRIPTION
12	H101166	WASHER LOCK INT 10x18 BLK
12	H101167	WASHER FLAT 11x25
12	H101168	T-NUT 3/8 BLK
12	H101170	BOLT HEX 3/8x5-3/4

**TIP:**  
**INSTALL T-NUTS IN WOOD FIRST**

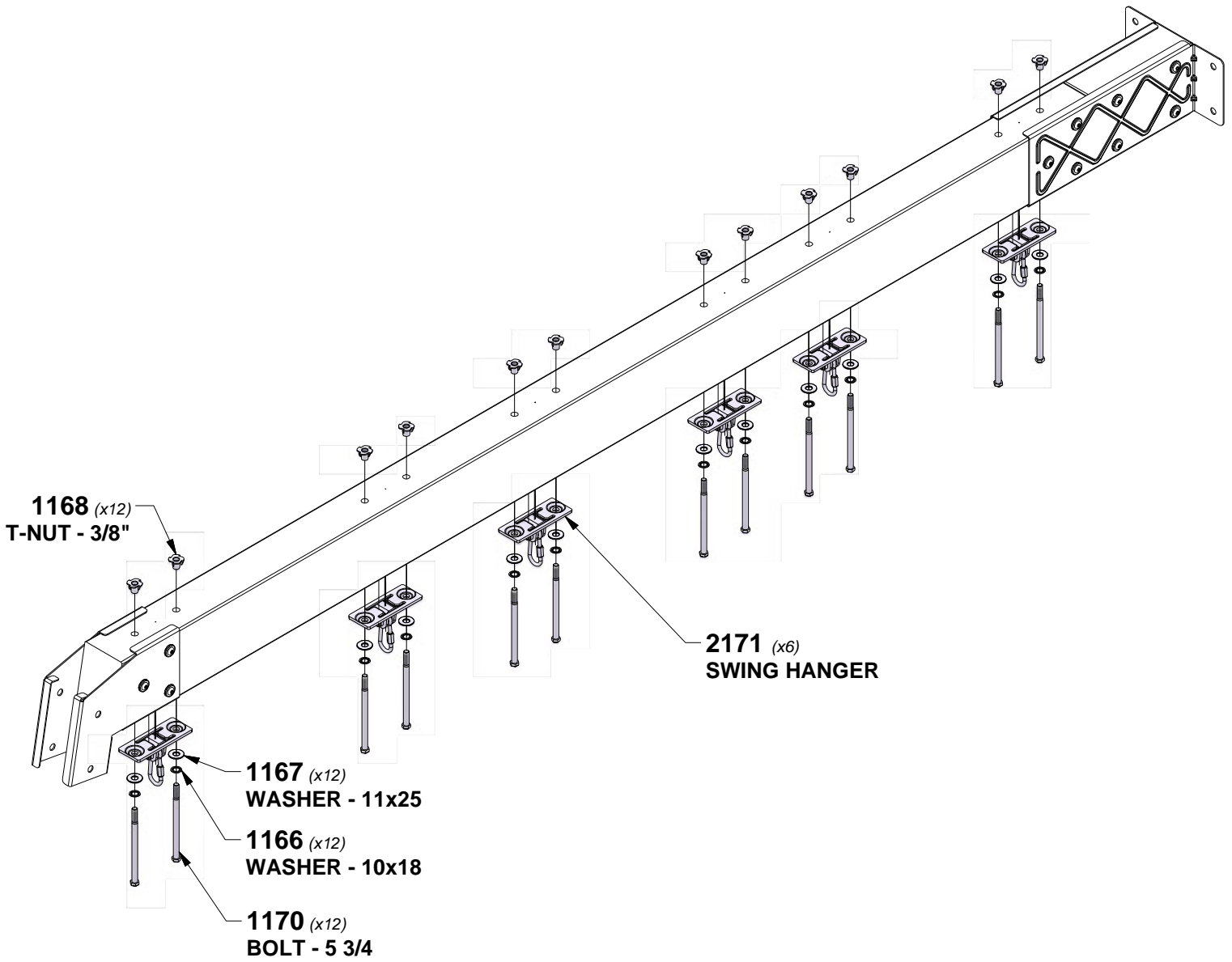

# STEP 3 - SWING BEAM ASSEMBLY

QTY	PART NUMBER	DESCRIPTION
4	H100202	SCREW PWH 8x5/8 BLK



**A100164**  
*(x1)* BYD ID TAG (LARGE) AGES 3-10

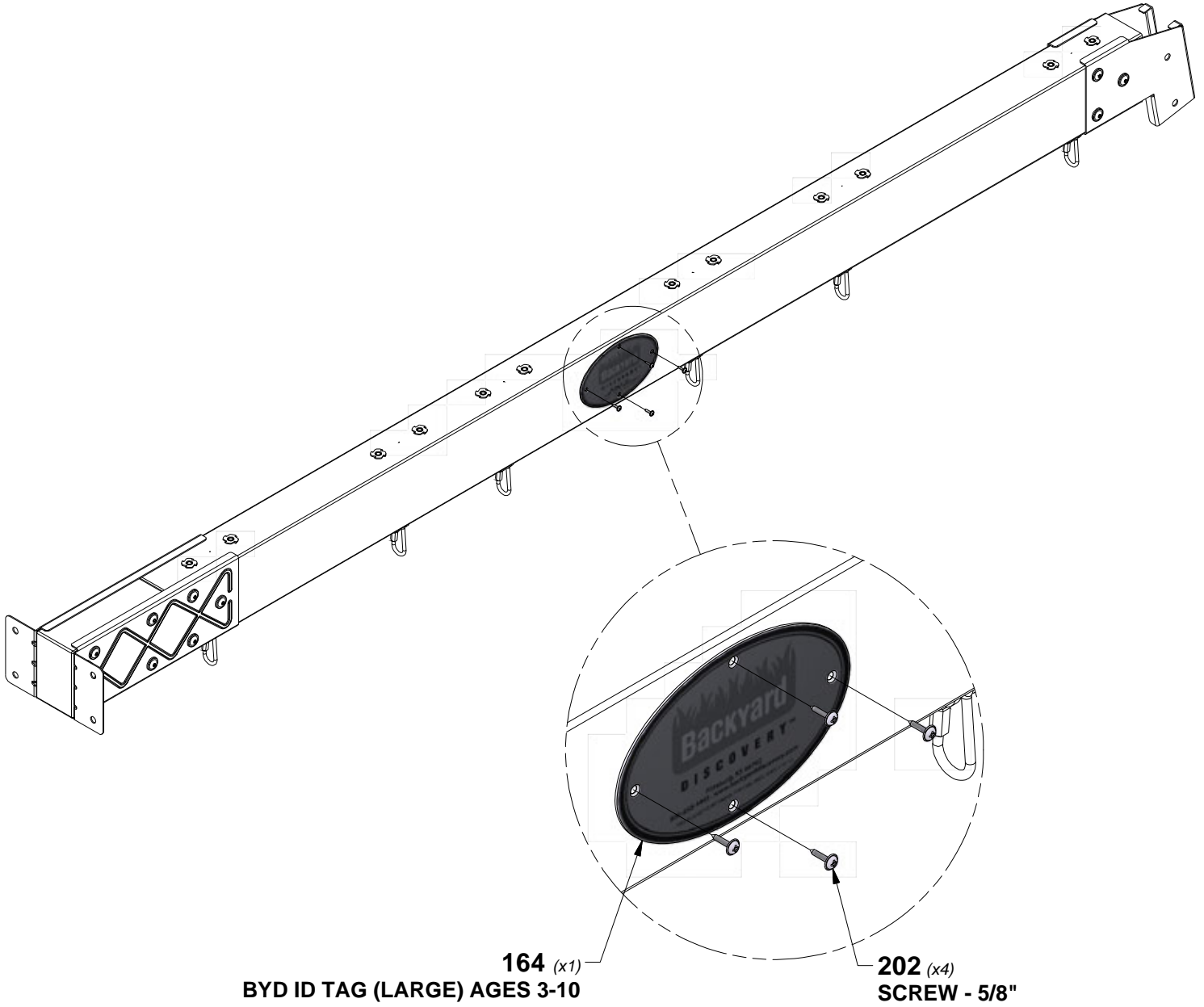

# STEP 4 - SWING BEAM ASSEMBLY

QTY	PART NUMBER	DESCRIPTION
6	H100379	T-NUT 5/16 BLK
4	H100407	BOLT WH 5/16x1 1/2 BLK
2	H100503	BOLT WH 5/16x3-1/2 BLK



**E77 ANGLE BRACE - W4L18495**  
(x2) 1 3/8"x3 3/8"x78" (36x86x1980)



**SP71 SWING BEAM SUPPORT - W4L18498**  
(x1) 3 3/8"x3 3/8"x49 1/2" (86x86x1256)

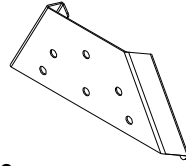

**A4M01782 A-FRAME BRACKET**  
(x1)

**TIP:**  
**INSTALL T-NUTS IN WOOD FIRST**

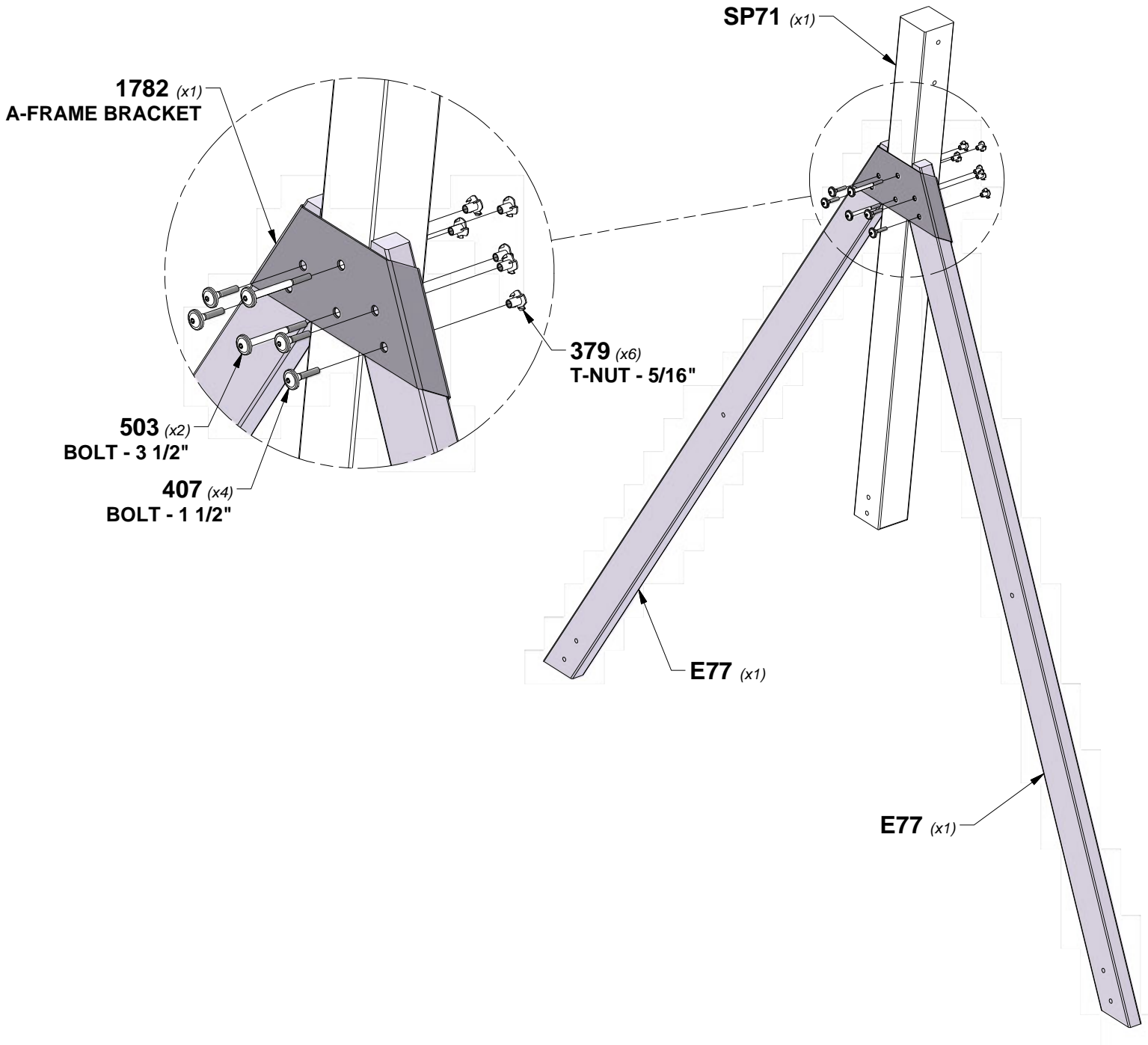

# STEP 5 - SWING BEAM ASSEMBLY

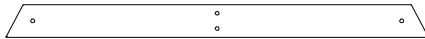

**E79 END SUPPORT - W4L18496**  
(x1) 1 1/2"x3 1/2"x44" (36x86x1120)



**G12 GROUND BOARD - W4L18497**  
(x1) 1"x5 1/4"x78 1/8" (24x134x1984)

QTY	PART NUMBER	DESCRIPTION
2	H100195	BOLT WH 5/16x2-3/4 BLK
8	H100198	WASHER LOCK EXT 8x19 BLK
4	H100205	BOLT WH 5/16x2-1/4 BLK
8	H100379	T-NUT 5/16 BLK
2	H100480	BOLT WH 5/16x4 3/4 BLK

**TIP:**  
**INSTALL T-NUTS IN WOOD FIRST**

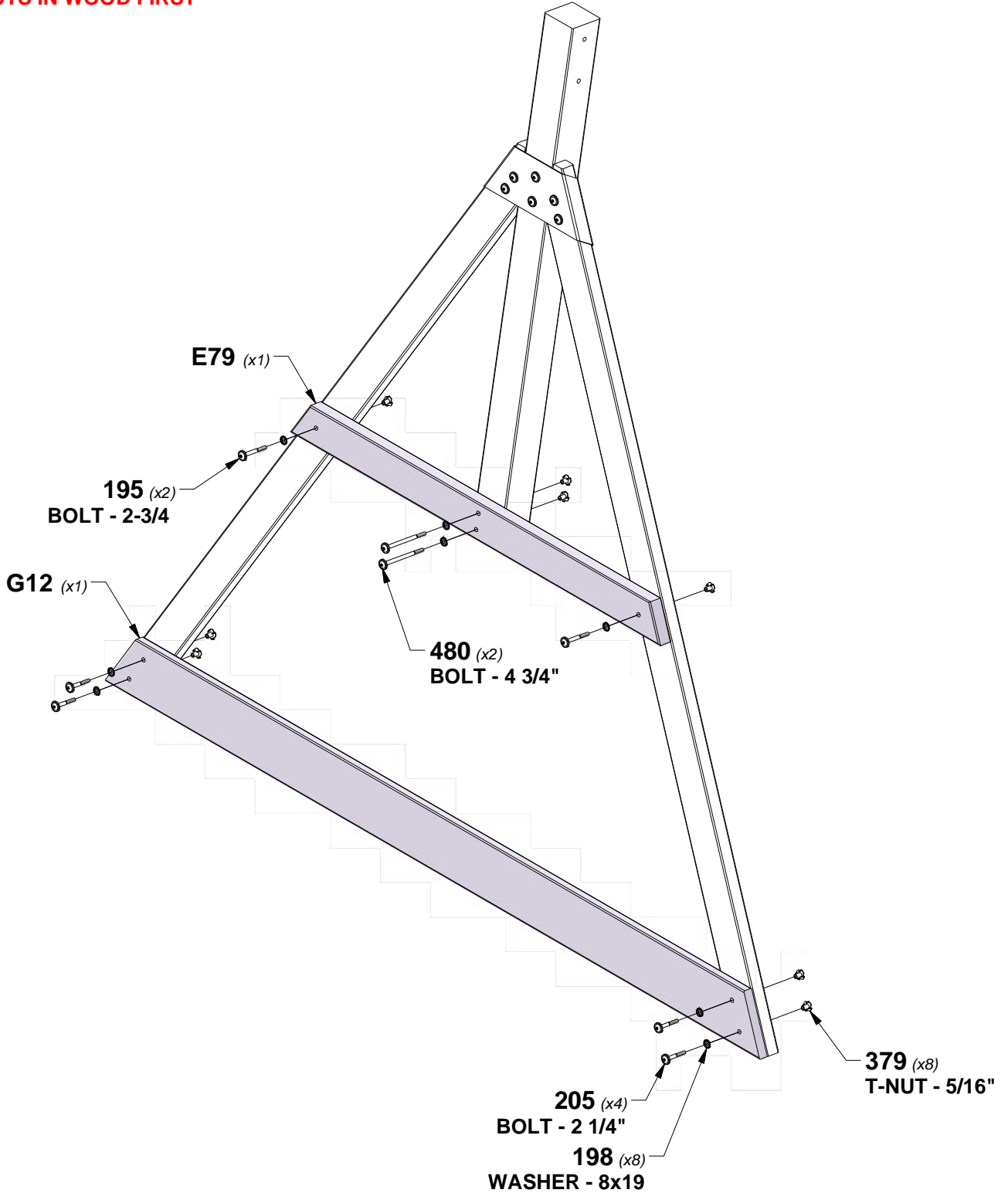

# STEP 6 - SWING BEAM ASSEMBLY

QTY	PART NUMBER	DESCRIPTION
2	H100192	NUT BARREL WH 5/16x7/8 BLK
2	H100416	BOLT WH 5/16x3 BLK

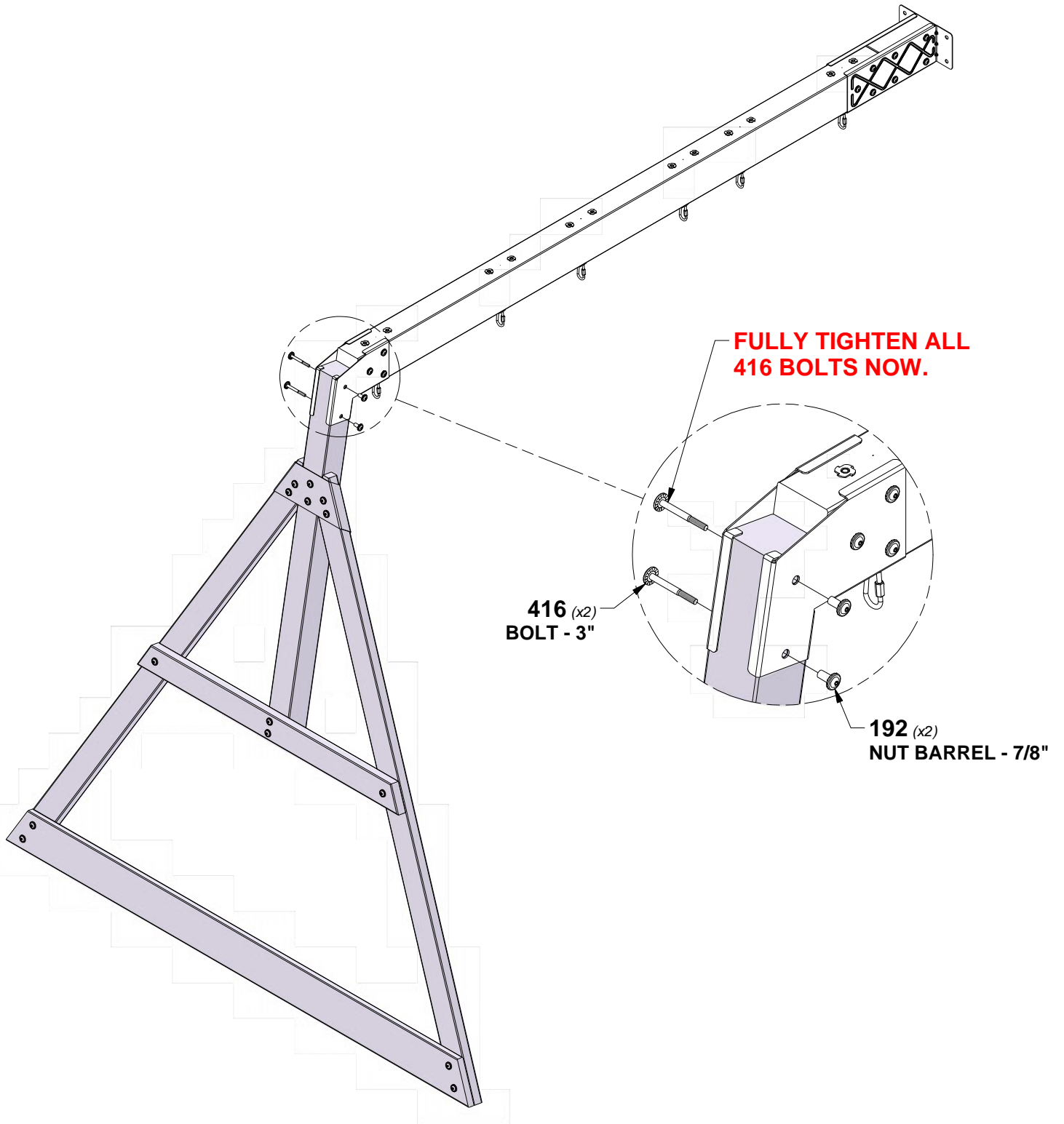

# STEP 1 - FORT ASSEMBLY

QTY	PART NUMBER	DESCRIPTION
4	H100195	BOLT WH 5/16x2-3/4 BLK
8	H100198	WASHER LOCK EXT 8x19 BLK
12	H100379	T-NUT 5/16 BLK
4	H100457	BOLT WH 5/16x2 BLK



**E7 RIGHT REAR UPRIGHT - W4L17831**  
(x1) 1 3/8"x3 3/8"x43 1/2" (36x86x1104)



**E9 RIGHT FRONT UPRIGHT - W4L17833**  
(x1) 1 3/8"x3 3/8"x43 1/2" (36x86x1104)



**D1 SWING BEAM MOUNT - W4L19015**  
(x1) 1 3/8"x5 1/4"x62 3/8" (36x134x1585)



**K12 ARCHED WALL RAIL - W4L11143**  
(x1) 5/8"x5 1/4"x40 5/8" (16x134x1032)

**TIP:**  
**INSTALL T-NUTS IN WOOD FIRST**

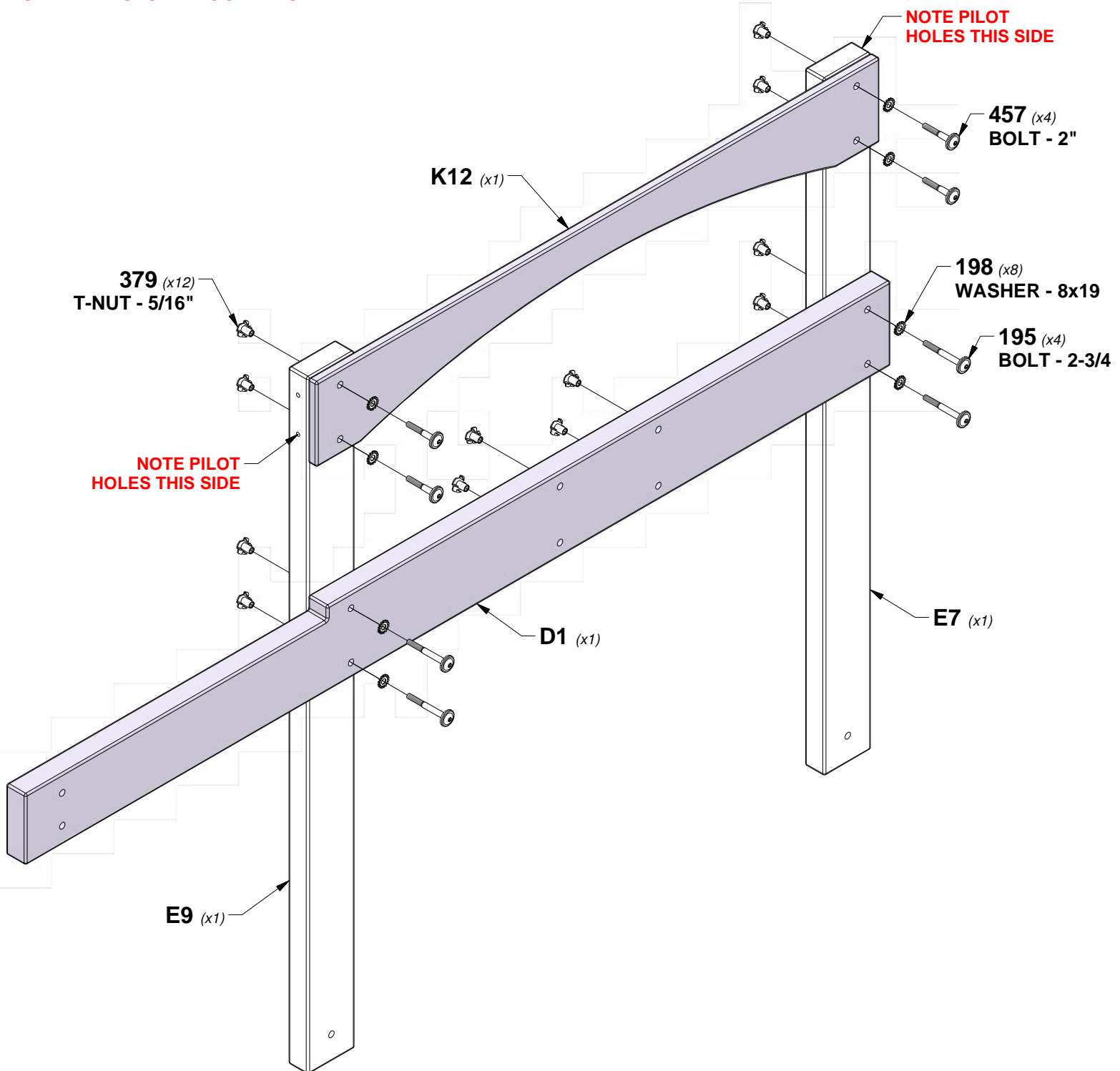

# STEP 2 - FORT ASSEMBLY

QTY	PART NUMBER	DESCRIPTION
6	H100198	WASHER LOCK EXT 8x19 BLK
6	H100205	BOLT WH 5/16x2-1/4 BLK
6	H100379	T-NUT 5/16 BLK



**G5 RIGHT CENTER WALL RAIL - W4L19006**  
(x1) 1"x5 1/4"x63 3/8" (24x134x1609)

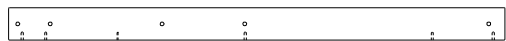

**E4 RIGHT FRONT UPRIGHT - W4L17825**  
(x1) 1 3/8"x3 3/8"x51 3/4" (36x86x1314)



**E13 RIGHT REAR UPRIGHT ASSEMBLY - W2A03847**  
(x1) 1 3/8"x3 3/8"x51 3/4" (36x86x1314)



**G2 GROUND BOARD - W4L19003**  
(x1) 1"x5 1/4"x42 1/4" (24x134x1072)

**TIP:**  
**INSTALL T-NUTS IN WOOD FIRST**

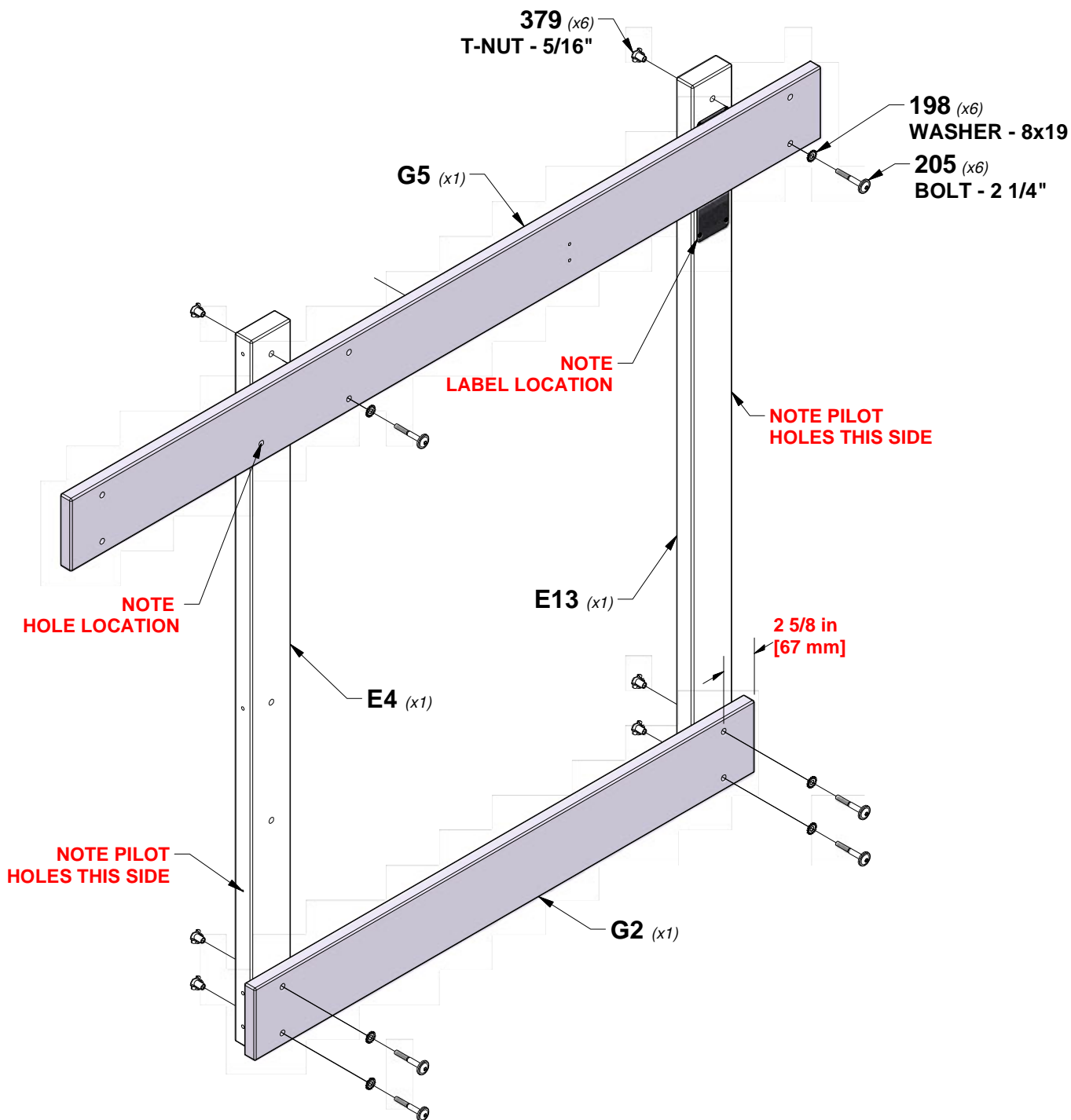

# STEP 3 - FORT ASSEMBLY

QTY	PART NUMBER	DESCRIPTION
2	H100198	WASHER LOCK EXT 8x19 BLK
2	H100205	BOLT WH 5/16x2-1/4 BLK
2	H100379	T-NUT 5/16 BLK

**TIP:**  
INSTALL T-NUTS IN WOOD FIRST

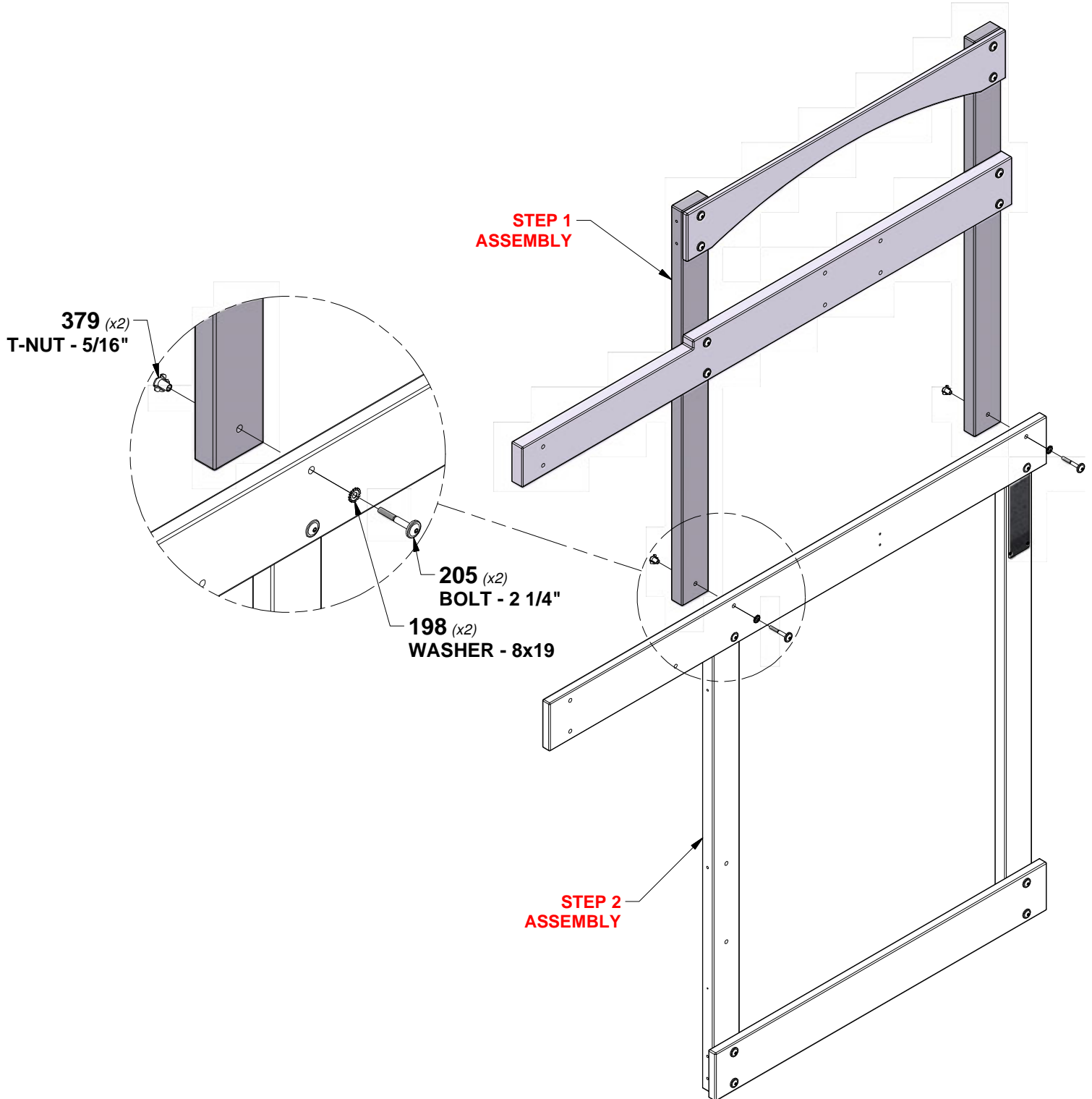



# STEP 4 - FORT ASSEMBLY

QTY	PART NUMBER	DESCRIPTION
12	H100198	WASHER LOCK EXT 8x19 BLK
12	H100205	BOLT WH 5/16x2-1/4 BLK
12	H100379	T-NUT 5/16 BLK

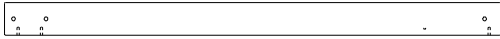

**E2 LEFT REAR UPRIGHT - W4L17823**  
(x1) 1 3/8"x3 3/8"x51 3/4" (36x86x1314)

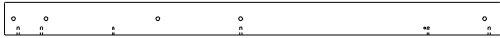

**E3 LEFT FRONT UPRIGHT - W4L17824**  
(x1) 1 3/8"x3 3/8"x51 3/4" (36x86x1314)

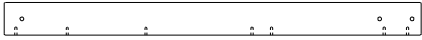

**E6 LEFT REAR UPRIGHT - W4L19001**  
(x1) 1 3/8"x3 3/8"x43 1/2" (36x86x1104)



**E8 LEFT FRONT UPRIGHT - W4L19002**  
(x1) 1 3/8"x3 3/8"x43 1/2" (36x86x1104)

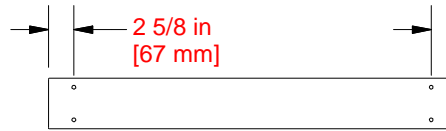

**G3 GROUND BOARD - W4L19004**  
(x1) 1"x5 1/4"x42 1/4" (24x134x1072)

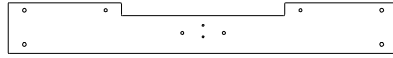

**G8 LEFT CENTER WALL RAIL - W4L19000**  
(x1) 1"x5 1/4"x40 5/8" (24x134x1032)



**G13 ARCHED WALL RAIL - W4L19010**  
(x1) 1"x5 1/4"x40 5/8" (24x134x1032)

**TIP:**  
**INSTALL T-NUTS IN WOOD FIRST**

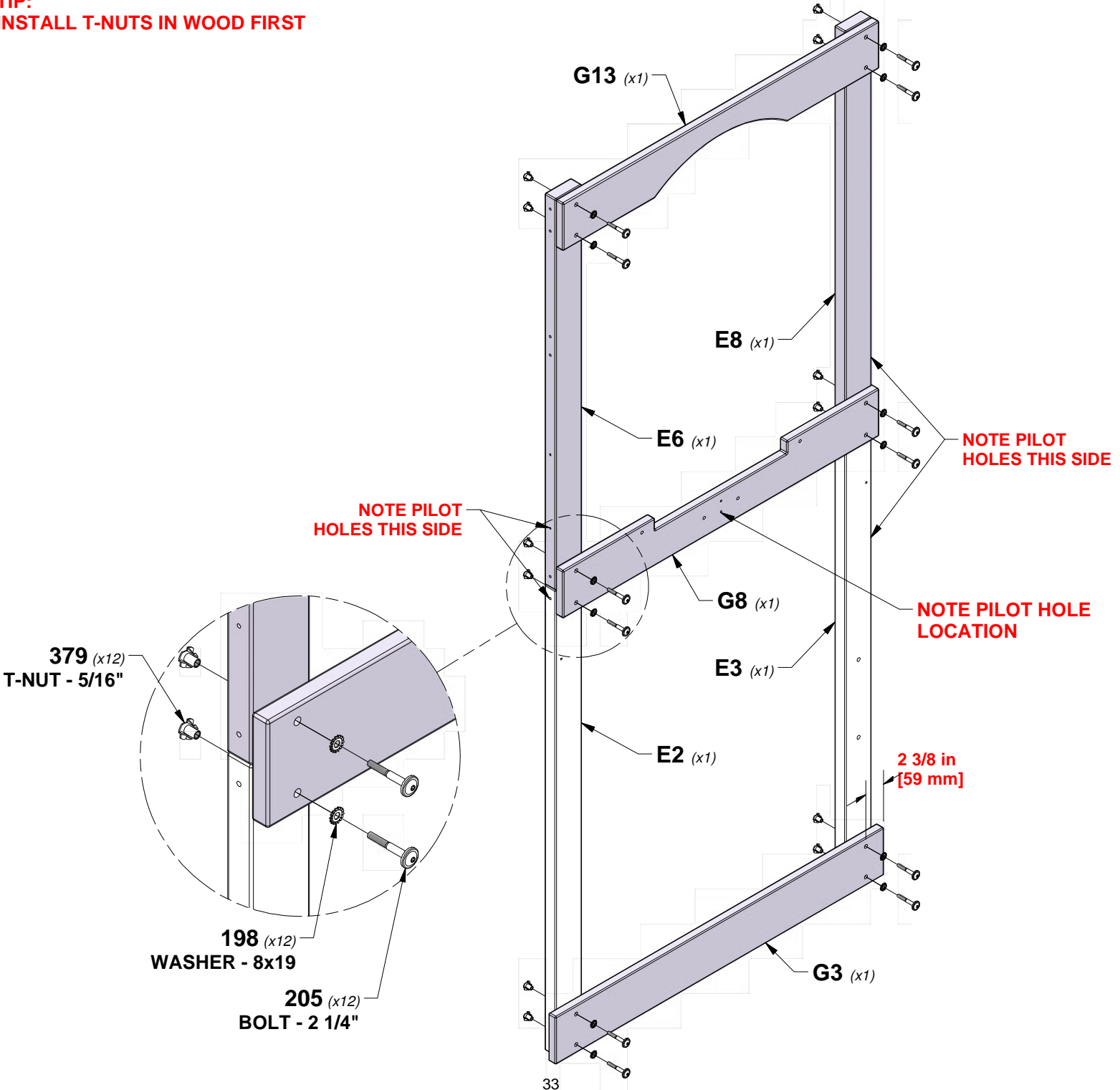

# STEP 5 - FORT ASSEMBLY

QTY	PART NUMBER	DESCRIPTION
3	H100197	LAG SCREW WH 5/16x2-1/2 BLK
12	H100198	WASHER LOCK EXT 8x19 BLK
2	H100206	LAG SCREW WH 5/16x3 BLK
8	H100458	LAG SCREW WH 5/16x2 BLK



**G6 FRONT CENTER WALL RAIL - W4L19014**  
(x1) 1"x5 1/4"x61 3/4" (24x134x1570)



**K4 GROUND BOARD - W4L19009**  
(x1) 5/8"x5 1/4"x40 1/2" (16x134x1030)

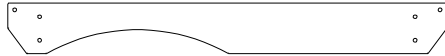

**G15 ANGLED WALL RAIL - W4L19012**  
(x1) 1"x5 1/4"x45 3/4" (24x134x1162)

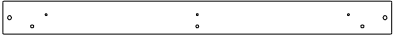

**M1 WALL RAIL - W4L19013**  
(x1) 5/8"x3 3/8"x40 1/2" (16x86x1030)



**J1 PORCH GROUND BOARD - W4L11128**  
(x1) 1"x2 3/8"x40 1/2" (24x60x1030)

1 3/8 in  
[36 mm]

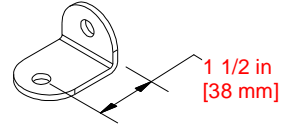

**A4M00710 L BRACKET BLACK 32x51**  
(x1)

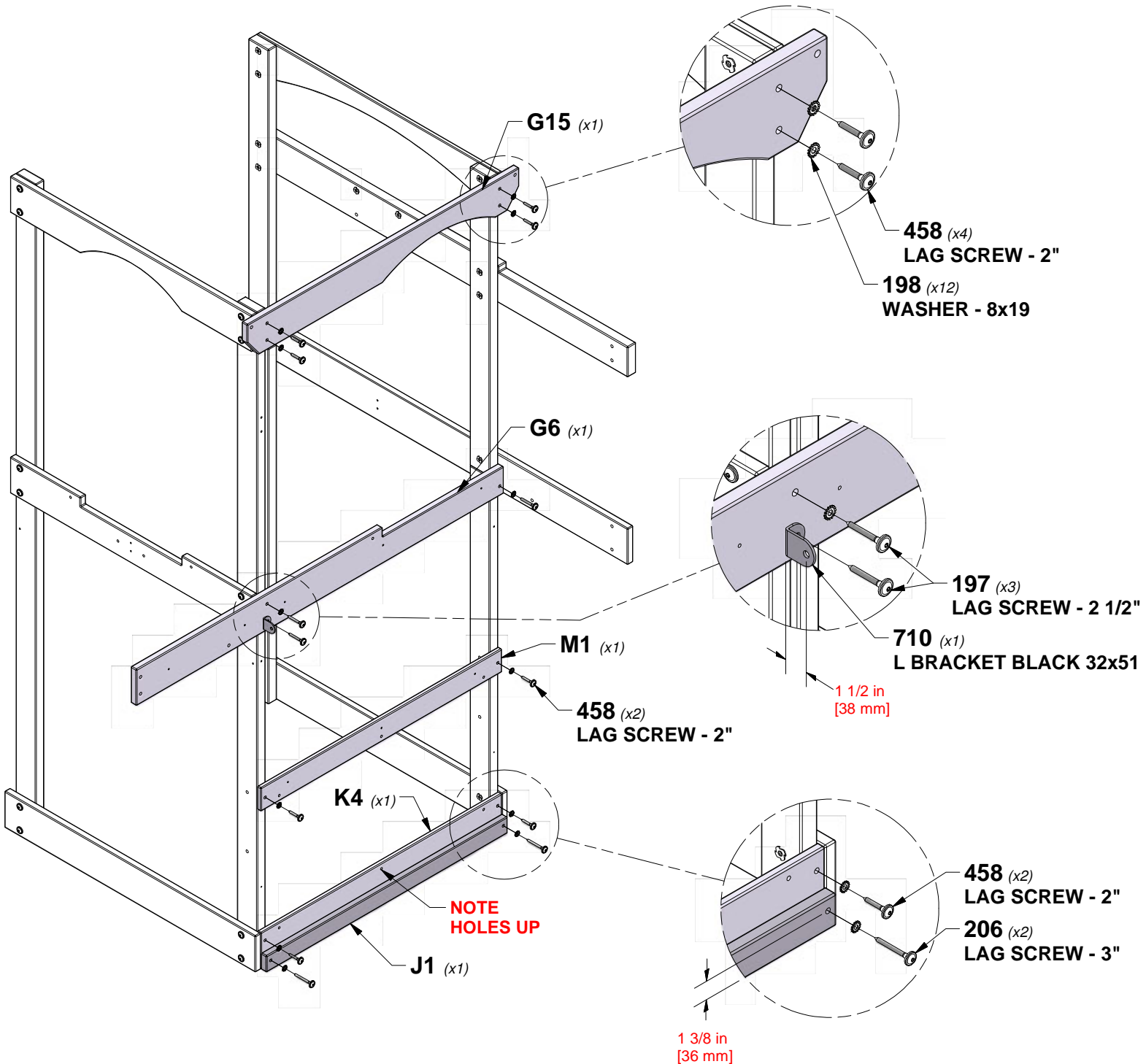

# STEP 6 - FORT ASSEMBLY

QTY	PART NUMBER	DESCRIPTION
8	H100197	LAG SCREW WH 5/16x2-1/2 BLK
12	H100198	WASHER LOCK EXT 8x19 BLK
2	H100379	T-NUT 5/16 BLK
4	H100458	LAG SCREW WH 5/16x2 BLK

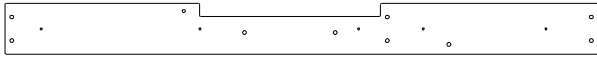

**G7 REAR CENTER WALL RAIL - W4L19007**  
(x1) 1"x5 1/4"x61 3/4" (24x134x1570)



**G4 GROUND BOARD - W4L19005**  
(x1) 1"x5 1/4"x40 1/2" (24x134x1030)



**G14 ANGLED WALL RAIL - W4L19011**  
(x1) 1"x5 1/4"x45 3/4" (24x134x1162)

**TIP:**  
**INSTALL T-NUTS IN WOOD FIRST**

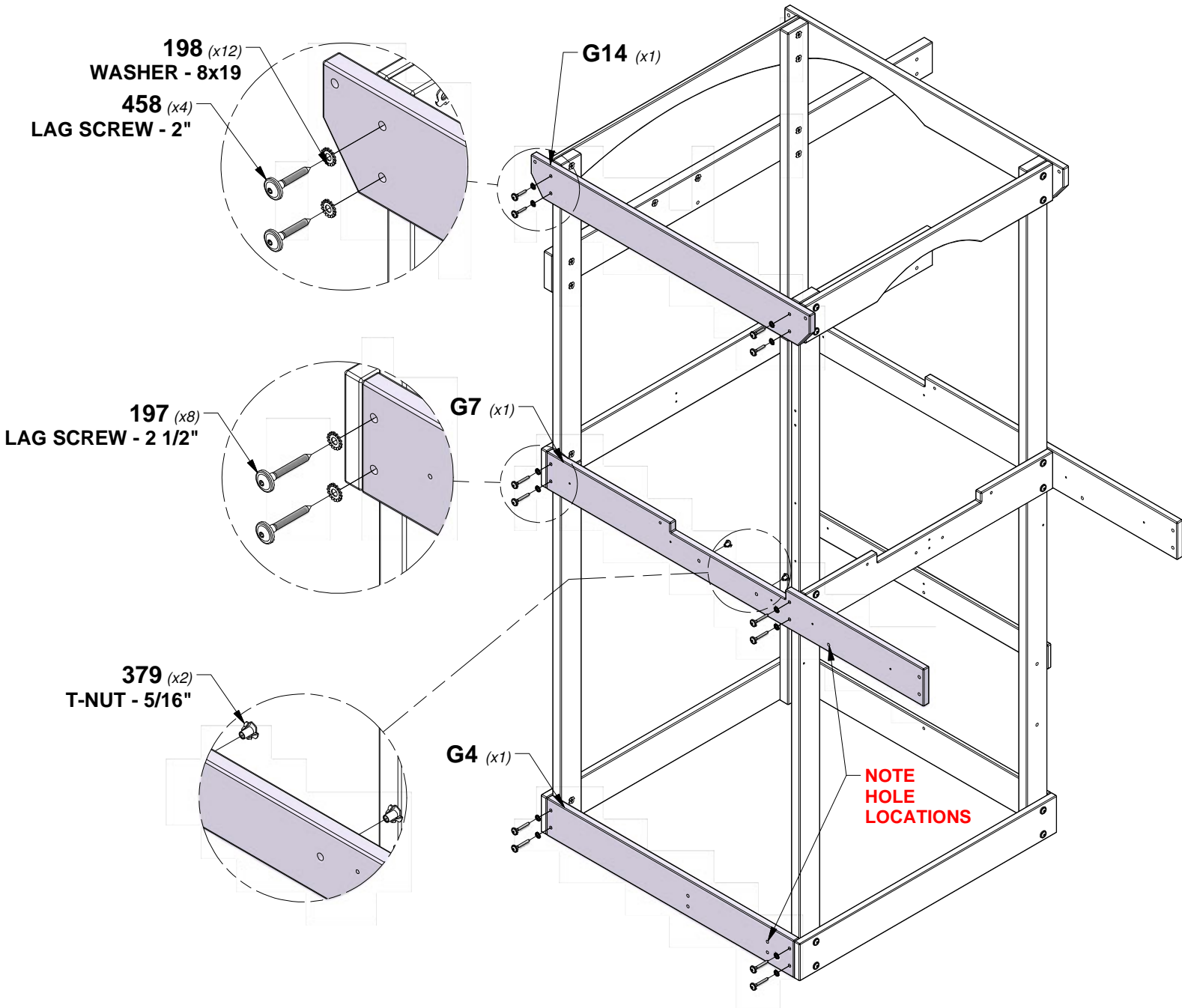

# STEP 7 - FORT ASSEMBLY

QTY	PART NUMBER	DESCRIPTION
4	H100197	LAG SCREW WH 5/16x2-1/2 BLK
3	H100198	WASHER LOCK EXT 8x19 BLK

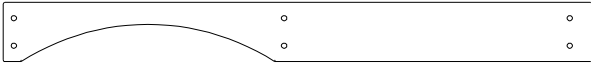

**Q6** **ARCHED WALL RAIL - W4L19016**  
 (x1) 1"x4 3/8"x43 7/8" (24x112x1113)



**Q4** **WALL RAIL - W4L17654**  
 (x1) 1"x4 3/8"x23 5/8" (24x112x600)

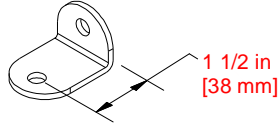

**A4M00710** **L BRACKET**  
 (x1) **BLACK 32x51**

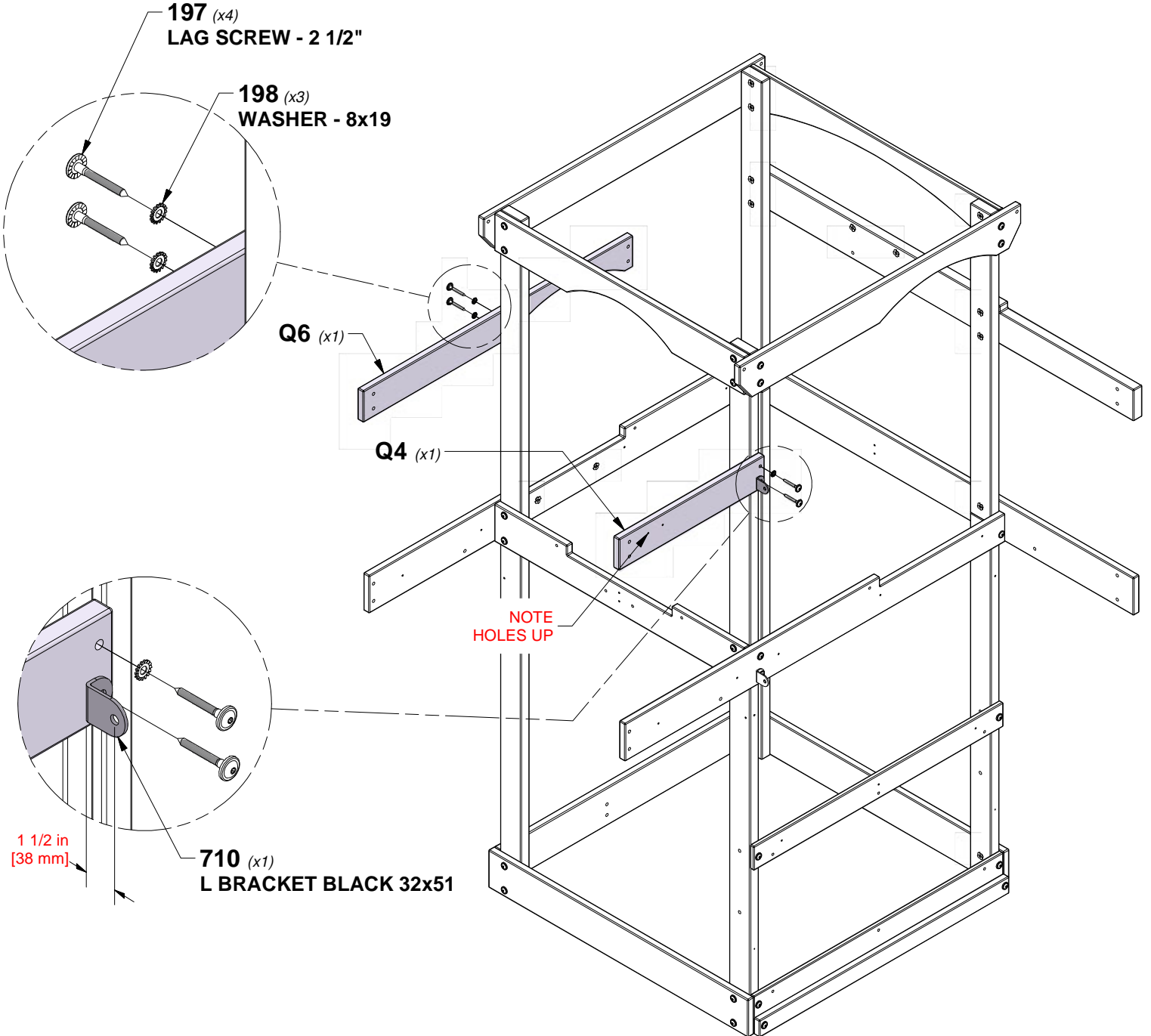

# STEP 8 - FORT ASSEMBLY

QTY	PART NUMBER	DESCRIPTION
8	H100197	LAG SCREW WH 5/16x2-1/2 BLK
16	H100198	WASHER LOCK EXT 8x19 BLK
8	H100205	BOLT WH 5/16x2-1/4 BLK
8	H100379	T-NUT 5/16 BLK



**F1 RIGHT BALCONY UPRIGHT - W4L17806**  
(x1) 1 3/8"x2 3/8"x31 3/4" (36x60x805)



**F2 LEFT BALCONY UPRIGHT - W4L17807**  
(x1) 1 3/8"x2 3/8"x31 3/4" (36x60x805)

**PILOT HOLES INWARD WHEN INSTALLED**

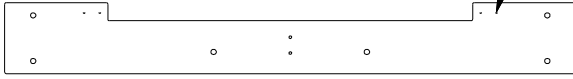

**G11 LEFT SIDE WALL BOARD - W4L19008**  
(x1) 1"x5 1/4"x42 1/2" (24x134x1080)

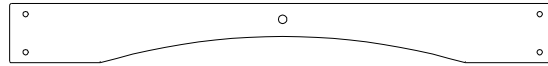

**Q1 ARCHED WALL RAIL - W4L11142**  
(x1) 1"x4 3/8"x40 5/8" (24x112x1032)

**TIP:**  
**INSTALL T-NUTS IN WOOD FIRST**

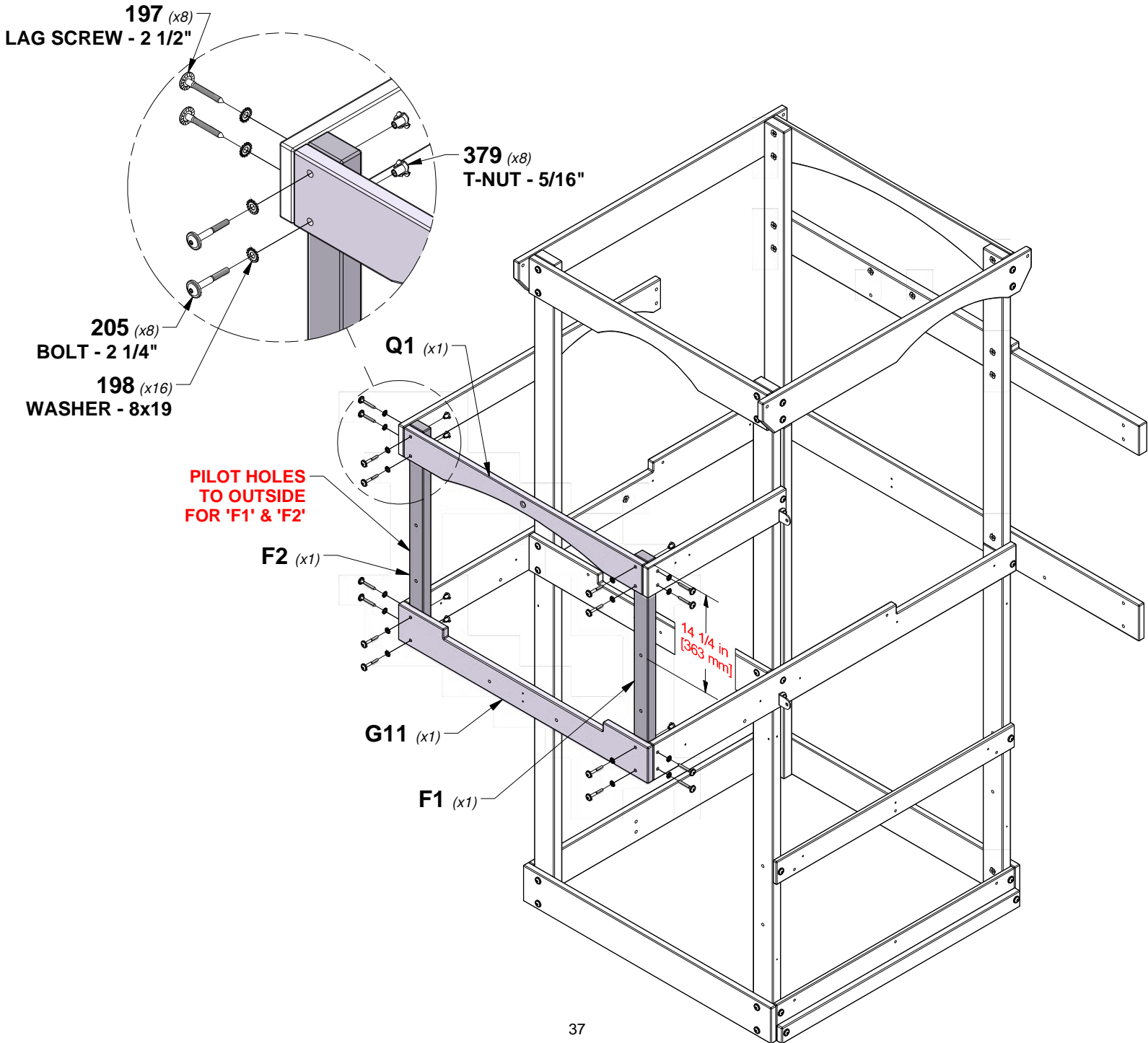

# STEP 9 - FORT ASSEMBLY

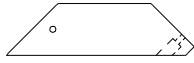

**E1 DECK BRACE - W4L17821**  
 (x2) 1 3/8"x3 3/8"x12 1/4" (36x86x311)

QTY	PART NUMBER	DESCRIPTION
2	H100198	WASHER LOCK EXT 8x19 BLK
2	H100205	BOLT WH 5/16x2-1/4 BLK
2	H100379	T-NUT 5/16 BLK
2	H100403	LAG SCREW WH 1/4x1-1/2 BLK
2	H100405	WASHER LOCK EXT 6x15 BLK

**TIP:**  
**INSTALL T-NUTS IN WOOD FIRST**

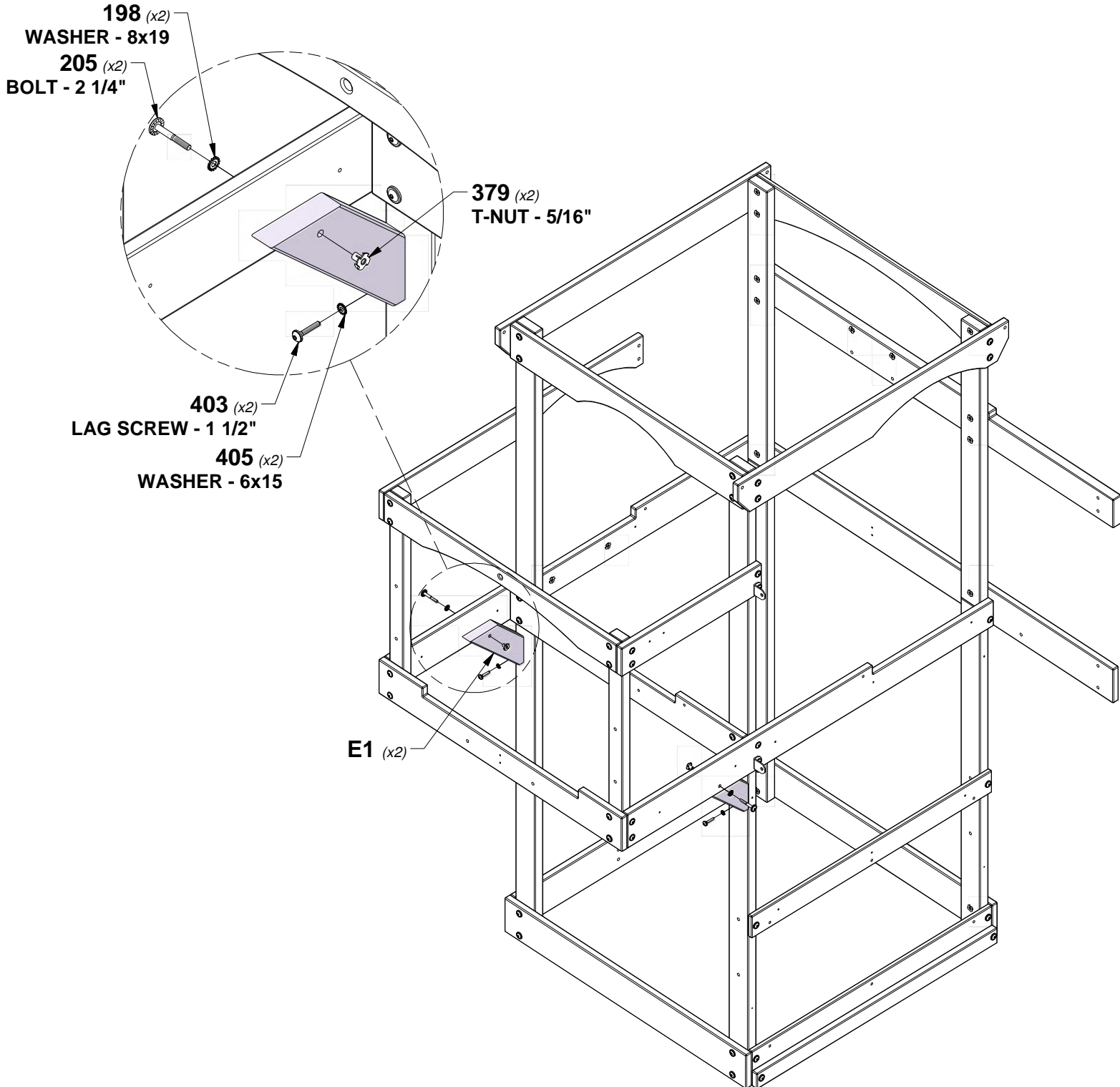



# STEP 10 - FORT ASSEMBLY

QTY	PART NUMBER	DESCRIPTION
2	H100192	NUT BARREL WH 5/16x7/8 BLK
2	H100199	WASHER LOCK EXT 12x19 BLK
4	H100382	SCREW PFH 8x1 3/4 BLK
2	H100396	BOLT WH 5/16x1/2 BLK



**J10 PORCH GROUND BOARD - W4L17650**  
(x2) 1"x2 3/8"x21 1/8" (24x60x537)



**G9 LEFT BALCONY WALL RAIL - W4L17648**  
(x1) 1"x5 1/4"x20 3/4" (24x134x528)

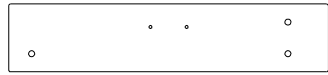

**Q5 WALL RAIL - W4L17655**  
(x1) 1"x4 3/8"x20 7/8" (24x112x529)

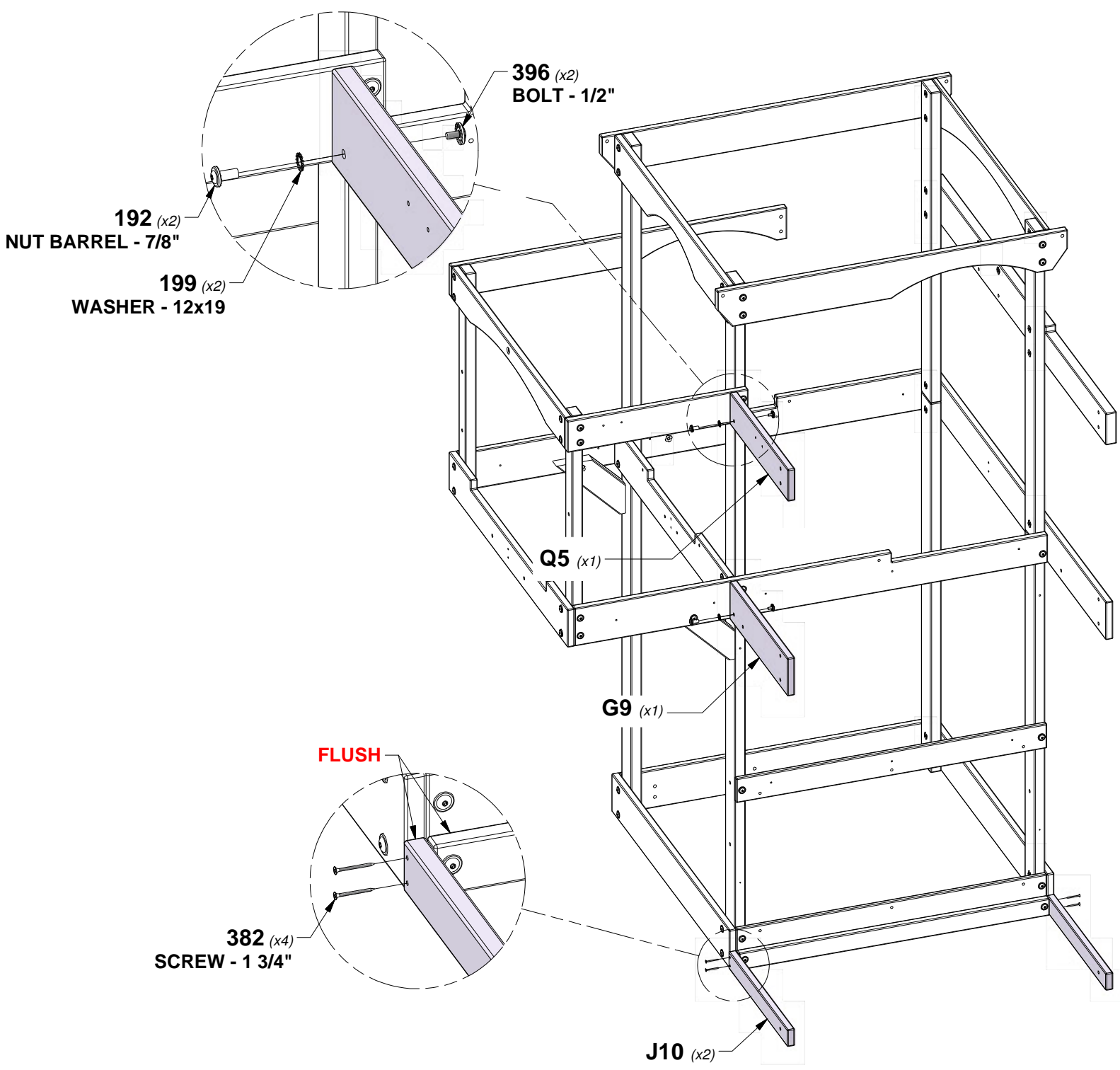

# STEP 11 - FORT ASSEMBLY

QTY	PART NUMBER	DESCRIPTION
2	H100195	BOLT WH 5/16x2-3/4 BLK
10	H100198	WASHER LOCK EXT 8x19 BLK
8	H100205	BOLT WH 5/16x2-1/4 BLK
10	H100379	T-NUT 5/16 BLK



**E5 RIGHT FRONT BALCONY UPRIGHT - W4L17826**  
 (x1) 1 3/8"x3 3/8"x80 3/4" (36x86x2052)



**E11 RIGHT FRONT BALCONY UPRIGHT - W4L17827**  
 (x1) 1 3/8"x3 3/8"x80 3/4" (36x86x2052)

**TIP:**  
**INSTALL T-NUTS IN WOOD FIRST**

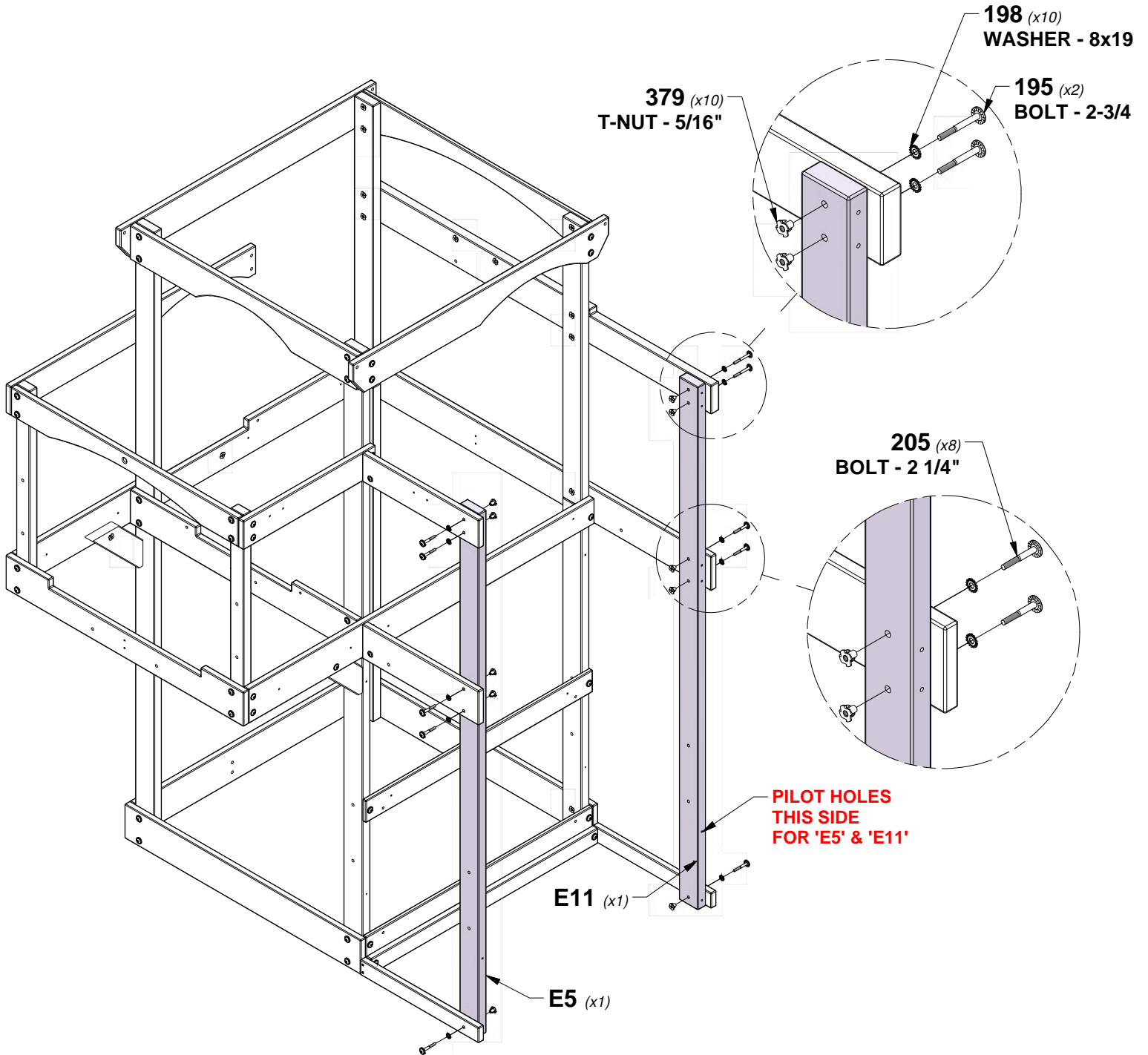



# STEP 12 - FORT ASSEMBLY

QTY	PART NUMBER	DESCRIPTION
8	H100197	LAG SCREW WH 5/16x2-1/2 BLK
10	H100198	WASHER LOCK EXT 8x19 BLK
2	H100458	LAG SCREW WH 5/16x2 BLK



**Q3** **ARCHED WALL RAIL - W4L17653**  
 (x1) 1"x4 3/8"x40 5/8" (24x112x1032)

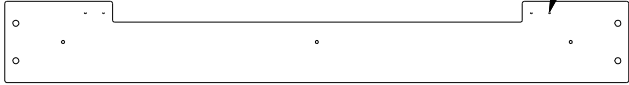

**G10** **FRONT BALCONY WALL RAIL - W4L17649**  
 (x1) 1"x5 1/4"x40 5/8" (24x134x1032)

**PILOT HOLES INWARD WHEN INSTALLED**

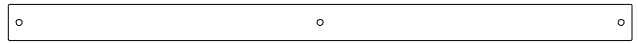

**J2** **PORCH GROUND BOARD - W4L11129**  
 (x1) 1"x2 3/8"x40 5/8" (24x60x1032)

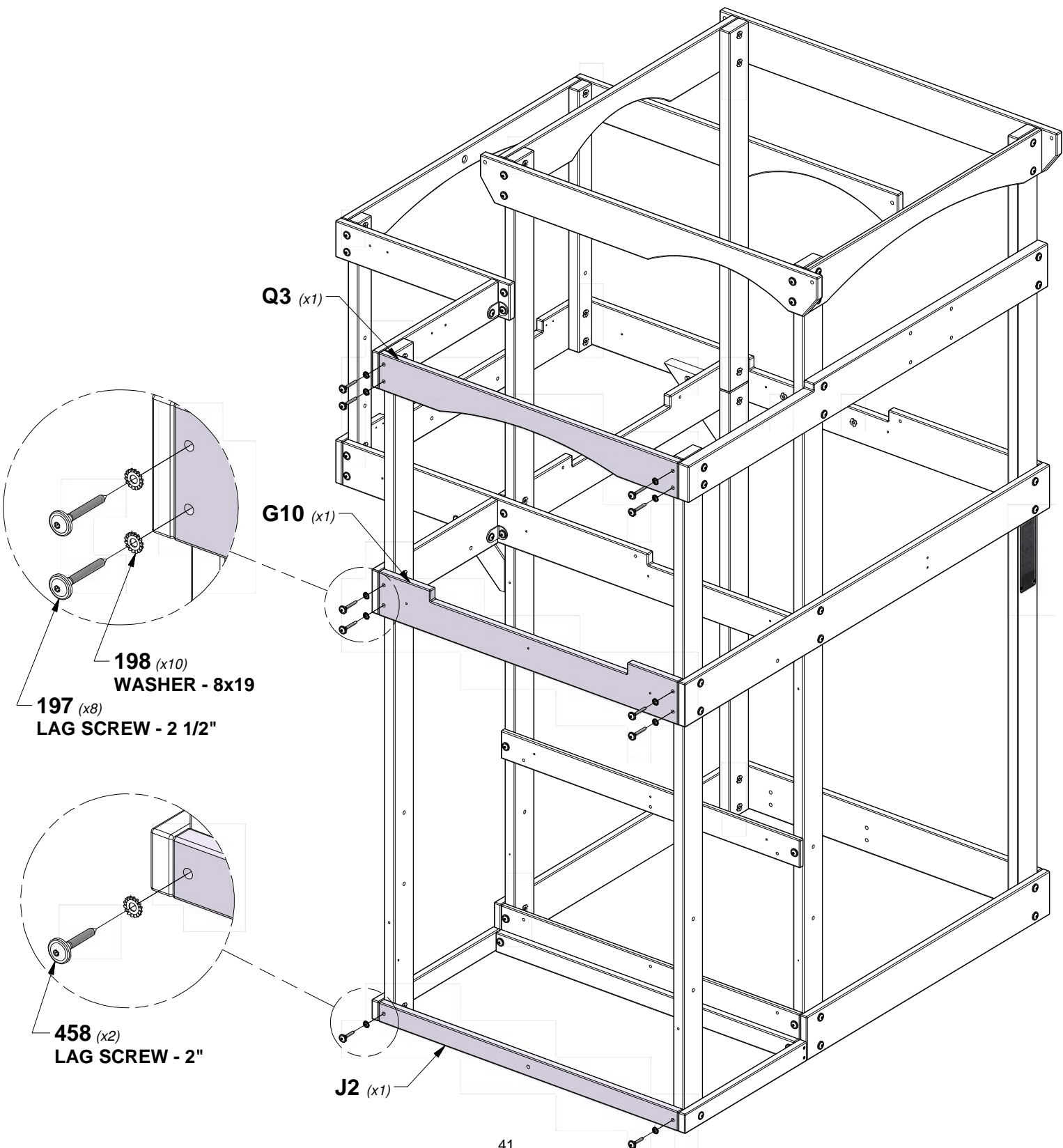

# STEP 13 - FORT ASSEMBLY

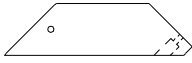

**E1 DECK BRACE - W4L17821**  
 (x2) 1 3/8"x3 3/8"x12 1/4" (36x86x311)

QTY	PART NUMBER	DESCRIPTION
2	H100198	WASHER LOCK EXT 8x19 BLK
2	H100205	BOLT WH 5/16x2-1/4 BLK
2	H100379	T-NUT 5/16 BLK
2	H100403	LAG SCREW WH 1/4x1-1/2 BLK
2	H100405	WASHER LOCK EXT 6x15 BLK

**TIP:**  
 INSTALL T-NUTS IN WOOD FIRST

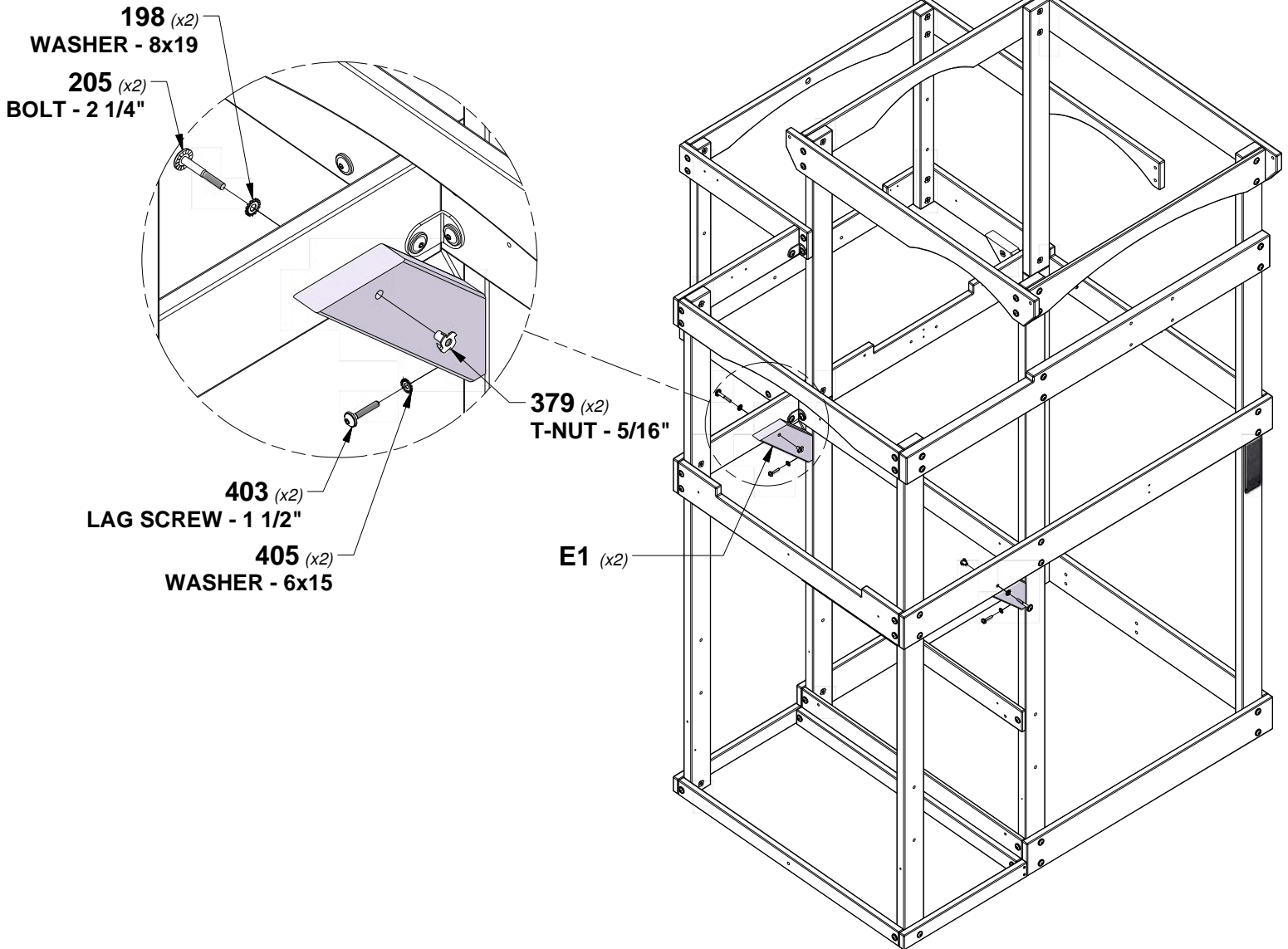

# STEP 14 - FORT ASSEMBLY

QTY	PART NUMBER	DESCRIPTION
4	H100201	SCREW PFH 8x2-1/2 BLK
6	H100382	SCREW PFH 8x1 3/4 BLK



**F06 FLOOR JOIST - W4L18510**  
 (x1) 1 3/8"x2"x40 1/2" (36x50x1030)



**T01 SUPPORT BOARD - W4L18507**  
 (x2) 1"x1 3/8"x37 5/8" (24x34x957)

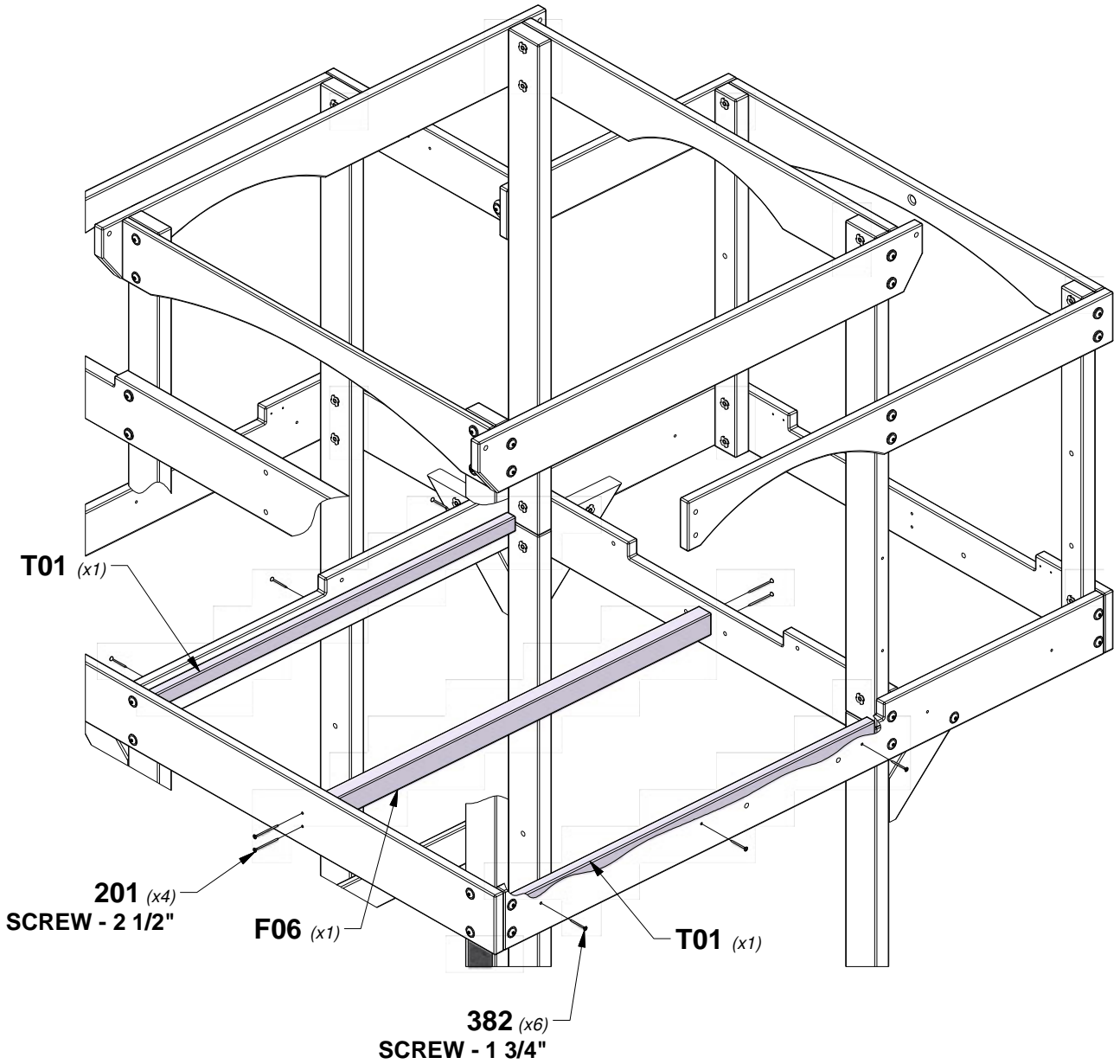
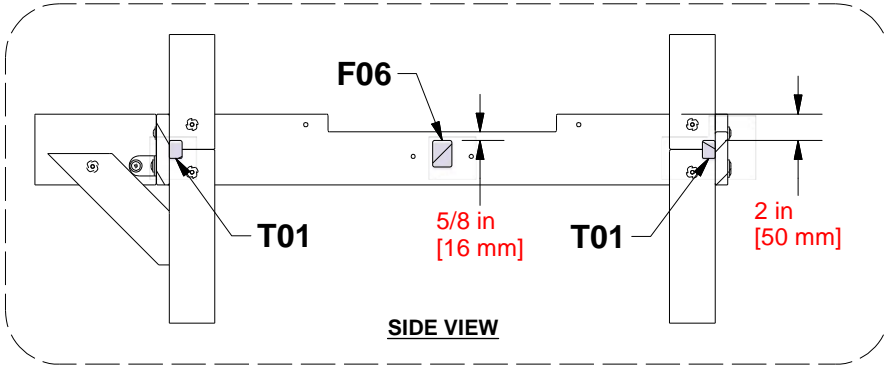

# STEP 15 - FORT ASSEMBLY

QTY	PART NUMBER	DESCRIPTION
2	H100171	BOLT WH 1/4x1 BLK
2	H100201	SCREW PFH 8x2-1/2 BLK
4	H100382	SCREW PFH 8x1 3/4 BLK
2	H100398	T-NUT 1/4 BLK
1	H100399	NUT BARREL WH 1/4x7/8 BLK
1	H100401	BOLT WH 1/4x1/2 BLK



**J09 FLOOR JOIST - W4L18527**  
(x1) 1"x2 3/8"x20 1/4" (24x60x515)

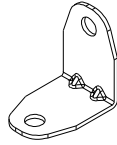

**A4M01047 L BRACKET**  
(x2) 2.5x38x55x55



**T03 SUPPORT BOARD - W4L18509**  
(x2) 1"x1 3/8"x18 3/4" (24x34x477)

**TIP:**  
**INSTALL T-NUTS IN WOOD FIRST**

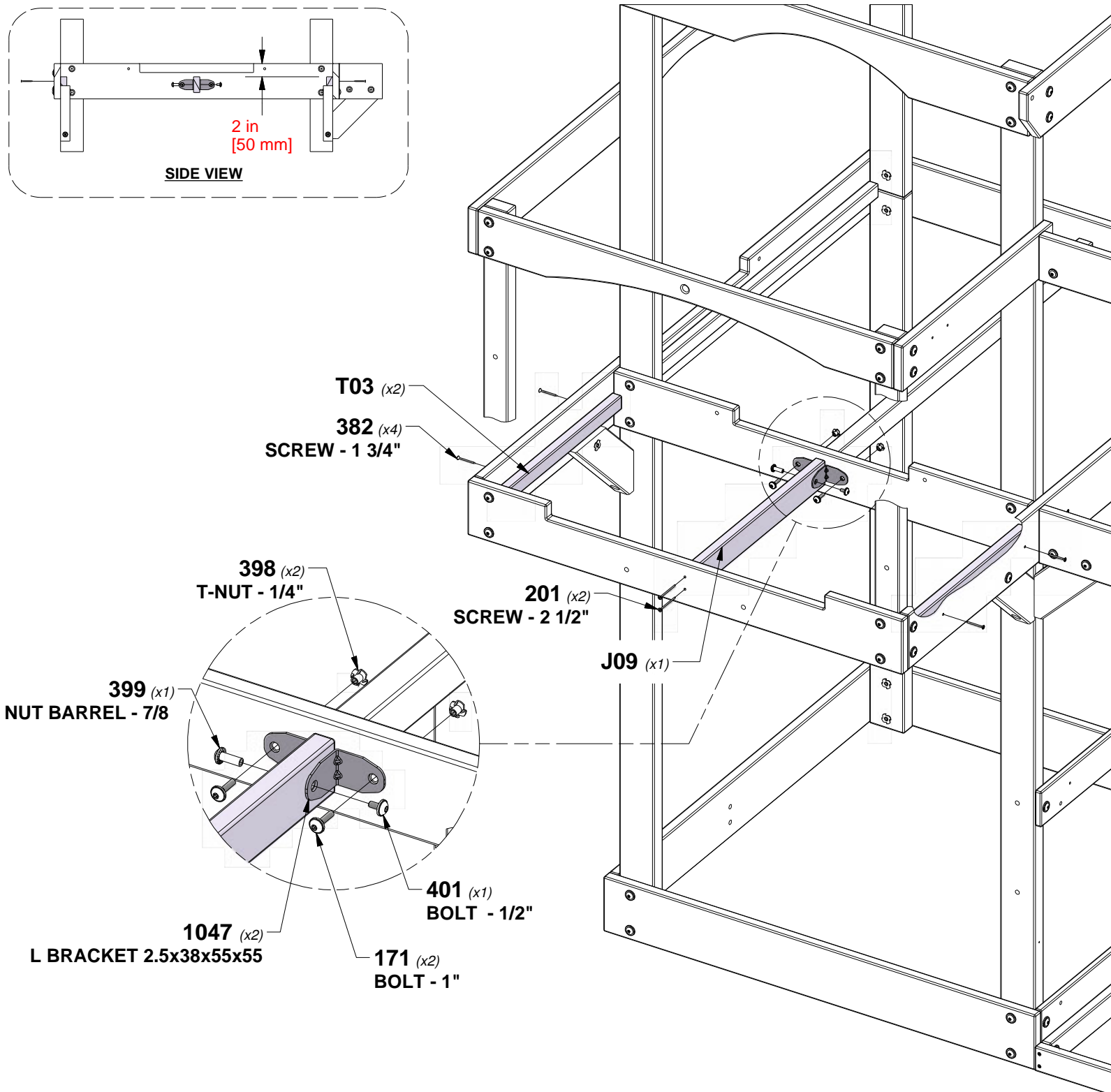
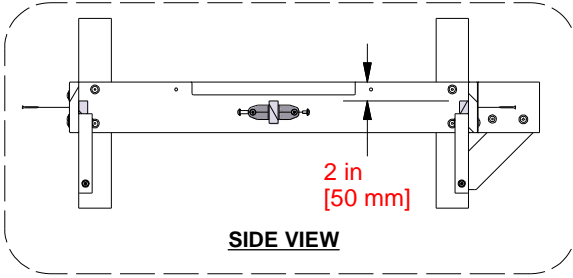

# STEP 16 - FORT ASSEMBLY

QTY	PART NUMBER	DESCRIPTION
56	H100200	SCREW PFH 8x1-1/2 BLK



**M11 FLOOR BOARD - W4L18522**  
(x10) 5/8"x3 3/8"x40 5/8" (16x86x1031)

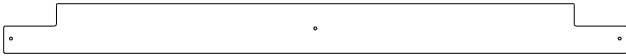

**M12 FLOOR BOARD - W4L18528**  
(x2) 5/8"x3 1/4"x40 5/8" (16x82x1031)

**TIP:**  
**PLACE BOARDS EVENLY**  
**BEFORE INSERTING SCREWS**

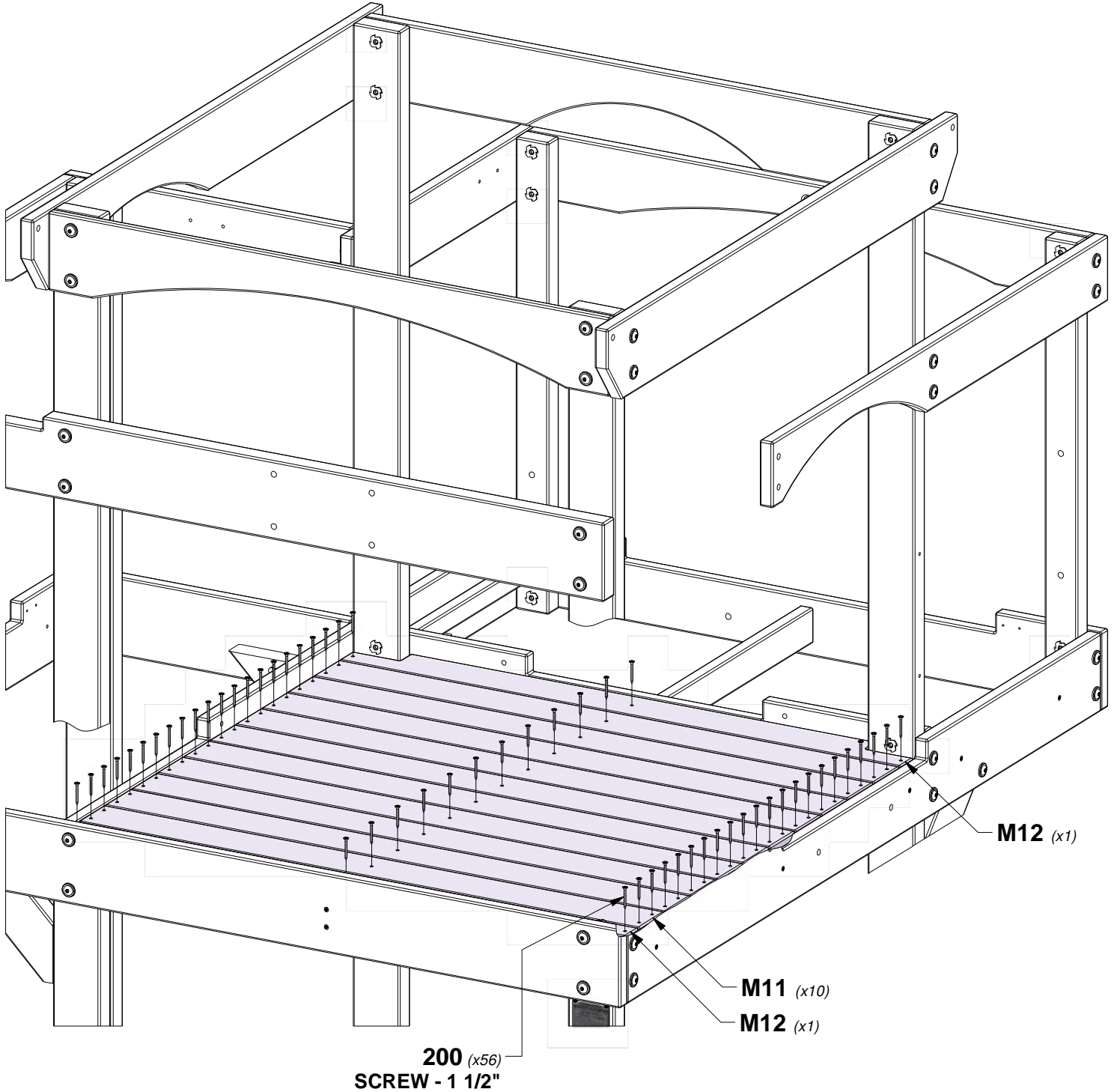

# STEP 17 - FORT ASSEMBLY

QTY	PART NUMBER	DESCRIPTION
28	H100200	SCREW PFH 8x1-1/2 BLK



**M10 FLOOR BOARD - W4L18513**  
(x1) 5/8"x3 3/8"x40 5/8" (16x86x1031)

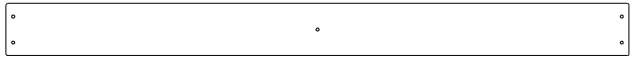

**M11 FLOOR BOARD - W4L18522**  
(x5) 5/8"x3 3/8"x40 5/8" (16x86x1031)

**TIP:**  
**PLACE BOARDS EVENLY**  
**BEFORE INSERTING SCREWS**

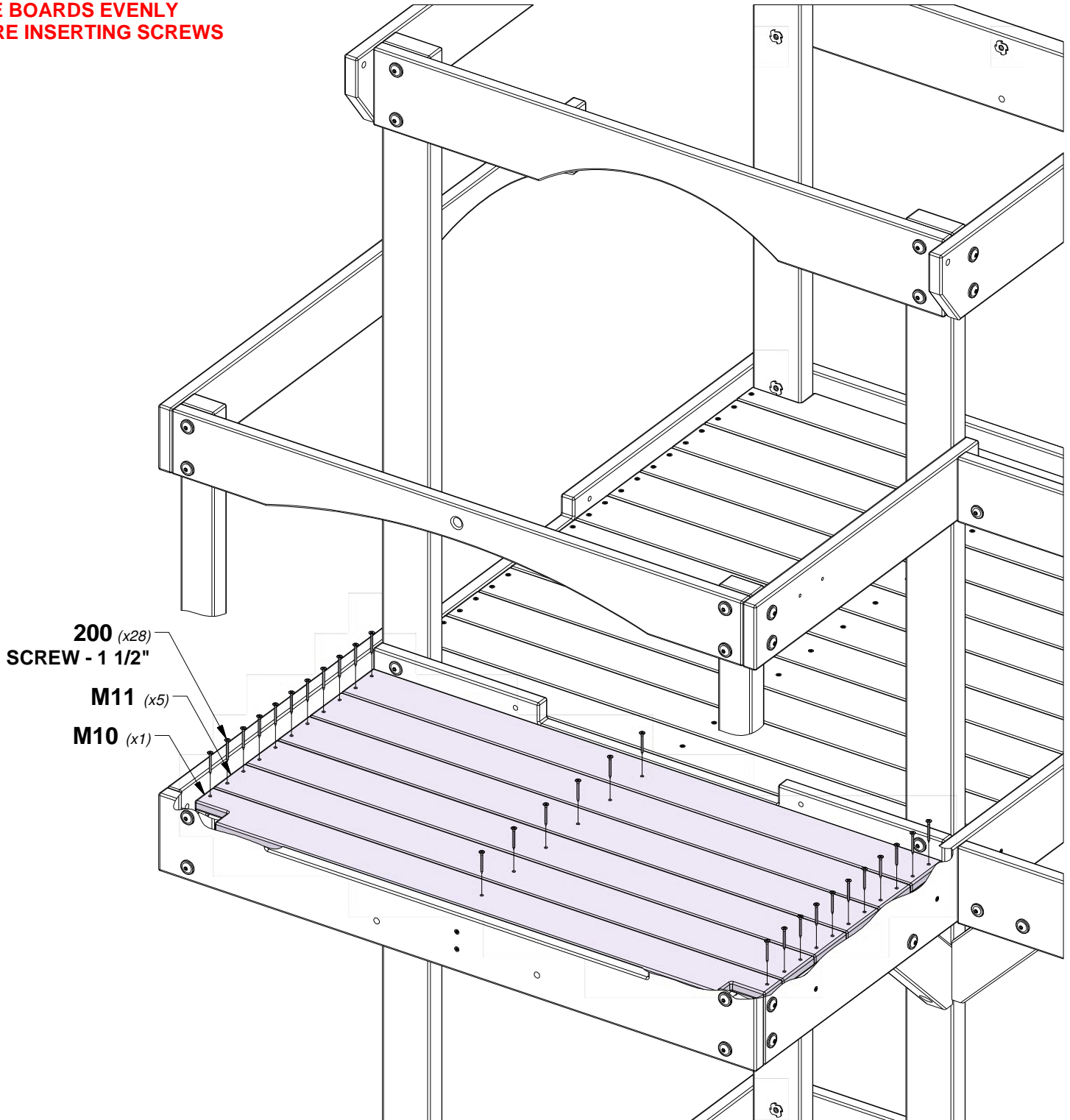



# STEP 18 - FORT ASSEMBLY

QTY	PART NUMBER	DESCRIPTION
6	H100382	SCREW PFH 8x1 3/4 BLK

**T01 SUPPORT BOARD - W4L18507**  
 (x1) 1"x1 3/8"x37 5/8" (24x34x957)

**T02 SUPPORT BOARD - W4L18508**  
 (x1) 1"x1 3/8"x37 3/4" (24x34x959)

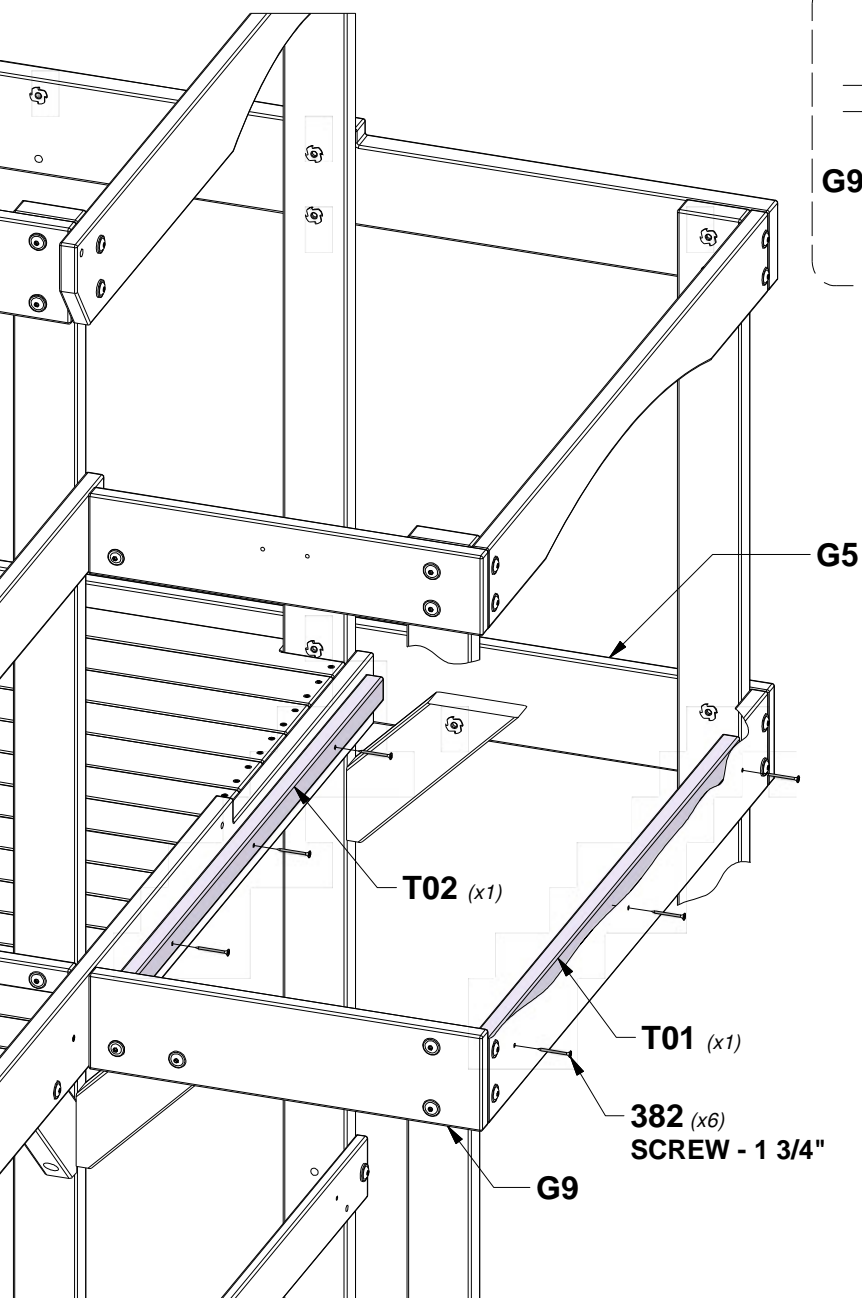
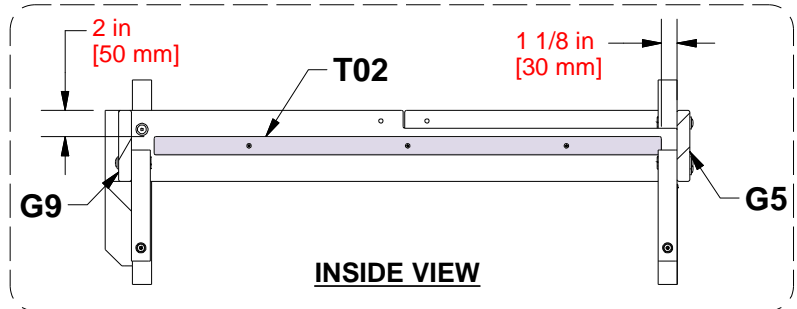
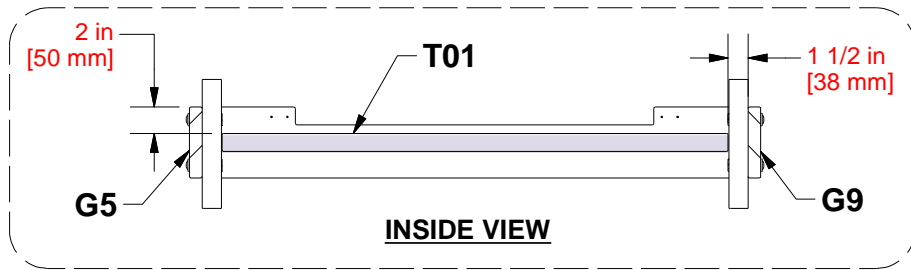

# STEP 19 - FORT ASSEMBLY

QTY	PART NUMBER	DESCRIPTION
44	H100200	SCREW PFH 8x1-1/2 BLK



**M08 FLOOR BOARD - W4L18526**  
(x1) 5/8"x3 1/4"x19 7/8" (16x82x504)



**M09 FLOOR BOARD - W4L18521**  
(x10) 5/8"x3 3/8"x19 7/8" (16x86x504)



**M13 FLOOR BOARD - W4L18525**  
(x1) 5/8"x3 1/4"x19 7/8" (16x82x504)

**TIP:**  
**PLACE BOARDS EVENLY**  
**BEFORE INSERTING SCREWS**

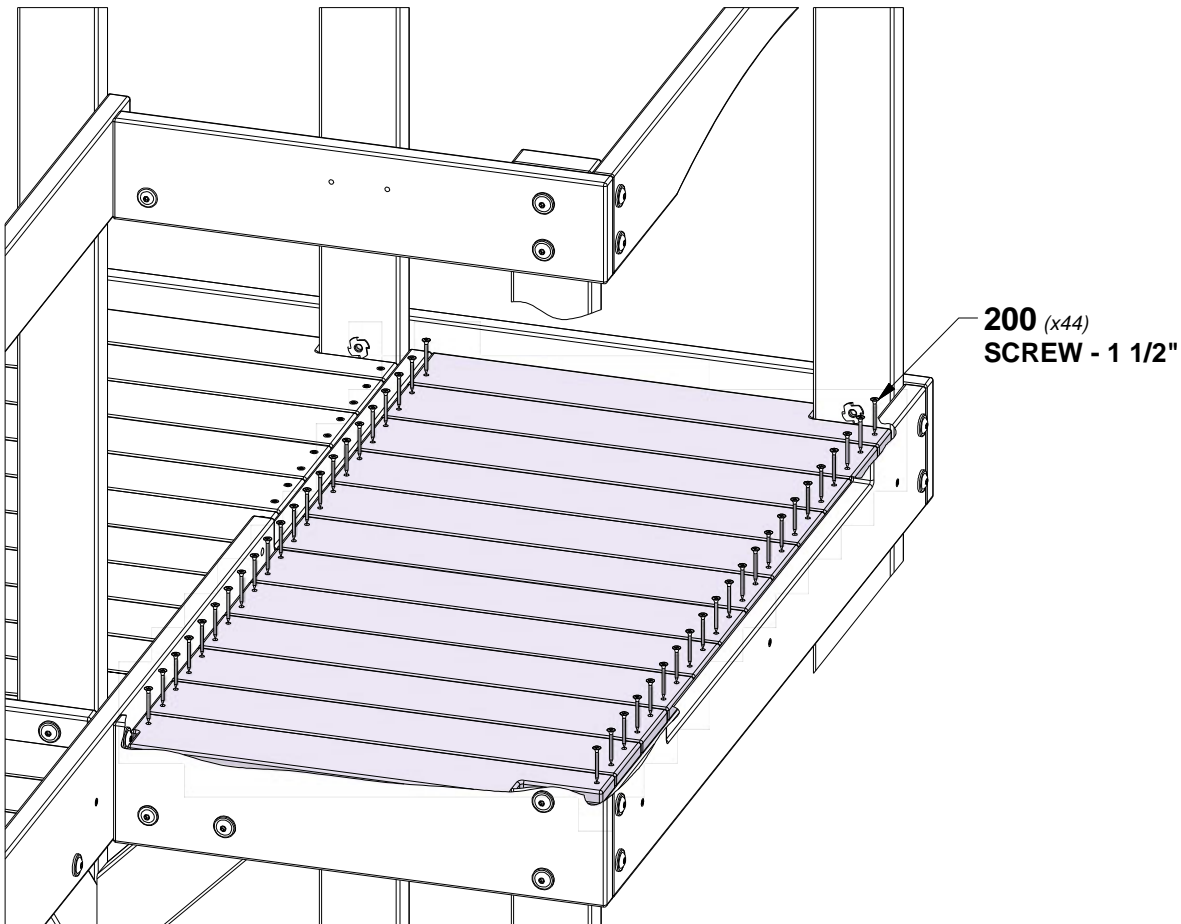
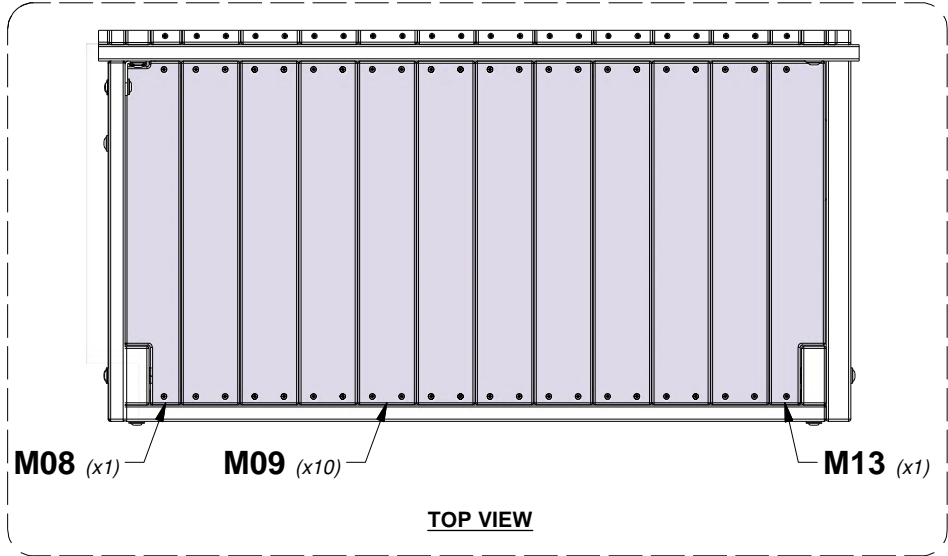



# STEP 20 - FORT ASSEMBLY

QTY	PART NUMBER	DESCRIPTION
6	H100398	T-NUT 1/4 BLK
6	H100405	WASHER LOCK EXT 6x15 BLK
6	H100406	BOLT WH 1/4x1 1/2 BLK

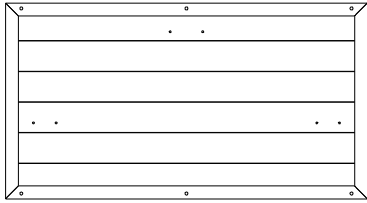

**WP01 WALL PANEL - W2A03778**  
 (x1) 1"x20 3/8"x37 3/4" (24x517x958)

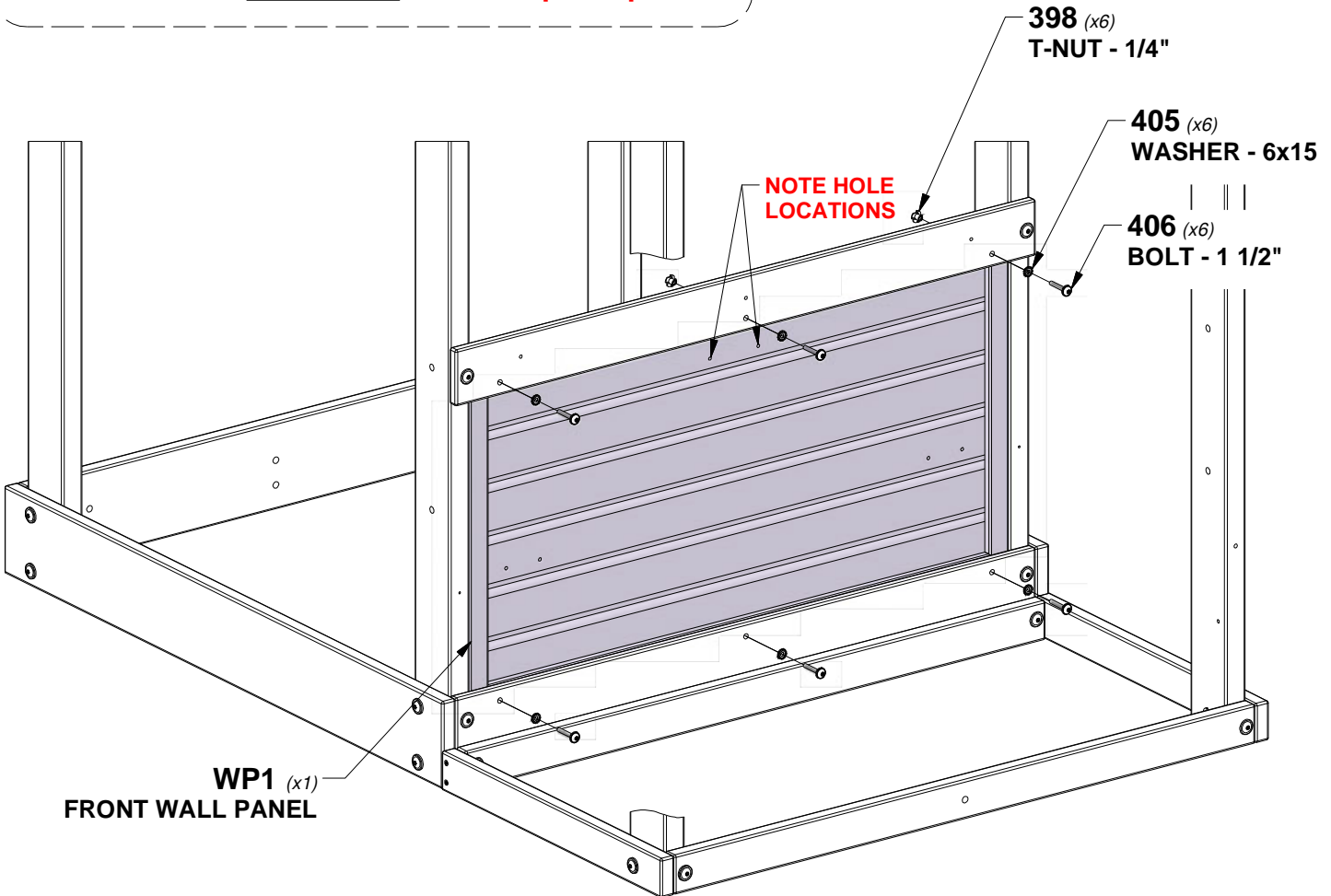
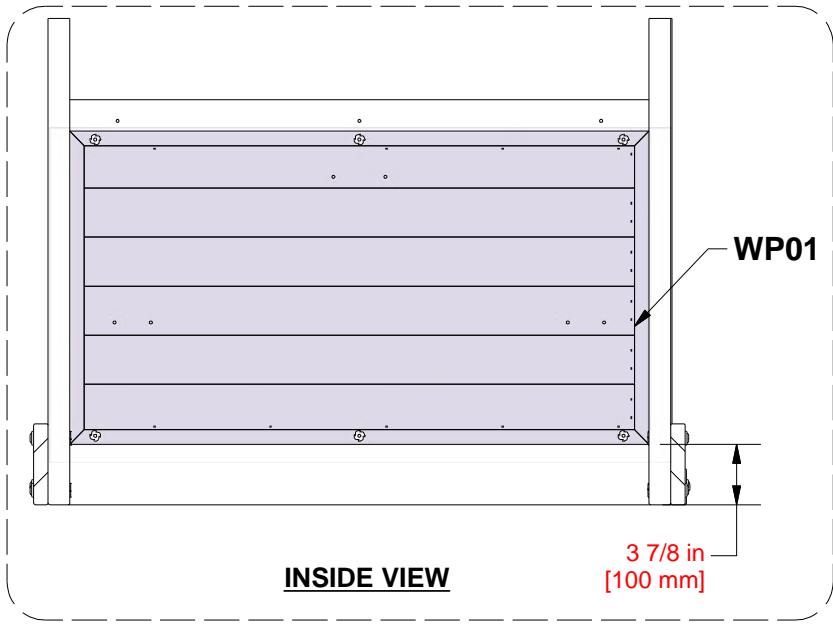

# STEP 21 - FORT ASSEMBLY

QTY	PART NUMBER	DESCRIPTION
3	H100387	SCREW PFH 8x1-1/4 BLK

**T04 SUPPORT BOARD - W4L18515**  
(x1) 1"x1 3/8"x37 3/4" (24x34x958)

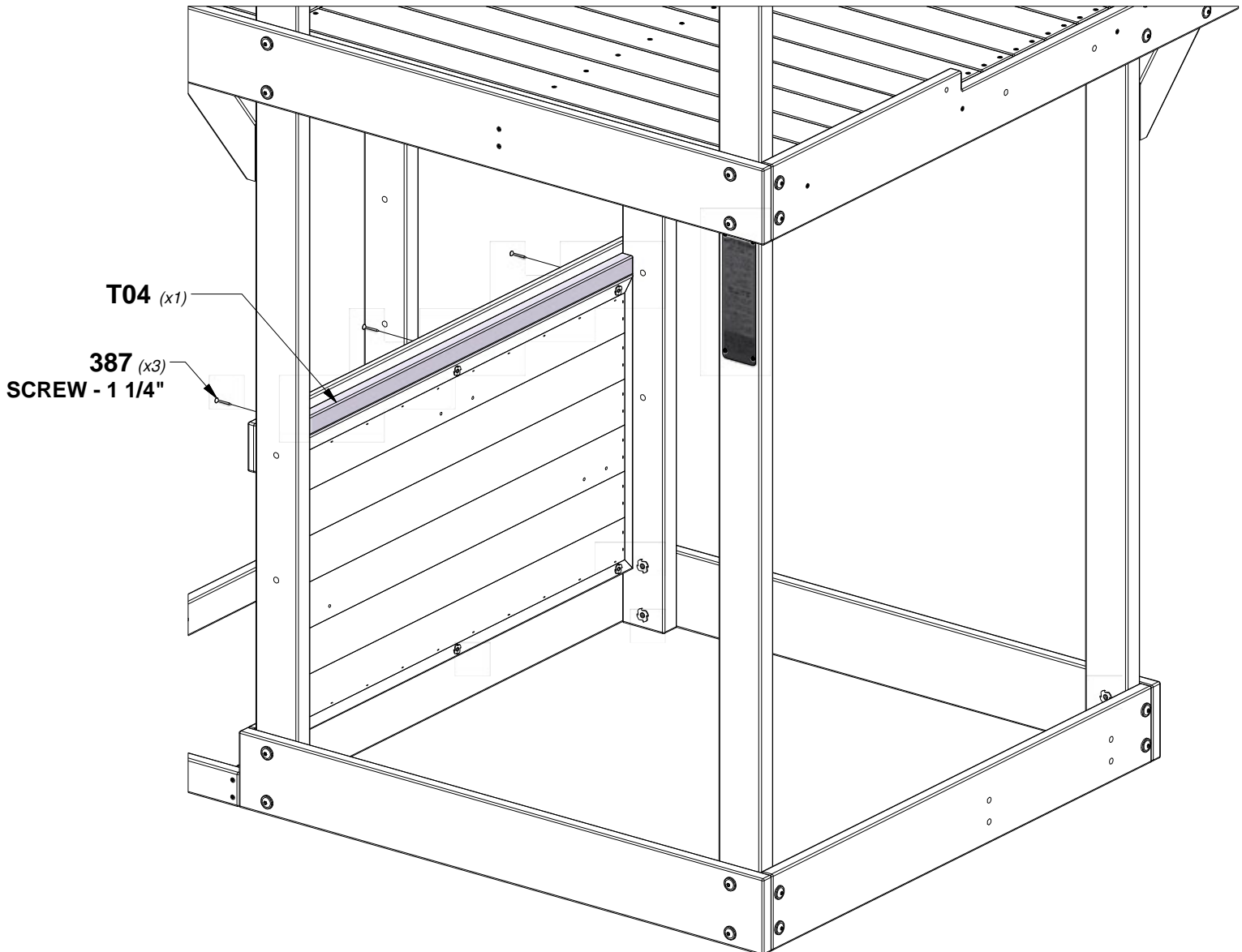

# STEP 22 - FORT ASSEMBLY

QTY	PART NUMBER	DESCRIPTION
4	H100387	SCREW PFH 8x1-1/4 BLK

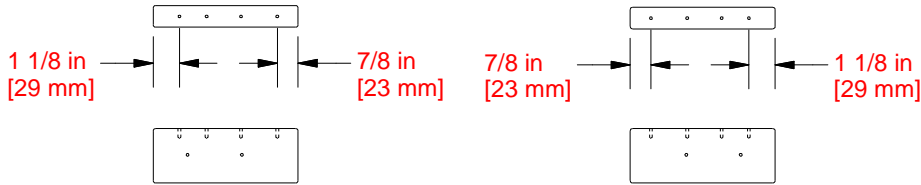

**J6 SUPPORT BLOCK - W4L17817**  
 (x1) 1"x2 3/8"x6 1/4" (24x60x160)

**J11 SUPPORT BLOCK - W4L17818**  
 (x1) 1"x2 3/8"x6 1/4" (24x60x160)

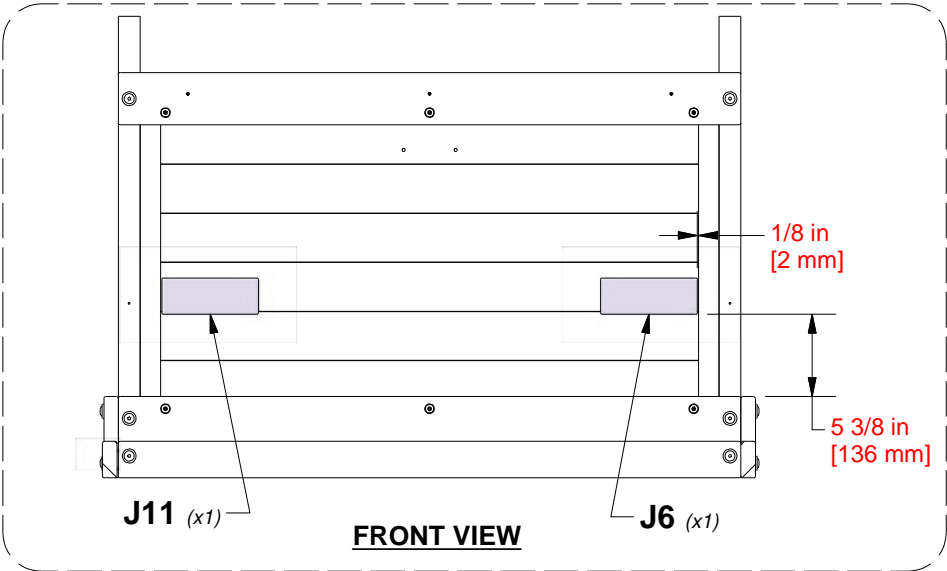

**TIP:**  
 ALIGN PILOT HOLES IN WALL PANEL TO  
 PILOT HOLES IN (J) BOARDS.

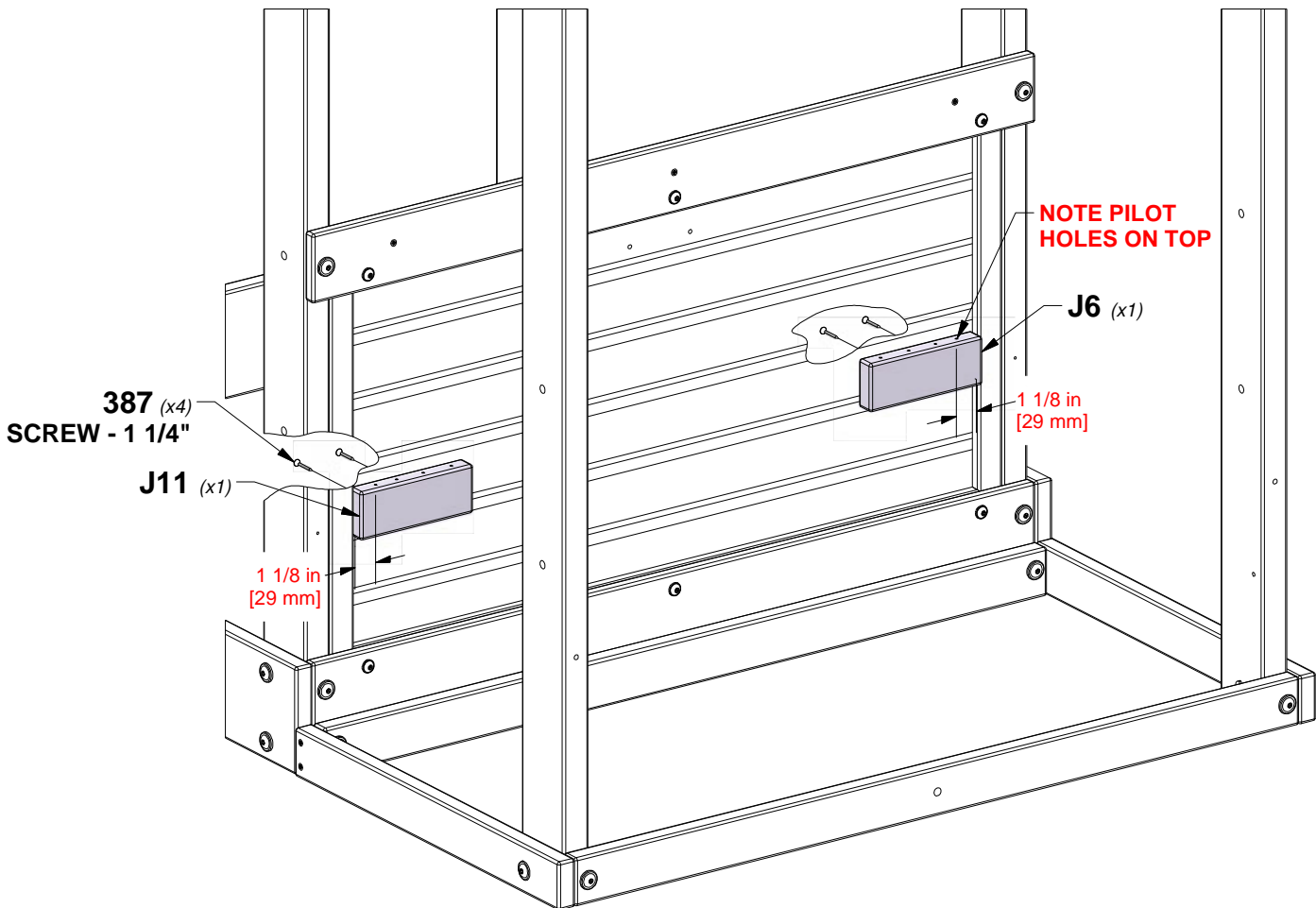

# STEP 23 - FORT ASSEMBLY

QTY	PART NUMBER	DESCRIPTION
1	H100195	BOLT WH 5/16x2-3/4 BLK
1	H100198	WASHER LOCK EXT 8x19 BLK
1	H100379	T-NUT 5/16 BLK



**H1 TABLE SUPPORT - W4L11147**  
 (x1) 1"x3 3/8"x22 3/8" (24x86x567)

**J7 SUPPORT BLOCK - W4L11158**  
 (x1) 1"x2 3/8"x3 3/8" (24x60x86)

**TIP:**  
**INSTALL T-NUTS IN WOOD FIRST**

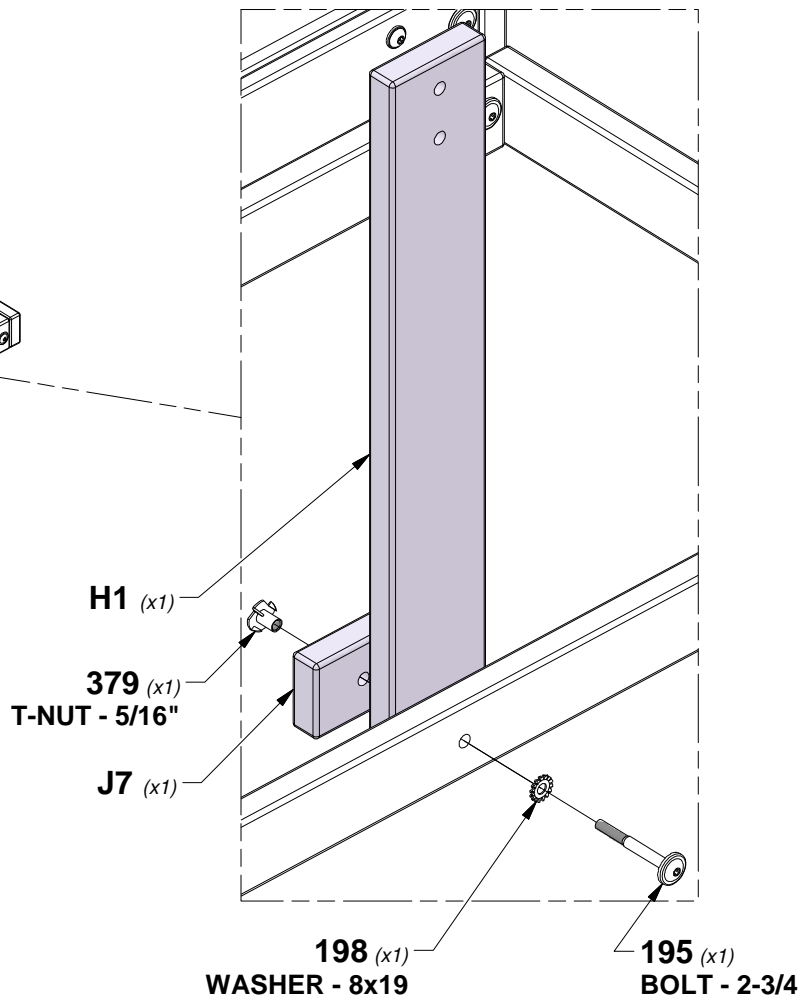
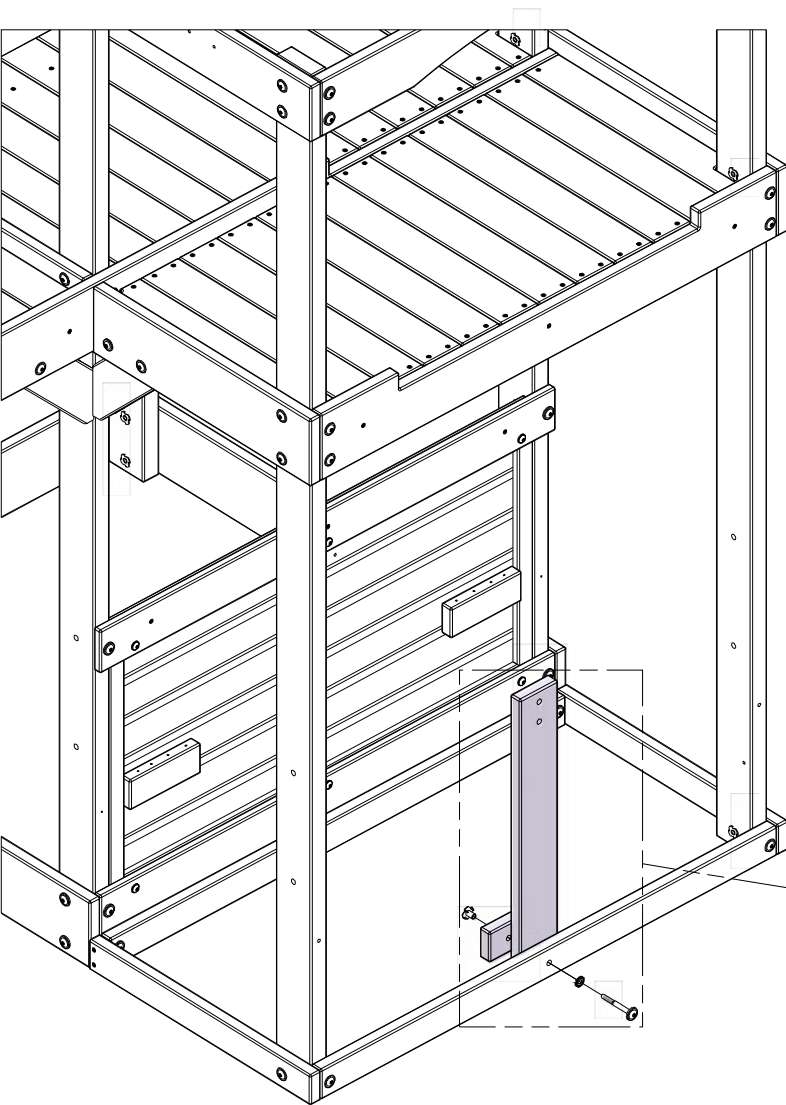

# STEP 24 - FORT ASSEMBLY

QTY	PART NUMBER	DESCRIPTION
42	H100200	SCREW PFH 8x1-1/2 BLK

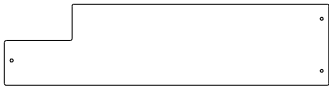

**K17 FLOOR BOARD - W4L18523**  
(x2) 5/8"x5 1/4"x21 1/8" (16x134x537)

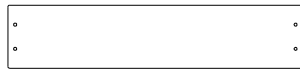

**L05 FLOOR BOARD - W4L18524**  
(x1) 5/8"x4 1/8"x19 1/4" (16x104x488)



**M04 FLOOR BOARD - W4L18506**  
(x8) 5/8"x3 3/8"x21 1/8" (16x86x537)

**TIP:**  
**PLACE BOARDS EVENLY**  
**BEFORE INSERTING SCREWS**

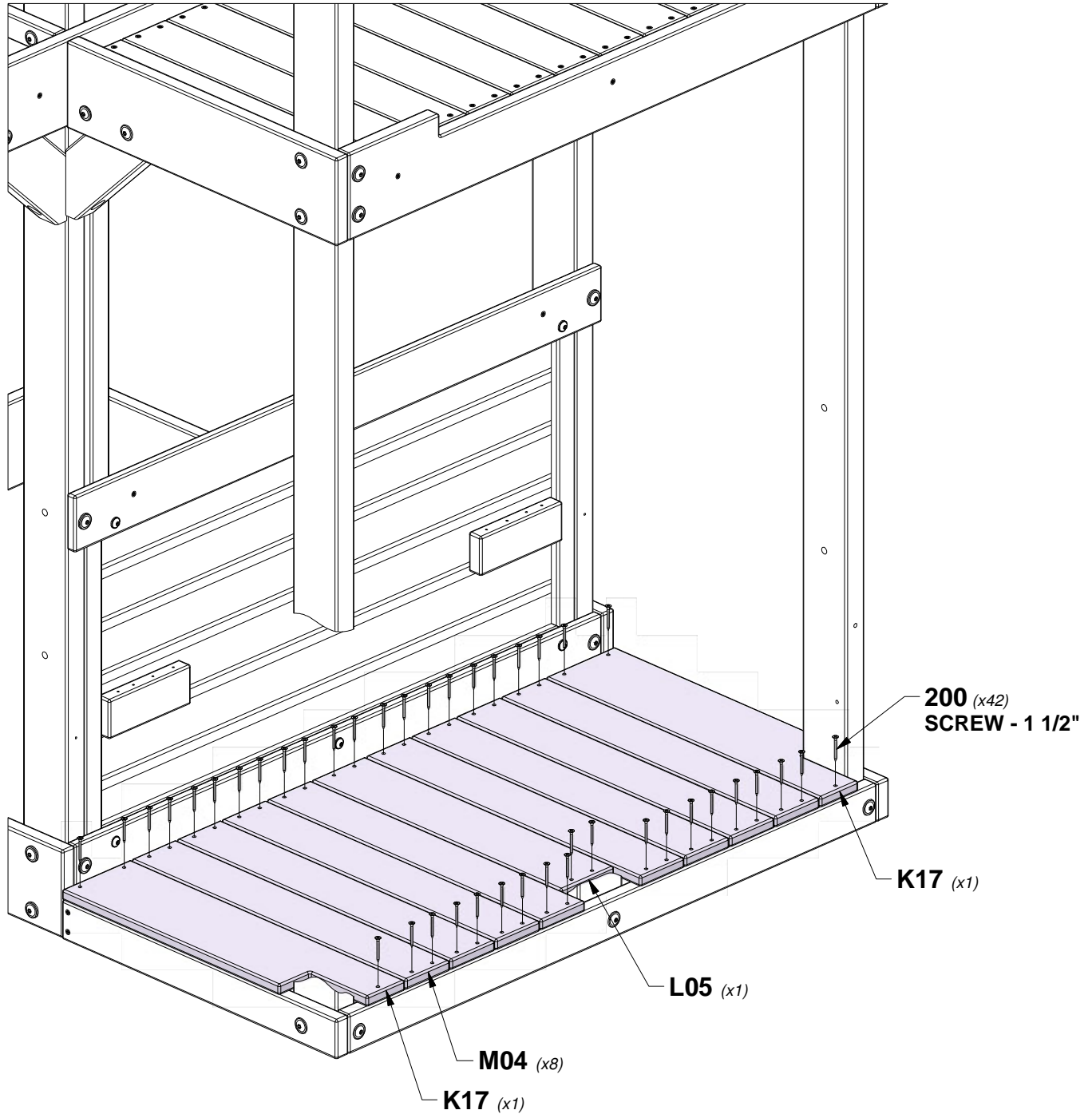

# STEP 25 - FORT ASSEMBLY

QTY	PART NUMBER	DESCRIPTION
4	H100198	WASHER LOCK EXT 8x19 BLK
2	H100205	BOLT WH 5/16x2-1/4 BLK
2	H100379	T-NUT 5/16 BLK
4	H100382	SCREW PFH 8x1 3/4 BLK
2	H100405	WASHER LOCK EXT 6x15 BLK
2	H100458	LAG SCREW WH 5/16x2 BLK
2	H100487	LAG SCREW WH 1/4x2 BLK

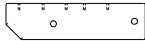

**J3 BENCH SUPPORT - W4L18017**  
(x2) 1"x2 3/8"x9" (24x60x230)



**J5 SUPPORT BLOCK - W4L18022**  
(x2) 1"x2 3/8"x2 7/8" (24x60x72)



**F5 ANGLE BRACE - W4L17822**  
(x2) 1 3/8"x2 3/8"x9 1/2" (36x60x240)

**TIP:**  
**INSTALL T-NUTS IN WOOD FIRST**

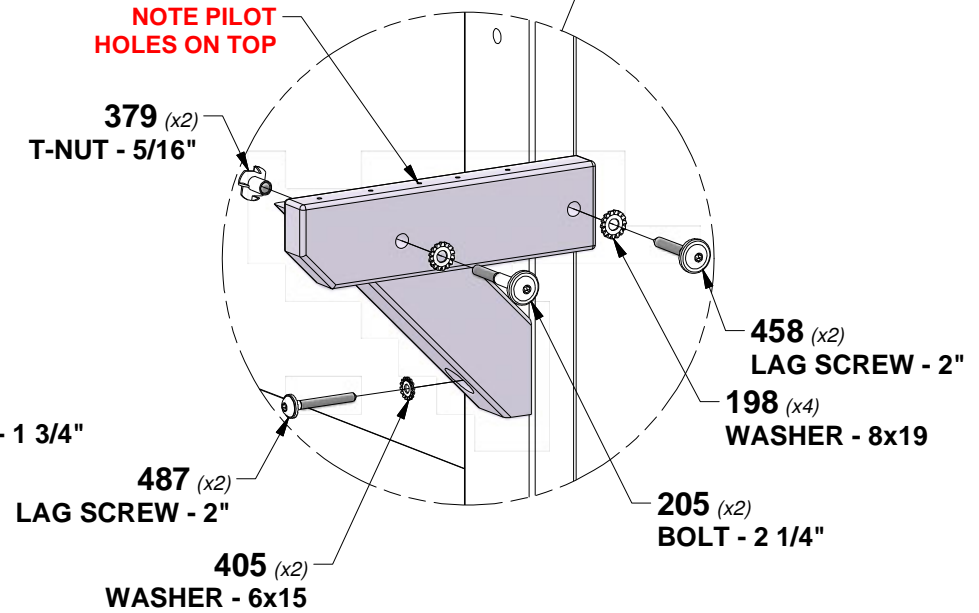
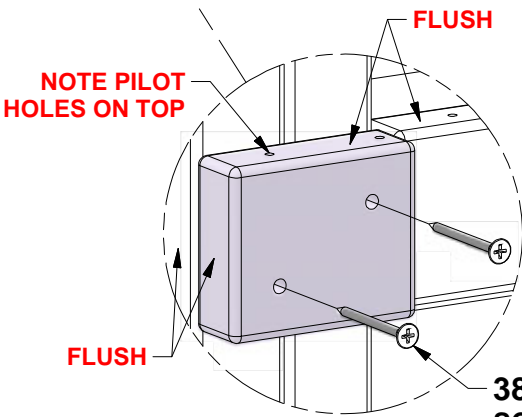
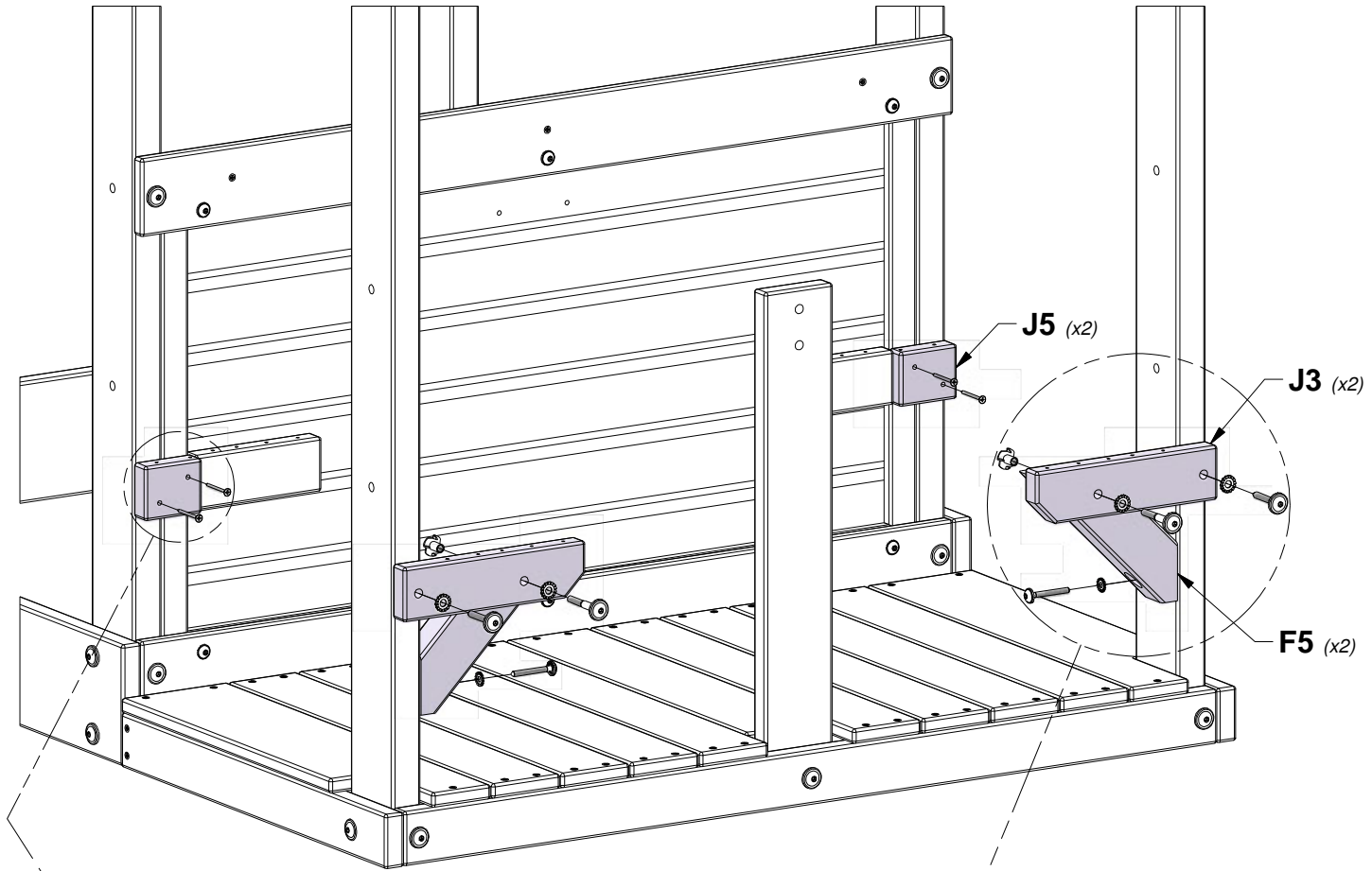

# STEP 26 - FORT ASSEMBLY

QTY	PART NUMBER	DESCRIPTION
22	H100382	SCREW PFH 8x1 3/4 BLK

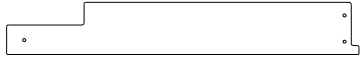

**H06 BENCH BOARD - W4L18518**  
(x2) 1"x3 3/8"x23" (24x86x583)



**H07 BENCH BOARD - W4L18519**  
(x2) 1"x2 3/8"x23" (24x60x583)



**H08 BENCH BOARD - W4L18520**  
(x2) 1"x3 3/8"x23" (24x86x583)

**TIP:**  
**ALIGN PILOT HOLES BEFORE INSERTING SCREWS**

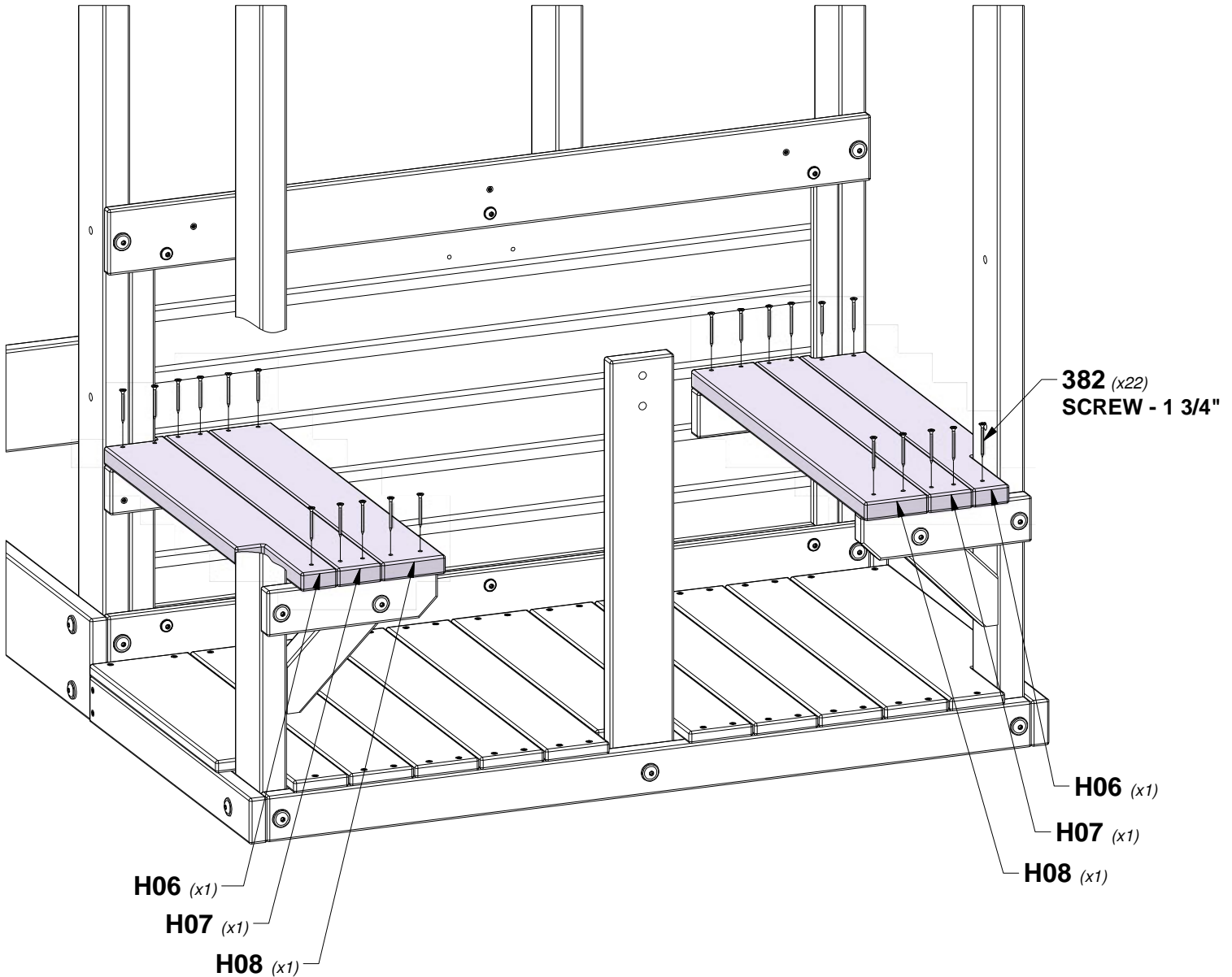



# STEP 27 - FORT ASSEMBLY

QTY	PART NUMBER	DESCRIPTION
12	H100200	SCREW PFH 8x1-1/2 BLK
2	H100387	SCREW PFH 8x1-1/4 BLK
2	H100198	WASHER LOCK EXT 8x19 BLK
2	H100378	BOLT WH 5/16x1 3/4 BLK
2	H100379	T-NUT 5/16 BLK

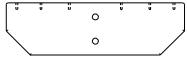

**H2 TABLE SUPPORT - W4L18018**  
(x1) 1"x3 3/8"x11 5/8" (24x86x295)

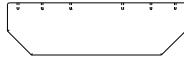

**H3 TABLE SUPPORT - W4L18021**  
(x1) 1"x3 3/8"x11 5/8" (24x86x295)



**K16 TABLE BOARD - W4L18530**  
(x1) 5/8"x5 1/4"x23" (16x134x583)



**M03 BENCH BOARD - W4L18529**  
(x2) 5/8"x3 3/8"x23" (16x86x583)

**TIP:**  
INSTALL T-NUTS IN WOOD FIRST.  
ALIGN PILOT HOLES.

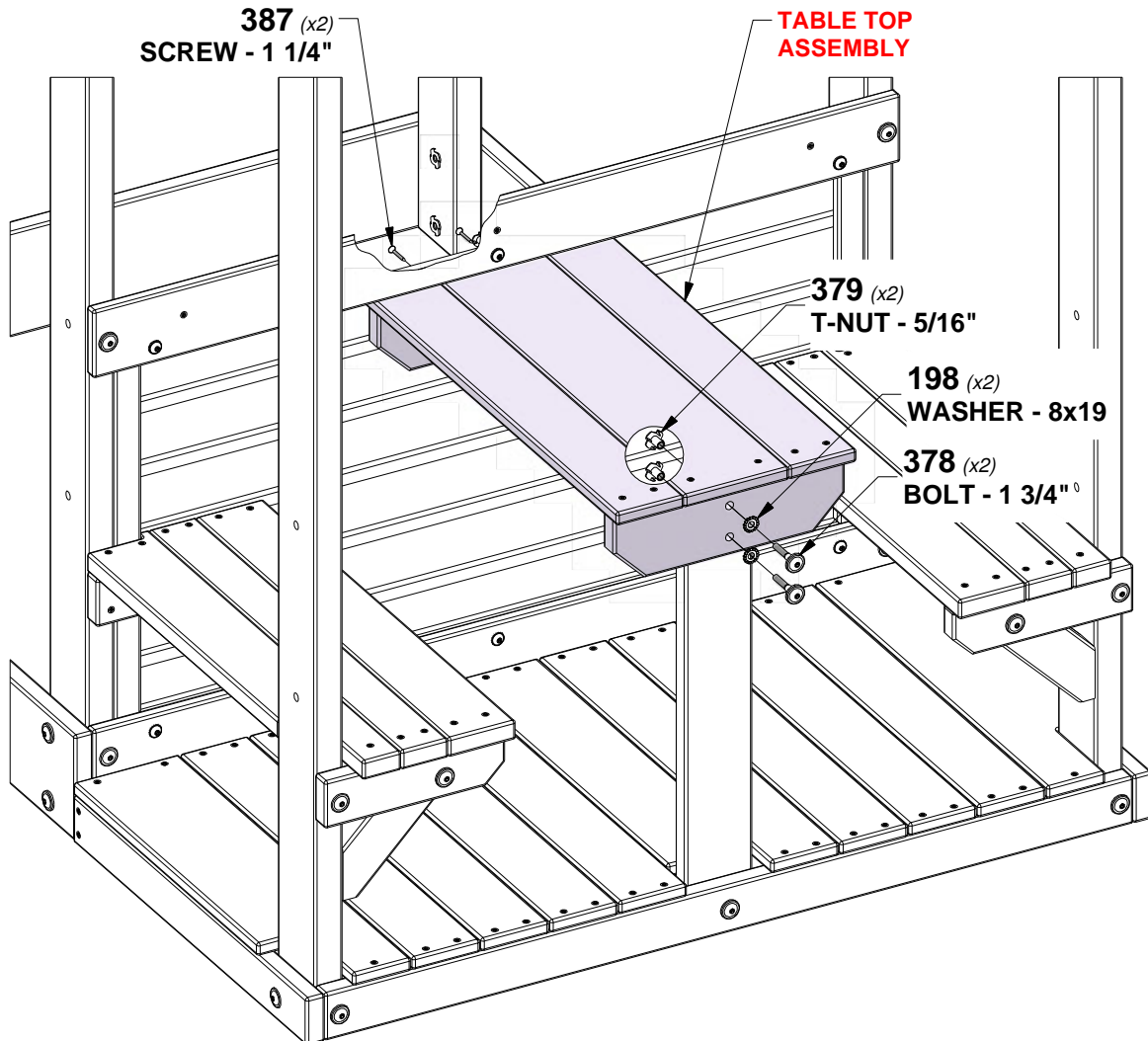
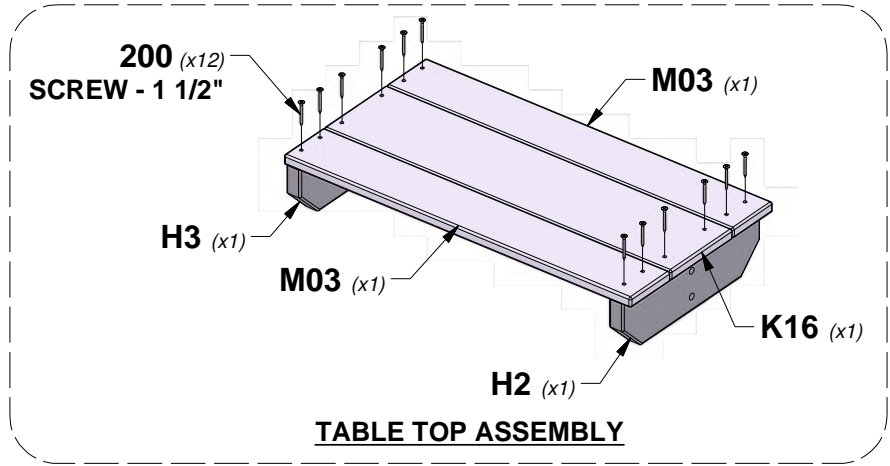



# STEP 28 - FORT ASSEMBLY

QTY	PART NUMBER	DESCRIPTION
8	H100382	SCREW PFH 8x1 3/4 BLK

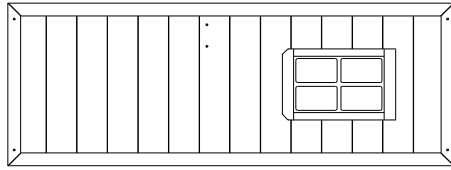
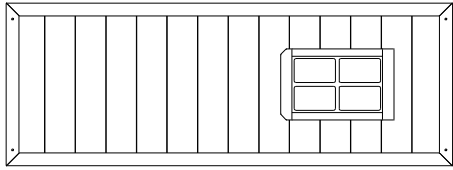

**WP02 WALL PANEL - W2A03779**

**WP11 WALL PANEL - W2A03788**

(x1) 1"x16 7/8"x46 1/2" (24x430x1181)

(x1) 1"x16 7/8"x46 1/2" (24x430x1181)

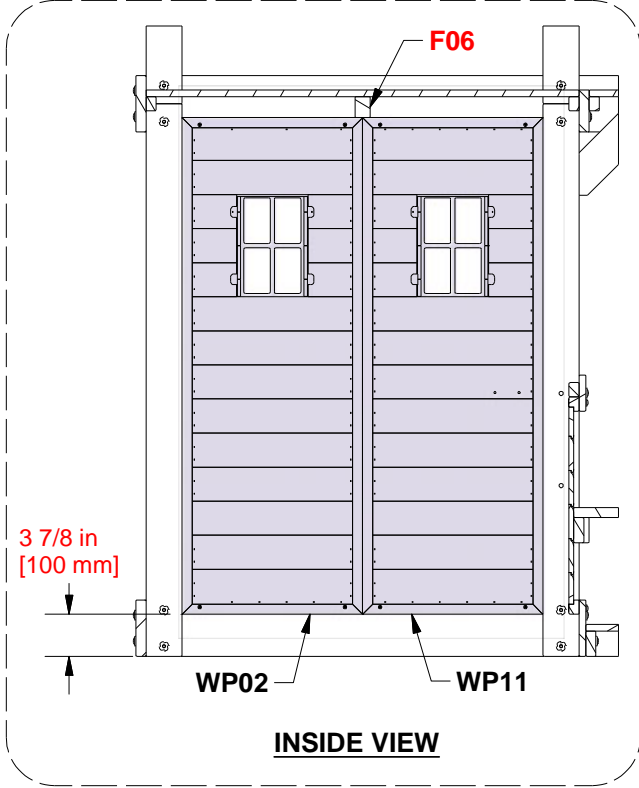

**FLUSH TOP OF PANELS TO BOTTOM OF (F06)**

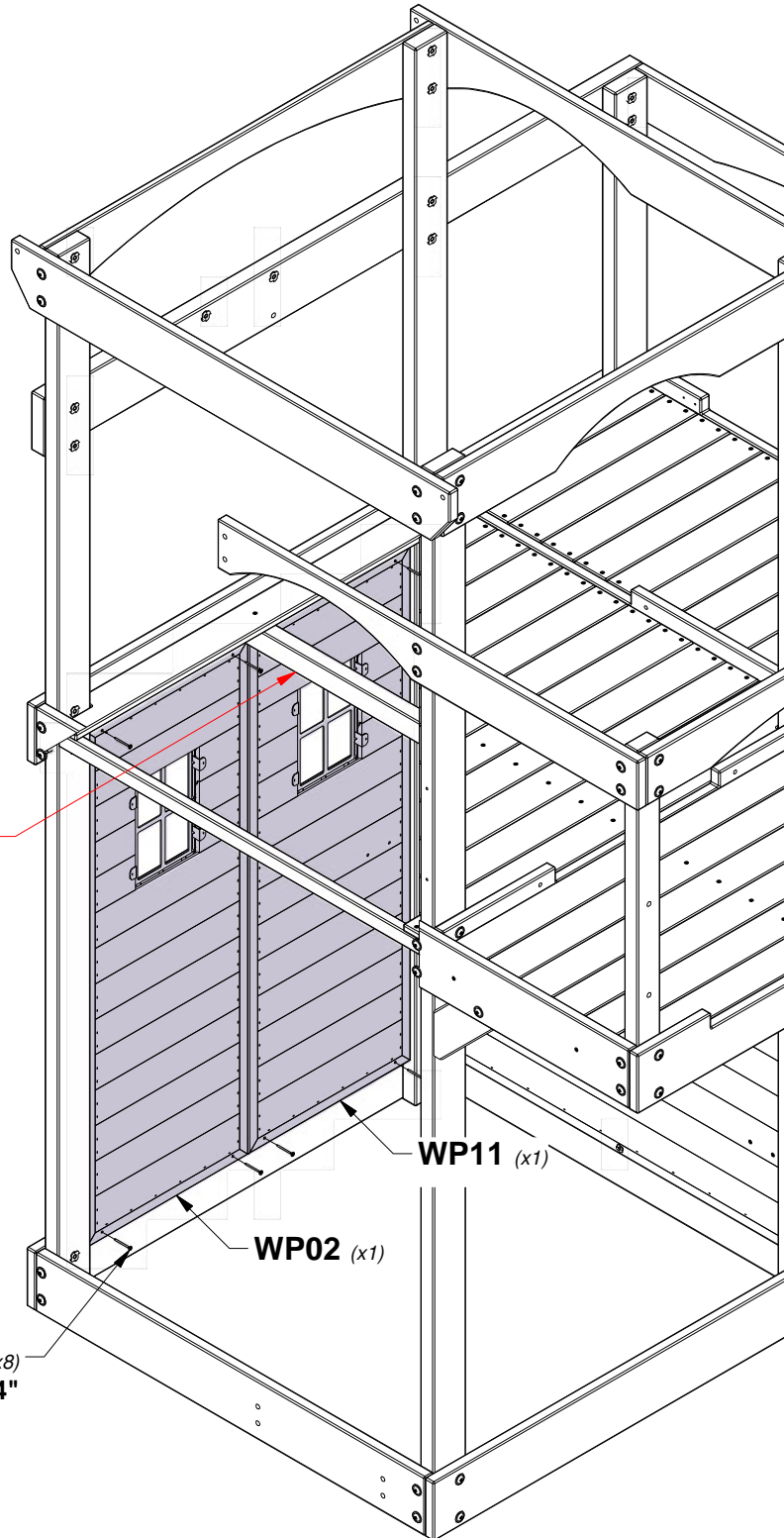

# STEP 29 - FORT ASSEMBLY

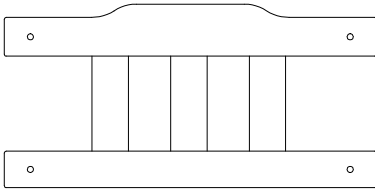

**F03 SUPPORT BLOCK - W4L18516**  
 (x1) 1 3/8"x2 3/8"x9 1/4" (36x60x234)

**WP10 BENCH BACK ASSEMBLY - W2A037777**  
 (x1) 1 1/8"x11 7/8"x24 1/4" (27x303x615)

QTY	PART NUMBER	DESCRIPTION
1	H100195	BOLT WH 5/16x2-3/4 BLK
4	H100198	WASHER LOCK EXT 8x19 BLK
3	H100200	SCREW PFH 8x1-1/2 BLK
4	H100379	T-NUT 5/16 BLK
3	H100457	BOLT WH 5/16x2 BLK

**TIP:**  
**INSTALL T-NUTS IN WOOD FIRST**

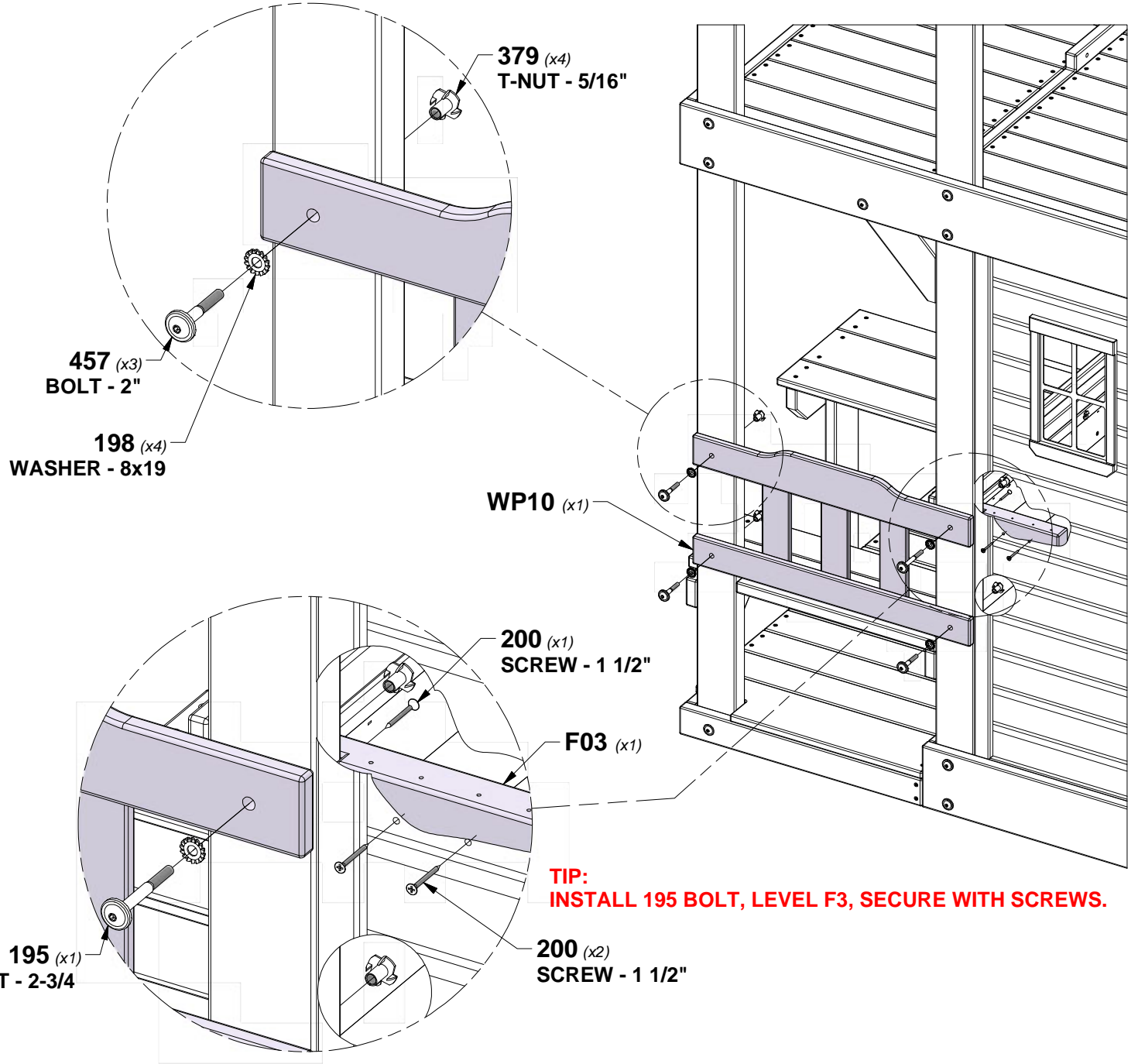

# STEP 30 - FORT ASSEMBLY

QTY	PART NUMBER	DESCRIPTION
4	H100382	SCREW PFH 8x1 3/4 BLK

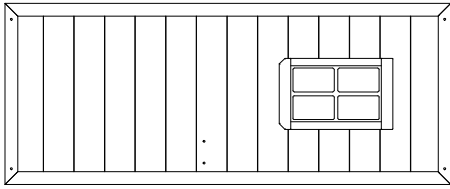

**WP12 WALL PANEL - W2A03789**  
 (x1) 1"x16 7/8"x46 1/2" (24x479x1181)

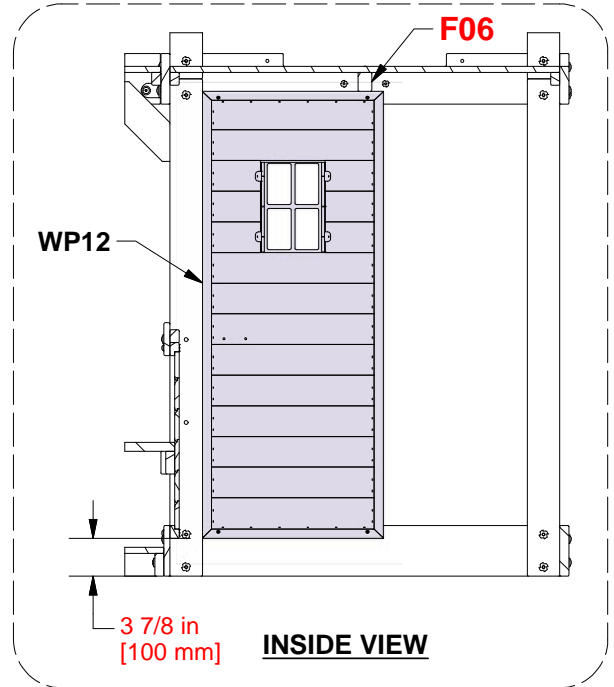
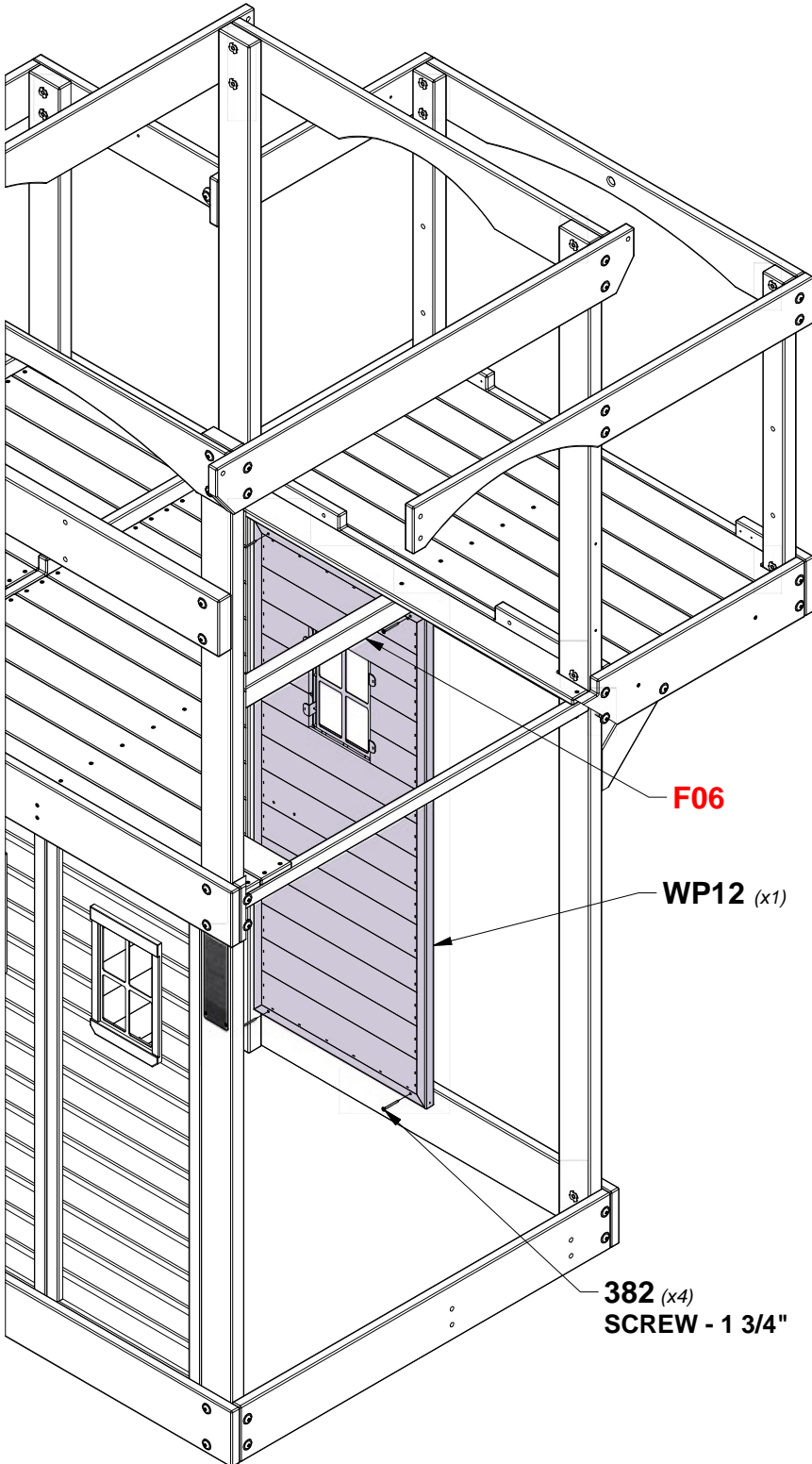

# STEP 31 - FORT ASSEMBLY

QTY	PART NUMBER	DESCRIPTION
1	H100195	BOLT WH 5/16x2-3/4 BLK
4	H100198	WASHER LOCK EXT 8x19 BLK
3	H100200	SCREW PFH 8x1-1/2 BLK
4	H100379	T-NUT 5/16 BLK
3	H100457	BOLT WH 5/16x2 BLK

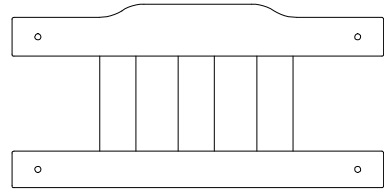

**F04 SUPPORT BLOCK - W4L18517**  
 (x1) 1 3/8"x2 3/8"x9 1/4" (36x60x234)

**WP10 BENCH BACK ASSEMBLY - W2A037777**  
 (x1) 1 1/8"x11 7/8"x24 1/4" (27x303x615)

**TIP:**  
**INSTALL T-NUTS IN WOOD FIRST**

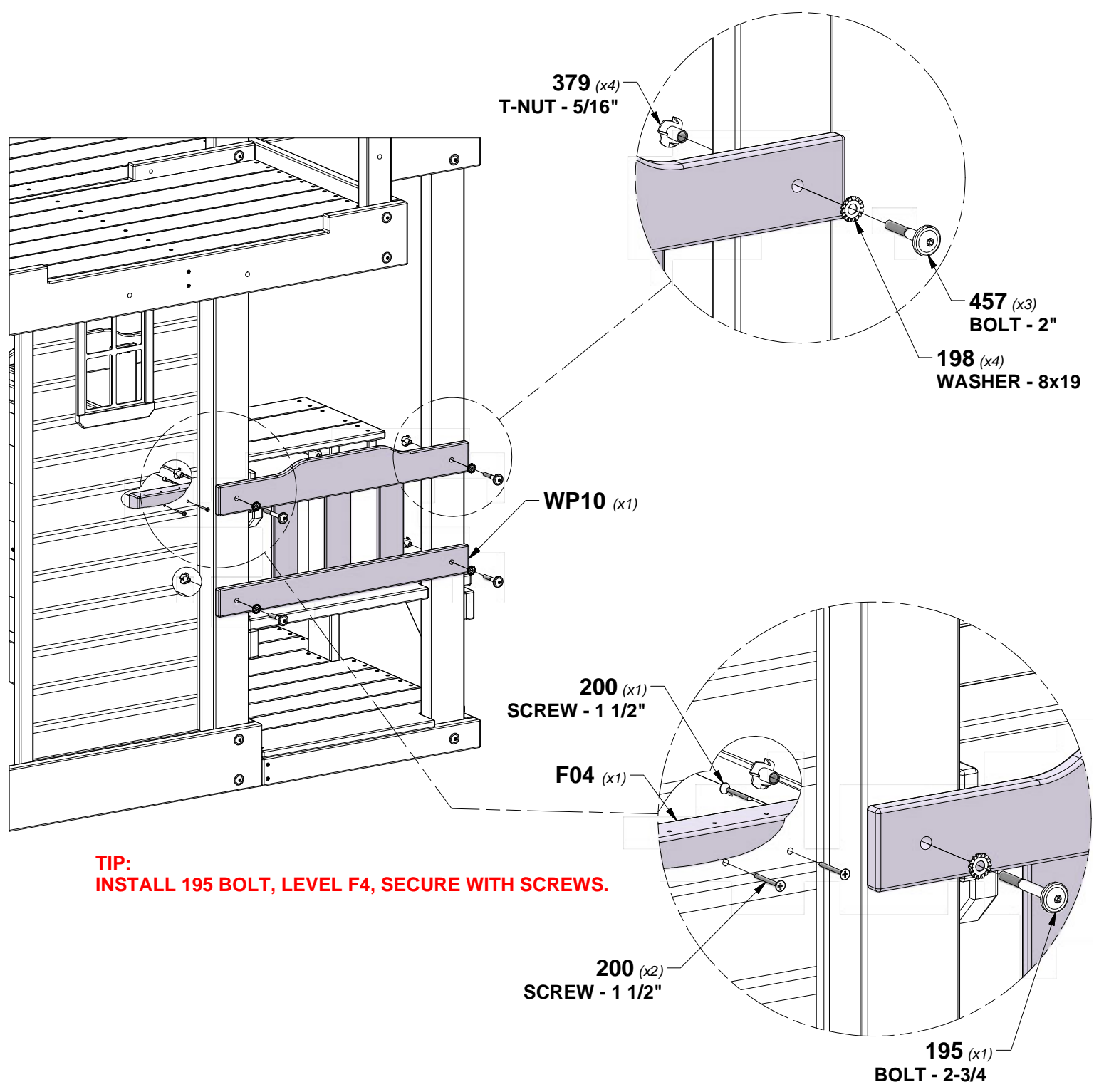

**TIP:**  
**INSTALL 195 BOLT, LEVEL F4, SECURE WITH SCREWS.**

# STEP 32 - FORT ASSEMBLY

QTY	PART NUMBER	DESCRIPTION
14	H100200	SCREW PFH 8x1-1/2 BLK



**M06 COUNTER TOP - W4L18511**  
(x1) 5/8"x3 3/8"x37 5/8" (16x86x957)



**M07 COUNTER TOP - W4L18512**  
(x2) 5/8"x3 3/8"x38 5/8" (16x86x981)

**TIP:**  
**ALIGN PILOT HOLES**

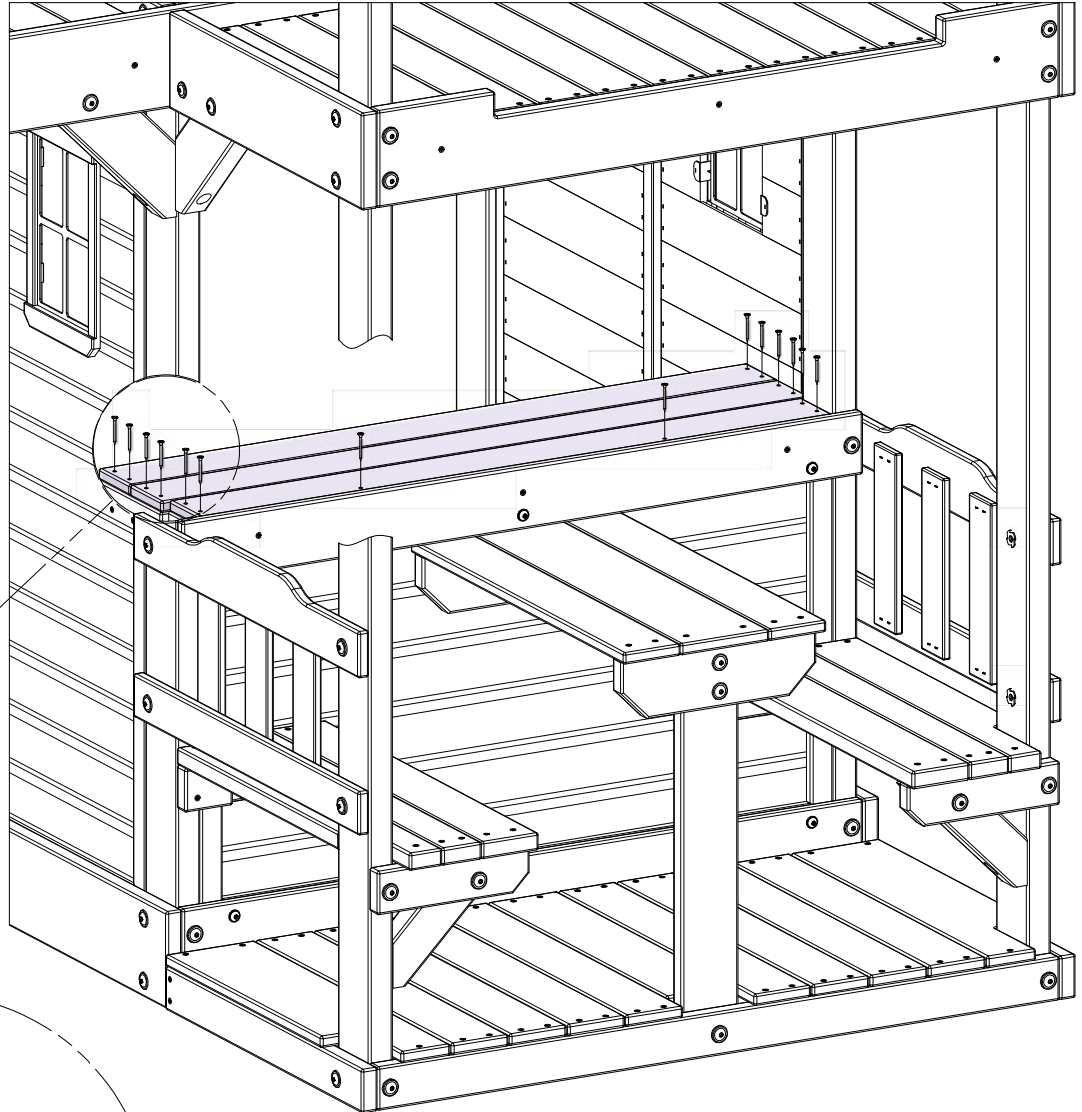

**200 (x14)**  
**SCREW - 1 1/2"**

**M07 (x2)**

**M06 (x1)**

# STEP 33 - FORT ASSEMBLY

QTY	PART NUMBER	DESCRIPTION
4	H100382	SCREW PFH 8x1 3/4 BLK

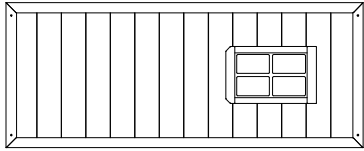

**WP09 WALL PANEL - W2A03781**  
 (x1) 1"x16 7/8"x46 1/2" (24x479x1181)

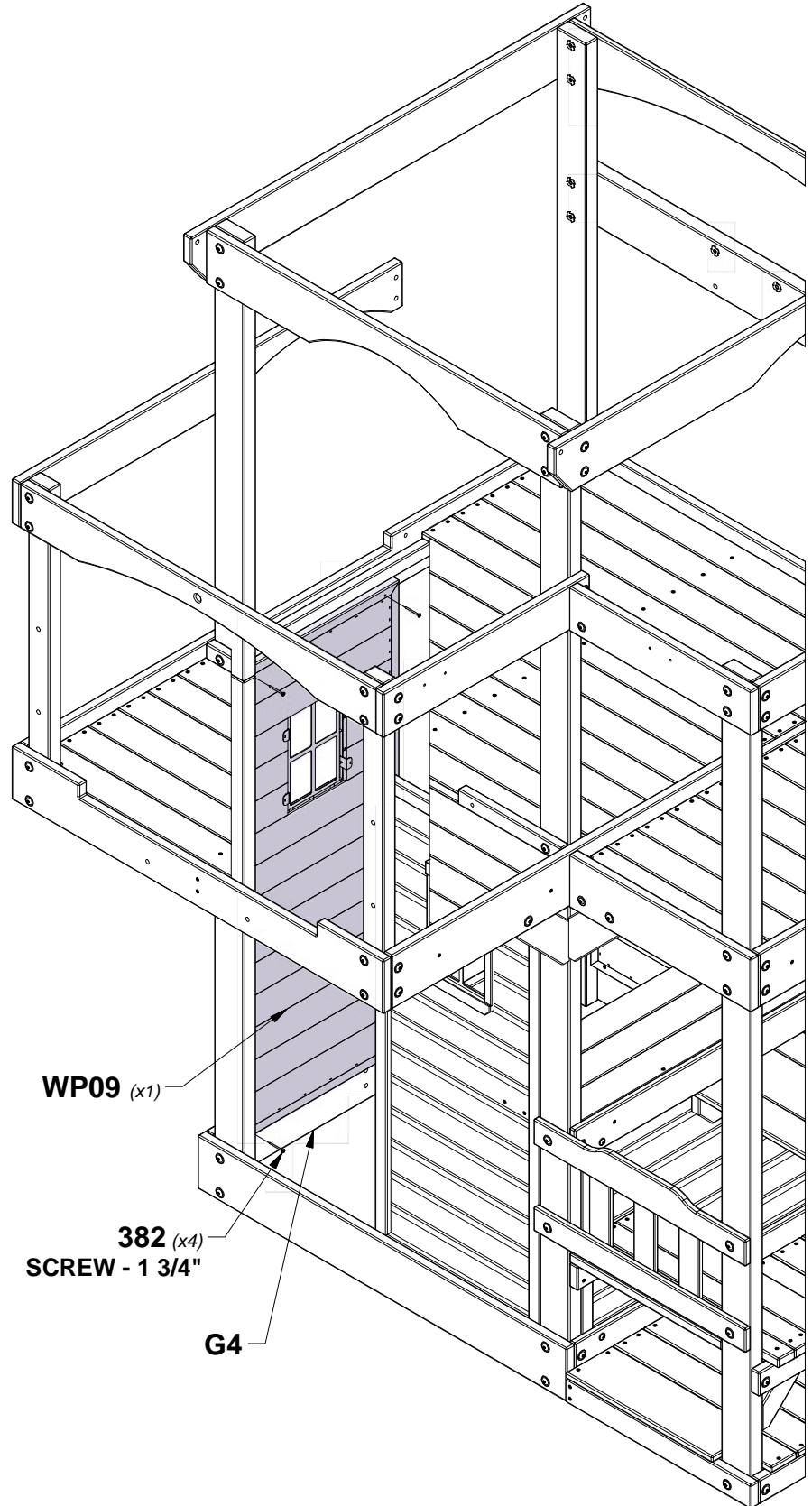
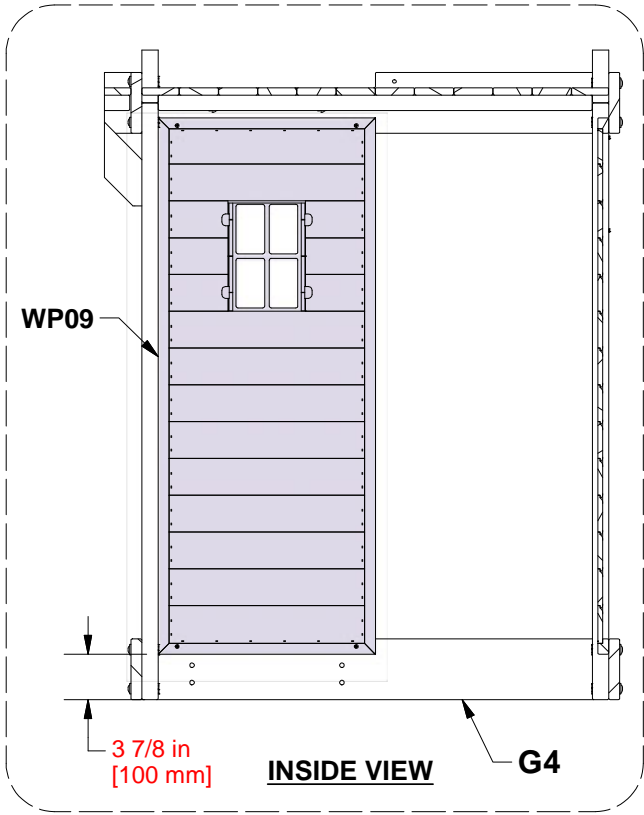



# STEP 34 - FORT ASSEMBLY

QTY	PART NUMBER	DESCRIPTION
2	H100538	SCREW PFH 8x1 1/2 SD
2	H100544	SCREW PWH 8x5/8 SD

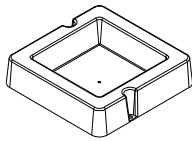
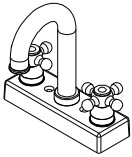

**A6P00024**  
(x1) **FAUCET KIT**

**A6P00032**  
(x1) **SURFACE MOUNT BASIN**

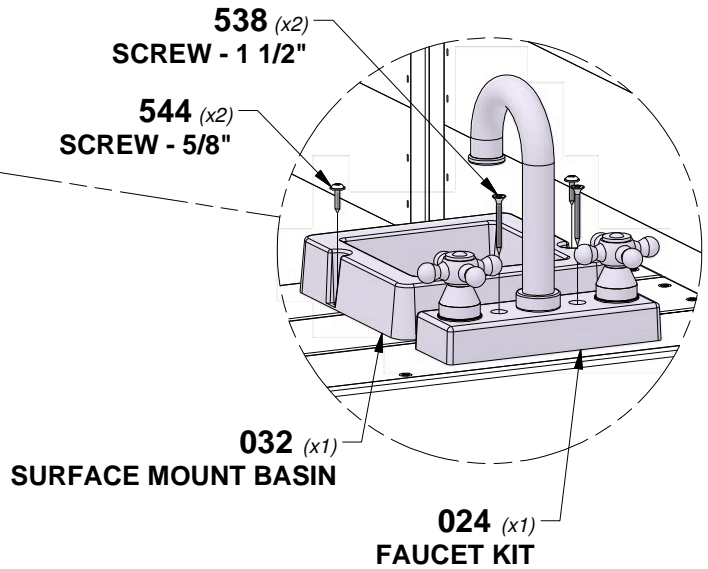
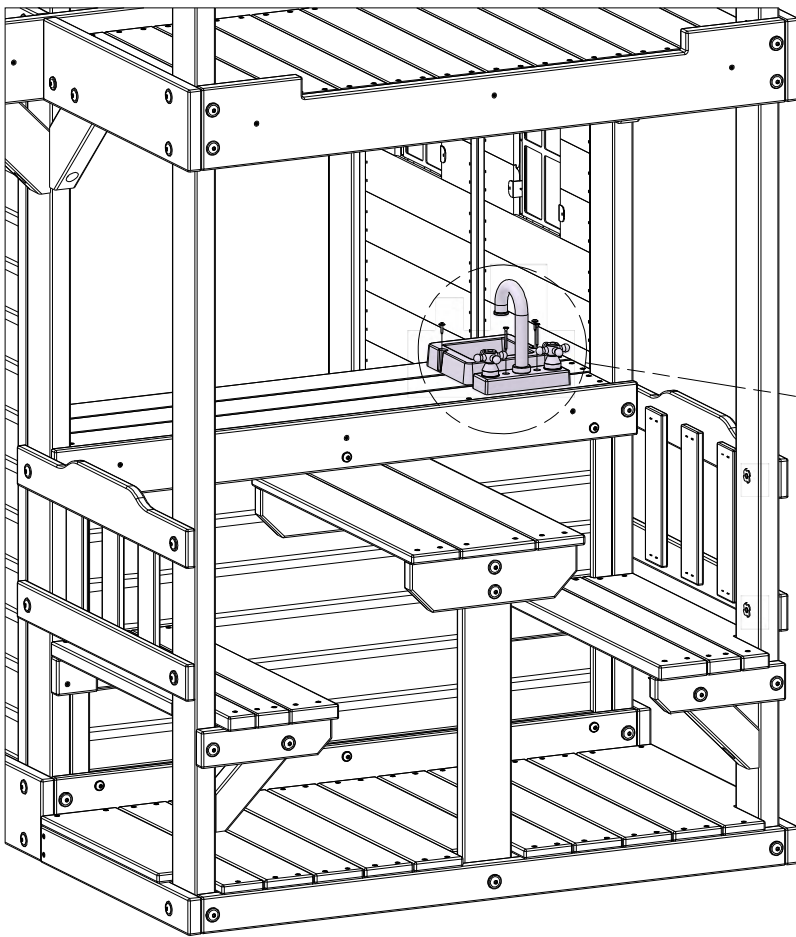
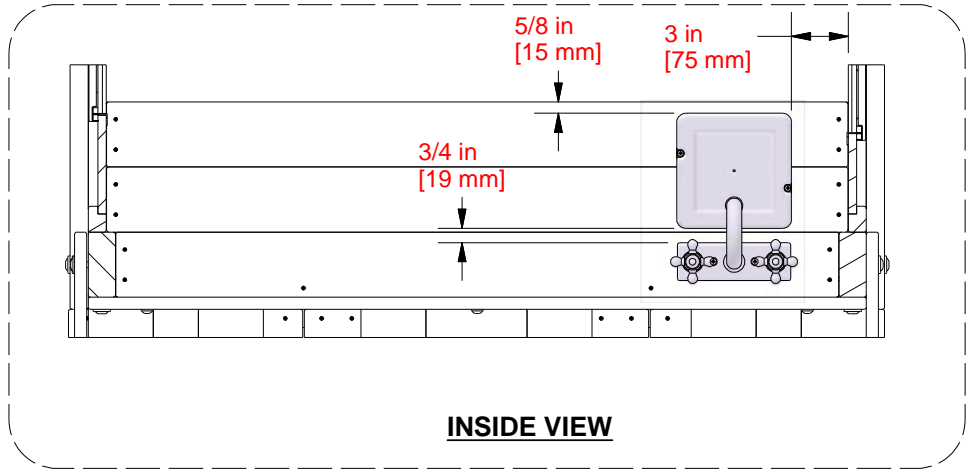

# STEP 35 - FORT ASSEMBLY

QTY	PART NUMBER	DESCRIPTION
4	H100544	SCREW PWH 8x5/8 SD

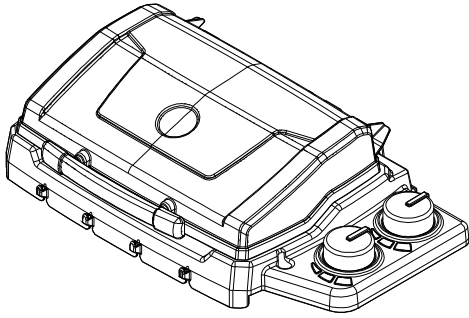

**A6P00282** BBQ GRILL  
(x1)

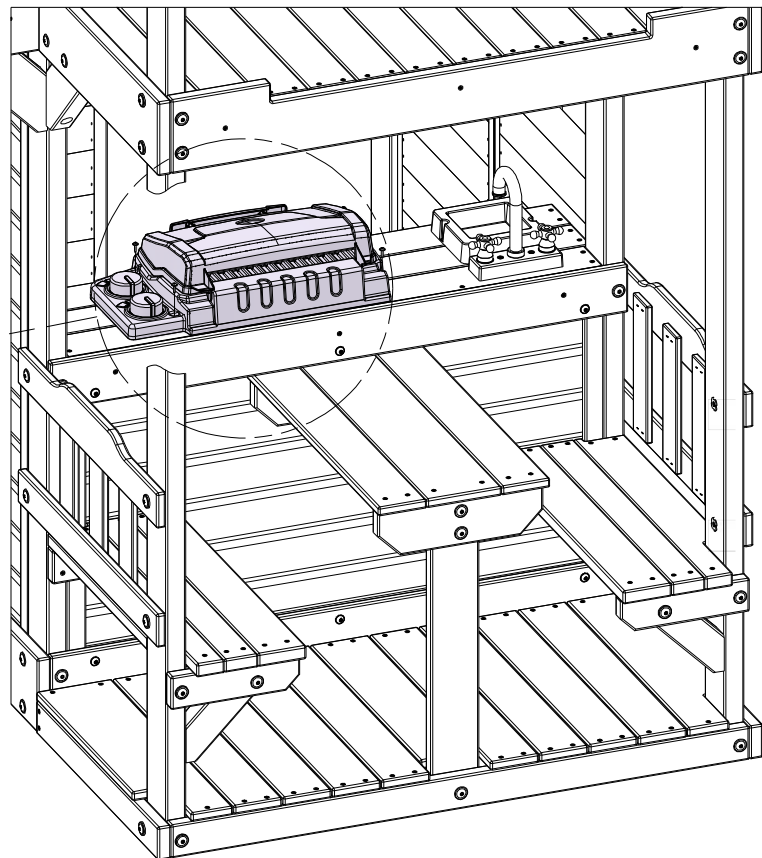
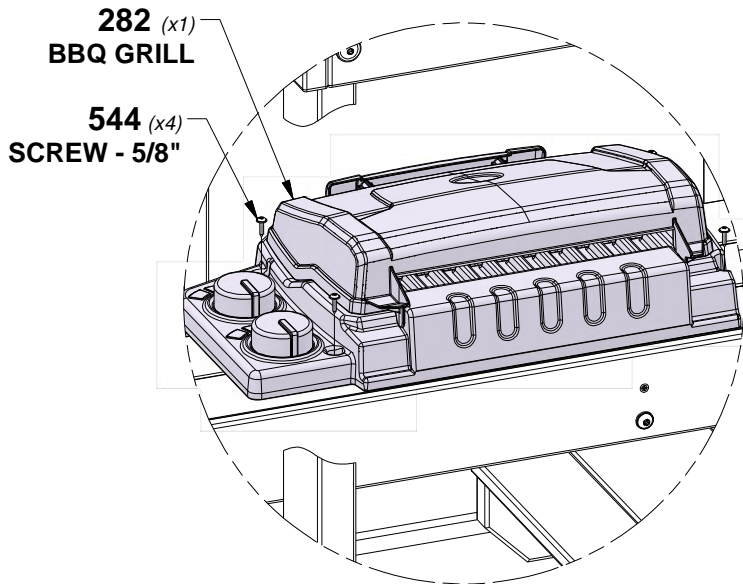
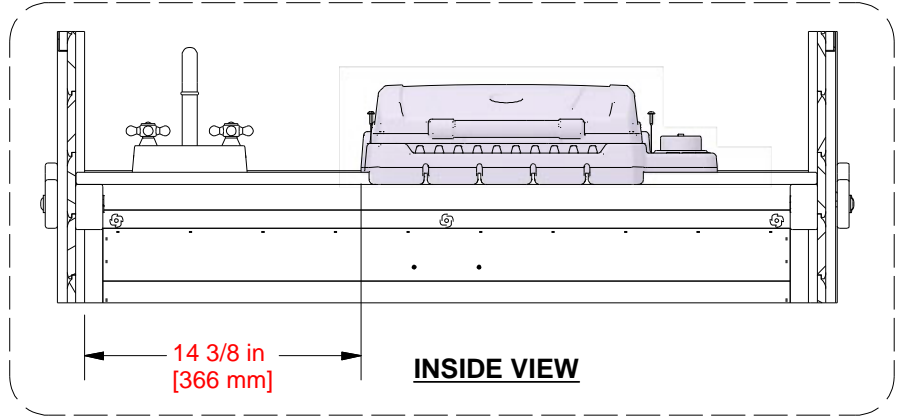



# STEP 36 - FORT ASSEMBLY

QTY	PART NUMBER	DESCRIPTION
2	H100198	WASHER LOCK EXT 8x19 BLK
2	H100378	BOLT WH 5/16x1 3/4 BLK

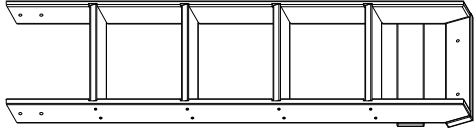

LADDER ASSEMBLY (x1)

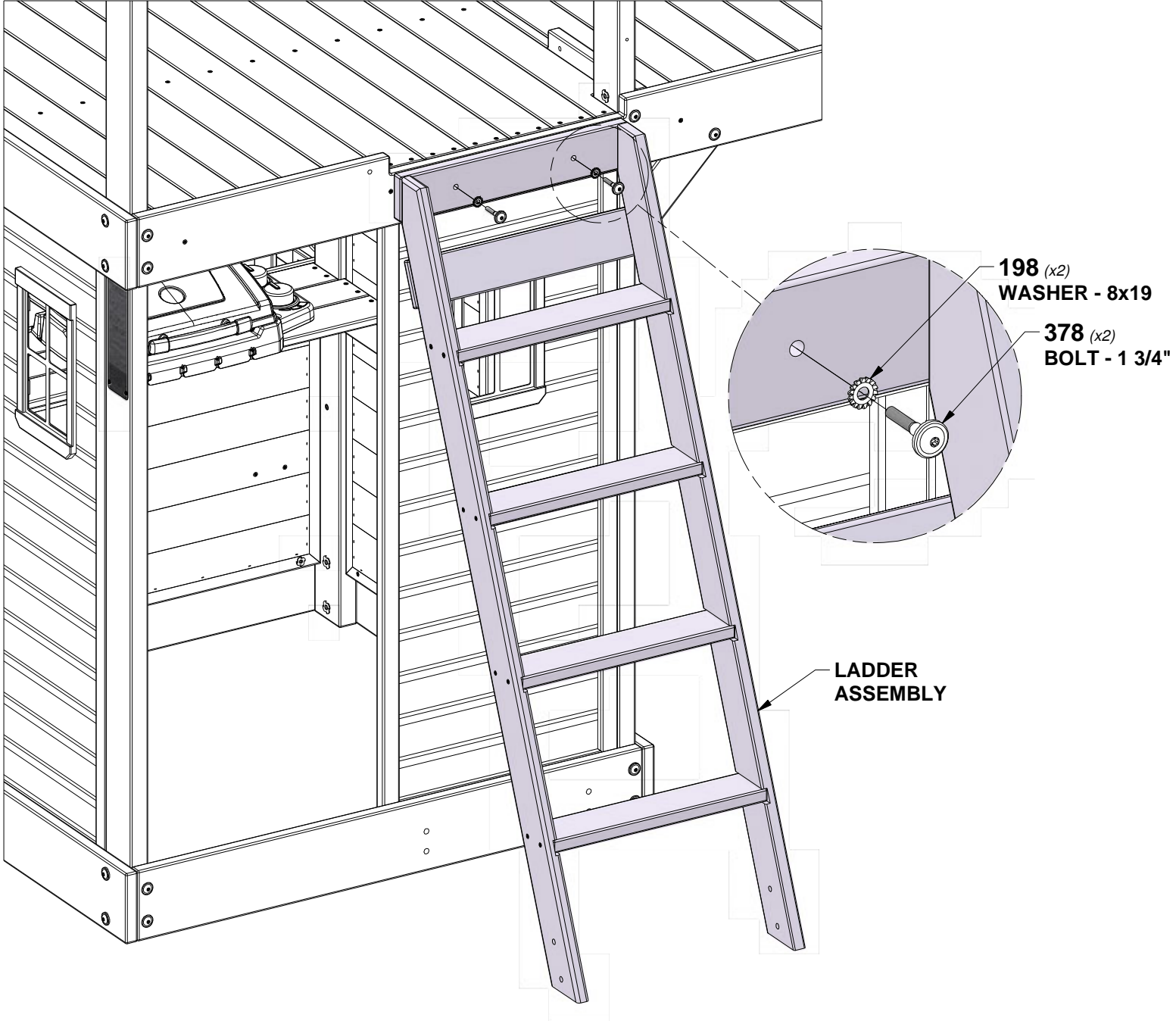

# STEP 37 - FORT ASSEMBLY

QTY	PART NUMBER	DESCRIPTION
4	H100198	WASHER LOCK EXT 8x19 BLK
4	H100378	BOLT WH 5/16x1 3/4 BLK
12	H100379	T-NUT 5/16 BLK
8	H100468	BOLT WH 5/16x1 BLK

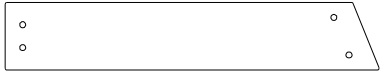

**Q2 GROUND BOARD - W4L17640**  
(x2) 1"x4 3/8"x24 3/8" (24x112x620)

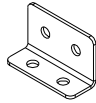

**A4M00855 L BRACKET**  
(x2) 32x51x82

**TIP:**  
**INSTALL T-NUTS IN WOOD FIRST**

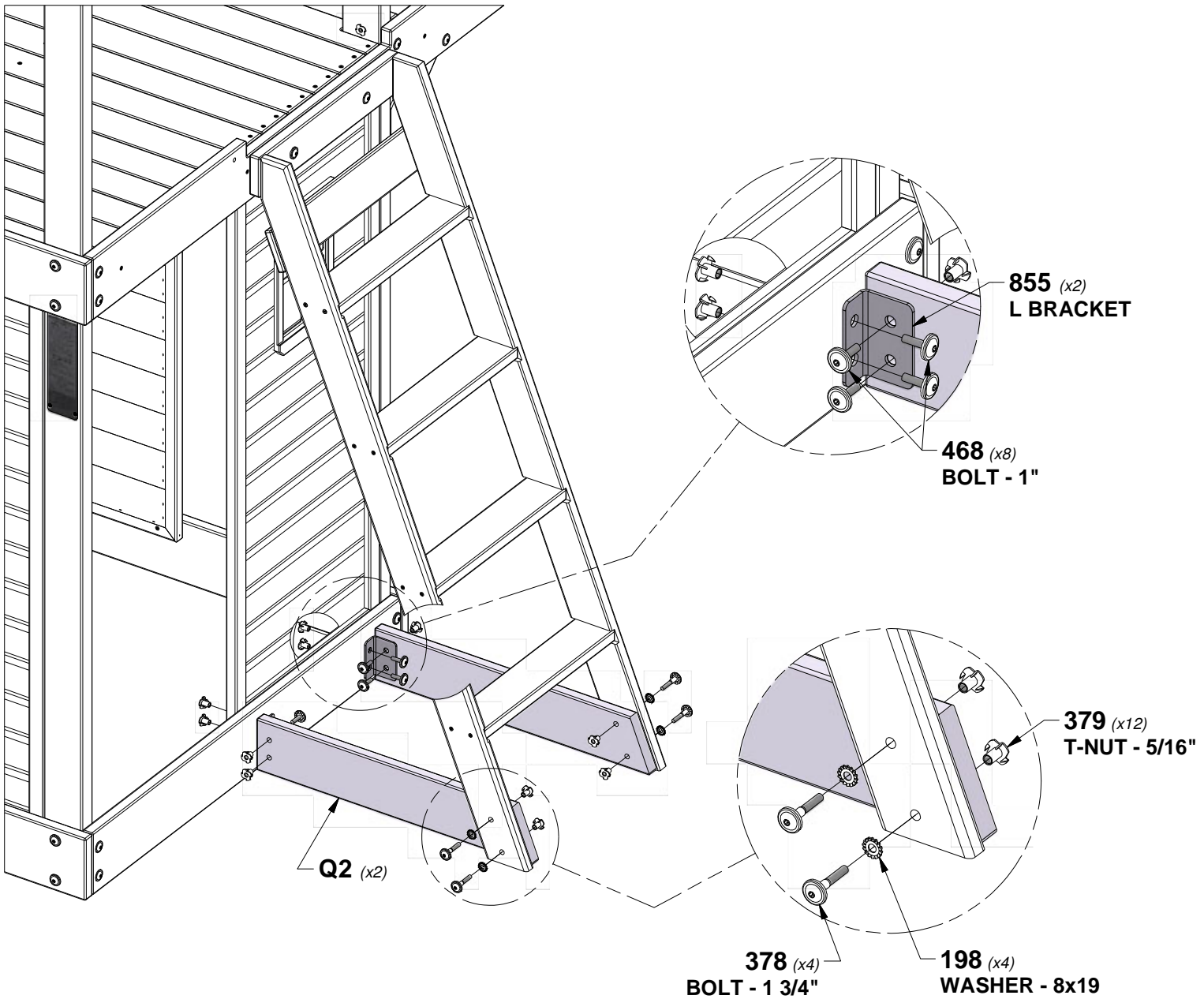

# STEP 38 - FORT ASSEMBLY

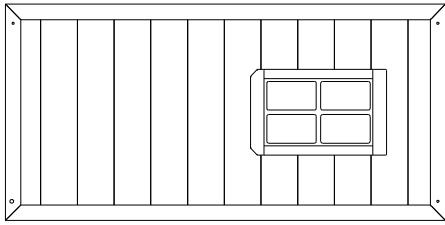

**WP07 WALL PANEL - W2A03783**  
 (x1) 1"x16 7/8"x46 1/2" (24x476x971)

QTY	PART NUMBER	DESCRIPTION
3	H100382	SCREW PFH 8x1-3/4 BLK
1	H100398	T-NUT 1/4 BLK
1	H100405	WASHER LOCK EXT 6x15 BLK
1	H101026	BOLT WH 1/4x1-3/4 BLK

**TIP:**  
**INSTALL T-NUTS IN WOOD FIRST**

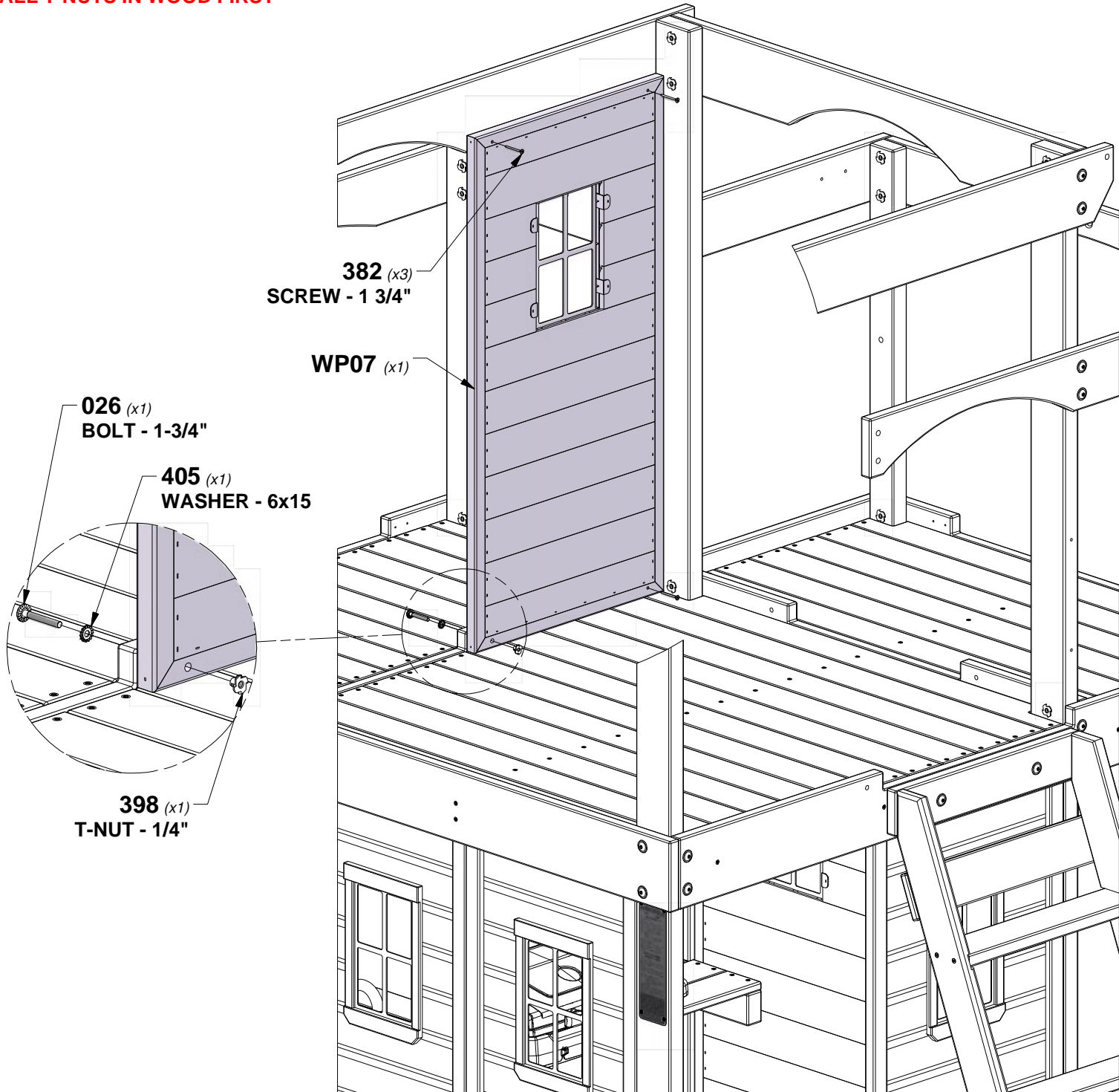

# STEP 39 - FORT ASSEMBLY

QTY	PART NUMBER	DESCRIPTION
4	H100382	SCREW PFH 8x1 3/4 BLK
4	H100391	SCREW PFH 8x2 BLK

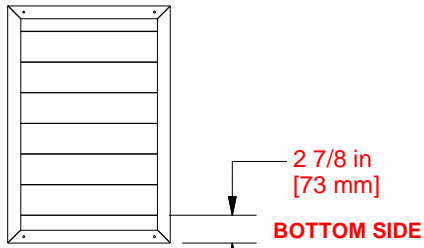

**WP04 WALL PANEL - W2A03784**  
 (x2) 1"x16 7/8"x24 5/8" (24x430x627)

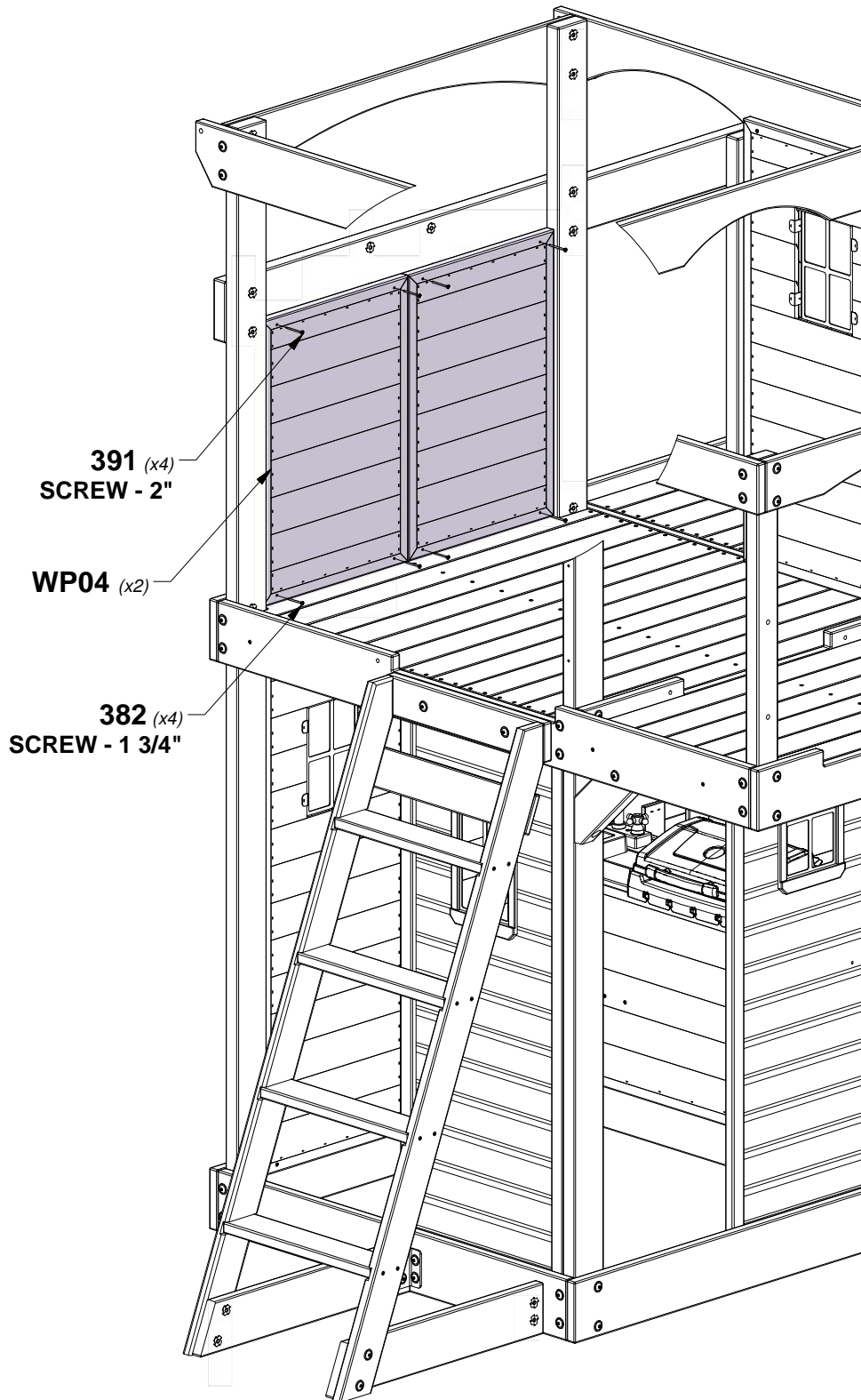
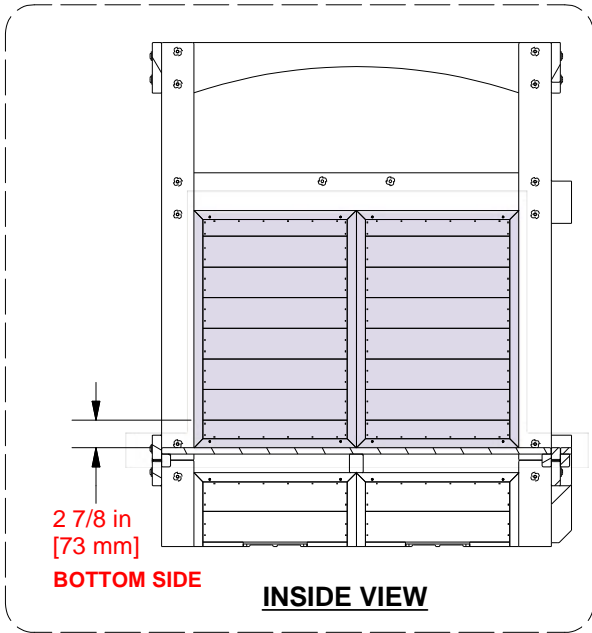

# STEP 40 - FORT ASSEMBLY

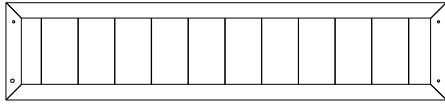

**WP03 WALL PANEL - W2A03786**  
(x1) 1"x18 7/8"x11 3/4" (24x214x971)

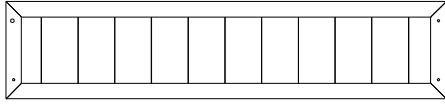

**WP08 WALL PANEL - W2A03787**  
(x1) 1"x18 7/8"x11 3/4" (24x214x971)

QTY	PART NUMBER	DESCRIPTION
6	H100382	SCREW PFH 8x1-3/4 BLK
2	H100398	T-NUT 1/4 BLK
2	H100405	WASHER LOCK EXT 6x15 BLK
2	H101026	BOLT WH 1/4x1-3/4 BLK

**TIP:**  
**INSTALL T-NUTS IN WOOD FIRST**

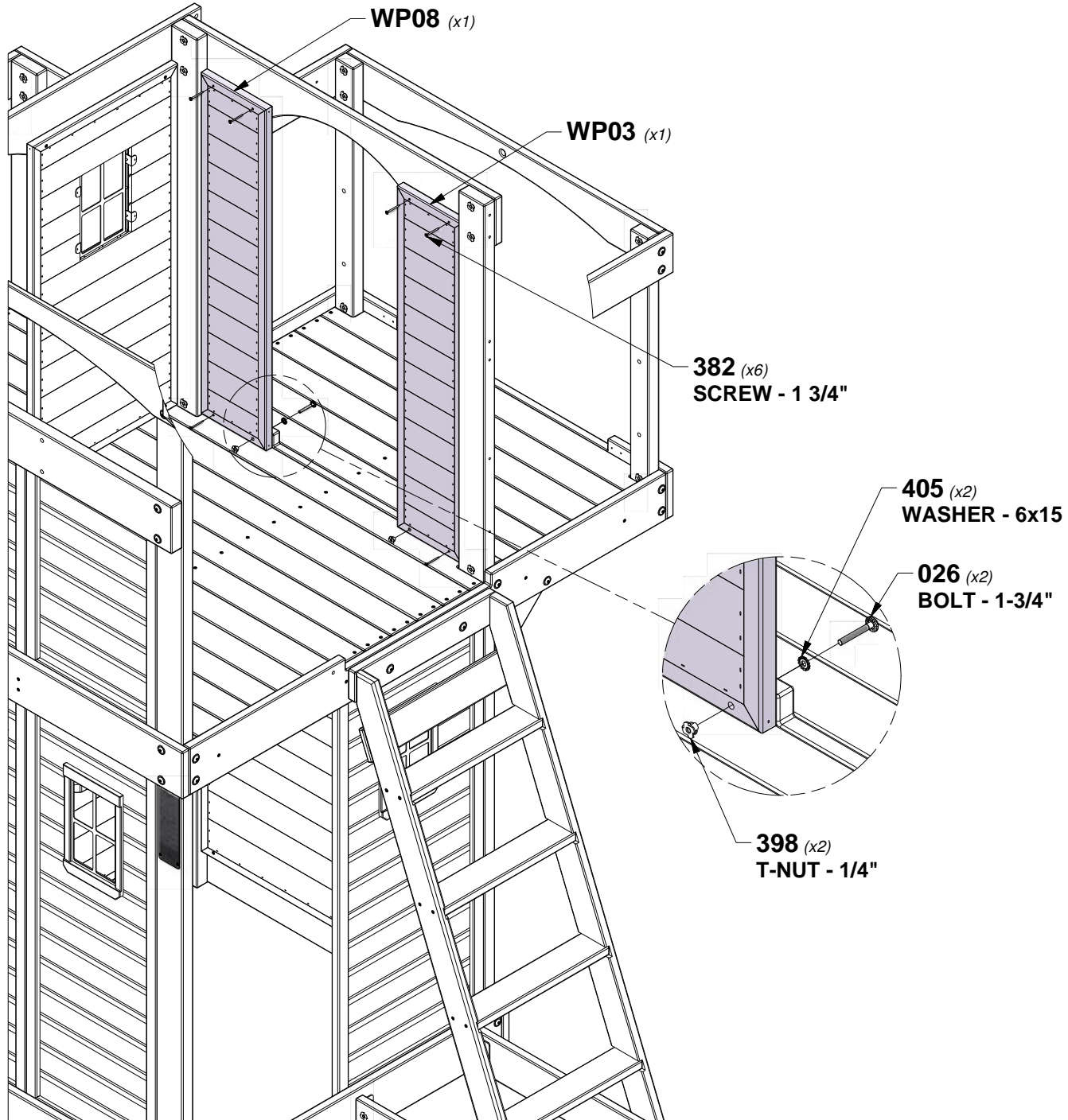



# STEP 41 - FORT ASSEMBLY

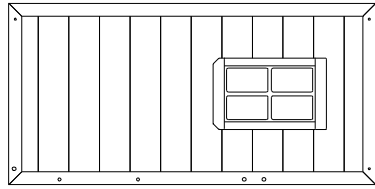

**WP05 WALL PANEL - W2A03785**  
(x1) 1"x16 7/8"x46 1/2" (24x479x971)

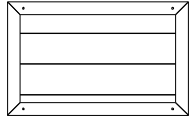

**WP06 WALL PANEL - W2A03780**  
(x1) 1"x18 7/8"x11 3/4" (24x479x300)

QTY	PART NUMBER	DESCRIPTION
2	H100198	WASHER LOCK EXT 8x19 BLK
2	H100378	BOLT WH 5/16x1 3/4 BLK
2	H100379	T-NUT 5/16 BLK
7	H100382	SCREW PFH 8x1-3/4 BLK
1	H100398	T-NUT 1/4 BLK
1	H100405	WASHER LOCK EXT 6x15 BLK
1	H101026	BOLT WH 1/4x1-3/4 BLK

**TIP:**  
INSTALL T-NUTS IN WOOD FIRST

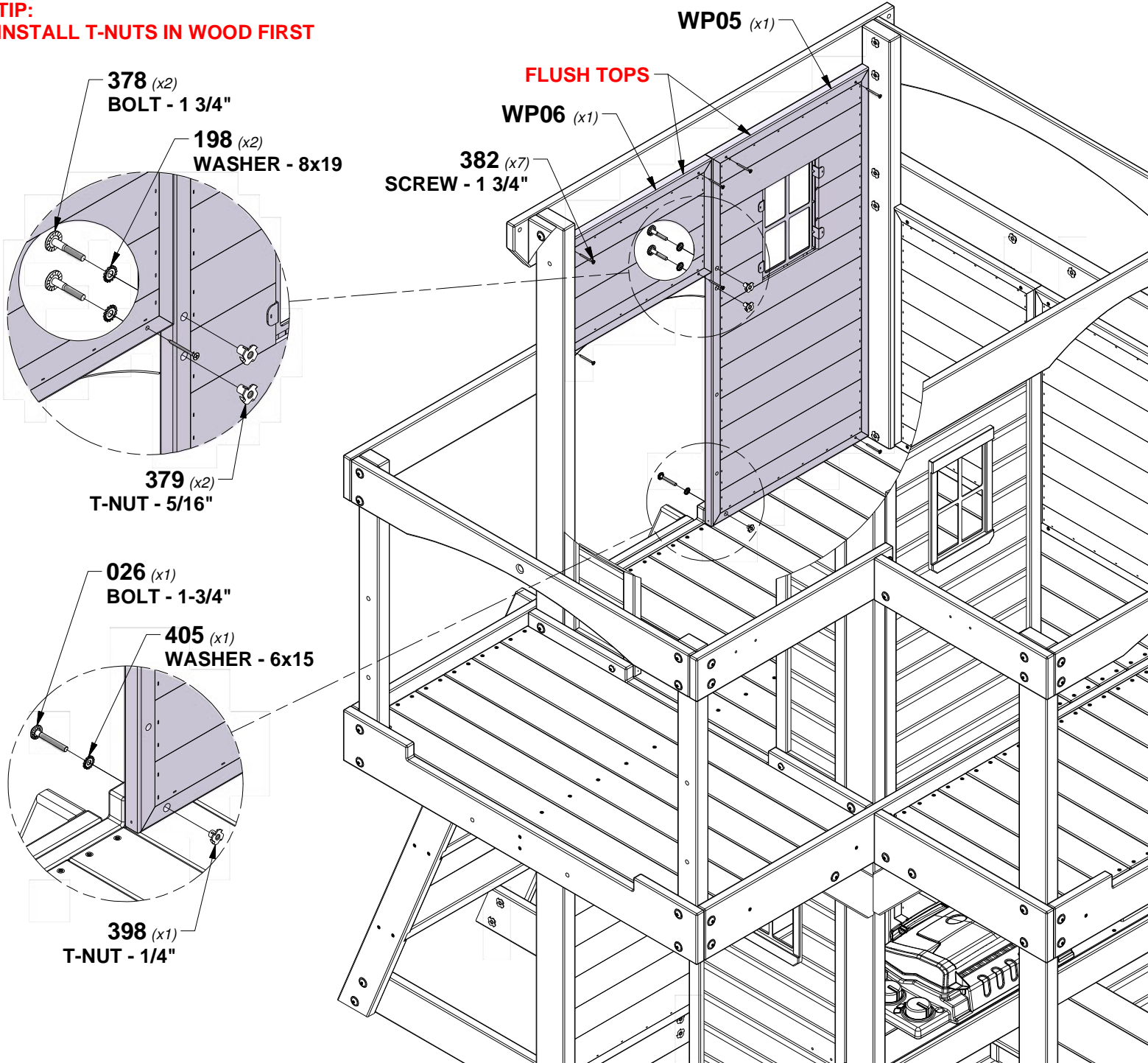

# STEP 42 - FORT ASSEMBLY

QTY	PART NUMBER	DESCRIPTION
32	H100387	SCREW PFH 8x1-1/4 BLK

**N02 PICKET - W4L18514**  
(x8) 5/8"x2 3/8"x24 3/4" (16x60x628)

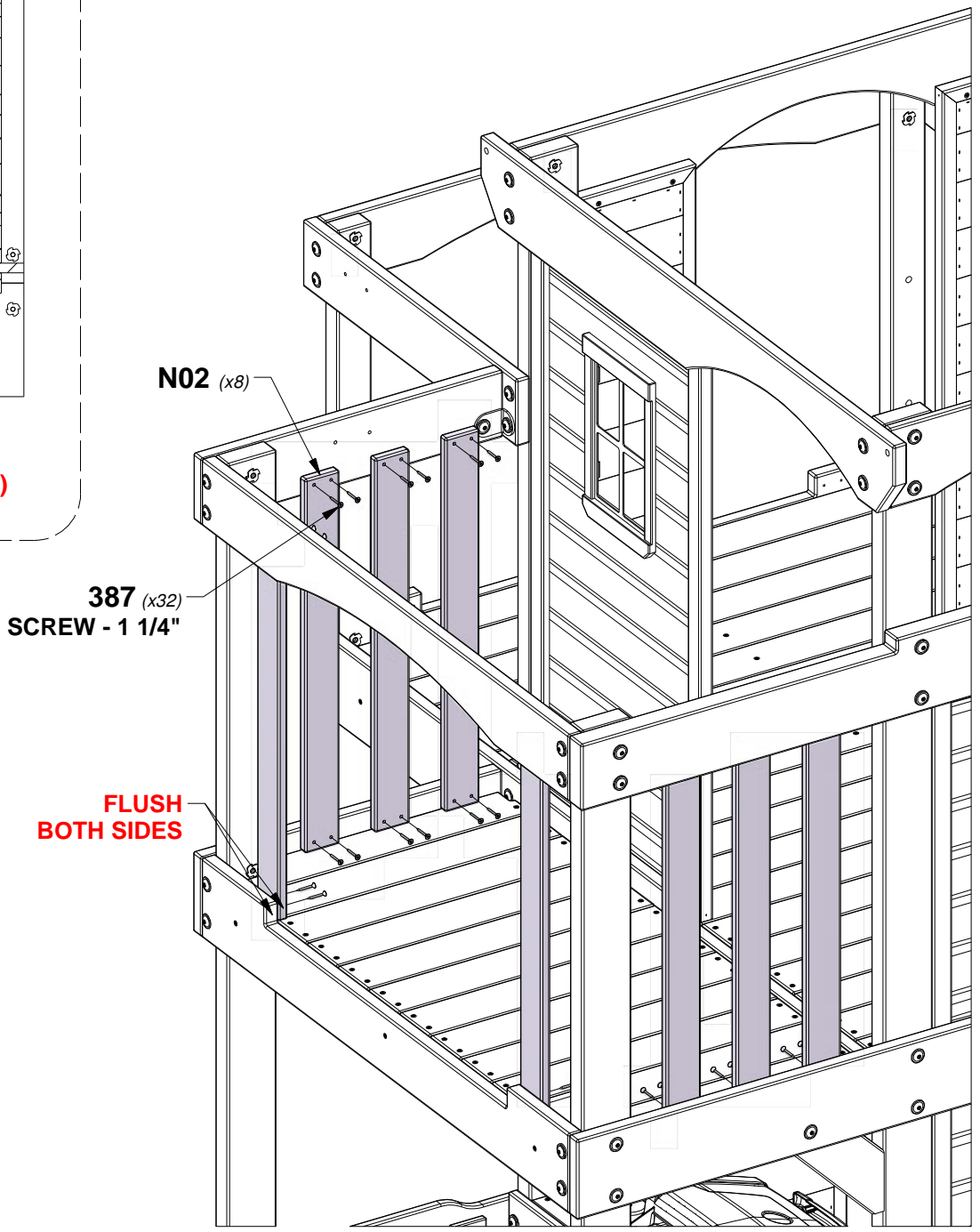
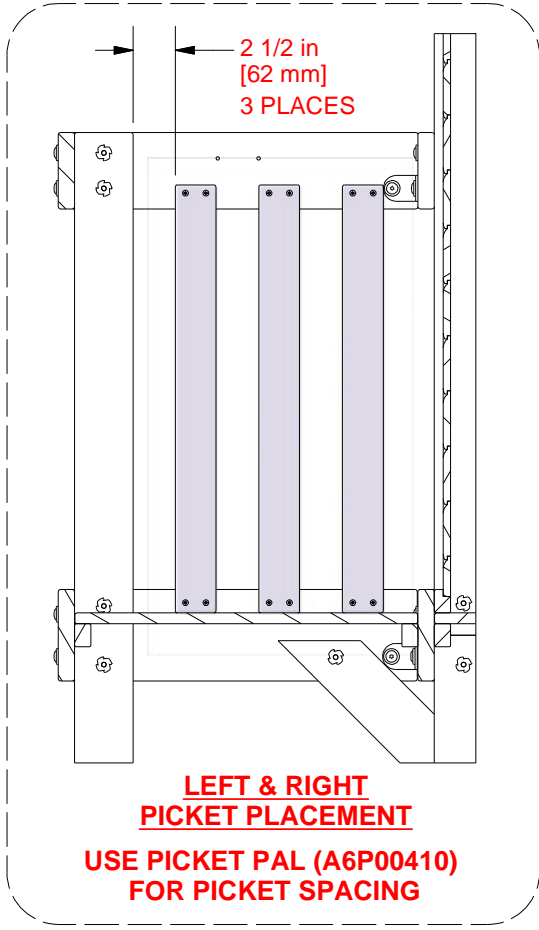

# STEP 43 - FORT ASSEMBLY

QTY	PART NUMBER	DESCRIPTION
40	H100387	SCREW PFH 8x1-1/4 BLK



**N02 PICKET - W4L18514**  
(x10) 5/8"x2 3/8"x24 3/4" (16x60x628)

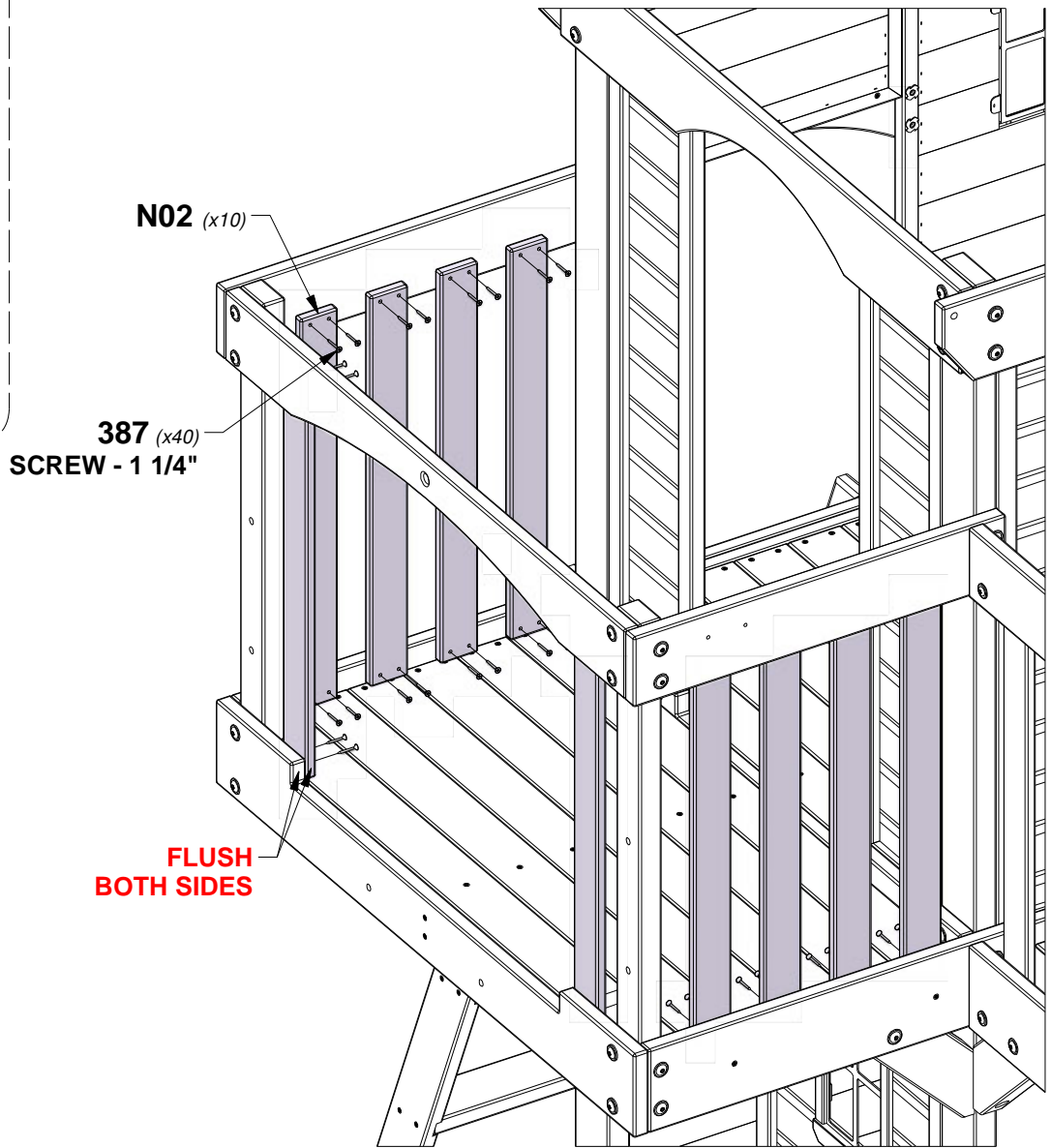
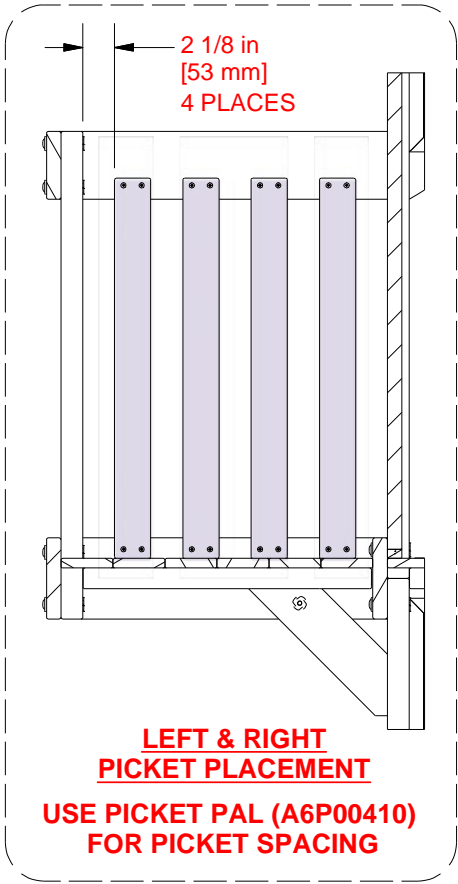



# STEP 44 - FORT ASSEMBLY

QTY	PART NUMBER	DESCRIPTION
2	H100198	WASHER LOCK EXT 8x19 BLK
2	H100379	T-NUT 5/16 BLK
2	H100407	BOLT WH 5/16x1 1/2 BLK
6	H100408	SCREW PWH 8x1/2 BLK

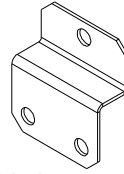
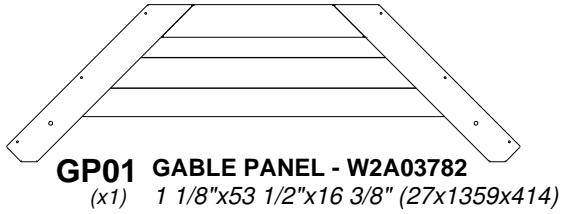
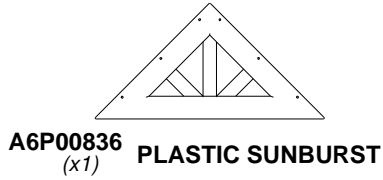

**TIP:**  
**INSTALL T-NUTS IN WOOD FIRST**

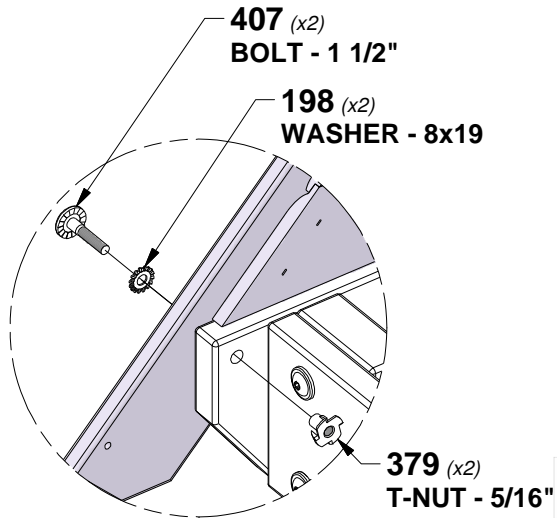

**INSTALL BRACKET TO SUNBURST  
THEN PRE-DRILL USING AN  
1/8" [3mm] DRILL BIT**

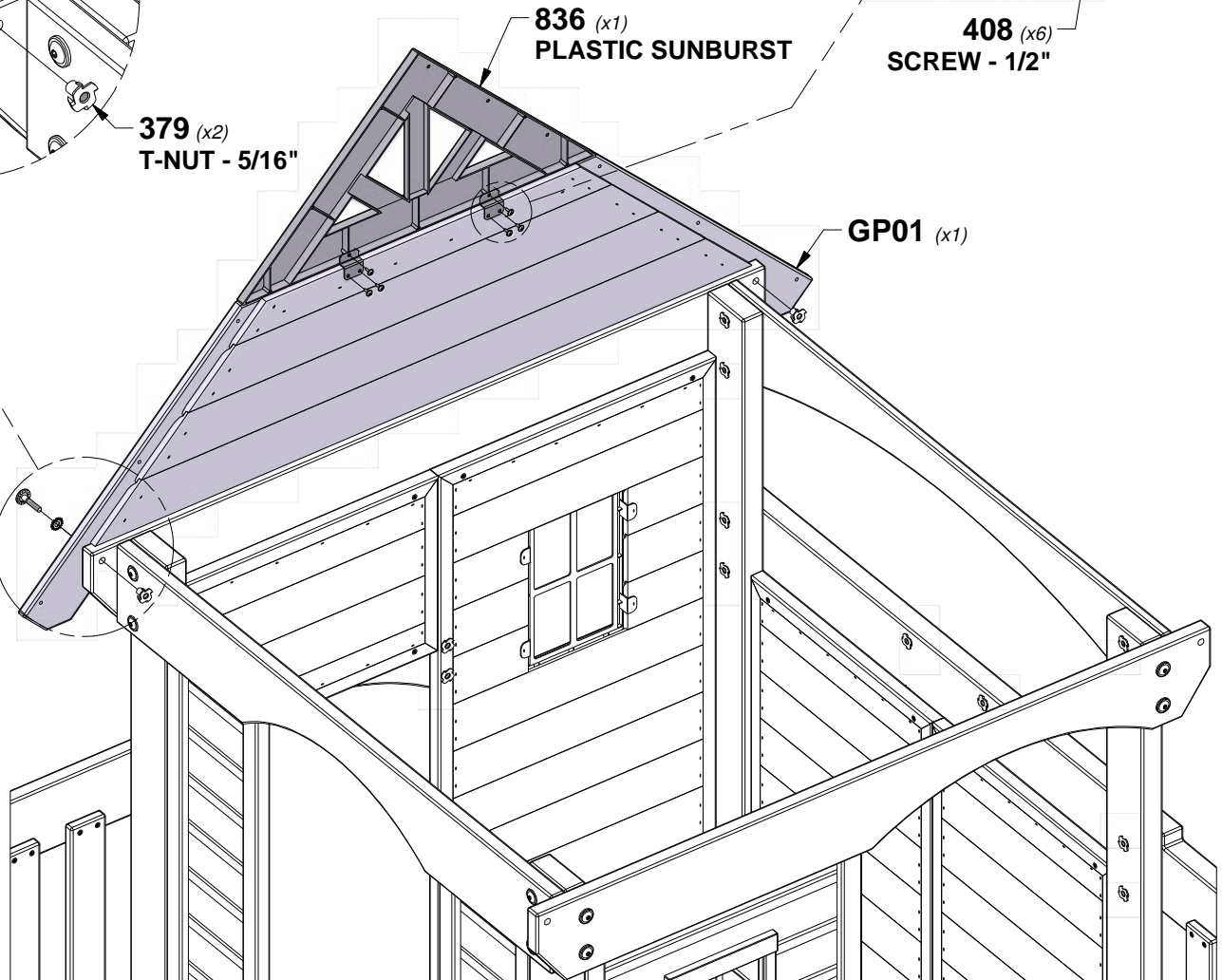
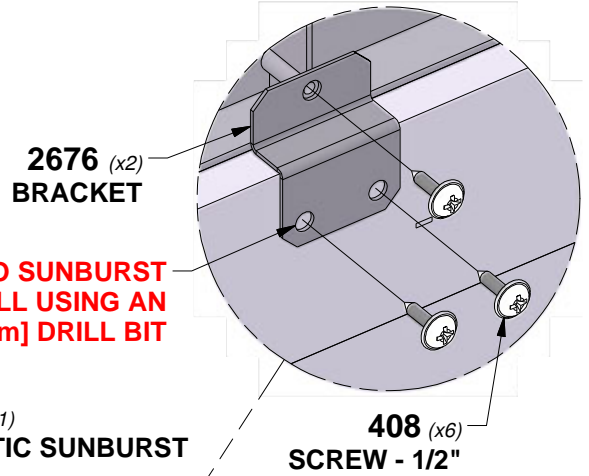

# STEP 45 - FORT ASSEMBLY

QTY	PART NUMBER	DESCRIPTION
2	H100198	WASHER LOCK EXT 8x19 BLK
2	H100379	T-NUT 5/16 BLK
2	H100407	BOLT WH 5/16x1 1/2 BLK
6	H100408	SCREW PWH 8x1/2 BLK

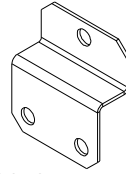
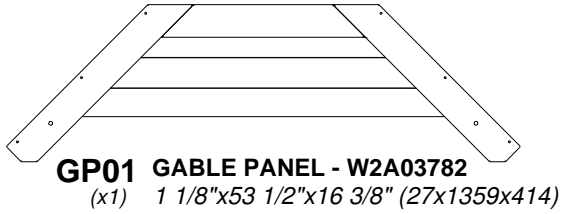
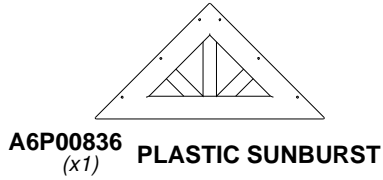

**TIP:**  
**INSTALL T-NUTS IN WOOD FIRST**

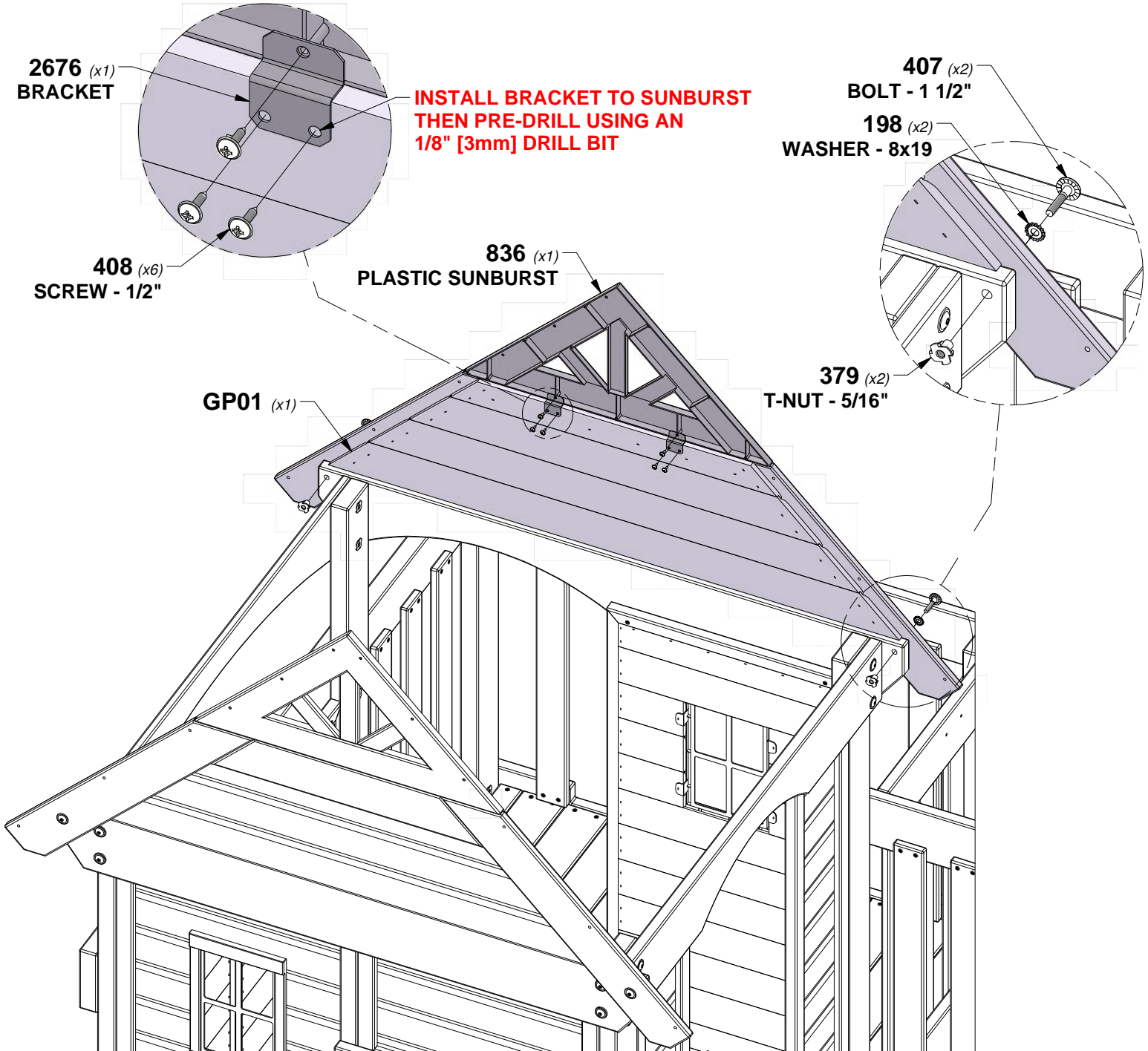

# STEP 46 - FORT ASSEMBLY

QTY	PART NUMBER	DESCRIPTION
12	H100347	SCREW PWH 8x1-1/4 WZ
4	H100382	SCREW PFH 8x1 3/4 BLK

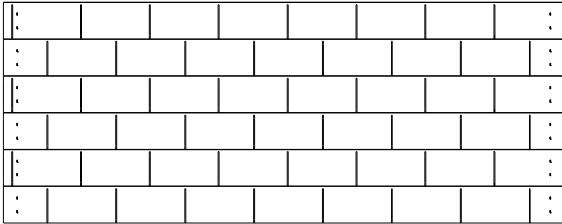

**RP2 TOP ROOF PANEL - W2A04025**  
 (x2) 1 3/8"x19 1/8"x48 5/8" (35x486x1236)

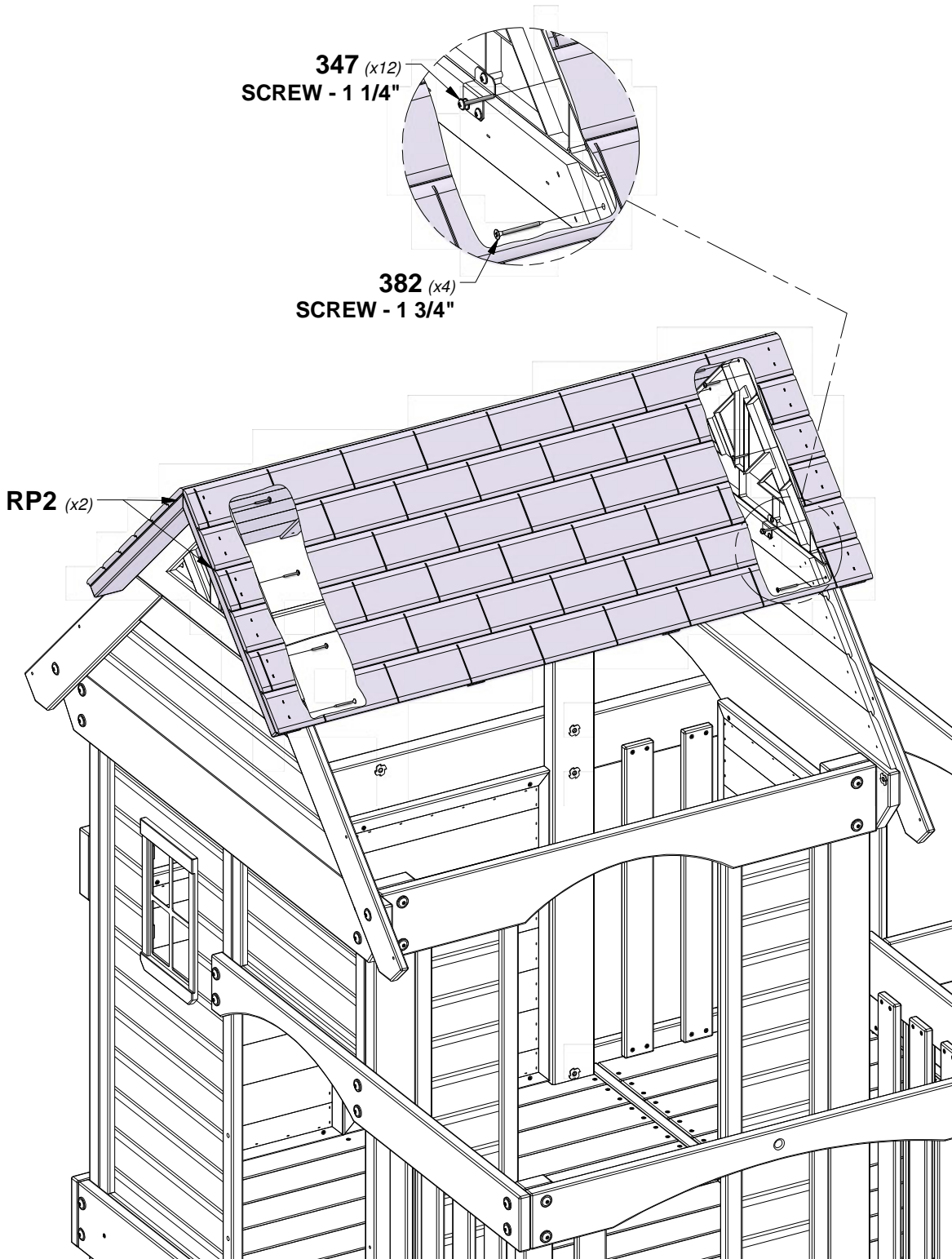

# STEP 47 - FORT ASSEMBLY

QTY	PART NUMBER	DESCRIPTION
8	H100382	SCREW PFH 8x1 3/4 BLK

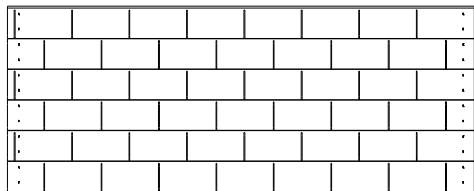

**RP1 LOWER ROOF PANEL - W2A04024**  
(x2) 1 3/8"x19 3/8"x48 5/8" (35x491x1236)

**382 (x8)**  
**SCREW - 1 3/4"**

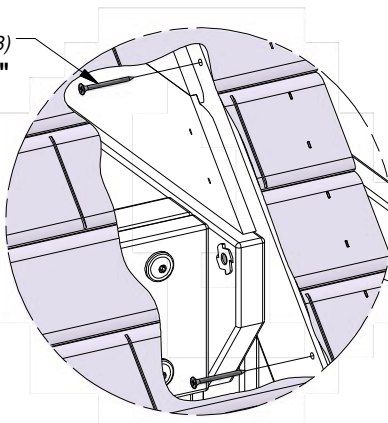

**RP1 (x2)**

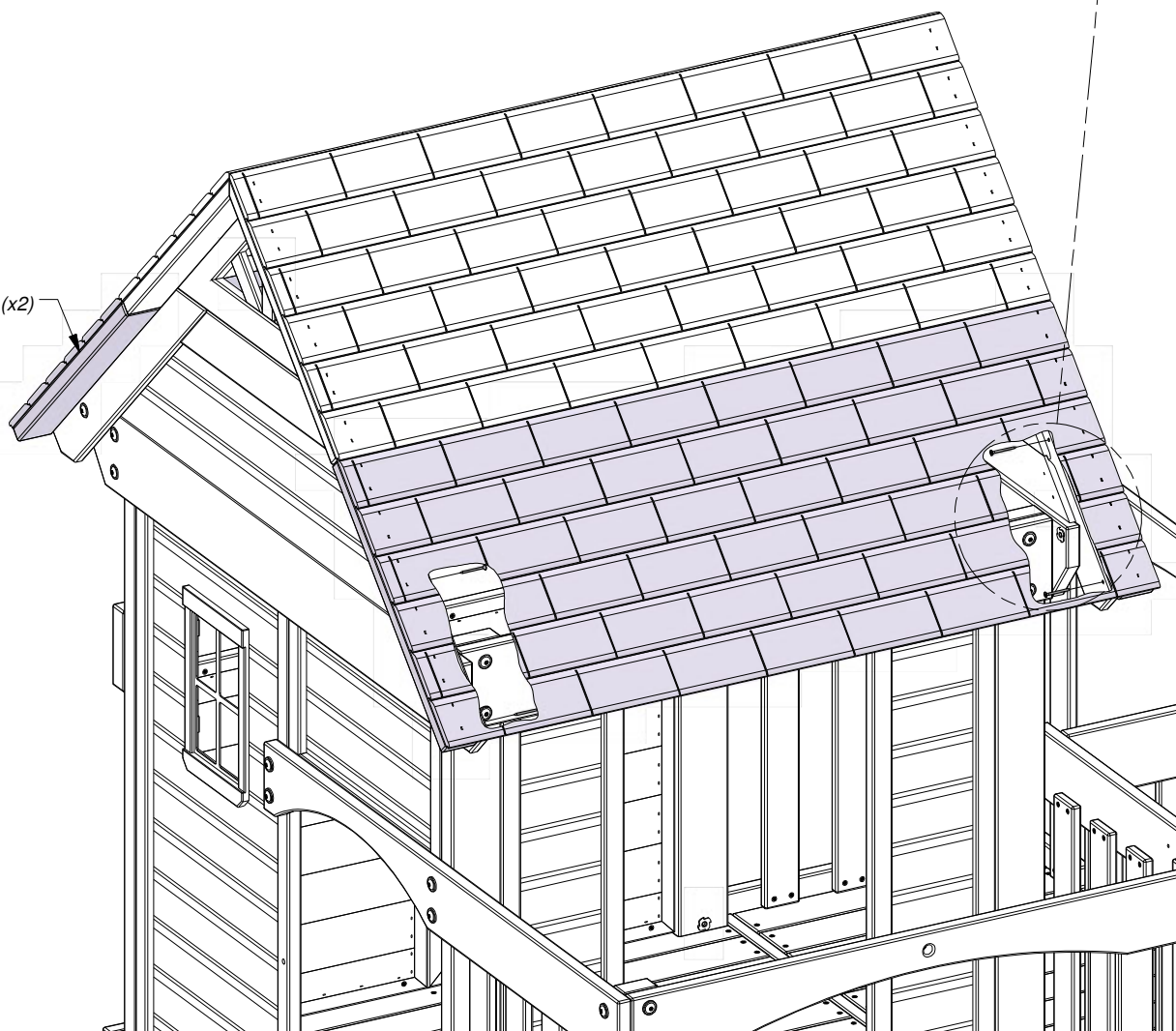



# STEP 48 - FORT ASSEMBLY

QTY	PART NUMBER	DESCRIPTION
2	H100382	SCREW PFH 8x1 3/4 BLK
3	H100105	WASHER FLAT 8x27

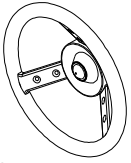

**A6P00618**  
(x1) **STEERING WHEEL**

**E12 MOUNTING BLOCK - W4L17816**  
(x1) 1 3/8"x3"x4 3/4" (36x76x120)

**TIP:**  
**ALIGN PILOT HOLES**

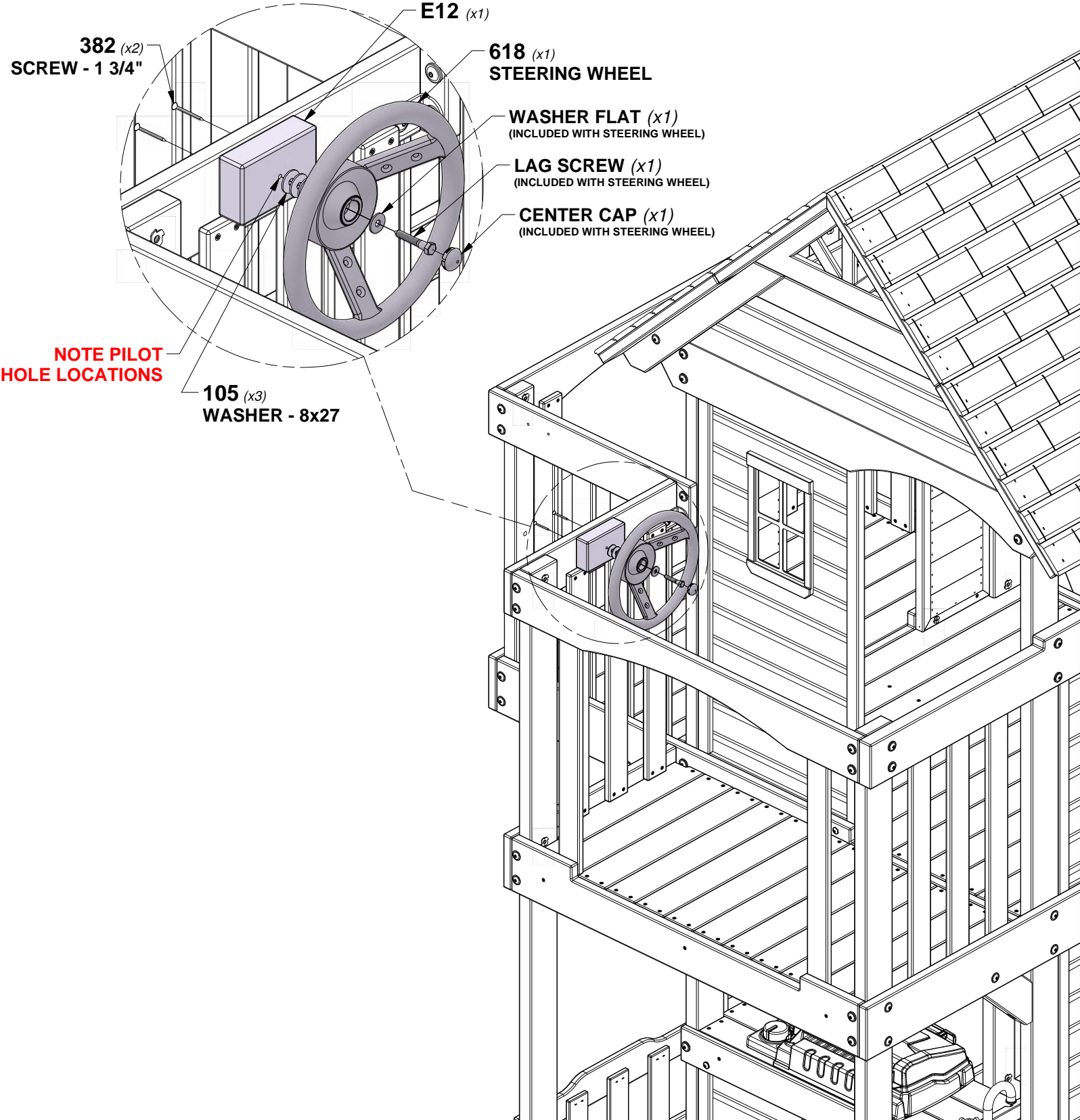

# STEP 49 - FORT ASSEMBLY

QTY	PART NUMBER	DESCRIPTION
2	H100382	SCREW PFH 8x1 3/4 BLK
2	H100387	SCREW PFH 8x1-1/4 BLK

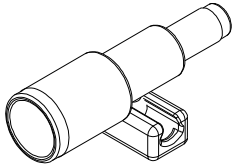

**A6P00596**  
(x1) **TELESCOPE**



**E10 MOUNTING BLOCK - W4L17815**  
(x1) 1 3/8"x3"x4 3/4" (36x76x120)

**TIP:**  
**ALIGN PILOT HOLES**

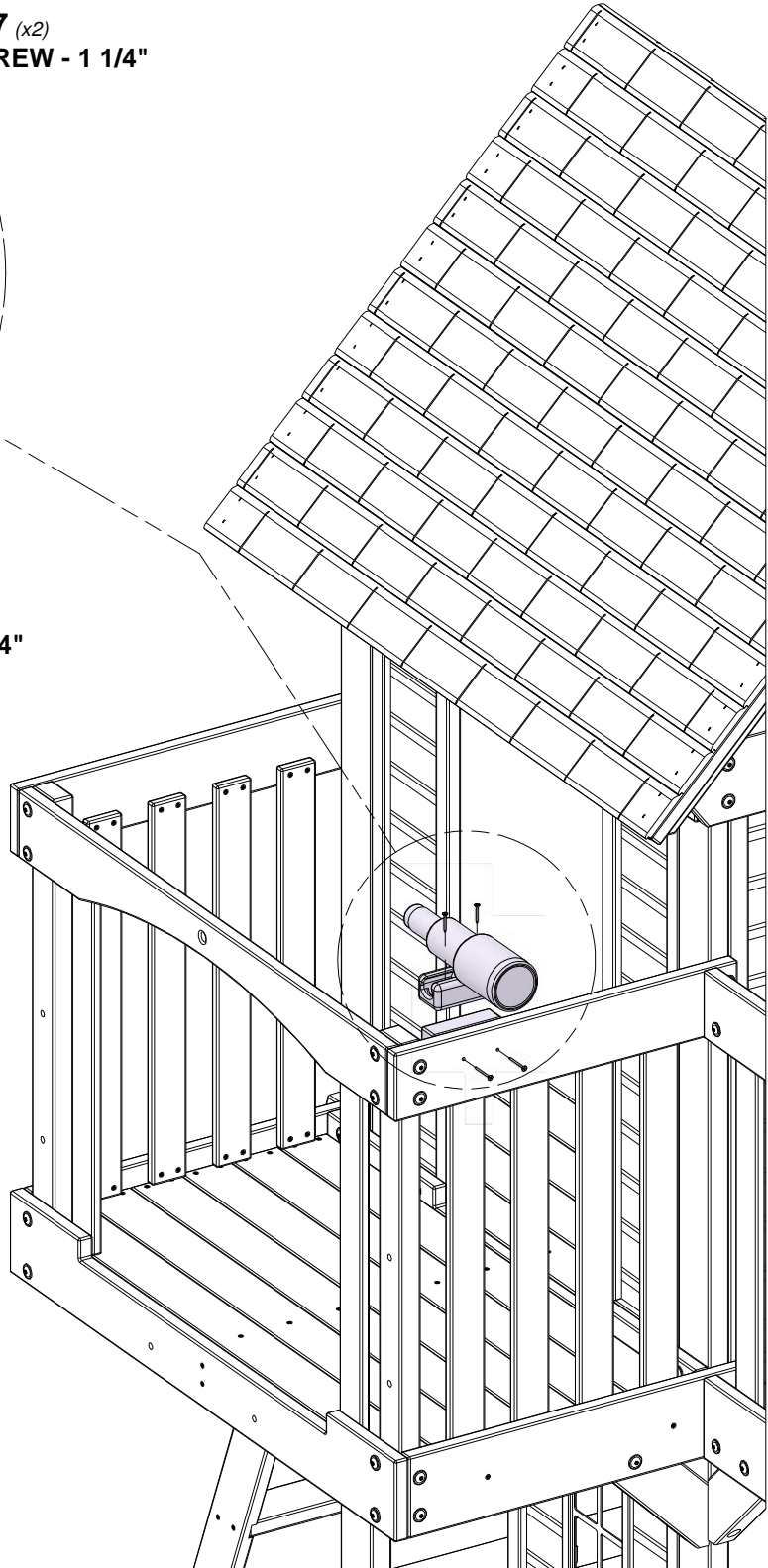
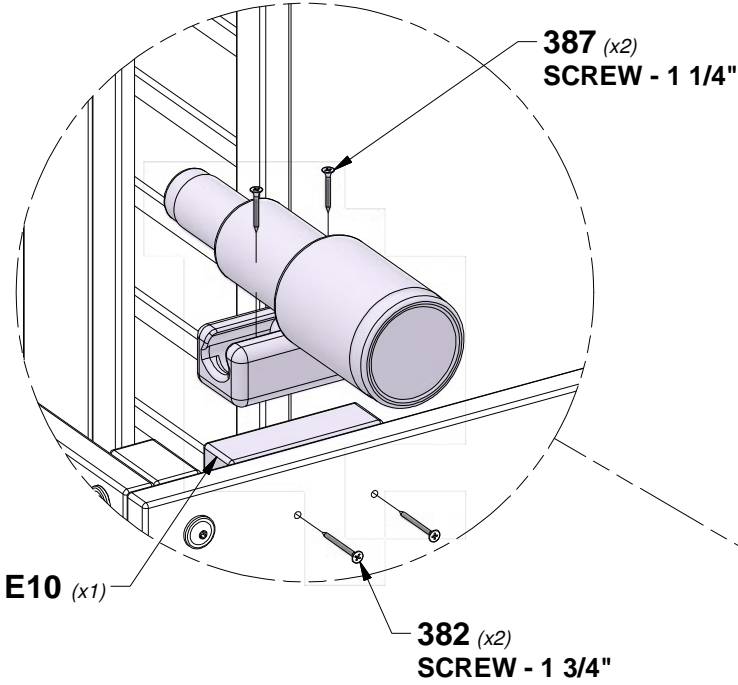

# STEP 50 - FORT ASSEMBLY

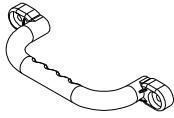

**A6P00654 HAND GRIP**  
*(x4)* **GREY PLASTIC**

QTY	PART NUMBER	DESCRIPTION
2	H100397	BOLT WH 1/4x1-1/4 BLK
6	H100398	T-NUT 1/4 BLK
2	H100403	LAG SCREW WH 1/4x1-1/2 BLK
8	H100405	WASHER LOCK EXT 6x15 BLK
4	H101026	BOLT WH 1/4x1-3/4 BLK

**TIP:**  
**INSTALL T-NUTS IN WOOD FIRST**

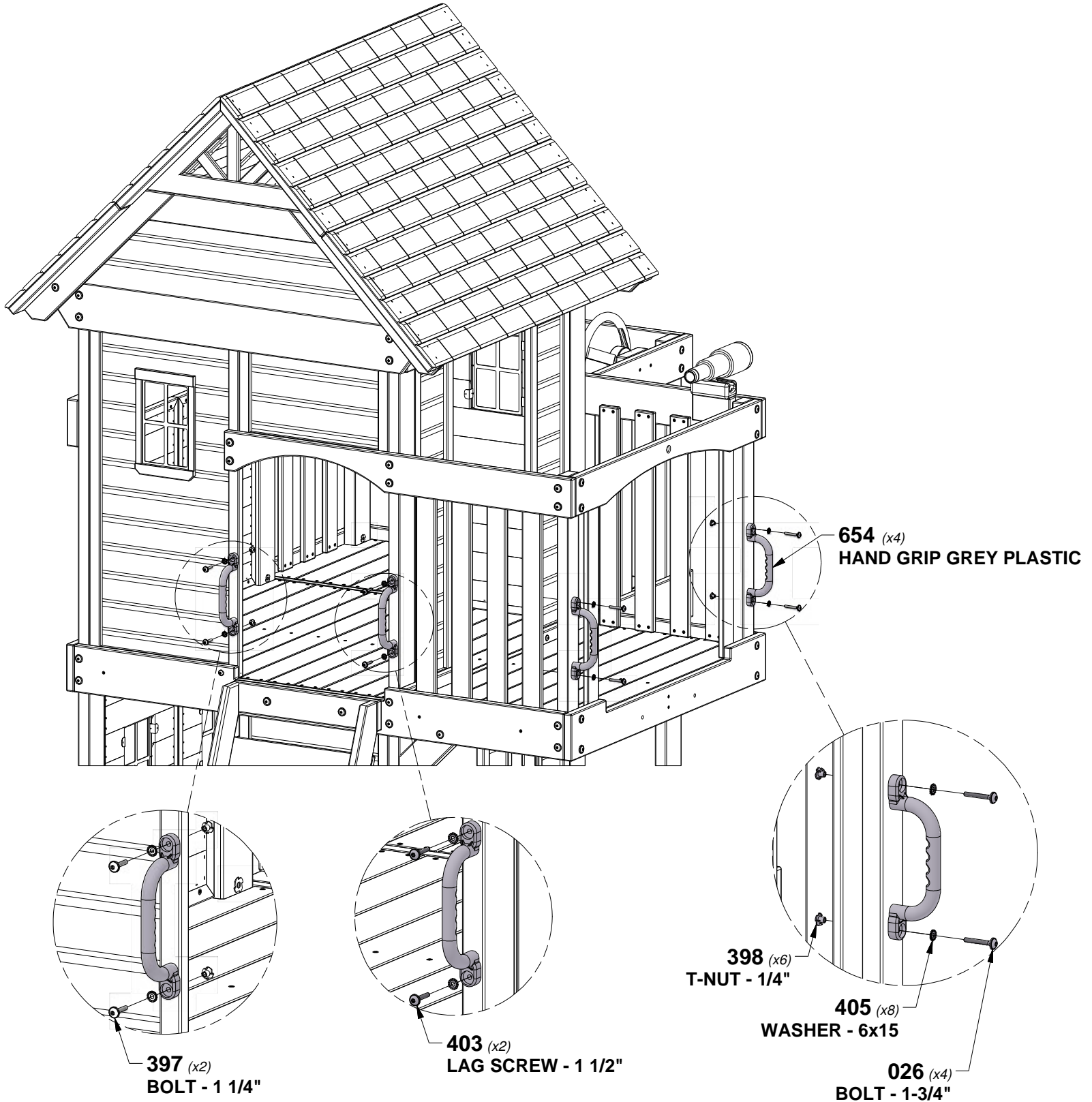

# STEP 51 - FORT ASSEMBLY

QTY	PART NUMBER	DESCRIPTION
8	H100202	SCREW PWH 8x5/8 BLK

**TOP**

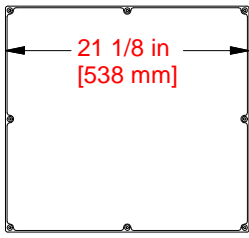

**A6P00324 CHALK BOARD  
(x1) LARGE**

**TIP:  
CENTER CHALK BOARD ON WALL AS SHOWN.**

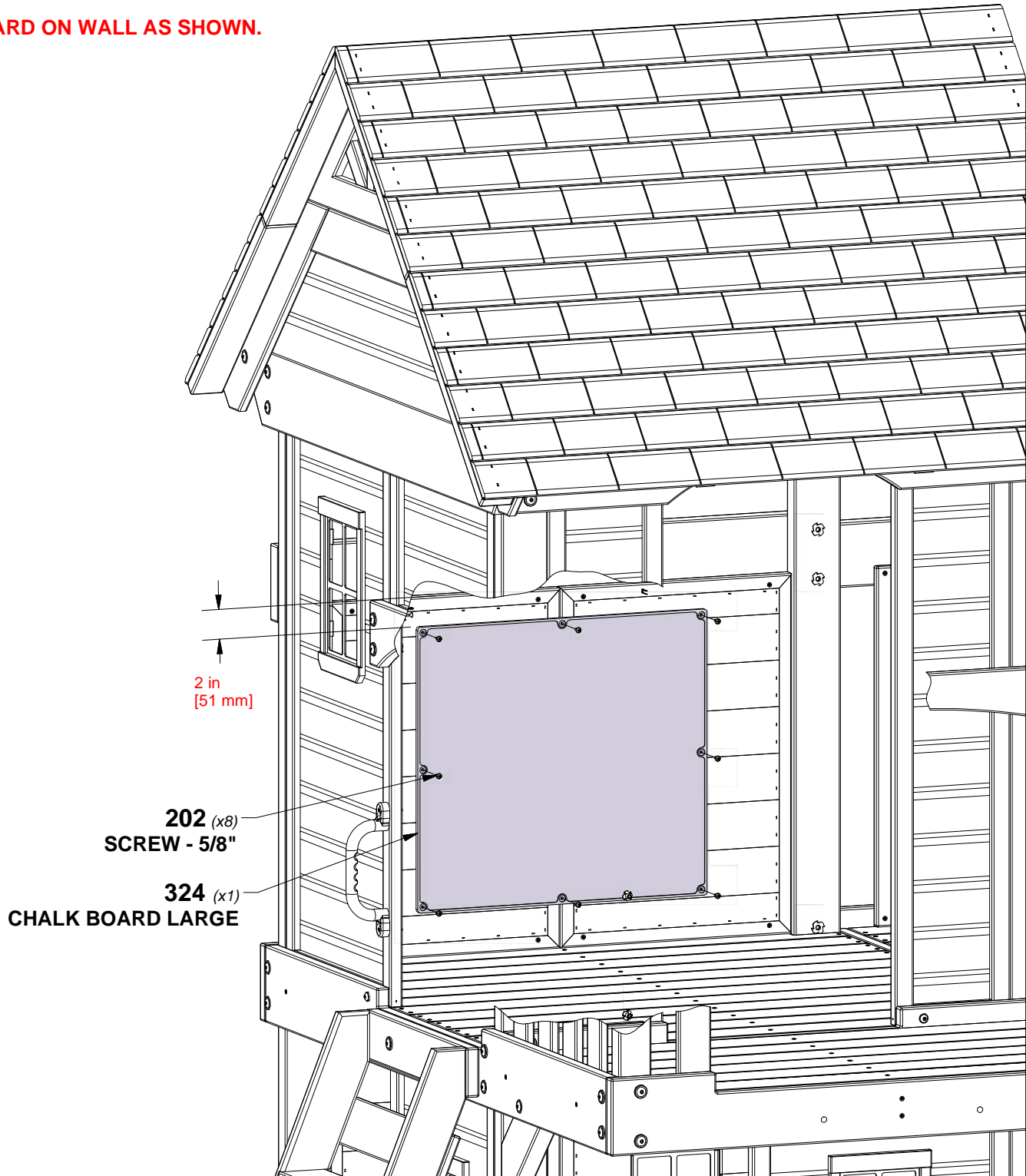



# STEP 1 - FINAL ASSEMBLY

QTY	PART NUMBER	DESCRIPTION
2	H100198	WASHER LOCK EXT 8x19 BLK
2	H100378	BOLT WH 5/16x1 3/4 BLK

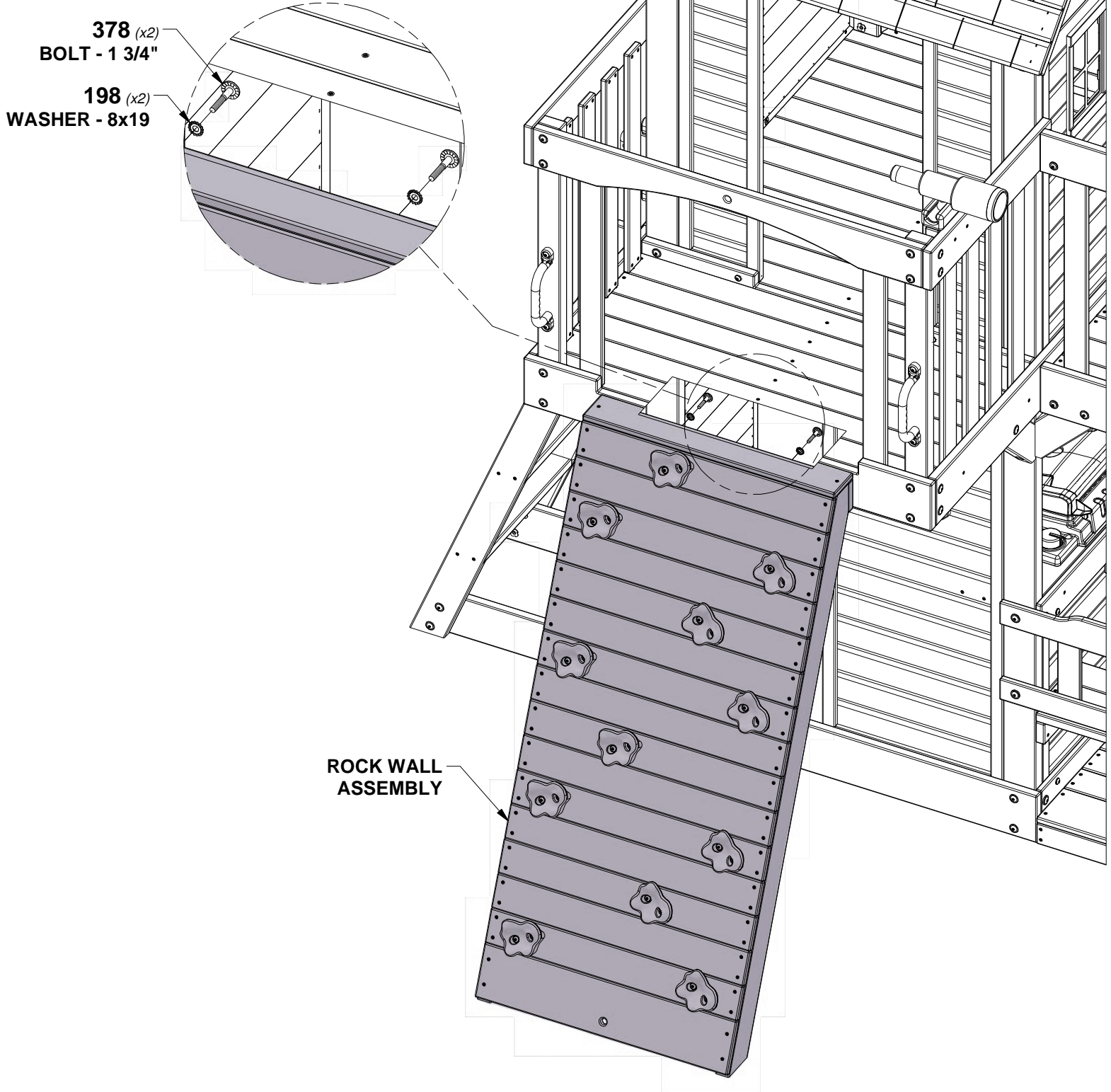

# STEP 2 - FINAL ASSEMBLY

A6P00537  
(x1) CLIMBING ROPE

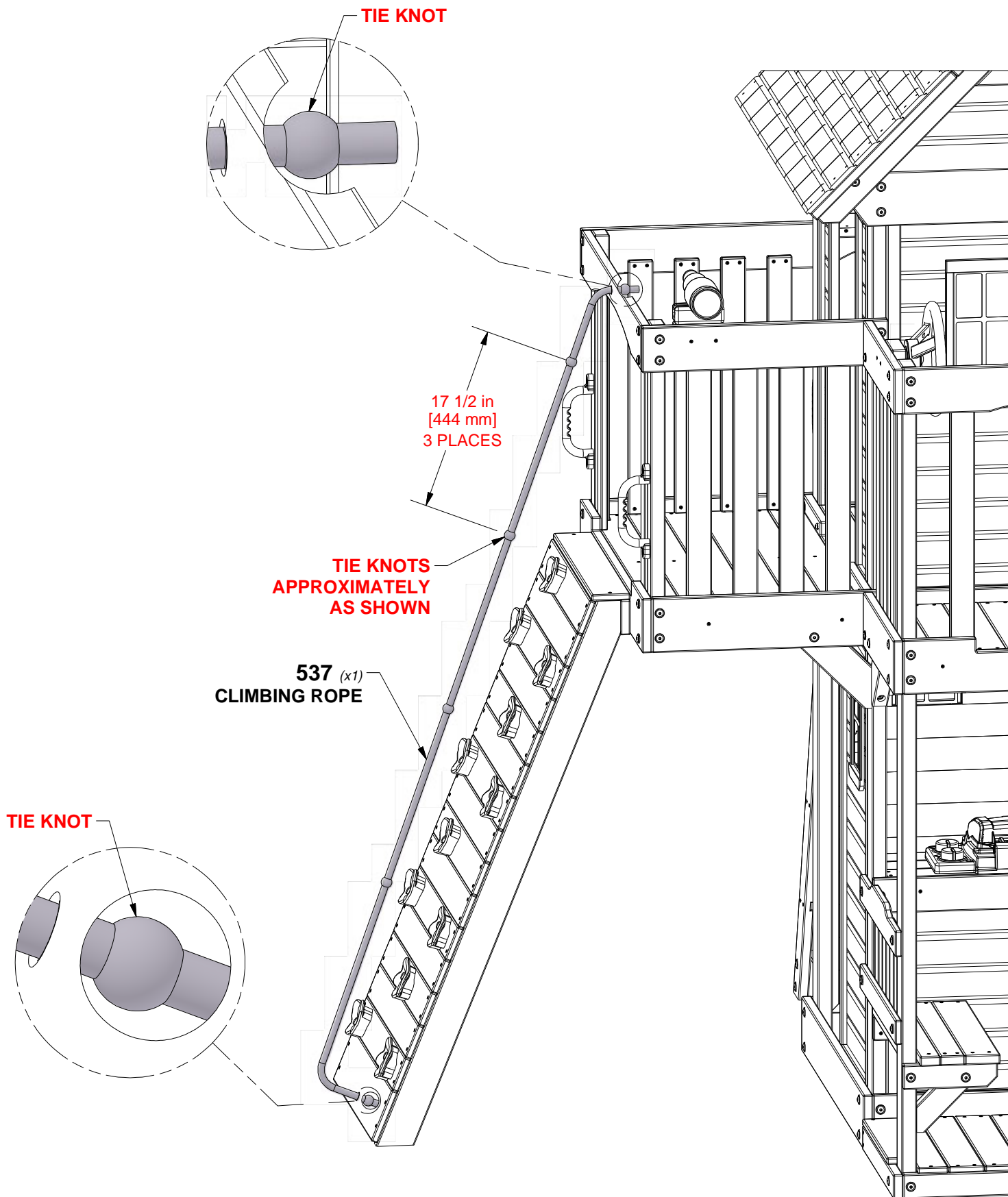

# STEP 3 - FINAL ASSEMBLY

QTY	PART NUMBER	DESCRIPTION
2	H100379	T-NUT 5/16 BLK
2	H100468	BOLT WH 5/16x1 BLK

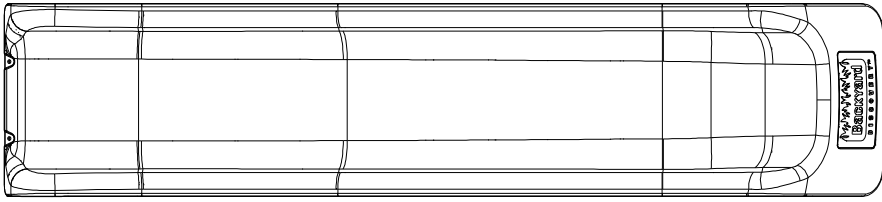

**A6P00554**  
(x1) **8' BLOW MOLDED SLIDE - GREY**

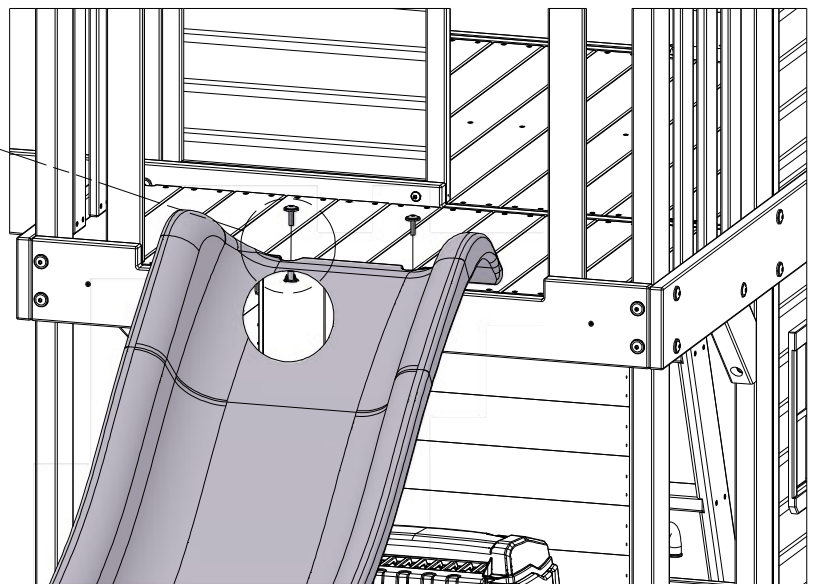
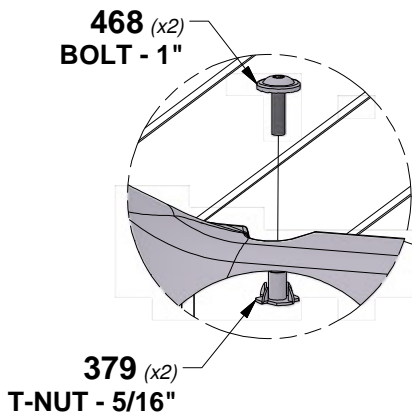
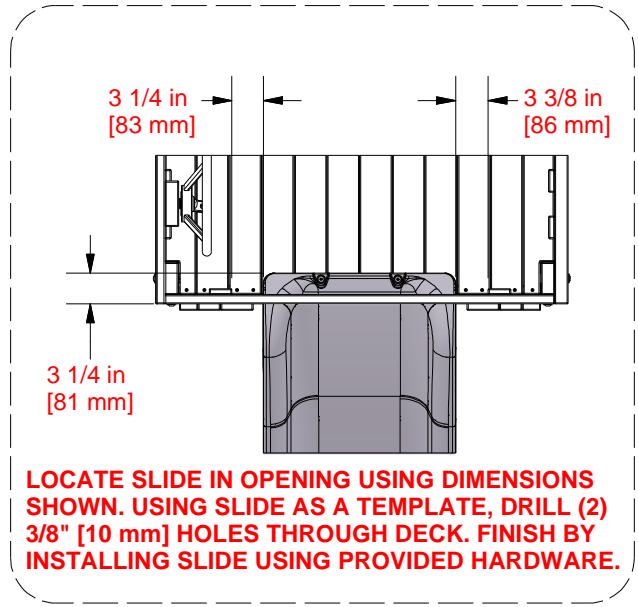
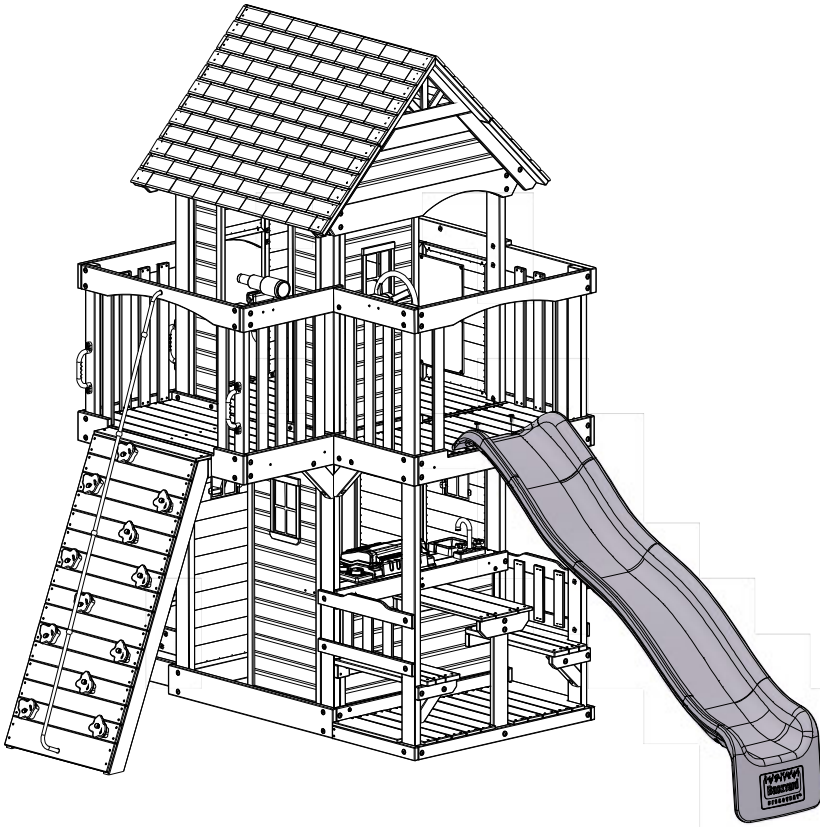

# STEP 4 - FINAL ASSEMBLY

QTY	PART NUMBER	DESCRIPTION
4	H100477	WASHER SPLIT 5/16 BLK
4	H100478	WASHER FLAT 8x27 BLK
4	H100498	BOLT HEX 5/16x1-1/2 - BLK

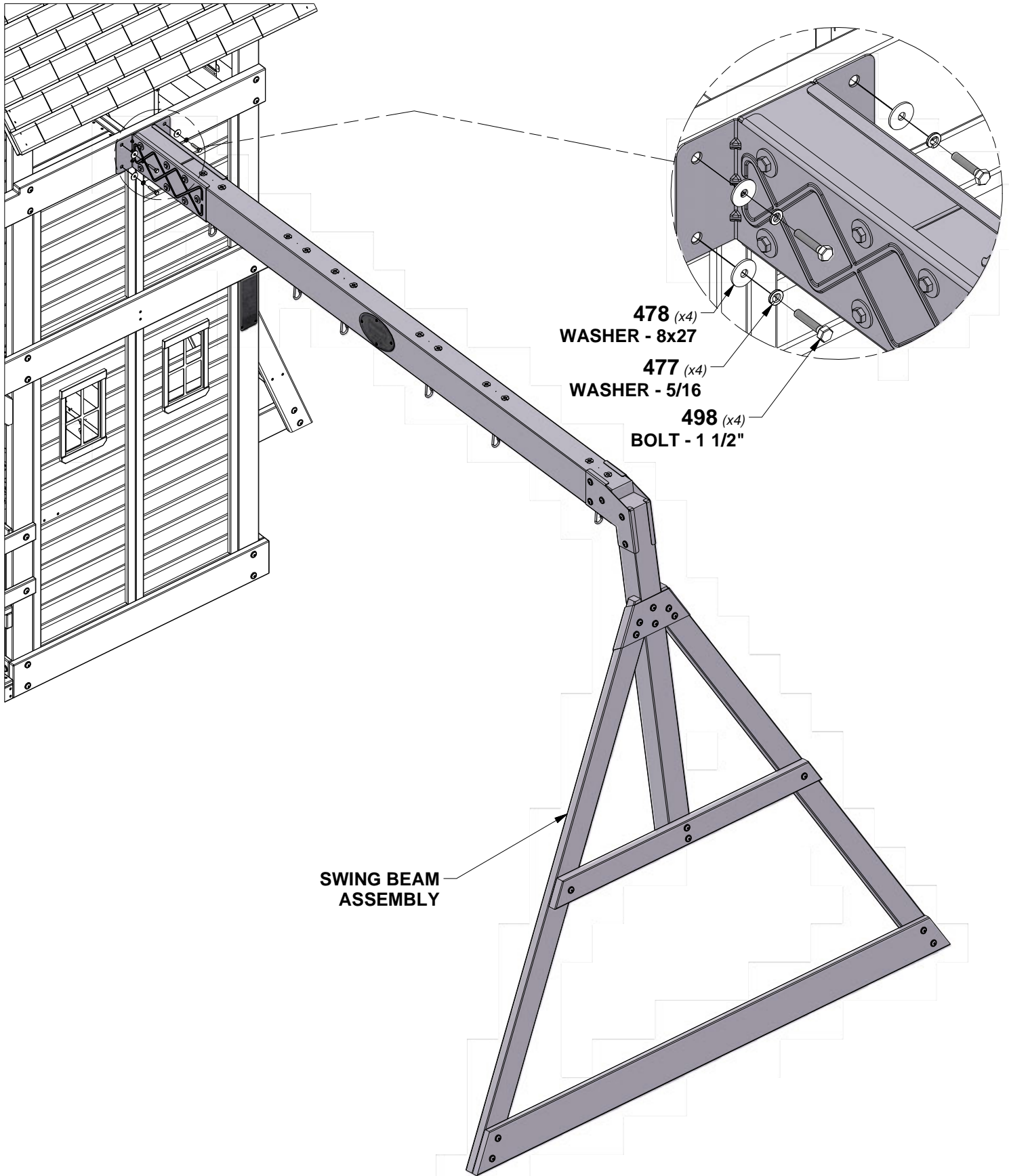

# STEP 1 - WEB SWING ASSEMBLY

QTY	PART NUMBER	DESCRIPTION
4	H100831	NUT BARREL PTH BLK 1/4x3/4
4	H100832	BOLT PTH 1/4x3/4

**IMPORTANT: SLIDE ROPE LOOPS OVER TUBE ENDS FIRST!**

SLIDE NARROW END OF TUBES INTO LARGER OPENING AFTER SLIDING ROPE LOOPS ONTO TUBES.

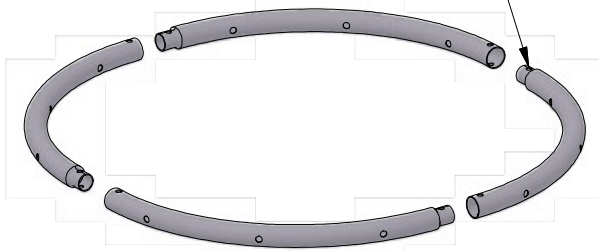

NOTE: ROPE WEBBING NOT SHOWN IN ILLUSTRATION FOR CLARITY.

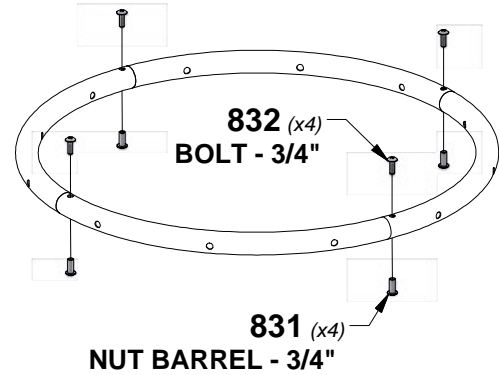

NOTE: IT IS IMPORTANT THAT THE WEB SWING HANG LEVEL.

TO ENSURE STRAIGHT SWINGING MOTION, ADJUST BOTH "S" BRACKETS UNTIL WEB SEAT IS LEVEL.

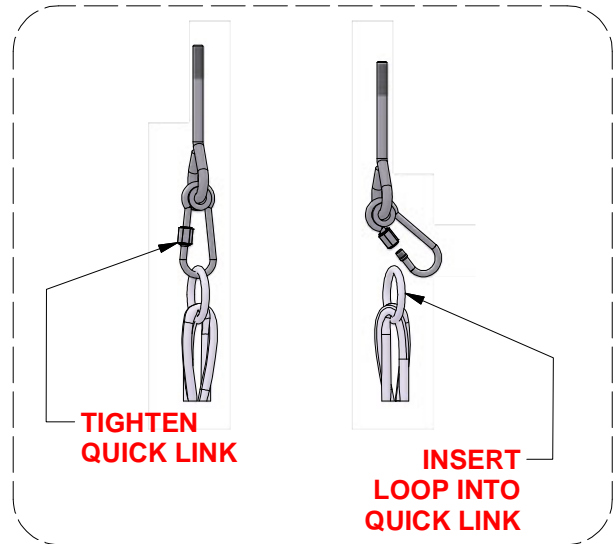

SWING MUST BE SET AT A MINIMUM OF 8 INCHES OFF THE GROUND WHEN INSTALLED.

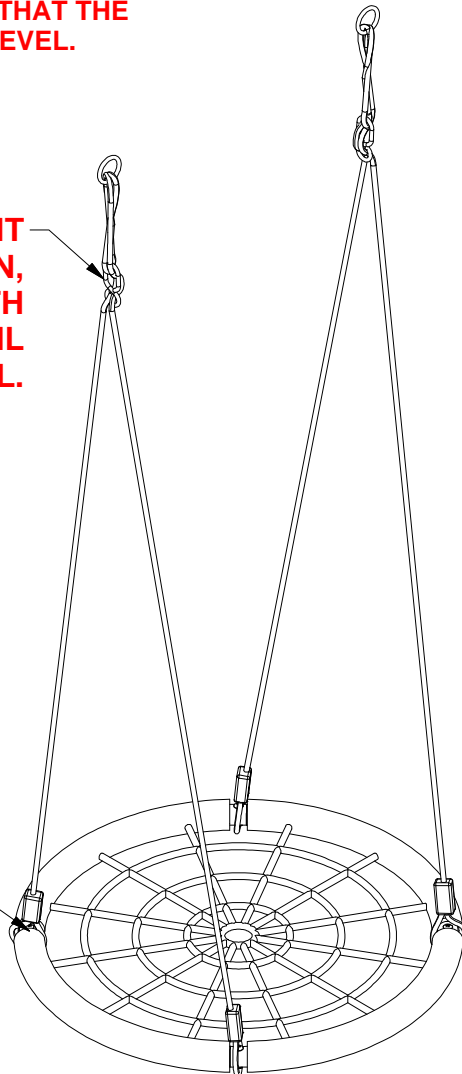



# STEP 5 - FINAL ASSEMBLY

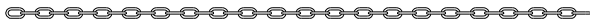

**A4M02256**  
(x4) **CHAIN BLACK 51.25"**

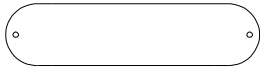

**A6P00595**  
(x2) **SWING SEAT GREY 22"**



**A4M00633**  
(x4) **QUICK LINK BLK**



**A4M01126**  
(x1) **26" WEB SWING**

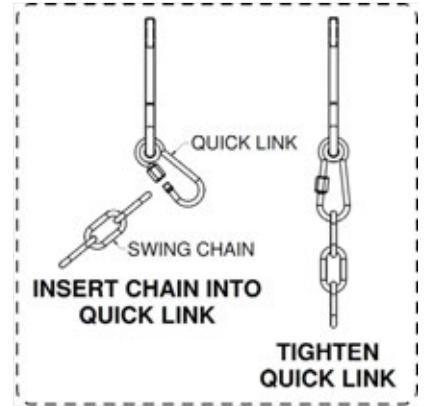
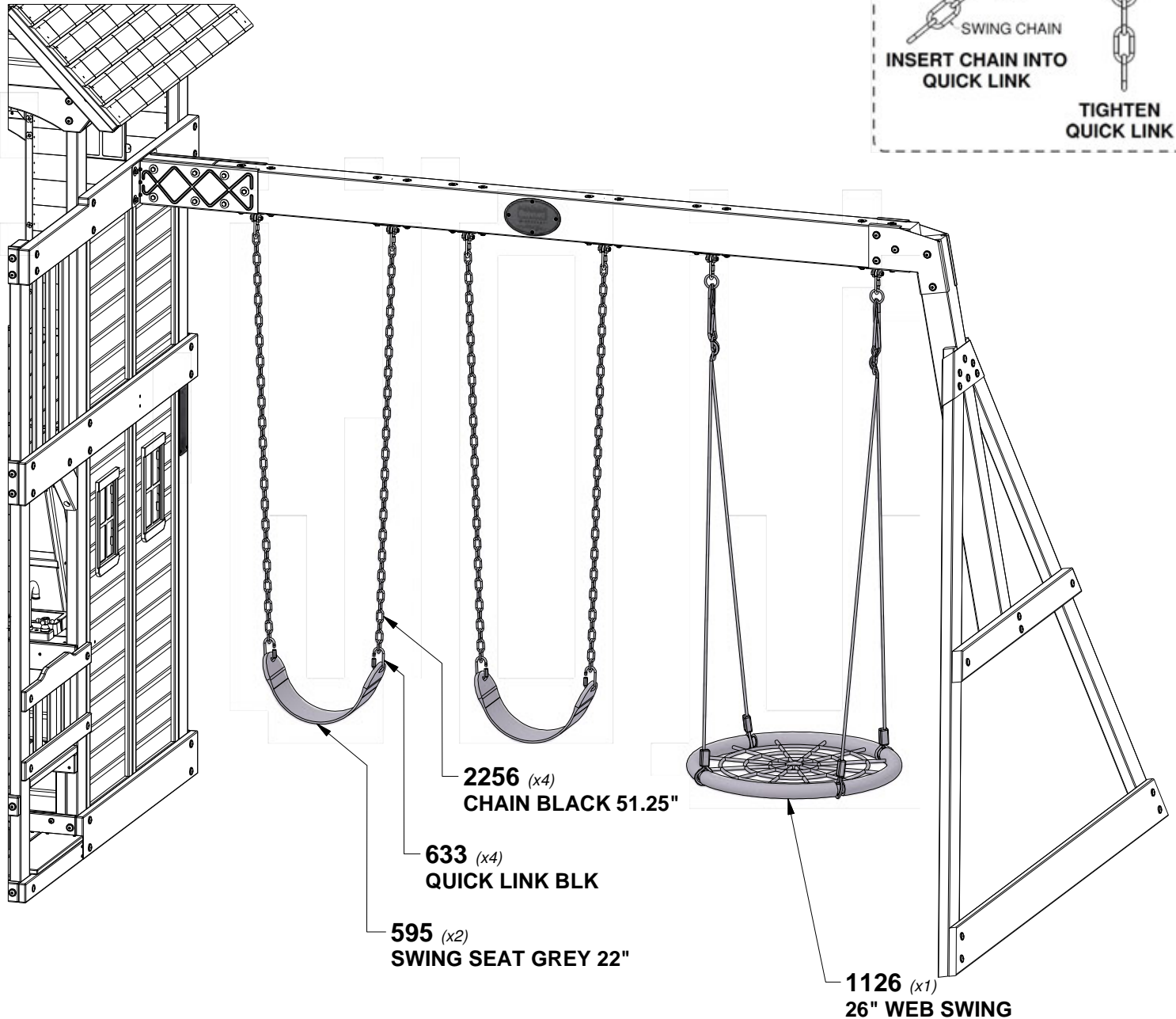

# STEP 6 - FINAL ASSEMBLY

QTY	PART NUMBER	DESCRIPTION
6	H100379	T-NUT 5/16 BLK
6	H100459	BOLT WH 5/16x1 1/4 BLK

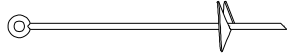

**A4M02252 AUGER GROUND STAKE**  
(x6)

**TWIST GROUND STAKE INTO GROUND AT LOCATIONS SHOWN. USING AUGER STAKE AS A GUIDE, DRILL A 3/8" [10mm] HOLE FOR HARDWARE.**

