



Manufactured by:  
Backyard Discovery  
3305 Airport Drive, Pittsburg, KS 66762  
800-856-4445

Basepoint Business Centre: Rivermead Drive, Westlea, Swindon SN5 7EX Phone: 0800-118-2476  
J.P. Coenstraat 7, The Bridge, The Hague, 2595 WP, Netherlands Phone: 08005678990

# 8x6 PRIVACY PANEL

## MODEL # : 2304017



Please visit [www.backyarddiscovery.com](http://www.backyarddiscovery.com)  
For the most up to date assembly manual, to register your product, or to order  
replacement parts *Para obtener instrucciones en español, visite*  
[www.backyarddiscovery.com](http://www.backyarddiscovery.com)

# OWNER'S MANUAL - BASIC SETUP DIMENSIONS & ASSEMBLY NOTES

It is critically important that you start with a square and level concrete pad to attach your structure

- Pay close attention to the items needed for each step. Make sure you are using the correct hardware for each step. Using incorrect hardware may result in improper assembly
- Remember to double check for underground utilities and overhead electrical lines

Post mounts are provided with your structure which allows you to permanently install your product to a concrete surface. See Anchor Instructions for further details and recommendations.

- The hardware to attach the post mounts to the structure is included.
- The hardware to mount the structure permanently to a concrete surface is included.

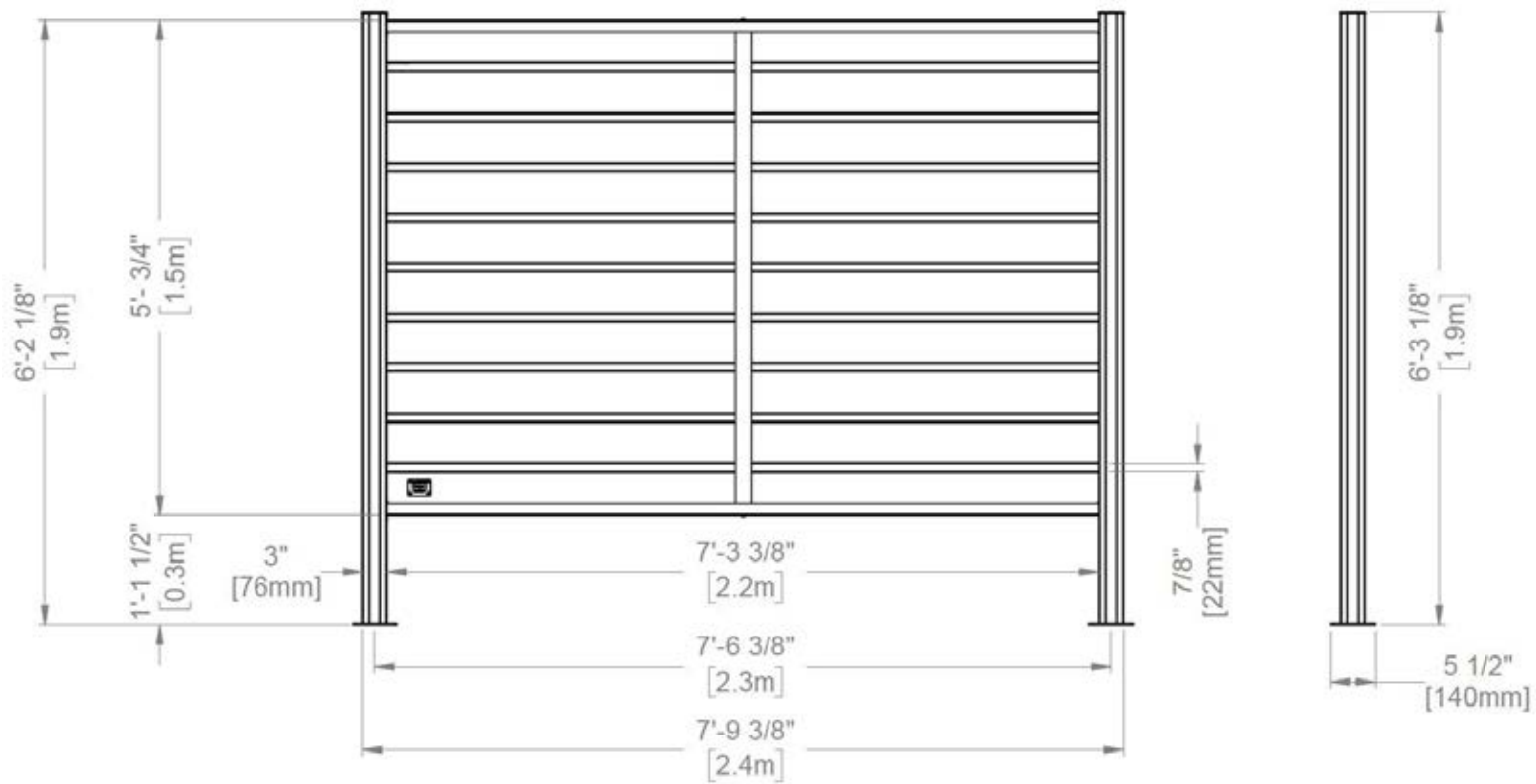

# OWNER'S MANUAL - ANCHORING LAYOUT

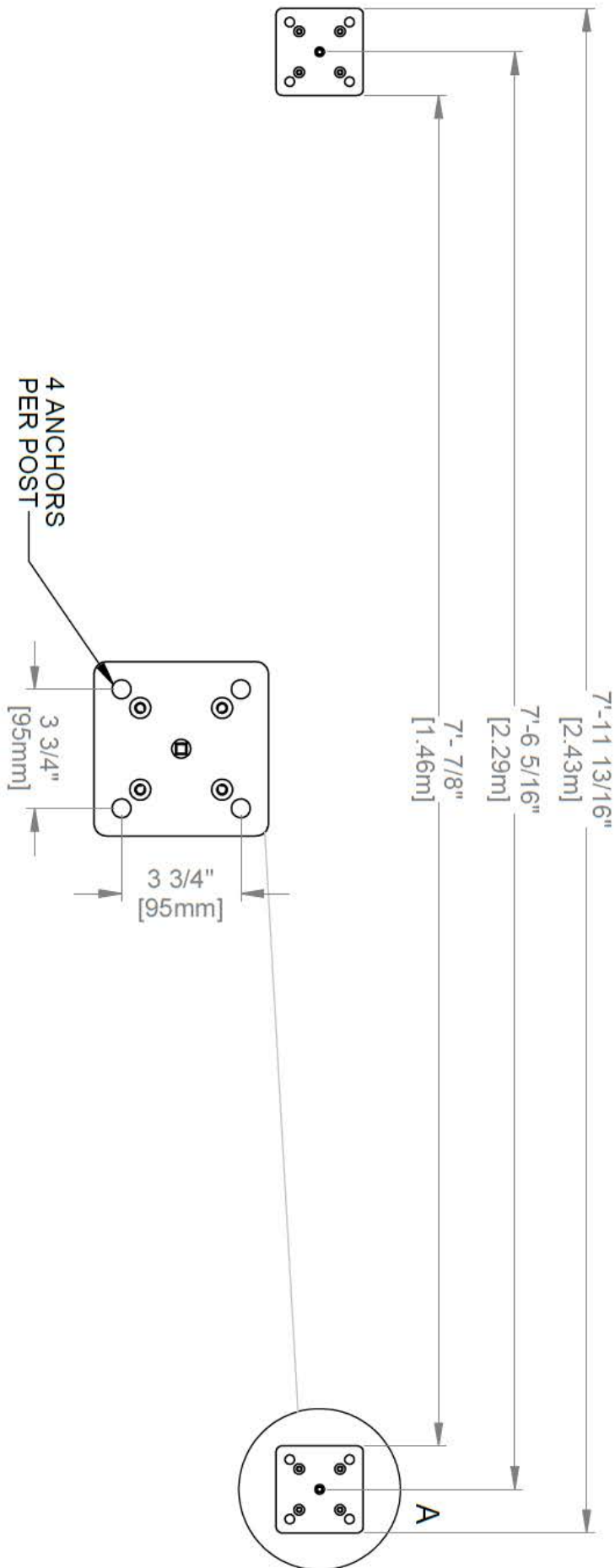

NOTE: DIMENSIONS ARE TO ANCHOR PLATES ON BOTTOM OF POST EXCEPT WHERE NOTED.

# OWNER'S MANUAL - PARTS IDENTIFICATION

## METAL COMPONENTS (NOT TO SCALE)

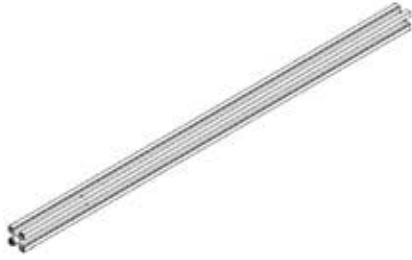

P01 POST ASSEMBLY - A4M02244  
(x2) 3"x3"x74 13/16" (76x76x1900)

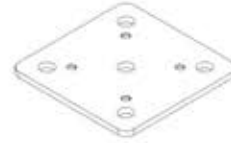

P02 POST FOOT - A4M02182  
(x2) 1/4"x5 1/2"x5 1/2" 6x139x139)



A1 HORIZONTAL BRACE ASSEMBLY - A4M01806  
(x2) 1 7/16"X2 5/16"X88" (36x58x2235)



A2 VERTICAL SUPPORT - A4M02039  
(x1) 1 15/16"X1 3/16"X57 7/8" (30x50x1470)

## ACCESSORY COMPONENTS (NOT TO SCALE)



A6P00545 INSERT  
(x2)

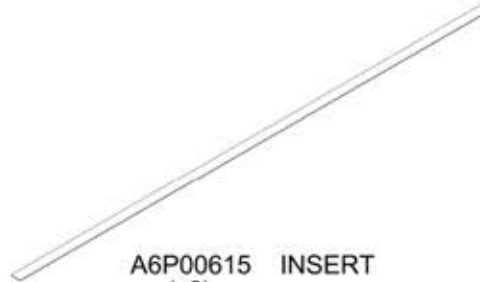

A6P00615 INSERT  
(x6)



A6P00544 POST CAP  
(x2)



A6P00560 SPACER  
(x36)



A4M02158 BYD ID TAG PATIO  
(x1)

## WOOD COMPONENTS (NOT TO SCALE)



B01 WOOD SLAT - W4L18023  
(x3) 15/16"x5 1/4"x44 1/8" (24x134x1120)



B02 WOOD SLAT - W4L18024  
(x16) 15/16"x5 1/4"x44 1/8" (24x134x1120)



B03 WOOD SLAT WITH TAG - W2A04020  
(x1) 15/16"x5 1/4"x44 1/8" (24x134x1120)

# OWNER'S MANUAL - PARTS IDENTIFICATION

## HARDWARE COMPONENTS (NOT TO SCALE)



H100392 SCREW PWH  
(x4) 8x3/4 BLK

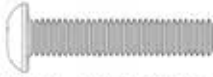

H101271 TORX PAN HEAD  
(x4) 1/4-20x1 1/4" BLK

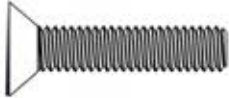

H101164 TORX FLAT HEAD  
(x8) 5/16-18x1 1/2" BLK

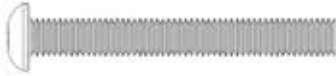

H101126 TORX PAN HEAD  
(x4) 1/4-20x2 1/8" BLK

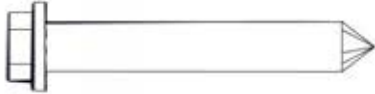

H101165 CONCRETE ANCHOR  
(x8) 3/8"x3" BLK

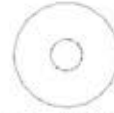

H101053 STEEL WASHER  
(x4) 6x20



H101054 SEALANT WASHER  
(x4)

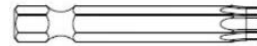

H100147 TORX BIT  
(x1) T-30



H100114 TORX WRENCH  
(x1) T-30



H101100 MAGNETIC DRIVER  
(x1)

# PRE-ASSEMBLY STEP 1 - SORTING PARTS

It is critical for ease of assembly that you take the time to sort and organize the parts and hardware.

---

## METAL PARTS:

- Organize metal parts by the three-digit, alpha-numeric number stamped on each part (ex. P01).
- If there are multiple parts with the same stamped number, stack those pieces together.
- Stamps can be found on the flat surface of the parts or on the end of the parts.
- Allow yourself plenty of room - the parts can take up a significant amount of space.

**NOTE: CARTONS ARE NOT ORGANIZED BY PART NUMBER.**

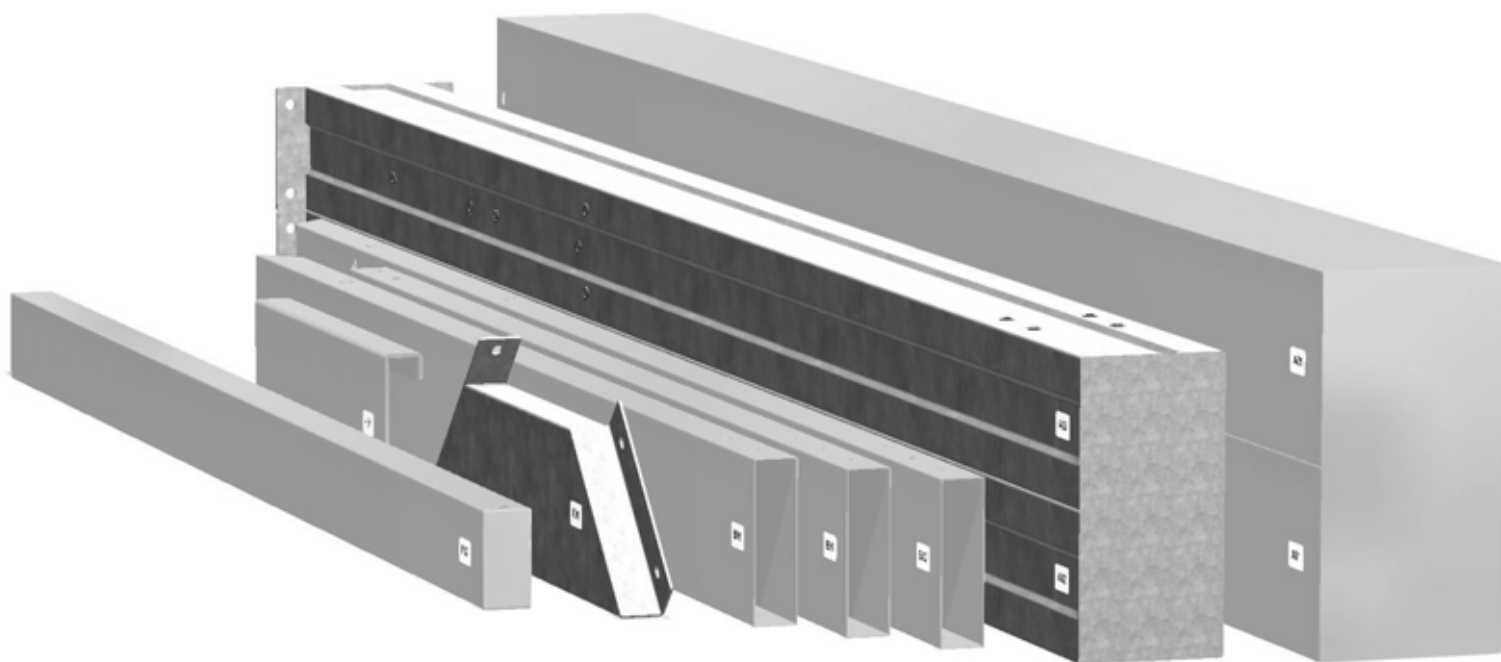

---

## HARDWARE PARTS:

- We recommend that you have a separate table to organize the hardware.
- Hardware bags are printed with a seven-digit, alpha-numeric part number.
- You can organize your hardware by part number or group by hardware type (i.e. bolts, nuts, etc.).
- During assembly you only need to reference the last four digits of the number.

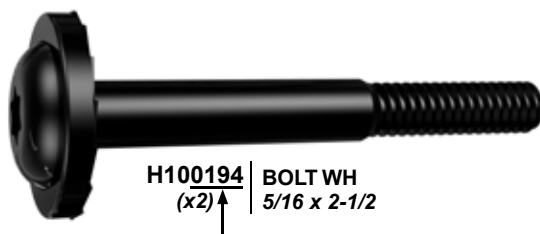

# PRE-ASSEMBLY STEP 2 - TOOLS REQUIRED



Cordless Drill or Electric Drill



Drill Attachments:  
Phillips Head



1/8", 3/16", 3/8" &  
7/16" Drill Bits



Phillips Screw Driver



Open End Wrench  
7/16"



3/8" Drive Ratchet, 1/2" &  
7/16" STD Sockets 1/2" & 7/16"  
Deep Sockets



Claw Hammer



Rubber Mallet -  
Optional

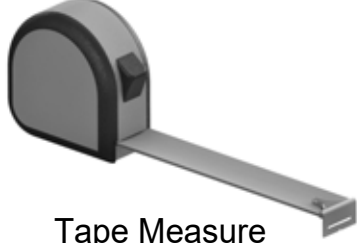

Tape Measure

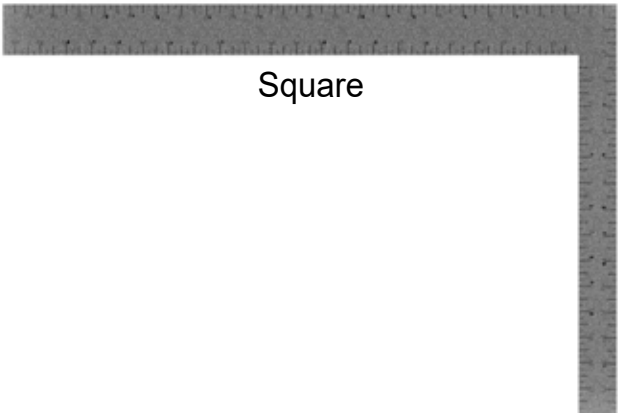

Square



Level 24"



# STEP 1 - POST ASSEMBLY

Qty	PART NUMBER	DESCRIPTION
8	H101164	TORX FLAT HEAD 5/16-18x1 1/2" BLK

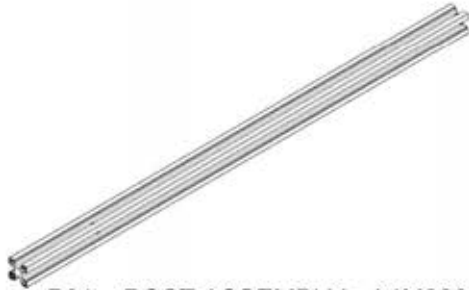

P01 POST ASSEMBLY - A4M02244  
(x2) 3"x3"x74 13/16" (76x76x1900)

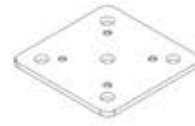

P02 POST FOOT - A4M02182  
(x2) 1/4"x5 1/2"x5 1/2" (6x139x139)

**REPEAT THIS STEP TWICE**

**NOTE: POST MUST BE ORIENTED AS SHOWN BELOW**

**NOTE: THREADED INSERTS ON END OF POST INDICATE TOP**

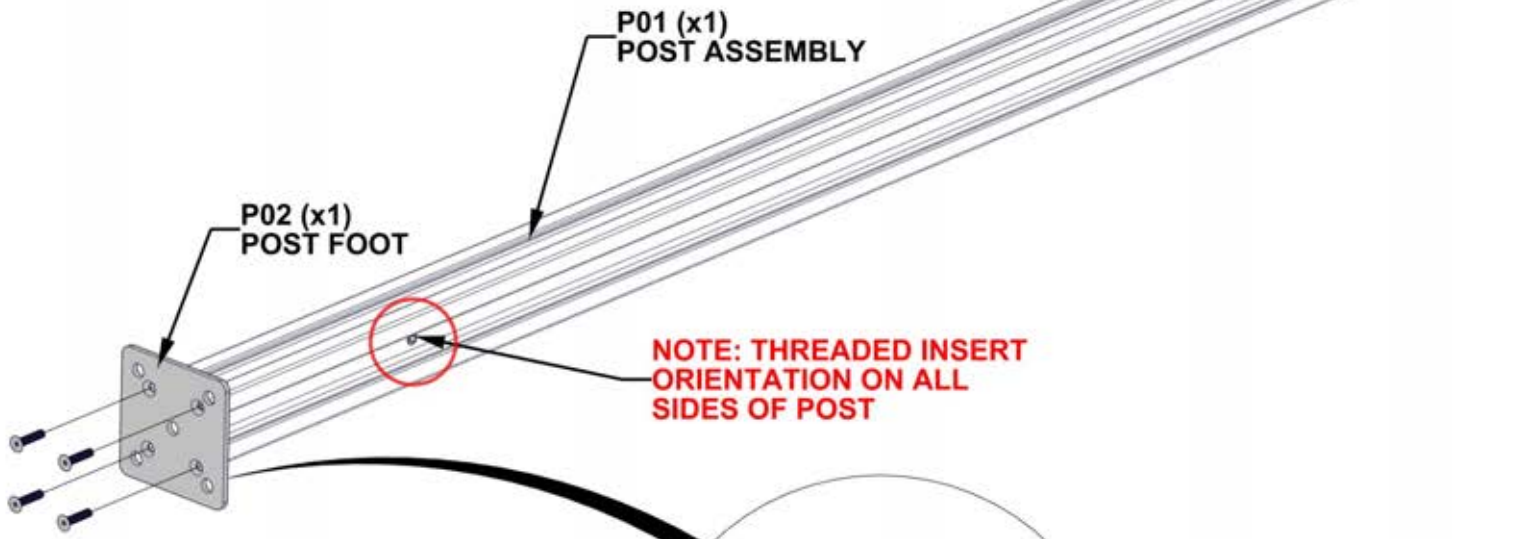
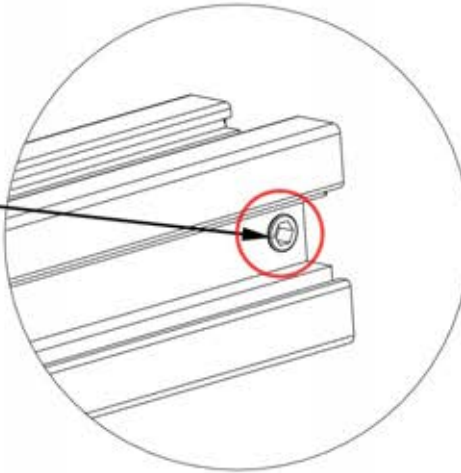

**NOTE: THREADED INSERT ORIENTATION ON ALL SIDES OF POST**

1164 (x4)  
TORX FLAT HEAD 5/16-18x1 1/2" BLK

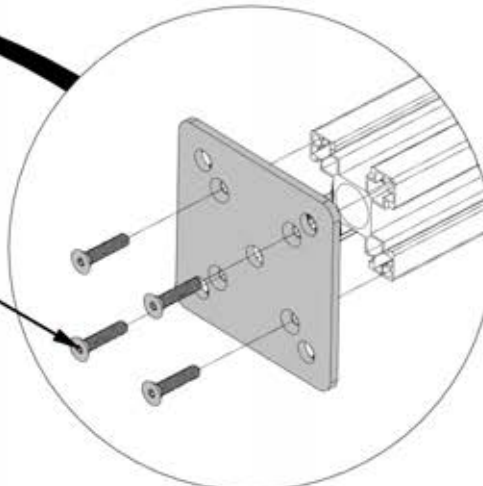



# STEP 2 - POST ASSEMBLY



A6P00545 INSERT  
(x2)

REPEAT THIS STEP FOR EACH POST

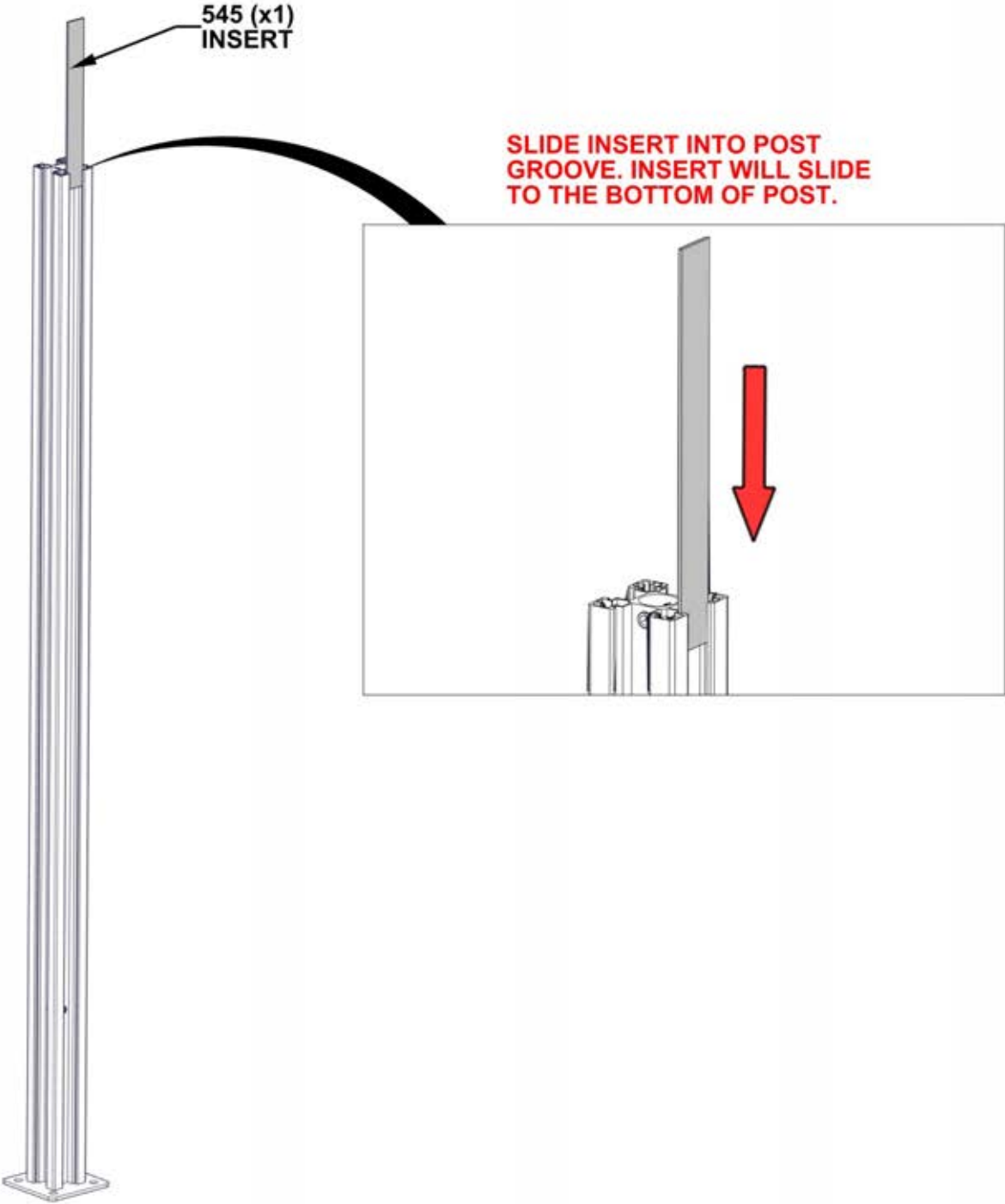

# STEP 3A - FRAME ASSEMBLY

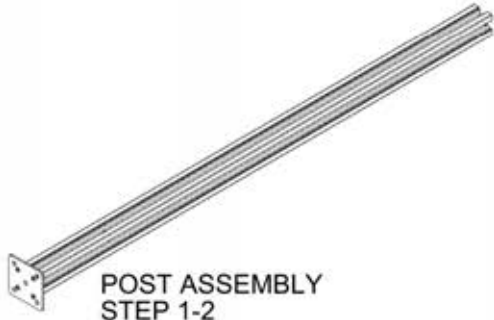

**NOTE: TWO PEOPLE ARE RECOMMENDED FOR THIS STEP.**

**ORIENT EACH POST TO WHERE INSERTS FROM PREVIOUS STEP ARE FACING EACH OTHER**

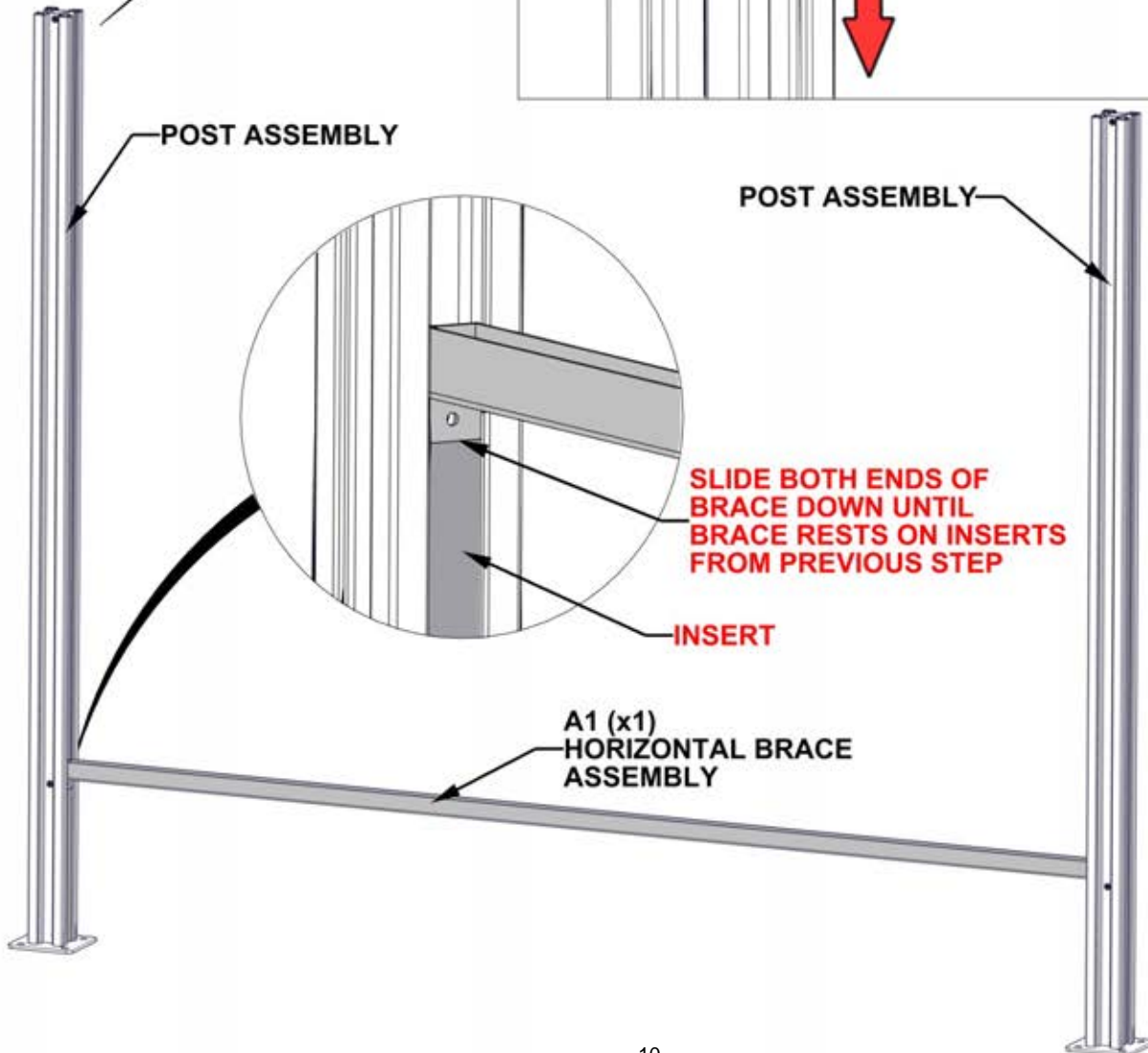
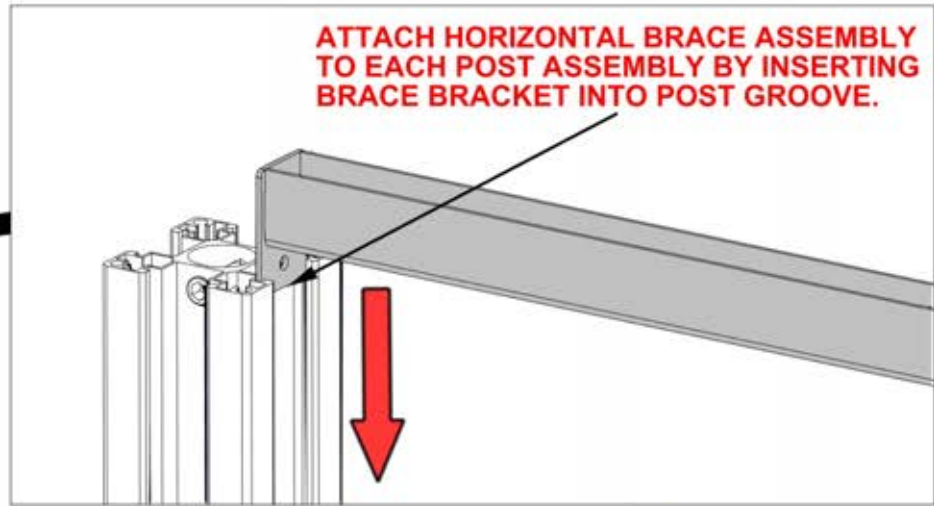

# STEP 3B - FRAME ASSEMBLY

Qty	PART NUMBER	DESCRIPTION
2	H101053	STEEL WASHER 6x20
2	H101054	SEALANT WASHER
2	H101271	TORX PAN HEAD 1/4-20x1 1/4"

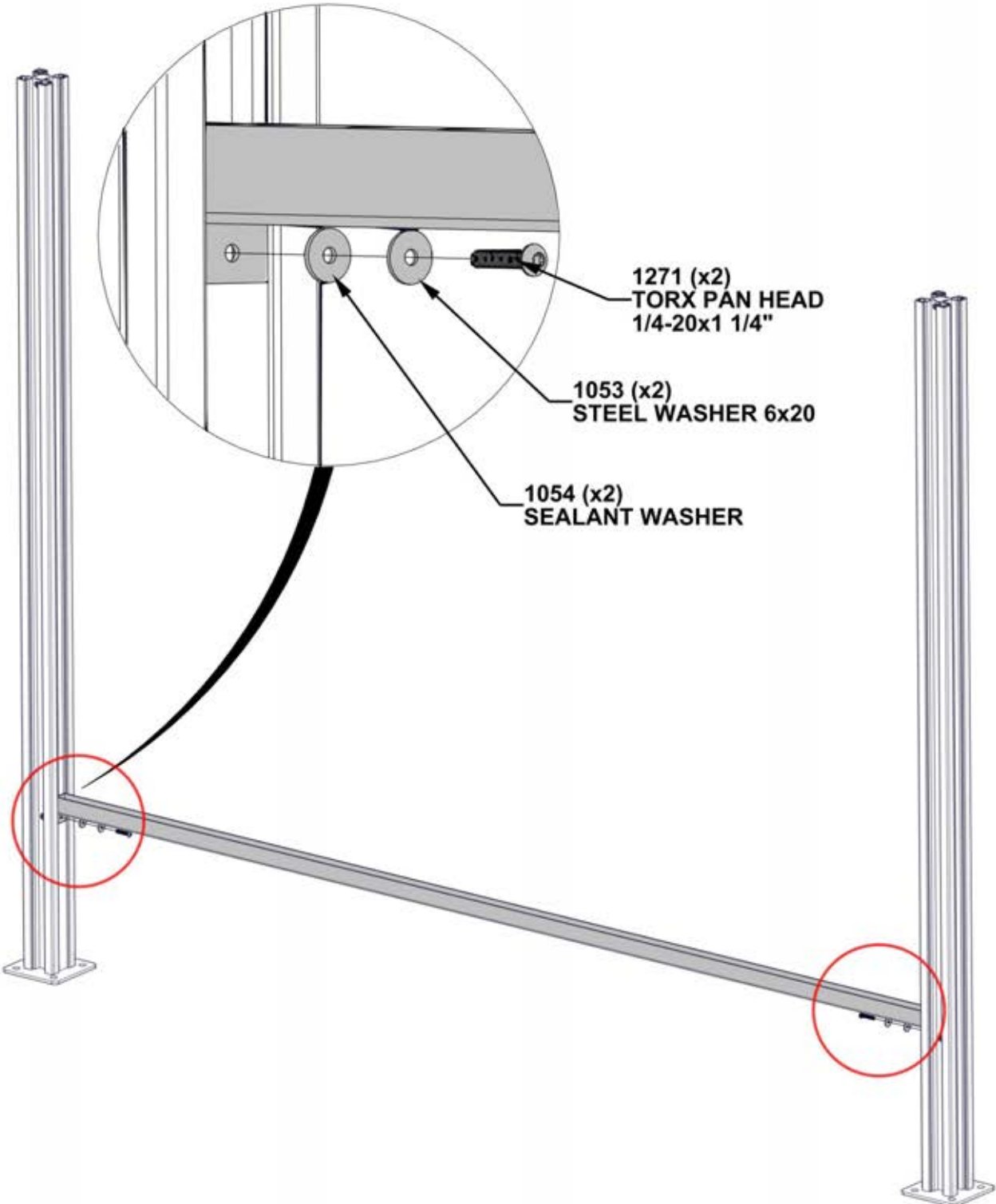

# STEP 4 - FRAME ANCHORING

Qty	PART NUMBER	DESCRIPTION
8	H101165	CONCRETE ANCHOR-3"

**MANUFACTURER RECOMMENDS INSTALLATION ON CONCRETE SURFACE AS SHOWN BELOW.**

**SQUARE POST AS NEEDED BEFORE INSTALLING CONCRETE ANCHORS.**

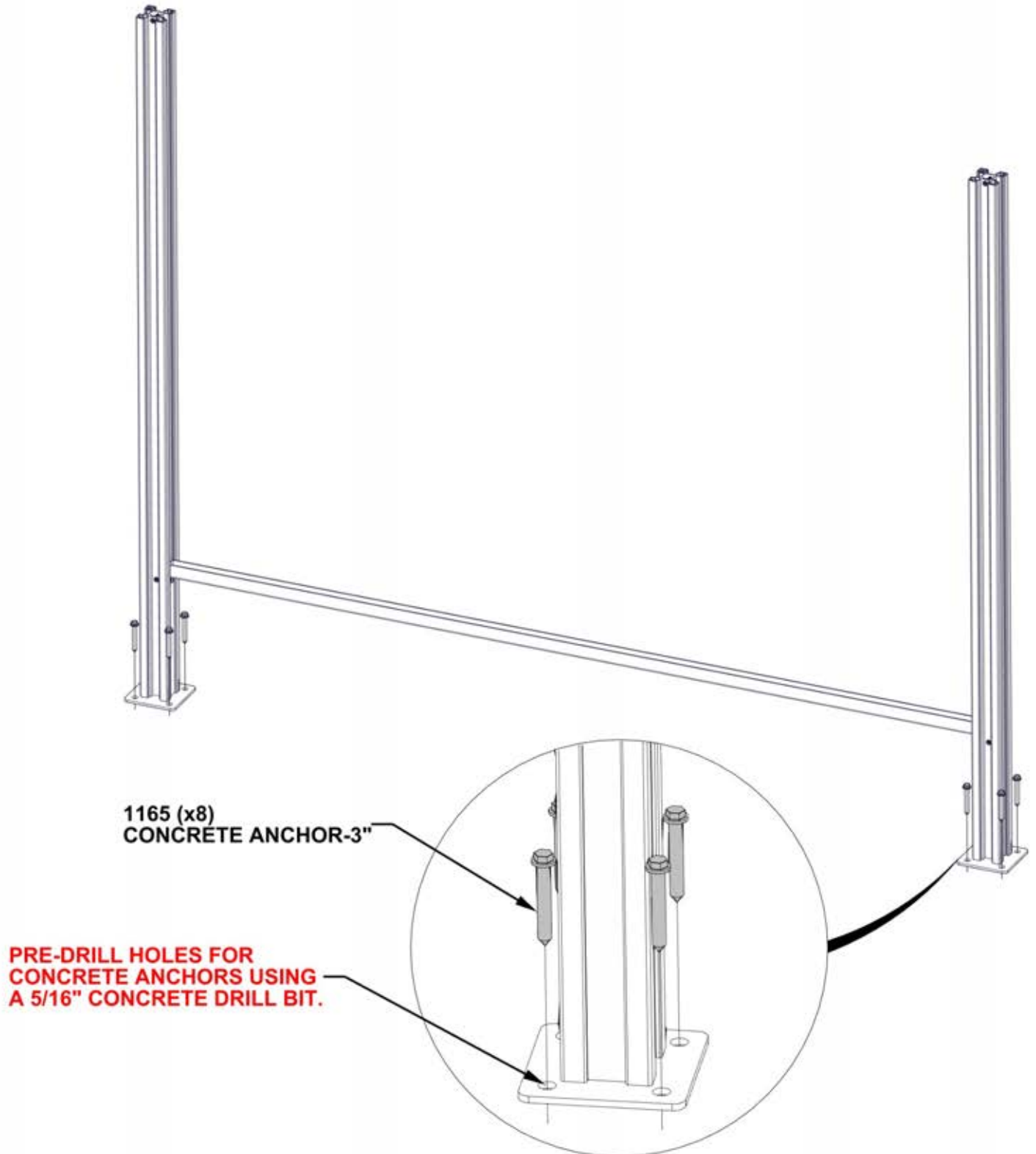

# STEP 5 - FRAME ASSEMBLY



Qty	PART NUMBER	DESCRIPTION
2	H101126	TORX PAN HEAD 1/4-20x2 1/8" BLK

A2 VERTICAL SUPPORT - A4M02039  
(x1) 1 15/16"X1 3/16"X57 7/8" (30x50x1470)

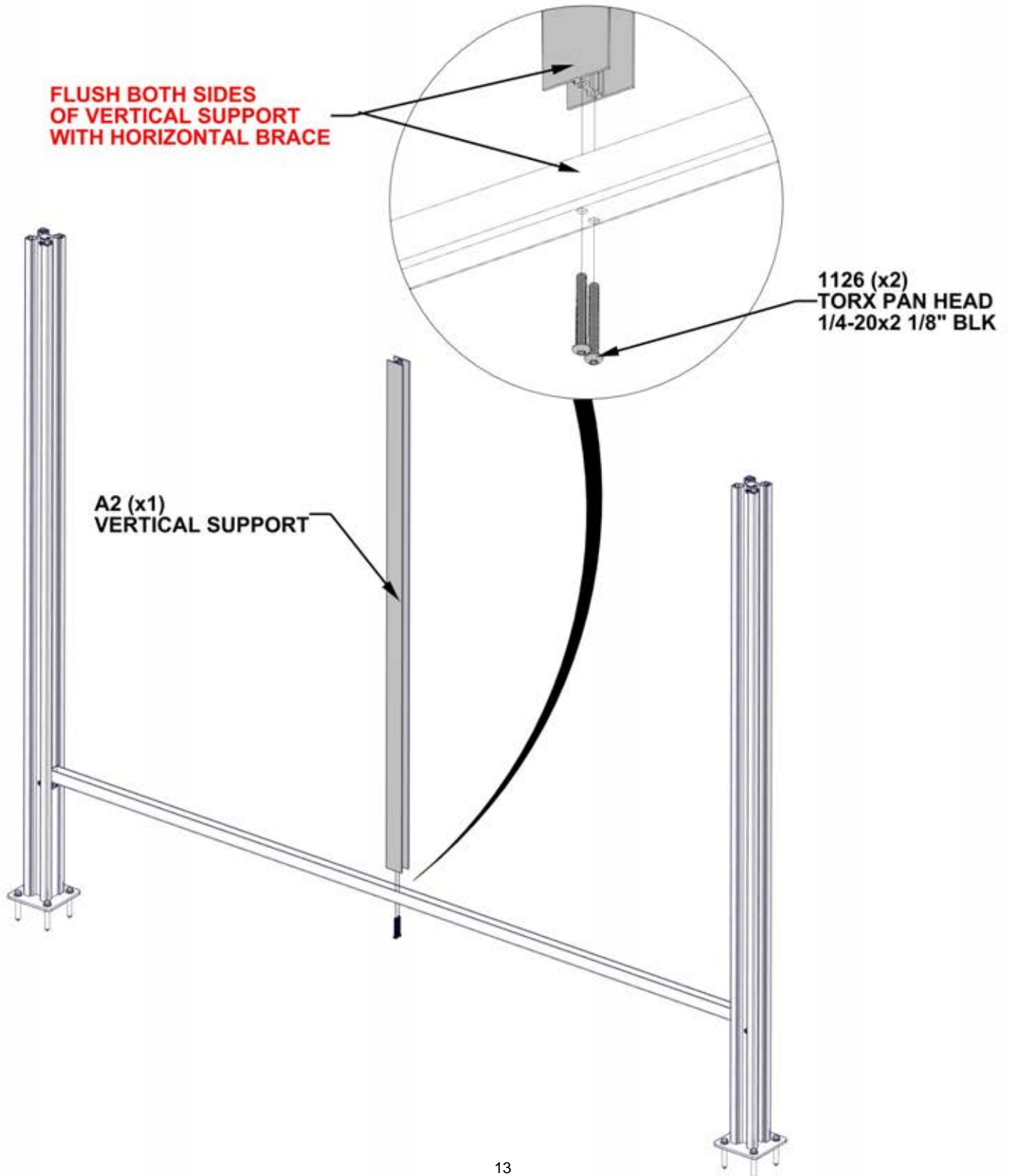

# STEP 6 - SLAT INSTALLATION



B01 WOOD SLAT - W4L18023  
(x2) 15/16"x5 1/4"x44 1/8" (24x134x1120)

**INSTALL WOOD SLATS BY ALIGNING  
ENDS OF BOARDS WITH GROOVES  
IN POST AND VERTICAL SUPPORT**

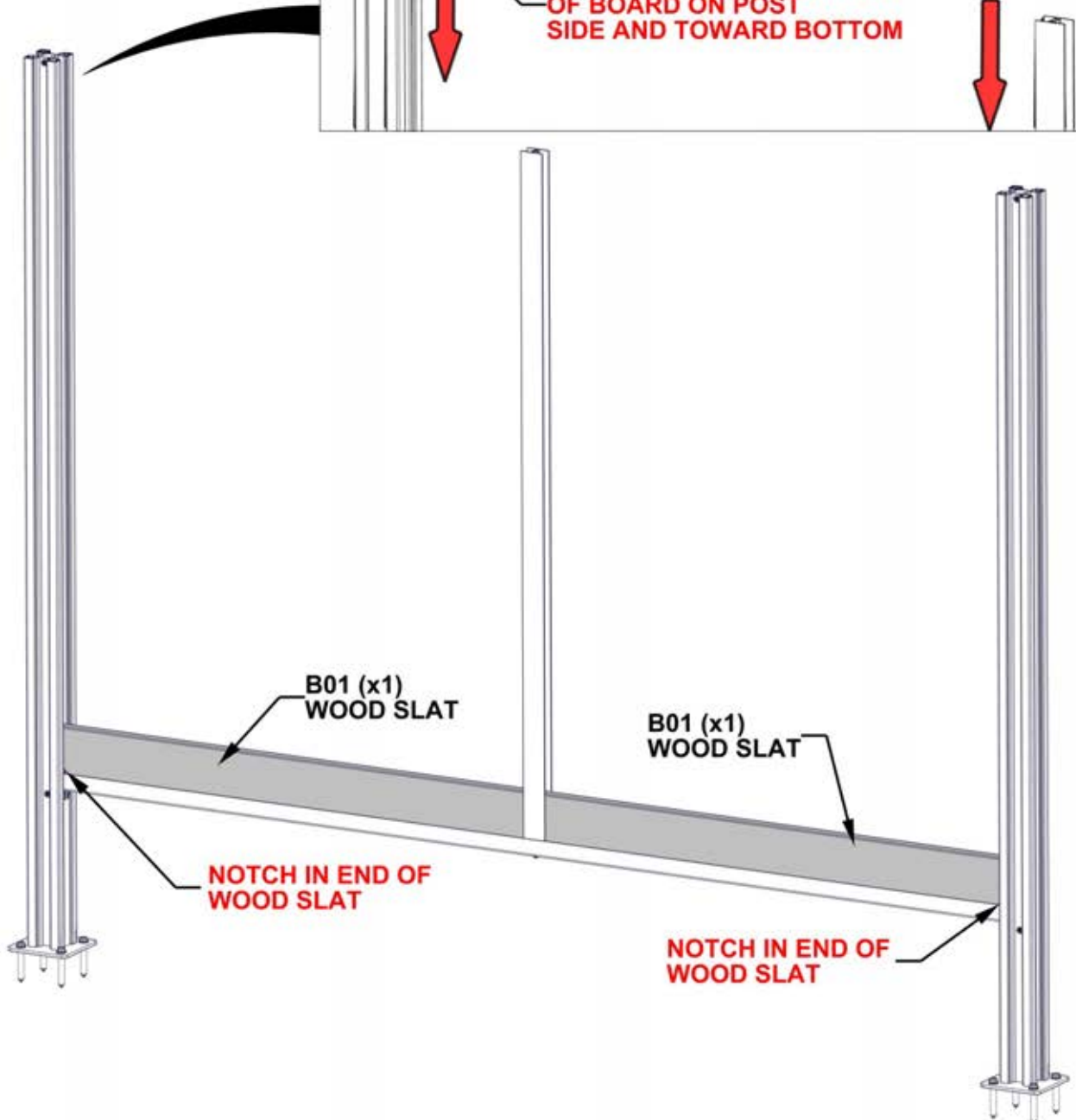
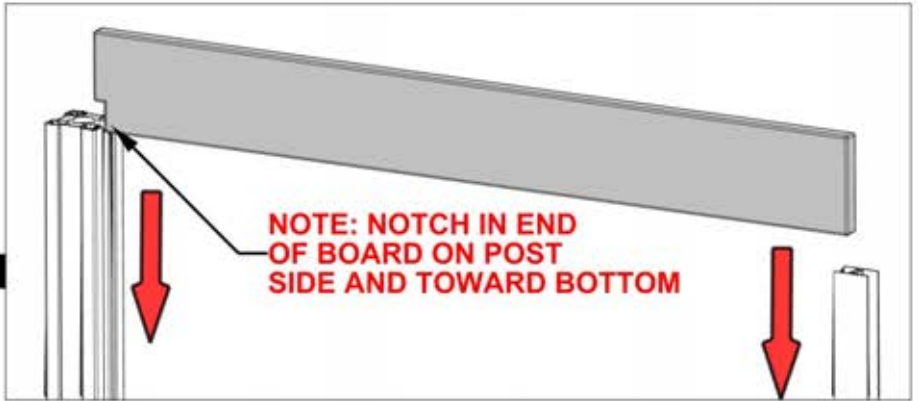



# STEP 7 - SPACER INSTALLATION

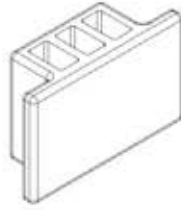

A6P00560 SPACER  
(x4)

**NOTE: THE DIFFERENT ORIENTATION OF THE SPACERS IS CRITICAL TO ASSEMBLY**

**NOTE: ORIENTATION OF EACH SPACER IN EACH POST GROOVE**

**NOTE: ORIENTATION OF TWO SPACERS IN VERTICAL SUPPORT**

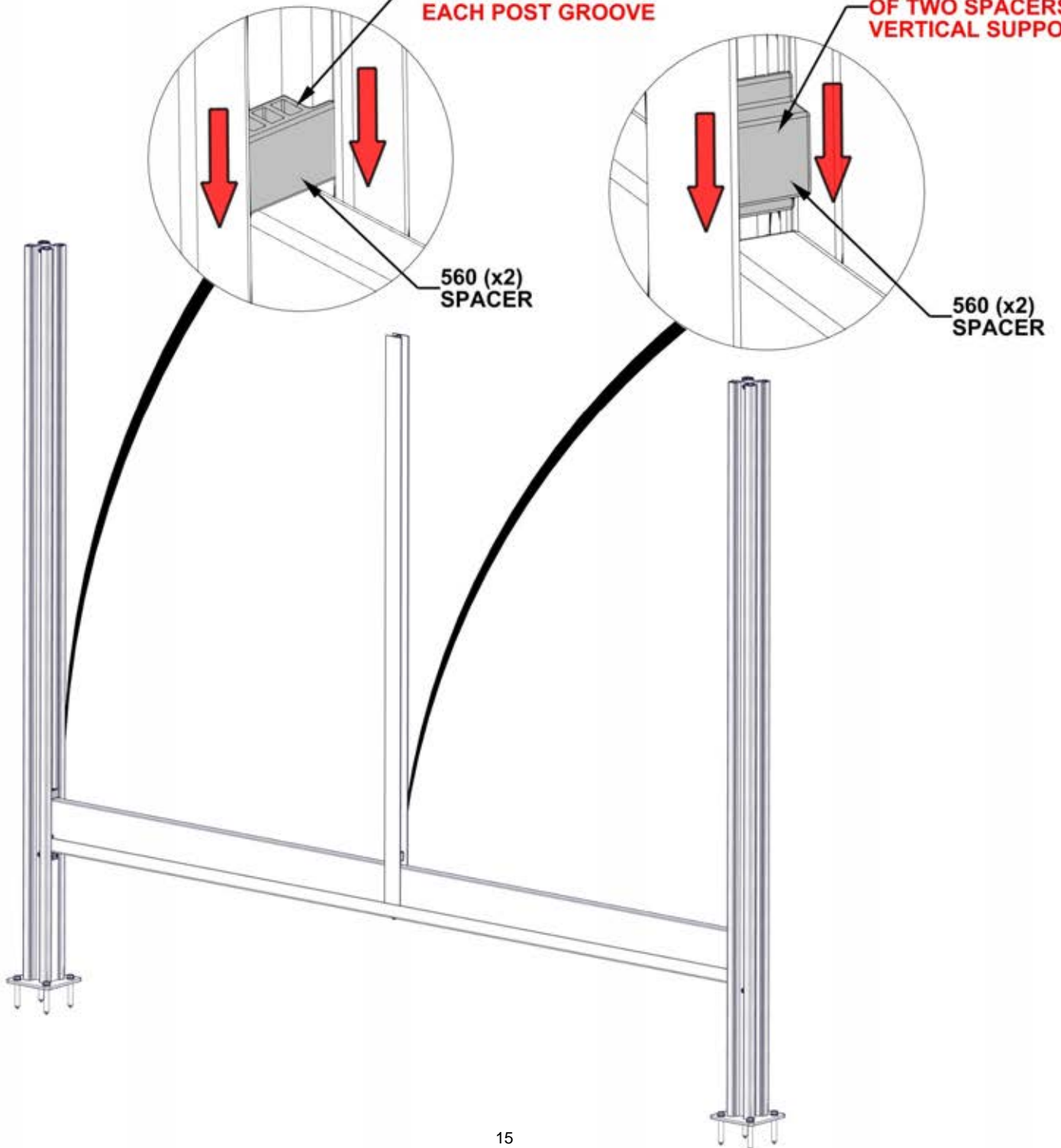



# STEP 8 - SLAT INSTALLATION



B02 WOOD SLAT - W4L18024  
(x2) 15/16"x5 1/4"x44 1/8" (24x134x1120)

**INSTALL WOOD SLATS BY ALIGNING  
ENDS OF BOARDS WITH GROOVES  
IN POST AND VERTICAL SUPPORT**

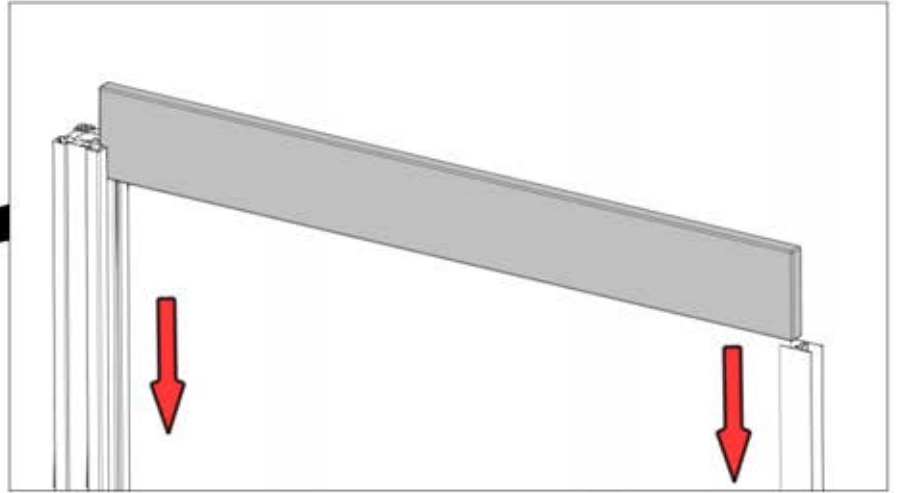

**MAKE SURE POST  
REMAIN SQUARE  
WHEN INSTALLING  
WOOD SLATS**

**MAKE SURE POST  
REMAIN SQUARE  
WHEN INSTALLING  
WOOD SLATS**

B02 (x1)  
WOOD SLAT

B02 (x1)  
WOOD SLAT

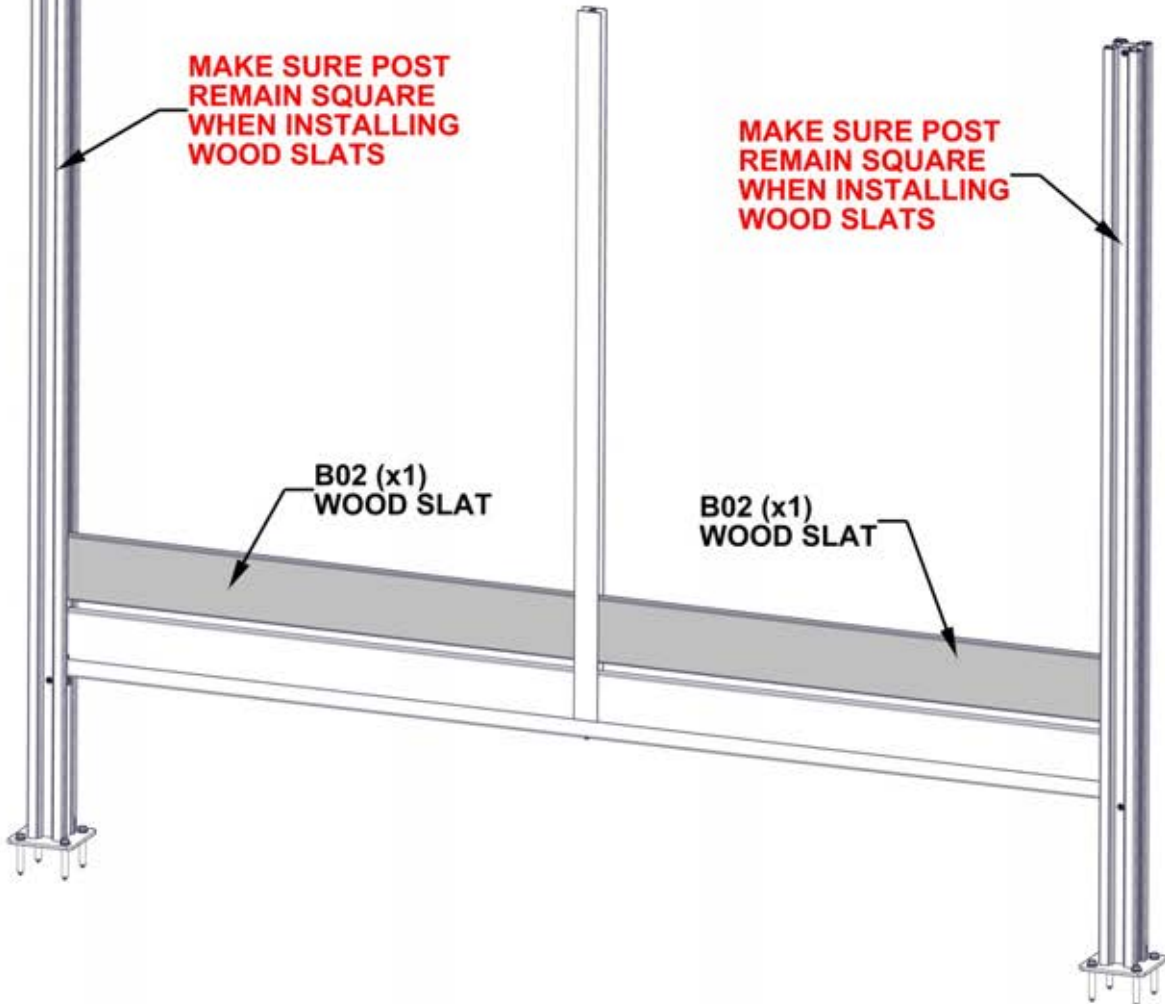

# STEP 9 - SLAT INSTALLATION



B02 WOOD SLAT - W4L18024  
(x14) 15/16"x5 1/4"x44 1/8" (24x134x1120)



A6P00560 SPACER  
(x28)

**REPEAT STEPS 7 - 8 TO INSTALL  
REMAINING B02 WOOD SLATS**

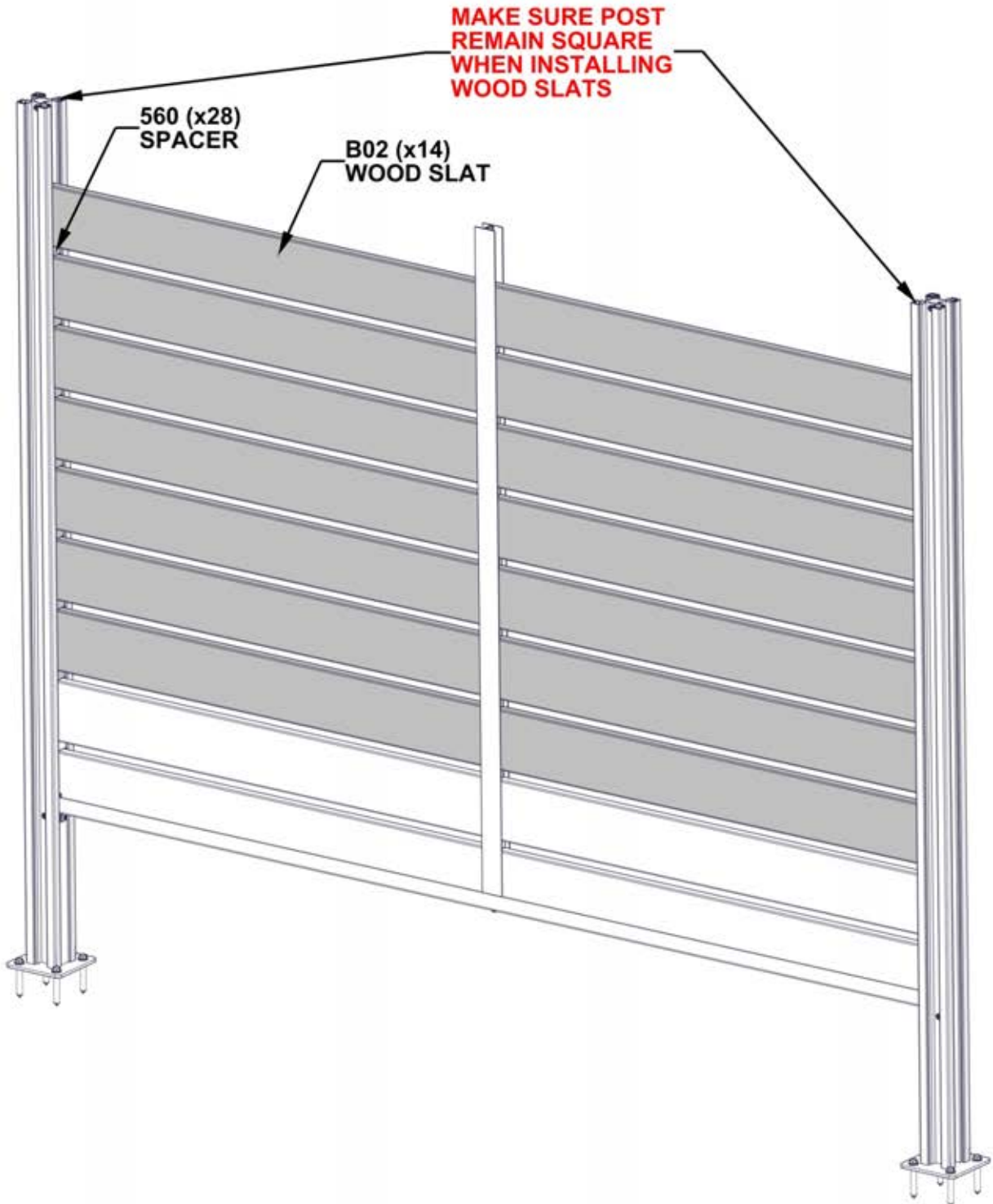

# STEP 10 - SLAT INSTALLATION



B01 WOOD SLAT - W4L18023  
(x) 15/16"x5 1/4"x44 1/8" (24x134x1120)



B03 WOOD SLAT WITH TAG - W2A04020  
(x1) 15/16"x5 1/4"x44 1/8" (24x134x1120)



A6P00560 SPACER  
(x4)

**NOTE: NOTCH IN END  
OF BOARDS ON POST  
SIDE AND TOWARD TOP**

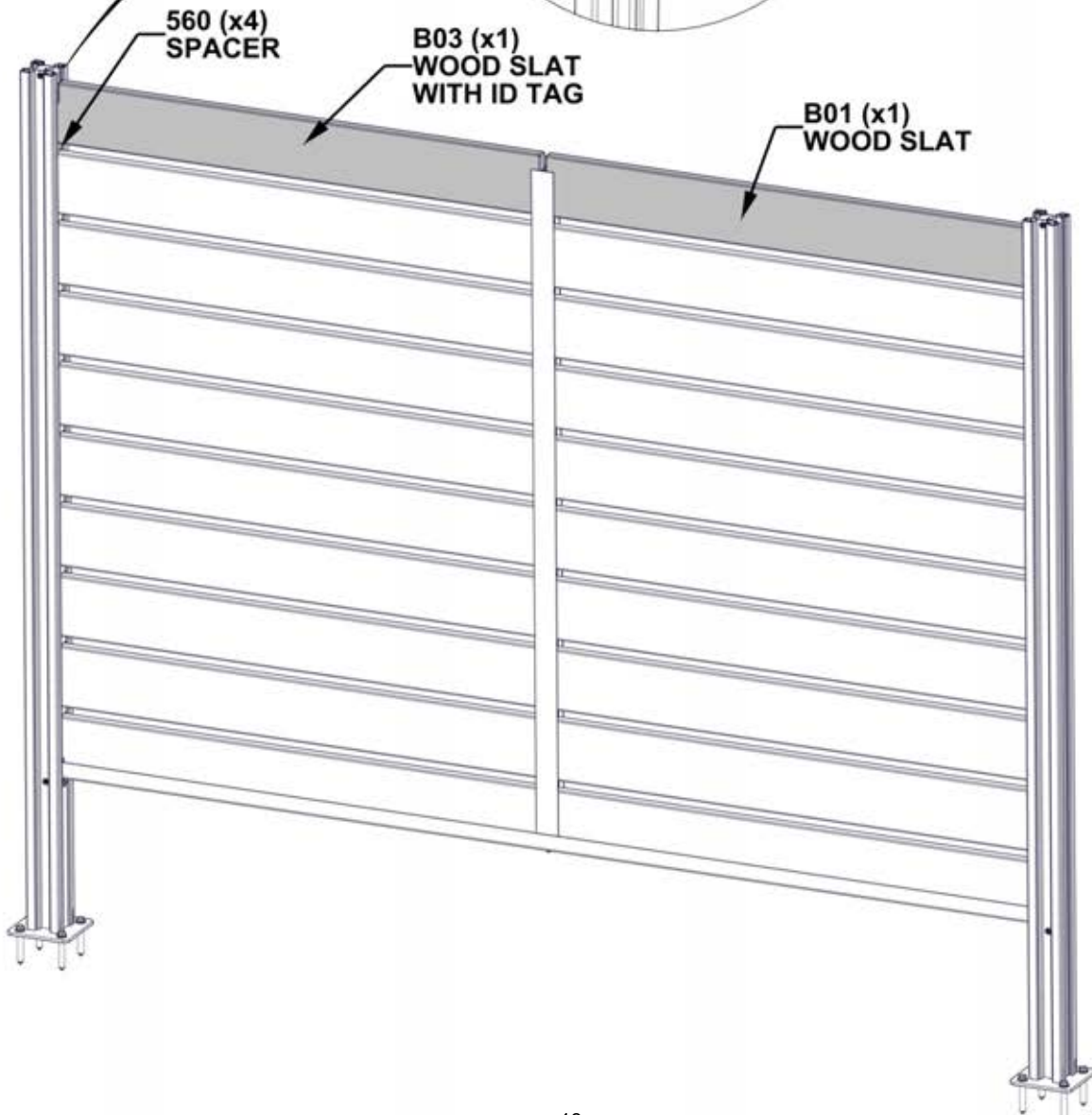
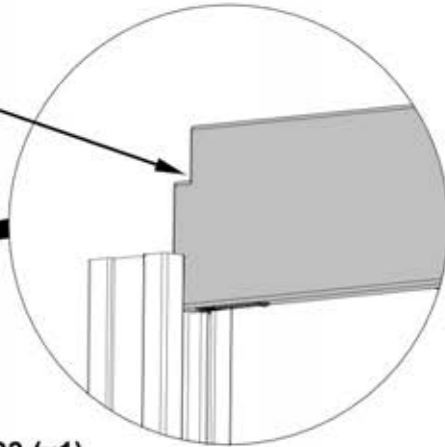

# STEP 11A - FRAME ASSEMBLY



Qty	PART NUMBER	DESCRIPTION
2	H101126	TORX PAN HEAD 1/4-20x2 1/8"

A1 HORIZONTAL BRACE ASSEMBLY - A4M01806  
(x1) 1 7/16"X2 5/16"X88" (36x58x2235)

**DO NOT TIGHTEN HARDWARE AT THIS STEP**

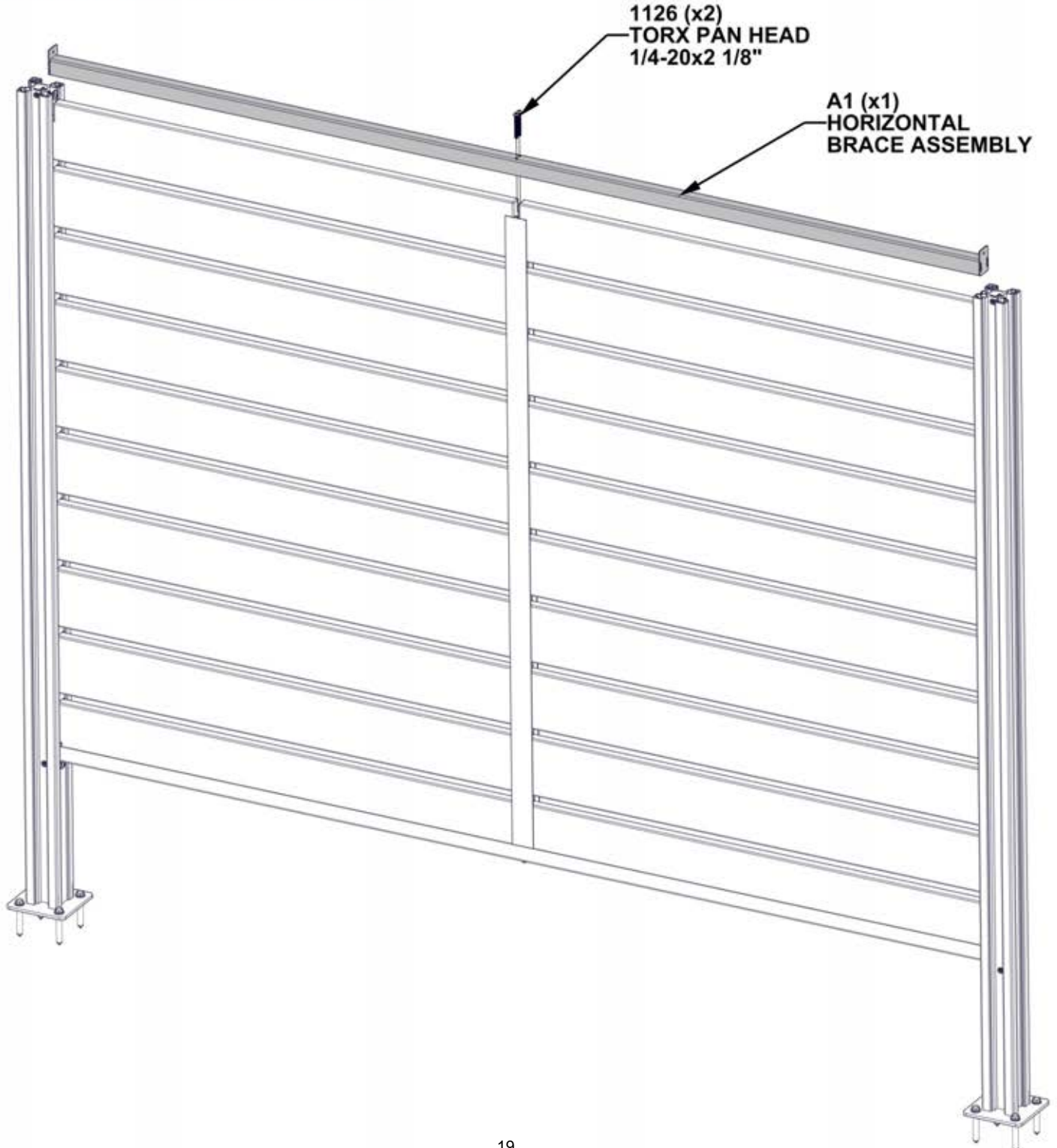



# STEP 11B - FRAME ASSEMBLY

Qty	PART NUMBER	DESCRIPTION
2	H101053	STEEL WASHER 6x20
2	H101054	SEALANT WASHER
2	H101271	TORX PAN HEAD 1/4-20x1 1/4"

**INSTALL HARDWARE TO HOLD BRACE TO POST.  
TIGHTEN HARDWARE FROM PREVIOUS STEP.**

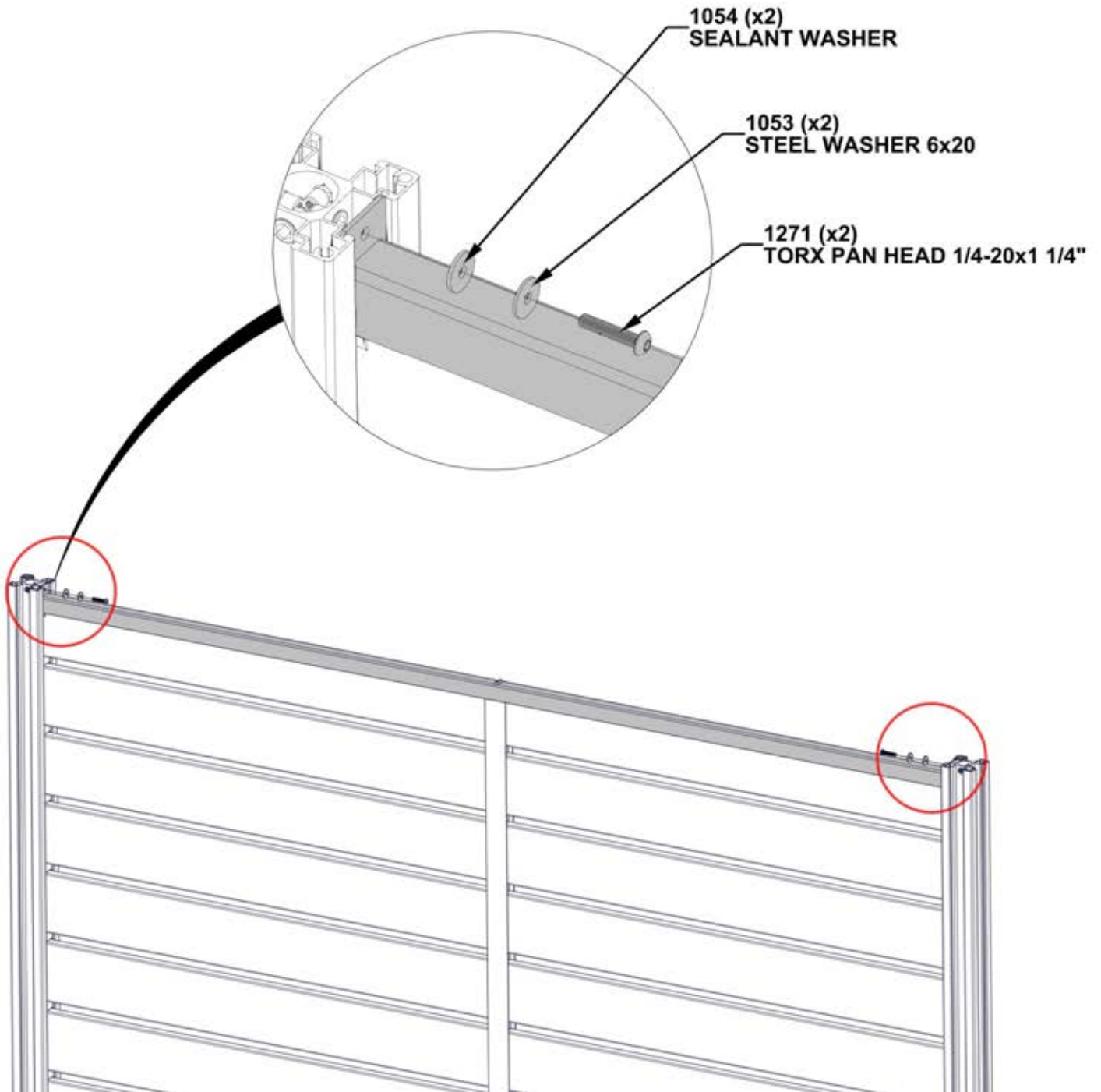

# STEP 12 - PANEL ACCESSORIES

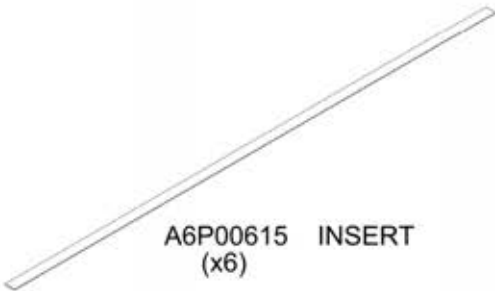

**INSTALL INSERTS TO EACH  
SIDE OF POST TO HIDE HARDWARE**

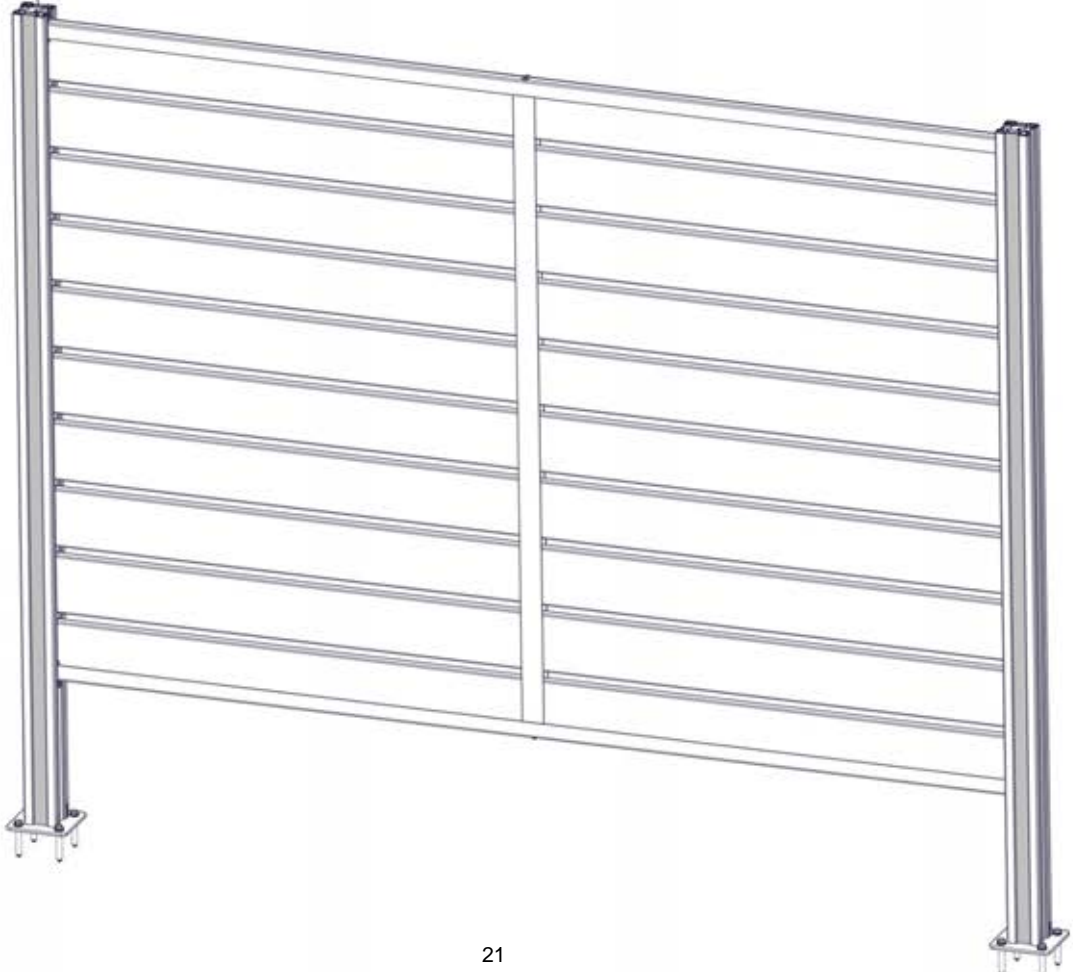
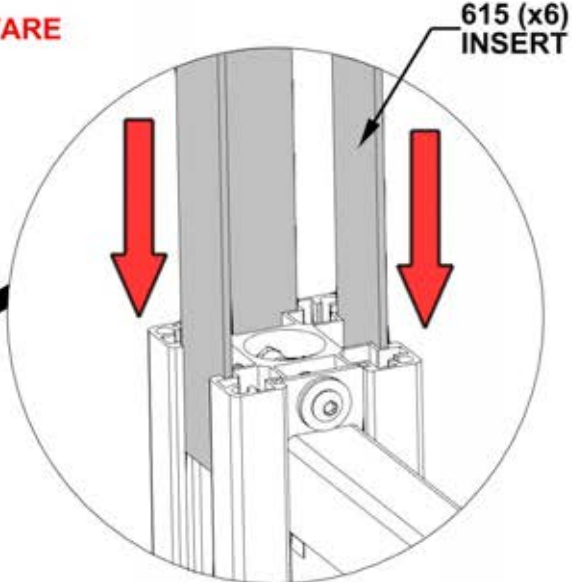

# STEP 13 - PANEL ACCESSORIES



A6P00544 POST CAP  
(x2)

**USE A RUBBER Mallet TO  
TAP POST CAP IN PLACE**

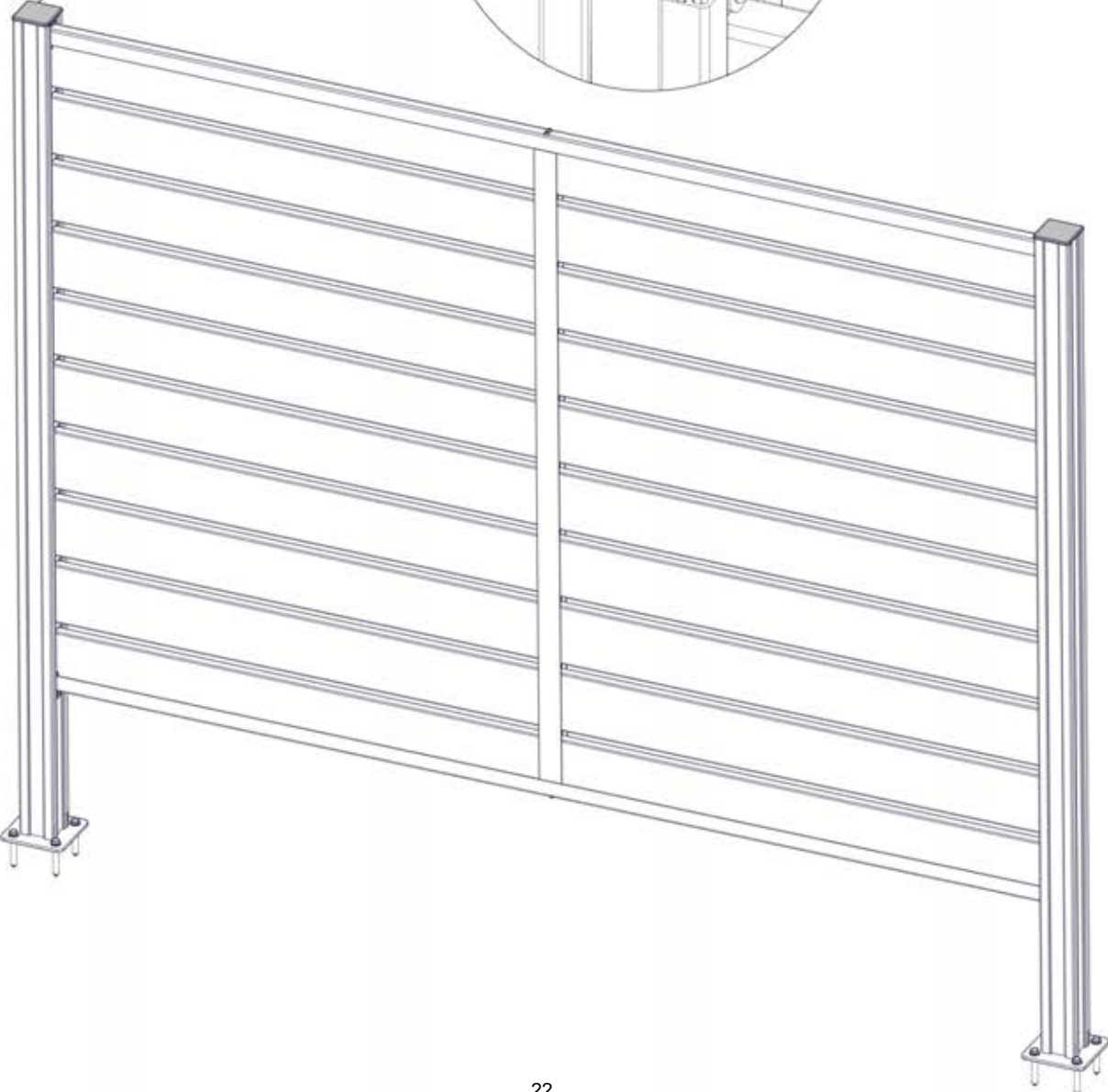
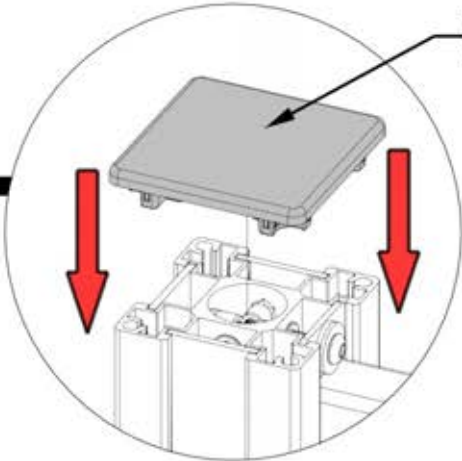



# STEP 14 - PANEL ACCESSORIES



Qty	PART NUMBER	DESCRIPTION
4	H100392	SCREW PWH 8x3/4 BLK

A4M02158 BYD ID TAG PATIO  
(x1)

