



Manufactured by:  
Backyard Discovery  
3305 Airport Drive, Pittsburg, KS 66762  
800-856-4445

Basepoint Business Centre: Rivermead Drive, Westlea, Swindon SN5 7EX Phone: 0800-118-2476  
J.P. Coenstraat 7, The Bridge, The Hague, 2595 WP, Netherlands Phone: 08005678990

# FUSION FLAME OUTDOOR KITCHEN

## MODEL # : 2304079



Please visit [www.backyarddiscovery.com](http://www.backyarddiscovery.com)  
For the most up to date assembly manual, to register your product, or to order replacement parts *Para obtener instrucciones en español, visite*  
[www.backyarddiscovery.com](http://www.backyarddiscovery.com)



EASY STEP-BY-STEP  
3D INTERACTIVE INSTRUCTIONS  
DOWNLOAD THE FREE APP



Made in China

INS-2304079-A-FUSION FLAME OUTDOOR KITCHEN-ENG 10-18-2023

# OWNER'S MANUAL - BASIC SETUP DIMENSIONS & ASSEMBLY NOTES

It is critically important that you start with square and level footings, concrete pad or deck to attach your structure

- Pay close attention to the items needed for each step. Make sure you are using the correct hardware for each step. Using incorrect hardware may result in improper assembly
- Remember to double check for underground utilities and overhead electrical lines

Post mounts are provided with your structure which allows you to permanently install your structure to a pre-existing or new wood or concrete surface. See Anchor Instructions for further details and recommendations.

- The hardware to attach the post mounts to the structure is included.
- The hardware to mount the structure permanently to a concrete surface is included.
- The hardware to mount the structure permanently to a wood deck is NOT included and will need to be purchased separately. You must ensure there is ample structural support under the deck before permanently attaching.

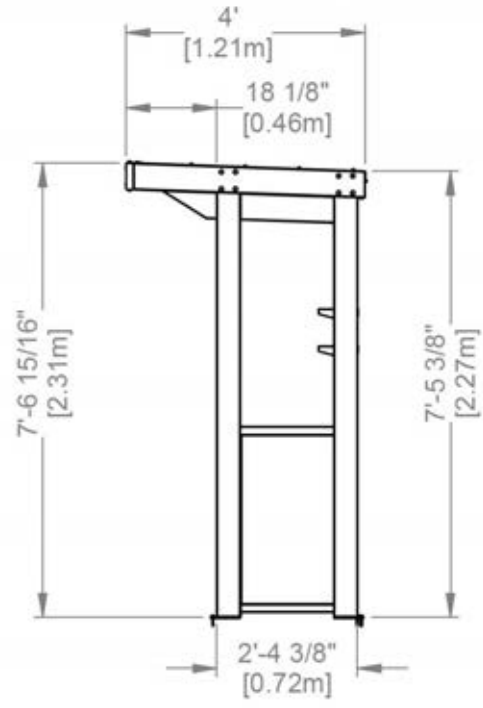
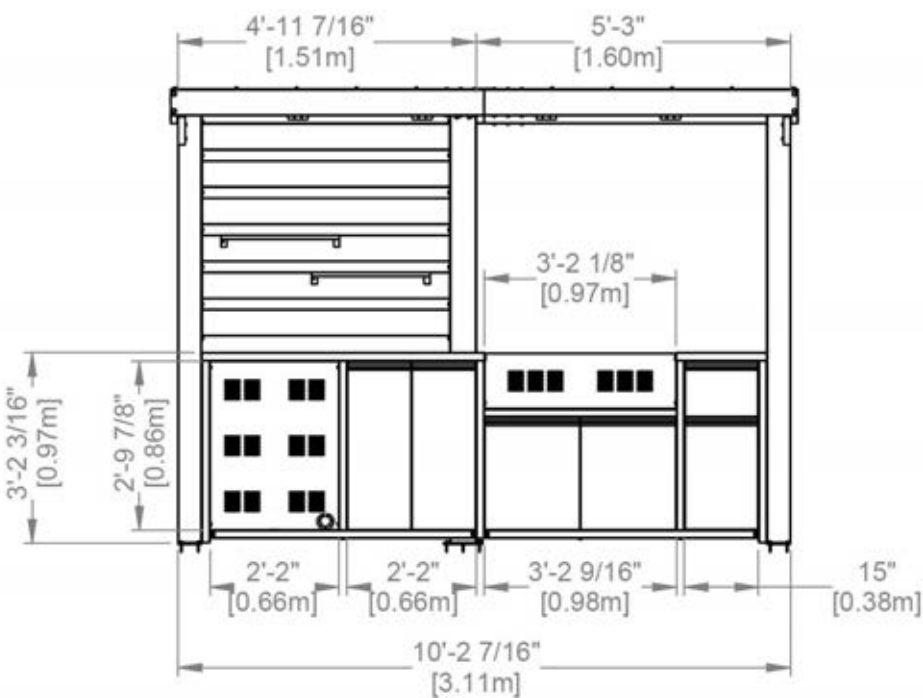
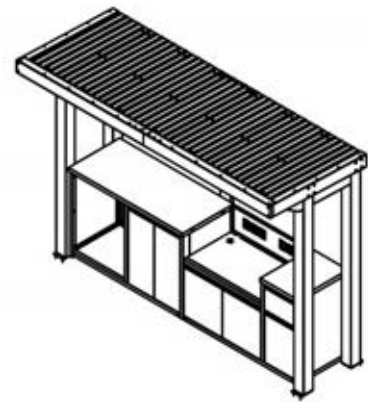
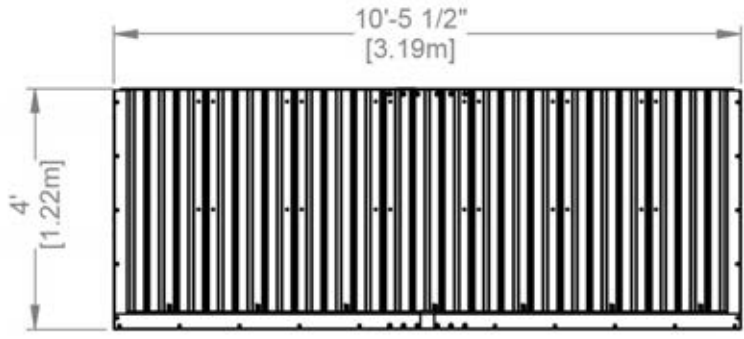

# OWNER'S MANUAL - ANCHORING LAYOUT

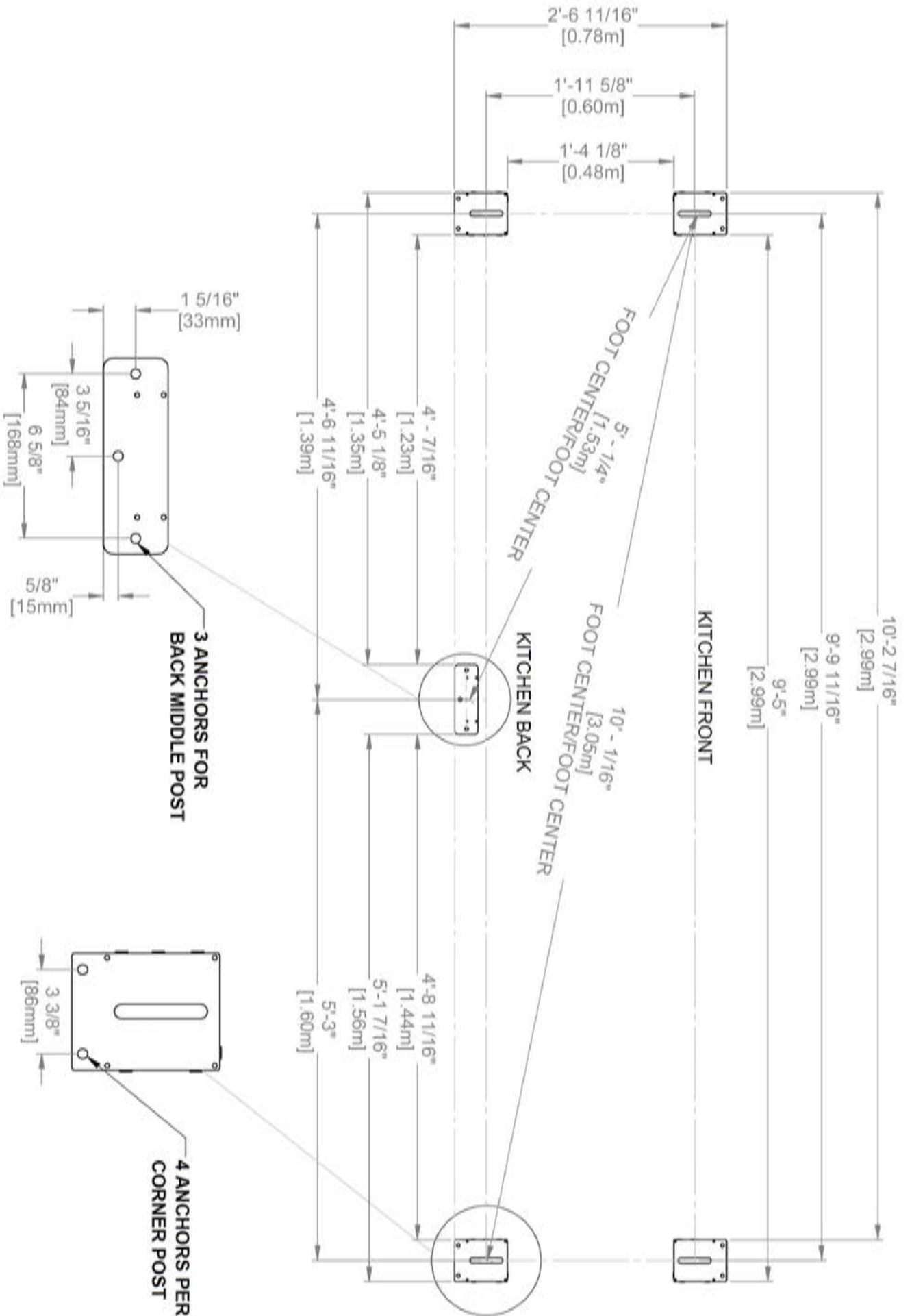

NOTE: DIMENSIONS ARE TO ANCHOR PLATES ON BOTTOM OF POST EXCEPT WHERE NOTED.

# OWNER'S MANUAL - PARTS IDENTIFICATION

## METAL COMPONENTS (NOT TO SCALE)

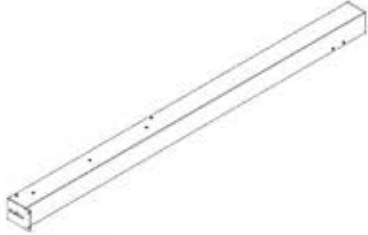

P01 FRONT POST - A4M02008  
(x1) 4 3/4"x5 15/16"x89 1/2" (120x151x2274)

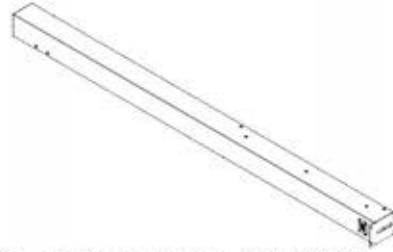

P02 FRONT POST - A4M02009  
(x1) 4 3/4"x5 15/16"x89 1/2" (120x151x2274)

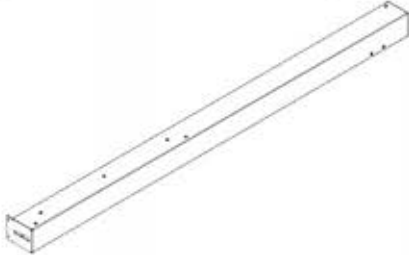

P04 BACK POST - A4M02011  
(x1) 4 3/4"x5 15/16"x88 3/4" (120x151x2254)

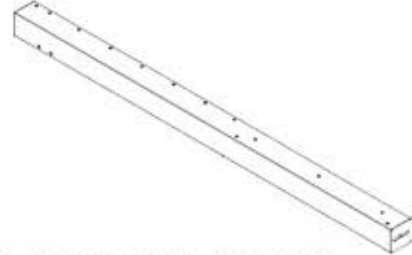

P03 BACK POST - A4M02010  
(x1) 4 3/4"x5 15/16"x88 3/4" (120x151x2254)



P05 BACK POST - A4M02015  
(x1) 2 5/8"x7 7/8"x88 3/4" (66x200x2254)



B10 BACK PANEL - A4M02043  
(x2) 1 7/16"x22 11/16"x49 5/8" (36x576.5x1261)

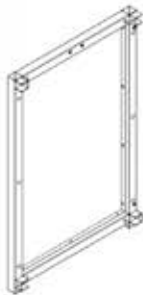

C01 CABINET PANEL - A4M02016  
(x1) 2 3/4"x25"x38" (70x635x965)

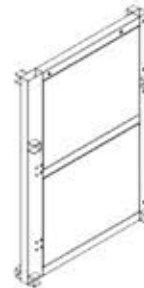

C02 CABINET PANEL - A4M02017  
(x1) 3 15/16"x25"x37" (100x635x940)

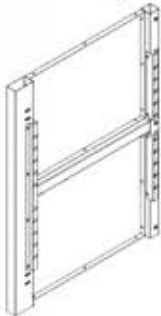

C05 CABINET PANEL - A4M02045  
(x1) 2 3/16"x25"x33 7/8" (56x635x860)



C08 CABINET PANEL - A4M02048  
(x1) 4 1/8"x25"x35 7/16" (105x635x900)

# OWNER'S MANUAL - PARTS IDENTIFICATION

## METAL COMPONENTS (NOT TO SCALE)



**C06 CABINET PANEL - A4M02046**  
(x1) 2 15/16"x25"x38" (75x635x965)

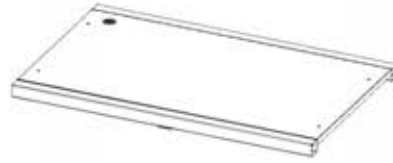

**C09 CABINET TABLE FRAME - A4M02049**  
(x1) 2 3/8"x25"x38 7/16" (60x635x977)



**BP01 BACK PANEL - A4M02051**  
(x1) 1 3/16"x14 13/16"x33 13/16" (30x377x859)



**BP02 BACK PANEL - A4M02052**  
(x1) 1 3/16"x22 5/8"x38 7/16" (30x575x976)

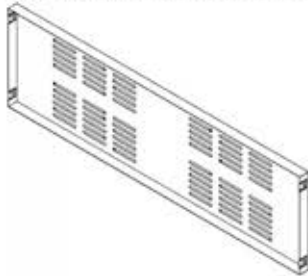

**BP03 BACK PANEL - A4M02053**  
(x1) 1 3/16"x11 3/16"x38 3/8" (30x284x975)



**BP04 BACK PANEL - A4M02054**  
(x1) 1 3/16"x25 13/16"x33 7/8" (30x656x860)



**BP05 BACK PANEL - A4M02055**  
(x1) 1 3/16"x25 13/16"x33 13/16" (30x656x859)



**A04 7 GALLON TRASH CAN HOLDER - A4M02074**  
(x1) 1 1/4"x12 9/16"x21 5/8" (32x319.5x550)

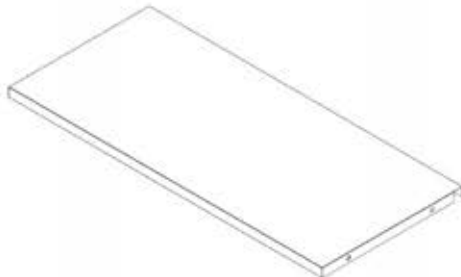

**C10 COUNTERTOP - A4M02058**  
(x1) 1 5/8"x25 3/8"x56 5/8" (41x645x1438)



**C11 COUNTERTOP - A4M02059**  
(x1) 1 5/8"x18 3/16"x25 3/8" (41x462x645)

# OWNER'S MANUAL - PARTS IDENTIFICATION

## METAL COMPONENTS (NOT TO SCALE)

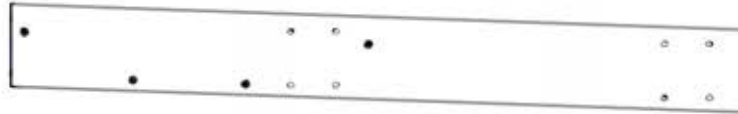

**B01 SIDE BEAM - A4M02012**  
(x1) 36x5 1/4"x46 1/2" (36x134x1181)



**B02 BACK BEAM - A4M02013**  
(x1) 1 7/16"x4 13/16"x61 1/4" (36x122x1556)



**B03 FRONT BEAM - A4M02014**  
(x1) 1 7/16"x5 1/4"x62 11/16" (36x134x1593)



**B04 SIDE BEAM - A4M02019**  
(x1) 1 7/16"x5 1/4"x18 7/8" (36x134x480)



**B05 SIDE BEAM - A4M02022**  
(x1) 1 7/16"x5 1/4"x46 1/2" (36x134x1181)



**B06 BACK BEAM - A4M02024**  
(x1) 1 7/16"x4 13/16"x (36x122x1556)



**B07 FRONT BEAM - A4M02027**  
(x1) 1 7/16"x5 1/4"x62 11/16" (36x134x1593)

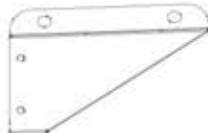

**B08 CORBEL - A4M02041**  
(x1) 1 7/16"x6 11/16"x11 1/8" (36x170x282)



**B09 CORBEL - A4M02042**  
(x1) 1 7/16"x6 11/16"x11 1/8" (36x170x282)



**B11 SIDE BEAM - A4M02106**  
(x1) 1 7/16"x5 1/4"x18 7/8" (36x134x480)



**J1 SPLICE BRACKET - A4M02183**  
(x1) 1 5/16"x5 3/16"x19 11/16" (33.2x131.2x500)



**J2 SPLICE BRACKET - A4M02184**  
(x1) 1 5/16"x4 11/16"x19 11/16" (33.2x119.2x500)

# OWNER'S MANUAL - PARTS IDENTIFICATION

## METAL COMPONENTS (NOT TO SCALE)



D01 DOOR PANEL - A4M02064  
(x1) 22x12 3/4"x33 5/8" (22x324x854)



D02 DOOR PANEL - A4M02066  
(x1) 7/8"x12 3/4"x33 5/8" (22x324x854)



D03 DOOR PANEL - A4M02067  
(x1) 7/8"x14 5/8"x22 7/16" (22x372x570)

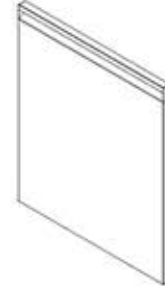

D04 DOOR PANEL - A4M02068  
(x1) 7/8"x19 1/16"x22 7/16" (22x484.5x570)

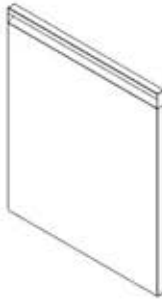

D05 DOOR PANEL - A4M02069  
(x1) 7/8"x19 1/16"x22 7/16" (22x484.5x570)

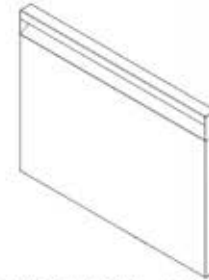

D06 DRAWER FACE - A4M02060  
(x1) 7/8"x11 1/16"x14 5/8" (22x281x372)

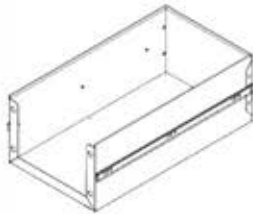

D07 8" DRAWER - A4M02075  
(x1) 8 1/16"x12 9/16"x21 11/16" (204x319.5x551)

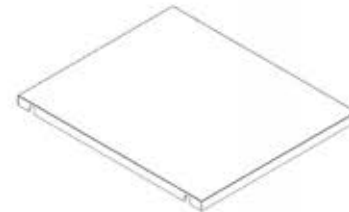

F03 FLOOR PANEL - A4M02202  
(x2) 1 3/16"x21 3/4"x25 13/16" (30x553x655)

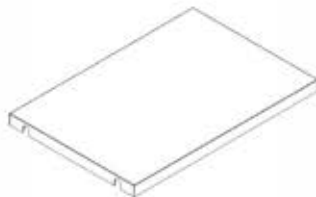

F11 FLOOR PANEL - A4M02209  
(x1) 1 3/16"x14 13/16"x21 3/4" (30x376x553)

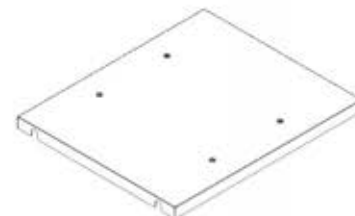

F12 FLOOR PANEL FOR PROPANE TANK - A4M02173  
(x1) 1 3/16"x18 3/8"x21 3/4" (30x466.5x553)

# OWNER'S MANUAL - PARTS IDENTIFICATION

## METAL COMPONENTS (NOT TO SCALE)

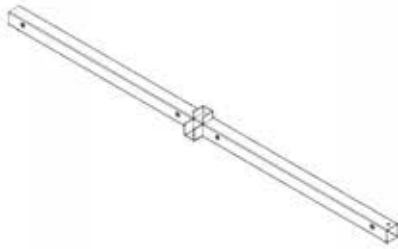

F01 BOTTOM PANEL RAIL - A4M02200  
(x1) 2 3/8"x2 3/4"x53 5/16" (60x70x1354)

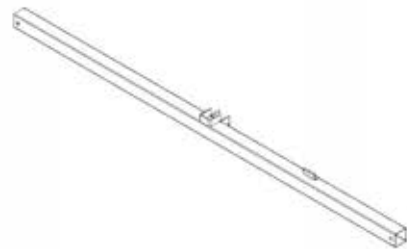

F02 BOTTOM PANEL RAIL - A4M02201  
(x1) 2 3/8"x2 3/4"x53 5/16" (60x70x1354)



F04 FLOOR TUBE - A4M02203  
(x2) 1 9/16"x1 9/16"x21 7/8" (40x40x555)

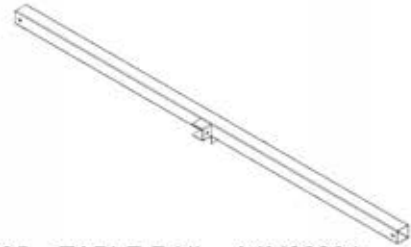

F05 TABLE RAIL - A4M02204  
(x1) 2 3/8"x2 3/4"x53 5/16" (60x70x1354)



F06 TABLE TUBE SUPPORT - A4M02205  
(x1) 1 9/16"x1 9/16"x21 7/8" (40x40x555)

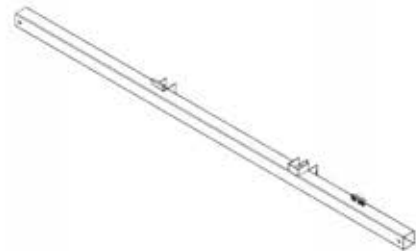

F07 BOTTOM PANEL RAIL - A4M02206  
(x1) 2 3/8"x2 3/4"x54 15/16" (60x70x1395)

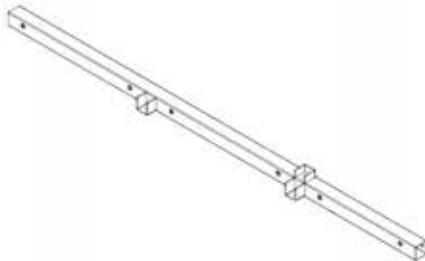

F08 BOTTOM PANEL RAIL - A4M02207  
(x1) 2 3/8"x2 3/4"x54 15/16" (60x70x1395)



F09 BOTTOM FLOOR TUBE - A4M02210  
(x1) 1 9/16"x2 3/8"x21 7/8" (40x60x555)

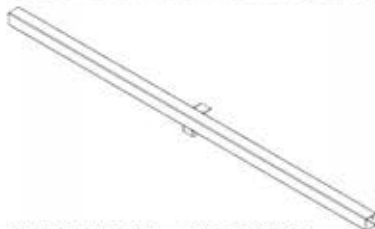

F13 TABLE RAIL - A4M02274  
(x1) 2 3/8"x2 3/4"x53 5/16" (60x70x1354)



R01 RAFTER - A4M02020  
(x4) 3 1/8"x3 15/16"x45 1/16" (80x100x1144)



T01 TUBE - A4M02050  
(x2) 1 9/16"x1 9/16"x14 7/8" (40x40x378)



T02 UPRIGHT TUBE - A4M02104  
(x1) 1 9/16"x1 9/16"x22 11/16" (40x40x576)



# OWNER'S MANUAL - PARTS IDENTIFICATION

## METAL COMPONENTS (NOT TO SCALE)



E01 PURLIN - A4M02021  
(x2) 1 9/16"x1 3/4"x48 13/16" (40x45x1239.75)



E02 PURLIN - A4M02023  
(x2) 1 9/16"x1 3/4"x73 5/8" (40x45x1870.75)



E03 PURLIN - A4M02025  
(x1) 1 9/16"x1 3/4"x49 5/8" (40x45x1260)



E04 PURLIN - A4M02026  
(x1) 1 9/16"x1 3/4"x58 1/16" (40x45x1475)



A4M02107 DRIP EDGE  
(x1)



A4M02272 DRIP EDGE  
(x1)



A4M02029 DRIP EDGE  
(x2)



A4M02186 DRIP EDGE  
(x1)



A4M02187 DRIP EDGE  
(x1)



A4M02273 DRIP EDGE SPLICE  
(x1)



A4M02108 DRIP EDGE SPLICE  
(x1)



A4M02007 29GA STEEL SHEETING  
(x5)



A4M02079 29GA STEEL SHEETING LEFT  
(x1)

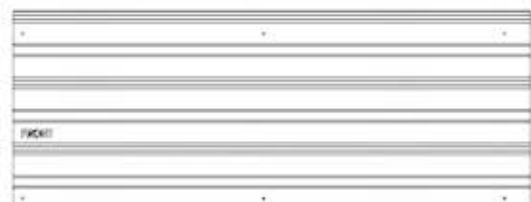

A4M02080 29GA STEEL SHEETING RIGHT  
(x1)

# OWNER'S MANUAL - PARTS IDENTIFICATION

## METAL COMPONENTS (NOT TO SCALE)

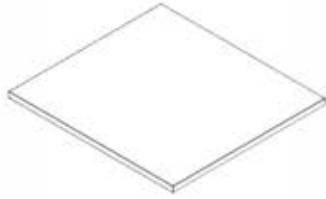

S01 CABINET SHELF - A4M02057  
(x2) 13/16"x22 11/16"x24 1/2" (21x577x622)



A11 SHELF - A4M02105  
(x1) 13/16"x18 3/8"x21 1/2" (21x467x546)

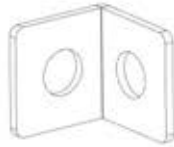

A02 BRACKET - A4M02056  
(x3) 1 7/16"x1 7/16"x1 7/16" (36x36x36)



A03 BACK SHELF - A4M02072  
(x2) 2 7/16"x7 15/16"x23 3/4" (61x201x603)

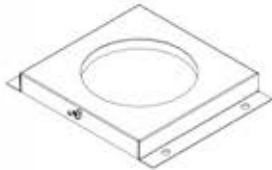

A12 PROPANE TANK HOLDER - A4M02028  
(x1) 1 5/8"x11 13/16"x14 9/16" (41x300x370)



A06 ADJUSTABLE SHELF TAB - A4M02077  
(x8) 11/16"x7/8"x1 3/16" (17x22x31)



A01 BRACKET - A4M02018  
(x6) 1"x1 5/16"x5 1/16" (25x33.2x128)



F10 FLOOR PANEL - A4M02208  
(x1) 1 3/16"x18 3/8"x21 3/4" (30x467x553)



A10 ANGLE BRACKET - A4M02276  
(x1) 13/16"x5 15/16"x9 13/16" (20x151x250)



A07 ANGLE BRACKET - A4M02277  
(x1) 13/16"x5 15/16"x9 13/16" (20x151x250)

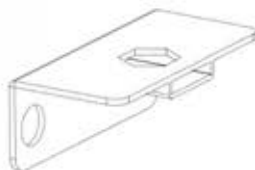

A05 HOSE CLAMP - A4M02258  
(x1) 1 3/16"x1 9/16"x 3 1/8" (30x40x80)



T03 UPRIGHT TUBE WITH MATCH HOLDER - A4M02404  
(x1) 1 9/16"x1 9/16"x22 11/16" (40x40x576)

# OWNER'S MANUAL - PARTS IDENTIFICATION

## METAL COMPONENTS (NOT TO SCALE)



A4M02070 CABINET HINGE  
(x8)

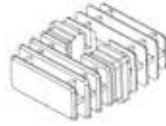

A6P00530 2-WAY SQUARE PLUG  
(x2)



A6P00559 ADJUSTABLE FOOT  
(x2)



A4M02078 WOOD GRAIN  
HOLE COVER  
(x28)



A4M01352 HOLE COVER  
(x14)



A6P00679 ADHESIVE  
EVA TAPE  
(x8)

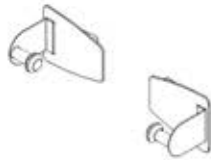

A4M02290 MAGNETIC PAPER  
TOWEL HOLDER  
(x1)

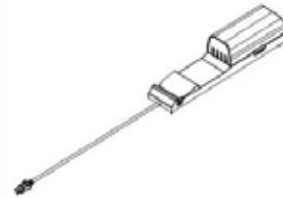

9205413 ELECTRICAL  
ENCLOSURE  
(x1)

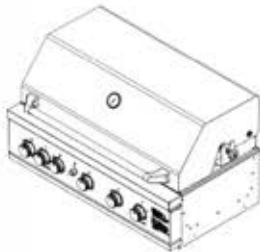

9230118 OUTDOOR KITCHEN  
GRILL KIT  
(x1)



9230132 OUTDOOR KITCHEN  
FRIDGE  
(x1)

# OWNER'S MANUAL - PARTS IDENTIFICATION

## HARDWARE COMPONENTS (NOT TO SCALE)

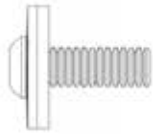

H101202 TORX PAN HEAD  
(x188) 1/4-20x3/4" ASSY

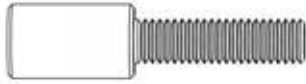

H101132 TORX SOCKET SCREW SHORT  
(x32) 1/4-20



H101103 TORX SOCKET SCREW  
(x52) 1/4-20



H100120 CONCRETE  
(x11) ANCHOR

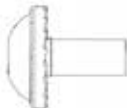

H100401 BOLT WH  
(x4) 1/4x1/2 BLK



H101185 PHILLIPS FLAT HEAD  
(x48) 8-32x1/2

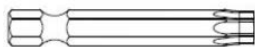

H100147 TORX BIT  
(x1) T-30



H100114 TORX WRENCH  
(x1) T-30



H101133 WASHER FLAT  
(x4) 7x14 BLK



H100630 WASHER FLAT  
(x11) 8x19 BLK

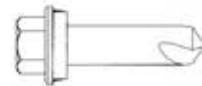

H101116 SCREW SELF TAPPING  
(x20) 1/4x1 BLK

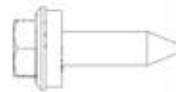

H101117 SCREW WOODGRIP  
(x42) 10x3/4 BLK

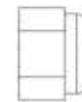

H100653 NUT LOCK  
(x4) 1/4 BLK

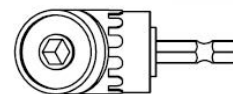

H101114 RIGHT ANGLE  
(x1) DRILL ADAPTER



H101100 MAGNETIC DRIVER  
(x1)



H101106 SOCKET DRIVER  
(x1)

# PRE-ASSEMBLY STEP 1 - SORTING PARTS

It is critical for ease of assembly that you take the time to sort and organize the parts and hardware.

---

## METAL PARTS:

- Organize metal parts by the three-digit, alpha-numeric number stamped on each part (ex. P01).
- If there are multiple parts with the same stamped number, stack those pieces together.
- Stamps can be found on the flat surface of the parts or on the end of the parts.
- Allow yourself plenty of room - the parts can take up a significant amount of space.

**NOTE: CARTONS ARE NOT ORGANIZED BY PART NUMBER.**

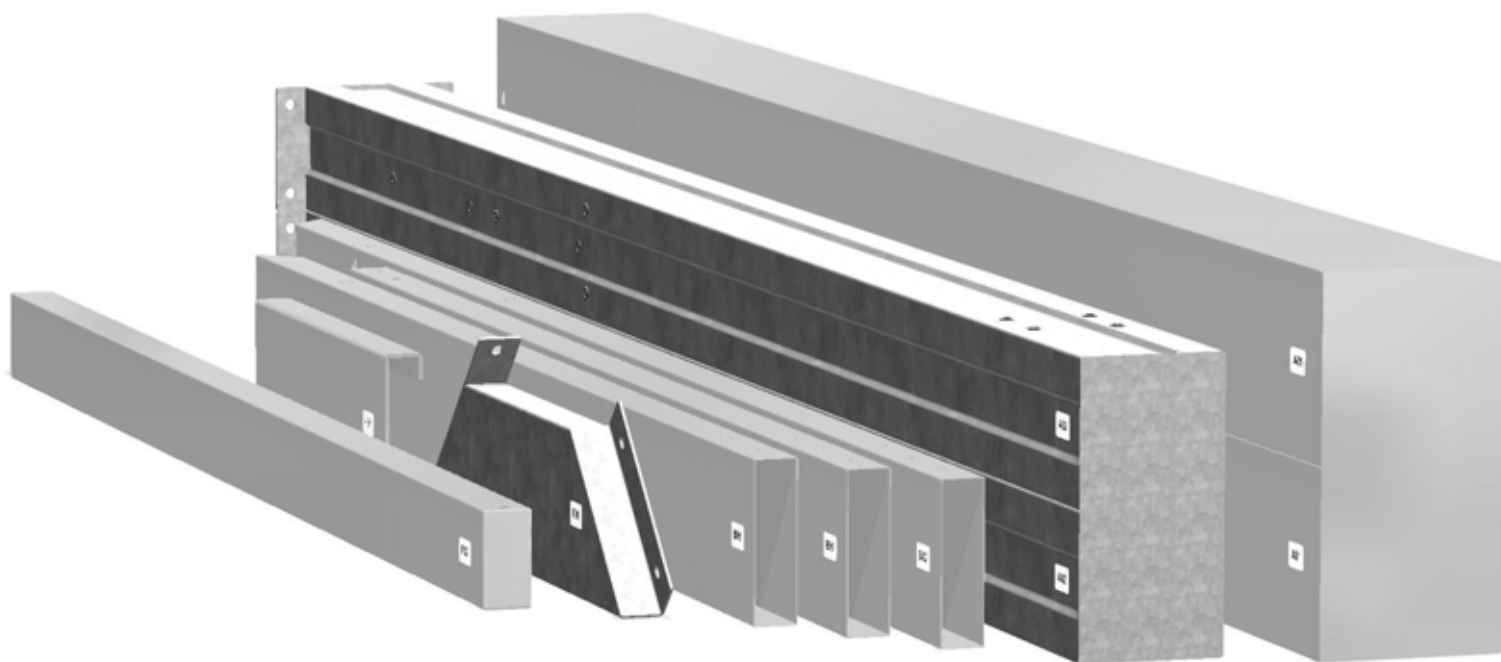

---

## HARDWARE PARTS:

- We recommend that you have a separate table to organize the hardware.
- Hardware bags are printed with a seven-digit, alpha-numeric part number.
- You can organize your hardware by part number or group by hardware type (i.e. bolts, nuts, etc.).
- During assembly you only need to reference the last four digits of the number.

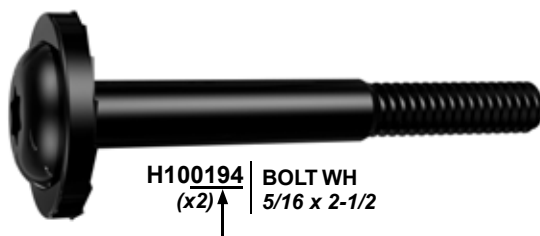

# PRE-ASSEMBLY STEP 2 - TOOLS REQUIRED



Cordless Drill or Electric Drill



Drill Attachments:  
Phillips Head



1/8", 3/16", 3/8" & 7/16" Drill Bits



Phillips Screw Driver



Open End Wrench  
7/16"



3/8" Drive Ratchet, 1/2" & 7/16" STD Sockets 1/2" & 7/16" Deep Sockets



Claw Hammer



Rubber Mallet -  
Optional



Tape Measure

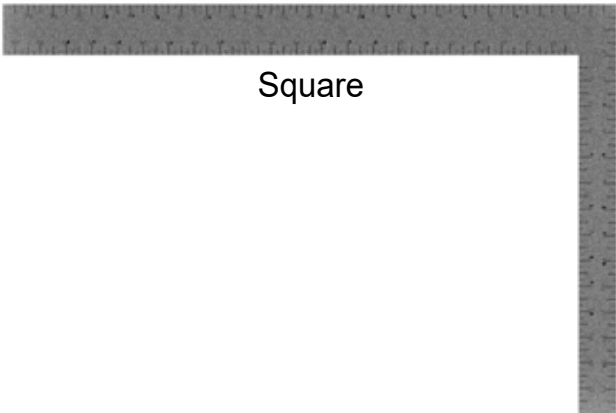

Square



Level 24"

# PRE-ASSEMBLY STEP 3 - CHOOSE YOUR ASSEMBLY METHOD

There are several types of assembly instructions available to you.

1. Printed Assembly Manual included with your set
2. BILT APP - 3D interactive instructions
3. Combination of the Printed Manual and BILT APP (Note: Step numbers can differ between the two methods)



**BILT.**

Scan for easy  
**3D instructions**

Download the BILT app  
before you begin

Download on the  
App Store

GET IT ON  
Google Play

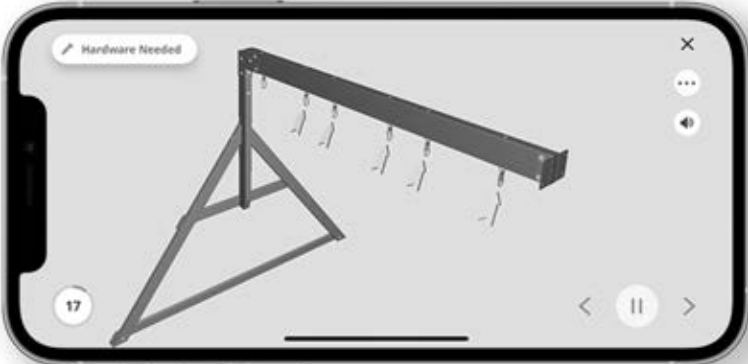

The image shows a smartphone screen displaying a 3D assembly instruction. The screen features a 3D model of a metal frame structure. At the top left, there is a button labeled "Hardware Needed". At the bottom left, there is a circular icon with the number "17". At the bottom right, there are navigation icons: a back arrow, a pause button, and a forward arrow. The entire advertisement is enclosed in a grey border.

# STEP 1 - FLOOR PANEL ASSEMBLY

QTY	PART NUMBER	Description
2	H101202	TORX PAN HEAD 1/4-20x3/4 ASSY

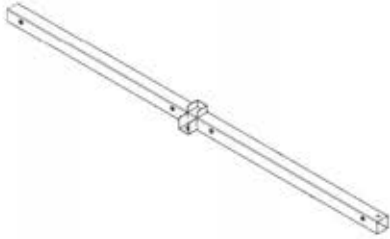

F01 BOTTOM PANEL RAIL - A4M02200  
(x1) 2 3/8"x2 3/4"x53 5/16" (60x70x1354)

F02 BOTTOM PANEL RAIL - A4M02201  
(x1) 2 3/8"x2 3/4"x53 5/16" (60x70x1354)

F04 FLOOR TUBE - A4M02203  
(x1) 1 9/16"x1 9/16"x21 7/8" (40x40x555)

FOR EASE OF ASSEMBLY, WE RECOMMEND USING SAW HORSES FOR STEPS 1-6

**SLIDE F04 INTO TUBE CONNECTOR ON EACH PANEL RAIL ASSEMBLY**

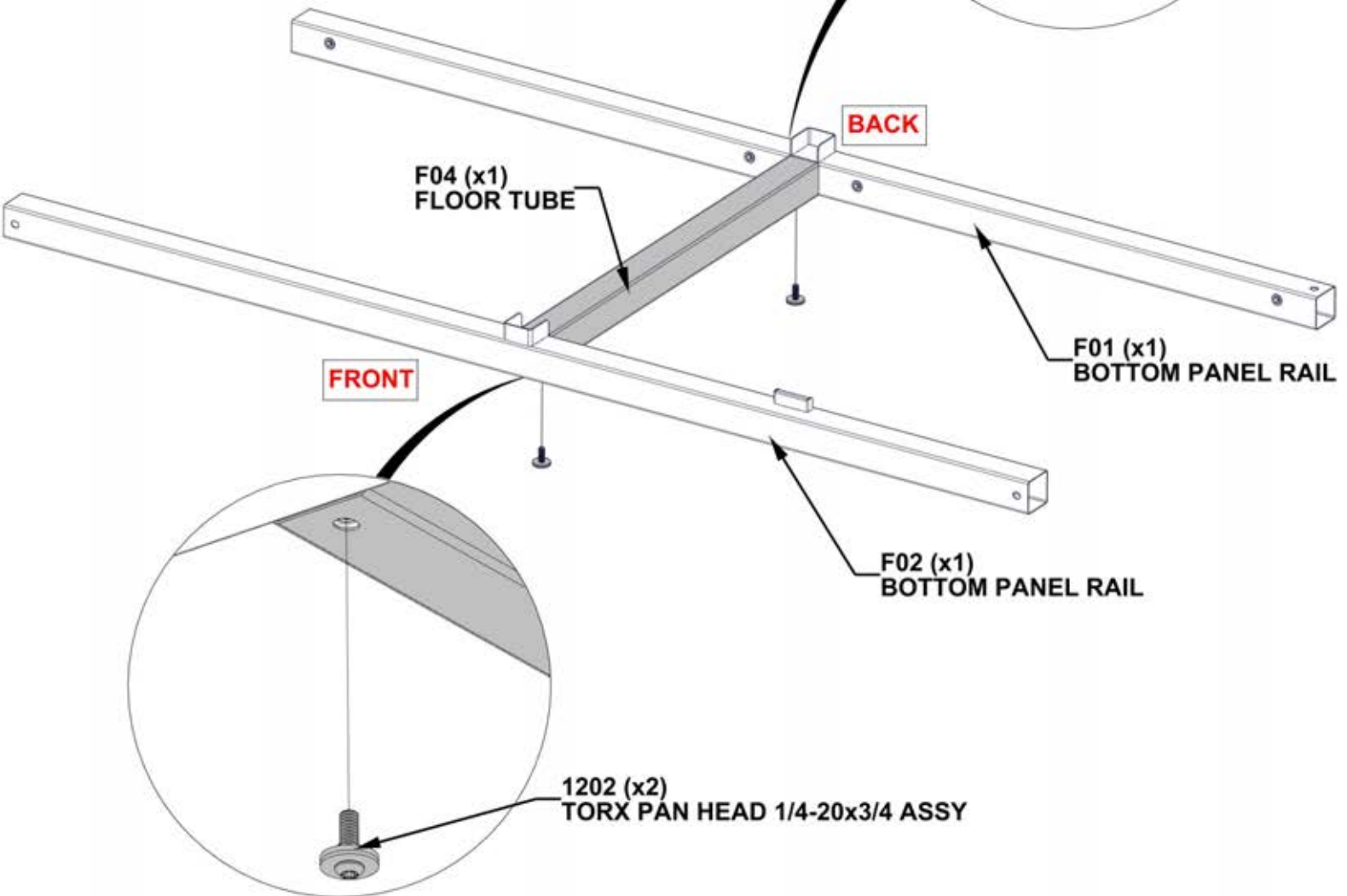
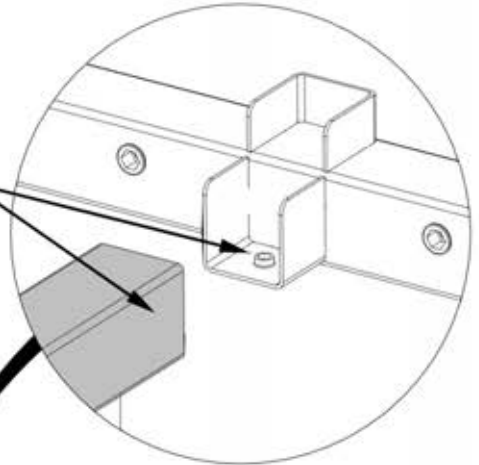



# STEP 2 - FLOOR PANEL ASSEMBLY

QTY	PART NUMBER	Description
4	H101202	TORX PAN HEAD 1/4-20x3/4 ASSY

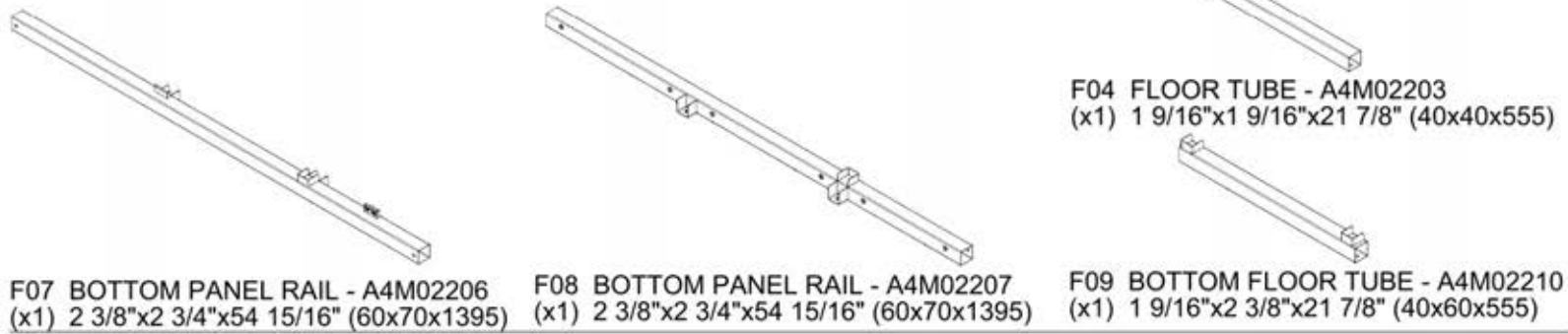

**SLIDE F04 AND F09 INTO TUBE CONNECTORS ON EACH PANEL RAIL ASSEMBLY**

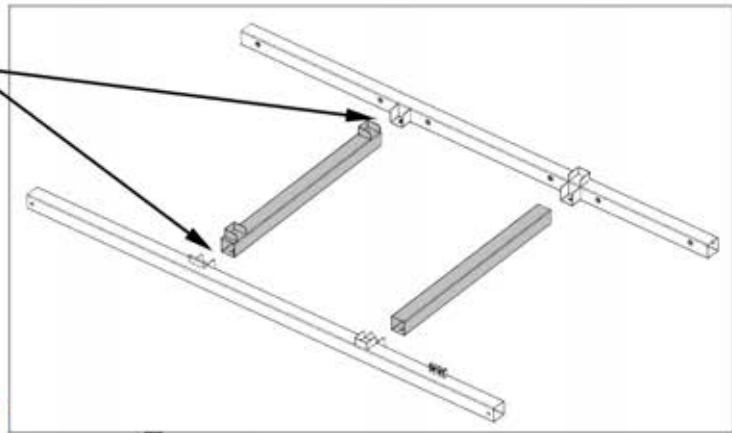

**NOTE: ORIENTATION OF F09. TUBE CONNECTOR FURTHEST FROM END IS FRONT OF TUBE.**

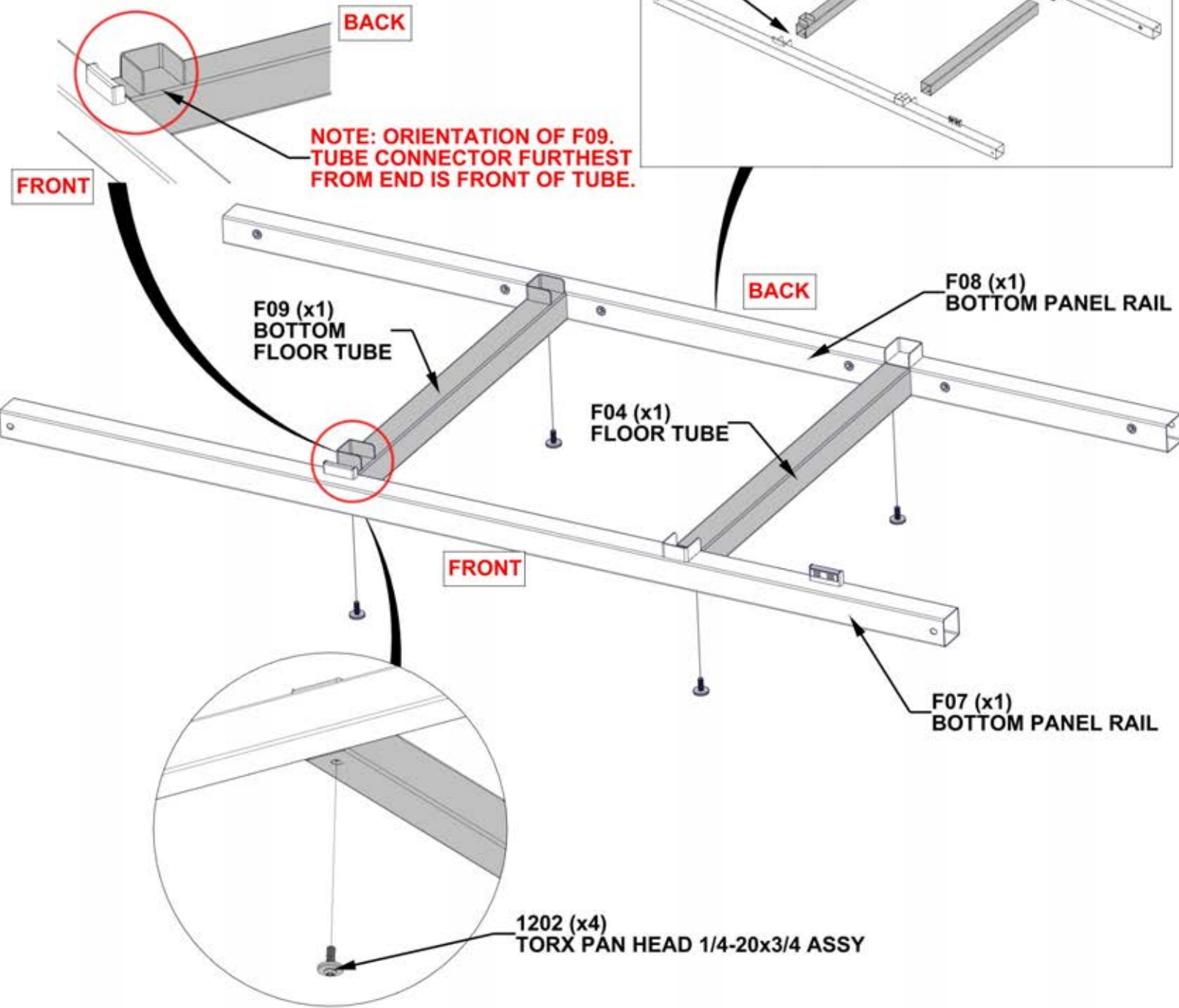

# STEP 3 - COUNTERTOP FRAME ASSEMBLY

QTY	PART NUMBER	Description
2	H101202	TORX PAN HEAD 1/4-20x3/4 ASSY

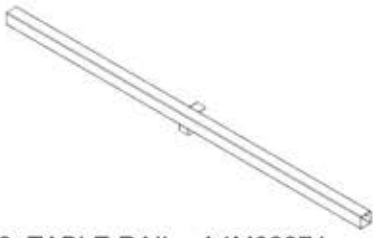

F13 TABLE RAIL - A4M02274  
(x1) 2 3/8"x2 3/4"x53 5/16" (60x70x1354)

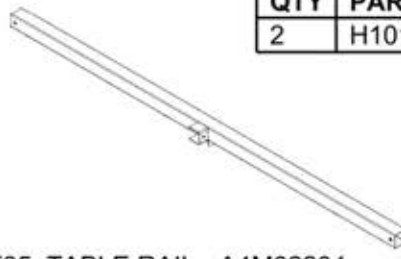

F05 TABLE RAIL - A4M02204  
(x1) 2 3/8"x2 3/4"x53 5/16" (60x70x1354)



F06 TABLE TUBE SUPPORT - A4M02205  
(x1) 1 9/16"x1 9/16"x21 7/8" (40x40x555)

**ORIENTATION OF F06 SUPPORT IS CRITICAL TO ASSEMBLY.**

**SET FRAME ASSEMBLY TO THE SIDE FOR LATER USE.**

**SLIDE F06 INTO TUBE CONNECTOR ON EACH TABLE RAIL ASSEMBLY**

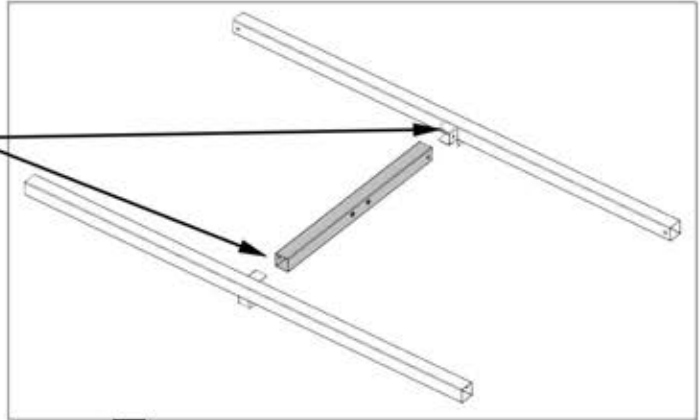

**NOTE: THREADED INSERTS CLOSEST TO TOP EDGE OF TUBE**

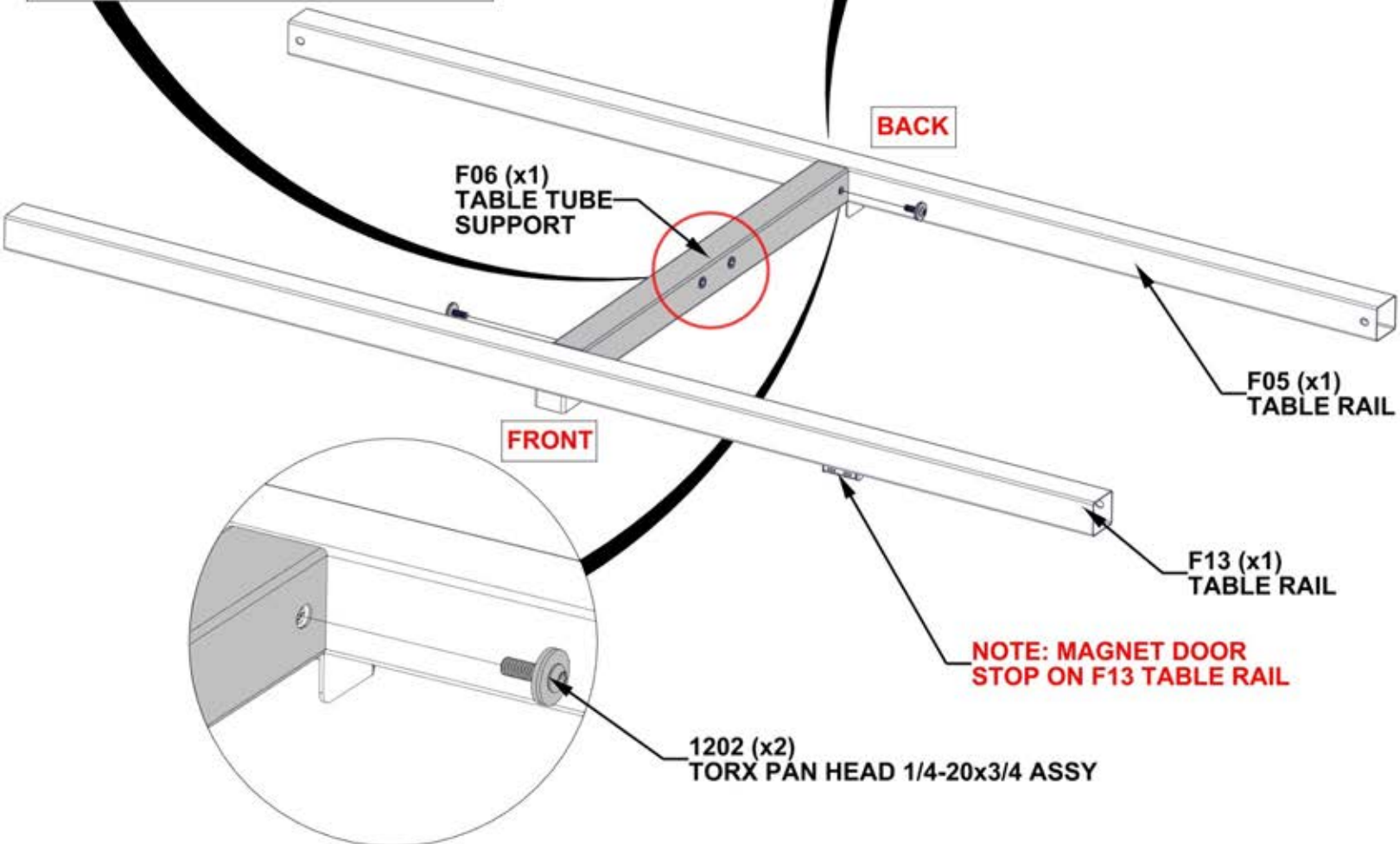
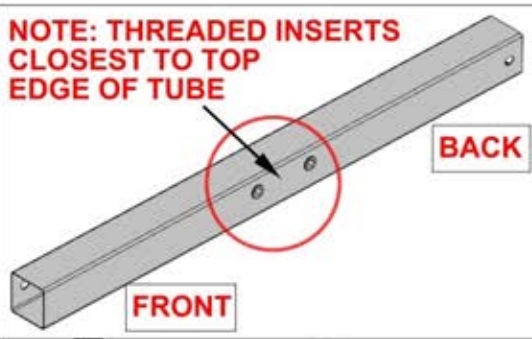

# STEP 4 - CABINET PANEL ASSEMBLY



C02 CABINET PANEL - A4M02017  
(x1) 3 15/16"x25"x37" (100x635x940)



A6P00559 ADJUSTABLE FOOT  
(x2)

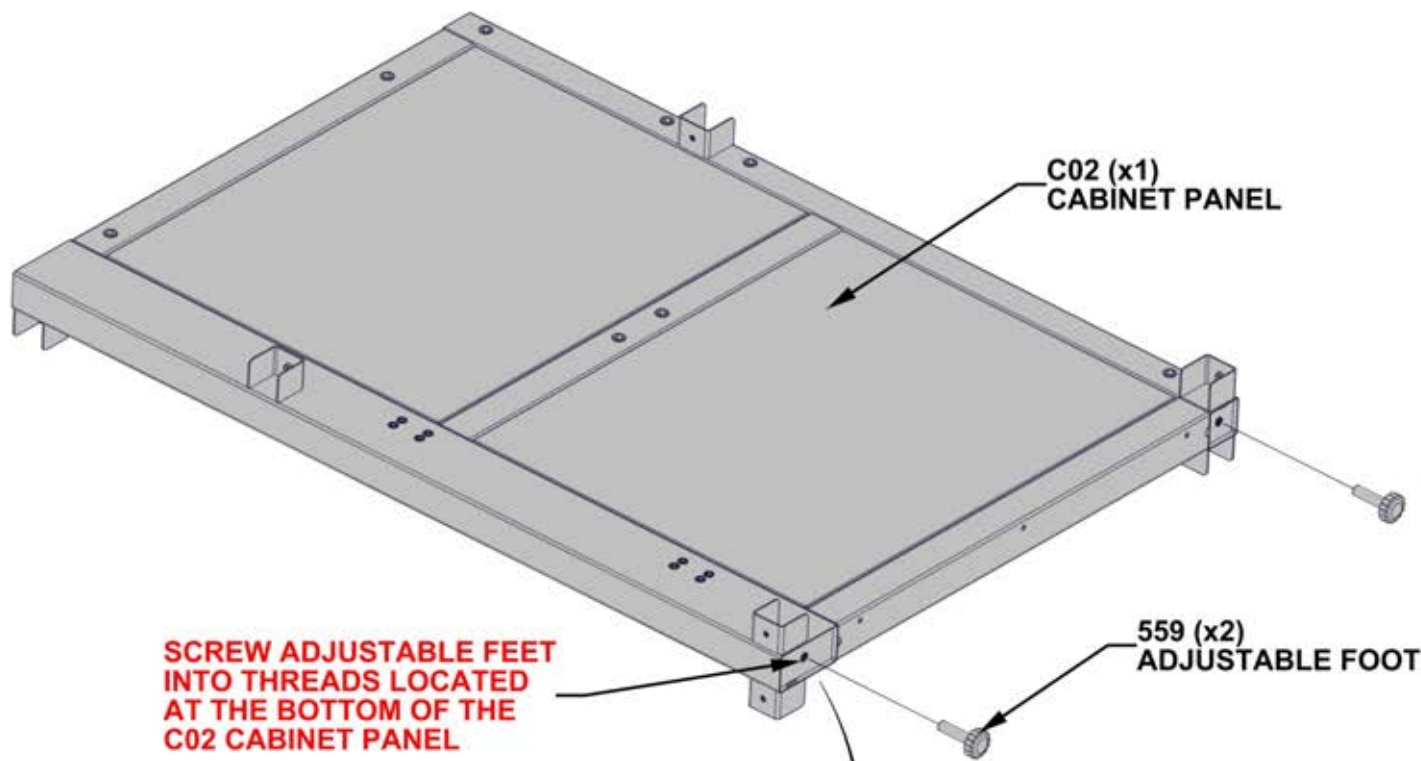

**SCREW ADJUSTABLE FEET INTO THREADS LOCATED AT THE BOTTOM OF THE C02 CABINET PANEL.**

**559 (x2) ADJUSTABLE FOOT**

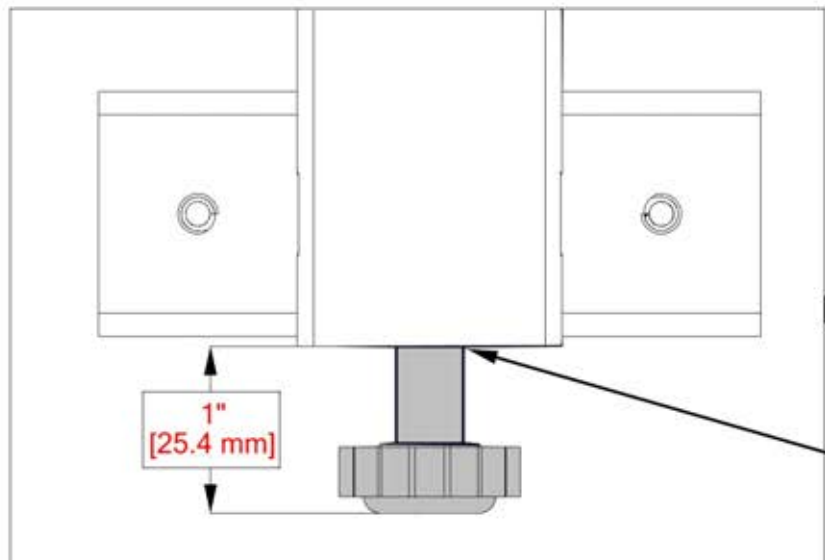

**SET ADJUSTABLE FEET AT A DISTANCE OF APPROX. 1" [25.4 mm]. DEPENDING ON SURFACE, FEET CAN BE SCREWED IN OR OUT AS NEEDED.**

# STEP 5A - KITCHEN CABINET ASSEMBLY

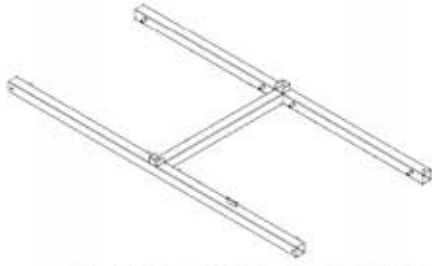

FLOOR PANEL ASSEMBLY  
STEP 1

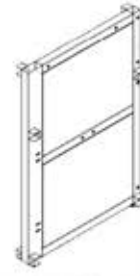

CABINET PANEL WITH FEET  
STEP 4

TIP:  
- RUBBER MALLET MAY NEED TO BE USED TO TAP PANELS IN PLACE

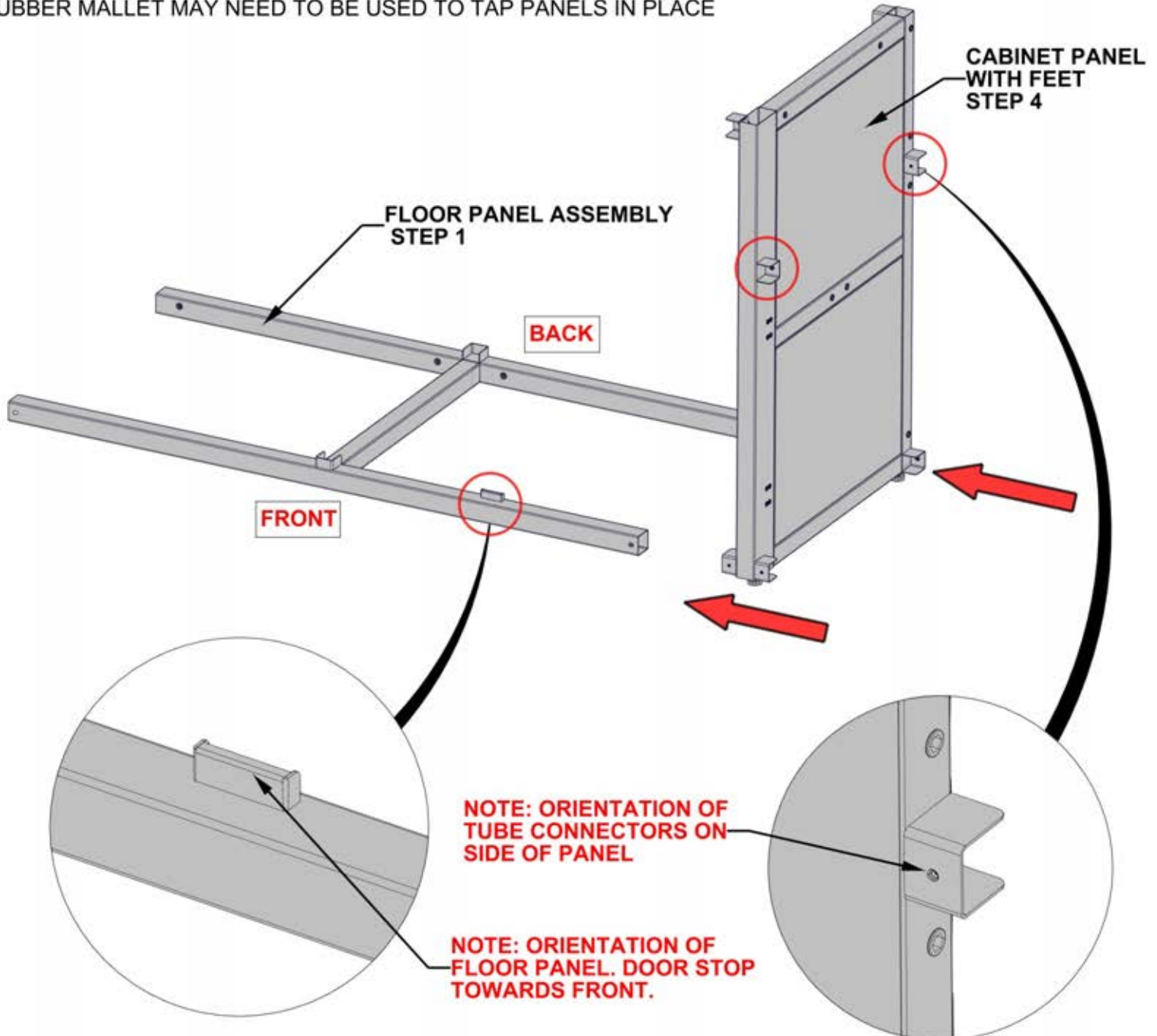

# STEP 5B - KITCHEN CABINET ASSEMBLY

QTY	PART NUMBER	Description
2	H101202	TORX PAN HEAD 1/4-20x3/4 ASSY

**DO NOT TIGHTEN HARDWARE AT THIS STEP**

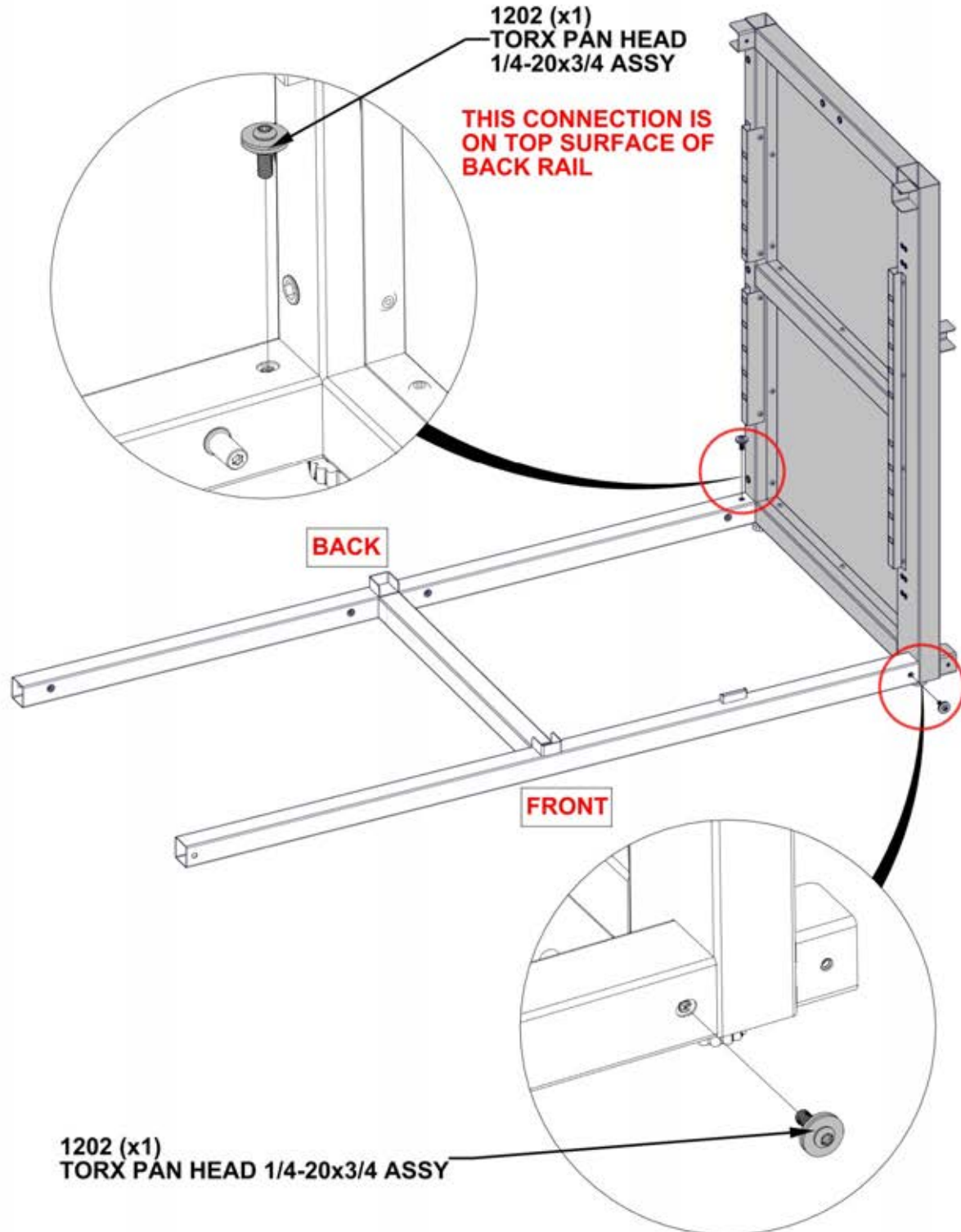

# STEP 6 - KITCHEN CABINET ASSEMBLY

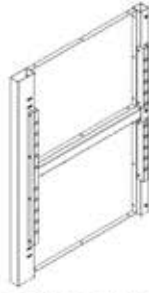

C05 CABINET PANEL - A4M02045  
(x1) 2 3/16"x25"x33 7/8" (56x635x860)

**PLACE C05 PANEL IN PLACE, ALIGNING TUBES WITH TUBE CONNECTORS.  
THREADED INSERTS ON SIDE OF PANEL TOWARDS THE FRONT.**

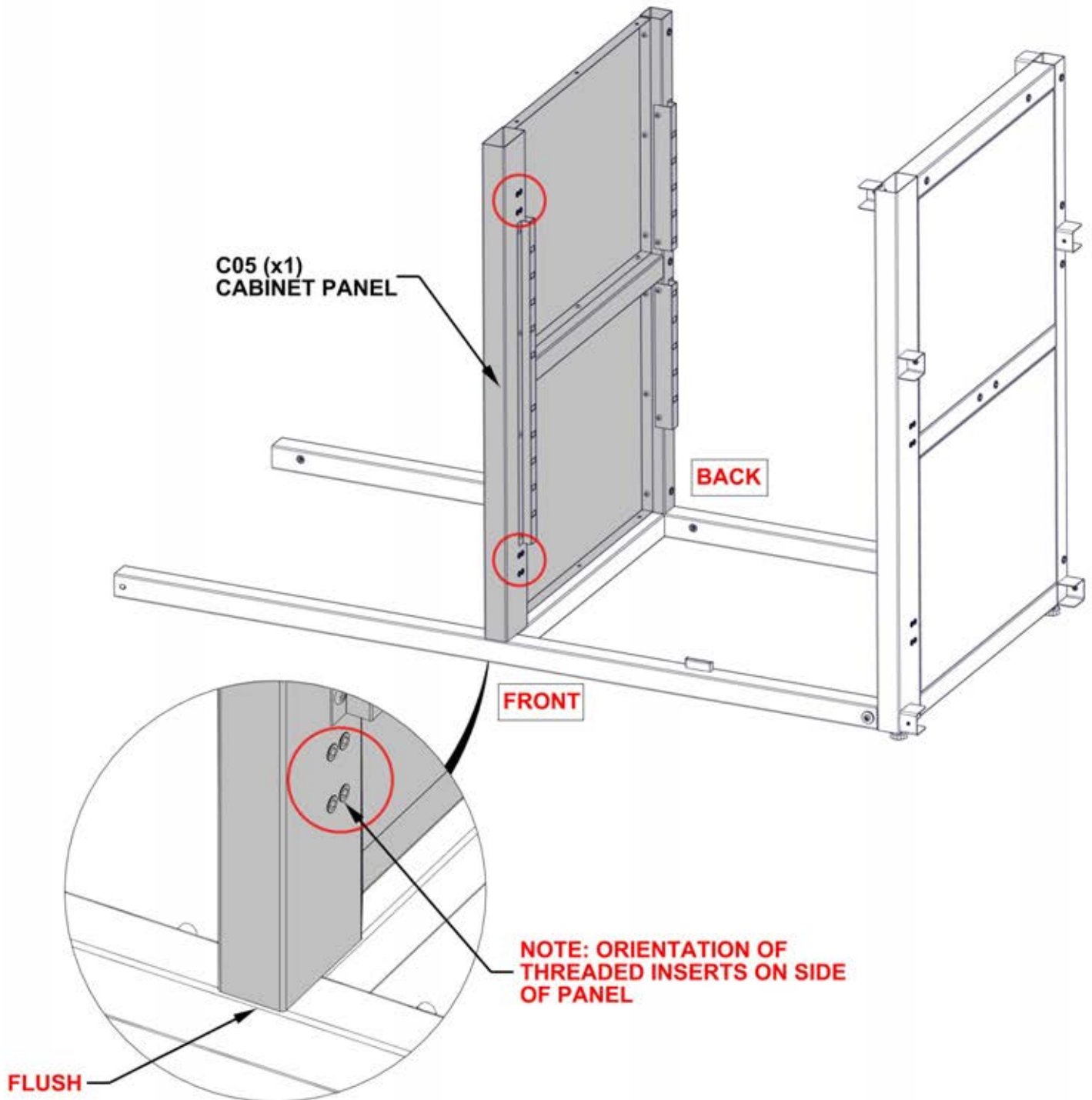

# STEP 7A - KITCHEN CABINET ASSEMBLY

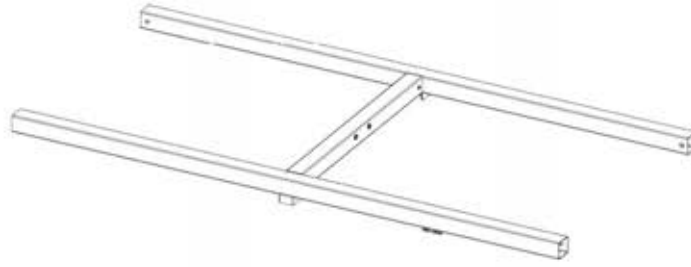

COUNTERTOP FRAME  
ASSEMBLY STEP 3

**SLIDE COUNTERTOP FRAME ASSEMBLY UNTIL TUBES ALIGN WITH TUBE CONNECTORS ON CABINET PANEL C02**

**TOP OF C05 CABINET PANEL WILL HAVE TO BE MOVED OUTWARD TO ALLOW COUNTERTOP FRAME TO SLIDE INTO PLACE.**

**TIP:**  
- RUBBER MALLET MAY NEED TO BE USED TO TAP PANELS IN PLACE

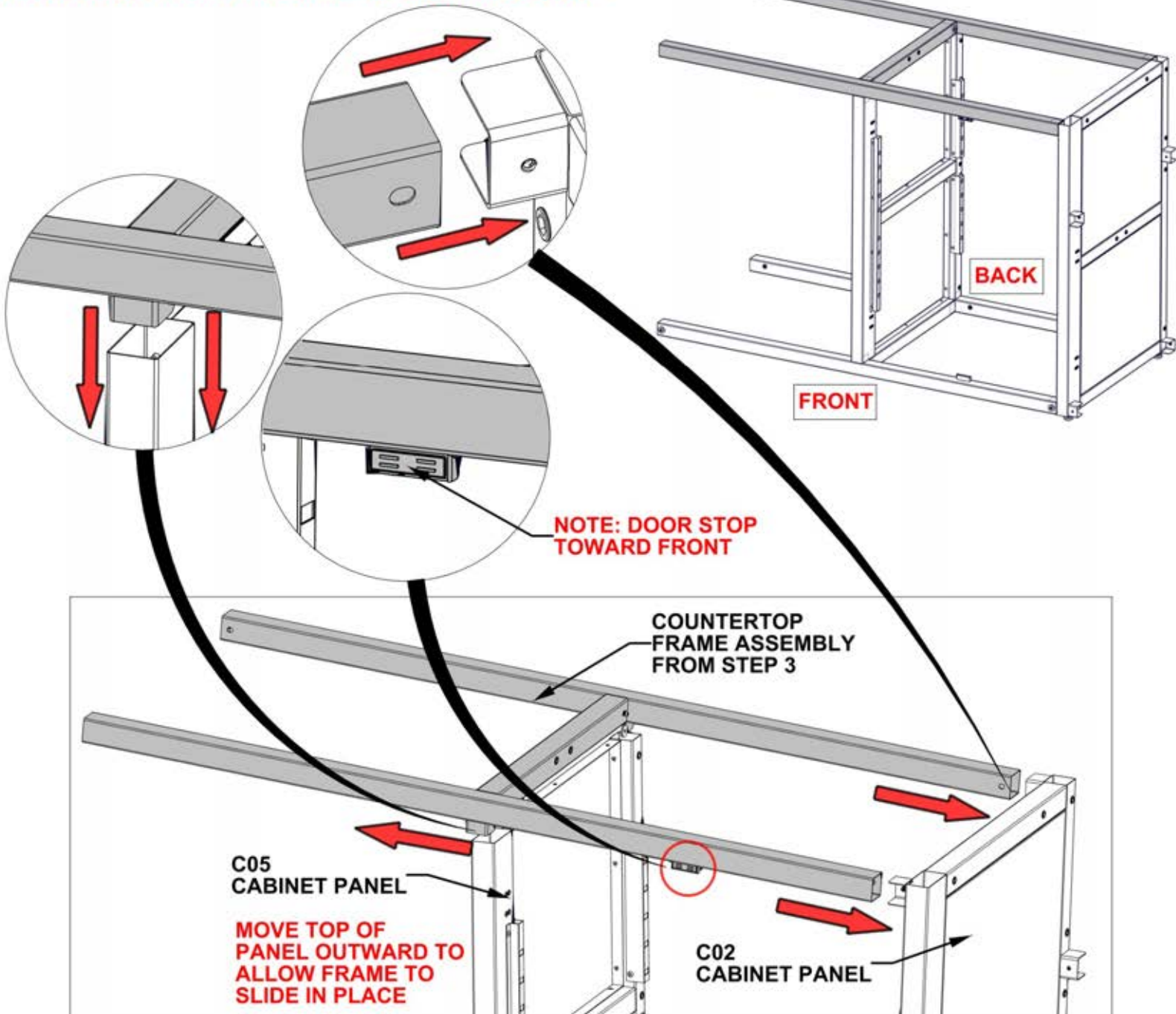

# STEP 7B - KITCHEN CABINET ASSEMBLY

QTY	PART NUMBER	Description
2	H101202	TORX PAN HEAD 1/4-20x3/4 ASSY

**DO NOT TIGHTEN HARDWARE AT THIS STEP**

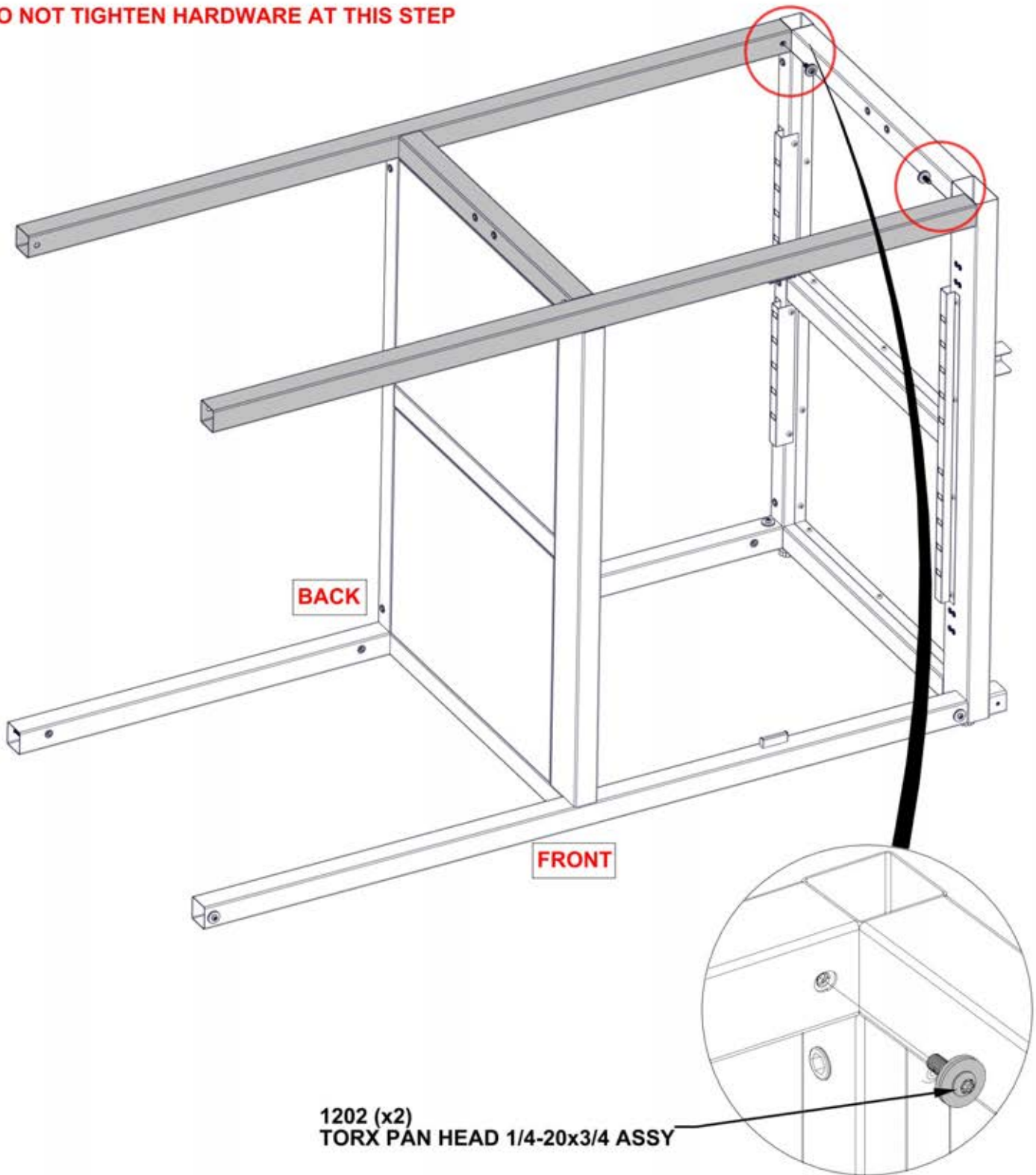



# STEP 8A - KITCHEN CABINET ASSEMBLY



C01 CABINET PANEL - A4M02016  
(x1) 2 3/4"x25"x38" (70x635x965)

**ALIGN TUBE CONNECTORS ON C01 PANEL WITH TUBES ON TOP RAILS AND BOTTOM RAILS**

TIP:  
- RUBBER MALLET MAY NEED TO BE USED TO TAP PANELS IN PLACE

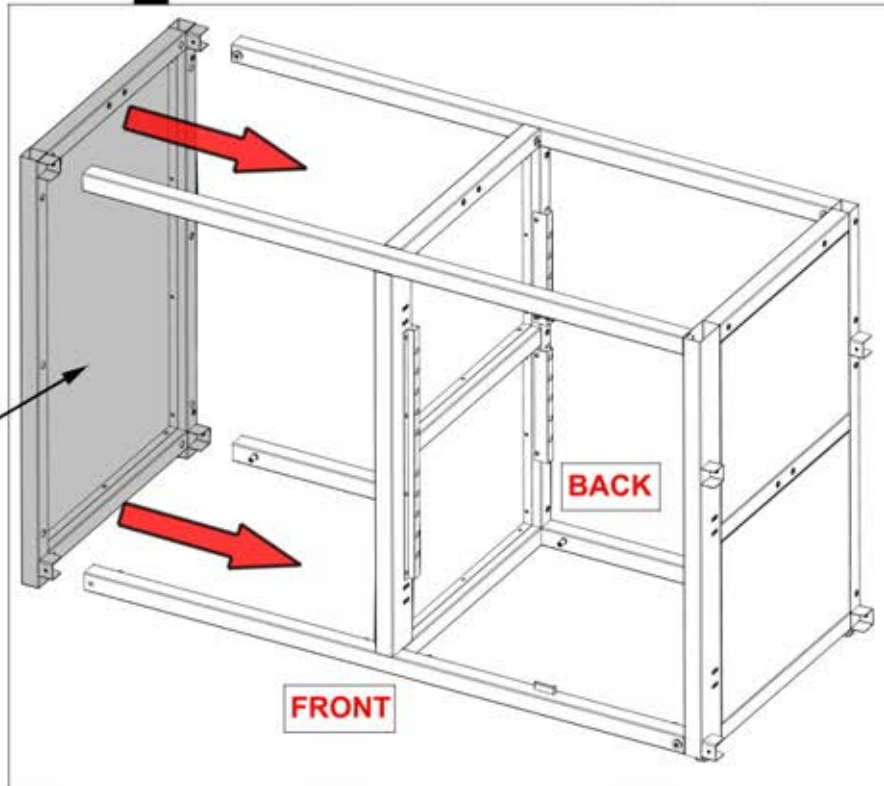
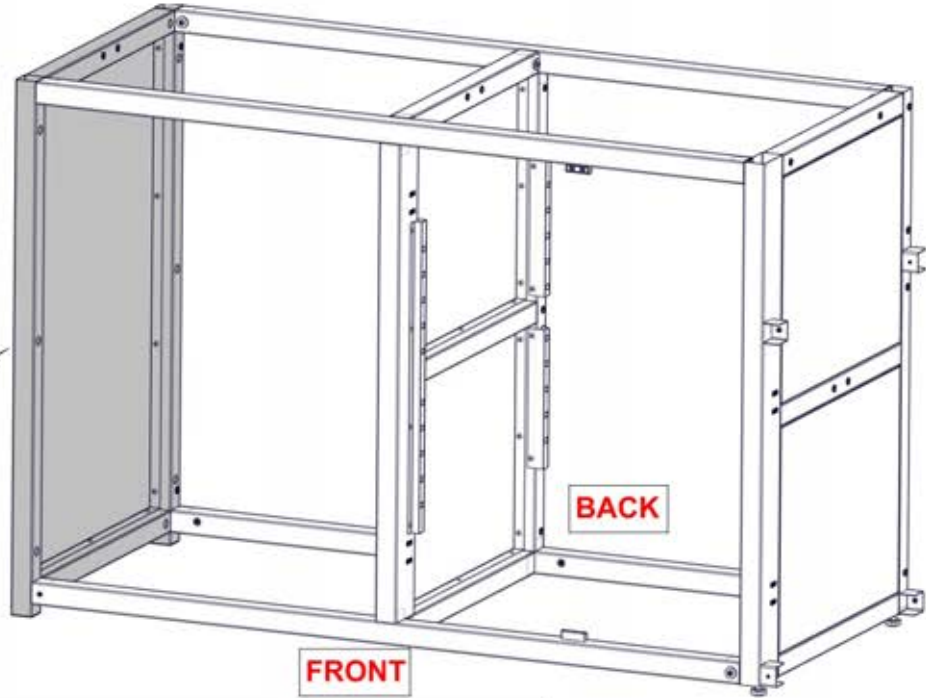

# STEP 8B - KITCHEN CABINET ASSEMBLY

QTY	PART NUMBER	Description
4	H101202	TORX PAN HEAD 1/4-20x3/4 ASSY

**DO NOT TIGHTEN HARDWARE AT THIS STEP**

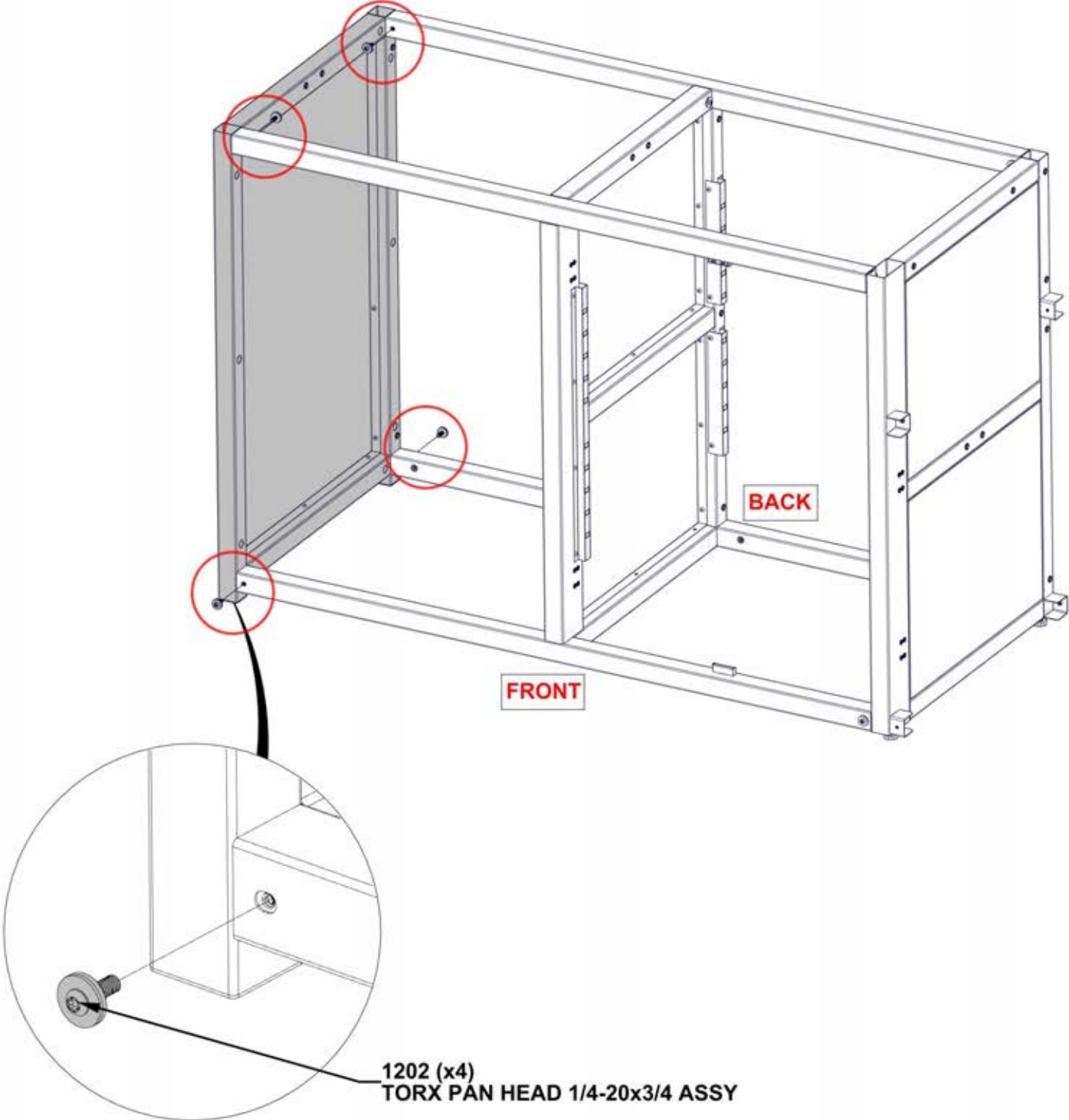

# STEP 9A - KITCHEN CABINET ASSEMBLY

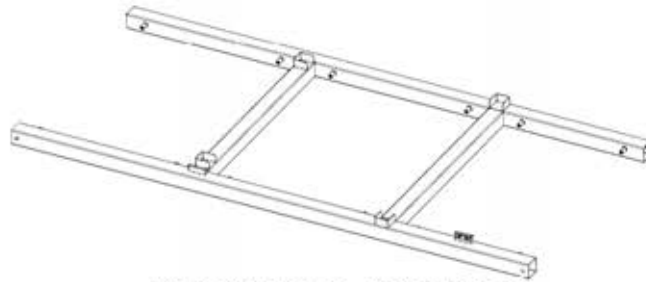

FLOOR PANEL ASSEMBLY  
STEP 2

**SLIDE FLOOR PANEL ASSEMBLY UNTIL TUBES ALIGN WITH  
TUBE CONNECTORS ON CABINET PANEL C02**

**MAKE SURE ALL DOOR STOPS ARE TOWARD THE FRONT**

**TIP:**  
- RUBBER MALLET MAY NEED TO  
BE USED TO TAP PANELS IN PLACE

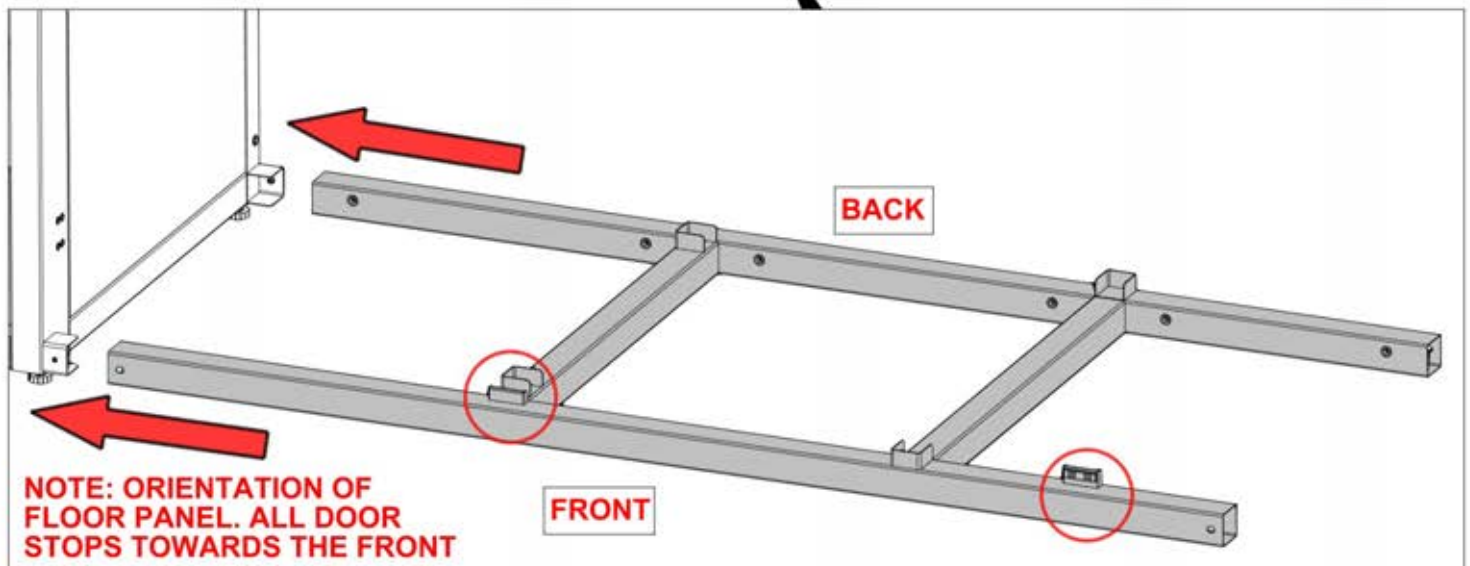
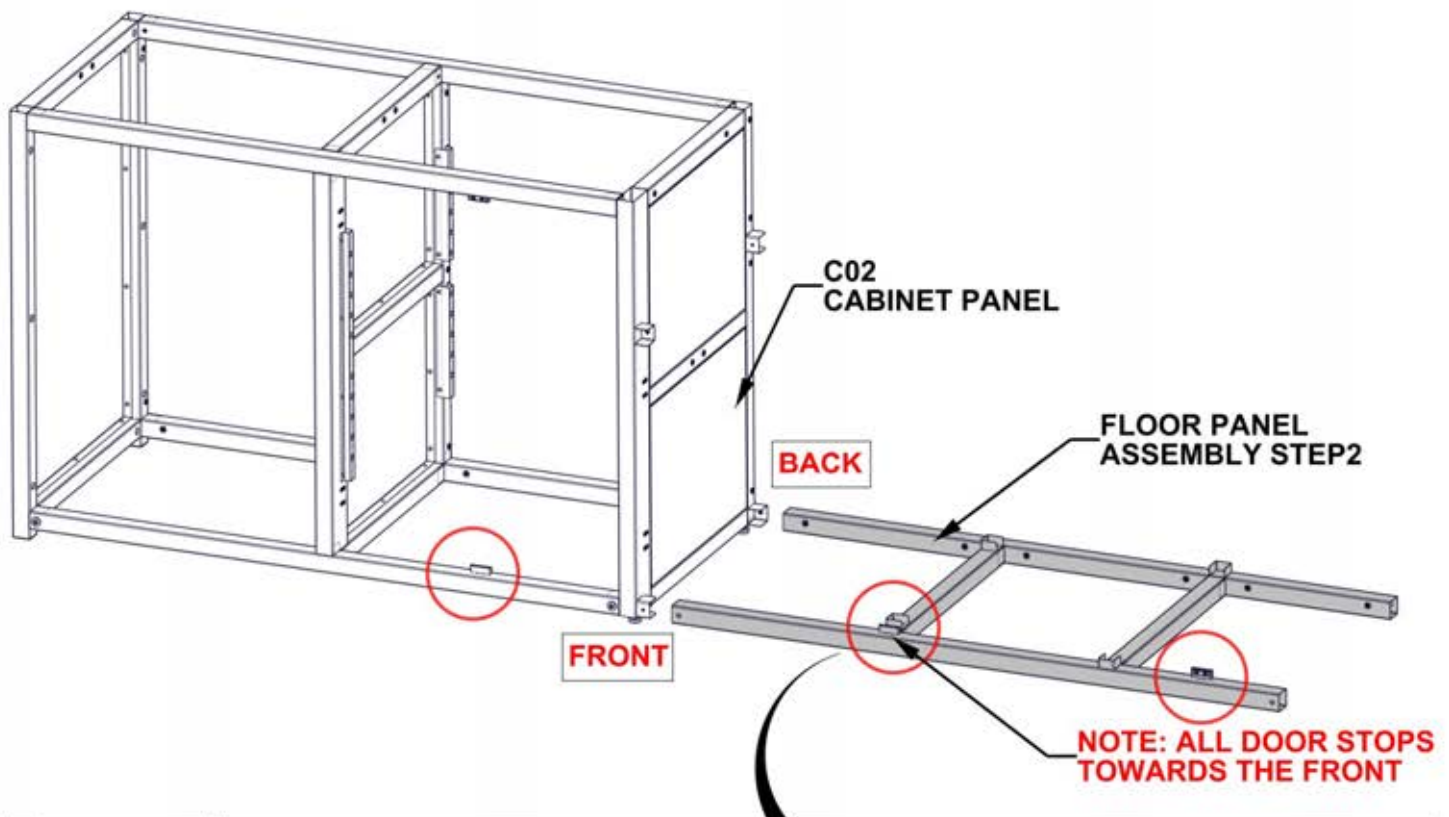

# STEP 9B - KITCHEN CABINET ASSEMBLY

QTY	PART NUMBER	Description
2	H101202	TORX PAN HEAD 1/4-20x3/4 ASSY

**DO NOT TIGHTEN HARDWARE AT THIS STEP**

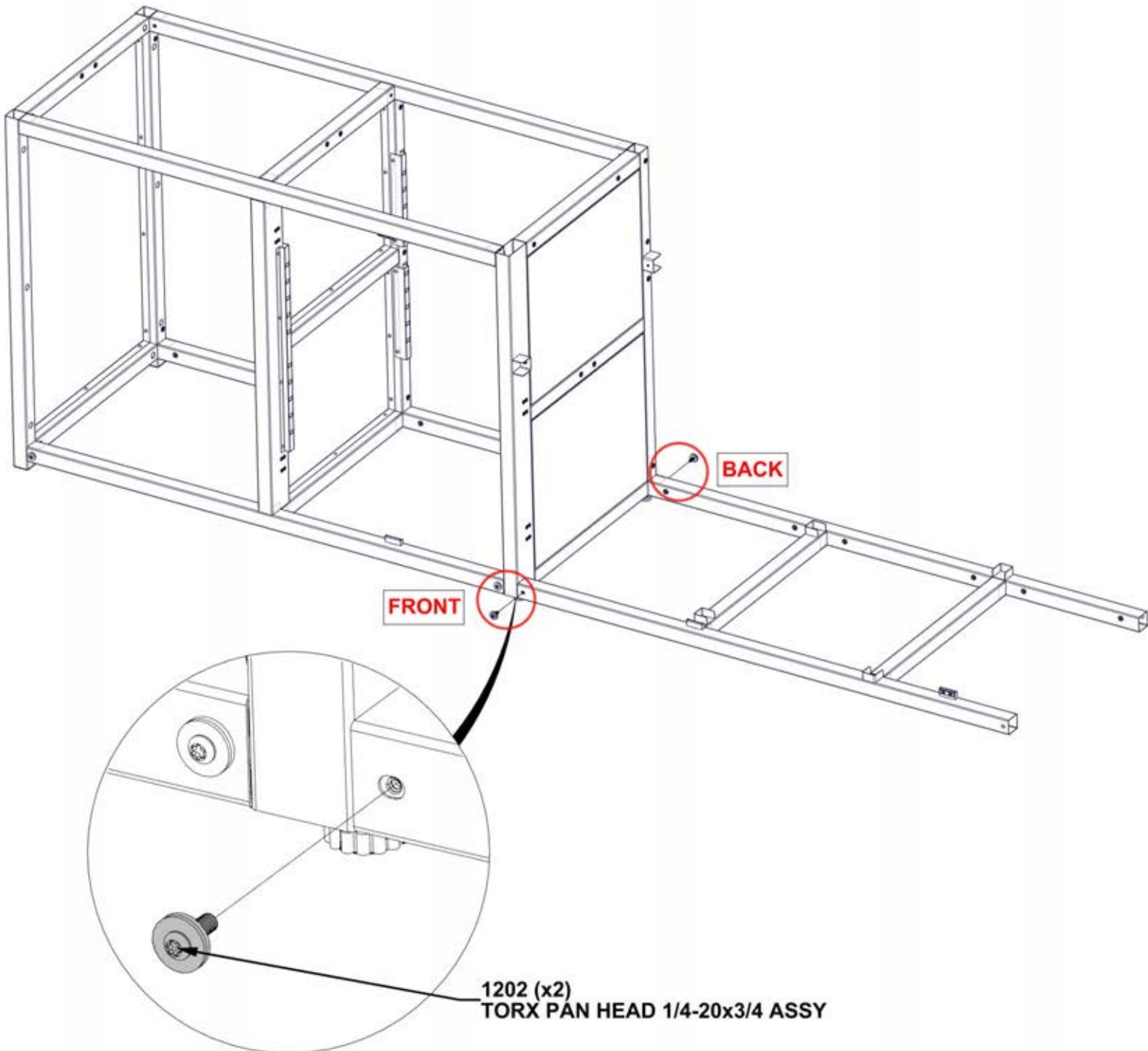

# STEP 10 - KITCHEN CABINET ASSEMBLY



T02 UPRIGHT TUBE - A4M02104  
(x1) 1 9/16"x1 9/16"x22 11/16" (40x40x576)



T03 UPRIGHT TUBE WITH MATCH HOLDER - A4M02404  
(x1) 1 9/16"x1 9/16"x22 11/16" (40x40x576)

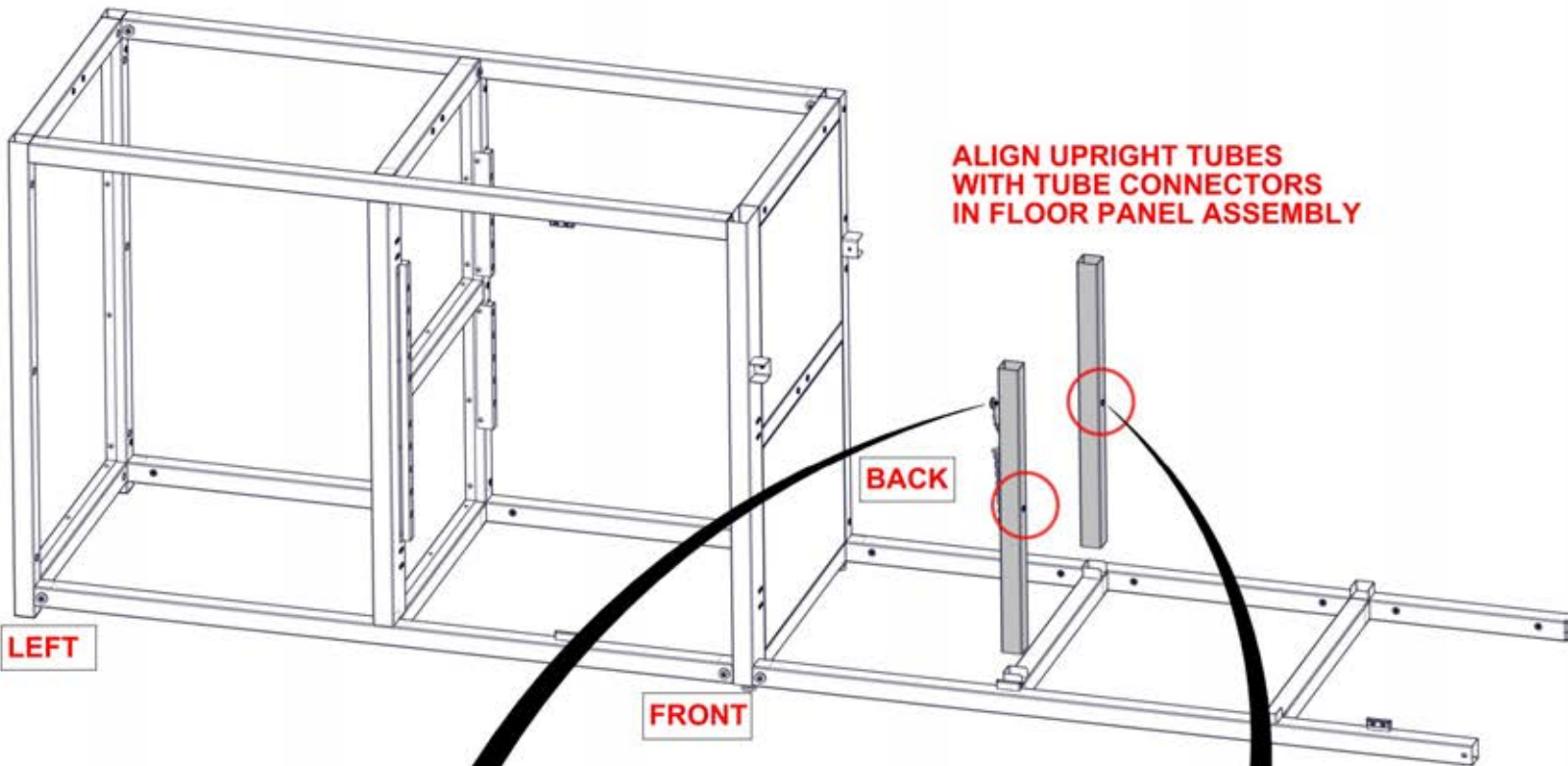

**ALIGN UPRIGHT TUBES WITH TUBE CONNECTORS IN FLOOR PANEL ASSEMBLY**

LEFT

BACK

FRONT

RIGHT

**NOTE: THREADED INSERT IN MIDDLE OF UPRIGHTS ON RIGHT SIDE**

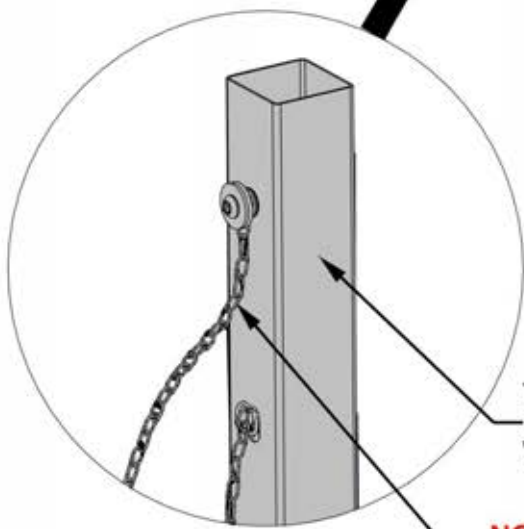

T03 (x1) UPRIGHT TUBE WITH MATCH HOLDER

**NOTE: MATCH HOLDER ON LEFT SIDE TOWARDS TOP OF UPRIGHT**

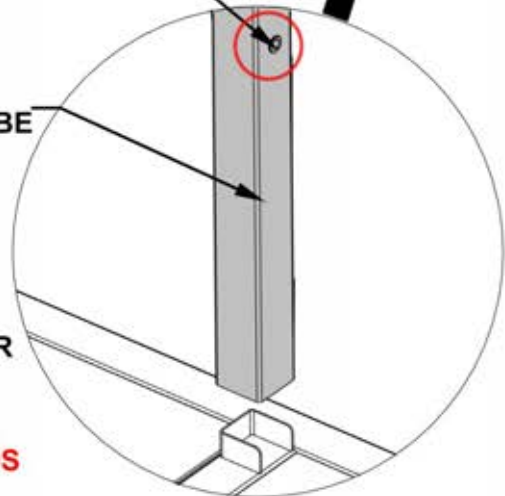

T02 (x1) UPRIGHT TUBE

# STEP 11A - KITCHEN CABINET ASSEMBLY



C09 CABINET TABLE - A4M02049  
(x1) 2 3/8"x25"x38 7/16" (60x635x977)

**SLIDE CABINET TABLE FRAME UNTIL TUBES ALIGN WITH TUBE CONNECTORS ON CABINET PANEL C02**

**TOP OF T02 AND T03 UPRIGHT TUBES WILL HAVE TO BE MOVED OUTWARD TO ALLOW CABINET TABLE FRAME TO SLIDE INTO PLACE**

**TIP:**  
- RUBBER MALLET MAY NEED TO BE USED TO TAP PANELS IN PLACE

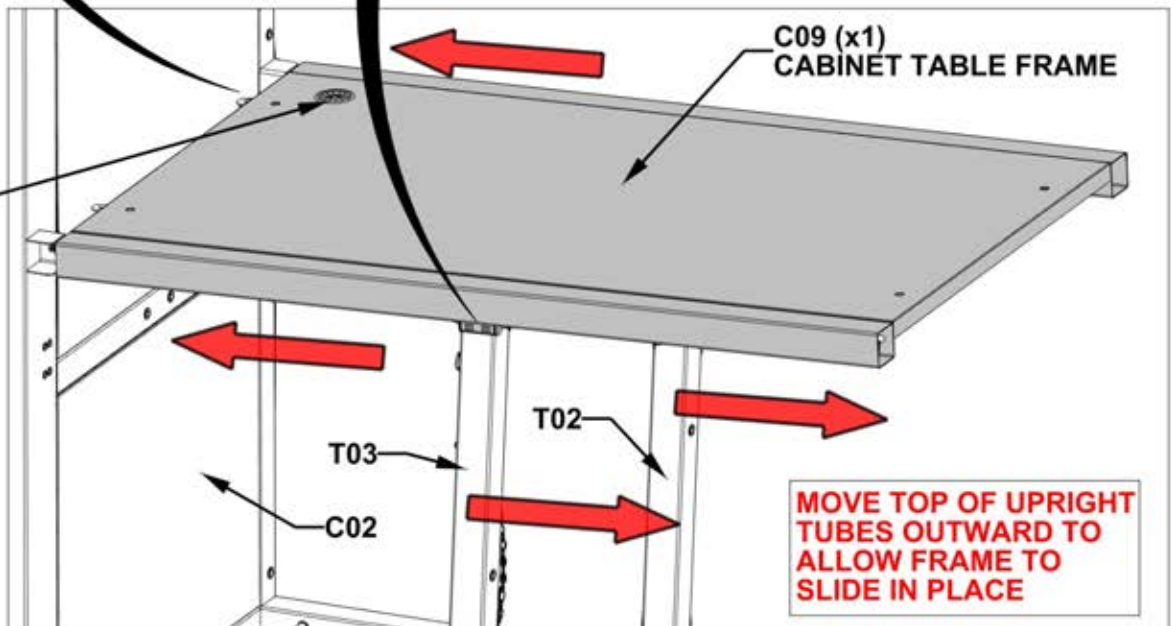
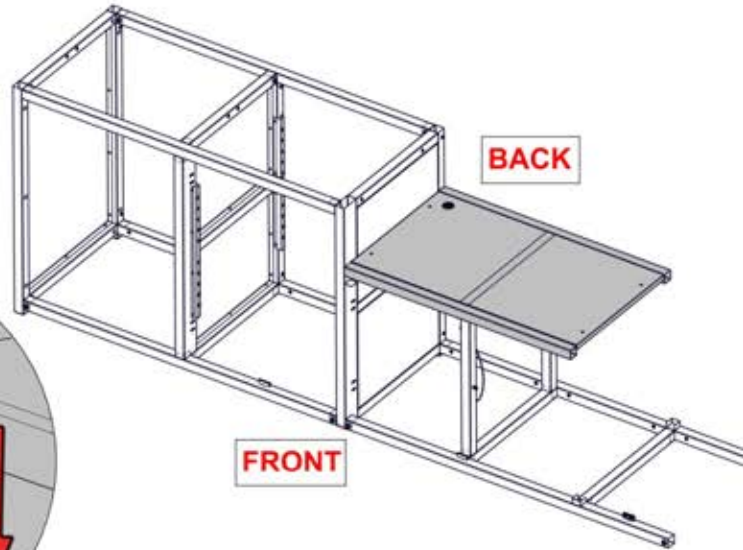
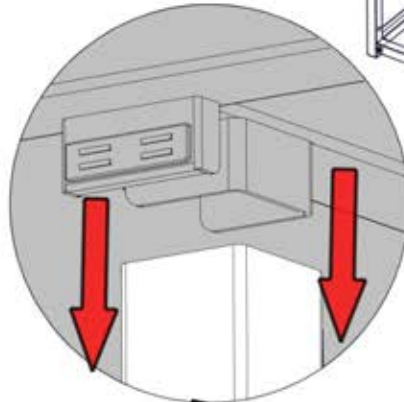

**NOTE: GROMET IN CABINET TABLE TOWARDS BACK LEFT CORNER**

**MOVE TOP OF UPRIGHT TUBES OUTWARD TO ALLOW FRAME TO SLIDE IN PLACE**

# STEP 11B - KITCHEN CABINET ASSEMBLY

QTY	PART NUMBER	Description
2	H101202	TORX PAN HEAD 1/4-20x3/4 ASSY

**DO NOT TIGHTEN HARDWARE AT THIS STEP**

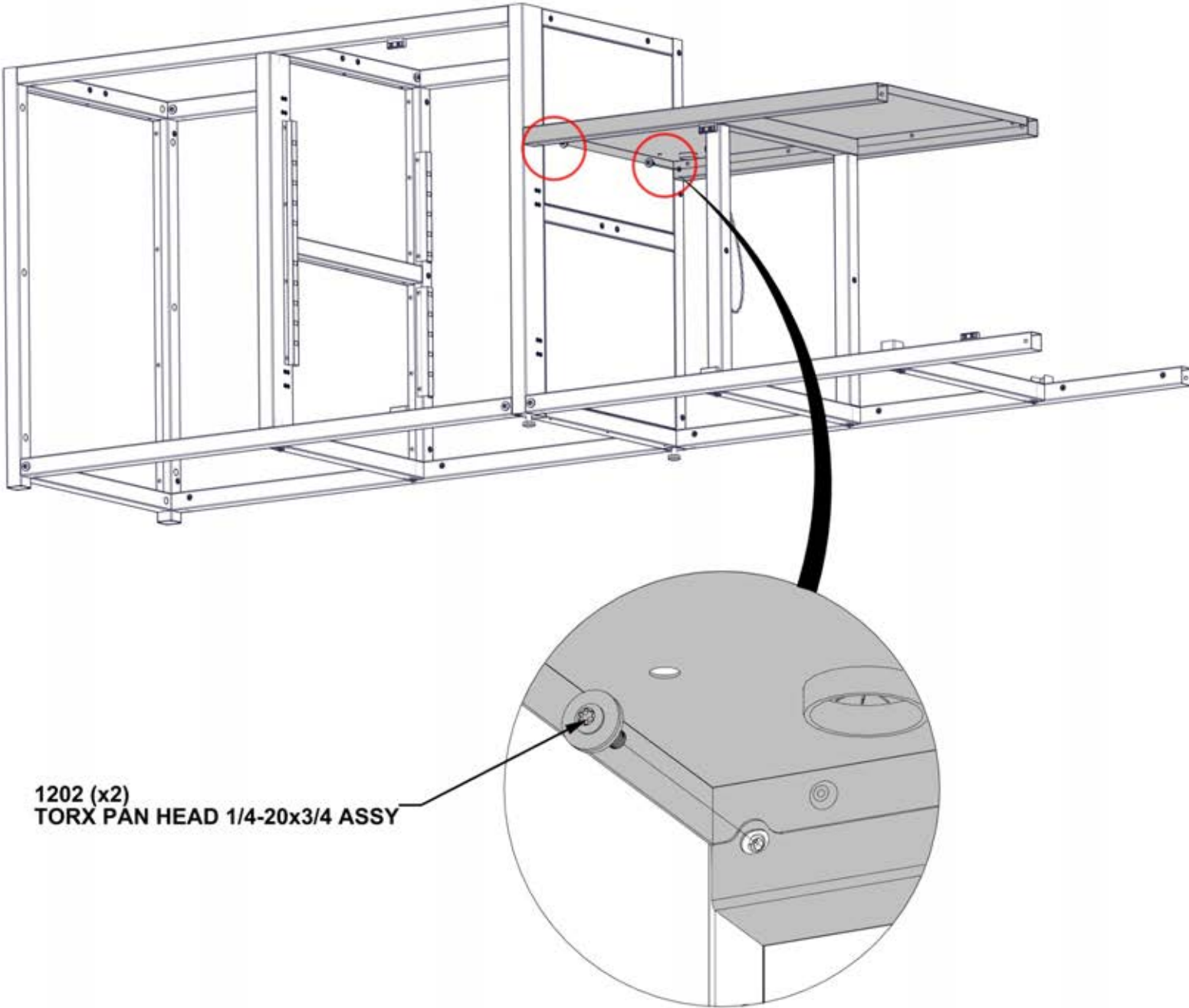

1202 (x2)  
TORX PAN HEAD 1/4-20x3/4 ASSY

# STEP 12A - KITCHEN CABINET ASSEMBLY



C08 CABINET PANEL - A4M02048  
(x1) 4 1/8"x25"x35 7/16" (105x635x900)

**SLIDE CABINET PANEL C08 UNTIL TUBES ALIGN WITH  
TUBE CONNECTORS ON TABLE FRAME C09**

**TOP OF C08 PANEL WILL HAVE TO BE MOVED OUTWARD**

**TIP:**  
- RUBBER Mallet MAY NEED TO  
BE USED TO TAP PANELS IN PLACE

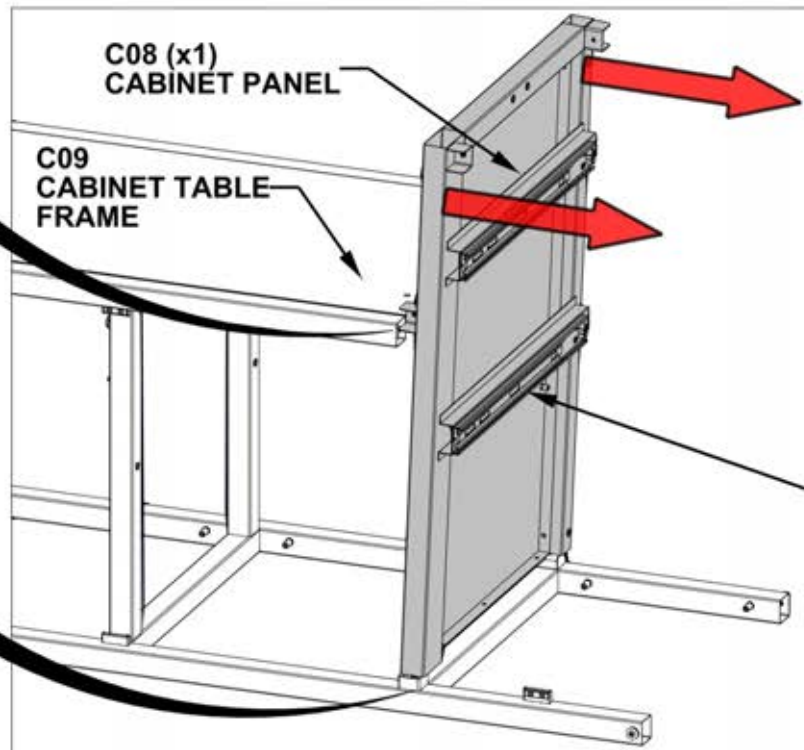
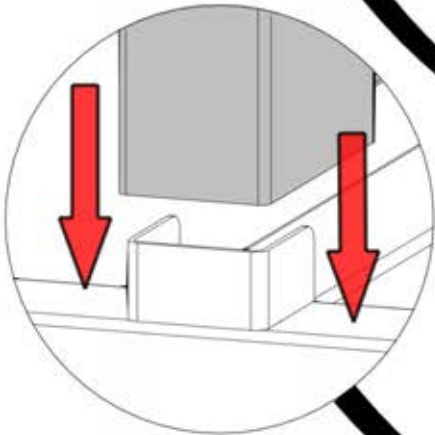
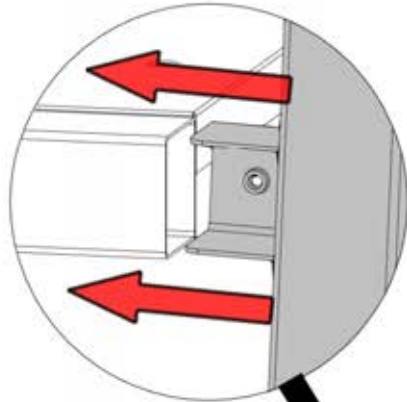
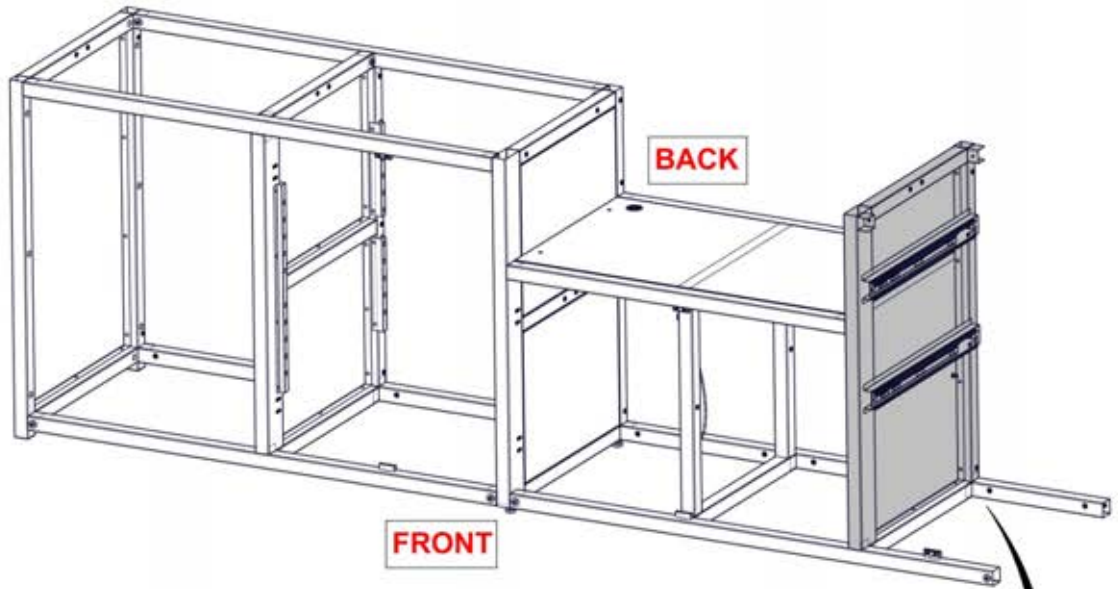

**NOTE: DRAWER  
SLIDES ON RIGHT  
SIDE OF CABINET**



# STEP 12B - KITCHEN CABINET ASSEMBLY

QTY	PART NUMBER	Description
2	H101202	TORX PAN HEAD 1/4-20x3/4 ASSY

**DO NOT TIGHTEN HARDWARE AT THIS STEP**

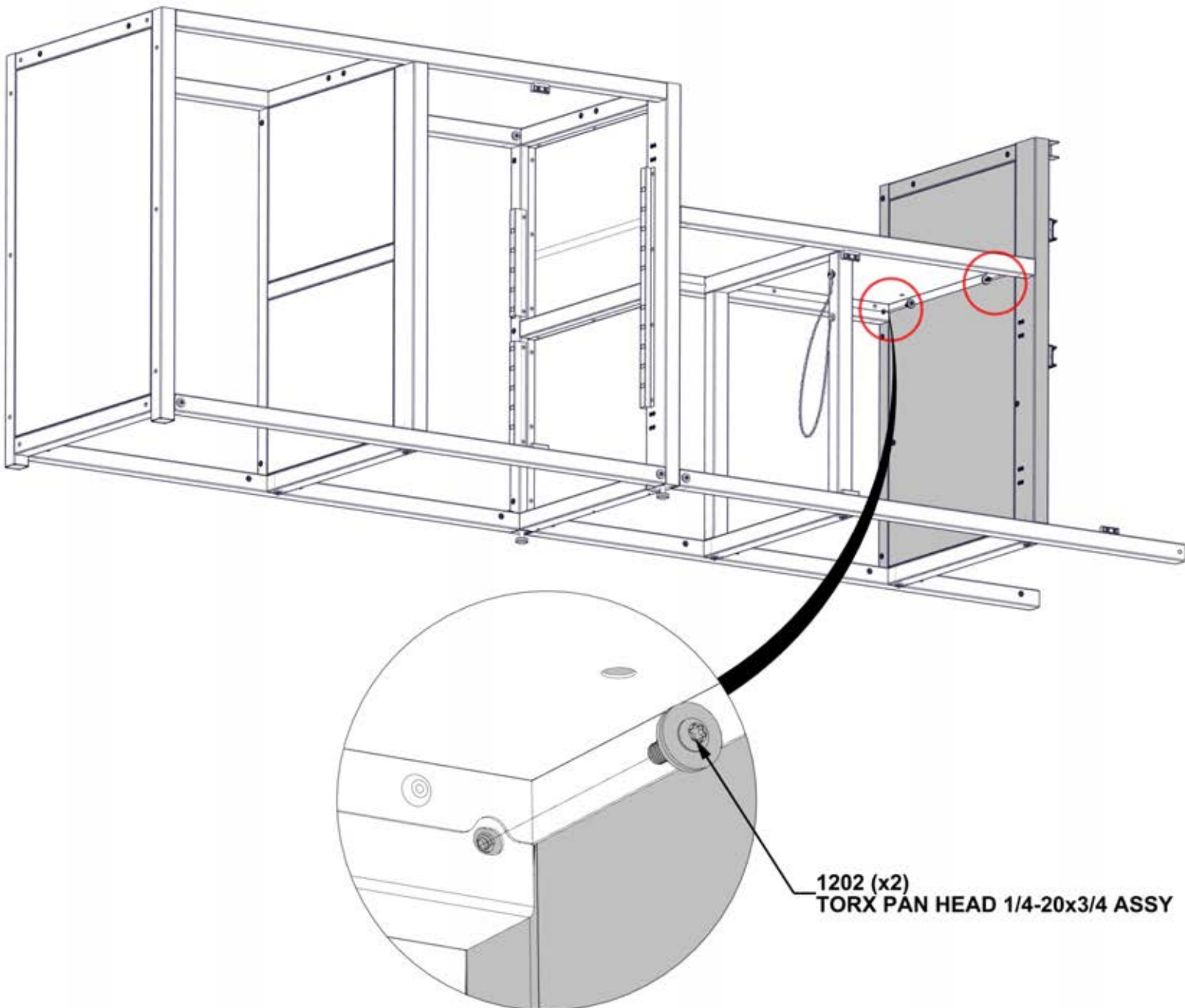

# STEP 13A - KITCHEN CABINET ASSEMBLY



C06 CABINET PANEL - A4M02046  
(x1) 2 15/16"x25"x38" (75x635x965)

**ALIGN TUBE CONNECTORS ON C06 PANEL WITH TUBES ON BOTTOM RAILS**

TIP:  
- RUBBER MALLET MAY NEED TO  
BE USED TO TAP PANELS IN PLACE

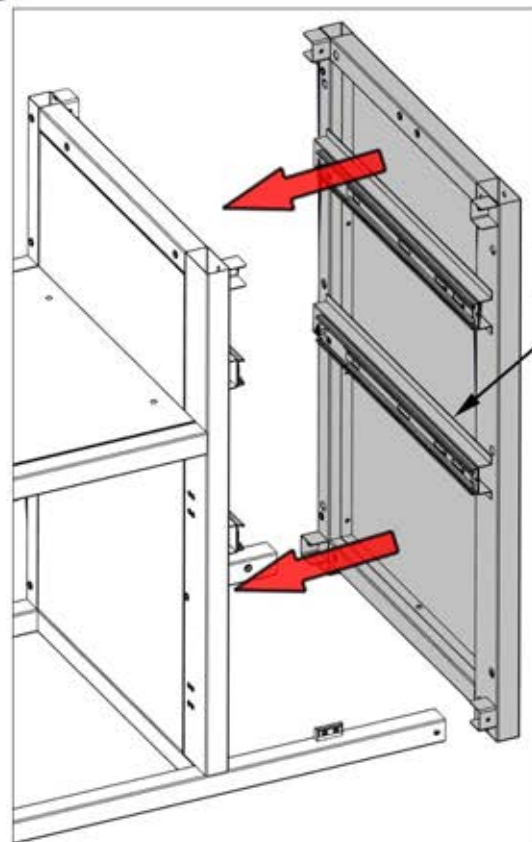
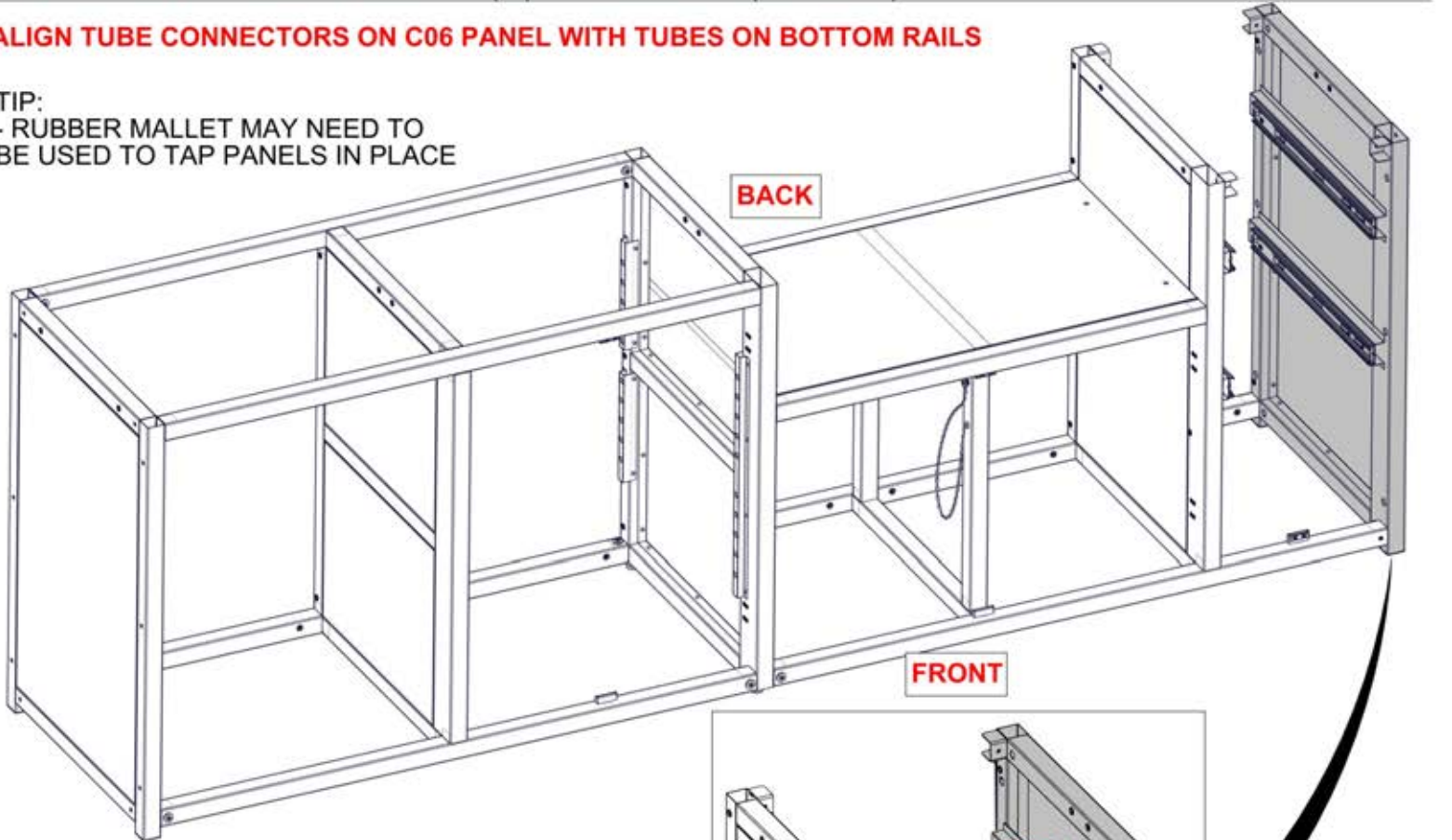

C06 (x1)  
CABINET PANEL

# STEP 13B - KITCHEN CABINET ASSEMBLY

QTY	PART NUMBER	Description
2	H101202	TORX PAN HEAD 1/4-20x3/4 ASSY

**DO NOT TIGHTEN HARDWARE AT THIS STEP**

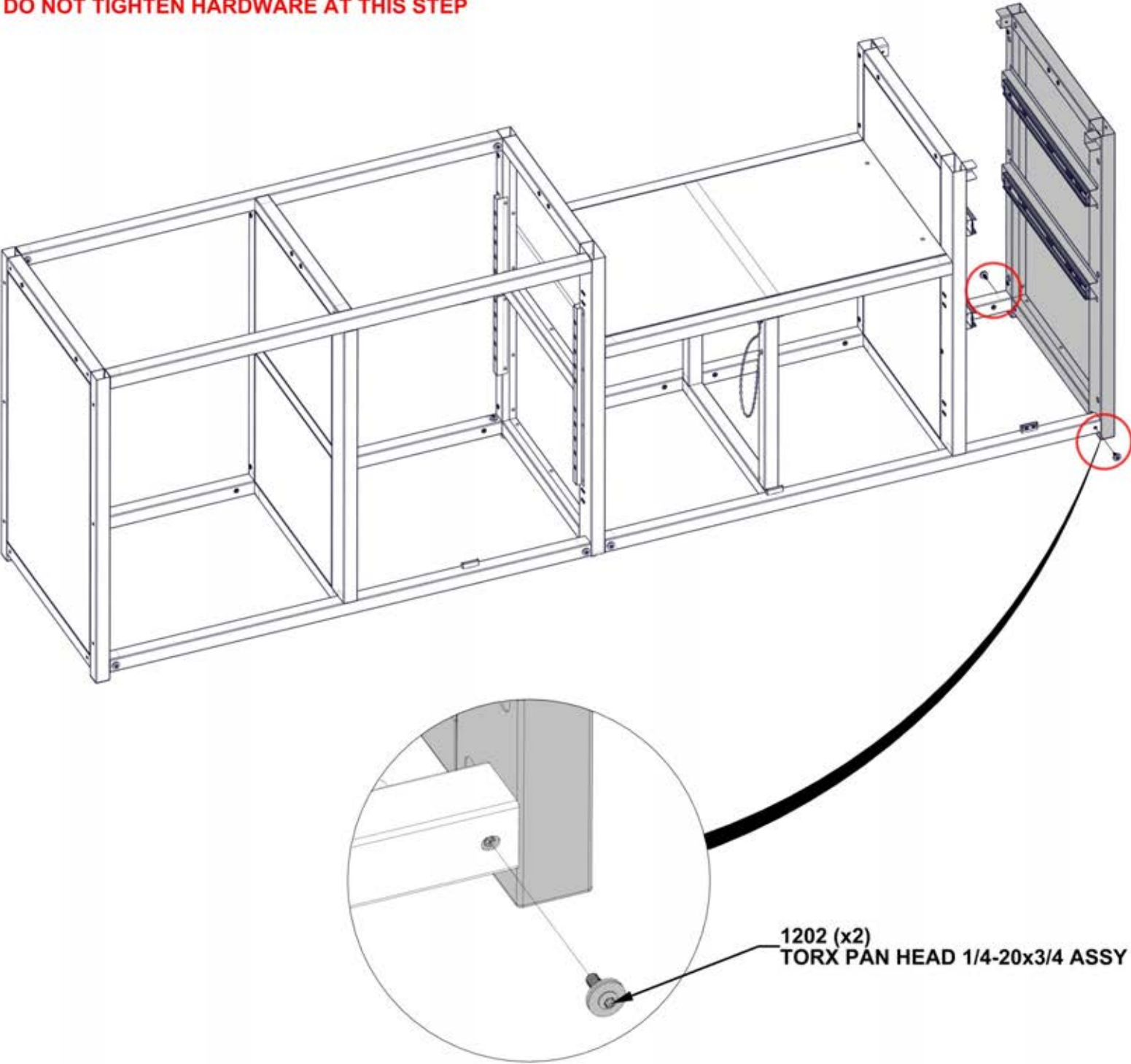

# STEP 14A - KITCHEN CABINET ASSEMBLY

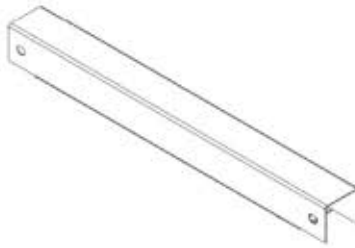

T01 TUBE - A4M02050  
(x2) 1 9/16"x1 9/16"x14 7/8" (40x40x378)

**PLACE T01 TUBES IN PLACE WITH NOTCH IN BOTTOM OF TUBE FACING DOWN**

**MAKE SURE SLOT IN TUBES FACE EACH OTHER TOWARDS INSIDE OF CABINET**

**TIP:**  
- RUBBER Mallet MAY NEED TO BE USED TO TAP TUBES IN PLACE

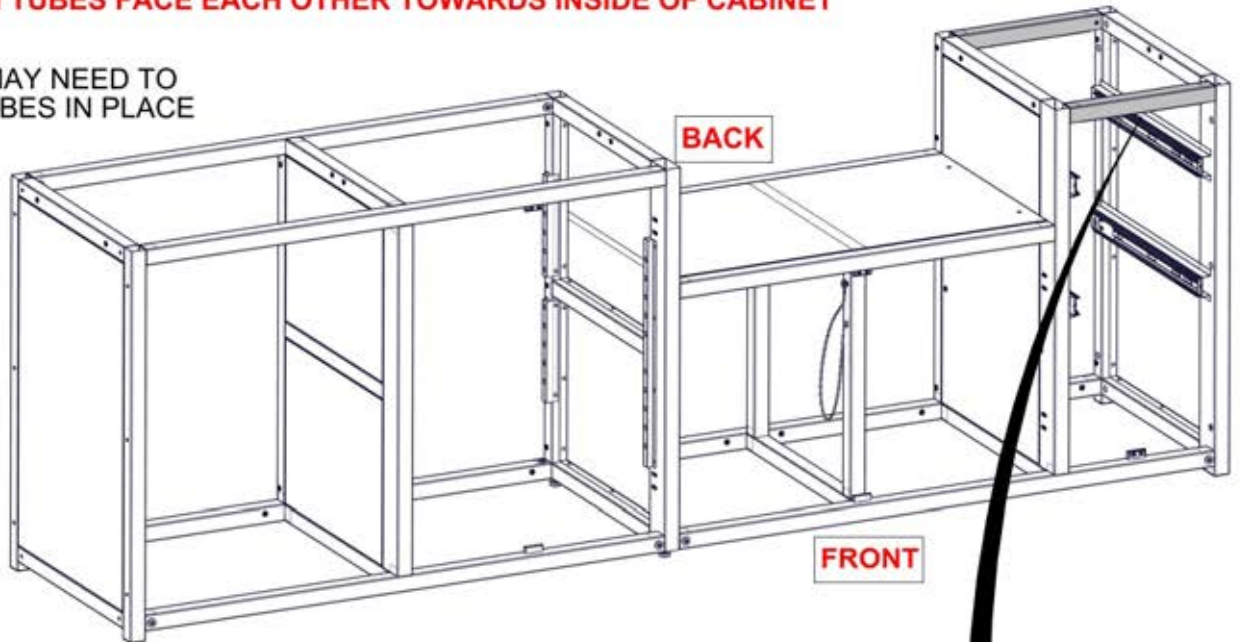

**NOTE: SLOT IN TUBE WILL ALIGN WITH THREADED HOLE. MAKE SURE SLOTS ON EACH TUBE FACE EACH OTHER TOWARD INSIDE OF CABINET.**

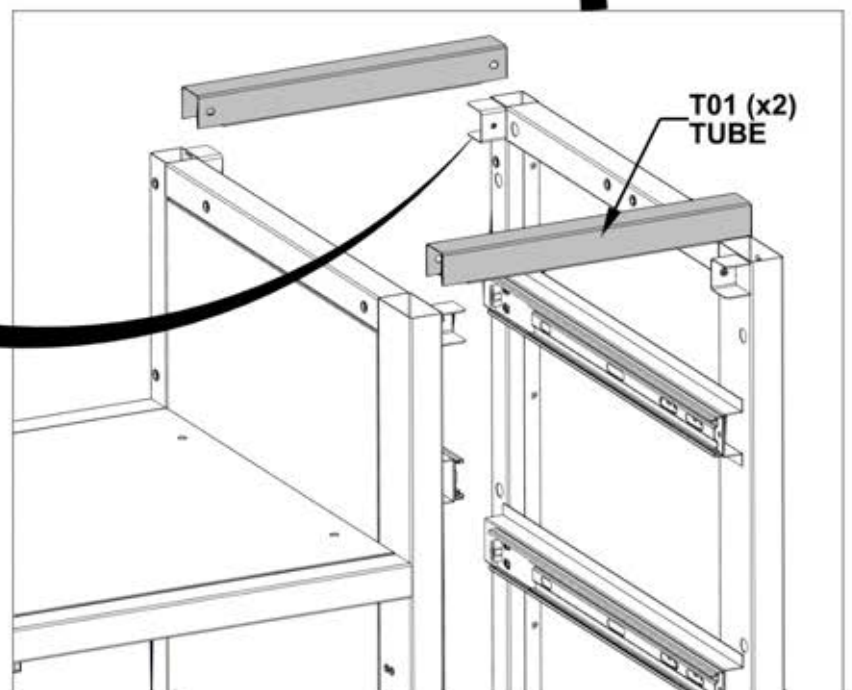
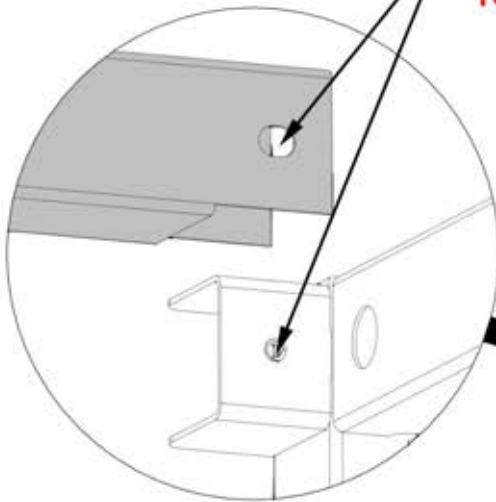

# STEP 14B - KITCHEN CABINET ASSEMBLY

QTY	PART NUMBER	Description
4	H101202	TORX PAN HEAD 1/4-20x3/4 ASSY

**DO NOT TIGHTEN HARDWARE AT THIS STEP**

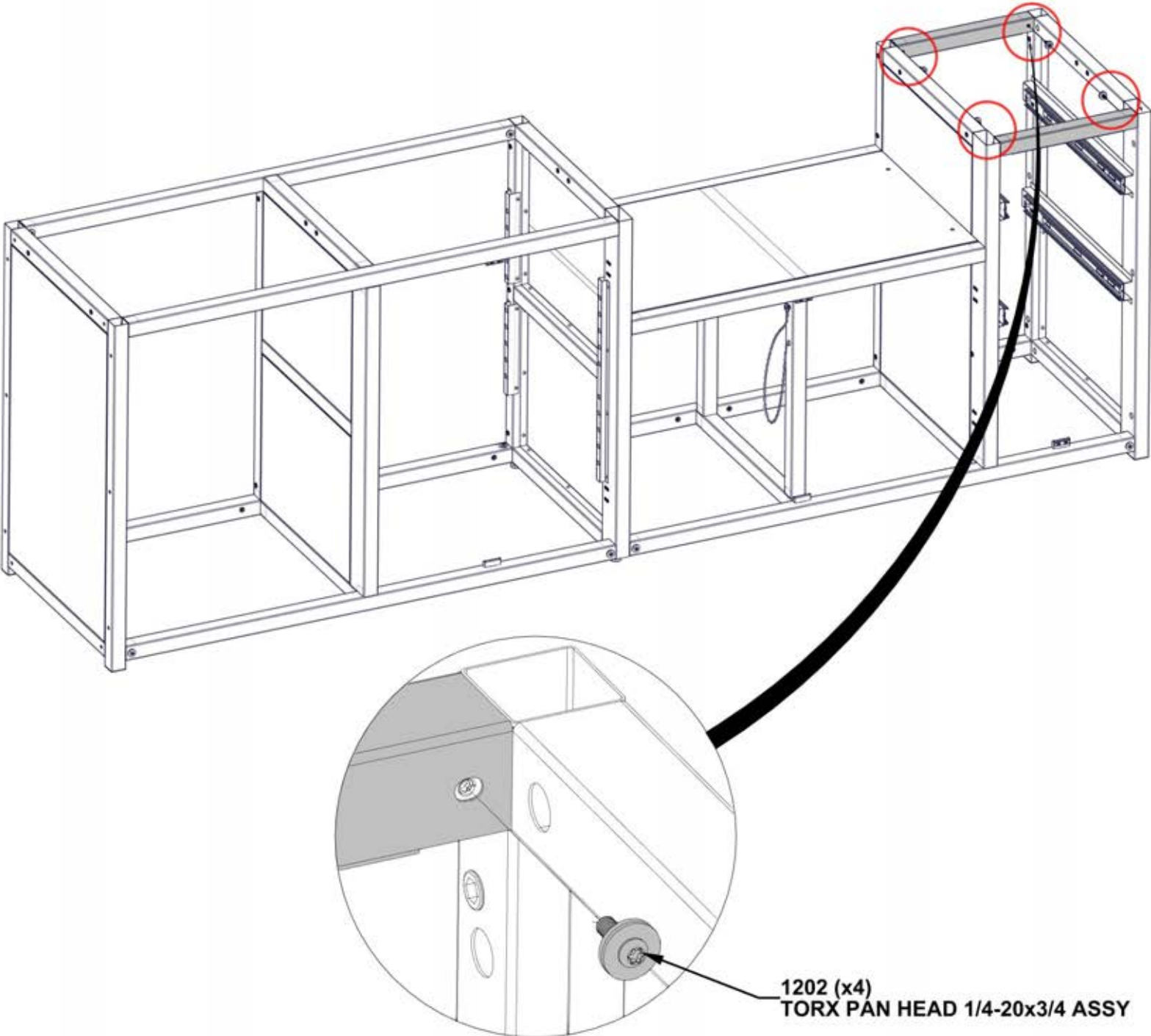

# STEP 15 - SQUARE THE ASSEMBLY

**CRITICAL: SQUARE KITCHEN CABINETS BEFORE PROCEEDING TO NEXT STEPS. ONCE SQUARE, TIGHTEN ALL HARWARE FROM PREVIOUS STEPS.**

**MEASUREMENTS TAKEN FROM OUTSIDE CORNER OF CABINET TO OUTSIDE CORNER OF CABINET.**

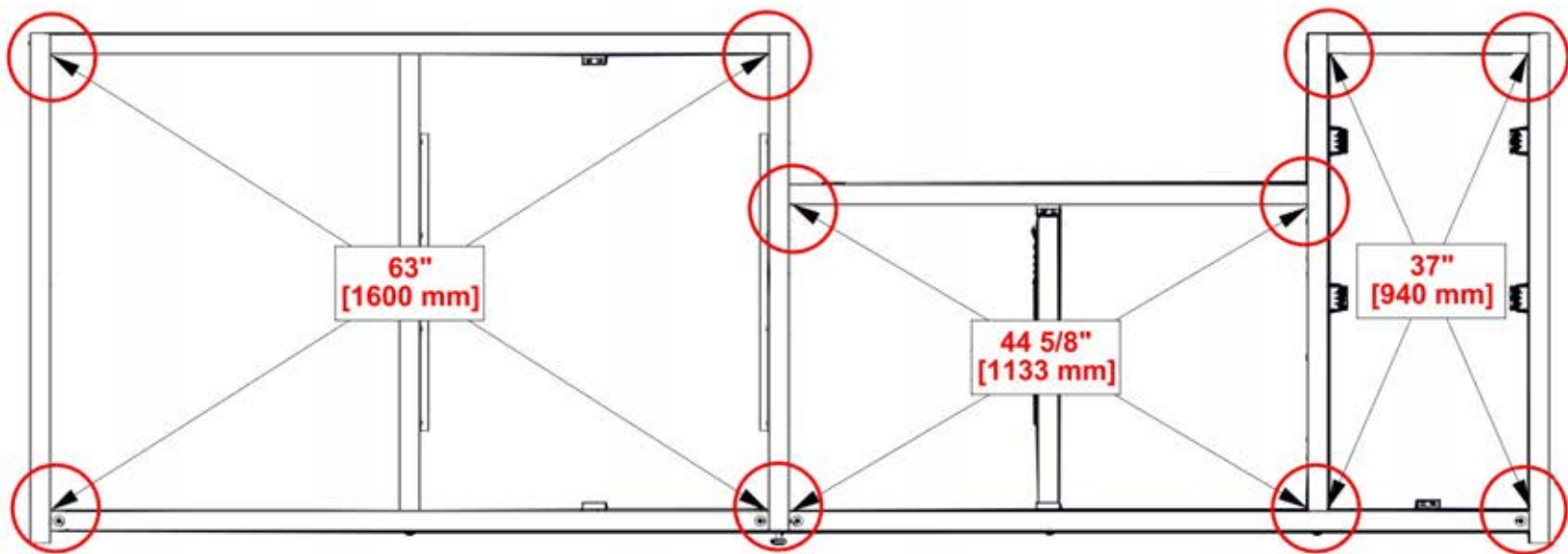
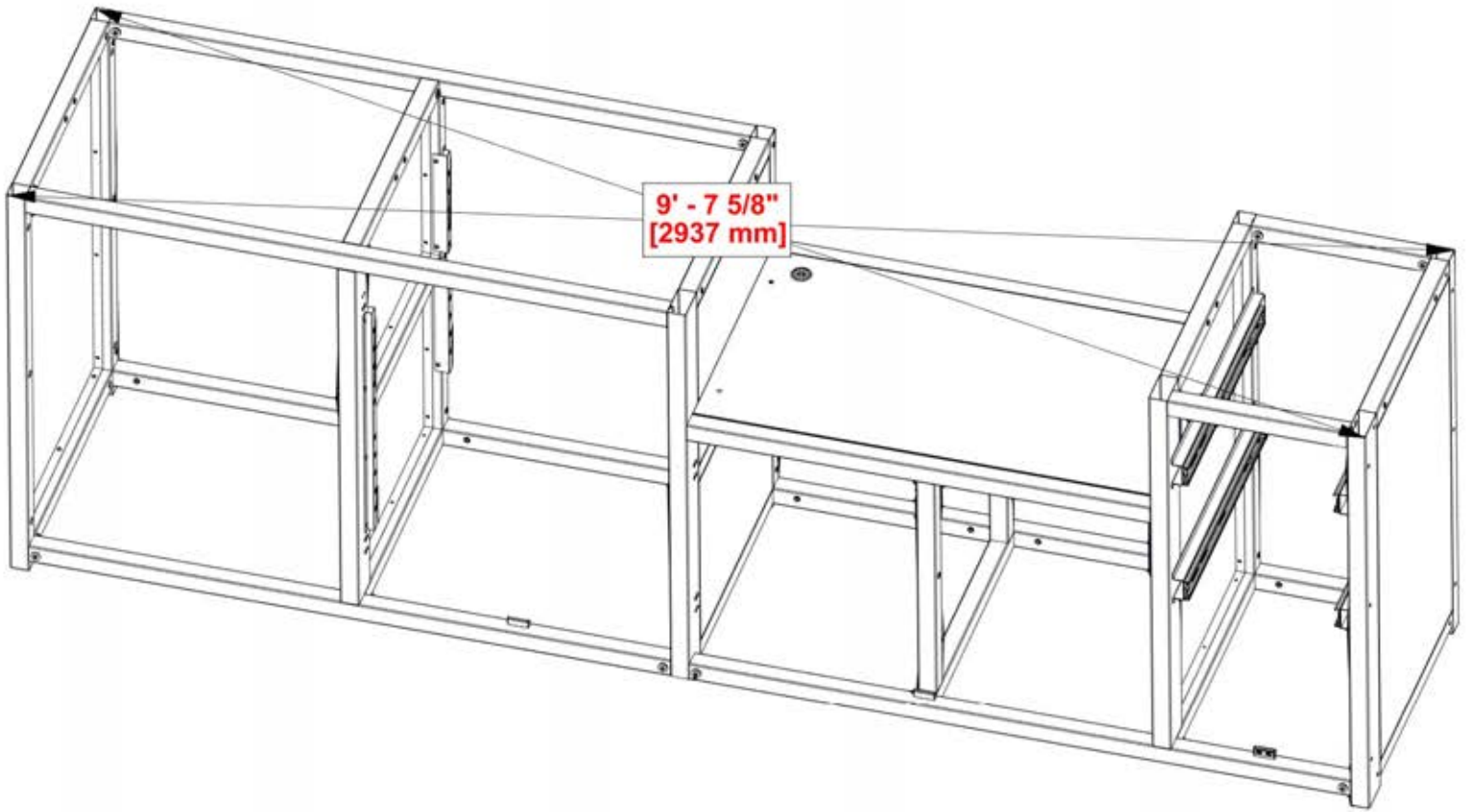

**CRITICAL: SQUARE ALL CABINET OPENINGS TO ENSURE PROPER DOOR, COUTERTOP, AND DRAWER FITMENT**

**BEFORE PROCEEDING, MAKE SURE ALL HARDWARE  
IS TIGHT AND KITCHEN CABINETS ARE SQUARE.**

# STEP 16 - POST ASSEMBLY

QTY	PART NUMBER	Description
4	H101202	TORX PAN HEAD 1/4-20x3/4 ASSY

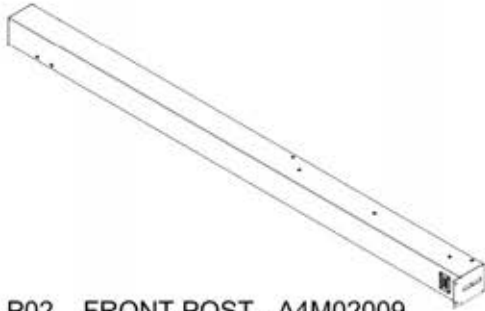

P02 FRONT POST - A4M02009  
(x1) 4 3/4"x5 15/16"x89 1/2" (120x151x2274)



A01 BRACKET - A4M02018  
(x2) 1"x1 5/16"x5 1/16" (25x33.2x128)

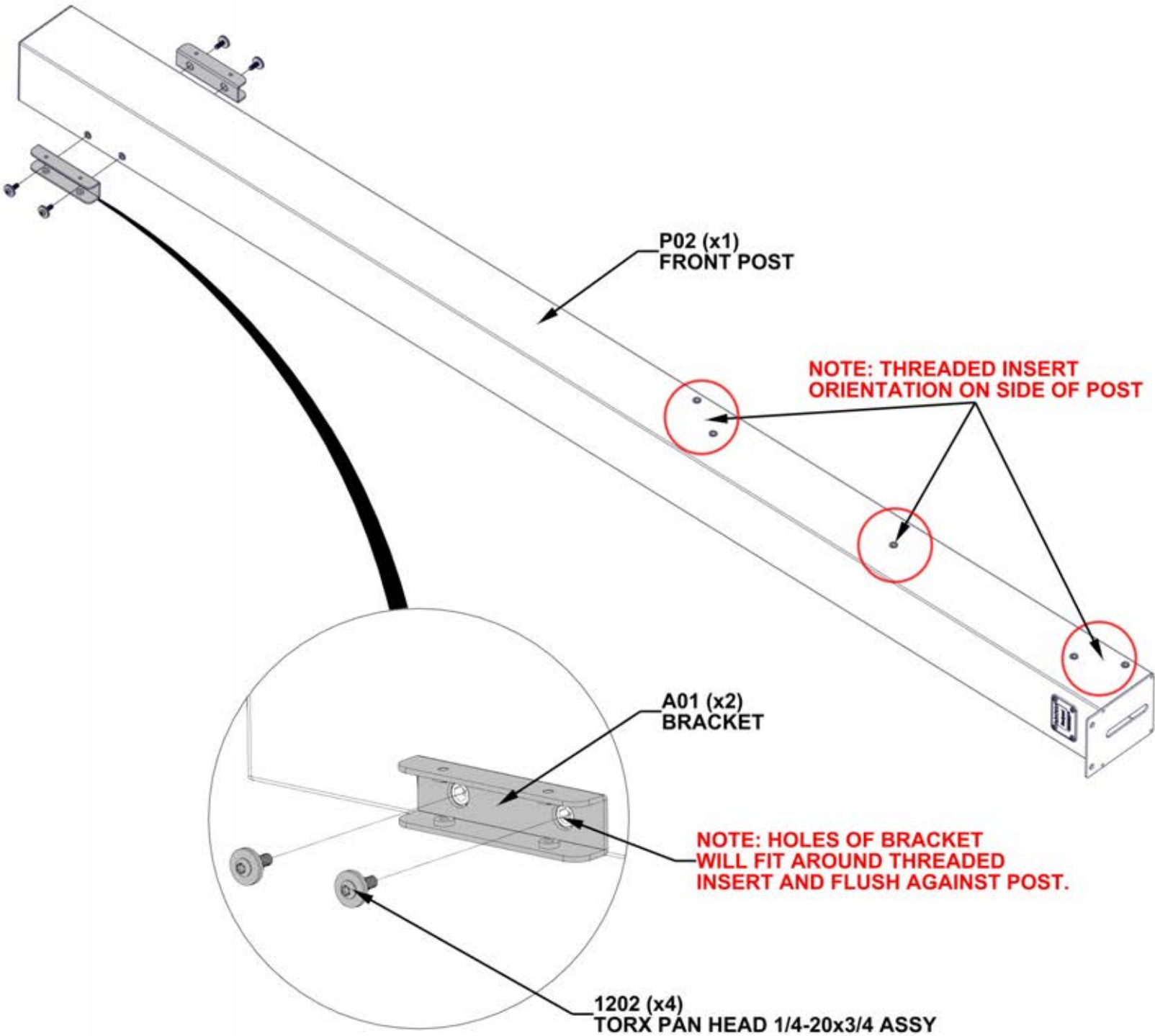



# STEP 17 - POST ASSEMBLY

QTY	PART NUMBER	Description
2	H101202	TORX PAN HEAD 1/4-20x3/4 ASSY

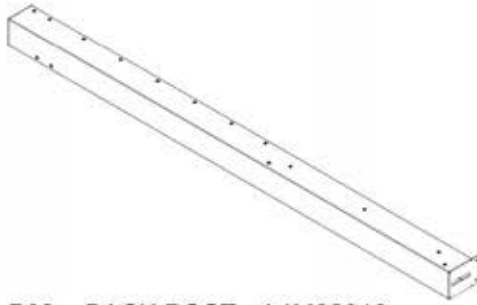

P03 BACK POST - A4M02010  
(x1) 4 3/4"x5 15/16"x88 3/4" (120x151x2254)



A01 BRACKET - A4M02018  
(x1) 1"x1 5/16"x5 1/16" (25x33.2x128)

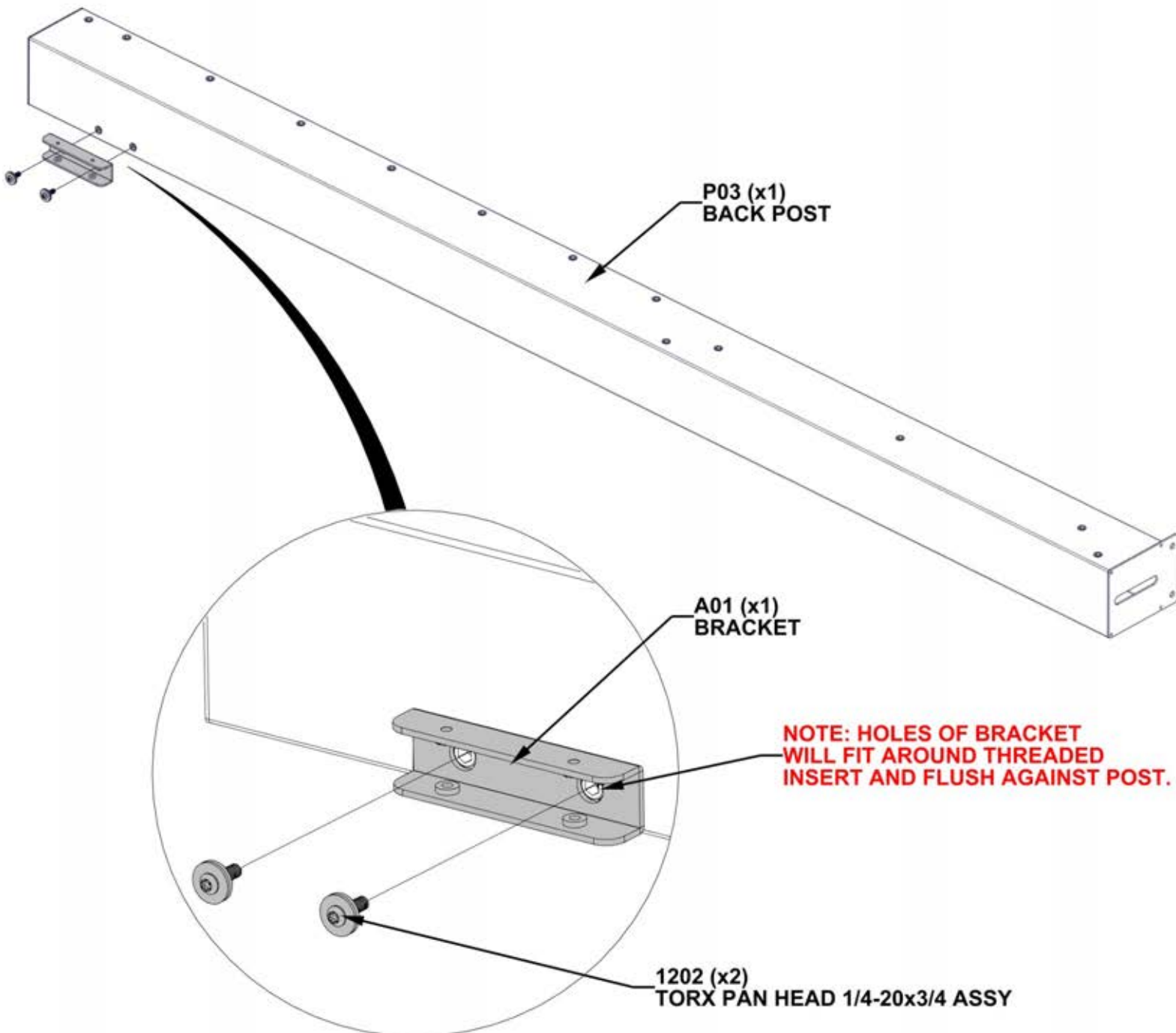

# STEP 18 - POST ASSEMBLY

QTY	PART NUMBER	Description
4	H101202	TORX PAN HEAD 1/4-20x3/4 ASSY

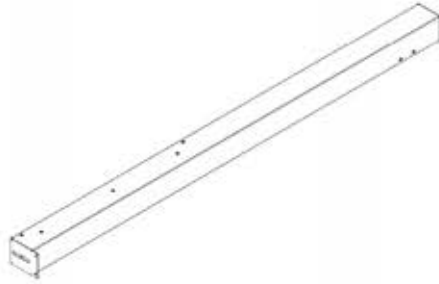

P01 FRONT POST - A4M02008  
(x1) 4 3/4"x5 15/16"x89 1/2" (120x151x2274)



A01 BRACKET - A4M02018  
(x2) 1"x1 5/16"x5 1/16" (25x33.2x128)

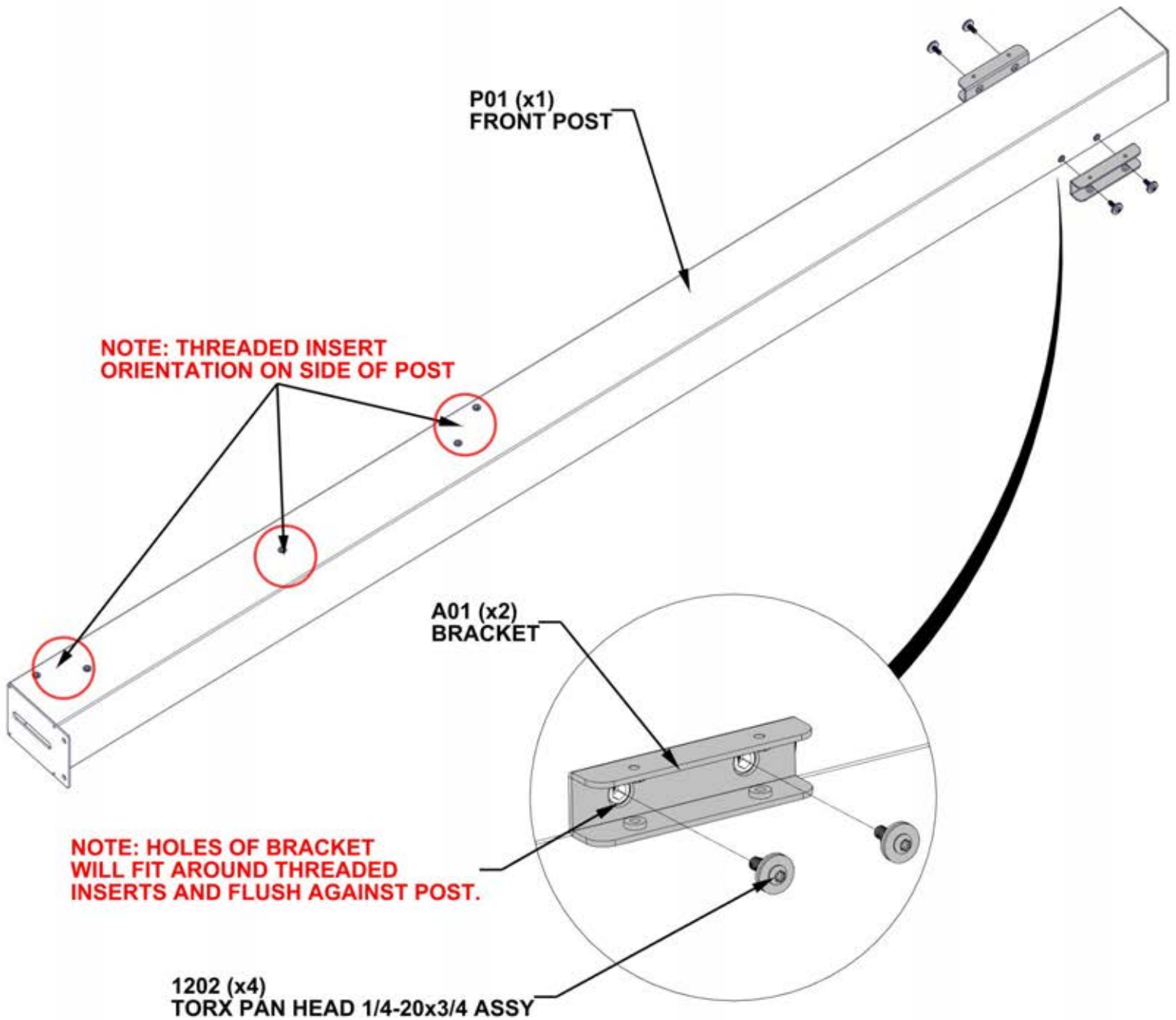

# STEP 19 - POST ASSEMBLY

QTY	PART NUMBER	Description
2	H101202	TORX PAN HEAD 1/4-20x3/4 ASSY

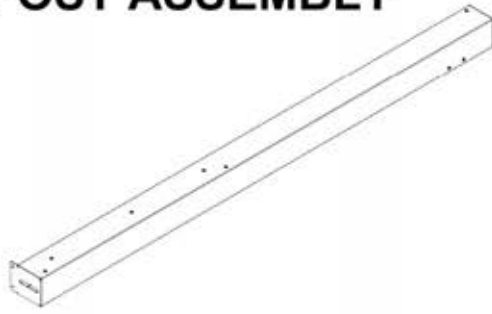

P04 BACK POST - A4M02011  
(x1) 4 3/4"x5 15/16"x88 3/4" (120x151x2254)



A01 BRACKET - A4M02018  
(x1) 1"x1 5/16"x5 1/16" (25x33.2x128)

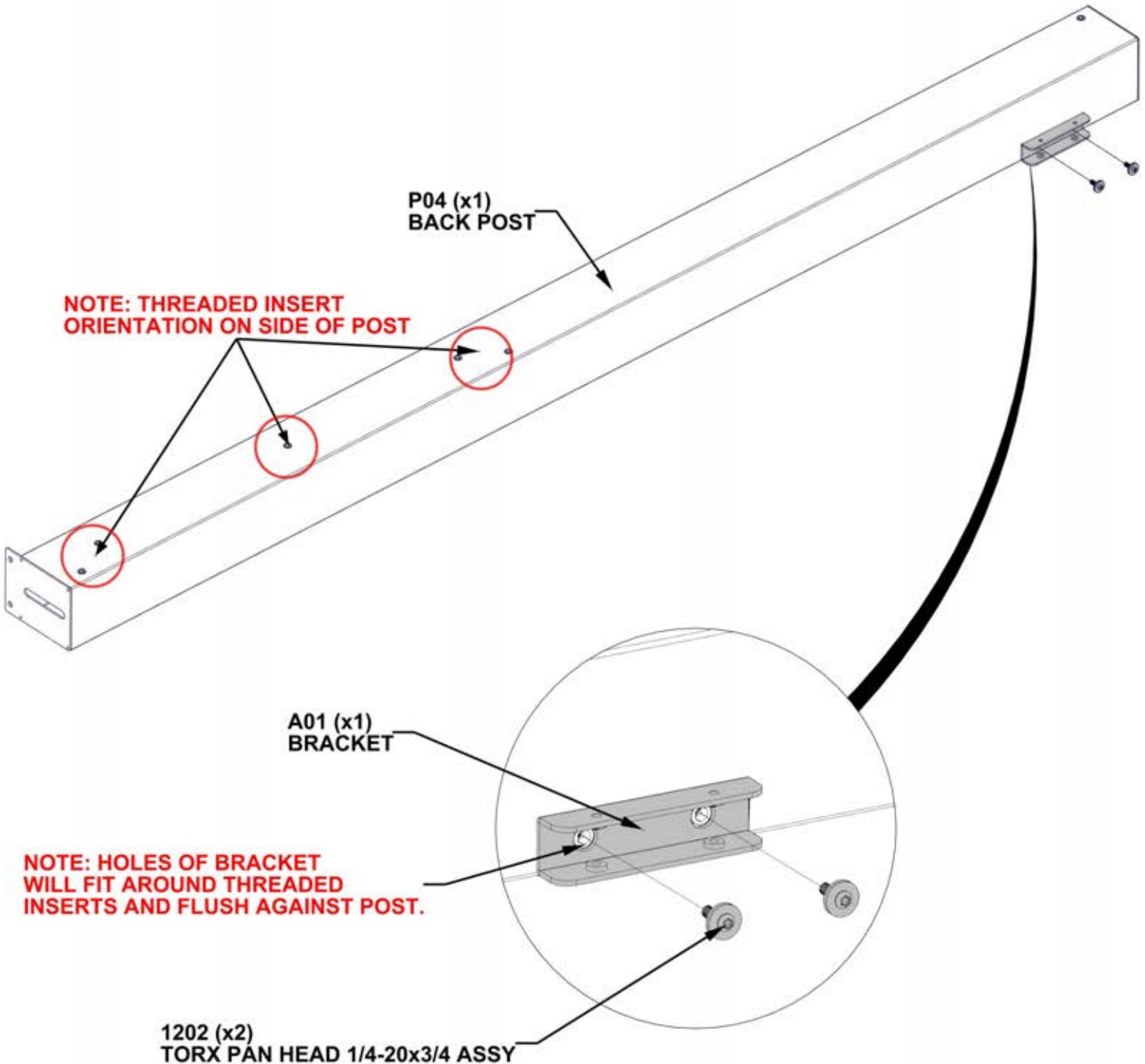

# STEP 20 - KITCHEN ASSEMBLY

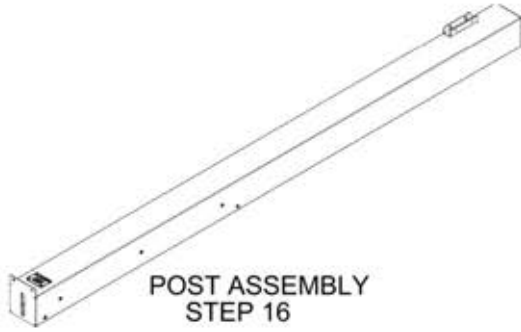

QTY	PART NUMBER	Description
5	H101103	TORX SOCKET SCREW 1/4-20

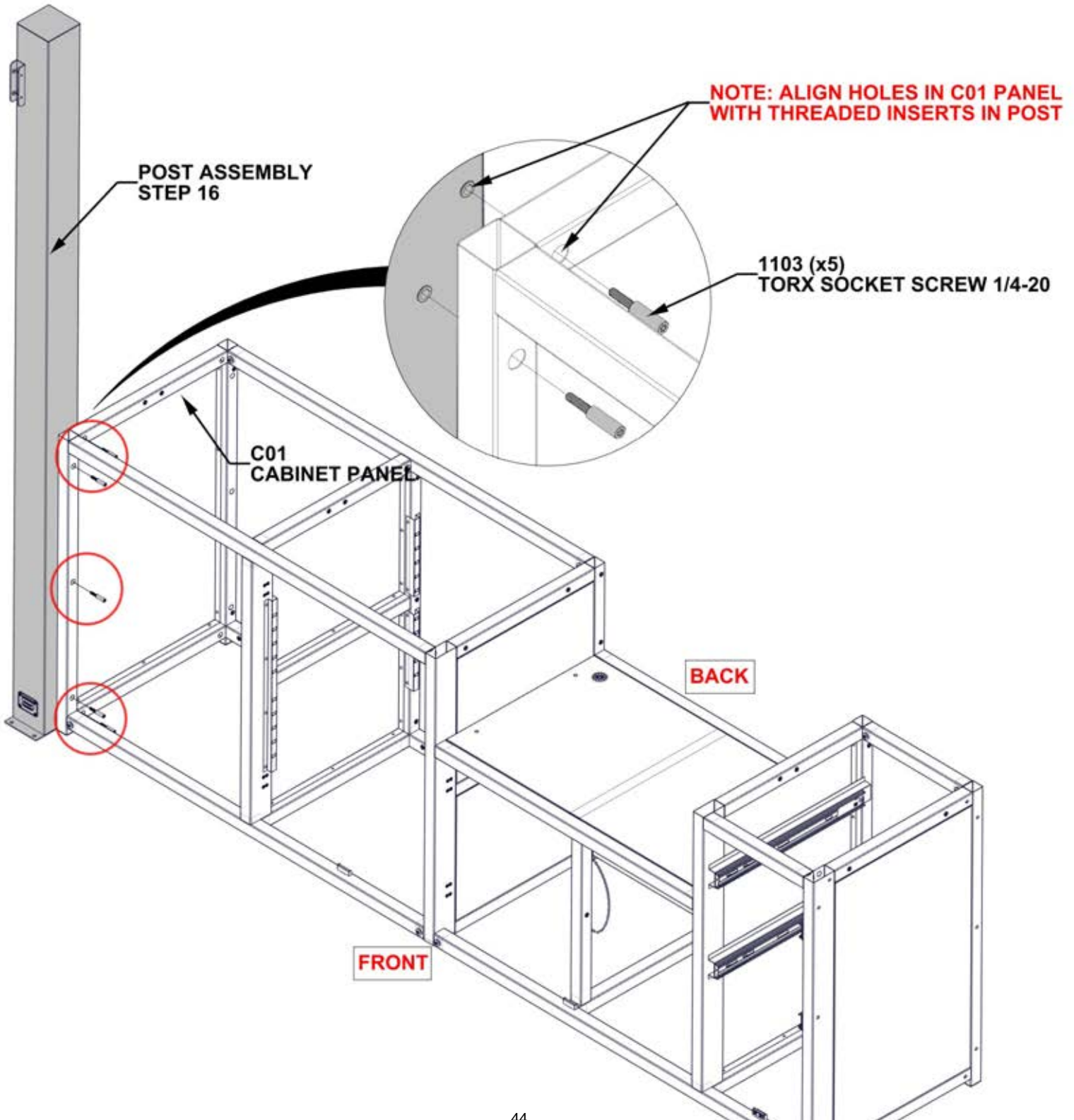

# STEP 21 - KITCHEN ASSEMBLY



B04 SIDE BEAM - A4M02019  
 (x1) 1 7/16"x5 1/4"x18 7/8" (36x134x480)

QTY	PART NUMBER	Description
2	H101202	TORX PAN HEAD 1/4-20x3/4 ASSY

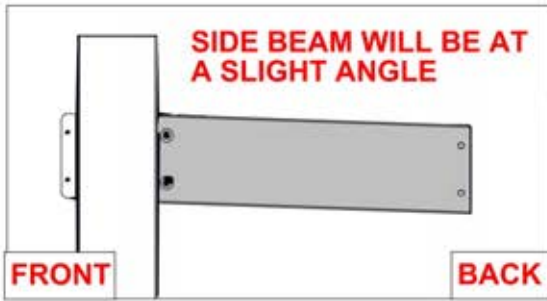

**SLIDE BEAM ON TO POST BRACKET**

**B04 (x1)  
SIDE BEAM**

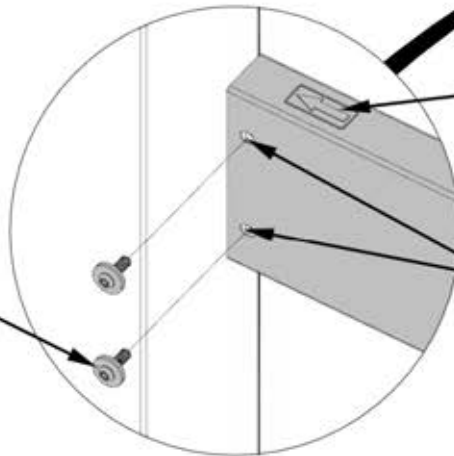

**NOTE: ARROW ON TOP OF SIDE BEAM TOWARDS FRONT**

**NOTE: ALIGN HOLES IN B04 BEAM WITH THREADED HOLES IN POST BRACKET**

**1202 (x2)  
TORX PAN HEAD  
1/4-20x3/4 ASSY**

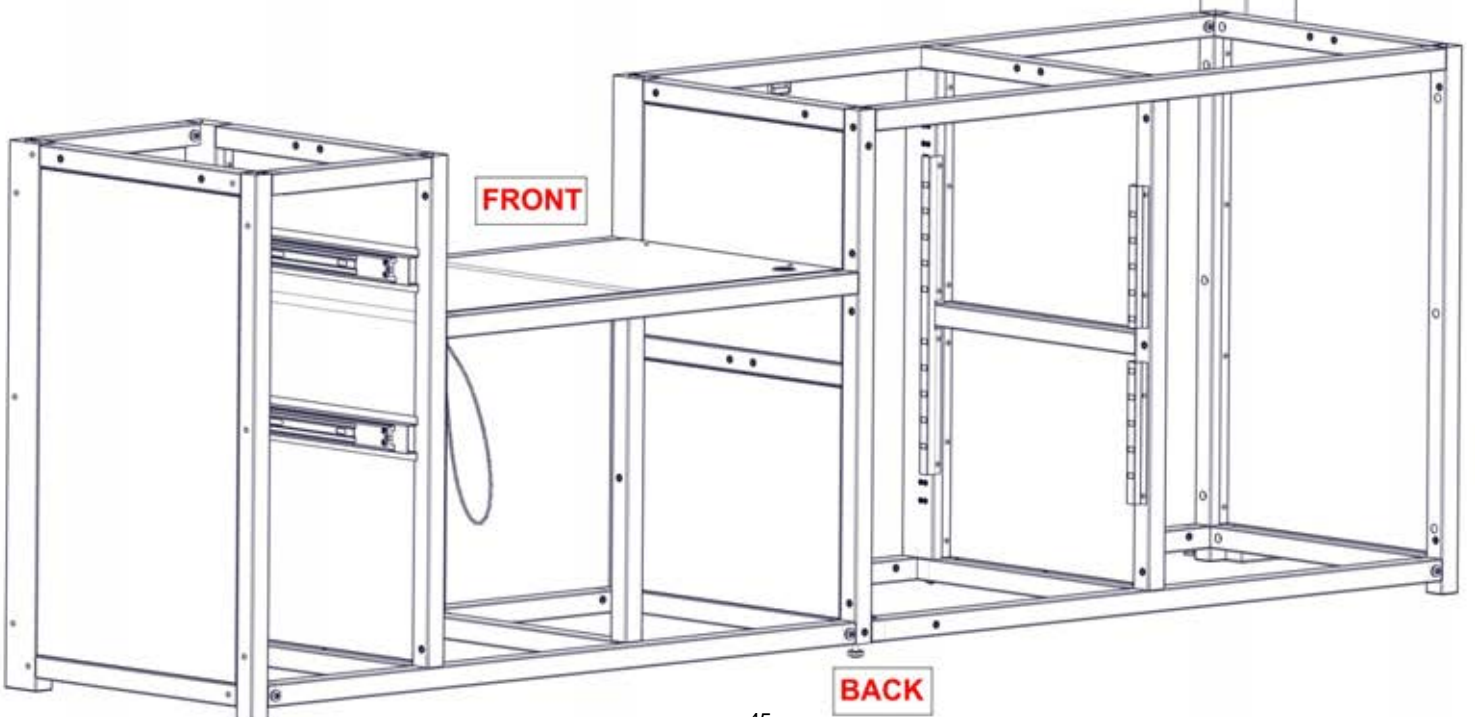

# STEP 22 - KITCHEN ASSEMBLY

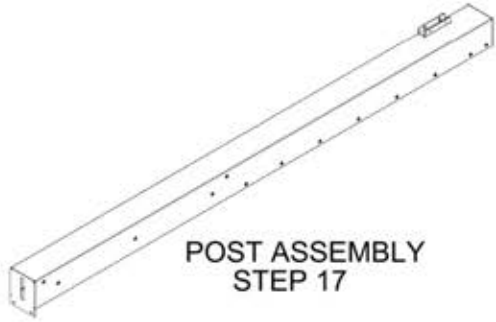

QTY	PART NUMBER	Description
5	H101103	TORX SOCKET SCREW 1/4-20
2	H101202	TORX PAN HEAD 1/4-20x3/4 ASSY

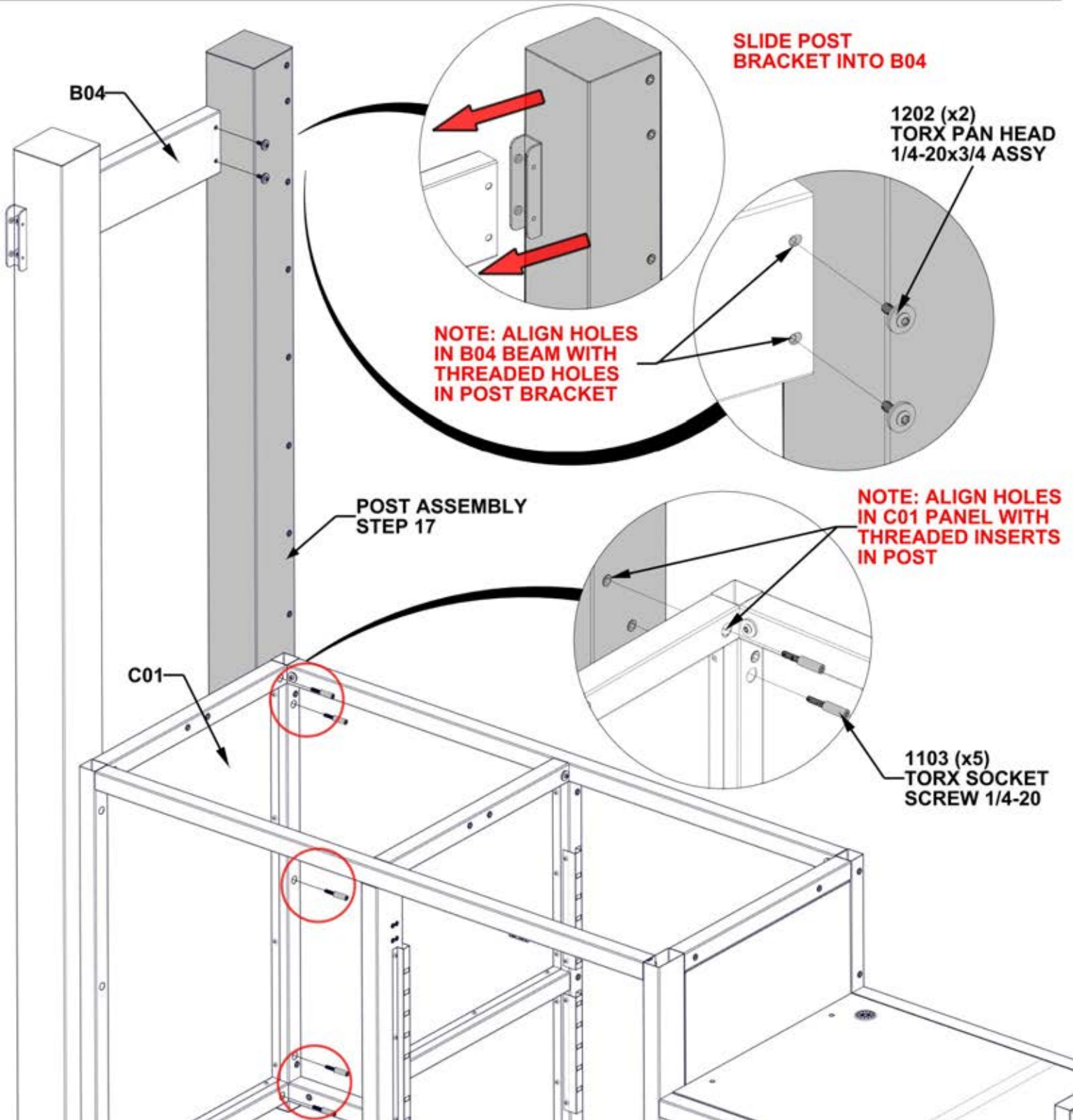

# STEP 23 - KITCHEN ASSEMBLY

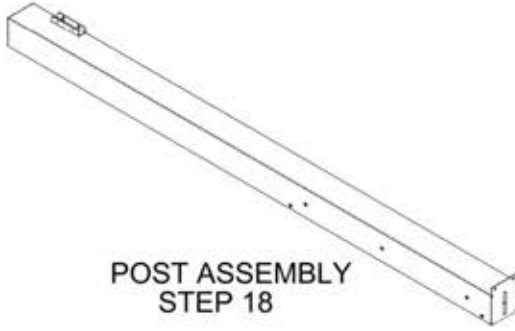

QTY	PART NUMBER	Description
5	H101103	TORX SOCKET SCREW 1/4-20

POST ASSEMBLY  
STEP 18

**NOTE: ALIGN HOLES IN C06 PANEL WITH THREADED INSERTS IN POST**

1103 (x5)  
TORX SOCKET SCREW 1/4-20

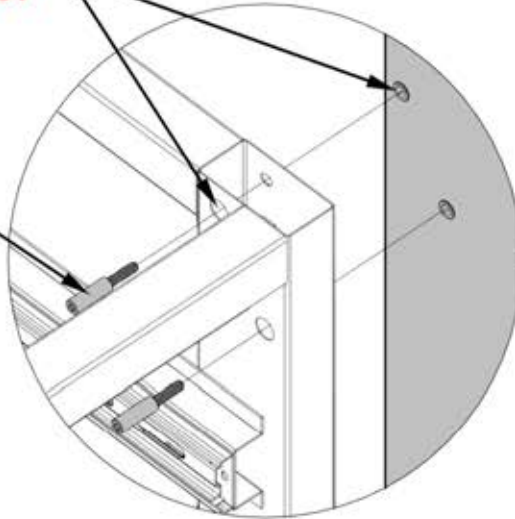

POST ASSEMBLY  
STEP 18

C06

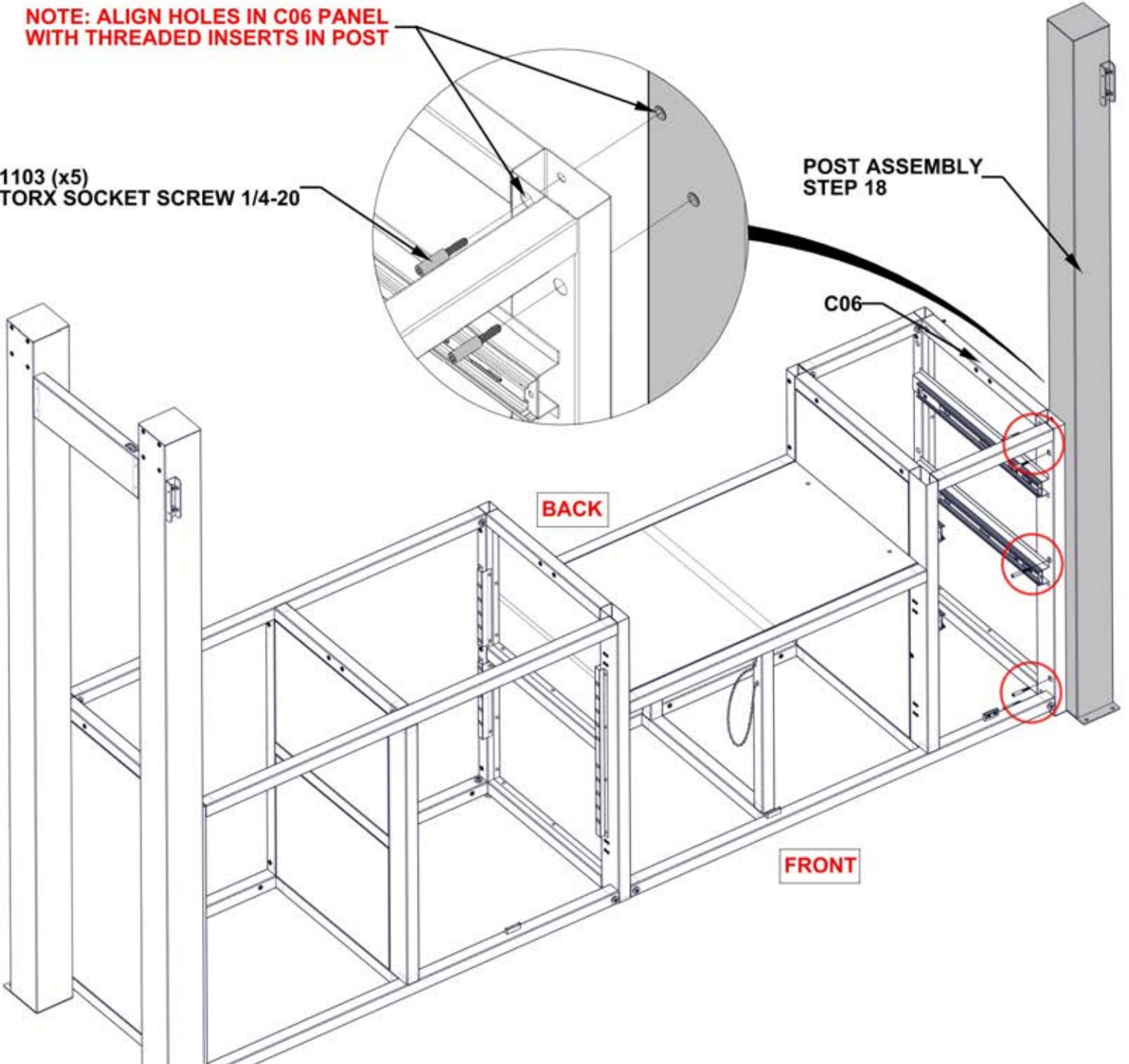

# STEP 24 - KITCHEN ASSEMBLY



B11 SIDE BEAM - A4M02106  
 (x1) 1 7/16"x5 1/4"x18 7/8" (36x134x480)

QTY	PART NUMBER	Description
2	H101202	TORX PAN HEAD 1/4-20x3/4 ASSY

**SLIDE BEAM ON TO POST BRACKET**

**SIDE BEAM WILL BE AT A SLIGHT ANGLE**

B11 (x1)  
SIDE BEAM

BACK

FRONT

**NOTE: ARROW ON TOP OF SIDE BEAM TOWARDS FRONT**

**NOTE: ALIGN HOLES IN B11 BEAM WITH THREADED HOLES IN POST BRACKET**

1202 (x2)  
TORX PAN HEAD  
1/4-20x3/4 ASSY

FRONT

BACK



# STEP 25 - KITCHEN ASSEMBLY

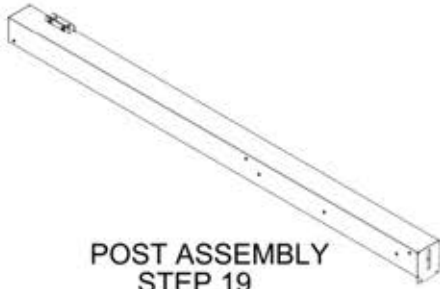

QTY	PART NUMBER	Description
5	H101103	TORX SOCKET SCREW 1/4-20
2	H101202	TORX PAN HEAD 1/4-20x3/4 ASSY

1202 (x2)  
TORX PAN HEAD  
1/4-20x3/4 ASSY

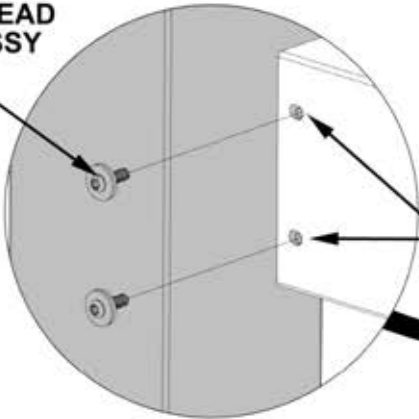

**NOTE: ALIGN HOLES  
IN B11 BEAM WITH  
THREADED HOLES  
IN POST BRACKET**

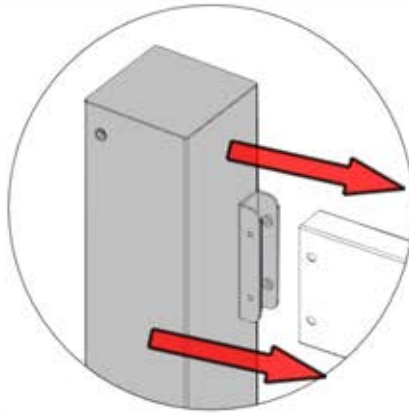

**SLIDE POST  
BRACKET INTO B11**

B11

**NOTE: ALIGN HOLES  
IN C06 PANEL WITH  
THREADED INSERTS  
IN POST**

1103 (x5)  
TORX SOCKET  
SCREW 1/4-20

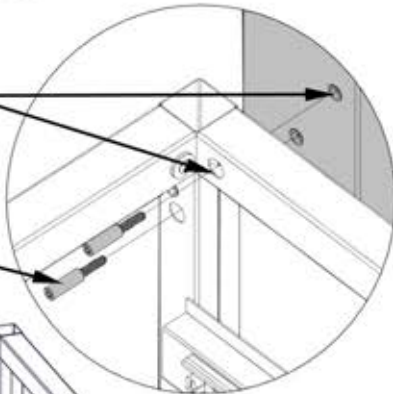

POST ASSEMBLY  
STEP 19

C06

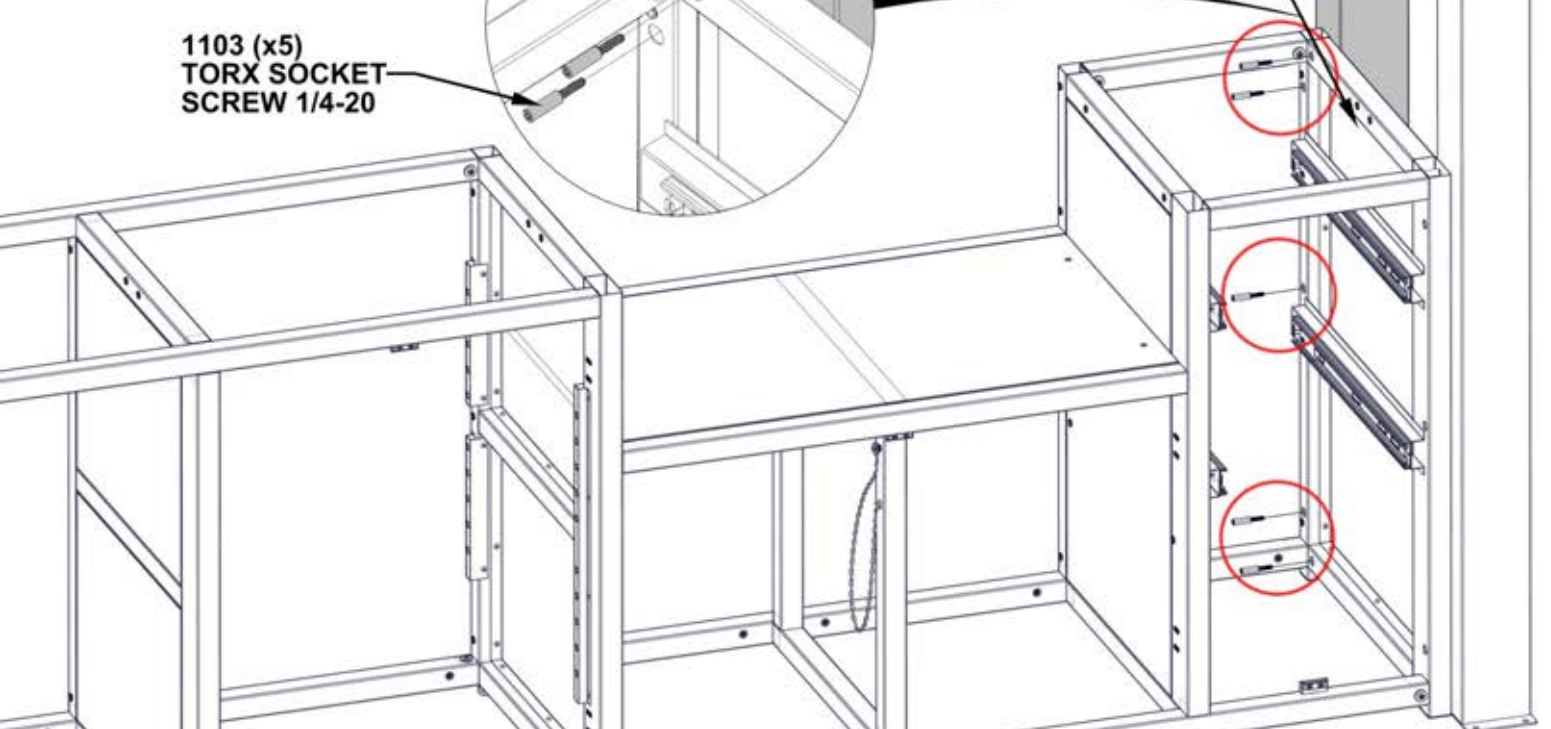

# STEP 26 - KITCHEN ASSEMBLY

QTY	PART NUMBER	Description
20	H101132	TORX SOCKET SCREW 1/4-20

**INSTALL TORX SOCKET SCREWS INTO  
THREADED INSERT IN BOTTOM FLOOR RAILS**

**NOTE: THREADED INSERT  
IN BOTTOM RAILS**

1132 (x20)  
TORX SOCKET SCREW 1/4-20

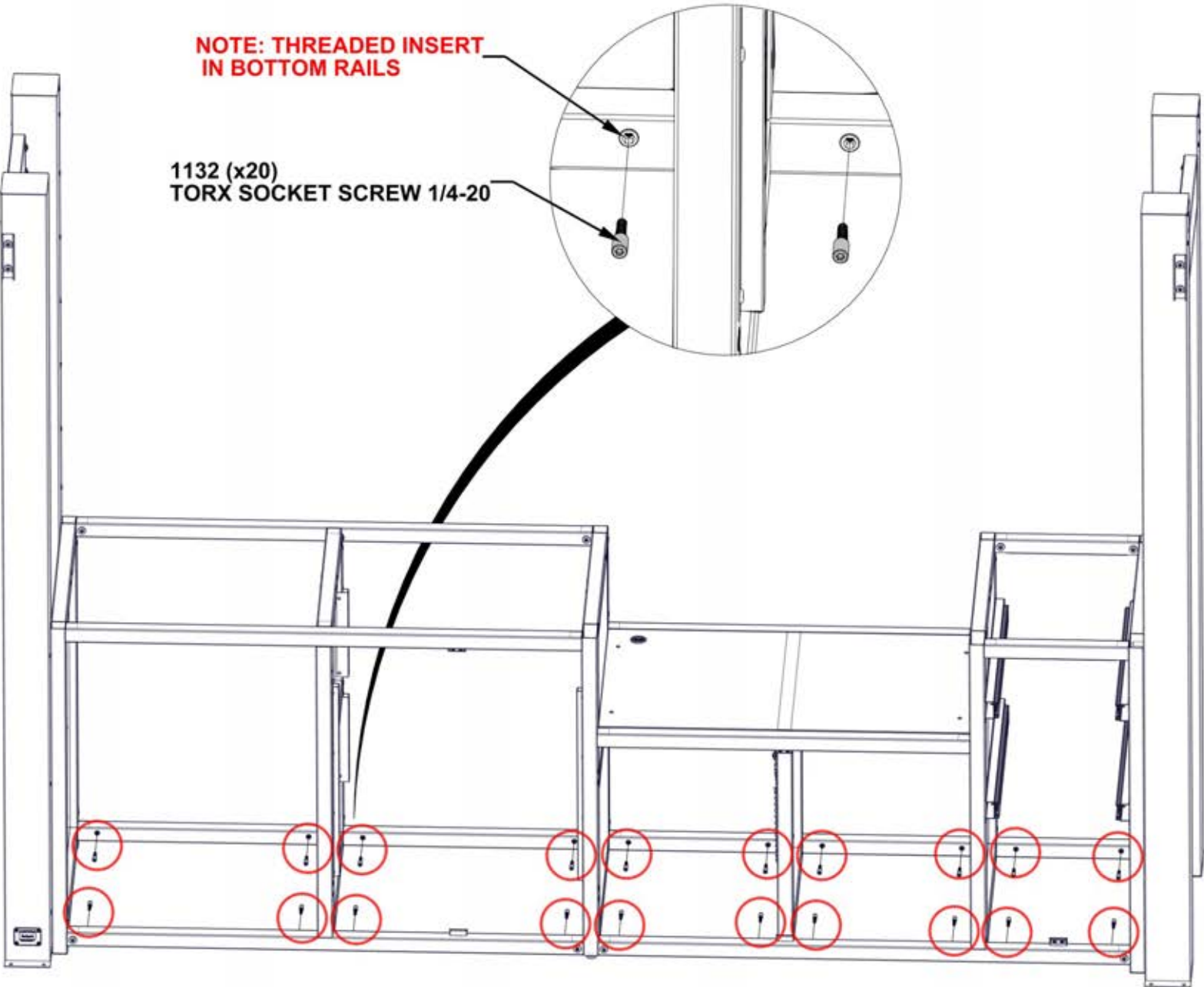

# STEP 27 - KITCHEN ASSEMBLY

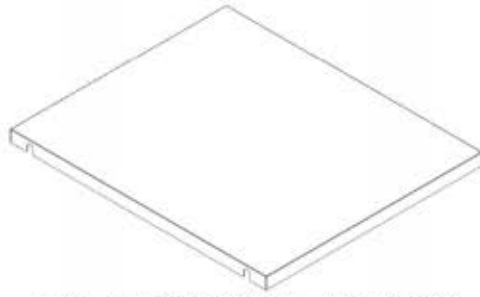

F03 FLOOR PANEL - A4M02202  
(x2) 1 3/16"x21 3/4"x25 13/16" (30x553x655)

**INSTALL FLOOR PANEL FROM INSIDE OF CABINET. MAKE SURE FINGERS ARE CLEAR, AS FLOOR PANEL DROP IN PLACE**

**NOTE: SLOTS IN FLOOR PANEL WILL SIT AROUND SOCKET SCREWS FROM STEP 26**

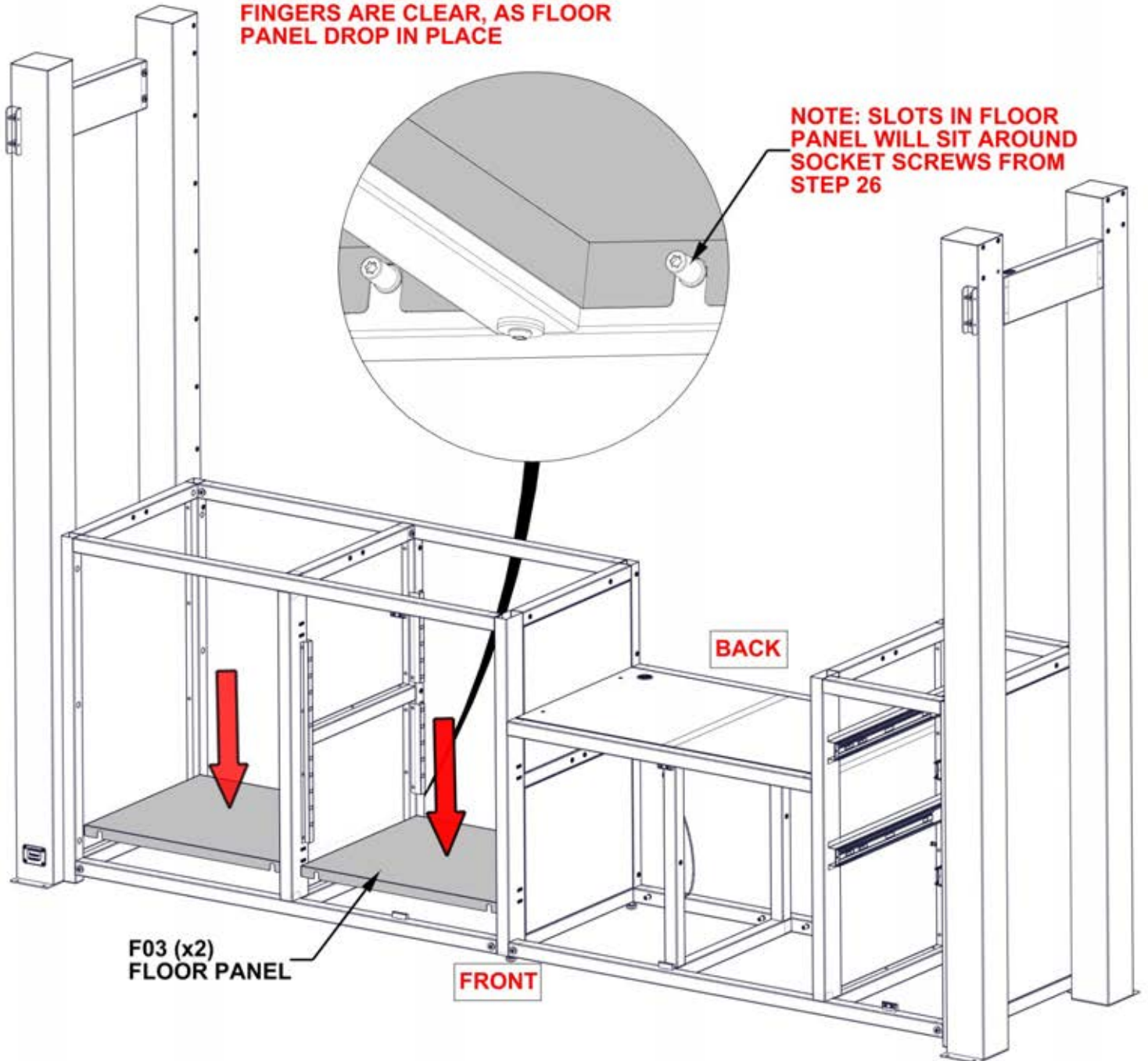

# STEP 28A - KITCHEN ASSEMBLY

QTY	PART NUMBER	Description
4	H101202	TORX PAN HEAD 1/4-20x3/4 ASSY

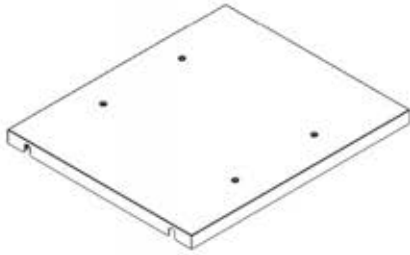

F12 FLOOR PANEL FOR PROPANE TANK - A4M02173  
(x1) 1 3/16"x18 3/8"x21 3/4" (30x466.5x553)

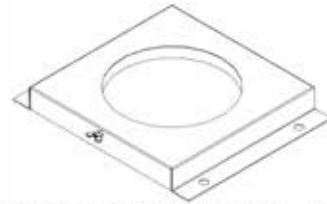

A12 PROPANE TANK HOLDER - A4M02028  
(x1) 1 5/8"x11 13/16"x14 9/16" (41x300x370)

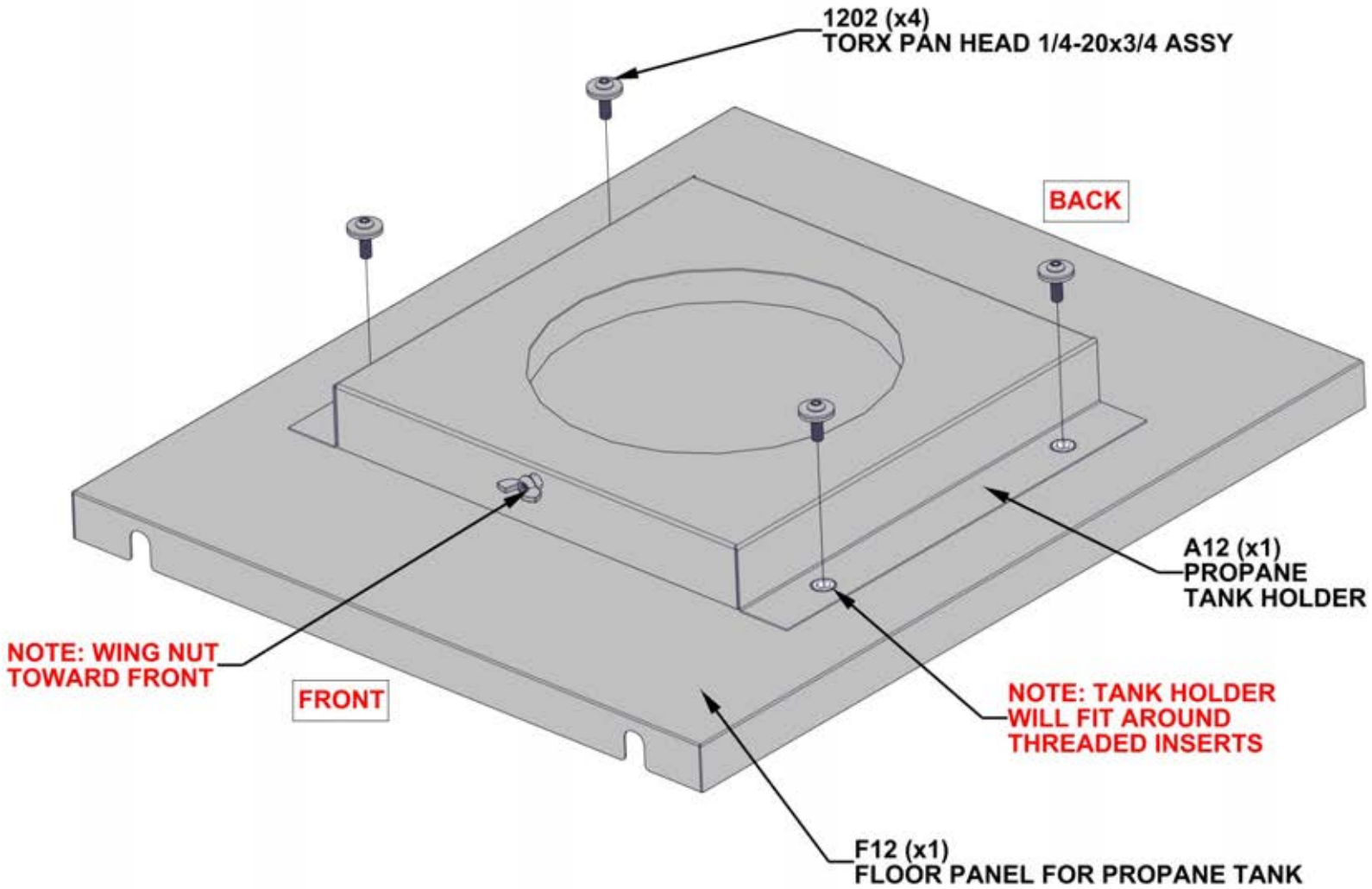

# STEP 28B - KITCHEN ASSEMBLY

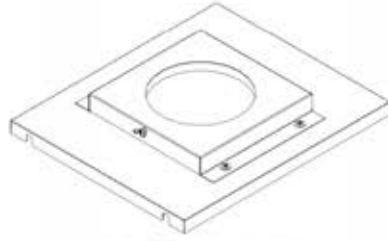

FLOOR PANEL  
WITH TANK HOLDER  
STEP 28A

**INSTALL FLOOR PANEL FROM  
INSIDE OF CABINET. MAKE SURE  
FINGERS ARE CLEAR, AS FLOOR  
PANEL DROP IN PLACE**

**NOTE: SLOTS IN FLOOR  
PANEL WILL SIT AROUND  
SOCKET SCREWS FROM  
STEP 26**

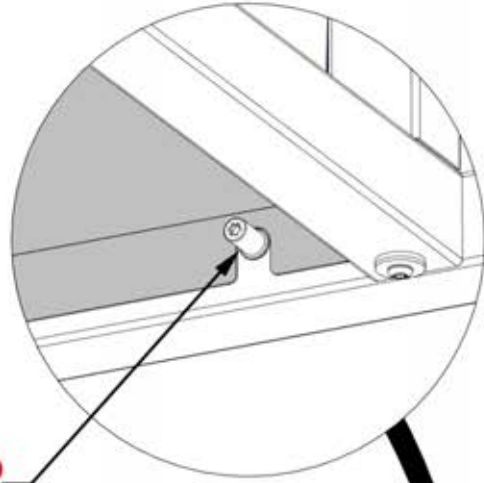

**BACK**

**FRONT**

FLOOR PANEL  
WITH TANK HOLDER  
STEP 28A

# STEP 29 - KITCHEN ASSEMBLY

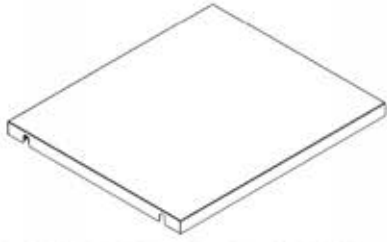

F10 FLOOR PANEL - A4M02208  
(x1) 1 3/16"x18 3/8"x21 3/4" (30x467x553)

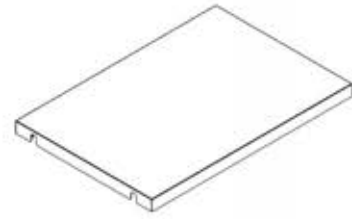

F11 FLOOR PANEL - A4M02209  
(x1) 1 3/16"x14 13/16"x21 3/4" (30x376x553)

**INSTALL FLOOR PANEL FROM INSIDE OF CABINET. MAKE SURE FINGERS ARE CLEAR, AS FLOOR PANEL DROP IN PLACE**

**NOTE: SLOTS IN FLOOR PANEL WILL SIT AROUND SOCKET SCREWS FROM STEP 26**

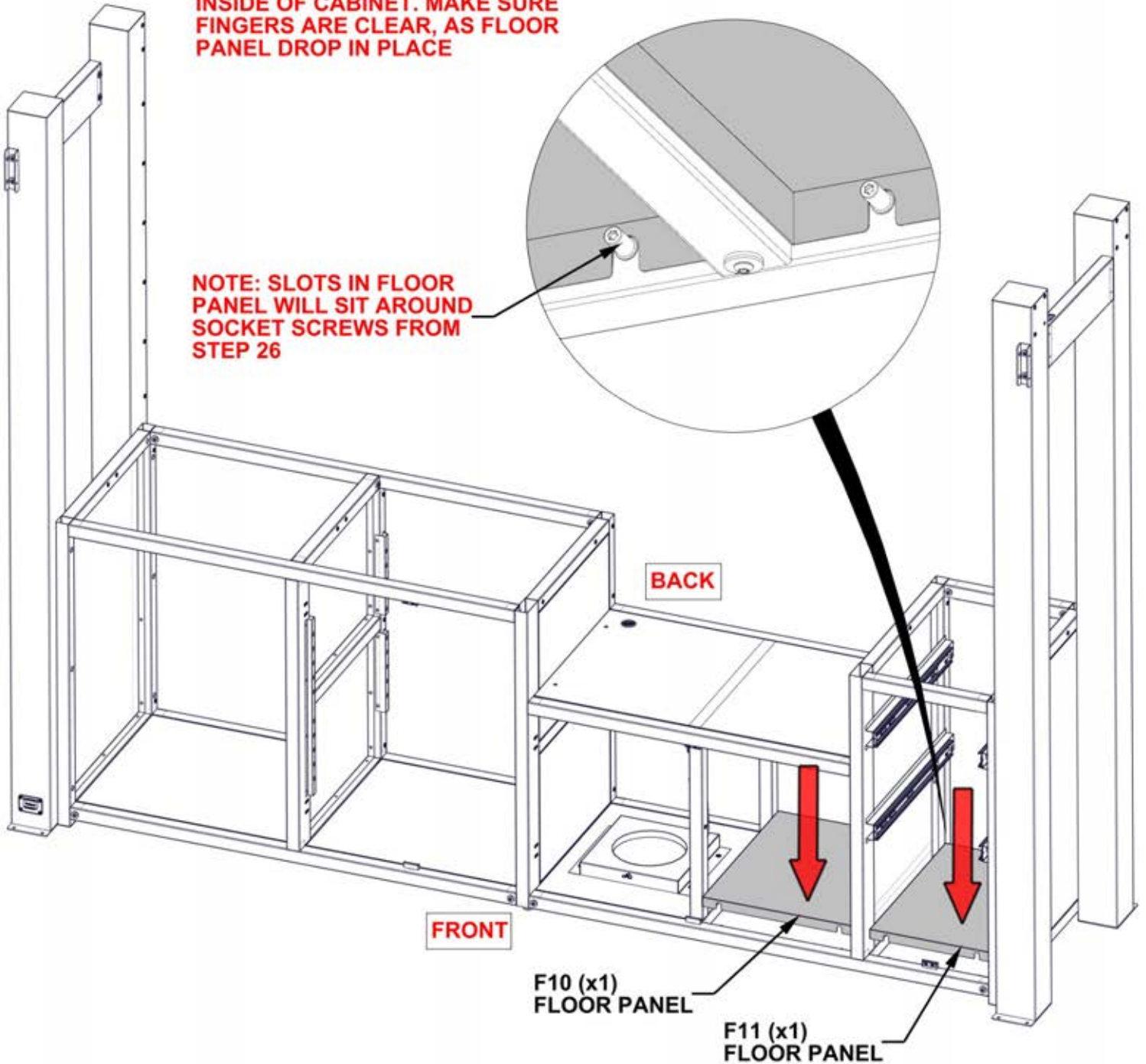
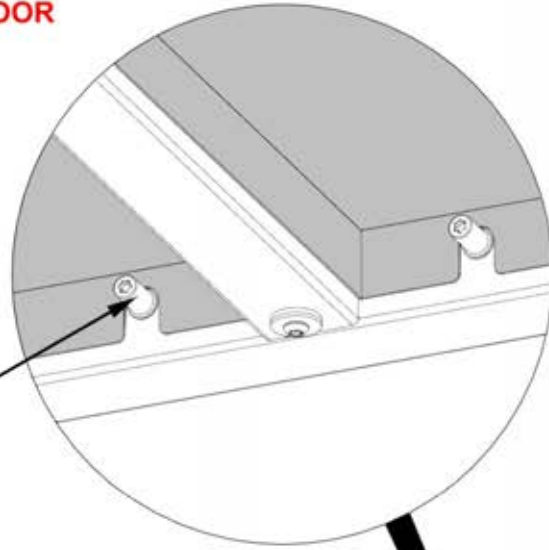

# STEP 30 - KITCHEN ASSEMBLY

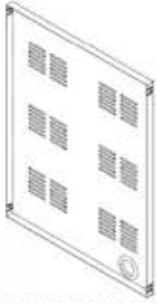

QTY	PART NUMBER	Description
4	H101202	TORX PAN HEAD 1/4-20x3/4 ASSY

BP05 BACK PANEL - A4M02055  
(x1) 1 3/16"x25 13/16"x33 13/16" (30x656x859)

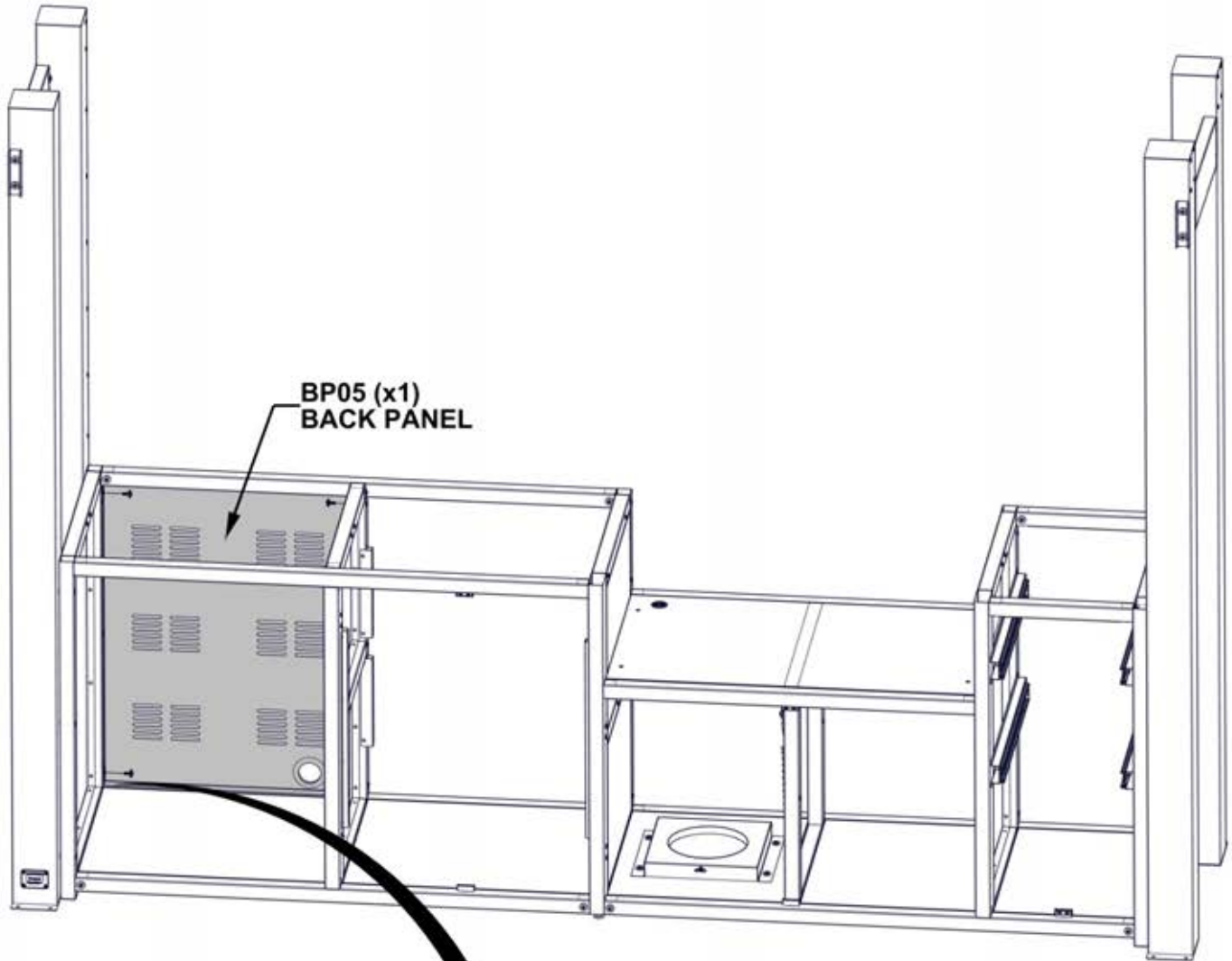

**NOTE: PANEL WILL FIT  
AROUND THREADED INSERT**

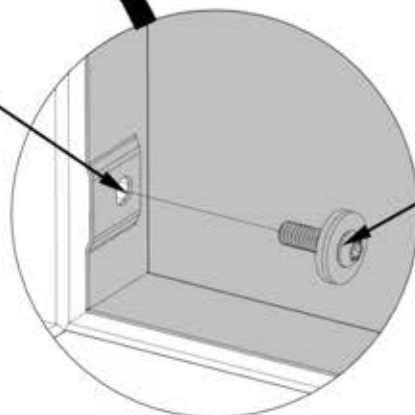

**1202 (x4)  
TORX PAN HEAD 1/4-20x3/4 ASSY**

# STEP 31 - KITCHEN ASSEMBLY



QTY	PART NUMBER	Description
6	H101202	TORX PAN HEAD 1/4-20x3/4 ASSY

BP04 BACK PANEL - A4M02054  
 (x1) 1 3/16"x25 13/16"x33 7/8" (30x656x860)

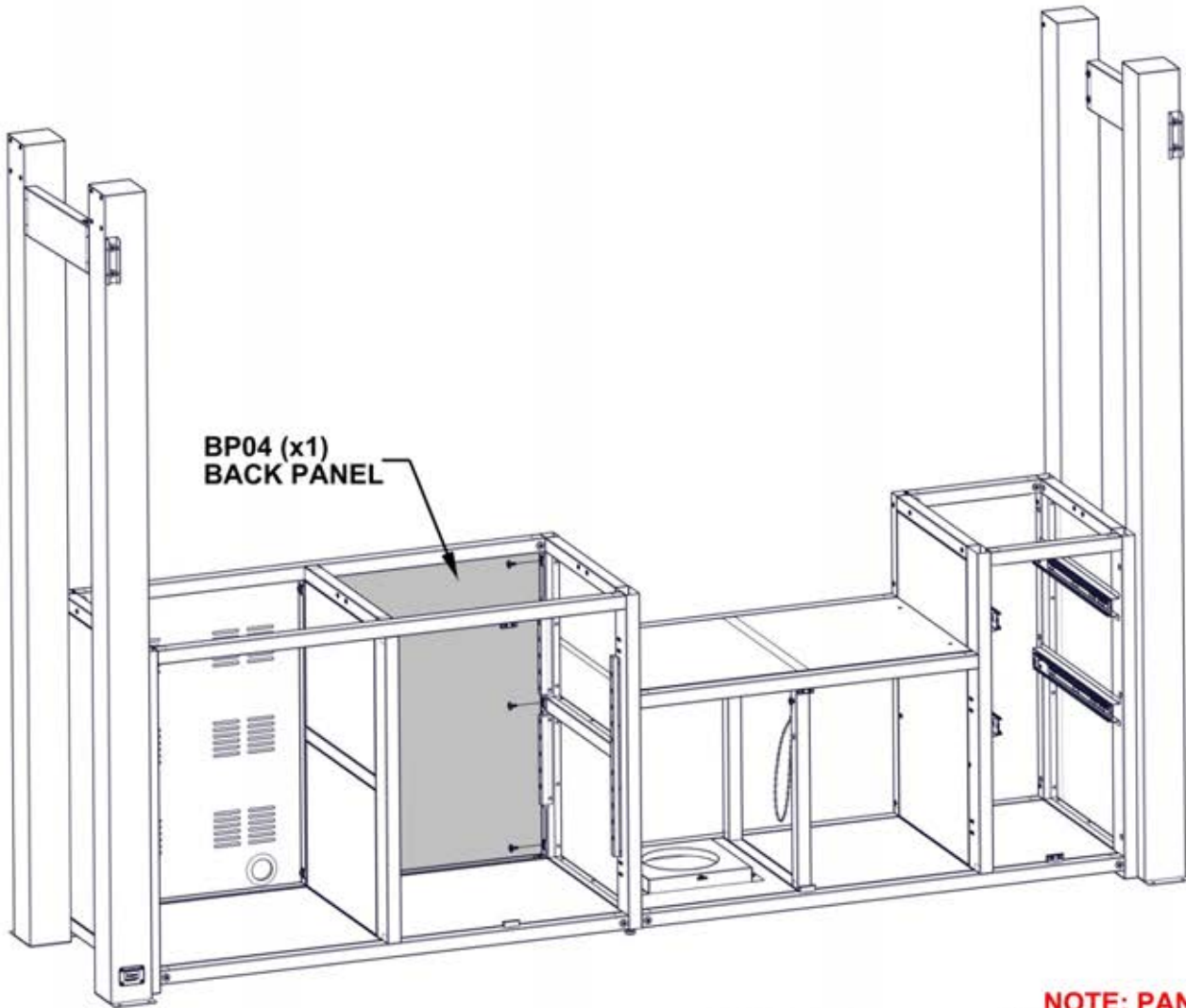

1202 (x6)  
 TORX PAN HEAD 1/4-20x3/4 ASSY

**NOTE: PANEL WILL FIT  
 AROUND THREADED INSERT**

**NOTE: ORIENTATION OF PANEL  
 NOTCH IN CORNER WILL FIT  
 AROUND BOLT CONNECTION**

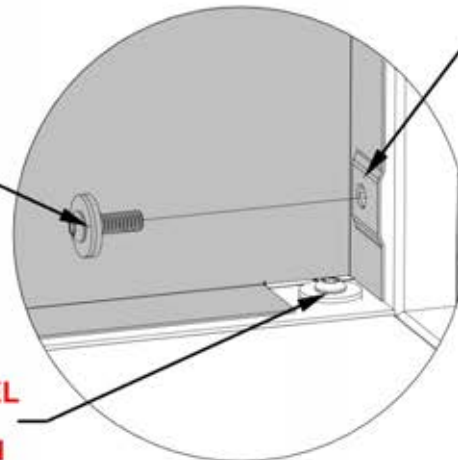



# STEP 32 - KITCHEN ASSEMBLY

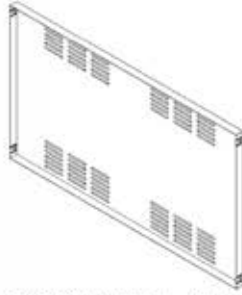

QTY	PART NUMBER	Description
4	H101202	TORX PAN HEAD 1/4-20x3/4 ASSY

BP02 BACK PANEL - A4M02052  
 (x1) 1 3/16"x22 5/8"x38 7/16" (30x575x976)

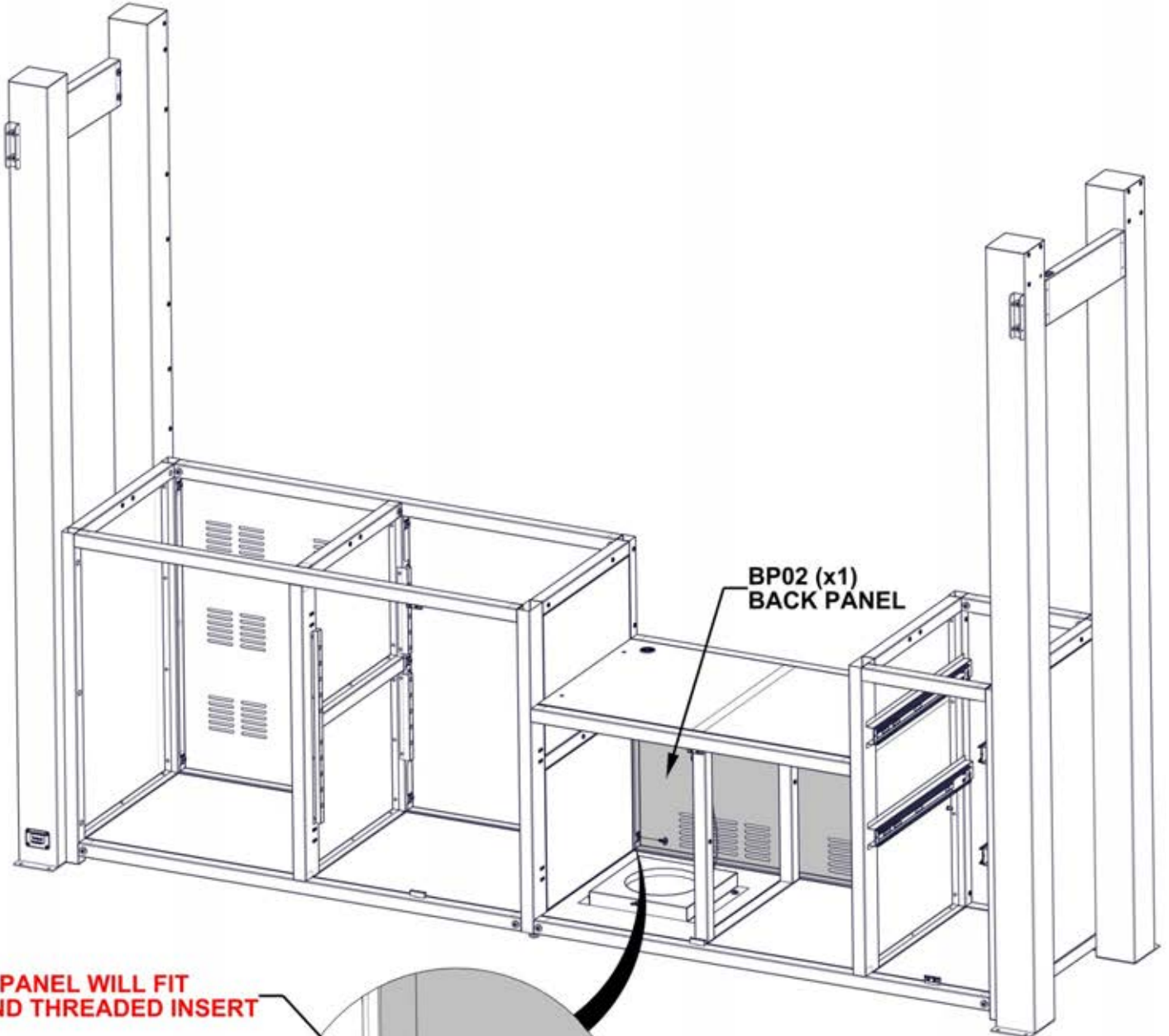

**NOTE: PANEL WILL FIT AROUND THREADED INSERT**

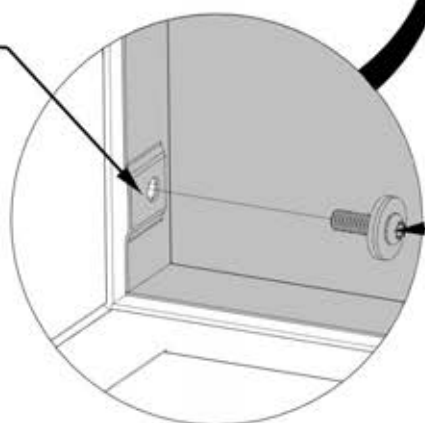

1202 (x4)  
 TORX PAN HEAD 1/4-20x3/4 ASSY

# STEP 33 - KITCHEN ASSEMBLY

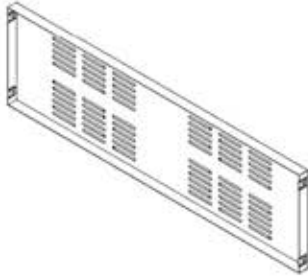

QTY	PART NUMBER	Description
4	H101202	TORX PAN HEAD 1/4-20x3/4 ASSY

BP03 BACK PANEL - A4M02053  
(x1) 1 3/16"x11 3/16"x38 3/8" (30x284x975)

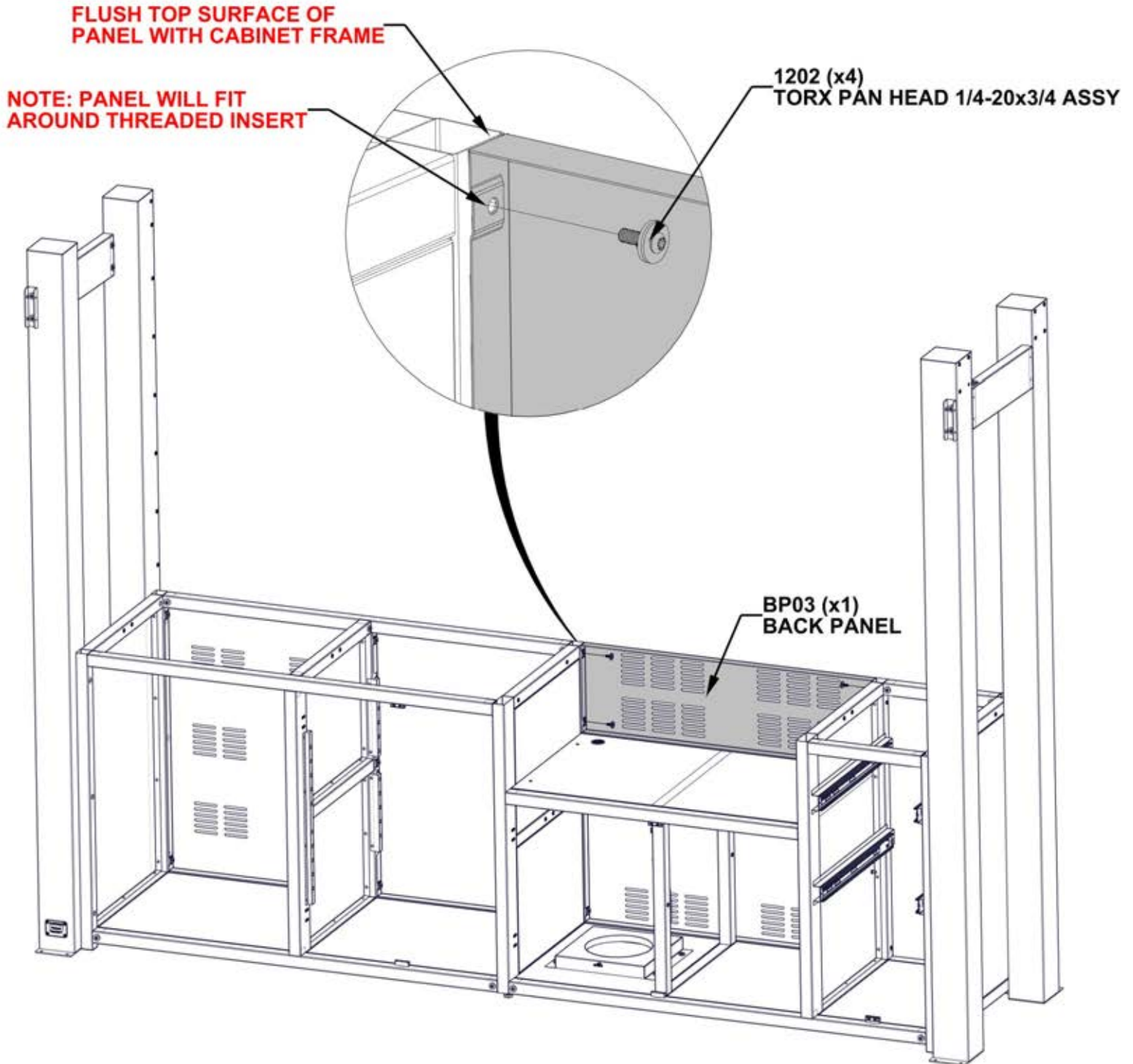

# STEP 34 - KITCHEN ASSEMBLY



QTY	PART NUMBER	Description
4	H101202	TORX PAN HEAD 1/4-20x3/4 ASSY

BP01 BACK PANEL - A4M02051  
(x1) 1 3/16"x14 13/16"x33 13/16" (30x377x859)

**NOTE: PANEL WILL FIT  
AROUND THREADED INSERT**

1202 (x4)  
TORX PAN HEAD 1/4-20x3/4 ASSY

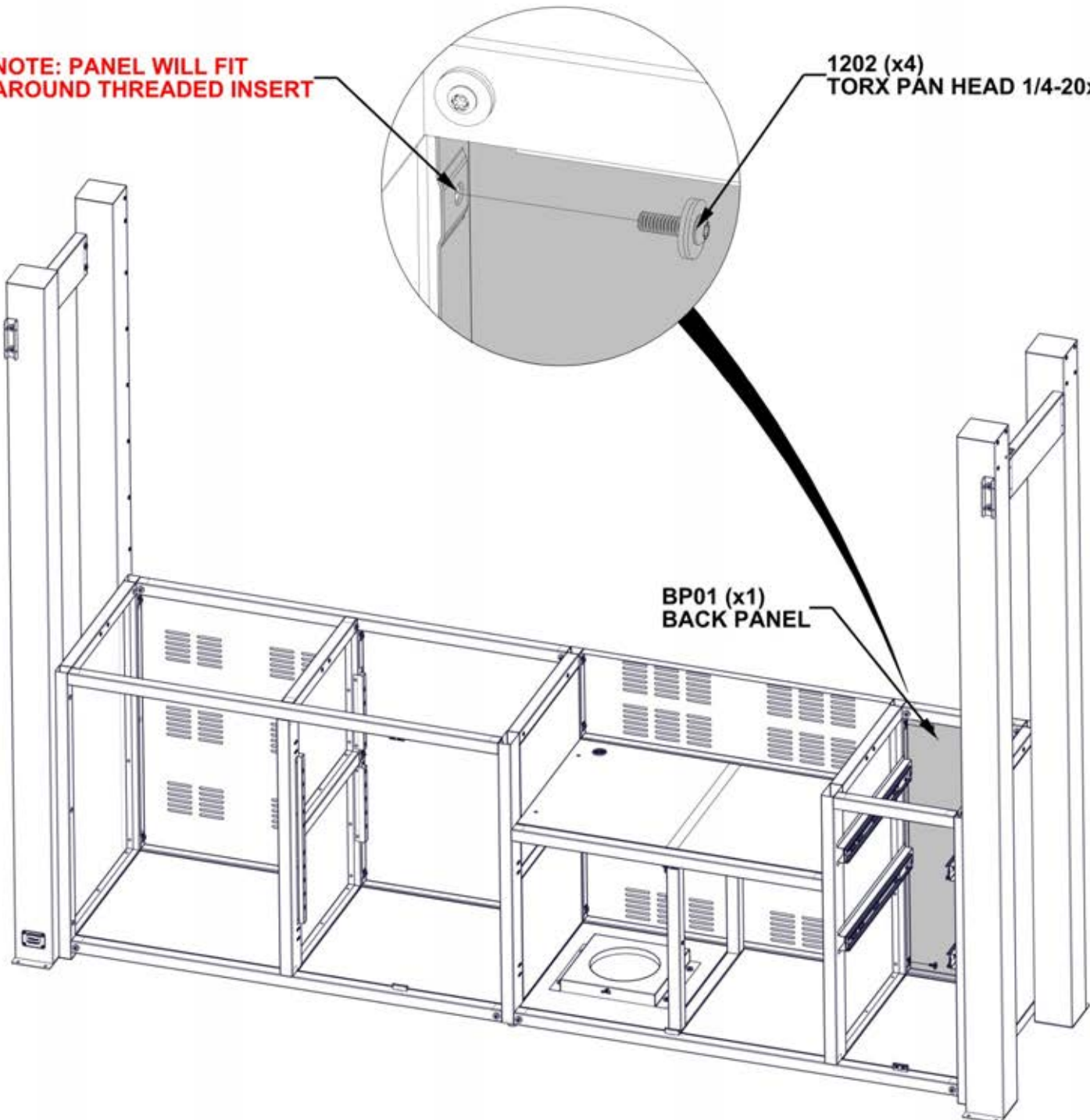

BP01 (x1)  
BACK PANEL

# STEP 35 - KITCHEN ASSEMBLY

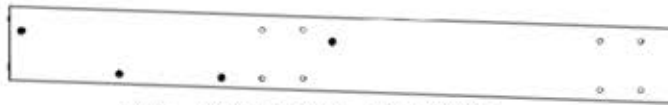

B01 SIDE BEAM - A4M02012  
 (x1) 36x5 1/4"x46 1/2" (36x134x1181)

QTY	PART NUMBER	Description
8	H101103	TORX SOCKET SCREW 1/4-20

**DO NOT TIGHTEN HARDWARE AT THIS STEP**

**NOTE: SIDE BEAM WILL BE AT A SLIGHT ANGLE**

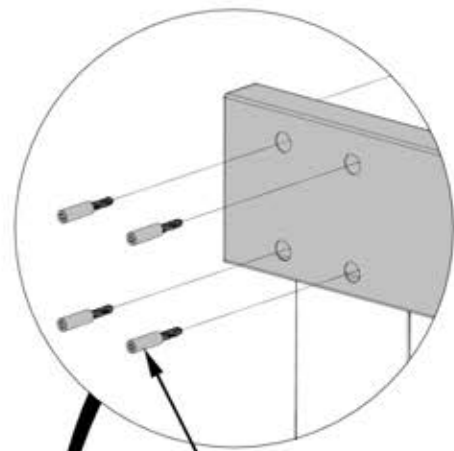

1103 (x8)  
 TORX SOCKET  
 SCREW 1/4-20

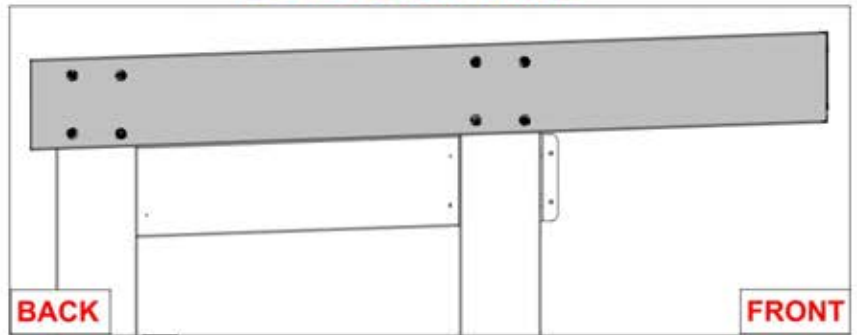

B01 (x1)  
 SIDE BEAM

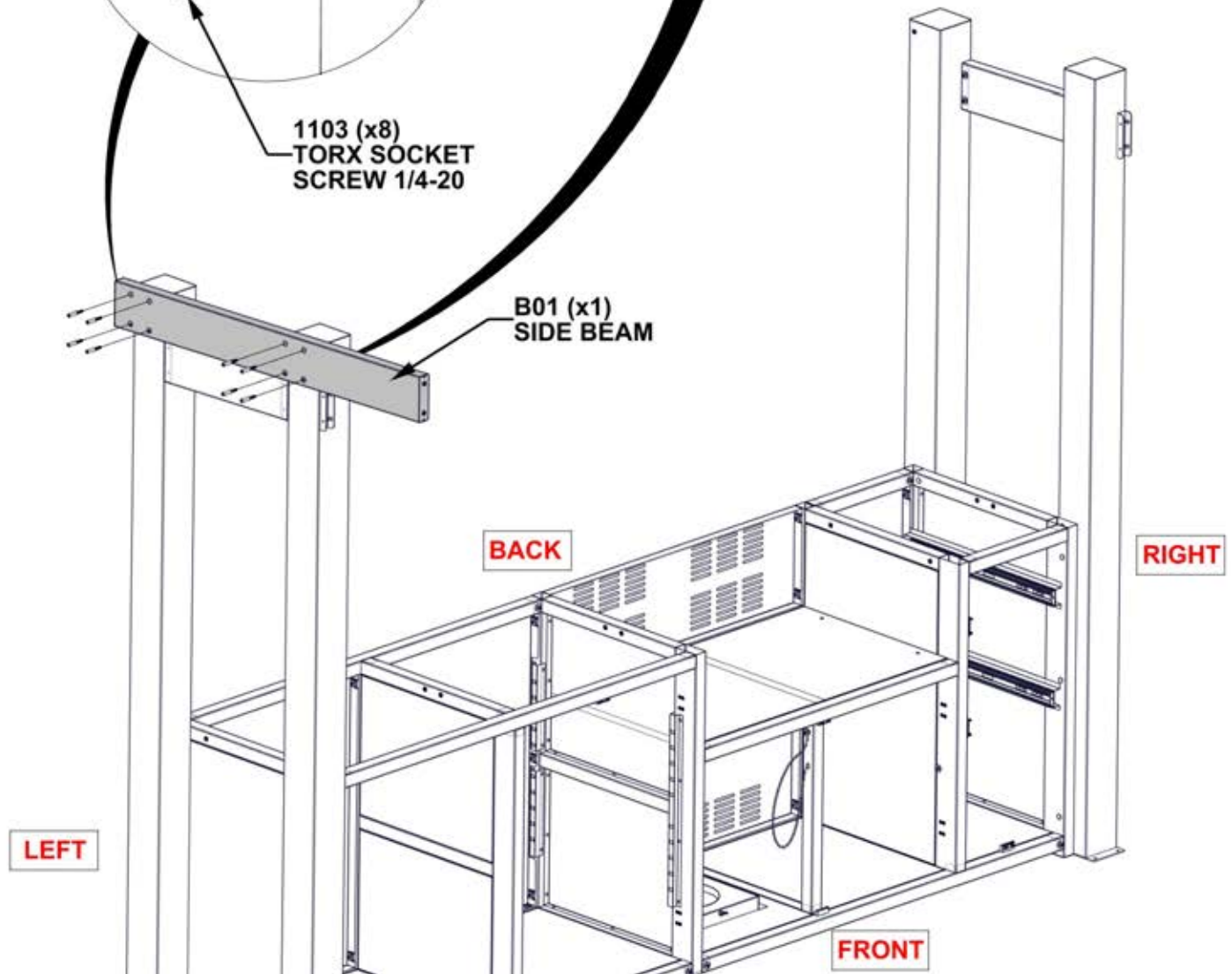

# STEP 36A - KITCHEN ASSEMBLY



B09 CORBEL - A4M02042  
(x1) 1 7/16"x6 11/16"x11 1/8" (36x170x282)

**NOTE: CORBEL BRACKET SLOTS  
WILL FIT AROUND THREADED  
INSERTS AND FLUSH AGAINST BEAM**

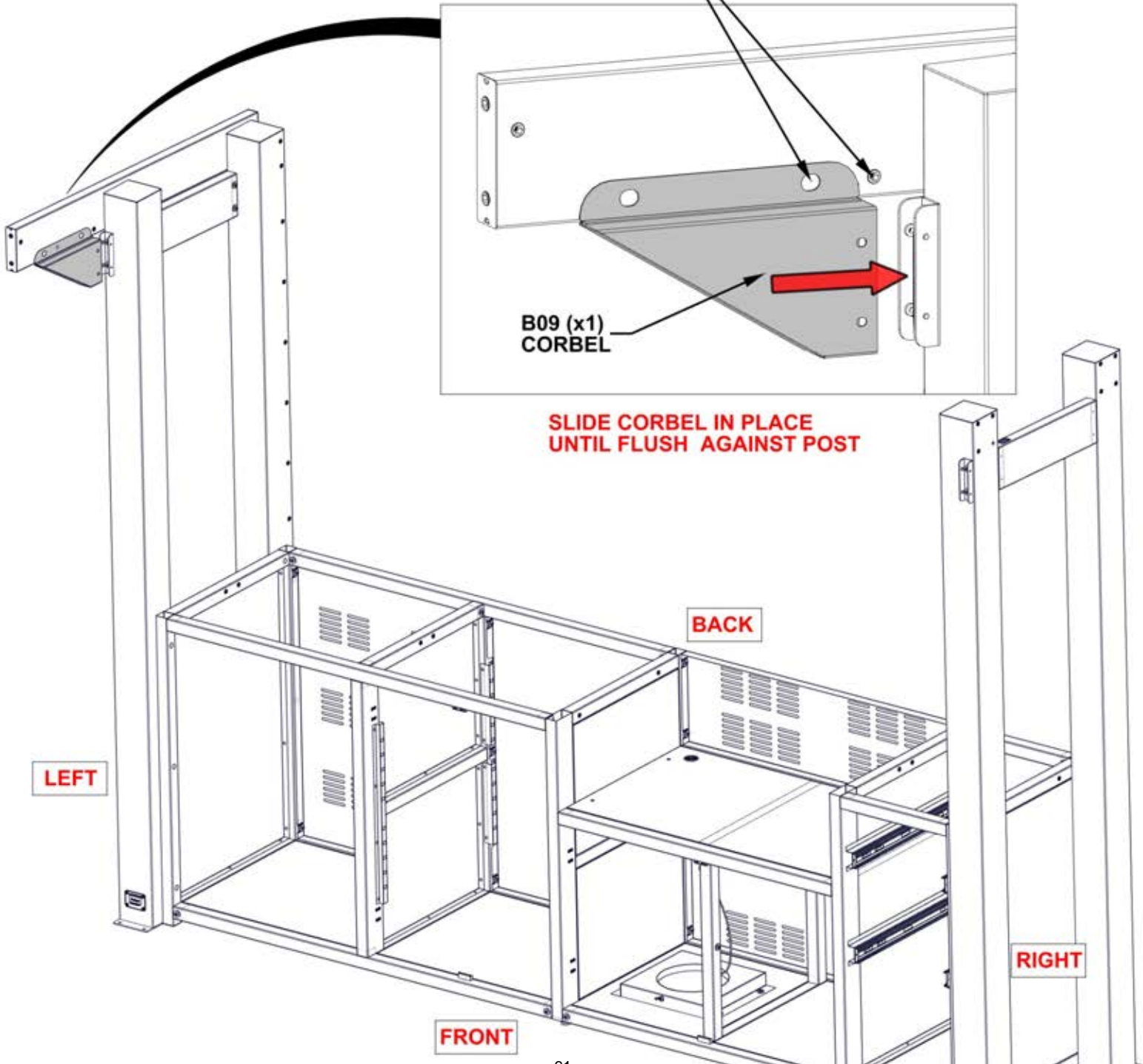

# STEP 36B - KITCHEN ASSEMBLY

QTY	PART NUMBER	Description
4	H101202	TORX PAN HEAD 1/4-20x3/4 ASSY

**DO NOT TIGHTEN HARDWARE AT THIS STEP**

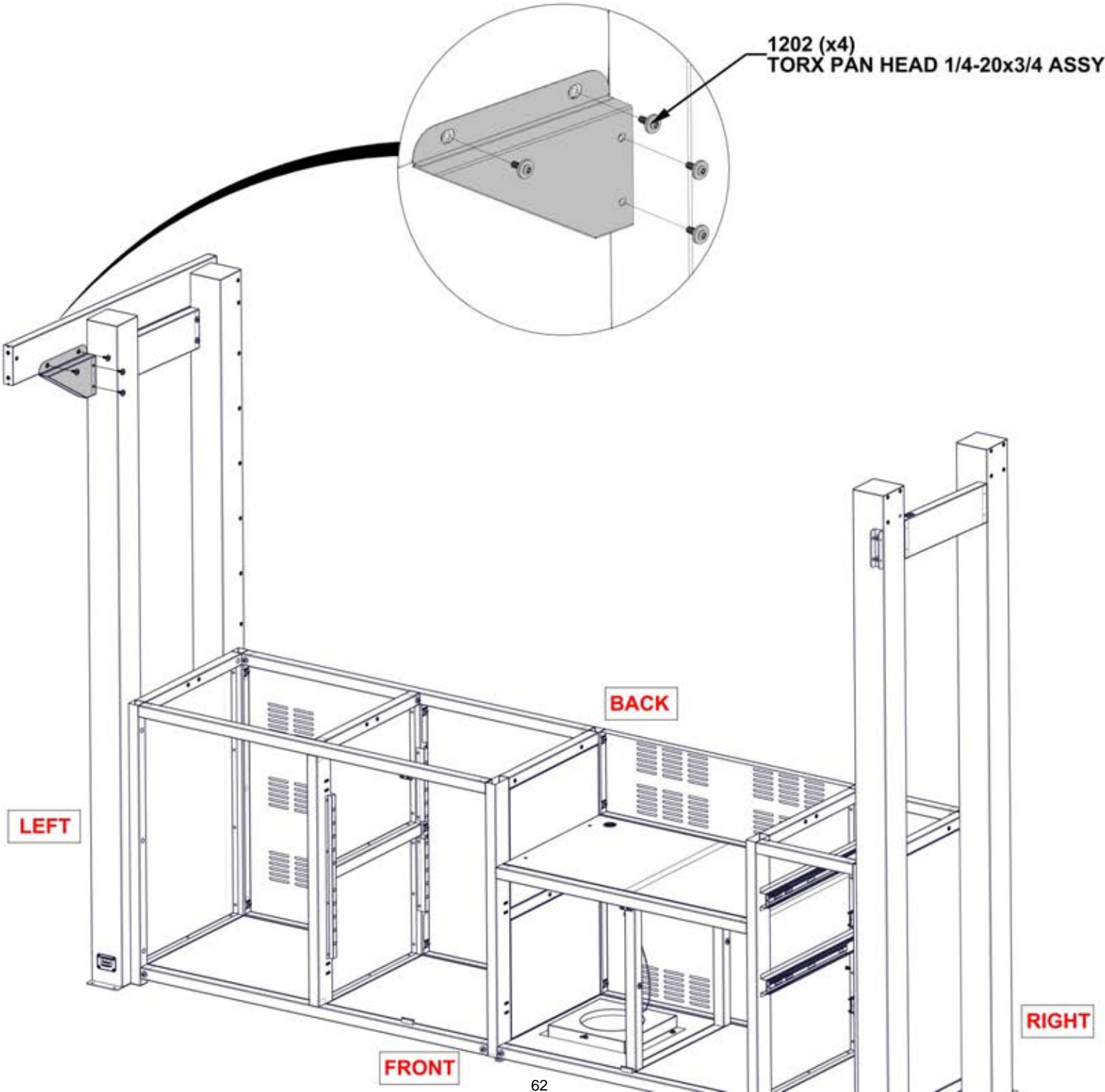

# STEP 37 - KITCHEN ASSEMBLY

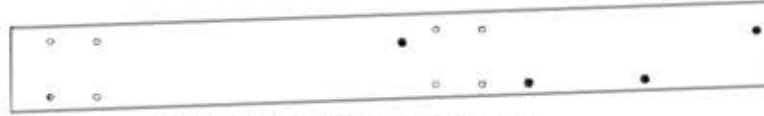

B05 SIDE BEAM - A4M02022  
 (x1) 1 7/16"x5 1/4"x46 1/2" (36x134x1181)

QTY	PART NUMBER	Description
8	H101103	TORX SOCKET SCREW 1/4-20

**DO NOT TIGHTEN HARDWARE AT THIS STEP**

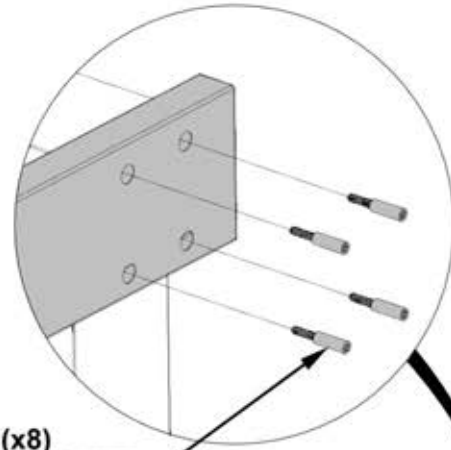
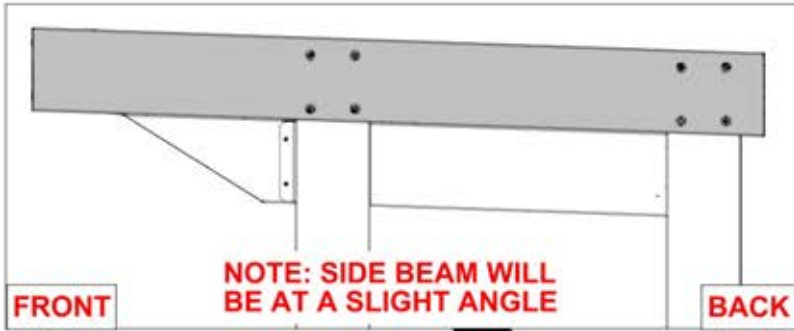

1103 (x8)  
 TORX SOCKET  
 SCREW 1/4-20

B05 (x1)  
 SIDE BEAM

BACK

LEFT

FRONT

RIGHT

# STEP 38A - KITCHEN ASSEMBLY

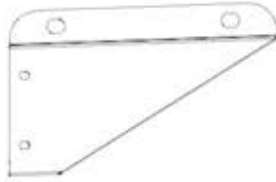

B08 CORBEL - A4M02041  
(x1) 1 7/16"x6 11/16"x11 1/8" (36x170x282)

**NOTE: CORBEL BRACKET SLOTS  
WILL FIT AROUND THREADED  
INSERTS AND FLUSH AGAINST BEAM**

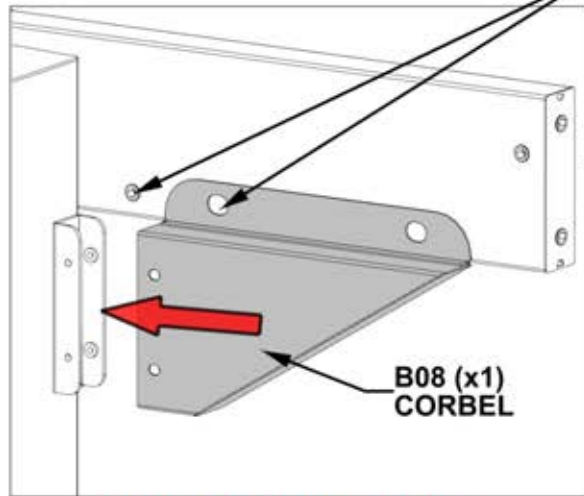

**SLIDE CORBEL IN PLACE  
UNTIL FLUSH AGAINST POST**

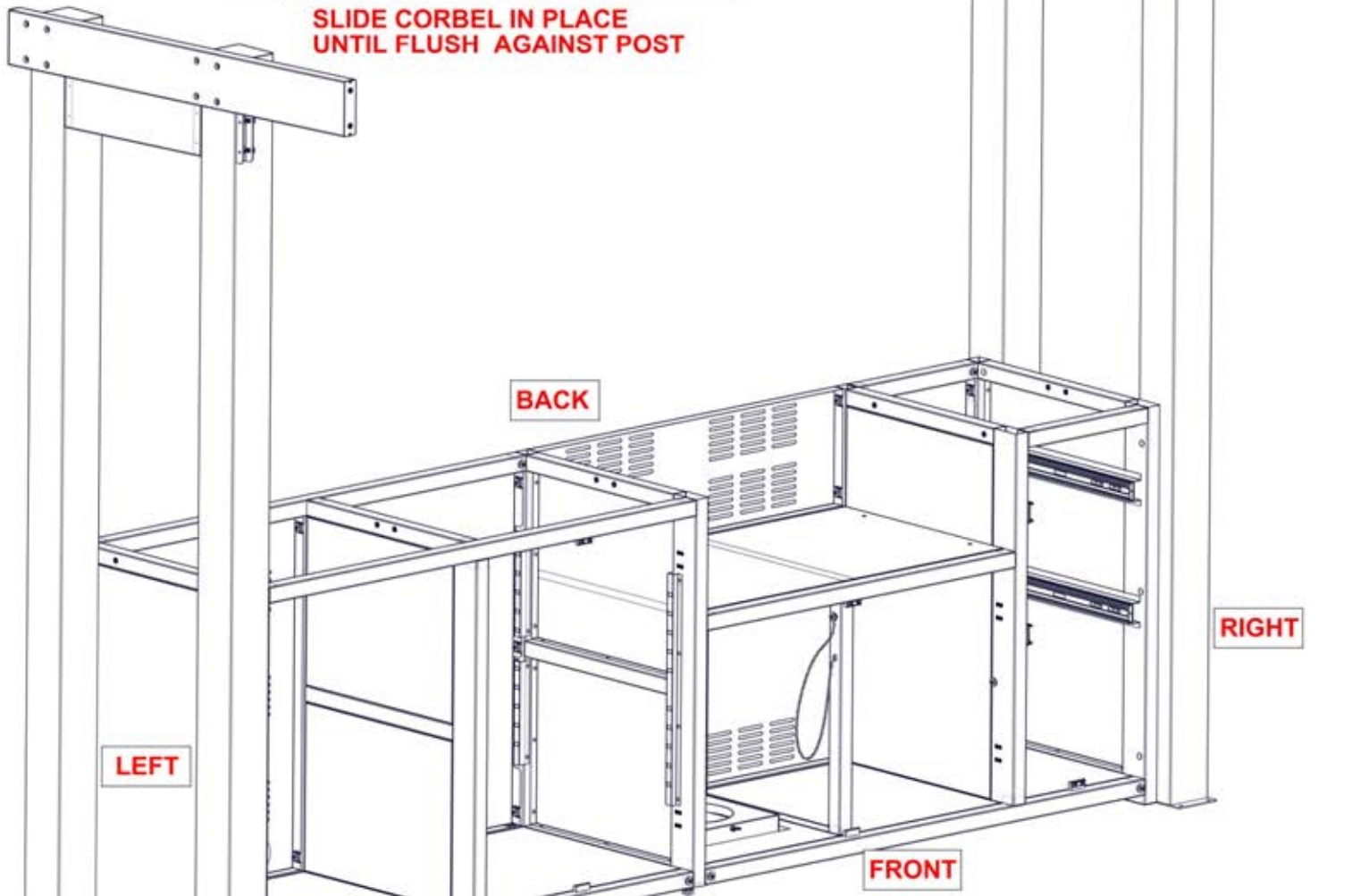



# STEP 38B - KITCHEN ASSEMBLY

QTY	PART NUMBER	Description
4	H101202	TORX PAN HEAD 1/4-20x3/4 ASSY

**DO NOT TIGHTEN HARDWARE AT THIS STEP**

1202 (x4)  
TORX PAN HEAD 1/4-20x3/4 ASSY

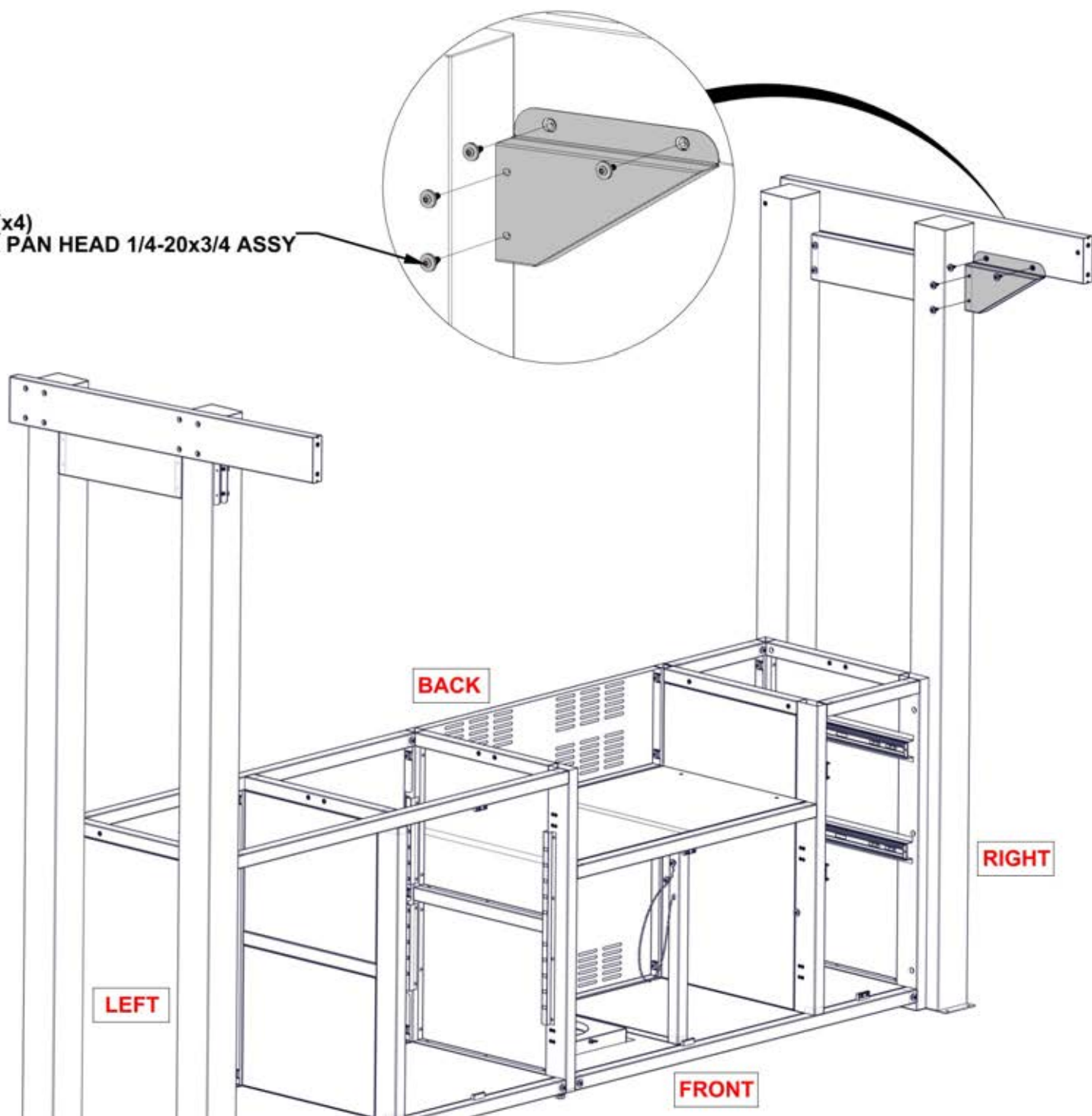

# STEP 39 - BACK BEAM ASSEMBLY



QTY	PART NUMBER	Description
6	H101202	TORX PAN HEAD 1/4-20x3/4 ASSY

J2 SPLICE BRACKET - A4M02184  
(x1) 1 5/16"x4 11/16"x19 11/16" (33.2x119.2x500)



B02 BACK BEAM - A4M02013  
(x1) 1 7/16"x4 13/16"x61 1/4" (36x122x1556)

**DO NOT TIGHTEN HARDWARE AT THIS STEP**

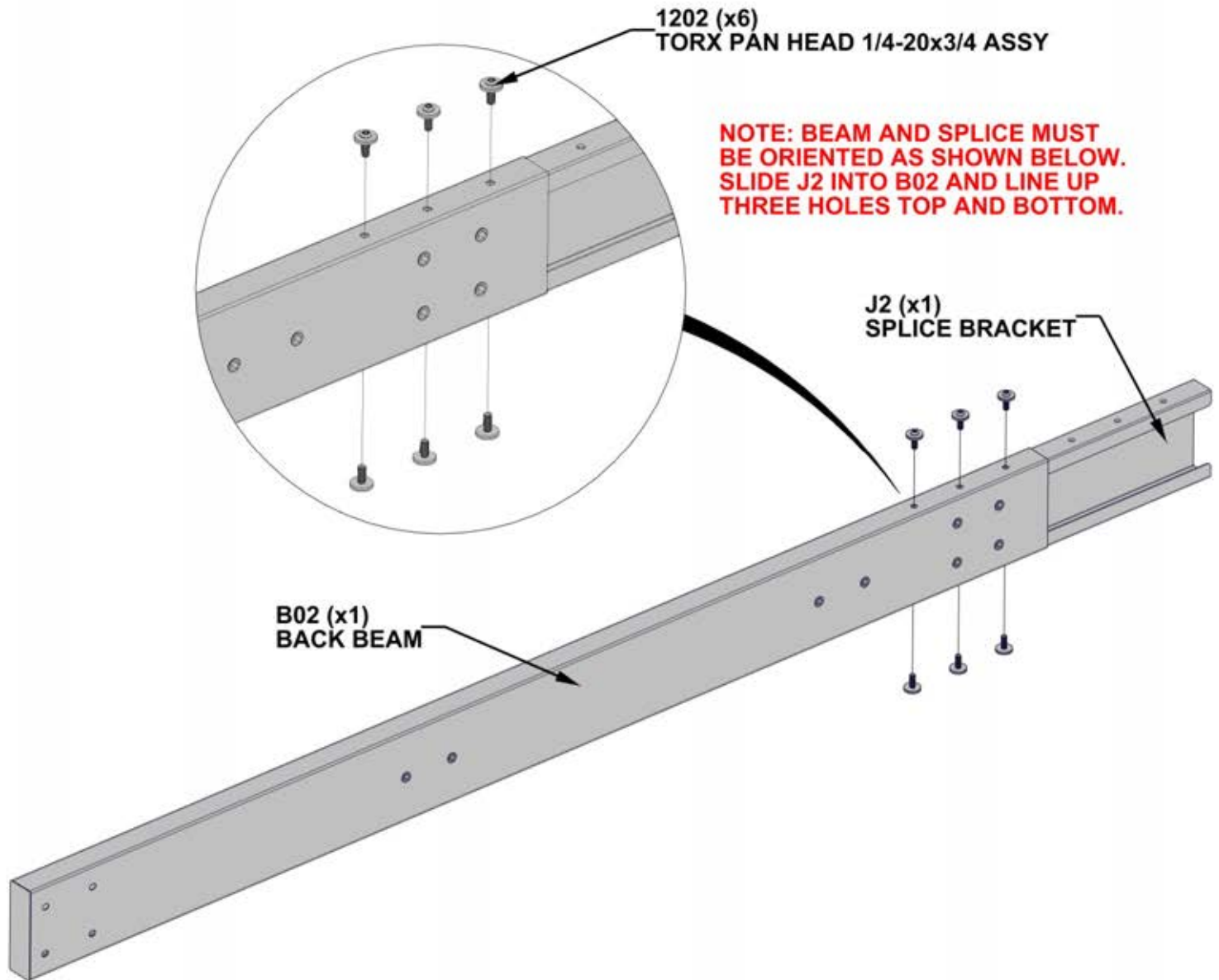

# STEP 40 - BACK BEAM ASSEMBLY



B06 BACK BEAM - A4M02024  
(x1) 1 7/16"x4 13/16"x (36x122x1556)

QTY	PART NUMBER	Description
6	H101202	TORX PAN HEAD 1/4-20x3/4 ASSY

**SLIDE B06 ONTO SPLICE BRACKET.  
GENTLY TAP ENDS OF ASSEMBLY  
WITH RUBBER Mallet UNTIL GAP  
CLOSES, THEN TIGHTEN ALL BOLTS  
ON BEAM.**

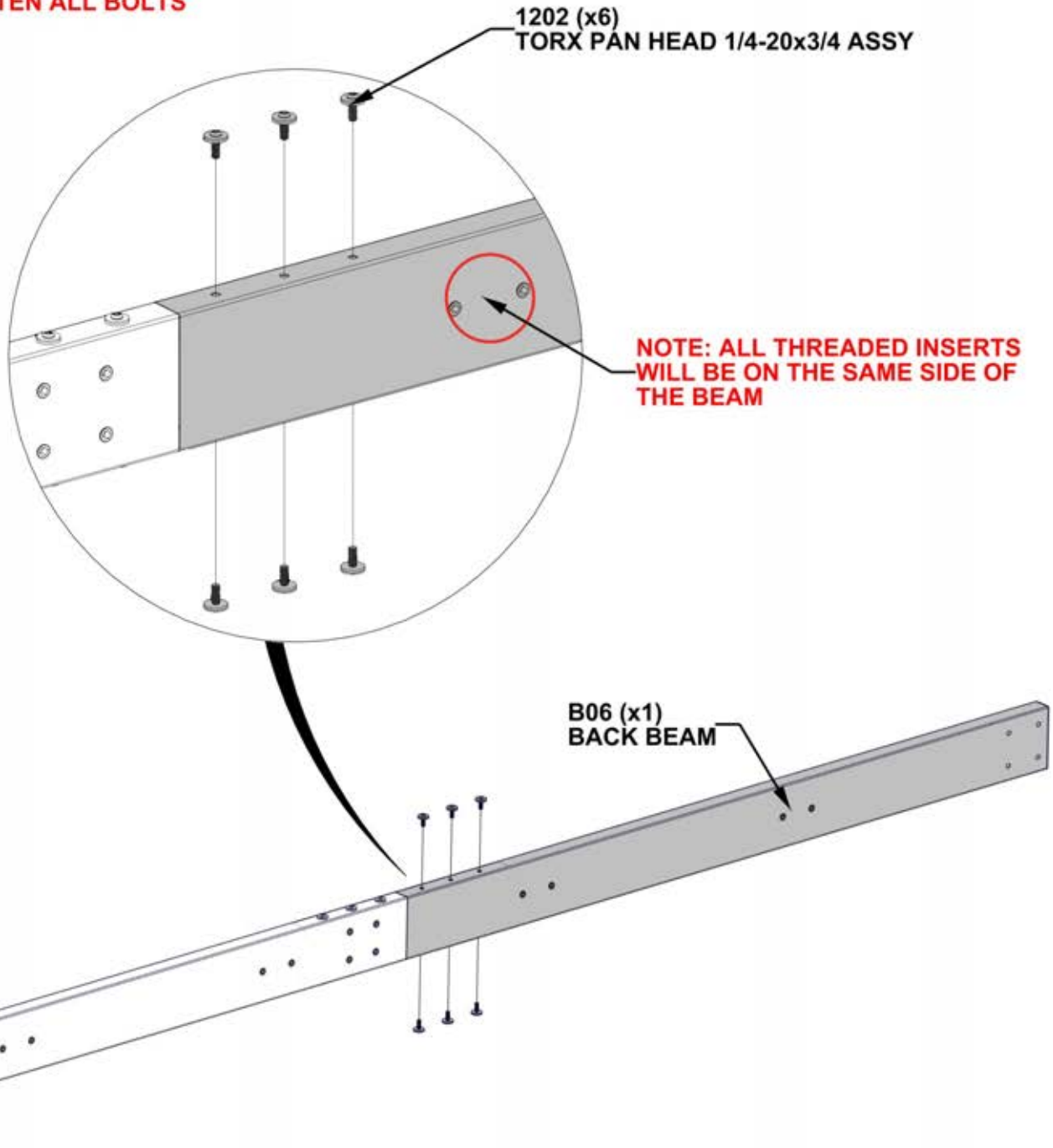

# STEP 41 - FRONT BEAM ASSEMBLY



QTY	PART NUMBER	Description
6	H101202	TORX PAN HEAD 1/4-20x3/4 ASSY

J1 SPLICE BRACKET - A4M02183  
 (x1) 1 5/16"x5 3/16"x19 11/16" (33.2x131.2x500)



B03 FRONT BEAM - A4M02014  
 (x1) 1 7/16"x5 1/4"x62 11/16" (36x134x1593)

**DO NOT TIGHTEN HARDWARE AT THIS STEP**

**NOTE: BEAM AND SPLICE MUST BE ORIENTED AS SHOWN BELOW. SLIDE J1 INTO B03 AND LINE UP THREE HOLES TOP AND BOTTOM.**

**NOTE: ARROW INDICATES TOP SURFACE OF BEAM**

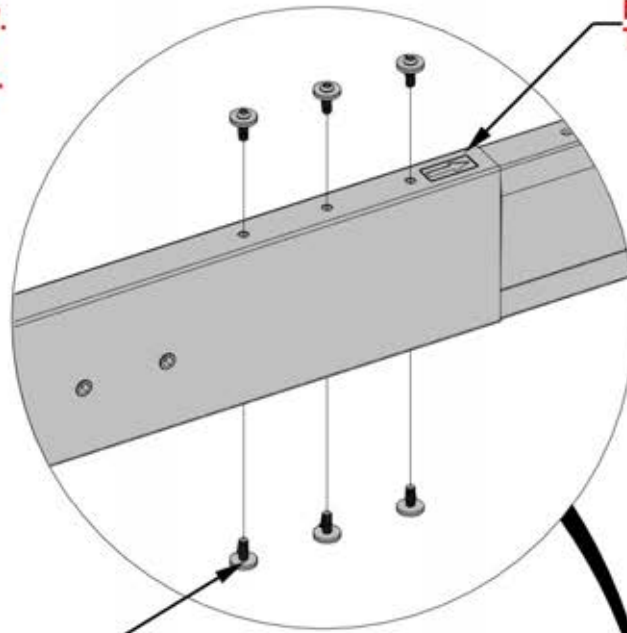

1202 (x6)  
 TORX PAN HEAD 1/4-20x3/4 ASSY

J1 (x1)  
 SPLICE BRACKET

B03 (x1)  
 FRONT BEAM

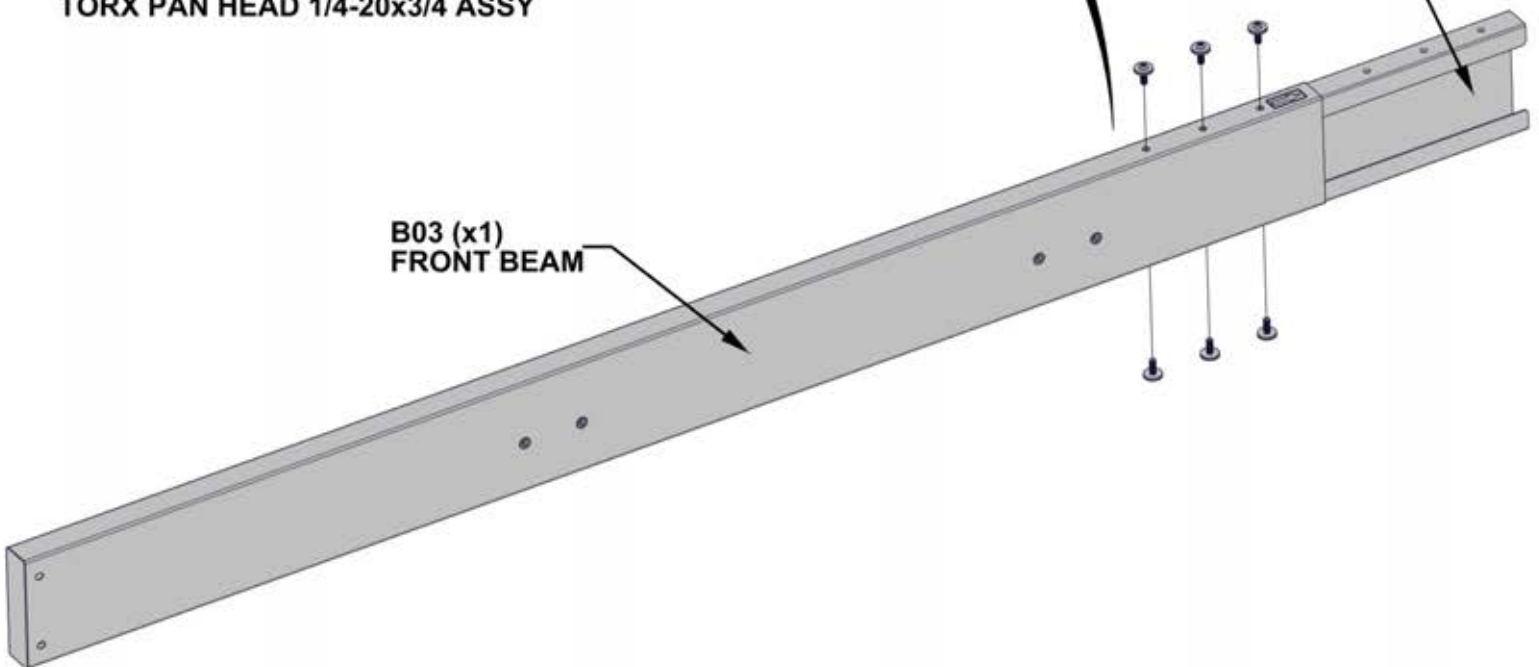

# STEP 42 - FRONT BEAM ASSEMBLY



B07 FRONT BEAM - A4M02027  
 (x1) 1 7/16"x5 1/4"x62 11/16" (36x134x1593)

QTY	PART NUMBER	Description
6	H101202	TORX PAN HEAD 1/4-20x3/4 ASSY

**SLIDE B07 ONTO SPLICE BRACKET. GENTLY TAP ENDS OF ASSEMBLY WITH RUBBER Mallet UNTIL GAP CLOSES, THEN TIGHTEN ALL BOLTS ON BEAM.**

**NOTE: ARROWS INDICATE TOP SURFACE OF BEAM. BOTH ARROWS WILL FACE EACH OTHER ON BEAM ASSEMBLY**

**1202 (x6)  
TORX PAN HEAD 1/4-20x3/4 ASSY**

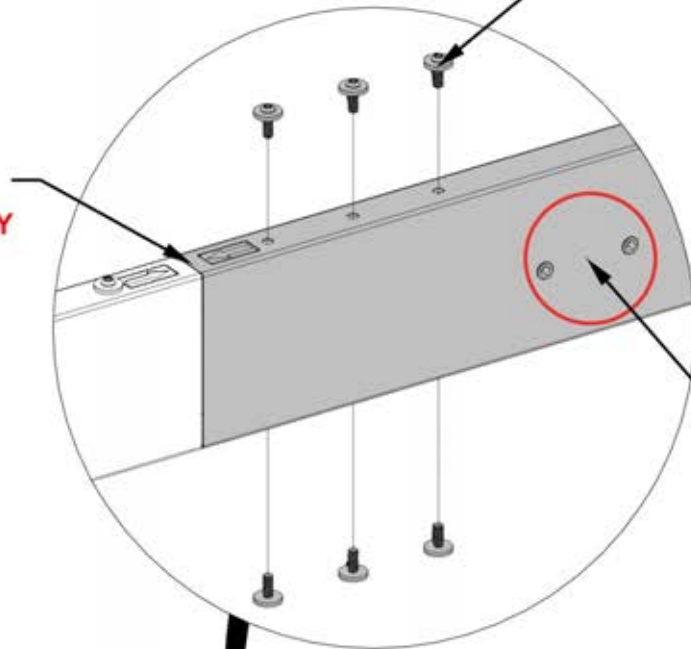

**NOTE: ALL THREADED INSERTS WILL BE ON THE SAME SIDE OF THE BEAM**

**B07 (x1)  
FRONT BEAM**

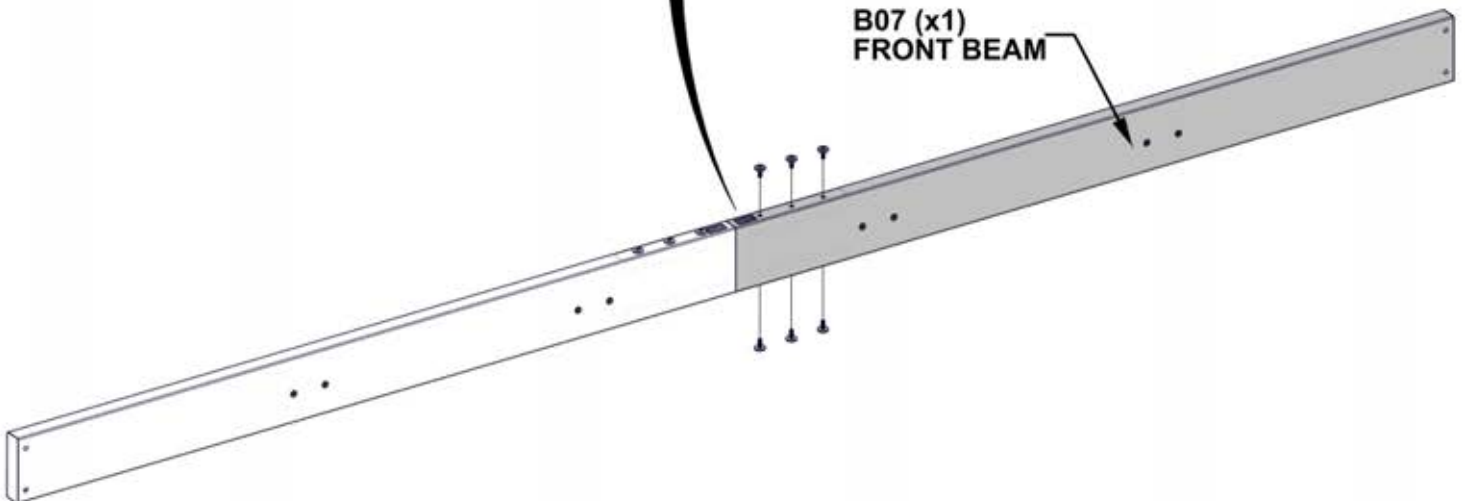

# STEP 43 - ROOF ASSEMBLY



BACK BEAM ASSEMBLY  
STEPS 39-40

QTY	PART NUMBER	Description
8	H101103	TORX SOCKET SCREW 1/4-20

**FOR THIS STEP IT IS HELPFUL TO HAVE THREE ADDITIONAL PEOPLE TO HELP HOLD BACK BEAM IN PLACE AND ATTACH HARDWARE.**

**DO NOT STAND ON CABINET FRAME TO INSTALL BEAM.  
DO NOT FULLY TIGHTEN HARDWARE AT THIS STEP.**

**CRITICAL: BACK BEAM MUST BE ORIENTED IN THE EXACT WAY SHOWN BELOW.**

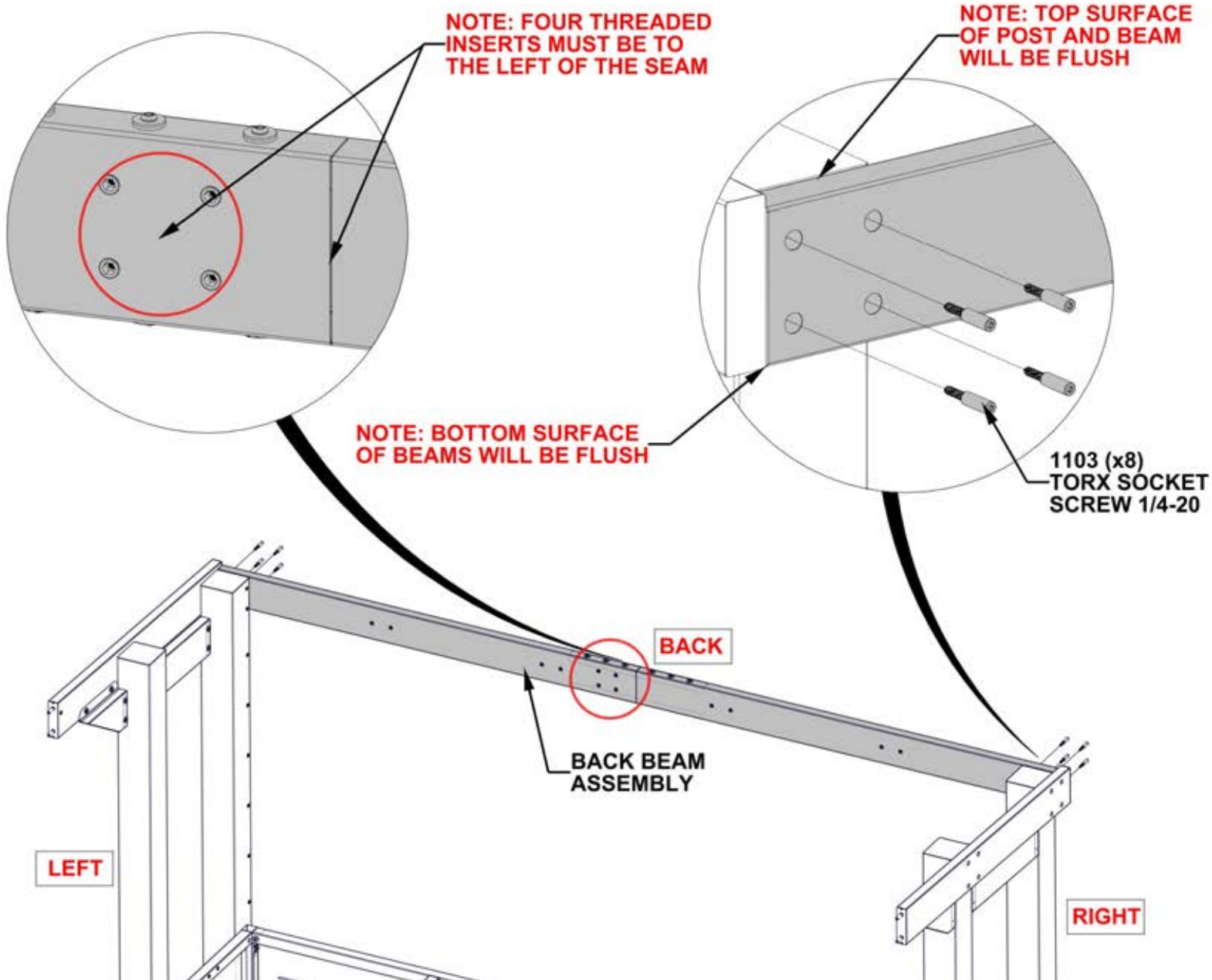

# STEP 44A - ROOF ASSEMBLY

**USE THIS STEP TO POSITION THE FRONT BEAM ASSEMBLY IN THE EXACT ORIENTATION SHOWN BELOW**

FRONT BEAM ASSEMBLY  
STEPS 41 - 42

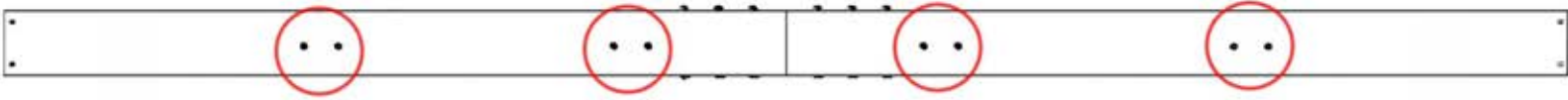

**NOTE: ARROWS INDICATE TOP SURFACE OF BEAM. BOTH ARROWS WILL FACE EACH OTHER ON BEAM ASSEMBLY**

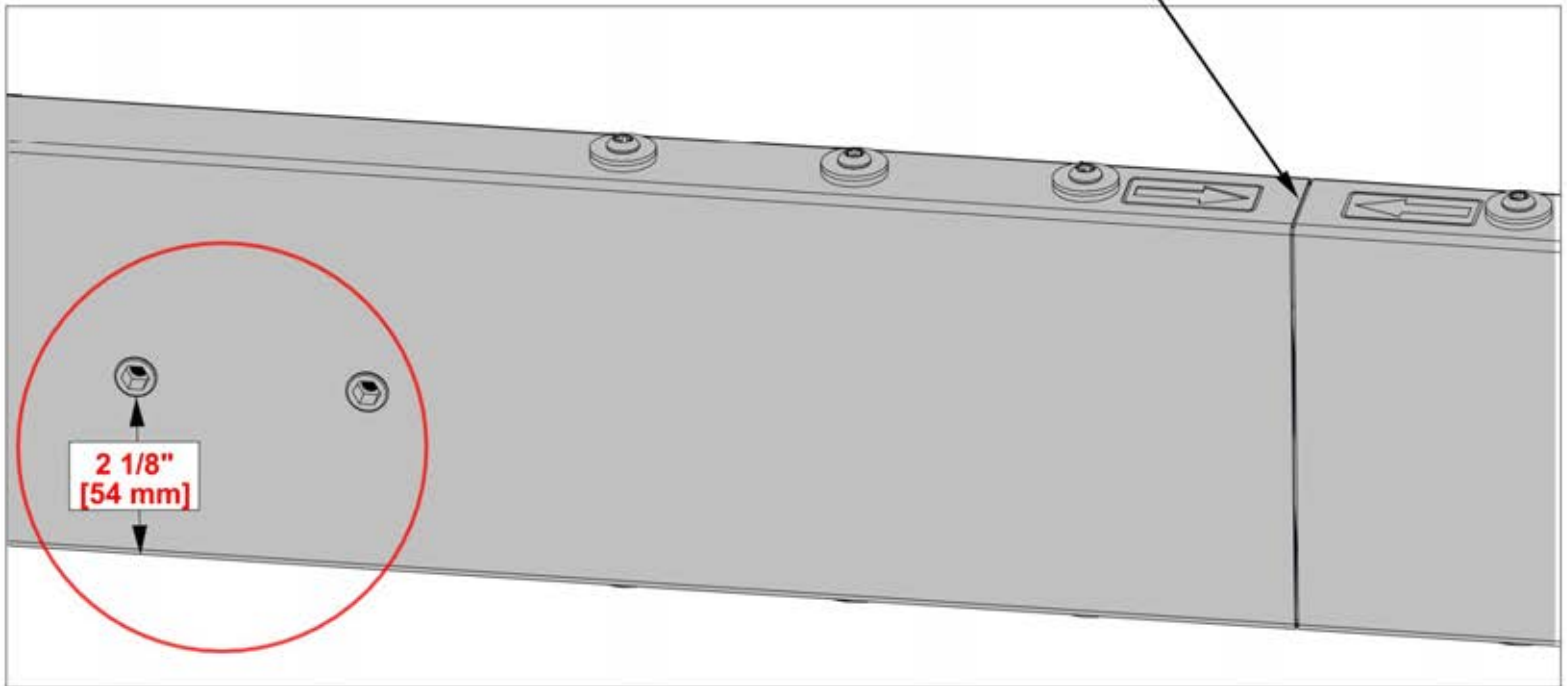

**MEASURE FROM THE BOTTOM OF FRONT BEAM TO BOTTOM OF THREADED INSERTS OUTLINED IN RED. IF THE DIMENSION IS NOT CLOSE, FRONT BEAM WILL NEED TO BE FLIPPED.**

# STEP 44B - ROOF ASSEMBLY

QTY	PART NUMBER	Description
4	H101103	TORX SOCKET SCREW 1/4-20

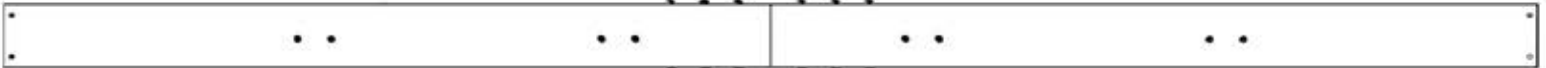

FRONT BEAM ASSEMBLY  
STEPS 41 - 42

**FOR THIS STEP IT IS HELPFUL TO HAVE THREE ADDITIONAL PEOPLE TO HELP HOLD FRONT BEAM IN PLACE AND ATTACH HARDWARE.**

**DO NOT STAND ON CABINET FRAME TO INSTALL BEAM.  
DO NOT FULLY TIGHTEN HARDWARE AT THIS STEP.**

**CRITICAL: FRONT BEAM MUST  
BE ORIENTED IN THE EXACT  
WAY SHOWN BELOW**

**NOTE: ARROWS INDICATE  
TOP SURFACE OF BEAM.  
BOTH ARROWS WILL FACE  
EACH OTHER ON BEAM ASSEMBLY**

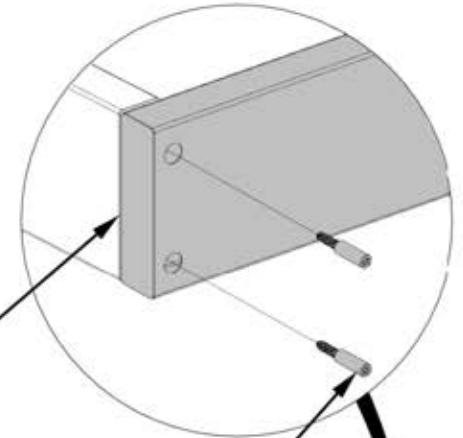
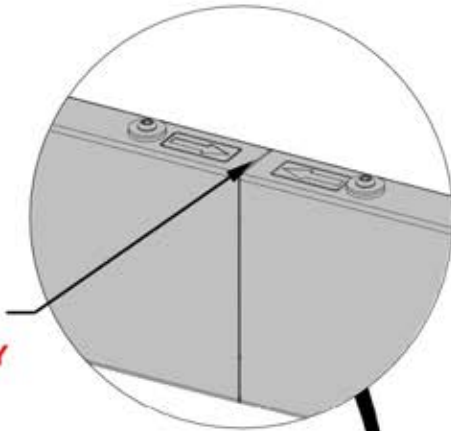

**FRONT**

**1103 (x4)  
TORX SOCKET  
SCREW 1/4-20**

**FRONT BEAM  
ASSEMBLY**

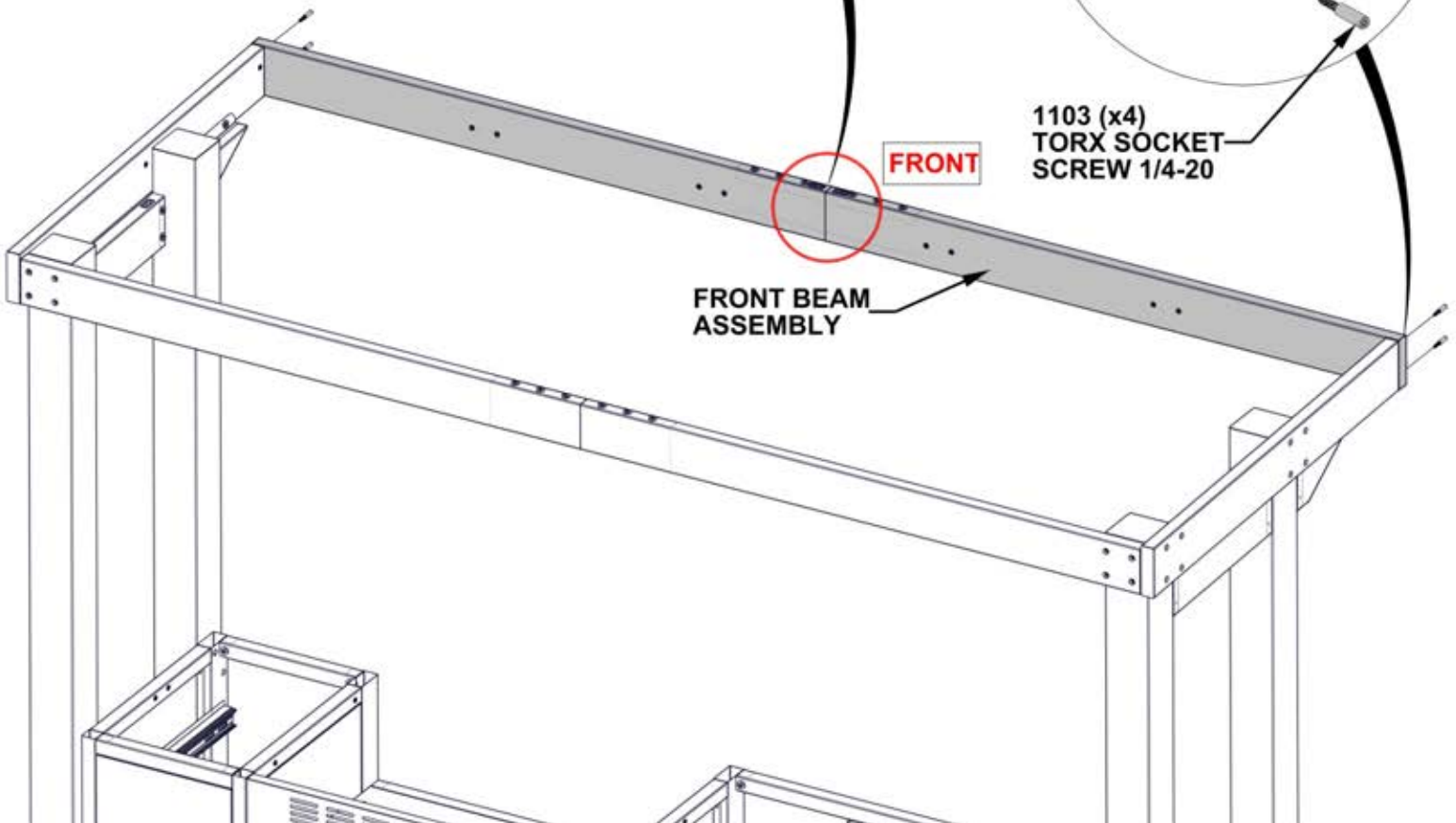



# STEP 45 - KITCHEN ASSEMBLY

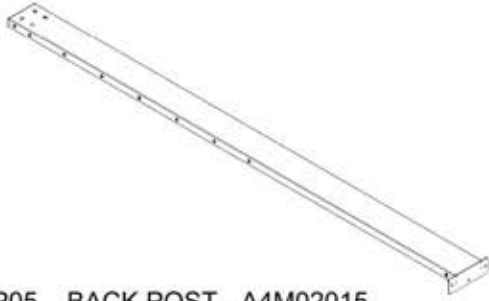

QTY	PART NUMBER	Description
4	H101103	TORX SOCKET SCREW 1/4-20

P05 BACK POST - A4M02015  
 (x1) 2 5/8"x7 7/8"x88 3/4" (66x200x2254)

**DO NOT STAND ON CABINET FRAME TO INSTALL POST HARDWARE.**  
**DO NOT TIGHTEN HARDWARE AT THIS STEP**

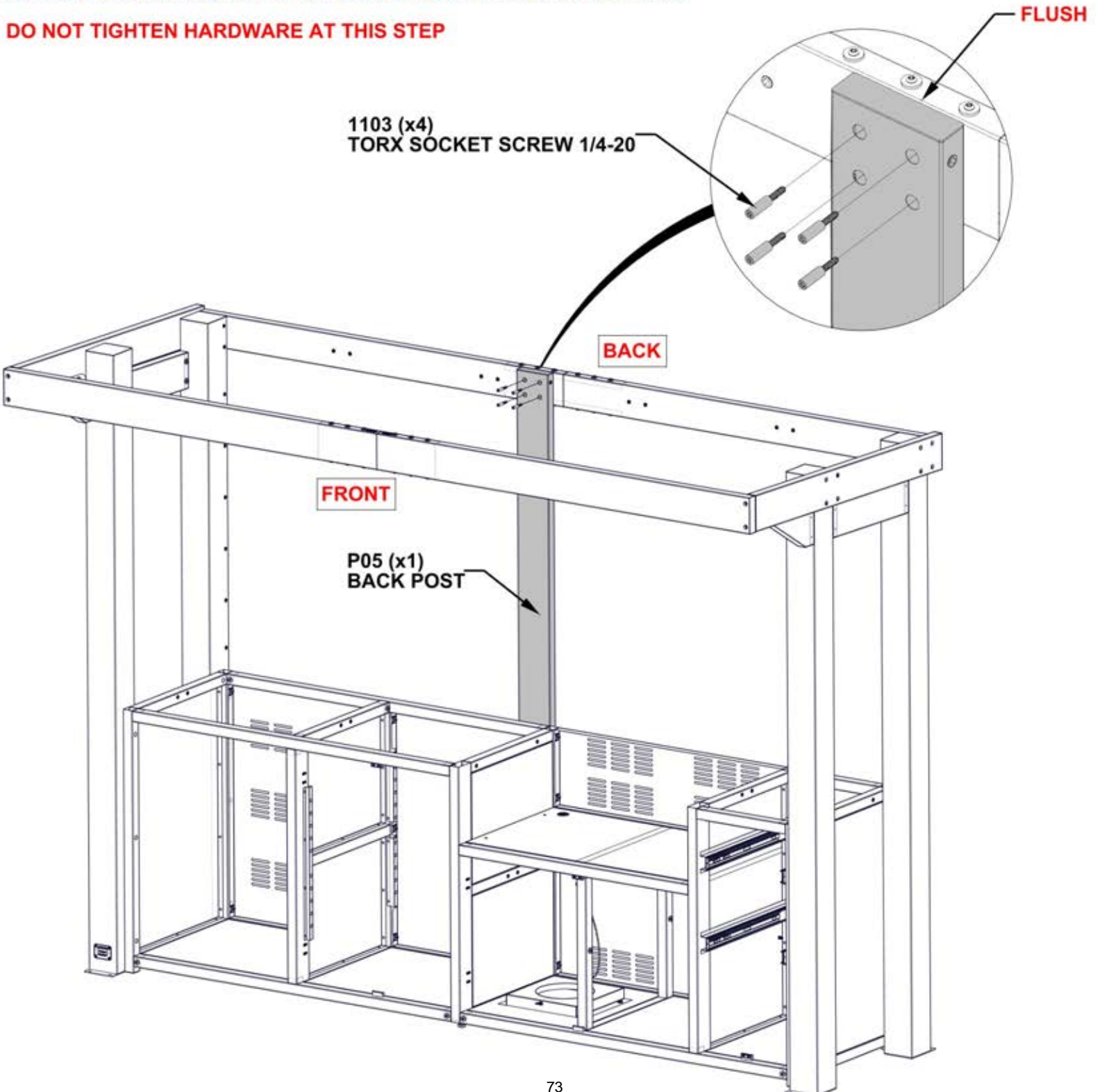

# STEP 46 - KITCHEN ASSEMBLY



QTY	PART NUMBER	Description
6	H101202	TORX PAN HEAD 1/4-20x3/4 ASSY

B10 BACK PANEL - A4M02043  
(x1) 1 7/16"x22 11/16"x49 5/8" (36x576.5x1261)

**DO NOT TIGHTEN HARDWARE AT THIS STEP**

**NOTE: USE RIGHT ANGLE DRILL ADAPTER FOR THIS STEP**

**NOTE: BACK PANEL WILL FIT AROUND THREADED INSERTS AND FLUSH AGAINST POST**

1202 (x6)  
TORX PAN HEAD  
1/4-20x3/4 ASSY

**NOTE: NOTCH IN BRACKET TOWARD BOTTOM**

B10 (x1)  
BACK PANEL

# STEP 47 - KITCHEN ASSEMBLY

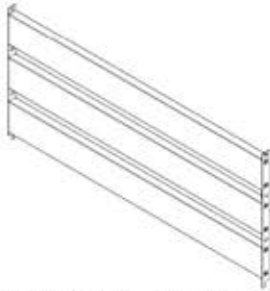

QTY	PART NUMBER	Description
8	H101202	TORX PAN HEAD 1/4-20x3/4 ASSY

B10 BACK PANEL - A4M02043  
(x1) 1 7/16"x22 11/16"x49 5/8" (36x576.5x1261)

**DO NOT TIGHTEN HARDWARE AT THIS STEP**

**NOTE: USE RIGHT ANGLE DRILL ADAPTER FOR THIS STEP**

**NOTE: BACK PANEL WILL FIT AROUND THREADED INSERTS AND FLUSH AGAINST POST**

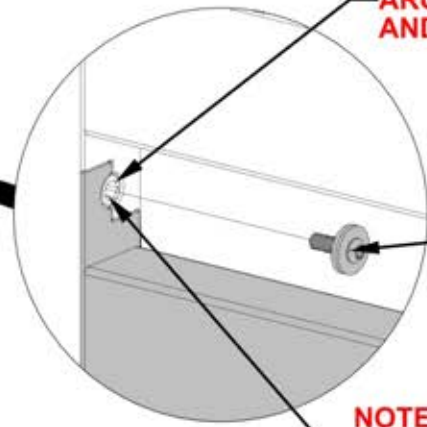

1202 (x8)  
TORX PAN HEAD  
1/4-20x3/4 ASSY

**NOTE: CONNECT NOTCHED BRACKETS IN THE ORIENTATION SHOWN**

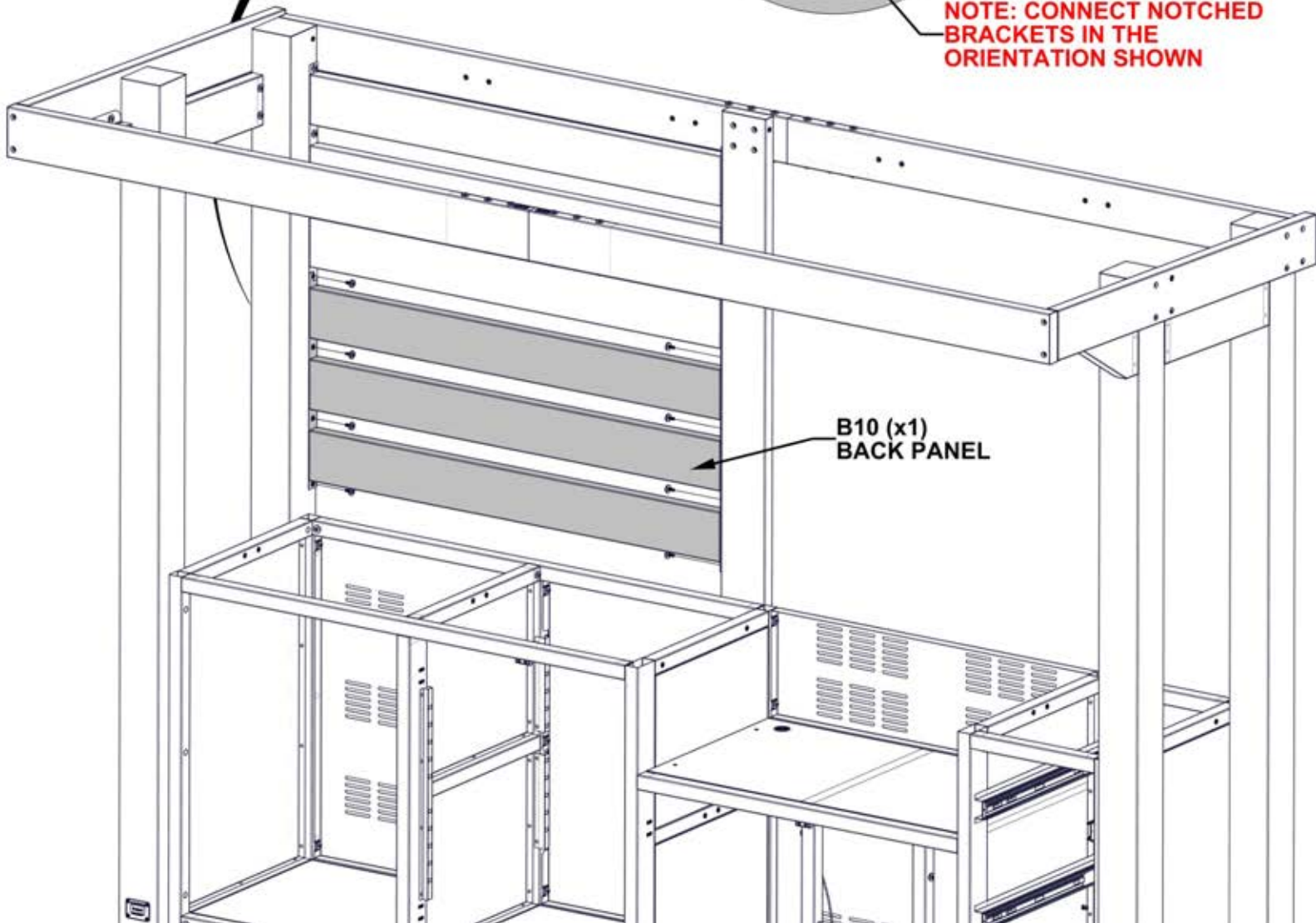

B10 (x1)  
BACK PANEL

# STEP 48 - ROOF ASSEMBLY

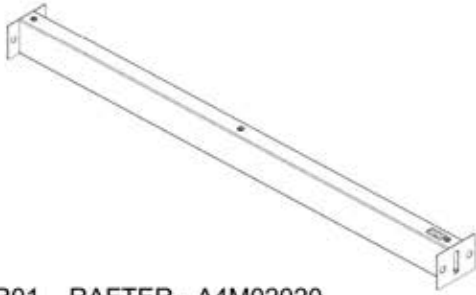

QTY	PART NUMBER	Description
16	H101202	TORX PAN HEAD 1/4-20x3/4 ASSY

R01 RAFTER - A4M02020  
(x4) 3 1/8"x3 15/16"x45 1/16" (80x100x1144)

**DO NOT STAND ON CABINET FRAME TO INSTALL RAFTERS**

**DO NOT TIGHTEN HARDWARE AT THIS STEP**

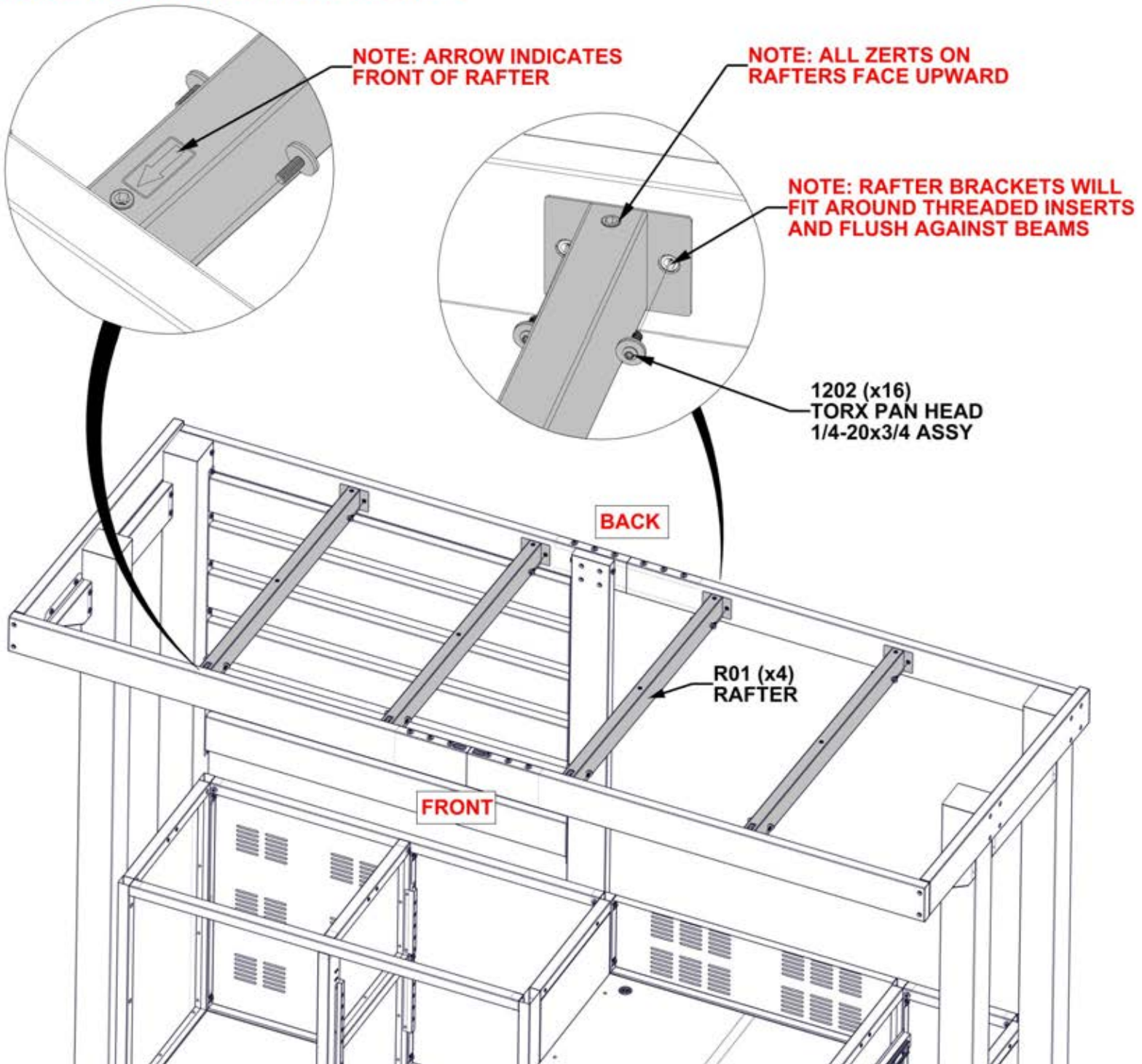

# STEP 49 - PURLIN ASSEMBLY



A6P00530 2-WAY SQUARE PLUG  
(x2)



E02 PURLIN - A4M02023  
(x2) 1 9/16"x1 3/4"x73 5/8" (40x45x1870.75)

**COMPLETE THIS STEP 2 TIMES**

**USE A RUBBER Mallet TO TAP 2-WAY SQUARE PLUG INTO END OF PURLINS**

**ENSURE E02 IS ORIENTED  
CORRECTLY WITH PILOT  
HOLES FACING UP**

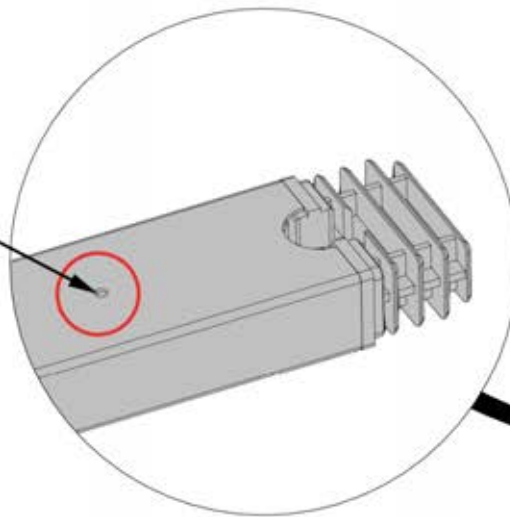

530 (x1)  
2-WAY SQUARE PLUG

E02 (x1)  
PURLIN

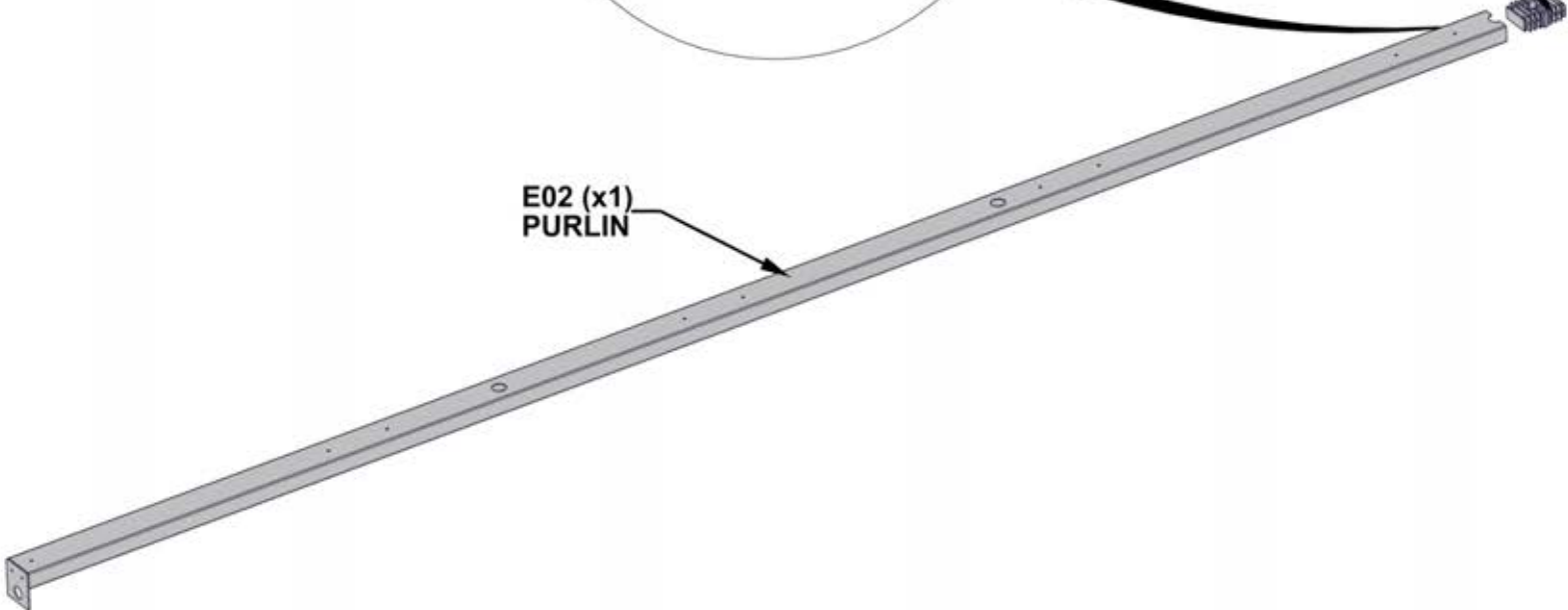

# STEP 50 - PURLIN ASSEMBLY



E01 PURLIN - A4M02021  
(x2) 1 9/16"x1 3/4"x48 13/16" (40x45x1239.75)

**COMPLETE THIS STEP 2 TIMES**

**USE A RUBBER Mallet TO TAP ENDS OF EACH PURLIN UNTIL TIGHT AGAINST 2-WAY PLUG**

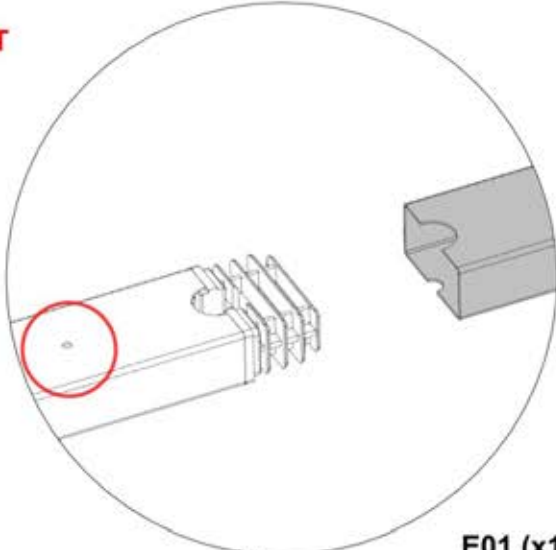

E01 (x1)  
PURLIN

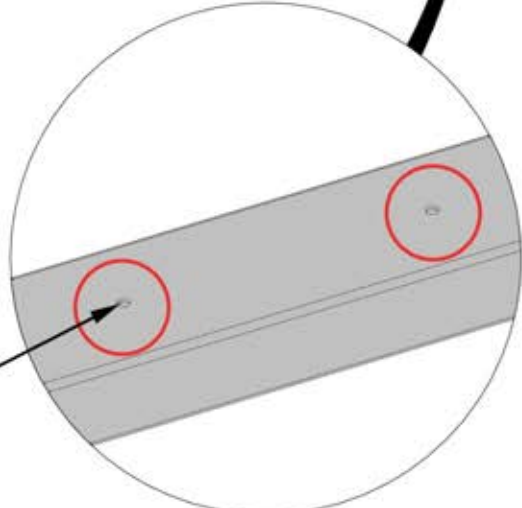
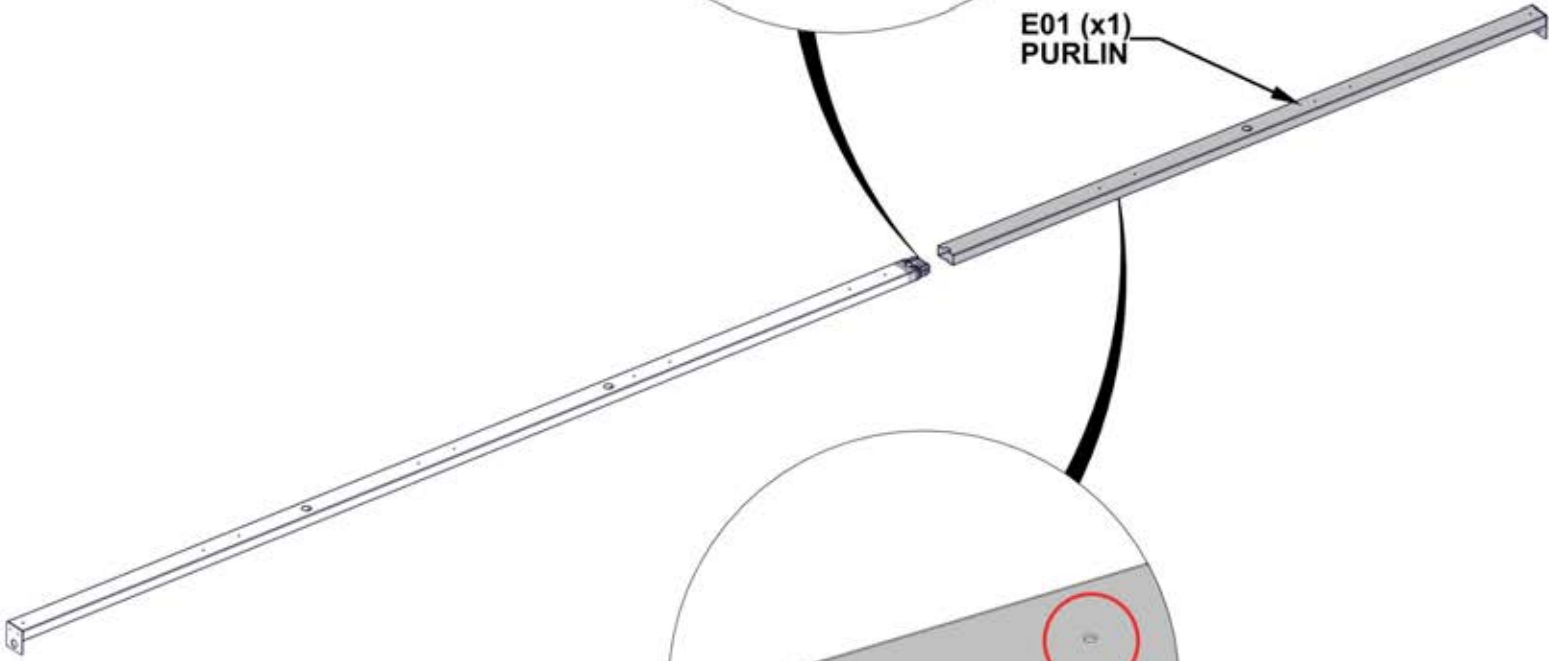

**ENSURE E01 IS ORIENTED CORRECTLY WITH PILOT HOLES FACING UP**

# STEP 51A - ROOF ASSEMBLY

## PURLIN ASSEMBLY STEP 49 - 50

QTY	PART NUMBER	Description
8	H101132	TORX SOCKET SCREW 1/4-20

**DO NOT STAND ON CABINET FRAME TO  
INSTALL PURLINS**

**DO NOT TIGHTEN HARDWARE AT THIS STEP**

**NOTE: MAKE SURE MIDDLE OF PURLIN  
ASSEMBLY IS SUPPORTED WHEN LIFTING**

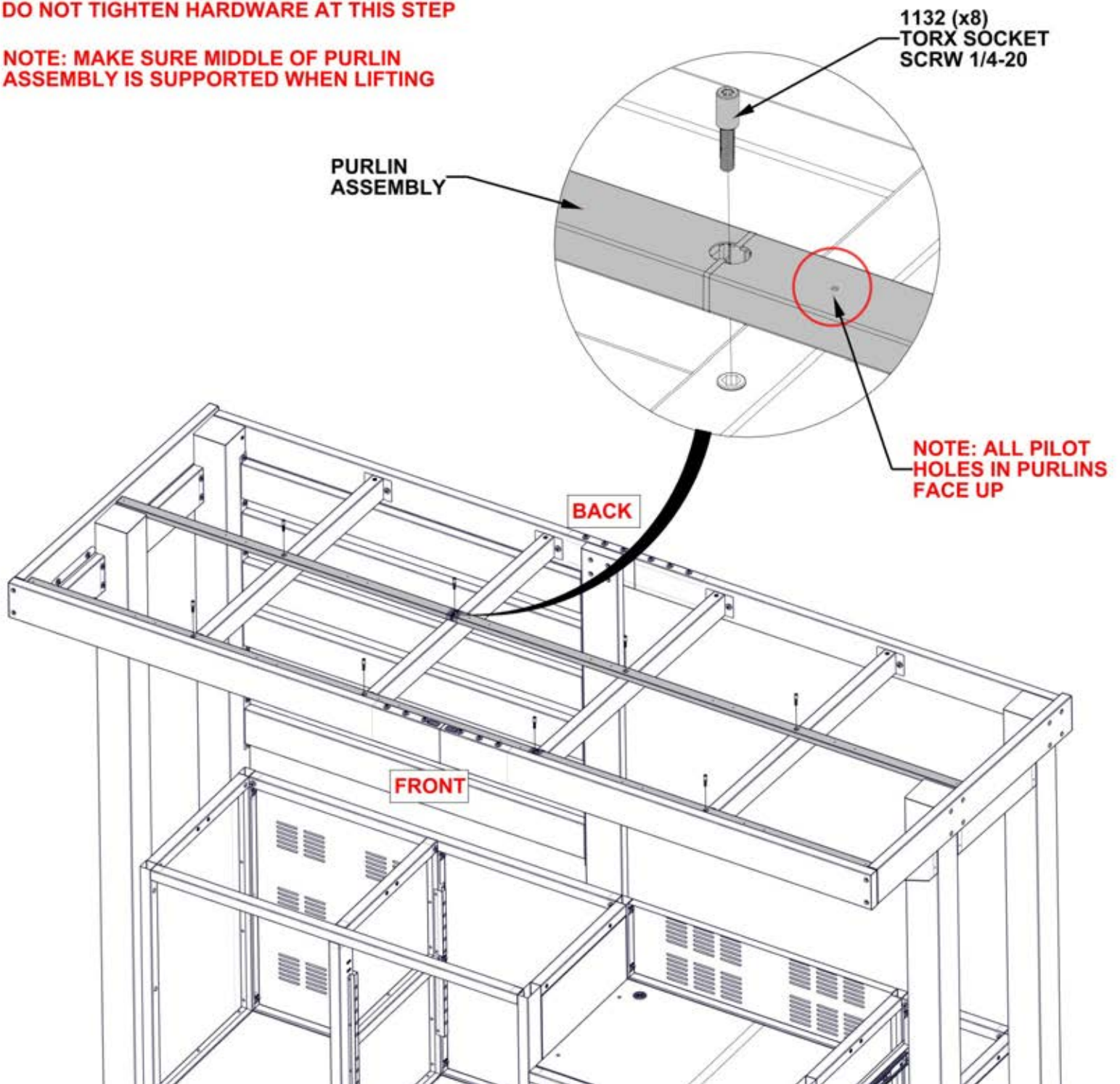

# STEP 51B - ROOF ASSEMBLY

QTY	PART NUMBER	Description
4	H101202	TORX PAN HEAD 1/4-20x3/4 ASSY

**DO NOT STAND ON CABINET FRAME TO INSTALL PURLINS**

**DO NOT TIGHTEN HARDWARE AT THIS STEP**

**REPEAT THIS STEP FOR BOTH SIDES OF KITCHEN ROOF**

1202 (x2)  
TORX PAN HEAD 1/4-20x3/4 ASSY

**NOTE: BRACKET HOLE WILL FIT AROUND THREADED INSERT AND FLUSH AGAINST BEAM**

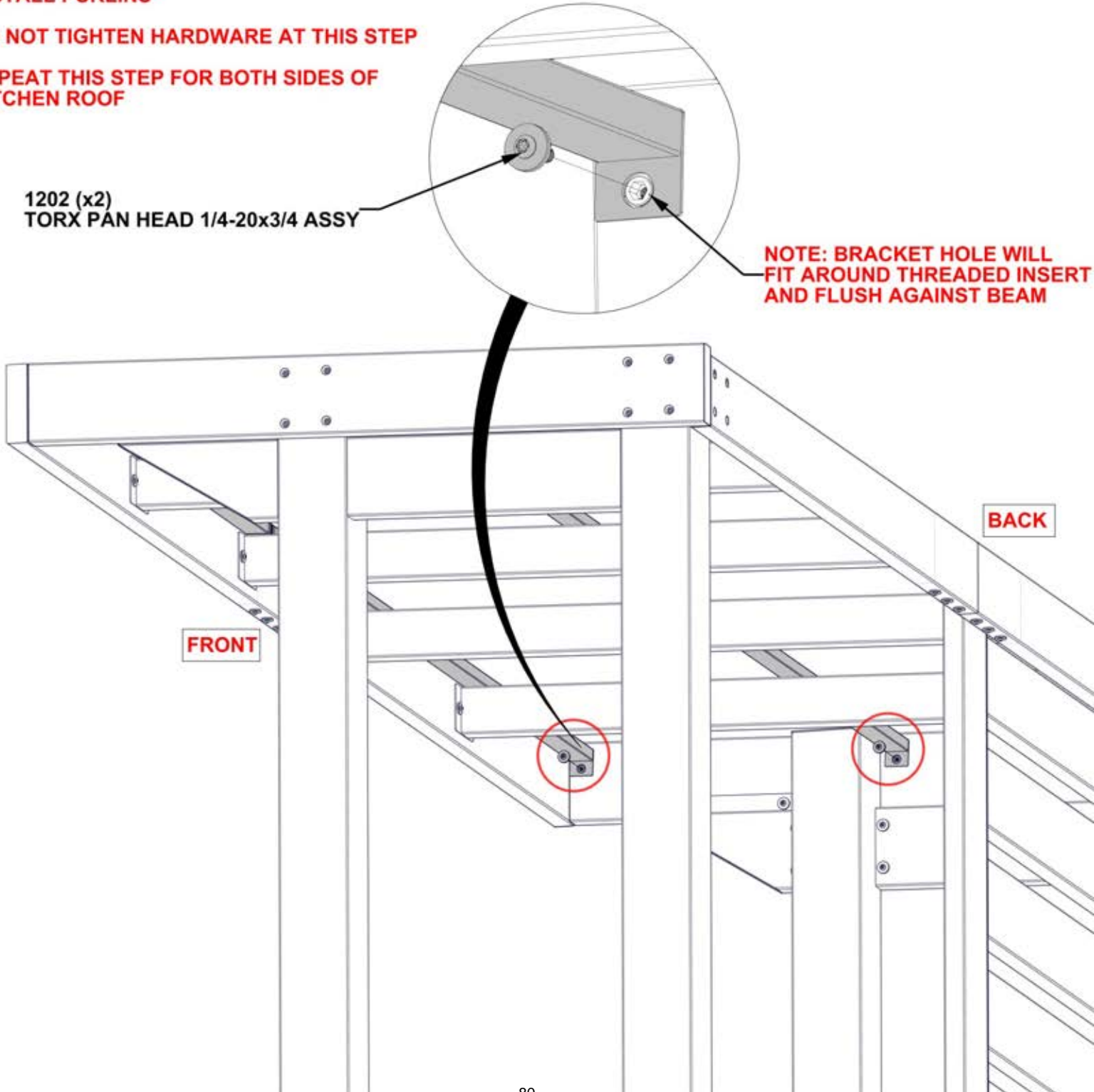



# STEP 52A - ROOF ASSEMBLY



E03 PURLIN - A4M02025  
(x1) 1 9/16"x1 3/4"x49 5/8" (40x45x1260)

QTY	PART NUMBER	Description
2	H101132	TORX SOCKET SCREW 1/4-20

**DO NOT STAND ON CABINET FRAME TO INSTALL PURLIN**

**DO NOT TIGHTEN HARDWARE AT THIS STEP**

**NOTE: ORIENTATION OF PURLIN. TWO PILOT HOLES ON PURLIN WILL BE CLOSEST TO MIDDLE POST.**

1132 (x2)  
TORX SOCKET  
SCREW 1/4-20

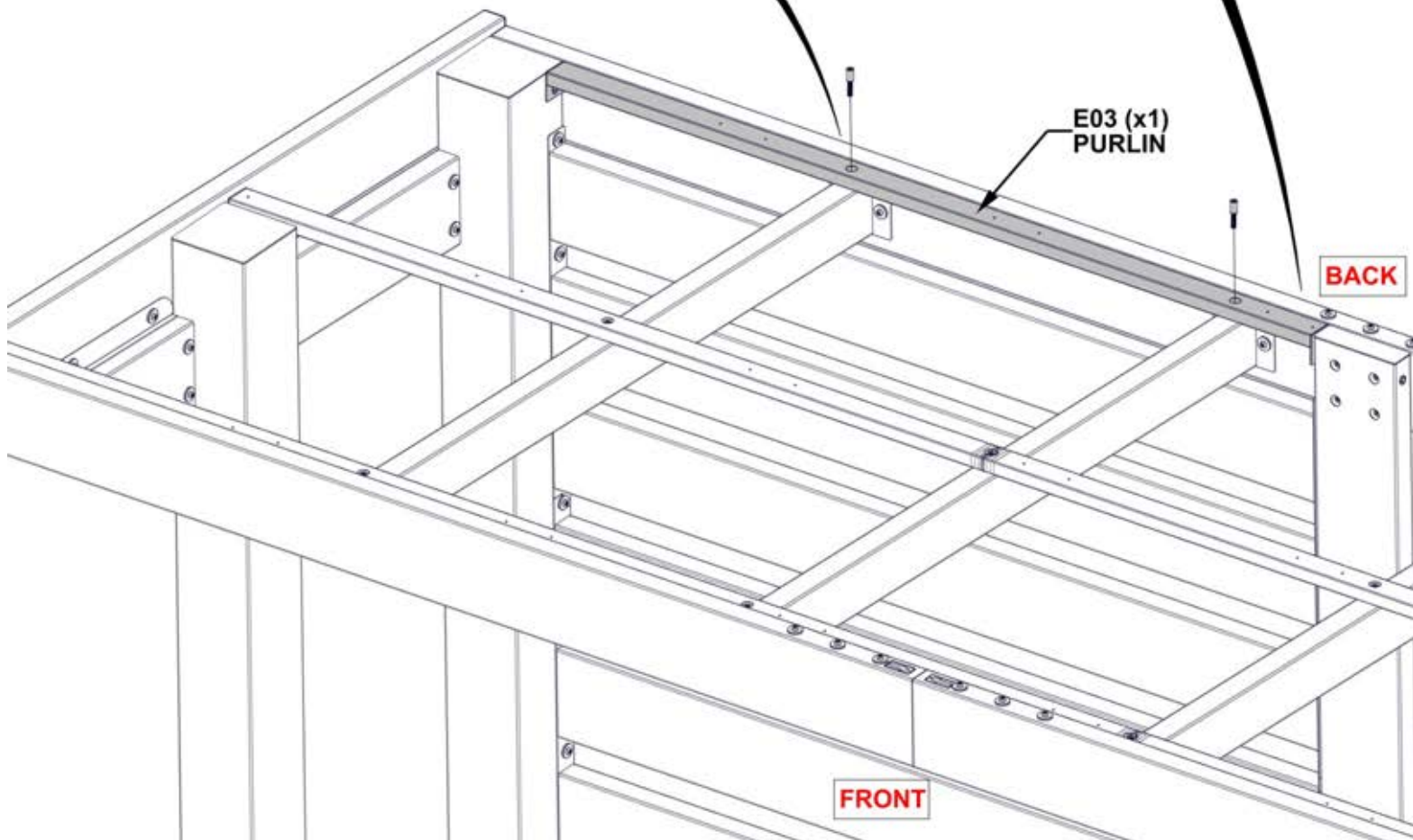
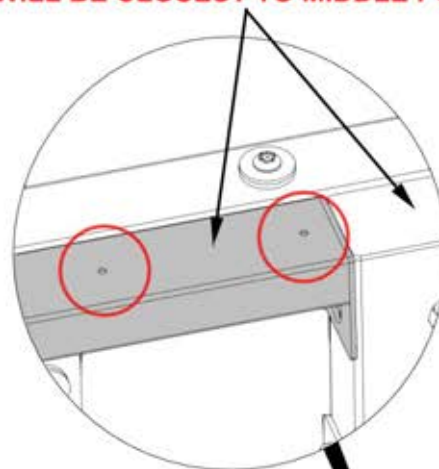
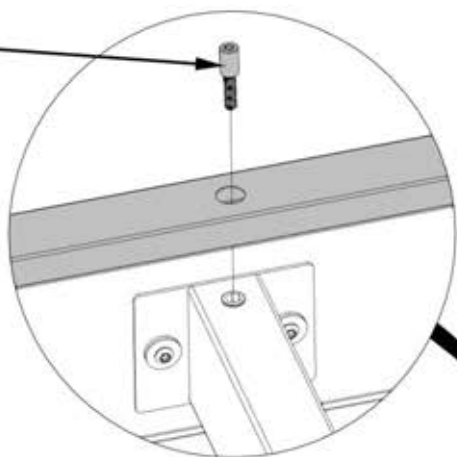

# STEP 52B - ROOF ASSEMBLY

QTY	PART NUMBER	Description
2	H101202	TORX PAN HEAD 1/4-20x3/4 ASSY

**DO NOT STAND ON CABINET FRAME TO INSTALL PURLIN**

**DO NOT TIGHTEN HARDWARE AT THIS STEP**

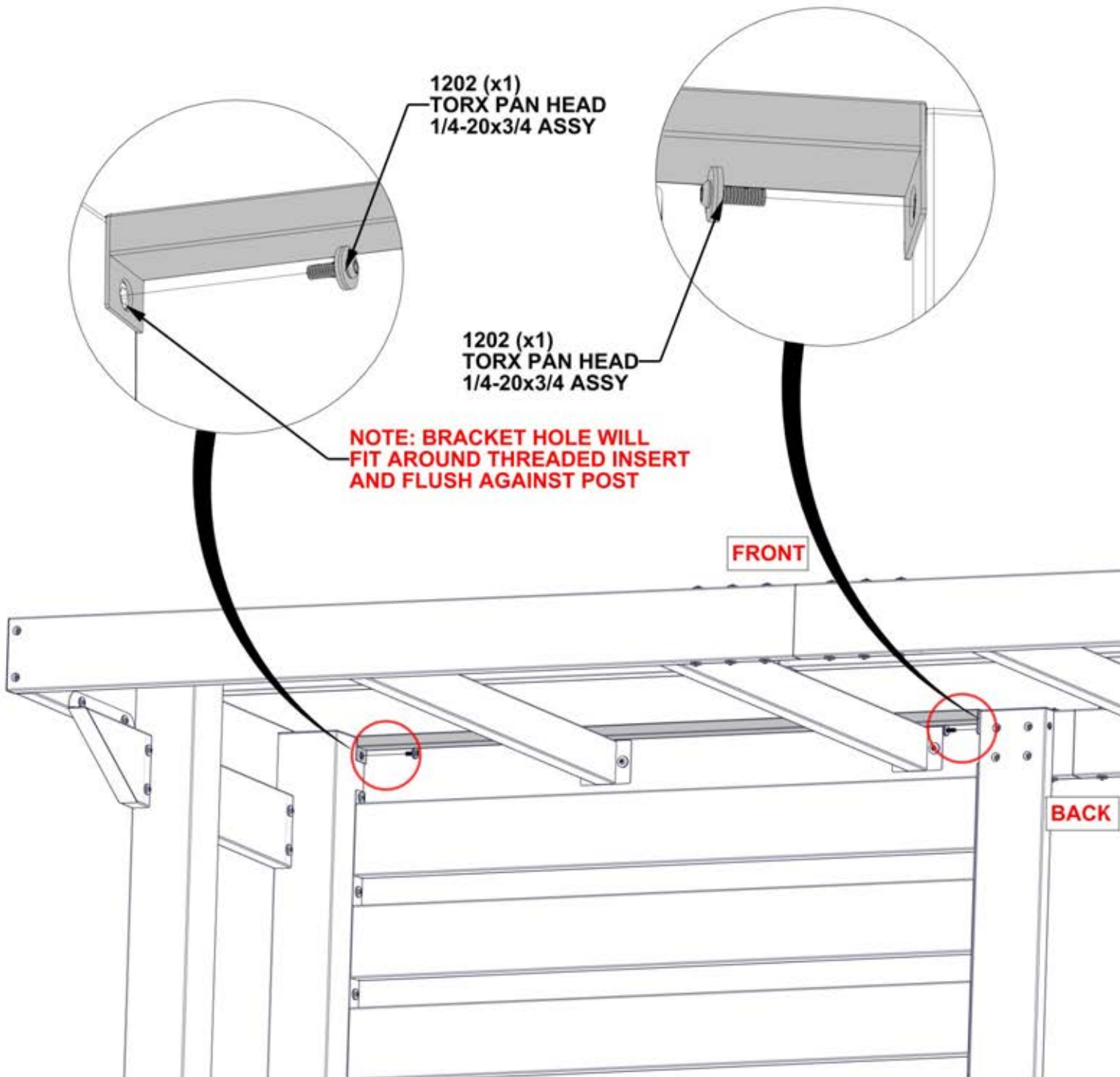

# STEP 53A - ROOF ASSEMBLY



E04 PURLIN - A4M02026  
(x1) 1 9/16"x1 3/4"x58 1/16" (40x45x1475)

QTY	PART NUMBER	Description
2	H101132	TORX SOCKET SCREW 1/4-20

**DO NOT STAND ON CABINET FRAME TO INSTALL PURLIN**

**DO NOT TIGHTEN HARDWARE AT THIS STEP**

**NOTE: ORIENTATION OF PURLIN. PILOT HOLES WILL BE CLOSEST TO MIDDLE POST AND IN LINE WITH OTHER PURLIN HOLES.**

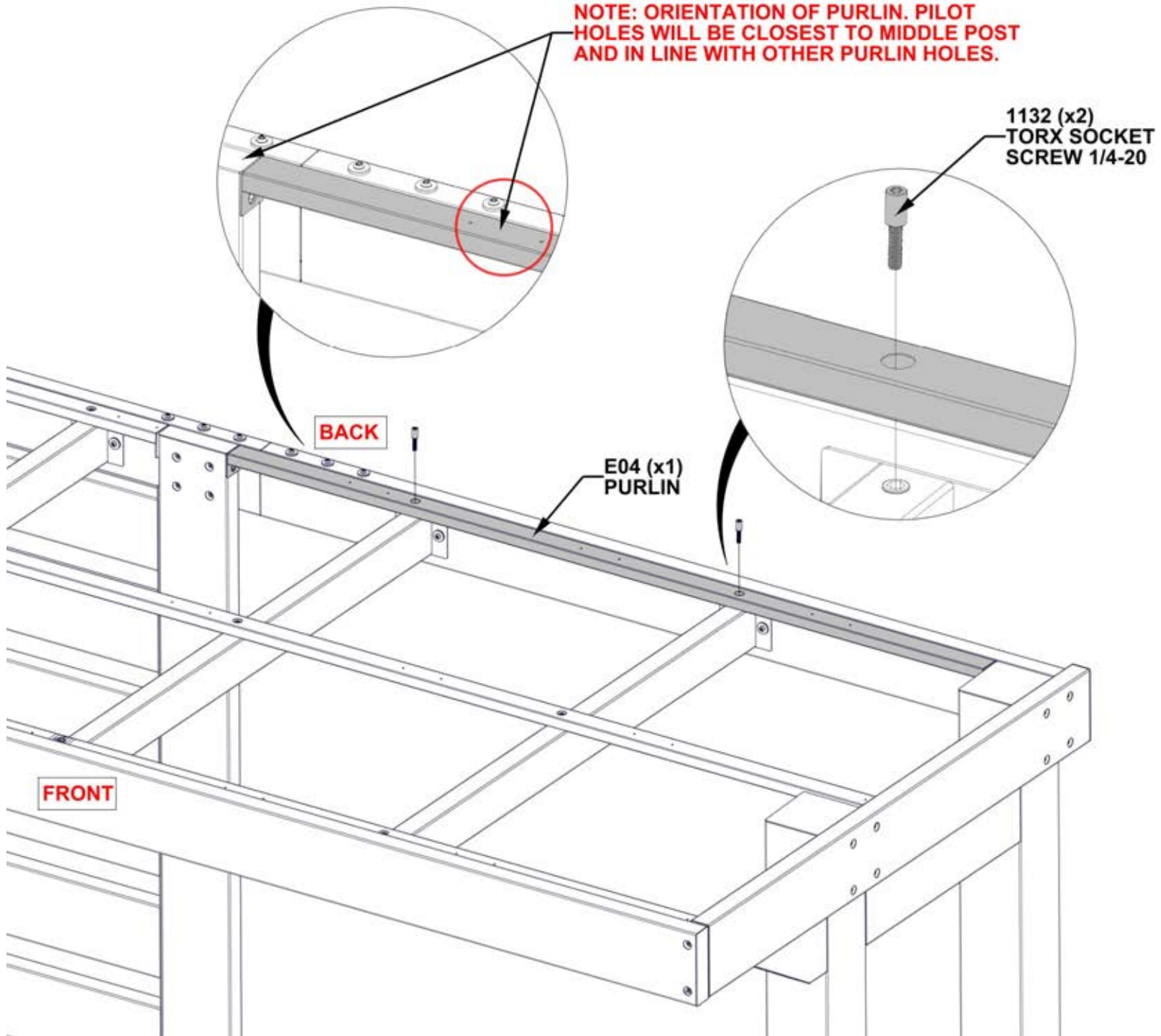

# STEP 53B - ROOF ASSEMBLY

QTY	PART NUMBER	Description
2	H101202	TORX PAN HEAD 1/4-20x3/4 ASSY

**DO NOT STAND ON CABINET FRAME TO INSTALL PURLIN**

**DO NOT TIGHTEN HARDWARE AT THIS STEP**

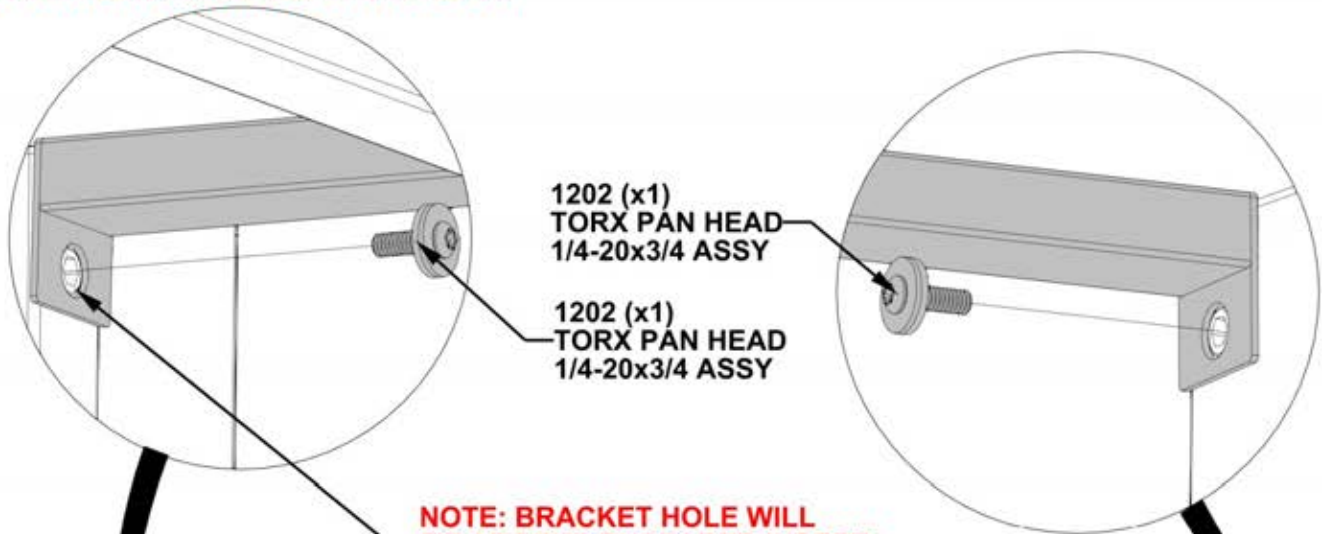

**NOTE: BRACKET HOLE WILL FIT AROUND THREADED INSERT AND FLUSH AGAINST POST**

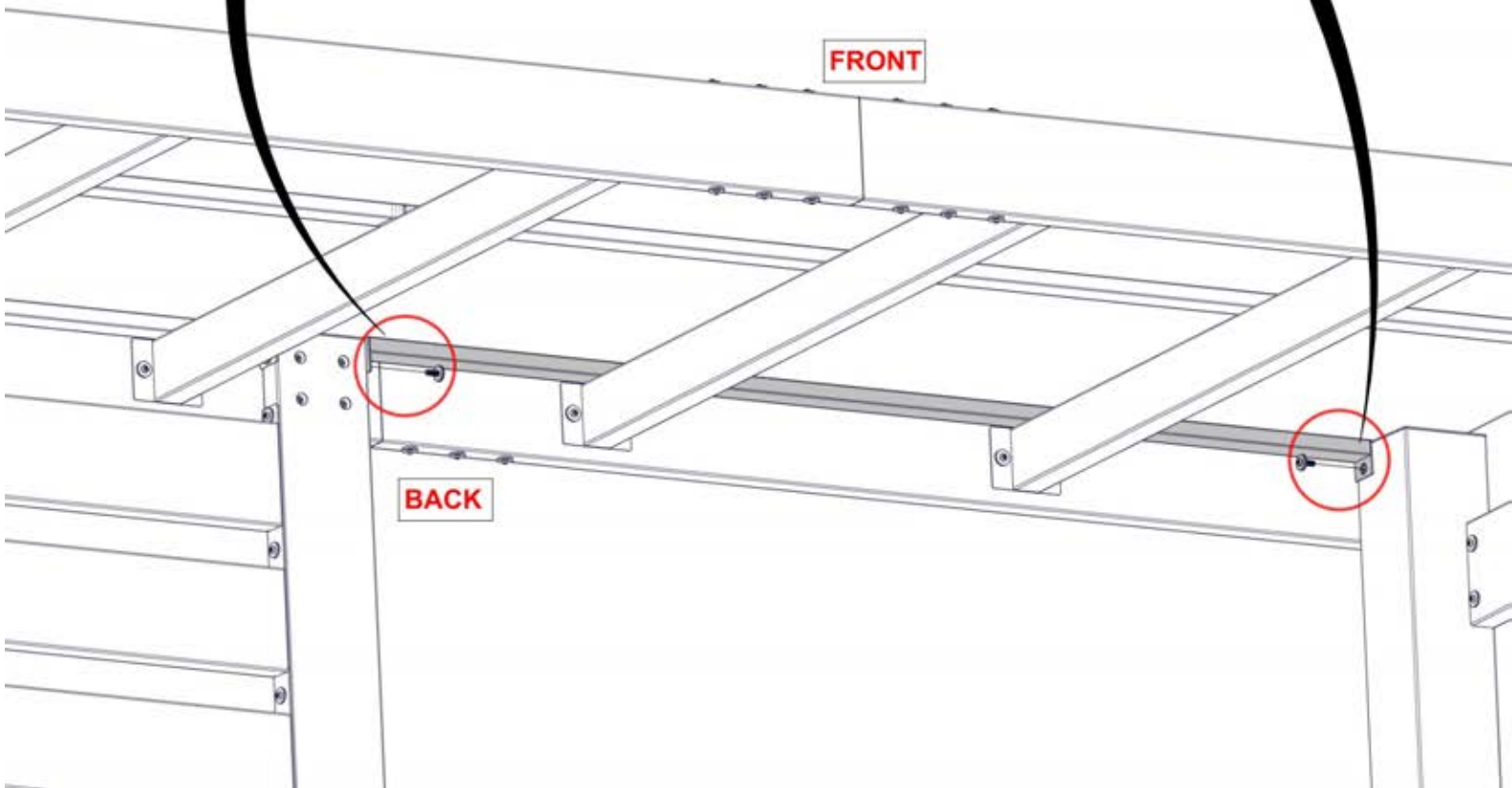

# STEP 54 - SQUARE THE ASSEMBLY

**CRITICAL: SQUARE KITCHEN ROOF BEFORE PROCEEDING TO NEXT STEPS  
ONCE SQUARE, TIGHTEN ALL HARDWARE.**

**MEASUREMENTS TAKEN FROM CORNER TO CORNER OF ROOF.**

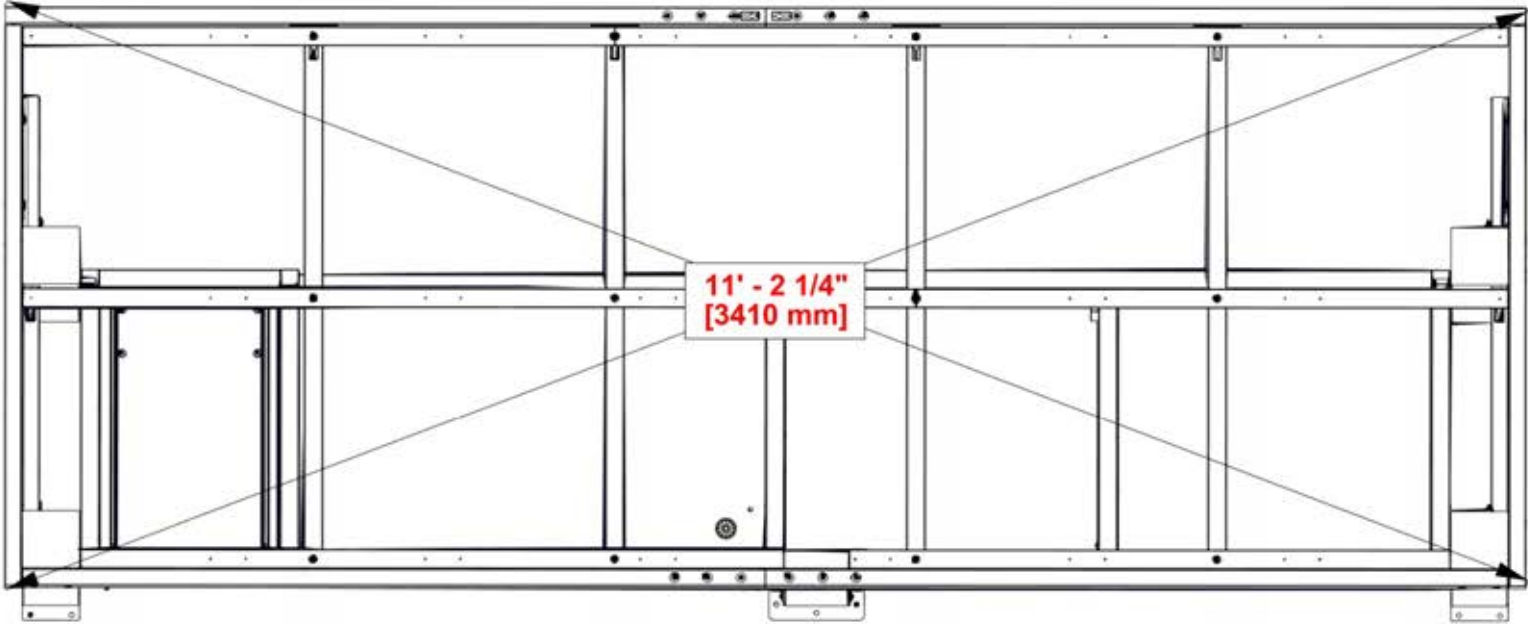

**BEFORE PROCEEDING, MAKE SURE ALL HARDWARE  
IS TIGHT AND KITCHEN ROOF IS SQUARE.**

# STEP 55 - KITCHEN ACCESSORIES



A4M02078 WOOD GRAIN HOLE COVER  
(x28)

**USE A SMALL PIECE OF WOOD AND RUBBER Mallet TO TAP HOLE COVERS IN.**

**DO NOT TAP DIRECTLY WITH A HAMMER AS YOU MAY DAMAGE THE FINISH ON PRODUCT.**

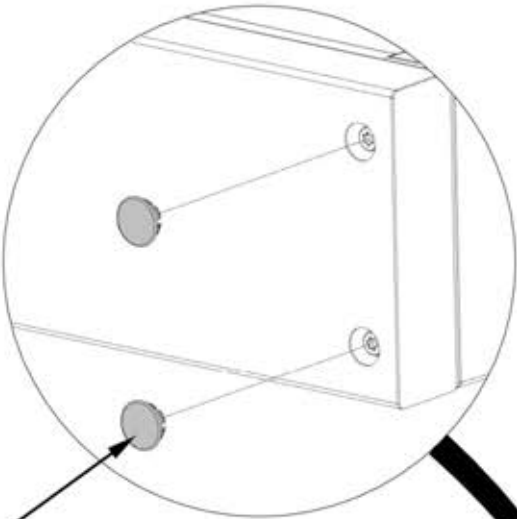

H2 (x28)  
WOOD GRAIN HOLE COVER

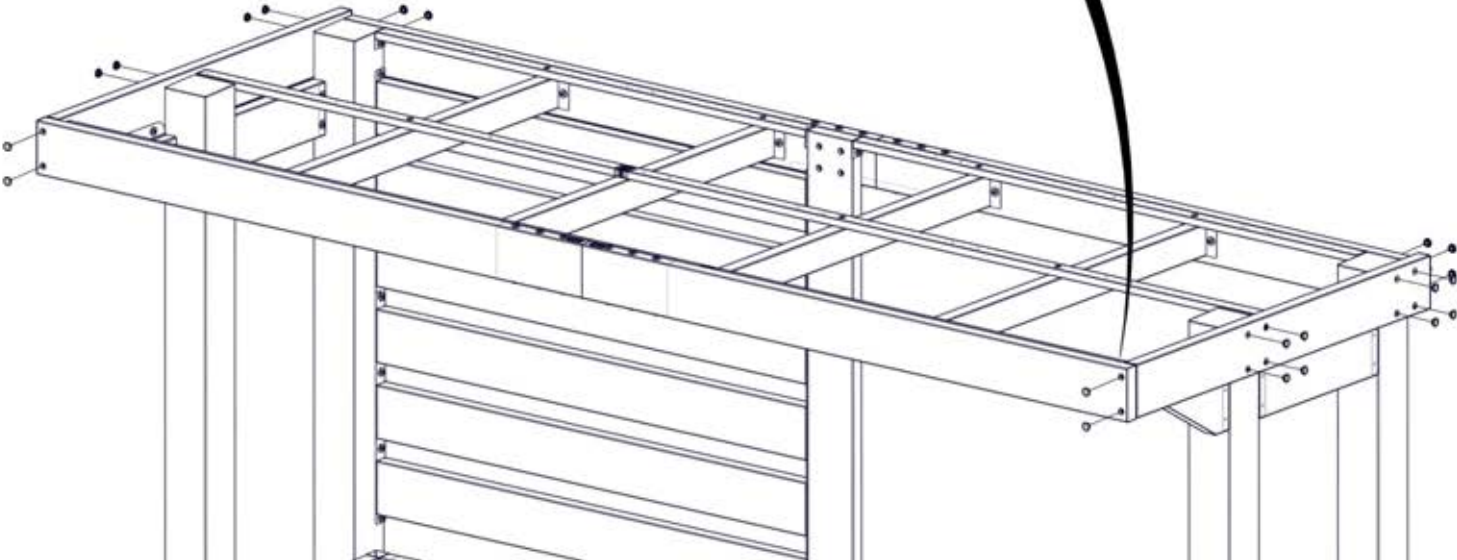

# STEP 56 - ROOF ASSEMBLY

QTY	PART NUMBER	Description
4	H101117	SCREW WOODGRIP 10-16x3/4" BLK



A4M02079 29GA STEEL SHEETING LEFT  
(x1)

TIPS:  
- REMOVE PROTECTIVE FILM

**WARNING: GLOVES ARE RECOMMENDED WHEN HANDLING STEEL ROOF PIECES**

**STARTING AT THE LEFT SIDE AND WORKING TO THE RIGHT, LINE UP THE HOLES IN THE ROOF SHEET WITH THE PILOT HOLES IN THE PURLINS**

**NOTE: DO NOT ADD SCREWS TO THE BACK ROW UNTIL LATER STEPS**

**ORIENT ROOF SHEET WITH "FRONT" STICKER TOWARDS THE FRONT SIDE OF THE GAZEBO AS SHOWN.**

1117 (x4)  
SCREW WOODGRIP 3/4"

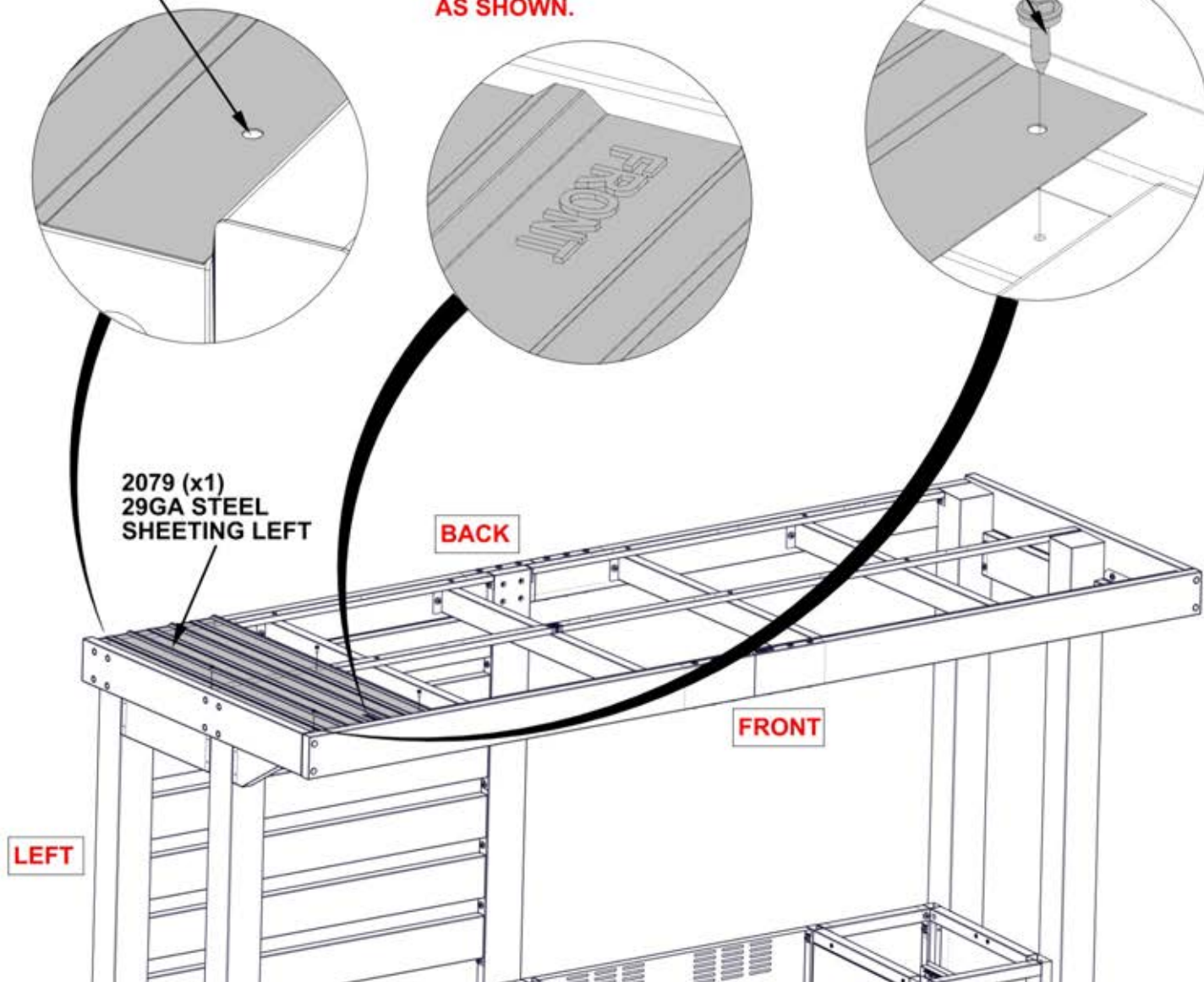



# STEP 57 - ROOF ASSEMBLY

QTY	PART NUMBER	Description
20	H101117	SCREW WOODGRIP 10-16x3/4" BLK



A4M02007 29GA STEEL SHEETING  
(x5)

TIPS:  
- REMOVE PROTECTIVE FILM

**WARNING: GLOVES ARE RECOMMENDED WHEN HANDLING STEEL ROOF PIECES**

**ATTACH AND FULLY TIGHTEN ALL SCREWS ON EACH ROOF SHEET BEFORE ATTACHING THE NEXT ONE. THIS MAKES IT POSSIBLE TO REACH ALL THE SCREWS WITHOUT GETTING ON THE ROOF.**

**STARTING AT THE LEFT SIDE AND WORKING TO THE RIGHT, LINE UP THE HOLES IN THE ROOF SHEET WITH THE PILOT HOLES IN THE PURLINS**

**NOTE: SHEETS OVERLAP BY ONE RIB**

1117 (x20)  
SCREW WOODGRIP 3/4"

**NOTE: DO NOT ADD SCREWS TO THE BACK ROW UNTIL LATER STEPS**

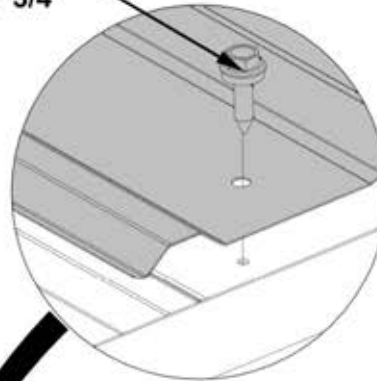

**ORIENT ROOF SHEET WITH "FRONT" STICKER TOWARDS THE FRONT SIDE OF THE GAZEBO AS SHOWN.**

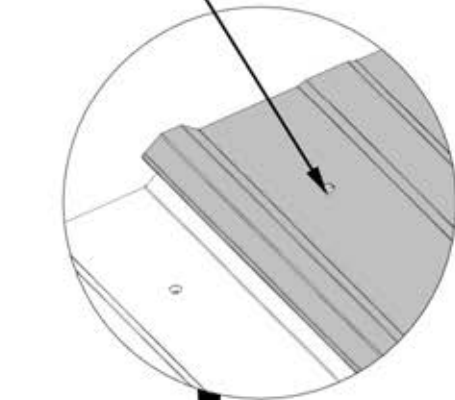
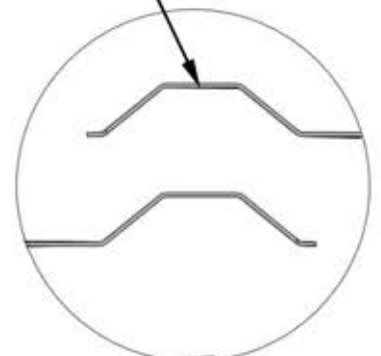

**BACK**

**FRONT**

2007 (x5)  
29GA STEEL SHEETING

**LEFT**

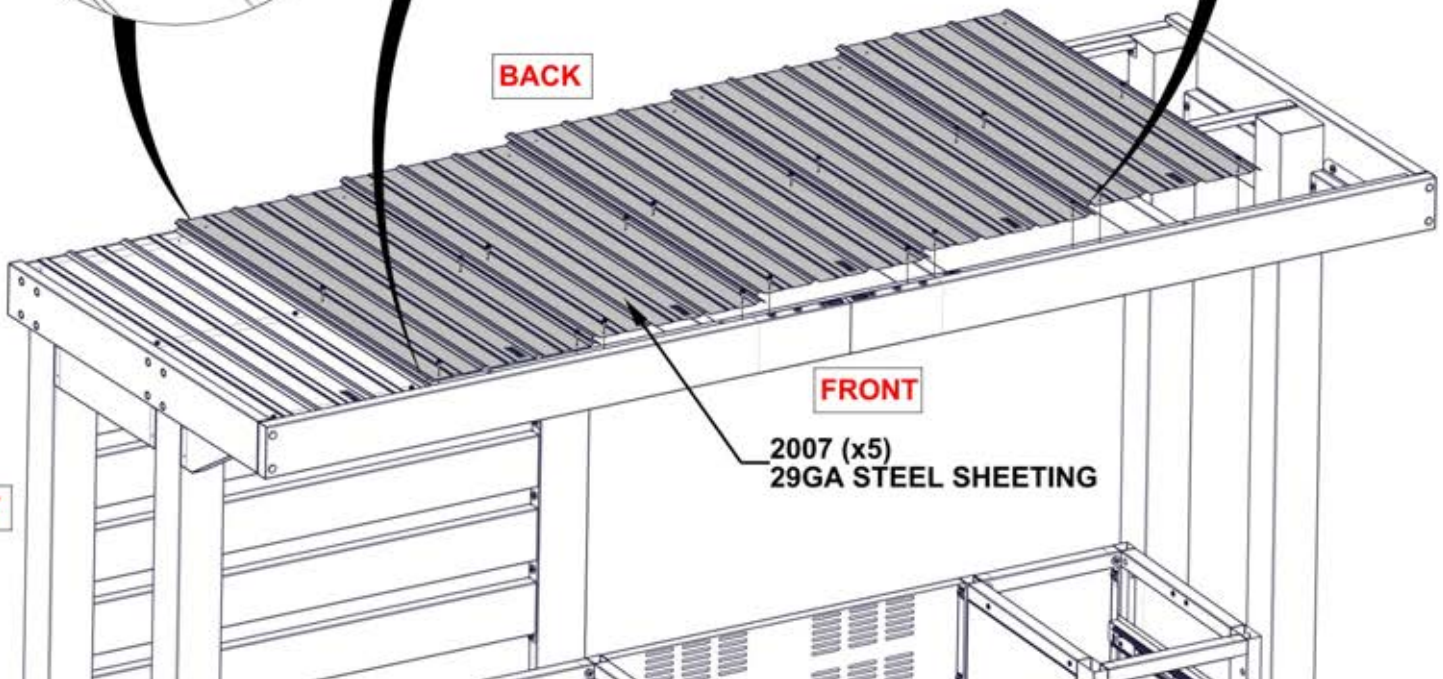

# STEP 58 - ROOF ASSEMBLY

QTY	PART NUMBER	Description
4	H101117	SCREW WOODGRIP 10-16x3/4" BLK



A4M02080 29GA STEEL SHEETING RIGHT  
(x1)

TIPS:  
- REMOVE PROTECTIVE FILM

**WARNING: GLOVES ARE RECOMMENDED WHEN HANDLING STEEL ROOF PIECES**

**ORIENT ROOF SHEET WITH "FRONT" STICKER TOWARDS THE FRONT SIDE OF THE GAZEBO AS SHOWN.**

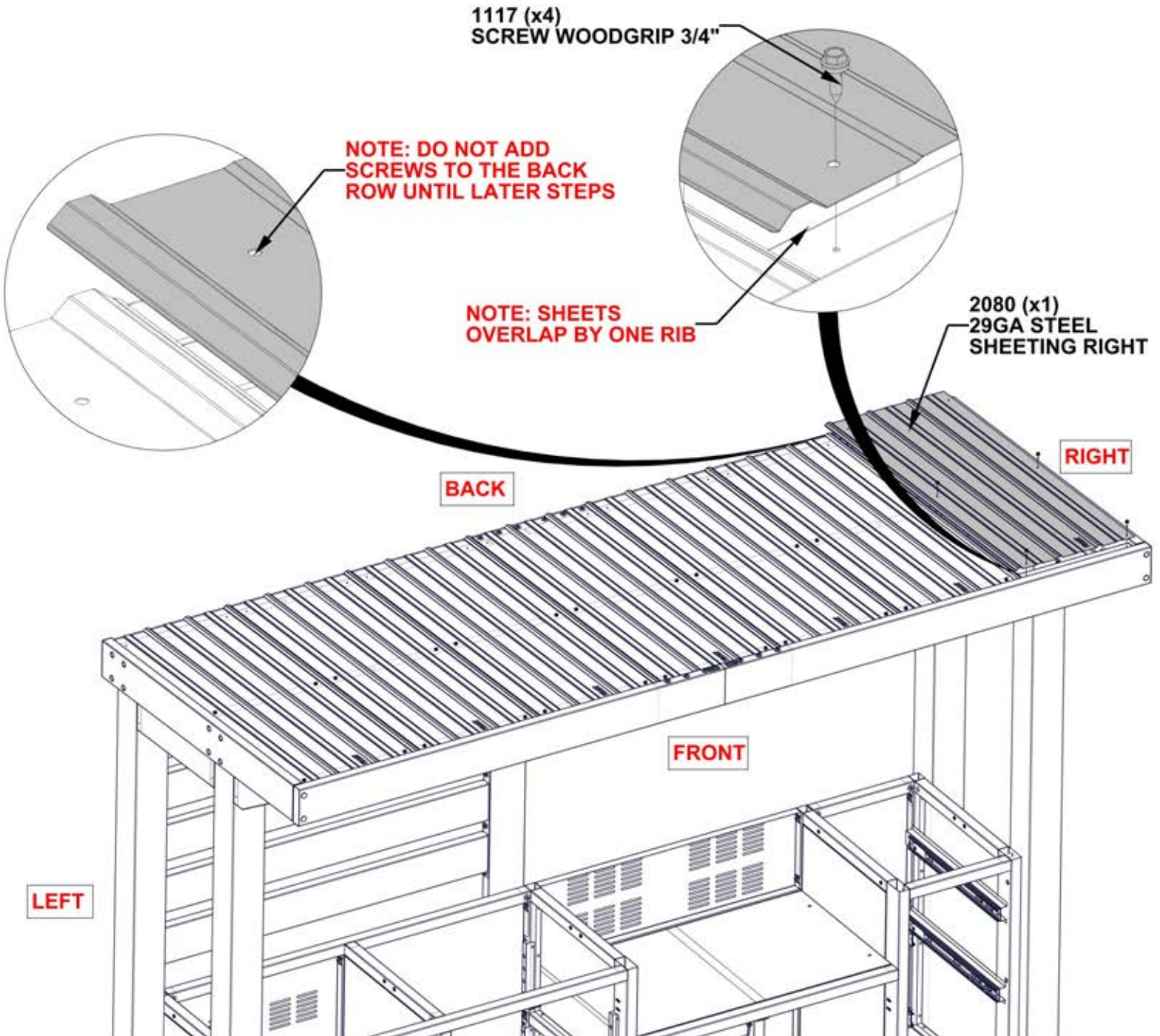

# STEP 59 - ROOF ASSEMBLY

QTY	PART NUMBER	Description
14	H101117	SCREW WOODGRIP 10-16x3/4" BLK



A4M02107 DRIP EDGE  
(x1)



A4M02272 DRIP EDGE  
(x1)



A4M02108 DRIP EDGE SPLICE  
(x1)

**WARNING: GLOVES ARE RECOMMENDED WHEN HANDLING STEEL ROOF PIECES**

**NOTES:**

- REMOVE BLUE FILM FROM DRIP EDGE AND DRIP EDGE SPLICE.
- DUE TO MULTIPLE LAYERS OF METAL ON THE DRIP EDGE, IT IS RECOMMENDED THAT A 1/8" DRILL BIT BE USED TO CREATE STARTER HOLES.
- ORIENT DRIP EDGE AND SPLICE AS SHOWN BELOW.
- ATTACH USING HOLES IN SHEETING. DO NOT GET ON ROOF TO ATTACH SCREWS.

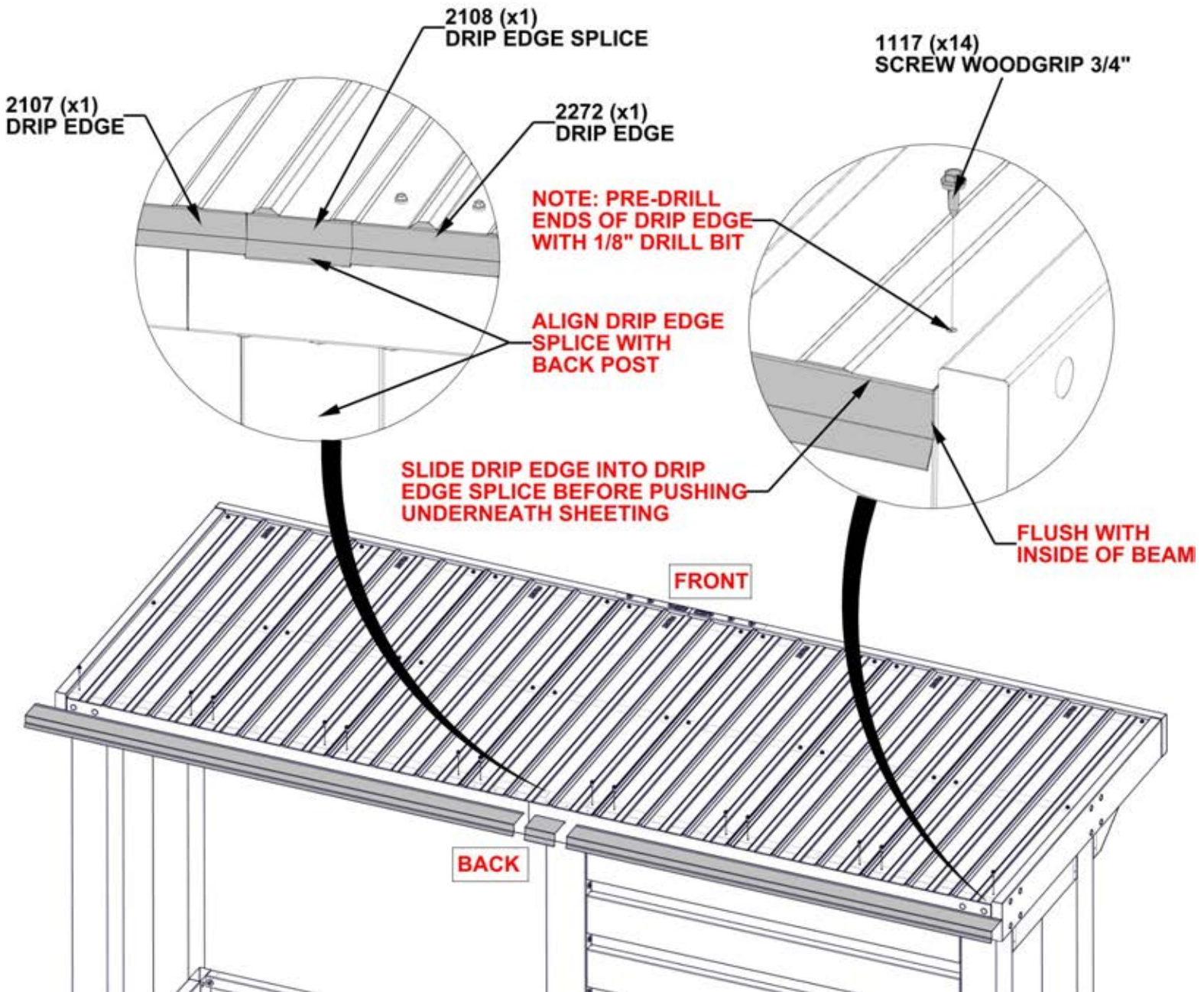

# STEP 60 - ROOF ASSEMBLY



A4M02029 DRIP EDGE  
(x2)

QTY	PART NUMBER	Description
8	H101116	SCREW SELF TAPPING 1/4x1 BLK

**WARNING: GLOVES ARE RECOMMENDED WHEN HANDLING STEEL ROOF PIECES**

**NOTES:**

- REMOVE PROTECTIVE BLUE FILM.
- DUE TO MULTIPLE LAYERS OF METAL ON THE EDGE TRIM, IT IS RECOMMENDED THAT A 1/8" DRILL BIT BE USED TO CREATE STARTER HOLES.

**EVENLY SPACE SCREWS ALONG DRIP EDGE**

**RECESS DRIP EDGE FROM EDGE OF BEAM**

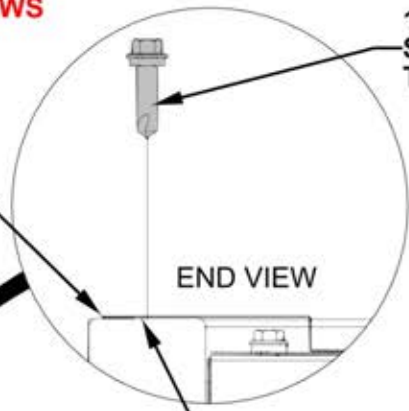

1116 (x8)  
SCREW SELF TAPPING - 1"

END VIEW

**SCREWS WILL GO THROUGH DRIP EDGE INTO SIDE BEAM**

**SLIDE DRIP EDGE UNTIL IT REACHES FRONT BEAM**

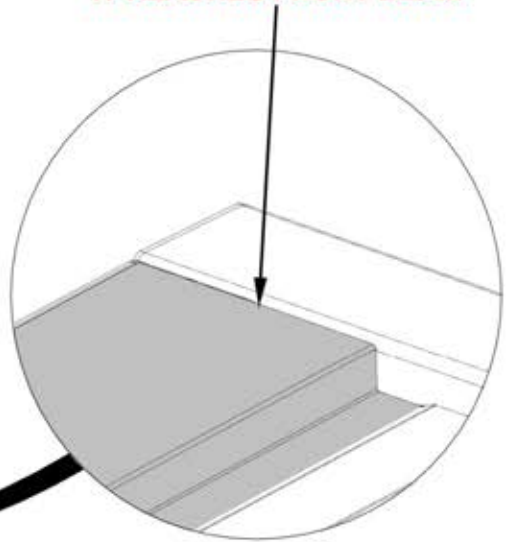

**FRONT**

2029 (x2)  
DRIP EDGE

**BACK**

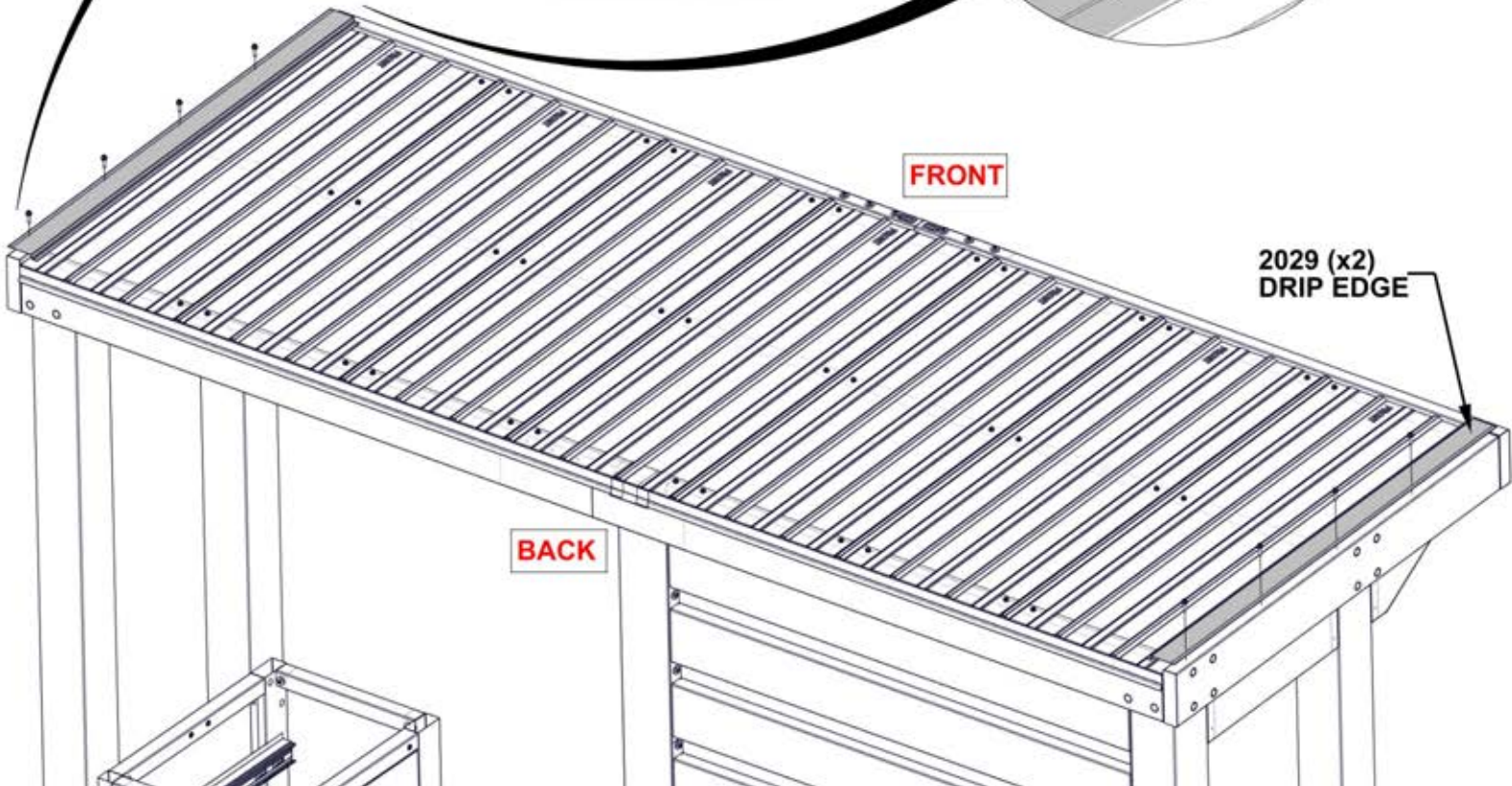

# STEP 61A - ROOF ASSEMBLY

**REMOVE THE 6 TORX BOLT/WASHER FROM TOP SURFACE OF FRONT BEAM ASSEMBLY AND SET ASIDE. HARDWARE WILL BE USED IN LATER STEP.**

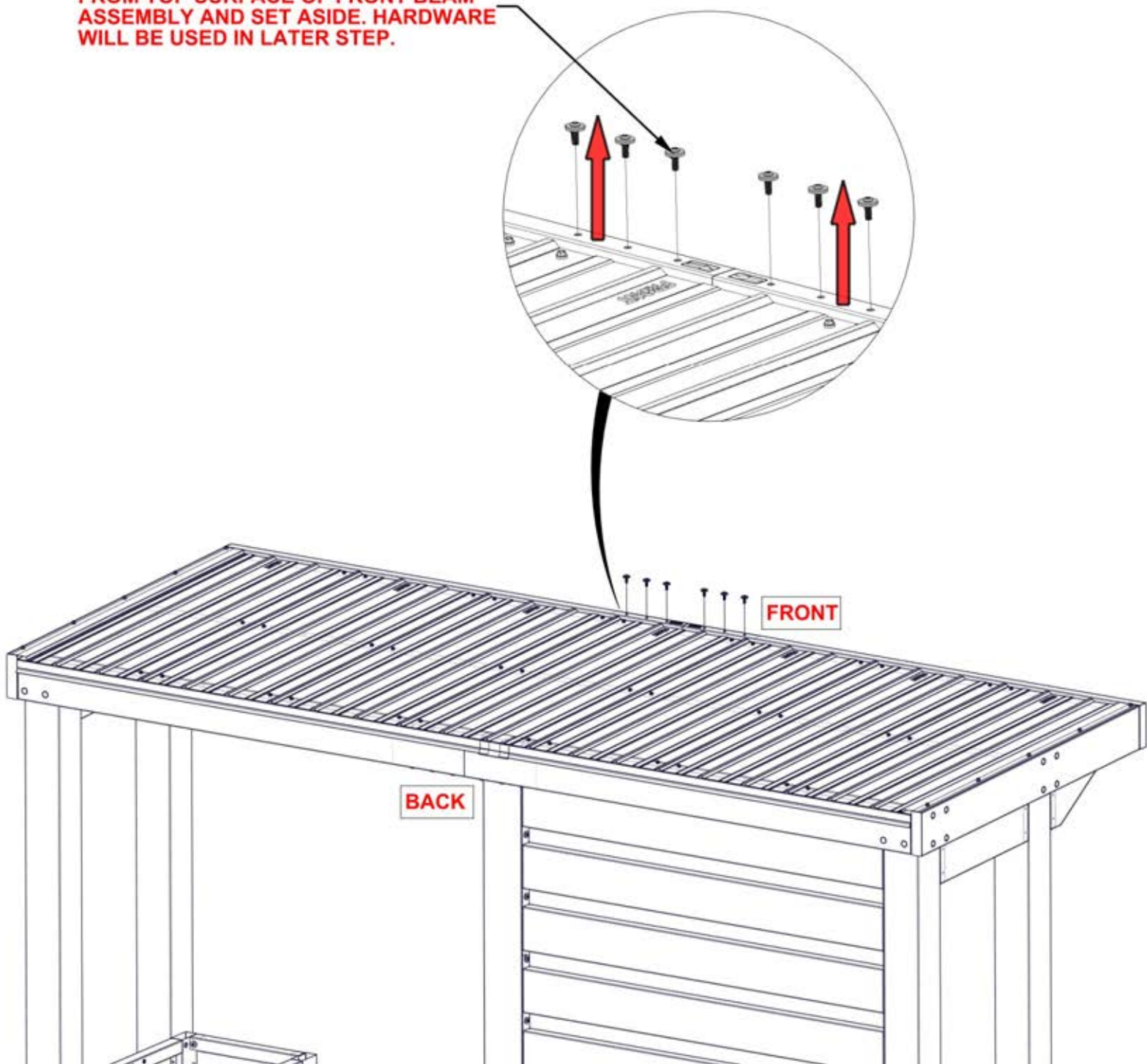

# STEP 61B - ROOF ASSEMBLY



A4M02186 DRIP EDGE  
(x1)



A4M02187 DRIP EDGE  
(x1)



A4M02273 DRIP EDGE SPLICE  
(x1)

**WARNING: GLOVES ARE RECOMMENDED WHEN HANDLING STEEL ROOF PIECES**

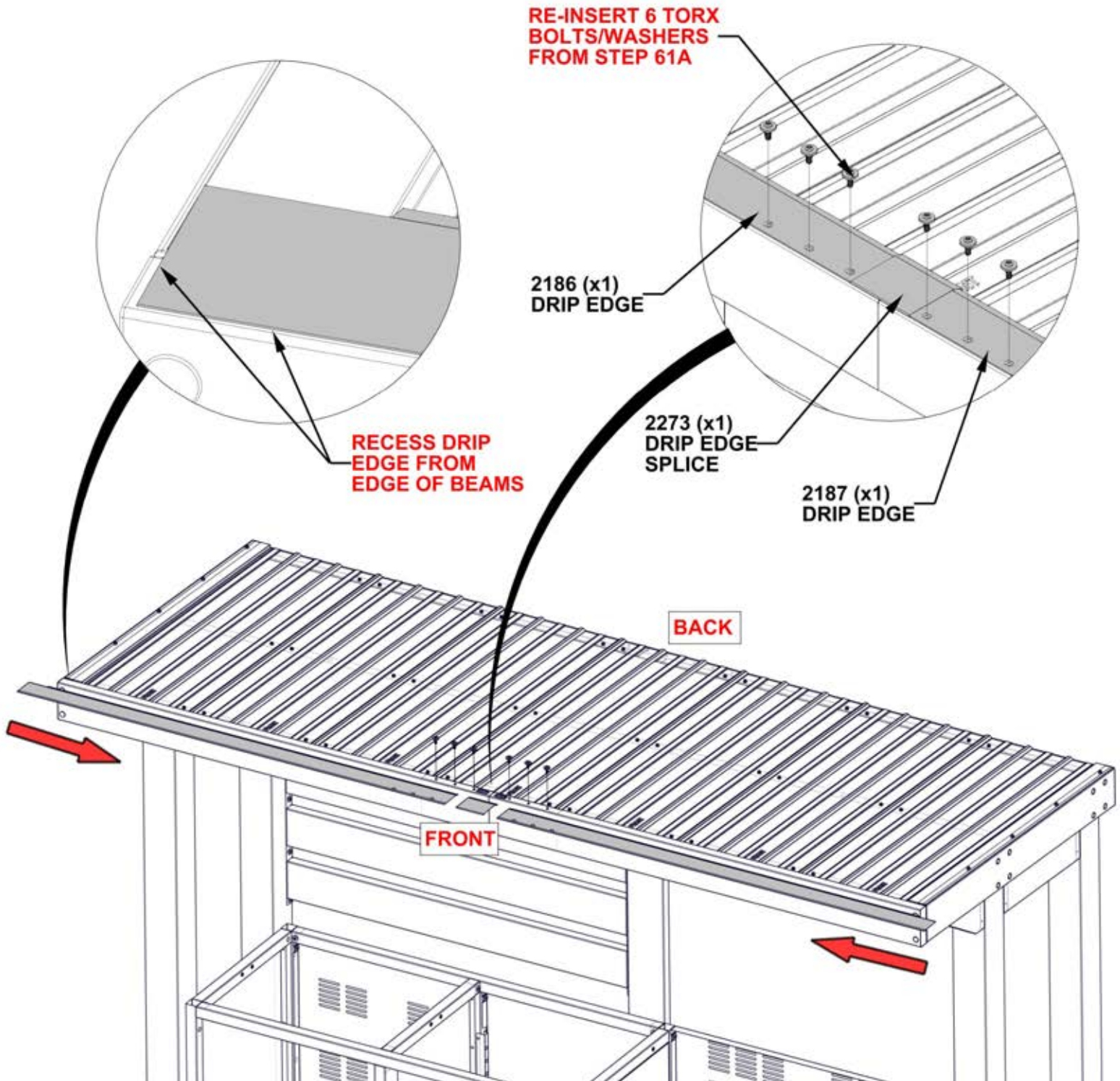

# STEP 61C - ROOF ASSEMBLY

QTY	PART NUMBER	Description
12	H101116	SCREW SELF TAPPING 1/4x1 BLK

**WARNING: GLOVES ARE RECOMMENDED WHEN HANDLING STEEL ROOF PIECES**

**NOTES:**

- REMOVE PROTECTIVE BLUE FILM.
- DUE TO MULTIPLE LAYERS OF METAL ON THE EDGE TRIM, IT IS RECOMMENDED THAT A 1/8" DRILL BIT BE USED TO CREATE STARTER HOLES.

**EVENLY SPACE SCREWS ALONG DRIP EDGE**

**1116 (x12)  
SCREW SELF  
TAPPING - 1"**

**SCREWS WILL GO  
THROUGH DRIP EDGE  
INTO BEAMS**

**SIDE VIEW**

**BACK**

**FRONT**

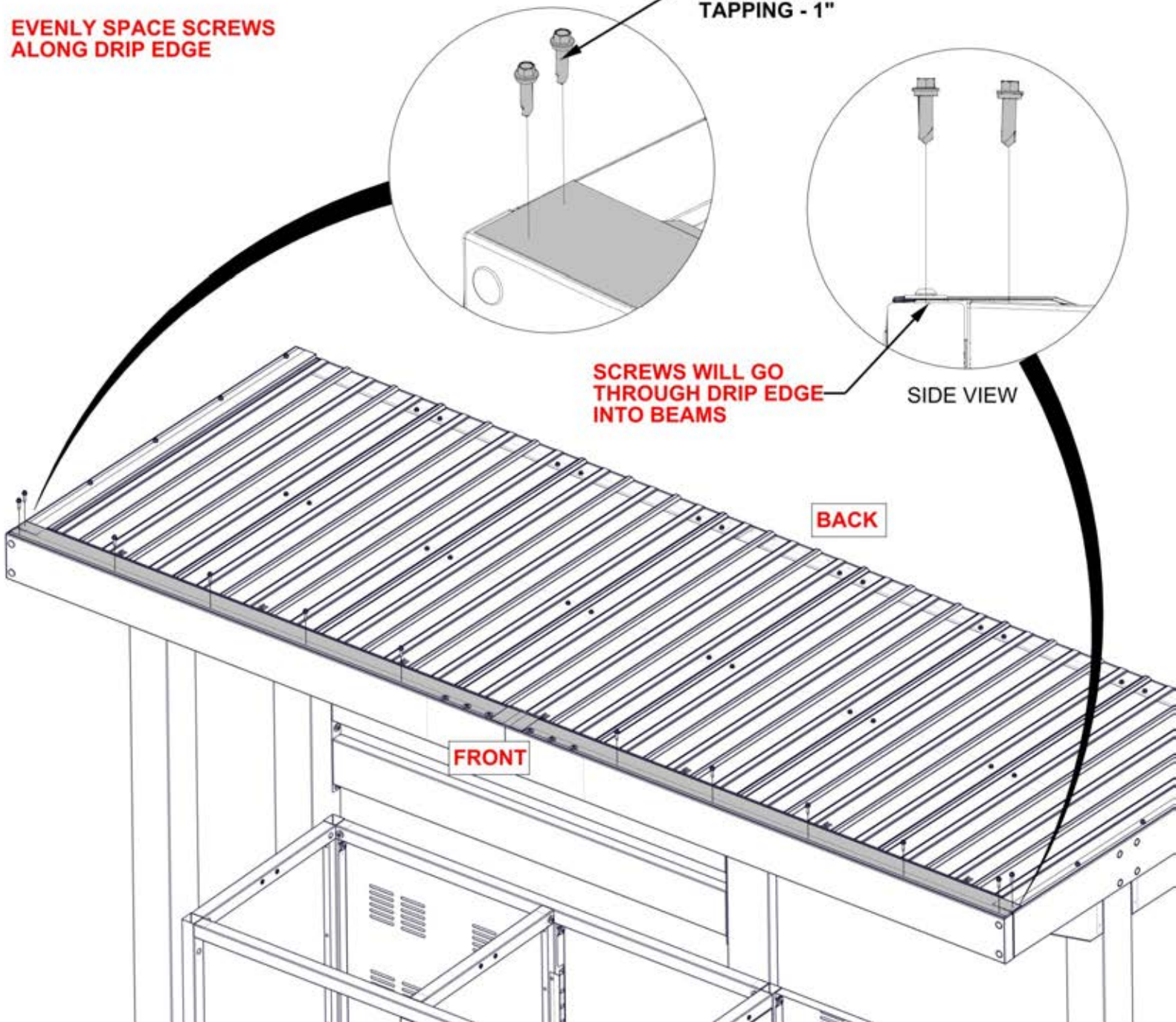

# STEP 62A - KITCHEN CABINET ASSEMBLY

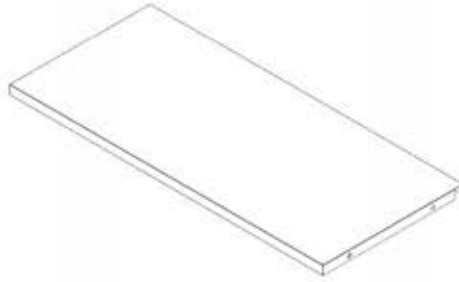

C10 COUNTERTOP - A4M02058  
(x1) 1 5/8"x25 3/8"x56 5/8" (41x645x1438)

**TIPS:**  
- REMOVE PROTECTIVE FILM FROM SIDES OF COUNTERTOP, LEAVING FILM ONLY ON TOP SURFACE UNTIL ASSEMBLY IS FINISHED TO PREVENT SCRATCHES.

**WARNING: GLOVES ARE RECOMMENDED WHEN HANDLING STAINLESS STEEL COUNTERTOP**

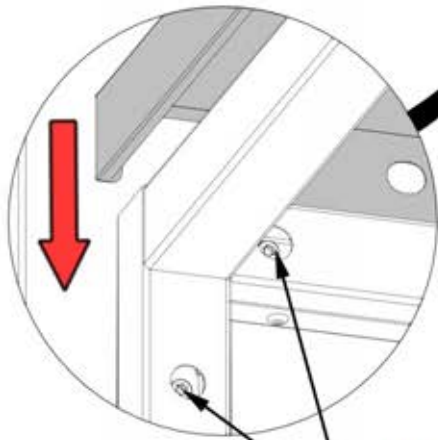
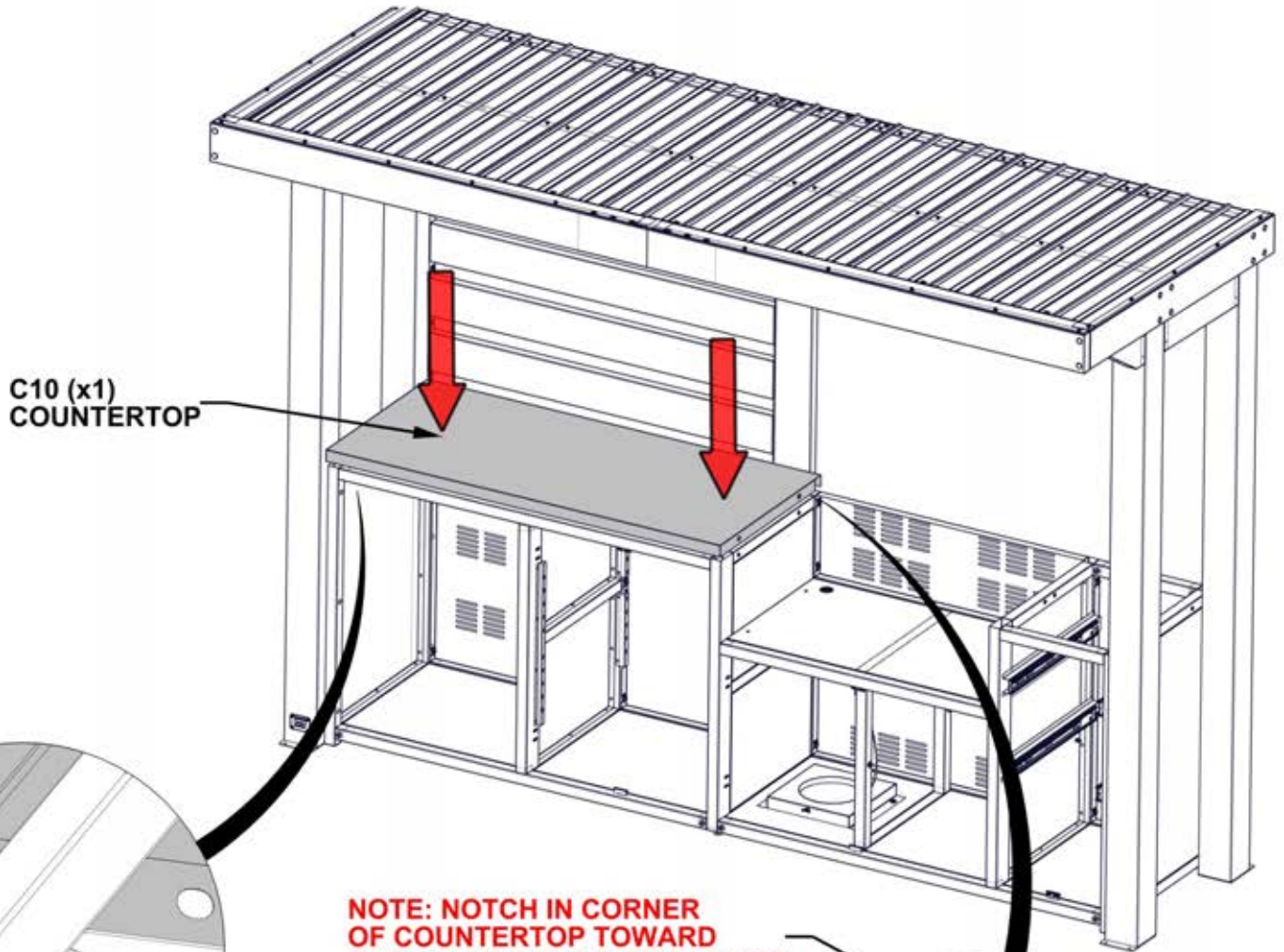

**NOTE: HARDWARE FROM STEPS 20 AND 22 MAY NEED TO BE LOOSENED TO ALLOW COUNTERTOP TO SLIDE IN PLACE BETWEEN POST AND PANEL**

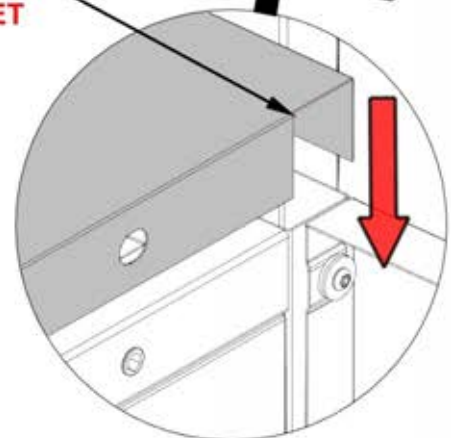



# STEP 62B - KITCHEN CABINET ASSEMBLY

QTY	PART NUMBER	Description
2	H101202	TORX PAN HEAD 1/4-20x3/4 ASSY

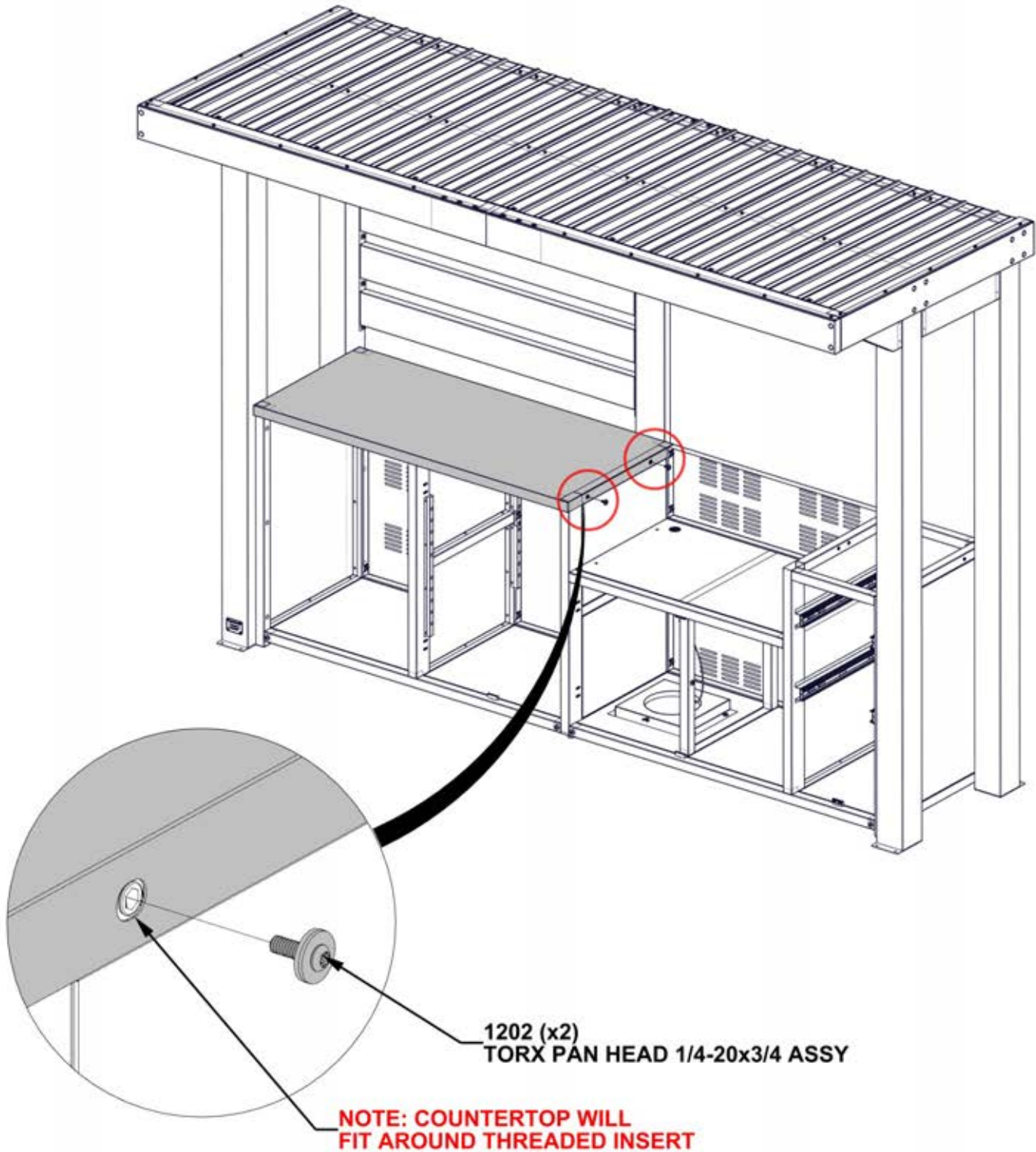

# STEP 62C - KITCHEN CABINET ASSEMBLY

QTY	PART NUMBER	Description
2	H101202	TORX PAN HEAD 1/4-20x3/4 ASSY

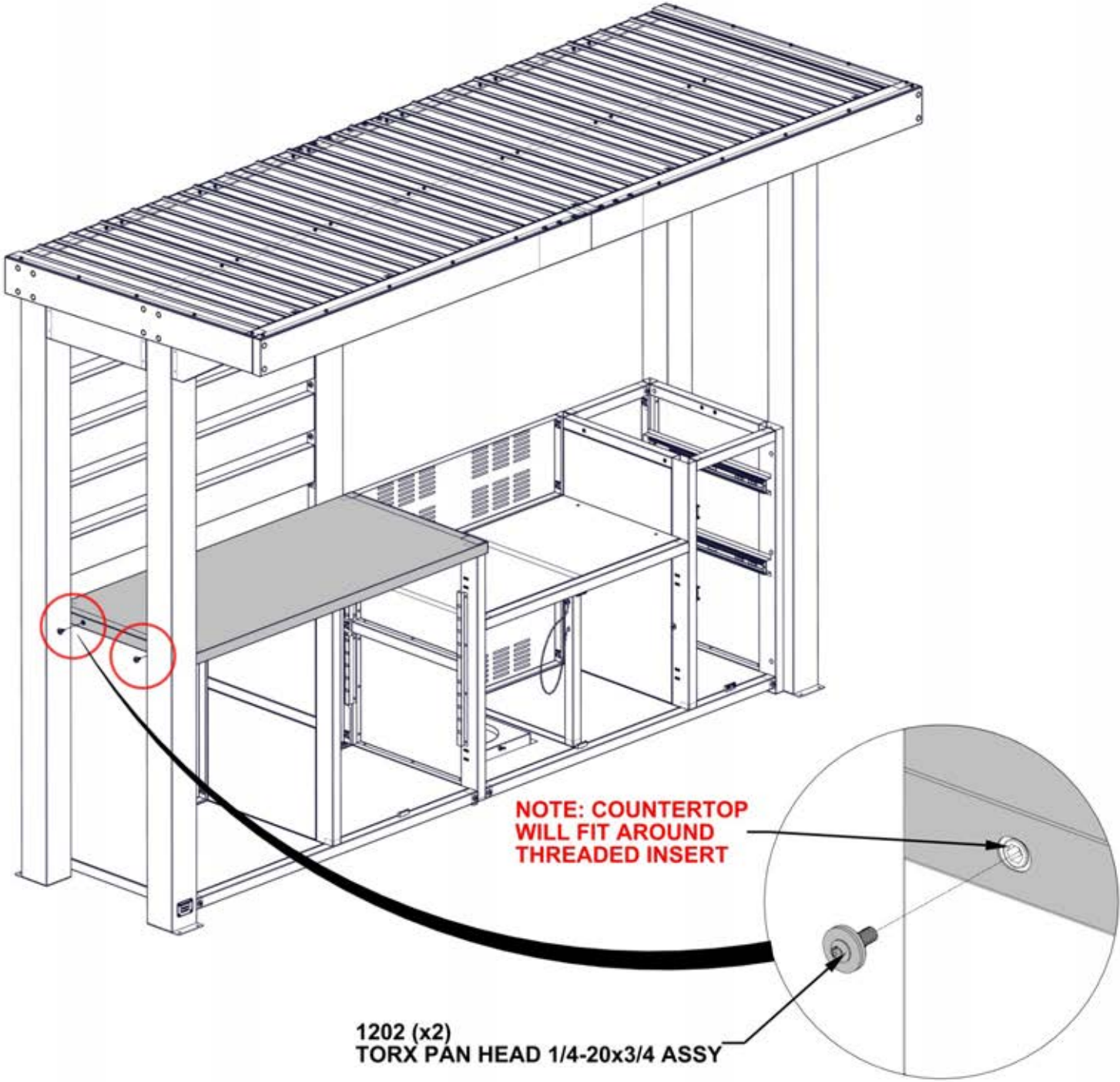

# STEP 62D - KITCHEN CABINET ASSEMBLY

QTY	PART NUMBER	Description
8	H101202	TORX PAN HEAD 1/4-20x3/4 ASSY

**ATTACH HARDWARE FROM UNDERSIDE OF COUNTERTOP.  
RIGHT ANGLE DRILL ADAPTER IS HELPFUL FOR THIS STEP.**

1202 (x8)  
TORX PAN HEAD  
1/4-20x3/4 ASSY

**NOTE: BRACKET  
WILL FIT AROUND  
THREADED INSERT**

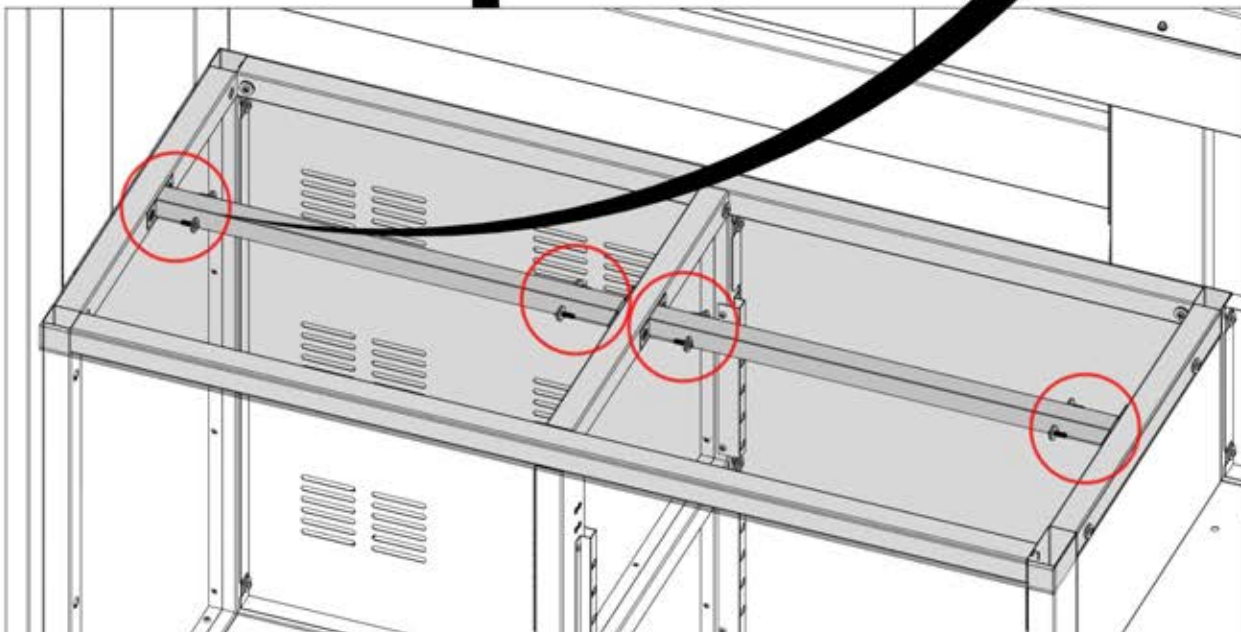
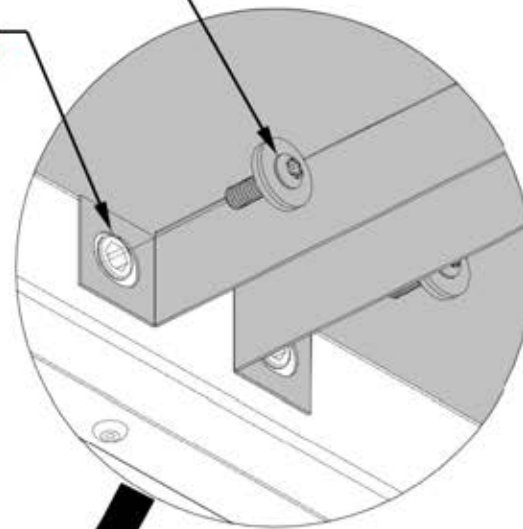
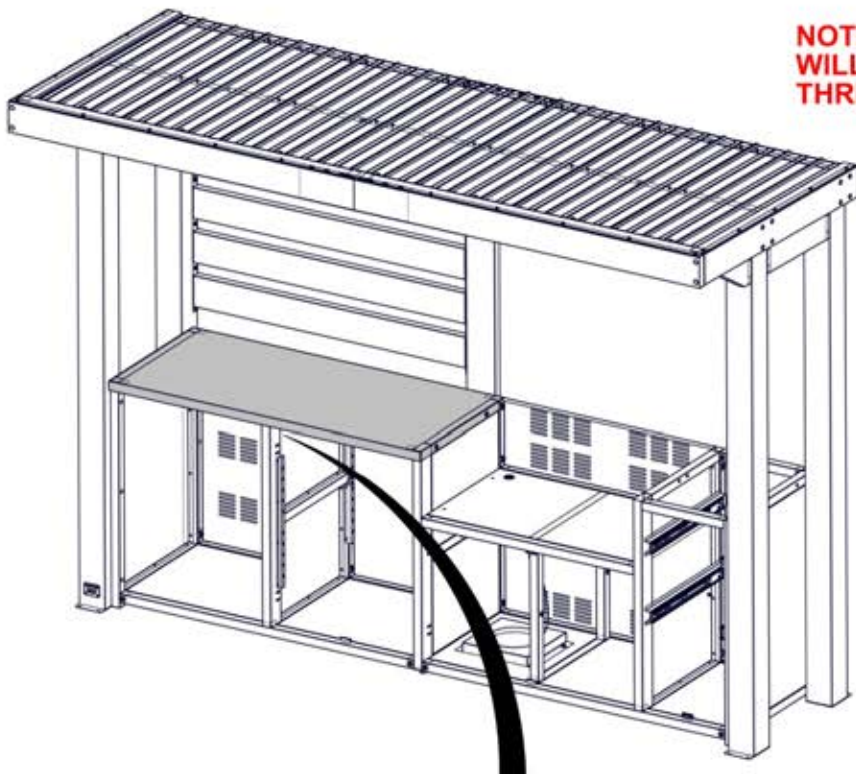

# STEP 63A - KITCHEN CABINET ASSEMBLY

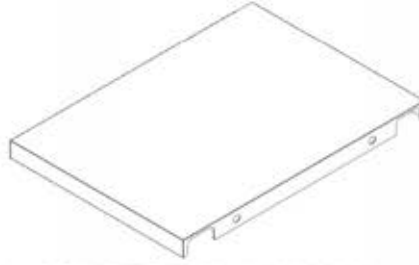

C11 COUNTERTOP - A4M02059  
(x1) 1 5/8"x18 3/16"x25 3/8" (41x462x645)

**TIPS:**  
- REMOVE PROTECTIVE FILM FROM SIDES OF COUNTERTOP, LEAVING FILM ONLY ON TOP SURFACE UNTIL ASSEMBLY IS FINISHED TO PREVENT SCRATCHES.

**WARNING: GLOVES ARE RECOMMENDED WHEN HANDLING STAINLESS STEEL COUNTERTOP**

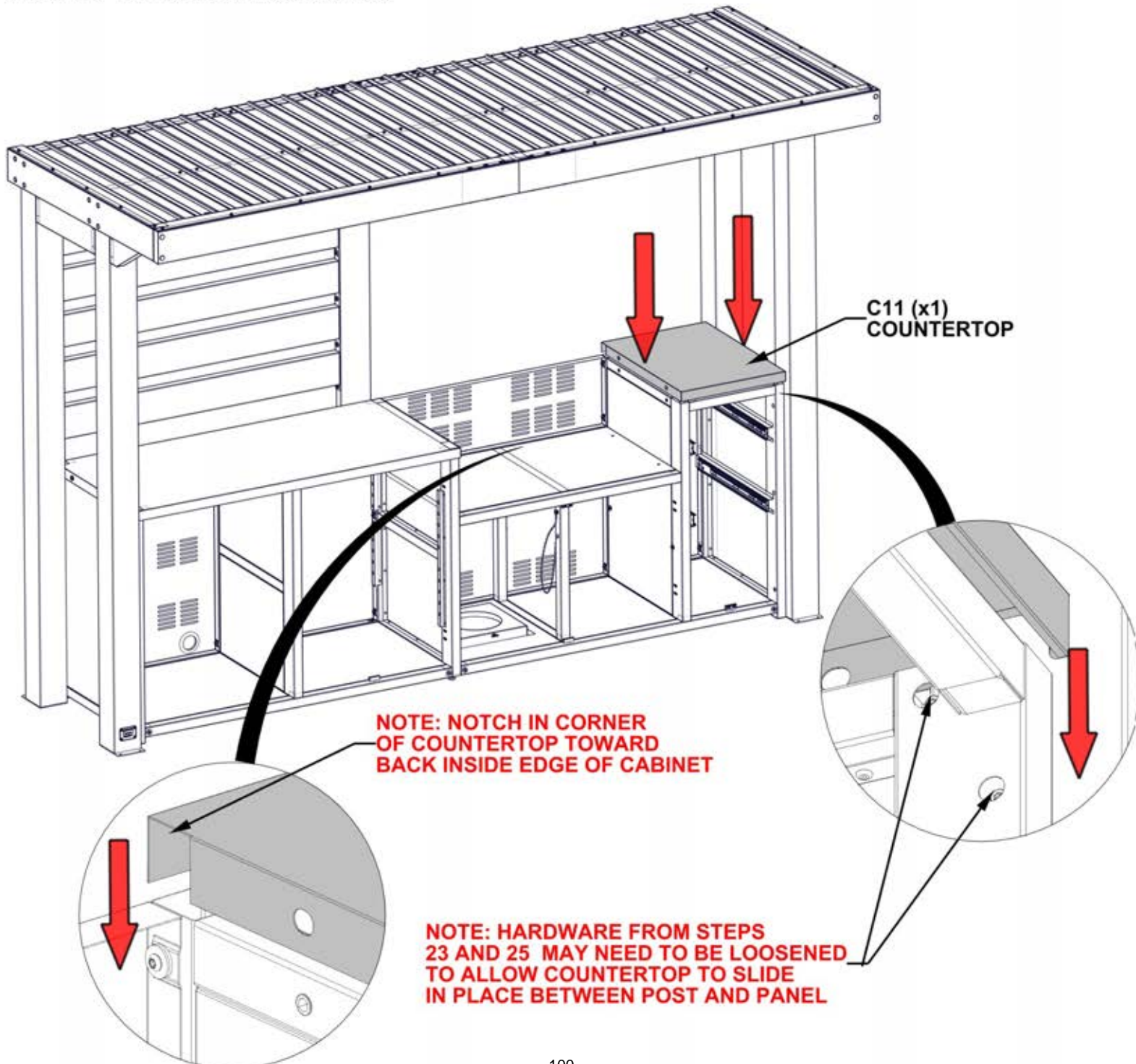

# STEP 63B - KITCHEN CABINET ASSEMBLY

QTY	PART NUMBER	Description
2	H101202	TORX PAN HEAD 1/4-20x3/4 ASSY

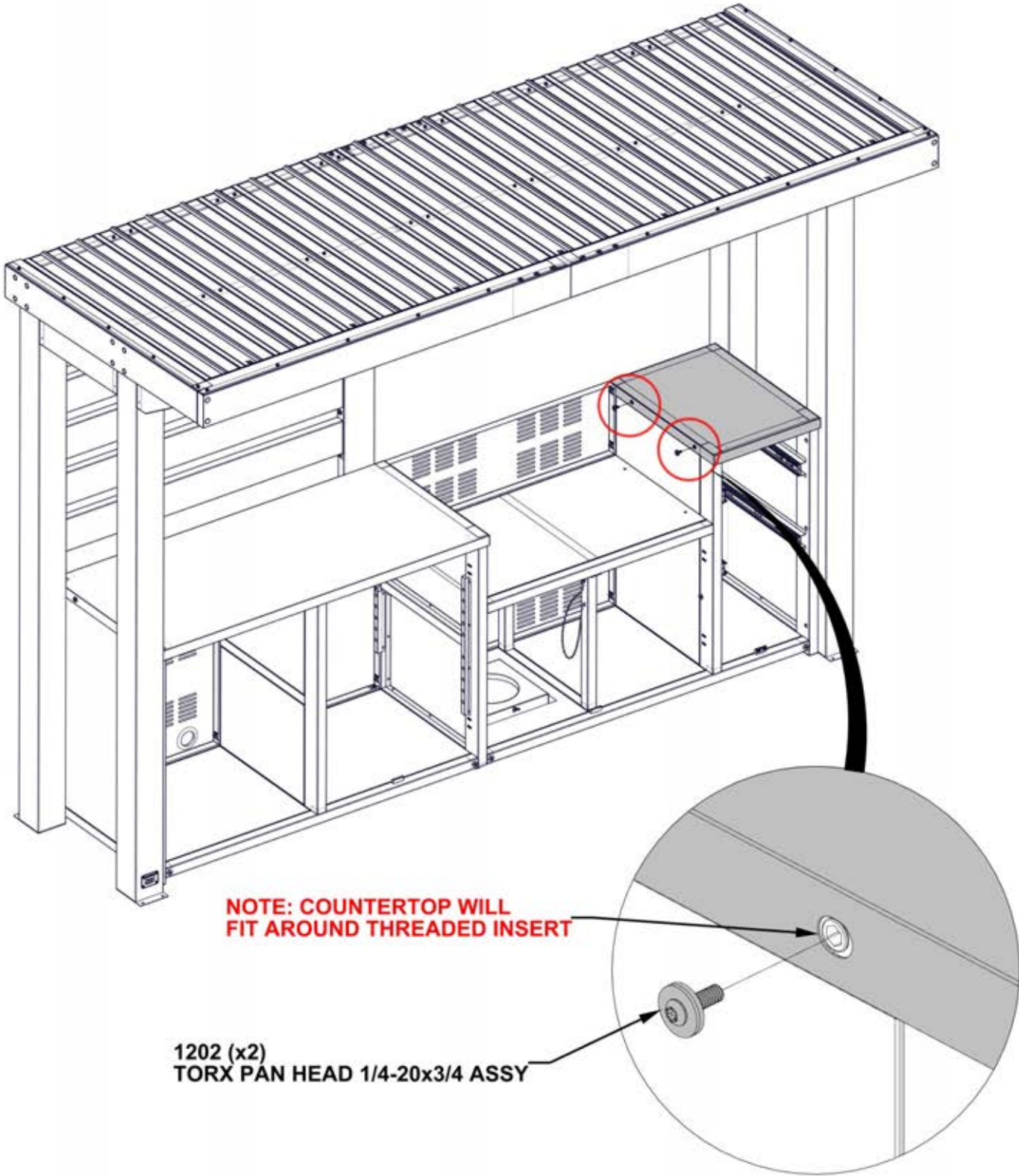

# STEP 63C - KITCHEN CABINET ASSEMBLY

QTY	PART NUMBER	Description
2	H101202	TORX PAN HEAD 1/4-20x3/4 ASSY

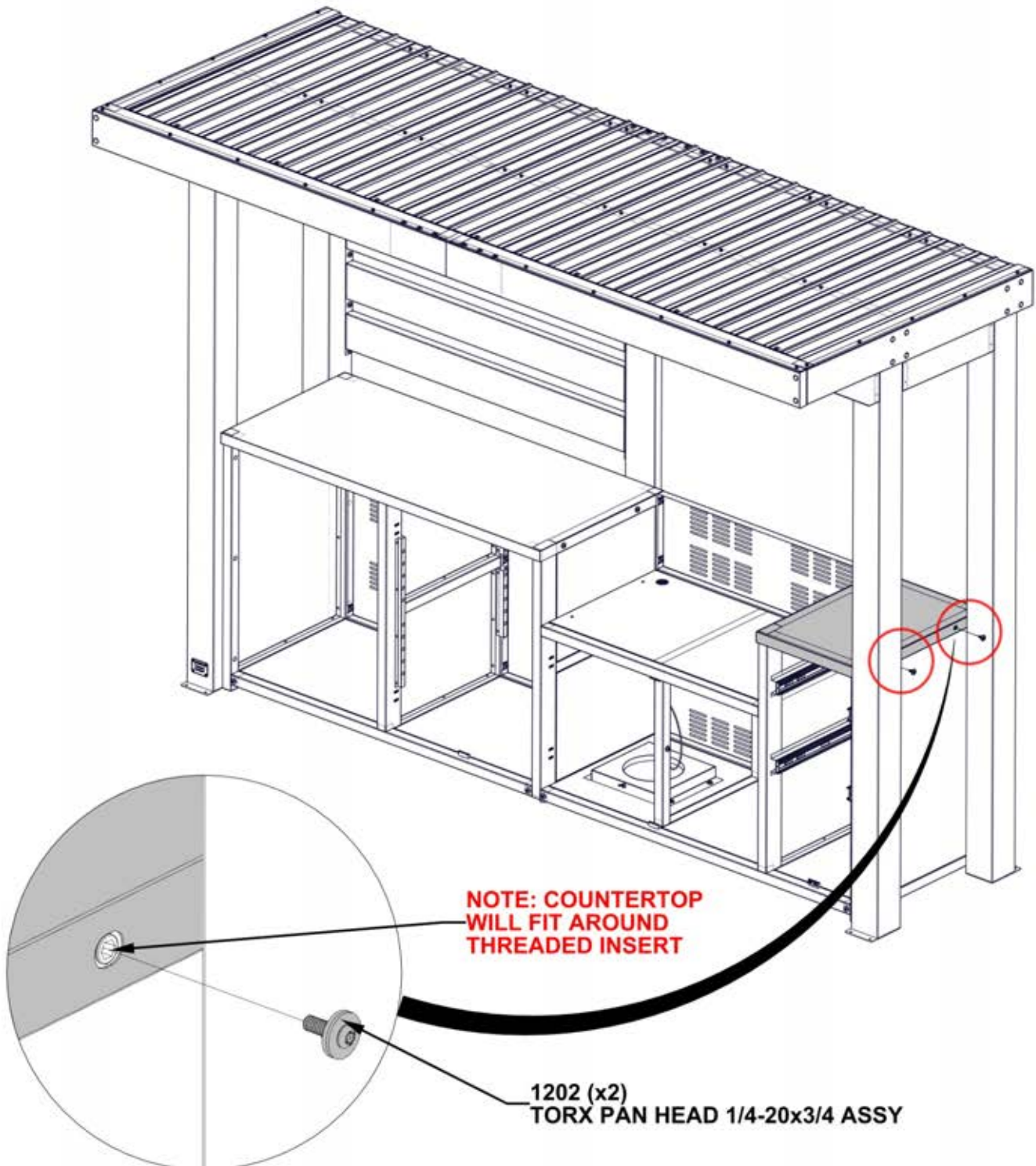

# STEP 63D - KITCHEN CABINET ASSEMBLY

QTY	PART NUMBER	Description
4	H101202	TORX PAN HEAD 1/4-20x3/4 ASSY

**ATTACH HARDWARE FROM UNDERSIDE OF COUNTERTOP.  
RIGHT ANGLE DRILL ADAPTER IS HELPFUL FOR THIS STEP.**

**NOTE: BRACKET  
WILL FIT AROUND  
THREADED INSERT**

**1202 (x4)  
TORX PAN HEAD  
1/4-20x3/4 ASSY**

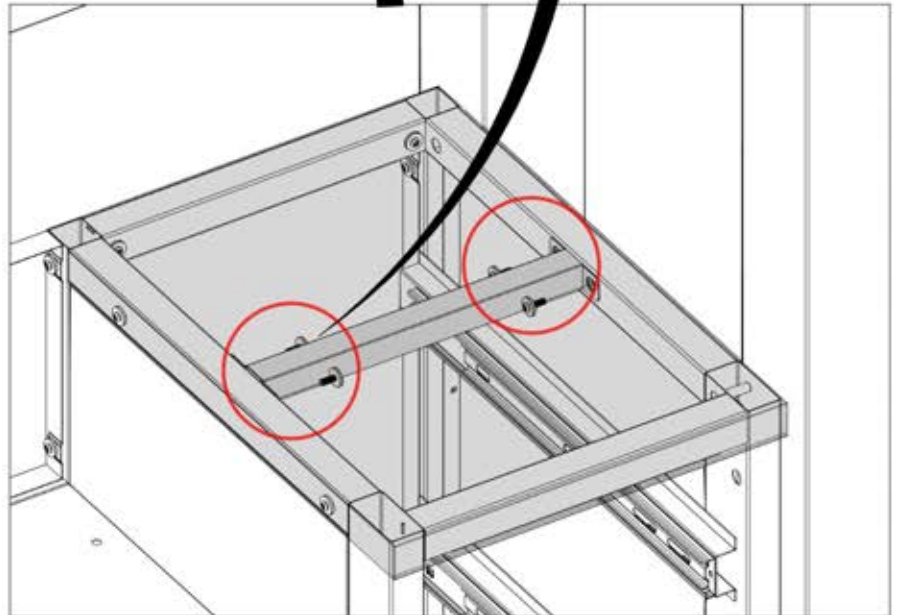
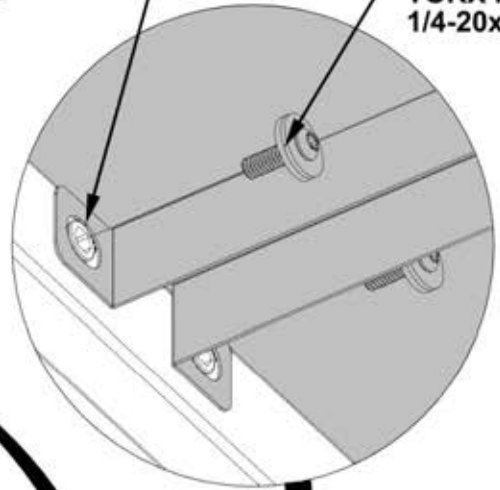
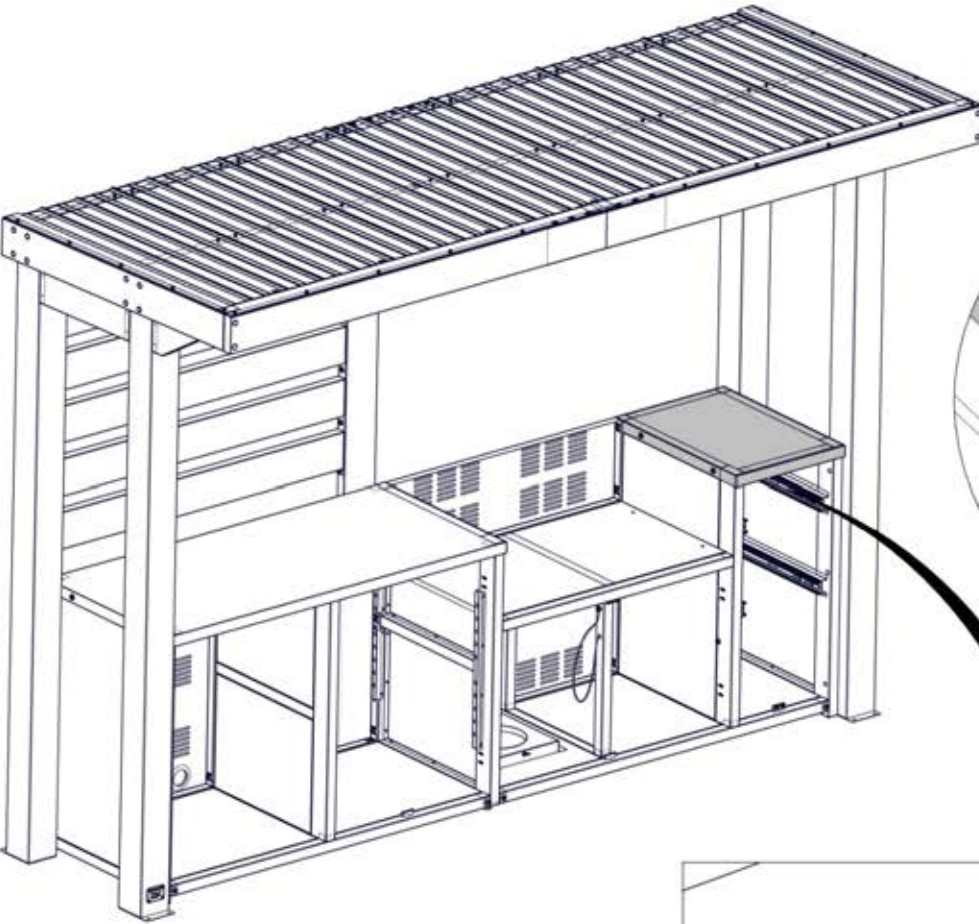

# STEP 64 - KITCHEN CABINET ASSEMBLY

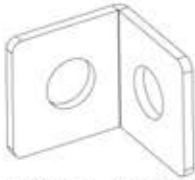

A02 BRACKET - A4M02056  
(x3) 1 7/16"x1 7/16"x1 7/16" (36x36x36)

QTY	PART NUMBER	Description
6	H101202	TORX PAN HEAD 1/4-20x3/4 ASSY

**ATTACH A02 BRACKETS TO CONNECT  
P05 BACK POST TO C02 CABINET PANEL  
AND F01 BOTTOM PANEL RAIL**

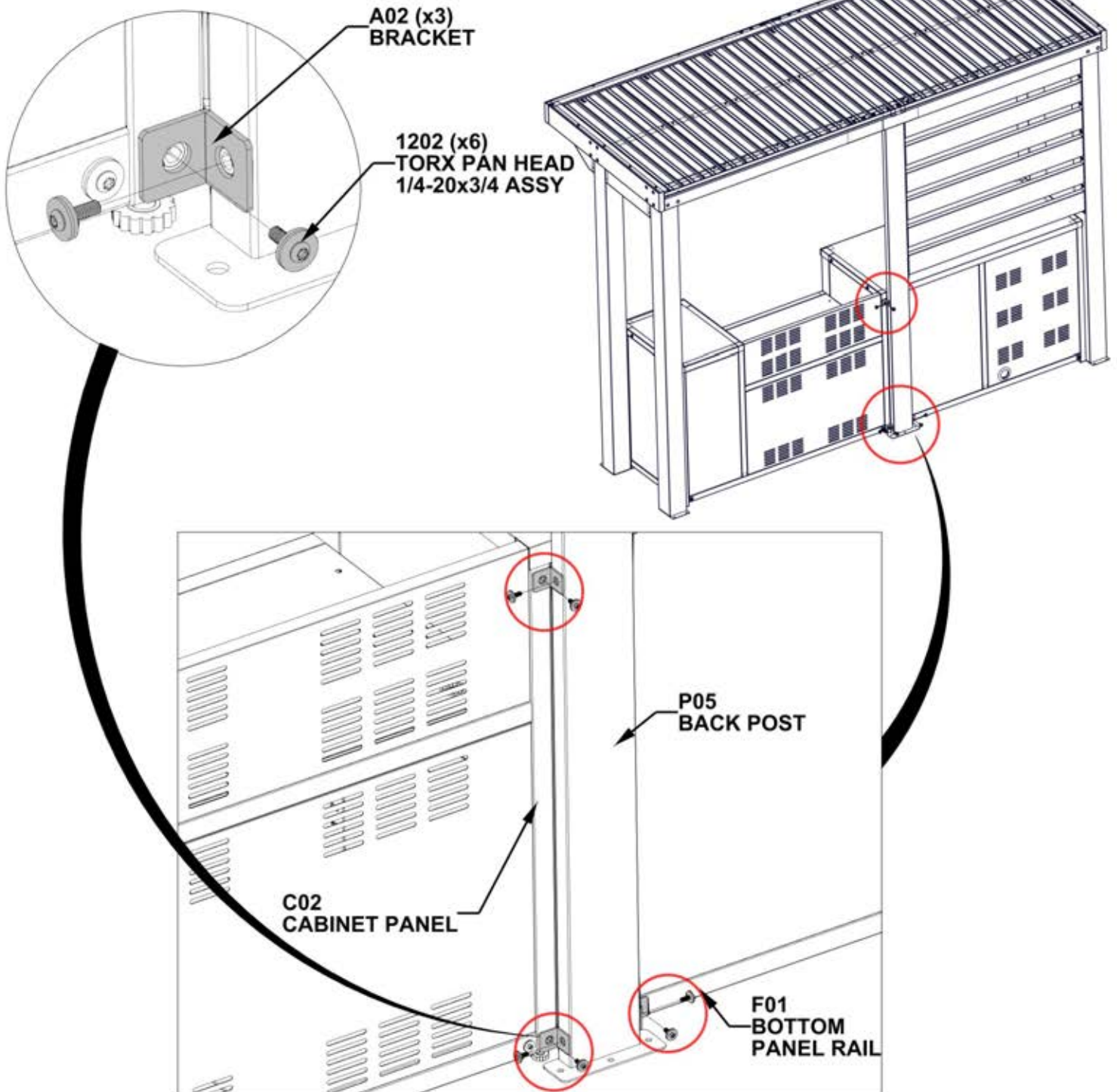



# STEP 65 - KITCHEN CABINET ACCESSORIES



A06 ADJUSTABLE SHELF TAB - A4M02077  
(x8) 1 1/16"x7/8"x1 3/16" (17x22x31)

**ATTACH ADJUSTABLE SHELF TABS ON BOTH SIDES OF CENTER CABINET**

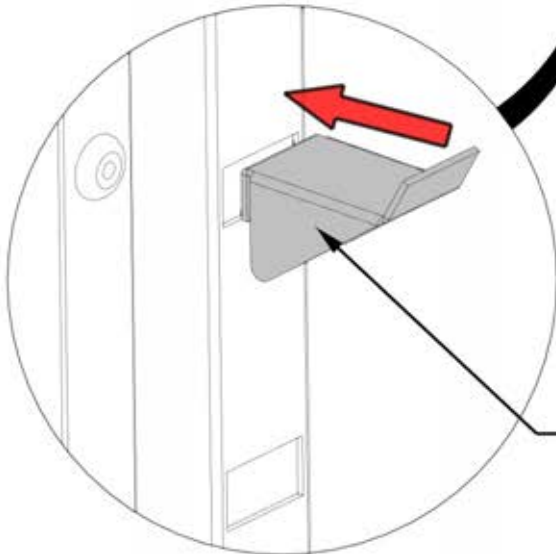
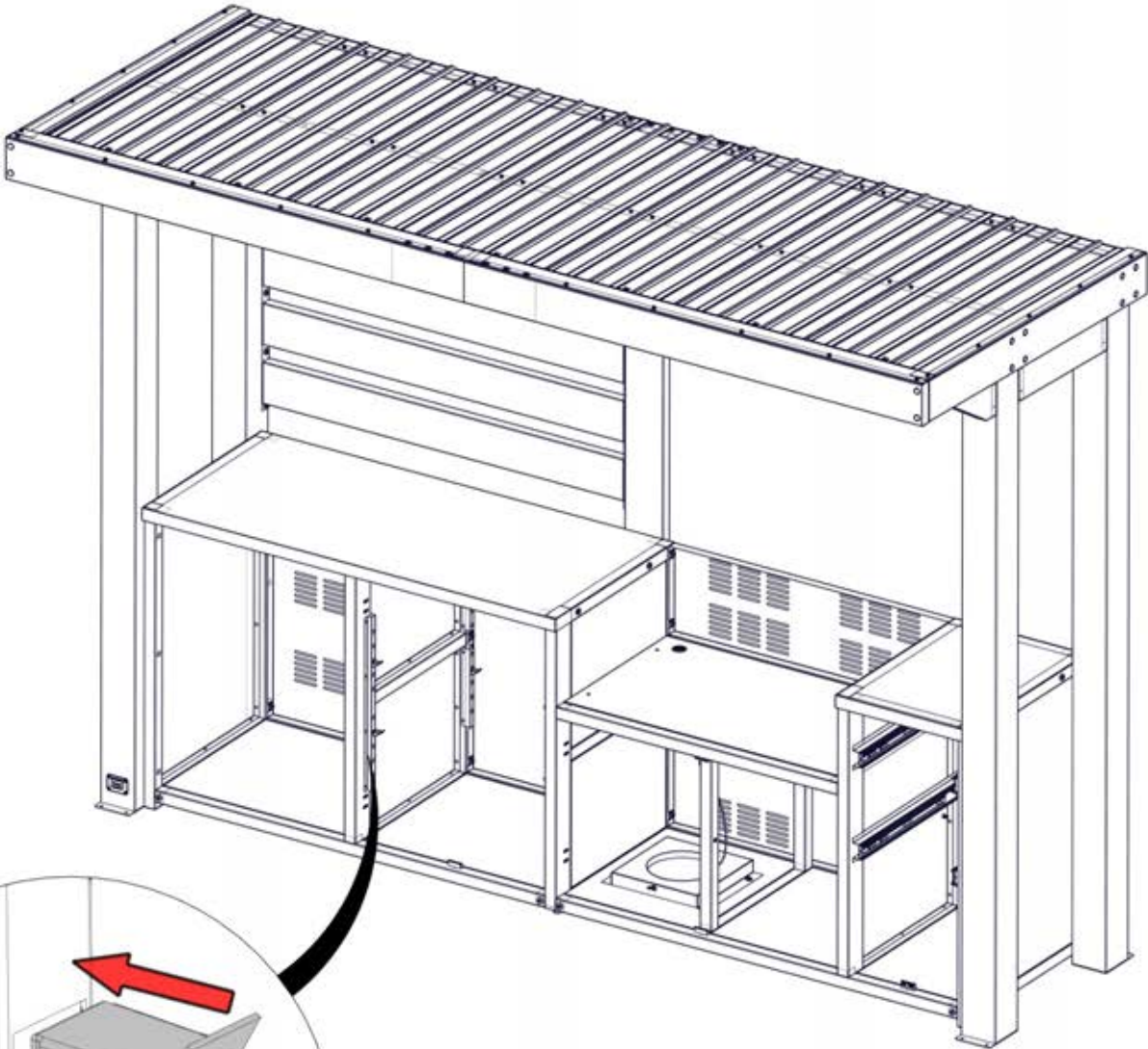

A06 (x8)  
ADJUSTABLE SHELF TAB

## STEP 66 - KITCHEN CABINET ACCESSORIES

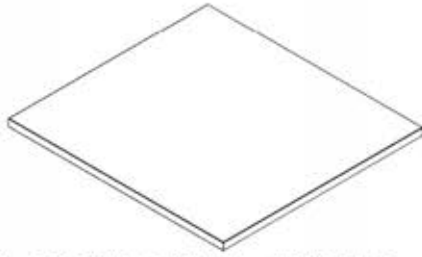

S01 CABINET SHELF - A4M02057  
(x2) 13/16"x22 11/16"x24 1/2" (21x577x622)

**INSTALL CABINET SHELVES IN CENTER CABINET.**

**SHELVES WILL REST ON ADJUSTABLE TABS FROM PREVIOUS STEP AND CAN BE POSITIONED AS DESIRED.**

S01 (x2)  
CABINET SHELF

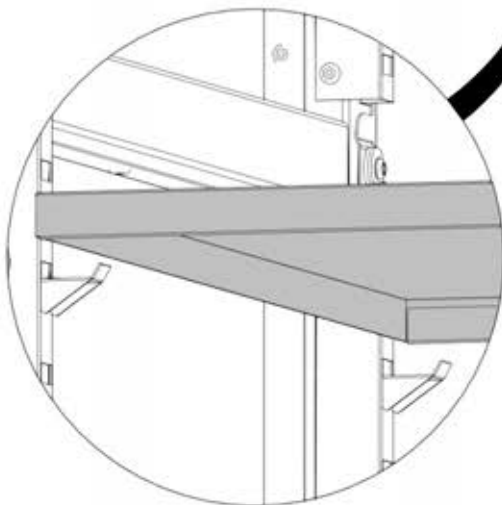

# STEP 67 - KITCHEN CABINET ACCESSORIES



QTY	PART NUMBER	Description
4	H101202	TORX PAN HEAD 1/4-20x3/4 ASSY

A11 SHELF - A4M02105  
(x1) 13/16"x18 3/8"x21 1/2" (21x467x546)

**ATTACH HARDWARE FROM UNDERSIDE OF SHELF**

**RIGHT ANGLE DRILL ADAPTER IS HELPFUL FOR THIS STEP**

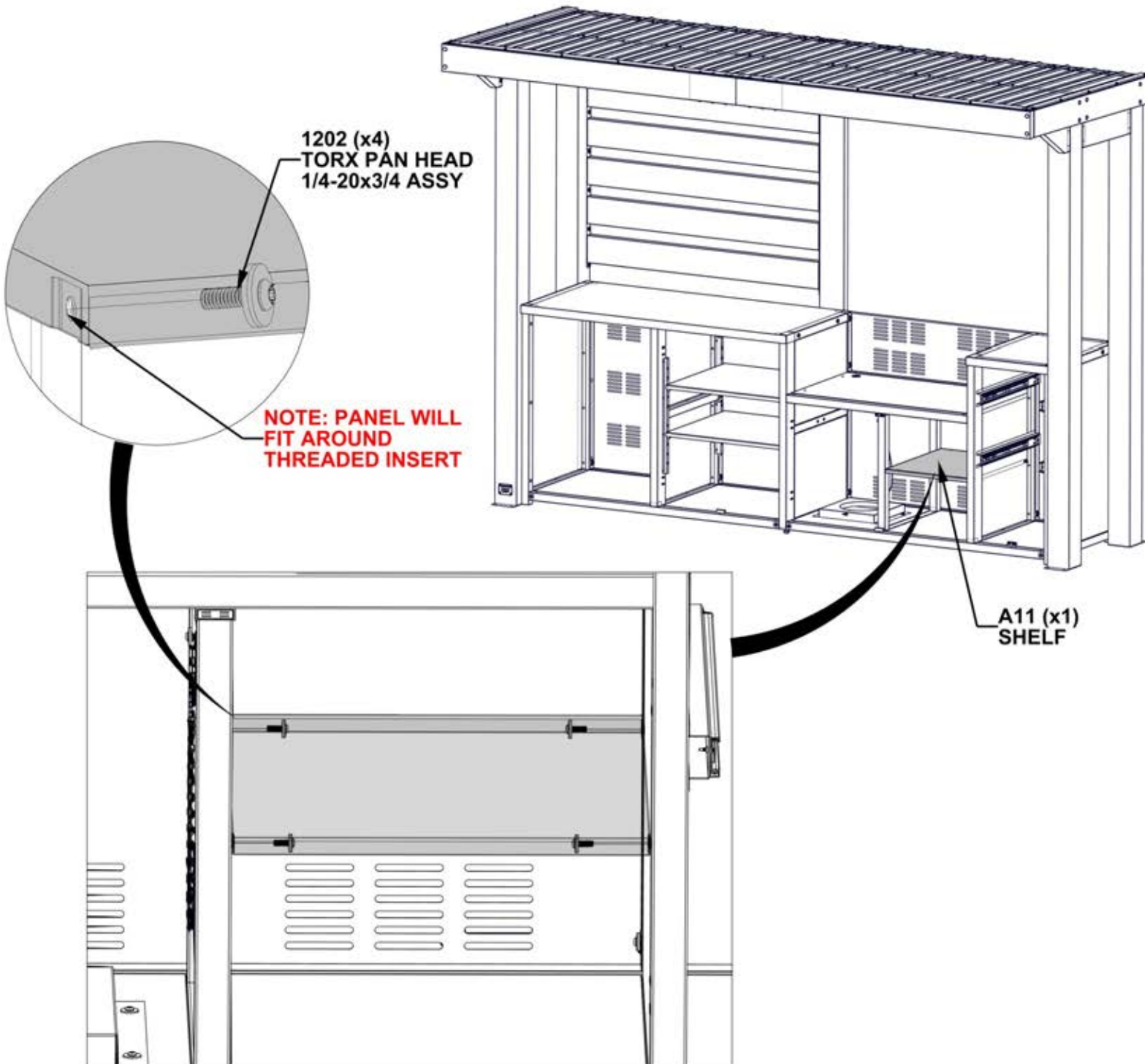

1202 (x4)  
TORX PAN HEAD  
1/4-20x3/4 ASSY

**NOTE: PANEL WILL  
FIT AROUND  
THREADED INSERT**

A11 (x1)  
SHELF

# STEP 68A - BACK SHELF

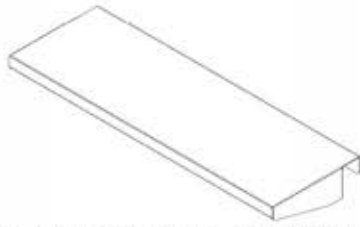

A03 BACK SHELF - A4M02072  
(x2) 2 7/16"x7 15/16"x23 3/4" (61x201x603)



A6P00679 EVA TAPE  
(x8)

**APPLY EVA TAPE IN THE APPROXIMATE LOCATIONS SHOWN**

**REPEAT FOR BOTH A03 SHELVES**

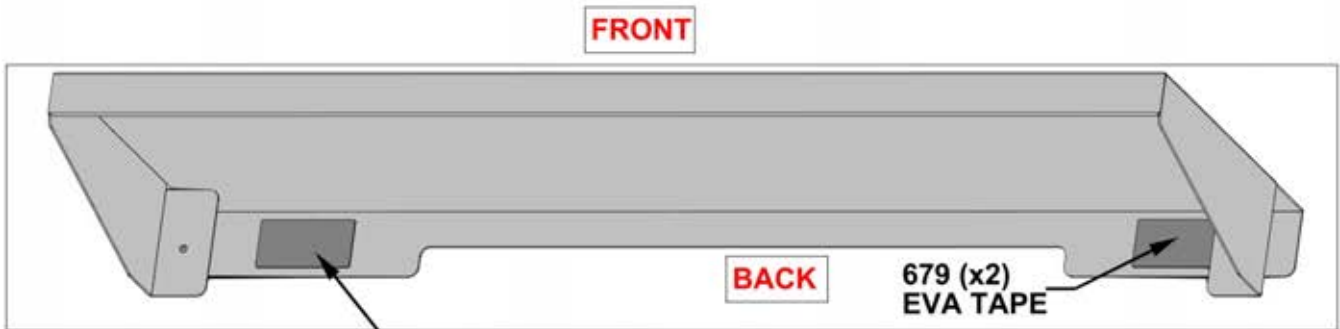
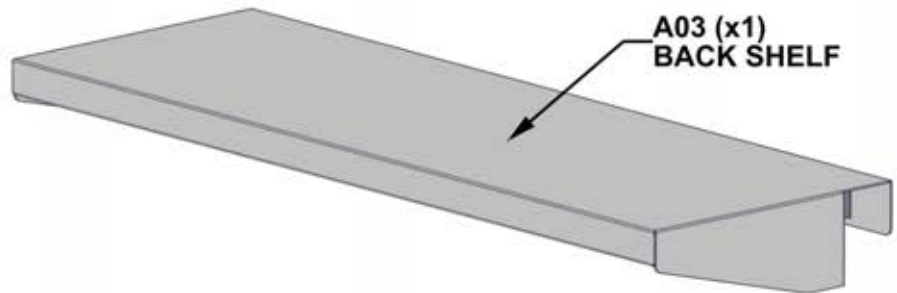

**APPLY EVA TAPE ALONG BACK FLANGE OF SHELF**

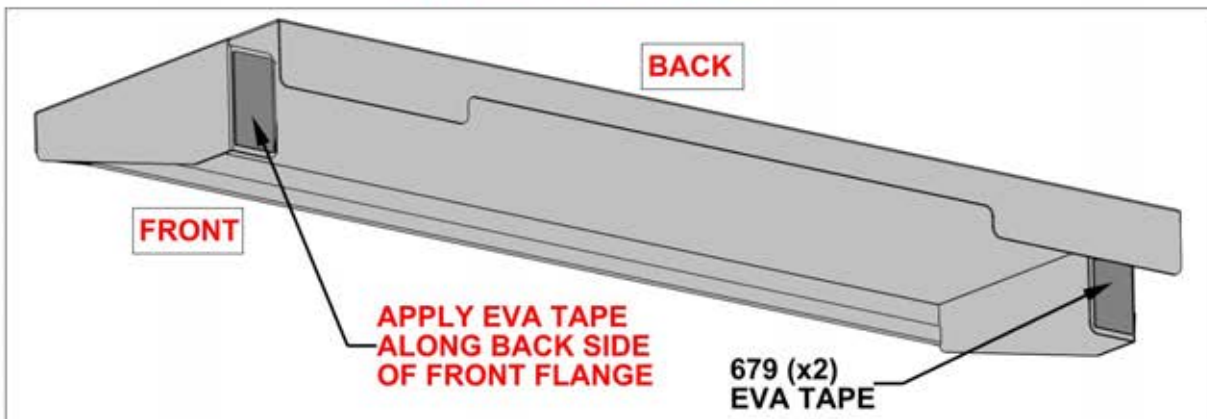

**APPLY EVA TAPE ALONG BACK SIDE OF FRONT FLANGE**

## STEP 68B - KITCHEN CABINET ACCESSORIES

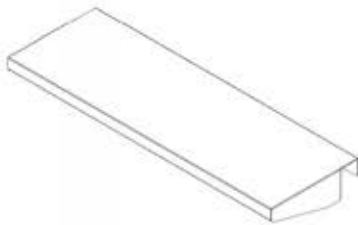

A03 BACK SHELF - A4M02072  
(x2) 2 7/16"x7 15/16"x23 3/4" (61x201x603)

**MAKE SURE EVA TAPE FROM PREVIOUS STEP, HAS BEEN APPLIED TO FLANGES OF EACH A03 SHELF BEFORE INSTALLING. THIS WILL PREVENT SHELVES FROM SCRATCHING SURFACE OF BACK PANEL**

**SLIDE BACK SHELF OVER ANY TUBE ALONG B10 BACK PANEL. SHELVES CAN BE POSITIONED ANYWHERE DESIRED.**

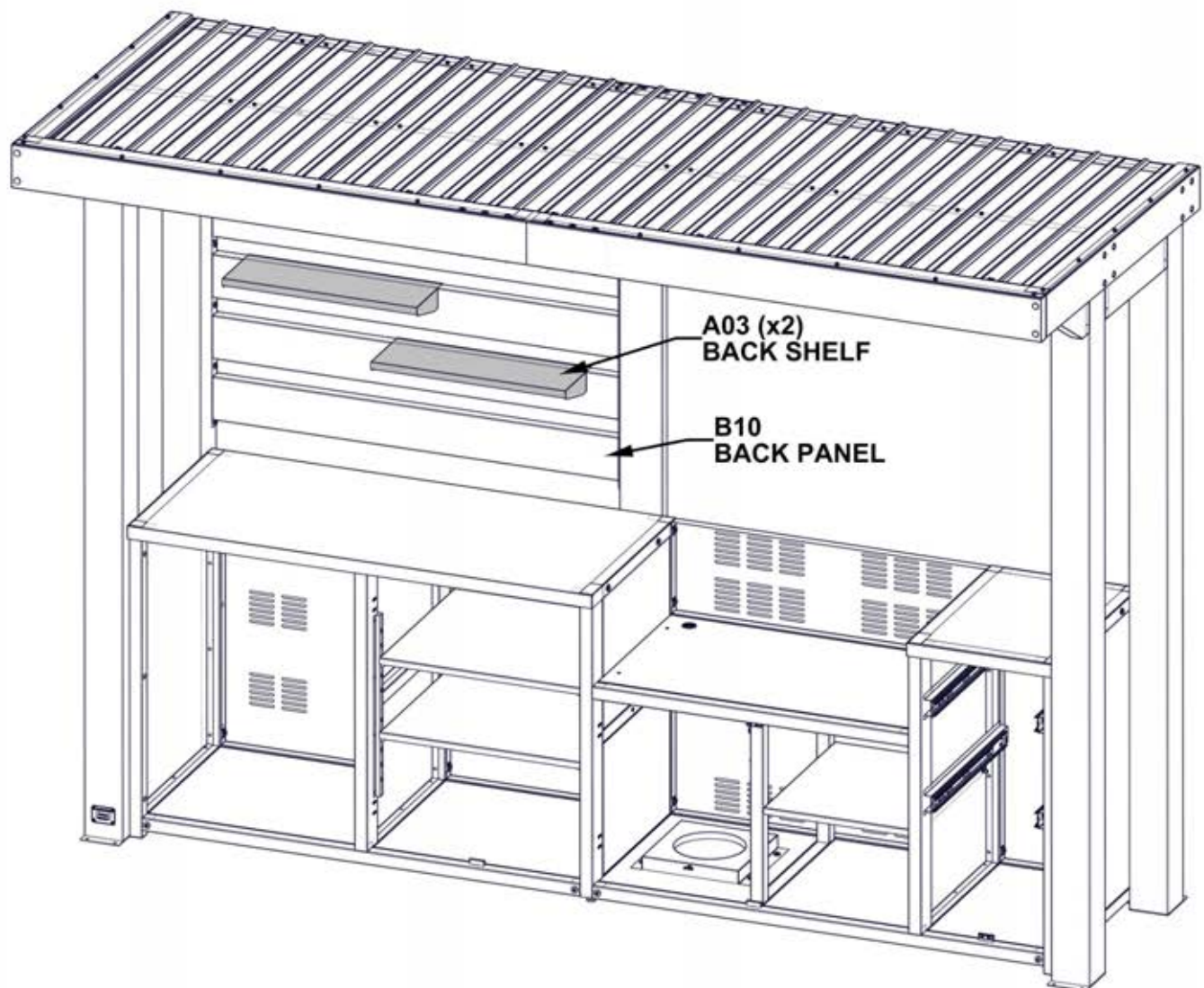

## STEP 68C - KITCHEN CABINET ACCESSORIES

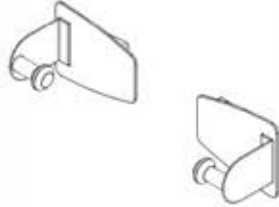

A4M02290 MAGNETIC PAPER TOWEL HOLDER  
(x1)

**MAGNETIC PAPER TOWEL HOLDER CAN BE ATTACHED TO ANY METAL SURFACE ON KITCHEN. WE RECOMMEND ATTACHING ALONG BACK PANEL.**

**MAKE SURE TO KEEP PAPER TOWEL HOLDER AT A SAFE DISTANCE FROM GRILLING SURFACE.**

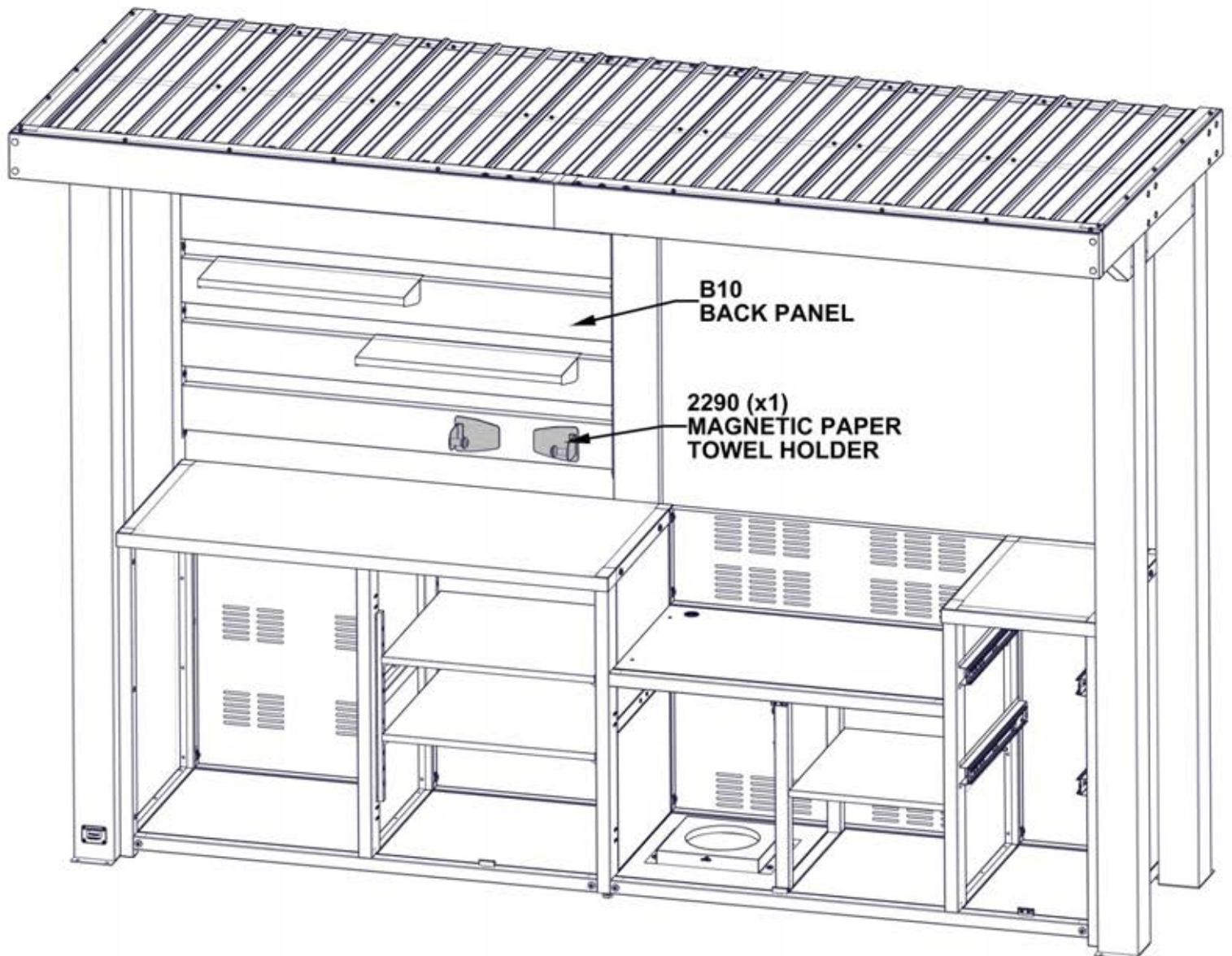

# STEP 69A - KITCHEN CABINET ACCESSORIES



A4M01352 HOLE COVER  
(x5)

**USE A SMALL PIECE OF WOOD AND RUBBER Mallet TO TAP HOLE COVERS IN.**

**DO NOT TAP DIRECTLY WITH A HAMMER AS YOU MAY DAMAGE THE FINISH ON PRODUCT.**

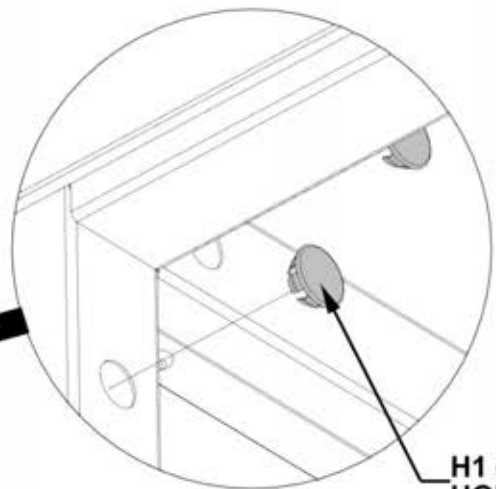
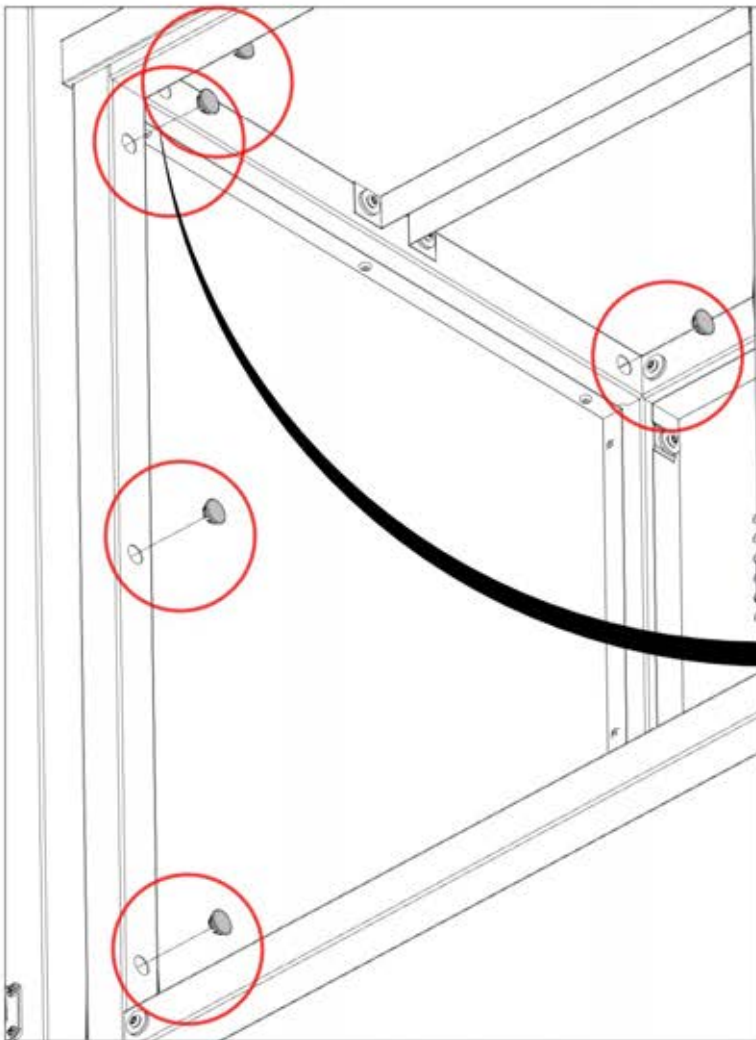
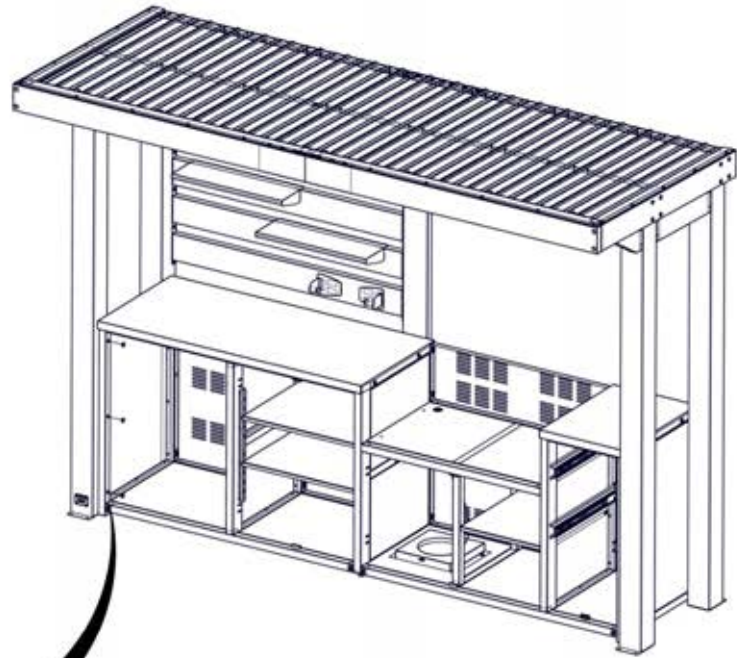

H1 (x5)  
HOLE COVER

# STEP 69B - KITCHEN CABINET ACCESSORIES



A4M01352 HOLE COVER  
(x5)

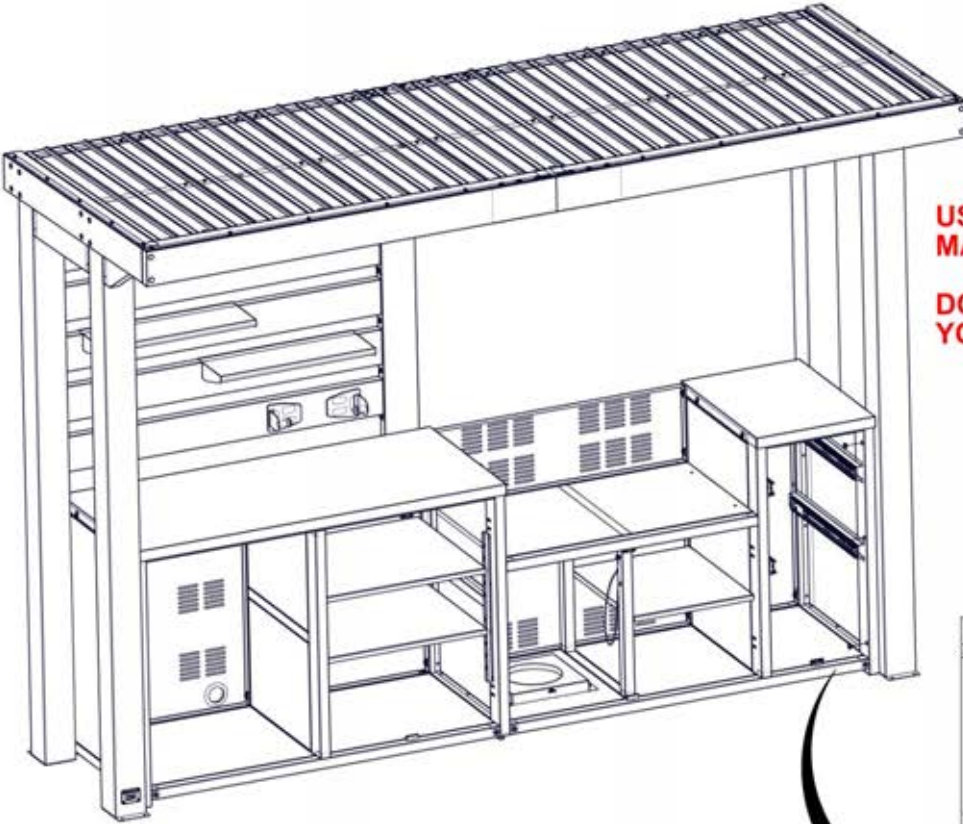

**USE A SMALL PIECE OF WOOD AND RUBBER Mallet TO TAP HOLE COVERS IN.**

**DO NOT TAP DIRECTLY WITH A HAMMER AS YOU MAY DAMAGE THE FINISH ON PRODUCT.**

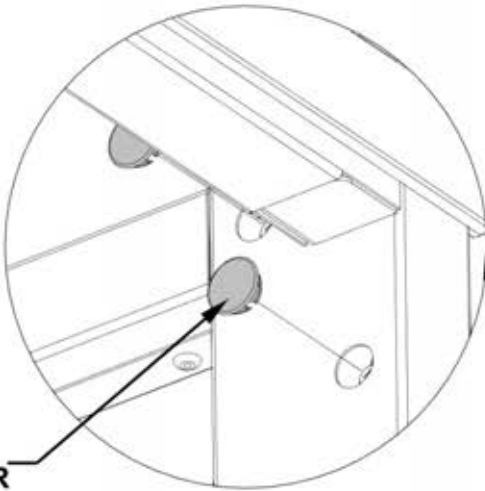

H1 (x5)  
HOLE COVER





# STEP 69C - KITCHEN CABINET ACCESSORIES



A4M01352 HOLE COVER  
(x4)

**DO NOT STAND ON CABINET FRAME TO  
INSTALL HOLE COVERS**

**USE A SMALL PIECE OF WOOD AND RUBBER  
MALLET TO TAP HOLE COVERS IN.**

**DO NOT TAP DIRECTLY WITH A HAMMER AS  
YOU MAY DAMAGE THE FINISH ON PRODUCT.**

H1 (x4)  
HOLE COVER

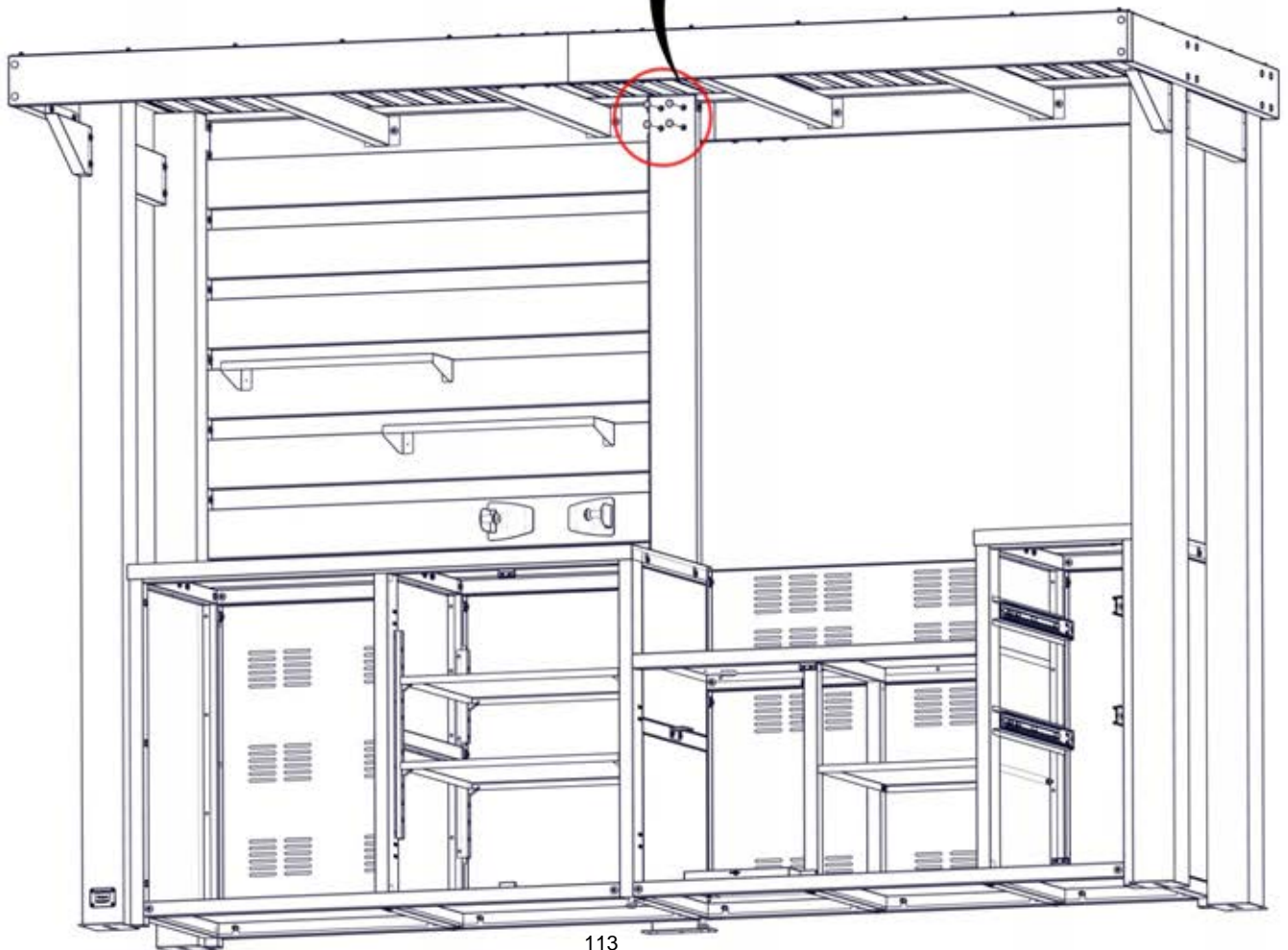
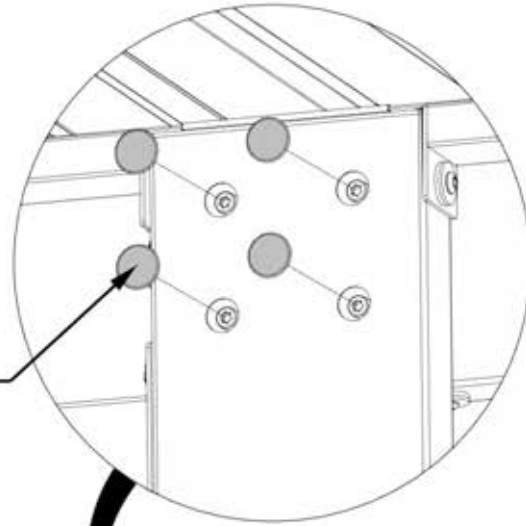

# STEP 70A - KITCHEN TRASH CAN ASSEMBLY



A10 ANGLE BRACKET - A4M02276  
(x1) 13/16"x5 15/16"x9 13/16" (20x151x250)



A07 ANGLE BRACKET - A4M02277  
(x1) 13/16"x5 15/16"x9 13/16" (20x151x250)

QTY	PART NUMBER	Description
4	H100653	NUT LOCK 1/4 BLK
4	H100401	BOLT WH 1/4x1/2 BLK
4	H101133	WASHER FLAT 7x14 BLK

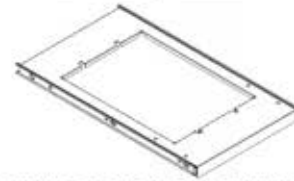

A04 7 GALLON TRASH CAN HOLDER - A4M02074  
(x1) 1 1/4"x12 9/16"x21 5/8" (32x319.5x550)

**ALIGN HOLES IN TOP OF ANGLE BRACKETS WITH HOLES IN TRASH CAN HOLDER.**

**MAKE SURE FLAT SIDE OF BRACKETS FACE OUTWARD AND FRONT EDGE IS FLUSH.**

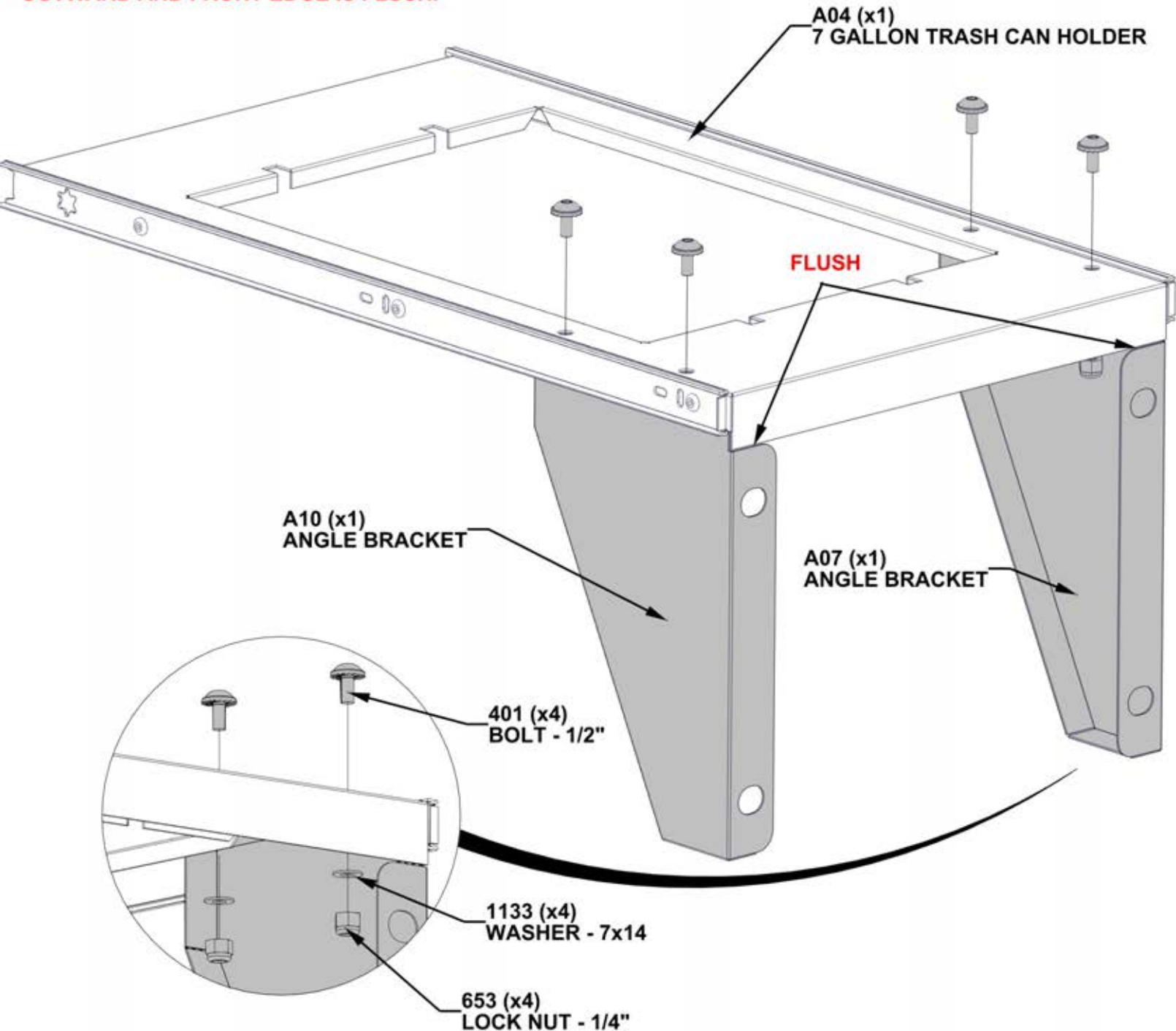

# STEP 70B - KITCHEN TRASH CAN ASSEMBLY



QTY	PART NUMBER	Description
4	H101202	TORX PAN HEAD 1/4-20x3/4 ASSY

D03 DOOR PANEL - A4M02067  
(x1) 7/8"x14 5/8"x22 7/16" (22x372x570)

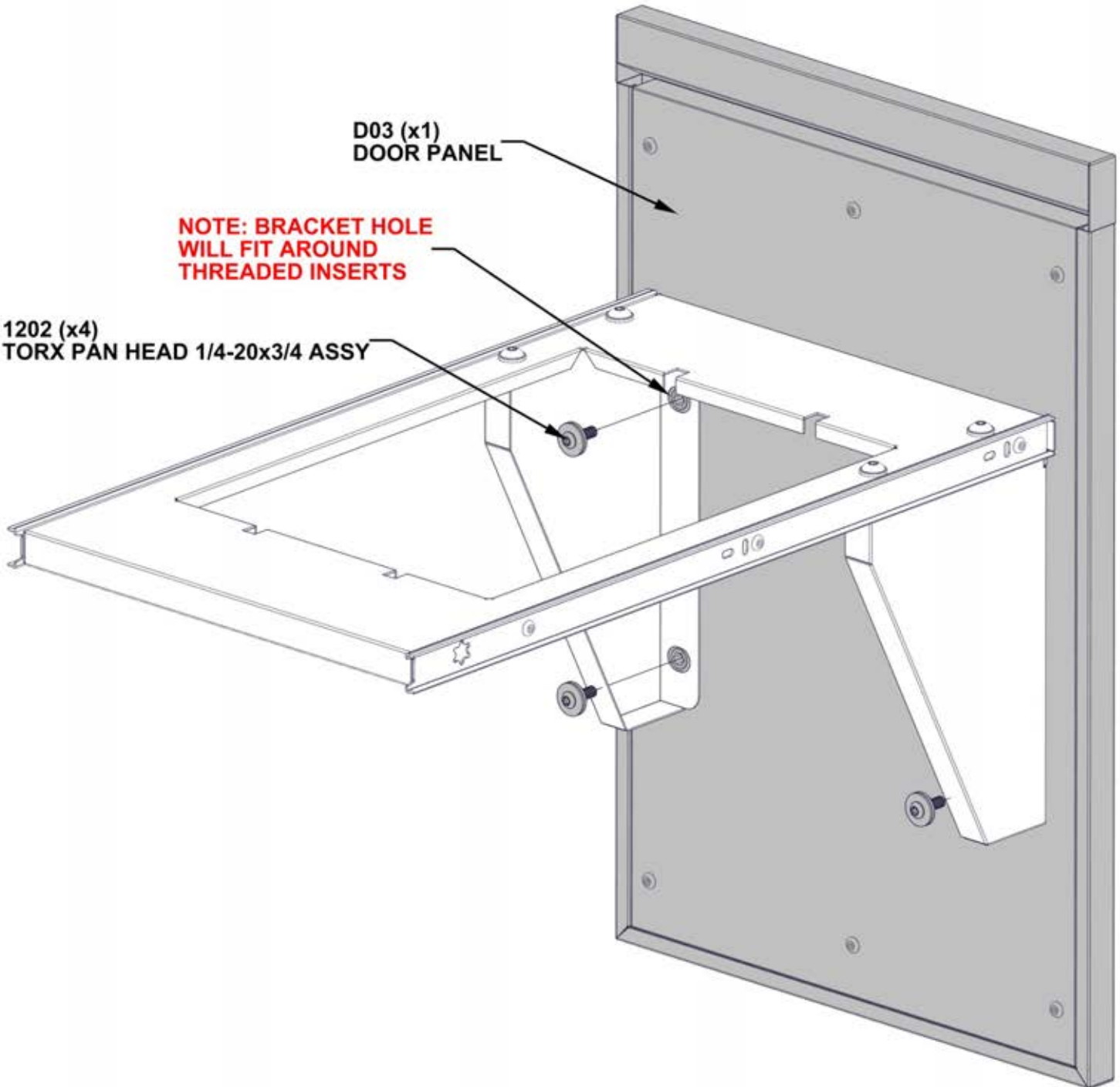

# STEP 71 - KITCHEN CABINET ACCESSORIES



TRASH CAN HOLDER ASSEMBLY  
STEPS 70A - 70B

**ATTACH TRASH CAN HOLDER BY ALIGNING BOTH ENDS OF  
FACTORY ASSEMBLED DRAWER SLIDES WITH ONE ANOTHER.**

**PRESS TOGETHER UNTIL DRAWER SLIDES CONNECT.**

**TIP: REFER TO STEP 79:  
KITCHEN DOOR ADJUSTMENT**

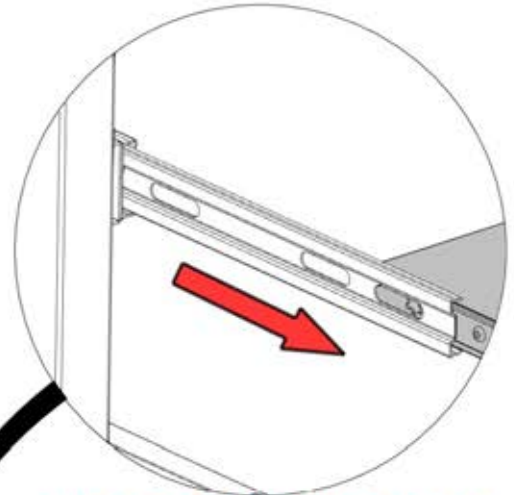
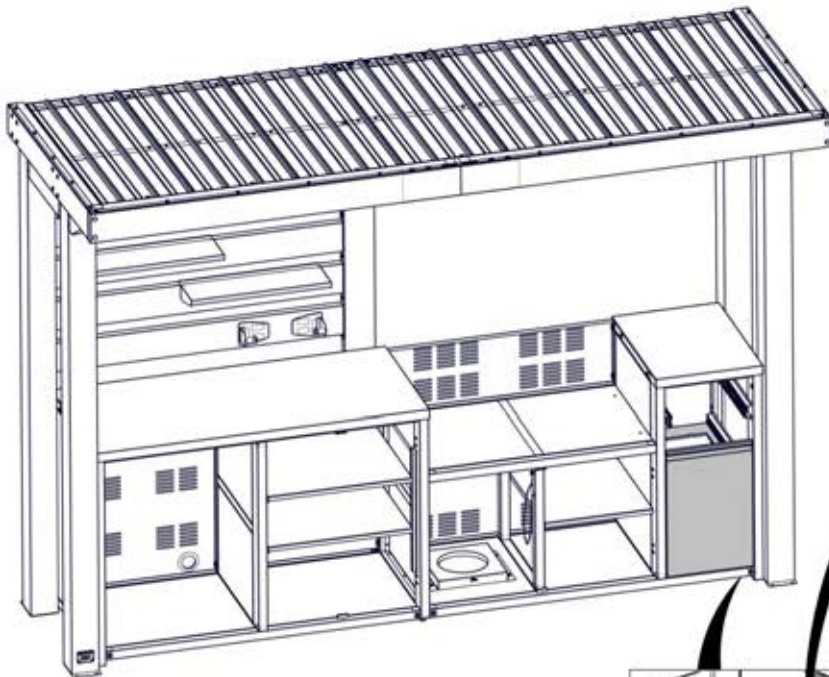

**NOTE: SLIDE INNER RACE OF  
DRAWER SLIDE OUT BEFORE  
ATTACHING SLIDES**

**ALIGN DRAWER SLIDES  
ON BOTH SIDES OF TRASH  
CAN HOLDER**

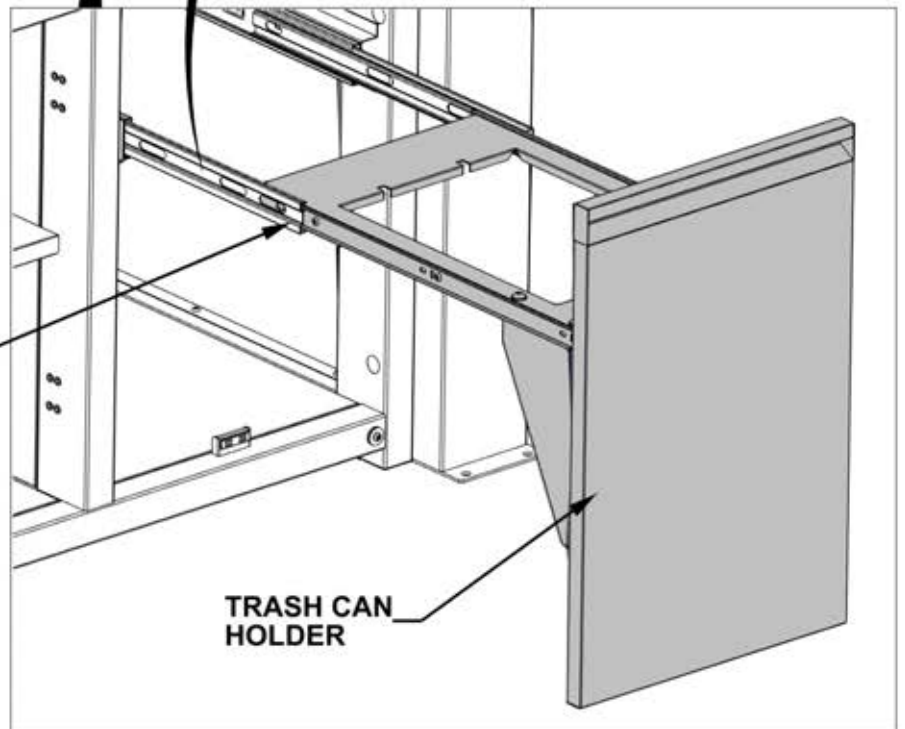

**TRASH CAN  
HOLDER**

# STEP 72 - CABINET DRAWER ASSEMBLY

QTY	PART NUMBER	Description
4	H101202	TORX PAN HEAD 1/4-20x3/4 ASSY

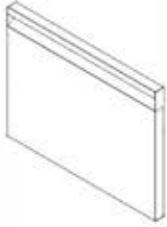

D06 DRAWER FACE - A4M02060  
(x1) 7/8"x11 1/16"x14 5/8" (22x281x372)

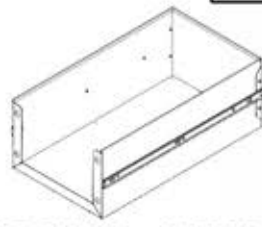

D07 8" DRAWER - A4M02075  
(x1) 8 1/16"x12 9/16"x21 11/16" (204x319.5x551)

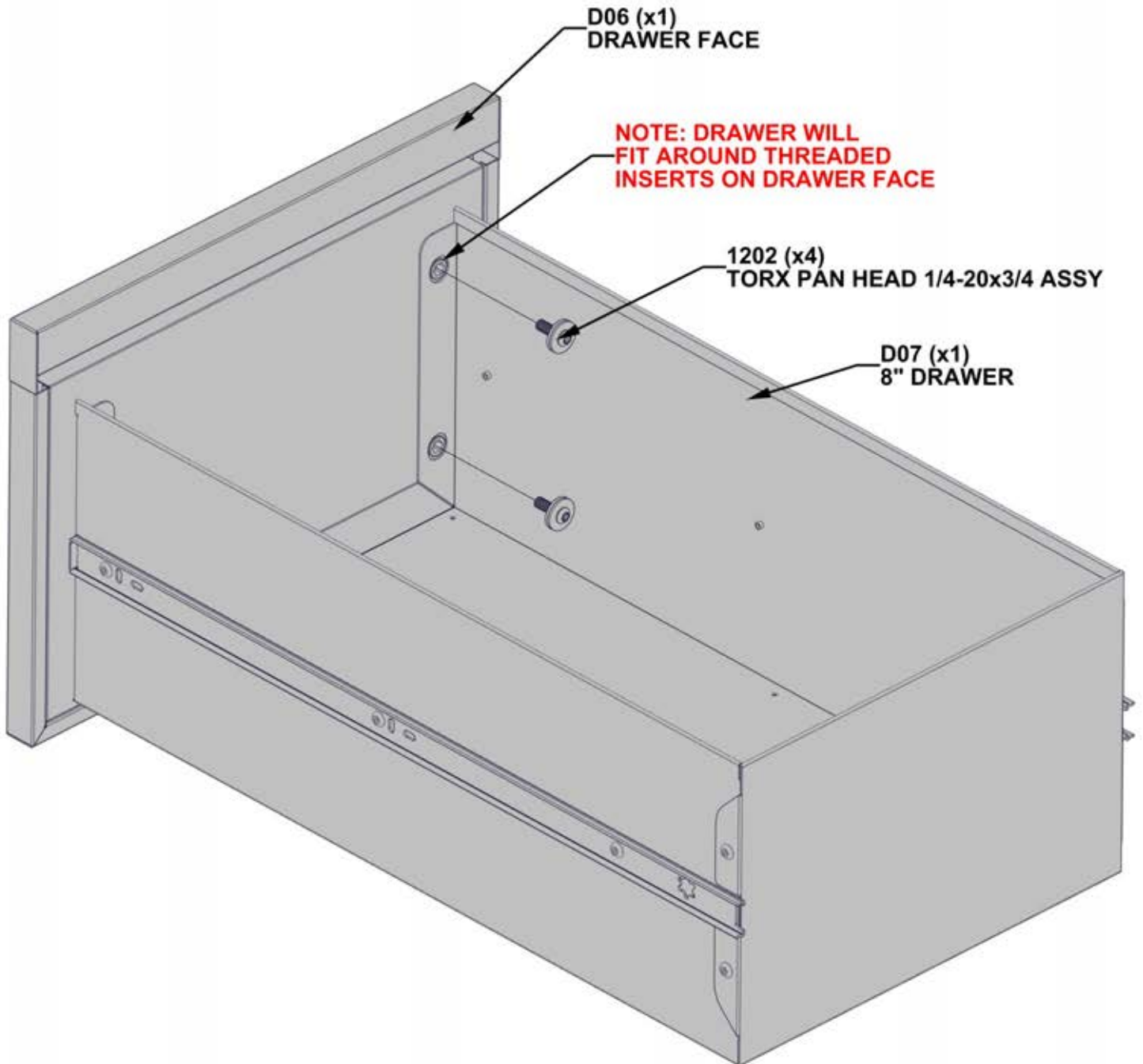

# STEP 73 - KITCHEN CABINET ACCESSORIES

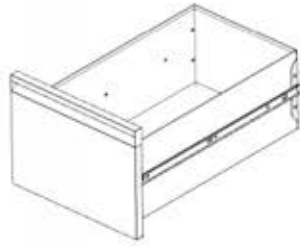

PULL OUT DRAWER  
ASSEMBLY STEP 72

**ATTACH PULL OUT DRAWER BY ALIGNING BOTH ENDS OF  
FACTORY ASSEMBLED DRAWER SLIDES WITH ONE ANOTHER.**

TIP: REFER TO STEP 79:  
KITCHEN DOOR ADJUSTMENT

**PRESS TOGETHER UNTIL DRAWER SLIDES CONNECT.**

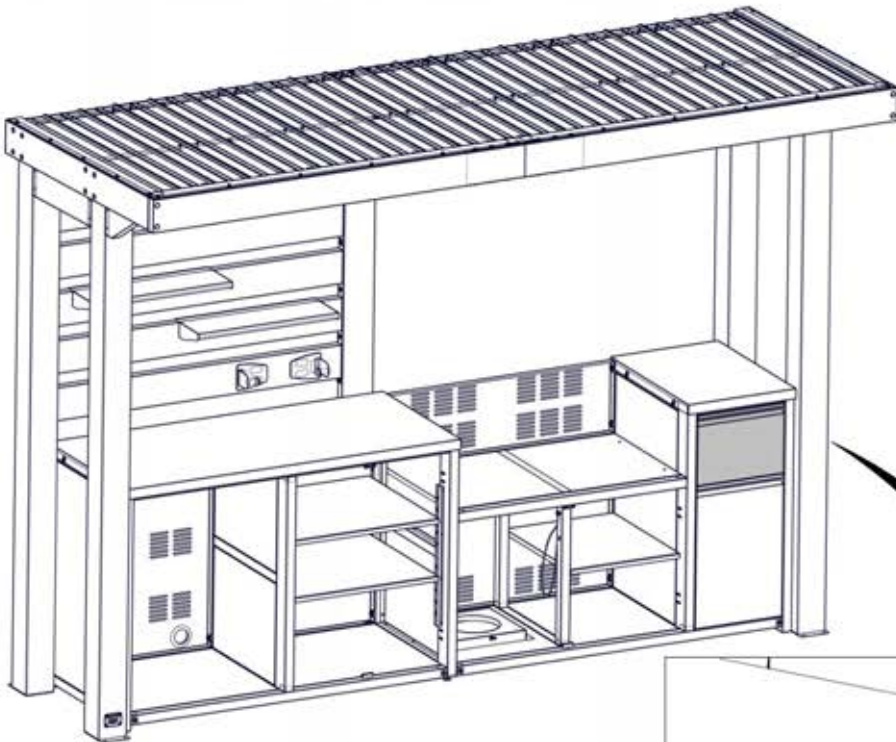

**NOTE: SLIDE INNER RACE OF  
DRAWER SLIDE OUT BEFORE  
ATTACHING SLIDES**

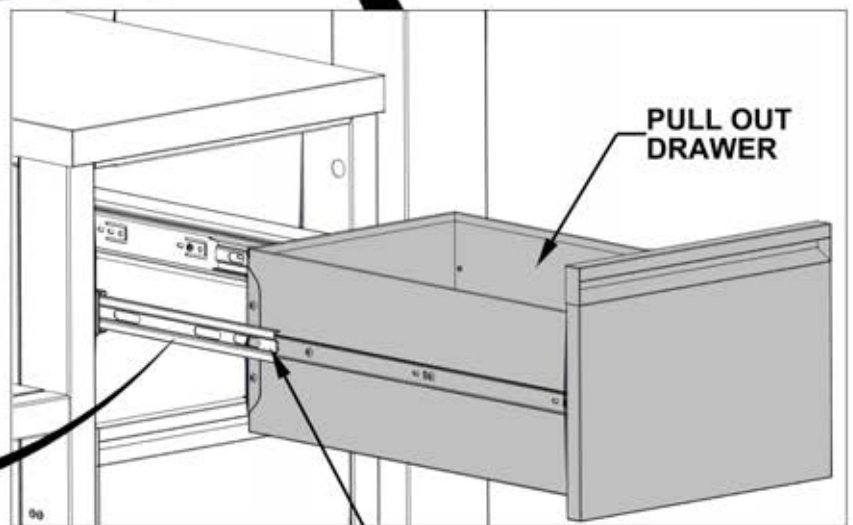
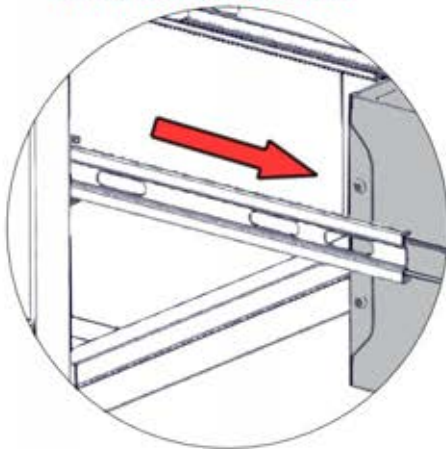

**ALIGN DRAWER SLIDES  
ON BOTH SIDES OF PULL  
OUT DRAWER**

# STEP 74 - CABINET DOOR ASSEMBLY

QTY	PART NUMBER	DESCRIPTION
16	H101185	PHILLIPS FLAT HEAD 8-32x.5 SCREW

D01 DOOR PANEL - A4M02064  
(x1) 22x12 3/4"x33 5/8" (22x324x854)

D02 DOOR PANEL - A4M02066  
(x1) 7/8"x12 3/4"x33 5/8" (22x324x854)

D04 DOOR PANEL - A4M02068  
(x1) 7/8"x19 1/16"x22 7/16" (22x484.5x570)

D05 DOOR PANEL - A4M02069  
(x1) 7/8"x19 1/16"x22 7/16" (22x484.5x570)

A4M02070 CABINET HINGE  
(x8)

**INSTALL CABINET HINGES TO ALL DOORS.**

**DO NOT OVERTIGHTEN HARDWARE**

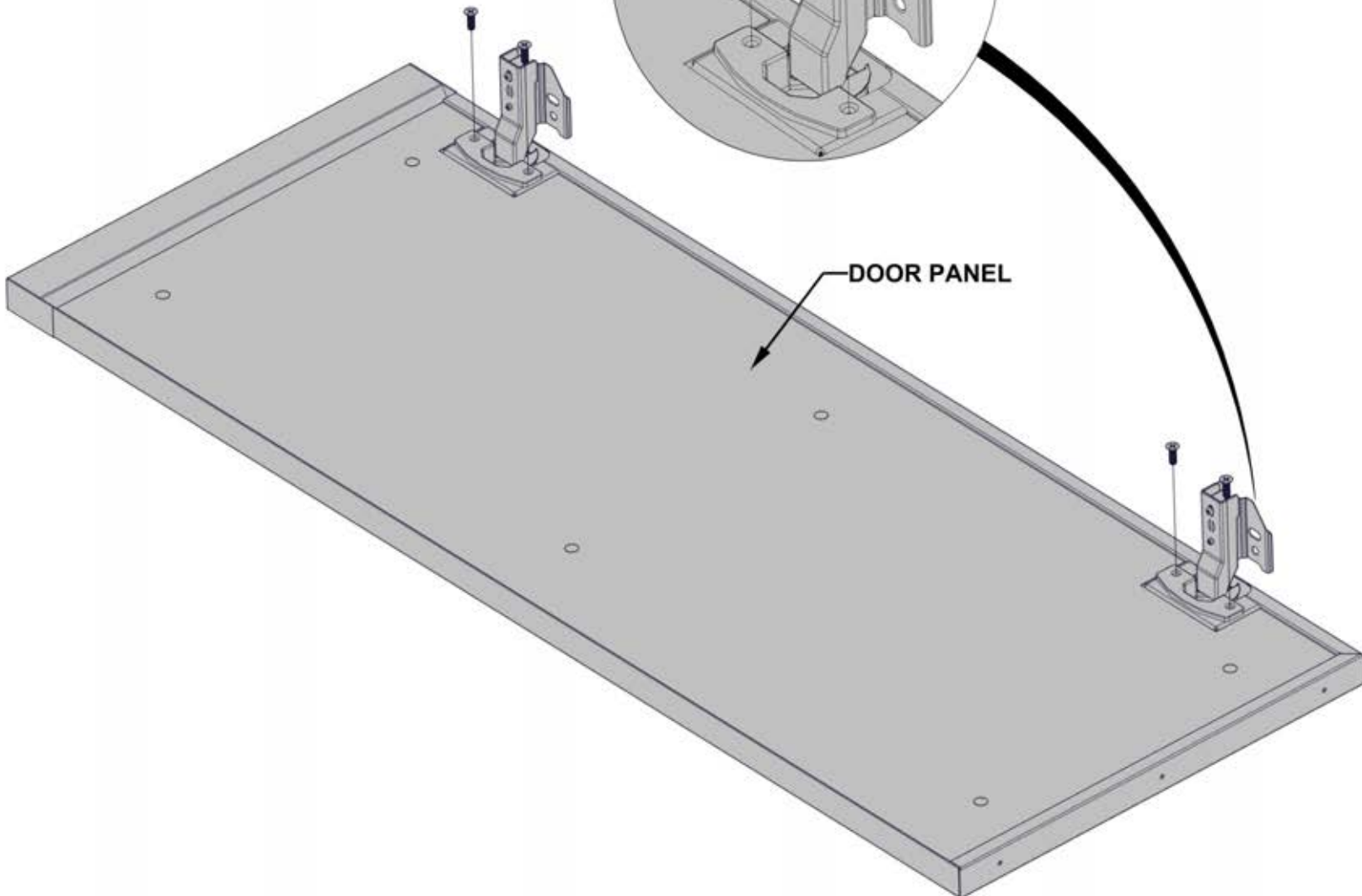
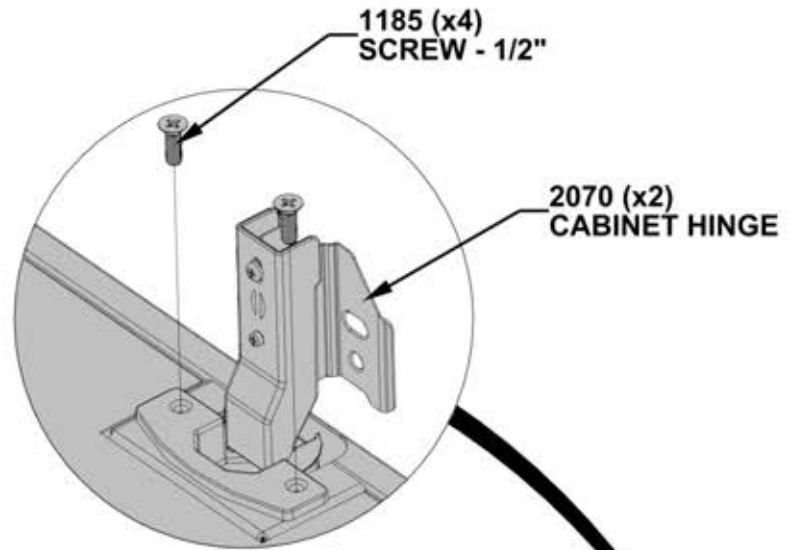

# STEP 75 - CABINET DOOR ATTACHMENT



QTY	PART NUMBER	DESCRIPTION
8	H101185	PHILLIPS FLAT HEAD 8-32x.5 SCREW

D02 DOOR PANEL - A4M02066  
(x1) 7/8"x12 3/4"x33 5/8" (22x324x854)

**FOR THIS STEP IT IS HELPFUL TO HAVE AN ADDITIONAL PERSON HELP HOLD DOOR IN PLACE.**

TIP: REFER TO STEP 79: ADJUSTING DOOR HINGES AS NEEDED

**WITH CABINET HINGES ATTACHED TO DOOR, ALIGN HOLES IN HINGE BRACKET WITH ZERTS IN SIDE OF CABINET PANEL.**

**DO NOT OVERTIGHTEN HARDWARE.**

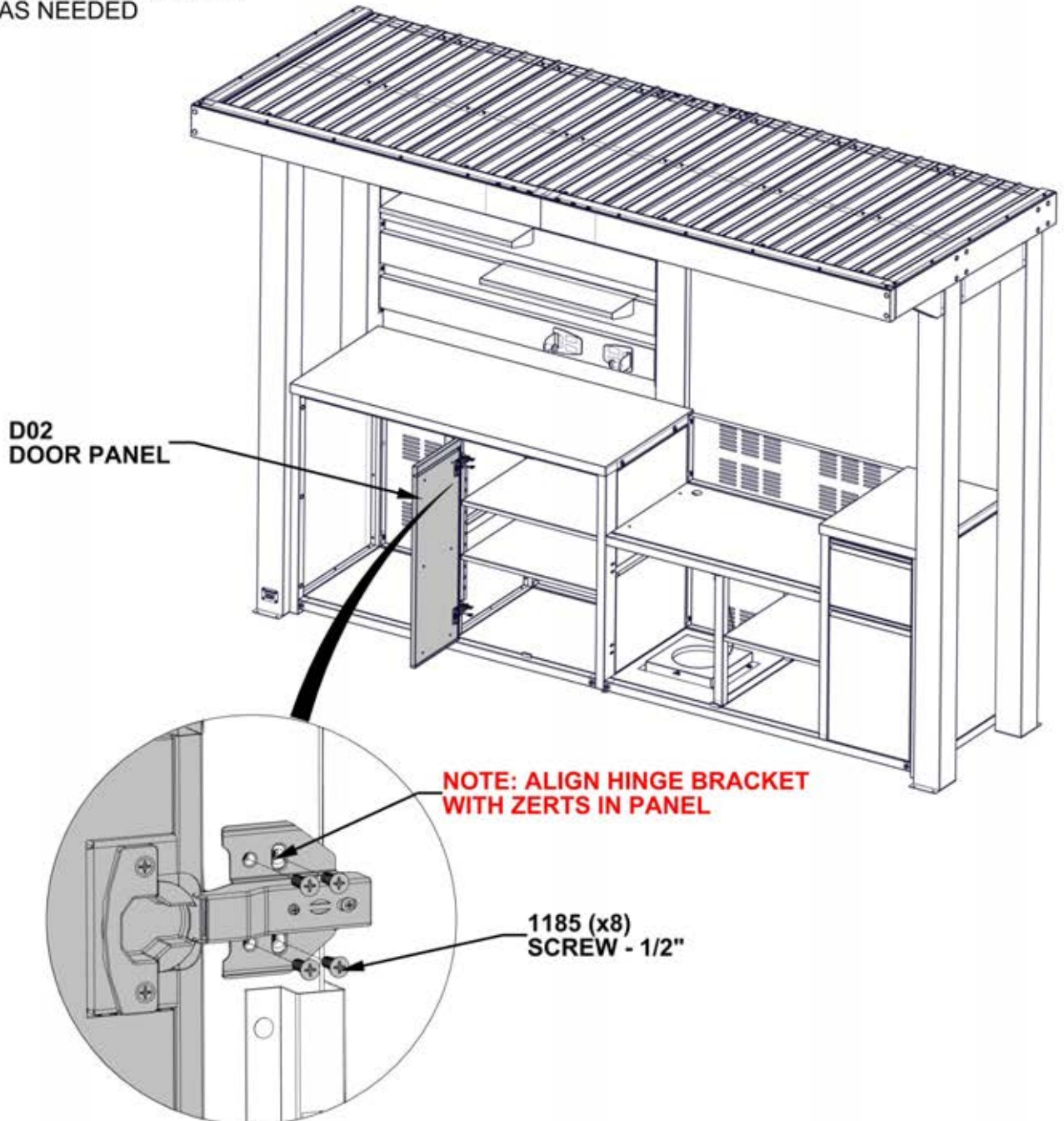



# STEP 76 - CABINET DOOR ATTACHMENT



QTY	PART NUMBER	DESCRIPTION
8	H101185	PHILLIPS FLAT HEAD 8-32x.5 SCREW

D01 DOOR PANEL - A4M02064  
(x1) 22x12 3/4"x33 5/8" (22x324x854)

**FOR THIS STEP IT IS HELPFUL TO HAVE AN ADDITIONAL PERSON HELP HOLD DOOR IN PLACE.**

**WITH CABINET HINGES ATTACHED TO DOOR, ALIGN HOLES IN HINGE BRACKET IN SIDE OF CABINET PANEL.**

**DO NOT OVERTIGHTEN HARDWARE.**

TIP: REFER TO STEP 79: ADJUSTING DOOR HINGES AS NEEDED

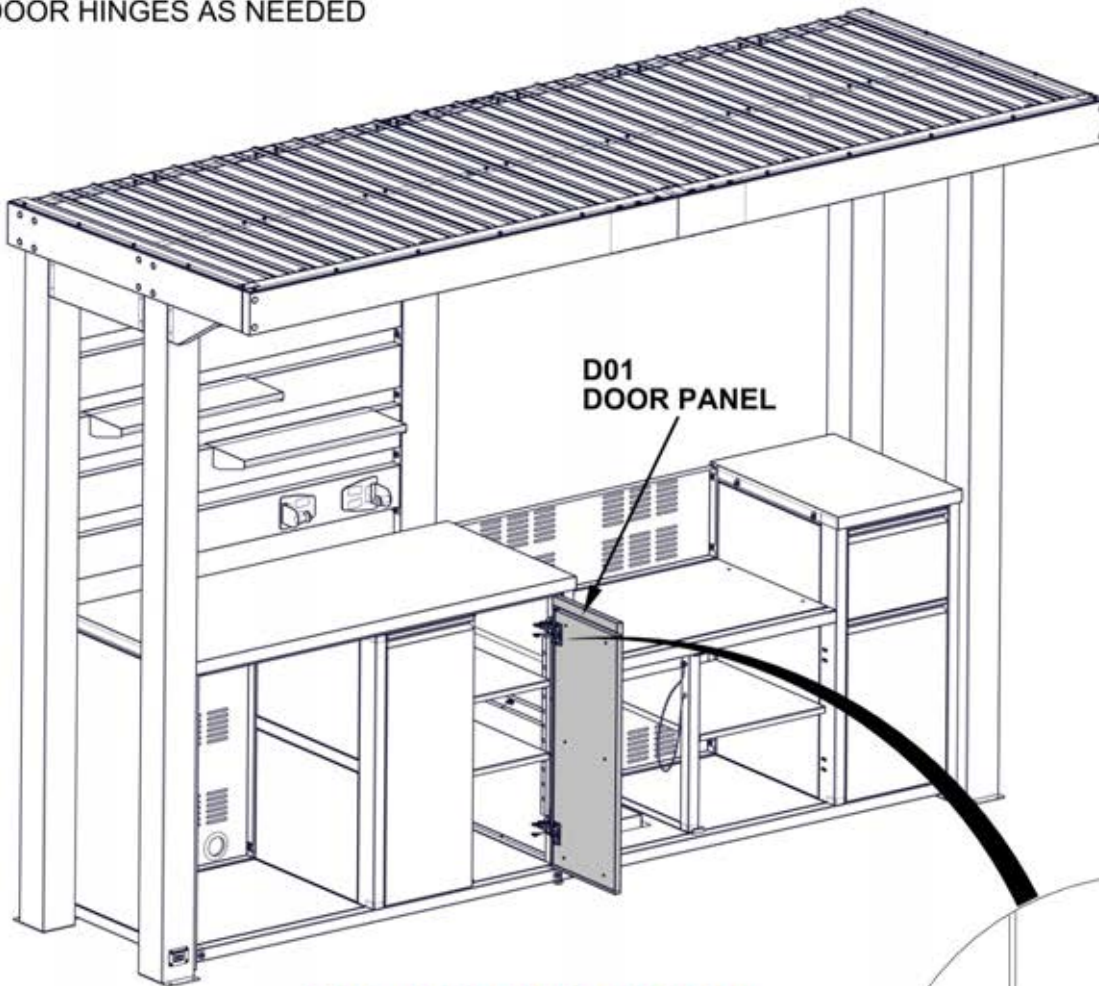

**NOTE: ALIGN HINGE BRACKET WITH ZERTS IN TUBE**

1185 (x8)  
SCREW - 1/2"

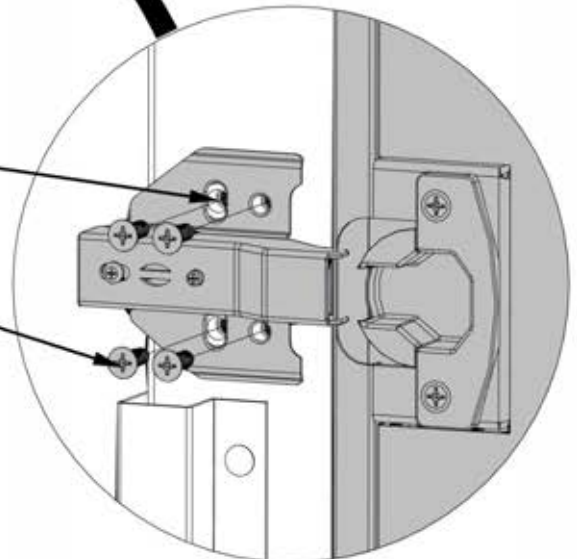

# STEP 77 - CABINET DOOR ATTACHMENT

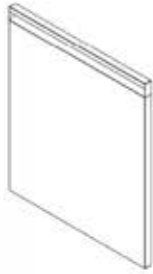

QTY	PART NUMBER	DESCRIPTION
8	H101185	PHILLIPS FLAT HEAD 8-32x.5 SCREW

D05 DOOR PANEL - A4M02069  
(x1) 7/8"x19 1/16"x22 7/16" (22x484.5x570)

**FOR THIS STEP IT IS HELPFUL TO HAVE AN ADDITIONAL PERSON HELP HOLD DOOR IN PLACE.**

**TIP: REFER TO STEP 79: ADJUSTING DOOR HINGES AS NEEDED**

**WITH CABINET HINGES ATTACHED TO DOOR, ALIGN HOLES IN HINGE BRACKET WITH ZERTS IN SIDE OF CABINET PANEL.**

**DO NOT OVERTIGHTEN HARDWARE.**

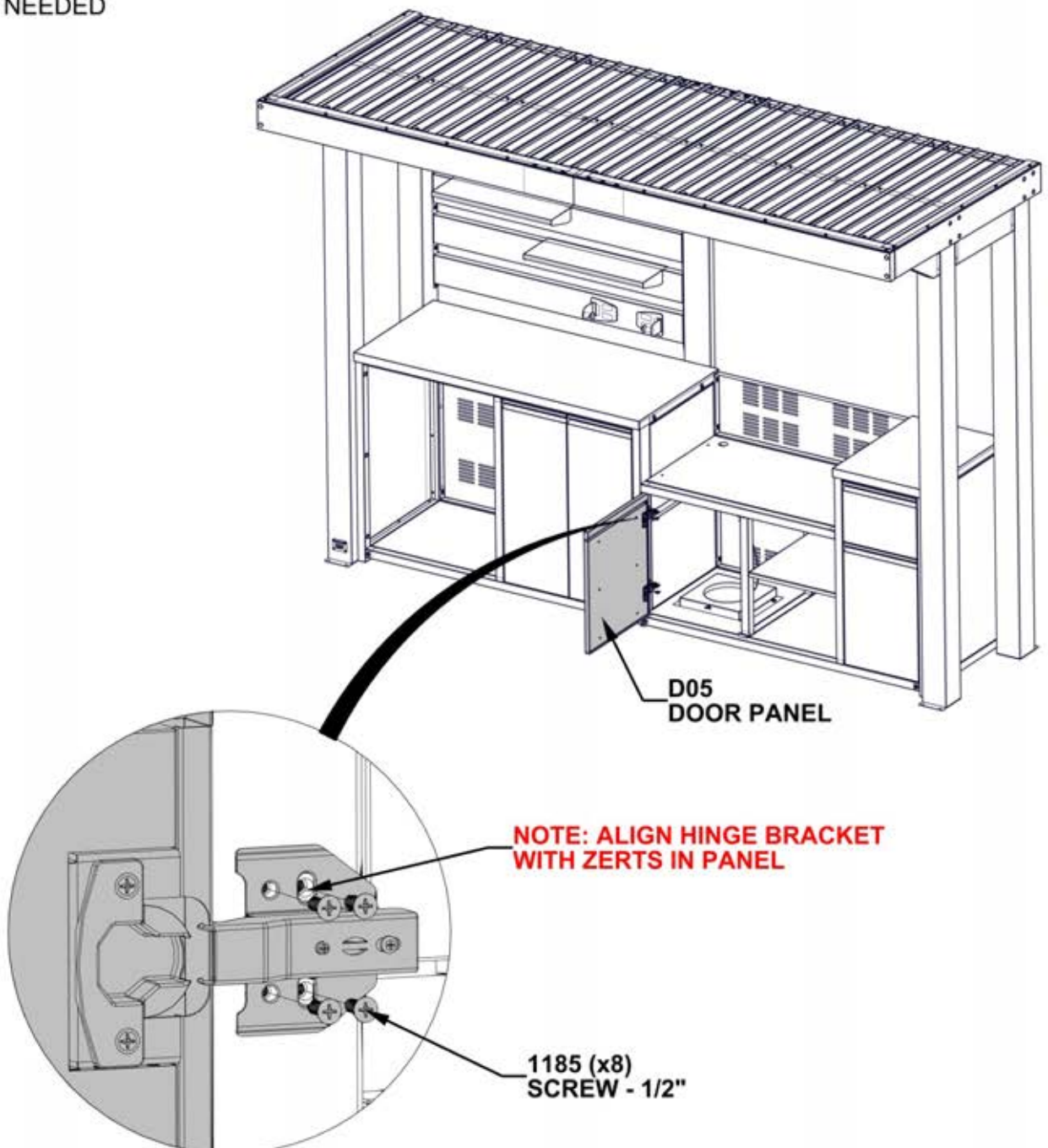

# STEP 78 - CABINET DOOR ATTACHMENT



QTY	PART NUMBER	DESCRIPTION
8	H101185	PHILLIPS FLAT HEAD 8-32x.5 SCREW

D04 DOOR PANEL - A4M02068  
(x1) 7/8"x19 1/16"x22 7/16" (22x484.5x570)

**FOR THIS STEP IT IS HELPFUL TO HAVE AN ADDITIONAL PERSON HELP HOLD DOOR IN PLACE.**

**TIP: REFER TO STEP 79: ADJUSTING DOOR HINGES AS NEEDED**

**WITH CABINET HINGES ATTACHED TO DOOR, ALIGN HOLES IN HINGE BRACKET WITH ZERTS IN SIDE OF CABINET PANEL.**

**DO NOT OVERTIGHTEN HARDWARE.**

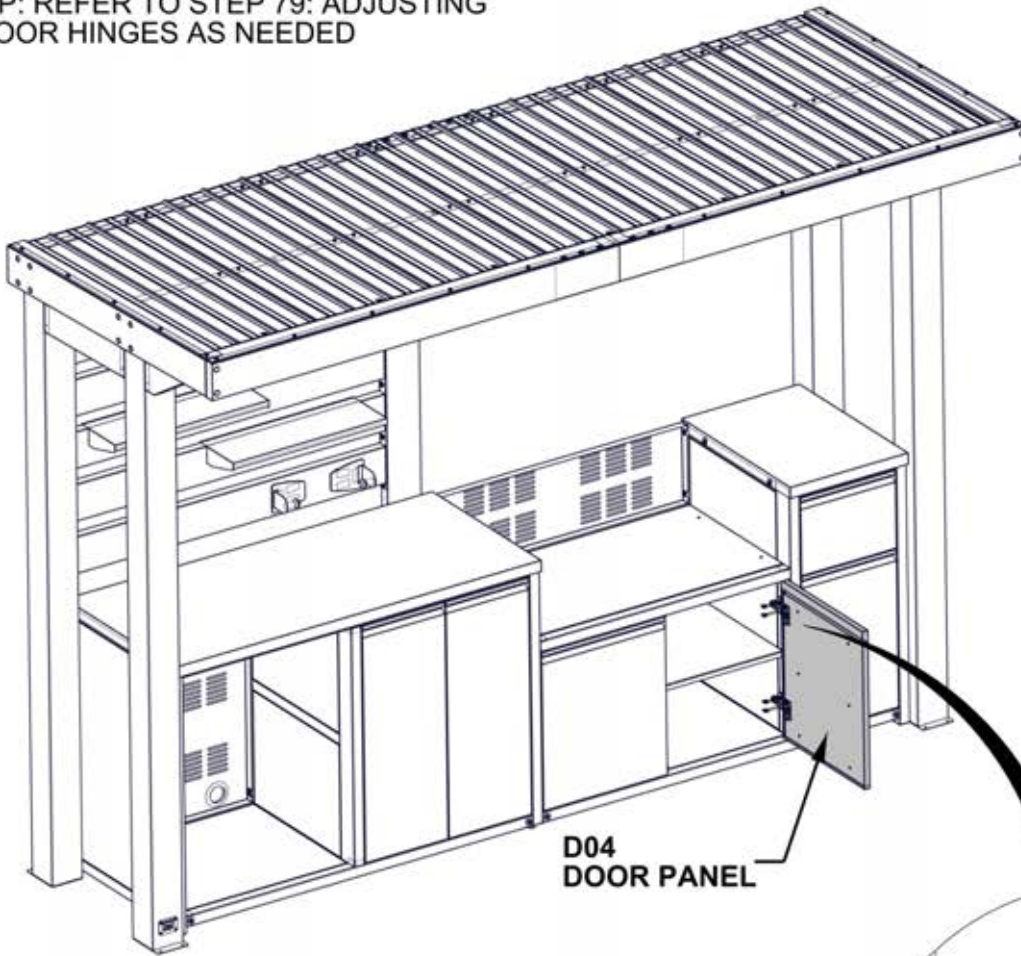

**NOTE: ALIGN HINGE BRACKET WITH ZERTS IN PANEL**

1185 (x8)  
SCREW - 1/2"

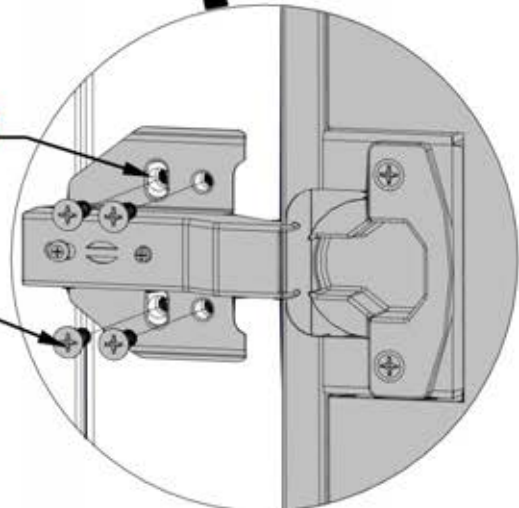

# STEP 79 - KITCHEN DOOR ADJUSTMENT (AS NEEDED)

**SCREW #1:**  
SCREW CLOCKWISE TO BRING EDGE OF DOOR AWAY FROM CABINET. SCREW COUNTER CLOCKWISE TO BRING EDGE OF DOOR CLOSER TO CABINET

**SCREW #2:**  
LOOSEN THESE SCREWS TO SLIDE DOOR IN OR OUT OF CABINET, UNTIL FACE OF DOOR IS FLUSH WITH CABINET WHEN CLOSED.

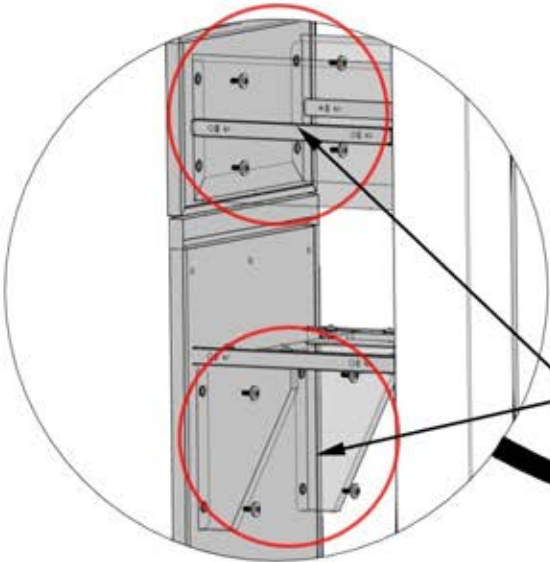
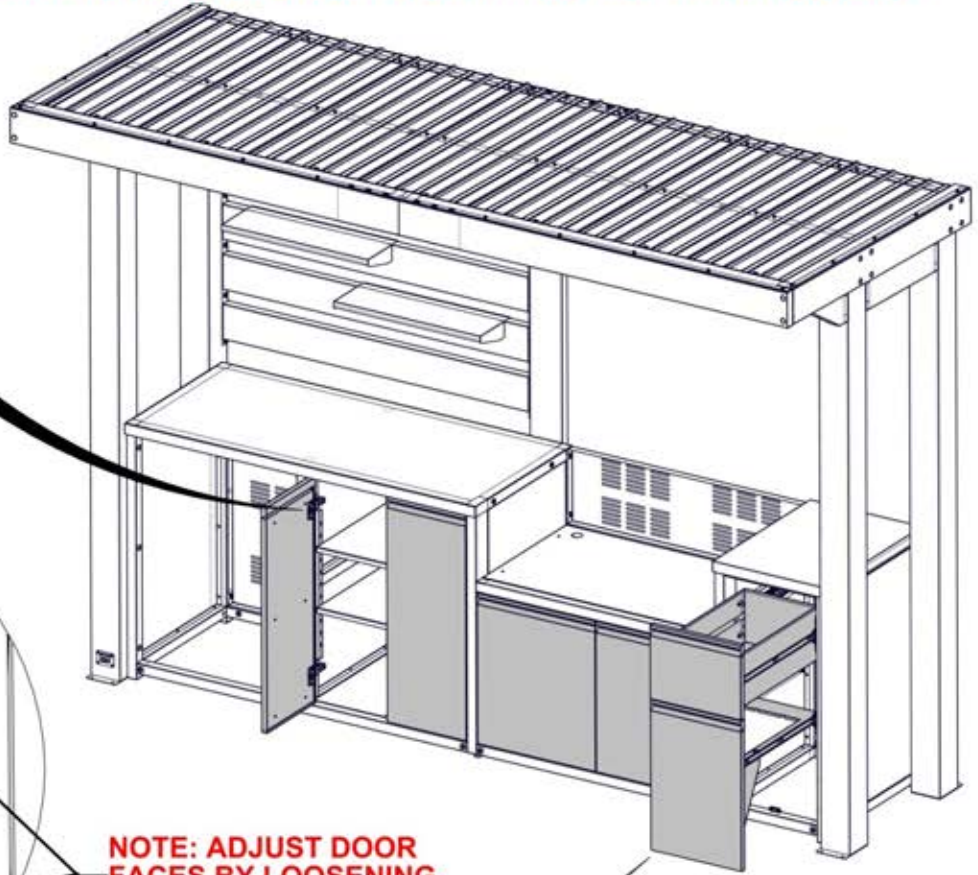
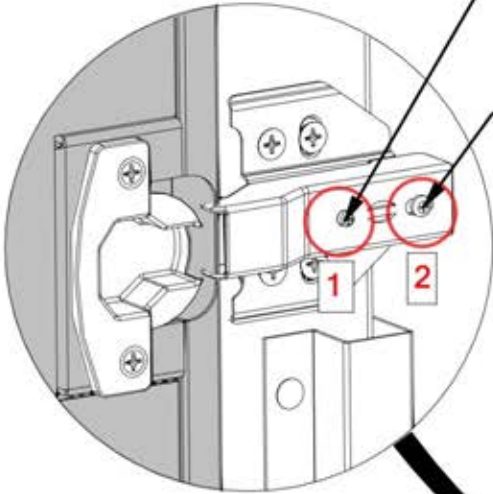

**NOTE: ADJUST DOOR FACES BY LOOSENING SCREWS AS NEEDED**

**ADJUST HINGES SO THAT THE GAP AROUND ALL DOORS AND DRAWER FACE IS THE SAME, AND THERE IS NO INTERFERENCE BETWEEN DOORS AND CABINETS**

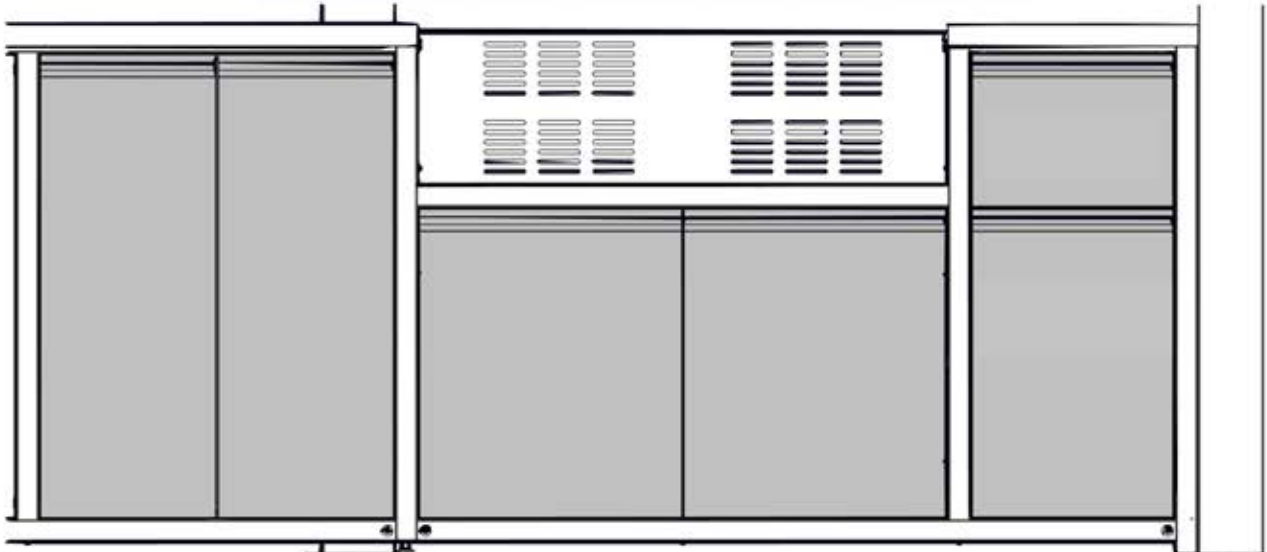

# STEP 80 - KITCHEN ANCHORING

QTY	PART NUMBER	DESCRIPTION
11	H100630	WASHER FLAT 8x19 BLK
11	H100120	CONCRETE ANCHOR

**MANUFACTURER RECOMMENDS INSTALLATION ON CONCRETE SURFACE OR CONCRETE POST PADS AS SHOWN BELOW.**

**FOR INSTALLATION ON WOOD DECK, YOU MUST ENSURE THERE IS AMPLE STRUCTURAL SUPPORT UNDER THE DECK. HARDWARE NOT INCLUDED FOR DECK ATTACHMENT.**

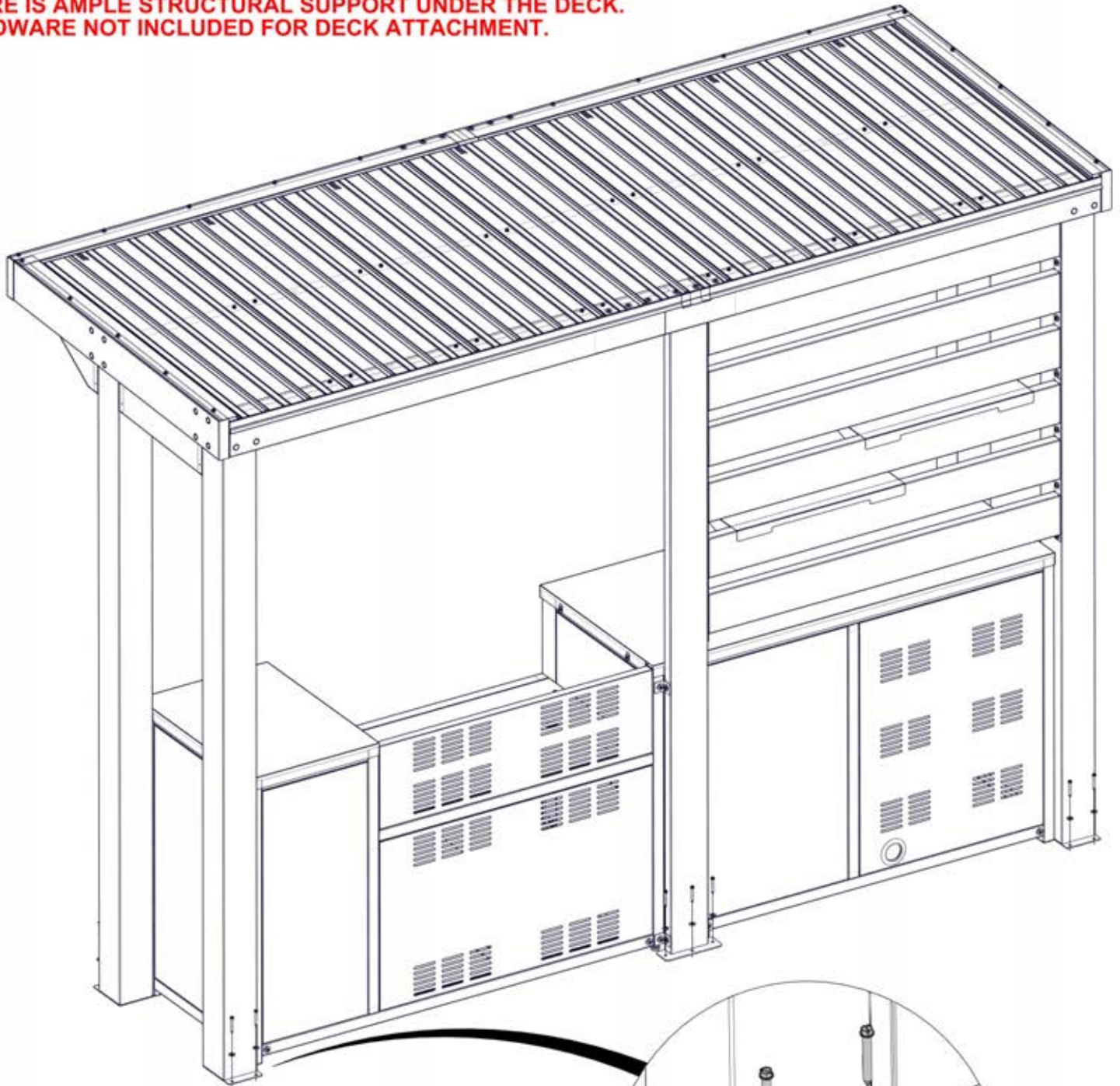

**120 (x11)  
CONCRETE SCREW-2"**

**630 (x11)  
WASHER - 8x19**

**PRE-DRILL HOLES FOR  
CONCRETE ANCHORS USING  
A 3/16" CONCRETE DRILL BIT.**

**REMOVE ANY PROTECTIVE FILM REMAINING ON STAINLESS STEEL  
COUNTERTOPS**

**COUNTERTOP AND APPLIANCE CARE INSTRUCTIONS:**

- WIPE DOWN COUNTERTOPS AND GRILL USING A DAMP MICROFIBER CLOTH TO REMOVE DUST AND SMUDGES. WIPE ALONG THE GRAIN OF THE STAINLESS STEEL TO PREVENT SCRATCHING.
- TO DEEP CLEAN USE A COMMERCIAL STAINLESS STEEL CLEANER AND MICROFIBER CLOTH WIPING ALONG THE GRAIN DIRECTION TO PREVENT SCRATCHES.
- SCRATCHES WILL HAPPEN TO COUNTERTOPS OVERTIME. DO NOT USE SANDPAPER OR STEEL WOOL AGAINST STAINLESS STEEL AS THIS WILL MAKE IT WORSE.
- IF YOU DENT OR DING THE SURFACE OF THE COUNTERTOP, APPLY PRESSURIZED AIR OR ICE TO THE SURFACE UNTIL COLD AND THEN HEAT USING A HAIR DRYER TO POP DENT OUT.

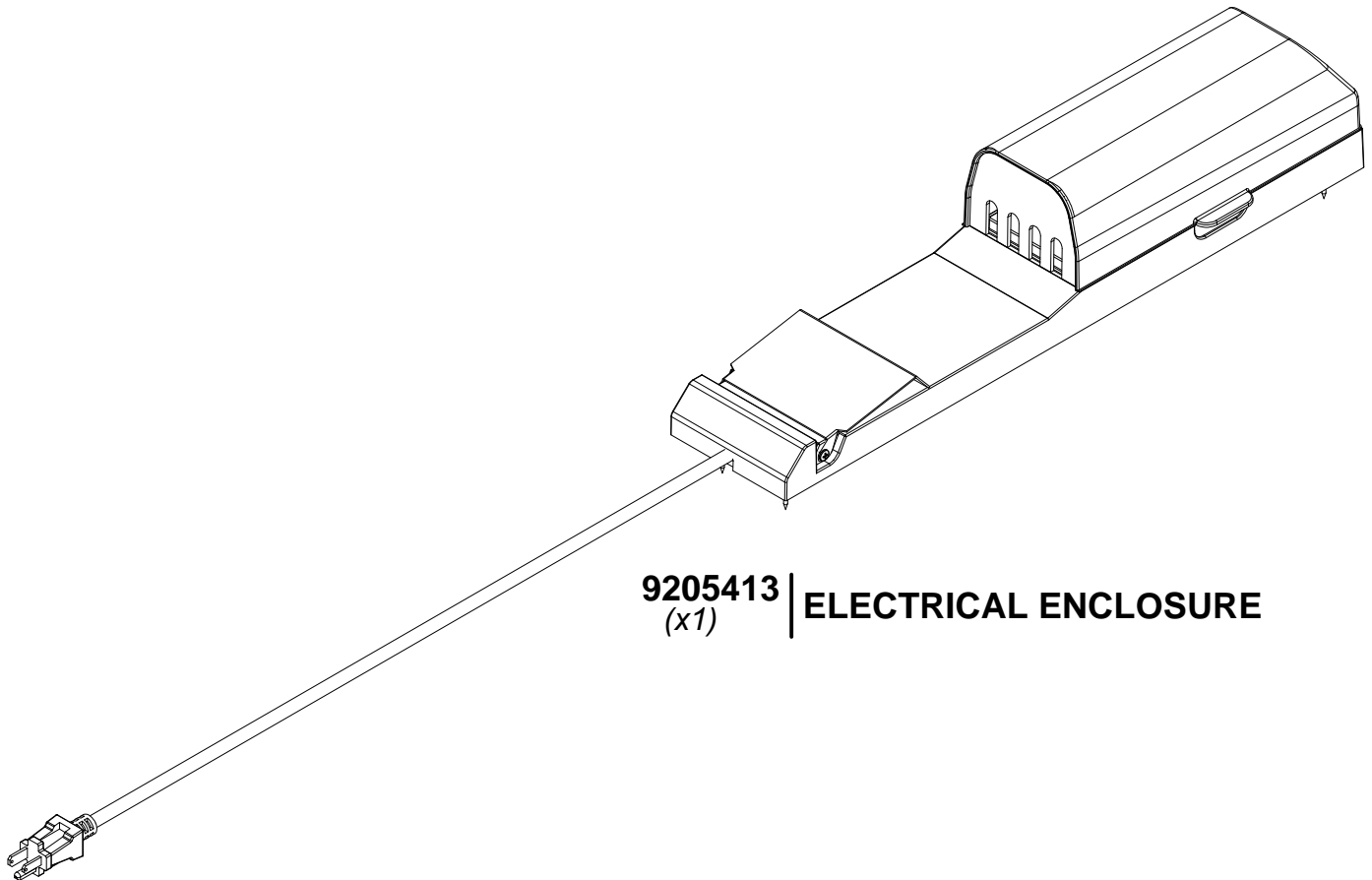

**9205413** | **ELECTRICAL ENCLOSURE**  
(x1)

FOR POWERPORT INSTALLATION REFER TO ASSEMBLY INSTRUCTIONS THAT COME PACKAGED WITH THE POWERPORT KIT. INSTALL ON ANY EXTERIOR POST THAT IS DESIRED. FOLLOW DIRECTIONS FOR PROPER INSTALLATION.

**DO NOT INSTALL POWERPORT ON MIDDLE POST OF ASSEMBLY, AS THIS WILL BE TOO CLOSE TO THE GRILL.**