



Manufactured by:  
Backyard Discovery  
3305 Airport Drive, Pittsburg, KS 66762  
800-856-4445

Basepoint Business Centre: Rivermead Drive, Westlea, Swindon SN5 7EX Phone: 0800-118-2476  
J.P. Coenstraat 7, The Bridge, The Hague, 2595 WP, Netherlands Phone: 08005678990

# ARGENTINE GRILL

## MODEL # : 2304093



Please visit [www.backyarddiscovery.com](http://www.backyarddiscovery.com)  
For the most up to date assembly manual, to register your product, or to order  
replacement parts *Para obtener instrucciones en español, visite*  
[www.backyarddiscovery.com](http://www.backyarddiscovery.com)



EASY STEP-BY-STEP  
3D INTERACTIVE INSTRUCTIONS  
DOWNLOAD THE FREE APP



# OWNER'S MANUAL - BASIC SETUP DIMENSIONS & ASSEMBLY NOTES

It is critically important that you start with square and level footings, concrete pad or deck to attach your structure

- Pay close attention to the items needed for each step. Make sure you are using the correct hardware for each step. Using incorrect hardware may result in improper assembly
- Remember to double check for underground utilities and overhead electrical lines

Post mounts are provided with your structure which allows you to permanently install your structure to a pre-existing or new wood or concrete surface. See Anchor Instructions for further details and recommendations.

- The hardware to attach the post mounts to the structure is included.
- The hardware to mount the structure permanently to a concrete surface is included.
- The hardware to mount the structure permanently to a wood deck is NOT included and will need to be purchased separately. You must ensure there is ample structural support under the deck before permanently attaching.

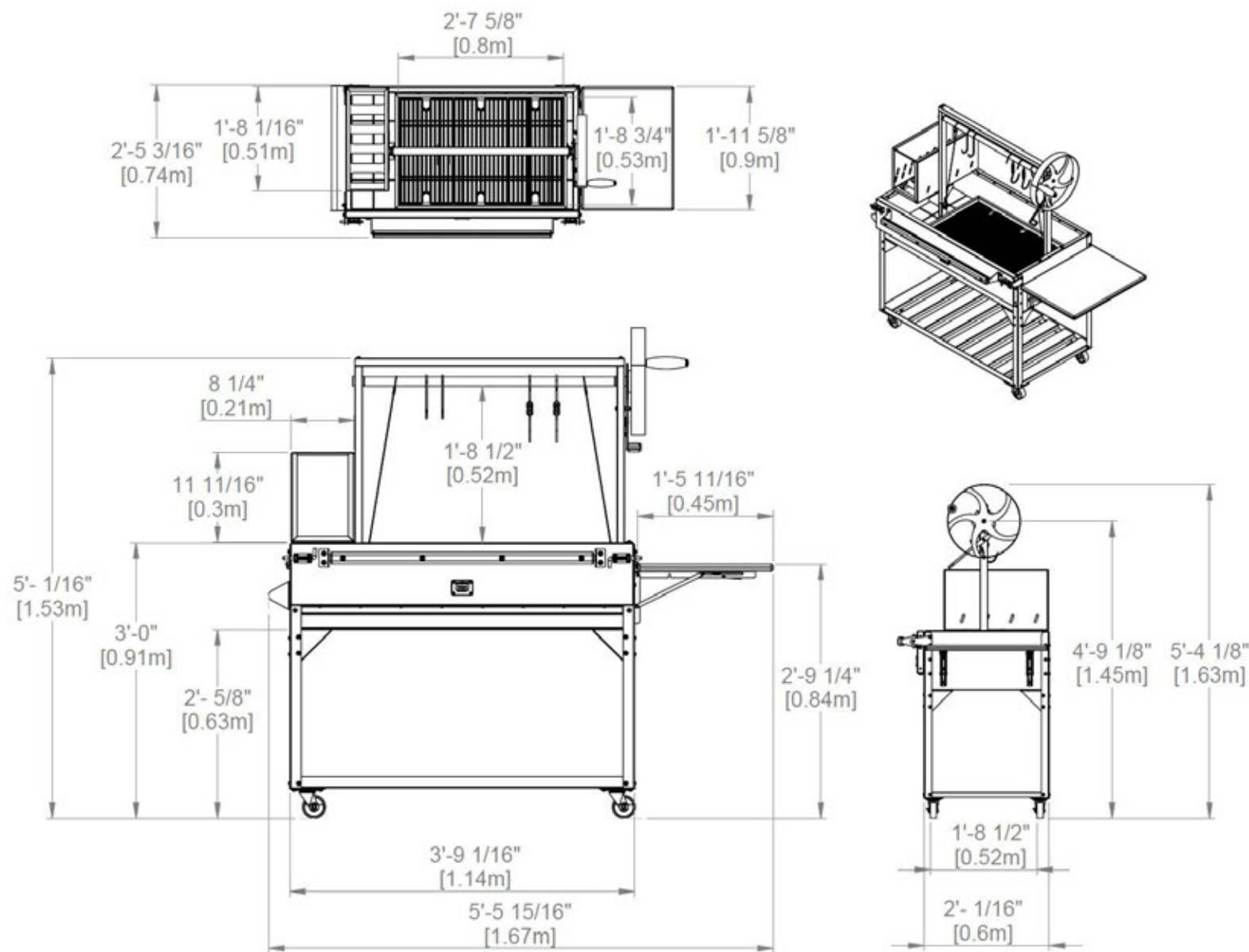

# OWNER'S MANUAL - PARTS IDENTIFICATION

## METAL COMPONENTS (NOT TO SCALE)

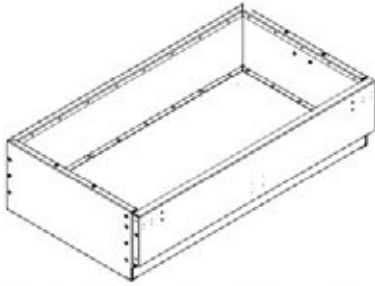

C01 COAL PAN ASSEMBLY - A4M02135  
(x1) 2"x25 1/4"x44 13/16" (292x642x1139)

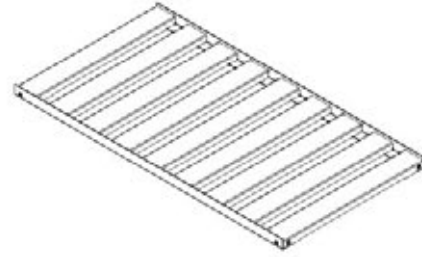

B02 BOTTOM RACK ASSEMBLY - A4M02142  
(x1) 1 5/8"x24 1/16"x 45 1/16" (40.5x611.5x1144.5)

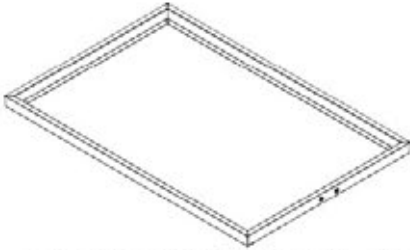

G01 GRATE TRAY ASSEMBLY - A4M02144  
(x1) 1 1/4"x 21 13/16"x33 1/16" (31.8x554x839)



S01 SPINDLE ASSEMBLY - A4M02150  
(x1) (1 3/16"x37 1/2") (30x955)

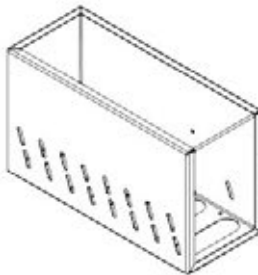

F01 FIRE BOX - A4M02151  
(x1) 8 1/4"x11 11/16"x20 1/16" (210x298x510)



W01 WHEEL ASSEMBLY - A4M02146  
(x1) 2 3/8"x7" (59.7x178)

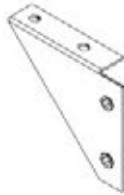

B01 LEG BRACE - A4M02136  
(x4) 1 1/8"x4"x4 15/16" (28x102x125)



B04 LEG BRACE - A4M02387  
(x4) 1 1/8"x4"x4 15/16" (28x102x125)



U01 UPRIGHT ASSEMBLY - A4M02148  
(x1) (2 1/2"x7 7/8"x32 3/8") (63x200x803.2)



U02 UPRIGHT ASSEMBLY - A4M02214  
(x1) 2 5/16"x7 7/8"x31" (58.8x200x788)

# OWNER'S MANUAL - PARTS IDENTIFICATION

## METAL COMPONENTS (NOT TO SCALE)



H01 DOOR HANDLE ASSEMBLY - A4M02412  
(x1) 2 3/8"x3 3/4"x37 7/16" (60x95x951)

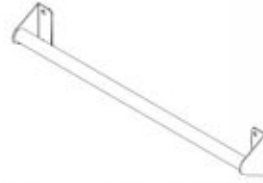

H03 HANDLE ASSEMBLY - A4M02152  
(x1) 2 3/4"x3 3/4"x23 15/16" (70x94.5x609)

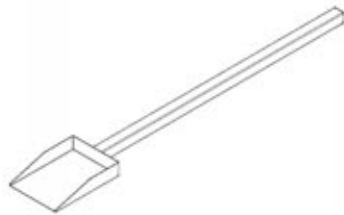

SH01 SHOVEL - A4M02513  
(x1) 2 1/4"x4 7/8"x26 7/16" (57x124x671)

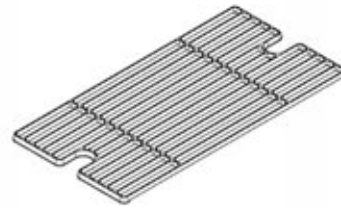

G02 GRATE - A4M02145  
(x3) 7/16"x10 1/2"x20 1/2" (12x266x520)



L01 LEG - A4M02414  
(x1) 1 1/2"x1 1/2"x31 13/16" (38x38x808)



L02 LEG - A4M02415  
(x1) 1 1/2"x1 1/2"x31 13/16" (38x38x808)



L03 LEG - A4M02416  
(x1) 1 1/2"x1 1/2"x31 13/16" (38x38x808)

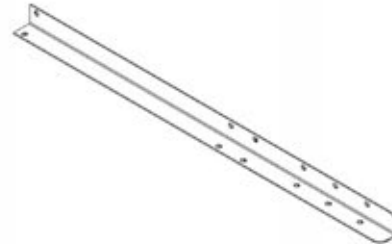

L04 LEG - A4M02417  
(x1) 1 1/2"x1 1/2"x31 13/16" (38x38x808)

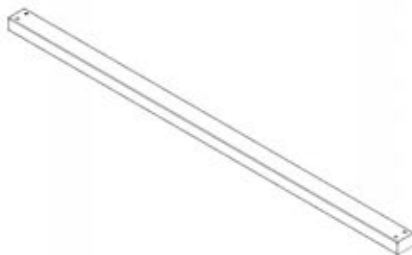

U03 TOP RAIL - A4M02149  
(x1) 1"x1 1/2"x35 1/4" (25x38x896)

# OWNER'S MANUAL - PARTS IDENTIFICATION

## METAL COMPONENTS (NOT TO SCALE)



**B03 LATCH BRACKET - A4M02413**  
(x2) 1/8"x2 3/16"x4 1/8" (2.5x56x104)



**S02 SPROCKET - A4M02147**  
(x1) 3/16"x4 11/16"x4 11/16" (4x119x119)



**DC01 DOOR CABLE - A4M02504**  
(x2) 1/8"x9 7/16" (2.5x240)



**H02 SPROCKET HANDLE - A4M02497**  
(x1) 7/8"x3 5/8"x11 1/4" (22x92x285)



**MH01 MEAT HOOK - A4M02402**  
(x2) 3/16"x3 7/8"x5 11/16" (5x98x145)



**MH02 MEAT HOOK - A4M02407**  
(x2) 3/16"x3"x8 13/16" (5x77x224)

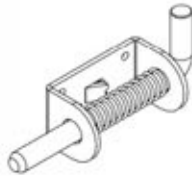

**DL01 DOOR LATCH - A4M02496**  
(x2) 1 5/16"x1 7/8"x4 3/8" (33x47x111)



**B05 UPRIGHT CABLE BRACKET - A4M02270**  
(x2) 1 3/16"x2 15/16"x5 11/16" (30x74.5x143.8)



**2094 FOLDING TABLE BRACKET - A4M02094**  
(x2) 1 3/8"x6 13/16"x15 15/16" (34x173x405)



**S03 SPRING - A4M02506**  
(x1) 1/16"x7/16"x1 13/16" (1.5x11x46)



**2605 CASTER - A4M02605**  
(x4) 2 9/16"x3 13/16" (65x96)

# OWNER'S MANUAL - PARTS IDENTIFICATION

## ACCESSORY COMPONENTS (NOT TO SCALE)



2499 BUSHING - A4M02499  
(x4) 1/4"x3/8"x1/4" (6.5x9.7x6.35)



A4M02158 BYD ID TAG PATIO  
(x1)

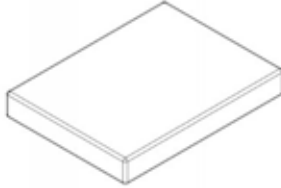

0729 FIRE BRICK - A6P00729  
(x40) 13/16"x4 3/16"x5 9/16" (20x107x142)

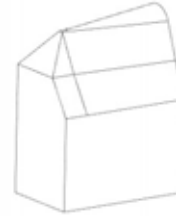

A6P00803 GRILL COVER  
(x1)

## WOOD COMPONENTS (NOT TO SCALE)



H04 WHEEL HANDLE - W4L19101  
(x1) 1 9/16"x5 1/8" (40x130)

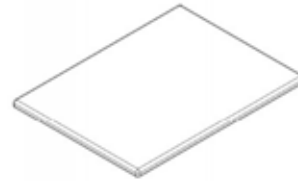

T01 TABLE TOP - W4L18241  
(x1) 1 1/4"x17 11/16"x23 5/8" (32x450x600)

# OWNER'S MANUAL - PARTS IDENTIFICATION

## HARDWARE COMPONENTS (NOT TO SCALE)

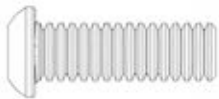

H101264 TORX PAN HEAD  
(x80) 1/4-20 x 3/4 BLK (LOCTITE)

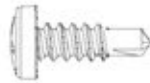

H101159 PHILLIPS ROUNDED HEAD  
(x8) 8-18x.5 BLK



H101183 WASHER FLAT  
(x22) 8 x 16 SS

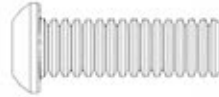

H101265 TORX PAN HEAD  
(x15) 1/4-20 x 3/4 SS (LOCTITE)

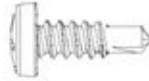

H101262 PHILLIPS ROUNDED HEAD  
(x4) 8-18x.5



H100630 WASHER FLAT  
(x2) 8 x 19 BLK

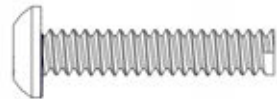

H101279 TORX PAN HEAD  
(x4) 1/4-20 x 1 BLK (LOCTITE)



H100797 SCREW PWH  
(x6) 8 x 1 BLK



H101280 WASHER FLAT  
(x84) 7 x 14 SS

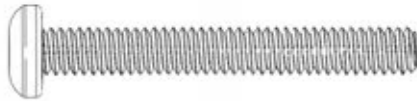

H101200 TORX PAN HEAD  
(x4) 1/4-20 x 2 SS (LOCTITE)

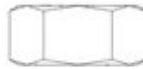

H101273 HEX JAM NUT  
(x3) 1/4-20 SS (LOCTITE)



H101167 WASHER FLAT  
(x1) 11 x 25 BLK



H101266 SCREW TFH  
(x6) 1/4-20 x 1 BLK (LOCTITE)



H101274 NUT LOCK  
(x1) 3/8-16 SS

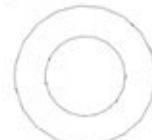

H100497 WASHER FLAT  
(x1) 17 x 30 BLK



H101263 BOLT WH  
(x1) 5/16 x 6 3/8 BLK (LOCTITE)



H101182 WASHER SPLIT  
(x7) 1/4 SS

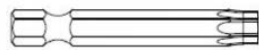

H100147 TORX BIT  
(x1) T-30



H100114 TORX WRENCH  
(x1) T-30

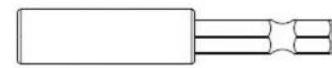

H101100 MAGNETIC DRIVER  
(x1)

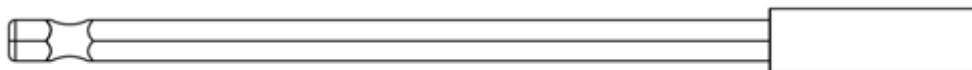

H101278 6" MAGNETIC  
(x1) DRIVER EXTENSION

# PRE-ASSEMBLY STEP 1 - SORTING PARTS

It is critical for ease of assembly that you take the time to sort and organize the parts and hardware.

---

## METAL PARTS:

- Organize metal parts by the three-digit, alpha-numeric number stamped on each part (ex. P01).
- If there are multiple parts with the same stamped number, stack those pieces together.
- Stamps can be found on the flat surface of the parts or on the end of the parts.
- Allow yourself plenty of room - the parts can take up a significant amount of space.

**NOTE: CARTONS ARE NOT ORGANIZED BY PART NUMBER.**

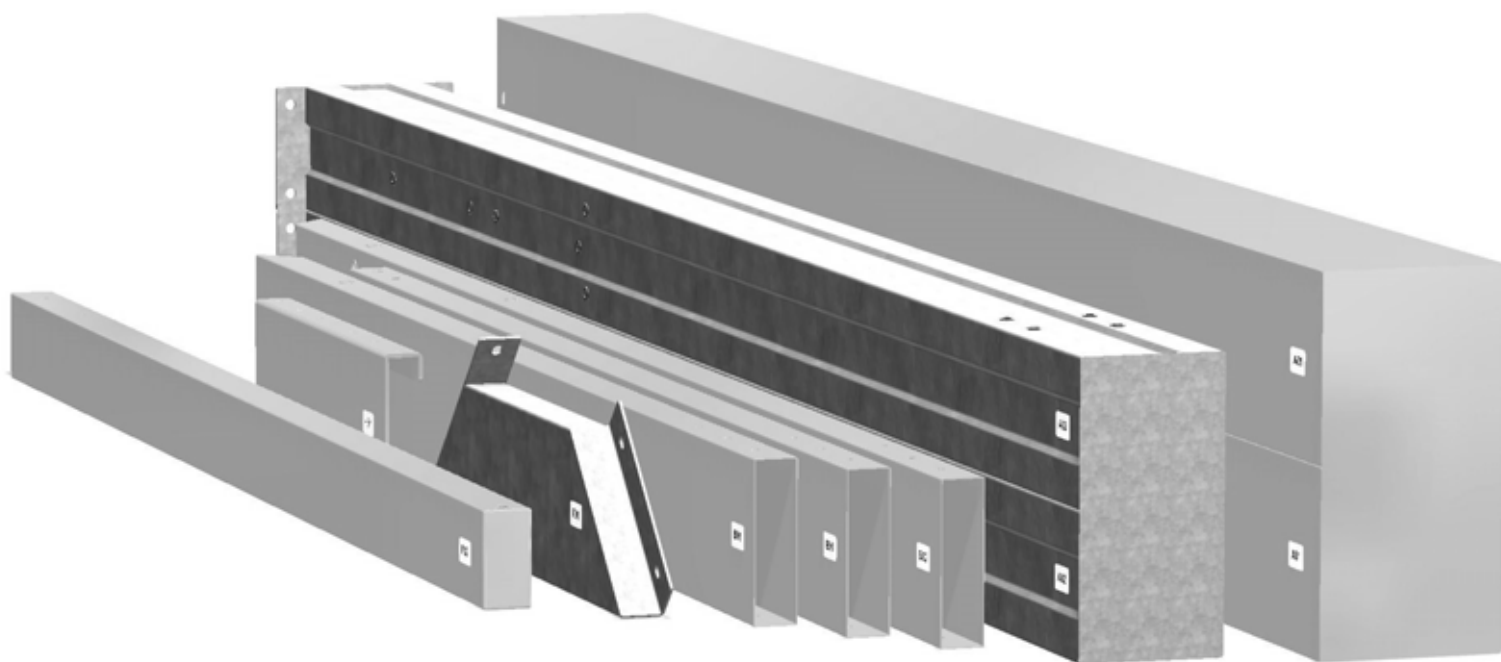

---

## HARDWARE PARTS:

- We recommend that you have a separate table to organize the hardware.
- Hardware bags are printed with a seven-digit, alpha-numeric part number.
- You can organize your hardware by part number or group by hardware type (i.e. bolts, nuts, etc.).
- During assembly you only need to reference the last four digits of the number.

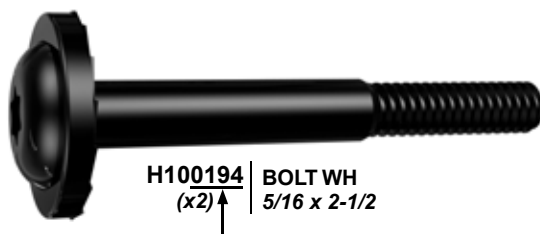



# PRE-ASSEMBLY STEP 2 - TOOLS REQUIRED



Cordless Drill or  
Electric Drill



Drill Attachments:  
Phillips Head



1/8", 3/16", 3/8" &  
7/16" Drill Bits



Phillips Screw Driver



Open End Wrench  
7/16"



3/8" Drive Ratchet, 1/2" &  
7/16" STD Sockets 1/2" & 7/16"  
Deep Sockets



Claw Hammer



Rubber Mallet -  
Optional



Tape Measure

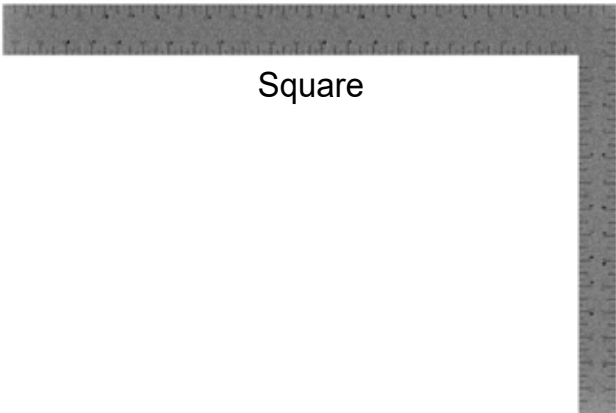

Square



Level 24"

# PRE-ASSEMBLY STEP 3 - CHOOSE YOUR ASSEMBLY METHOD

There are several types of assembly instructions available to you.

1. Printed Assembly Manual included with your set
2. BILT APP - 3D interactive instructions
3. Combination of the Printed Manual and BILT APP (Note: Step numbers can differ between the two methods)

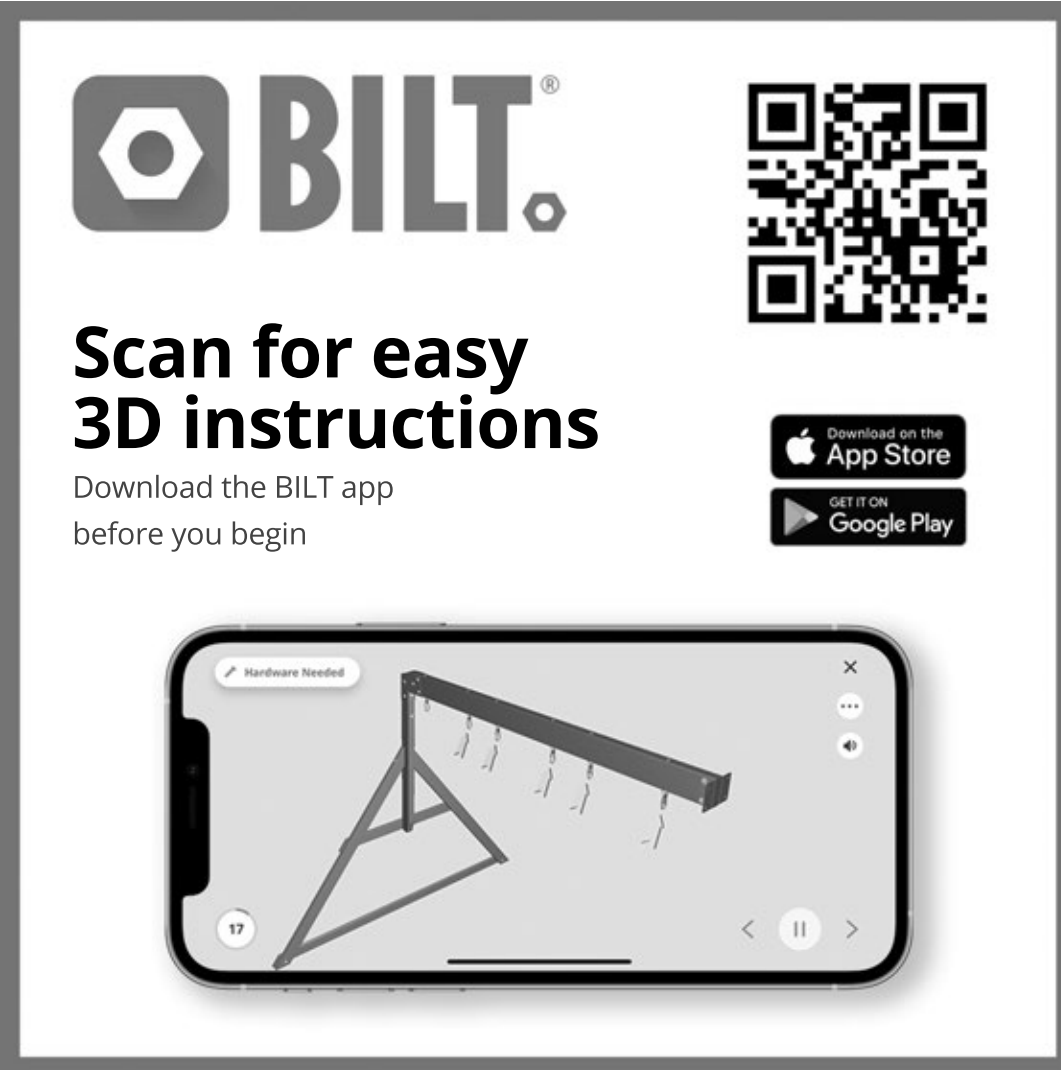

The graphic features the BILT logo (a hexagon with a white dot inside) and the word "BILT." in a bold, sans-serif font. To the right is a large QR code. Below the logo, the text "Scan for easy 3D instructions" is written in a large, bold font. Underneath that, it says "Download the BILT app before you begin". To the right of this text are two buttons: "Download on the App Store" and "GET IT ON Google Play". At the bottom, a smartphone screen displays a 3D assembly instruction for step 17, showing a metal frame with a horizontal bar and several screws being attached. The screen has a "Hardware Needed" label at the top left, a close button (X) at the top right, and navigation arrows at the bottom.

# STEP 1A - CART ASSEMBLY

QTY	PART NUMBER	DESCRIPTION
1	H101266	SCREW TFH 1/4-20 X 1 BLK (LOCTITE)

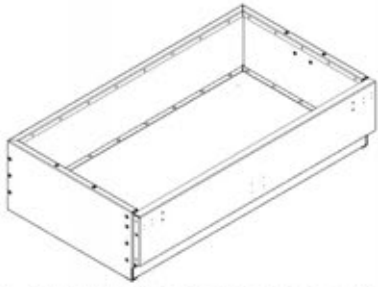

**C01 COAL PAN ASSEMBLY - A4M02135**  
 (x1) 1 15/16"x25 1/4"x44 13/16" (292x642x1139)



**L01 LEG - A4M02414**  
 (x1) 1 1/2"x1 1/2"x31 13/16" (38x38x808)

**PLACE COAL PAN ASSEMBLY UPSIDE DOWN AND ATTACH LEG AS SHOWN BELOW.**

FOR EASE OF ASSEMBLY, WE RECOMMEND USING SAWHORSES FOR STEPS 1 - 7

TIP: IF ASSEMBLING ON THE GROUND, LAY A PIECE OF CARDBOARD, BLANKET, OR RUG DOWN BEFORE SETTING COAL PAN ASSEMBLY UPSIDE DOWN.

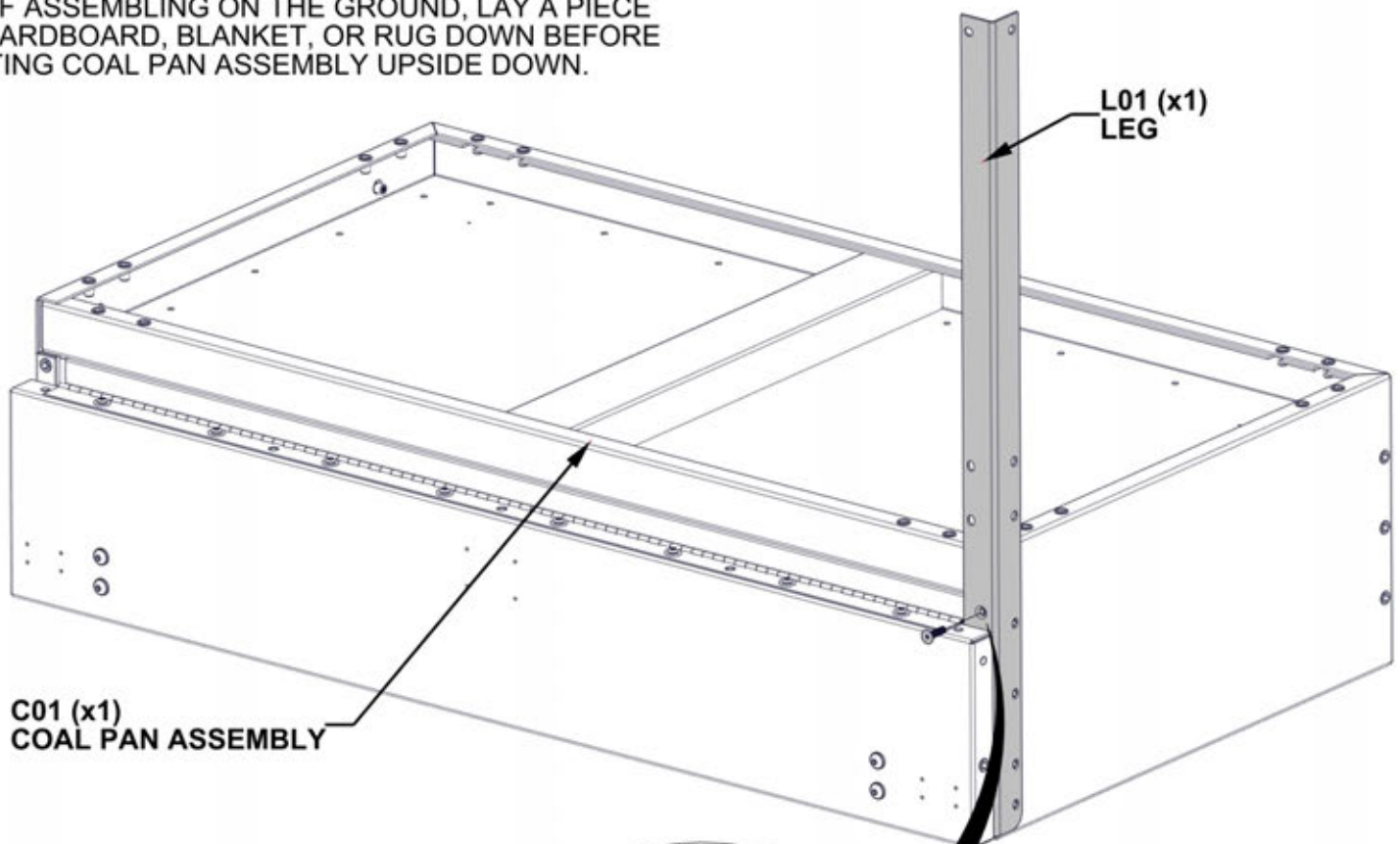

**C01 (x1)**  
**COAL PAN ASSEMBLY**

**L01 (x1)**  
**LEG**

**1266 (x1)**  
**SCREW TFH**  
**1/4-20x1 BLK**

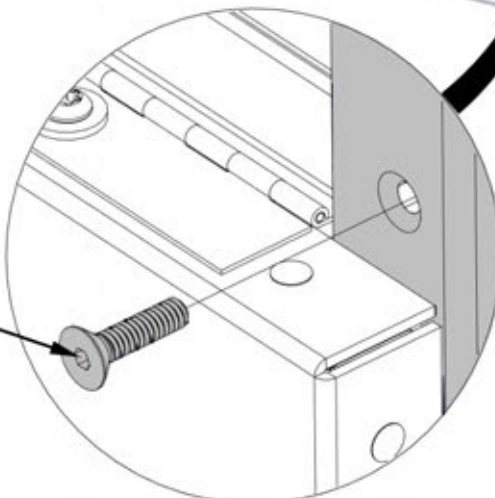

# STEP 1B - CART ASSEMBLY

QTY	PART NUMBER	DESCRIPTION
2	H101266	SCREW TFH 1/4-20 X 1 BLK (LOCTITE)

**OPEN COAL PAN ASSEMBLY DOOR AND ATTACH LEG HARDWARE AS SHOWN BELOW.**

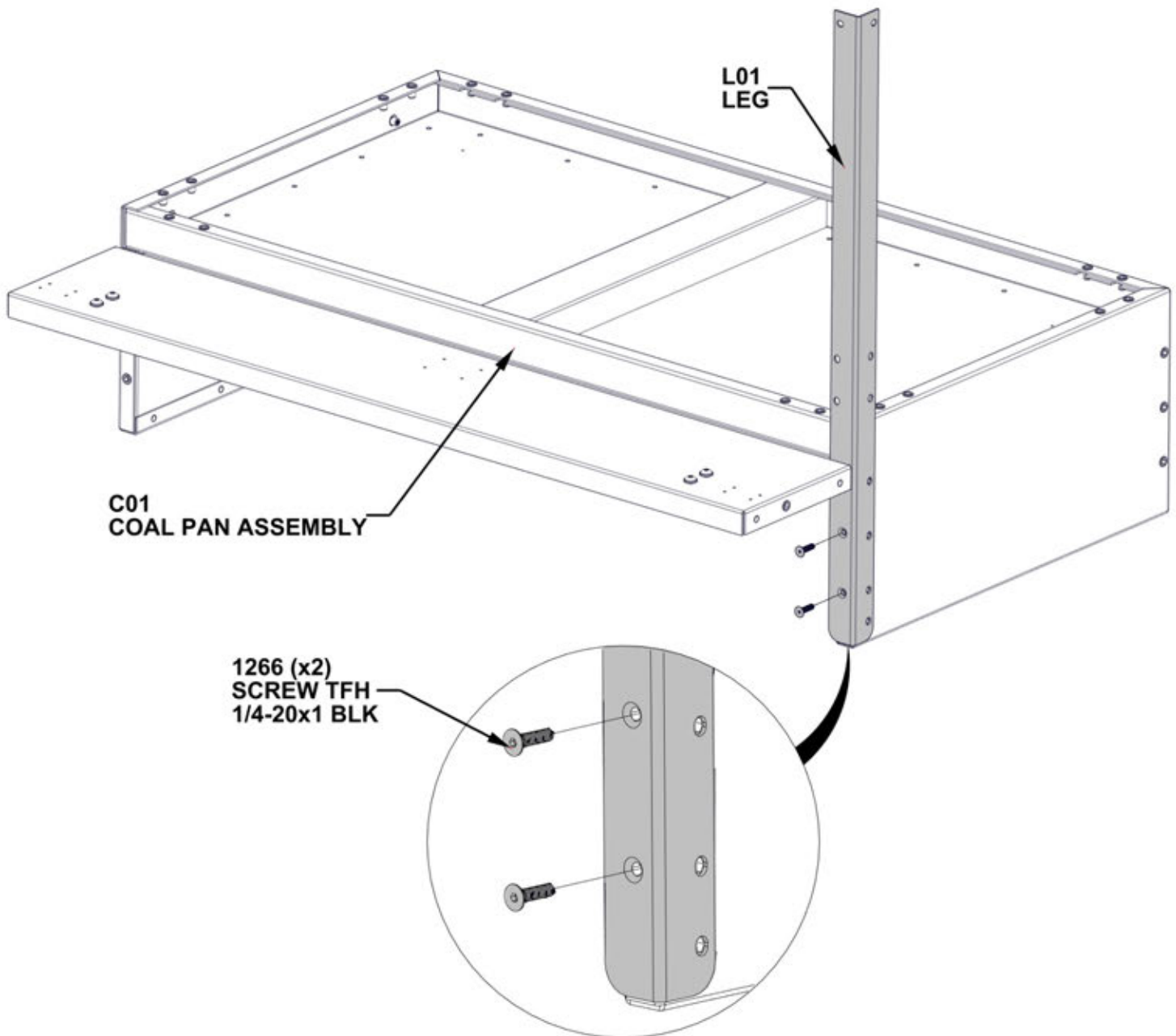

# STEP 2A - CART ASSEMBLY

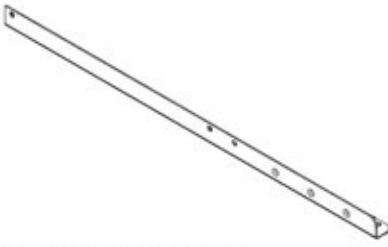

QTY	PART NUMBER	DESCRIPTION
1	H101266	SCREW TFH 1/4-20 X 1 BLK (LOCTITE)
2	H101264	TORX PAN HEAD 1/4-20x3/4" BLK (LOCTITE)
2	H101280	WASHER FLAT 7x14 SS

L03 LEG - A4M02416  
 (x1) 1 1/2"x1 1/2"x31 13/16" (38x38x808)

**POSITION LEG AS SHOWN BELOW. ENSURE BOLTS ARE INSERTED IN THE CORRECT HOLES SHOWN BELOW**

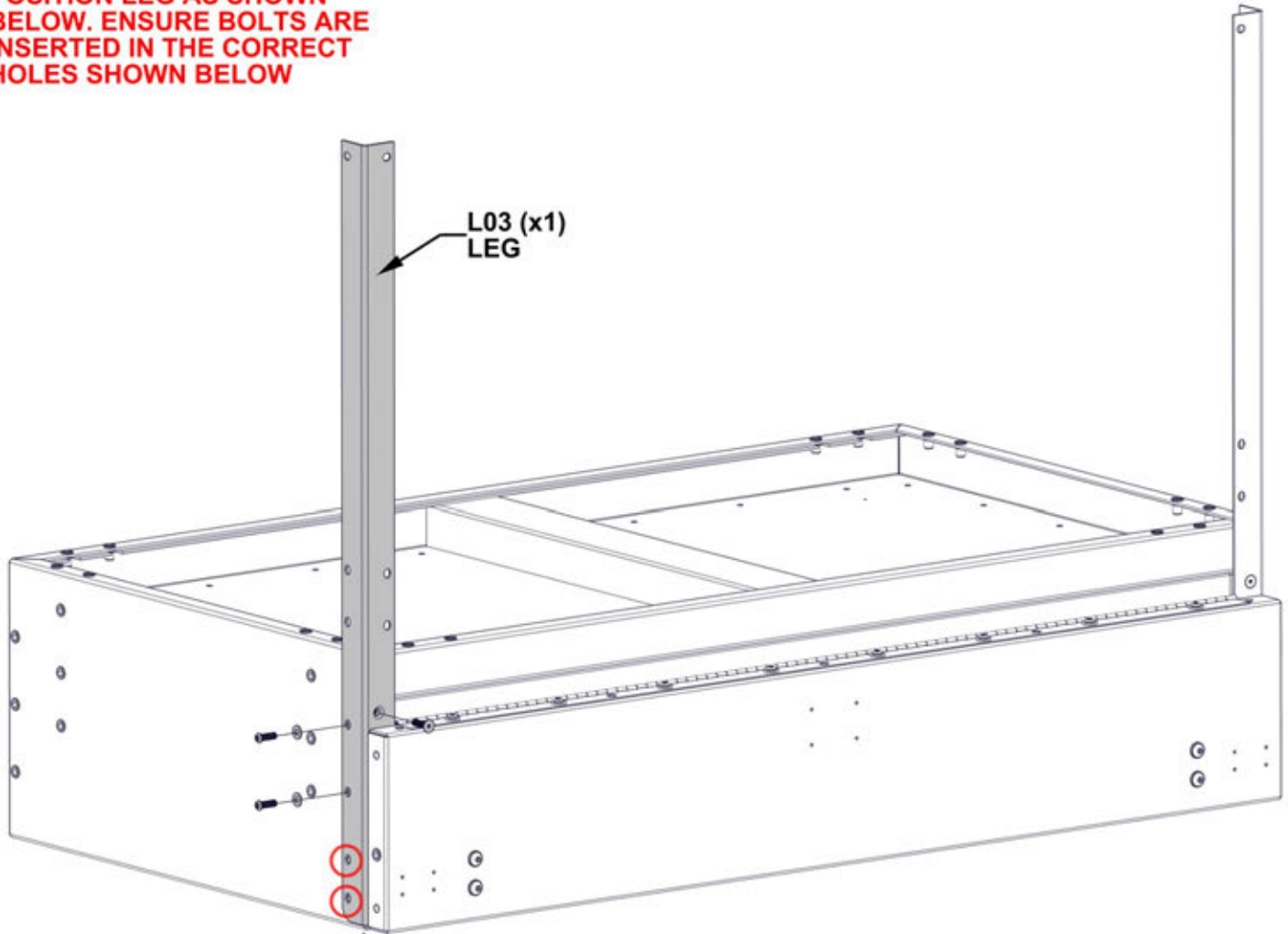

L03 (x1)  
LEG

1280 (x2)  
WASHER - 7x14

1264 (x2)  
TORX PAN HEAD  
1/4-20x3/4" BLK

1266 (x1)  
SCREW TFH  
1/4-20x1 BLK

**ENSURE TWO HOLES ON SIDE OF L03 LEG ARE LEFT OPEN AS SHOWN**

# STEP 2B - CART ASSEMBLY

QTY	PART NUMBER	DESCRIPTION
2	H101266	SCREW TFH 1/4-20 X 1 BLK (LOCTITE)

**OPEN COAL PAN ASSEMBLY DOOR AND ATTACH LEG HARDWARE AS SHOWN BELOW.**

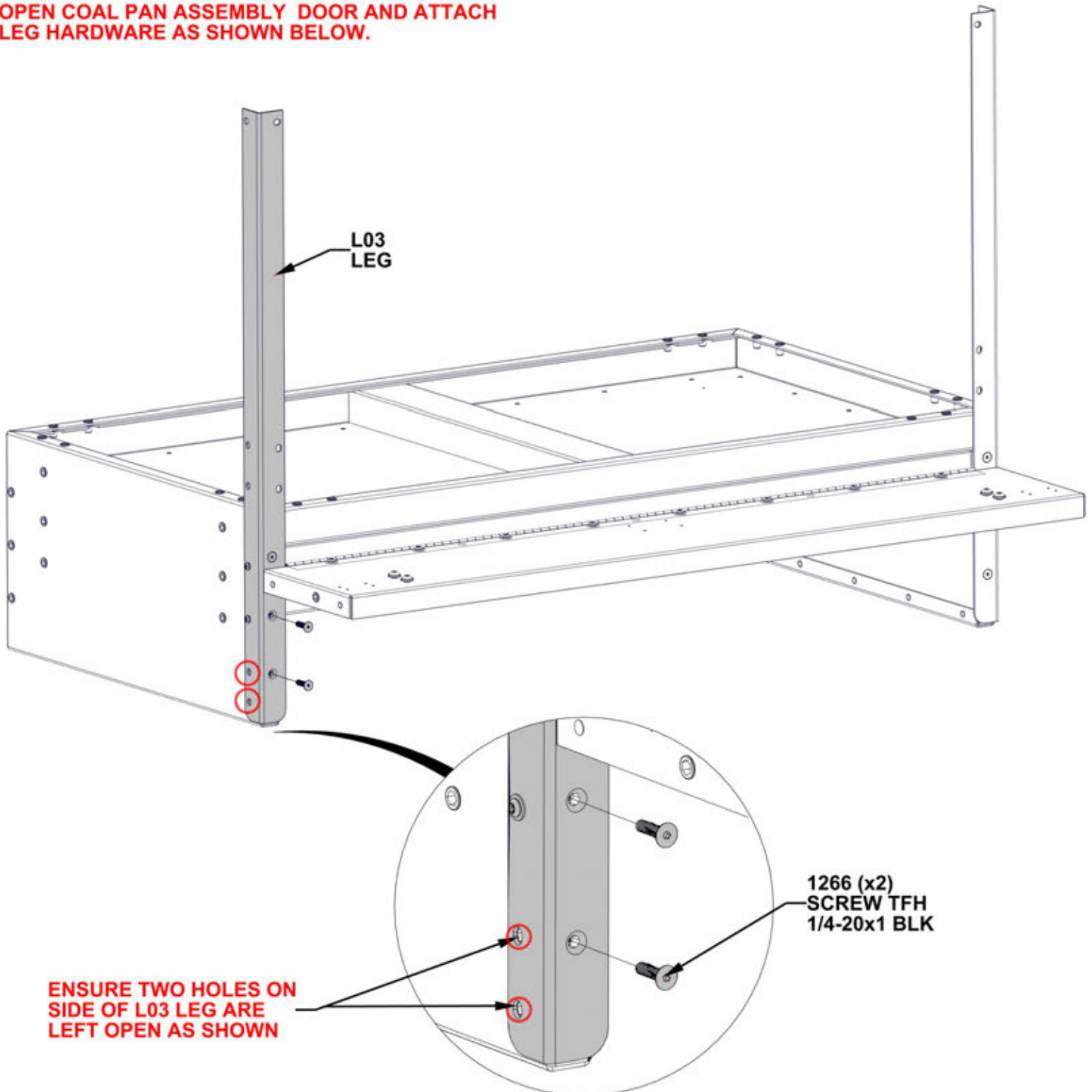

# STEP 3 - CART ASSEMBLY

QTY	PART NUMBER	DESCRIPTION
10	H101264	TORX PAN HEAD 1/4-20x3/4" BLK (LOCTITE)
10	H101280	WASHER FLAT 7x14 SS

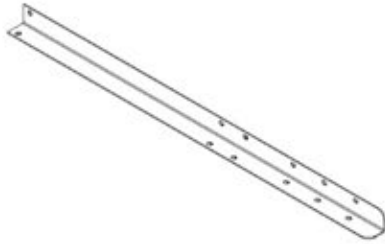

L04 LEG - A4M02417  
(x1) 3 3/4"x4 3/4"x31 15/16" (95x120x811)

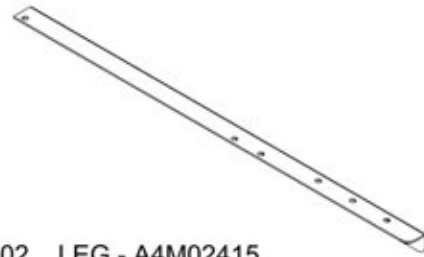

L02 LEG - A4M02415  
(x1) 1 1/2"x1 1/2"x31 13/16" (38x38x808)

**INSTALL BACK LEGS AS SHOWN BELOW.  
ENSURE HARWARE IS IN THE CORRECT  
LOCATIONS ON L02 LEG**

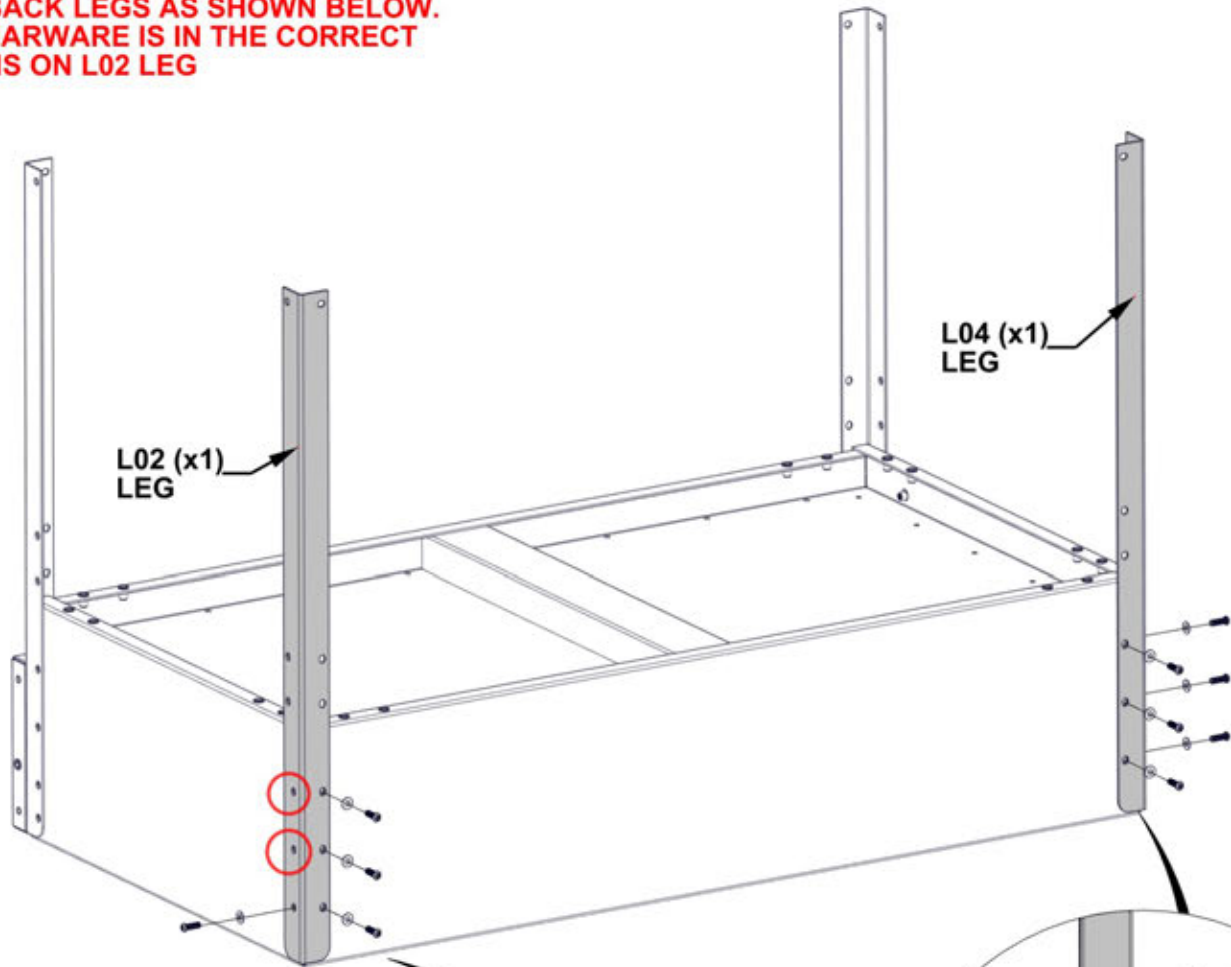

**ENSURE TWO HOLES ON  
SIDE OF L02 LEG ARE LEFT  
OPEN AS SHOWN**

1280 (x4)  
WASHER - 7x14

1264 (x4)  
TORX PAN HEAD  
1/4-20x3/4" BLK

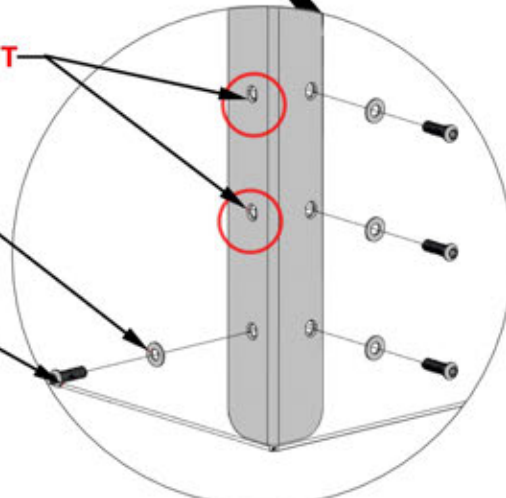

1280 (x6)  
WASHER - 7x14

1264 (x6)  
TORX PAN HEAD  
1/4-20x3/4" BLK

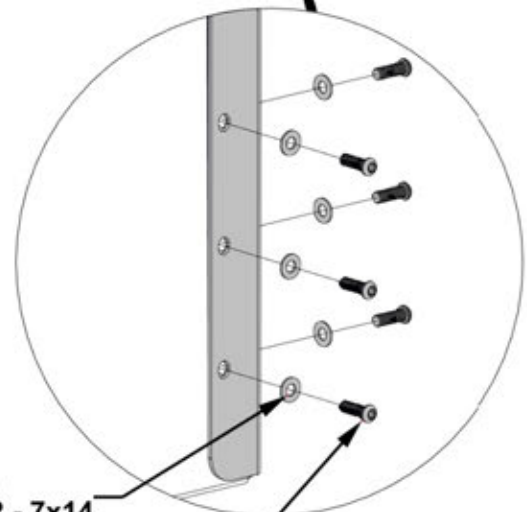

# STEP 4 - CART ASSEMBLY

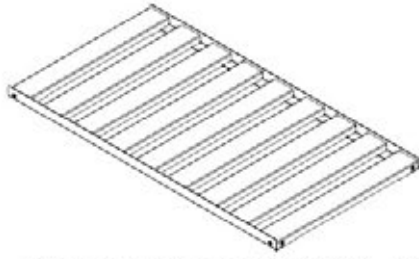

QTY	PART NUMBER	DESCRIPTION
8	H101264	TORX PAN HEAD 1/4-20x3/4" BLK (LOCTITE)
8	H101280	WASHER FLAT 7x14 SS

B02 BOTTOM RACK ASSEMBLY - A4M02142  
(x1) 1 5/8"x24 1/16"x 45 1/16" (40.5x611.5x1144.5)

**CAREFULLY LAY CART ASSEMBLY ON ITS BACK. INSTALL BOTTOM RACK ASSEMBLY AS SHOWN BELOW.**

TIP: IF ASSEMBLING ON THE GROUND, LAY A PIECE OF CARDBOARD, BLANKET, OR RUG DOWN BEFORE SETTING COAL PAN ASSEMBLY UPSIDE DOWN.

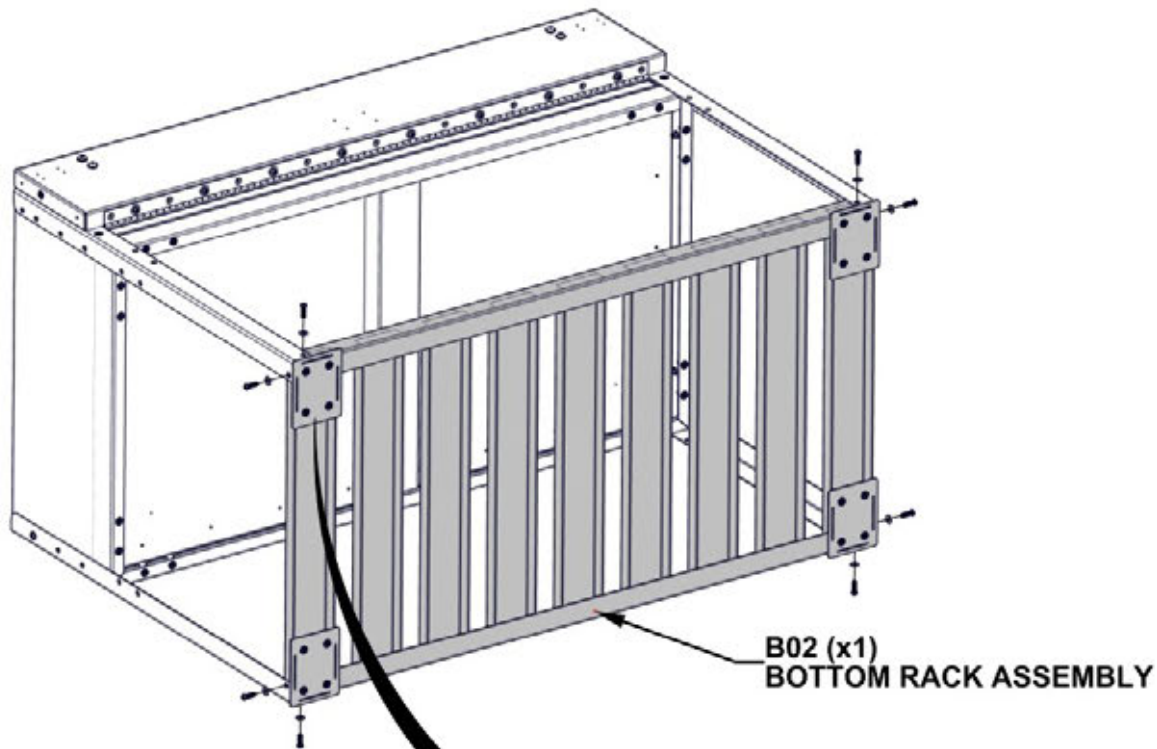

1280 (x8)  
WASHER - 7x14

1264 (x8)  
TORX PAN HEAD  
1/4-20x3/4" BLK

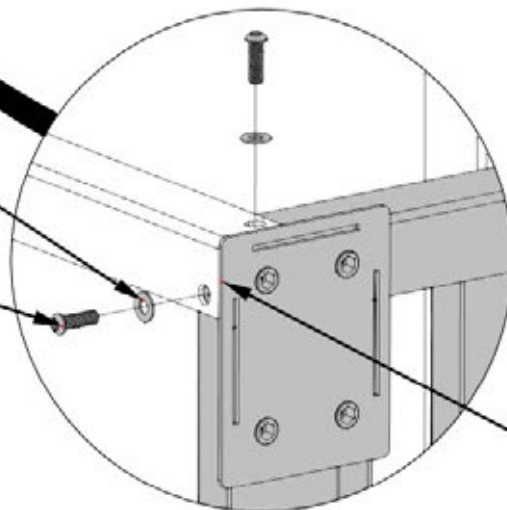

**NOTE: CART LEGS  
WILL REST ON  
SURFACE OF RACK**



# STEP 5 - CART ASSEMBLY



A4M02605 CASTER  
(x4)

QTY	PART NUMBER	DESCRIPTION
16	H101264	TORX PAN HEAD 1/4-20x3/4" BLK (LOCTITE)
16	H101280	WASHER FLAT 7x14 SS

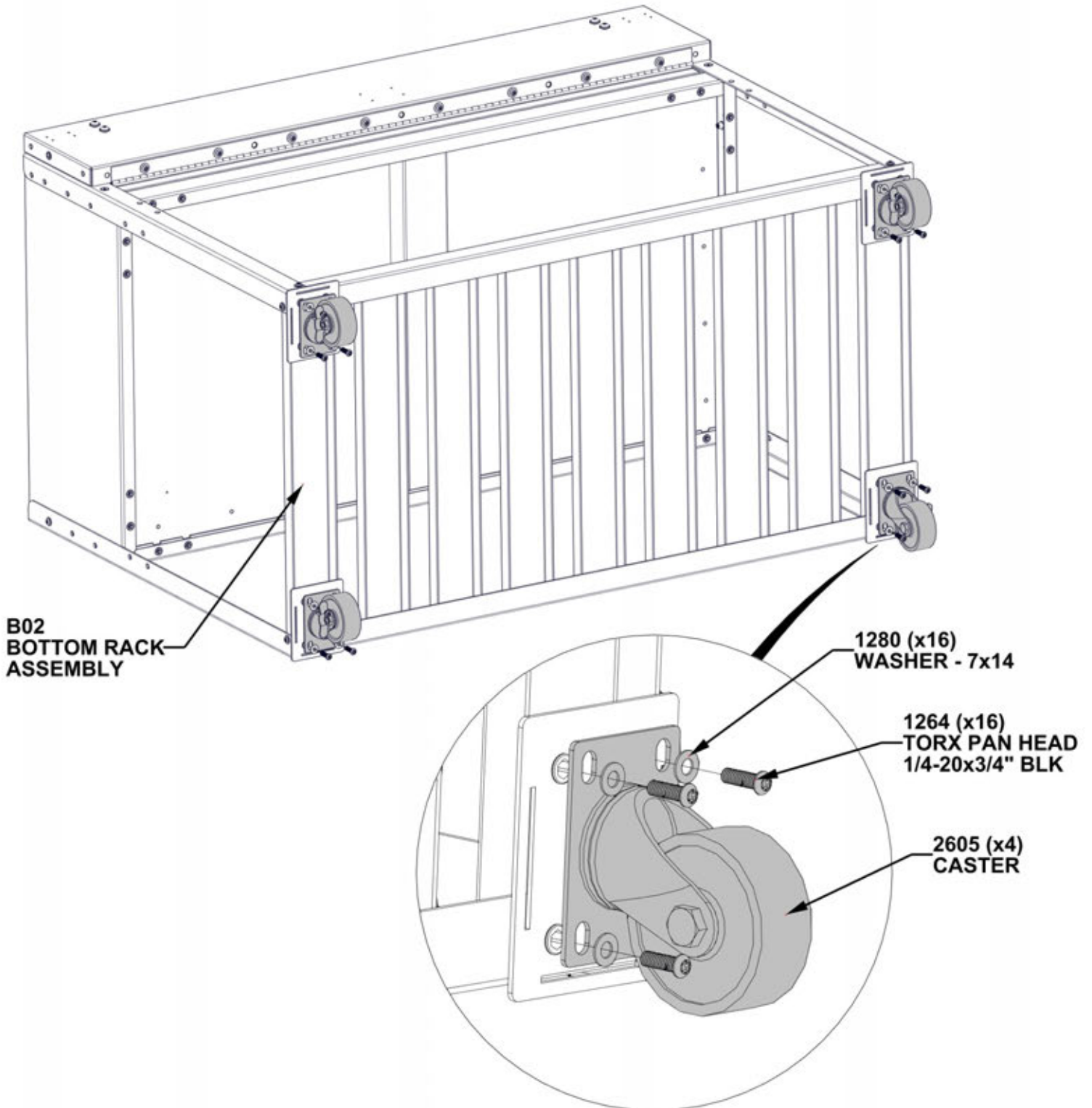

# STEP 6 - CART ASSEMBLY

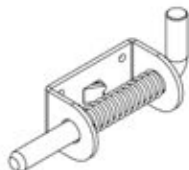

QTY	PART NUMBER	DESCRIPTION
8	H101159	Phillips Rounded Head 8-18x.5

DL01 DOOR LATCH - A4M02496  
 (x2) 1 5/16"x1 7/8"x4 3/8" (33x47x111)

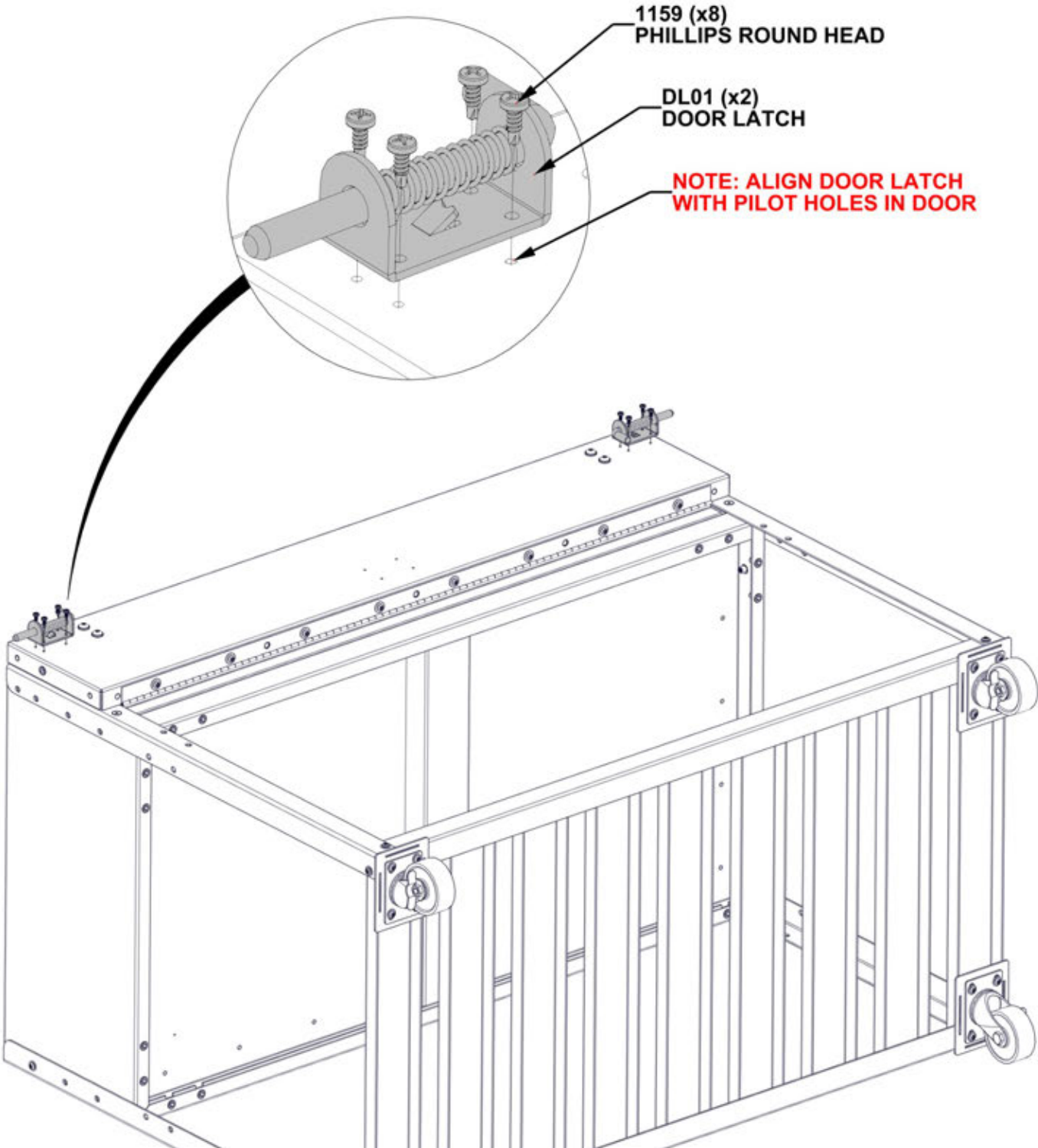

# STEP 7 - CART ASSEMBLY

QTY	PART NUMBER	DESCRIPTION
2	H101264	TORX PAN HEAD 1/4-20x3/4" BLK (LOCTITE)
4	H101279	TORX PAN HEAD 1/4-20x1" (LOCTITE)
6	H101280	WASHER FLAT 7x14 SS



B03 LATCH BRACKET - A4M02413  
(x2) 1/8"x2 3/16"x4 1/8" (2.5x56x104)



DC01 DOOR CABLE - A4M02504  
(x2) 1/8"x9 7/16" (2.5x240)



A4M02499 BUSHING  
(x4)

**REPEAT THIS STEP ON BOTH SIDES OF COAL BOX DOOR**

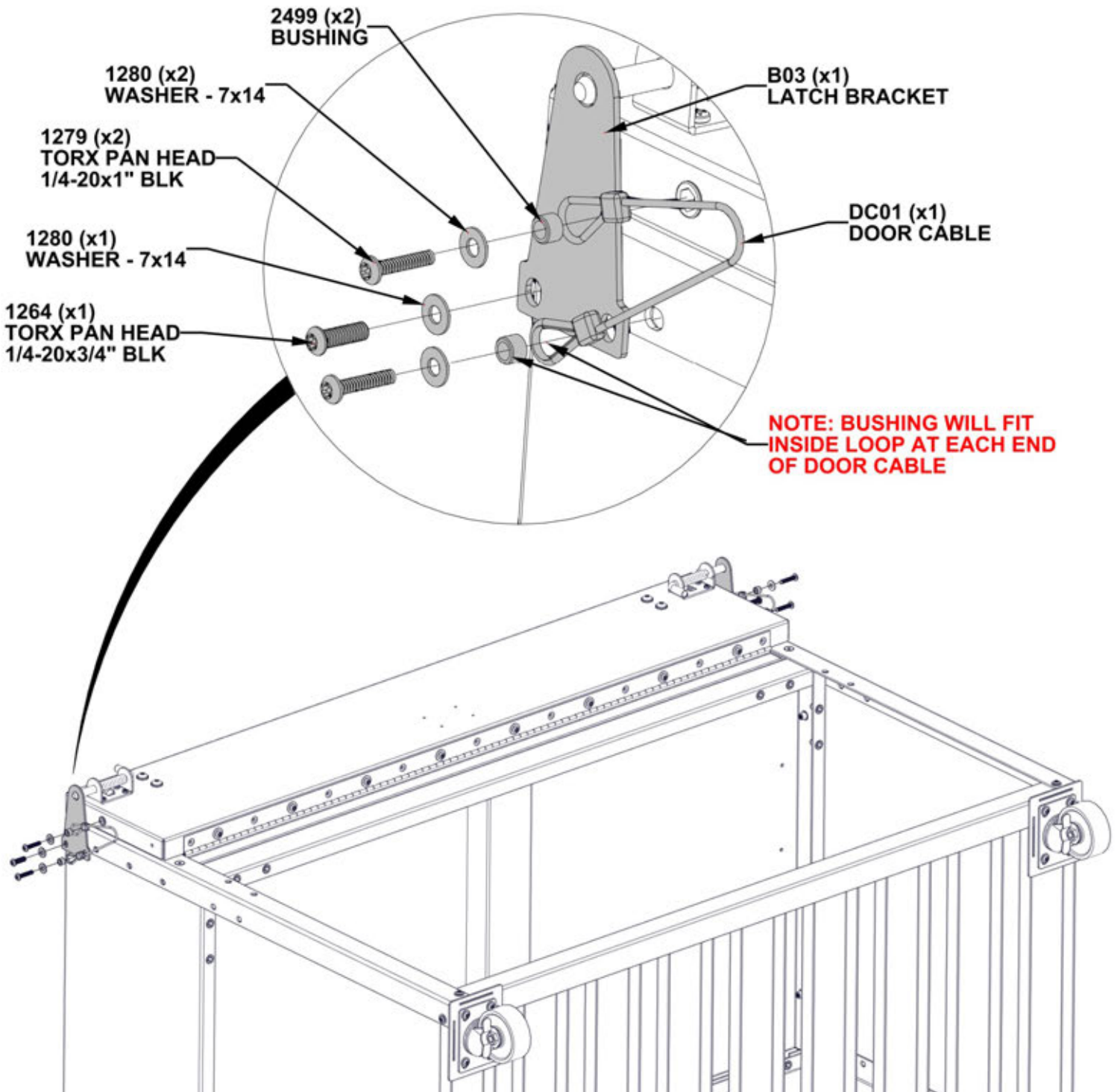

# STEP 8 - CART ASSEMBLY

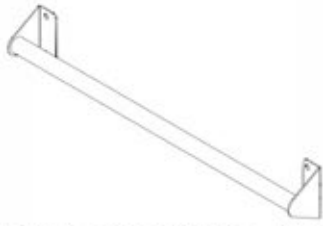

QTY	PART NUMBER	DESCRIPTION
4	H101264	TORX PAN HEAD 1/4-20x3/4" BLK (LOCTITE)
4	H101280	WASHER FLAT 7x14 SS

H03 HANDLE ASSEMBLY - A4M02152  
 (x1) 2 3/4"x3 3/4"x23 15/16" (70x94.5x609)

**WITH AT LEAST TWO PEOPLE,  
 SET CART ASSEMBLY ON ALL  
 FOUR CASTERS.**

**ATTACH HANDLE ASSEMBLY AS  
 SHOWN BELOW.**

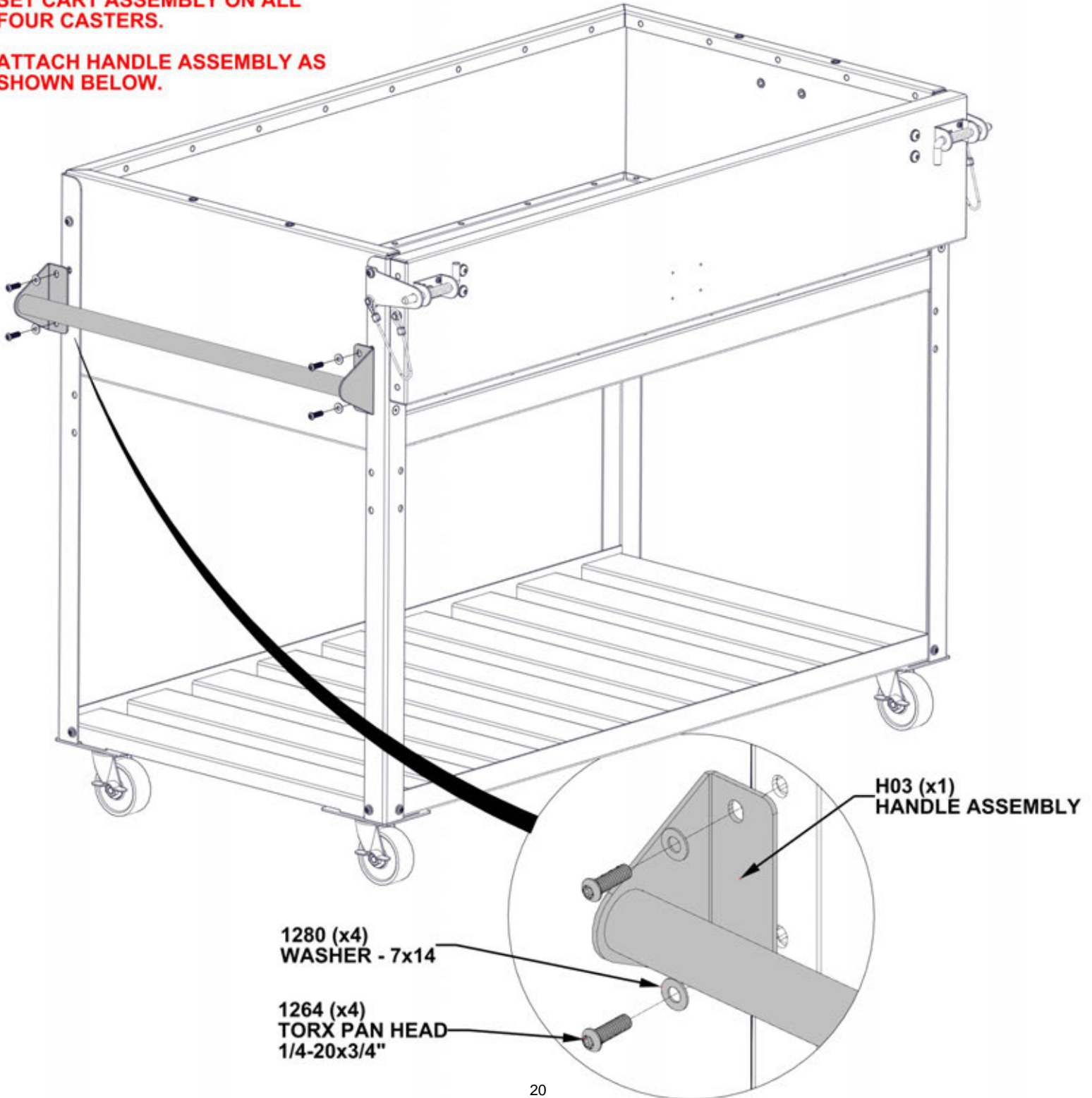

# STEP 9 - CART ASSEMBLY

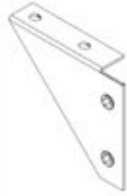

QTY	PART NUMBER	DESCRIPTION
16	H101264	TORX PAN HEAD 1/4-20x3/4" BLK (LOCTITE)
16	H101280	WASHER FLAT 7x14 SS

B01 LEG BRACE - A4M02136  
 (x4) 1 1/8"x4"x4 15/16" (28x102x125)

**DO NOT FULLY TIGHTEN HARDWARE**

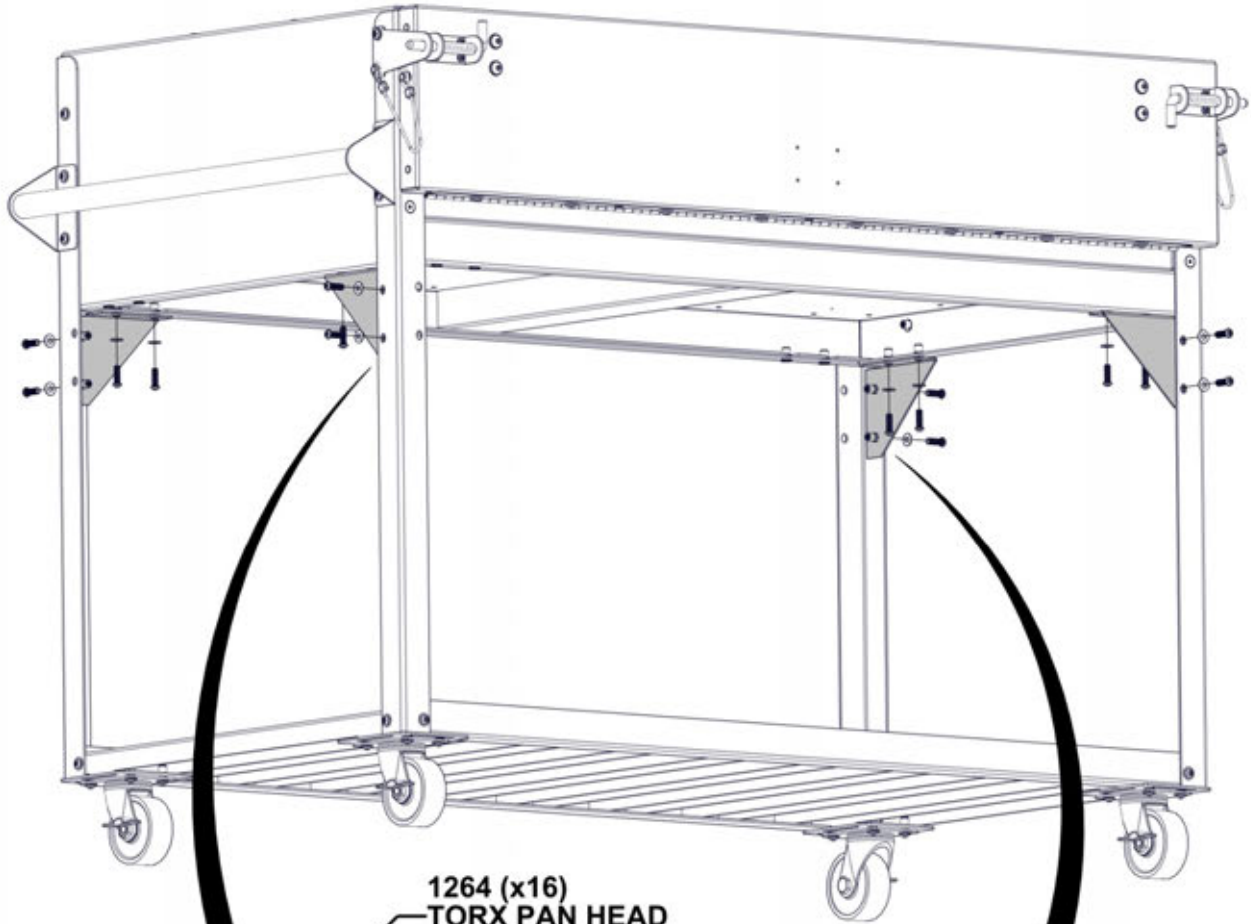

1264 (x16)  
 TORX PAN HEAD  
 1/4-20x3/4" BLK

1280 (x16)  
 WASHER - 7x14

B01 (x4)  
 LEG BRACE

# STEP 10 - CART ASSEMBLY



QTY	PART NUMBER	DESCRIPTION
16	H101264	TORX PAN HEAD 1/4-20x3/4" BLK (LOCTITE)
16	H101280	WASHER FLAT 7x14 SS

B04 LEG BRACE - A4M02387  
 (x4) 1 1/8"x4"x4 15/16" (28x102x125)

**ONCE ALL LEG BRACES ARE ATTACHED,  
 FULLY TIGHTEN HARDWARE.**

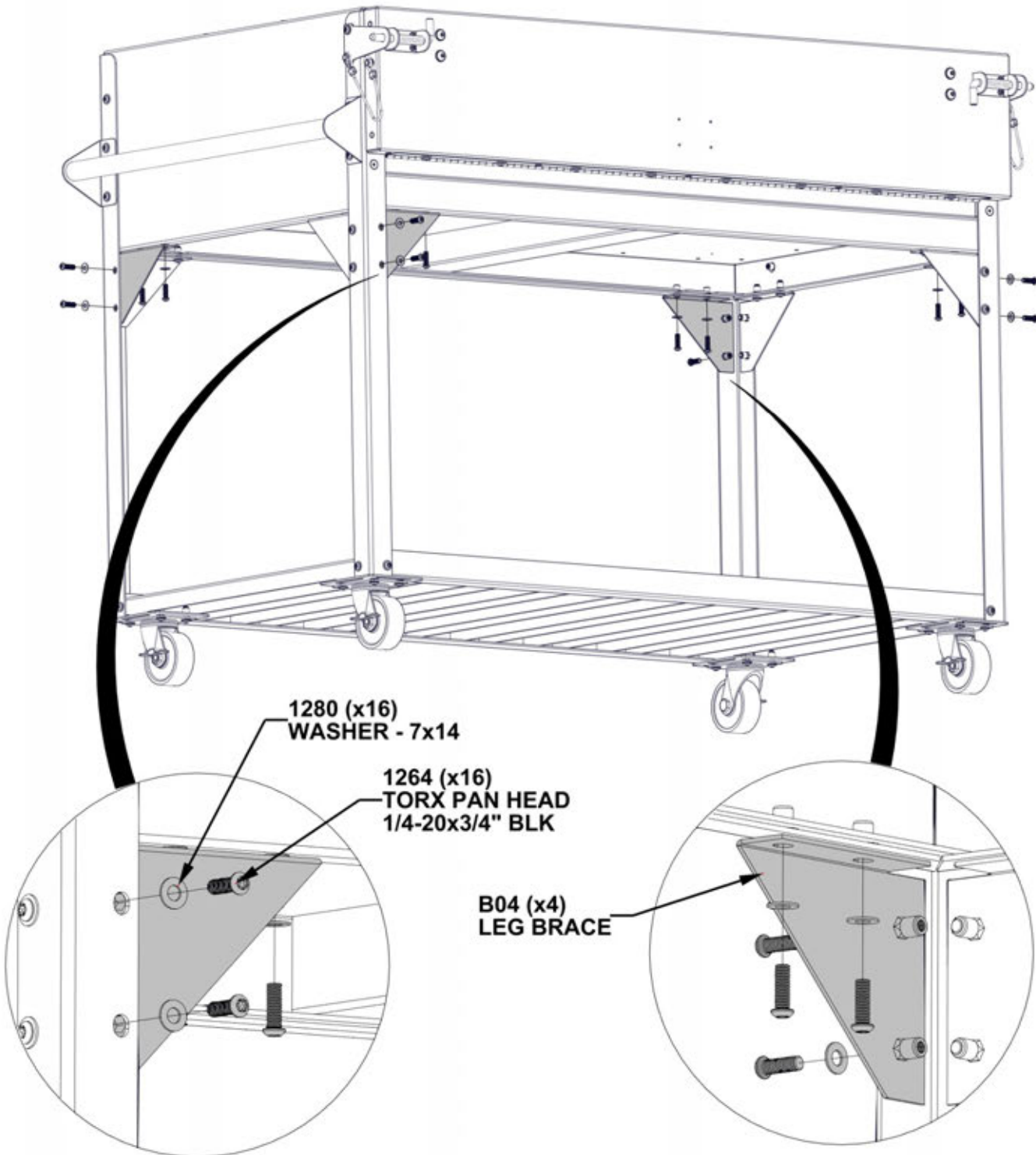

1280 (x16)  
 WASHER - 7x14

1264 (x16)  
 TORX PAN HEAD  
 1/4-20x3/4" BLK

B04 (x4)  
 LEG BRACE

# STEP 11 - CART ASSEMBLY



0729 FIRE BRICK - A6P00729  
(x40) 13/16"x4 3/16"x5 9/16" (20x107x142)

**PLACE ALL FIRE BRICKS IN THE GRILL CART.  
ENSURE BRICKS ARE ORIENTED AS SHOWN.**

**EVENLY SPACE ALL BRICKS**

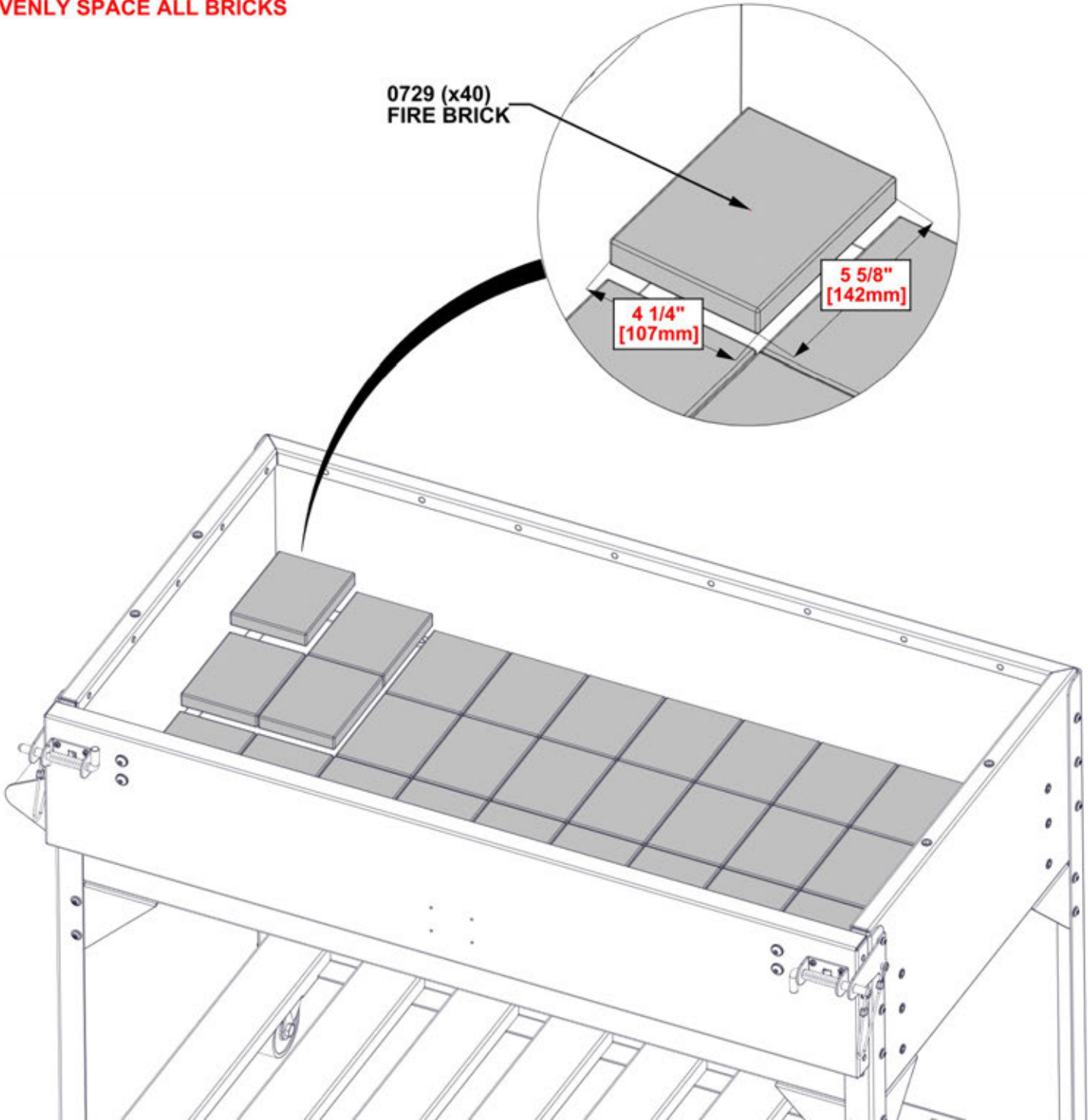

# STEP 12A - CART ASSEMBLY

**REMOVE THE 4 FACTORY ASSEMBLED BOLTS FROM THE FRONT OF COAL PAN DOOR. KEEP HARDWARE TO BE USED IN THE NEXT STEP TO ATTACH HANDLE.**

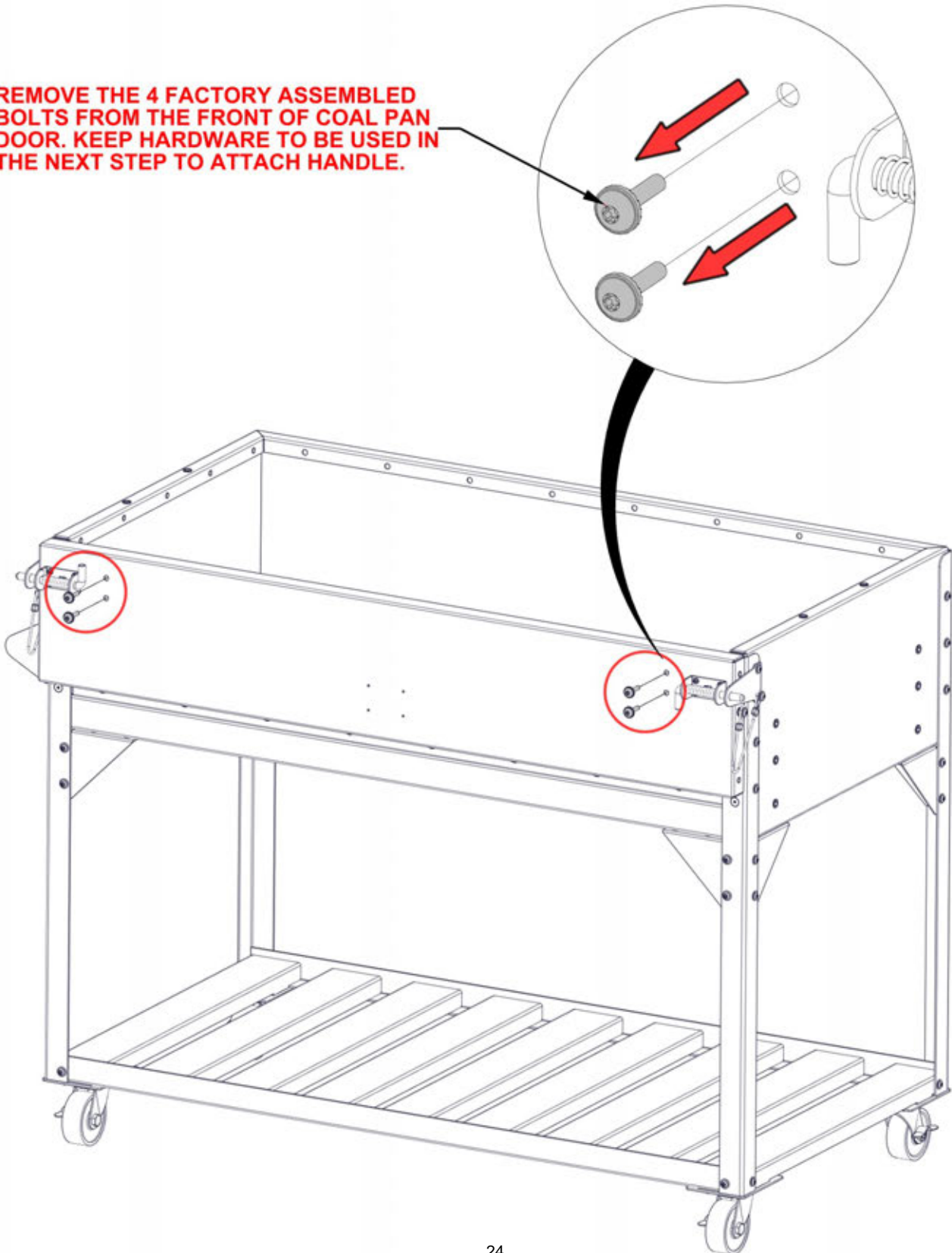



# STEP 12B - CART ASSEMBLY



QTY	PART NUMBER	DESCRIPTION
4	H101277	BOLT WH 1/4x1 BLK (LOCTITE)

H01 DOOR HANDLE ASSEMBLY - A4M02412  
(x1) 2 3/8"x3 3/4"x37 7/16" (60x95x951)

**USING BOLTS FROM PREVIOUS STEP,  
ATTACH DOOR HANDLE AS SHOWN BELOW**

H01 (x1)  
DOOR HANDLE  
ASSEMBLY

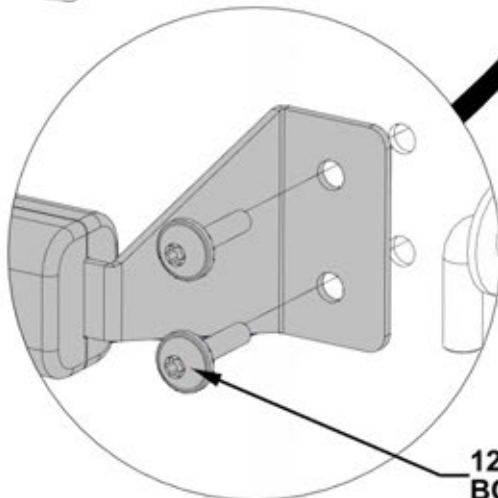
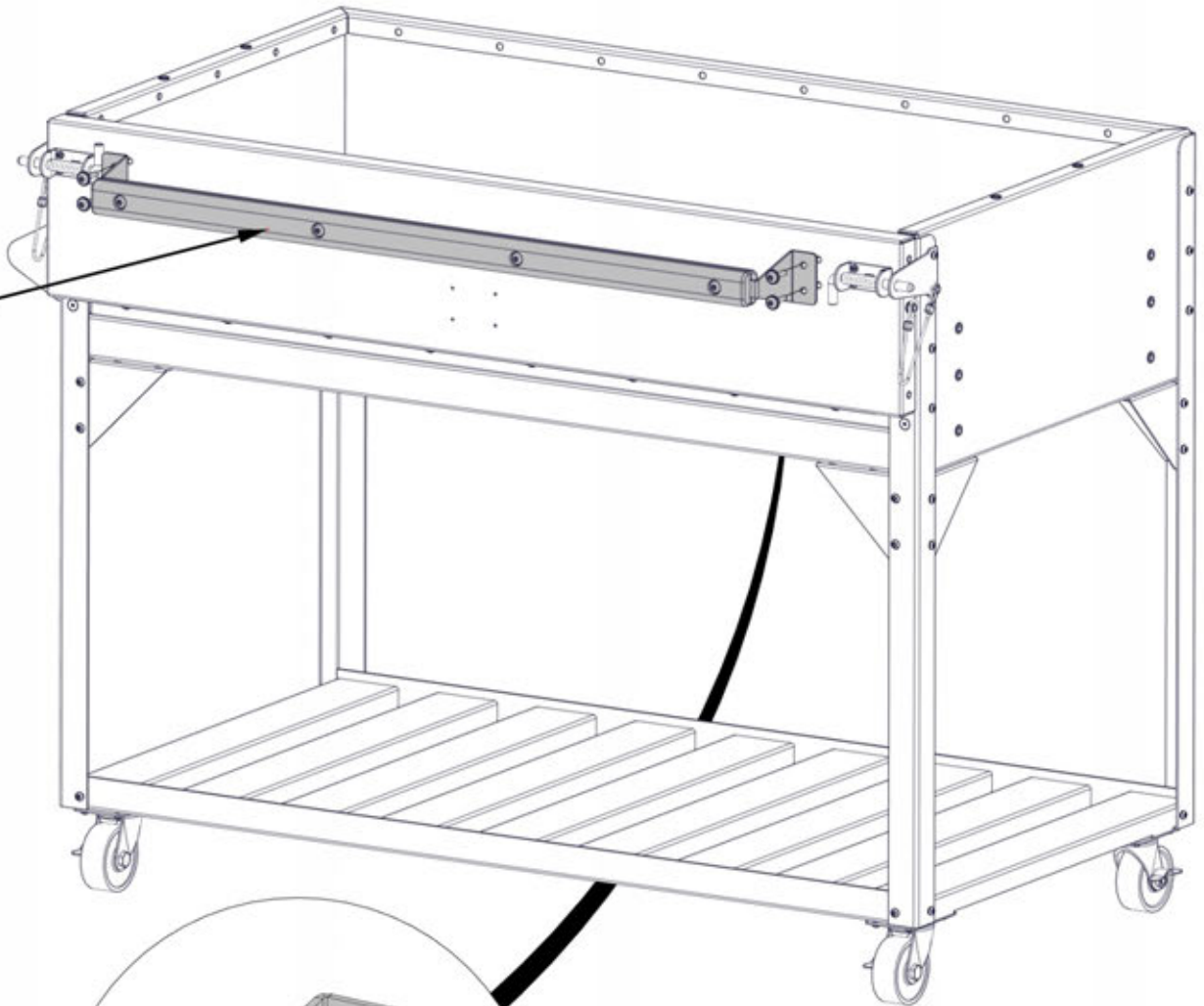

1277 (x4)  
BOLT - 1"

# STEP 13 - GRILL ASSEMBLY

QTY	PART NUMBER	DESCRIPTION
4	H101265	TORX PAN HEAD 1/4-20x3/4" SS (LOCTITE)
4	H101183	WASHER FLAT 8x16 SS
4	H101182	WASHER SPLIT 1/4 SS

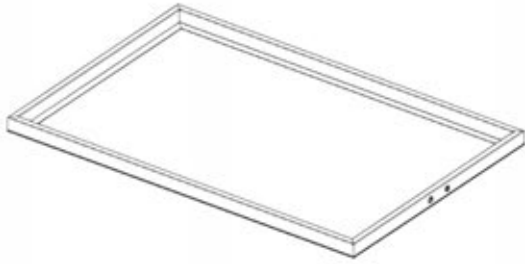

G01 GRATE TRAY ASSEMBLY - A4M02144  
(x1) 1 1/4"x21 13/16"x33 1/16" (31.80x554x839)



B05 UPRIGHT CABLE BRACKET - A4M02270  
(x2) 1 3/16"x2 15/16"x5 11/16" (30x74.5x143.8)

- ENSURE CORRECT ORIENTATION OF GRATE TRAY BRACKETS
- SQUARE UPRIGHT BRACKETS TO GRATE TRAY BEFORE TIGHTENING HARDWARE.

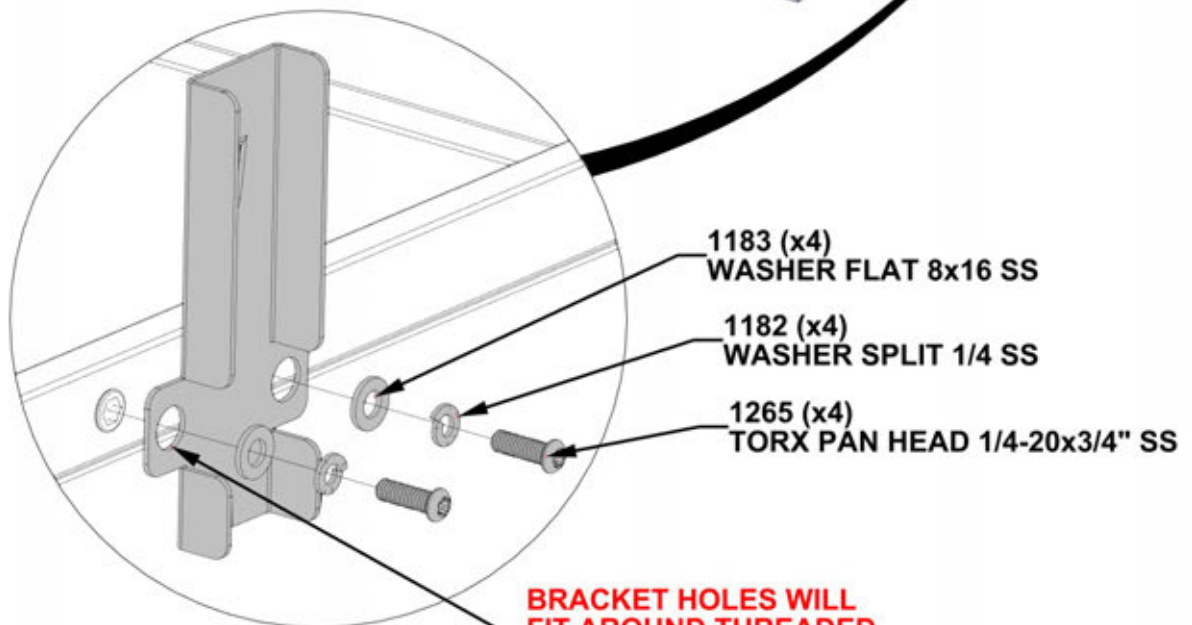
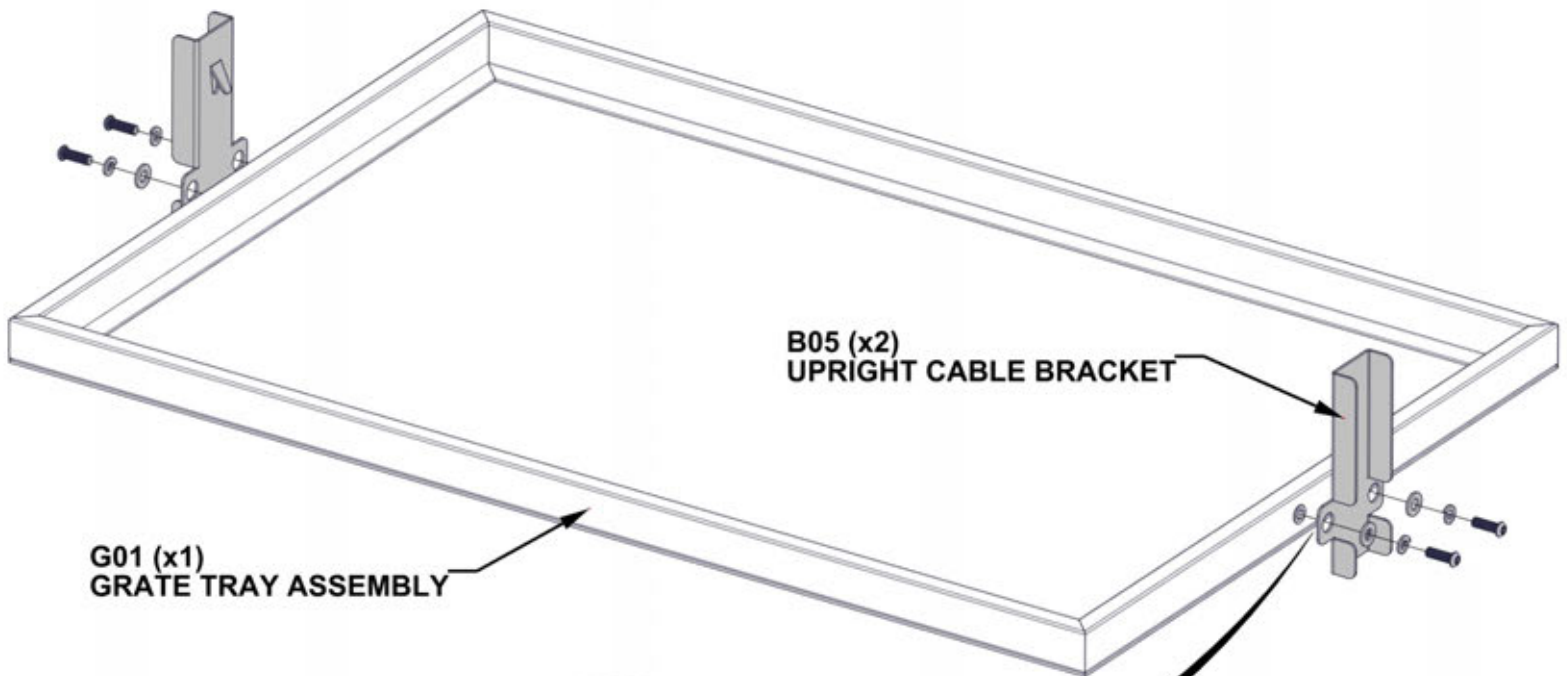

**BRACKET HOLES WILL FIT AROUND THREADED INSERTS IN GRATE TRAY**

# STEP 14 - GRILL ASSEMBLY



U01 UPRIGHT ASSEMBLY - A4M02148  
(x1) (2 1/2"x7 7/8"x32 3/8") (63x200x803.2)

U02 UPRIGHT ASSEMBLY - A4M02214  
(x1) 2 5/16"x7 7/8"x31" (58.8x200x788)

S01 SPINDLE ASSEMBLY - A4M02150  
(x1) (1 3/16"x37 1/2") (30x955)

**SLIDE UPRIGHT ASSEMBLIES ONTO SPINDLE ASSEMBLY AS SHOWN**

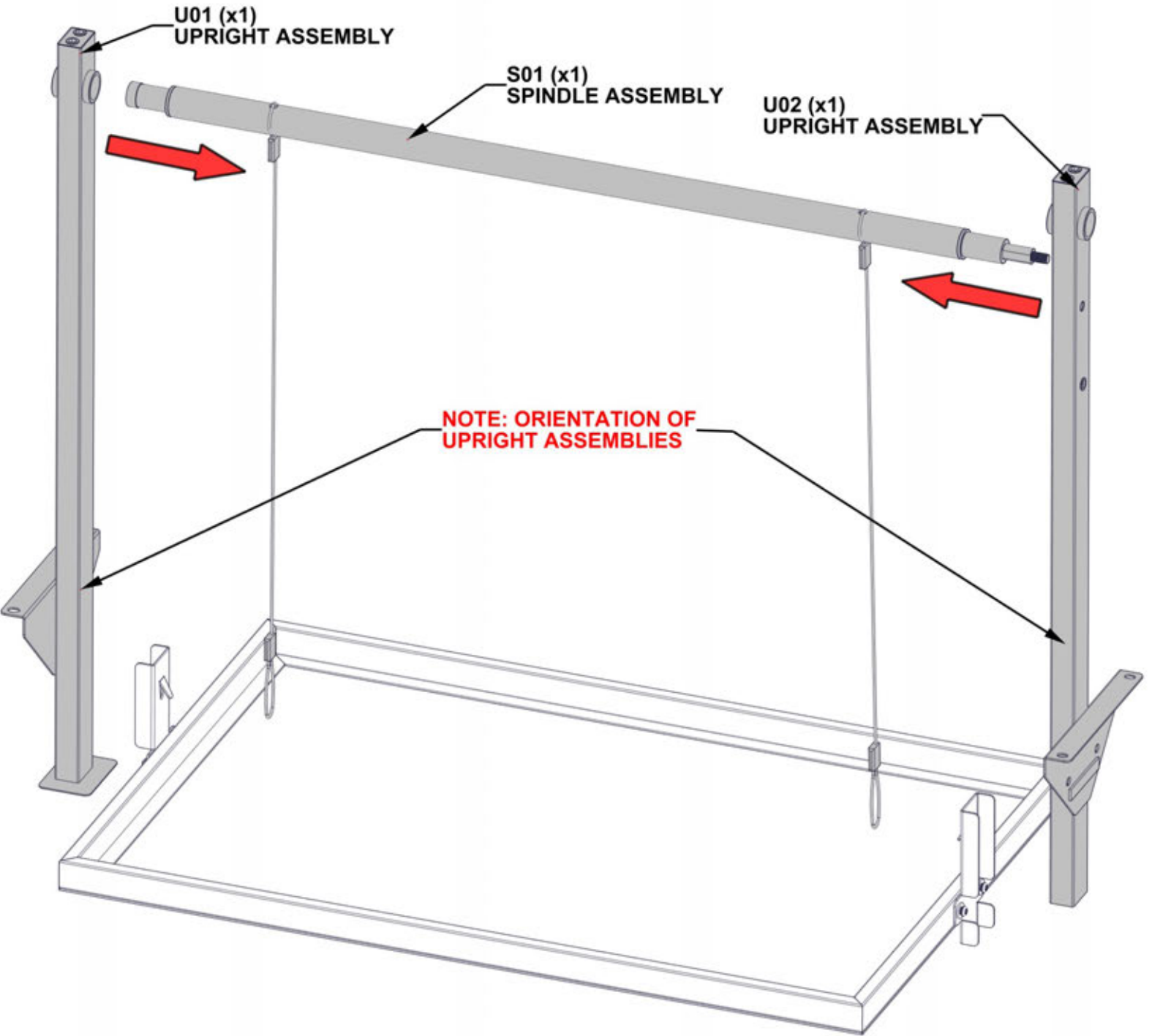

# STEP 15 - GRILL ASSEMBLY

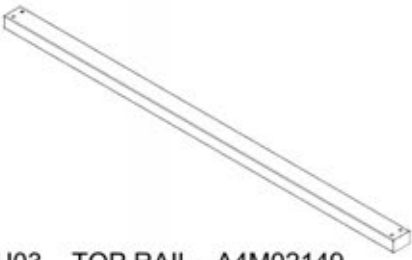

QTY	PART NUMBER	DESCRIPTION
4	H101200	TORX PAN HEAD 1/4-20x2 SS (LOCTITE)
4	H101183	WASHER FLAT 8x16 SS

U03 TOP RAIL - A4M02149  
(x1) 1"x1 1/2"x35 1/4" (25x38x896)

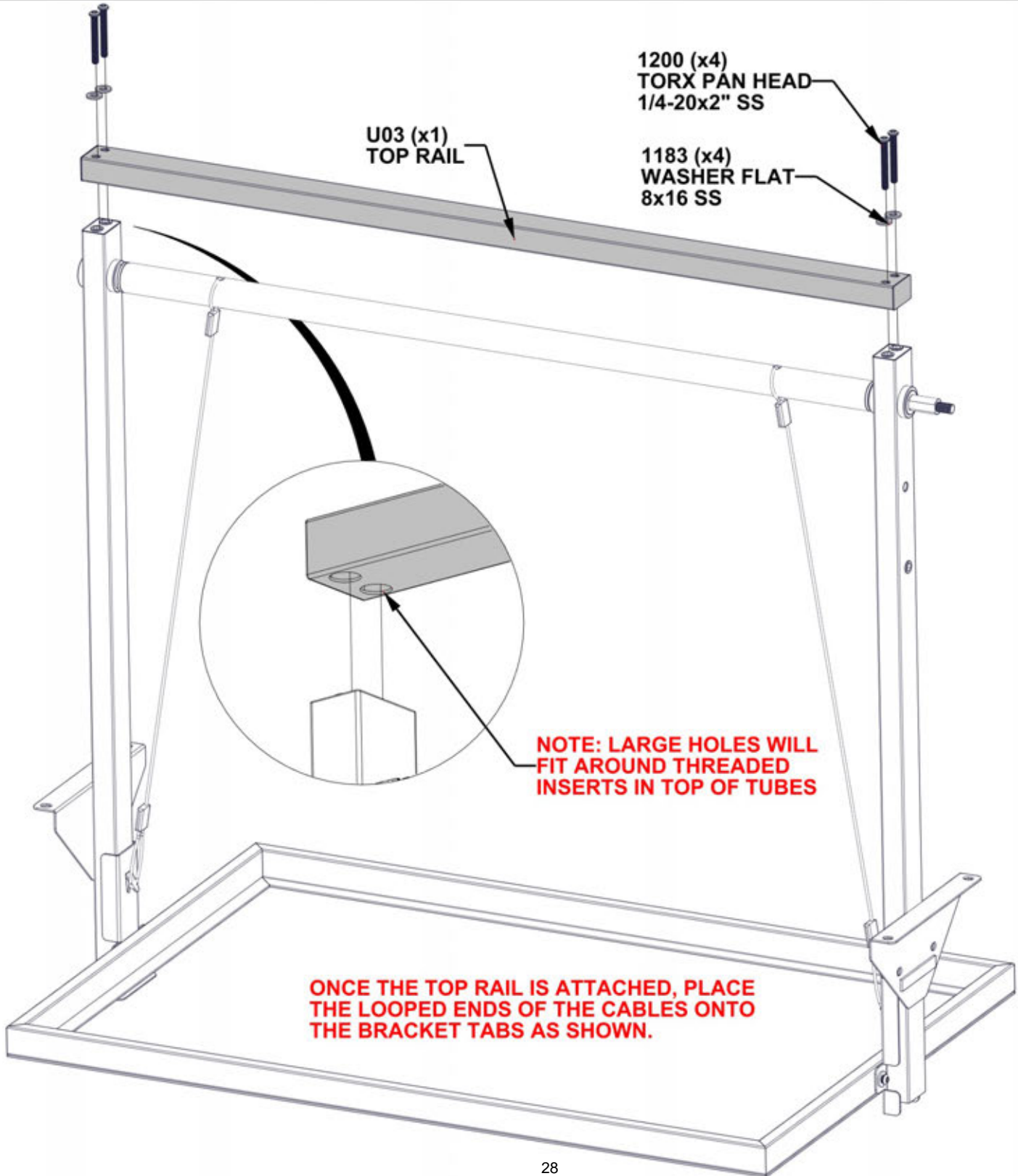

# STEP 16A - GRILL ASSEMBLY



QTY	PART NUMBER	DESCRIPTION
1	H101273	HEX JAM NUT 1/4"-20 SS (LOCTITE)
1	H101182	WASHER SPLIT 1/4 SS
1	H101183	WASHER FLAT 8x16 SS

H02 SPROCKET HANDLE - A4M02497  
 (x1) 7/8"x3 5/8"x11 1/4" (22x92x285)

**DO NOT OVERTIGHTEN HARDWARE**

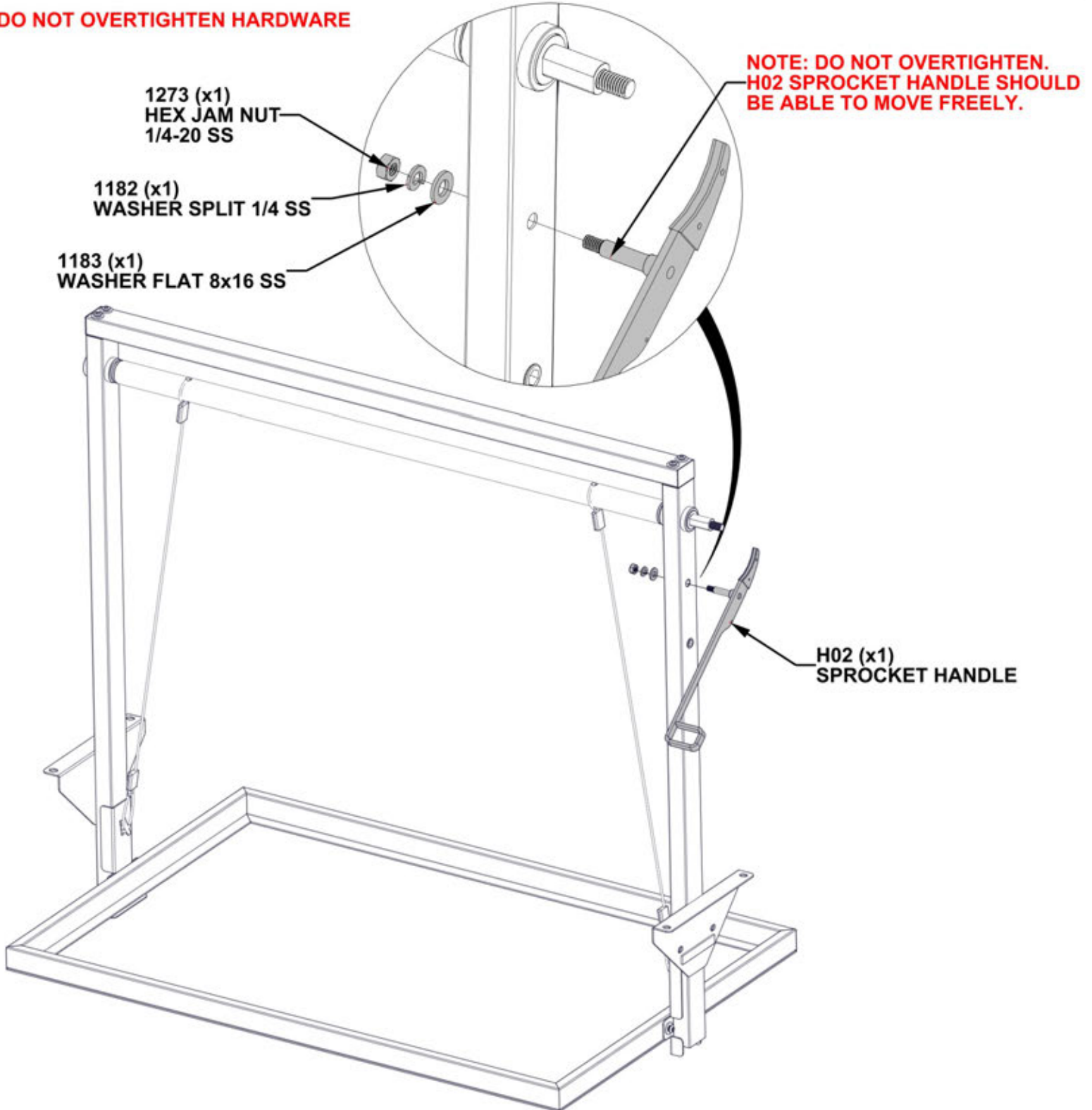

# STEP 16B - GRILL ASSEMBLY



QTY	PART NUMBER	DESCRIPTION
1	H101265	TORX PAN HEAD 1/4-20x3/4" SS (LOCTITE)
1	H101183	WASHER FLAT 8x16 SS

S03 SPRING - A4M02506  
(x1) 1/16"x7/16"x1 13/16" (1.5x11x46)

**DO NOT OVERTIGHTEN HARDWARE**

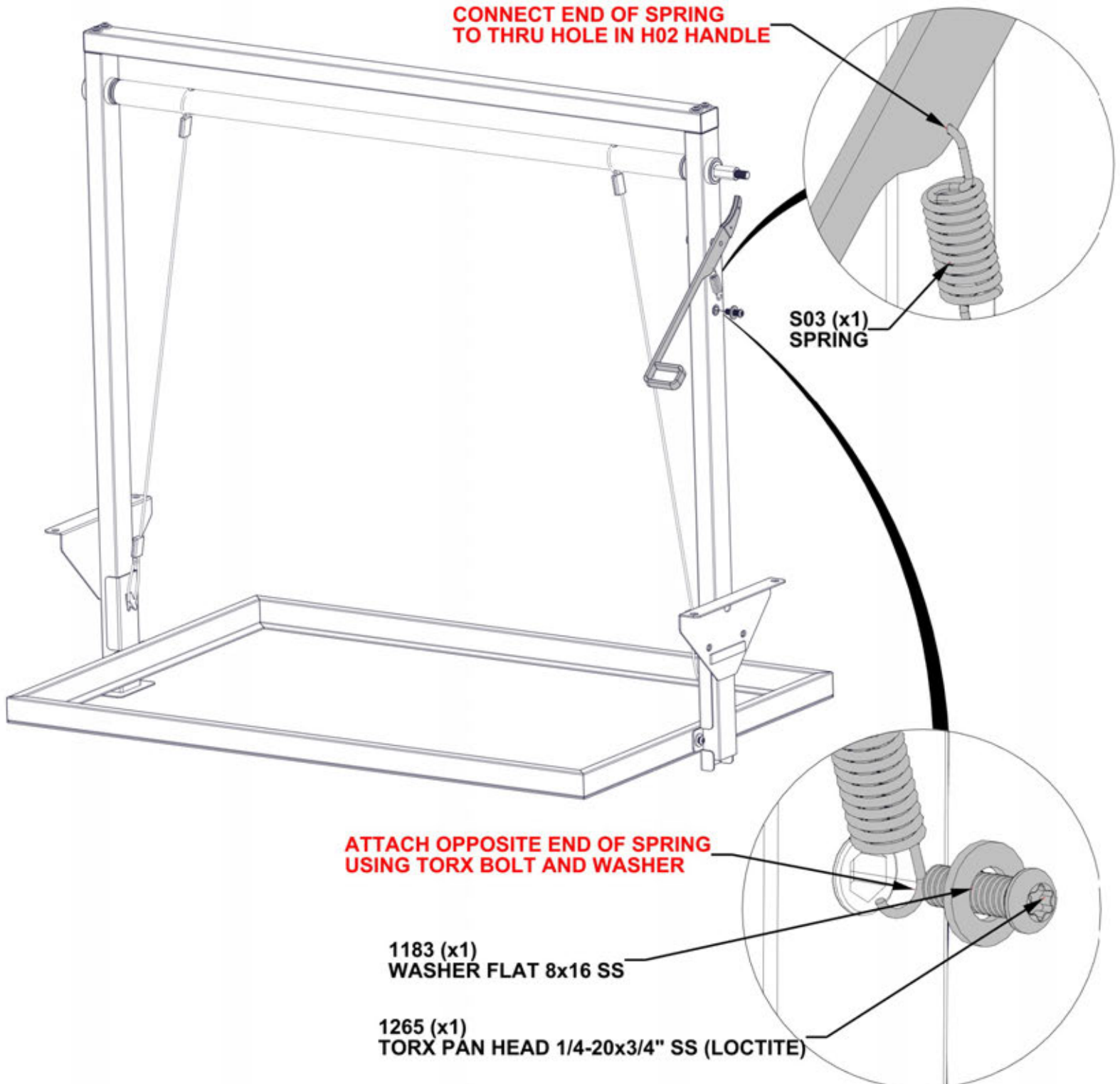

# STEP 17 - GRILL ASSEMBLY

QTY	PART NUMBER	DESCRIPTION
1	H100497	WASHER FLAT 17x30 BLK
1	H101167	WASHER FLAT 11x25 BLK
1	H101274	NUT LOCK 3/8"-16 SS



W01 WHEEL ASSEMBLY - A4M02146  
(x1) 2 3/8"x7" (59.7x178)



S02 SPROCKET - A4M02147  
(x1) 3/16"x4 11/16"x4 11/16" (4x119x119)

**DO NOT OVERTIGHTEN HARDWARE**

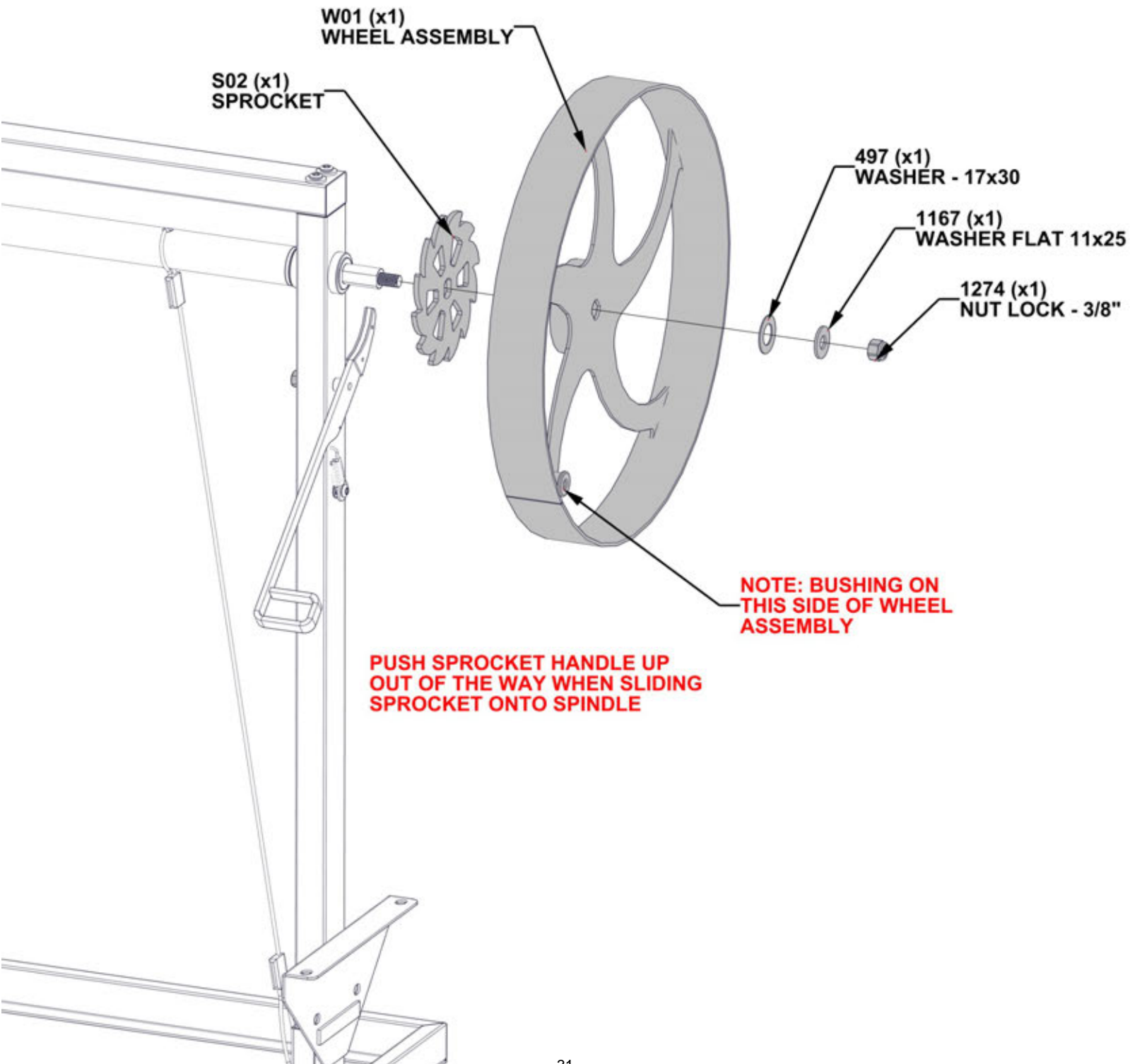

# STEP 18 - GRILL ASSEMBLY



H04 WHEEL HANDLE - W4L19101  
(x1) 1 9/16"x5 1/8" (40x130)

QTY	PART NUMBER	DESCRIPTION
1	H101263	BOLT WH 5/16x6 3/8 BLK (LOCTITE)
2	H100630	WASHER FLAT 8x19 BLK

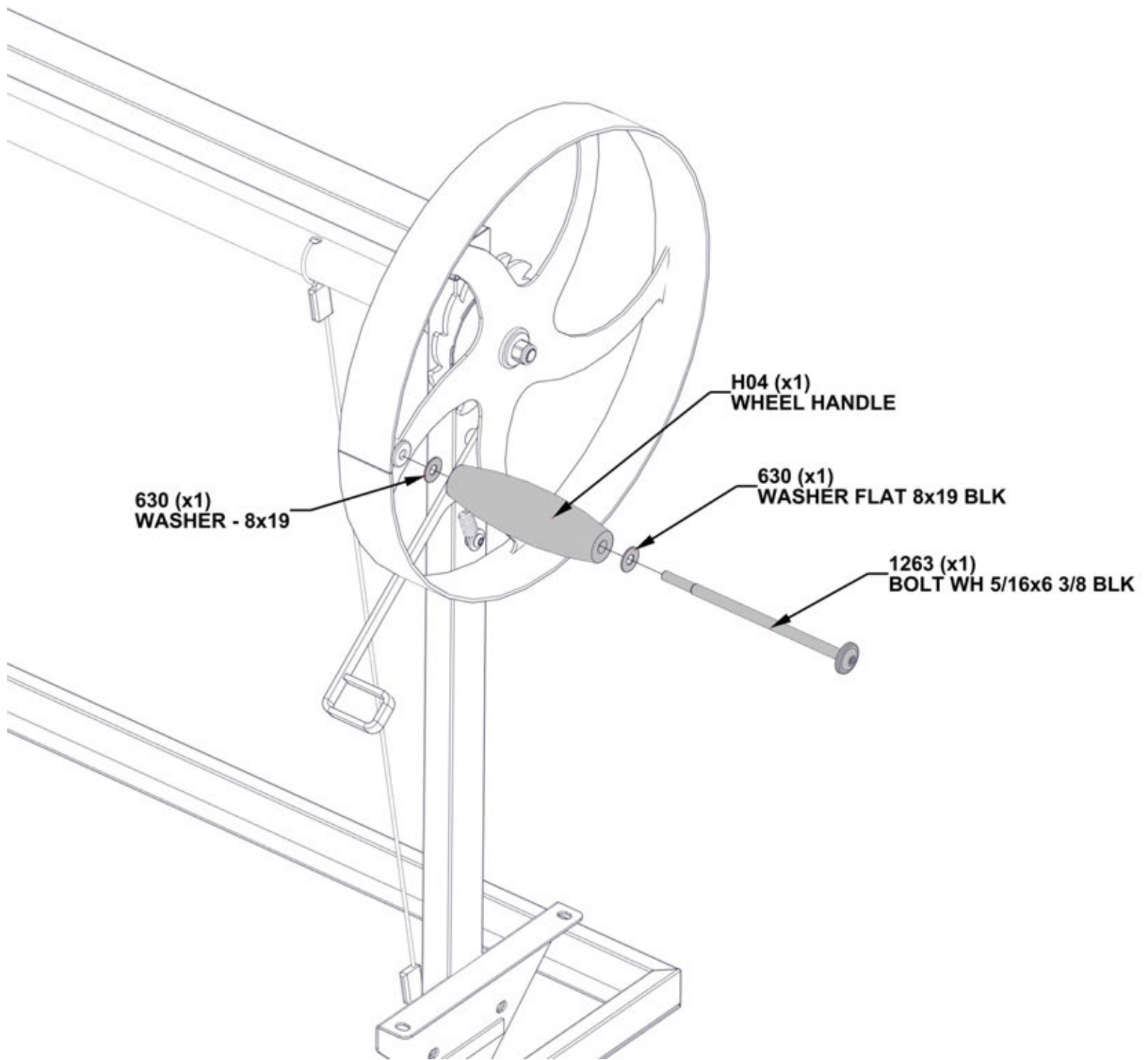



# STEP 19 - GRILL CART ASSEMBLY



QTY	PART NUMBER	DESCRIPTION
4	H101265	TORX PAN HEAD 1/4-20x3/4" SS (LOCTITE)
4	H101183	WASHER FLAT 8x16 SS

GRILL ASSEMBLY - FROM PREVIOUS STEPS

**CAREFULLY SET GRILL ASSEMBLY INTO  
COAL PAN ASSEMBLY**

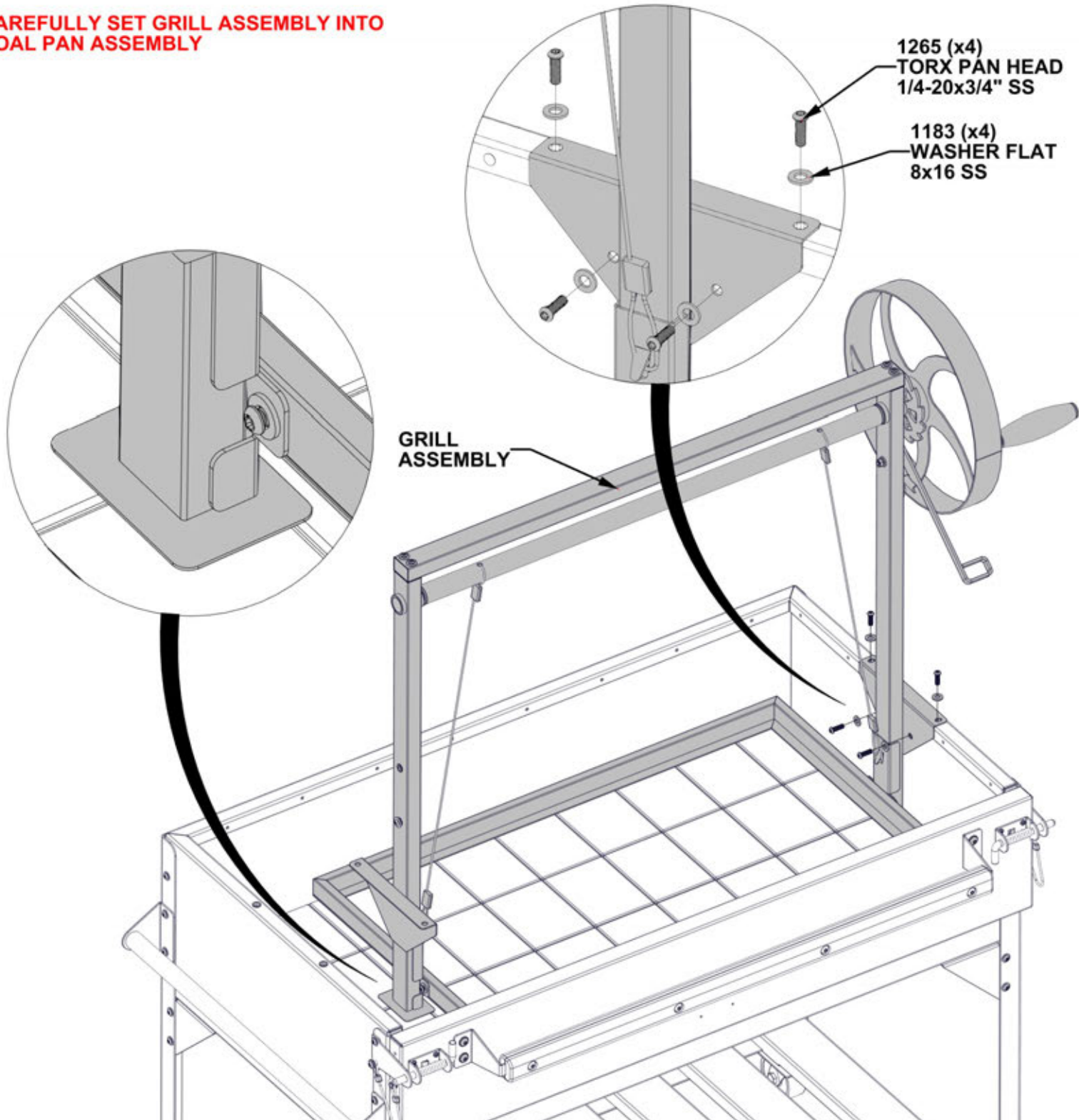

# STEP 20 - GRILL CART ASSEMBLY

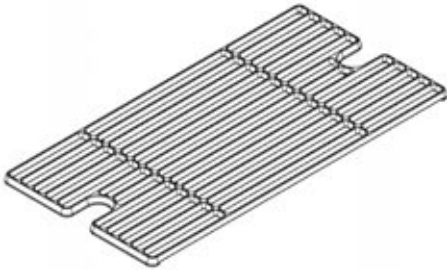

G02 GRATE - A4M02145  
(x3) 7/16"x10 1/2"x20 1/2" (12x266x520)

**PLACE GRATES INTO GRATE TRAY**

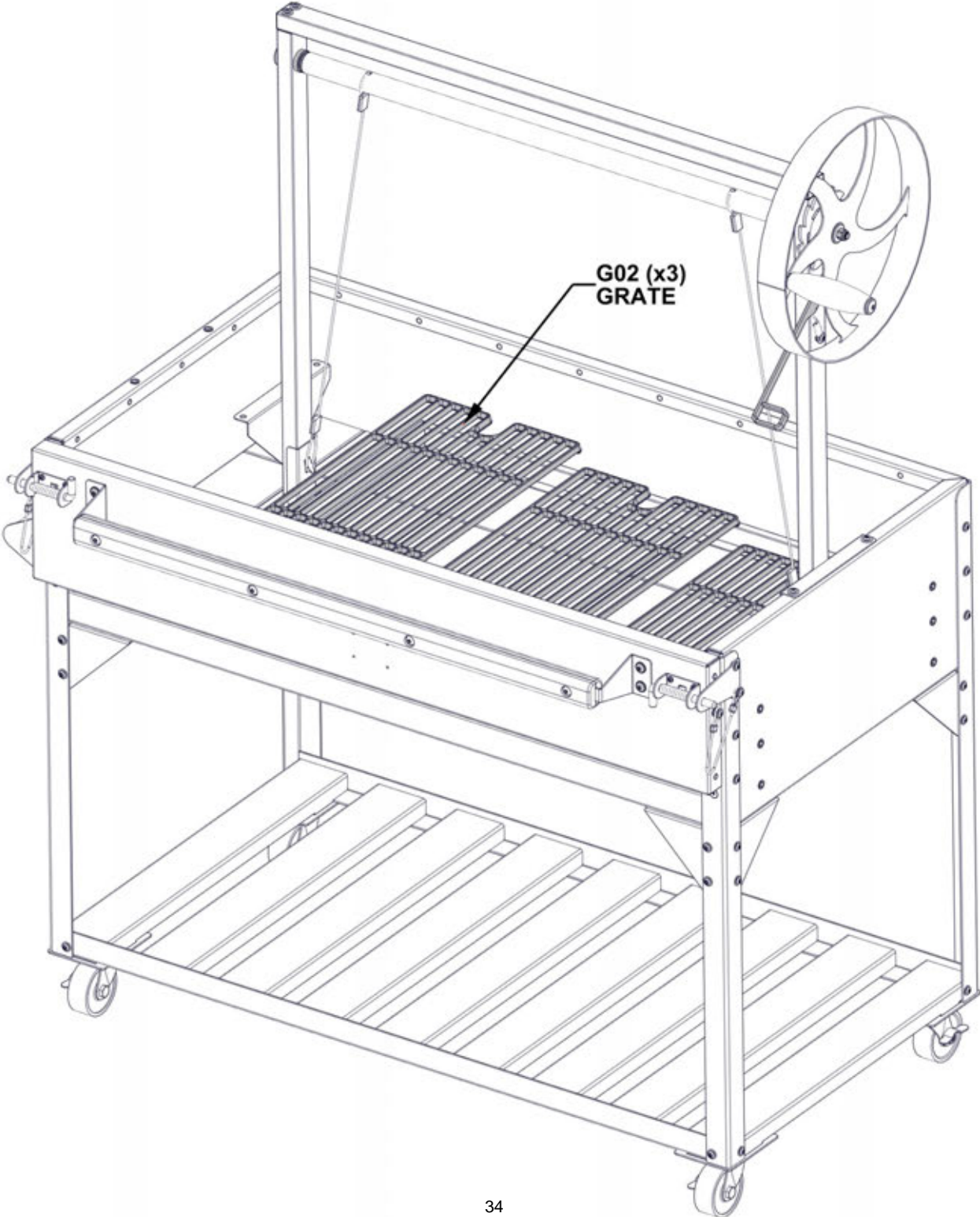

# STEP 21A - GRILL CART ASSEMBLY

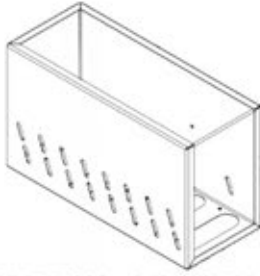

F01 FIRE BOX - A4M02151  
 (x1) 8 1/4"x11 11/16"x20 1/16" (210x298x510)

QTY	PART NUMBER	DESCRIPTION
2	H101273	HEX JAM NUT
2	H101182	WASHER SPLIT 1/4 SS
4	H101265	TORX PAN HEAD 1/4-20x3/4" SS (LOCTITE)
6	H101183	WASHER FLAT 8x16 SS

**DO NOT TIGHTEN HARDWARE AT THIS STEP**

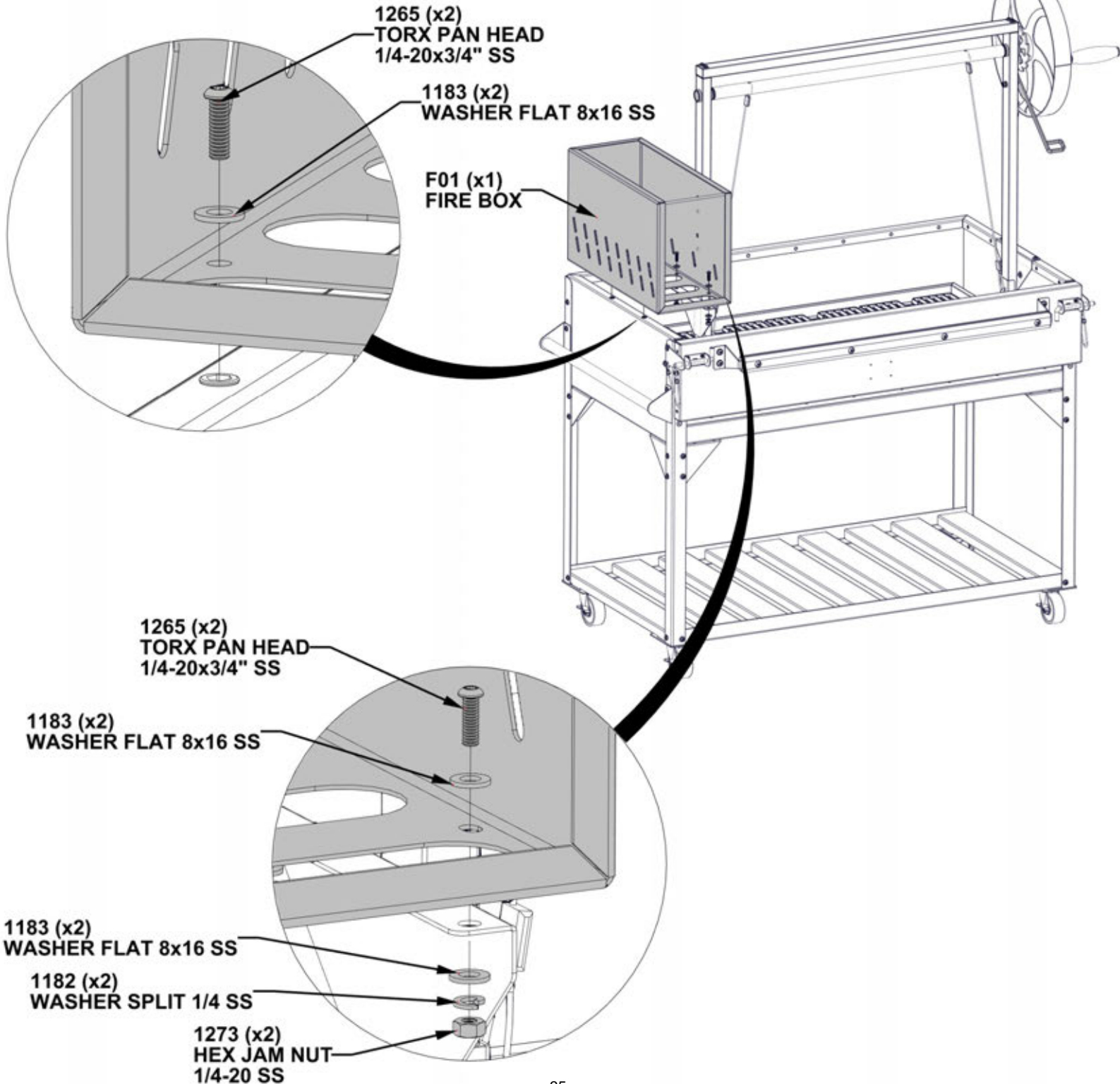

# STEP 21B - GRILL CART ASSEMBLY

QTY	PART NUMBER	DESCRIPTION
2	H101183	WASHER FLAT 8x16 SS
2	H101265	TORX PAN HEAD 1/4-20x3/4" SS (LOCTITE)

**ATTACH BOLTS ON INSIDE OF FIREBOX TO UPRIGHT**

**TIGHTEN HARDWARE FROM PREVIOUS STEP**

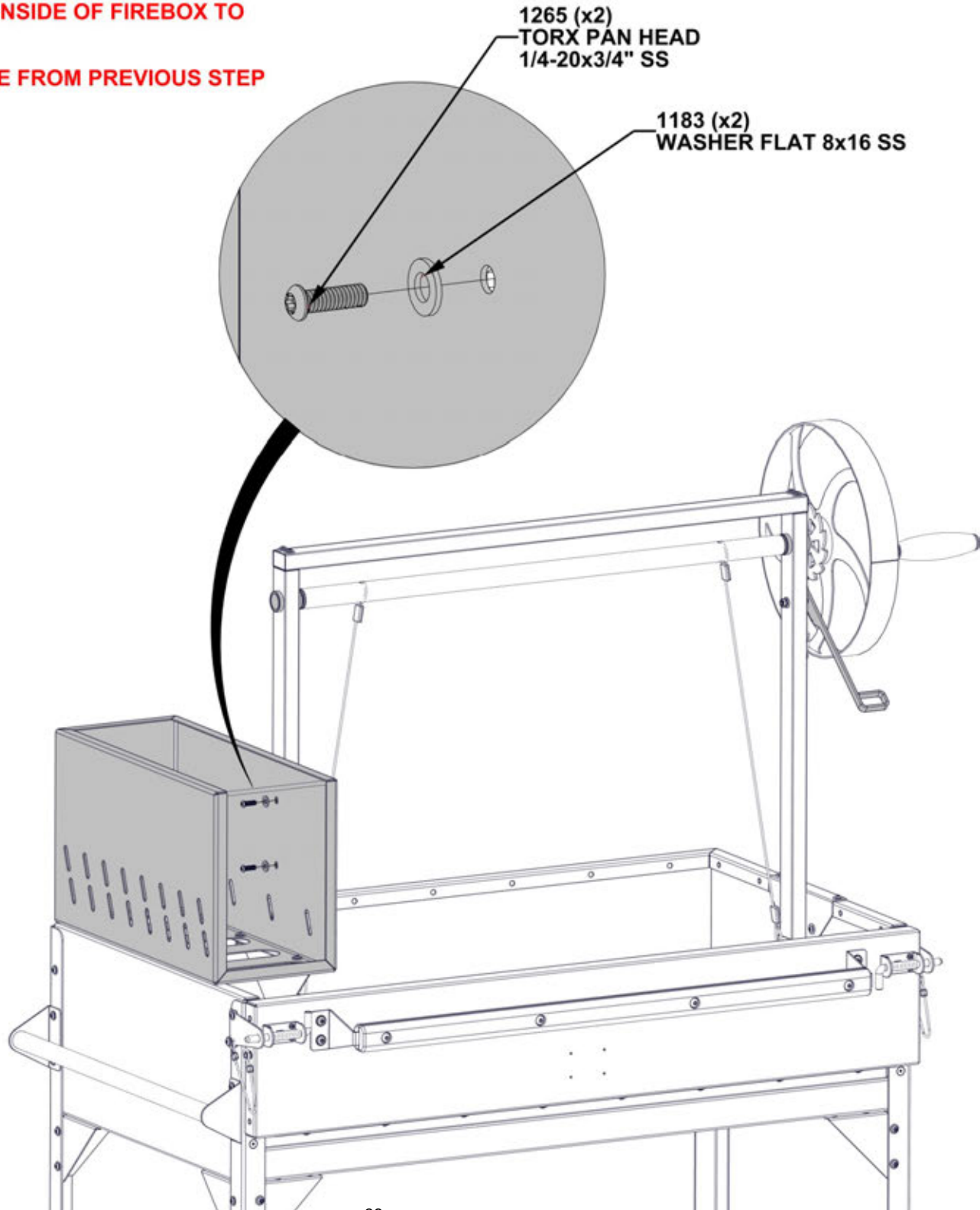

# STEP 22A - GRILL CART ASSEMBLY

QTY	PART NUMBER	DESCRIPTION
6	H100797	SCREW PWH 8x3/4 BLK



2094 TABLE BRACKET - A4M02094  
(x2) 1 3/8"x6 13/16"x15 15/16" (34x173x405)



T01 TABLE TOP - W4L18241  
(x1) 1 1/4"x17 11/16"x23 5/8" (32x450x600)

## DO NOT OVERTIGHTEN SCREWS

IT IS RECOMMENDED TO USE THE 6" MAGNETIC DRIVER EXTENSION FOR THIS STEP

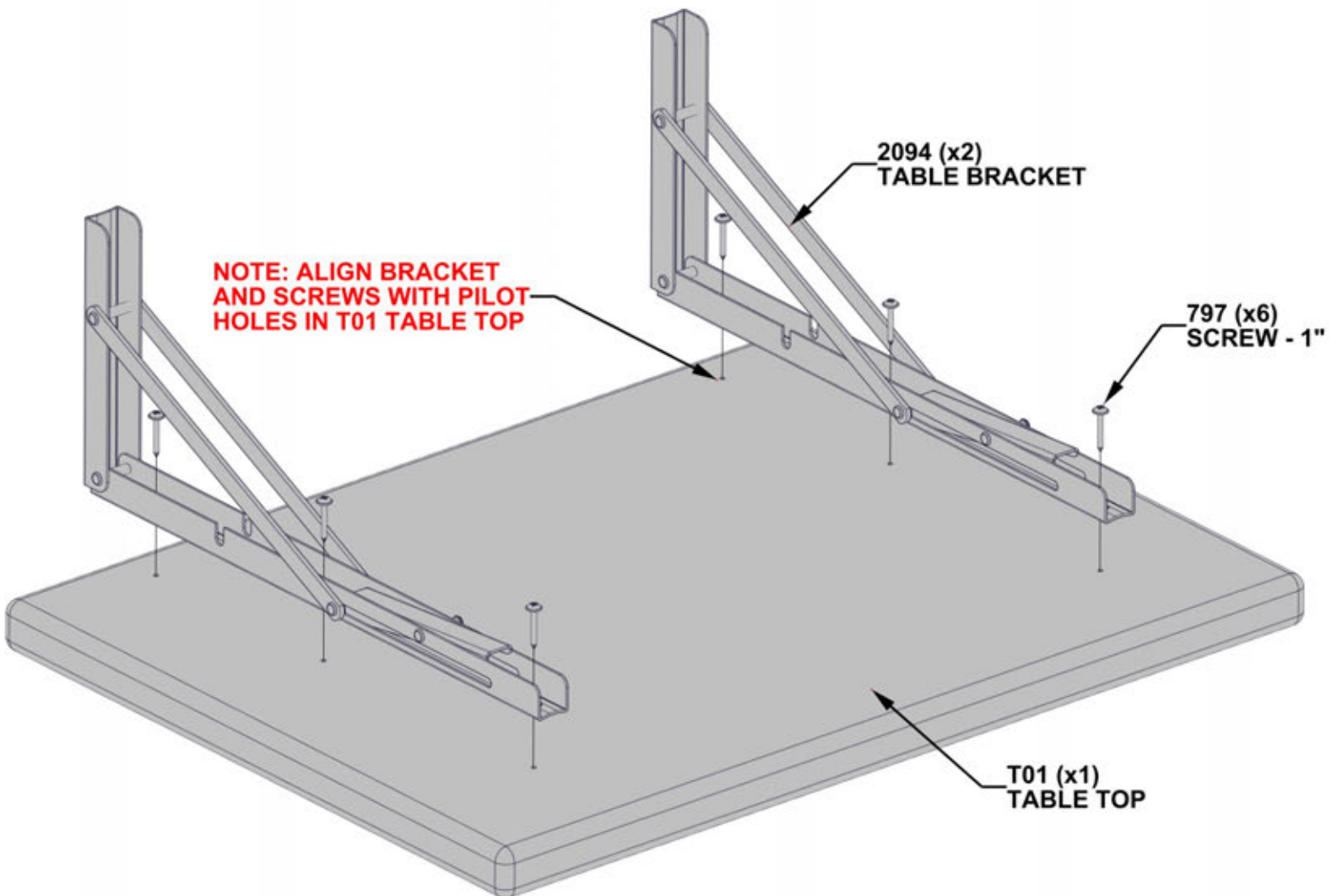

# STEP 22B - GRILL CART ASSEMBLY



QTY	PART NUMBER	DESCRIPTION
6	H101264	TORX PAN HEAD 1/4-20x3/4" BLK (LOCTITE)
6	H101280	WASHER FLAT 7x14 SS

TABLE ASSEMBLY - FROM PREVIOUS STEP

IT IS RECOMMENDED TO USE THE 6" MAGNETIC DRIVER EXTENSION FOR THIS STEP

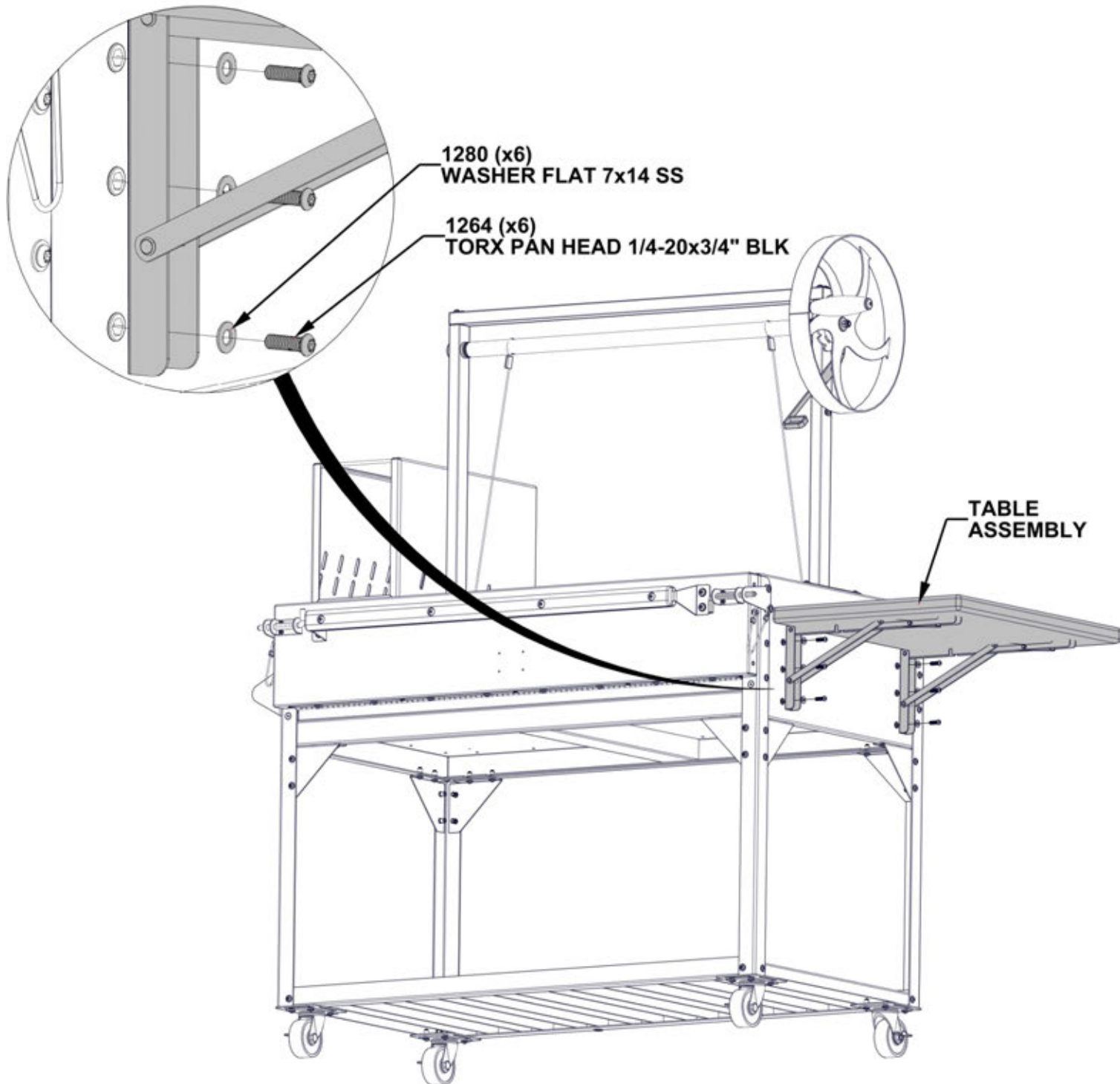

# STEP 23 - GRILL CART ASSEMBLY



QTY	PART NUMBER	DESCRIPTION
4	H101262	PHILLIPS ROUNDED HEAD 8-18x.5

A4M02158 BYD ID TAG PATIO  
(x1)

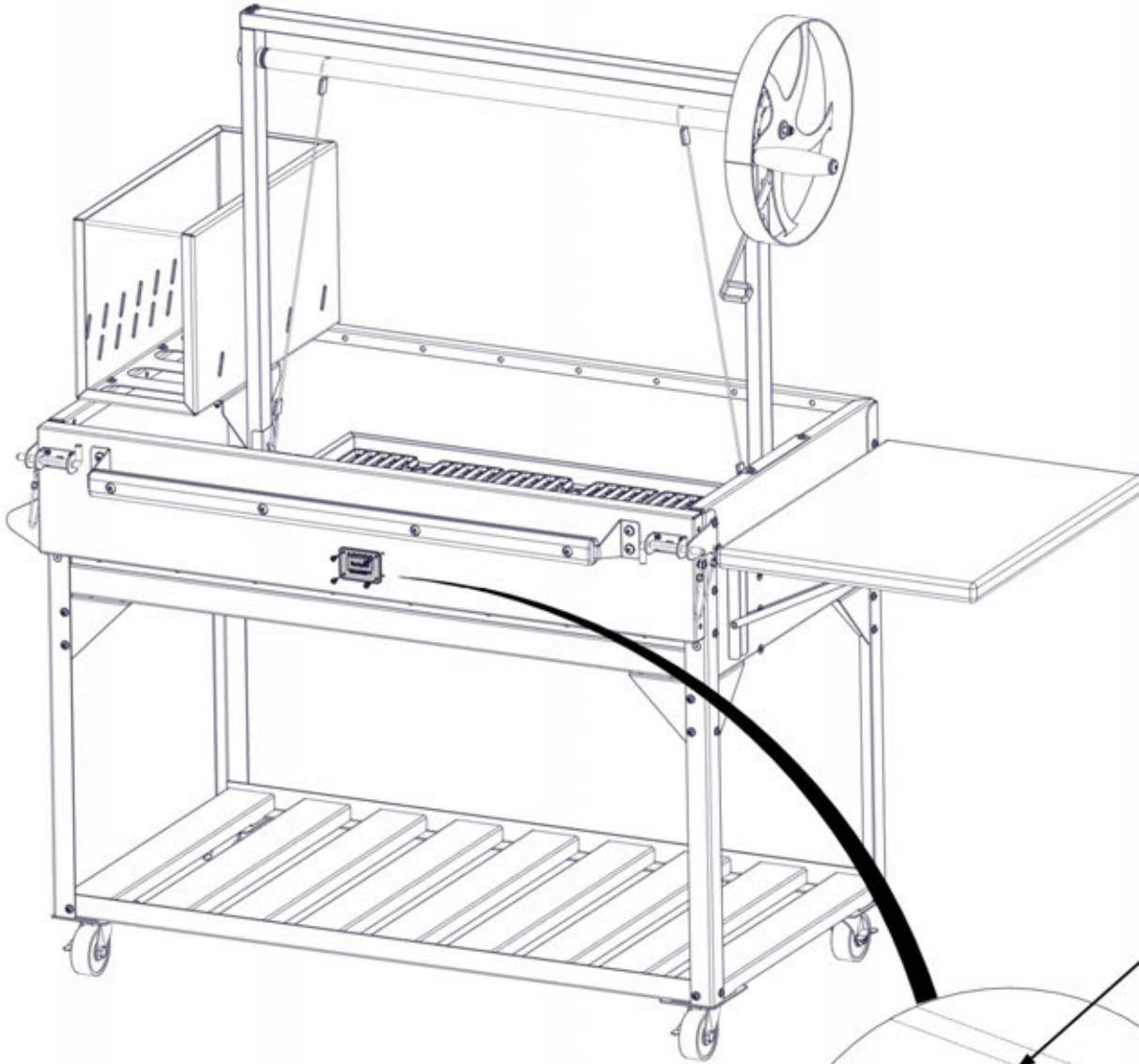

**ATTACH ID TAG  
USING PILOT HOLES**

**1262 (x4)  
PHILLIPS ROUNDED HEAD 8-18x.5**

**2158 (x1)  
BYD ID TAG PATIO**

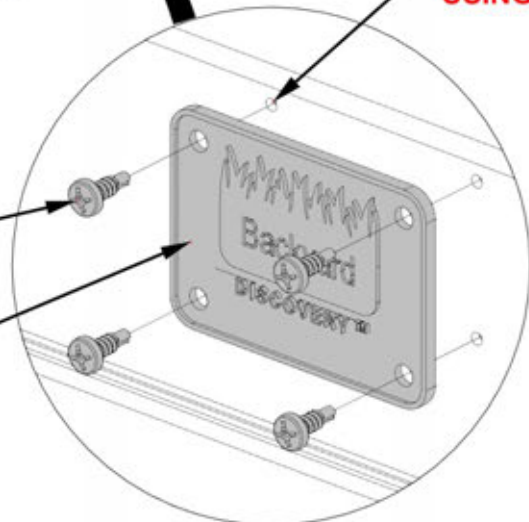

# STEP 24 - GRILL CART ASSEMBLY



MH01 MEAT HOOK - A4M02402  
(x2) 3/16"x3 7/8"x5 11/16" (5x98x145)



MH02 MEAT HOOK - A4M02407  
(x2) 3/16"x3"x8 13/16" (5x77x224)

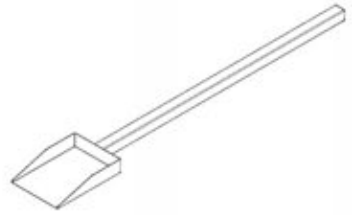

SH01 SHOVEL - A4M02513  
(x1) 2 1/4"x4 7/8"x26 7/16" (57x124x671)

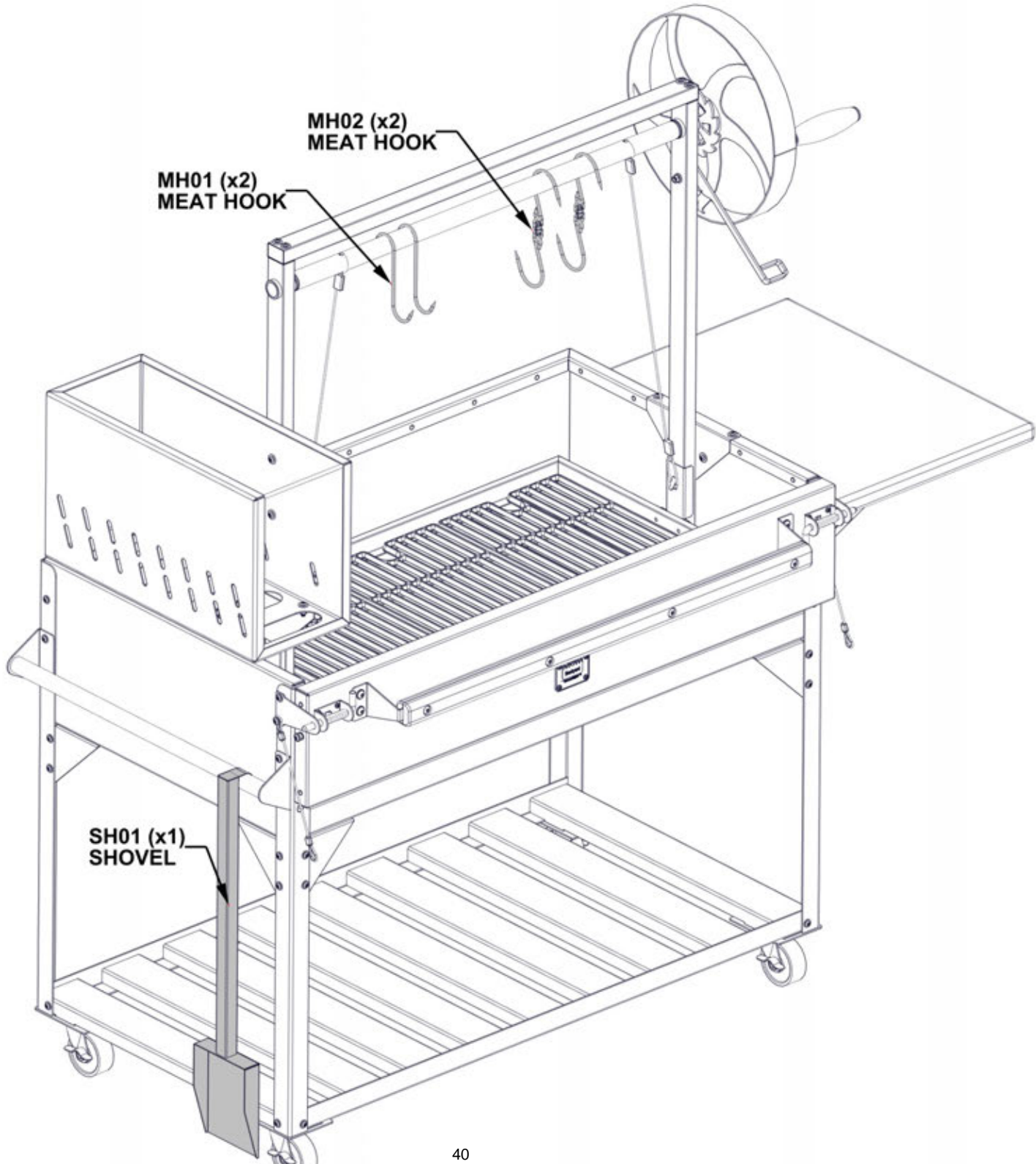



# STEP 25 - GRILL CART ASSEMBLY

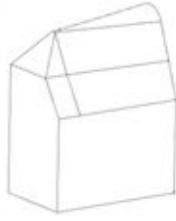

A6P00803 GRILL COVER  
(x1)

**NOTE: INSTALL COVER TO PROPERLY CARE  
FOR YOUR GRILL WHEN NOT IN USE**

**MAKE SURE GRILL HAS COOLED TO AN AMBIENT  
TEMPERATURE BEFORE COVERING WITH COVER.**

803 (x1)  
GRILL COVER

