



Manufactured by:
Backyard Discovery
3305 Airport Drive, Pittsburg, KS 66762
800-856-4445

Basepoint Business Centre: Rivermead Drive, Westlea, Swindon SN5 7EX Phone: 0800-118-2476
J.P. Coenstraat 7, The Bridge, The Hague, 2595 WP, Netherlands Phone: 08005678990

Bellerose Greenhouse

MODEL # : 2304109
For Horticulture Use Only



Please visit www.backyarddiscovery.com
For the most up to date assembly manual, to register your product, or to order
replacement parts *Para obtener instrucciones en español, visite*
www.backyarddiscovery.com



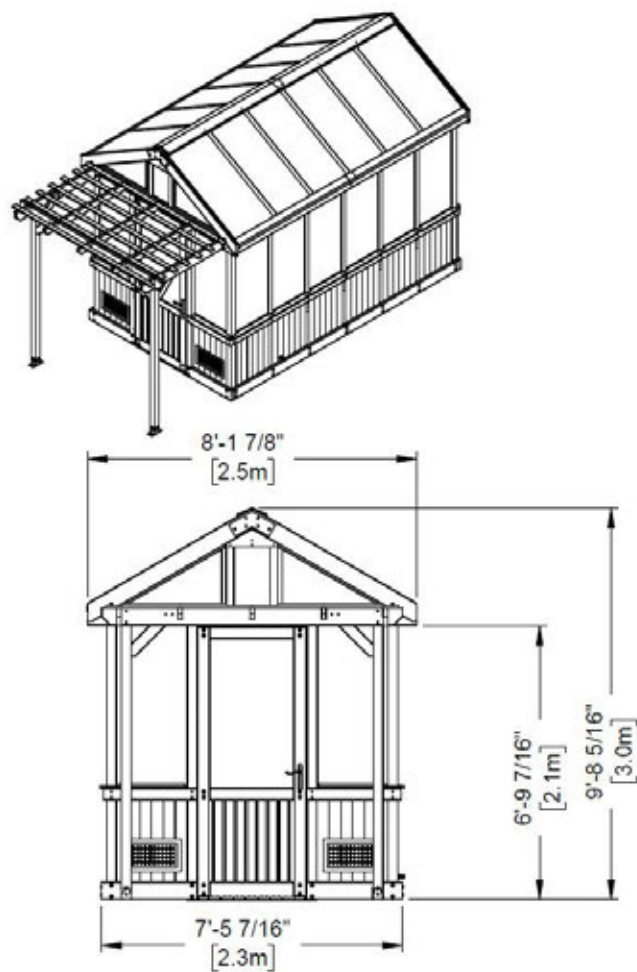
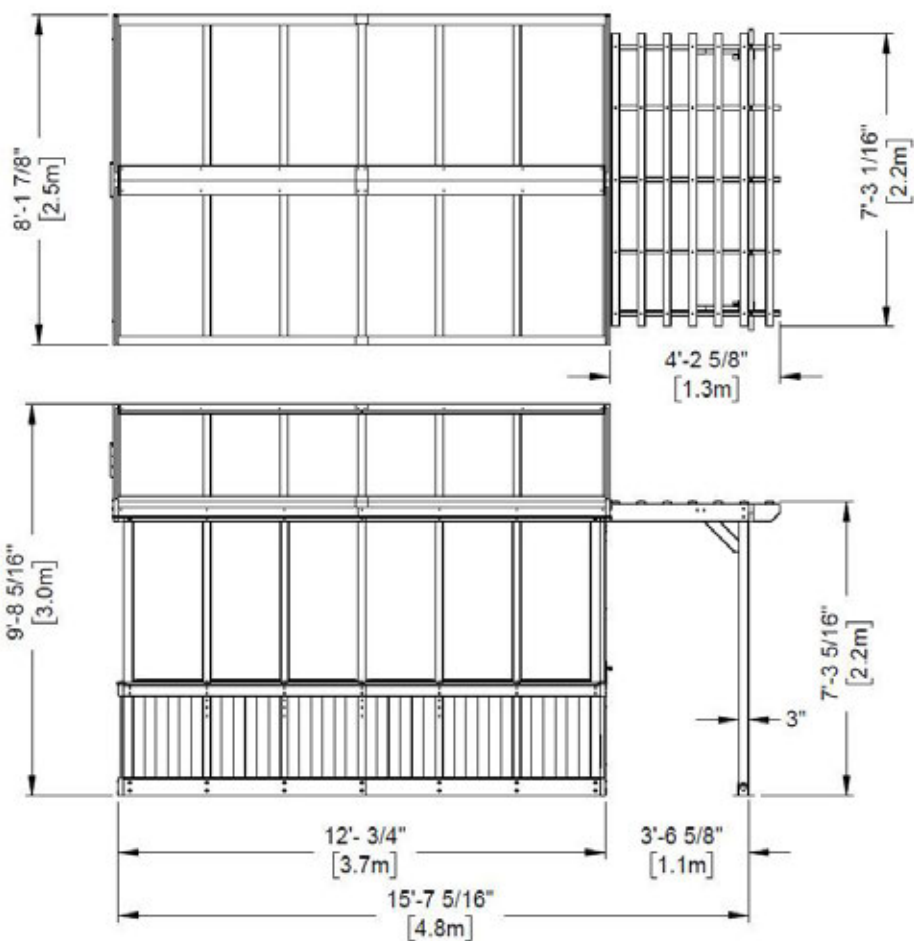
EASY STEP-BY-STEP
3D INTERACTIVE INSTRUCTIONS
DOWNLOAD THE FREE APP

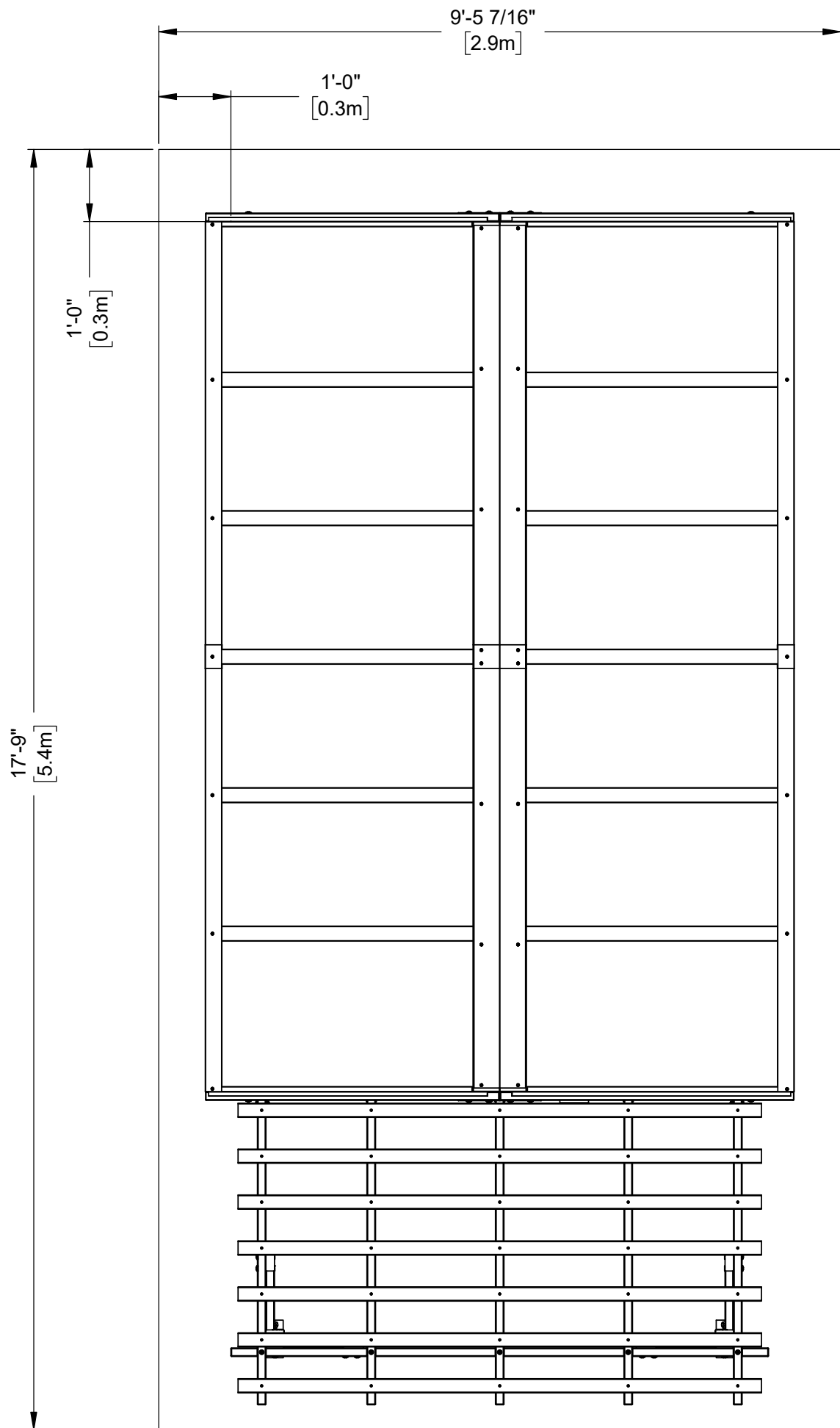


OWNER'S MANUAL - BASIC SETUP DIMENSIONS & ASSEMBLY NOTES

It is critically important that you start with square and level footings or concrete pad to attach your structure

- Pay close attention to the items needed for each step. Make sure you are using the correct hardware for each step. Using incorrect hardware may result in improper assembly
- Remember to double check for underground utilities and overhead electrical lines
- The hardware to attach the mounts to the ground is included.
- The hardware to mount the structure permanently to a concrete surface is not included.





RECOMMENDED LEVEL PAD SIZE
 IMPORTANT! WITH ADEQUATE DRAINING

Bellerose Greenhouse

Site Location and Preparation

- A. Check your local building and city codes for permit requirements or restrictions, including any HOA restrictions.
- B. Select a location with lots of sun, good drainage, and the ability to create a level firm surface for your greenhouse.
 - A firm, level surface is critically important to the longevity of your greenhouse.
 - Ensure it is accessible on all sides to clean and conduct annual maintenance
 - Consider a site location with a close proximity to both water and electrical sources
 - Make sure site drains well and avoid low lying areas.
- C. Before preparing your surface – double check for possibility of any underground utilities (example: gas, cable, or sprinkler lines)
 - Remove any grass, dirt, landscaping to create a level, hard-packed surface
 - This may involve some digging to create a level spot, dependent on your site location.
- D. Determine your preferred site pad materials for your greenhouse
 - It is NOT recommended to set the greenhouse directly on soil or grass. This will shorten the lifespan of your greenhouse.
 - Site pad options include gravel, patio or brick pavers, concrete pad
 - Anchors for a natural surface, such as gravel are included
 - If building on a concrete foundation (or brick/pavers); anchors will need to be purchased at your local hardware store

OWNER'S MANUAL - PARTS IDENTIFICATION

WOOD COMPONENTS (NOT TO SCALE)



B01 POST - W4L18025
(x1) 3"x3"x88 3/4" (76x76x2254)



B02 POST - W4L18047
(x1) 3"x3"x88 3/4" (76x76x2254)



B03 PERGOLA POST - W4L18070
(x1) 3"x3"x86 1/16" (76x76x2186)



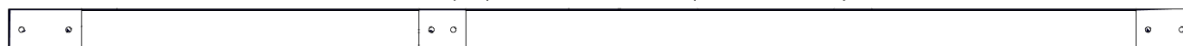
B04 PERGOLA POST - W4L18073
(x1) 3"x3"x86 1/16" (76x76x2186)



B05 POST - W4L18075
(x1) 3"x3"x88 3/4" (76x76x2254)



B06 POST - W4L18076
(x1) 3"x3"x88 3/4" (76x76x2254)



B07 SIDE UPRIGHT - W4L18059
(x1) 3"x3"x85 11/16" (76x76x2177)



B08 SIDE UPRIGHT - W4L18060
(x1) 3"x3"x85 11/16" (76x76x2177)



B09 UPRIGHT - W4L18066
(x1) 3"x3"x85 11/16" (76x76x2177)



B10 UPRIGHT - W4L18344
(x1) 3"x3"x85 11/16" (76x76x2177)



D02 BASE BOARD - W4L18026
(x2) 1 7/16"x5 1/4"x72 1/8" (36x134x1832)



D03 HEADER - W4L18028
(x2) 1 7/16"x5 1/4"x72 1/8" (36x134x1832)



D05 BASE BOARD - W4L18037
(x2) 1 7/16"x5 1/4"x28 3/8" (36x134x721)



D06 HEADER - W4L18038
(x1) 1 7/16"x5 1/4"x89 7/16" (36x134x2272)

OWNER'S MANUAL - PARTS IDENTIFICATION

WOOD COMPONENTS (NOT TO SCALE)



D07 GABLE - W4L18041
(x2) 1 7/16"x5 1/4"x59 1/8" (36x134x1502)



D08 GABLE - W4L18042
(x2) 1 7/16"x5 1/4"x59 1/8" (36x134x1502)



D10 BASE BOARD - W4L18031
(x1) 1 7/16"x5 1/4"x89 7/16" (36x134x2272)



D11 RAFTER - W4L18067
(x2) 1 7/16"x5 1/4"x52 1/16" (36x134x1322)



D12 BRACE BEAM - W4L18068
(x1) 1 7/16"x5 1/4"x89 7/16" (36x134x2272)



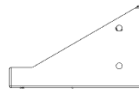
D13 HEADER - W4L18074
(x1) 1 7/16"x5 1/4"x89 7/16" (36x134x2272)



D14 HEADER - W4L18401
(x2) 1 7/16"x5 1/4"x72 1/8" (36x134x1832)



D16 BASE BOARD - W4L18399
(x2) 1 7/16"x5 1/4"x72 1/8" (36x134x1832)



D18 END TRIM - W4L18422
(x4) 1 7/16"x134x219 (36x134x219)



E01 GABLE - W4L18046
(x4) 1 7/16"x3 3/8"x56 1/2" (36x86x1434)



E02 LEDGE BOARD - W4L18033
(x8) 1 7/16"x3 3/8"x23 1/16" (36x86x585)



E03 LEDGE BOARD - W4L18034
(x2) 1 7/16"x3 3/8"x24 7/8" (36x86x632)



E04 RAFTER - W4L18036
(x6) 1 7/16"x3 3/8"x55 3/8" (36x86x1407)



E05 LEDGE BOARD - W4L18035
(x2) 1 7/16"x3 3/8"x24 7/8" (36x86x632)



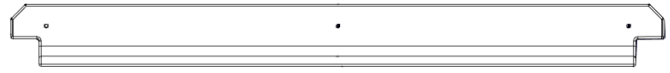
E06 LEDGE BOARD - W4L18063
(x1) 1 7/16"x3 3/8"x24 7/8" (36x86x632)

OWNER'S MANUAL - PARTS IDENTIFICATION

WOOD COMPONENTS (NOT TO SCALE)



E07 LEDGE BOARD - W4L18064
(x1) 1 7/16"x3 3/8"x24 7/8" (36x86x632)



E08 LEDGE BOARD - W4L18065
(x1) 1 7/16"x3 3/8"x35 11/16" (36x86x906)



E09 RAFTER - W4L18069
(x3) 1 7/16"x3 3/8"x52 1/16" (36x86x1322)



E10 CORBEL - W4L18072
(x4) 1 7/16"x3 3/8"x18 11/16" (36x86x474)



E11 HORIZONTAL WALL BOARD - W4L18051
(x2) 1 7/16"x3 3/8"x27 15/16" (36x86x709)



E12 HORIZONTAL WALL BOARD - W4L18032
(x1) 1 7/16"x3 3/8"x88 1/2" (36x86x2248)



E13 DOOR STOP - W4L18054
(x1) 1 7/16"x3 3/8"x32 11/16" (36x86x830)



E17 TABLE FRAME - W4L18405
(x1) 1 7/16"x3 3/8"x16 5/8" (36x86x423)



E18 TABLE FRAME - W4L18406
(x1) 1 7/16"x3 3/8"x16 5/8" (36x86x423)



E19 FAN PANEL BOARD - W4L18392
(x1) 1 7/16"x3 3/8"x10 9/16" (36x86x268)



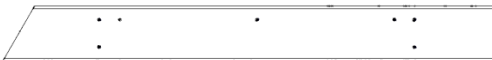
E20 JOIST - W4L18420
(x3) 1 7/16"x3 3/8"x54 1/8" (36x86x1374)



E21 RAFTER - W4L18421
(x4) 1 7/16"x3 3/8"x55 3/8" (36x86x1407)



F01 VERTICAL UPRIGHT - W4L18058
(x8) 1 7/16"x2 3/8"x86 11/16" (36x60x2202)



F03 GABLE SUPPORT - W4L18368
(x1) 1 7/16"x2 3/8"x21 3/16" (36x60x538)



F04 GABLE SUPPORT - W4L18369
(x1) 1 7/16"x2 3/8"x21 3/16" (36x60x538)



F06 VERTICAL UPRIGHT - W4L18039
(x2) 1 7/16"x2 3/8"x86 11/16" (36x60x2202)



F07 FAN SUPPORT - W4L18390
(x1) 1 7/16"x2 3/8"x10 9/16" (36x60x268)



F09 DIAGONAL BRACE - W4L18084
(x6) 1 7/16"x2 3/8"x18 1/16" (36x60x458)



F11 FAN SUPPORT - W4L18408
(x1) 1 7/16"x2 3/8"x10 9/16" (36x60x268)



F12 FAN SUPPORT - W4L18409
(x1) 1 7/16"x2 3/8"x21 3/16" (36x60x538)



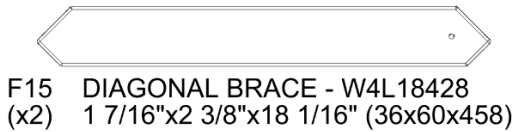
F13 FAN PANEL BOARD - W4L18393
(x1) 1 7/16"x2 3/8"x10 9/16" (36x60x268)



F14 WINDOW FRAME - W4L18419
(x1) 1 7/16"x2 3/8"x10 9/16" (36x60x268)

OWNER'S MANUAL - PARTS IDENTIFICATION

WOOD COMPONENTS (NOT TO SCALE)



F15 DIAGONAL BRACE - W4L18428
(x2) 1 7/16"x2 3/8"x18 1/16" (36x60x458)



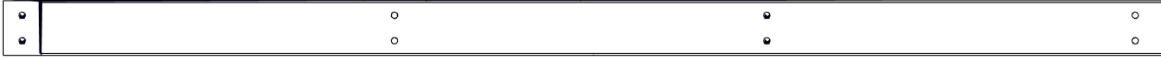
F16 WINDOW LATCH BOARD - W4L18774
(x2) 1 7/16"x2 3/8"x21" (36x60x533)



F17 WINDOW FRAME - W4L18777
(x1) 1 7/16"x2 3/8"x10 9/16" (36x60x268)



F19 WINDOW FRAME - W4L18778
(x1) 1 7/16"x2 3/8"x21 3/16" (36x60x538)



H01 HORIZONTAL WALL BOARD - W4L18030
(x1) 15/16"x3 3/8"x72 1/8" (24x86x1832)



H02 HORIZONTAL WALL BOARD - W4L18053
(x1) 15/16"x3 3/8"x72 1/8" (24x86x1832)



H03 HORIZONTAL WALL BOARD - W4L18061
(x1) 15/16"x3 3/8"x72 1/8" (24x86x1832)



H04 HORIZONTAL WALL BOARD - W4L18062
(x1) 15/16"x3 3/8"x72 1/8" (24x86x1832)



H05 TRIM BOARD - W4L18425
(x4) 15/16"x3 3/8"x24 5/16" (24x86x618)



H06 LEDGE BOARD - W4L18340
(x1) 15/16"x2 13/16"x26 7/16" (24x72x671)



H07 LEDGE BOARD - W4L18341
(x1) 15/16"x2 13/16"x26 7/16" (24x72x671)



J01 SHELF BOARD - W4L18411
(x2) 15/16"x2 3/8"x4 13/16" (24x60x122)



J02 SHELF BOARD - W4L18413
(x2) 15/16"x2 3/8"x34 3/4" (24x60x882)



J03 PURLIN - W4L18044
(x8) 24x2 3/8"x73" (24x60x1854)



J04 RIDGE STIFFENER - W4L18045
(x2) 15/16"x2 3/8"x84 7/8" (24x60x2156)



J05 RIDGE STIFFENER - W4L18424
(x2) 15/16"x2 3/8"x59 7/16" (24x60x1510)



J06 LOUVER TRIM - W4L18426
(x4) 15/16"x2 3/8"x20 11/16" (24x60x526)



J07 LOUVER TRIM - W4L18427
(x4) 15/16"x2 3/8"x8" (24x60x203)



J09 WINDOW CAP BOARD - W4L18770
(x2) 15/16"x2 3/8"x19 13/16" (24x60x504)



J10 WINDOW CAP BOARD - W4L18771
(x2) 15/16"x2 3/8"x19 13/16" (24x60x504)

OWNER'S MANUAL - PARTS IDENTIFICATION

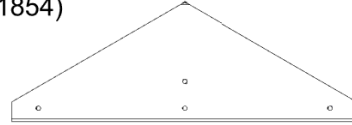
WOOD COMPONENTS (NOT TO SCALE)



J12 PURLIN - W4L18779
(x4) 15/16"x2 3/8"x73" (24x60x1854)



J11 WINDOW HANDLE - W4L18772
(x4) 15/16"x2 3/8"x15 1/2" (24x60x394)



K01 EXHAUST FAN TRIM - W4L18416
(x2) 5/8"x5 1/4"x15 1/4" (16x134x388)



M01 TABLE TOP - W4L18085
(x5) 5/8"x3 3/8"x79 1/16" (16x86x2008)



M03 TABLE TRIM - W4L18348
(x2) 5/8"x3 3/8"x36 1/2" (16x86x927)



M05 TABLE TRIM - W4L18350
(x2) 5/8"x3 3/8"x45 1/2" (16x86x1156)



M07 TABLE TRIM - W4L18356
(x1) 5/8"x3 3/8"x26 1/4" (16x86x667)



M08 TABLE TRIM - W4L18364
(x1) 5/8"x3 3/8"x35 5/16" (16x86x897)



M11 WATER LINE BOARD - W4L18870
(x1) 5/8"x3 3/8"x20 15/16" (16x86x532)



N01 TABLE TOP - W4L18086
(x2) 5/8"x2 3/8"x19 1/2" (16x60x495)



N03 PERGOLA PURLIN - W4L18071
(x7) 5/8"x2 3/8"x87 1/16" (16x60x2212)



N06 WALL BOARD - W4L18366
(x1) 5/8"x2 3/8"x83 11/16" (16x60x2126)



N07 WALL BOARD - W4L18367
(x11) 5/8"x2 3/8"x38 11/16" (16x60x982)



N08 SHELF BOARD - W4L18412
(x1) 5/8"x2 3/8"x36 5/8" (16x60x930)



N09 EXHAUST FAN TRIM - W4L18414
(x2) 5/8"x2 3/8"x10 1/2" (16x60x267)



N10 EXHAUST FAN TRIM - W4L18415
(x1) 5/8"x2 3/8"x15 1/4" (16x60x388)



N12 WINDOW TRIM - W4L18418
(x4) 5/8"x2 3/8"x17 3/4" (16x60x451)



N11 WINDOW TRIM - W4L18417
(x4) 5/8"x2 3/8"x40 1/2" (16x60x1028)



N14 WINDOW STOP - W4L18773
(x2) 5/8"x2 3/8"x18 7/8" (16x60x480)



N13 WINDOW TRIM - W4L18423
(x4) 5/8"x2 3/8"x33 7/8" (16x60x860)



O01 DOOR STOP - W4L18052
(x2) 5/8"x1 5/16"x79 15/16" (16x34x2030)



P01 TABLE FRAME - W4L18081
(x1) 1 7/16"x1 7/16"x83 3/4" (36x36x2128)



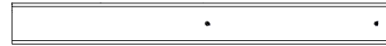
P02 TABLE FRAME - W4L18078
(x1) 1 7/16"x1 7/16"x83 3/4" (36x36x2128)

OWNER'S MANUAL - PARTS IDENTIFICATION

WOOD COMPONENTS (NOT TO SCALE)



P03 TABLE FRAME - W4L18077
(x2) 1 7/16"x1 7/16"x16 5/8" (36x36x423)



P05 TABLE FRAME - W4L18087
(x6) 1 7/16"x1 7/16"x13 1/4" (36x36x336)

P11 TABLE FRAME - W4L18394
(x1) 1 7/16"x1 7/16"x13 1/4" (36x36x336)



P12 TABLE FRAME - W4L18395
(x2) 1 7/16"x1 7/16"x13 1/4" (36x36x336)



P13 WINDOW CAP BOARD - W4L18396
(x14) 1 7/16"x1 7/16"x20 5/8" (36x36x524)



P14 WINDOW CAP BOARD - W4L18397
(x1) 1 7/16"x1 7/16"x31 9/16" (36x36x802)



P15 CLEAT - W4L18407
(x1) 1 7/16"x1 7/16"x84 5/8" (36x36x2150)



Q01 WALL BOARD - W4L18057
(x67) 15/16"x3 15/16"x33" (24x100x838)



Q03 FASCIA - W4L18048
(x2) 15/16"x4 7/16"x73 9/16" (24x112x1868)



Q04 FASCIA - W4L18049
(x2) 15/16"x4 7/16"x73 9/16" (24x112x1868)



Q06 PANEL RIDGE - W4L18055
(x2) 15/16"x4 7/16"x48 5/8" (24x112x1235)



Q05 PANEL RIDGE - W4L18050
(x2) 15/16"x4 7/16"x70 1/2" (24x112x1791)



Q08 WALL BOARD - W4L18088
(x12) 15/16"x4 1/8"x33" (24x104x838)



Q09 WALL BOARD - W4L18089
(x7) 15/16"x4 1/8"x33" (24x104x838)



Q10 WALL BOARD - W4L18342
(x5) 15/16"x3 3/4"x33" (24x95x838)



Q12 WALL BOARD - W4L18351
(x2) 15/16"x3 15/16"x33" (24x100x838)



Q13 WALL BOARD - W4L18352
(x8) 15/16"x3 15/16"x15 13/16" (24x100x401)



Q14 WALL BOARD - W4L18353
(x8) 15/16"x3 15/16"x9 3/16" (24x100x234)



Q15 WALL BOARD - W4L18354
(x2) 15/16"x4 7/16"x (24x112x838)



Q16 WALL BOARD - W4L18365
(x1) 15/16"x3 15/16"x33" (24x100x838)



Q17 WALL BOARD - W4L18775
(x1) 15/16"x3 3/4"x33" (24x95x838)



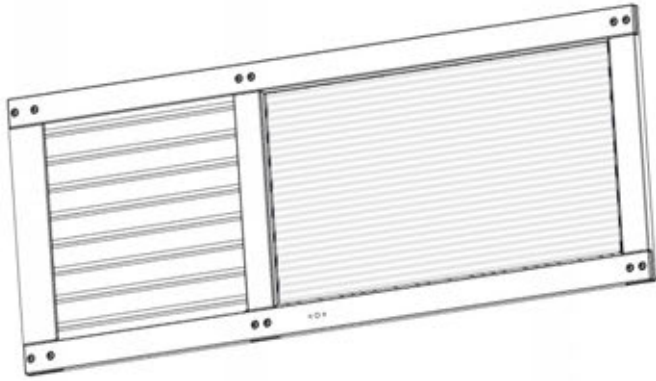
Q18 PANEL RIDGE - W4L18776
(x2) 15/16"x4 7/16"x25 9/16" (24x112x650)



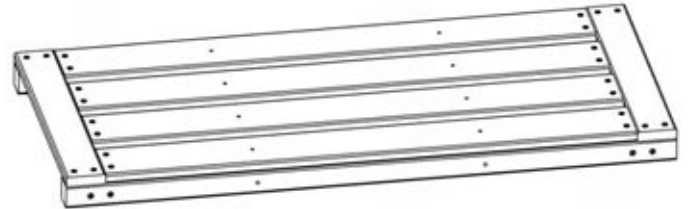
Y01 HANGER WALL BOARD - W4L18410
(x1) 5/8"x4"x38 11/16" (16x102x982)

OWNER'S MANUAL - PARTS IDENTIFICATION

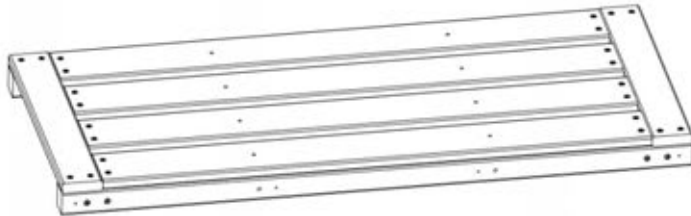
WOOD COMPONENTS (NOT TO SCALE)



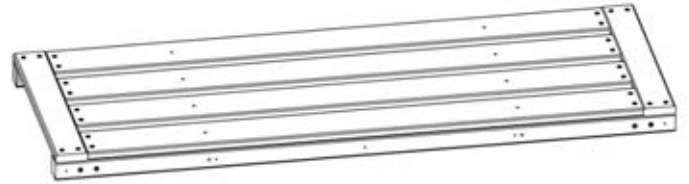
D01 DOOR ASSEMBLY - W2A03900
(x1) 1 7/16"x31 15/16"x80" (36x812x642)



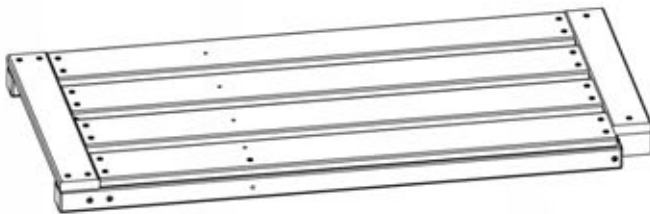
T1 LEFT REAR TABLE ASSEMBLY - W2A03901
(x1) 2 1/16"x16 1/16"x36 1/2" (52x408x807)



T2 RIGHT REAR TABLE ASSEMBLY - W2A03902
(x1) 2 1/16"x16 1/16"x36 1/2" (52x408x807)



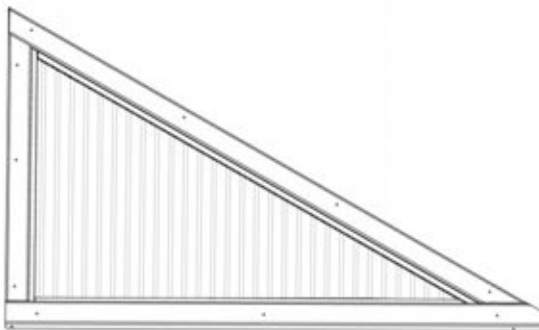
T3 MIDDLE TABLE ASSEMBLY - W2A03903
(x2) 2 1/16"x16 1/16"x45 1/2" (52x408x1036)



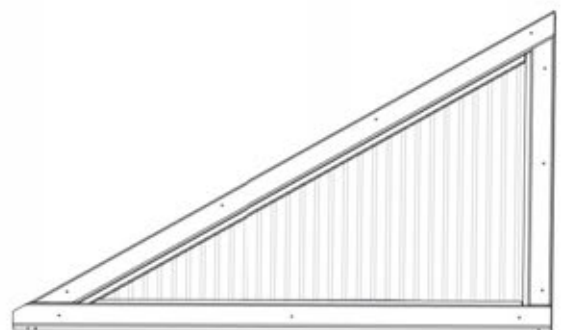
T4 LEFT FRONT TABLE ASSEMBLY - W2A03904
(x1) 2 1/16"x16 1/4"x35 5/16" (52x412x777)



T5 RIGHT FRONT TABLE ASSEMBLY - W2A03905
(x1) 2 1/16"x16 1/4"x26 1/4" (52x412x547)



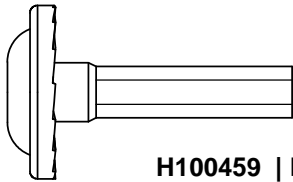
WP01 WINDOW PANEL ASSEMBLY - W2A03899
(x2) 1 7/16"x19 11/16"x32 11/16" (36x501x449)



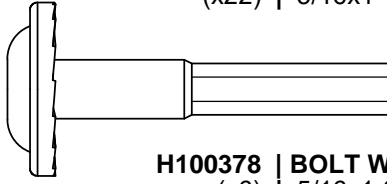
WP02 WINDOW PANEL ASSEMBLY - W2A03906
(x2) 1 7/16"x19 11/16"x32 11/16" (36x501x449)

OWNER'S MANUAL - PARTS IDENTIFICATION

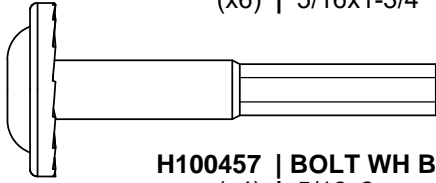
Hardware Components



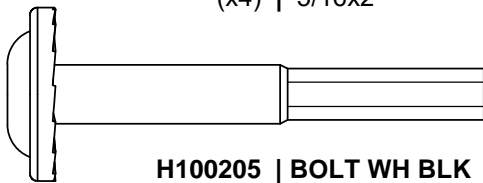
H100459 | BOLT WH BLK
(x22) | 5/16x1-1/4



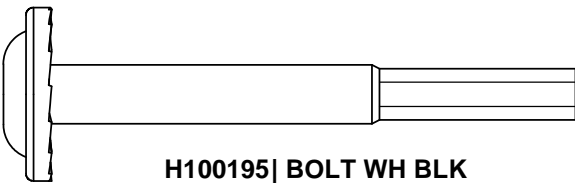
H100378 | BOLT WH BLK
(x6) | 5/16x1-3/4



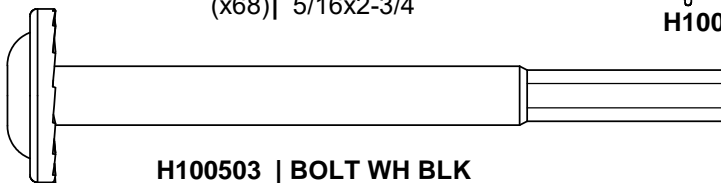
H100457 | BOLT WH BLK
(x4) | 5/16x2



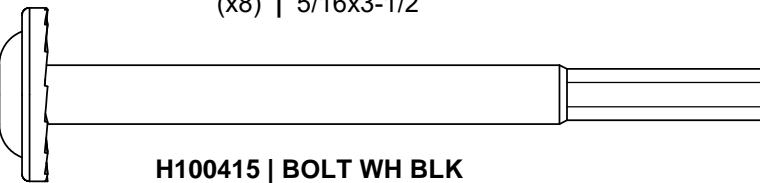
H100205 | BOLT WH BLK
(x24) | 5/16x2-1/4



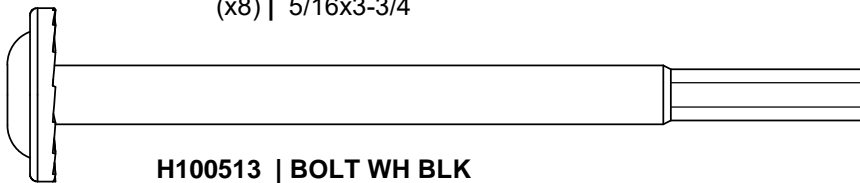
H100195 | BOLT WH BLK
(x68) | 5/16x2-3/4



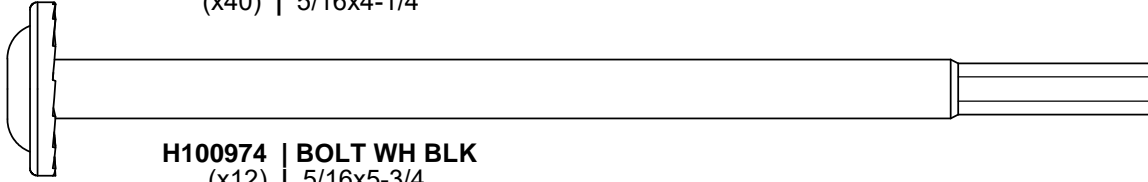
H100503 | BOLT WH BLK
(x8) | 5/16x3-1/2



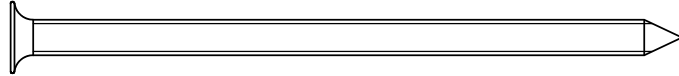
H100415 | BOLT WH BLK
(x8) | 5/16x3-3/4



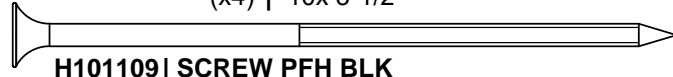
H100513 | BOLT WH BLK
(x40) | 5/16x4-1/4



H100974 | BOLT WH BLK
(x12) | 5/16x5-3/4



H100777 | SCREW PFH BLK
(x4) | 10x 3-1/2



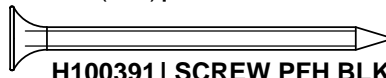
H101109 | SCREW PFH BLK
(x18) | 8x3-1/2



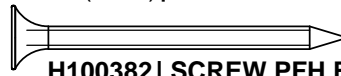
H100201 | SCREW PFH BLK
(x115) | 8x2-1/2



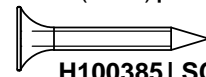
H100483 | SCREW PFH BLK
(x69) | 8x2-1/4



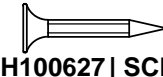
H100391 | SCREW PFH BLK
(x342) | 8x2



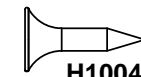
H100382 | SCREW PFH BLK
(x419) | 8x1-3/4



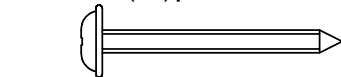
H100385 | SCREW PFH BLK
(x72) | 8x1



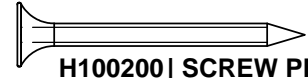
H100627 | SCREW PFH BLK
(x8) | 6x3/4



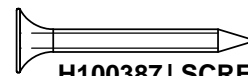
H100411 | SCREW PFH BLK
(x3) | 8x5/8



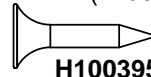
H100536 | SCREW PWH BLK
(x2) | 8x1-1/4



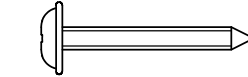
H100200 | SCREW PFH BLK
(x90) | 8x1-1/2



H100387 | SCREW PFH BLK
(x268) | 8x1-1/4



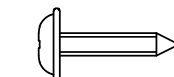
H100395 | SCREW PFH BLK
(x40) | 8x3/4



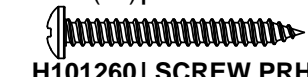
H100797 | SCREW PWH BLK
(x5) | 8x1



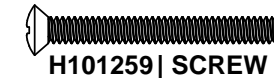
H100392 | SCREW PWH BLK
(x40) | 8x3/4



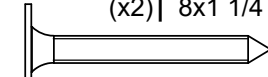
H100202 | SCREW PWH BLK
(x6) | 8x5/8



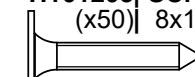
H101260 | SCREW PRH SS
(x2) | 8x1 1/4



H101259 | SCREW POH BLK
(x2) | 8x1 1/4



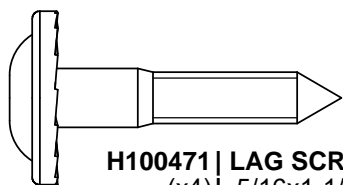
H101203 | SCREW PWH BLK
(x50) | 8x1 1/4



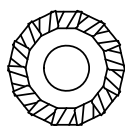
H101207 | SCREW PWH BLK
(x24) | 8x7/8

OWNER'S MANUAL - PARTS IDENTIFICATION

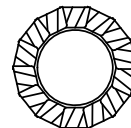
Hardware Components



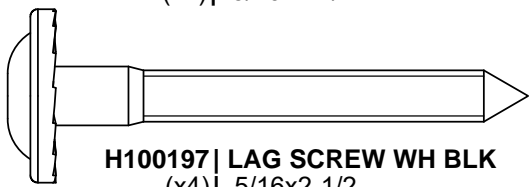
H100471 | LAG SCREW WH BLK
(x4) | 5/16x1-1/2



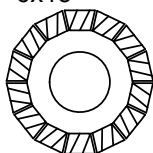
H100405 | WASHER LOCK EXT BLK
(x59) | 6x15



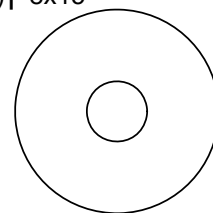
H100400 | WASHER LOCK EXT BLK
(x8) | 8x15



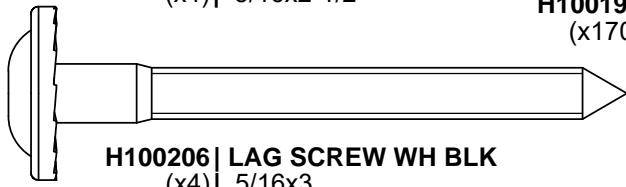
H100197 | LAG SCREW WH BLK
(x4) | 5/16x2-1/2



H100198 | WASHER LOCK EXT BLK
(x170) | 8x19



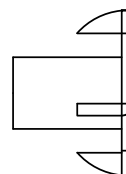
H100478 | WASHER FLAT BLK
(x6) | 8x27



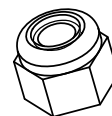
H100206 | LAG SCREW WH BLK
(x4) | 5/16x3



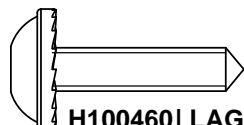
H100630 | WASHER FLAT BLK
(x41) | 8x19



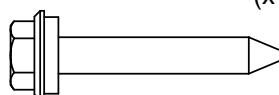
H100379 | T-NUT BLK
(x166) | 5/16



H100653 | NUT LOCK BLK
(x37) | 1/4



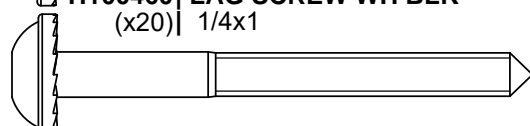
H100460 | LAG SCREW WH BLK
(x20) | 1/4x1



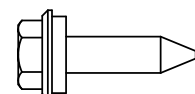
H100760 | SCREW WOODGRIP
(x14) | 10x1-1/4



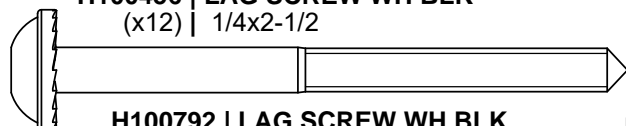
H100479 | NUT LOCK BLK
(x10) | 5/16



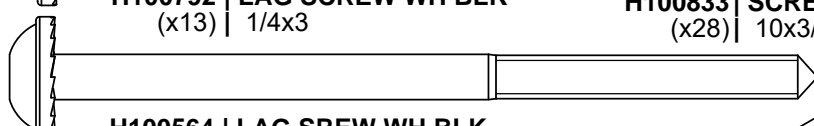
H100456 | LAG SCREW WH BLK
(x12) | 1/4x2-1/2



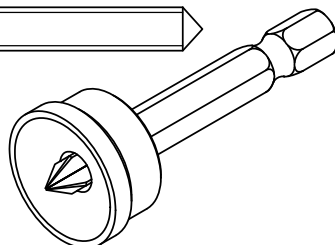
H100833 | SCREW WOODGRIP
(x28) | 10x3/4



H100792 | LAG SCREW WH BLK
(x13) | 1/4x3



H100564 | LAG SREW WH BLK
(x2) | 1/4x4

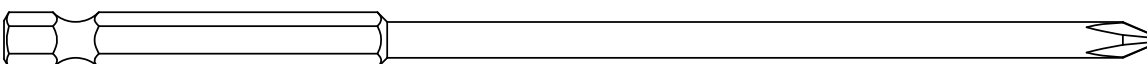
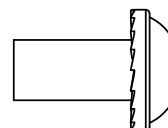


H100764 | SCREW SETTER
(x1) |

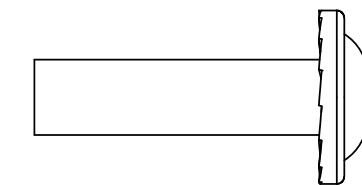


H100488 | BOLT WH BLK
(x45) | 1/4x2

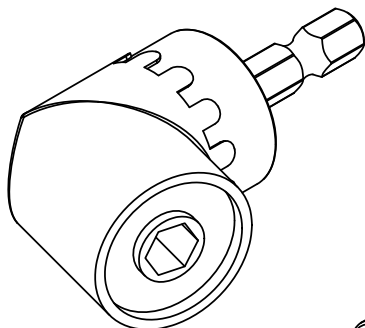
H100404 | NUT BARREL WH BLK
(x8) | 1/4x5/8



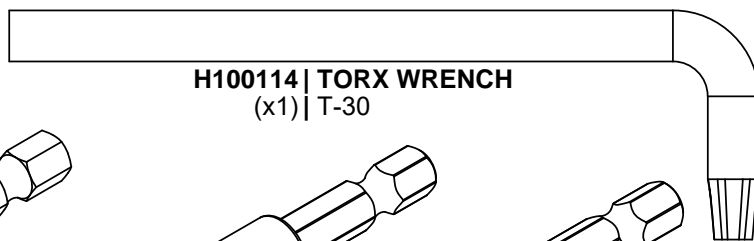
H101261 | PHILLIPS EXTENSION BIT
(x1) |



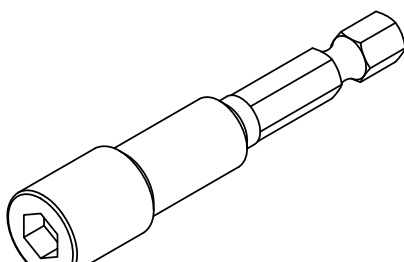
H100193 | NUT BARREL WH BLK
(x8) | 5/16x1-1/2



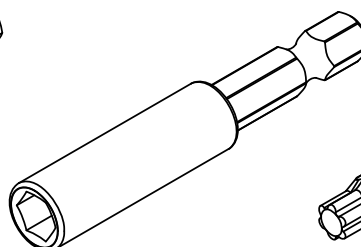
**H101114 | RIGHT HAND
(x1) | DRILL ADAPTER**



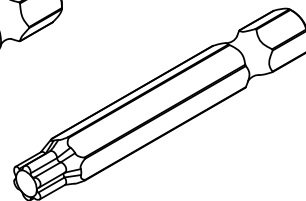
H100114 | TORX WRENCH
(x1) | T-30



H101106 | SOCKET DRIVER
(x1) |



H101100 | MAGNETIC DRIVER
(x1) |



H100147 | TORX BIT
(x1) | T-30

OWNER'S MANUAL - PARTS IDENTIFICATION

ACCESSORY COMPONENTS (NOT TO SCALE)



A4M00555 L BRACKET BLK
(x4)



9205413 ELECTRICAL ENCLOSURE
(x1)



A4M00557 HINGE
(x4)



A4M01591 HOOK
(x6)



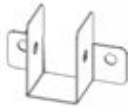
A4M01787 RAFTER BRACKET
(x3)



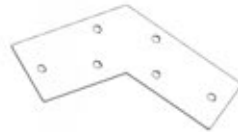
A4M02081 SOFFIT FLANGE
(x2)



A4M02082 SOFFIT SPLICE
(2)



A4M02085 RIDGE CLIP
(x2)



A4M02086 GABLE BRACKET
(x2)



A4M02089 STELL POST PLATE
(x4)



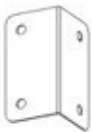
A4M02092 POST ANCHOR PLATE
(x4)



A4M02093 RAFTER BRACKET
(x10)



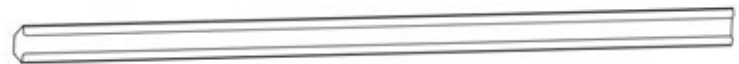
A4M02094 FOLDING TABLE BRACKET
(x8)



A4M02095 L-BRACKET
(x2)



A4M02096 BRACKET
(x4)



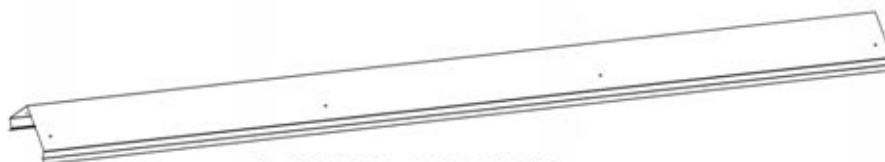
A4M02097 SPLICE COVER
(x10)



A4M02098 SOFFIT FLANGE
(x2)



A4M02158 BYD ID TAG PATIO
(x1)



A4M02378 RIDGE CAP
(x2)



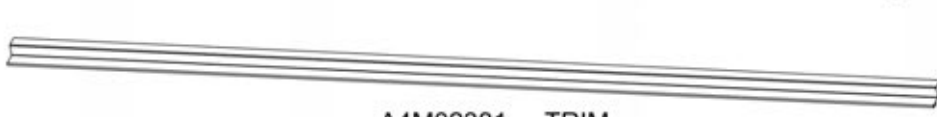
A4M02380 EDGE TRIM SPLICE
(x2)



A4M02379 EDGE TRIM
(x4)

OWNER'S MANUAL - PARTS IDENTIFICATION

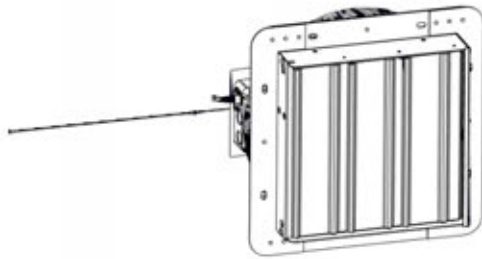
ACCESSORY COMPONENTS (NOT TO SCALE)



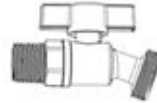
A4M02381 TRIM
(x4)



A4M02382 DOOR BRACKET
(x1)



A4M02383 EXHAUST FAN
(x1)



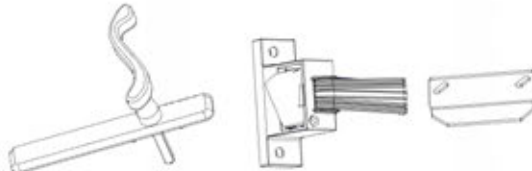
A4M02384 HOSE FAUCET
(x1)



A4M02385 PIPE CLAMP
(x2)



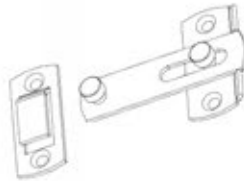
A4M02411 DOOR PROTECTION CHAIN
(x1)



A4M02410 STORM DOOR HANDLE
(x1)



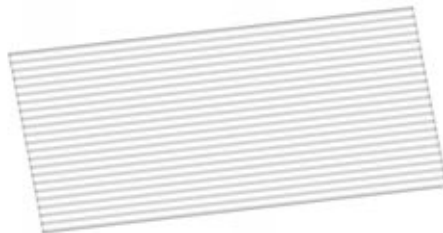
A4M02426 DOOR SWEEP
(x1)



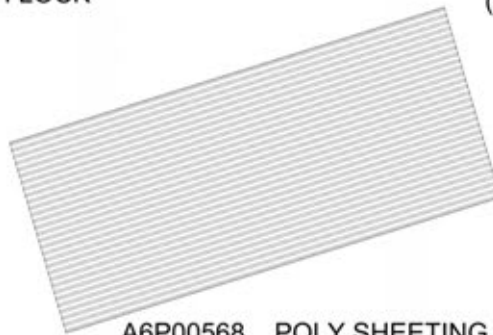
A4M02607 WINDOW LATCH LOCK
(x2)



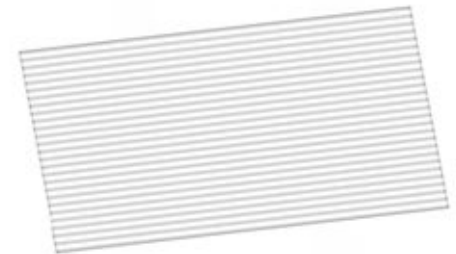
A4M02428 RIDGE CAP SPLICE
(x1)



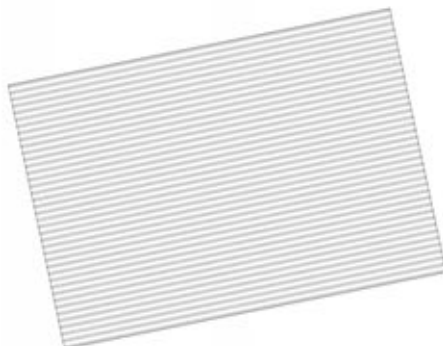
A6P00567 POLY SHEET
(x8)



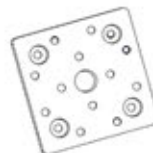
A6P00568 POLY SHEETING
(x12)



A6P00571 POLY SHEET
(x4)



A6P00572 POLY SHEETING
(x1)



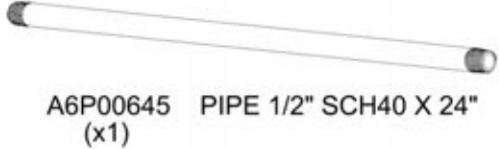
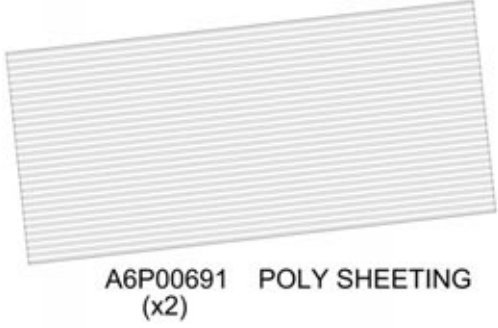
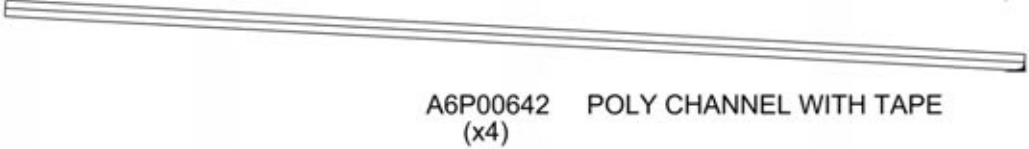
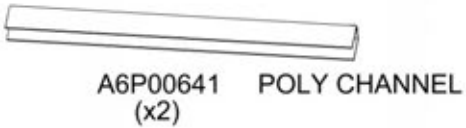
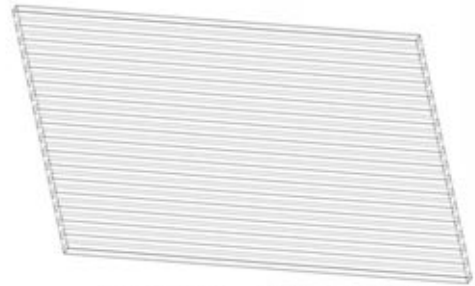
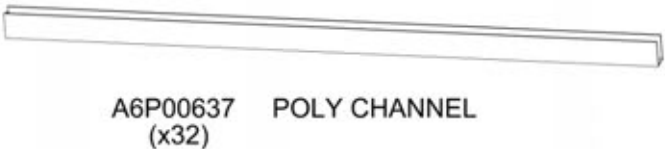
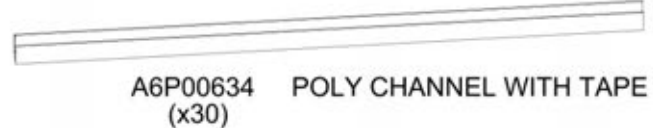
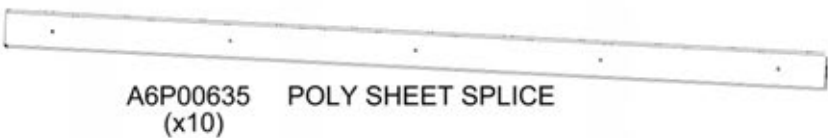
A6P00573 POST FOOT 3x3
(x2)



A6P00577 RUBBER GROMMET
(x1)

OWNER'S MANUAL - PARTS IDENTIFICATION

ACCESSORY COMPONENTS (NOT TO SCALE)

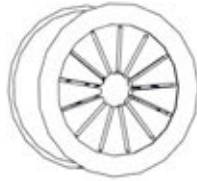


OWNER'S MANUAL - PARTS IDENTIFICATION

ACCESSORY COMPONENTS (NOT TO SCALE)



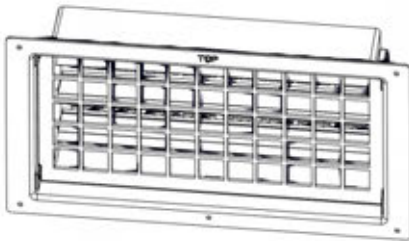
A6P00690 DUST SEAL TAPE
(x2)



A6P00692 CORD GROMMET
(x1)



A6P00693 RIDGE CAP PROTECTOR
(x2)



A6P00695 LOUVER
(x2)



A6P00754 THERMOSTAT
(x1)



A4M02091 GROUND STAKE
(x8)



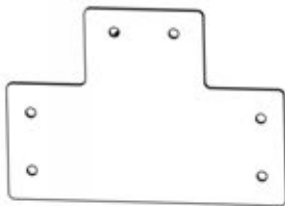
A6P00809 PLUMBERS TAPE
(x1)



A6P00807 POLY CHANNEL
(x8)



A6P00808 POLY CHANNEL
(x16)



A4M02099 T-CLEAT
(x8)

IMPORTANT!!

Polycarbonate Sheeting Information

The Polycarbonate Sheeting has UV protection on ONE (1) SIDE.

CRITICAL to install with the UV protection facing the OUTSIDE

- Wear safety gloves to protect against any sharp edges during handling or install.
- Do NOT use knife or sharp object to remove protective film as it may result in damage to polycarbonate sheeting
- Leave film on during install to ensure UV side is facing outside.
- Peel protective film back from edges approximately 2" (5cm) during installation.
- Remove film completely after installation.

NOTE: Do not store polycarbonate sheeting with film outside in direct sunlight or rain. It may make removal of film more difficult.

PRE-ASSEMBLY STEP 1 - SORTING PARTS

It is critical for ease of assembly that you take the time to sort and organize the wood and hardware.

WOOD PARTS:

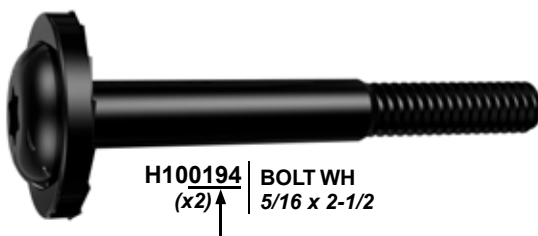
- Organize wood parts by the three-digit, alpha-numeric number stamped on each board (ex. P01).
- If there are multiple boards with the same stamped number, stack those pieces together.
- Stamps can be found on the flat surface of the boards or on the end of the boards.
- Allow yourself plenty of room - the wood pieces can take up a significant amount of space.

NOTE: CARTONS ARE NOT ORGANIZED BY BOARD NUMBER.



HARDWARE PARTS:

- We recommend that you have a separate table to organize the hardware.
- Hardware bags are printed with a seven-digit, alpha-numeric part number.
- You can organize your hardware by part number or group by hardware type (i.e. bolts, nuts, etc.).
- During assembly you only need to reference the last four digits of the number.



PRE-ASSEMBLY STEP 2 - TOOLS REQUIRED



Cordless Drill or Electric Drill



Drill Attachments:
Phillips Head



1/8", 3/16", 3/8" & 7/16" Drill Bits



Phillips Screw Driver



Tape Measure



Claw Hammer



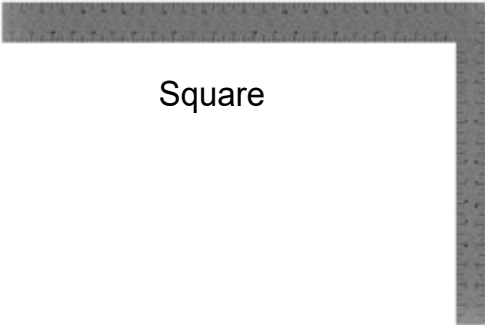
Open End Wrenches 1/2" & 7/16"



3/8" Drive Ratchet, 1/2" & 7/16" STD Sockets, 1/2" & 7/16" Deep Sockets



3/8 & 5/16" Nut Drivers



Square



Level 24"



Rubber Mallet - Optional

PRE-ASSEMBLY STEP 3 - CHOOSE YOUR ASSEMBLY METHOD

There are several types of assembly instructions available to you.

1. Printed Assembly Manual included with your set
2. BILT APP - 3D interactive instructions
3. Combination of the Printed Manual and BILT APP (Note: Step numbers can differ between the two methods)



The graphic is a rectangular advertisement for the BILT app. At the top left is the BILT logo, which consists of a stylized hexagonal icon with a dot inside, followed by the word "BILT." in a bold, sans-serif font. To the right of the logo is a large QR code. Below the logo and QR code, the text "Scan for easy 3D instructions" is written in a large, bold, black font. Underneath this, in a smaller font, it says "Download the BILT app before you begin". To the right of this text are two buttons: "Download on the App Store" with the Apple logo and "GET IT ON Google Play" with the Google Play logo. At the bottom of the graphic is a smartphone screen displaying a 3D assembly instruction. The screen shows a grey 3D model of a structure with a horizontal beam and a triangular support. A red arrow points to a specific part of the structure. The screen also has a "Partners Needed" label in the top left corner, a close button (X) in the top right, and a play button in the bottom right.

STEP 1 - BACK WALL ASSEMBLY

QTY	PART NUMBER	DESCRIPTION
8	H100198	WASHER LOCK EXT 8x19
4	H100206	LAG SCREW WH 5/16x3 BLK
4	H100379	TNUT-5/16" BLK
4	H100513	BOLT WH 5/16x4 1/4 BLK

E12 HORIZONTAL WALL BOARD - W4L18032
(x1) 1 7/16"x3 3/8"x88 1/2" (36x86x2248)

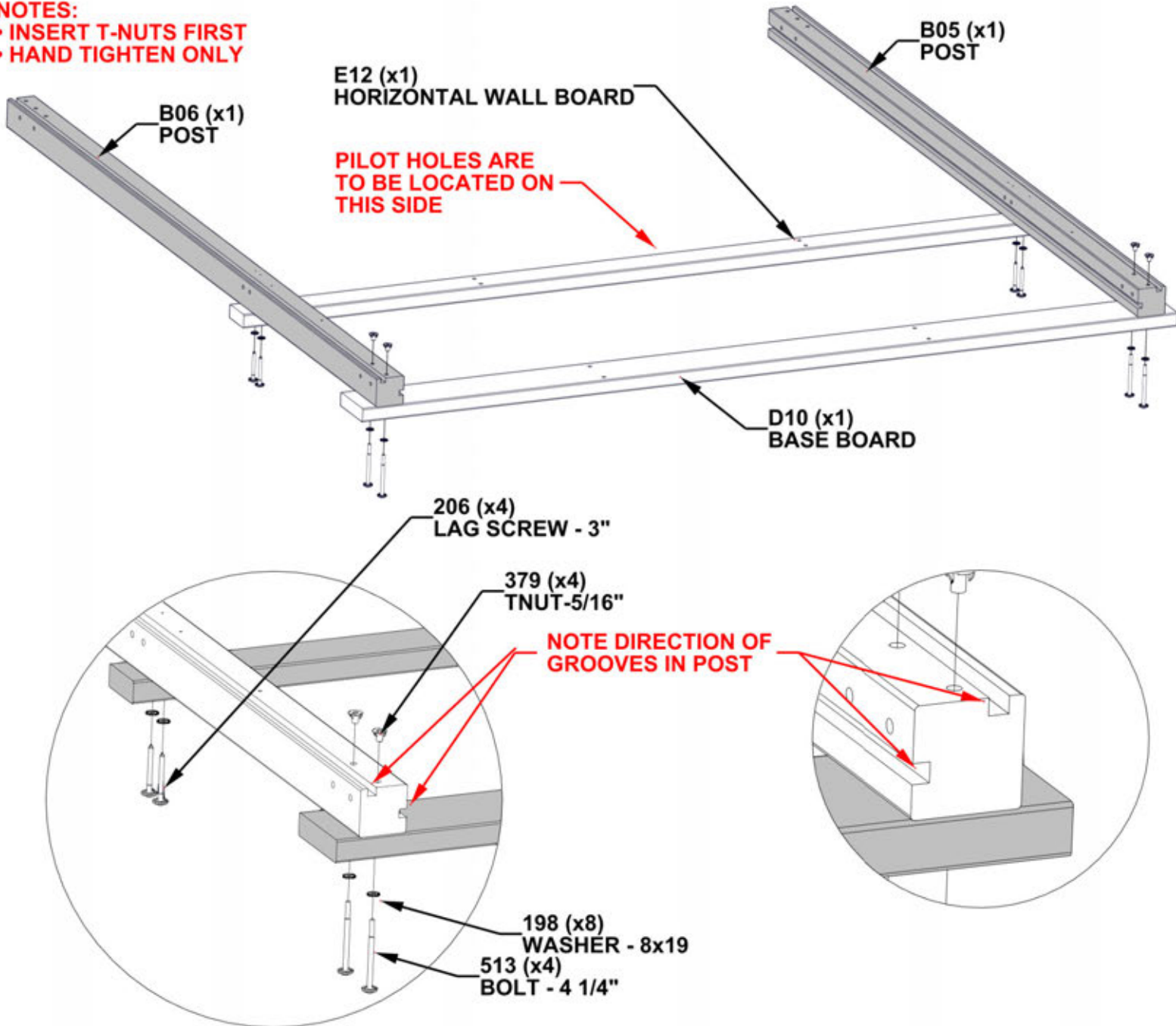
D10 BASE BOARD - W4L18031
(x1) 1 7/16"X5 1/4"X89 7/16" (36x134x2272)

B05 POST - W4L18075
(x1) 3"x3"x88 3/4" (76x76x2254)

B06 POST - W4L18076
(x1) 3"x3"x88 3/4" (76x76x2254)

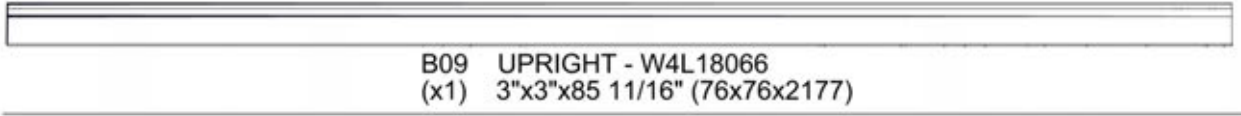
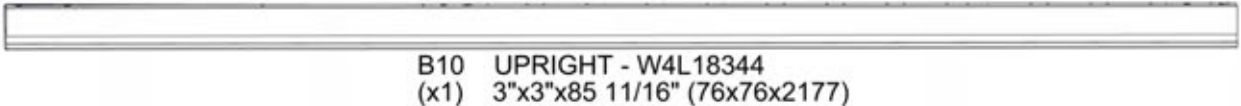
TIP: USE OF SAWHORSES IS RECOMMENDED DURING THE ASSEMBLY OF ALL WALL ASSEMBLIES.

NOTES:
 • INSERT T-NUTS FIRST
 • HAND TIGHTEN ONLY



STEP 2 - BACK WALL ASSEMBLY

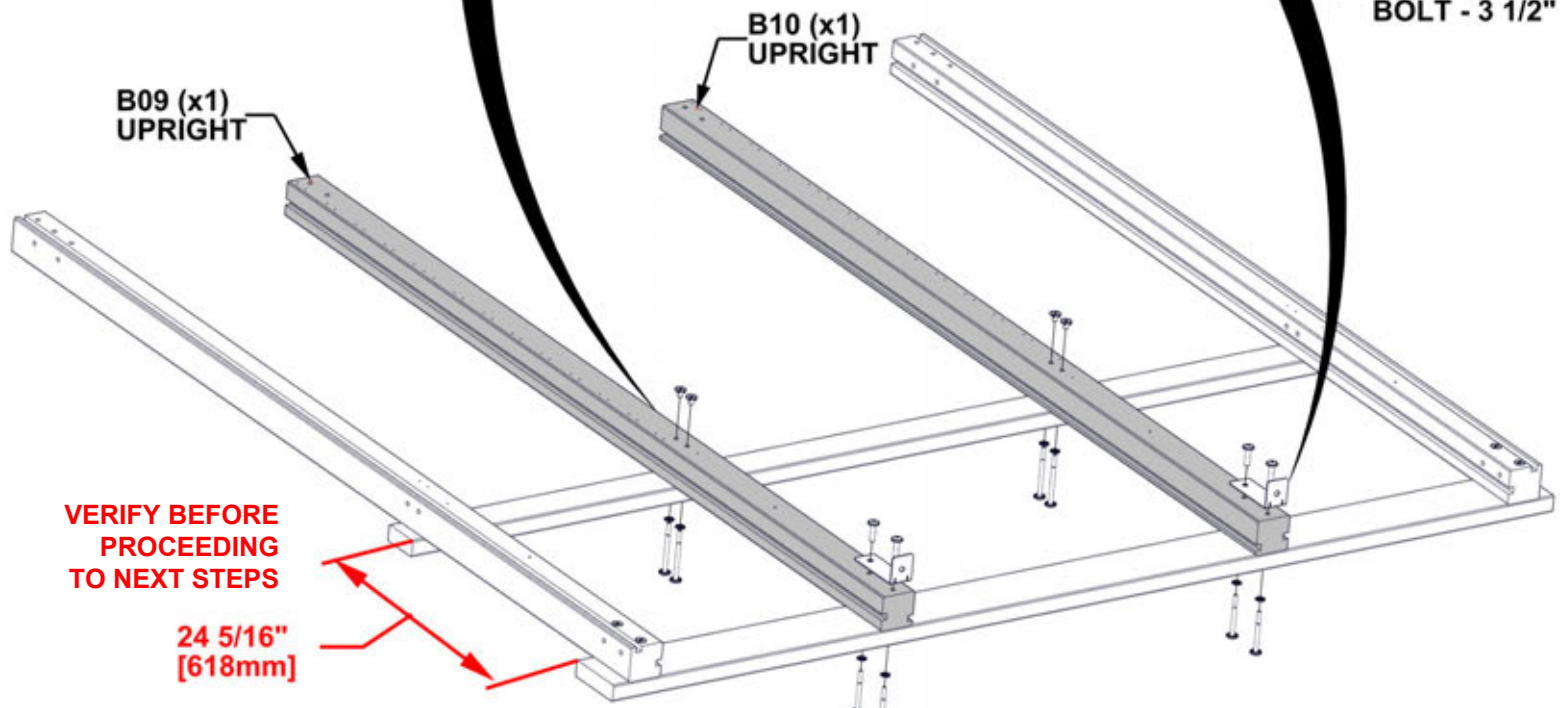
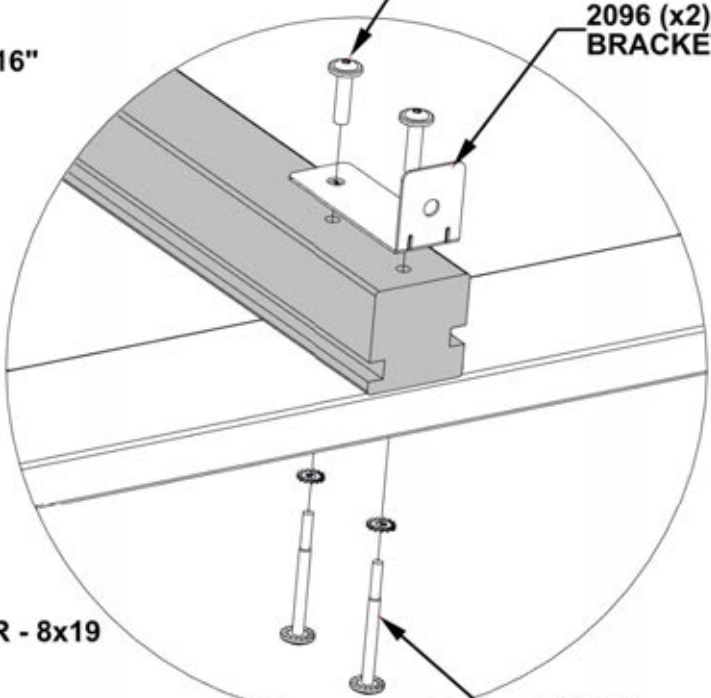
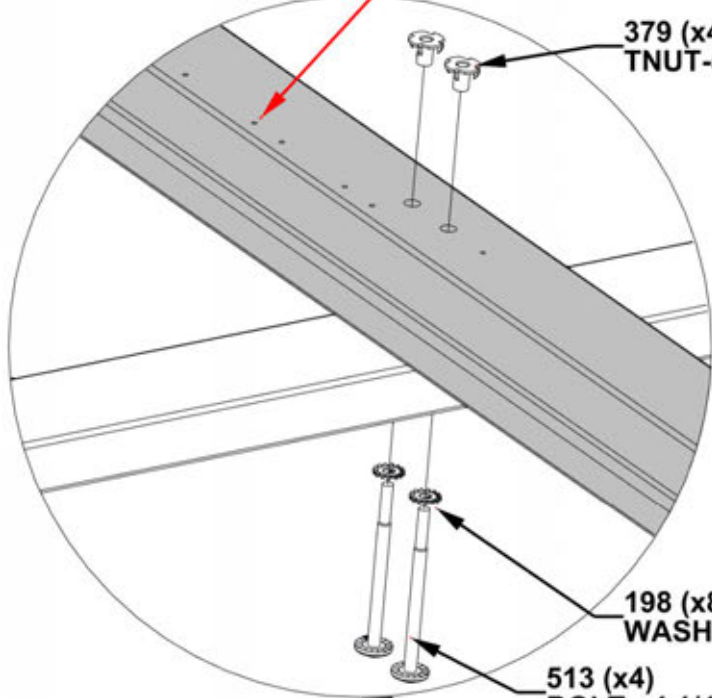
QTY	PART NUMBER	DESCRIPTION
4	H100193	NUT BARREL WH 5/16 X 1 1/2 BLK
8	H100198	WASHER LOCK EXT 8x19
4	H100379	TNUT-5/16" BLK
4	H100503	BOLT WH 5/16x3 1/2 BLK
4	H100513	BOLT WH 5/16x4 1/4 BLK



A4M02096 BRACKET
(x2)

NOTES:
 • INSERT T-NUTS FIRST
 • HAND TIGHTEN ONLY

**NOTE: PILOT HOLES ON B09 & B10
 FACE OUTWARDS**



STEP 3 - BACK WALL ASSEMBLY

QTY	PART NUMBER	DESCRIPTION
8	H100198	WASHER LOCK EXT 8x19
8	H100379	TNUT-5/16" BLK
4	H100513	BOLT WH 5/16x4 1/4 BLK
4	H100974	BOLT WH 5/16x5 3/4 BLK

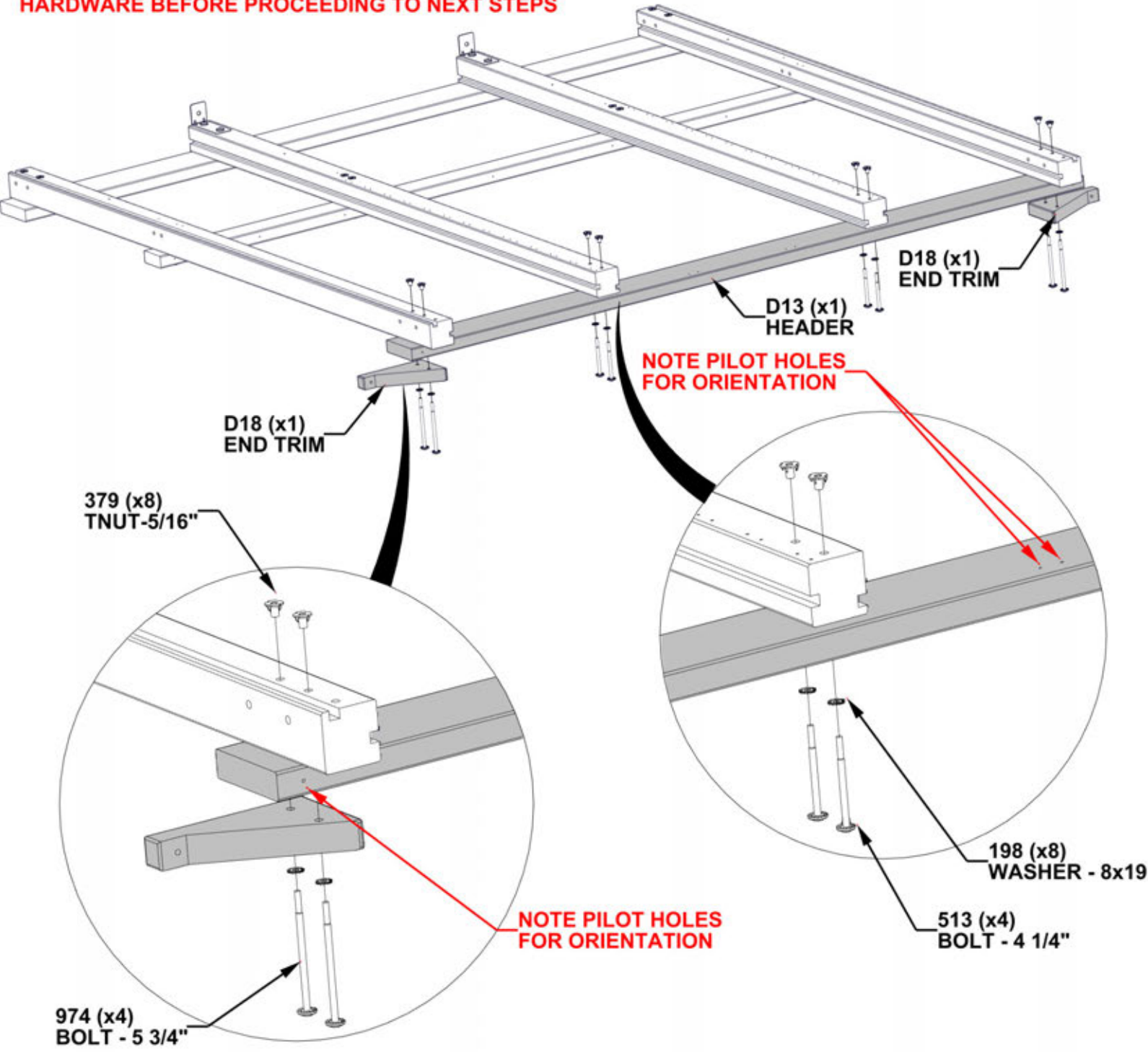


D18 END TRIM - W4L18422
(x2) 1 7/16"x134x219 (36x134x219)



D13 HEADER - W4L18074
(x1) 1 7/16"x5 1/4"x89 7/16" (36x134x2272)

- NOTES:**
- INSERT T-NUTS FIRST
 - IMPORTANT! SQUARE UNIT AND TIGHTEN ALL HARDWARE BEFORE PROCEEDING TO NEXT STEPS



STEP 4 - BACK WALL ASSEMBLY

QTY	PART NUMBER	DESCRIPTION
24	H100391	SCREW PFH 8x2 BLK



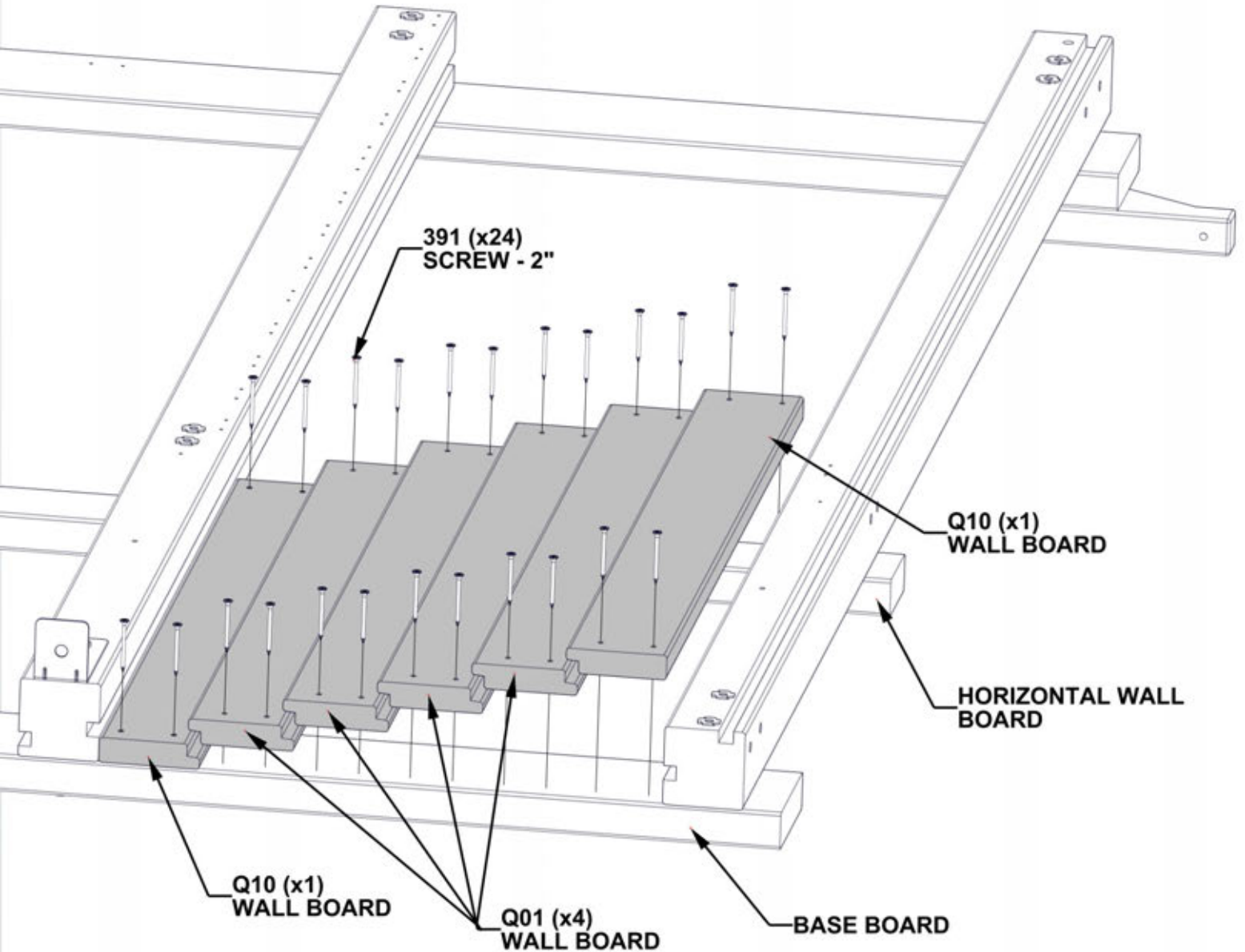
Q10 WALL BOARD - W4L18342
(x2) 15/16"x3 3/4"x33" (24x95x838)



Q01 WALL BOARD - W4L18057
(x4) 15/16"x3 15/16"x33" (24x100x838)

NOTE:

- WALL BOARDS SHOULD BE FLUSH WITH BOTTOM OF BASE BOARD AND TOP OF HORIZONTAL WALL BOARD.
- EVENLY SPACE WALL BOARDS TO AVOID ANY GAPS IN THE WALL PANEL



STEP 5 - BACK WALL ASSEMBLY

QTY	PART NUMBER	DESCRIPTION
36	H100391	SCREW PFH 8x2 BLK



Q09 WALL BOARD - W4L18089
(x7) 15/16"x4 1/8"x33" (24x104x838)



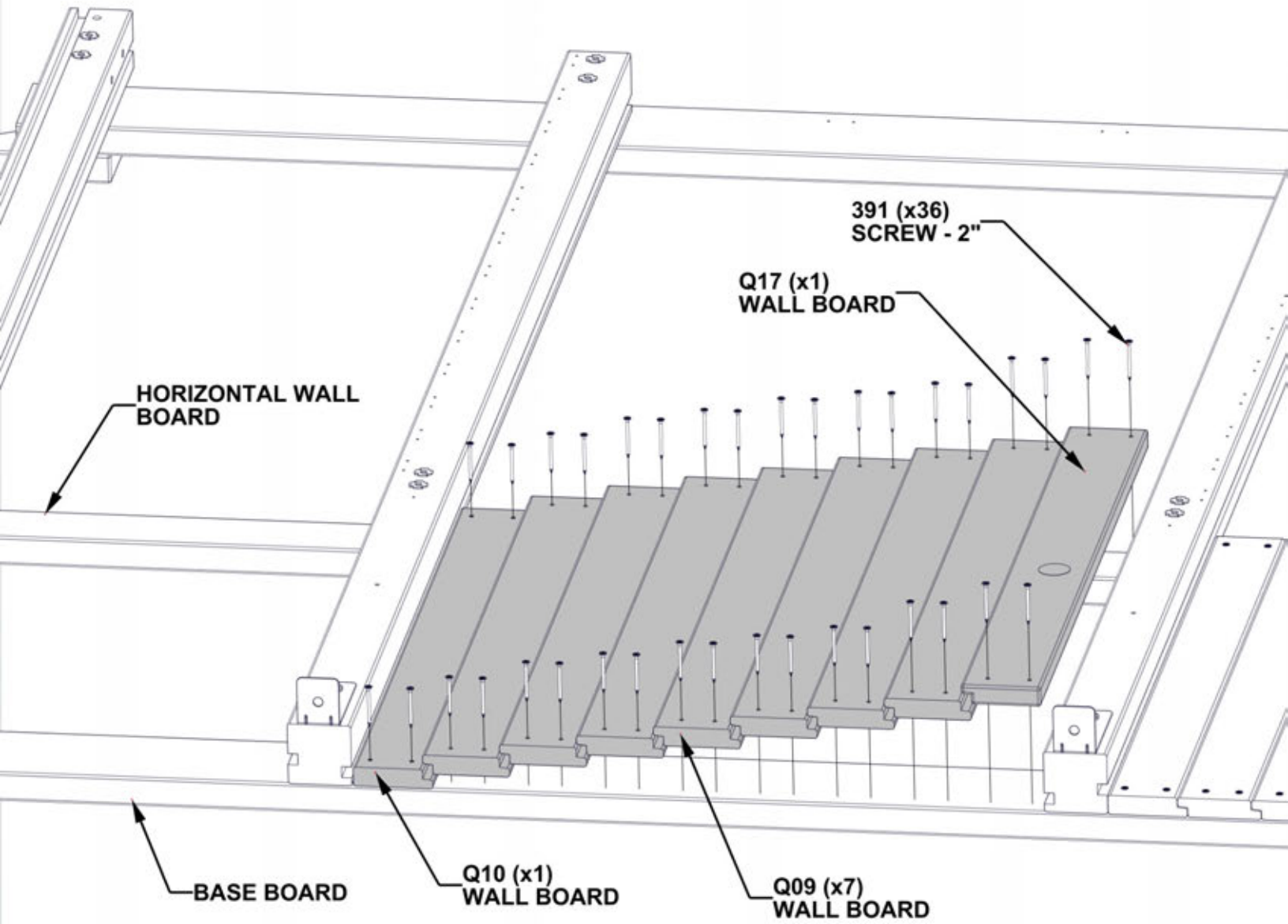
Q10 WALL BOARD - W4L18342
(x1) 15/16"x3 3/4"x33" (24x95x838)



Q17 WALL BOARD - W4L18775
(x1) 15/16"x3 3/4"x33" (24x95x838)

NOTE:

- WALL BOARDS SHOULD BE FLUSH WITH BOTTOM OF BASE BOARD AND TOP OF HORIZONTAL WALL BOARD.
- EVENLY SPACE WALL BOARDS TO AVOID ANY GAPS IN THE WALL PANEL.



STEP 6 - BACK WALL ASSEMBLY

QTY	PART NUMBER	DESCRIPTION
24	H100391	SCREW PFH 8x2 BLK



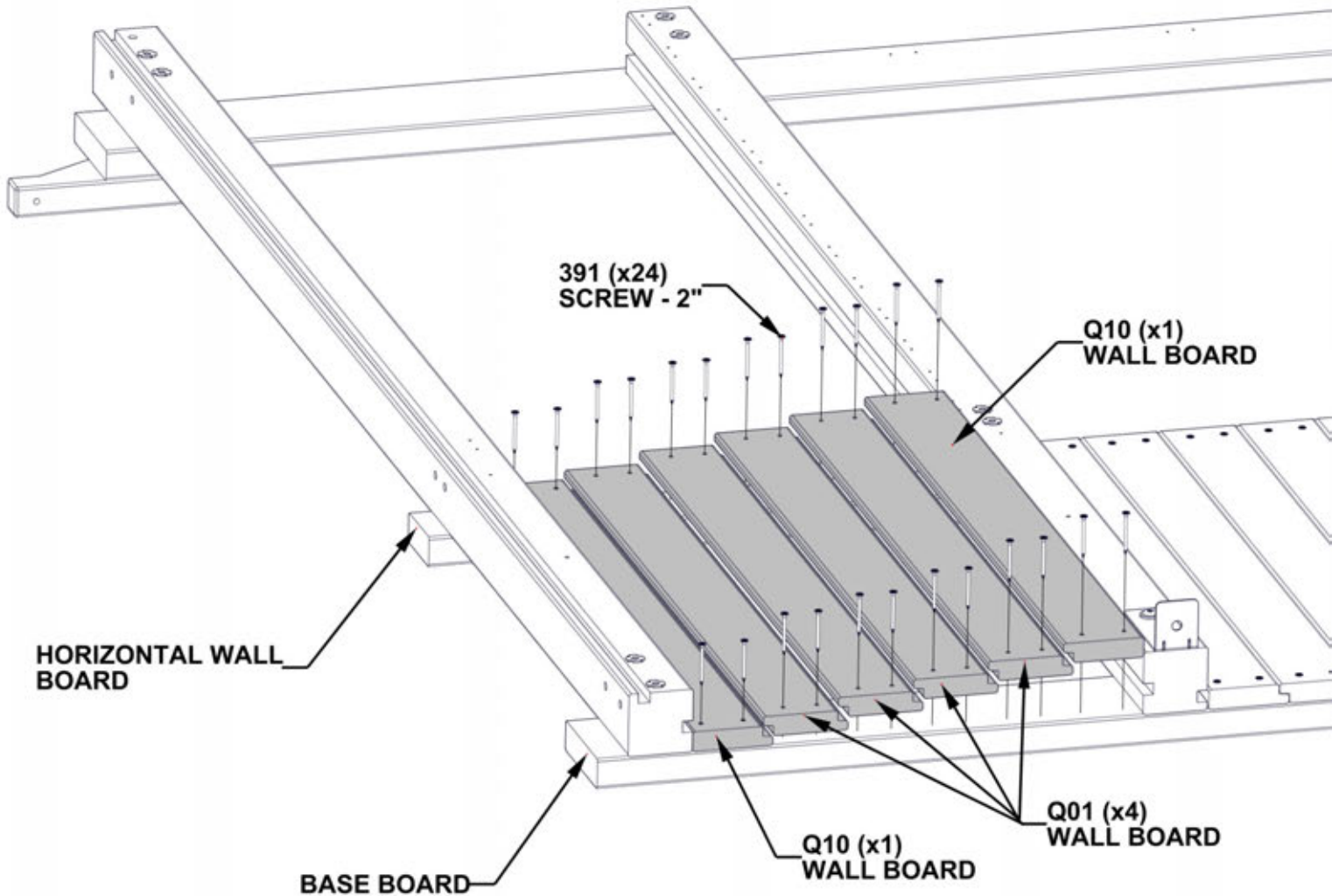
Q10 WALL BOARD - W4L18342
(x2) 15/16"x3 3/4"x33" (24x95x838)



Q01 WALL BOARD - W4L18057
(x4) 15/16"x3 15/16"x33" (24x100x838)

NOTE:

- WALL BOARDS SHOULD BE FLUSH WITH BOTTOM OF BASE BOARD AND TOP OF HORIZONTAL WALL BOARD.
- EVENLY SPACE WALL BOARDS TO AVOID ANY GAPS IN THE WALL PANEL



STEP 7 - BACK WALL ASSEMBLY

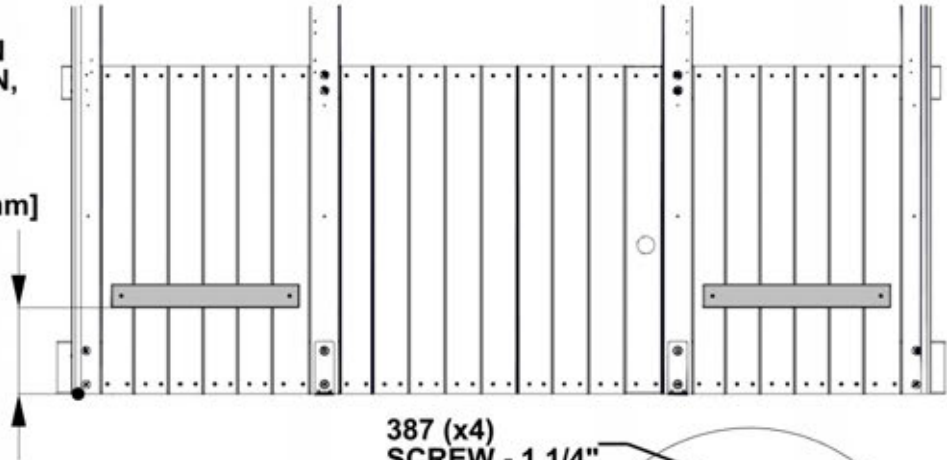
QTY	PART NUMBER	DESCRIPTION
4	H100387	SCREW PFH 8x1 1/4 BLK



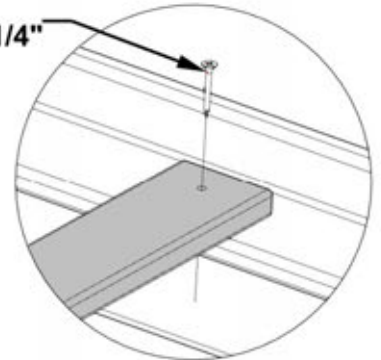
N14 WINDOW STOP - W4L18773
(x2) 5/8"x2 3/8"x18 7/8" (16x60x480)

NOTES:
• CENTER WINDOW STOP BOARDS BETWEEN THE UPRIGHTS, USING DIMENSIONS SHOWN, AND ATTACH TO THE WALL BOARDS

8 11/16" [220mm]



387 (x4)
SCREW - 1 1/4"



N14 (x1)
WINDOW STOP

N14 (x1)
WINDOW STOP

STEP 8 - LEFT REAR WALL ASSEMBLY

QTY	PART NUMBER	DESCRIPTION
4	H100195	BOLT WH 5/16x2 3/4 BLK
8	H100198	WASHER LOCK EXT 8x19
4	H100205	BOLT WH 5/16x2 1/4 BLK
8	H100379	TNUT-5/16" BLK



H01 HORIZONTAL WALL BOARD - W4L18030
(x1) 15/16"x3 3/8"x72 1/8" (24x86x1832)

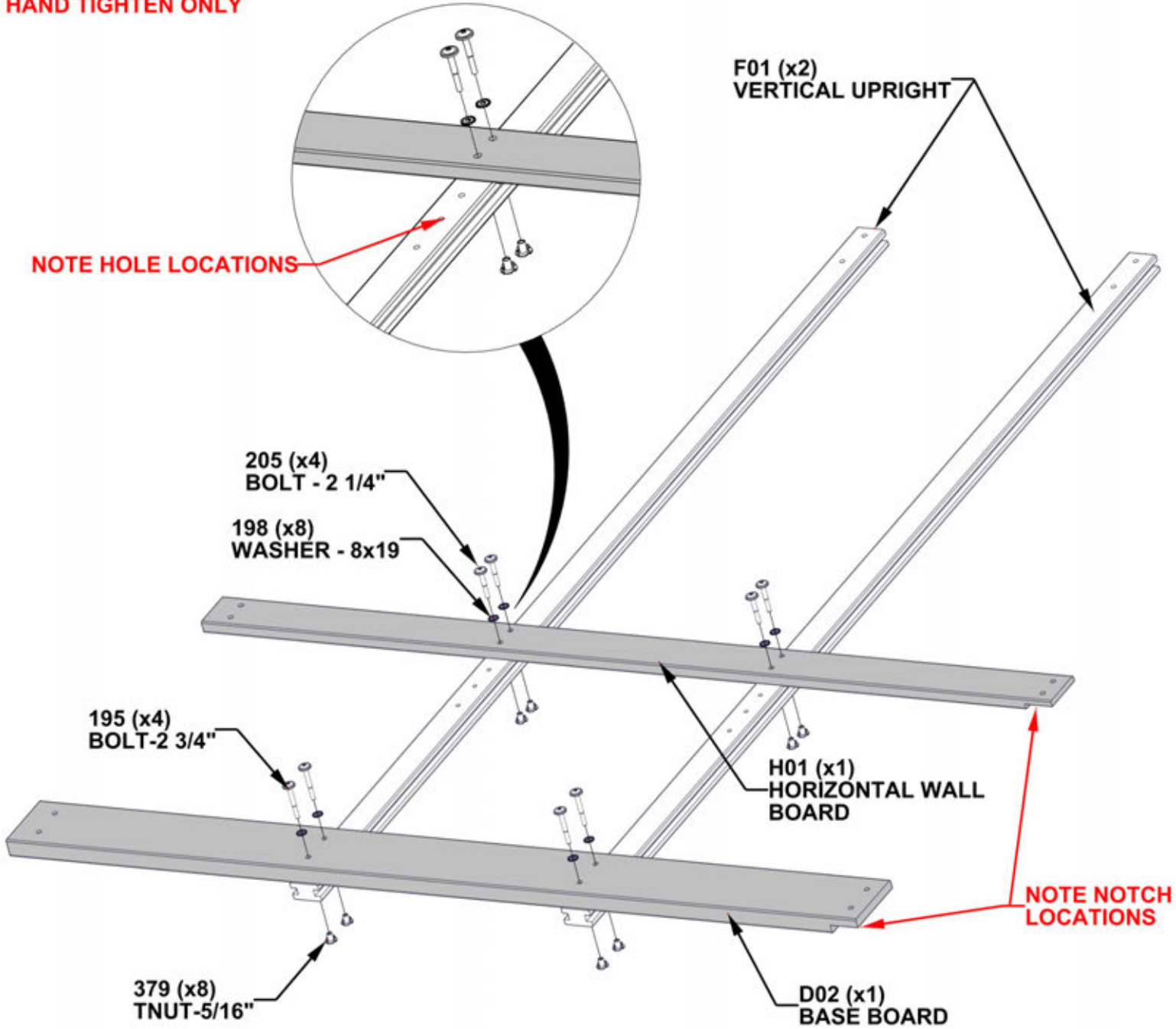


D02 BASE BOARD - W4L18026
(x1) 1 7/16"x5 1/4"x72 1/8" (36x134x1832)



F01 VERTICAL UPRIGHT - W4L18058
(x2) 1 7/16"x2 3/8"x86 11/16" (36x60x2202)

- NOTES:**
- INSERT T-NUTS FIRST
 - HAND TIGHTEN ONLY



STEP 9 - LEFT REAR WALL ASSEMBLY

QTY	PART NUMBER	DESCRIPTION
4	H100195	BOLT WH 5/16x2 3/4 BLK
2	H100198	WASHER LOCK EXT 8x19
4	H100379	TNUT-5/16" BLK

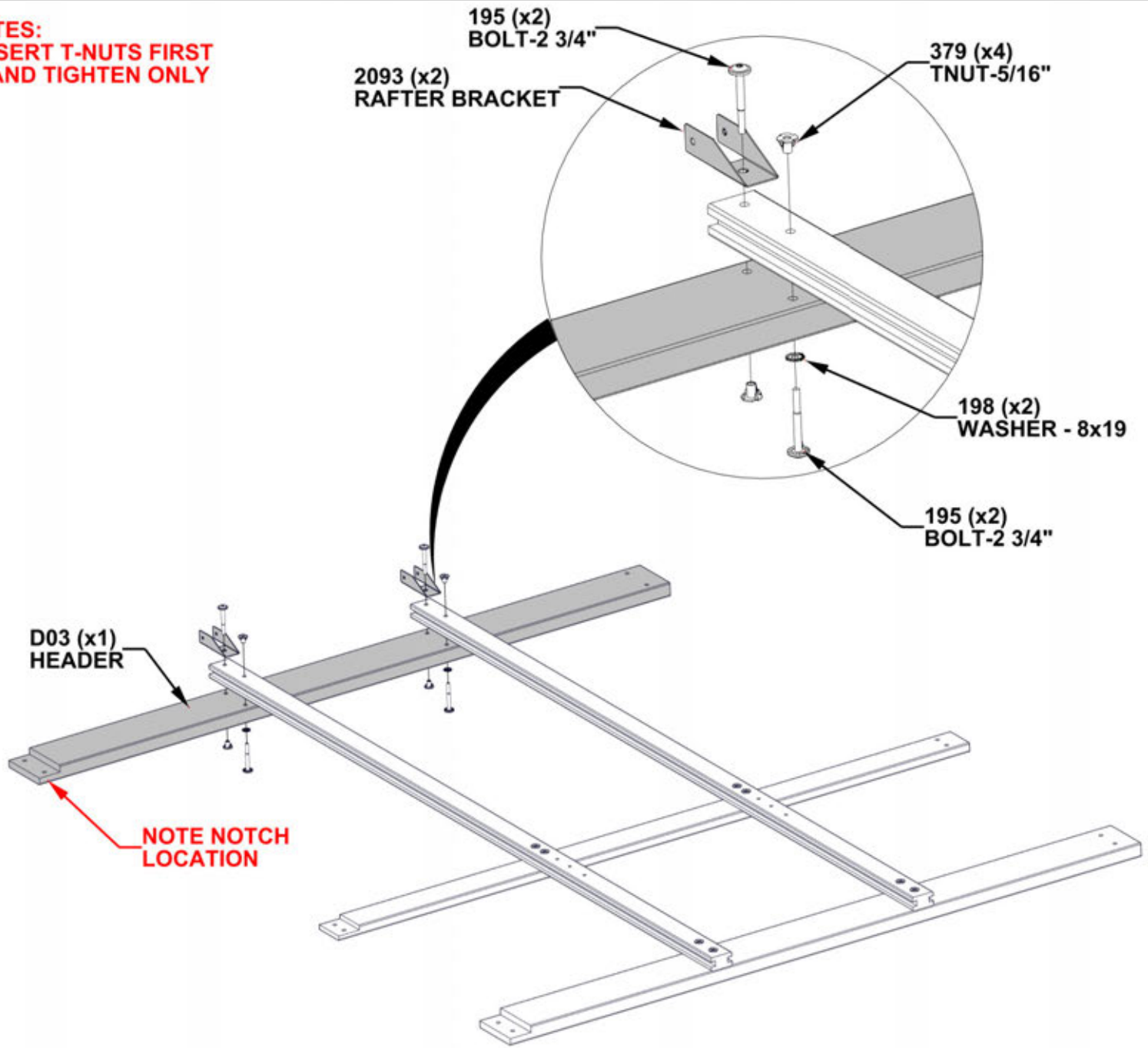


D03 HEADER - W4L18028
(x1) 1 7/16"x5 1/4"x72 1/8" (36x134x1832)



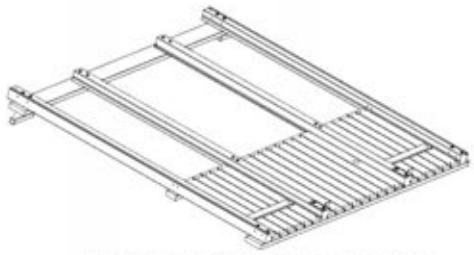
A4M02093 RAFTER BRACKET
(x2)

NOTES:
 • INSERT T-NUTS FIRST
 • HAND TIGHTEN ONLY

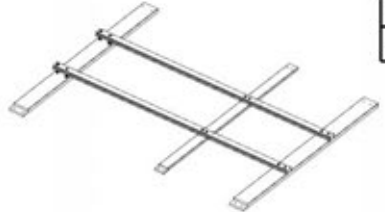


STEP 10 - WALL ASSEMBLY

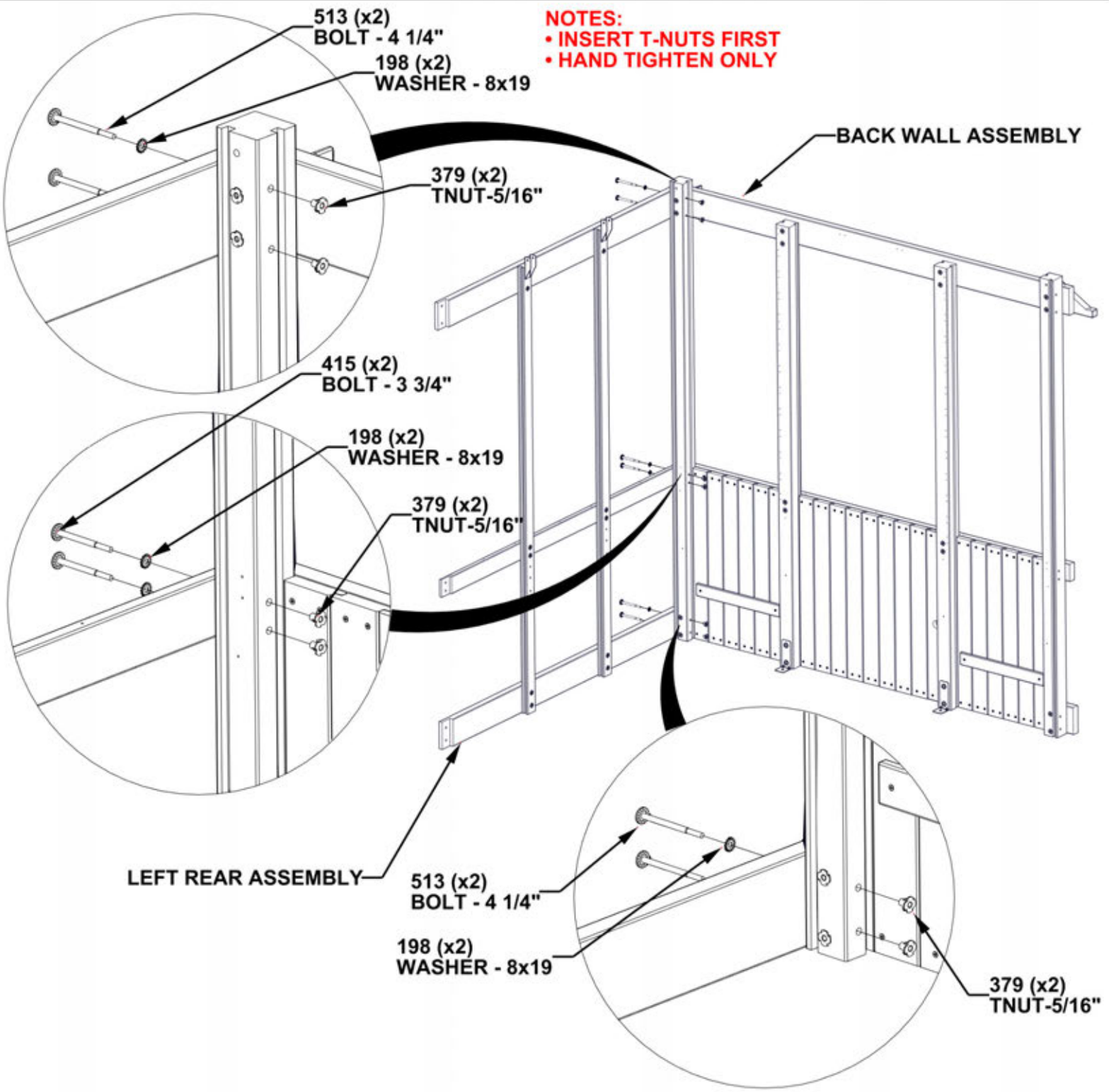
QTY	PART NUMBER	DESCRIPTION
6	H100198	WASHER LOCK EXT 8x19
6	H100379	TNUT-5/16" BLK
2	H100415	BOLT WH 5/16x3 3/4 BLK
4	H100513	BOLT WH 5/16x4 1/4 BLK



BACK WALL ASSEMBLY



LEFT REAR WALL ASSEMBLY



STEP 11 - RIGHT REAR WALL ASSEMBLY



H02 HORIZONTAL WALL BOARD - W4L18053
(x1) 15/16"x3 3/8"x72 1/8" (24x86x1832)



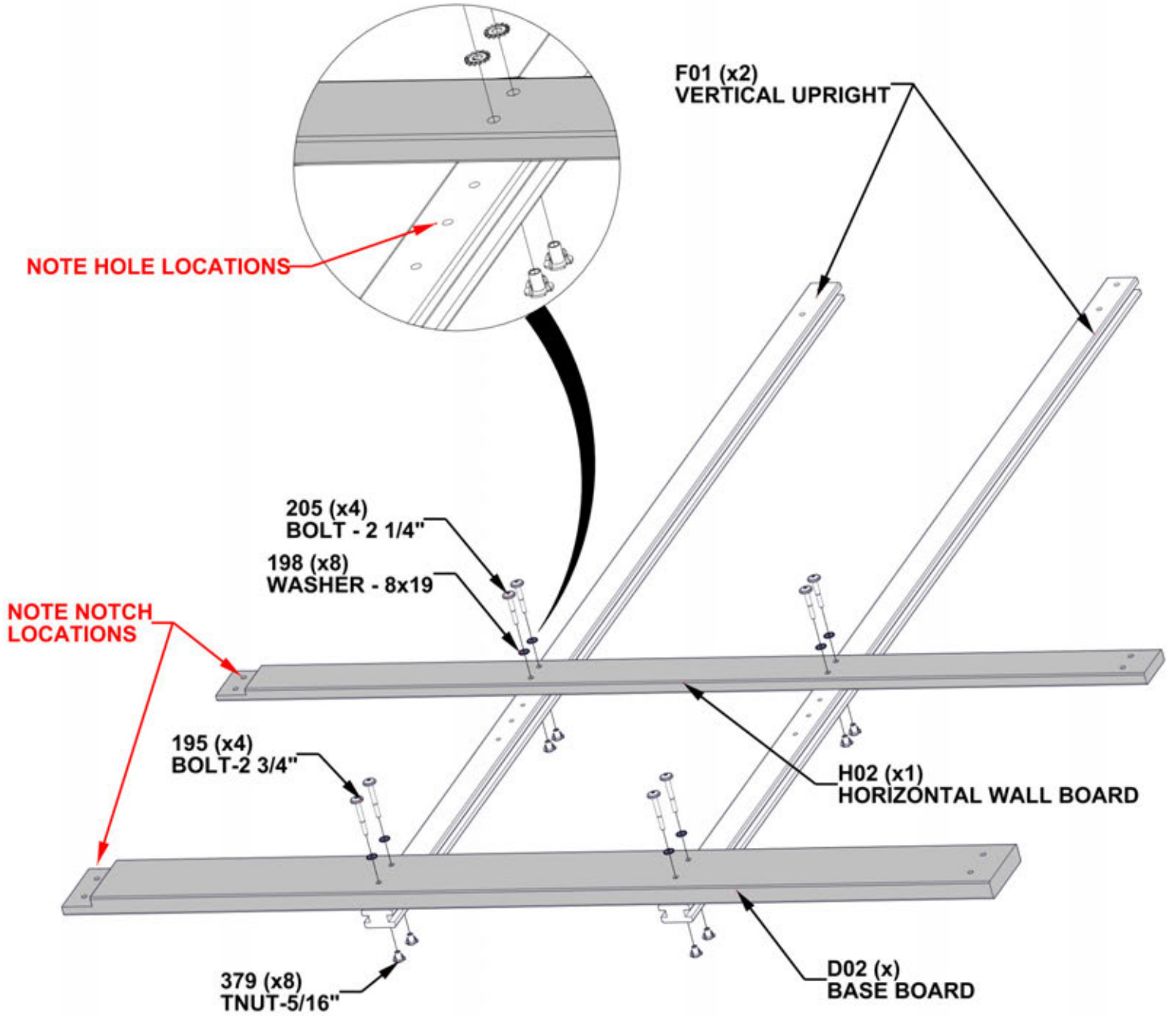
D02 BASE BOARD - W4L18026
(x1) 1 7/16"x5 1/4"x72 1/8" (36x134x1832)

QTY	PART NUMBER	DESCRIPTION
4	H100195	BOLT WH 5/16x2 3/4 BLK
8	H100198	WASHER LOCK EXT 8x19
4	H100205	BOLT WH 5/16x2 1/4 BLK
8	H100379	TNUT-5/16" BLK



F01 VERTICAL UPRIGHT - W4L18058
(x2) 1 7/16"x2 3/8"x86 11/16" (36x60x2202)

- NOTES:**
- INSERT T-NUTS FIRST
 - HAND TIGHTEN ONLY



STEP 12 - RIGHT REAR WALL ASSEMBLY

QTY	PART NUMBER	DESCRIPTION
4	H100195	BOLT WH 5/16x2 3/4 BLK
2	H100198	WASHER LOCK EXT 8x19
4	H100379	TNUT-5/16" BLK

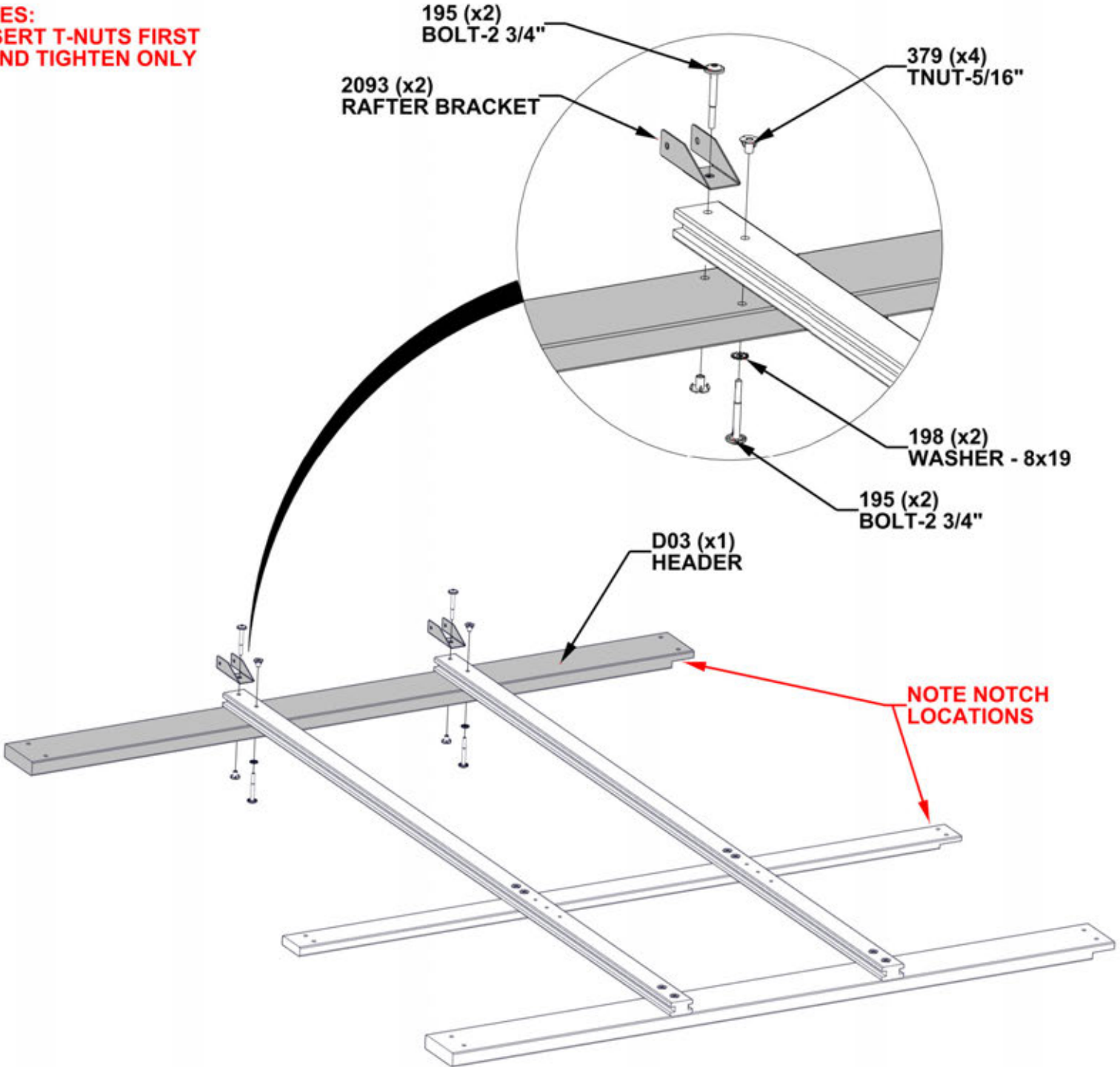


D03 HEADER - W4L18028
(x1) 1 7/16"x5 1/4"x72 1/8" (36x134x1832)



A4M02093 RAFTER BRACKET
(x2)

NOTES:
 • INSERT T-NUTS FIRST
 • HAND TIGHTEN ONLY



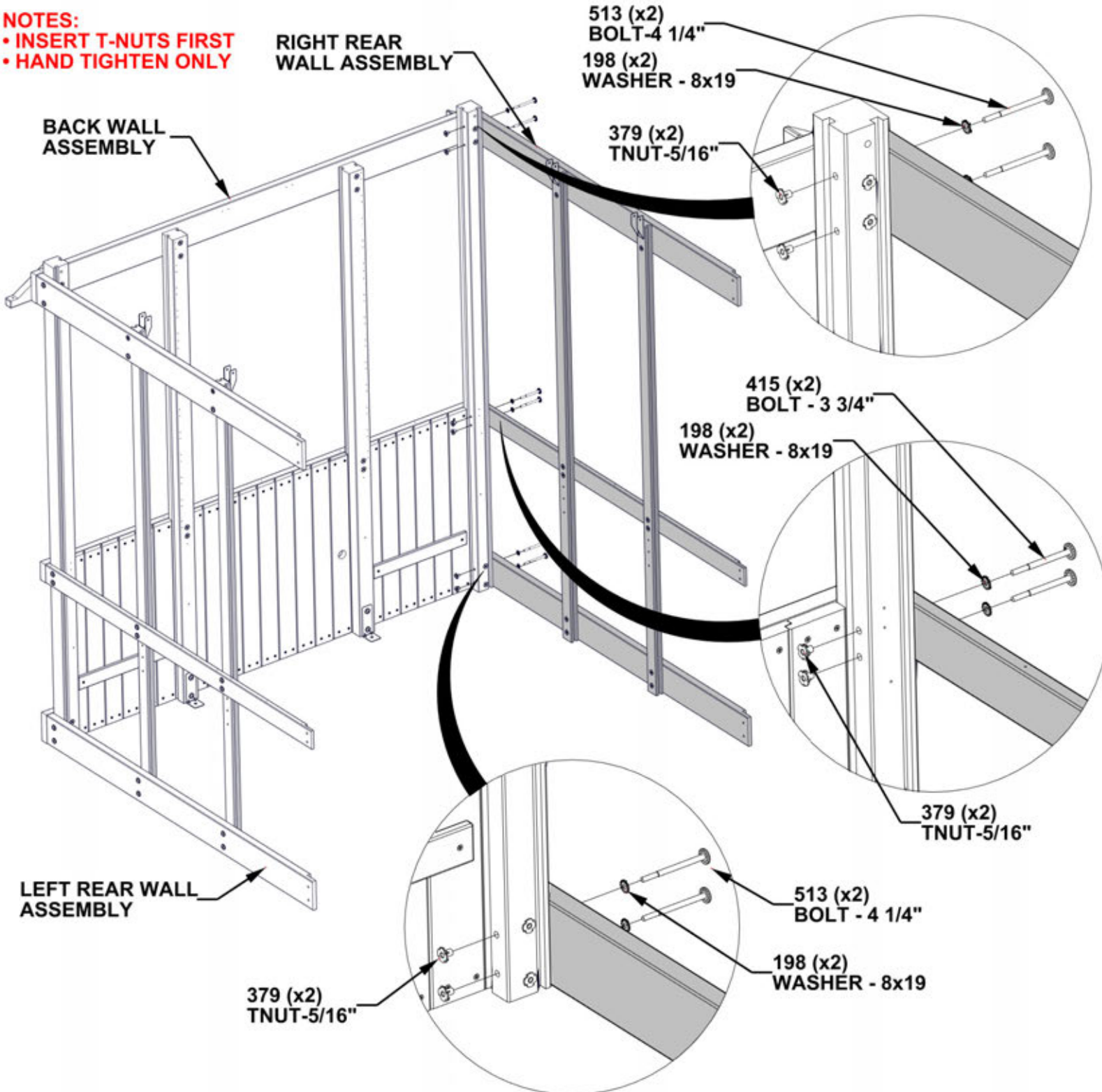
STEP 13 - WALL ASSEMBLY

QTY	PART NUMBER	DESCRIPTION
6	H100198	WASHER LOCK EXT 8x19
6	H100379	TNUT-5/16" BLK
2	H100415	BOLT WH 5/16x3 3/4 BLK
4	H100513	BOLT WH 5/16x4 1/4 BLK



RIGHT REAR WALL ASSEMBLY

- NOTES:**
 • INSERT T-NUTS FIRST
 • HAND TIGHTEN ONLY

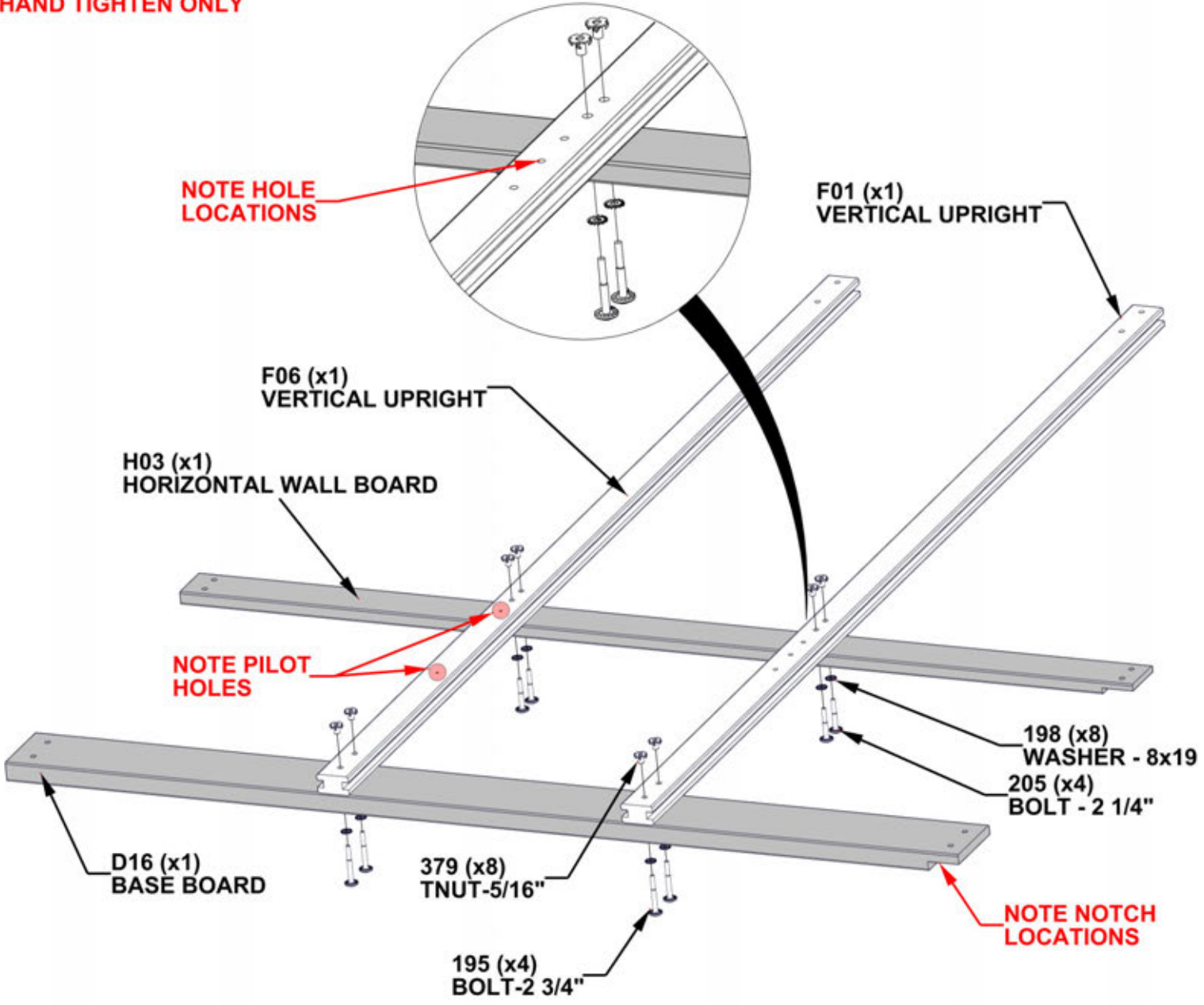


STEP 14 - LEFT FRONT WALL ASSEMBLY

- H03 HORIZONTAL WALL BOARD - W4L18061
(x1) 15/16"x3 3/8"x72 1/8" (24x86x1832)
- D16 BASE BOARD - W4L18399
(x1) 1 7/16"x5 1/4"x72 1/8" (36x134x1832)
- F06 VERTICAL UPRIGHT - W4L18039
(x1) 1 7/16"x2 3/8"x86 11/16" (36x60x2202)
- F01 VERTICAL UPRIGHT - W4L18058
(x1) 1 7/16"x2 3/8"x86 11/16" (36x60x2202)

QTY	PART NUMBER	DESCRIPTION
4	H100195	BOLT WH 5/16x2 3/4 BLK
8	H100198	WASHER LOCK EXT 8x19
4	H100205	BOLT WH 5/16x2 1/4 BLK
8	H100379	TNUT-5/16" BLK

NOTES:
 • INSERT T-NUTS FIRST
 • HAND TIGHTEN ONLY



STEP 15 - LEFT FRONT WALL ASSEMBLY

QTY	PART NUMBER	DESCRIPTION
4	H100195	BOLT WH 5/16x2 3/4 BLK
2	H100198	WASHER LOCK EXT 8x19
4	H100379	TNUT-5/16" BLK

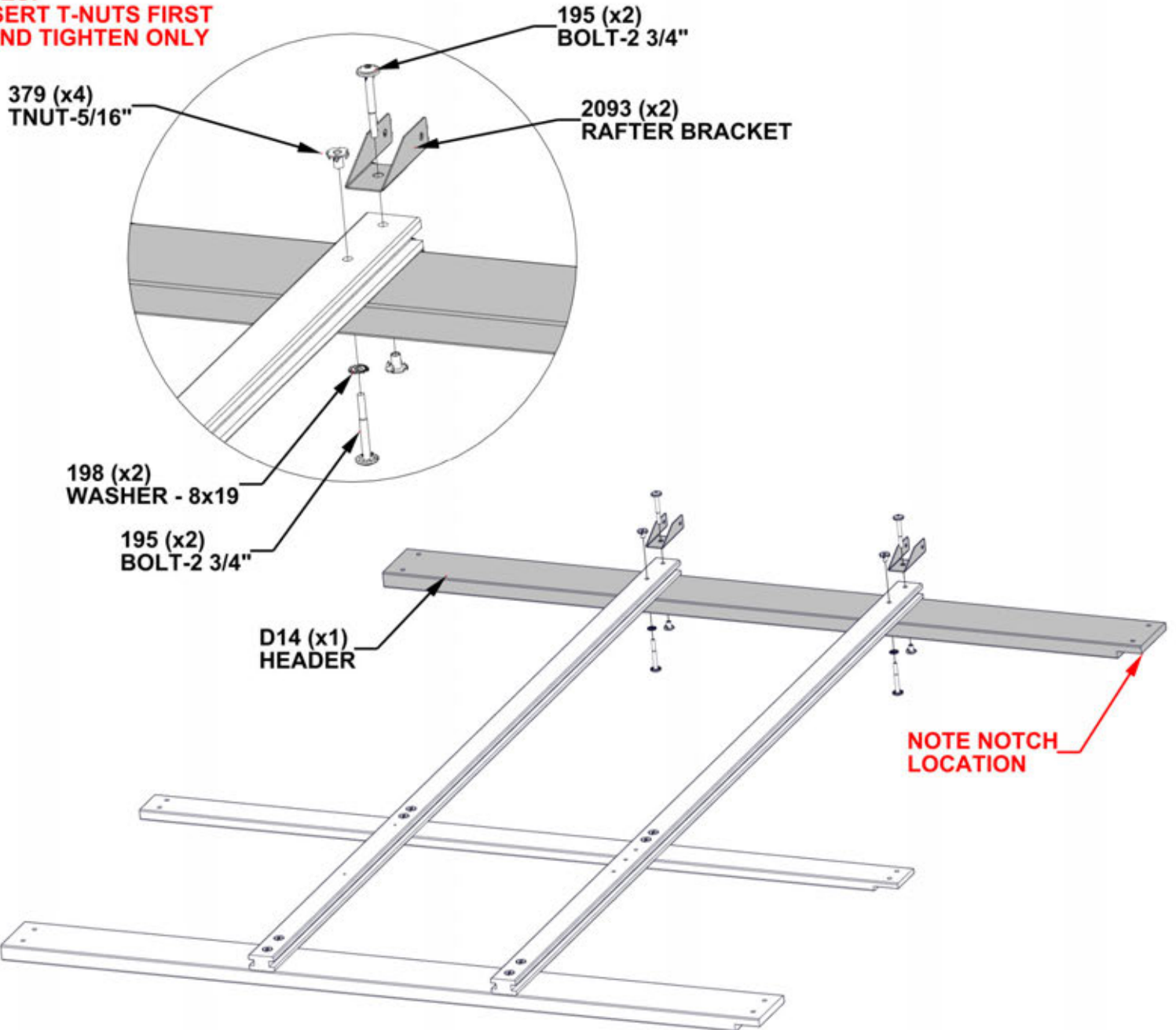


D14 HEADER - W4L18401
(x1) 1 7/16"x5 1/4"x72 1/8" (36x134x1832)



A4M02093 RAFTER BRACKET
(x2)

NOTES:
 • INSERT T-NUTS FIRST
 • HAND TIGHTEN ONLY



STEP 16 - WALL ASSEMBLY

QTY	PART NUMBER	DESCRIPTION
4	H100195	BOLT WH 5/16x2 3/4 BLK
5	H100198	WASHER LOCK EXT 8x19
2	H100205	BOLT WH 5/16x2 1/4 BLK
6	H100379	TNUT-5/16" BLK



LEFT FRONT WALL ASSEMBLY

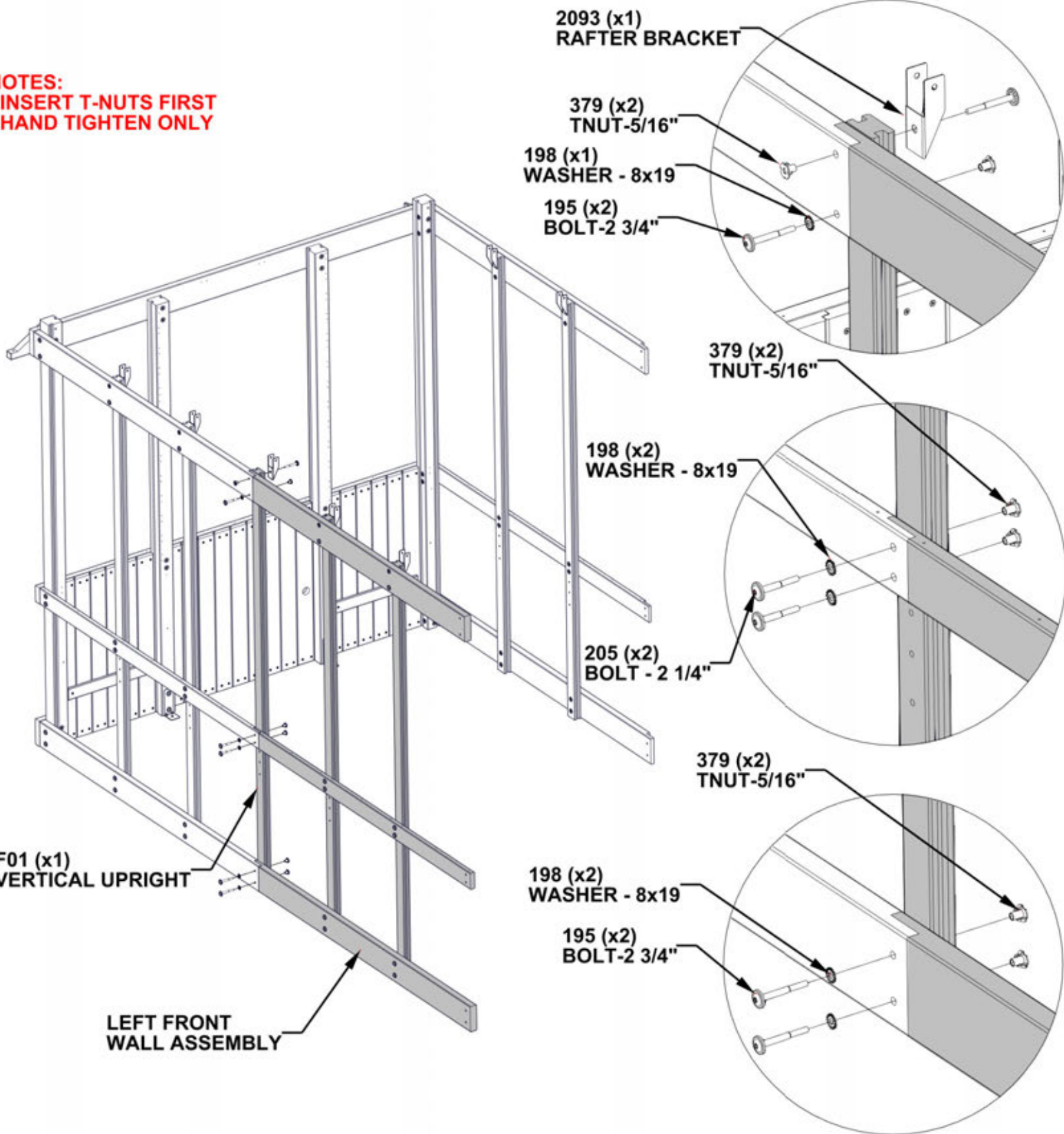


A4M02093 RAFTER BRACKET (x1)

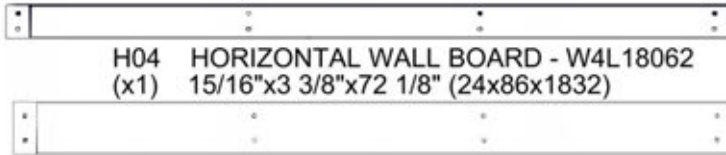


F01 VERTICAL UPRIGHT - W4L18058 (x1) 1 7/16"x2 3/8"x86 11/16" (36x60x2202)

NOTES:
 • INSERT T-NUTS FIRST
 • HAND TIGHTEN ONLY

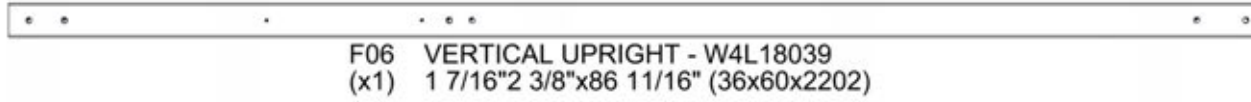
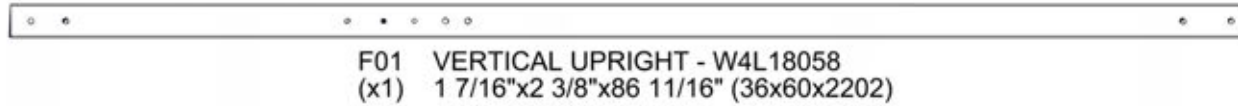


STEP 17 - RIGHT FRONT WALL ASSEMBLY

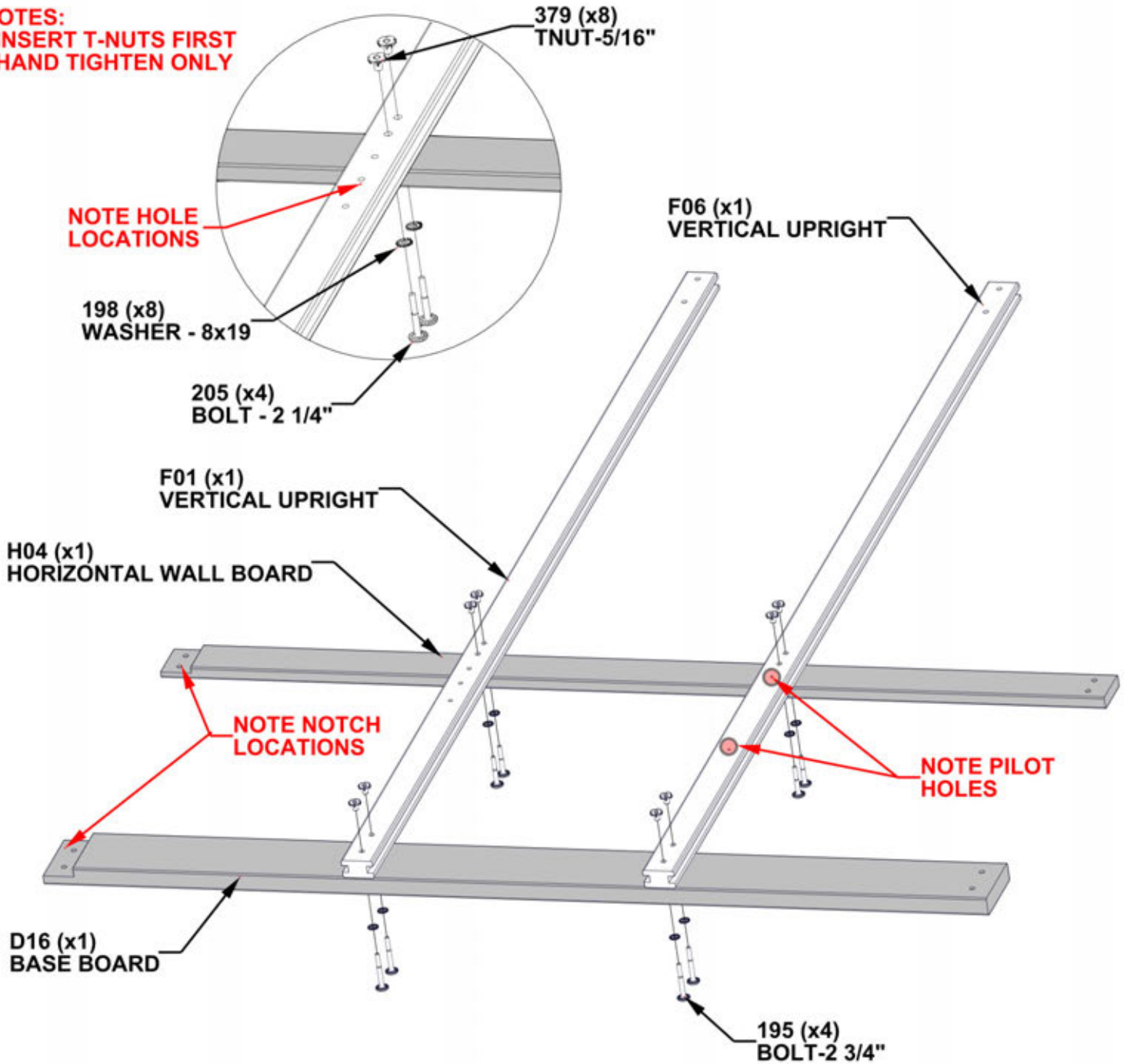


QTY	PART NUMBER	DESCRIPTION
4	H100195	BOLT WH 5/16x2 3/4 BLK
8	H100198	WASHER LOCK EXT 8x19
4	H100205	BOLT WH 5/16x2 1/4 BLK
8	H100379	TNUT-5/16" BLK

D16 BASE BOARD - W4L18399
(x1) 1 7/16"x5 1/4"x72 1/8" (36x134x1832)



NOTES:
 • INSERT T-NUTS FIRST
 • HAND TIGHTEN ONLY



STEP 18 - RIGHT FRONT WALL ASSEMBLY

QTY	PART NUMBER	DESCRIPTION
4	H100195	BOLT WH 5/16x2 3/4 BLK
2	H100198	WASHER LOCK EXT 8x19
4	H100379	TNUT-5/16" BLK

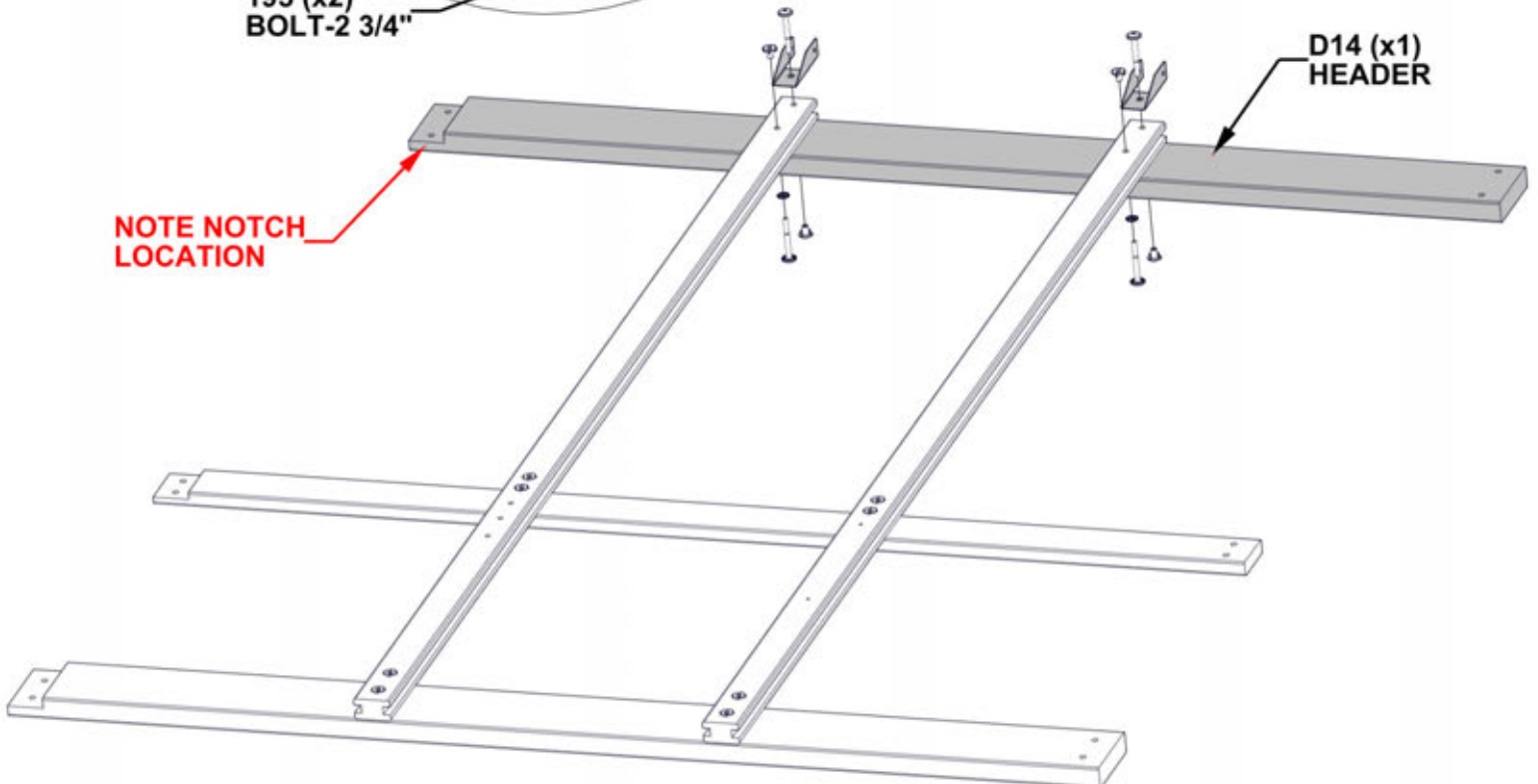
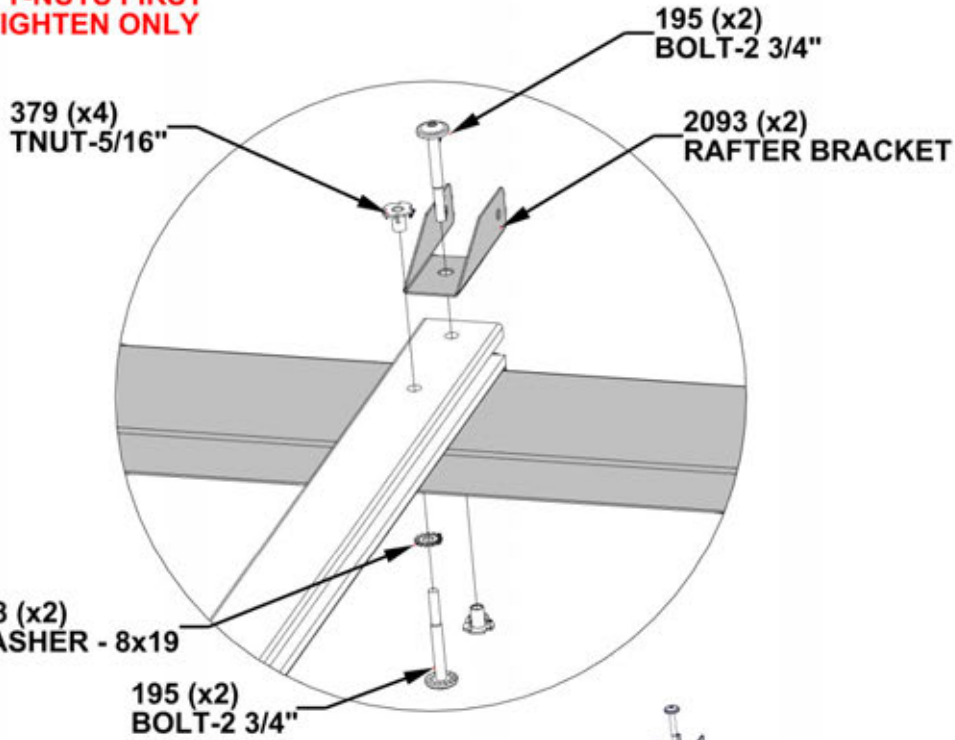


D14 HEADER - W4L18401
(x1) 1 7/16"x5 1/4"x72 1/8" (36x134x1832)



A4M02093 RAFTER BRACKET
(x2)

- NOTES:**
- INSERT T-NUTS FIRST
 - HAND TIGHTEN ONLY



STEP 19 - WALL ASSEMBLY



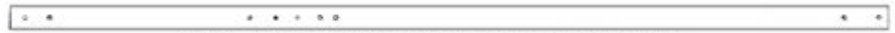
RIGHT FRONT WALL ASSEMBLY

A4M02093
(x1)



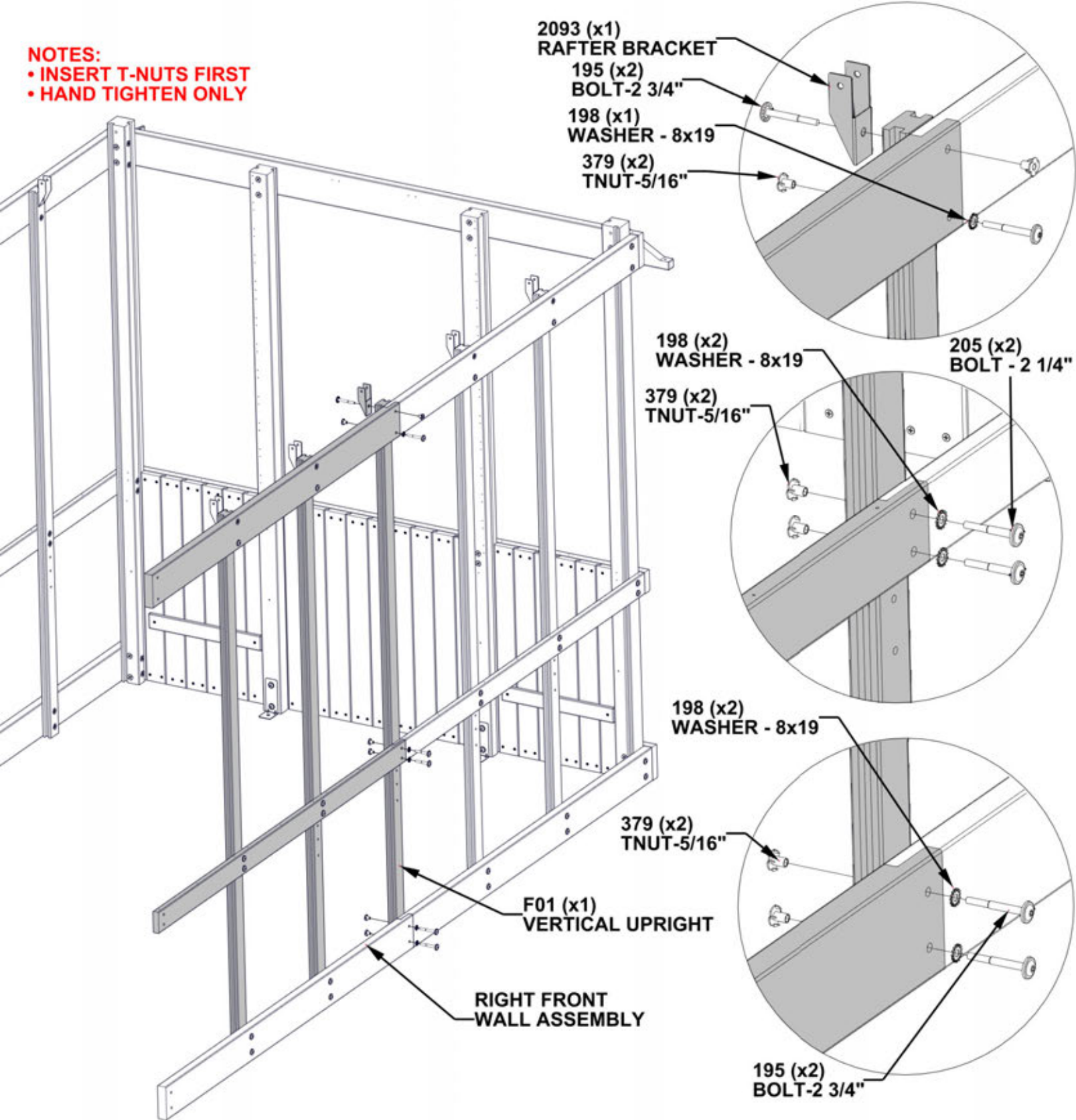
RAFTER BRACKET

QTY	PART NUMBER	DESCRIPTION
4	H100195	BOLT WH 5/16x2 3/4 BLK
5	H100198	WASHER LOCK EXT 8x19
2	H100205	BOLT WH 5/16x2 1/4 BLK
6	H100379	TNUT-5/16" BLK



F01 VERTICAL UPRIGHT - W4L18058
(x1) 1 7/16"x2 3/8"x86 11/16" (36x60x2202)

NOTES:
 • INSERT T-NUTS FIRST
 • HAND TIGHTEN ONLY



STEP 20 - FRONT LEFT WALL ASSEMBLY



E11 HORIZONTAL WALL BOARD - W4L18051
(x1) 1 7/16"X3 3/8"X27 15/16" (36x86x709)

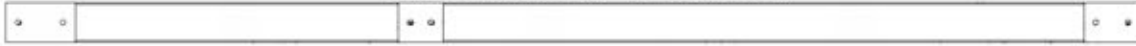


D05 BASE BOARD - W4L18037
(x1) 1 7/16"X5 1/4"X28 3/8" (36x134x721)

QTY	PART NUMBER	DESCRIPTION
2	H100195	BOLT WH 5/16x2 3/4 BLK
2	H100197	LAG SCREW WH 5/16x2 1/2 BLK
6	H100198	WASHER LOCK EXT 8x19
10	H100379	TNUT-5/16" BLK
2	H100513	BOLT WH 5/16x4 1/4 BLK

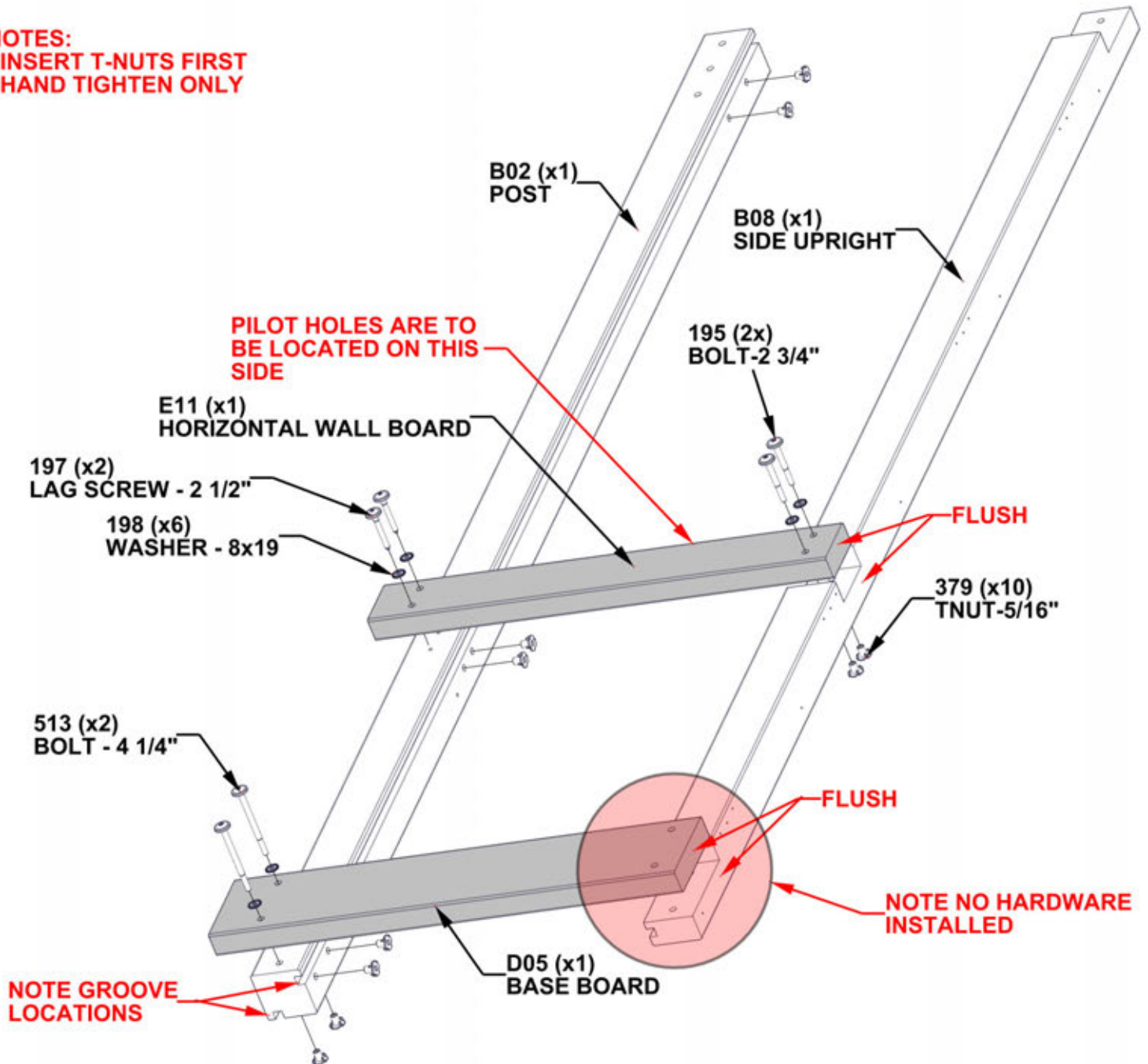


B02 POST - W4L18047
(x1) 3"x3"x88 3/4" (76x76x2254)



B08 SIDE UPRIGHT - W4L18060
(x1) 3"x3"x85 11/16" (76x76x2177)

- NOTES:**
- INSERT T-NUTS FIRST
 - HAND TIGHTEN ONLY



STEP 21 - FRONT RIGHT WALL ASSEMBLY

E11 HORIZONTAL WALL BOARD - W4L18051
(x1) 1 7/16"X3 3/8"X27 15/16" (36x86x709)



D05 BASE BOARD - W4L18037
(x1) 1 7/16"X5 1/4"X28 3/8" (36x134x721)

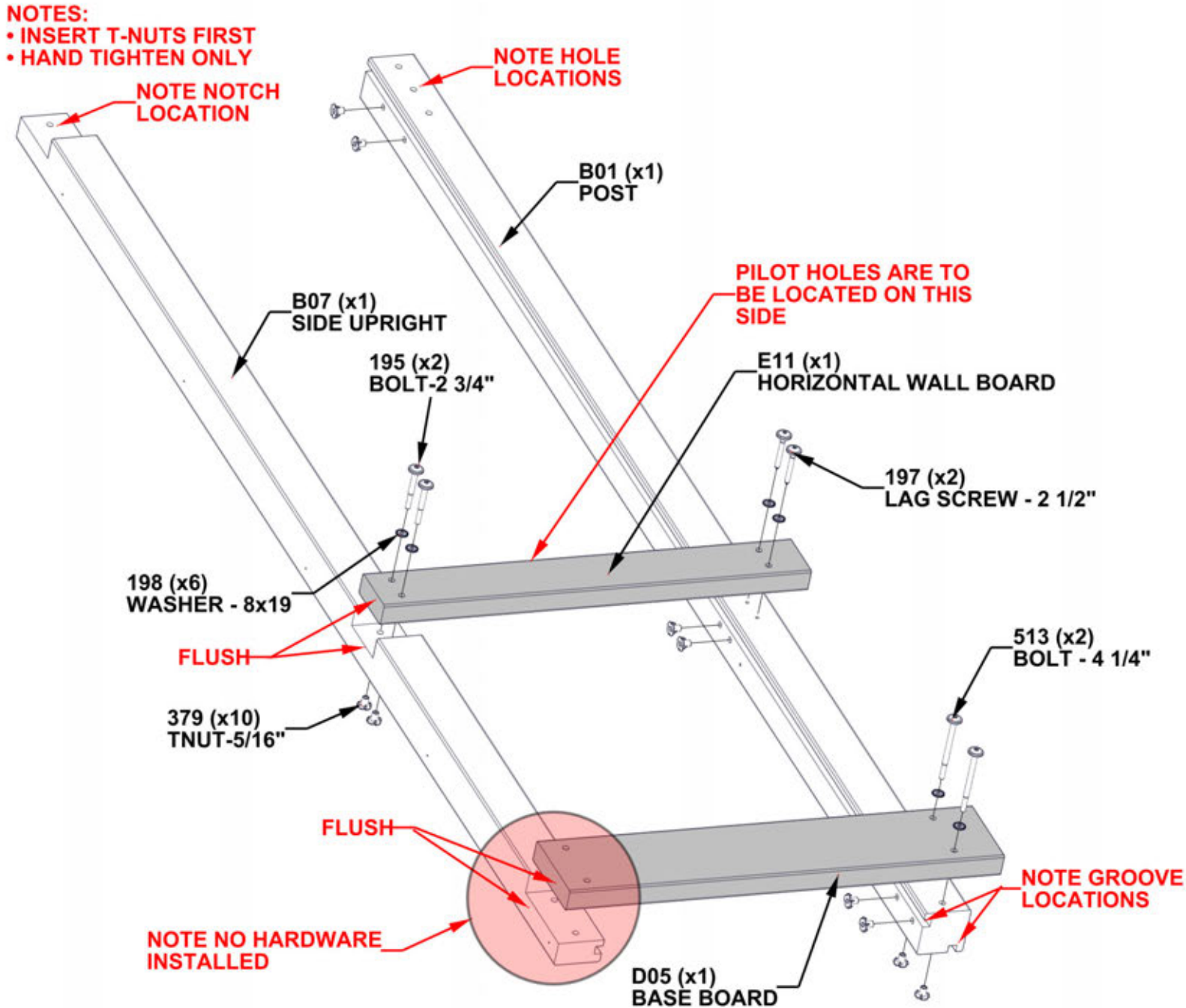


B01 POST - W4L18025
(x1) 3"x3"x88 3/4" (76x76x2254)



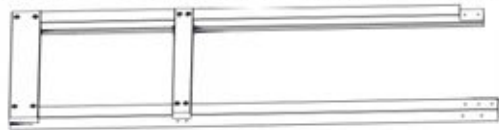
B07 SIDE UPRIGHT - W4L18059
(x1) 3"x3"x85 11/16" (76x76x2177)

QTY	PART NUMBER	DESCRIPTION
2	H100195	BOLT WH 5/16x2 3/4 BLK
2	H100197	LAG SCREW WH 5/16x2 1/2 BLK
6	H100198	WASHER LOCK EXT 8x19
10	H100379	TNUT-5/16" BLK
2	H100513	BOLT WH 5/16x4 1/4 BLK

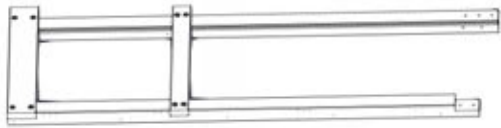


STEP 22 - FRONT WALL ASSEMBLY

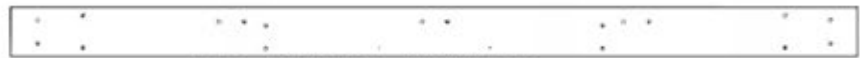
QTY	PART NUMBER	DESCRIPTION
4	H100195	BOLT WH 5/16x2 3/4 BLK
8	H100198	WASHER LOCK EXT 8x19
8	H100379	TNUT-5/16" BLK
4	H100974	BOLT WH 5/16x5 3/4 BLK



FRONT RIGHT WALL ASSEMBLY



FRONT LEFT WALL ASSEMBLY

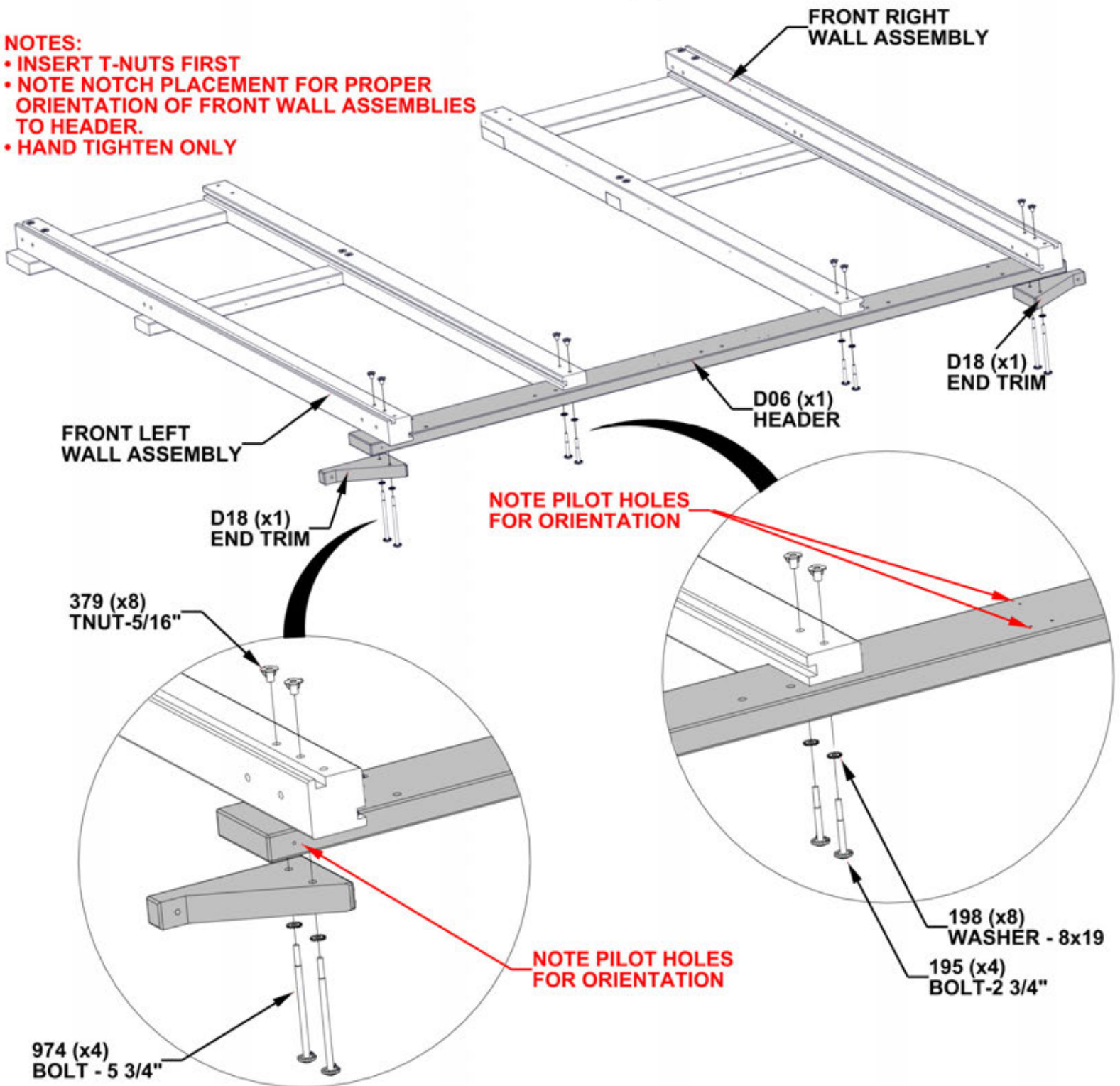


D06 HEADER - W4L18038
(x1) 1 7/16"x5 1/4"x89 7/16" (36x134x2272)



D18 END TRIM - W4L18422
(x2) 1 7/16"x134x219 (36x134x219)

- NOTES:**
- INSERT T-NUTS FIRST
 - NOTE NOTCH PLACEMENT FOR PROPER ORIENTATION OF FRONT WALL ASSEMBLIES TO HEADER.
 - HAND TIGHTEN ONLY



STEP 23 - FRONT WALL ASSEMBLY

QTY	PART NUMBER	DESCRIPTION
4	H100193	NUT BARREL WH 5/16 X 1 1/2 BLK
4	H100198	WASHER LOCK EXT 8x19
4	H100205	BOLT WH 5/16x2 1/4 BLK
10	H100379	T-NUT 5/16 BLK



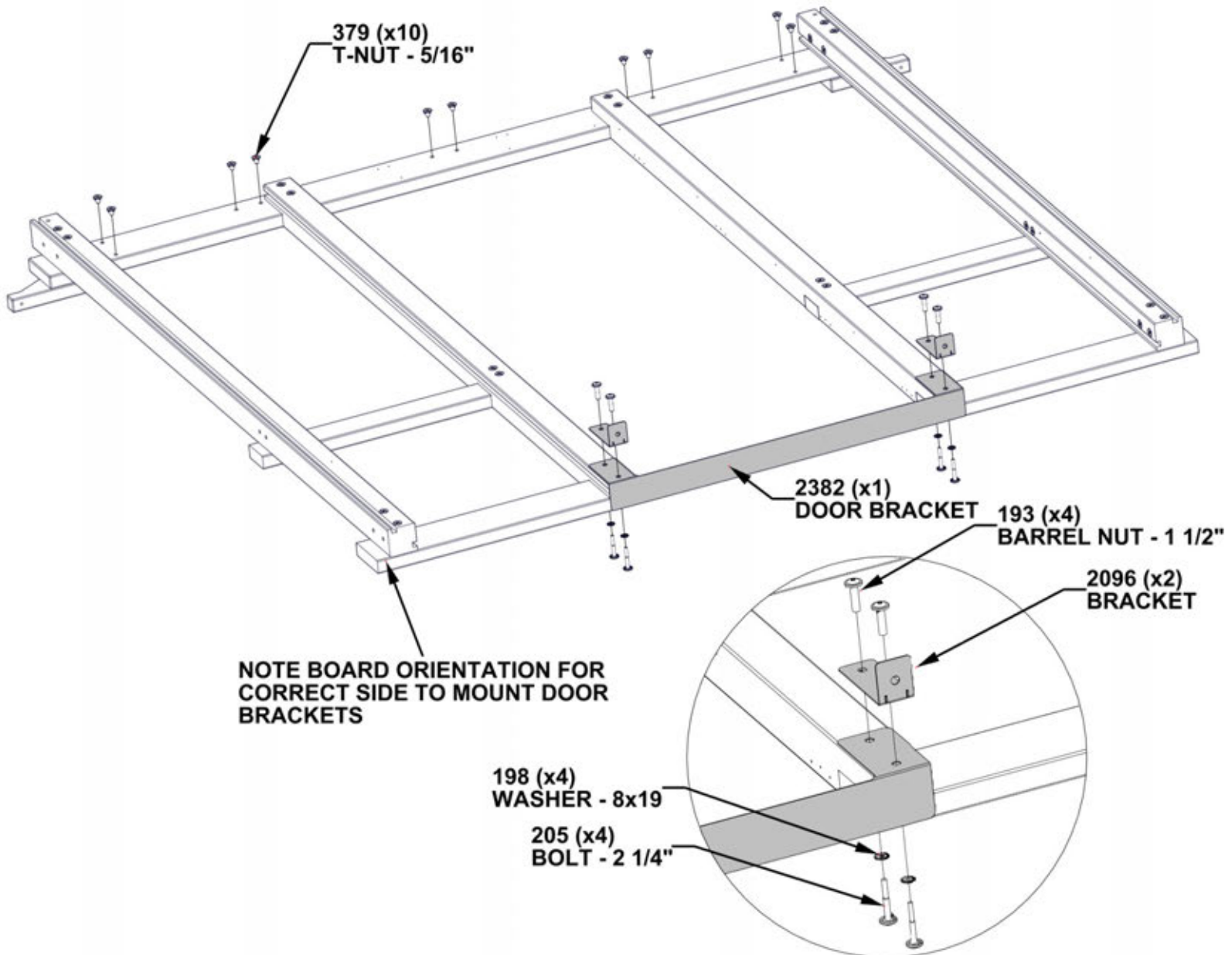
A4M02096 BRACKET
(x2)



A4M02382 DOOR BRACKET
(x1)

NOTES:

- INSERT T-NUTS FIRST
- IMPORTANT! SQUARE UNIT AND TIGHTEN ALL HARDWARE BEFORE PROCEEDING TO NEXT STEPS.



STEP 24 - FRONT WALL ASSEMBLY

QTY	PART NUMBER	DESCRIPTION
24	H100391	SCREW PFH 8x2 BLK



Q12 WALL BOARD - W4L18351
(x1) 15/16"x3 15/16"x33" (24x100x838)



Q13 WALL BOARD - W4L18352
(x4) 15/16"x3 15/16"x15 13/16" (24x100x401)



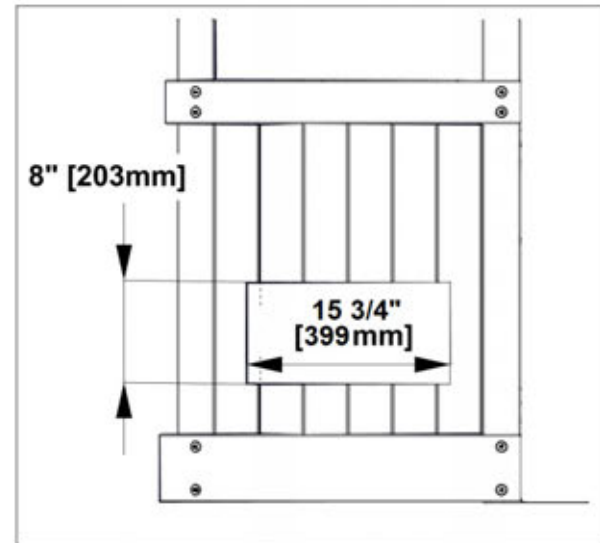
Q14 WALL BOARD - W4L18353
(x4) 15/16"x3 15/16"x9 3/16" (24x100x234)



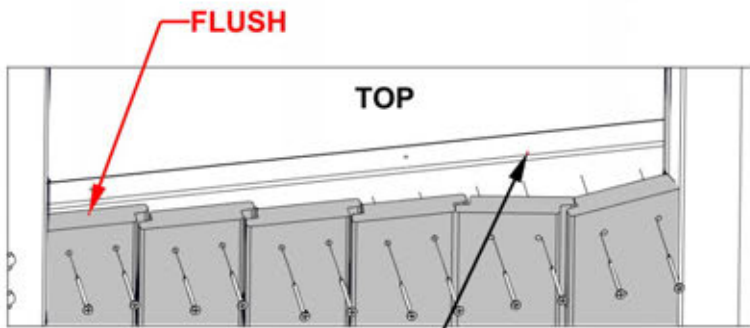
Q15 WALL BOARD - W4L18354
(x1) 15/16"x4 7/16"x (24x112x838)

NOTES:

- INSTALL Q12 & Q15 FIRST, THEN INSTALL EVENLY SPACED Q14 LOWER BOARDS FLUSH WITH BOTTOM OF BASE BOARD.
- INSTALL EVENLY SPACED Q13 UPPER BOARDS AND HOLD FLUSH WITH TOP HORIZONTAL WALL BOARD.
- BEFORE ADDING SCREWS, CONFIRM THE DIMENSIONS REQUIRED FOR THE LOUVER.



HOLD DIMENSIONS FOR PROPER LOUVER FIT



HORIZONTAL WALL BOARD

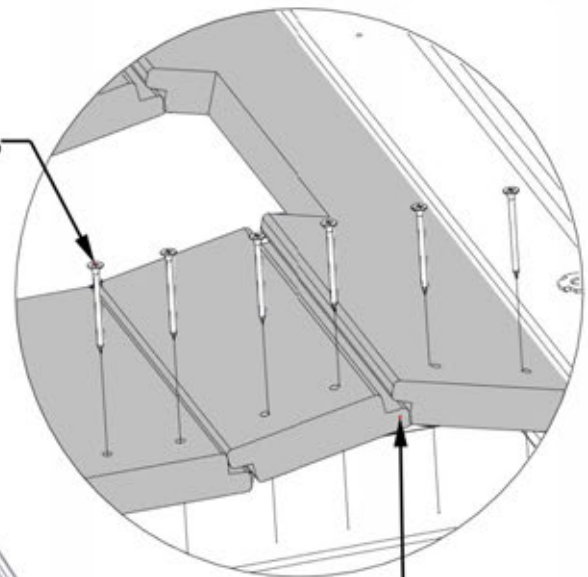
391 (24)
SCREW - 2"

Q13 (x4)
WALL BOARD

Q12 (x1)
WALL BOARD

Q15 (x1)
WALL BOARD

Q14 (x4)
WALL BOARD



NOTE BOARDS MAY NEED TO BE ROLLED UPWARDS THEN INSERTED INTO THE GROOVE ON POST.

STEP 25 - FRONT WALL ASSEMBLY

QTY	PART NUMBER	DESCRIPTION
24	H100391	SCREW PFH 8x2 BLK



Q12 WALL BOARD - W4L18351
(x1) 15/16"x3 15/16"x33" (24x100x838)



Q13 WALL BOARD - W4L18352
(x4) 15/16"x3 15/16"x15 13/16" (24x100x401)



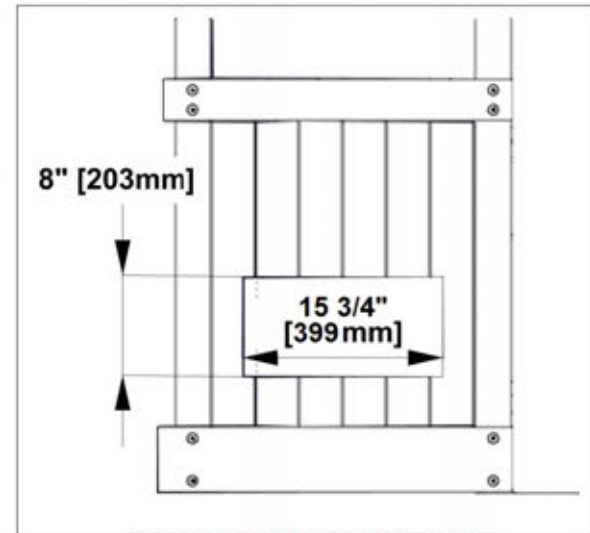
Q14 WALL BOARD - W4L18353
(x4) 15/16"x3 15/16"x9 3/16" (24x100x234)



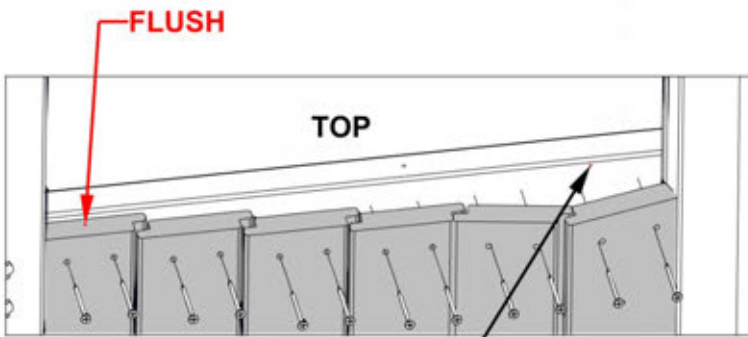
Q15 WALL BOARD - W4L18354
(x1) 15/16"x4 7/16"x (24x112x838)

NOTES:

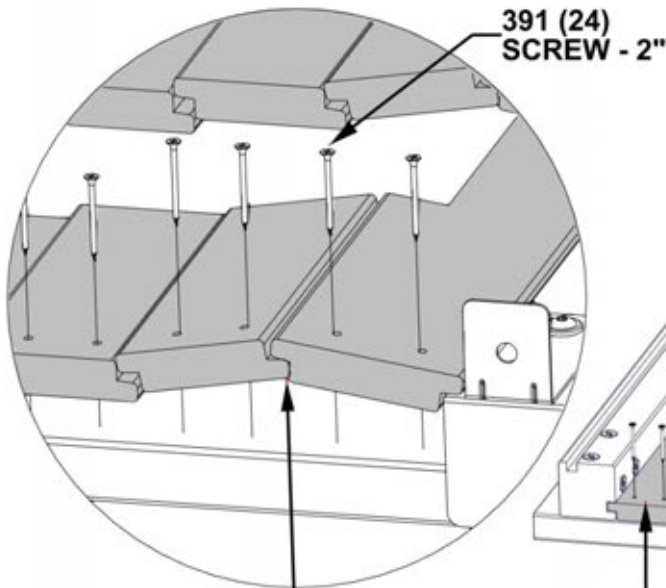
- INSTALL Q12 & Q15 FIRST, THEN INSTALL EVENLY SPACED Q14 LOWER BOARDS FLUSH WITH BOTTOM OF BASE BOARD
- INSTALL EVENLY SPACED Q13 UPPER BOARDS AND HOLD FLUSH WITH TOP HORIZONTAL WALL BOARD
- BEFORE ADDING SCREWS, CONFIRM THE DIMENSIONS REQUIRED FOR THE LOUVER



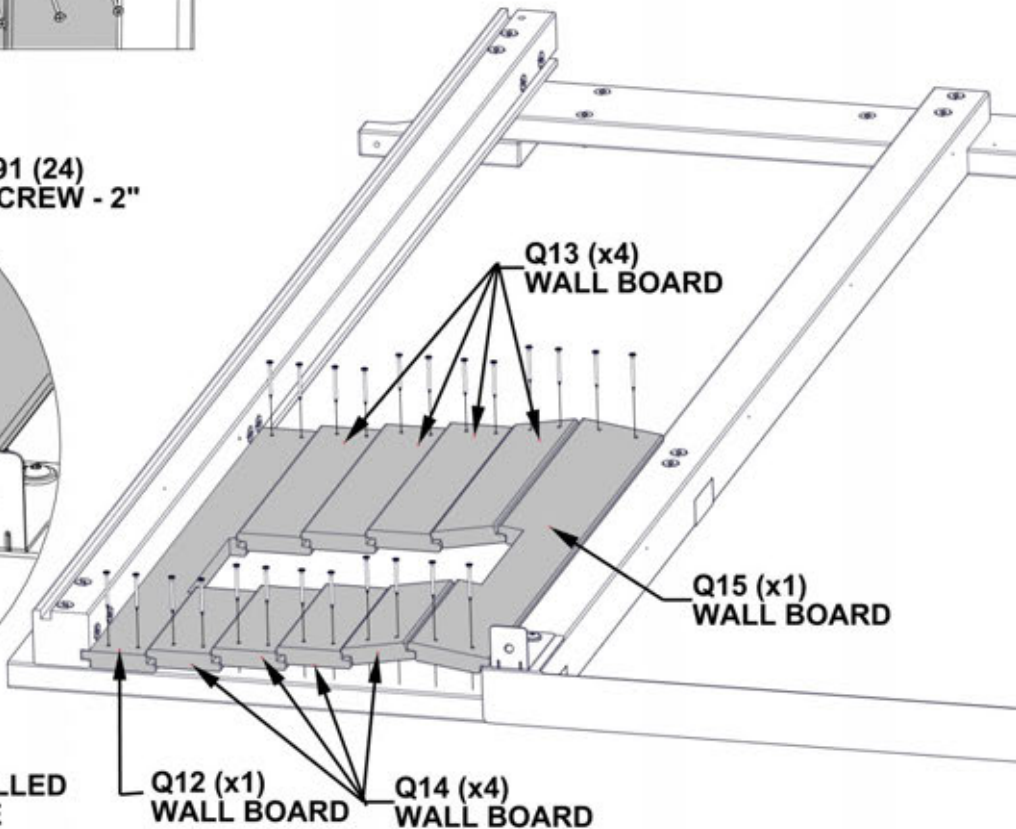
HOLD DIMENSIONS FOR PROPER LOUVER FIT



HORIZONTAL WALL BOARD



NOTE BOARDS MAY NEED TO BE ROLLED UPWARDS THEN INSERTED INTO THE GROOVE ON POST



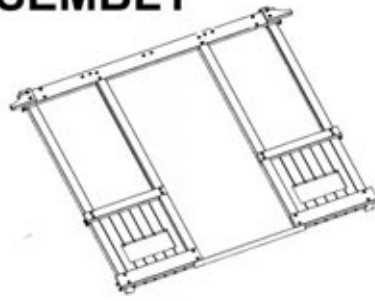
Q12 (x1) WALL BOARD Q14 (x4) WALL BOARD

Q13 (x4) WALL BOARD

Q15 (x1) WALL BOARD

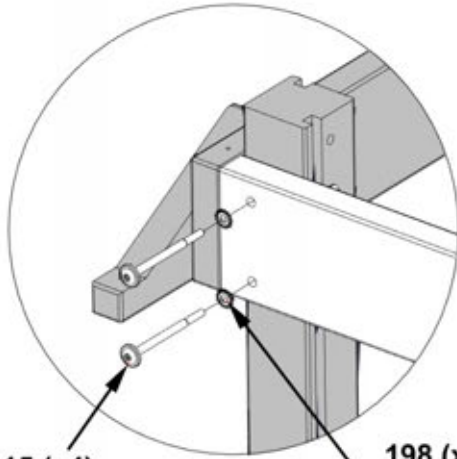
STEP 26 - WALL ASSEMBLY

QTY	PART NUMBER	DESCRIPTION
12	H100198	WASHER LOCK EXT 8x19
4	H100415	BOLT WH 5/16x3 3/4 BLK
8	H100513	BOLT WH 5/16x4 1/4 BLK



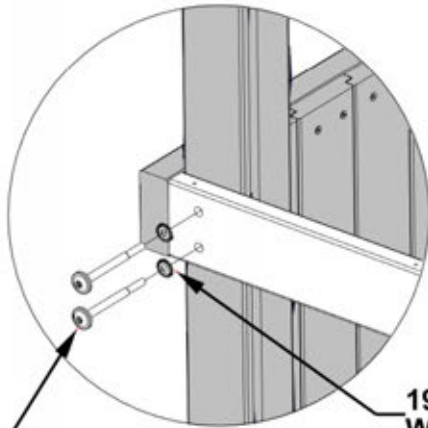
FRONT WALL ASSEMBLY

NOTES:
• HAND TIGHTEN ONLY



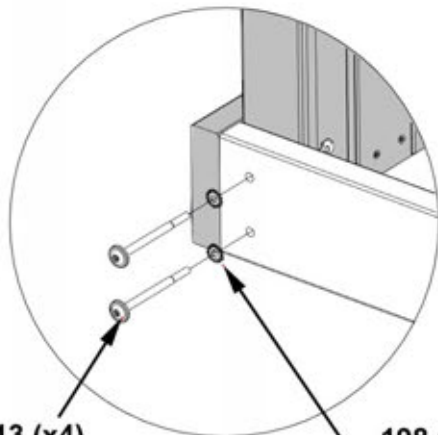
**415 (x4)
BOLT-3 3/4"**

**198 (x4)
WASHER - 8x19**



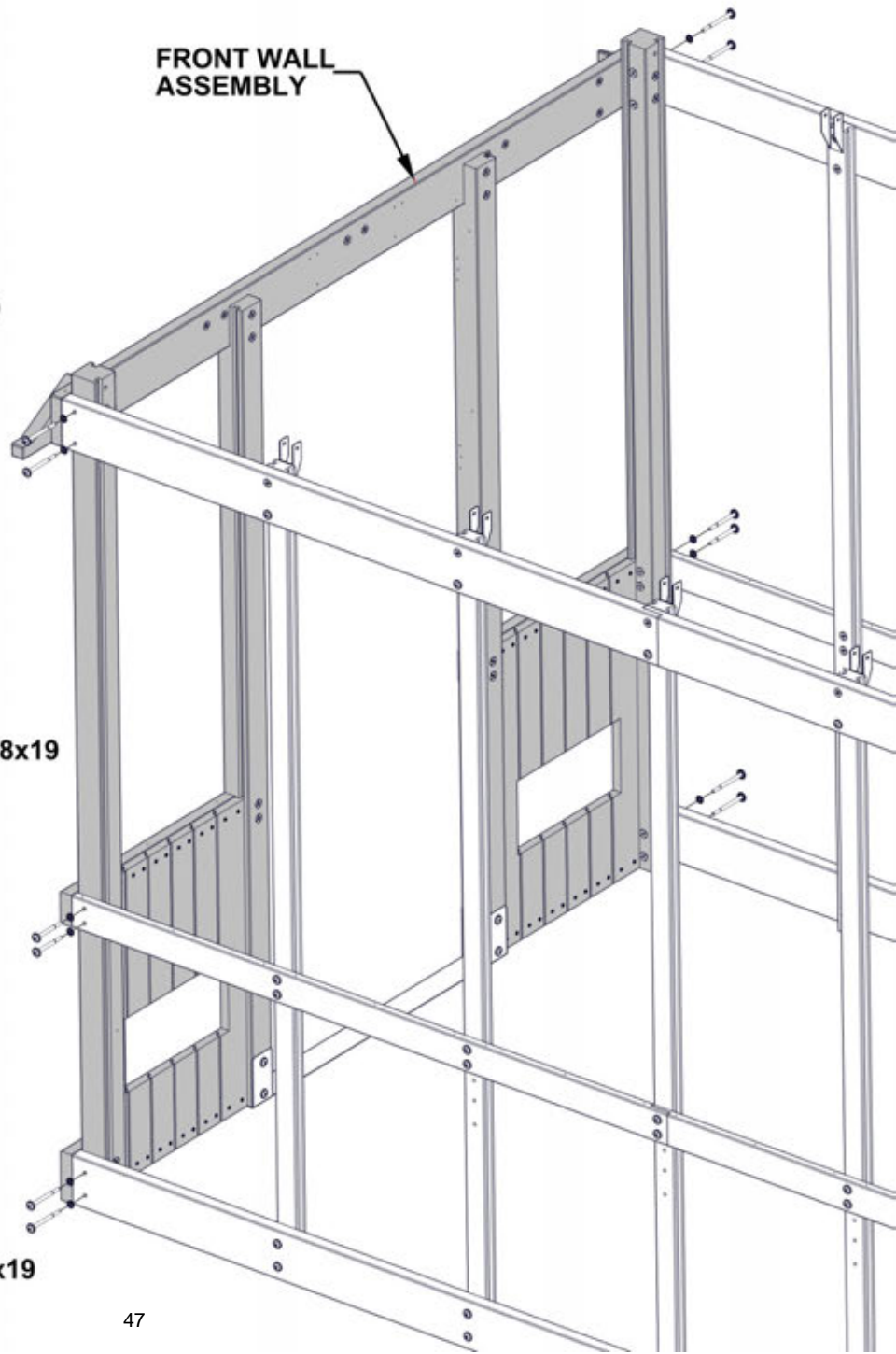
**513 (x4)
BOLT-4 1/4"**

**198 (x4)
WASHER - 8x19**



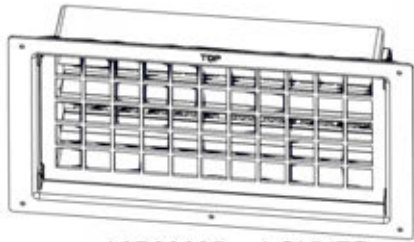
**513 (x4)
BOLT-4 1/4"**

**198 (x4)
WASHER - 8x19**



STEP 27 - LOUVER INSTALLATION

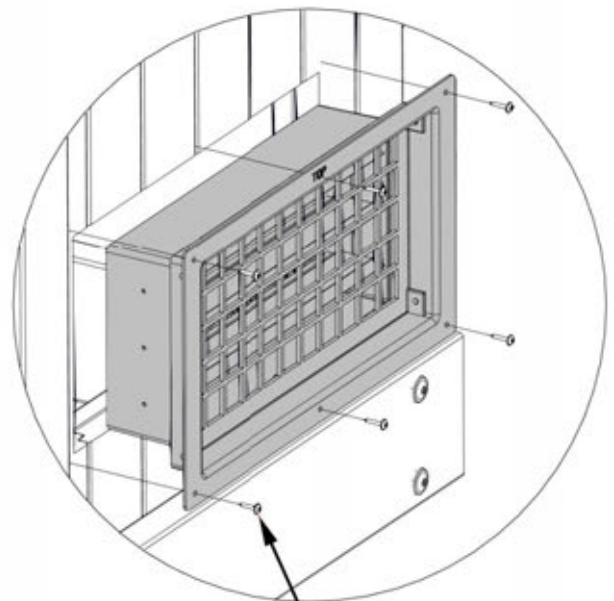
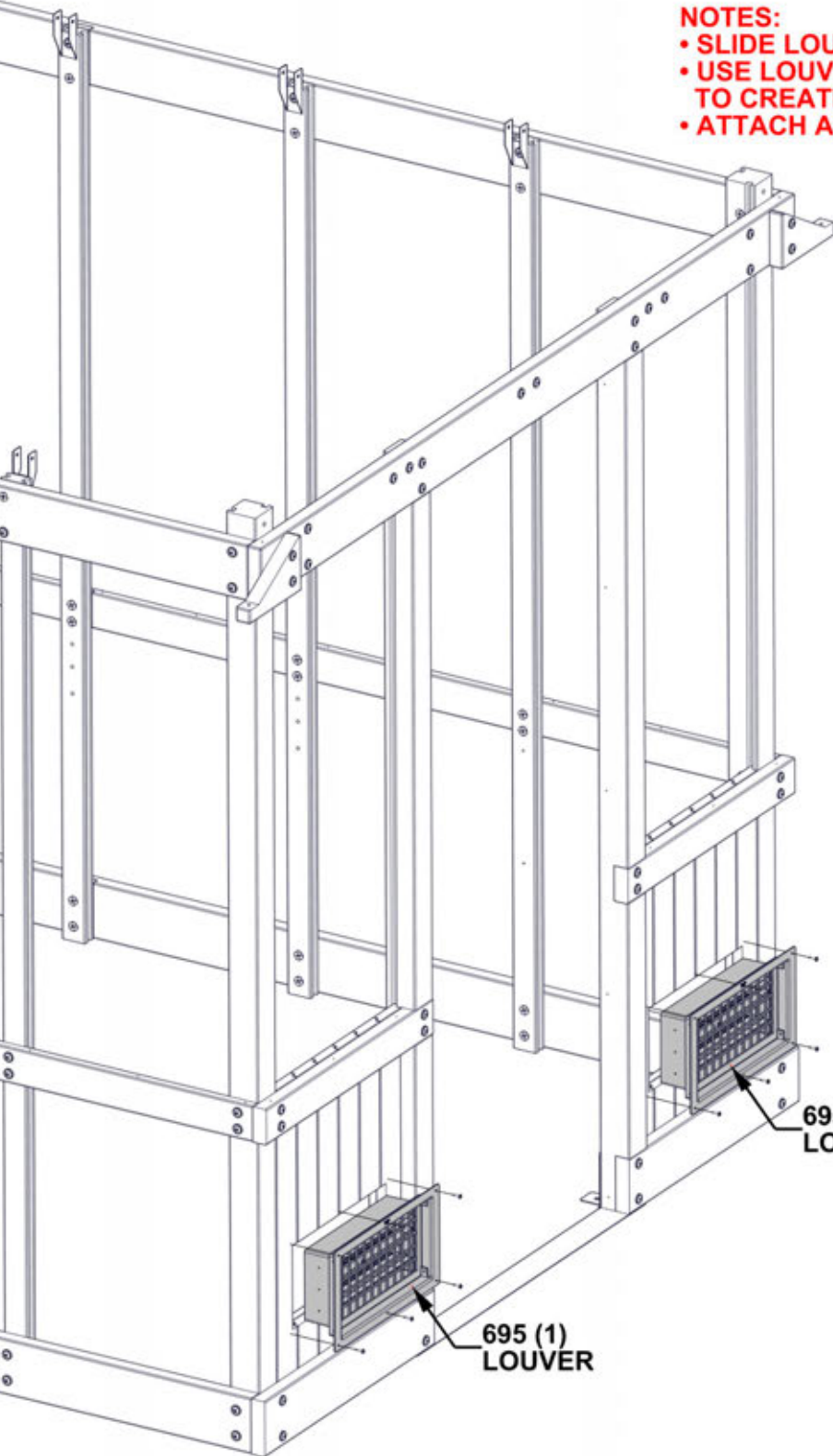
QTY	PART NUMBER	DESCRIPTION
12	H100392	SCREW PWH 8x3/4 BLK



A6P00695 LOUVER
(x2)

NOTES:

- SLIDE LOUVER INTO OPENINGS
- USE LOUVER FLANGE AS A GUIDE AND AN 1/8" DRILL BIT TO CREATE PILOT HOLES INTO WALL PANEL.
- ATTACH AS SHOWN



392 (x12)
SCREW - 3/4"

695 (1)
LOUVER

695 (1)
LOUVER

STEP 28 - LOUVER TRIM



J06 LOUVER TRIM - W4L18426
(x4) 15/16"x2 3/8"x20 11/16" (24x60x526)

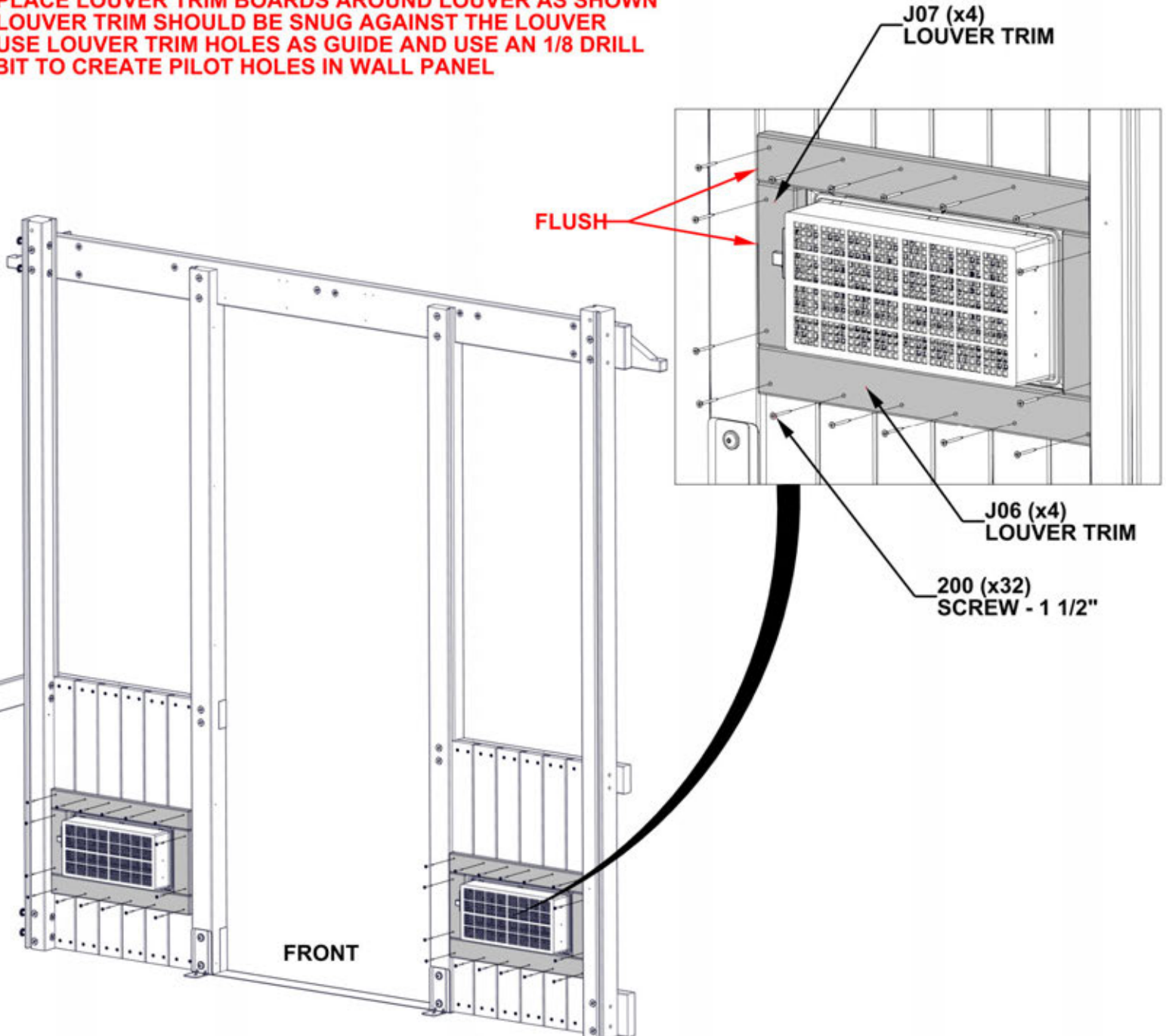


J07 LOUVER TRIM - W4L18427
(x4) 15/16"x2 3/8"x8" (24x60x203)

QTY	PART NUMBER	DESCRIPTION
32	H100200	SCREW PFH 8x1 1/2 BLK

NOTES:

- PLACE LOUVER TRIM BOARDS AROUND LOUVER AS SHOWN
- LOUVER TRIM SHOULD BE SNUG AGAINST THE LOUVER
- USE LOUVER TRIM HOLES AS GUIDE AND USE AN 1/8 DRILL BIT TO CREATE PILOT HOLES IN WALL PANEL



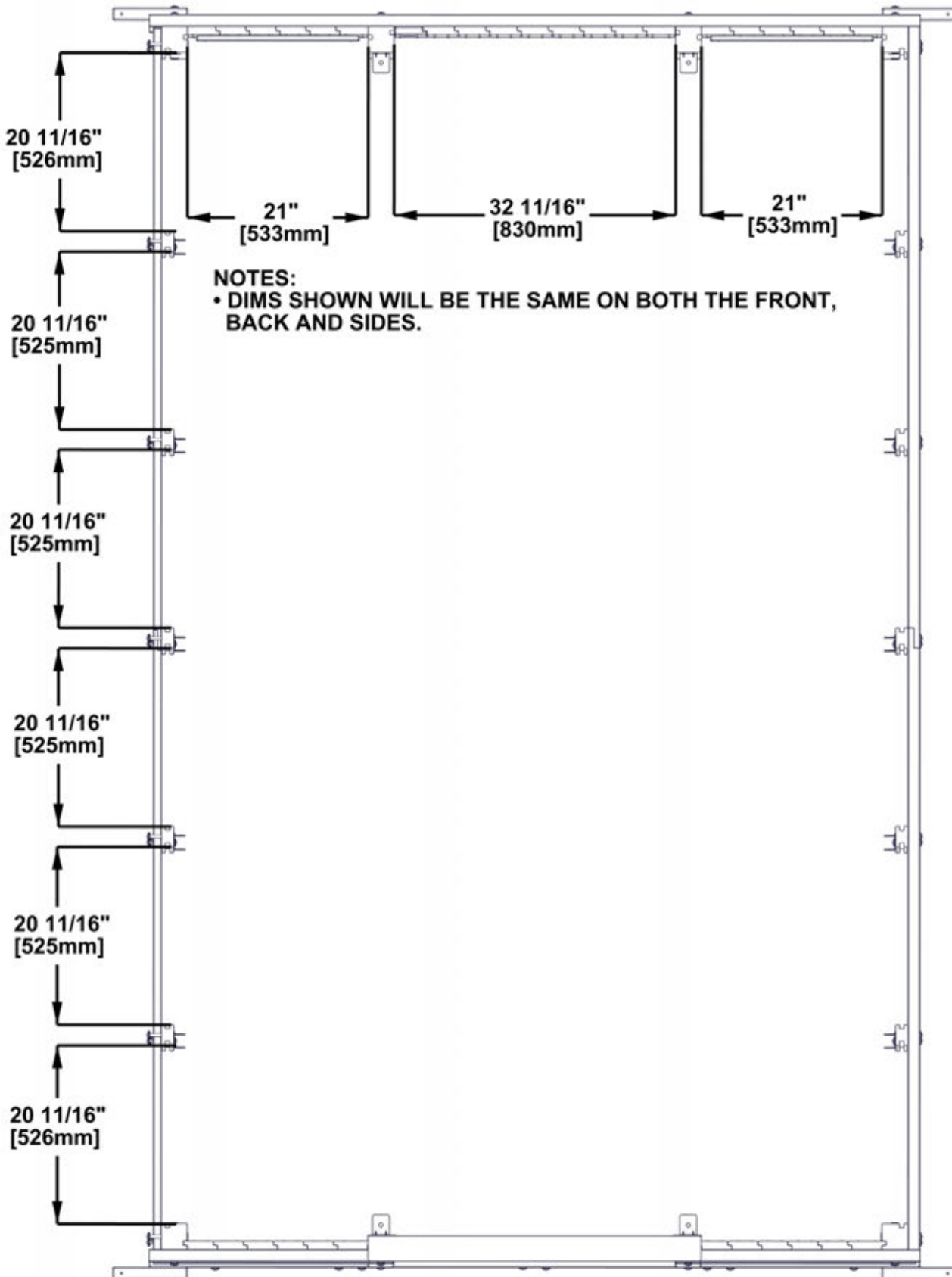
LEFT WALL ASSEMBLY NOT SHOWN ON THIS STEP

STEP 29A - SQUARE UNIT & TIGHTEN ALL HARDWARE

CRITICAL!!

- CHECK TO MAKE SURE ALL UPRIGHTS ARE SQUARE
- MEASURE FROM INSIDE TO INSIDE ON UPRIGHTS;
IF SQUARE, DIMENSIONS WILL MATCH
- ONCE CONFIRMED SQUARE, TIGHTEN ALL HARDWARE

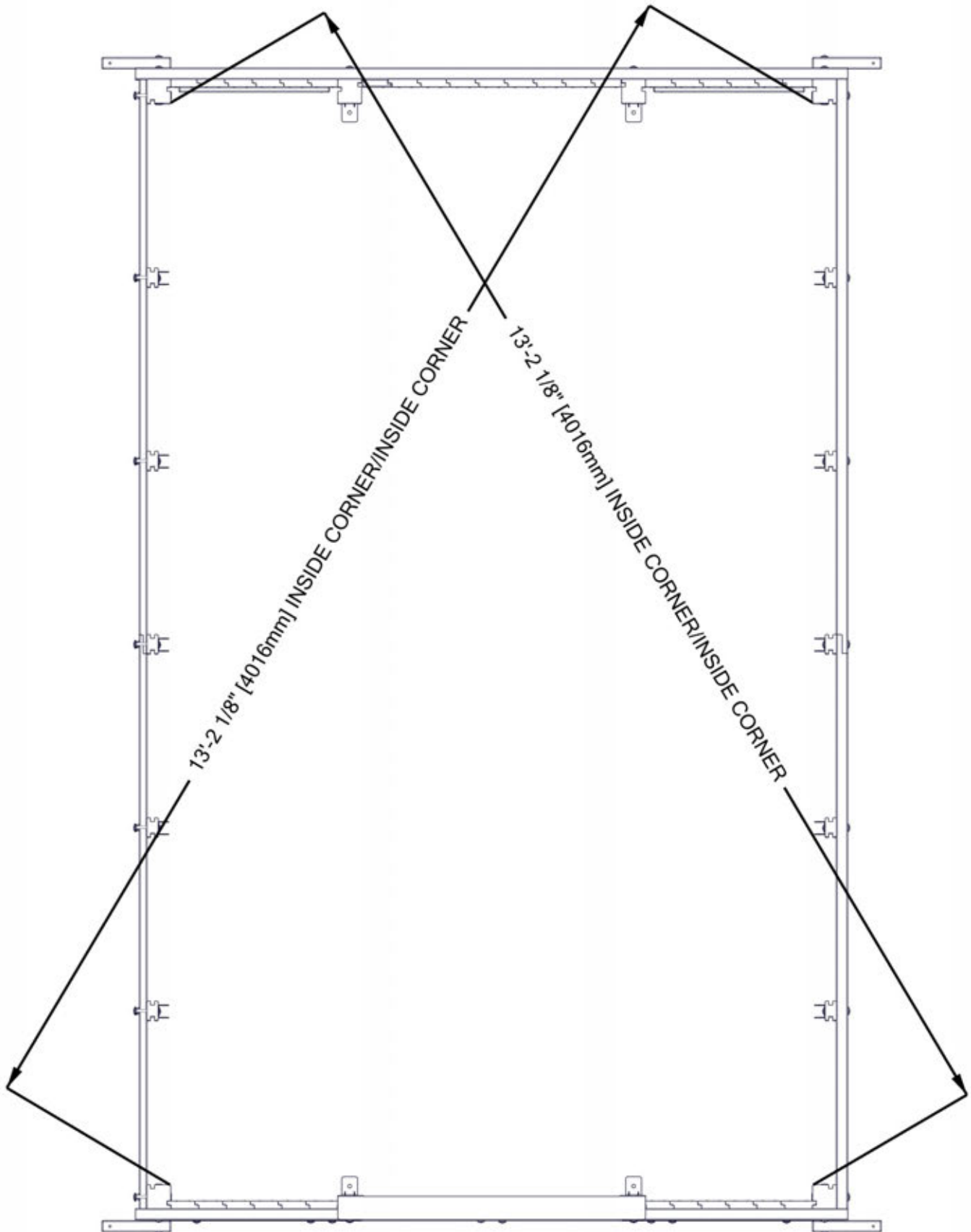
FAILURE TO MAKE UNIT SQUARE WILL IMPACT THE REMAINING SETUP PROCESS.



STEP 29B - SQUARE UNIT & TIGHTEN ALL HARDWARE

CRITICAL!!

- CHECK TO MAKE SURE ALL UPRIGHTS ARE SQUARE
 - MEASURE FROM INTERIOR CORNER TO INTERIOR CORNER;
IF SQUARE, DIMENSIONS WILL MATCH
 - ONCE CONFIRMED SQUARE, TIGHTEN ALL HARDWARE
- FAILURE TO MAKE UNIT SQUARE WILL IMPACT THE REMAINING SETUP PROCESS.



STEP 30 - RIGHT WALL ASSEMBLY

QTY	PART NUMBER	DESCRIPTION
24	H100382	SCREW PFH 8x1 3/4 BLK



Q08 WALL BOARD - W4L18088
(x1) 15/16"x4 1/8"x33" (24x104x838)

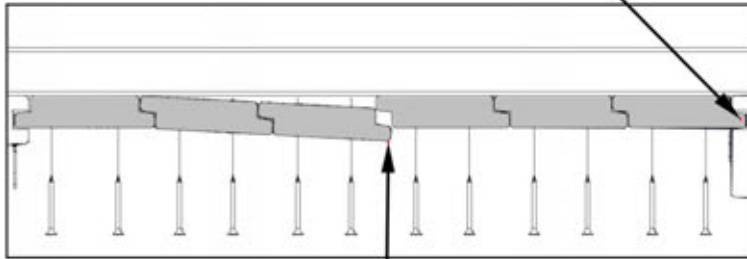


Q01 WALL BOARD - W4L18057
(x5) 15/16"x3 15/16"x33" (24x100x838)

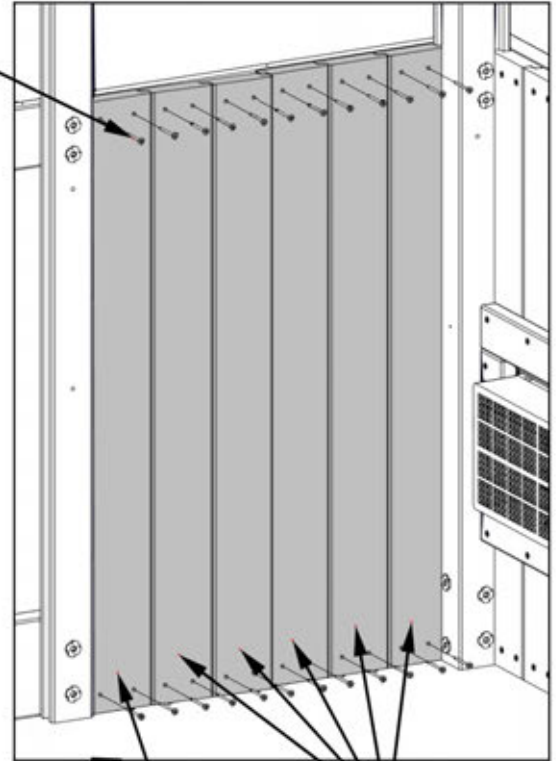
NOTE:
• **EVENLY SPACE WALL BOARDS TO AVOID ANY GAPS IN THE WALL PANEL.**

382 (x24) SCREW - 1 3/4"

INSERT WALL BOARDS INTO GROOVE ON POST/UPRIGHTS



TO GET WALL BOARDS TO PROPERLY SEAT MAY REQUIRE POSITIONING BOARDS AS SHOWN AND INSERTING TONGUE INTO GROOVE.



Q08 (x1) WALL BOARD **Q01 (x5) WALL BOARD**



BACK

FRONT

LEFT WALL ASSEMBLY NOT SHOWN ON THIS STEP

STEP 31 - RIGHT WALL ASSEMBLY

QTY	PART NUMBER	DESCRIPTION
24	H100382	SCREW PFH 8x1 3/4 BLK



Q08 WALL BOARD - W4L18088
(x1) 15/16"x4 1/8"x33" (24x104x838)

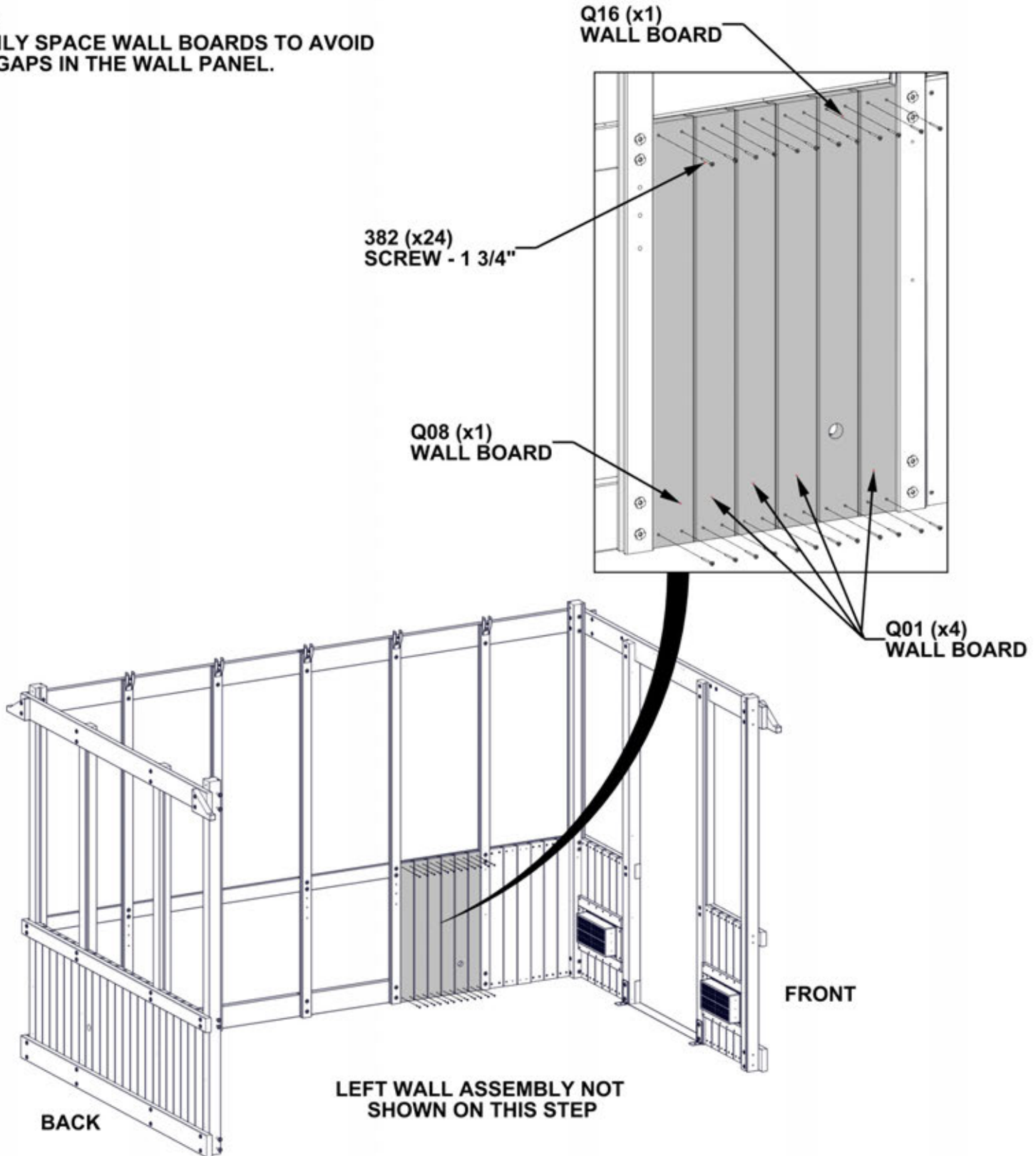


Q16 WALL BOARD - W4L18365
(x1) 15/16"x3 15/16"x33" (24x100x838)



Q01 WALL BOARD - W4L18057
(x4) 15/16"x3 15/16"x33" (24x100x838)

NOTE:
• EVENLY SPACE WALL BOARDS TO AVOID ANY GAPS IN THE WALL PANEL.



STEP 32 - RIGHT WALL ASSEMBLY

QTY	PART NUMBER	DESCRIPTION
24	H100382	SCREW PFH 8x1 3/4 BLK

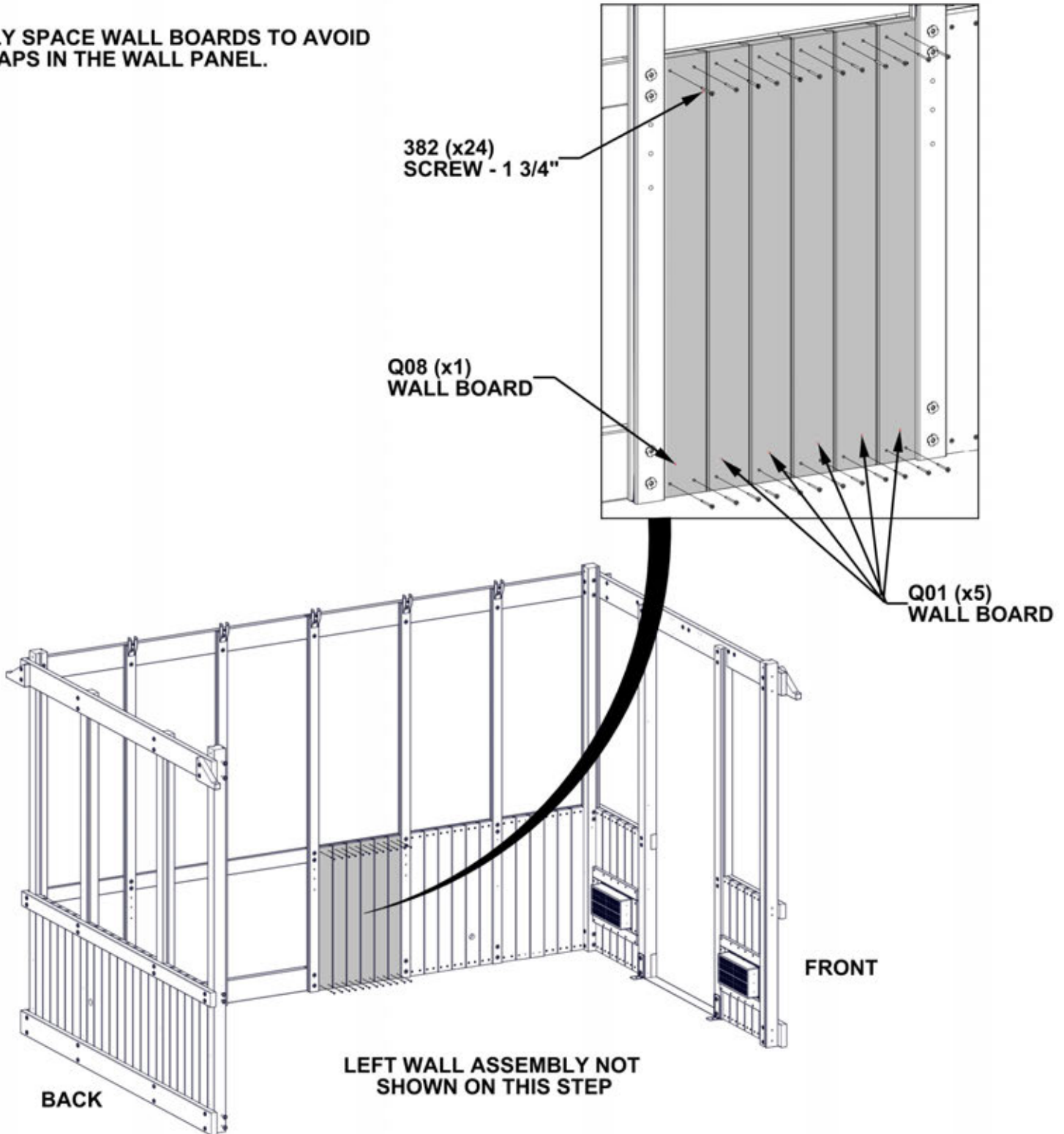


Q08 WALL BOARD - W4L18088
(x1) 15/16"x4 1/8"x33" (24x104x838)



Q01 WALL BOARD - W4L18057
(x5) 15/16"x3 15/16"x33" (24x100x838)

NOTE:
• EVENLY SPACE WALL BOARDS TO AVOID ANY GAPS IN THE WALL PANEL.



STEP 33 - RIGHT WALL ASSEMBLY

QTY	PART NUMBER	DESCRIPTION
24	H100382	SCREW PFH 8x1 3/4 BLK

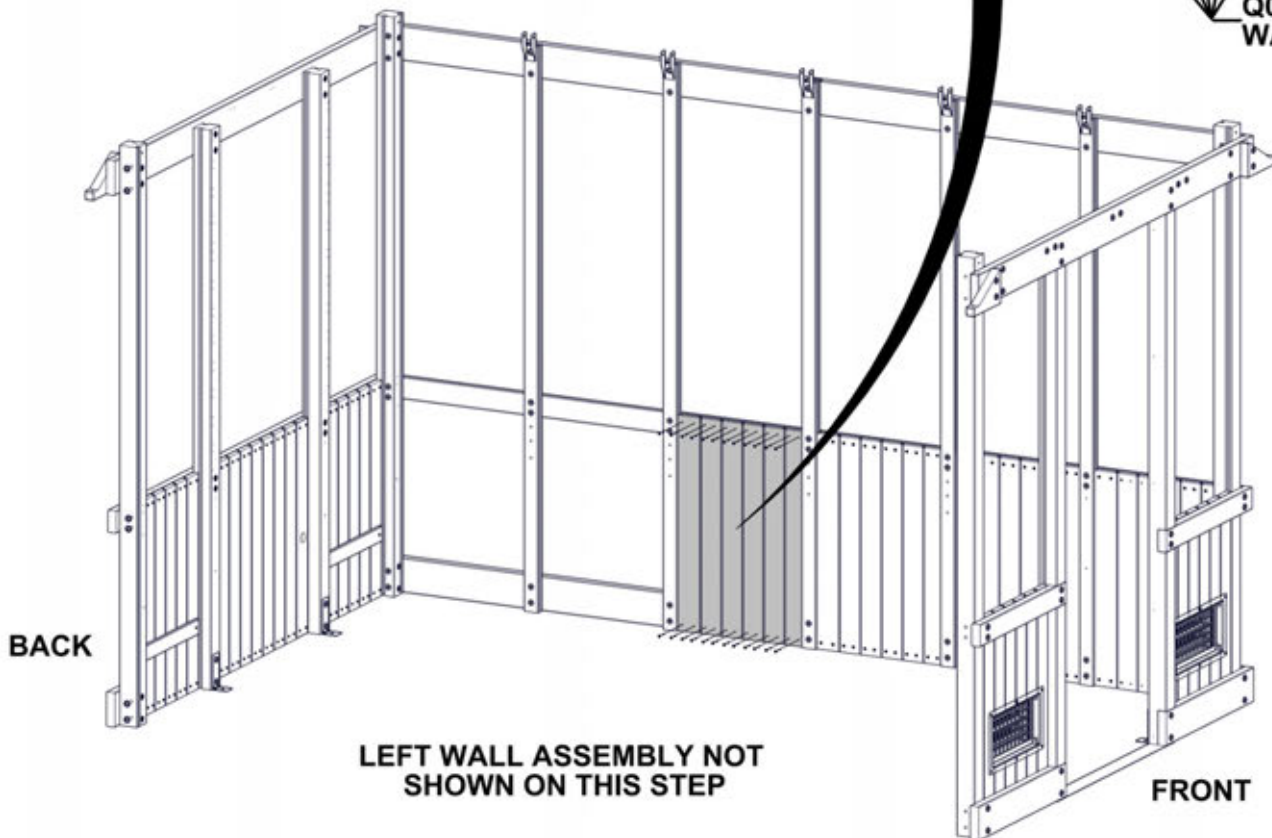
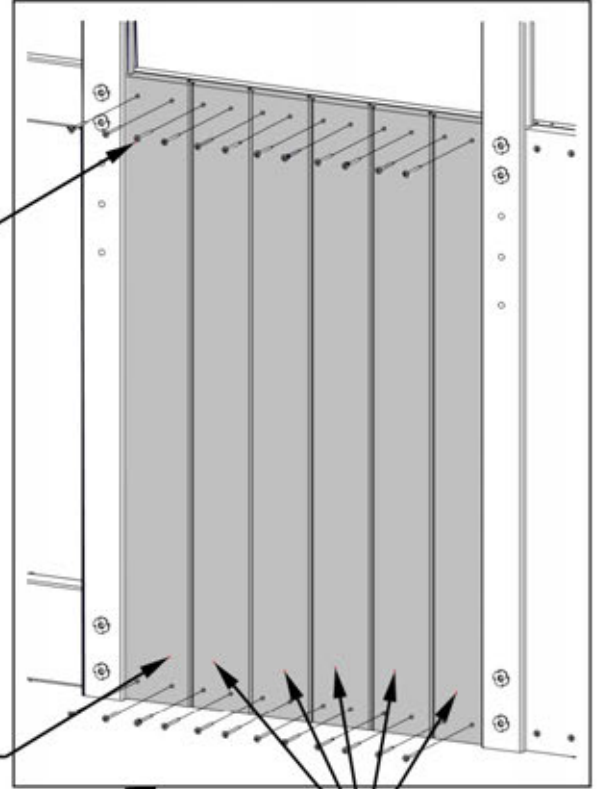


Q08 WALL BOARD - W4L18088
(x1) 15/16"x4 1/8"x33" (24x104x838)



Q01 WALL BOARD - W4L18057
(x5) 15/16"x3 15/16"x33" (24x100x838)

NOTE:
• EVENLY SPACE WALL BOARDS TO AVOID ANY GAPS IN THE WALL PANEL.



STEP 34 - RIGHT WALL ASSEMBLY

QTY	PART NUMBER	DESCRIPTION
24	H100382	SCREW PFH 8x1 3/4 BLK

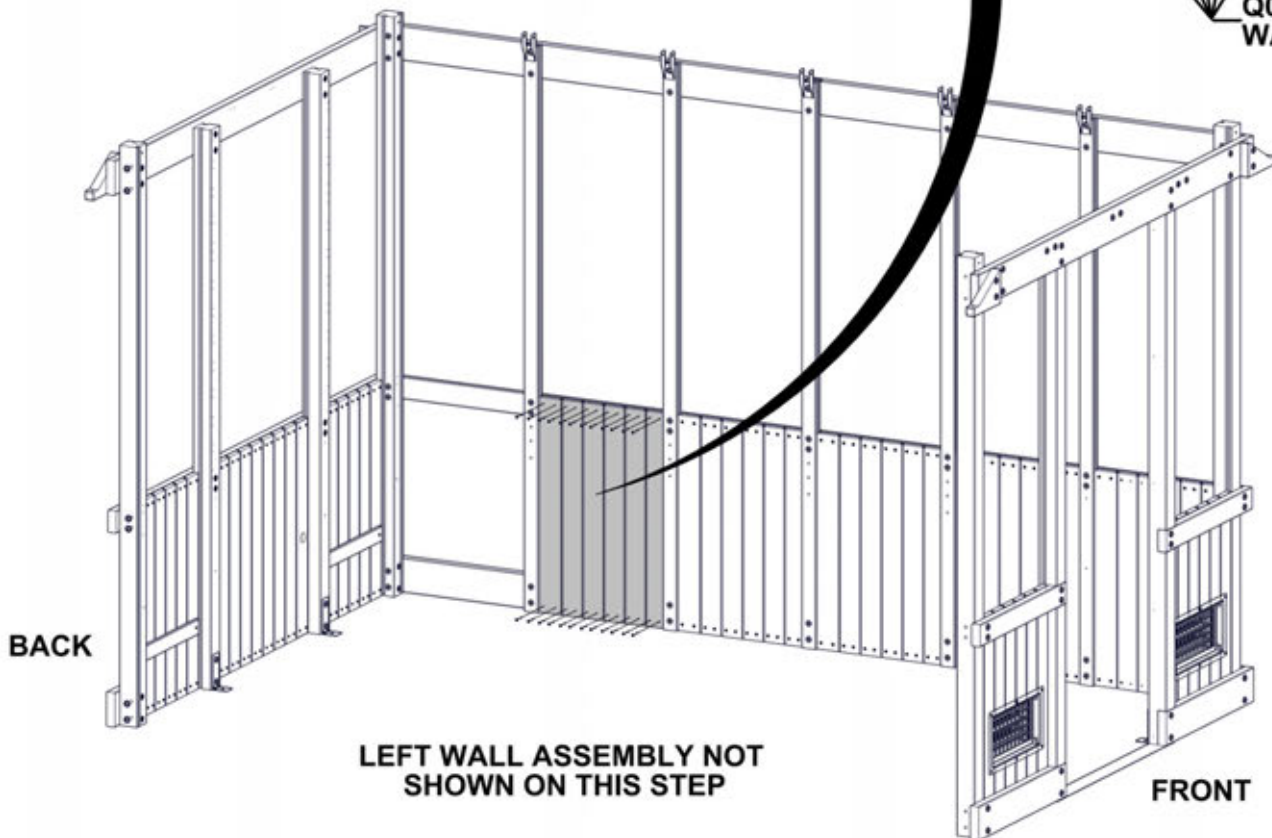
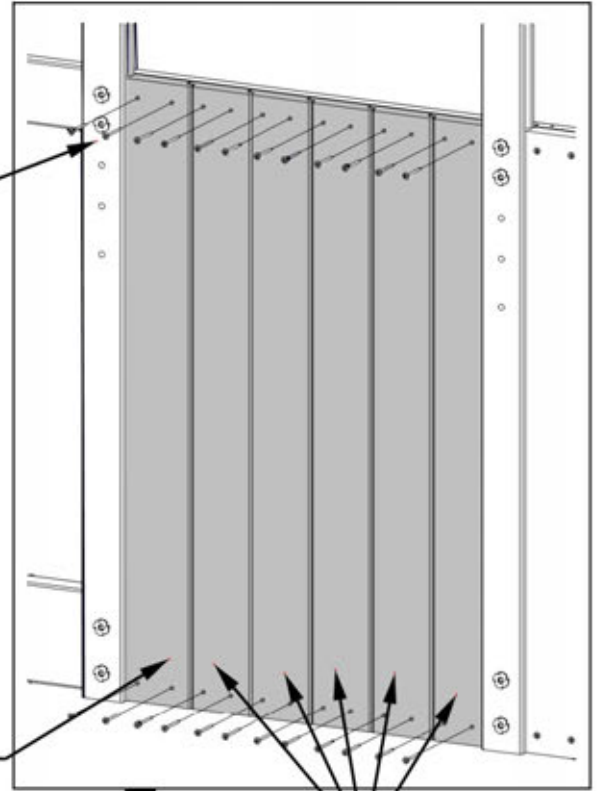


Q08 WALL BOARD - W4L18088
(x1) 15/16"x4 1/8"x33" (24x104x838)



Q01 WALL BOARD - W4L18057
(x5) 15/16"x3 15/16"x33" (24x100x838)

NOTE:
• EVENLY SPACE WALL BOARDS TO AVOID ANY GAPS IN THE WALL PANEL.



STEP 35 - RIGHT WALL ASSEMBLY

QTY	PART NUMBER	DESCRIPTION
24	H100382	SCREW PFH 8x1 3/4 BLK

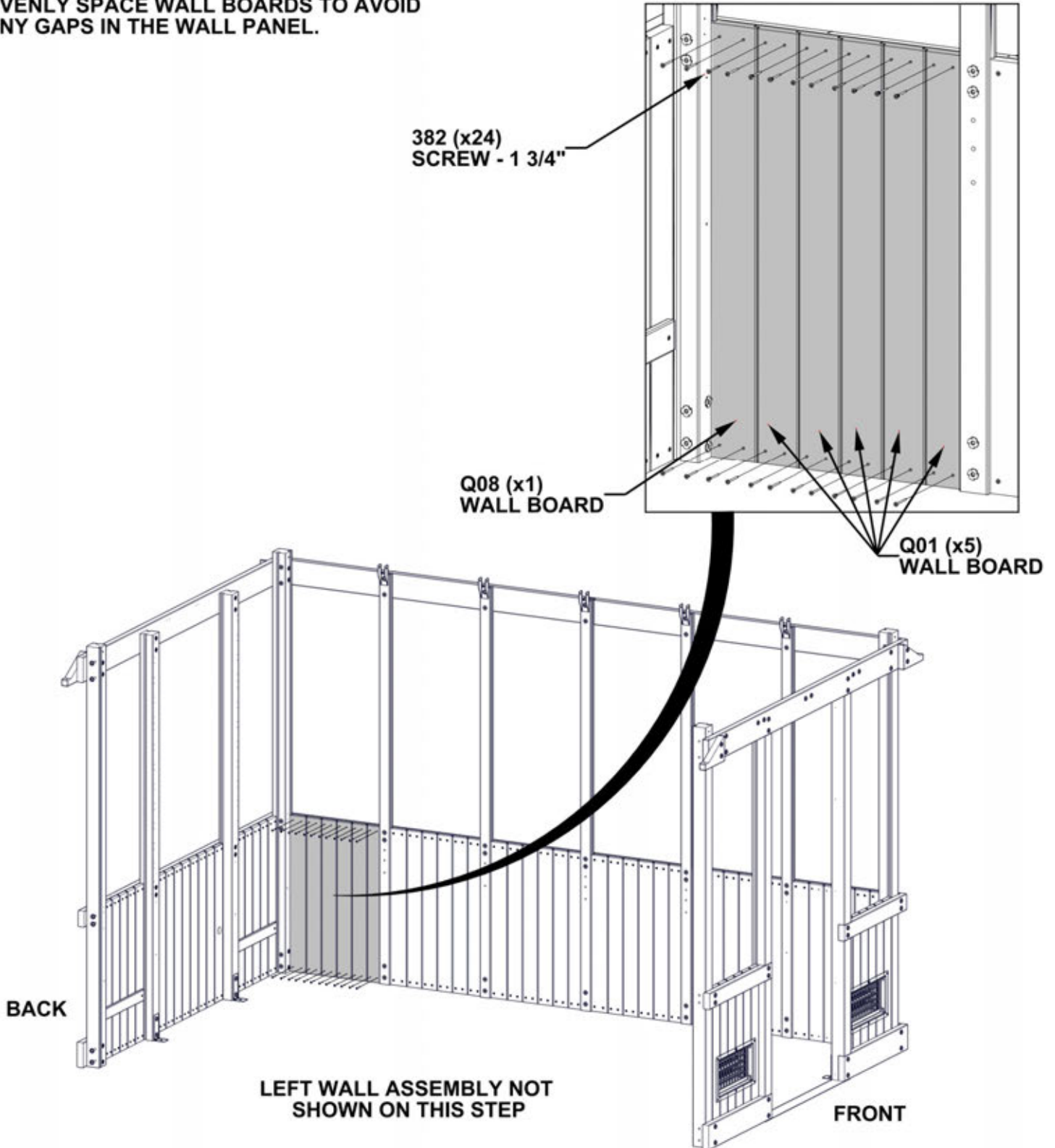


Q08 WALL BOARD - W4L18088
(x1) 15/16"x4 1/8"x33" (24x104x838)



Q01 WALL BOARD - W4L18057
(x5) 15/16"x3 15/16"x33" (24x100x838)

NOTE:
• EVENLY SPACE WALL BOARDS TO AVOID ANY GAPS IN THE WALL PANEL.



STEP 36 - LEFT WALL ASSEMBLY

QTY	PART NUMBER	DESCRIPTION
24	H100382	SCREW PFH 8x1 3/4 BLK



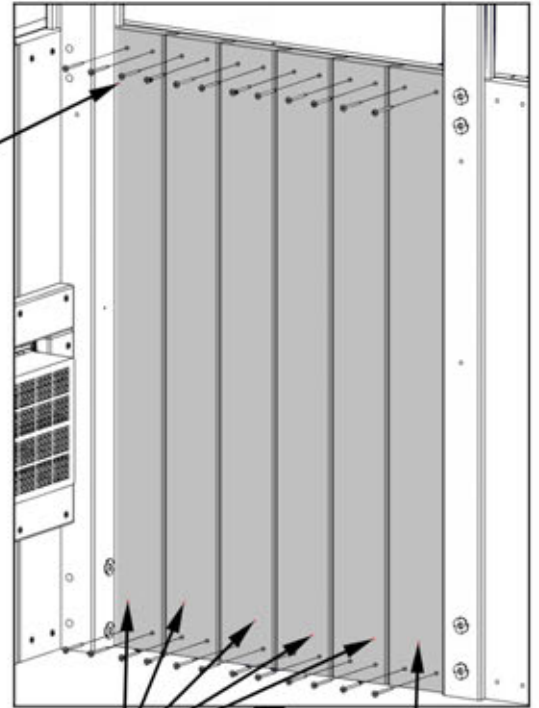
Q08 WALL BOARD - W4L18088
(x1) 15/16"x4 1/8"x33" (24x104x838)



Q01 WALL BOARD - W4L18057
(x5) 15/16"x3 15/16"x33" (24x100x838)

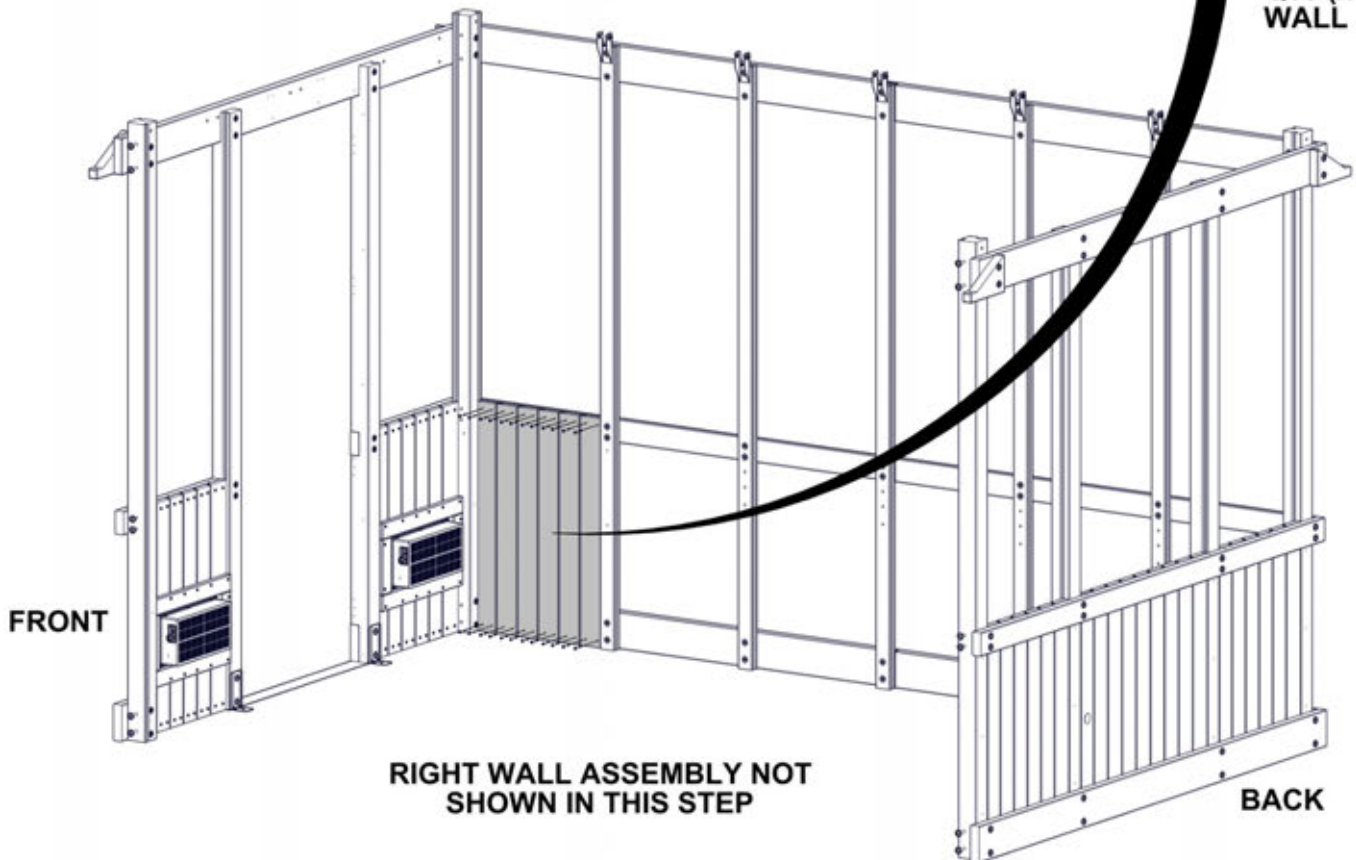
NOTE:
• EVENLY SPACE WALL BOARDS TO AVOID ANY GAPS IN THE WALL PANEL.

382 (x24)
SCREW - 1 3/4"



Q01 (x5)
WALL BOARD

Q08 (x1)
WALL BOARD



STEP 37 - LEFT WALL ASSEMBLY

QTY	PART NUMBER	DESCRIPTION
24	H100382	SCREW PFH 8x1 3/4 BLK



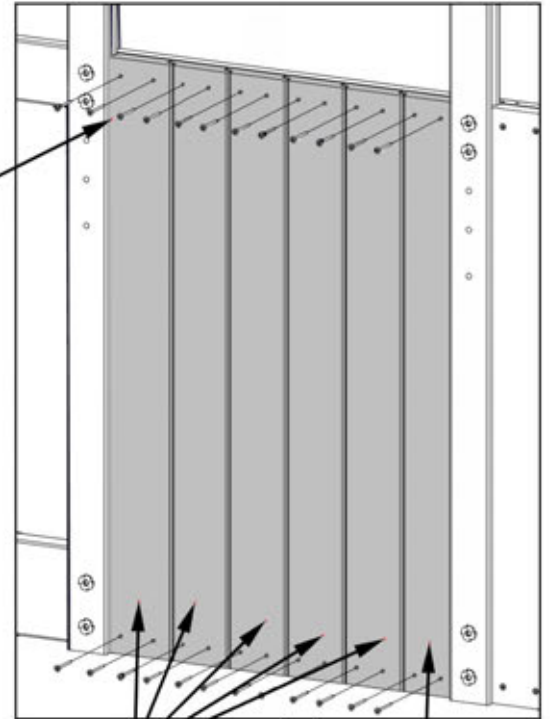
Q08 WALL BOARD - W4L18088
(x1) 15/16"x4 1/8"x33" (24x104x838)



Q01 WALL BOARD - W4L18057
(x5) 15/16"x3 15/16"x33" (24x100x838)

NOTE:
• EVENLY SPACE WALL BOARDS TO AVOID ANY GAPS IN THE WALL PANEL.

382 (x24)
SCREW - 1 3/4"



Q01 (x5)
WALL BOARD

Q08 (x1)
WALL BOARD

FRONT

RIGHT WALL ASSEMBLY NOT SHOWN IN THIS STEP

BACK

STEP 38 - LEFT WALL ASSEMBLY

QTY	PART NUMBER	DESCRIPTION
24	H100382	SCREW PFH 8x1 3/4 BLK



Q08 WALL BOARD - W4L18088
(x1) 15/16"x4 1/8"x33" (24x104x838)



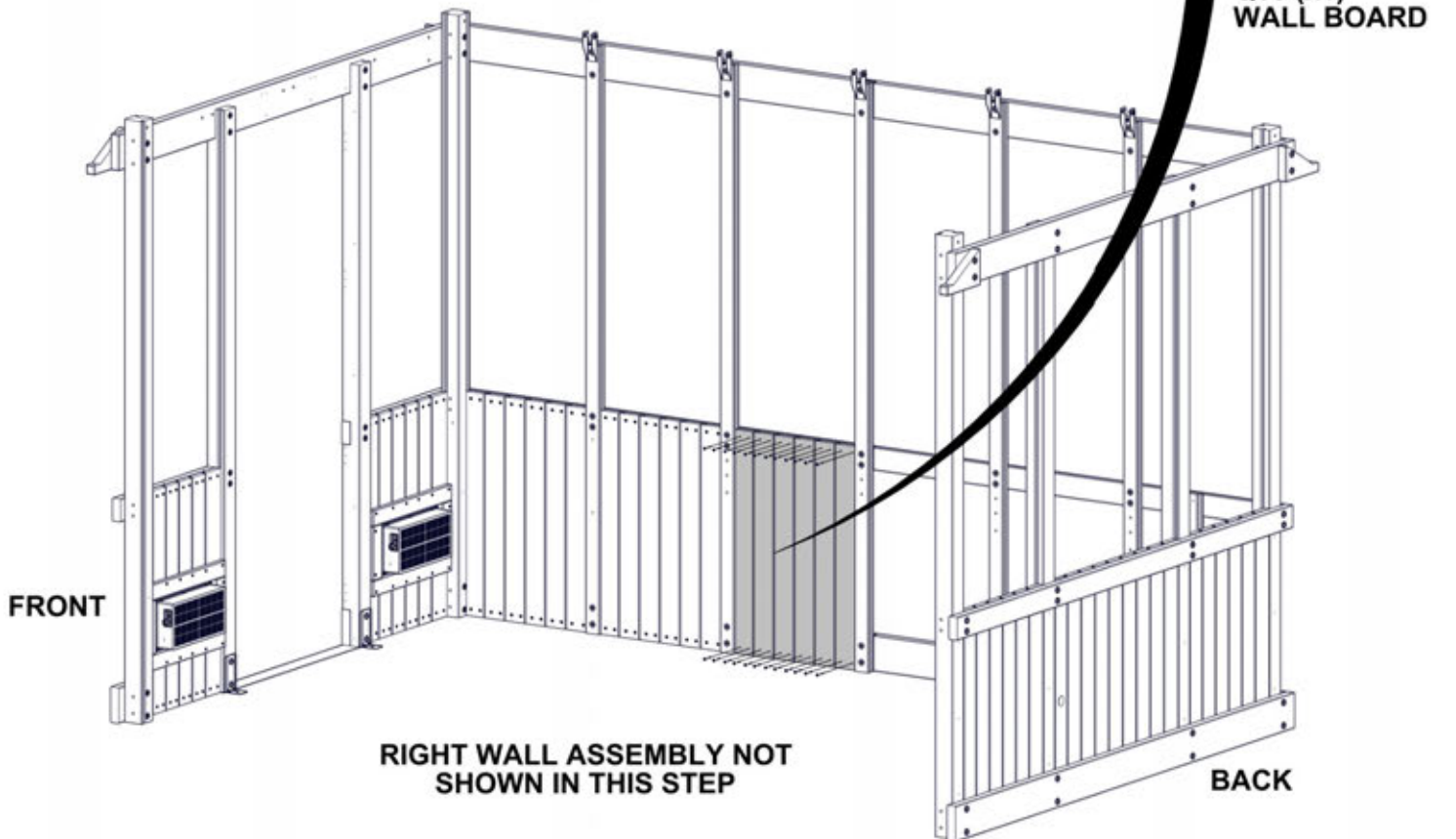
Q01 WALL BOARD - W4L18057
(x5) 15/16"x3 15/16"x33" (24x100x838)

NOTE:
• EVENLY SPACE WALL BOARDS TO AVOID ANY GAPS IN THE WALL PANEL.

382 (x24)
SCREW - 1 3/4"

Q01 (x5)
WALL BOARD

Q08 (x1)
WALL BOARD



STEP 39 - LEFT WALL ASSEMBLY

QTY	PART NUMBER	DESCRIPTION
24	H100382	SCREW PFH 8x1 3/4 BLK



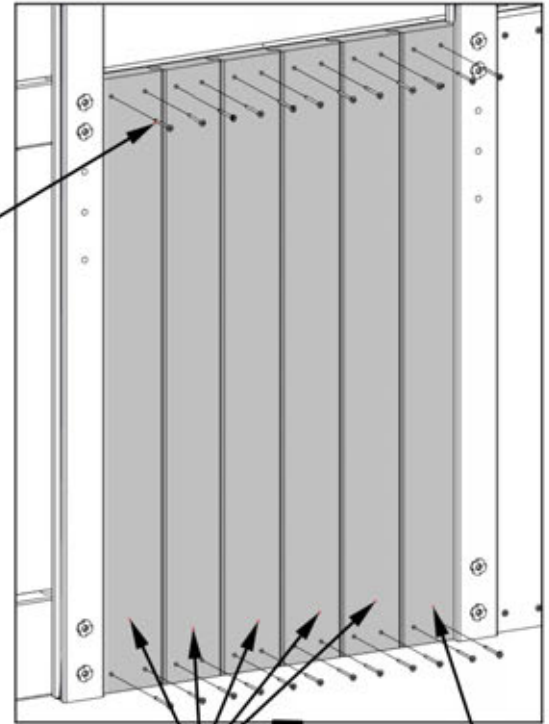
Q08 WALL BOARD - W4L18088
(x1) 15/16"x4 1/8"x33" (24x104x838)



Q01 WALL BOARD - W4L18057
(x5) 15/16"x3 15/16"x33" (24x100x838)

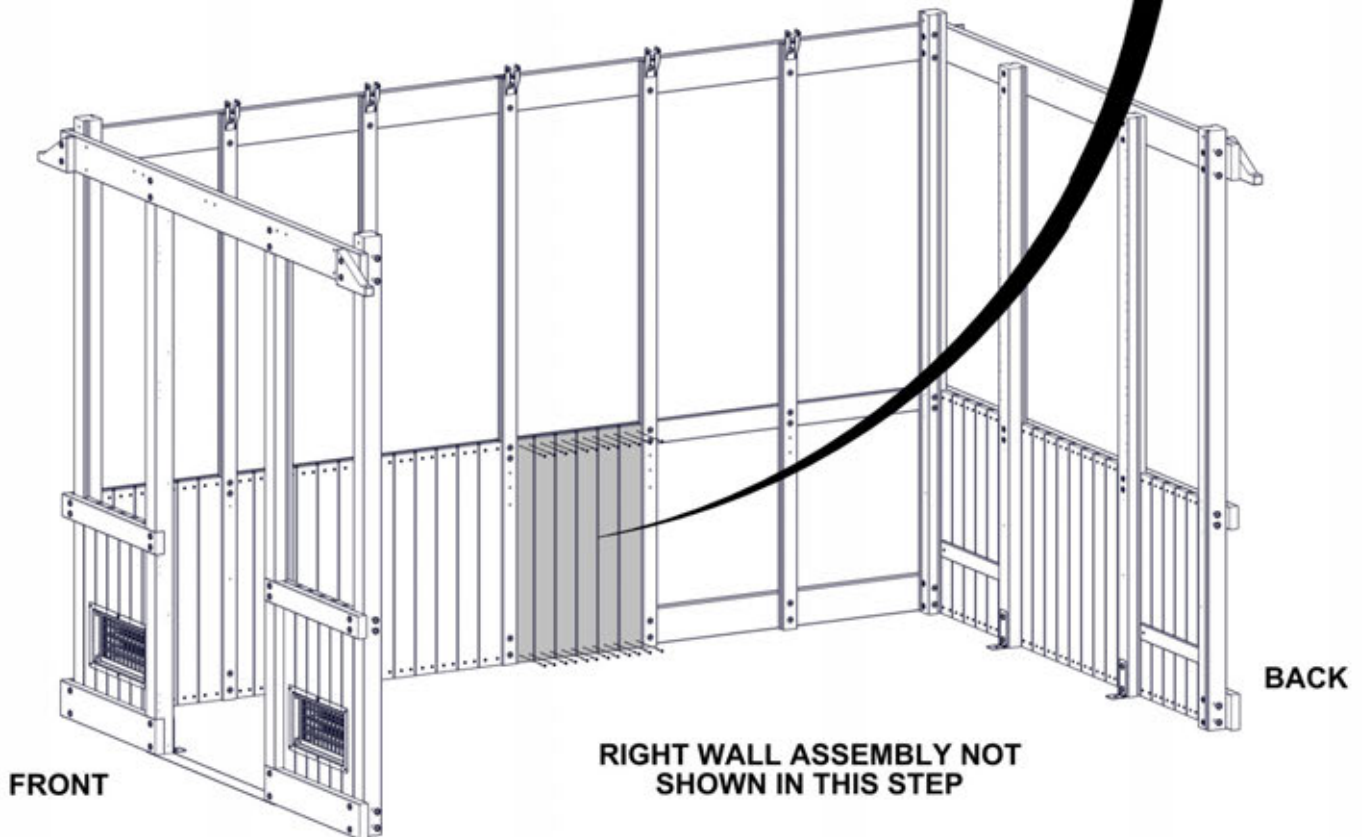
NOTE:
• EVENLY SPACE WALL BOARDS TO AVOID ANY GAPS IN THE WALL PANEL.

382 (x24)
SCREW - 1 3/4"



Q01 (x5)
WALL BOARD

Q08 (x1)
WALL BOARD



STEP 40 - LEFT WALL ASSEMBLY

QTY	PART NUMBER	DESCRIPTION
24	H100382	SCREW PFH 8x1 3/4 BLK



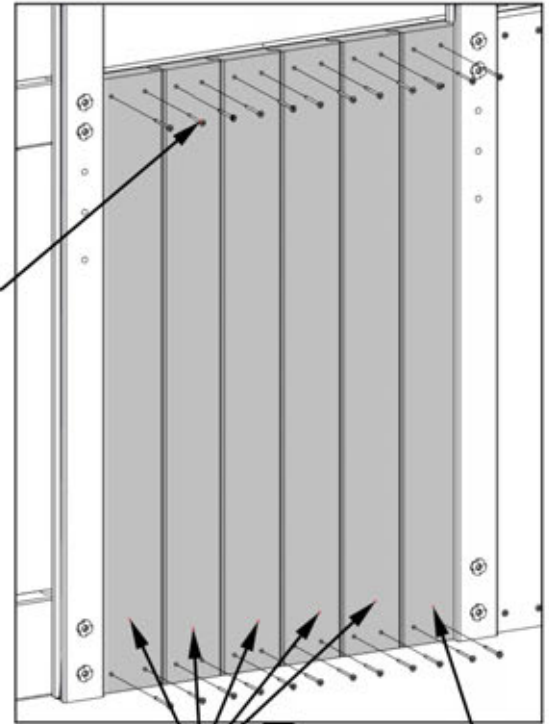
Q08 WALL BOARD - W4L18088
(x1) 15/16"x4 1/8"x33" (24x104x838)



Q01 WALL BOARD - W4L18057
(x5) 15/16"x3 15/16"x33" (24x100x838)

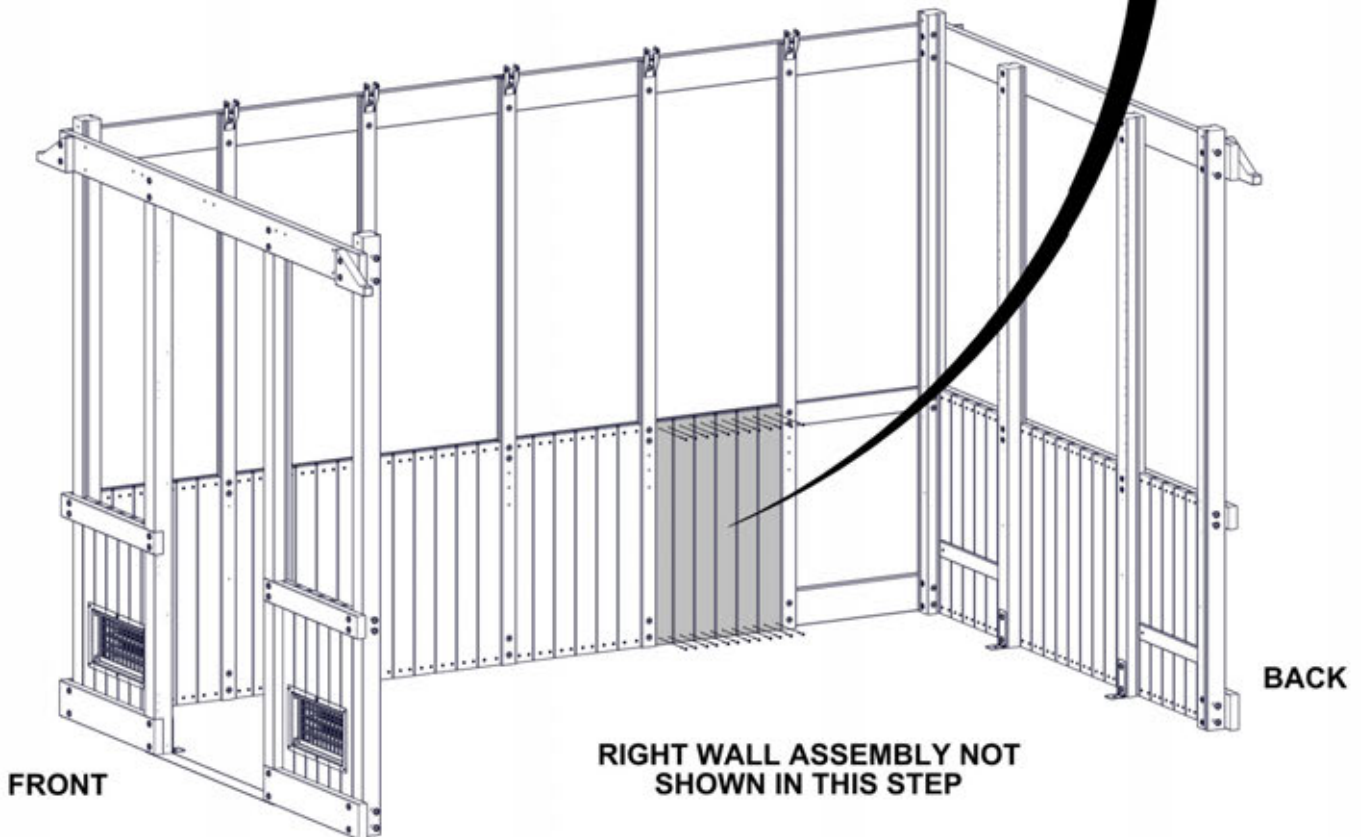
NOTE:
• EVENLY SPACE WALL BOARDS TO AVOID ANY GAPS IN THE WALL PANEL.

382 (x24)
SCREW - 1 3/4"



Q01 (x5)
WALL BOARD

Q08 (x1)
WALL BOARD



STEP 41 - LEFT WALL ASSEMBLY

QTY	PART NUMBER	DESCRIPTION
24	H100382	SCREW PFH 8x1 3/4 BLK



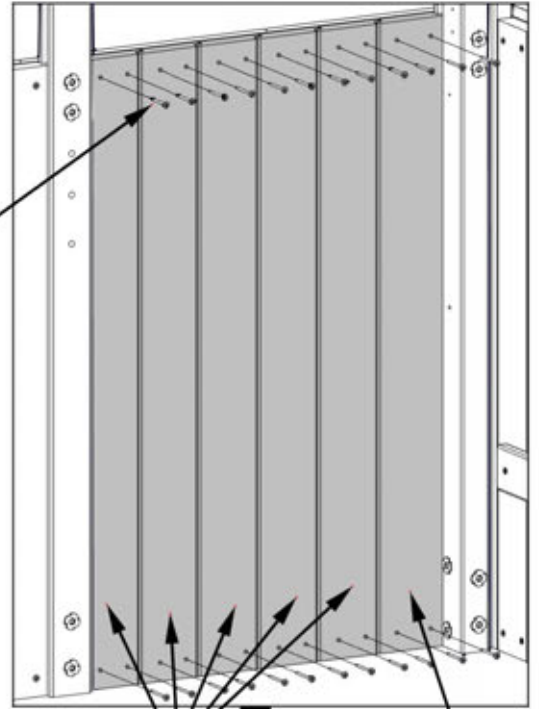
Q08 WALL BOARD - W4L18088
(x1) 15/16"x4 1/8"x33" (24x104x838)



Q01 WALL BOARD - W4L18057
(x5) 15/16"x3 15/16"x33" (24x100x838)

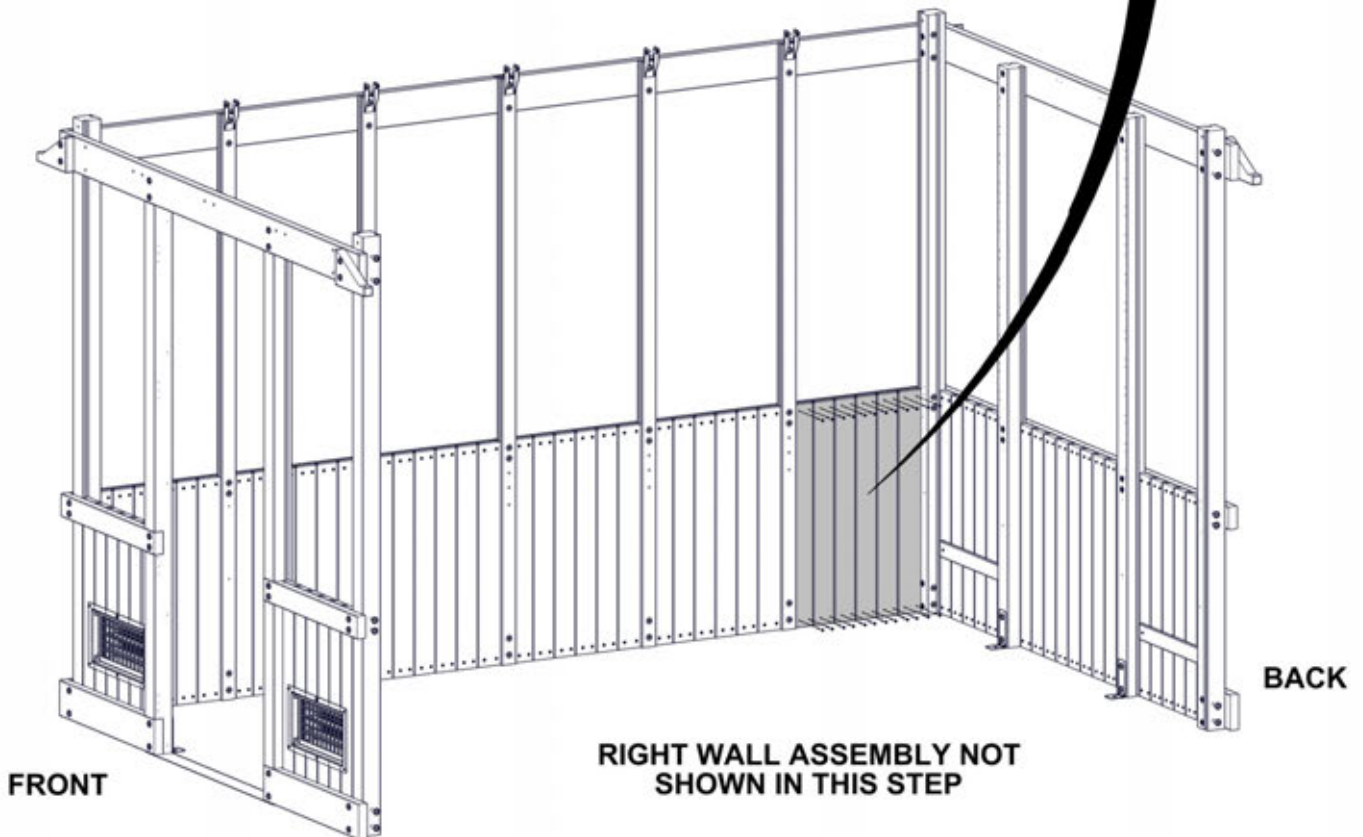
NOTE:
• EVENLY SPACE WALL BOARDS TO AVOID ANY GAPS IN THE WALL PANEL.

382 (x24)
SCREW - 1 3/4"



Q01 (x5)
WALL BOARD

Q08 (x1)
WALL BOARD



FRONT

BACK

RIGHT WALL ASSEMBLY NOT SHOWN IN THIS STEP

STEP 42 - FRONT WINDOW LEDGES

QTY	PART NUMBER	DESCRIPTION
6	H100382	SCREW PFH 8x1 3/4 BLK



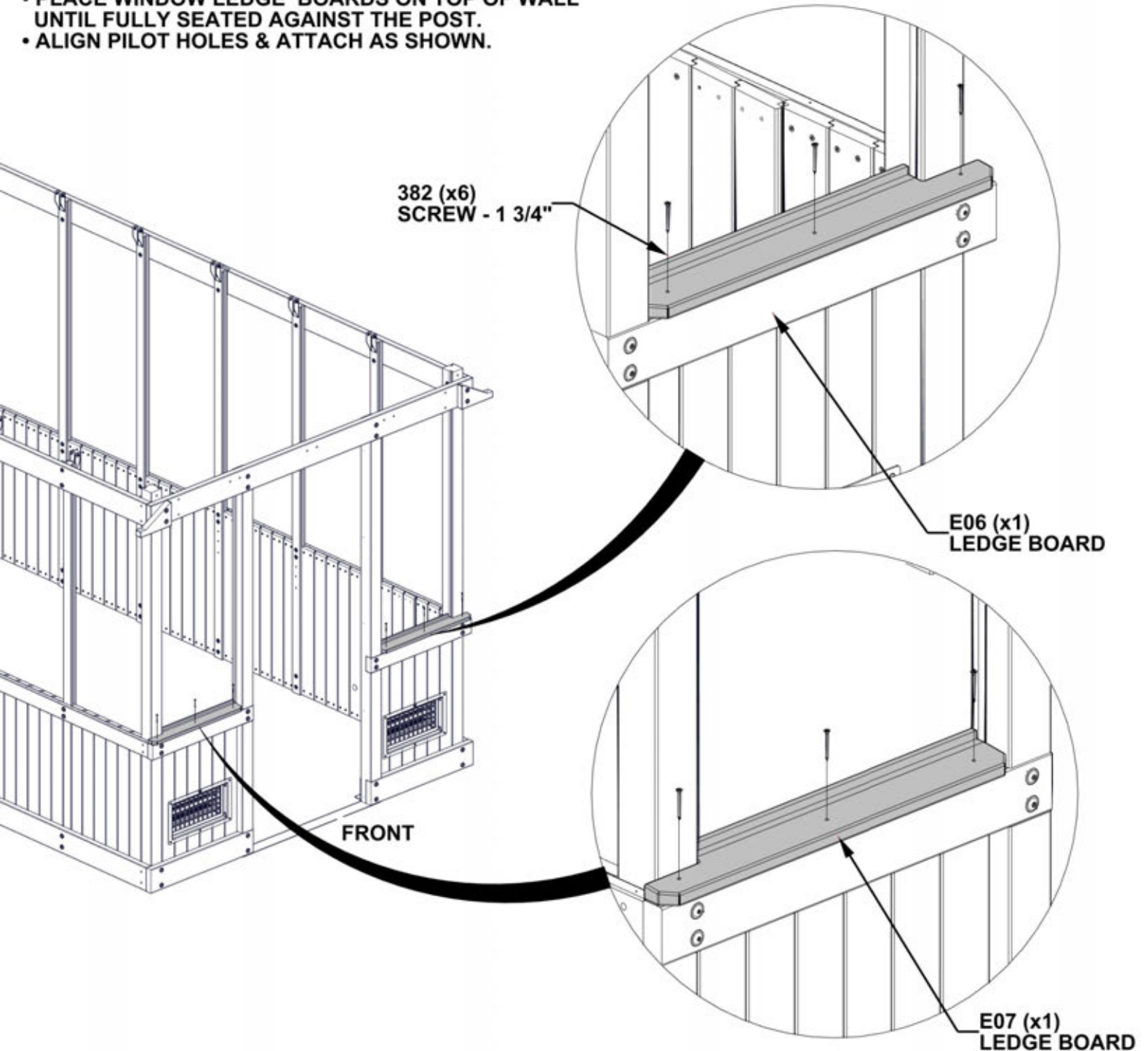
E06 LEDGE BOARD - W4L18063
(x1) 1 7/16"x3 3/8"x24 7/8" (36x86x632)



E07 LEDGE BOARD - W4L18064
(x1) 1 7/16"x3 3/8"x24 7/8" (36x86x632)

NOTES:

- PLACE WINDOW LEDGE BOARDS ON TOP OF WALL UNTIL FULLY SEATED AGAINST THE POST.
- ALIGN PILOT HOLES & ATTACH AS SHOWN.



STEP 43 - WINDOW LEDGES

QTY	PART NUMBER	DESCRIPTION
18	H100382	SCREW PFH 8x1 3/4 BLK



E05 LEDGE BOARD - W4L18035
(x1) 1 7/16"x3 3/8"x24 7/8" (36x86x632)



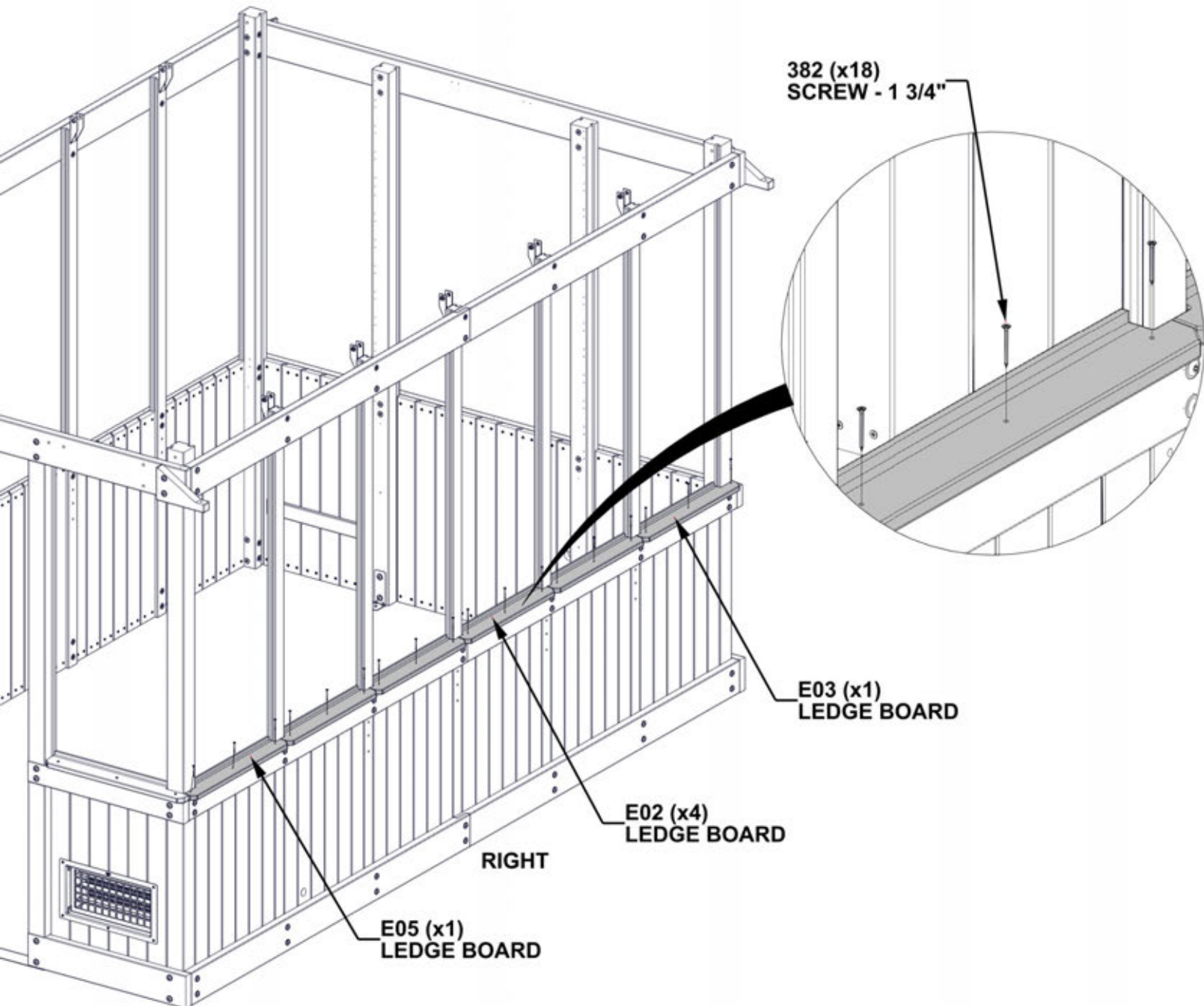
E03 LEDGE BOARD - W4L18034
(x1) 1 7/16"x3 3/8"x24 7/8" (36x86x632)



E02 LEDGE BOARD - W4L18033
(x4) 1 7/16"x3 3/8"x23 1/16" (36x86x585)

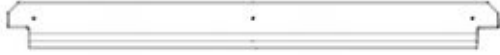
NOTES:

- PLACE WINDOW LEDGE BOARDS ON TOP OF WALL UNTIL FULLY SEATED AGAINST THE POST.
- ALIGN PILOT HOLES & ATTACH AS SHOWN.



STEP 44 - BACK WINDOW LEDGES

QTY	PART NUMBER	DESCRIPTION
9	H100382	SCREW PFH 8x1 3/4 BLK



E08 LEDGE BOARD - W4L18065
(x1) 1 7/16"x3 3/8"x35 11/16" (36x86x906)



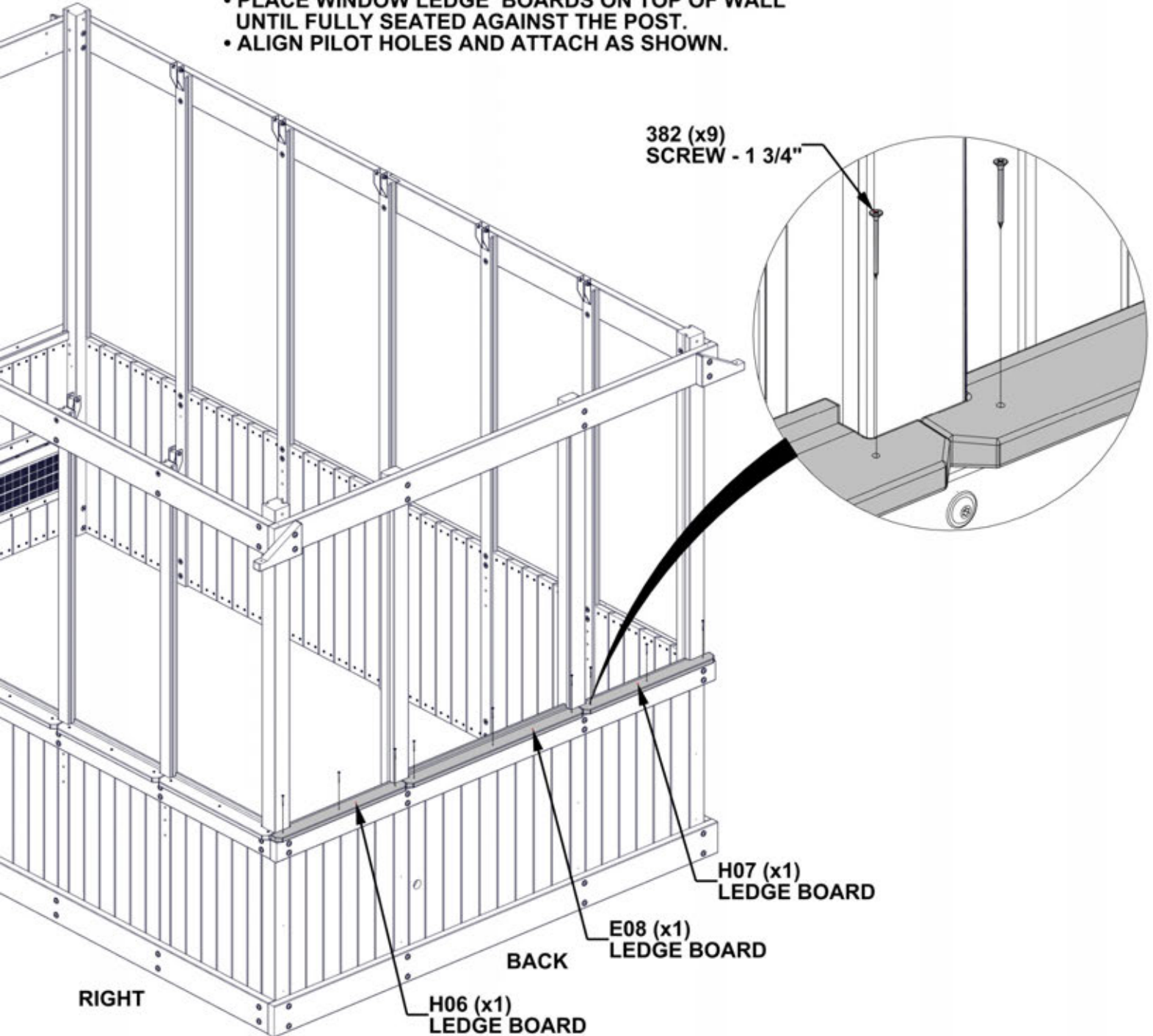
H07 LEDGE BOARD - W4L18341
(x1) 15/16"x2 13/16"x26 7/16" (24x72x671)



H06 LEDGE BOARD - W4L18340
(x1) 15/16"x2 13/16"x26 7/16" (24x72x671)

NOTES:

- PLACE WINDOW LEDGE BOARDS ON TOP OF WALL UNTIL FULLY SEATED AGAINST THE POST.
- ALIGN PILOT HOLES AND ATTACH AS SHOWN.



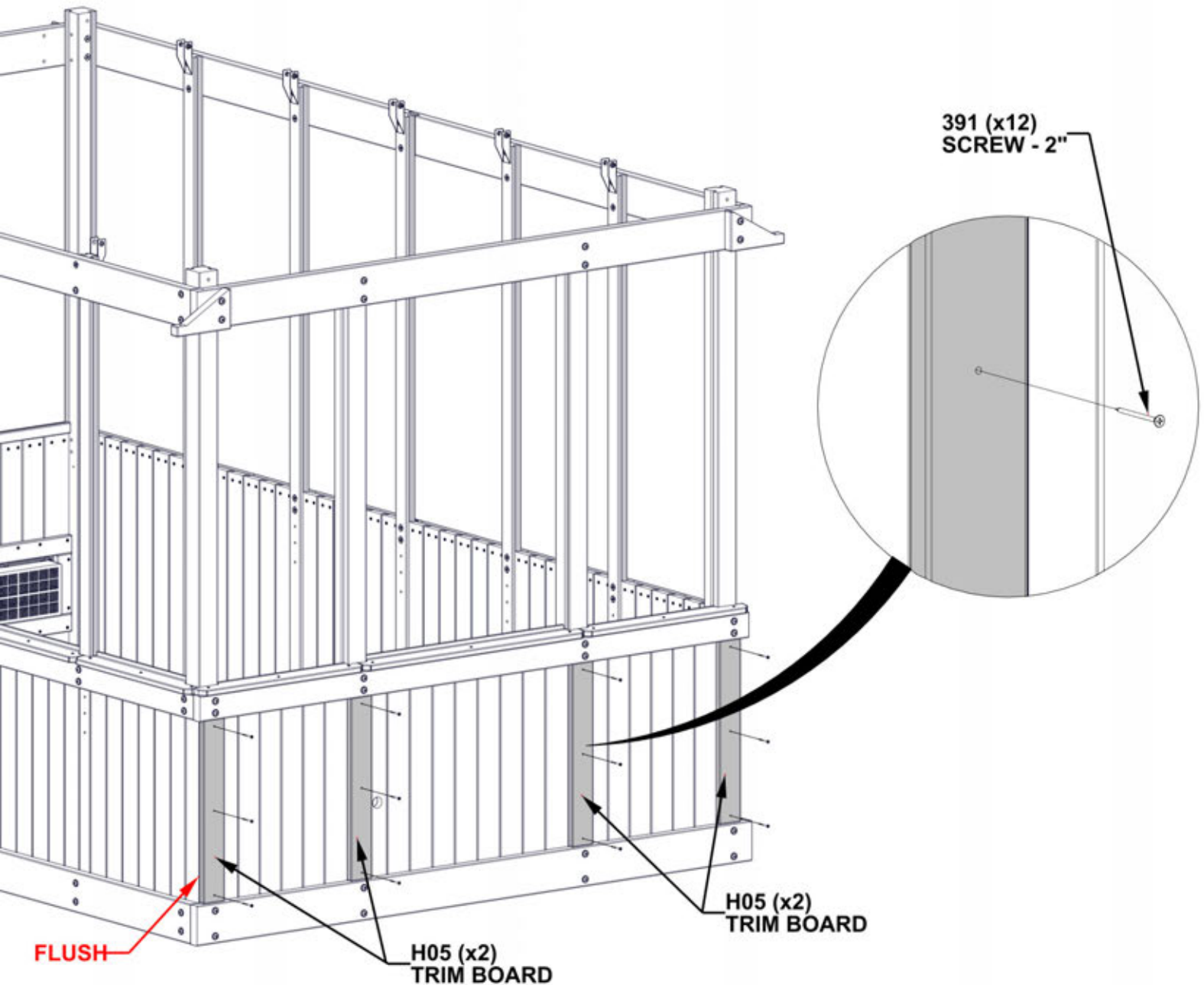
STEP 45 - BACK WALL TRIM

QTY	PART NUMBER	DESCRIPTION
12	H100391	SCREW PFH 8x2 BLK



H05 TRIM BOARD - W4L18425
(x4) 15/16"x3 3/8"x24 5/16" (24x86x618)

NOTES:
• ALIGN WITH PILOT HOLES AND ATTACH AS SHOWN.



STEP 46 - WINDOW LEDGES

QTY	PART NUMBER	DESCRIPTION
18	H100382	SCREW PFH 8x1 3/4 BLK



E02 LEDGE BOARD - W4L18033
(x4) 1 7/16"x3 3/8"x23 1/16" (36x86x585)



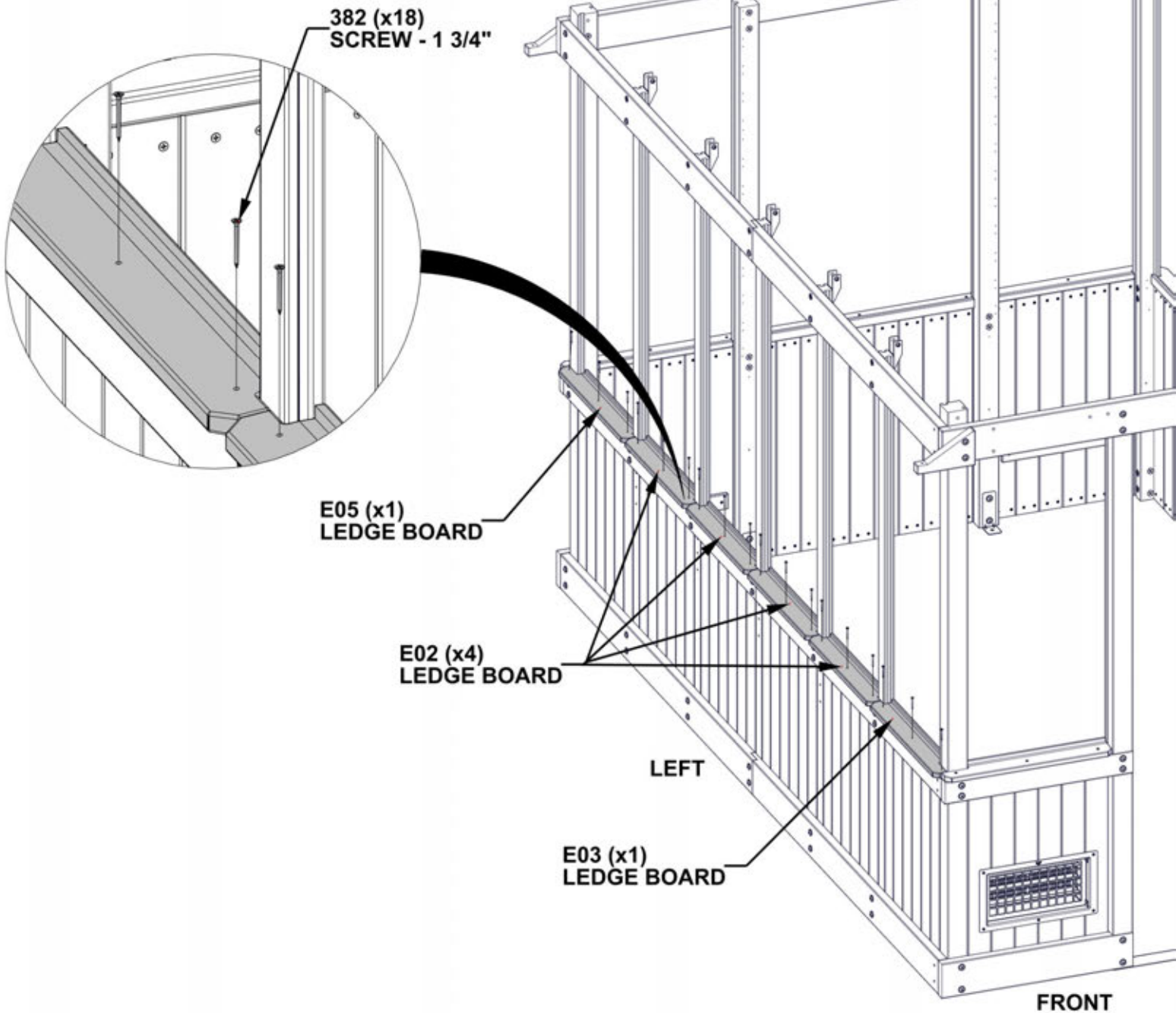
E03 LEDGE BOARD - W4L18034
(x1) 1 7/16"x3 3/8"x24 7/8" (36x86x632)



E05 LEDGE BOARD - W4L18035
(x1) 1 7/16"x3 3/8"x24 7/8" (36x86x632)

NOTES:

- PLACE WINDOW LEDGE BOARDS ON TOP OF WALL UNTIL FULLY SEATED AGAINST THE POST.
- ALIGN PILOT HOLES AND ATTACH AS SHOWN.



STEP 47 - WINDOW ASSEMBLY

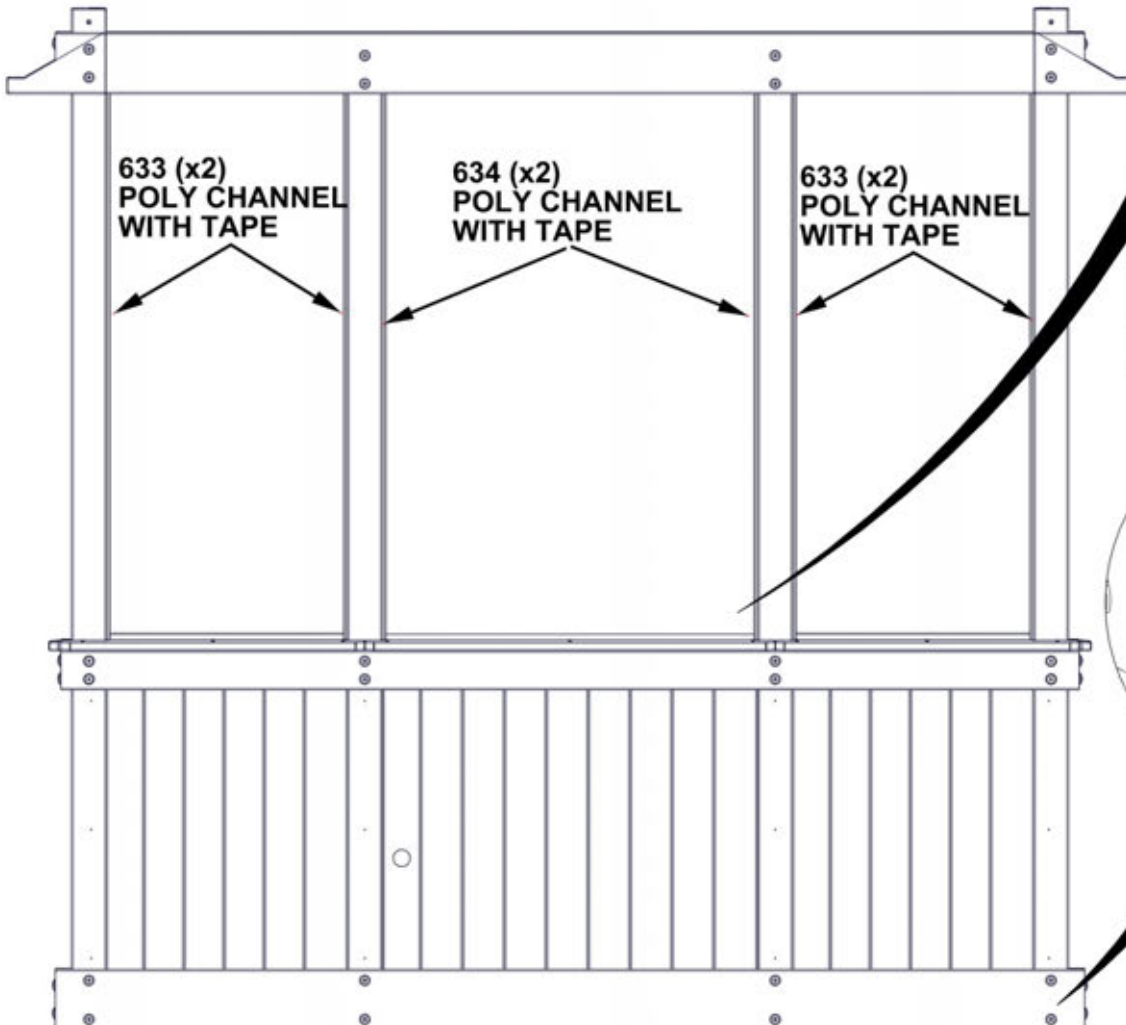
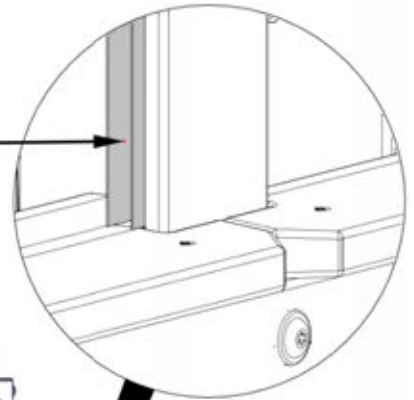
A6P00633 POLY CHANNEL WITH TAPE
(x4)

A6P00634 POLY CHANNEL WITH TAPE
(x2)

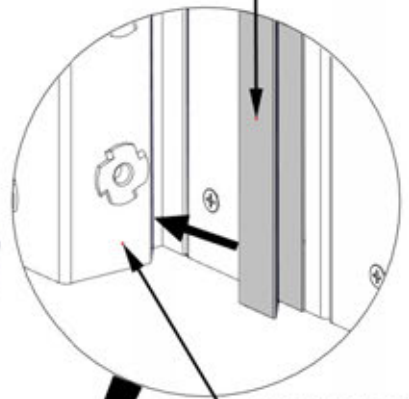


POLY CHANNEL WILL COME WITH DOUBLE SIDED TAPE INSTALLED. REMOVE LINER BEFORE INSTALLATION

INSERT POLY CHANNEL 634 INTO GROOVE STARTING AT THE WINDOW LEDGE AND WORK UPWARDS



INSERT CHANNEL 633 INTO GROOVE STARTING AT THE BOTTOM OF INTERIOR POSTS & WORK UPWARDS



INSIDE POST

INSIDE VIEW

STEP 48 - WINDOW ASSEMBLY

QTY	PART NUMBER	DESCRIPTION
16	H101207	SCREW PWH 8x15x7/8 BLK



NOTES:

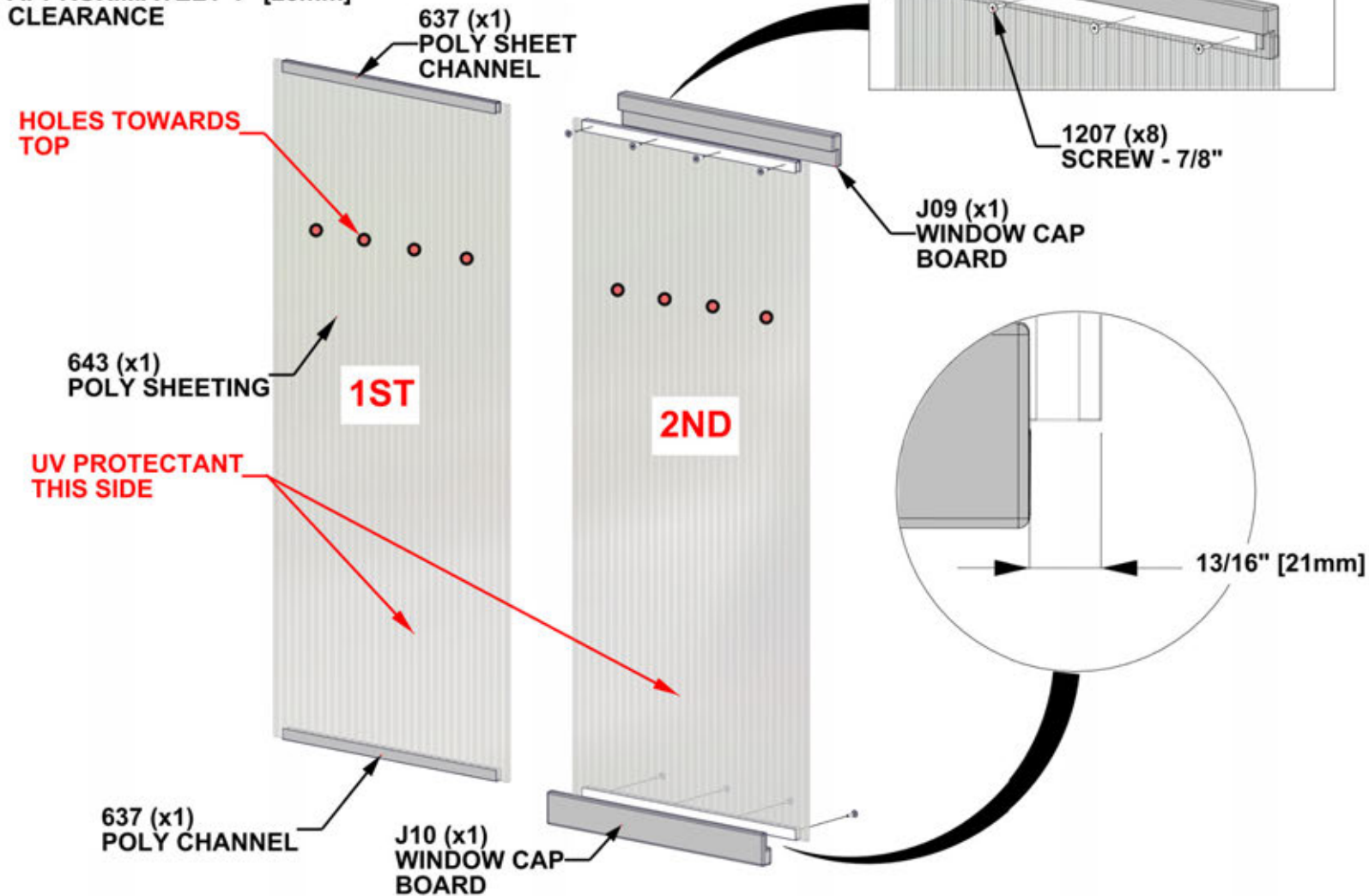
- **IMPORTANT! ENSURE UV SIDE OF POLY SHEETING IS ORIENTED CORRECTLY AS SHOWN.**
- **NOTE HOLE LOCATION IN POLY SHEETING WHEN INSTALLING WINDOW CAP BOARDS.**
- **REPEAT FOR SECOND WINDOW ASSEMBLY.**



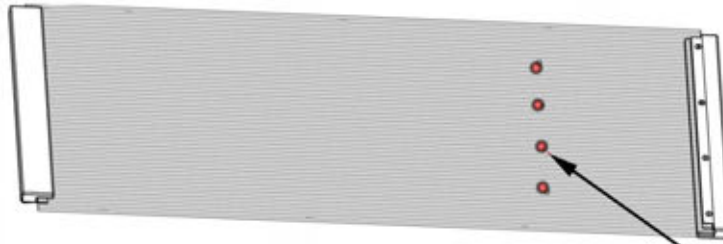
FIRST, APPLY DUST SEAL TAPE AND CHANNEL:

- CUT (2) STRIPS OF DUST SEAL TAPE THE SAME WIDTH AS THE POLY SHEETING.
- WRAP DUST TAPE ALONG EDGE OF POLY SHEETING WIDTH.
- AFTER TAPE IS SECURE, PUSH CHANNEL ON OVER THE TAPE, CENTERING ON POLY SHEETING (APPROX 1" [25mm]) CLEARANCE ON EACH SIDE AS SHOWN.
- REPEAT ON THE BOTTOM SIDE OF POLY SHEETING SECOND, ATTACH WINDOW CAP BOARDS, AS SHOWN.

APPROXIMATELY 1" [25mm] CLEARANCE



STEP 49 - WINDOW ASSEMBLY

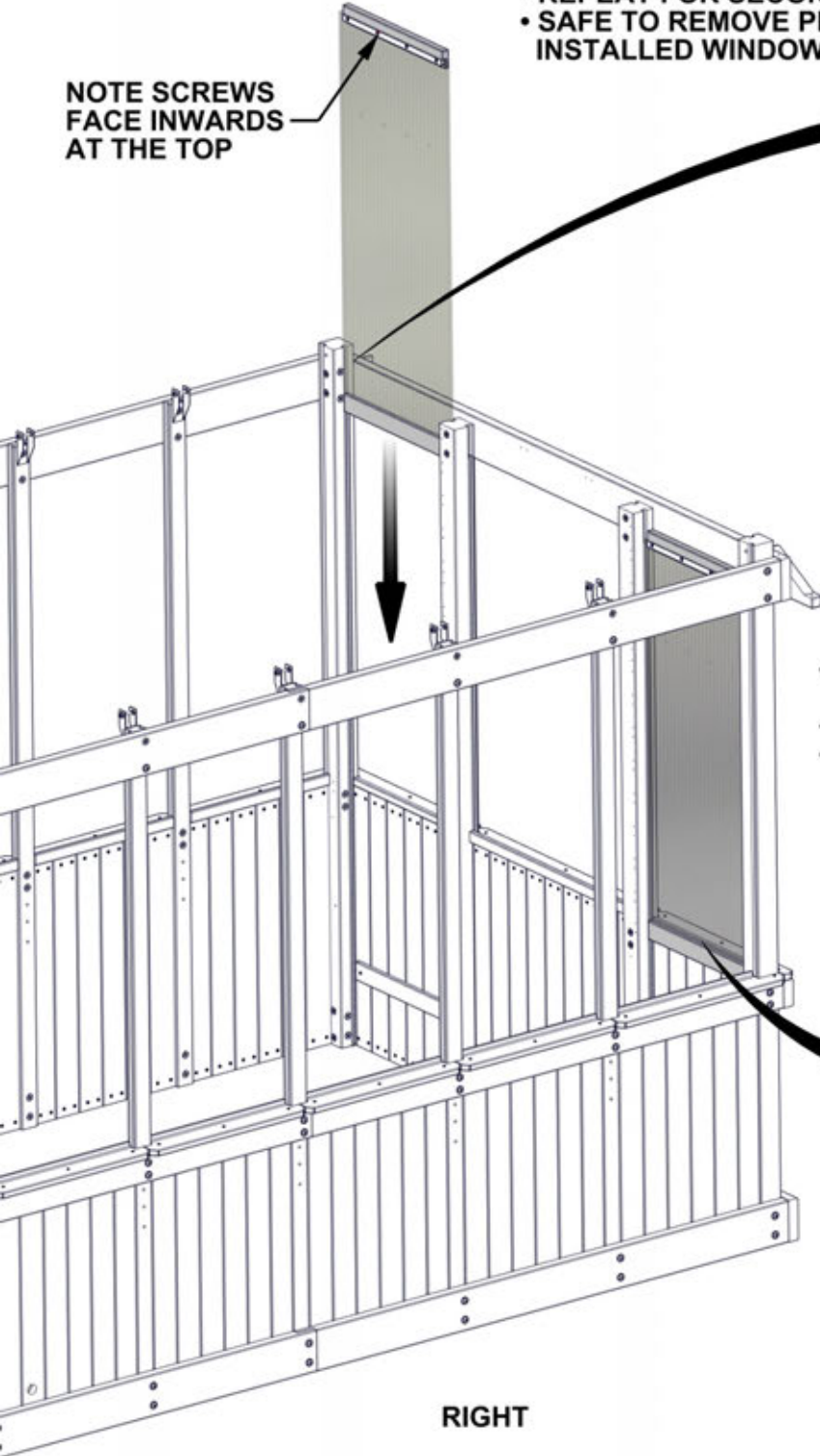


WINDOW ASSEMBLIES FROM STEP 48 (X2)

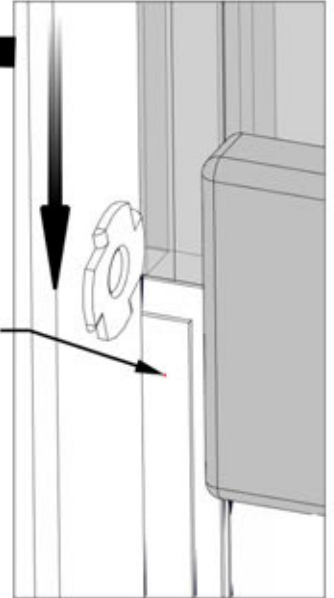
NOTE HOLES ARE TO BE POSITIONED TOWARDS THE TOP OF THE WINDOW WHEN INSTALLED.

- NOTES:
- REPEAT FOR SECOND WINDOW.
 - SAFE TO REMOVE PROTECTIVE FILM FROM INSTALLED WINDOWS.

NOTE SCREWS FACE INWARDS AT THE TOP

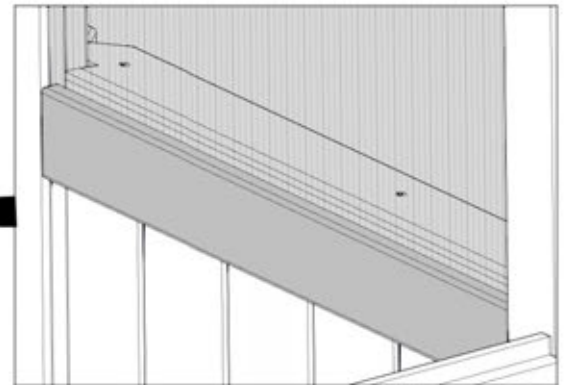


PREVIOUSLY INSTALLED POLY CHANNEL



- INSERT WINDOW ASSEMBLY INTO PREVIOUSLY INSTALLED CHANNEL ON BOTH SIDES OF WINDOW.
- SLIDE WINDOW DOWN TO THE CLOSED POSITION.
- WHEN CLOSED, WINDOW CAP BOARD WILL BE FLUSH WITH WINDOWSILL AS SHOWN BELOW

BACK



RIGHT

STEP 50 - WINDOW ASSEMBLY

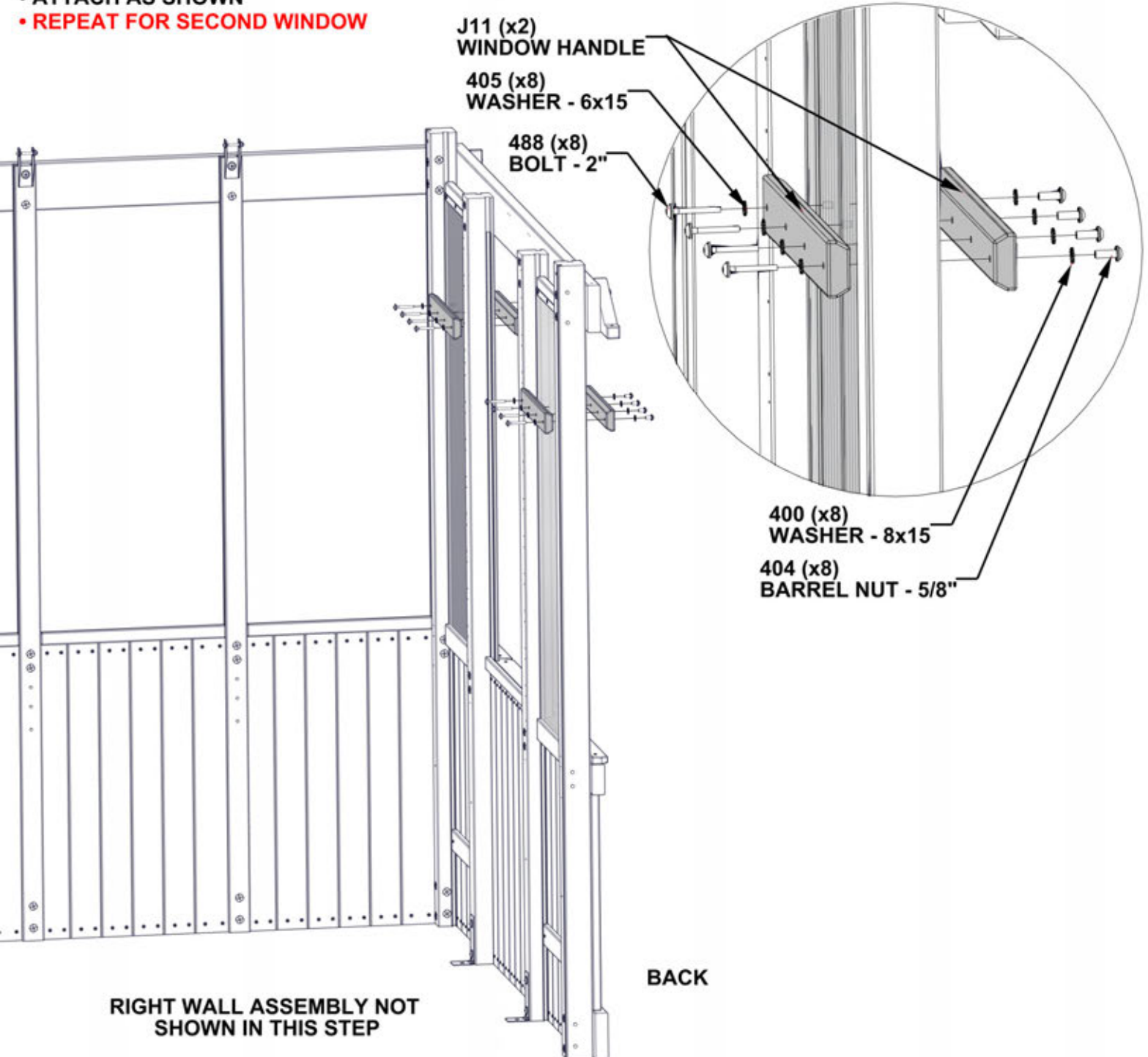
QTY	PART NUMBER	DESCRIPTION
8	H100400	WASHER LOCK EXT 8x15
8	H100404	NUT BARREL WH 1/4X5/8 BLK
8	H100405	WASHER LOCK EXT 6x15
8	H100488	BOLT WH 1/4x2 BLK



J11 WINDOW HANDLE - W4L18772
(x4) 15/16"x2 3/8"x15 1/2" (24x60x394)

NOTES:

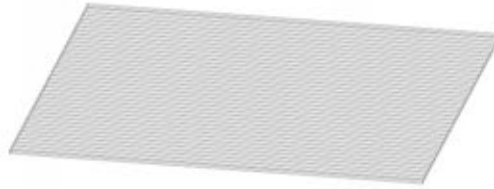
- LINE UP WINDOW HANDLE WITH HOLES IN POLY SHEETING.
- ATTACH AS SHOWN
- REPEAT FOR SECOND WINDOW



STEP 51 - WINDOW ASSEMBLY



A6P00638 POLY CHANNEL
(x2)



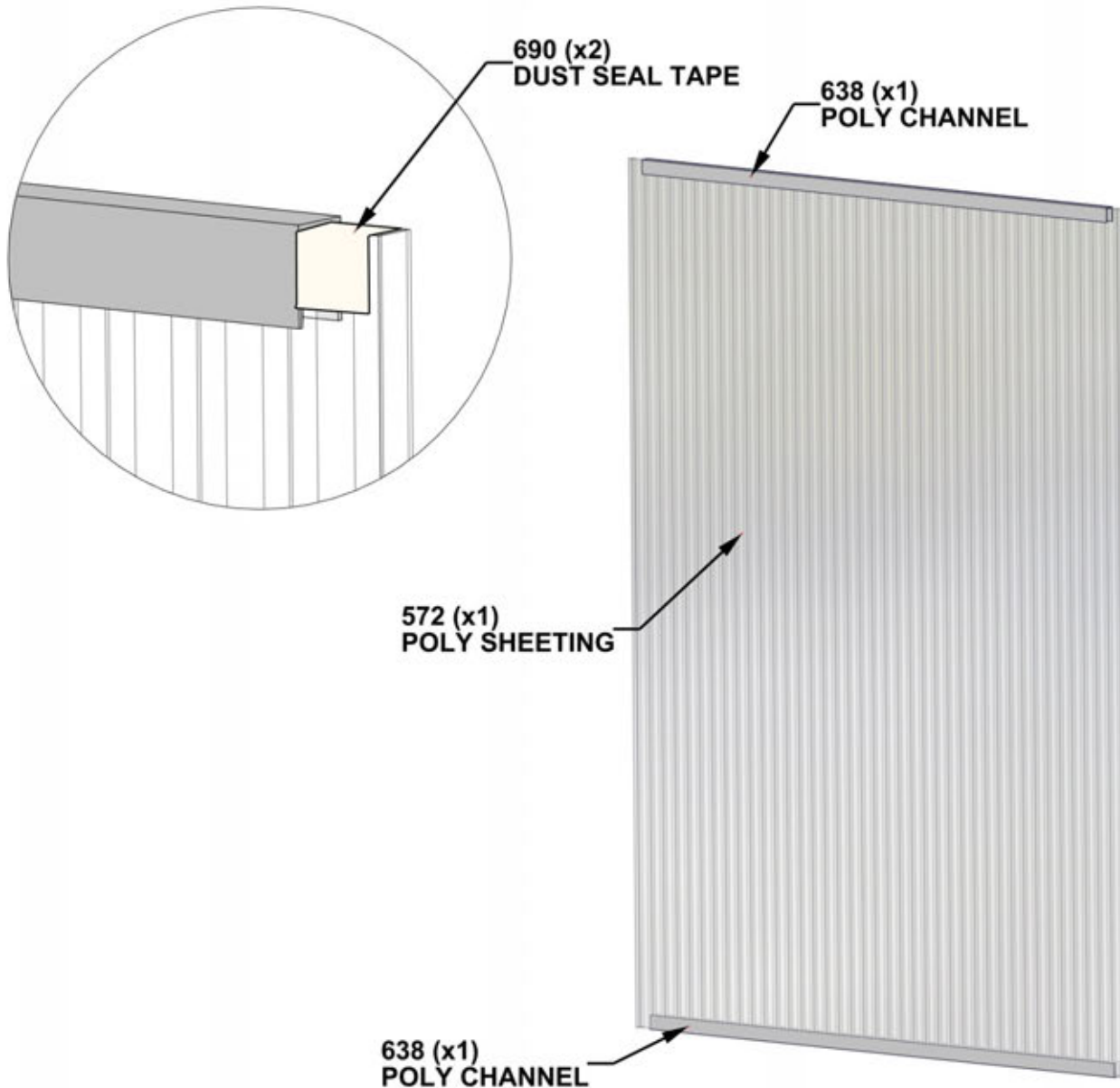
A6P00572 POLY SHEETING
(x1)



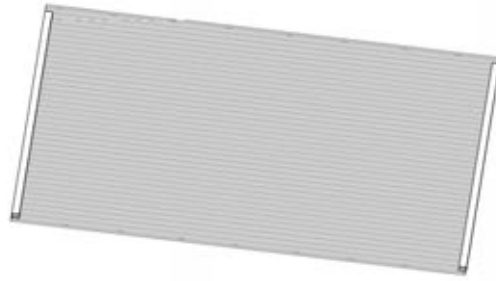
A6P00690 DUST SEAL TAPE

TO APPLY DUST TAPE & POLY CHANNEL:

- CUT (2) STRIPS OF DUST SEAL TAPE THE SAME WIDTH AS THE POLY SHEETING
- WRAP DUST TAPE ALONG EDGE OF POLY SHEETING WIDTH
- AFTER TAPE IS SECURE, PUSH CHANNEL ON OVER THE TAPE, CENTERING ON POLY SHEETING (APPROX 1" (25MM) CLEARANCE ON EACH SIDE AS SHOWN)
- REPEAT ON THE BOTTOM SIDE OF POLY SHEETING



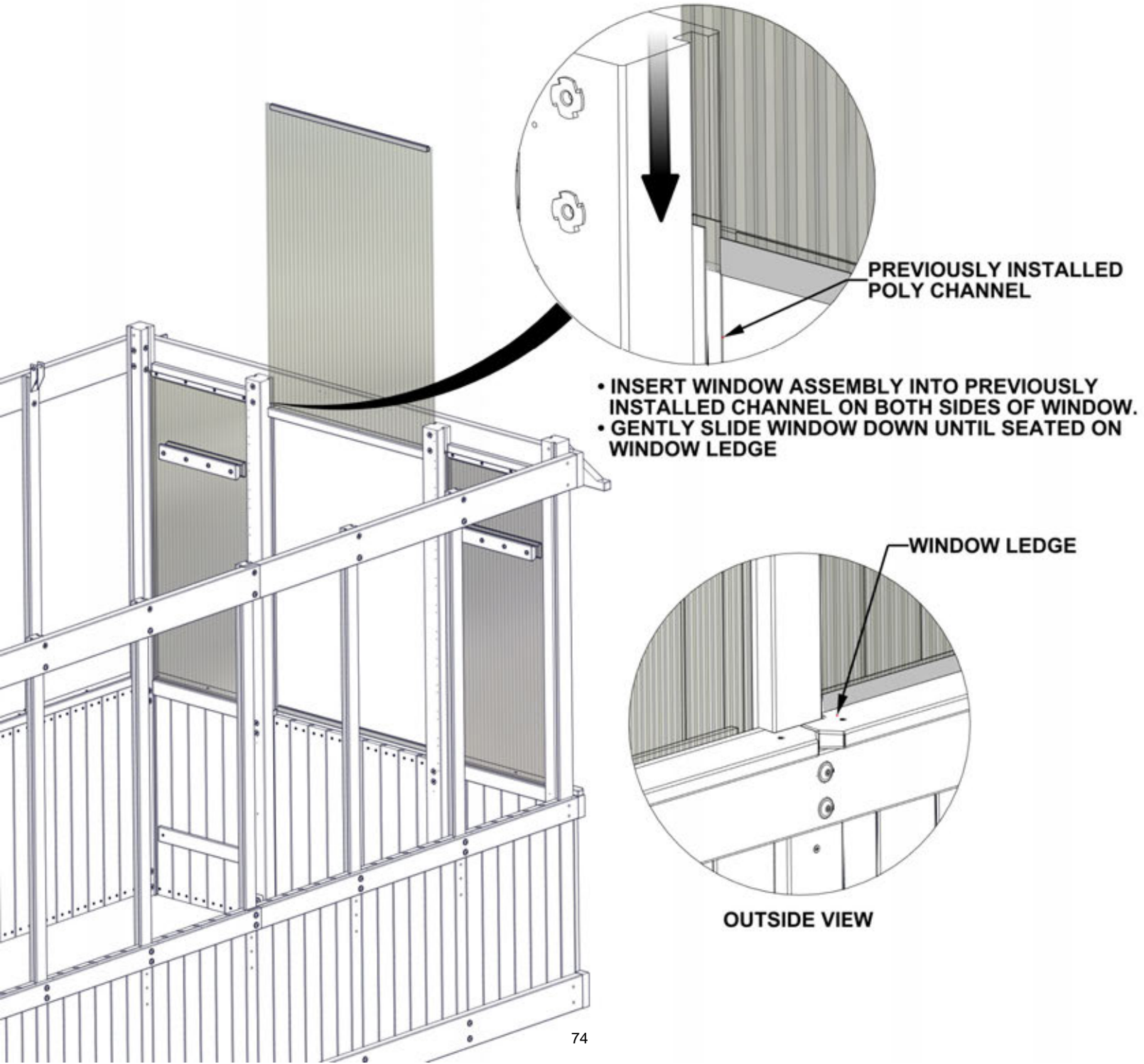
STEP 52 - WINDOW ASSEMBLY



WINDOW ASSEMBLY FROM
STEP 51

NOTES:

- IMPORTANT! ENSURE UV SIDE OF POLY SHEETING IS FACING OUTSIDE
- SAFE TO REMOVE PROTECTIVE FILM FROM INSTALLED WINDOW



STEP 53 - WINDOW ASSEMBLY

QTY	PART NUMBER	DESCRIPTION
3	H100483	SCREW PFH 8x2 1/4 BLK

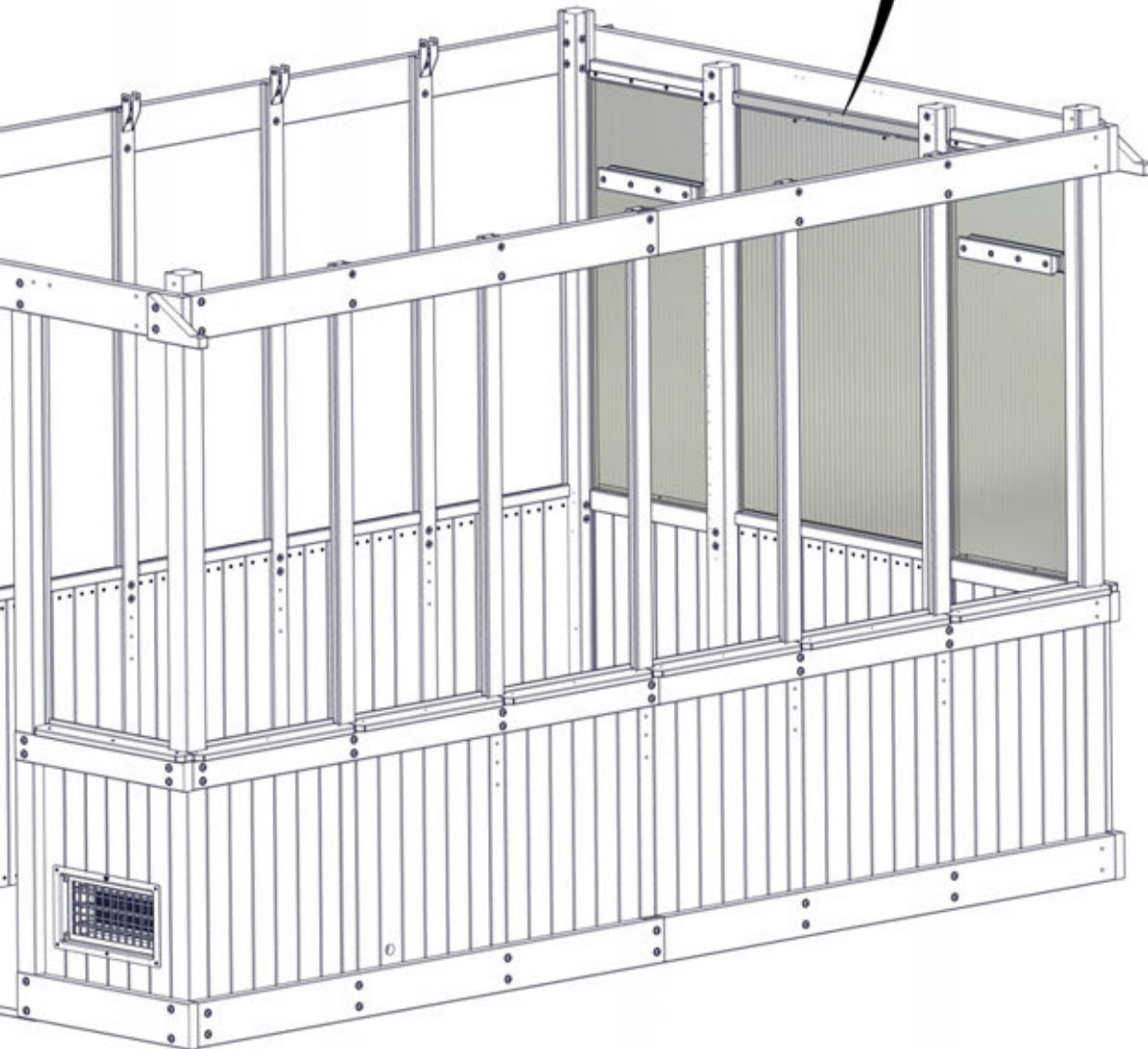
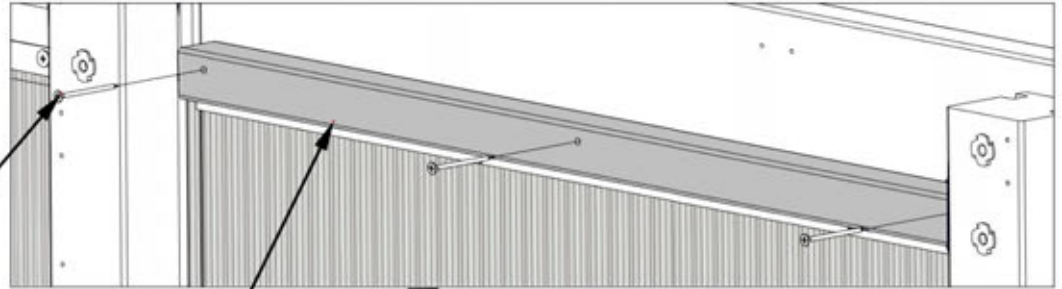


P14 WINDOW CAP BOARD - W4L18397
(x1) 1 7/16"x1 7/16"x32 1/4" (36x36x820)

NOTES:
• CENTER WINDOW CAP BOARD AND ATTACH AS SHOWN.

483 (x3)
SCREW - 2 1/4"

P14 (x1)
WINDOW CAP BOARD

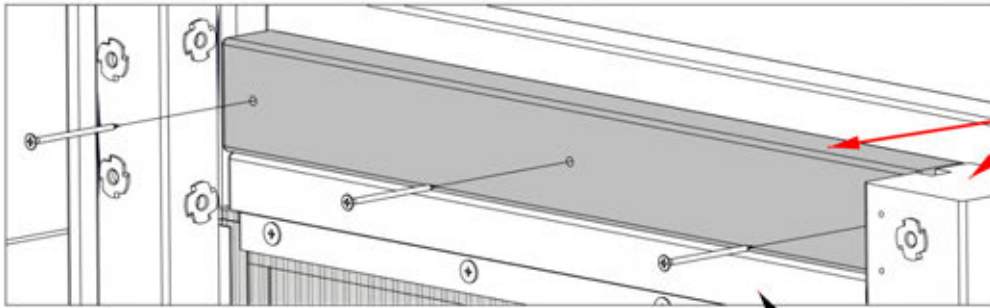


STEP 54 - WINDOW ASSEMBLY

QTY	PART NUMBER	DESCRIPTION
6	H100201	SCREW PFH 8x2 1/2 BLK



F16 WINDOW LATCH BOARD - W4L18774
(x2) 1 7/16"x2 3/8"x21" (36x60x533)



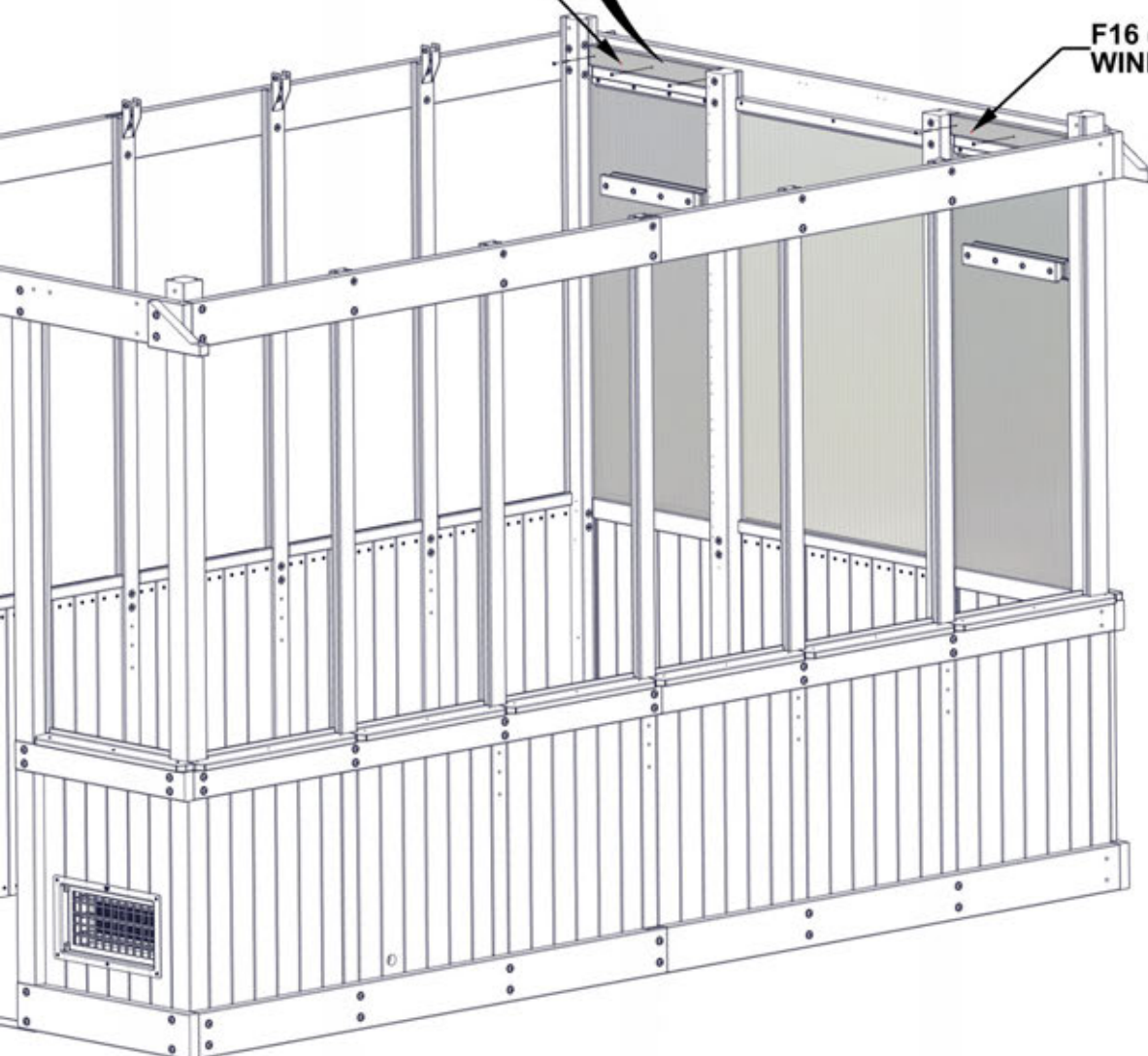
NOTES:
• CENTER WINDOW LATCH BOARDS AND ATTACH AS SHOWN.

FLUSH

F16 (x1)
WINDOW LATCH BOARD

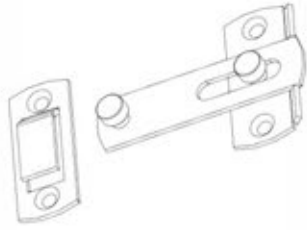
201 (x6)
SCREW - 2 1/2"

F16 (x1)
WINDOW LATCH BOARD



STEP 55 - WINDOW ASSEMBLY

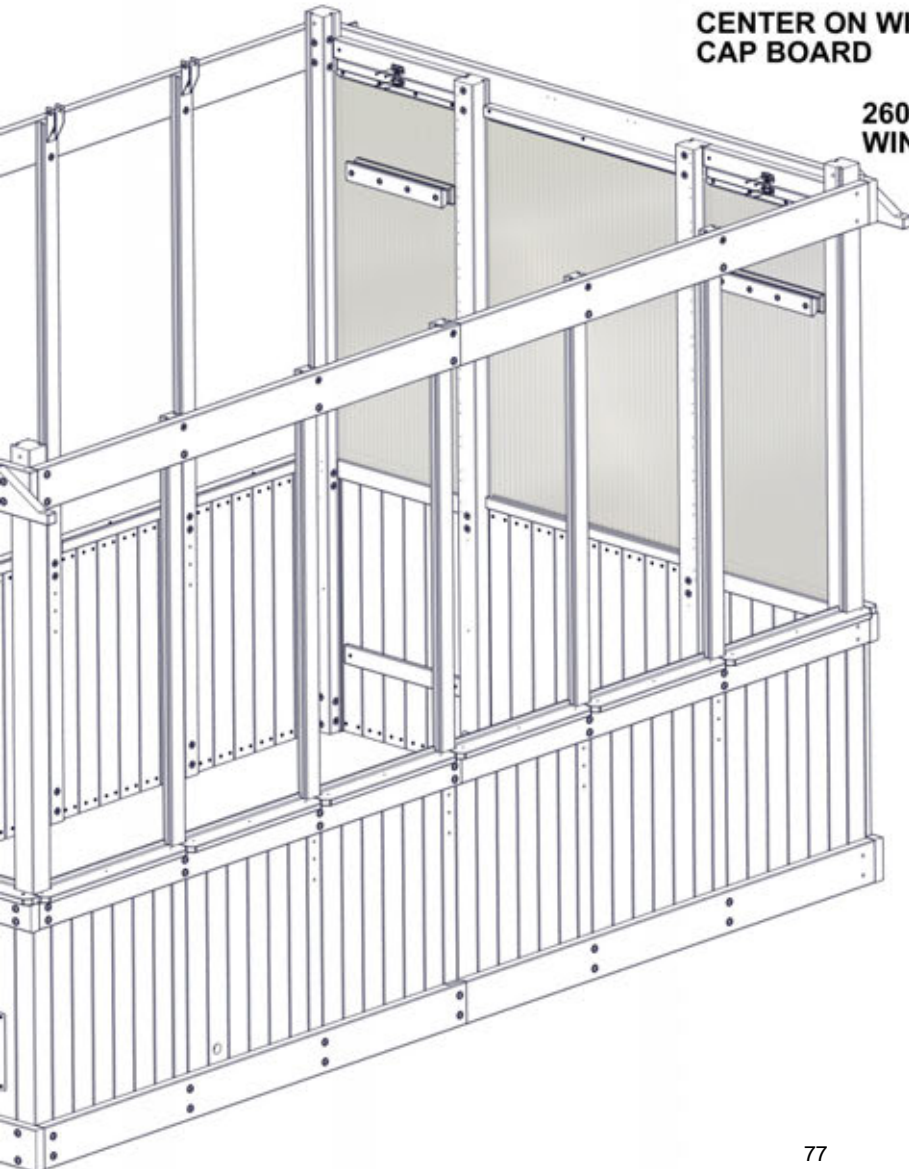
QTY	PART NUMBER	DESCRIPTION
8	H100627	SCREW PFH 6x3/4 BLK



A4M02607 WINDOW LATCH LOCK
(x2)

NOTES:

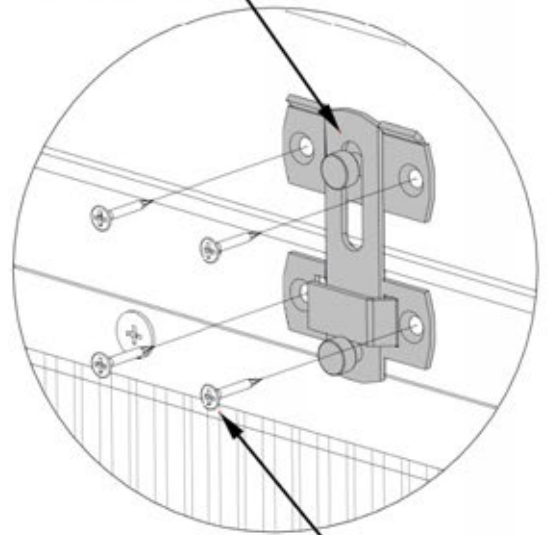
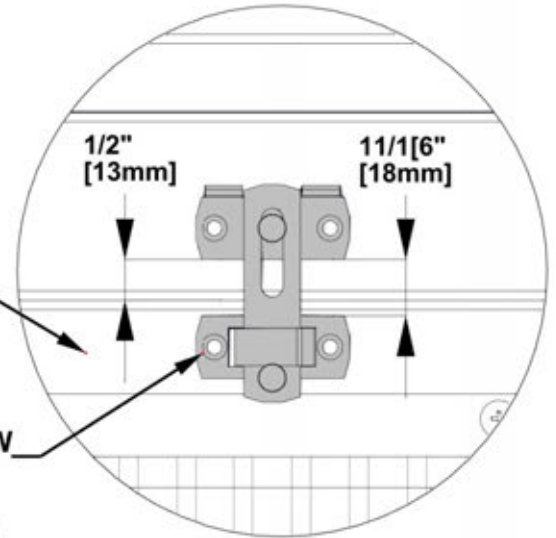
- CENTER WINDOW LATCH ON WINDOW CAP BOARD.
- WITH THE WINDOW LOCK ASSEMBLED AS SHOWN IN DETAIL, MARK HOLES AND DRILL PILOT HOLES USING A 3/32" DRILL BIT.
- ATTACH AS SHOWN.



WINDOW CAP BOARD

CENTER ON WINDOW CAP BOARD

2607 (x2)
WINDOW LATCH LOCK



627 (x8)
SCREW - 3/4"

STEP 56 - BACK WALL ASSEMBLY

QTY	PART NUMBER	DESCRIPTION
8	H100391	SCREW PFH 8x2 BLK



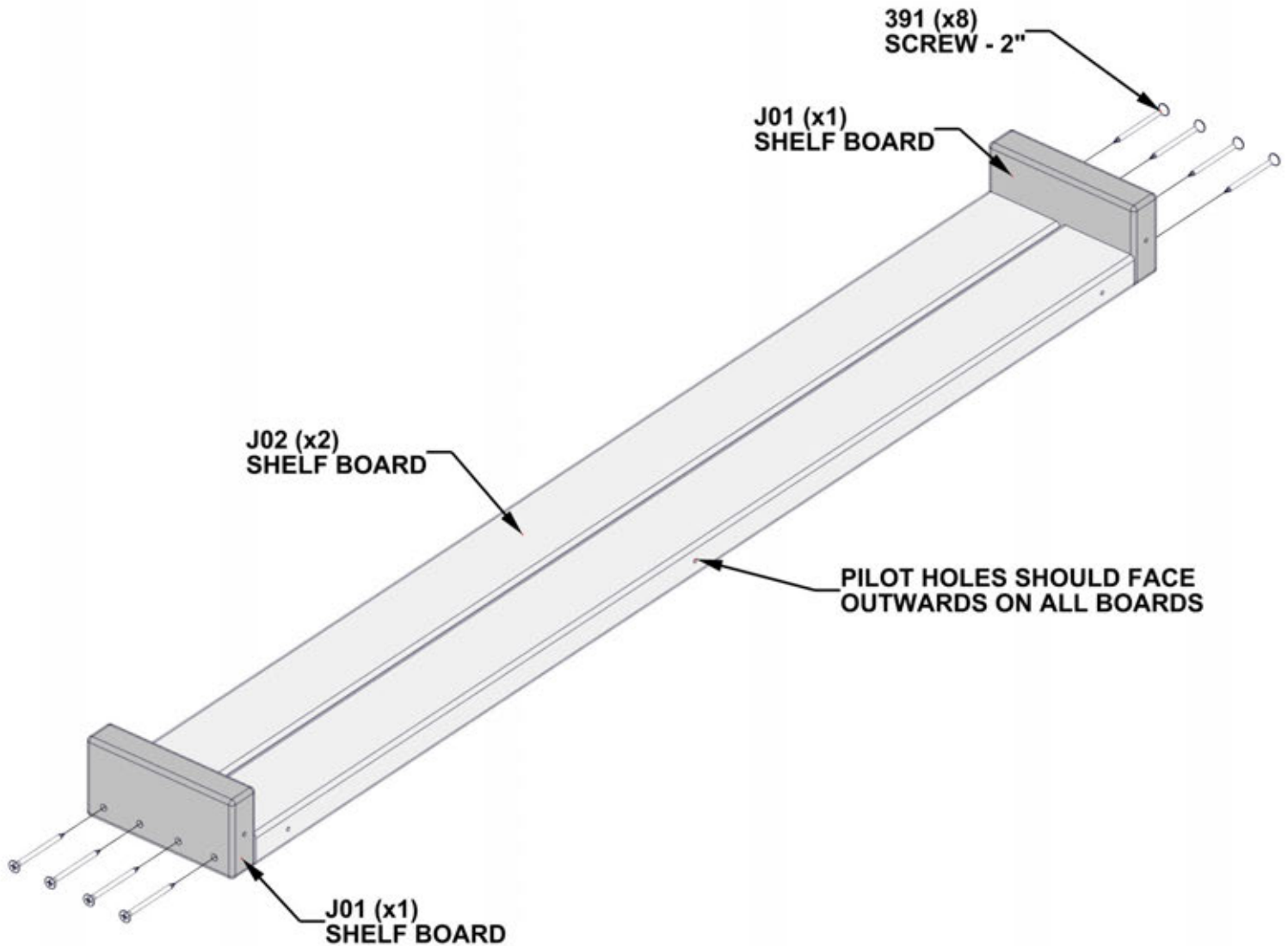
J01 SHELF BOARD - W4L18411
(x2) 15/16"x2 3/8"x4 13/16" (24x60x122)



J02 SHELF BOARD - W4L18413
(x2) 15/16"x2 3/8"x34 3/4" (24x60x882)

NOTES:

- ALIGN PILOT HOLES & FASTEN AS SHOWN.



STEP 57 - BACK WALL ASSEMBLY

QTY	PART NUMBER	DESCRIPTION
10	H100391	SCREW PFH 8x2 BLK



SHELF ASSEMBLY FROM STEP 56

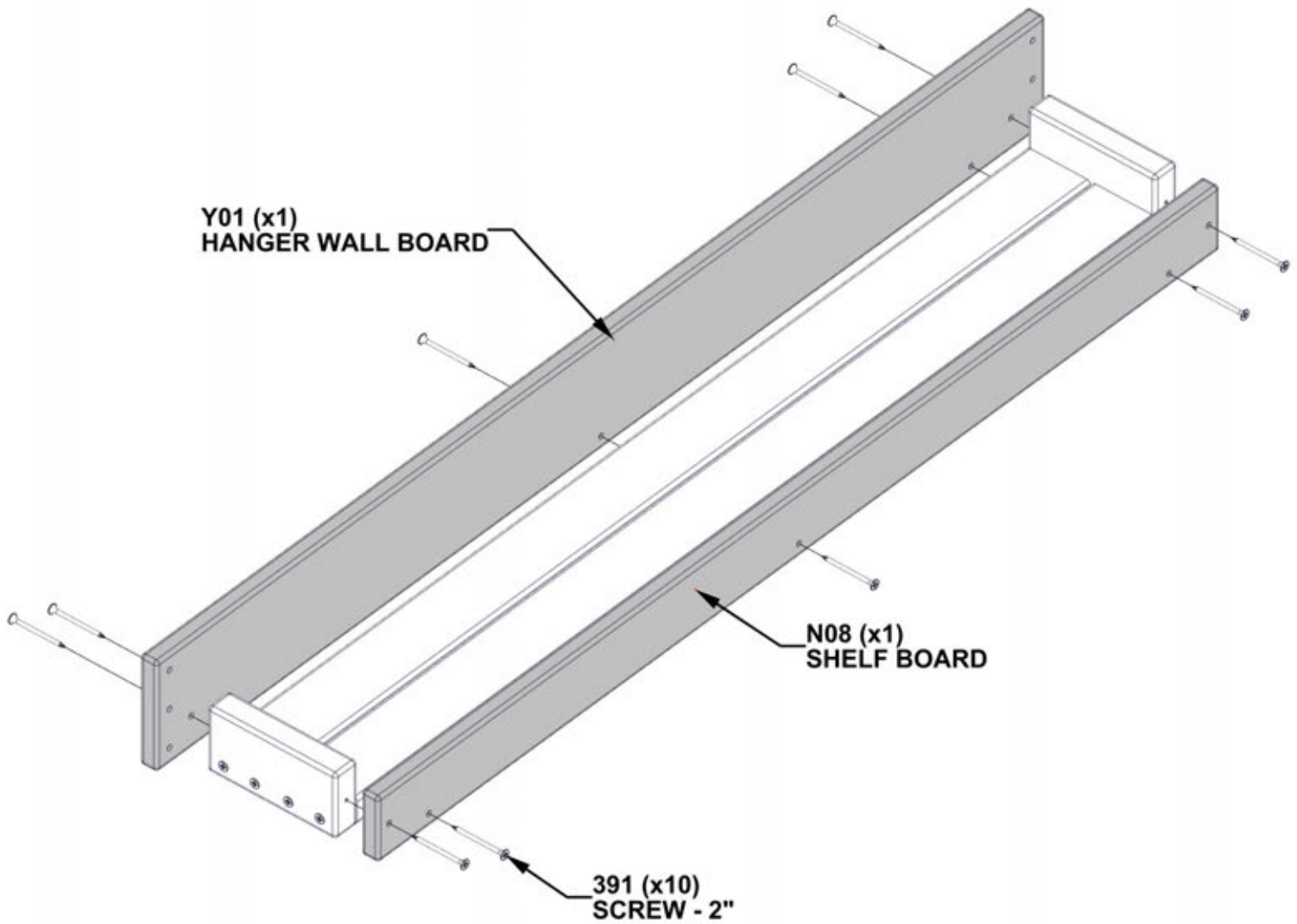


N08 SHELF BOARD - W4L18412
(x1) 5/8"x2 3/8"x36 5/8" (16x60x930)



Y01 HANGER WALL BOARD - W4L18410
(x1) 5/8"x4"x38 11/16" (16x102x982)

NOTES:
• ALIGN PILOT HOLES AND ATTACH AS SHOWN.



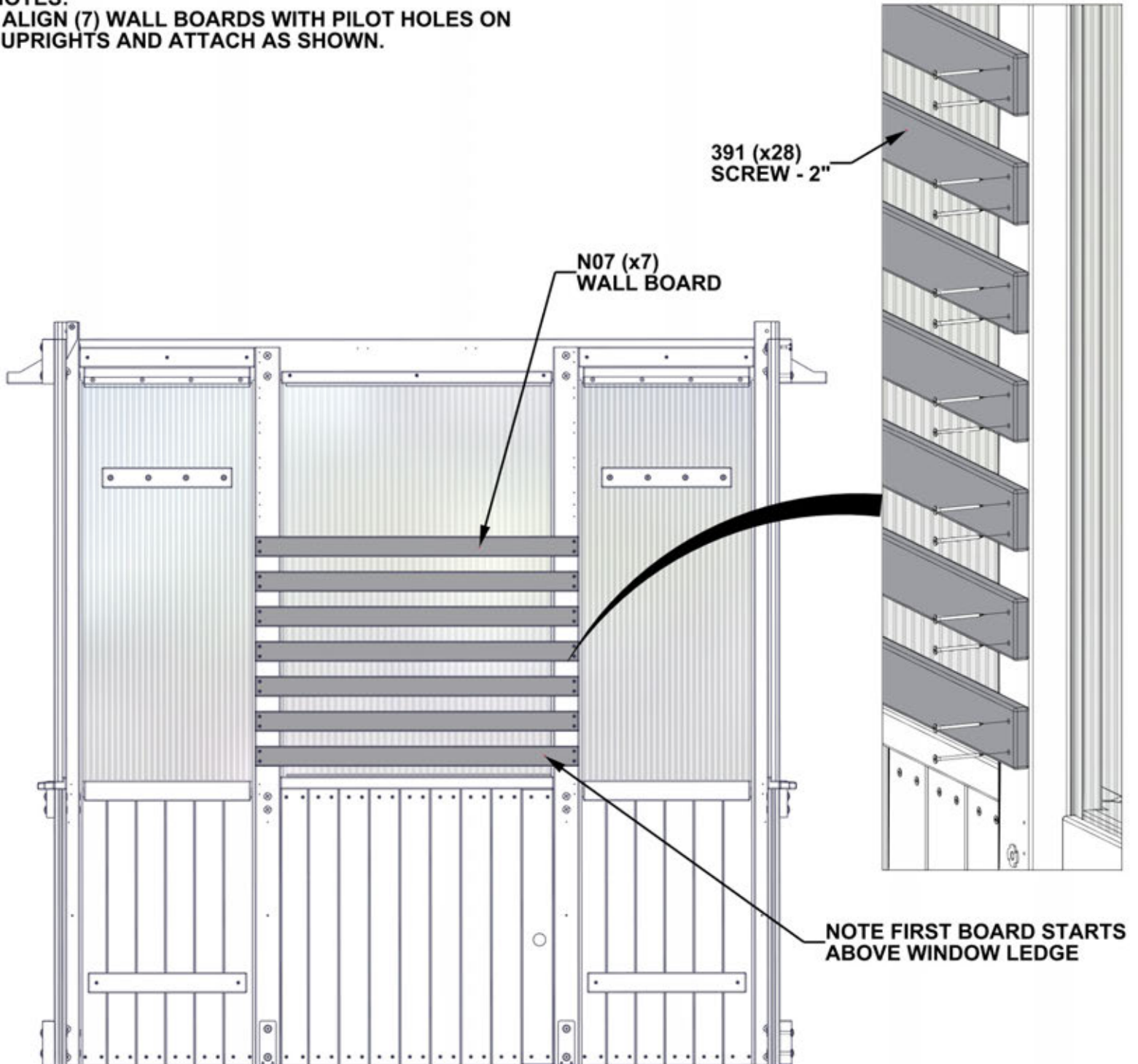
STEP 58 - BACK WALL ASSEMBLY

QTY	PART NUMBER	DESCRIPTION
28	H100391	SCREW PFH 8x2 BLK



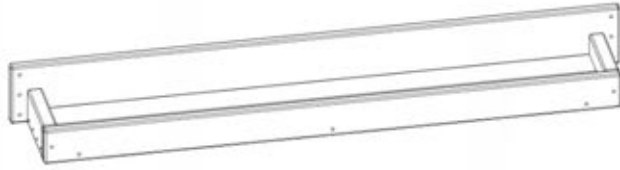
N07 WALL BOARD - W4L18367
(x7) 5/8"x2 3/8"x38 11/16" (16x60x982)

- NOTES:**
- ALIGN (7) WALL BOARDS WITH PILOT HOLES ON UPRIGHTS AND ATTACH AS SHOWN.



STEP 59 - BACK WALL ASSEMBLY

QTY	PART NUMBER	DESCRIPTION
18	H100391	SCREW PFH 8x2 BLK

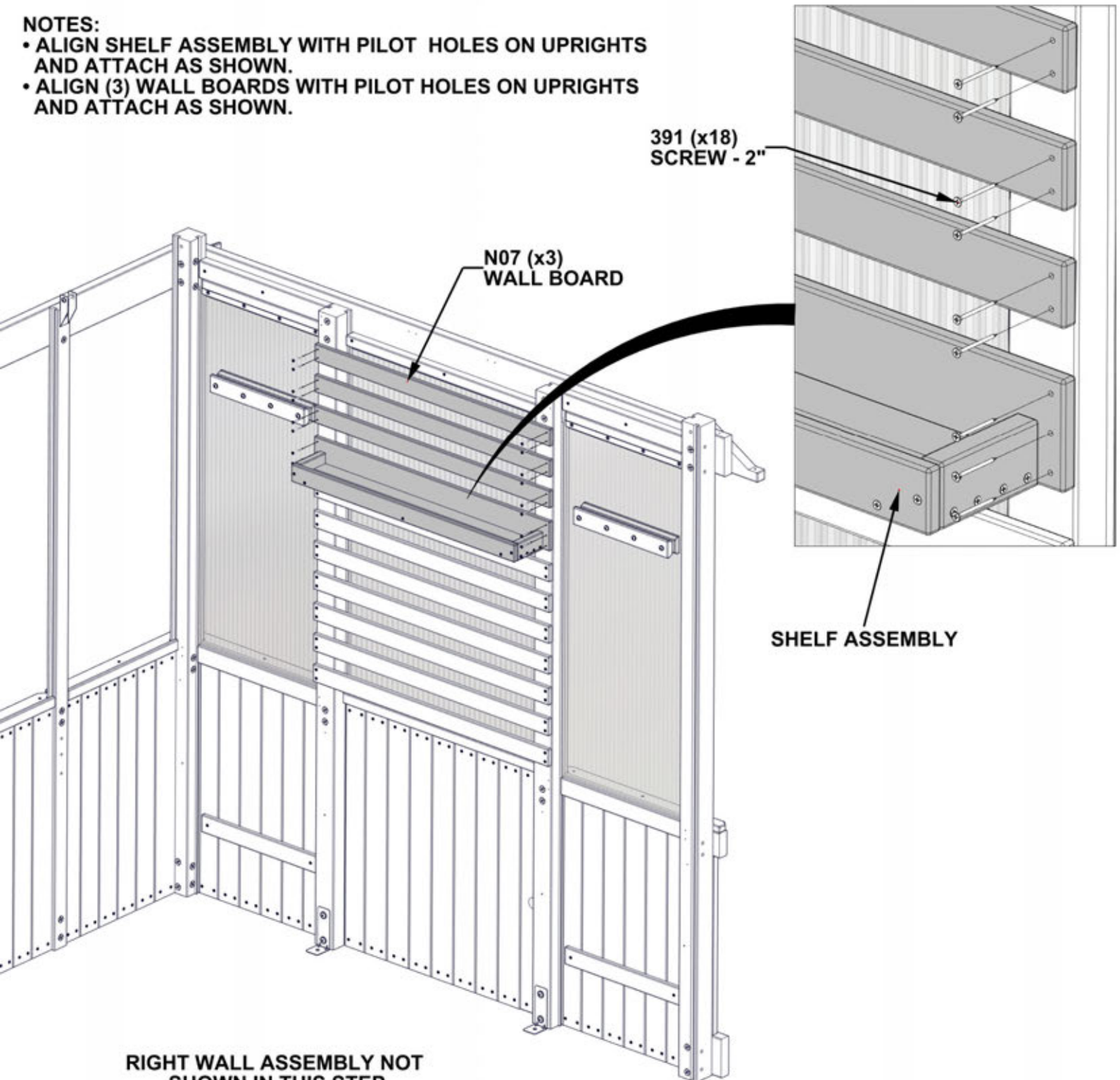


SHELF ASSEMBLY



N07 WALL BOARD - W4L18367
(x3) 5/8"x2 3/8"x38 11/16" (16x60x982)

- NOTES:**
- ALIGN SHELF ASSEMBLY WITH PILOT HOLES ON UPRIGHTS AND ATTACH AS SHOWN.
 - ALIGN (3) WALL BOARDS WITH PILOT HOLES ON UPRIGHTS AND ATTACH AS SHOWN.

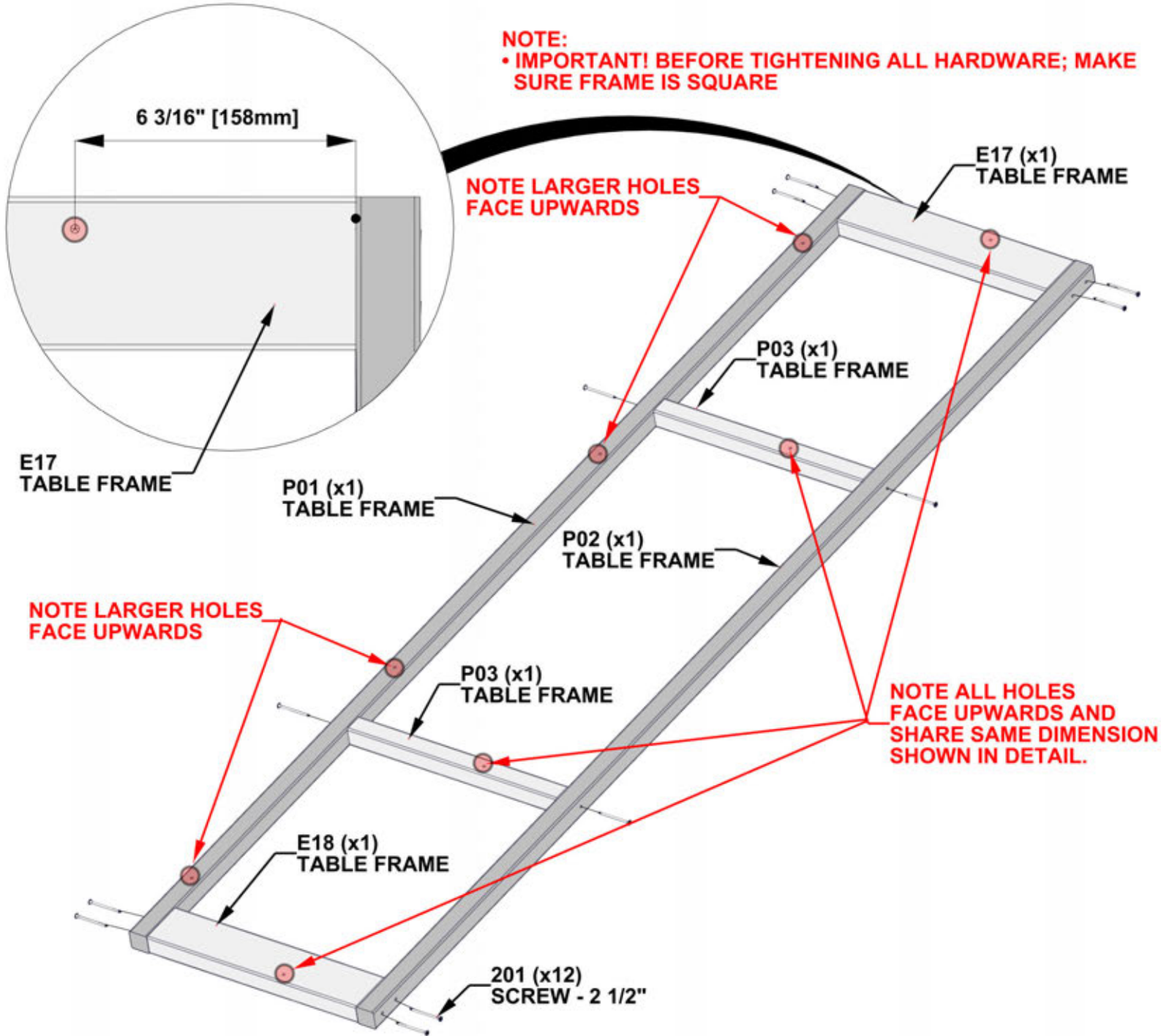


RIGHT WALL ASSEMBLY NOT SHOWN IN THIS STEP

STEP 60 TABLE ASSEMBLY

QTY	PART NUMBER	DESCRIPTION
12	H100201	SCREW PFH 8x2 1/2 BLK

- E18 TABLE FRAME - W4L18406
(x1) 1 7/16"x3 3/8"x16 5/8" (36x86x423)
- E17 TABLE FRAME - W4L18405
(x1) 1 7/16"x3 3/8"x16 5/8" (36x86x423)
- P02 TABLE FRAME - W4L18078
(x1) 1 7/16"x1 7/16"x83 3/4" (36x36x2128)
- P01 TABLE FRAME - W4L18081
(x1) 1 7/16"x1 7/16"x83 3/4" (36x36x2128)
- P03 TABLE FRAME - W4L18077
(x2) 1 7/16"x1 7/16"x16 5/8" (36x36x423)



STEP 61 - TABLE ASSEMBLY

QTY	PART NUMBER	DESCRIPTION
40	H100387	SCREW PFH 8x1 1/4 BLK



TABLE FRAME FROM
STEP 60



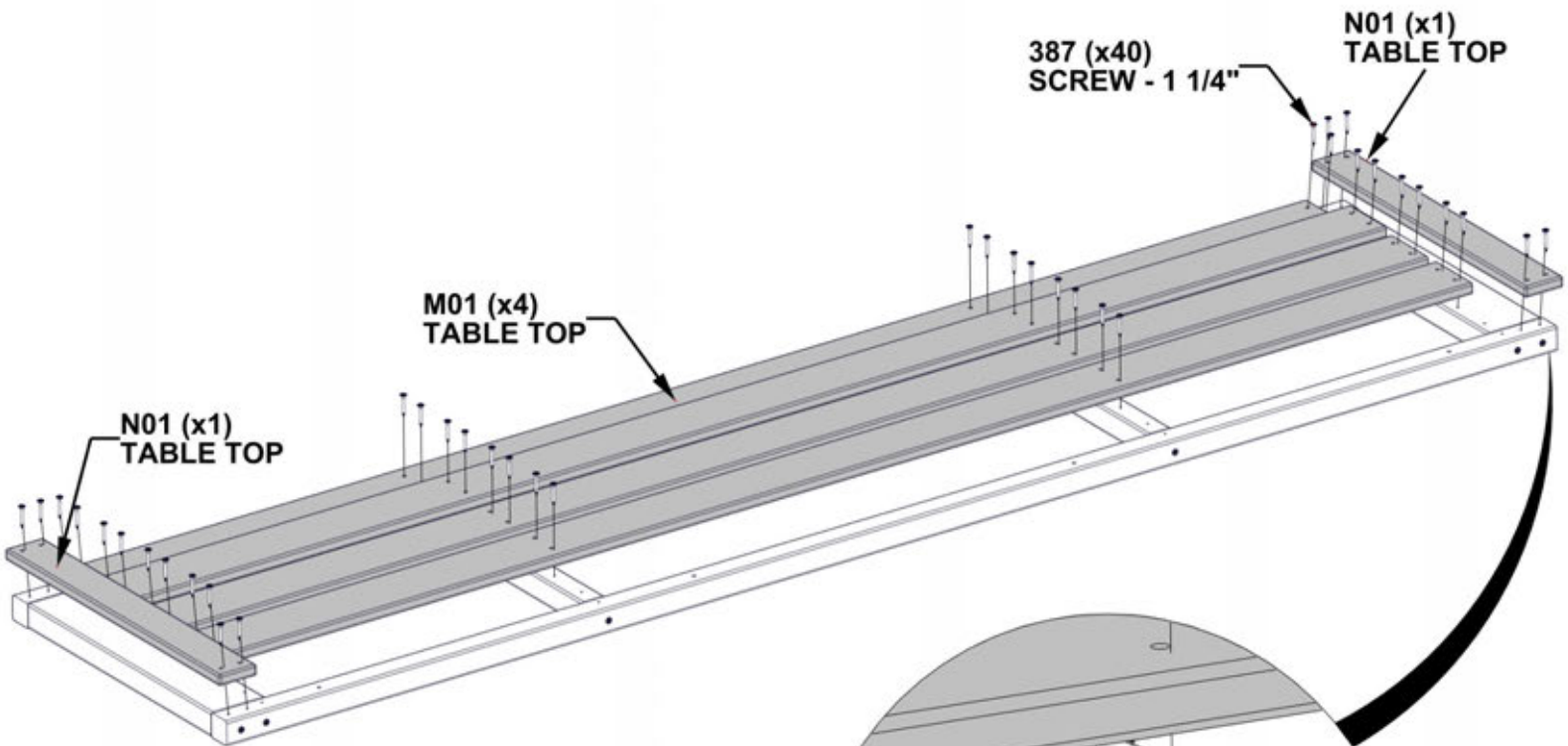
M01 TABLE TOP - W4L18085
(x4) 5/8"x3 3/8"x79 1/16" (16x86x2008)



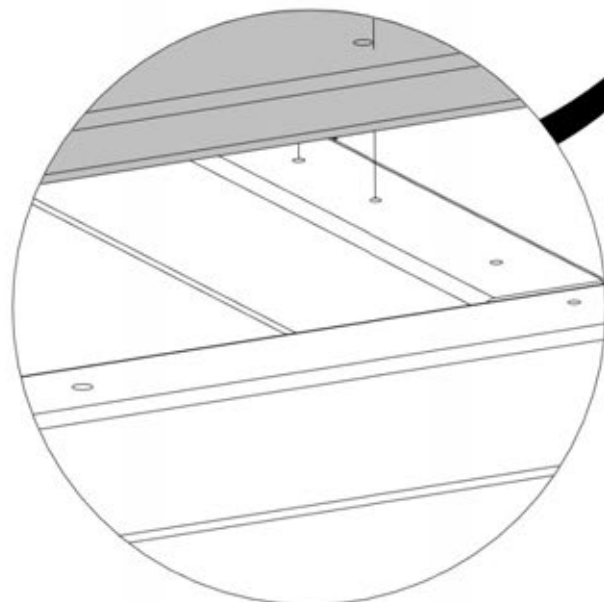
N01 TABLE TOP - W4L18086
(x2) 5/8"x2 3/8"x19 1/2" (16x60x495)

NOTES

- LAY BOARDS ON FRAME AS SHOWN
- N01 BOARDS SHOULD BE FLUSH WITH FRAME.
- THE FIRST M01 BOARD SHOULD BE INSTALLED OPPOSITE OF THE 4 PILOT HOLES AND FLUSH TO FRAME EDGE. ALIGN WITH PILOT HOLES AND ATTACH AS SHOWN.
- THE REMAINING M01 BOARD WILL BE INSTALLED AT A LATER STEP.



- SMALL PILOT HOLES ALONG SIDE OF TABLE FRAME TO LINE UP THE M01 BOARDS.
- SIDE OF TABLE FRAME WITH 4 PILOT HOLES DOES NOT HAVE M1 BOARD AT THIS TIME.



STEP 62 - TABLE ASSEMBLY

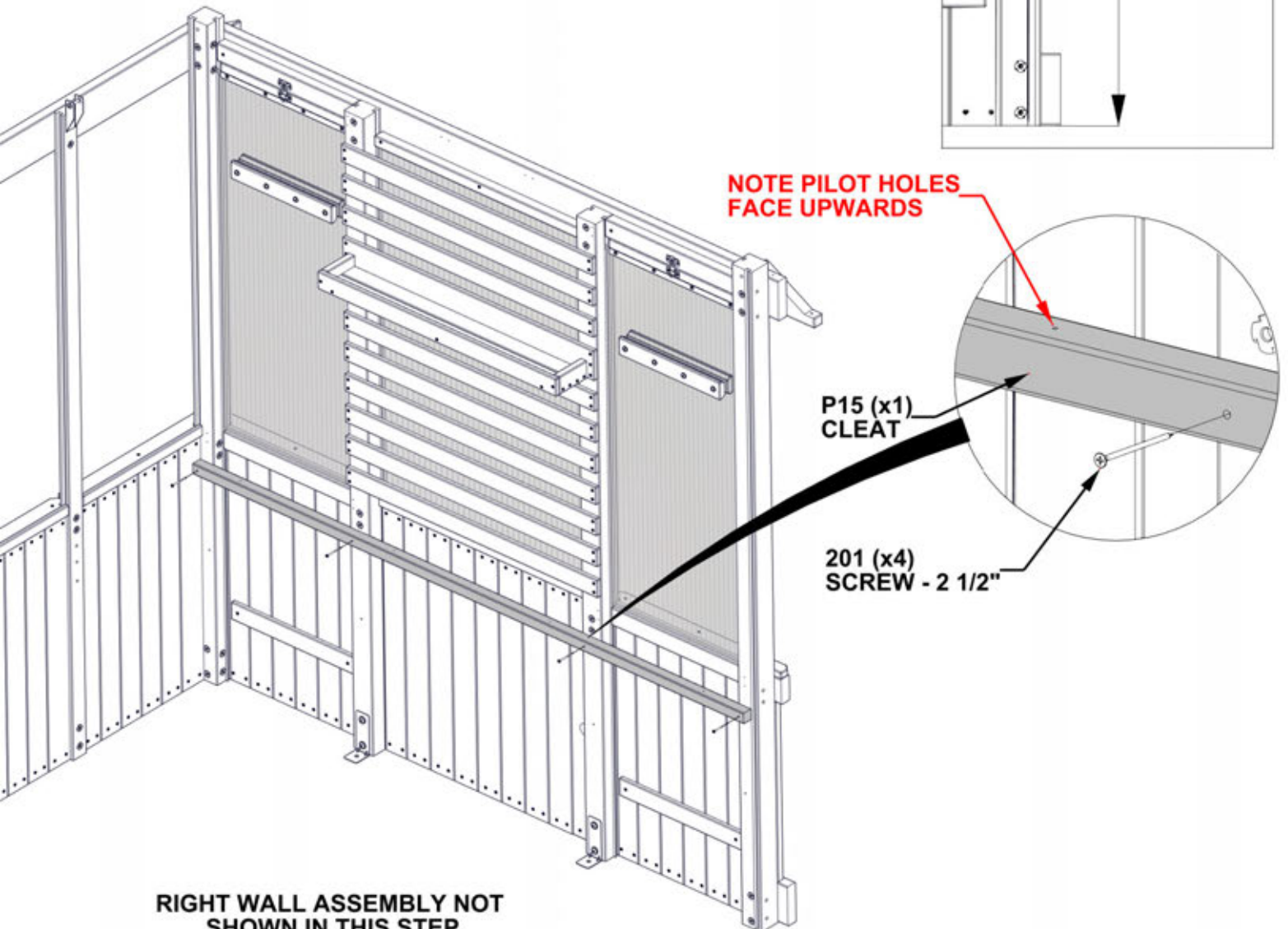
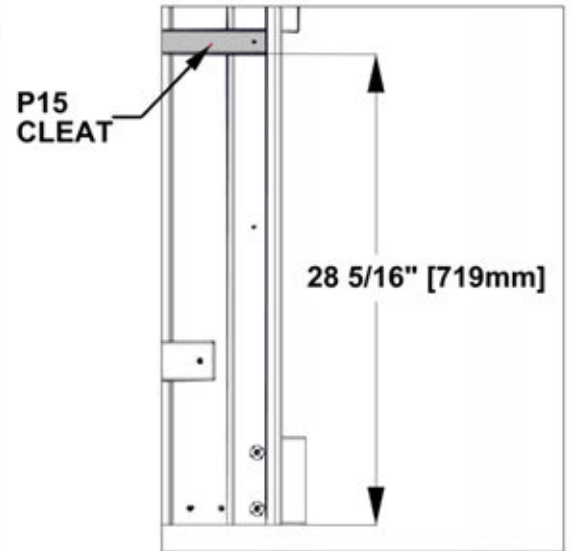
QTY	PART NUMBER	DESCRIPTION
4	H100201	SCREW PFH 8x2 1/2 BLK



P15 CLEAT - W4L18407
(x1) 1 7/16"x1 7/16"x84 5/8" (36x36x2150)

NOTES:

- ALIGN HOLES IN CLEAT WITH PILOT HOLE IN POST/UPRIGHTS.
- SEE REFERENCE DIMENSION SHOWN IN DETAIL.



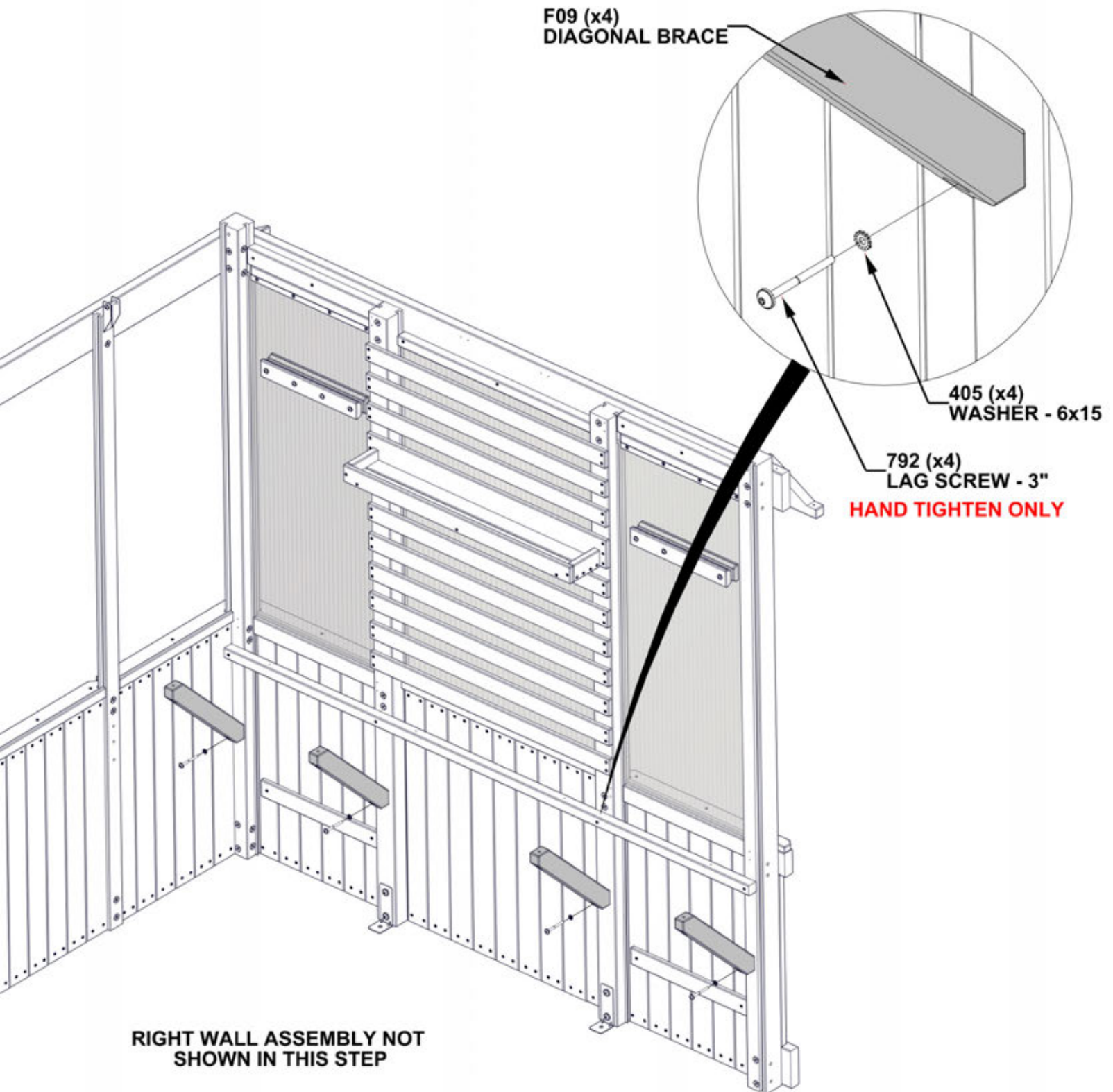
RIGHT WALL ASSEMBLY NOT SHOWN IN THIS STEP

STEP 63 - TABLE ASSEMBLY

QTY	PART NUMBER	DESCRIPTION
4	H100405	WASHER LOCK EXT 6x15
4	H100792	LAG SCREW WH 1/4x3 BLK



F09 DIAGONAL BRACE - W4L18084
(x4) 1 7/16"x2 3/8"x18 1/16" (36x60x458)



STEP 64 - TABLE ASSEMBLY

QTY	PART NUMBER	DESCRIPTION
4	H100405	WASHER LOCK EXT 6x15
4	H100456	LAG SCREW WH 1/4x2 1/2 BLK

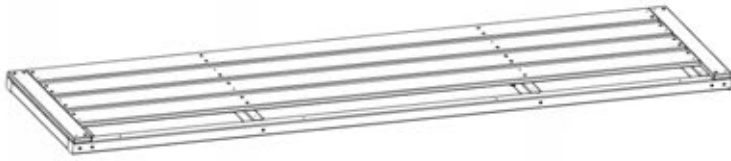
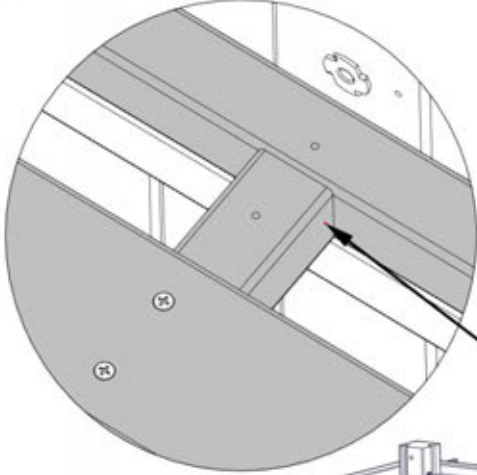


TABLE ASSEMBLY

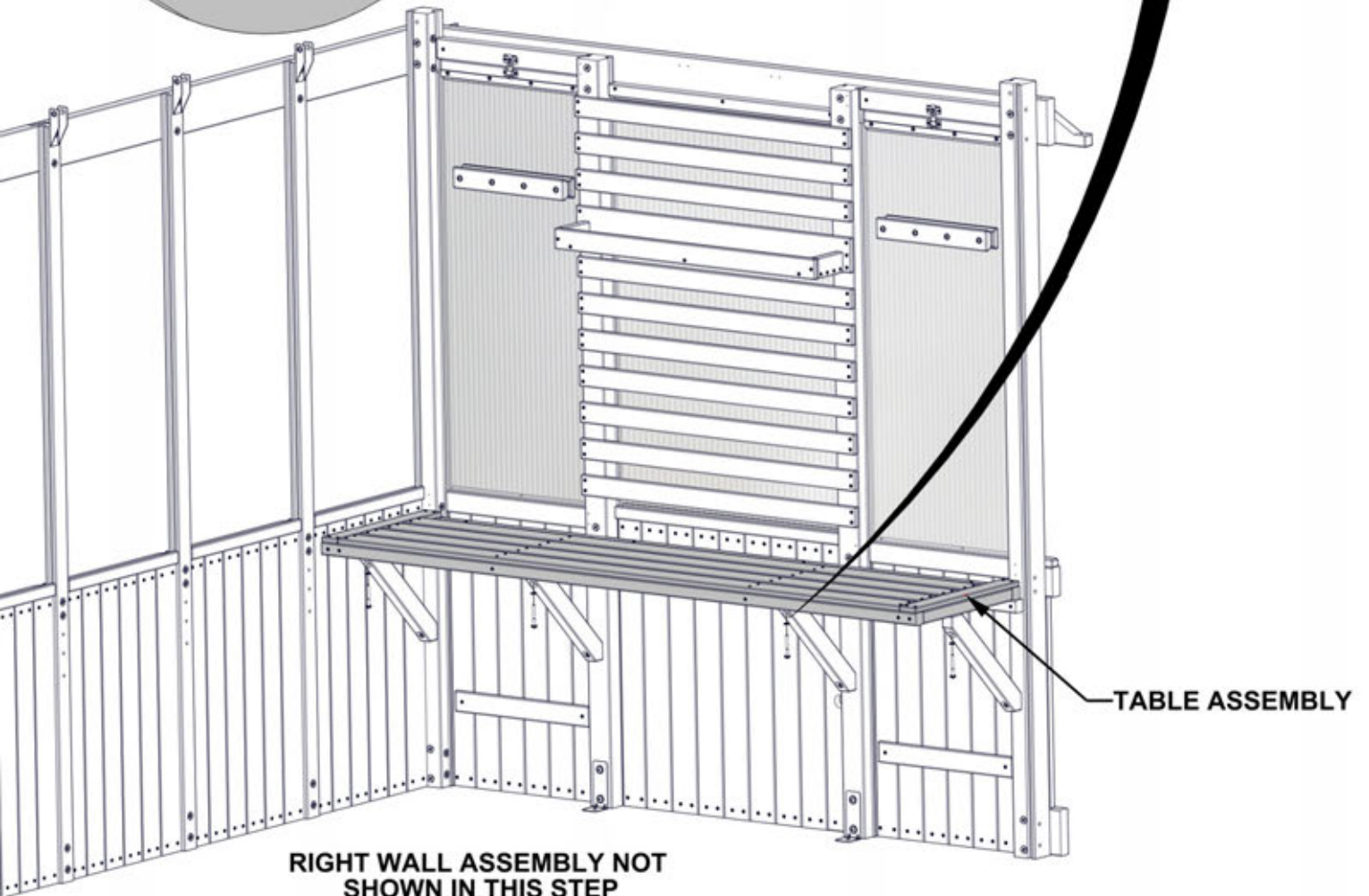
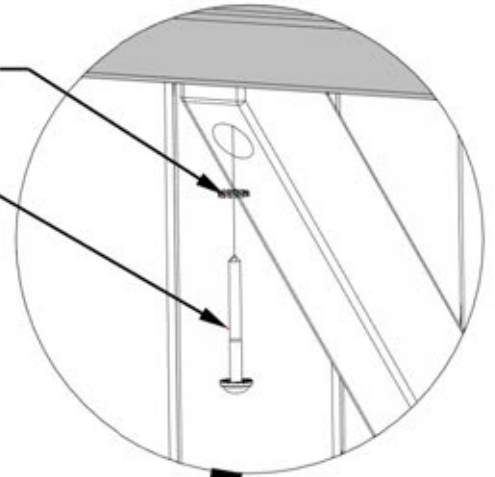
NOTES:
 • TIGHTEN LAGS FROM PREVIOUS STEP AFTER ATTACHING LAGS IN DETAIL



NOTE THE SIDE OF THE TABLE WITHOUT THE TOP BOARD FACES THE WALL.

405 (x4)
WASHER - 6x15

456 (x4)
LAG SCREW - 2 1/2"



RIGHT WALL ASSEMBLY NOT SHOWN IN THIS STEP

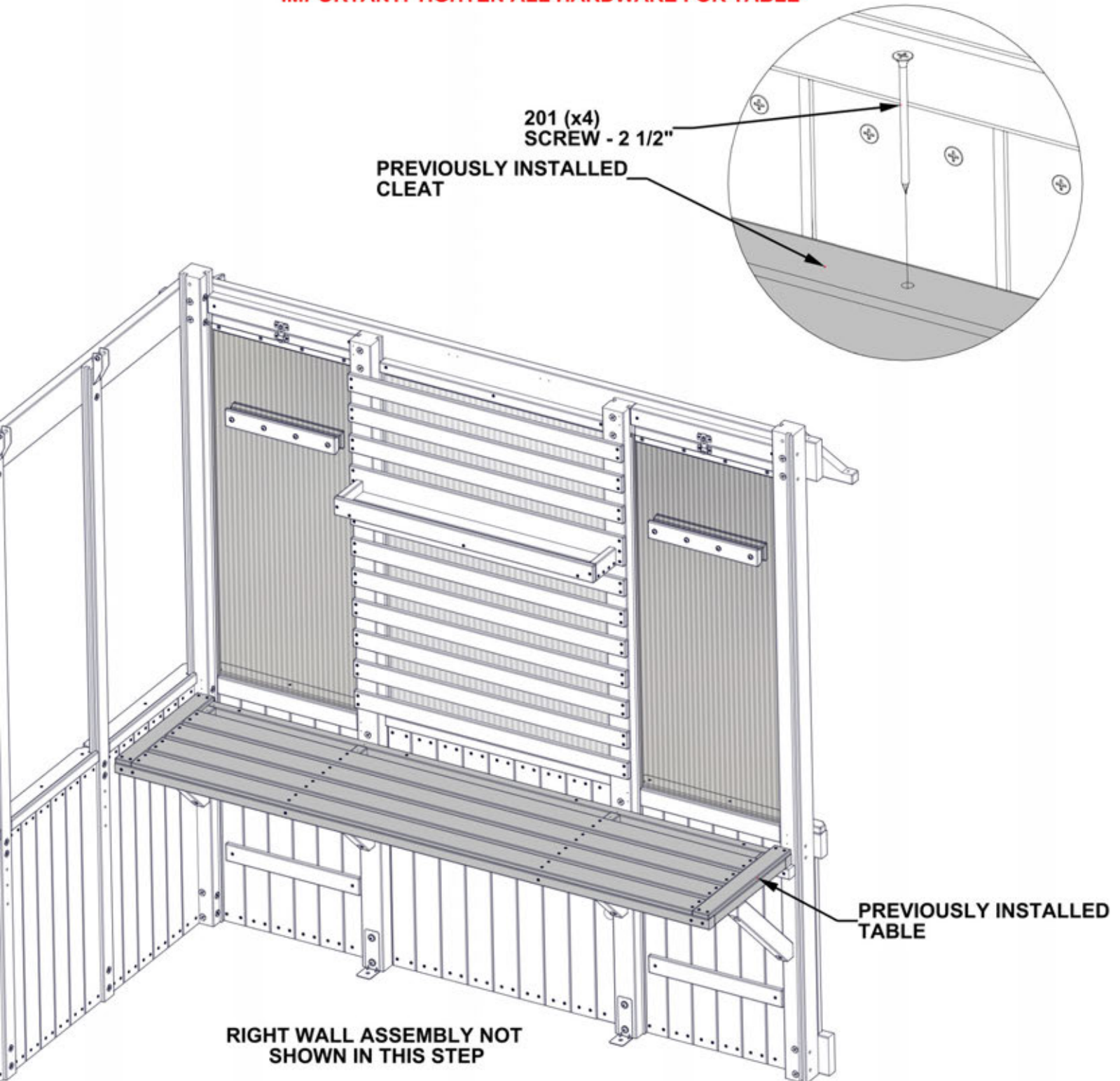
STEP 65 - TABLE ASSEMBLY

QTY	PART NUMBER	DESCRIPTION
4	H100201	SCREW PFH 8x2 1/2 BLK

NOTES:

- ALIGN HOLES ON PREVIOUSLY INSTALLED TABLE TO PREVIOUSLY INSTALLED CLEAT AND ATTACH AS SHOWN.

IMPORTANT! TIGHTEN ALL HARDWARE FOR TABLE



STEP 66 - TABLE ASSEMBLY

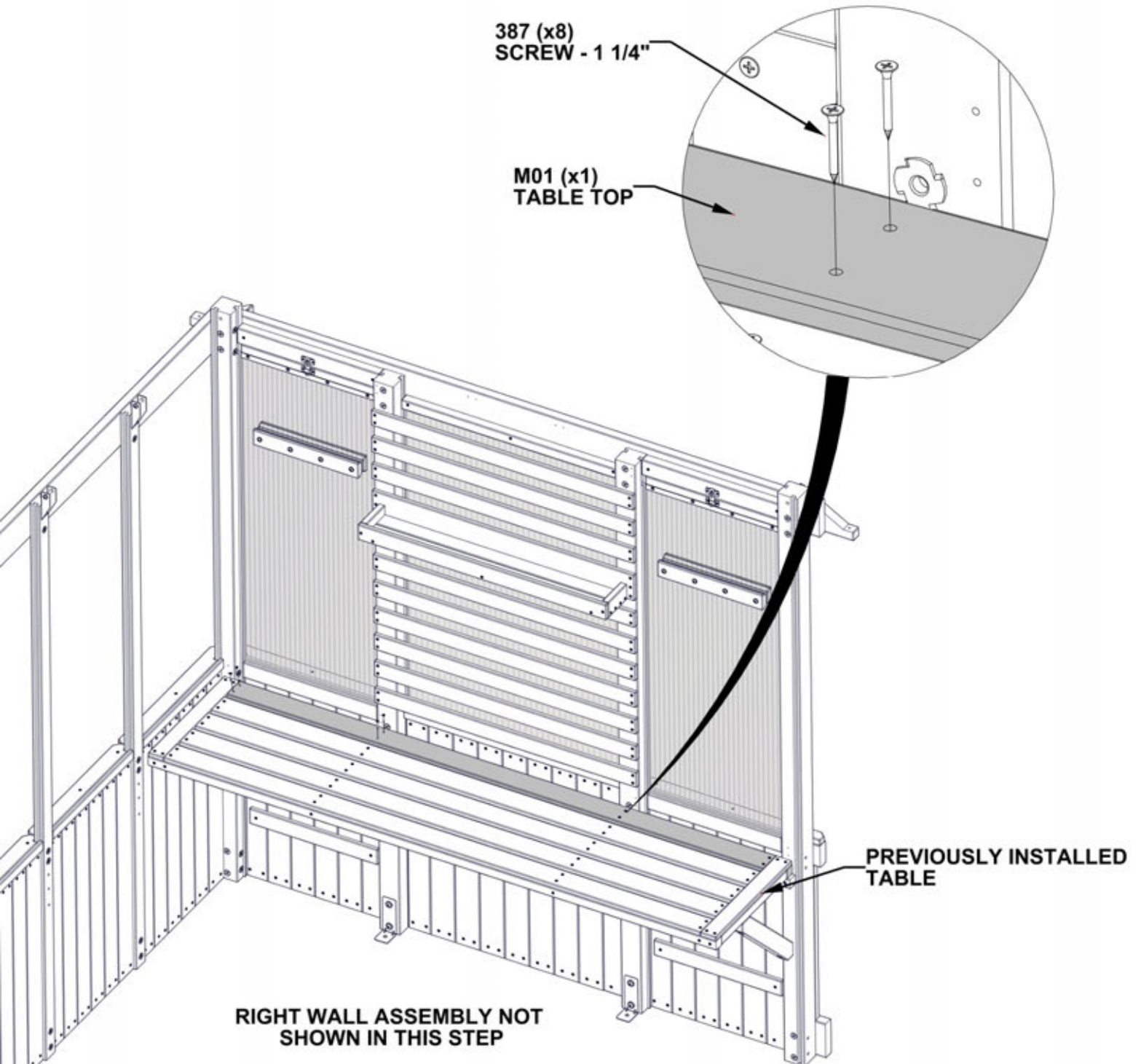
QTY	PART NUMBER	DESCRIPTION
8	H100387	SCREW PFH 8x1 1/4 BLK



M01 TABLE TOP - W4L18085
(x1) 5/8"x3 3/8"x79 1/16" (16x86x2008)

NOTES:

- ALIGN HOLES ON TABLE TOP BOARD WITH PILOT HOLES ON PREVIOUSLY INSTALLED TABLE AND ATTACH AS SHOWN.



STEP 67 - TABLE ASSEMBLY

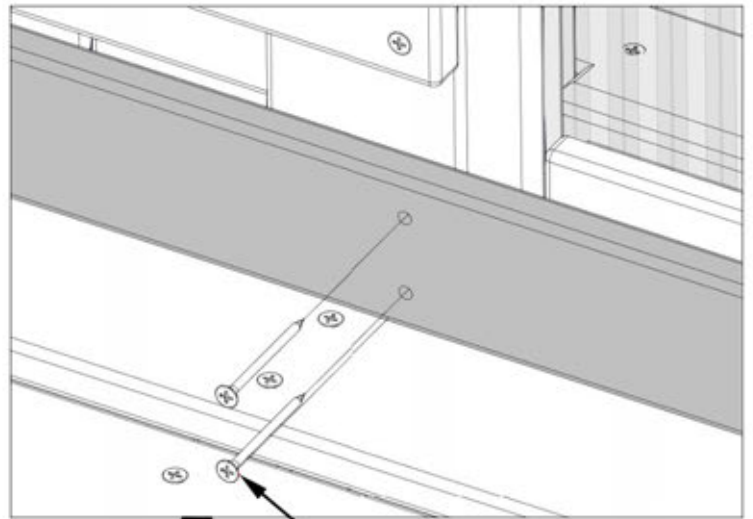
QTY	PART NUMBER	DESCRIPTION
8	H100391	SCREW PFH 8x2 BLK



N06 WALL BOARD - W4L18366
(x1) 5/8"x2 3/8"x83 11/16" (16x60x2126)

NOTES:

- ALIGN HOLES ON WALL BOARD WITH PILOT HOLES ON POST/UPRIGHTS.
- WALL BOARD SHOULD SIT DIRECTLY ON TOP OF TABLE AS SHOWN.



391 (x8)
SCREW - 2"

N06 (x1)
WALL BOARD

RIGHT WALL ASSEMBLY NOT
SHOWN IN THIS STEP

STEP 68 - TABLE ASSEMBLY

QTY	PART NUMBER	DESCRIPTION
4	H100201	SCREW PFH 8x2 1/2 BLK
8	H100387	SCREW PFH 8x1 1/4 BLK



T1 LEFT REAR TABLE ASSEMBLY - W2A03901
(x1) 2 1/16"x16 1/16"x36 1/2" (52x408x807)



P05 TABLE FRAME - W4L18087
(x1) 1 7/16"x1 7/16"x13 1/4" (36x36x336)



P12 TABLE FRAME - W4L18395
(x1) 1 7/16"x1 7/16"x13 1/4" (36x36x336)

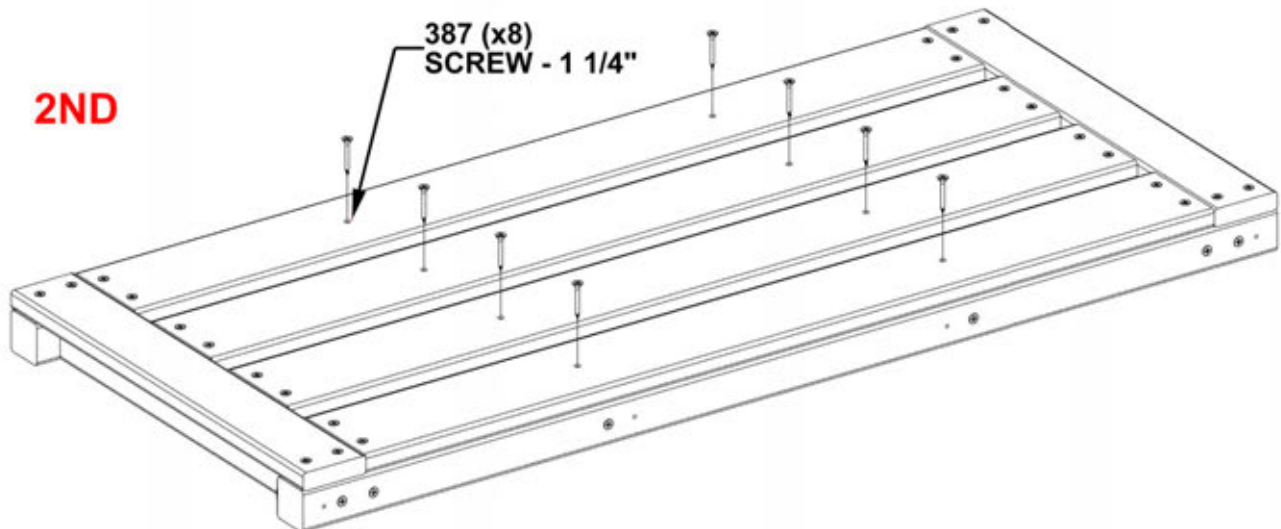
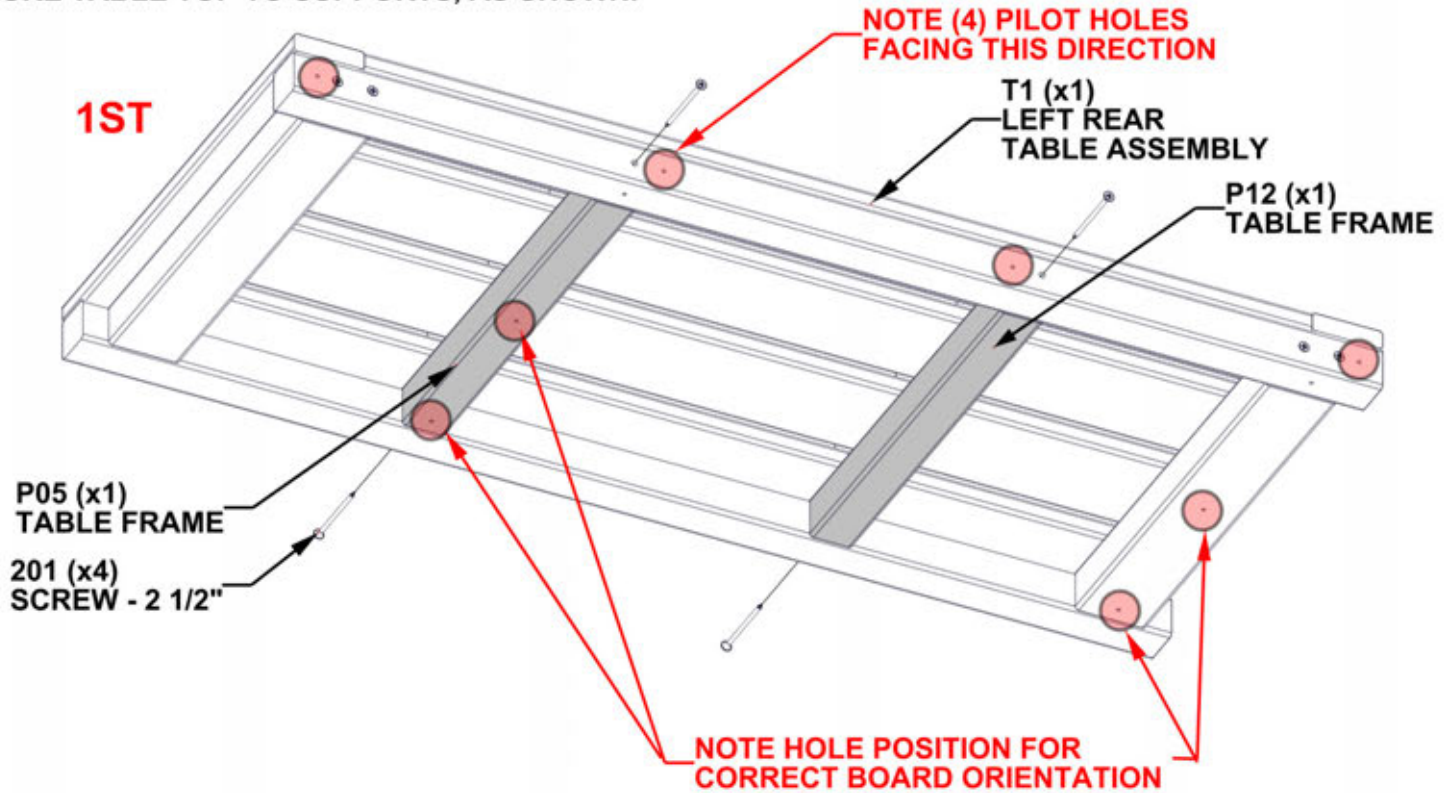
NOTES:

• PAY CLOSE ATTENTION TO PILOT HOLE DIRECTION FOR CORRECT INSTALLATION

1) INSTALL TABLE SUPPORTS:

- BOTH TABLE FRAME BOARDS HAVE SMALL PILOT HOLES WHICH WILL FACE UP.
- NOTE PROPER ORIENTATION OF LARGER HOLES ON THE BOTTOM OF TABLE FRAME BOARDL (P05) AS SHOWN.

2) SECURE TABLE TOP TO SUPPORTS, AS SHOWN.



STEP 69 - TABLE ASSEMBLY

QTY	PART NUMBER	DESCRIPTION
4	H100200	SCREW PFH 8x1 1/2 BLK
6	H100392	SCREW PWH 8x3/4 BLK

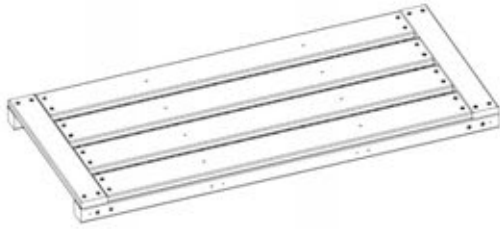


TABLE ASSEMBLY FROM
STEP 68



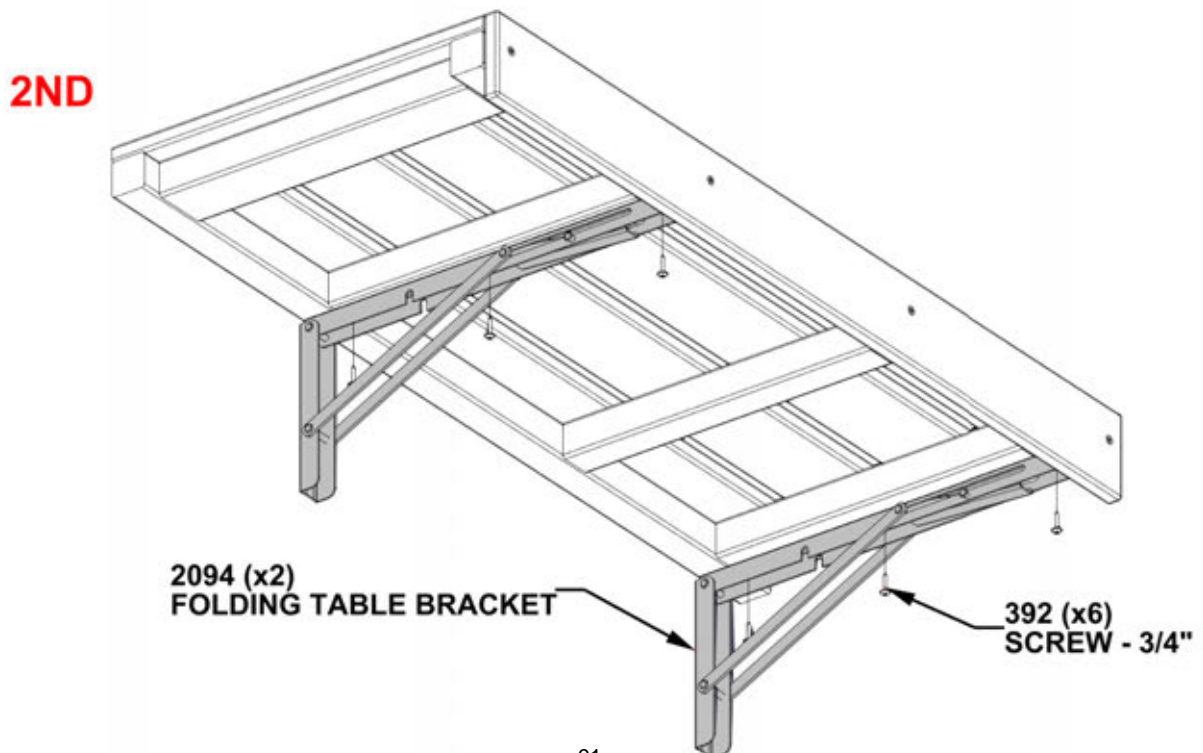
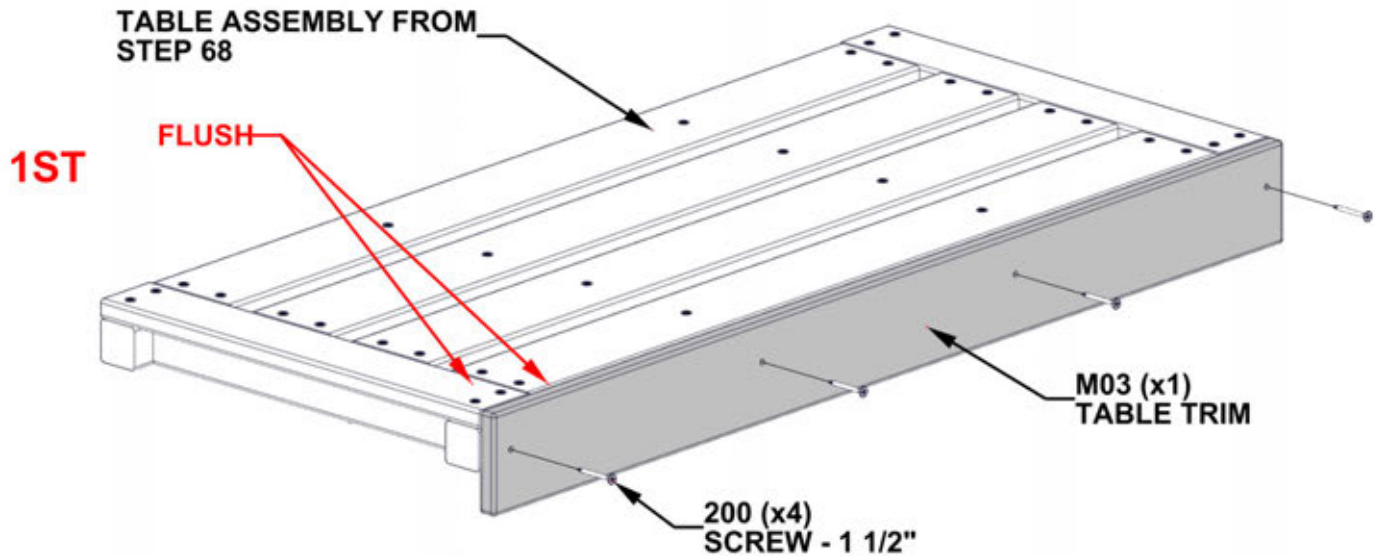
A4M02094 FOLDING TABLE BRACKET
(x2)



M03 TABLE TRIM - W4L18348
(x1) 5/8"x3 3/8"x36 1/2" (16x86x927)

NOTES:

- 1) INSTALL TABLE TRIM (M03):
 - ALIGN PILOT HOLES OF TABLE ASSEMBLY TO HOLES ON TABLE TRIM BOARD.
 - THERE ARE PILOT HOLES ON ONLY ONE SIDE OF TABLE ASSEMBLY.
- 2) SECURE FOLDING TABLE BRACKETS
 - LINE BRACKETS UP WITH HOLES AND ATTACH AS SHOWN.
 - MAY NEED TO USE PHILLIPS EXTENSION BIT



STEP 70 - TABLE ASSEMBLY

QTY	PART NUMBER	DESCRIPTION
6	H100405	WASHER LOCK EXT 6x15
6	H100488	BOLT WH 1/4x2 BLK
6	H100630	WASHER FLAT 8x19 BLK
6	H100653	NUT LOCK 1/4 BLK

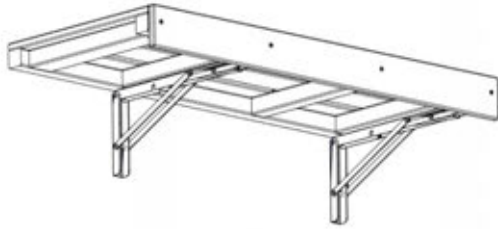


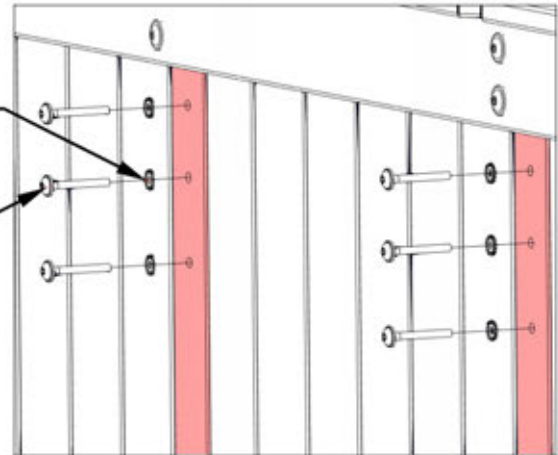
TABLE ASSEMBLY

NOTES:

- **NEED TWO (2) ADULTS FOR THIS STEP**
- ON HIGHLIGHTED UPRIGHTS, PUSH BOLTS IN FROM THE OUTSIDE THROUGH THE TABLE BRACKETS.
- FASTEN AS SHOWN.

405 (x6)
WASHER - 6x15

488 (x6)
BOLT - 2"



OUTSIDE VIEW

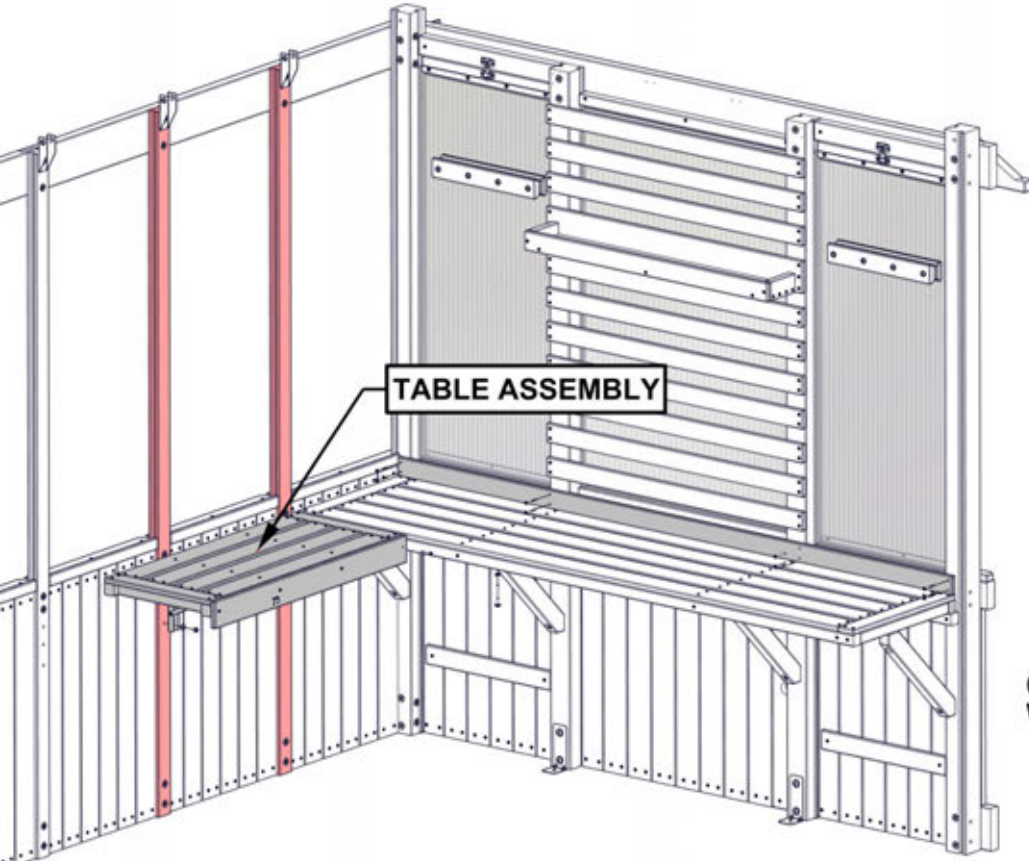
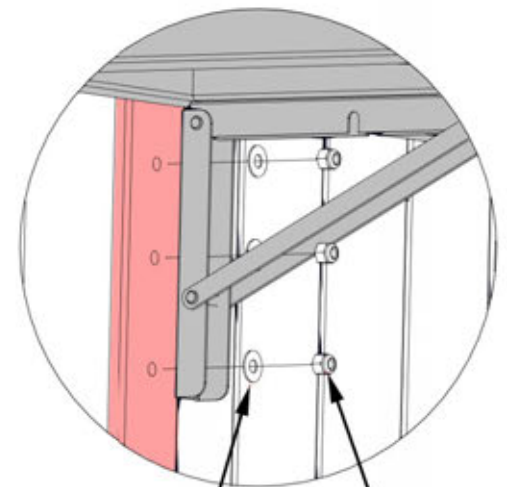


TABLE ASSEMBLY

RIGHT WALL ASSEMBLY NOT SHOWN IN THIS STEP



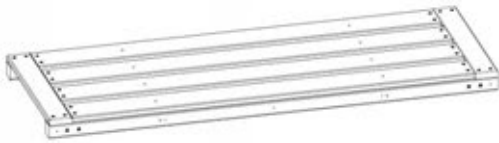
630 (x6)
WASHER - 8x19

653 (x6)
LOCK NUT - 1/4"

INSIDE VIEW

STEP 71 - TABLE ASSEMBLY

QTY	PART NUMBER	DESCRIPTION
4	H100201	SCREW PFH 8x2 1/2 BLK
8	H100387	SCREW PFH 8x1 1/4 BLK



T3 MIDDLE TABLE ASSEMBLY - W2A03903
(x1) 2 1/16"x16 1/16"x45 1/2" (52x408x1156)



P05 TABLE FRAME - W4L18087
(x2) 1 7/16"x1 7/16"x13 1/4" (36x36x336)

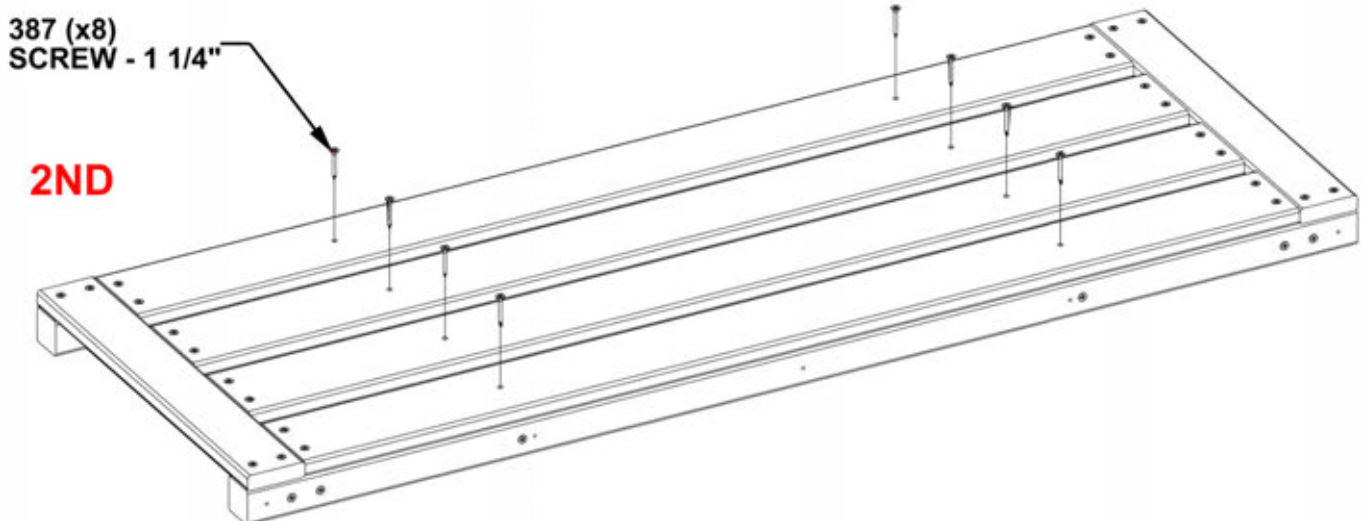
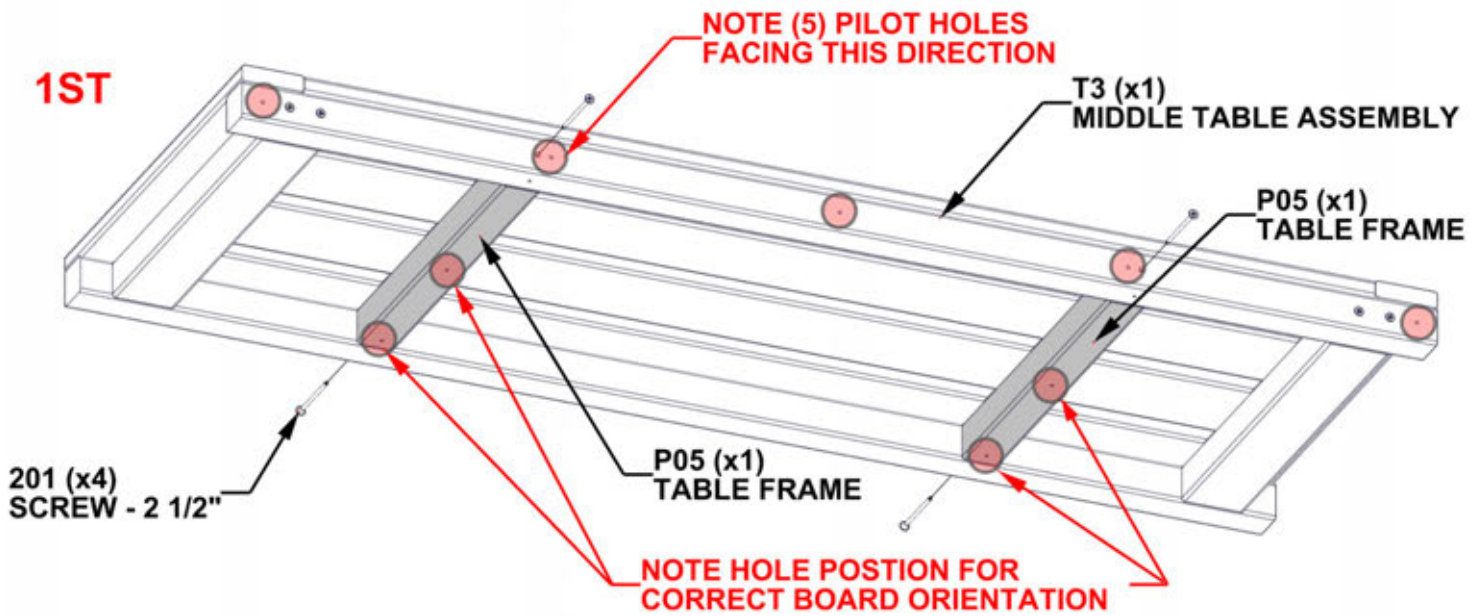
NOTES:

• **PAY CLOSE ATTENTION TO PILOT HOLE DIRECTION FOR CORRECT INSTALLATION.**

1) INSTALL TABLE SUPPORTS:

- TABLE FRAME BOARDS HAVE SMALL PILOT HOLES FACING UP
- NOTE PROPER ORIENTATION OF LARGER HOLES ON THE BOTTOM OF TABLE FRAME BOARD (P05) AS SHOWN.

2) SECURE TABLETOP TO SUPPORTS, AS SHOWN



STEP 72 - TABLE ASSEMBLY

QTY	PART NUMBER	DESCRIPTION
5	H100200	SCREW PFH 8x1 1/2 BLK
6	H100392	SCREW PWH 8x3/4 BLK

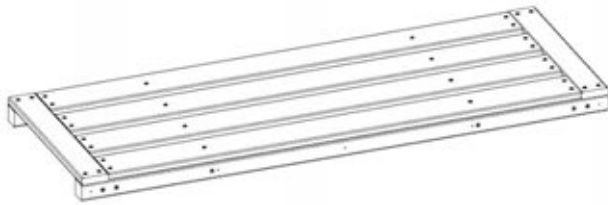


TABLE ASSEMBLY FROM STEP 71



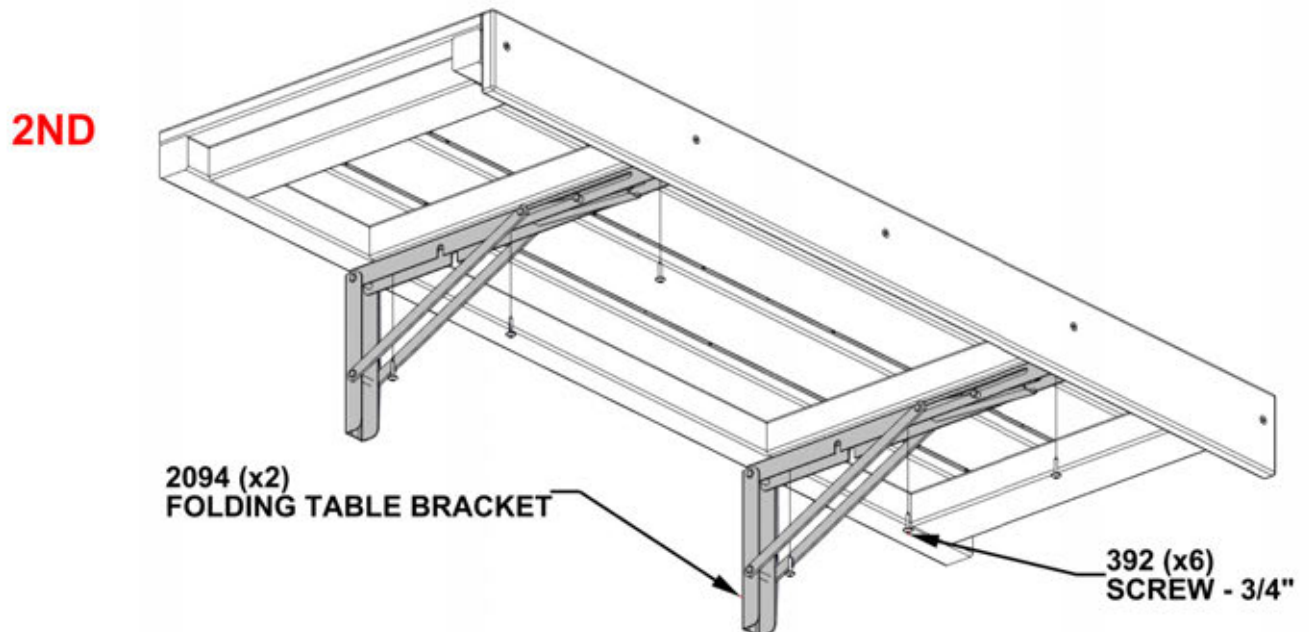
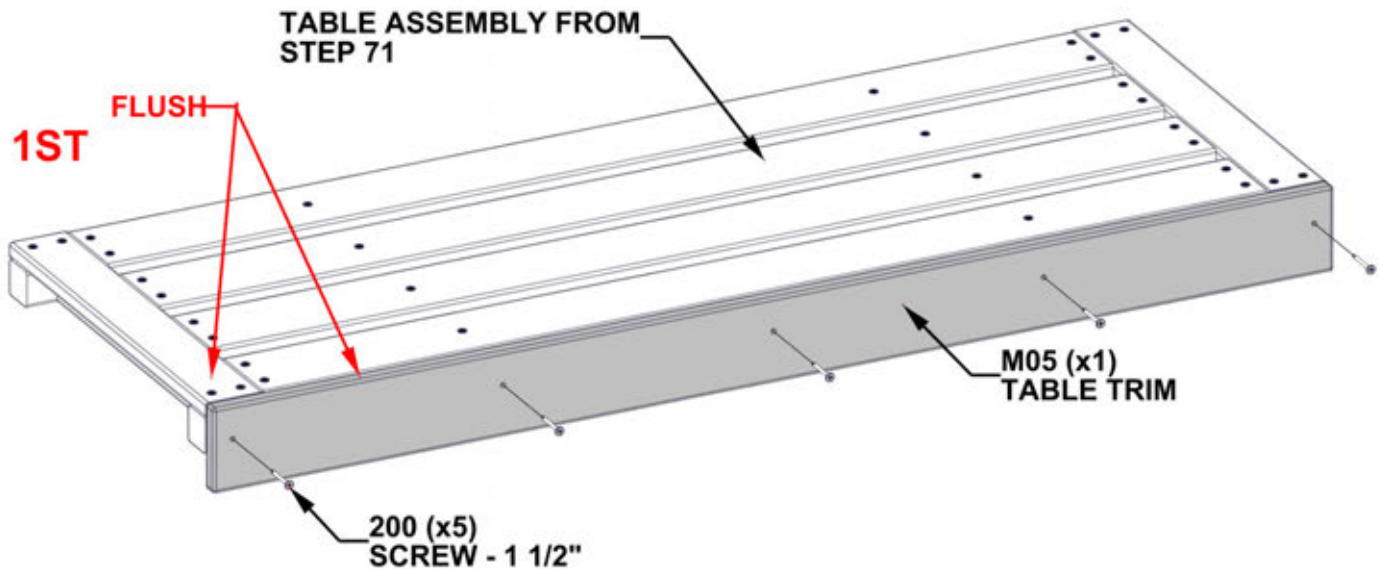
A4M02094 FOLDING TABLE BRACKET (x2)



M05 TABLE TRIM - W4L18350 (x1) 5/8"x3 3/8"x45 1/2" (16x86x1156)

NOTES:

- 1) INSTALL TABLE TRIM (M05):
 - ALIGN PILOT HOLES OF TABLE ASSEMBLY TO PILOT HOLES ON TABLE TRIM BOARD
 - THERE ARE PILOT HOLES ON ONLY ONE SIDE OF TABLE ASSEMBLY
- 2) SECURE FOLDING TABLE BRACKETS
 - LINE BRACKETS UP WITH PILOT HOLES AND ATTACH AS SHOWN
 - MAY NEED TO USE PHILLIPS EXTENSION BIT PROVIDED IN KIT



STEP 73 - TABLE ASSEMBLY

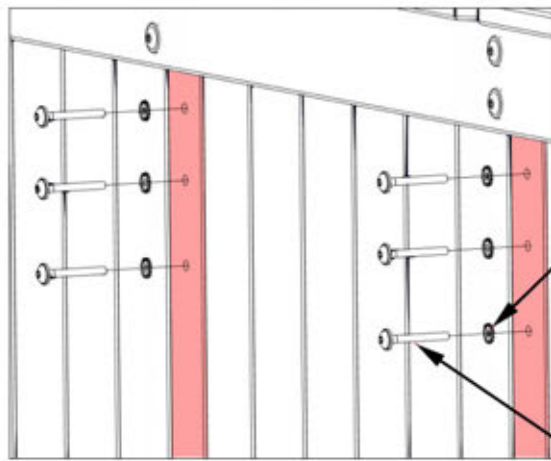
QTY	PART NUMBER	DESCRIPTION
6	H100405	WASHER LOCK EXT 6x15
6	H100488	BOLT WH 1/4x2 BLK
6	H100630	WASHER FLAT 8x19 BLK
6	H100653	NUT LOCK 1/4 BLK



TABLE ASSEMBLY

NOTES:

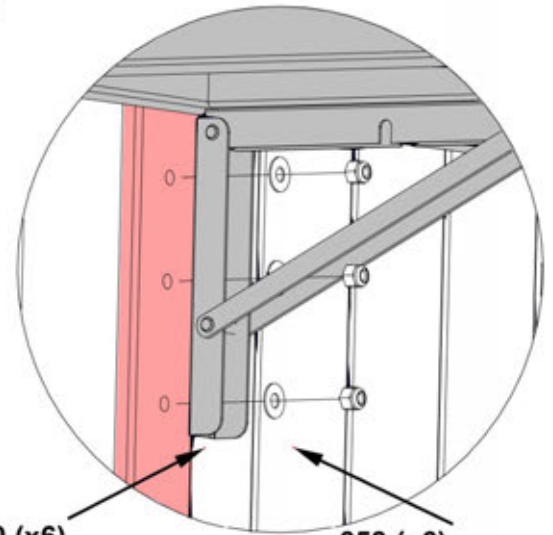
- **NEED TWO (2) ADULTS FOR THIS STEP**
- ON HIGHLIGHTED UPRIGHTS, PUSH BOLTS IN FROM THE OUTSIDE THROUGH TABLE BRACKETS.
- FASTEN AS SHOWN



OUTSIDE VIEW

405 (x6)
WASHER - 6x15

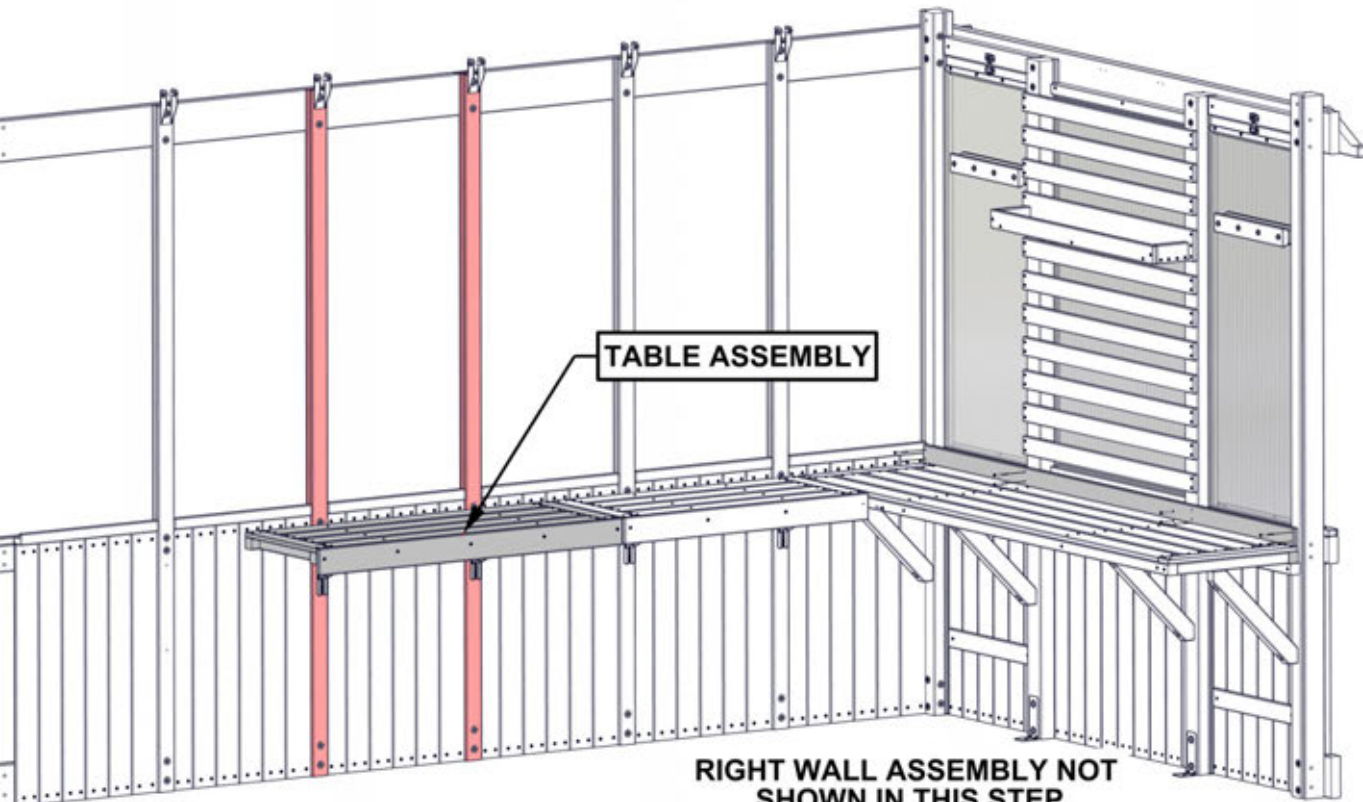
488 (x6)
BOLT - 2"



INSIDE VIEW

630 (x6)
WASHER - 8x19

653 (x6)
LOCK NUT - 1/4"



RIGHT WALL ASSEMBLY NOT SHOWN IN THIS STEP

STEP 74 - TABLE ASSEMBLY

QTY	PART NUMBER	DESCRIPTION
2	H100201	SCREW PFH 8x2 1/2 BLK
4	H100387	SCREW PFH 8x1 1/4 BLK

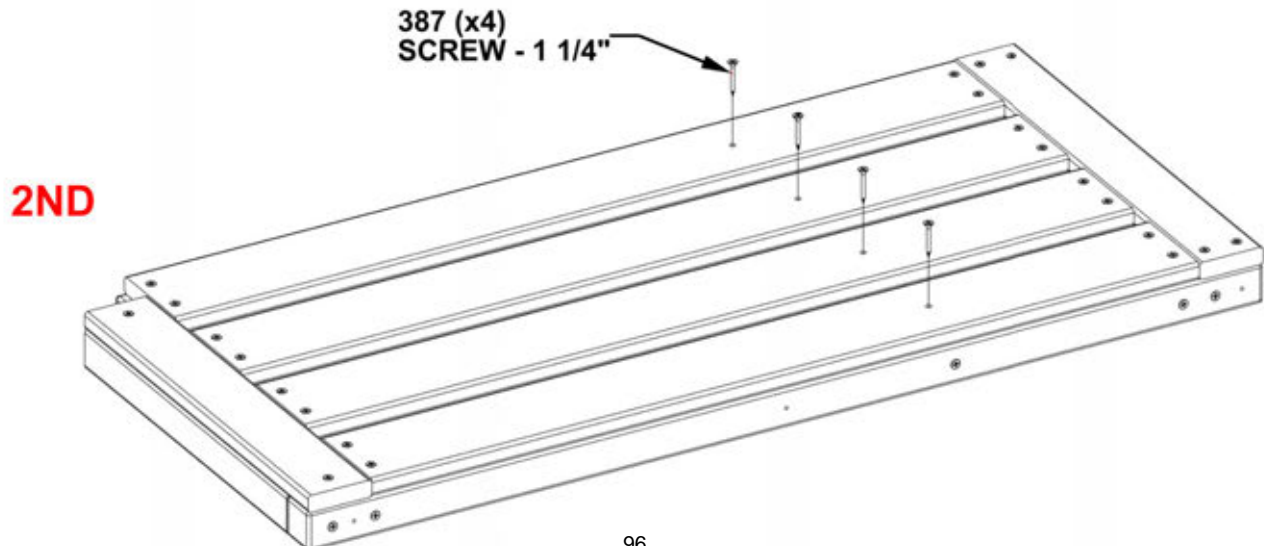
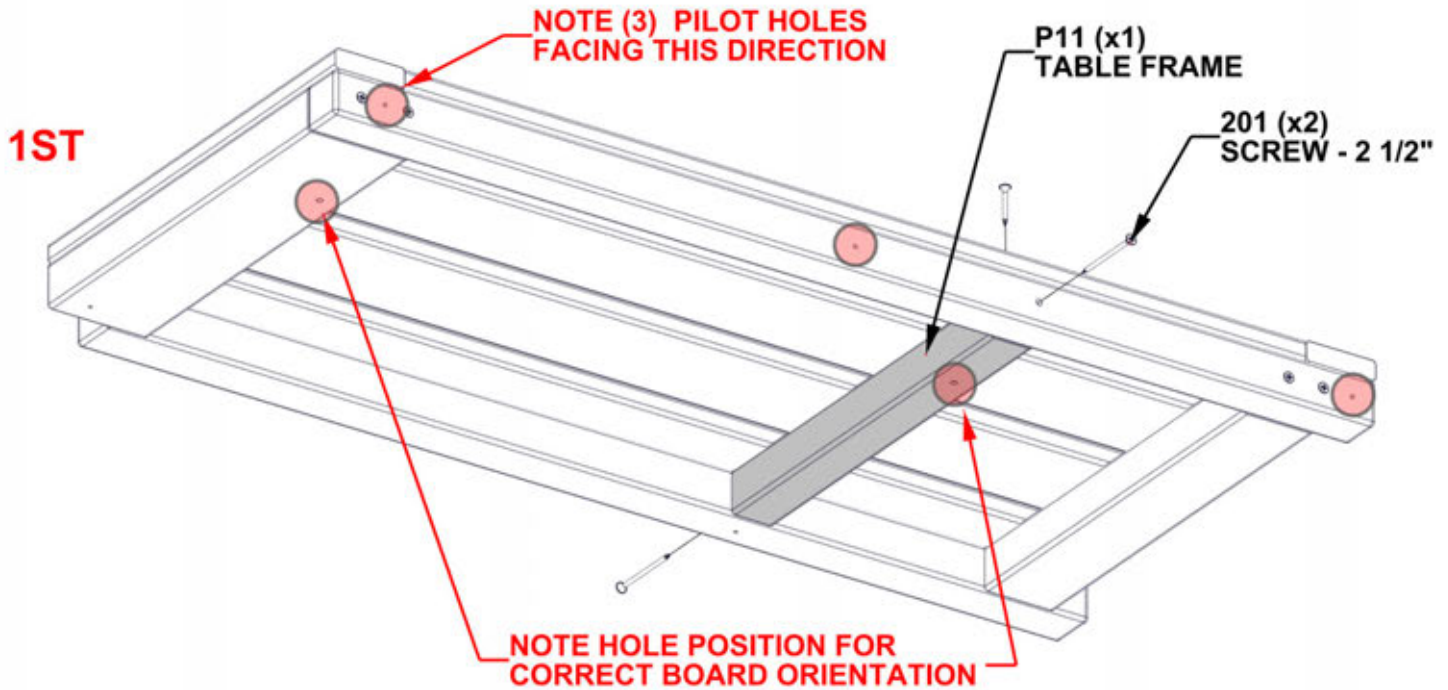


T4 LEFT FRONT TABLE ASSEMBLY - W2A03904
(x1) 2 1/16"x16 1/4"x35 5/16" (52x412x777)



P11 TABLE FRAME - W4L18394
(x1) 1 7/16"x1 7/16"x13 1/4" (36x36x336)

- NOTES:**
- PAY CLOSE ATTENTION TO PILOT HOLE DIRECTION FOR CORRECT INSTALLTION.
- 1) INSTALL TABLE SUPPORT:
 - TABLE FRAME BOARD HAS SMALL PILOT HOLES WHICH WILL FACE UP
 - NOTE PROPER ORIENTATION OF LARGER HOLE ON BOTTOM OF TABLE FRAME BOARD AS SHOWN
 - 2) SECURE TABLETOP TO SUPPORTS, AS SHOWN



STEP 75 - TABLE ASSEMBLY

QTY	PART NUMBER	DESCRIPTION
3	H100200	SCREW PFH 8x1 1/2 BLK
1	H100202	SCREW PWH 8x5/8 BLK
2	H100405	WASHER LOCK EXT 6x15
2	H100456	LAG SCREW WH 1/4x2 1/2 BLK
1	H100536	SCREW PWH 8x1 1/4 BLK



M08 TABLE TRIM - W4L18364
(x1) 5/8"x3 3/8"x35 5/16" (16x86x897)



F09 DIAGONAL BRACE - W4L18084
(x1) 1 7/16"x2 3/8"x18 1/16" (36x60x458)



F15 DIAGONAL BRACE - W4L18428
(x1) 1 7/16"x2 3/8"x18 1/16" (36x60x458)



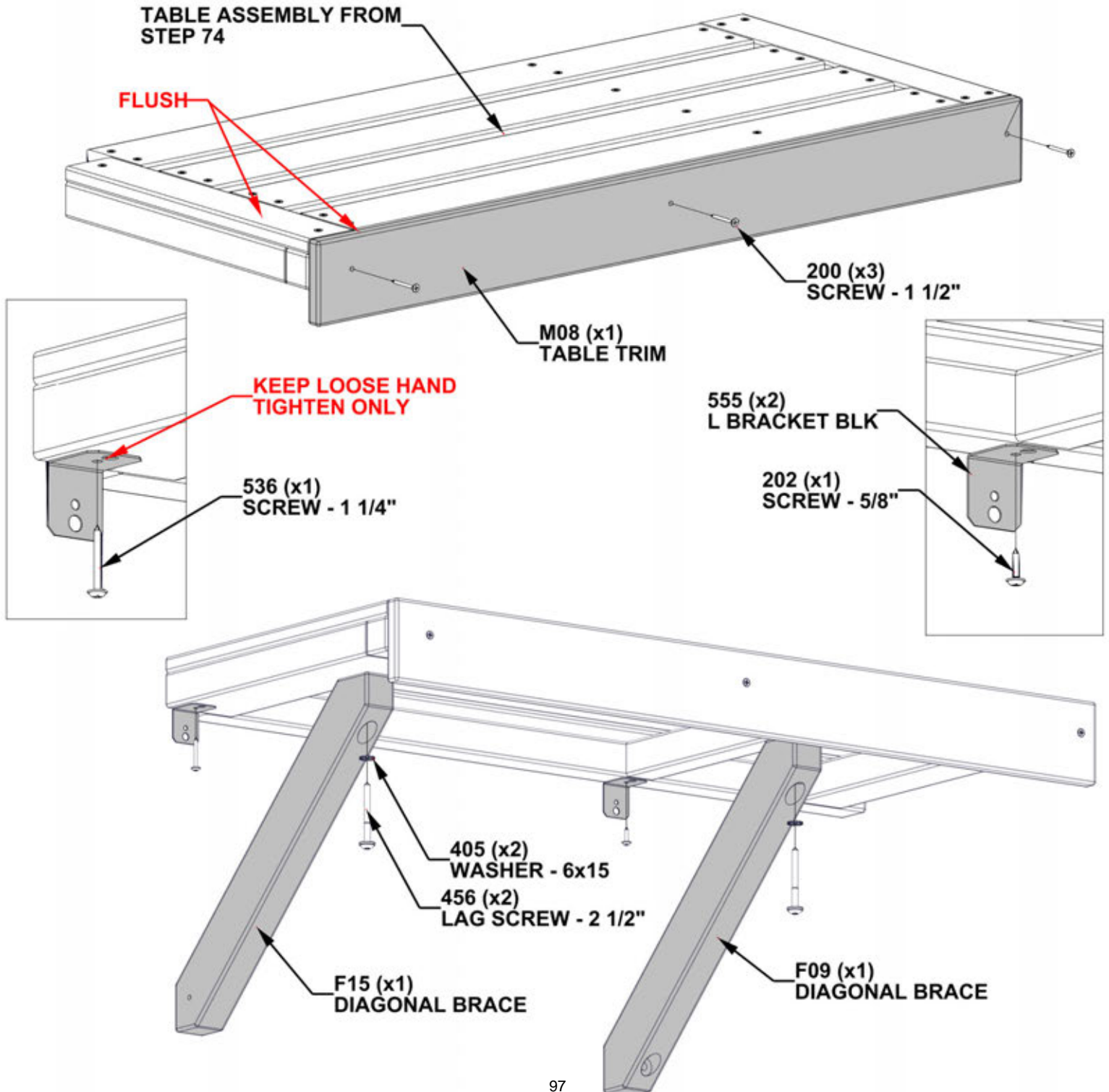
A4M00555 L BRACKET BLK
(x2)



TABLE ASSEMBLY FROM STEP 74

NOTES:

• ALIGN PILOT HOLES AND FASTEN AS SHOWN.



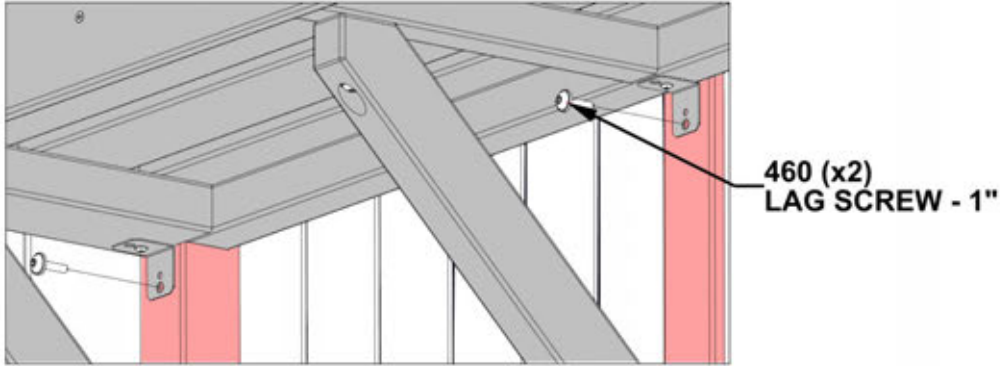
STEP 76 - TABLE ASSEMBLY

QTY	PART NUMBER	DESCRIPTION
1	H100201	SCREW PFH 8x2 1/2 BLK
1	H100405	WASHER LOCK EXT 6x15
2	H100460	LAG SCREW WH 1/4x1 BLK
1	H100792	LAG SCREW WH 1/4x3 BLK

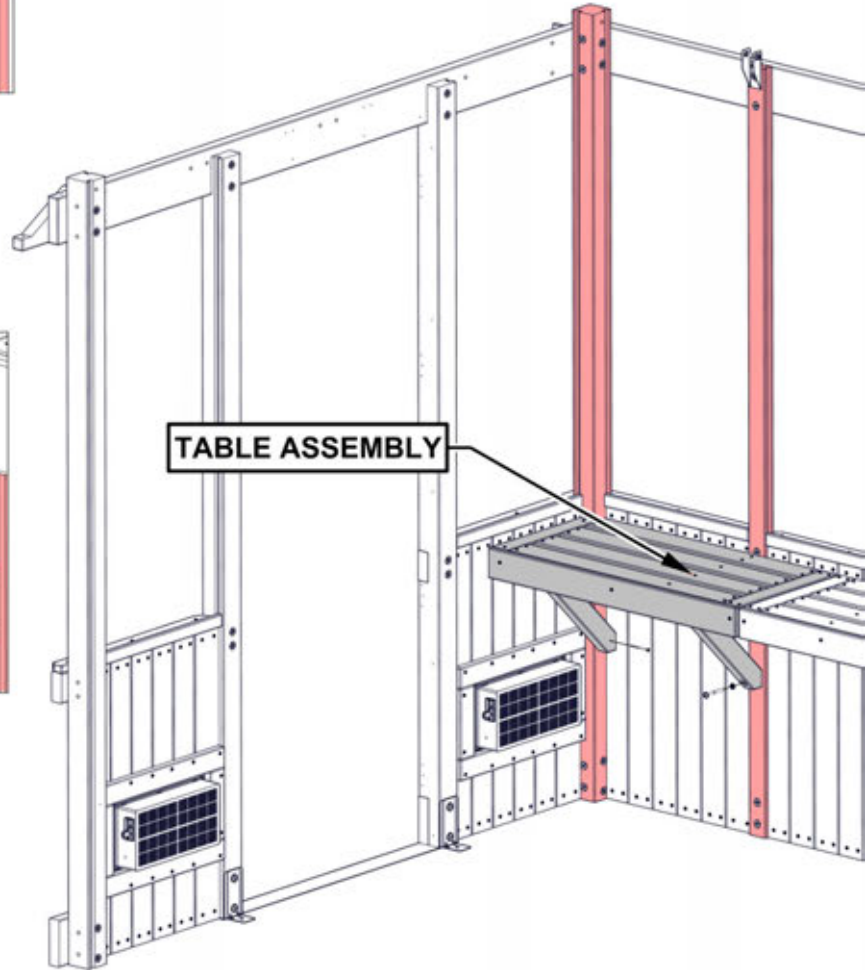
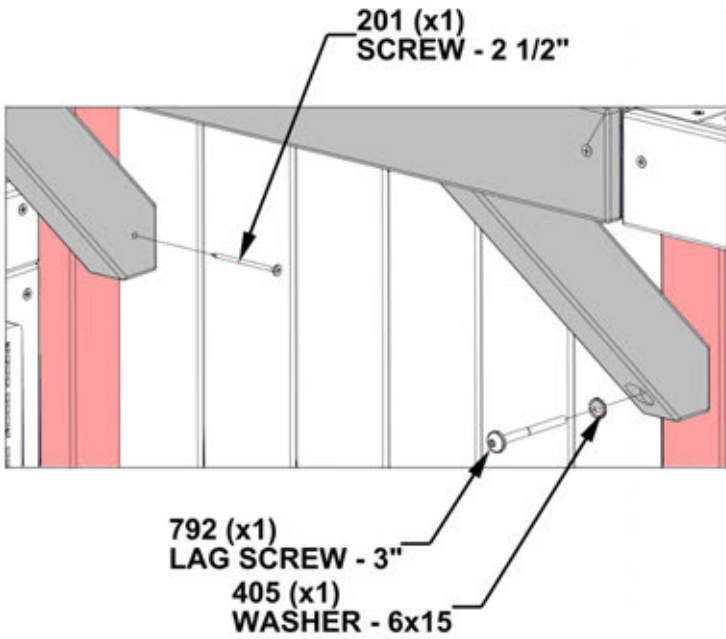


TABLE ASSEMBLY

- NOTES:**
- LOCATE PILOT HOLES ON HIGHLIGHTED POST/UPRIGHTS AND FASTEN AS SHOWN.
 - TIGHTEN ALL HARDWARE ON TABLE.



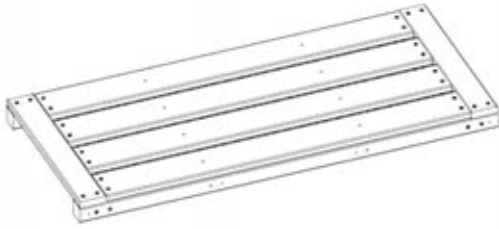
VIEW UNDERNEATH TABLE



RIGHT WALL ASSEMBLY NOT SHOWN IN THIS STEP

STEP 77 - TABLE ASSEMBLY

QTY	PART NUMBER	DESCRIPTION
4	H100201	SCREW PFH 8x2 1/2 BLK
8	H100387	SCREW PFH 8x1 1/4 BLK



T2 RIGHT REAR TABLE ASSEMBLY - W2A03902
(x1) 2 1/16"x16 1/16"x36 1/2" (52x408x927)



P05 TABLE FRAME - W4L18087
(x1) 1 7/16"x1 7/16"x13 1/4" (36x36x336)



P12 TABLE FRAME - W4L18395
(x1) 1 7/16"x1 7/16"x13 1/4" (36x36x336)

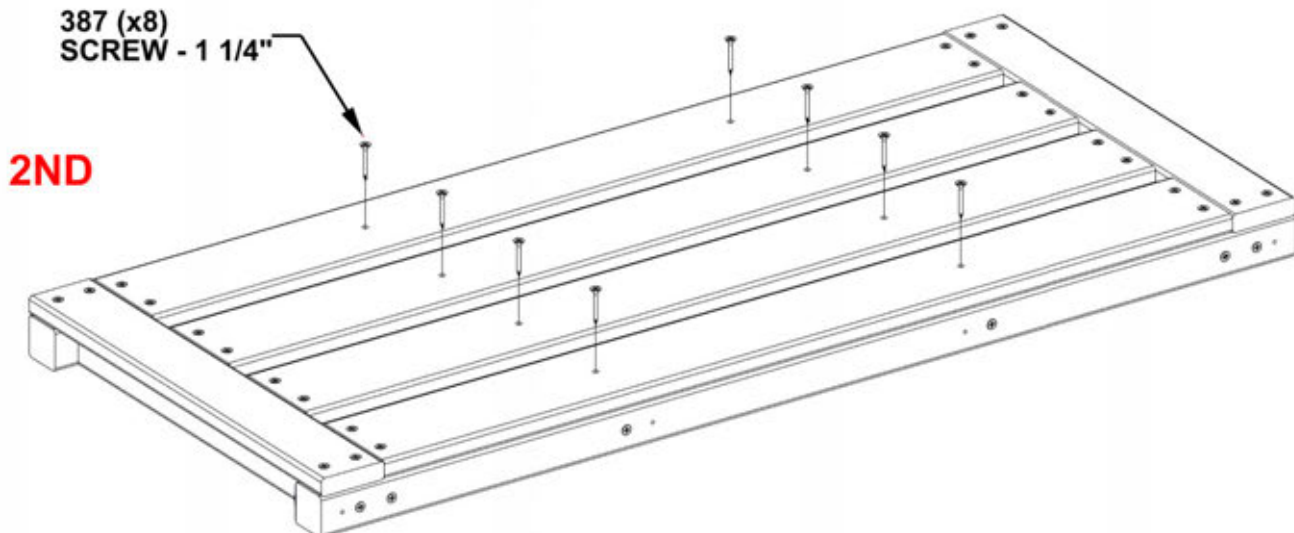
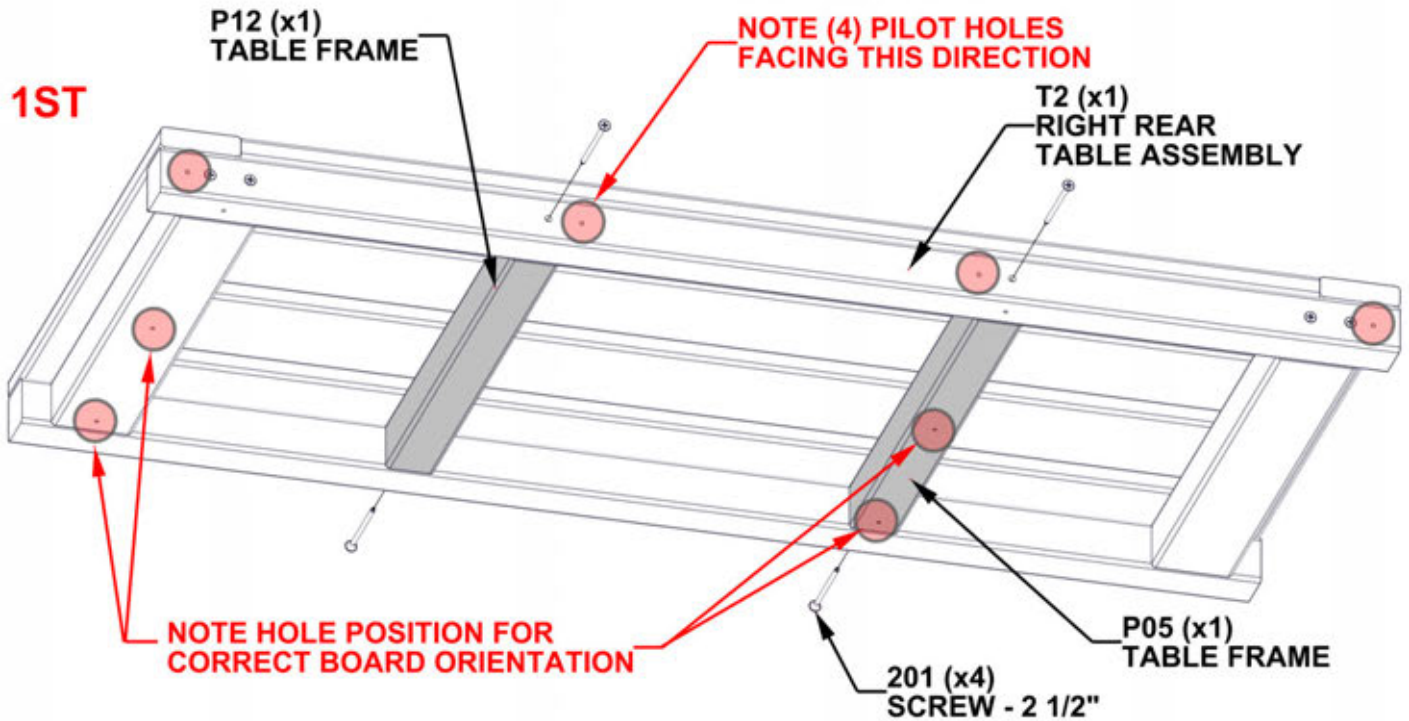
NOTES:

• **PAY CLOSE ATTENTION TO PILOT HOLE DIRECTION FOR CORRECT INSTALLATION**

1) INSTALL TABLE SUPPORTS:

- BOTH TABLE FRAME BOARDS HAVE SMALL PILOT HOLES WHICH WILL FACE UP.
- NOTE PROPER ORIENTATION OF LARGER HOLES ON THE BOTTOM OF TABLE FRAME BOARD (P05) AS SHOWN BELOW.

2) SECURE TABLETOP TO SUPPORTS, AS SHOWN.



STEP 78 - TABLE ASSEMBLY

QTY	PART NUMBER	DESCRIPTION
4	H100200	SCREW PFH 8x1 1/2 BLK
6	H100392	SCREW PWH 8x3/4 BLK

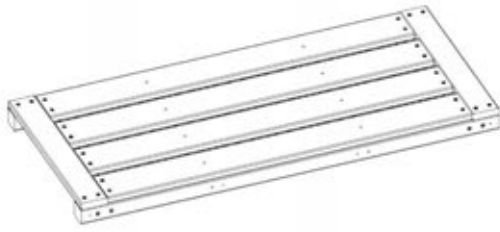


TABLE ASSEMBLY FROM
STEP 77

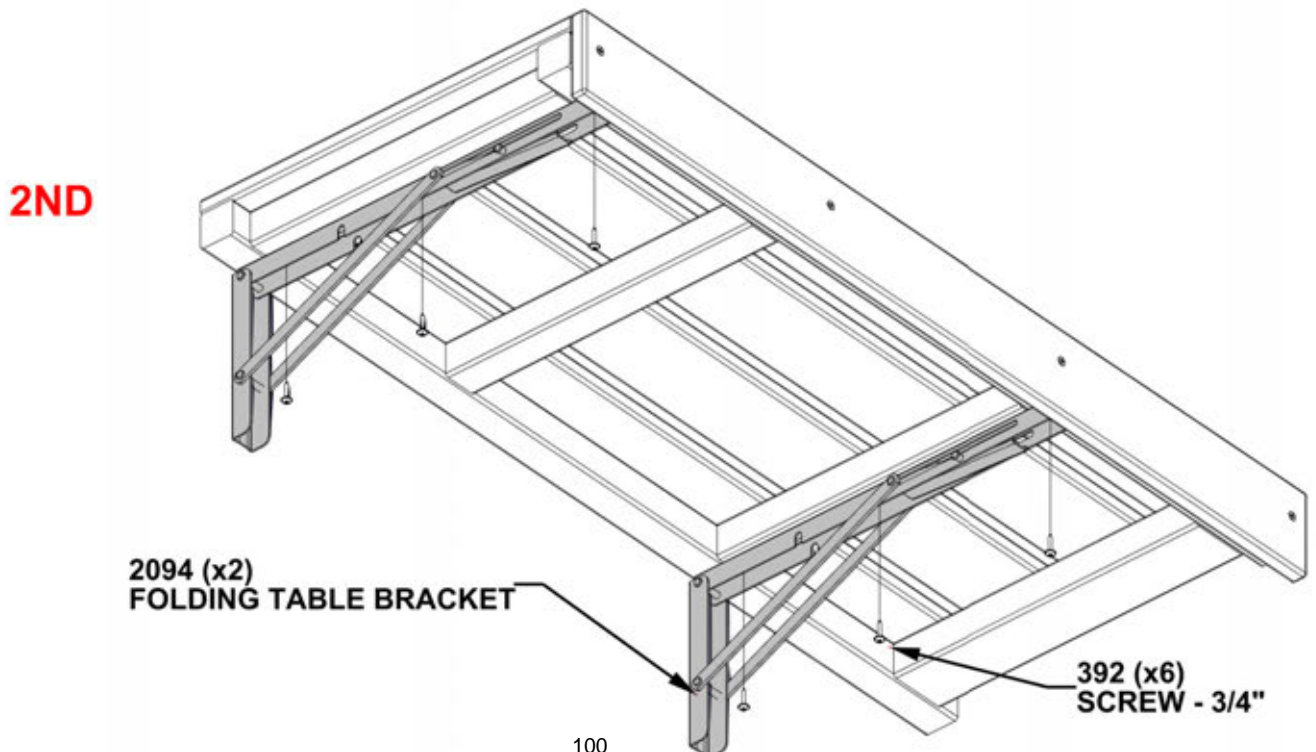
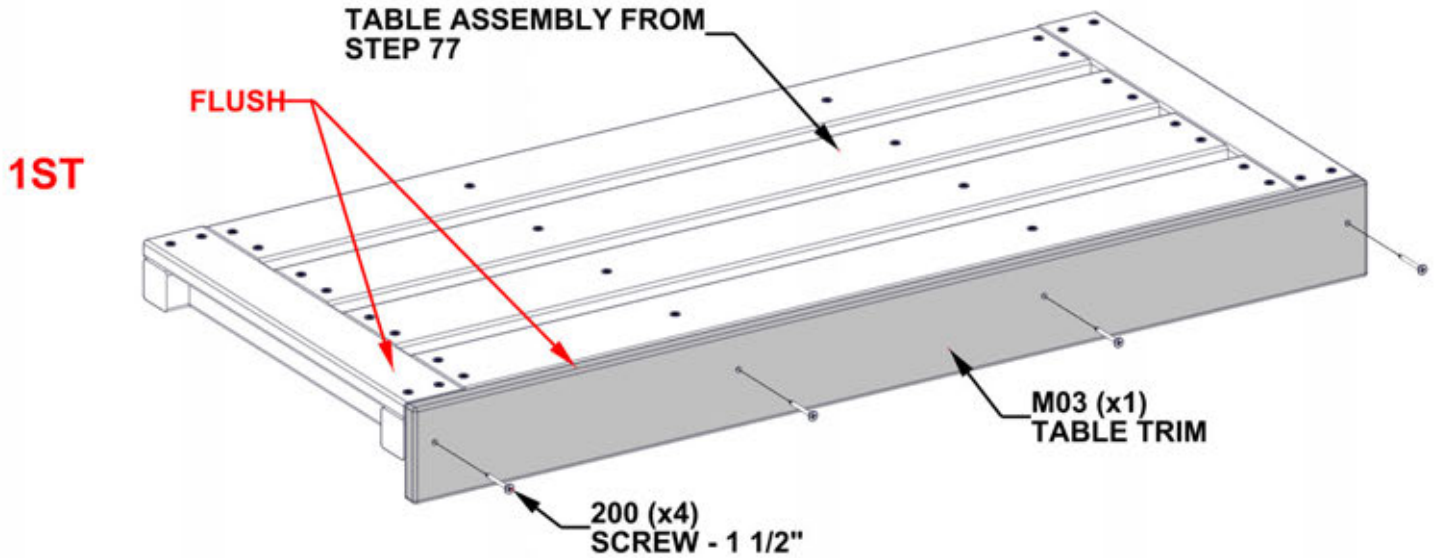


A4M02094) FOLDING TABLE BRACKET
(x2)



M03 TABLE TRIM - W4L18348
(x1) 5/8"x3 3/8"x36 1/2" (16x86x927)

- NOTES:**
- 1) INSTALL TABLE TRIM (M03):
 - ALIGN PILOT HOLES OF TABLE ASSEMBLY TO PILOT HOLES ON TABLE TRIM BOARD.
 - THERE ARE PILOT HOLES ON ONLY ONE SIDE OF TABLE ASSEMBLY.
 - 2) SECURE FOLDING TABLE BRACKETS
 - LINE BRACKETS UP WITH PILOT HOLES AND ATTACH AS SHOWN.
 - MAY NEED TO USE PHILLIPS EXTENSION BIT (PROVIDED IN KIT).



STEP 79 - TABLE ASSEMBLY

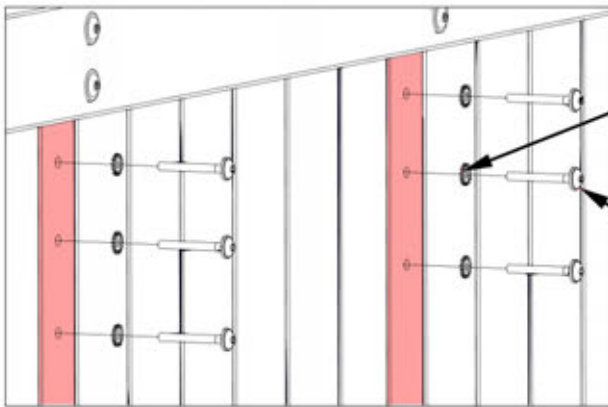
QTY	PART NUMBER	DESCRIPTION
6	H100405	WASHER LOCK EXT 6x15
6	H100488	BOLT WH 1/4x2 BLK
6	H100630	WASHER FLAT 8x19 BLK
6	H100653	NUT LOCK 1/4 BLK



TABLE ASSEMBLY

NOTES:

- **NEED TWO (2) ADULTS FOR THIS STEP**
- ON HIGHLIGHTED UPRIGHTS, PUSH BOLTS IN FROM THE OUTSIDE THROUGH TABLE BRACKETS.
- FASTEN AS SHOWN.



OUTSIDE VIEW

405 (x6)
WASHER - 6x15

488 (x6)
BOLT - 2"

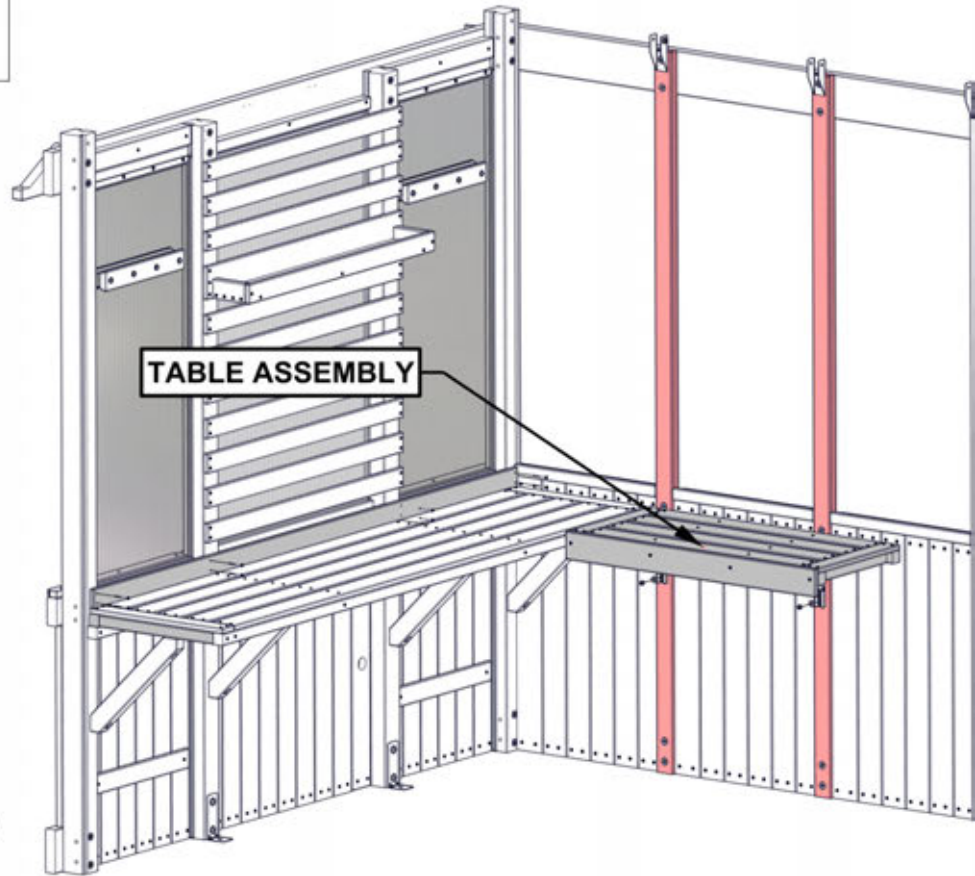
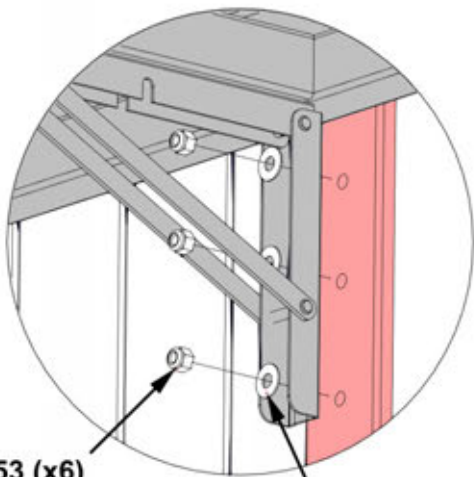


TABLE ASSEMBLY

LEFT WALL ASSEMBLY NOT SHOWN ON THIS STEP



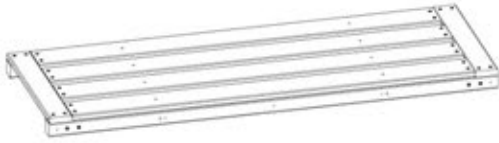
653 (x6)
LOCK NUT - 1/4"

630 (x6)
WASHER - 8x19

INSIDE VIEW

STEP 80 - TABLE ASSEMBLY

QTY	PART NUMBER	DESCRIPTION
4	H100201	SCREW PFH 8x2 1/2 BLK
8	H100387	SCREW PFH 8x1 1/4 BLK



T3 MIDDLE TABLE ASSEMBLY - W2A03903
(x1) 2 1/16"x16 1/16"x45 1/2" (52x408x1156)



P05 TABLE FRAME - W4L18087
(x2) 1 7/16"x1 7/16"x13 1/4" (36x36x336)

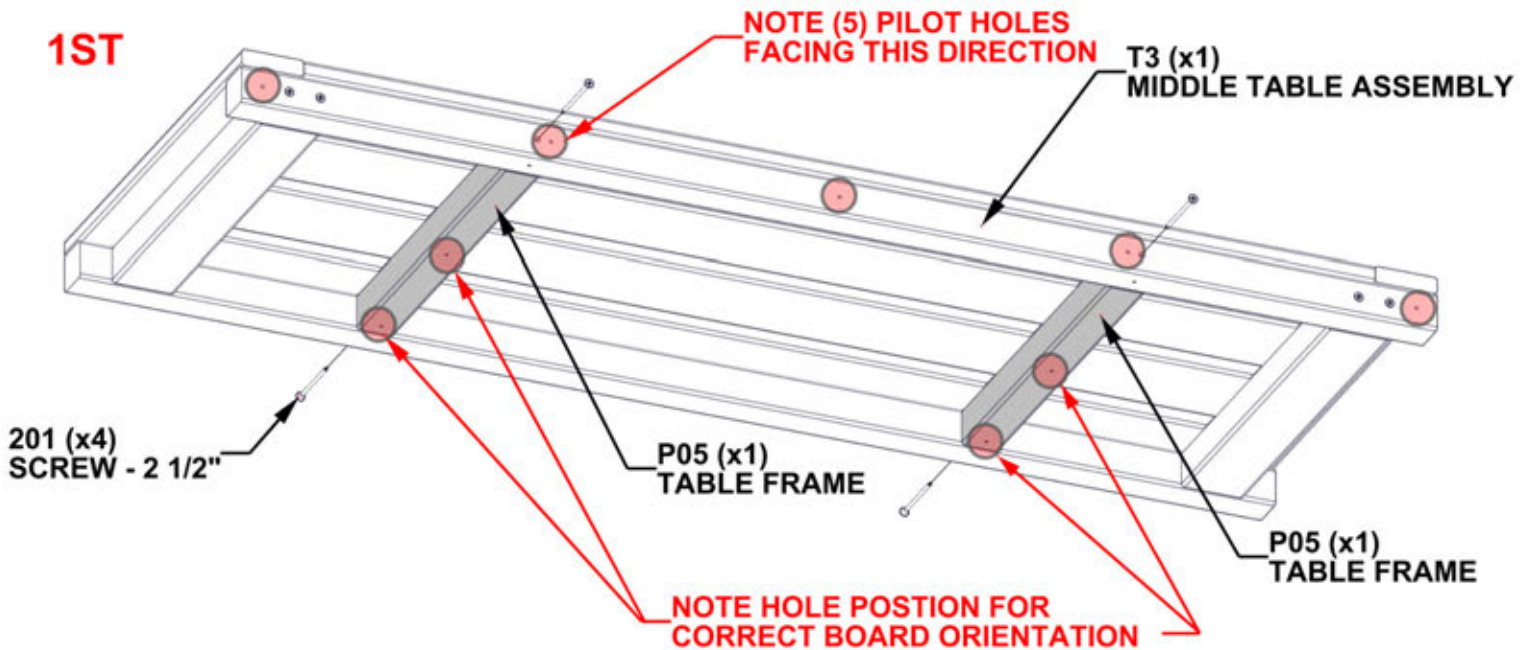
NOTES:

• **PAY CLOSE ATTENTION TO PILOT HOLE DIRECTION FOR CORRECT INSTALLATION**

1) INSTALL TABLE SUPPORTS:

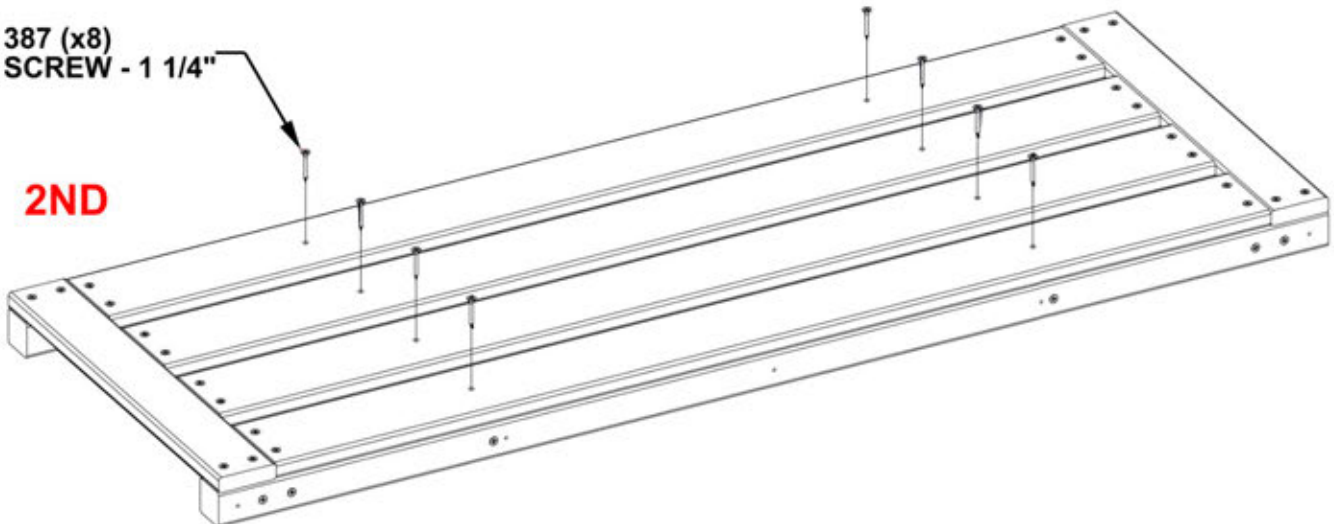
- TABLE FRAME BOARDS HAVE SMALL PILOT HOLES FACING UP.
- NOTE PROPER ORIENTATION OF LARGER HOLES ON THE BOTTOM OF TABLE FRAME BOARD (P05) AS SHOWN.

2) SECURE TABLETOP TO SUPPORTS, AS SHOWN.



387 (x8) SCREW - 1 1/4"

2ND



STEP 81 - TABLE ASSEMBLY

QTY	PART NUMBER	DESCRIPTION
5	H100200	SCREW PFH 8x1 1/2 BLK
6	H100392	SCREW PWH 8x3/4 BLK

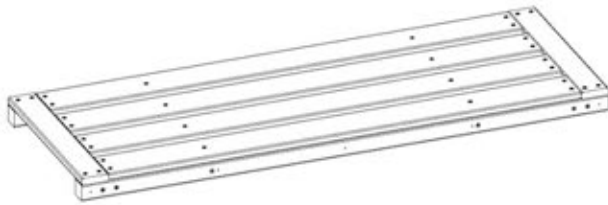


TABLE ASSEMBLY FROM
STEP 80



A4M02094 FOLDING TABLE BRACKET
(x2)



M05 TABLE TRIM - W4L18350
(x1) 5/8"x3 3/8"x45 1/2" (16x86x1156)

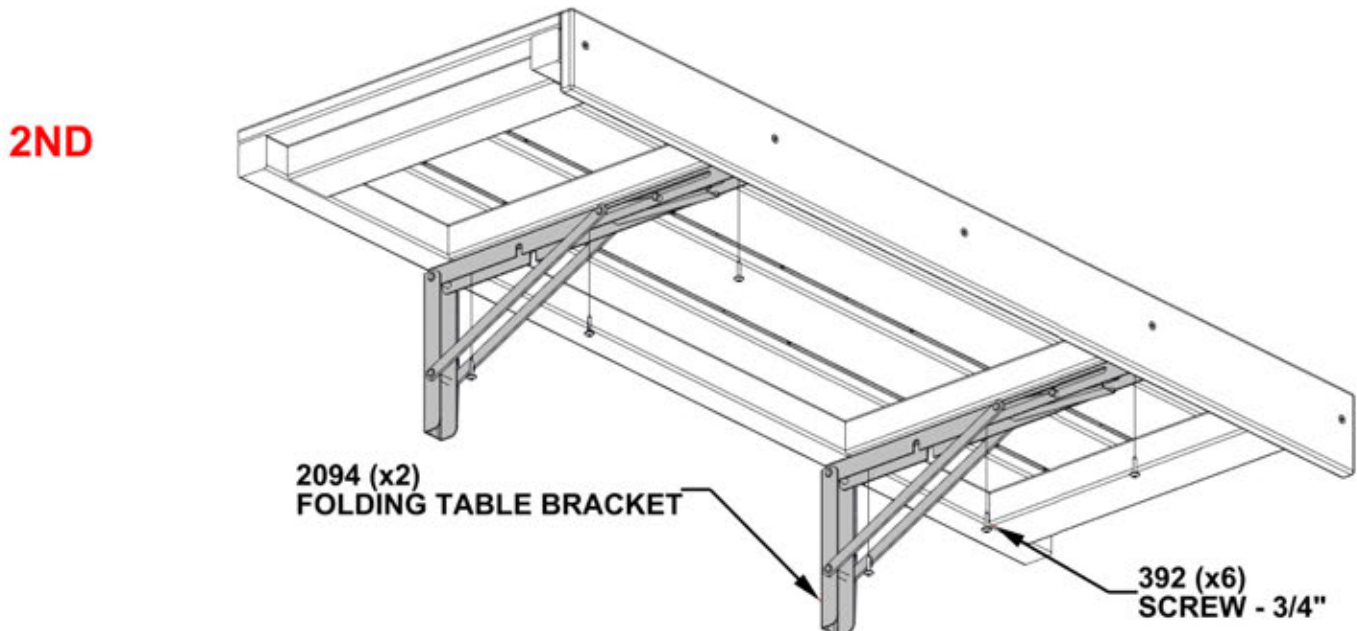
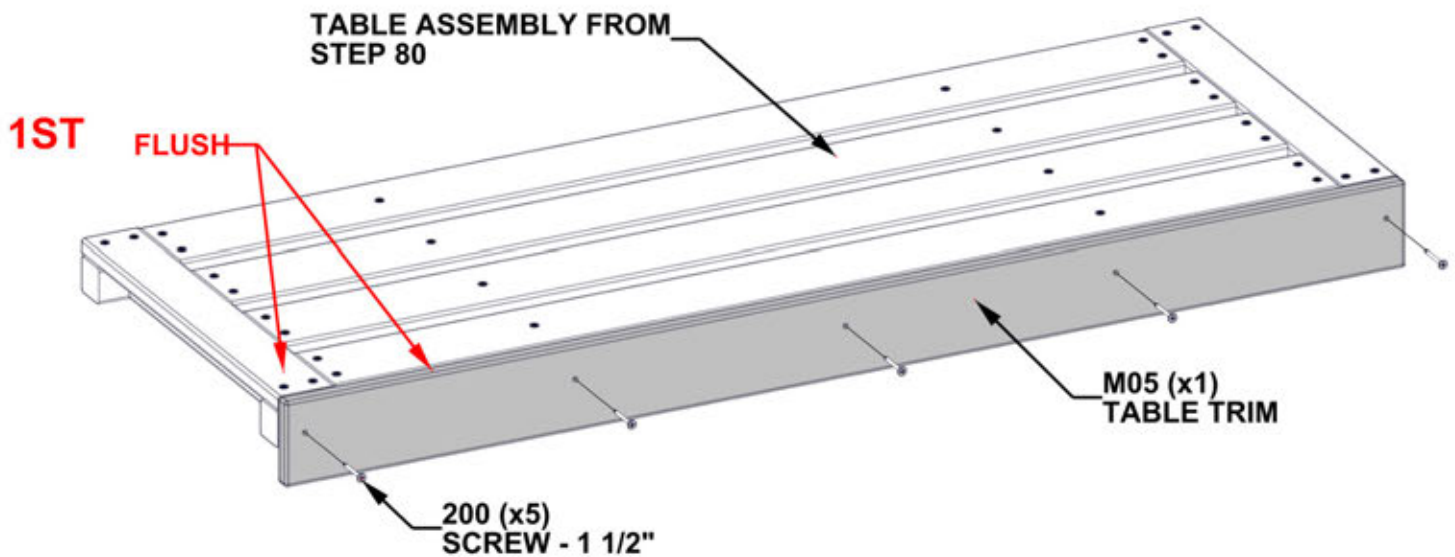
NOTES:

1) INSTALL TABLE TRIM (M05):

- ALIGN PILOT HOLES OF TABLE ASSEMBLY TO PILOT HOLES ON TABLE TRIM BOARD.
- THERE ARE PILOT HOLES ON ONLY ONE SIDE OF TABLE ASSEMBLY.

2) SECURE FOLDING TABLE BRACKETS:

- LINE BRACKETS UP WITH PILOT HOLES AND ATTACH AS SHOWN.
- MAY NEED TO USE PHILLIPS EXTENSION BIT (PROVIDED IN KIT).



STEP 82 - TABLE ASSEMBLY

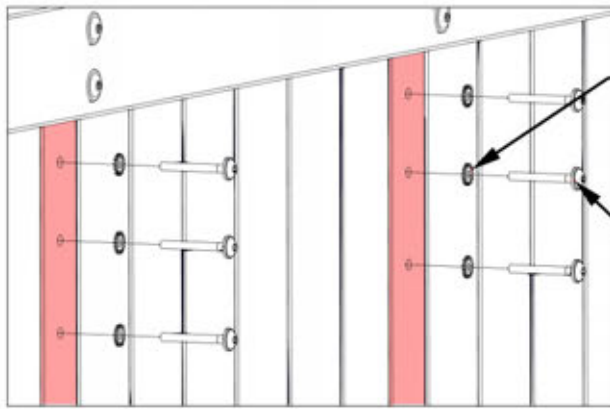
QTY	PART NUMBER	DESCRIPTION
6	H100405	WASHER LOCK EXT 6x15
6	H100488	BOLT WH 1/4x2 BLK
6	H100630	WASHER FLAT 8x19 BLK
6	H100653	NUT LOCK 1/4 BLK



TABLE ASSEMBLY

NOTES:

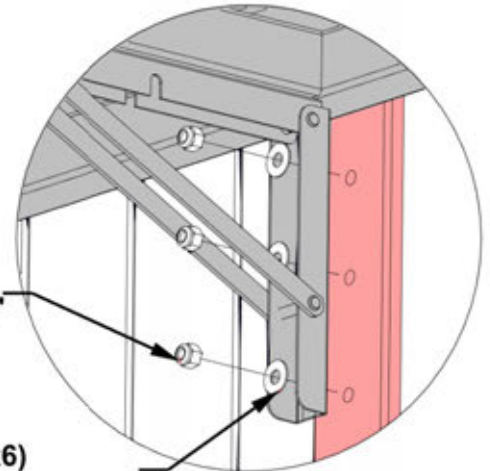
- **WILL NEED TWO (2) ADULTS FOR THIS STEP**
- ON HIGHLIGHTED UPRIGHTS, PUSH BOLTS IN FROM THE OUTSIDE THROUGH TABLE BRACKETS.
- FASTEN AS SHOWN.



OUTSIDE VIEW

405 (x6)
WASHER - 6x15

488 (x6)
BOLT - 2"



653 (x6)
LOCK NUT - 1/4"

630 (x6)
WASHER - 8x19

INSIDE VIEW

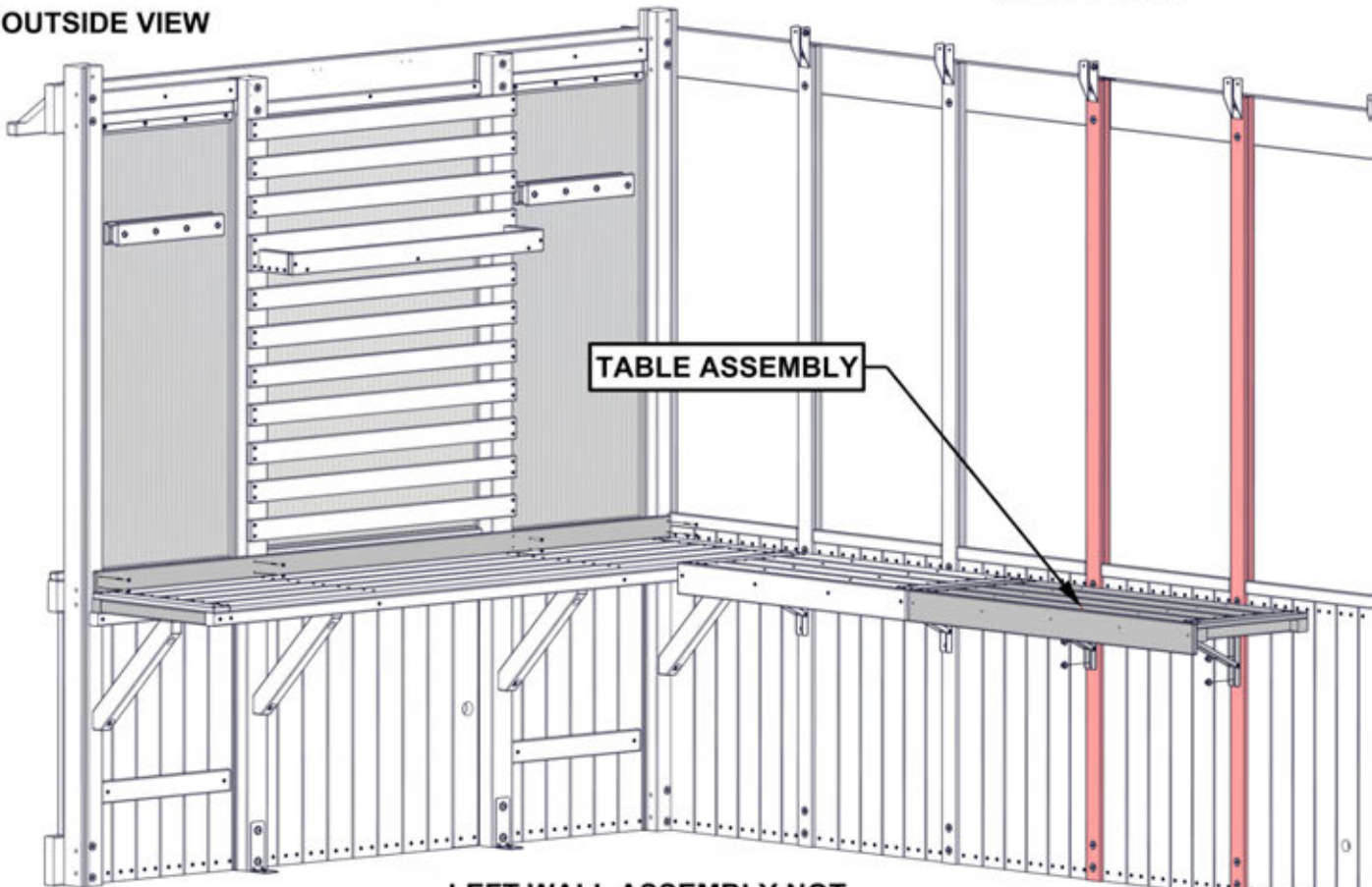


TABLE ASSEMBLY

LEFT WALL ASSEMBLY NOT SHOWN ON THIS STEP

STEP 83 - TABLE ASSEMBLY

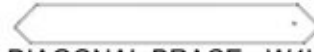
QTY	PART NUMBER	DESCRIPTION
3	H100200	SCREW PFH 8x1 1/2 BLK
1	H100202	SCREW PWH 8x5/8 BLK
2	H100405	WASHER LOCK EXT 6x15
2	H100456	LAG SCREW WH 1/4x2 1/2 BLK
1	H100536	SCREW PWH 8x1 1/4 BLK



M07 TABLE TRIM - W4L18356
(x1) 5/8"x3 3/8"x26 1/4" (16x86x667)



F09 DIAGONAL BRACE - W4L18084
(x1) 1 7/16"x2 3/8"x18 1/16" (36x60x458)



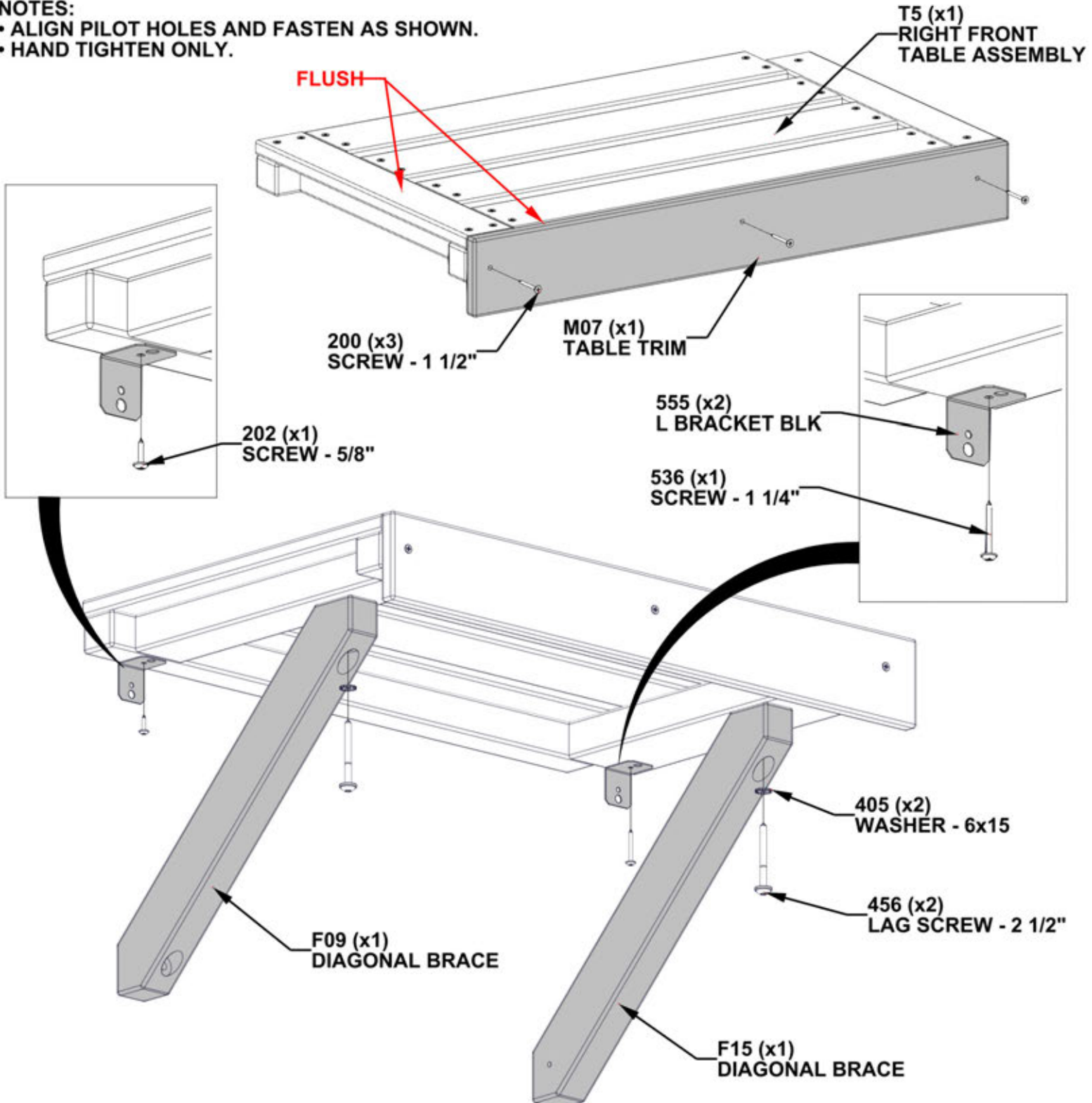
F15 DIAGONAL BRACE - W4L18428
(x1) 1 7/16"x2 3/8"x18 1/16" (36x60x458)

A4M00555 L BRACKET BLK
(x2)



T5 RIGHT FRONT TABLE ASSEMBLY - W2A03905
(x1) 2 1/16"x16 1/4"x26 1/4" (52x412x547)

- NOTES:**
- ALIGN PILOT HOLES AND FASTEN AS SHOWN.
 - HAND TIGHTEN ONLY.



STEP 84 - TABLE ASSEMBLY



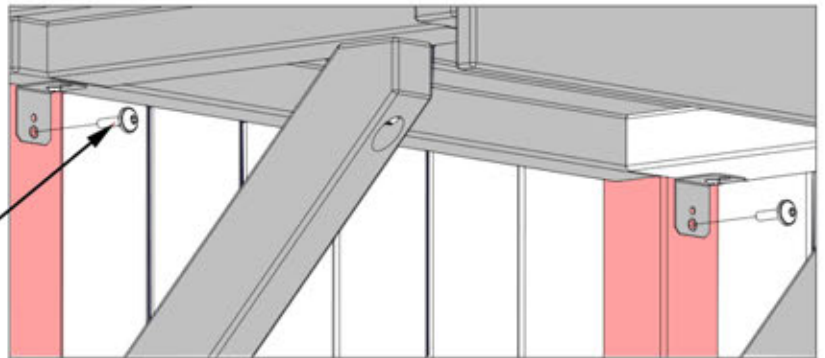
TABLE ASSEMBLY FROM
STEP 83

QTY	PART NUMBER	DESCRIPTION
1	H100201	SCREW PFH 8x2 1/2 BLK
1	H100405	WASHER LOCK EXT 6x15
2	H100460	LAG SCREW WH 1/4x1 BLK
1	H100792	LAG SCREW WH 1/4x3 BLK

NOTES:

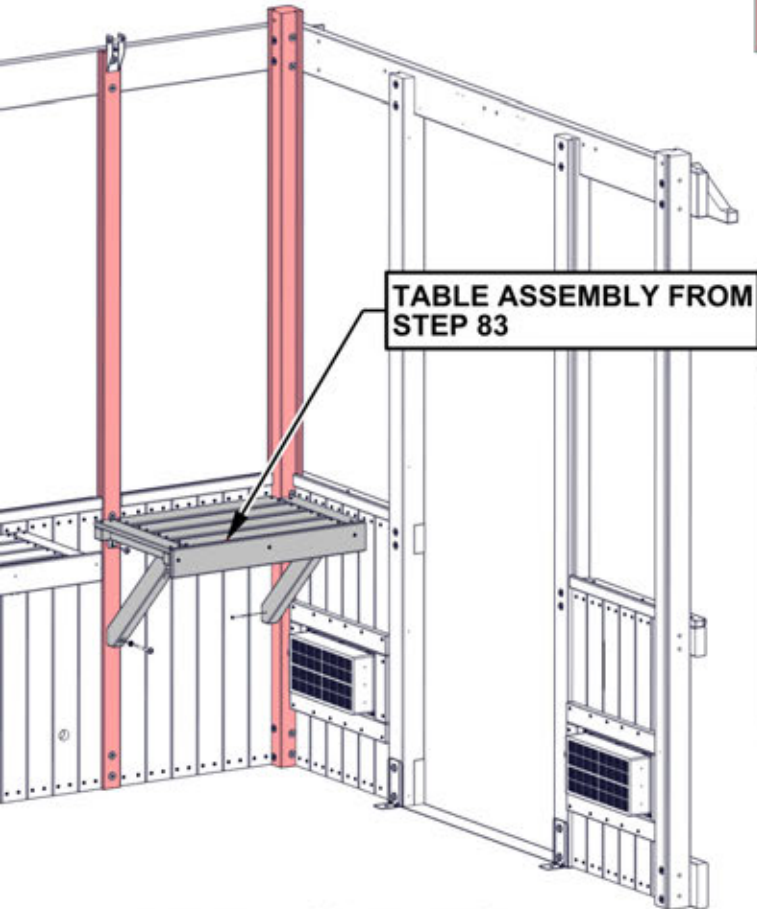
- LOCATE PILOT HOLES ON HIGHLIGHTED POST/UPRIGHTS AND FASTEN AS SHOWN.
- TIGHTEN ALL HARDWARE.

460 (x2)
LAG SCREW - 1"



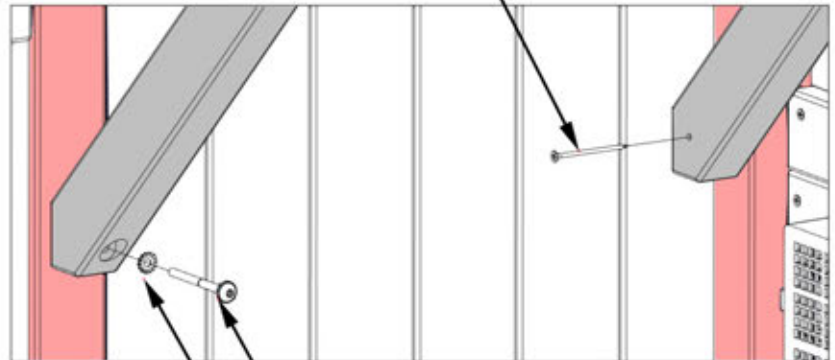
VIEW UNDERNEATH
TABLE

TABLE ASSEMBLY FROM
STEP 83



LEFT WALL ASSEMBLY NOT
SHOWN ON THIS STEP

201 (x1)
SCREW - 2 1/2"



792 (x1)
LAG SCREW - 3"
405 (x1)
WASHER - 6x15

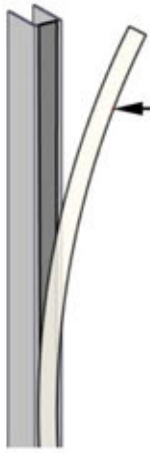
STEP 85 - WINDOW ASSEMBLY



A6P00634 POLY CHANNEL WITH TAPE
(x24)

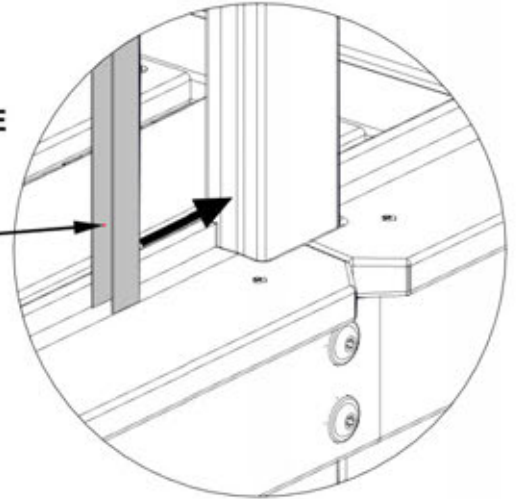
NOTES:

- REPEAT INSTALLATION OF POLY CHANNELS FOR EACH WINDOW ON RIGHT AND LEFT SIDE OF GREENHOUSE.

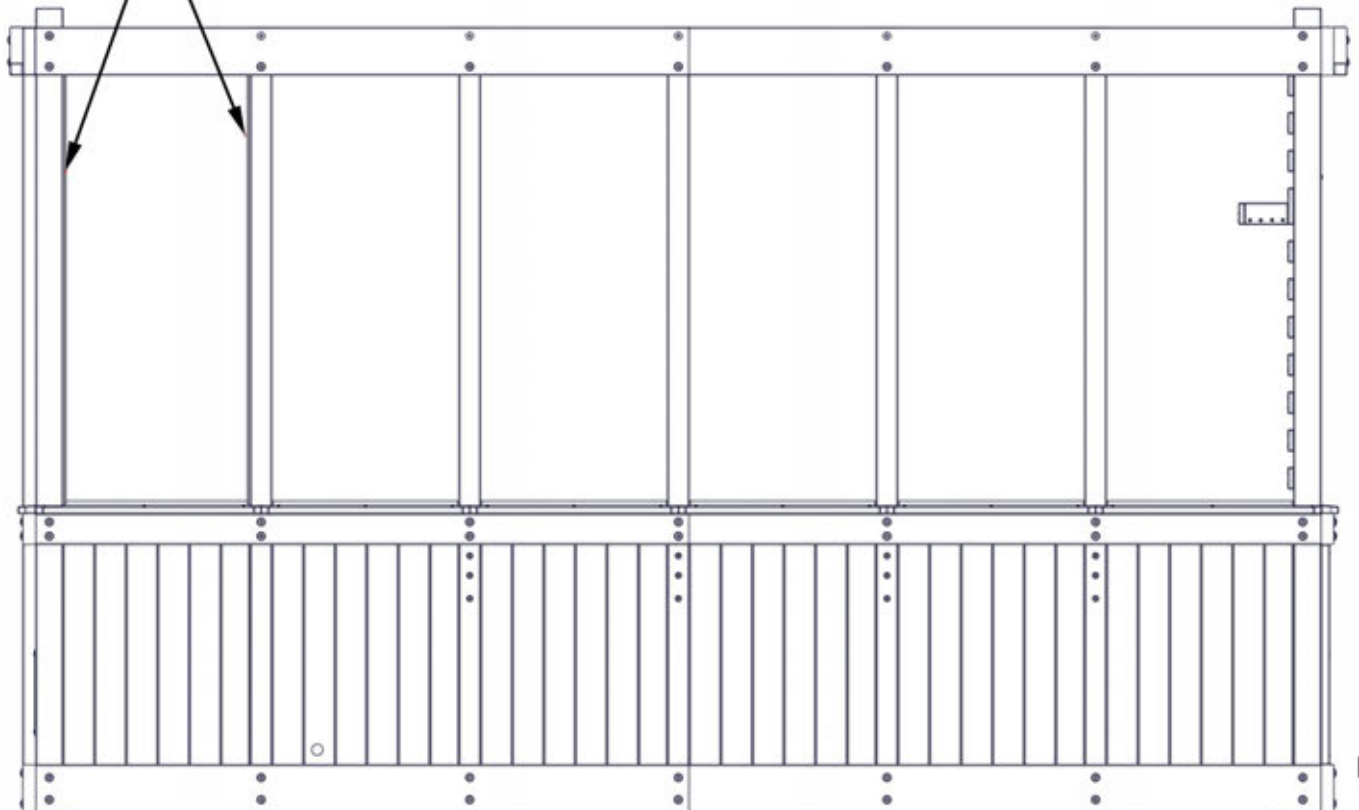


POLY CHANNEL WILL COME WITH DOUBLE SIDED TAPE INSTALLED. REMOVE LINER BEFORE INSTALLATION

INSERT POLY CHANNEL 634 INTO GROOVE STARTING AT THE WINDOW LEDGE AND WORK UPWARDS



634 (x12)
POLY CHANNEL
WITH TAPE

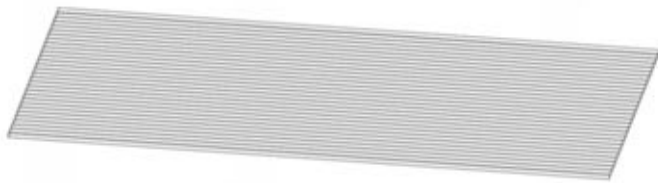


FRONT

BACK

RIGHT

STEP 86 - WINDOW ASSEMBLY



A6P00568 POLY SHEETING
(x12)



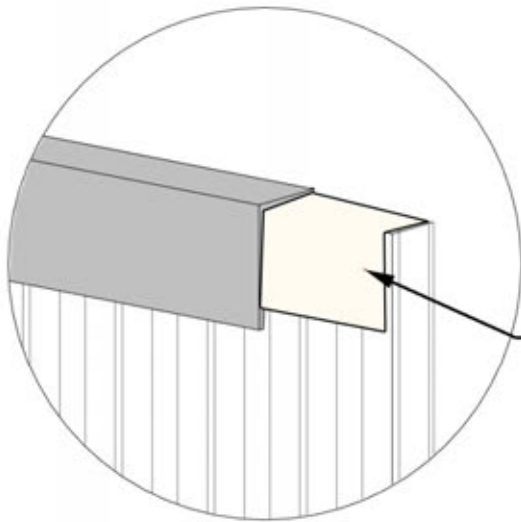
A6P00637 POLY CHANNEL
(x24)



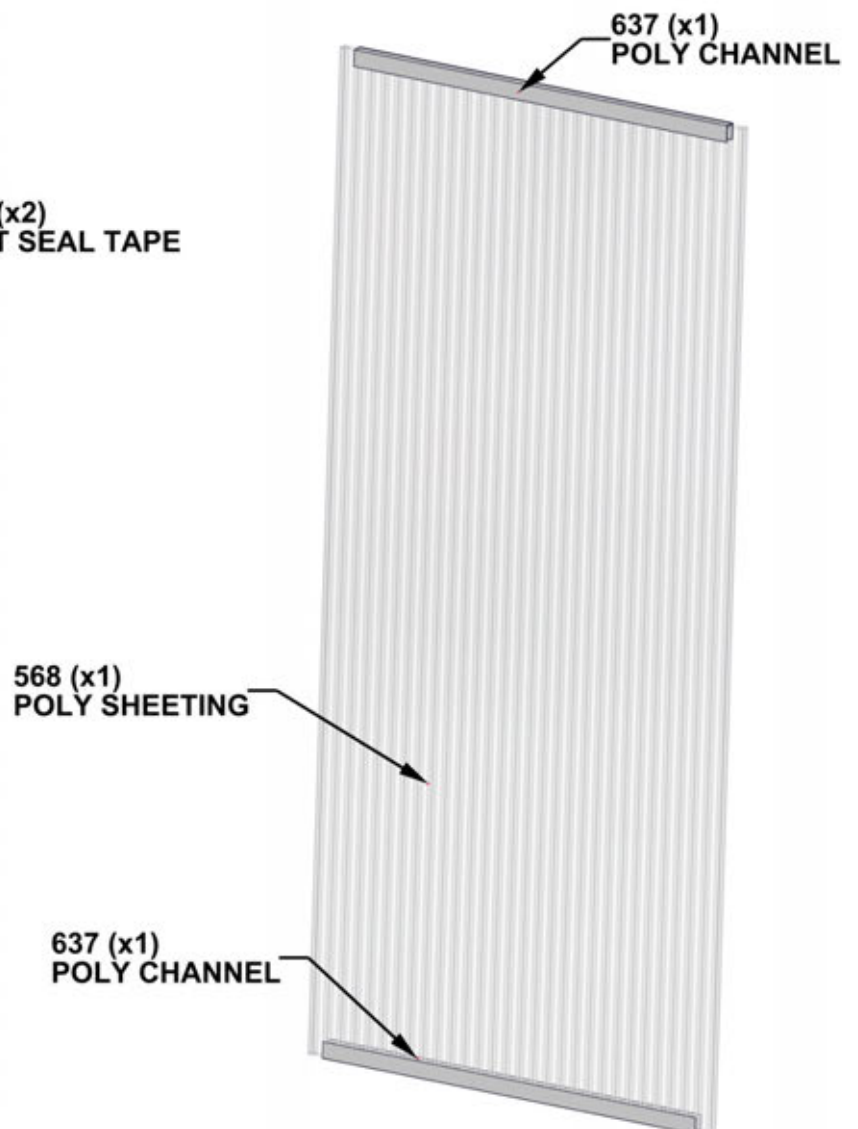
A6P00690 DUST TAPE

TO APPLY DUST TAPE & POLY CHANNEL:

- CUT (2) STRIPS OF DUST SEAL TAPE THE SAME WIDTH AS THE POLY SHEETING
 - WRAP DUST TAPE ALONG EDGE OF POLY SHEETING WIDTH
 - AFTER TAPE IS SECURE, PUSH CHANNEL ON OVER THE TAPE, CENTERING ON POLY SHEETING (APPROX 1" [25mm]) CLEARANCE ON EACH SIDE AS SHOWN
 - REPEAT ON THE BOTTOM SIDE OF POLY SHEETING
- **REPEAT FOR ALL (12) WINDOWS.**



690 (x2)
DUST SEAL TAPE

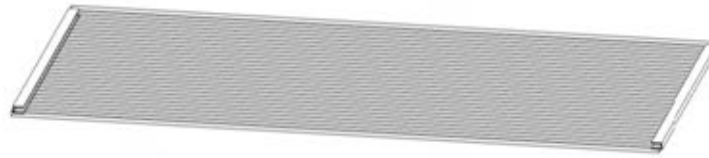


637 (x1)
POLY CHANNEL

568 (x1)
POLY SHEETING

637 (x1)
POLY CHANNEL

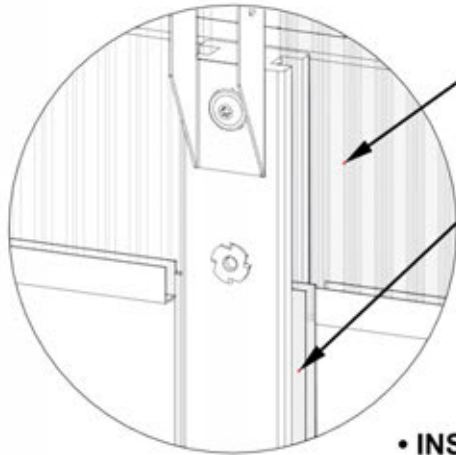
STEP 87 - WINDOW ASSEMBLY



WINDOW ASSEMBLY FROM
STEP 86 (x12)

NOTES:

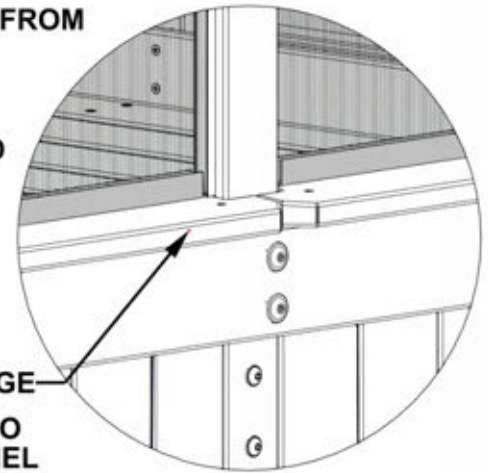
- **IMPORTANT! ENSURE UV SIDE OF POLY SHEETING IS FACING OUTSIDE**
- **REPEAT THIS STEP FOR OPPOSITE SIDE OF GREENHOUSE**



INSIDE VIEW

WINDOW ASSEMBLIES FROM
STEP 86

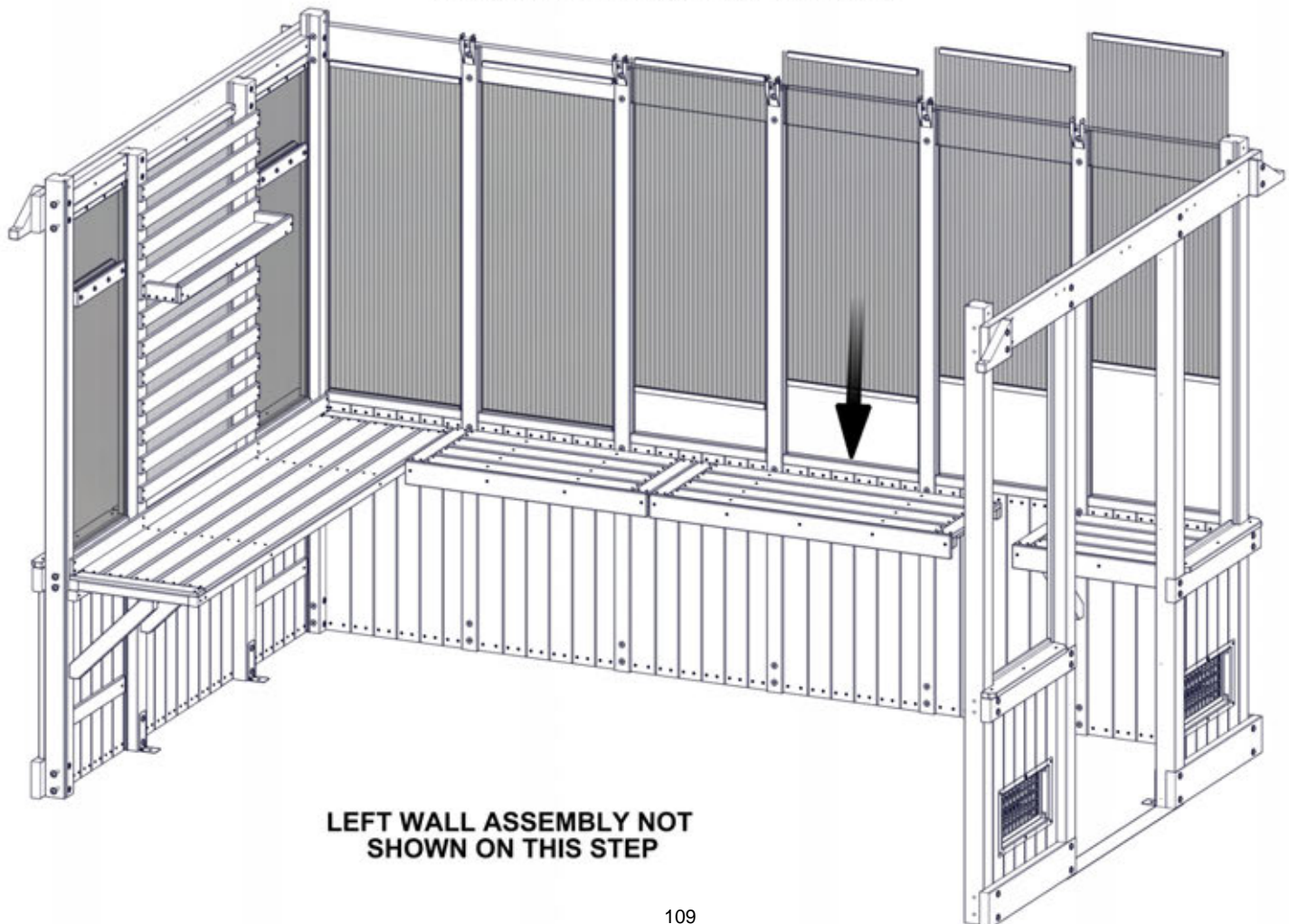
PREVIOUSLY INSTALLED
POLY CHANNEL



WINDOW LEDGE

OUTSIDE VIEW

- **INSERT WINDOW ASSEMBLY INTO
PREVIOUSLY INSTALLED CHANNEL
ON BOTH SIDES OF WINDOW.**
- **GENTLY SLIDE WINDOW DOWN
UNTIL SEATED ON WINDOW LEDGE**

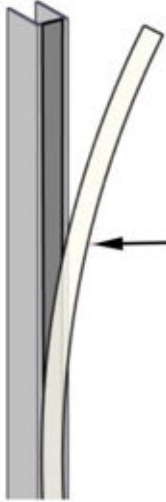


LEFT WALL ASSEMBLY NOT
SHOWN ON THIS STEP

STEP 88 - WINDOW ASSEMBLY

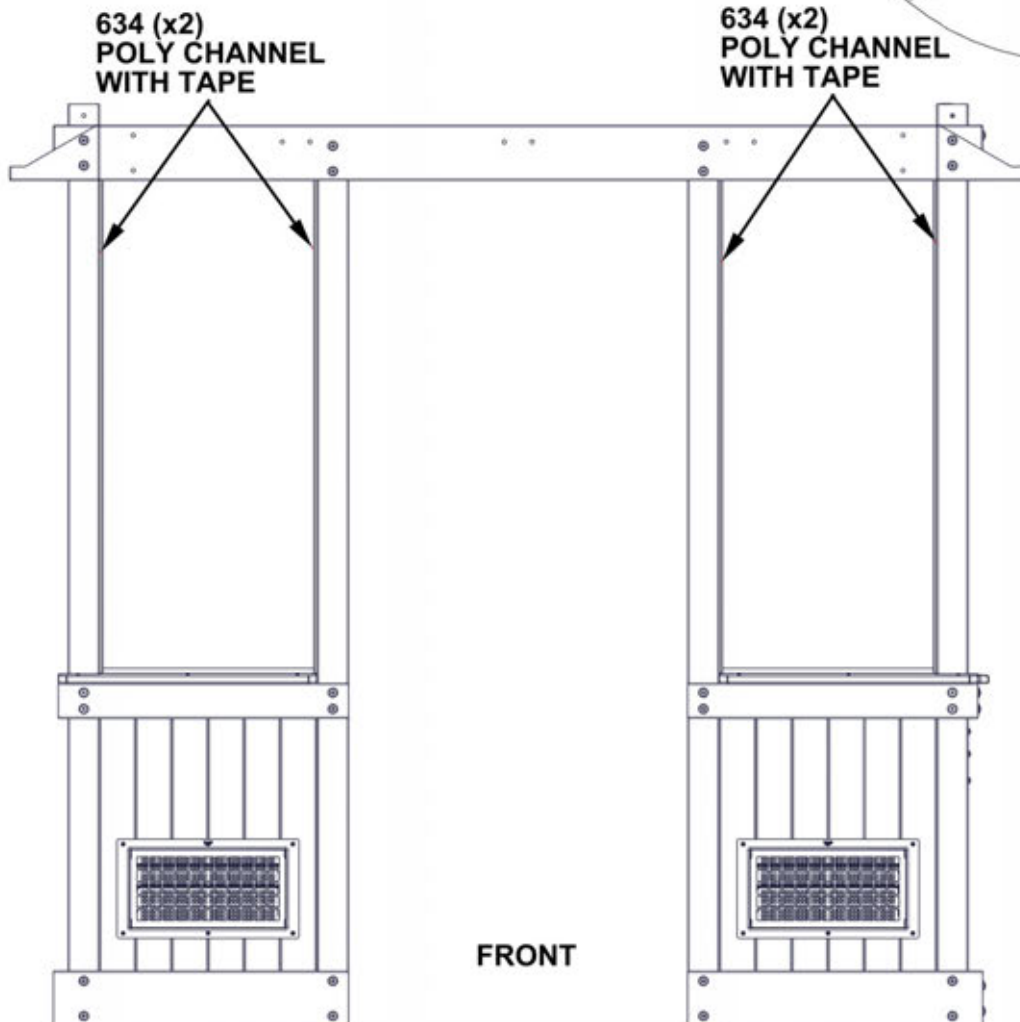
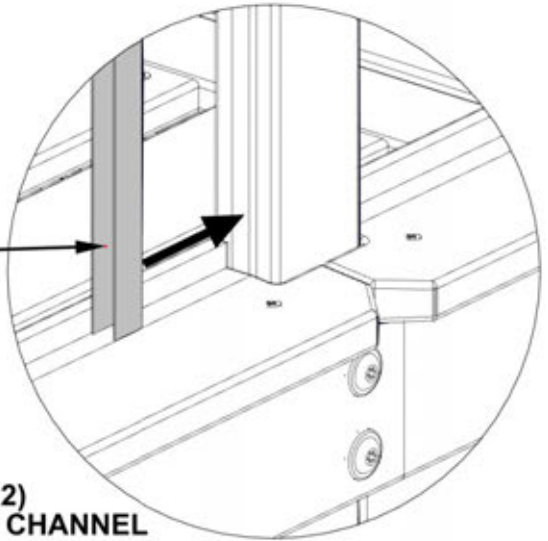


A6P00634 POLY CHANNEL WITH TAPE
(x4)



POLY CHANNEL WILL COME WITH DOUBLE SIDED TAPE INSTALLED. REMOVE LINER BEFORE INSTALLATION

INSERT POLY CHANNEL 634 INTO GROOVE STARTING AT THE WINDOW LEDGE AND WORK UPWARDS



STEP 89 - WINDOW ASSEMBLY



A6P00691 POLY SHEETING
(x2)



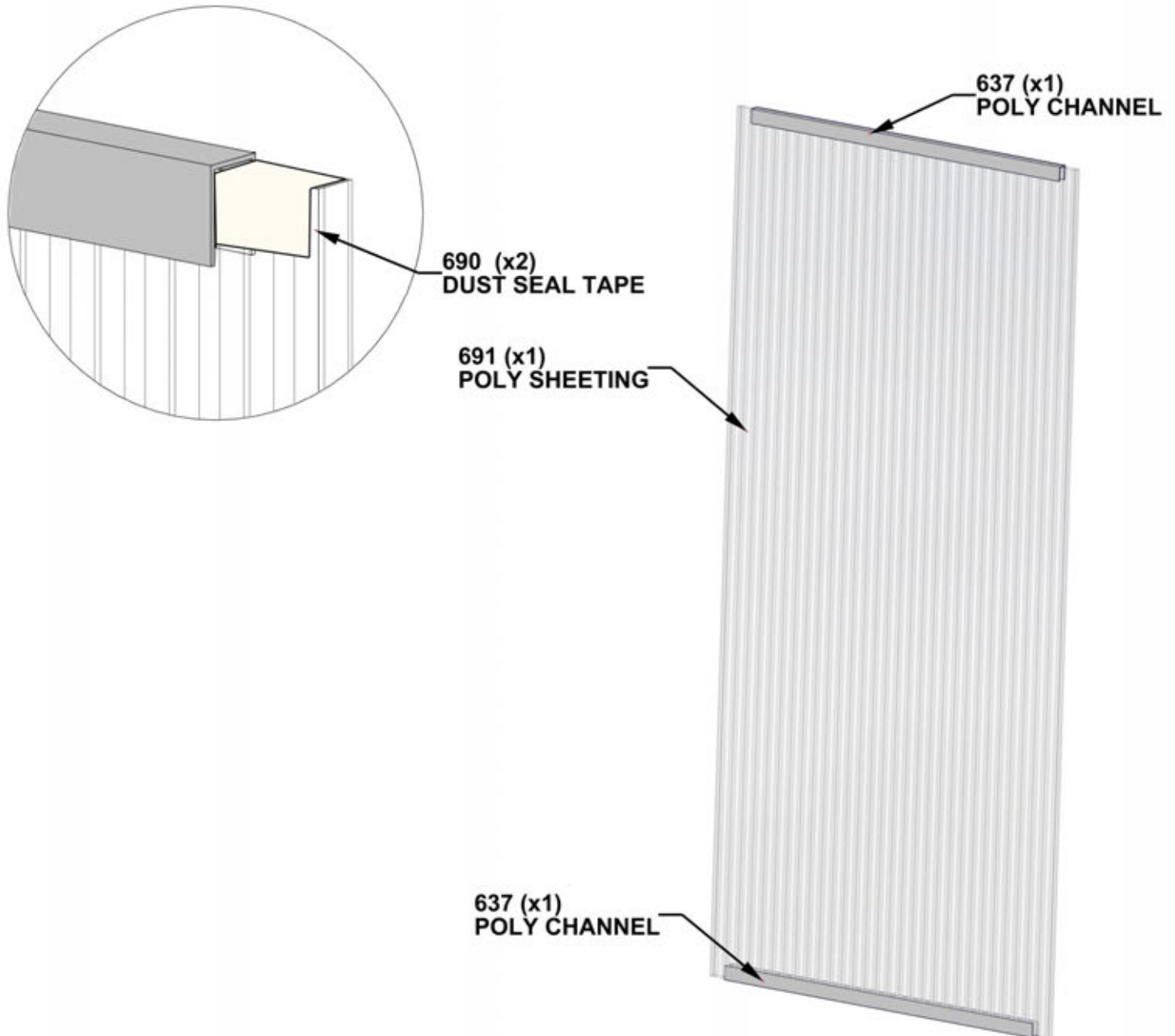
A6P00637 POLY CHANNEL
(x4)



A6P00690 DUST TAPE

TO APPLY DUST TAPE & POLY CHANNEL:

- CUT (2) STRIPS OF DUST SEAL TAPE THE SAME WIDTH AS THE POLY SHEETING
- WRAP DUST TAPE ALONG EDGE OF POLY SHEETING WIDTH
- AFTER TAPE IS SECURE, PUSH CHANNEL ON OVER THE TAPE, CENTERING ON POLY SHEETING (APPROX 1" [25mm]) CLEARANCE ON EACH SIDE AS SHOWN
- REPEAT ON THE BOTTOM SIDE OF POLY SHEETING
- **REPEAT FOR (2) WINDOWS**



STEP 90 - WINDOW ASSEMBLY

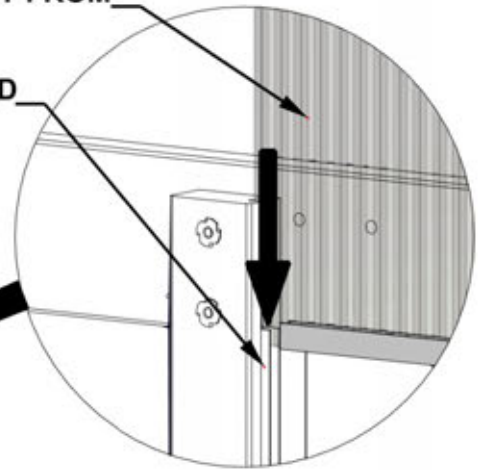


WINDOW ASSEMBLY FROM
STEP 89 (x2)

- NOTES:**
- **IMPORTANT! ENSURE UV SIDE OF POLY SHEETING IS FACING OUTSIDE.**
 - **SAFE TO REMOVE ALL PROTECTIVE FILM FROM THE ALL THE INSTALLED WINDOWS.**

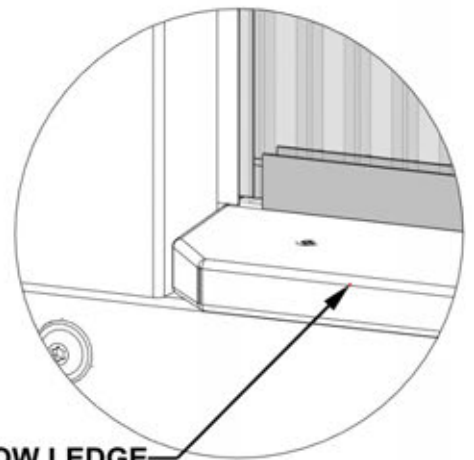
WINDOW ASSEMBLY FROM
STEP 89

PREVIOUSLY INSTALLED
CHANNEL



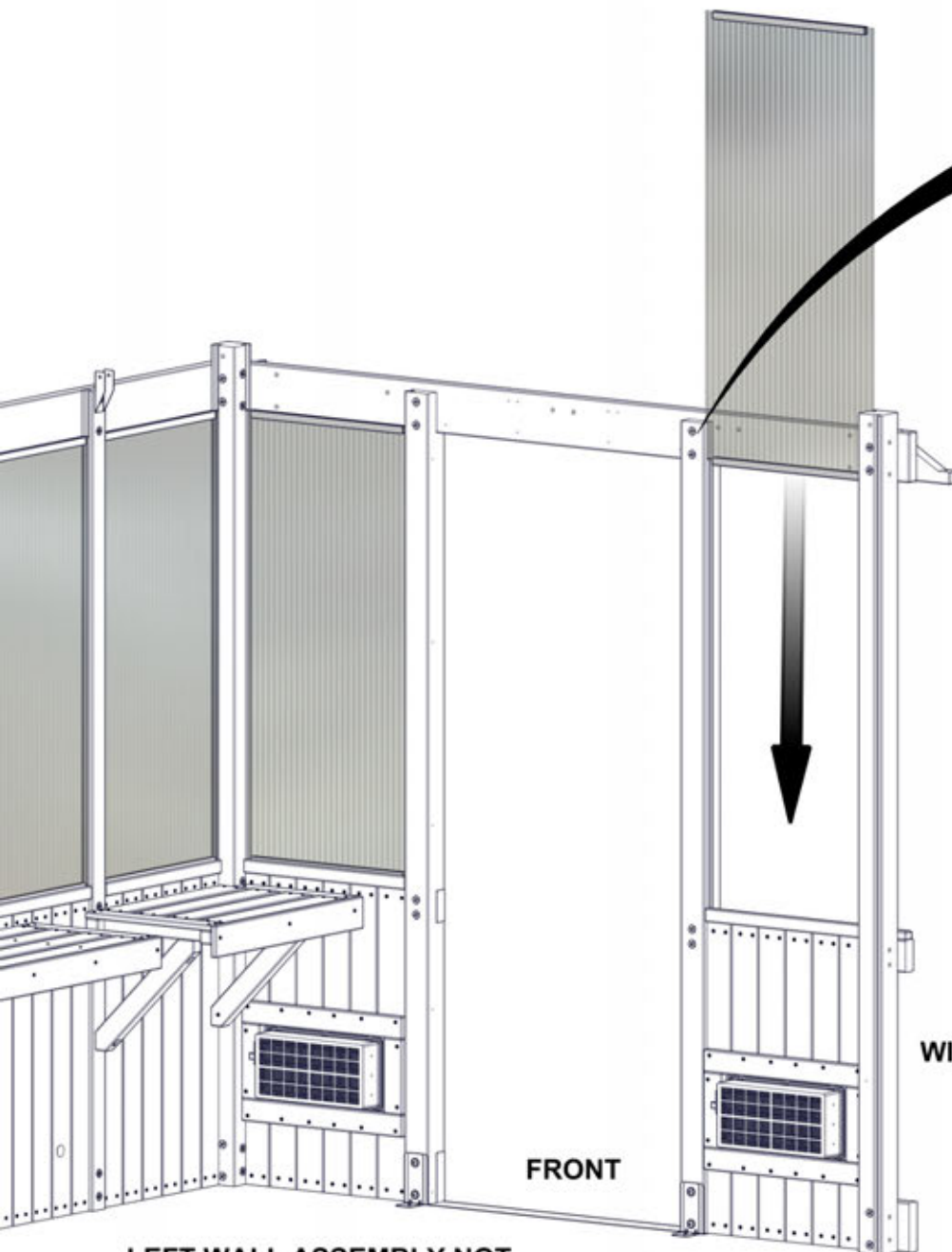
INSIDE VIEW

- **INSERT WINDOW ASSEMBLY INTO PREVIOUSLY INSTALLED CHANNEL ON BOTH SIDES OF WINDOW.**
- **GENTLY SLIDE WINDOW DOWN UNTIL SEATED ON WINDOW LEDGE**
- **REPEAT FOR BOTH WINDOWS**



WINDOW LEDGE

OUTSIDE VIEW



FRONT

LEFT WALL ASSEMBLY NOT
SHOWN ON THIS STEP

STEP 91 - WINDOW ASSEMBLY

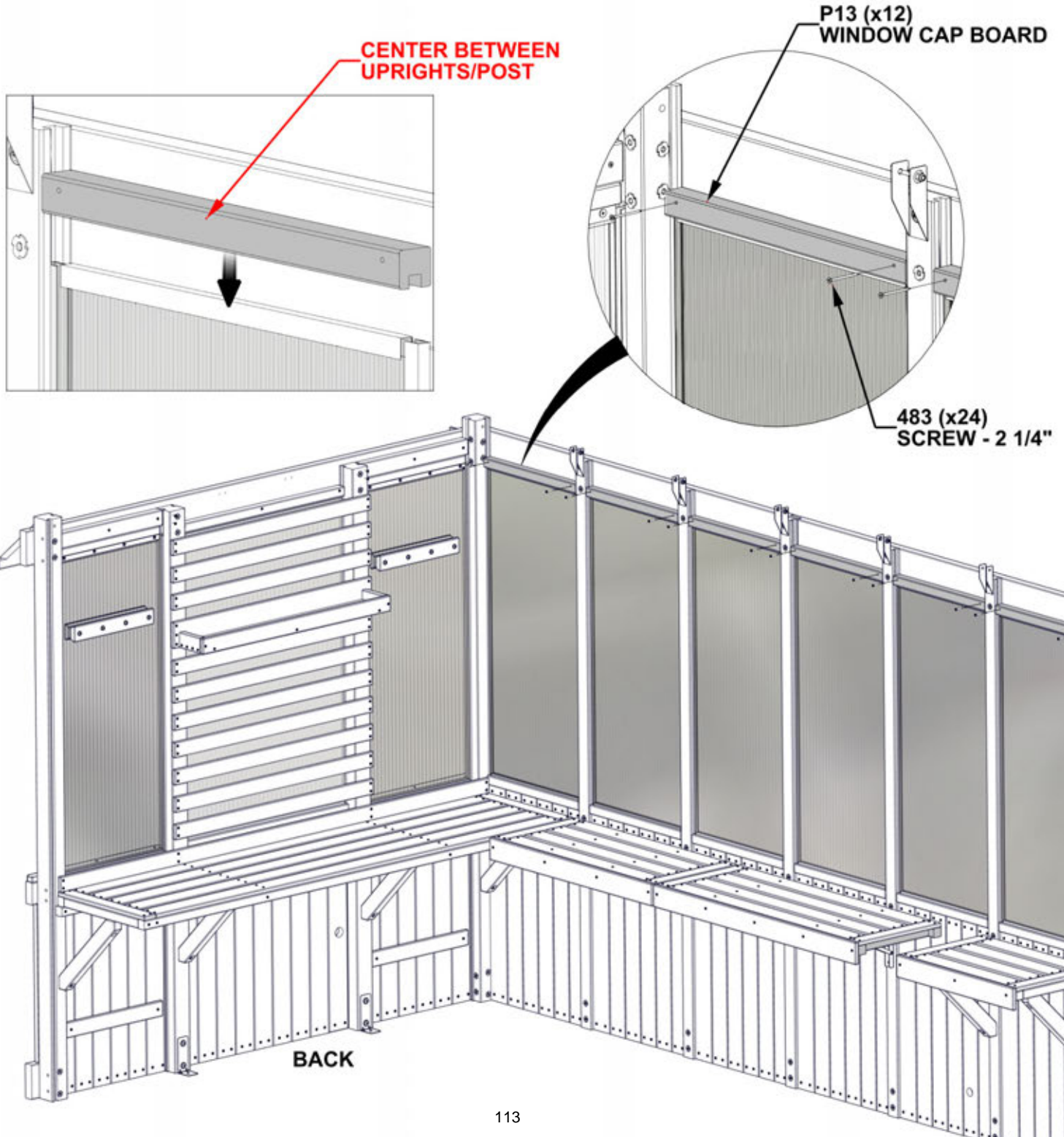
QTY	PART NUMBER	DESCRIPTION
24	H100483	SCREW PFH 8x2 1/4 BLK



P13 WINDOW CAP BOARD - W4L18396
(x12) 1 7/16"x1 7/16"x20 5/8" (36x36x524)

NOTES:

- START AT ONE END OF THE SIDEWALL AND ATTACH P13 BOARDS TO THE TOP OF THE WINDOW AS SHOWN.
- REPEAT THIS ON THE OPPOSITE SIDE OF GREENHOUSE.



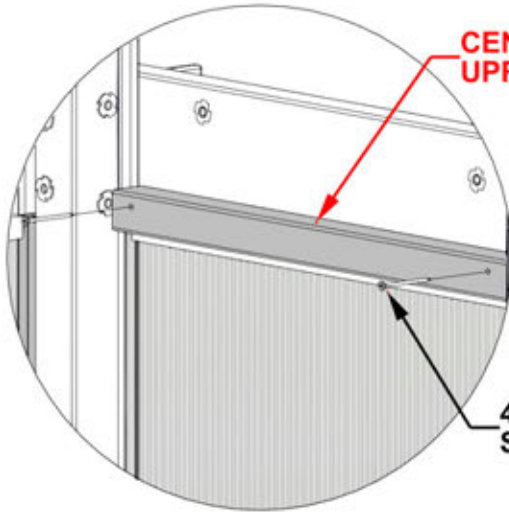
STEP 92 - WINDOW ASSEMBLY

QTY	PART NUMBER	DESCRIPTION
4	H100483	SCREW PFH 8x2 1/4 BLK



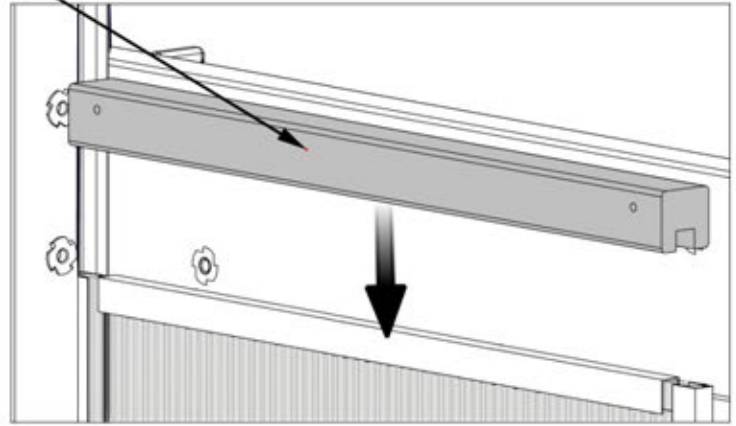
P13 WINDOW CAP BOARD - W4L18396
(x2) 1 7/16"x1 7/16"x20 5/8" (36x36x524)

SLIDE WINDOW CAP BOARD
ON TOP OF THE WINDOW
ASSEMBLY AS SHOWN.

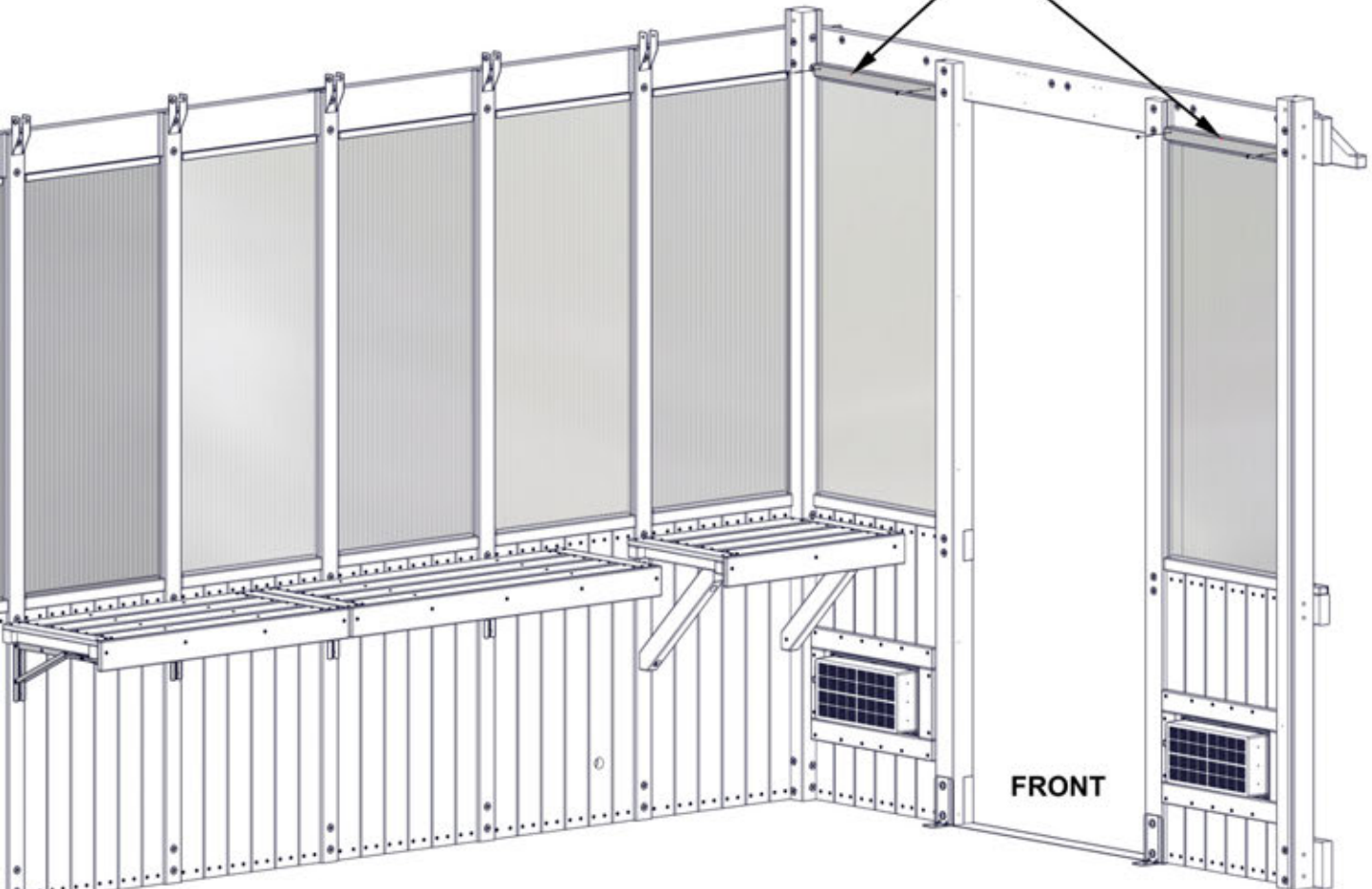


CENTER BETWEEN
UPRIGHTS

483 (x4)
SCREW - 2 1/4"



P13 (x2)
WINDOW CAP BOARD



FRONT

STEP 93 - ROOF PANEL ASSEMBLY

QTY	PART NUMBER	DESCRIPTION
10	H100391	SCREW PFH 8x2 BLK

Q18 PANEL RIDGE - W4L18776
(x1) 15/16"x4 7/16"x25 9/16" (24x112x650)

Q05 PANEL RIDGE - W4L18050
(x1) 15/16"x4 7/16"x70 1/2" (24x112x1791)

Q06 PANEL RIDGE - W4L18055
(x1) 15/16"x4 7/16"x48 5/8" (24x112x1235)

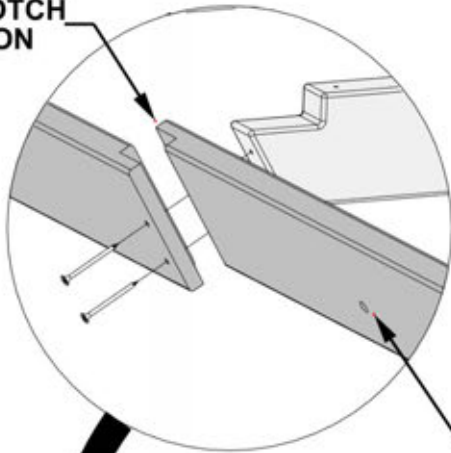
E21 RAFTER - W4L18421
(x2) 1 7/16"x3 3/8"x55 3/8" (36x86x1407)

E04 RAFTER - W4L18036
(x3) 1 7/16"x3 3/8"x55 3/8" (36x86x1407)

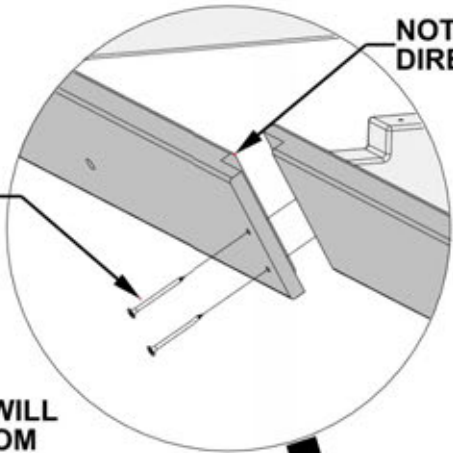
NOTES:

- USE OF SAWHORSES OR A TABLE IS RECOMMENDED FOR EASE OF ASSEMBLY OF ROOF.
- **IMPORTANT! MAKE NOTE OF ALL NOTCH DIRECTIONS FOR CORRECT ASSEMBLY.**

NOTE NOTCH DIRECTION



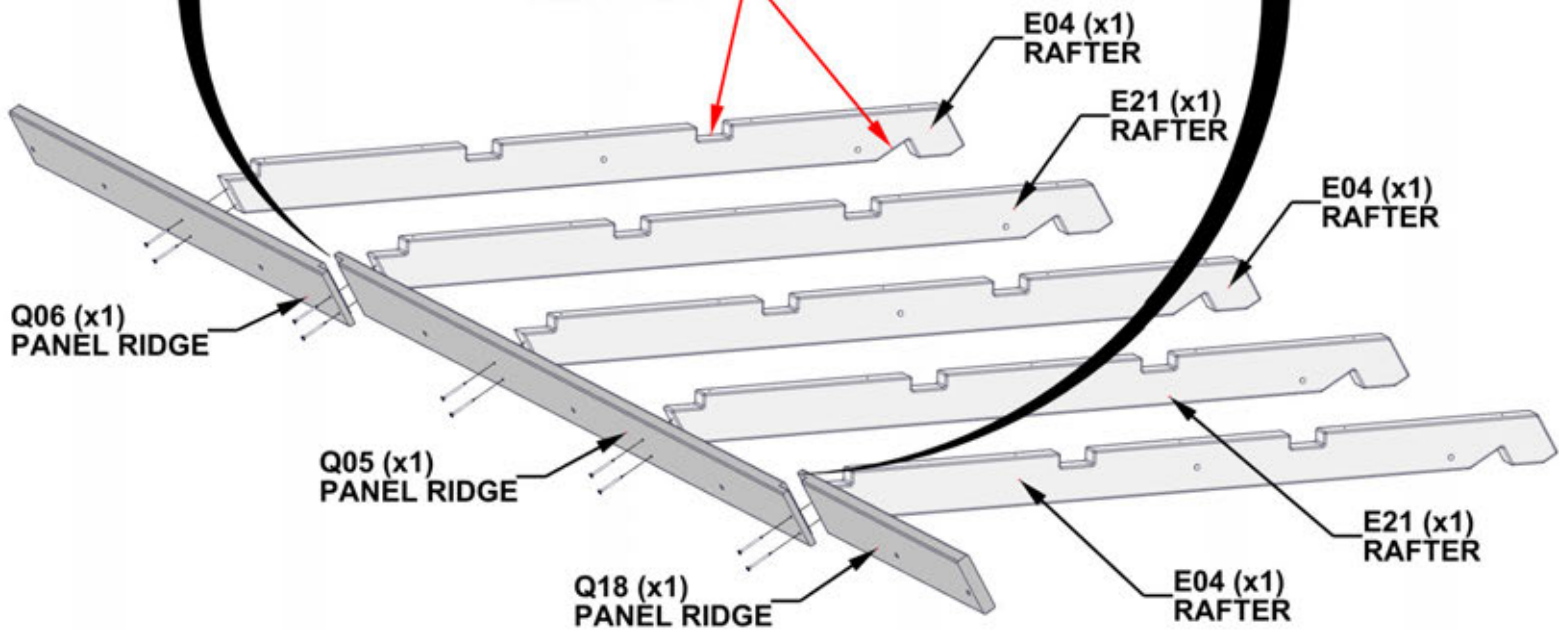
NOTE NOTCH DIRECTION



391 (x10)
SCREW - 2"

NOTE THESE HOLES WILL BE CLOSER TO BOTTOM OF THE BOARDS

NOTE NOTCH DIRECTIONS



STEP 94 - ROOF PANEL ASSEMBLY

QTY	PART NUMBER	DESCRIPTION
5	H100200	SCREW PFH 8x1 1/2 BLK
25	H100391	SCREW PFH 8x2 BLK

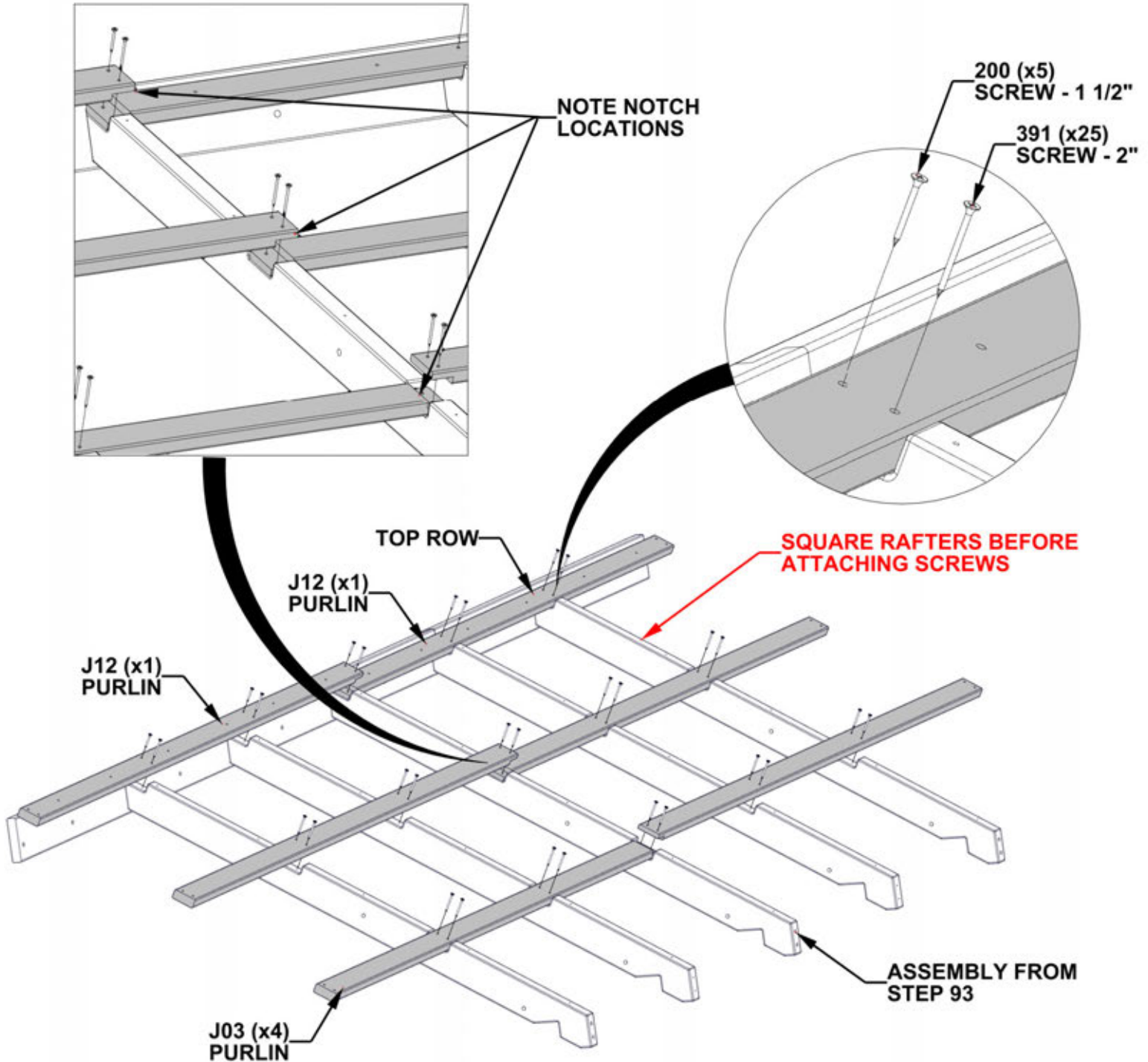


J12 PURLIN - W4L18779
(x2) 15/16"x2 3/8"x73" (24x60x1854)



J03 PURLIN - W4L18044
(x4) 24x2 3/8"x73" (24x60x1854)

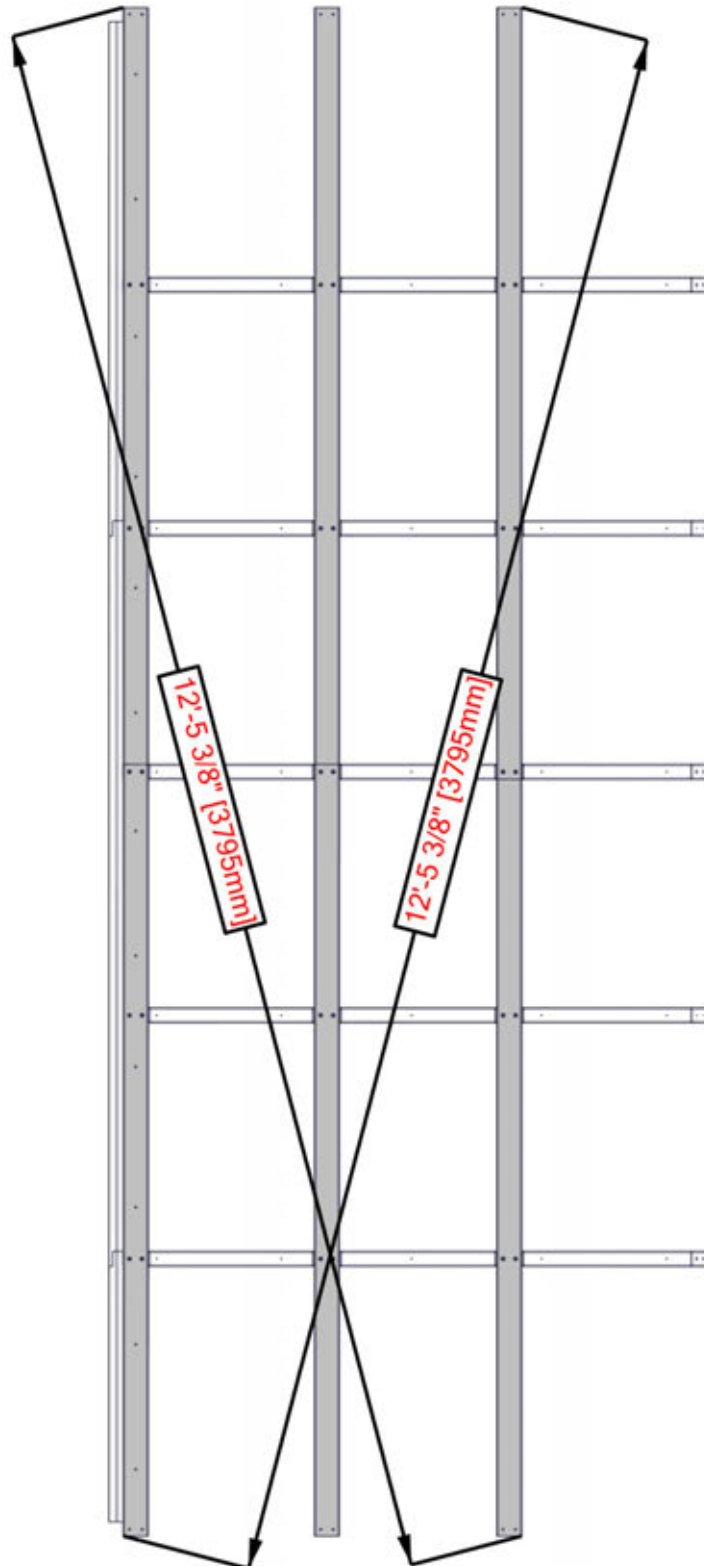
NOTE: USE SHORTER SCREWS IN THE TOP ROW ONLY.



STEP 95 - ROOF PANEL ASSEMBLY

- **IMPORTANT! SQUARE UNIT BEFORE PROCEEDING TO NEXT STEPS.**
- **THE BELOW DIMENSIONS ARE CRITICAL TO THE FINAL ROOF ASSEMBLY.**
- **MEASUREMENTS SHOULD BE HELD WITHIN +/- 1/4".**
- **MEASUREMENTS OUTSIDE OF TOLERANCE WILL LEAD TO THE INABILITY TO ASSEMBLE THE ROOF.**

TIP: LOOSEN HARDWARE TO ADJUST FOR SQUARING IF NEEDED.



STEP 96 - ROOF PANEL ASSEMBLY

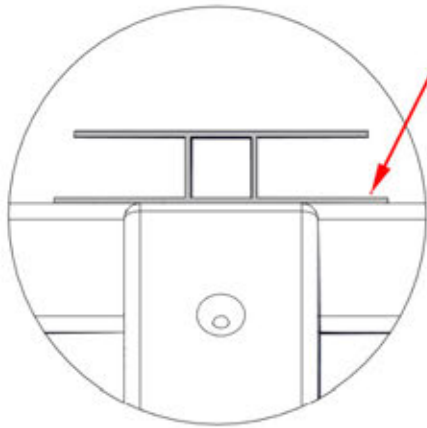
QTY	PART NUMBER	DESCRIPTION
25	H101203	SCREW PWH 8x15x1 1/4 BLK



A6P00635 POLY SHEET SPLICE
(x5)

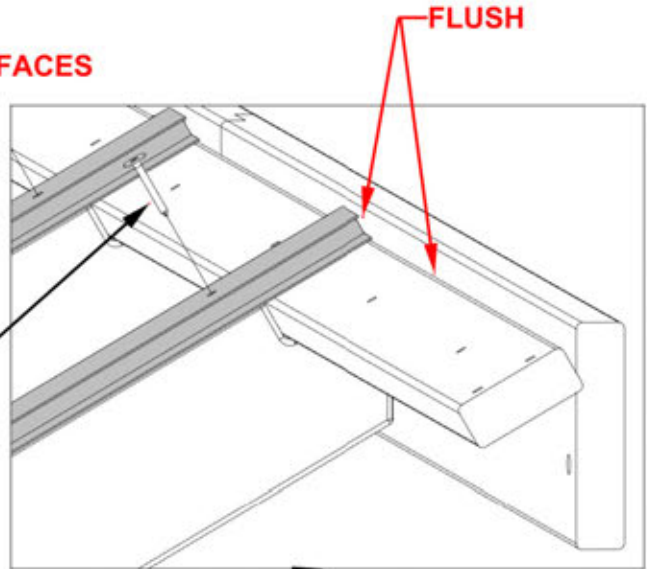
NOTES:

- ALIGN HOLES IN POLY SHEET SPLICES WITH PILOT HOLES ON RAFTERS.
- **IMPORTANT! DO NOT OVERTIGHTEN**
- SET ASSEMBLY TO THE SIDE

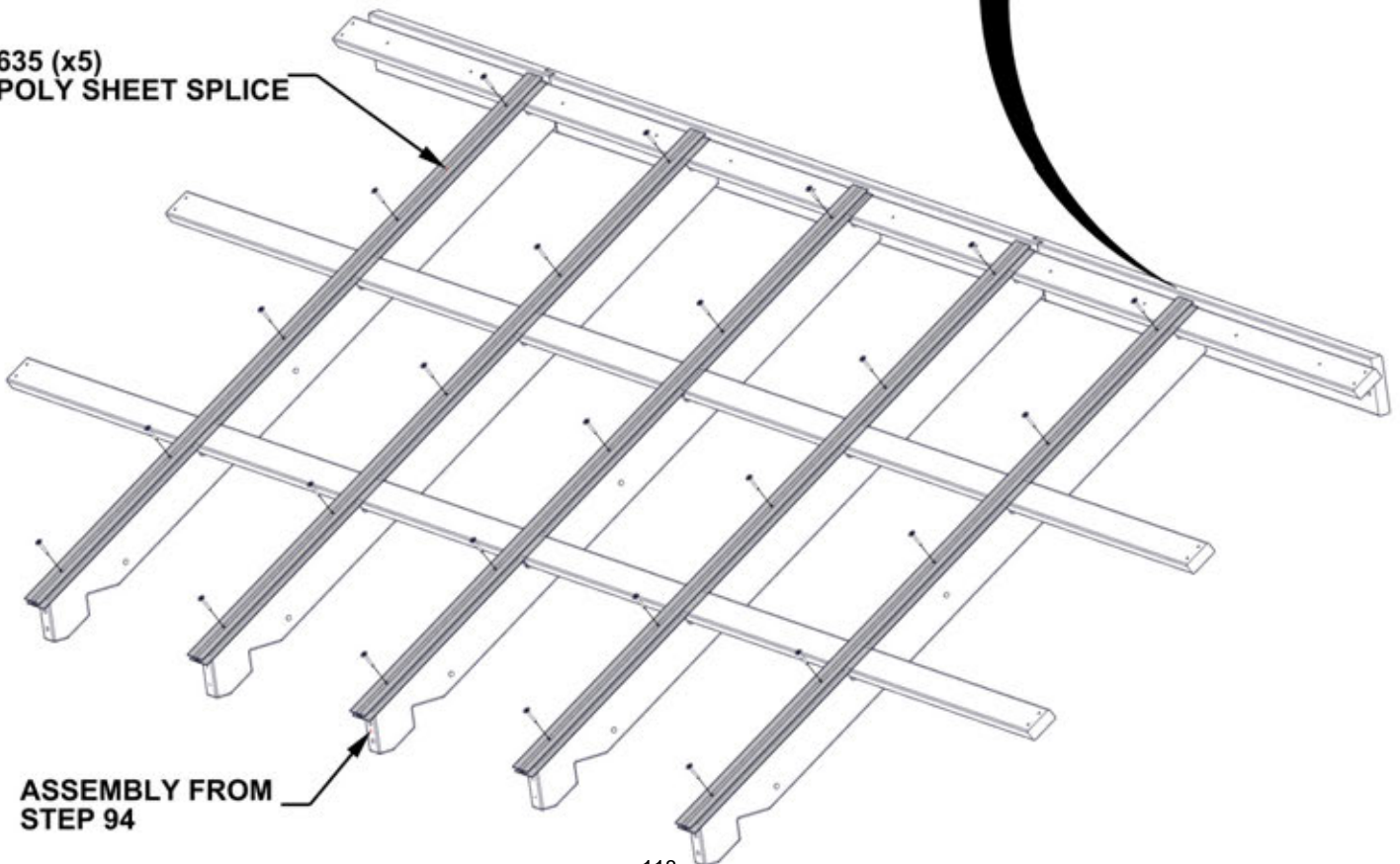


**NOTE LONG SIDE FACES
DOWNWARDS**

1203 (x25)
SCREW - 1 1/4"



635 (x5)
POLY SHEET SPLICE



ASSEMBLY FROM
STEP 94

**REPEAT STEPS 93 THRU 96
FOR 2ND ROOF PANEL**

STEP 97 - ROOF PANEL ASSEMBLY

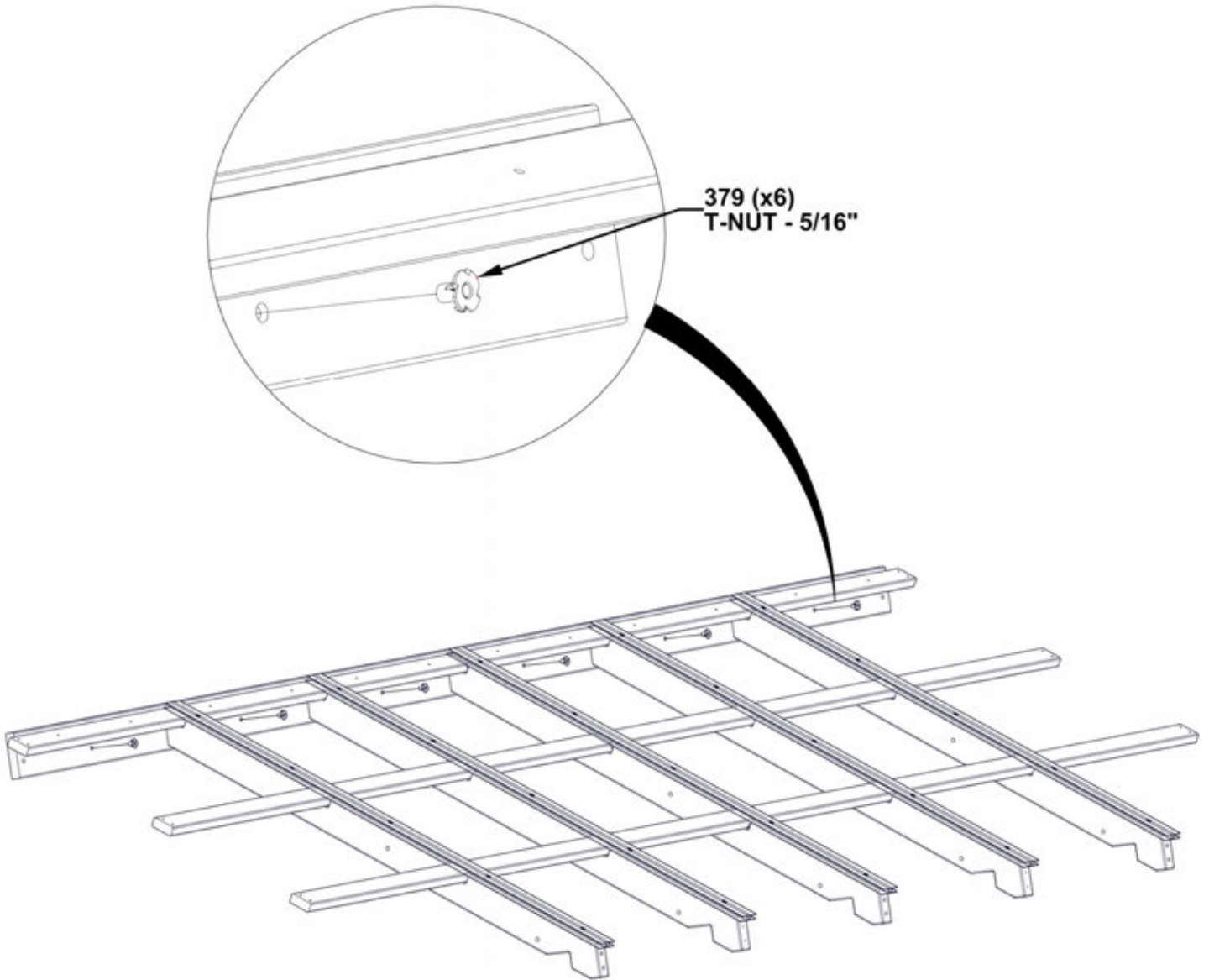
QTY	PART NUMBER	DESCRIPTION
6	H100379	T-NUT 5/16 BLK



ROOF PANEL ASSEMBLY FROM PREVIOUS STEPS (x1)

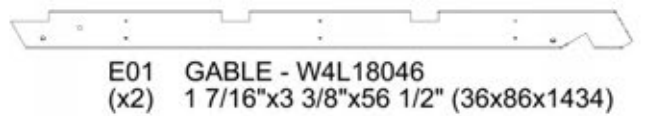
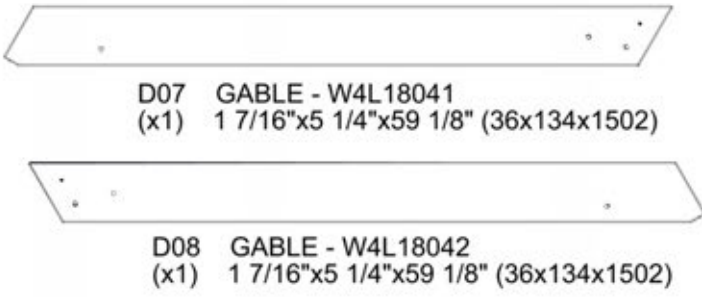
NOTES:

- ADD T-NUTS TO ONE PANEL ASSEMBLY FROM PREVIOUS STEPS
- SET ASIDE FOR FUTURE STEPS



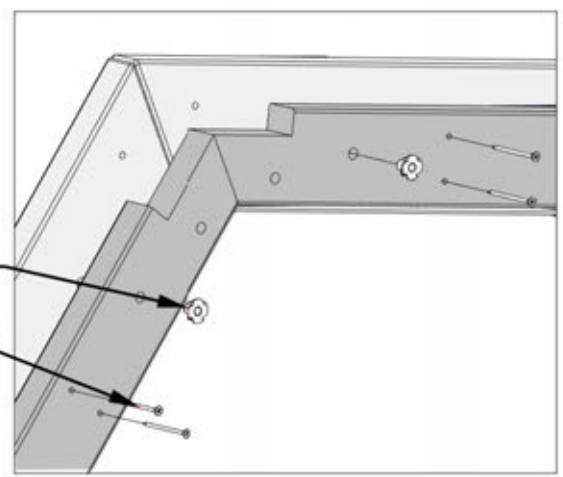
STEP 98 - GABLE ASSEMBLY

QTY	PART NUMBER	DESCRIPTION
12	H100201	SCREW PFH 8x2 1/2 BLK
2	H100379	TNUT-5/16" BLK

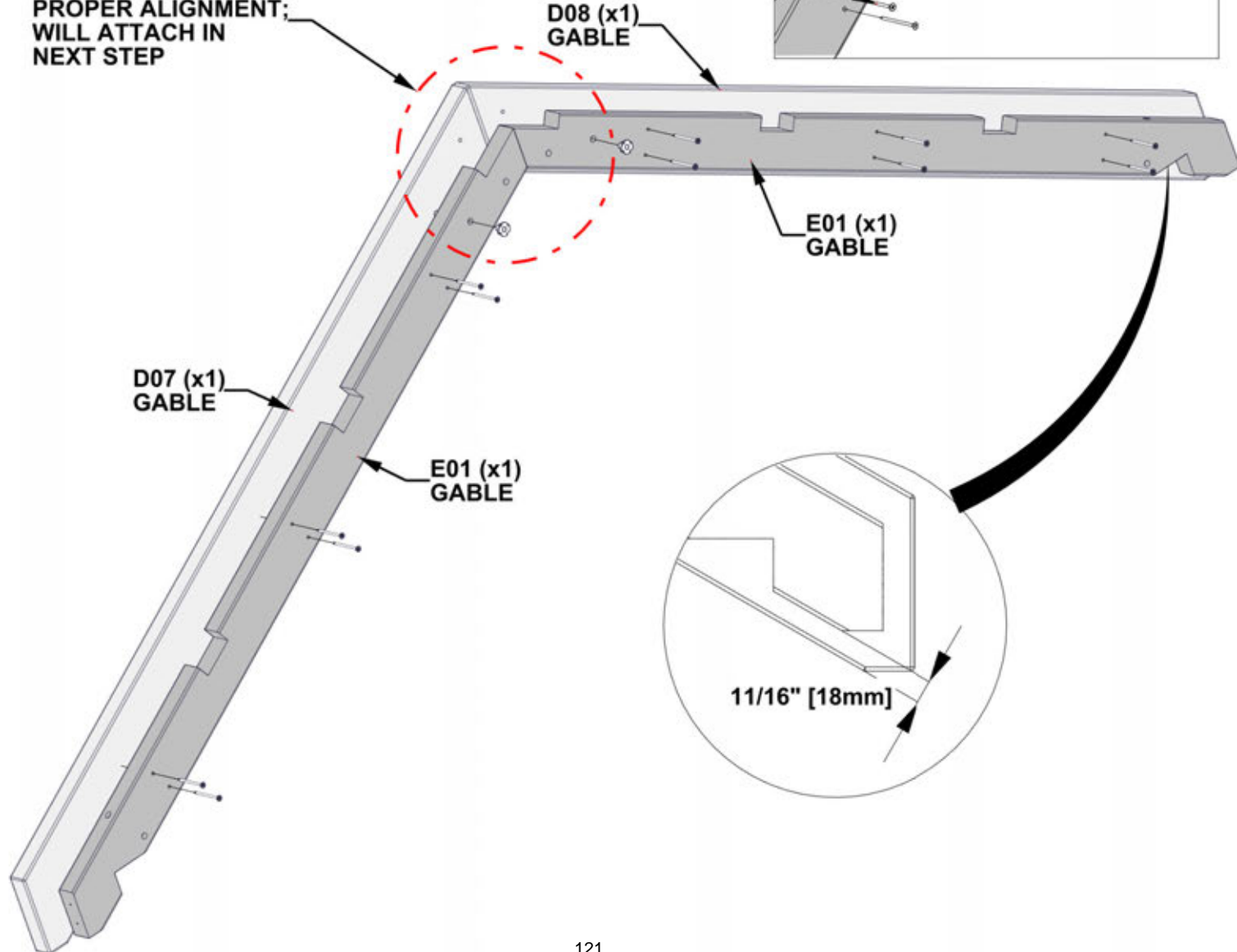


NOTES:

- **INSERT T-NUTS FIRST**
- **BUTT TOGETHER THE 2 BOARDS (D07 TO E01 & D08 TO E01)**
 - MAKE SURE ALL LARGE HOLES LINE UP
 - CHECK DIMENSION SHOWN IN DETAIL
 - TIGHTEN ALL HARDWARE

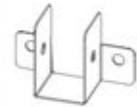
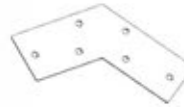


BUTT THESE UP FOR PROPER ALIGNMENT; WILL ATTACH IN NEXT STEP



STEP 99 - GABLE ASSEMBLY

QTY	PART NUMBER	DESCRIPTION
2	H100195	BOLT WH 5/16x2 3/4 BLK
2	H100471	LAG SCREW WH 5/16x1 1/2 BLK
2	H100478	WASHER FLAT 8x27 BLK
2	H100479	NUT LOCK 5/16 BLK
2	H100503	BOLT WH 5/16x3 1/2 BLK

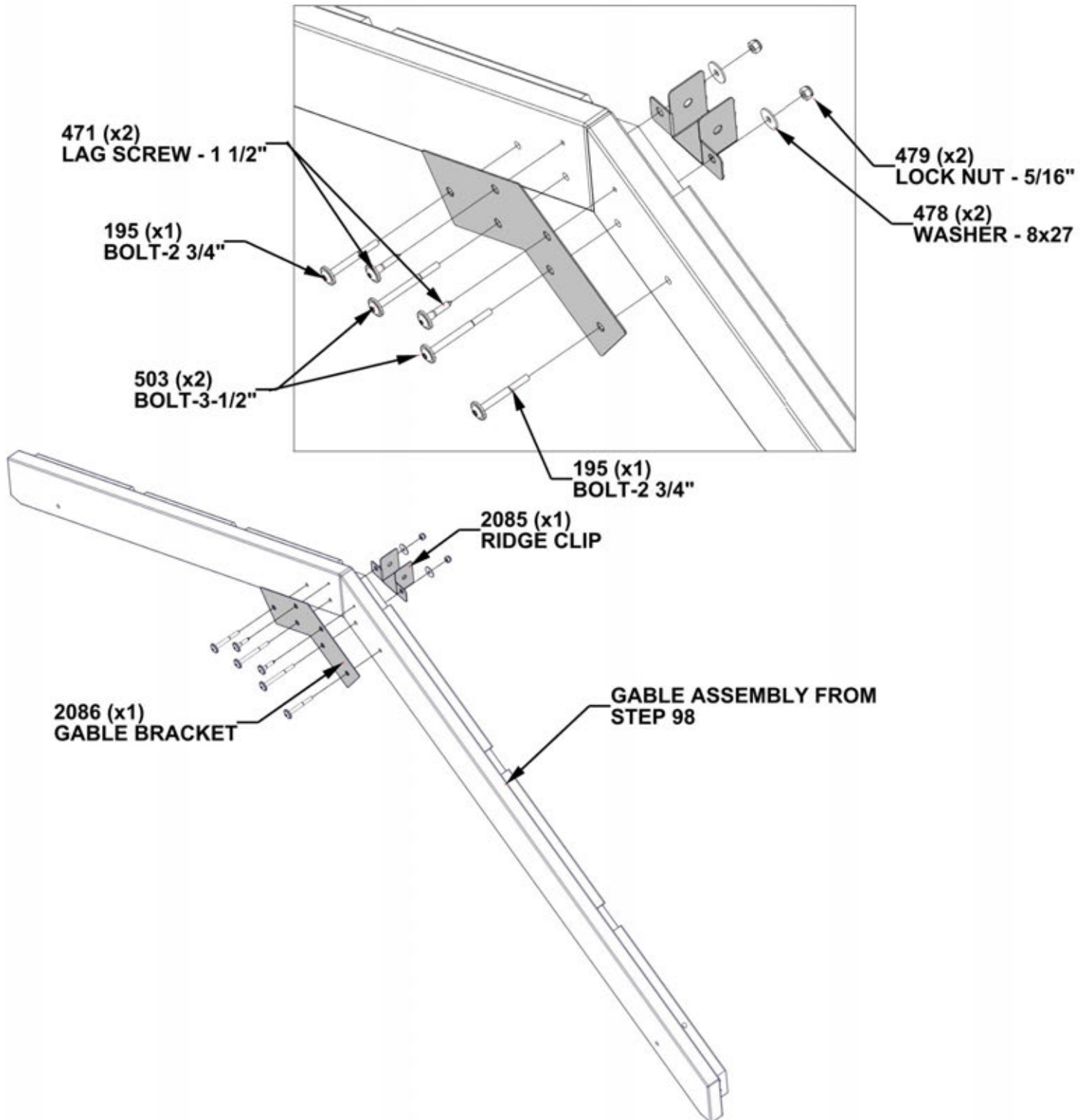


A4M02086
(x1)

GABLE BRACKET

A4M02085
(x1)

RIDGE CLIP



**REPEAT STEPS 98 & 99
FOR 2ND GABLE ASSEMBLY**

STEP 100 - GABLE ASSEMBLY

QTY	PART NUMBER	DESCRIPTION
4	H100198	WASHER LOCK EXT 8x19
4	H100379	TNUT-5/16" BLK
4	H100405	WASHER LOCK EXT 6x15
4	H100456	LAG SCREW WH 1/4x2 1/2 BLK
4	H100777	SCREW PFH 10x3 1/2 BLK
4	H100974	BOLT WH 5/16x5 3/4 BLK

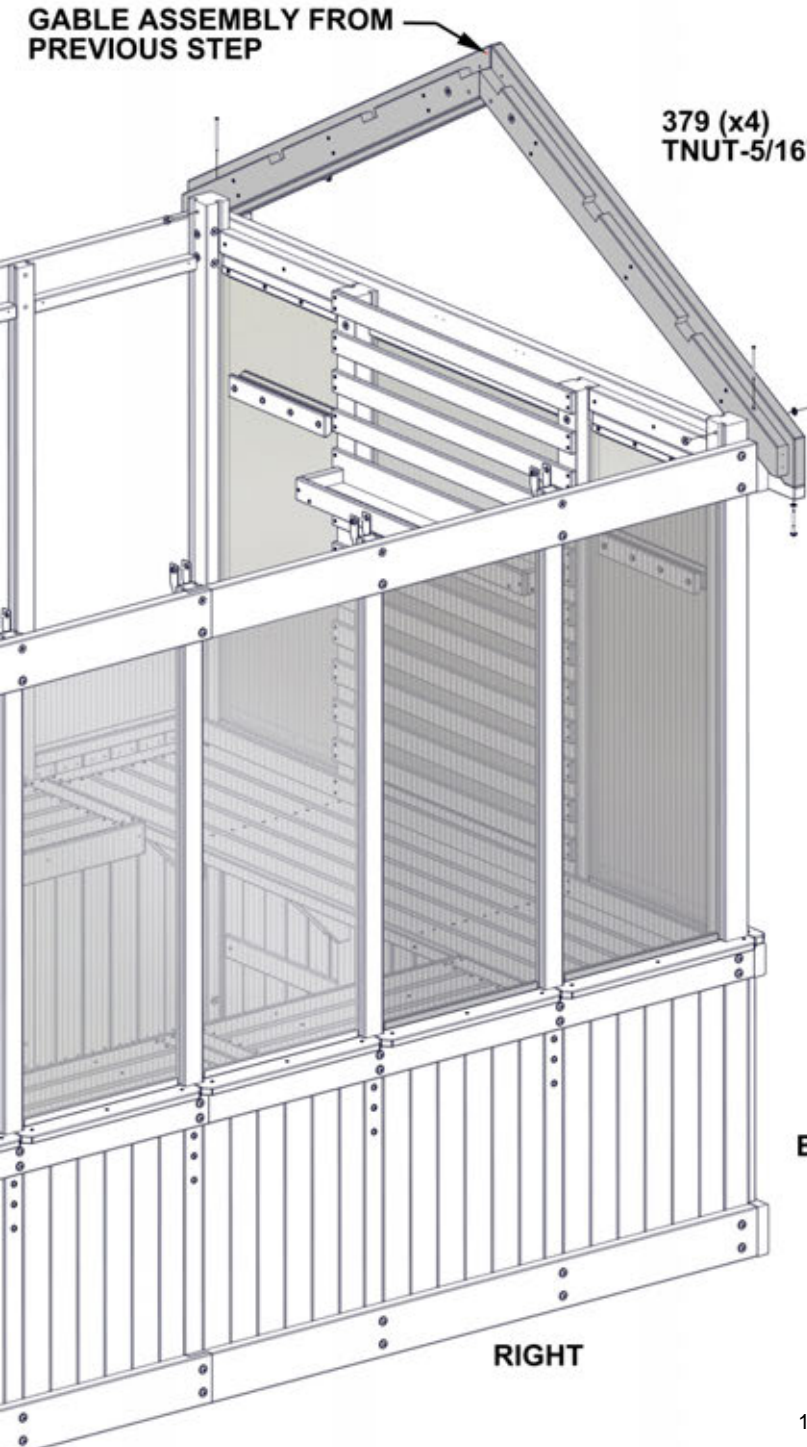


GABLE ASSEMBLY FROM PREVIOUS STEPS

NOTES:

- **INSERT T-NUTS FIRST**
- REPEAT STEP FOR GABLE ON FRONT OF GREENHOUSE

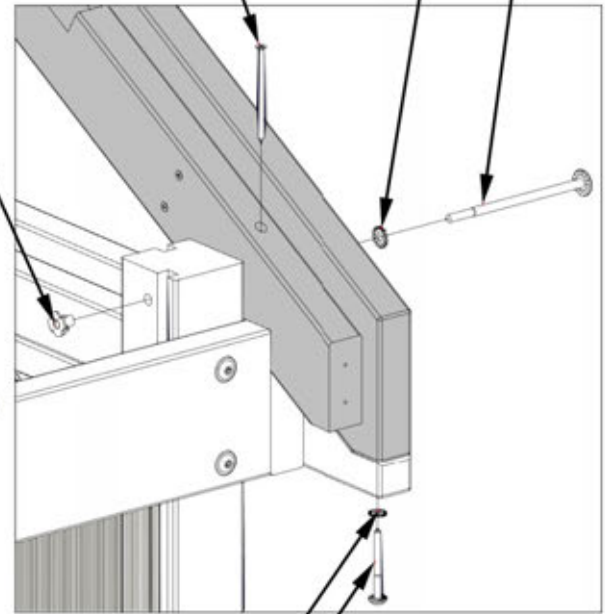
GABLE ASSEMBLY FROM PREVIOUS STEP



777 (x4)
SCREW - 3 1/2"

198 (x4)
WASHER - 8x19

974 (x4)
BOLT - 5 3/4"



379 (x4)
TNUT-5/16"

405 (x4)
WASHER - 6x15

456 (x4)
LAG SCREW - 2 1/2"

BACK

RIGHT

STEP 101 - EXHAUST SUPPORT

QTY	PART NUMBER	DESCRIPTION
7	H101109	SCREW PFH 8x3-1/2 BLK



E19 FAN PANEL BOARD - W4L18392
(x1) 1 7/16"x3 3/8"x10 9/16" (36x86x268)



F13 FAN PANEL BOARD - W4L18393
(x1) 1 7/16"x2 3/8"x10 9/16" (36x60x268)



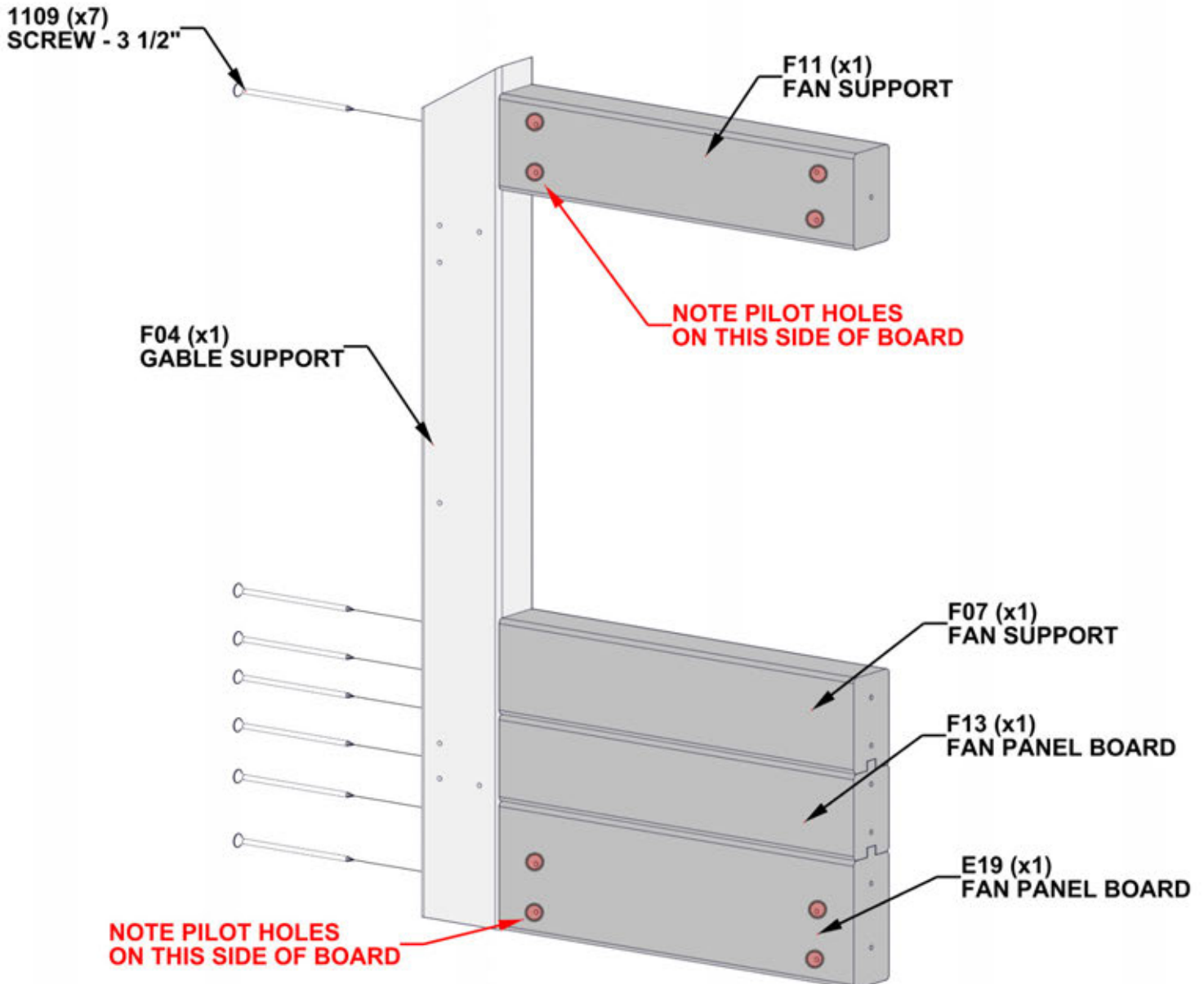
F07 FAN SUPPORT - W4L18390
(x1) 1 7/16"x2 3/8"x10 9/16" (36x60x268)



F11 FAN SUPPORT - W4L18408
(x1) 1 7/16"x2 3/8"x10 9/16" (36x60x268)

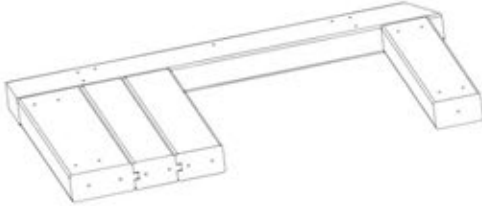


F04 GABLE SUPPORT - W4L18369
(x1) 1 7/16"x2 3/8"x21 3/16" (36x60x538)



STEP 102 - EXHAUST SUPPORT

QTY	PART NUMBER	DESCRIPTION
7	H101109	SCREW PFH 8x3-1/2 BLK

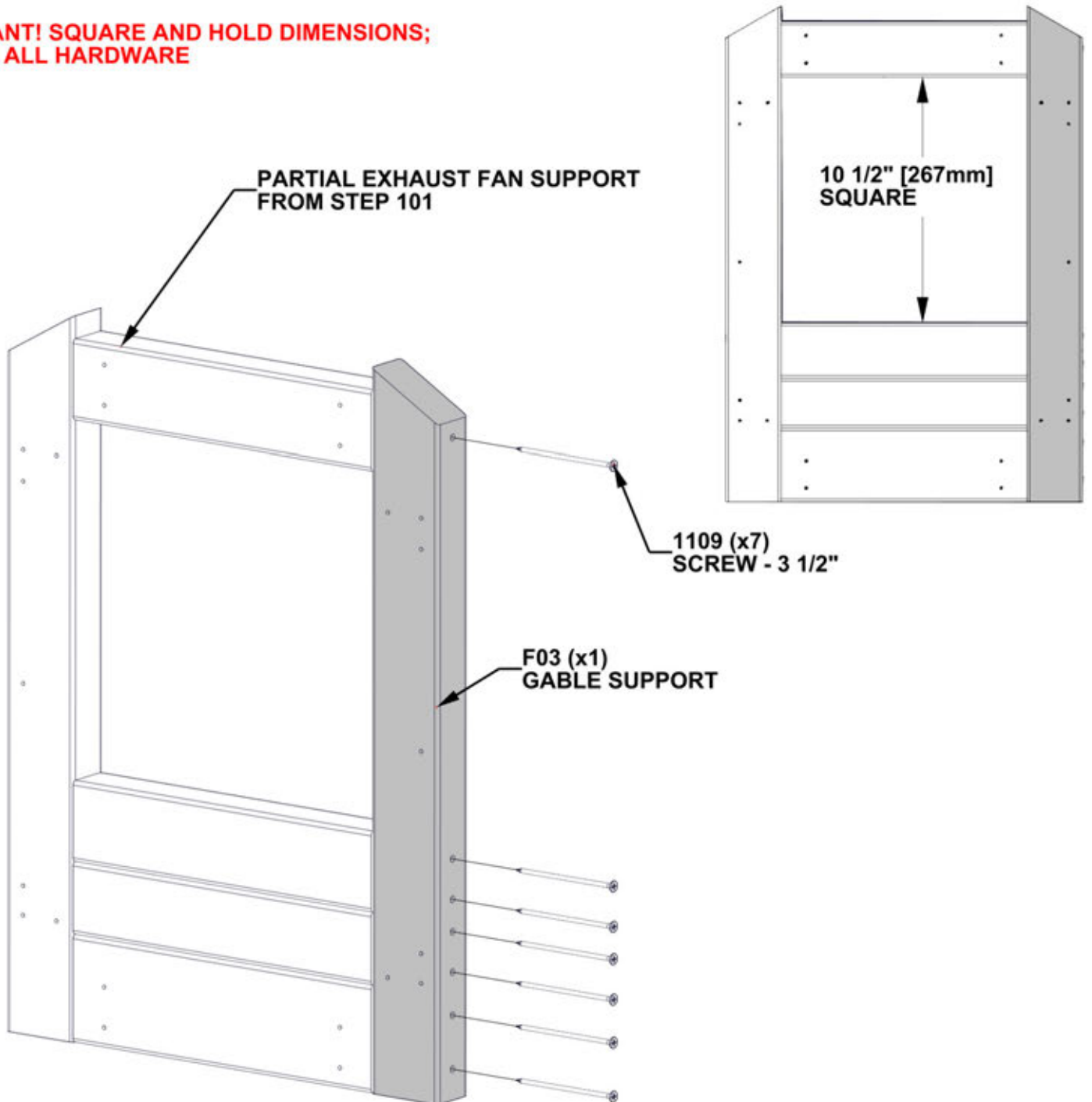


**PARTIAL EXHAUST FAN SUPPORT
FROM STEP 101**



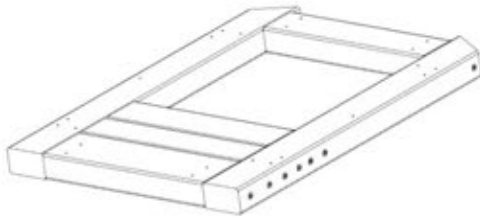
**F03 GABLE SUPPORT - W4L18368
(x1) 1 7/16"x2 3/8"x21 3/16" (36x60x538)**

NOTE:
 • **IMPORTANT! SQUARE AND HOLD DIMENSIONS;
 TIGHTEN ALL HARDWARE**

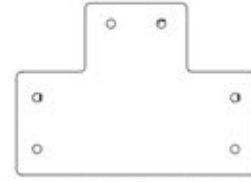


STEP 103 - EXHAUST SUPPORT

QTY	PART NUMBER	DESCRIPTION
16	H100385	SCREW PFH 8x1 BLK



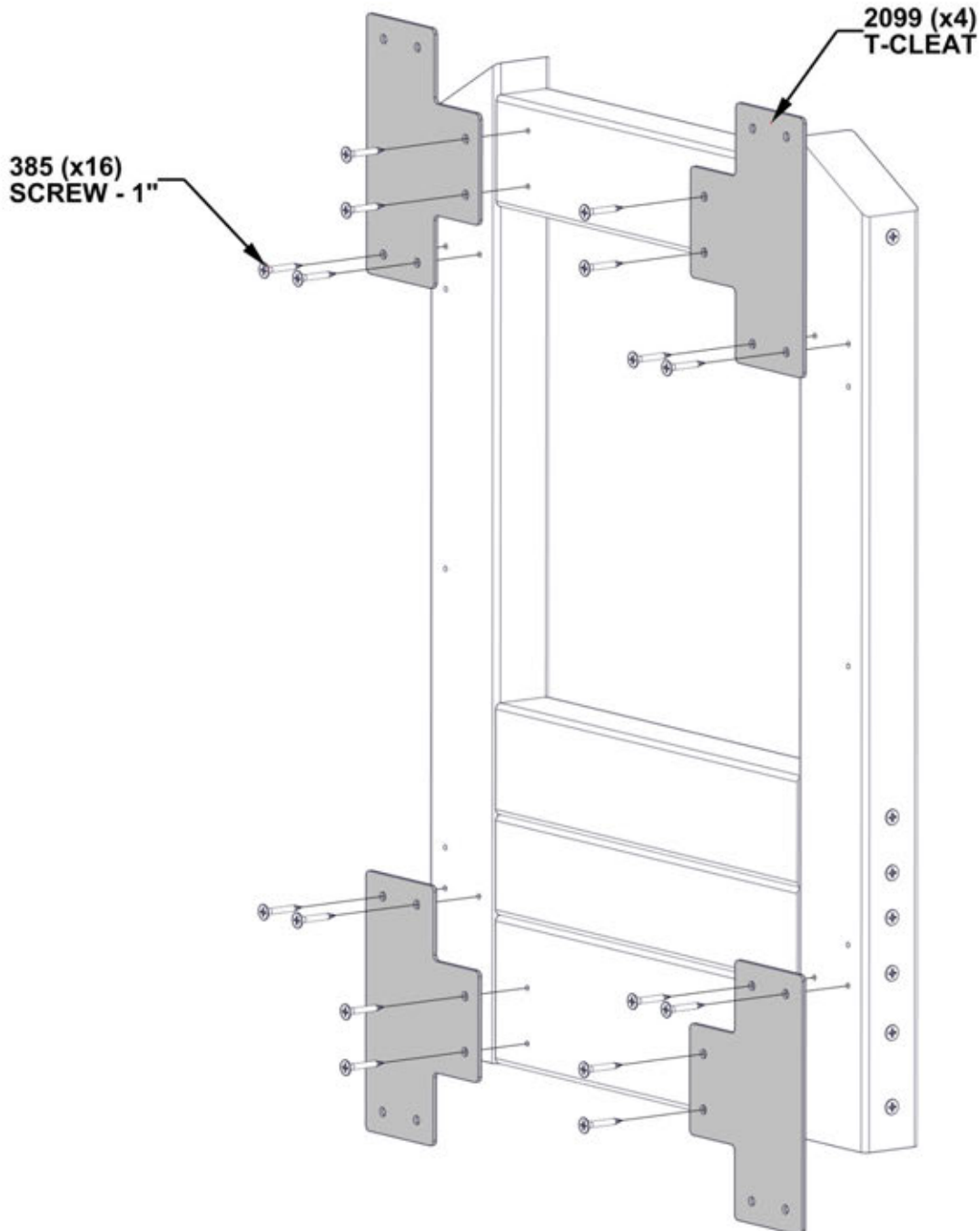
EXHAUST FAN SUPPORT



A4M02099 T-CLEAT
(x4)

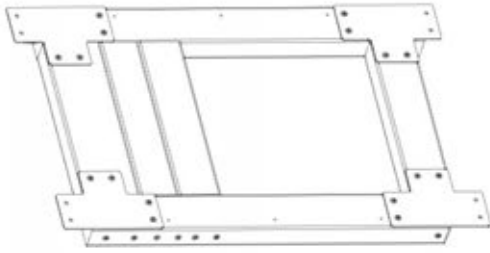
NOTE:

- ALIGN CLEAT HOLES WITH PILOT HOLES IN EXHAUST FAN SUPPORT AND ATTACH HARDWARE AS SHOWN.



STEP 104 - EXHAUST SUPPORT

QTY	PART NUMBER	DESCRIPTION
8	H100385	SCREW PFH 8x1 BLK
4	H100391	SCREW PFH 8x2 BLK



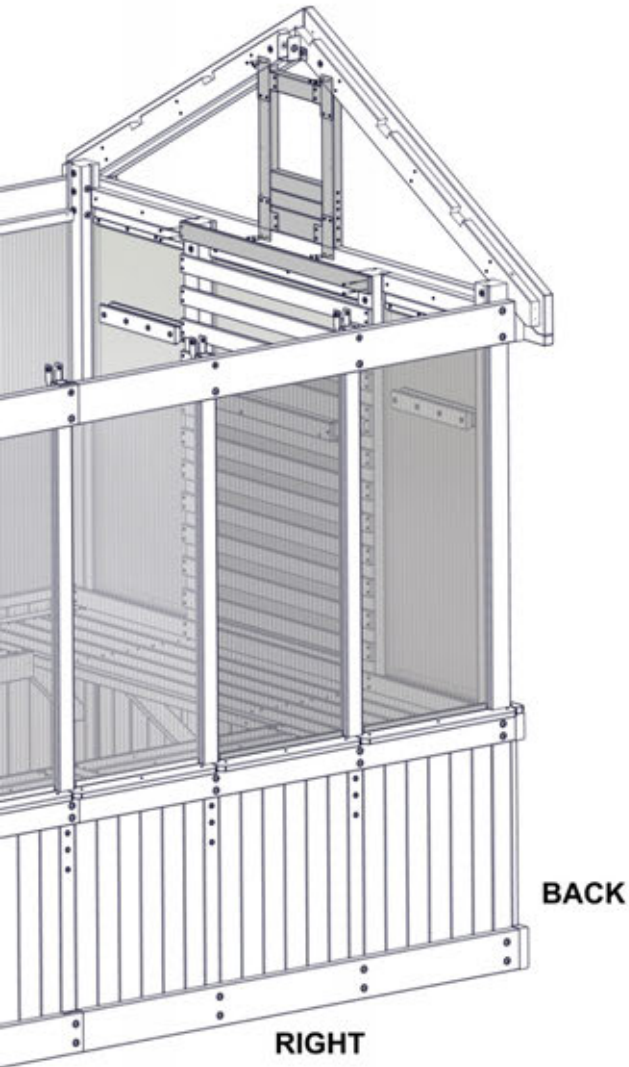
EXHAUST FAN SUPPORT



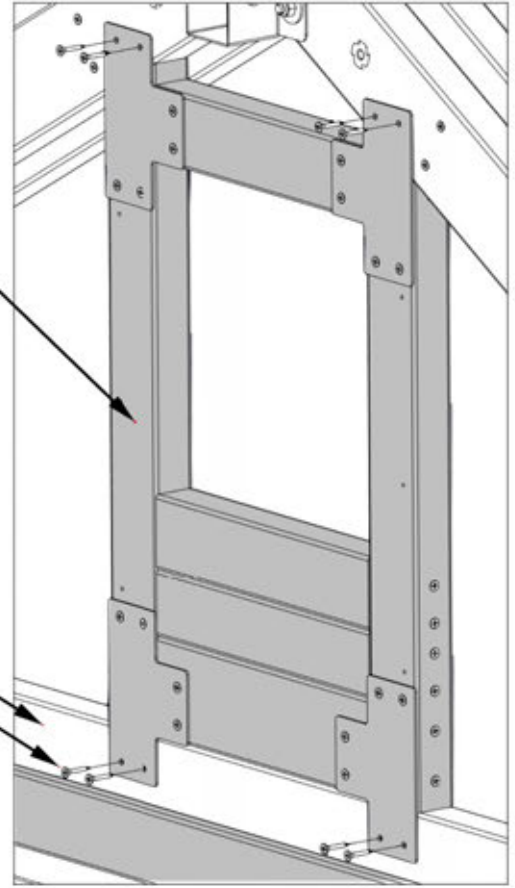
N07 WALL BOARD - W4L18367
(x1) 5/8"x2 3/8"x38 11/16" (16x60x982)

NOTES:

- 1) INSTALL EXHAUST FAN SUPPORT
 - ENSURE EXHAUST FAN SUPPORT IS CENTERED
 - ALIGN HOLES IN CLEATS WITH PILOT HOLES ON HEADER
 - USE 1/8" DRILL BIT AND CLEAT AS GUIDE TO DRILL PILOT HOLES IN GABLE
- 2) ATTACH WALL BOARD (N07) AS SHOWN

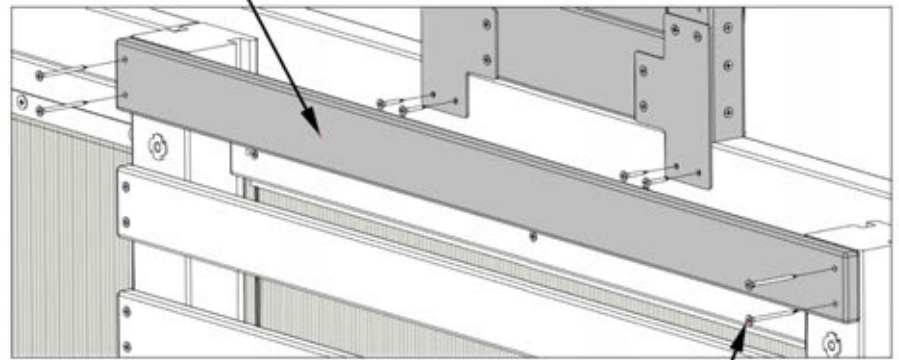


EXHAUST FAN SUPPORT



HEADER
385 (x8)
SCREW - 1"

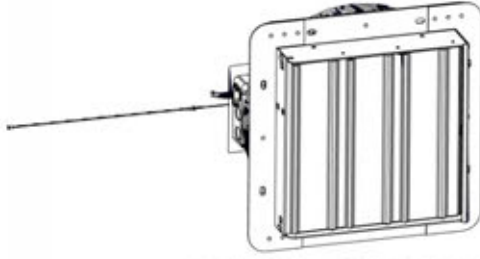
**N07 (x1)
WALL BOARD**



**391 (x4)
SCREW - 2"**

STEP 105 - EXHAUST FAN

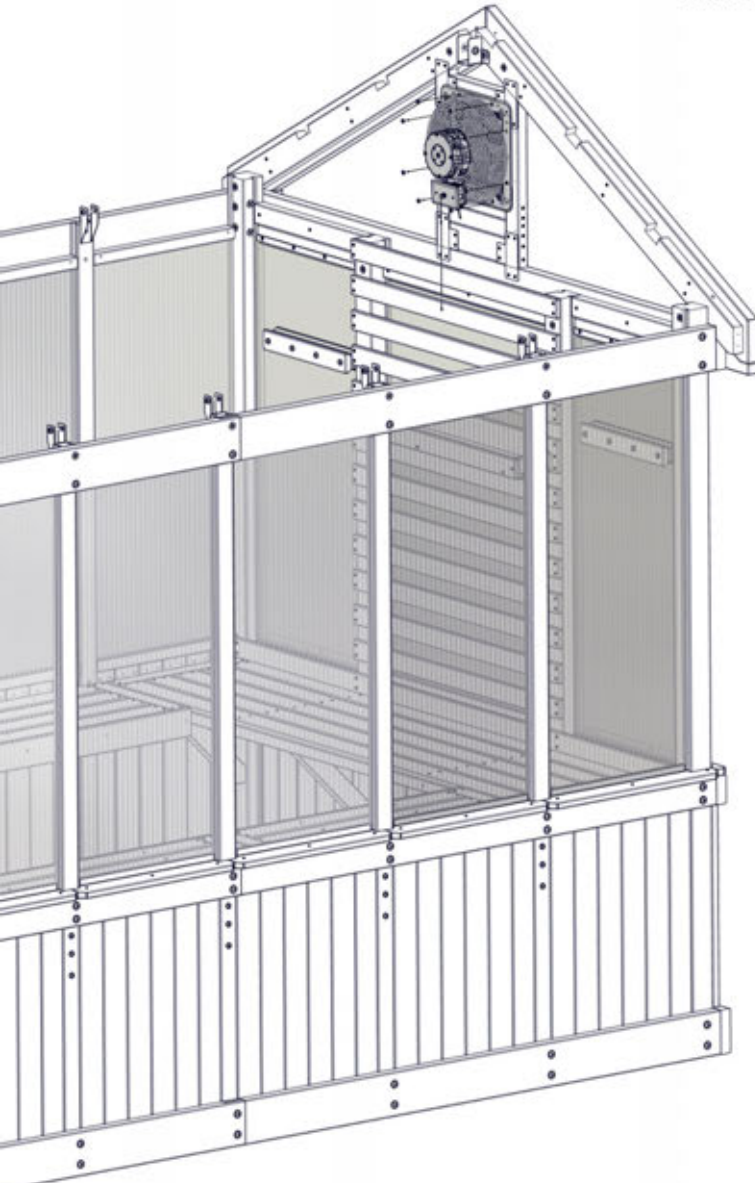
QTY	PART NUMBER	DESCRIPTION
8	H101207	SCREW PWH 8x15x7/8 BLK



A4M02383 EXHAUST FAN
(1)

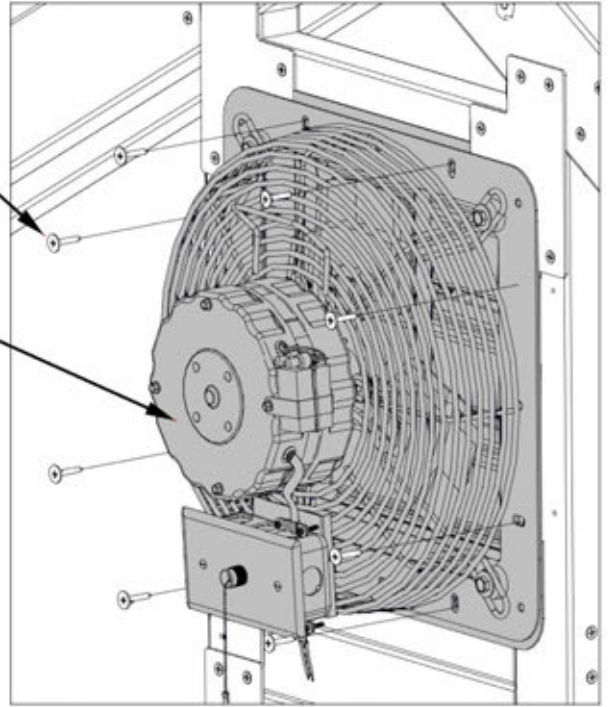
NOTE:

- CENTER EXHAUST FAN IN THE OPENING OF THE EXHAUST FAN SUPPORT AND ATTACH AS SHOWN.



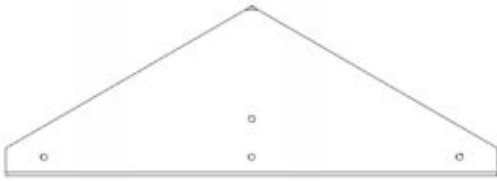
1207 (x8)
SCREW - 7/8"

2383 (x1)
EXHAUST FAN



STEP 106 - EXHAUST FAN

QTY	PART NUMBER	DESCRIPTION
10	H100200	SCREW PFH 8x1 1/2 BLK

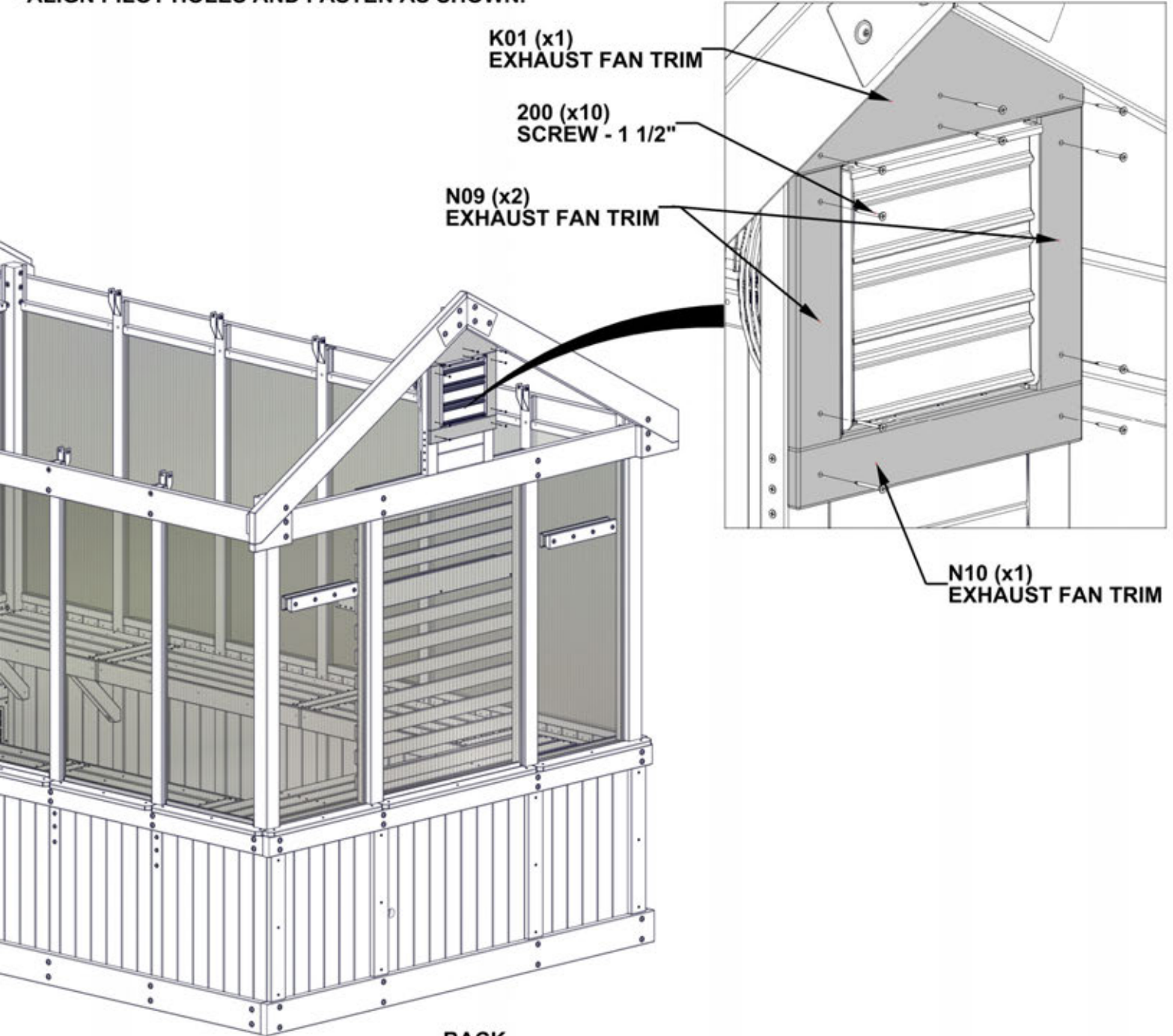


K01 EXHAUST FAN TRIM - W4L18416
(x1) 5/8"x5 1/4"x15 1/4" (16x134x388)

N09 EXHAUST FAN TRIM - W4L18414
(x2) 5/8"x2 3/8"x10 1/2" (16x60x267)

N10 EXHAUST FAN TRIM - W4L18415
(x1) 5/8"x2 3/8"x15 1/4" (16x60x388)

NOTES:
• ALIGN PILOT HOLES AND FASTEN AS SHOWN.



STEP 107 - WINDOW ASSEMBLY



A6P00640 POLY SHEET
(x1)



A6P00639 POLY CHANNEL WITH TAPE
(x2)

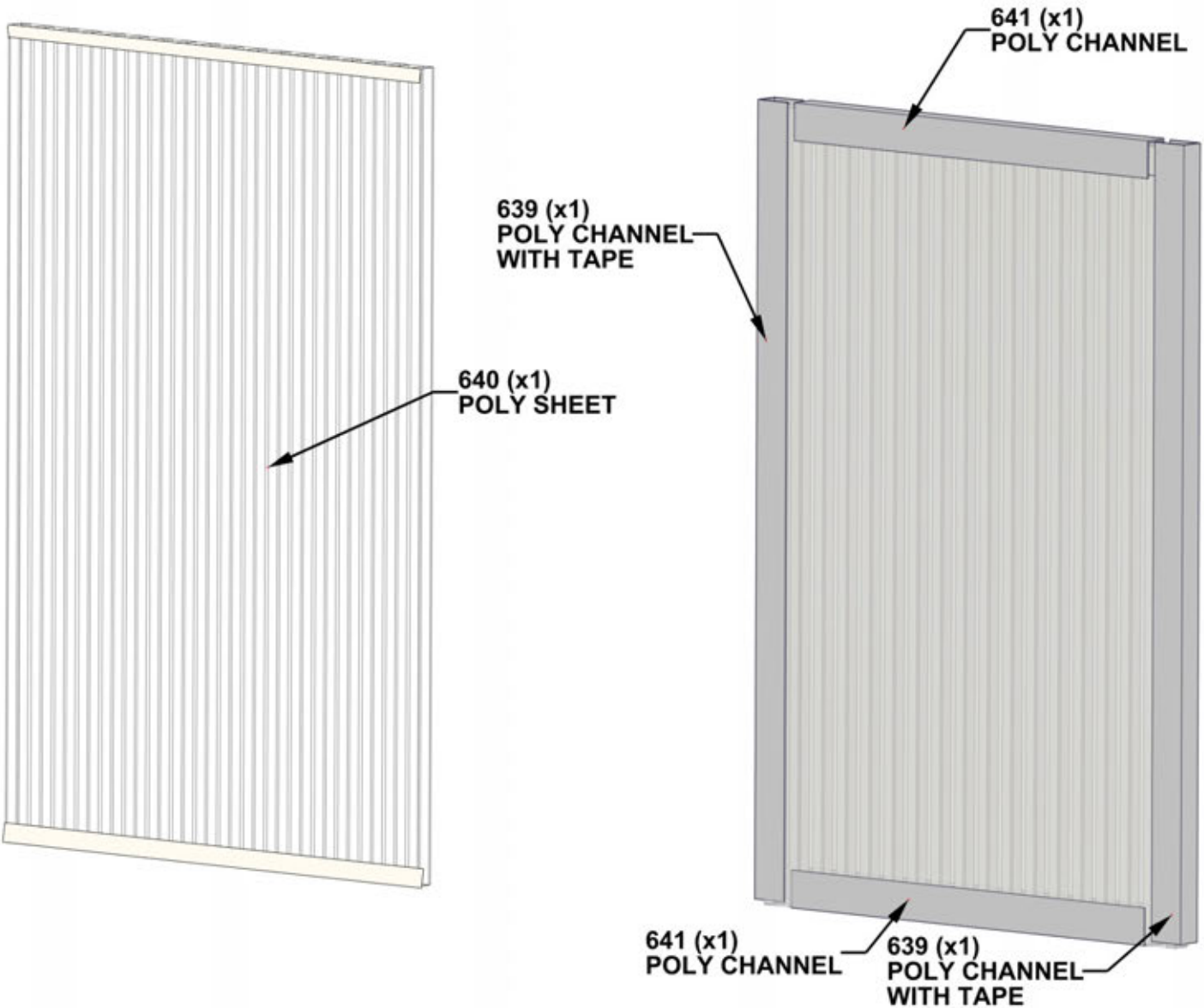


A6P00641 POLY CHANNEL
(x2)



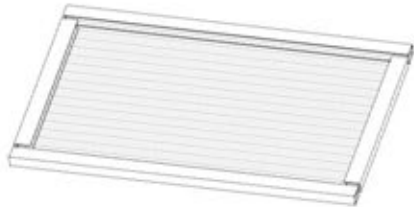
A6P00690 DUST SEAL TAPE

- 1) INSTALL DUST TAPE ON TOP & BOTTOM ON EACH POLY SHEETING
 - CUT (2) STRIPS OF DUST SEAL TAPE THE SAME WIDTH AS THE POLY SHEETING
 - WRAP DUST TAPE ALONG EDGE OF POLY SHEETING WIDTH
- 2) AFTER TAPE IS SECURE, PUSH CHANNEL ON OVER THE TOP OF THE TAPE
 - ATTACH CHANNEL 639 ALONG SIDES THEN CHANNEL 641 ON TOP & BOTTOM



STEP 108 - WINDOW ASSEMBLY

QTY	PART NUMBER	DESCRIPTION
4	H101109	SCREW PFH 8x3-1/2 BLK



WINDOW ASSEMBLY

F14 WINDOW FRAME - W4L18419
(x1) 1 7/16"x2 3/8"x10 9/16" (36x60x268)

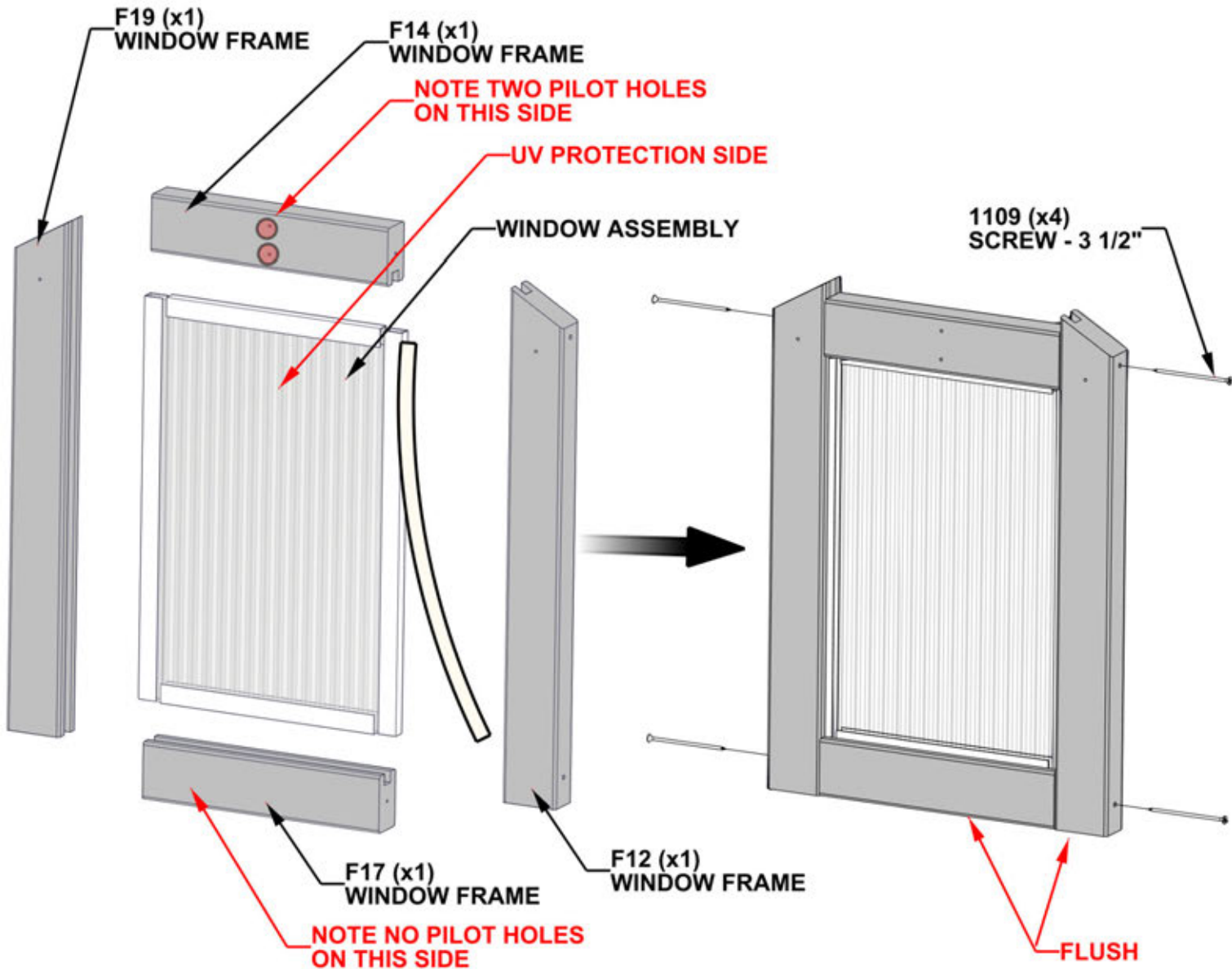
F12 FAN SUPPORT - W4L18409
(x1) 1 7/16"x2 3/8"x21 3/16" (36x60x538)

F17 WINDOW FRAME - W4L18777
(x1) 1 7/16"x2 3/8"x10 9/16" (36x60x268)

F19 WINDOW FRAME - W4L18778
(x1) 1 7/16"x2 3/8"x21 3/16" (36x60x538)

NOTES:

- BEFORE INSTALLATION REMOVE LINER FROM THE POLY CHANNELS.
- FIRMLY PUSH BOARDS ON ENSURING THE WINDOW SLIDES ALL THE WAY INTO THE GROOVES.
- THE BOTTOM OF F12 & F19 BOARDS ARE TO BE FLUSH WITH THE BOTTOM OF THE F17 BOARD.

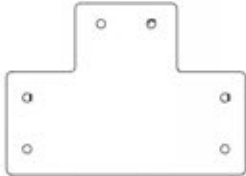


STEP 109 - WINDOW ASSEMBLY

QTY	PART NUMBER	DESCRIPTION
16	H100385	SCREW PFH 8x1 BLK

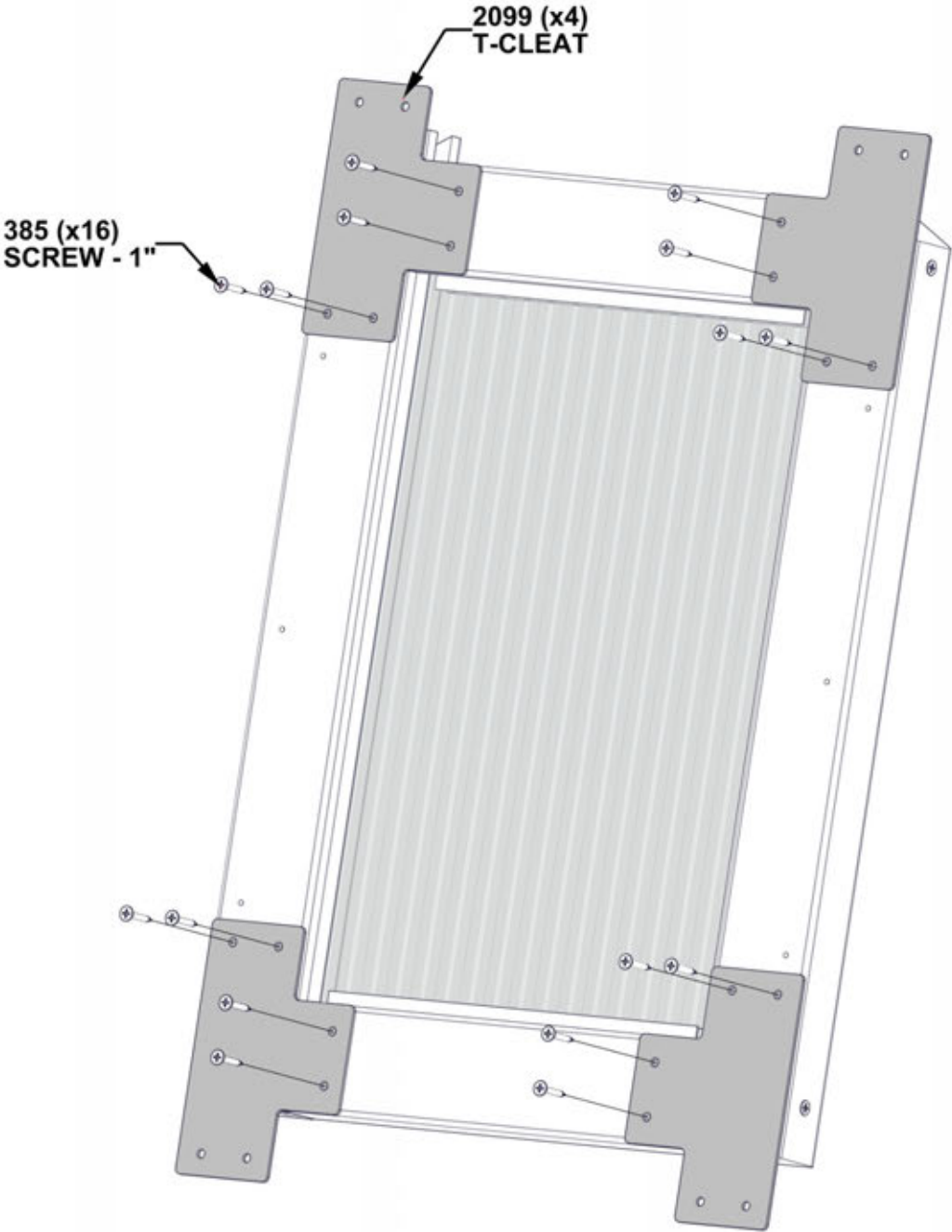


WINDOW ASSEMBLY



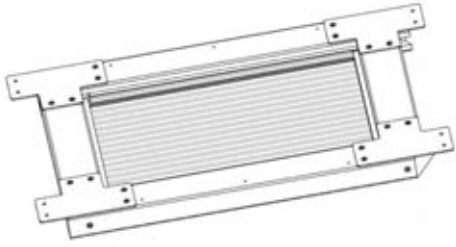
A4M02099 T-CLEAT
(x4)

- NOTES:**
- ALIGN CLEAT HOLES WITH PILOT HOLES IN THE WINDOW ASSEMBLY AND ATTACH HARDWARE AS SHOWN.



STEP 110A - WINDOW ASSEMBLY

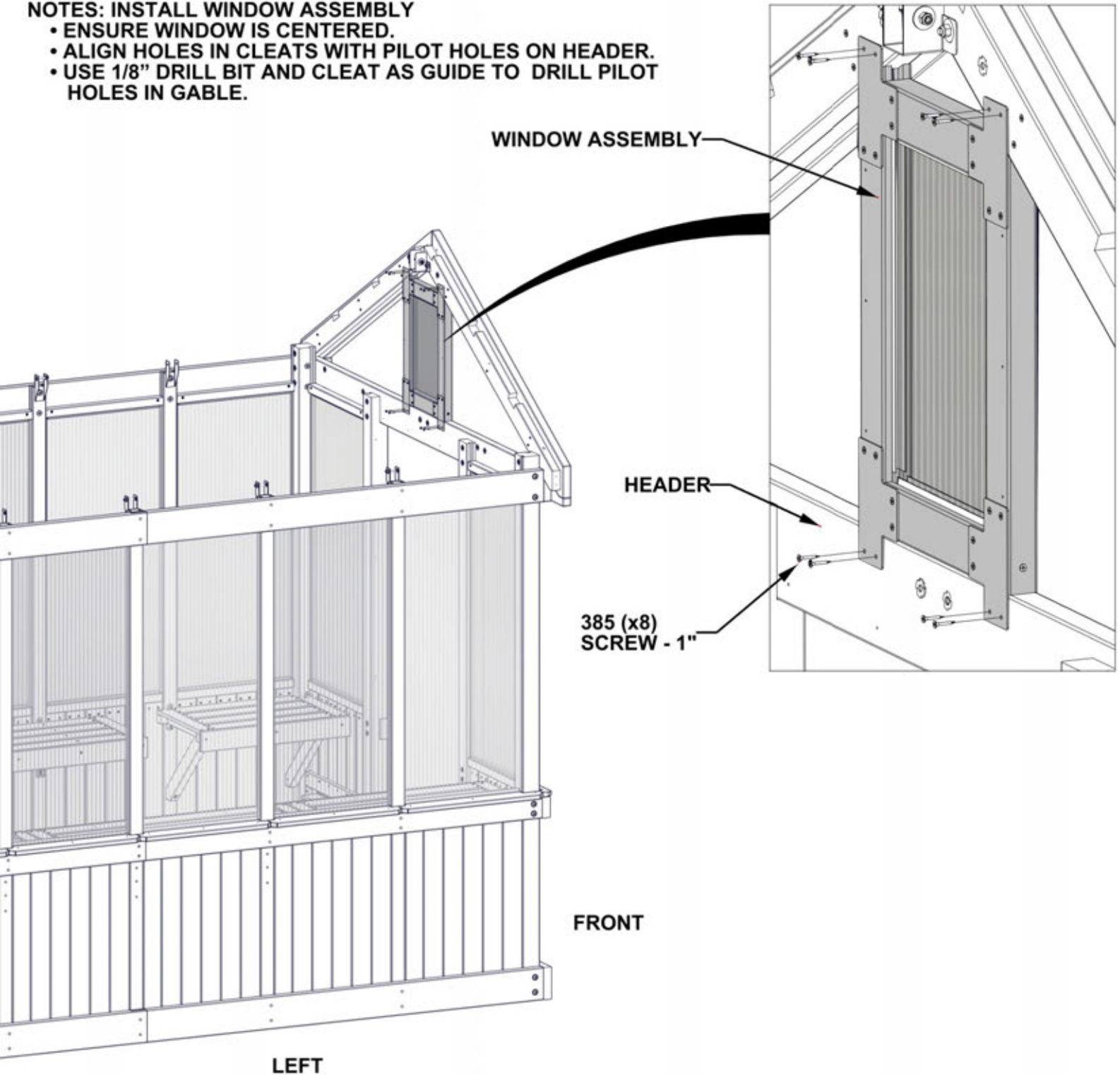
QTY	PART NUMBER	DESCRIPTION
8	H100385	SCREW PFH 8x1 BLK



WINDOW ASSEMBLY

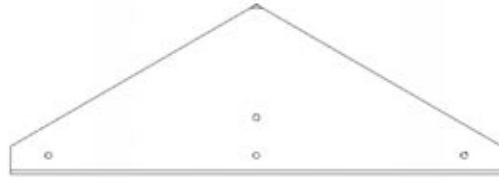
NOTES: INSTALL WINDOW ASSEMBLY

- ENSURE WINDOW IS CENTERED.
- ALIGN HOLES IN CLEATS WITH PILOT HOLES ON HEADER.
- USE 1/8" DRILL BIT AND CLEAT AS GUIDE TO DRILL PILOT HOLES IN GABLE.



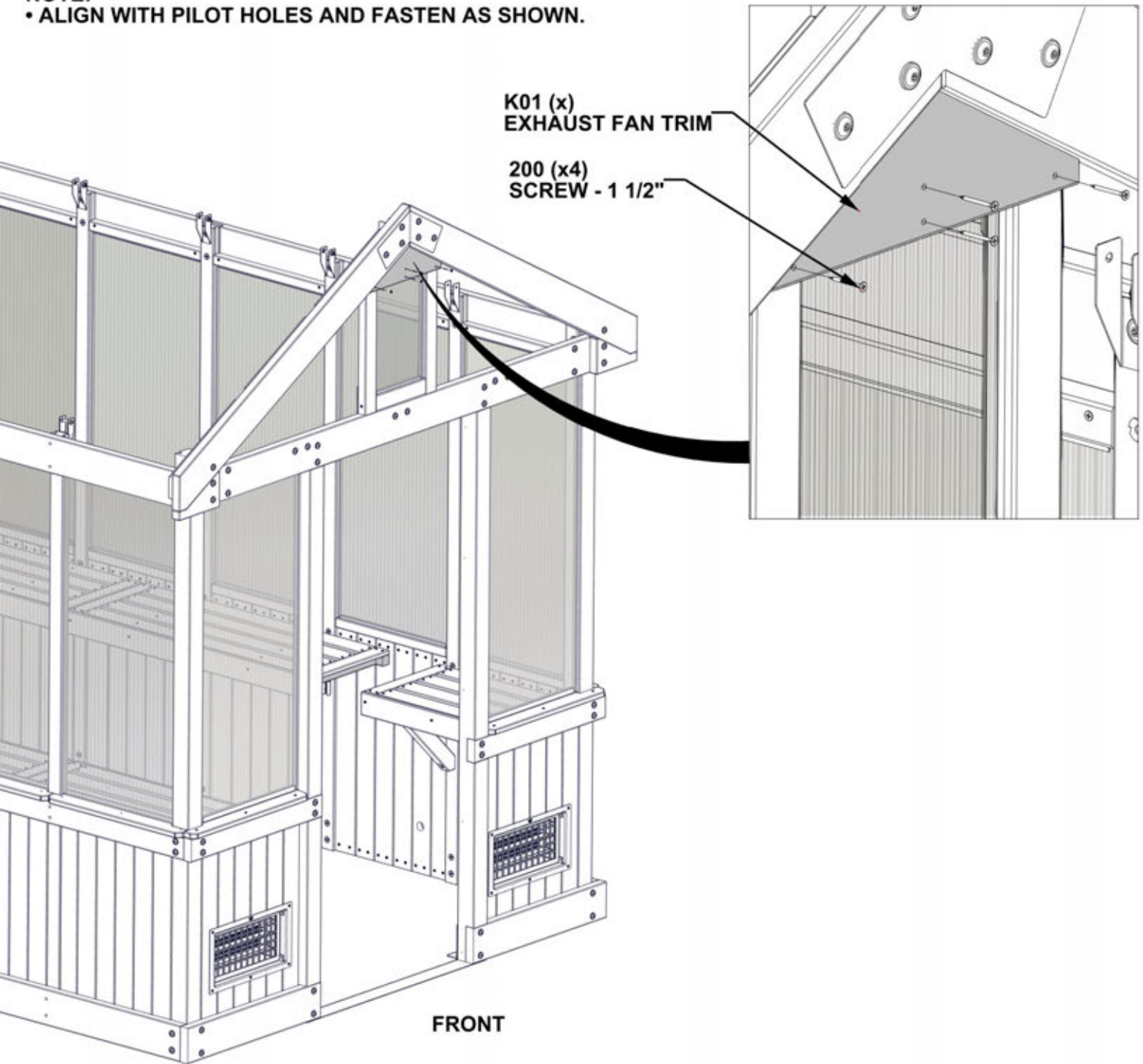
STEP 110B - WINDOW ASSEMBLY

QTY	PART NUMBER	DESCRIPTION
4	H100200	SCREW PFH 8x1 1/2 BLK



K01 EXHAUST FAN TRIM - W4L18416
(x1) 5/8"x5 1/4"x15 1/4" (16x134x388)

NOTE:
• ALIGN WITH PILOT HOLES AND FASTEN AS SHOWN.

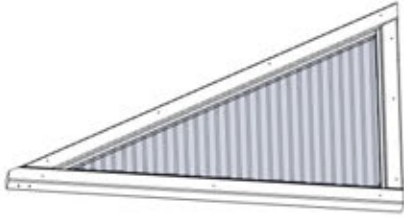


K01 (x)
EXHAUST FAN TRIM

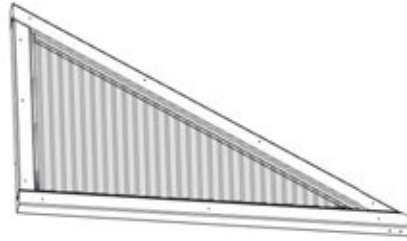
200 (x4)
SCREW - 1 1/2"

FRONT

STEP 111A - BACK WINDOW



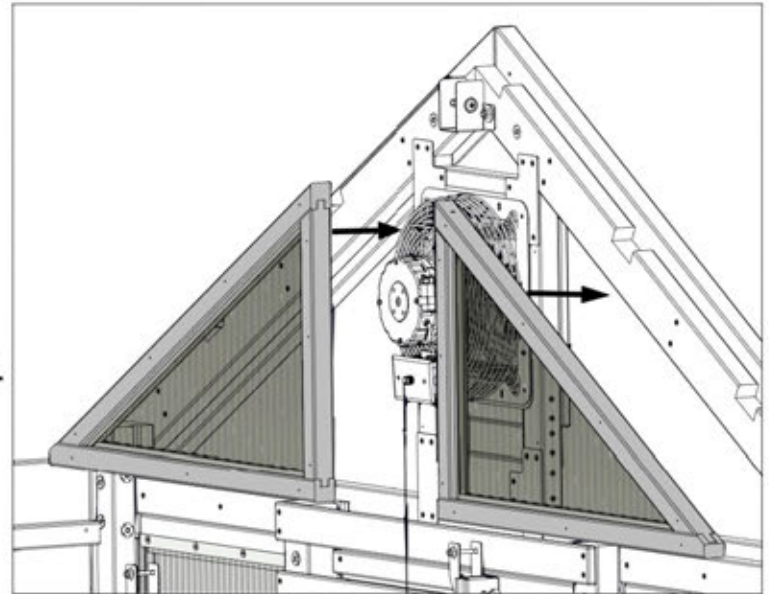
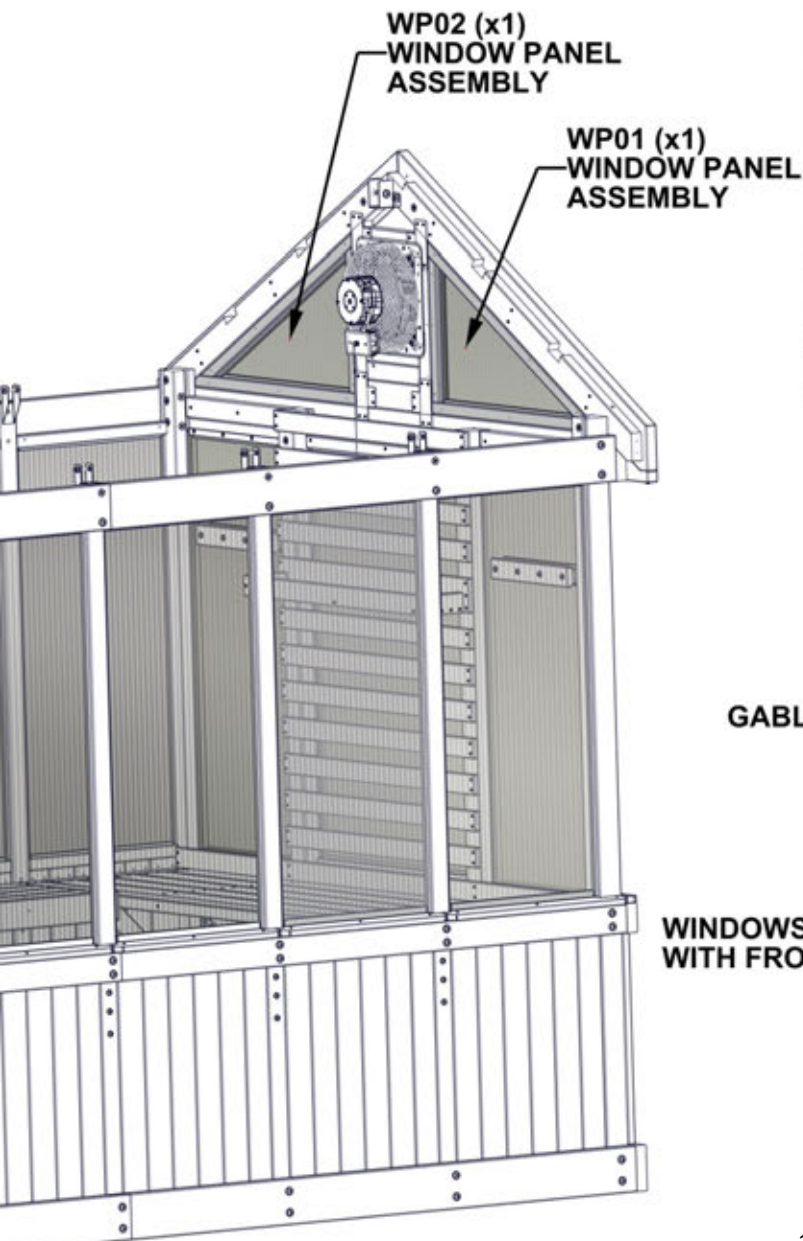
WP02 WINDOW PANEL ASSEMBLY - W2A03906
(x1) 1 7/16"x19 11/16"x32 11/16" (36x501x736)



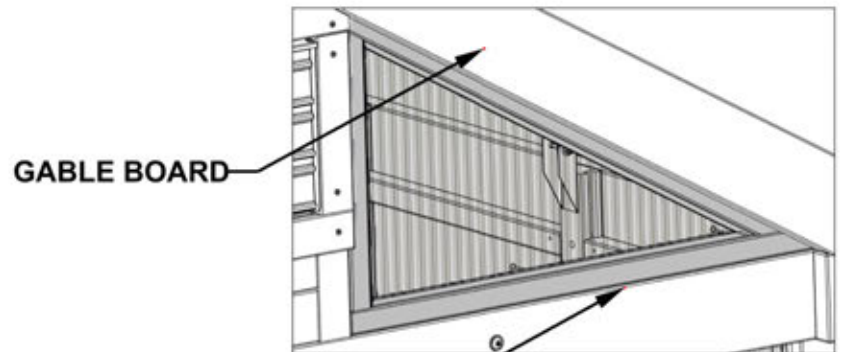
WP01 WINDOW PANEL ASSEMBLY - W2A03899
(x1) 1 7/16"x19 11/16"x32 11/16" (36x501x736)

NOTES:

- SLIDE WINDOW PANEL ASSEMBLIES INTO OPENING.
- SLIDE WINDOWS UNTIL THEY CONTACT THE GABLE BOARDS.
SEE DETAIL.



INSIDE VIEW



WINDOWS WILL BE FLUSH WITH FRONT OF GREENHOUSE

OUTSIDE VIEW

STEP 111B - BACK WINDOW

QTY	PART NUMBER	DESCRIPTION
40	H100382	SCREW PFH 8x1 3/4 BLK

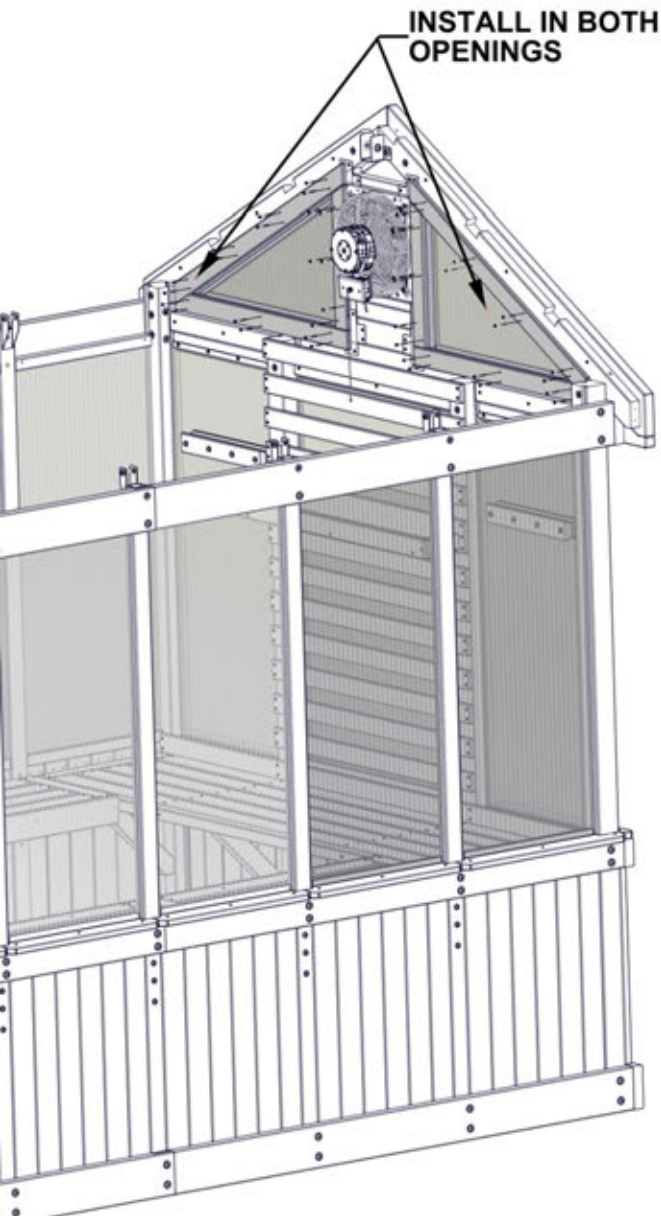
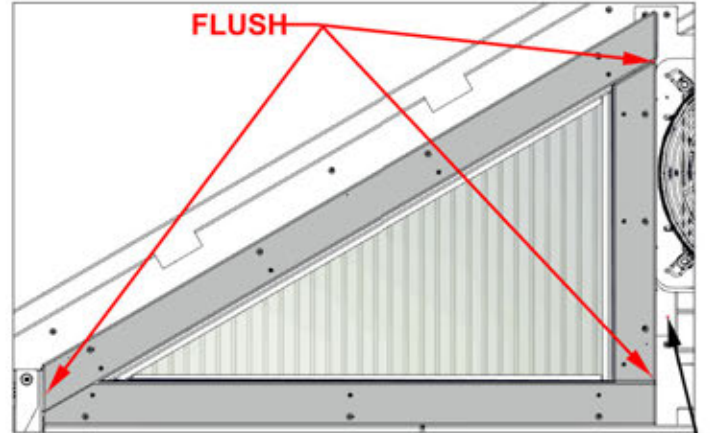
N12 WINDOW TRIM - W4L18418
(x2) 5/8"x2 3/8"x17 3/4" (16x60x451)

N11 WINDOW TRIM - W4L18417
(x2) 5/8"x2 3/8"x40 1/2" (16x60x1028)

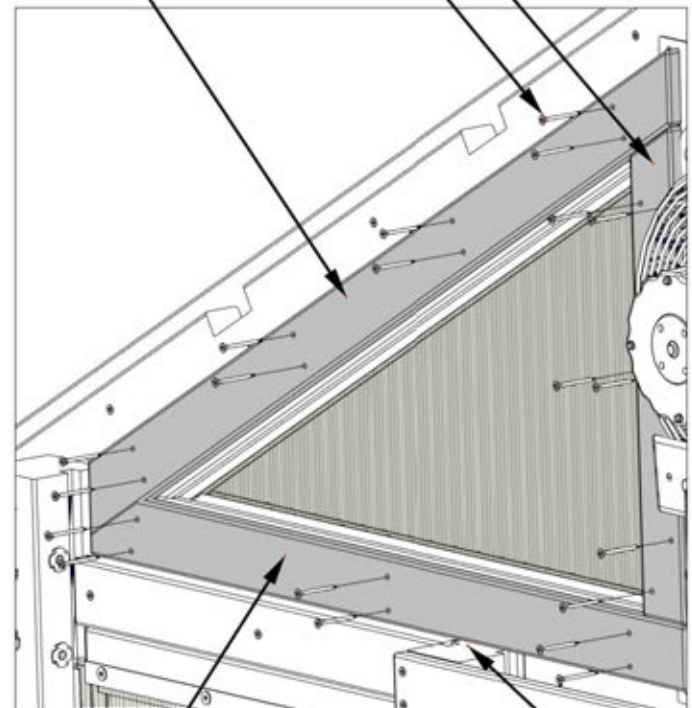
N13 WINDOW TRIM - W4L18423
(x2) 5/8"x2 3/8"x33 7/8" (16x60x860)

NOTES:

- LINE N12 WINDOW TRIM WITH PILOT HOLES ON EXHAUST FAN SUPPORT AND WINDOW AND INSTALL HARDWARE.
- REMAINING BOARDS ARE TO BUTT AGAINST N12 AND FLUSHED UP ON THE OUTSIDE AS SHOWN.
- ALIGN HOLES ON N13 & N11 WITH PILOT HOLES ON WINDOW & INSTALL HARDWARE.
- USE AN 1/8 DRILL BIT AND N13 & N11 AS A GUIDE AND DRILL PILOT HOLES.
- INSTALL REMAINING HARDWARE SHOWN.
- REPEAT FOR OTHER WINDOW OPENING.



N12 (x2) WINDOW TRIM
382 (x40) SCREW - 1 3/4"

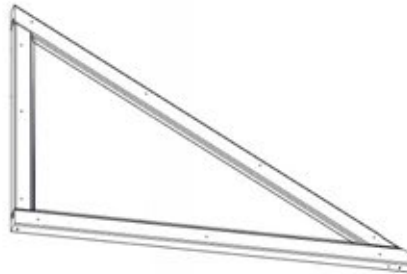


N13 WILL LAY LEVEL ON INSIDE POST

STEP 112A - FRONT WINDOW



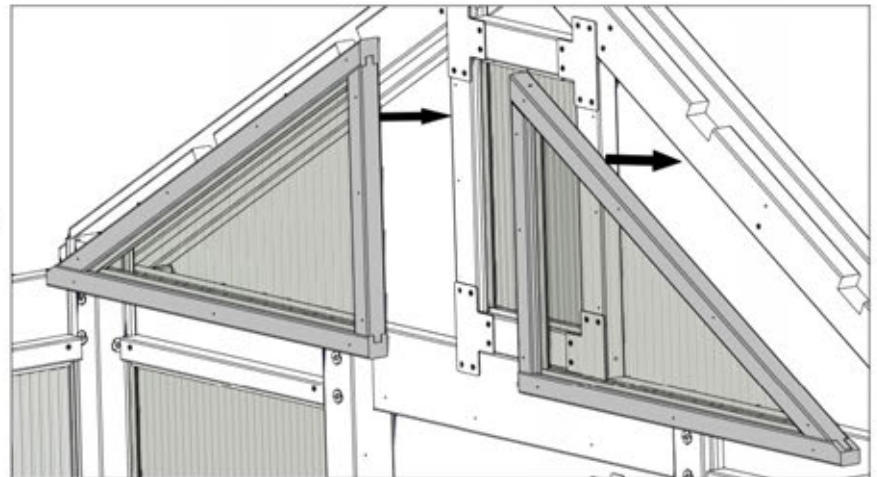
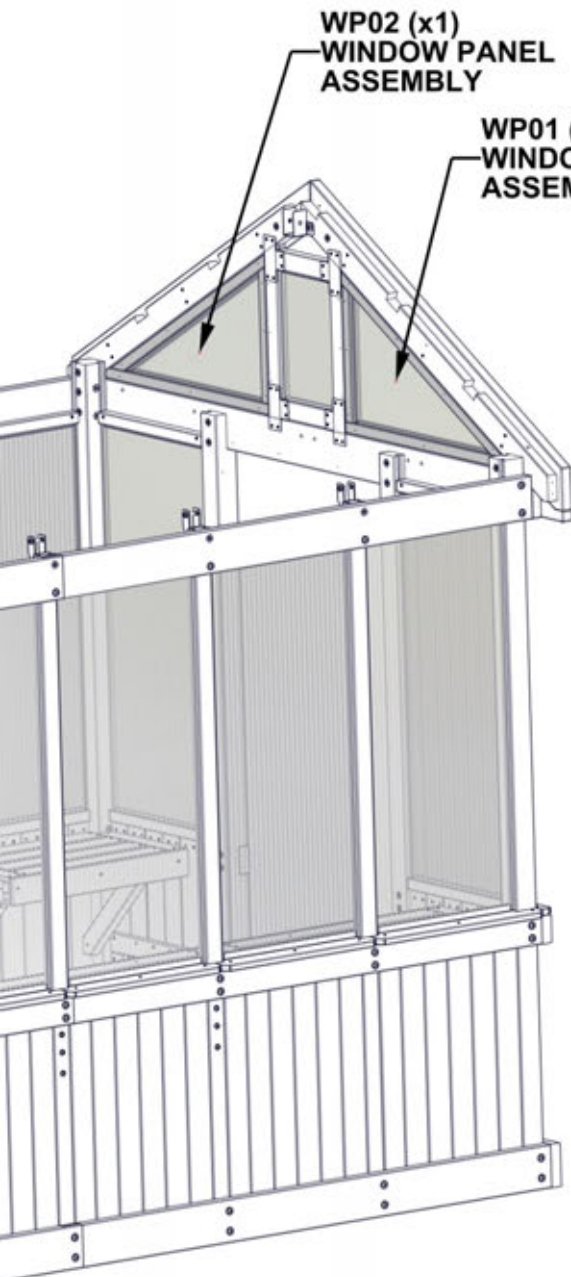
WP02 WINDOW PANEL ASSEMBLY - W2A03906
(x1) 1 7/16"x19 11/16"x32 11/16" (36x501x736)



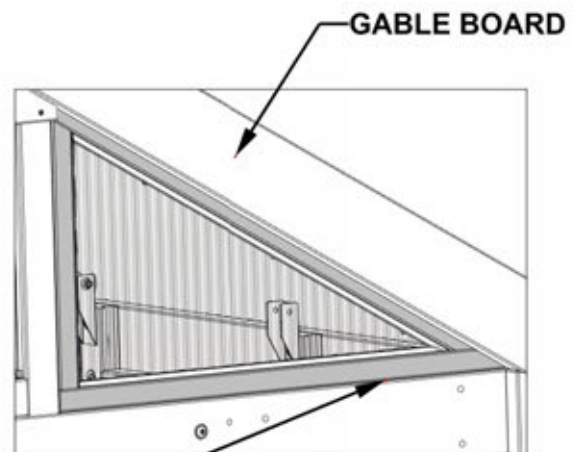
WP01 WINDOW PANEL ASSEMBLY - W2A03899
(x1) 1 7/16"x19 11/16"x32 11/16" (36x501x736)

NOTES:

- SLIDE WINDOW PANEL ASSEMBLIES INTO OPENING.
- SLIDE WINDOWS UNTIL THEY CONTACT THE GABLE BOARDS.
SEE DETAIL.



INSIDE VIEW



OUTSIDE VIEW

STEP 112B - FRONT WINDOW

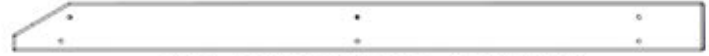
QTY	PART NUMBER	DESCRIPTION
40	H100382	SCREW PFH 8x1 3/4 BLK



N12 WINDOW TRIM - W4L18418
(x2) 5/8"x2 3/8"x17 3/4" (16x60x451)



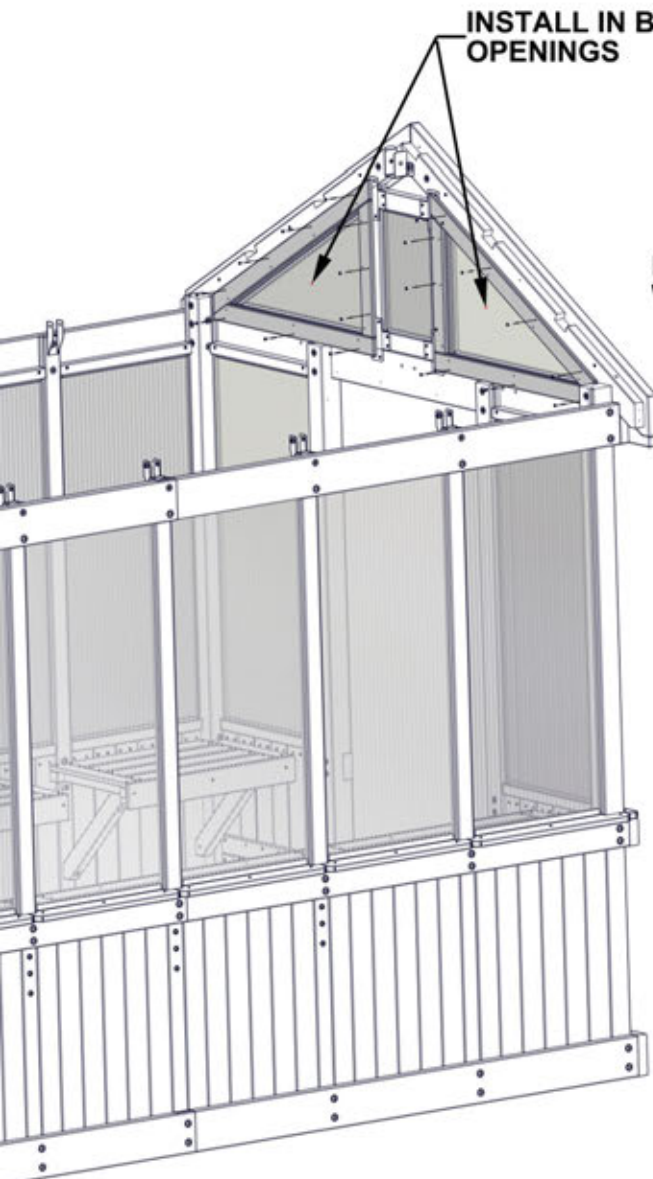
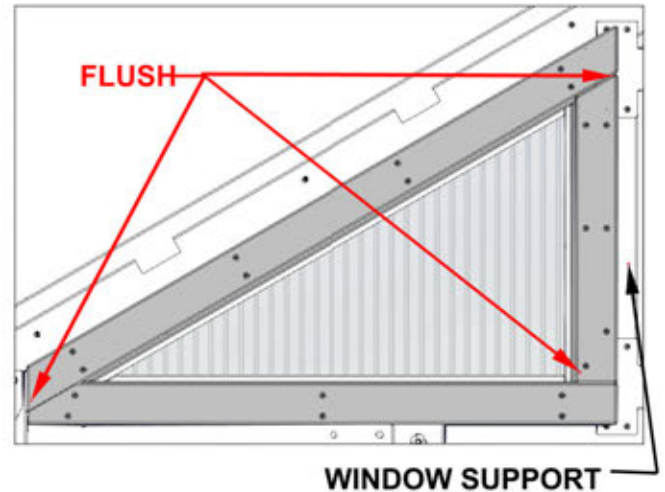
N11 WINDOW TRIM - W4L18417
(x2) 5/8"x2 3/8"x40 1/2" (16x60x1028)



N13 WINDOW TRIM - W4L18423
(x2) 5/8"x2 3/8"x33 7/8" (16x60x860)

NOTES:

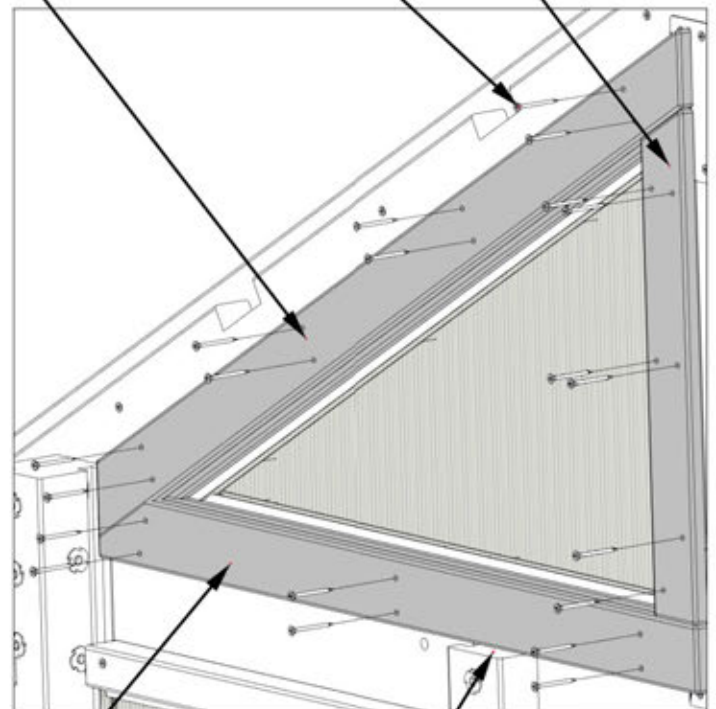
- LINE N12 WINDOW TRIM WITH PILOT HOLES ON WINDOW SUPPORT BOARD AND WINDOW AND INSTALL HARDWARE.
- REMAINING BOARDS ARE TO BUTT AGAINST N12 AND FLUSHED UP ON THE OUTSIDE AS SHOWN.
- ALIGN HOLES ON N13 & N11 WITH PILOT HOLES ON WINDOW & INSTALL HARDWARE.
- USE AN 1/8 DRILL BIT AND N13 & N11 AS A GUIDE AND DRILL PILOT HOLES.
- INSTALL REMAINING HARDWARE SHOWN.
- REPEAT FOR OTHER WINDOW OPENING.



INSTALL IN BOTH
OPENINGS

N11 (x2)
WINDOW TRIM

N12 (x2)
WINDOW TRIM
382 (x40)
SCREW - 1 3/4"



N13 (x2)
WINDOW TRIM

N13 WILL LAY LEVEL
ON INSIDE POST

STEP 113 - ROOF ASSEMBLY

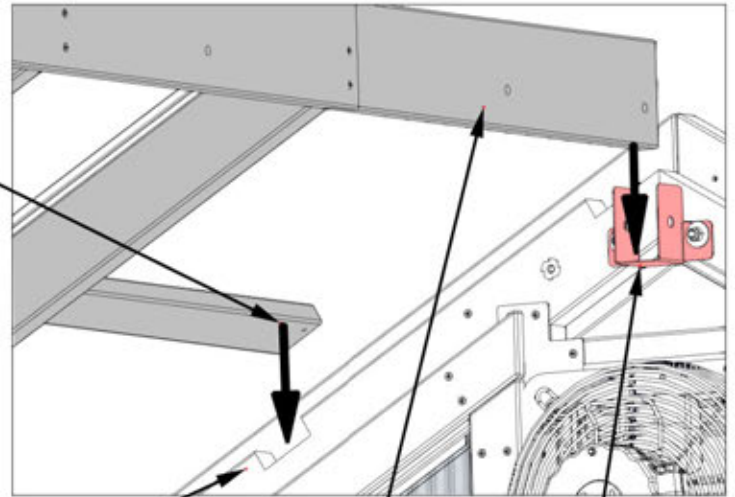


ROOF ASSEMBLY FROM
PREVIOUS STEPS (x2)

NOTES:

- WILL REQUIRE (2) ADULTS FOR THIS STEP.
- LIFT ROOF ASSEMBLY OVER WALL AND CAREFULLY PLACE ROOF PURLINS IN SLOTS ON GABLE BOARDS.
- PLACE RIDGE BOARD INTO BRACKET LOCATED ON GABLE BOARDS.

REPEAT THIS STEP FOR OTHER SIDE



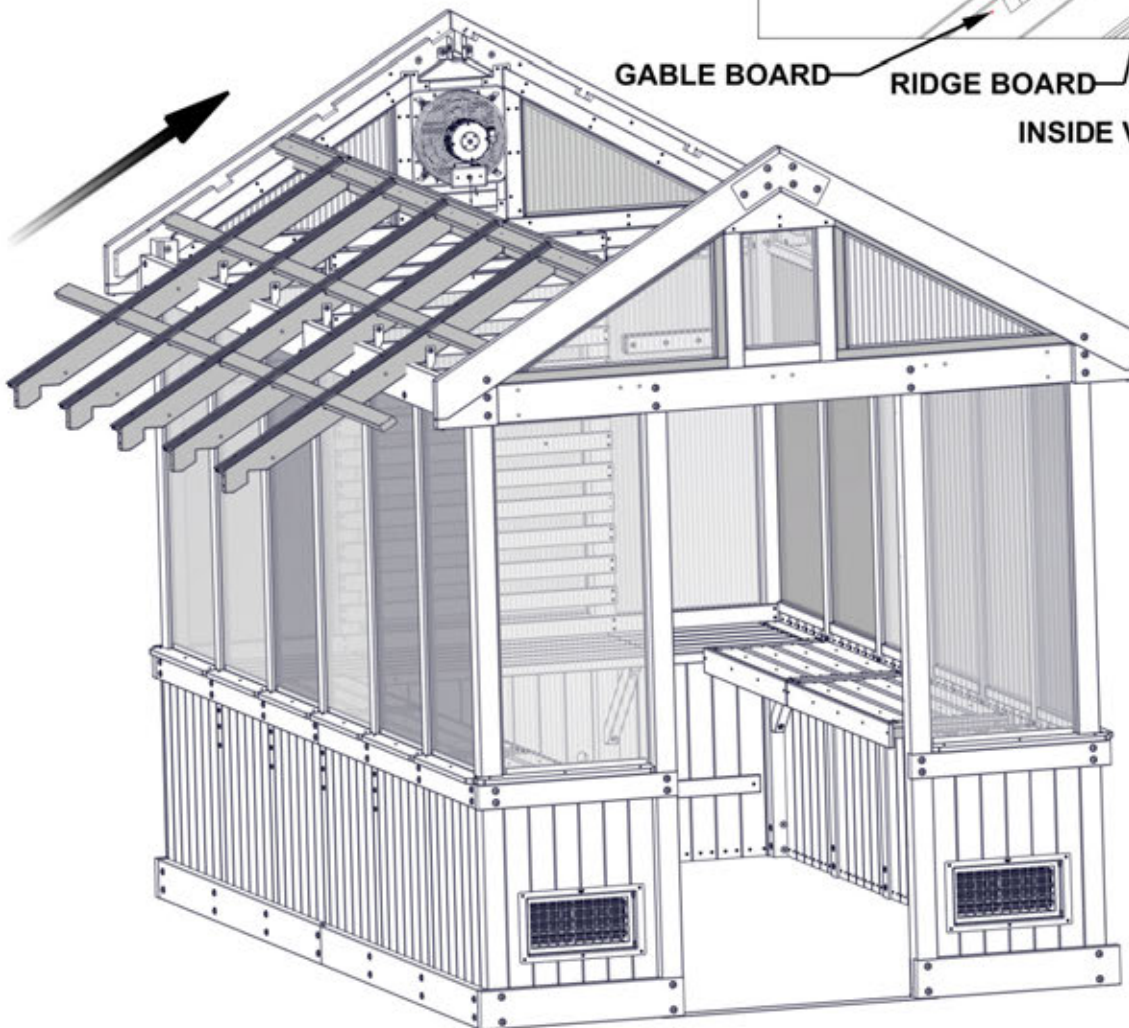
PURLIN

GABLE BOARD

RIDGE BOARD

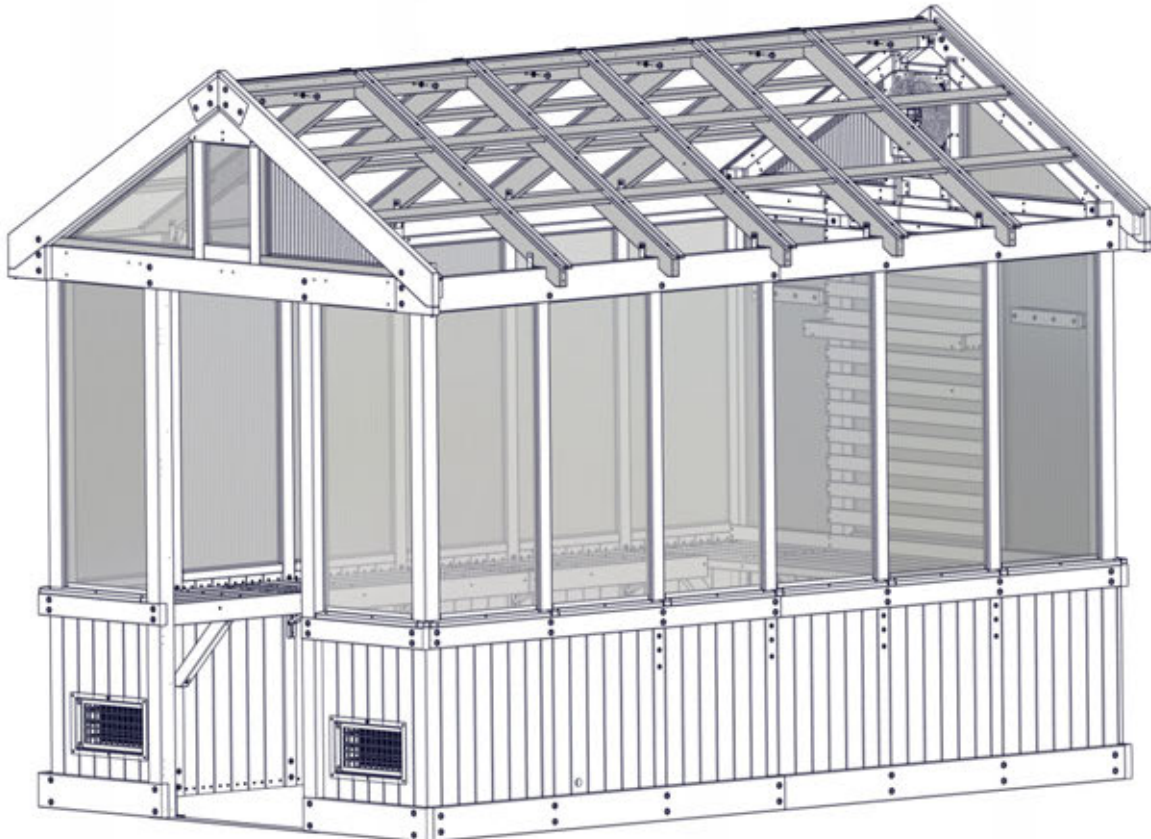
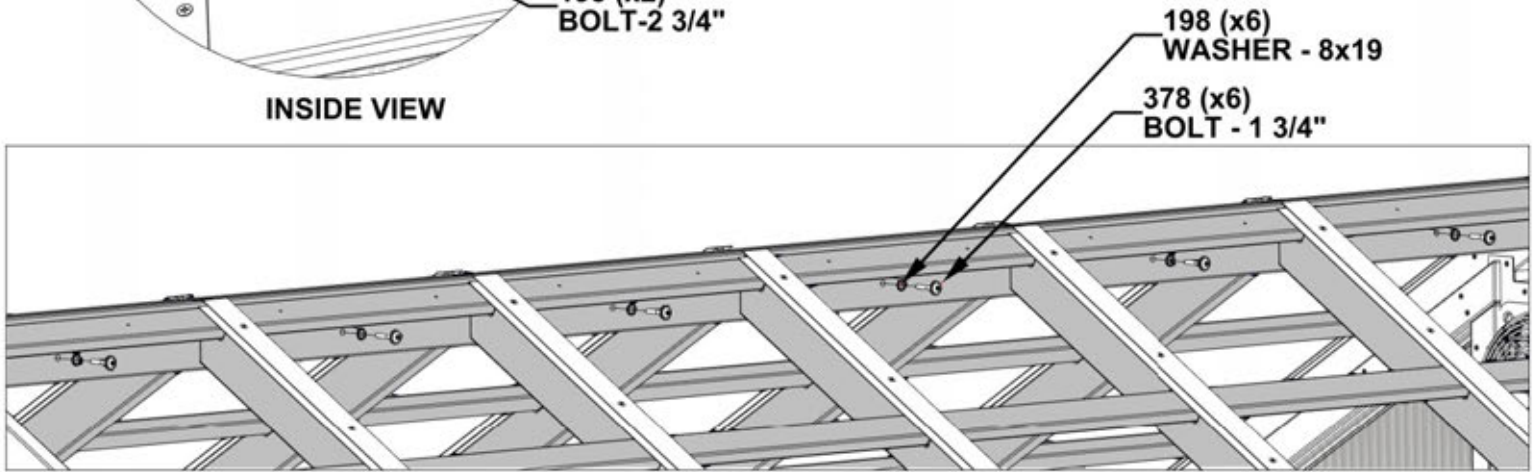
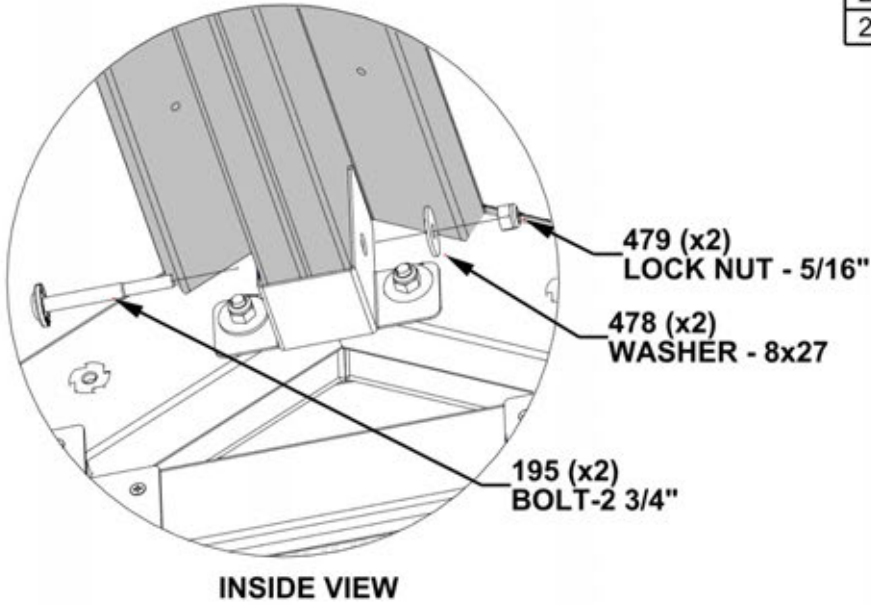
BRACKET

INSIDE VIEW



STEP 114 - ROOF ASSEMBLY

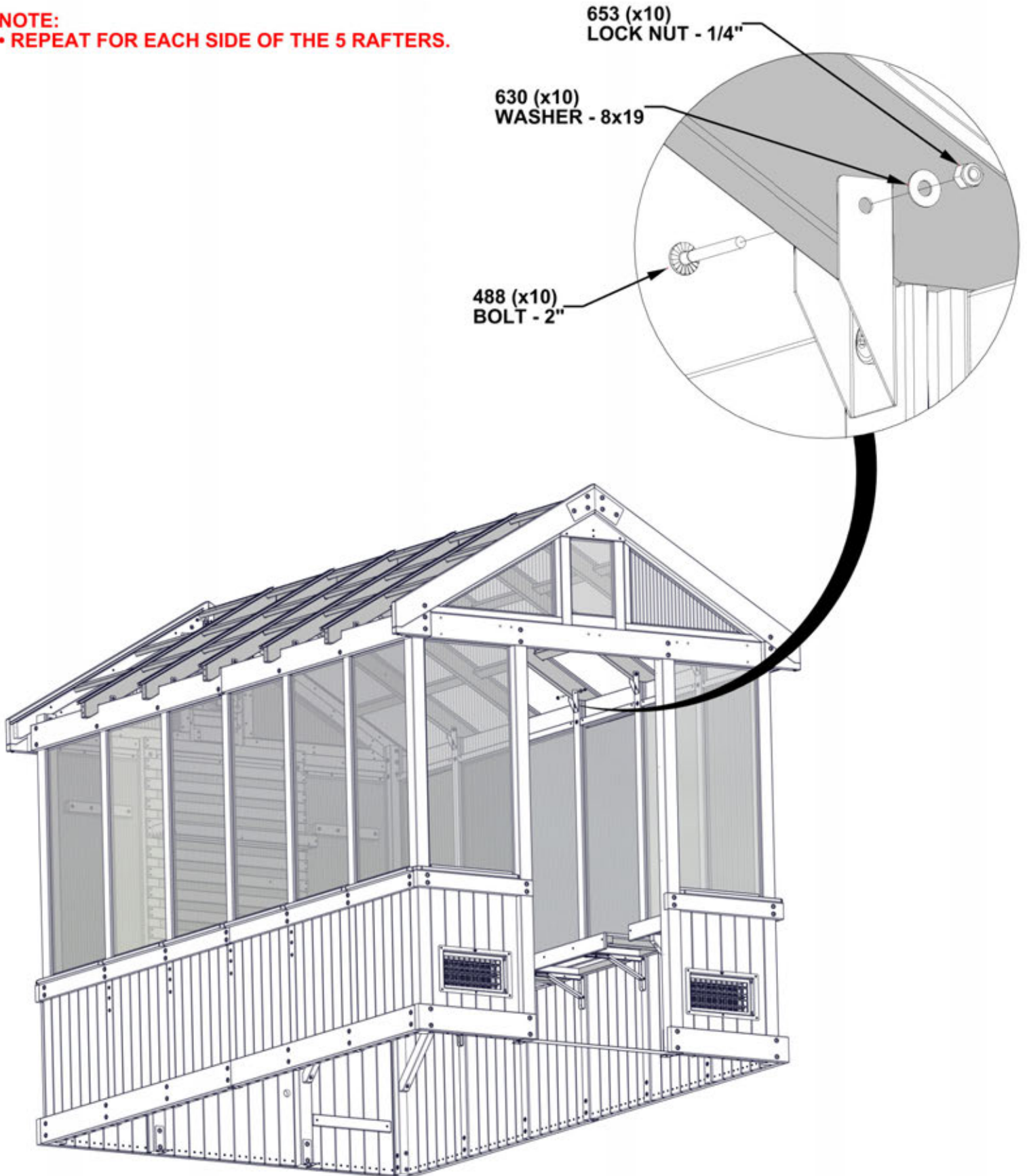
QTY	PART NUMBER	DESCRIPTION
2	H100195	BOLT WH 5/16x2 3/4 BLK
6	H100198	WASHER LOCK EXT 8x19
6	H100378	BOLT WH 5/16x1 3/4 BLK
2	H100478	WASHER FLAT 8x27 BLK
2	H100479	NUT LOCK 5/16 BLK



STEP 115 - ROOF ASSEMBLY

QTY	PART NUMBER	DESCRIPTION
10	H100488	BOLT WH 1/4x2 BLK
10	H100630	WASHER FLAT 8x19 BLK
10	H100653	NUT LOCK 1/4 BLK

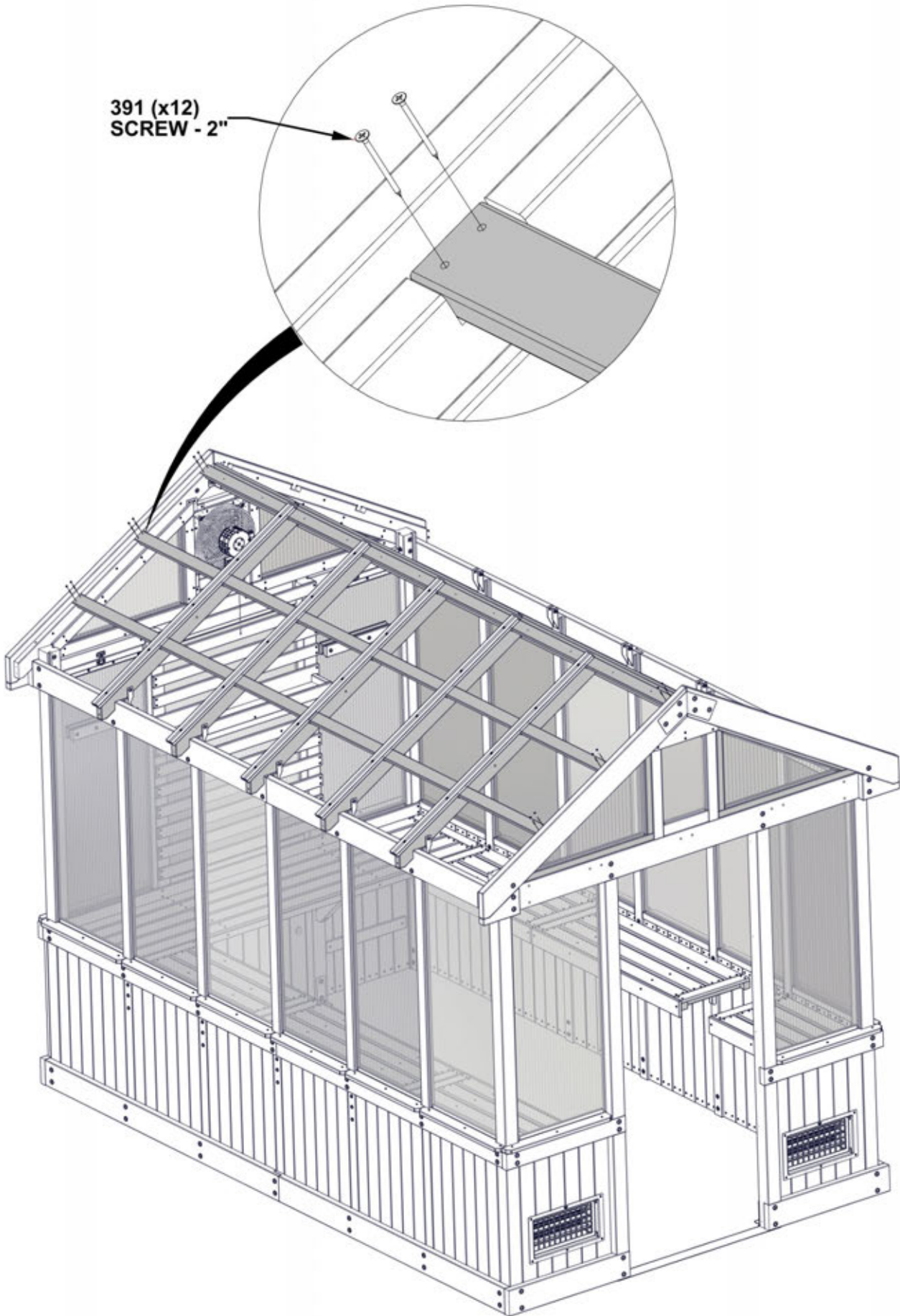
NOTE:
• REPEAT FOR EACH SIDE OF THE 5 RAFTERS.



STEP 116 - ROOF ASSEMBLY

REPEAT THIS STEP FOR OTHER SIDE

QTY	PART NUMBER	DESCRIPTION
24	H100391	SCREW PFH 8x2 BLK

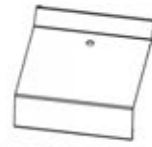


STEP 117A - ROOF ASSEMBLY

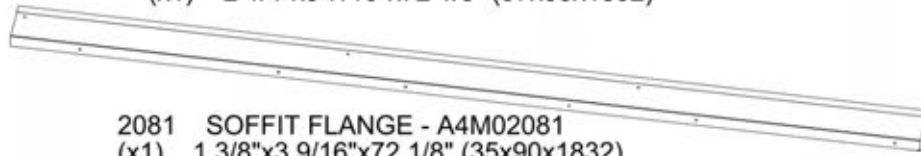
QTY	PART NUMBER	DESCRIPTION
7	H100395	SCREW PFH 8x3/4 BLK



2098 SOFFIT FLANGE - A4M02098
(x1) 2 1/4"x3 7/16"x72 1/8" (57x88x1832)



2082 SOFFIT SPLICE - A4M02082
(x1) 1 7/16"x3 1/8"x3 5/8" (37x80x92)

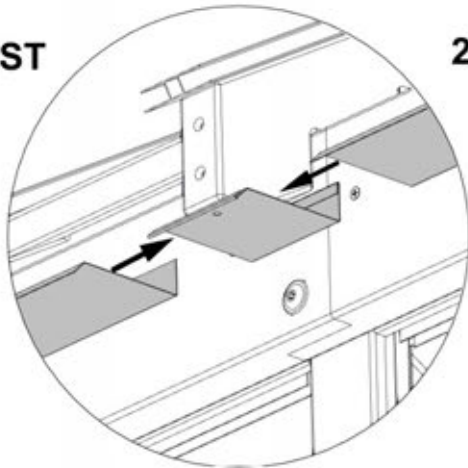


2081 SOFFIT FLANGE - A4M02081
(x1) 1 3/8"x3 9/16"x72 1/8" (35x90x1832)

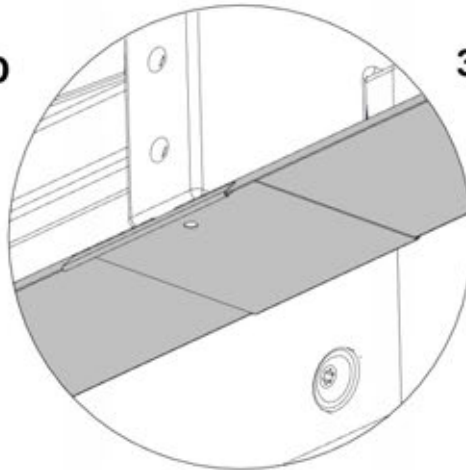
NOTES:

- SLIDE SOFFIT FLANGES INTO SOFFIT SPLICE.
- ADJUST AS NEEDED
- FASTEN AS SHOWN TO THE BOTTOM OF (7) TOTAL RAFTERS.

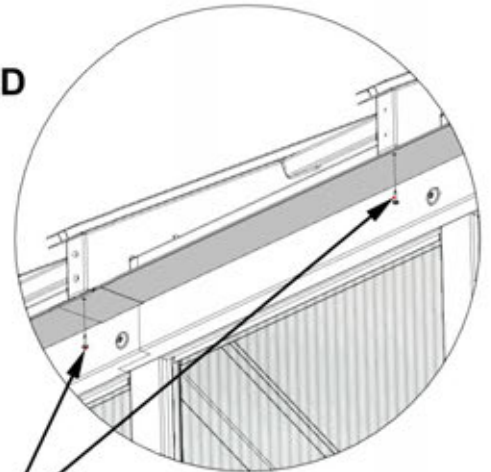
1ST



2ND



3RD



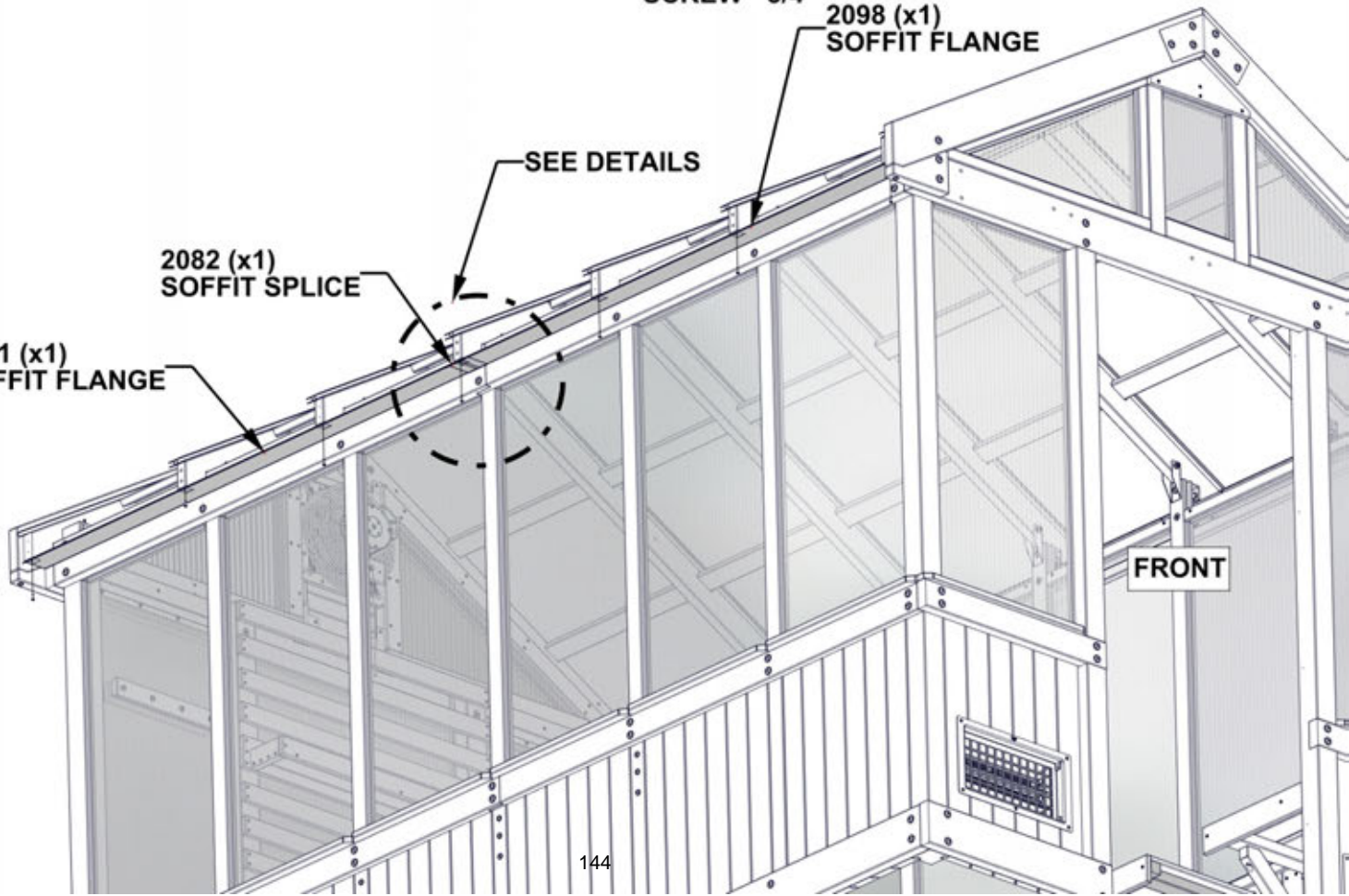
395 (x7)
SCREW - 3/4"

2098 (x1)
SOFFIT FLANGE

SEE DETAILS

2082 (x1)
SOFFIT SPLICE

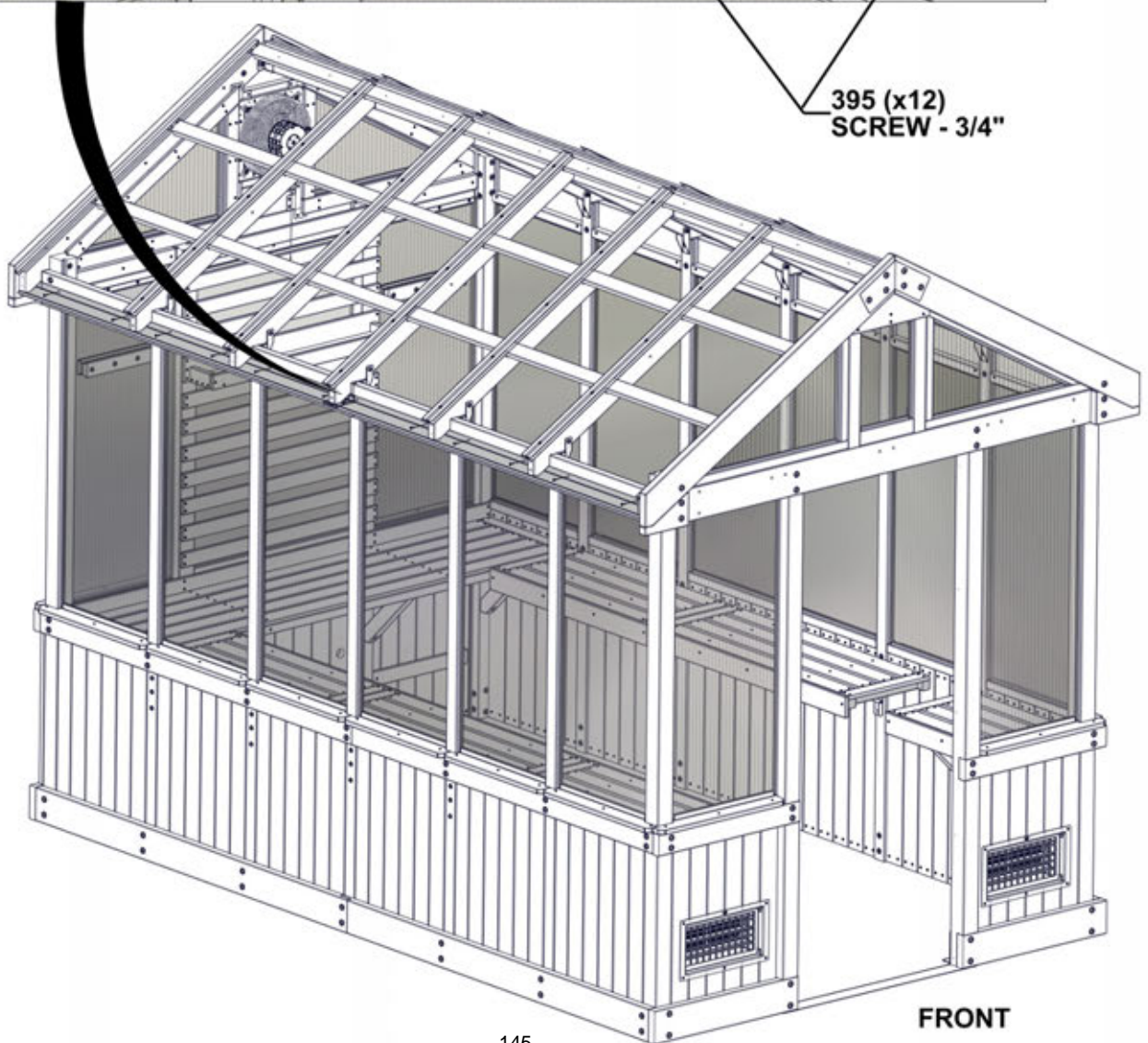
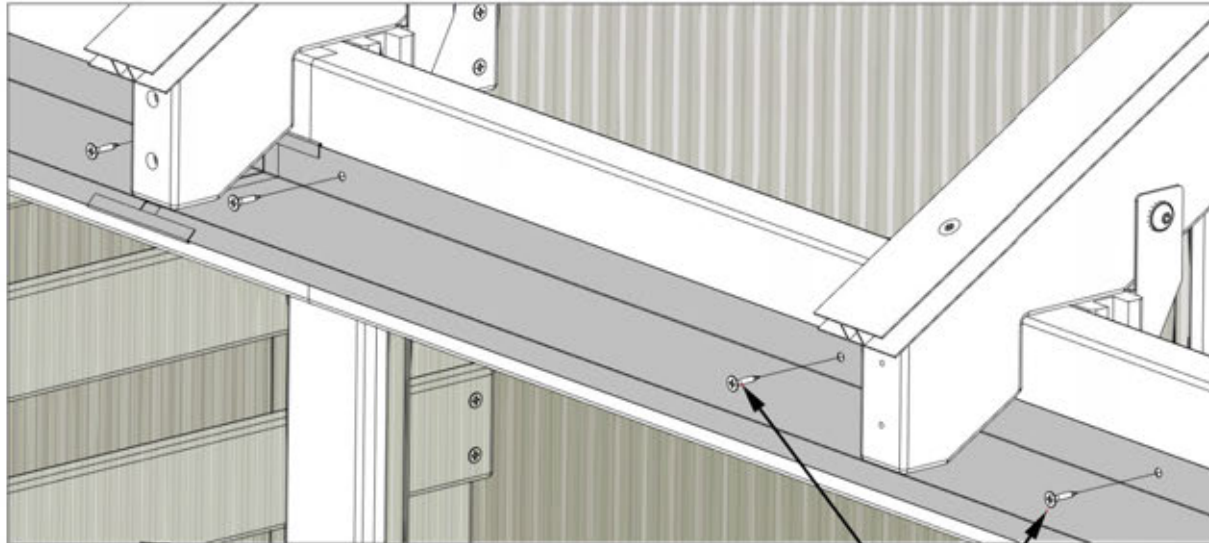
2081 (x1)
SOFFIT FLANGE



STEP 117B - ROOF ASSEMBLY

QTY	PART NUMBER	DESCRIPTION
12	H100395	SCREW PFH 8x3/4 BLK

NOTE:
• INSTALL SCREWS IN HOLES PROVIDED ON SOFFITS.



395 (x12)
SCREW - 3/4"

STEP 117C - ROOF ASSEMBLY

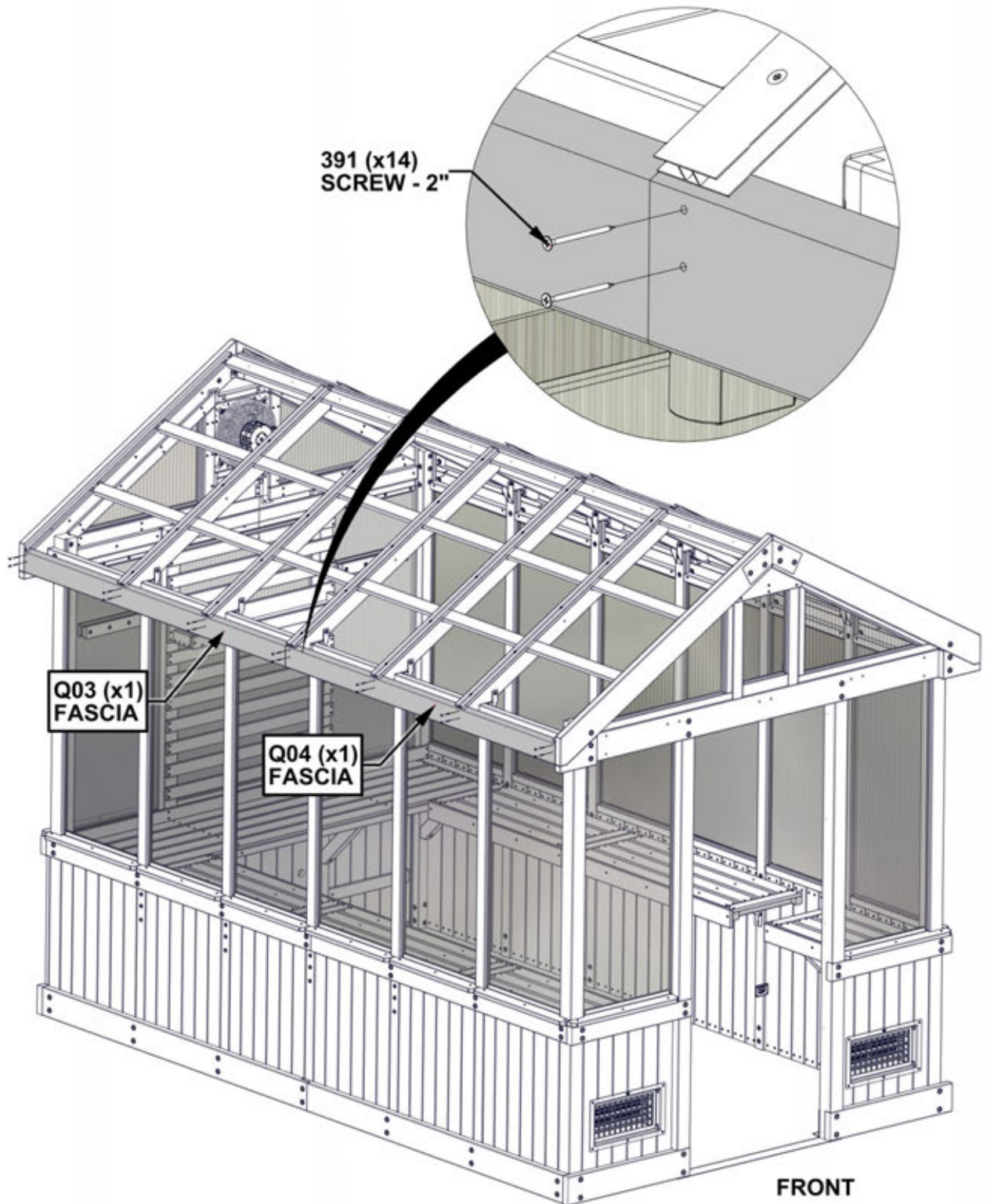
QTY	PART NUMBER	DESCRIPTION
14	H100391	SCREW PFH 8x2 BLK



Q03 FASCIA - W4L18048
(x1) 15/16"x4 7/16"x73 9/16" (24x112x1868)

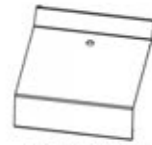
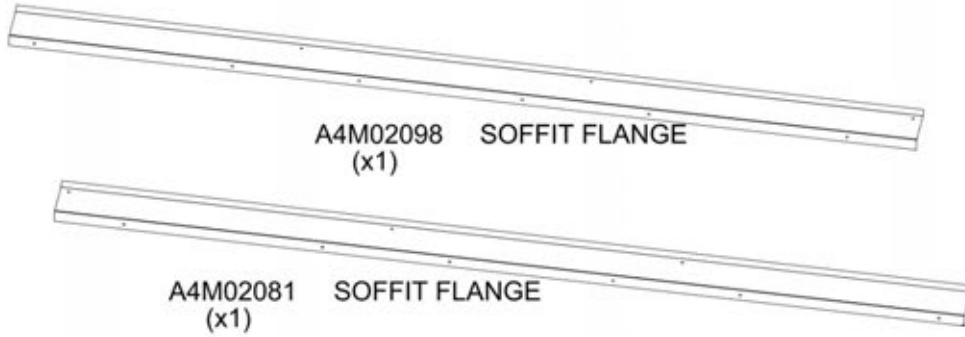


Q04 FASCIA - W4L18049
(x1) 15/16"x4 7/16"x73 9/16" (24x112x1868)



STEP 118A - ROOF ASSEMBLY

QTY	PART NUMBER	DESCRIPTION
7	H100395	SCREW PFH 8x3/4 BLK

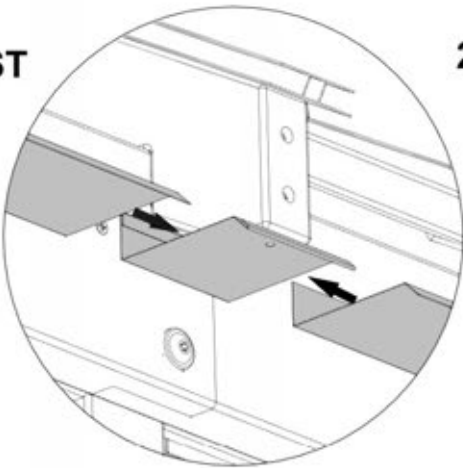


A4M02082 SOFFIT SPLICE (x1)

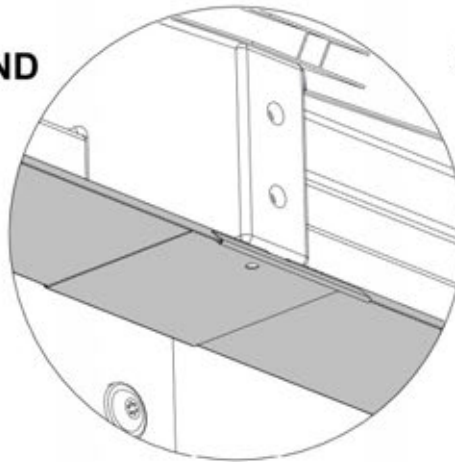
NOTES:

- SLIDE SOFFIT FLANGES INTO SOFFIT SPLICE.
- ADJUST AS NEEDED.
- FASTEN AS SHOWN TO THE BOTTOM OF (7) TOTAL RAFTERS.

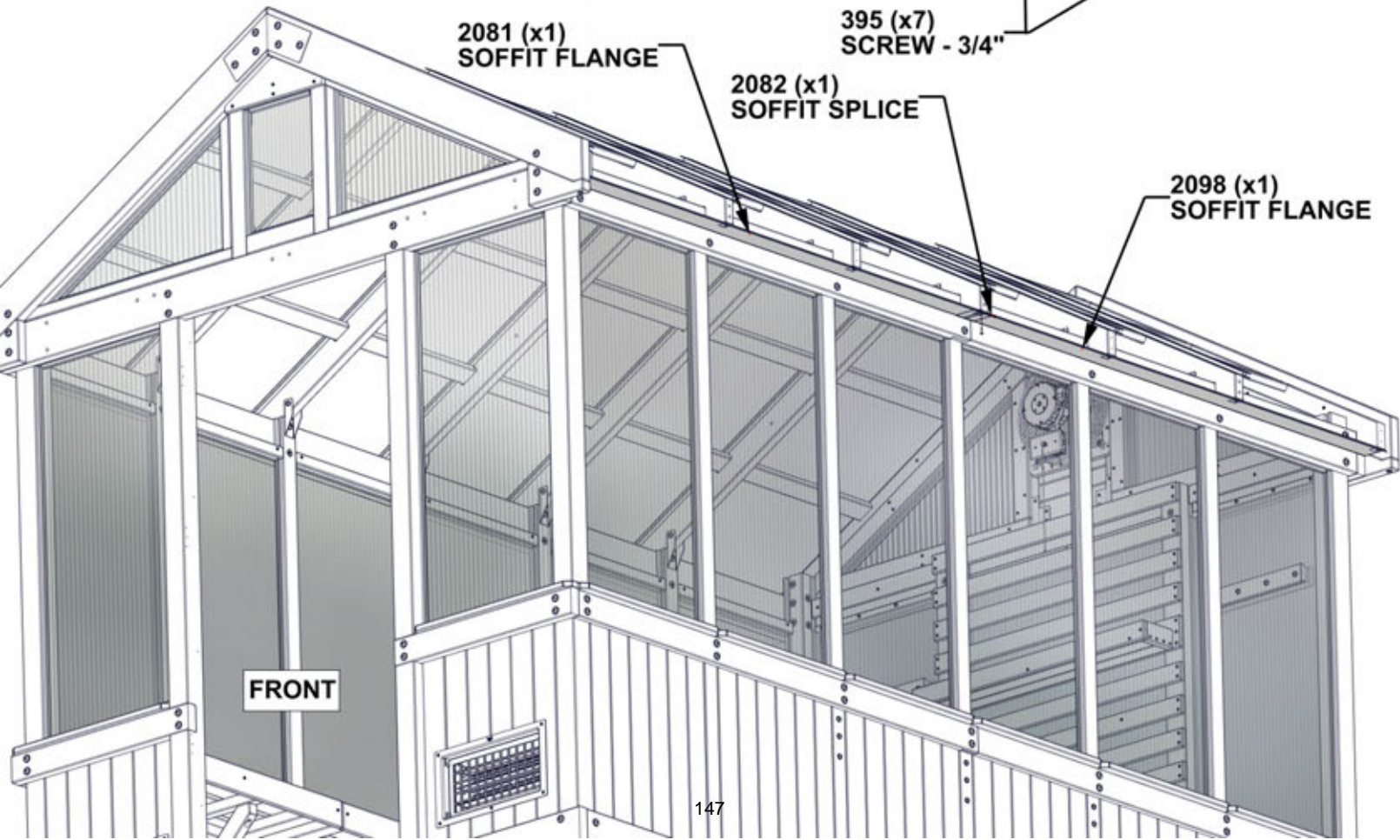
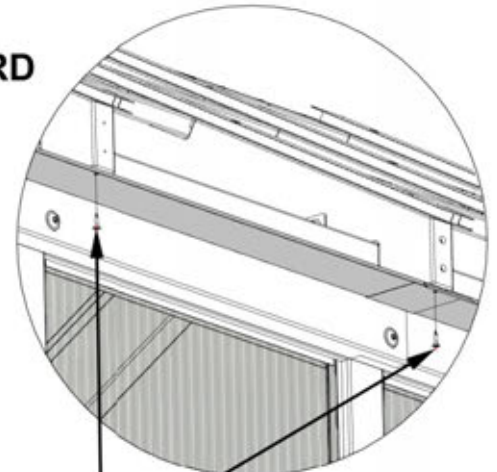
1ST



2ND



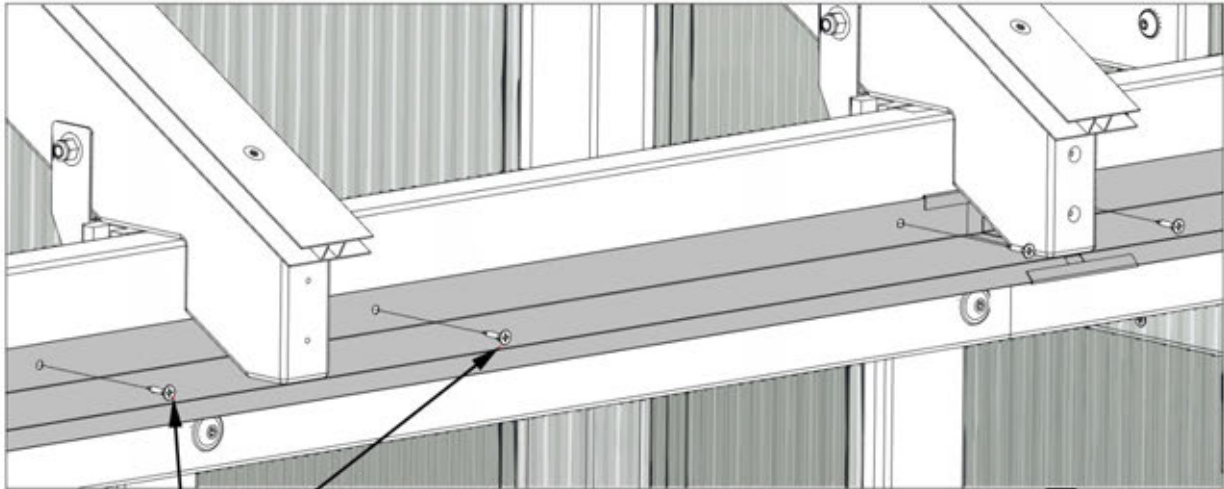
3RD



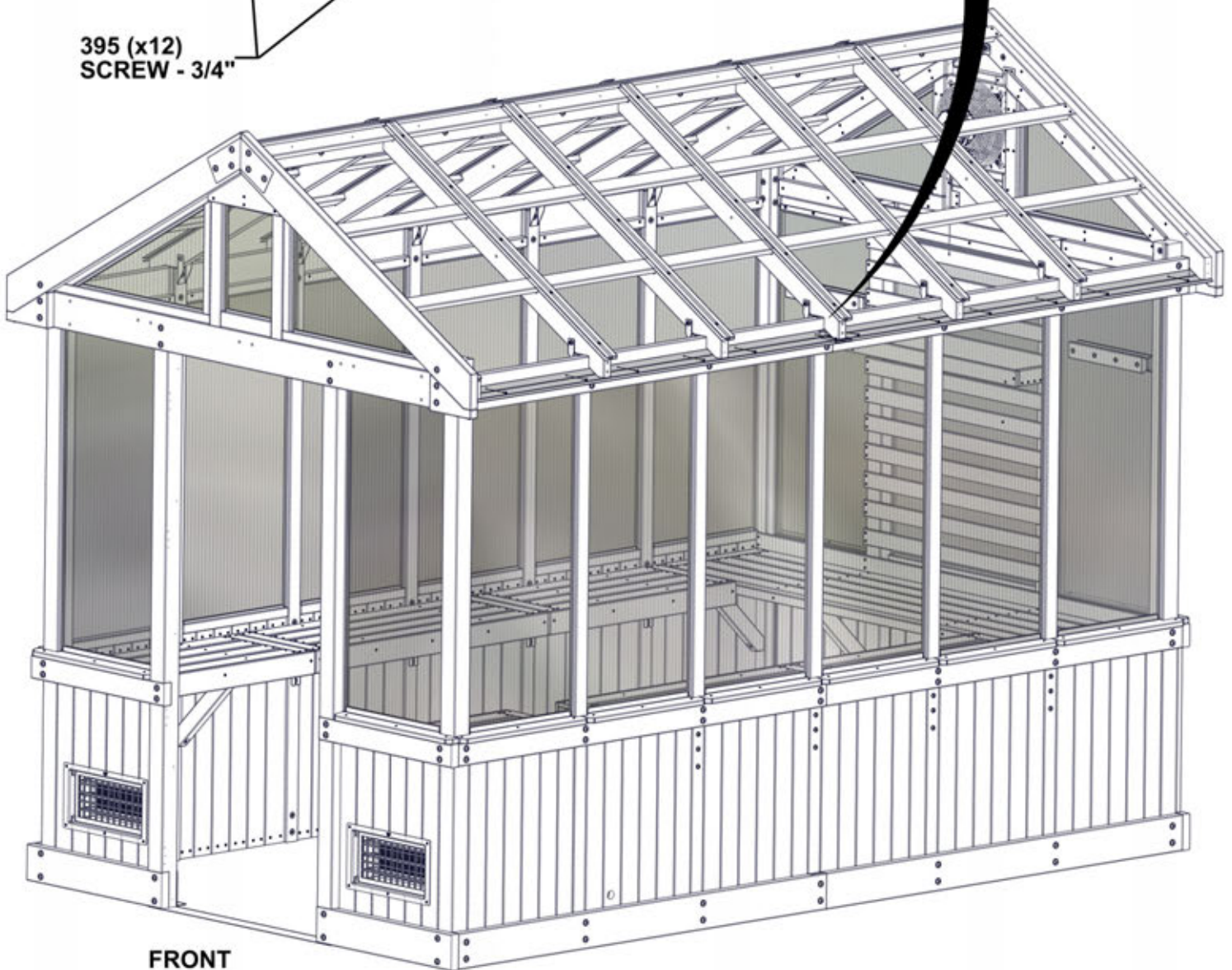
STEP 118B - ROOF ASSEMBLY

QTY	PART NUMBER	DESCRIPTION
12	H100395	SCREW PFH 8x3/4 BLK

NOTE:
• INSTALL SCREWS IN HOLES PROVIDED ON SOFITS.



395 (x12)
SCREW - 3/4"



FRONT

STEP 118C - ROOF ASSEMBLY

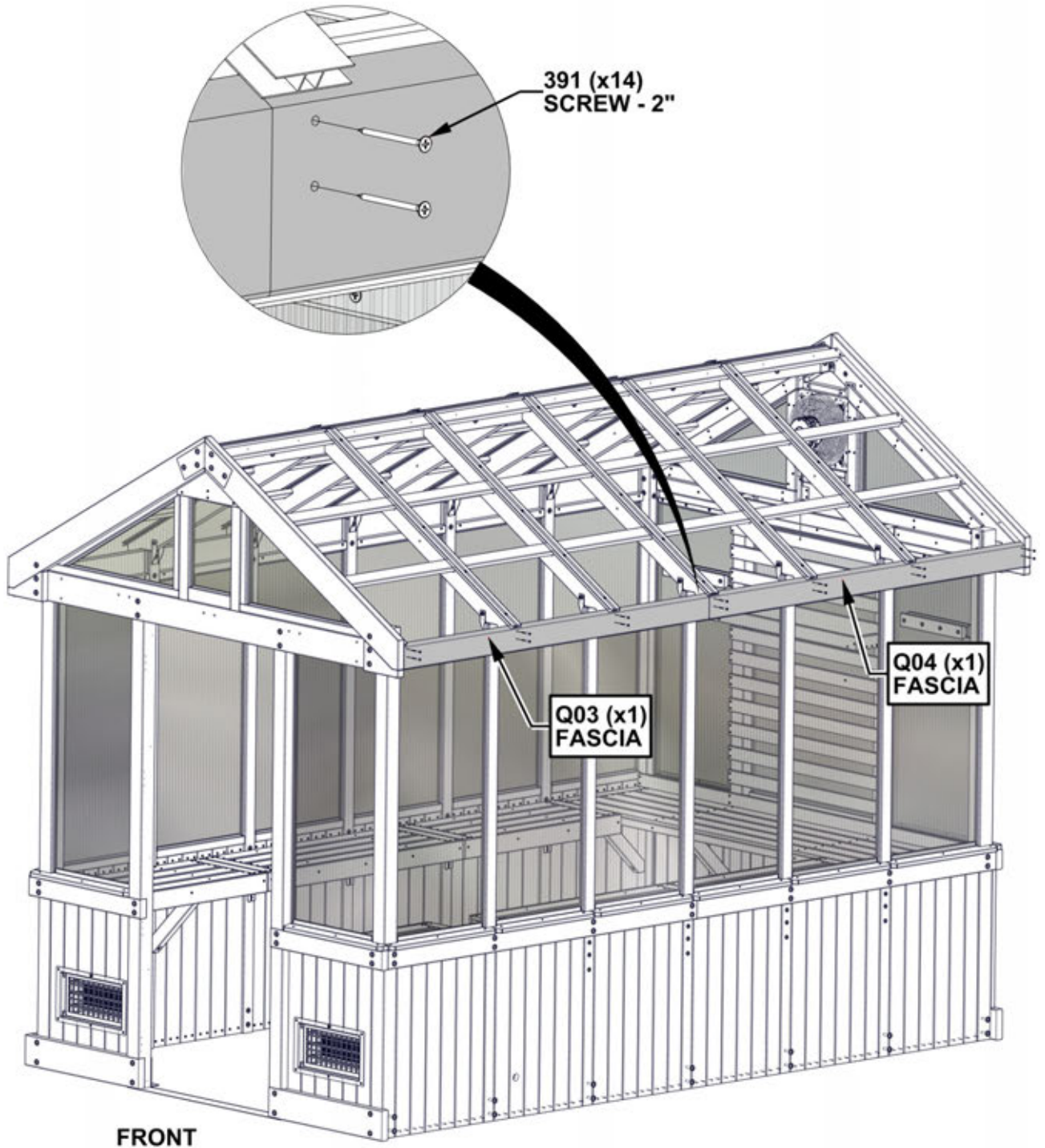
QTY	PART NUMBER	DESCRIPTION
14	H100391	SCREW PFH 8x2 BLK



Q03 FASCIA - W4L18048
(x1) 15/16"x4 7/16"x73 9/16" (24x112x1868)



Q04 FASCIA - W4L18049
(x1) 15/16"x4 7/16"x73 9/16" (24x112x1868)



FRONT

STEP 119 - ROOF ASSEMBLY

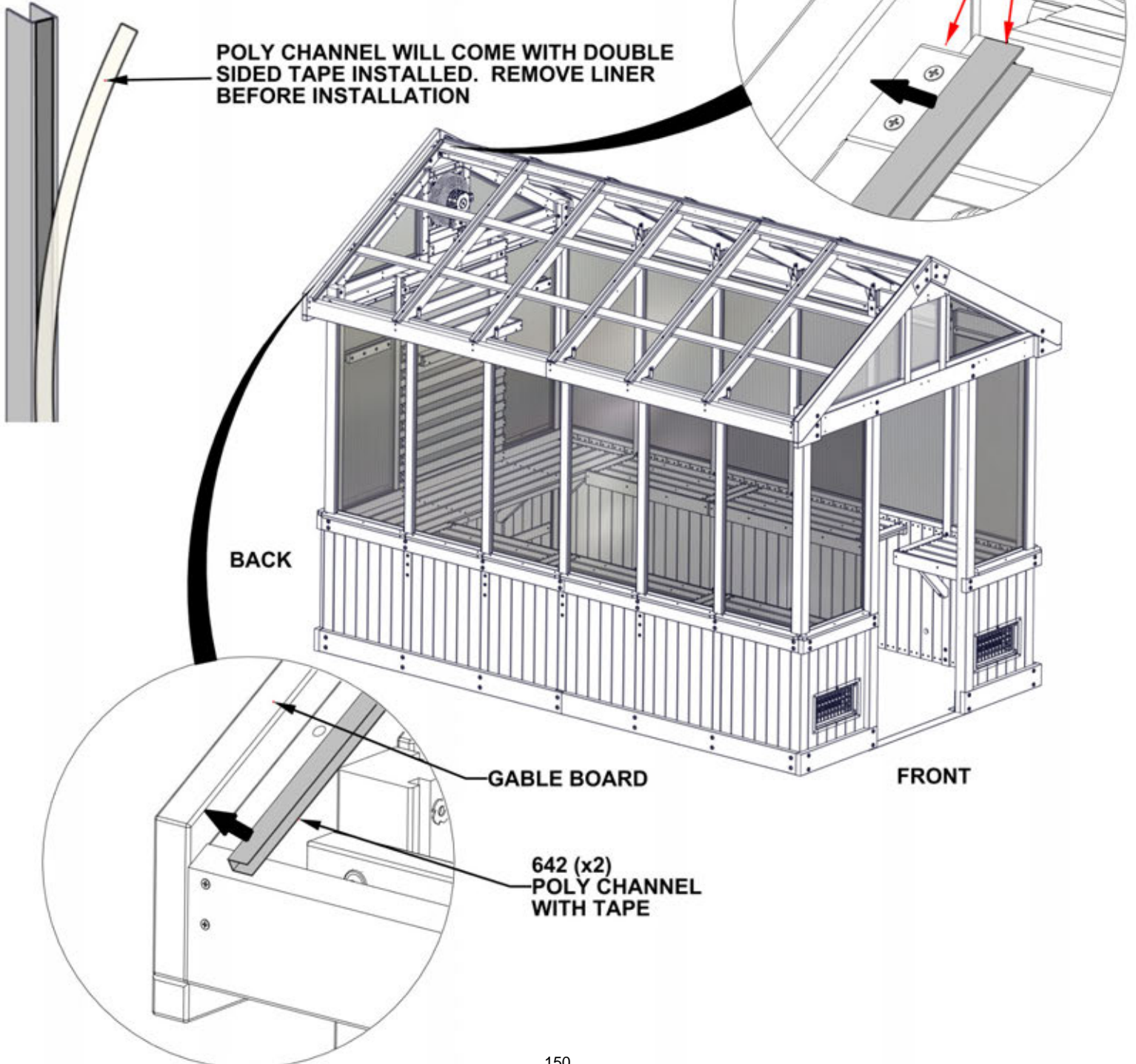


A6P00642 POLY CHANNEL WITH TAPE
(x4)

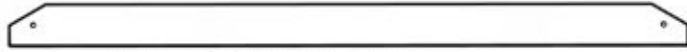
NOTES:

- REMOVE LINER AND FIRMLY PRESS ONTO THE GABLE.
- NOTE ORIENTATION OF POLY CHANNEL AND
- REPEAT STEP FOR THE FRONT GABLE

REPEAT THIS STEP FOR THE RIGHT SIDE
FLUSH



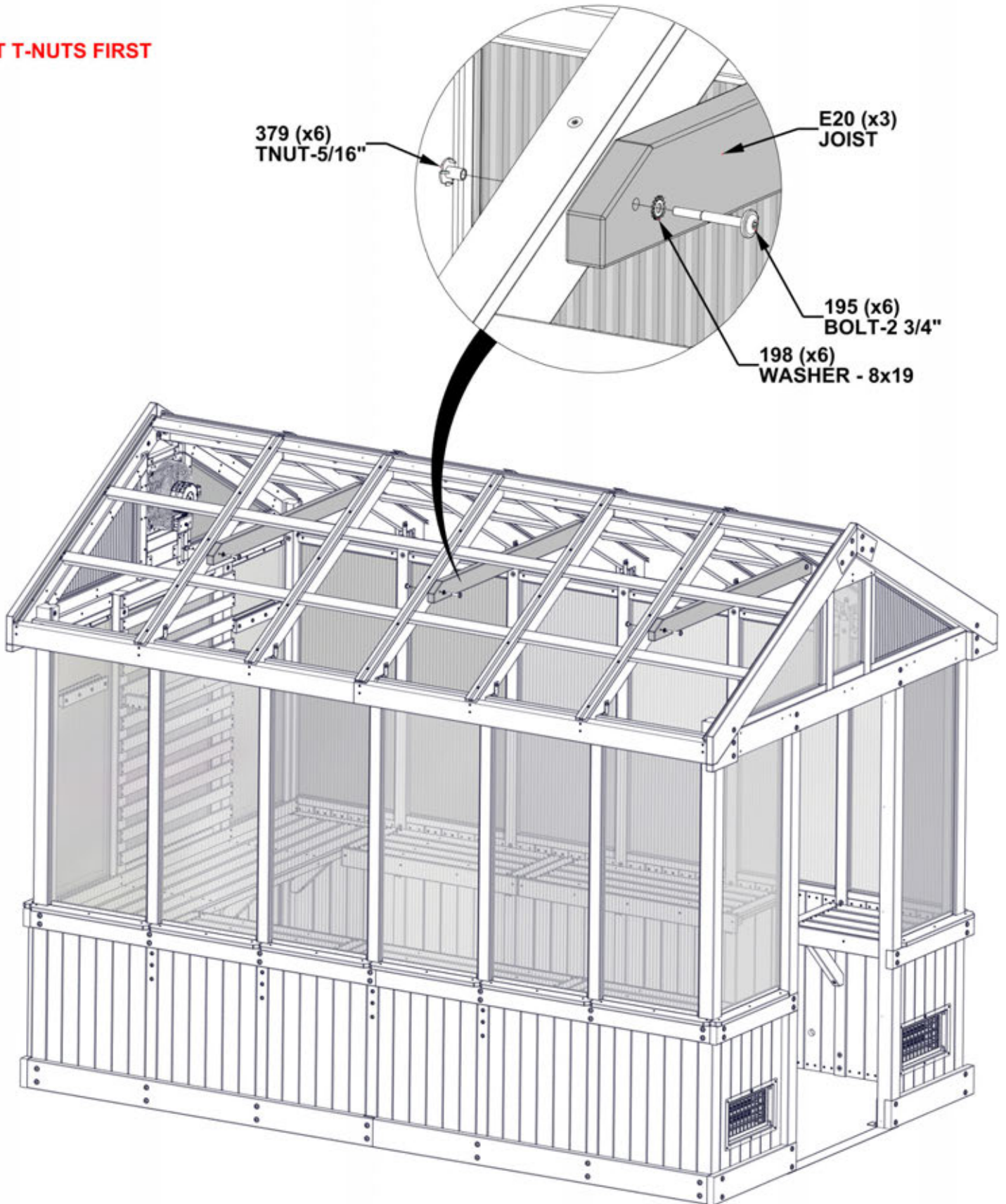
STEP 120 - ROOF ASSEMBLY



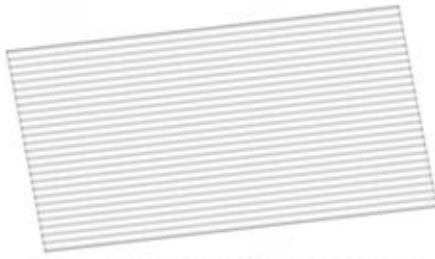
E20 JOIST - W4L18420
(x3) 1 7/16"x3 3/8"x54 1/8" (36x86x1374)

QTY	PART NUMBER	DESCRIPTION
6	H100195	BOLT WH 5/16x2 3/4 BLK
6	H100198	WASHER LOCK EXT 8x19
6	H100379	TNUT-5/16" BLK

INSERT T-NUTS FIRST



STEP 121 - ROOF ASSEMBLY



571 POLY SHEET - A6P00571
(x4) 3/8"x25 3/4"x54 1/2" (10x654x1385)



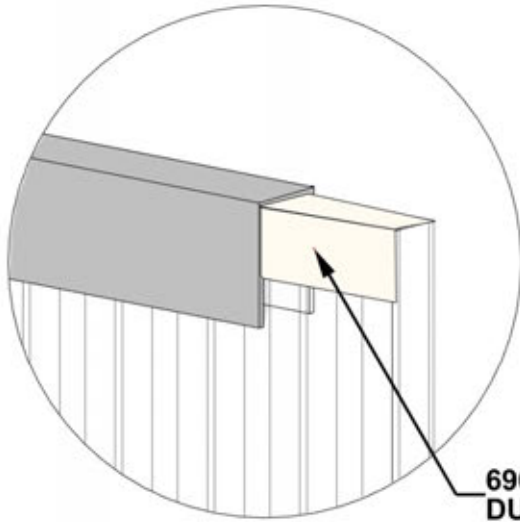
807 POLY CHANNEL - A6P00807
(x8) 1/2"x13/16"x24 1/8" (13x20x612)



A6P00690 DUST TAPE

TO APPLY DUST TAPE & POLY CHANNEL:

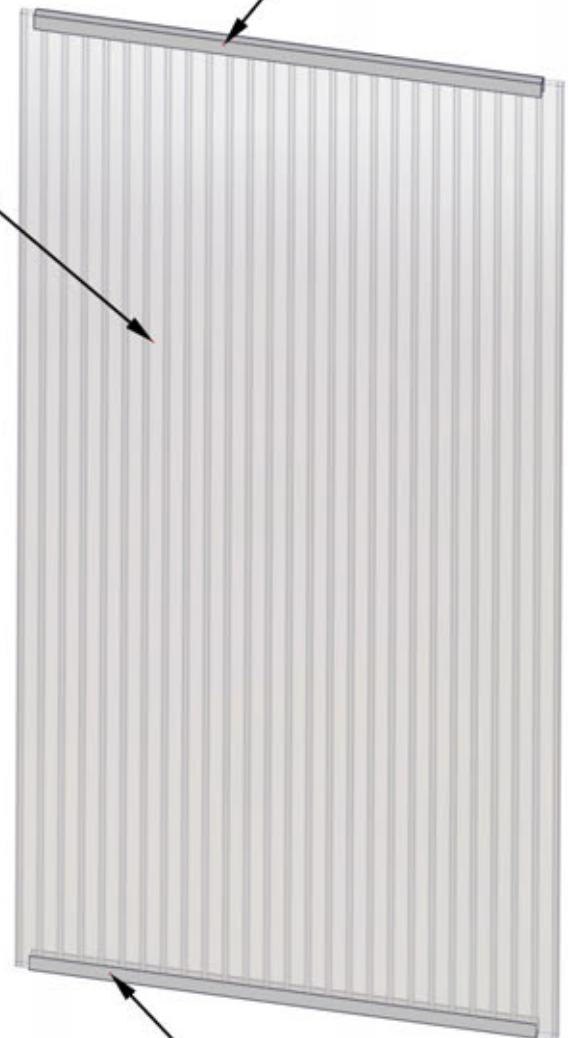
- CUT (2) STRIPS OF DUST SEAL TAPE THE SAME WIDTH AS THE POLY SHEETING
- WRAP DUST TAPE ALONG EDGE OF POLY SHEETING WIDTH
- AFTER TAPE IS SECURE, PUSH CHANNEL ON OVER THE TAPE, CENTERING ON POLY SHEETING (APPROX 1" [25mm]) CLEARANCE ON EACH SIDE AS SHOWN
- REPEAT ON THE BOTTOM SIDE OF POLY SHEETING
- **REPEAT FOR (4) ROOF PANELS**



571 (x1)
POLY SHEET

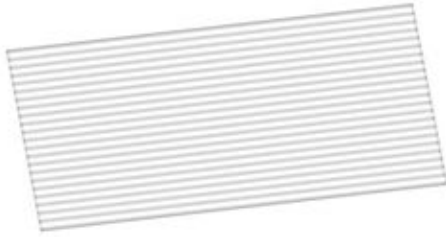
690 (x2)
DUST SEAL TAPE

807 (x1)
POLY CHANNEL



807 (x1)
POLY CHANNEL

STEP 122 - ROOF ASSEMBLY



567 POLY SHEET - A6P00567
(x8) 3/8"x22 5/16"x54 7/16" (10x566x1383)



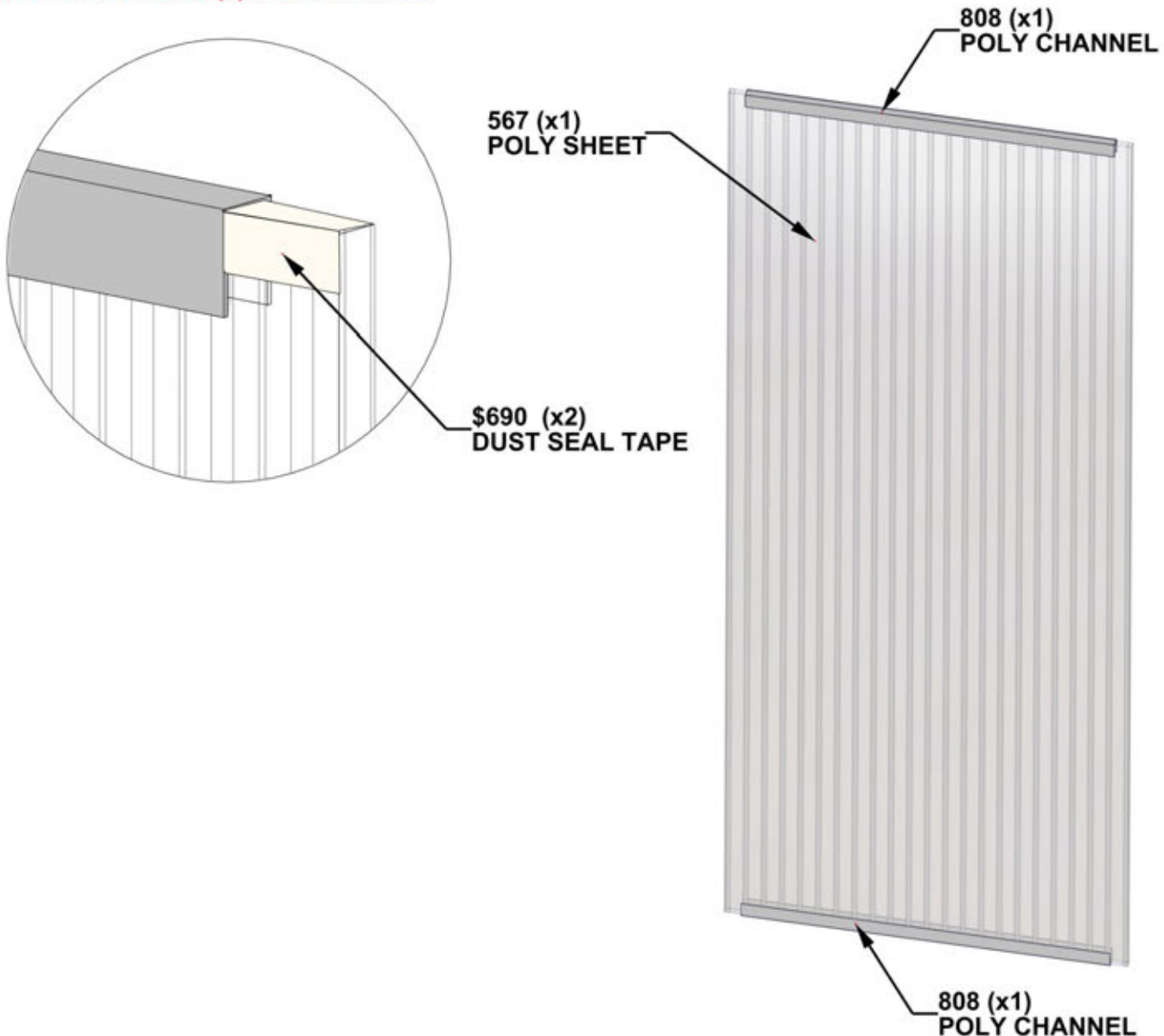
808 POLY CHANNEL - A6P00808
(x16) 1/2"x13/16"x20 3/8" (13x20x518)



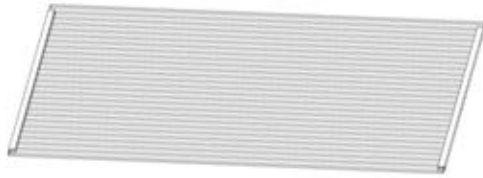
A6P00690 DUST TAPE

TO APPLY DUST TAPE & POLY CHANNEL:

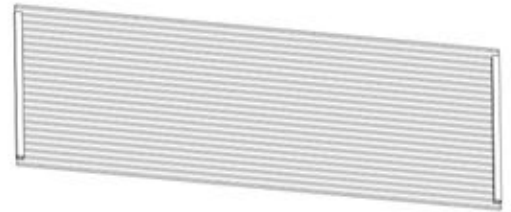
- CUT (2) STRIPS OF DUST SEAL TAPE THE SAME WIDTH AS THE POLY SHEETING
- WRAP DUST TAPE ALONG EDGE OF POLY SHEETING WIDTH
- AFTER TAPE IS SECURE, PUSH CHANNEL ON OVER THE TAPE, CENTERING ON POLY SHEETING (APPROX 1" [25mm]) CLEARANCE ON EACH SIDE AS SHOWN
- REPEAT ON THE BOTTOM SIDE OF POLY SHEETING
- **REPEAT FOR ALL (8) ROOF PANELS**



STEP 123 - ROOF ASSEMBLY



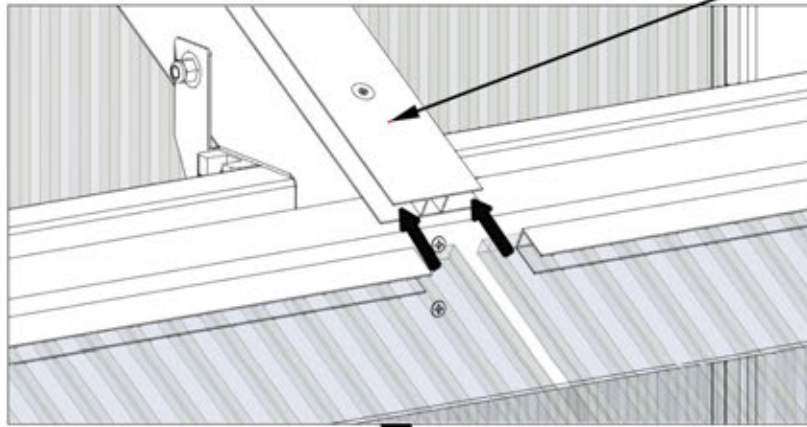
A6P00571 POLY SHEET
(x4)



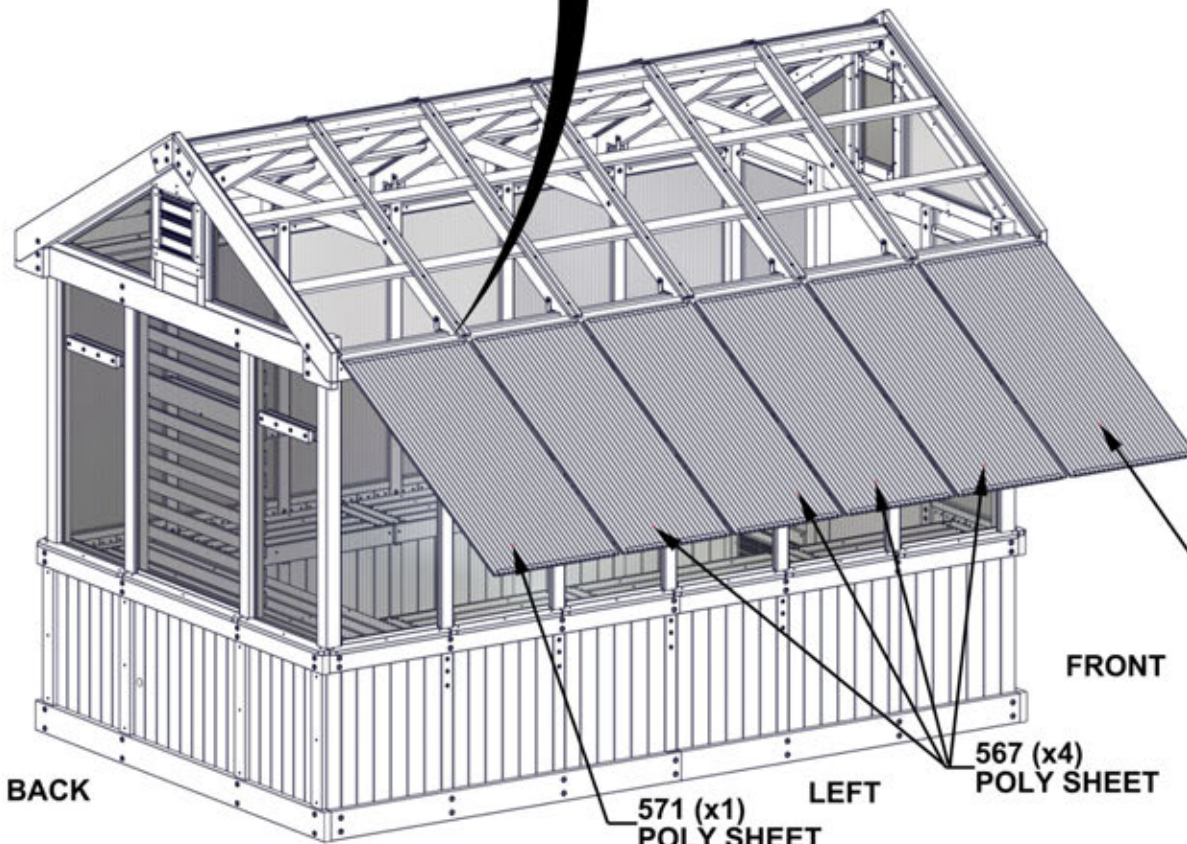
A6P00567 POLY SHEET
(x8)

NOTES:

- REMOVED PROTECTIVE FILM JUST BEFORE INSTALLATION.
- SLIDE POLY SHEETS FROM STEPS 121 & 122 INTO CHANNELS.
- POLY SHEETS WILL BE FLUSH WITH THE BOTTOM OF THE CHANNEL
- REPEAT FOR ALL 12 ROOF PANELS.
- **IMPORTANT! ENSURE UV SIDE OF POLY SHEETING IS FACING OUTSIDE.**



PREVIOUSLY INSTALLED
POLY CHANNEL



571 (x1)
POLY SHEET

FRONT

567 (x4)
POLY SHEET

LEFT

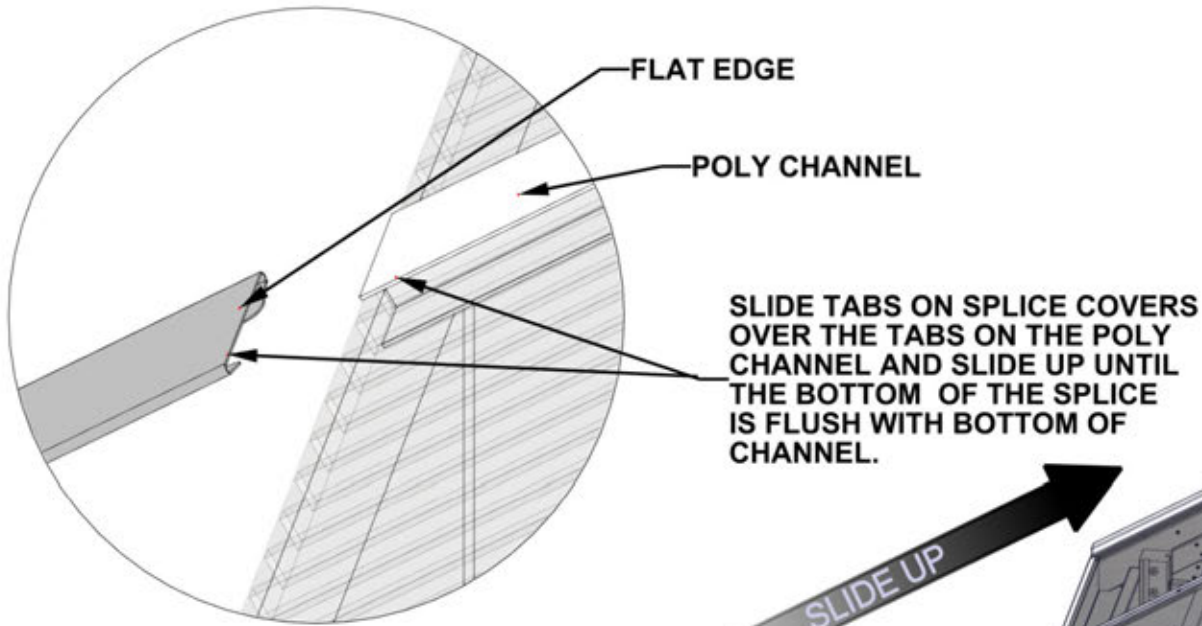
571 (x1)
POLY SHEET

BACK

STEP 124 - ROOF ASSEMBLY

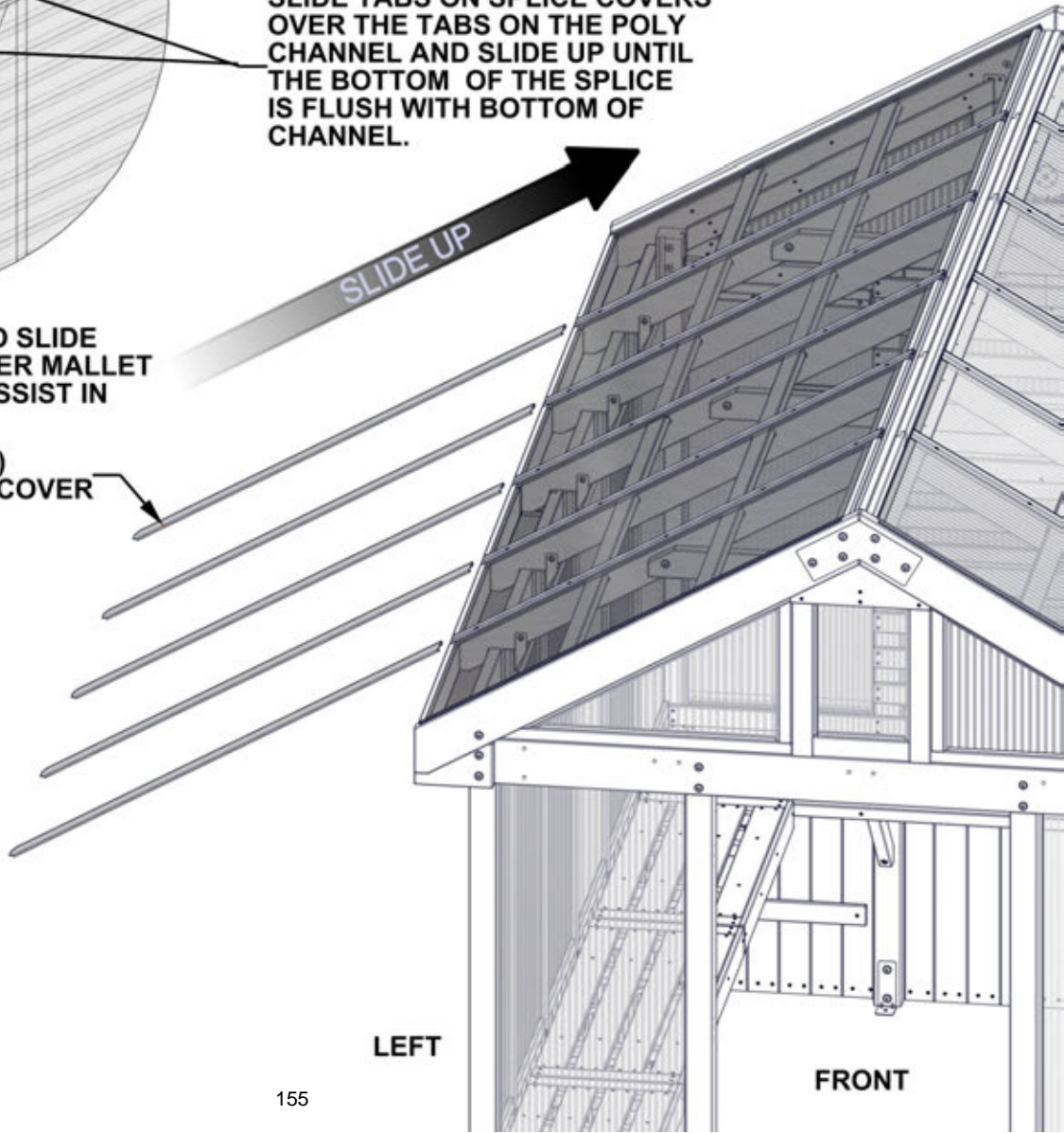


**WARNING! GLOVES ARE RECOMMENDED WHEN HANDLING STEEL ROOF PIECES.
REPEAT THIS STEP FOR RIGHT SIDE**



TIP: IF IT BECOMES DIFFICULT TO SLIDE SPLICE COVER UP, USE A RUBBER Mallet AND TAP THE END GENTLY TO ASSIST IN ASSEMBLY.

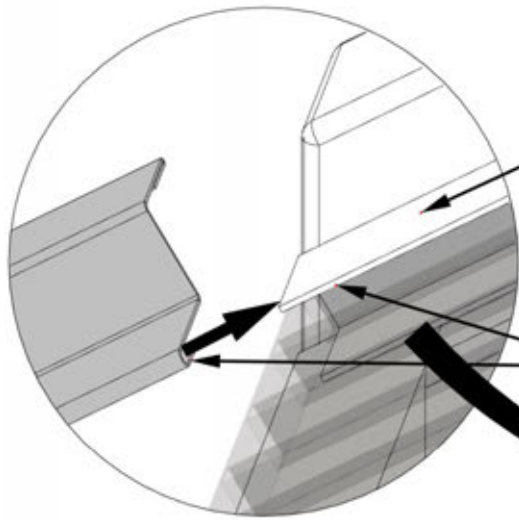
2097 (x5)
SPLICE COVER



STEP 125 - ROOF ASSEMBLY



**WARNING! GLOVES ARE RECOMMENDED WHEN HANDLING STEEL ROOF PIECES.
REPEAT THIS STEP FOR RIGHT SIDE**



SLIDE TABS ON TRIM OVER THE TABS ON THE POLY SHEET CHANNEL AND SLIDE UP UNTIL THE BOTTOM OF THE TRIM IS FLUSH WITH BOTTOM OF CHANNEL.

2381 (x1)
TRIM

SLIDE UP

2381 (x1)
TRIM

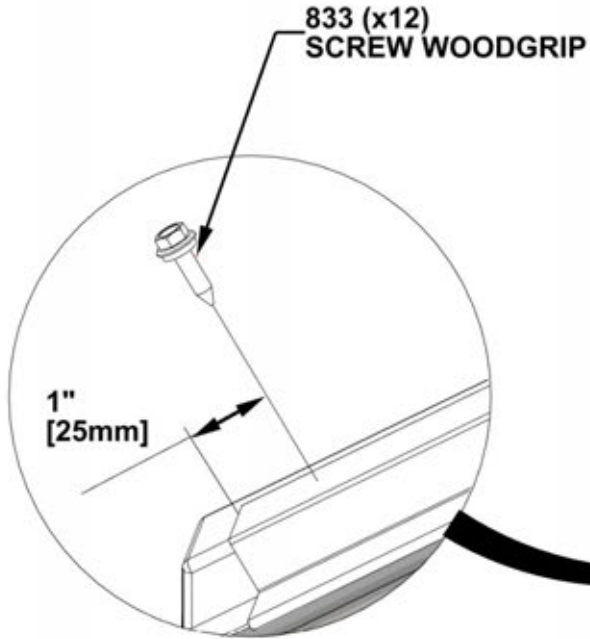
LEFT

FRONT

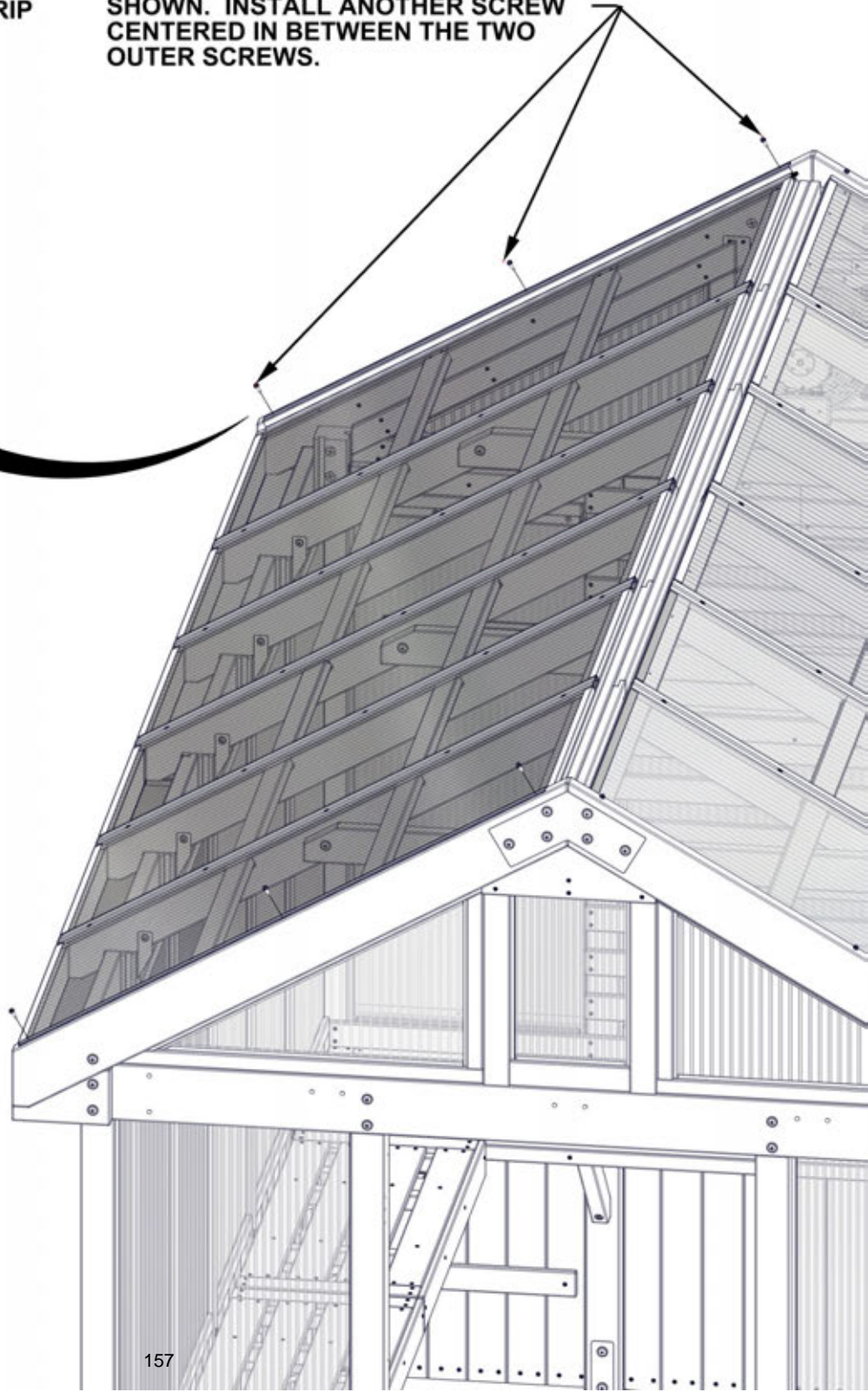
STEP 126 - ROOF ASSEMBLY

REPEAT THIS STEP FOR RIGHT SIDE

QTY	PART NUMBER	DESCRIPTION
12	H100833	SCREW WOODGRIP 10-16x3/4



INSTALL SCREWS IN CENTER OF TRIM APPROXIMATELY 1" FROM EDGES AS SHOWN. INSTALL ANOTHER SCREW CENTERED IN BETWEEN THE TWO OUTER SCREWS.



LEFT

STEP 127 - ROOF ASSEMBLY

QTY	PART NUMBER	DESCRIPTION
14	H100760	SCREW WOODGRIP 10-16x1-1/4"

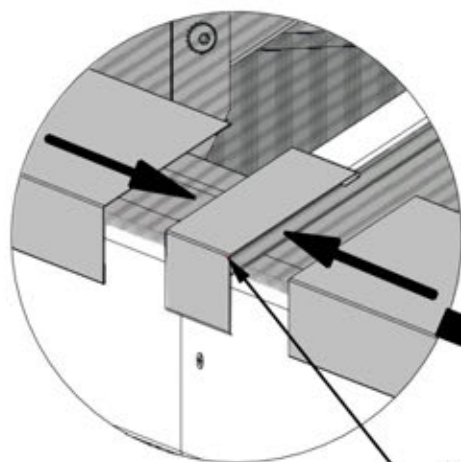
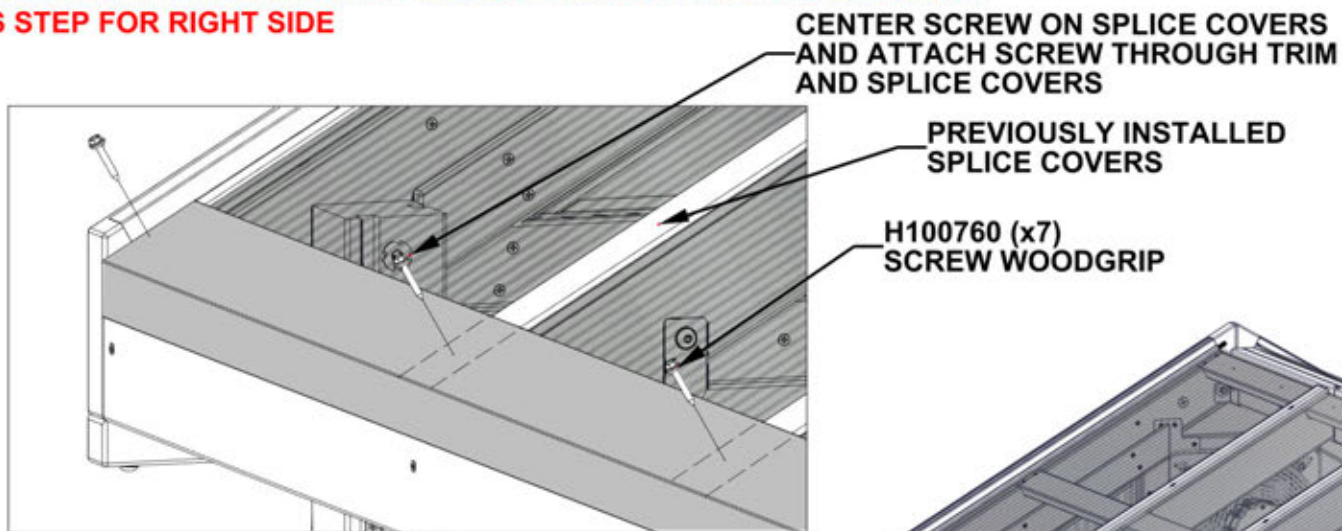


A4M02379 EDGE TRIM
(x4)



A4M02380 EDGE TRIM SPLICE
(x2)

WARNING! GLOVES ARE RECOMMENDED WHEN HANDLING STEEL ROOF PIECES.
REPEAT THIS STEP FOR RIGHT SIDE



2380 (x1) EDGE TRIM SPLICE

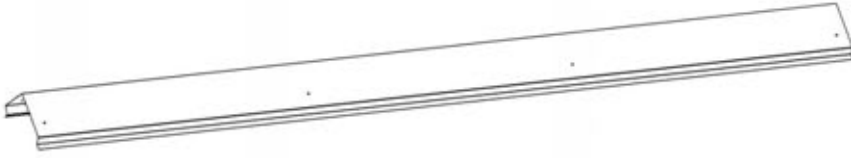
SLIDE EDGE TRIM INTO EDGE TRIM SPLICE; ADJUST AS NEEDED

2379 (x1) EDGE TRIM

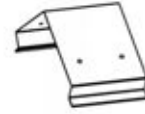
2379 (x1) EDGE TRIM

BACK

STEP 128 - ROOF ASSEMBLY

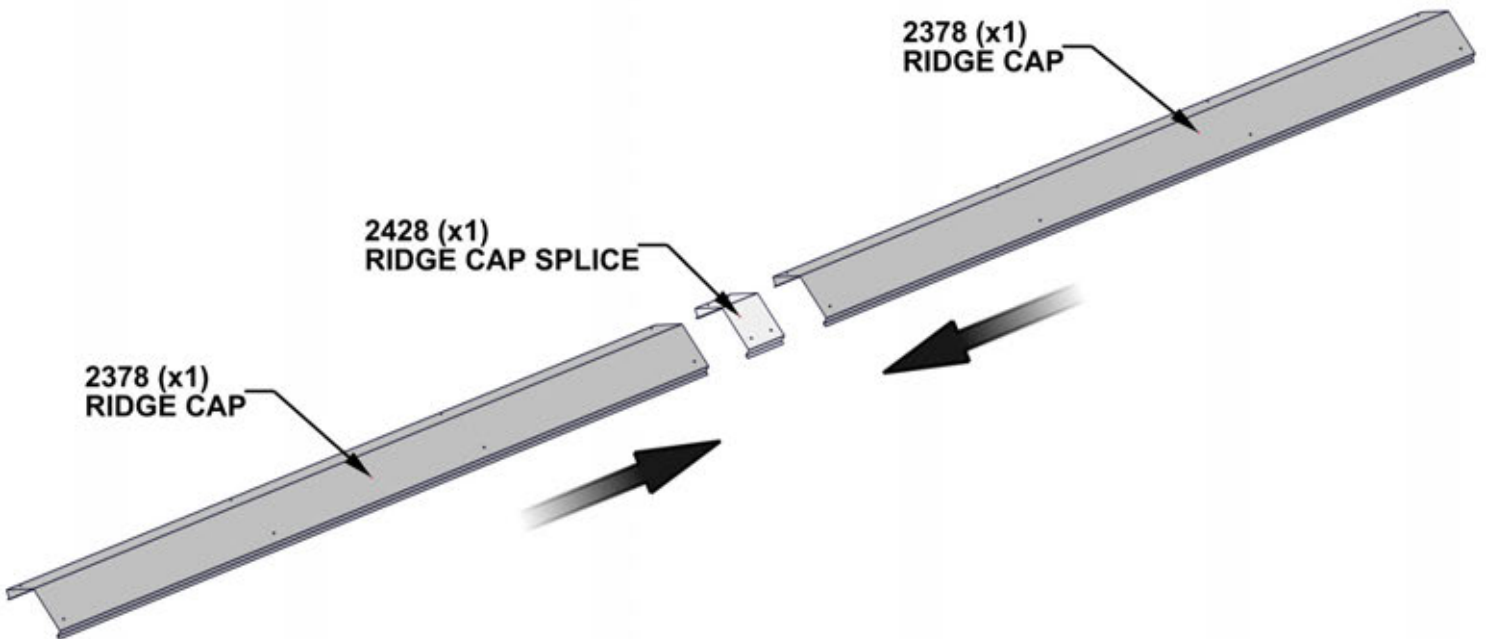


2378 RIDGE CAP - A4M02378
(x2) 3 5/16"x7 15/16"x72 1/8" (85x201x1832)



2428 RIDGE CAP SPLICE - A4M02428
(x1) 3 3/8"x3 15/16"x8" (86x100x203)

WARNING! GLOVES ARE RECOMMENDED WHEN HANDLING STEEL ROOF PIECES.



STEP 129 - ROOF ASSEMBLY

QTY	PART NUMBER	DESCRIPTION
16	H100833	SCREW WOODGRIP 10-16x3/4



RIDGE CAP FROM
STEP 128



A6P00693 RIDGE CAP PROTECTOR
(x2)



J05 RIDGE STIFFENER - W4L18424
(x2) 15/16"x2 3/8"x59 7/16" (24x60x1510)

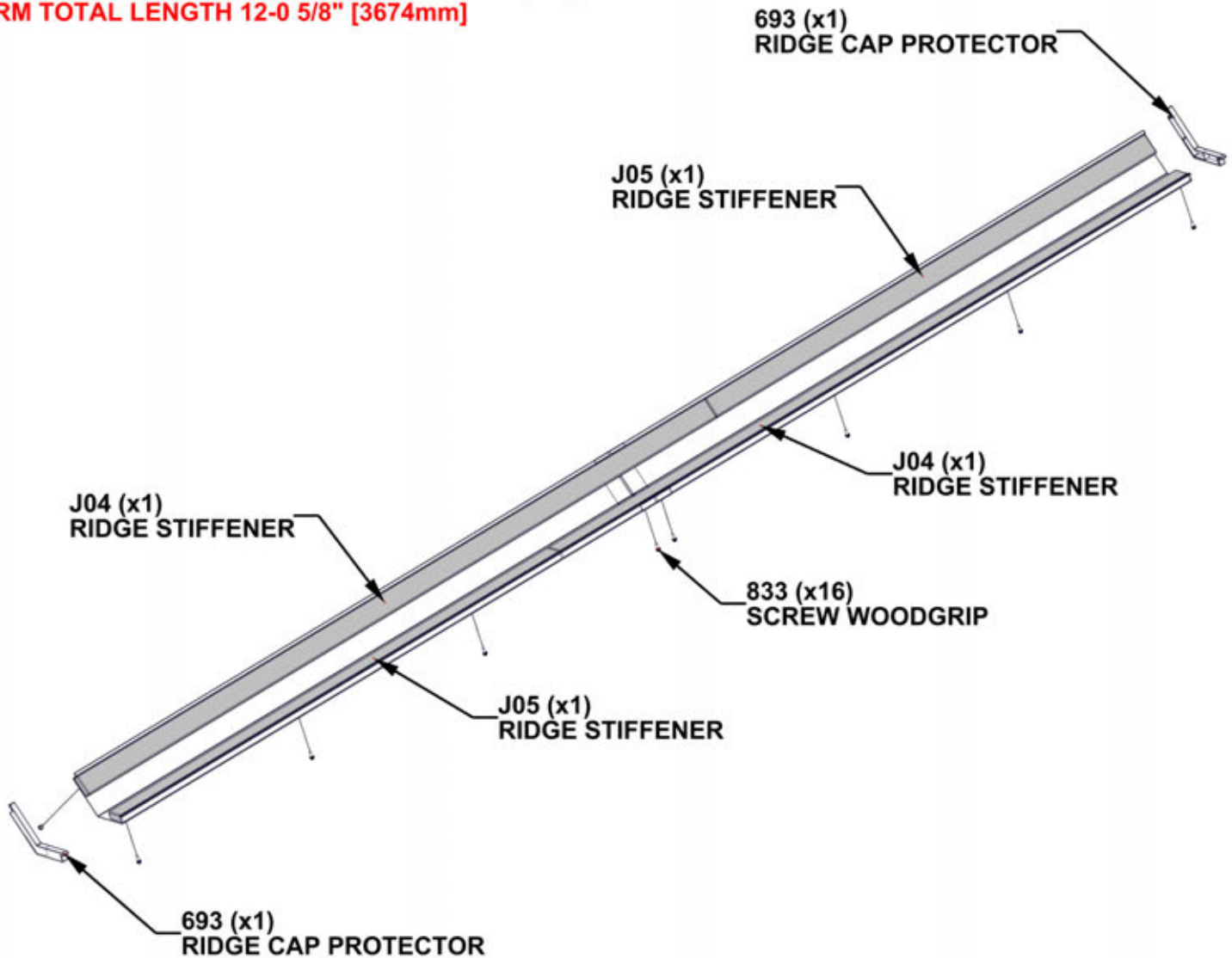


J04 RIDGE STIFFENER - W4L18045
(x2) 15/16"x2 3/8"x84 7/8" (24x60x2156)

WARNING! GLOVES ARE RECOMMENDED WHEN HANDLING STEEL ROOF PIECES.

NOTES:

- ALIGN HOLES OF RIDGE CAP WITH HOLES ON RIDGE CAP SPLICE
- ARRANGE THE RIDGE STIFFENERS AS SHOWN
- ATTACH RIDGE CAP ASSEMBLY USING SCREWS (833); EIGHT ALONG EACH SIDE
- **CONFIRM TOTAL LENGTH 12-0 5/8" [3674mm]**



REMOVE SPACERS FROM RIDGE CAP PROTECTORS BEFORE INSTALLING

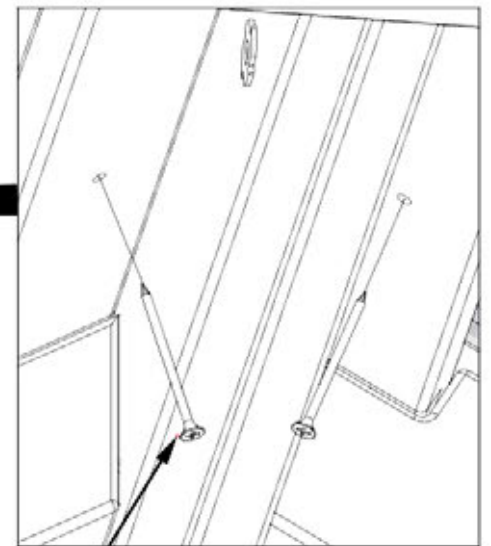
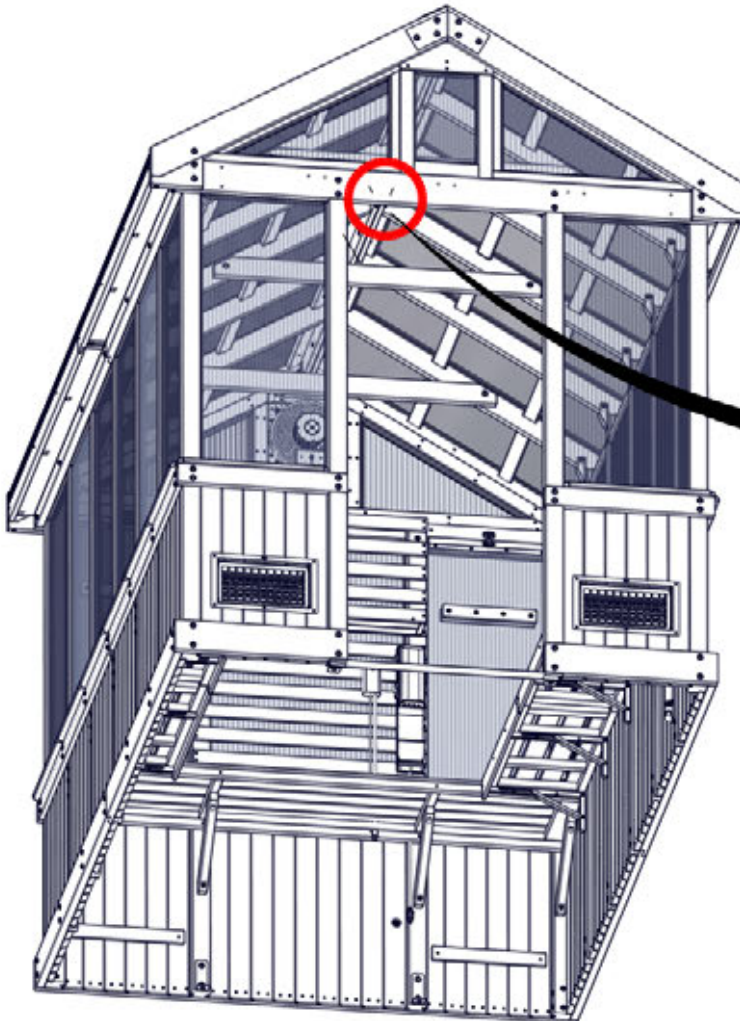
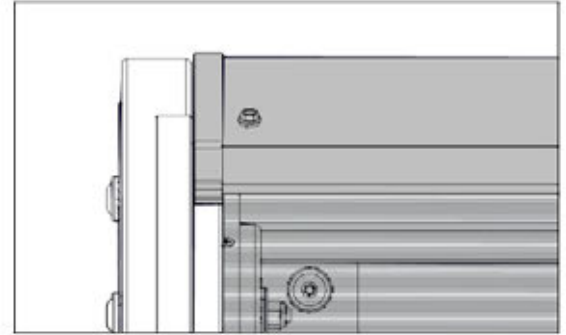
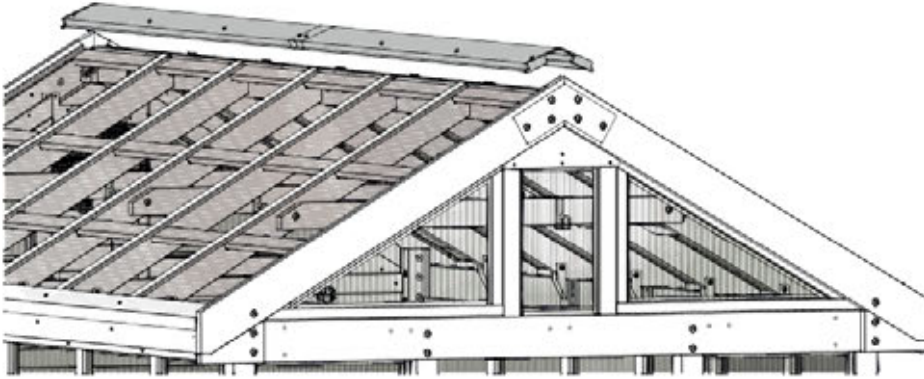
STEP 130 - ROOF ASSEMBLY

QTY	PART NUMBER	DESCRIPTION
24	H100483	SCREW PFH 8x2 1/4 BLK



NOTES:

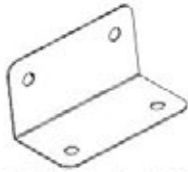
- WILL NEED TWO (2) ADULTS FOR THIS STEP.
- DO NOT CLIMB ON ROOF TO INSTALL.
- RIDGE CAP HAS BEEN DESIGNED TO INSTALL WITH THE USE OF A LADDER.
- PLACE RIDGE CAP ASSEMBLY ON TOP OF ROOF RIDGE UNTIL BOTH ENDS ARE SEATED INSIDE THE GABLES, AS SHOWN.
- ONE ADULT TO KEEP DOWNWARD PRESSURE ON THE RIDGE CAP ASSEMBLY WHILE SECOND ADULT IS INSIDE AND ATTACHING THE SCREWS.
- INSTALL SCREWS THROUGH PILOT HOLES IN ROOF PANELS INTO RIDGE CAP ASSEMBLY.



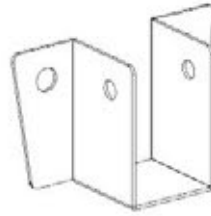
483 (x24)
SCREW - 2 1/4"

STEP 131 - PERGOLA ASSEMBLY

QTY	PART NUMBER	DESCRIPTION
10	H100459	BOLT WH 5/16x1 1/4 BLK

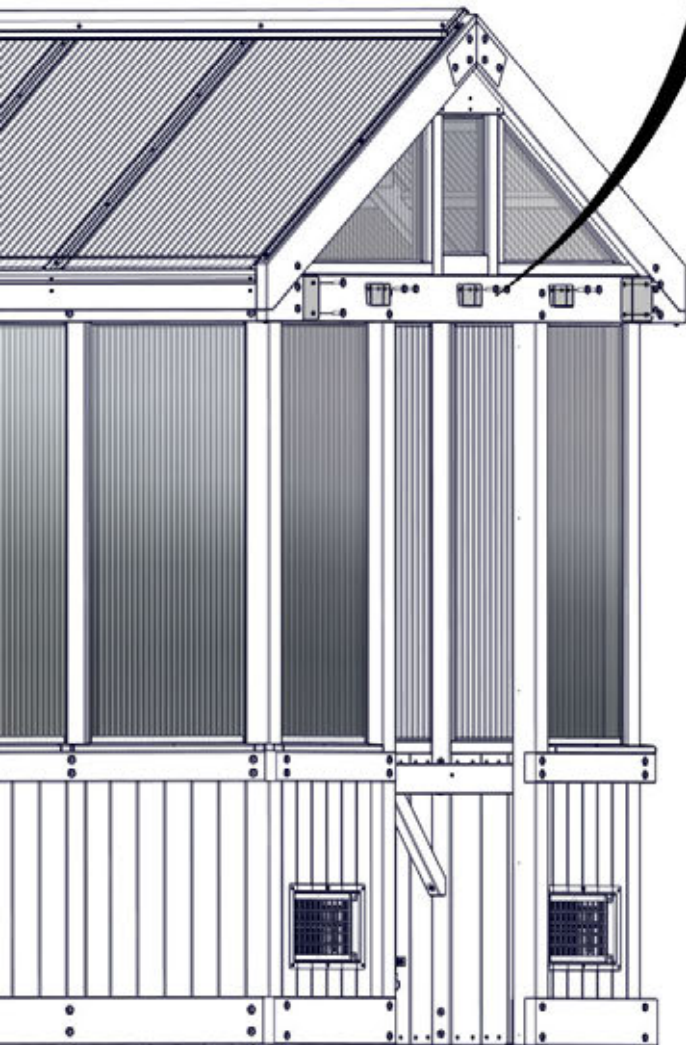
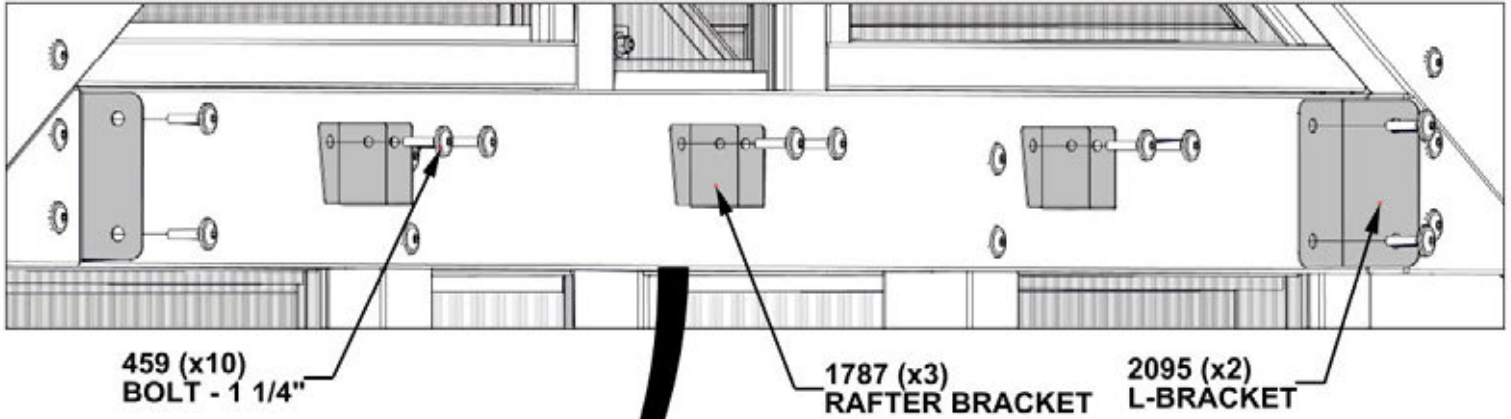


A4M02095 L-BRACKET
(x2)



A4M01787 RAFTER BRACKET
(x3)

NOTE:
• ALIGN BRACKETS WITH HOLES AND ATTACH AS SHOWN.



FRONT

STEP 132 - PERGOLA ASSEMBLY

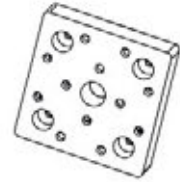
QTY	PART NUMBER	DESCRIPTION
8	H100200	SCREW PFH 8x1 1/2 BLK



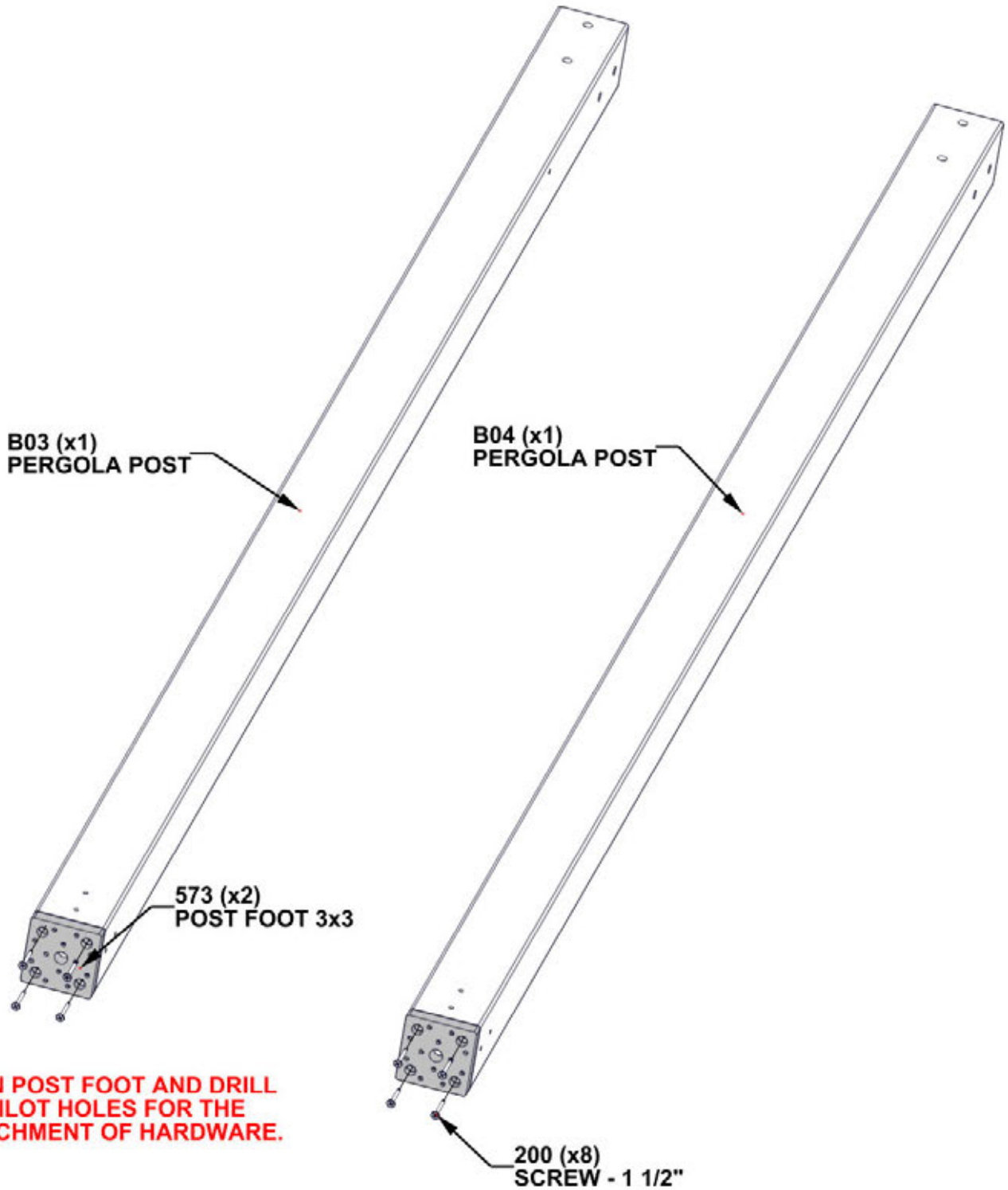
B03 PERGOLA POST - W4L18070
(x1) 3"x3"x86 1/16" (76x76x2186)



B04 PERGOLA POST - W4L18073
(x1) 3"x3"x86 1/16" (76x76x2186)

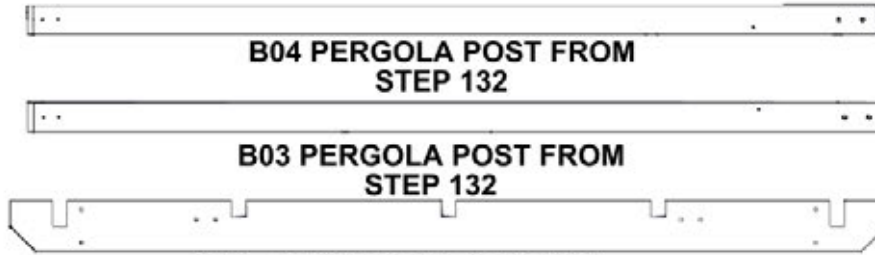


A6P00573 POST FOOT 3x3
(x2)



STEP 133 - PERGOLA ASSEMBLY

QTY	PART NUMBER	DESCRIPTION
4	H100195	BOLT WH 5/16x2 3/4 BLK
8	H100198	WASHER LOCK EXT 8x19
12	H100379	TNUT-5/16" BLK
2	H100405	WASHER LOCK EXT 6x15
4	H100513	BOLT WH 5/16x4 1/4 BLK
2	H100792	LAG SCREW WH 1/4x3 BLK



B04 PERGOLA POST FROM STEP 132
B03 PERGOLA POST FROM STEP 132
D12 BRACE BEAM - W4L18068
 (x1) 1 7/16"x5 1/4"x89 7/16" (36x134x2272)



E10 CORBEL - W4L18072
 (x2) 1 7/16"x3 3/8"x18 11/16" (36x86x474)

NOTES:

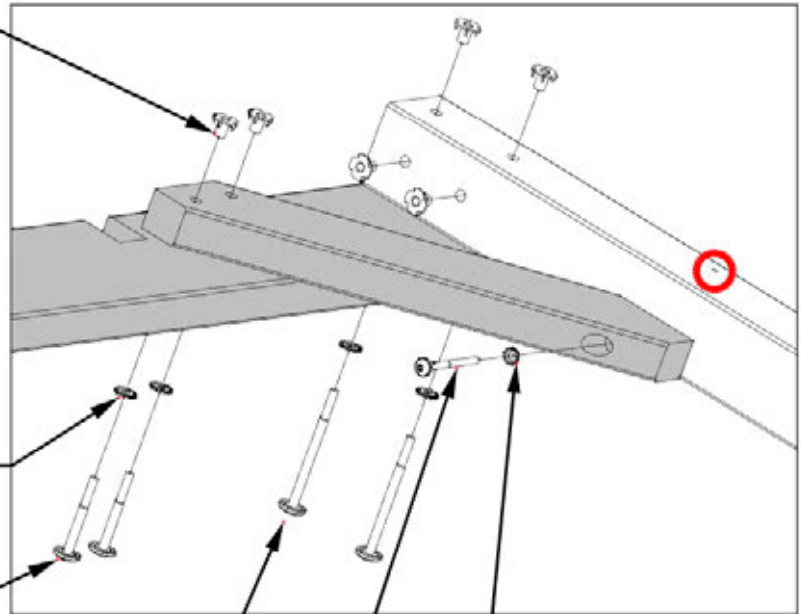
• INSERT T-NUTS FIRST

- NOTE DIRECTION OF HIGHLIGHTED PILOT HOLE
- CONFIRM ASSEMBLY IS SQUARE AND TIGHTEN ALL HARDWARE

CAUTION:

- TO AVOID SPLITTING POST, MAKE SURE LAG SCREWS GO INTO PILOT HOLES
- IF BOLT DOES NOT ENGAGE WITH T-NUT, CHECK FOR SAWDUST BUILD UP IN HOLES, CLEAN WITH A LONG SCREWDRIVER IF NEEDED

379 (x12)
TNUT-5/16"



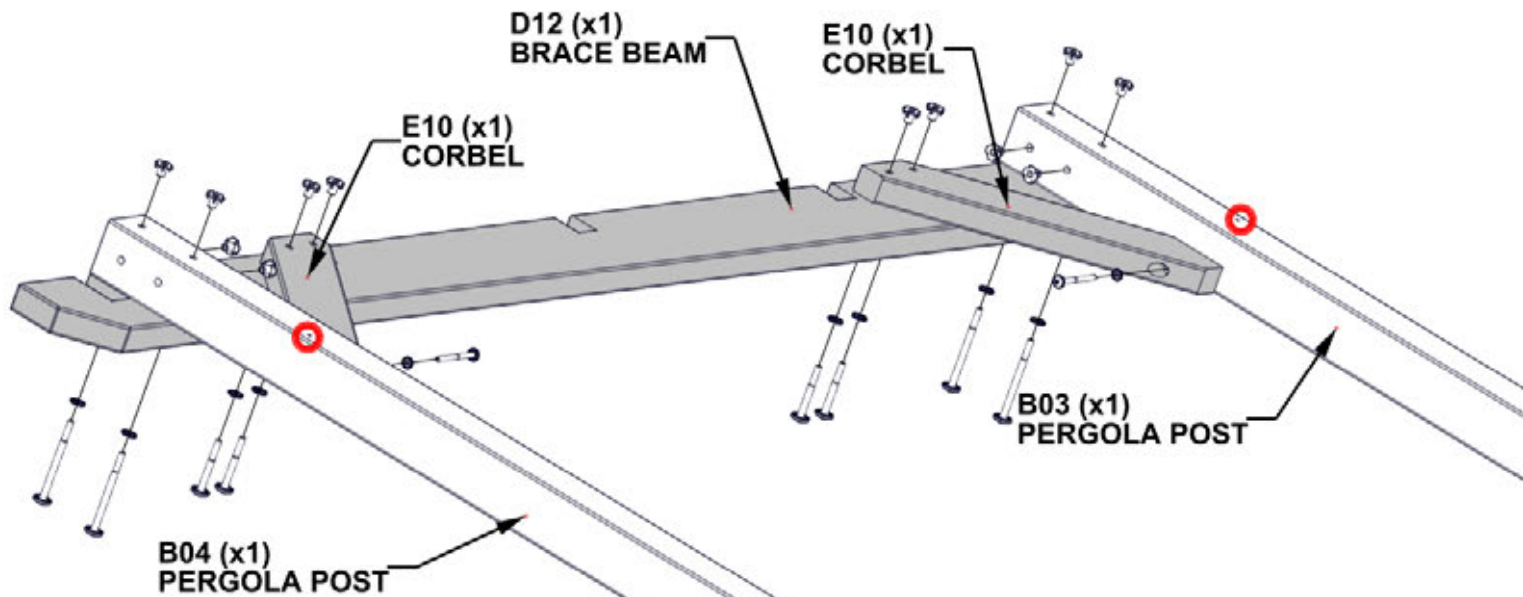
198 (x8)
WASHER - 8x19

195 (x4)
BOLT-2 3/4"

513 (x4)
BOLT - 4 1/4"

405 (x2)
WASHER - 6x15

792 (x2)
LAG SCREW - 3"



D12 (x1)
BRACE BEAM

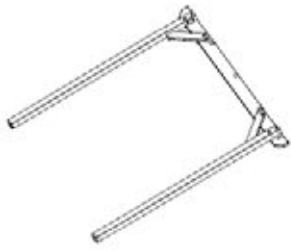
E10 (x1)
CORBEL

E10 (x1)
CORBEL

B03 (x1)
PERGOLA POST

B04 (x1)
PERGOLA POST

STEP 134 - PERGOLA ASSEMBLY



E10 CORBEL - W4L18072
(x2) 1 7/16"x3 3/8"x18 11/16" (36x86x474)

D11 RAFTER - W4L18067
(x2) 1 7/16"x5 1/4"x52 1/16" (36x134x1322)

QTY	PART NUMBER	DESCRIPTION
4	H100195	BOLT WH 5/16x2 3/4 BLK
12	H100198	WASHER LOCK EXT 8x19
4	H100379	TNUT-5/16" BLK
4	H100405	WASHER LOCK EXT 6x15
4	H100457	BOLT WH 5/16x2 BLK
4	H100479	NUT LOCK 5/16 BLK
4	H100513	BOLT WH 5/16x4 1/4 BLK
2	H100564	LAG SCREW WH 1/4x4 BLK
4	H100630	WASHER FLAT 8x19 BLK
2	H100792	LAG SCREW WH 1/4x3 BLK

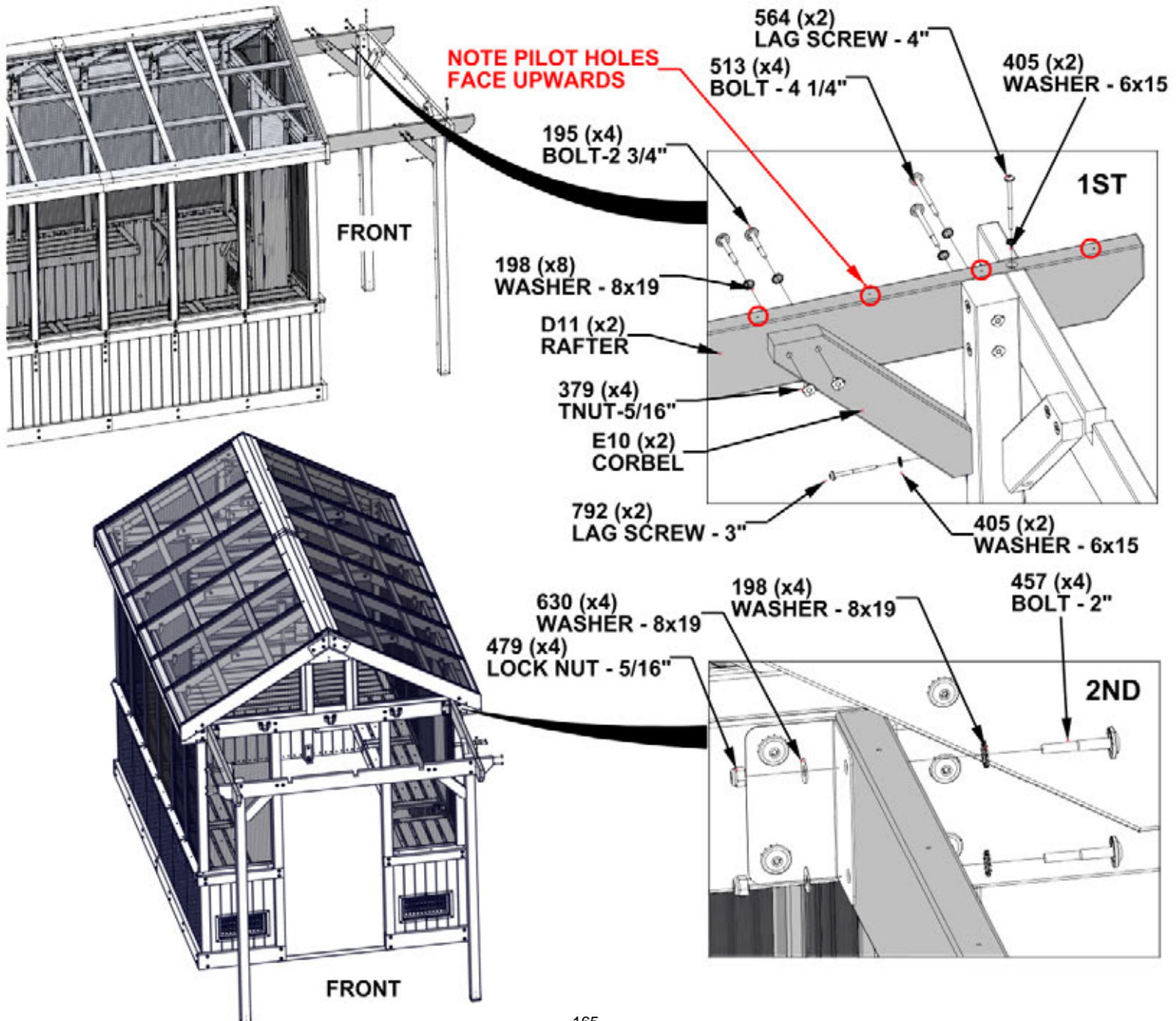
PERGOLA FRONT ASSEMBLY

NOTES:

- INSERT T-NUTS FIRST
- HAND TIGHTEN ONLY

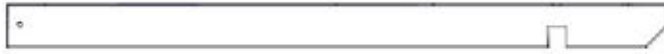
CAUTION:

- TO AVOID SPLITTING POST, MAKE SURE LAG SCREWS GO INTO PILOT HOLES
- IF BOLT DOES NOT ENGAGE WITH T-NUT, CHECK FOR SAWDUST BUILD UP IN HOLES, CLEAN WITH A LONG SCREWDRIVER IF NEEDED

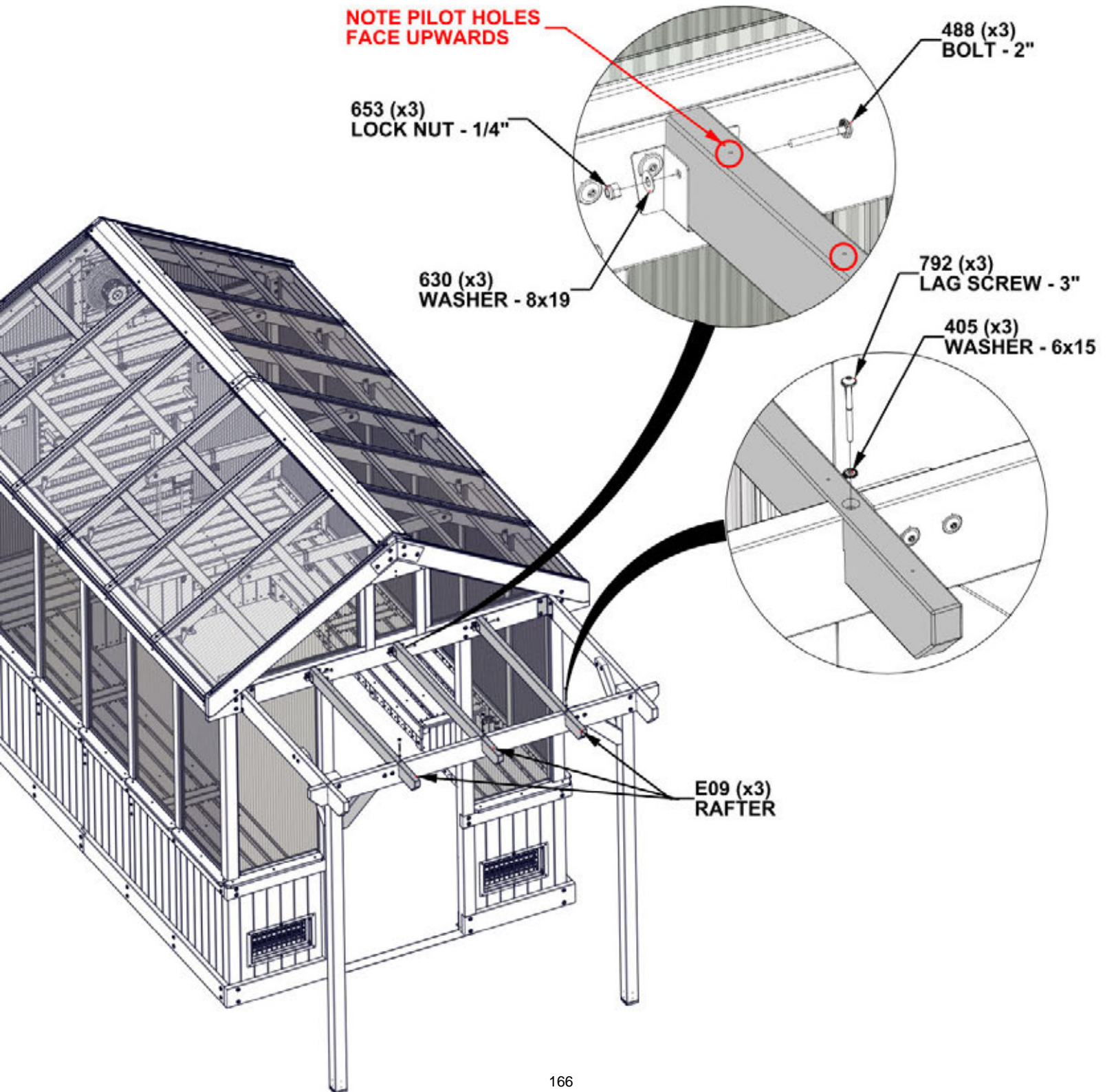


STEP 135 - PERGOLA ASSEMBLY

QTY	PART NUMBER	DESCRIPTION
3	H100405	WASHER LOCK EXT 6x15
3	H100488	BOLT WH 1/4x2 BLK
3	H100630	WASHER FLAT 8x19 BLK
3	H100653	NUT LOCK 1/4 BLK
3	H100792	LAG SCREW WH 1/4x3 BLK

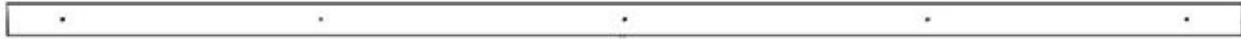


E09 RAFTER - W4L18069
(x3) 1 7/16"x3 3/8"x52 1/16" (36x86x1322)



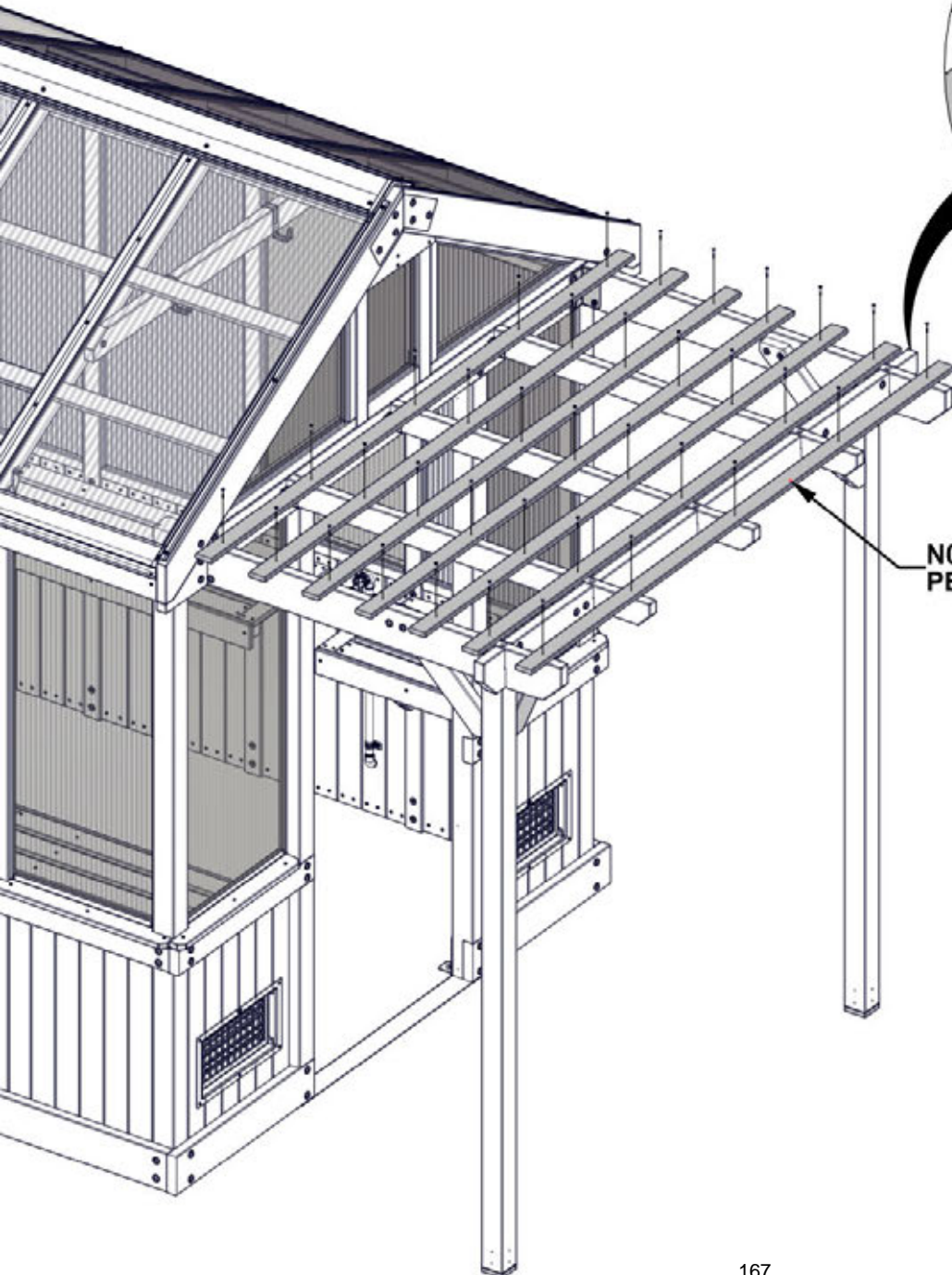
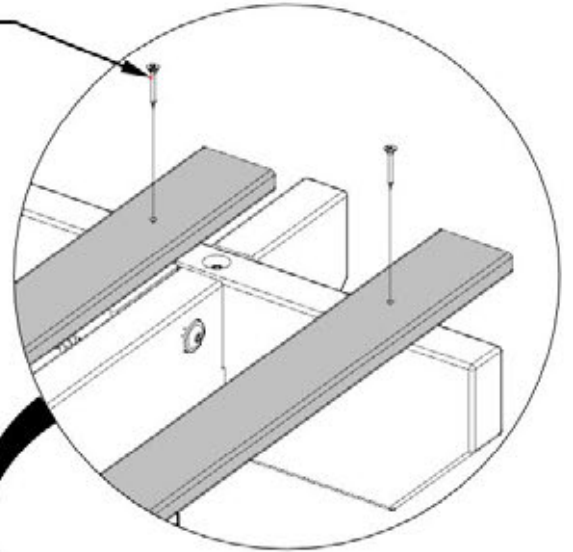
STEP 136 - PERGOLA ASSEMBLY

QTY	PART NUMBER	DESCRIPTION
35	H100387	SCREW PFH 8x1 1/4 BLK



N03 PERGOLA PURLIN - W4L18071
(x7) 5/8"x2 3/8"x87 1/16" (16x60x2212)

387 (x35)
SCREW - 1 1/4"



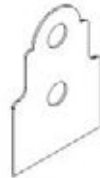
N03 (x7)
PERGOLA PURLIN

STEP 137 - PERGOLA ASSEMBLY

QTY	PART NUMBER	DESCRIPTION
16	H100460	LAG SCREW WH 1/4x1 BLK



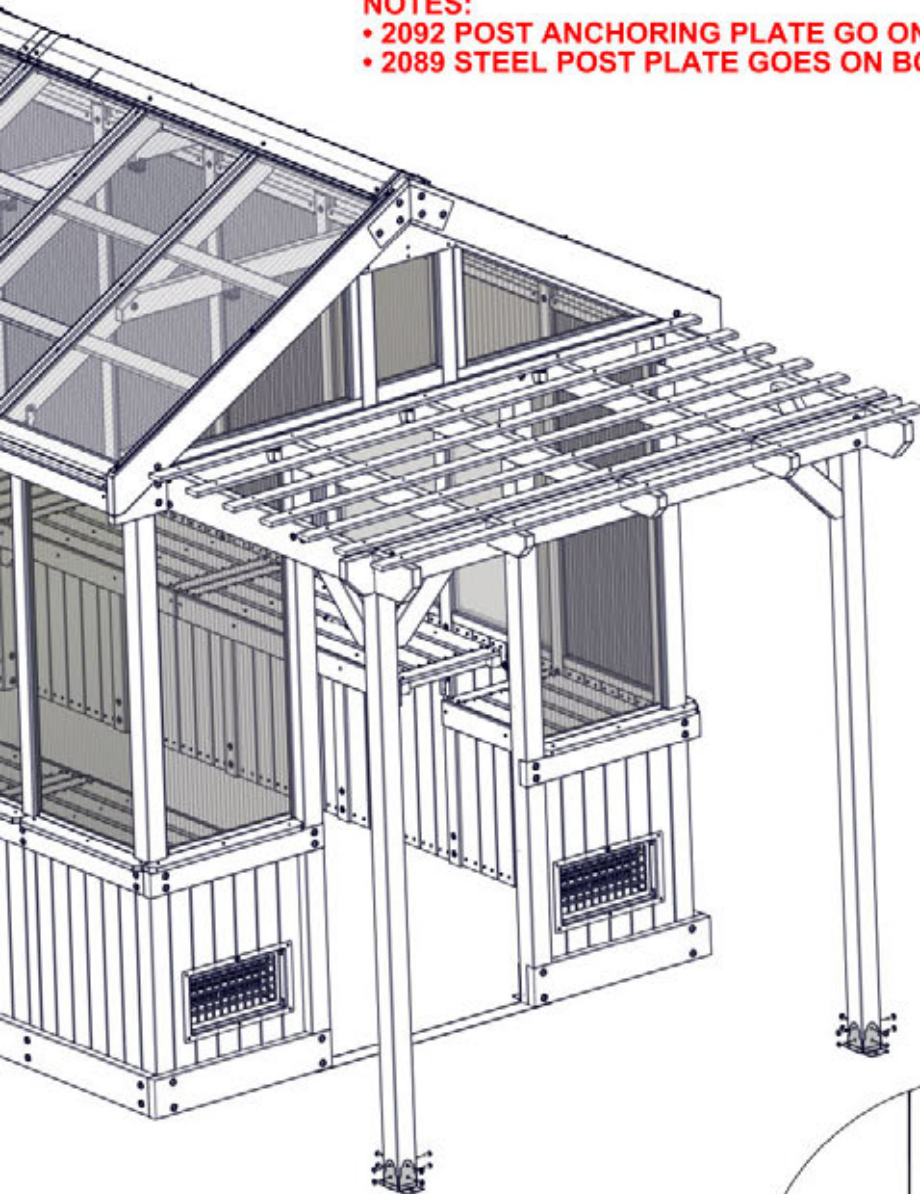
A4M02092 POST ANCHOR PLATE
(x4)



A4M02089 STEEL POST PLATE
(x4)

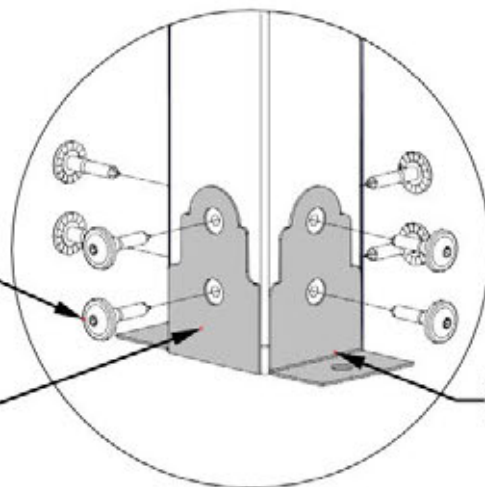
NOTES:

- 2092 POST ANCHORING PLATE GO ON FRONT AND BACK OF POST.
- 2089 STEEL POST PLATE GOES ON BOTH SIDES OF POST.



460 (x16)
LAG SCREW - 1"

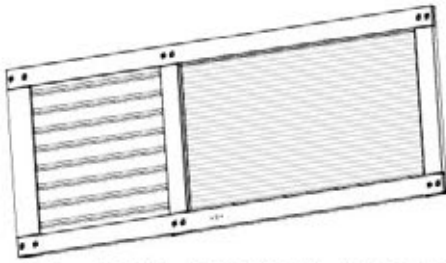
2089 (x4)
STEEL POST PLATE



2092 (x4)
POST ANCHOR PLATE

STEP 138 - DOOR ASSEMBLY

QTY	PART NUMBER	DESCRIPTION
12	H100385	SCREW PFH 8x1 BLK

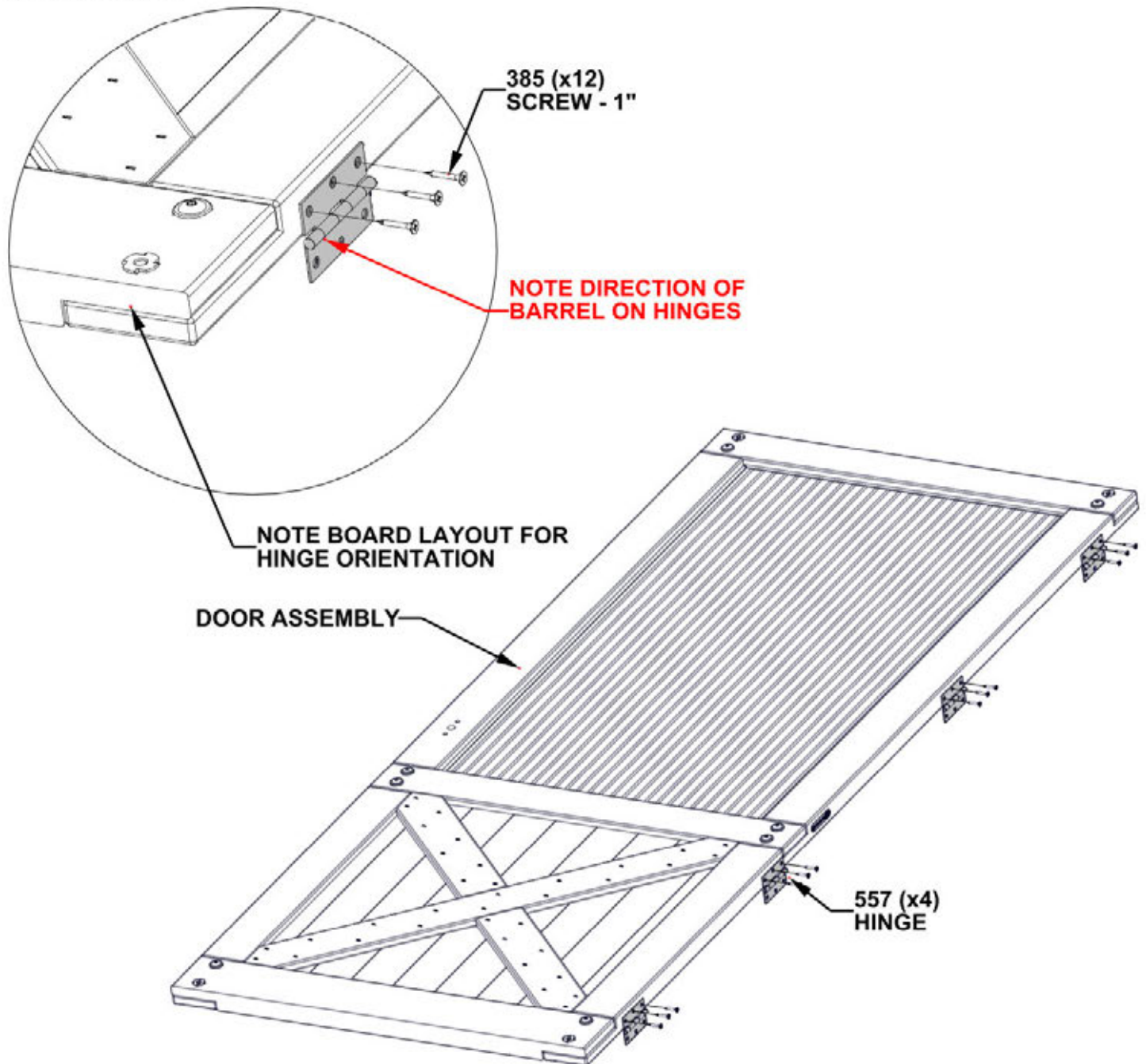


D01 DOOR ASSEMBLY - W2A03900
(x1) 1 7/16"x31 15/16"x80" (36x812x642)



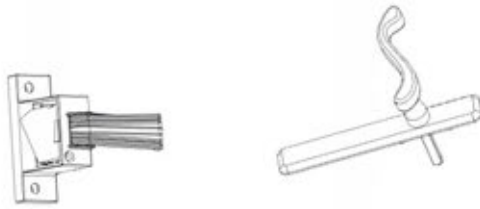
A4M00557 HINGE
(x4)

- NOTES:**
- ALIGN HOLES ON HINGES WITH PILOT HOLES ON DOOR.
 - ATTACH AS SHOWN

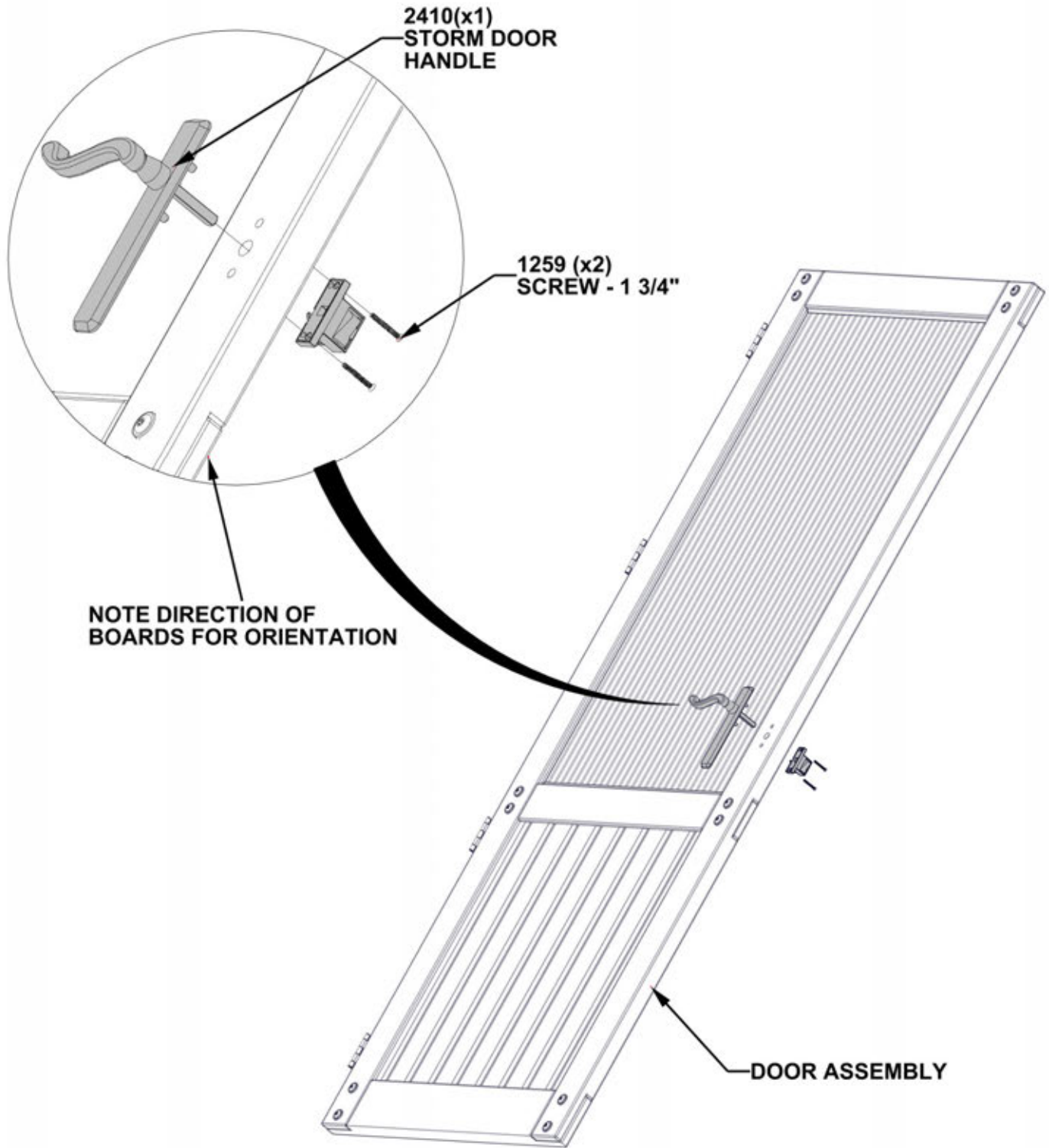


STEP 139 - DOOR ASSEMBLY

QTY	PART NUMBER	DESCRIPTION
2	H101259	SCREW POH 8x1 3/4 BLK



A4M02410 STORM DOOR HANDLE
(x1)



2410(x1)
STORM DOOR
HANDLE

1259 (x2)
SCREW - 1 3/4"

NOTE DIRECTION OF
BOARDS FOR ORIENTATION

DOOR ASSEMBLY

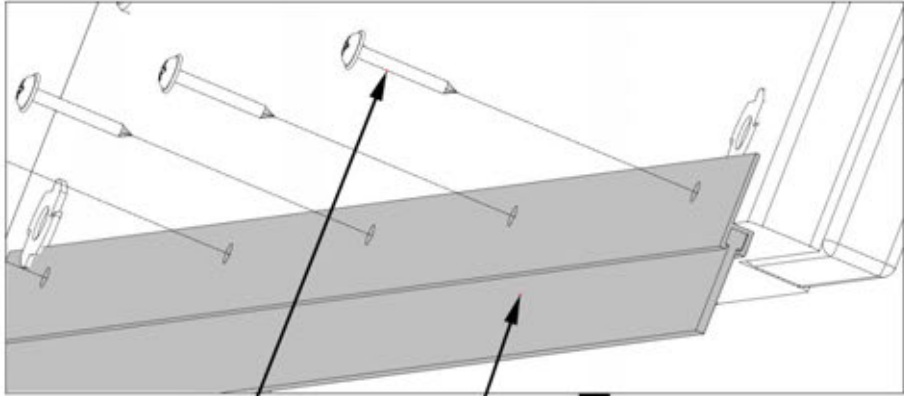
STEP 140 - DOOR ASSEMBLY

QTY	PART NUMBER	DESCRIPTION
5	H100797	SCREW PWH 8x1 BLK



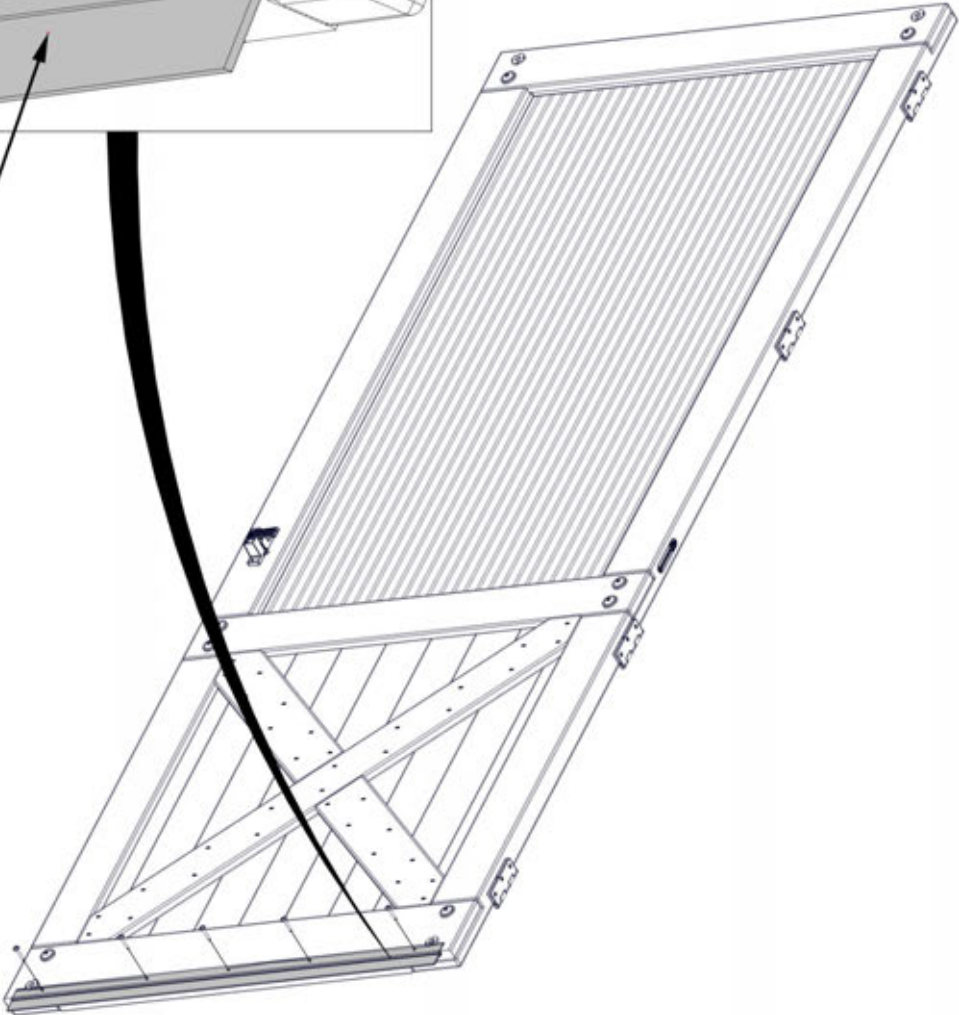
A4M02426 DOOR SWEEP
(x1)

- NOTES:**
- CENTER DOOR SWEEP ON DOOR.
 - USE AN 1/8" DRILL BIT AND THE DOOR GUIDE TO CREATE PILOT HOLES.
 - FASTEN AS SHOWN.



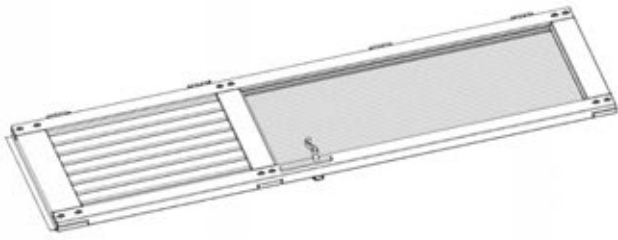
797 (x5)
SCREW - 1"

2426 (x1)
DOOR SWEEP



STEP 141 - DOOR ASSEMBLY

QTY	PART NUMBER	DESCRIPTION
12	H100385	SCREW PFH 8x1 BLK



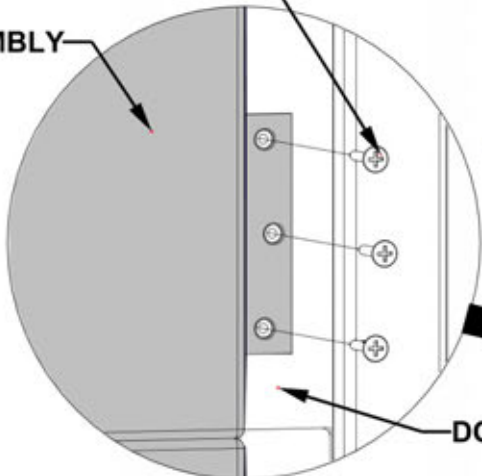
DOOR ASSEMBLY

- NOTES:
- ALIGN HINGES ON DOOR ASSEMBLY WITH PILOT HOLES ON UPRIGHTS.
 - ATTACH AS SHOWN.



385 (x12)
SCREW - 1"

DOOR ASSEMBLY



DOOR UPRIGHT

STEP 142 - DOOR ASSEMBLY

QTY	PART NUMBER	DESCRIPTION
14	H100483	SCREW PFH 8x2 1/4 BLK

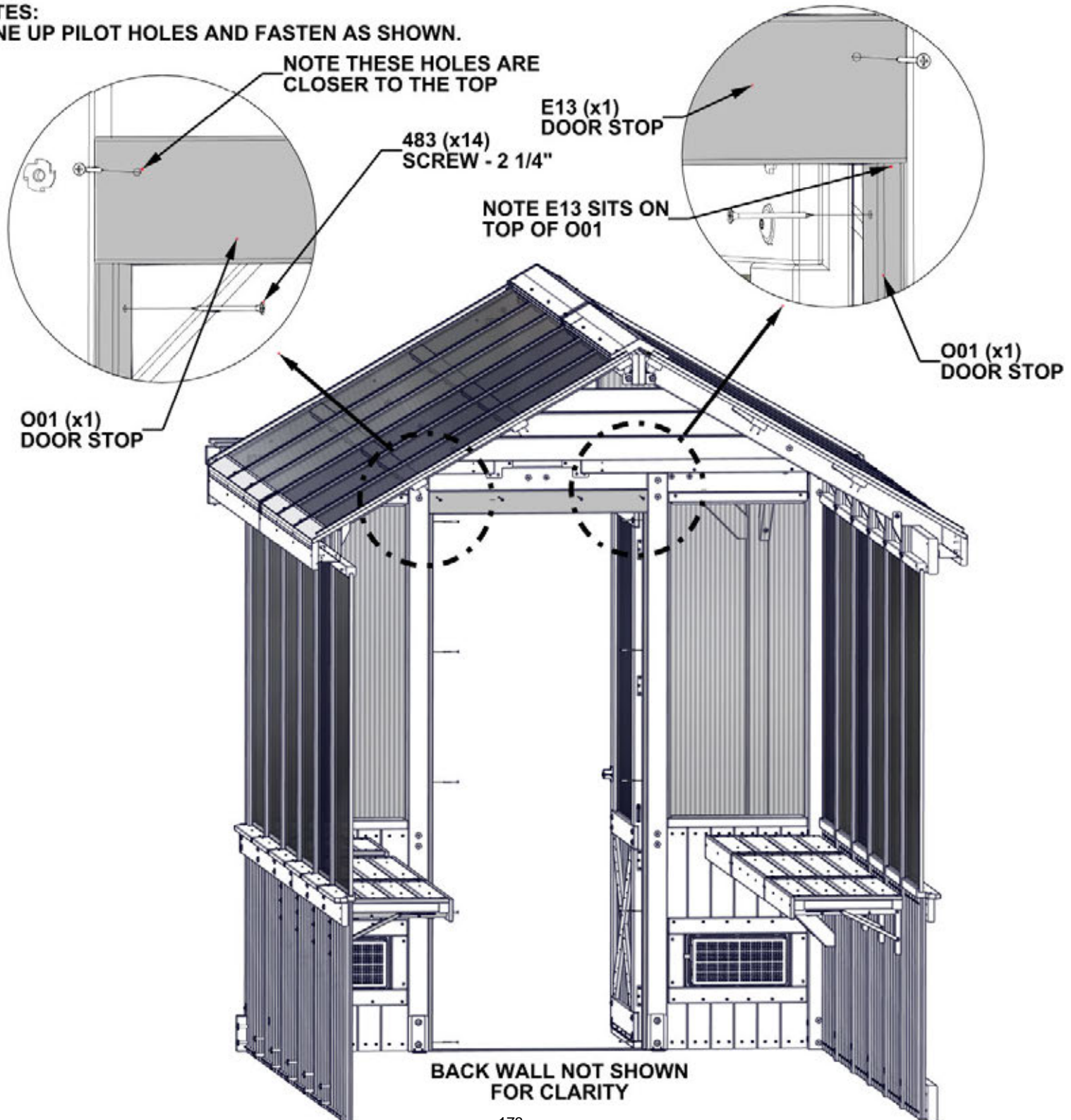


E13 DOOR STOP - W4L18054
(x1) 1 7/16"x3 3/8"x32 11/16" (36x86x830)



O01 DOOR STOP - W4L18052
(x2) 5/8"x1 5/16"x79 15/16" (16x34x2030)

NOTES:
• LINE UP PILOT HOLES AND FASTEN AS SHOWN.



STEP 143A - DOOR ASSEMBLY

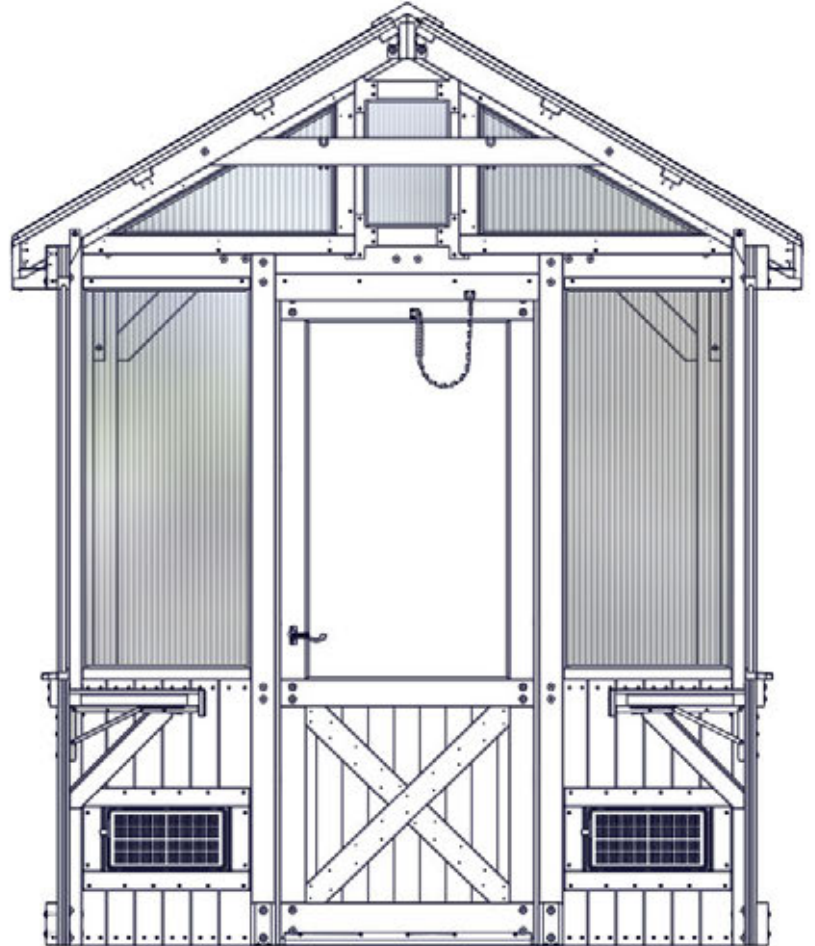
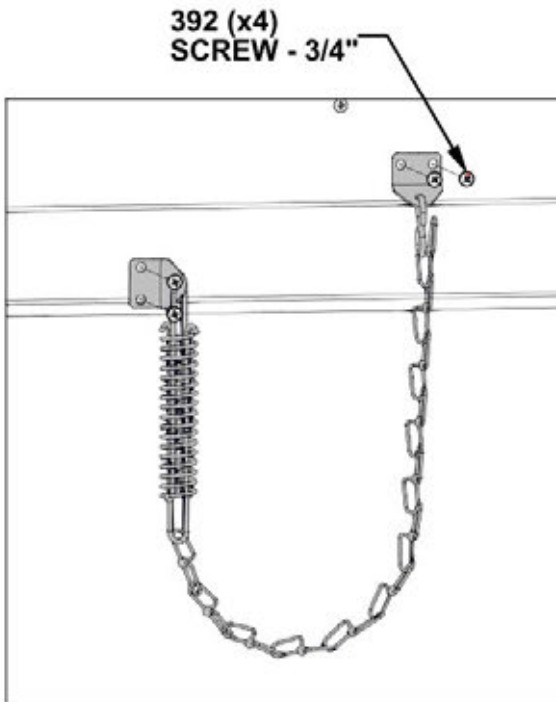
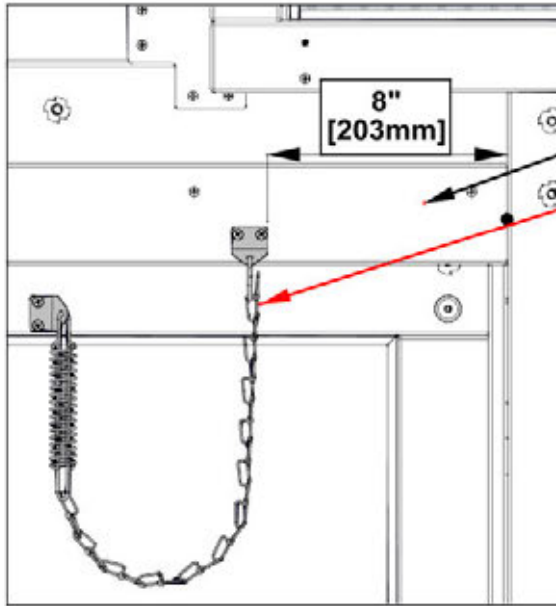
QTY	PART NUMBER	DESCRIPTION
4	H100392	SCREW PWH 8x3/4 BLK



A4M02411 DOOR PROTECTOR CHAIN
(x1)



A4M02410 LATCH
(x1)



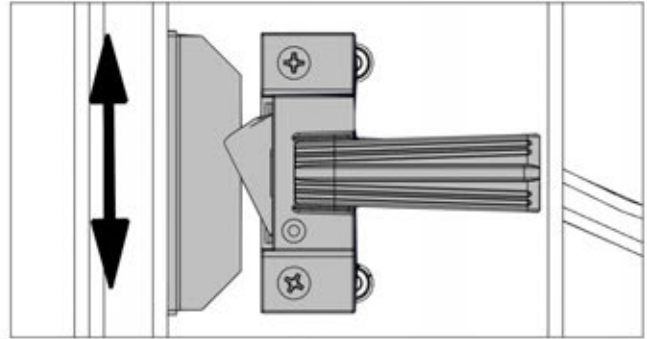
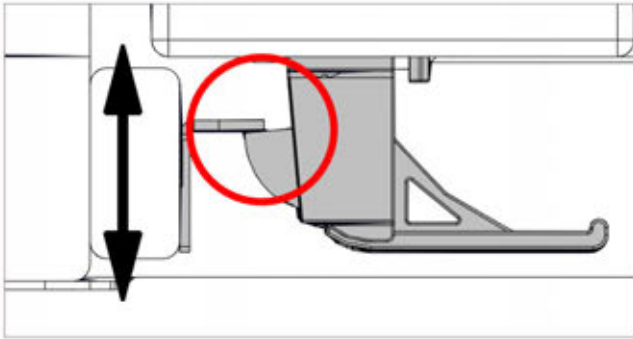
BACK WALL NOT SHOWN
FOR CLARITY

STEP 143B - DOOR ASSEMBLY

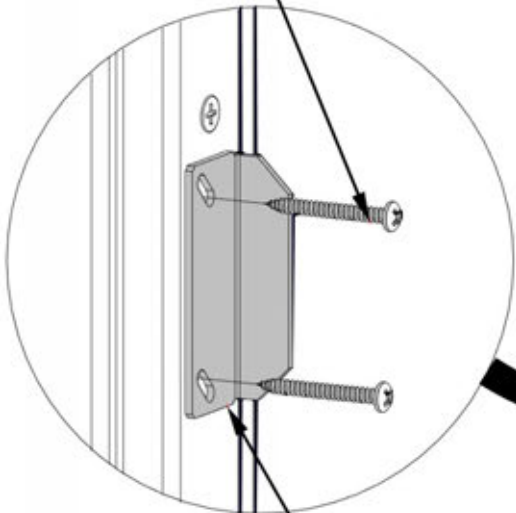
QTY	PART NUMBER	DESCRIPTION
2	H101260	SCREW PRH 8x1 1/4 SS

NOTES:

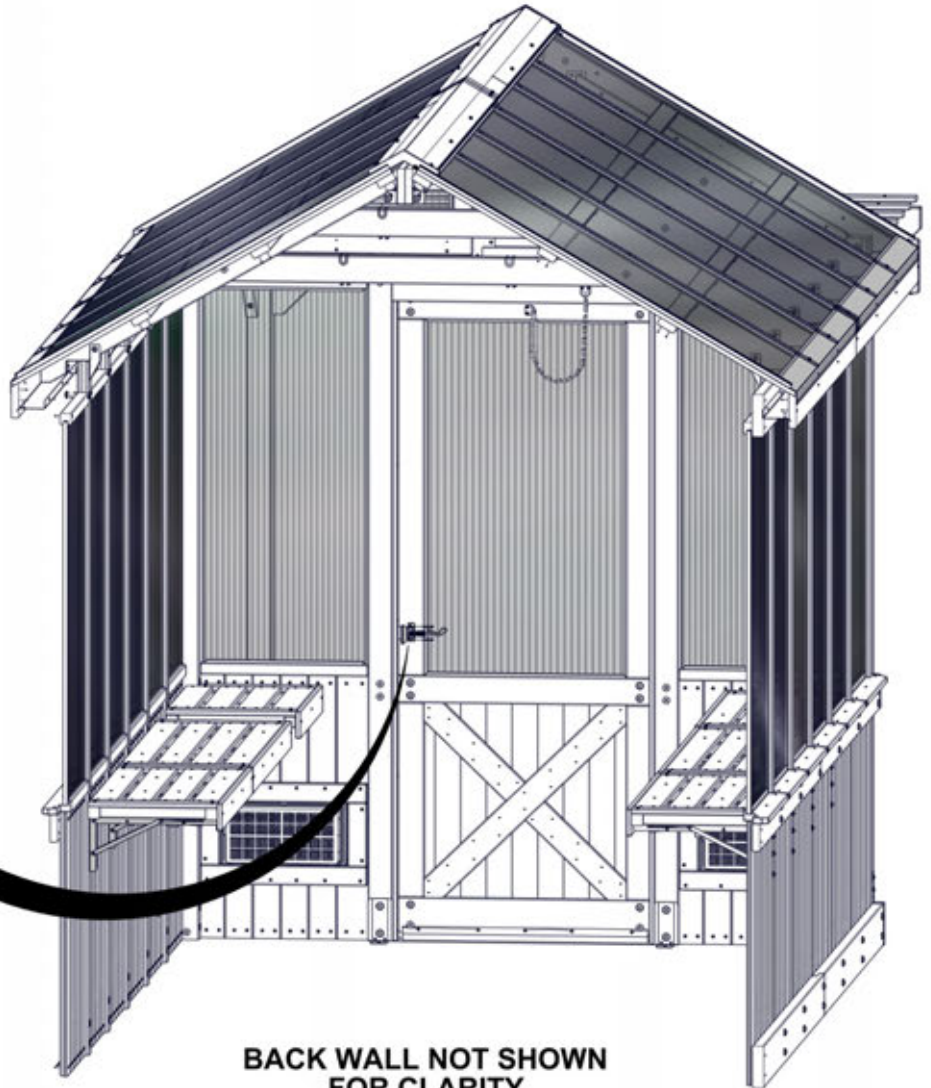
- HOLD DOOR SHUT AND POSITION LATCH PLATE WHERE IT SECURES DOOR HANDLE LATCH WHEN DOOR IS CLOSED
- MARK AND USE 1/8" DRILL BIT TO CREATE PILOT HOLES
- ATTACH AS SHOWN



1260 (x2)
SCREW - 1 1/4"



2410 (x1)
LATCH



BACK WALL NOT SHOWN
FOR CLARITY

STEP 144 - ELECTRIC

QTY	PART NUMBER	DESCRIPTION
2	H100200	SCREW PFH 8x1 1/2 BLK
2	H100411	SCREW PFH 8x5/8 BLK

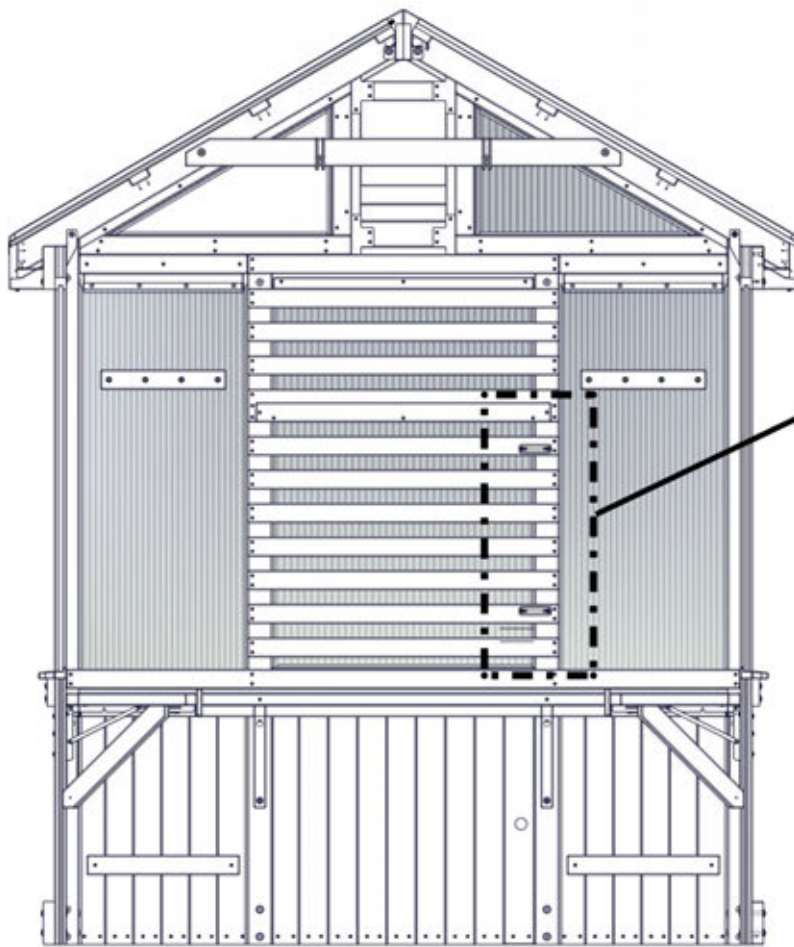


A4M01292 MOUNTING BRACKET
(x2)

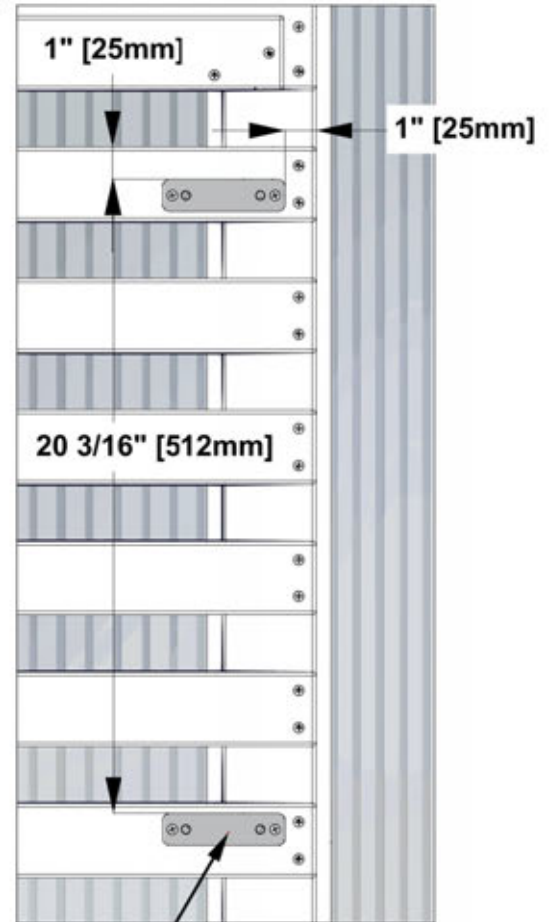
MOUNTING BRACKETS ARE INCLUDED IN ELECTRICAL PACKAGE

NOTES:

- USE AN 1/8" DRILL BIT TO CREATE PILOT HOLES; USING MOUNTING BRACKETS AND DIMENSIONS AS A GUIDE
- ATTACH AS SHOWN



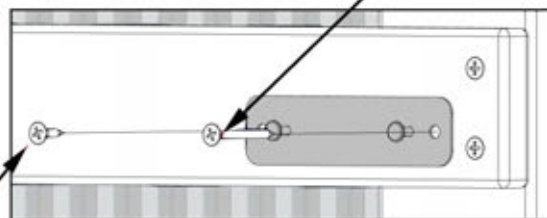
FRONT WALL NOT SHOWN FOR CLARITY



1292 (x12)
MOUNTING BRACKET

200 (x2)
SCREW - 1 1/2"

411 (x2)
SCREW - 5/8"



STEP 145 - ELECTRIC



9205413 ELECTRICAL ENCLOSURE
(x1)

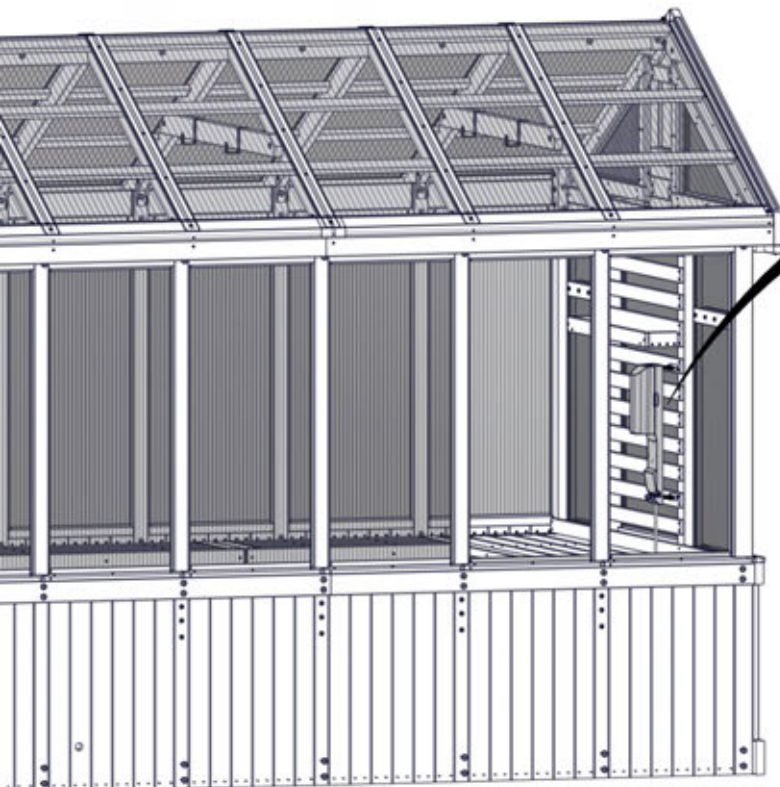
NOTES:

- HANG ELECTRICAL ENCLOSURE ON THE MOUNTING BRACKETS FROM STEP 144.
- RUN CORD BEHIND THE SLAT WALL TOWARDS ACCESS HOLE IN WALL PANEL UNDER TABLE
- SEE ELECTRIC ENCLOSURE MANUAL FOR COMPLETE DETAILS.

**WARNING! KEEP AWAY FROM WATER.
RISK OF ELECTRIC SHOCK!**

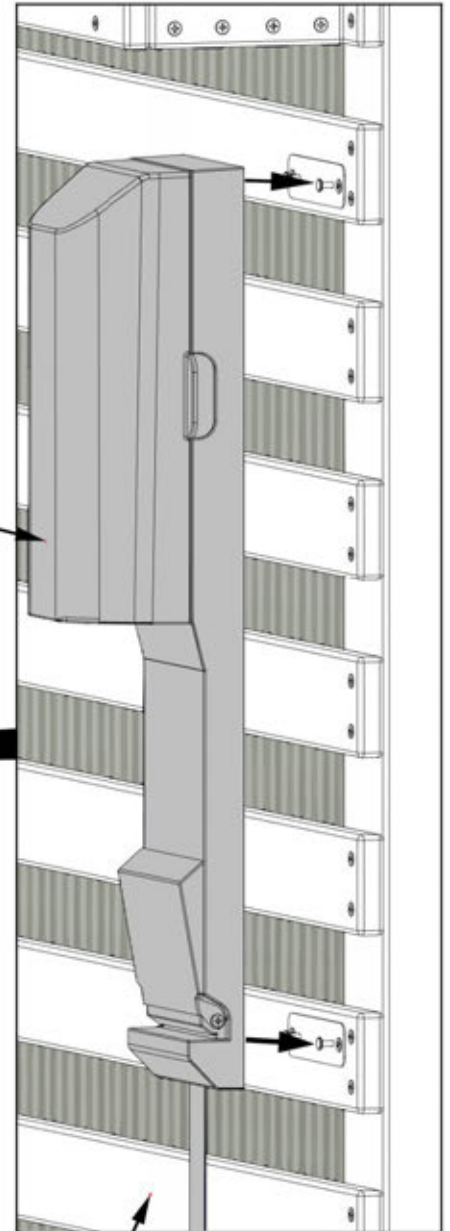
SEE ELECTRIC ENCLOSURE MANUAL
FOR COMPLETE DETAILS.

413 (x1)
ELECTRICAL ENCLOSURE



BACK

RUN CORD BEHIND
HANGER BOARDS



STEP 146 - THERMOSTAT

QTY	PART NUMBER	DESCRIPTION
1	H100411	SCREW PFH 8x5/8 BLK

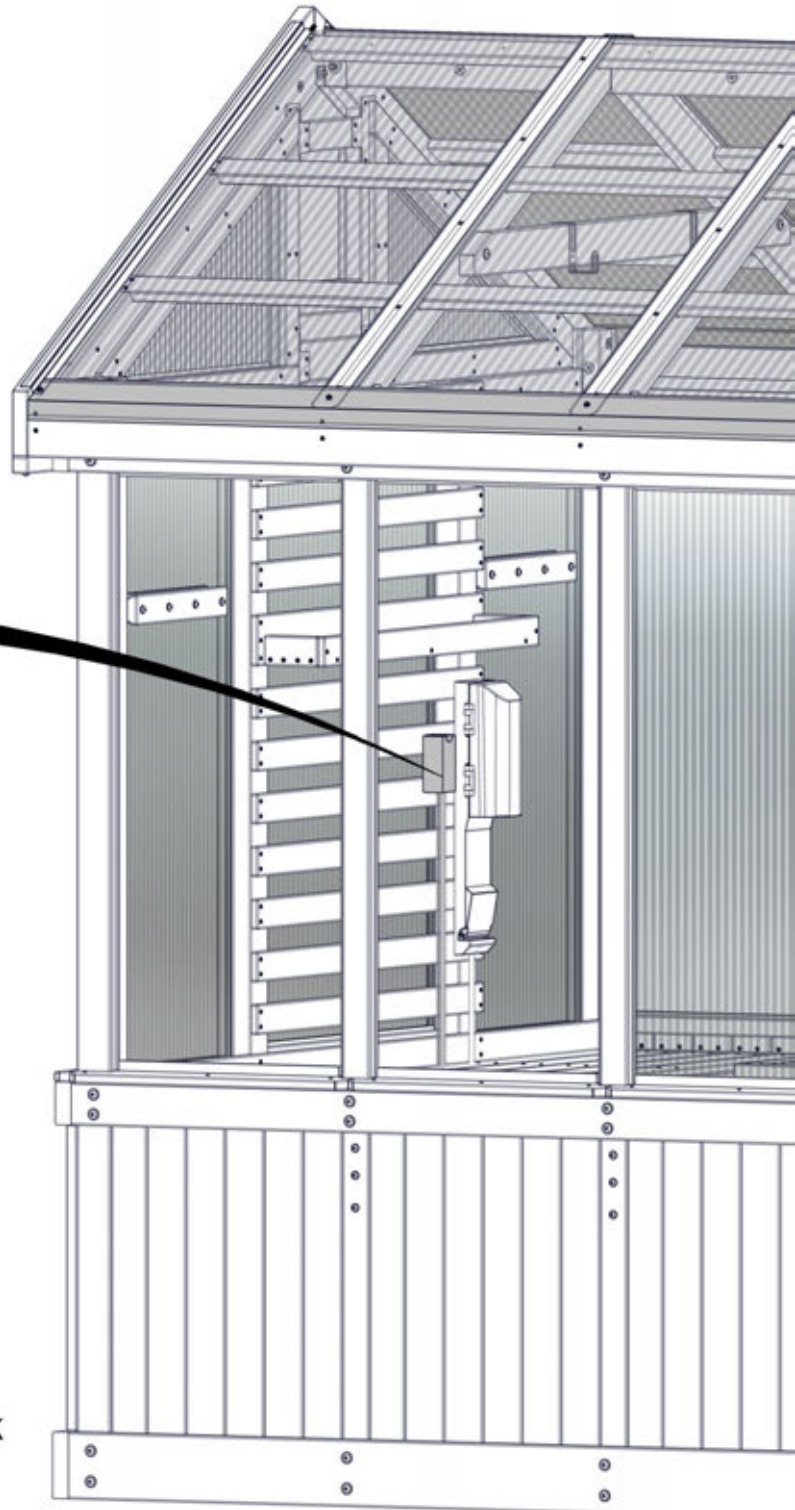


A6P00754 THERMOSTAT
(x1)

NOTES:

- LOCATE THERMOSTAT IN A DESIRED LOCATION SOMEWHAT CLOSE TO THE ELECTRICAL ENCLOSURE.
- INSTALL SCREW LEAVING IT PARTIALLY STICKING OUT AND HANG THERMOSTAT.
- HANG THE PROBE IN AN ELEVATED LOCATION.

SEE THERMOSTAT MANUAL FOR OPERATING INSTRUCTIONS



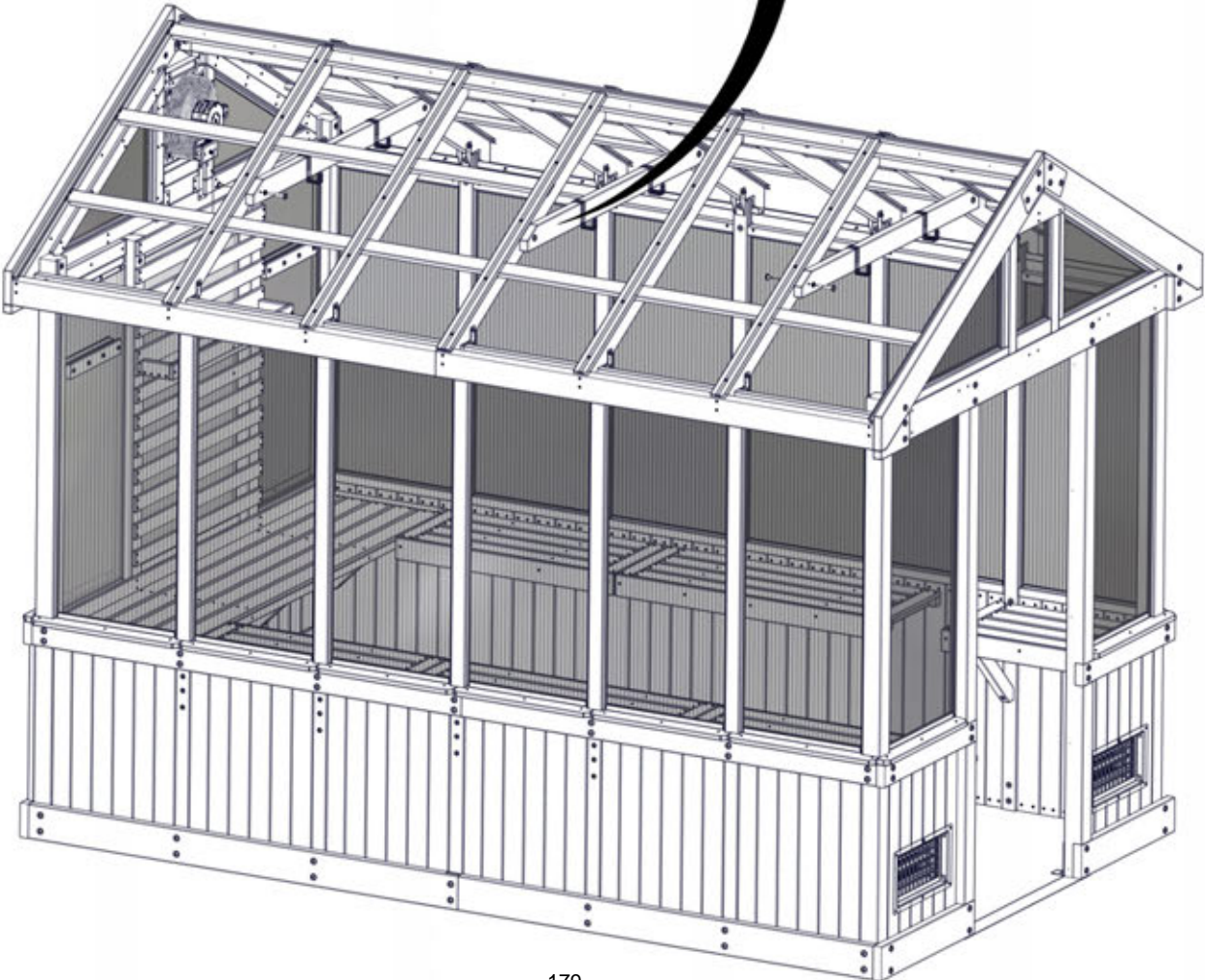
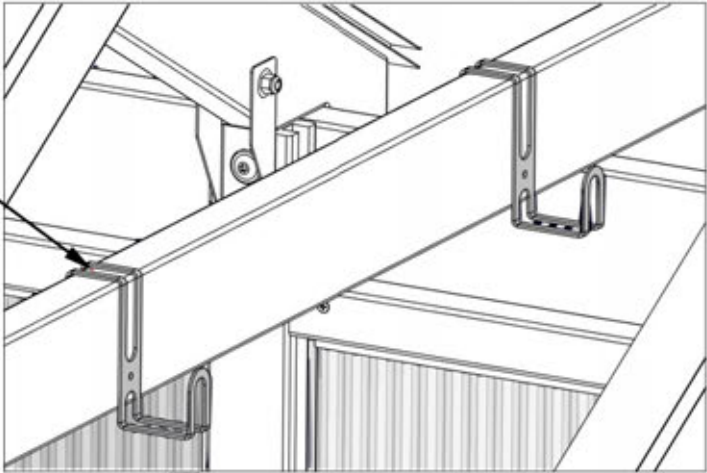
STEP 147 - ROOF ASSEMBLY



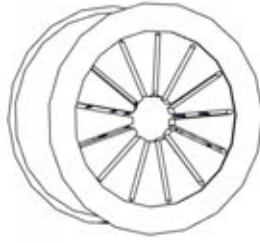
A4M01591 HOOK
(x6)

NOTE:
• HOOKS FIT OVER ANY JOIST OR PERGOLA RAFTER.

591 (x6)
HOOK

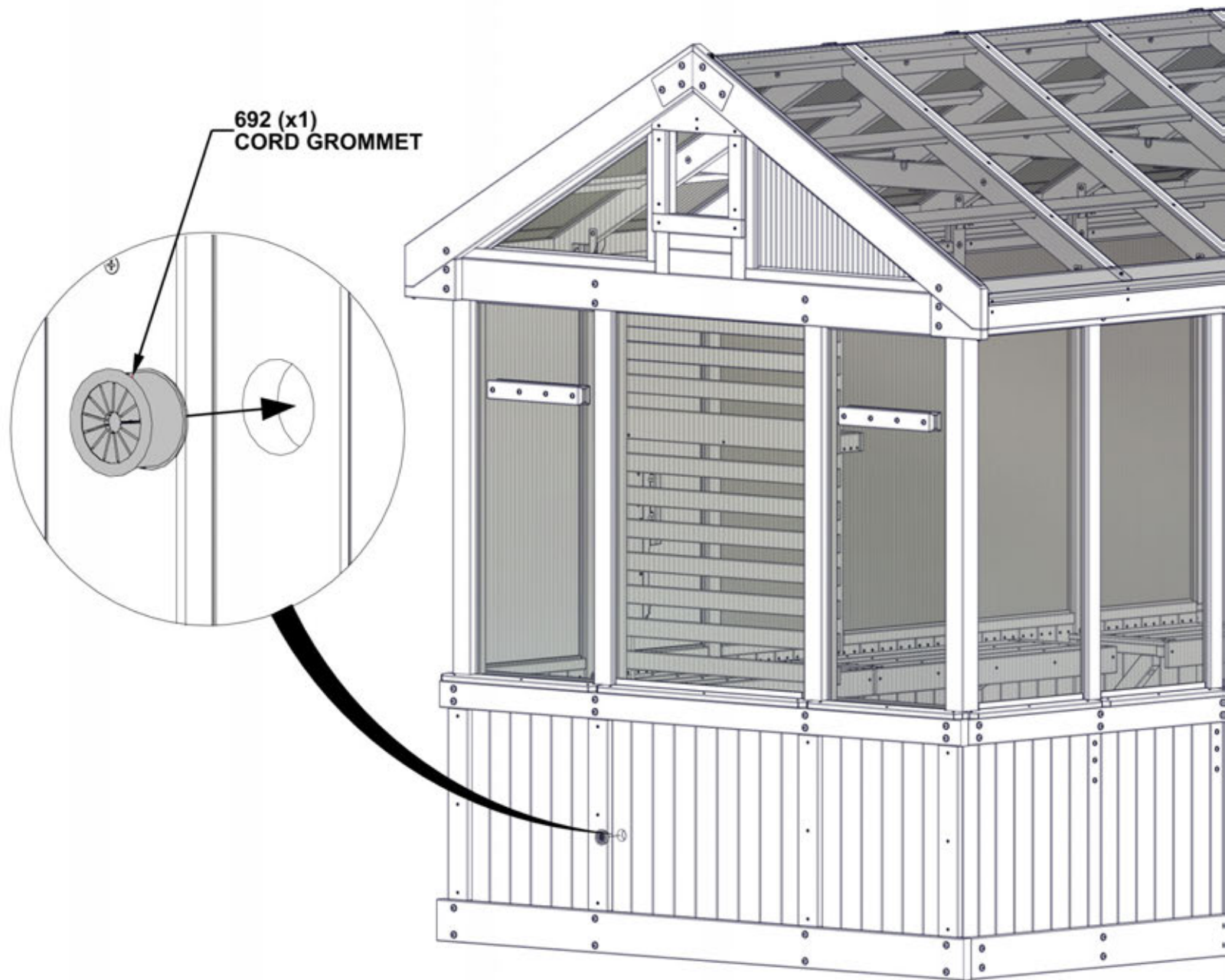


STEP 148



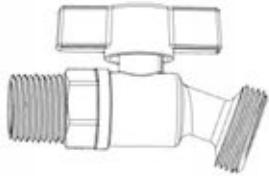
A6P00692 CORD GROMMET
(x1)

INSERT GROMMET IN HOLE PROVIDED
ON BACK OF GREENHOUSE.



BACK

STEP 149 - WATER LINE



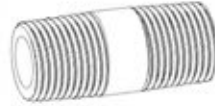
A4M02384 HOSE FAUCET
(x1)



A6P00645 PIPE 1/2" SCH40 X 24"
(x1)



A6P00646 ELBOW 1/2" NPT
(x2)



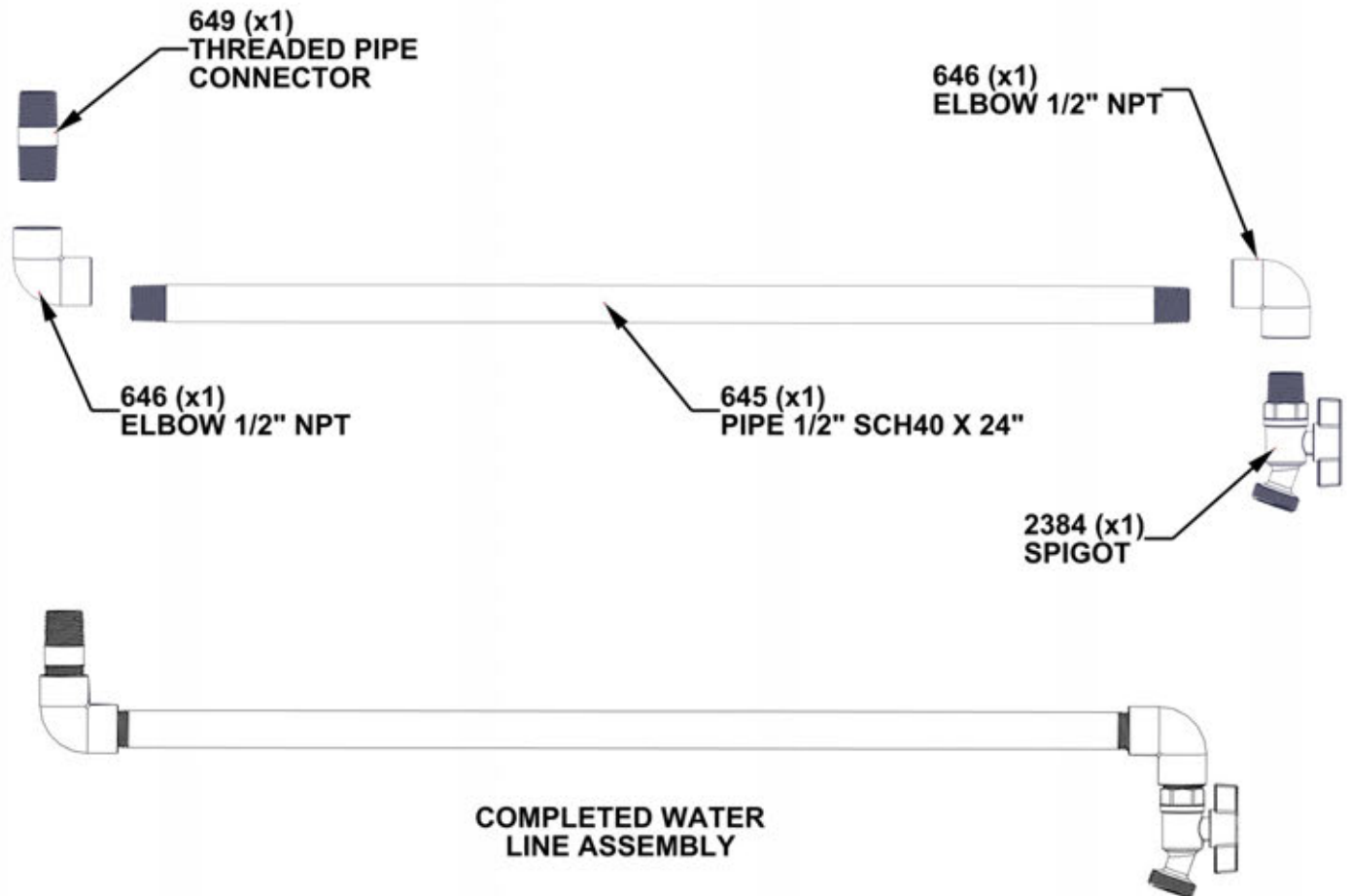
A6P00649 THREADED PIPE CONNECTOR
(x1)



A6P00809 PLUMBERS TAPE

NOTES:

- USE PLUMBERS TAPE AND WRAP THREADS OF MALE FITTINGS.
- FASTEN FITTINGS TO FORM THE COMPLETED WATER LINE ASSEMBLY BELOW.



STEP 150 - WATER LINE

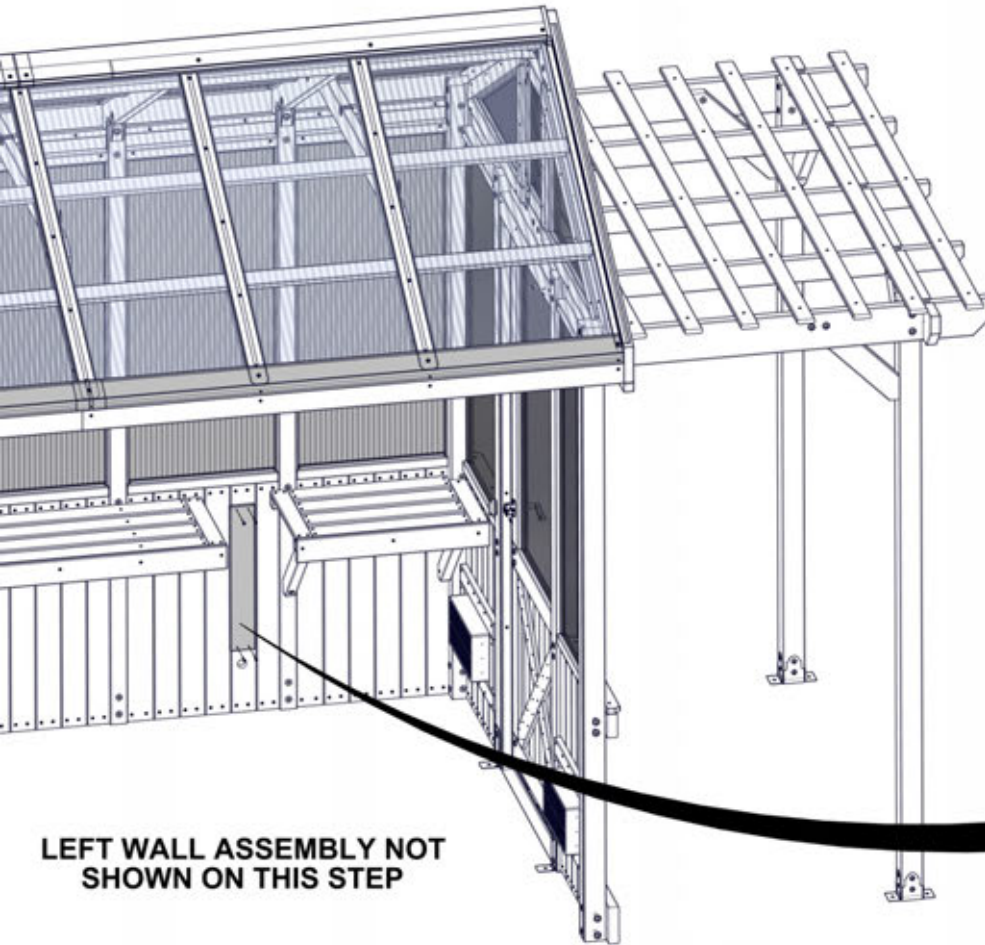
QTY	PART NUMBER	DESCRIPTION
4	H100387	SCREW PFH 8x1 1/4 BLK



M11 WATER LINE BOARD - W4L18870
(x1) 5/8"x3 3/8"x20 15/16" (16x86x532)

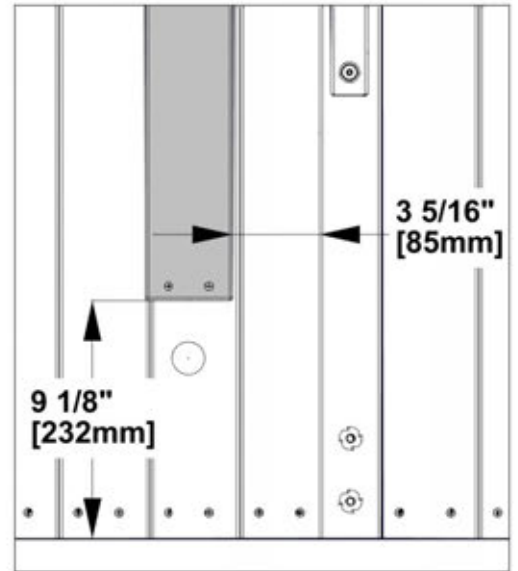
NOTES:

- USE DIMENSIONS SHOW TO LOCATE WATER LINE BOARD.
- USE AN 1/8" DRILL BIT AND WATER LINE BOARD TO CREATE PILOT HOLES.
- ATTACH AS SHOWN.

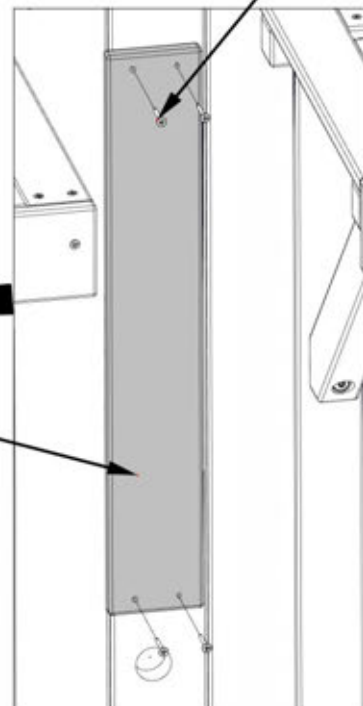


LEFT WALL ASSEMBLY NOT SHOWN ON THIS STEP

M11 (x1)
WATER LINE BOARD



387 (x)
SCREW - 1 1/4"



STEP 151 - WATER LINE

QTY	PART NUMBER	DESCRIPTION
2	H100395	SCREW PFH 8x3/4 BLK



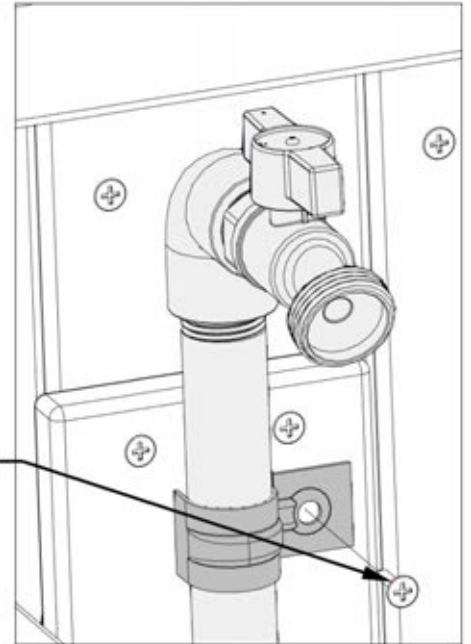
A4M02385 PIPE CLAMP
(x2)



WATER LINE ASSEMBLY
STEP 149

NOTES:

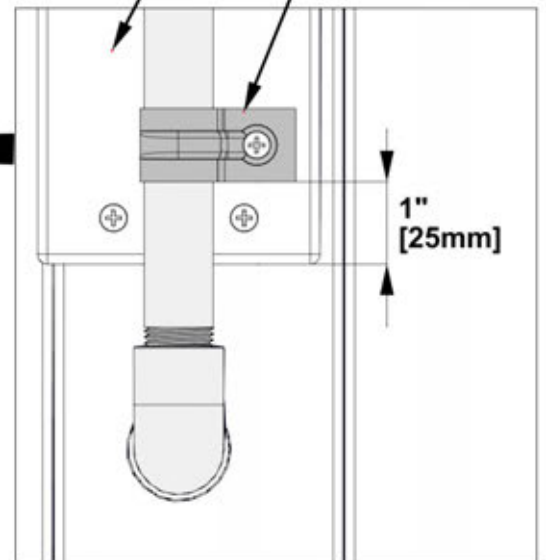
- INSERT WATER LINE ASSEMBLY THROUGH HOLE IN THE SIDE WALL
- SECURE WATER LINE TO WATER LINE BOARD FROM STEP 150 WITH THE PIPE CLAMPS
- FASTEN CLAMPS USING DIMENSIONS AS A GUIDE AT BOTH THE TOP AND BOTTOM



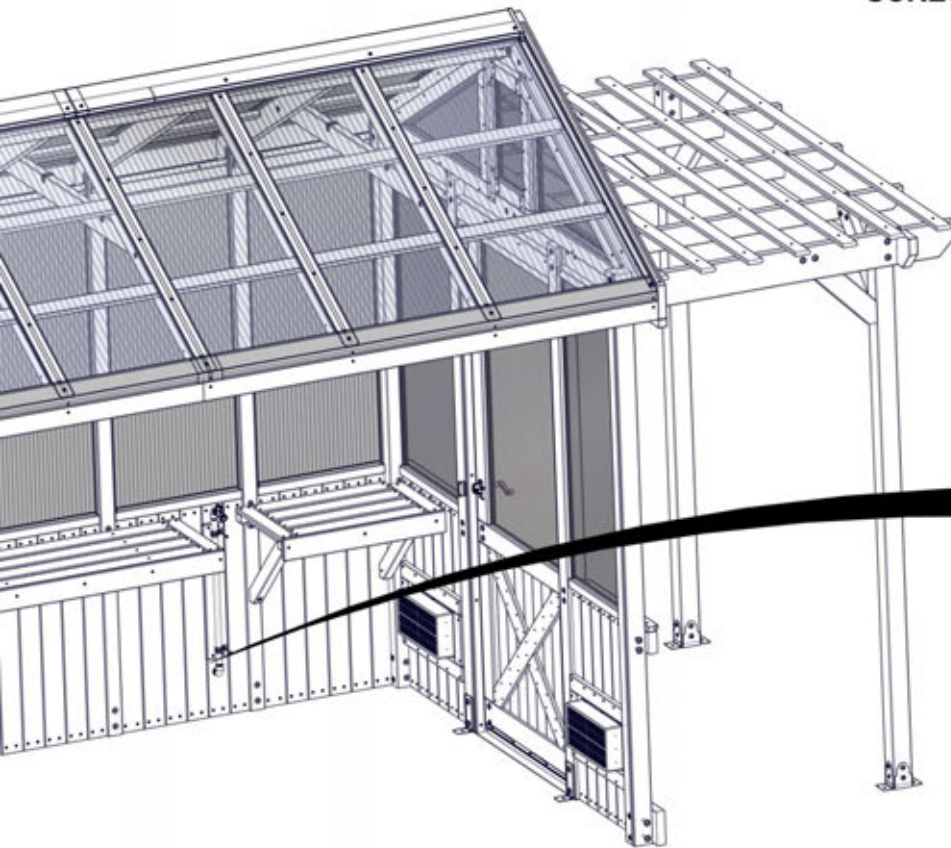
395 (x2)
SCREW - 3/4"

WATER LINE BOARD
FROM STEP 150

2385 (x2)
PIPE CLAMP



1"
[25mm]



STEP 152 - WATER LINE



A6P00577 RUBBER GROMMET
(x1)



A6P00648 THREADED HOSE FITTING
(x1)



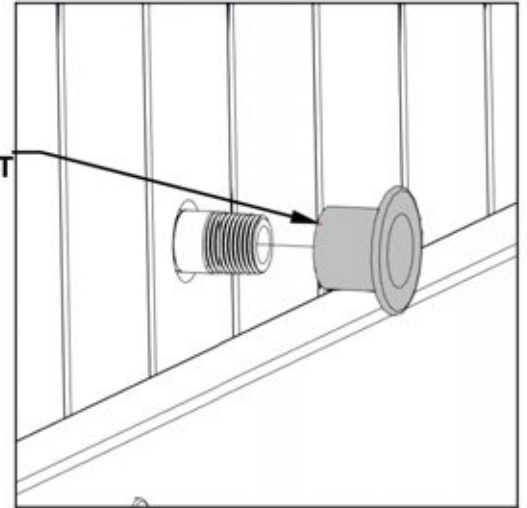
A6O00809 PLUMBERS TAPE

NOTES:

- PUSH RUBBER GROMMET IN HOLE AROUND THE WATER LINE ASSEMBLY FROM PREVIOUS STEPS.
- USE PLUMBERS TAPE AND WRAP THREADS OF MALE FITTINGS.
- FASTEN THREADED HOSE FITTING.

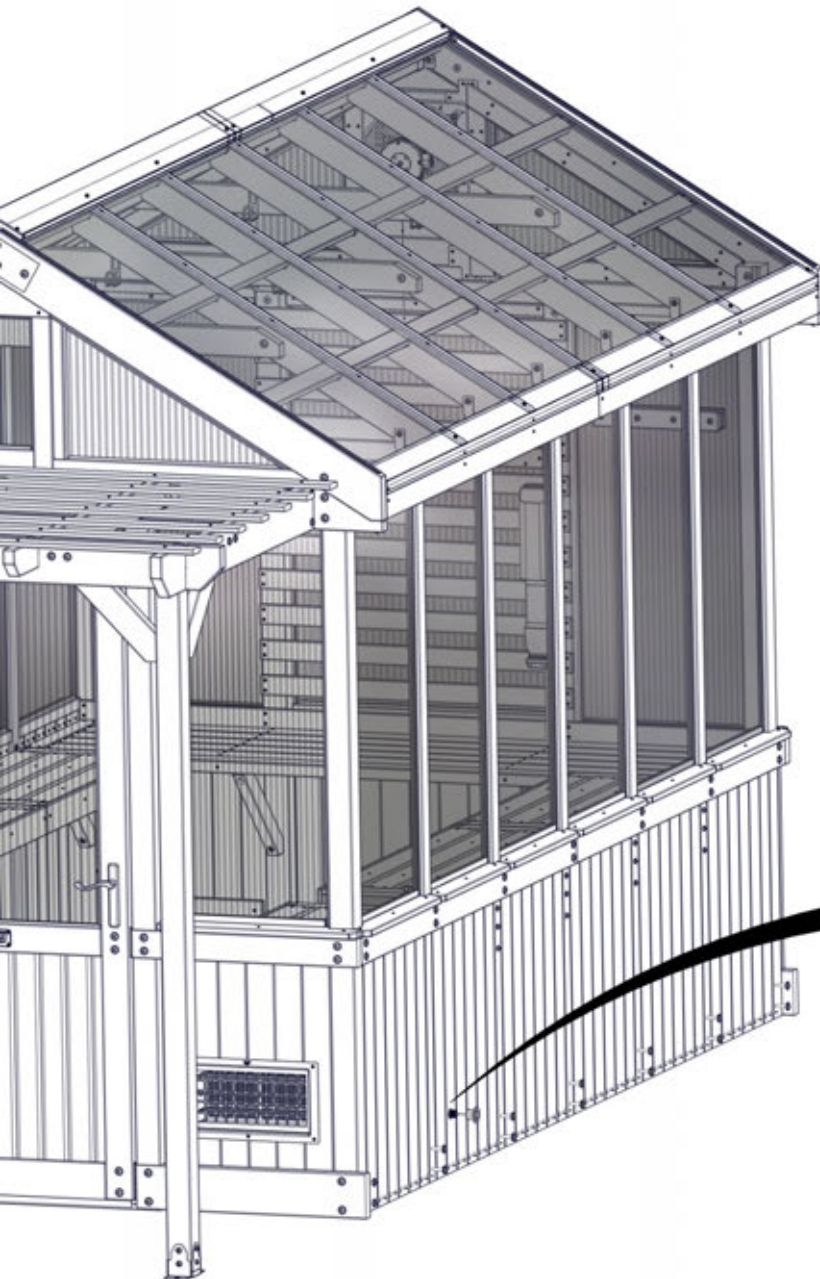
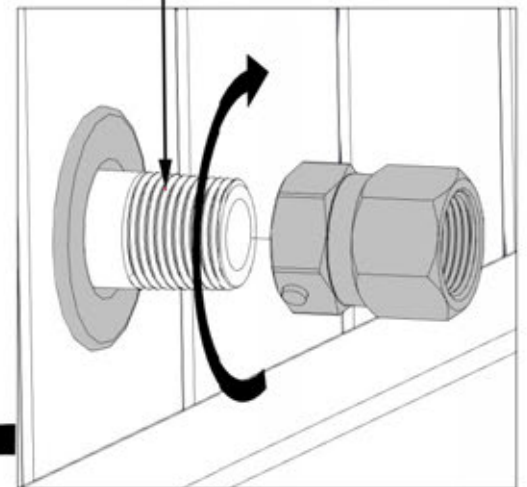
1ST

577 (x1)
RUBBER GROMMET



WATER LINE ASSEMBLY FROM PREVIOUS STEPS

2ND



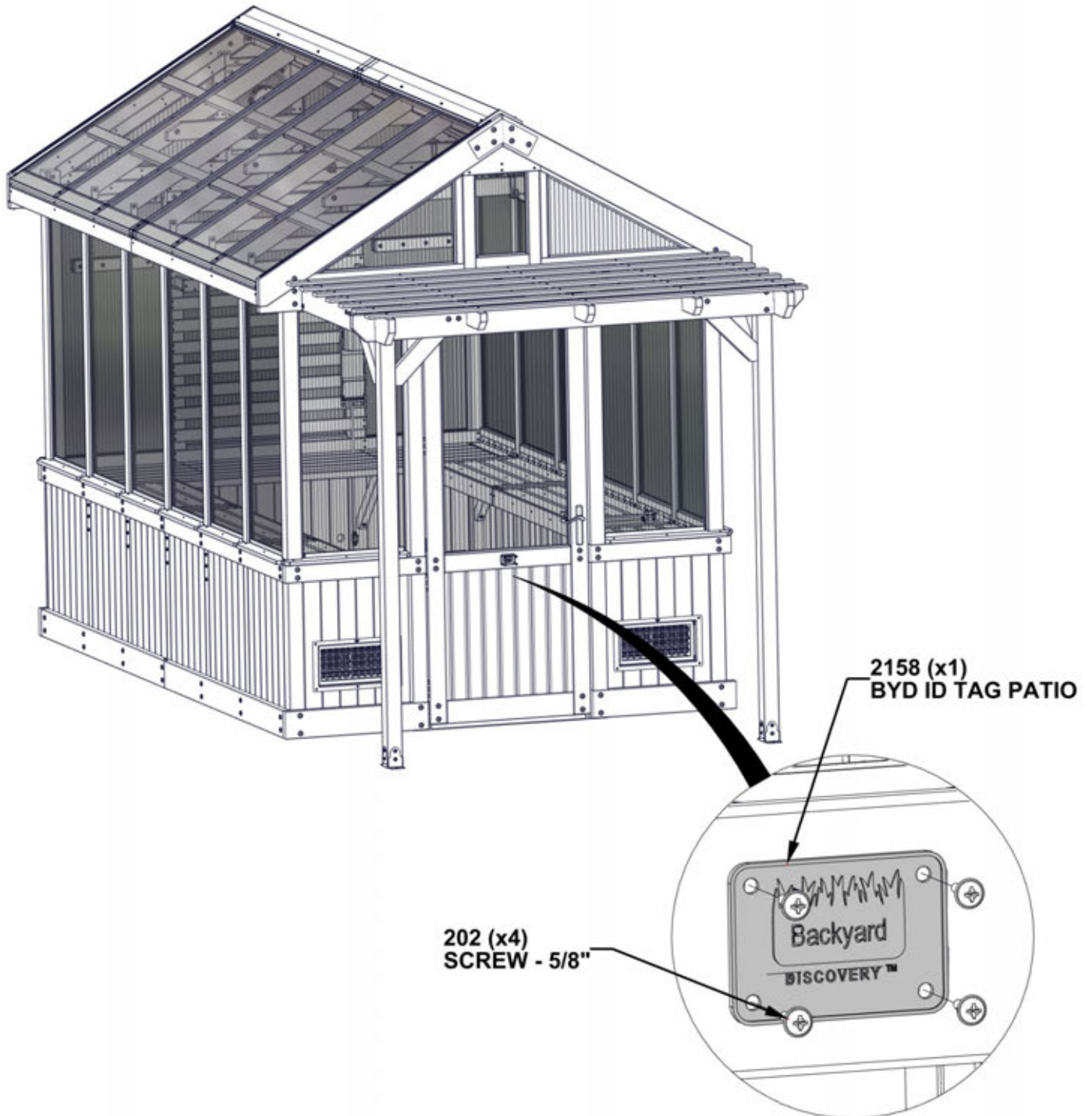
STEP 153 - I.D. TAG

QTY	PART NUMBER	DESCRIPTION
4	H100202	SCREW PWH 8x5/8 BLK



A4M02158 BYD ID TAG PATIO
(x1)

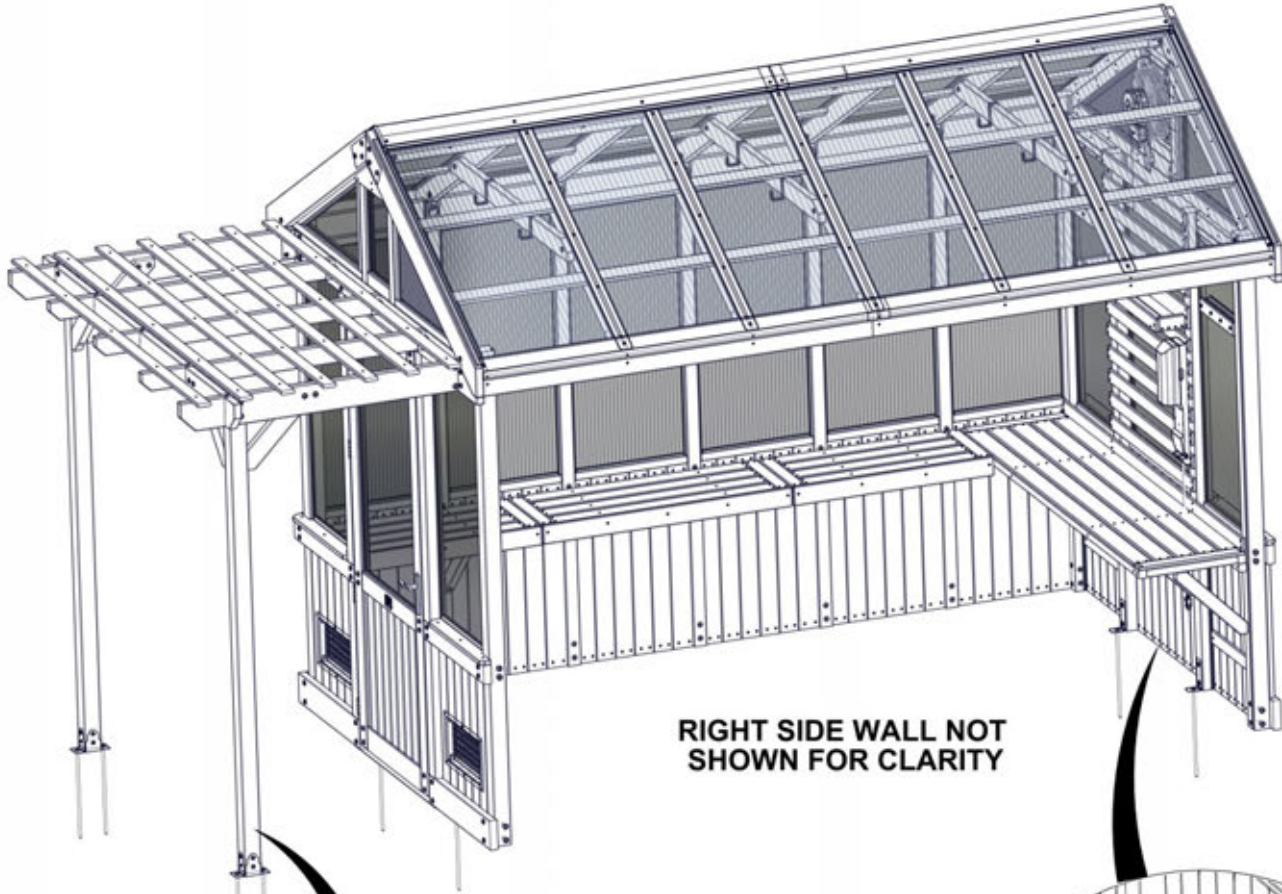
- NOTES:**
- CENTER TAG ON DOOR RAIL.
 - FASTEN AS SHOWN.



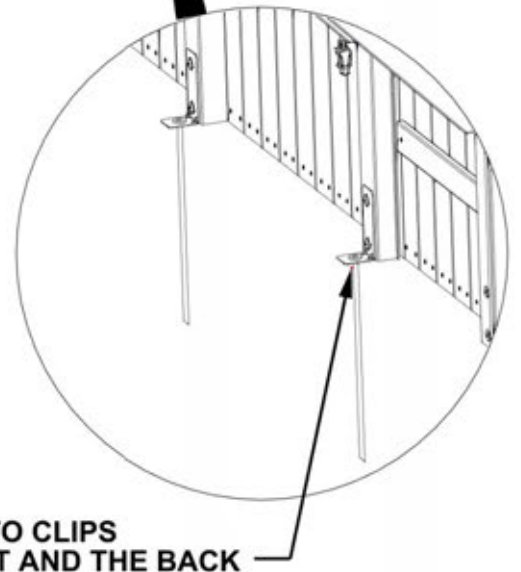
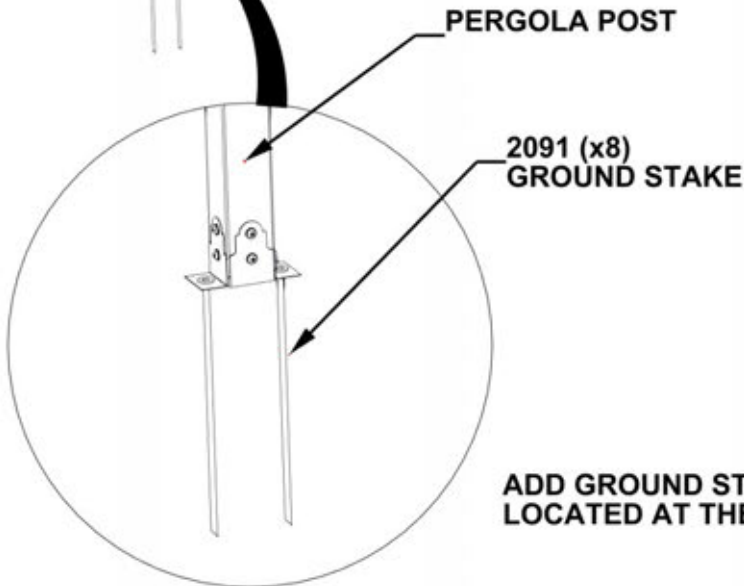
STEP 154 - GROUND STAKES



A4M02091 GROUND STAKE REBAR
(x8)



RIGHT SIDE WALL NOT SHOWN FOR CLARITY



ADD GROUND STAKES TO CLIPS LOCATED AT THE FRONT AND THE BACK