



Manufactured by:
Backyard Discovery
3305 Airport Drive, Pittsburg,
KS 66762 800-856-4445

Basepoint Business Centre: Rivermead Drive, Westlea, Swindon SN5 7EX Phone: 0800-118-2476
J.P. Coenstraat 7, The Bridge, The Hague, 2595 WP, Netherlands Phone: 08005678990

BELLEROSE GREENHOUSE

MODEL # : 2304109B

For Horticulture Use Only



Please visit www.backyarddiscovery.com
For the most up to date assembly manual, to register your product, or to order
replacement parts *Para obtener instrucciones en español, visite*
www.backyarddiscovery.com



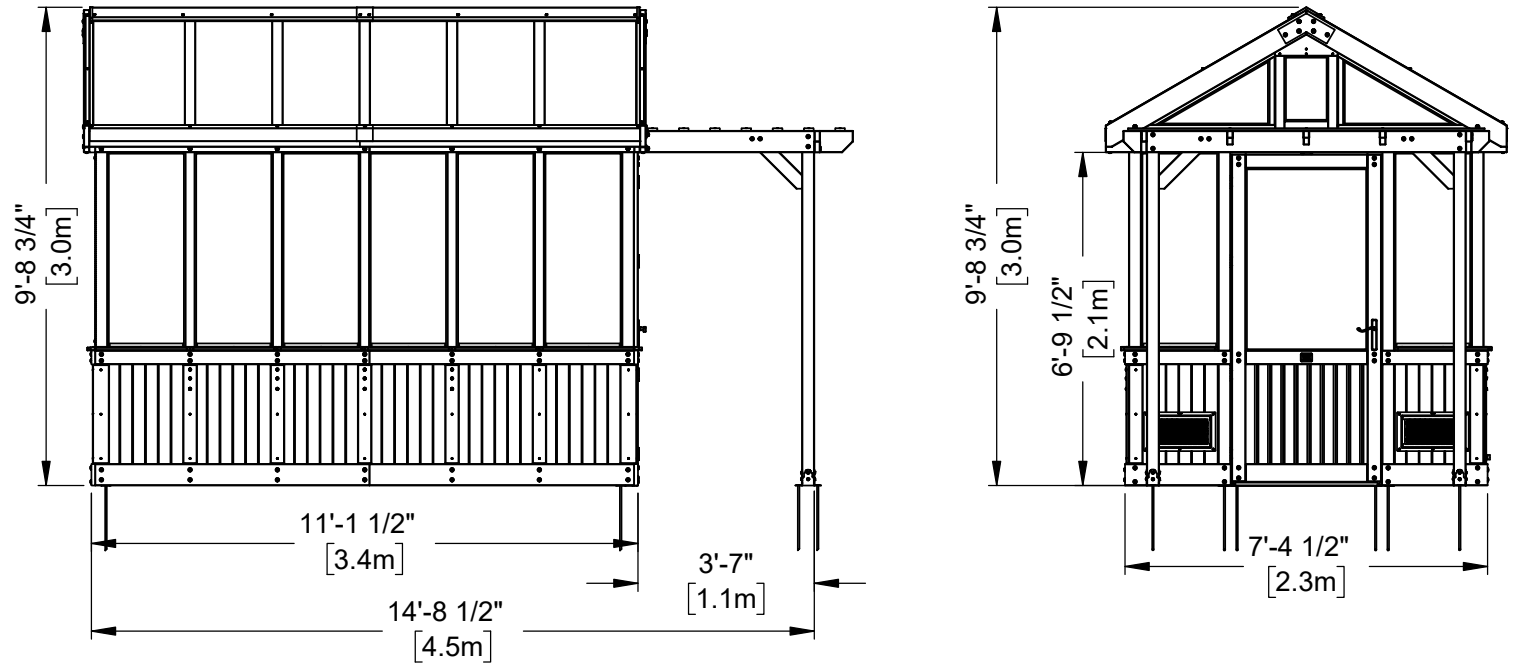
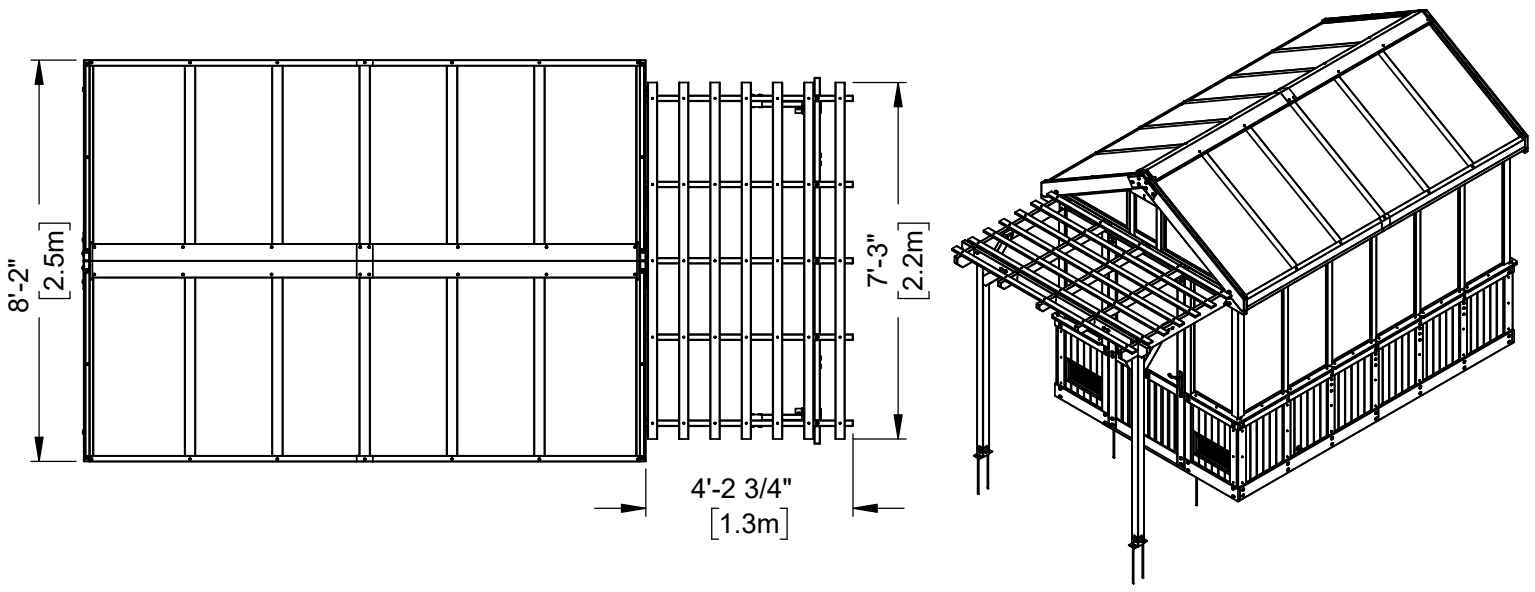
EASY STEP-BY-STEP
3D INTERACTIVE INSTRUCTIONS
DOWNLOAD THE FREE APP



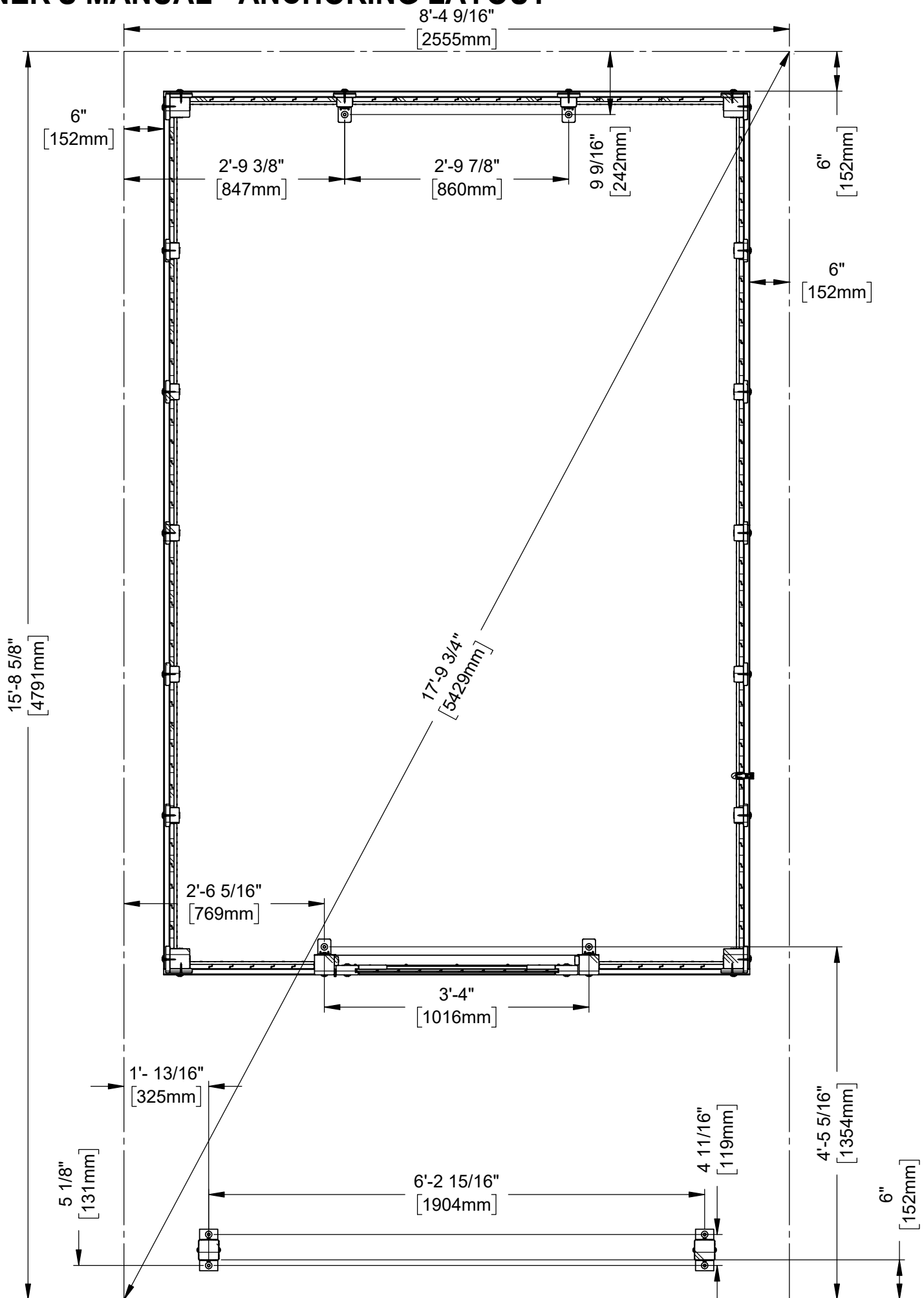
OWNER'S MANUAL - BASIC SETUP DIMENSIONS & ASSEMBLY NOTES

It is critically important that you start with square and level footings or concrete pad to attach your structure

- Pay close attention to the items needed for each step. Make sure you are using the correct hardware for each step. Using incorrect hardware may result in improper assembly
- Remember to double check for underground utilities and overhead electrical lines
- The hardware to attach the post mounts to the structure is included.
- The hardware to mount the structure permanently to a concrete surface is included.



OWNER'S MANUAL - ANCHORING LAYOUT



OWNER'S MANUAL - SITE LOCATION AND PREPARATION

- A. Check your local building and city codes for permit requirements or restrictions, including any HOA restrictions.
- B. Select a location with lots of sun, good drainage, and the ability to create a level firm surface for your greenhouse.
 - A firm, level surface is critically important to the longevity of your greenhouse.
 - Ensure it is accessible on all sides to clean and conduct annual maintenance
 - Consider a site location with a close proximity to both water and electrical sources
 - Make sure site drains well and avoid low lying areas.
 - Recommended area for site preparation of the Willow Greenhouse is 15'-8 5/8" x 8'-4 9/16" x 9'-8 3/4" (4791mm x 2555mm x 2968mm).
- C. Before preparing your surface – double check for possibility of any underground utilities (example: gas, cable, or sprinkler lines)
 - Remove any grass, dirt, landscaping to create a level, hard-packed surface
 - This may involve some digging to create a level spot, dependent on your site location.
- D. Determine your preferred site pad materials for your greenhouse
 - It is NOT recommended to set the greenhouse directly on soil or grass. This will shorten the lifespan of your greenhouse.
 - Site pad options include gravel, patio or brick pavers, concrete pad.
 - Anchors are included for either natural surface, such as gravel, or for a concrete foundation.
 - Manufacturer recommends installation on concrete surface or concrete post pads.

OWNER'S MANUAL - PARTS IDENTIFICATION

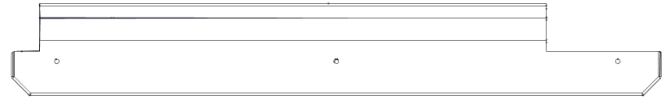
WOOD COMPONENTS (NOT TO SCALE)



AA01 DOOR STOP - W4L19558
(x1) 1 7/8"x1 15/16"x37" (47x50x940)



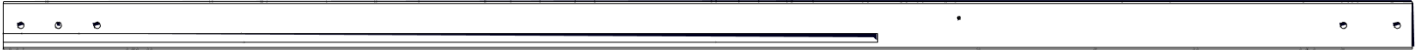
AJ01 WINDOW SILL - W4L19569
(x1) 1 7/16"x4"x28 3/8" (36x102x721)



AJ02 WINDOW SILL - W4L19570
(x1) 1 7/16"x4"x28 3/8" (36x102x721)



B01 POST - W4L19471
(x1) 3"x3"x88 3/4" (76x76x2254)



B02 POST - W4L19478
(x1) 3"x3"x88 3/4" (76x76x2254)



B03 POST - W4L19492
(x1) 3"x3"x88 3/4" (76x76x2254)



B04 POST - W4L19493
(x1) 3"x3"x88 3/4" (76x76x2254)



B05 POST - W4L19497
(x1) 3"x3"x85 11/16" (76x76x2177)



B06 POST - W4L19499
(x1) 3"x3"x85 11/16" (76x76x2177)



B07 PERGOLA POST - W4L19563
(x1) 3"x3"x86 1/16" (76x76x2186)



B08 PERGOLA POST - W4L19564
(x1) 3"x3"x86 1/16" (76x76x2186)



CB01 SLAT FRAME - W4L19589
(x2) 5/8"x3"x53 7/8" (16x76x1368)



D01 HEADER - W4L19480
(x4) 1 7/16"x5 1/4"x67" (36x134x1702)



D02 HEADER - W4L19500
(x2) 1 7/16"x5 1/4"x89 1/2" (36x134x2274)



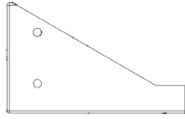
D03 GABLE - W4L19504
(x2) 1 7/16"x5 1/4"x59 3/16" (36x134x1504)

OWNER'S MANUAL - PARTS IDENTIFICATION

WOOD COMPONENTS (NOT TO SCALE)



D04 GABLE - W4L19505
(x2) 1 7/16"x5 1/4"x59 3/16" (36x134x1504)



D05 END TRIM - W4L19556
(x4) 1 7/16"x134x219 (36x134x219)



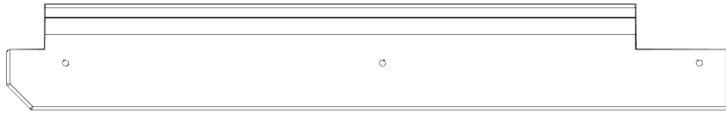
D06 PERGOLA BEAM - W4L19559
(x1) 1 7/16"x5 1/4"x89 7/16" (36x134x2272)



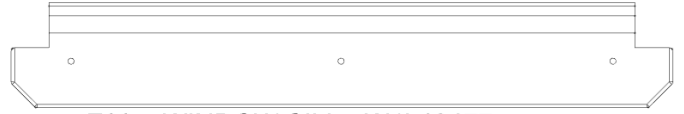
D07 PERGOLA RAFTER - W4L19560
(x2) 1 7/16"x5 1/4"x52 1/16" (36x134x1322)



D08 HEADER - W4L19571
(x1) 1 7/16"x5 1/4"x89 1/2" (36x134x2274)



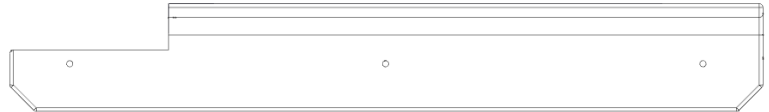
E01 WINDOW SILL - W4L19476
(x2) 1 7/16"x3 3/8"x23 1/8" (36x86x588)



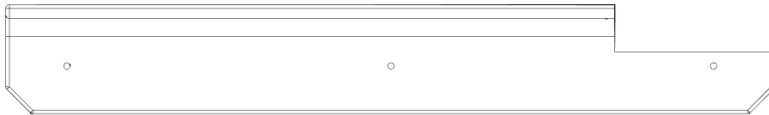
E02 WINDOW SILL - W4L19477
(x8) 1 7/16"x3 3/8"x21 5/16" (36x86x542)



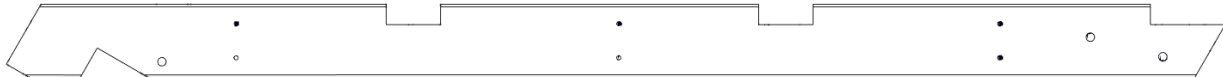
E03 WINDOW SILL - W4L19479
(x2) 1 7/16"x3 3/8"x23 1/8" (36x86x588)



E04 WINDOW SILL - W4L19502
(x1) 1 7/16"x3 3/8"x23 3/4" (36x86x604)



E05 WINDOW SILL - W4L19503
(x1) 1 7/16"x3 3/8"x23 3/4" (36x86x604)



E06 RAFTER - W4L19506
(x4) 1 7/16"x3 3/8"x56 1/2" (36x86x1435)



E07 PERGOLA RAFTER - W4L19561
(x3) 1 7/16"x3 3/8"x52 1/16" (36x86x1322)



E08 ANGLE BRACE - W4L19565
(x4) 1 7/16"x3 3/8"x18 11/16" (36x86x474)



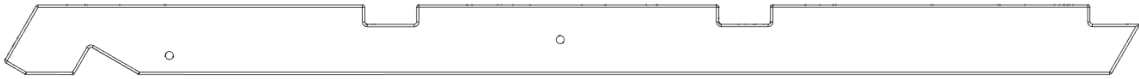
E09 WINDOW SILL - W4L19568
(x1) 1 7/16"x3 3/8"x33 3/4" (36x86x858)

OWNER'S MANUAL - PARTS IDENTIFICATION

WOOD COMPONENTS (NOT TO SCALE)



E10 FAN FRAME - W4L19598
(x1) 1 7/16"x3 3/8"x10 9/16" (36x86x268)



E11 RAFTER - W4L19606
(x6) 1 7/16"x3 3/8"x55 7/16" (36x86x1408)



E12 RAFTER - W4L19609
(x4) 1 7/16"x3 3/8"x55 7/16" (36x86x1408)



E13 JOIST - W4L19616
(x3) 1 7/16"x3 3/8"x54 1/8" (36x86x1375)



F01 UPRIGHT - W4L19473
(x2) 1 7/16"x2 3/8"x86 11/16" (36x60x2202)



F02 UPRIGHT - W4L19475
(x8) 1 7/16"x2 3/8"x86 11/16" (36x60x2202)



F03 ANGLE BRACE - W4L19487
(x4) 1 7/16"x2 3/8"x18 1/16" (36x60x458)



F04 ANGLE BRACE - W4L19488
(x4) 1 7/16"x2 3/8"x18 1/16" (36x60x458)



F05 UPRIGHT - W4L19495
(x1) 1 7/16"x2 3/8"x85 11/16" (36x60x2177)



F06 UPRIGHT - W4L19496
(x1) 1 7/16"x2 3/8"x85 11/16" (36x60x2177)



F07 WINDOW FRAME - W4L19507
(x1) 1 7/16"x2 3/8"x21 3/16" (36x60x538)



F08 WINDOW FRAME - W4L19508
(x1) 1 7/16"x2 3/8"x21 3/16" (36x60x538)



F09 WINDOW FRAME - W4L19509
(x1) 1 7/16"x2 3/8"x10 9/16" (36x60x268)



F10 WINDOW FRAME - W4L19510
(x1) 1 7/16"x2 3/8"x10 9/16" (36x60x268)



F11 WINDOW FRAME - W4L19574
(x1) 1 7/16"x2 3/8"x22 3/16" (36x60x563)



F12 WINDOW FRAME - W4L19588
(x1) 1 7/16"x2 3/8"x22 3/16" (36x60x563)



F13 FAN FRAME - W4L19596
(x1) 1 7/16"x2 3/8"x21 3/16" (36x60x538)



F14 FAN FRAME - W4L19597
(x1) 1 7/16"x2 3/8"x21 3/16" (36x60x538)



F15 FAN FRAME - W4L19599
(x1) 1 7/16"x2 3/8"x10 9/16" (36x60x268)



F16 FAN FRAME - W4L19600
(x1) 1 7/16"x2 3/8"x10 9/16" (36x60x268)

OWNER'S MANUAL - PARTS IDENTIFICATION

WOOD COMPONENTS (NOT TO SCALE)



F17 FAN FRAME - W4L19601
(x1) 1 7/16"x2 3/8"x10 9/16" (36x60x268)



G01 BASE BOARD - W4L19474
(x4) 15/16"x5 1/4"x67" (24x134x1702)



G02 BASE BOARD - W4L19491
(x1) 15/16"x5 1/4"x88 9/16" (24x134x2250)



G03 BASE BOARD - W4L19501
(x2) 15/16"x5 1/4"x25 13/16" (24x134x655)



H01 RUNNING BOARD - W4L19472
(x4) 15/16"x3 3/8"x67" (24x86x1702)



H02 RUNNING BOARD - W4L19494
(x1) 15/16"x3 3/8"x88 9/16" (24x86x2250)



H03 RUNNING BOARD - W4L19498
(x2) 15/16"x3 3/8"x25 13/16" (24x86x655)



J01 SHELF BOTTOM - W4L19590
(x2) 15/16"x2 3/8"x32 5/16" (24x60x820)



J02 SHELF SIDE - W4L19593
(x2) 15/16"x2 3/8"x4 13/16" (24x60x122)



J03 PURLIN - W4L19610
(x8) 24x2 3/8"x67 15/16" (24x60x1725)



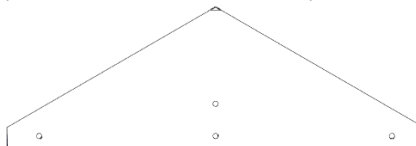
J04 PURLIN - W4L19611
(x4) 24x2 3/8"x67 15/16" (24x60x1725)



J05 RIDGE STIFFENER - W4L19613
(x2) 15/16"x2 3/8"x79 13/16" (24x60x2028)




J06 RIDGE STIFFENER - W4L19614
(x2) 15/16"x2 3/8"x54 1/4" (24x60x1378)




K01 PEAK TRIM - W4L19554
(x2) 5/8"x5 1/4"x15 1/4" (16x134x388)

OWNER'S MANUAL - PARTS IDENTIFICATION


WOOD COMPONENTS (NOT TO SCALE)



M01 TABLE TRIM - W4L19482
(x1) 5/8"x3 3/8"x32 1/2" (16x86x825)



M02 TABLE TRIM - W4L19485
(x2) 5/8"x3 3/8"x42 11/16" (16x86x1084)




M03 TABLE TRIM - W4L19486
(x2) 5/8"x3 3/8"x36 9/16" (16x86x929)




M04 COVER BOARD - W4L19489
(x8) 5/8"x3 3/8"x24 3/16" (16x86x614)



M05 COVER BOARD - W4L19490
(x8) 5/8"x3 3/8"x24 3/16" (16x86x614)




M06 TABLE TRIM - W4L19566
(x1) 5/8"x3 3/8"x24 1/2" (16x86x622)




M07 TABLE TRIM - W4L19573
(x1) 5/8"x3 3/8"x84 1/2" (16x86x2146)




N01 WINDOW TRIM - W4L19551
(x4) 5/8"x2 3/8"x40 1/2" (16x60x1028)




N02 WINDOW TRIM - W4L19552
(x4) 5/8"x2 3/8"x17 3/4" (16x60x451)




N03 WINDOW TRIM - W4L19553
(x4) 5/8"x2 3/8"x33 7/8" (16x60x861)




N04 PERGOLA PURLIN - W4L19562
(x7) 5/8"x2 3/8"x87 1/16" (16x60x2212)



N05 SPIGOT BOARD - W4L19567
(x1) 5/8"x2 3/8"x20 11/16" (16x60x526)




N06 WINDOW TRIM - W4L19575
(x2) 5/8"x2 3/8"x21 9/16" (16x60x547)




N07 SLAT - W4L19591
(x11) 5/8"x2 3/8"x37 1/2" (16x60x952)




N08 SHELF FRONT - W4L19594
(x1) 5/8"x2 3/8"x34 3/16" (16x60x868)




N09 FAN TRIM - W4L19604
(x2) 5/8"x2 3/8"x10 1/2" (16x60x267)




N10 FAN TRIM - W4L19605
(x1) 5/8"x2 3/8"x15 1/4" (16x60x388)




O01 DOOR STOP - W4L19557
(x2) 5/8"x1 5/16"x80 5/16" (16x34x2040)




P01 TABLE CLEAT - W4L19481
(x1) 1 7/16"x1 7/16"x13 1/16" (36x36x332)




P02 WINDOW CAP - W4L19483
(x12) 1 7/16"x1 7/16"x18 7/8" (36x36x480)




P03 TABLE CLEAT - W4L19484
(x8) 1 7/16"x1 7/16"x13 1/4" (36x36x336)



P04 WINDOW CAP - W4L19555
(x2) 1 7/16"x1 7/16"x18 3/4" (36x36x477)



P05 TABLE CLEAT - W4L19572
(x1) 1 7/16"x1 7/16"x80 5/8" (36x36x2048)



P06 WINDOW CAP - W4L19595
(x1) 1 7/16"x1 7/16"x31 7/16" (36x36x798)

OWNER'S MANUAL - PARTS IDENTIFICATION

WOOD COMPONENTS (NOT TO SCALE)



Q02 FASCIA - W4L19603
(x2) 15/16"x4 7/16"x68 7/16" (24x112x1738)



Q01 FASCIA - W4L19602
(x2) 15/16"x4 7/16"x68 7/16" (24x112x1738)



Q03 RIDGE BOARD - W4L19607
(x2) 15/16"x4 7/16"x87 13/16" (24x112x2230)



Q04 RIDGE BOARD - W4L19608
(x2) 15/16"x4 7/16"x45 1/8" (24x112x1146)



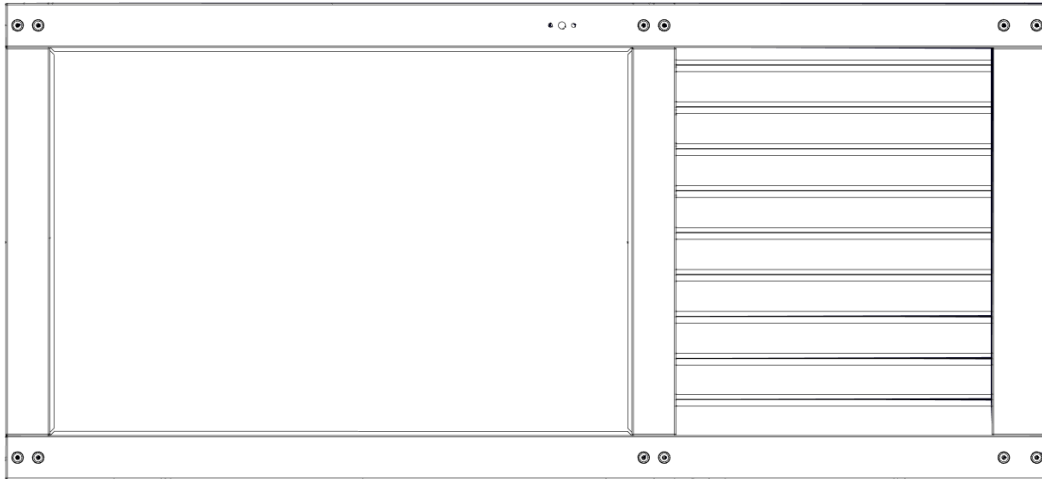
V01 LATCH BLOCK - W4L19615
(x2) 1 1/4"x1 1/4"x3" (32x32x76)



Y01 SHELF BACK - W4L19592
(x1) 5/8"x4"x37 1/2" (16x102x952)



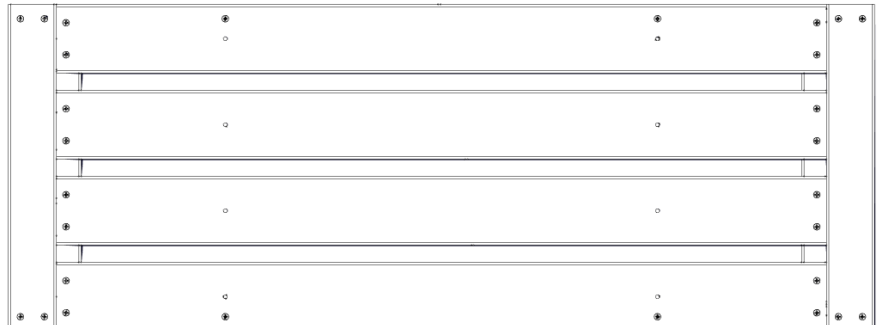
Y02 COVER BOARD - W4L19612
(x4) 5/8"x4"x24 3/16" (16x102x614)



DA01 DOOR ASSEMBLY - W2A04009
(x1) 1 7/8"x36 9/16"x80" (48x928x2032)



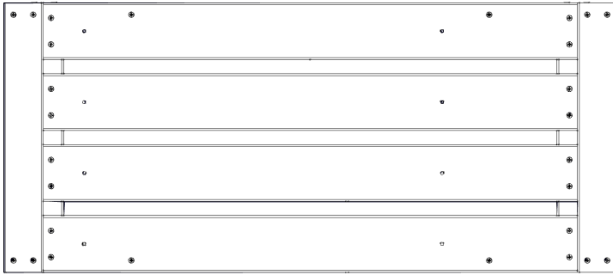
TB01 TABLE ASSEMBLY - W2A04151
(x1) 2 1/16"x16 1/16"x32 1/2" (52x408x825)



TB02 TABLE ASSEMBLY - W2A04152
(x2) 2 1/16"x16 1/16"x42 11/16" (52x408x1084)

OWNER'S MANUAL - PARTS IDENTIFICATION

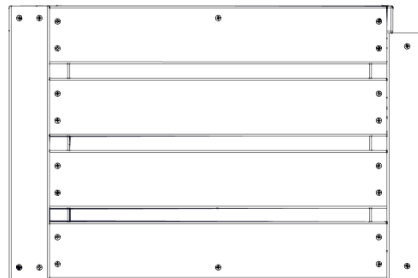
WOOD COMPONENTS (NOT TO SCALE)



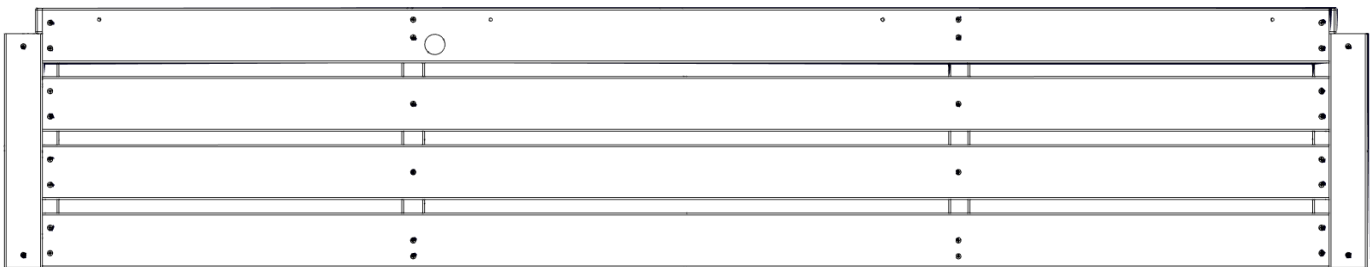
TB03 TABLE ASSEMBLY - W2A04153
(x1) 2 1/16"x16 1/16"x36 9/16" (52x408x929)



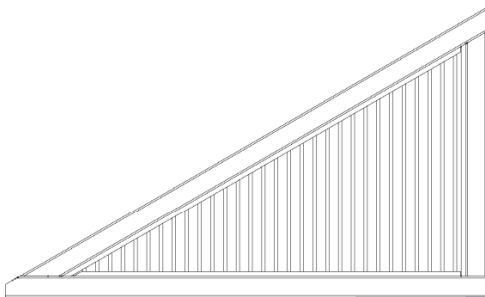
TB04 TABLE ASSEMBLY - W2A04159
(x1) 2 1/16"x16 1/16"x36 9/16" (52x408x929)



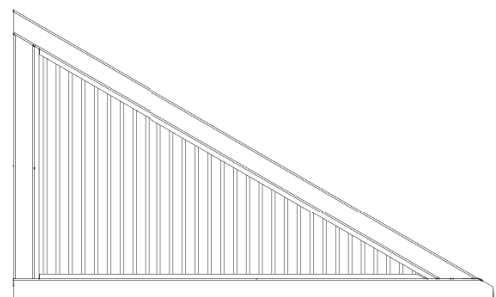
TB05 TABLE ASSEMBLY - W2A04160
(x1) 2 1/16"x16 1/16"x24 1/2" (52x408x622)



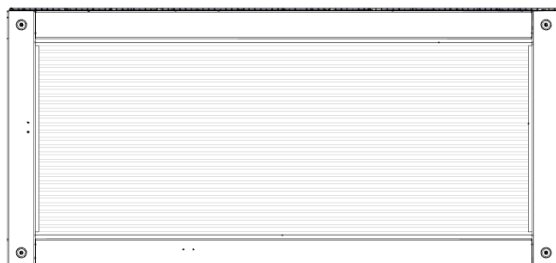
TB06 TABLE ASSEMBLY - W2A04165
(x1) 2 1/16"x16 1/16"x84 1/2" (52x408x2146)



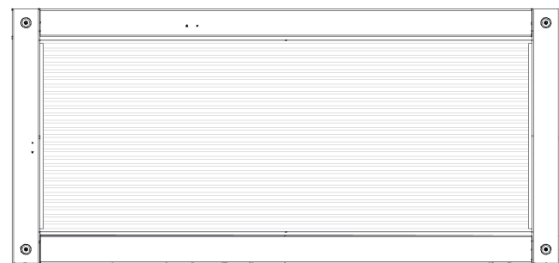
WA01 WINDOW ASSEMBLY - W2A04157
(x2) 1 7/16"x19 11/16"x32 11/16" (36x501x830)



WA02 WINDOW ASSEMBLY - W2A04158
(x2) 1 7/16"x19 11/16"x32 11/16" (36x501x830)



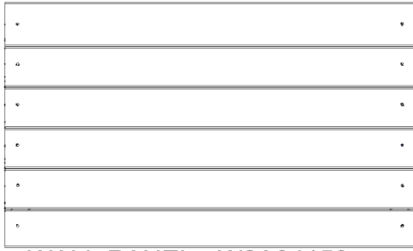
WA04 WINDOW ASSEMBLY - W2A04164
(x1) 1 7/8"x21 13/16"x47 3/16" (48x554x1198)



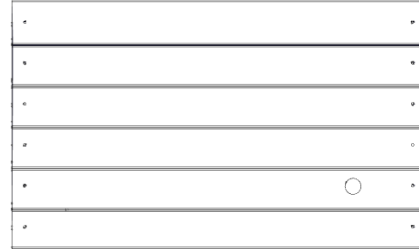
WA03 WINDOW ASSEMBLY - W2A04163
(x1) 1 7/8"x21 13/16"x47 3/16" (48x554x1198)

OWNER'S MANUAL - PARTS IDENTIFICATION

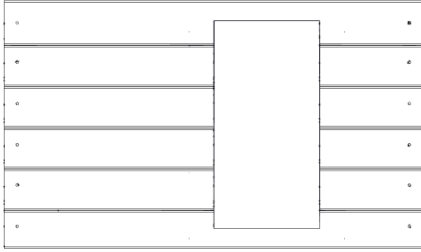
WOOD COMPONENTS (NOT TO SCALE)



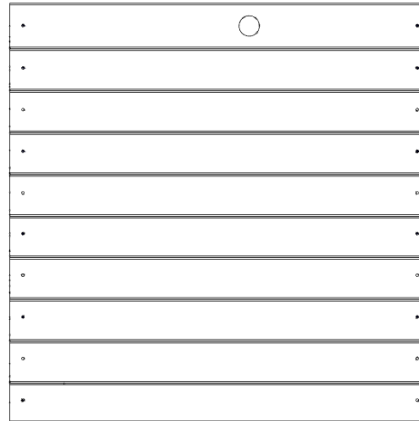
WP01 WALL PANEL - W2A04150
(x11) 1 1/16"x18 7/8"x31 9/16" (27x480x802)



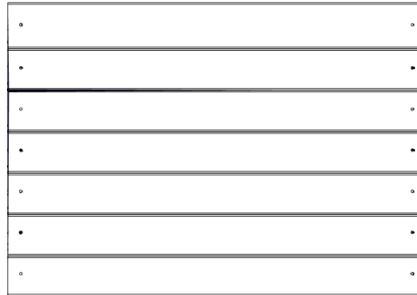
WP02 WALL PANEL - W2A04154
(x1) 1 1/16"x18 7/8"x31 9/16" (27x480x802)



WP03 WALL PANEL - W2A04156
(x2) 1 1/16"x18 3/4"x31 9/16" (27x477x802)



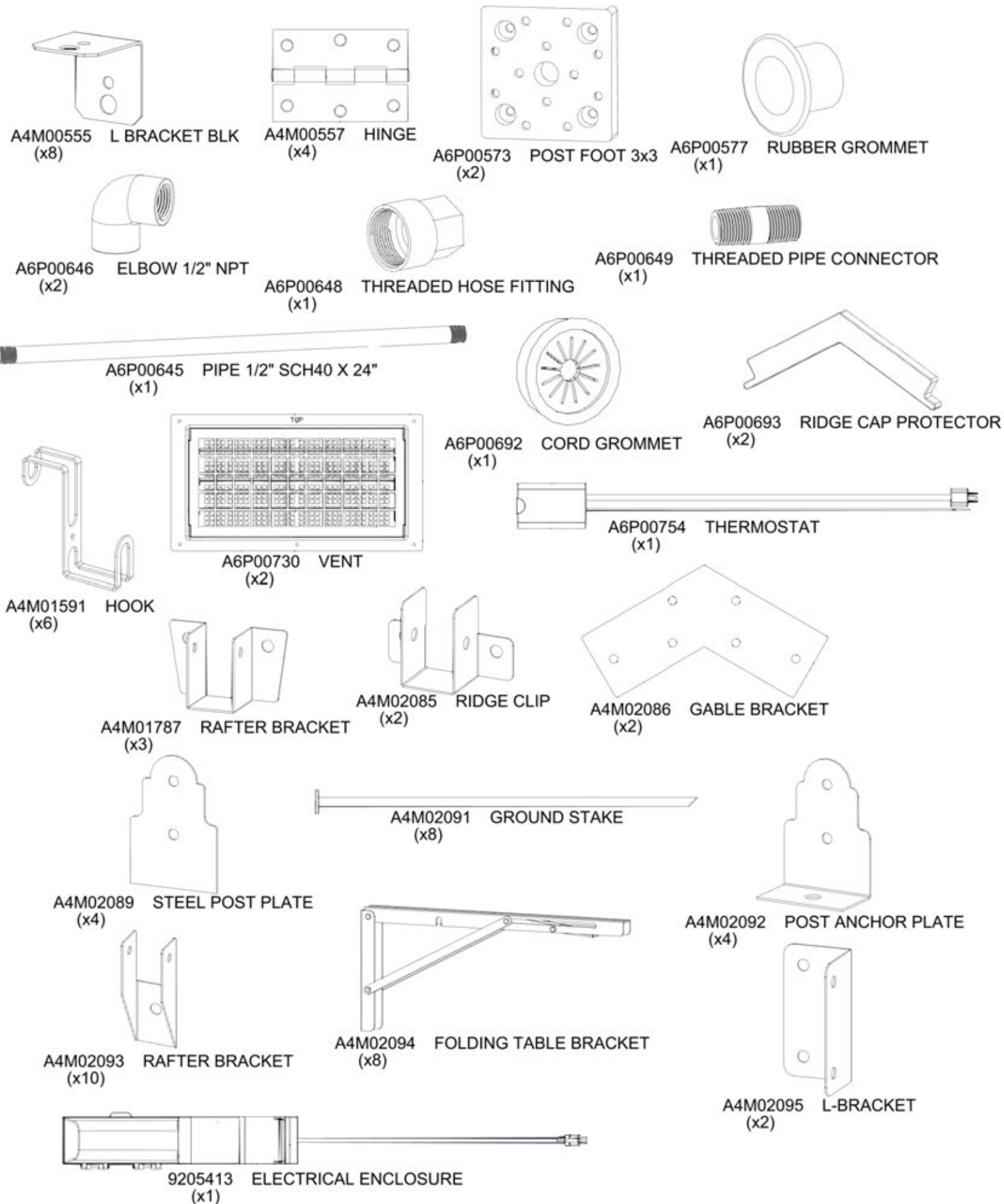
WP04 WALL PANEL - W2A04161
(x1) 1 1/16"x31 3/8"x31 9/16" (27x798x802)



WP05 WALL PANEL - W2A04162
(x2) 1 1/16"x22 1/8"x31 9/16" (27x563x802)

OWNER'S MANUAL - PARTS IDENTIFICATION

ACCESSORY COMPONENTS (NOT TO SCALE)



OWNER'S MANUAL - PARTS IDENTIFICATION

ACCESSORY COMPONENTS (NOT TO SCALE)



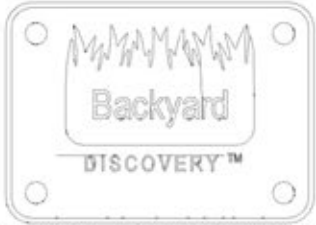
A4M02096 BRACKET
(x4)



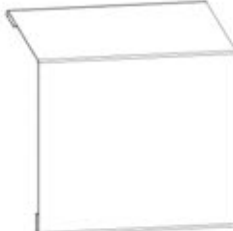
A4M02097 SPLICE COVER
(x10)



A4M02099 T-CLEAT
(x8)



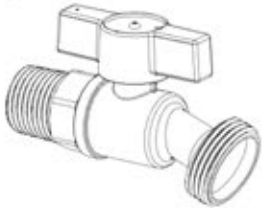
A4M02158 BYD ID TAG PATIO
(x1)



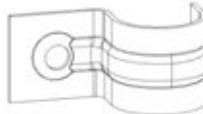
A4M02380 EDGE TRIM SPLICE
(x2)



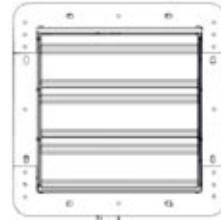
A4M02381 TRIM
(x4)



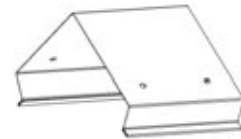
A4M02384 HOSE FAUCET
(x1)



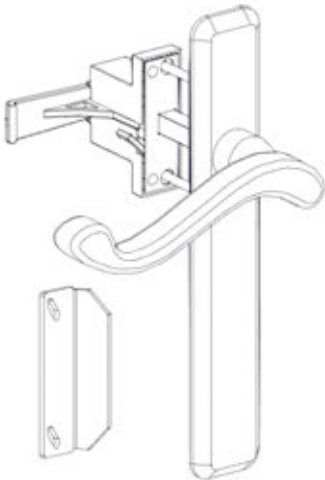
A4M02385 PIPE CLAMP
(x2)



A4M02383 EXHAUST FAN
(x1)



A4M02428 RIDGE CAP SPLICE
(x1)



A4M02410 STORM DOOR HANDLE
(x1)



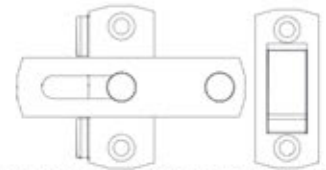
A4M02411 DOOR PROTECTOR CHAIN
(x1)



A4M02533 SUPPORT HINGE
(x2)



A4M02526 DOOR BRACKET
(x1)



A4M02607 WINDOW LATCH LOCK
(x2)



A4M02532 DOOR SWEEP
(x1)



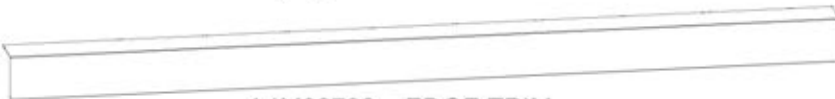
A4M02795 SOFFIT
(x2)



A4M02791 RIDGE CAP
(x2)



A4M02796 SOFFIT
(x2)



A4M02792 EDGE TRIM
(x4)



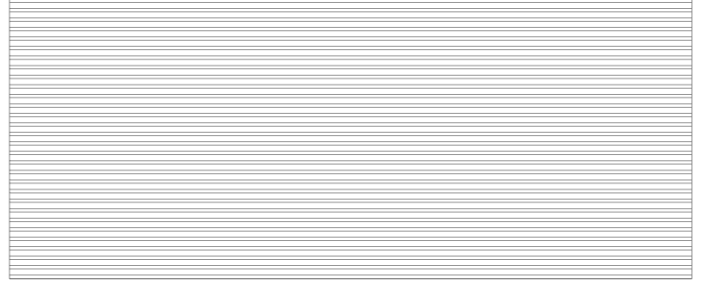
A4M02797 SOFFIT SPLICE
(x2)

OWNER'S MANUAL - PARTS IDENTIFICATION

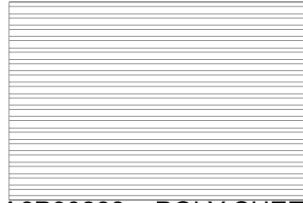
ACCESSORY COMPONENTS (NOT TO SCALE)



A6P00870 POLY SHEET
(x12)



A6P00876 POLY SHEET
(x2)



A6P00883 POLY SHEET
(x1)



A6P00899 POLY SHEET
(x1)



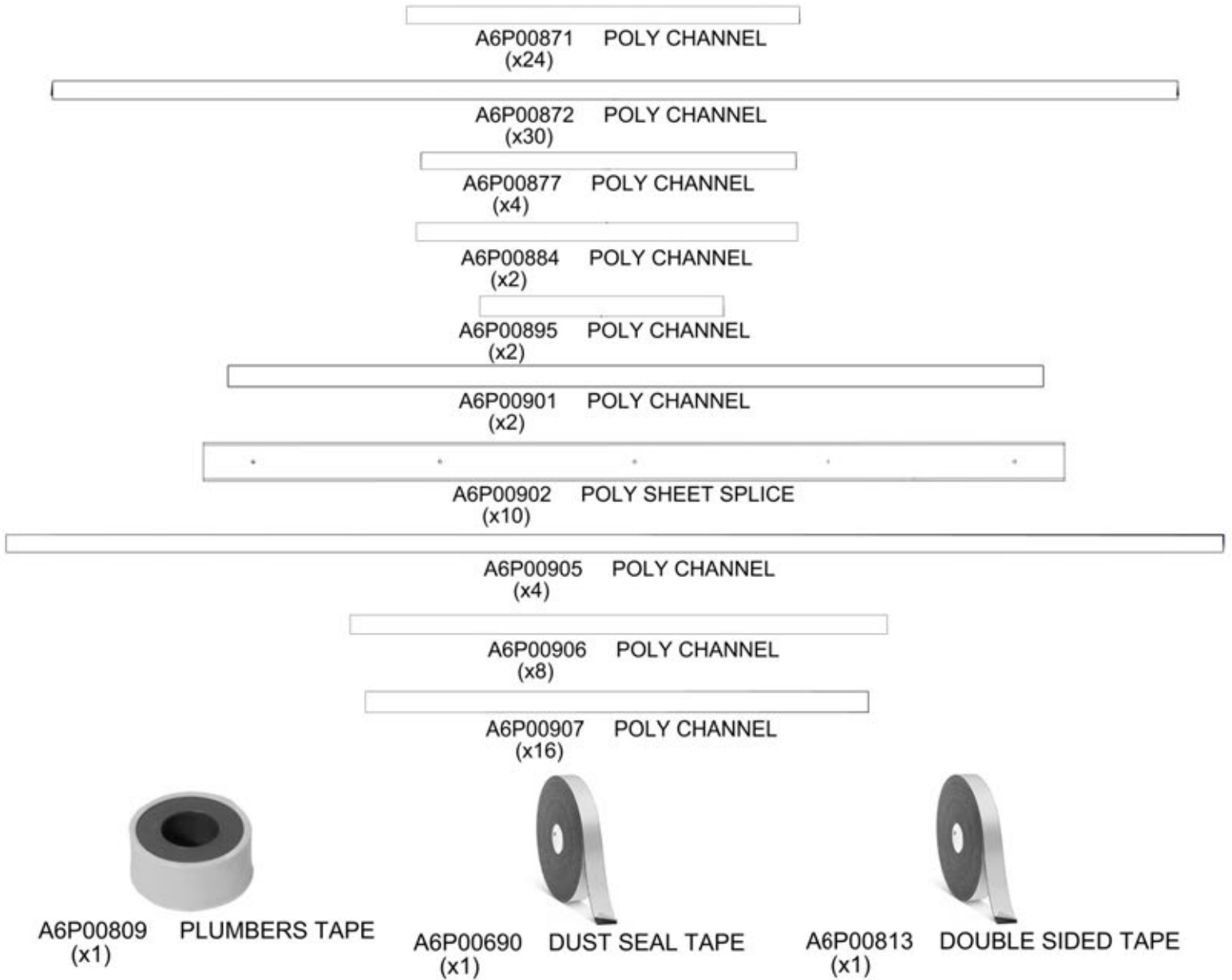
A6P00903 POLY SHEET
(x8)



A6P00904 POLY SHEET
(x4)

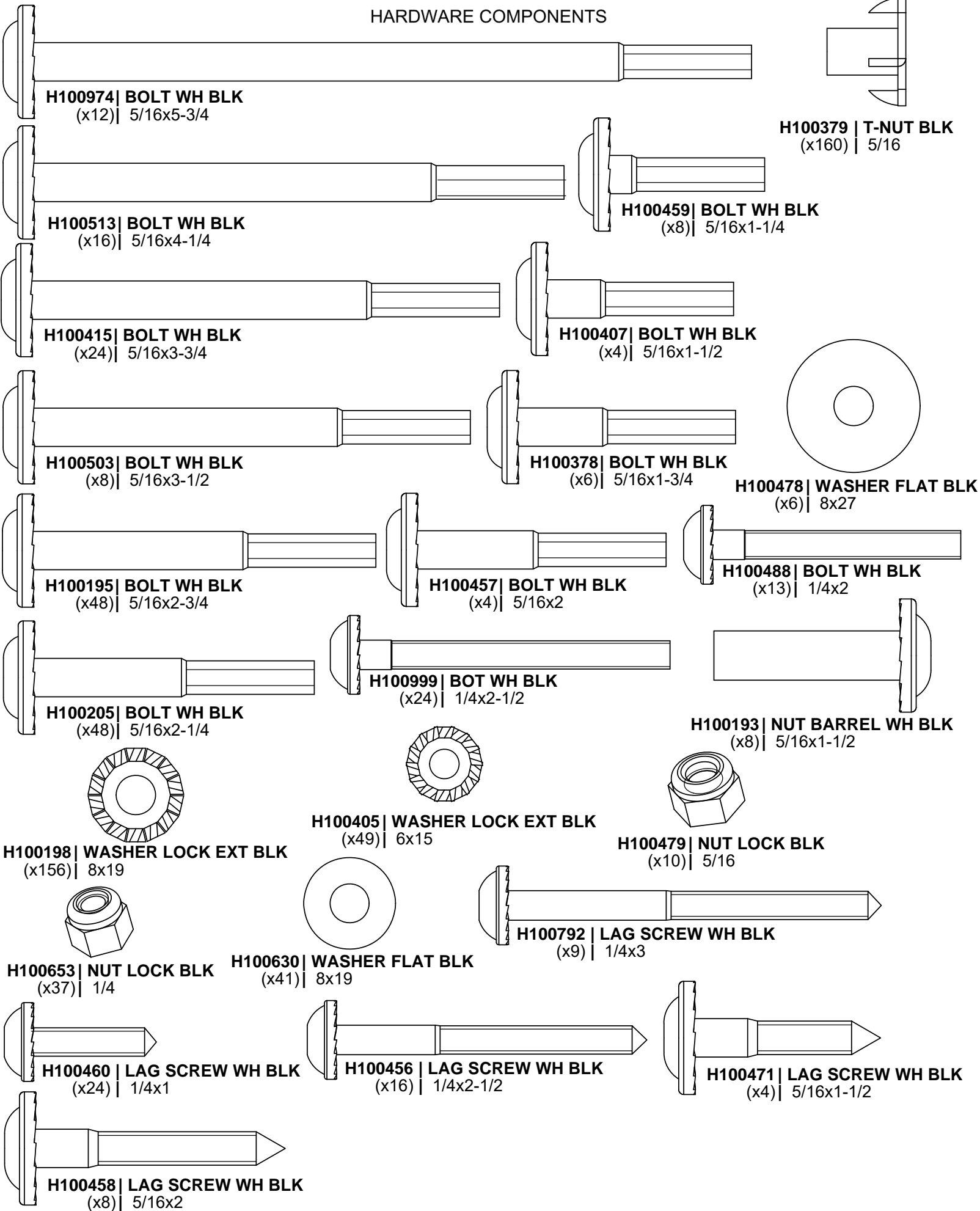
OWNER'S MANUAL - PARTS IDENTIFICATION

ACCESSORY COMPONENTS (NOT TO SCALE)



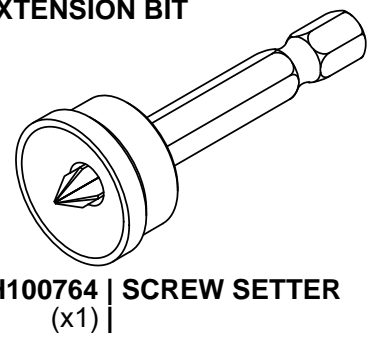
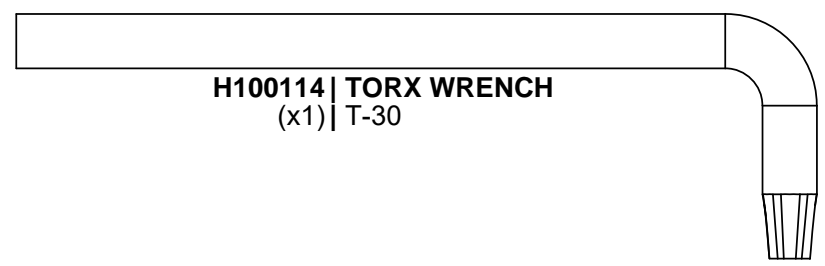
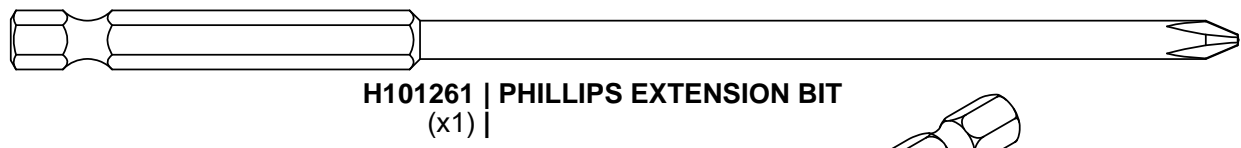
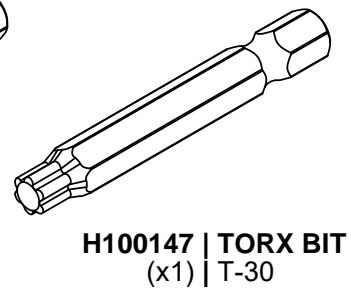
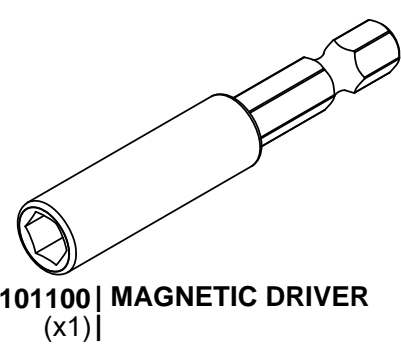
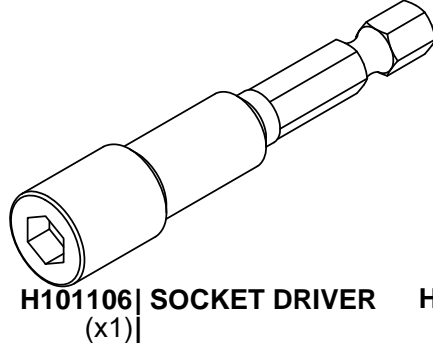
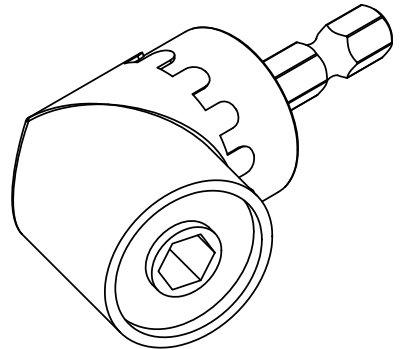
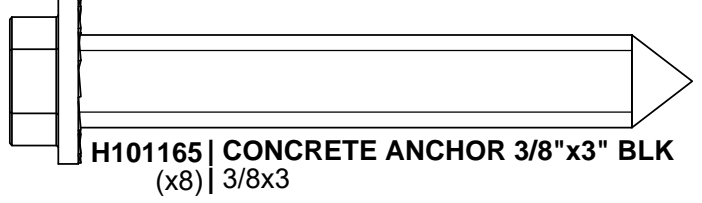
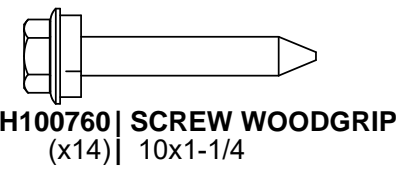
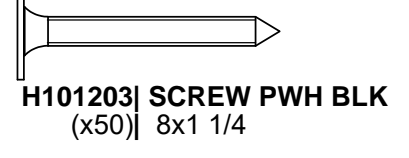
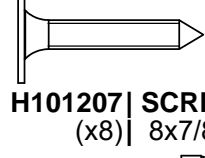
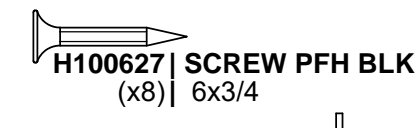
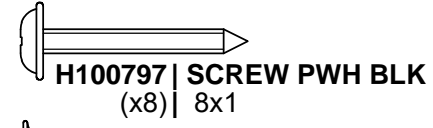
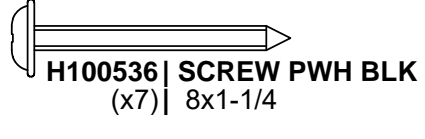
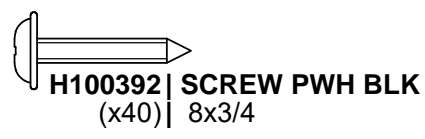
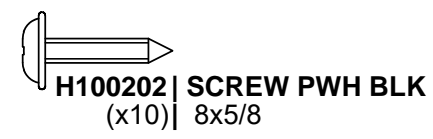
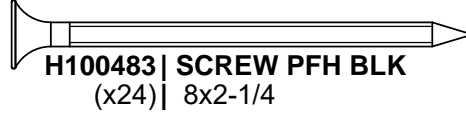
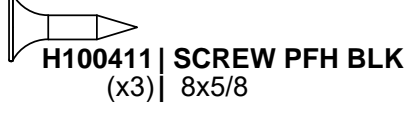
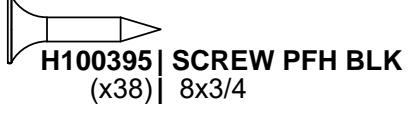
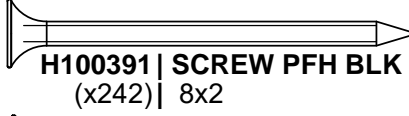
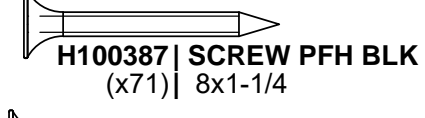
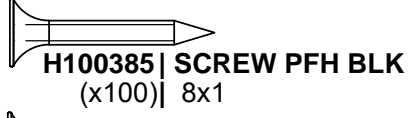
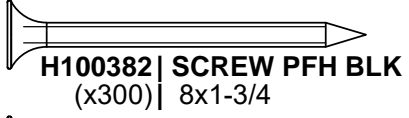
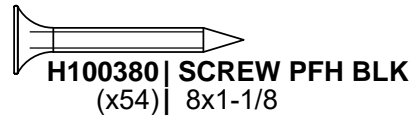
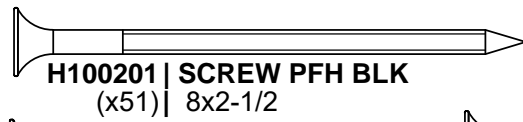
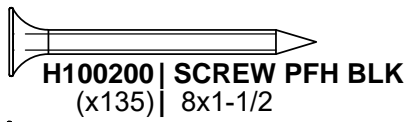
OWNER'S MANUAL - PARTS IDENTIFICATION

HARDWARE COMPONENTS



OWNER'S MANUAL - PARTS IDENTIFICATION

HARDWARE COMPONENTS



PRE-ASSEMBLY STEP 1 - SORTING PARTS

It is critical for ease of assembly that you take the time to sort and organize the wood and hardware.

WOOD PARTS:

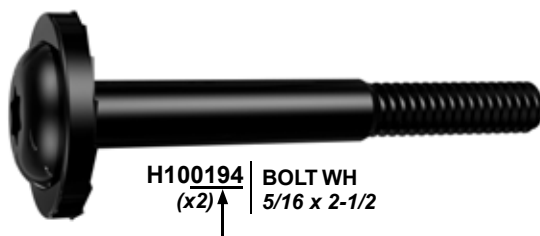
- Organize wood parts by the three-digit, alpha-numeric number stamped on each board (ex. P01).
- If there are multiple boards with the same stamped number, stack those pieces together.
- Stamps can be found on the flat surface of the boards or on the end of the boards.
- Allow yourself plenty of room - the wood pieces can take up a significant amount of space.

NOTE: CARTONS ARE NOT ORGANIZED BY BOARD NUMBER.



HARDWARE PARTS:

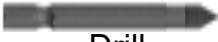
- We recommend that you have a separate table to organize the hardware.
- Hardware bags are printed with a seven-digit, alpha-numeric part number.
- You can organize your hardware by part number or group by hardware type (i.e. bolts, nuts, etc.).
- During assembly you only need to reference the last four digits of the number.



PRE-ASSEMBLY STEP 2 - TOOLS REQUIRED



Cordless Drill
or Electric Drill



Drill
Attachments:
Phillips Head



1/8", 3/16", 3/8" &
7/16" Drill Bits



Phillips Screw Driver



Open End
Wrenches 1/2"
& 9/16"



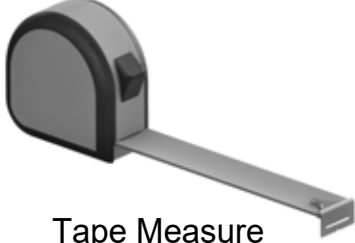
3/8" Drive Ratchet, 1/2" &
7/16" STD Sockets 1/2" & 7/16"
Deep Sockets



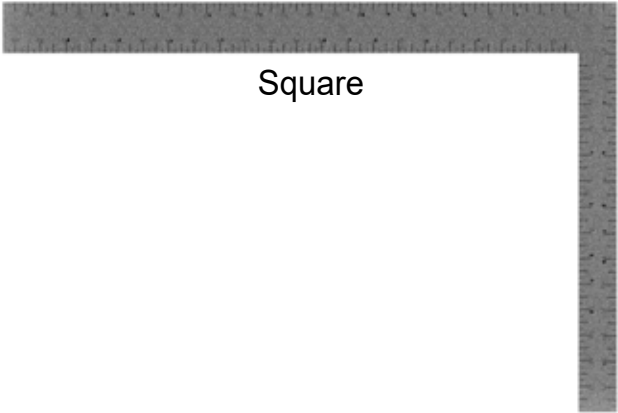
Claw Hammer



Rubber Mallet
- Optional



Tape Measure



Square

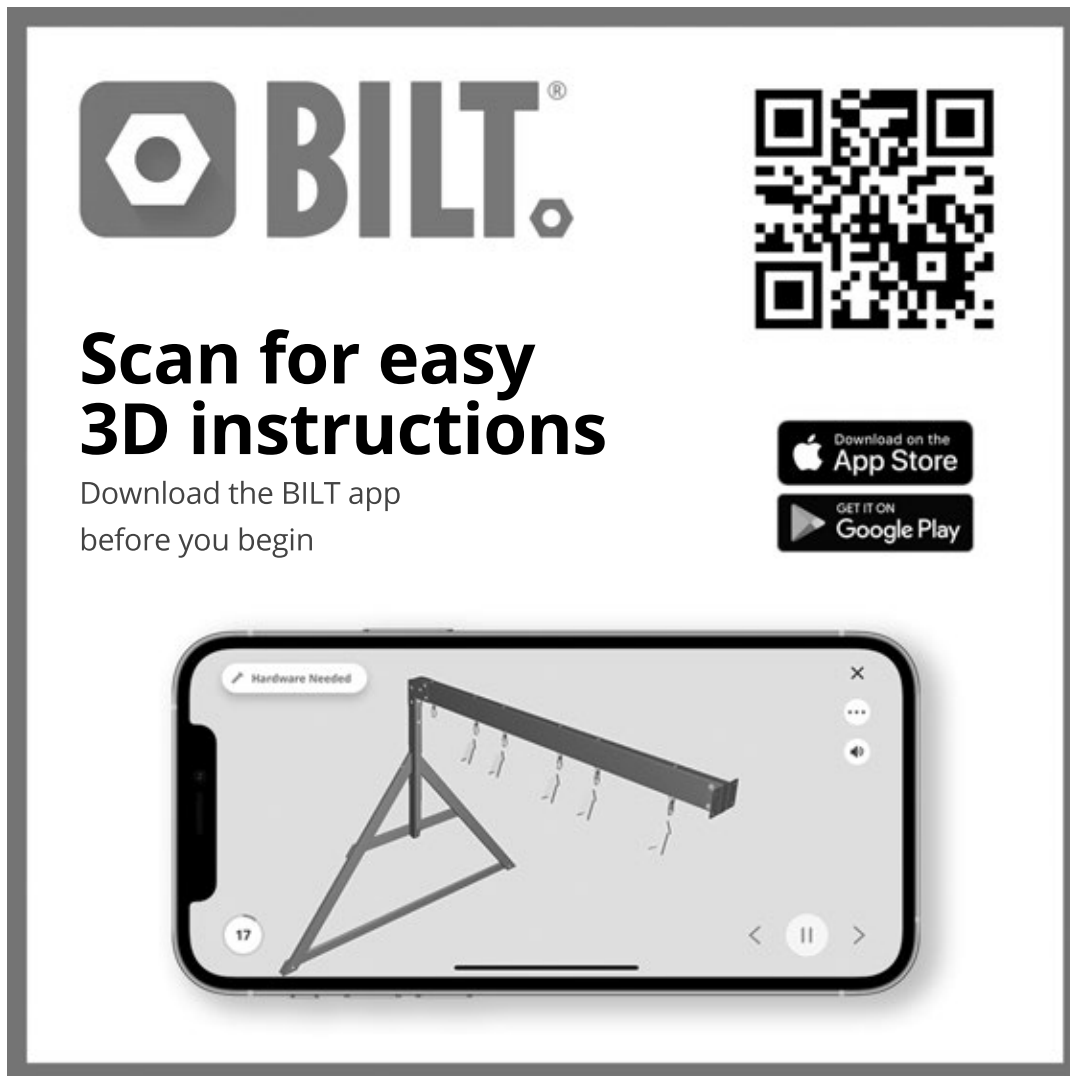


Level 24"

PRE-ASSEMBLY STEP 3 - CHOOSE YOUR ASSEMBLY METHOD

There are several types of assembly instructions available to you.

1. Printed Assembly Manual included with your set
2. BILT APP - 3D interactive instructions
3. Combination of the Printed Manual and BILT APP (Note: Step numbers can differ between the two methods)



The graphic features the BILT logo (a hexagon with a bolt head inside) and the word "BILT." in a bold, sans-serif font. To the right is a large QR code. Below the logo, the text "Scan for easy 3D instructions" is written in a large, bold font. Underneath that, it says "Download the BILT app before you begin". To the right of this text are two buttons: "Download on the App Store" and "GET IT ON Google Play". At the bottom, a smartphone screen displays a 3D assembly instruction for step 17, showing a metal frame with a horizontal bar and several bolts being attached. The screen has a "Hardware Needed" label at the top left, a close button (X) at the top right, and navigation arrows at the bottom.

STEP 4 - BACK WALL ASSEMBLY

QTY	PART NUMBER	DESCRIPTION
8	H100198	WASHER LOCK EXT 8x19
4	H100379	TNUT-5/16" BLK
4	H100415	BOLT WH 5/16x3 3/4 BLK
4	H100458	LAG SCREW WH 5/16x2 BLK

B02 POST - W4L19478
(x1) 3"x3"x88 3/4" (76x76x2254)

B04 POST - W4L19493
(x1) 3"x3"x88 3/4" (76x76x2254)

G02 BASE BOARD - W4L19491
(x1) 15/16"x5 1/4"x88 9/16" (24x134x2250)

H02 RUNNING BOARD - W4L19494
(x1) 15/16"x3 3/8"x88 9/16" (24x86x2250)

415 (x4)
BOLT - 3 3/4"

198 (x8)
WASHER - 8x19

379 (x4)
TNUT-5/16"

THE USE OF SAWHORSES IS RECOMMENDED DURING THE ASSEMBLY OF ALL WALL ASSEMBLIES.

INSERT T-NUTS FIRST. HAND TIGHTEN ONLY.

458 (x4)
LAG SCREW - 2"

PILOT HOLES FACE UP ON H02 AS SHOWN.

G02 (x1)
BASE BOARD

H02 (x1)
RUNNING BOARD

B02 (x1)
POST

B04 (x1)
POST

NOTE GROOVES FOR CORRECT ORIENTATION OF B02 AND B04. THIS IS CRITICAL TO LATER STEPS.

STEP 5 - BACK WALL ASSEMBLY

QTY	PART NUMBER	DESCRIPTION
4	H100193	NUT BARREL WH 5/16 X 1 1/2 BLK
8	H100198	WASHER LOCK EXT 8x19
4	H100205	BOLT WH 5/16x2 1/4 BLK
4	H100379	TNUT-5/16" BLK
4	H100407	BOLT WH 5/16x1 1/2 BLK

F05 UPRIGHT - W4L19495
(x1) 1 7/16"x2 3/8"x85 11/16" (36x60x2177)

F06 UPRIGHT - W4L19496
(x1) 1 7/16"x2 3/8"x85 11/16" (36x60x2177)



A4M02096 BRACKET
(x2)

193 (x4)
BARREL NUT - 1 1/2"

2096 (x2)
BRACKET

198 (x8)
WASHER - 8x19

407 (x4)
BOLT - 1 1/2"

INSERT T-NUTS FIRST. HAND TIGHTEN ONLY.

379 (x4)
TNUT-5/16"

205 (x4)
BOLT - 2 1/4"

F05 (x1)
UPRIGHT

F06 (x1)
UPRIGHT

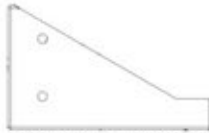
**NOTE GROOVES FOR CORRECT
ORIENTATION OF F05 AND F06.
THIS IS CRITICAL TO LATER STEPS.**

STEP 6 - BACK WALL ASSEMBLY

QTY	PART NUMBER	DESCRIPTION
4	H100195	BOLT WH 5/16x2 3/4 BLK
8	H100198	WASHER LOCK EXT 8x19
8	H100379	TNUT-5/16" BLK
4	H100974	BOLT WH 5/16x5 3/4 BLK

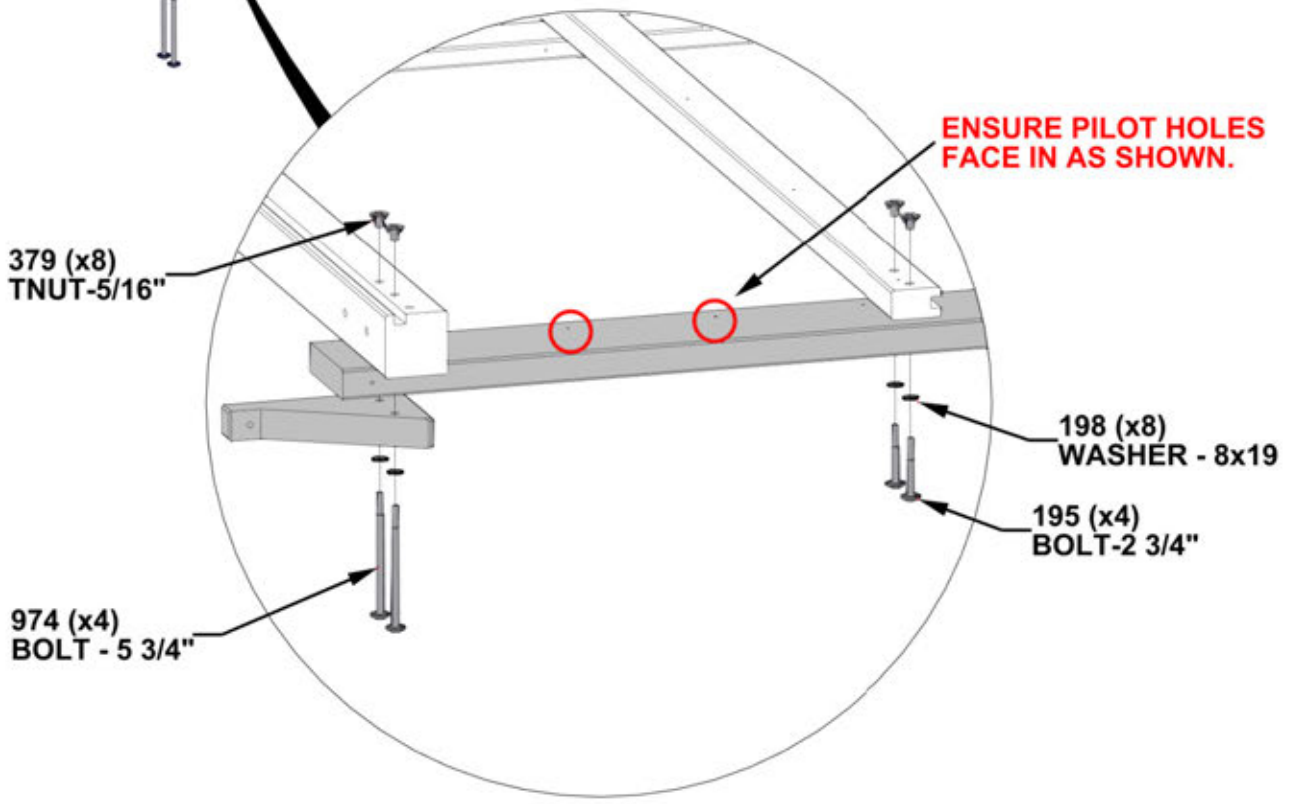
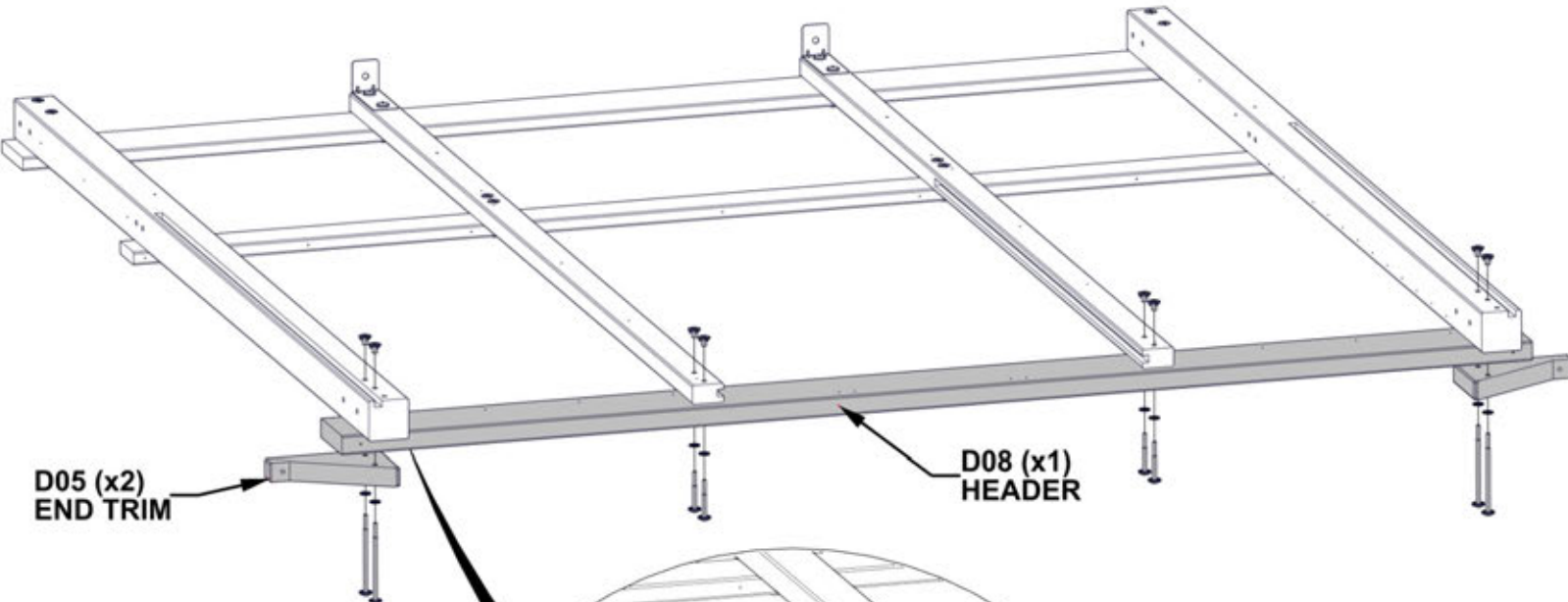


D08 HEADER - W4L19571
 (x1) 1 7/16"x5 1/4"x89 1/2" (36x134x2274)



D05 END TRIM - W4L19556
 (x2) 1 7/16"x134x219 (36x134x219)

INSERT T-NUTS FIRST. HAND TIGHTEN ONLY.



STEP 7 - SIDE WALL ASSEMBLY

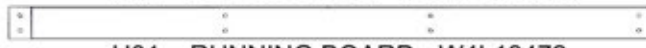
QTY	PART NUMBER	DESCRIPTION
2	H100195	BOLT WH 5/16x2 3/4 BLK
10	H100198	WASHER LOCK EXT 8x19
8	H100205	BOLT WH 5/16x2 1/4 BLK
10	H100379	TNUT-5/16" BLK



D01 HEADER - W4L19480
(x1) 1 7/16"x5 1/4"x67" (36x134x1702)



G01 BASE BOARD - W4L19474
(x1) 15/16"x5 1/4"x67" (24x134x1702)

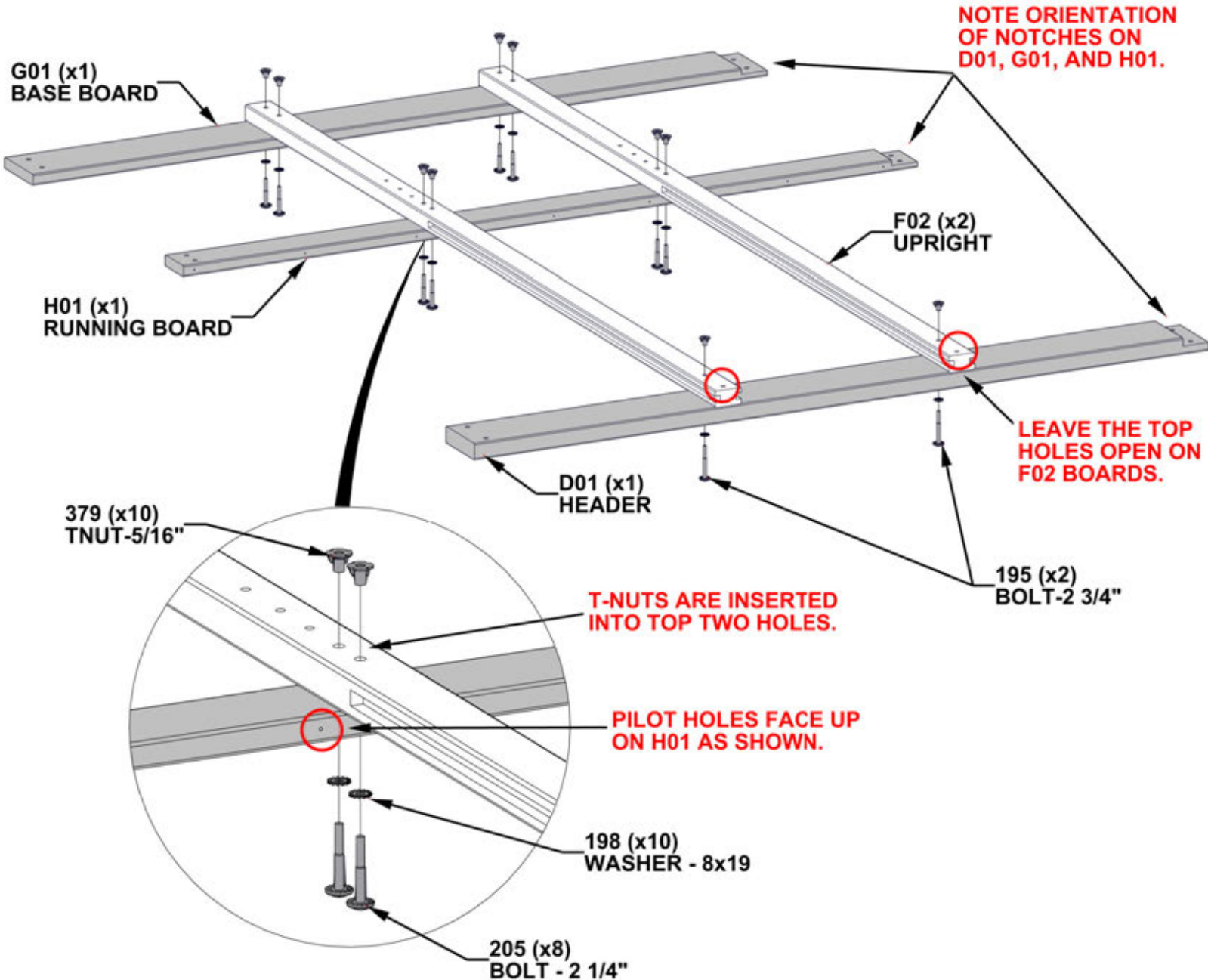


H01 RUNNING BOARD - W4L19472
(x1) 15/16"x3 3/8"x67" (24x86x1702)



F02 UPRIGHT - W4L19475
(x2) 1 7/16"x2 3/8"x86 11/16" (36x60x2202)

INSERT T-NUTS FIRST. HAND TIGHTEN ONLY.

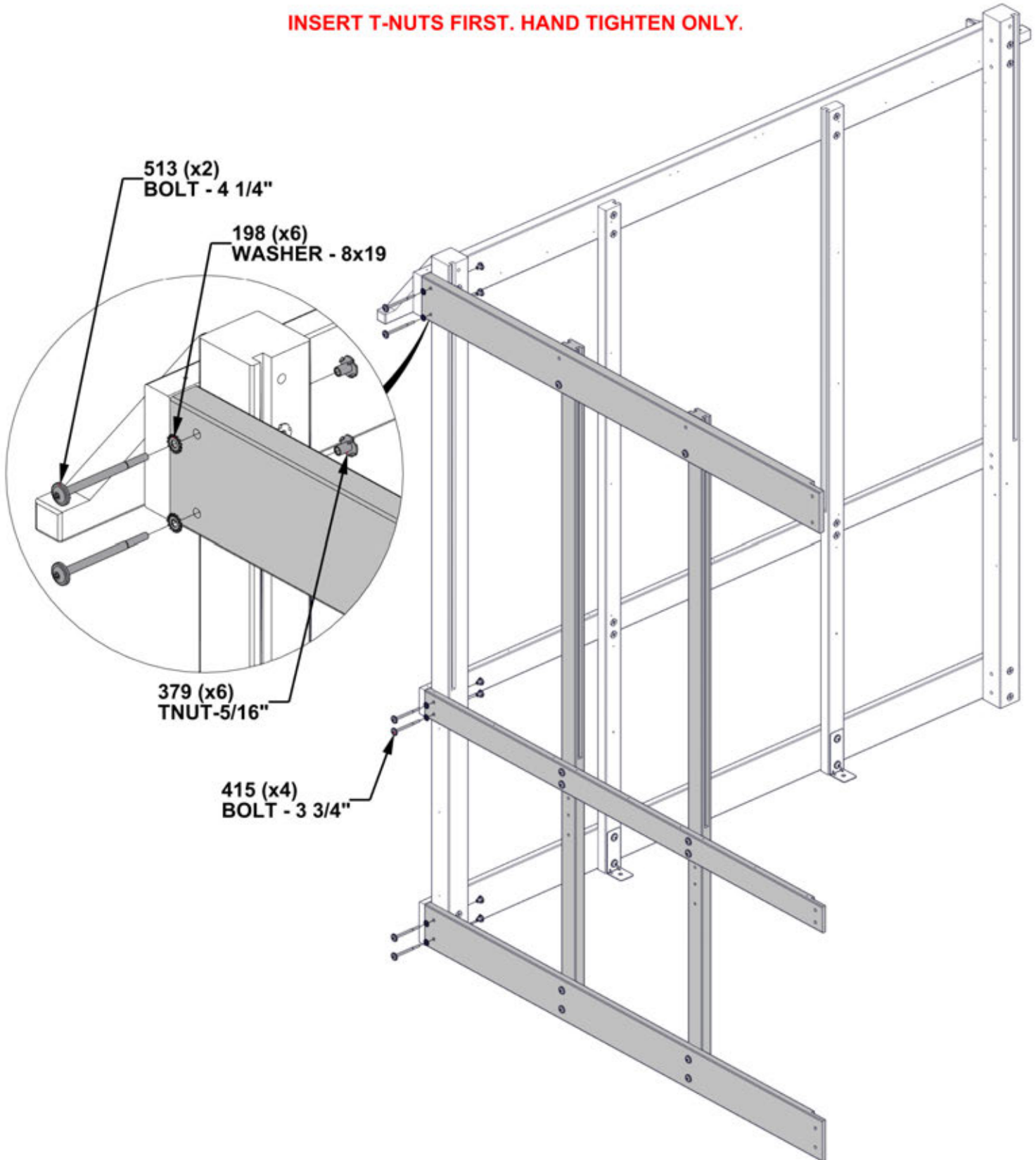


STEP 8 - GREENHOUSE ASSEMBLY

QTY	PART NUMBER	DESCRIPTION
6	H100198	WASHER LOCK EXT 8x19
6	H100379	TNUT-5/16" BLK
4	H100415	BOLT WH 5/16x3 3/4 BLK
2	H100513	BOLT WH 5/16x4 1/4 BLK

STAND UP THE SIDE AND BACK ASSEMBLIES AND BOLT TOGETHER AS SHOWN.

INSERT T-NUTS FIRST. HAND TIGHTEN ONLY.



STEP 9 - SIDE WALL ASSEMBLY

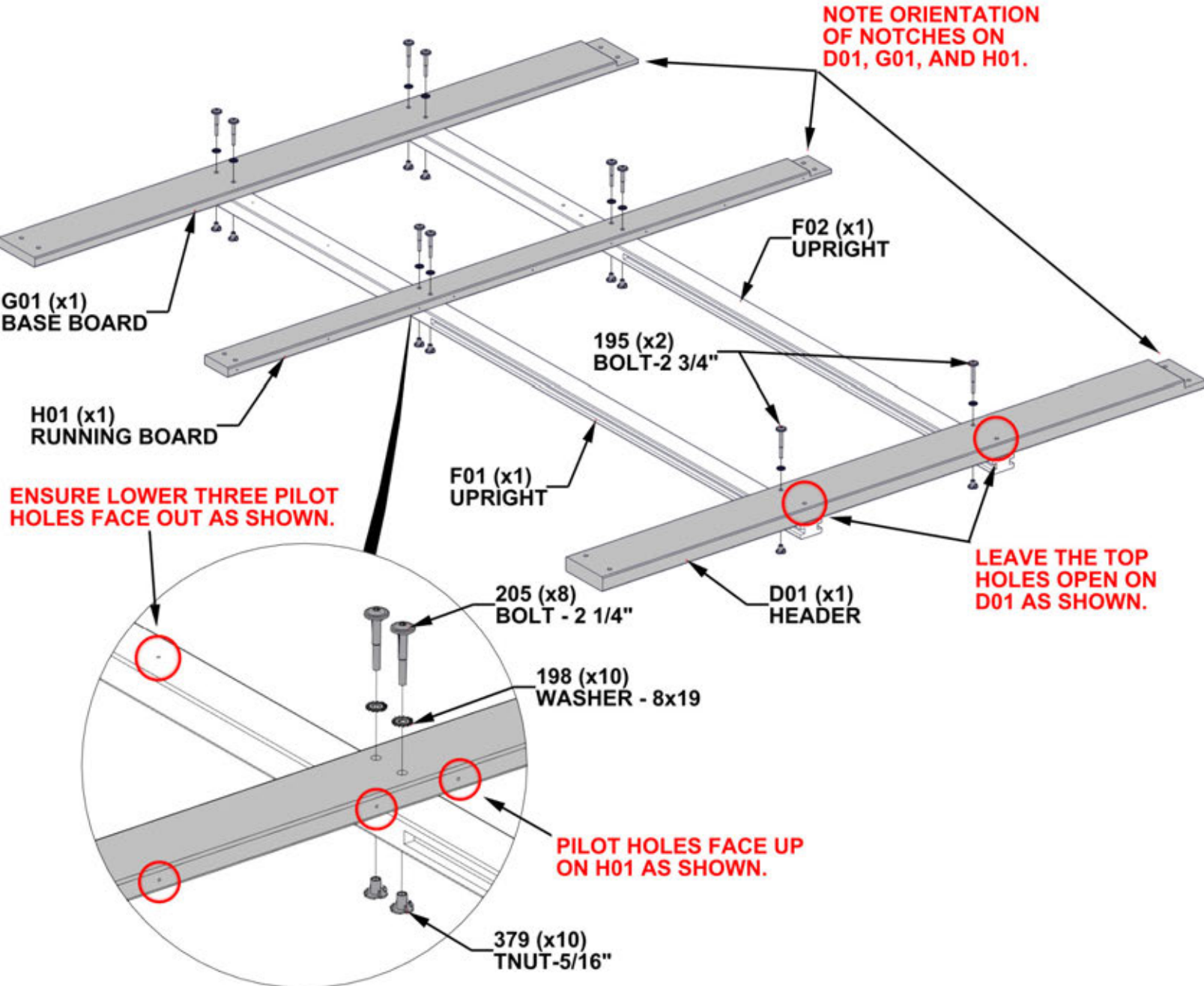
QTY	PART NUMBER	DESCRIPTION
2	H100195	BOLT WH 5/16x2 3/4 BLK
10	H100198	WASHER LOCK EXT 8x19
8	H100205	BOLT WH 5/16x2 1/4 BLK
10	H100379	TNUT-5/16" BLK

- D01 HEADER - W4L19480
(x1) 1 7/16"x5 1/4"x67" (36x134x1702)
- G01 BASE BOARD - W4L19474
(x1) 15/16"x5 1/4"x67" (24x134x1702)
- H01 RUNNING BOARD - W4L19472
(x1) 15/16"x3 3/8"x67" (24x86x1702)

- F01 UPRIGHT - W4L19473
(x1) 1 7/16"x2 3/8"x86 11/16" (36x60x2202)
- F02 UPRIGHT - W4L19475
(x1) 1 7/16"x2 3/8"x86 11/16" (36x60x2202)

INSERT T-NUTS FIRST. HAND TIGHTEN ONLY.

NOTE ORIENTATION OF NOTCHES ON D01, G01, AND H01.



STEP 10 - GREENHOUSE ASSEMBLY

QTY	PART NUMBER	DESCRIPTION
1	H100195	BOLT WH 5/16x2 3/4 BLK
5	H100198	WASHER LOCK EXT 8x19
4	H100205	BOLT WH 5/16x2 1/4 BLK
5	H100379	TNUT-5/16" BLK

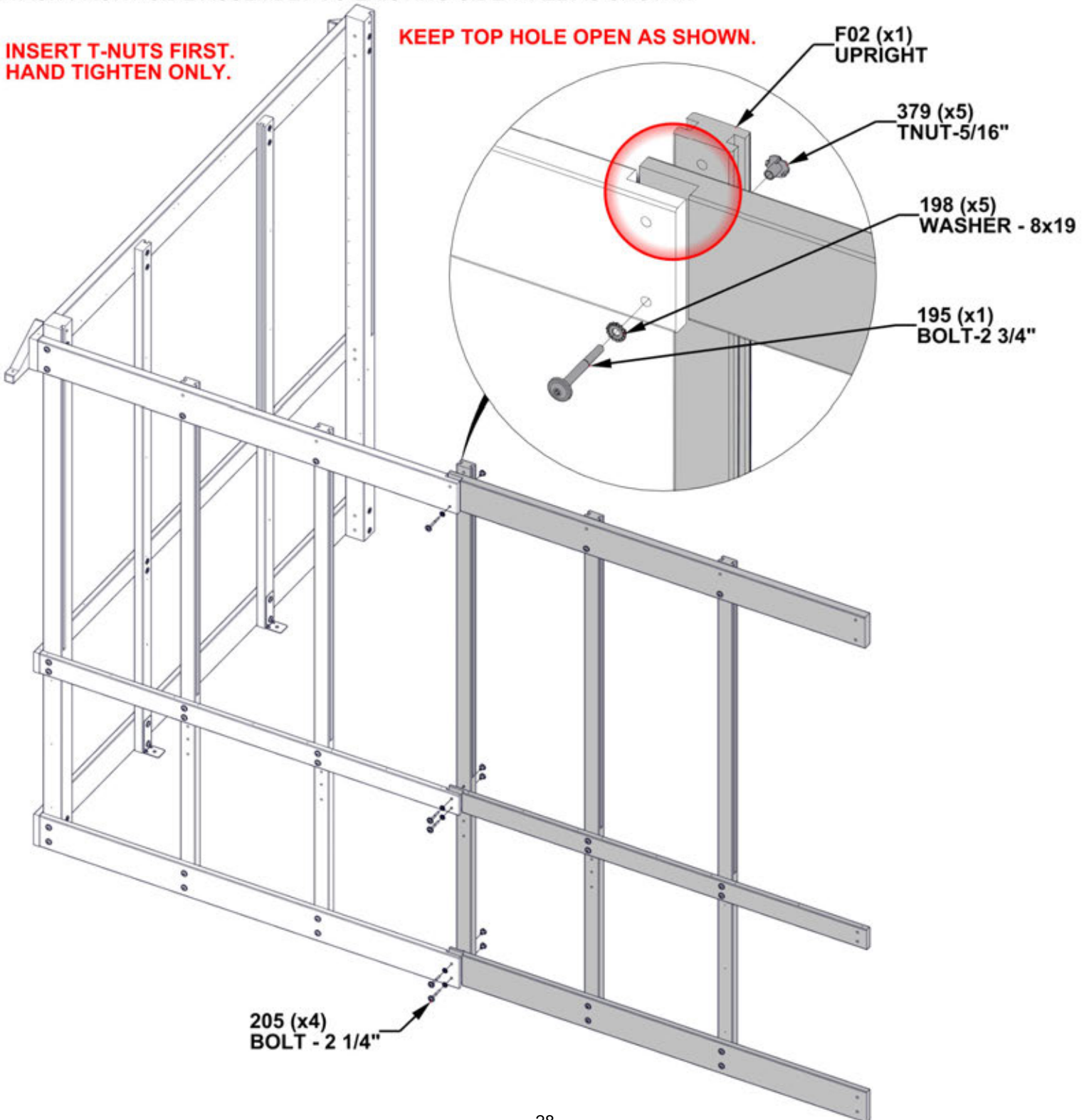


F02 UPRIGHT - W4L19475
(x1) 1 7/16"x2 3/8"x86 11/16" (36x60x2202)

ATTACH FRONT SIDE ASSEMBLY TO EXISTING SIDE WALL AS SHOWN.

**INSERT T-NUTS FIRST.
HAND TIGHTEN ONLY.**

KEEP TOP HOLE OPEN AS SHOWN.



STEP 11 - SIDE WALL ASSEMBLY

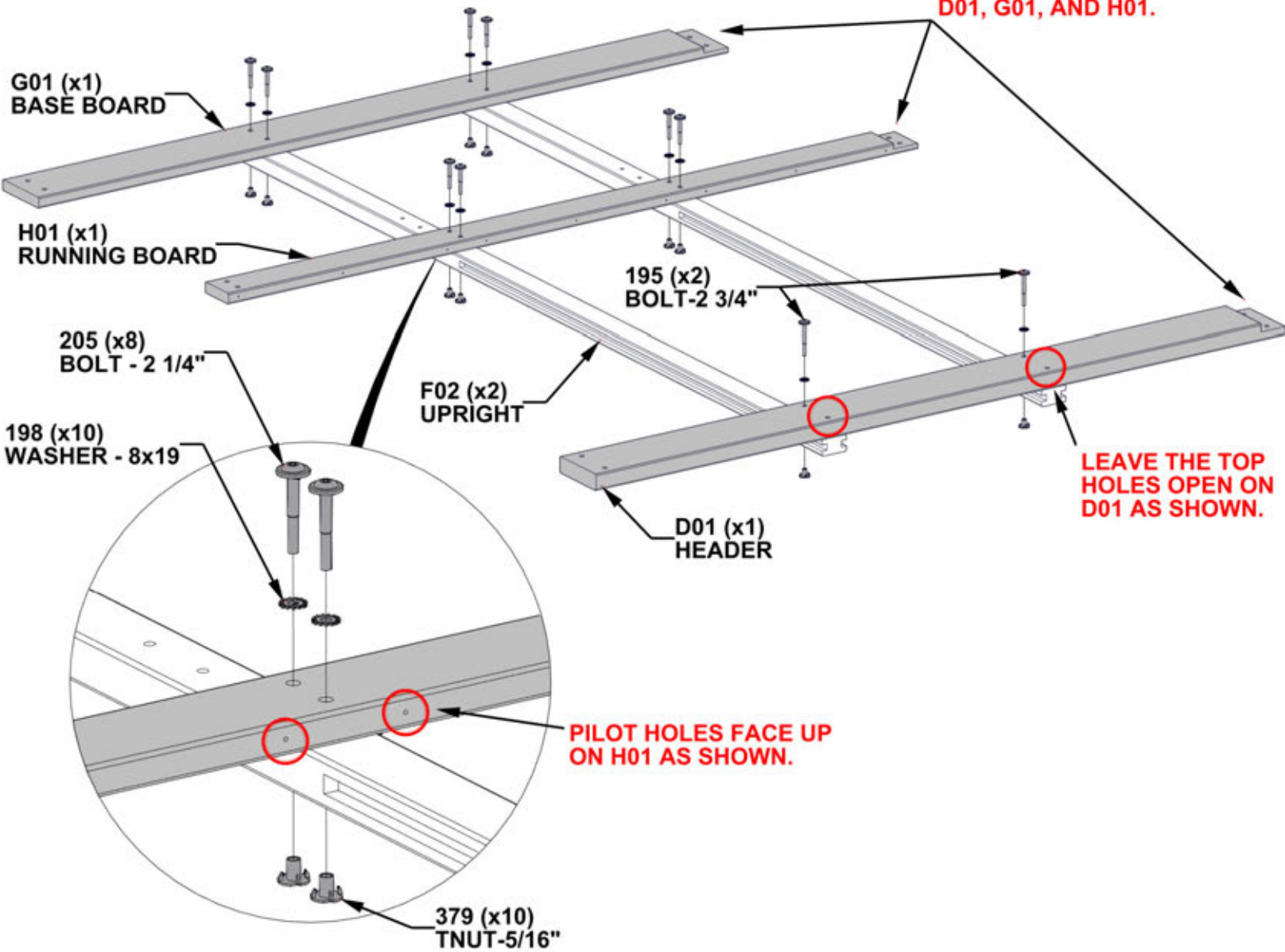
QTY	PART NUMBER	DESCRIPTION
2	H100195	BOLT WH 5/16x2 3/4 BLK
10	H100198	WASHER LOCK EXT 8x19
8	H100205	BOLT WH 5/16x2 1/4 BLK
10	H100379	TNUT-5/16" BLK

- D01 HEADER - W4L19480
(x1) 1 7/16"x5 1/4"x67" (36x134x1702)
- G01 BASE BOARD - W4L19474
(x1) 15/16"x5 1/4"x67" (24x134x1702)
- H01 RUNNING BOARD - W4L19472
(x1) 15/16"x3 3/8"x67" (24x86x1702)

- F02 UPRIGHT - W4L19475
(x2) 1 7/16"x2 3/8"x86 11/16" (36x60x2202)

INSERT T-NUTS FIRST. HAND TIGHTEN ONLY.

NOTE ORIENTATION OF NOTCHES ON D01, G01, AND H01.

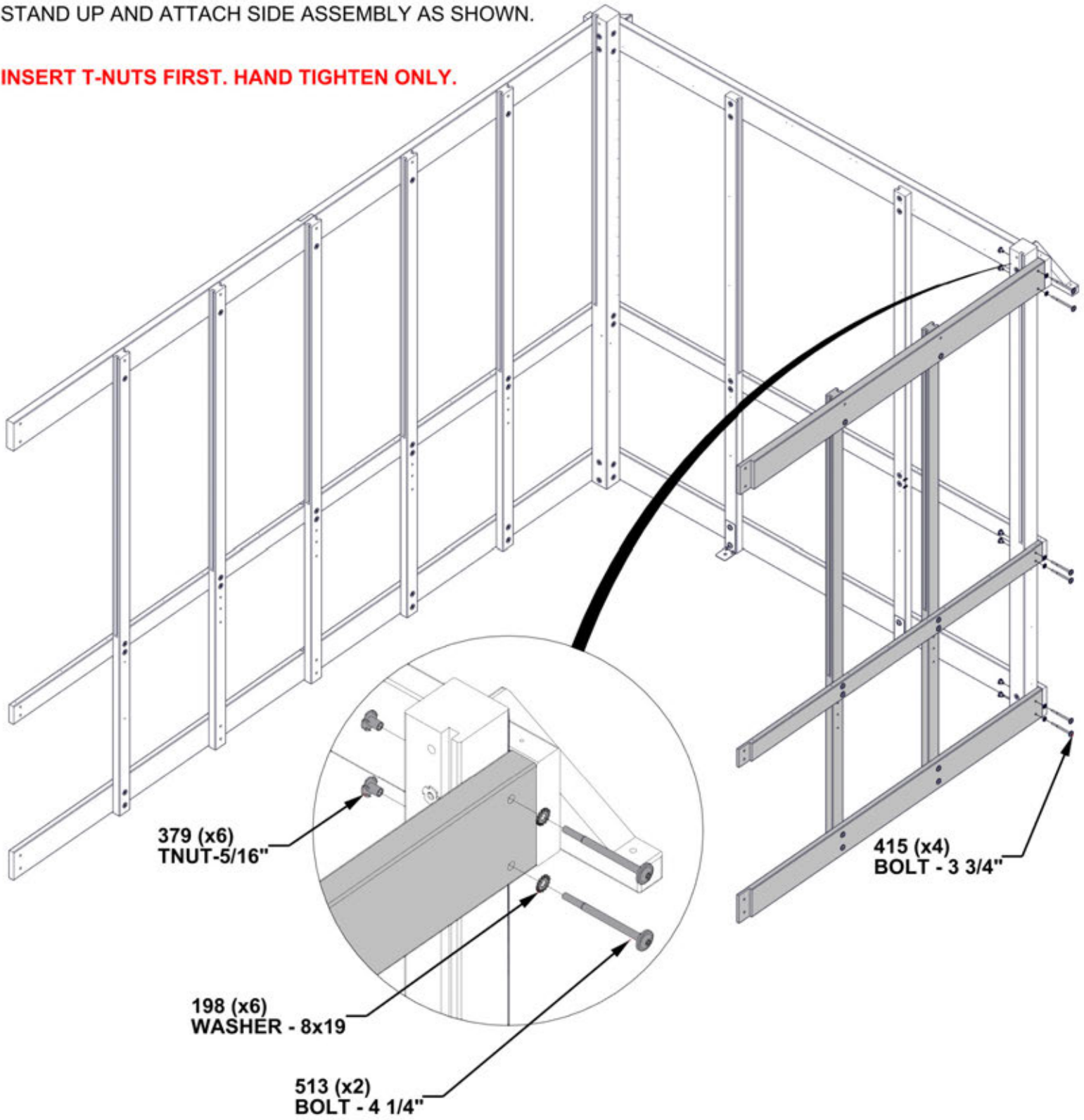


STEP 12 - GREENHOUSE ASSEMBLY

QTY	PART NUMBER	DESCRIPTION
6	H100198	WASHER LOCK EXT 8x19
6	H100379	TNUT-5/16" BLK
4	H100415	BOLT WH 5/16x3 3/4 BLK
2	H100513	BOLT WH 5/16x4 1/4 BLK

STAND UP AND ATTACH SIDE ASSEMBLY AS SHOWN.

INSERT T-NUTS FIRST. HAND TIGHTEN ONLY.



STEP 13 - SIDE WALL ASSEMBLY

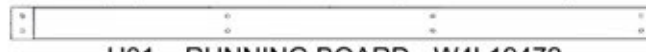
QTY	PART NUMBER	DESCRIPTION
2	H100195	BOLT WH 5/16x2 3/4 BLK
10	H100198	WASHER LOCK EXT 8x19
8	H100205	BOLT WH 5/16x2 1/4 BLK
10	H100379	TNUT-5/16" BLK



D01 HEADER - W4L19480
(x1) 1 7/16"x5 1/4"x67" (36x134x1702)



G01 BASE BOARD - W4L19474
(x1) 15/16"x5 1/4"x67" (24x134x1702)



H01 RUNNING BOARD - W4L19472
(x1) 15/16"x3 3/8"x67" (24x86x1702)



F01 UPRIGHT - W4L19473
(x1) 1 7/16"x2 3/8"x86 11/16" (36x60x2202)



F02 UPRIGHT - W4L19475
(x1) 1 7/16"x2 3/8"x86 11/16" (36x60x2202)

INSERT T-NUTS FIRST. HAND TIGHTEN ONLY.

ENSURE LOWER THREE PILOT HOLES FACE OUT AS SHOWN.

PILOT HOLES FACE UP ON H01 AS SHOWN.

205 (x8)
BOLT - 2 1/4"

198 (x10)
WASHER - 8x19

379 (x10)
TNUT-5/16"

195 (x2)
BOLT-2 3/4"

G01 (x1)
BASE BOARD

H01 (x1)
RUNNING BOARD

F02 (x1)
UPRIGHT

F01 (x1)
UPRIGHT

D01 (x1)
HEADER

NOTE ORIENTATION OF NOTCHES ON D01, G01, AND H01.

LEAVE THE TOP HOLES OPEN ON D01 AS SHOWN.

STEP 14 - GREENHOUSE ASSEMBLY

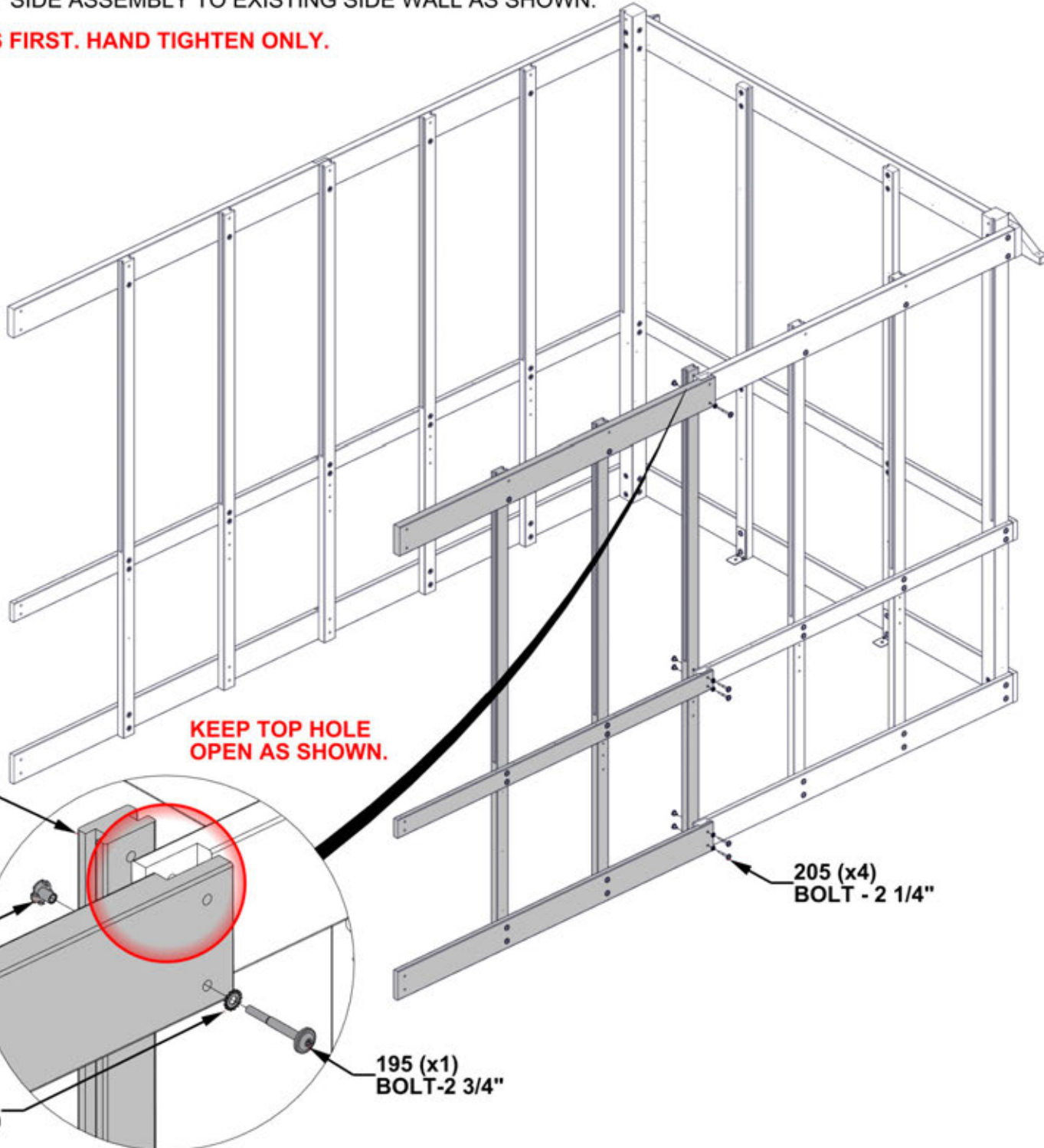
QTY	PART NUMBER	DESCRIPTION
1	H100195	BOLT WH 5/16x2 3/4 BLK
5	H100198	WASHER LOCK EXT 8x19
4	H100205	BOLT WH 5/16x2 1/4 BLK
5	H100379	TNUT-5/16" BLK



F02 UPRIGHT - W4L19475
(x1) 1 7/16"x2 3/8"x86 11/16" (36x60x2202)

ATTACH FRONT SIDE ASSEMBLY TO EXISTING SIDE WALL AS SHOWN.

INSERT T-NUTS FIRST. HAND TIGHTEN ONLY.



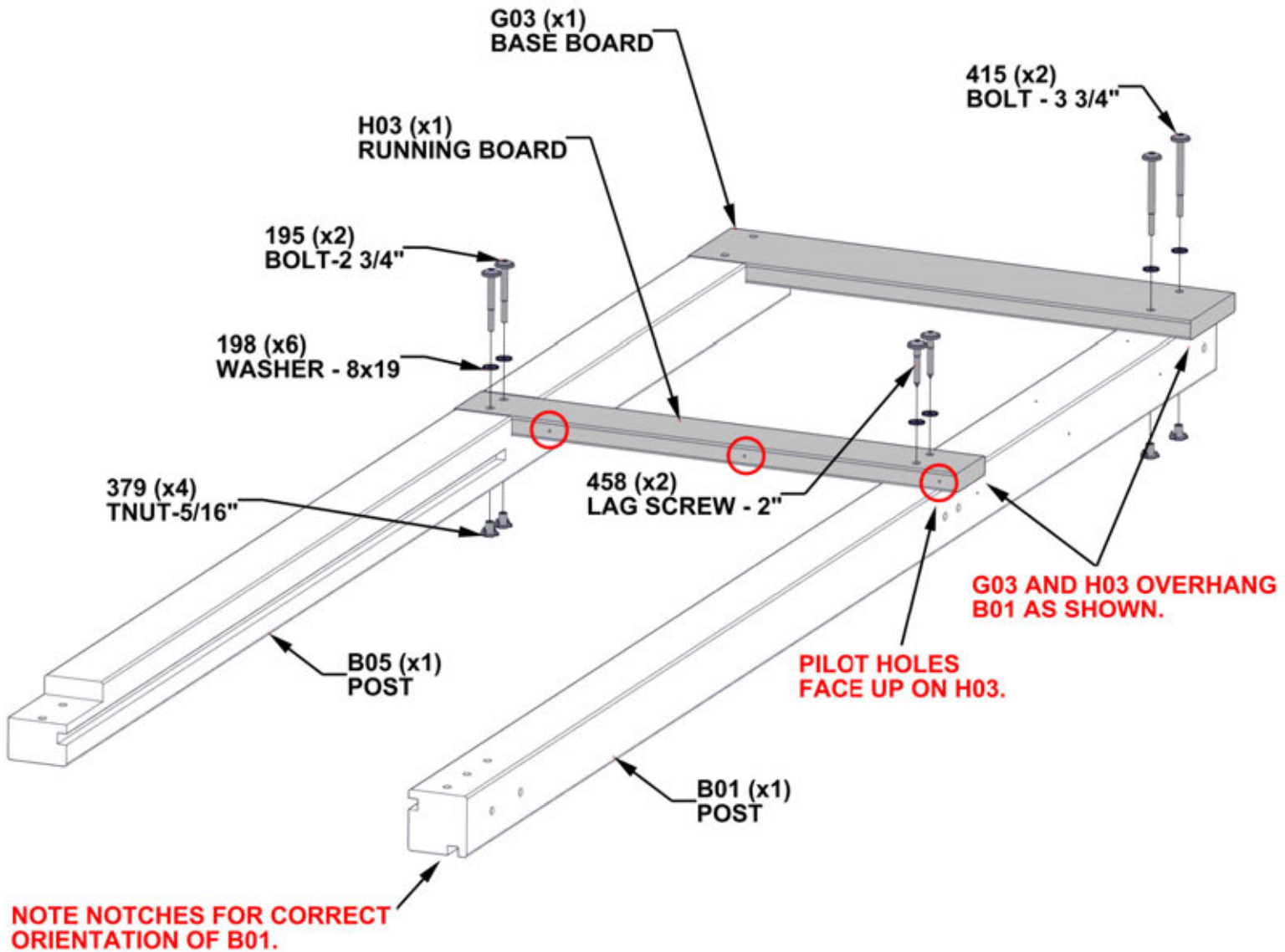
STEP 15 - FRONT WALL ASSEMBLY

QTY	PART NUMBER	DESCRIPTION
2	H100195	BOLT WH 5/16x2 3/4 BLK
6	H100198	WASHER LOCK EXT 8x19
4	H100379	TNUT-5/16" BLK
2	H100415	BOLT WH 5/16x3 3/4 BLK
2	H100458	LAG SCREW WH 5/16x2 BLK

- B01 POST - W4L19471
(x1) 3"x3"x88 3/4" (76x76x2254)
- B05 POST - W4L19497
(x1) 3"x3"x85 11/16" (76x76x2177)
- G03 BASE BOARD - W4L19501
(x1) 15/16"x5 1/4"x25 13/16" (24x134x655)

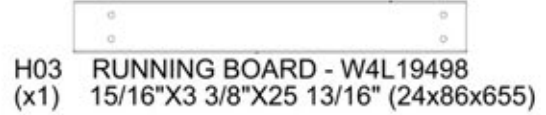
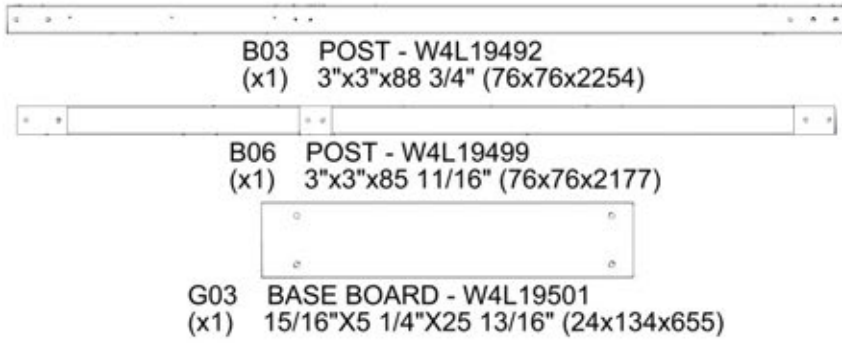
- H03 RUNNING BOARD - W4L19498
(x1) 15/16"x3 3/8"x25 13/16" (24x86x655)

INSERT T-NUTS FIRST. HAND TIGHTEN ONLY.

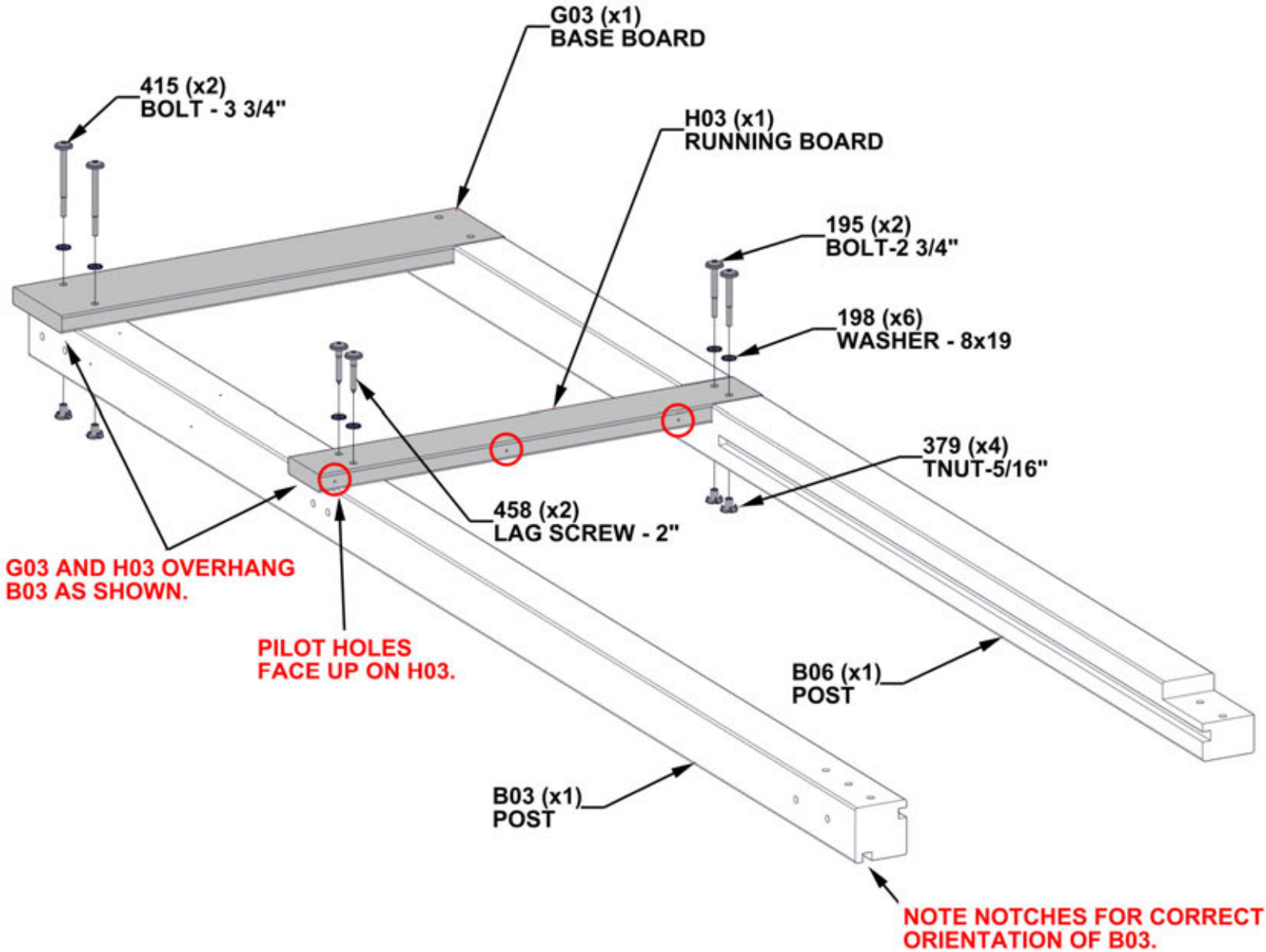


STEP 16 - FRONT WALL ASSEMBLY

QTY	PART NUMBER	DESCRIPTION
2	H100195	BOLT WH 5/16x2 3/4 BLK
6	H100198	WASHER LOCK EXT 8x19
4	H100379	TNUT-5/16" BLK
2	H100415	BOLT WH 5/16x3 3/4 BLK
2	H100458	LAG SCREW WH 5/16x2 BLK



INSERT T-NUTS FIRST. HAND TIGHTEN ONLY.



STEP 17 - FRONT WALL ASSEMBLY

QTY	PART NUMBER	DESCRIPTION
6	H100198	WASHER LOCK EXT 8x19
6	H100379	TNUT-5/16" BLK
2	H100503	BOLT WH 5/16x3 1/2 BLK
4	H100974	BOLT WH 5/16x5 3/4 BLK

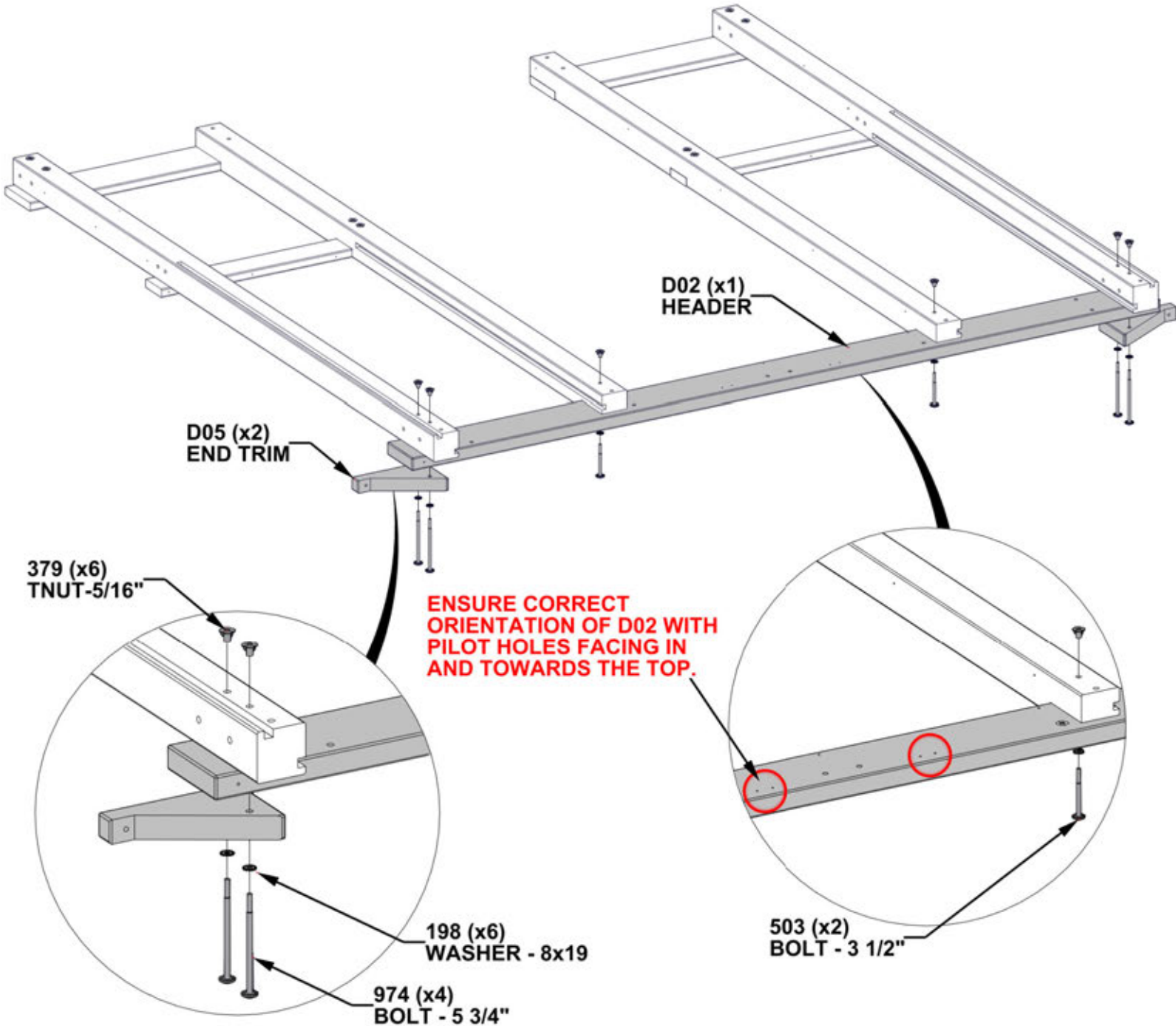


D02 HEADER - W4L19500
(x1) 1 7/16"x5 1/4"x89 1/2" (36x134x2274)



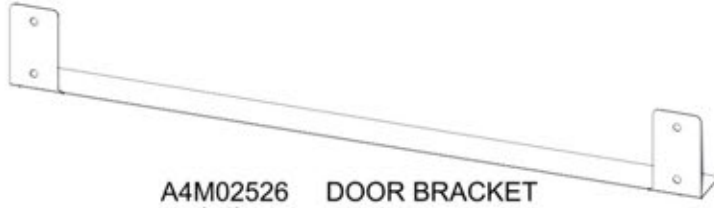
D05 END TRIM - W4L19556
(x2) 1 7/16"x134x219 (36x134x219)

INSERT T-NUTS FIRST. HAND TIGHTEN ONLY.



STEP 18 - FRONT WALL ASSEMBLY

QTY	PART NUMBER	DESCRIPTION
4	H100193	NUT BARREL WH 5/16 X 1 1/2 BLK
4	H100198	WASHER LOCK EXT 8x19
4	H100205	BOLT WH 5/16x2 1/4 BLK

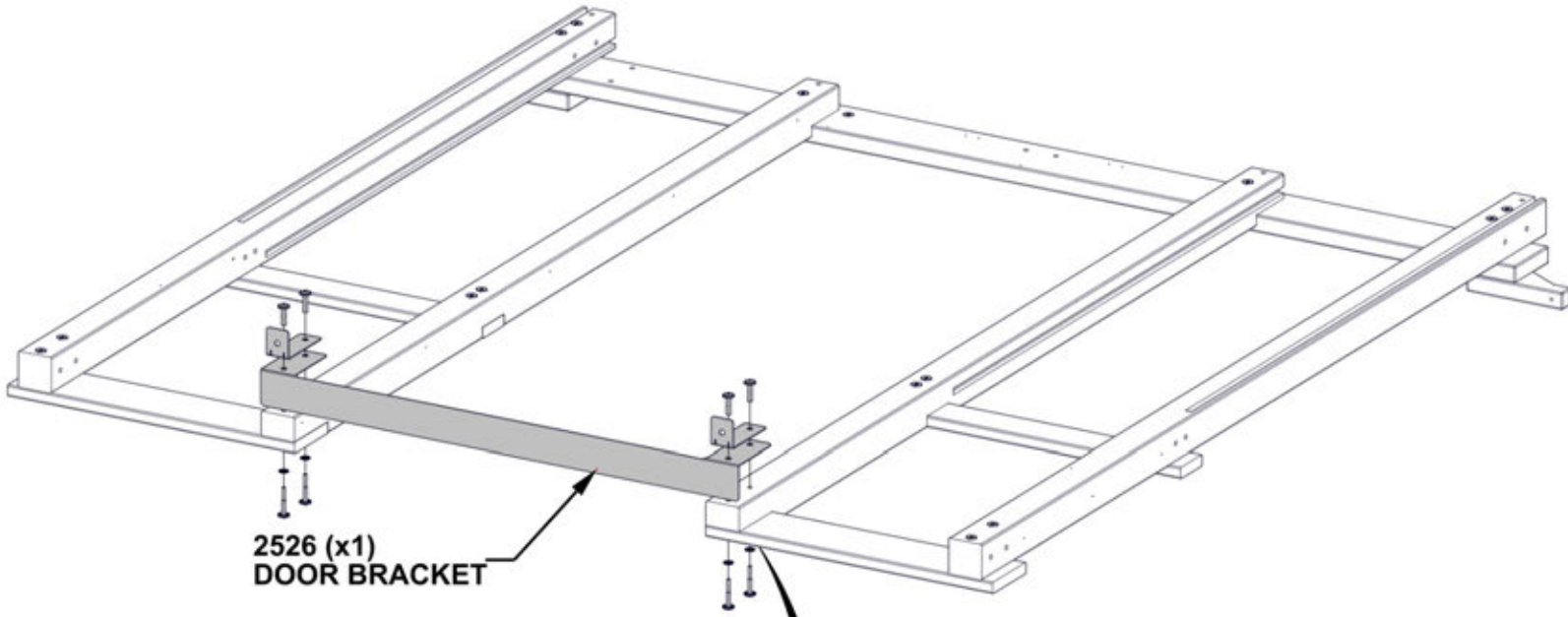


A4M02526 DOOR BRACKET
(x1)

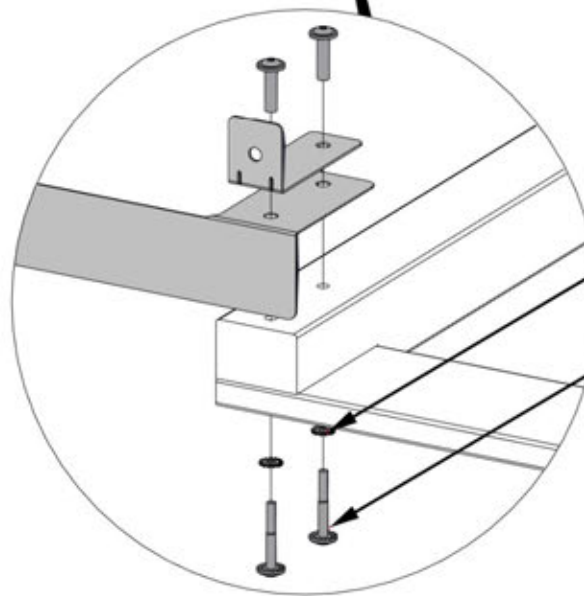


A4M02096 BRACKET
(x2)

HAND TIGHTEN ONLY.



2526 (x1)
DOOR BRACKET

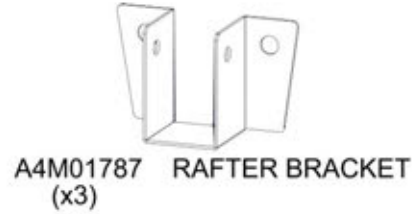
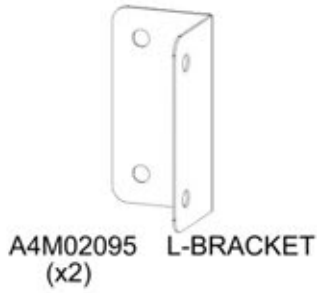


198 (x4)
WASHER - 8x19

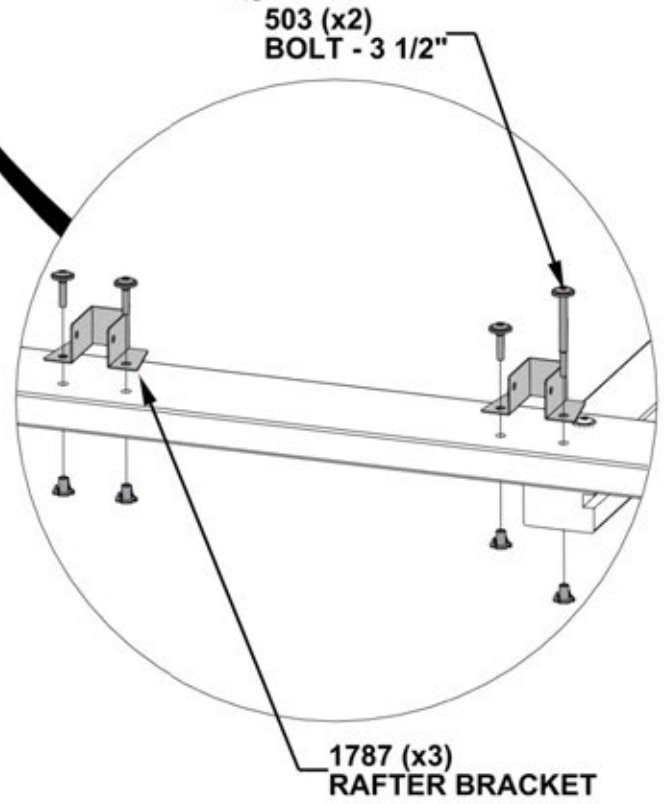
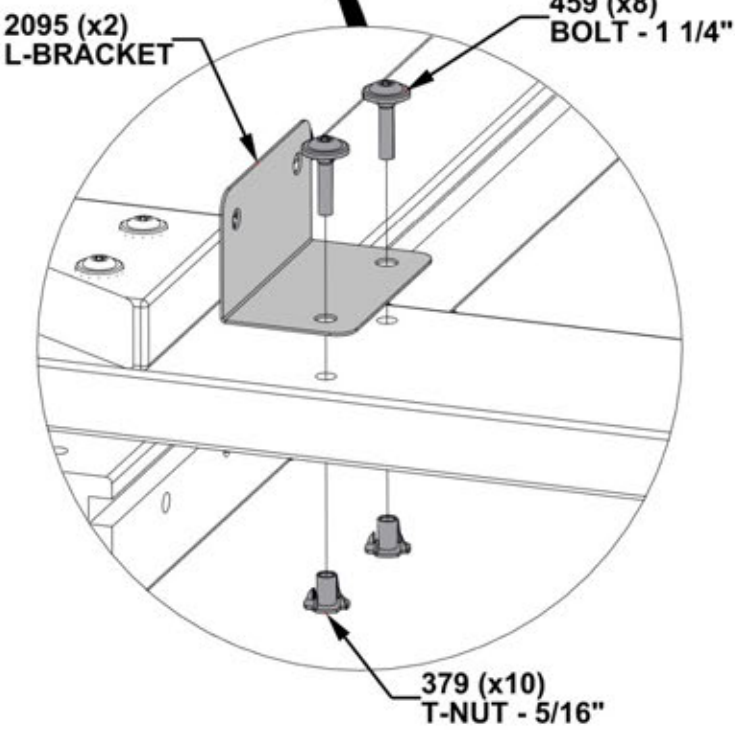
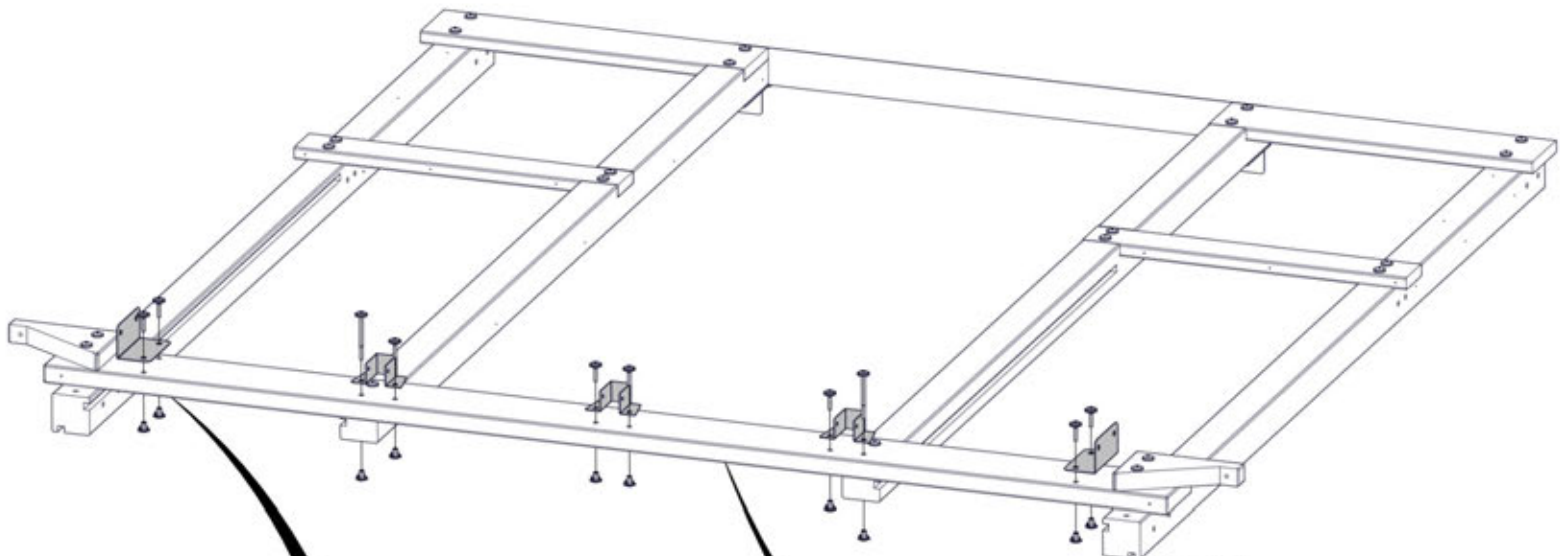
205 (x4)
BOLT - 2 1/4"

STEP 19 - FRONT WALL ASSEMBLY

QTY	PART NUMBER	DESCRIPTION
10	H100379	T-NUT 5/16 BLK
8	H100459	BOLT WH 5/16x1 1/4 BLK
2	H100503	BOLT WH 5/16x3 1/2 BLK



INSERT T-NUTS FIRST. HAND TIGHTEN ONLY.



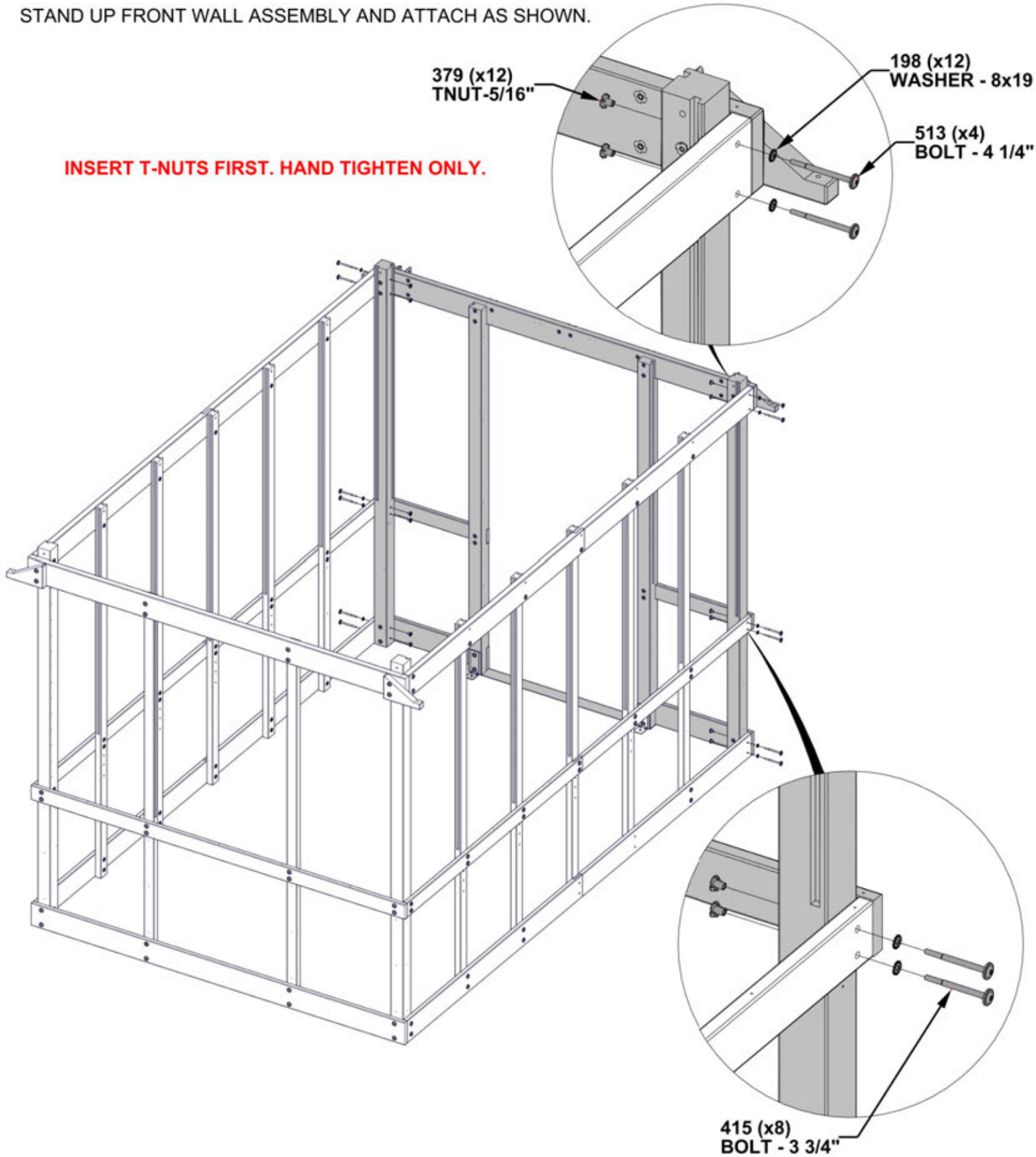
ENSURE CORRECT ORIENTATION OF BRACKETS AS SHOWN.

STEP 20 - GAZEBO ASSEMBLY

QTY	PART NUMBER	DESCRIPTION
12	H100198	WASHER LOCK EXT 8x19
12	H100379	TNUT-5/16" BLK
8	H100415	BOLT WH 5/16x3 3/4 BLK
4	H100513	BOLT WH 5/16x4 1/4 BLK

STAND UP FRONT WALL ASSEMBLY AND ATTACH AS SHOWN.

INSERT T-NUTS FIRST. HAND TIGHTEN ONLY.



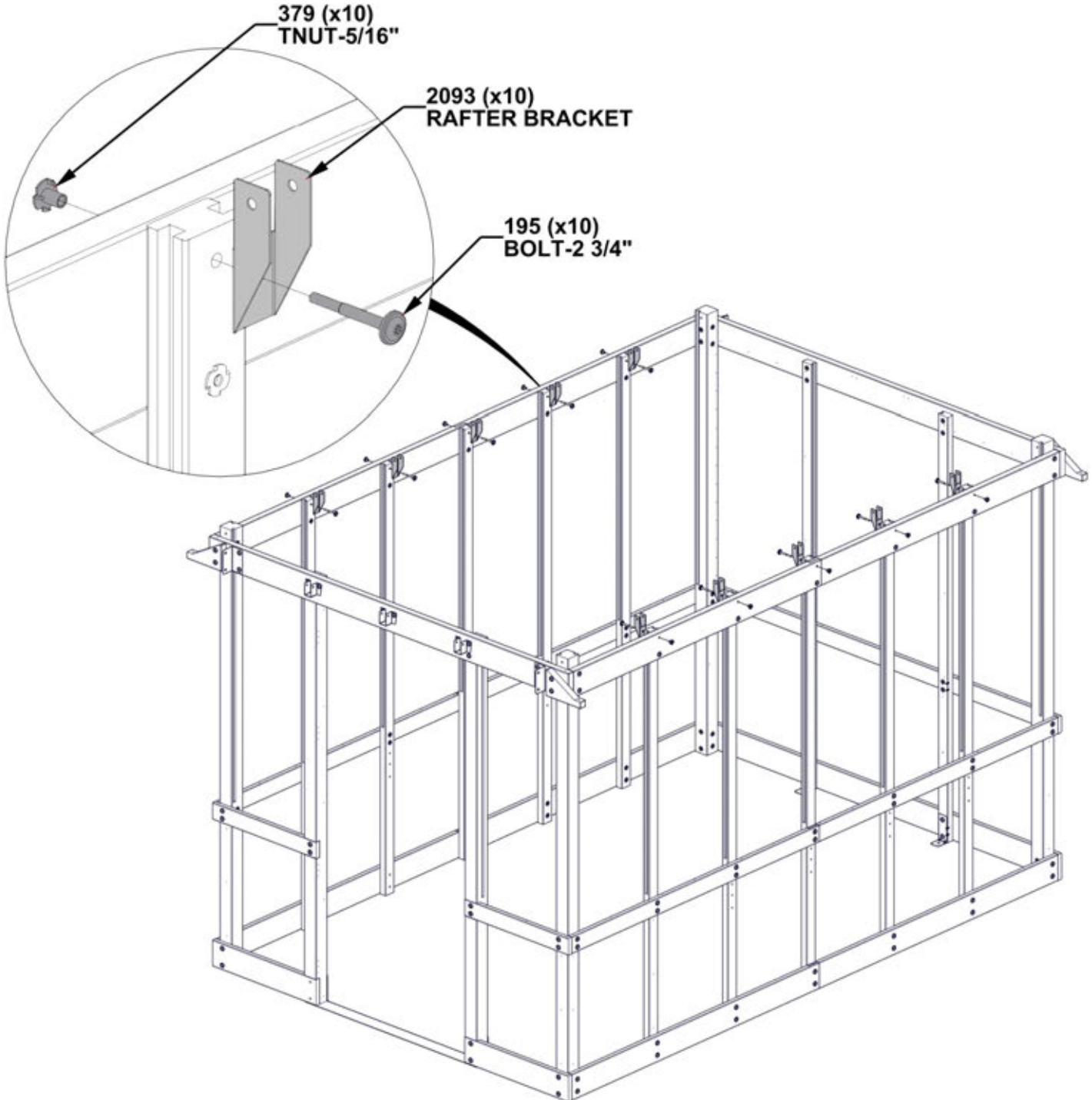
STEP 21 - RAFTER BRACKET ASSEMBLY

QTY	PART NUMBER	DESCRIPTION
10	H100195	BOLT WH 5/16x2 3/4 BLK
10	H100379	TNUT-5/16" BLK



A4M02093 RAFTER BRACKET
(x10)

INSERT T-NUTS FIRST. HAND TIGHTEN ONLY.

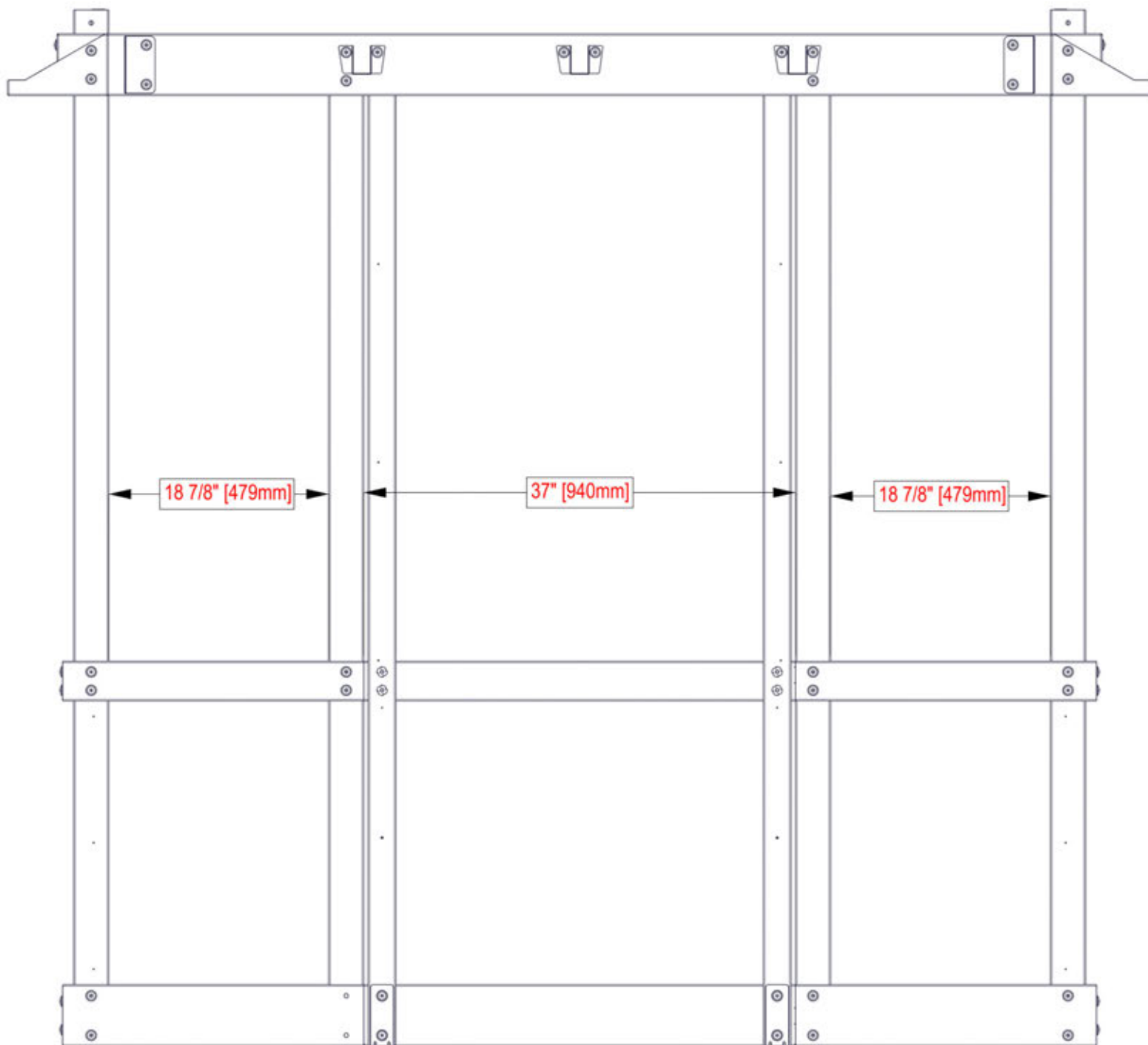


STEP 22 - GREENHOUSE ASSEMBLY

IMPORTANT!

STARTING WITH THIS SIDE, ENSURE THAT:

- POSTS AND UPRIGHTS ARE PLUMB (STRAIGHT UP AND DOWN) WITH A LEVEL.
- MEASUREMENTS BETWEEN POSTS AND UPRIGHTS ARE AS SHOWN +/- 1/8".
- RUNNING AND BASE BOARDS ARE SQUARED TO THE UPRIGHTS.
- ALL HARDWARE ON THIS SIDE IS FULLY TIGHTENED.

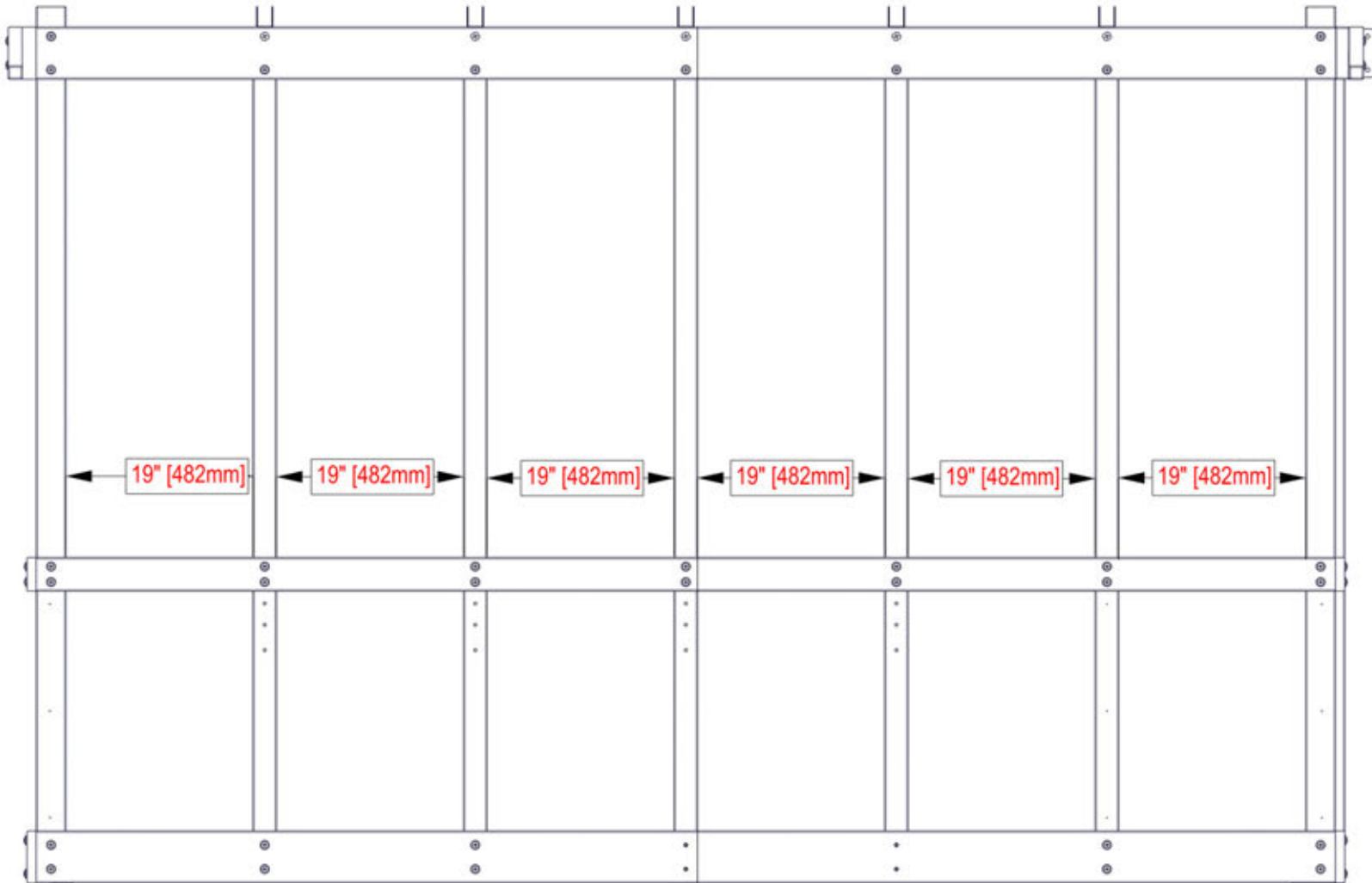


STEP 23 - GREENHOUSE ASSEMBLY

IMPORTANT!

GOING TO THE NEXT SIDE, ENSURE THAT:

- POSTS AND UPRIGHTS ARE PLUMB (STRAIGHT UP AND DOWN) WITH A LEVEL.
- MEASUREMENTS BETWEEN POSTS AND UPRIGHTS ARE 19" +/- 1/8" [482mm] AS SHOWN.
- RUNNING AND BASE BOARDS ARE SQUARED TO THE UPRIGHTS.
- ALL HARDWARE ON THIS SIDE IS FULLY TIGHTENED.

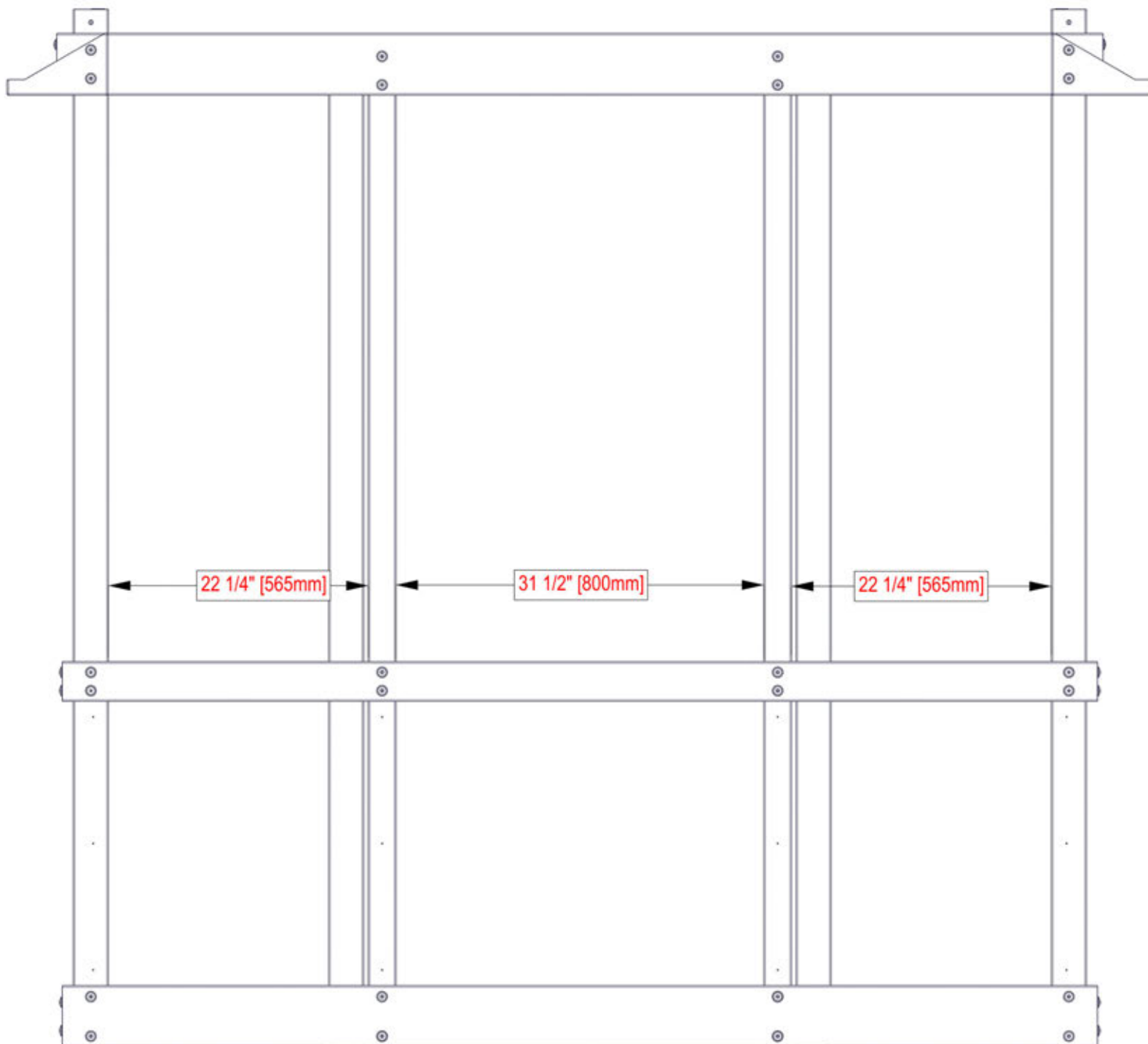


STEP 24 - GREENHOUSE ASSEMBLY

IMPORTANT!

GOING TO THE NEXT SIDE, ENSURE THAT:

- POSTS AND UPRIGHTS ARE PLUMB (STRAIGHT UP AND DOWN) WITH A LEVEL.
- MEASUREMENTS BETWEEN POSTS AND UPRIGHTS ARE AS SHOWN +/- 1/8".
- RUNNING AND BASE BOARDS ARE SQUARED TO THE UPRIGHTS.
- ALL HARDWARE ON THIS SIDE IS FULLY TIGHTENED.

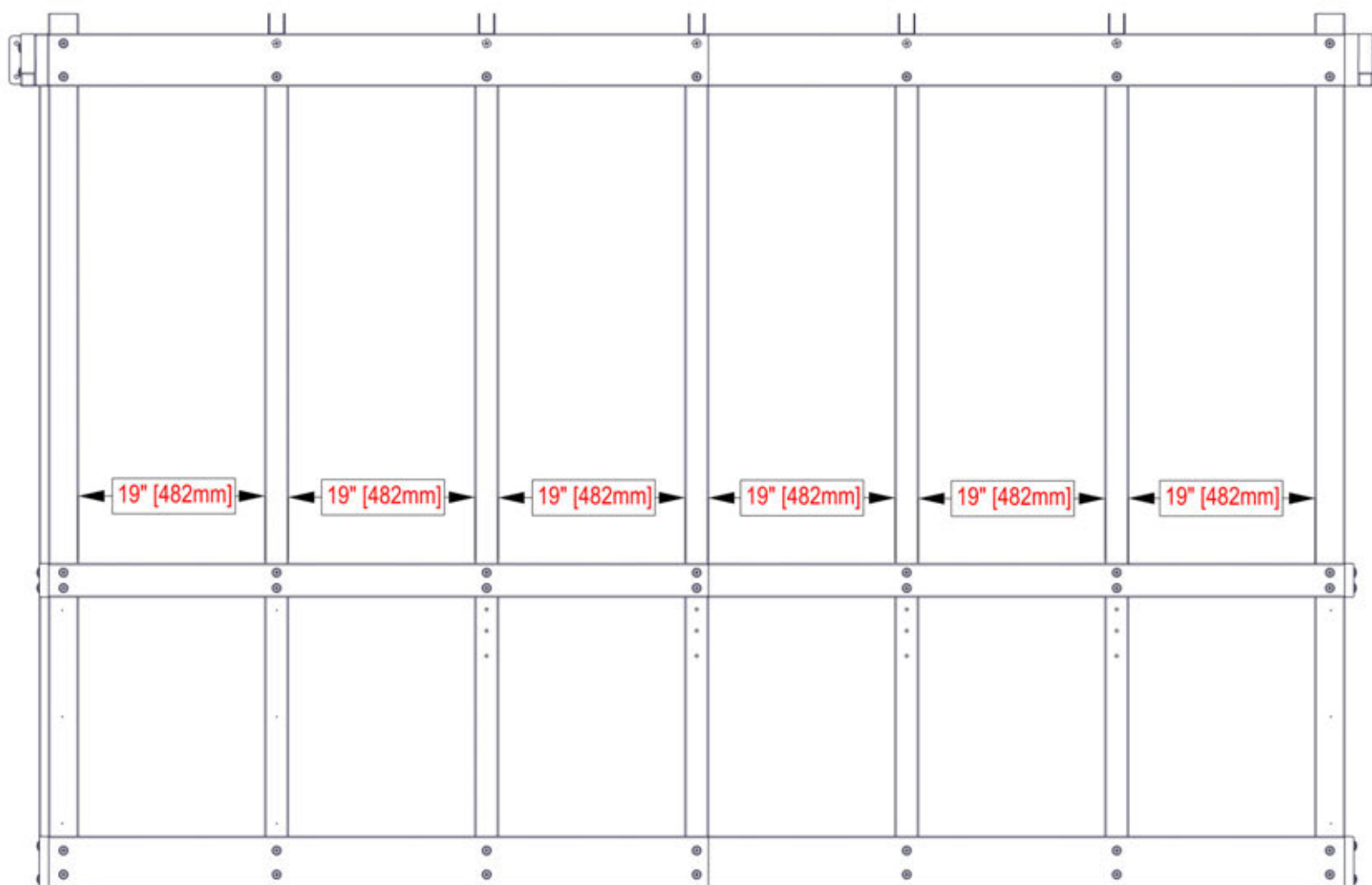


STEP 25 - GREENHOUSE ASSEMBLY

IMPORTANT!

GOING TO THE NEXT SIDE, ENSURE THAT:

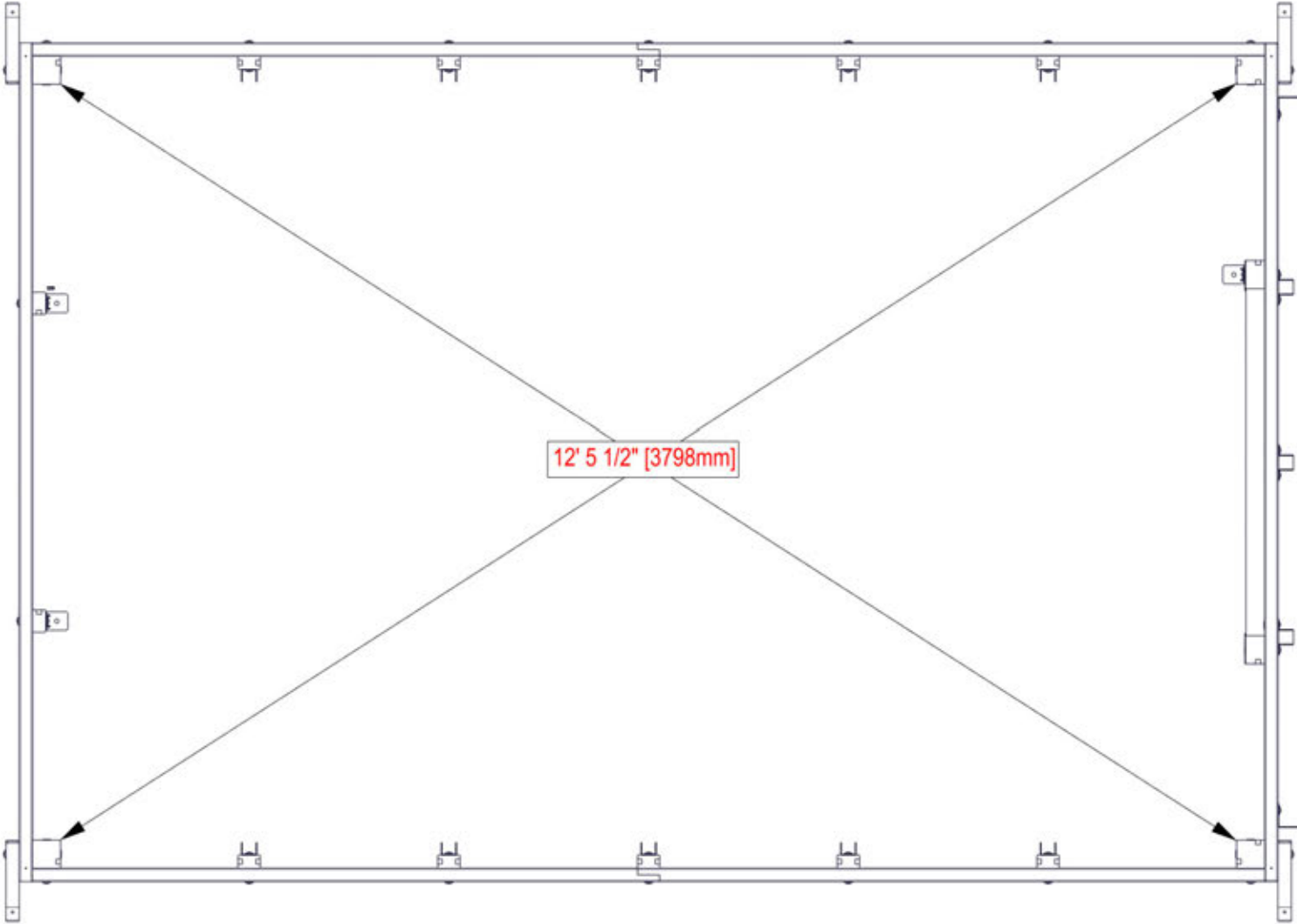
- POSTS AND UPRIGHTS ARE PLUMB (STRAIGHT UP AND DOWN) WITH A LEVEL.
- MEASUREMENTS BETWEEN POSTS AND UPRIGHTS ARE 19" +/- 1/8" [482mm] AS SHOWN.
- RUNNING AND BASE BOARDS ARE SQUARED TO THE UPRIGHTS.
- ALL HARDWARE ON THIS SIDE IS FULLY TIGHTENED.



STEP 26 - GREENHOUSE ASSEMBLY

CRITICAL: SQUARE ASSEMBLY BEFORE PROCEEDING TO NEXT STEPS.

WARNING: THERE WILL BE ALIGNMENT ISSUES IF THE STRUCTURE IS NOT PROPERLY SQUARED.



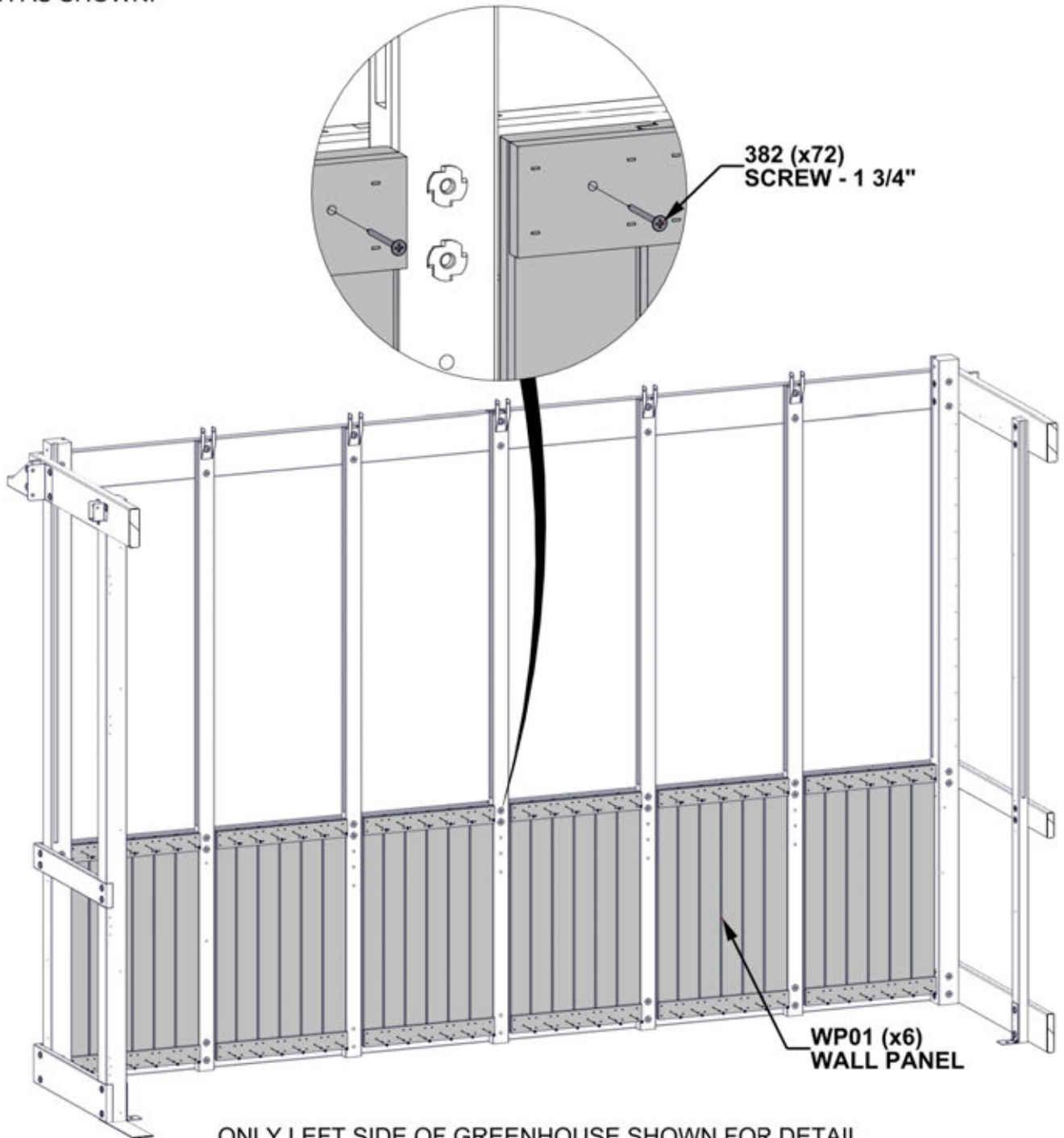
STEP 27 - SIDE WALL ASSEMBLY

QTY	PART NUMBER	DESCRIPTION
72	H100382	SCREW PFH 8x1 3/4 BLK



WP01 WALL PANEL - W2A04150
(x6) 1 1/16"x18 7/8"x31 9/16" (27x480x802)

- TOP OF PANELS SHOULD BE FLUSH WITH TOP OF RUNNING BOARD.
- CENTER BETWEEN POSTS AND UPRIGHTS.
- ATTACH AS SHOWN.



ONLY LEFT SIDE OF GREENHOUSE SHOWN FOR DETAIL.

STEP 28 - BACK WALL ASSEMBLY

QTY	PART NUMBER	DESCRIPTION
48	H100382	SCREW PFH 8x1 3/4 BLK



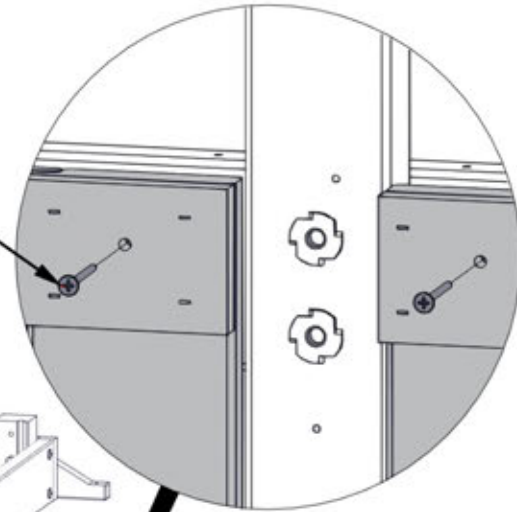
WP04 WALL PANEL - W2A04161
(x1) 1 1/16"x31 3/8"x31 9/16" (27x798x802)



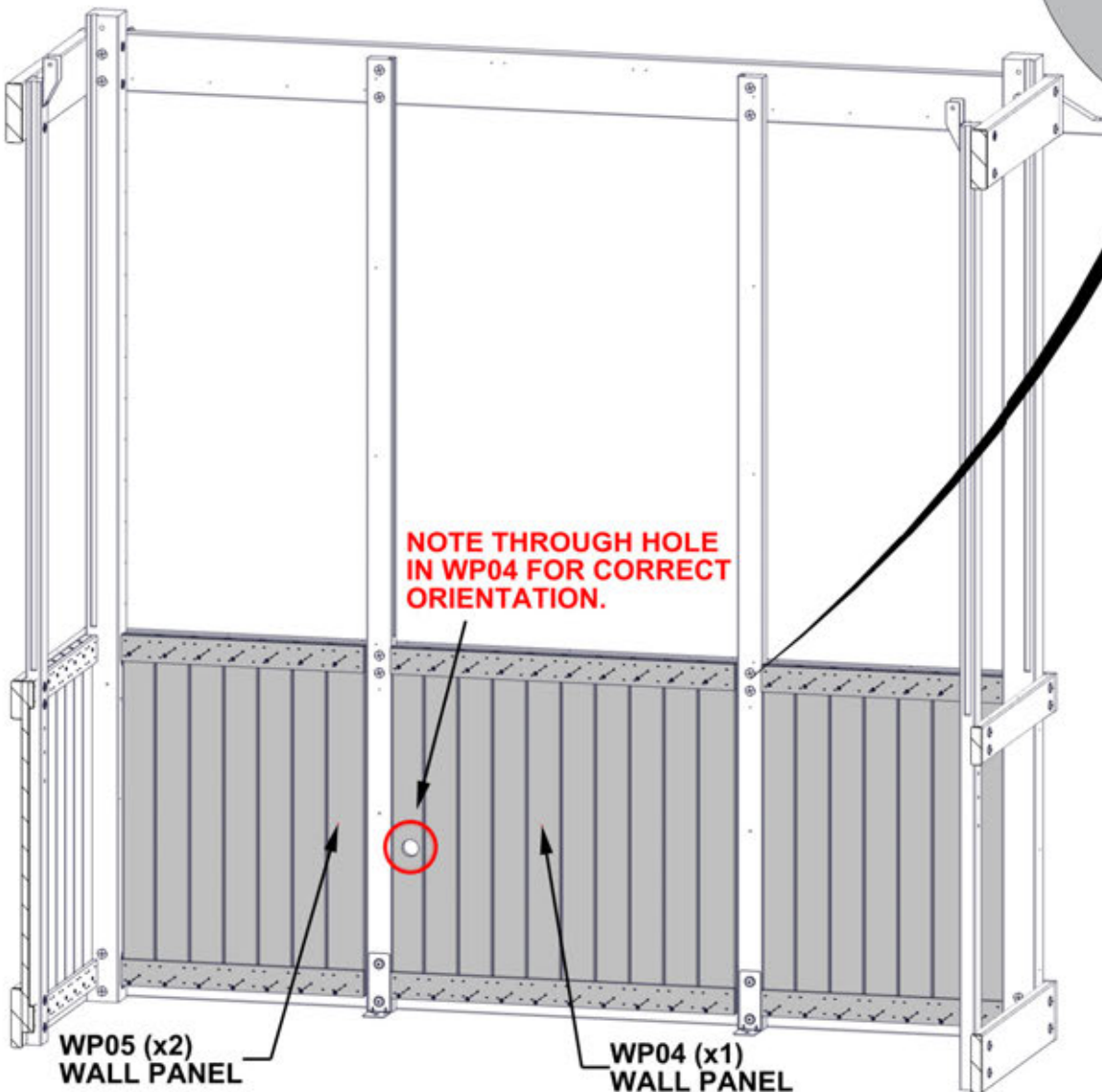
WP05 WALL PANEL - W2A04162
(x2) 1 1/16"x22 1/8"x31 9/16" (27x563x802)

- TOP OF PANELS SHOULD BE FLUSH WITH TOP OF RUNNING BOARD.
- CENTER BETWEEN POSTS AND UPRIGHTS.
- ATTACH AS SHOWN.

382 (x48)
SCREW - 1 3/4"



**NOTE THROUGH HOLE
IN WP04 FOR CORRECT
ORIENTATION.**



WP05 (x2)
WALL PANEL

WP04 (x1)
WALL PANEL

ONLY BACK SIDE OF GREENHOUSE SHOWN FOR DETAIL.

STEP 29 - SIDE WALL ASSEMBLY

QTY	PART NUMBER	DESCRIPTION
72	H100382	SCREW PFH 8x1 3/4 BLK



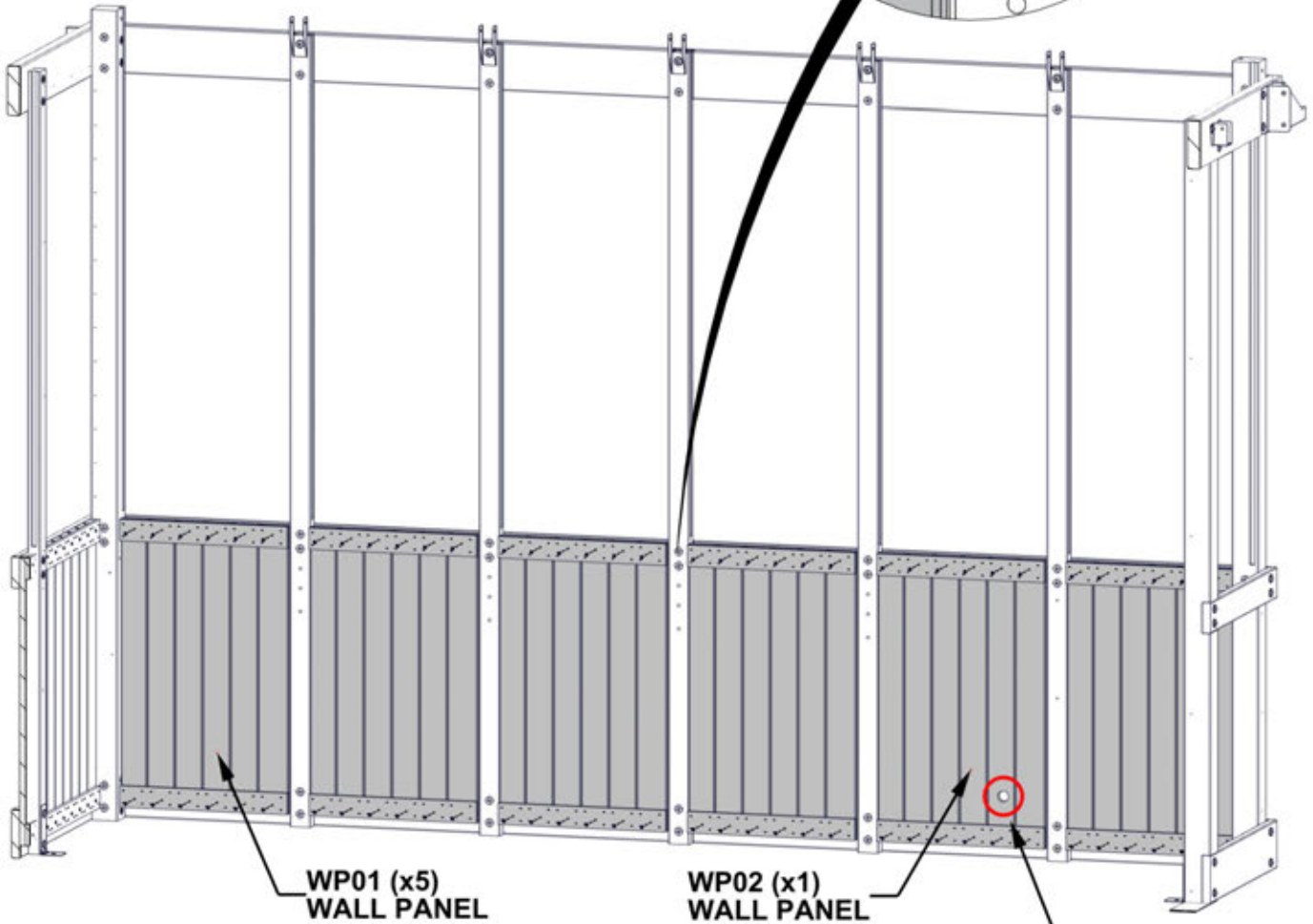
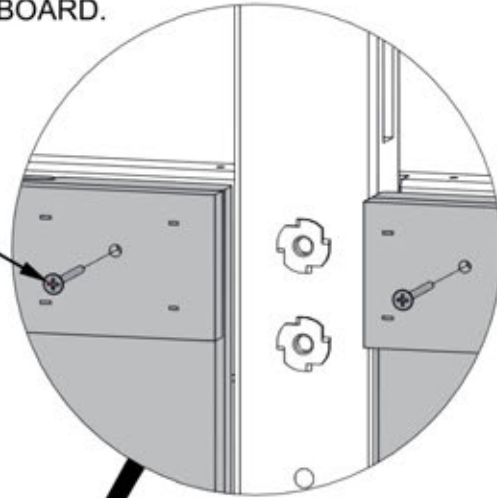
WP01 WALL PANEL - W2A04150
(x5) 1 1/16"x18 7/8"x31 9/16" (27x480x802)



WP02 WALL PANEL - W2A04154
(x1) 1 1/16"x18 7/8"x31 9/16" (27x480x802)

- TOP OF PANELS SHOULD BE FLUSH WITH TOP OF RUNNING BOARD.
- CENTER BETWEEN POSTS AND UPRIGHTS.
- ATTACH AS SHOWN.

382 (x72)
SCREW - 1 3/4"

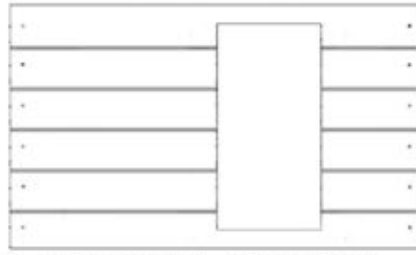


ONLY RIGHT SIDE OF GREENHOUSE SHOWN FOR DETAIL.

**NOTE THROUGH HOLE
IN WP02 FOR CORRECT
ORIENTATION.**

STEP 30 - FRONT WALL ASSEMBLY

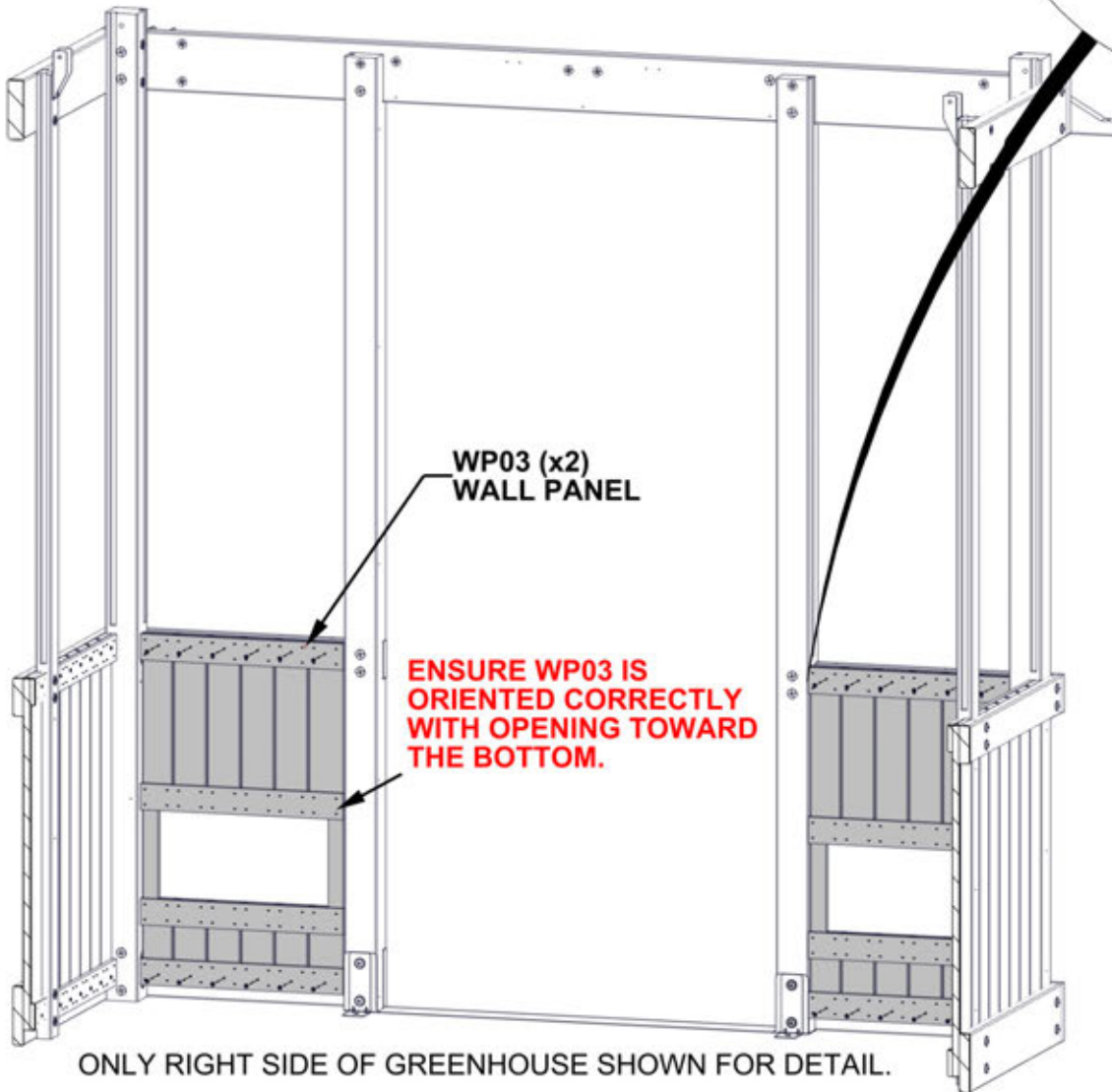
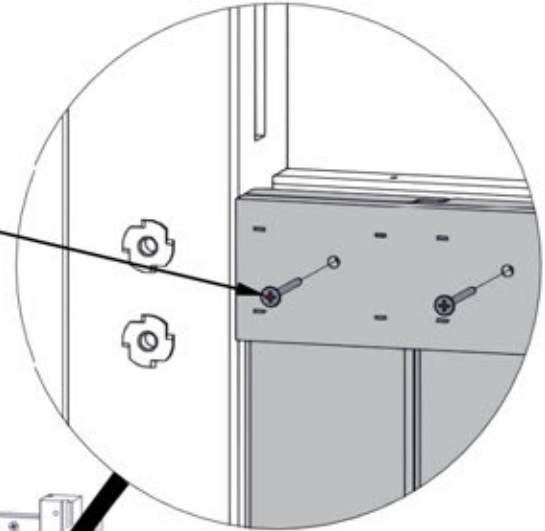
QTY	PART NUMBER	DESCRIPTION
24	H100382	SCREW PFH 8x1 3/4 BLK



WP03 WALL PANEL - W2A04156
(x2) 1 1/16"x18 3/4"x31 9/16" (27x477x802)

- TOP OF PANELS SHOULD BE FLUSH WITH TOP OF RUNNING BOARD.
- CENTER BETWEEN POSTS AND UPRIGHTS.
- ATTACH AS SHOWN.

382 (x24)
SCREW - 1 3/4"



WP03 (x2)
WALL PANEL

**ENSURE WP03 IS
ORIENTED CORRECTLY
WITH OPENING TOWARD
THE BOTTOM.**

ONLY RIGHT SIDE OF GREENHOUSE SHOWN FOR DETAIL.

STEP 31 - WINDOW SILL ASSEMBLY

QTY	PART NUMBER	DESCRIPTION
18	H100391	SCREW PFH 8x2 BLK



E01 WINDOW SILL - W4L19476
(x1) 1 7/16"x3 3/8"x23 1/8" (36x86x588)

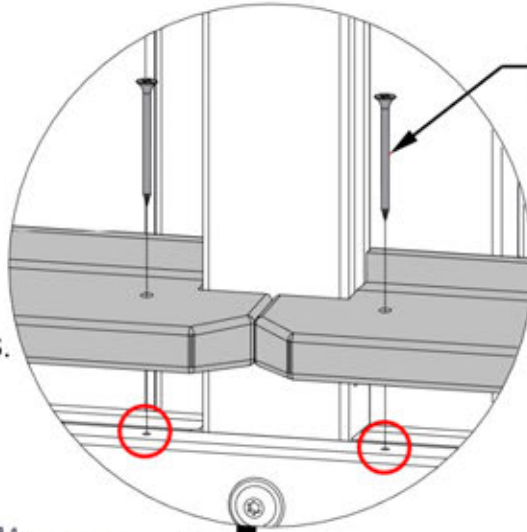


E02 WINDOW SILL - W4L19477
(x4) 1 7/16"x3 3/8"x21 5/16" (36x86x542)

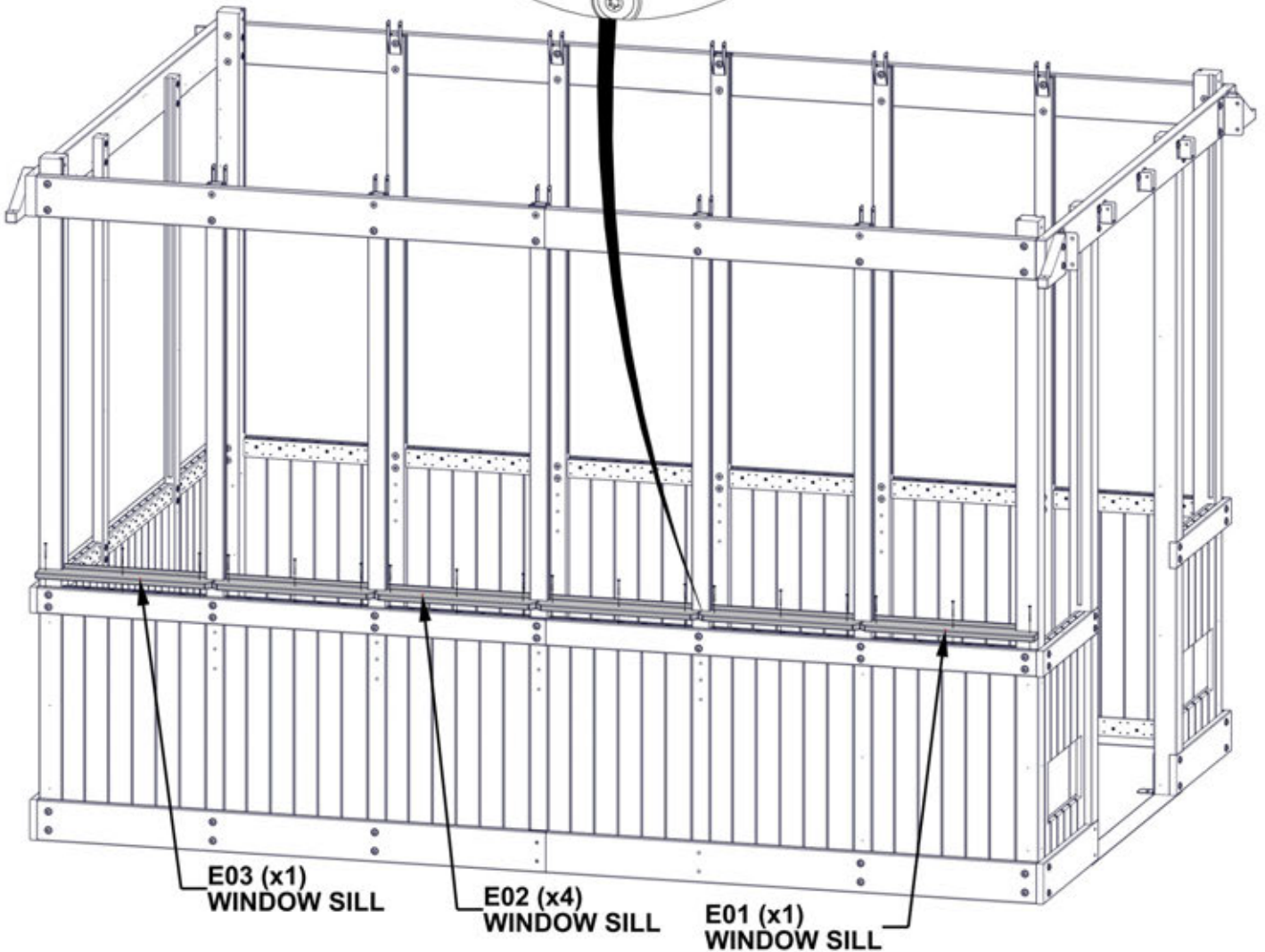


E03 WINDOW SILL - W4L19479
(x1) 1 7/16"x3 3/8"x23 1/8" (36x86x588)

ATTACH WINDOW SILLS USING
PILOT HOLES IN RUNNING BOARDS.



391 (x18)
SCREW - 2"



E03 (x1)
WINDOW SILL

E02 (x4)
WINDOW SILL

E01 (x1)
WINDOW SILL

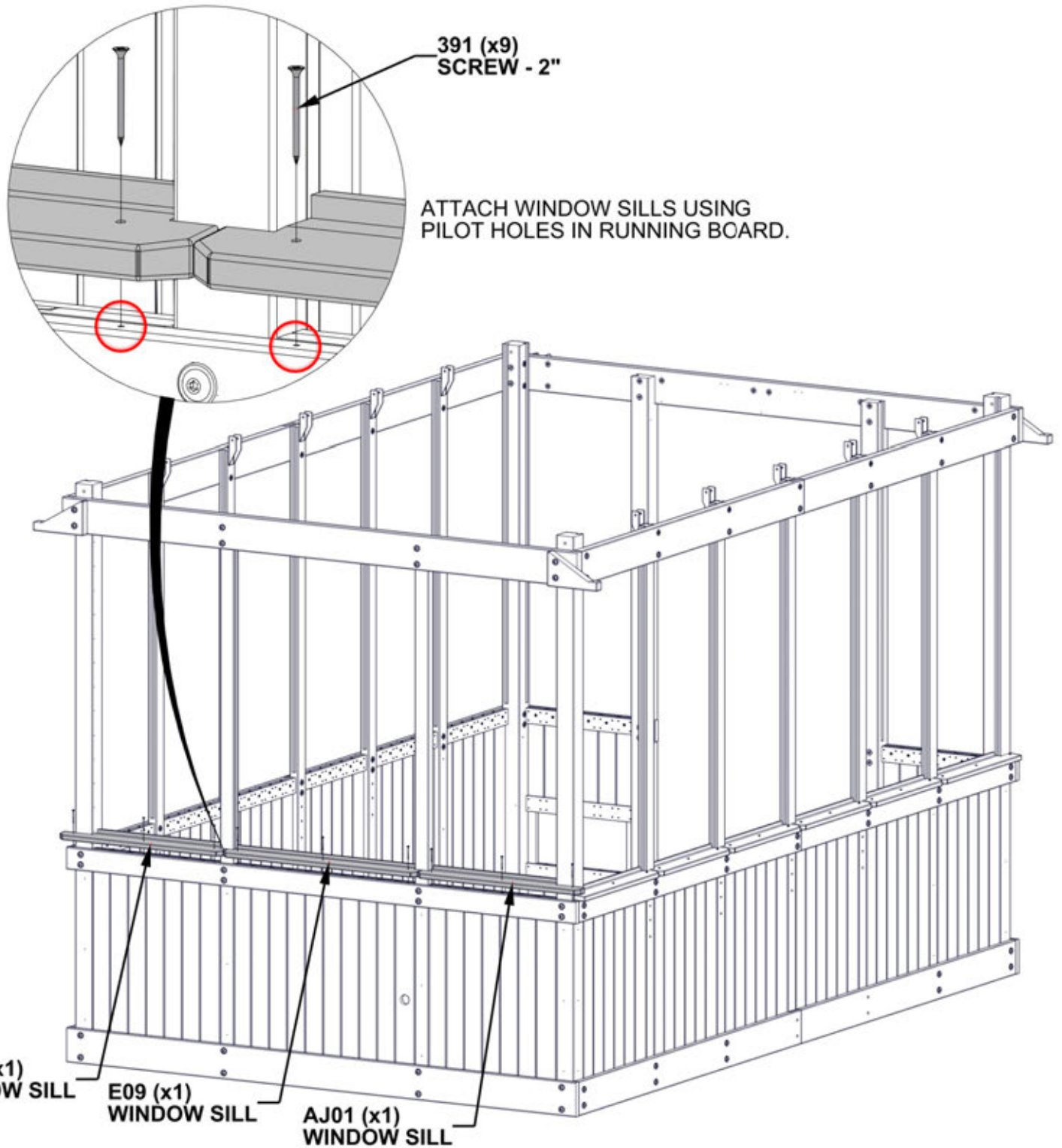
STEP 32 - WINDOW SILL ASSEMBLY

QTY	PART NUMBER	DESCRIPTION
9	H100391	SCREW PFH 8x2 BLK

AJ01 WINDOW SILL - W4L19569
(x1) 1 7/16"x4"x28 3/8" (36x102x721)

E09 WINDOW SILL - W4L19568
(x1) 1 7/16"x3 3/8"x33 3/4" (36x86x858)

AJ02 WINDOW SILL - W4L19570
(x1) 1 7/16"x4"x28 3/8" (36x102x721)



391 (x9)
SCREW - 2"

ATTACH WINDOW SILLS USING
PILOT HOLES IN RUNNING BOARD.

AJ02 (x1)
WINDOW SILL

E09 (x1)
WINDOW SILL

AJ01 (x1)
WINDOW SILL

STEP 33 - WINDOW SILL ASSEMBLY

QTY	PART NUMBER	DESCRIPTION
18	H100391	SCREW PFH 8x2 BLK



E01 WINDOW SILL - W4L19476
(x1) 1 7/16"x3 3/8"x23 1/8" (36x86x588)

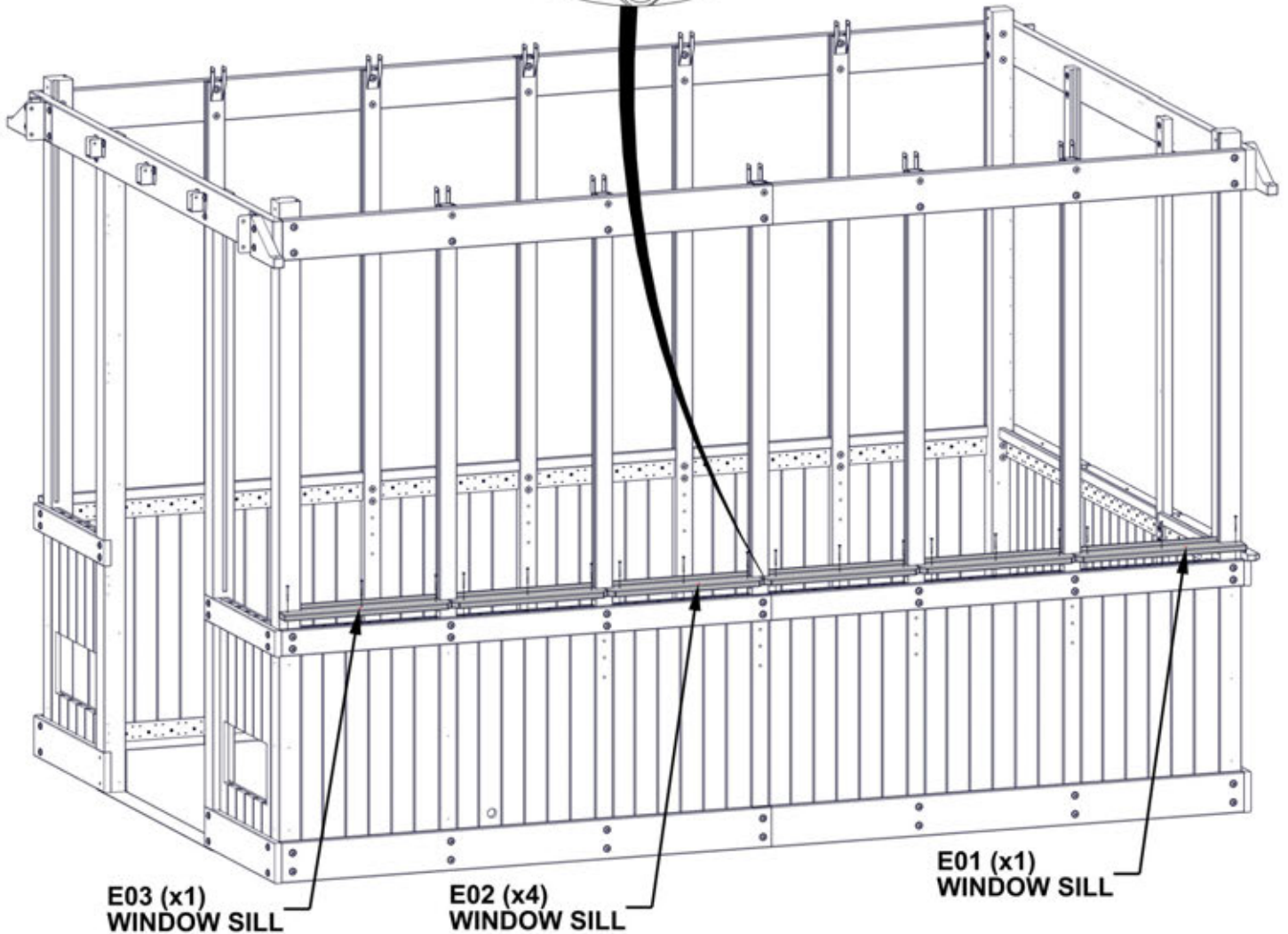
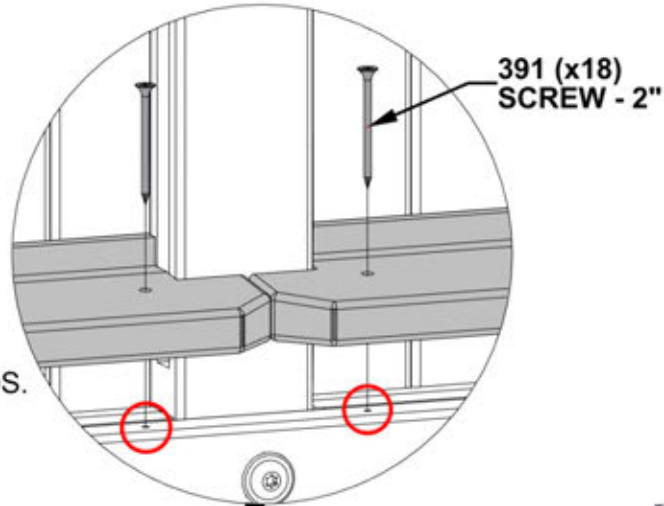


E02 WINDOW SILL - W4L19477
(x4) 1 7/16"x3 3/8"x21 5/16" (36x86x542)



E03 WINDOW SILL - W4L19479
(x1) 1 7/16"x3 3/8"x23 1/8" (36x86x588)

ATTACH WINDOW SILLS USING
PILOT HOLES IN RUNNING BOARDS.



STEP 34 - WINDOW SILL ASSEMBLY

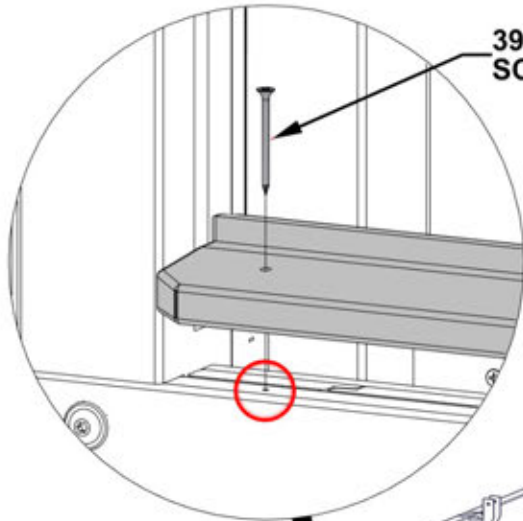
QTY	PART NUMBER	DESCRIPTION
6	H100391	SCREW PFH 8x2 BLK



E04 WINDOW SILL - W4L19502
(x1) 1 7/16"x3 3/8"x23 3/4" (36x86x604)

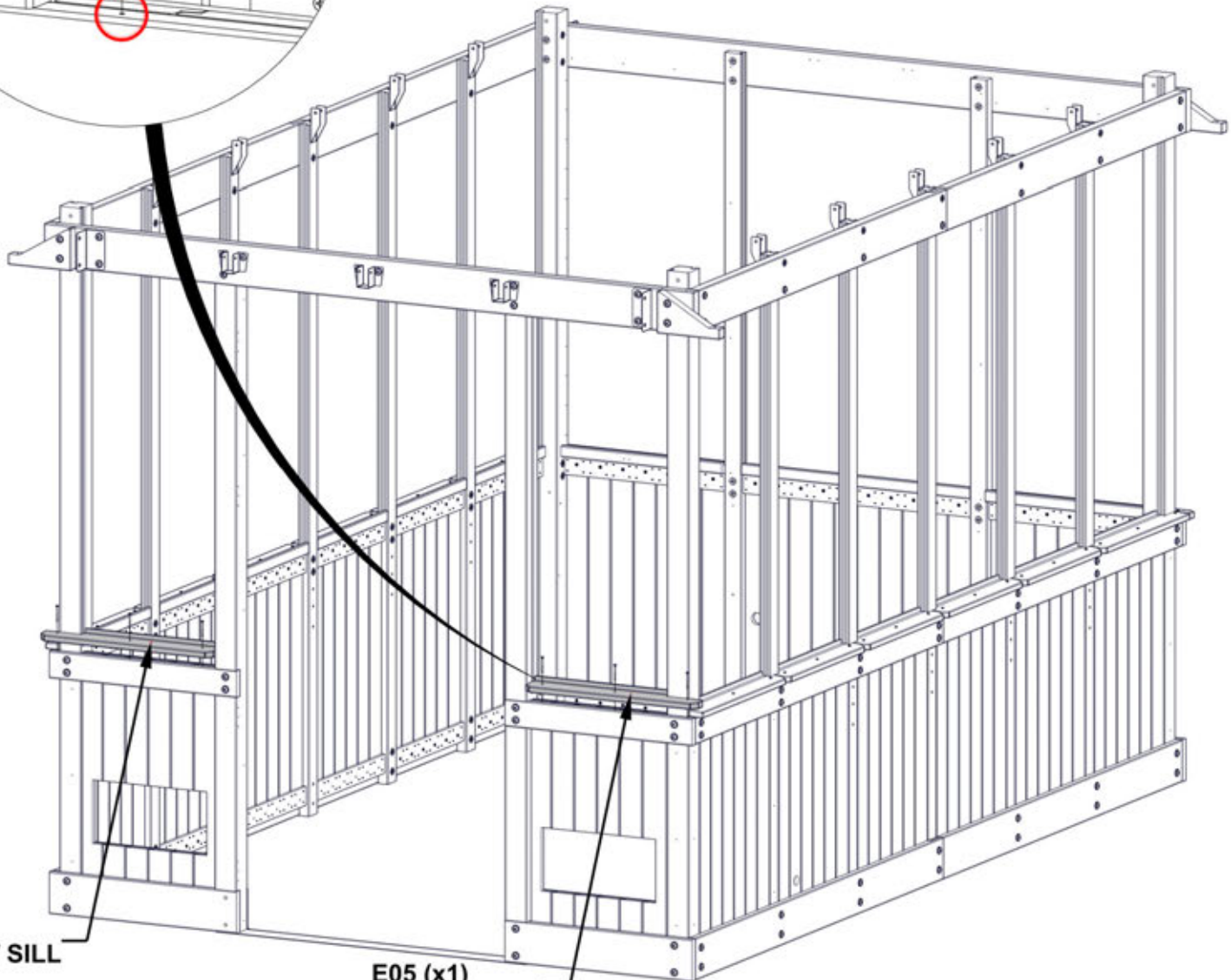


E05 WINDOW SILL - W4L19503
(x1) 1 7/16"x3 3/8"x23 3/4" (36x86x604)



**391 (x6)
SCREW - 2"**

ATTACH WINDOW SILLS USING
PILOT HOLES IN RUNNING BOARDS.

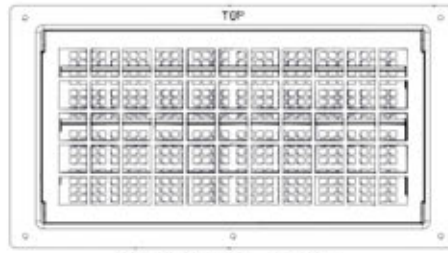


**E04 (x1)
WINDOW SILL**

**E05 (x1)
WINDOW SILL**

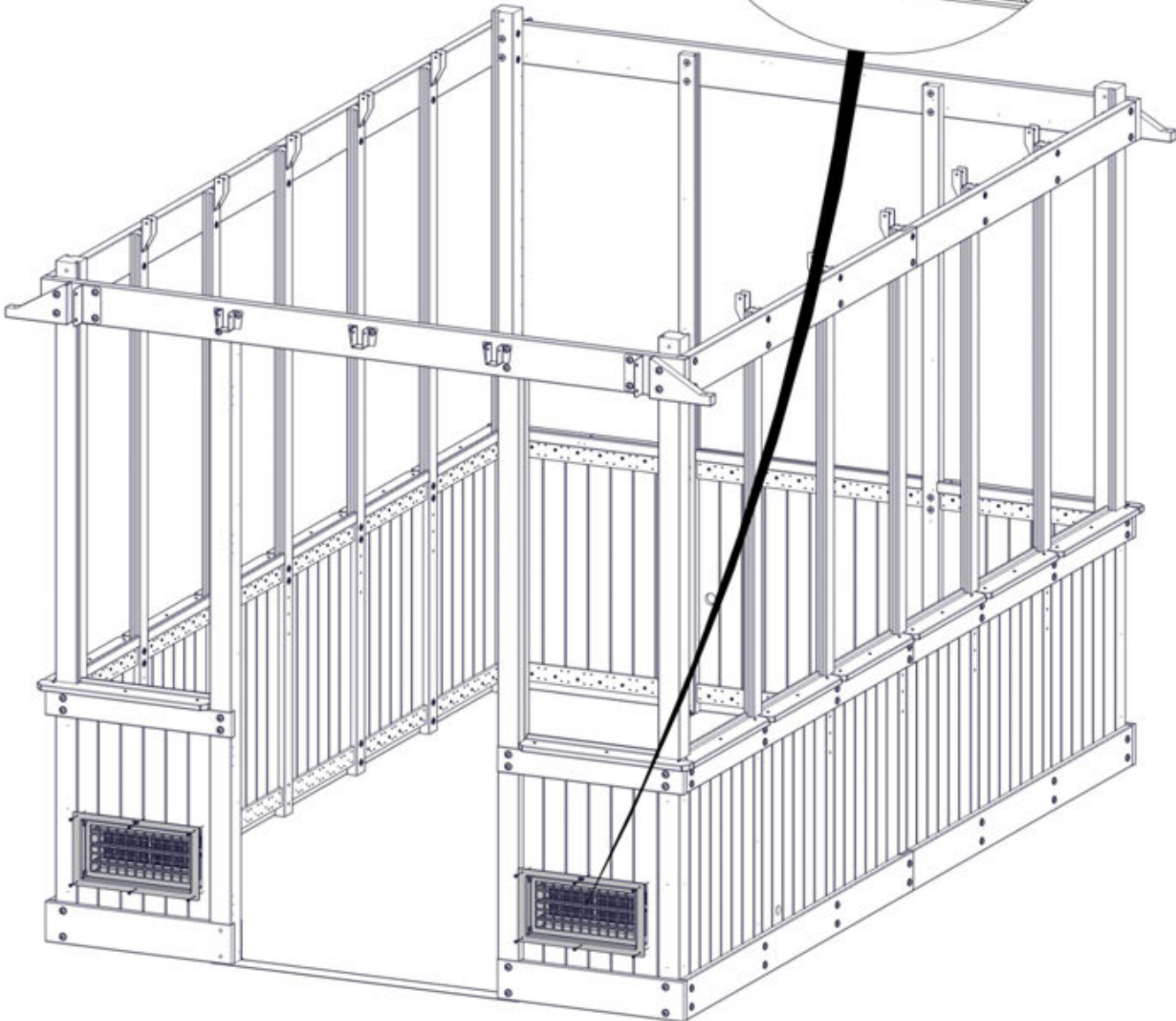
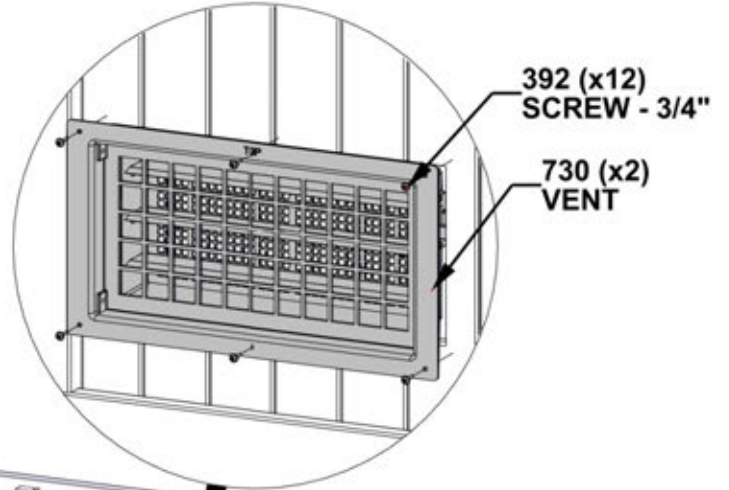
STEP 35 - VENT ASSEMBLY

QTY	PART NUMBER	DESCRIPTION
12	H100392	SCREW PWH 8x3/4 BLK



A6P00730 VENT
(x2)

USE VENT CENTERED IN OPENING AS A TEMPLATE TO PRE-DRILL PILOT HOLES WITH AN 1/8" [3mm] DRILL BIT BEFORE SCREWS ARE INSTALLED. DO NOT DRILL ALL THE WAY THROUGH WALL PANEL.



STEP 36 - WINDOW ASSEMBLY

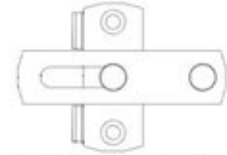
QTY	PART NUMBER	DESCRIPTION
2	H100391	SCREW PFH 8x2 BLK
2	H100627	SCREW PFH 6x3/4 BLK



WA04 WINDOW ASSEMBLY - W2A04164
(x1) 1 7/8"x21 13/16"x47 3/16" (48x554x1198)

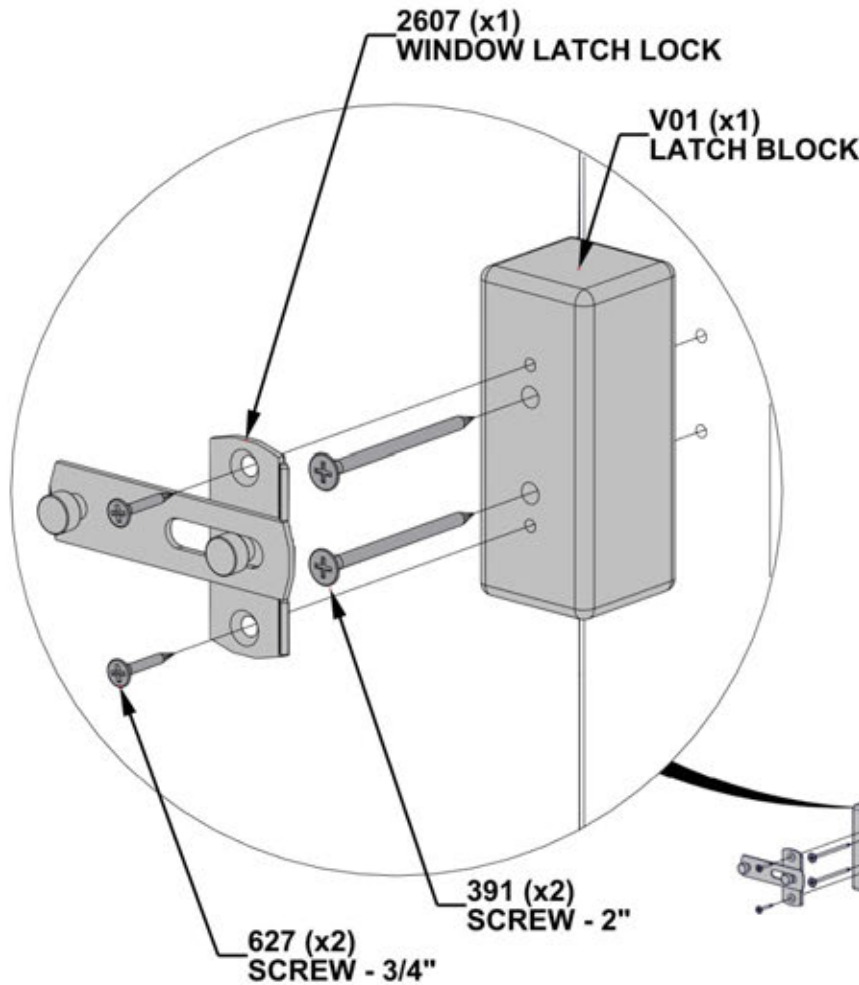


V01 LATCH BLOCK - W4L19615
(x1) 1 1/4"x1 1/4"x3" (32x32x76)

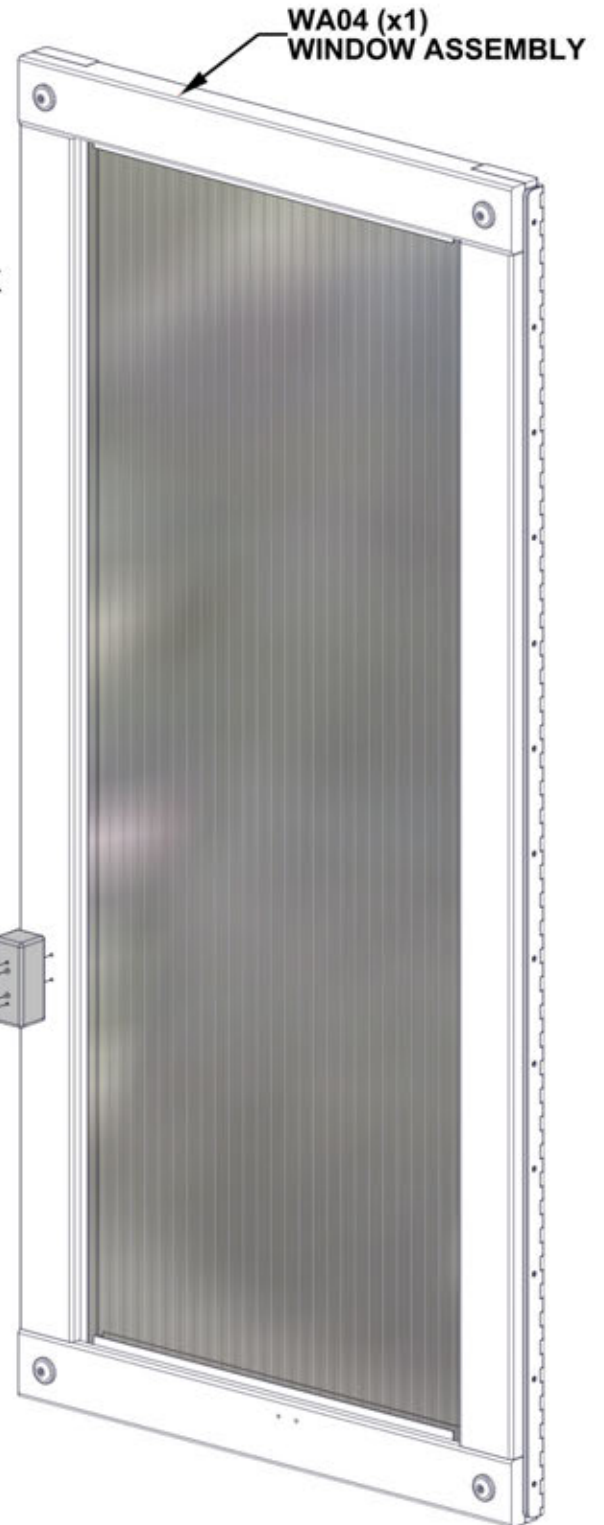


A4M02607 WINDOW LATCH LOCK
(x1)

ALIGN TWO MIDDLE PILOT HOLES IN LATCH BLOCK WITH PILOT HOLES IN WINDOW ASSEMBLY SIDE AS SHOWN.



AFTER LATCH BLOCK IS ATTACHED, ENSURE CORRECT ORIENTATION OF WINDOW LATCH LOCK AS SHOWN.

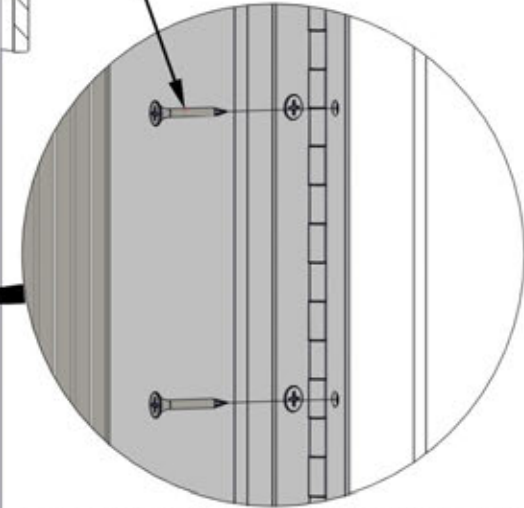


STEP 37 - WINDOW ASSEMBLY

QTY	PART NUMBER	DESCRIPTION
13	H100385	SCREW PFH 8x1 BLK

WINDOW ASSEMBLY

385 (x13)
SCREW - 1"



ATTACH WINDOW ASSEMBLY USING
PILOT HOLES IN POST AS SHOWN.

ONLY BACK OF GREENHOUSE SHOWN FOR DETAIL.

STEP 38 - WINDOW ASSEMBLY

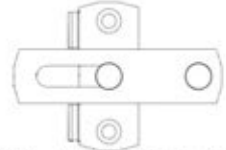
QTY	PART NUMBER	DESCRIPTION
2	H100391	SCREW PFH 8x2 BLK
2	H100627	SCREW PFH 6x3/4 BLK



WA03 WINDOW ASSEMBLY - W2A04163
(x1) 1 7/8"x21 13/16"x47 3/16" (48x554x1198)



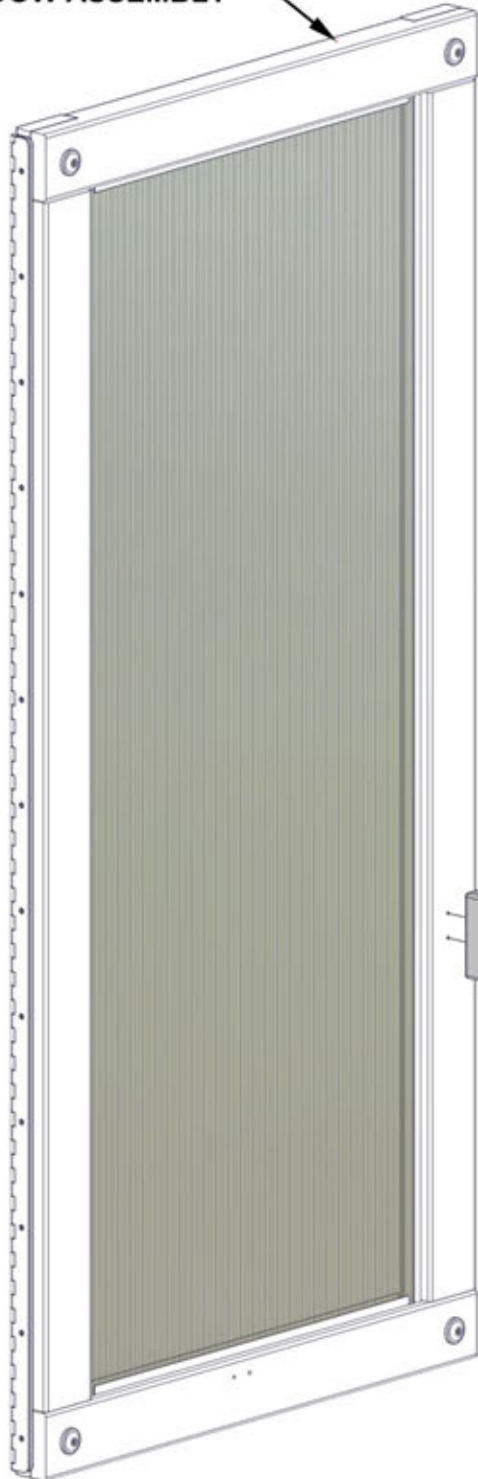
V01 LATCH BLOCK - W4L19615
(x1) 1 1/4"x1 1/4"x3" (32x32x76)



A4M02607 WINDOW LATCH LOCK
(x1)

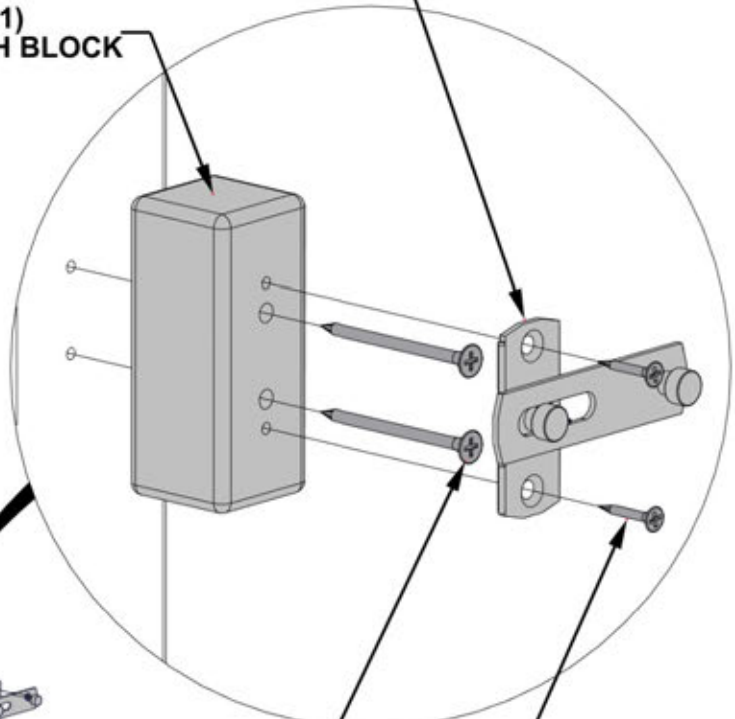
WA03 (x1)
WINDOW ASSEMBLY

ALIGN TWO MIDDLE PILOT HOLES IN LATCH BLOCK WITH PILOT HOLES IN WINDOW ASSEMBLY SIDE AS SHOWN.



2607 (x1)
WINDOW LATCH LOCK

V01 (x1)
LATCH BLOCK



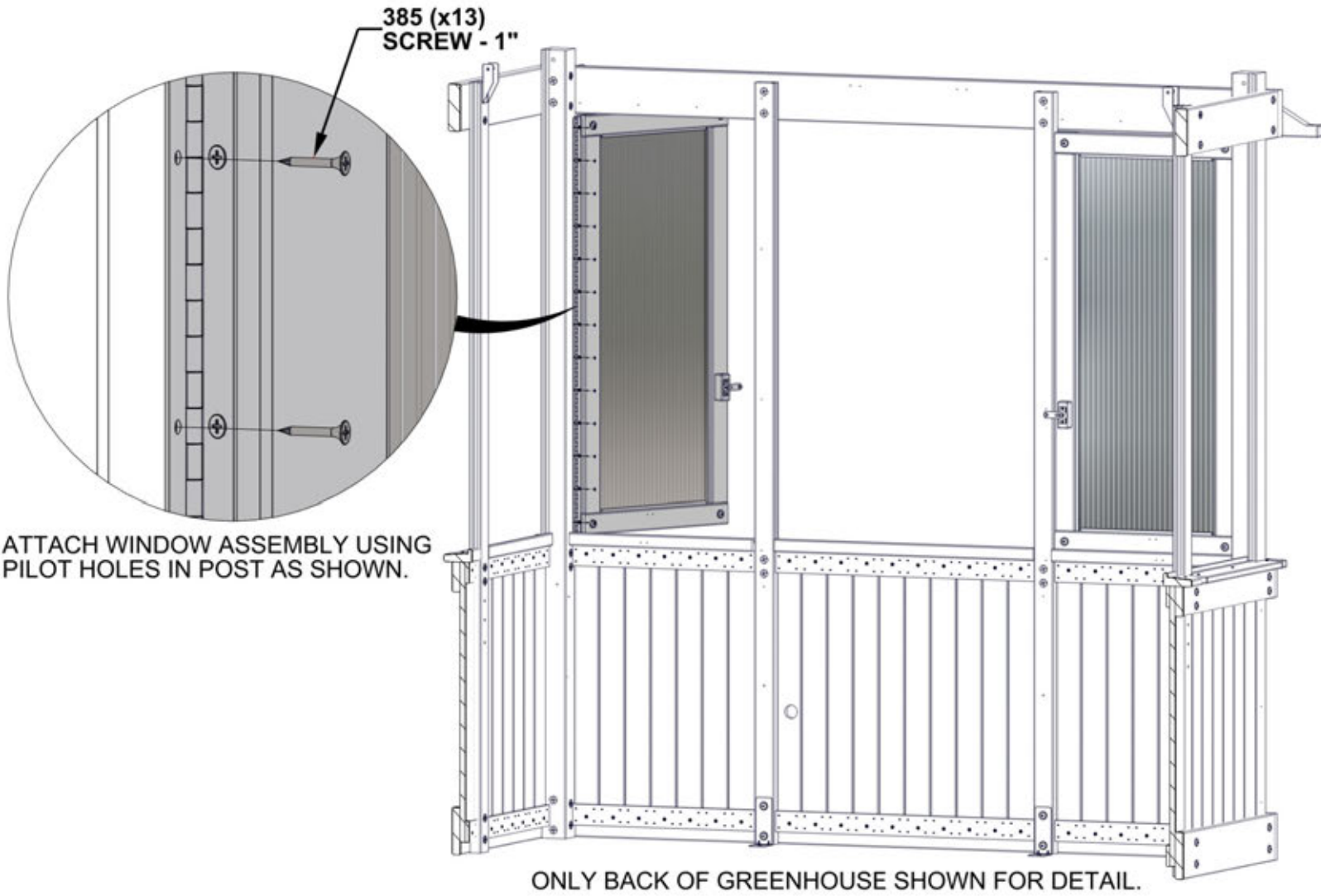
391 (x2)
SCREW - 2"

627 (x2)
SCREW - 3/4"

**AFTER LATCH BLOCK IS ATTACHED,
ENSURE CORRECT ORIENTATION OF
WINDOW LATCH LOCK AS SHOWN.**

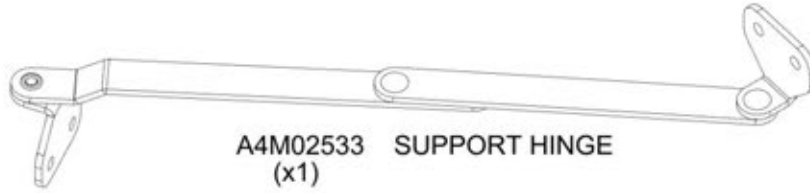
STEP 39 - WINDOW ASSEMBLY

QTY	PART NUMBER	DESCRIPTION
13	H100385	SCREW PFH 8x1 BLK

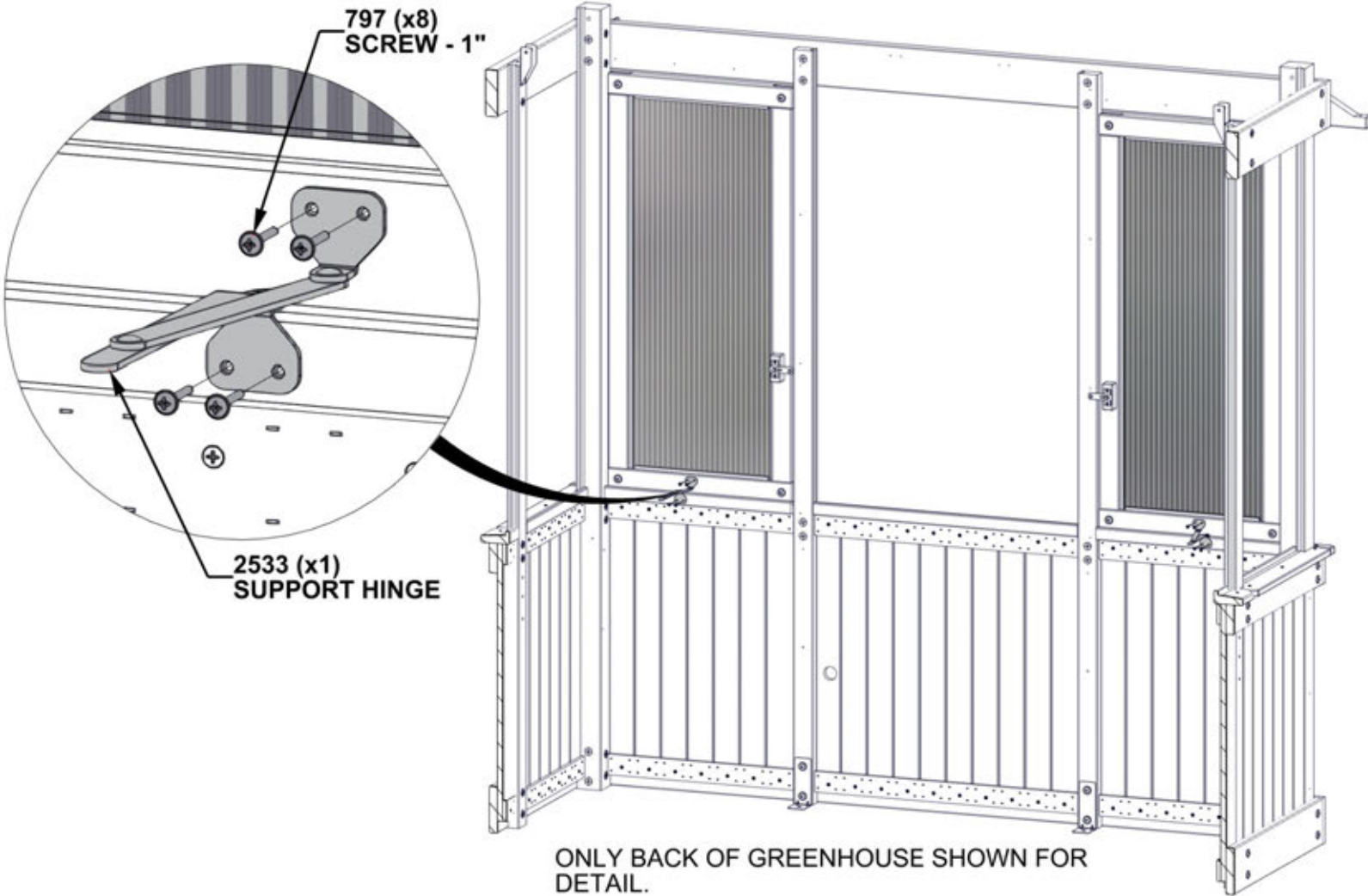


STEP 40 - WINDOW ASSEMBLY

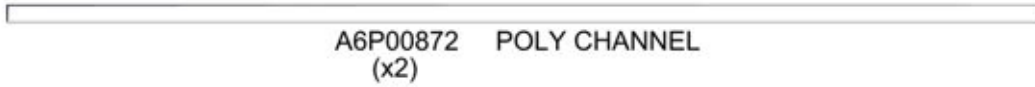
QTY	PART NUMBER	DESCRIPTION
8	H100797	SCREW PWH 8x1 BLK



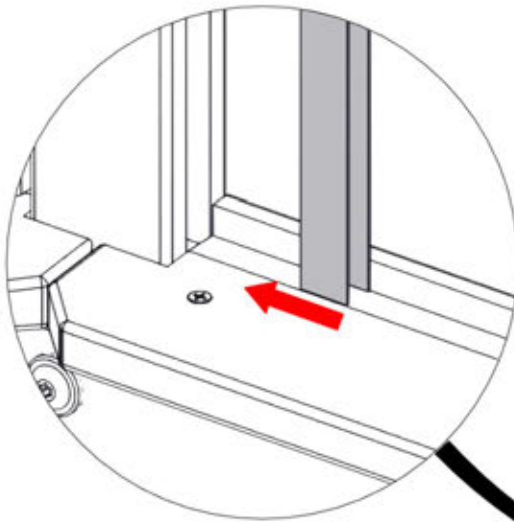
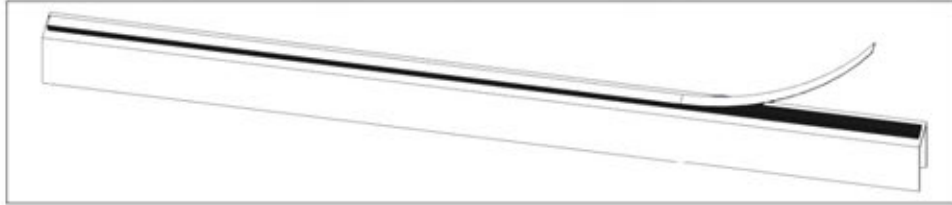
ATTACH SUPPORT HINGE USING PILOT HOLES IN WINDOW ASSEMBLY AND WINDOW SILL AS SHOWN.



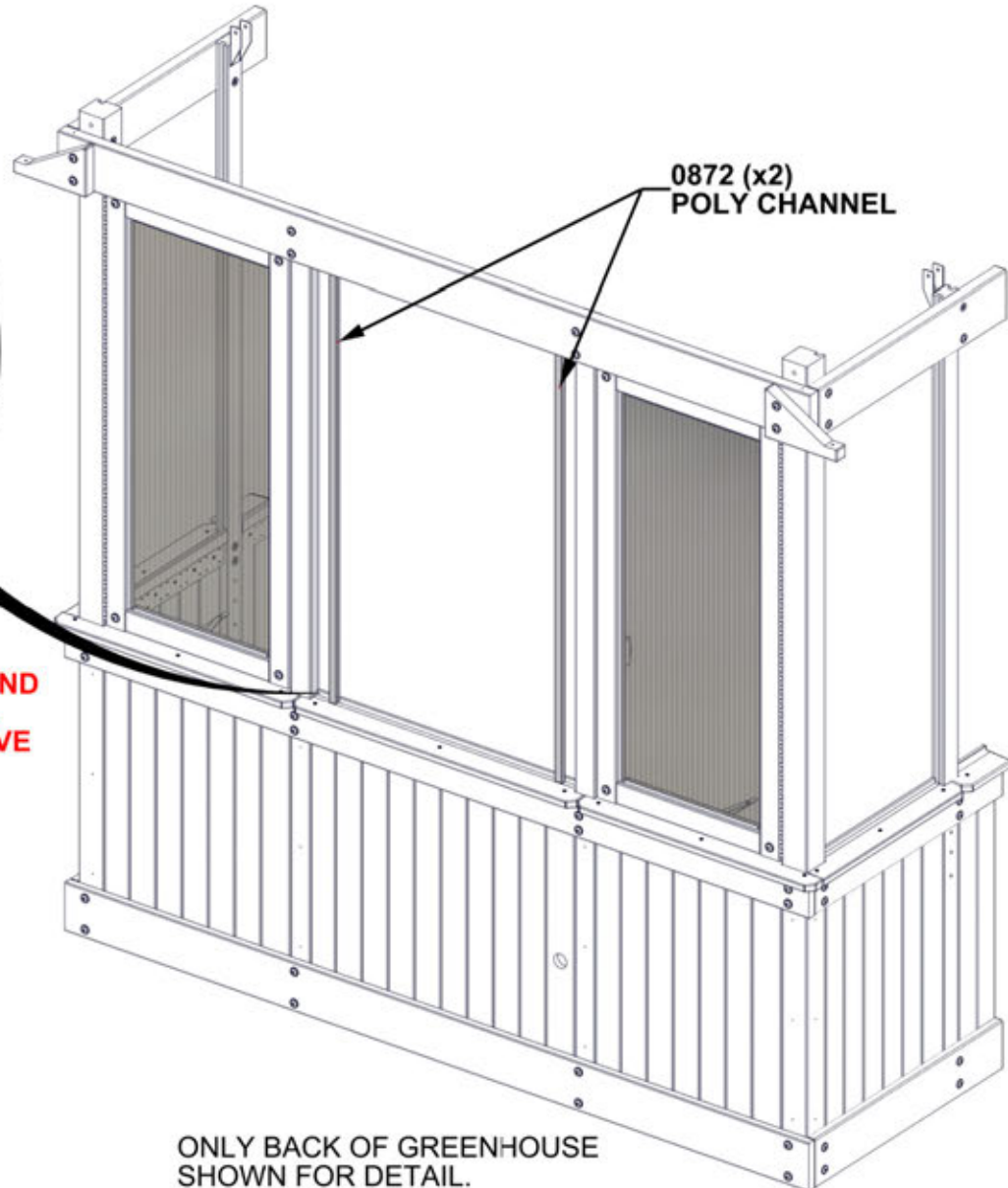
STEP 41 - WINDOW ASSEMBLY



REMOVE TAPE LINER ON POLY CHANNELS BEFORE INSTALLING.



POLY SHEET SITS ON WINDOW SILL AND SLIDES INTO GROOVES IN UPRIGHTS. FIRMLY PRESS CHANNEL INTO GROOVE TO ENSURE TAPE ADHESION.



POLYCARBONATE SHEETING INFORMATION - IMPORTANT

The Polycarbonate Sheeting has UV protection on ONE SIDE.

CRITICAL to install with the UV protection facing the OUTSIDE

- Wear safety gloves to protect against any sharp edges during handling or install.
- Do NOT use knife or sharp object to remove protective film as it may result in damage to polycarbonate sheeting
- Leave film on during install to ensure UV side is facing outside.
- Peel protective film back from edges approximately 2" (5cm) during installation.
- Remove film completely after installation.

NOTE: Do not store polycarbonate sheeting with film outside in direct sunlight or rain. It may make removal of film more difficult.

STEP 42 - WINDOW ASSEMBLY



A6P00899 POLY SHEET
(x1)



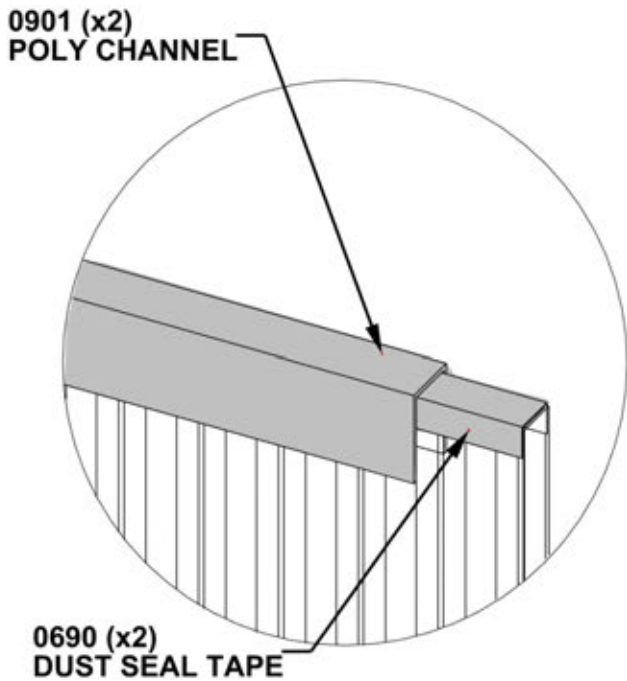
A6P00901 POLY CHANNEL
(x2)



A6P00690 DUST SEAL TAPE

TO APPLY DUST SEAL TAPE AND POLY CHANNEL:

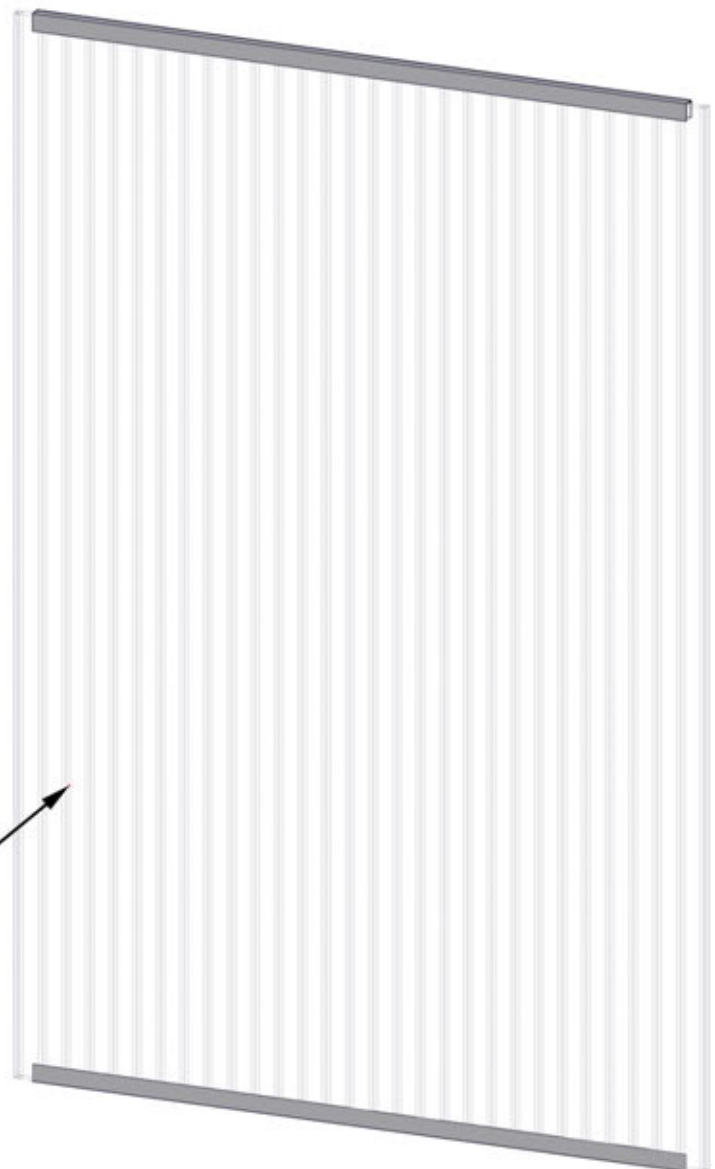
- CUT 2 STRIPS OF DUST SEAL TAPE THE SAME WIDTH AS THE POLY SHEET.
- WRAP DUST SEAL TAPE ALONG EDGE OF POLY SHEET WIDTH.
- AFTER TAPE IS SECURE, PUSH CHANNEL ON OVER THE TAPE, CENTERING ON THE POLY SHEET.
- REPEAT ON THE BOTTOM SIDE OF POLY SHEET.



0901 (x2)
POLY CHANNEL

0690 (x2)
DUST SEAL TAPE

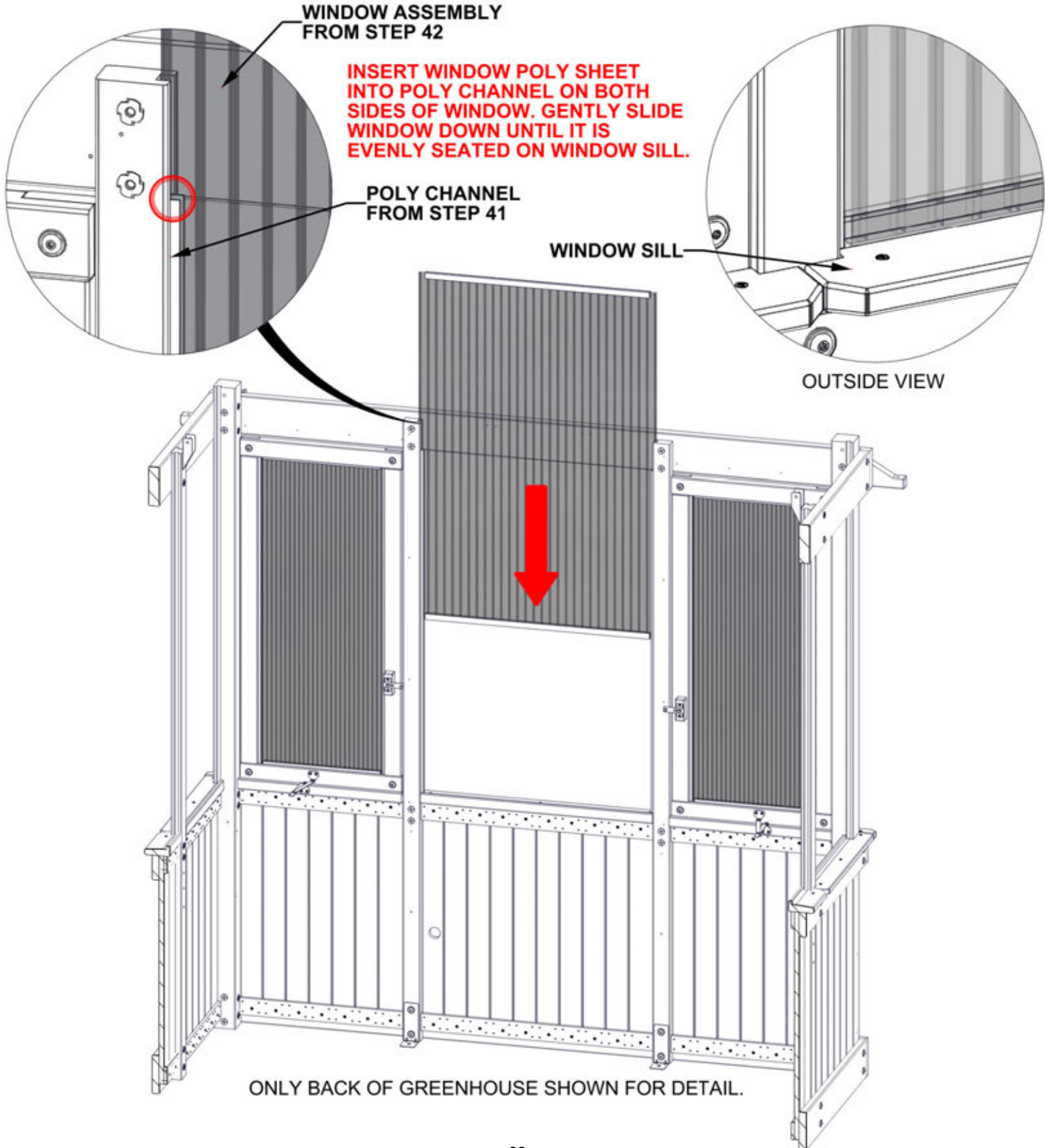
0899 (x1)
POLY SHEET



STEP 43 - WINDOW ASSEMBLY

IMPORTANT!

- ENSURE UV SIDE OF WINDOWS ARE FACING OUTSIDE.
- ONCE WINDOWS ARE INSTALLED, IT IS SAFE TO REMOVE THE PROTECTIVE FILM.

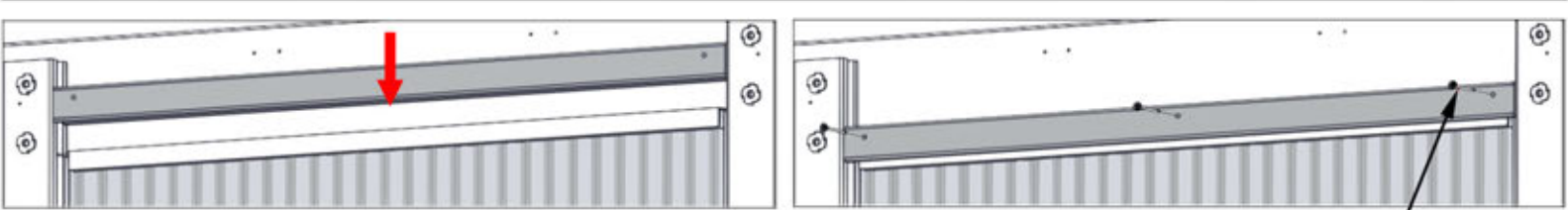


STEP 44 - WINDOW ASSEMBLY

QTY	PART NUMBER	DESCRIPTION
3	H100391	SCREW PFH 8x2 BLK



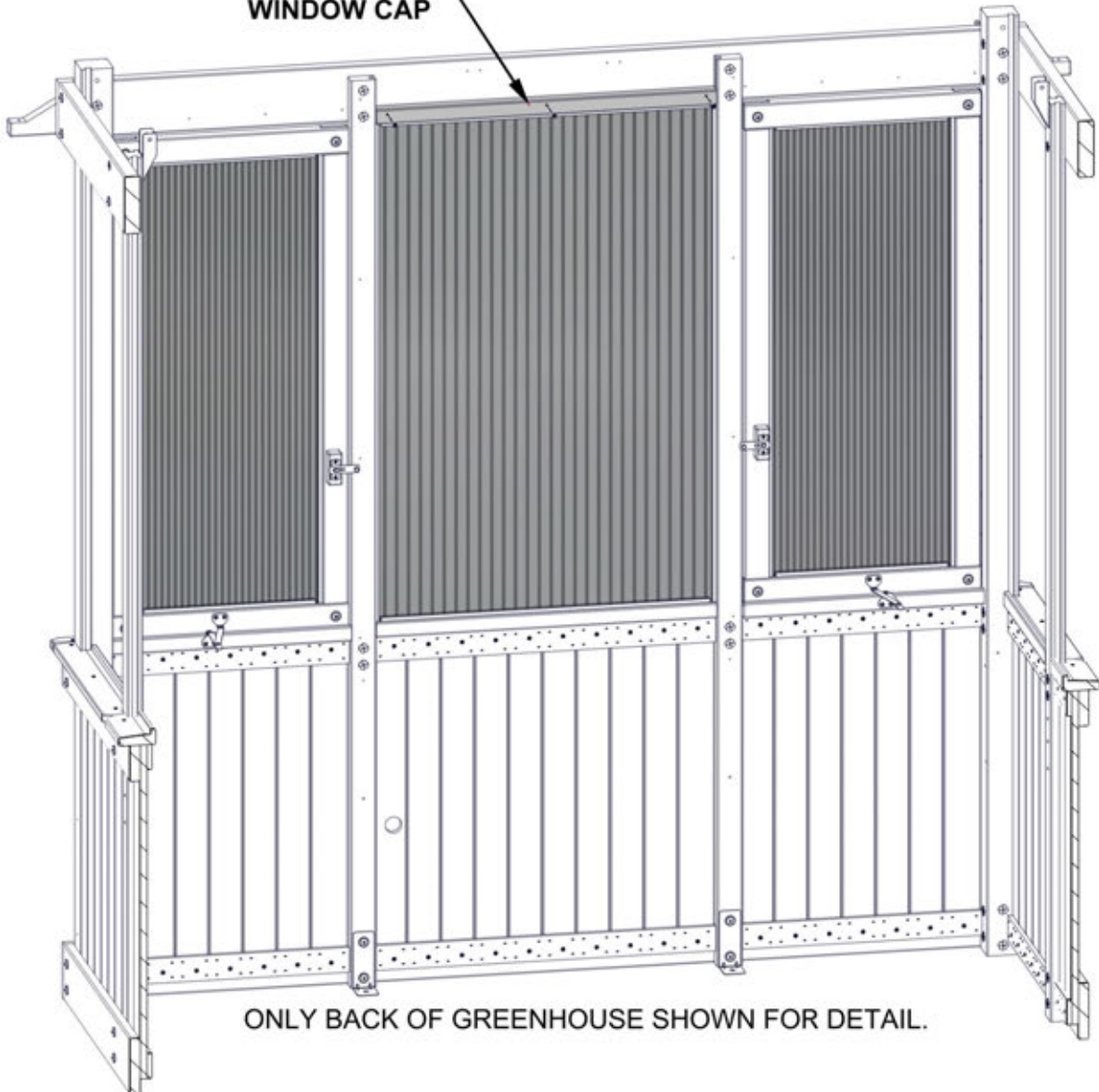
P06 WINDOW CAP - W4L19595
(x1) 1 7/16"x1 7/16"x31 7/16" (36x36x798)



FIRST, SLIDE DOWN WINDOW CAPS WITH THE WINDOW ASSEMBLY FITTING INTO THE GROOVE, THEN SCREW INTO PLACE.

391 (x3)
SCREW - 2"

P06 (x1)
WINDOW CAP



ONLY BACK OF GREENHOUSE SHOWN FOR DETAIL.

STEP 45 - BACK WALL ASSEMBLY

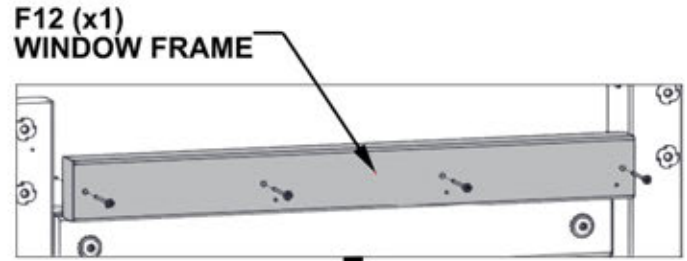
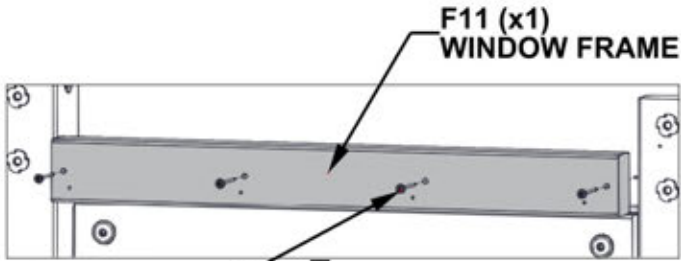
QTY	PART NUMBER	DESCRIPTION
8	H100391	SCREW PFH 8x2 BLK



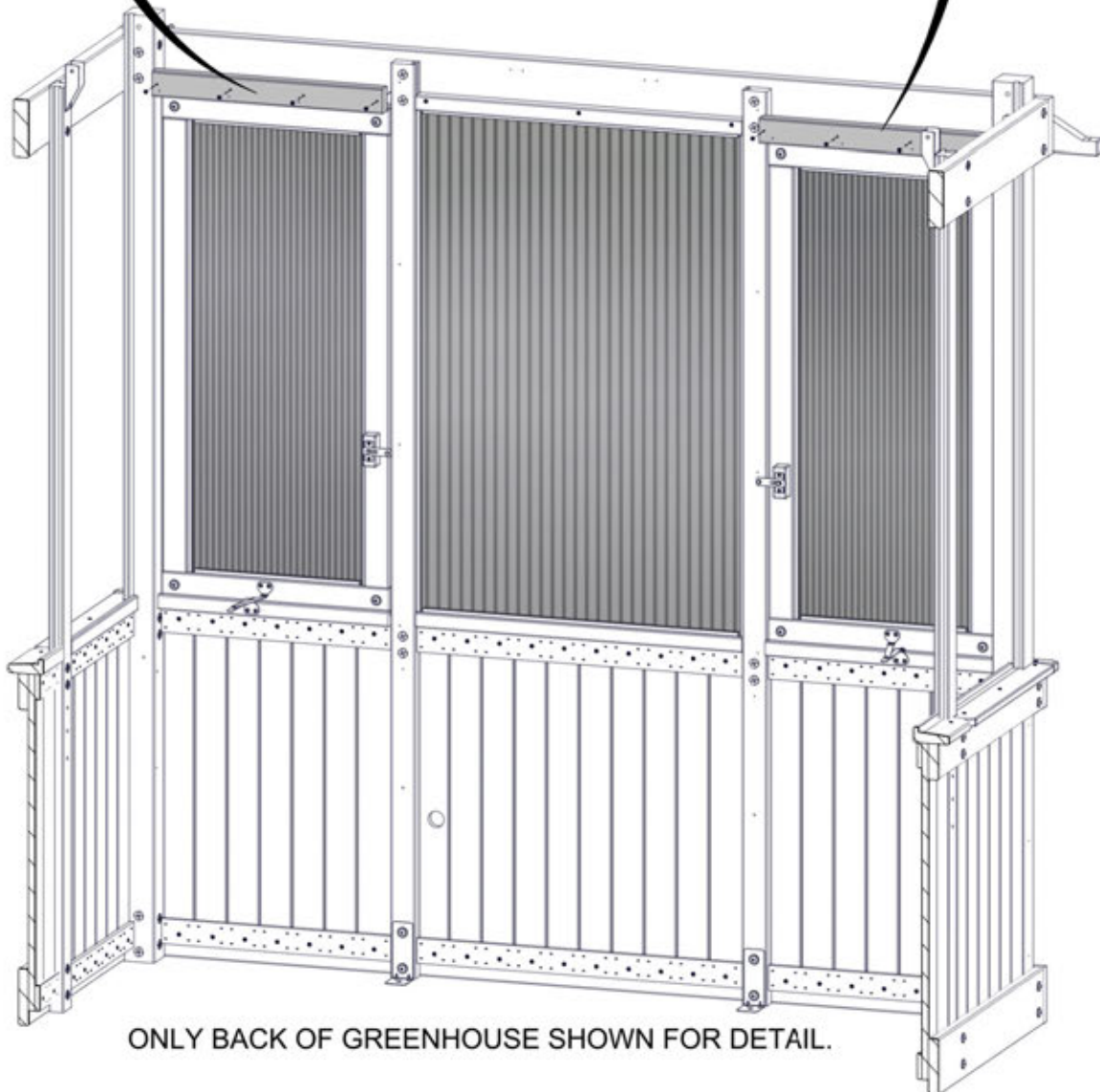
F11 WINDOW FRAME - W4L19574
(x1) 1 7/16"x2 3/8"x22 3/16" (36x60x563)



F12 WINDOW FRAME - W4L19588
(x1) 1 7/16"x2 3/8"x22 3/16" (36x60x563)



**ENSURE CORRECT ORIENTATION
OF F11 AND F12 WITH PILOT HOLES
FACING IN AND TO THE BOTTOM.**



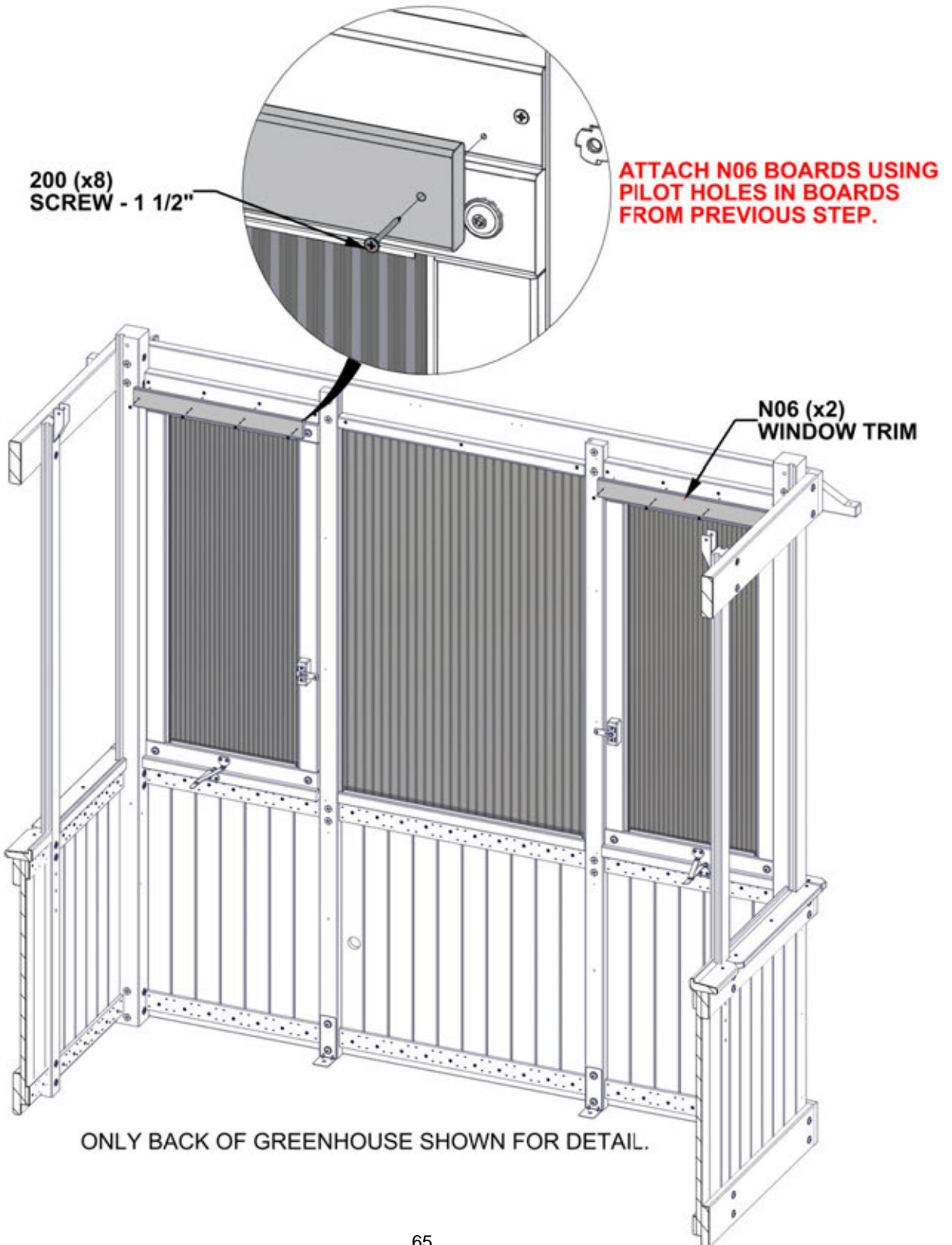
ONLY BACK OF GREENHOUSE SHOWN FOR DETAIL.

STEP 46 - BACK WALL ASSEMBLY

QTY	PART NUMBER	DESCRIPTION
8	H100200	SCREW PFH 8x1 1/2 BLK



N06 WINDOW TRIM - W4L19575
(x2) 5/8"x2 3/8"x21 9/16" (16x60x547)

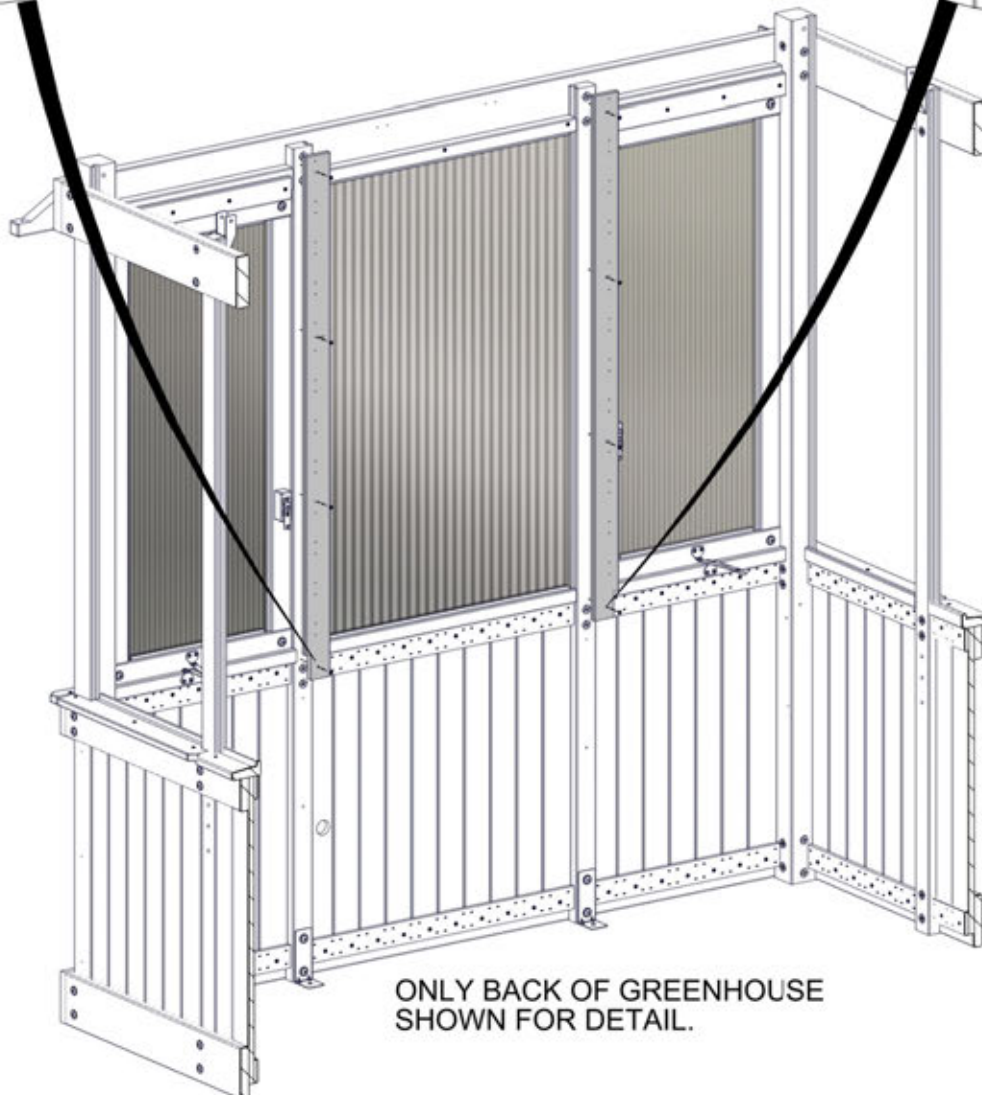
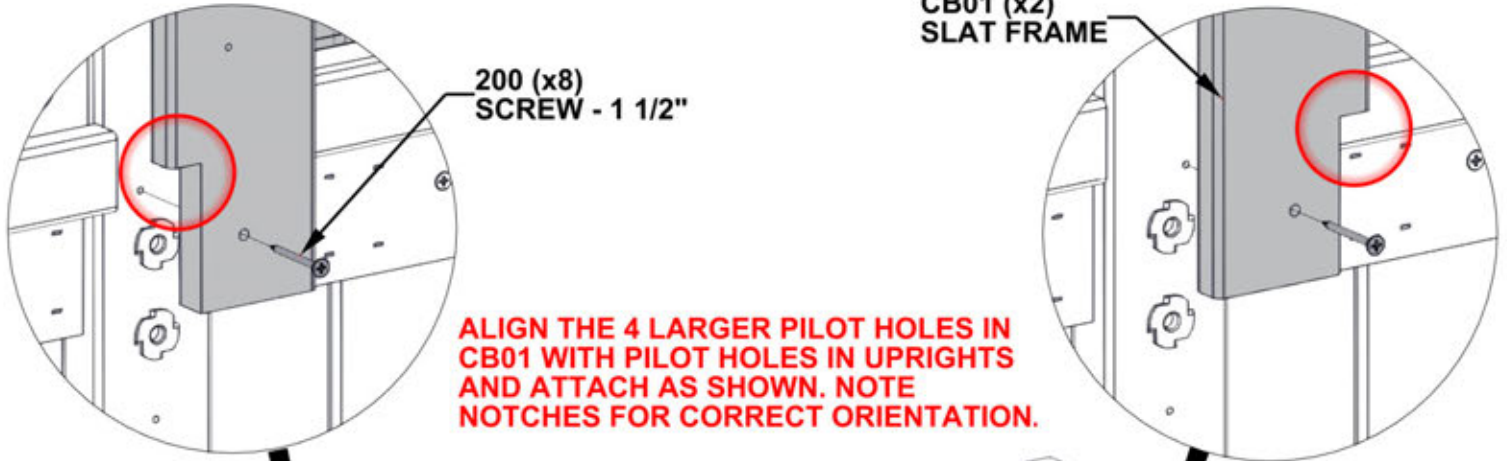


STEP 47 - BACK WALL ASSEMBLY

QTY	PART NUMBER	DESCRIPTION
8	H100200	SCREW PFH 8x1 1/2 BLK



CB01 SLAT FRAME - W4L19589
(x2) 5/8"x3"x53 7/8" (16x76x1368)



ONLY BACK OF GREENHOUSE
SHOWN FOR DETAIL.

STEP 48 - BACK WALL ASSEMBLY

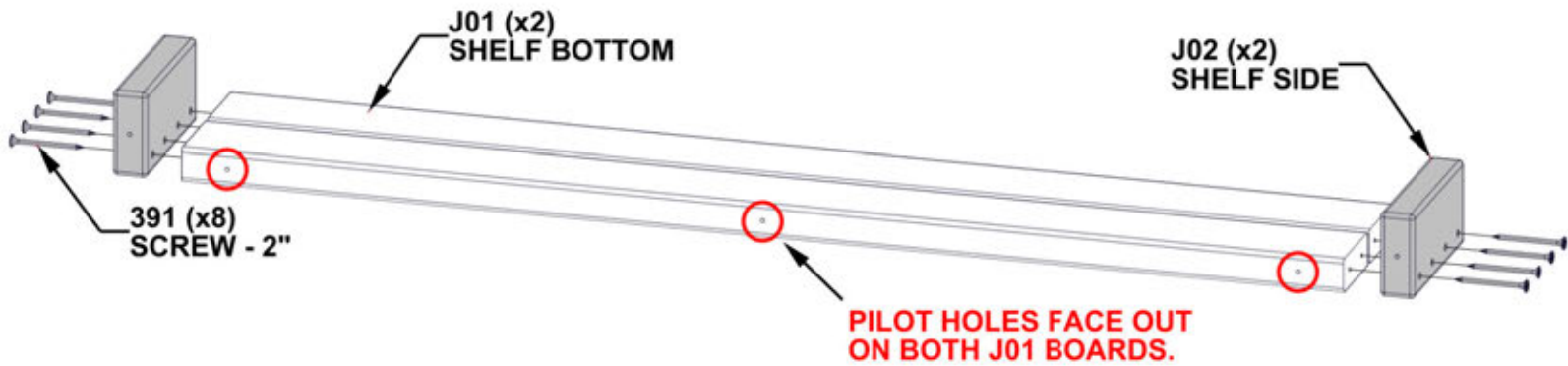
QTY	PART NUMBER	DESCRIPTION
8	H100391	SCREW PFH 8x2 BLK



J01 SHELF BOTTOM - W4L19590
(x2) 15/16"x2 3/8"x32 5/16" (24x60x820)



J02 SHELF SIDE - W4L19593
(x2) 15/16"x2 3/8"x4 13/16" (24x60x122)



STEP 49 - BACK WALL ASSEMBLY

QTY	PART NUMBER	DESCRIPTION
10	H100391	SCREW PFH 8x2 BLK

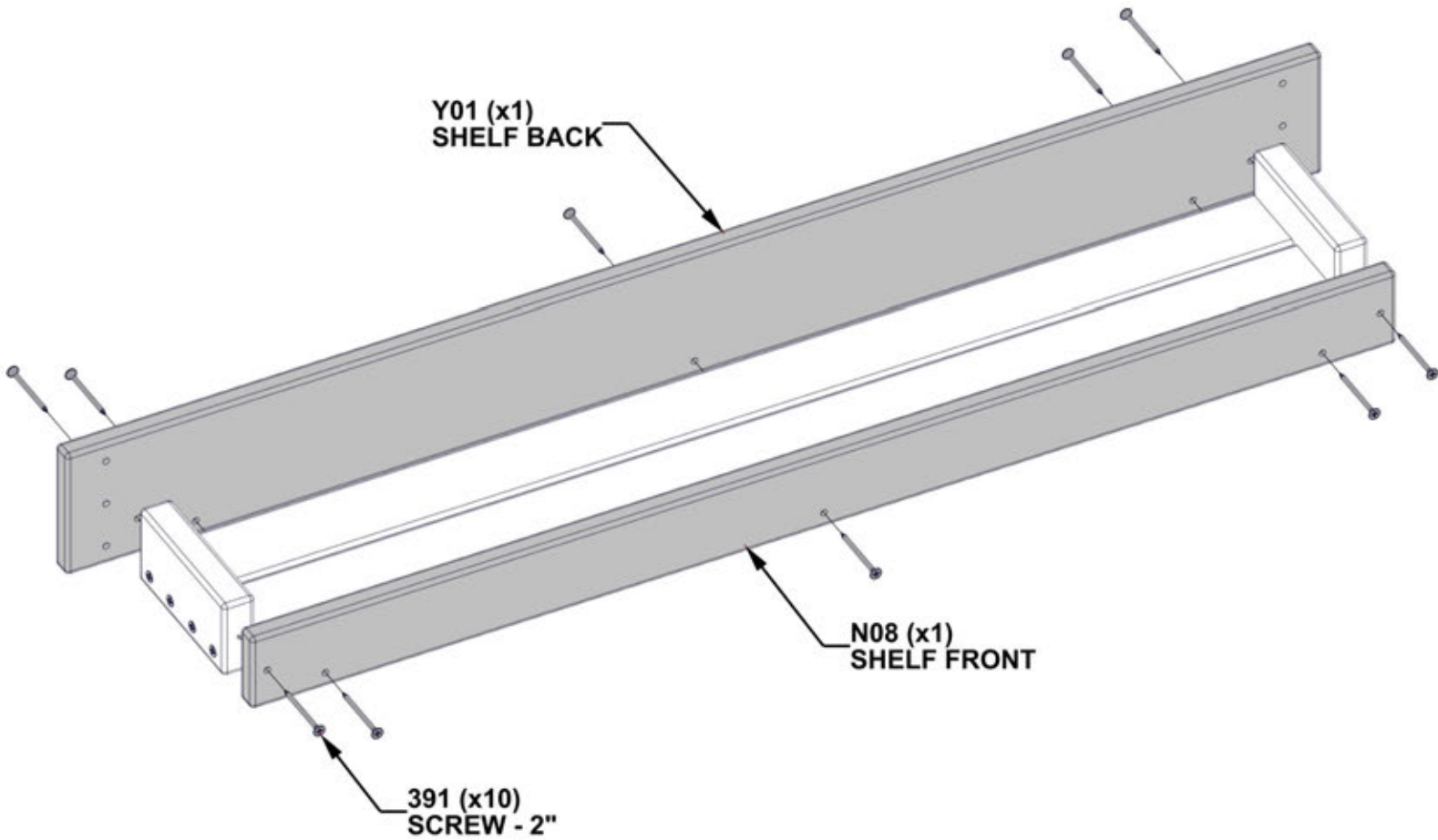


N08 SHELF FRONT - W4L19594
(x1) 5/8"x2 3/8"x34 3/16" (16x60x868)



Y01 SHELF BACK - W4L19592
(x1) 5/8"x4"x37 1/2" (16x102x952)

ALIGN PILOT HOLES AND ASSEMBLE AS SHOWN.



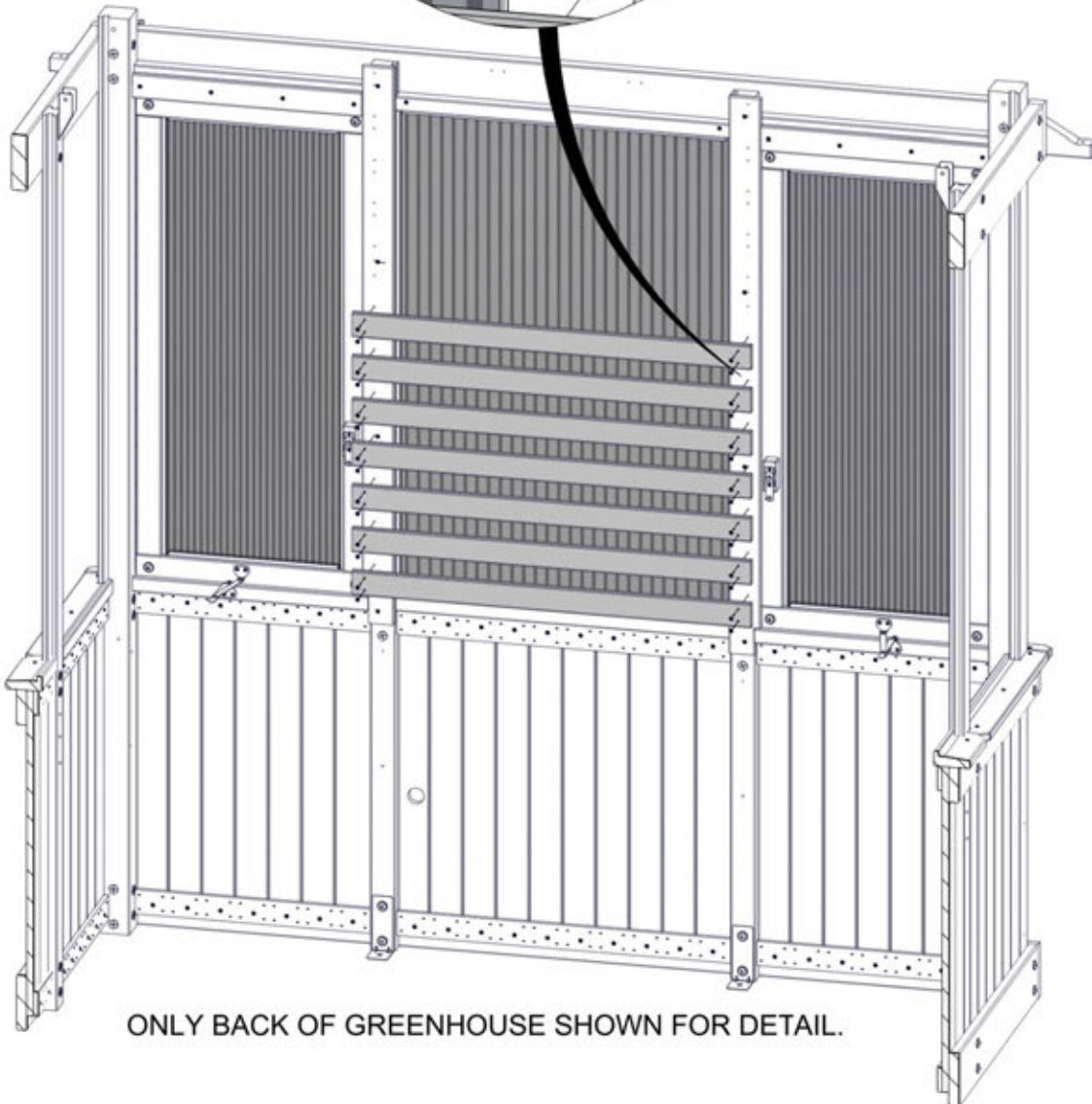
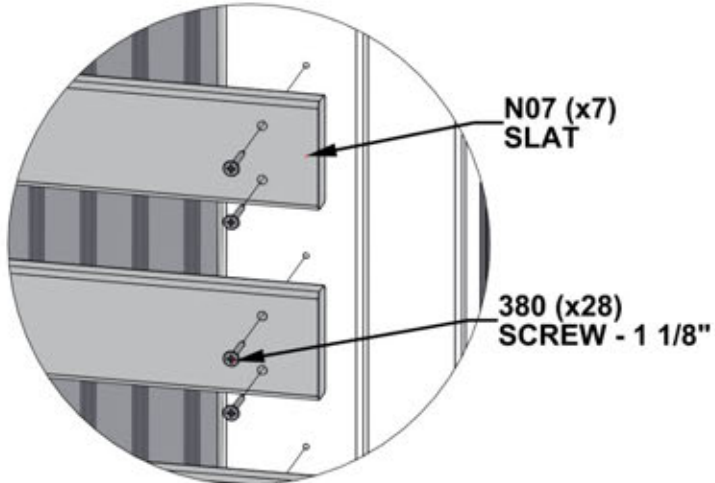
STEP 50 - BACK WALL ASSEMBLY

QTY	PART NUMBER	DESCRIPTION
28	H100380	SCREW PFH 8x1 1/8 BLK



N07 SLAT - W4L19591
(x7) 5/8"x2 3/8"x37 1/2" (16x60x952)

ATTACH THE FIRST 7 SLATS
STARTING FROM THE BOTTOM
USING PILOT HOLES AS SHOWN.



ONLY BACK OF GREENHOUSE SHOWN FOR DETAIL.

STEP 51 - BACK WALL ASSEMBLY

QTY	PART NUMBER	DESCRIPTION
18	H100380	SCREW PFH 8x1 1/8 BLK

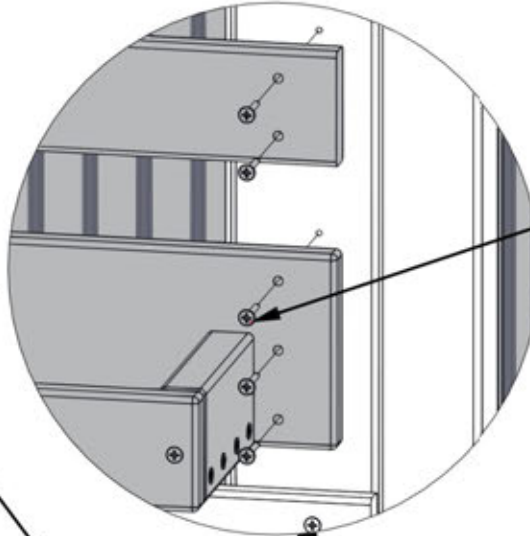


SHELF ASSEMBLY - FROM PREVIOUS STEPS



N07 SLAT - W4L19591
(x3) 5/8"x2 3/8"x37 1/2" (16x60x952)

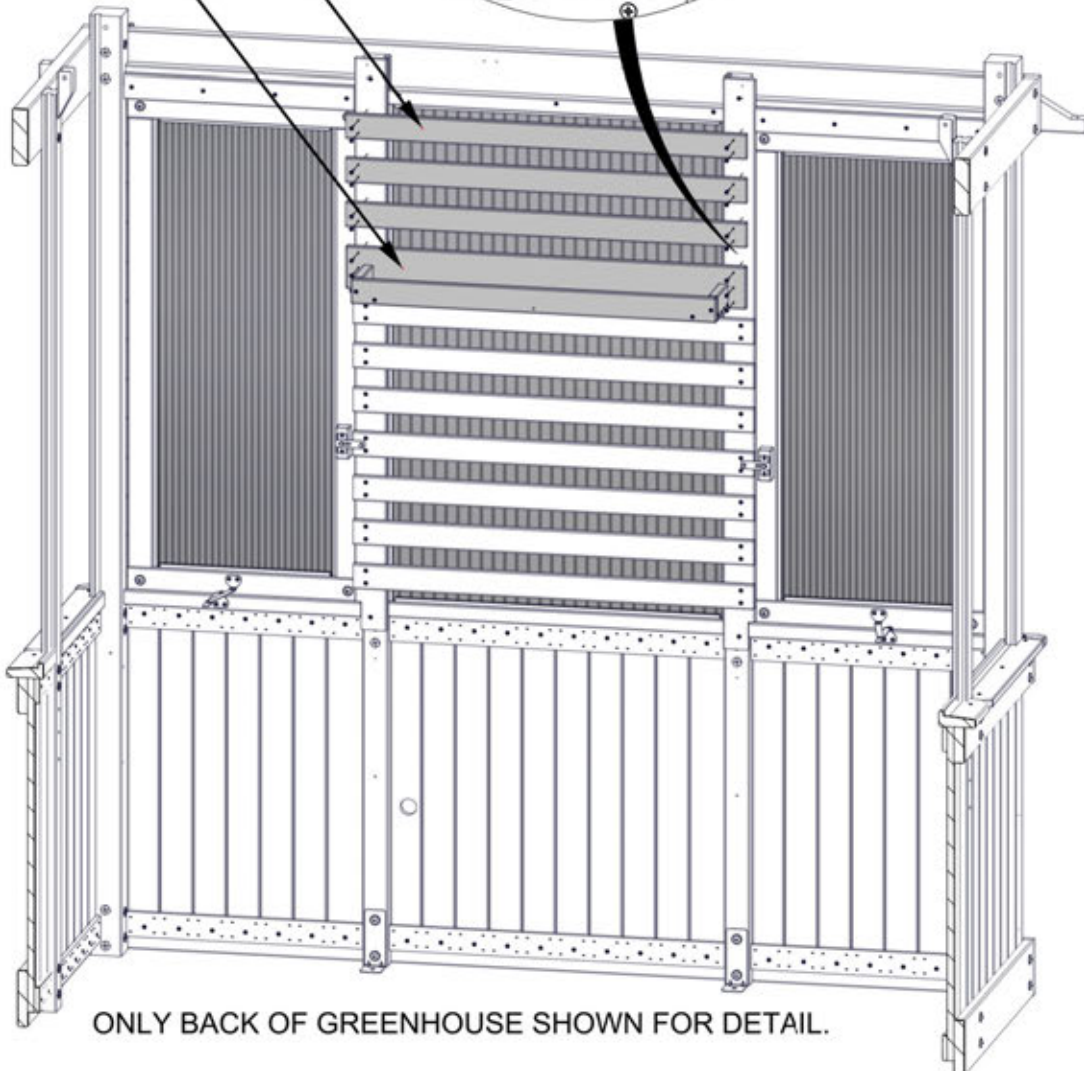
ATTACH SHELF ASSEMBLY AND
NEXT THREE SLATS AS SHOWN.



380 (x18)
SCREW - 1 1/8"

N07 (x3)
SLAT

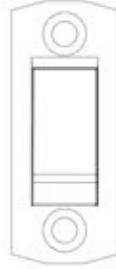
SHELF ASSEMBLY



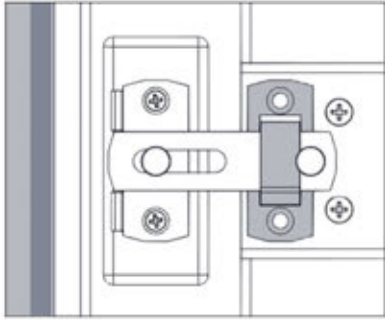
ONLY BACK OF GREENHOUSE SHOWN FOR DETAIL.

STEP 52 - BACK WALL ASSEMBLY

QTY	PART NUMBER	DESCRIPTION
4	H100627	SCREW PFH 6x3/4 BLK

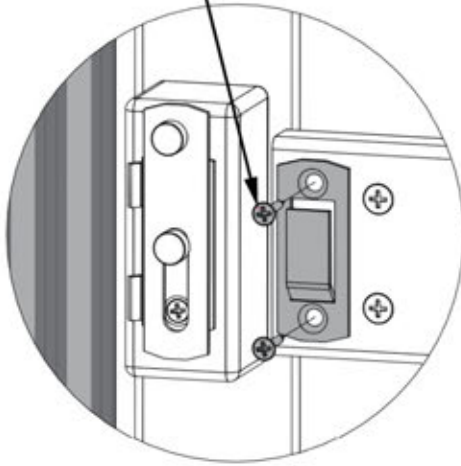


A4M02607 WINDOW LATCH LOCK (x2)

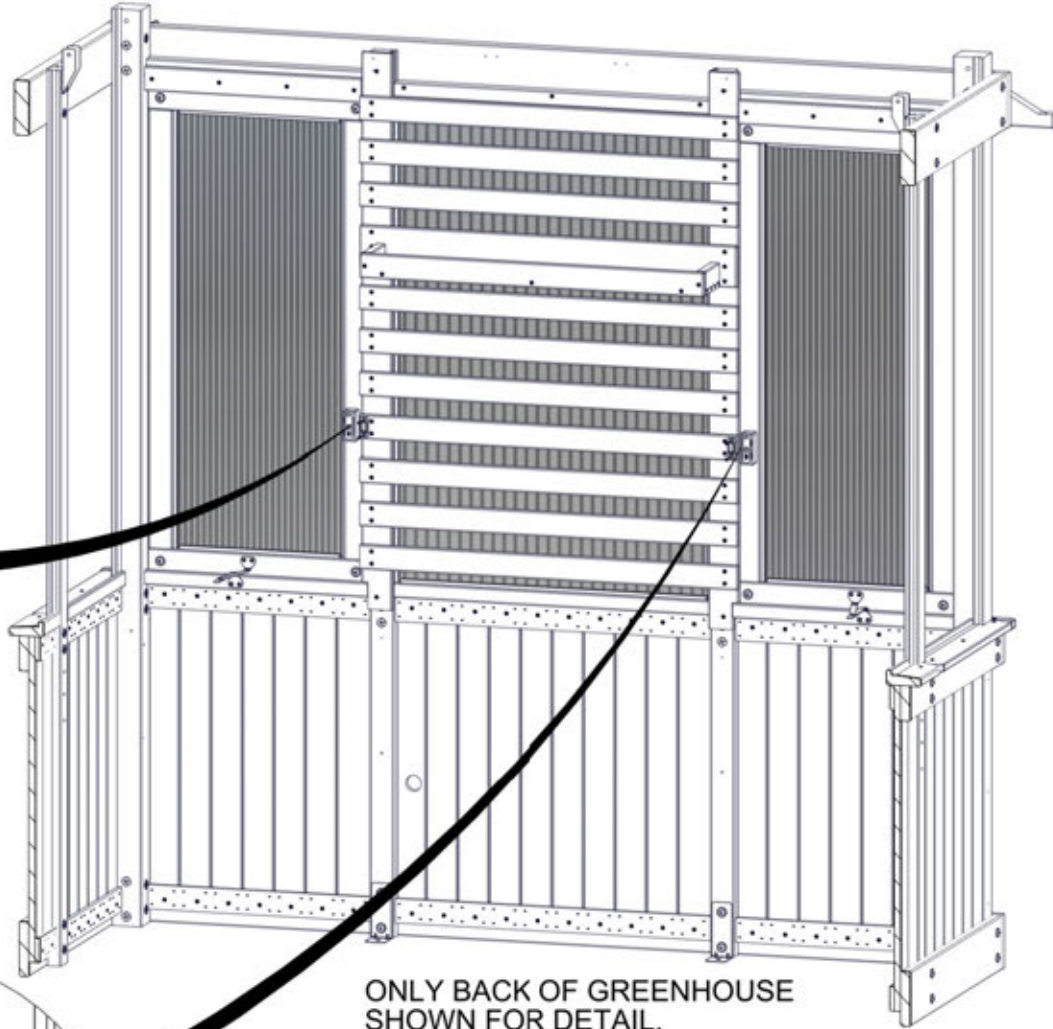


WITH WINDOW CLOSED, ALIGN LATCH LOCK AS SHOWN. MARK HOLE LOCATIONS AND PRE-DRILL WITH 1/8" [3mm] DRILL BIT.

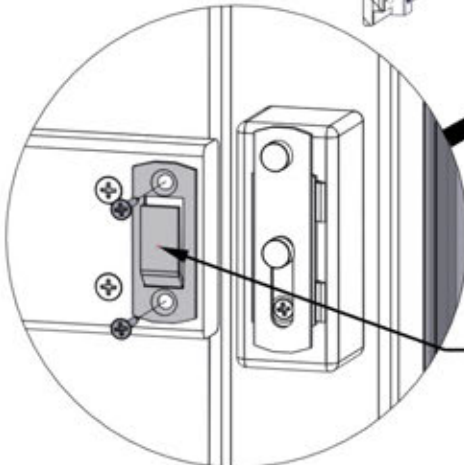
627 (x4)
SCREW - 3/4"



ATTACH LATCH LOCK USING PRE-DRILLED



ONLY BACK OF GREENHOUSE SHOWN FOR DETAIL.



2607 (x2)
WINDOW LATCH CATCH

STEP 53 - BACK WALL ASSEMBLY

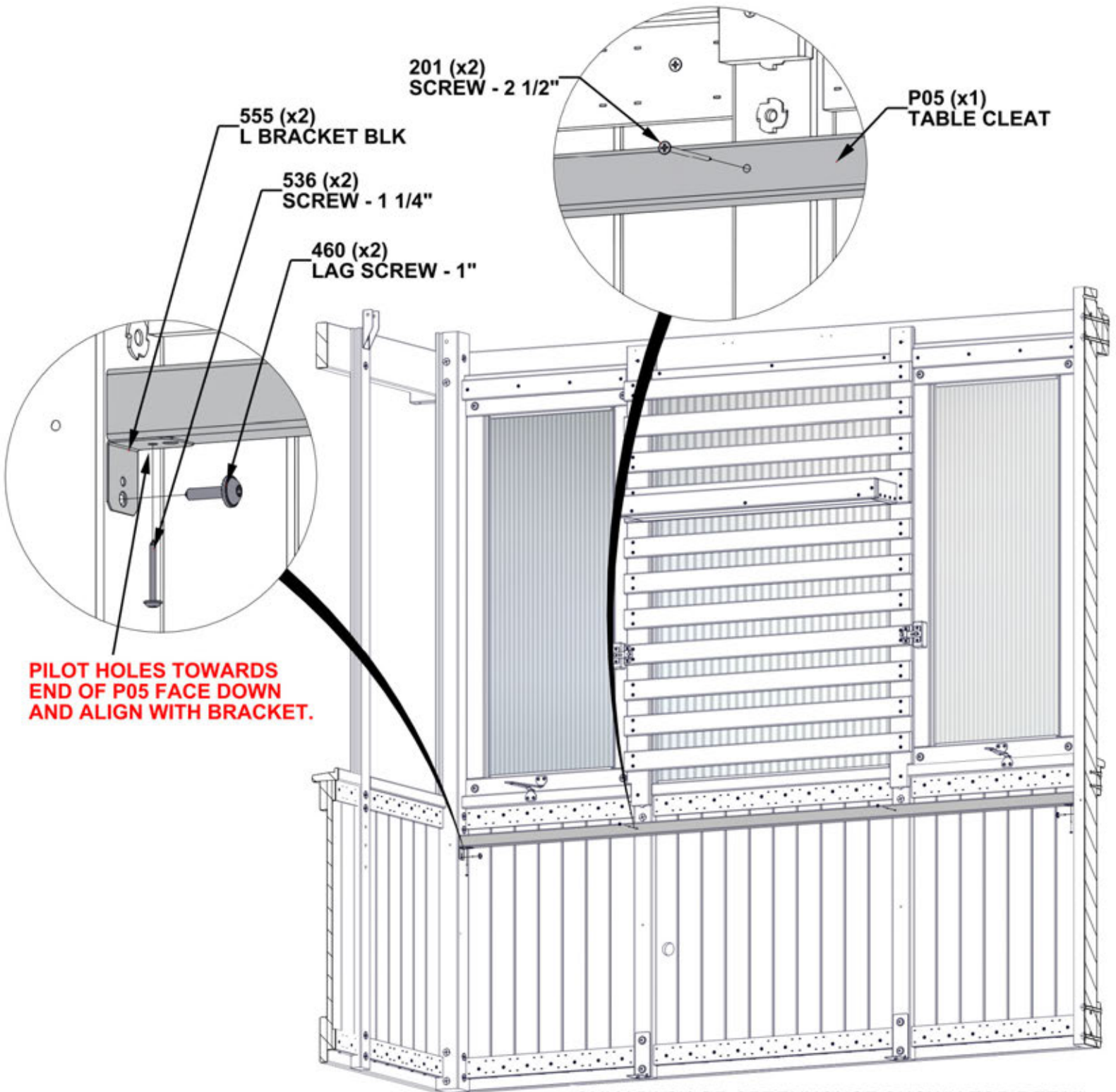
QTY	PART NUMBER	DESCRIPTION
2	H100201	SCREW PFH 8x2 1/2 BLK
2	H100460	LAG SCREW WH 1/4x1 BLK
2	H100536	SCREW PWH 8x1 1/4 BLK



P05 TABLE CLEAT - W4L19572
(x1) 1 7/16"x1 7/16"x80 5/8" (36x36x2048)



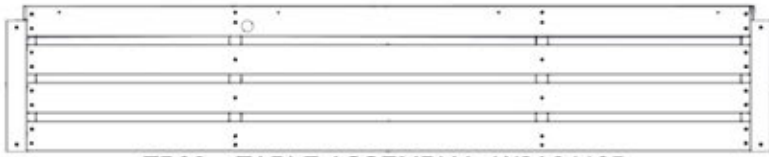
A4M00555 L BRACKET BLK
(x2)



ONLY BACK OF GREENHOUSE SHOWN FOR DETAIL.

STEP 54 - TABLE ASSEMBLY

QTY	PART NUMBER	DESCRIPTION
7	H100200	SCREW PFH 8x1 1/2 BLK
2	H100536	SCREW PWH 8x1 1/4 BLK



TB06 TABLE ASSEMBLY - W2A04165
(x1) 2 1/16"x16 1/16"x84 1/2" (52x408x2146)

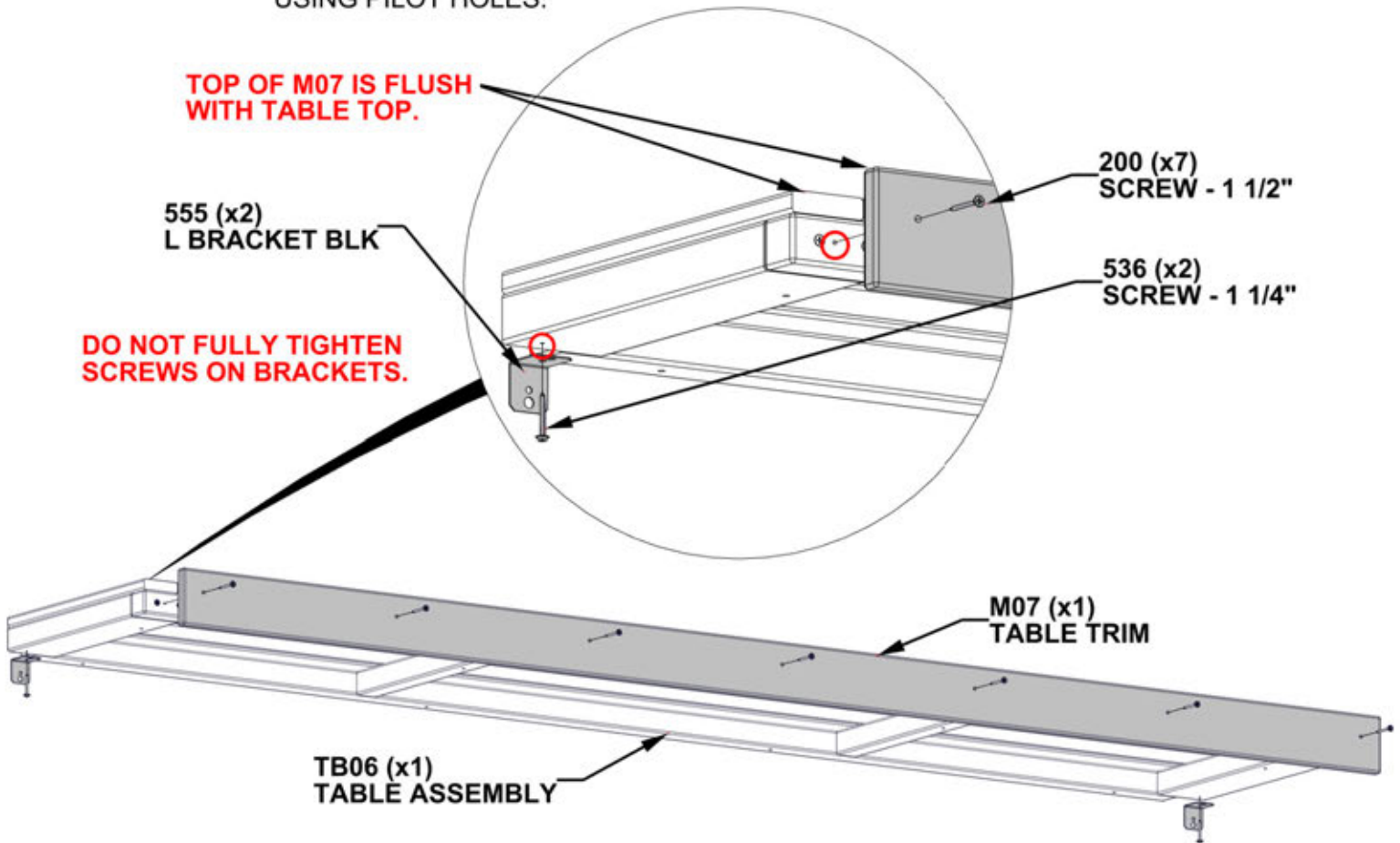


A4M00555 L BRACKET BLK
(x2)



M07 TABLE TRIM - W4L19573
(x1) 5/8"x3 3/8"x84 1/2" (16x86x2146)

ATTACH TRIM AND BRACKETS USING PILOT HOLES.



STEP 55 - TABLE ASSEMBLY

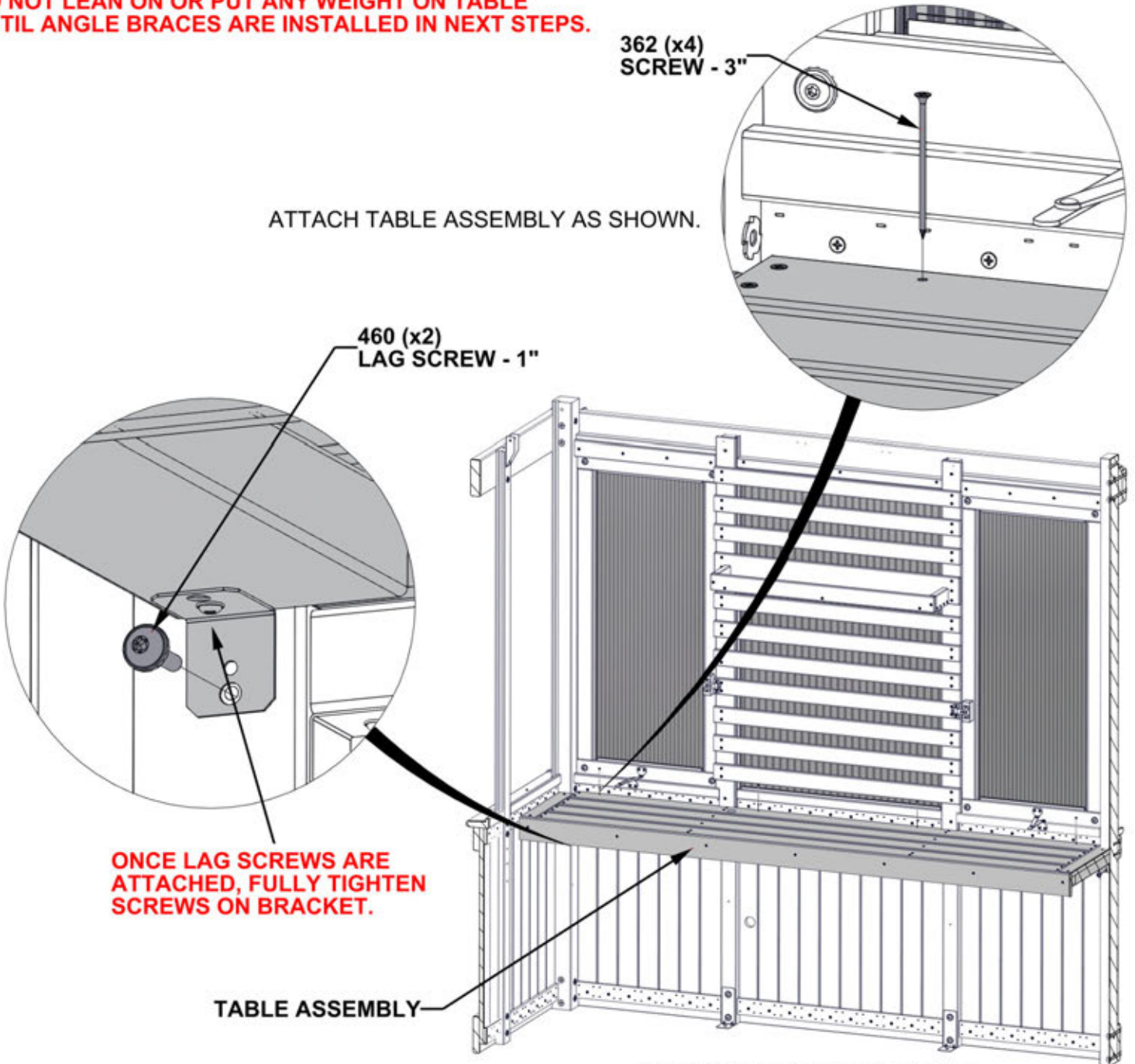
QTY	PART NUMBER	DESCRIPTION
4	H100362	SCREW PFH 8x3 BLK
2	H100460	LAG SCREW WH 1/4x1 BLK



TABLE ASSEMBLY - FROM PREVIOUS STEPS

DO NOT LEAN ON OR PUT ANY WEIGHT ON TABLE UNTIL ANGLE BRACES ARE INSTALLED IN NEXT STEPS.

ATTACH TABLE ASSEMBLY AS SHOWN.



362 (x4)
SCREW - 3"

460 (x2)
LAG SCREW - 1"

ONCE LAG SCREWS ARE ATTACHED, FULLY TIGHTEN SCREWS ON BRACKET.

TABLE ASSEMBLY

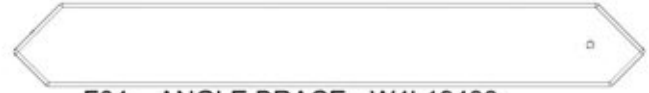
ONLY BACK OF GREENHOUSE SHOWN FOR DETAIL.

STEP 56 - TABLE ASSEMBLY

QTY	PART NUMBER	DESCRIPTION
2	H100201	SCREW PFH 8x2 1/2 BLK
6	H100405	WASHER LOCK EXT 6x15
6	H100456	LAG SCREW WH 1/4x2 1/2 BLK

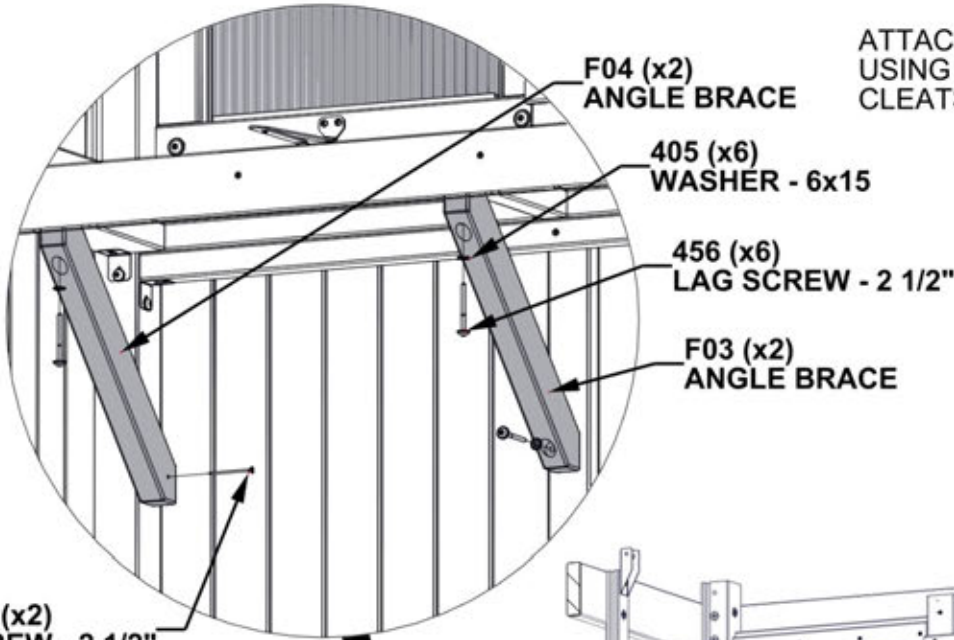


F03 ANGLE BRACE - W4L19487
(x2) 1 7/16"x2 3/8"x18 1/16" (36x60x458)

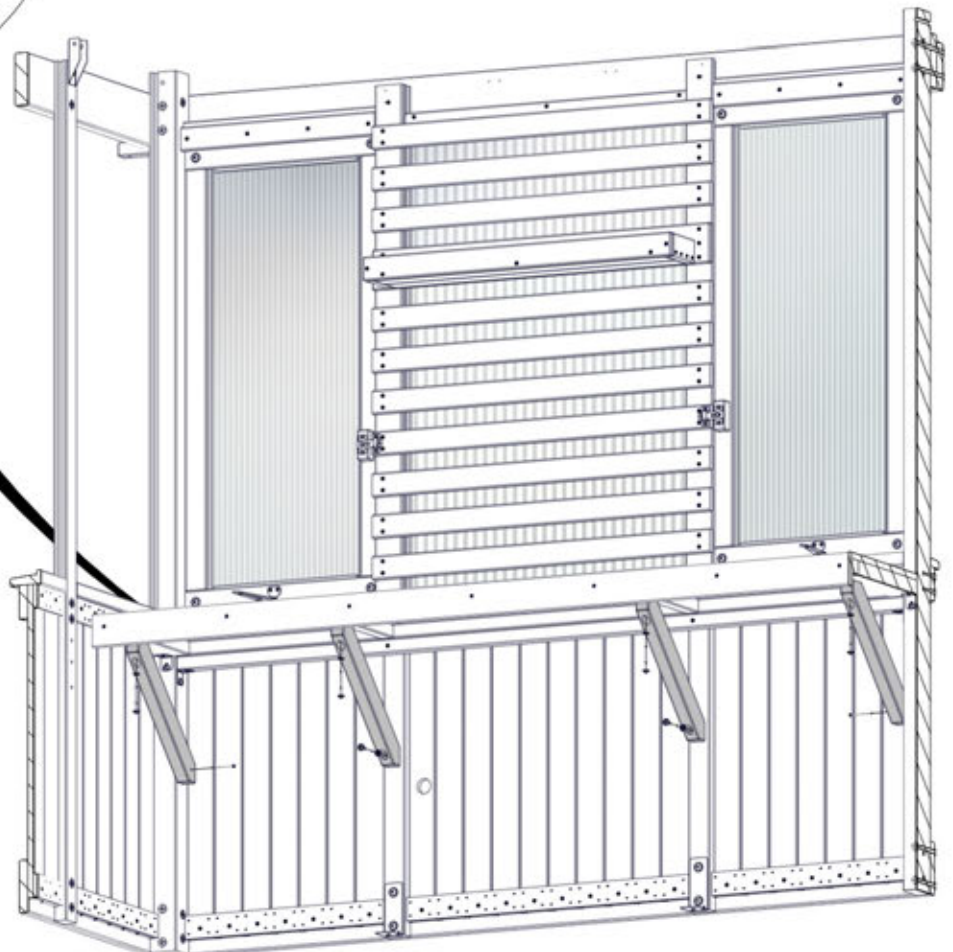


F04 ANGLE BRACE - W4L19488
(x2) 1 7/16"x2 3/8"x18 1/16" (36x60x458)

ATTACH ANGLE BRACES AS SHOWN USING PILOT HOLES IN TABLE CLEATS, UPRIGHTS, AND POSTS.



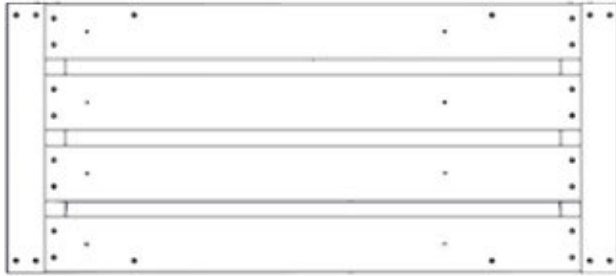
201 (x2) SCREW - 2 1/2"



ONLY BACK OF GREENHOUSE SHOWN FOR DETAIL.

STEP 57 - TABLE ASSEMBLY

QTY	PART NUMBER	DESCRIPTION
4	H100201	SCREW PFH 8x2 1/2 BLK
8	H100387	SCREW PFH 8x1 1/4 BLK



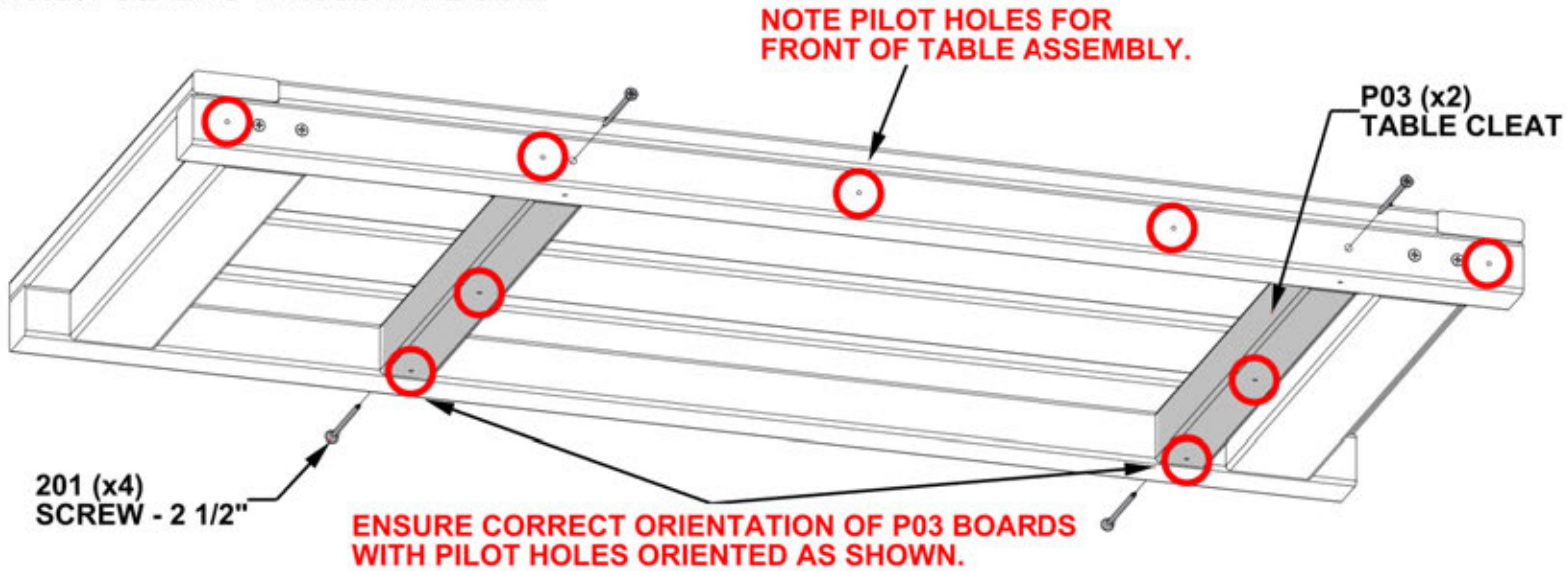
TB03 TABLE ASSEMBLY - W2A04153
(x1) 2 1/16"x16 1/16"x36 9/16" (52x408x929)



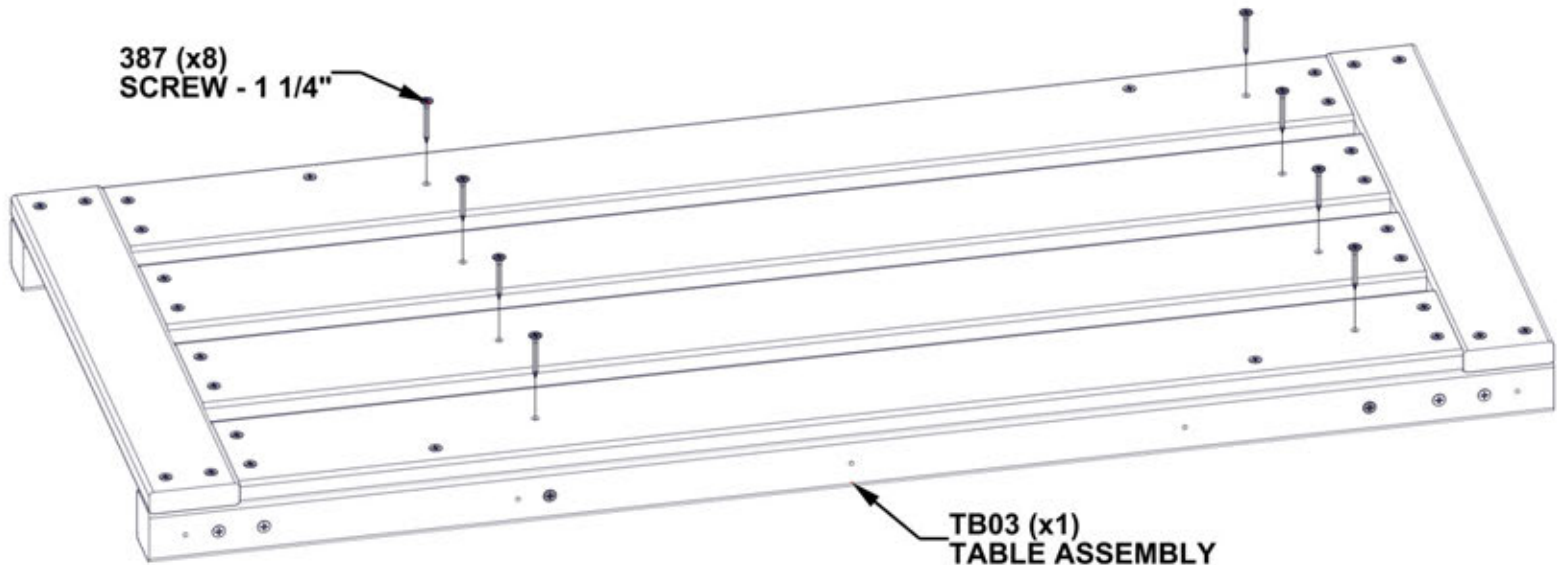
P03 TABLE CLEAT - W4L19484
(x2) 1 7/16"x1 7/16"x13 1/4" (36x36x336)

PAY CLOSE ATTENTION TO PILOT HOLES FOR CORRECT INSTALLATION.

FIRST, ATTACH P03 BOARDS USING H100201 SCREWS THROUGH THE SIDE.



NEXT, INSERT H100387 SCREWS THROUGH PILOT HOLES IN TABLE TOP.

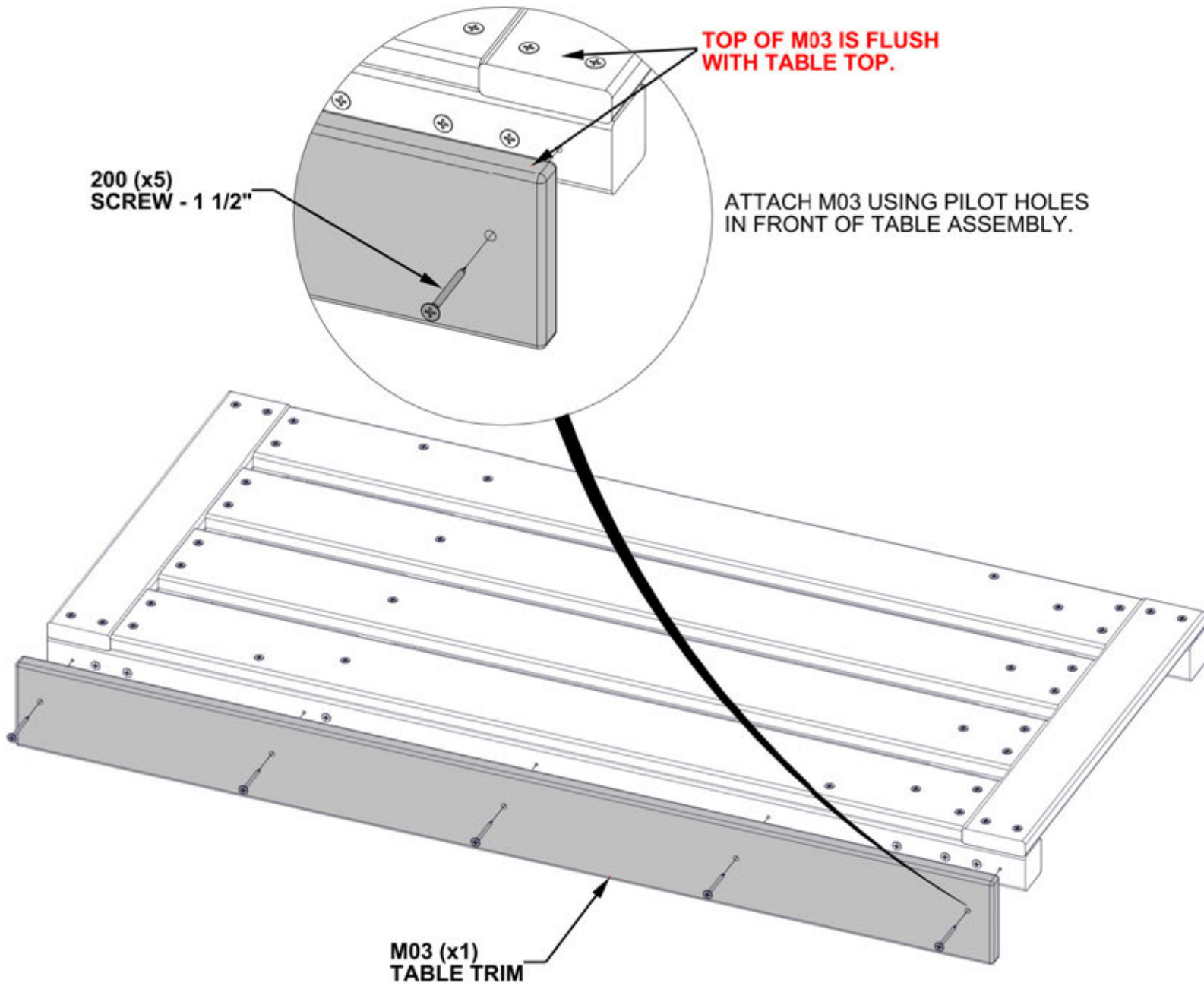


STEP 58 - TABLE ASSEMBLY

QTY	PART NUMBER	DESCRIPTION
5	H100200	SCREW PFH 8x1 1/2 BLK



M03 TABLE TRIM - W4L19486
(x1) 5/8"x3 3/8"x36 9/16" (16x86x929)



STEP 59 - TABLE ASSEMBLY

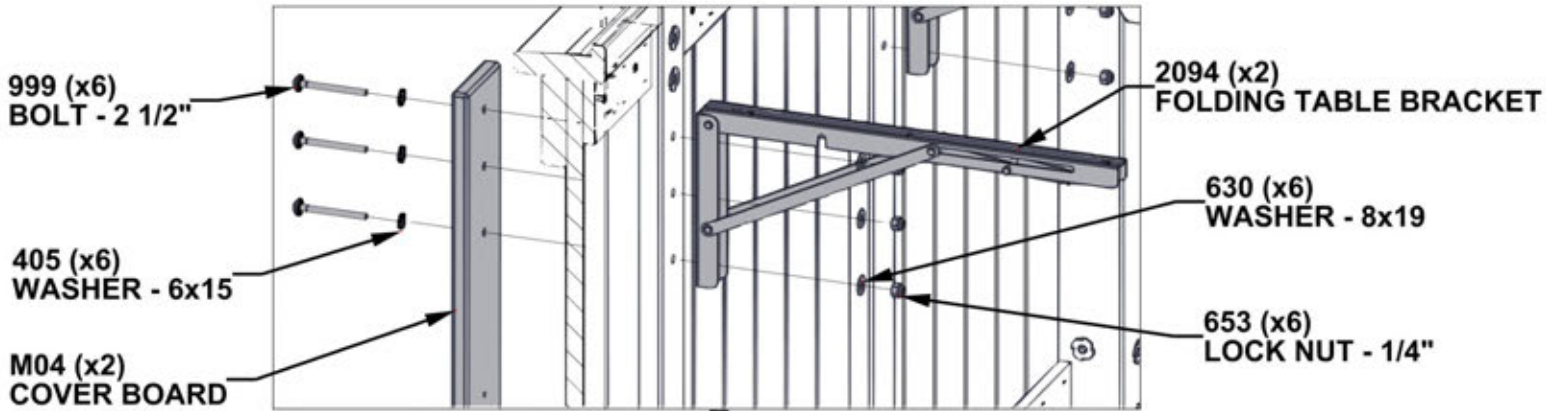
QTY	PART NUMBER	DESCRIPTION
6	H100405	WASHER LOCK EXT 6x15
6	H100630	WASHER FLAT 8x19 BLK
6	H100653	NUT LOCK 1/4 BLK
6	H100999	BOLT WH 1/4x2 1/2 BLK



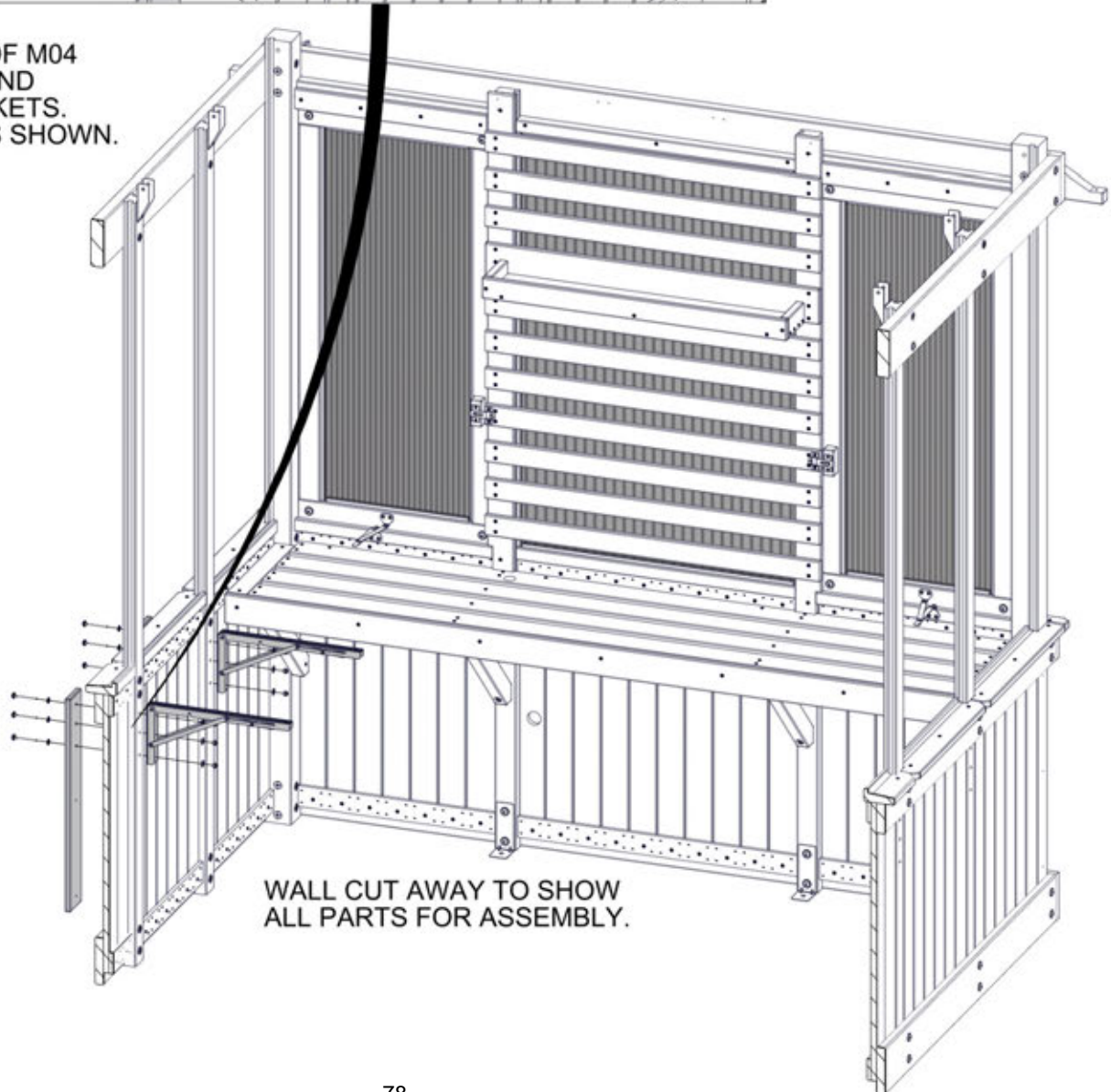
M04 COVER BOARD - W4L19489
(x2) 5/8"x3 3/8"x24 3/16" (16x86x614)



A4M02094 FOLDING TABLE BRACKET
(x2)



ALIGN THREE HOLES OF M04 BOARDS, UPRIGHTS, AND FOLDING TABLE BRACKETS. INSERT HARDWARE AS SHOWN.



WALL CUT AWAY TO SHOW ALL PARTS FOR ASSEMBLY.

STEP 60 - TABLE ASSEMBLY

QTY	PART NUMBER	DESCRIPTION
6	H100392	SCREW PWH 8x3/4 BLK

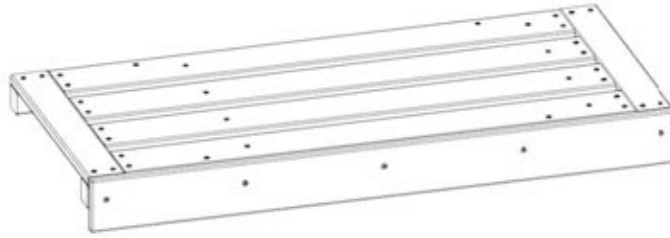


TABLE ASSEMBLY - FROM PREVIOUS STEPS

ALIGN HOLES IN TABLE BRACKET WITH PILOT HOLES IN TABLE ASSEMBLY AND ATTACH AS SHOWN.

392 (x6)
SCREW - 3/4"

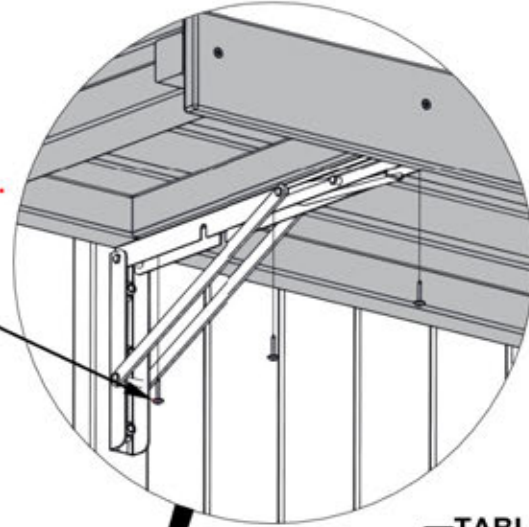
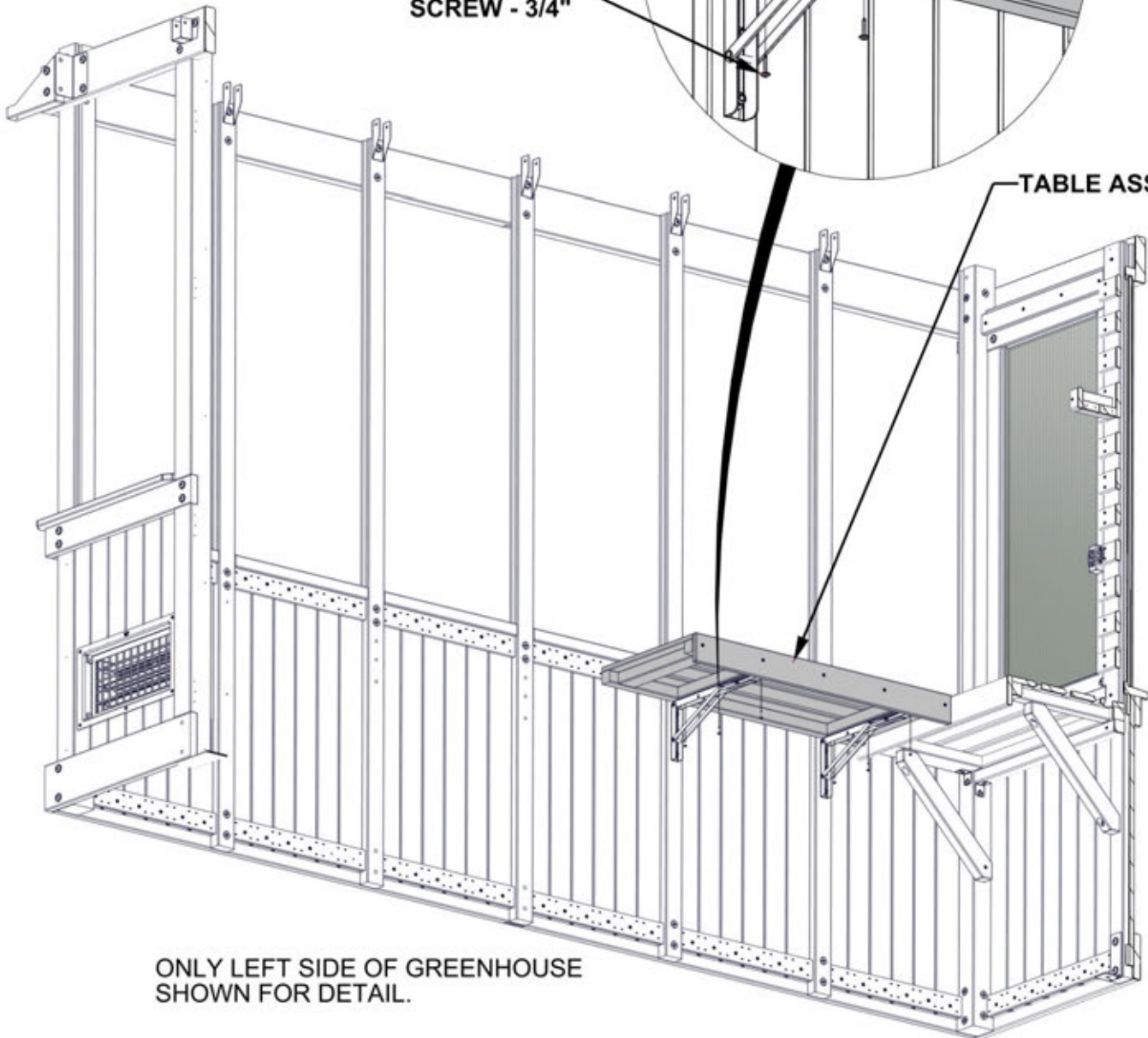


TABLE ASSEMBLY



ONLY LEFT SIDE OF GREENHOUSE SHOWN FOR DETAIL.

STEP 61 - TABLE ASSEMBLY

QTY	PART NUMBER	DESCRIPTION
4	H100201	SCREW PFH 8x2 1/2 BLK
8	H100387	SCREW PFH 8x1 1/4 BLK



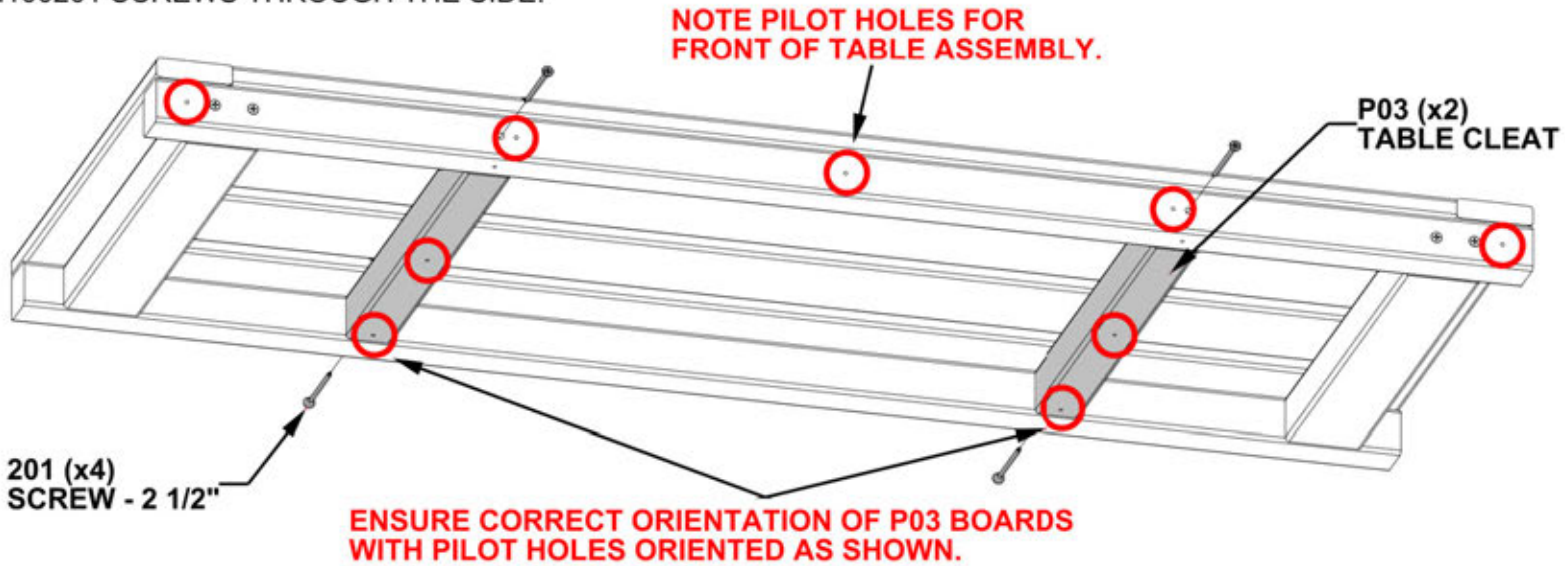
TB02 TABLE ASSEMBLY - W2A04152
(x1) 2 1/16"x16 1/16"x42 11/16" (52x408x1084)



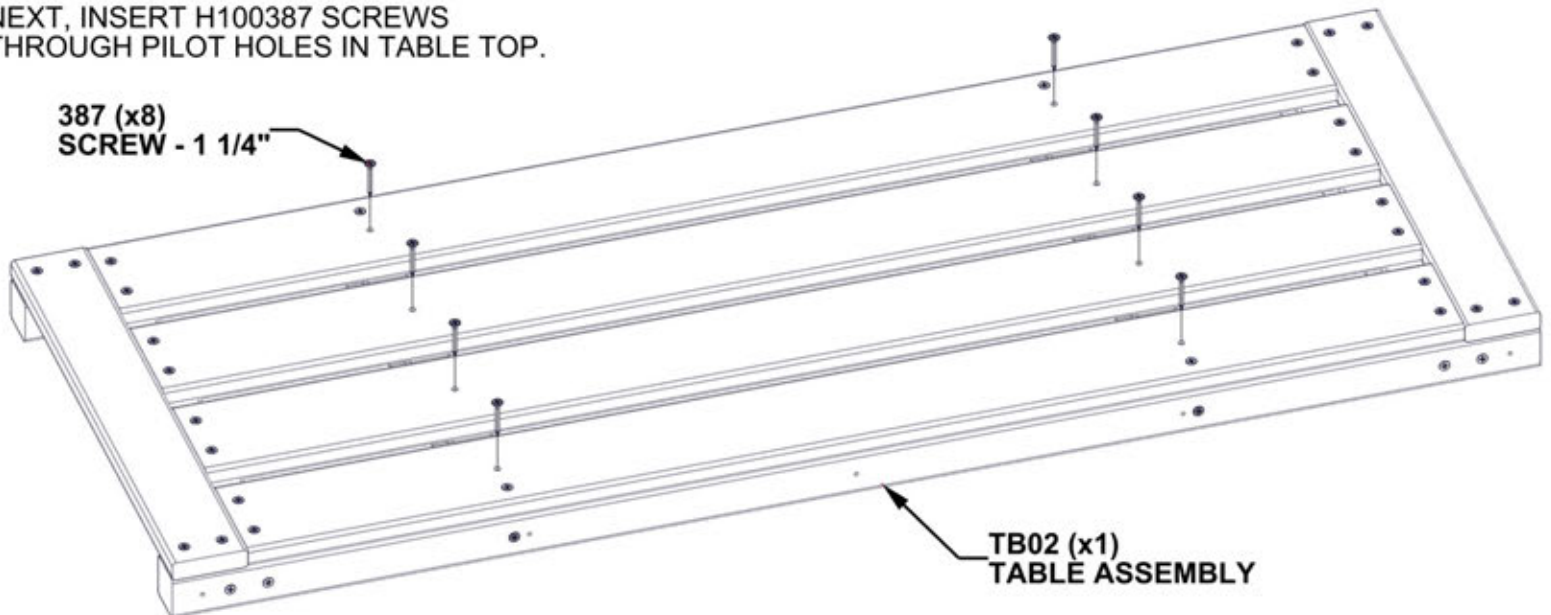
P03 TABLE CLEAT - W4L19484
(x2) 1 7/16"x1 7/16"x13 1/4" (36x36x336)

PAY CLOSE ATTENTION TO PILOT HOLES FOR CORRECT INSTALLATION.

FIRST, ATTACH P03 BOARDS USING H100201 SCREWS THROUGH THE SIDE.



NEXT, INSERT H100387 SCREWS THROUGH PILOT HOLES IN TABLE TOP.

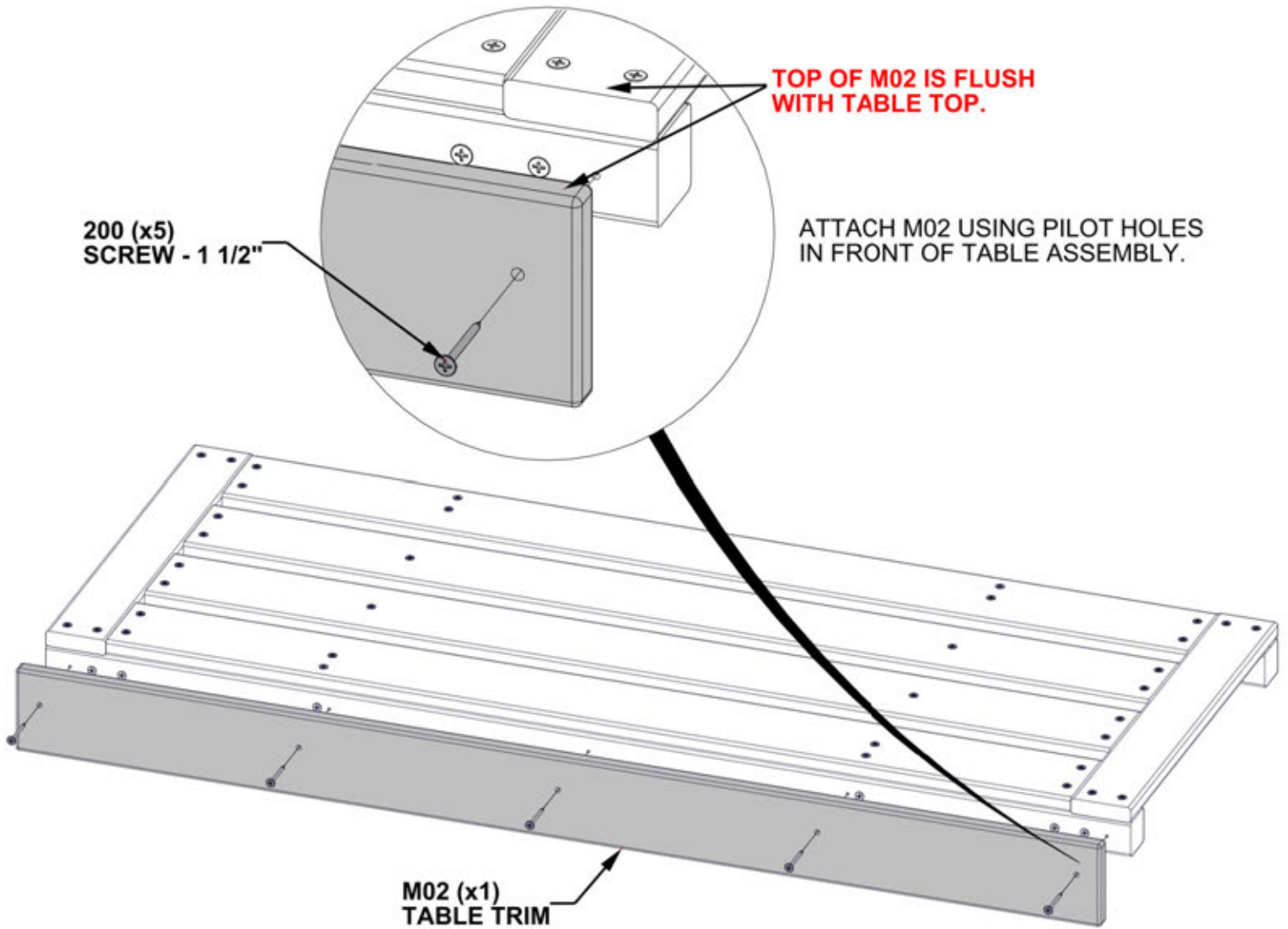


STEP 62 - TABLE ASSEMBLY

QTY	PART NUMBER	DESCRIPTION
5	H100200	SCREW PFH 8x1 1/2 BLK



M02 TABLE TRIM - W4L19485
(x1) 5/8"x3 3/8"x42 11/16" (16x86x1084)



STEP 63 - TABLE ASSEMBLY

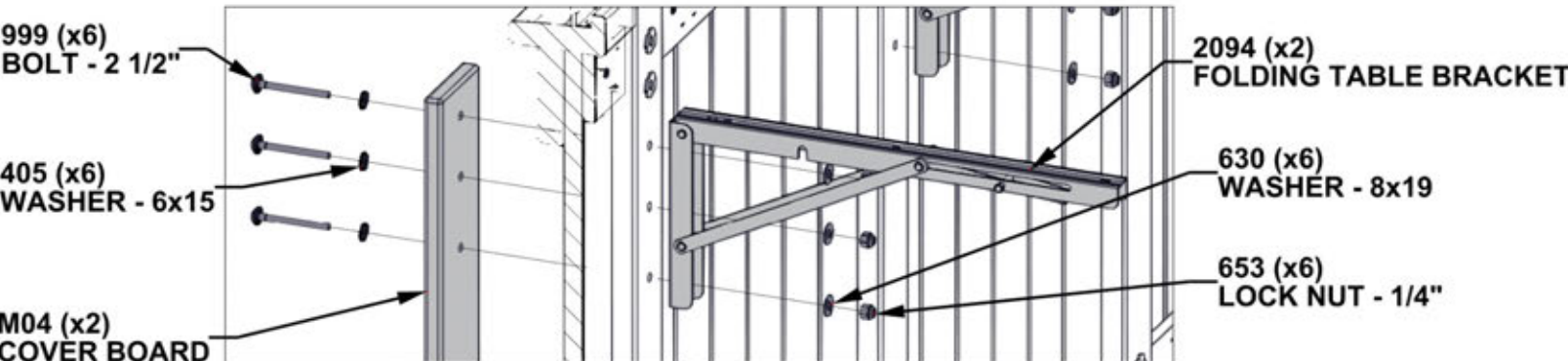
QTY	PART NUMBER	DESCRIPTION
6	H100405	WASHER LOCK EXT 6x15
6	H100630	WASHER FLAT 8x19 BLK
6	H100653	NUT LOCK 1/4 BLK
6	H100999	BOLT WH 1/4x2 1/2 BLK



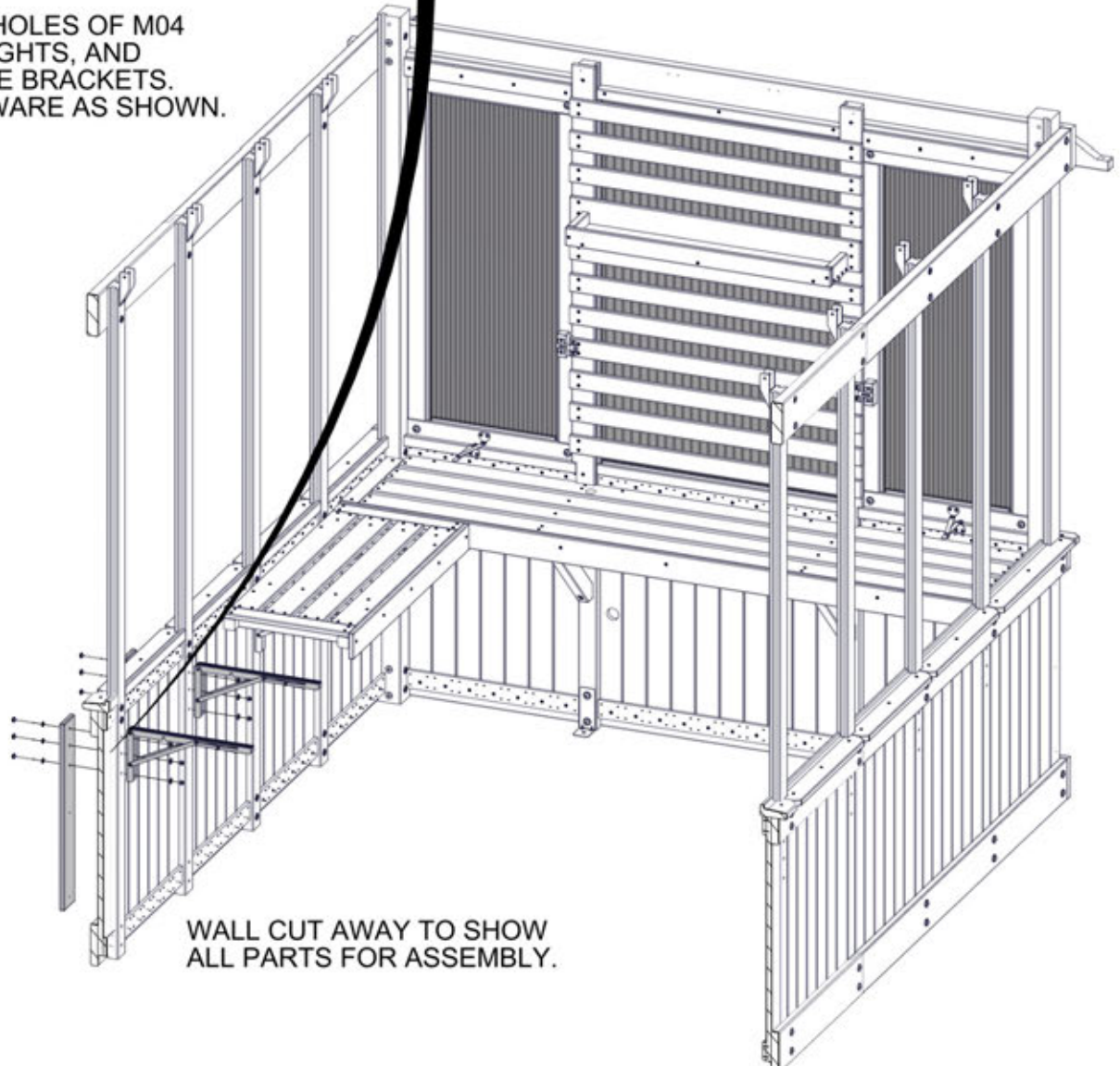
M04 COVER BOARD - W4L19489
(x2) 5/8"x3 3/8"x24 3/16" (16x86x614)



A4M02094 FOLDING TABLE BRACKET
(x2)



ALIGN THREE HOLES OF M04 BOARDS, UPRIGHTS, AND FOLDING TABLE BRACKETS. INSERT HARDWARE AS SHOWN.



WALL CUT AWAY TO SHOW ALL PARTS FOR ASSEMBLY.

STEP 64 - TABLE ASSEMBLY

QTY	PART NUMBER	DESCRIPTION
6	H100392	SCREW PWH 8x3/4 BLK

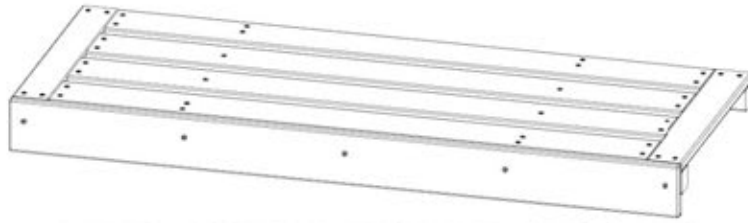
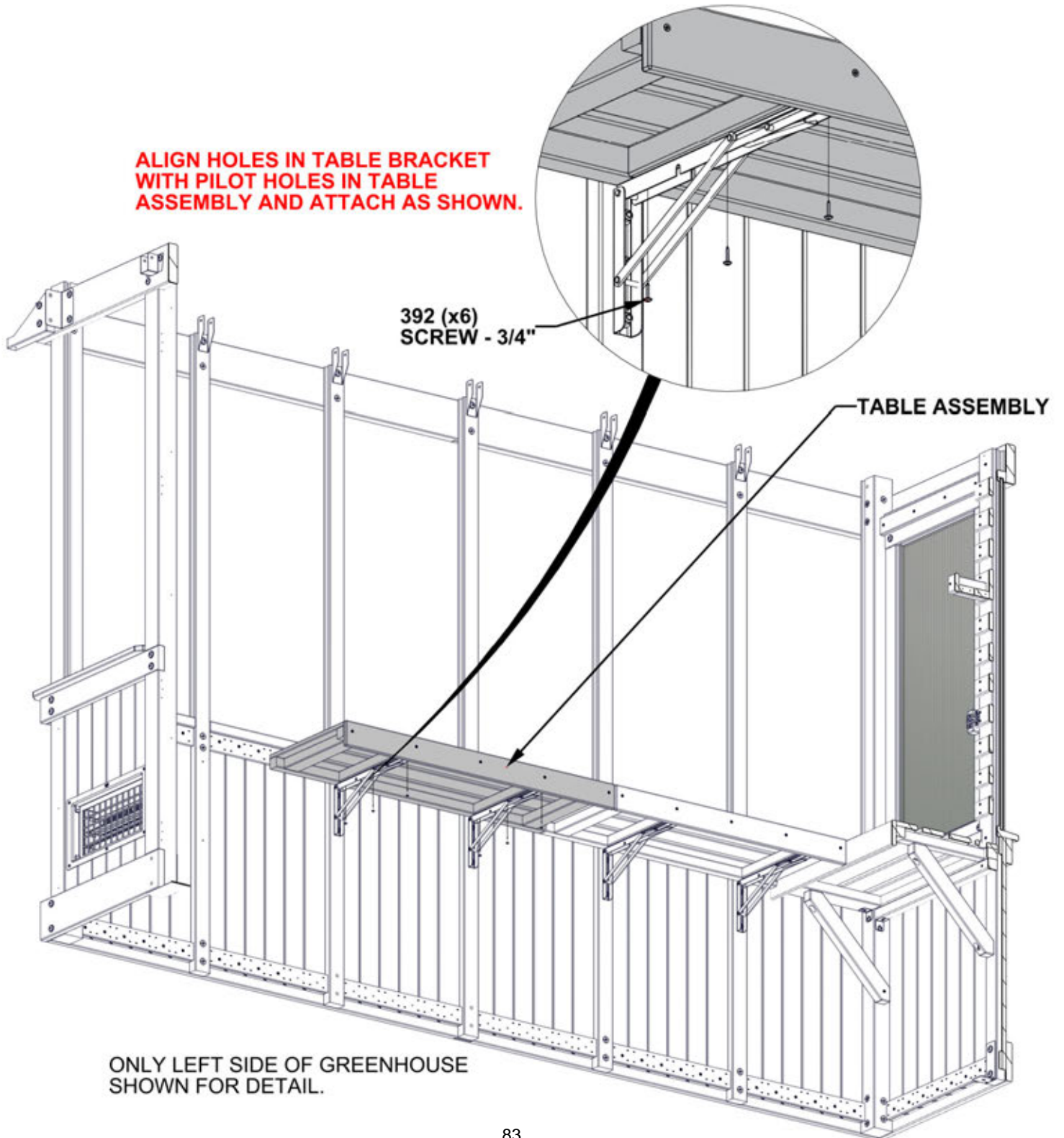
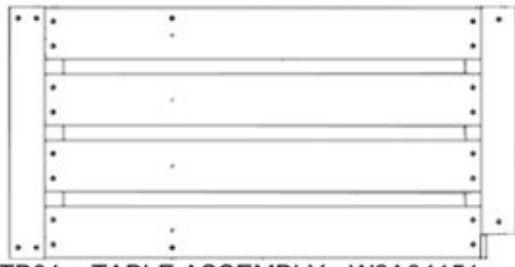


TABLE ASSEMBLY - FROM PREVIOUS STEPS



STEP 65 - TABLE ASSEMBLY

QTY	PART NUMBER	DESCRIPTION
2	H100201	SCREW PFH 8x2 1/2 BLK
4	H100387	SCREW PFH 8x1 1/4 BLK



TB01 TABLE ASSEMBLY - W2A04151
(x1) 2 1/16"x16 1/16"x32 1/2" (52x408x825)

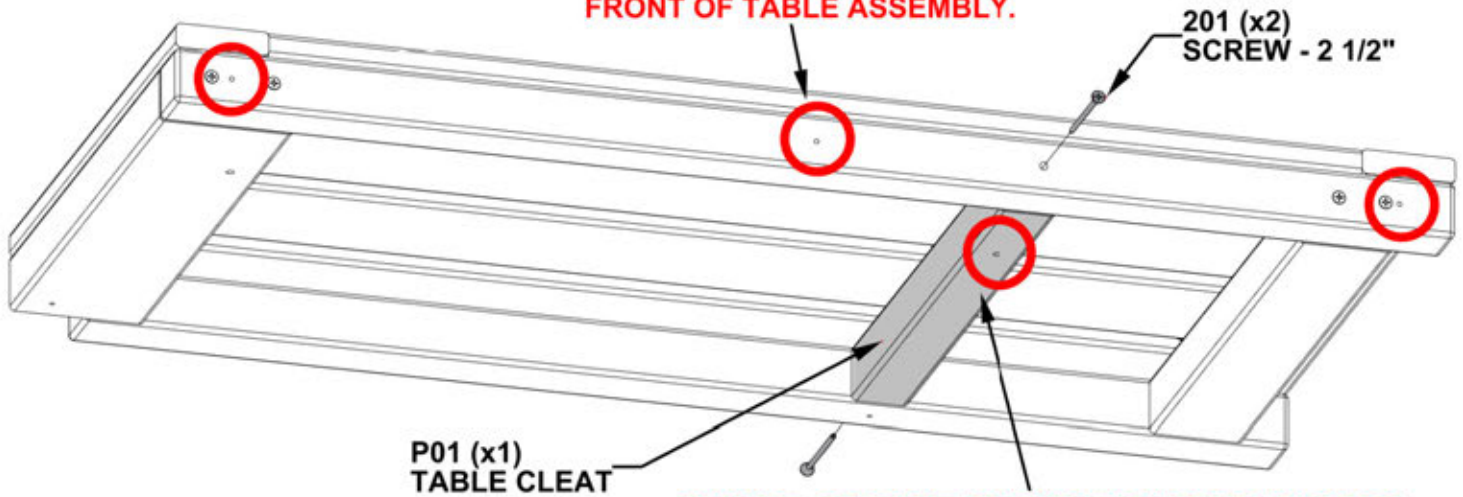


P01 TABLE CLEAT - W4L19481
(x1) 1 7/16"x1 7/16"x13 1/16" (36x36x332)

PAY CLOSE ATTENTION TO PILOT HOLES FOR CORRECT INSTALLATION.

FIRST, ATTACH P01 BOARDS USING H100201 SCREWS THROUGH THE SIDE.

NOTE PILOT HOLES FOR FRONT OF TABLE ASSEMBLY.



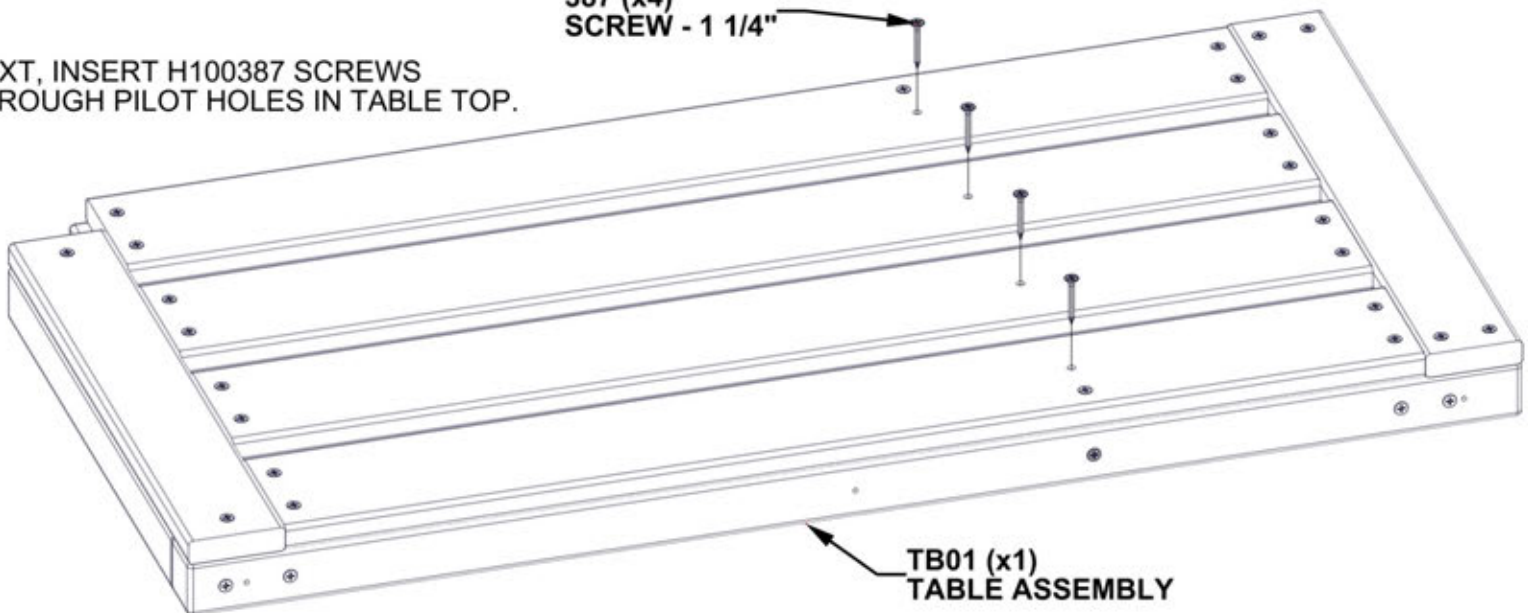
201 (x2)
SCREW - 2 1/2"

P01 (x1)
TABLE CLEAT

ENSURE CORRECT ORIENTATION OF P01 BOARDS WITH PILOT HOLE ORIENTED AS SHOWN.

NEXT, INSERT H100387 SCREWS THROUGH PILOT HOLES IN TABLE TOP.

387 (x4)
SCREW - 1 1/4"



TB01 (x1)
TABLE ASSEMBLY

STEP 66 - TABLE ASSEMBLY

QTY	PART NUMBER	DESCRIPTION
3	H100200	SCREW PFH 8x1 1/2 BLK
1	H100202	SCREW PWH 8x5/8 BLK
1	H100536	SCREW PWH 8x1 1/4 BLK

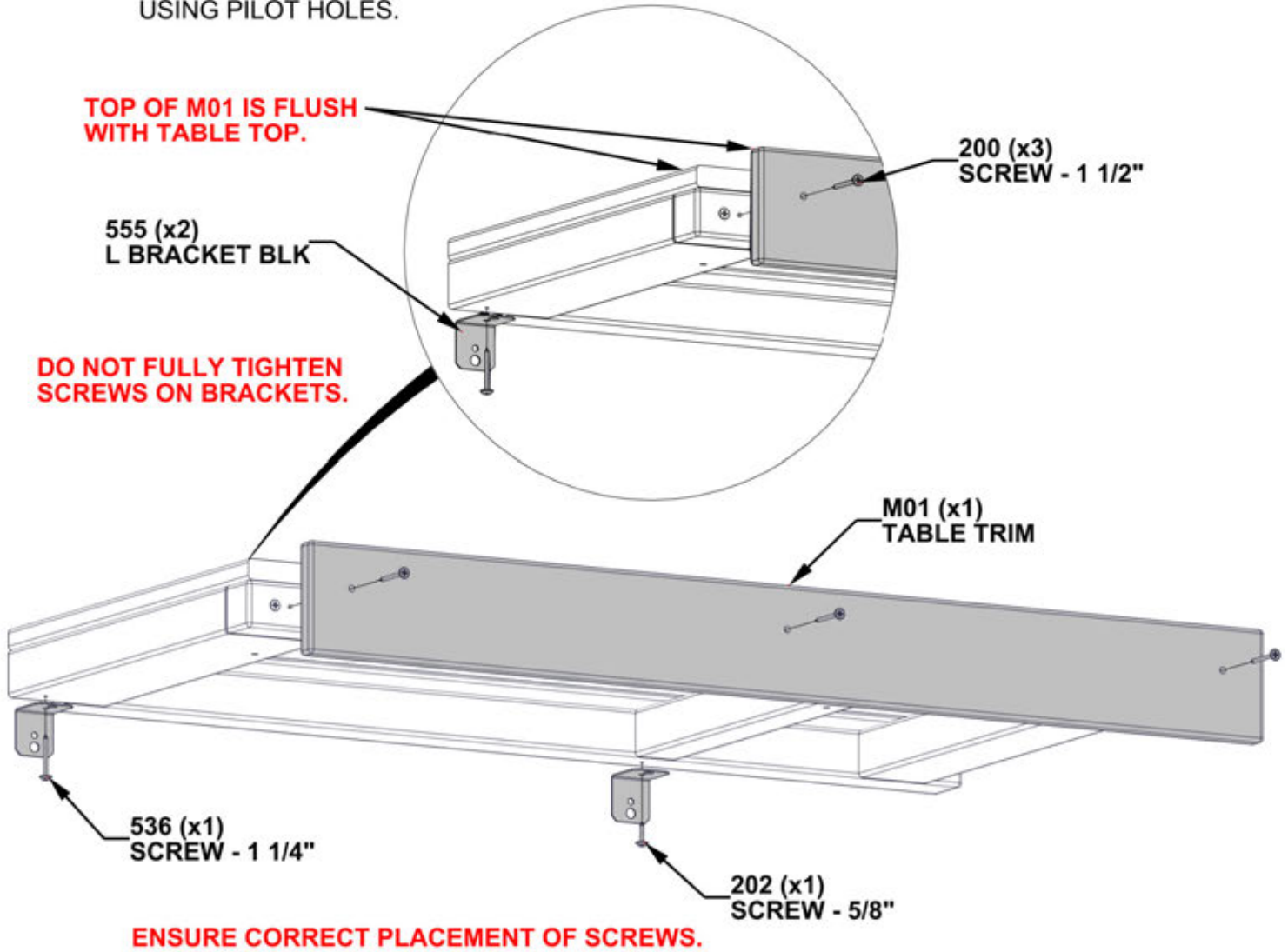


M01 TABLE TRIM - W4L19482
(x1) 5/8"x3 3/8"x32 1/2" (16x86x825)



A4M00555 L BRACKET BLK
(x2)

ATTACH TRIM AND BRACKETS
USING PILOT HOLES.



STEP 67 - TABLE ASSEMBLY

QTY	PART NUMBER	DESCRIPTION
2	H100405	WASHER LOCK EXT 6x15
2	H100456	LAG SCREW WH 1/4x2 1/2 BLK



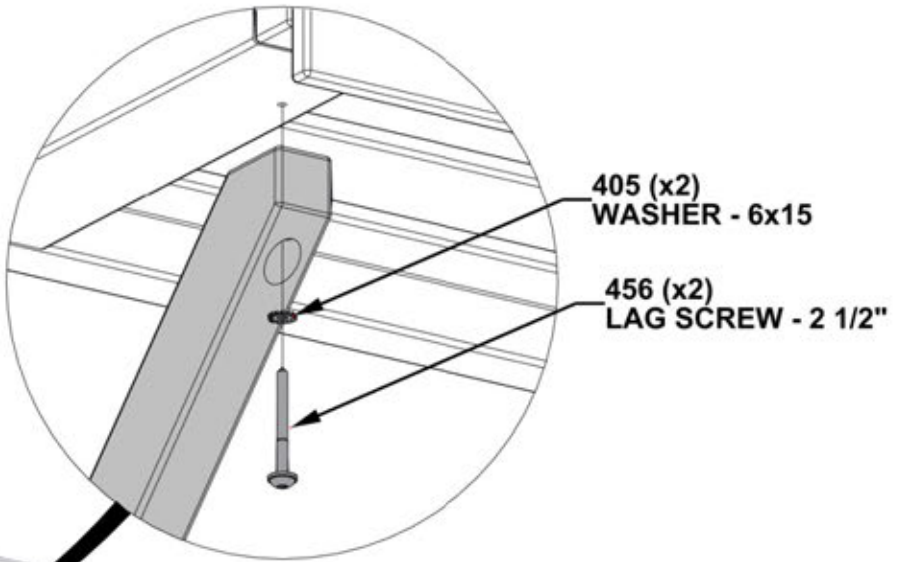
F03 ANGLE BRACE - W4L19487
(x1) 1 7/16"x2 3/8"x18 1/16" (36x60x458)



F04 ANGLE BRACE - W4L19488
(x1) 1 7/16"x2 3/8"x18 1/16" (36x60x458)

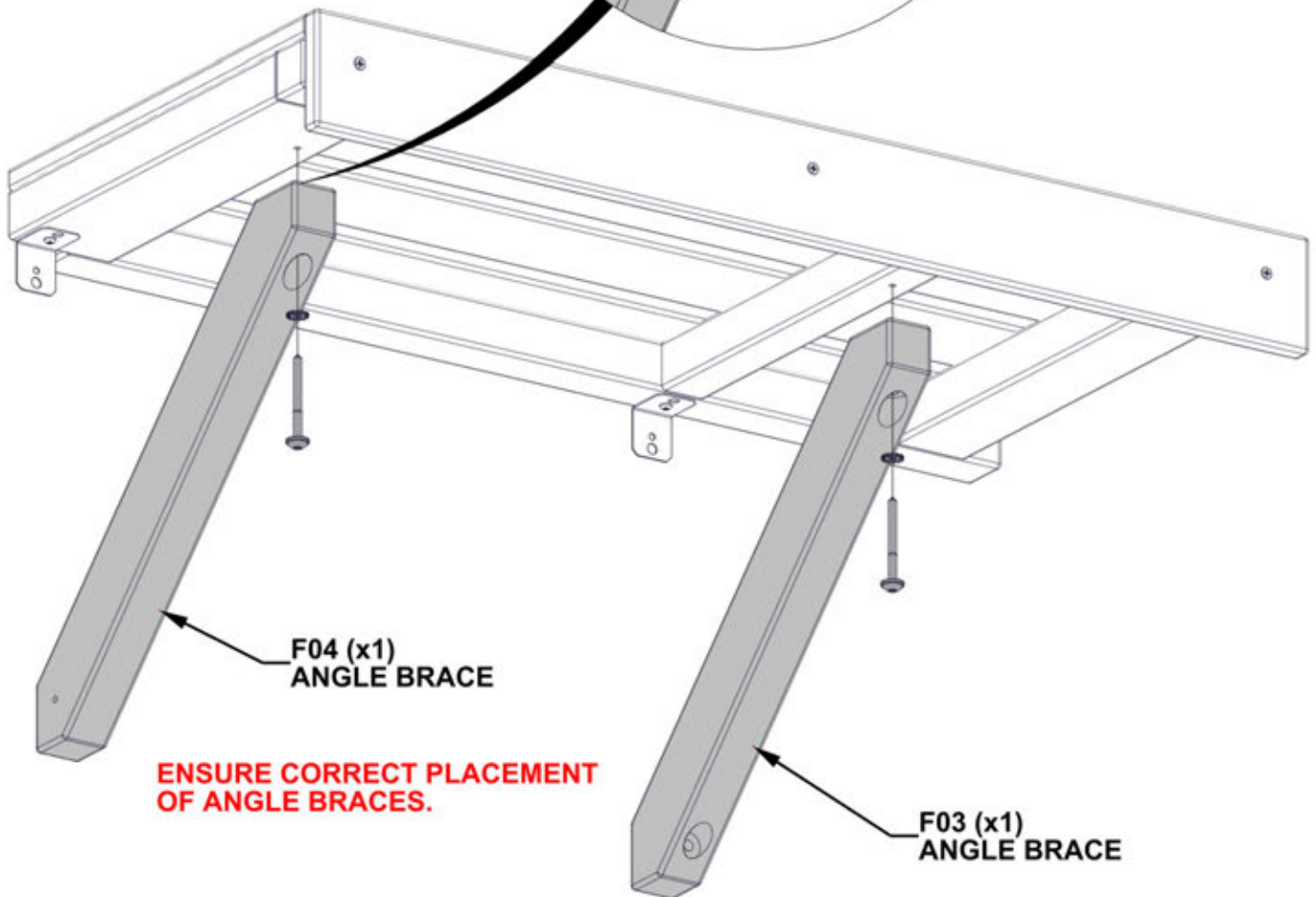
HAND TIGHTEN ONLY.

ATTACH ANGLE BRACES USING
PILOT HOLES AS SHOWN.



405 (x2)
WASHER - 6x15

456 (x2)
LAG SCREW - 2 1/2"



F04 (x1)
ANGLE BRACE

**ENSURE CORRECT PLACEMENT
OF ANGLE BRACES.**

F03 (x1)
ANGLE BRACE

STEP 68 - TABLE ASSEMBLY

QTY	PART NUMBER	DESCRIPTION
1	H100201	SCREW PFH 8x2 1/2 BLK
1	H100405	WASHER LOCK EXT 6x15
1	H100456	LAG SCREW WH 1/4x2 1/2 BLK
2	H100460	LAG SCREW WH 1/4x1 BLK

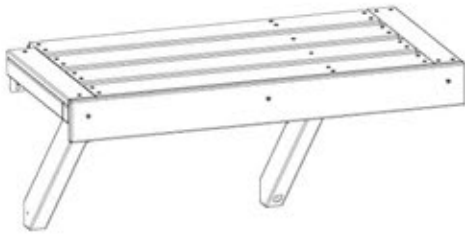


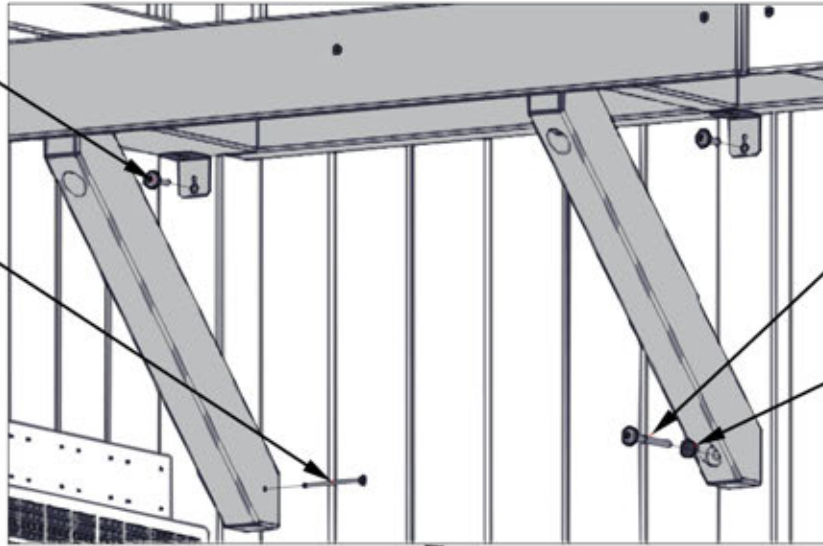
TABLE ASSEMBLY - FROM PREVIOUS STEPS

460 (x2)
LAG SCREW - 1"

201 (x1)
SCREW - 2 1/2"

ATTACH TABLE
ASSEMBLY USING PILOT
HOLES IN POST AND
UPRIGHT AS SHOWN.

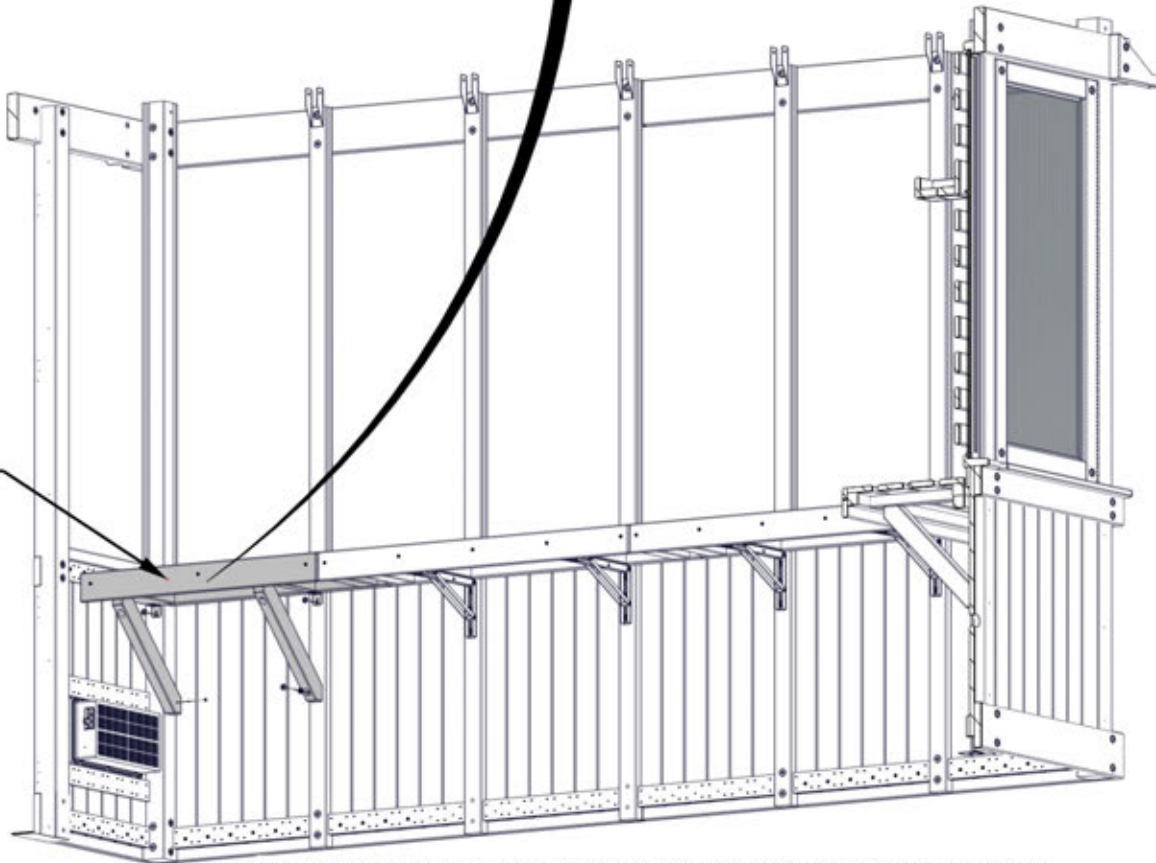
**FULLY TIGHTEN
ALL HARDWARE.**



456 (x1)
LAG SCREW - 2 1/2"

405 (x1)
WASHER - 6x15

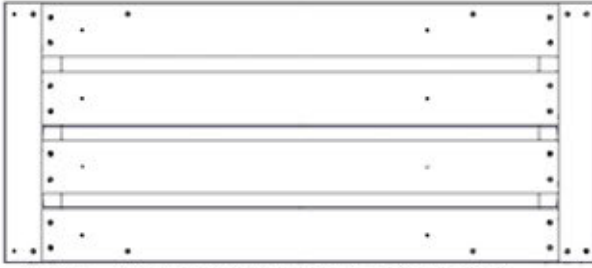
TABLE
ASSEMBLY



ONLY LEFT SIDE OF GREENHOUSE SHOWN FOR DETAIL.

STEP 69 - TABLE ASSEMBLY

QTY	PART NUMBER	DESCRIPTION
4	H100201	SCREW PFH 8x2 1/2 BLK
8	H100387	SCREW PFH 8x1 1/4 BLK



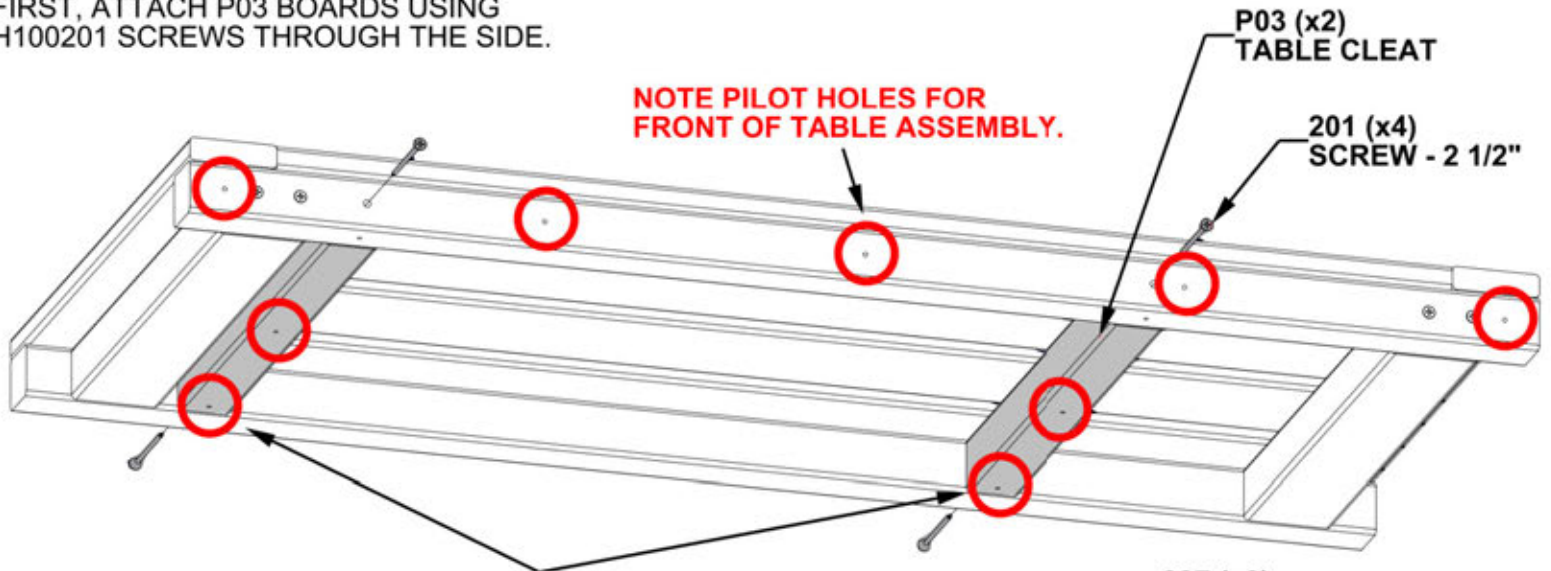
TB04 TABLE ASSEMBLY - W2A04159
(x1) 2 1/16"x16 1/16"x36 9/16" (52x408x929)



P03 TABLE CLEAT - W4L19484
(x2) 1 7/16"x1 7/16"x13 1/4" (36x36x336)

PAY CLOSE ATTENTION TO PILOT HOLES FOR CORRECT INSTALLATION.

FIRST, ATTACH P03 BOARDS USING H100201 SCREWS THROUGH THE SIDE.



NOTE PILOT HOLES FOR FRONT OF TABLE ASSEMBLY.

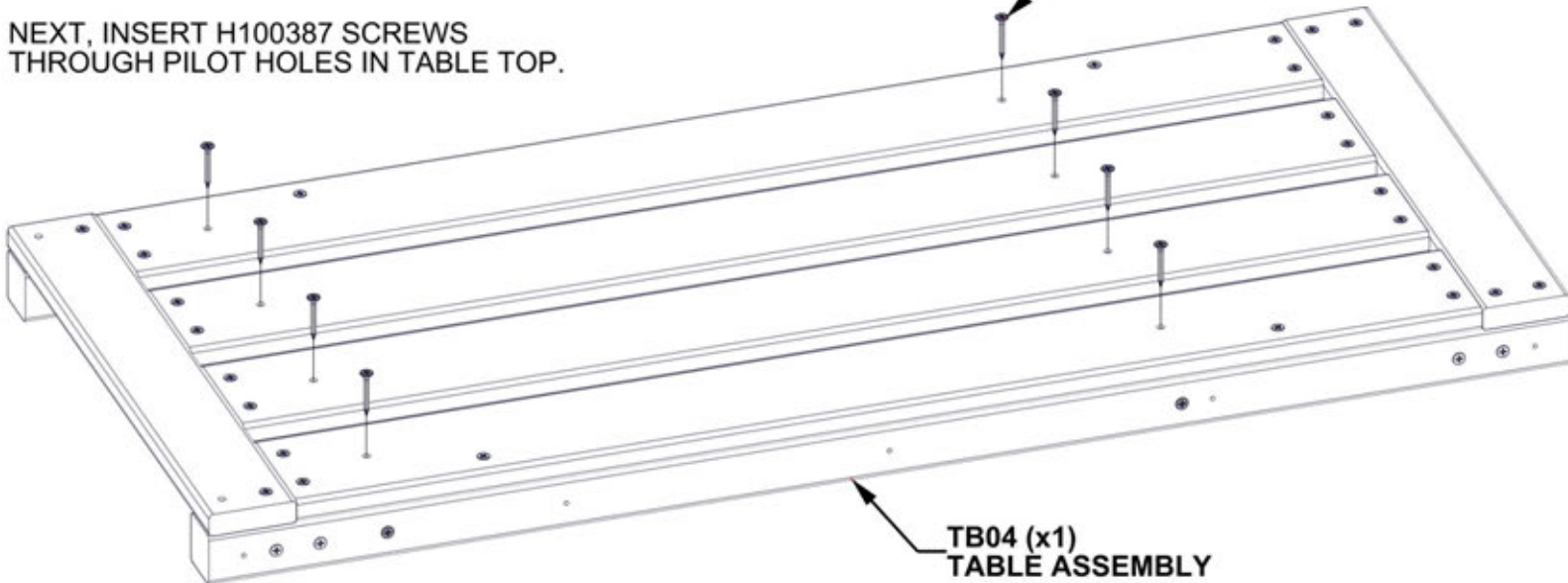
P03 (x2)
TABLE CLEAT

201 (x4)
SCREW - 2 1/2"

ENSURE CORRECT ORIENTATION OF P03 BOARDS WITH PILOT HOLES ORIENTED AS SHOWN.

387 (x8)
SCREW - 1 1/4"

NEXT, INSERT H100387 SCREWS THROUGH PILOT HOLES IN TABLE TOP.



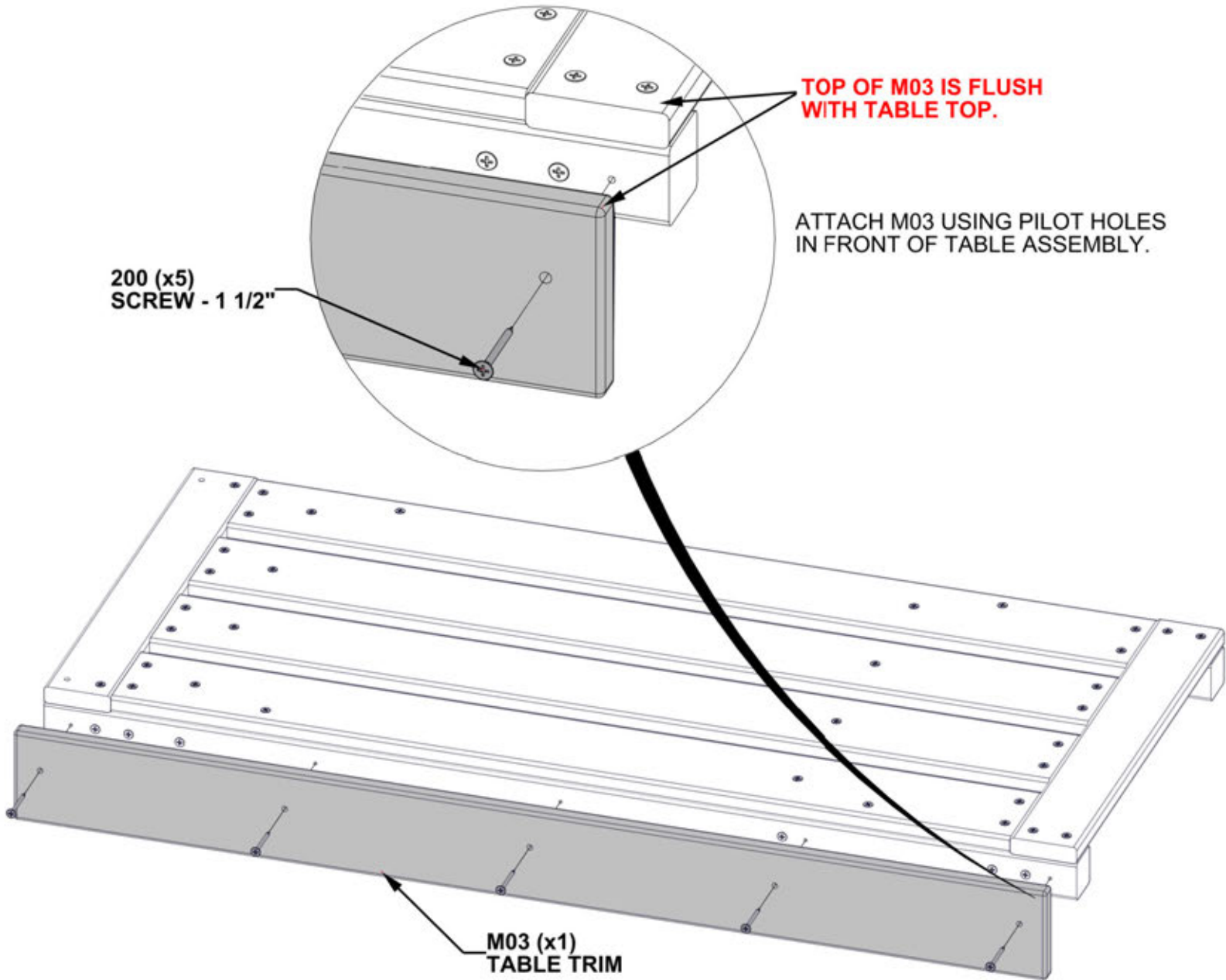
TB04 (x1)
TABLE ASSEMBLY

STEP 70 - TABLE ASSEMBLY

QTY	PART NUMBER	DESCRIPTION
5	H100200	SCREW PFH 8x1 1/2 BLK



M03 TABLE TRIM - W4L19486
(x1) 5/8"x3 3/8"x36 9/16" (16x86x929)



STEP 71 - TABLE ASSEMBLY

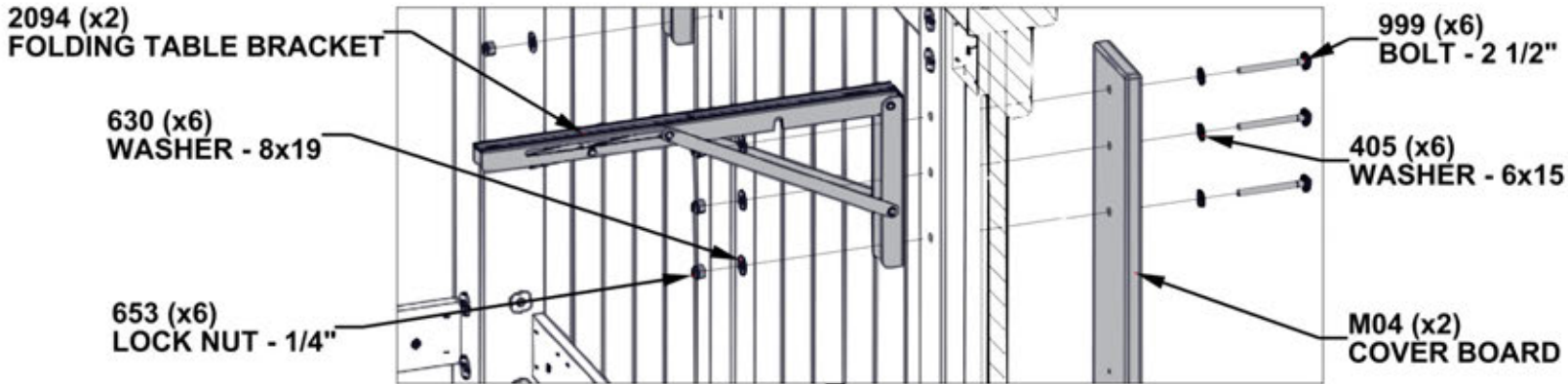
QTY	PART NUMBER	DESCRIPTION
6	H100405	WASHER LOCK EXT 6x15
6	H100630	WASHER FLAT 8x19 BLK
6	H100653	NUT LOCK 1/4 BLK
6	H100999	BOLT WH 1/4x2 1/2 BLK



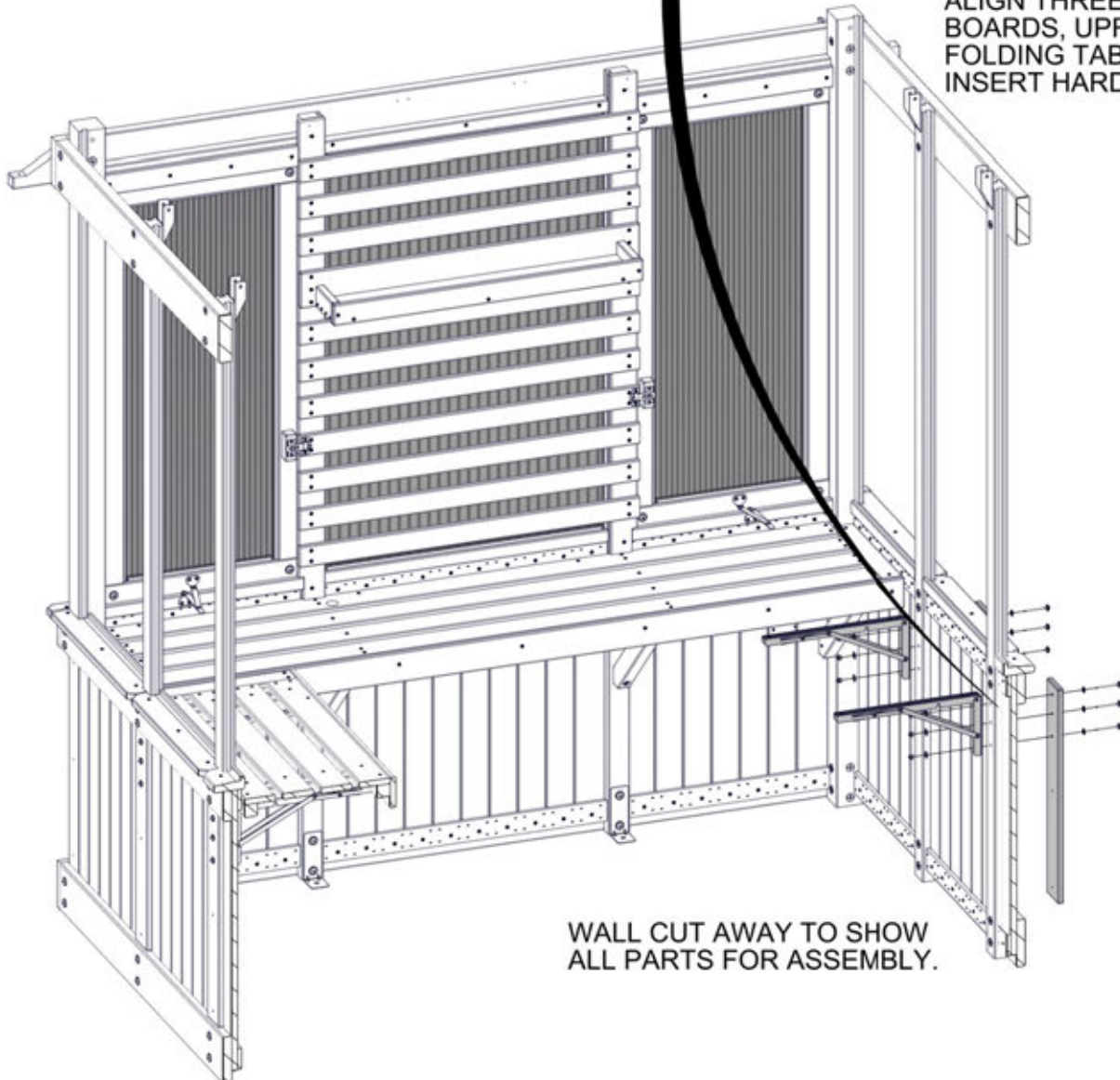
M04 COVER BOARD - W4L19489
(x2) 5/8"x3 3/8"x24 3/16" (16x86x614)



A4M02094 FOLDING TABLE BRACKET
(x2)



ALIGN THREE HOLES OF M04 BOARDS, UPRIGHTS, AND FOLDING TABLE BRACKETS. INSERT HARDWARE AS SHOWN.



WALL CUT AWAY TO SHOW ALL PARTS FOR ASSEMBLY.

STEP 72 - TABLE ASSEMBLY

QTY	PART NUMBER	DESCRIPTION
6	H100392	SCREW PWH 8x3/4 BLK

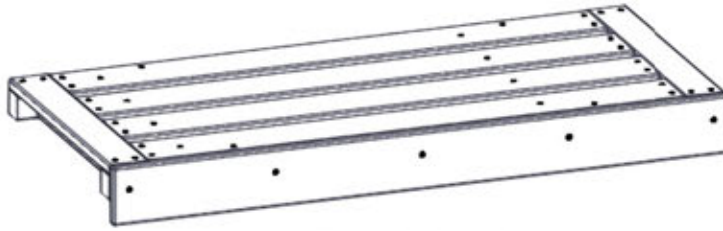
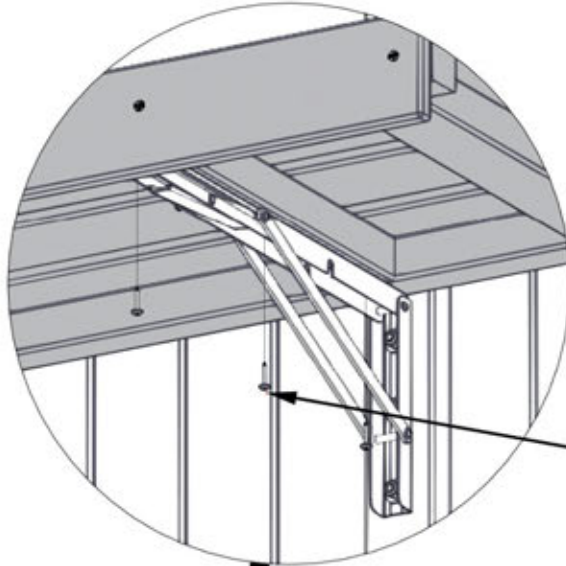


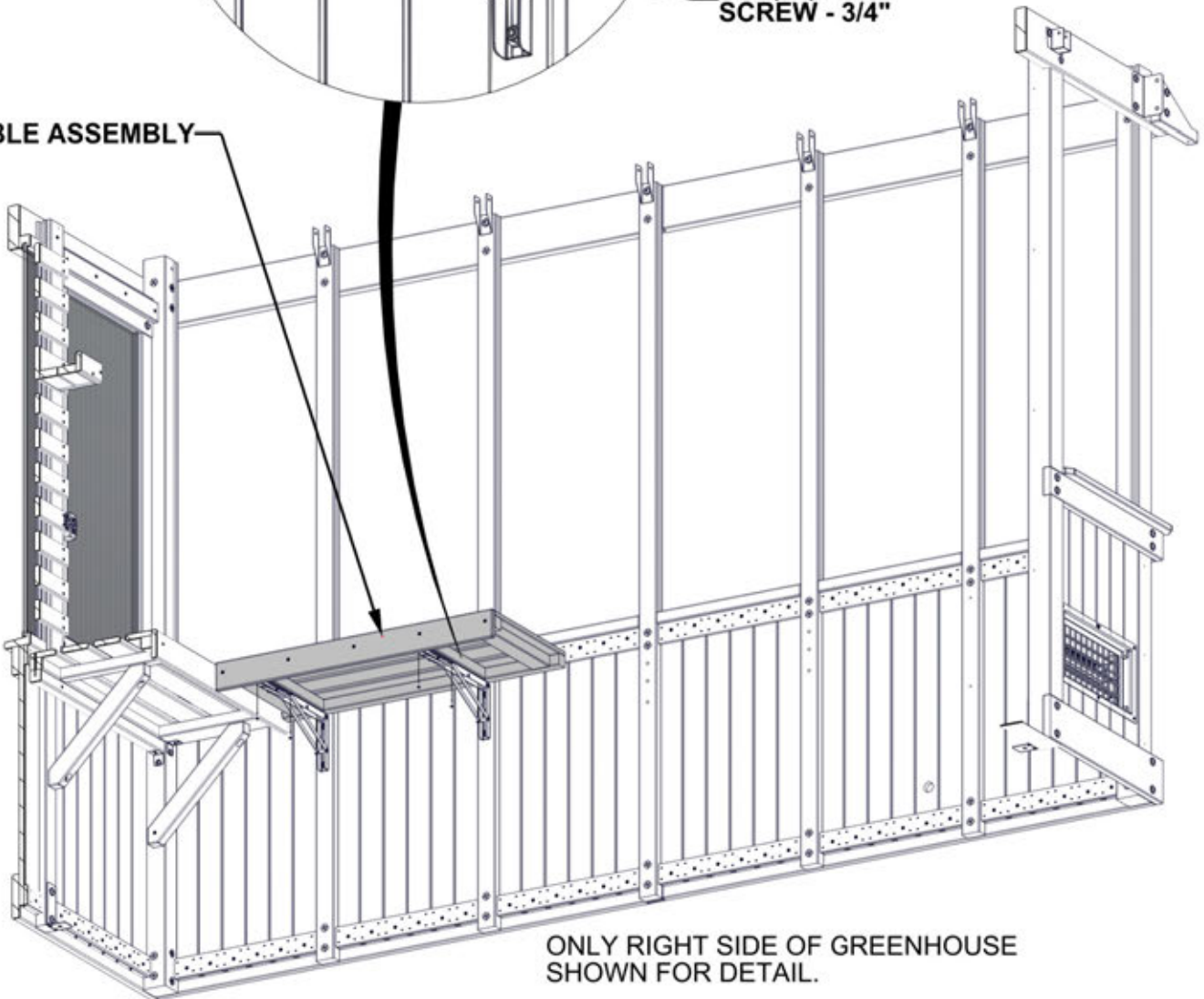
TABLE ASSEMBLY - FROM PREVIOUS STEPS



ALIGN HOLES IN TABLE BRACKET WITH PILOT HOLES IN TABLE ASSEMBLY AND ATTACH AS SHOWN.

**392 (x6)
SCREW - 3/4"**

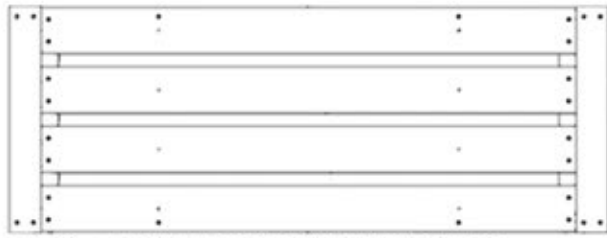
TABLE ASSEMBLY



ONLY RIGHT SIDE OF GREENHOUSE SHOWN FOR DETAIL.

STEP 73 - TABLE ASSEMBLY

QTY	PART NUMBER	DESCRIPTION
4	H100201	SCREW PFH 8x2 1/2 BLK
8	H100387	SCREW PFH 8x1 1/4 BLK



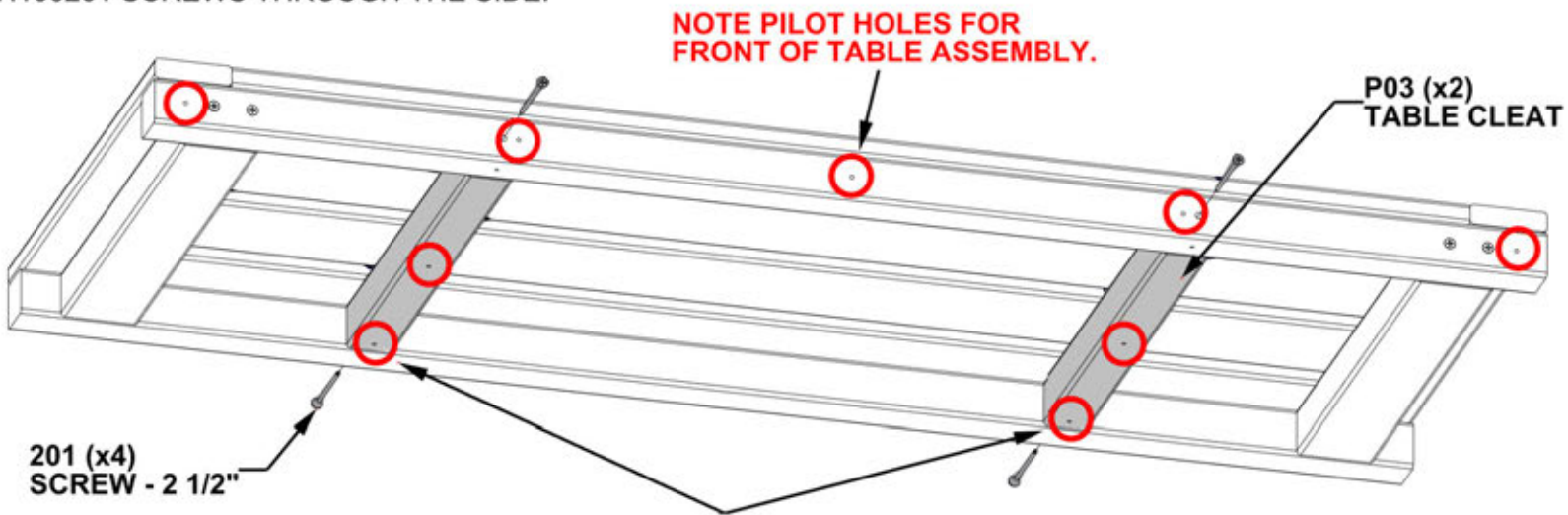
TB02 TABLE ASSEMBLY - W2A04152
(x1) 2 1/16"x16 1/16"x42 11/16" (52x408x1084)



P03 TABLE CLEAT - W4L19484
(x2) 1 7/16"x1 7/16"x13 1/4" (36x36x336)

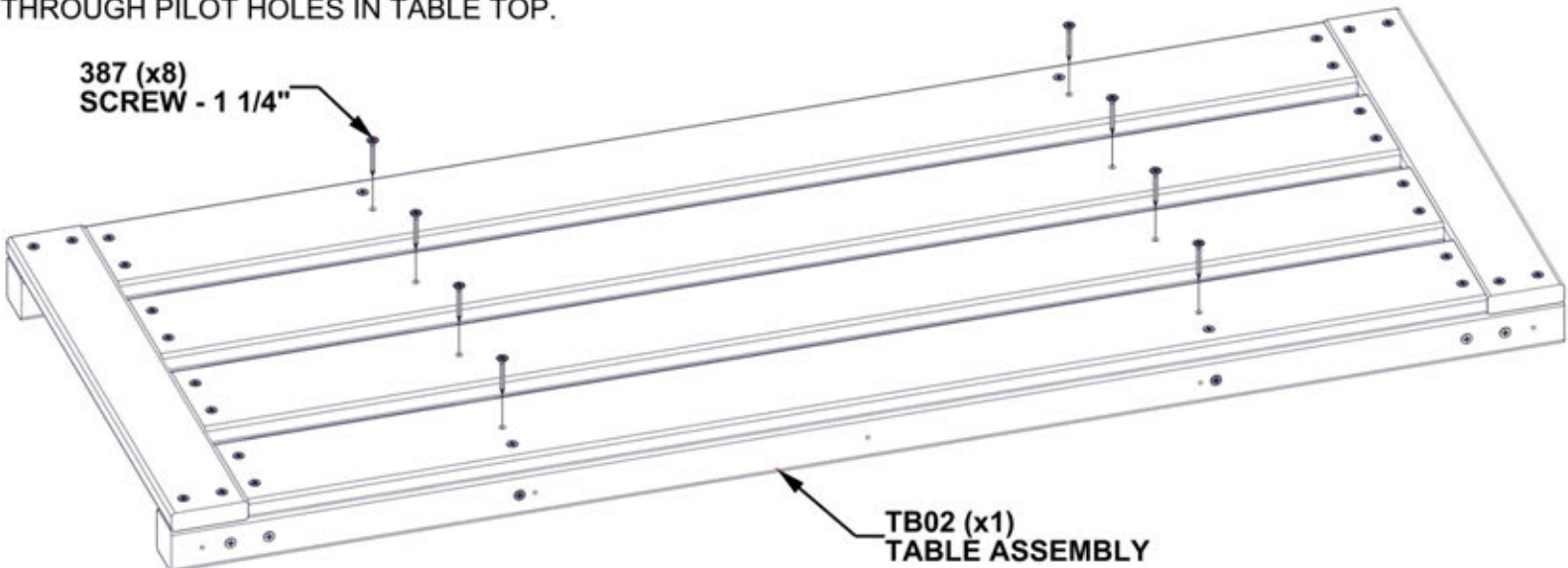
PAY CLOSE ATTENTION TO PILOT HOLES FOR CORRECT INSTALLATION.

FIRST, ATTACH P03 BOARDS USING H100201 SCREWS THROUGH THE SIDE.



ENSURE CORRECT ORIENTATION OF P03 BOARDS WITH PILOT HOLES ORIENTED AS SHOWN.

NEXT, INSERT H100387 SCREWS THROUGH PILOT HOLES IN TABLE TOP.

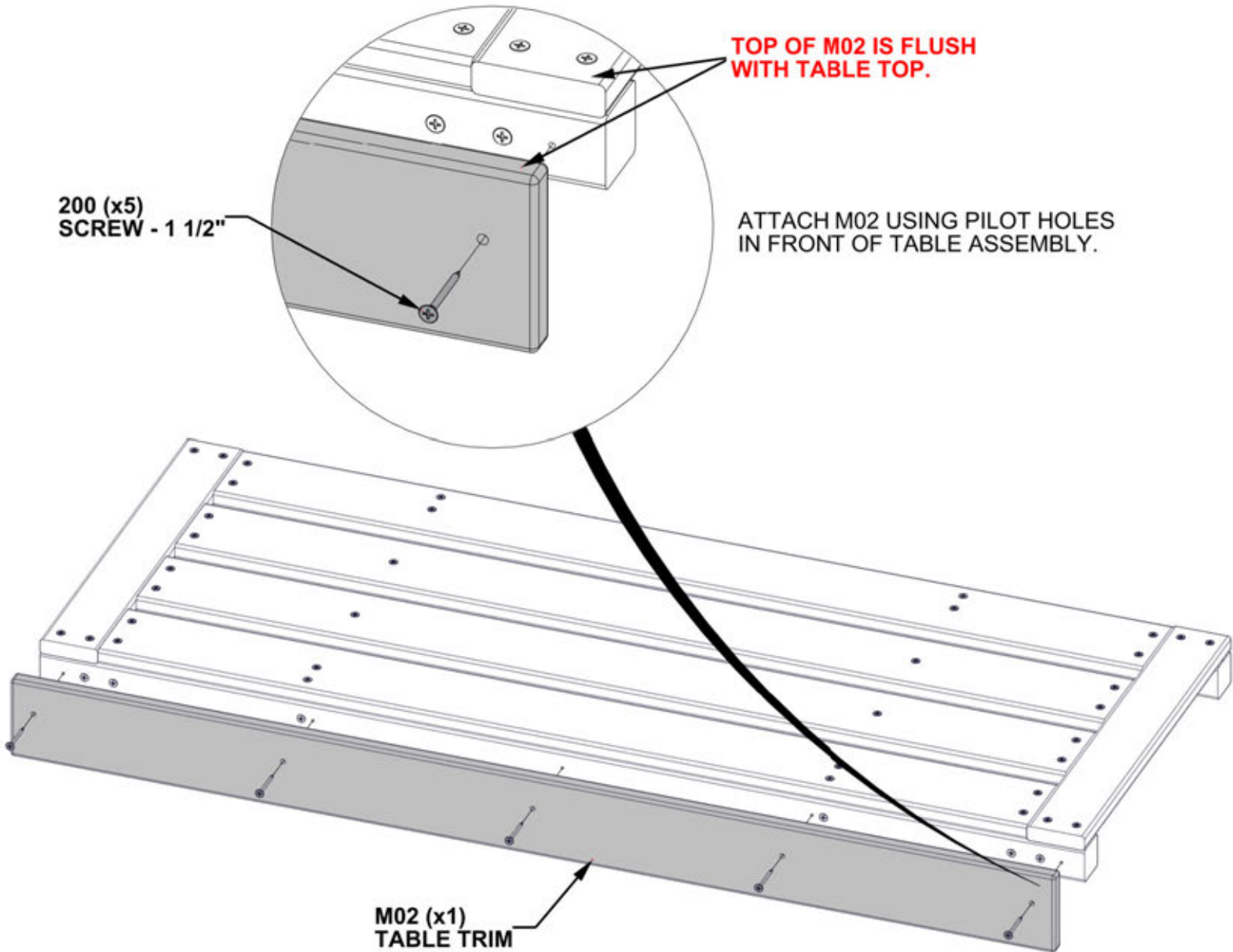


STEP 74 - TABLE ASSEMBLY

QTY	PART NUMBER	DESCRIPTION
5	H100200	SCREW PFH 8x1 1/2 BLK



M02 TABLE TRIM - W4L19485
(x1) 5/8"x3 3/8"x42 11/16" (16x86x1084)



STEP 75 - TABLE ASSEMBLY

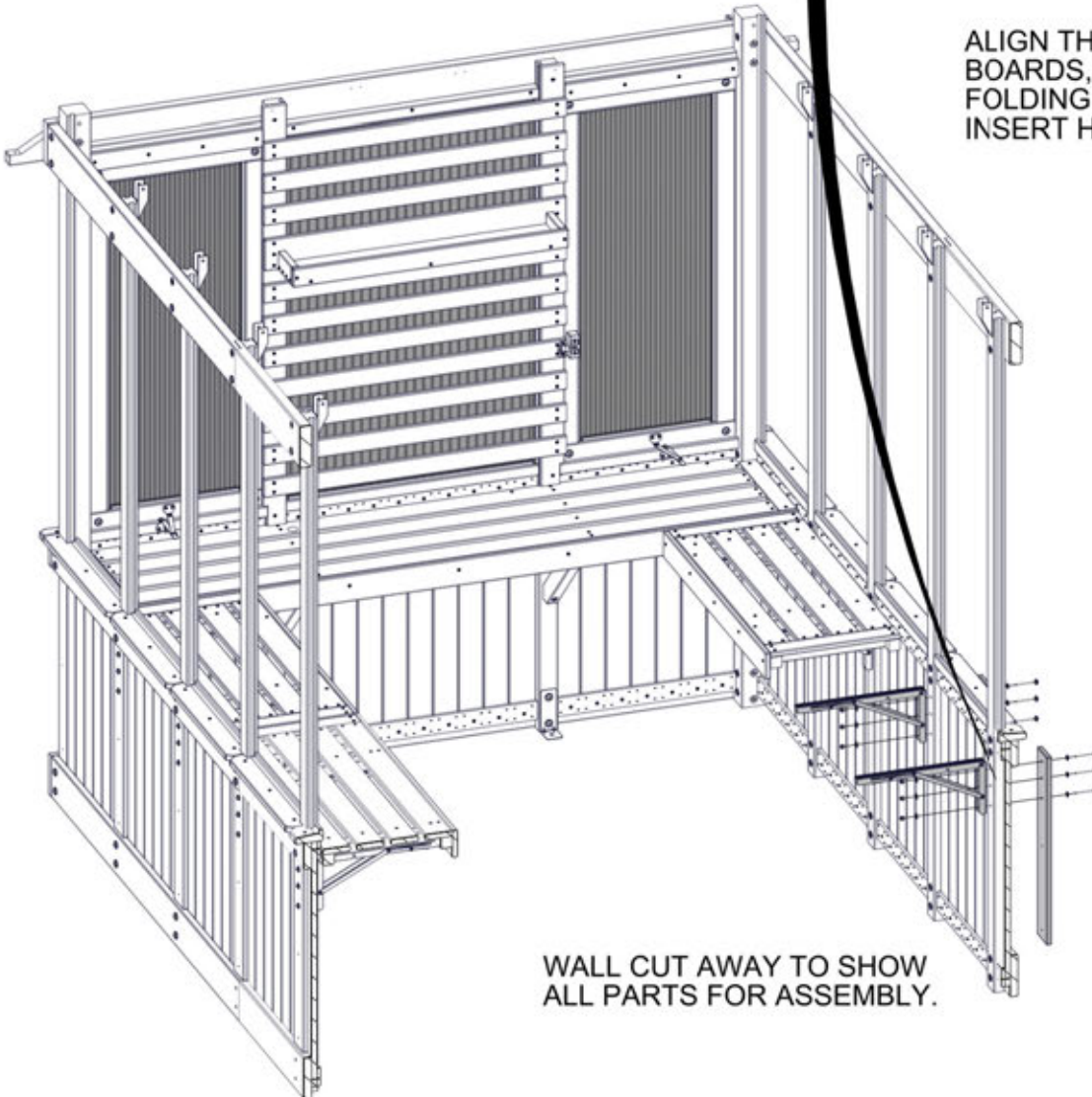
QTY	PART NUMBER	DESCRIPTION
6	H100405	WASHER LOCK EXT 6x15
6	H100630	WASHER FLAT 8x19 BLK
6	H100653	NUT LOCK 1/4 BLK
6	H100999	BOLT WH 1/4x2 1/2 BLK



M04 COVER BOARD - W4L19489
(x2) 5/8"x3 3/8"x24 3/16" (16x86x614)



A4M02094 FOLDING TABLE BRACKET
(x2)



ALIGN THREE HOLES OF M04 BOARDS, UPRIGHTS, AND FOLDING TABLE BRACKETS. INSERT HARDWARE AS SHOWN.

WALL CUT AWAY TO SHOW ALL PARTS FOR ASSEMBLY.

STEP 76 - TABLE ASSEMBLY

QTY	PART NUMBER	DESCRIPTION
6	H100392	SCREW PWH 8x3/4 BLK

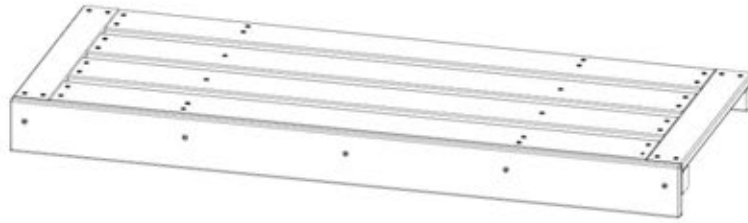
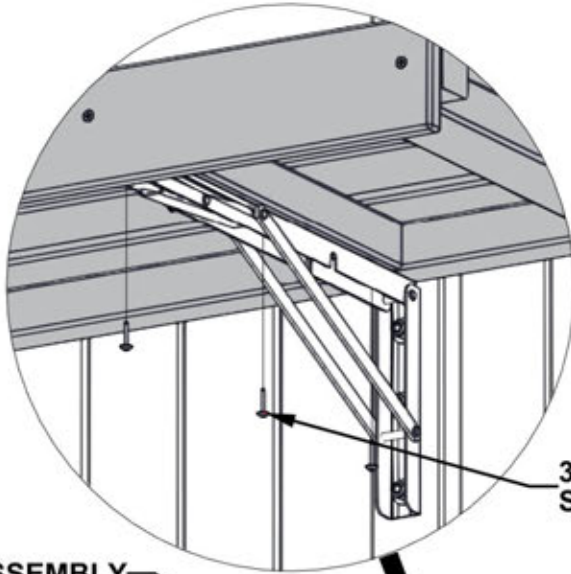


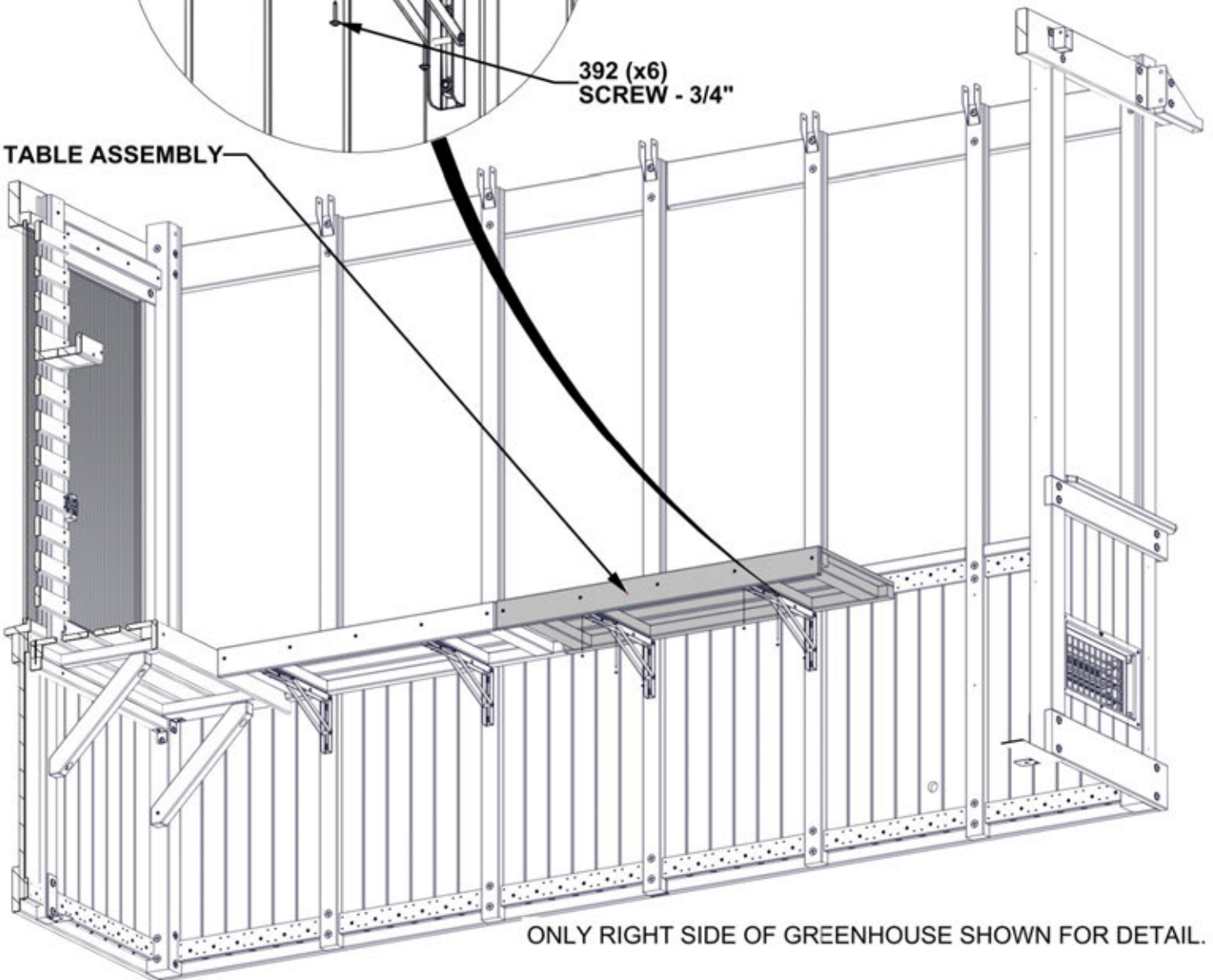
TABLE ASSEMBLY - FROM PREVIOUS STEPS



ALIGN HOLES IN TABLE BRACKET WITH PILOT HOLES IN TABLE ASSEMBLY AND ATTACH AS SHOWN.

**392 (x6)
SCREW - 3/4"**

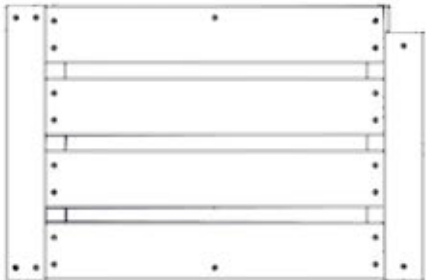
TABLE ASSEMBLY



ONLY RIGHT SIDE OF GREENHOUSE SHOWN FOR DETAIL.

STEP 77 - TABLE ASSEMBLY

QTY	PART NUMBER	DESCRIPTION
3	H100200	SCREW PFH 8x1 1/2 BLK
2	H100536	SCREW PWH 8x1 1/4 BLK



TB05 TABLE ASSEMBLY - W2A04160
(x1) 2 1/16"x16 1/16"x24 1/2" (52x408x622)

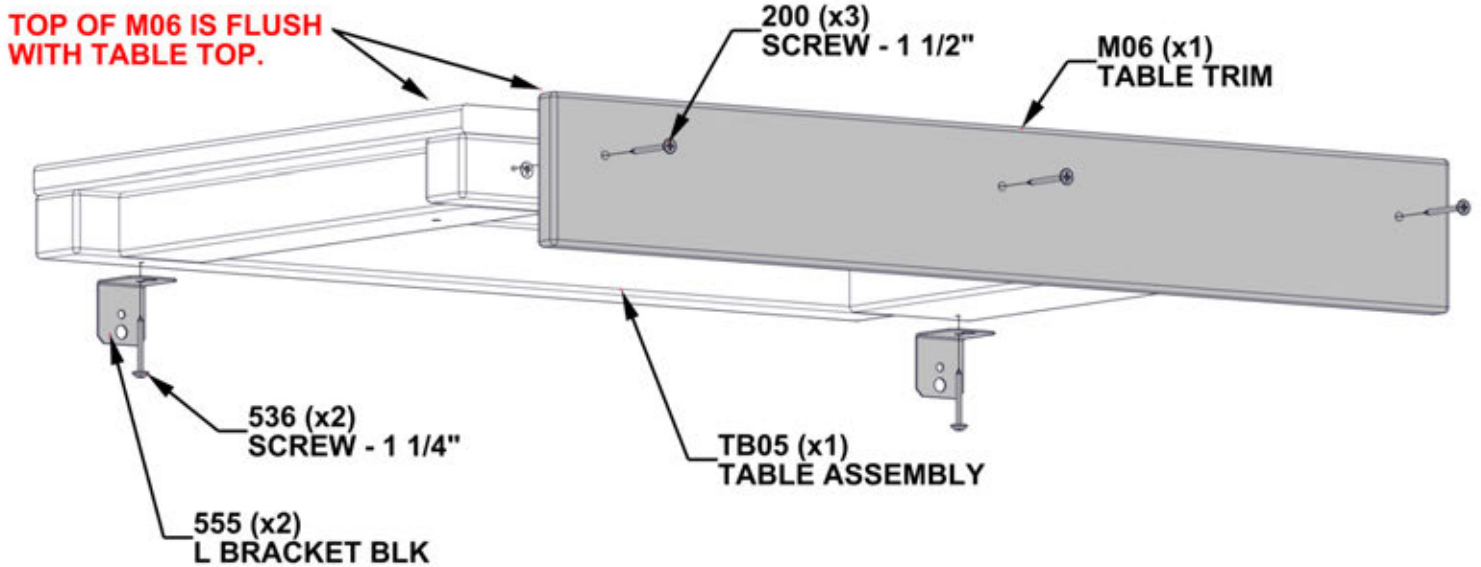


M06 TABLE TRIM - W4L19566
(x1) 5/8"x3 3/8"x24 1/2" (16x86x622)



A4M00555 L BRACKET BLK
(x2)

ATTACH TRIM AND BRACKETS USING PILOT HOLES.



**DO NOT FULLY TIGHTEN
SCREWS ON BRACKETS.**

STEP 78 - TABLE ASSEMBLY

QTY	PART NUMBER	DESCRIPTION
2	H100405	WASHER LOCK EXT 6x15
2	H100456	LAG SCREW WH 1/4x2 1/2 BLK



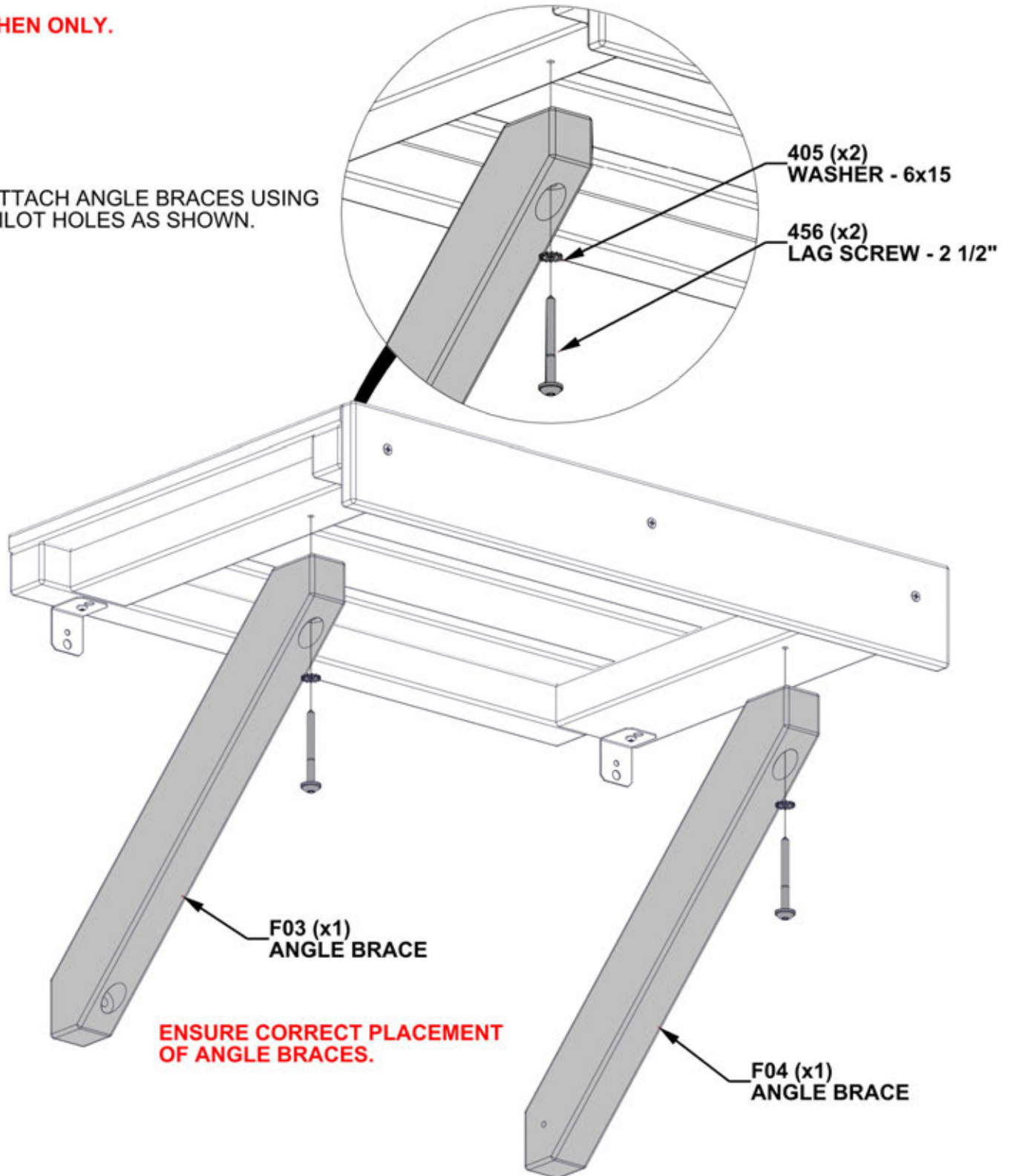
F03 ANGLE BRACE - W4L19487
(x1) 1 7/16"x2 3/8"x18 1/16" (36x60x458)



F04 ANGLE BRACE - W4L19488
(x1) 1 7/16"x2 3/8"x18 1/16" (36x60x458)

HAND TIGHTEN ONLY.

ATTACH ANGLE BRACES USING
PILOT HOLES AS SHOWN.



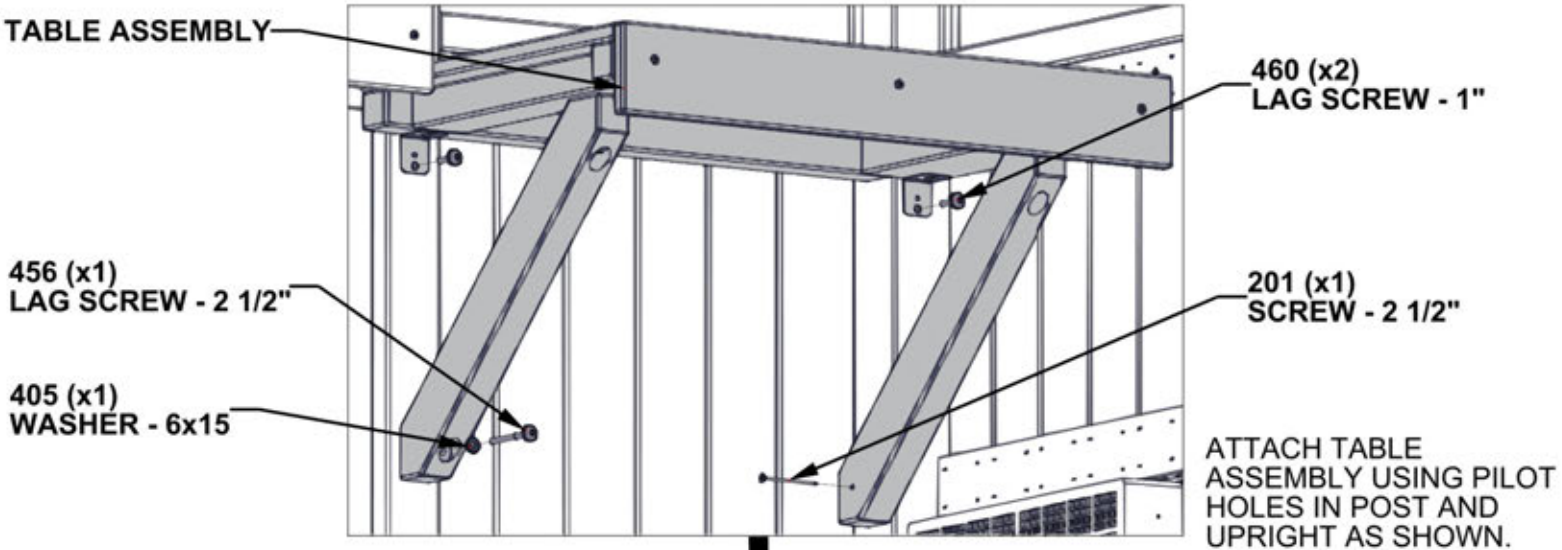
STEP 79 - TABLE ASSEMBLY

QTY	PART NUMBER	DESCRIPTION
1	H100201	SCREW PFH 8x2 1/2 BLK
1	H100405	WASHER LOCK EXT 6x15
1	H100456	LAG SCREW WH 1/4x2 1/2 BLK
2	H100460	LAG SCREW WH 1/4x1 BLK

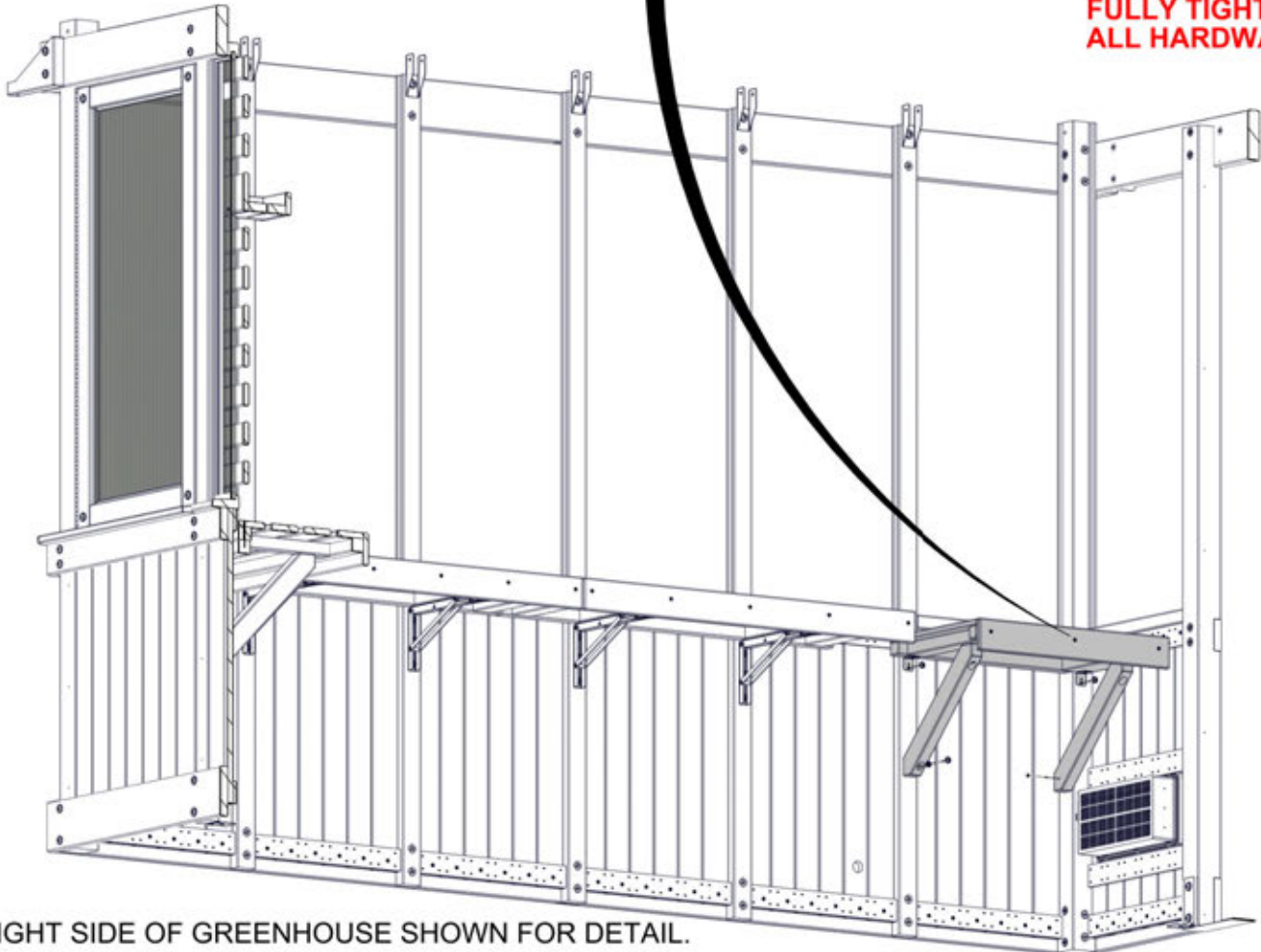


TABLE ASSEMBLY - FROM PREVIOUS STEPS

TABLE ASSEMBLY



FULLY TIGHTEN ALL HARDWARE.



ONLY RIGHT SIDE OF GREENHOUSE SHOWN FOR DETAIL.

STEP 80 - COVER BOARD ASSEMBLY

QTY	PART NUMBER	DESCRIPTION
17	H100200	SCREW PFH 8x1 1/2 BLK



M05 COVER BOARD - W4L19490
(x1) 5/8"x3 3/8"x24 3/16" (16x86x614)

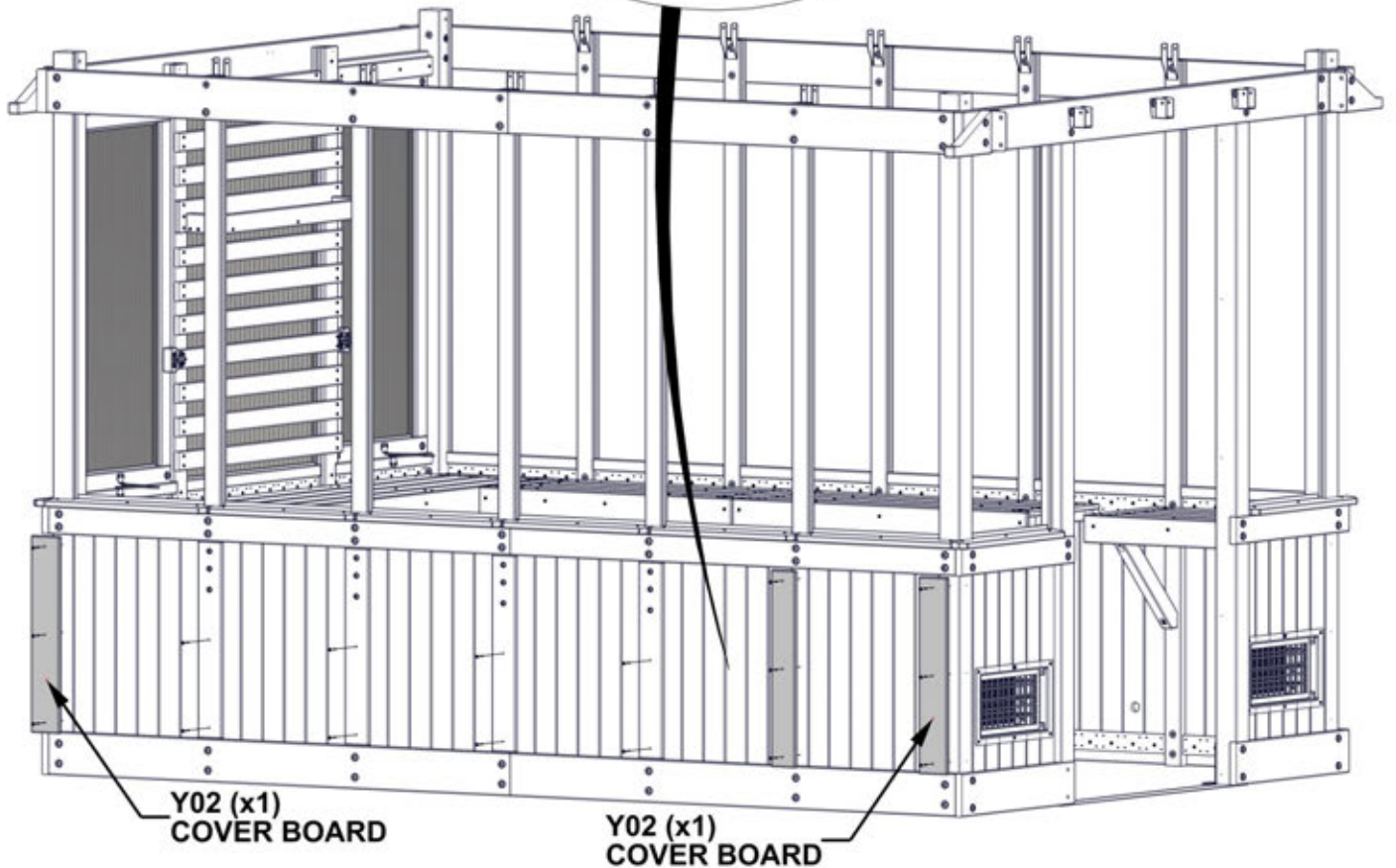
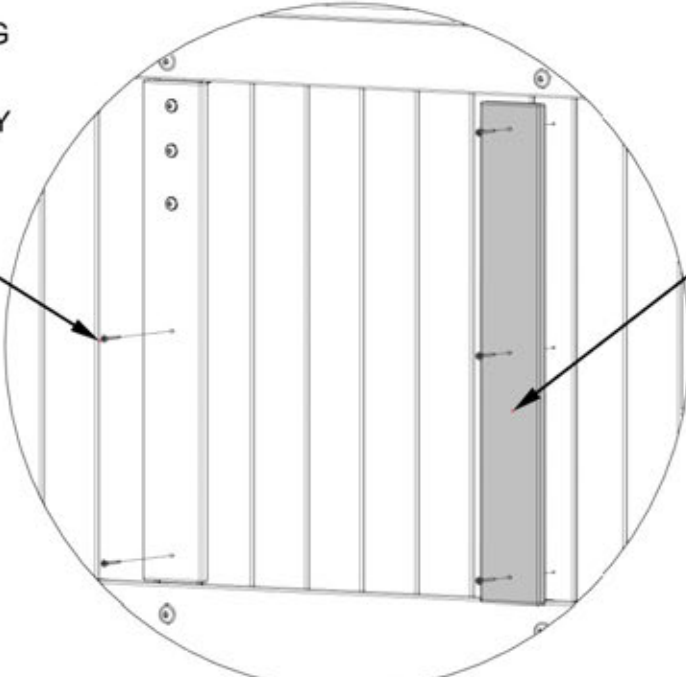


Y02 COVER BOARD - W4L19612
(x2) 5/8"x4"x24 3/16" (16x102x614)

ATTACH COVER BOARDS USING PILOT HOLES IN POSTS AND UPRIGHTS. INSERT SCREWS INTO PILOT HOLES OF ALREADY INSTALLED COVER BOARDS.

200 (x17)
SCREW - 1 1/2"

M05 (x1)
COVER BOARD



STEP 81 - COVER BOARD ASSEMBLY

QTY	PART NUMBER	DESCRIPTION
12	H100200	SCREW PFH 8x1 1/2 BLK

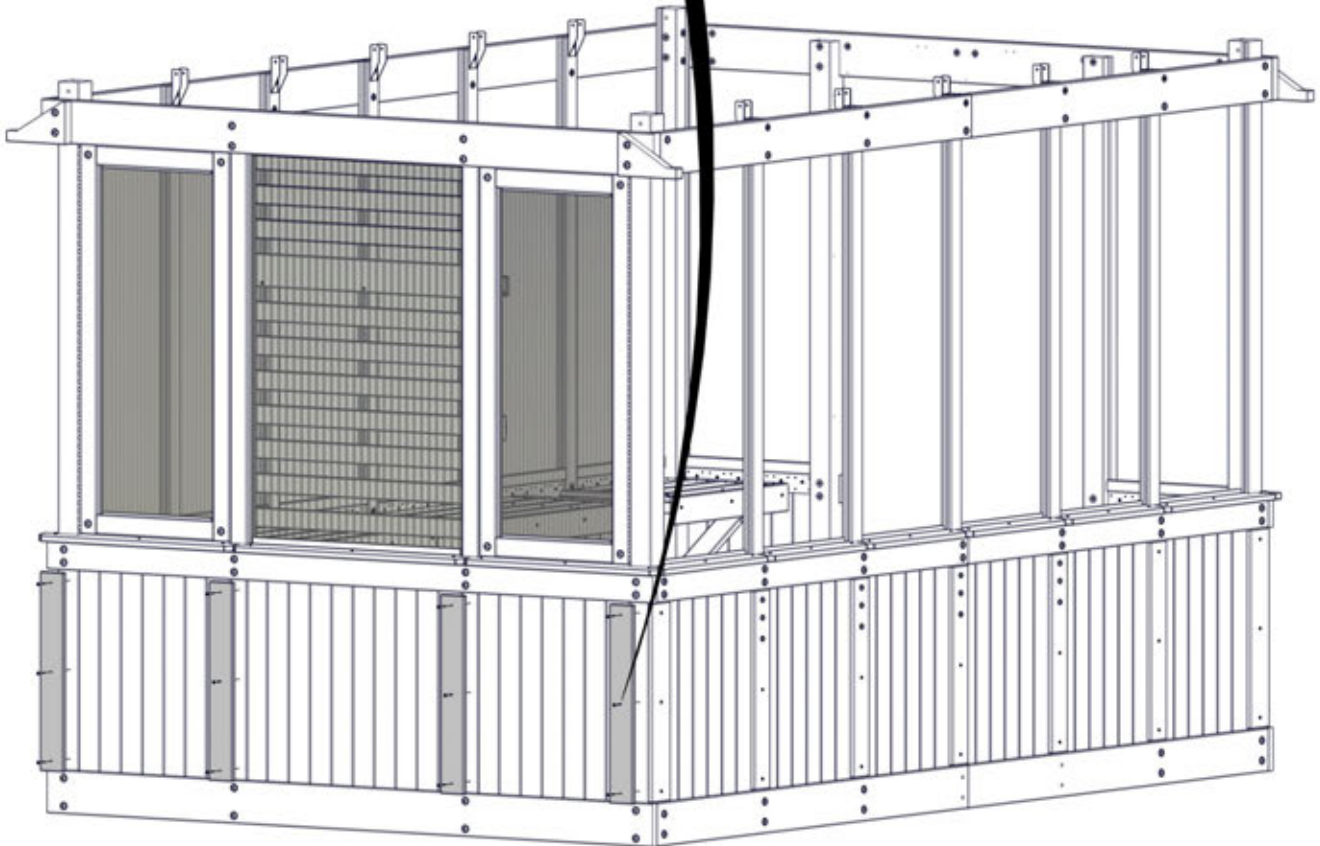
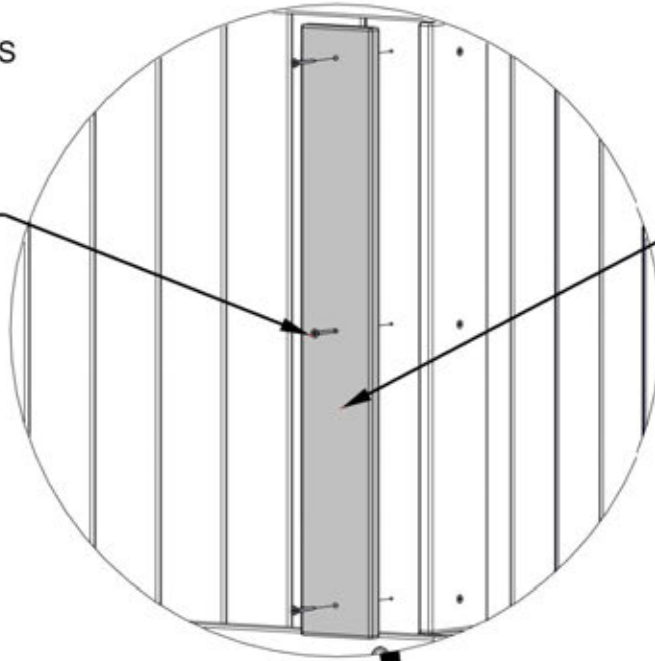


M05 COVER BOARD - W4L19490
(x4) 5/8"x3 3/8"x24 3/16" (16x86x614)

ATTACH COVER BOARDS USING PILOT HOLES IN POSTS AND UPRIGHTS AS SHOWN.

200 (x12)
SCREW - 1 1/2"

M05 (x4)
COVER BOARD



STEP 82 - COVER BOARD ASSEMBLY

QTY	PART NUMBER	DESCRIPTION
17	H100200	SCREW PFH 8x1 1/2 BLK



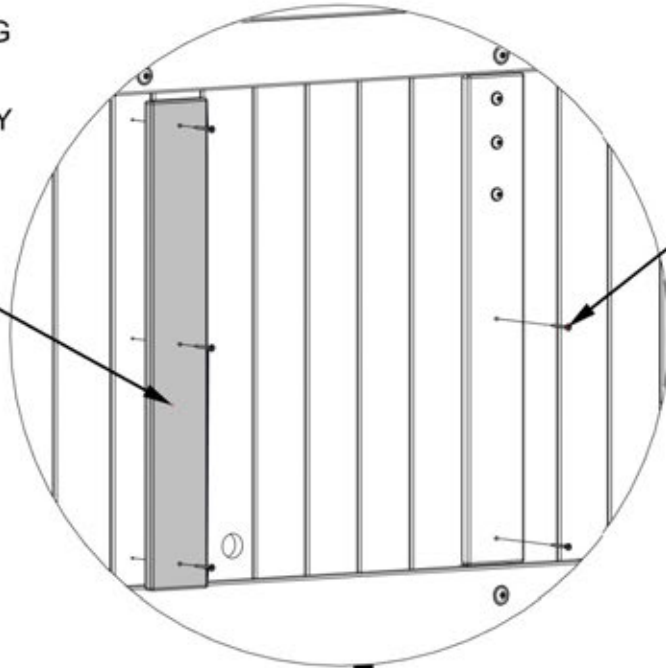
M05 COVER BOARD - W4L19490
(x1) 5/8"x3 3/8"x24 3/16" (16x86x614)



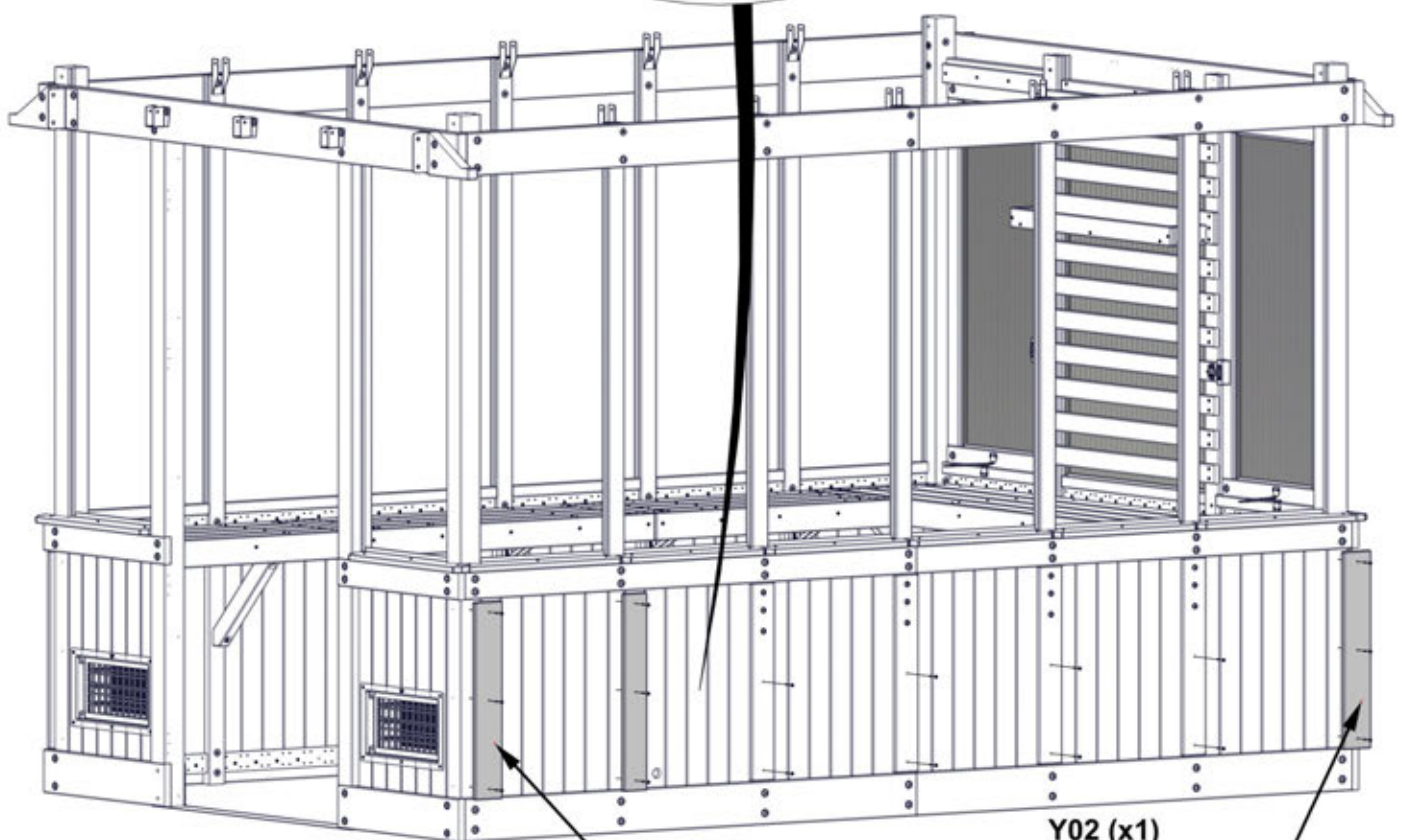
Y02 COVER BOARD - W4L19612
(x2) 5/8"x4"x24 3/16" (16x102x614)

ATTACH COVER BOARDS USING PILOT HOLES IN POSTS AND UPRIGHTS. INSERT SCREWS INTO PILOT HOLES OF ALREADY INSTALLED COVER BOARDS.

M05 (x1)
COVER BOARD



200 (x17)
SCREW - 1 1/2"



Y02 (x1)
COVER BOARD

Y02 (x1)
COVER BOARD

STEP 83 - COVER BOARD ASSEMBLY

QTY	PART NUMBER	DESCRIPTION
6	H100200	SCREW PFH 8x1 1/2 BLK

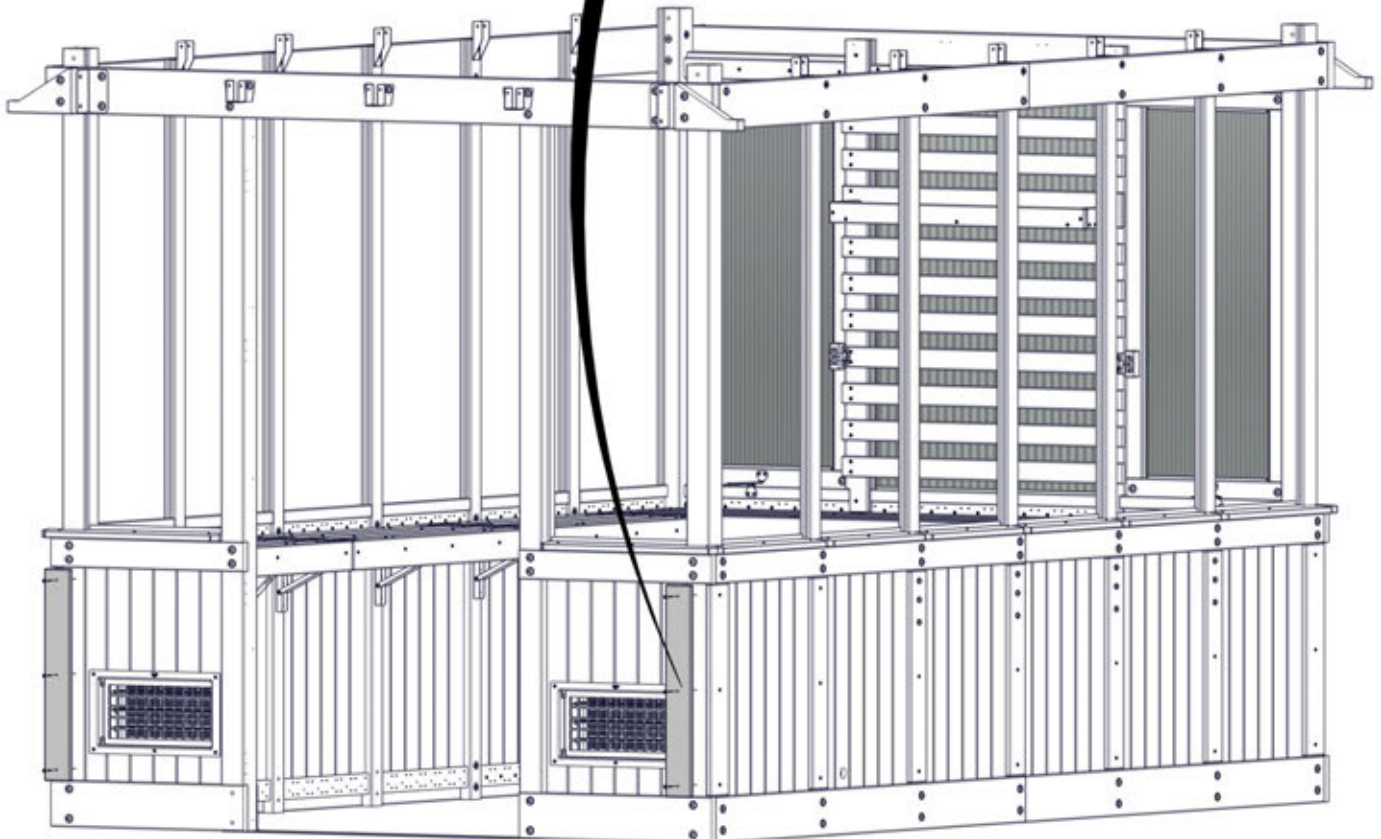
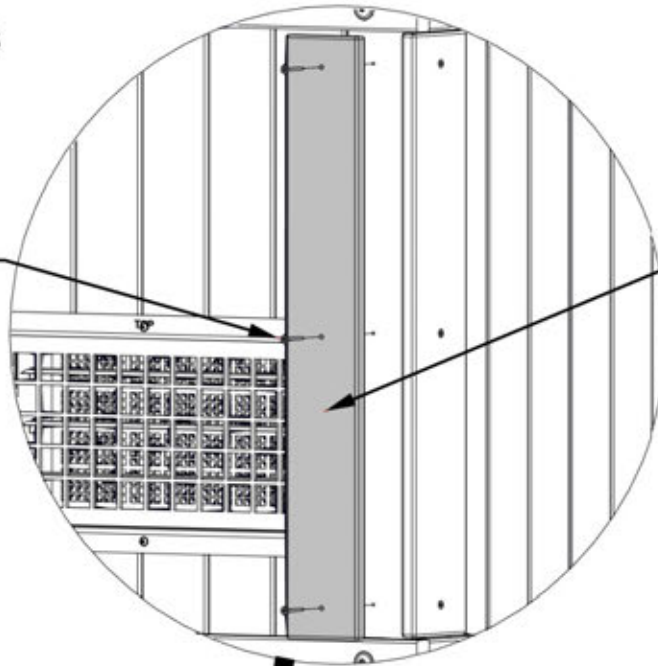


M05 COVER BOARD - W4L19490
(x2) 5/8"x3 3/8"x24 3/16" (16x86x614)

ATTACH COVER BOARDS
USING PILOT HOLES IN
POSTS AS SHOWN.

200 (x6)
SCREW - 1 1/2"

M05 (x2)
COVER BOARD

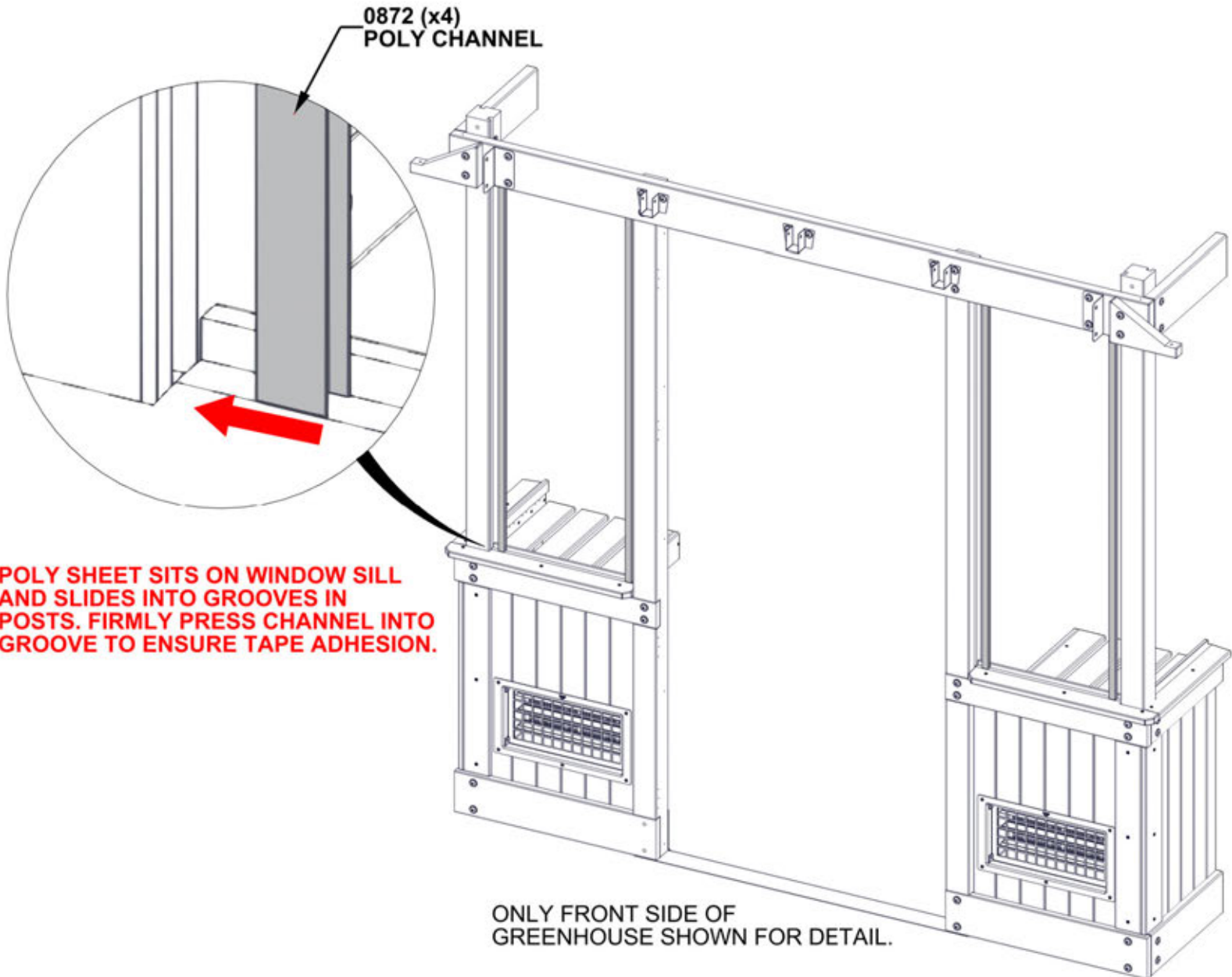
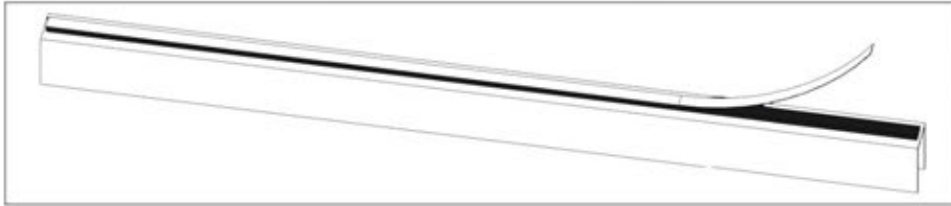


STEP 84 - WINDOW ASSEMBLY



A6P00872 POLY CHANNEL
(x4)

REMOVE TAPE LINER ON POLY CHANNELS BEFORE INSTALLING.

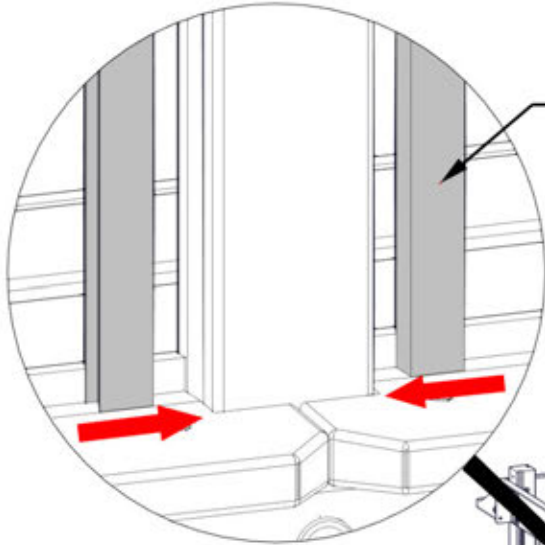
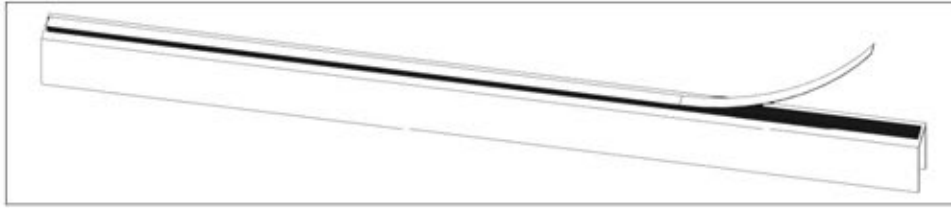


STEP 85 - WINDOW ASSEMBLY



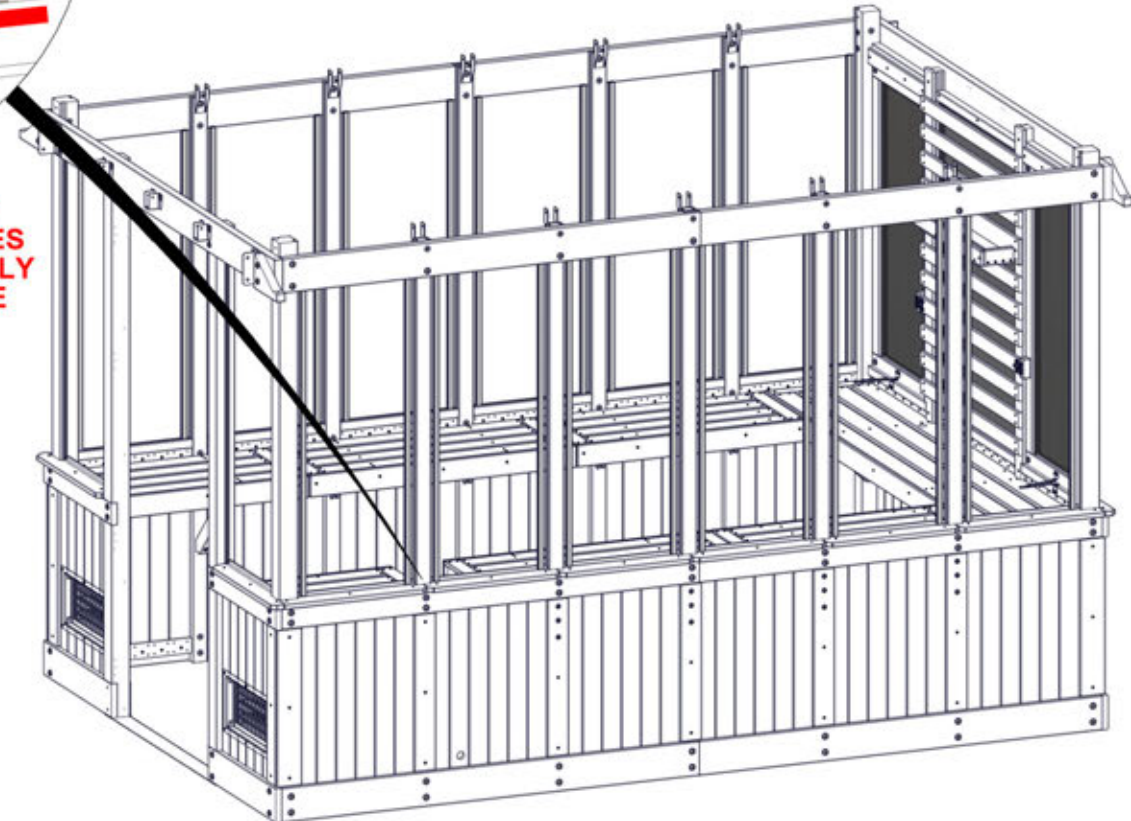
A6P00872 POLY CHANNEL
(x24)

REMOVE TAPE LINER ON POLY CHANNELS BEFORE INSTALLING.



0872 (x24)
POLY CHANNEL

POLY SHEET SITS ON WINDOW SILL AND SLIDES INTO GROOVES IN UPRIGHTS AND POSTS. FIRMLY PRESS CHANNEL INTO GROOVE TO ENSURE TAPE ADHESION.



STEP 86 - WINDOW ASSEMBLY



A6P00870 POLY SHEET
(x12)



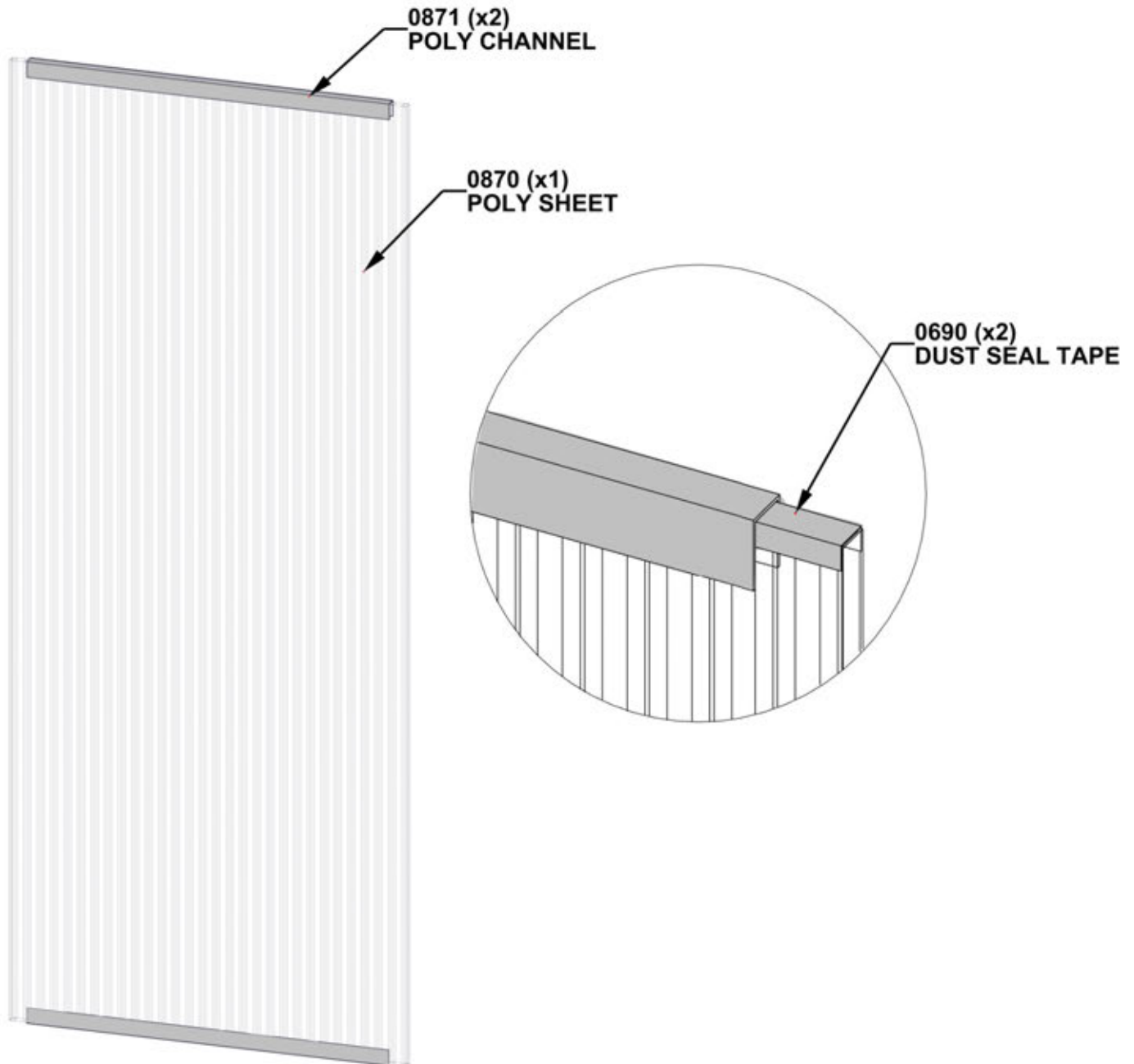
A6P00871 POLY CHANNEL
(x24)



A6P00690 DUST SEAL TAPE

TO APPLY DUST SEAL TAPE AND POLY CHANNEL:

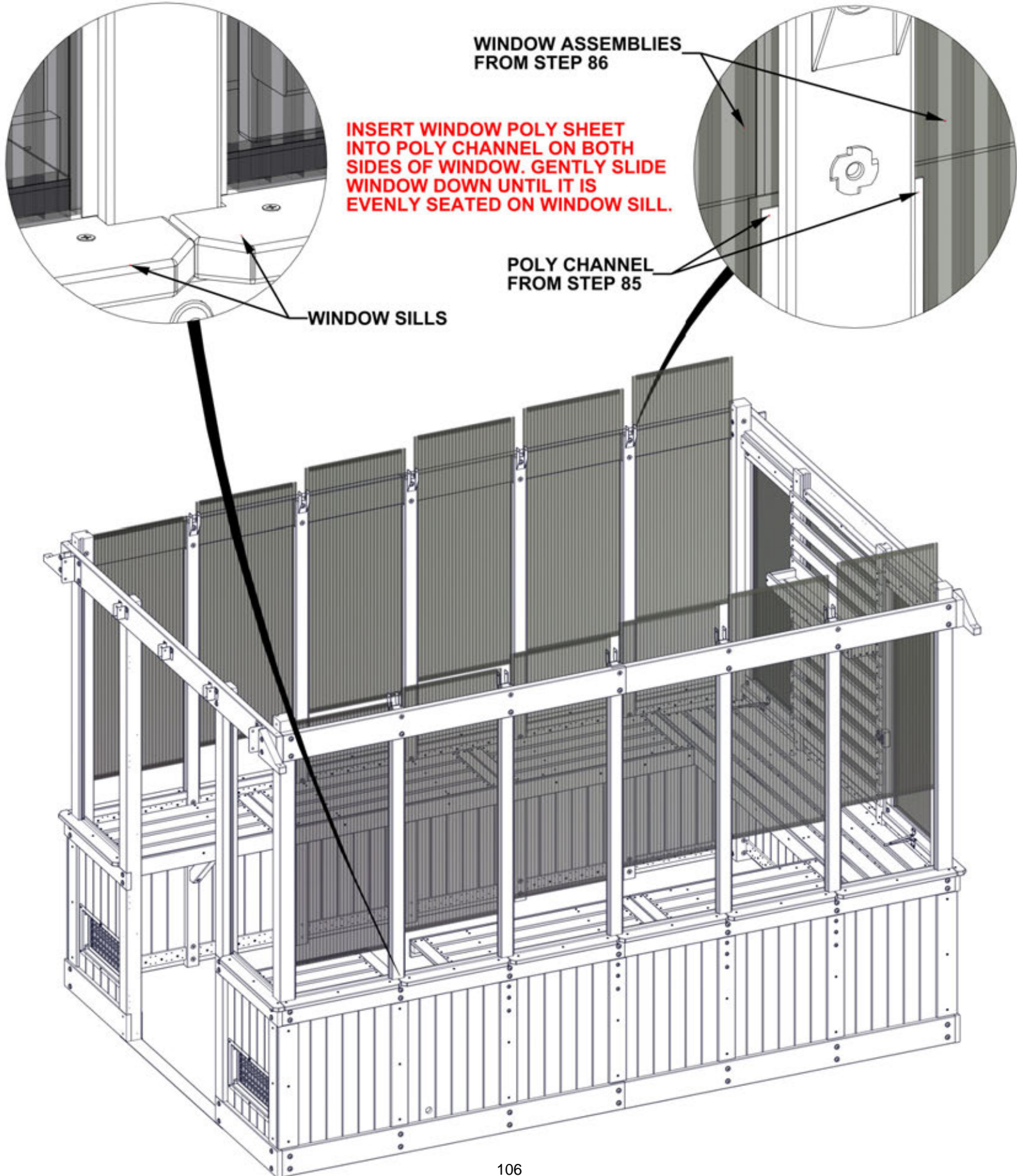
- CUT 2 STRIPS OF DUST SEAL TAPE THE SAME WIDTH AS THE POLY SHEET.
- WRAP DUST SEAL TAPE ALONG EDGE OF POLY SHEET WIDTH.
- AFTER TAPE IS SECURE, PUSH CHANNEL ON OVER THE TAPE, CENTERING ON THE POLY SHEET.
- REPEAT ON THE BOTTOM SIDE OF POLY SHEET.
- REPEAT FOR ALL 12 WINDOW ASSEMBLIES.



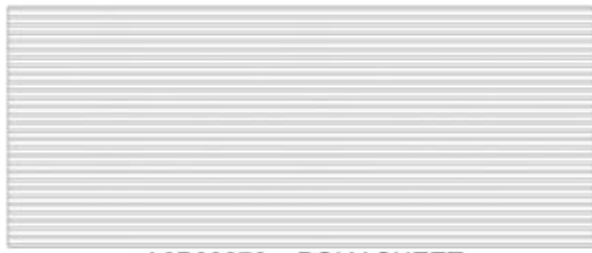
STEP 87 - WINDOW ASSEMBLY

IMPORTANT!

- ENSURE UV SIDE OF WINDOWS ARE FACING OUTSIDE.
- ONCE WINDOWS ARE INSTALLED, IT IS SAFE TO REMOVE THE PROTECTIVE FILM.



STEP 88 - WINDOW ASSEMBLY



A6P00876 POLY SHEET
(x2)



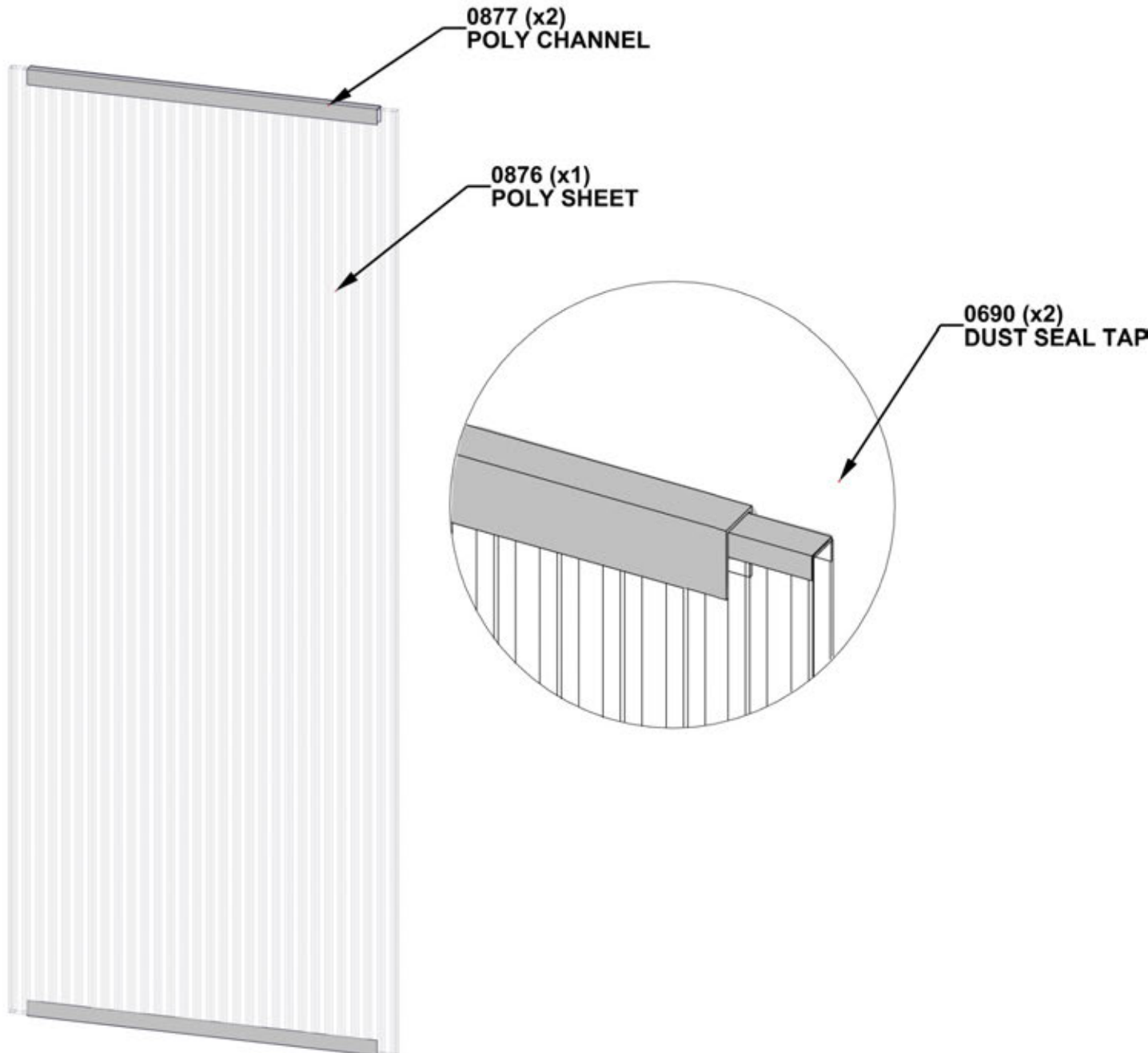
A6P00877 POLY CHANNEL
(x4)



A6P00690 DUST SEAL TAPE

TO APPLY DUST SEAL TAPE AND POLY CHANNEL:

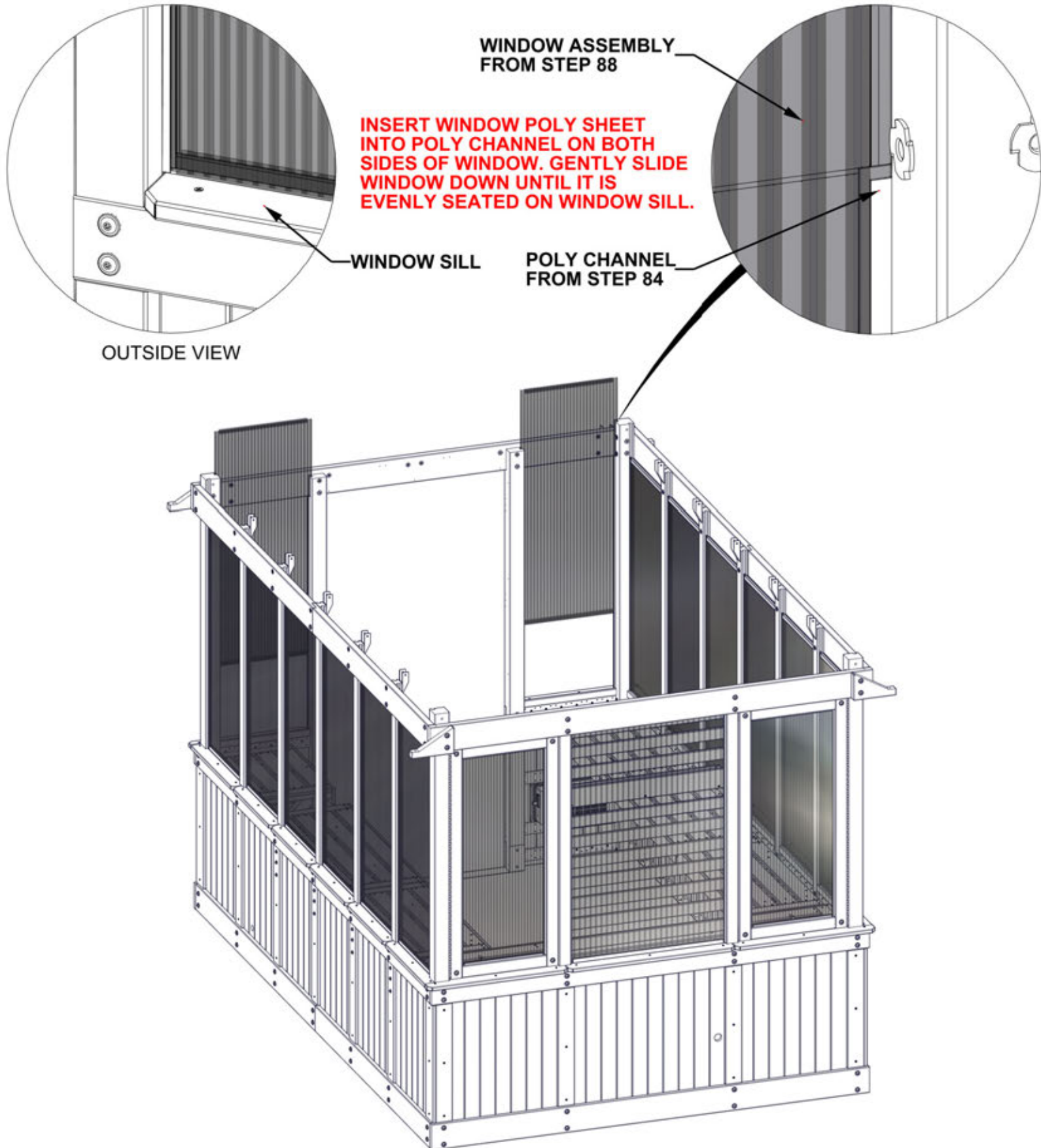
- CUT 2 STRIPS OF DUST SEAL TAPE THE SAME WIDTH AS THE POLY SHEET.
- WRAP DUST SEAL TAPE ALONG EDGE OF POLY SHEET WIDTH.
- AFTER TAPE IS SECURE, PUSH CHANNEL ON OVER THE TAPE, CENTERING ON THE POLY SHEET.
- REPEAT ON THE BOTTOM SIDE OF POLY SHEET.
- REPEAT FOR BOTH WINDOW ASSEMBLIES.



STEP 89 - WINDOW ASSEMBLY

IMPORTANT!

- ENSURE UV SIDE OF WINDOWS ARE FACING OUTSIDE.
- ONCE WINDOWS ARE INSTALLED, IT IS SAFE TO REMOVE THE PROTECTIVE FILM.

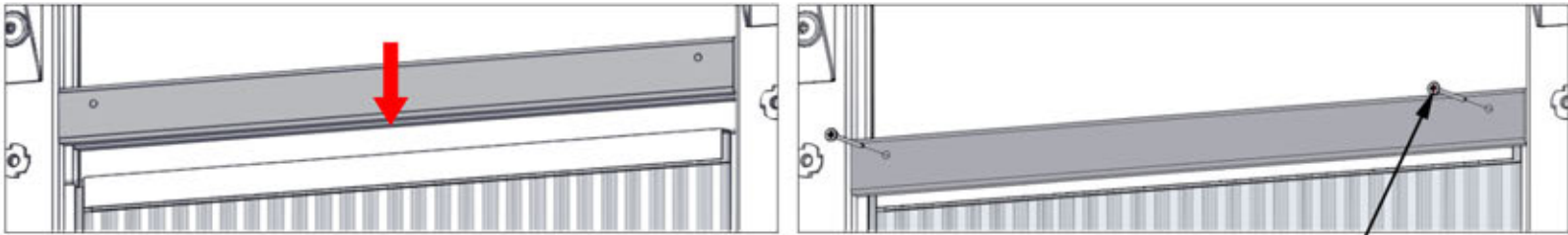


STEP 90 - WINDOW ASSEMBLY

QTY	PART NUMBER	DESCRIPTION
24	H100391	SCREW PFH 8x2 BLK



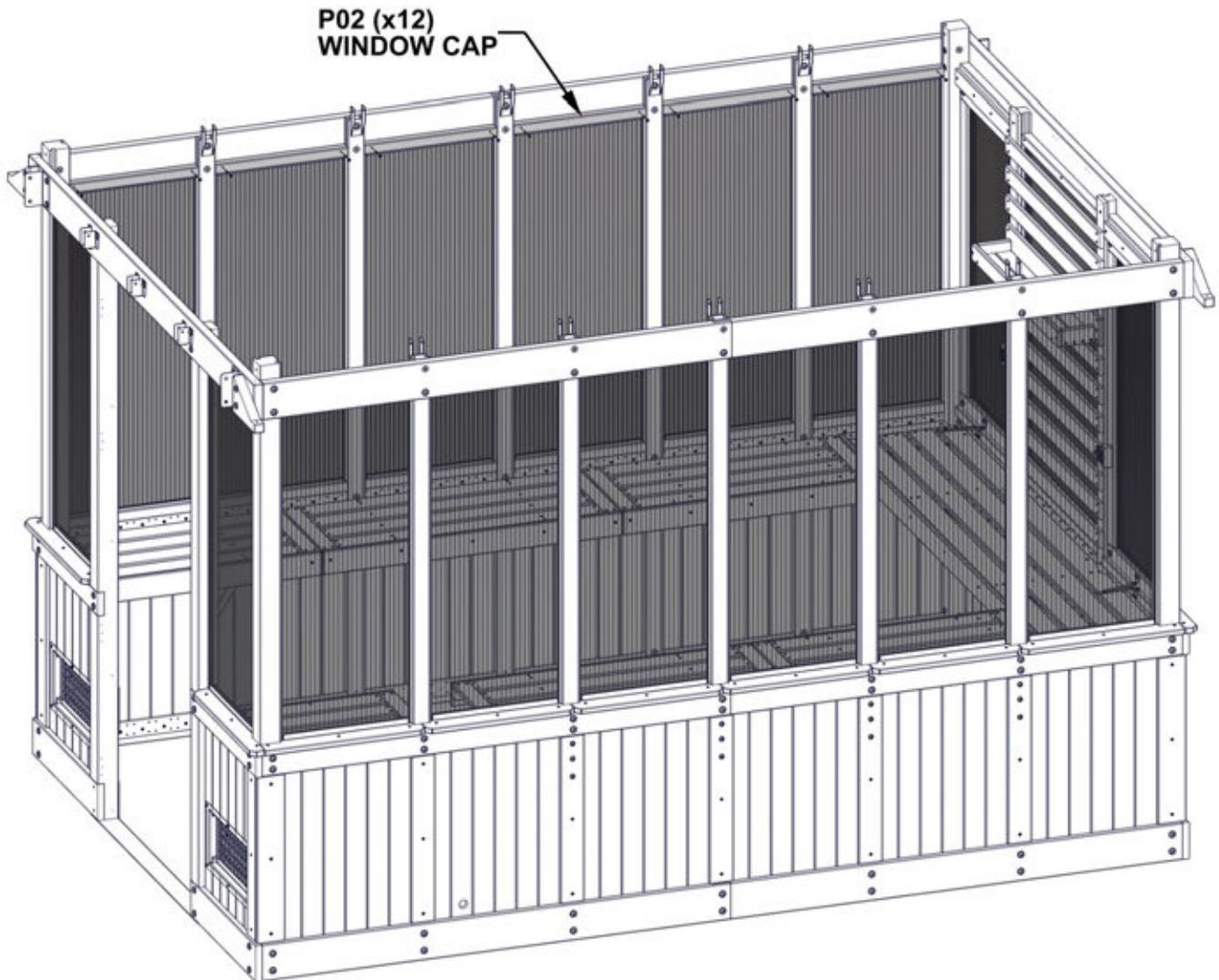
P02 WINDOW CAP - W4L19483
(x12) 1 7/16"x1 7/16"x18 7/8" (36x36x480)



FIRST, SLIDE DOWN WINDOW CAPS WITH THE WINDOW ASSEMBLY FITTING INTO THE GROOVE. THEN, SCREW INTO PLACE.

391 (x24)
SCREW - 2"

INSTALL WINDOW CAPS ON BOTH SIDES OF THE GREENHOUSE.

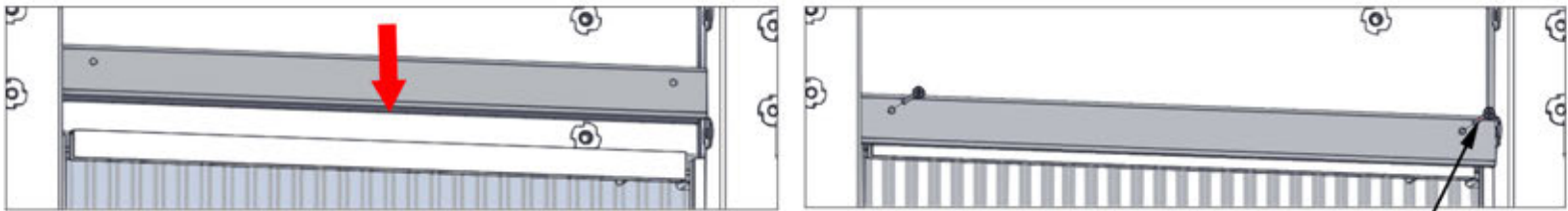


STEP 91 - WINDOW ASSEMBLY

QTY	PART NUMBER	DESCRIPTION
4	H100391	SCREW PFH 8x2 BLK

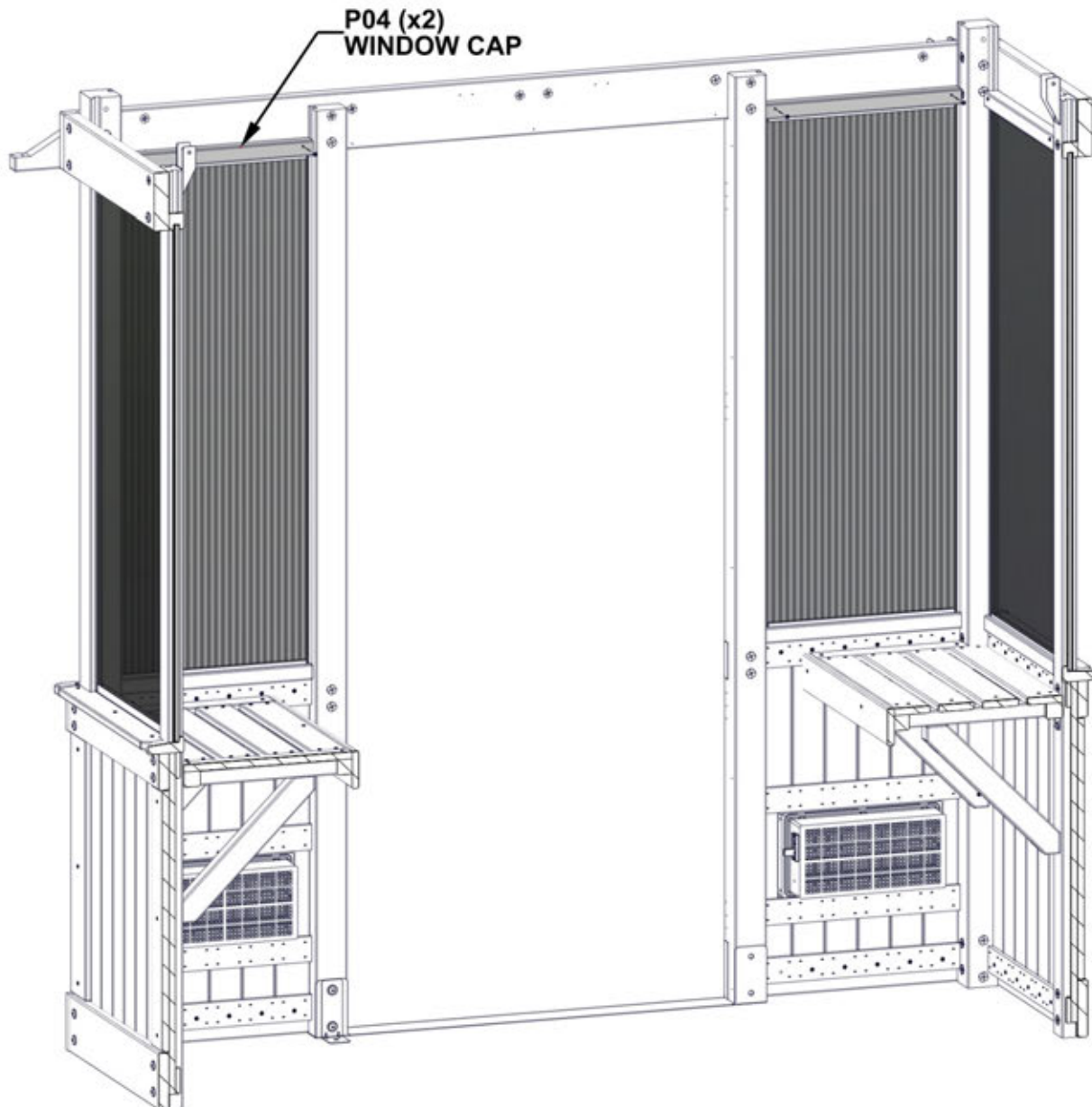


P04 WINDOW CAP - W4L19555
(x2) 1 7/16"x1 7/16"x18 3/4" (36x36x477)



FIRST, SLIDE DOWN WINDOW CAPS WITH THE WINDOW ASSEMBLY FITTING INTO THE GROOVE. THEN, SCREW INTO PLACE.

391 (x4)
SCREW - 2"



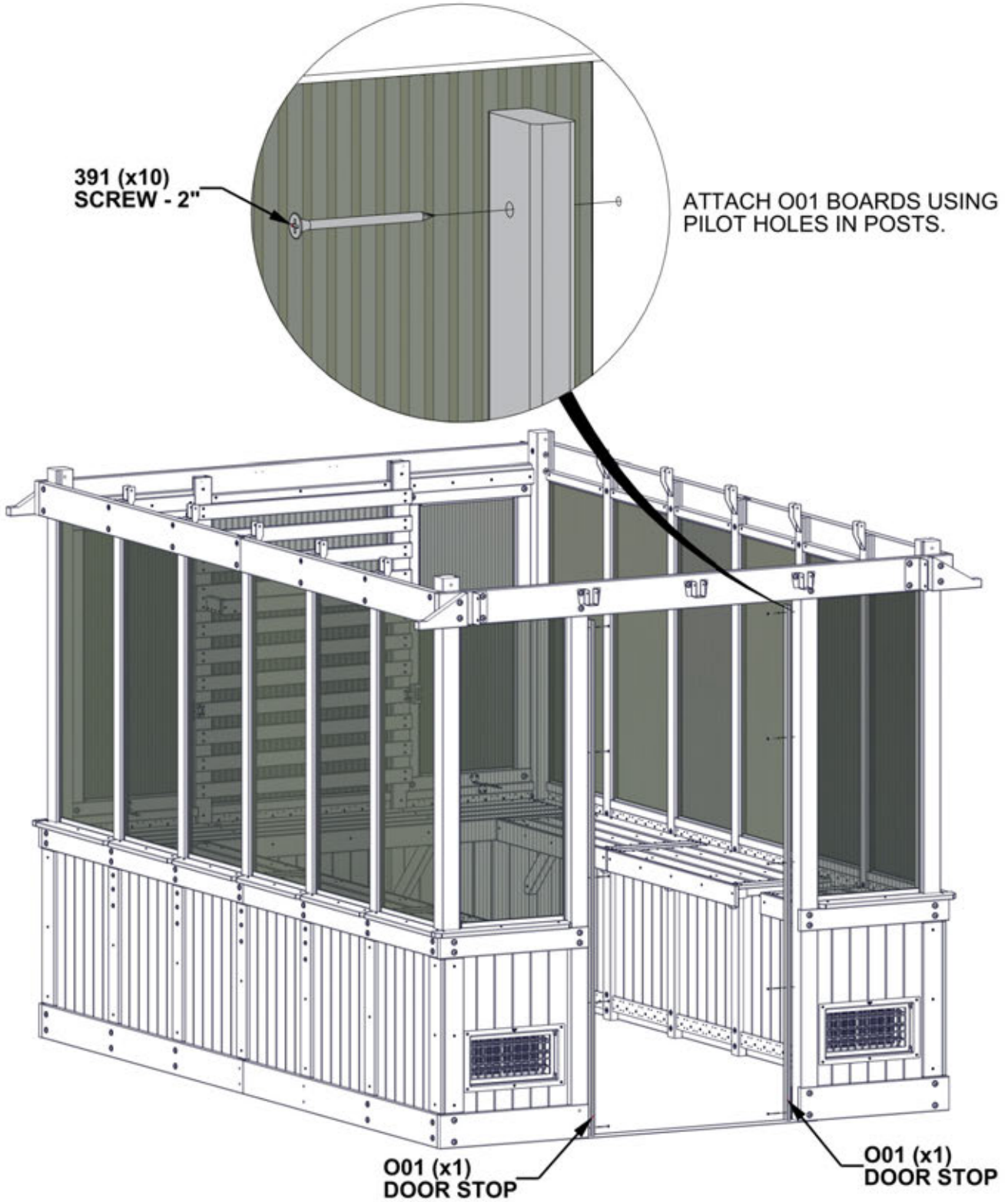
STEP 92 - DOOR TRIM ASSEMBLY

QTY	PART NUMBER	DESCRIPTION
10	H100391	SCREW PFH 8x2 BLK

O01 DOOR STOP - W4L19557
(x2) 5/8"x1 5/16"x80 5/16" (16x34x2040)

391 (x10)
SCREW - 2"

ATTACH O01 BOARDS USING
PILOT HOLES IN POSTS.



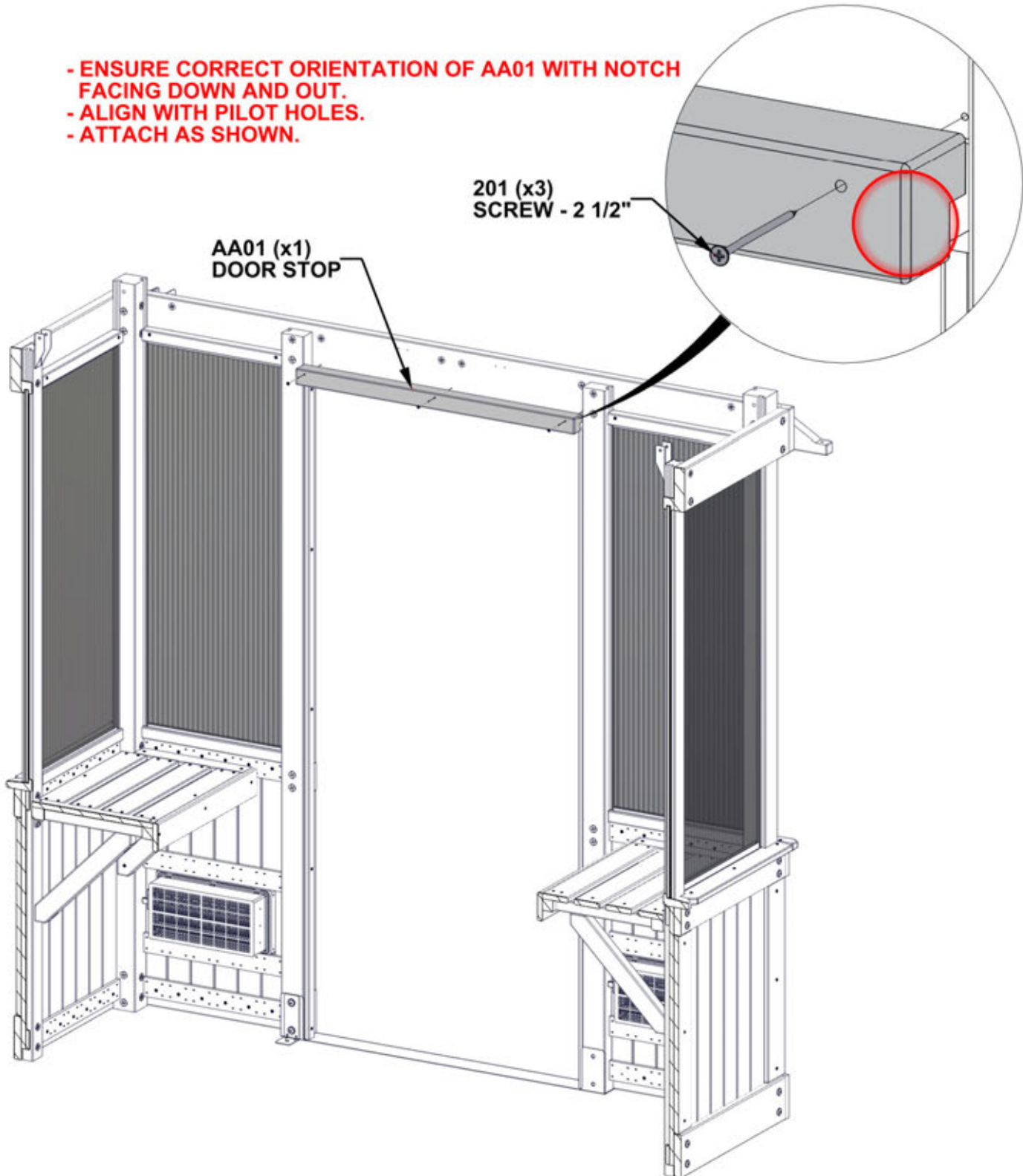
STEP 93 - DOOR TRIM ASSEMBLY

QTY	PART NUMBER	DESCRIPTION
3	H100201	SCREW PFH 8x2 1/2 BLK



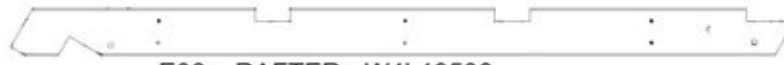
AA01 DOOR STOP - W4L19558
(x1) 1 7/8"x1 15/16"x37" (47x50x940)

- ENSURE CORRECT ORIENTATION OF AA01 WITH NOTCH FACING DOWN AND OUT.
- ALIGN WITH PILOT HOLES.
- ATTACH AS SHOWN.



STEP 94 - GABLE ASSEMBLY

QTY	PART NUMBER	DESCRIPTION
12	H100201	SCREW PFH 8x2 1/2 BLK



E06 RAFTER - W4L19506
(x2) 1 7/16"x3 3/8"x56 1/2" (36x86x1435)

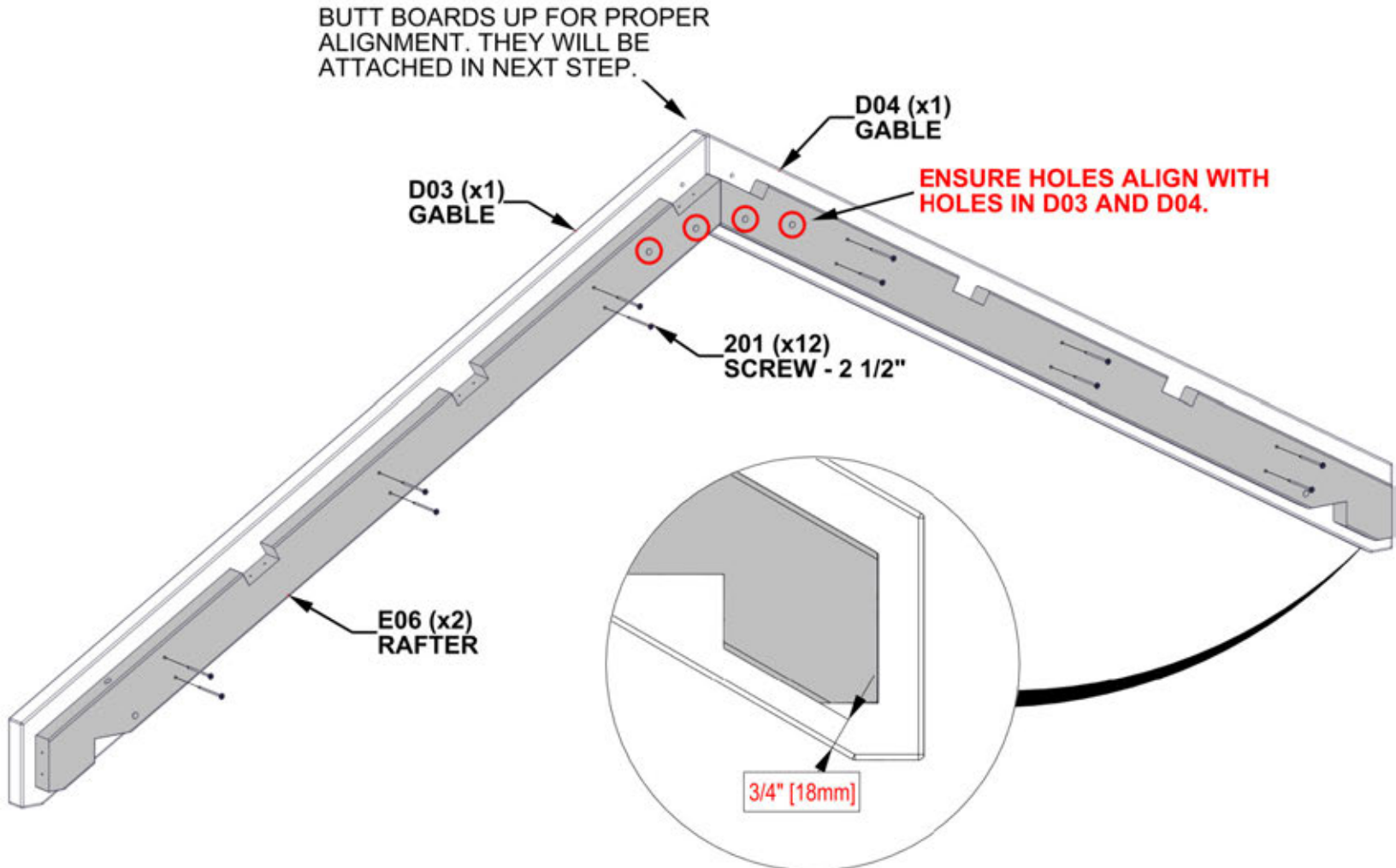


D03 GABLE - W4L19504
(x1) 1 7/16"x5 1/4"x59 3/16" (36x134x1504)



D04 GABLE - W4L19505
(x1) 1 7/16"x5 1/4"x59 3/16" (36x134x1504)

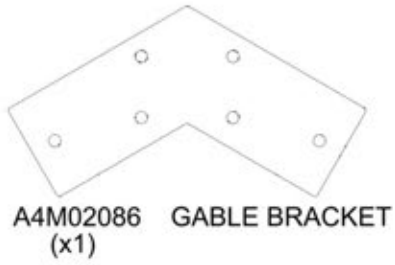
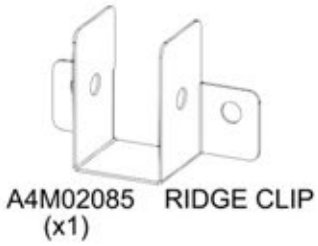
BUTT BOARDS UP FOR PROPER ALIGNMENT. THEY WILL BE ATTACHED IN NEXT STEP.



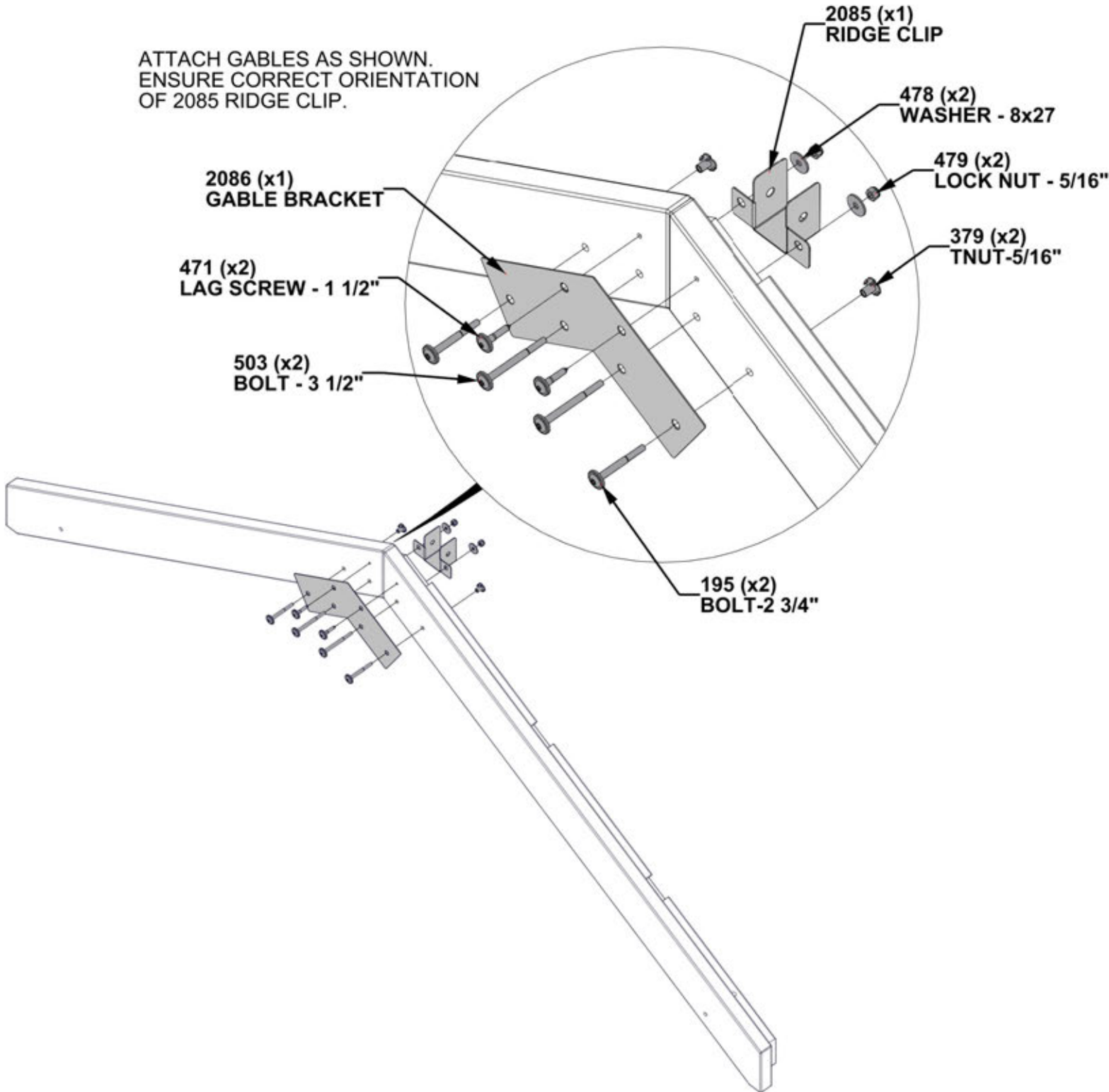
ENSURE MEASUREMENT IS CORRECT ON BOTH D03 AND D04.

STEP 95 - GABLE ASSEMBLY

QTY	PART NUMBER	DESCRIPTION
2	H100195	BOLT WH 5/16x2 3/4 BLK
2	H100379	TNUT-5/16" BLK
2	H100471	LAG SCREW WH 5/16x1 1/2 BLK
2	H100478	WASHER FLAT 8x27 BLK
2	H100479	NUT LOCK 5/16 BLK
2	H100503	BOLT WH 5/16x3 1/2 BLK



ATTACH GABLES AS SHOWN.
ENSURE CORRECT ORIENTATION
OF 2085 RIDGE CLIP.



**REPEAT STEPS 93 AND 94
FOR 2ND GABLE ASSEMBLY**

STEP 96 - GABLE ASSEMBLY

QTY	PART NUMBER	DESCRIPTION
4	H100198	WASHER LOCK EXT 8x19
4	H100379	TNUT-5/16" BLK
4	H100405	WASHER LOCK EXT 6x15
4	H100456	LAG SCREW WH 1/4x2 1/2 BLK
4	H100777	SCREW PFH 10x3 1/2 BLK
4	H100974	BOLT WH 5/16x5 3/4 BLK



GABLE ASSEMBLY (x2) - FROM PREVIOUS STEPS

INSERT T-NUTS FIRST.

777 (x4)
SCREW - 3 1/2"

379 (x4)
TNUT-5/16"

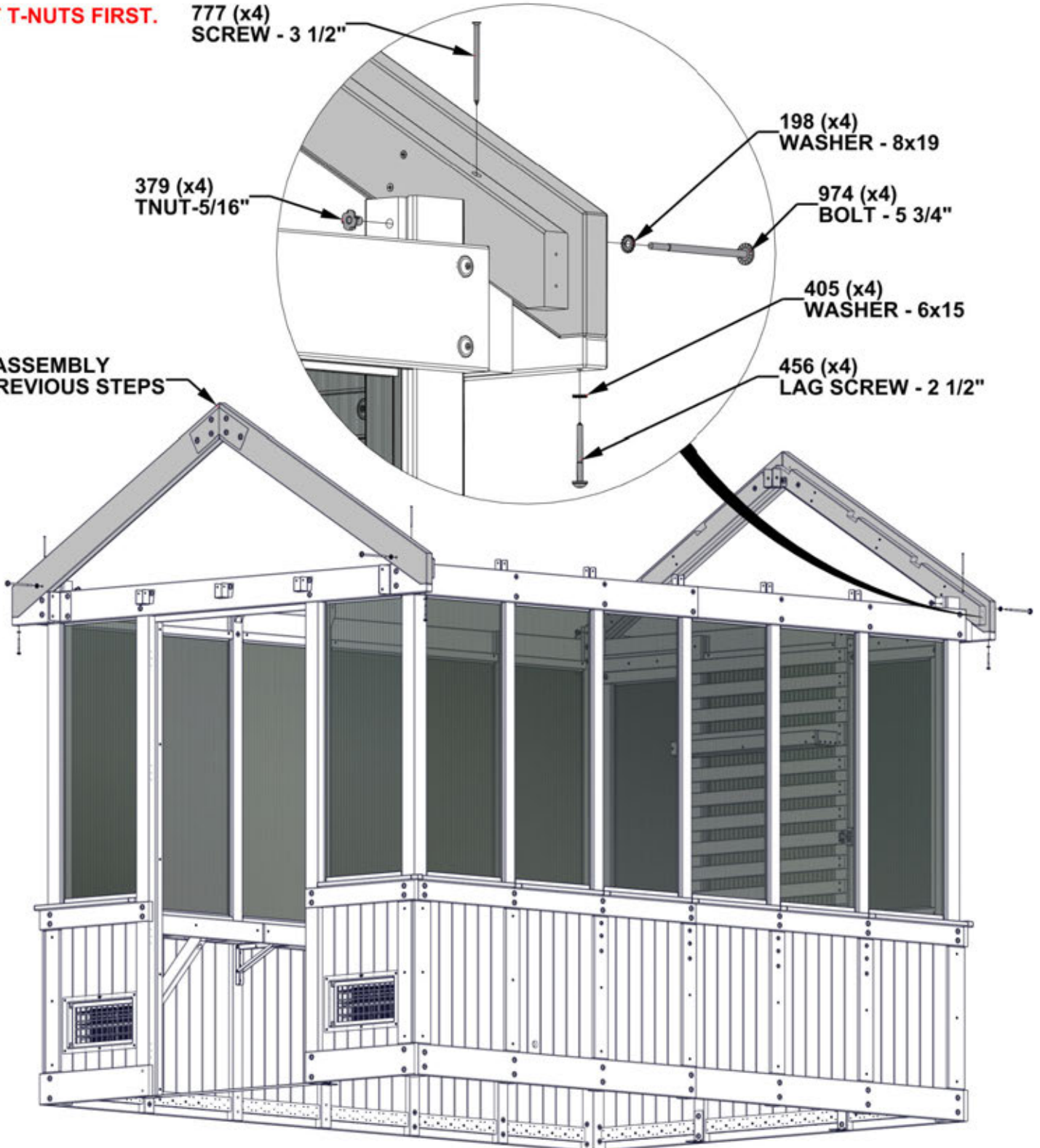
198 (x4)
WASHER - 8x19

974 (x4)
BOLT - 5 3/4"

405 (x4)
WASHER - 6x15

456 (x4)
LAG SCREW - 2 1/2"

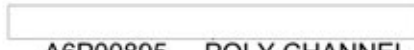
GABLE ASSEMBLY
FROM PREVIOUS STEPS



STEP 97 - WINDOW ASSEMBLY



A6P00883 POLY SHEET
(x1)



A6P00895 POLY CHANNEL
(x2)



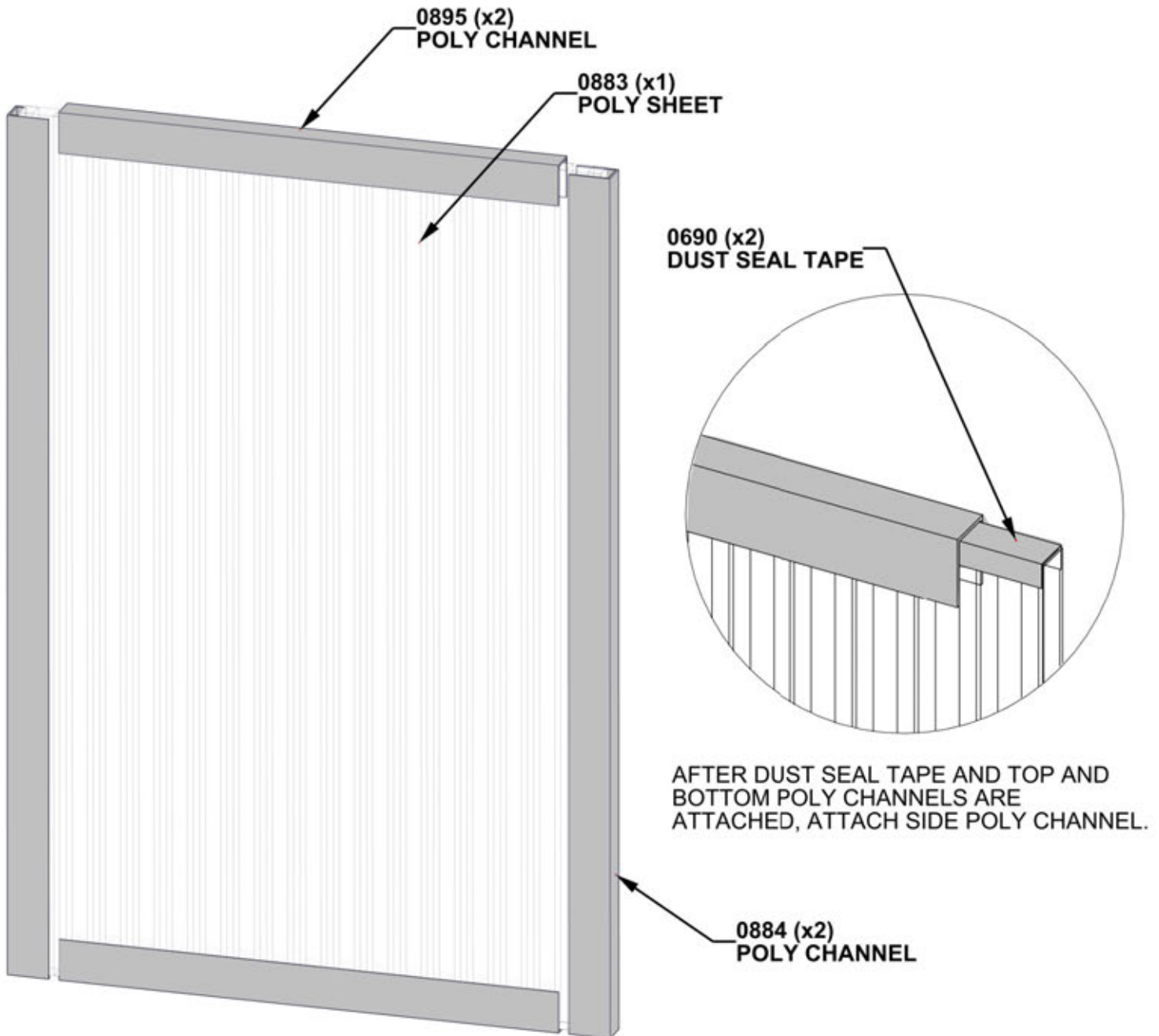
A6P00884 POLY CHANNEL
(x2)



A6P00690 DUST SEAL TAPE

TO APPLY DUST SEAL TAPE AND POLY CHANNEL:

- CUT 2 STRIPS OF DUST SEAL TAPE THE SAME WIDTH AS THE POLY SHEET.
- WRAP DUST SEAL TAPE ALONG EDGE OF POLY SHEET WIDTH.
- AFTER TAPE IS SECURE, PUSH CHANNEL ON OVER THE TAPE, CENTERING ON THE POLY SHEET.
- REPEAT ON THE BOTTOM SIDE OF POLY SHEET.



STEP 98 - WINDOW ASSEMBLY

QTY	PART NUMBER	DESCRIPTION
4	H101109	SCREW PFH 8x3-1/2 BLK



F07 WINDOW FRAME - W4L19507
(x1) 1 7/16"x2 3/8"x21 3/16" (36x60x538)



F08 WINDOW FRAME - W4L19508
(x1) 1 7/16"x2 3/8"x21 3/16" (36x60x538)



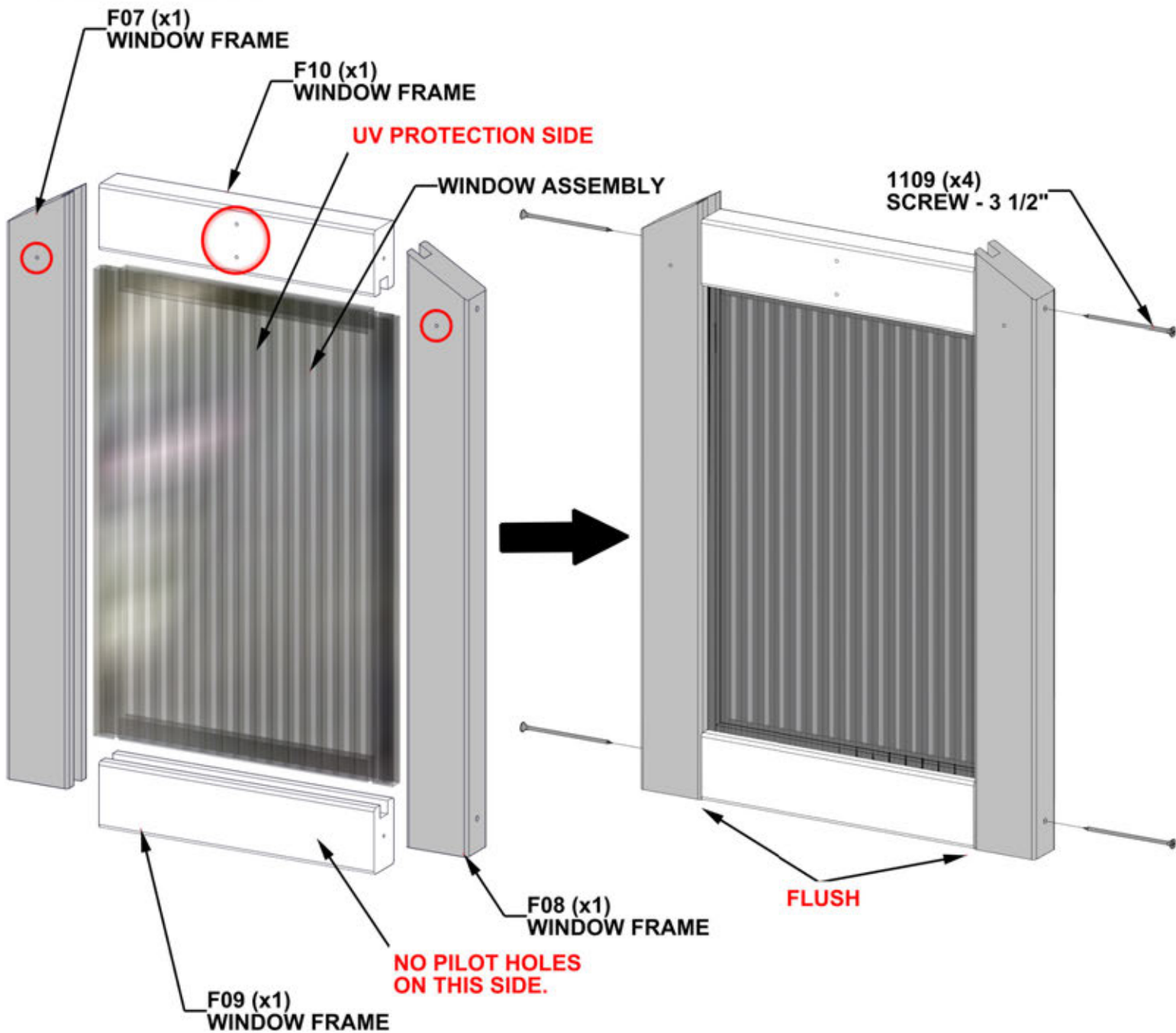
F09 WINDOW FRAME - W4L19509
(x1) 1 7/16"x2 3/8"x10 9/16" (36x60x268)



F10 WINDOW FRAME - W4L19510
(x1) 1 7/16"x2 3/8"x10 9/16" (36x60x268)

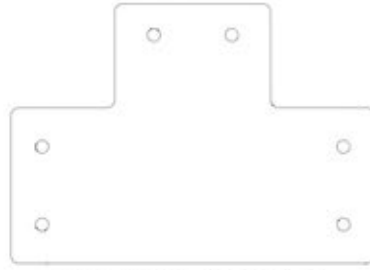
- BEFORE INSTALLATION REMOVE LINER FROM THE POLY CHANNELS.
- FIRMLY PUSH BOARDS ON ENSURING THE WINDOW ASSEMBLY SLIDES ALL THE WAY INTO THE GROOVES.

NOTE PILOT HOLES FOR CORRECT ORIENTATION OF BOARDS.



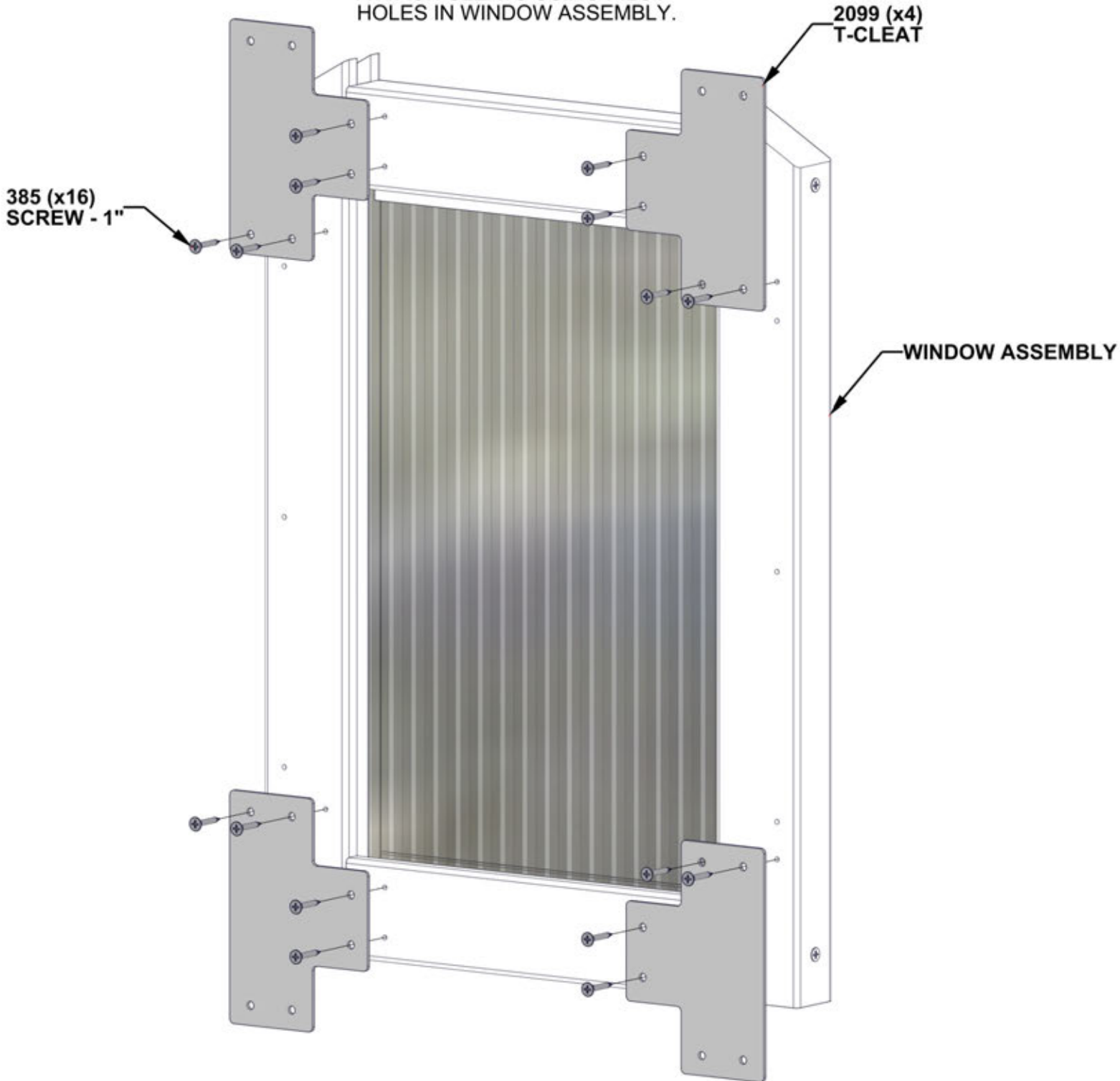
STEP 99 - WINDOW ASSEMBLY

QTY	PART NUMBER	DESCRIPTION
16	H100385	SCREW PFH 8x1 BLK



A4M02099 T-CLEAT
(x4)

ATTACH CLEATS USING PILOT HOLES IN WINDOW ASSEMBLY.



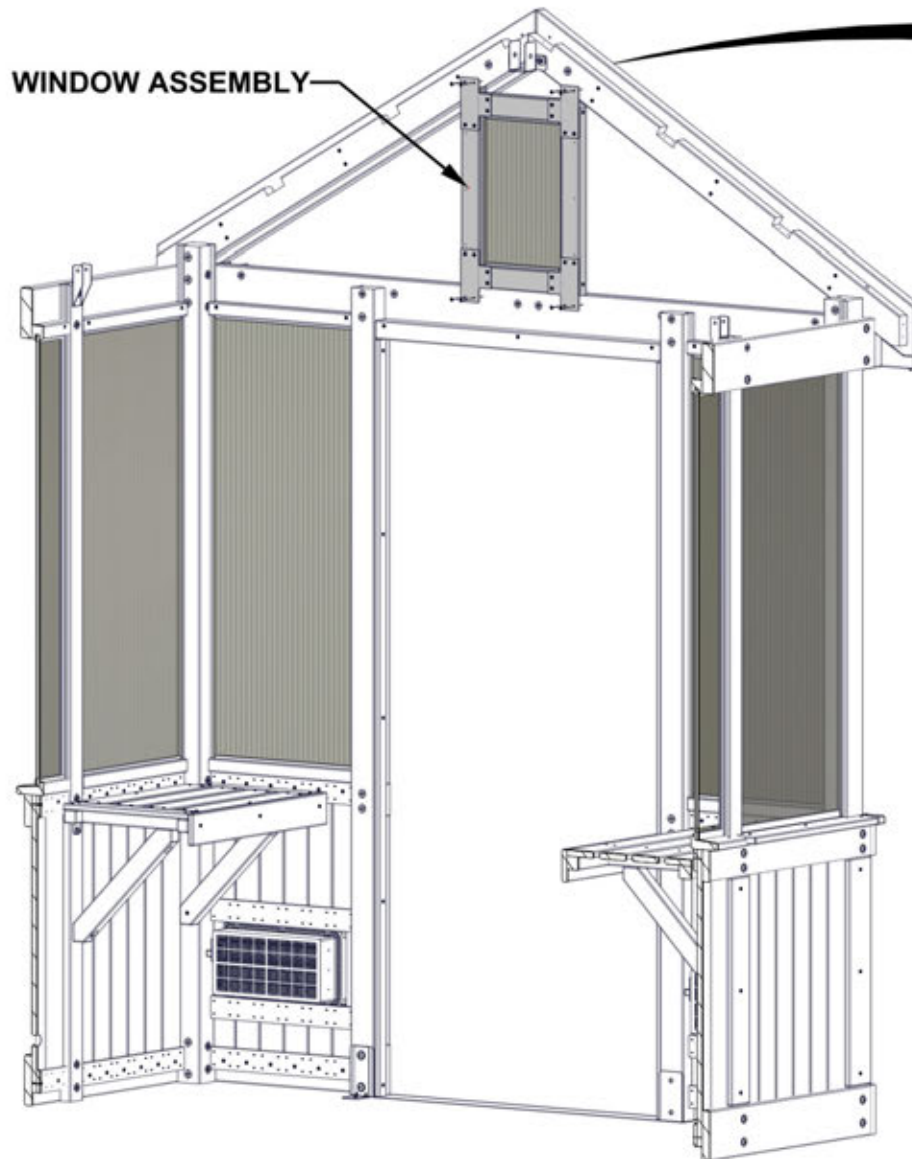
STEP 100 - GABLE ASSEMBLY

QTY	PART NUMBER	DESCRIPTION
8	H100385	SCREW PFH 8x1 BLK

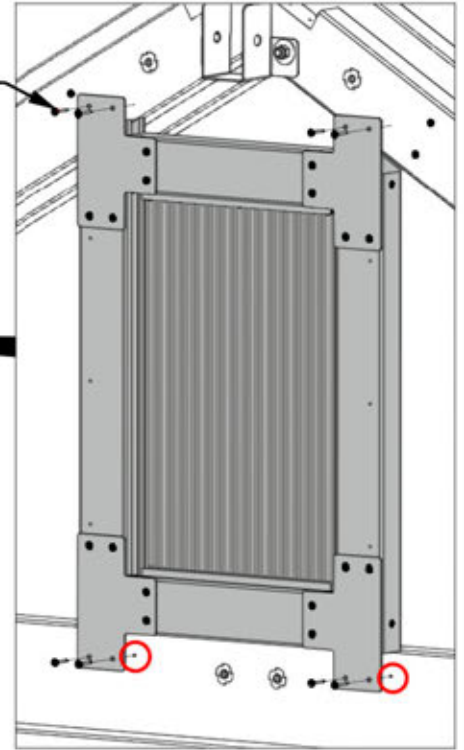


WINDOW ASSEMBLY - FROM PREVIOUS STEPS

WITH PILOT HOLES IN HEADER ALIGNED WITH HOLES IN BOTTOM CLEATS, USE TOP CLEATS AS A GUIDE TO DRILL PILOT HOLES INTO GABLE. USE AN 1/8" [3mm] DRILL BIT.



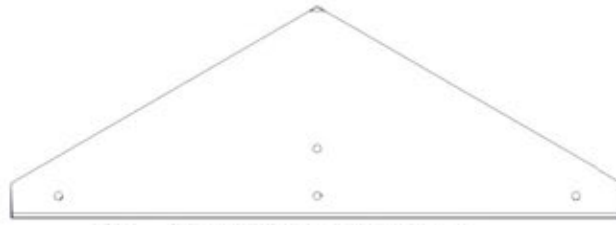
385 (x8)
SCREW - 1"



**ATTACH WINDOW ASSEMBLY
USNG PILOT HOLES IN HEADER.**

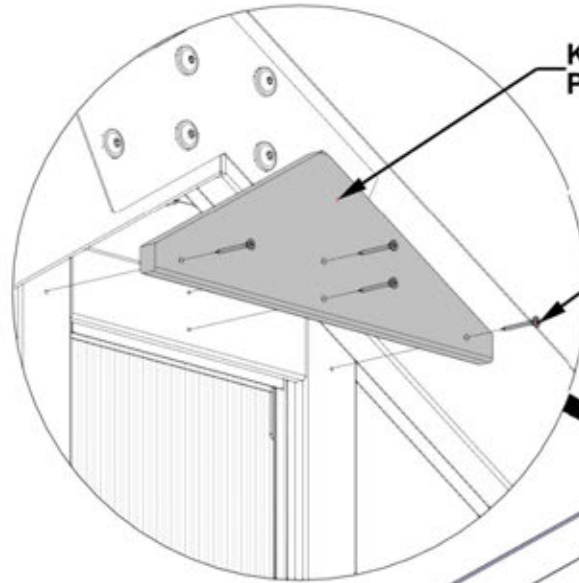
STEP 101 - GABLE ASSEMBLY

QTY	PART NUMBER	DESCRIPTION
4	H100200	SCREW PFH 8x1 1/2 BLK



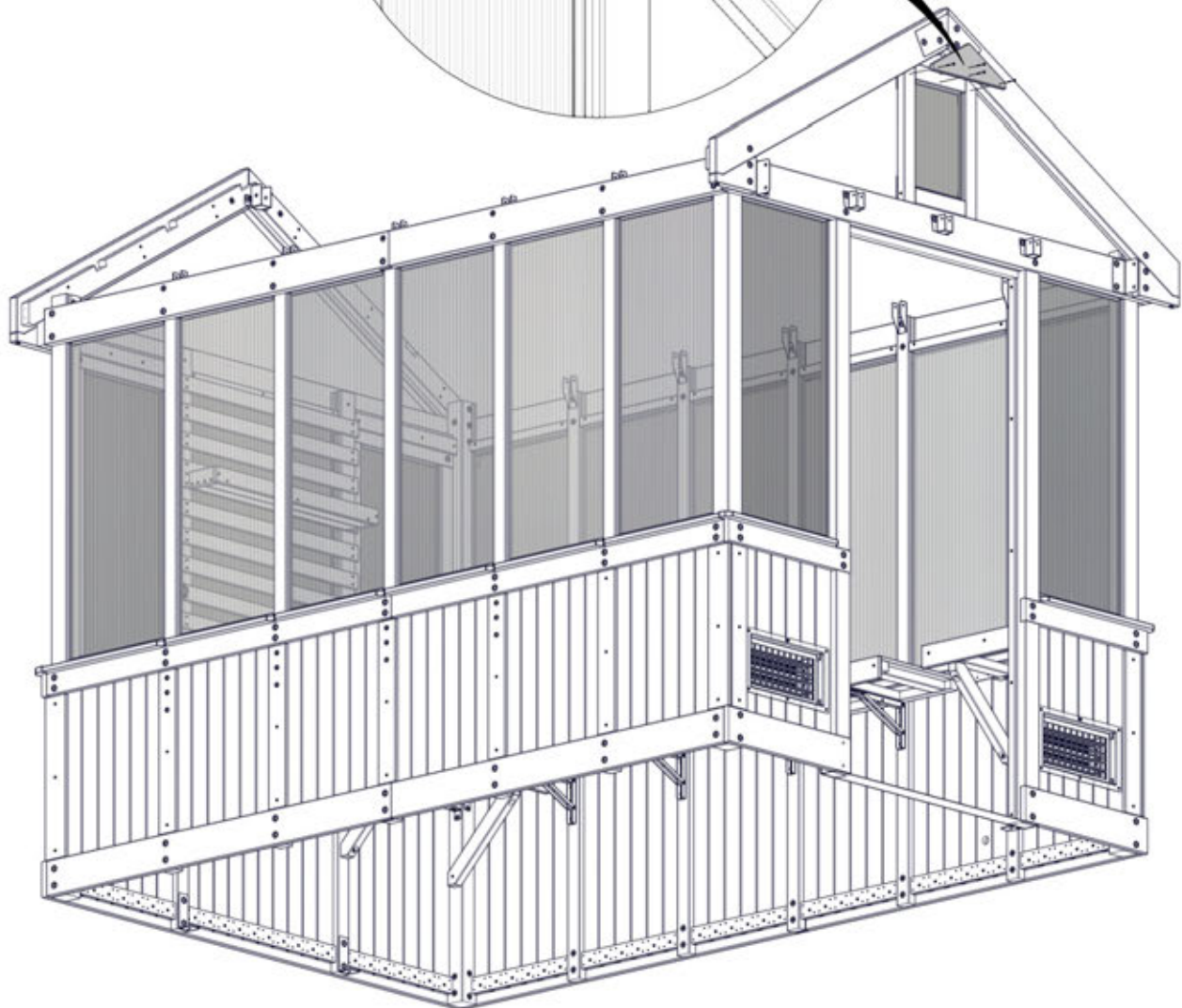
K01 PEAK TRIM - W4L19554
(x1) 5/8"x5 1/4"x15 1/4" (16x134x388)

USE PILOT HOLES TO ATTACH K01 AS SHOWN.

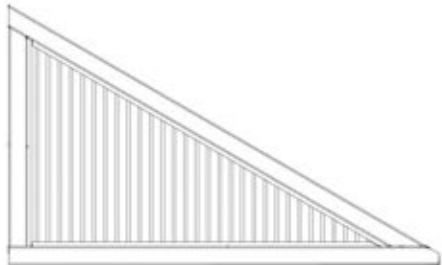


K01 (x1)
PEAK TRIM

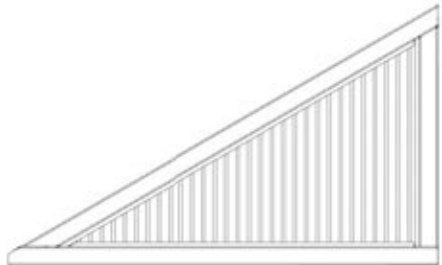
200 (x4)
SCREW - 1 1/2"



STEP 102 - GABLE ASSEMBLY

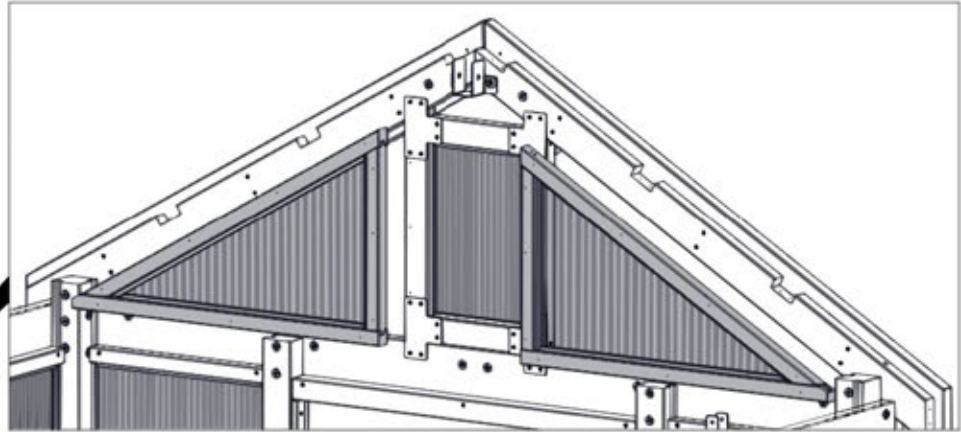


WA01 WINDOW ASSEMBLY - W2A04157
(x1) 1 7/16"x19 11/16"x32 11/16" (36x501x830)



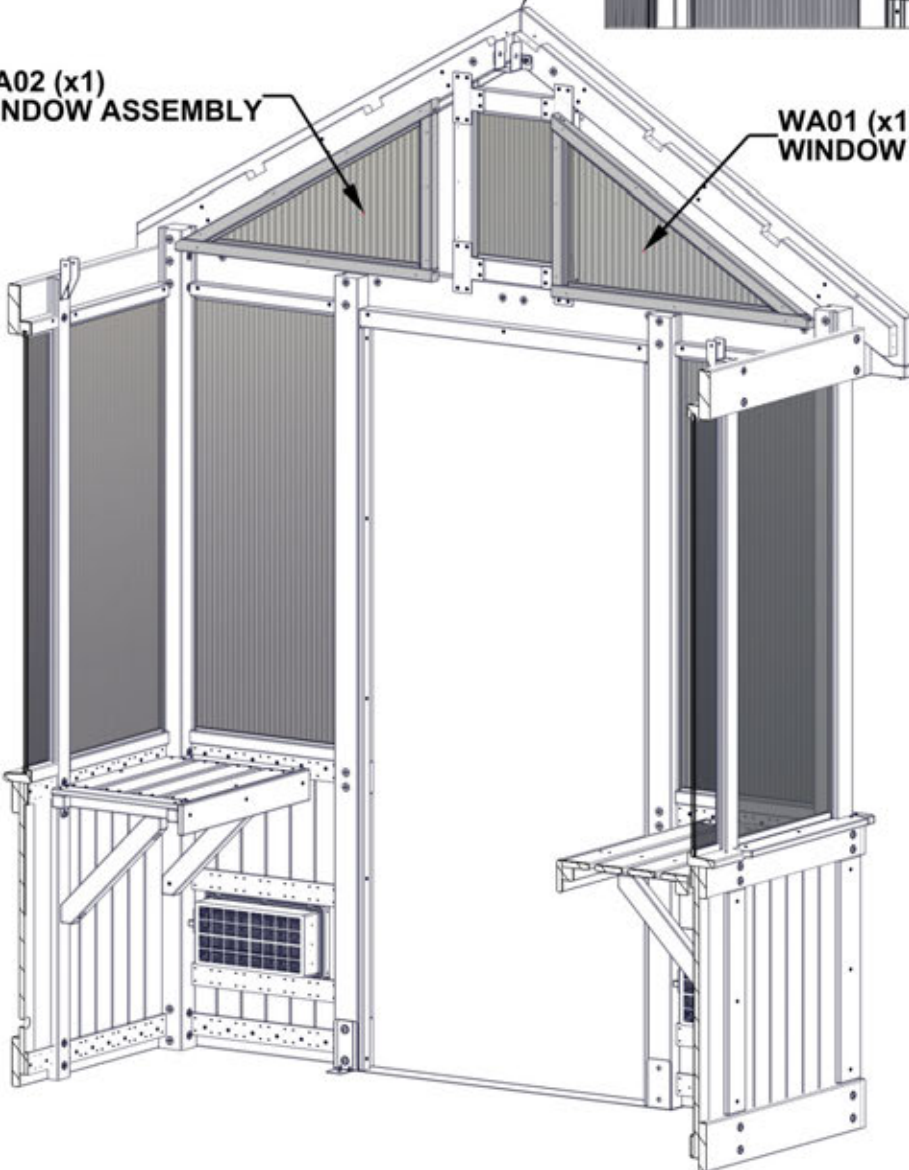
WA02 WINDOW ASSEMBLY - W2A04158
(x1) 1 7/16"x19 11/16"x32 11/16" (36x501x830)

SLIDE WINDOW ASSEMBLIES INTO OPENINGS UNTIL THEY CONTACT GABLE BOARDS.



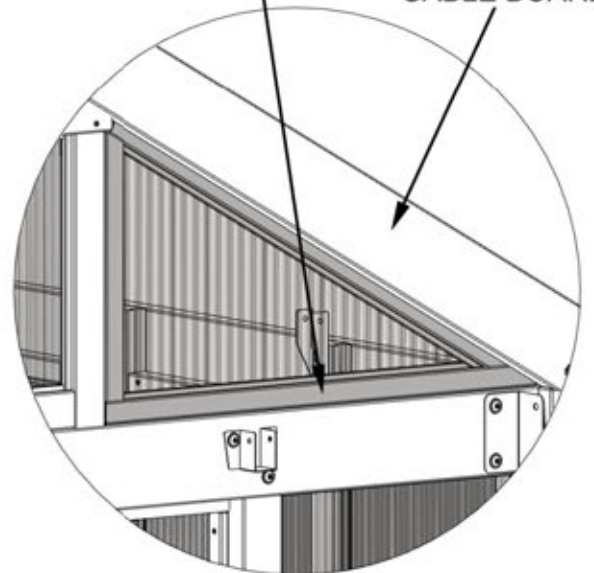
WA02 (x1)
WINDOW ASSEMBLY

WA01 (x1)
WINDOW ASSEMBLY



WINDOWS WILL BE FLUSH WITH FRONT OF GREENHOUSE.

GABLE BOARD



OUTSIDE VIEW

STEP 103 - GABLE ASSEMBLY

QTY	PART NUMBER	DESCRIPTION
40	H100382	SCREW PFH 8x1 3/4 BLK



N01 WINDOW TRIM - W4L19551
(x2) 5/8"x2 3/8"x40 1/2" (16x60x1028)



N02 WINDOW TRIM - W4L19552
(x2) 5/8"x2 3/8"x17 3/4" (16x60x451)



N03 WINDOW TRIM - W4L19553
(x2) 5/8"x2 3/8"x33 7/8" (16x60x861)



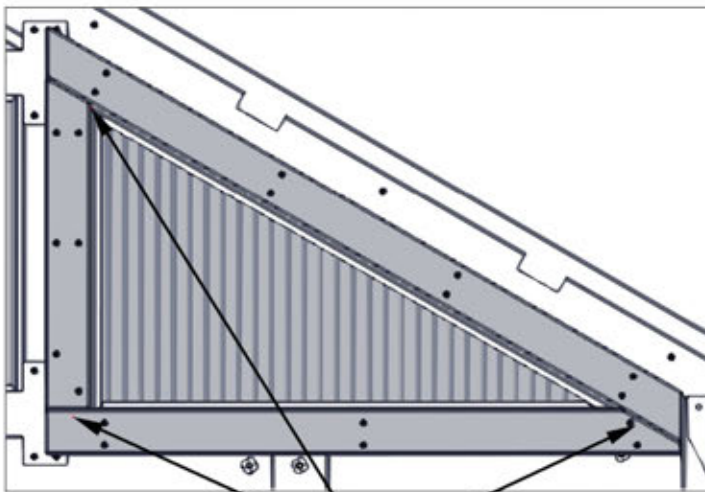
N01 (x2)
WINDOW TRIM

- INSTALL N02 BOARDS FIRST BY ALIGNING THROUGH HOLES IN BOARD WITH PILOT HOLES IN WINDOW ASSEMBLY AND WINDOW FRAME.
- REMAINING BOARDS BUTT UP AGAINST N02 AND ARE FLUSH ON THE OUTSIDE AS SHOWN.
- ALIGN HOLES ON N01 AND N03 WITH PILOT HOLES IN WINDOW AND ATTACH.
- USE AN 1/8" [3mm] DRILL BIT WITH N01 AND N03 AS GUIDES TO DRILL PILOT HOLES.
- ATTACH WITH REMAINING HARDWARE.

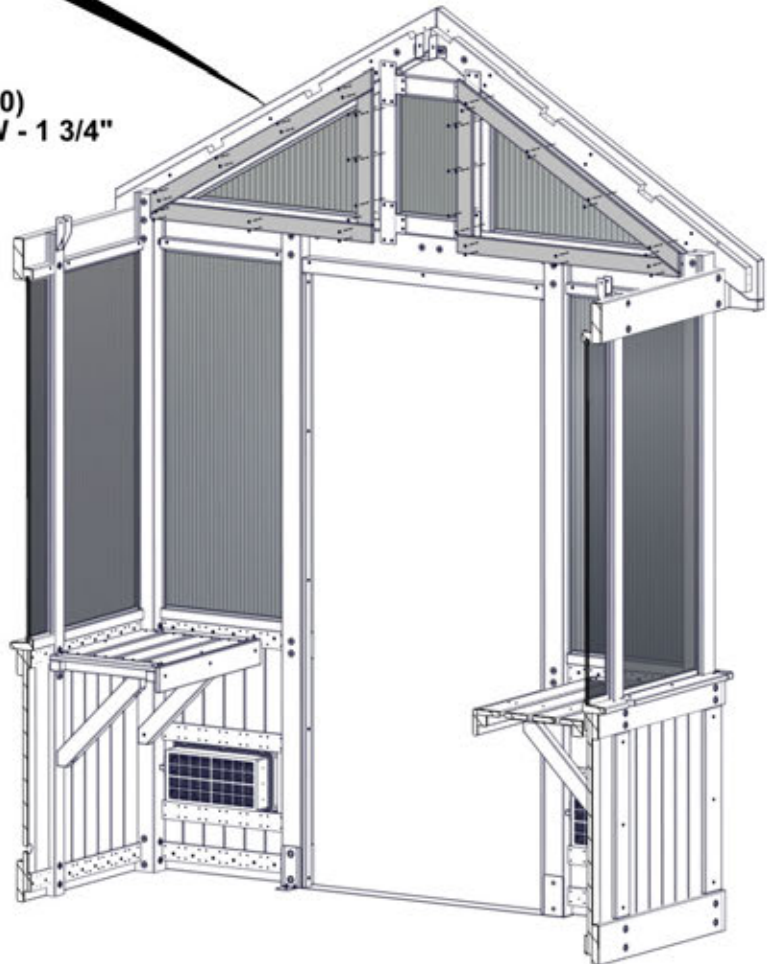
N02 (x2)
WINDOW TRIM

N03 (x2)
WINDOW TRIM

382 (x40)
SCREW - 1 3/4"

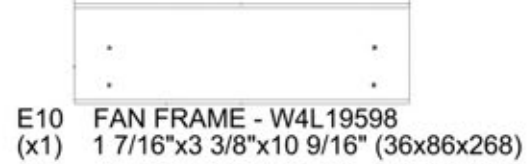
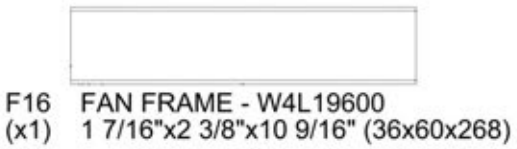
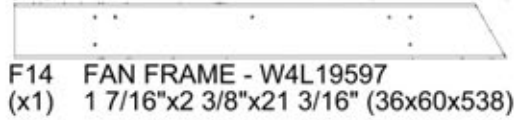
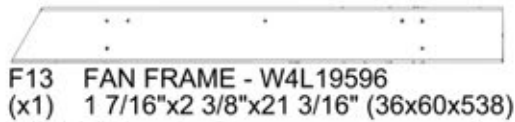


FLUSH

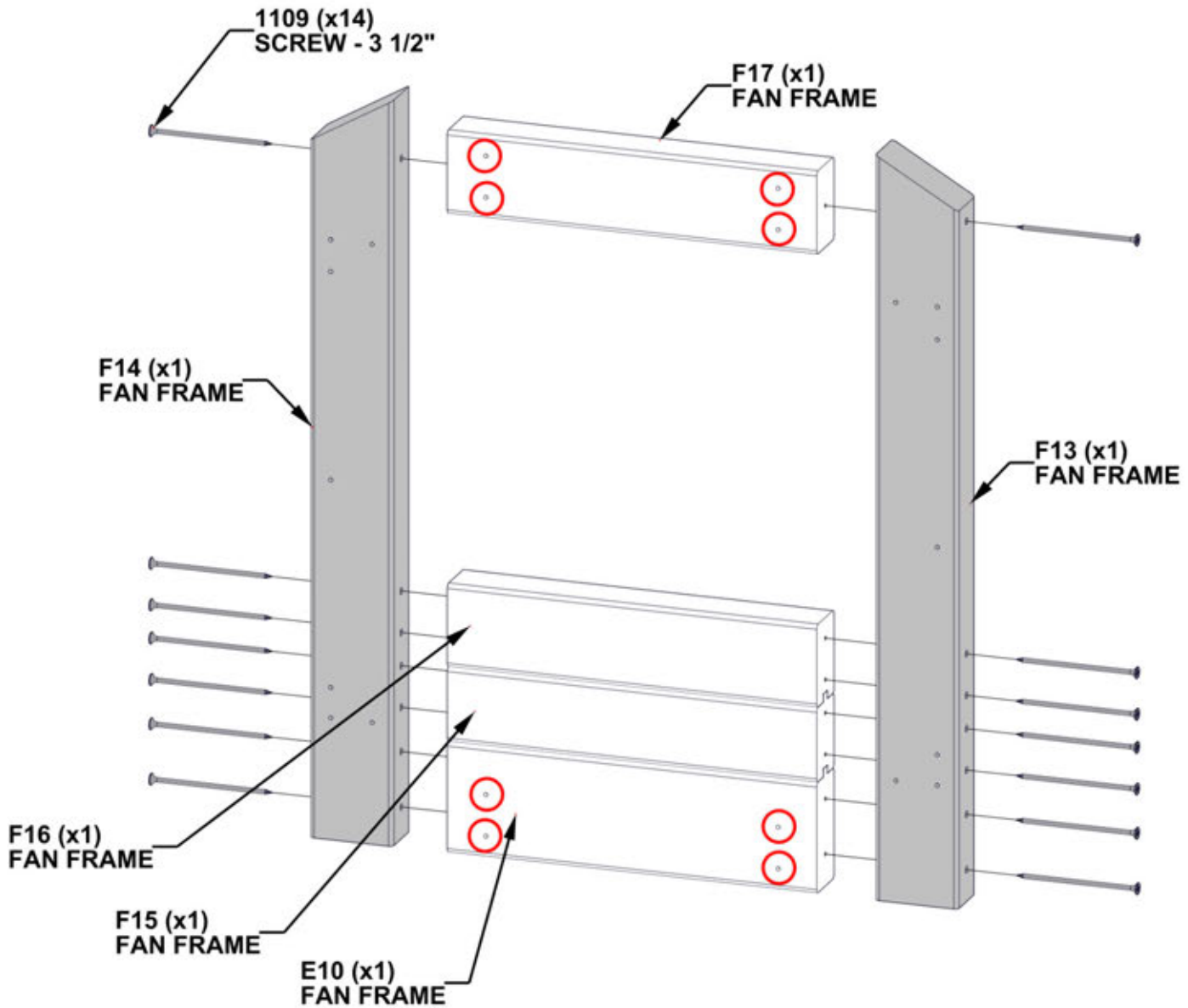


STEP 104 - FAN SUPPORT ASSEMBLY

QTY	PART NUMBER	DESCRIPTION
14	H101109	SCREW PFH 8x3-1/2 BLK

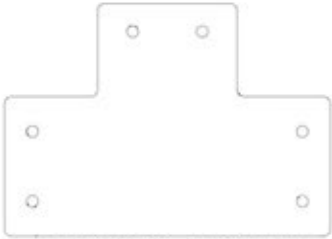


NOTE PILOT HOLES FOR CORRECT ORIENTATION OF F17 AND E10.



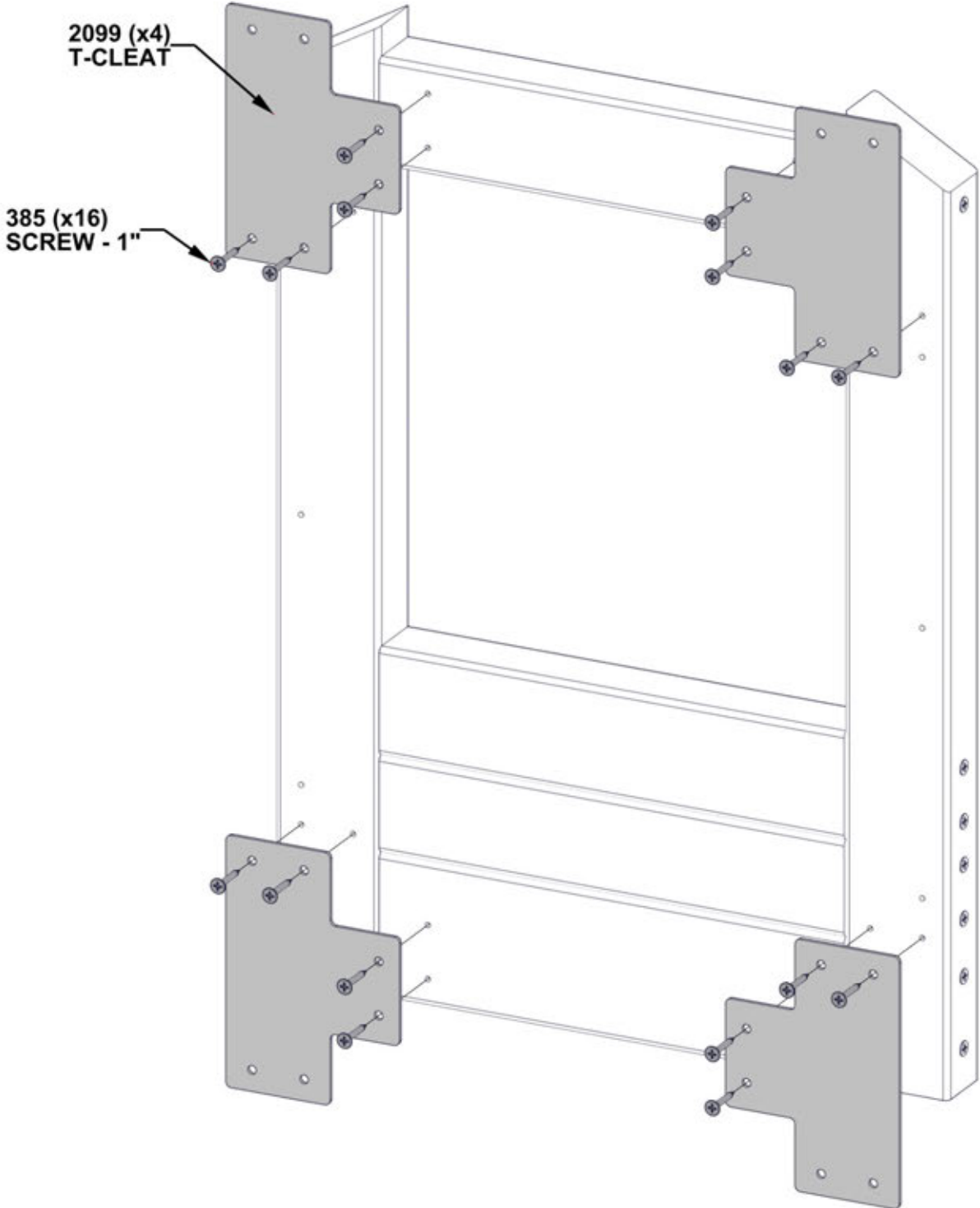
STEP 105 - FAN SUPPORT ASSEMBLY

QTY	PART NUMBER	DESCRIPTION
16	H100385	SCREW PFH 8x1 BLK



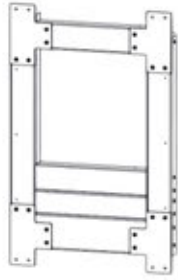
A4M02099 T-CLEAT
(x4)

USE PILOT HOLES IN FAN SUPPORT ASSEMBLY TO ATTACH T-CLEATS.



STEP 106 - GABLE ASSEMBLY

QTY	PART NUMBER	DESCRIPTION
4	H100380	SCREW PFH 8x1 1/8 BLK
8	H100385	SCREW PFH 8x1 BLK



FAN SUPPORT ASSEMBLY
- FROM PREVIOUS STEPS

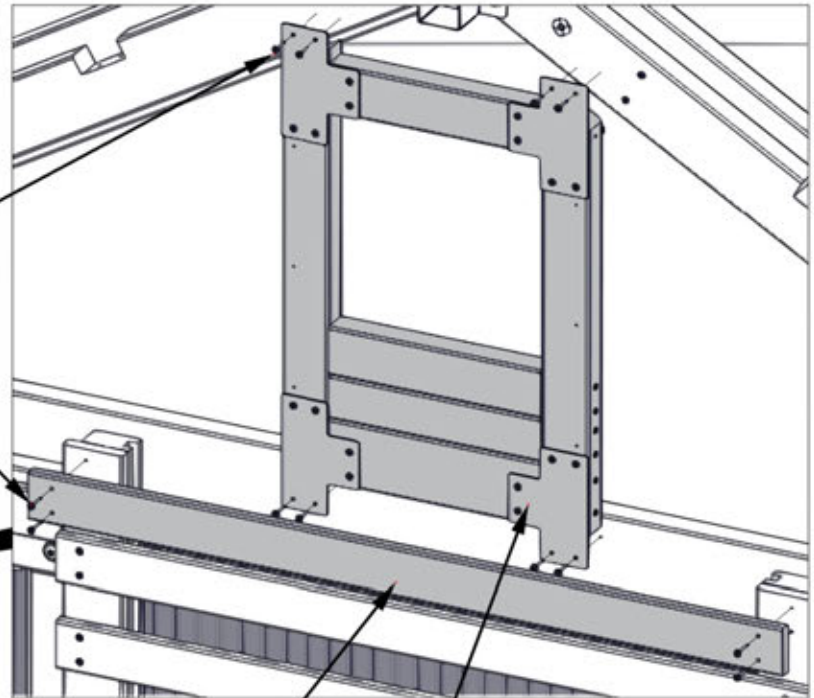


N07 SLAT - W4L19591
(x1) 5/8"x2 3/8"x37 1/2" (16x60x952)

WITH PILOT HOLES IN HEADER ALIGNED WITH HOLES IN BOTTOM CLEATS, USE TOP CLEATS AS A GUIDE TO DRILL PILOT HOLES INTO GABLE. USE AN 1/8" [3mm] DRILL BIT.

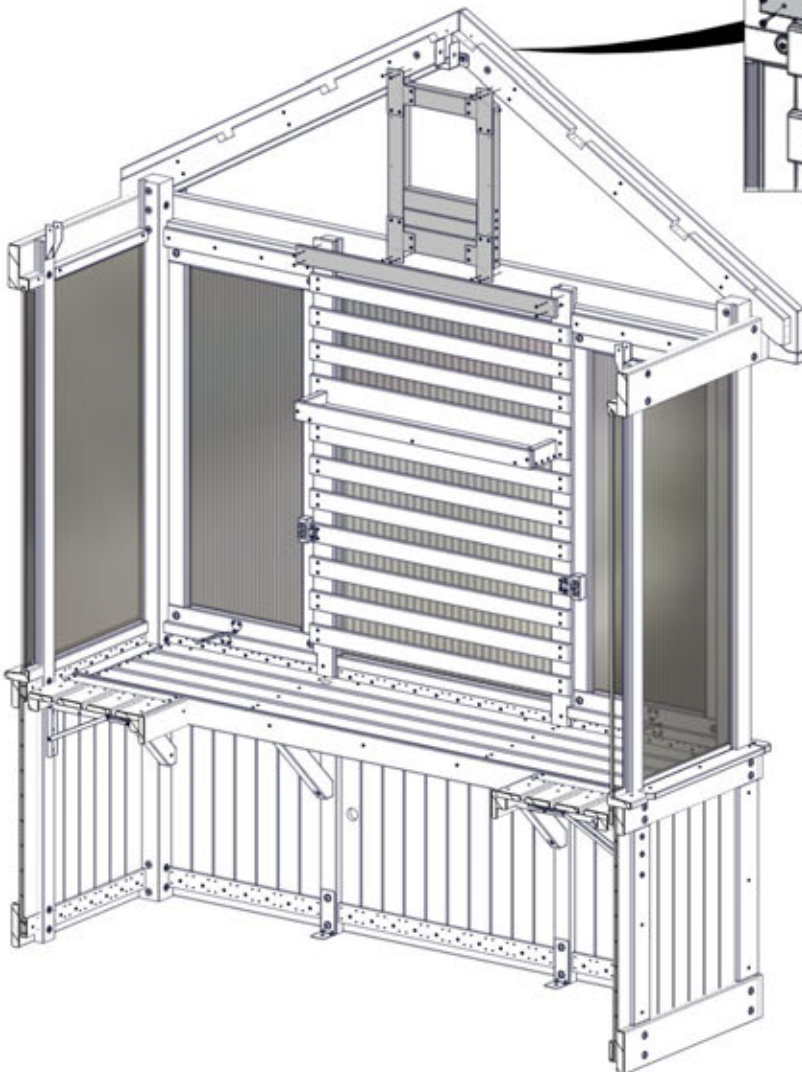
385 (x8)
SCREW - 1"

380 (x4)
SCREW - 1 1/8"



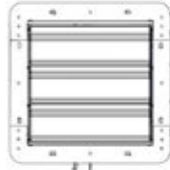
N07 (x1)
SLAT

FAN SUPPORT
ASSEMBLY

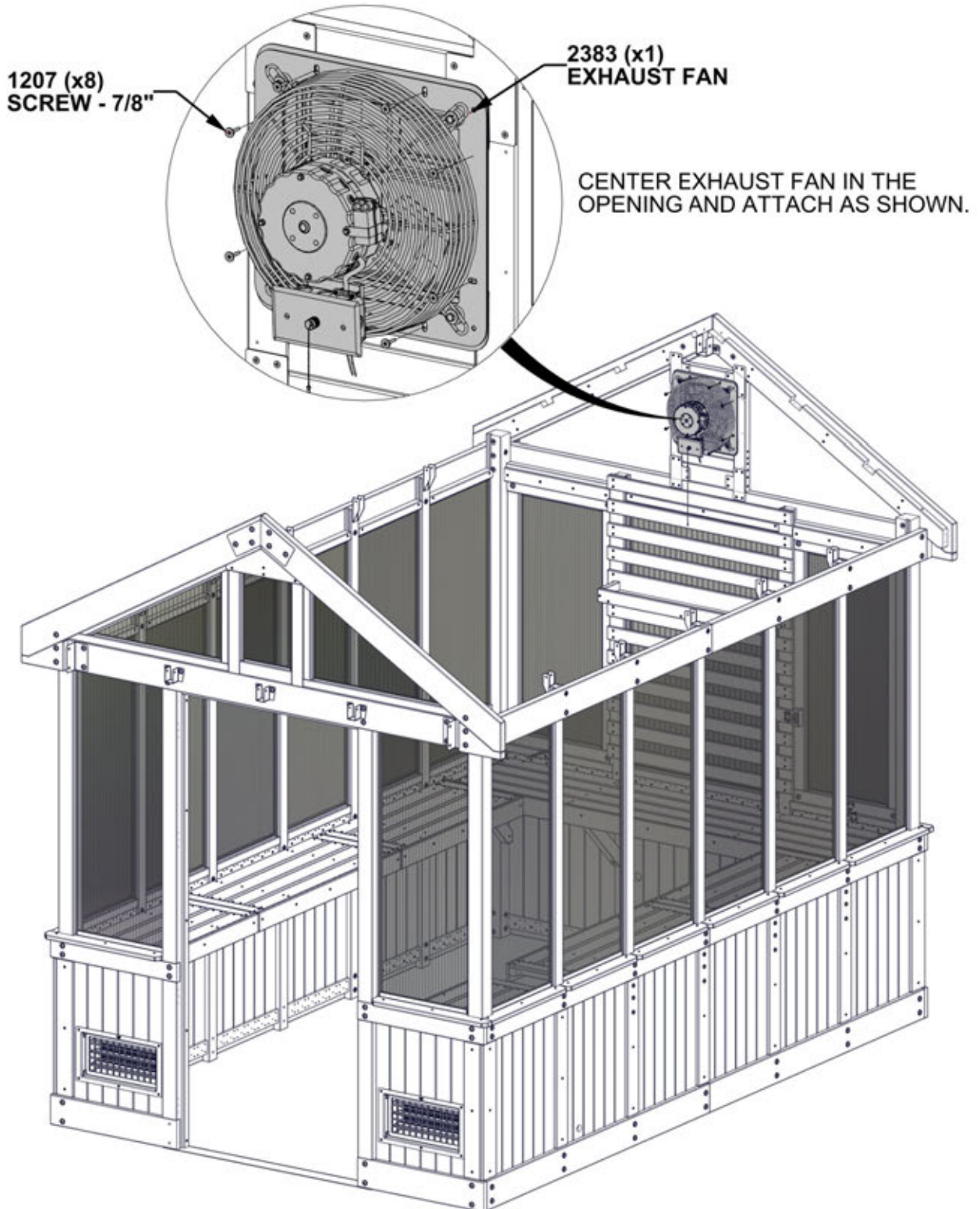


STEP 107 - FAN ASSEMBLY

QTY	PART NUMBER	DESCRIPTION
8	H101207	SCREW PWH 8x15x7/8 BLK



A4M02383 EXHAUST FAN
(x1)



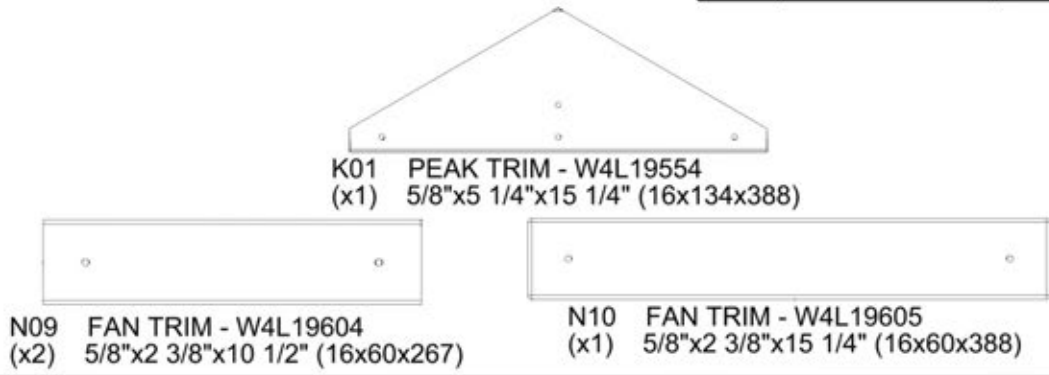
1207 (x8)
SCREW - 7/8"

2383 (x1)
EXHAUST FAN

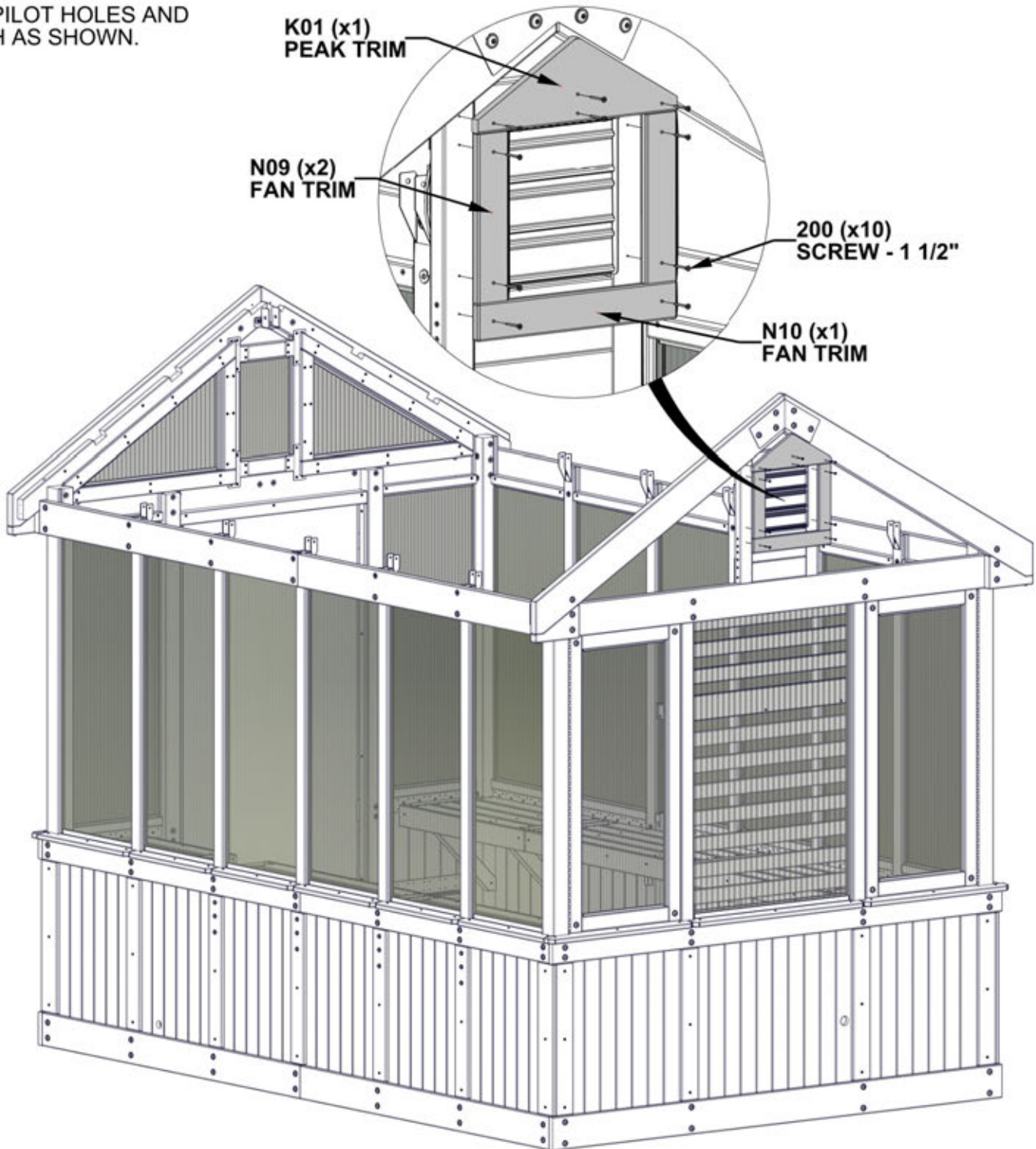
CENTER EXHAUST FAN IN THE
OPENING AND ATTACH AS SHOWN.

STEP 109 - GABLE ASSEMBLY

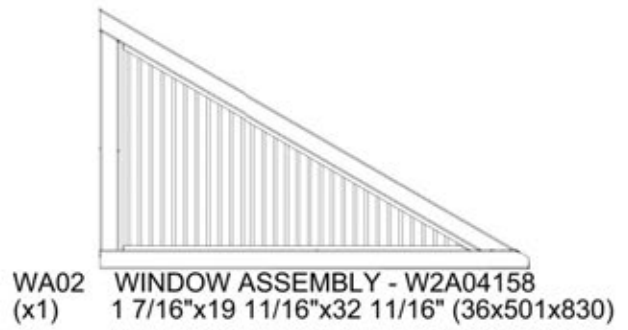
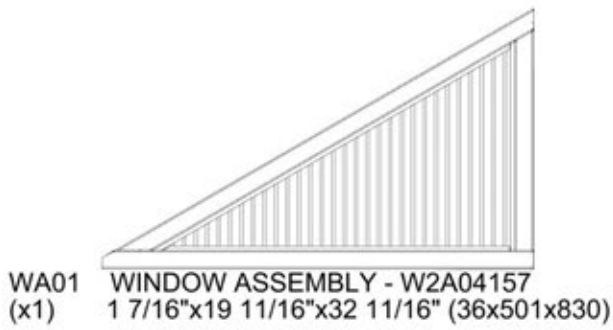
QTY	PART NUMBER	DESCRIPTION
10	H100200	SCREW PFH 8x1 1/2 BLK



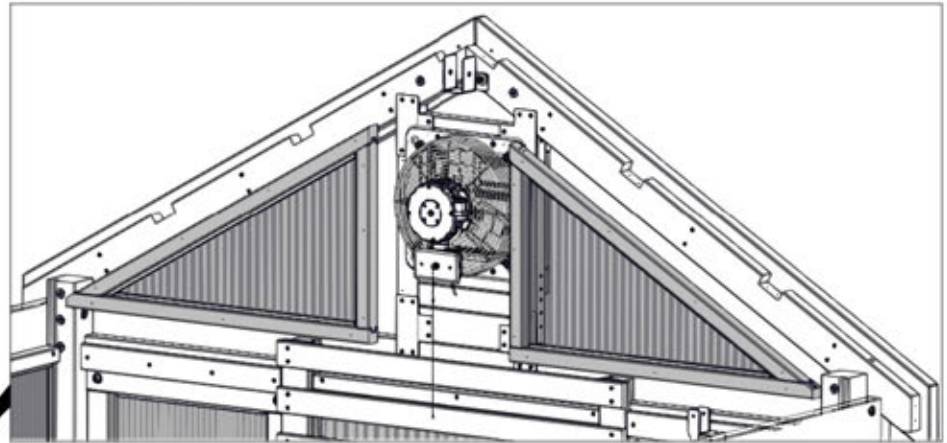
ALIGN PILOT HOLES AND ATTACH AS SHOWN.



STEP 109 - GABLE ASSEMBLY



SLIDE WINDOW ASSEMBLIES INTO OPENINGS UNTIL THEY CONTACT GABLE BOARDS.

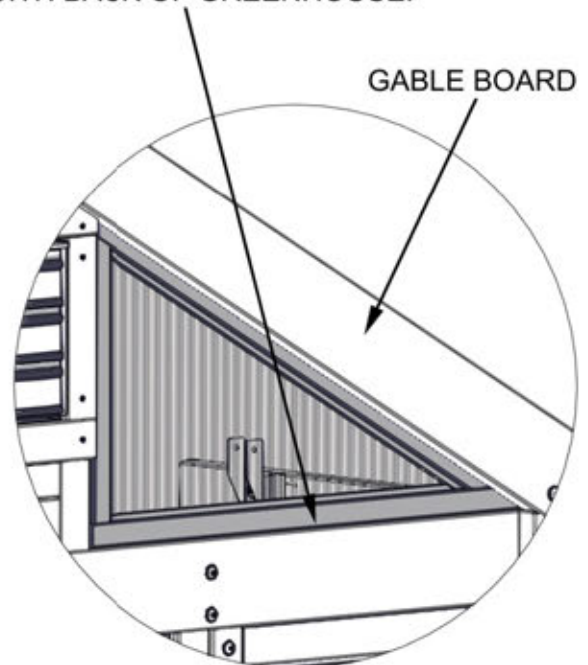
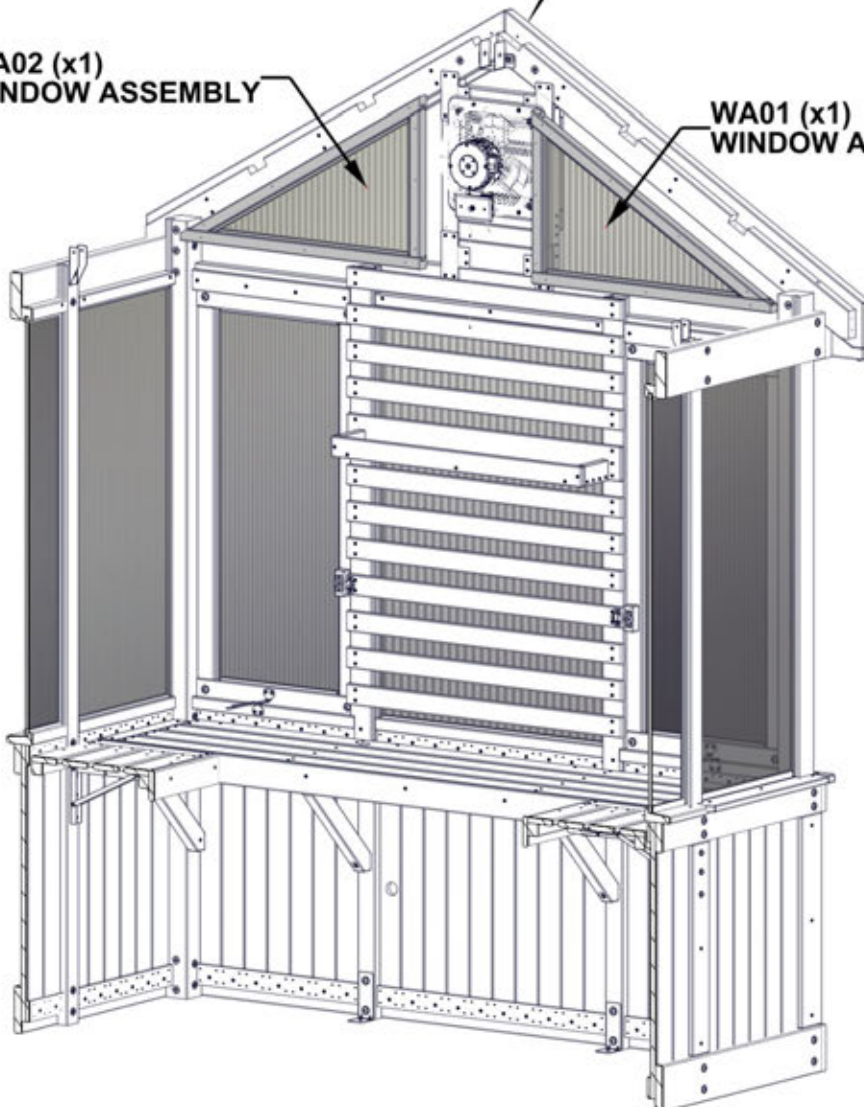


WA02 (x1)
WINDOW ASSEMBLY

WA01 (x1)
WINDOW ASSEMBLY

WINDOWS WILL BE FLUSH WITH BACK OF GREENHOUSE.

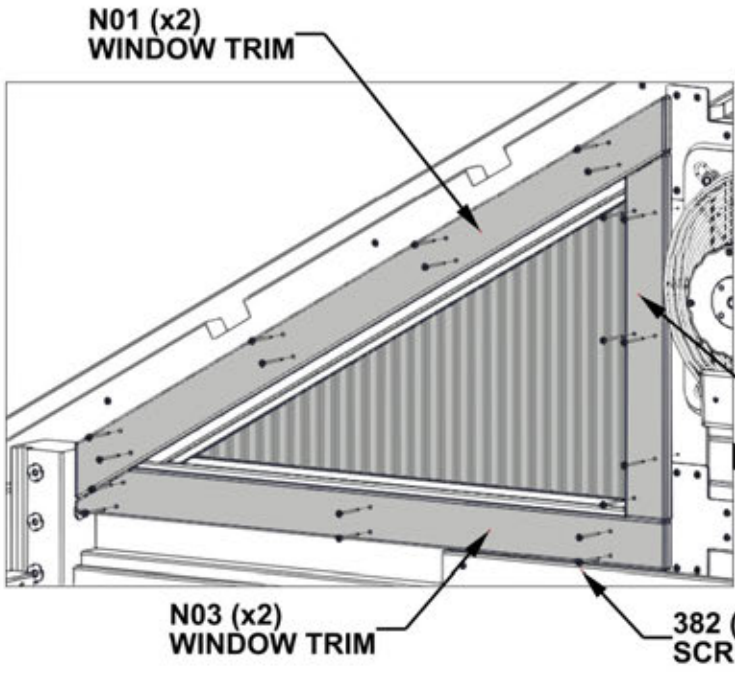
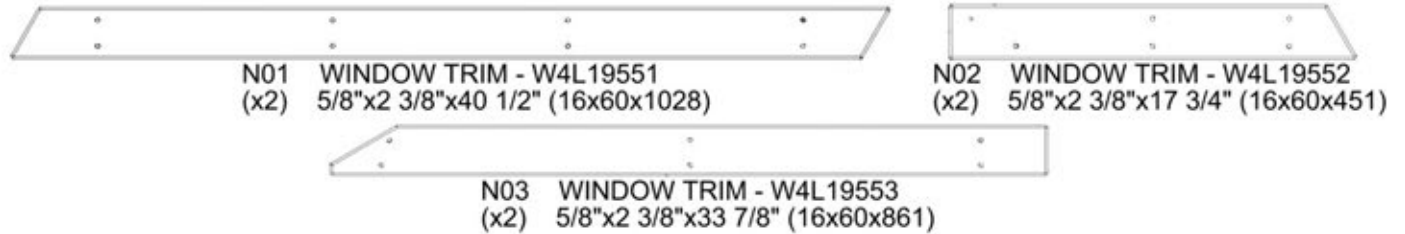
GABLE BOARD



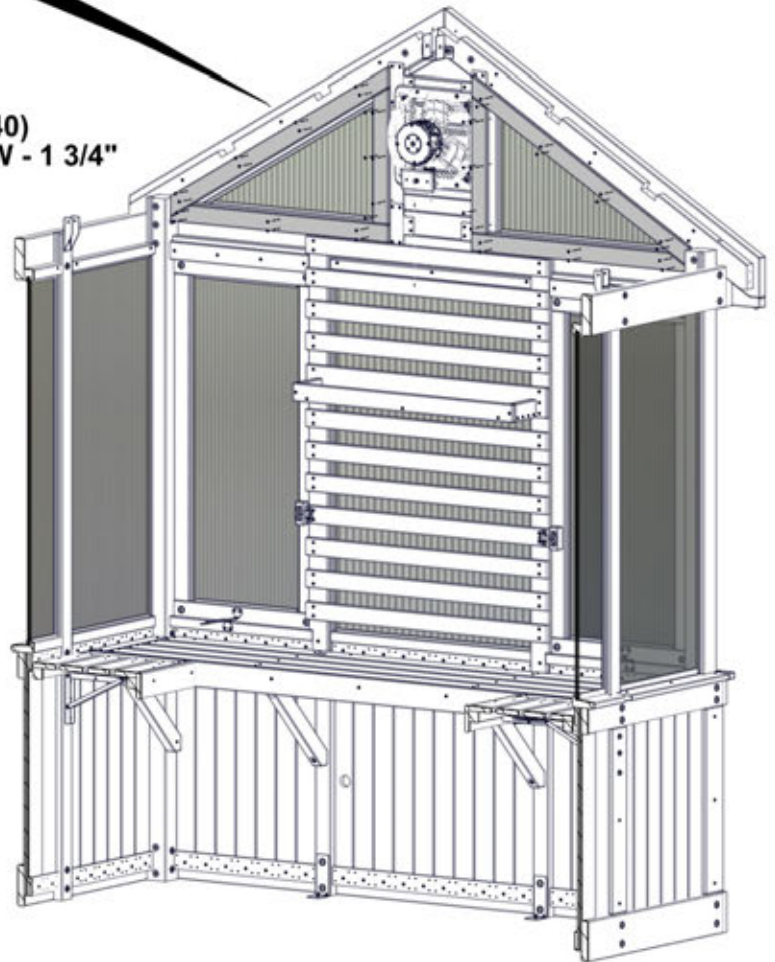
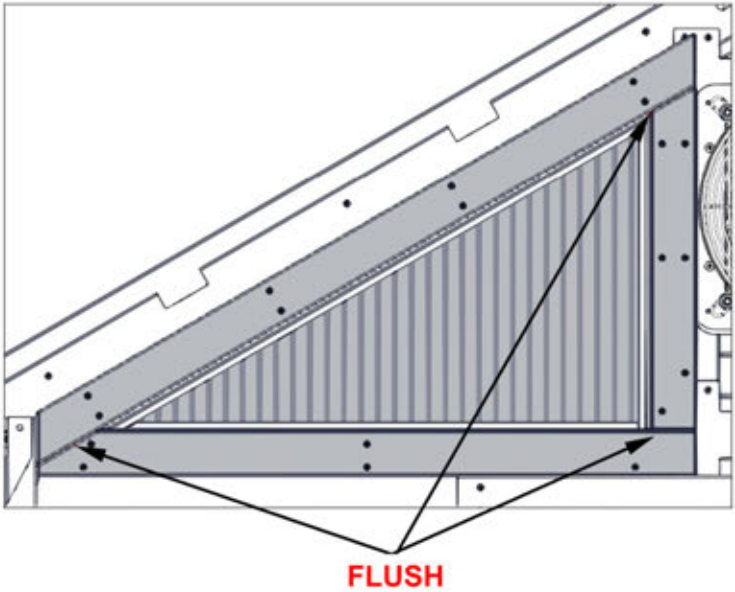
OUTSIDE VIEW

STEP 111 - GABLE ASSEMBLY

QTY	PART NUMBER	DESCRIPTION
40	H100382	SCREW PFH 8x1 3/4 BLK



- INSTALL N02 BOARDS FIRST BY ALIGNING THROUGH HOLES IN BOARD WITH PILOT HOLES IN WINDOW ASSEMBLY AND WINDOW FRAME.
- REMAINING BOARDS BUTT UP AGAINST N02 AND ARE FLUSH ON THE OUTSIDE AS SHOWN.
- ALIGN HOLES ON N01 AND N03 WITH PILOT HOLES IN WINDOW AND ATTACH.
- USE AN 1/8" [3mm] DRILL BIT WITH N01 AND N03 AS GUIDES TO DRILL PILOT HOLES.
- ATTACH WITH REMAINING HARDWARE.



STEP 112 - ROOF ASSEMBLY

QTY	PART NUMBER	DESCRIPTION
10	H100391	SCREW PFH 8x2 BLK

E11 RAFTER - W4L19606
(x3) 1 7/16"x3 3/8"x55 7/16" (36x86x1408)

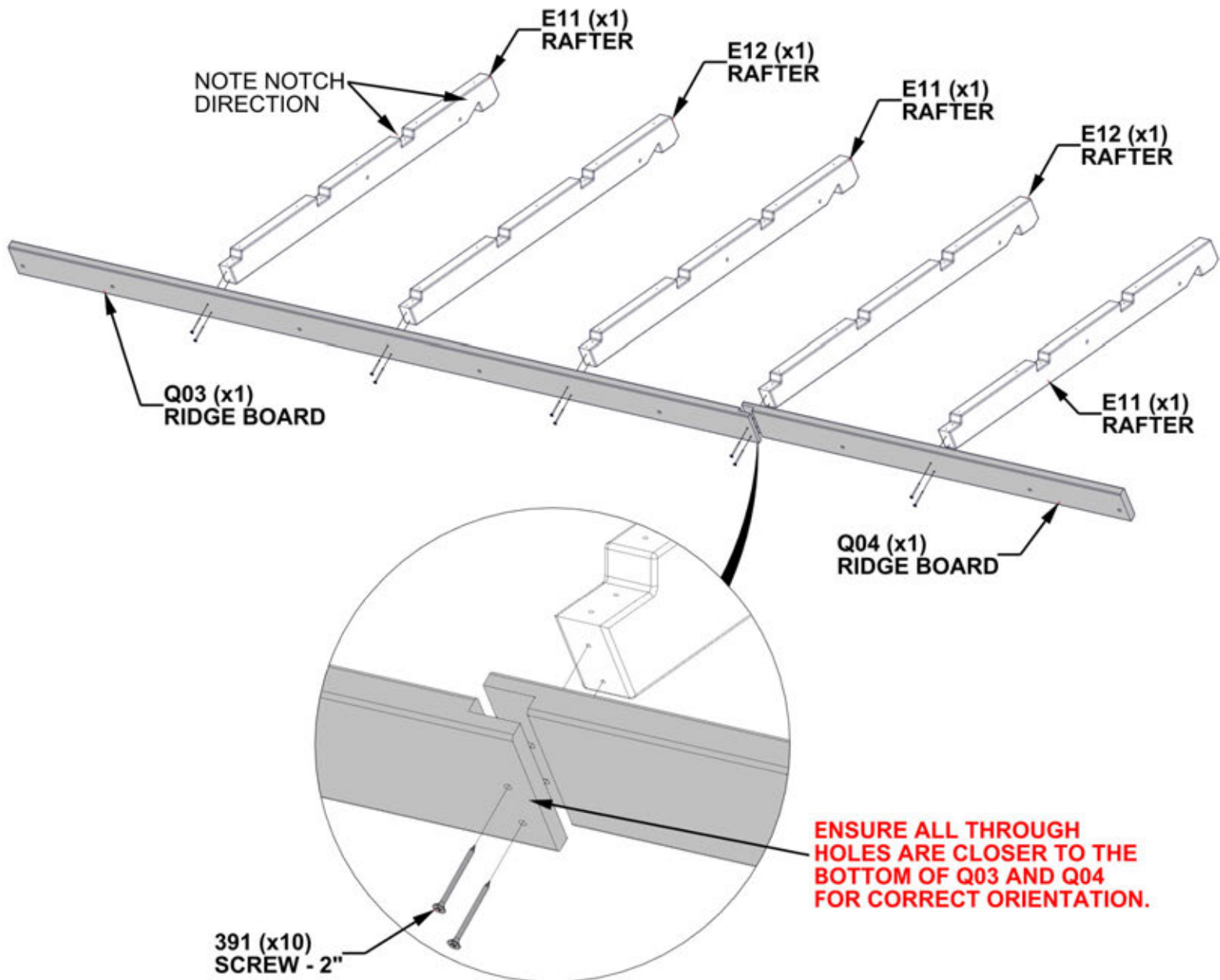
E12 RAFTER - W4L19609
(x2) 1 7/16"x3 3/8"x55 7/16" (36x86x1408)

Q03 RIDGE BOARD - W4L19607
(x1) 15/16"x4 7/16"x87 13/16" (24x112x2230)

Q04 RIDGE BOARD - W4L19608
(x1) 15/16"x4 7/16"x45 1/8" (24x112x1146)

IMPORTANT!

NOTE ALL NOTCH DIRECTIONS AND BOARD PLACEMENT FOR CORRECT ASSEMBLY.



STEP 113 - ROOF ASSEMBLY

QTY	PART NUMBER	DESCRIPTION
5	H100200	SCREW PFH 8x1 1/2 BLK
25	H100391	SCREW PFH 8x2 BLK

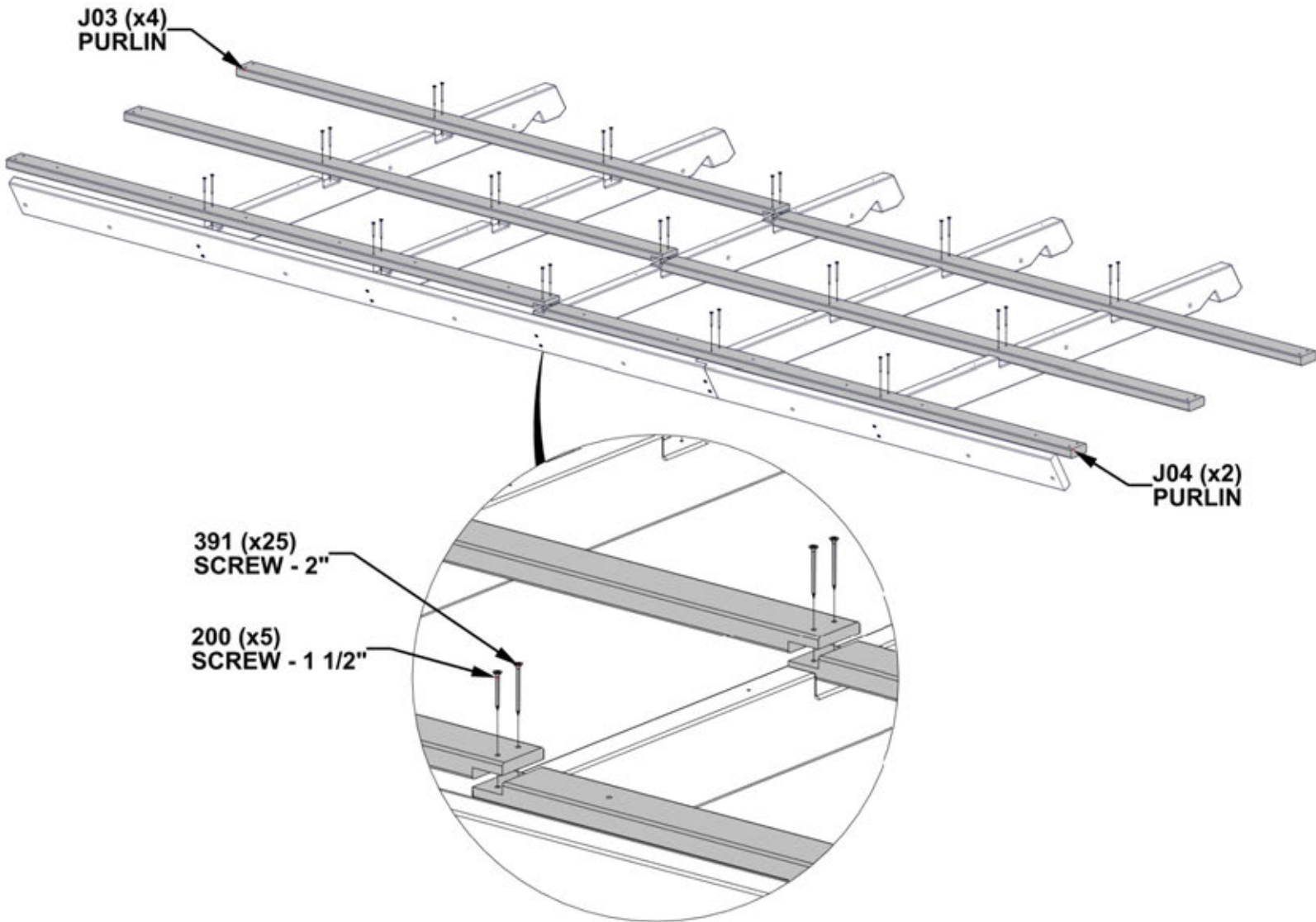


J03 PURLIN - W4L19610
(x4) 24x2 3/8"x67 15/16" (24x60x1725)



J04 PURLIN - W4L19611
(x2) 24x2 3/8"x67 15/16" (24x60x1725)

USE SHORTER SCREWS ON TOP ROW ONLY.

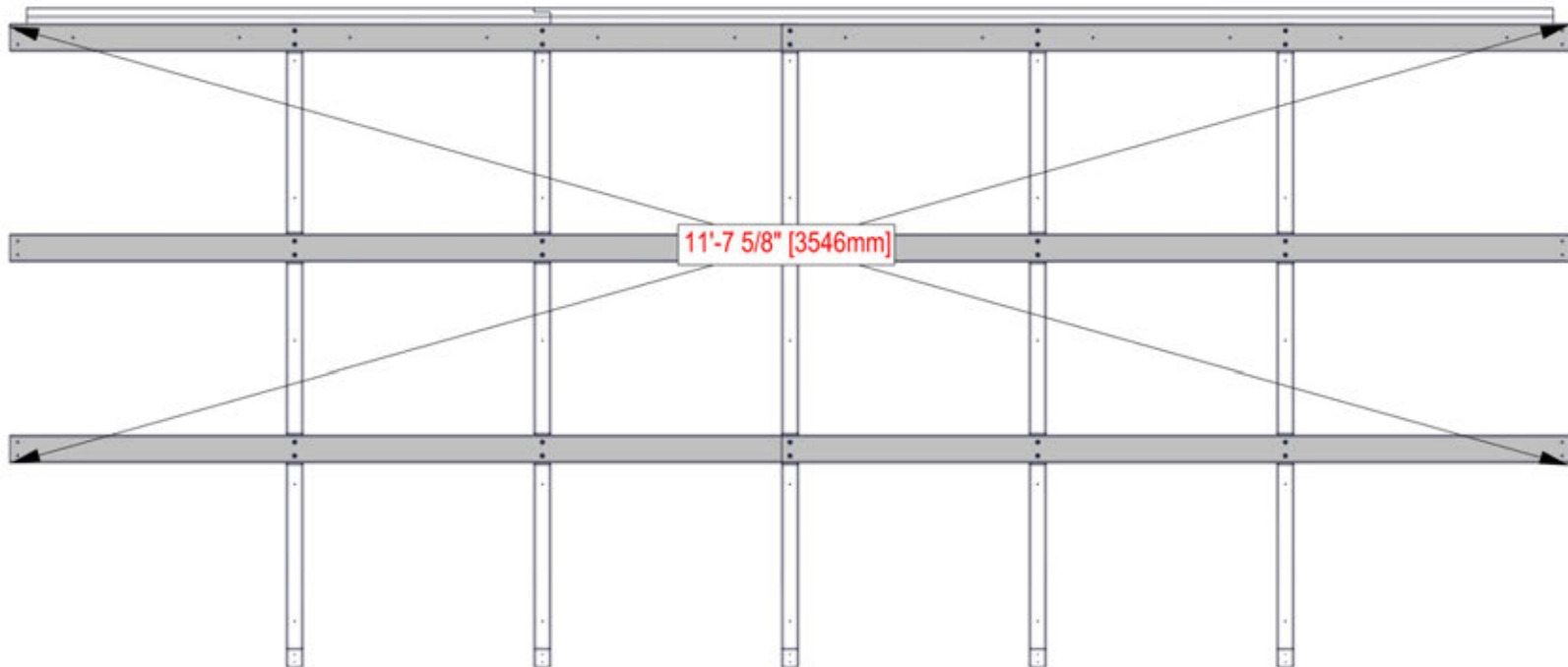


STEP 114 - ROOF ASSEMBLY

IMPORTANT!

BEFORE PROCEEDING:

- ENSURE UNIT IS SQUARE.
- THE BELOW DIMENSIONS ARE CRITICAL TO THE FINAL ROOF ASSEMBLY.
- MEASUREMENTS SHOULD BE HELD WITHIN +/- 1/4" [6mm].
- MEASUREMENTS OUTSIDE OF TOLERANCE WILL LEAD TO INABILITY TO ASSEMBLY THE ROOF.



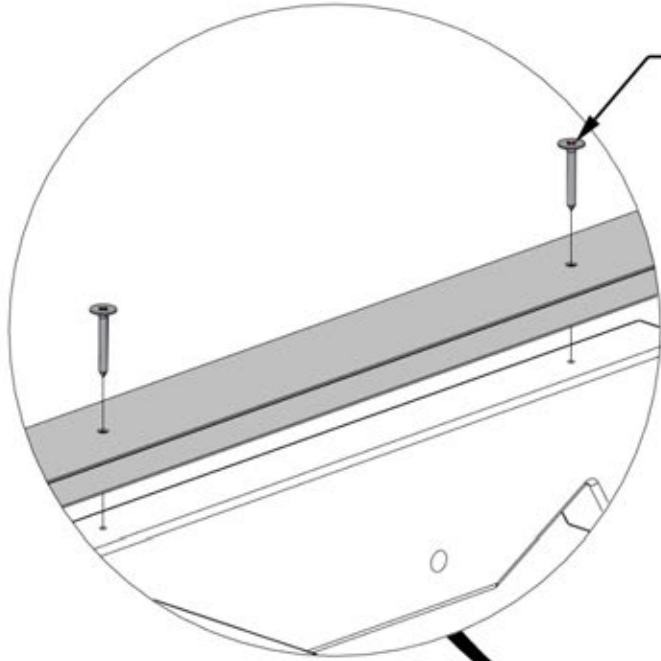
LOOSEN HARDWARE TO ADJUST FOR SQUARING IF NEEDED.

STEP 115 - ROOF ASSEMBLY

QTY	PART NUMBER	DESCRIPTION
25	H101203	SCREW PWH 8x15x1 1/4 BLK



A6P00902 POLY SHEET SPLICE
(x5)

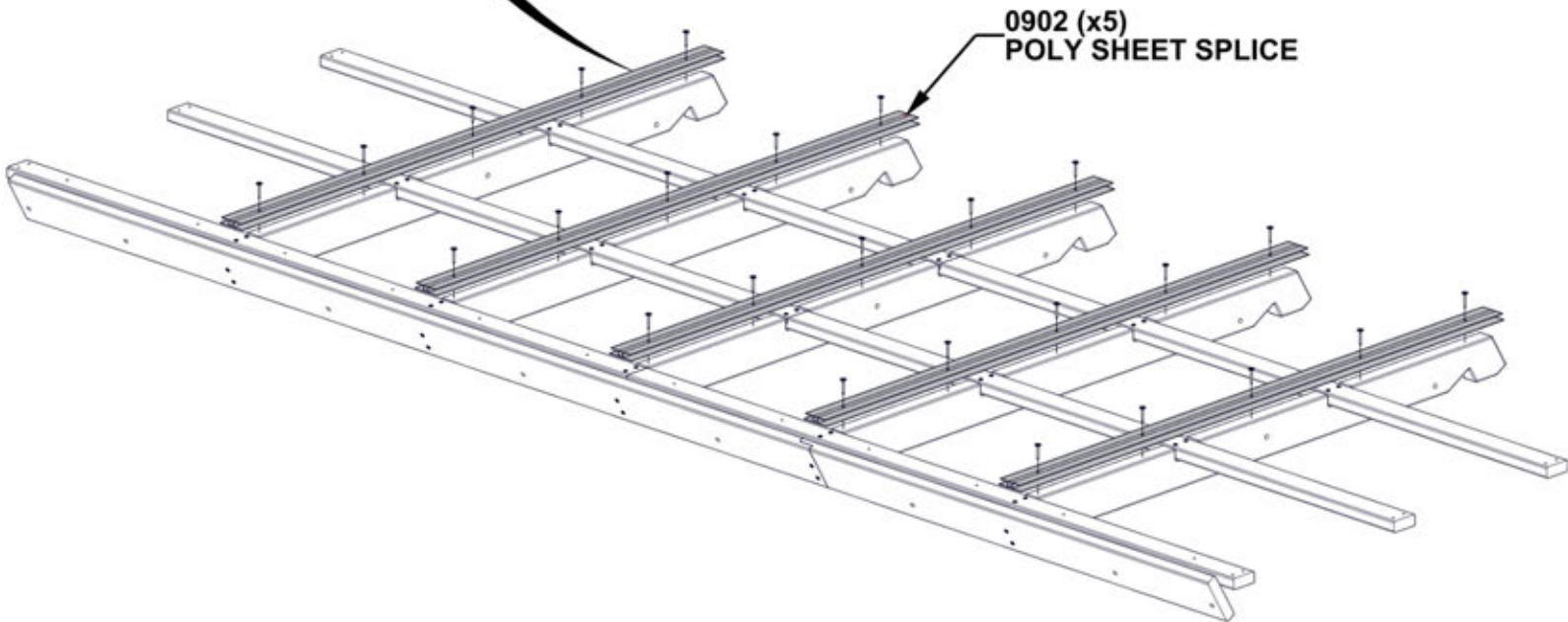


1203 (x25)
SCREW - 1 1/4"

**ENSURE THE NARROWER SIDE
OF POLY SPLICE FACES UP.**



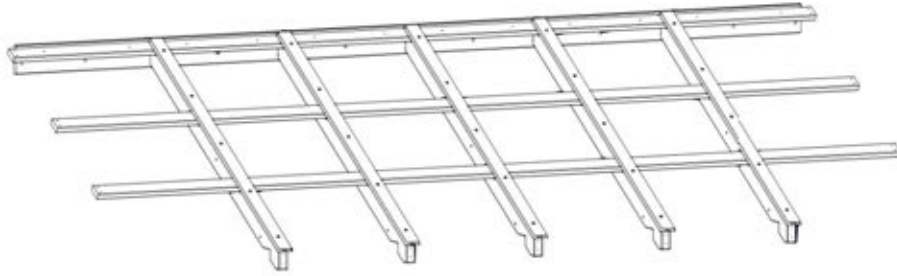
END VIEW OF POLY SPLICE



0902 (x5)
POLY SHEET SPLICE

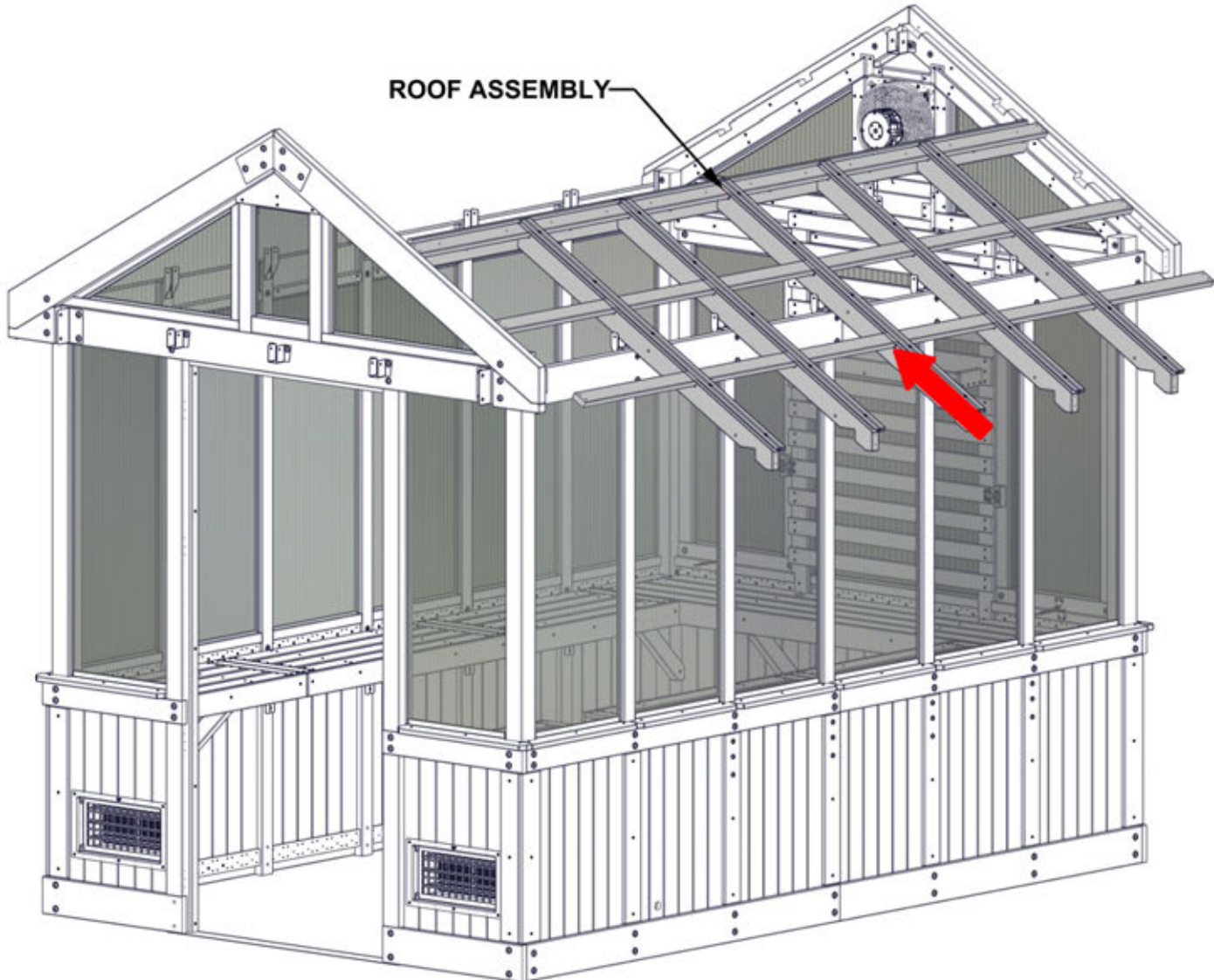
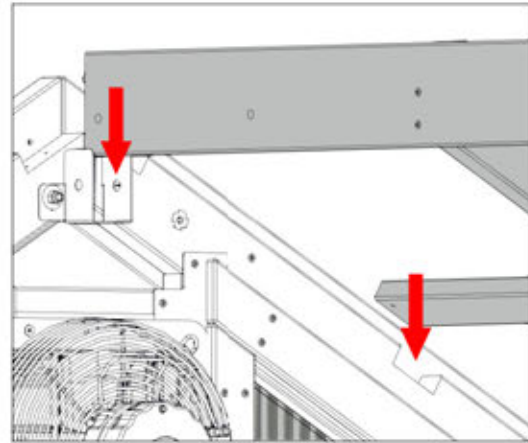
**REPEAT STEPS 112 THROUGH 115
FOR 2ND ROOF ASSEMBLY**

STEP 116 - ROOF ASSEMBLY



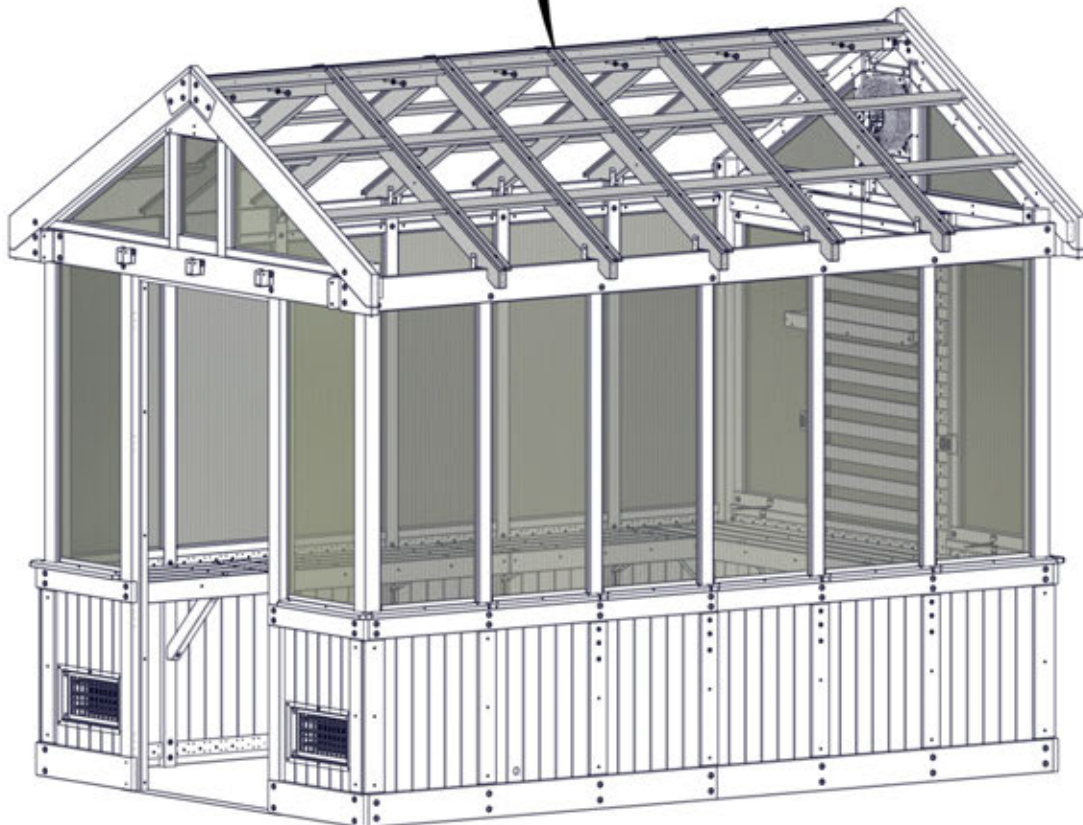
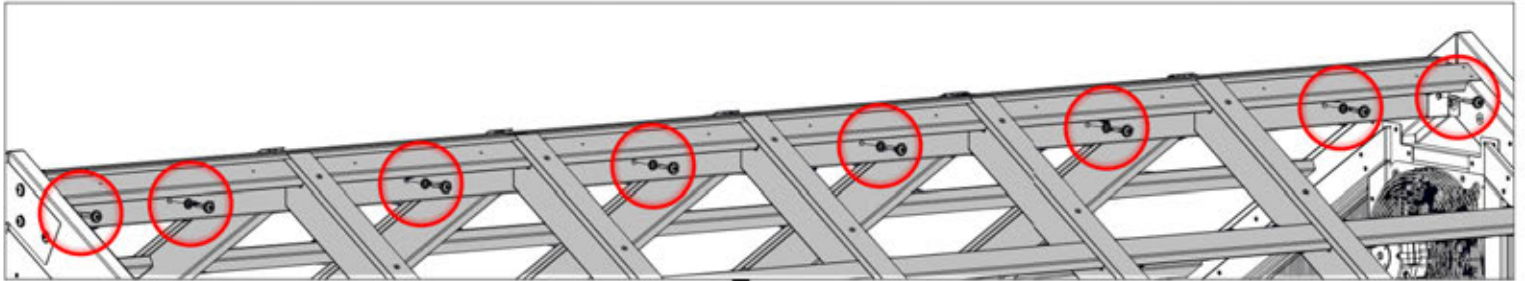
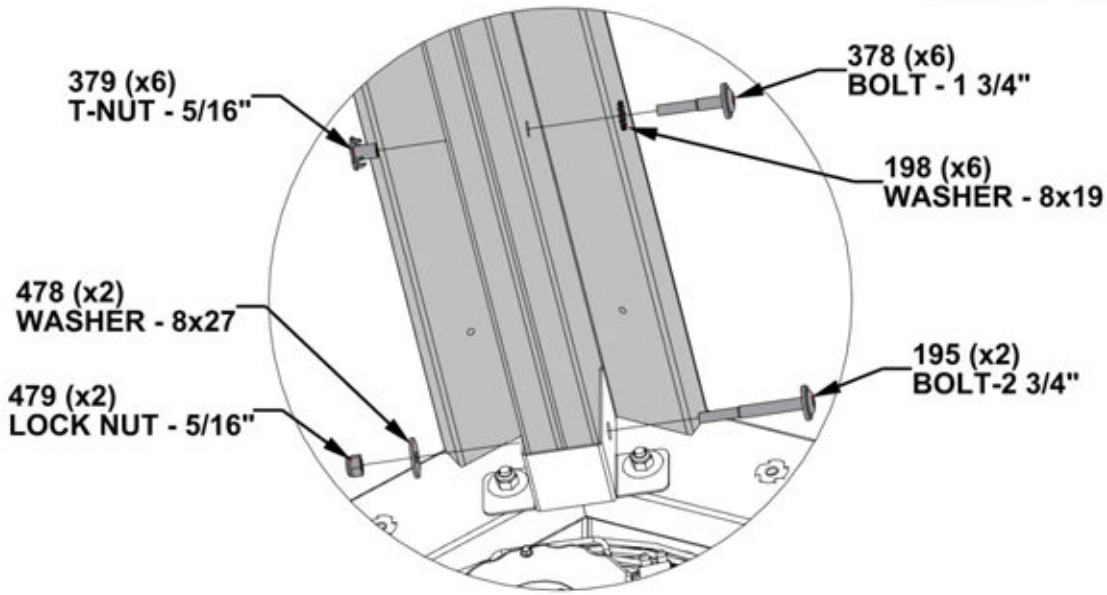
ROOF ASSEMBLY (x2) - FROM PREVIOUS STEPS

- TWO ADULTS REQUIRED FOR THIS STEP.
- PURLINS REST IN NOTCHES IN GABLE AS SHOWN.
- RIDGE RESTS IN BRACKETS AS SHOWN.
- **REPEAT THIS STEP FOR OTHER SIDE WITH SECOND ROOF ASSEMBLY.**



STEP 117 - ROOF ASSEMBLY

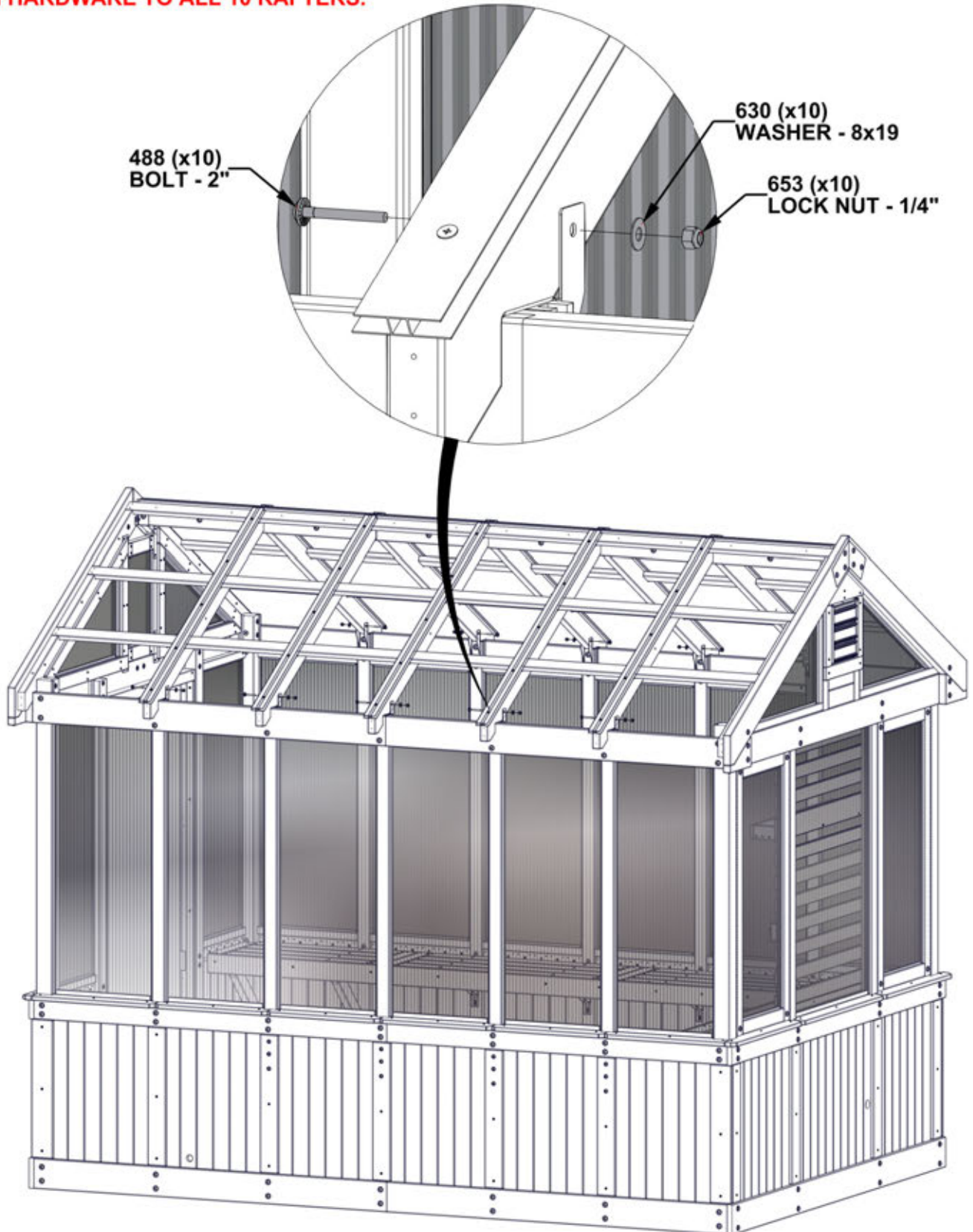
QTY	PART NUMBER	DESCRIPTION
2	H100195	BOLT WH 5/16x2 3/4 BLK
6	H100198	WASHER LOCK EXT 8x19
6	H100378	BOLT WH 5/16x1 3/4 BLK
6	H100379	T-NUT 5/16 BLK
2	H100478	WASHER FLAT 8x27 BLK
2	H100479	NUT LOCK 5/16 BLK



STEP 118 - ROOF ASSEMBLY

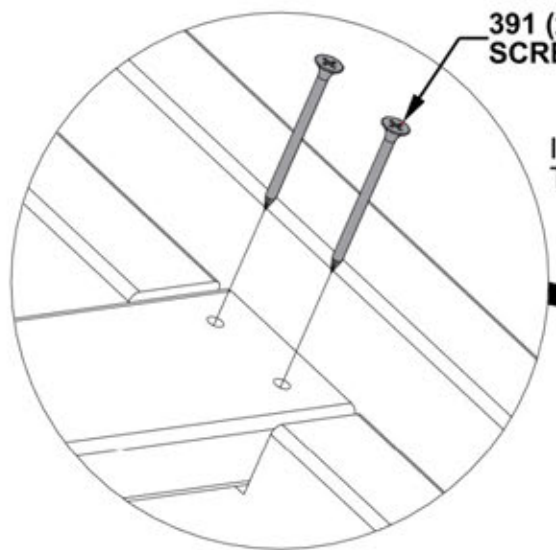
QTY	PART NUMBER	DESCRIPTION
10	H100488	BOLT WH 1/4x2 BLK
10	H100630	WASHER FLAT 8x19 BLK
10	H100653	NUT LOCK 1/4 BLK

ATTACH HARDWARE TO ALL 10 RAFTERS.



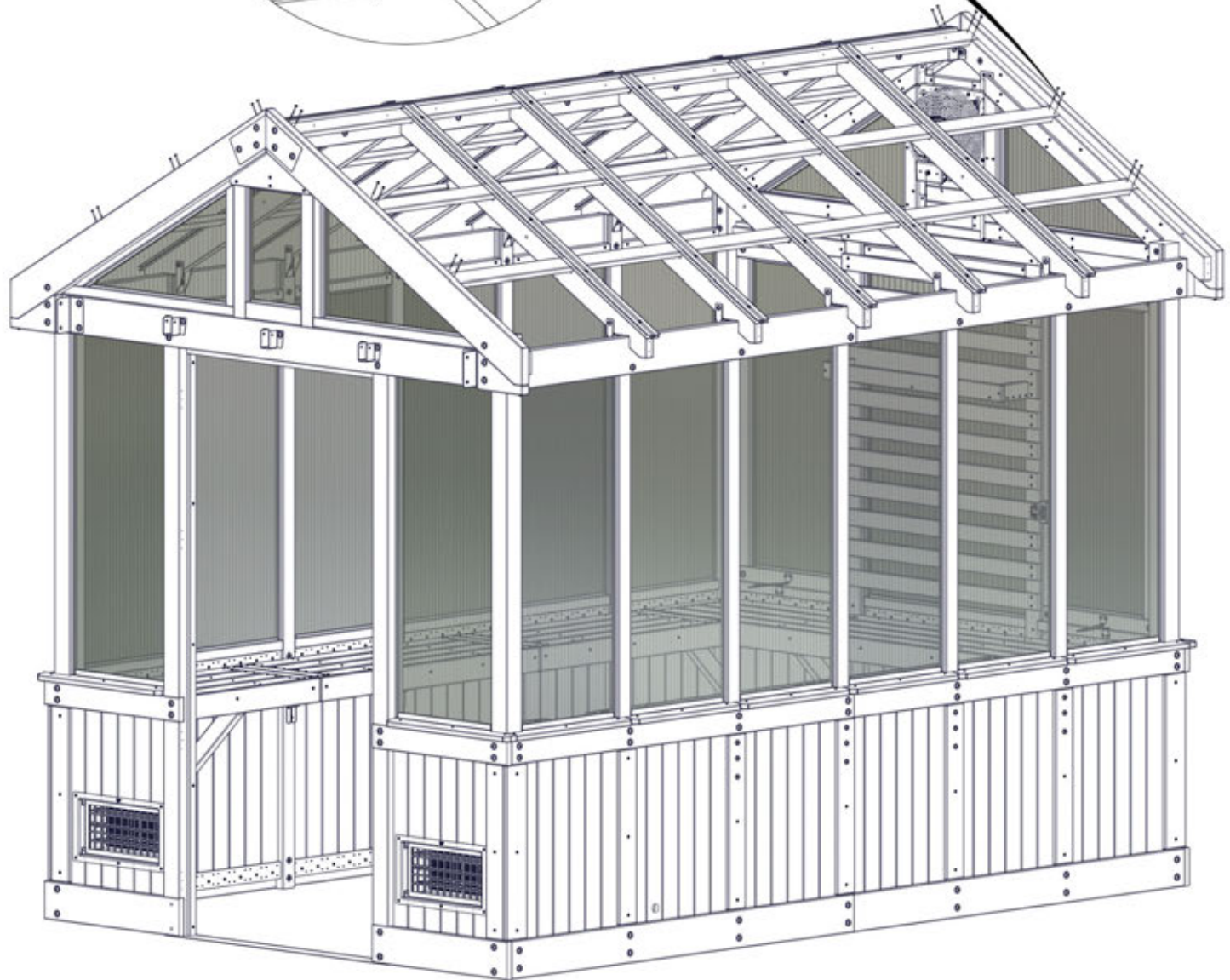
STEP 119 - ROOF ASSEMBLY

QTY	PART NUMBER	DESCRIPTION
24	H100391	SCREW PFH 8x2 BLK



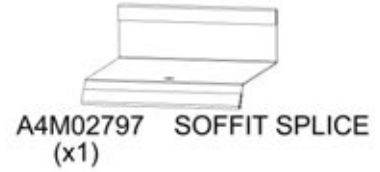
391 (x24)
SCREW - 2"

INSERT SCREWS IN PILOT HOLES AT THE ENDS OF ALL PURLINS AS SHOWN.



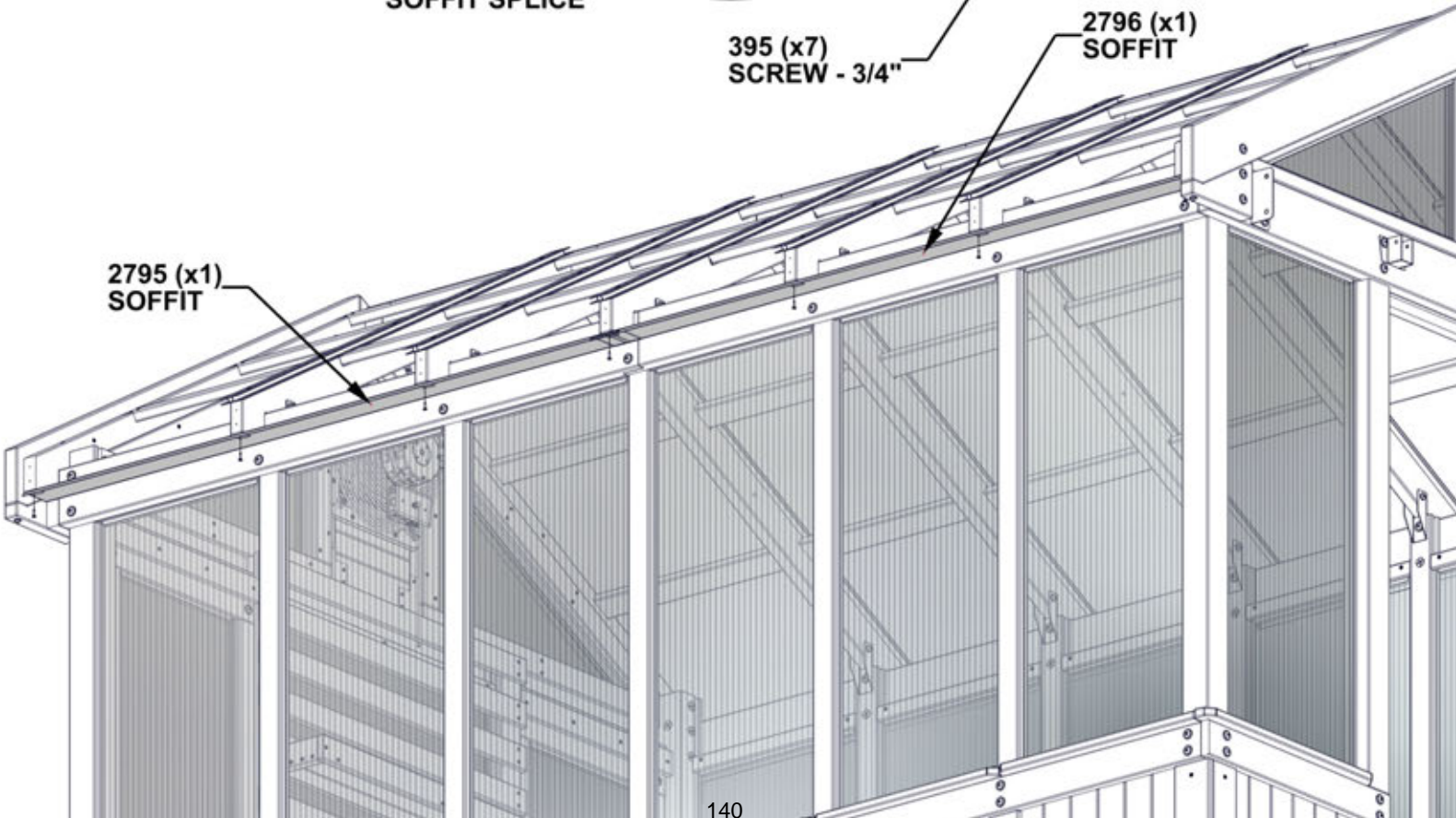
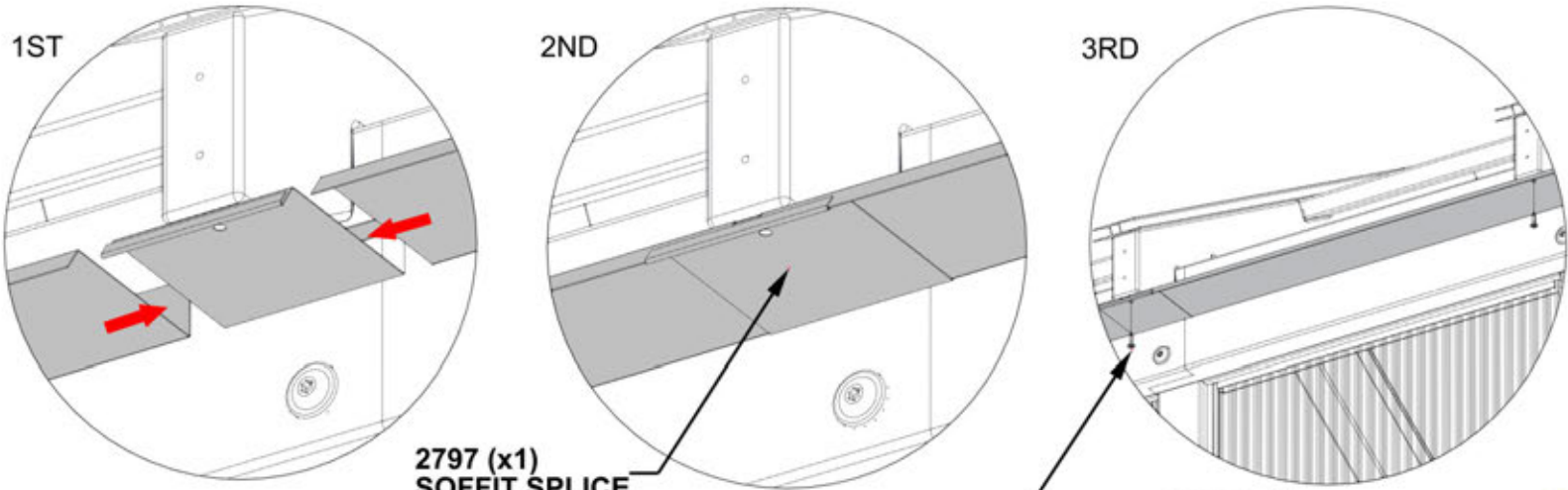
STEP 120 - ROOF ASSEMBLY

QTY	PART NUMBER	DESCRIPTION
7	H100395	SCREW PFH 8x3/4 BLK



WARNING: GLOVES ARE RECOMMENDED WHEN HANDLING STEEL.

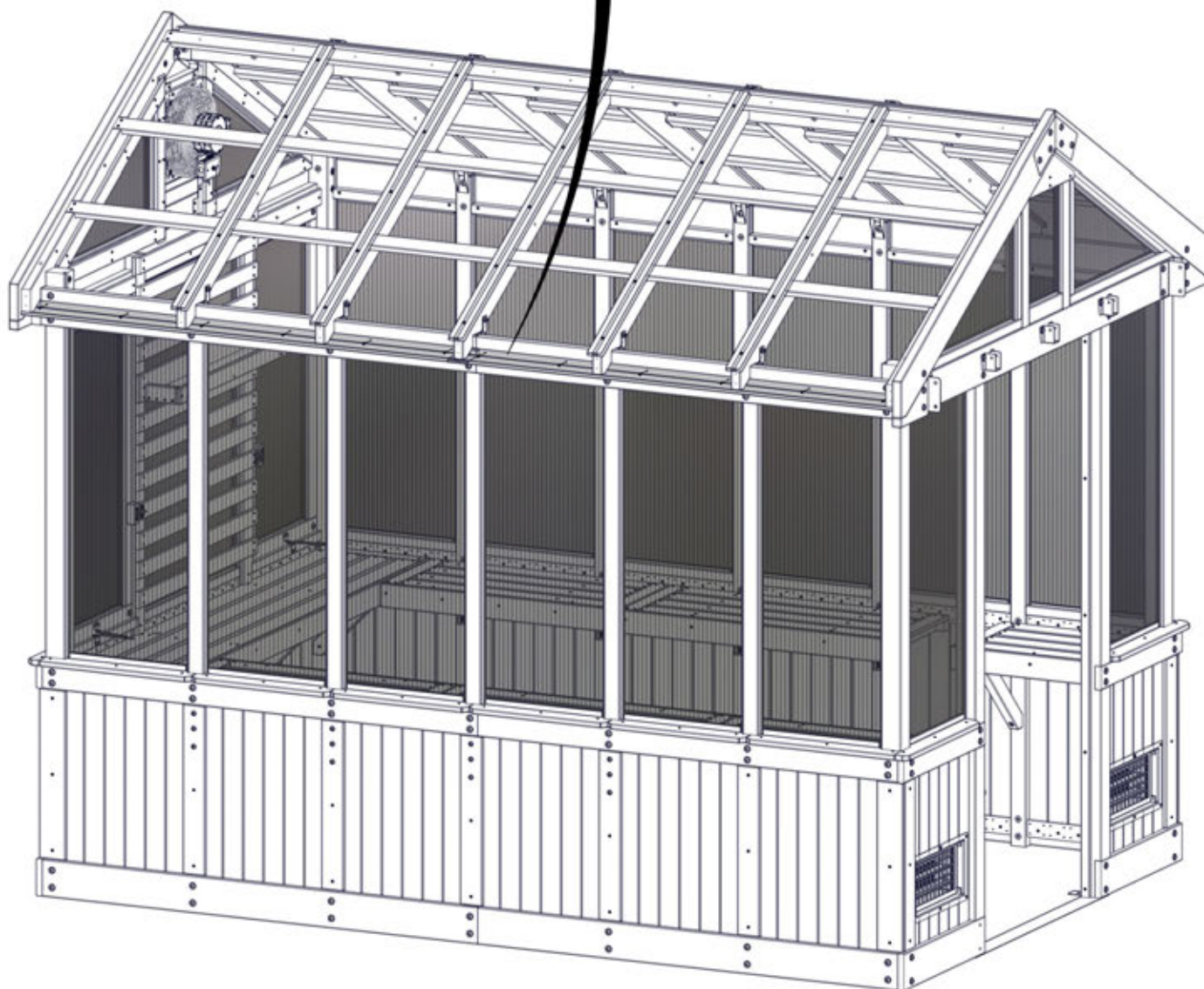
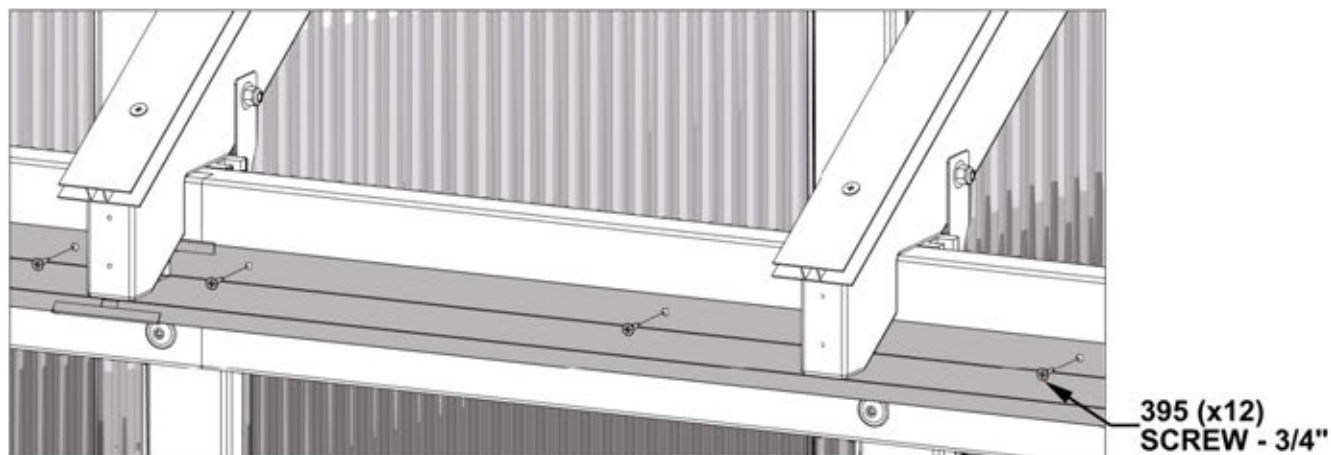
- REMOVE BLUE FILM FROM SOFFIT AND SOFFIT SPLICE.
- 90 DEGREE BEND ON SOFFIT BUTTS UP AGAINST HEADER AS SHOWN.
- SLIDE SOFFIT INTO SOFFIT SPLICE AS SHOWN.
- ENDS OF SOFFIT SHOULD BE FLUSH WITH GABLE END.
- ATTACH WITH SCREWS AS SHOWN.



STEP 121 - ROOF ASSEMBLY

QTY	PART NUMBER	DESCRIPTION
12	H100395	SCREW PFH 8x3/4 BLK

ATTACH SOFFIT WITH SCREWS USING THROUGH HOLES IN SOFFIT AS SHOWN.



STEP 122 - ROOF ASSEMBLY

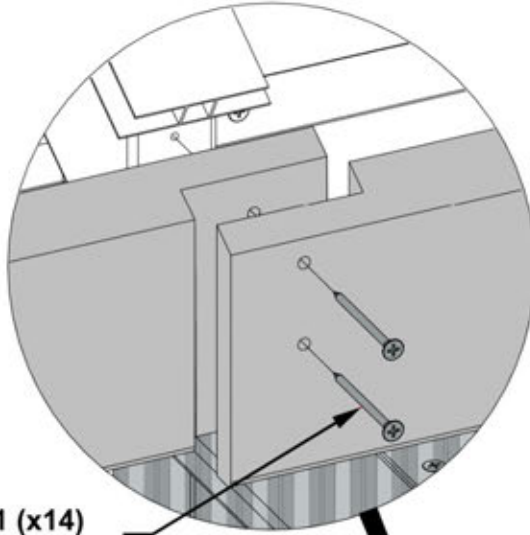
QTY	PART NUMBER	DESCRIPTION
14	H100391	SCREW PFH 8x2 BLK



Q01 FASCIA - W4L19602
(x1) 15/16"x4 7/16"x68 7/16" (24x112x1738)



Q02 FASCIA - W4L19603
(x1) 15/16"x4 7/16"x68 7/16" (24x112x1738)

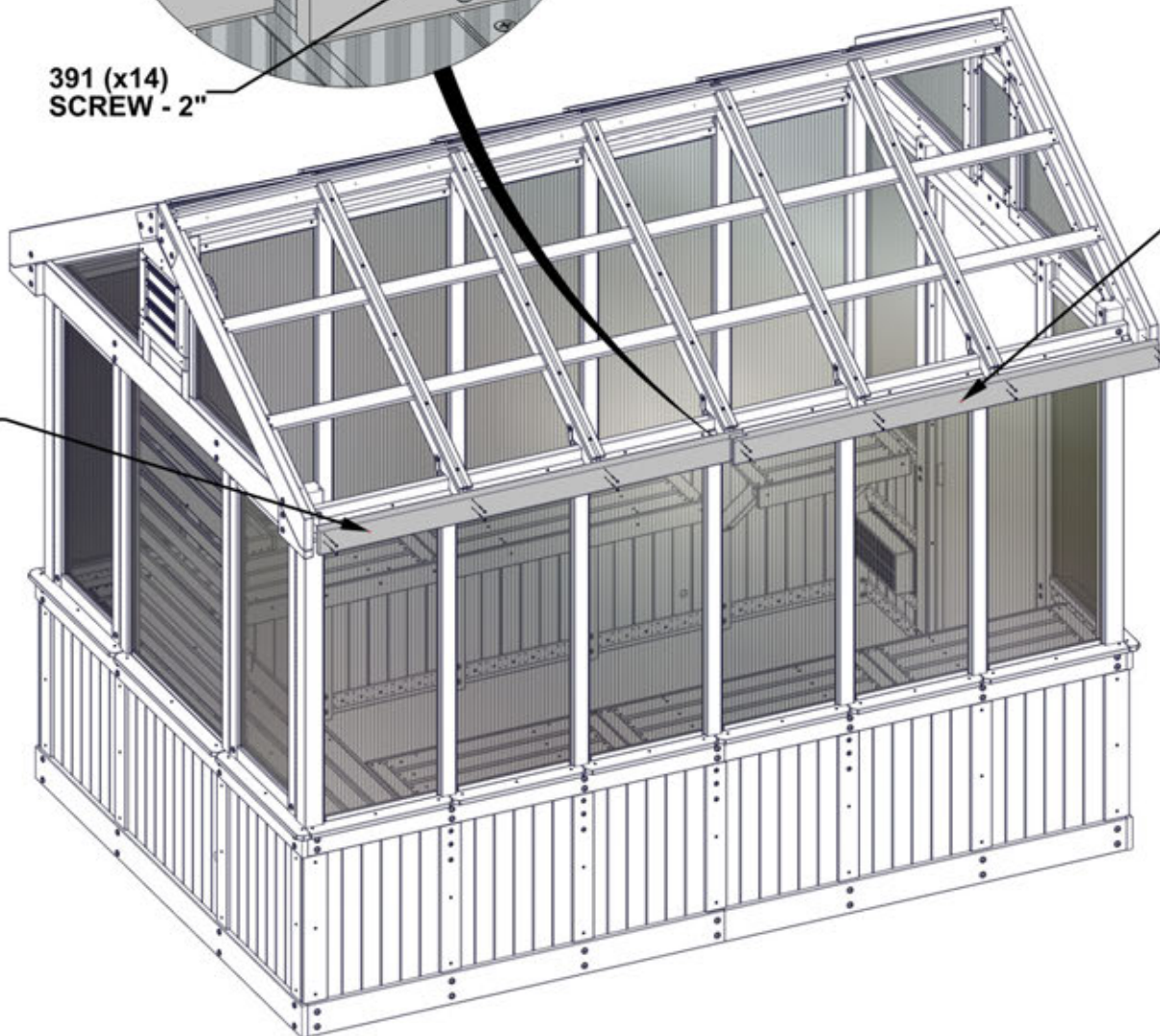


ATTACH FASCIA ALIGNING THROUGH HOLES WITH PILOT HOLES IN ENDS OF RAFTERS AS SHOWN.

391 (x14)
SCREW - 2"

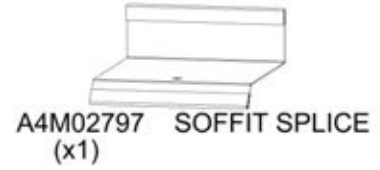
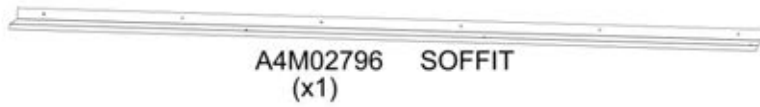
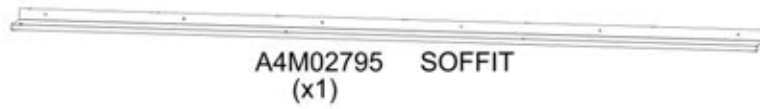
Q02 (x1)
FASCIA

Q01 (x1)
FASCIA



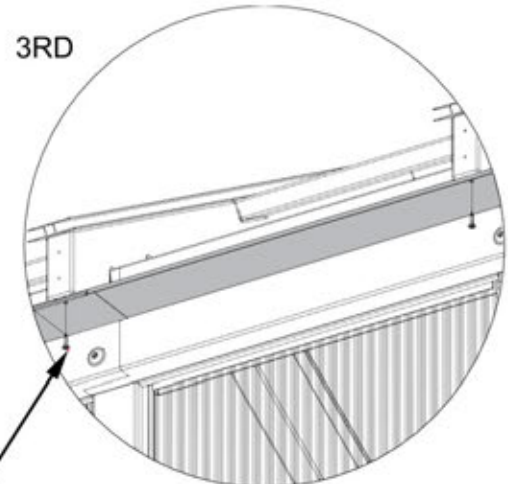
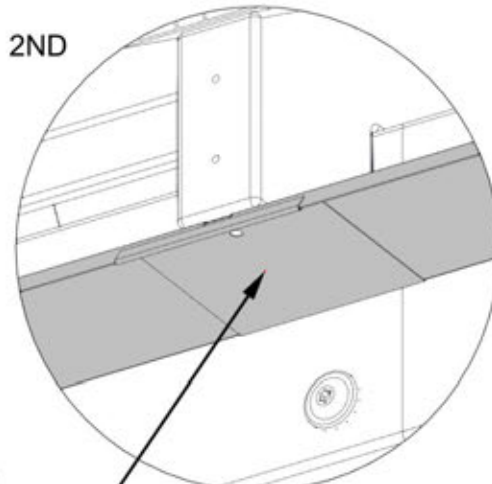
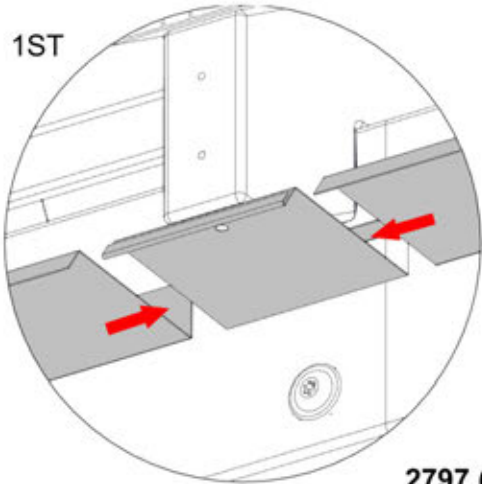
STEP 123 - ROOF ASSEMBLY

QTY	PART NUMBER	DESCRIPTION
7	H100395	SCREW PFH 8x3/4 BLK



WARNING: GLOVES ARE RECOMMENDED WHEN HANDLING STEEL.

- REMOVE BLUE FILM FROM SOFFIT AND SOFFIT SPLICE.
- 90 DEGREE BEND ON SOFFIT BUTTS UP AGAINST HEADER AS SHOWN.
- SLIDE SOFFIT INTO SOFFIT SPLICE AS SHOWN.
- ENDS OF SOFFIT SHOULD BE FLUSH WITH GABLE END.
- ATTACH WITH SCREWS AS SHOWN.

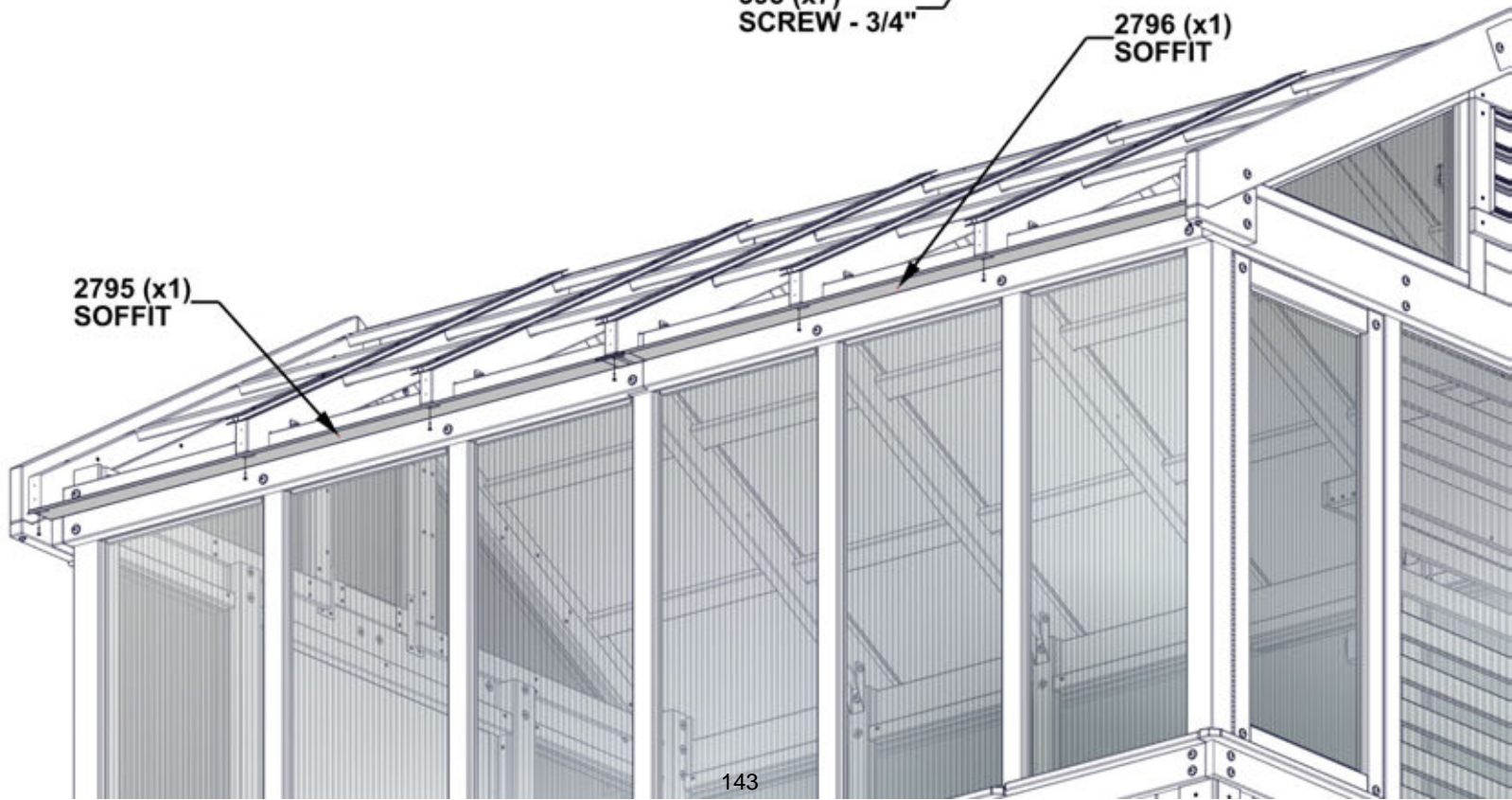


2797 (x1)
SOFFIT SPLICE

395 (x7)
SCREW - 3/4"

2796 (x1)
SOFFIT

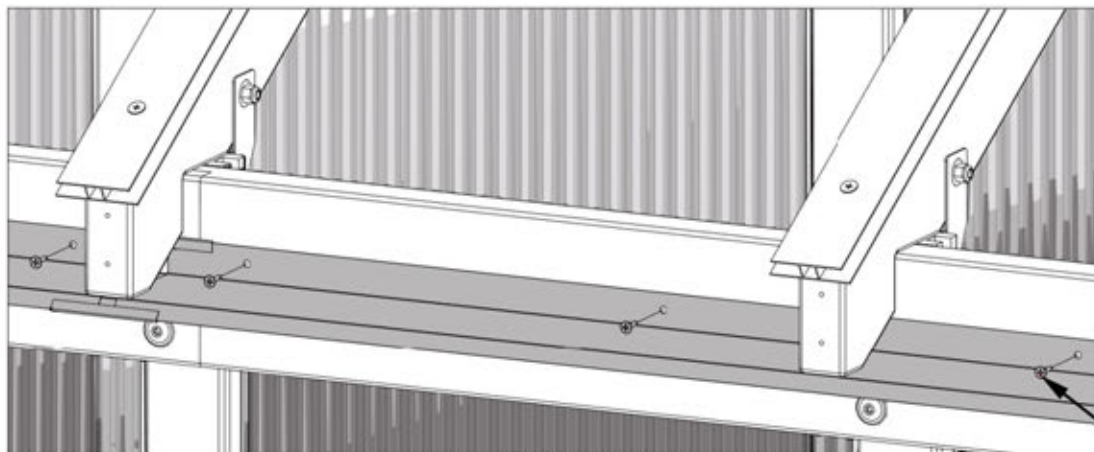
2795 (x1)
SOFFIT



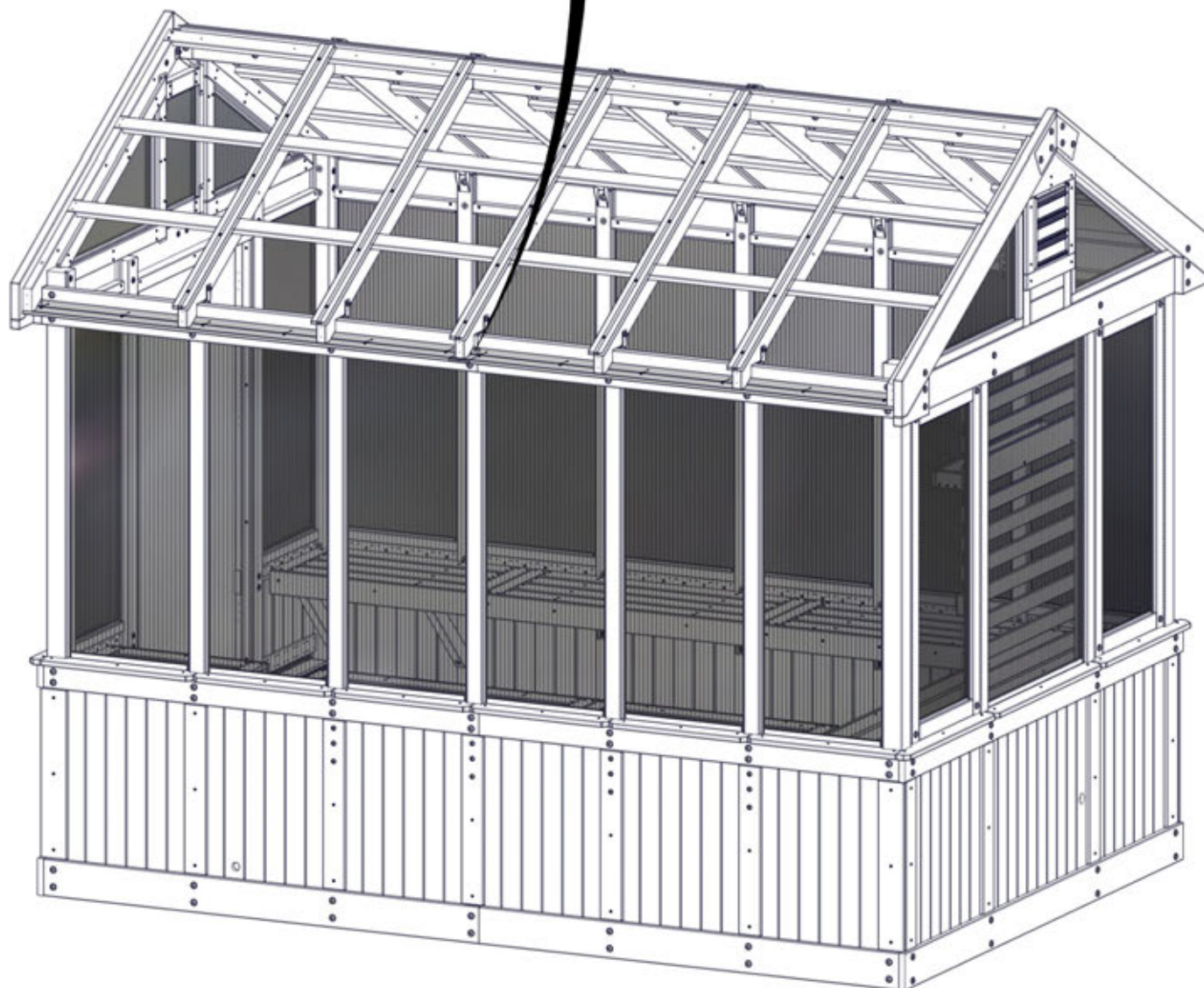
STEP 124 - ROOF ASSEMBLY

QTY	PART NUMBER	DESCRIPTION
12	H100395	SCREW PFH 8x3/4 BLK

ATTACH SOFFIT WITH SCREWS USING THROUGH HOLES IN SOFFIT AS SHOWN.



395 (x12)
SCREW - 3/4"



STEP 125 - ROOF ASSEMBLY

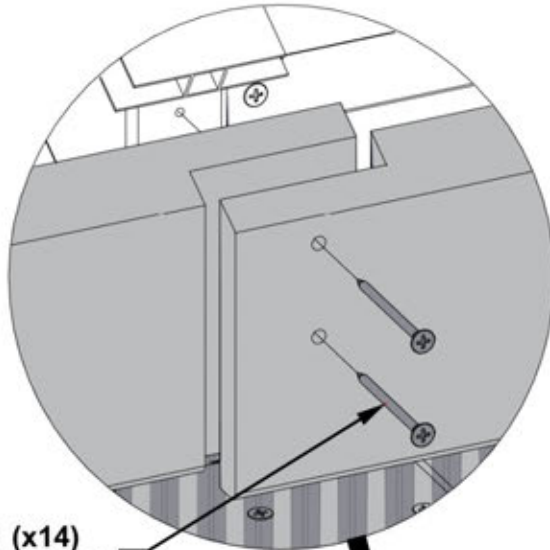
QTY	PART NUMBER	DESCRIPTION
14	H100391	SCREW PFH 8x2 BLK



Q01 FASCIA - W4L19602
(x1) 15/16"x4 7/16"x68 7/16" (24x112x1738)



Q02 FASCIA - W4L19603
(x1) 15/16"x4 7/16"x68 7/16" (24x112x1738)

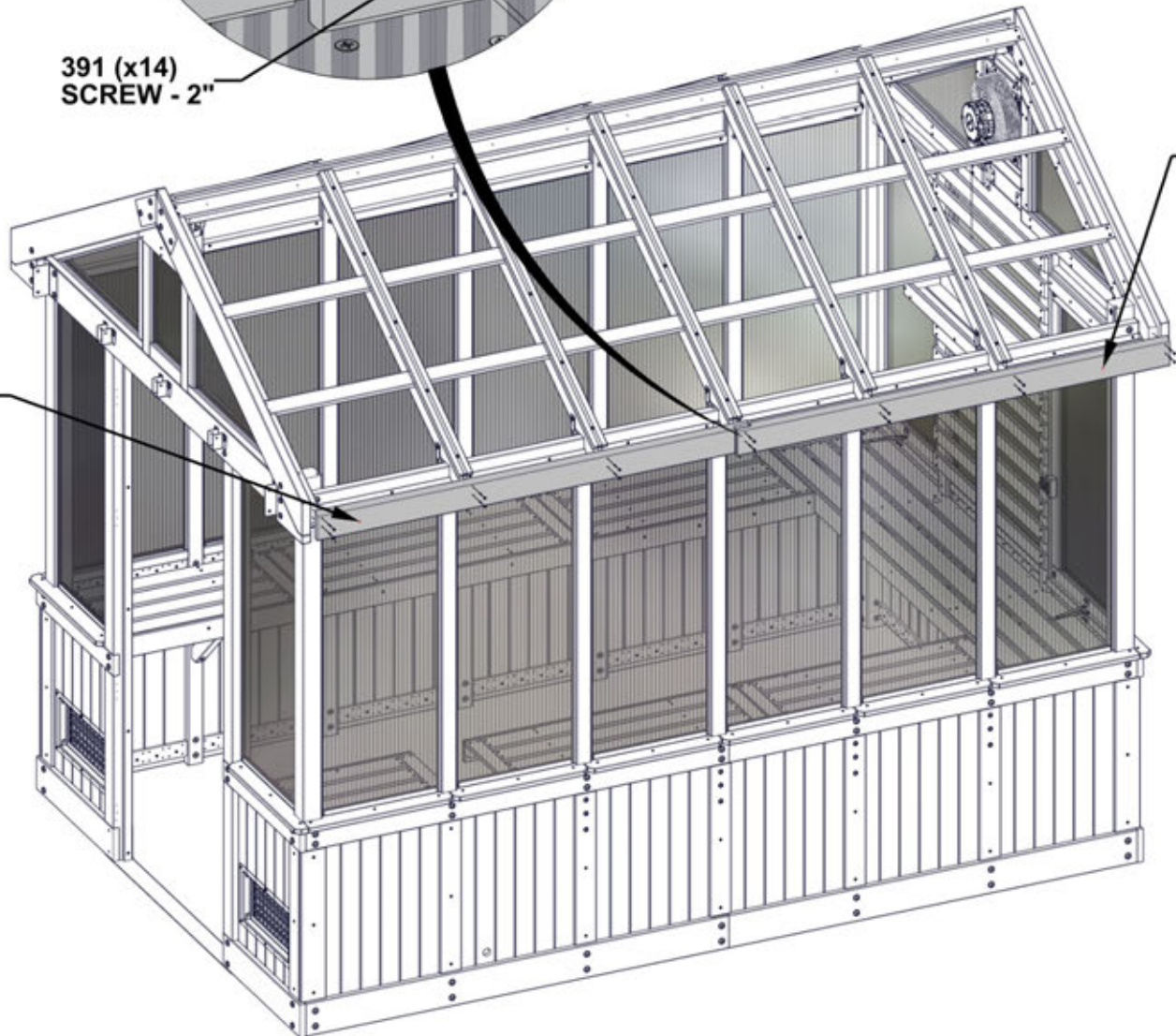


ATTACH FASCIA ALIGNING THROUGH HOLES WITH PILOT HOLES IN ENDS OF RAFTERS AS SHOWN.

391 (x14)
SCREW - 2"

Q01 (x1)
FASCIA

Q02 (x1)
FASCIA



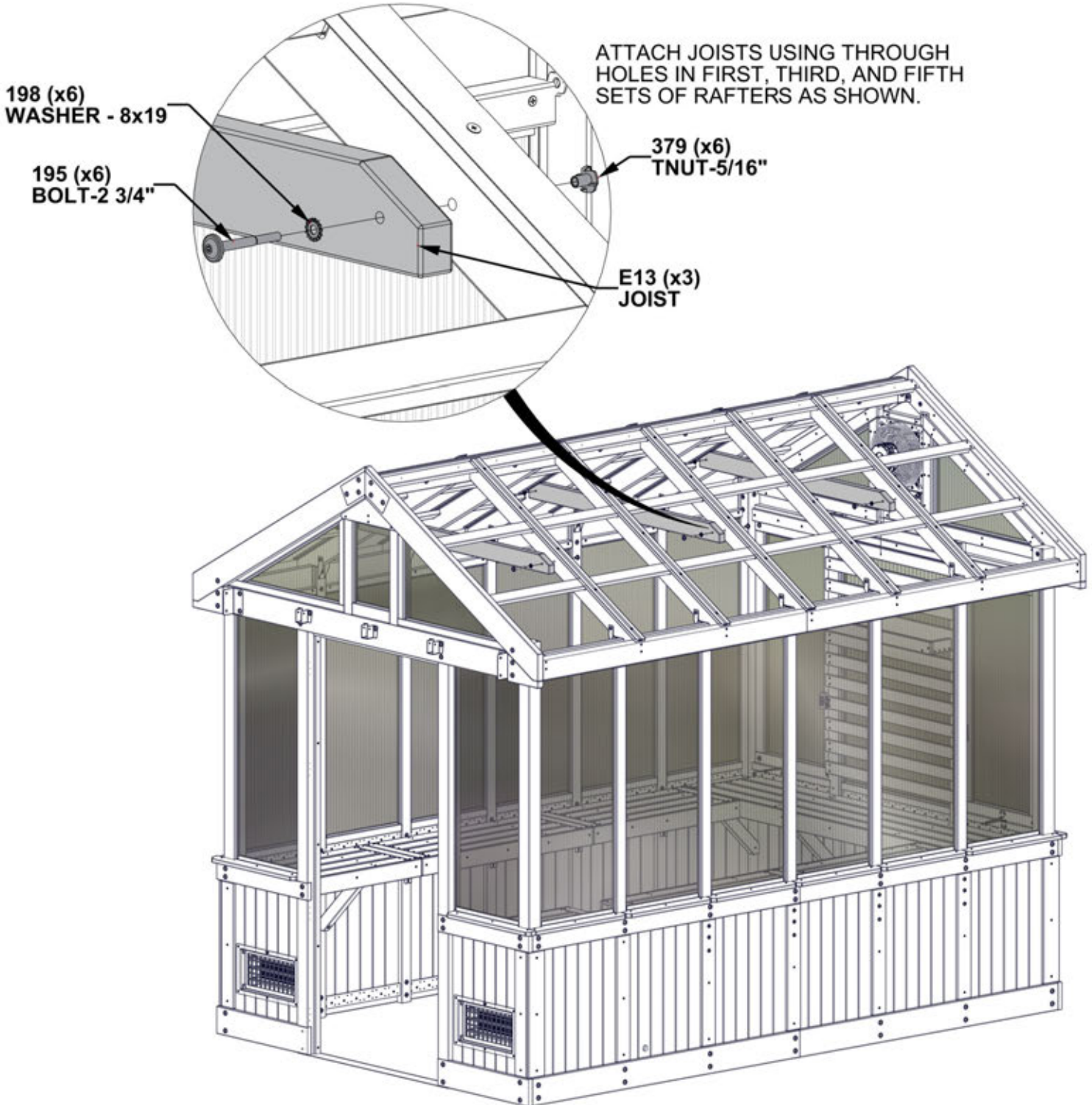
STEP 126 - ROOF ASSEMBLY

QTY	PART NUMBER	DESCRIPTION
6	H100195	BOLT WH 5/16x2 3/4 BLK
6	H100198	WASHER LOCK EXT 8x19
6	H100379	TNUT-5/16" BLK



E13 JOIST - W4L19616
(x3) 1 7/16"x3 3/8"x54 1/8" (36x86x1375)

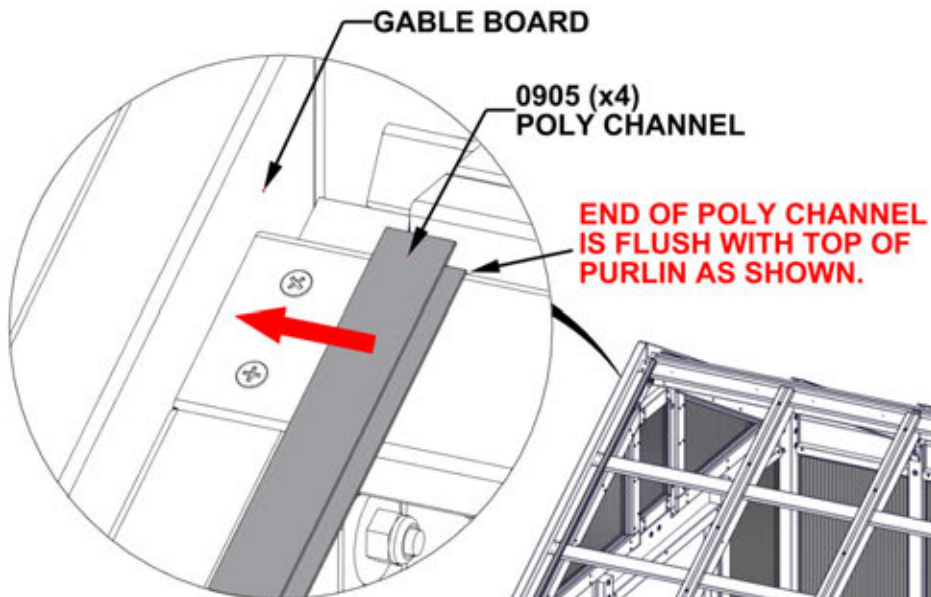
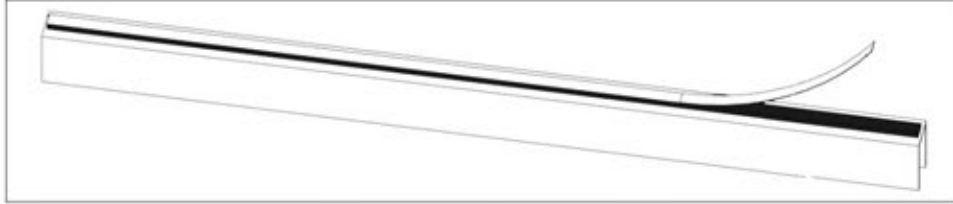
INSERT T-NUTS FIRST.



STEP 127 - ROOF ASSEMBLY

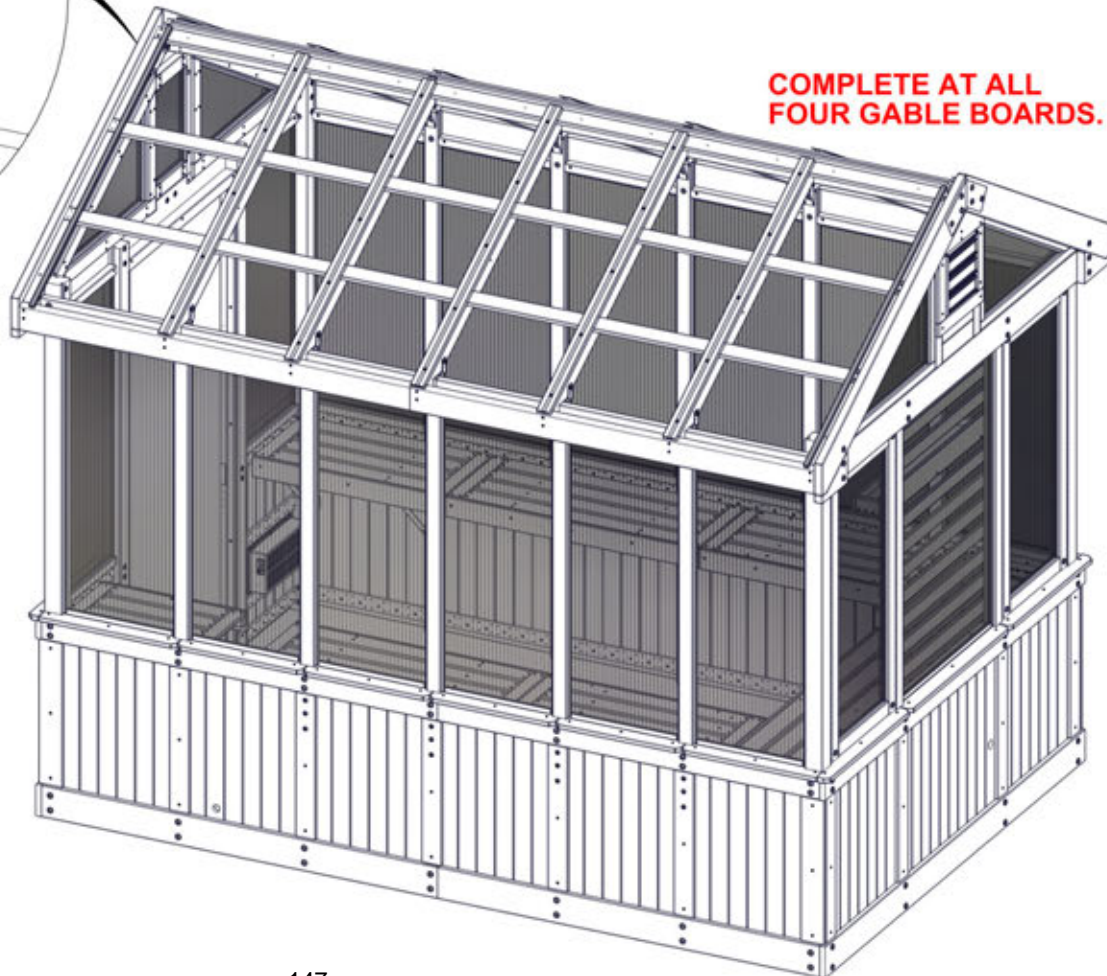
A6P00905 POLY CHANNEL
(x4)

REMOVE TAPE LINER ON POLY CHANNELS BEFORE INSTALLING.

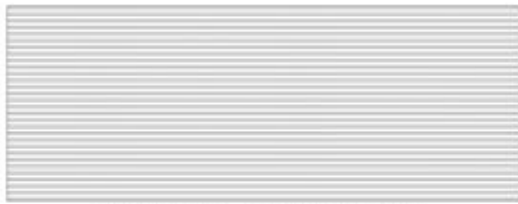


FIRMLY PRESS POLY CHANNEL AGAINST GABLE BOARD TO ENSURE ADHESION.

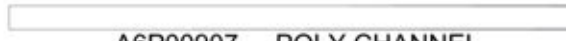
COMPLETE AT ALL FOUR GABLE BOARDS.



STEP 128 - ROOF ASSEMBLY



A6P00903 POLY SHEET
(x8)



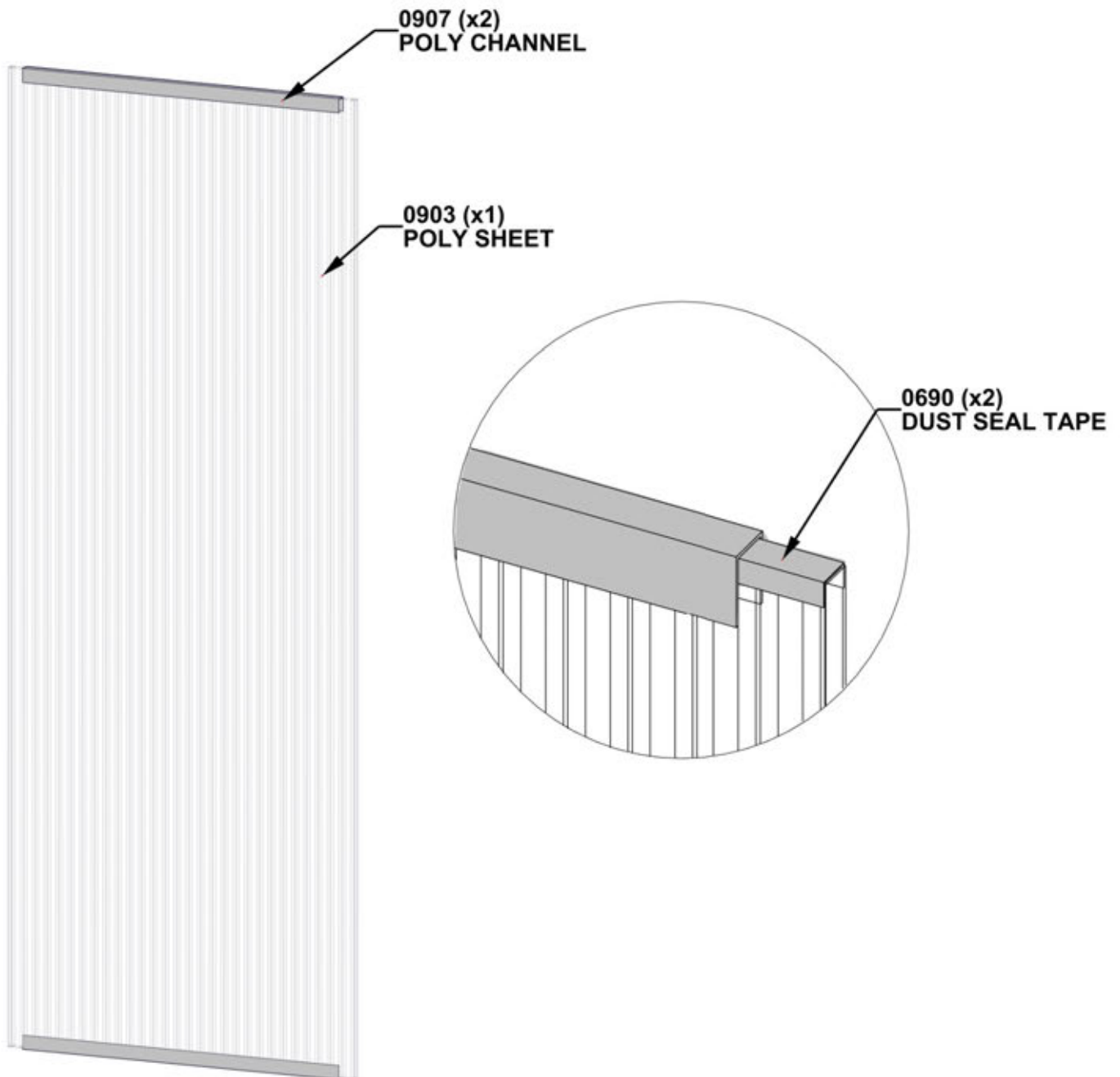
A6P00907 POLY CHANNEL
(x16)



A6P00690 DUST SEAL TAPE

TO APPLY DUST SEAL TAPE AND POLY CHANNEL:

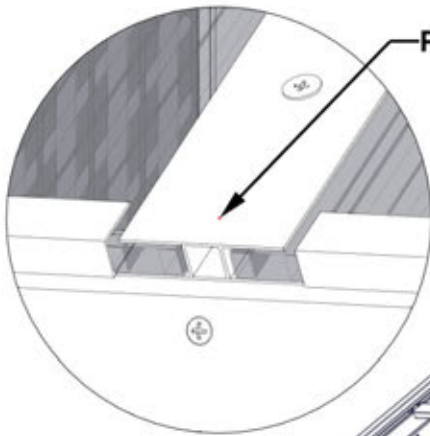
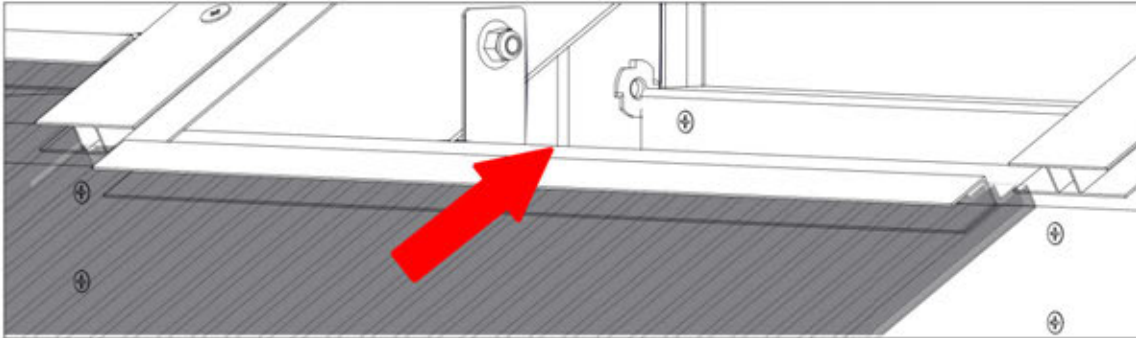
- CUT 2 STRIPS OF DUST SEAL TAPE THE SAME WIDTH AS THE POLY SHEET.
- WRAP DUST SEAL TAPE ALONG EDGE OF POLY SHEET WIDTH.
- AFTER TAPE IS SECURE, PUSH CHANNEL ON OVER THE TAPE, CENTERING ON THE POLY SHEET.
- REPEAT ON THE BOTTOM SIDE OF POLY SHEET.
- REPEAT FOR ALL 8 ROOF ASSEMBLIES.



STEP 129 - ROOF ASSEMBLY

IMPORTANT!

- ENSURE UV SIDE OF WINDOWS ARE FACING OUTSIDE.
- REMOVE THE PROTECTIVE FILM PRIOR TO INSTALLATION OF ROOF PANELS.



POLY SHEET SPLICE

SLIDE POLY SHEETS INTO POLY SHEET SPLICES.
PUSH THE SHEETS UNTIL BOTTOM OF SHEET IS
FLUSH WITH POLY SHEET SPLICE AS SHOWN.



STEP 130 - ROOF ASSEMBLY



A6P00904 POLY SHEET
(x4)



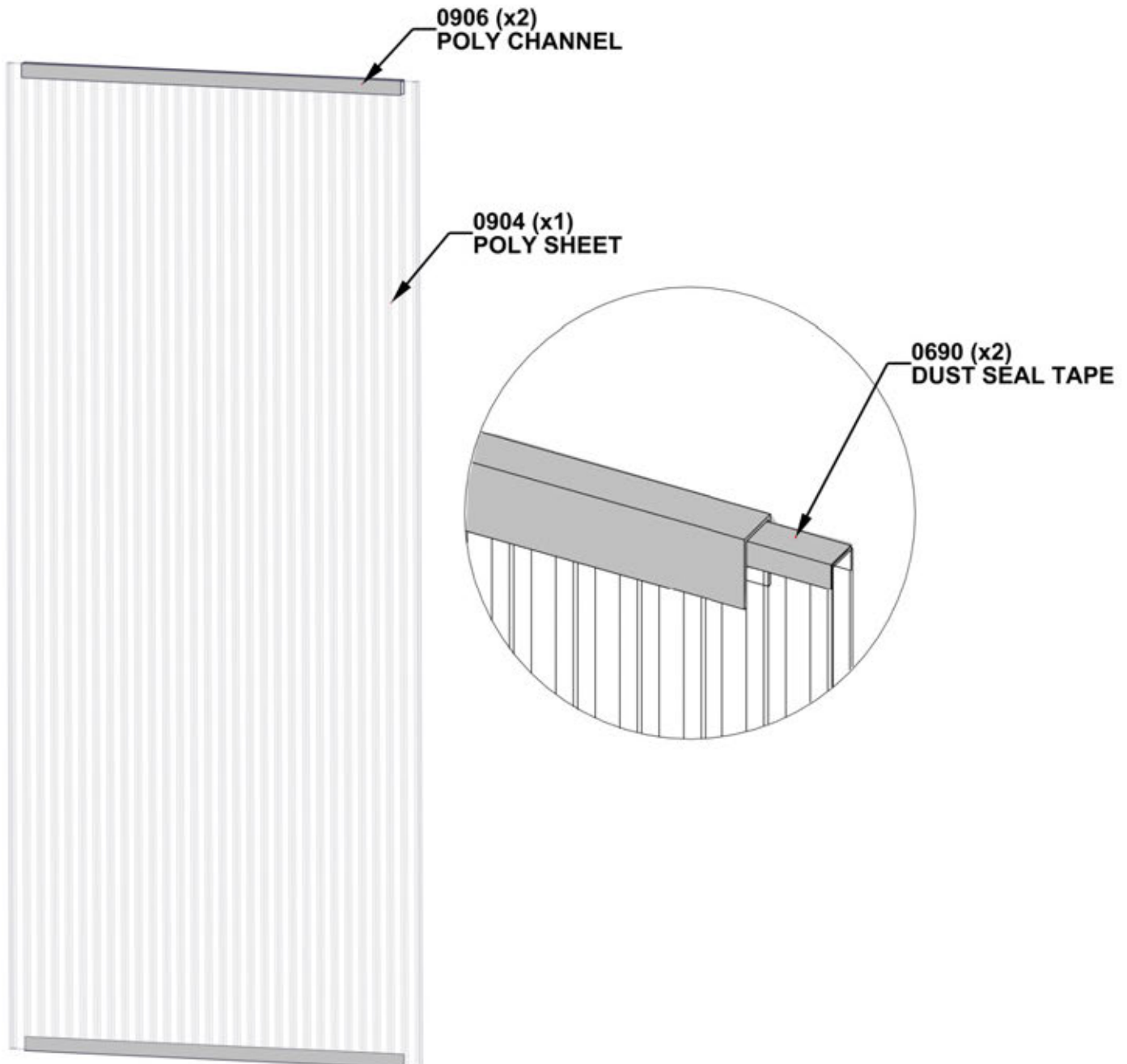
A6P00906 POLY CHANNEL
(x8)



A6P00690 DUST SEAL TAPE

TO APPLY DUST SEAL TAPE AND POLY CHANNEL:

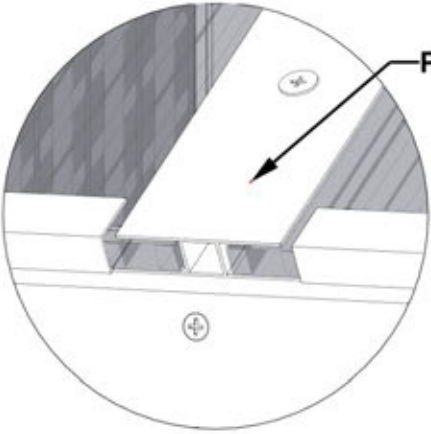
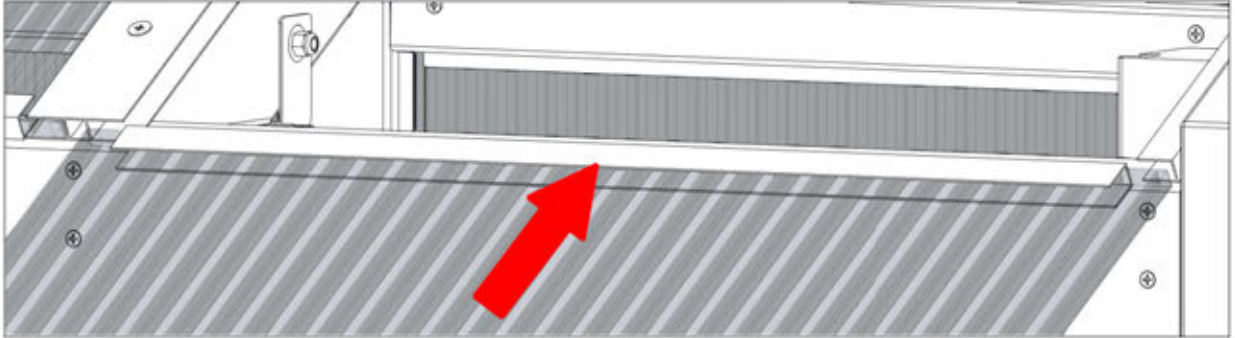
- CUT 2 STRIPS OF DUST SEAL TAPE THE SAME WIDTH AS THE POLY SHEET.
- WRAP DUST SEAL TAPE ALONG EDGE OF POLY SHEET WIDTH.
- AFTER TAPE IS SECURE, PUSH CHANNEL ON OVER THE TAPE, CENTERING ON THE POLY SHEET.
- REPEAT ON THE BOTTOM SIDE OF POLY SHEET.
- REPEAT FOR ALL 4 ROOF ASSEMBLIES.



STEP 131 - ROOF ASSEMBLY

IMPORTANT!

- ENSURE UV SIDE OF WINDOWS ARE FACING OUTSIDE.
- REMOVE THE PROTECTIVE FILM PRIOR TO INSTALLATION OF ROOF PANELS.



POLY SHEET SPLICE

SLIDE POLY SHEETS INTO POLY SHEET SPLICES AND POLY CHANNELS. PUSH THE SHEETS UNTIL BOTTOM OF SHEET IS FLUSH WITH POLY SHEET SPLICE AS SHOWN.



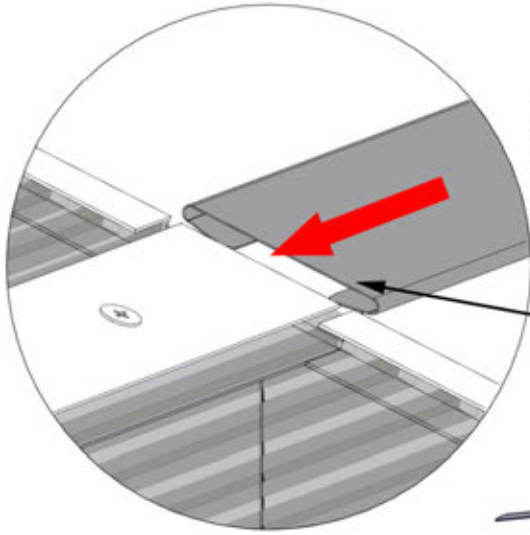
STEP 132 - ROOF ASSEMBLY



A4M02097 SPLICE COVER
(x10)

WARNING: GLOVES ARE RECOMMENDED WHEN HANDLING STEEL.

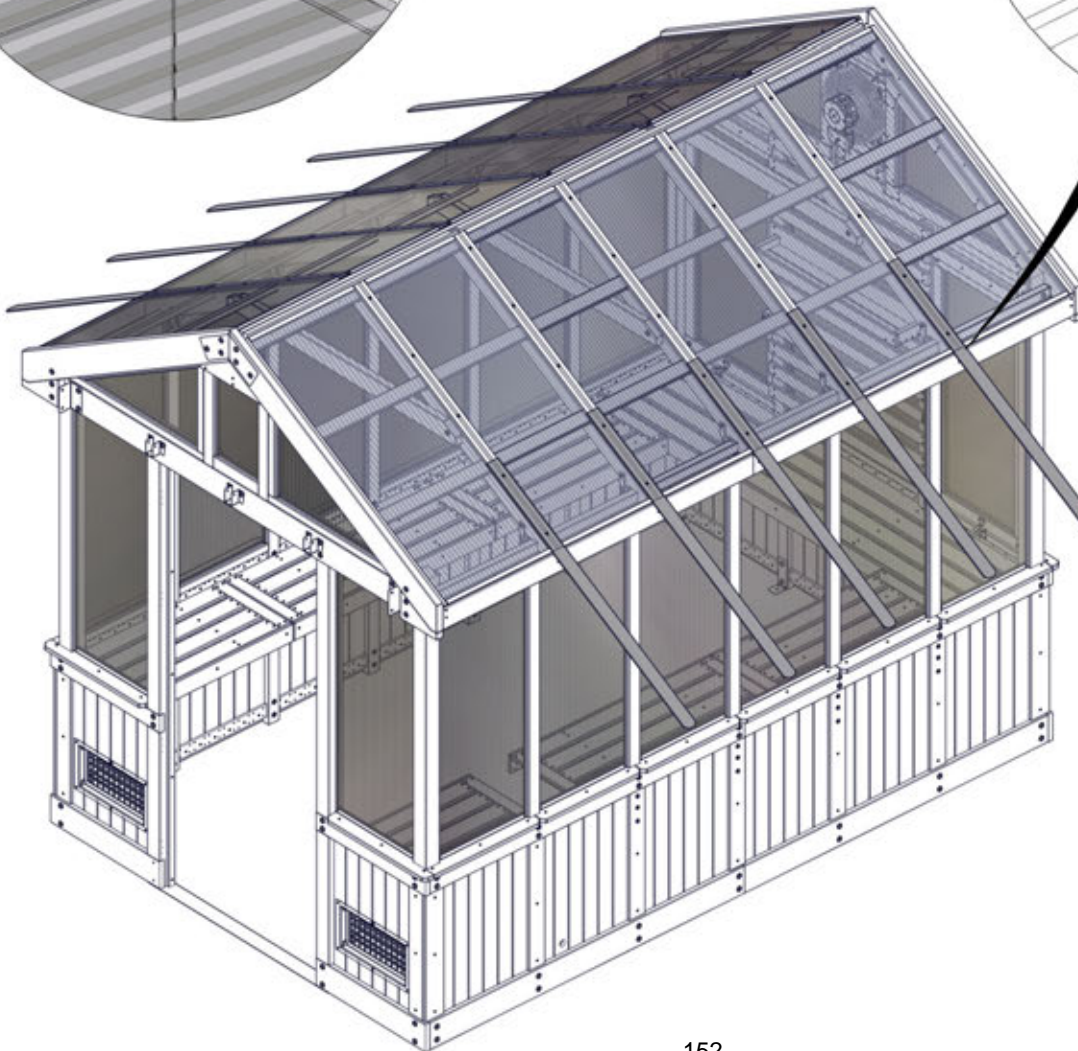
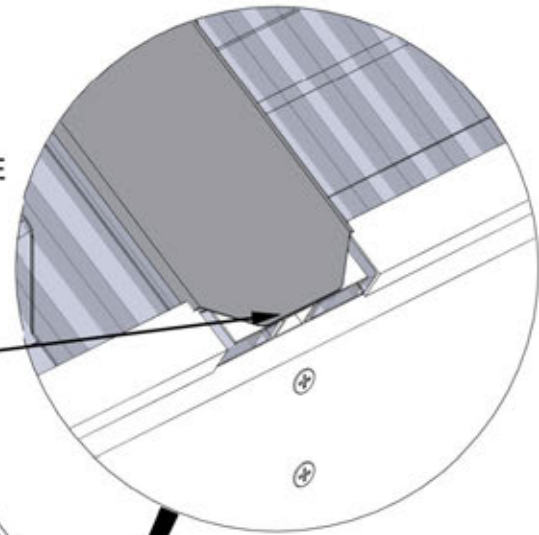
REMOVE BLUE FILM FROM SPLICE COVERS.



SLIDE TABS ON SPLICE COVERS OVER THE TABS ON THE POLY CHANNEL AND SLIDE UP UNTIL THE BOTTOM OF THE SPLICE IS FLUSH WITH BOTTOM OF THE CHANNEL.

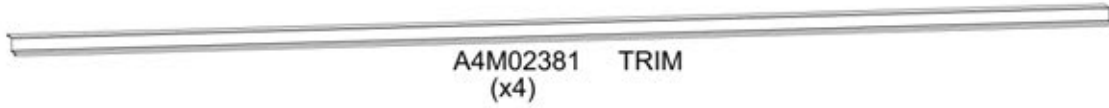
**FLAT EDGE
SLIDES ON FIRST.**

FLUSH



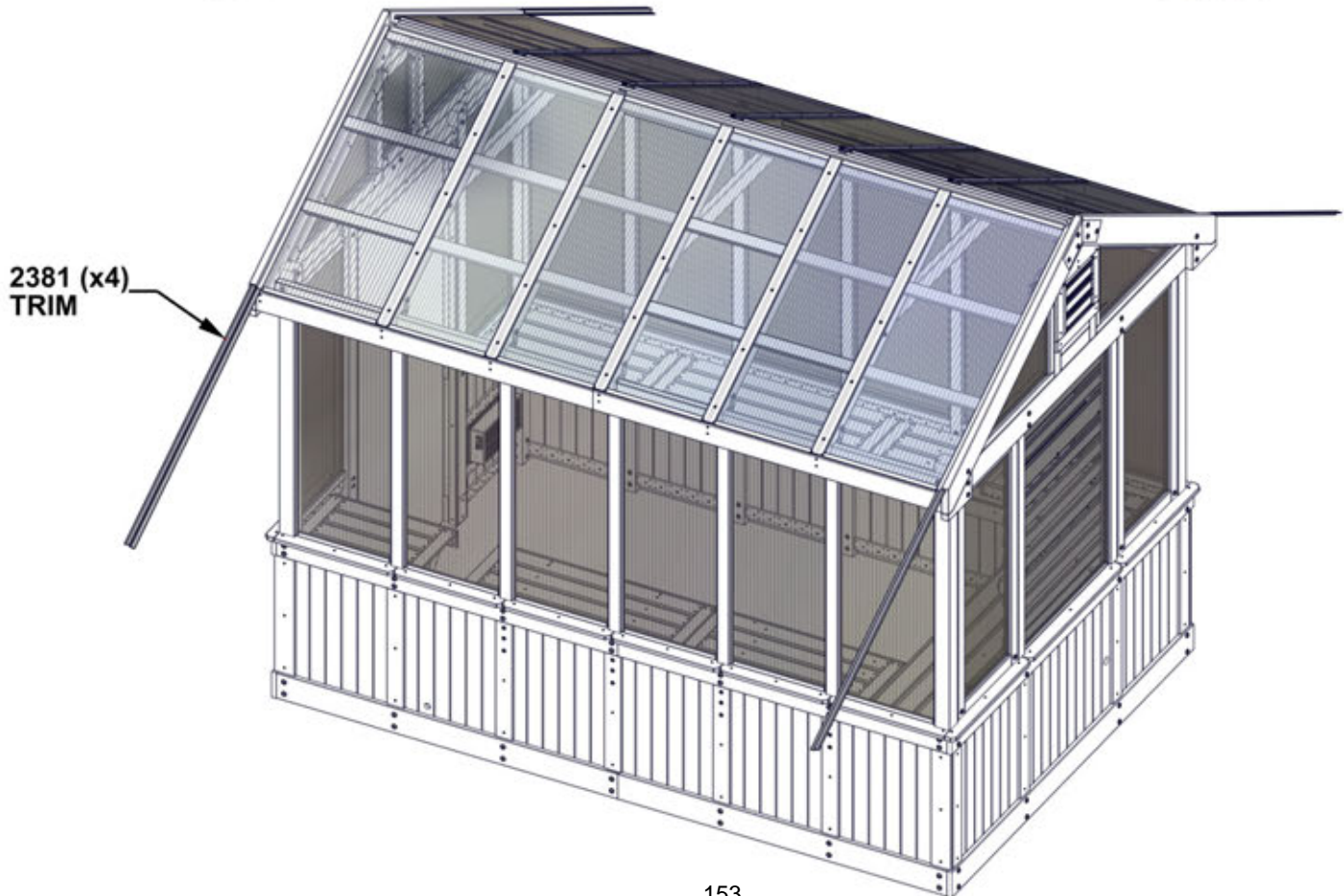
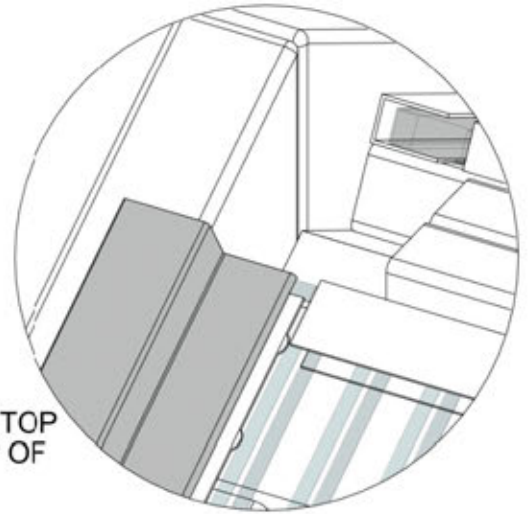
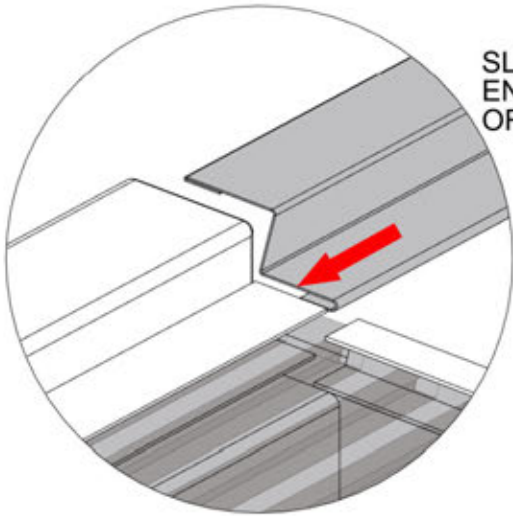
2097 (x10)
SPLICE COVER

STEP 133 - ROOF ASSEMBLY



WARNING: GLOVES ARE RECOMMENDED WHEN HANDLING STEEL.

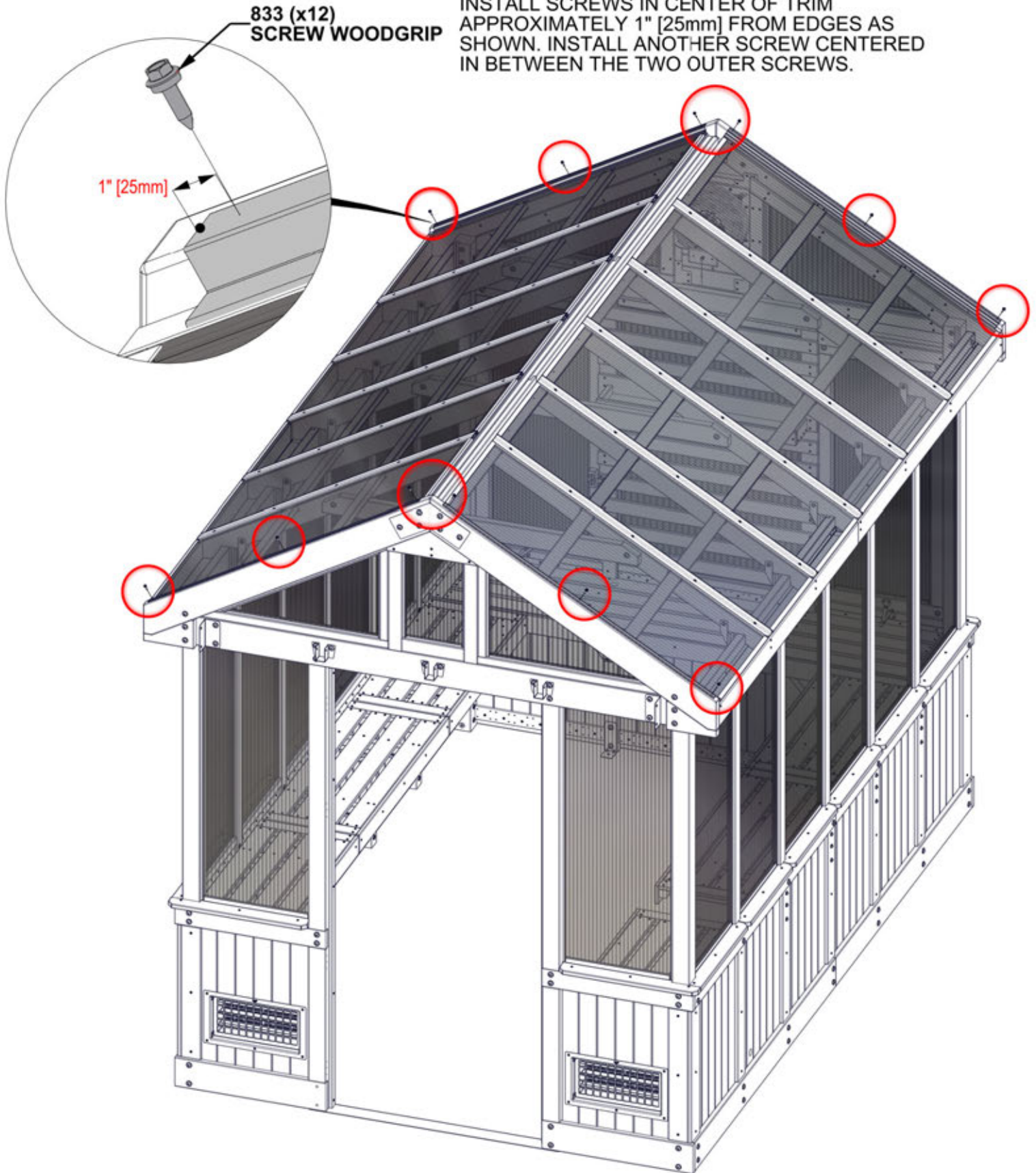
REMOVE BLUE FILM FROM TRIM.



STEP 134 - ROOF ASSEMBLY

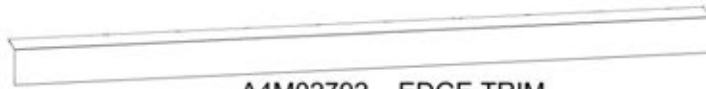
QTY	PART NUMBER	DESCRIPTION
12	H100833	SCREW WOODGRIP 10-16x3/4"

INSTALL SCREWS IN CENTER OF TRIM APPROXIMATELY 1" [25mm] FROM EDGES AS SHOWN. INSTALL ANOTHER SCREW CENTERED IN BETWEEN THE TWO OUTER SCREWS.

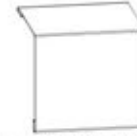


STEP 135 - ROOF ASSEMBLY

QTY	PART NUMBER	DESCRIPTION
14	H100760	SCREW WOODGRIP 10-16x1-1/4"



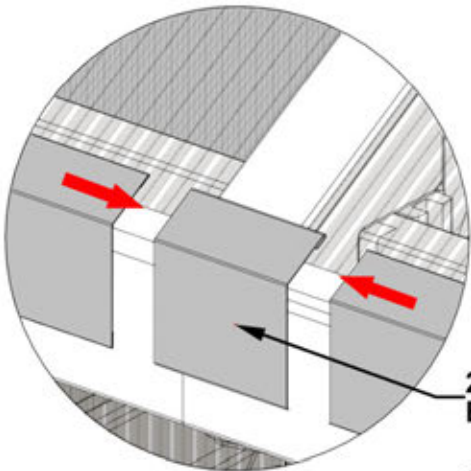
A4M02792 EDGE TRIM
(x4)



A4M02380 EDGE TRIM SPLICE
(x2)

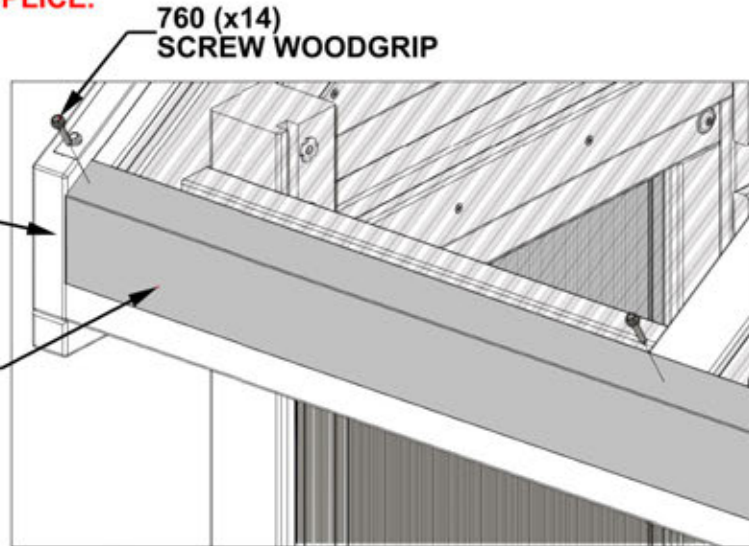
WARNING: GLOVES ARE RECOMMENDED WHEN HANDLING STEEL.

REMOVE BLUE FILM FROM EDGE TRIM AND EDGE TRIM SPLICE.



EDGE TRIM IS FLUSH WITH GABLE

2380 (x2)
EDGE TRIM SPLICE

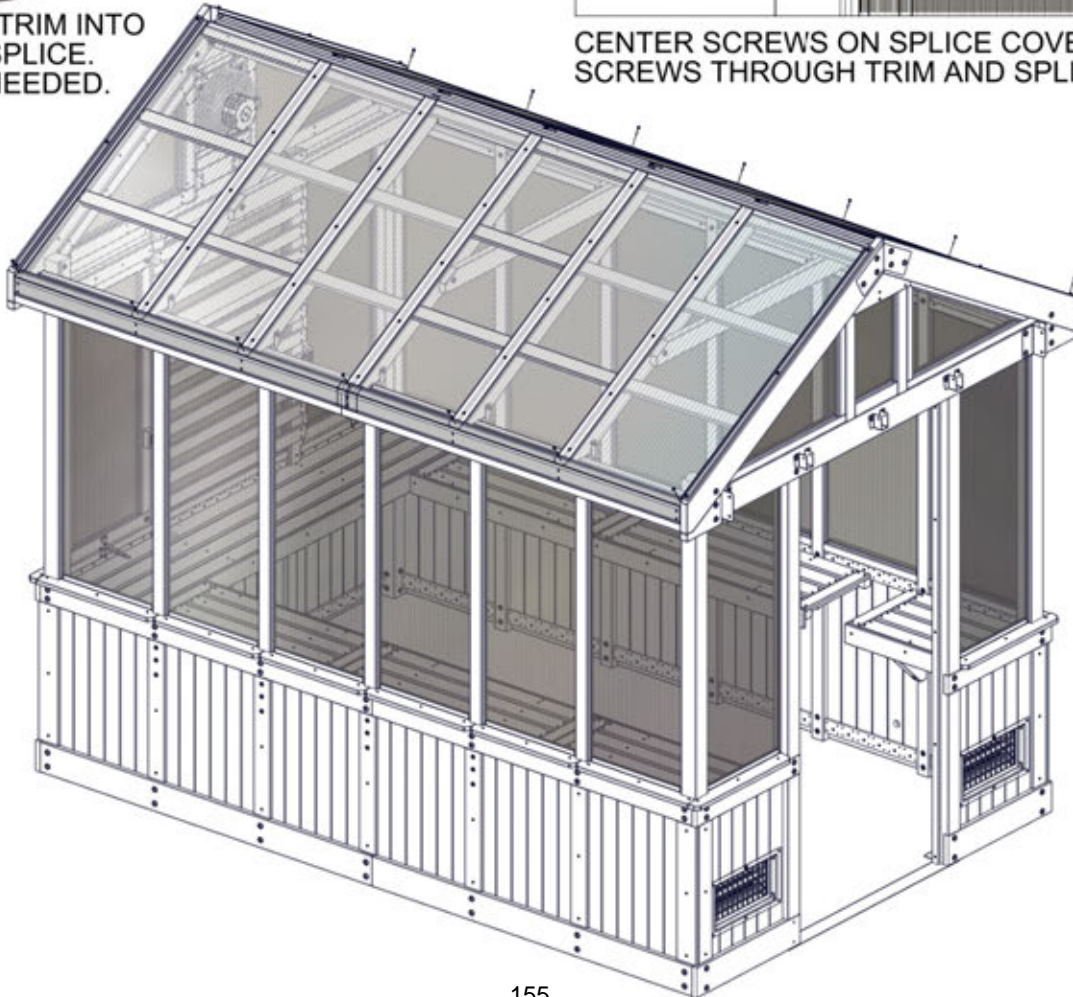


760 (x14)
SCREW WOODGRIP

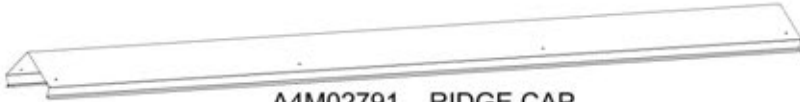
2792 (x4)
EDGE TRIM

CENTER SCREWS ON SPLICE COVERS AND ATTACH SCREWS THROUGH TRIM AND SPLICE COVERS.

**SLIDE EDGE TRIM INTO
EDGE TRIM SPLICE.
ADJUST AS NEEDED.**



STEP 136 - ROOF ASSEMBLY

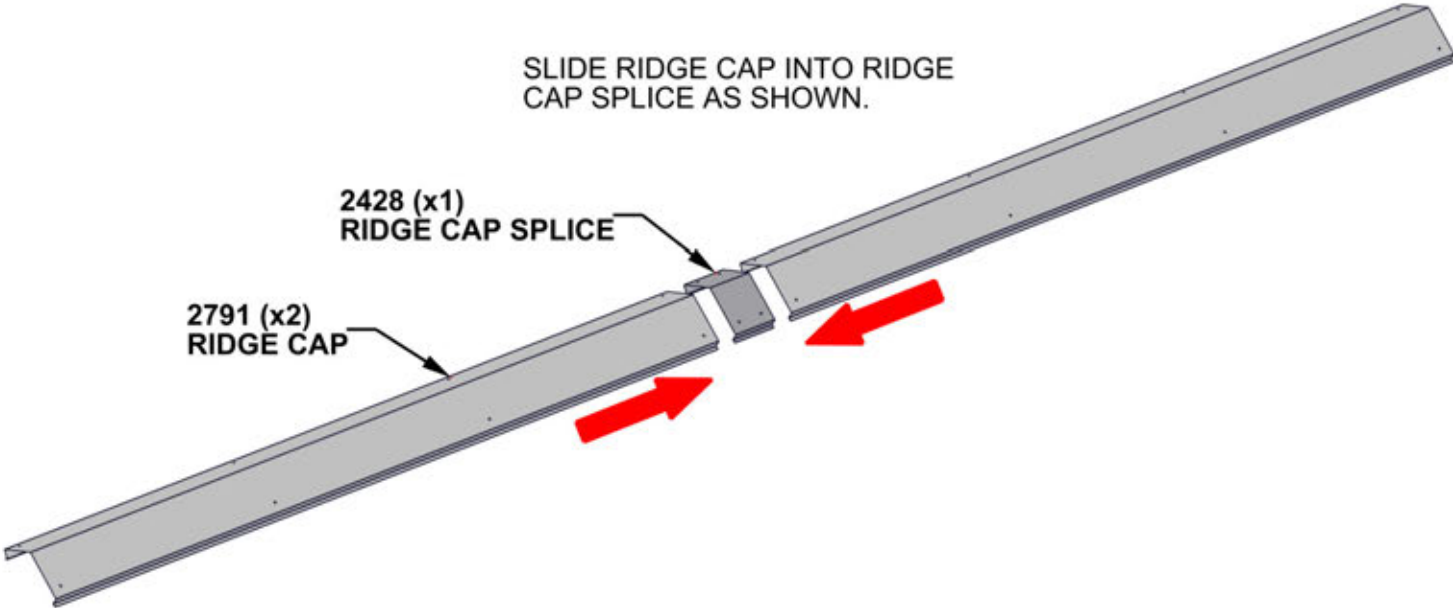


A4M02791 RIDGE CAP
(x2)



A4M02428 RIDGE CAP SPLICE
(x1)

WARNING: GLOVES ARE RECOMMENDED WHEN HANDLING STEEL.
REMOVE BLUE FILM FROM RIDGE CAP AND RIDGE CAP SPLICE.



STEP 137 - ROOF ASSEMBLY

QTY	PART NUMBER	DESCRIPTION
16	H100833	SCREW WOODGRIP 10-16x3/4"



J05 RIDGE STIFFENER - W4L19613
(x2) 15/16"x2 3/8"x79 13/16" (24x60x2028)



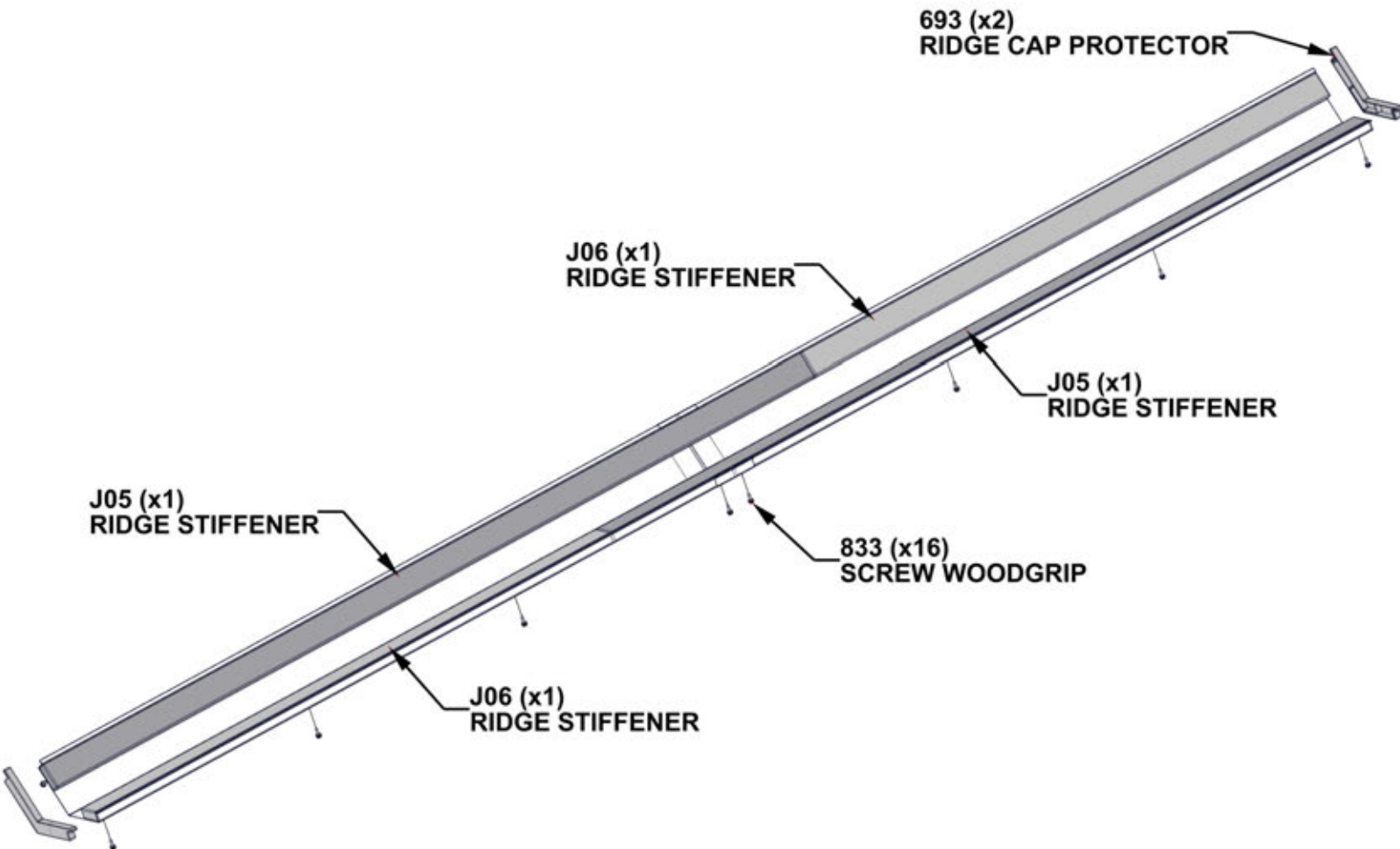
J06 RIDGE STIFFENER - W4L19614
(x2) 15/16"x2 3/8"x54 1/4" (24x60x1378)



A6P00693 RIDGE CAP PROTECTOR
(x2)

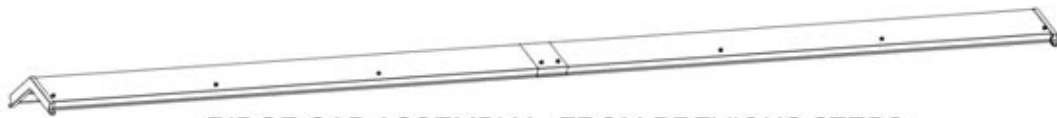
WARNING: GLOVES ARE RECOMMENDED WHEN HANDLING STEEL.

- ALIGN HOLES OF RIDGE CAP WITH HOLES ON RIDGE CAP SPLICE.
- ARRANGE RIDGE STIFFENERS AS SHOWN.
- ATTACH RIDGE CAP ASSEMBLY USING EIGHT SCREWS ALONG EACH SIDE.
- **CONFIRM TOTAL LENGTH OF ASSEMBLED RIDGE CAP TO BE 11'-2 1/4" +/- 1/8" [3410mm].**



**REMOVE SPACERS FROM
RIDGE CAP PROTECTORS
BEFORE INSTALLING.**

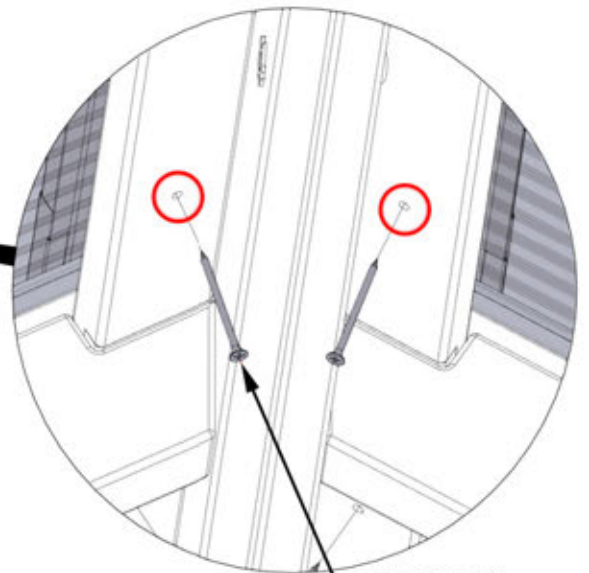
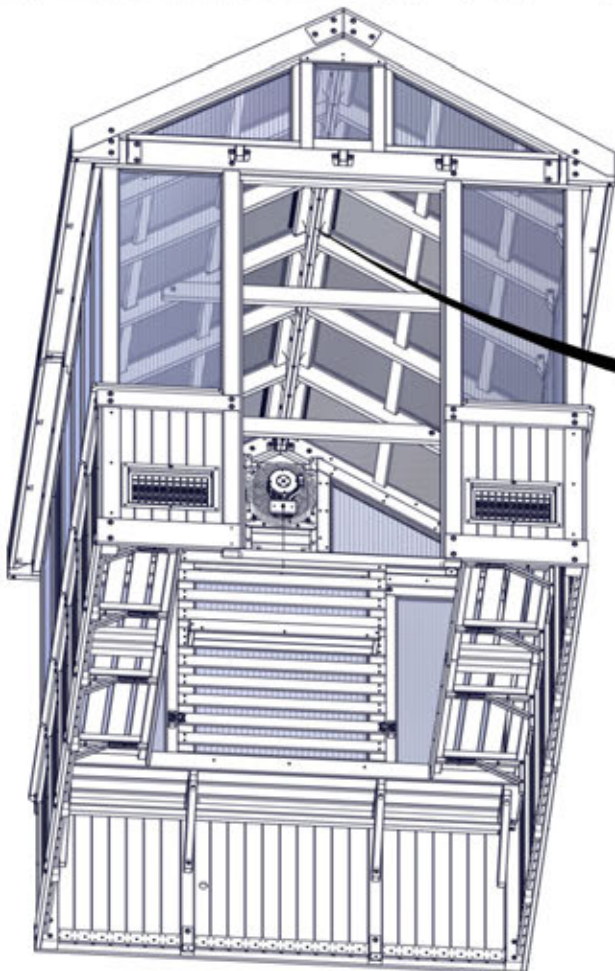
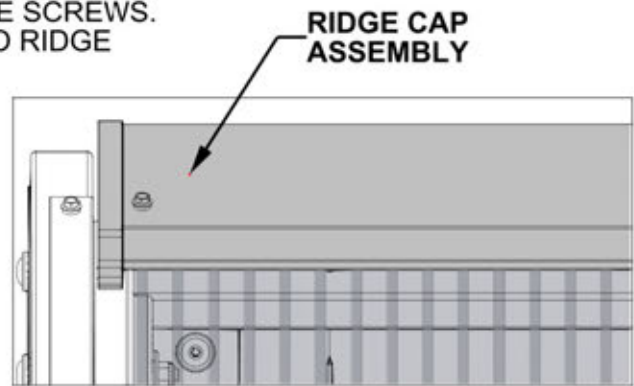
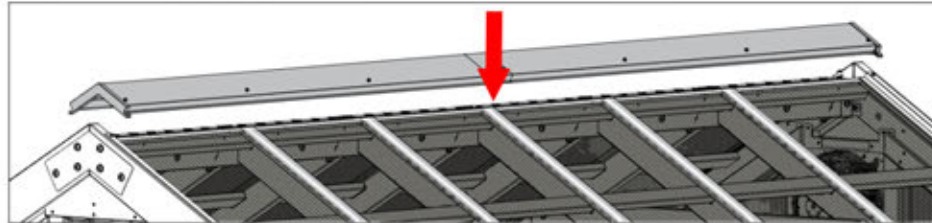
QTY	PART NUMBER	DESCRIPTION
24	H100483	SCREW PFH 8x2 1/4 BLK



RIDGE CAP ASSEMBLY - FROM PREVIOUS STEPS

WARNING: GLOVES ARE RECOMMENDED WHEN HANDLING STEEL.

- TWO ADULTS WILL BE NEEDED FOR THIS STEP.
- DO NOT CLIMB ON ROOF TO INSTALL RIDGE CAP.
- RIDGE CAP HAS BEEN DESIGNED TO INSTALL WITH THE USE OF A LADDER.
- PLACE RIDGE CAP ASSEMBLY ON TOP OF ROOF RIDGE UNTIL BOTH ENDS ARE SEATED INSIDE THE GABLES AS SHOWN.
- ONE ADULT MUST KEEP DOWNWARD PRESSURE ON THE RIDGE CAP ASSEMBLY WHILE THE SECOND ADULT IS INSIDE ATTACHING THE SCREWS.
- INSTALL SCREWS THROUGH PILOT HOLES IN ROOF PANELS INTO RIDGE CAP ASSEMBLY.



483 (x24)
SCREW - 2 1/4"

STEP 139 - PERGOLA ASSEMBLY

QTY	PART NUMBER	DESCRIPTION
8	H100200	SCREW PFH 8x1 1/2 BLK



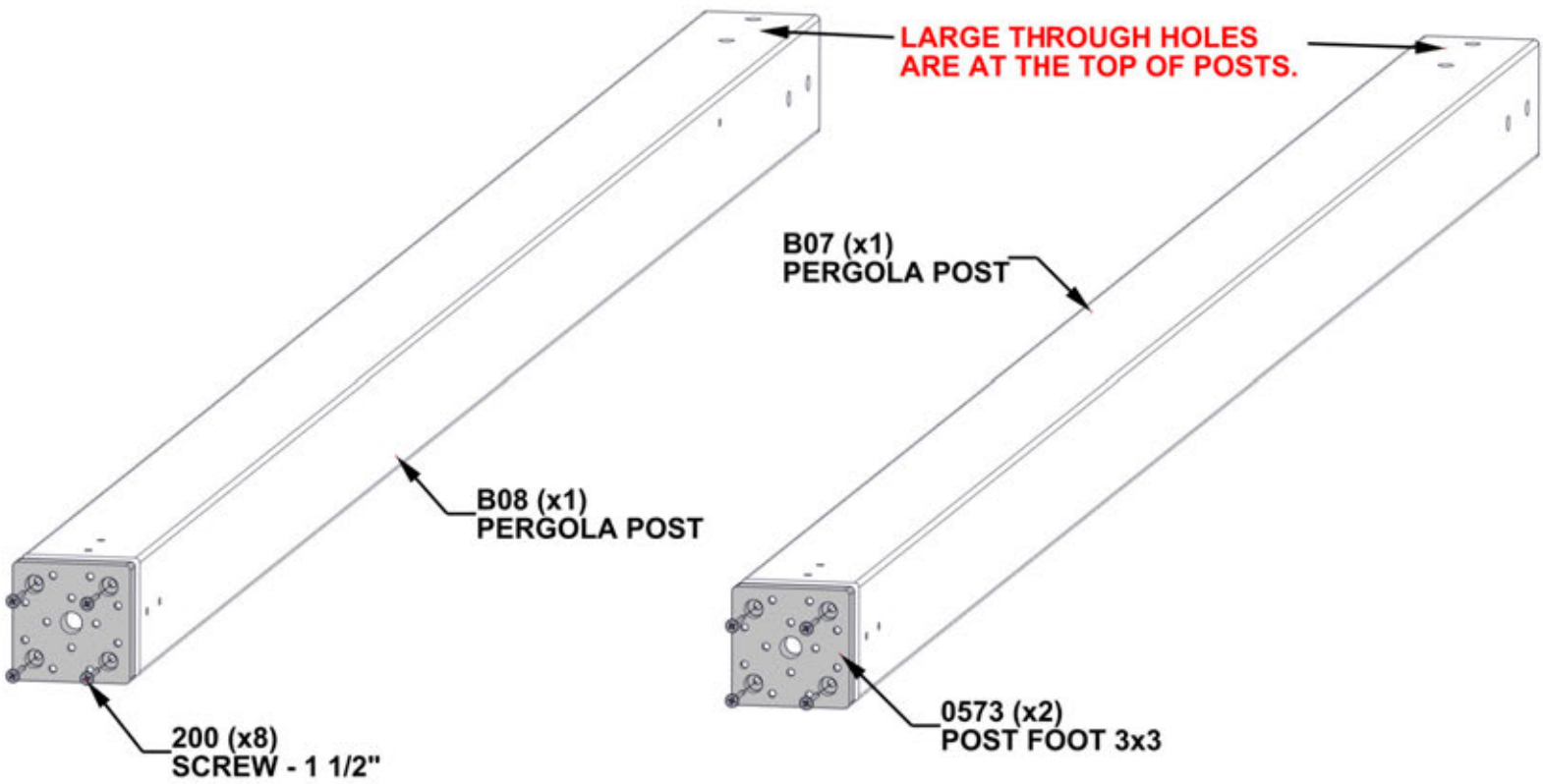
B07 PERGOLA POST - W4L19563
(x1) 3"x3"x86 1/16" (76x76x2186)



B08 PERGOLA POST - W4L19564
(x1) 3"x3"x86 1/16" (76x76x2186)



A6P00573 POST FOOT 3x3
(x2)



**ALIGN POST FOOT AND DRILL
1/8" [3mm] PILOT HOLES FOR THE
ATTACHMENT OF HARDWARE.**

STEP 140 - PERGOLA ASSEMBLY

QTY	PART NUMBER	DESCRIPTION
4	H100195	BOLT WH 5/16x2 3/4 BLK
8	H100198	WASHER LOCK EXT 8x19
8	H100379	TNUT-5/16" BLK
2	H100405	WASHER LOCK EXT 6x15
4	H100513	BOLT WH 5/16x4 1/4 BLK
2	H100792	LAG SCREW WH 1/4x3 BLK



B07 POST ASSEMBLY - FROM PREVIOUS STEP



B08 POST ASSEMBLY - FROM PREVIOUS STEP



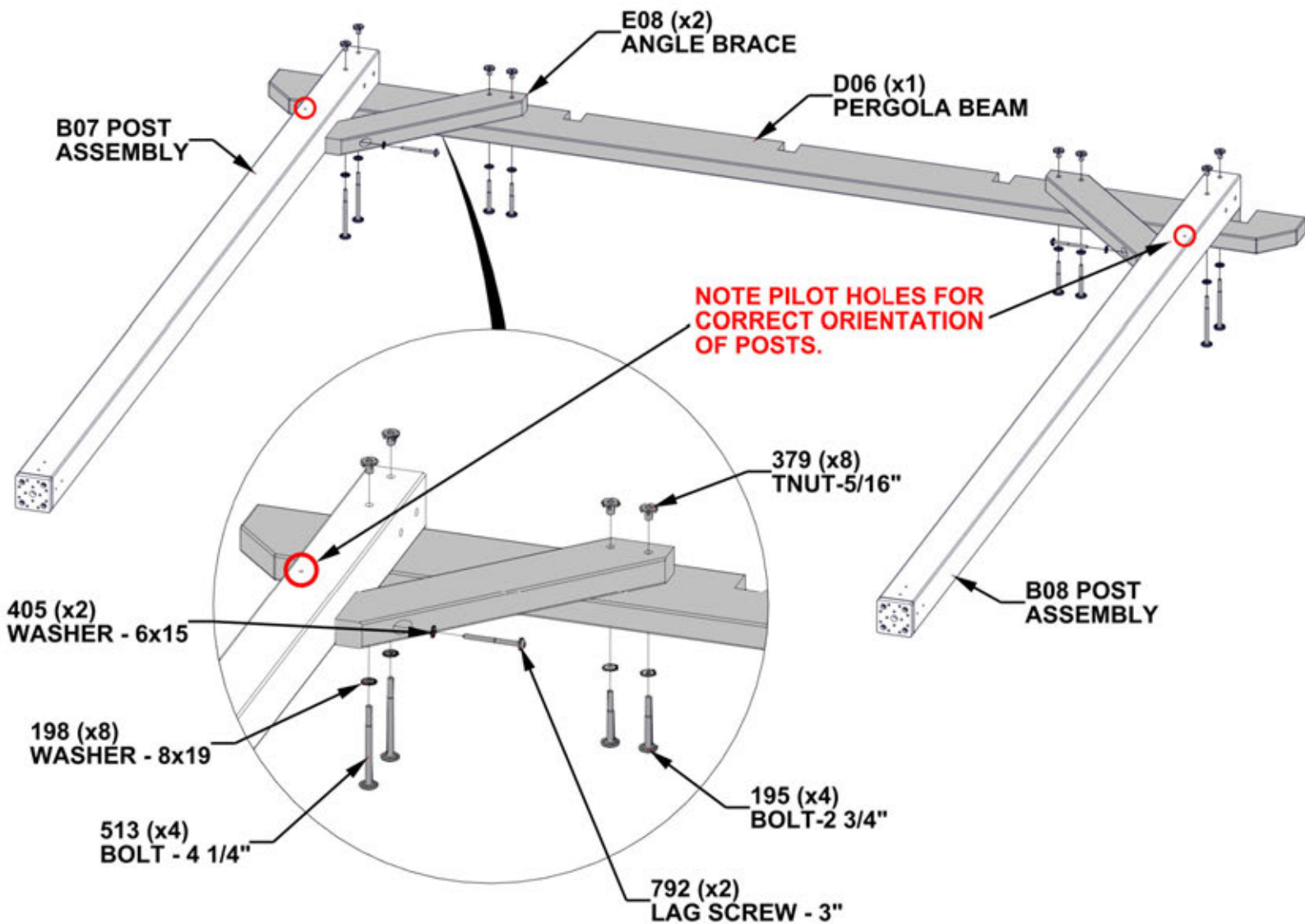
D06 PERGOLA BEAM - W4L19559
(x1) 1 7/16"x5 1/4"x89 7/16" (36x134x2272)



E08 ANGLE BRACE - W4L19565
(x2) 1 7/16"x3 3/8"x18 11/16" (36x86x474)

INSERT T-NUTS FIRST.

- TO AVOID SPLITTING POSTS, MAKE SURE LAG SCREWS GO INTO PILOT HOLES.



SQUARE POSTS TO BEAM AND FULLY TIGHTEN ALL HARDWARE.

STEP 141 - PERGOLA ASSEMBLY

QTY	PART NUMBER	DESCRIPTION
4	H100195	BOLT WH 5/16x2 3/4 BLK
4	H100198	WASHER LOCK EXT 8x19
4	H100379	TNUT-5/16" BLK
4	H100405	WASHER LOCK EXT 6x15
4	H100792	LAG SCREW WH 1/4x3 BLK



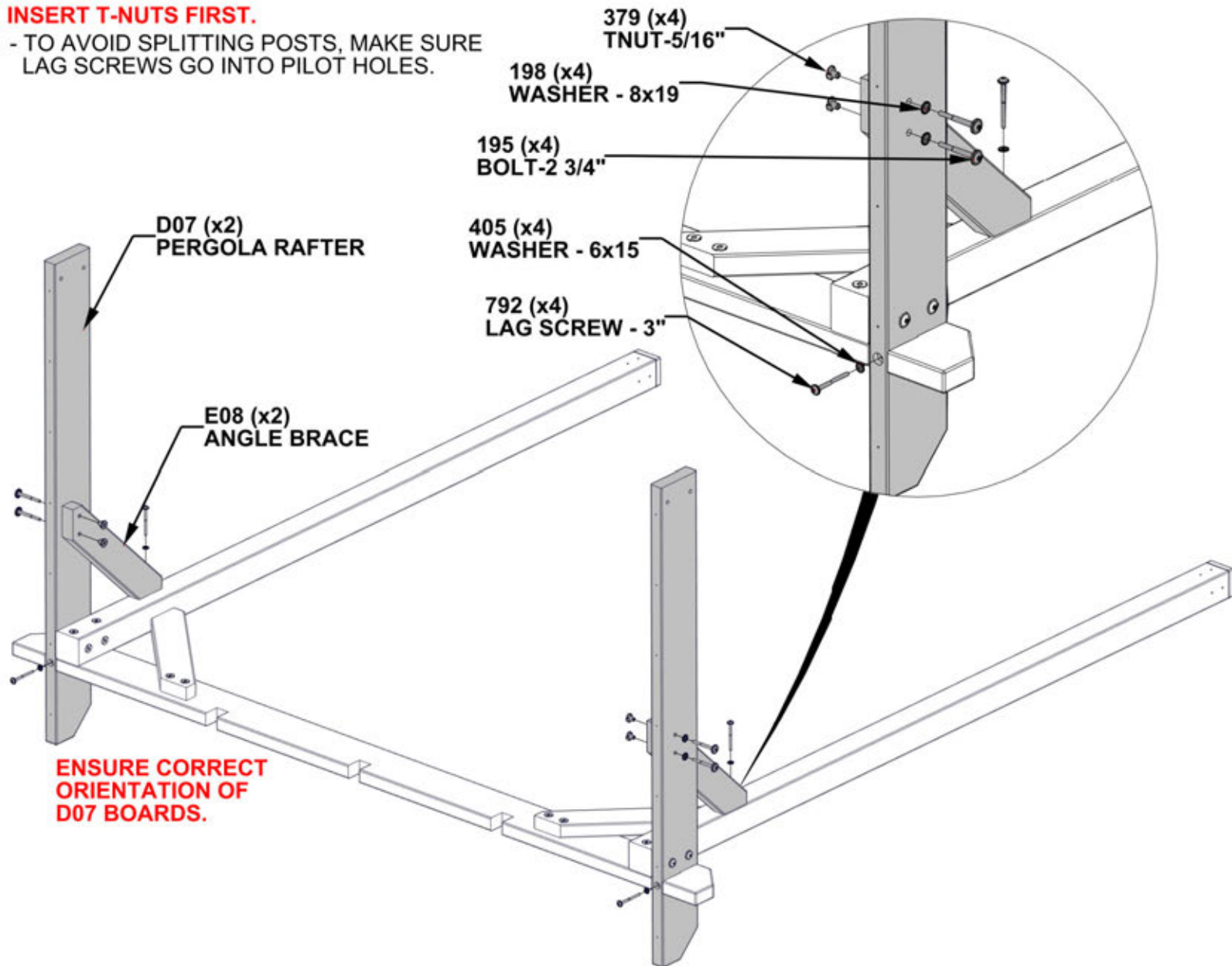
D07 PERGOLA RAFTER - W4L19560
(x2) 1 7/16"x5 1/4"x52 1/16" (36x134x1322)



E08 ANGLE BRACE - W4L19565
(x2) 1 7/16"x3 3/8"x18 11/16" (36x86x474)

INSERT T-NUTS FIRST.

- TO AVOID SPLITTING POSTS, MAKE SURE LAG SCREWS GO INTO PILOT HOLES.



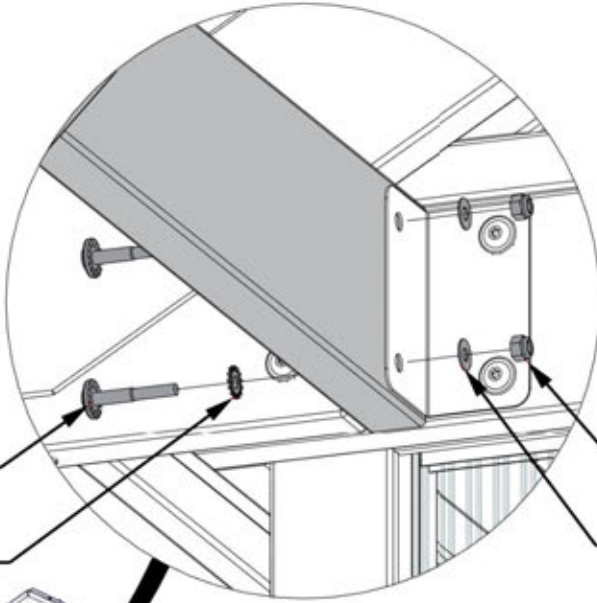
SQUARE POSTS TO BEAM AND FULLY TIGHTEN ALL HARDWARE.

STEP 142 - PERGOLA ASSEMBLY

QTY	PART NUMBER	DESCRIPTION
4	H100198	WASHER LOCK EXT 8x19
4	H100457	BOLT WH 5/16x2 BLK
4	H100479	NUT LOCK 5/16 BLK
4	H100630	WASHER FLAT 8x19 BLK

TWO ADULTS WILL BE NEEDED FOR THIS STEP.

STAND UP PERGOLA ASSEMBLY FROM PREVIOUS STEPS AND ATTACH AS SHOWN.



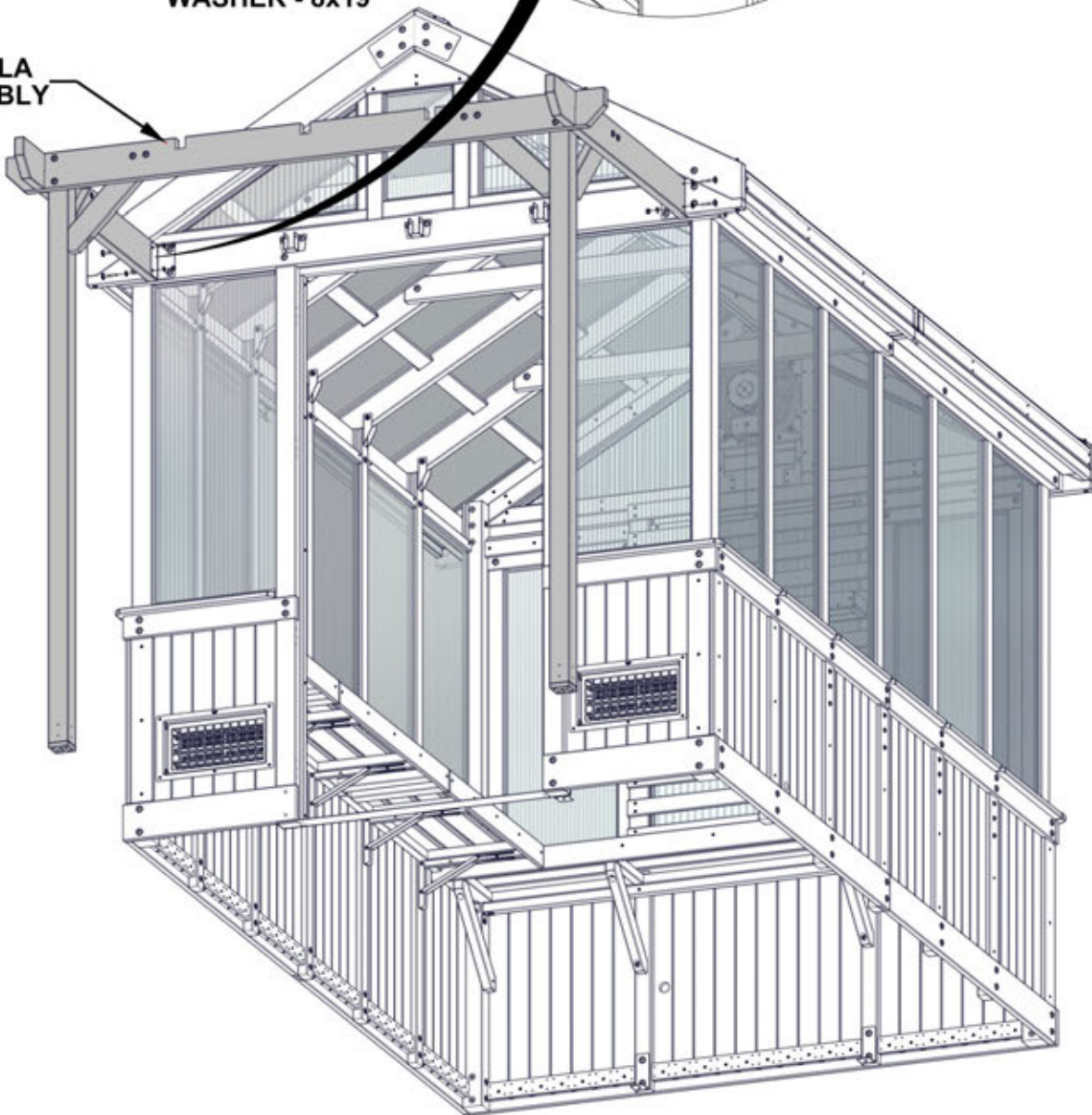
457 (x4)
BOLT - 2"

479 (x4)
LOCK NUT - 5/16"

198 (x4)
WASHER - 8x19

630 (x4)
WASHER - 8x19

PERGOLA ASSEMBLY

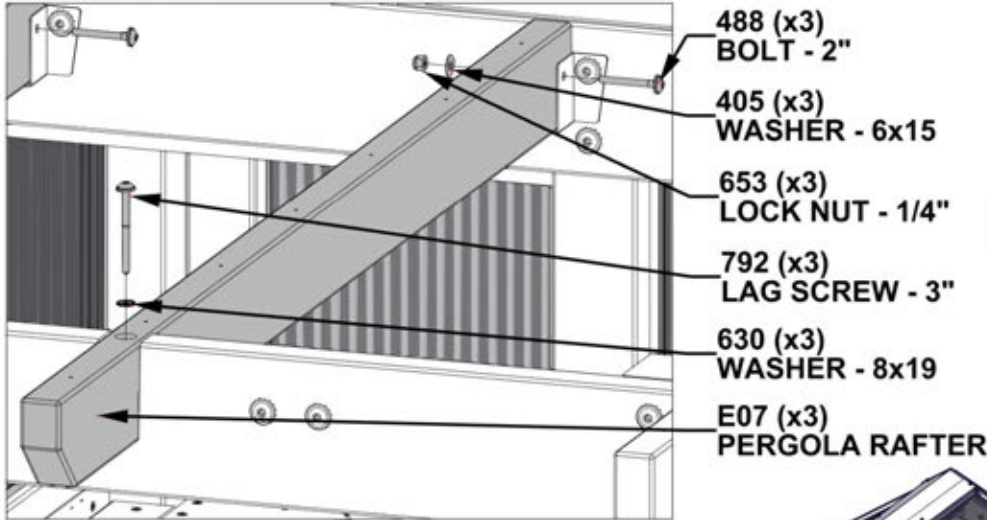


STEP 143 - PERGOLA ASSEMBLY

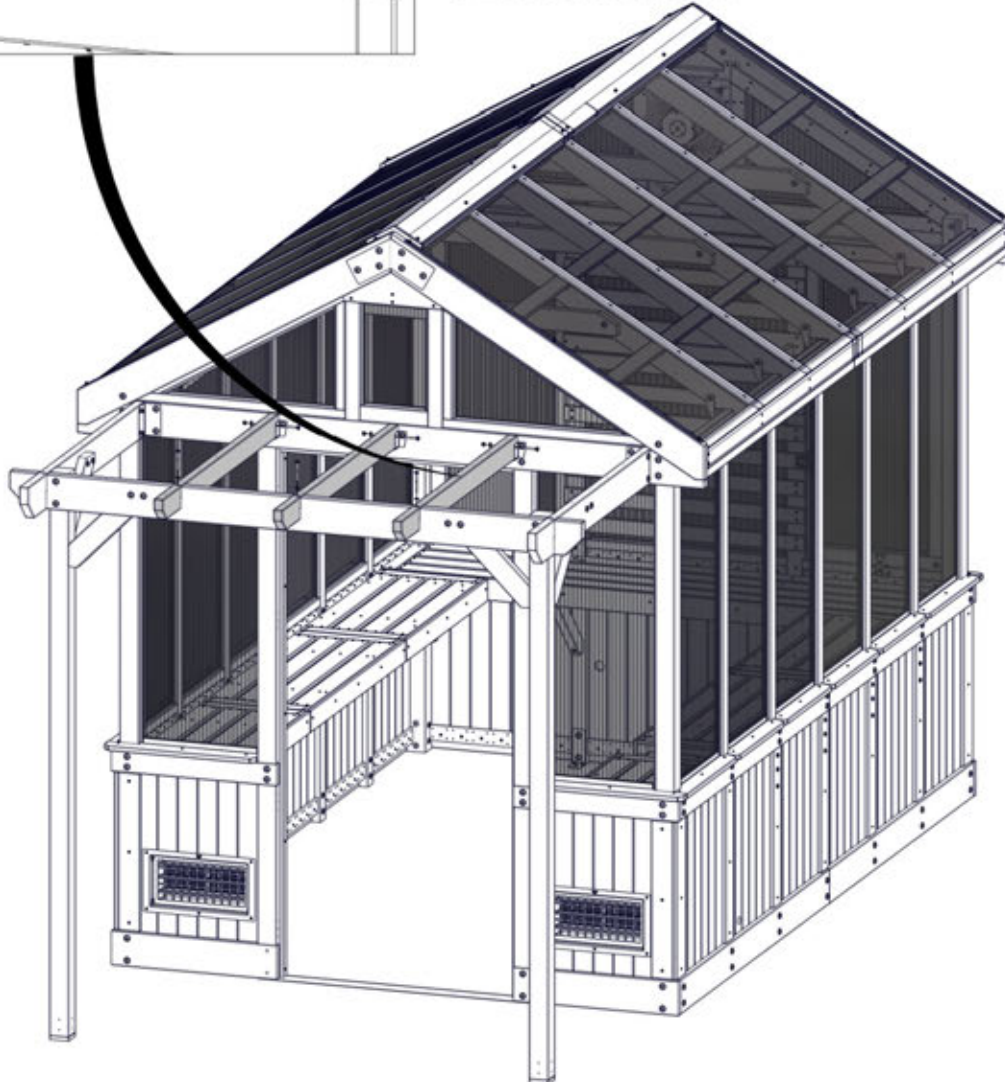
QTY	PART NUMBER	DESCRIPTION
3	H100405	WASHER LOCK EXT 6x15
3	H100488	BOLT WH 1/4x2 BLK
3	H100630	WASHER FLAT 8x19 BLK
3	H100653	NUT LOCK 1/4 BLK
3	H100792	LAG SCREW WH 1/4x3 BLK



E07 PERGOLA RAFTER - W4L19561
(x3) 1 7/16"x3 3/8"x52 1/16" (36x86x1322)



ENSURE CORRECT ORIENTATION OF E07 BOARDS AS SHOWN.

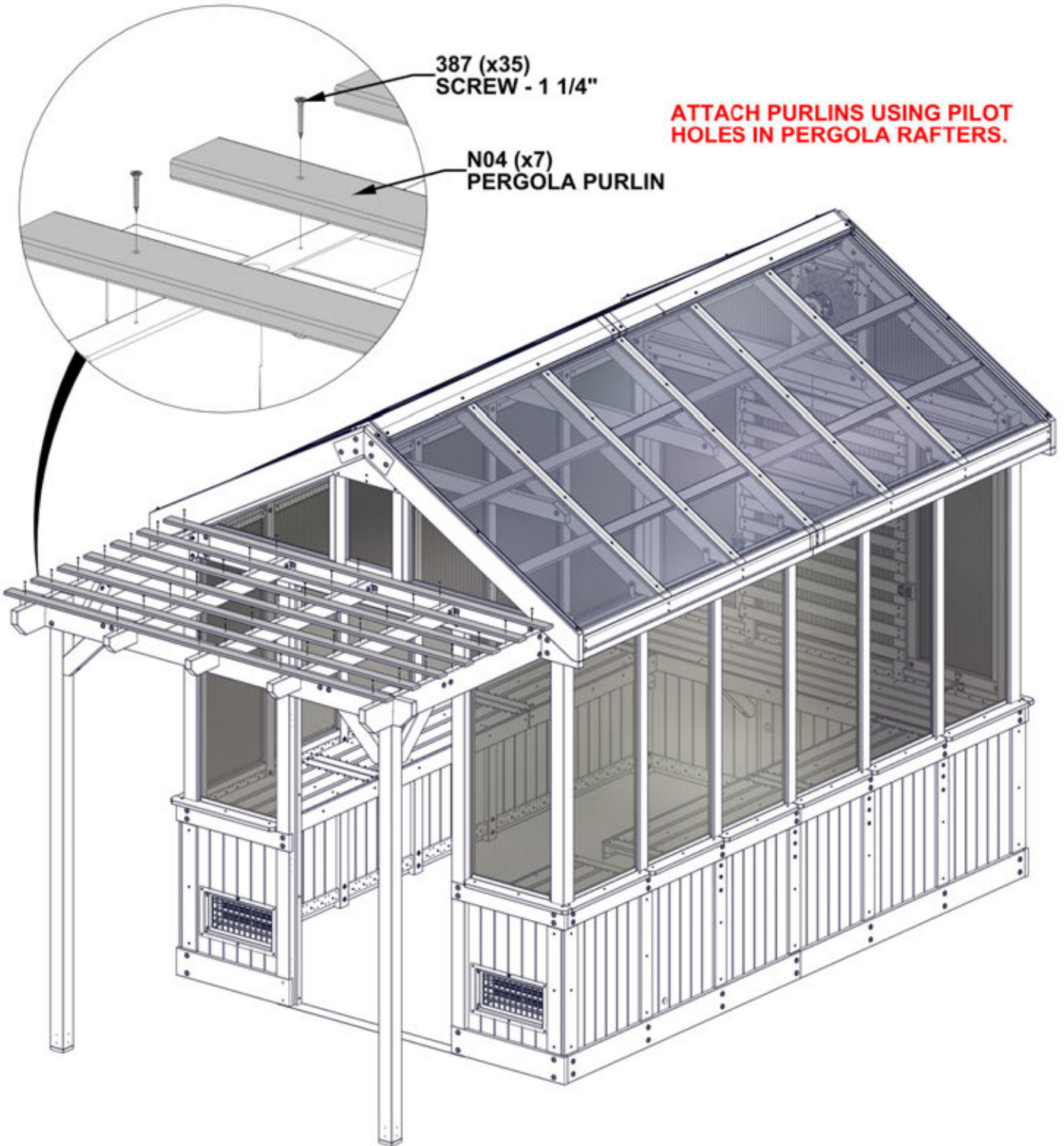


STEP 144 - PERGOLA ASSEMBLY

QTY	PART NUMBER	DESCRIPTION
35	H100387	SCREW PFH 8x1 1/4 BLK



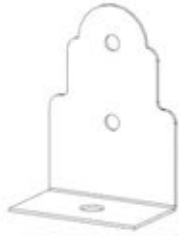
N04 PERGOLA PURLIN - W4L19562
(x7) 5/8"x2 3/8"x87 1/16" (16x60x2212)



ATTACH PURLINS USING PILOT HOLES IN PERGOLA RAFTERS.

STEP 145 - PERGOLA ASSEMBLY

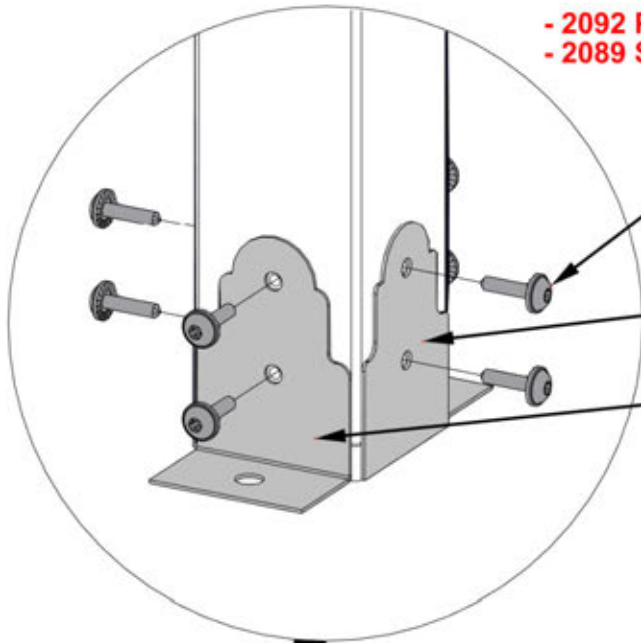
QTY	PART NUMBER	DESCRIPTION
16	H100460	LAG SCREW WH 1/4x1 BLK



A4M02092 POST ANCHOR PLATE
(x4)



A4M02089 STEEL POST PLATE
(x4)

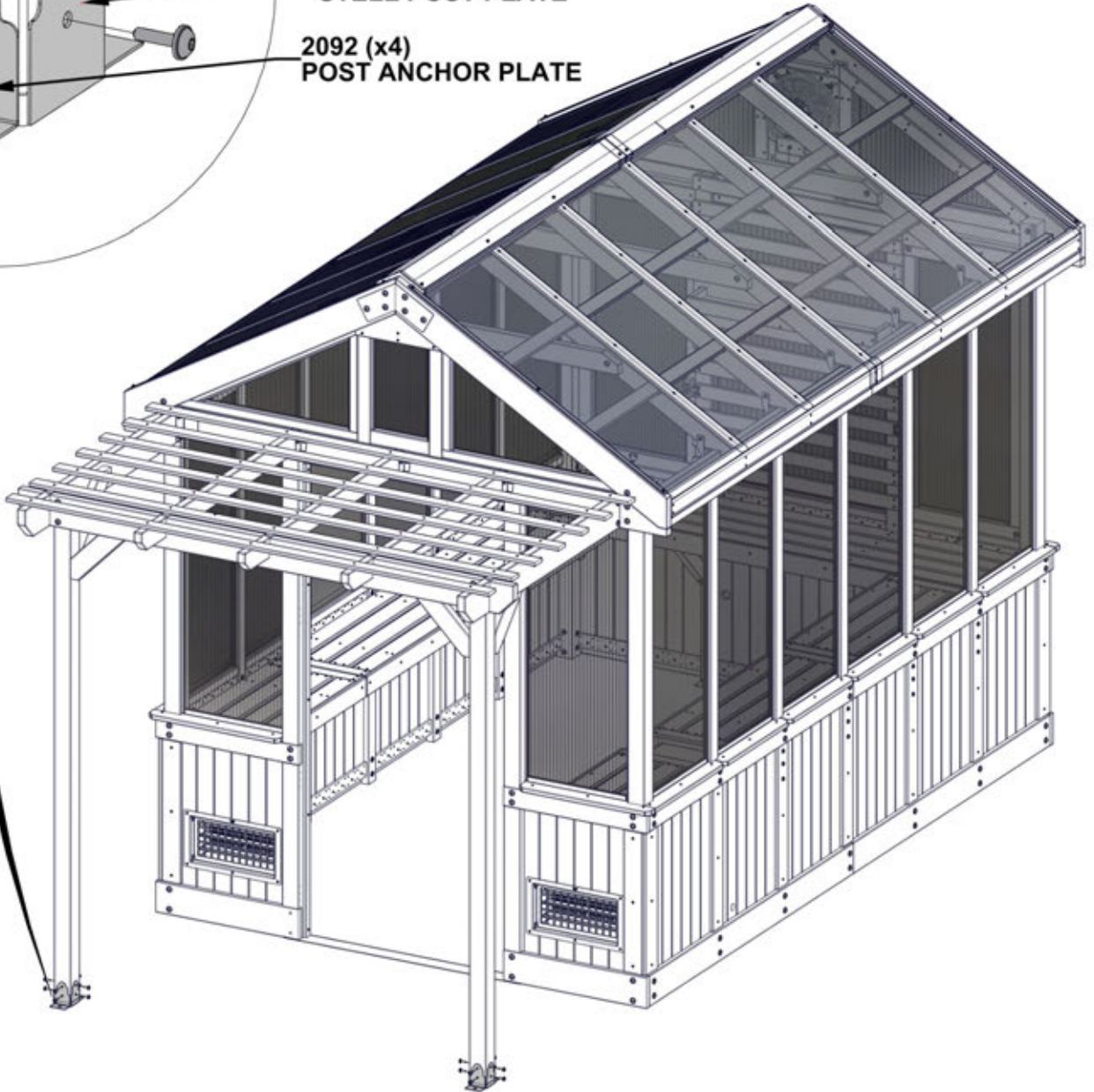


- 2092 POST ANCHORING PLATES GO ON FRONT AND BACK OF POSTS.
- 2089 STEEL POST PLATES GO ON BOTH SIDES OF POSTS.

460 (x16)
LAG SCREW - 1"

2089 (x4)
STEEL POST PLATE

2092 (x4)
POST ANCHOR PLATE



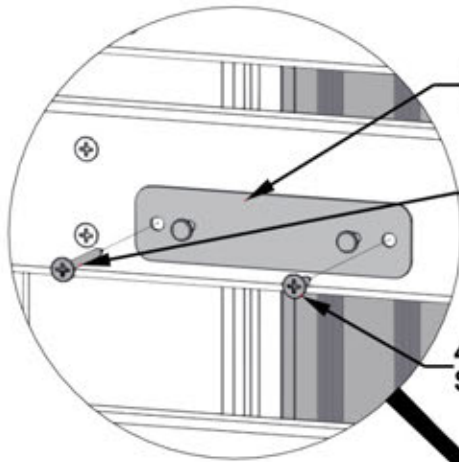
STEP 145 - BACK WALL ASSEMBLY

QTY	PART NUMBER	DESCRIPTION
2	H100200	SCREW PFH 8x1 1/2 BLK
2	H100411	SCREW PFH 8x5/8 BLK



A4M01292 MOUNTING BRACKET
(x2)

INCLUDED WITH THE ELECTRICAL ENCLOSURE



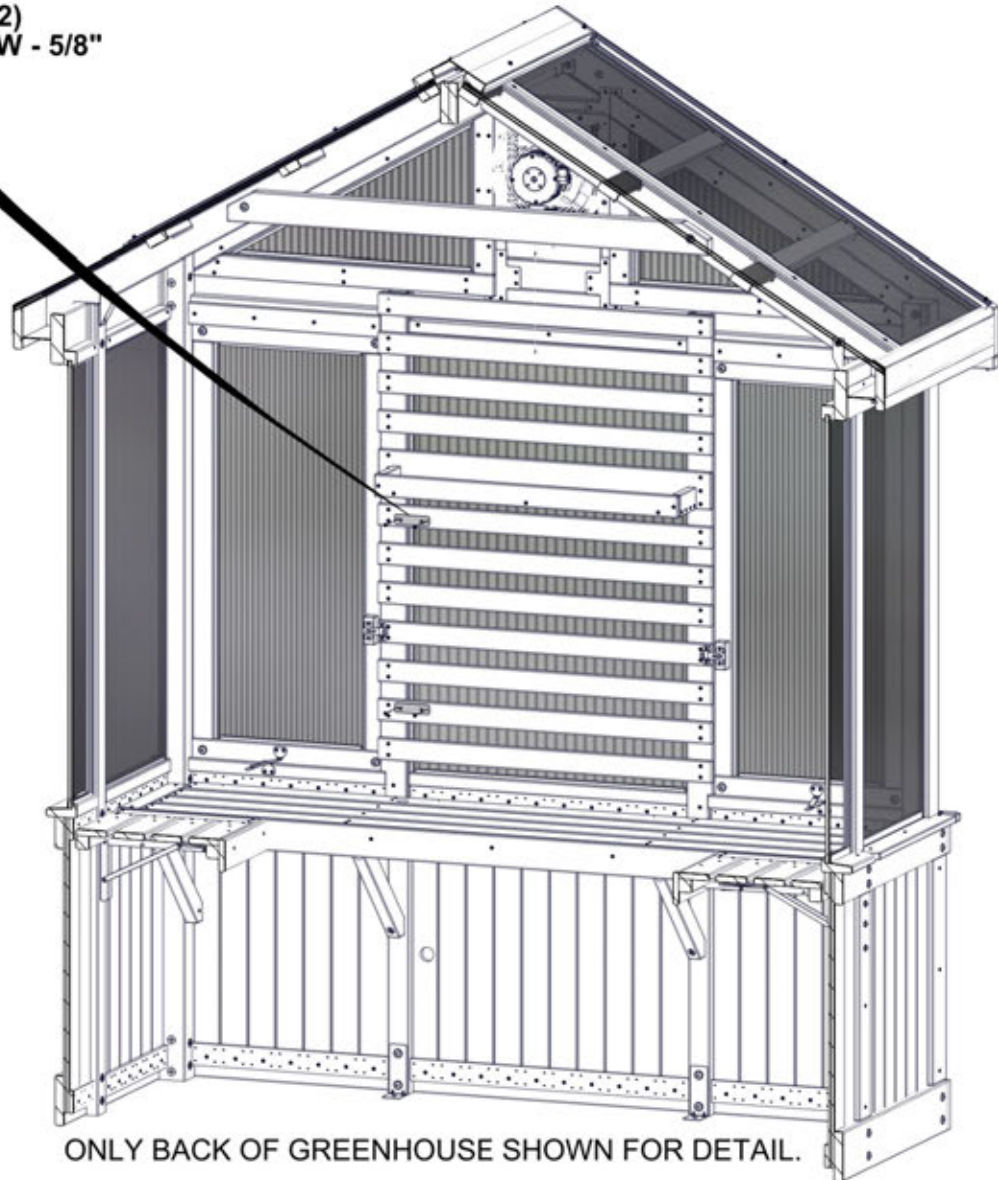
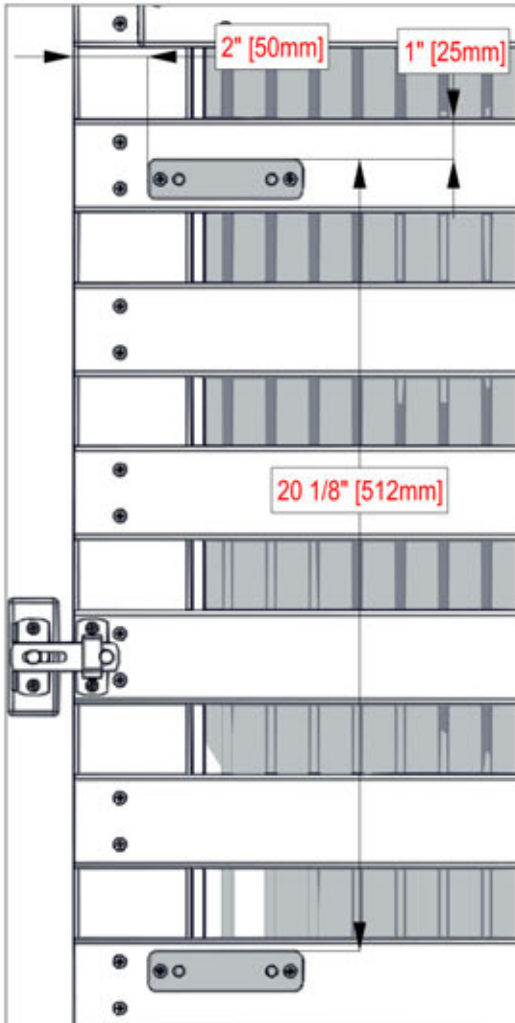
1292 (x2)
MOUNTING BRACKET

200 (x2)
SCREW - 1 1/2"

LONGER SCREWS ATTACH TO UPRIGHT ON BOTH BRACKETS.

411 (x2)
SCREW - 5/8"

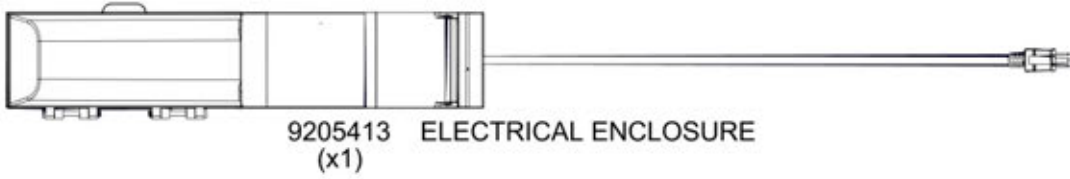
- DRILL PILOT HOLES USING AN 1/8" [3mm] DRILL BIT.
- USE MOUNTING BRACKETS AND DIMENSIONS AS A GUIDE.



ONLY BACK OF GREENHOUSE SHOWN FOR DETAIL.

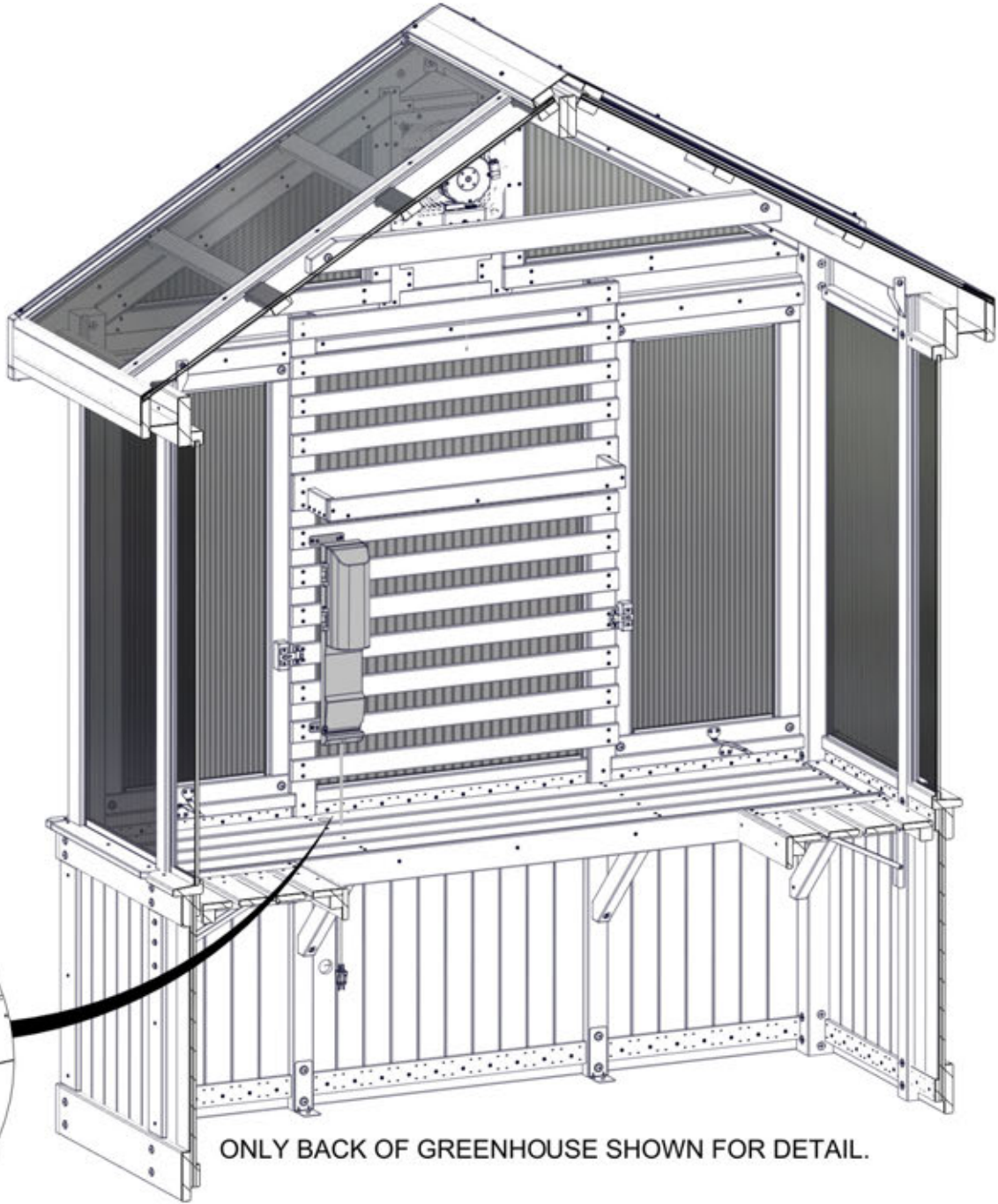
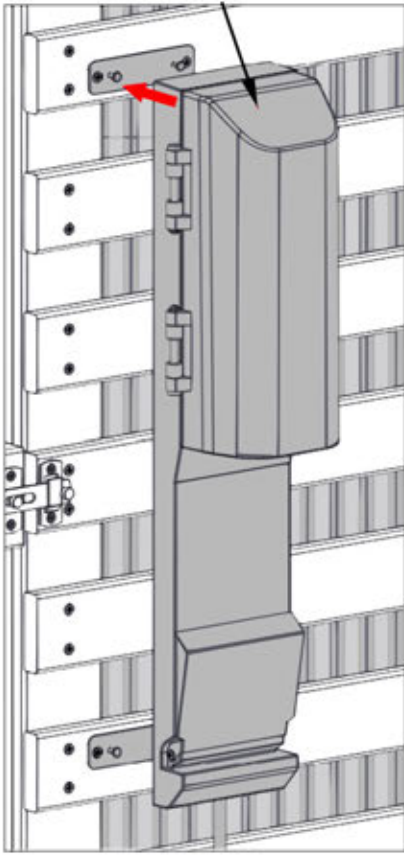
ATTACH BRACKETS USING DIMENSIONS GIVEN.

STEP 147 - BACK WALL ASSEMBLY



HANG ELECTRICAL ENCLOSURE ON THE MOUNTING BRACKETS, THEN RUN ELECTRICAL CORD THROUGH HOLE IN TABLE AS SHOWN.

413 (x1)
ELECTRICAL ENCLOSURE

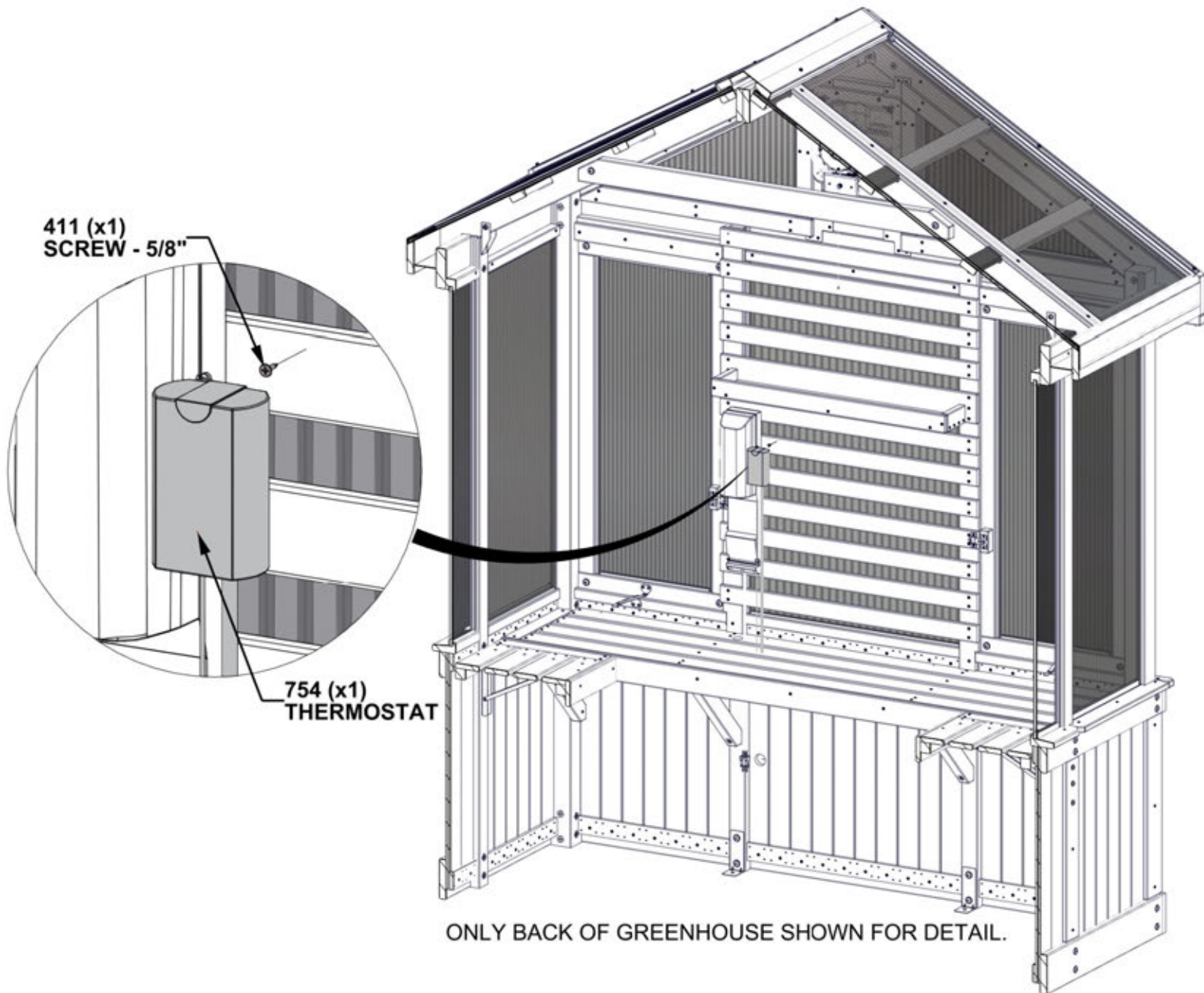


STEP 148 - BACK WALL ASSEMBLY

QTY	PART NUMBER	DESCRIPTION
1	H100411	SCREW PFH 8x5/8 BLK



- NOTES:
- LOCATE THERMOSTAT IN A DESIRED LOCATION CLOSE TO THE ELECTRICAL ENCLOSURE.
 - INSTALL SCREW LEAVING IT PARTIALLY STICKING OUT AND HANG ON THERMOSTAT.
 - HANG THE PROBE IN AN ELEVATED LOCATION.

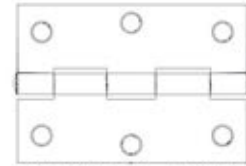


STEP 149 - DOOR ASSEMBLY

QTY	PART NUMBER	DESCRIPTION
12	H100385	SCREW PFH 8x1 BLK

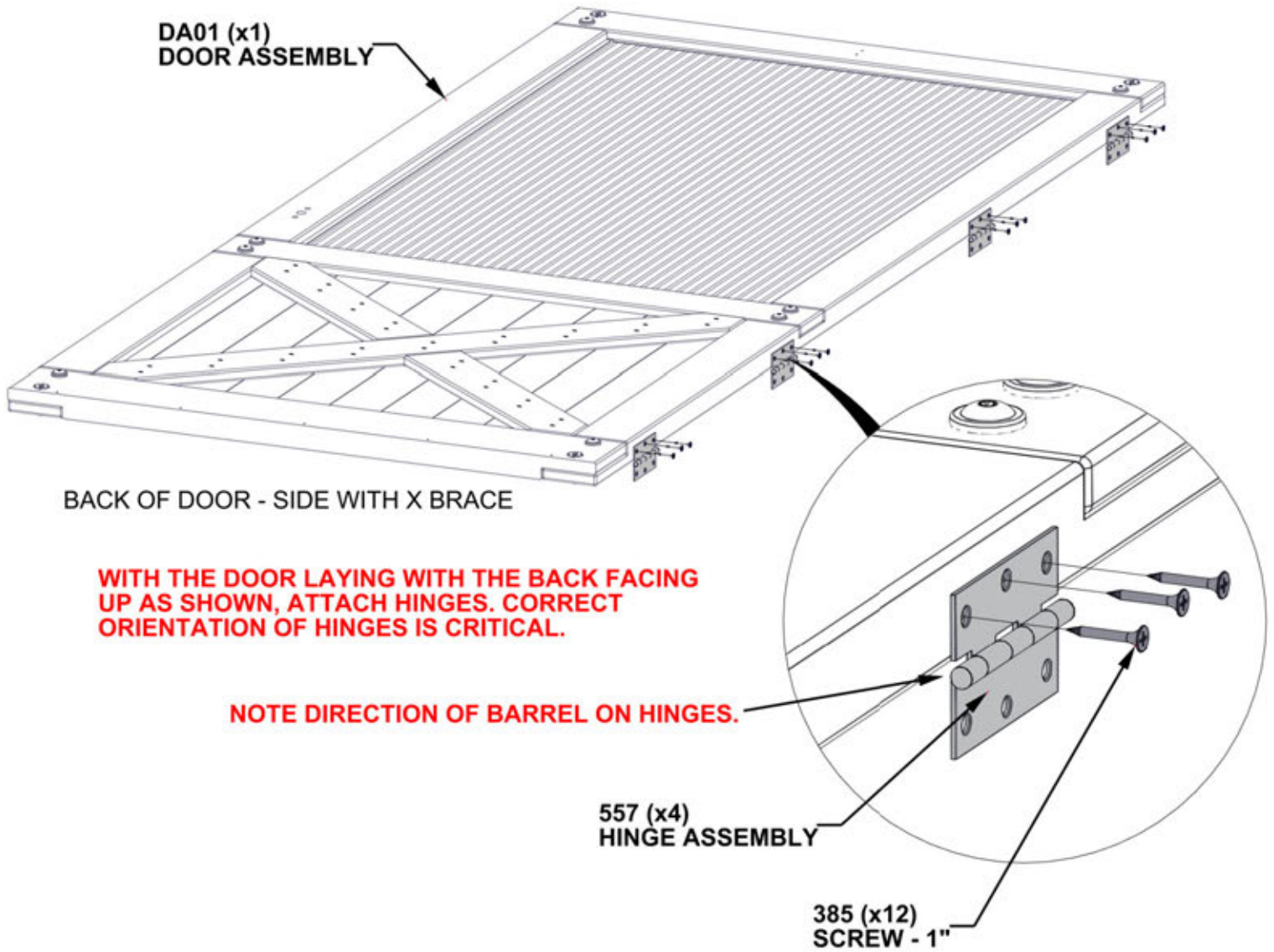


DA01 DOOR ASSEMBLY - W2A04009
(x1) 1 7/8"x36 9/16"x80" (48x928x2032)



A4M00557 HINGE
(x4)

ALIGN PILOT HOLES IN HINGES WITH PILOT HOLES ON DOOR.



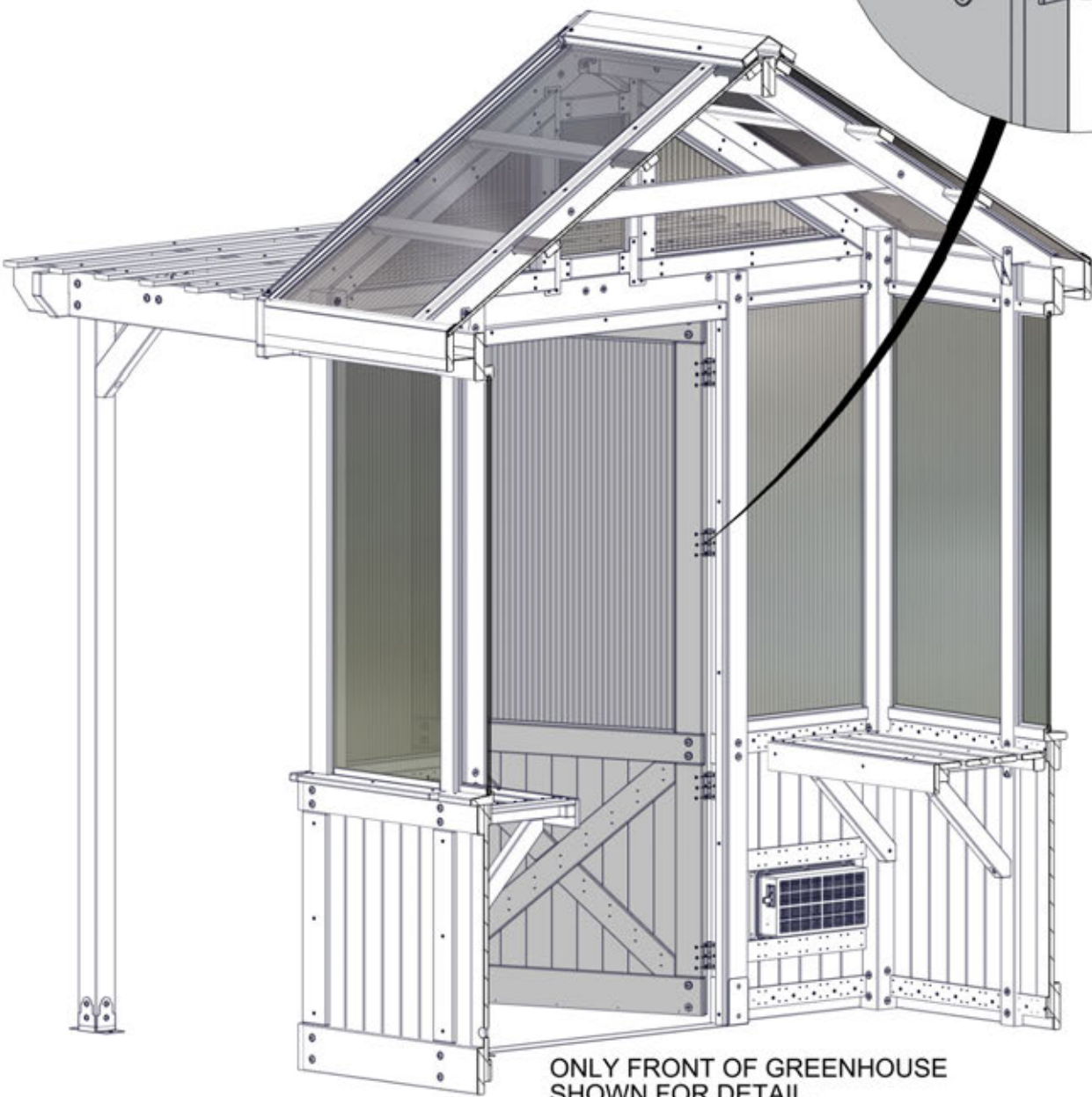
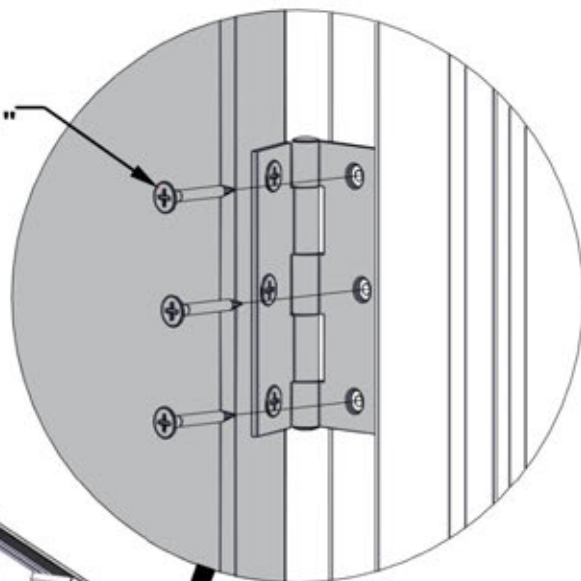
STEP 150 - DOOR ASSEMBLY

QTY	PART NUMBER	DESCRIPTION
12	H100385	SCREW PFH 8x1 BLK

LIFT DOOR INTO PLACE AND ATTACH AS SHOWN.

**ALIGN HOLES IN HINGES WITH
PILOT HOLES IN DOOR FRAME.**

385 (x12)
SCREW - 1"



ONLY FRONT OF GREENHOUSE
SHOWN FOR DETAIL.

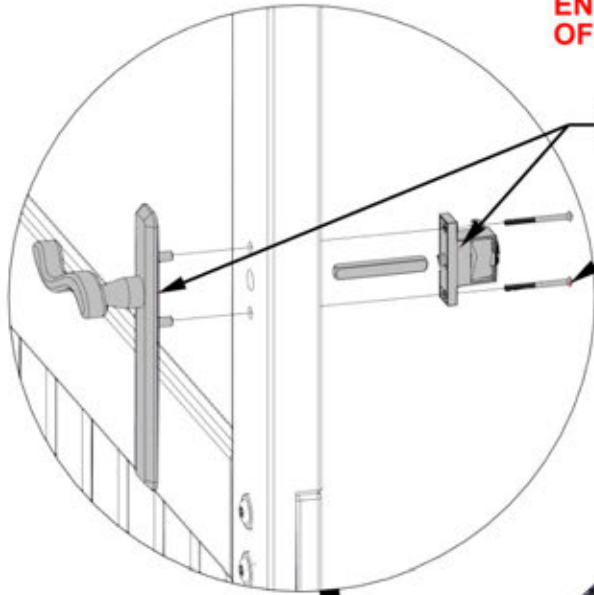
STEP 151 - DOOR ASSEMBLY

QTY	PART NUMBER	DESCRIPTION
2	H101259	SCREW POH 8x1 3/4 BLK



A4M02410 STORM DOOR HANDLE
(x1)

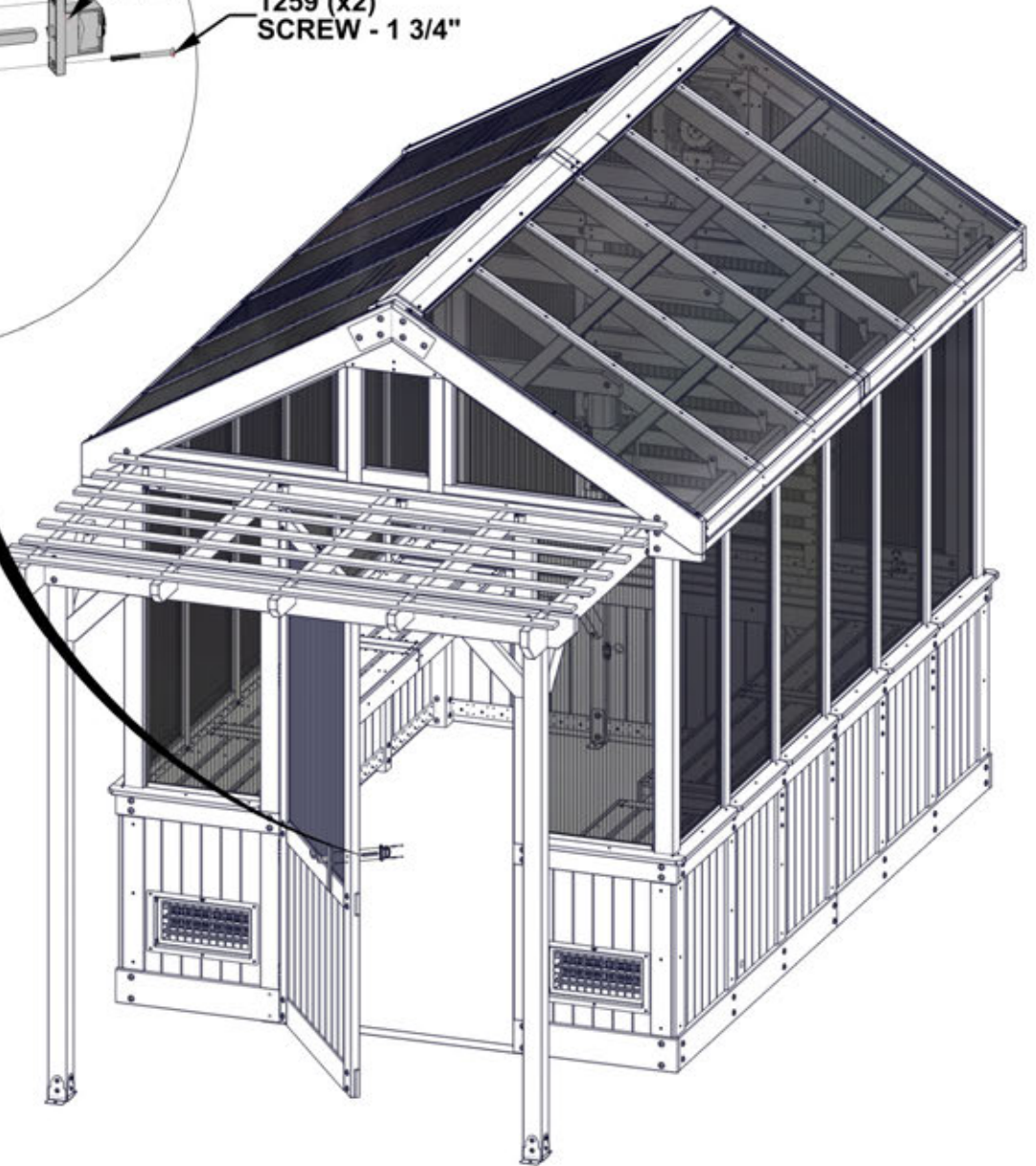
**ENSURE CORRECT ORIENTATION
OF DOOR HANDLE AS SHOWN.**



2410 (x1)
STORM DOOR HANDLE

1259 (x2)
SCREW - 1 3/4"

USE SCREWDRIVER. DO
NOT OVERTIGHTEN.

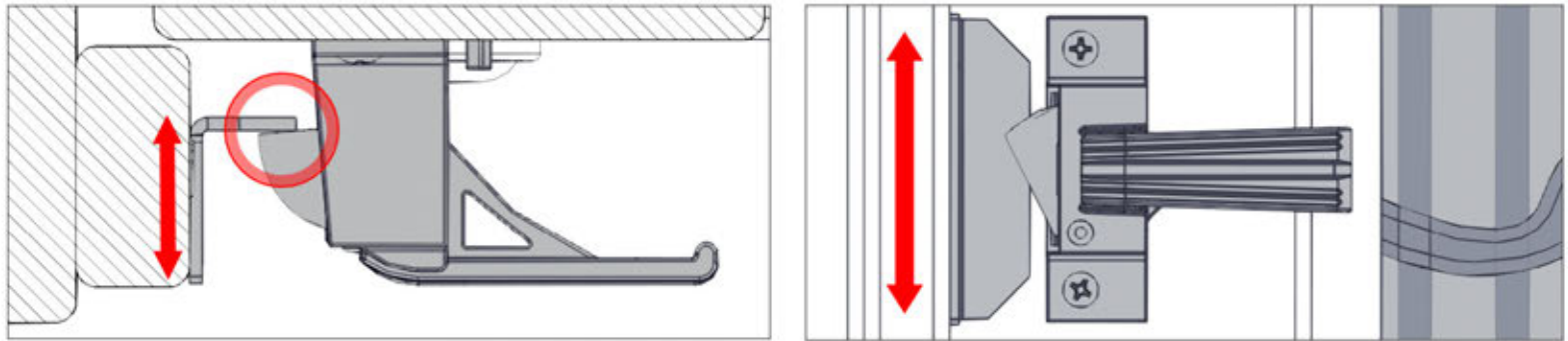


STEP 152 - DOOR ASSEMBLY

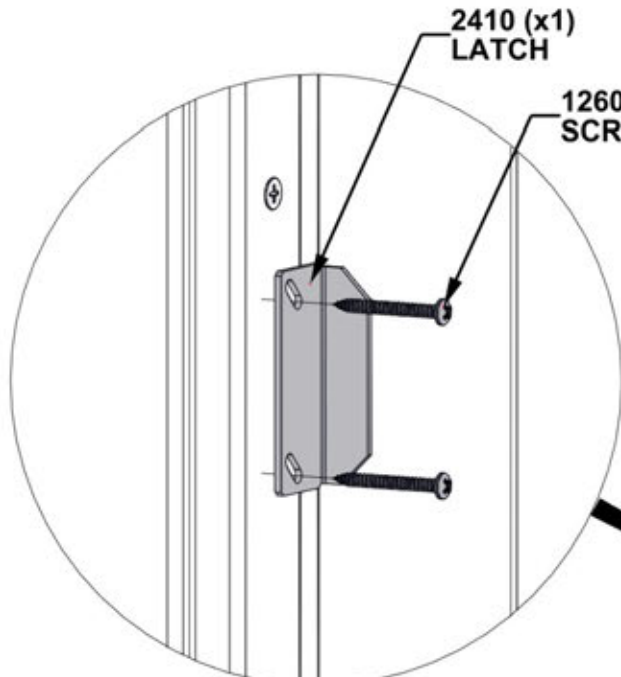
QTY	PART NUMBER	DESCRIPTION
2	H101260	SCREW PRH 8x1 1/4 SS



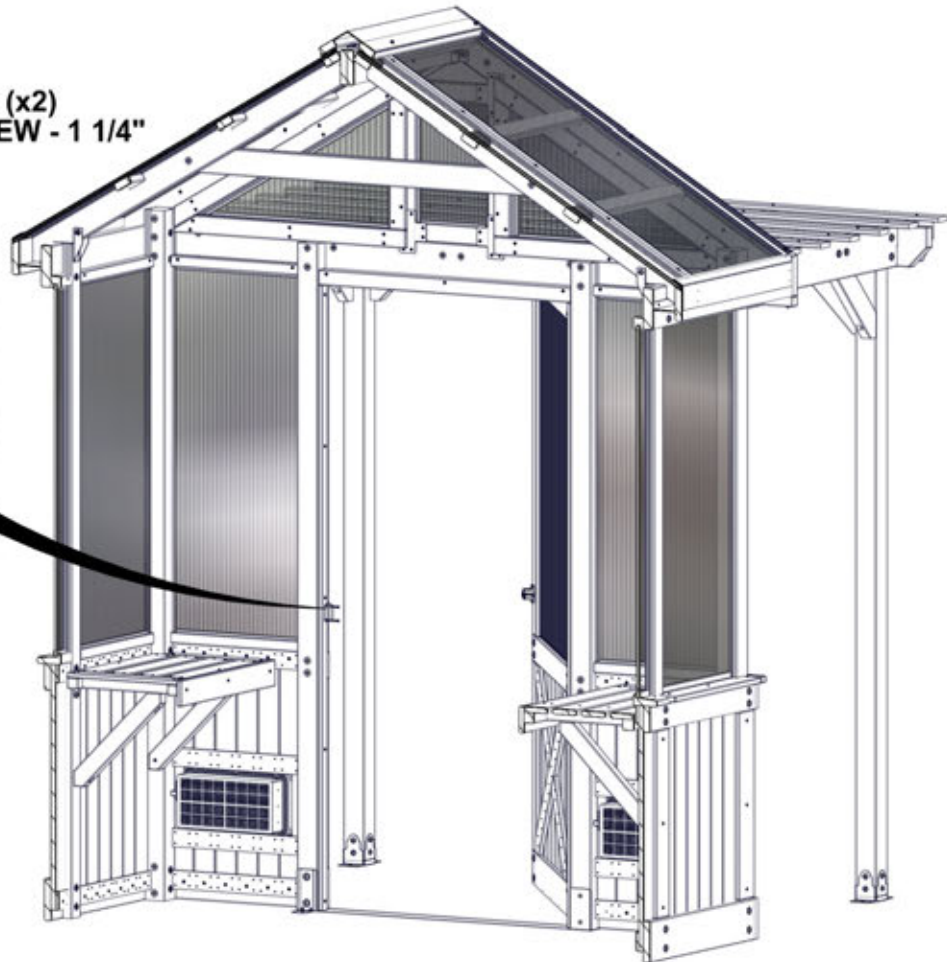
A4M02410 STORM DOOR HANDLE LATCH
(x1)



WITH THE DOOR SHUT, POSITION THE DOOR LATCH AS SHOWN. ADJUST FRONT TO BACK TO ENSURE THE LATCH MAKES CONTACT AS SHOWN. ADJUST UP AND DOWN TO ENSURE THE LATCH IS CENTERED WITH THE HANDLE AS SHOWN. MARK THE SLOTTED HOLE LOCATIONS AND PRE-DRILL WITH AN 1/8" [3mm] DRILL BIT.



ATTACH USING PILOT HOLES.



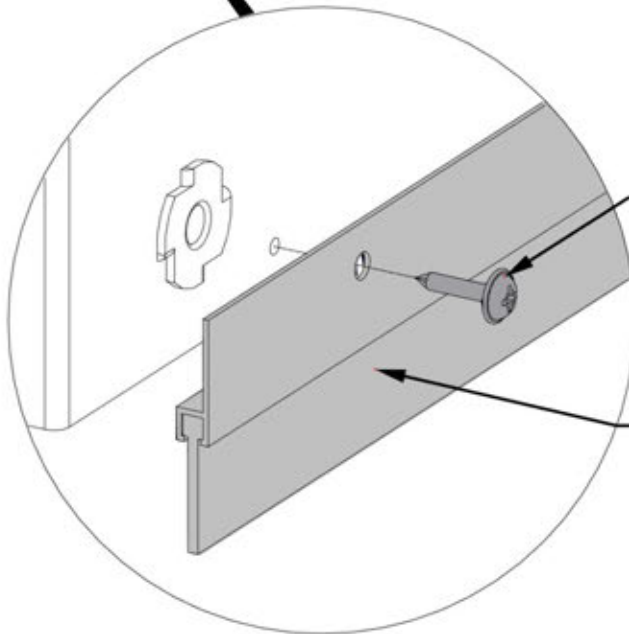
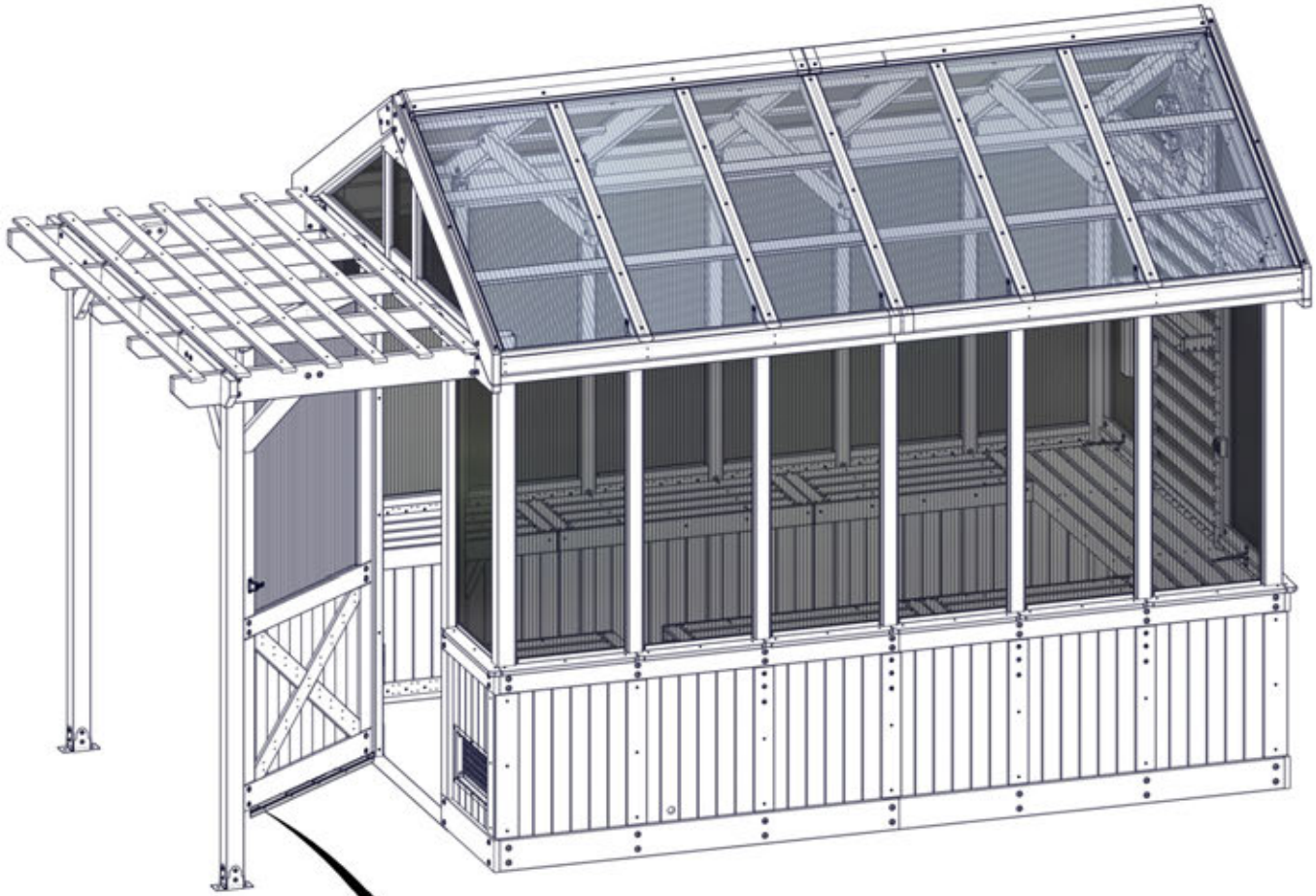
ONLY FRONT OF GREENHOUSE SHOWN FOR DETAIL.

STEP 153 - DOOR ASSEMBLY

QTY	PART NUMBER	DESCRIPTION
5	H100202	SCREW PWH 8x5/8 BLK



A4M02532 DOOR SWEEP
(x1)



202 (x5)
SCREW - 5/8"

ATTACH DOOR SWEEP USING PILOT
HOLES IN DOOR ASSEMBLY AS SHOWN.

2532 (x1)
DOOR SWEEP

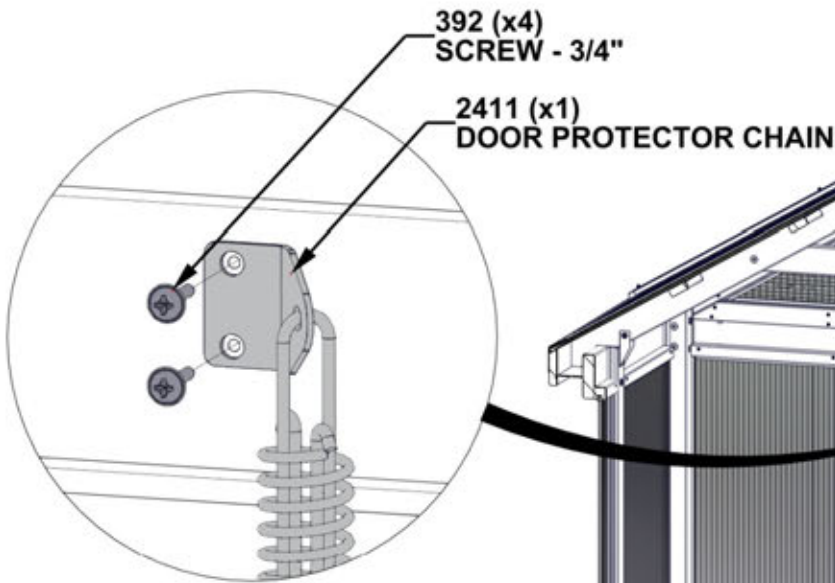
STEP 154 - DOOR ASSEMBLY

QTY	PART NUMBER	DESCRIPTION
4	H100392	SCREW PWH 8x3/4 BLK



A4M02411 DOOR PROTECTOR CHAIN
(x1)

ATTACH DOOR CHAIN IN APROXIMATE LOCATION AS SHOWN.



392 (x4)
SCREW - 3/4"

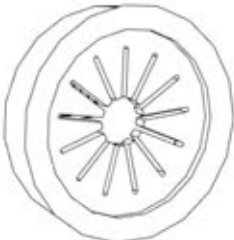
2411 (x1)
DOOR PROTECTOR CHAIN

ATTACH SPRING SIDE
BRACKET TO DOOR USING
PILOT HOLES AS SHOWN.

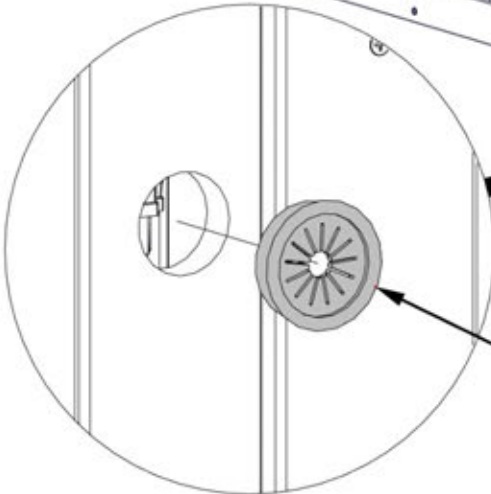
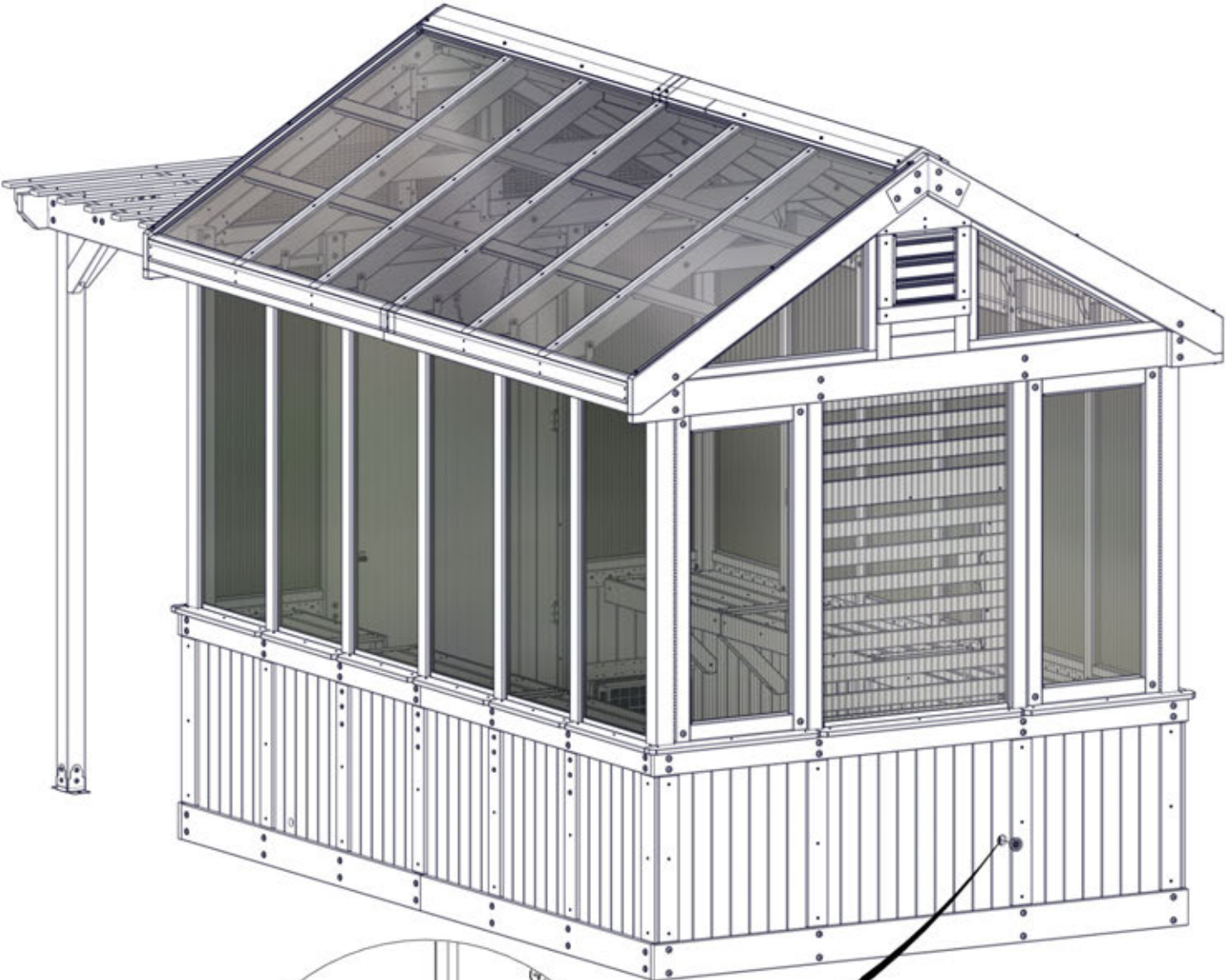


ONLY FRONT OF GREENHOUSE SHOWN FOR DETAIL.

STEP 155 - BACK WALL ASSEMBLY



A6P00692 CORD GROMMET
(x1)



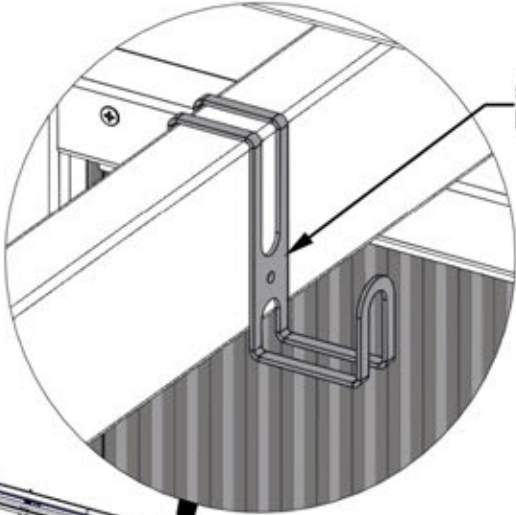
0692 (x1)
CORD GROMMET

STEP 156 - ROOF ASSEMBLY

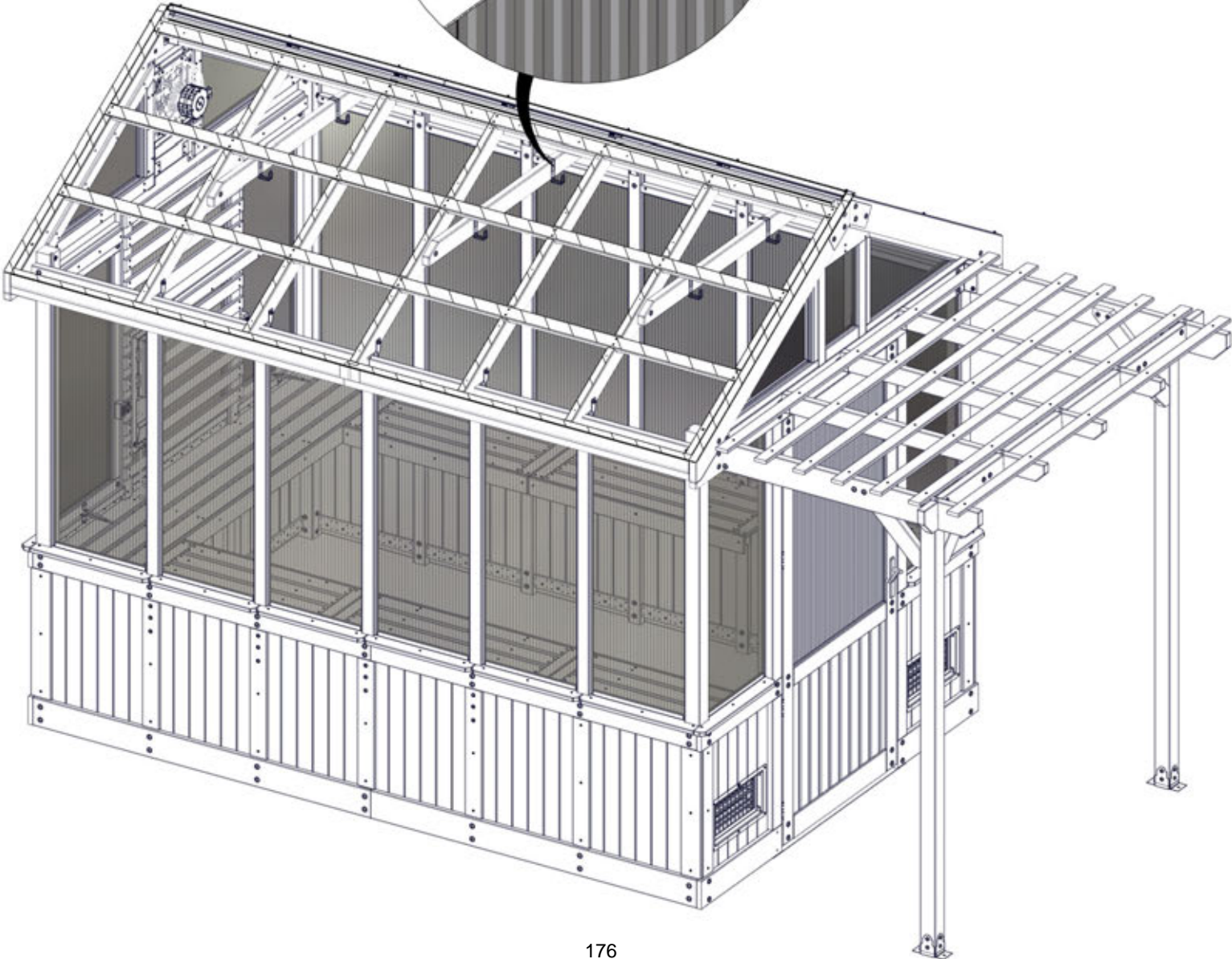


A4M01591 HOOK
(x6)

HOOKS FIT OVER ANY JOIST
OR PERGOLA RAFTER.



591 (x6)
HOOK



STEP 157 - WATER LINE ASSEMBLY



A4M02384 SPIGOT
(x1)



A6P00649 THREADED PIPE
CONNECTOR
(x1)



A6P00646 ELBOW 1/2" NPT
(x2)

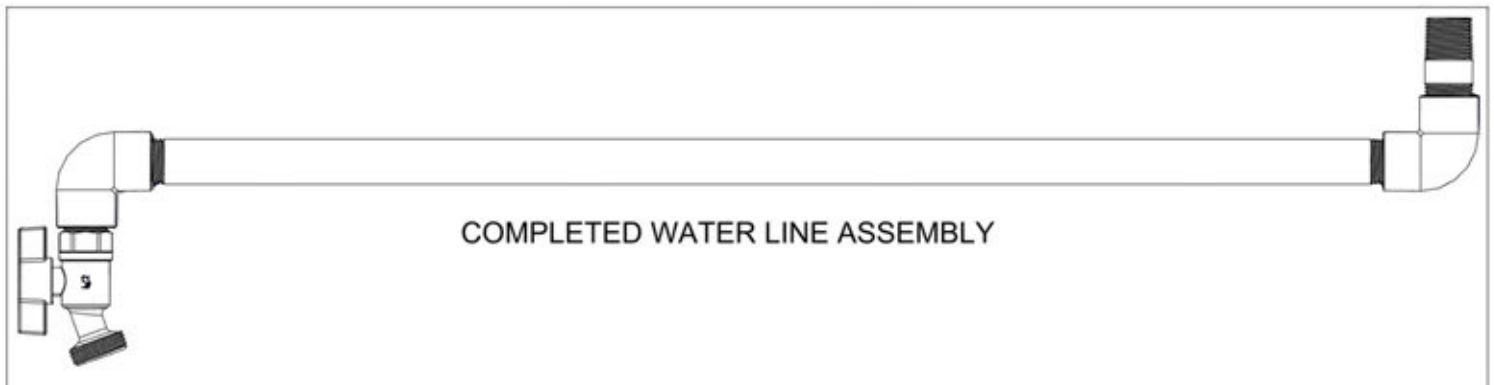
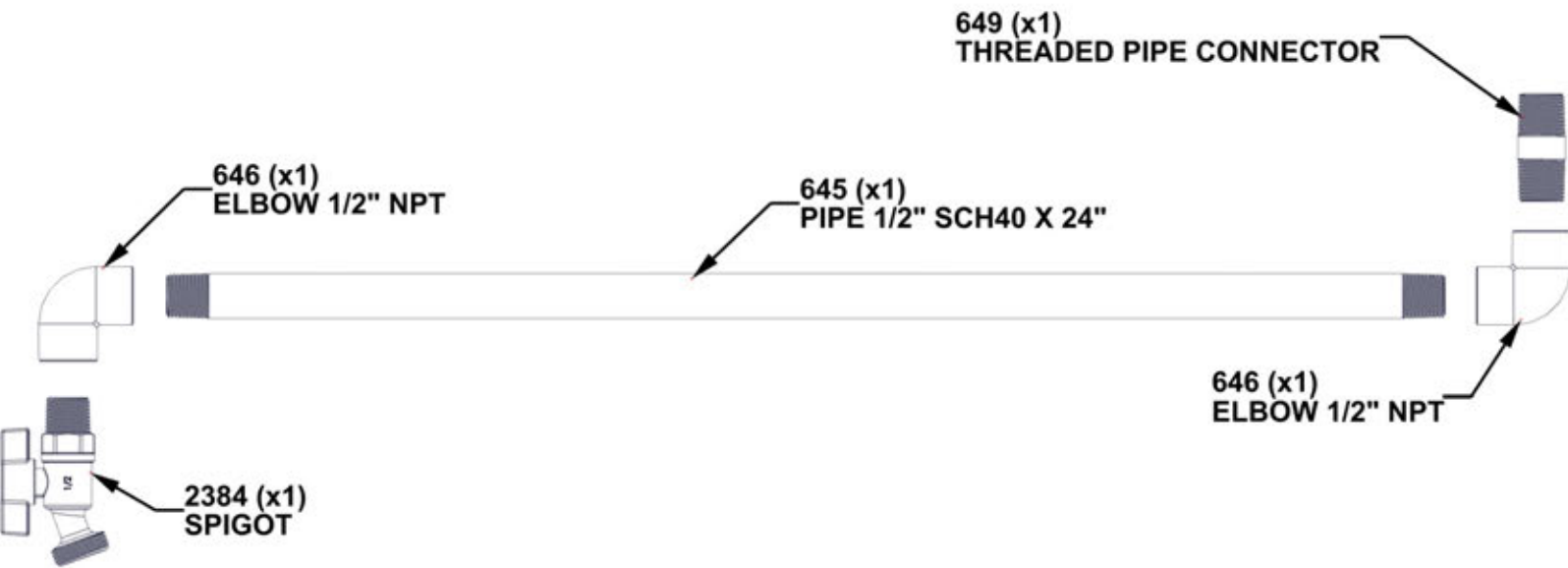


A6P00809 PLUMBERS TAPE



A6P00645 PIPE 1/2" SCH40 X 24"
(x1)

- USE PLUMBERS TAPE AND WRAP THREADS OF MALE FITTINGS.
- FASTEN FITTINGS TO FORM THE COMPLETED WATER LINE ASSEMBLY BELOW.



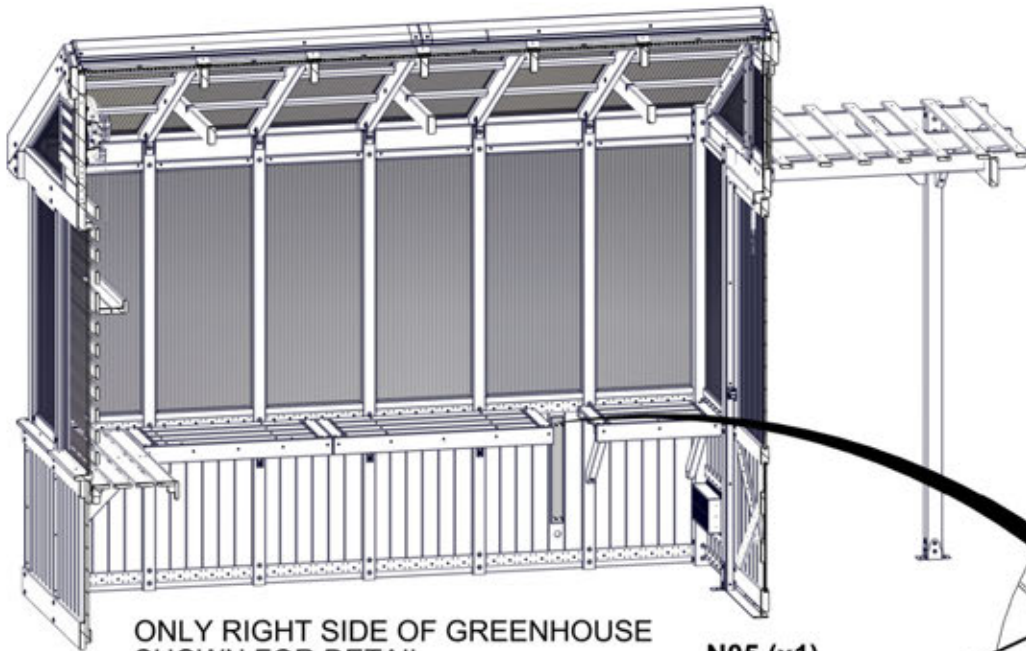
STEP 158 - WATER LINE ASSEMBLY

QTY	PART NUMBER	DESCRIPTION
4	H100380	SCREW PFH 8x1 1/8 BLK

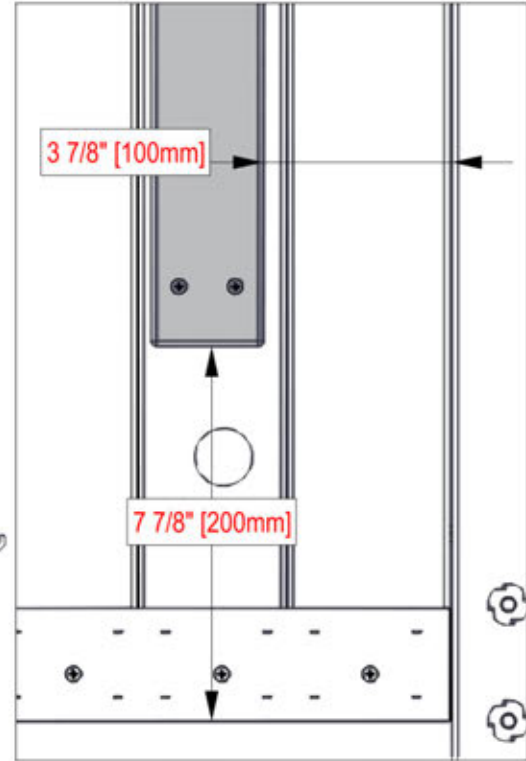


N05 SPIGOT BOARD - W4L19567
(x1) 5/8"x2 3/8"x20 11/16" (16x60x526)

- USE DIMENSIONS SHOWN TO LOCATE SPIGOT BOARD.
- USE THE SPIGOT BOARD AS A GUIDE TO DRILL PILOT HOLES WITH AN 1/8" [3mm] DRILL BIT.

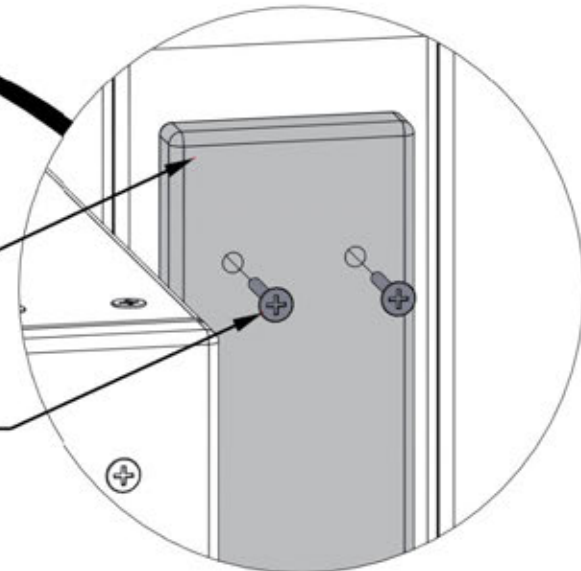


ONLY RIGHT SIDE OF GREENHOUSE SHOWN FOR DETAIL.



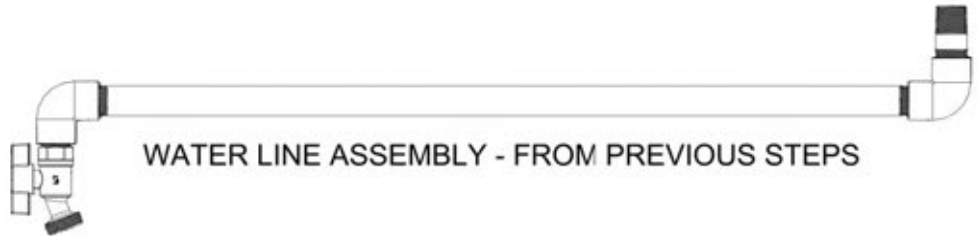
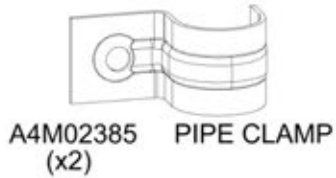
N05 (x1)
SPIGOT BOARD

380 (x4)
SCREW - 1 1/8"

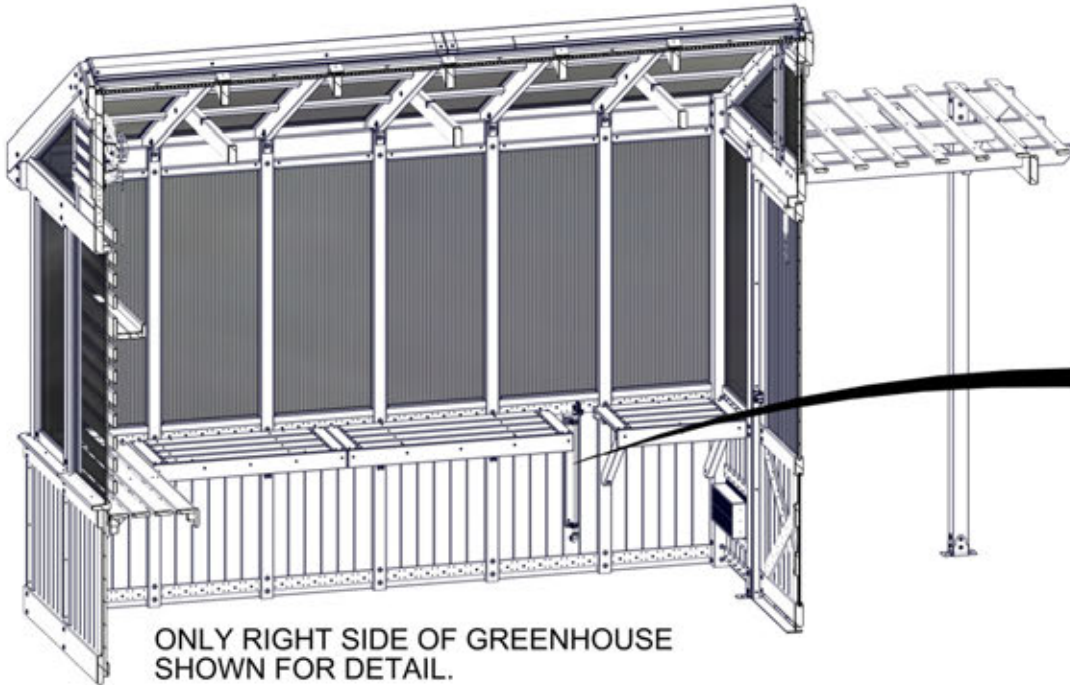
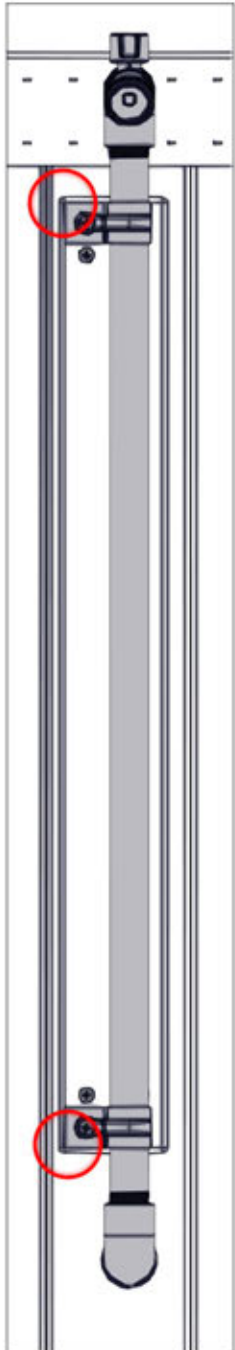


STEP 159 - WATER LINE ASSEMBLY

QTY	PART NUMBER	DESCRIPTION
2	H100385	SCREW PFH 8x1 BLK



- INSERT WATER LINE ASSEMBLY THROUGH HOLE IN WALL PANEL.
- SECURE WATER LINE TO BOARD FROM PREVIOUS STEP WITH PIPE CLAMPS.
- PRE-DRILL WITH AN 1/8" [3mm] DRILL BIT WITH CLAMPS LINED UP IN POSITION.
- FASTEN CLAMPS FLUSH TO OUTSIDE CORNERS AS SHOWN.



STEP 160 - WATER LINE ASSEMBLY



A6P00648 THREADED HOSE FITTING
(x1)



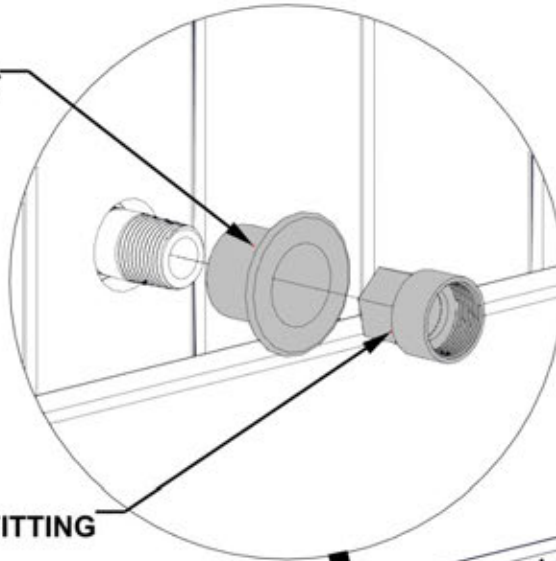
A6P00577 RUBBER GROMMET
(x1)



A6P00809 PLUMBERS TAPE

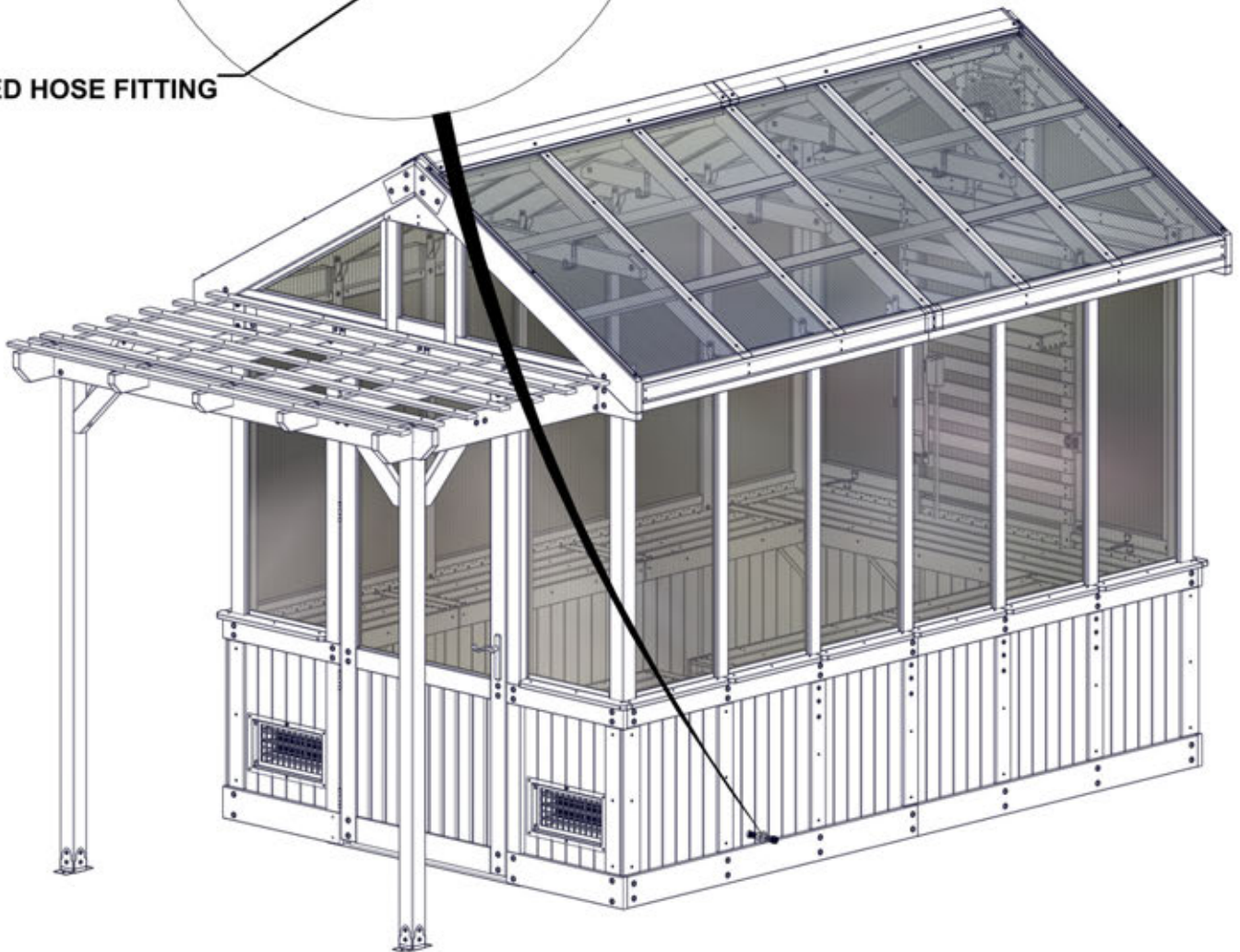
- PUSH RUBBER GROMMET IN HOLE AROUND THE WATER LINE ASSEMBLY FROM PREVIOUS STEPS.
- USE PLUMBERS TAPE AND WRAP THREADS OF MALE FITTINGS.
- FASTEN THREADED HOSE FITTING.

0577 (x1)
RUBBER GROMMET



**INSTALL RUBBER GROMMET
BEFORE THREADED HOSE FITTING.**

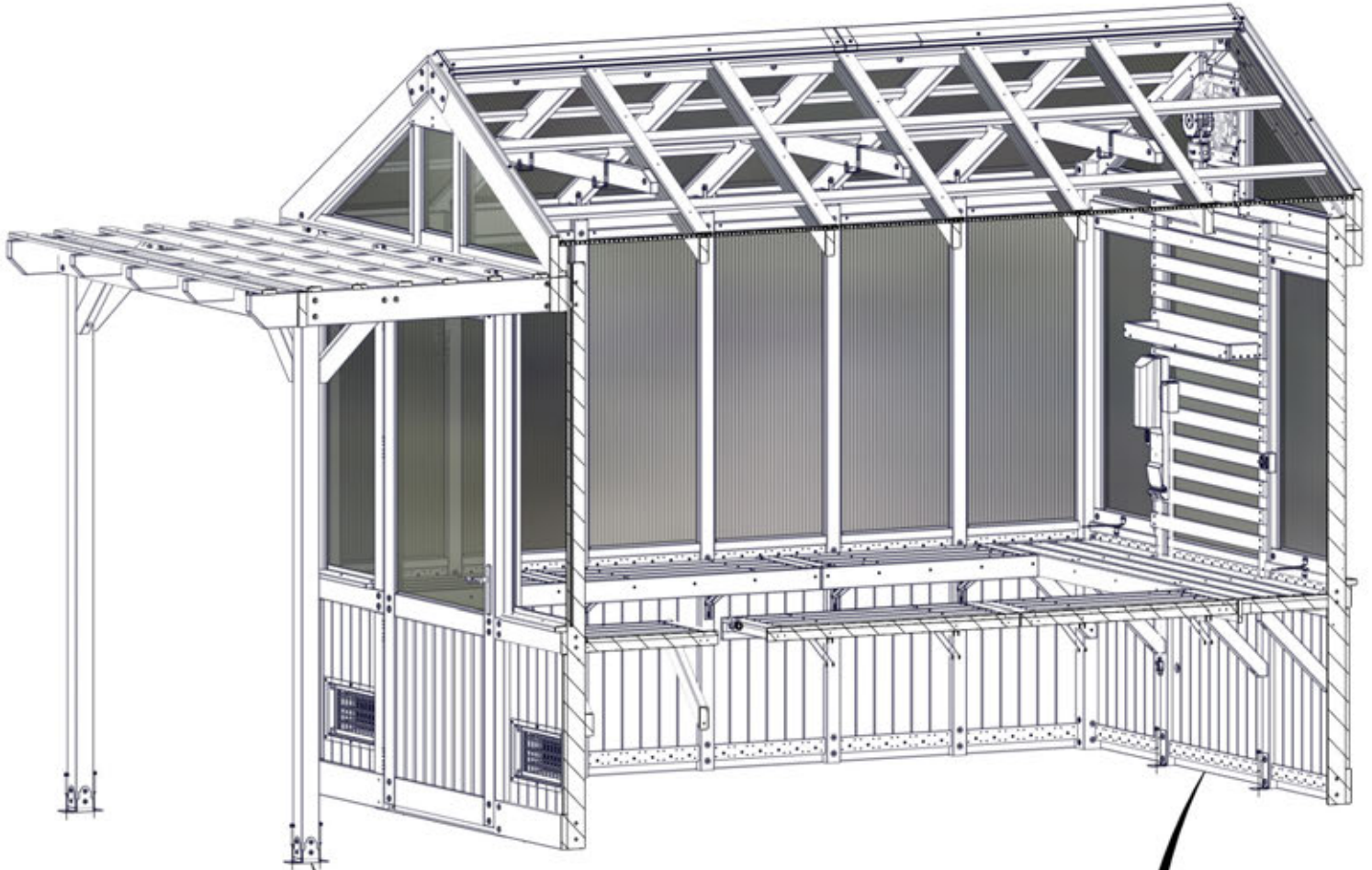
0648 (x1)
THREADED HOSE FITTING



STEP 161 - ANCHORING

QTY	PART NUMBER	DESCRIPTION
8	H101165	CONCRETE ANCHOR 3/8x3" BLK

IF GREENHOUSE IS NOT ON A CONCRETE SURFACE, SEE STEP 162 FOR ANCHORING STRUCTURE.



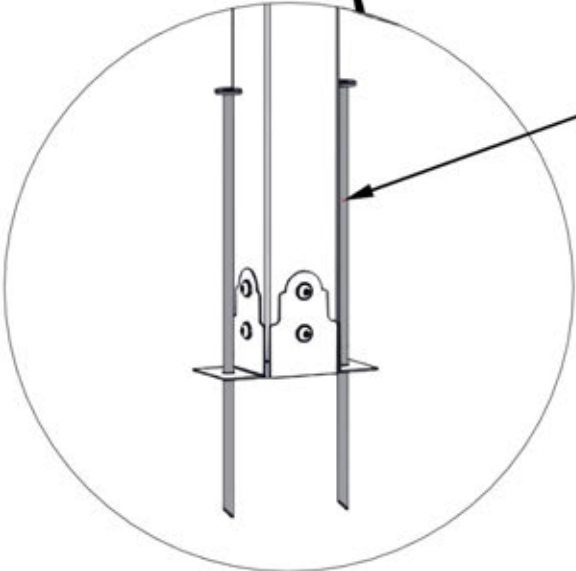
**1165 (x8)
CONCRETE ANCHOR-3"**

**PRE-DRILL HOLES FOR
CONCRETE ANCHORS USING A
5/16" [8mm] CONCRETE DRILL BIT.**

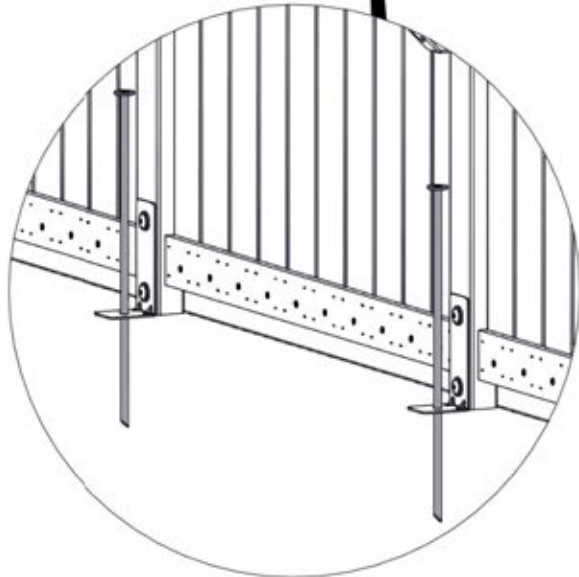
STEP 162 - ANCHORING



IF GREENHOUSE IS ON A CONCRETE SURFACE, SEE STEP 161 FOR ANCHORING STRUCTURE.

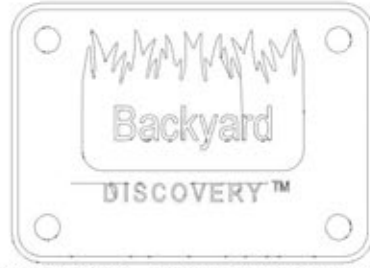


2091 (x8)
GROUND STAKE

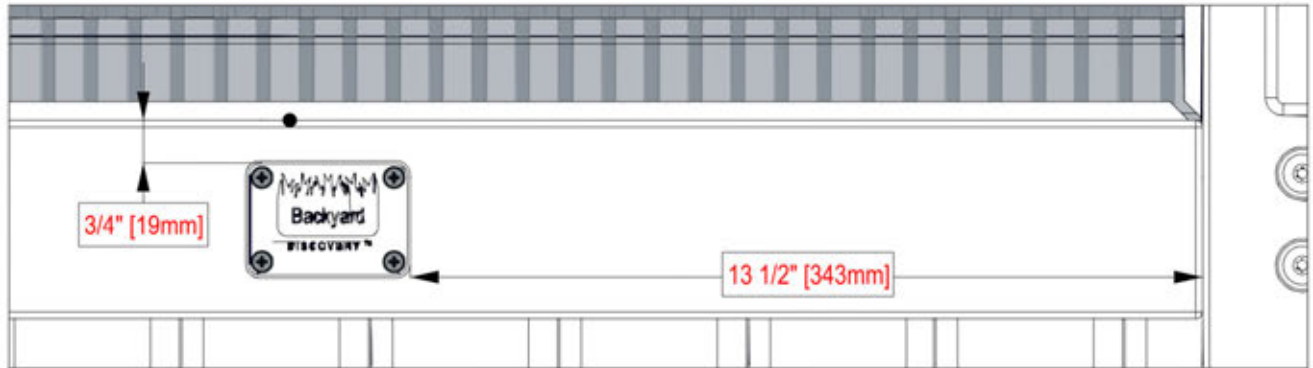


STEP 163 - DOOR ASSEMBLY

QTY	PART NUMBER	DESCRIPTION
4	H100202	SCREW PWH 8x5/8 BLK



A4M02158 BYD ID TAG PATIO
(x1)



CENTER ID TAG ON BOARD WITH MEASUREMENTS GIVEN.

2158 (x1)
BYD ID TAG PATIO

202 (x4)
SCREW - 5/8"

