



Manufactured by:
Backyard Discovery
3305 Airport Drive, Pittsburg, KS 66762
800-856-4445

*Basepoint Business Centre: Rivermead Drive, Westlea, Swindon SN5 7EX Phone: 0800-118-2476
J.P. Coenstraat 7, The Bridge, The Hague, 2595 WP, Netherlands Phone: 08005678990*

HUTCH / SERVING STATION

MODEL #: 2304116



Please visit www.backyarddiscovery.com
For the most up to date assembly manual, to register your product, or to order
replacement parts Para obtener instrucciones en español, visite
www.backyarddiscovery.com

OWNER'S MANUAL - BASIC SETUP DIMENSIONS & ASSEMBLY NOTES

- Pay close attention to the items needed for each step. Make sure you are using the correct hardware for each step. Using incorrect hardware may result in improper assembly.

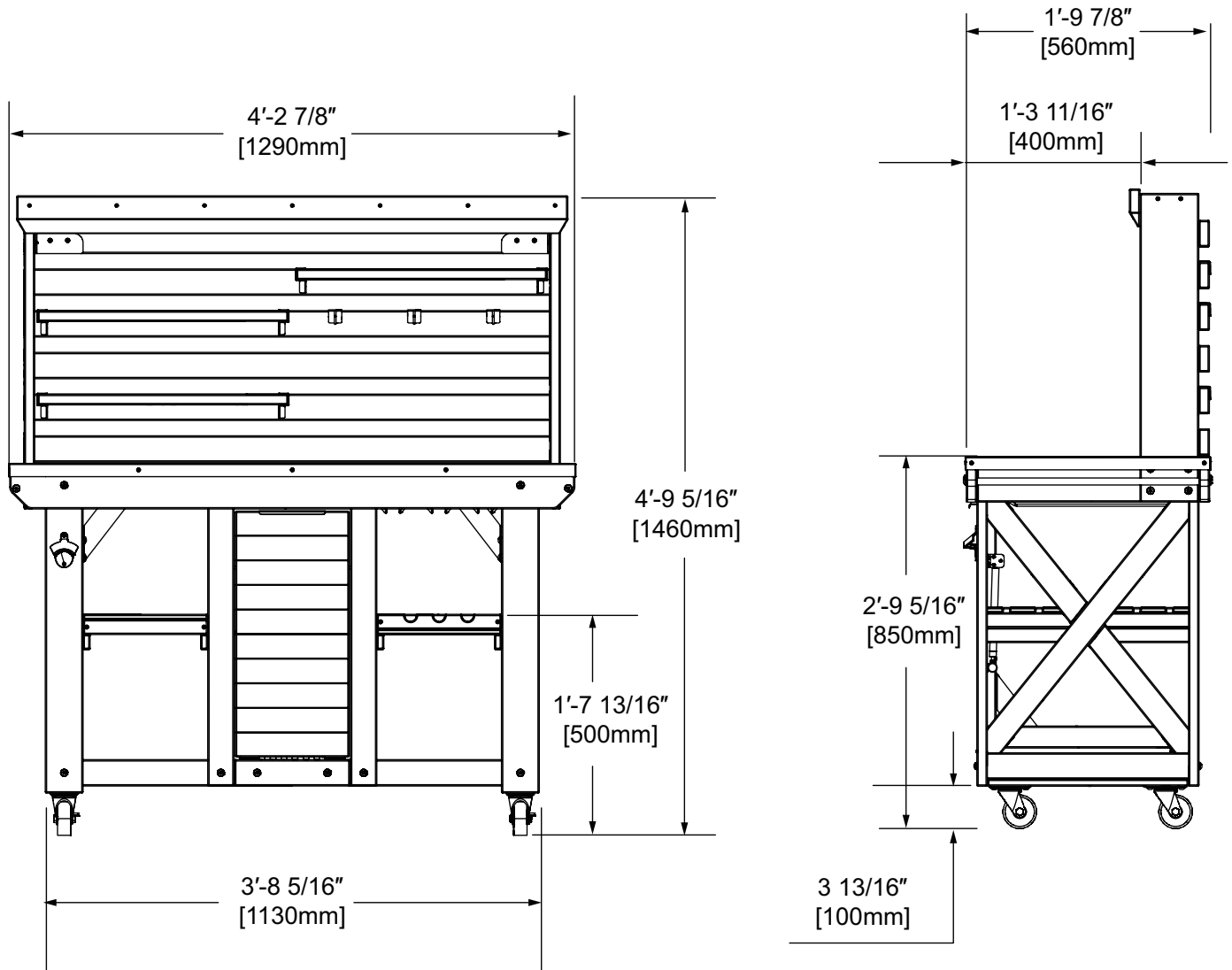

OWNER'S MANUAL - PARTS IDENTIFICATION

WOOD COMPONENTS (NOT TO SCALE)



FL1 - FRONT RIGHT LEG - W2A04482
(x1) 15/16"x3 3/8"x29 1/2" (24x86x749)



FL2 - FRONT LEFT LEG - W2A04483
(x1) 15/16"x3 3/8"x29 1/2" (24x86x749)



CB1 - CROSS BRACE - W4L18892
(x2) 15/16"x2 3/8"x29 3/8" (24x60x746)



TR1 - TABLE BACK LONG RAIL - W4L18894
(x1) 15/16"x4"x50 11/16" (24x102x1287)



TR2 - TABLE FRONT LONG RAIL - W4L18895
(x1) 15/16"x4"x50 11/16" (24x102x1287)



MV1 - MIDDLE LEFT BACK VERTICAL - W4L18896
(x1) 15/16"x2 3/8"x27 15/16" (24x60x709)



MV2 - MIDDLE LEFT FRONT VERTICAL - W4L18897
(x1) 15/16"x2 3/8"x27 15/16" (24x60x709)



DB1 - DRAWER SIDE BOARD - W4L20011
(x1) 5/8"x1 15/16"x16 1/2" (16x50x420)



DB2 - DRAWER BACK BOARD - W4L20012
(x1) 5/8"x2 3/8"x9 1/2" (16x60x241)



TA1 - TABLE SHORT RAIL - W2A04018
(x2) 15/16"x4"x19 7/8" (24x102x505)



BL1 - BACK RIGHT LEG - W2A04484
(x1) 15/16"x3 3/8"x29 1/2" (24x86x749)



BL2 - BACK LEFT LEG - W2A04485
(x1) 15/16"x3 3/8"x29 1/2" (24x86x749)

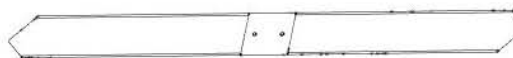

CB2 - CROSS BRACE - W4L18893
(x2) 15/16"x2 3/8"x29 3/8" (24x60x746)



SB1 - SUPPORT BOARD - W4L18900
(x4) 5/8"x1 5/16"x19 15/16" (16x34x506)



BS3 - TOP MIDDLE SHORT CLEAT - W4L18903
(x2) 15/16"x15/16"x19 15/16" (24x24x506)



MV3 - MIDDLE RIGHT BACK VERTICAL - W4L18898
(x1) 15/16"x2 3/8"x27 15/16" (24x60x709)



MV4 - MIDDLE RIGHT FRONT VERTICAL - W4L18899
(x1) 15/16"x2 3/8"x27 15/16" (24x60x709)



DB3 - DRAWER SIDE BOARD - W4L20013
(x1) 5/8"x1 15/16"x16 1/2" (16x50x420)



BS1 - BOTTOM SLAT - W4L18901
(x1) 15/16"x2 3/8"x10 3/8" (24x60x263)



CB4 - CASTER BOARD - W2A04019
(x2) 5/8"x3 3/8"x17 15/16" (16x86x457)

OWNER'S MANUAL - PARTS IDENTIFICATION

WOOD COMPONENTS (NOT TO SCALE)

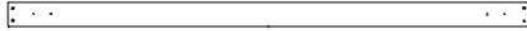

TS1 - TOP SLAT 1 - W4L18907
(x5) 15/16"x2 3/8"x48 1/16" (24x60x1221)



TS2 - TOP SLAT 2 - W4L18908
(x1) 15/16"x2 3/8"x48 1/16" (24x60x1221)

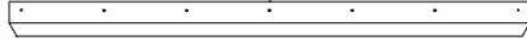

CB3 - CHAMFERED TOP BOARD - W4L18911
(x1) 15/16"x3 3/8"x 49 3/8" (24x86x1255)



BS4-CUP HANGER BOARD - W4L18904
(x2) 15/16"x15/16"x13 7/8" (24x24x352)



BH1-BOTTLE HOLD BOARD - W4L21182
(x2) 5/8"x2 3/8"x9 15/16" (16x60x250)



SB2-SHELF BOARD - W4L18910
(x3) 15/16"x5 1/4"x22 7/16" (24x134x570)



BS5 - BACK LEFT SHELF UPRIGHT - W4L18905
(x1) 15/16"x5 1/4"x27 11/16" (24x134x703)



BS6 - BACK RIGHT SHELF UPRIGHT - W4L18906
(x1) 15/16"x5 1/4"x27 11/16" (24x134x703)



TS3 TOP SHELF BOARD - W4L18909
(x1) 15/16"x5 1/4"x48 3/16" (24x134x1173)

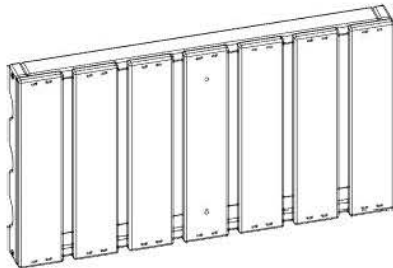

WR1-WINE RACK ASSY - W2A04016
(x2) 1 13/16"x11 1/8"x19 15/16" (46x283x506)

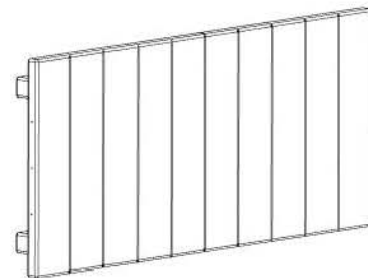

DA1 - DRAWER ASSY - W2A04017
(x1) 1 9/16"x10 3/16"x22 1/16" (40x259x560)

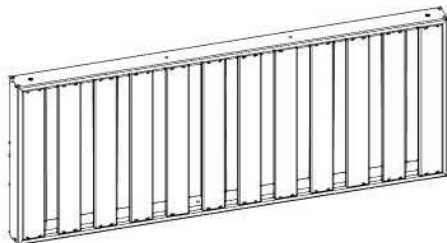

BP1 - BOTTOM PANEL - W2A04015
(x1) 2 3/8"x18"x44 5/16" (60x458x1125)

OWNER'S MANUAL - PARTS IDENTIFICATION

METAL COMPONENTS (NOT TO SCALE)

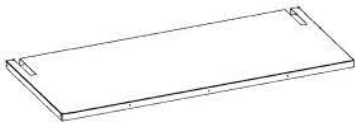
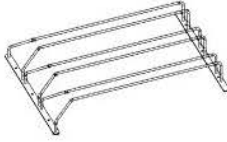
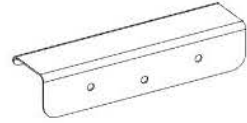

TABLE - A4M02543
(x1)



HANGER TUBE - A4M02541
(x1)



HANDLE - A4M02550
(x1)



CASTER - A4M02605
(x4)



TOWEL BAR - A4M02542
(x2)



TRASH CAN DOOR CHAIN - A4M04127
(x2)



PIANO HINGE - A4M02549
(x1)



TRASH SUPPORT - A4M02554
(x1)

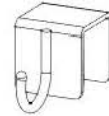

HOOK - A4M02548
(x3)

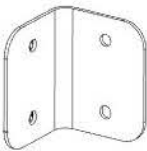

METAL BRACKET - A4M02540
(x6)

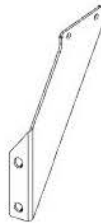

METAL ANGLE BRACE LEFT - A4M02539
(x2)



METAL ANGLE BRACE RIGHT - A4M02538
(x2)

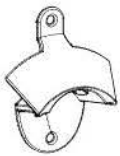

BOTTLE CAP OPENER - A4M01187
(x1)

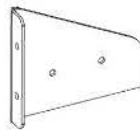

METAL ANGLE TOP BRACE LEFT - A4M02544
(x1)

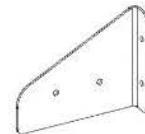

METAL ANGLE TOP BRACE RIGHT - A4M02545
(x1)

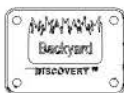

BYD ID TAG PATIO - A4M02158
(x1)

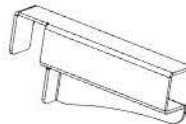

SHELF SUPPORT LEFT - A4M02547
(x3)

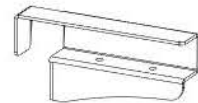

SHELF SUPPORT RIGHT - A4M02546
(x3)



TRASH SUPPORT - A4M02553
(x4)

OWNER'S MANUAL - PARTS IDENTIFICATION

HARDWARE COMPONENTS (NOT TO SCALE)

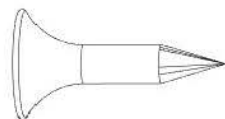

H100411 SCREW PFH
(x12) 8x5/8 BLK



H100823 SCREW PWH
(x7) 8X1 1/2 BLK



H100382 SCREW PFH
(x40) 8x1-3/4 BLK

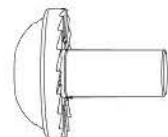

H100401 BOLT WH
(x16) 1/4x1/2 BLK



H100835 SCREW PWH
(x12) 8X2 BLK

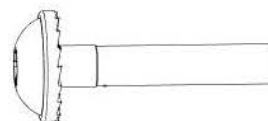

H100397 BOLT WH
(x6) 1/4x1-1/4 BLK

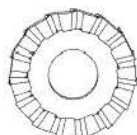

H100405 WASHER LOCK EXT
(x36) 6x15 BLK

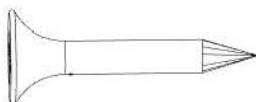

H100816 SCREW PFH
(x10) 8x7/8 BLK



H100387 SCREW PFH
(x10) 8x1-1/4 BLK

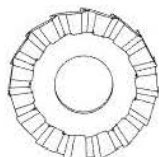

H100400 WASHER LOCK EXT
(x14) 8x15 BLK

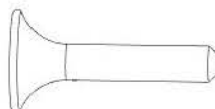

H101296 SCREW PFH-BLUNT TIP
(x6) 6x1/2



H100399 NUT BARREL WH
(x14) 1/4 X 7/8 BLK

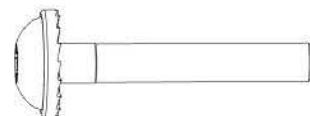

H100406 BOLT WH
(x30) 1/4x1 1/2 BLK (Lag)

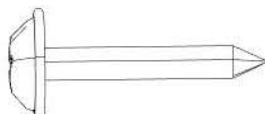

H100392 SCREW PWH
(x44) 8x3/4 BLK



H101069 SCREW PWH
(x6) 8X7/8 BLK

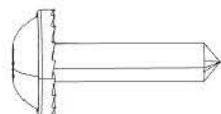

H100460 LAG SCREW WH
(x8) 1/4x1 BLK

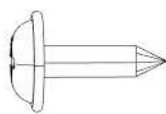

H100408 SCREW PWH
(x15) 8x1/2 BLK

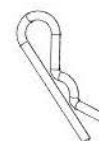

COTTER PIN - H101161
(x4)



H101100 MAGNETIC DRIVER
(x1)



H100147 T-30 TORX BIT
(x1)

H100114 T-30 TORX WRENCH
(x1)

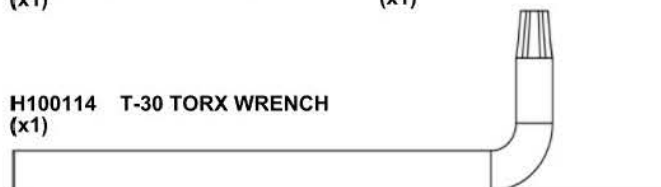

PRE-ASSEMBLY STEP 1 - SORTING PARTS

It is critical for ease of assembly that you take the time to sort and organize the wood and hardware.

WOOD PARTS:

- Organize wood parts by the three-digit, alpha-numeric number stamped on each board (ex. P01).
- If there are multiple boards with the same stamped number, stack those pieces together.
- Stamps can be found on the flat surface of the boards or on the end of the boards.
- Allow yourself plenty of room - the wood pieces can take up a significant amount of space.

NOTE: CARTONS ARE NOT ORGANIZED BY BOARD OR STEP NUMBER.



HARDWARE PARTS:

- We recommend that you have a separate table to organize the hardware.
- Hardware bags are printed with a seven-digit, alpha-numeric part number.
- You can organize your hardware by part number or group by hardware type (e.g. bolts, nuts, etc.).
- During assembly you only need to reference the last four digits of the number.

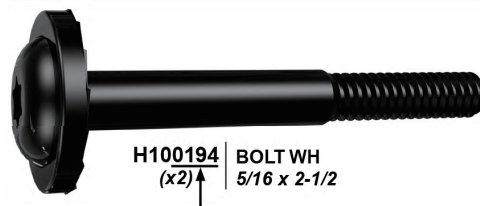

H100194 | BOLT WH
(x2) ↑ 5/16 x 2-1/2

PRE-ASSEMBLY STEP 2 - TOOLS REQUIRED



Cordless Drill or
Electric Drill



Drill Attachments:
Phillips Head



1/8", 3/16", 3/8" &
7/16" Drill Bits



Phillips Screw Driver

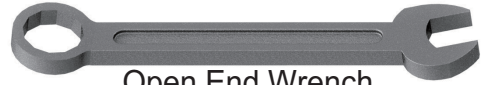

Open End Wrench
7/16"



3/8" Drive Ratchet, 1/2" &
7/16" STD Sockets 1/2" & 7/16"
Deep Sockets



Claw Hammer



Rubber Mallet -
Optional

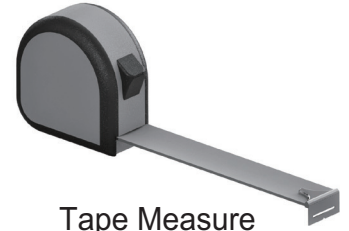

Tape Measure

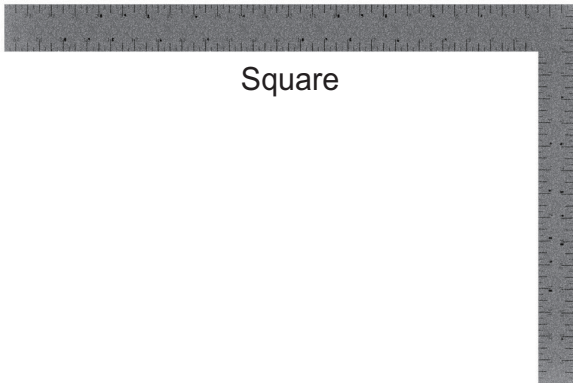

Square



Level 24"

STEP 1A - LEG AND CROSS BRACE ASSEMBLY

Qty	Part No	Description
4	H100835	SCREW PWH 8X2 BLK



FL1- FRONT RIGHT LEG - W2A04482
(x1) 15/16"x3 3/8"x29 1/2" (24x86x749)



BL1- BACK RIGHT LEG - W2A04484
(x1) 15/16"x3 3/8"x29 1/2" (24x86x749)

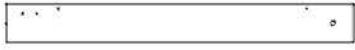

FL2- FRONT LEFT LEG - W2A04483
(x1) 15/16"x3 3/8"x29 1/2" (24x86x749)



BL2- BACK LEFT LEG - W2A04485
(x1) 15/16"x3 3/8"x29 1/2" (24x86x749)

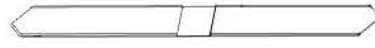

CB1- CROSS BRACE - W4L18892
(x2) 15/16"x2 3/8"x29 3/8" (24x60x746)

- BE SURE TO MATCH CB1 WITH FL1 / BL1 AND FL2 / BL2.
- ALIGN CB1 WITH PILOT HOLES IN LEGS FL1 / BL1 AND FL2 / BL2.
- INSERT SCREWS.
- PLACE LEGS AND CROSS BRACE ON A FLAT SURFACE. TOP AND BOTTOM OF EACH LEG SHOULD BE ALONG THE SAME PLANE.

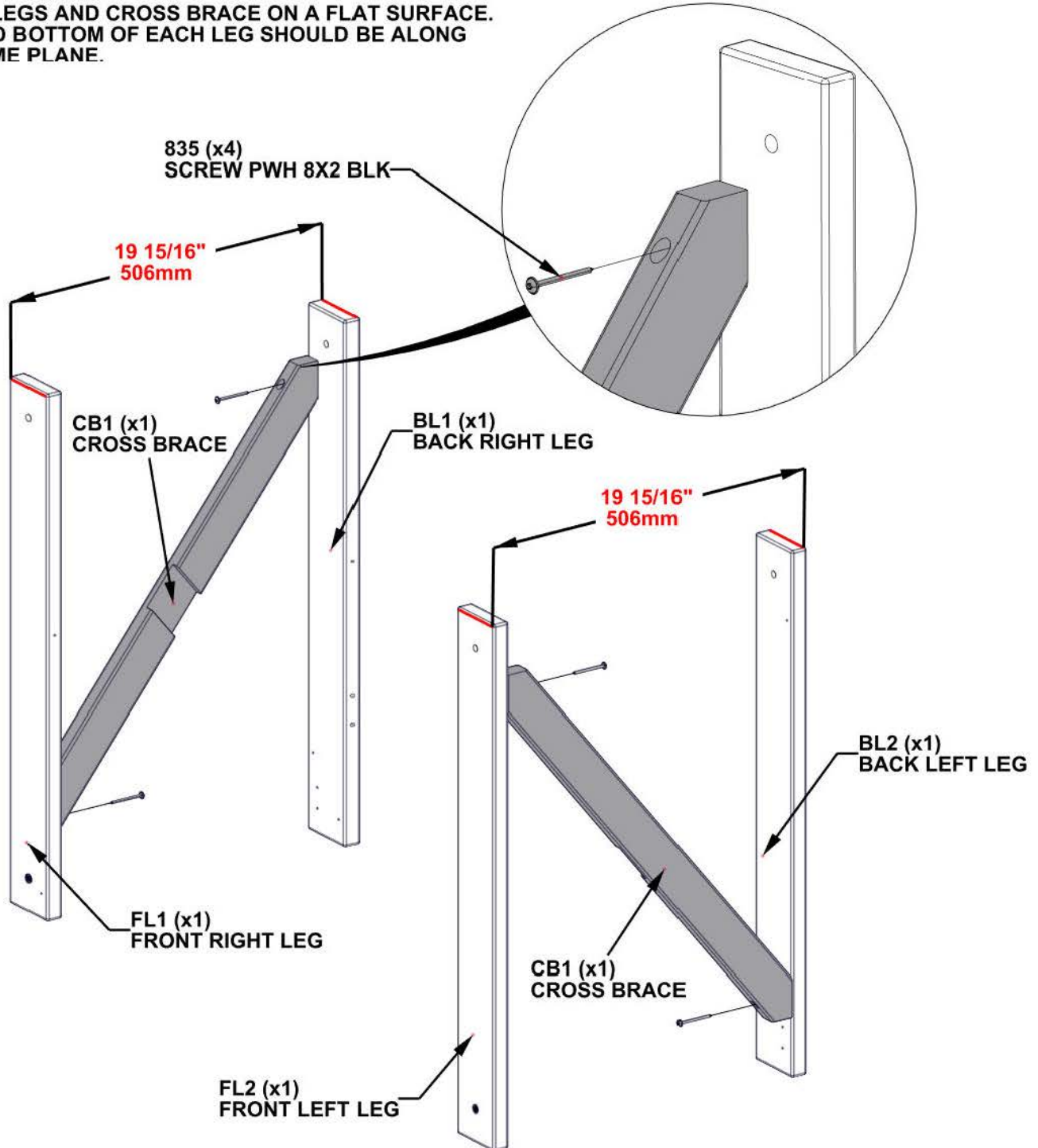

STEP 1B - LEG AND CROSS BRACE ASSEMBLY

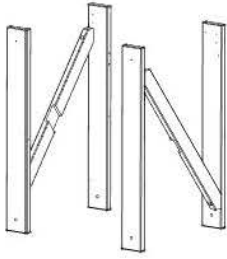

LEG AND CROSS BRACE ASSEMBLY - STEP - 1A

Qty	Part No	Description
4	H100816	SCREW PFH 8x7/8 BLK
4	H100835	SCREW PWH 8x2 BLK

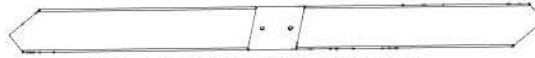

CB2 - CROSS BRACE - W4L18893
(x2) 15/16"x2 3/8"x29 3/8" (24x60x746)

- ALIGN CB2 WITH PILOT HOLES IN LEGS OF ASSEMBLY FROM STEP 1A.
- INSERT SCREWS.
- PLACE LEGS AND CROSS BRACE ON A FLAT SURFACE.
- TOP AND BOTTOM OF EACH LEG SHOULD BE ALONG THE SAME PLANE.

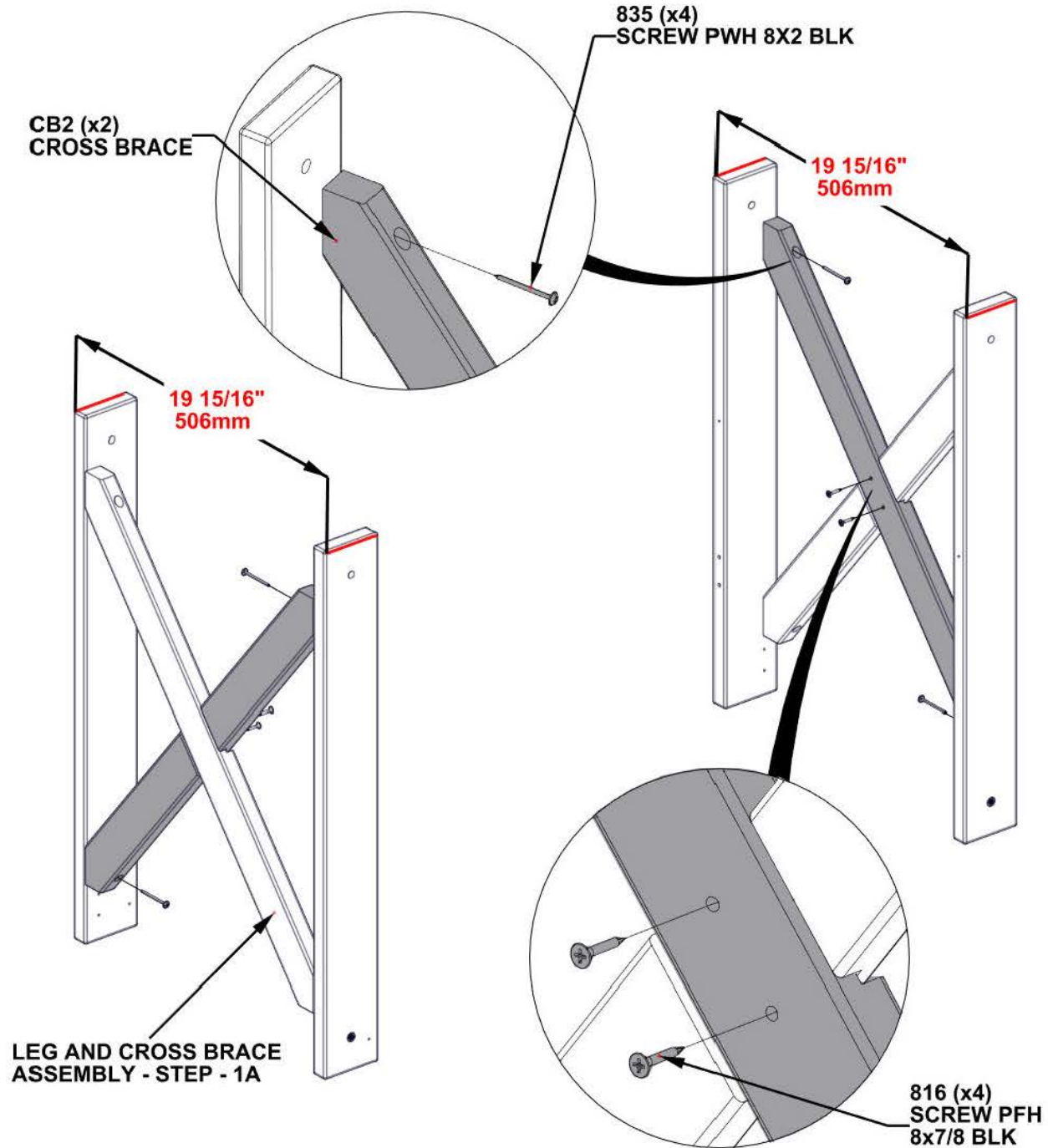

STEP 2 - BOTTOM PANEL ASSEMBLY

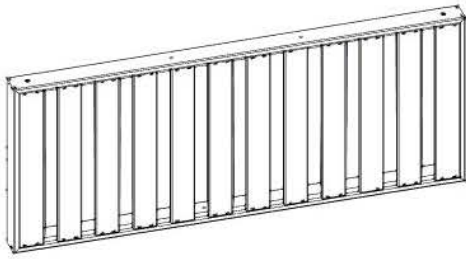

BP1 - BOTTOM PANEL - W2A04015
(x1) 2 3/8"x18"x44 5/16" (60x458x1125)

Qty	Part No	Description
4	H100405	WASHER LOCKEXT 6X15 BLK
4	H100406	BOLT WH 1/4x1 1/2 BLK

SQUARE BOTTOM PANEL ASSEMBLY TO EACH LEG BEFORE TIGHTENING.

PILOT HOLES FACE UP ON THE PANEL.

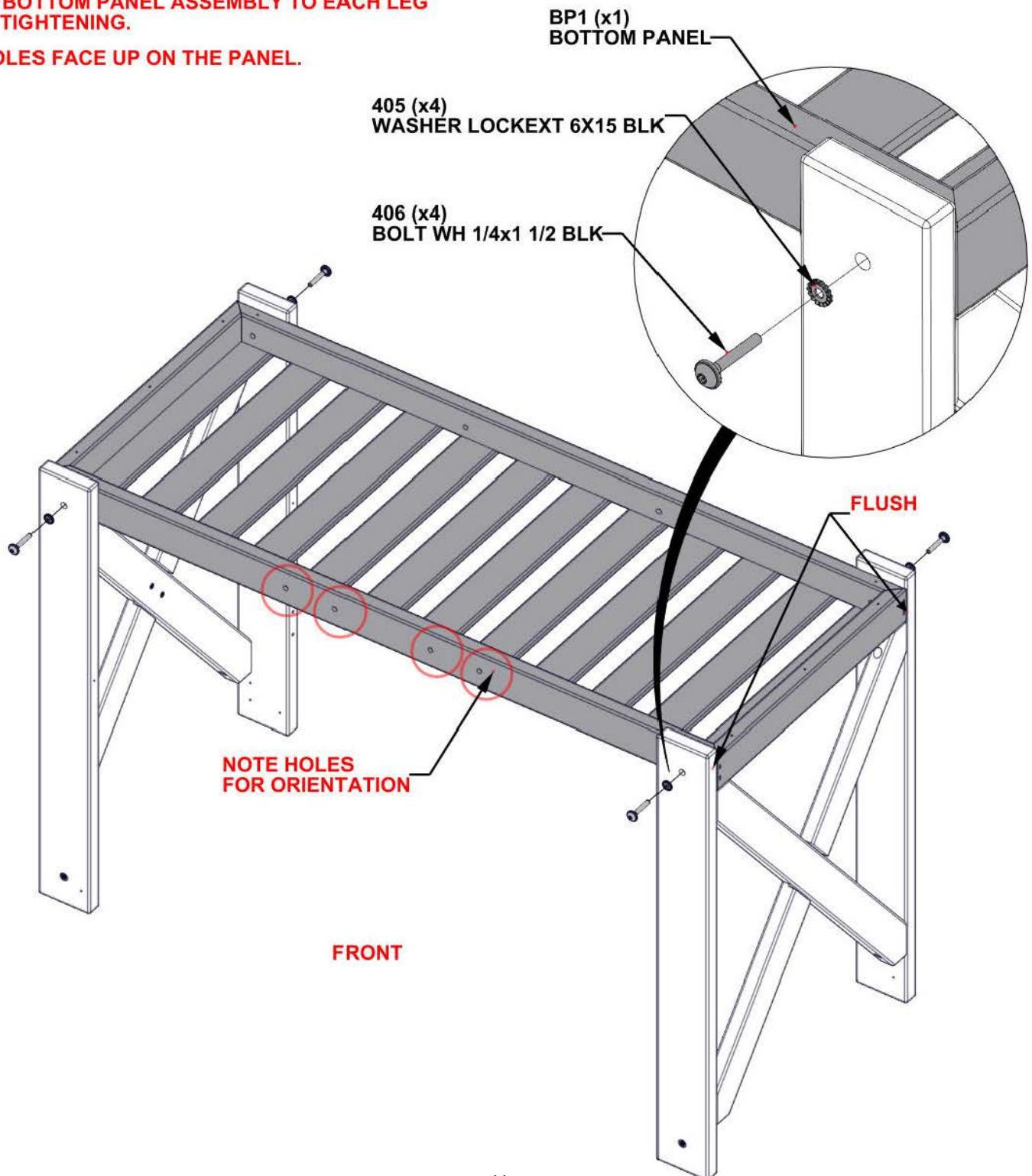

STEP 3 - CASTER BOARD ASSEMBLY

Qty	Part No	Description
10	H100387	SCREW PFH 8x1-1/4 BLK



CB4 - CASTER BOARD - W2A04019
(x2) 5/8"x3 3/8"x17 15/16" (16x86x457)

- ALIGN PILOT HOLES.

NOTE THREADED INSERTS FOR ORIENTATION.

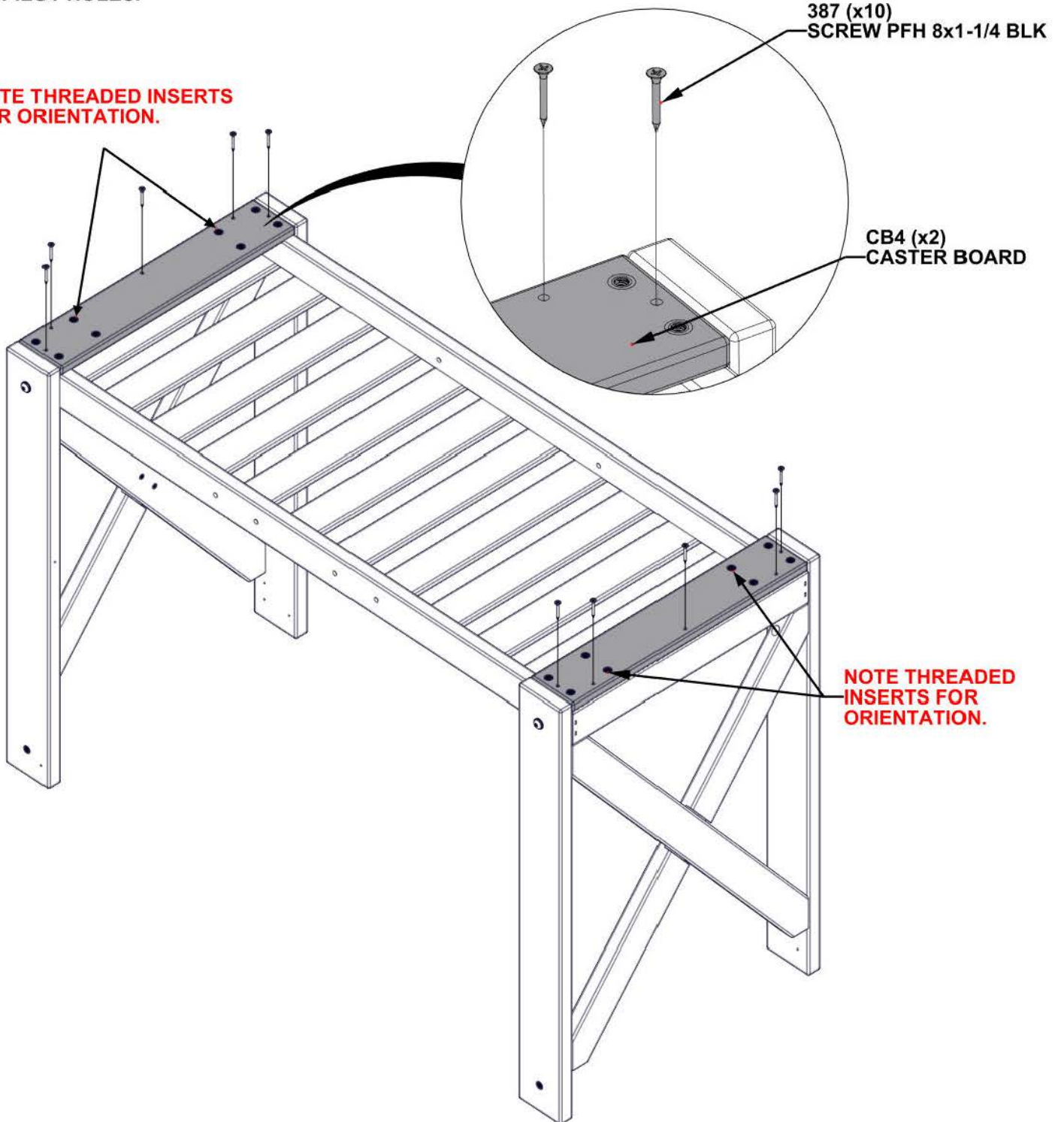

STEP 4 - CASTER ASSEMBLY

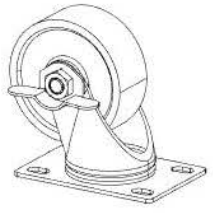

**CASTER - A4M02605
(x4)**

Qty	Part No	Description
16	H100401	BOLT WH 1/4x1/2 BLK

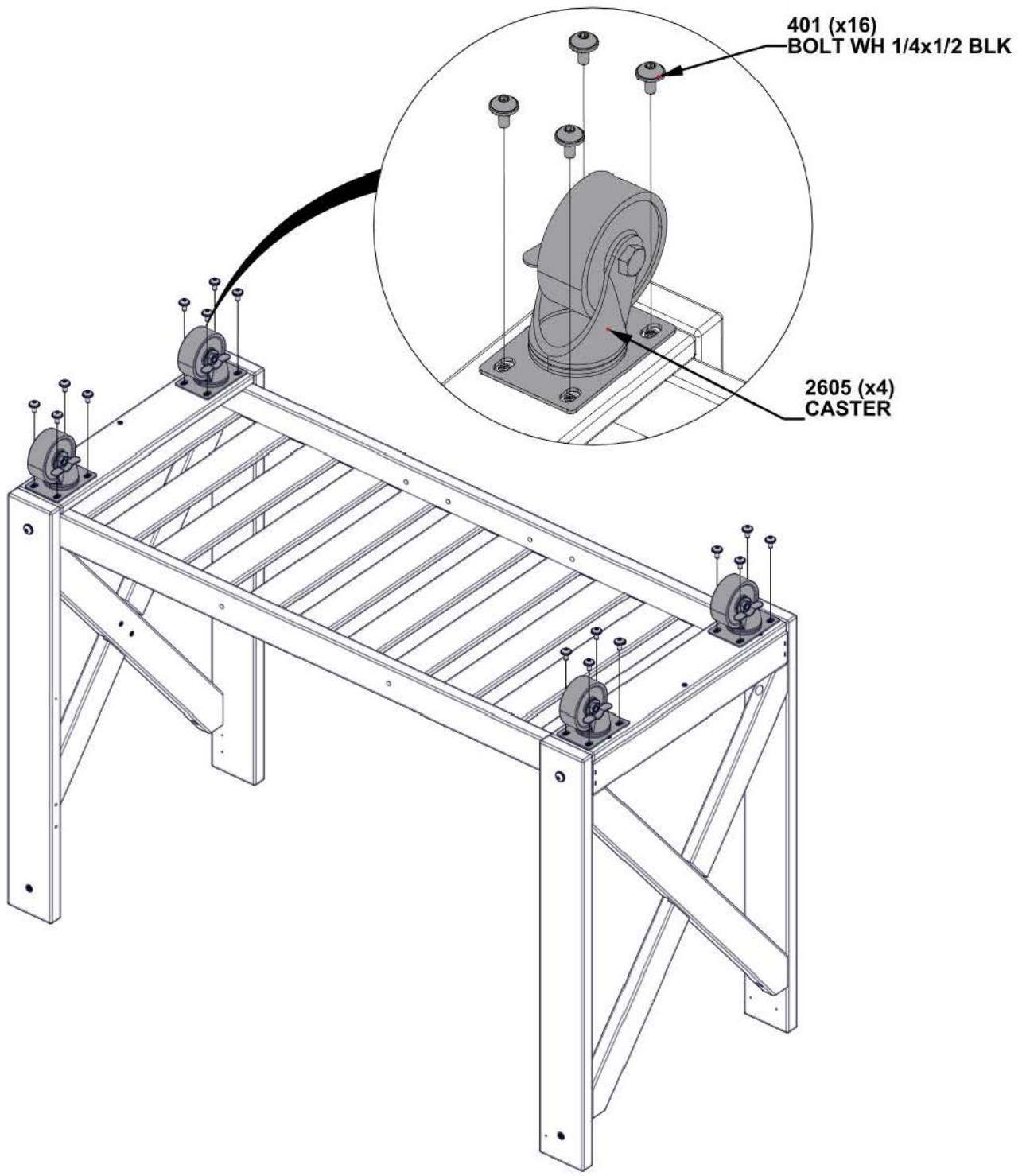

STEP 5 - TABLE LONG RAIL ASSEMBLY



TR1 - TABLE BACK LONG RAIL - W4L18894
(x1) 15/16"x4"x50 11/16" (24x102x1287)



TR2 - TABLE FRONT LONG RAIL- W4L18895
(x1) 15/16"x4"x50 11/16" (24x102x1287)

Qty	Part No	Description
4	H100405	WASHER LOCK EXT 6X15 BLK
4	H100406	BOLT WH 1/4x1 1/2 BLK

- ALIGN PILOT HOLES.

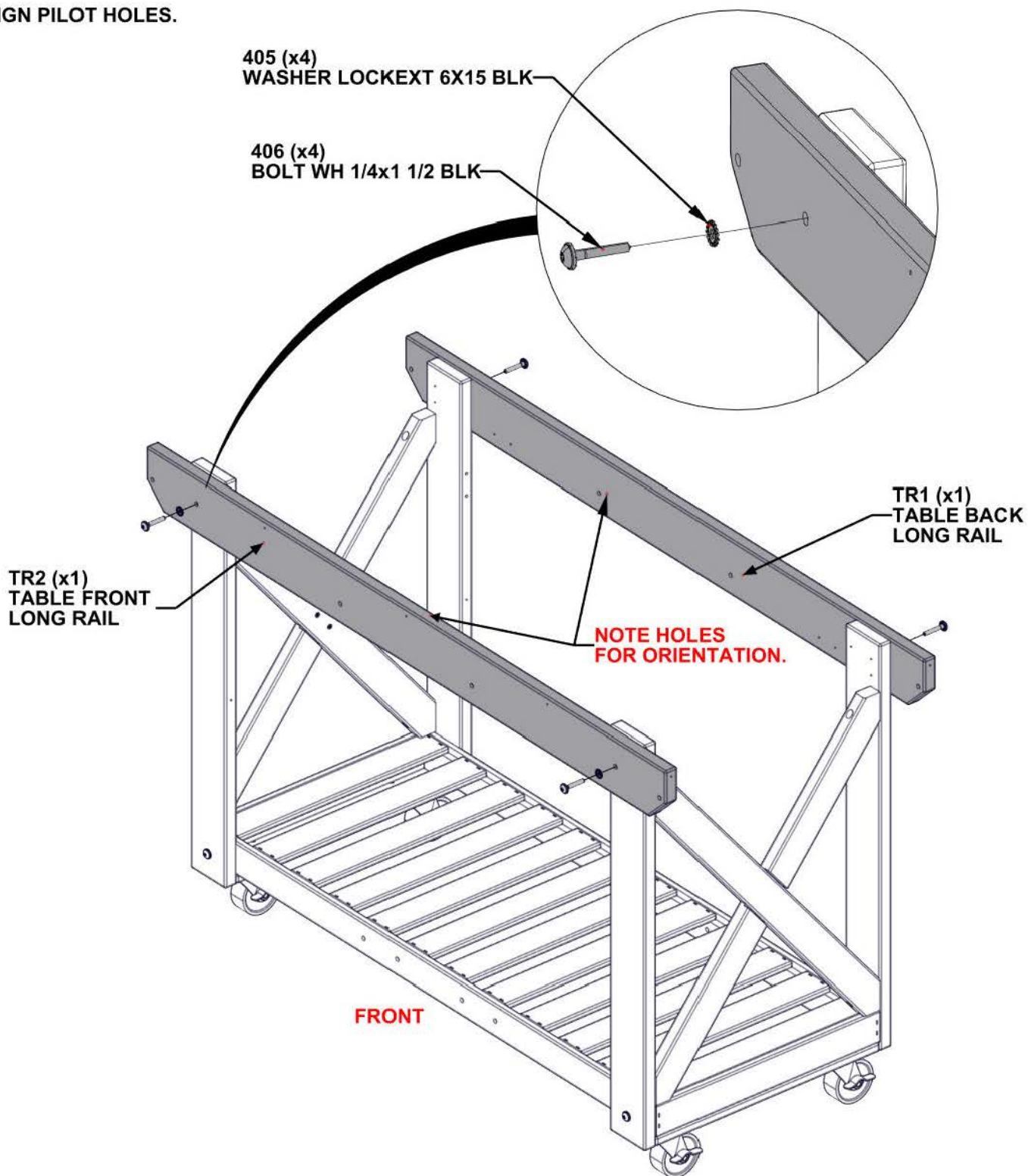

STEP 6 - METAL ANGLE BRACE ASSEMBLY

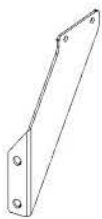

Qty	Part No	Description
4	H100392	SCREW PWH 8X3/4 BLK
4	H100460	LAG SCREW WH 1/4 X 1 BLK

METAL ANGLE BRACE LEFT- A4M02539
(x1)

METAL ANGLE BRACE RIGHT- A4M02538
(x1)

- ALIGN PILOT HOLES.

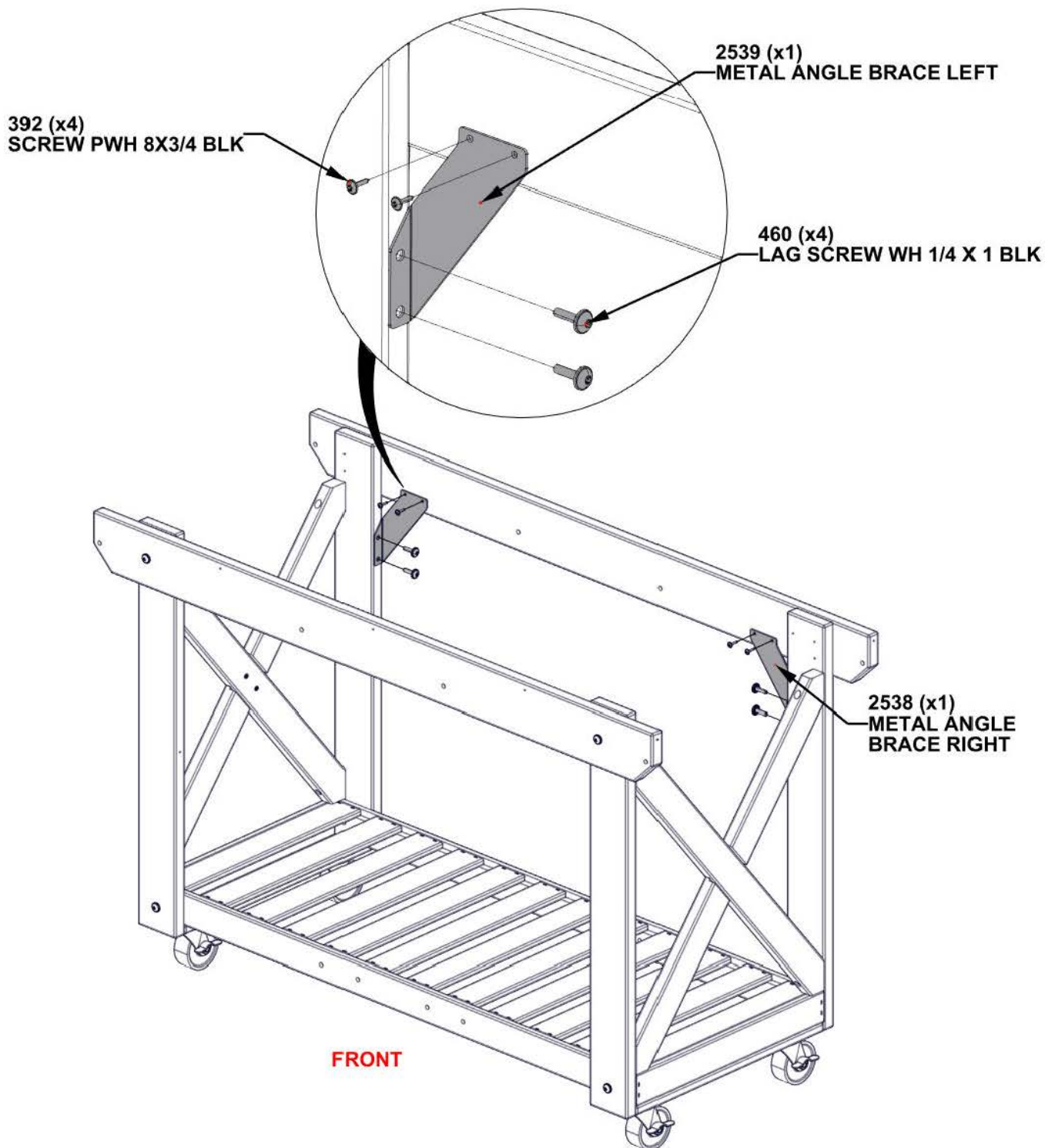

STEP 7A - MIDDLE VERTICAL ASSEMBLY

Qty	Part No	Description
4	H100399	NUT BARRELL WH 1/4 X 7/8 BLK
4	H100400	WASHER LOCKEXT 8X15 BLK
4	H100405	WASHER LOCKEXT 6X15 BLK
4	H100406	BOLT WH 1/4x1 1/2 BLK



MV1 - MIDDLE LEFT BACK VERTICAL - W4L18896
(x1) 15/16"x2 3/8"x27 15/16" (24x60x709)



MV3 - MIDDLE RIGHT BACK VERTICAL - W4L18898
(x1) 15/16"x2 3/8"x27 15/16" (24x60x709)



MV2 - MIDDLE LEFT FRONT VERTICAL - W4L18897
(x1) 15/16"x2 3/8"x27 15/16" (24x60x709)



MV4 - MIDDLE RIGHT FRONT VERTICAL - W4L18899
(x1) 15/16"x2 3/8"x27 15/16" (24x60x709)

- ALIGN PILOT HOLES.

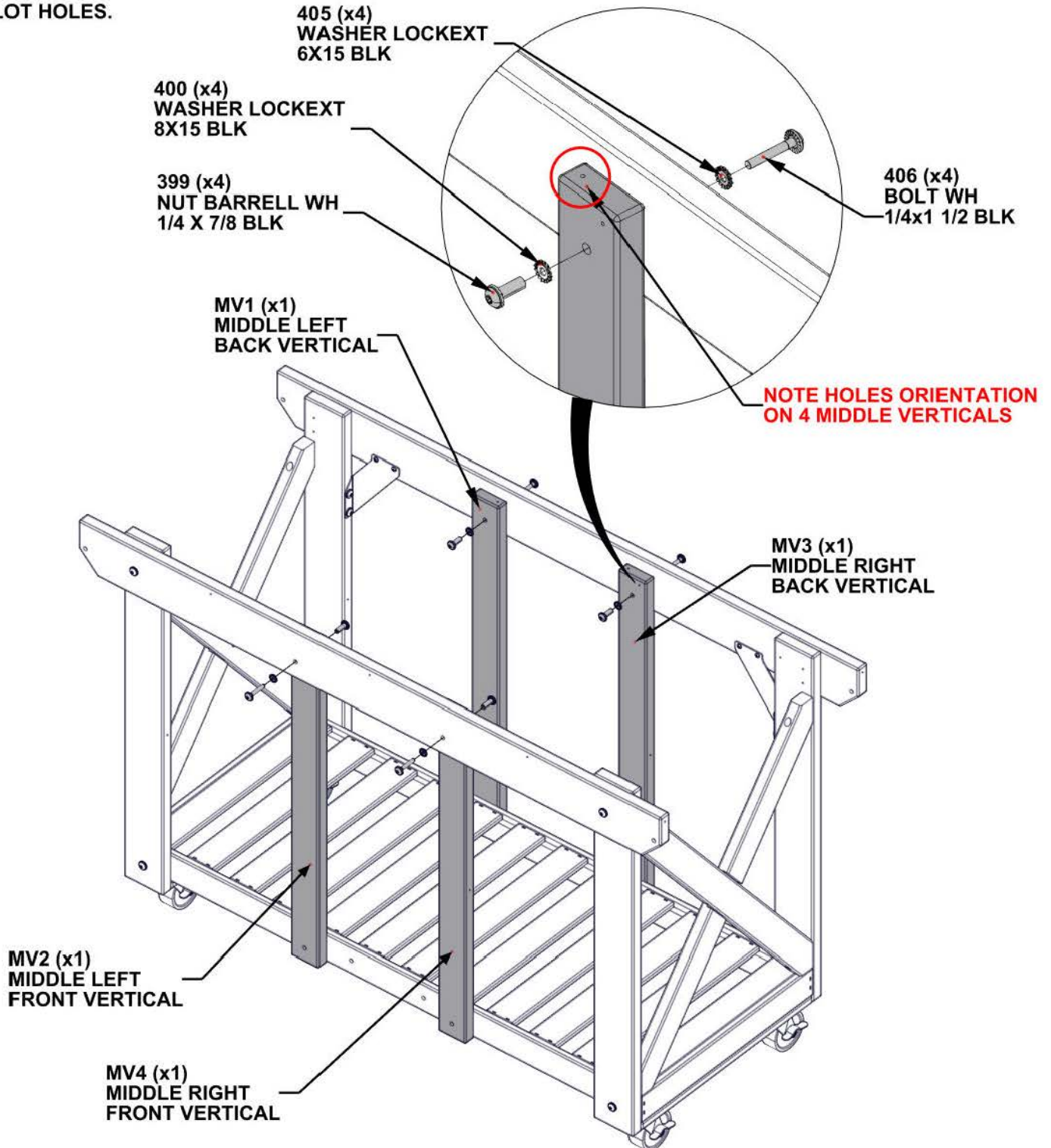

STEP 7B - MIDDLE VERTICAL ASSEMBLY

Qty	Part No	Description
4	H100399	NUT BARRELL WH 1/4 X 7/8 BLK
4	H100400	WASHER LOCKEXT 8X15 BLK
4	H100405	WASHER LOCKEXT 6X15 BLK
4	H100406	BOLT WH 1/4x1 1/2 BLK

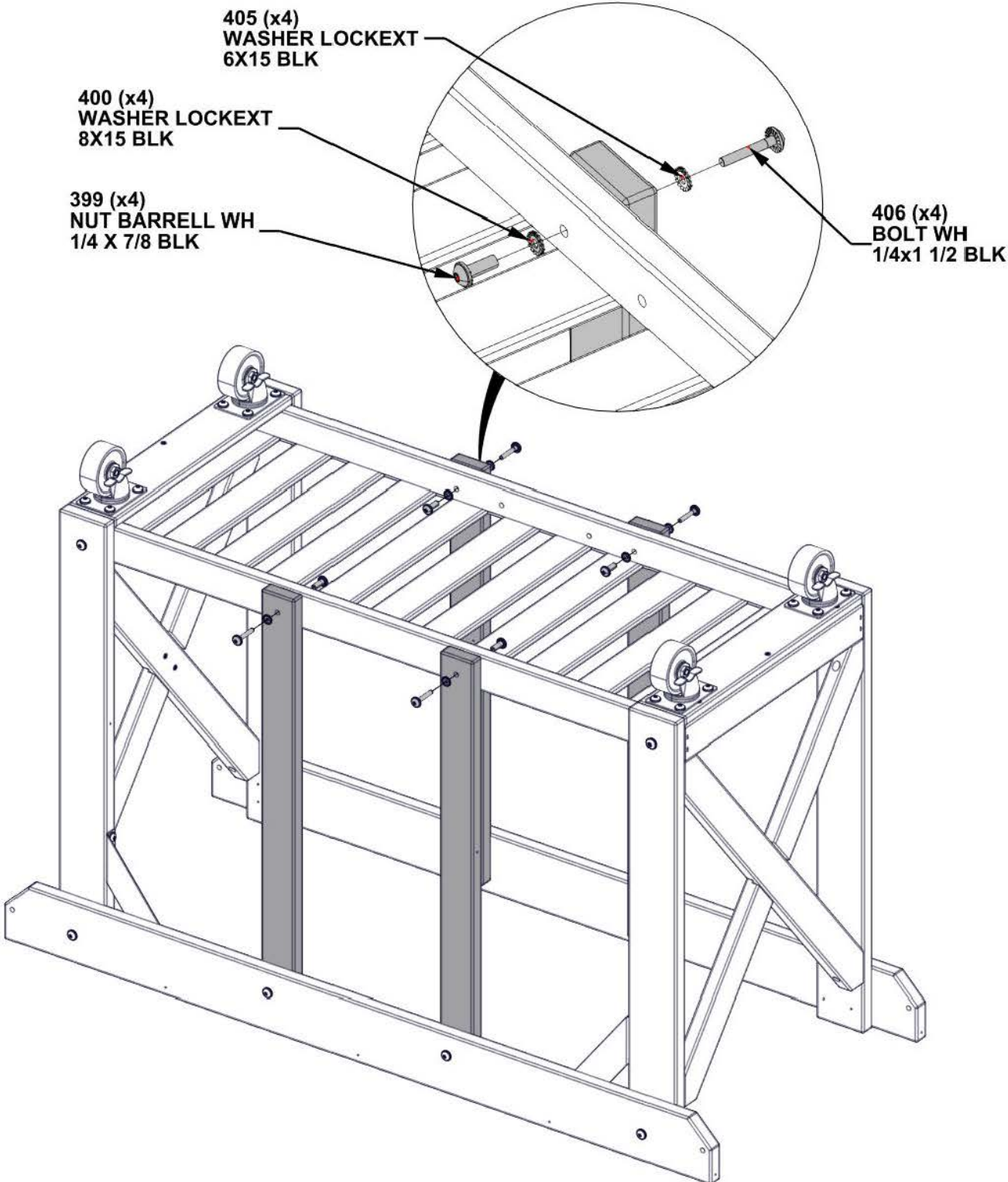

STEP 8 - SUPPORT BOARD ASSEMBLY

Qty	Part No	Description
8	H100382	SCREW PFH 8x1-3/4 BLK



SB1 - SUPPORT BOARD - W4L18900
(x4) 5/8"x1 5/16"x19 15/16" (16x34x506)

- ALIGN PILOT HOLES.

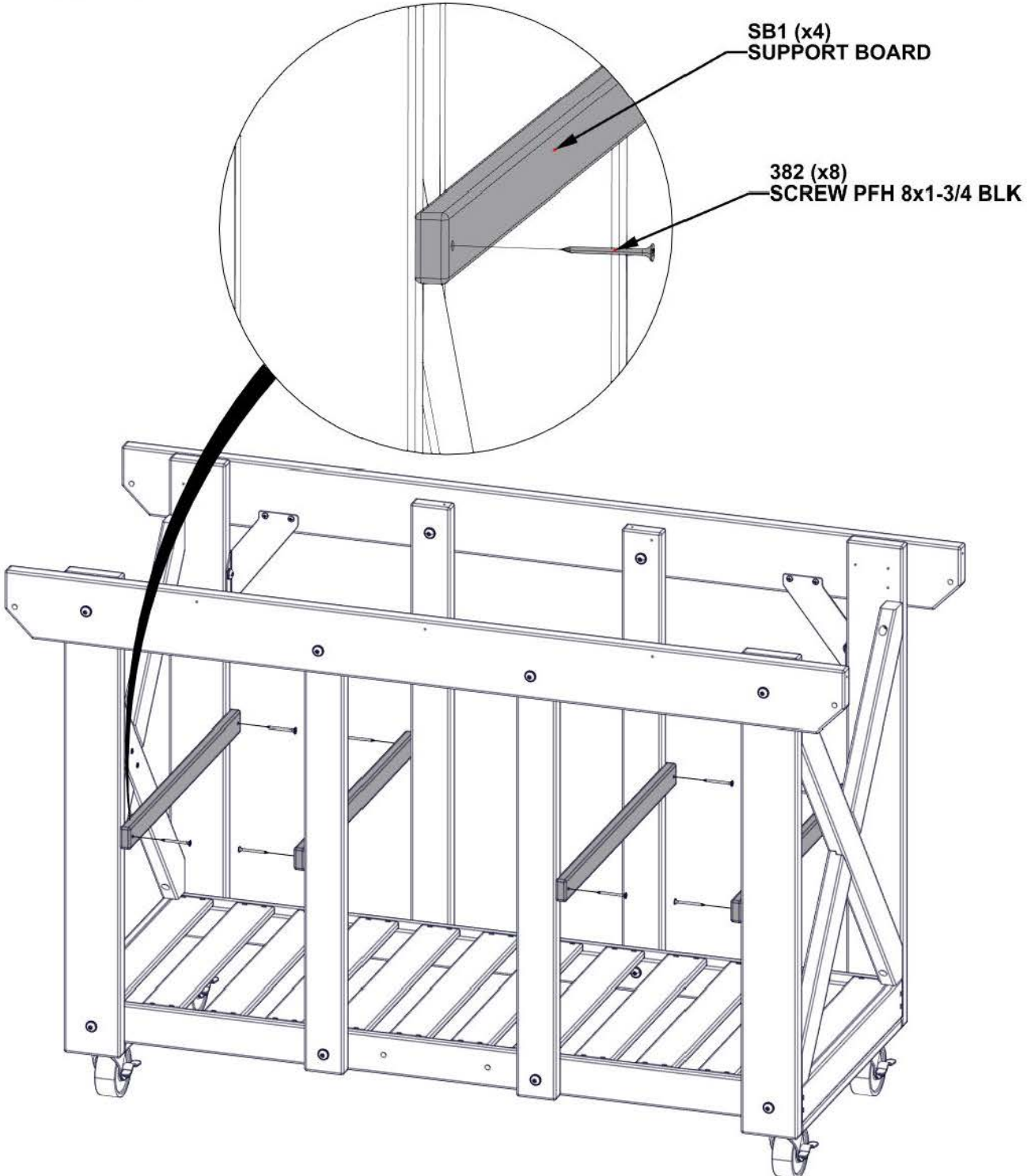

STEP 9 - TABLE SHORT RAIL ASSEMBLY

Qty	Part No	Description
16	H100392	SCREW PWH 8X3/4 BLK



TA1 - TABLE SHORT RAIL -W2A04018
(x2) 15/16"x4"x19 7/8" (24x102x505)

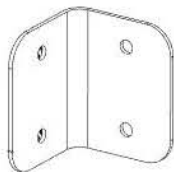

METAL BRACKET - A4M02540
(x4)

- ALIGN PILOT HOLES.

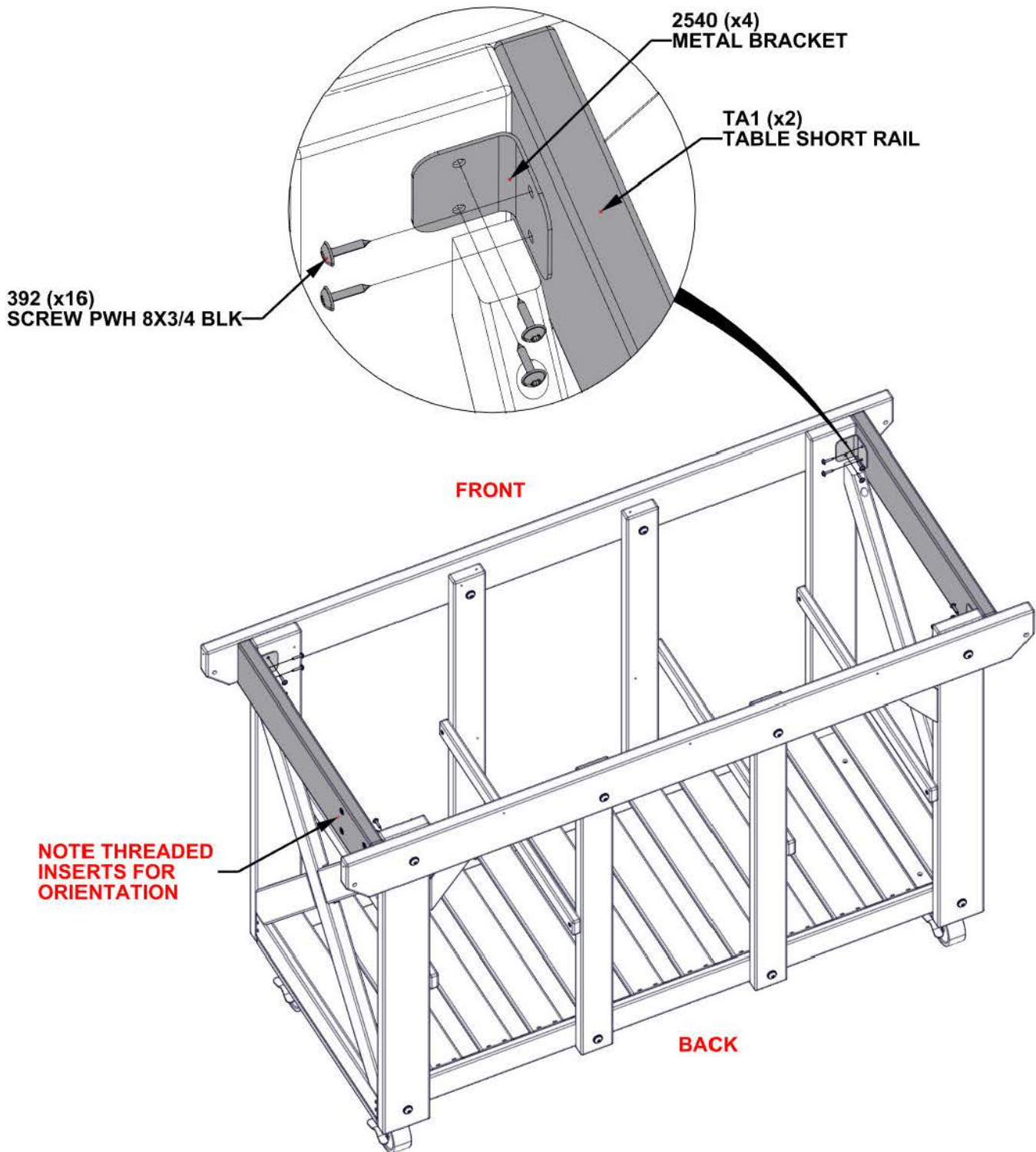

STEP 10 - BOTTOM SLAT ASSEMBLY

Qty	Part No	Description
2	H100399	NUT BARRELL WH 1/4 X 7/8 BLK
2	H100400	WASHER LOCKEXT 8X15 BLK
2	H100405	WASHER LOCKEXT 6X15 BLK
2	H100406	BOLT WH 1/4x1 1/2 BLK



BS1 - BOTTOM SLAT - W4L18901
 (x1) 15/16"x2 3/8"x10 3/8" (24x60x263)

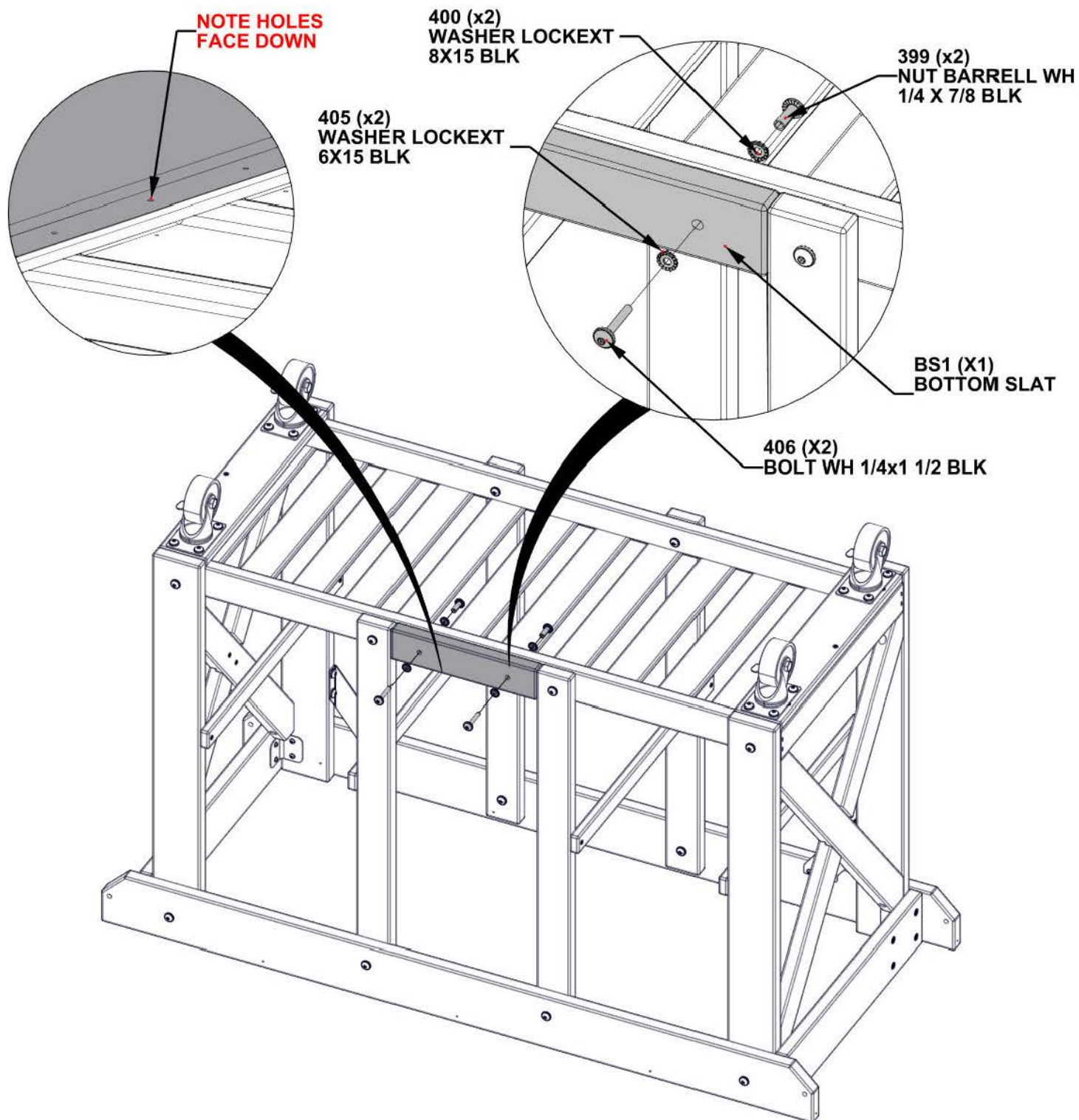

STEP 11A - DRAWER HANDLE ASSEMBLY

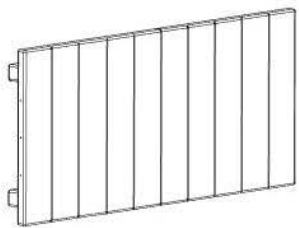

DA1 - DRAWER ASSEMBLY - W2A04017
 (x1) 1 9/16"x10 3/16"x22 1/16" (40x259x560)

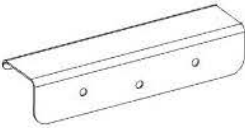

HANDLE - A4M02550
 (x1)

Qty	Part No	Description
3	H100408	SCREW PWH 8x1/2 BLK

- ALIGN PILOT HOLES.

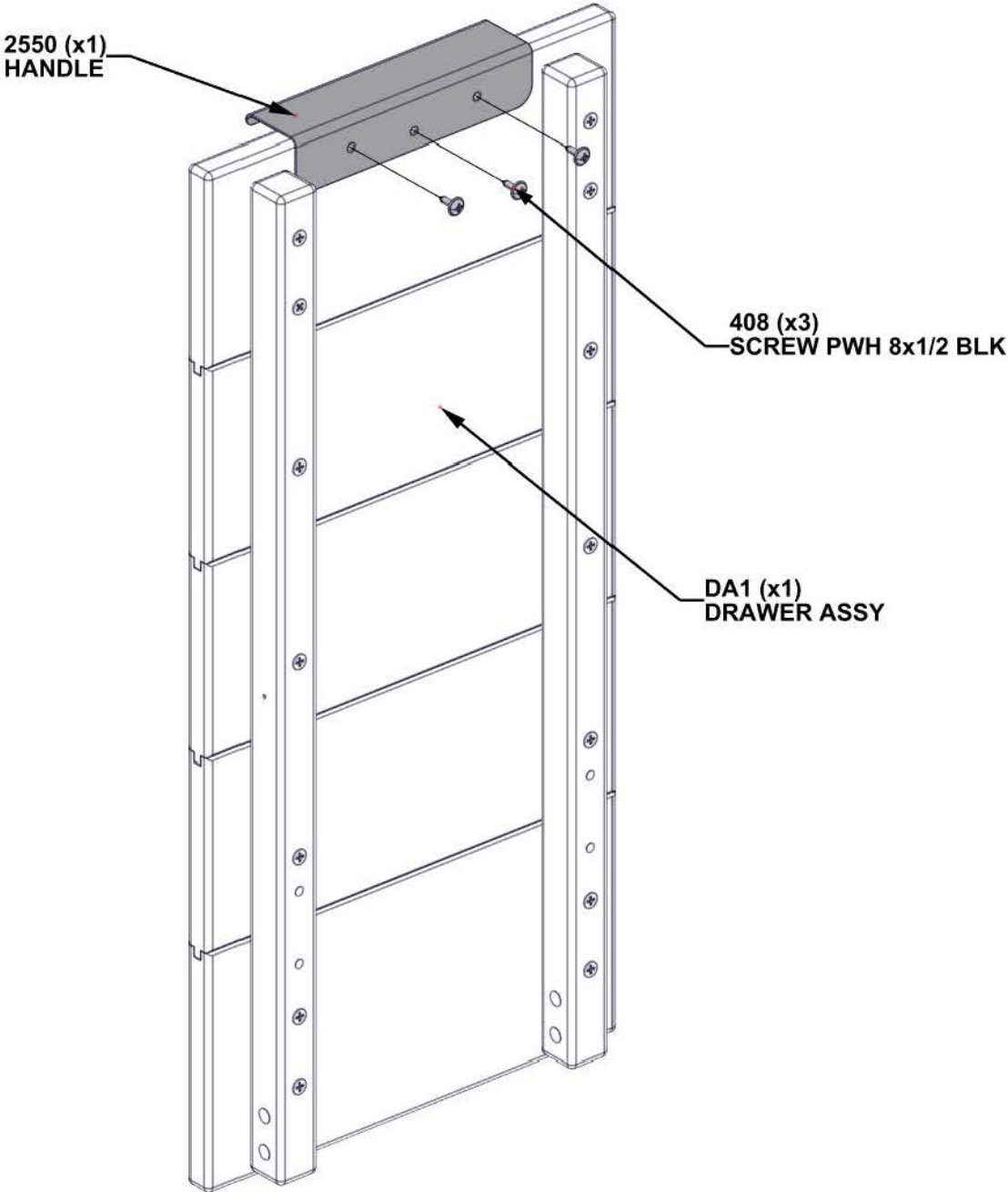

STEP 11B - DRAWER SIDE BOARD ASSEMBLY



DB1 - DRAWER SIDE BOARD - W4L20011
(x1) 5/8"x1 15/16"x16 1/2" (16x50x420)



DB3 - DRAWER SIDE BOARD- W4L20013
(x1) 5/8"x1 15/16"x16 1/2" (16x50x420)

Qty	Part No	Description
4	H100397	BOLT WH 1/4x1-1/4 BLK
4	H100399	NUT BARRELL WH 1/4 X 7/8 BLK
4	H100400	WASHER LOCKEXT 8X15 BLK
4	H100405	WASHER LOCKEXT 6X15 BLK

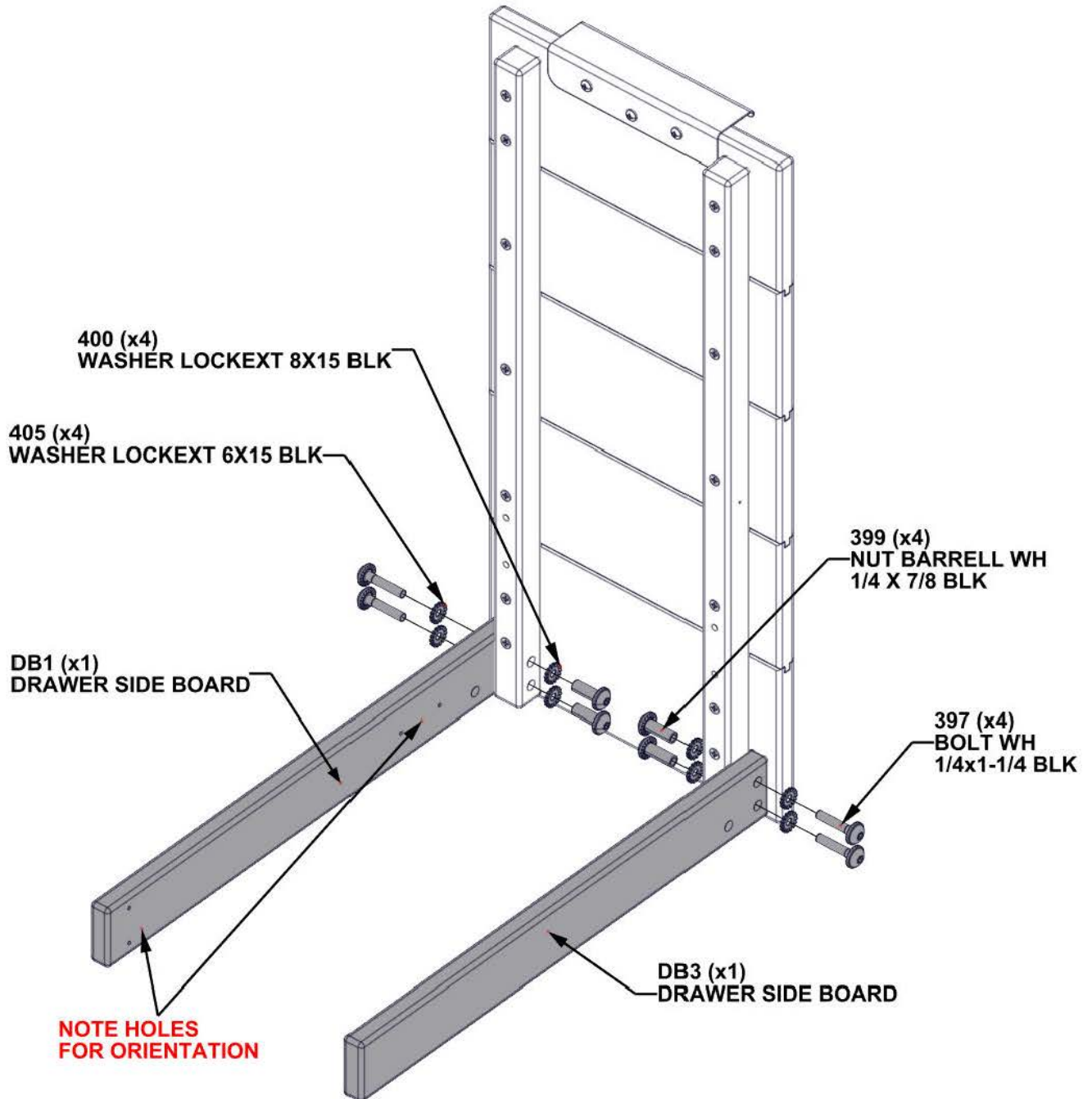

STEP 11C - DRAWER BACK BOARD ASSEMBLY

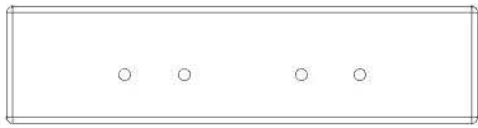

DB2 - DRAWER BACK BOARD - W4L20012
(x1) 5/8"x2 3/8"x9 1/2" (16x60x241)

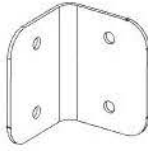

METAL BRACKET - A4M02540
(x2)

Qty	Part No	Description
8	H100408	SCREW PWH 8x1/2 BLK

- ALIGN PILOT HOLES.

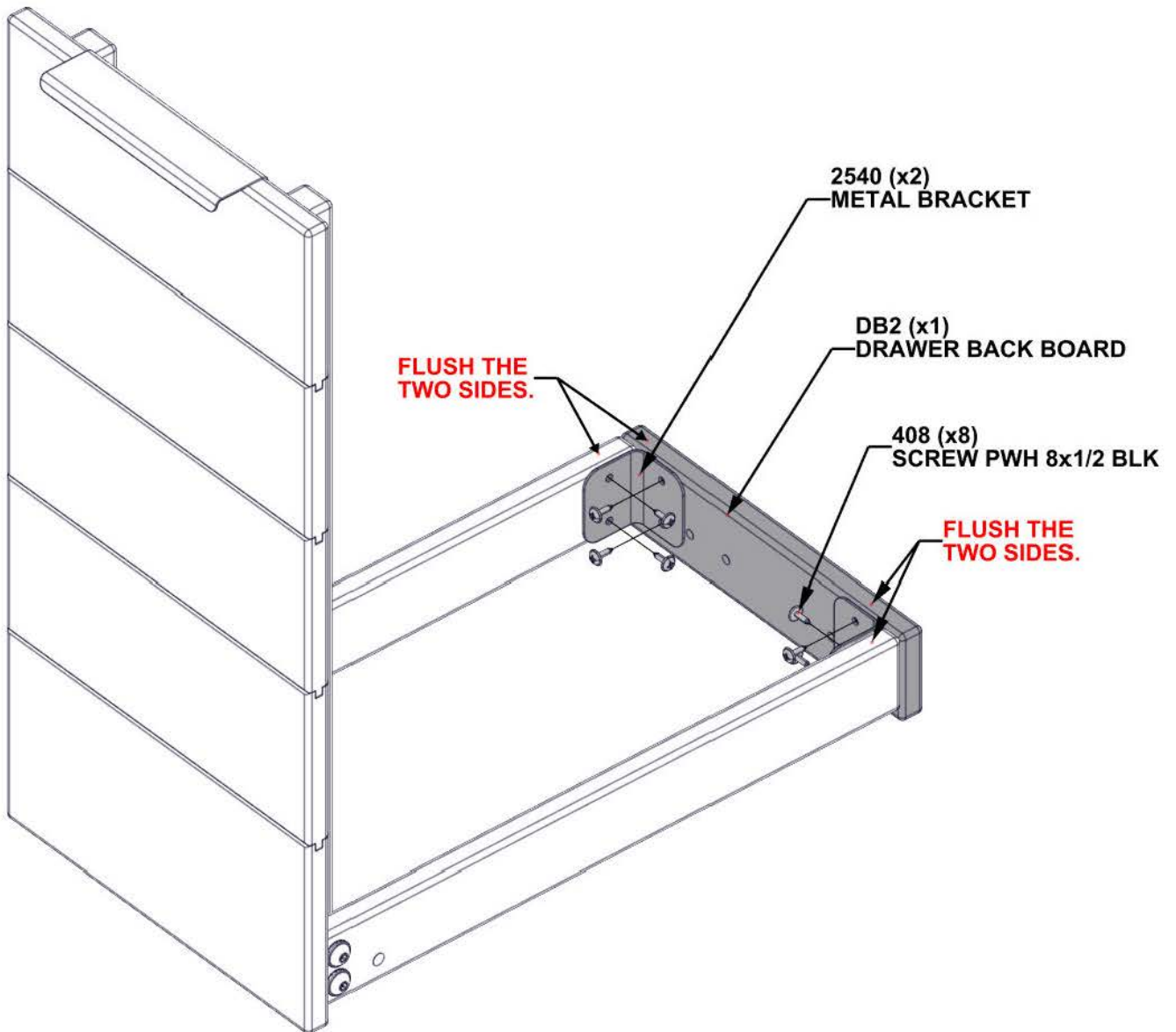

STEP 11D - TRASH SUPPORT ASSEMBLY



TRASH SUPPORT - A4M02553
(x4)

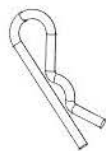

COTTER PIN - H101161
(x4)



TRASH SUPPORT - A4M02554
(x1)

Qty	Part No	Description
2	H100397	BOLT WH 1/4x1-1/4 BLK
2	H100405	WASHER LOCK EXT 6X15 BLK

- ALIGN 2554 TRASH SUPPORT WITH PILOT HOLES ON DRAWER SIDE BOARDS, THEN TIGHTEN BOLT AND WASHER.
- INSERT 2553 TRASH SUPPORT INTO 2554 TRASH SUPPORT THROUGH PILOT HOLES ON DRAWER BACK BOARD.
- USE COTTER PINS TO SECURE 2553.

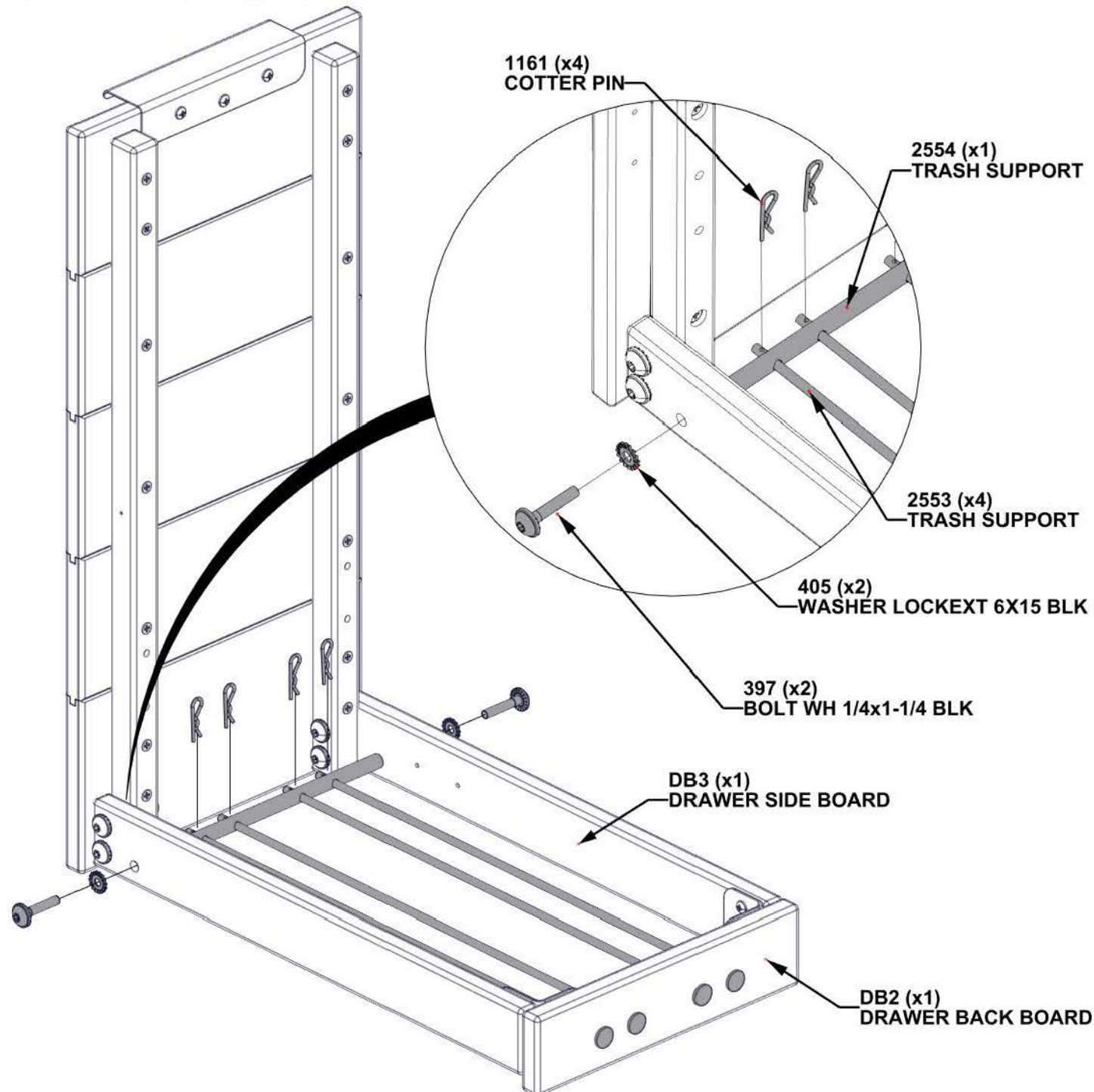

STEP 11E - METAL ANGLE BRACE ASSEMBLY

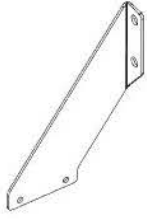

Qty	Part No	Description
4	H100408	SCREW PWH 8x1/2 BLK
4	H100460	LAG SCREW WH 1/4 X 1 BLK

METAL ANGLE BRACE LEFT - A4M02539
(x1)

METAL ANGLE BRACE RIGHT - A4M02538
(x1)

- ALIGN PILOT HOLES.

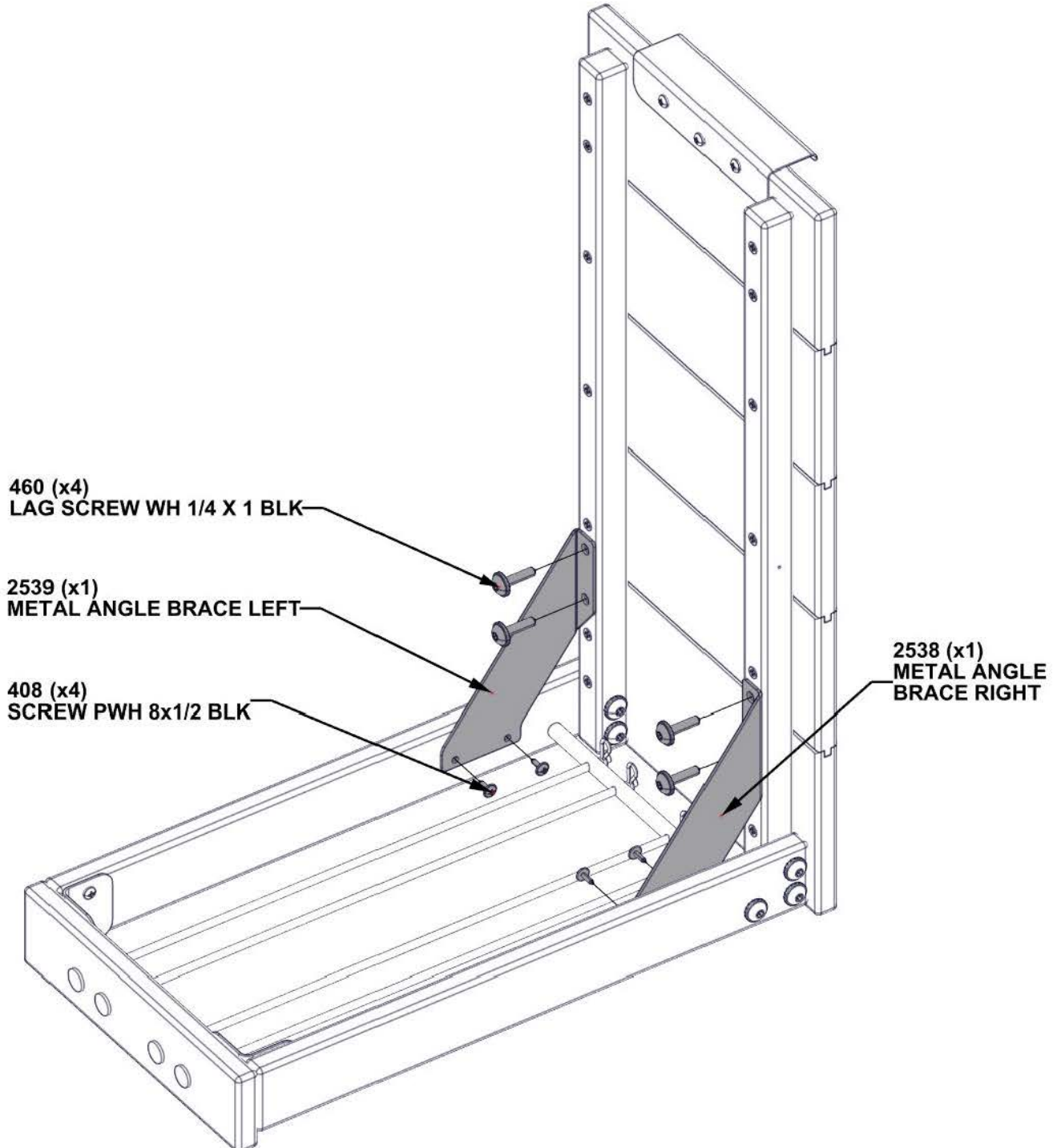

STEP 12A - PIANO HINGE ASSEMBLY

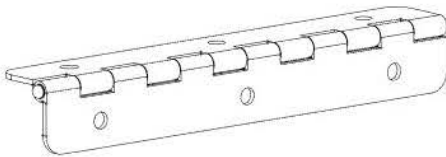

PIANO HINGE - A4M02549
(x1)

Qty	Part No	Description
3	H101296	SCREW PFH-BLUNT TIP 6x1/2

- ALIGN PILOT HOLES.

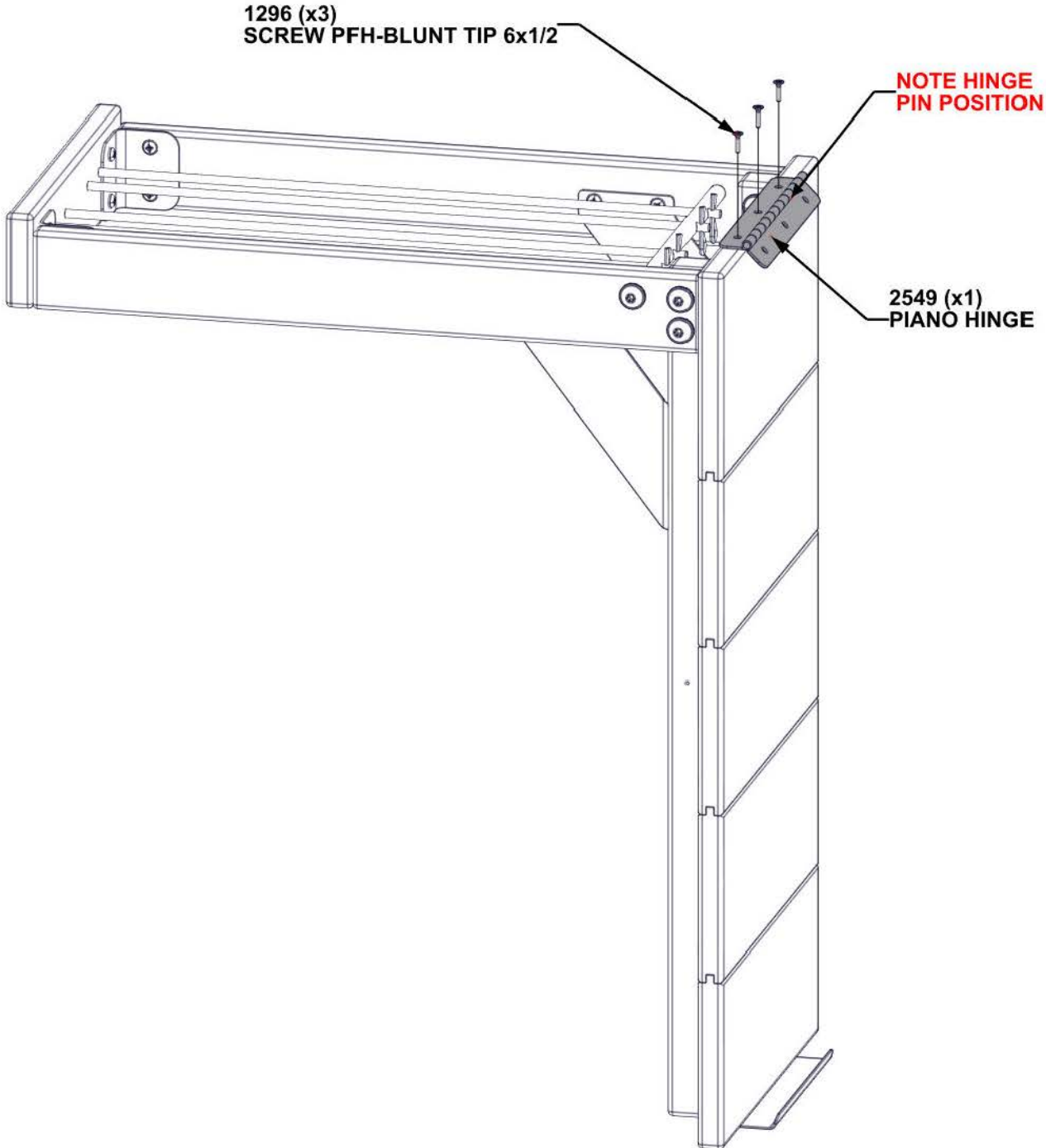

STEP 12B - PIANO HINGE ASSEMBLY

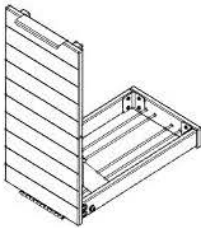

Qty	Part No	Description
3	H101296	SCREW PFH-BLUNT TIP 6x1/2

PIANO HINGE ASSEMBLY - STEP - 12A

- ALIGN PILOT HOLES.

1296 (x3)
SCREW PFH-BLUNT TIP 6x1/2

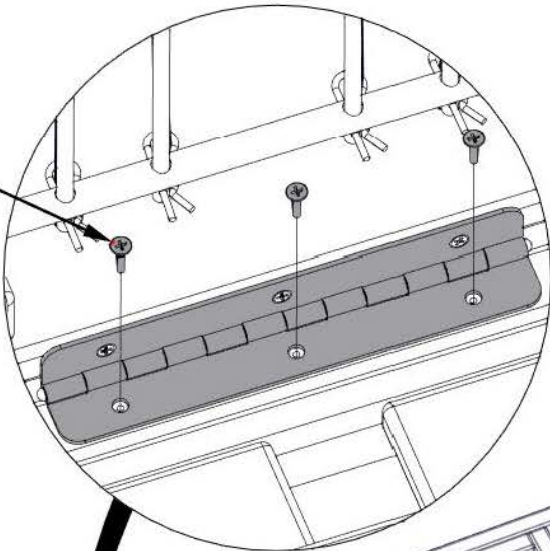

PIANO HINGE
ASSEMBLY - STEP - 12A

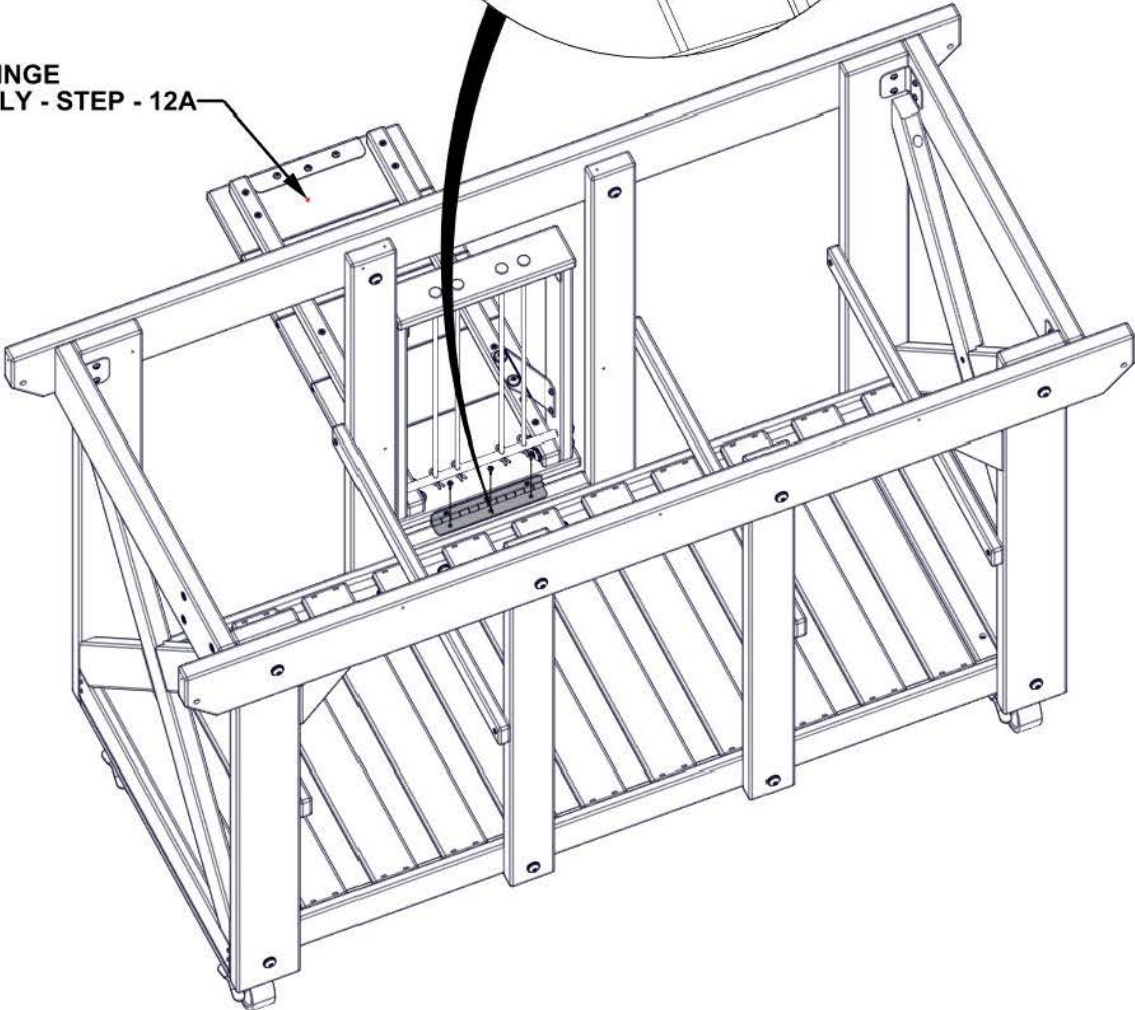

STEP 13 - TRASH CAN DOOR CHAIN ASSEMBLY



TRASH CAN DOOR CHAIN - A4M04127
(x2)

Qty	Part No	Description
2	H100392	SCREW PWH 8X3/4 BLK

- ATTACH TRASH CAN DOOR CHAIN
- TIGHTEN ALL SCREWS

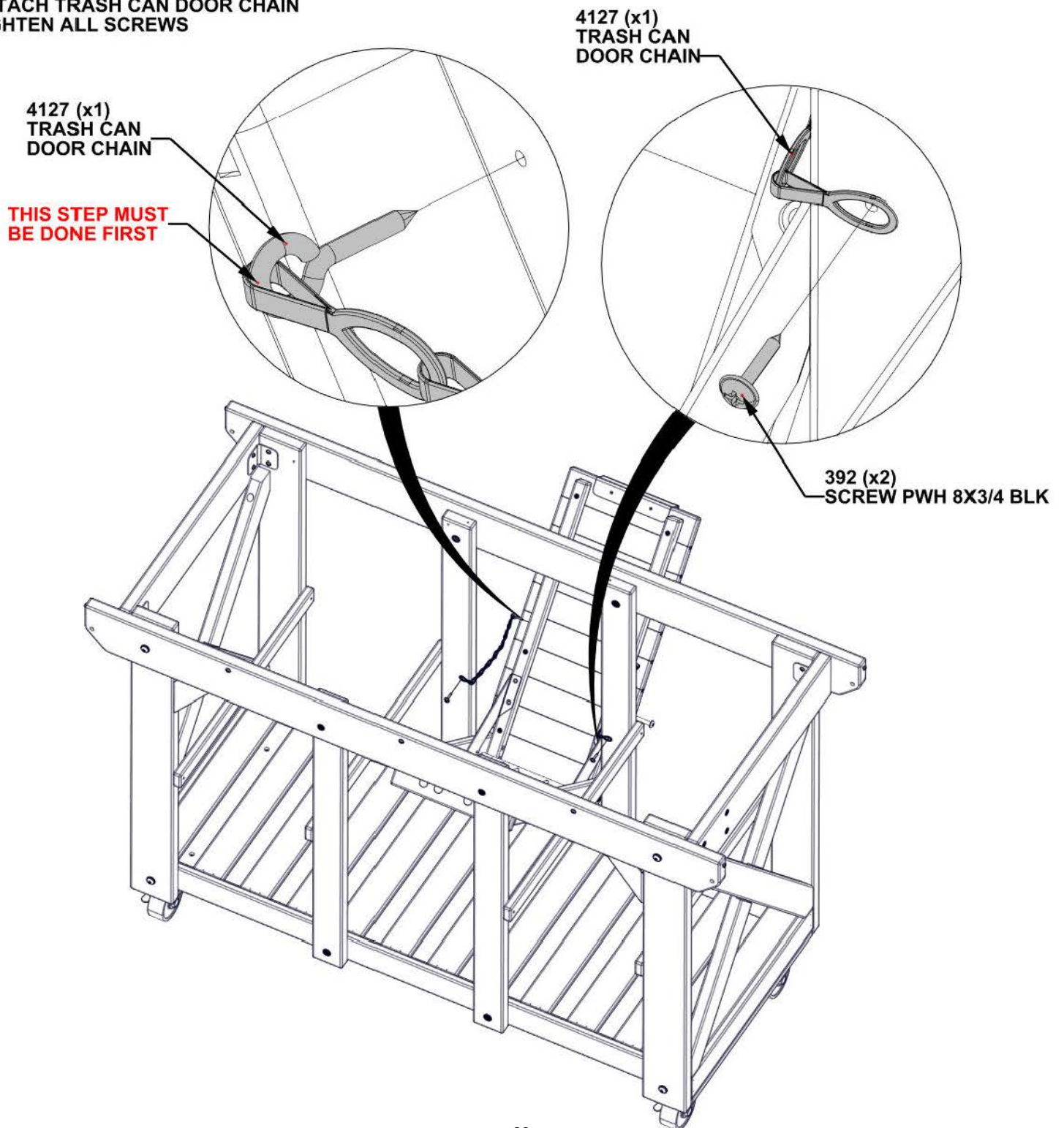

STEP 14 - TOP MIDDLE SHORT CLEAT ASSEMBLY

Qty	Part No	Description
4	H100382	SCREW PFH 8x1-3/4 BLK



BS3-TOP MIDDLE SHORT CLEAT - W4L18903
 (x2) 15/16"x15/16"x19 15/16" (24x24x506)

- ALIGN PILOT HOLES.

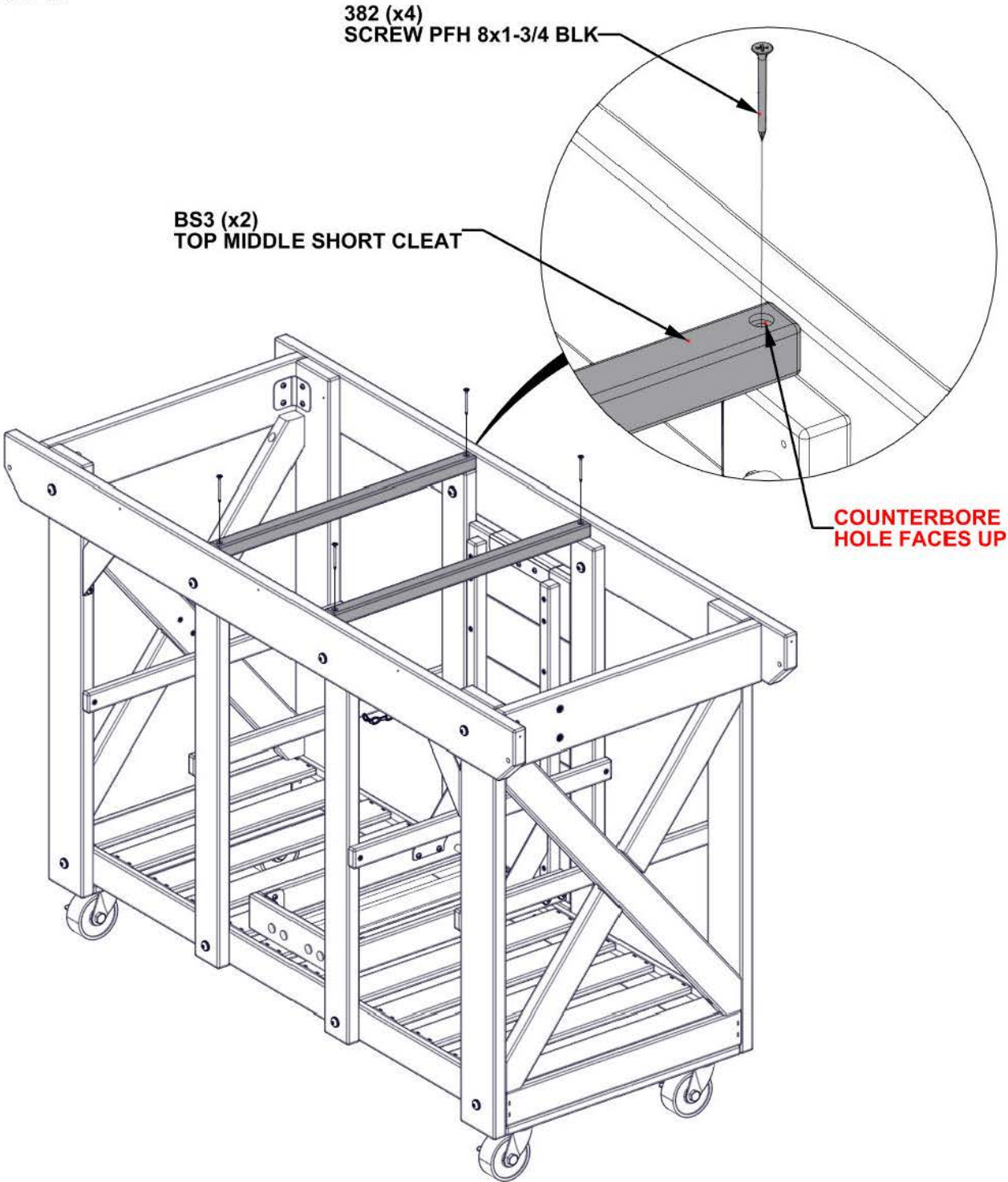

STEP 15 - CUP HANGER BOARD ASSEMBLY

Qty	Part No	Description
6	H101069	SCREW PWH 8X7/8 BLK



BS4-CUP HANGER BOARD - W4L18904
(x2) 15/16"x15/16"x13 7/8" (24x24x352)

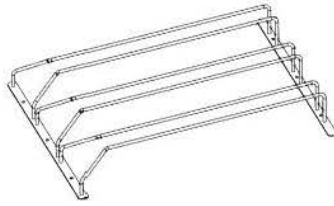

HANGER TUBE - A4M02541
(x1)

- ALIGN PILOT HOLES.

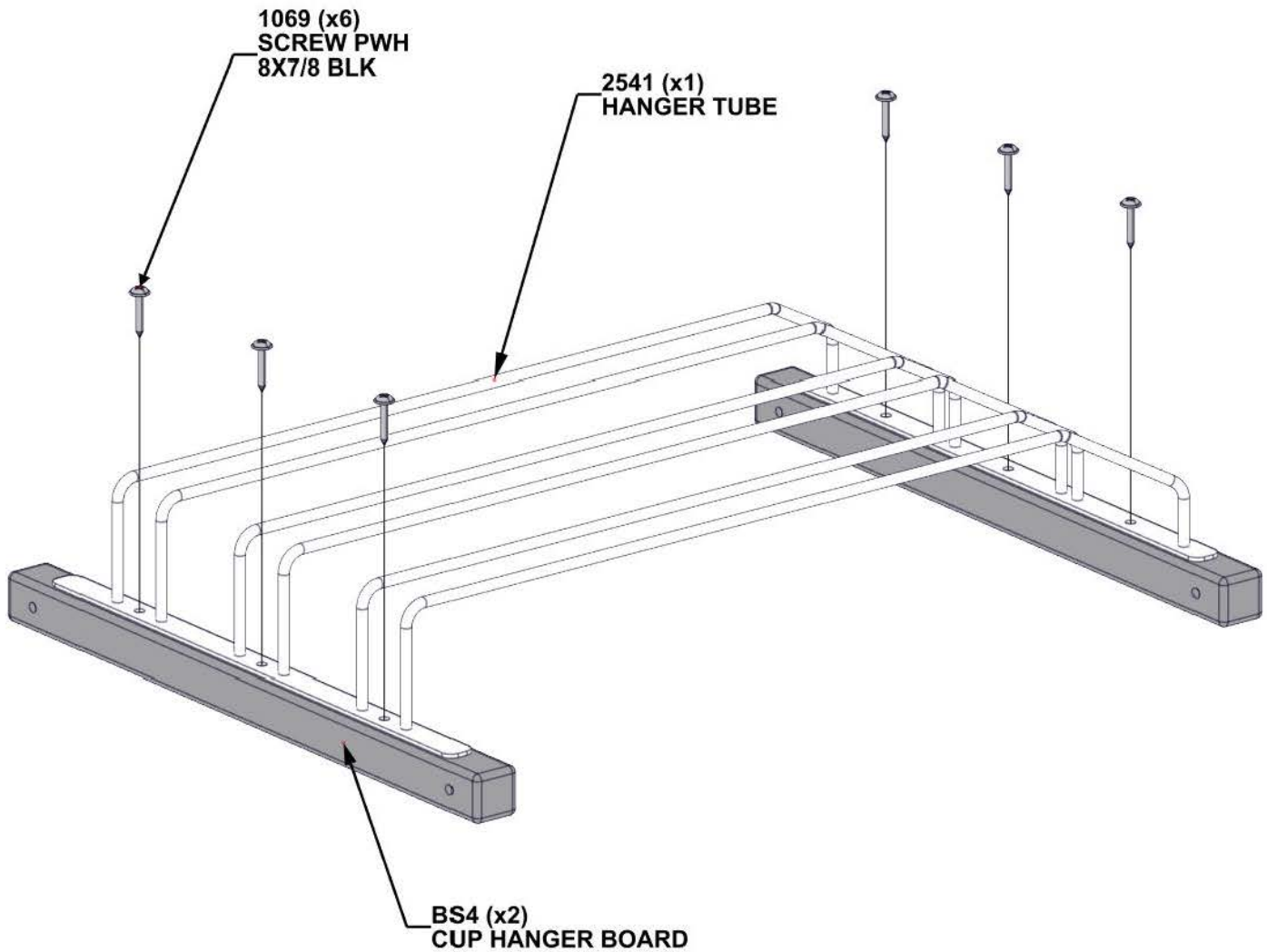

STEP 16 - CUP HANGER ASSEMBLY

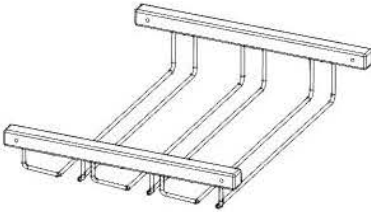

Qty	Part No	Description
4	H100835	SCREW PWH 8X2 BLK

CUP HANGER BOARD ASSEMBLY - STEP - 15

- ALIGN PILOT HOLES.

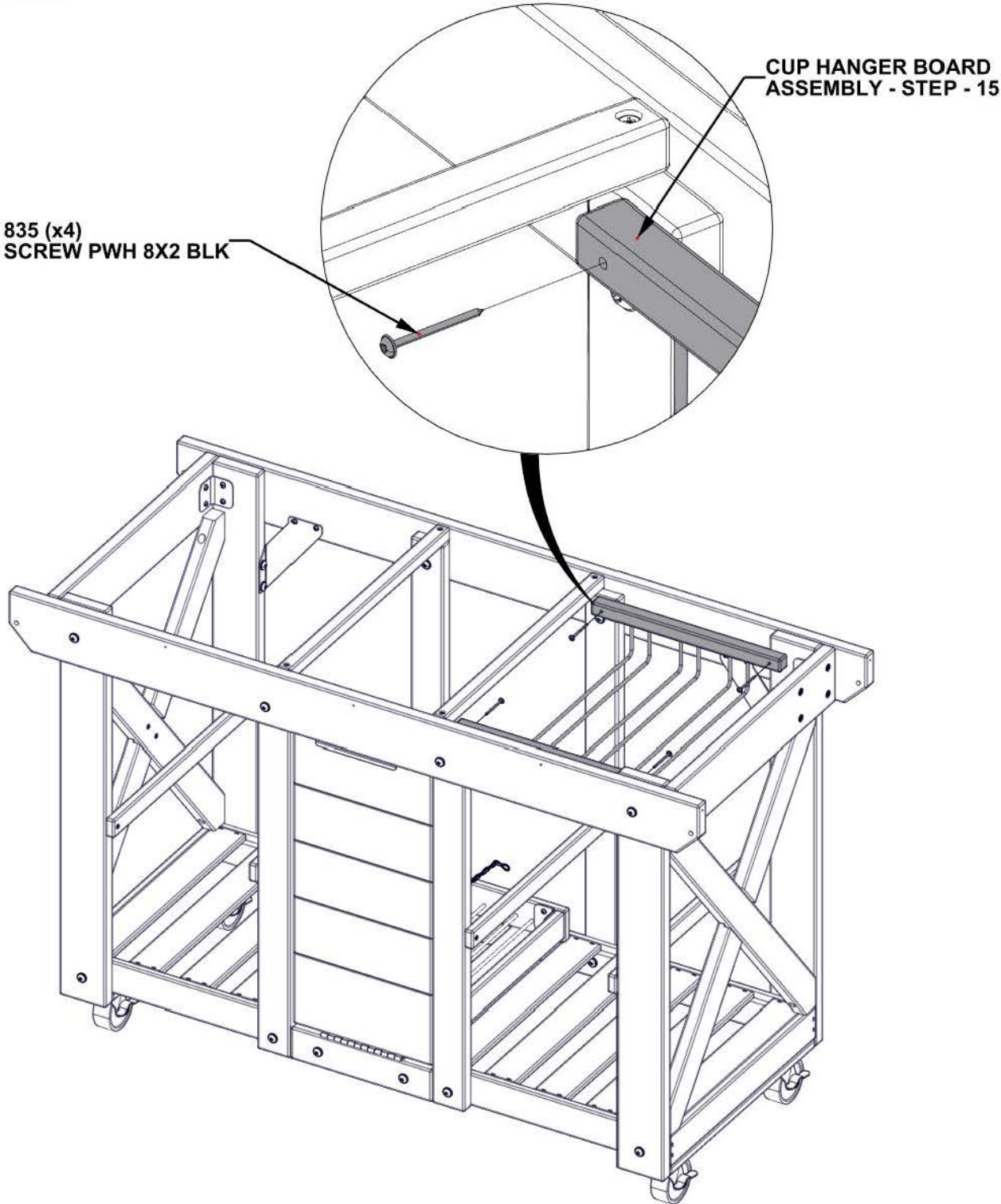

STEP 17 - BACK SHELF UPRIGHT ASSEMBLY

Qty	Part No	Description
8	H100405	WASHER LOCK EXT 6X15 BLK
8	H100406	BOLT WH 1/4x1 1/2 BLK



BS5 - BACK LEFT SHELF UPRIGHT - W4L18905
(x1) 15/16"x5 1/4"x27 11/16" (24x134x703)



BS6 - BACK RIGHT SHELF UPRIGHT - W4L18906
(x1) 15/16"x5 1/4"x27 11/16" (24x134x703)

- ALIGN PILOT HOLES.

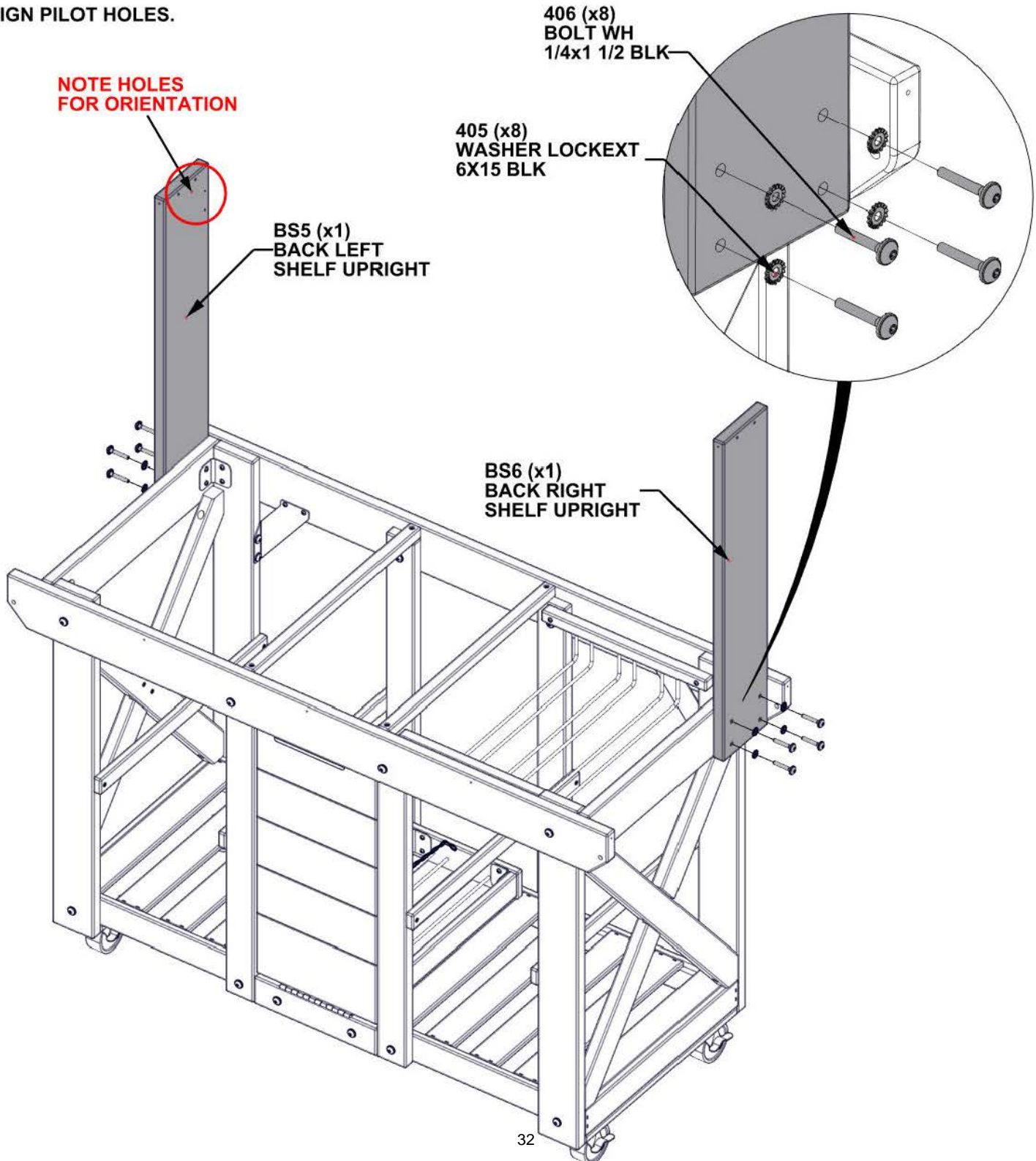

STEP 18 - TOWEL BAR ASSEMBLY

Qty	Part No	Description
4	H100405	WASHER LOCK EXT 6X15 BLK
4	H100406	BOLT WH 1/4x1 1/2 BLK

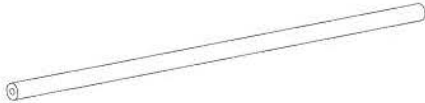

TOWEL BAR - A4M02542
(x2)

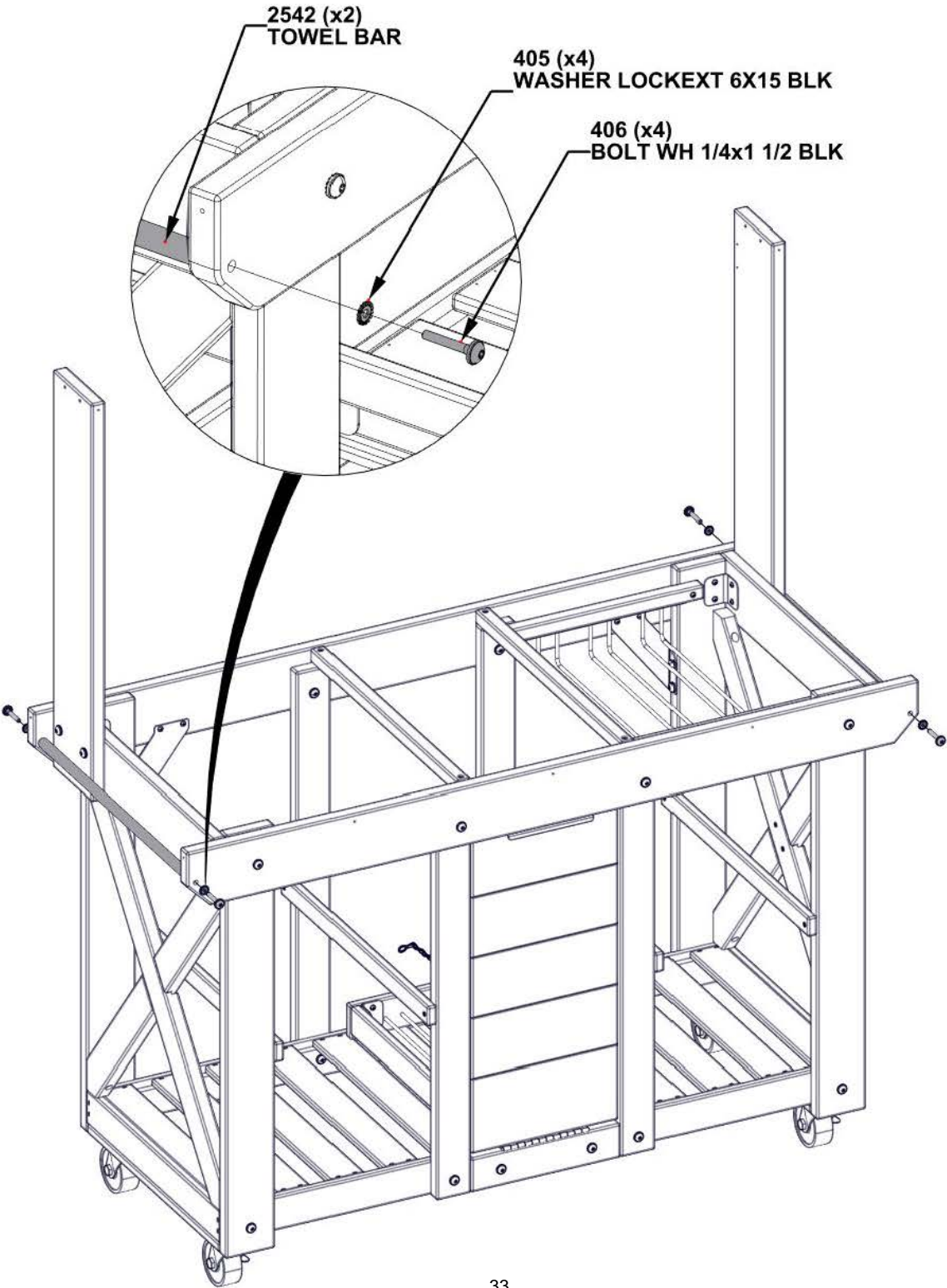

STEP 19 - TABLE ASSEMBLY

Qty	Part No	Description
10	H100392	SCREW PWH 8X3/4 BLK

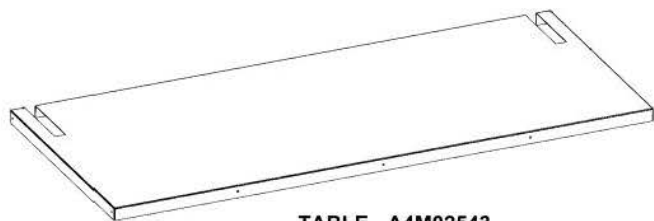
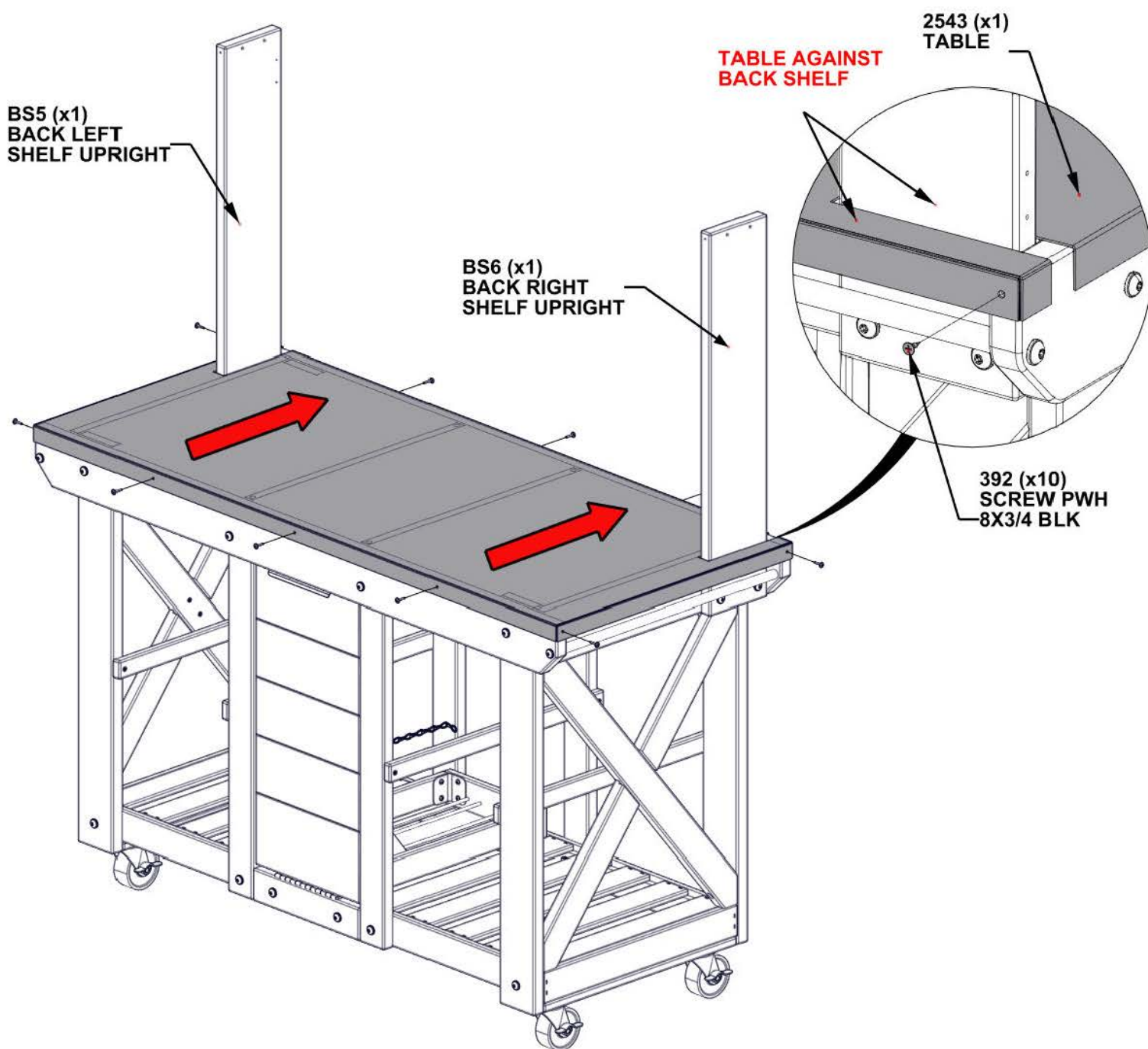

TABLE - A4M02543
(x1)

- IT IS RECOMMENDED TO HAVE TWO PEOPLE SET TABLE IN PLACE.
- SLIDE IN PLACE UNTIL TABLE IS AGAINST BACK SHELF UPRIGHT (BS5 AND BS6).
- ALIGN HARDWARE WITH PILOT HOLES TO AVOID SPLITTING.
- **WHEN SETTING TABLE IN PLACE, MAKE SURE YOUR FINGERS ARE CLEAR AND NOT UNDERNEATH TABLE.**
- **IT IS RECOMMENDED TO WEAR GLOVES WHEN HANDLING THE TABLE.**



STEP 20 - TOP SHELF BOARD ASSEMBLY

Qty	Part No	Description
4	H100382	SCREW PFH 8x1-3/4 BLK



TS3 TOP SHELF BOARD - W4L18909
(x1) 15/16"x5 1/4"x48 3/16" (24x134x1173)

- ALIGN PILOT HOLES.

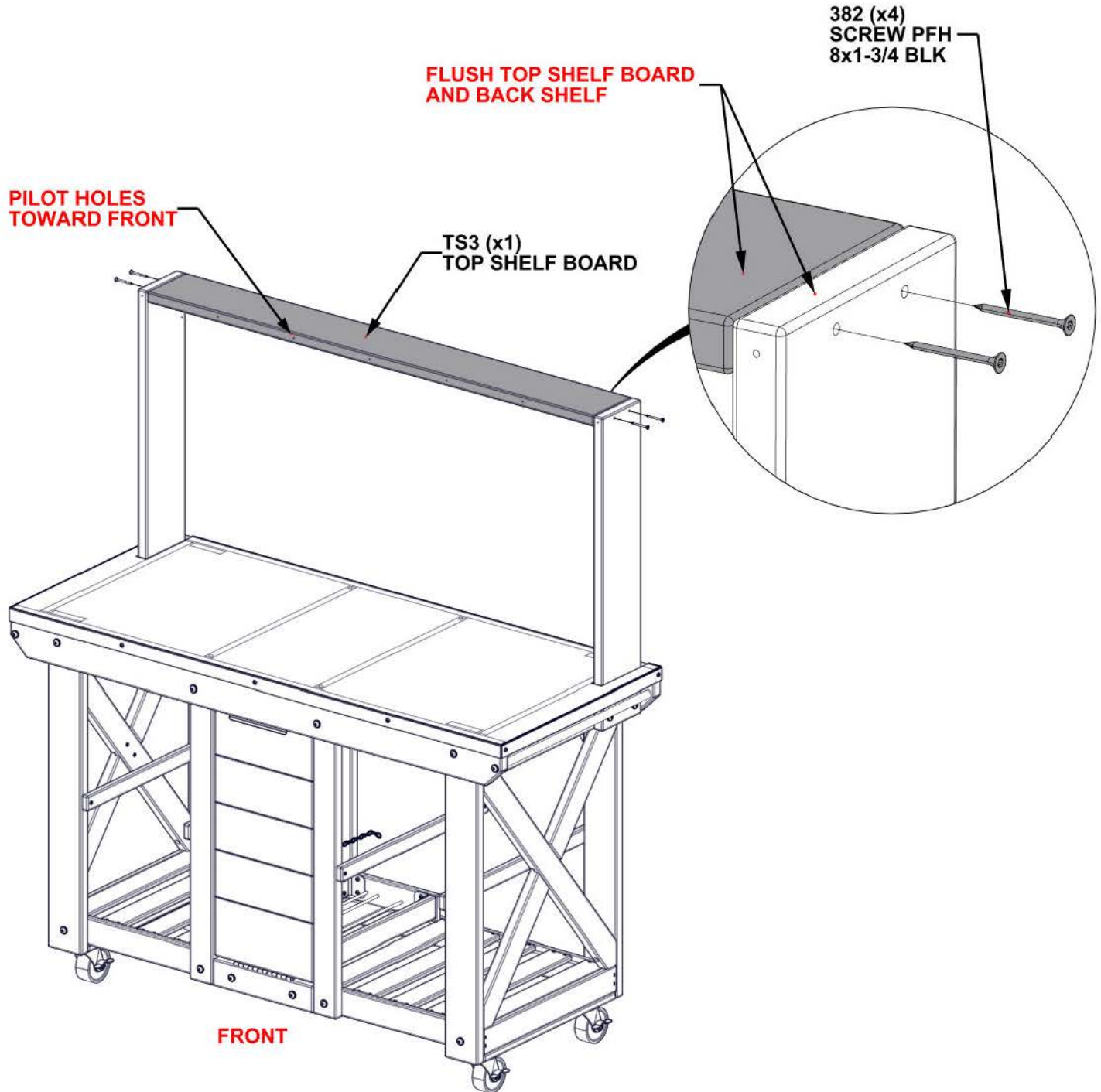

STEP 21 - TOP SLAT ASSEMBLY

Qty	Part No	Description
24	H100382	SCREW PFH 8x1-3/4 BLK



TS1 - TOP SLAT_1 - W4L18907
(x5) 15/16"x2 3/8"x48 1/16" (24x60x1221)



TS2 - TOP SLAT_2 - W4L18908
(x1) 15/16"x2 3/8"x48 1/16" (24x60x1221)

- ALIGN PILOT HOLES.

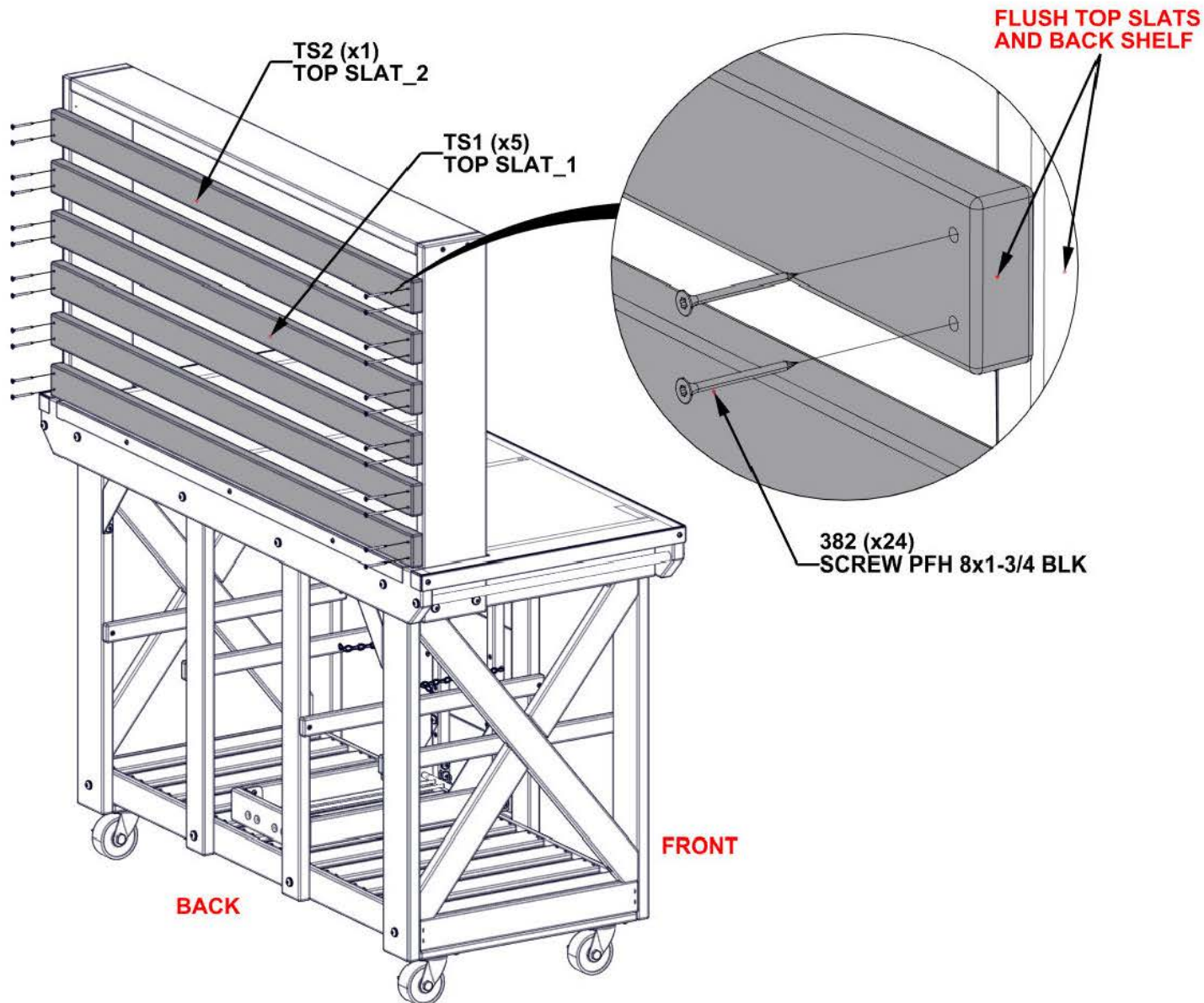
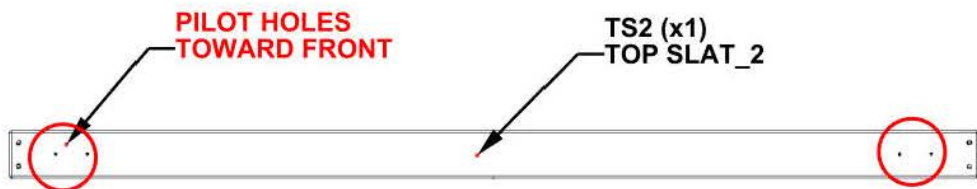

STEP 22 - METAL ANGLE TOP BRACE ASSEMBLY

Qty	Part No	Description
8	H100392	SCREW PWH 8X3/4 BLK

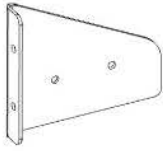

METAL ANGLE TOP BRACE LEFT - A4M02544
(x1)

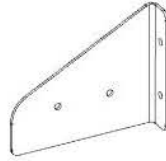

METAL ANGLE TOP BRACE RIGHT - A4M02545
(x1)

- ALIGN PILOT HOLES.

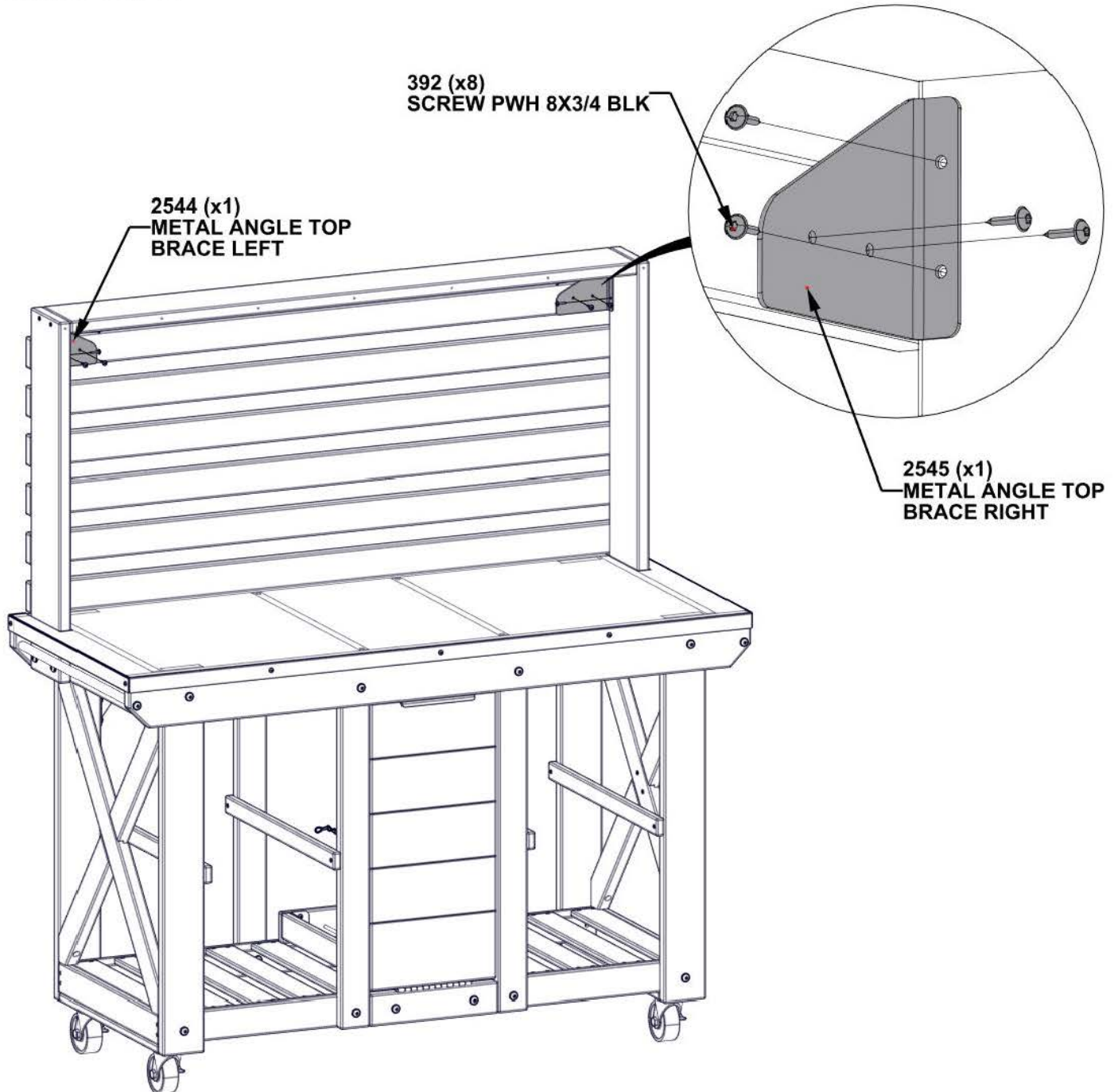

STEP 23 - CHAMFERED TOP BOARD ASSEMBLY

Qty	Part No	Description
7	H100823	SCREW PWH 8X1 1/2 BLK

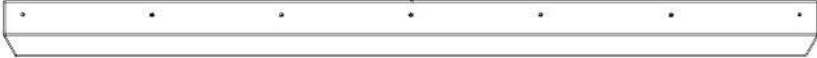

CB3 CHAMFERED TOP BOARD - W4L18911
(x1) 15/16"x3 3/8"x 49 3/8" (24x86x1255)

- ALIGN PILOT HOLES.

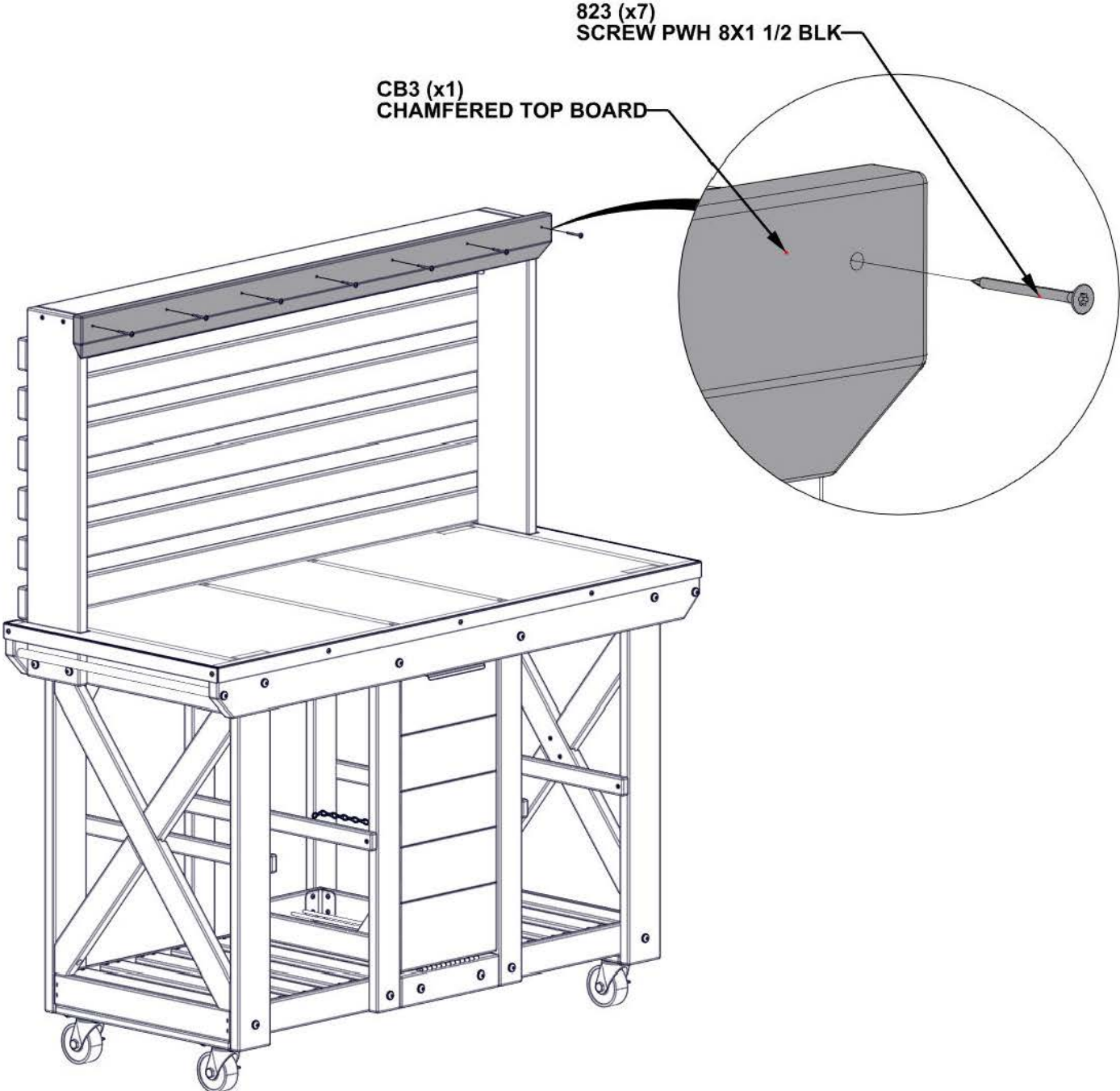

STEP 24 - SHELF BOARD ASSEMBLY

Qty	Part No	Description
12	H100411	SCREW PFH 8x5/8 BLK



SB2-SHELF BOARD - W4L18910
(x3) 15/16"x5 1/4"x22 7/16" (24x134x570)

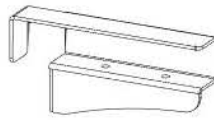

SHELF SUPPORT RIGHT - A4M02546
(x3)

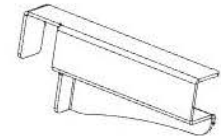

SHELF SUPPORT LEFT - A4M02547
(x3)

- ALIGN PILOT HOLES.

REPEAT THIS STEP 3 TIMES

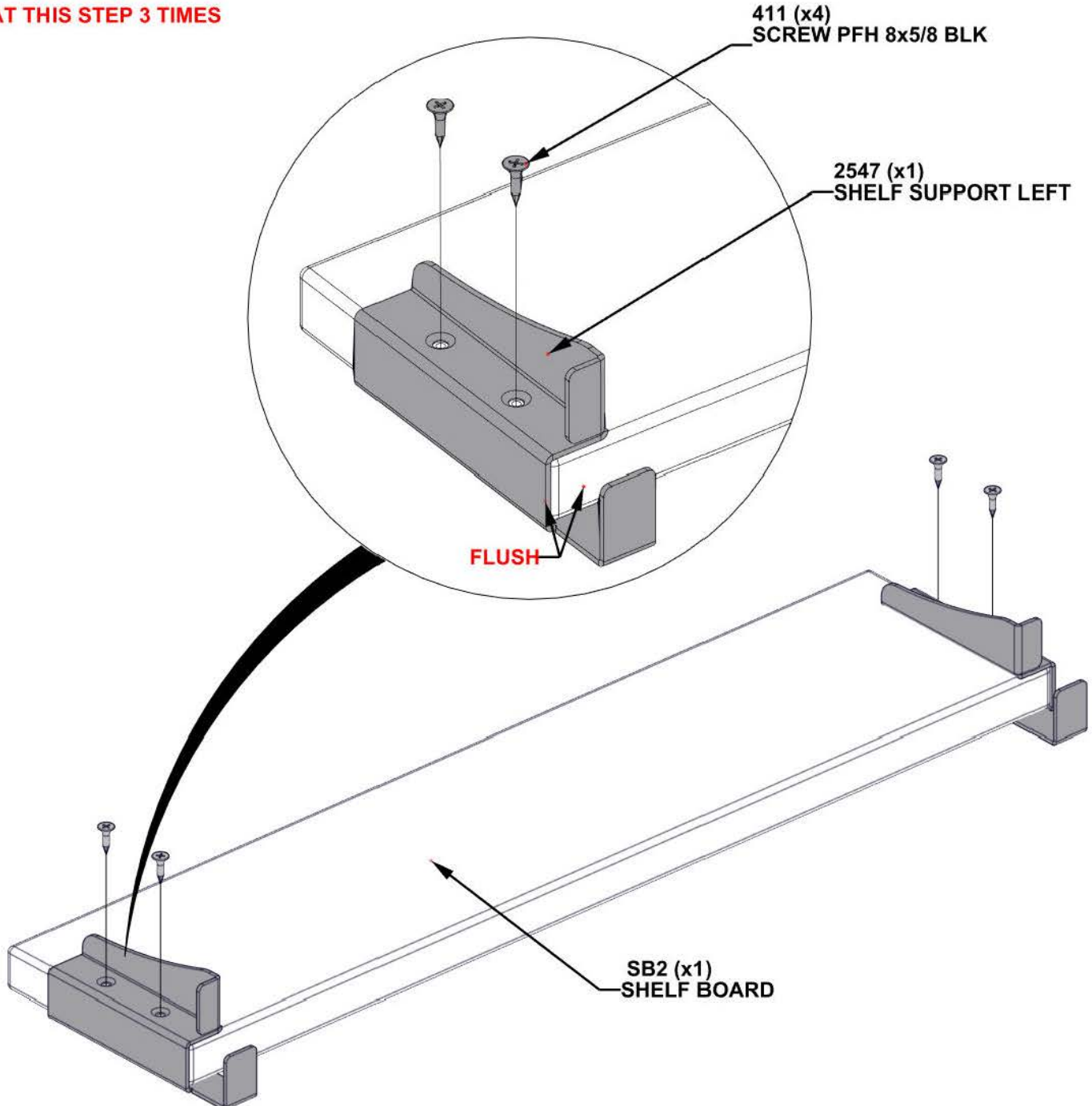

STEP 25 - SHELF BOARD ASSEMBLY

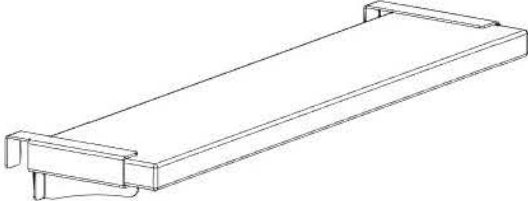

SHELF BOARD ASSEMBLY - STEP 24

- INSERT SHELVES IN DESIRED LOCATION AS SHOWN.

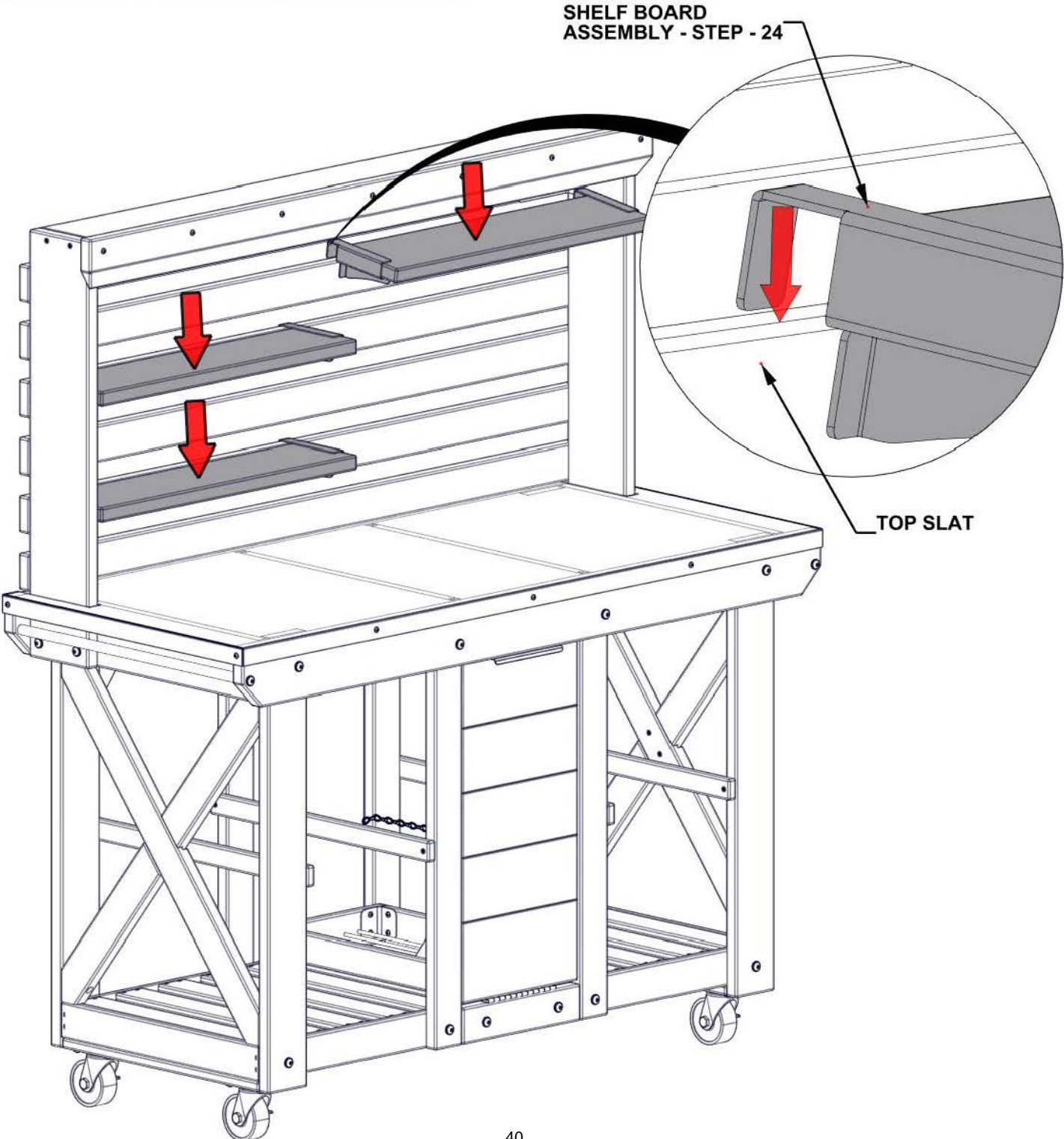

STEP 26 - HOOK ASSEMBLY

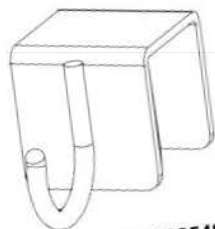

HOOK - A4M02548
(x3)

INSERT 3 HOOKS IN DESIRED LOCATION.

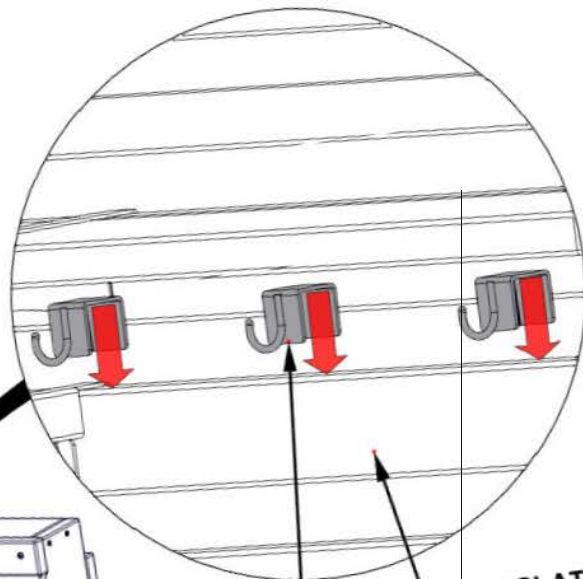

2548 (x3)
HOOK

TOP SLAT

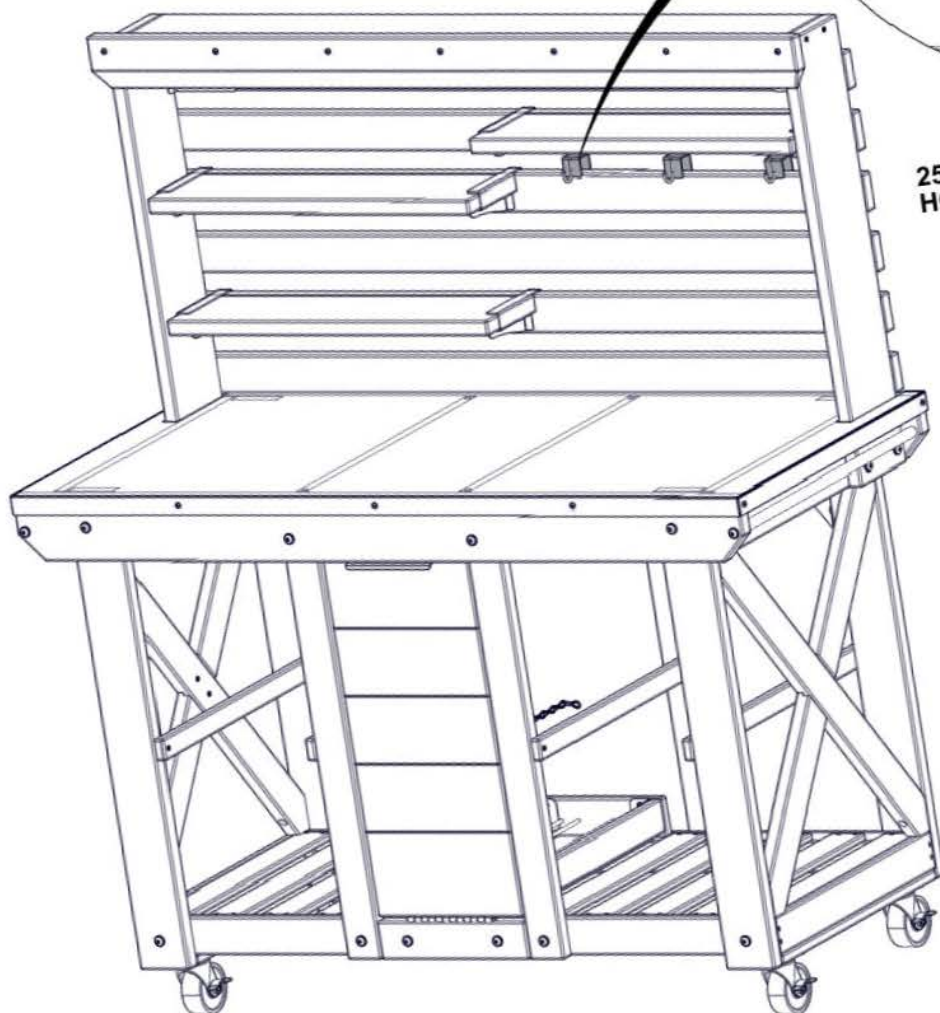

STEP 27A - WINE RACK ASSEMBLY

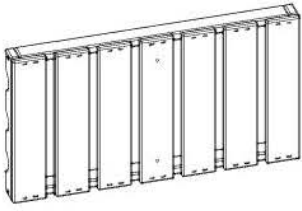

WR1-WINE RACK ASSY - W2A04016
(x2) 1 13/16"x11 1/8"x19 15/16" (46x283x506)



BH1-BOTTLE HOLD BOARD - W4L21182
(x2) 5/8"x2 3/8"x9 15/16" (16x60x250)

Qty	Part No	Description
4	H100816	SCREW PFH 8x7/8 BLK

- ALIGN PILOT HOLES.

REPEAT THIS STEP 2 TIMES

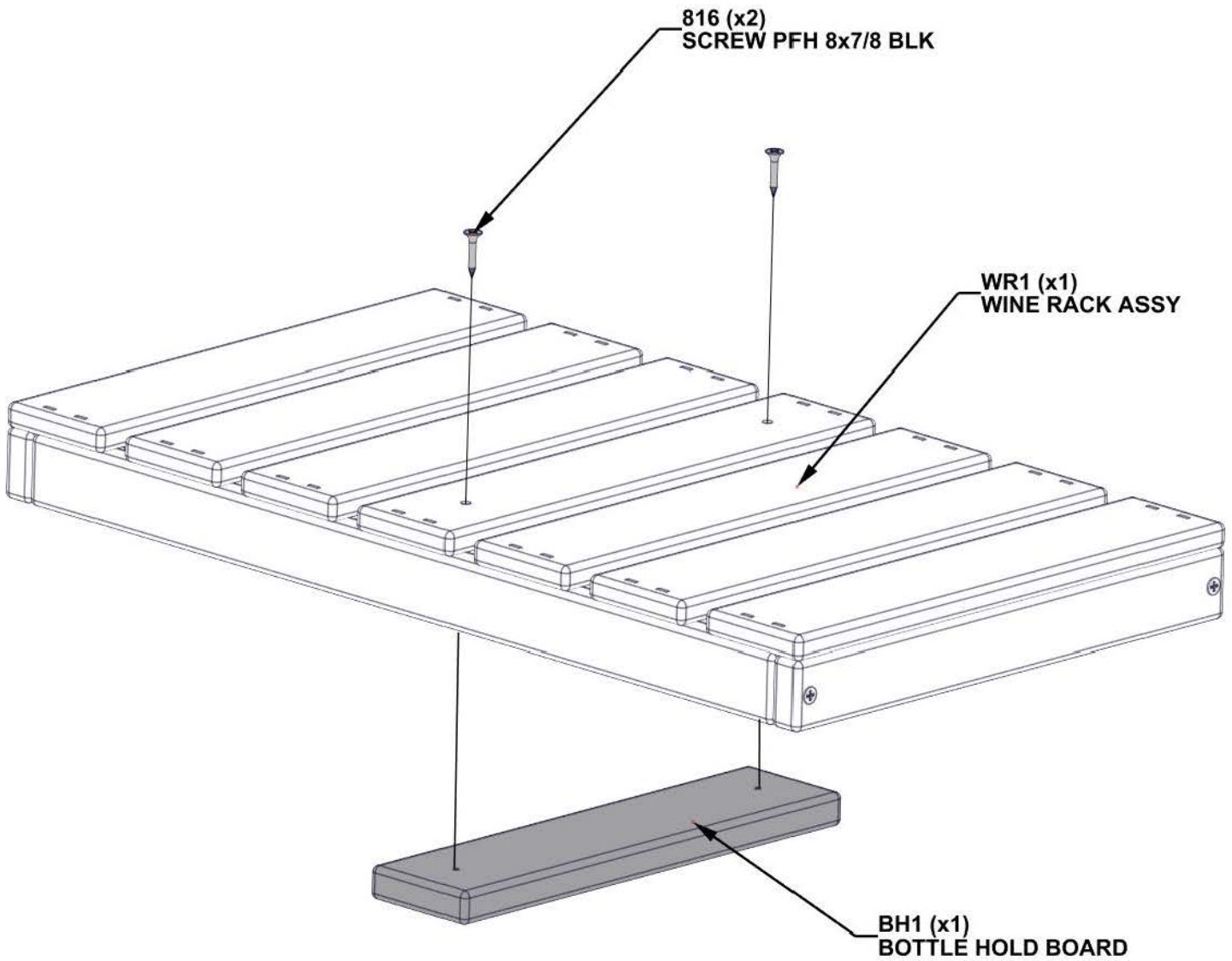

STEP 27B - WINE RACK ASSEMBLY



WINE RACK ASSEMBLY - STEP 27A

- INSERT 2 WINE RACKS ONTO SUPPORT BOARD IN DESIRED ORIENTATION.

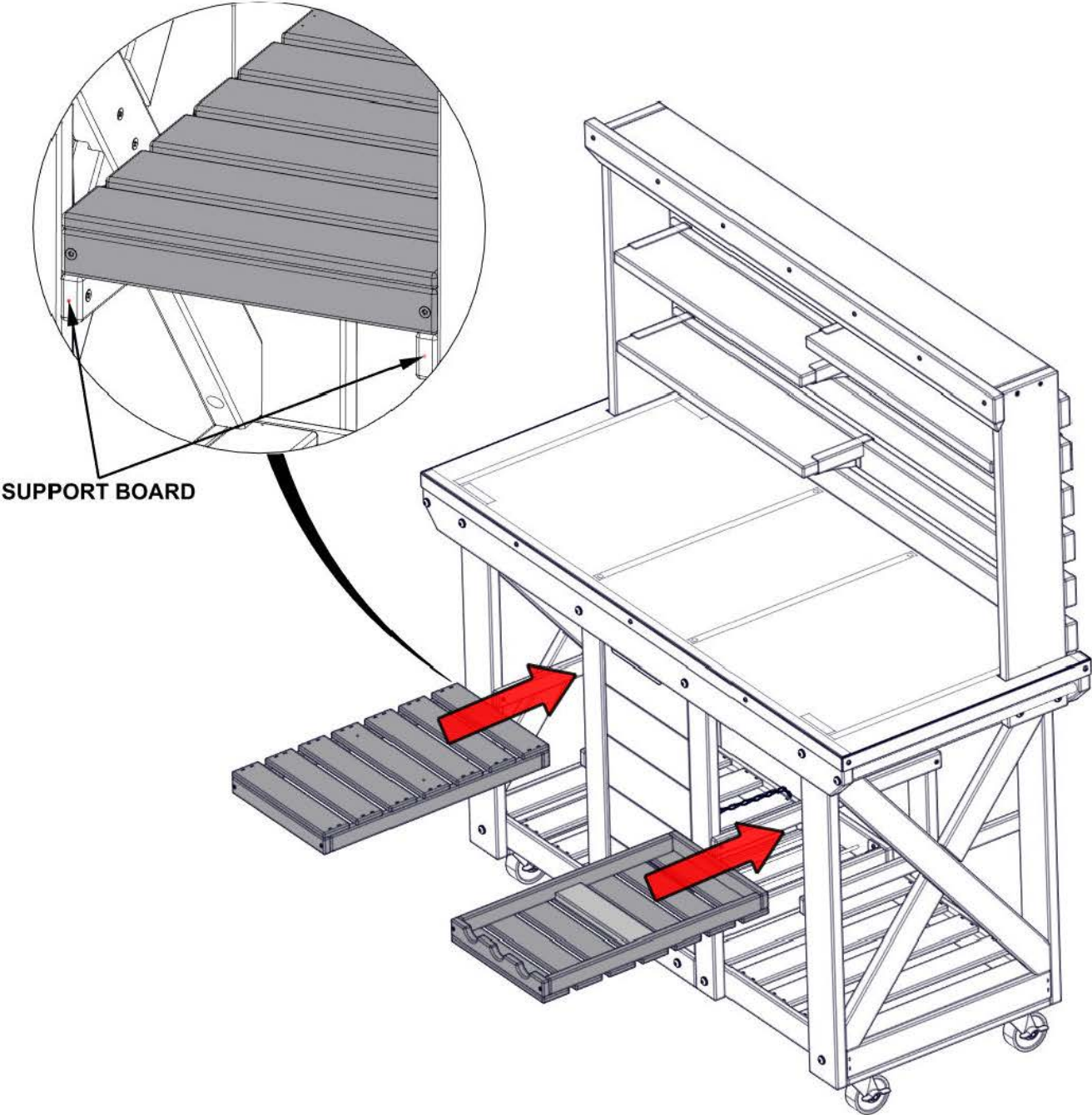

STEP 28 - BOTTLE CAP OPENER ASSEMBLY

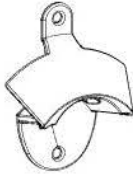

BOTTLE CAP OPENER - A4M01187
(x1)

Qty	Part No	Description
2	H100816	SCREW PFH 8x7/8 BLK

- BEFORE INSTALLING SCREWS, PRE-DRILL LOCATIONS SHOWN USING A 1/8" (3mm) DRILL BIT.

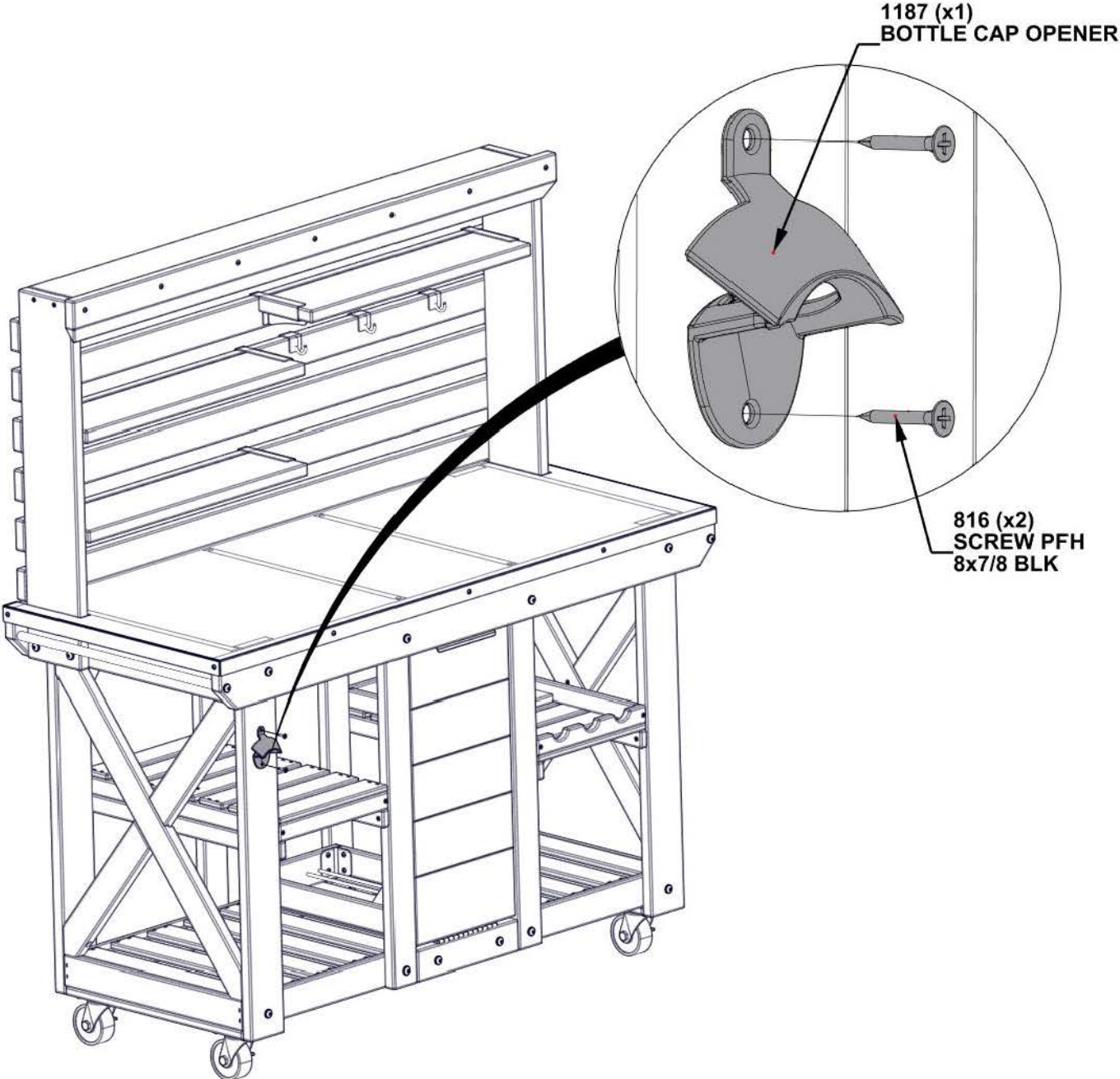

STEP 29 - BYD ID TAG PATIO ASSEMBLY



Qty	Part No	Description
4	H100392	SCREW PWH 8X3/4 BLK

BYD ID TAG PATIO - A4M02158
(x1)

- CENTER ID TAG ON FRONT OF BOTTOM PANEL AS SHOWN.
- BEFORE INSTALLING SCREWS, PRE-DRILL LOCATIONS SHOWN USING A 1/8" (3mm) DRILL BIT.

