



Manufactured by:
Backyard Discovery
3305 Airport Drive, Pittsburg, KS
66762 800-856-4445

Basepoint Business Centre: Rivermead Drive, Westlea, Swindon SN5 7EX Phone: 0800-118-2476
J.P. Coenstraat 7, The Bridge, The Hague, 2595 WP, Netherlands Phone: 08005678990

AGGIE CEDAR COLD BOX

MODEL # : 2304130

For Horticulture Use Only



Please visit www.backyarddiscovery.com

For the most up to date assembly manual, to register your product, or to order replacement parts *Para obtener instrucciones en español, visite* www.backyarddiscovery.com



EASY STEP-BY-STEP
3D INTERACTIVE INSTRUCTIONS
DOWNLOAD THE FREE APP



Made in China

INS-2304130-A-AGGIE CEDAR COLD BOX-ENG 11-28-2023

OWNER'S MANUAL - BASIC SETUP DIMENSIONS & ASSEMBLY NOTES

- Pay close attention to the items needed for each step. Make sure you are using the correct hardware for each step. Using incorrect hardware may result in improper assembly.

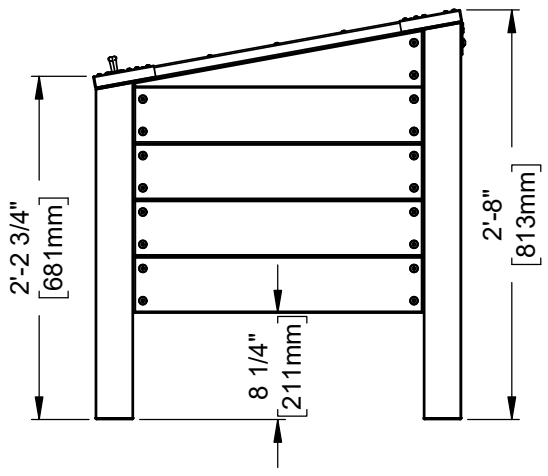
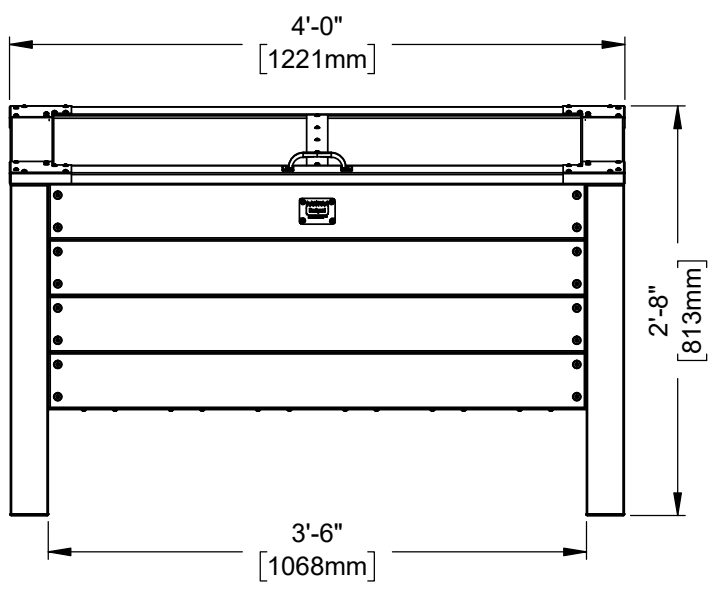
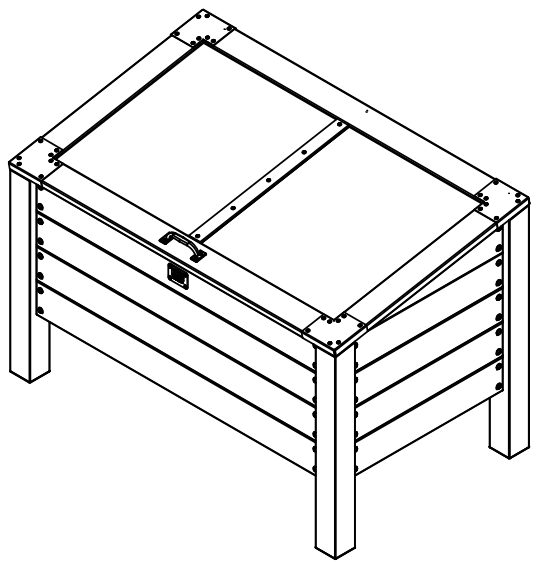
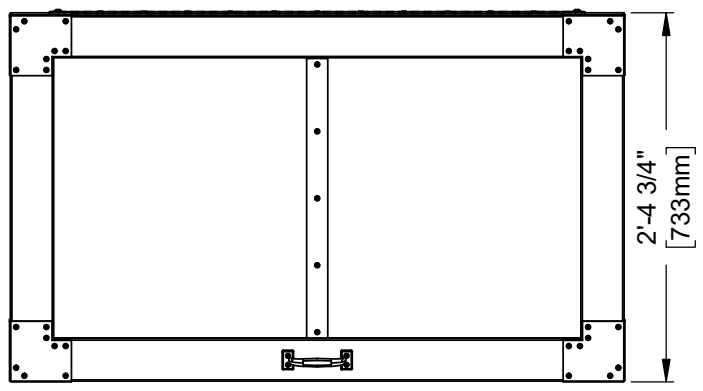

OWNER'S MANUAL - PARTS IDENTIFICATION

WOOD COMPONENTS (NOT TO SCALE)



AD01 LONG SIDE BOARD - W4L18781
(x8) 15/16"x4 7/16"x41 15/16" (24x112x1066)



AD02 SHORT SIDE BOARD - W4L18783
(x6) 15/16"x4 7/16"x22 5/8" (24x112x574)



AD03 SLAT - W4L18784
(x6) 15/16"x4 7/16"x24 11/16" (24x112x627)



AD04 LONG SIDE BOARD - W4L18790
(x1) 15/16"x4 7/16"x41 15/16" (24x112x1066)



H01 FRONT LID BOARD - W4L18786
(x1) 15/16"x3 3/8"x47 15/16" (24x86x1218)



H02 SIDE LID BOARD - W4L18785
(x2) 15/16"x3 3/8"x29 1/16" (24x86x738)



H03 BACK LID BOARD - W4L18787
(x1) 15/16"x3 3/8"x47 15/16" (24x86x1218)



J01 HINGE BOARD - W4L18788
(x1) 15/16"x2 3/8"x41 15/16" (24x60x1066)



O01 MIDDLE LID BOARD - W4L18789
(x1) 5/8"x1 5/16"x24 7/16" (16x34x620)

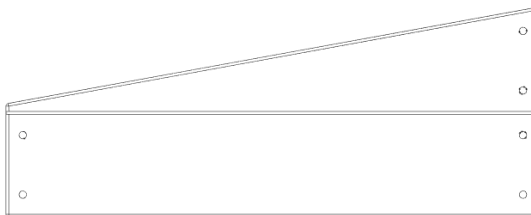

S01 SIDE BOARD - W4L18782
(x2) 15/16"x225x22 5/8" (24x225x574)

OWNER'S MANUAL - PARTS IDENTIFICATION

HARDWARE COMPONENTS (NOT TO SCALE)

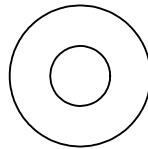
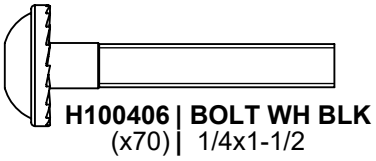

H100630 | WASHER FLAT BLK
(x72) | 8x19

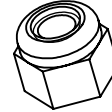

H100653 | NUT LOCK BLK
(x72) | 1/4

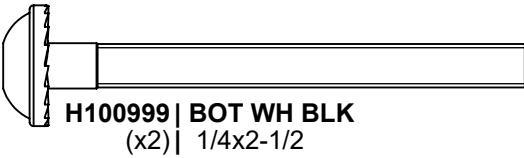

H100999 | BOT WH BLK
(x2) | 1/4x2-1/2

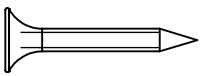

H100385 | SCREW PFH BLK
(x4) | 8x1

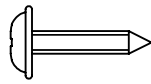

H100202 | SCREW PWH BLK
(x1) | 8x5/8



H100797 | SCREW PWH BLK
(x5) | 8x1

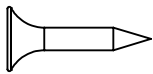

H100395 | SCREW PFH BLK
(x28) | 8x3/4

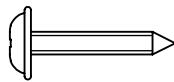

H100392 | SCREW PWH BLK
(x86) | 8x3/4

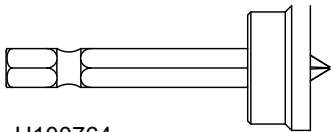

H100764 | SCREW SETTER
(x1)

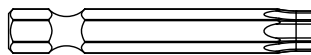

H100147 | TORX BIT
(x1) | T-30

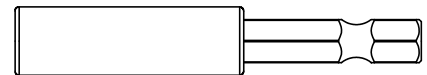

H101100 | MAGNETIC DRIVER
(x1)

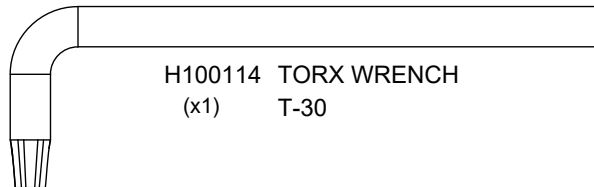

H100114 | TORX WRENCH
(x1) | T-30

OWNER'S MANUAL - PARTS IDENTIFICATION

ACCESSORY COMPONENTS (NOT TO SCALE)

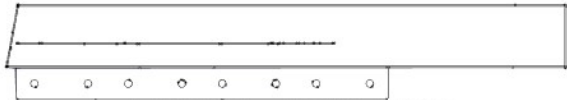

A4M02418 FRONT POST
(x1)



A4M02420 FRONT POST
(x1)



A4M02419 BACK POST
(x1)



A4M02421 BACK POST
(x1)



A4M00559 PULL HANDLE
(x1)

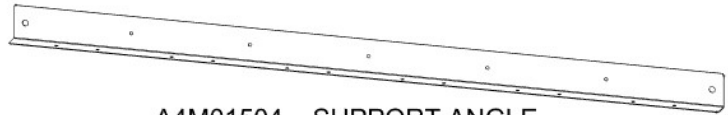

A4M01504 SUPPORT ANGLE
(x2)



A4M02158 BYD ID TAG PATIO
(x1)

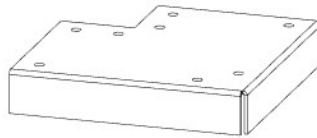

A4M02422 CORNER BRACKET
(x4)

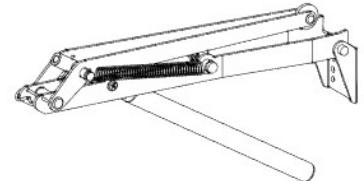

A4M02425 VENT OPENER
(x1)

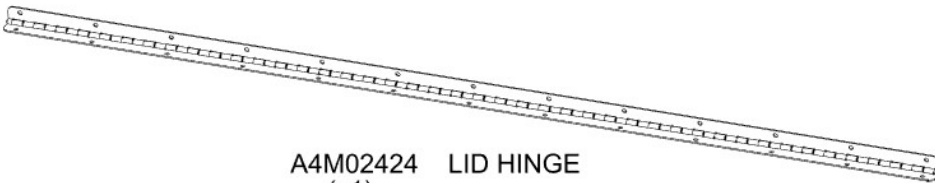

A4M02424 LID HINGE
(x1)



A6P00707 RAIL
(x1)



A6P00706 PC PANEL
(x2)

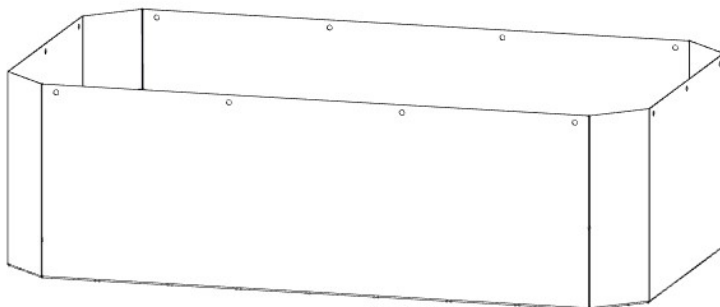

A6P00511 PLANTER LINER
(x1)



A4M02423 BAR CAP WITH GASKET
(x1)

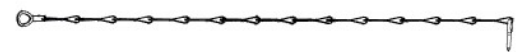

A4M00692 LID CHAIN
(x1)

PRE-ASSEMBLY STEP 1 - SORTING PARTS

It is critical for ease of assembly that you take the time to sort and organize the wood and hardware.

WOOD PARTS:

- Organize wood parts by the three-digit, alpha-numeric number stamped on each board (ex. P01).
- If there are multiple boards with the same stamped number, stack those pieces together.
- Stamps can be found on the flat surface of the boards or on the end of the boards.
- Allow yourself plenty of room - the wood pieces can take up a significant amount of space.

NOTE: CARTONS ARE NOT ORGANIZED BY BOARD NUMBER.



HARDWARE PARTS:

- We recommend that you have a separate table to organize the hardware.
- Hardware bags are printed with a seven-digit, alpha-numeric part number.
- You can organize your hardware by part number or group by hardware type (i.e. bolts, nuts, etc.).
- During assembly you only need to reference the last four digits of the number.

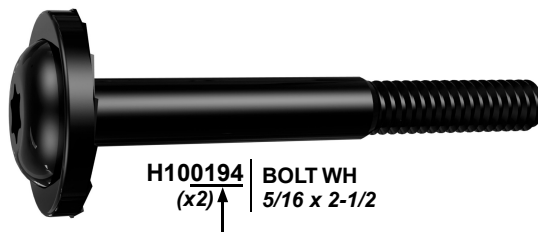

H100194 | BOLT WH
(x2) ↑ 5/16 x 2-1/2

PRE-ASSEMBLY STEP 2 - TOOLS REQUIRED



Cordless Drill
or Electric Drill



Drill
Attachments:
Phillips Head



1/8", 3/16", 3/8" &
7/16" Drill Bits

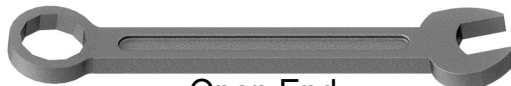

Open End
Wrenches 1/2" &
9/16"



3/8" Drive Ratchet, 1/2" &
7/16" STD Sockets 1/2" & 7/16"
Deep Sockets



Phillips Screw Driver



Claw Hammer



Rubber Mallet
- Optional



Tape Measure

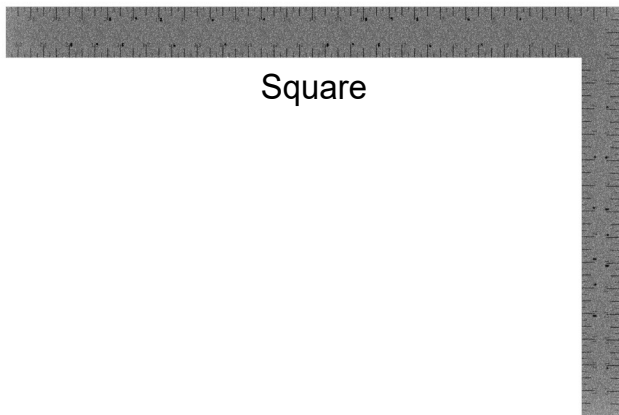

Square



Level 24"

PRE-ASSEMBLY STEP 3 - CHOOSE YOUR ASSEMBLY METHOD

There are several types of assembly instructions available to you.

1. Printed Assembly Manual included with your set
2. BILT APP - 3D interactive instructions
3. Combination of the Printed Manual and BILT APP (Note: Step numbers can differ between the two methods)



BILT.

Scan for easy
3D instructions

Download the BILT app
before you begin

Download on the
App Store

GET IT ON
Google Play

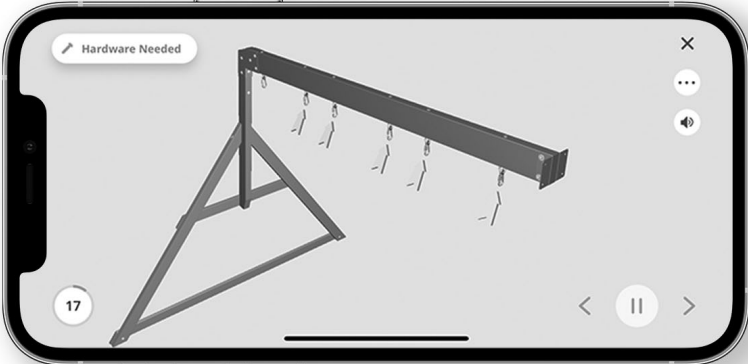

Hardware Needed

17

< || >

The image shows a smartphone screen displaying a 3D assembly instruction. The screen features a 3D model of a metal frame structure. At the top left, there is a button labeled 'Hardware Needed'. At the bottom left, a circular indicator shows the number '17'. At the bottom right, there are navigation controls: a back arrow, a pause button, and a forward arrow. The phone is shown in a perspective view, with a shadow underneath.

STEP 4 - COLD BOX ASSEMBLY

QTY	PART NUMBER	DESCRIPTION
18	H100406	BOLT WH 1/4 X 1 1/2 BLK
18	H100630	WASHER FLAT 8x19 BLK
18	H100653	NUT LOCK 1/4 BLK

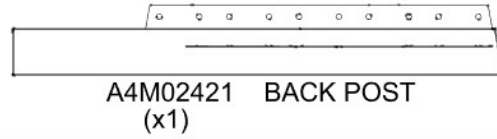
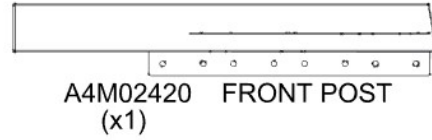
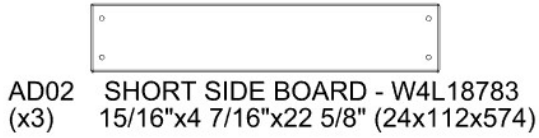
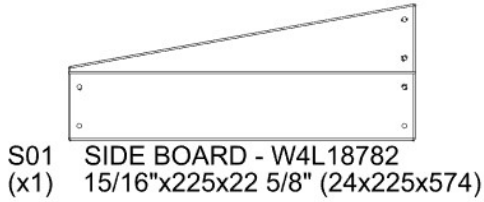

**BEFORE FULLY TIGHTENING
HARDWARE, ENSURE THAT THERE
ARE NO GAPS BETWEEN BOARDS.**

**ENSURE S01 BOARD IS
FLUSH WITH TOP OF POSTS.**

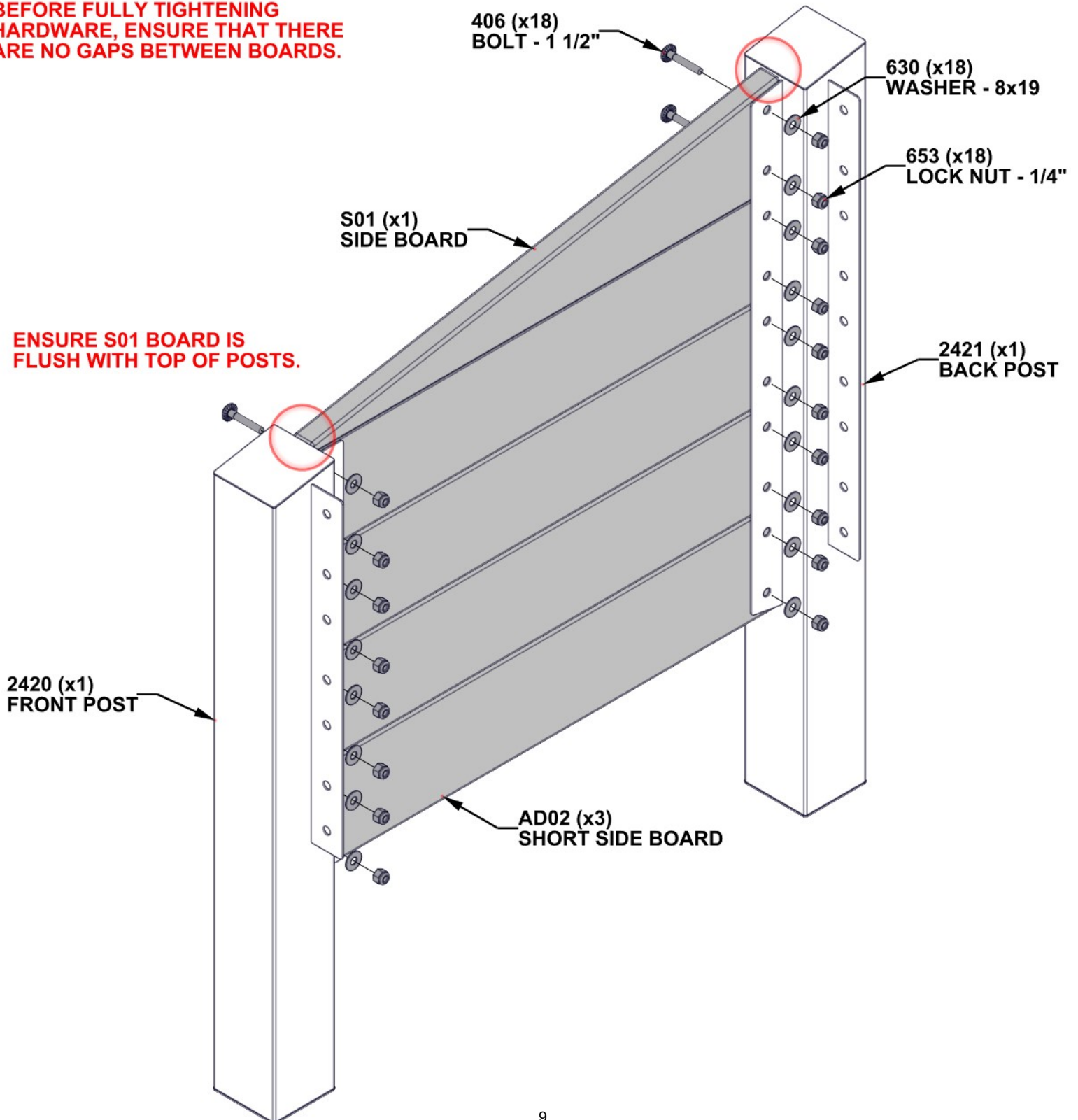

STEP 5 - COLD BOX ASSEMBLY

QTY	PART NUMBER	DESCRIPTION
18	H100406	BOLT WH 1/4 X 1 1/2 BLK
18	H100630	WASHER FLAT 8x19 BLK
18	H100653	NUT LOCK 1/4 BLK

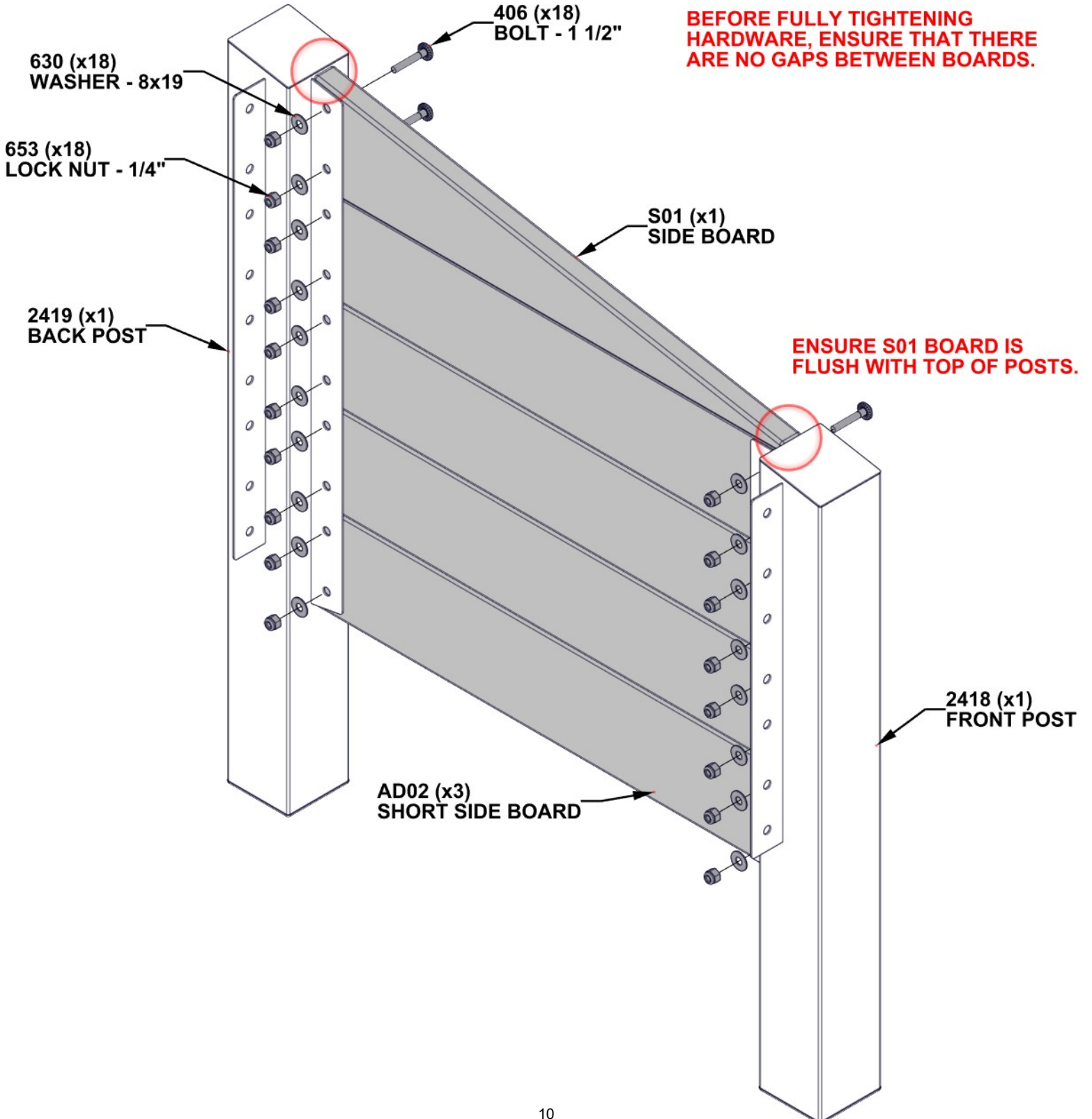
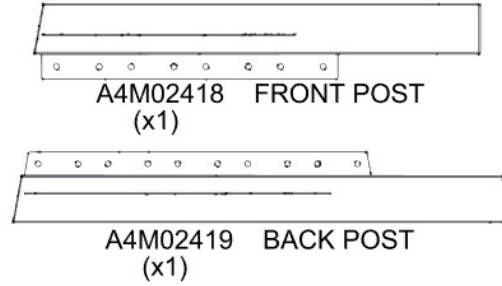
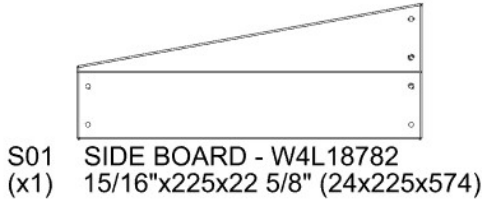

STEP 6 - COLD BOX ASSEMBLY

QTY	PART NUMBER	DESCRIPTION
8	H100406	BOLT WH 1/4 X 1 1/2 BLK
8	H100630	WASHER FLAT 8x19 BLK
8	H100653	NUT LOCK 1/4 BLK



AD01 LONG SIDE BOARD - W4L18781
(x2) 15/16"x4 7/16"x41 15/16" (24x112x1066)

DO NOT FULLY TIGHTEN HARDWARE.

ENSURE THAT BOTTOM HOLE AND TOP TWO HOLES ON BRACKET ARE LEFT OPEN.

AD01 (x2)
LONG SIDE BOARD

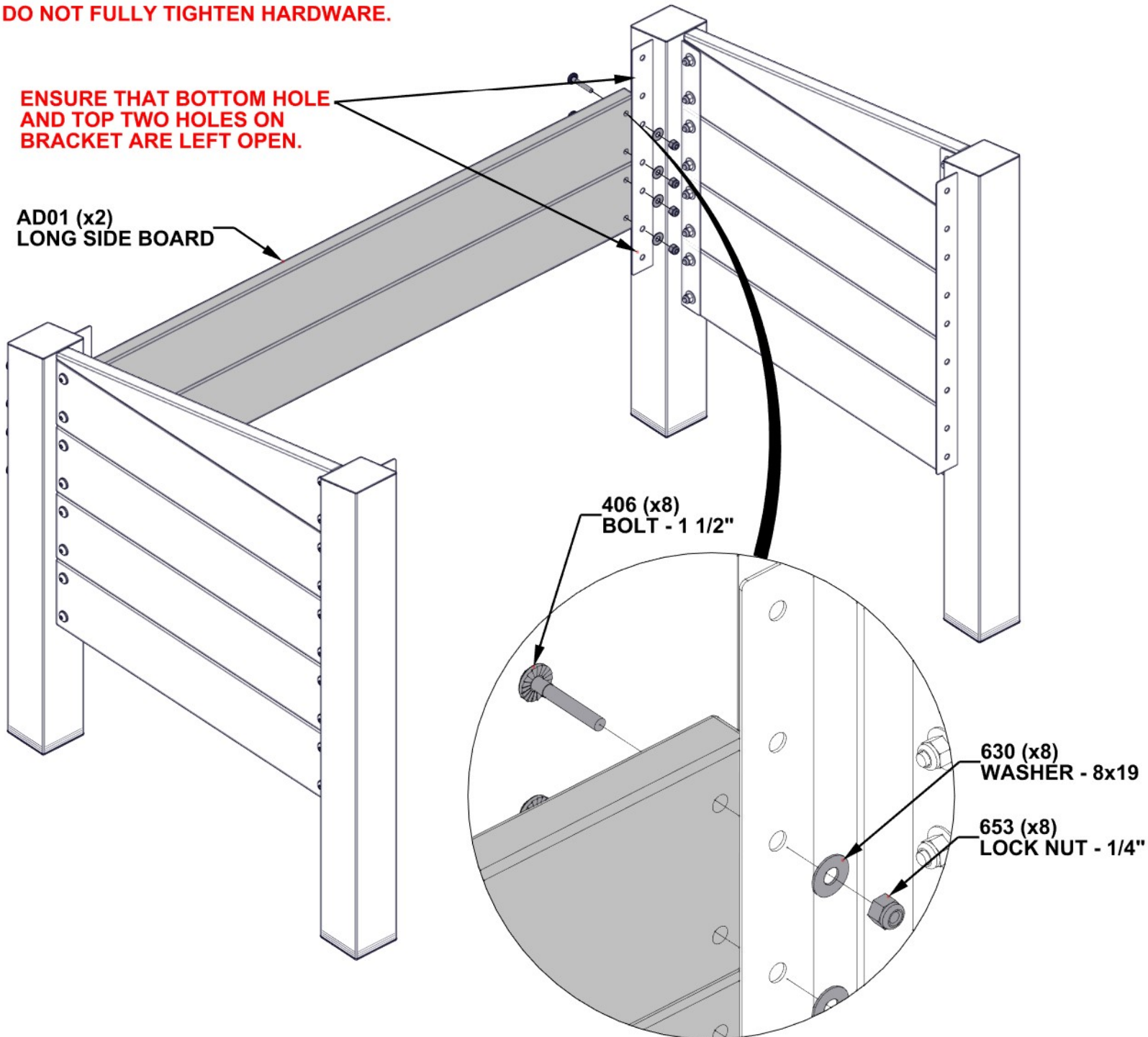

STEP 7 - COLD BOX ASSEMBLY

QTY	PART NUMBER	DESCRIPTION
14	H100406	BOLT WH 1/4 X 1 1/2 BLK
14	H100630	WASHER FLAT 8x19 BLK
14	H100653	NUT LOCK 1/4 BLK



AD01 LONG SIDE BOARD - W4L18781
(x4) 15/16"x4 7/16"x41 15/16" (24x112x1066)

DO NOT FULLY TIGHTEN HARDWARE.

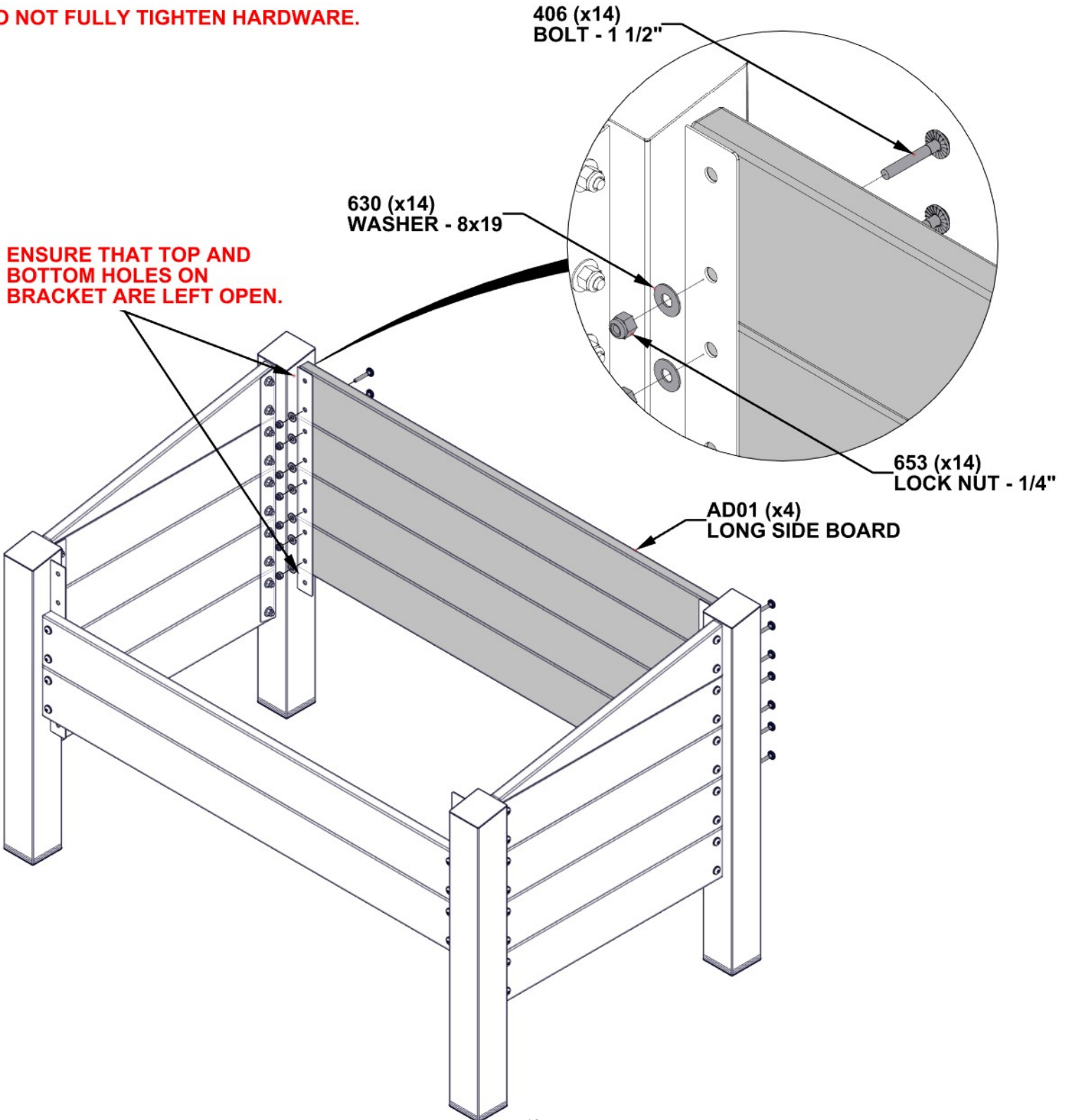

STEP 8 - COLD BOX ASSEMBLY

QTY	PART NUMBER	DESCRIPTION
4	H100406	BOLT WH 1/4 X 1 1/2 BLK
4	H100630	WASHER FLAT 8x19 BLK
4	H100653	NUT LOCK 1/4 BLK



AD04 LONG SIDE BOARD - W4L18790
(x1) 15/16"x4 7/16"x41 15/16" (24x112x1066)

DO NOT FULLY TIGHTEN HARDWARE.

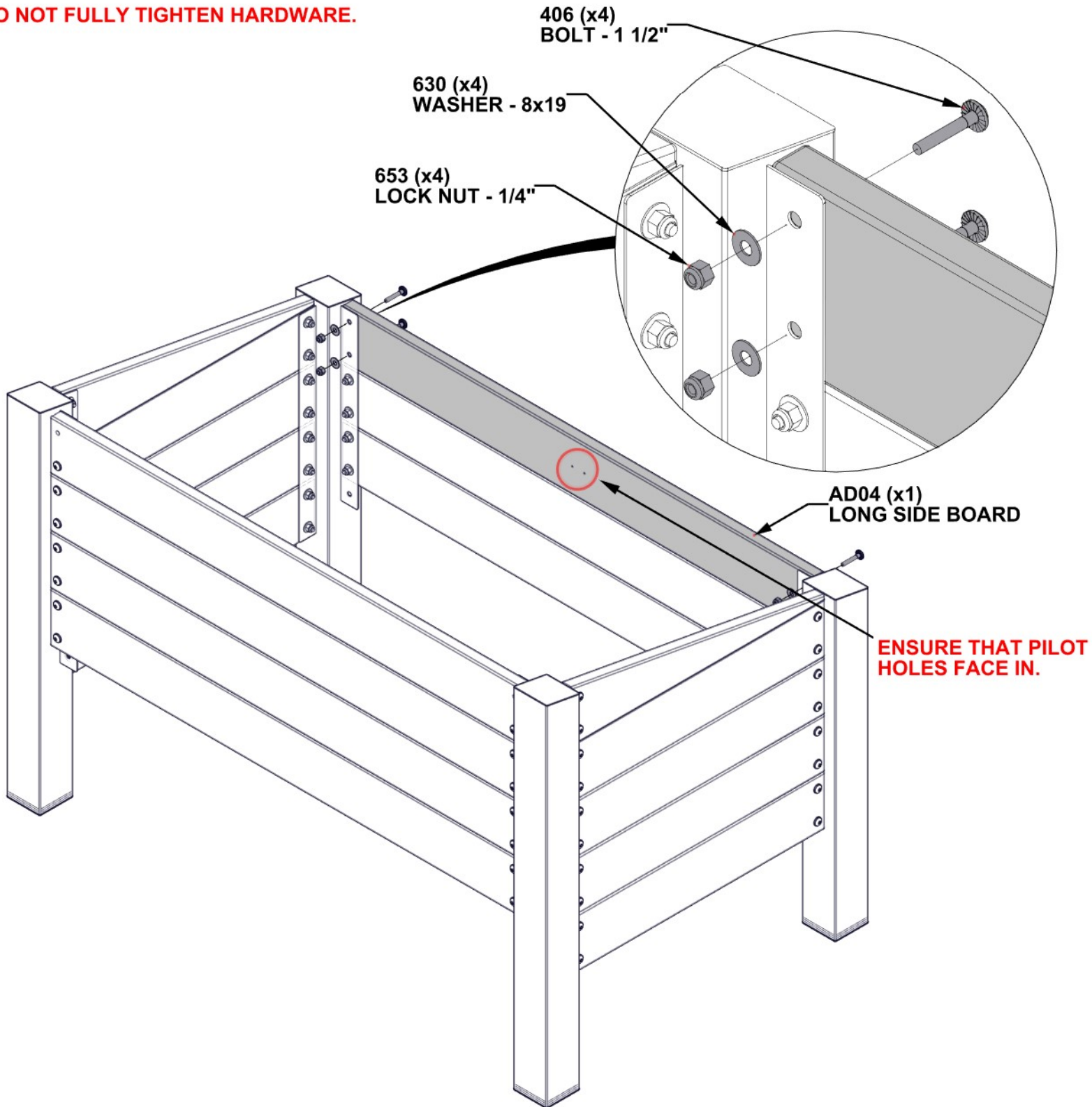

STEP 9 - COLD BOX ASSEMBLY

QTY	PART NUMBER	DESCRIPTION
2	H100630	WASHER FLAT 8x19 BLK
2	H100653	NUT LOCK 1/4 BLK
2	H100999	BOLT WH 1/4 X 2 1/2 BLK



J01 HINGE BOARD - W4L18788
 (x1) 15/16"x2 3/8"x41 15/16" (24x60x1066)

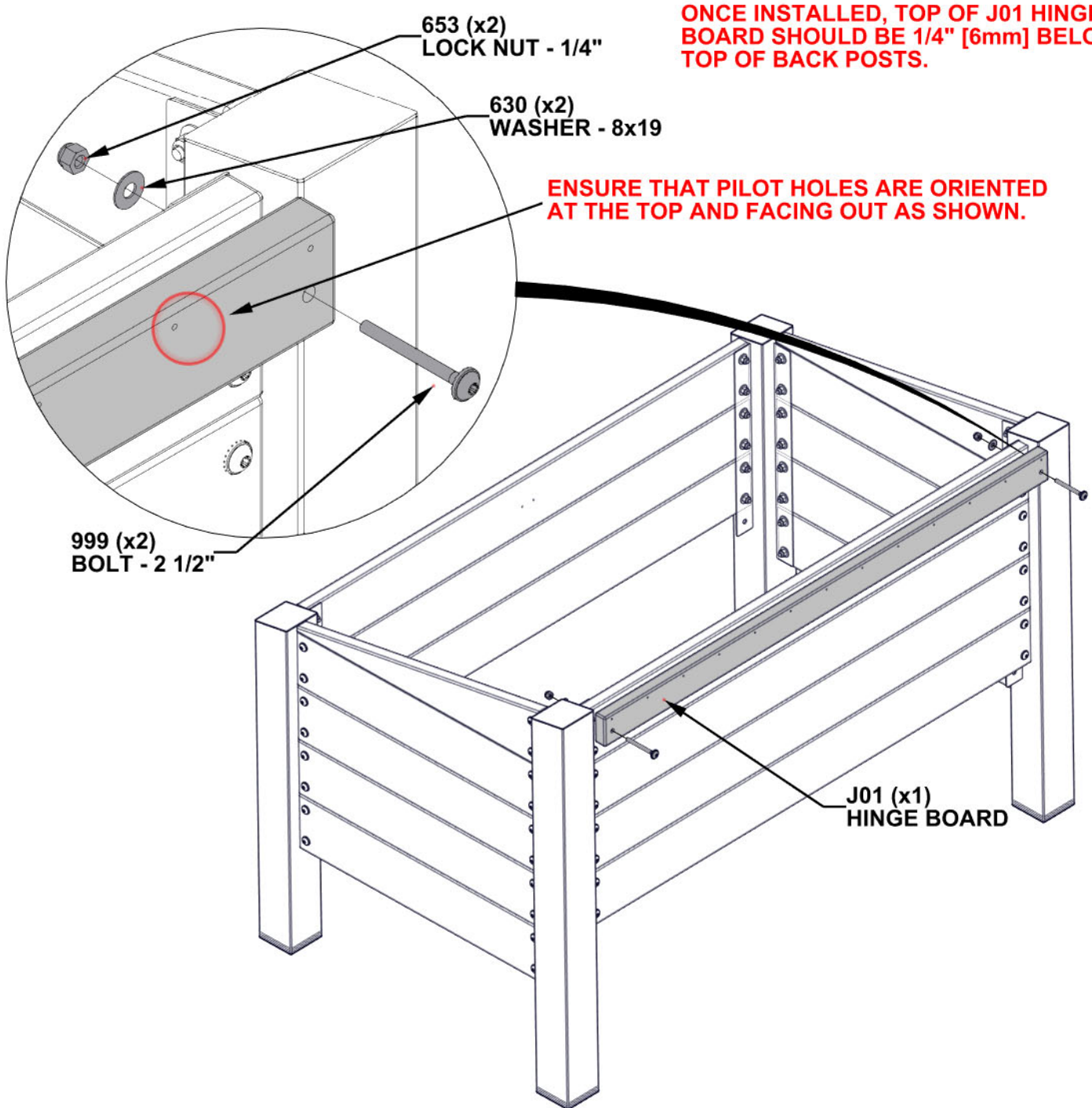

STEP 10 - COLD BOX ASSEMBLY

QTY	PART NUMBER	DESCRIPTION
4	H100406	BOLT WH 1/4 X 1 1/2 BLK
4	H100630	WASHER FLAT 8x19 BLK
4	H100653	NUT LOCK 1/4 BLK



AD01 LONG SIDE BOARD - W4L18781
(x2) 15/16"x4 7/16"x41 15/16" (24x112x1066)

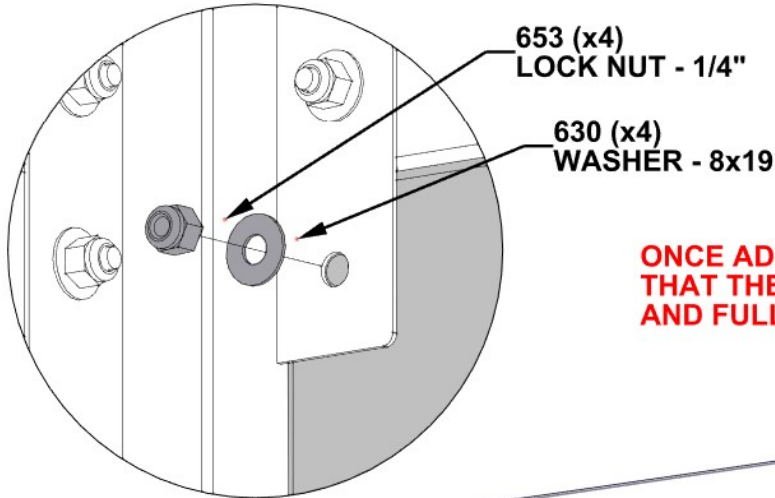

653 (x4)
LOCK NUT - 1/4"

630 (x4)
WASHER - 8x19

ONCE AD01 BOARDS ARE ATTACHED, ENSURE THAT THERE ARE NO GAPS BETWEEN BOARDS AND FULLY TIGHTEN ALL HARDWARE.

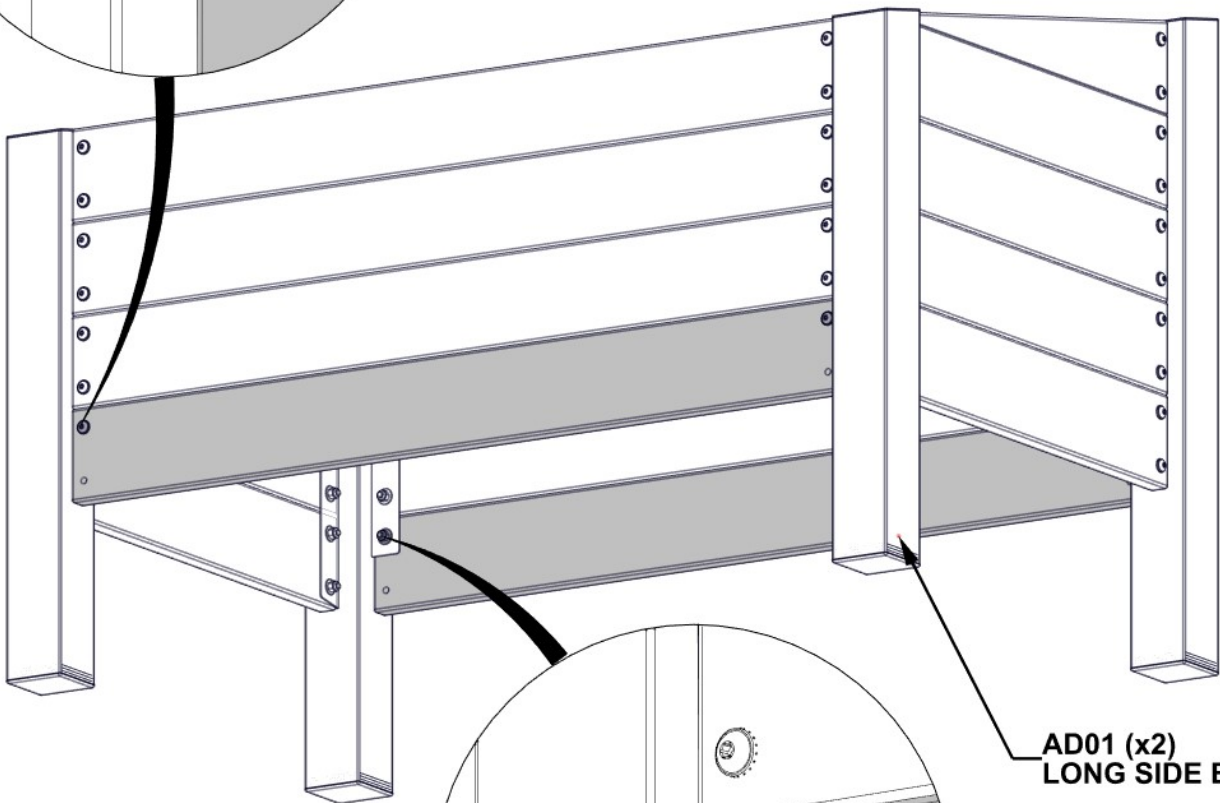

AD01 (x2)
LONG SIDE BOARD

406 (x4)
BOLT - 1 1/2"

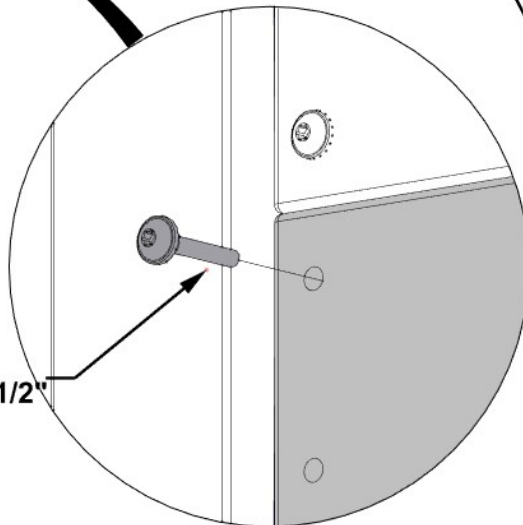

STEP 11 - COLD BOX ASSEMBLY

QTY	PART NUMBER	DESCRIPTION
4	H100406	BOLT WH 1/4 X 1 1/2 BLK
4	H100630	WASHER FLAT 8x19 BLK
4	H100653	NUT LOCK 1/4 BLK
10	H100392	SCREW PWH 8 X 3/4 BLK

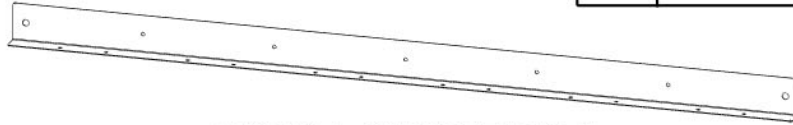

A4M01504 SUPPORT ANGLE
(x2)

ATTACH SUPPORT ANGLE TO FRONT AND BACK USING BOLTS FIRST AND THEN SCREWS.

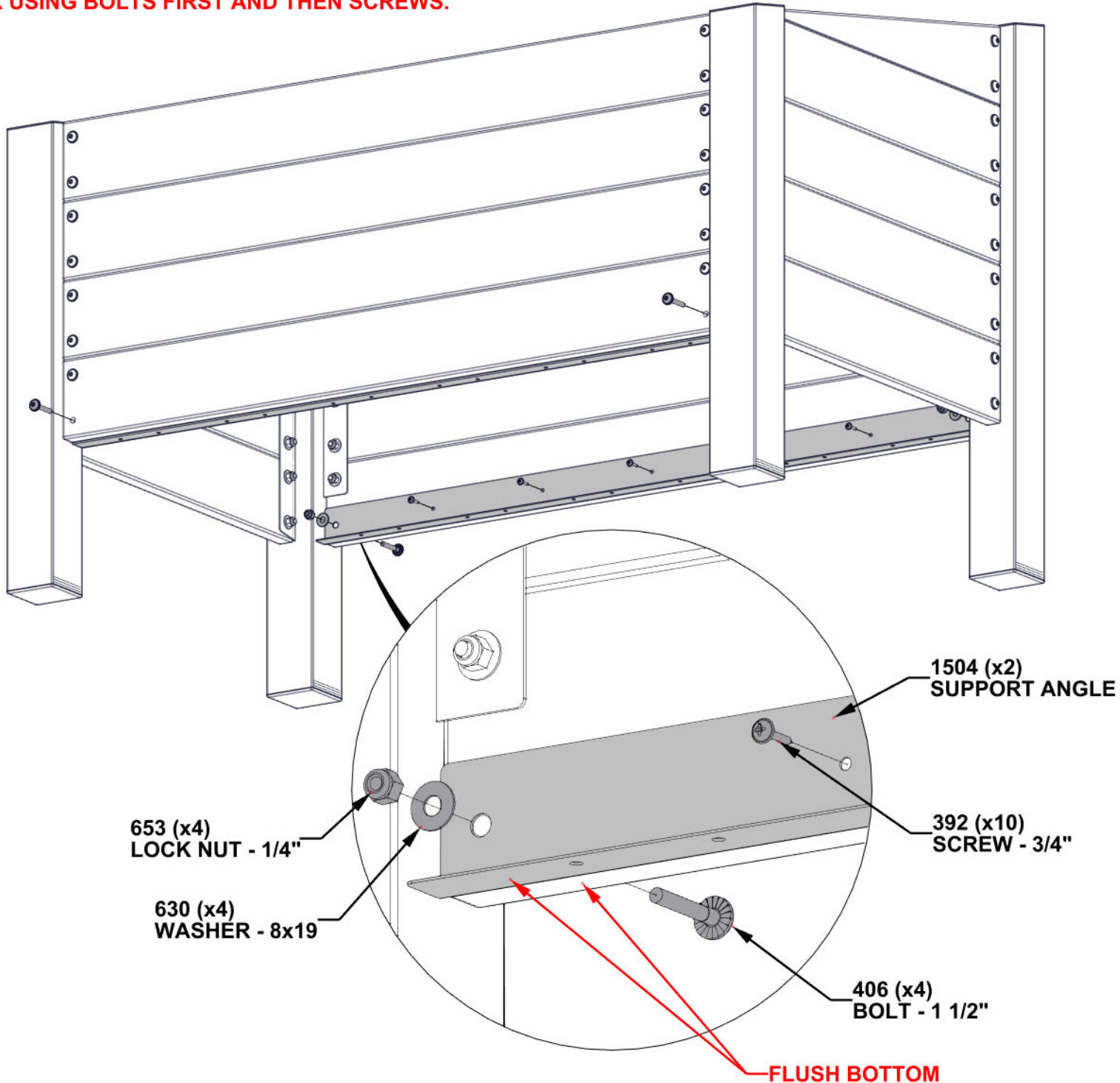

STEP 12 - COLD BOX ASSEMBLY

QTY	PART NUMBER	DESCRIPTION
24	H100392	SCREW PWH 8 X 3/4 BLK



AD03 SLAT - W4L18784
(x6) 15/16"x4 7/16"x24 11/16" (24x112x627)

ATTACH USING PILOT HOLES IN SLATS.

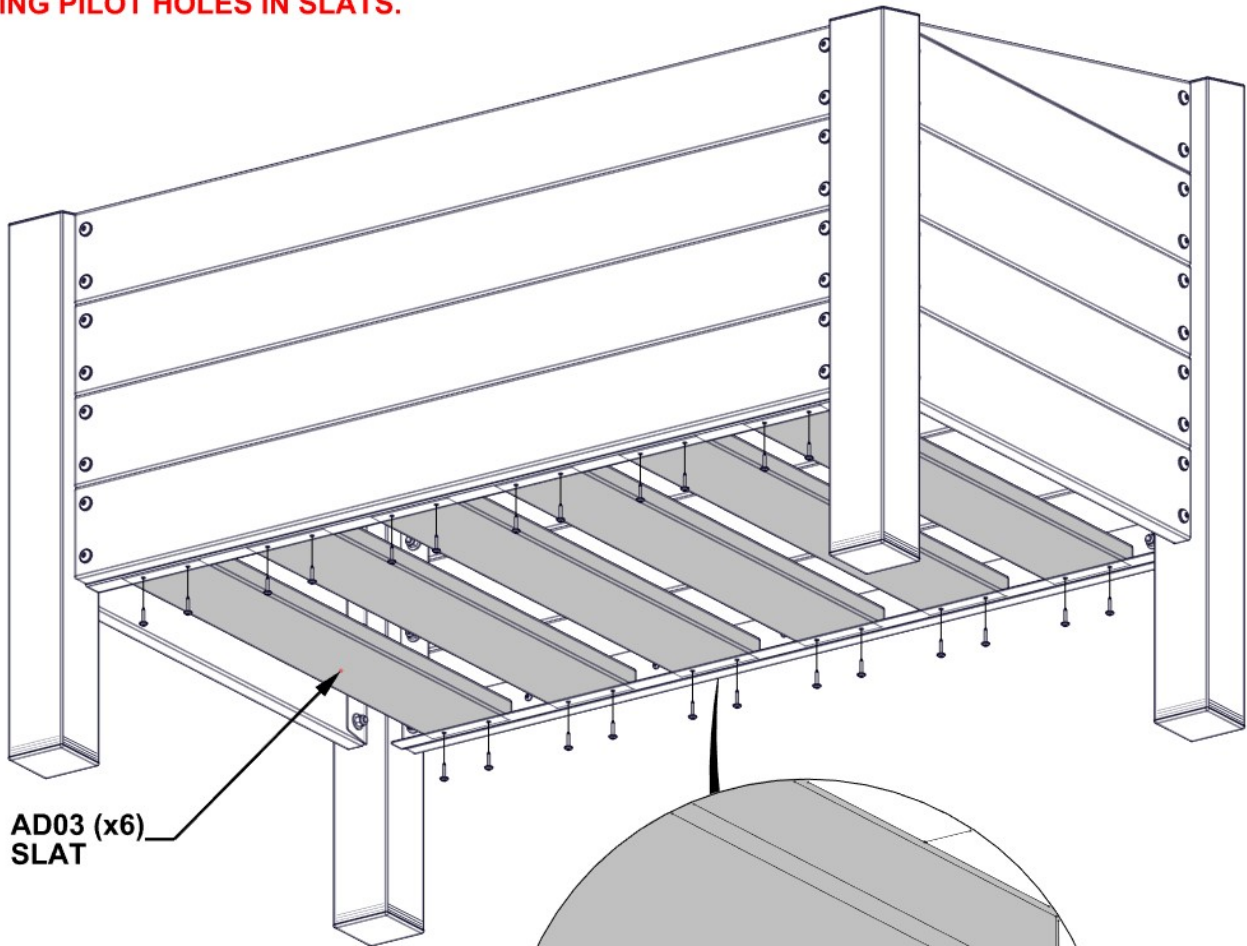

AD03 (x6)
SLAT

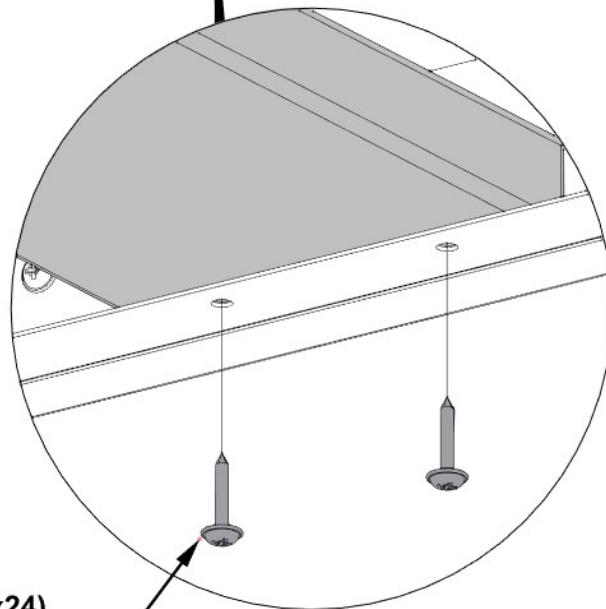

392 (x24)
SCREW - 3/4"

STEP 13 - COLD BOX ASSEMBLY

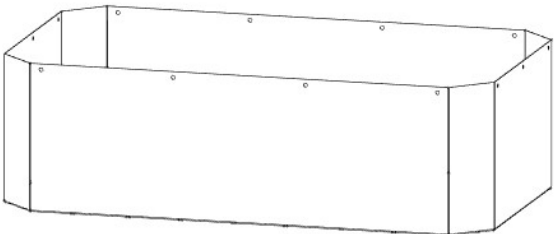

A6P00511 PLANTER LINER
(x1)

PLACE PLANTER LINER INTO COLD BOX FRAME.

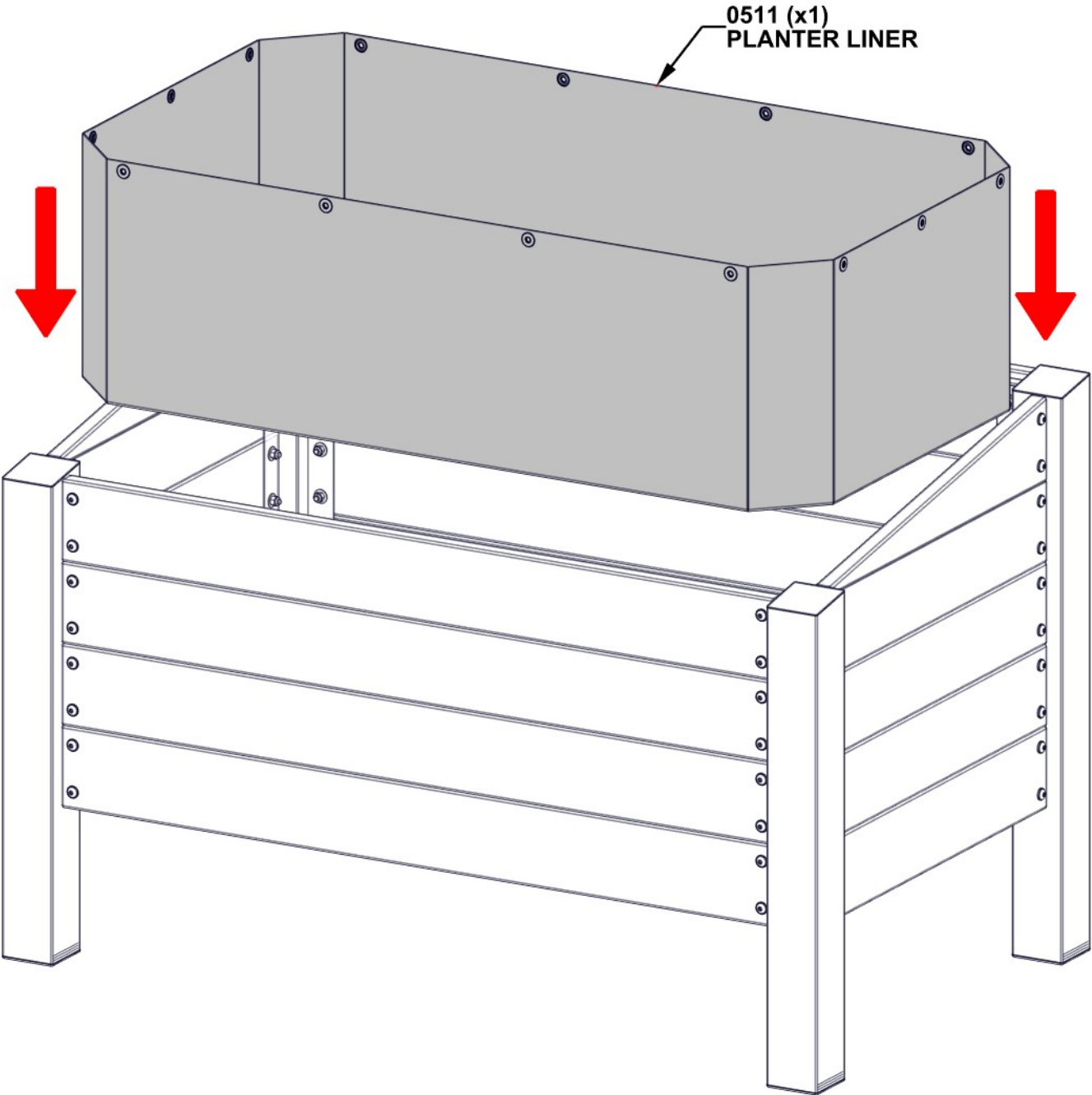

STEP 14 - COLD BOX ASSEMBLY

QTY	PART NUMBER	DESCRIPTION
14	H100392	SCREW PWH 8 X 3/4 BLK

NOTES:

- INSTALL PLANTER LINER BY PULLING CORNERS UP AGAINST EACH POST.
- BOTTOM OF LINER RESTS ON SLATS AND ALL SLACK SHOULD BE REMOVED FROM SIDES.
- SCREW LINER IN PLACE AS SHOWN.

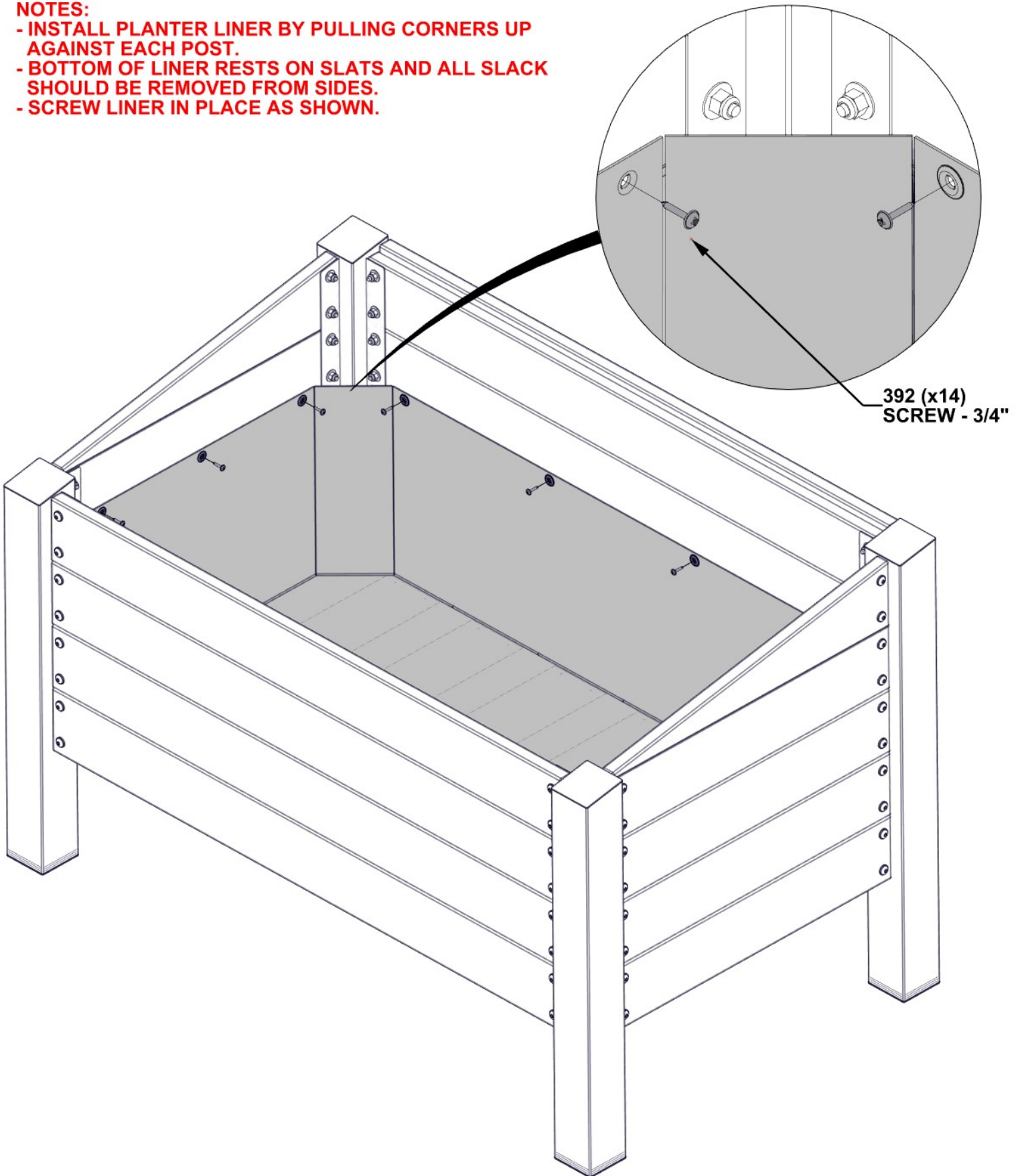

STEP 15 - COLD BOX ASSEMBLY

QTY	PART NUMBER	DESCRIPTION
2	H100392	SCREW PWH 8 X 3/4 BLK

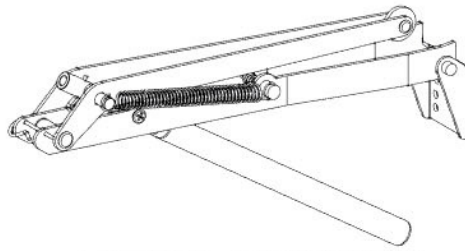

A4M02425 VENT OPENER
(x1)

Vent opener is designed to open and close automatically with changes in temperature.

When temperature nears 72-77 degrees F (22-25 degrees C) the vent opener will open. It will remain open until the temperature drops to 59-64 degrees F (15-18 degrees C). Then the vent opener will automatically close.

DO NOT MANUALLY FORCE the opener to OPEN OR CLOSE as this will damage the opener.

TIP: CAN SQUEEZE OPENER TO RELEASE BRACKET FOR EASIER INSTALLATION.

392 (x2)
SCREW - 3/4"

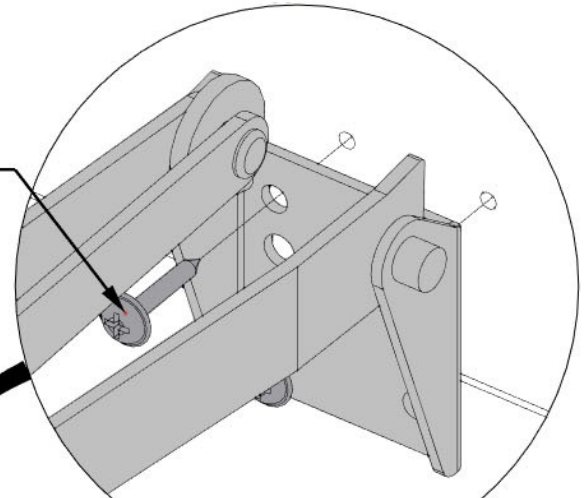

ATTACH VENT OPENER USING TOP HOLES IN BRACKET AS SHOWN.

2425 (x1)
VENT OPENER

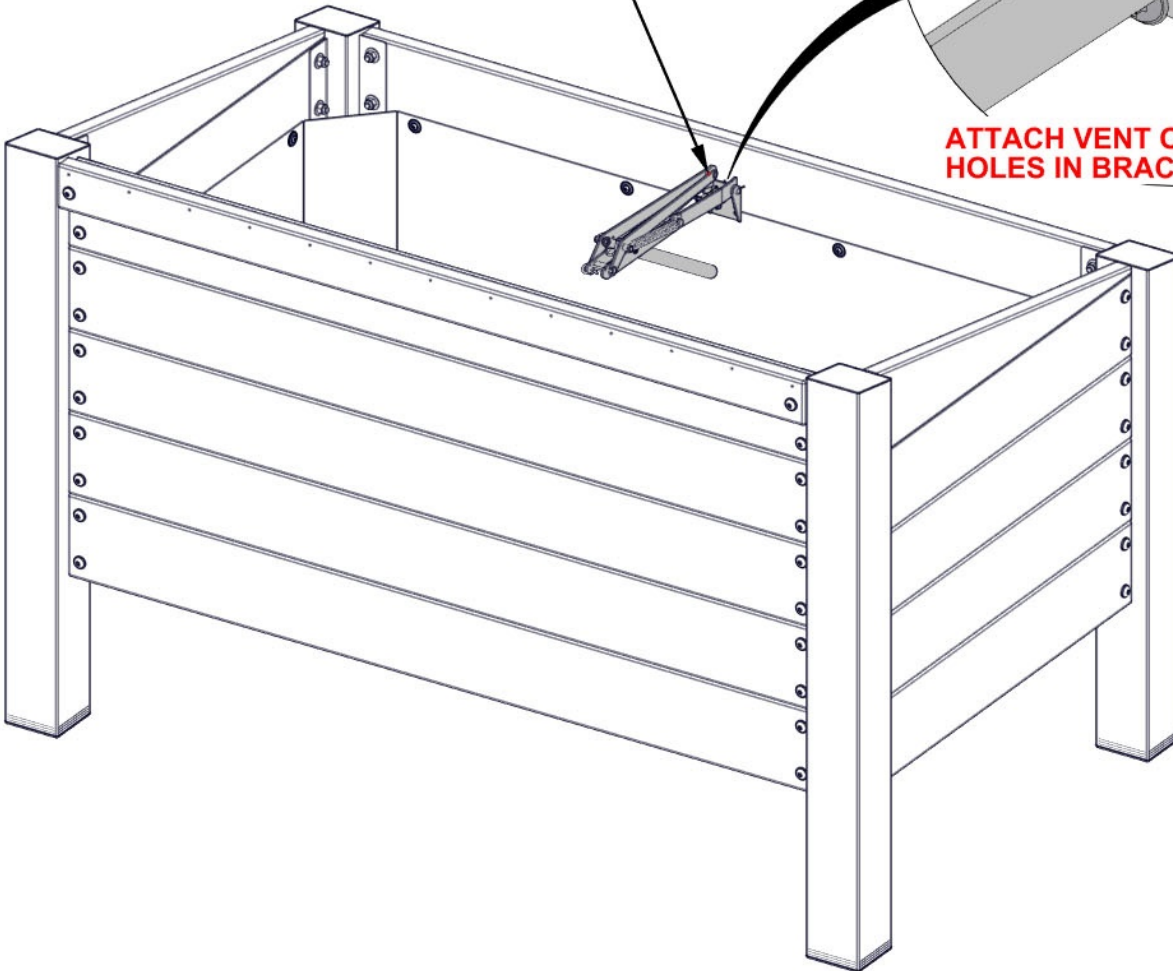

STEP 16 - COLD BOX ASSEMBLY

QTY	PART NUMBER	DESCRIPTION
16	H100392	SCREW PWH 8 X 3/4 BLK



H01 FRONT LID BOARD - W4L18786
(x1) 15/16"x3 3/8"x47 15/16" (24x86x1218)



H02 SIDE LID BOARD - W4L18785
(x2) 15/16"x3 3/8"x29 1/16" (24x86x738)

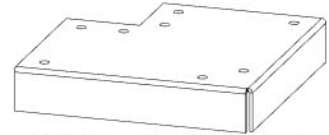

A4M02422 CORNER BRACKET
(x2)

**NOTE PILOT HOLES FOR
CORRECT OREINTATION.**

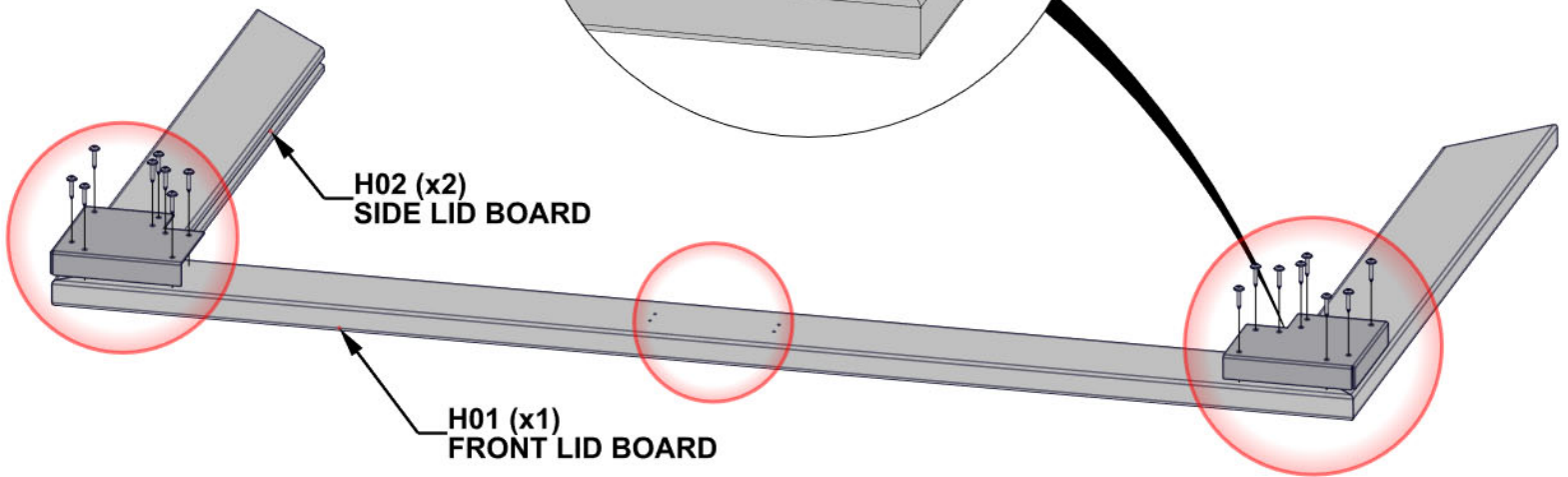
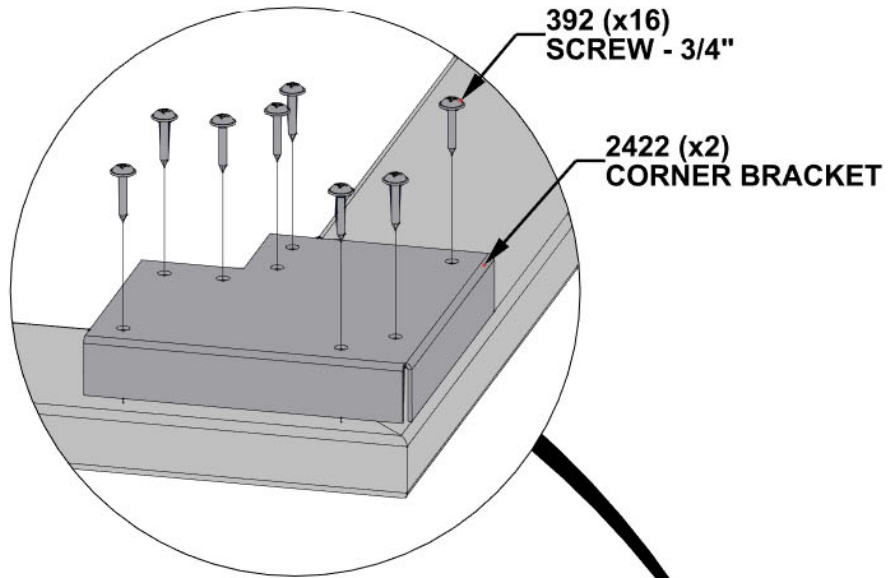

STEP 17 - COLD BOX ASSEMBLY



A6P00706 PC PANEL
(x2)

SLIDE PC PANELS INTO GROOVES ENSURING THAT THEY ARE PUSHED ALL THE WAY OUT TO THE SIDES AND ALL THE WAY DOWN.

ENSURE CORRECT ORIENTATION OF PC PANELS.

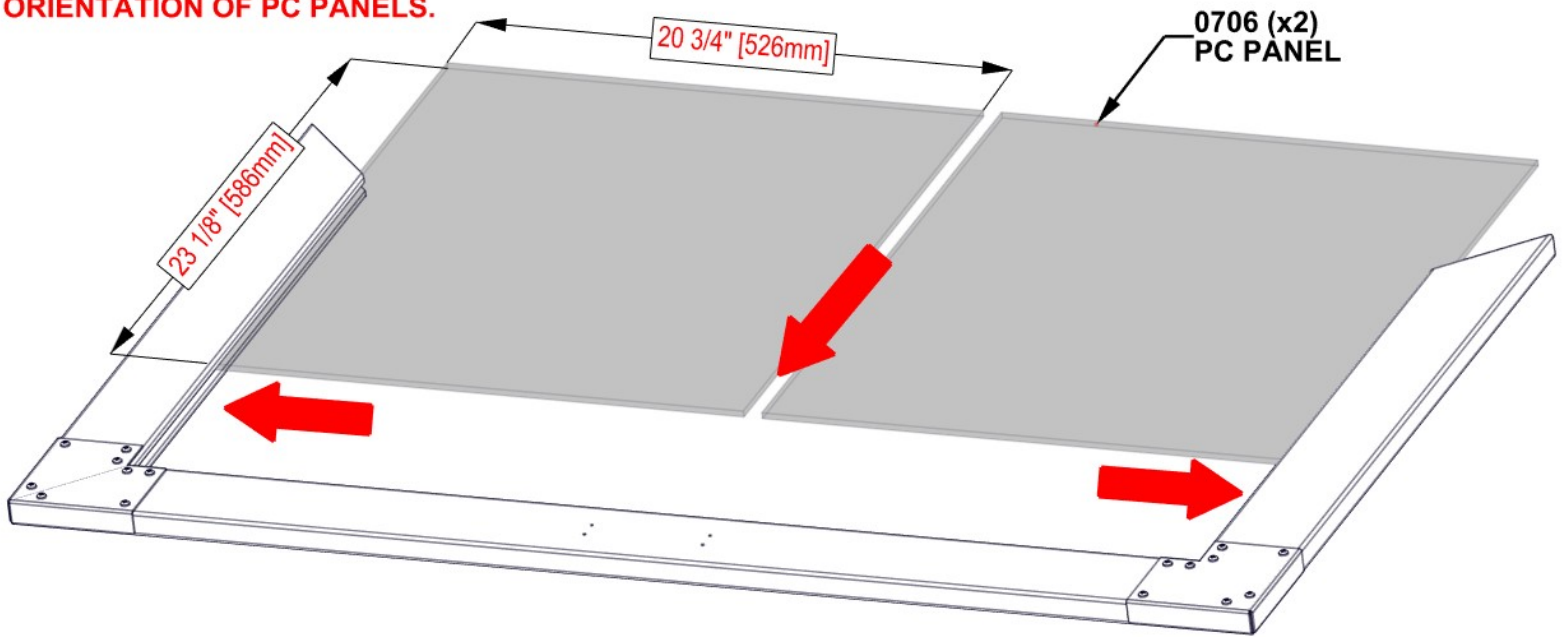

STEP 18 - COLD BOX ASSEMBLY

QTY	PART NUMBER	DESCRIPTION
16	H100392	SCREW PWH 8 X 3/4 BLK



H03 BACK LID BOARD - W4L18787
(x1) 15/16"x3 3/8"x47 15/16" (24x86x1218)

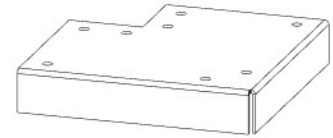

A4M02422 CORNER BRACKET
(x2)

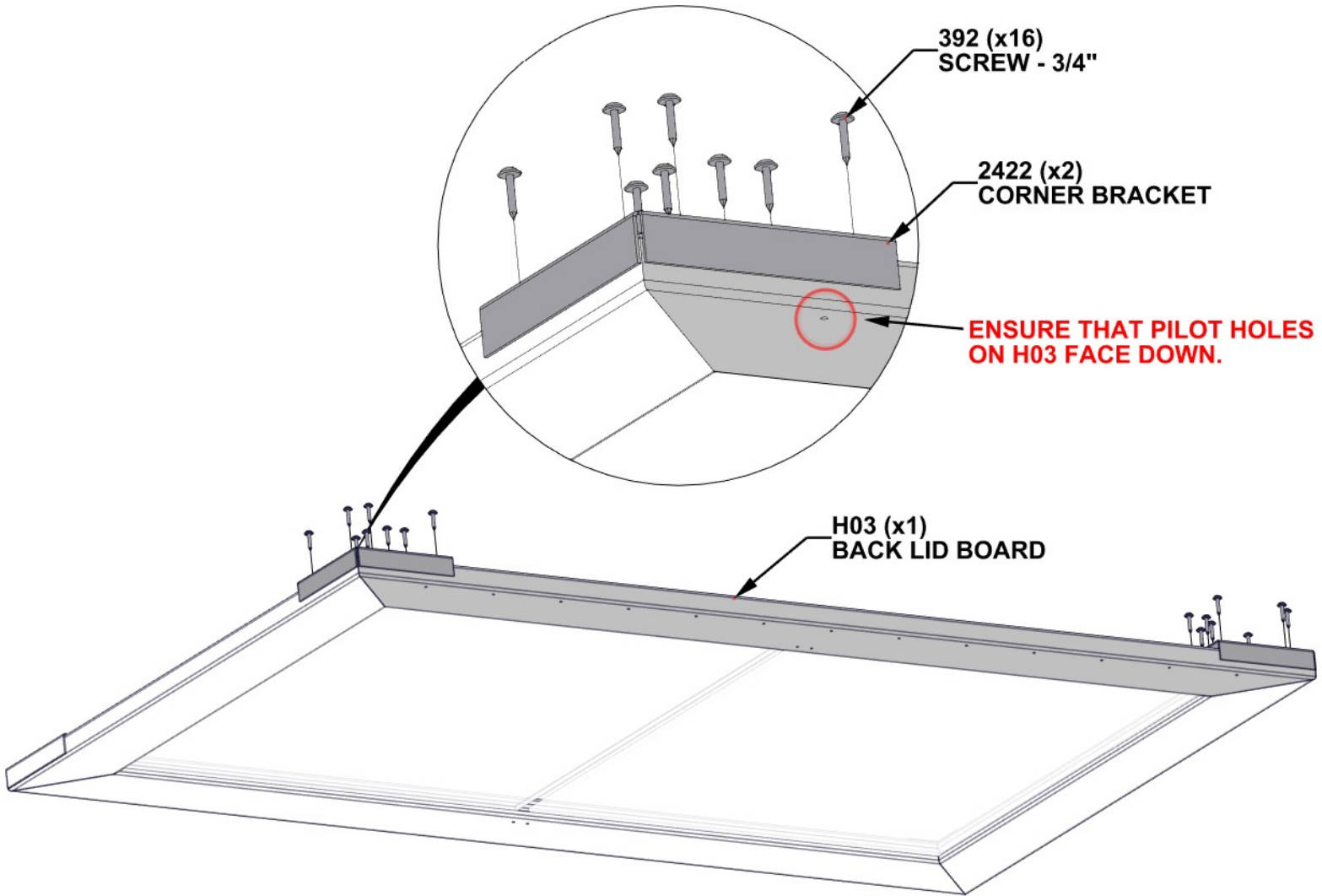

STEP 19 - COLD BOX ASSEMBLY

QTY	PART NUMBER	DESCRIPTION
4	H100385	SCREW PFH 8 X 1 BLK

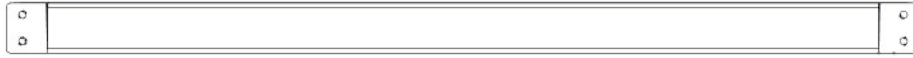

O01 MIDDLE LID BOARD - W4L18789
(x1) 5/8"x1 5/16"x24 7/16" (16x34x620)

ATTACH O01 USING PILOT HOLES IN BOTTOM OF LID.

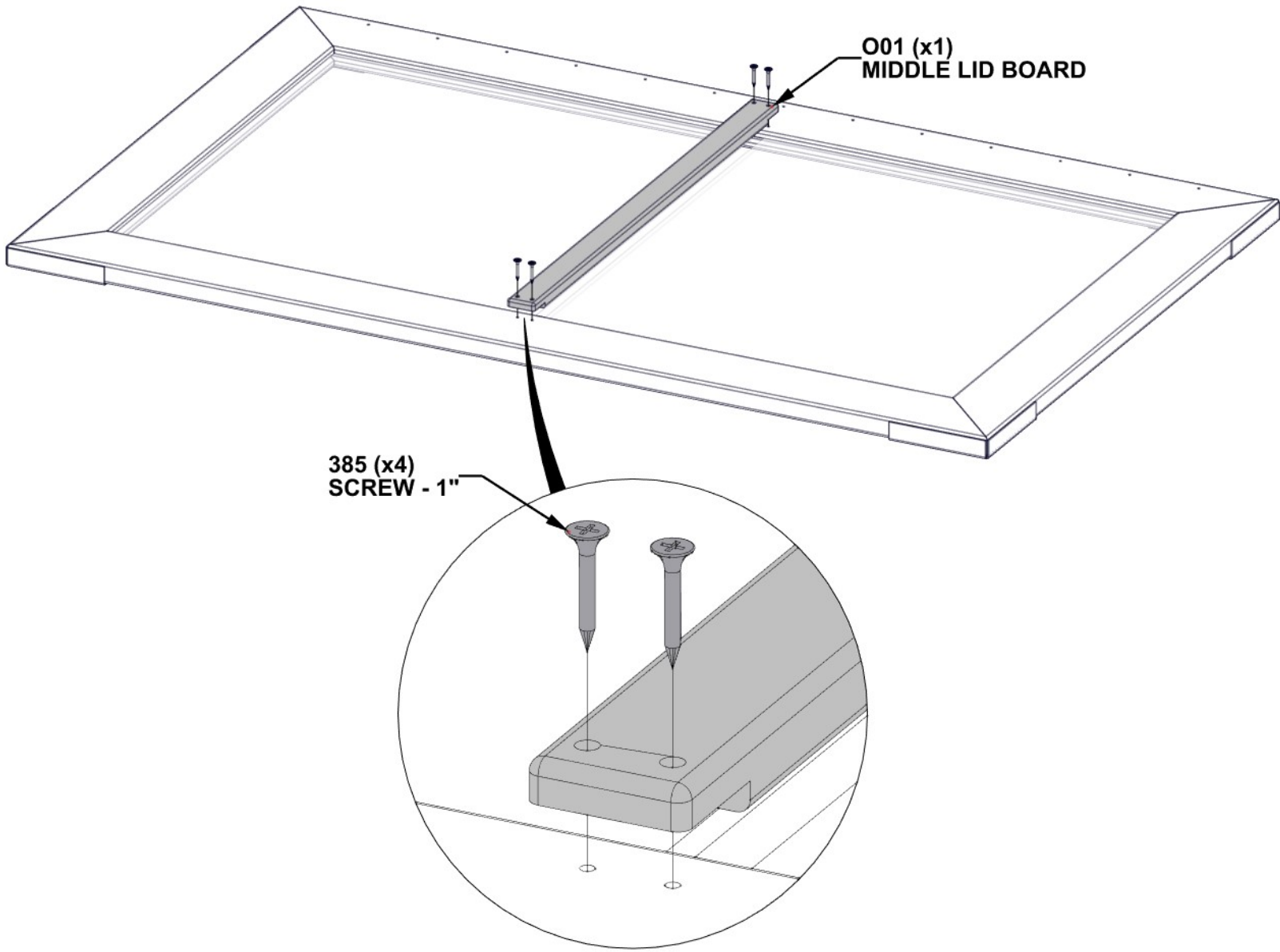

O01 (x1)
MIDDLE LID BOARD

385 (x4)
SCREW - 1"

STEP 20 - COLD BOX ASSEMBLY

QTY	PART NUMBER	DESCRIPTION
5	H100797	SCREW PWH 8 X 1 BLK



A4M02423 BAR CAP WITH GASKET
(x1)

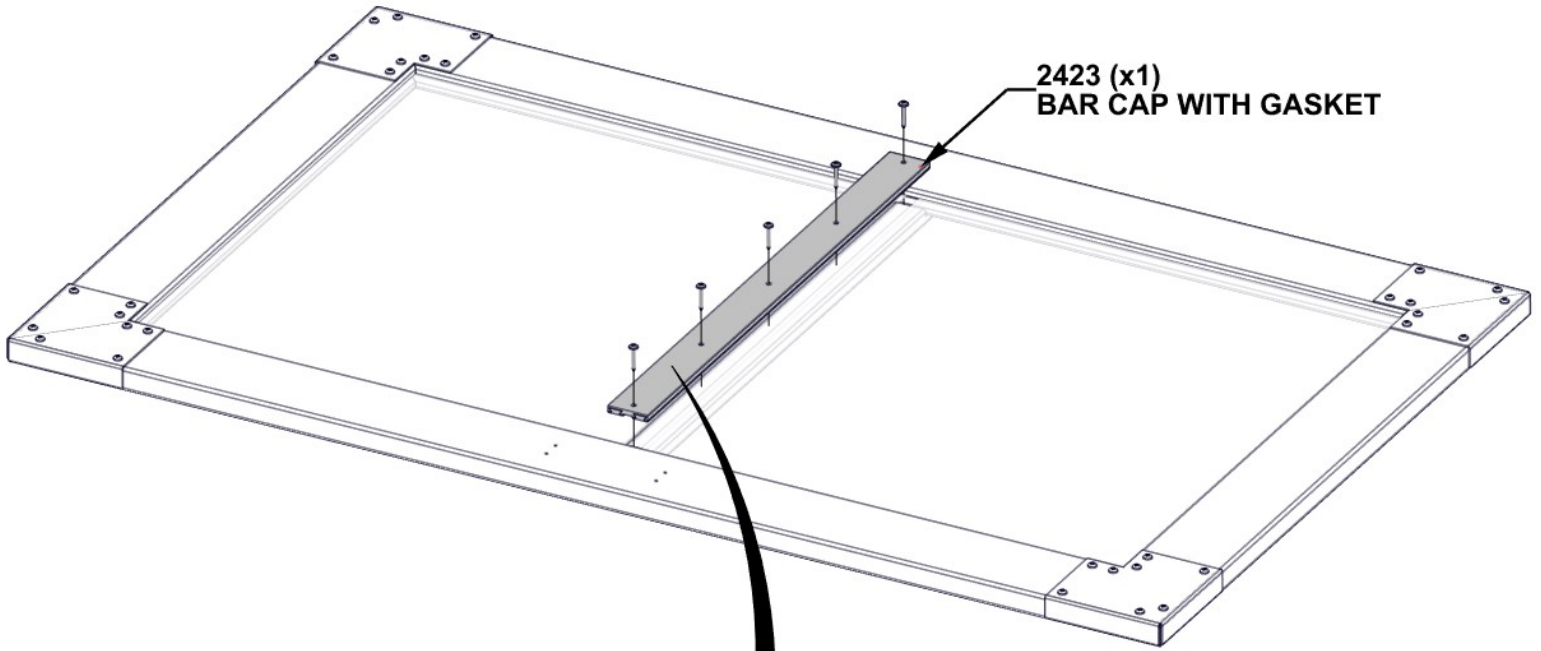

797 (x5)
SCREW - 1"

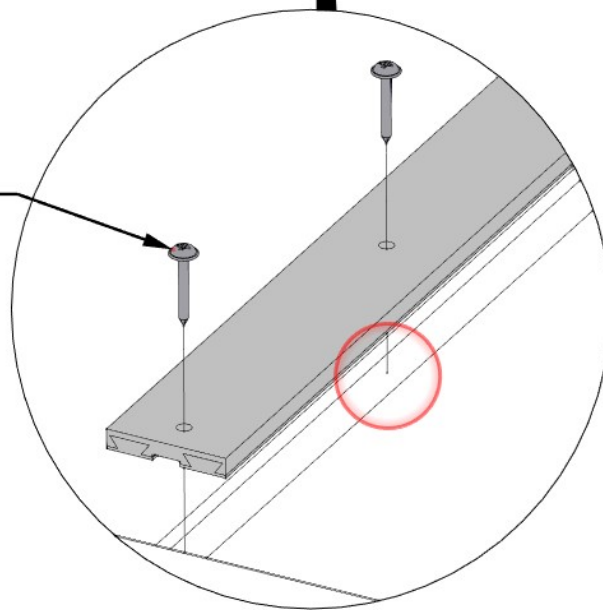

CENTER BAR CAP ON LID OVER GAP IN PC PANELS. ENSURE THAT SCREWS GO BETWEEN PANELS AND INTO MIDDLE LID BOARD.

STEP 21 - COLD BOX ASSEMBLY

QTY	PART NUMBER	DESCRIPTION
2	H100395	SCREW PFH 8 X 3/4 BLK



A6P00707 RAIL
(x1)

NOTE PILOT HOLES FOR CORRECT PLACEMENT OF RAIL TOWARDS THE FRONT OF THE LID.

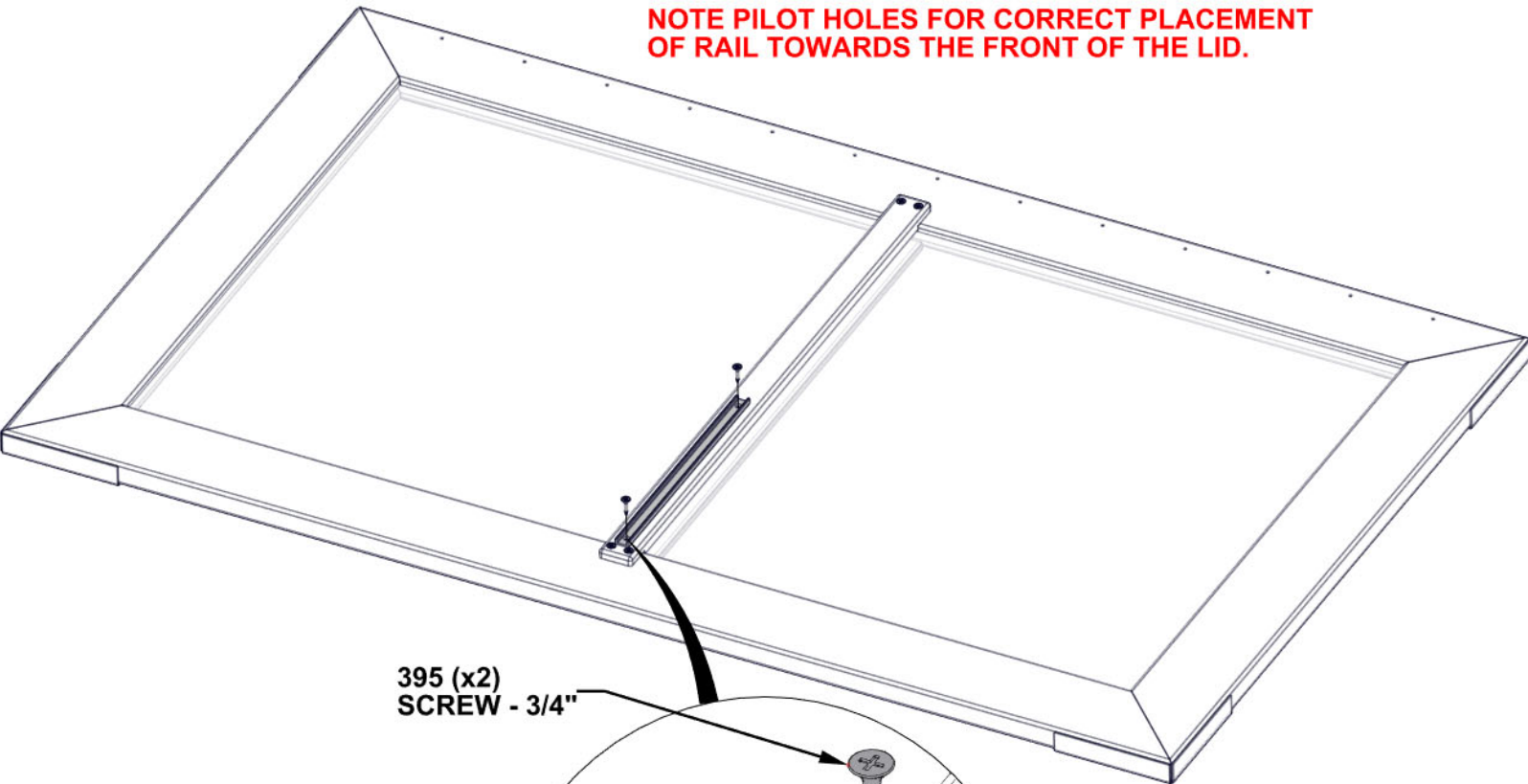

395 (x2)
SCREW - 3/4"

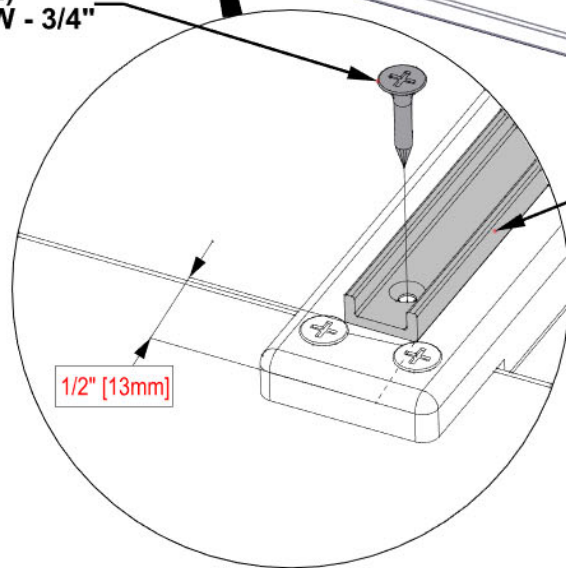

0707 (x1)
RAIL

1/2" [13mm]

ATTACH RAIL CENTERED SIDE TO SIDE ON MIDDLE LID BOARD. HOLD FRONT OF RAIL APPROXIMATELY 1/2" [13mm] BACK FROM FRONT OF BOARD AS SHOWN.

STEP 22 - COLD BOX ASSEMBLY

QTY	PART NUMBER	DESCRIPTION
13	H100395	SCREW PFH 8 X 3/4 BLK

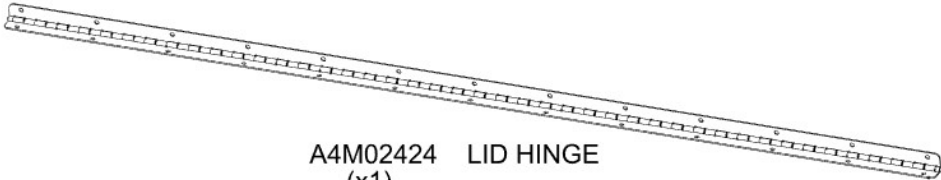

A4M02424 LID HINGE
(x1)

**ATTACH HINGE USING
PILOT HOLES IN LID.**

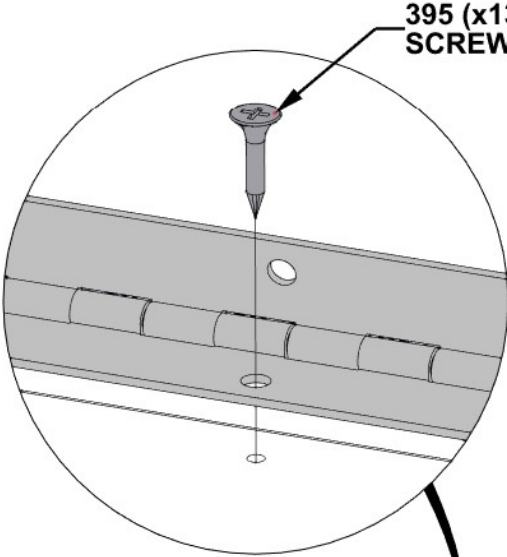

395 (x13)
SCREW - 3/4"

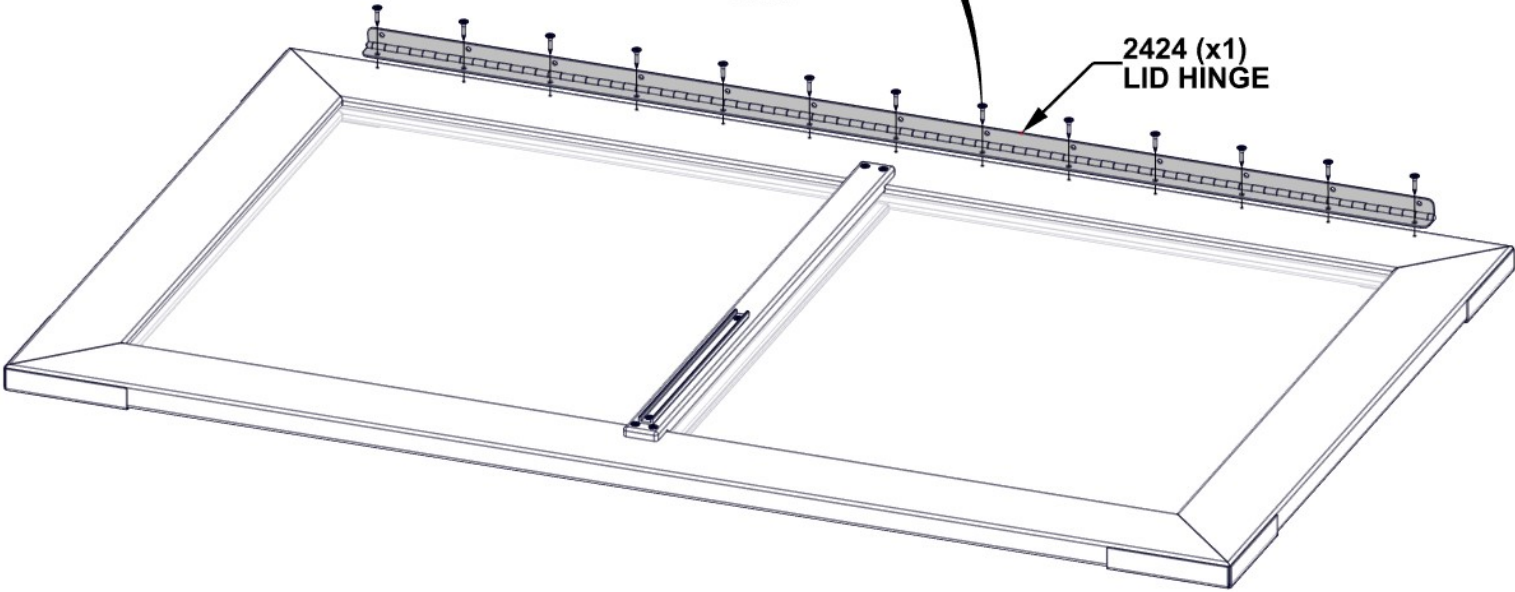

2424 (x1)
LID HINGE

STEP 23 - COLD BOX ASSEMBLY

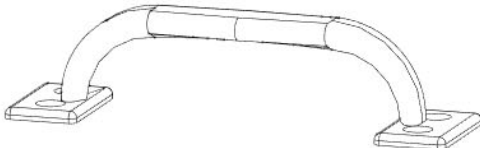

A4M00559 PULL HANDLE
(x1)

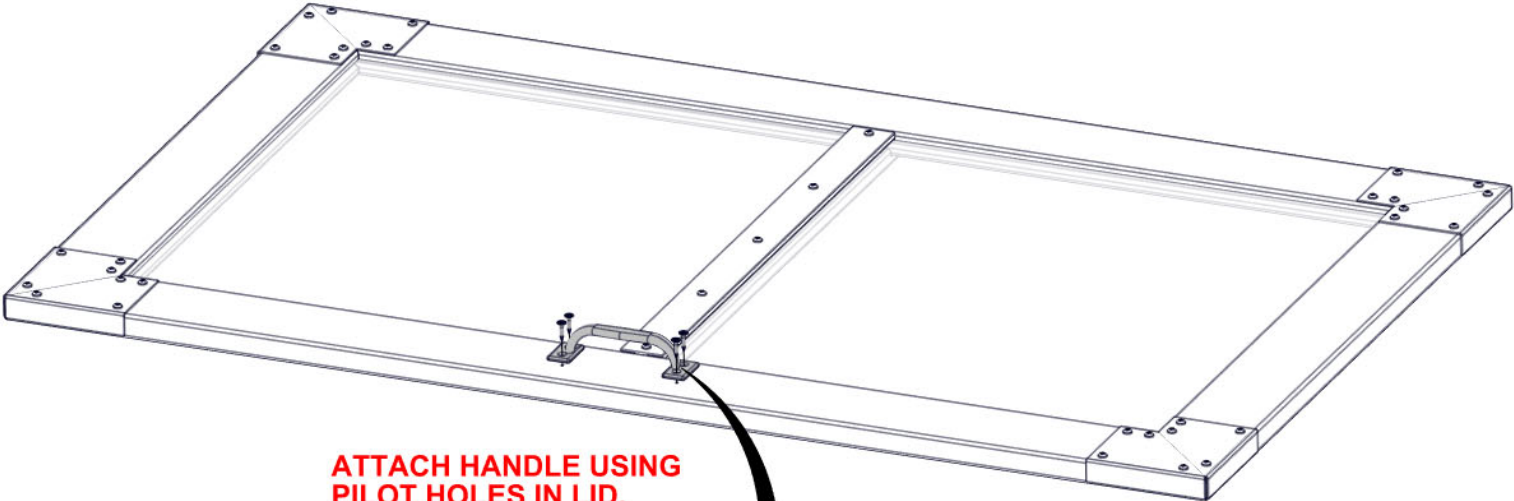

**ATTACH HANDLE USING
PILOT HOLES IN LID.**

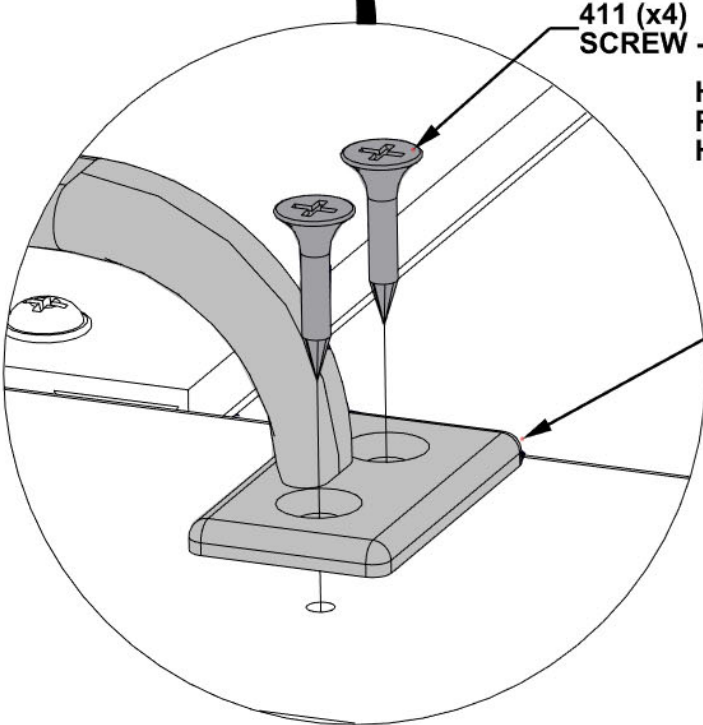

411 (x4)
SCREW - 5/8"

**HARDWARE
PROVIDED WITH
HANDLE**

0559 (x1)
PULL HANDLE

STEP 24 - COLD BOX ASSEMBLY

QTY	PART NUMBER	DESCRIPTION
13	H100395	SCREW PFH 8 X 3/4 BLK

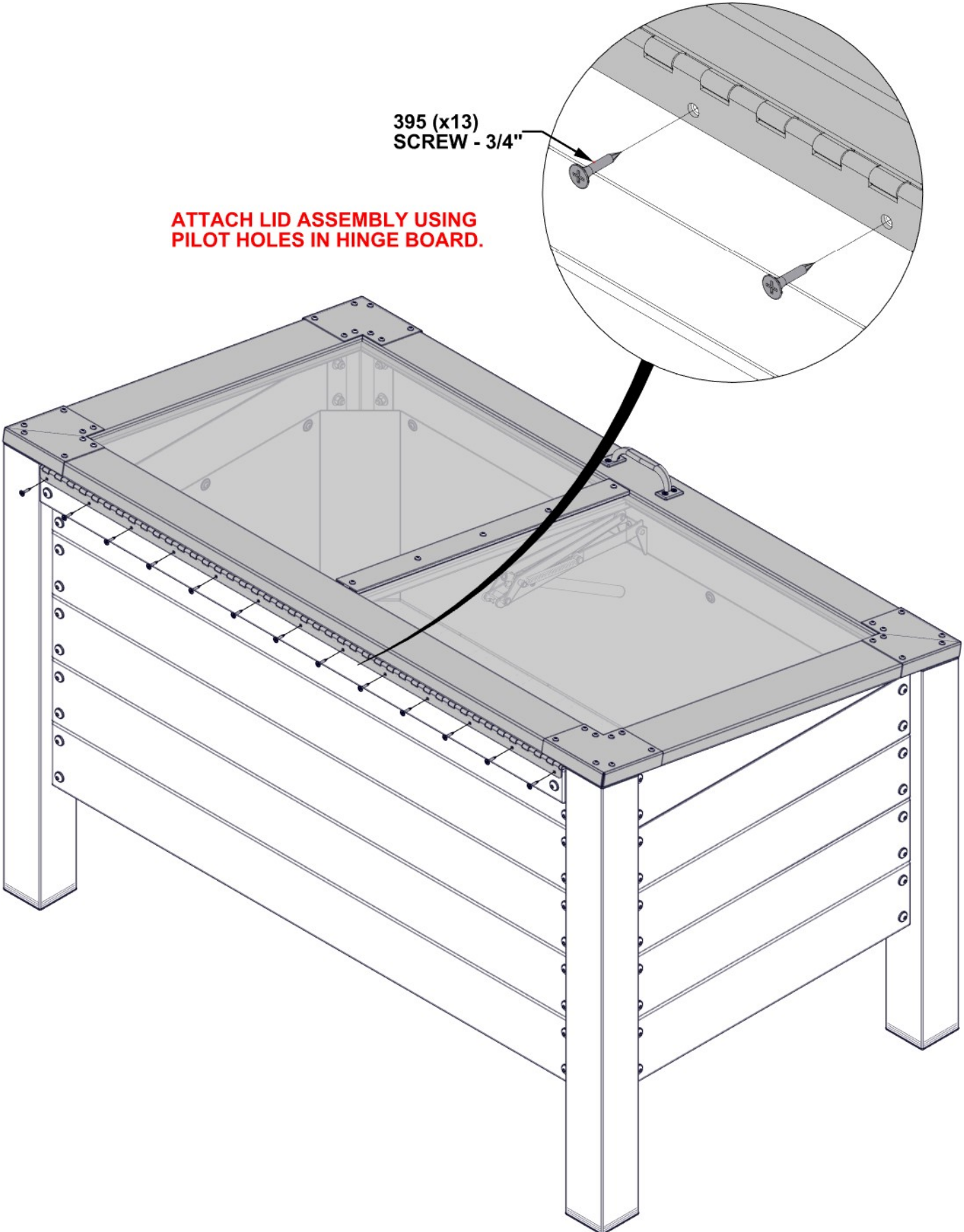

395 (x13)
SCREW - 3/4"

**ATTACH LID ASSEMBLY USING
PILOT HOLES IN HINGE BOARD.**

STEP 25 - COLD BOX ASSEMBLY

QTY	PART NUMBER	DESCRIPTION
4	H100392	SCREW PWH 8 X 3/4 BLK

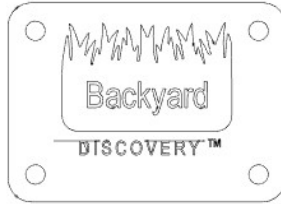

A4M02158 BYD ID TAG PATIO
(x1)

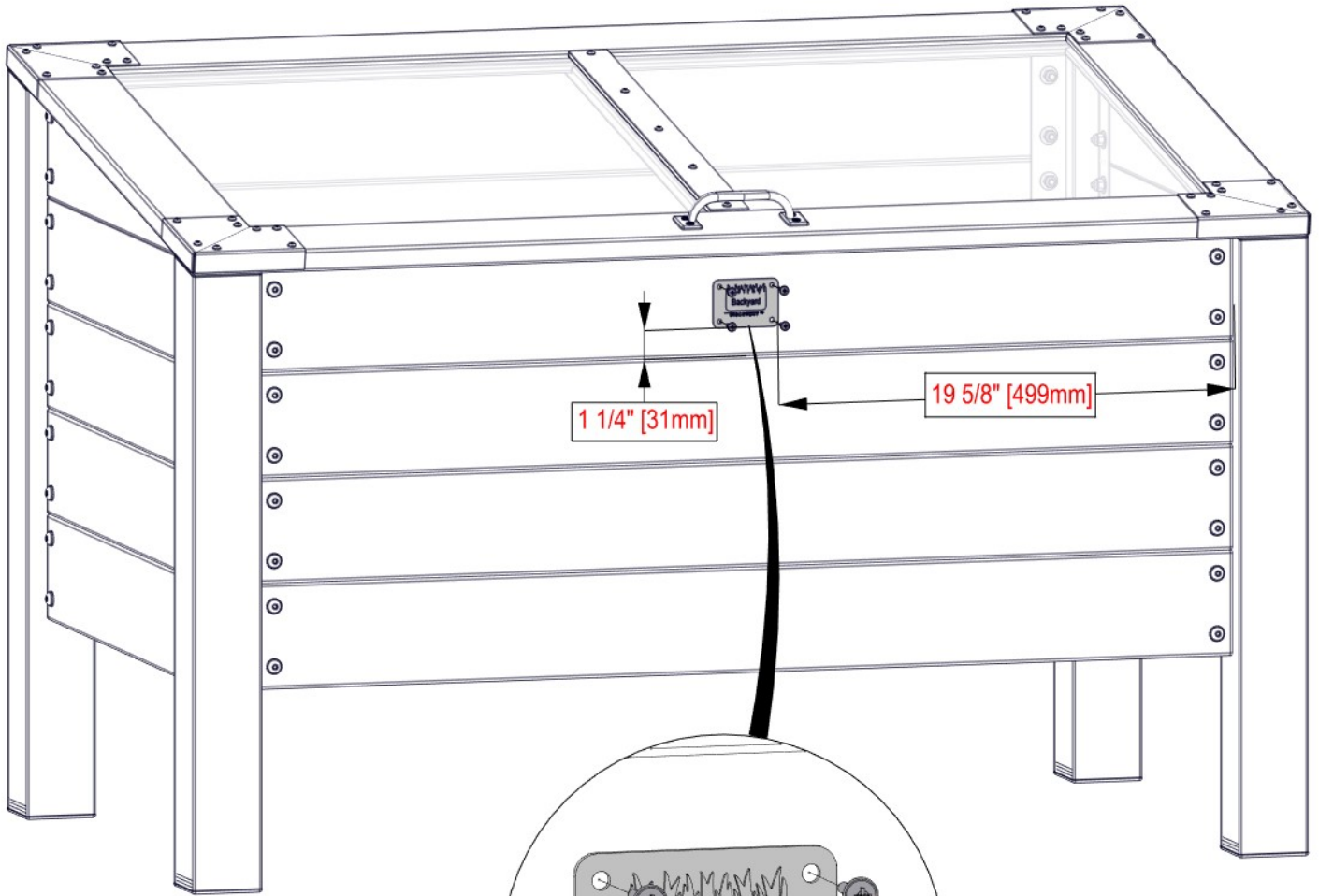

2158 (x1)
BYD ID TAG PATIO

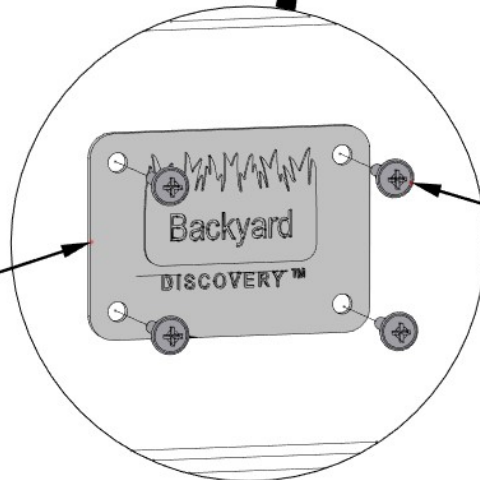

392 (x4)
SCREW - 3/4"

STEP 26A - COLD BOX ASSEMBLY



A4M00692 LID CHAIN
(x1)

OPEN COLD BOX LID, AND ATTACH LAG EYE BOLT TO THE INSIDE BOARD IN THE APPROXIMATE LOCATION SHOWN BELOW. IT IS RECOMMENDED TO DRILL A 2mm PILOT HOLE BEFORE SCREWING IN LAG EYE BOLT.

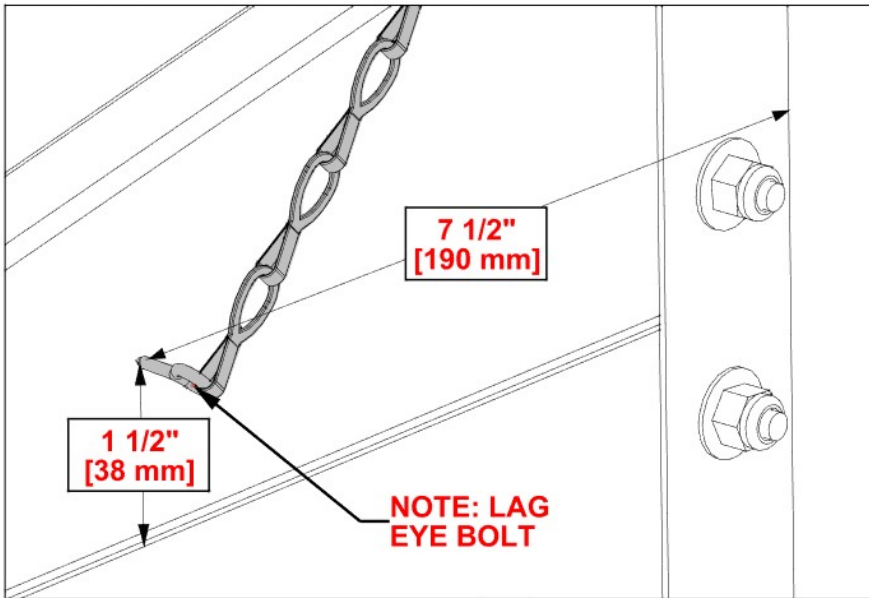

NOTE: DON'T DRILL ALL THE WAY THROUGH SIDE BOARD

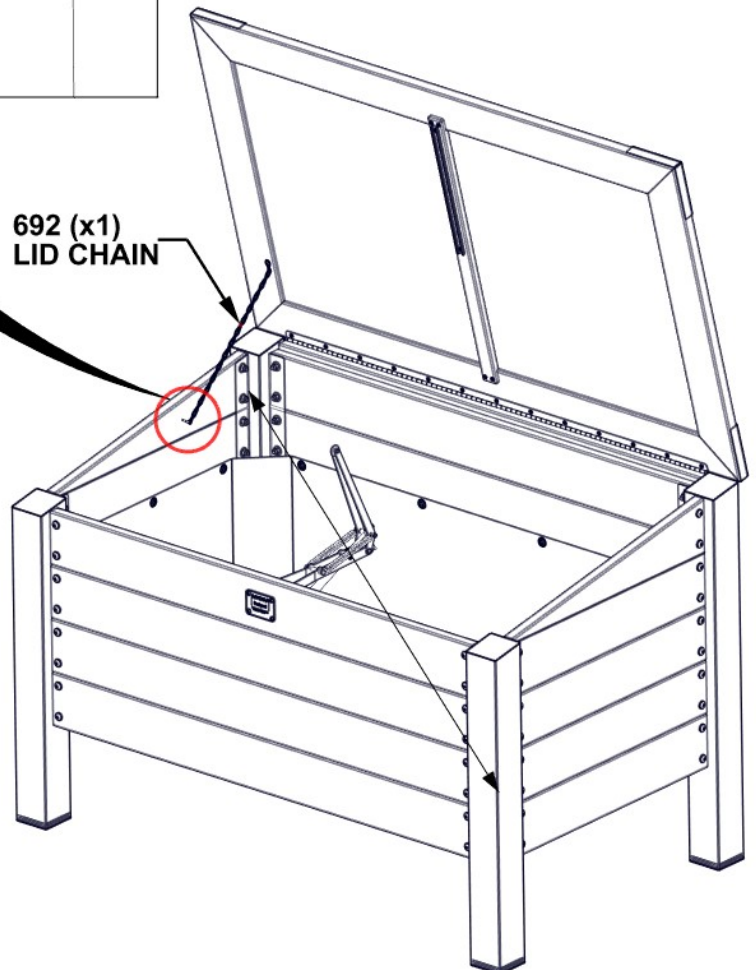

STEP 26B - COLD BOX ASSEMBLY

QTY.	PART NUMBER	DESCRIPTION
1	H100202	SCREW PWH 8 X 5/8 BLK

ATTACH OPPOSITE END OF LID CHAIN TO LID BOARD IN THE APPROXIMATE LOCATION SHOWN BELOW

