



Manufactured by: Backyard
Discovery
3305 Airport Drive,
Pittsburg, KS 66762
800-856-4445

Basepoint Business Centre: Rivermead Drive, Westlea, Swindon SN5 7EX Phone:
0800-118-2476 J.P. Coenstraat 7, The Bridge, The Hague, 2595 WP, Netherlands Phone: 08005678990

FUSION FIRE OUTDOOR KITCHEN

MODEL # : 2304154



Please visit www.backyarddiscovery.com
For the most up to date assembly manual, to register your product, or to order
replacement parts *Para obtener instrucciones en español, visite*
www.backyarddiscovery.com



EASY STEP-BY-STEP
3D INTERACTIVE INSTRUCTIONS
DOWNLOAD THE FREE APP



OWNER'S MANUAL - BASIC SETUP DIMENSIONS & ASSEMBLY NOTES

It is critically important that you start with square and level footings or concrete pad to attach your structure

- Pay close attention to the items needed for each step. Make sure you are using the correct hardware for each step. Using incorrect hardware may result in improper assembly
- Remember to double check for underground utilities and overhead electrical lines

Post mounts are provided with your structure which allows you to permanently install your structure to a pre-existing or new wood or concrete surface. See Anchor Instructions for further details and recommendations.

- The hardware to attach the post mounts to the structure is included.
- The hardware to mount the structure permanently to a concrete surface is included.
- The hardware to mount the structure permanently to a wood deck is NOT included and will need to be purchased separately. You must ensure there is ample structural support under the deck before permanently attaching.

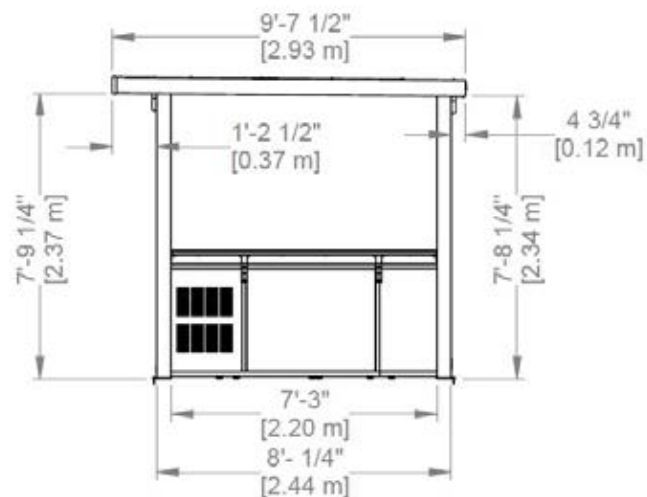
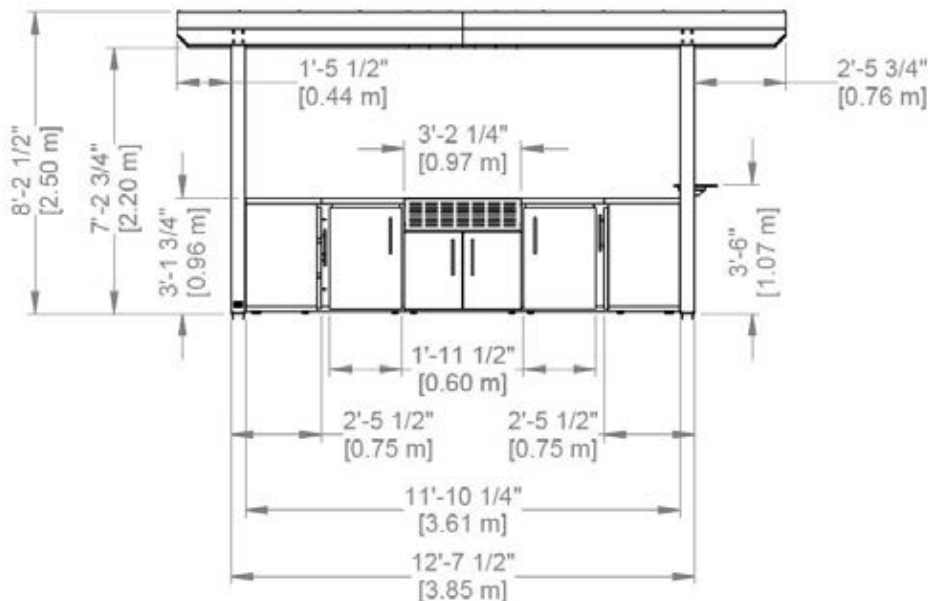
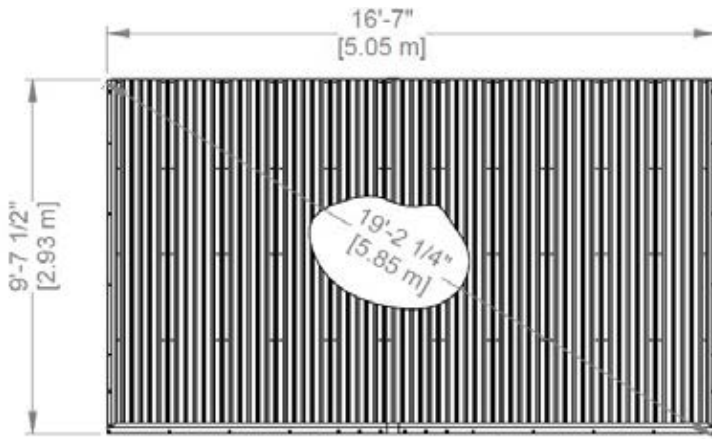

OWNER'S MANUAL - ANCHORING LAYOUT

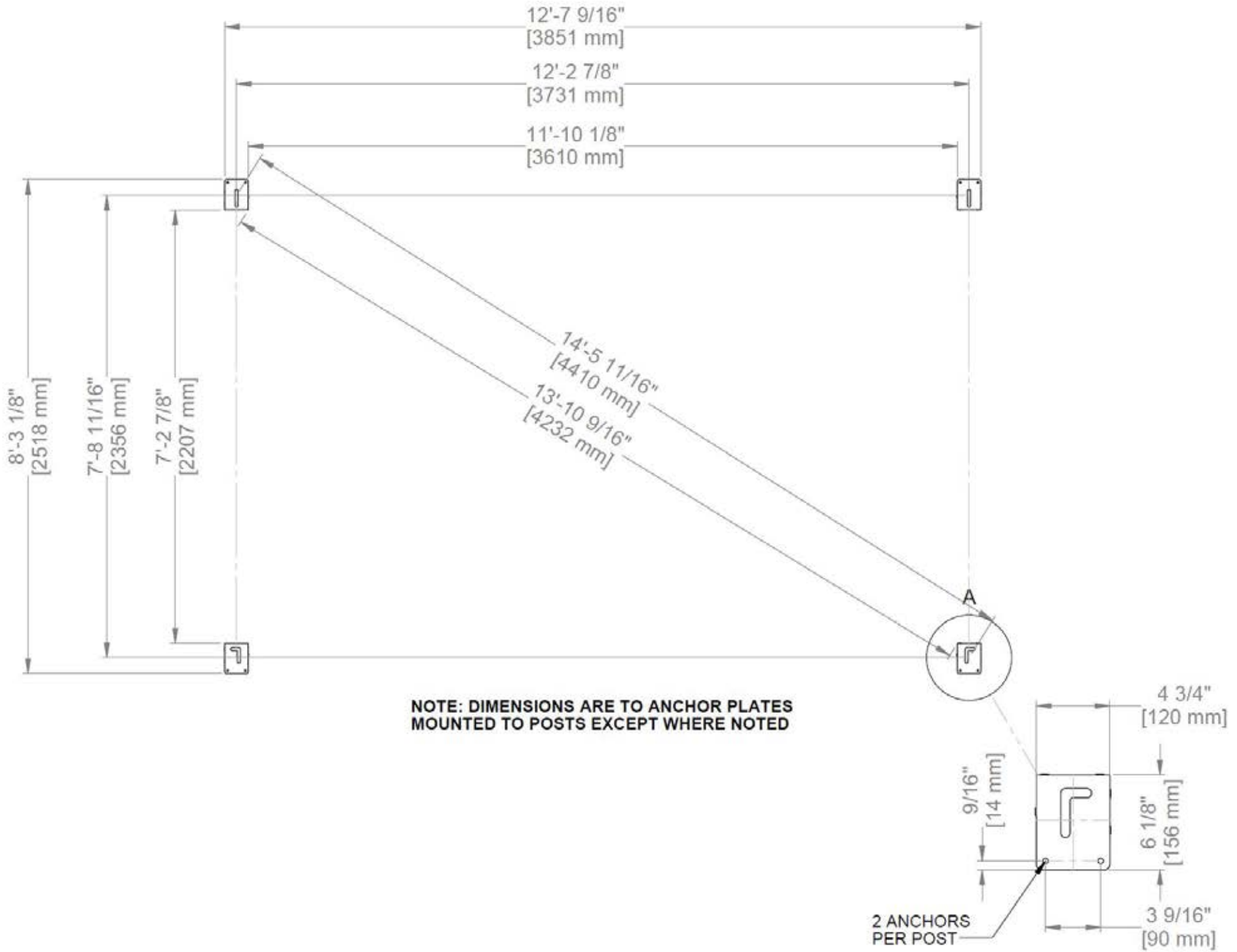

OWNER'S MANUAL - PARTS IDENTIFICATION

METAL COMPONENTS (NOT TO SCALE)

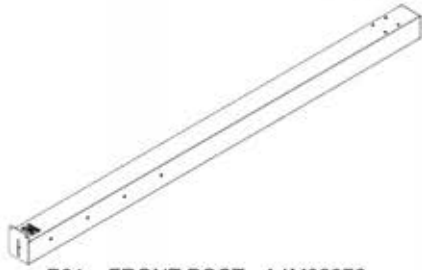

P01 FRONT POST - A4M02976
(x1) 4 3/4"x6 1/8"x96 5/8" (120x155x2455)

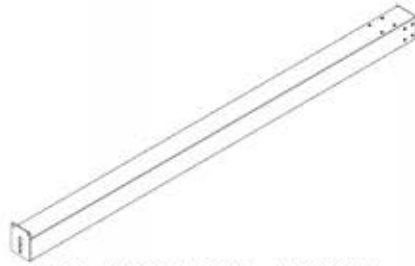

P02 FRONT POST - A4M02977
(x1) 4 3/4"x6 1/8"x96 5/8" (120x155x2455)

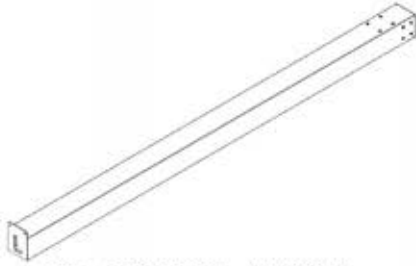

P03 BACK POST - A4M02978
(x1) 4 3/4"x6 1/8"x95 13/16" (120x155x2434)

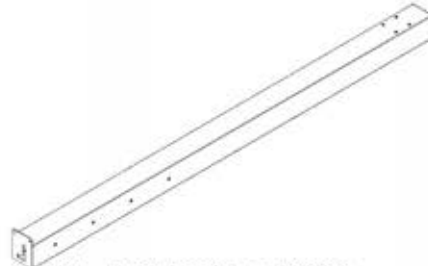

P04 BACK POST - A4M02979
(x1) 4 3/4"x6 1/8"x95 13/16" (120x155x2434)



B01 FRONT BEAM - A4M02980
(x1) 1 7/16"x5 1/4"x93 3/8" (36x134x2371)



B02 FRONT BEAM - A4M02981
(x1) 1 7/16"x5 1/4"x105 5/8" (36x134x2683)



B03 BACK BEAM - A4M02982
(x1) 1 7/16"x5 1/4"x93 3/8" (36x134x2371)

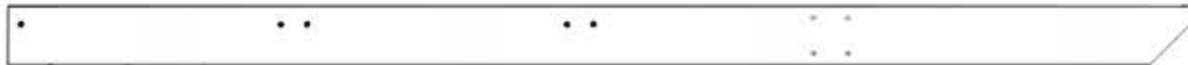

B04 BACK BEAM - A4M02983
(x1) 1 7/16"x5 1/4"x105 5/8" (36x134x2683)



B05 FRONT BEAM - A4M02988
(x1) 1 7/16"x5 1/4"x105 5/8" (36x134x2683)



B06 FRONT BEAM - A4M02989
(x1) 1 7/16"x5 1/4"x93 3/8" (36x134x2371)



B07 SIDE BEAM - A4M02991
(x1) 1 7/16"x5 1/4"x114 3/16" (36x134x2900)

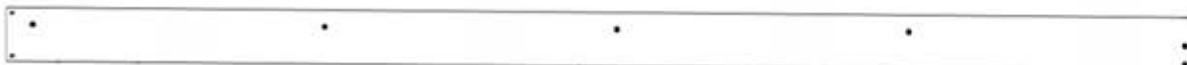

B08 SIDE BEAM - A4M02992
(x1) 1 7/16"x5 1/4"x114 3/16" (36x134x2900)



B09 BACK BEAM - A4M02995
(x1) 1 9/16"x3 1/8"x104 3/16" (40x80x2647)



B10 BACK BEAM - A4M02996
(x1) 1 9/16"x3 1/8"x91 15/16" (40x80x2335)

OWNER'S MANUAL - PARTS IDENTIFICATION

METAL COMPONENTS (NOT TO SCALE)



J1 SPLICE BRACKET - A4M02230
(x3) 1 5/16"x5 3/16"x39 3/8" (33.2x131.2x1000)



J2 SPLICE BRACKET - A4M02994
(x1) 1 7/16"x3"x15 3/4" (37.2x76.2x400)



R01 RAFTER - A4M02985
(x5) 3 1/8"x4 5/16"x112 1/2" (80x110x2858)



R02 RAFTER - A4M02986
(x1) 2 15/16"x3 1/8"x112 1/2" (75x80x2858)

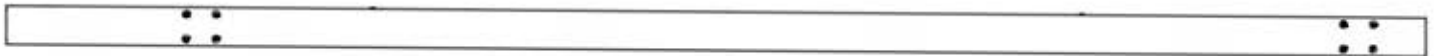

R03 RAFTER - A4M02987
(x1) 2 15/16"x3 1/8"x112 1/2" (75x80x2858)



E01 PURLIN - A4M02997
(x1) 13/16"x1 9/16"x104 3/16" (20x40x2646)



E02 PURLIN - A4M02998
(x1) 13/16"x1 9/16"x91 7/8" (20x40x2334)



E03 PURLIN - A4M02999
(x4) 13/16"x2 3/4"x91 13/16" (20x70x2332.5)



E04 PURLIN - A4M03000
(x4) 13/16"x2 3/4"x104 1/8" (20x70x2644.5)

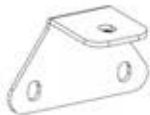

J3 RAFTER BRACKET - A4M02984
(x10) 2"x2 3/16"x3 5/8" (50x55x92)



J4 BEAM BRACKET - A4M02990
(x2) 1"x1 5/16"x5 1/16" (25x33.2x128)



J5 BEAM BRACKET - A4M02993
(x2) 1"x1 7/16"x2 15/16" (25x37.2x75)



A6P00530 2-WAY SQUARE PLUG
(x5)



A4M01352 HOLE COVER
(x32)

OWNER'S MANUAL - PARTS IDENTIFICATION

METAL COMPONENTS (NOT TO SCALE)



A4M03004 29GA STEEL SHEETING
(x11)



A4M03001 DRIP EDGE
(x1)



A4M03002 DRIP EDGE
(x1)



A4M03003 DRIP EDGE SPLICE
(x1)



A4M03009 EDGE TRIM SPLICE
(x1)

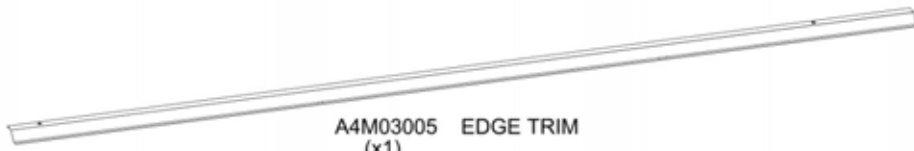

A4M03005 EDGE TRIM
(x1)

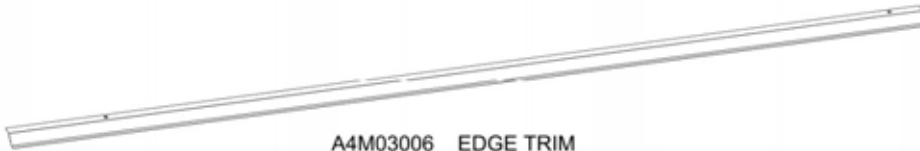

A4M03006 EDGE TRIM
(x1)



A4M03007 EDGE TRIM
(x1)



A4M03008 EDGE TRIM
(x1)

OWNER'S MANUAL - PARTS IDENTIFICATION

METAL COMPONENTS (NOT TO SCALE)

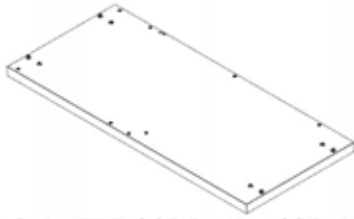

F1 CORNER CABINET FLOOR PANEL ASSEMBLY L - A4M03028
(x1) 2 5/8"x23 3/8"x51 7/8" (66x594x1317)

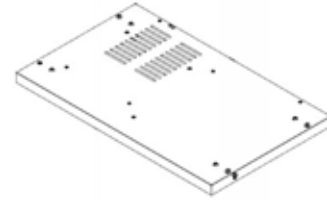

F2 GRILL CABINET FLOOR PANEL ASSEMBLY - A4M03048
(x1) 2 5/8"x23 3/8"x38 1/4" (66x594x972)

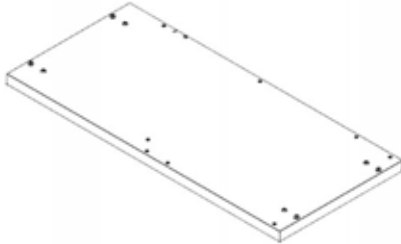

F3 CORNER CABINET FLOOR PANEL ASSEMBLY R - A4M03039
(x1) 2 5/8"x23 3/8"x51 7/8" (66x594x1317)

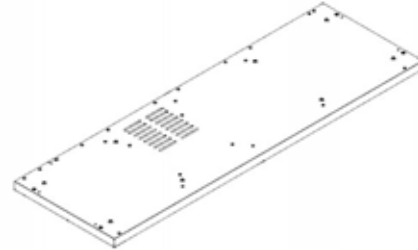

F4 PIZZA OVEN CABINET FLOOR PANEL ASSEMBLY - A4M03062
(x1) 2 5/8"x23 3/8"x72 3/16" (66x594x1834)

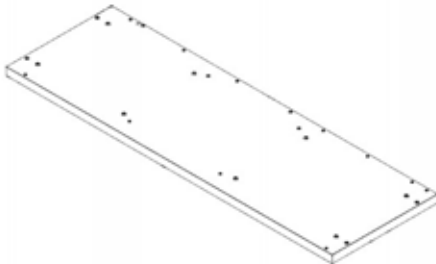

F5 SINK CABINET FLOOR PANEL ASSEMBLY - A4M03092
(x1) 2 5/8"x23 3/8"x72 3/16" (66x594x1834)

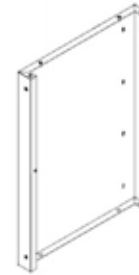

G1 LEFT CORNER CABINET SIDE WALL ASSEMBLY L - A4M03029
(x1) 2 9/16"x23 3/8"x33 3/8" (65x594x848)

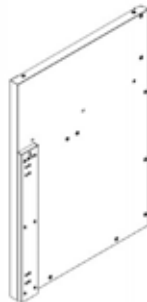

G2 LEFT CORNER CABINET SIDE WALL ASSEMBLY R - A4M03030
(x1) 2 1/16"x23 3/8"x33 3/8" (53x594x848)



G3 LEFT CORNER CABINET SIDE WALL ASSEMBLY M - A4M03031
(x1) 3 1/8"x7 1/16"x33 3/8" (80x180x848)



G4 CORNER CABINET BACK PANEL ASSEMBLY L - A4M03033
(x1) 1 3/16"x33 3/8"x47 13/16" (30x848x1215)



G5 GRILL CABINET SIDE WALL ASSEMBLY M - A4M03059
(x1) 1 3/4"x22 13/16"x23 1/4" (44x579x591)

OWNER'S MANUAL - PARTS IDENTIFICATION

METAL COMPONENTS (NOT TO SCALE)

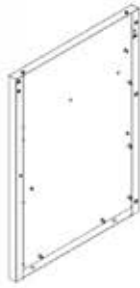

G6 RIGHT CORNER CABINET SIDE WALL ASSEMBLY L - A4M03040
(x1) 2 1/16"x23 3/8"x33 3/8" (53x594x848)



G7 RIGHT CORNER CABINET SIDE WALL ASSEMBLY R - A4M03041
(x1) 2 9/16"x23 3/8"x33 3/8" (65x594x848)



G8 RIGHT CORNER CABINET SIDE WALL ASSEMBLY M - A4M03042
(x1) 3 1/8"x7 1/16"x33 3/8" (80x180x848)



G9 CORNER CABINET BACK PANEL ASSEMBLY R - A4M03043
(x1) 1 3/16"x33 3/8"x47 13/16" (30x848x1215)



G10 GRILL CABINET BACK PANEL ASSEMBLY - A4M03055
(x1) 1 3/16"x22 7/8"x38 3/16" (30x581x970)



O1 PIZZA OVEN CABINET SIDE PANEL ASSEMBLY R - A4M03064
(x1) 4 3/4"x23 3/8"x33 3/8" (121x594x848)

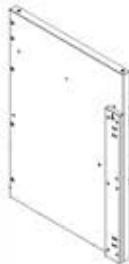

O2 PIZZA OVEN CABINET SIDE PANEL ASSEMBLY MR - A4M03067
(x1) 2 5/8"x23 3/8"x33 3/8" (67x594x848)



O3 PIZZA OVEN CABINET SIDE PANEL ASSEMBLY M - A4M03077
(x1) 1 3/4"x23 5/16"x26 7/16" (44x592x672)



O4 PIZZA OVEN CABINET SIDE PANEL ASSEMBLY ML - A4M03066
(x1) 2 5/8"x23 3/8"x33 3/8" (67x594x848)



O5 PIZZA OVEN CABINET SIDE PANEL ASSEMBLY L - A4M03063
(x1) 2 5/8"x23 3/8"x33 3/8" (67x594x848)

OWNER'S MANUAL - PARTS IDENTIFICATION

METAL COMPONENTS (NOT TO SCALE)



O6 PIZZA OVEN CABINET BACK PANEL R - A4M03076
(x1) 1 3/16"x18 9/16"x33 3/8" (30x472x848)



O7 PIZZA OVEN CABINET BACK PANEL ASSEMBLY M - A4M03075
(x1) 1 3/16"x26 7/16"x31 7/16" (30x672x798)

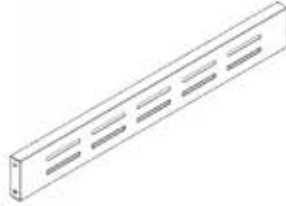

O8 PIZZA OVEN VENTILATION PANEL - A4M03078
(x1) 1 3/16"x4"x31 7/16" (30x102x798)



O9 PIZZA OVEN CABINET LEFT BACK PANEL - A4M03065
(x1) 1 3/16"x15 3/16"x33 3/8" (30x386x848)



O10 PIZZA OVEN SLIDE UPRIGHT ASSEMBLY - A4M03079
(x1) 1 3/16"x2 15/16"x33 1/4" (30x75x844)



S1 SINK CABINET SIDE PANEL ASSEMBLY L - A4M03094
(x1) 4 3/4"x23 3/8"x33 3/8" (121x594x848)

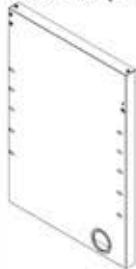

S2 SINK CABINET SIDE PANEL ASSEMBLY ML - A4M03096
(x1) 1 15/16"x23 5/16"x33 3/8" (50x593x847)

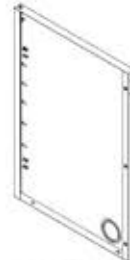

S3 SINK CABINET SIDE PANEL MR - A4M03095
(x1) 1 3/8"x23 3/8"x33 3/8" (35x594x848)

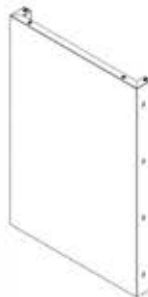

S4 SINK CABINET SIDE PANEL ASSEMBLY R - A4M03093
(x1) 2 5/8"x23 3/8"x33 3/8" (67x594x848)



S5 SINK CABINET BACK PANEL ASSEMBLY - A4M03098
(x1) 1 3/16"x33 3/8"x42 1/8" (30x848x1070)

OWNER'S MANUAL - PARTS IDENTIFICATION

METAL COMPONENTS (NOT TO SCALE)



S6 FRIDGE BACK PANEL ASSEMBLY - A4M03099
(x1) 1 3/16"x24 1/2"x33 3/8" (30x623x848)

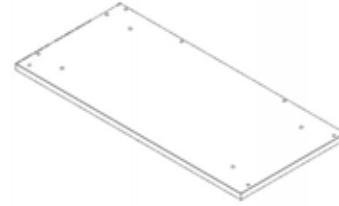

T1 CORNER CABINET MARBLE PANEL ASSEMBLY L - A4M03034
(x1) 1 1/4"x24 1/8"x51 7/8" (32x612x1317)

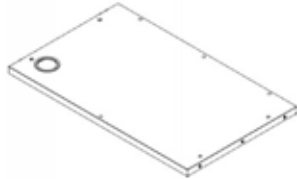

T2 GRILL TABLETOP ASSEMBLY - A4M03057
(x1) 1 1/4"x23 3/8"x38 3/16" (32x594x970)

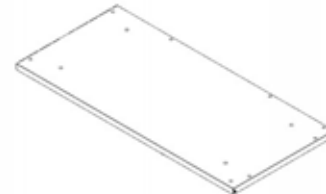

T3 CORNER CABINET MARBLE PANEL ASSEMBLY R - A4M03044
(x1) 1 1/4"x24 1/8"x51 7/8" (32x612x1317)

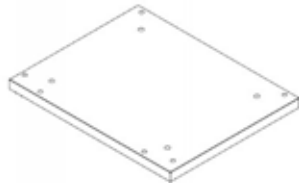

T4 PIZZA OVEN CABINET MARBLE PANEL L - A4M03068
(x1) 1 1/4"x19 5/16"x24 1/8" (32x490x612)

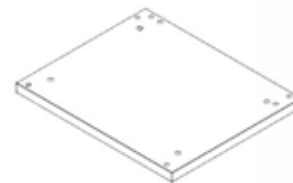

T5 PIZZA OVEN CABINET MARBLE PANEL R - A4M03069
(x1) 1 1/4"x20"x24 1/8" (32x508x612)

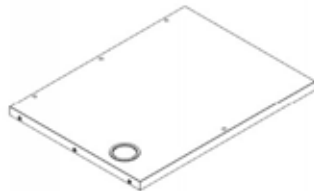

T6 PIZZA OVEN TABLETOP ASSEMBLY - A4M03070
(x1) 1 3/8"x23 3/8"x31 7/16" (35x594x798)

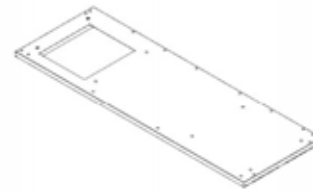

T7 SINK CABINET MARBLE PANEL ASSEMBLY - A4M03142
(x1) 1 1/4"x24 1/8"x70 13/16" (32x612x1798)



T8 BAR TABLE PAN ASSEMBLY - A4M03023
(x1) 1"x8 7/8"x86 1/4" (25x225x2190)

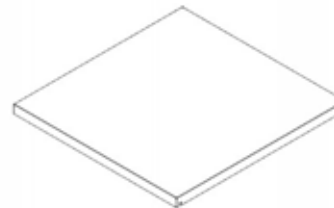

C1 CORNER CABINET SHELF - A4M03037
(x2) 1 3/16"x22 3/16"x23" (30x564x584)

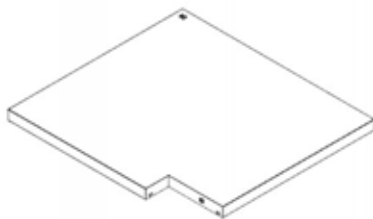

C2 CORNER CABINET SHELF ASSEMBLY L - A4M03038
(x1) 1 1/4"x23 1/8"x25 7/16" (32x588x646)

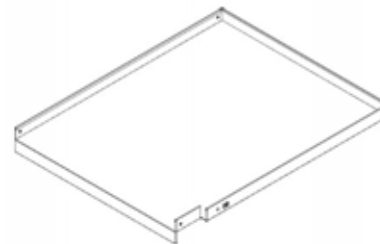

C3 GRILL CABINET SHELF - A4M03054
(x1) 2 5/16"x18 1/4"x22 11/16" (59x464x577)

OWNER'S MANUAL - PARTS IDENTIFICATION

METAL COMPONENTS (NOT TO SCALE)

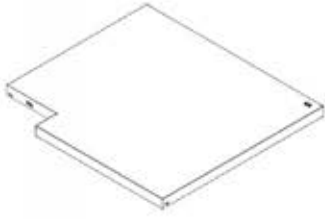

C4 CORNER CABINET SHELF ASSEMBLY R - A4M03046
(x1) 1 1/4"x23 1/8"x25 7/16" (32x588x646)



C5 PIZZA OVEN CABINET SHELF - A4M03074
(x1) 2 3/8"x14 7/8"x23 1/16" (60x378x585)

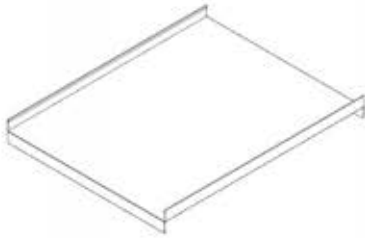

C6 SINK CABINET SHELF - A4M03100
(x2) 2 5/16"x18 1/4"x23 1/8" (59x464x587)



A1 CORNER CABINET HORIZONTAL BEAM ASSEMBLY - A4M03032
(x2) 1"x2 3/4"x22 1/4" (25x70x565)



A2 MAGNET BRACKET - A4M03026
(x8) 1"x1 1/4"x3 1/8" (25x31x80)

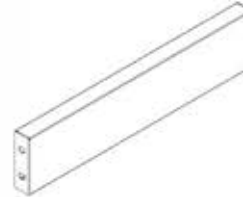

A3 HORIZONTAL CHANNEL - A4M03071
(x5) 1"x3 3/8"x15 3/16" (25x85x386)



A4 SINK CABINET HORIZONTAL CHANNEL - A4M03097
(x2) 1"x3 3/8"x18 3/8" (25x85x466)



A5 SHELF BRACKET - A4M03141
(x8) 5/8"x7/8"x2 1/16" (16x22x53)

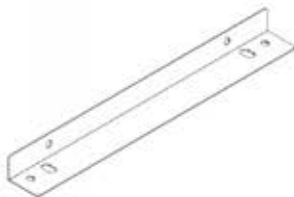

A6 ANGLED BRACKET - A4M03053
(x2) 1 3/8"x1 15/16"x17 1/8" (35x50x435)

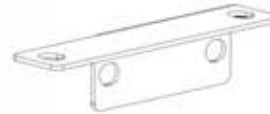

A7 TABLE BRACKET - A4M03148
(x1) 1 15/16"x1 15/16"x7 1/2" (50x50x191)

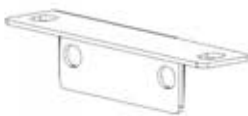

A8 TABLE BRACKET - A4M03149
(x1) 1 15/16"x1 15/16"x7 1/2" (50x50x191)



A9 HOSE BRACKET ASSEMBLY - A4M03060
(x2) 1 1/4"x1 7/16"x2 9/16" (31.5x36.5x65)

OWNER'S MANUAL - PARTS IDENTIFICATION

METAL COMPONENTS (NOT TO SCALE)



A10 SLIDE BRACKET ASSEMBLY - A4M03083
(x6) 15/16"x3 3/8"x22 5/8" (23x85x575)



A11 TRIANGLE PANEL - A4M03086
(x2) 13/16"x13 3/4"x13 3/4" (20x350x350)



A12 BAR TABLE BRACKET - A4M03022
(x2) 3 3/4"x7 7/8"x8 7/8" (95x200x225)



A13 GAS TANK HOLDER ASSEMBLY - A4M03047
(x2) 1 15/16"x12 7/8"x14 3/4" (49x327x374)



A15 TRASH CAN BRACKET ASSEMBLY - A4M03085
(x1) 1 3/8"x14 11/16"x450.00 (35x373x455)



A16 SINK ASSEMBLY - A4M03143
(x1) 15 1/8"x15 5/16"x16 7/8" (384x389x429)



D1 LEFT CORNER CABINET DOOR ASSEMBLY - A4M03036
(x1) 1 5/16"x23 5/8"x33 1/16" (34x600x840)



D2 RIGHT CORNER CABINET DOOR ASSEMBLY - A4M03045
(x1) 1 5/16"x23 5/8"x33 1/16" (34x600x840)



D3 GRILL CABINET DOOR ASSEMBLY L - A4M03058
(x1) 1 5/16"x19"x25 3/16" (34x483x639)



D4 GRILL CABINET DOOR ASSEMBLY R - A4M03059
(x1) 1 5/16"x19"x25 3/16" (34x483x639)



D5 PIZZA OVEN CABINET DOOR ASSEMBLY L - A4M03087
(x1) 1 5/16"x15 9/16"x28 1/8" (34x396x715)



D6 PIZZA OVEN CABINET DOOR ASSEMBLY R - A4M03088
(x1) 1 5/16"x15 9/16"x28 1/8" (34x396x715)

OWNER'S MANUAL - PARTS IDENTIFICATION

METAL COMPONENTS (NOT TO SCALE)



D7 SINK CABINET DOOR ASSEMBLY L - A4M03144
(x1) 1 5/16"x20"x33 1/16" (34x508x840)



D8 SINK CABINET DOOR ASSEMBLY R - A4M03145
(x1) 1 5/16"x20"x33 1/16" (34x508x840)

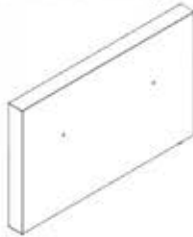

D9 DRAWER PANEL ASSEMBLY - A4M03080
(x4) 1 5/16"x10 1/4"x16 1/2" (34x260x419)

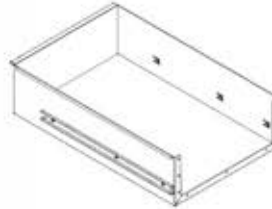

D10 DRAWER ASSEMBLY - A4M03081
(x4) 5 11/16"x14 5/8"x22 1/4" (145x372x565)



D11 TRASH CAN PANEL ASSEMBLY - A4M03084
(x1) 1 5/16"x16 1/2"x21 5/8" (34x419x550)

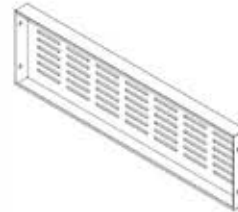

G11 GRILL VENTILATION PANEL - A4M03056
(x1) 1 5/16"x11 3/16"x38 3/16" (33x284x970)

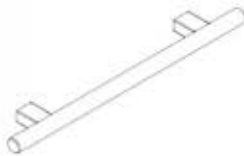

H2 STAINLESS STEEL HANDLE - A4M03024
(x13) 5/8"x1 9/16"x11 13/16" (16x40x300)

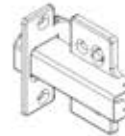

A4M03025 FULL OVERLAY HINGE
(x16)



A4M03151 GARDEN HOSE ADAPTER
(x1)

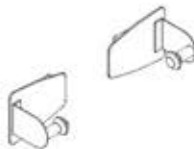

A4M02290 MAGNETIC PAPER TOWEL HOLDER
(x1)



9205413 ELECTRICAL ENCLOSURE
(x1)

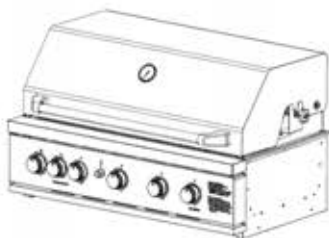

9240025 OUTDOOR KITCHEN GRILL KIT
(x1)

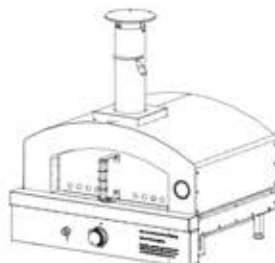

9240018 OUTDOOR KITCHEN PIZZA OVEN
(x1)



9240162 OUTDOOR KITCHEN FRIDGE - RIGHT OPEN
(x1)

OWNER'S MANUAL - PARTS IDENTIFICATION

ACCESSORY COMPONENTS (NOT TO SCALE)

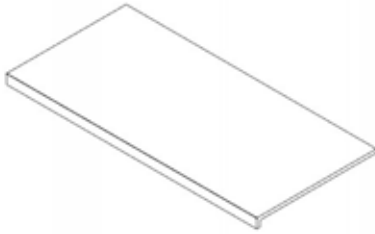

M1 CORNER CABINET MARBLE - A4M03035
(x2) 1 15/16"x24 13/16"x51 7/8" (50x630x1317)

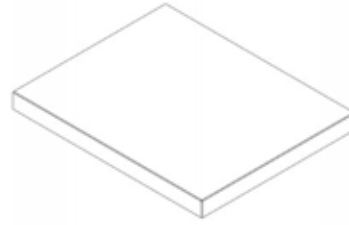

M2 PIZZA OVEN CABINET MARBLE L - A4M03089
(x1) 1 15/16"x20 1/16"x24 13/16" (50x509x630)

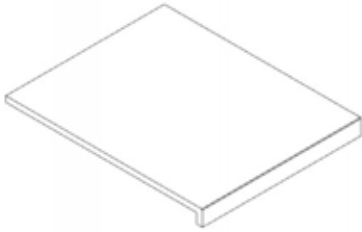

M3 PIZZA OVEN CABINET MARBLE R - A4M03090
(x1) 1 15/16"x20"x24 13/16" (50x508x630)

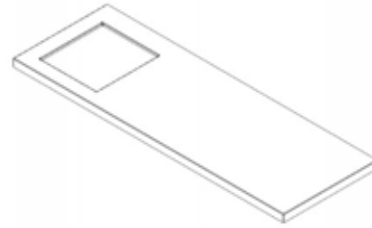

M4 SINK CABINET MARBLE - A4M03146
(x1) 1 15/16"x24 13/16"x71 1/2" (50x630x1816)

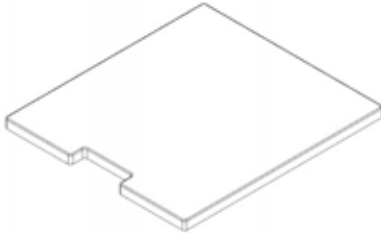

M5 SINK COVER MARBLE - A4M03147
(x1) 11/16"x14 3/4"x16 5/16" (18x375x415)



M6 BAR MARBLE RIGHT - A4M03020
(x1) 11/16"x14 1/16"x43 7/16" (18x358x1103)



M7 BAR MARBLE LEFT - A4M03021
(x1) 11/16"x14 1/16"x43 7/16" (18x358x1103)

OWNER'S MANUAL - PARTS IDENTIFICATION

HARDWARE COMPONENTS

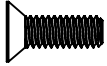

H101185 | PHILLIPS FLAT HEAD
(x96) | 8-32x.5 SCREW

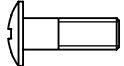

H101289 | PAN HEAD SCREW
(x111) | 8-32x1/2" SS

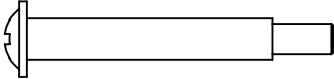

H101288 | SHOULDER BOLT
(x26) | 8-32x42mm

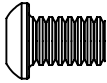

H101292 | TORX PAN HEAD
(x32) | 1/4-20x13/32"



H101293 | TORX PAN HEAD
(x8) | 1/4-20x1 3/8"

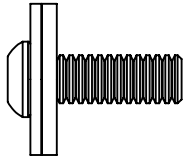

H101202 | TORX PAN HEAD
(x361) | 1/4-20x3/4 ASSY

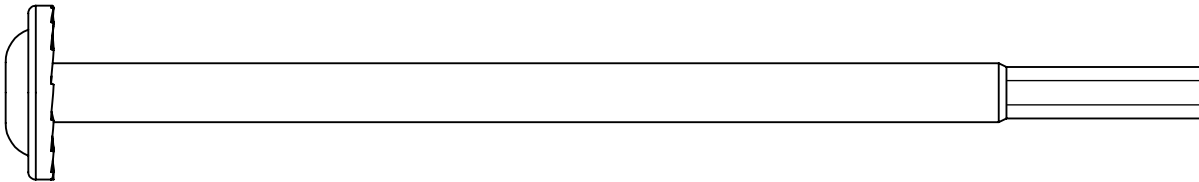

H101230 | BOLT WH 5/16x6 S.S.
(x4) |

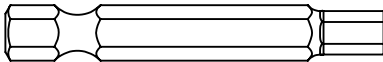

H101294 | HEX DRIVER
(x1)

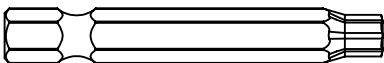

H100147 | TORX BIT
(x1) | T-30

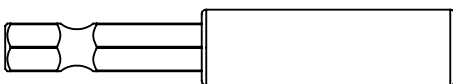

H101100 | MAGNETIC DRIVER
(x1)

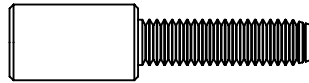

H101132 | TORX SOCKET SCREW SHORT
(x35) | 1/4-20

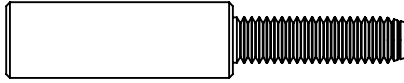

H101103 | TORX SOCKET SCREW 1/4-20
(x85) | 1/4-20

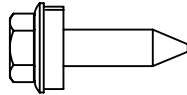

H101117 | SCREW WOODGRIP
(x110) | 10-16x3/4

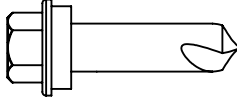

H101116 | SCREW SELF TAPPING
(x19) | 1/4x1 BLK

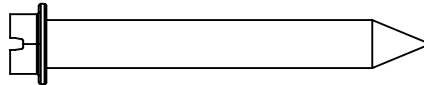

H100120 | CONCRETE ANCHOR
(x8) |

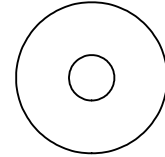

H101054 | SEALANT WASHER
(x32) |

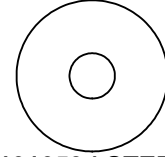

H101053 | STEEL WASHER
(x32) | 6x20

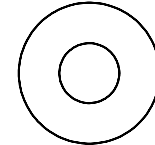

H100630 | WASHER FLAT
(x8) | 8x19 BLK

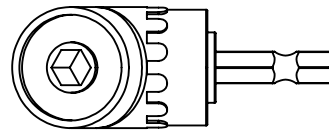

H101114 | RIGHT ANGLE DRILL ADAPTER
(x1) |

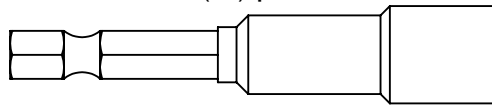

H101106 | SOCKET DRIVER
(x1) |

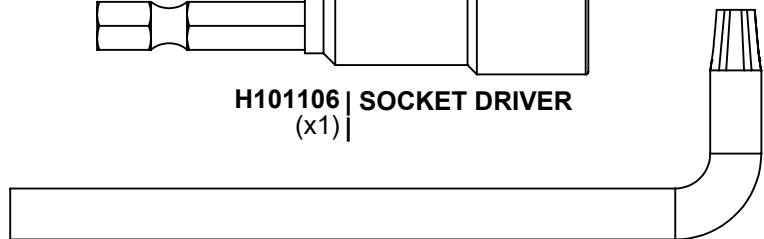

H100114 | TORX WRENCH
(x1) | T-30

PRE-ASSEMBLY STEP 1 - SORTING PARTS

It is critical for ease of assembly that you take the time to sort and organize the metal and hardware.

METAL PARTS:

- Organize metal parts by the three-digit, alpha-numeric part label on each bag (ex. A01).
- If there are multiple parts with the same part label, stack those pieces together.
- Part labels can be found on the bags of the parts.
- Keep parts in bags until required step.
- Allow yourself plenty of room - the metal pieces can take up a significant amount of space.

NOTE: CARTONS ARE NOT ORGANIZED BY PART OR STEP NUMBER.

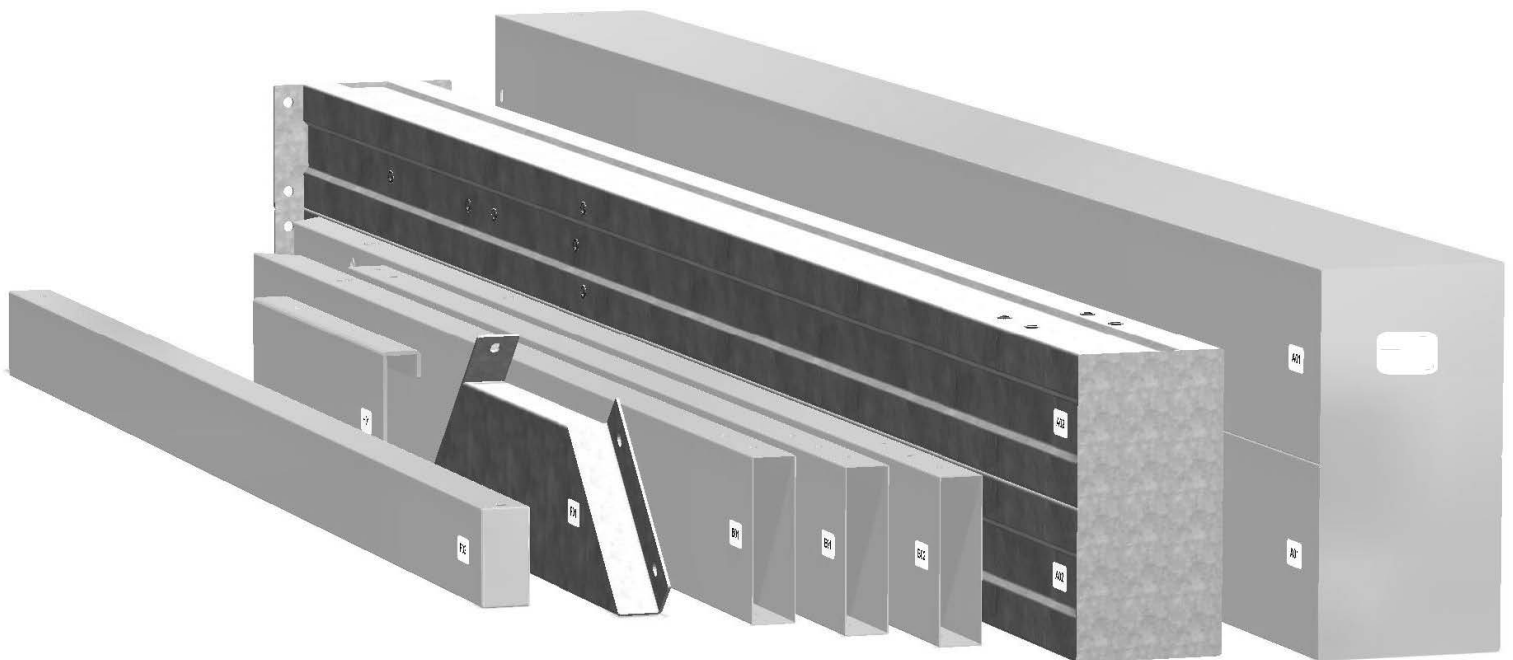

HARDWARE PARTS:

- We recommend that you have a separate table to organize the hardware.
- Hardware bags are printed with a seven-digit, alpha-numeric part number.
- You can organize your hardware by part number or group by hardware type (e.g. bolts, nuts, etc.).
- During assembly you only need to reference the last four digits of the number.

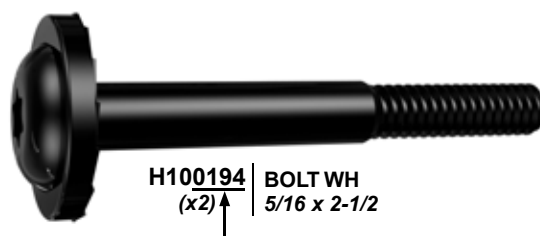

PRE-ASSEMBLY STEP 2 - TOOLS REQUIRED



Drill

Attachments:
Phillips Head



1/8", 3/16", 3/8" &
7/16" Drill Bits

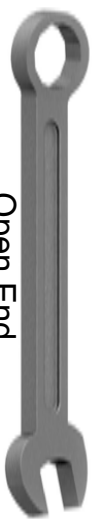

Open End
Wrenches
1/2" & 9/16"



3/8" Drive Ratchet, 1/2" &
7/16" STD Sockets 1/2" & 7/16"
Deep Sockets



Cordless Drill
or Electric Drill



Phillips Screw Driver



Claw Hammer

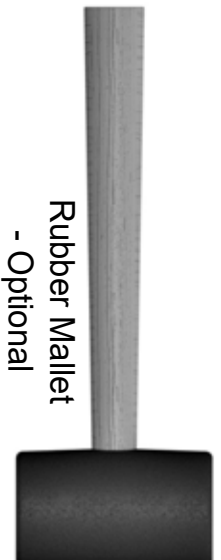

Rubber Mallet
- Optional



Tape Measure

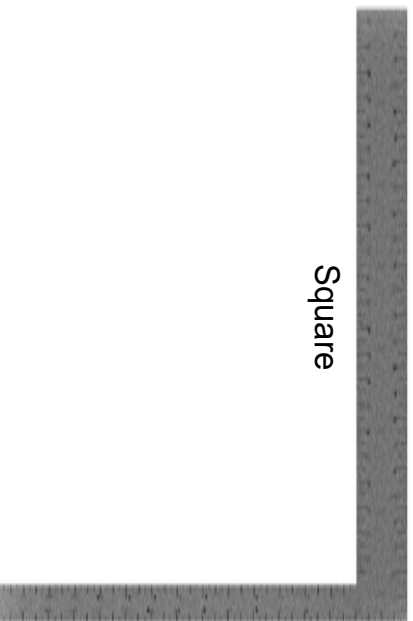

Square

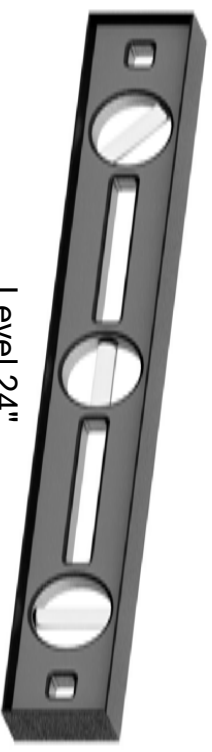

Level 24"

PRE-ASSEMBLY STEP 3 - CHOOSE YOUR ASSEMBLY METHOD

There are several types of assembly instructions available to you.

1. Printed Assembly Manual included with your set
2. BILT APP - 3D interactive instructions
3. Combination of the Printed Manual and BILT APP (Note: Step numbers can differ between the two methods)



BILT.

Scan for easy
3D instructions

Download the BILT app
before you begin

Download on the
App Store

GET IT ON
Google Play

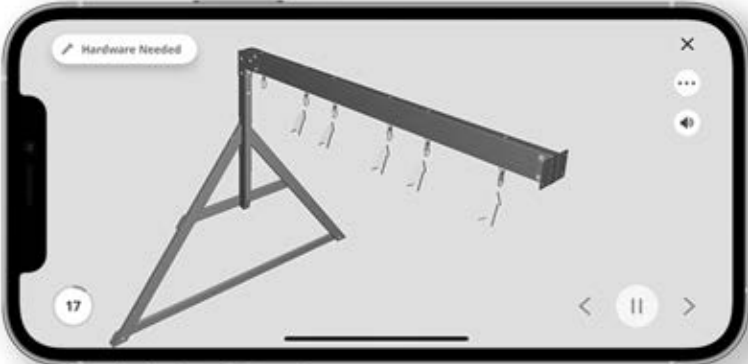

The image shows a smartphone screen displaying a 3D assembly instruction. The screen features a 3D model of a metal frame with a horizontal bar and several hanging components. A 'Hardware Needed' button is visible in the top left corner of the app interface. The number '17' is shown in a circle in the bottom left corner. Navigation icons for back, play/pause, and forward are visible at the bottom of the screen.

STEP 1 - BEAM ASSEMBLY

QTY	PartNo	DESCRIPTION
6	H101202	TORX PAN HEAD 1/4-20x3/4 ASSY



B02 FRONT BEAM - A4M02981
(x1) 1 7/16"x5 1/4"x105 5/8" (36x134x2683)



J1 SPLICE BRACKET - A4M02230
(x1) 1 5/16"x5 3/16"x39 3/8" (33.2x131.2x1000)

- FOR EASE OF ASSEMBLY, WE RECOMMEND USING SAW HORSES FOR STEPS 1 - 5

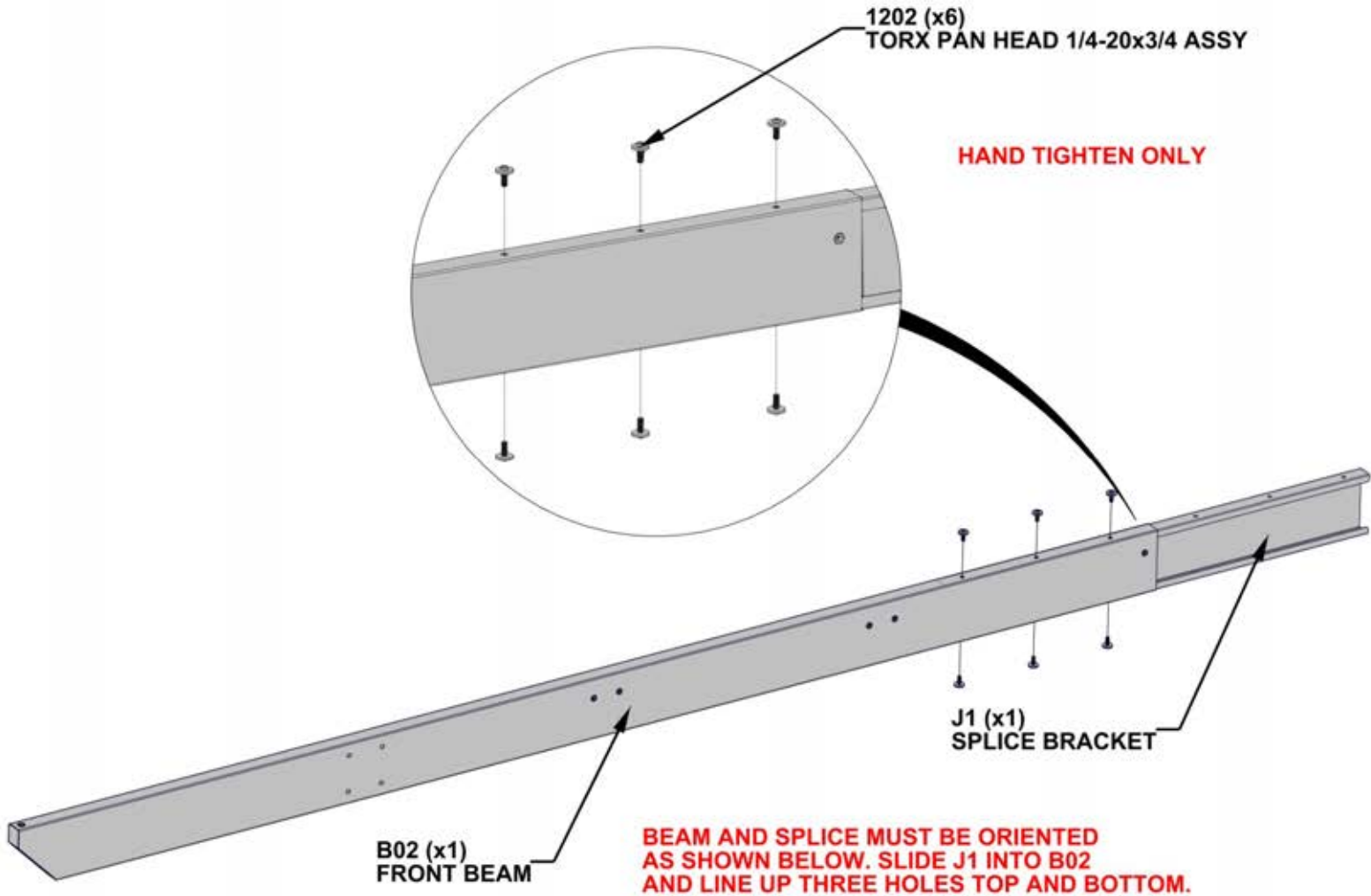

STEP 2 - BEAM ASSEMBLY

QTY	PartNo	DESCRIPTION
6	H101202	TORX PAN HEAD 1/4-20x3/4 ASSY



B01 FRONT BEAM - A4M02980
(x1) 1 7/16"x5 1/4"x93 3/8" (36x134x2371)

- SLIDE B01 INTO SPLICE BRACKET.
GENTLY TAP ENDS OF ASSEMBLY WITH
RUBBER Mallet UNTIL GAP CLOSES

1202 (x6)
TORX PAN HEAD 1/4-20x3/4 ASSY

TIGHTEN ALL HARDWARE

**ALL THREADED INSERTS
WILL BE ON THE SAME SIDE OF
THE BEAM**

B01 (x1)
FRONT BEAM

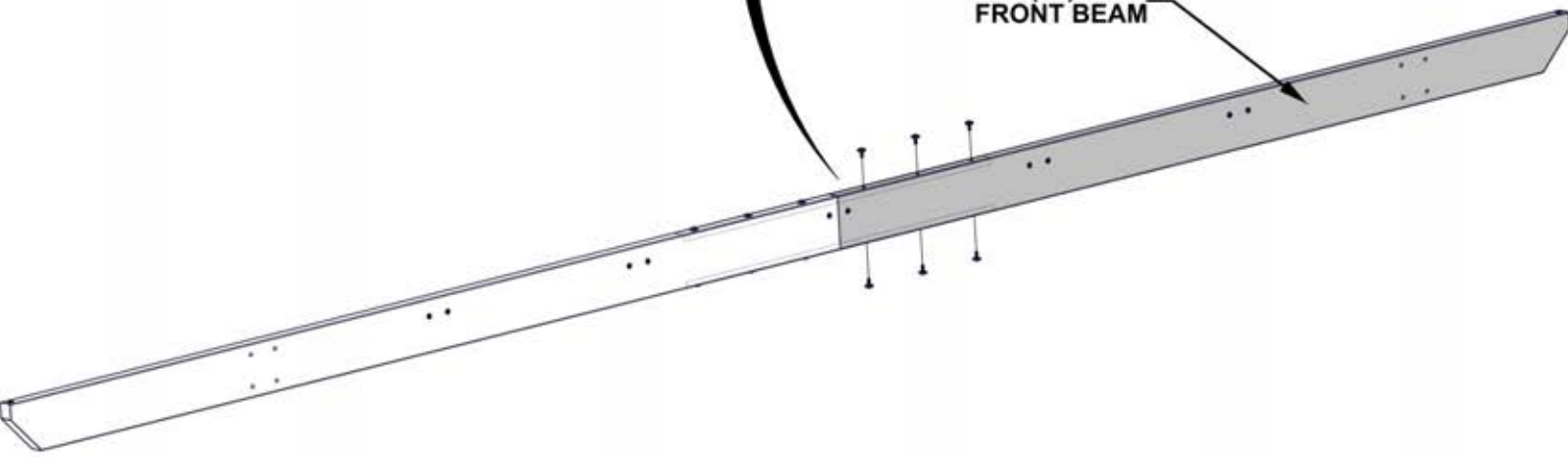

STEP 3 - BEAM ASSEMBLY

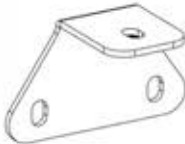

J3 RAFTER BRACKET - A4M02984
(x5) 2"x2 3/16"x3 5/8" (50x55x92)

QTY	PartNo	DESCRIPTION
10	H101202	TORX PAN HEAD 1/4-20x3/4 ASSY

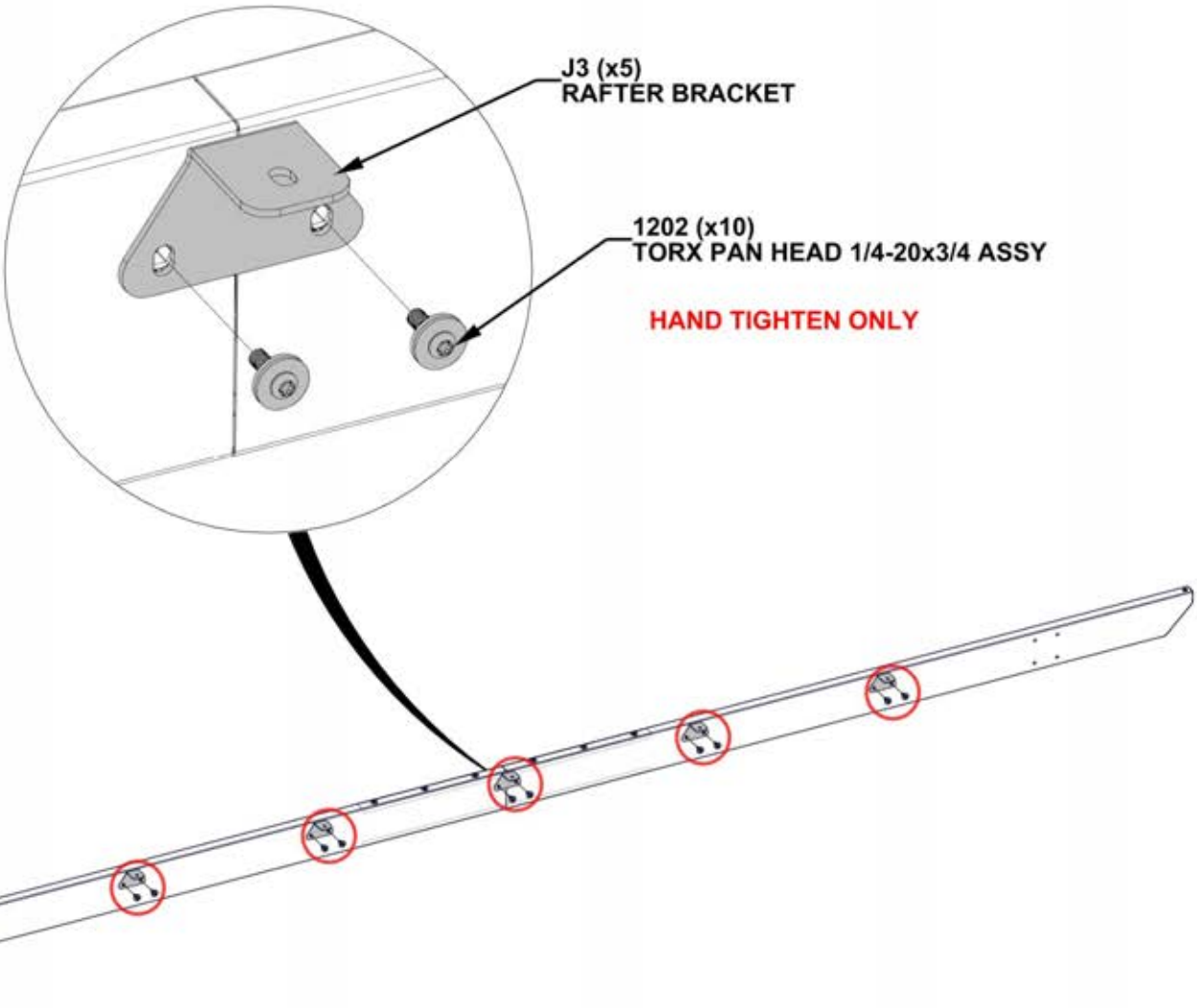

STEP 4 - FRAME ASSEMBLY

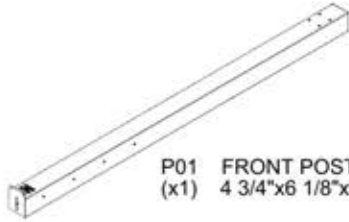

P01 FRONT POST - A4M02976
(x1) 4 3/4"x6 1/8"x96 5/8" (120x155x2455)

QTY	PartNo	DESCRIPTION
4	H101103	TORX SOCKET SCREW 1/4-20

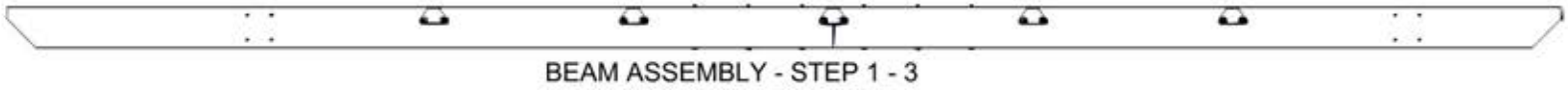

BEAM ASSEMBLY - STEP 1 - 3

- SQUARE BEAM ASSEMBLY TO POST

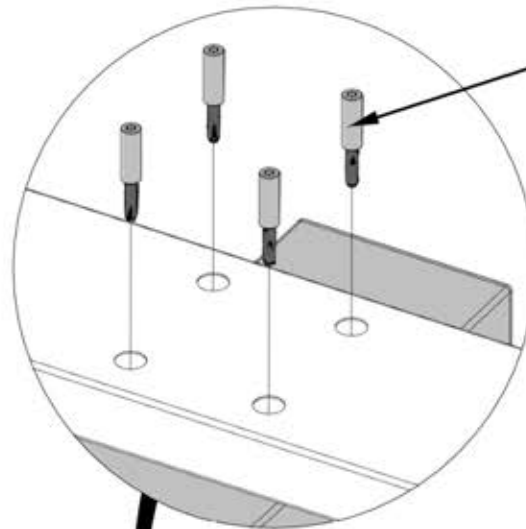

1103 (x4)
TORX SOCKET SCREW 1/4-20

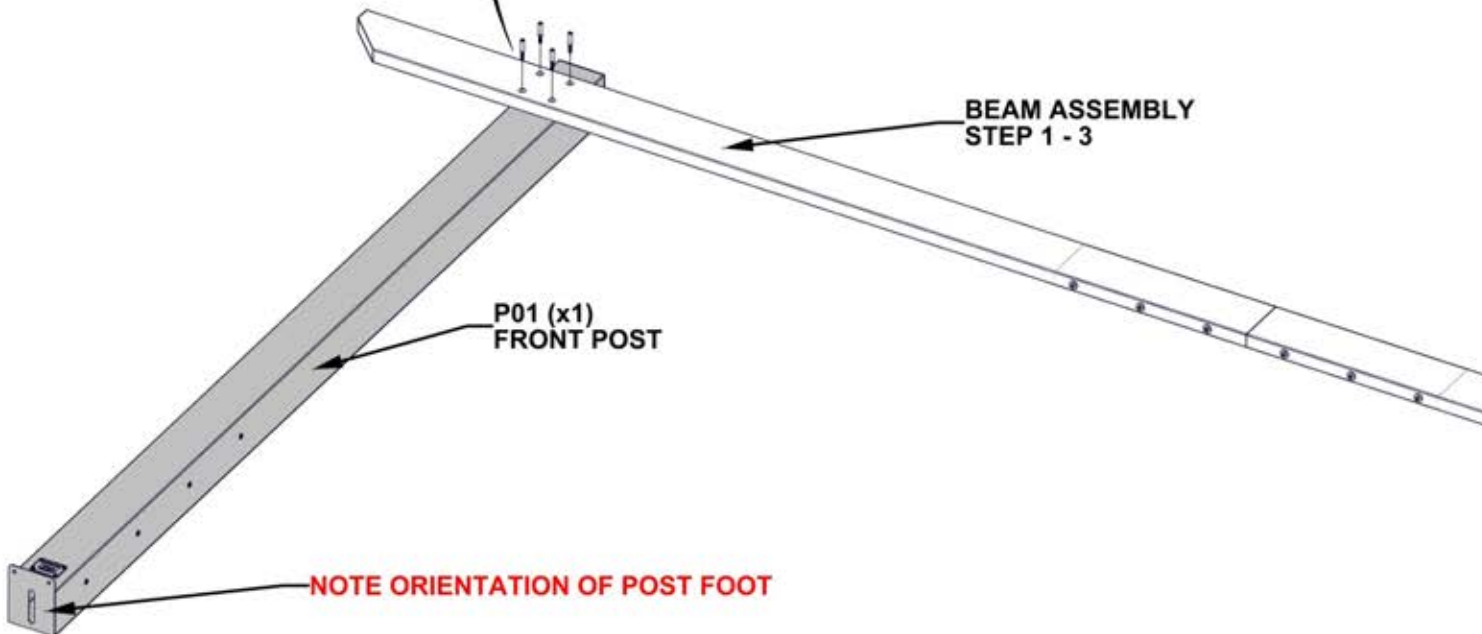

P01 (x1)
FRONT POST

BEAM ASSEMBLY
STEP 1 - 3

NOTE ORIENTATION OF POST FOOT

STEP 5 - FRAME ASSEMBLY

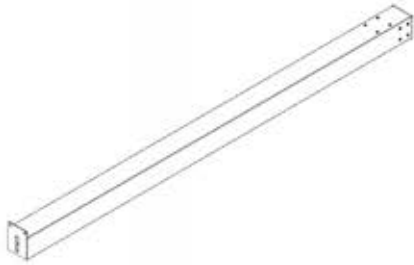

P02 FRONT POST - A4M02977
(x1) 4 3/4"x6 1/8"x96 5/8" (120x155x2455)

QTY	PartNo	DESCRIPTION
4	H101103	TORX SOCKET SCREW 1/4-20

- SQUARE BEAM ASSEMBLY TO POST

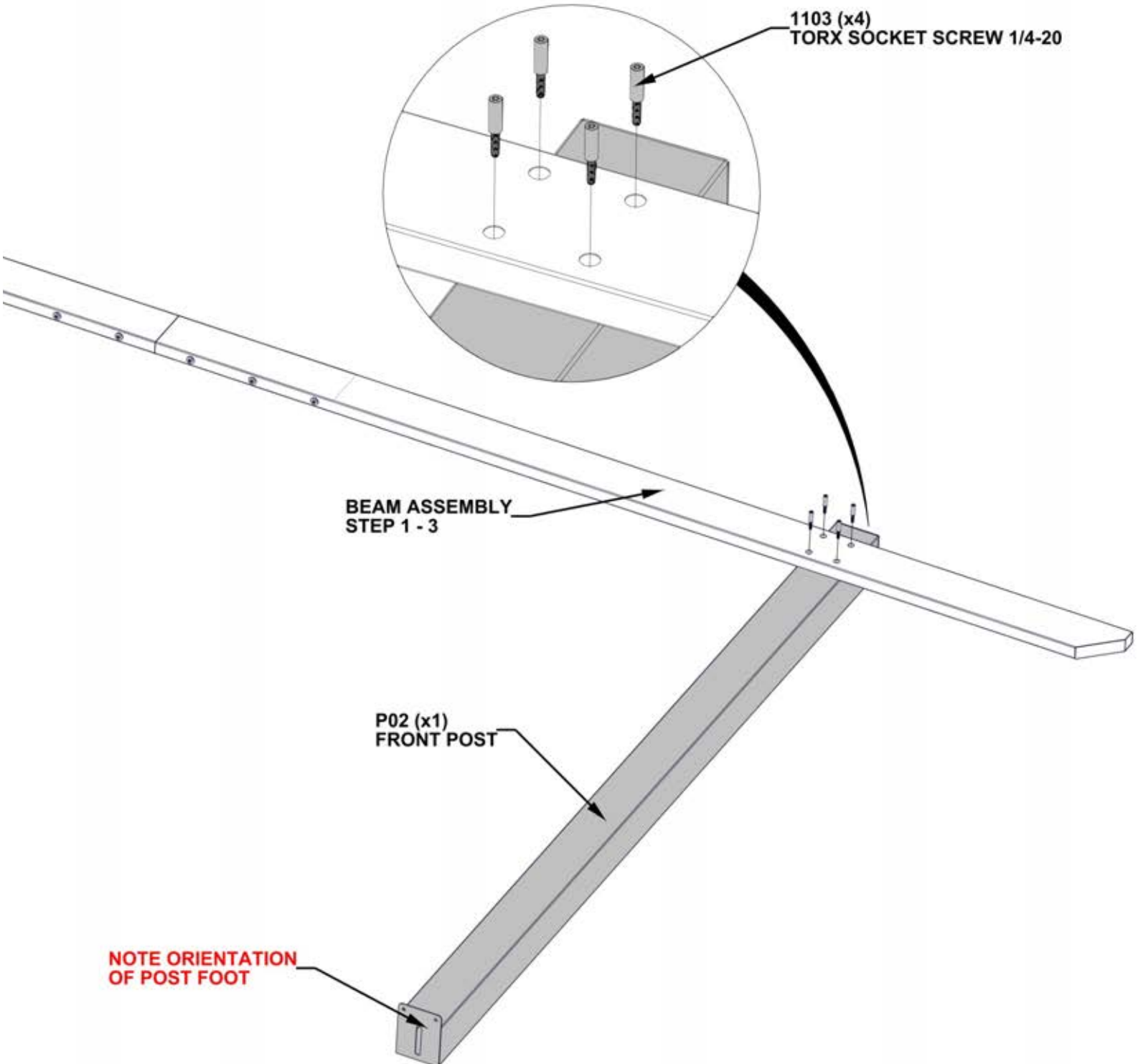

STEP 6 - FRAME ASSEMBLY

QTY	PartNo	DESCRIPTION
8	H101103	TORX SOCKET SCREW 1/4-20

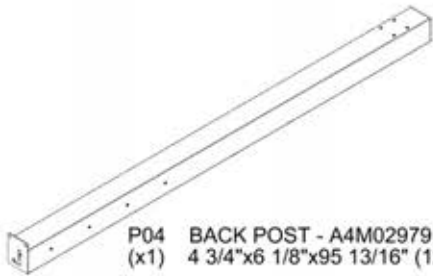

P04 BACK POST - A4M02979
(x1) 4 3/4"x6 1/8"x95 13/16" (120x155x2434)

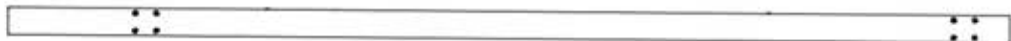

R03 RAFTER - A4M02987
(x1) 2 15/16"x3 1/8"x112 1/2" (75x80x2858)

- WITH AT LEAST THREE EXTRA PEOPLE, ATTACH R03 RAFTER TO P04 AND P02 POST.
- R03 RAFTER WILL BE AT A SLIGHT ANGLE.

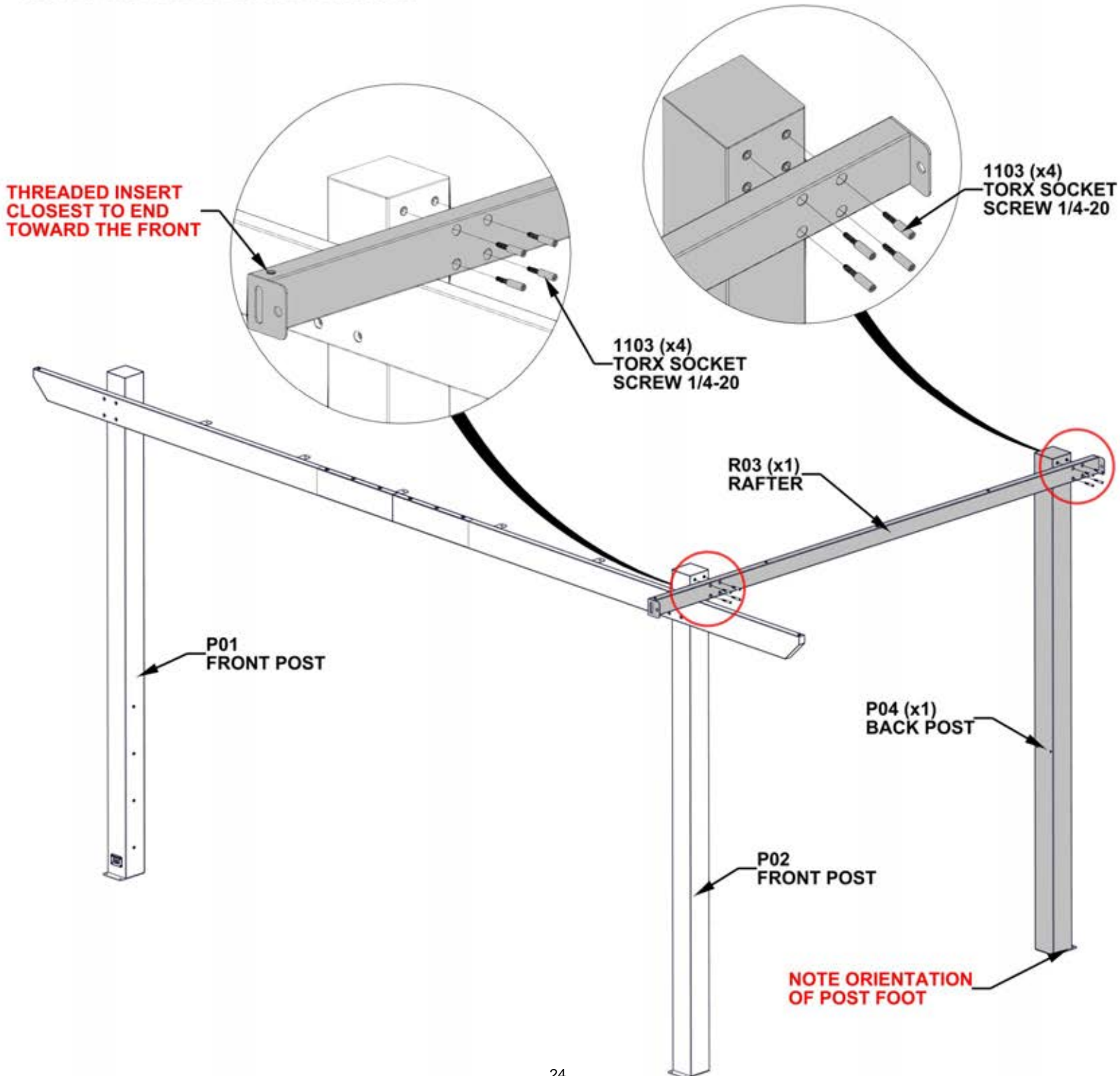

STEP 7 - FRAME ASSEMBLY

QTY	PartNo	DESCRIPTION
8	H101103	TORX SOCKET SCREW 1/4-20

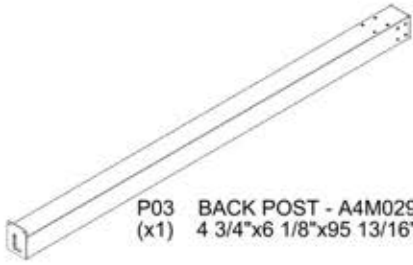

P03 BACK POST - A4M02978
(x1) 4 3/4"x6 1/8"x95 13/16" (120x155x2434)



R02 RAFTER - A4M02986
(x1) 2 15/16"x3 1/8"x112 1/2" (75x80x2858)

- WITH AT LEAST TWO EXTRA PEOPLE, ATTACH R02 RAFTER TO P03 AND P01 POST.
- R02 RAFTER WILL BE AT A SLIGHT ANGLE.

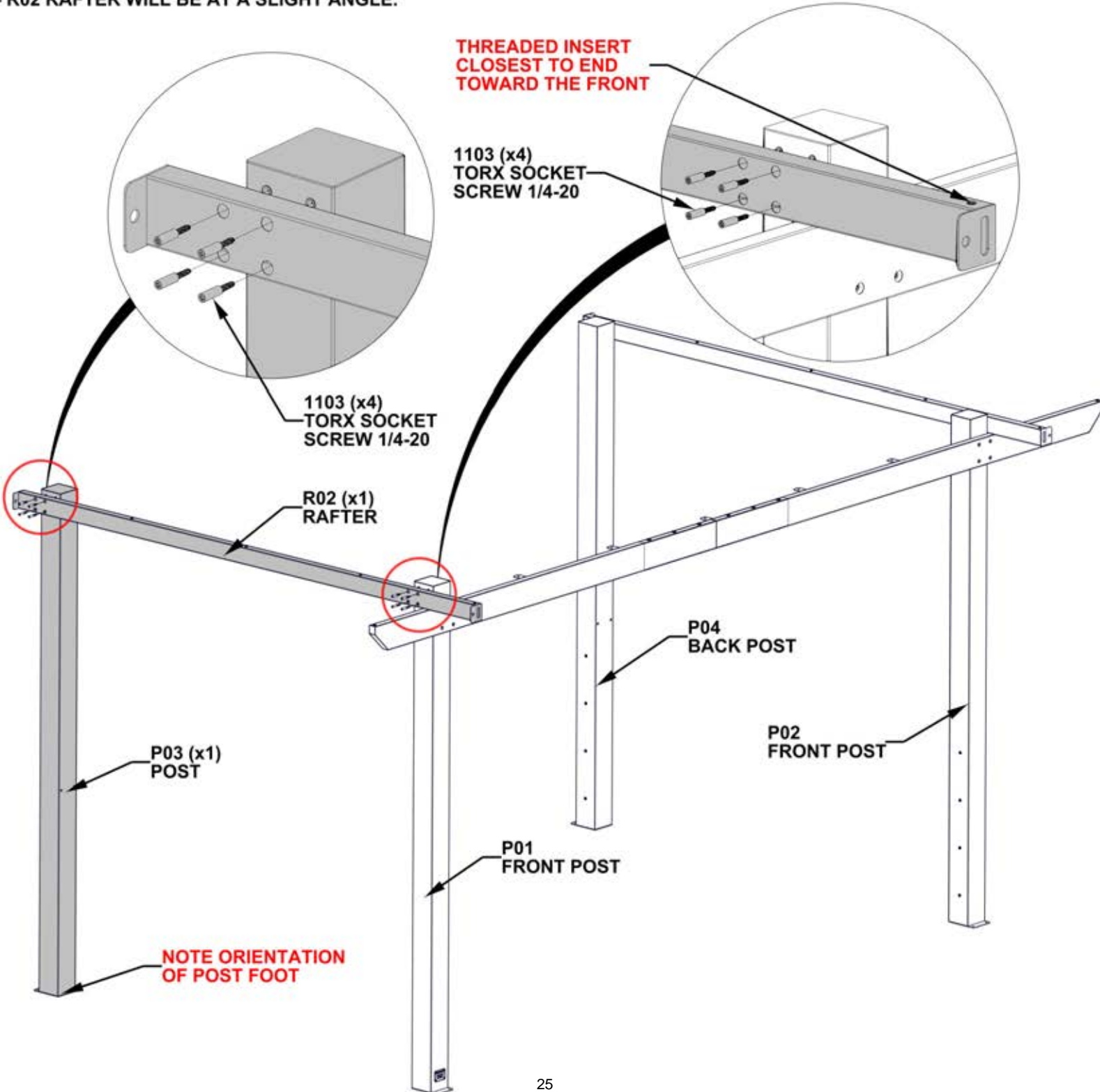

STEP 8 - BEAM ASSEMBLY

QTY	PartNo	DESCRIPTION
6	H101202	TORX PAN HEAD 1/4-20x3/4 ASSY



B03 BACK BEAM - A4M02982
(x1) 1 7/16"x5 1/4"x93 3/8" (36x134x2371)



J1 SPLICE BRACKET - A4M02230
(x1) 1 5/16"x5 3/16"x39 3/8" (33.2x131.2x1000)

- FOR EASE OF ASSEMBLY, WE RECOMMEND USING SAW HORSES FOR STEPS 8 - 10

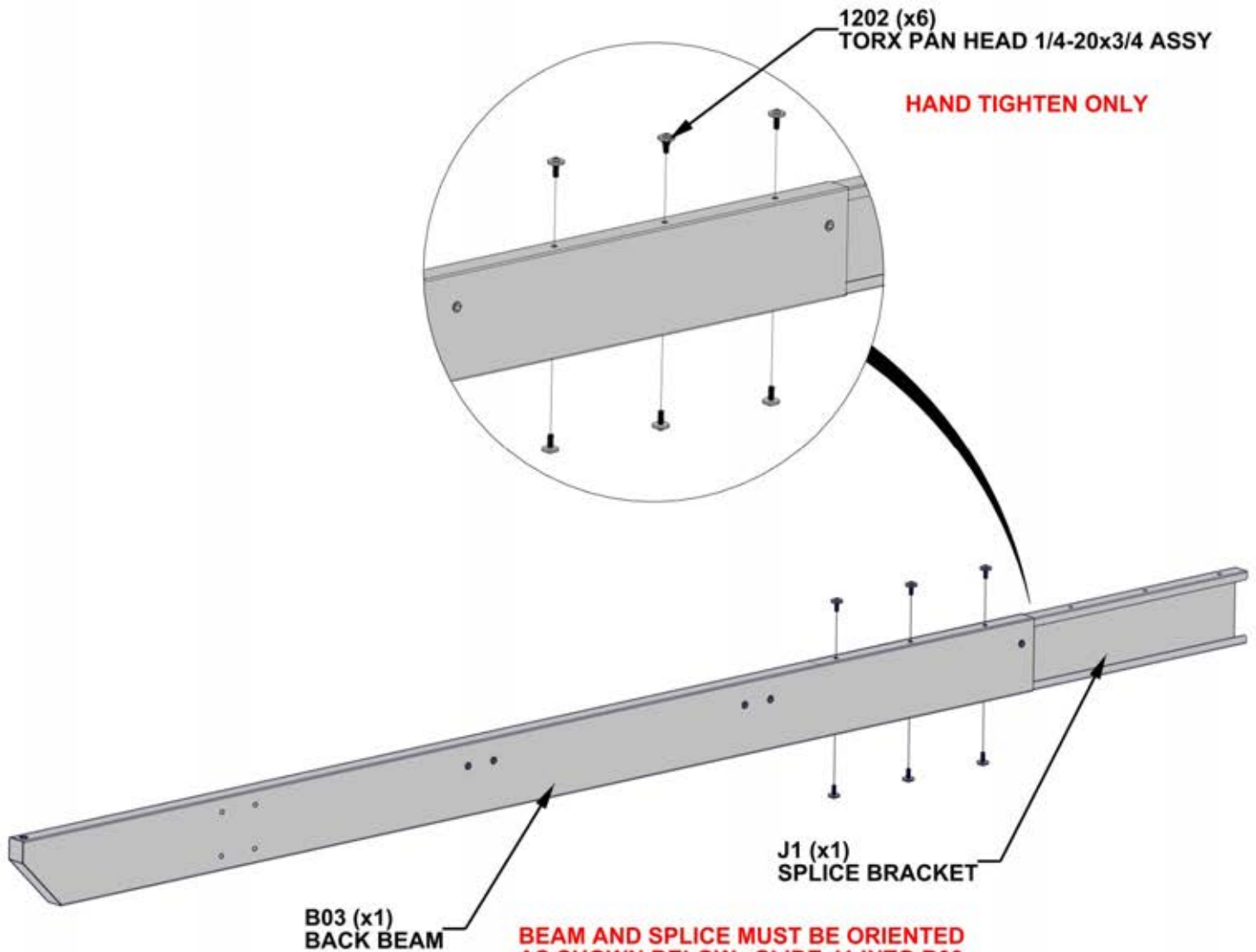

BEAM AND SPLICE MUST BE ORIENTED AS SHOWN BELOW. SLIDE J1 INTO B03 AND LINE UP THREE HOLES TOP AND BOTTOM

STEP 9 - BEAM ASSEMBLY

QTY	PartNo	DESCRIPTION
6	H101202	TORX PAN HEAD 1/4-20x3/4 ASSY



B04 BACK BEAM - A4M02983
(x1) 1 7/16"x5 1/4"x105 5/8" (36x134x2683)

- SLIDE B04 INTO SPLICE BRACKET.
GENTLY TAP ENDS OF ASSEMBLY WITH
RUBBER Mallet UNTIL GAP CLOSES

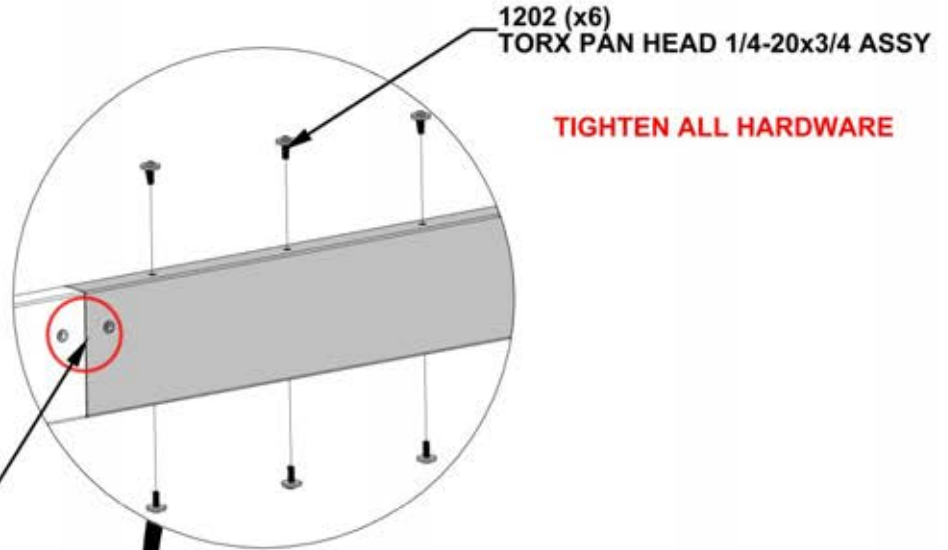

ALL THREADED INSERTS
WILL BE ON THE SAME SIDE OF
THE BEAM

TIGHTEN ALL HARDWARE

B04 (x1)
BACK BEAM

STEP 10 - BEAM ASSEMBLY

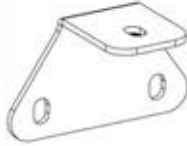

J3 RAFTER BRACKET - A4M02984
(x5) 2"x2 3/16"x3 5/8" (50x55x92)

QTY	PartNo	DESCRIPTION
10	H101202	TORX PAN HEAD 1/4-20x3/4 ASSY

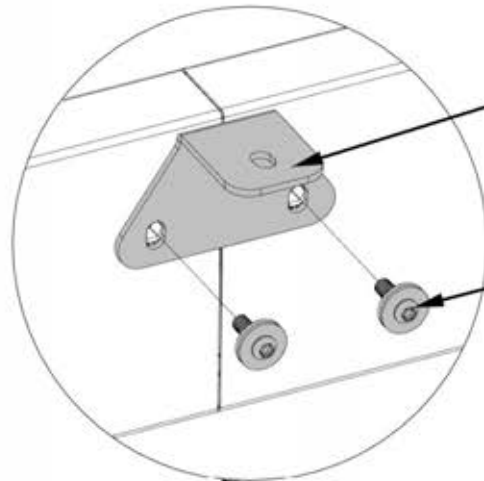

J3 (x5)
RAFTER BRACKET

1202 (x10)
TORX PAN HEAD 1/4-20x3/4 ASSY

HAND TIGHTEN ONLY

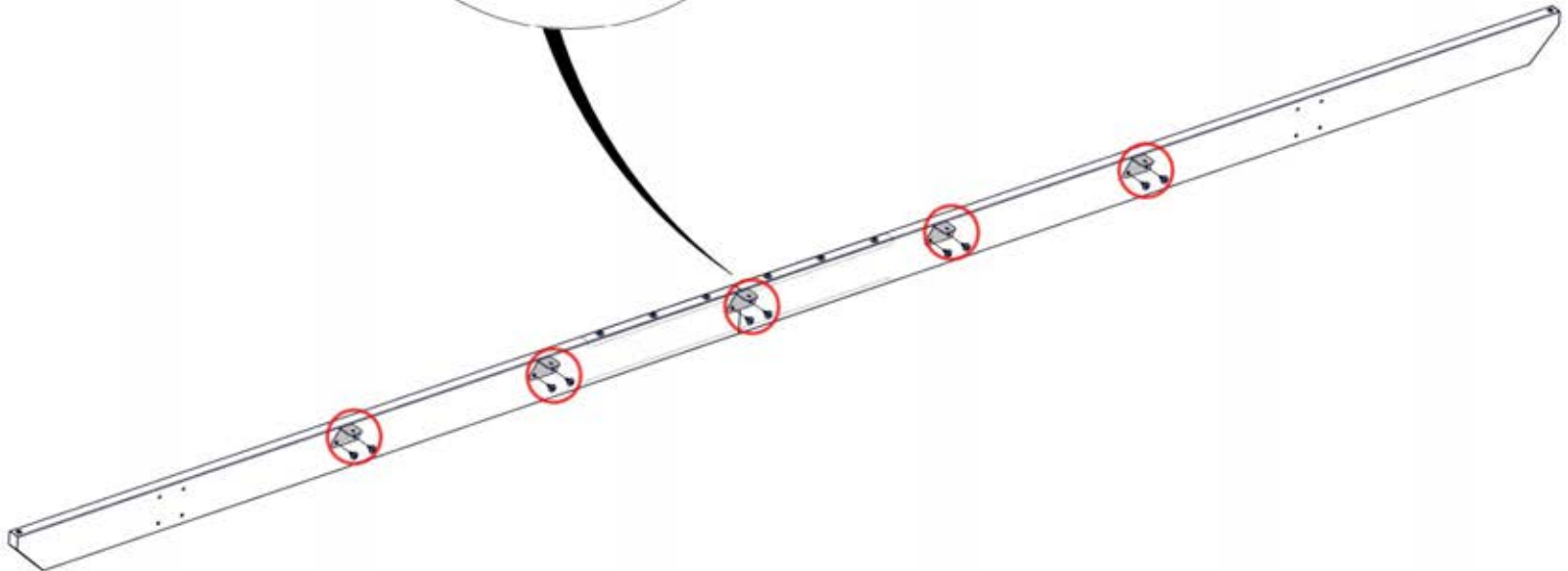

STEP 11 - FRAME ASSEMBLY

QTY	PartNo	DESCRIPTION
8	H101103	TORX SOCKET SCREW 1/4-20



BEAM ASSEMBLY - STEP 8 - 10

- WITH AT LEAST TWO EXTRA PEOPLE, ATTACH BEAM ASSEMBLY TO P04 AND P03 BACK POST.

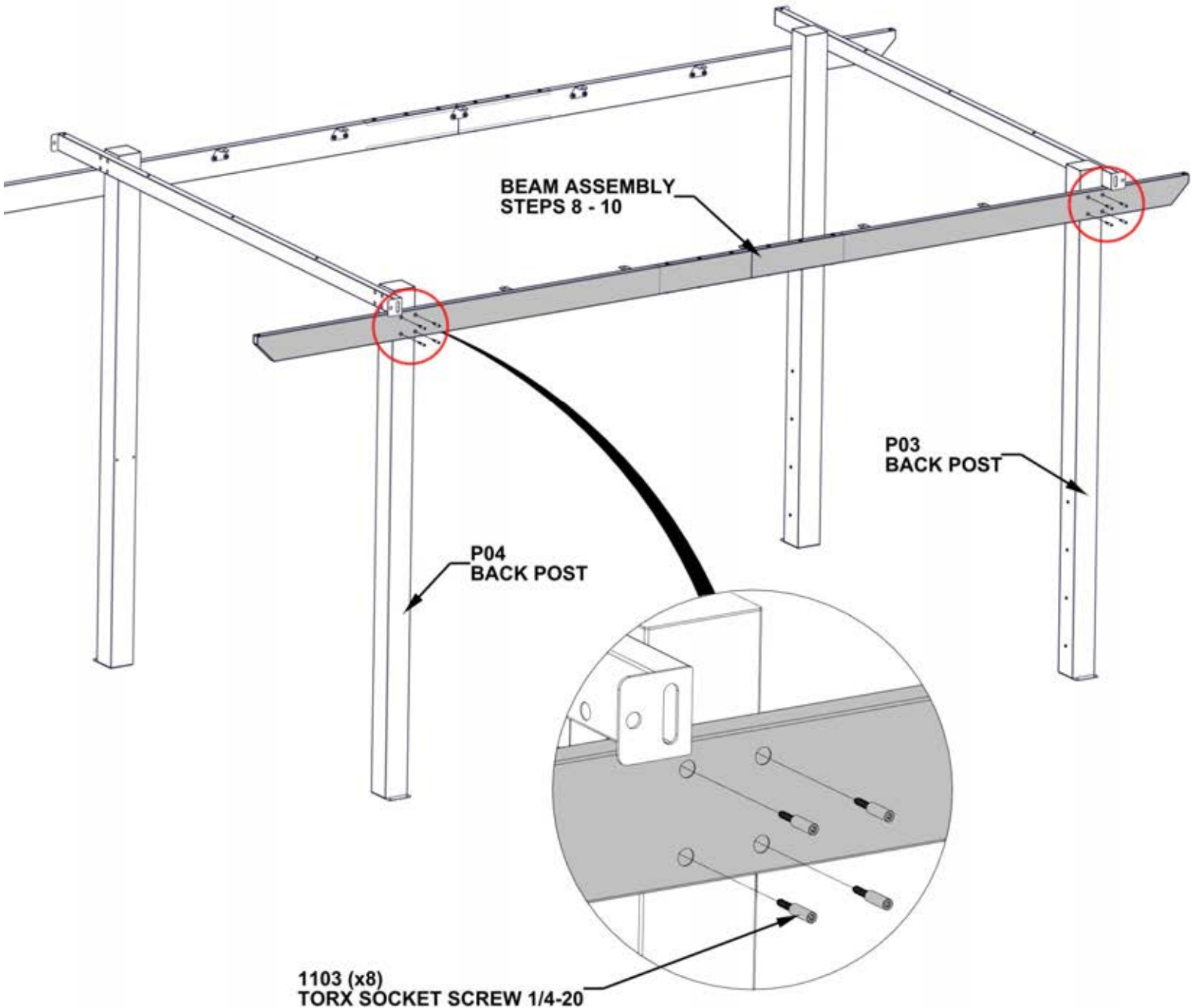

STEP 12 - ROOF ASSEMBLY

QTY	PartNo	DESCRIPTION
10	H101202	TORX PAN HEAD 1/4-20x3/4 ASSY



R01 RAFTER - A4M02985
(x5) 3 1/8"x4 5/16"x112 1/2" 112 1/2" (80x110x2858)

- CAREFULLY SET EACH RAFTER ON TOP OF FRAME.
- THREADED INSERT CLOSEST TO END OF RAFTER INDICATES FRONT.
- ALIGN RAFTER BRACKETS WITH THREADED INSERTS FRONT AND BACK.

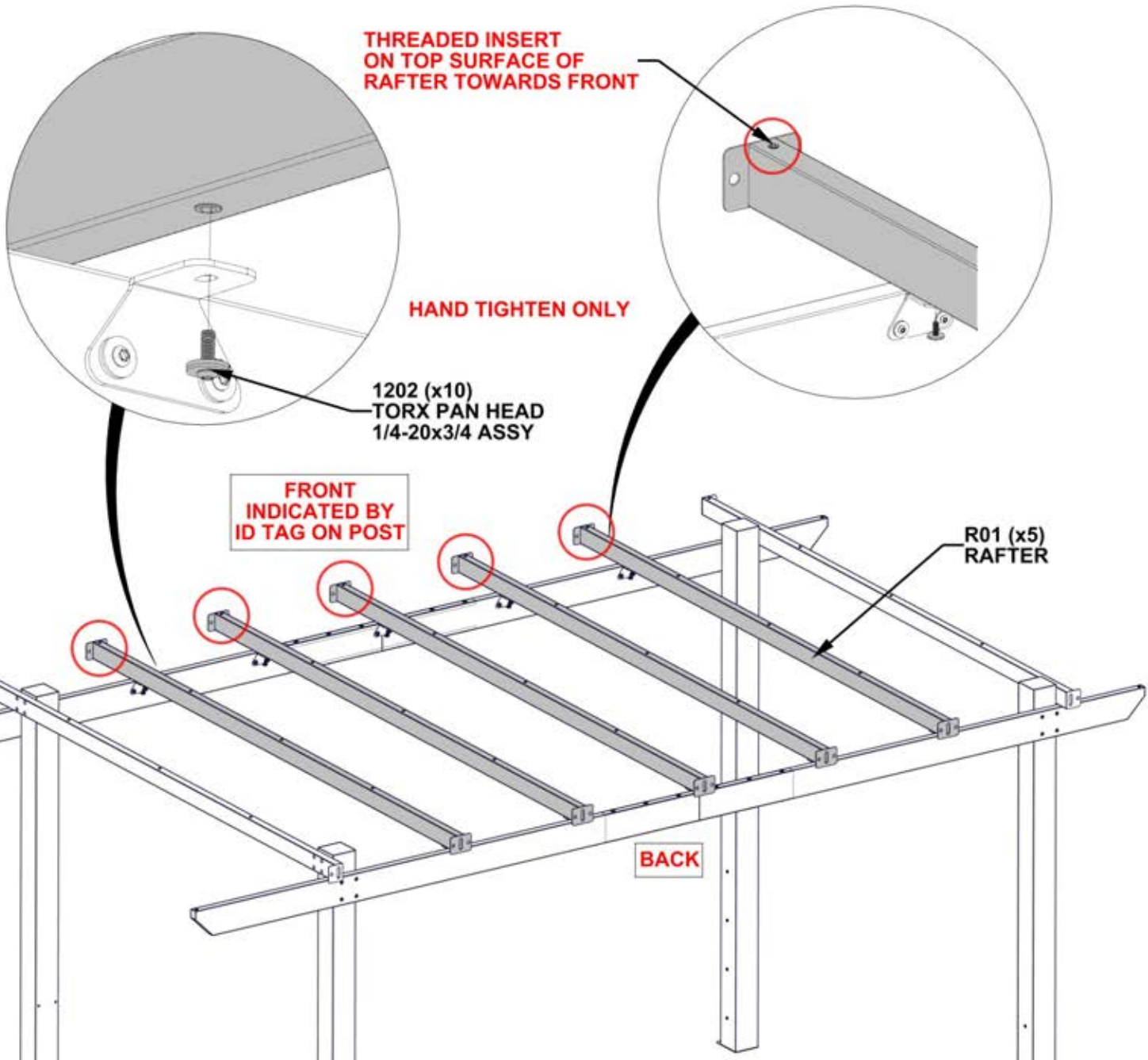

STEP 13 - BEAM ASSEMBLY

QTY	PartNo	DESCRIPTION
6	H101202	TORX PAN HEAD 1/4-20x3/4 ASSY



B05 FRONT BEAM - A4M02988
 (x1) 1 7/16"x5 1/4"x105 5/8" (36x134x2683)



J1 SPLICE BRACKET - A4M02230
 (x1) 1 5/16"x5 3/16"x39 3/8" (33.2x131.2x1000)

- FOR EASE OF ASSEMBLY, WE RECOMMEND USING SAW HORSES FOR STEPS 13 - 15

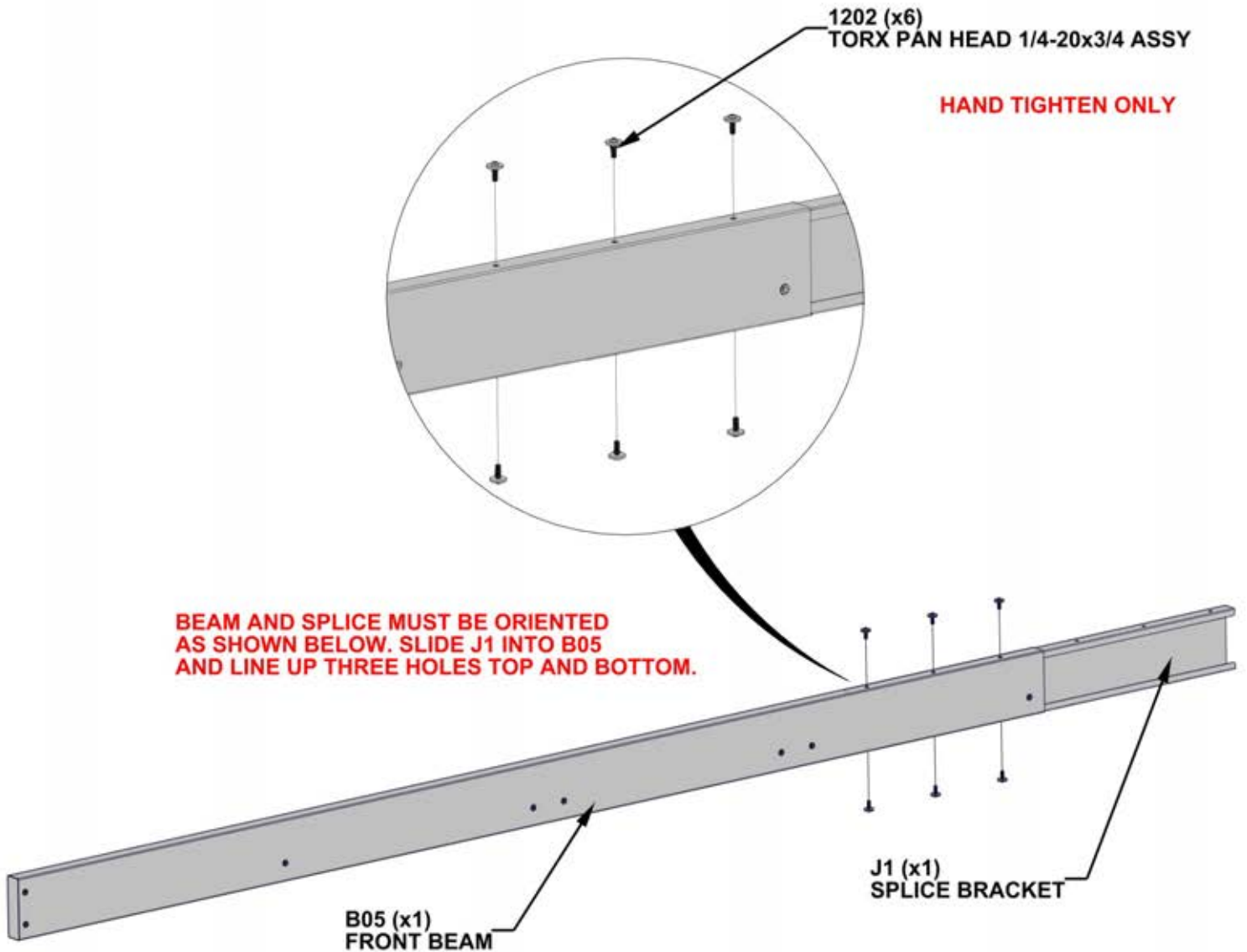

STEP 14 - BEAM ASSEMBLY

QTY	PartNo	DESCRIPTION
6	H101202	TORX PAN HEAD 1/4-20x3/4 ASSY



B06 FRONT BEAM - A4M02989
(x1) 1 7/16"x5 1/4"x93 3/8" (36x134x2371)

- SLIDE B06 INTO SPLICE BRACKET.
GENTLY TAP ENDS OF ASSEMBLY WITH
RUBBER Mallet UNTIL GAP CLOSES

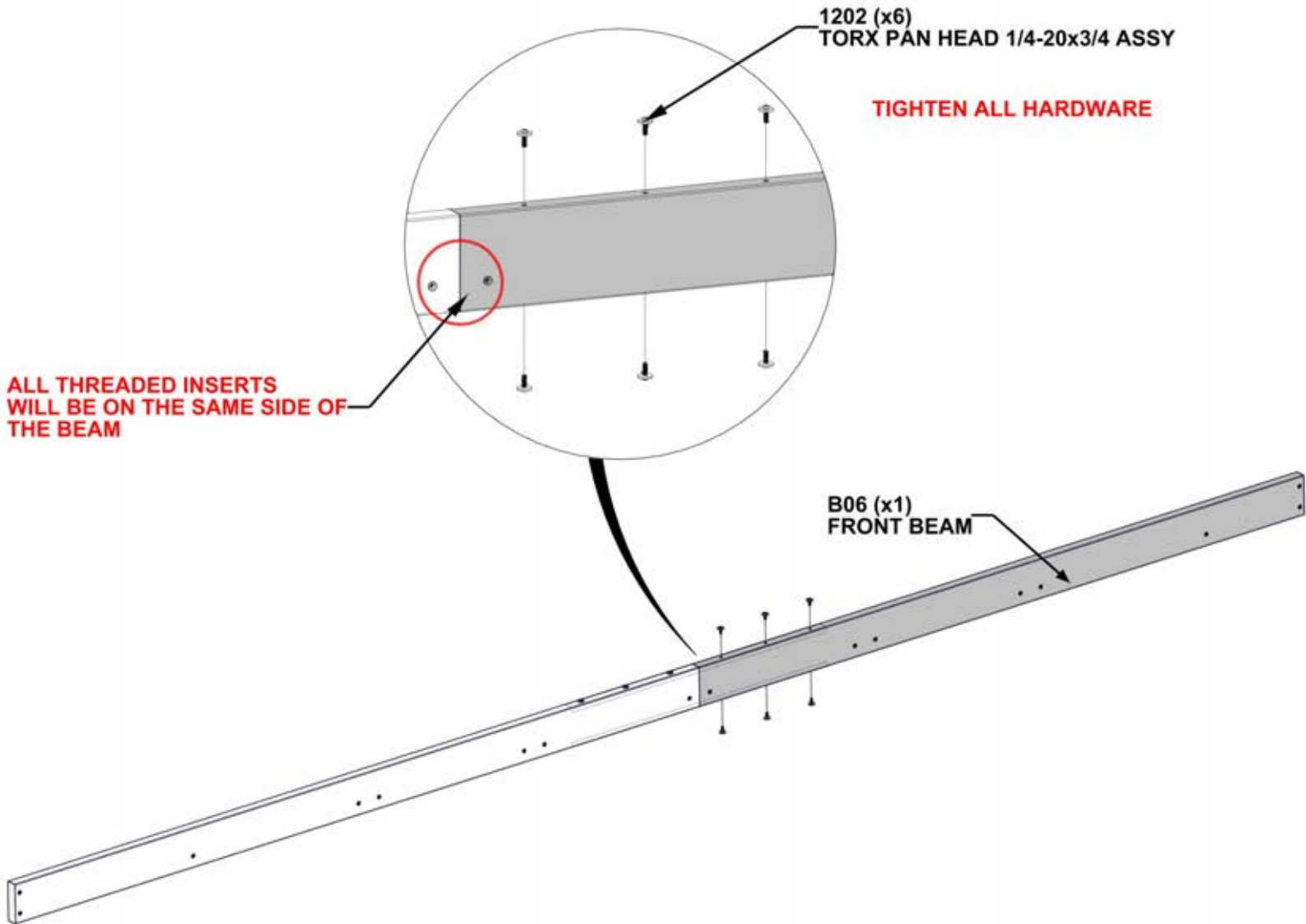

STEP 15 - BEAM ASSEMBLY

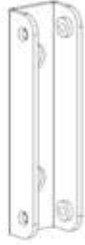

QTY	PartNo	DESCRIPTION
4	H101202	TORX PAN HEAD 1/4-20x3/4 ASSY

J4 BEAM BRACKET - A4M02990
(x2) 1"x1 5/16"x5 1/16" (25x33.2x128)

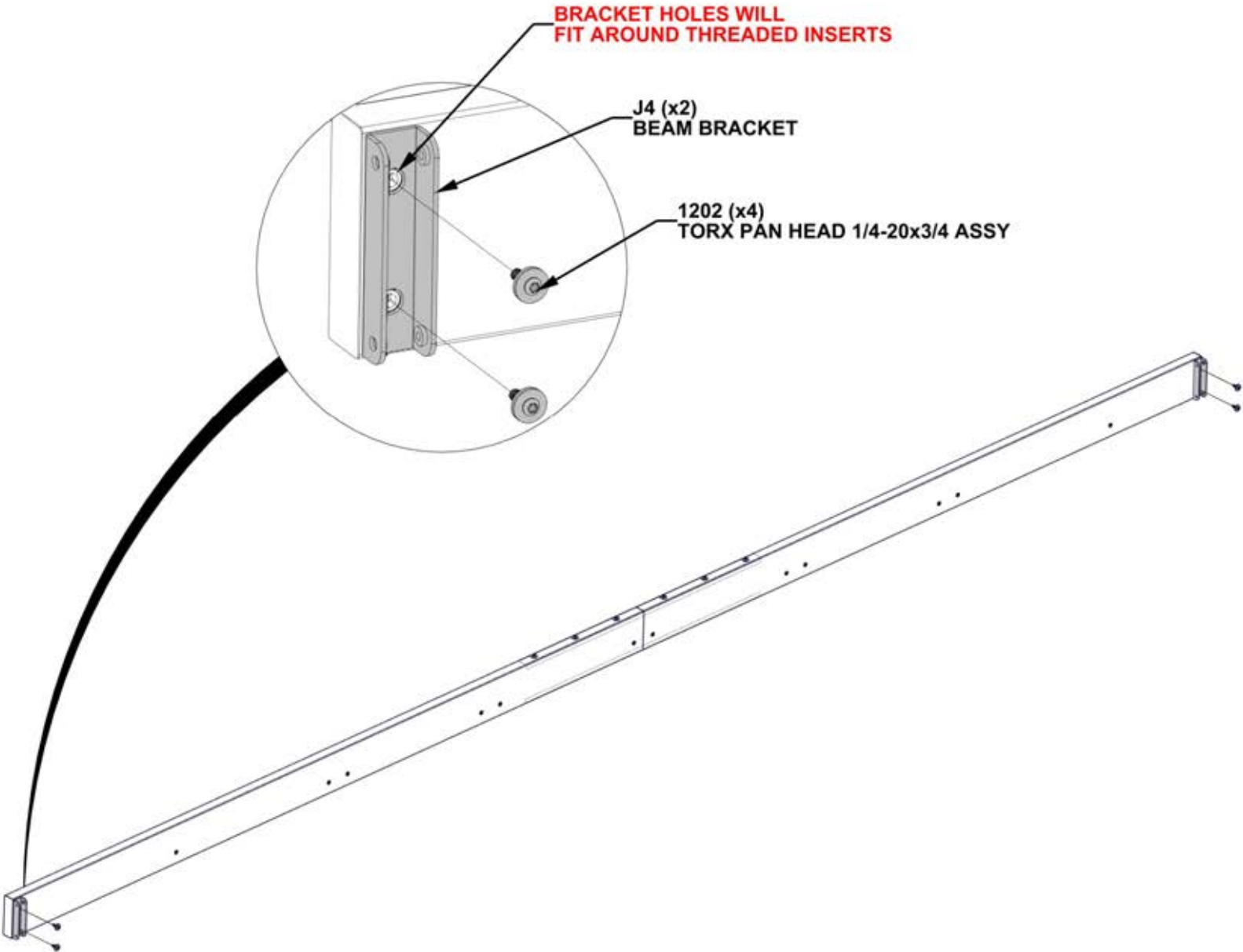

STEP 16A - ROOF ASSEMBLY

QTY	PartNo	DESCRIPTION
2	H101202	TORX PAN HEAD 1/4-20x3/4 ASSY



BEAM ASSEMBLY - STEP 13 - 15

- WITH AT LEAST TWO EXTRA PEOPLE, ATTACH BEAM ASSEMBLY TO RAFTERS.
- **THREADED INSERTS SHOULD BE POSITIONED CLOSEST TO THE BOTTOM SIDE OF BEAM ASSEMBLY.**

BRACKET HOLES WILL FIT AROUND THREADED INSERTS

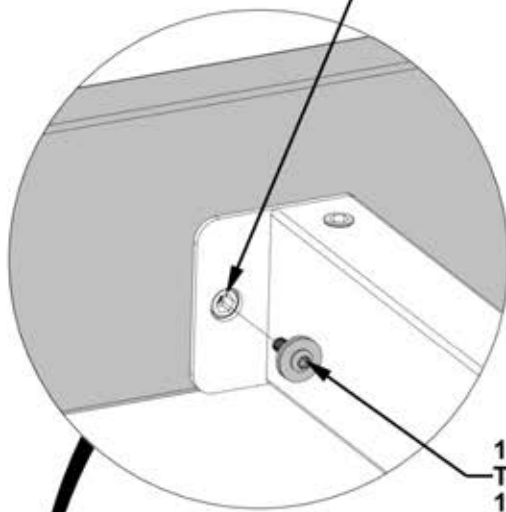

1202 (x1)
TORX PAN HEAD
1/4-20x3/4 ASSY

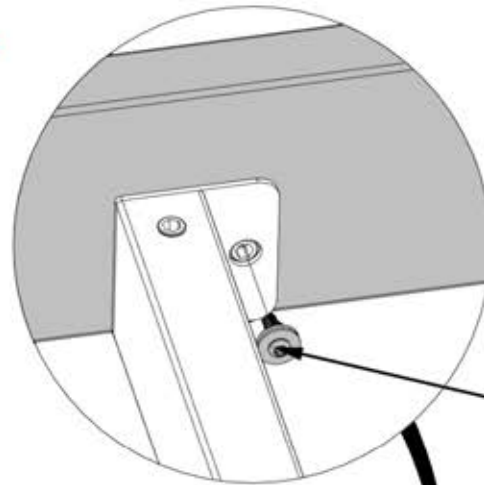

1202 (x1)
TORX PAN HEAD
1/4-20x3/4 ASSY

**FRONT
INDICATED BY
ID TAG ON POST**

BEAM ASSEMBLY
STEP 13 - 15

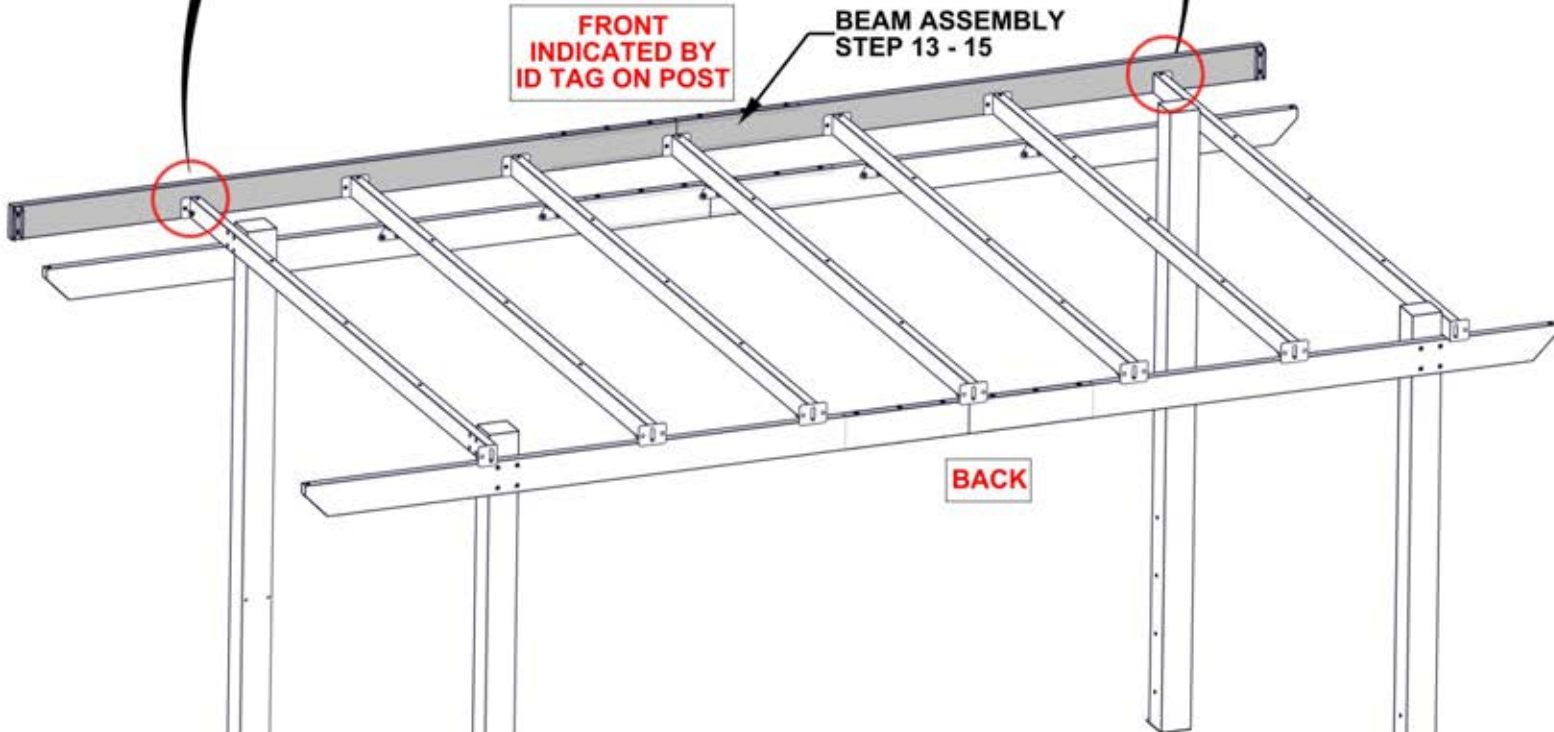

STEP 16B - ROOF ASSEMBLY

QTY	PartNo	DESCRIPTION
10	H101202	TORX PAN HEAD 1/4-20x3/4 ASSY

**BRACKET HOLES WILL
FIT AROUND THREADED INSERTS**

**1202 (x10)
TORX PAN HEAD
1/4-20x3/4 ASSY**

**FRONT
INDICATED BY
ID TAG ON POST**

BACK

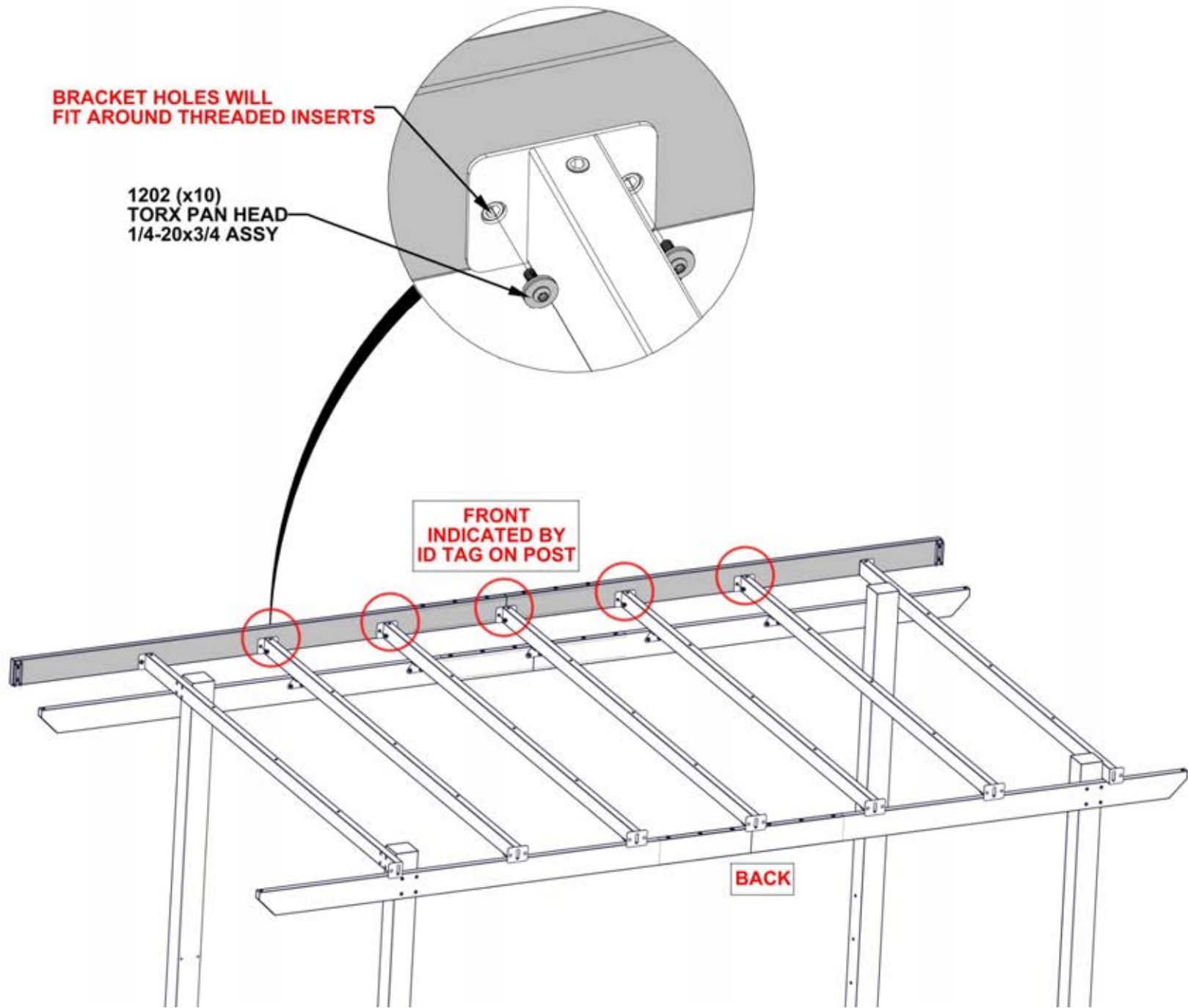

STEP 17A - BEAM ASSEMBLY

QTY	PartNo	DESCRIPTION
2	H101202	TORX PAN HEAD 1/4-20x3/4 ASSY



B07 SIDE BEAM - A4M02991
(x1) 1 7/16"x5 1/4"x114 3/16" (36x134x2900)



J5 BEAM BRACKET - A4M02993
(x1) 1"x1 7/16"x2 15/16" (25x37.2x75)

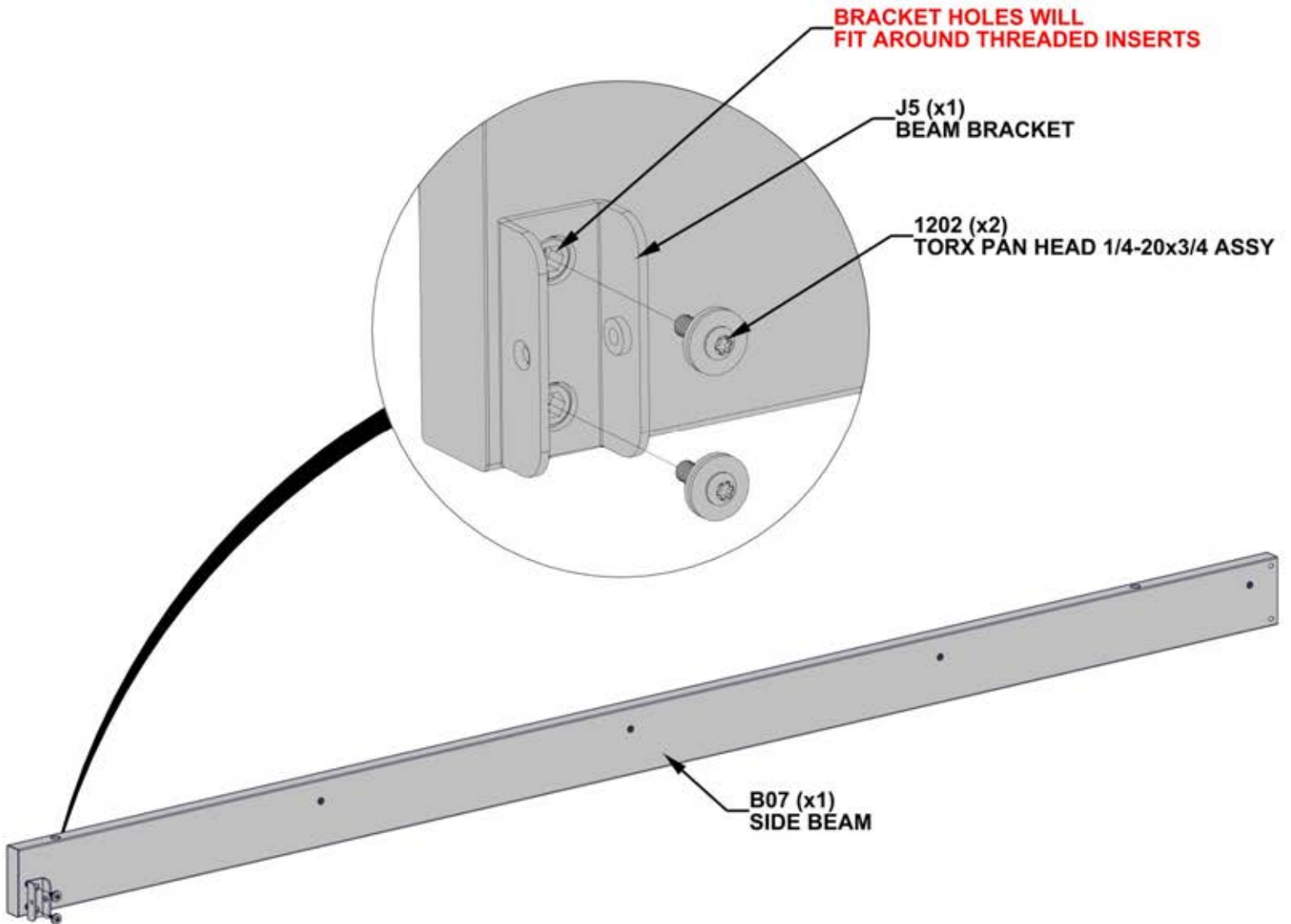

STEP 17B - ROOF ASSEMBLY

QTY	PartNo	DESCRIPTION
2	H101230	BOLT WH 5/16x6 S.S.
2	H101202	TORX PAN HEAD 1/4-20x3/4 ASSY

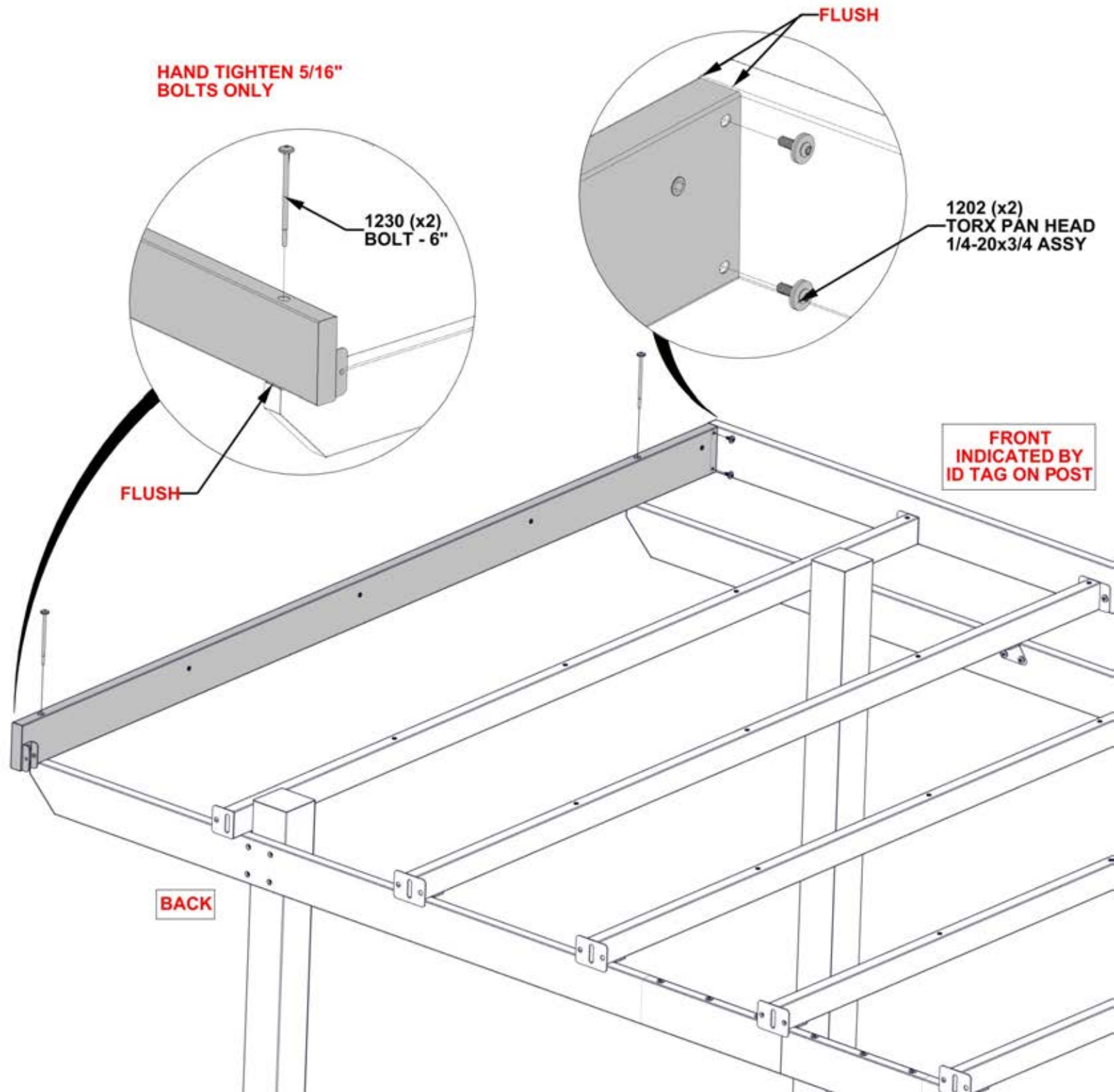

STEP 18 - BEAM ASSEMBLY

QTY	PartNo	DESCRIPTION
4	H101202	TORX PAN HEAD 1/4-20x3/4 ASSY



B10 BACK BEAM - A4M02996
 (x1) 1 9/16"x3 1/8"x91 15/16" (40x80x2335)



J2 SPLICE BRACKET - A4M02994
 (x1) 1 7/16"x3"x15 3/4" (37.2x76.2x400)

- FOR EASE OF ASSEMBLY, WE RECOMMEND USING SAW HORSES FOR STEPS 18 - 19

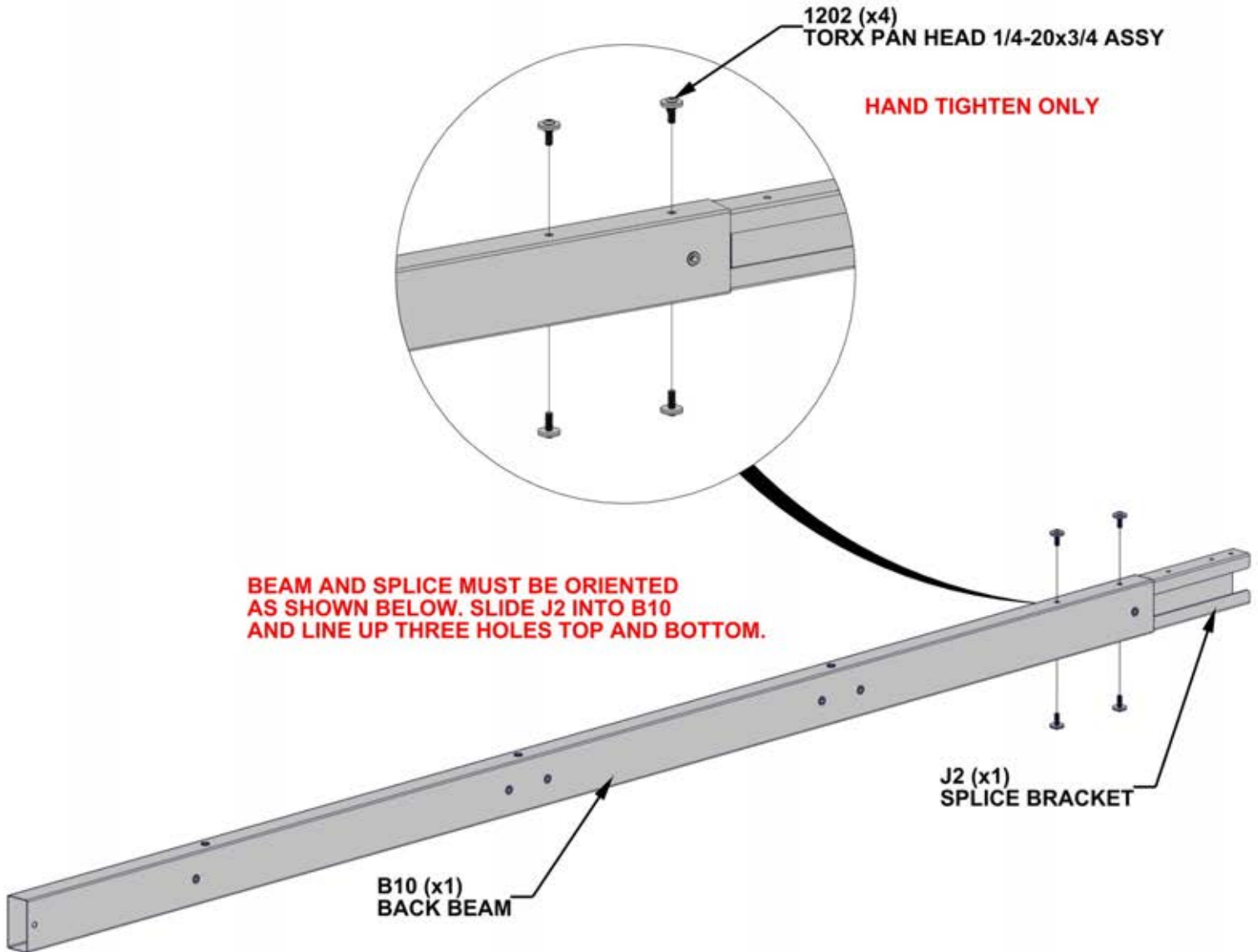

STEP 19 - BEAM ASSEMBLY

QTY	PartNo	DESCRIPTION
4	H101202	TORX PAN HEAD 1/4-20x3/4 ASSY



B09 BACK BEAM - A4M02995
(x1) 1 9/16"x3 1/8"x104 3/16" (40x80x2647)

- SLIDE B09 INTO SPLICE BRACKET.
GENTLY TAP ENDS OF ASSEMBLY WITH
RUBBER Mallet UNTIL GAP CLOSES

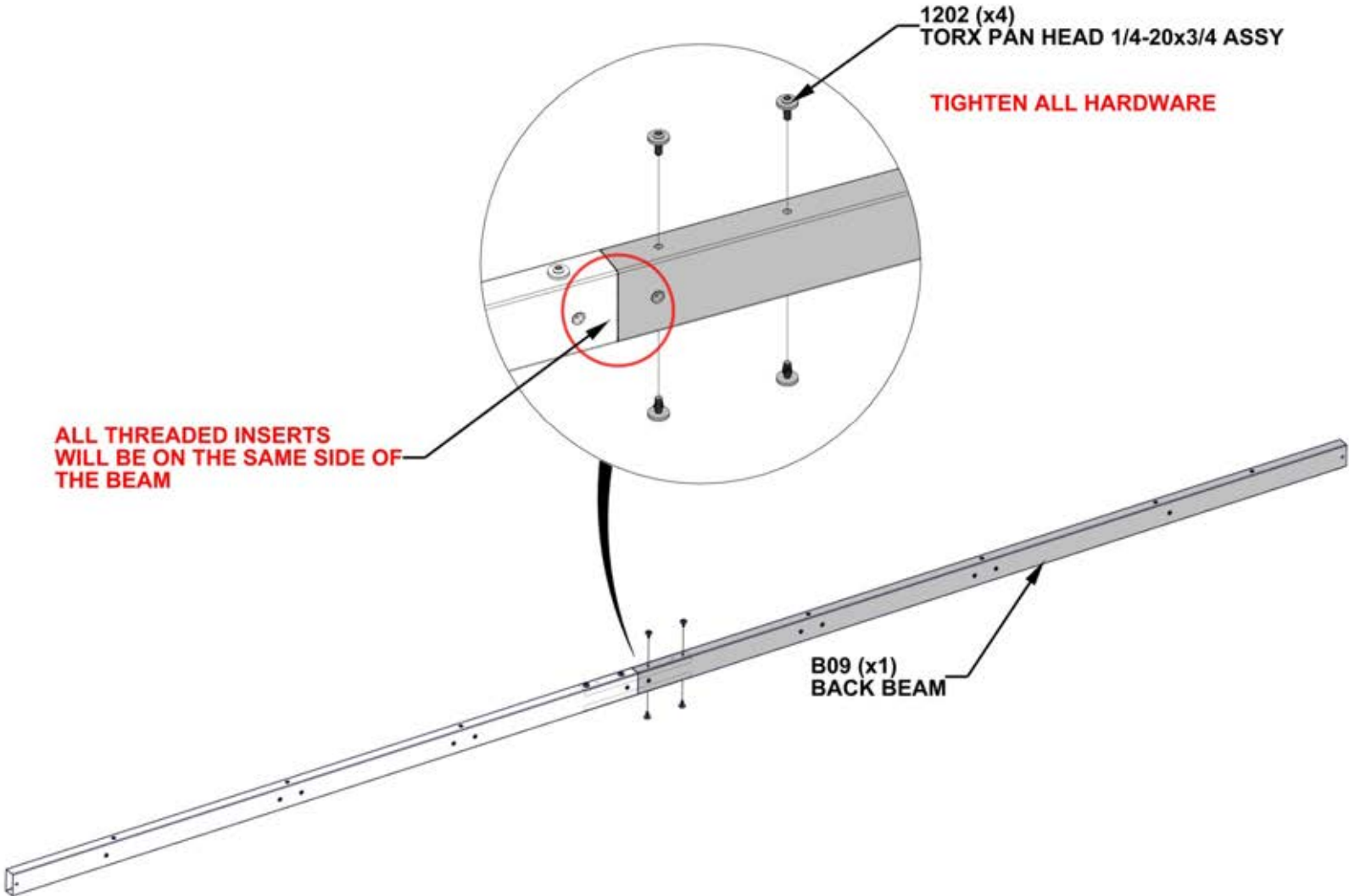

STEP 20A - ROOF ASSEMBLY

QTY	PartNo	DESCRIPTION
3	H101202	TORX PAN HEAD 1/4-20x3/4 ASSY



BEAM ASSEMBLY - STEP 18 - 19

- WITH AT LEAST TWO EXTRA PEOPLE, ATTACH BEAM ASSEMBLY TO RAFTERS.

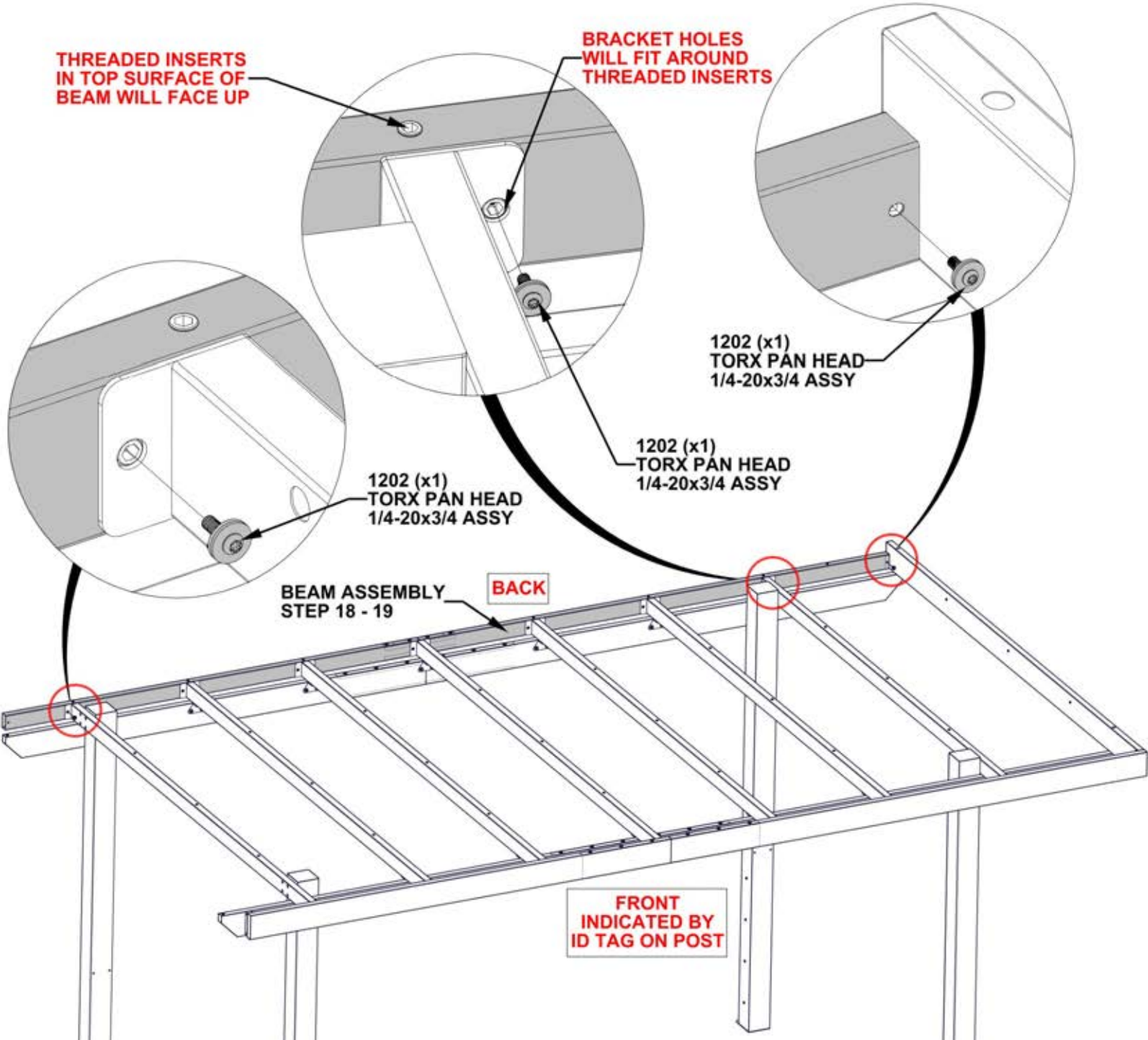

STEP 20B - ROOF ASSEMBLY

QTY	PartNo	DESCRIPTION
10	H101202	TORX PAN HEAD 1/4-20x3/4 ASSY

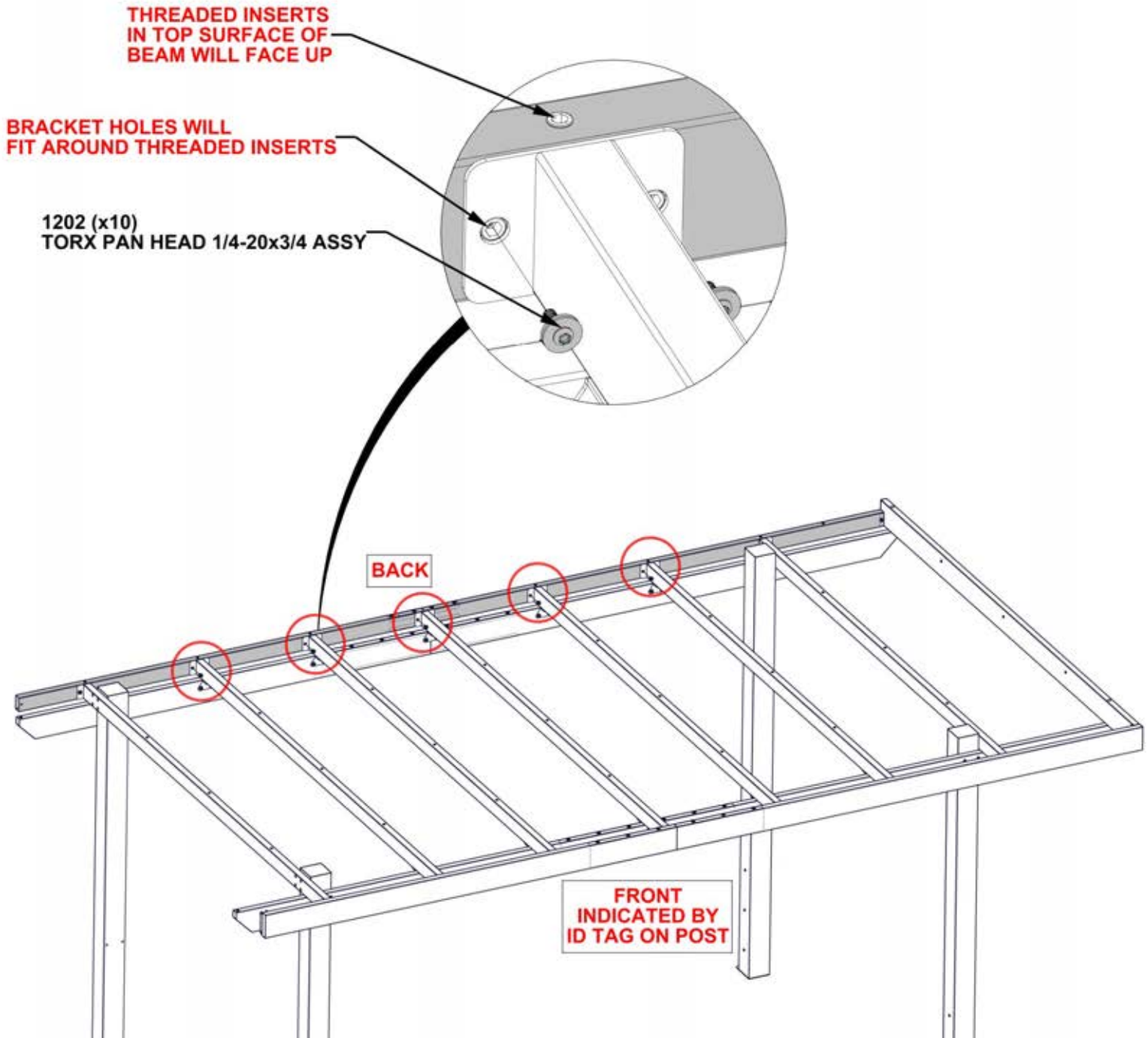

STEP 21A - BEAM ASSEMBLY

QTY	PartNo	DESCRIPTION
2	H101202	TORX PAN HEAD 1/4-20x3/4 ASSY



B08 SIDE BEAM - A4M02992
(x1) 1 7/16"x5 1/4"x114 3/16" (36x134x2900)



J5 BEAM BRACKET - A4M02993
(x1) 1"x1 7/16"x2 15/16" (25x37.2x75)

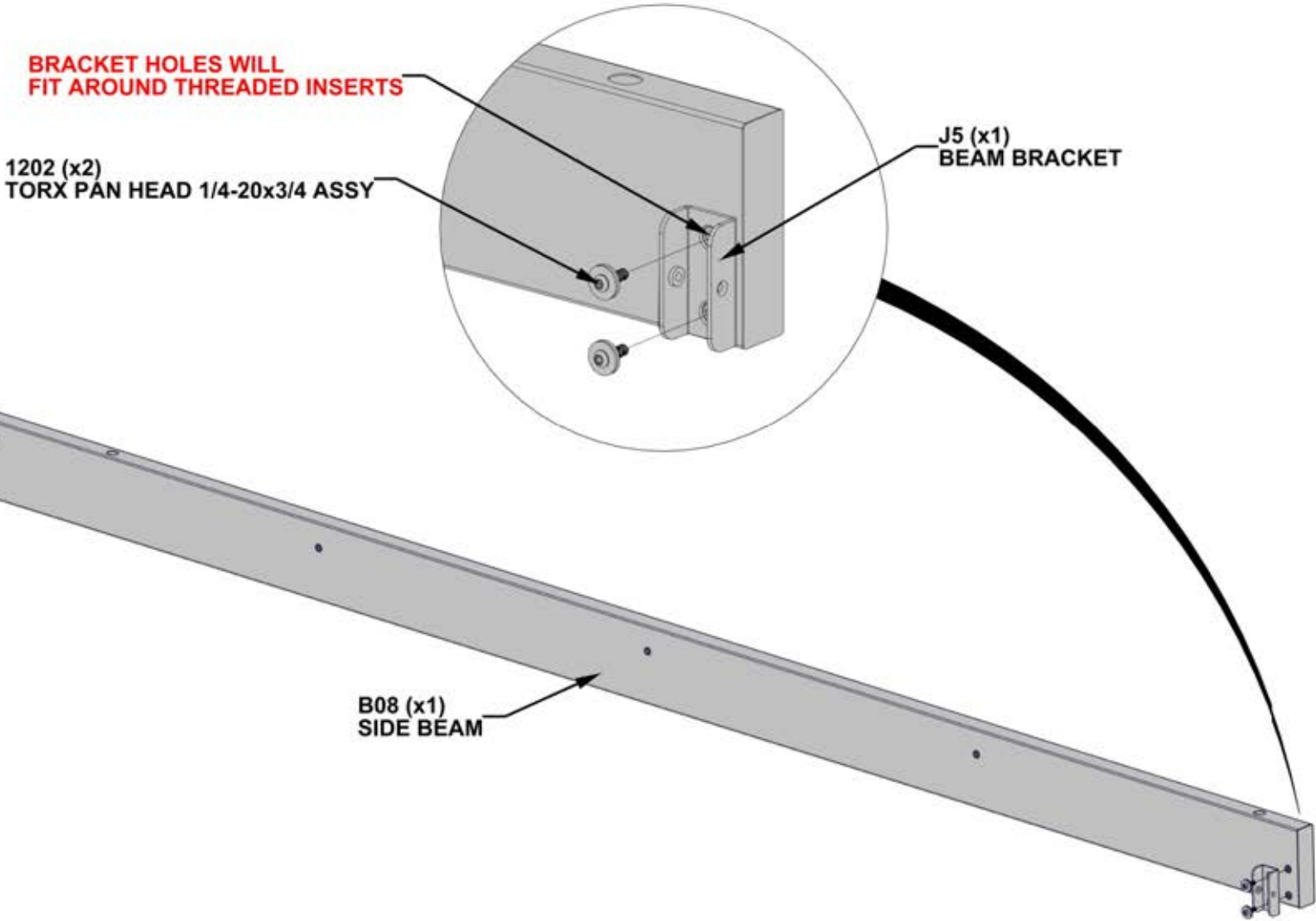

STEP 21B - ROOF ASSEMBLY

QTY	PartNo	DESCRIPTION
2	H101230	BOLT WH 5/16x6 S.S.
3	H101202	TORX PAN HEAD 1/4-20x3/4 ASSY

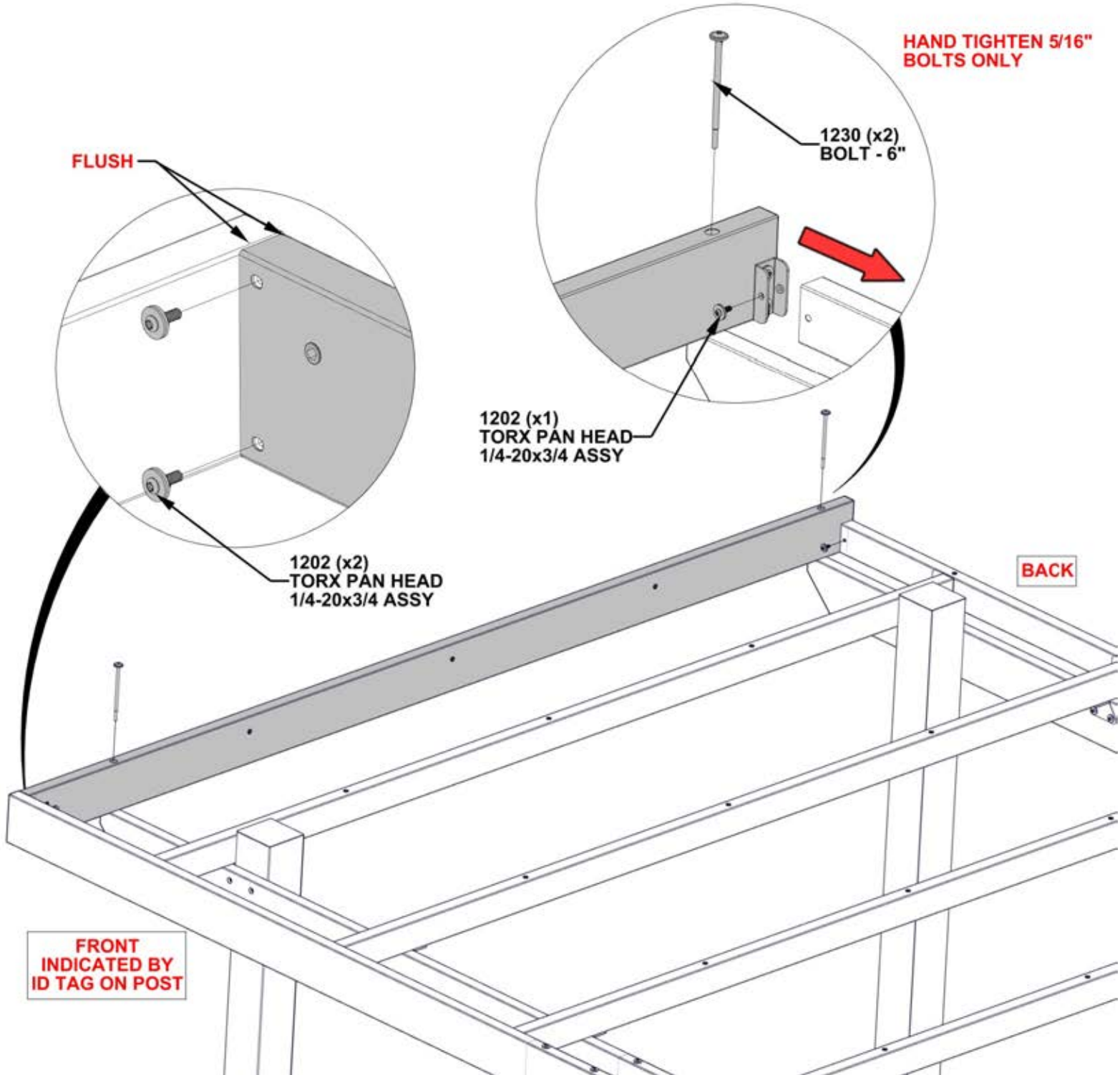

STEP 22 - PURLIN ASSEMBLY



E02 PURLIN - A4M02998
(x1) 13/16"x1 9/16"x91 7/8" (20x40x2334)



A6P00530 2-WAY SQUARE PLUG
(x1)

- USE A RUBBER Mallet TO TAP 2-WAY SQUARE PLUG INTO END OF PURLIN

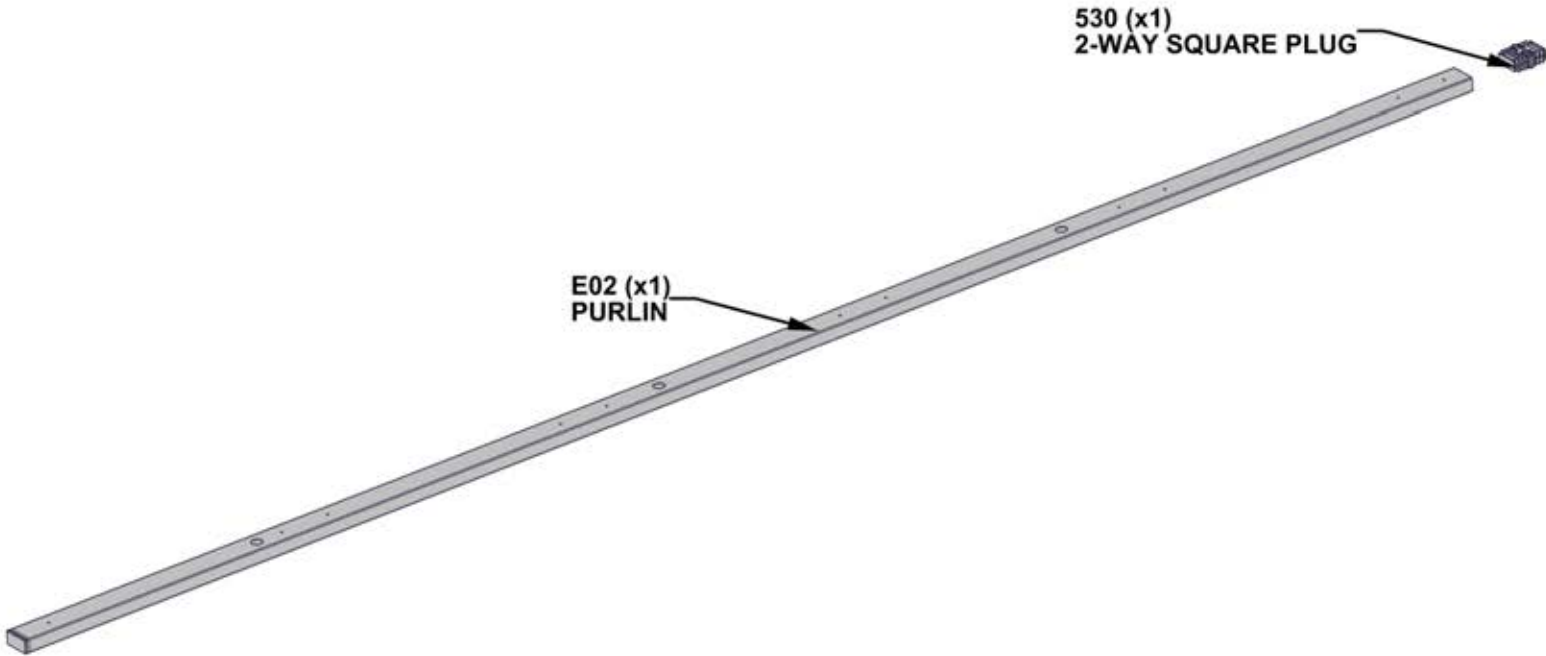

STEP 23 - PURLIN ASSEMBLY



E01 PURLIN - A4M02997
(x1) 13/16"x1 9/16"x104 3/16" (20x40x2646)

- USE A RUBBER Mallet TO TAP ENDS OF EACH PURLIN UNTIL TIGHT AGAINST 2-WAY PLUG

ENSURE E01 IS ORIENTED CORRECTLY WITH PILOT HOLES FACING UP

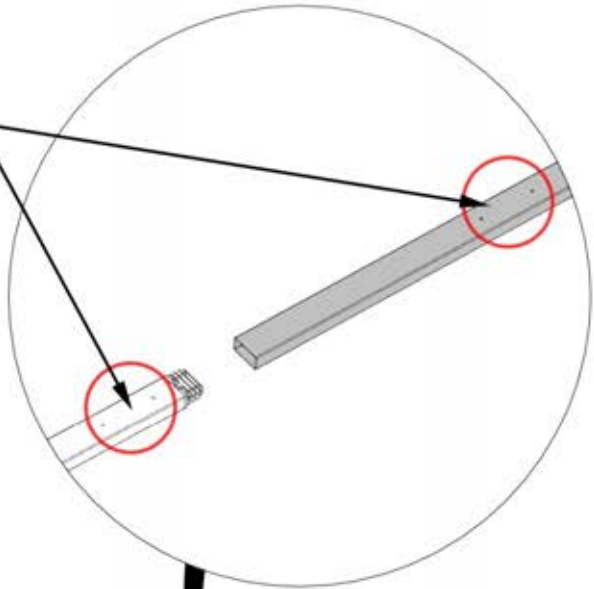

E01 (x1)
PURLIN

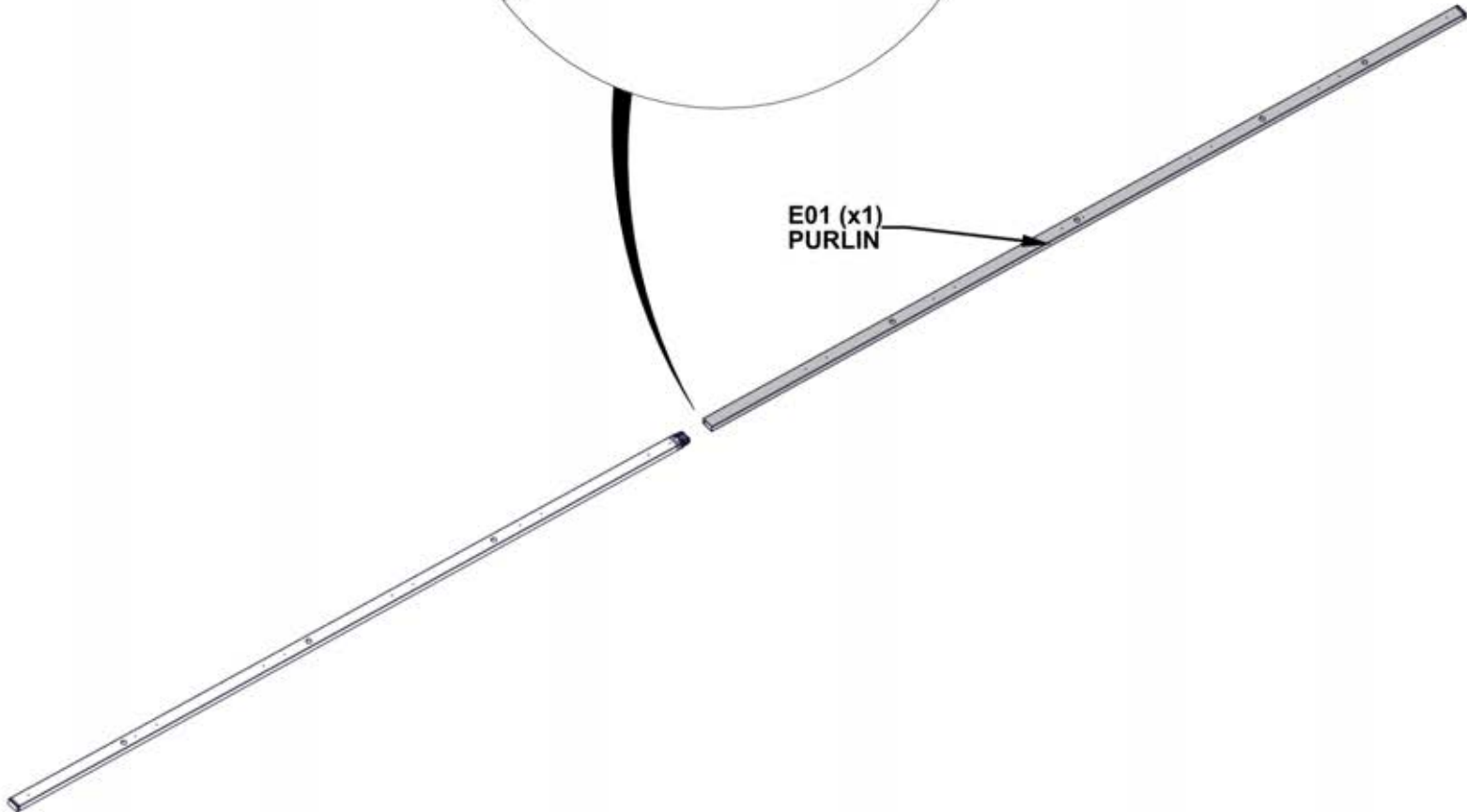

STEP 24 - ROOF ASSEMBLY

QTY	PartNo	DESCRIPTION
7	H101132	TORX SOCKET SCREW SHORT 1/4-20

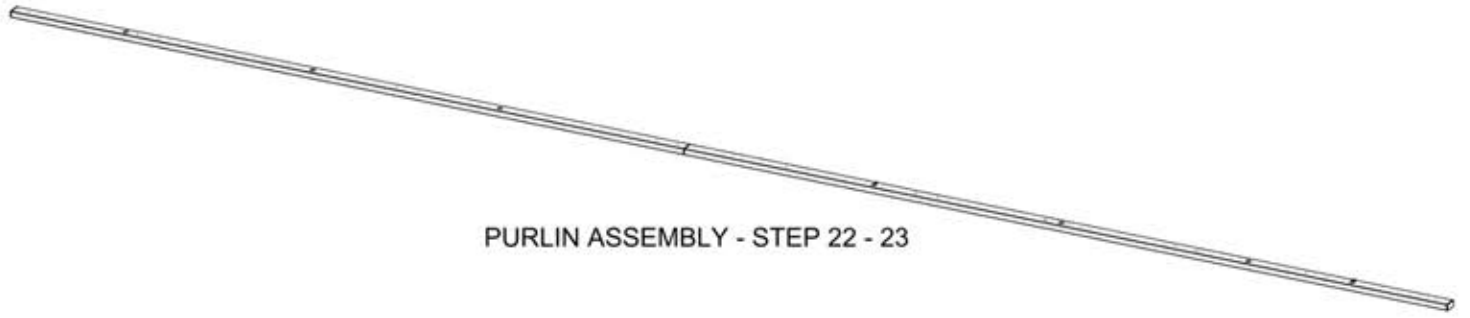

- MAKE SURE MIDDLE OF PURLIN ASSEMBLY IS SUPPORTED WHEN LIFTING

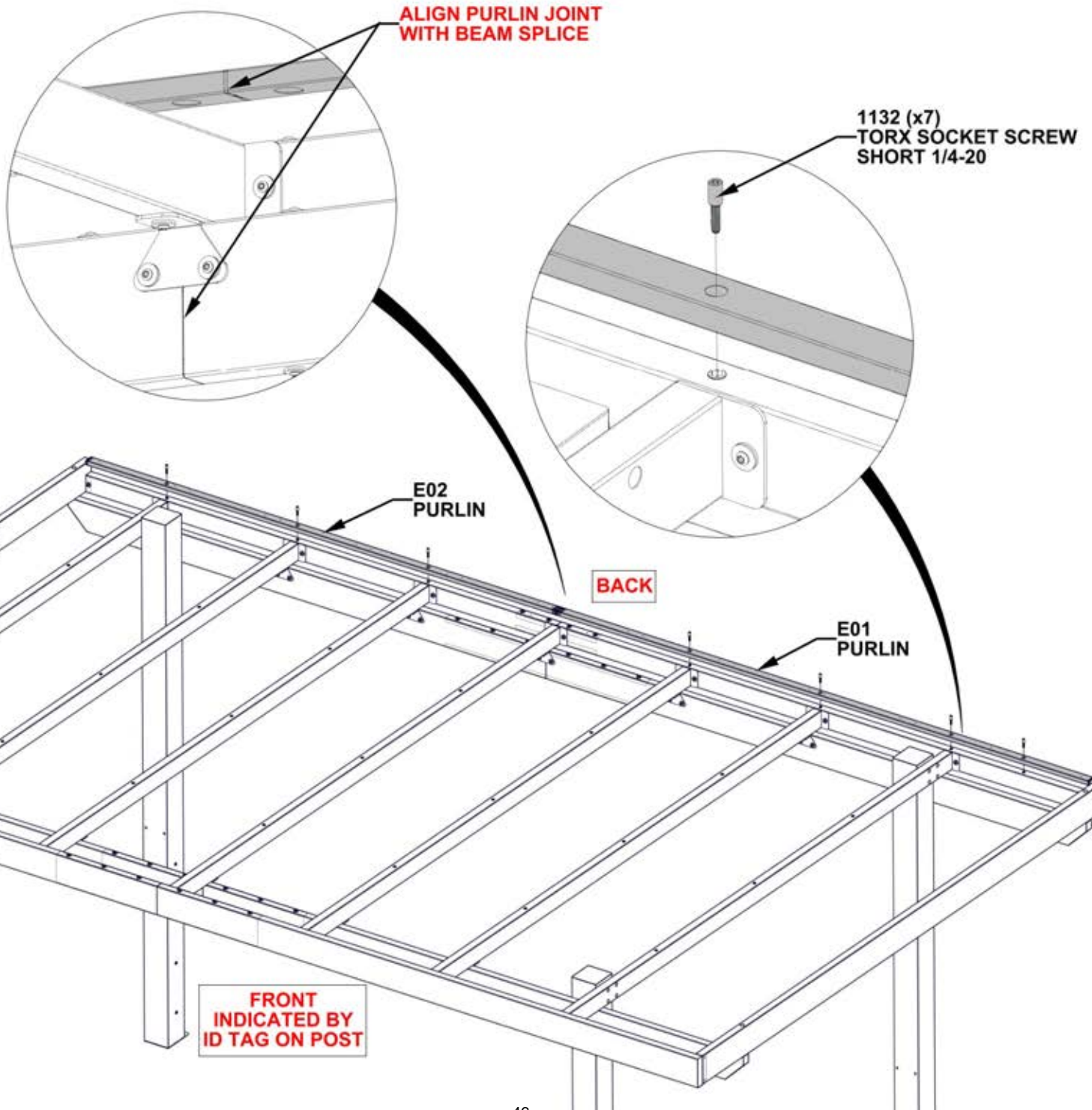

STEP 25 - PURLIN ASSEMBLY



E03 PURLIN - A4M02999
(x4) 13/16"x2 3/4"x91 13/16" (20x70x2332.5)



A6P00530 2-WAY SQUARE PLUG
(x4)

- COMPLETE THIS STEP FOUR TIMES
- USE A RUBBER Mallet TO TAP 2-WAY SQUARE PLUG INTO END OF PURLIN

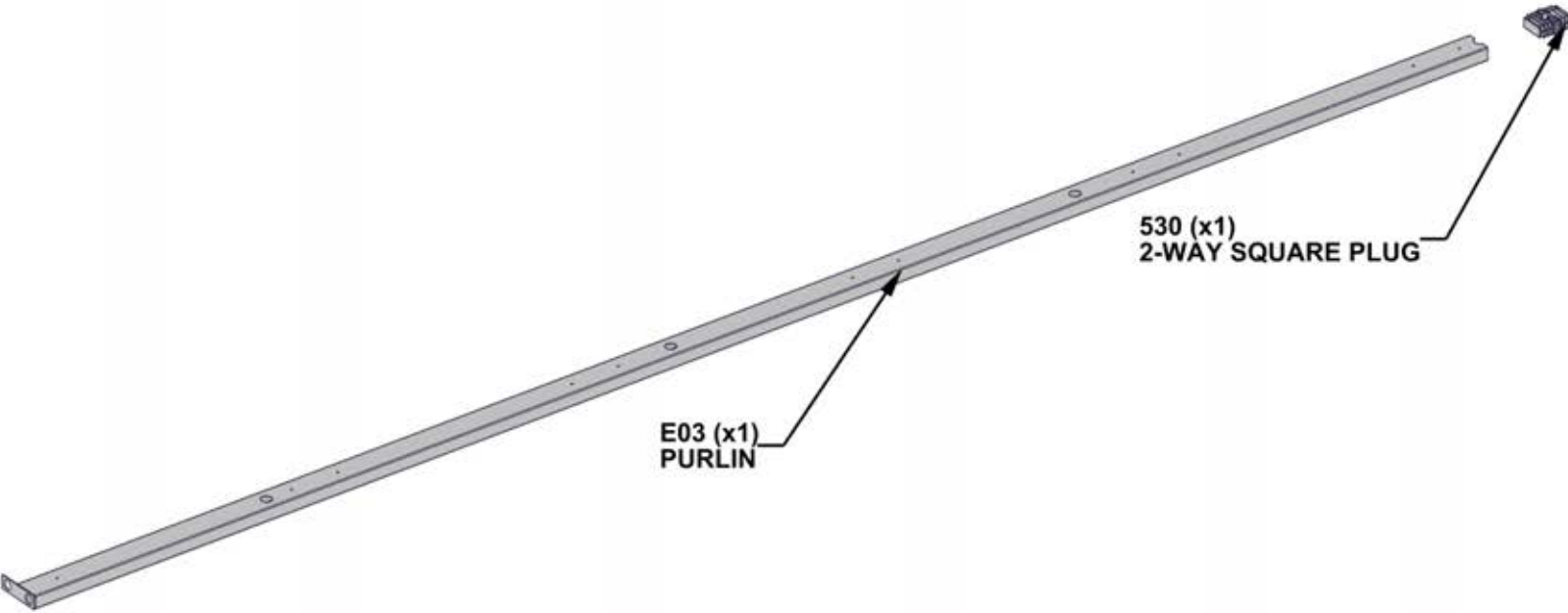

STEP 26 - PURLIN ASSEMBLY

E04 PURLIN - A4M03000
(x4) 13/16"x2 3/4"x104 1/8" (20x70x2644.5)

- COMPLETE THIS STEP FOUR TIMES.
- USE A RUBBER Mallet TO TAP ENDS OF EACH PURLIN UNTIL TIGHT AGAINST 2-WAY PLUG.

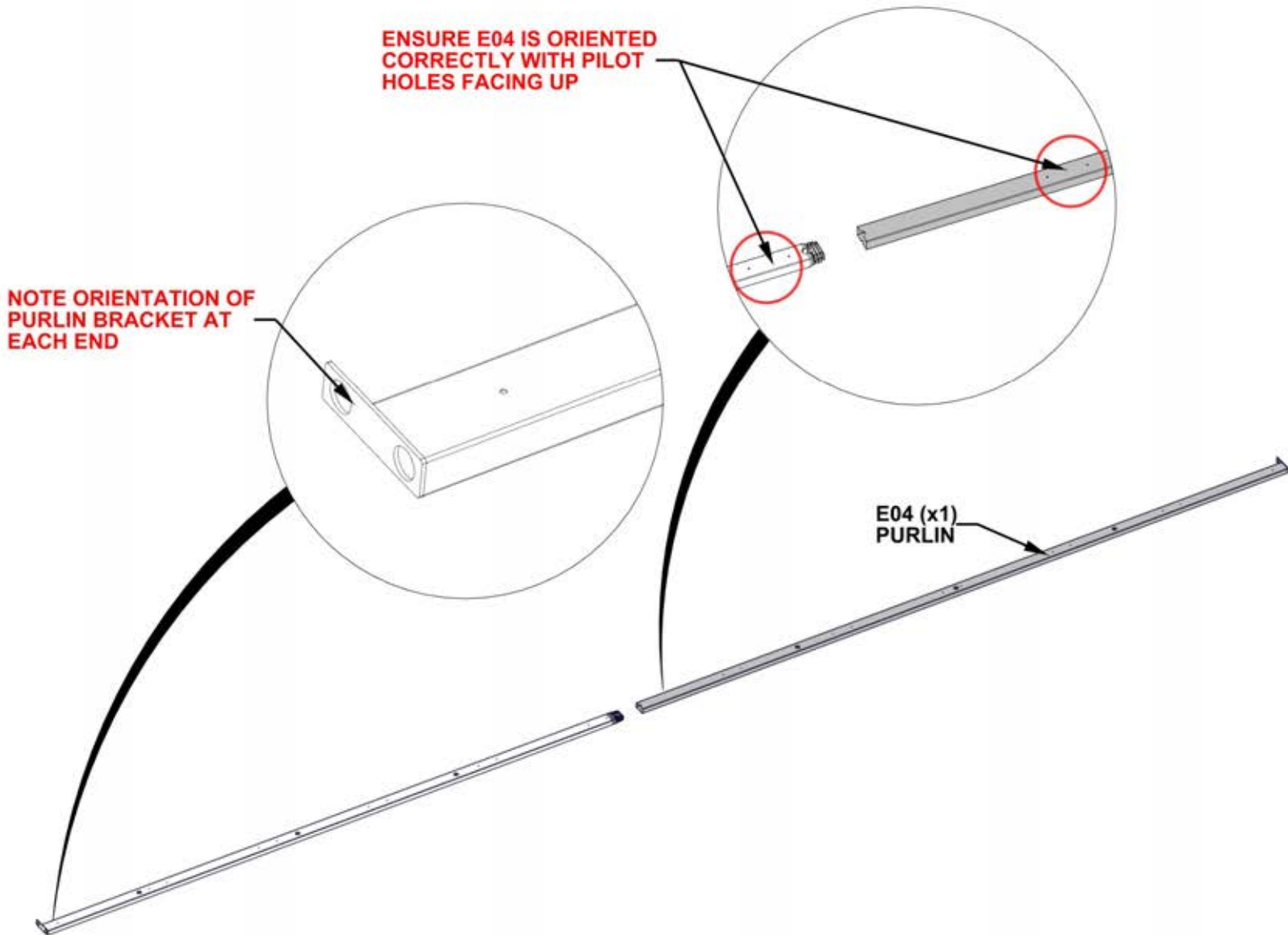

STEP 27A - ROOF ASSEMBLY

QTY	PartNo	DESCRIPTION
28	H101132	TORX SOCKET SCREW SHORT 1/4-20

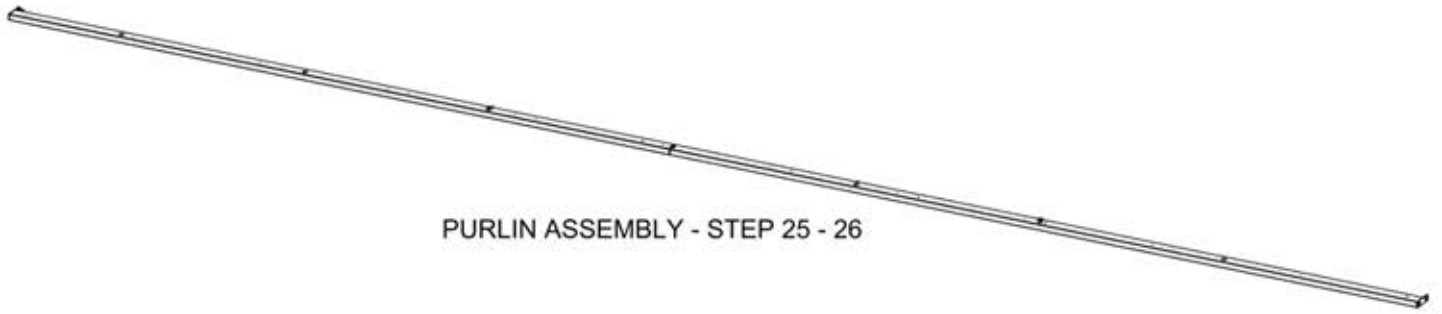

- MAKE SURE MIDDLE OF PURLIN ASSEMBLY IS SUPPORTED WHEN LIFTING.
- ALIGN ALL PURLIN JOINTS ALONG MIDDLE SPLICE.

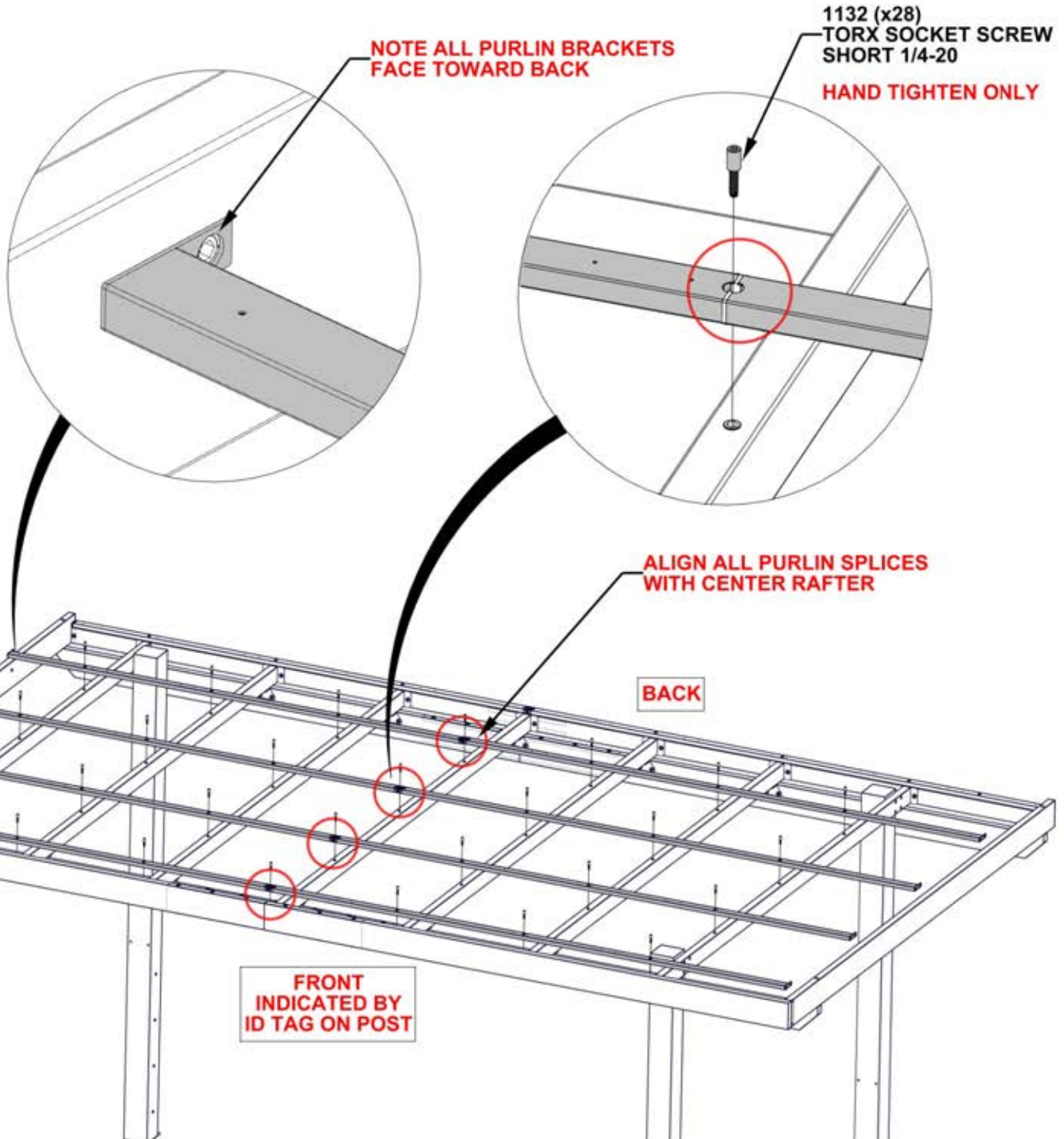

STEP 27B - ROOF ASSEMBLY

QTY	PartNo	DESCRIPTION
8	H101202	TORX PAN HEAD 1/4-20x3/4 ASSY

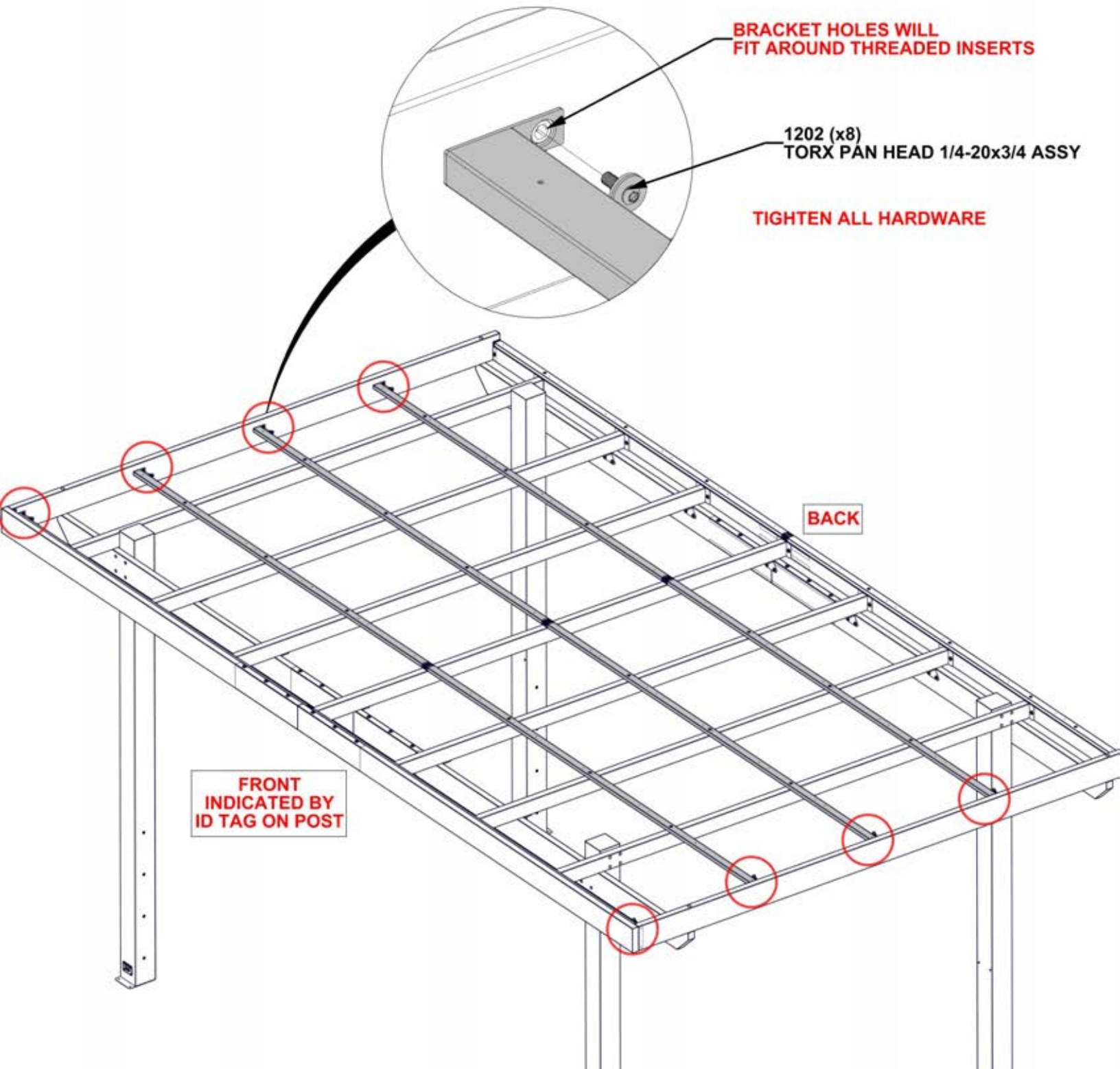

STEP 28 - SQUARE STRUCTURE

CRITICAL:

- SQUARE UNIT BEFORE PROCEEDING TO NEXT STEPS.
- THE BELOW DIMENSIONS ARE CRITICAL TO THE FINAL ASSEMBLY.
- MEASUREMENTS SHOULD BE WITHIN +/- 1/4" (6mm).
- MEASUREMENTS OUTSIDE OF TOLERANCE WILL LEAD TO ISSUES ON FUTURE ASSEMBLY STEPS.
- TIGHTEN ALL HARDWARE FROM PREVIOUS STEPS.

MEASUREMENTS TAKEN FROM INSIDE CORNER TO INSIDE CORNER OF POST

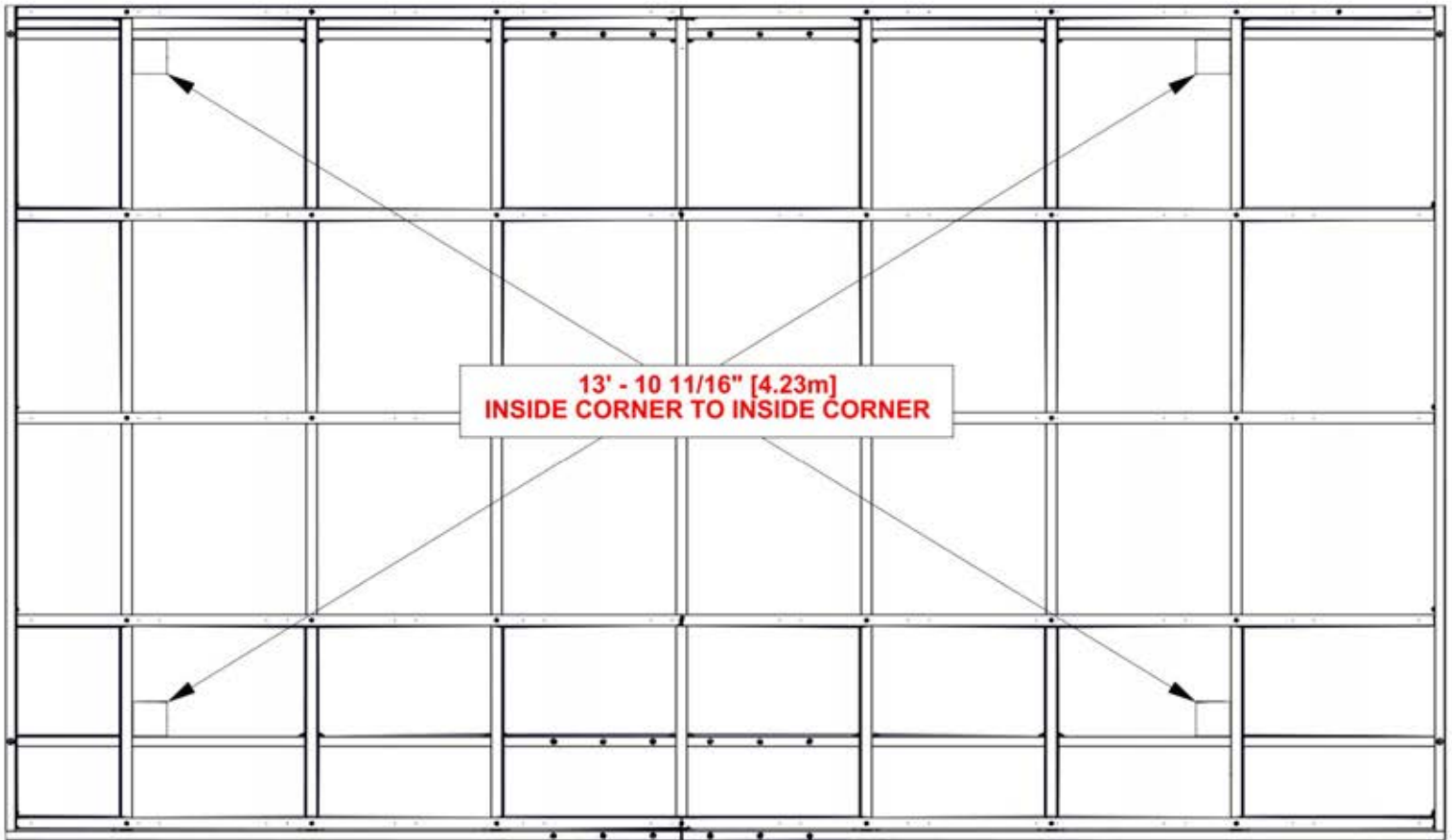

STEP 29 - ROOF ASSEMBLY

QTY	PartNo	DESCRIPTION
8	H101117	SCREW WOODGRIP 10-16x3/4" BLK



A4M03004 29GA STEEL SHEETING
(x1)

- REMOVE PROTECTIVE FILM.
- STARTING AT THE LEFT SIDE AND WORKING TO THE RIGHT, LINE UP THE HOLES IN THE ROOF SHEET WITH THE PILOT HOLES IN THE PURLINS.
- **WARNING: GLOVES ARE RECOMMENDED WHEN HANDLING STEEL ROOF PIECES.**

DO NOT ADD SCREWS TO THE BACK ROW UNTIL LATER STEPS

1117 (x8)
SCREW WOODGRIP
10-16x3/4 BLK

3004 (x1)
29GA STEEL SHEETING

LEFT

BACK

**FRONT
INDICATED BY
ID TAG ON POST**

STEP 30 - ROOF ASSEMBLY

QTY	PartNo	DESCRIPTION
8	H101117	SCREW WOODGRIP 10-16x3/4" BLK



A4M03004 29GA STEEL SHEETING
(x1)

- REMOVE PROTECTIVE FILM.
- STARTING AT THE LEFT SIDE AND WORKING TO THE RIGHT, LINE UP THE HOLES IN THE ROOF SHEET WITH THE PILOT HOLES IN THE PURLINS.
- **WARNING: GLOVES ARE RECOMMENDED WHEN HANDLING STEEL ROOF PIECES.**

DO NOT ADD SCREWS TO THE BACK ROW UNTIL LATER STEPS

1117 (x8)
SCREW WOODGRIP
10-16x3/4" BLK

SHEETS OVERLAP BY ONE RIB

3004 (x1)
29GA STEEL SHEETING

BACK

LEFT

FRONT INDICATED BY ID TAG ON POST

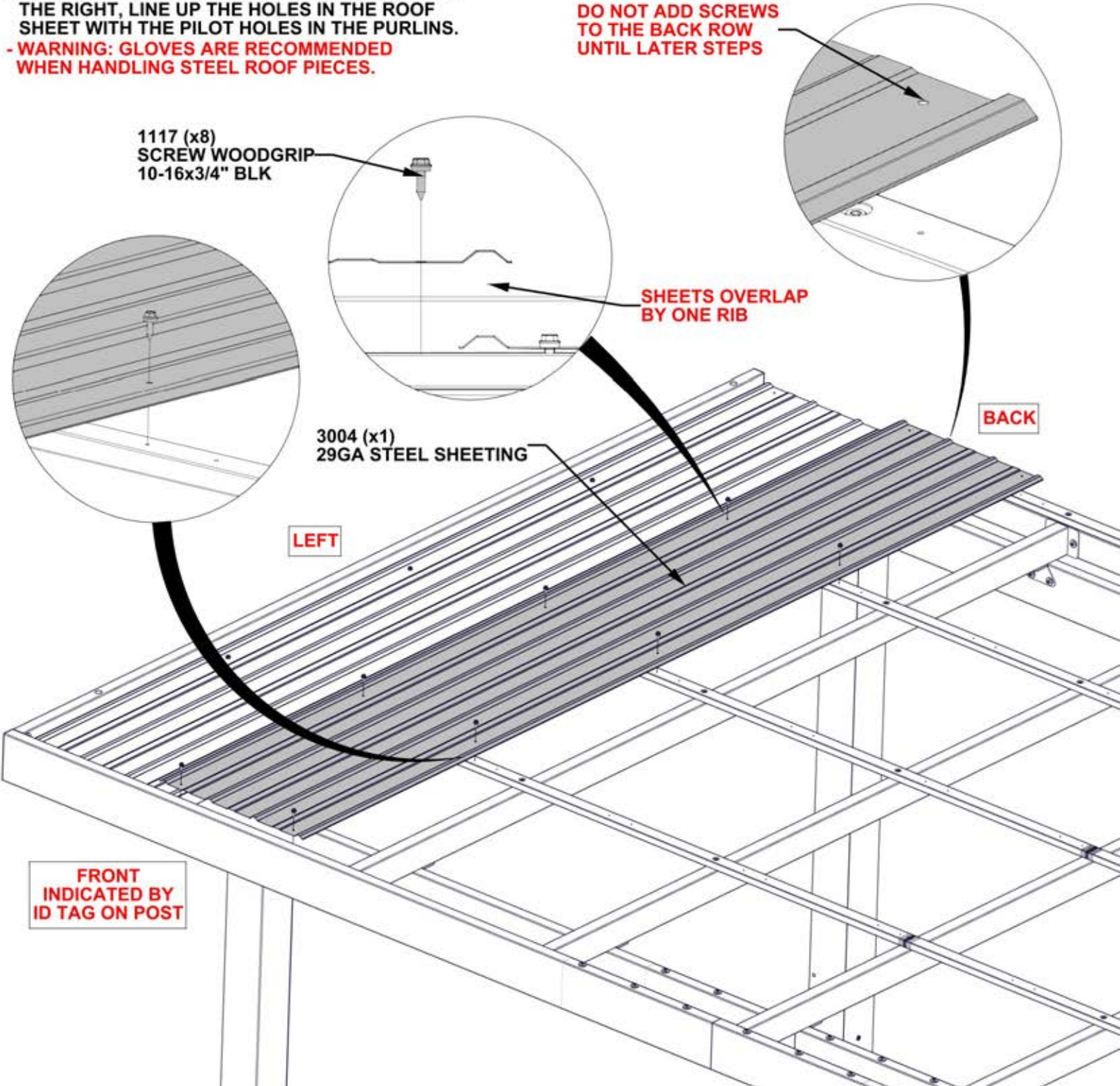

STEP 31 - ROOF ASSEMBLY

QTY	PartNo	DESCRIPTION
72	H101117	SCREW WOODGRIP 10-16x3/4" BLK



A4M03004 29GA STEEL SHEETING
(x9)

- REMOVE PROTECTIVE FILM.
- INSTALL THE REMAINING 9 SHEETS IN THE SAME WAY AS THE FIRST TWO.
- ATTACH AND FULLY TIGHTEN ALL SCREWS ON EACH ROOF SHEET BEFORE ATTACHING THE NEXT ONE. THIS MAKES IT POSSIBLE TO REACH ALL THE SCREWS WITHOUT GETTING ON THE ROOF.
- **WARNING: GLOVES ARE RECOMMENDED WHEN HANDLING STEEL ROOF PIECES.**

1117 (x72)
SCREW WOODGRIP
10-16x3/4" BLK

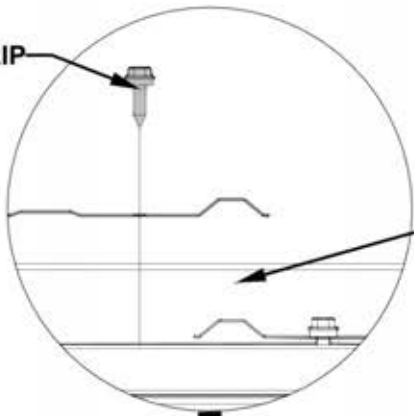

SHEETS OVERLAP
BY ONE RIB

DO NOT ADD SCREWS
TO THE BACK ROW
UNTIL LATER STEPS

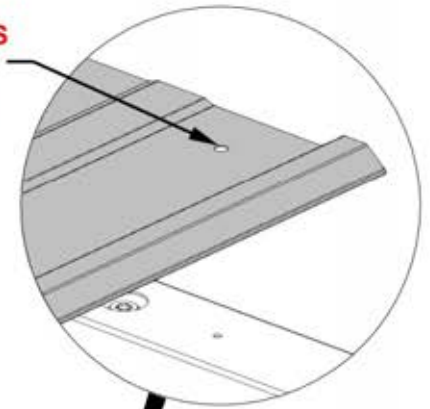

3004 (x9)
29GA STEEL
SHEETING

LEFT

BACK

FRONT
INDICATED BY
ID TAG ON POST

STEP 32 - ROOF ASSEMBLY

QTY	PartNo	DESCRIPTION
22	H101117	SCREW WOODGRIP 10-16x3/4" BLK

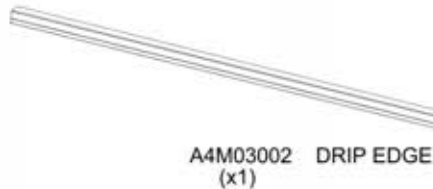
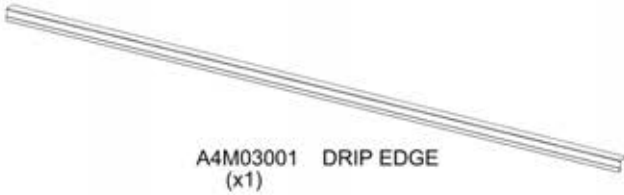

- REMOVE PROTECTIVE FILM.
- ORIENT DRIP EDGE AND SPLICE AS SHOWN BELOW.
- ATTACH USING HOLES IN SHEETING. DO NOT GET ON THE ROOF TO ATTACH SCREWS.
- DUE TO MULTIPLE LAYERS OF METAL ON THE DRIP EDGE, IT IS RECOMMENDED THAT A 1/8" (3mm) DRILL BIT BE USED TO CREATE STARTER HOLES.
- WARNING: GLOVES ARE RECOMMENDED WHEN HANDLING STEEL ROOF PIECES.

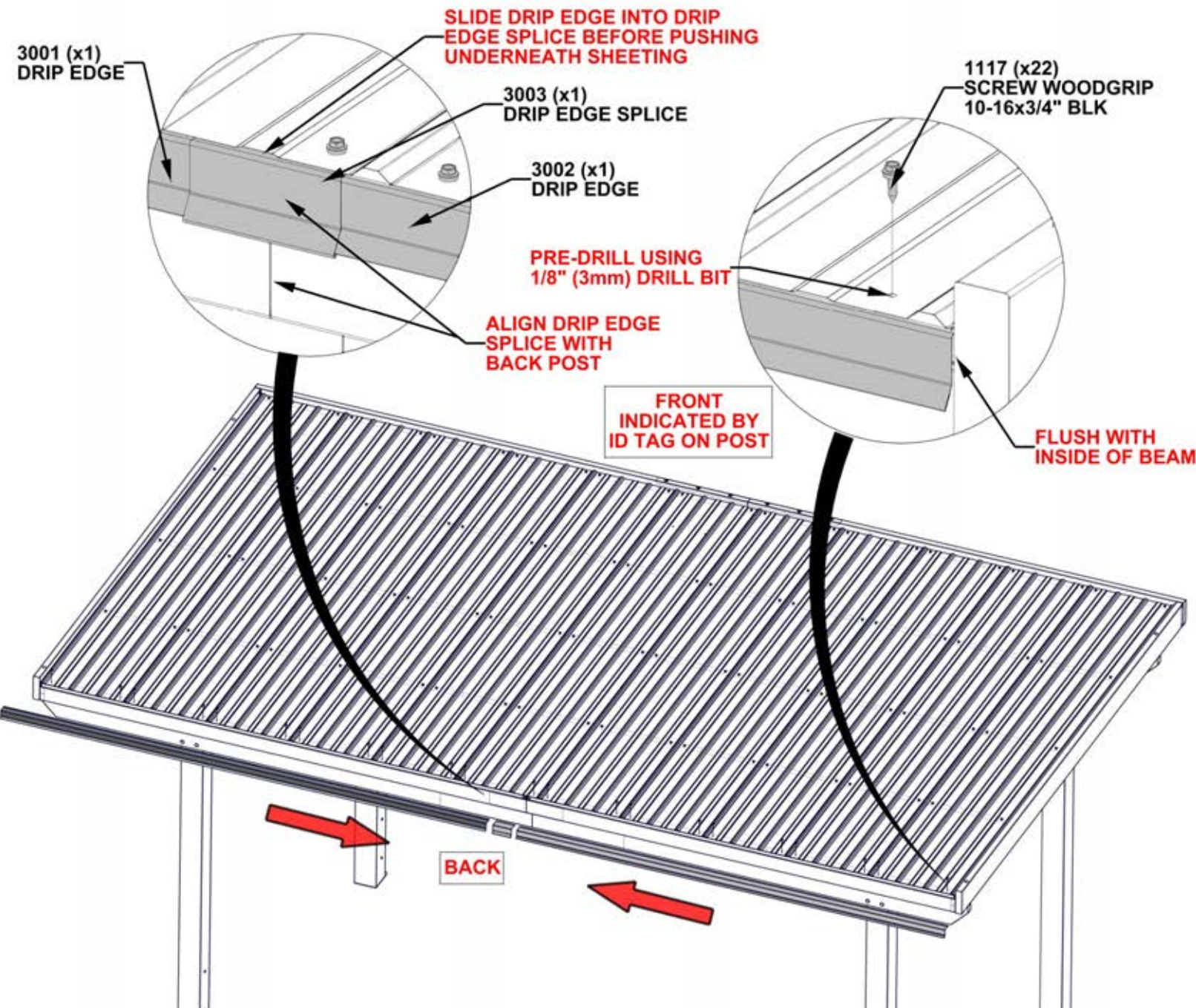

STEP 33A - ROOF ASSEMBLY

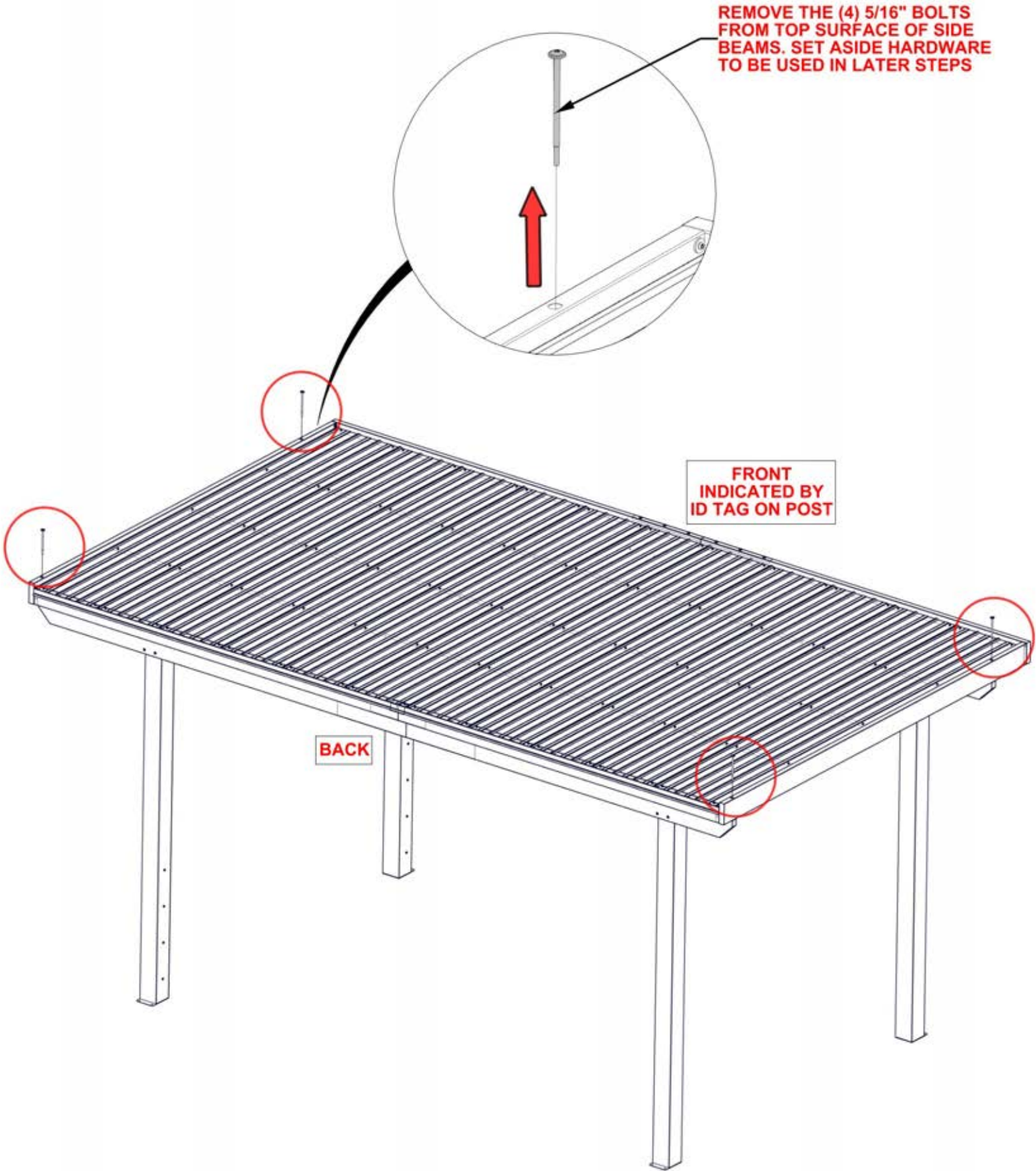

STEP 33B - ROOF ASSEMBLY

QTY	PartNo	DESCRIPTION
4	H101230	BOLT WH 5/16x6 S.S.

NOTE: USE HARDWARE FROM STEP 33A

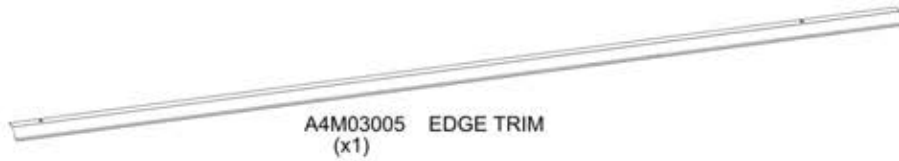

- REMOVE PROTECTIVE FILM

- WARNING: GLOVES ARE RECOMMENDED WHEN HANDLING ROOF PIECES.

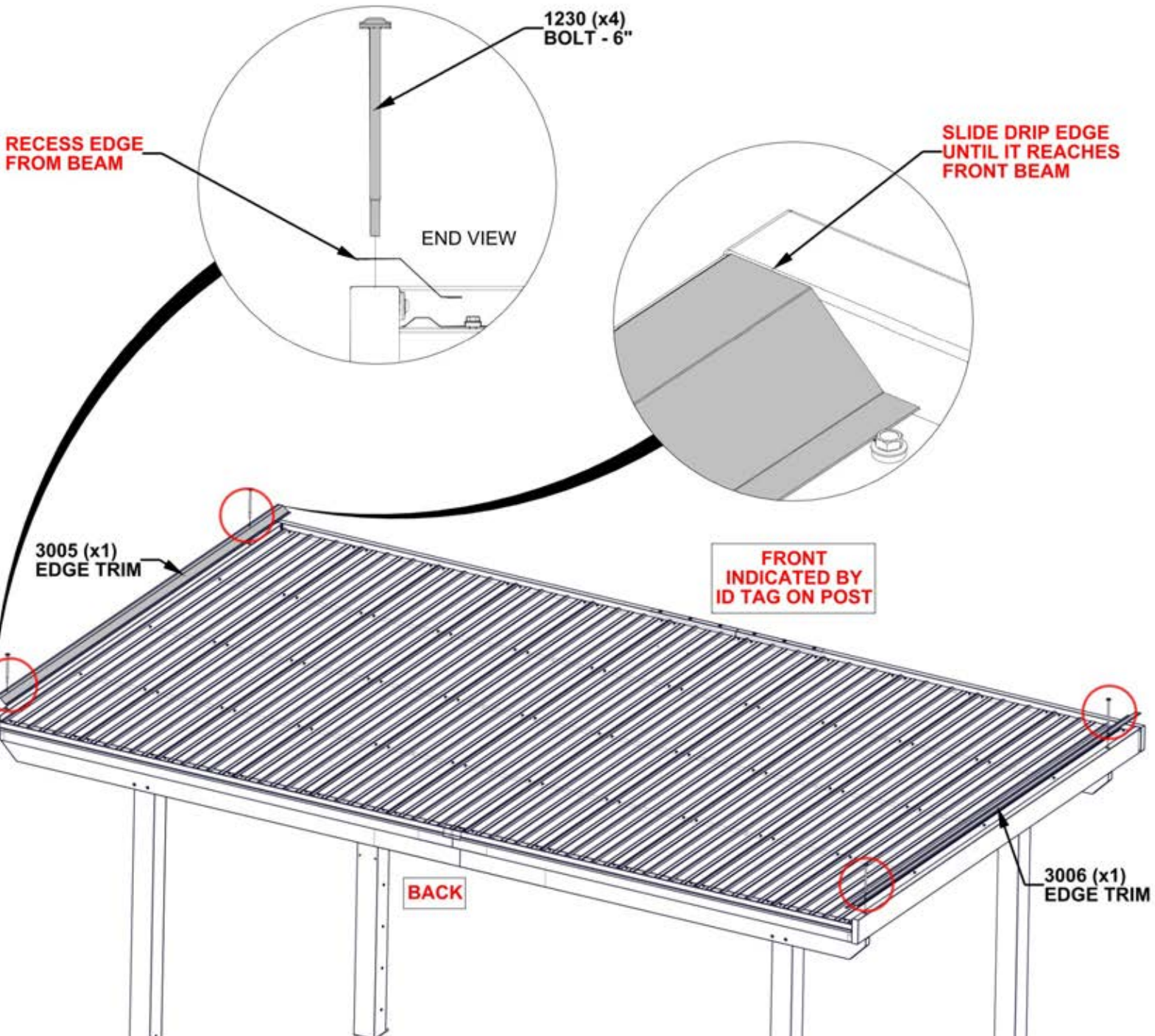

STEP 33C - ROOF ASSEMBLY

QTY	PartNo	DESCRIPTION
10	H101116	SCREW SELF TAPPING 1/4x1 BLK

- EVENLY SPACE SCREWS AS SHOWN BELOW
- DUE TO MULTIPLE LAYERS OF METAL ON THE EDGE TRIM, IT IS RECOMMENDED THAT A 1/8" (3mm) DRILL BIT BE USED TO CREATE STARTER HOLES.
- WARNING: GLOVES ARE RECOMMENDED WHEN HANDLING STEEL ROOF PIECES.

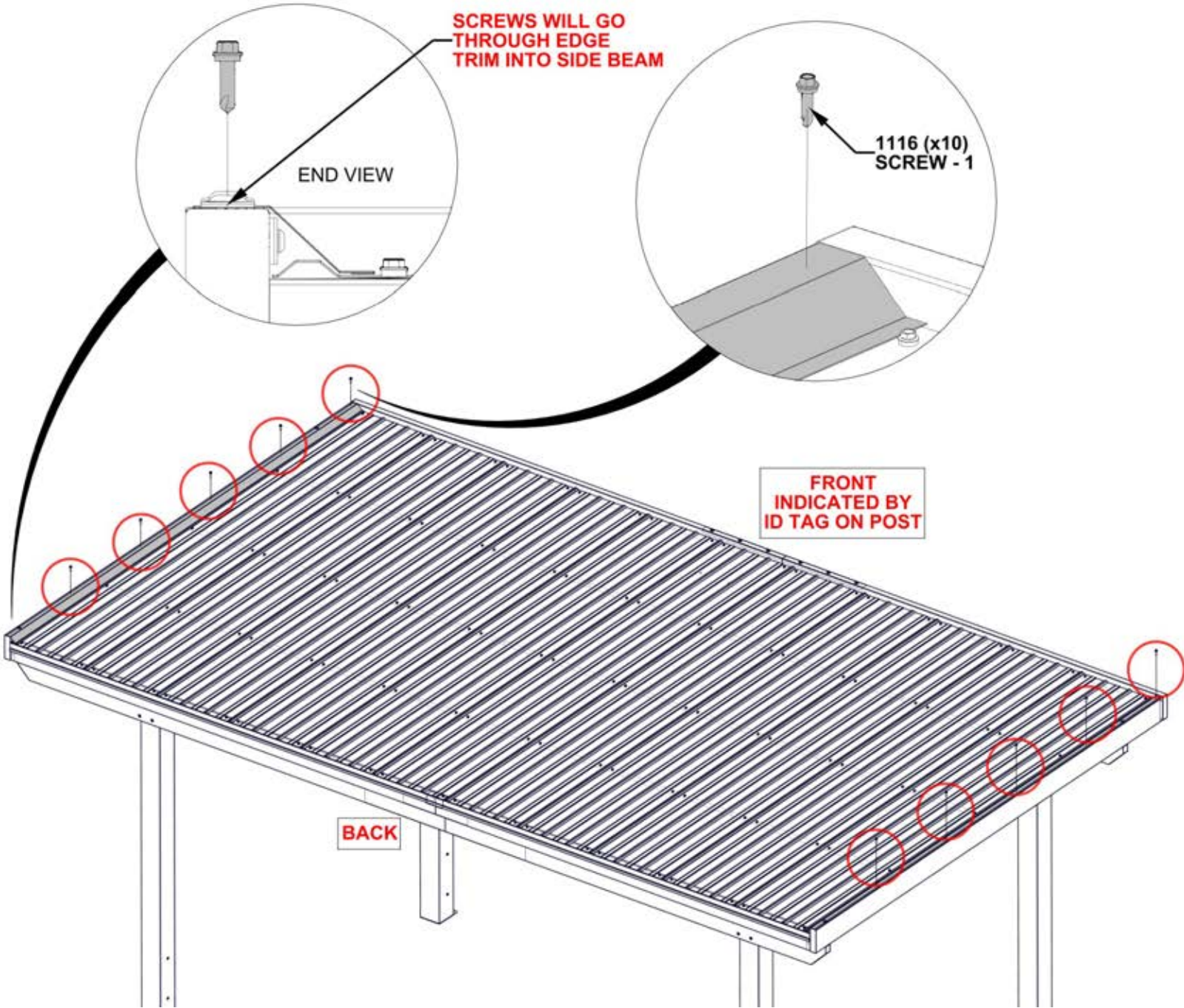

STEP 34A - ROOF ASSEMBLY

REMOVE THE (6) TORX BOLT/WASHER FROM TOP SURFACE OF FRONT BEAM. SET ASIDE HARDWARE TO BE USED IN LATER STEP

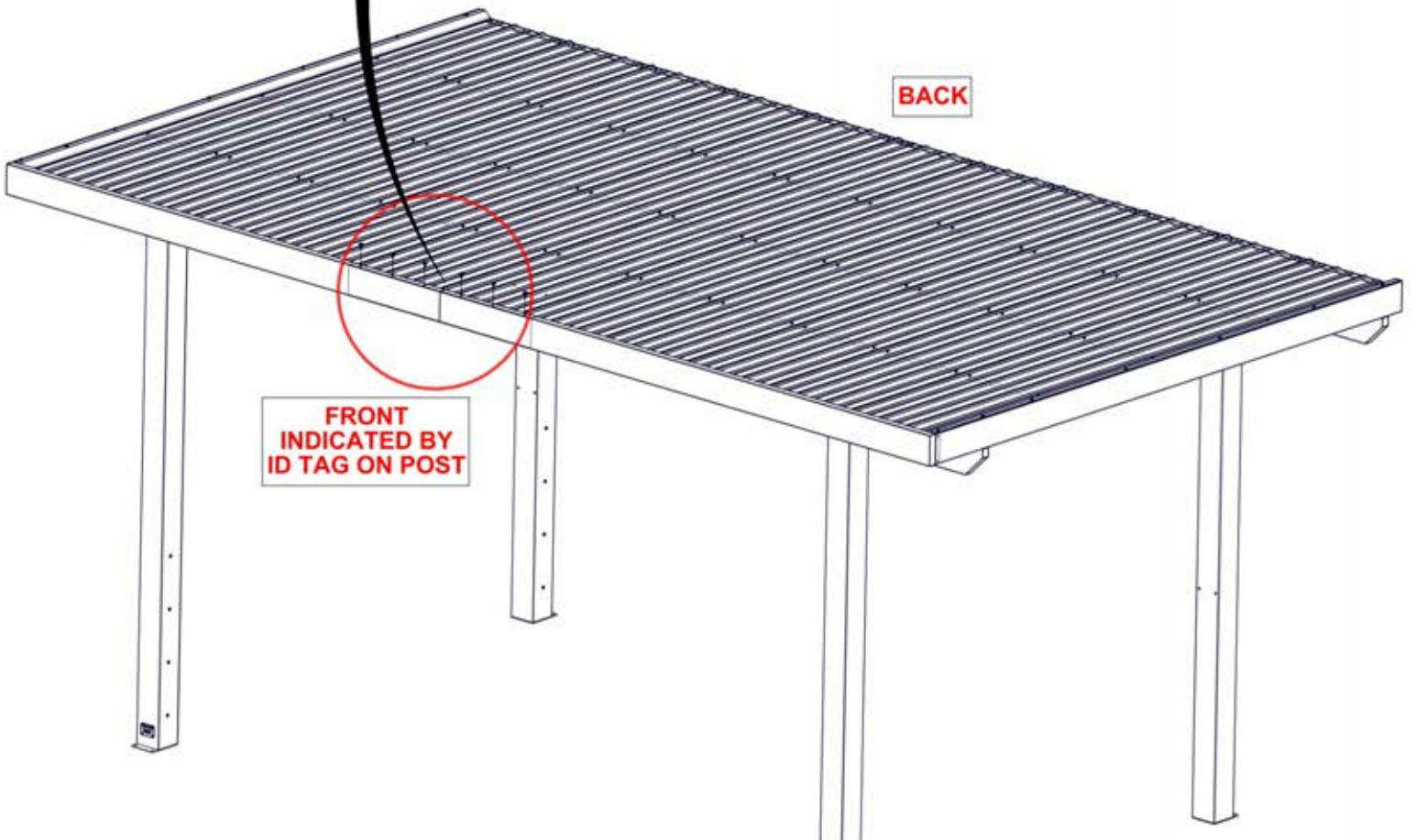
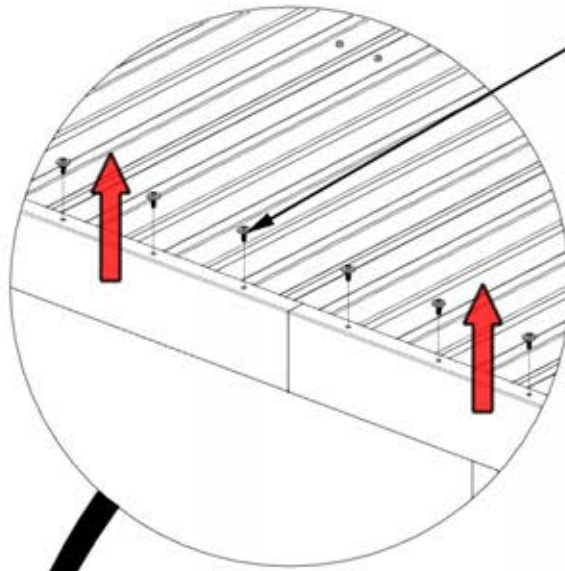

STEP 34B - ROOF ASSEMBLY

QTY	PartNo	DESCRIPTION
6	H101202	TORX PAN HEAD 1/4-20x3/4 ASSY

NOTE: USE HARDWARE FROM STEP 34A

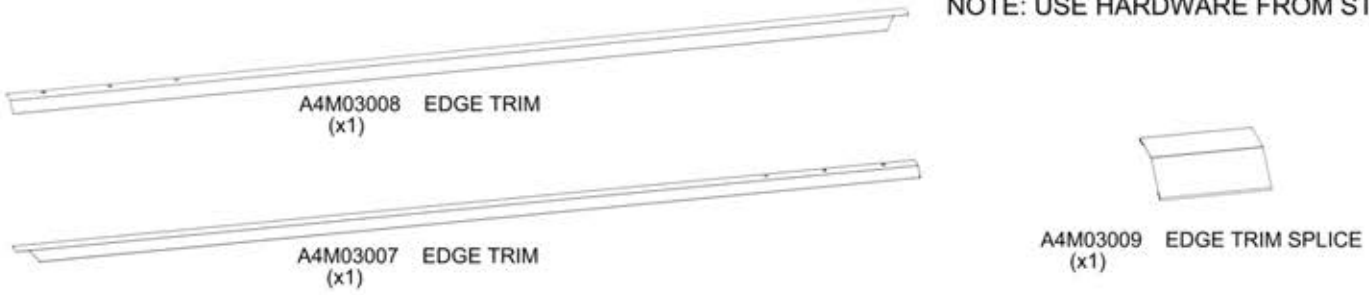

- REMOVE PROTECTIVE FILM

- WARNING: GLOVES ARE RECOMMENDED WHEN HANDLING ROOF PIECES.

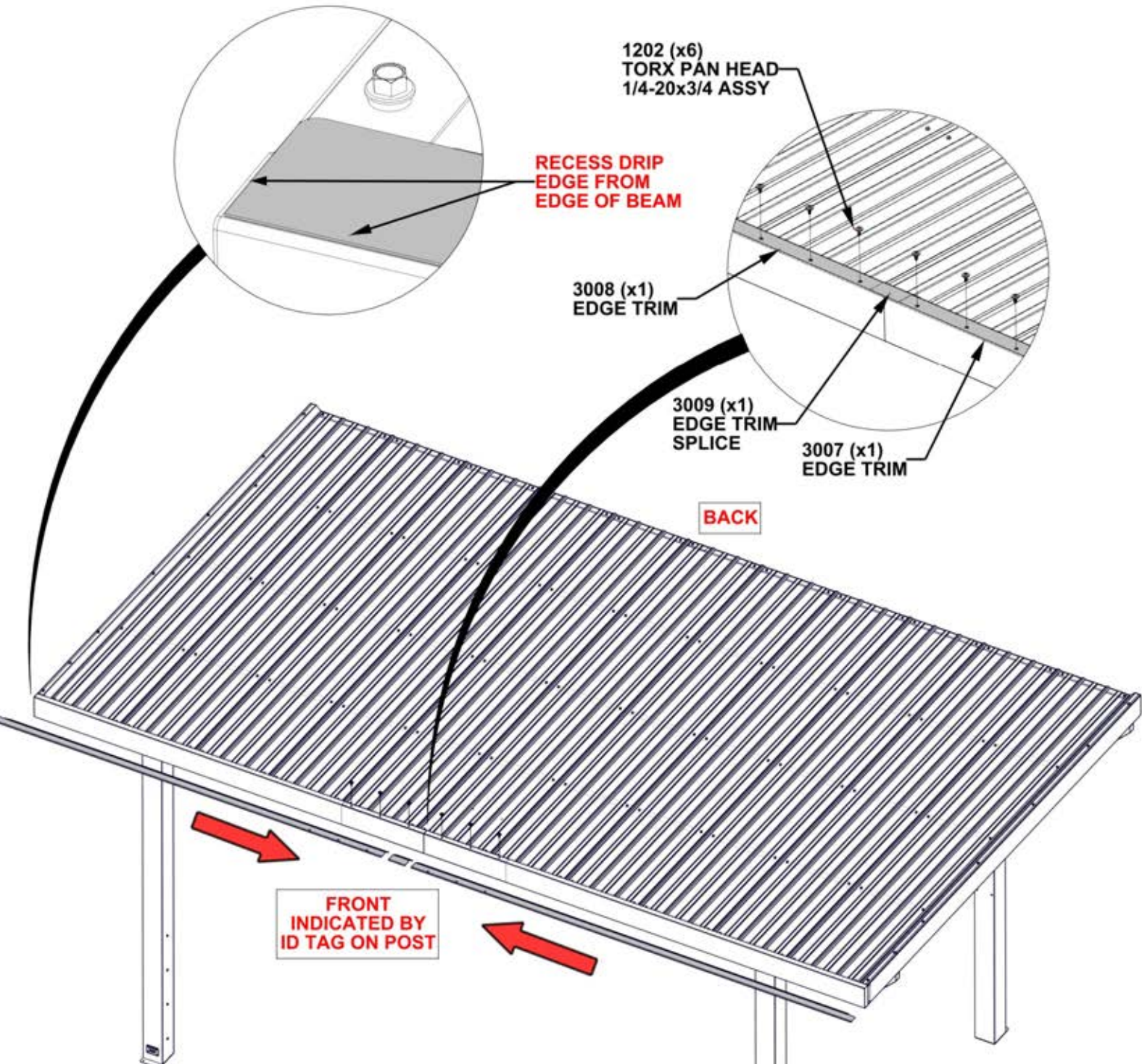

STEP 34C - ROOF ASSEMBLY

QTY	PartNo	DESCRIPTION
9	H101116	SCREW SELF TAPPING 1/4x1 BLK

- REMOVE PROTECTIVE FILM.
- EVENLY SPACE SCREWS ALONG DRIP EDGE.
- **WARNING: GLOVES ARE RECOMMENDED WHEN HANDLING ROOF PIECES.**
- **DUE TO MULTIPLE LAYERS OF METAL ON THE EDGE TRIM, IT IS RECOMMENDED THAT A 1/8" (3mm) DRILL BIT BE USED TO CREATE STARTER HOLES.**

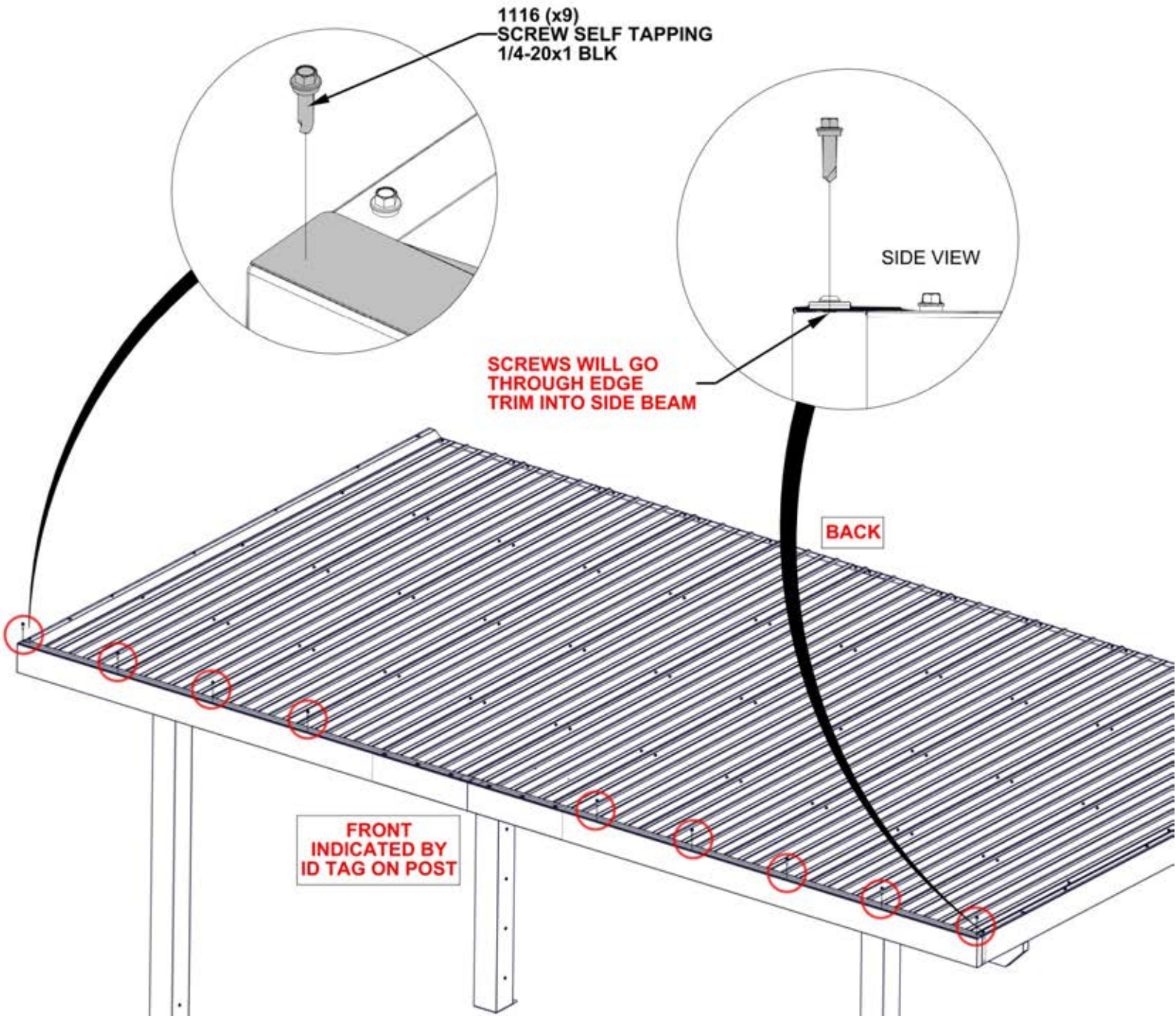

STEP 35 - STRUCTURE ASSEMBLY



A4M01352 HOLE COVER
(x32)

- USE A SMALL PIECE OF WOOD AND RUBBER Mallet TO TAP HOLE COVERS IN.
- DO NOT TAP DIRECTLY WITH A HAMMER AS YOU MAY DAMAGE THE POWDER COAT FINISH ON PRODUCT.

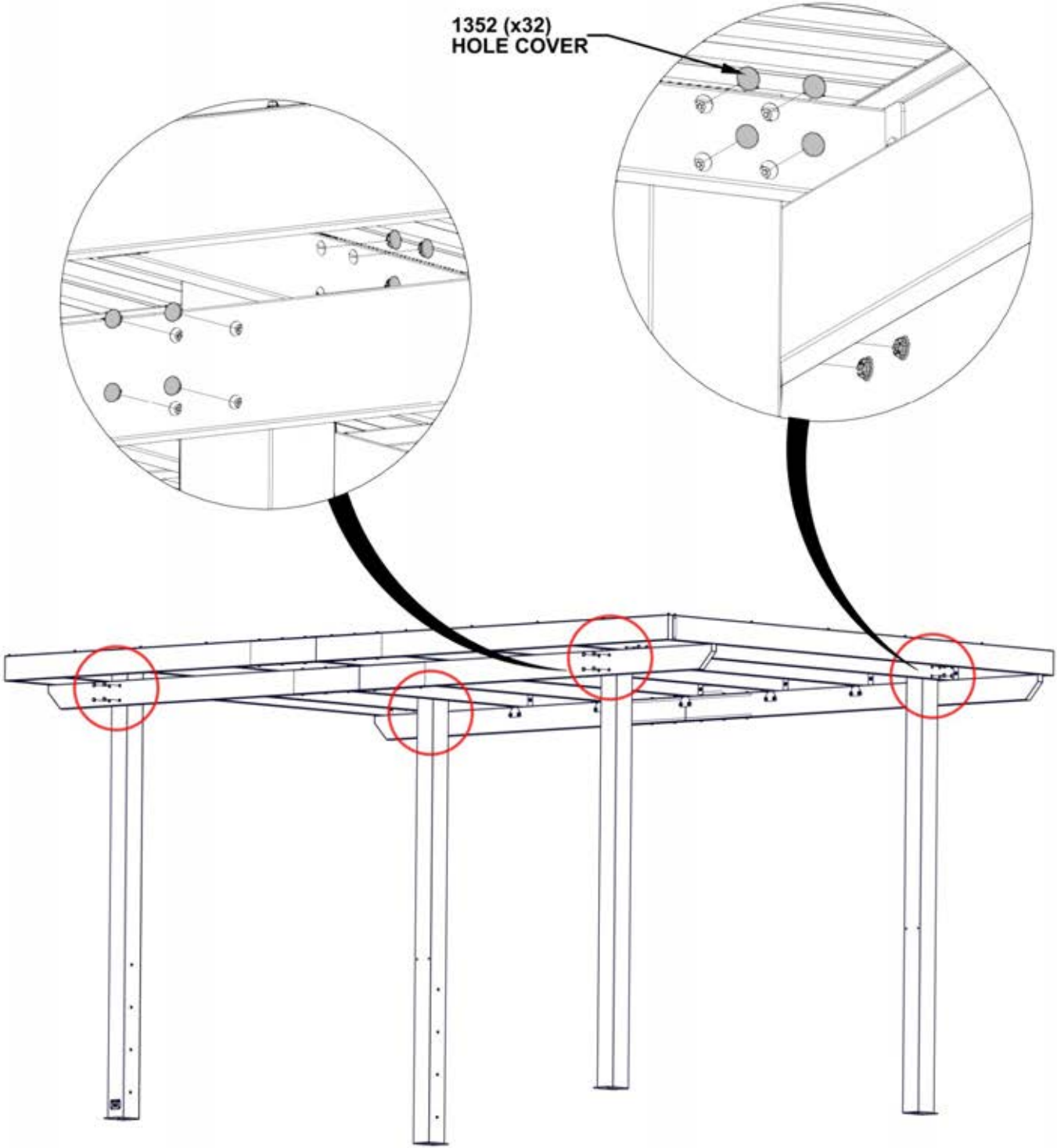

**COMPLETE STEPS 36 - 134 FOR
FUSION FIRE OUTDOOR KITCHEN CABINETS**

STEP 36 - GRILL CABINET ASSEMBLY

Qty	PartNo	Description
4	H101202	TORX PAN HEAD 1/4-20x3/4 ASSY

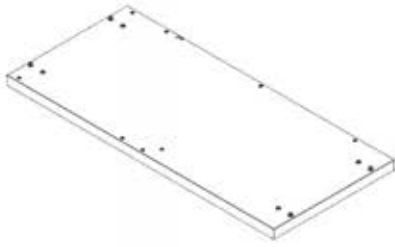

F1 CORNER CABINET FLOOR PANEL ASSEMBLY L - A4M03028
(x1) 2 5/8"x23 3/8"x51 7/8" (66x594x1317)

G1 LEFT CORNER CABINET SIDE WALL ASSEMBLY L - A4M03029
(x1) 2 9/16"x23 3/8"x33 3/8" (65x594x848)

- POSITION FLOOR PANEL IN THE PROXIMITY OF WHERE YOUR KITCHEN WILL BE.
- EACH FLOOR PANEL HAS FACTORY INSTALLED ADJUSTABLE FEET. USE PROVIDED HEX DRIVER TO ADJUST EACH FOOT UNTIL PANEL IS LEVEL.

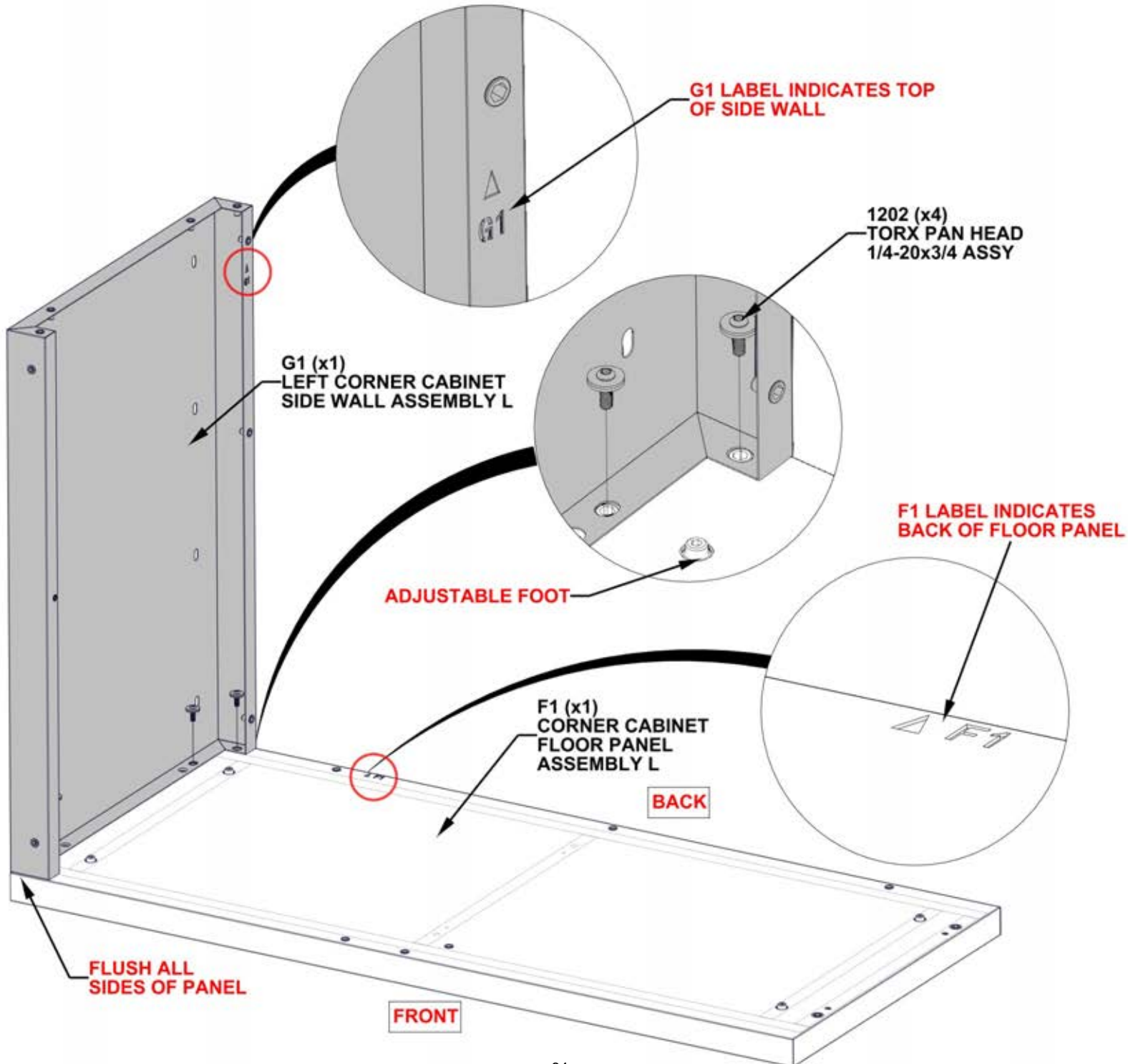

STEP 37 - GRILL CABINET ASSEMBLY

Qty	PartNo	Description
2	H101202	TORX PAN HEAD 1/4-20x3/4 ASSY



G2 LEFT CORNER CABINET SIDE WALL ASSEMBLY R - A4M03030
 (x1) 2 1/16"x23 3/8"x33 3/8" (53x594x848)

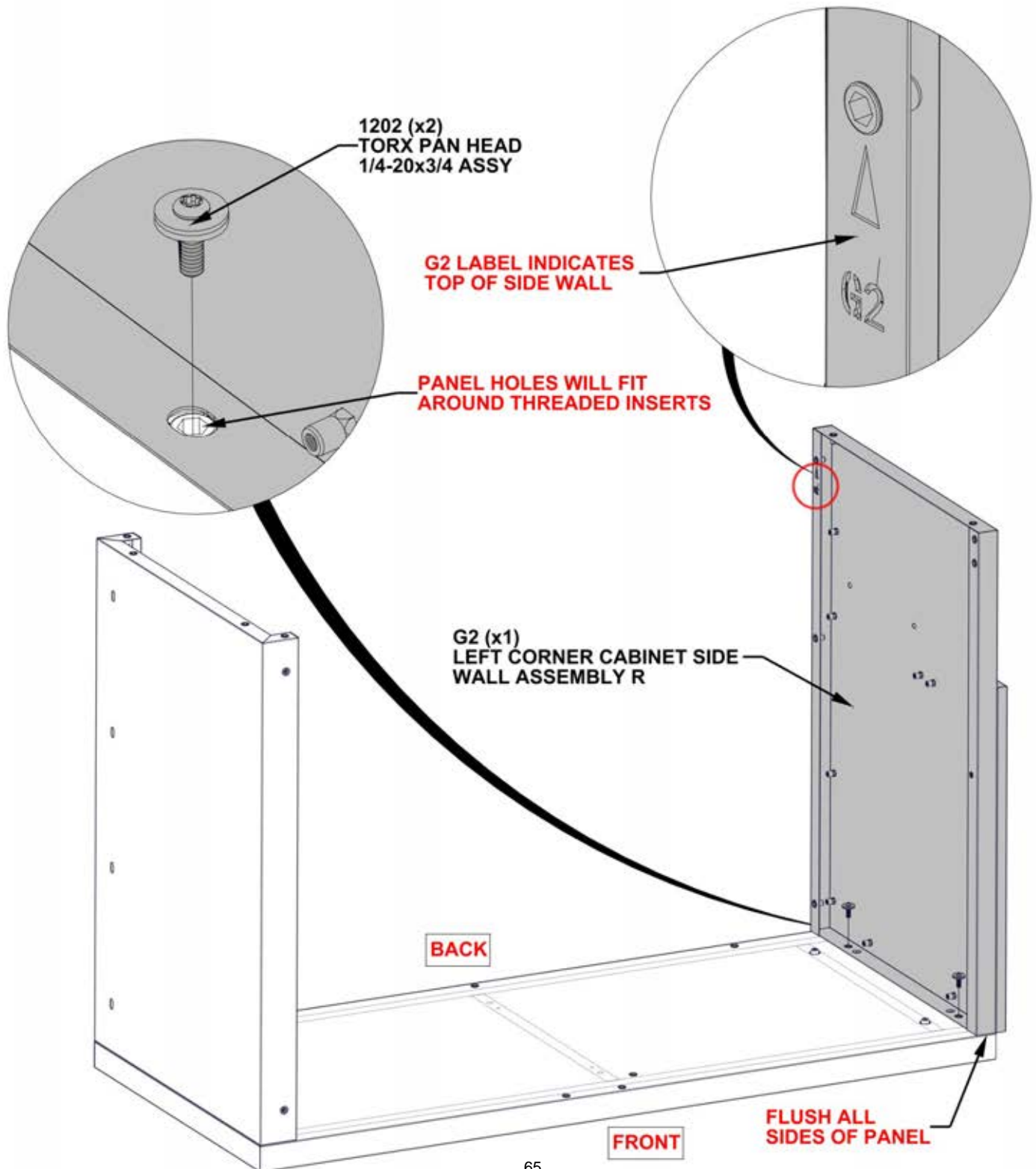

STEP 38 - GRILL CABINET ASSEMBLY

Qty	PartNo	Description
9	H101202	TORX PAN HEAD 1/4-20x3/4 ASSY



G4 CORNER CABINET BACK PANEL ASSEMBLY L - A4M03033
(x1) 1 3/16"x33 3/8"x47 13/16" (30x848x1215)

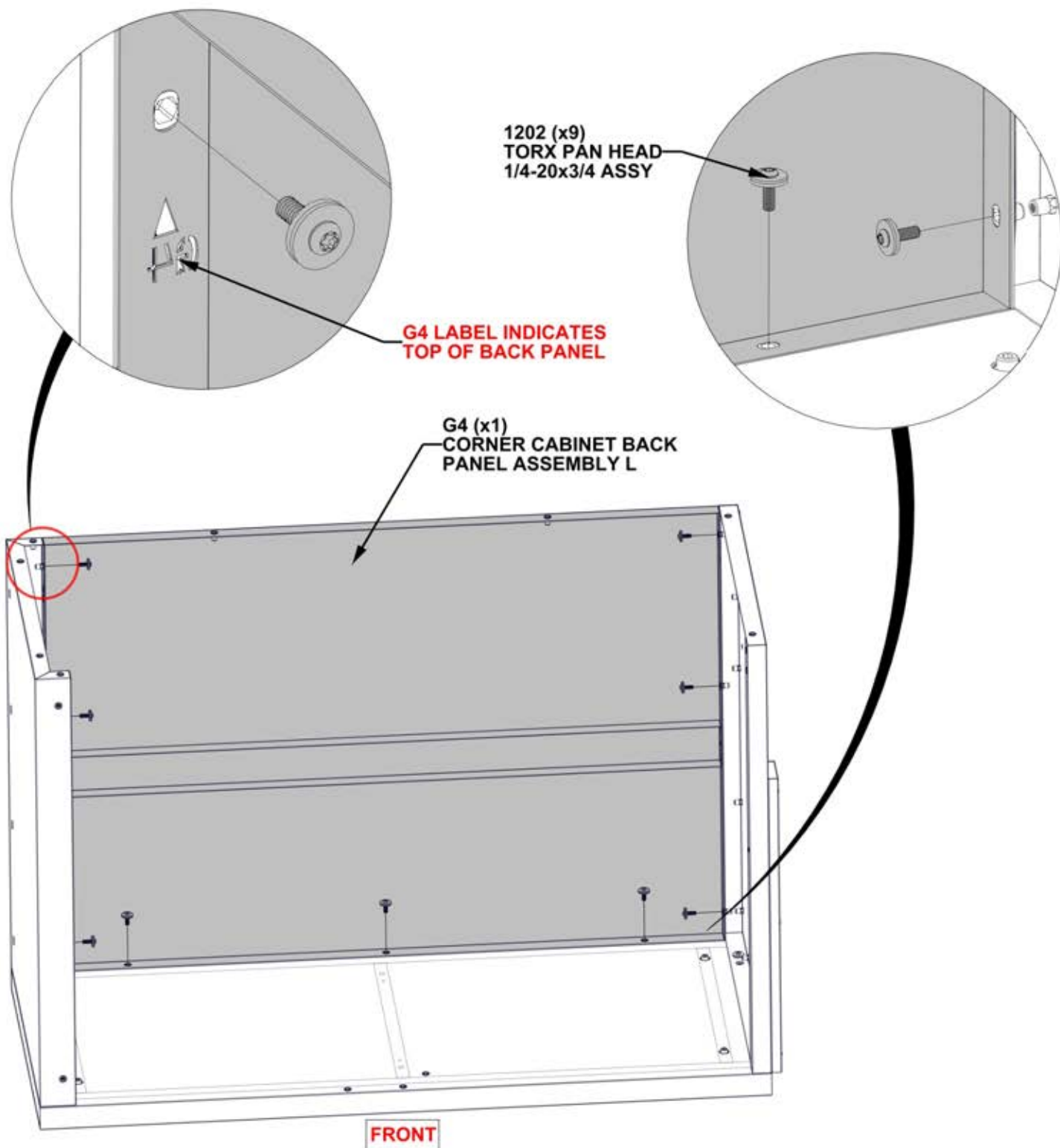

STEP 39 - GRILL CABINET ASSEMBLY

Qty	PartNo	Description
3	H101202	TORX PAN HEAD 1/4-20x3/4 ASSY



G3 LEFT CORNER CABINET SIDE WALL ASSEMBLY M - A4M03031
(x1) 3 1/8"x7 1/16"x33 3/8" (80x180x848)

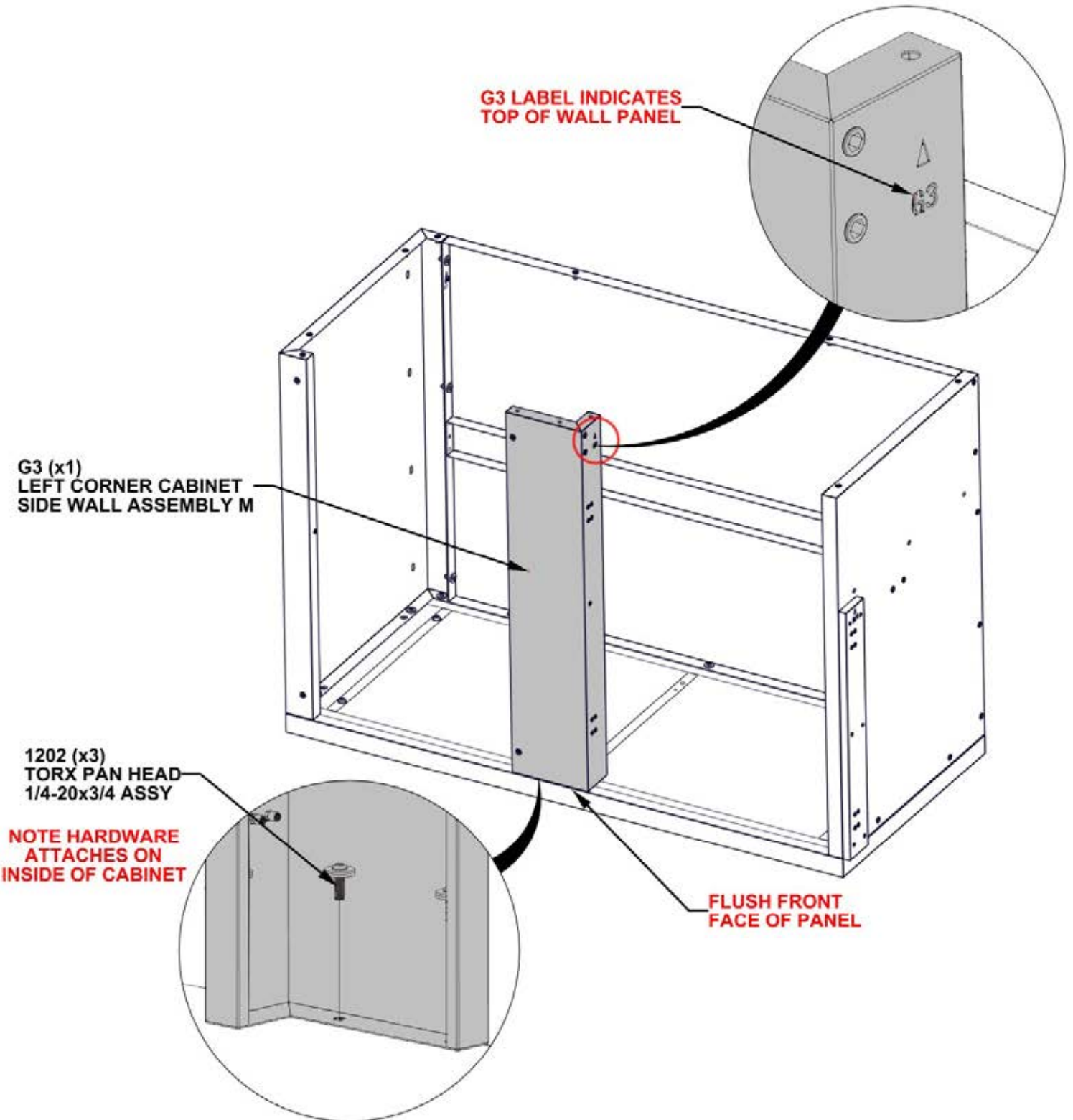

STEP 40 - GRILL CABINET ASSEMBLY

Qty	PartNo	Description
2	H101289	PAN HEAD SCREW 8-32x1/2" SS

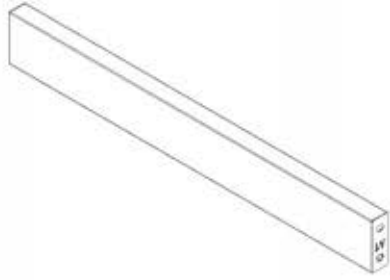

A1 CORNER CABINET HORIZONTAL BEAM ASSEMBLY - A4M03032
(x1) 1"x2 3/4"x22 1/4" (25x70x565)



A2 MAGNET BRACKET - A4M03026
(x1) 1"x1 1/4"x3 1/8" (25x31x80)

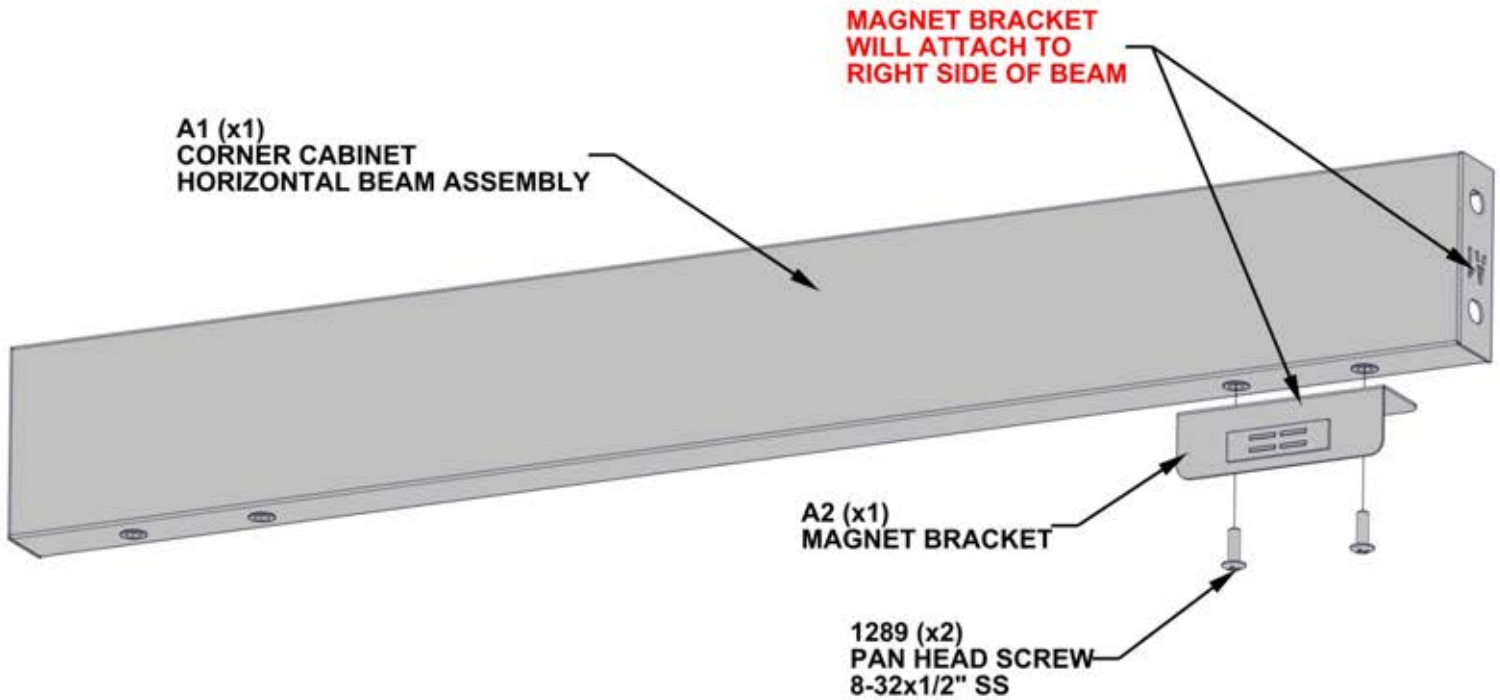

STEP 41 - GRILL CABINET ASSEMBLY

Qty	PartNo	Description
4	H101202	TORX PAN HEAD 1/4-20x3/4 ASSY



HORIZONTAL BEAM
ASSEMBLY FROM STEP 40

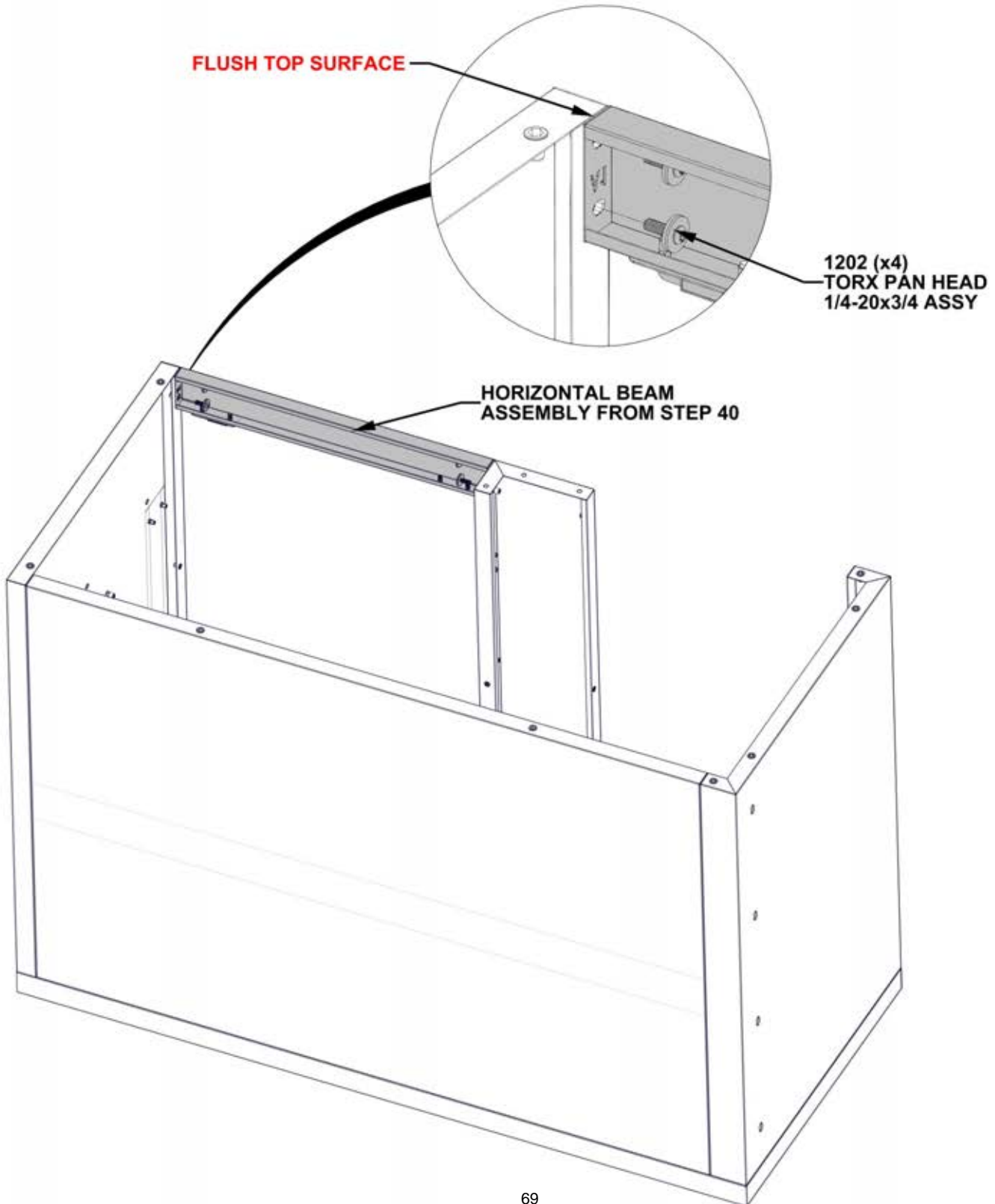

STEP 42A - GRILL CABINET ASSEMBLY

Qty	PartNo	Description
8	H101103	TORX SOCKET SCREW 1/4-20

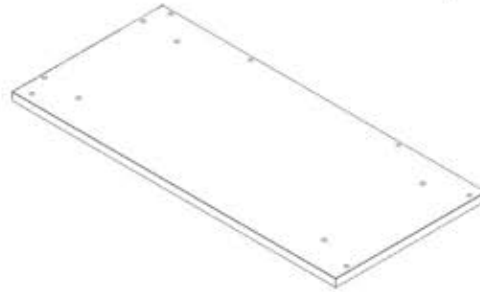

T1 CORNER CABINET MARBLE PANEL ASSEMBLY L - A4M03034
(x1) 1 1/4"x24 1/8"x51 7/8" (32x612x1317)

- FLUSH BACK AND SIDES OF PANEL ASSEMBLY.
- SQUARE ALL SIDES OF CABINET BEFORE TIGHTENING HARDWARE.

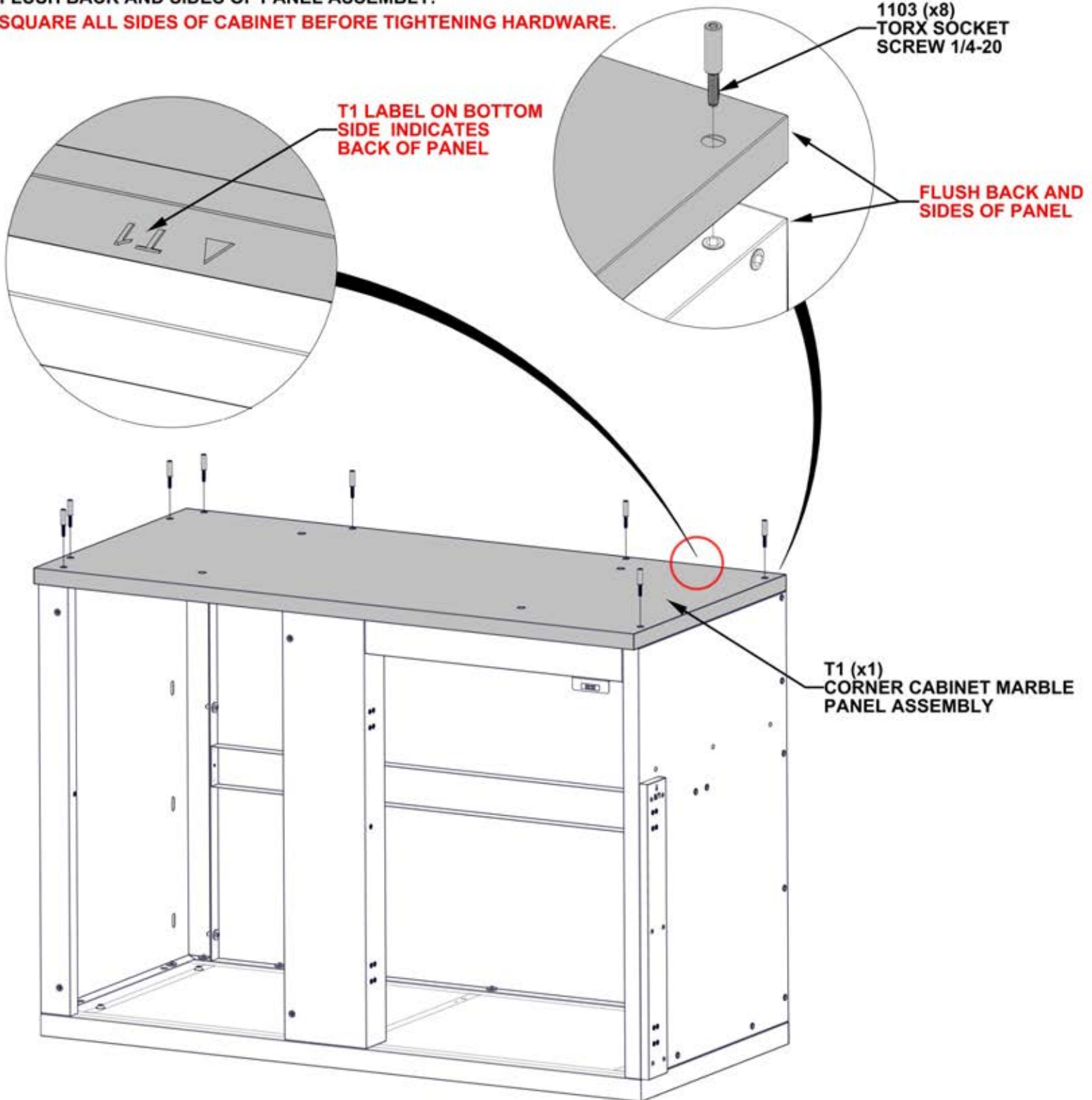

STEP 42B - GRILL CABINET ASSEMBLY

Qty	PartNo	Description
3	H101202	TORX PAN HEAD 1/4-20x3/4 ASSY

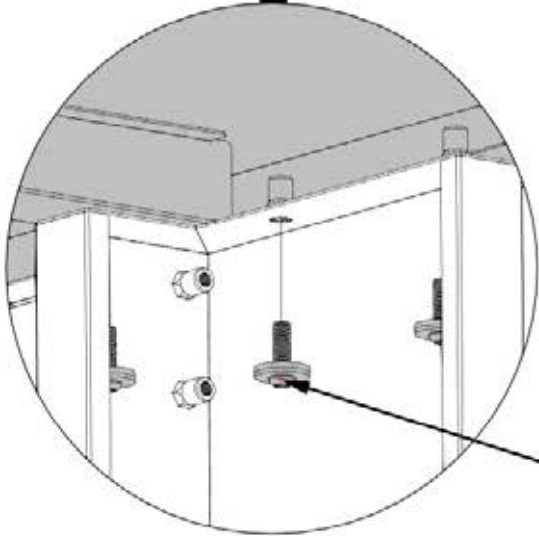
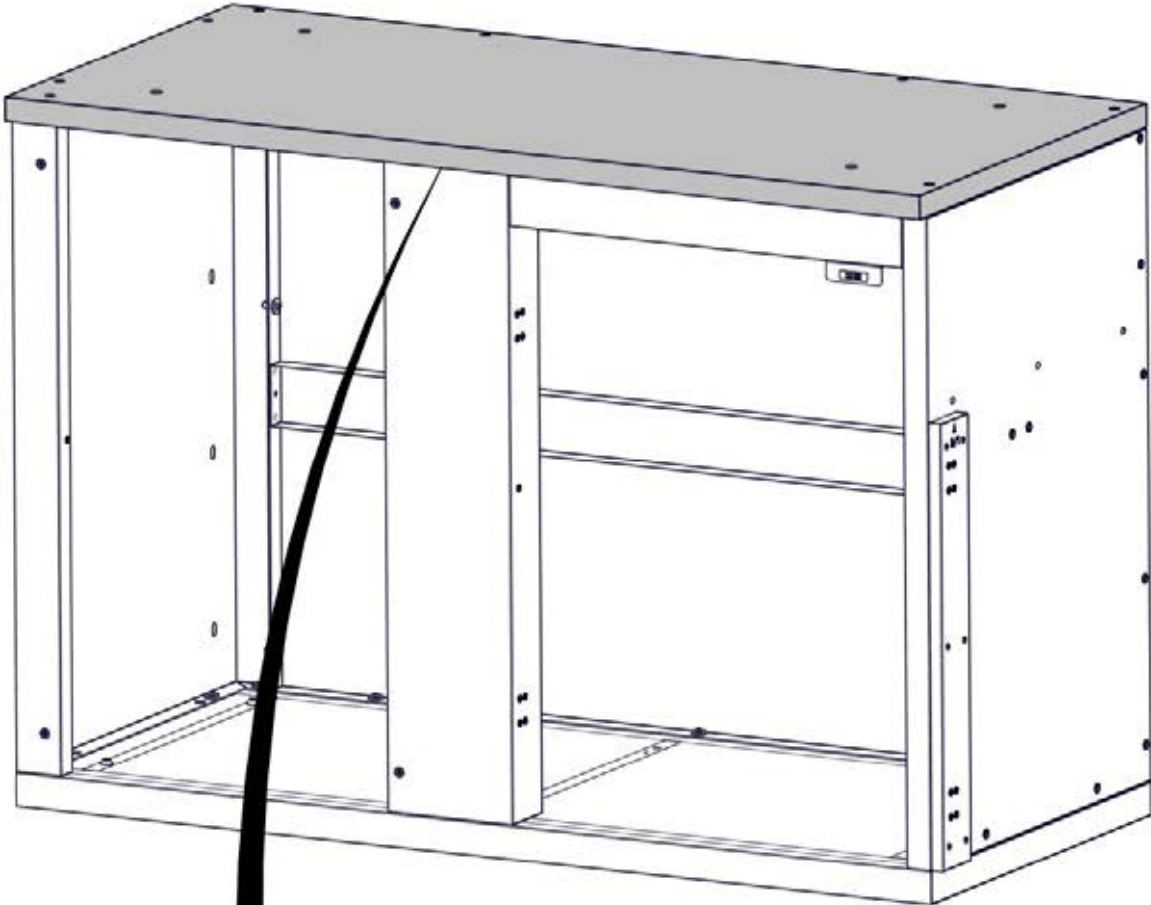

**NOTE HARDWARE
ATTACHES ON
INSIDE OF CABINET**

1202 (x3)
TORX PAN HEAD 1/4-20x3/4 ASSY

STEP 43 - GRILL CABINET INSTALLATION



GRILL CABINET FROM PREVIOUS STEPS

Qty	PartNo	Description
4	H101202	TORX PAN HEAD 1/4-20x3/4 ASSY

- POSITION GRILL CABINET ASSEMBLY UNDERNEATH FUSION FIRE STRUCTURE.
- SIDE OF GRILL CABINET WILL SIT AGAINST THE INSIDE OF BACK LEFT POST.
- BACKSIDE OF GRILL CABINET WILL SIT FLUSH WITH BACKSIDE OF POST.
- **BEFORE TIGHTENING HARDWARE, ADJUST CABINET FEET AS NEEDED UNTIL GRILL CABINET IS LEVEL**

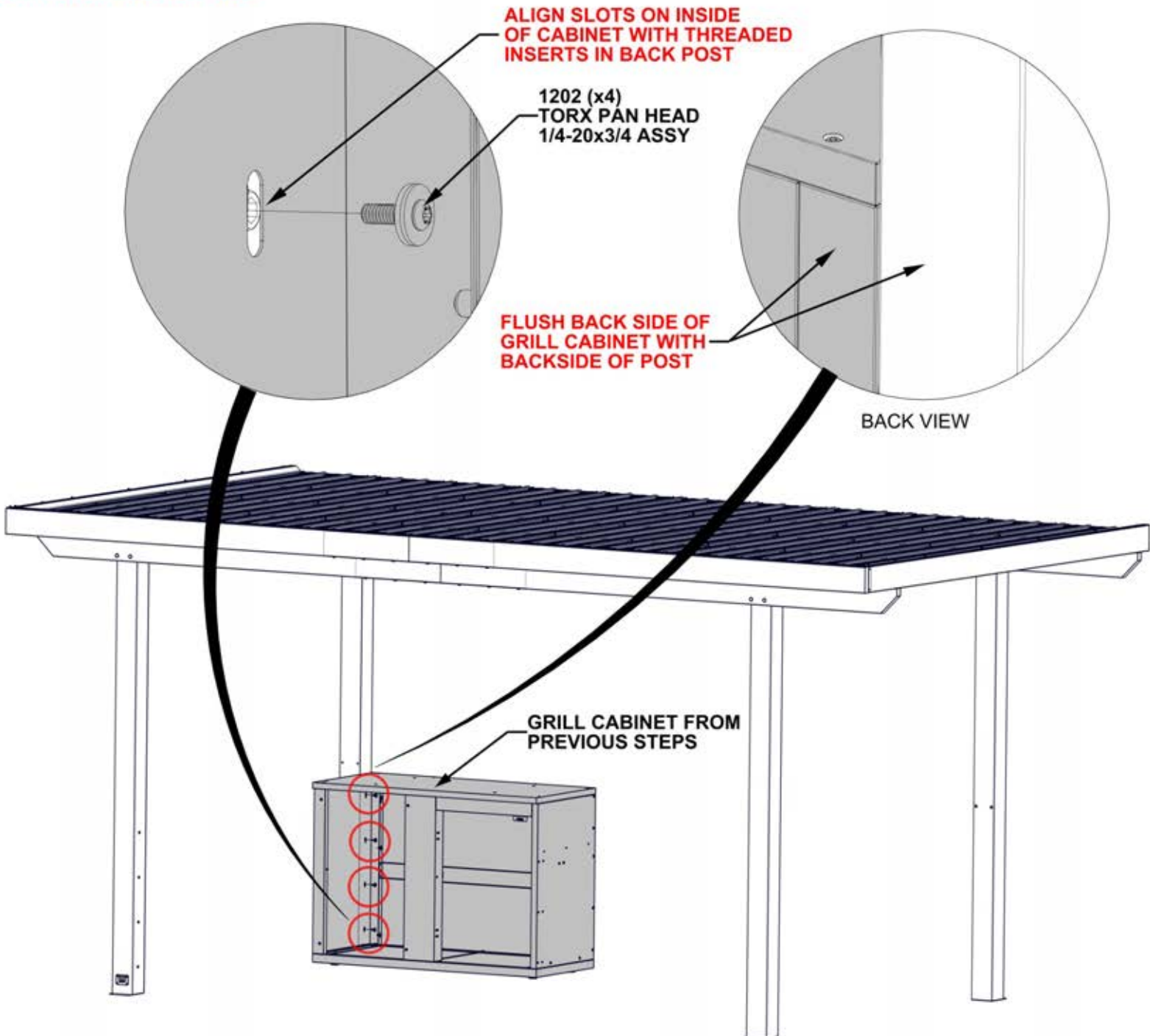

STEP 44 - GRILL CABINET ASSEMBLY

Qty	PartNo	Description
2	H101202	TORX PAN HEAD 1/4-20x3/4 ASSY

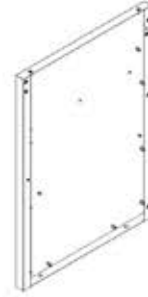
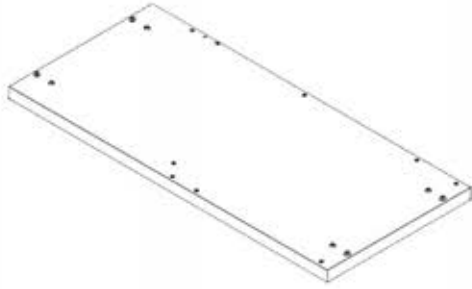

F3 CORNER CABINET FLOOR PANEL ASSEMBLY R - A4M03039
(x1) 2 5/8"x23 3/8"x51 7/8" (66x594x1317)

G6 RIGHT CORNER CABINET SIDE WALL ASSEMBLY L - A4M03040
(x1) 2 1/16"x23 3/8"x33 3/8" (53x594x848)

- POSITION FLOOR PANEL IN THE PROXIMITY OF WHERE YOUR KITCHEN WILL BE.
- EACH FLOOR PANEL HAS FACTORY INSTALLED ADJUSTABLE FEET. USE PROVIDED HEX DRIVER TO ADJUST EACH FOOT UNTIL PANEL IS LEVEL.

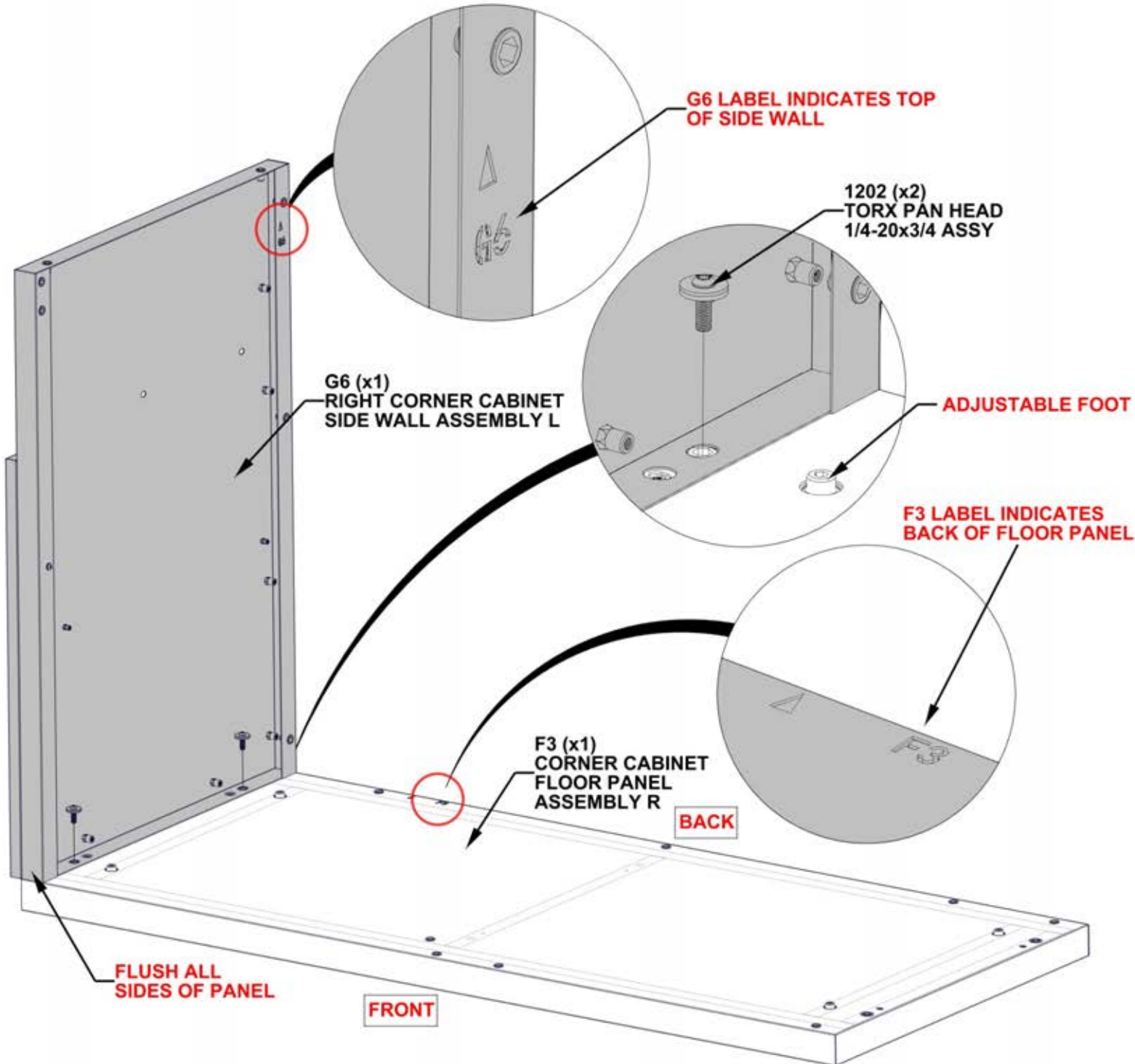

STEP 45 - GRILL CABINET ASSEMBLY

Qty	PartNo	Description
4	H101202	TORX PAN HEAD 1/4-20x3/4 ASSY

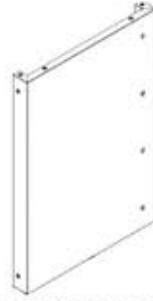

G7 RIGHT CORNER CABINET SIDE WALL ASSEMBLY R - A4M03041
(x1) 2 9/16"x23 3/8"x33 3/8" (65x594x848)

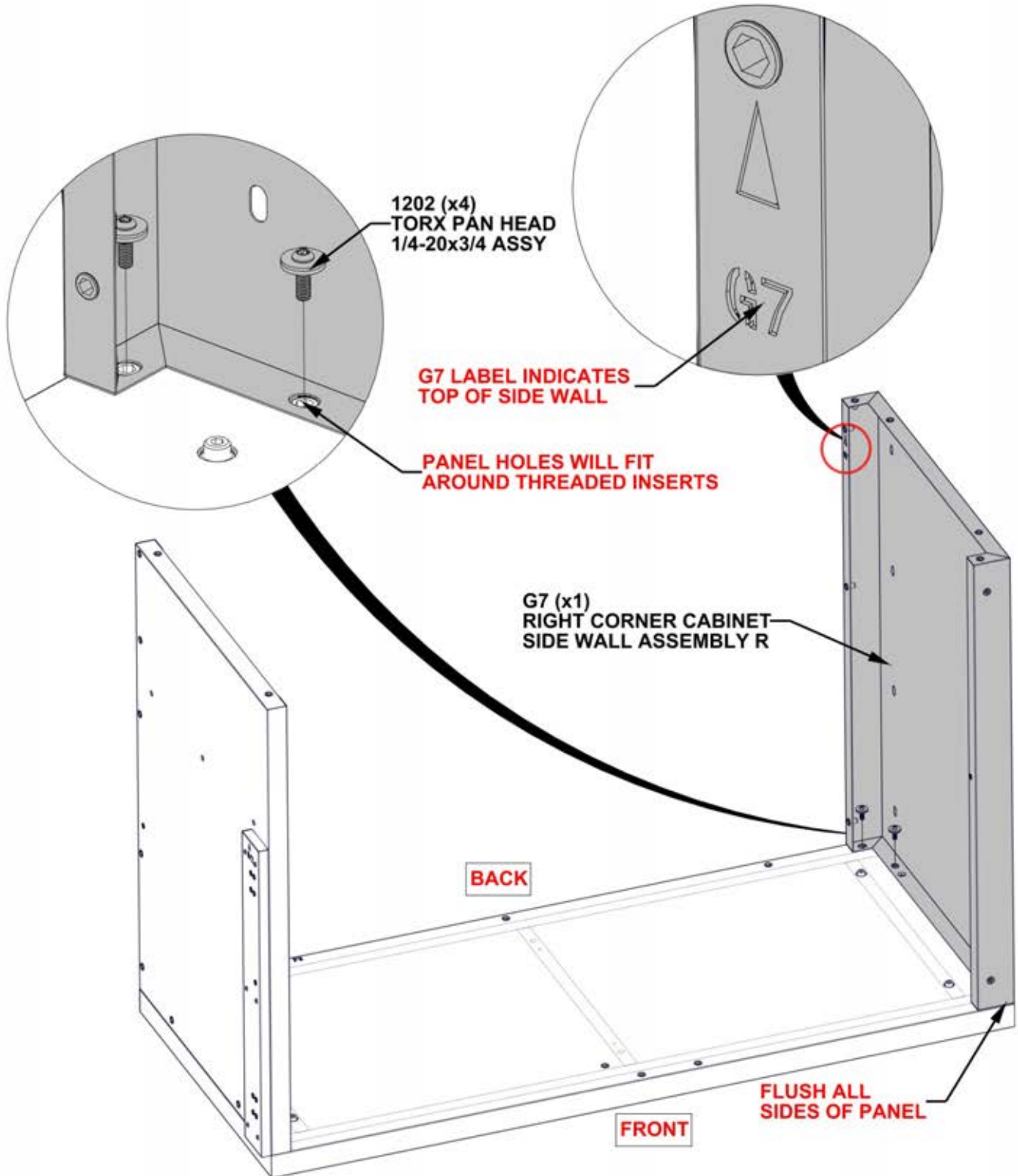

STEP 46 - GRILL CABINET ASSEMBLY

Qty	PartNo	Description
9	H101202	TORX PAN HEAD 1/4-20x3/4 ASSY



G9 CORNER CABINET BACK PANEL ASSEMBLY R - A4M03043
(x1) 1 3/16"x33 3/8"x47 13/16" (30x848x1215)

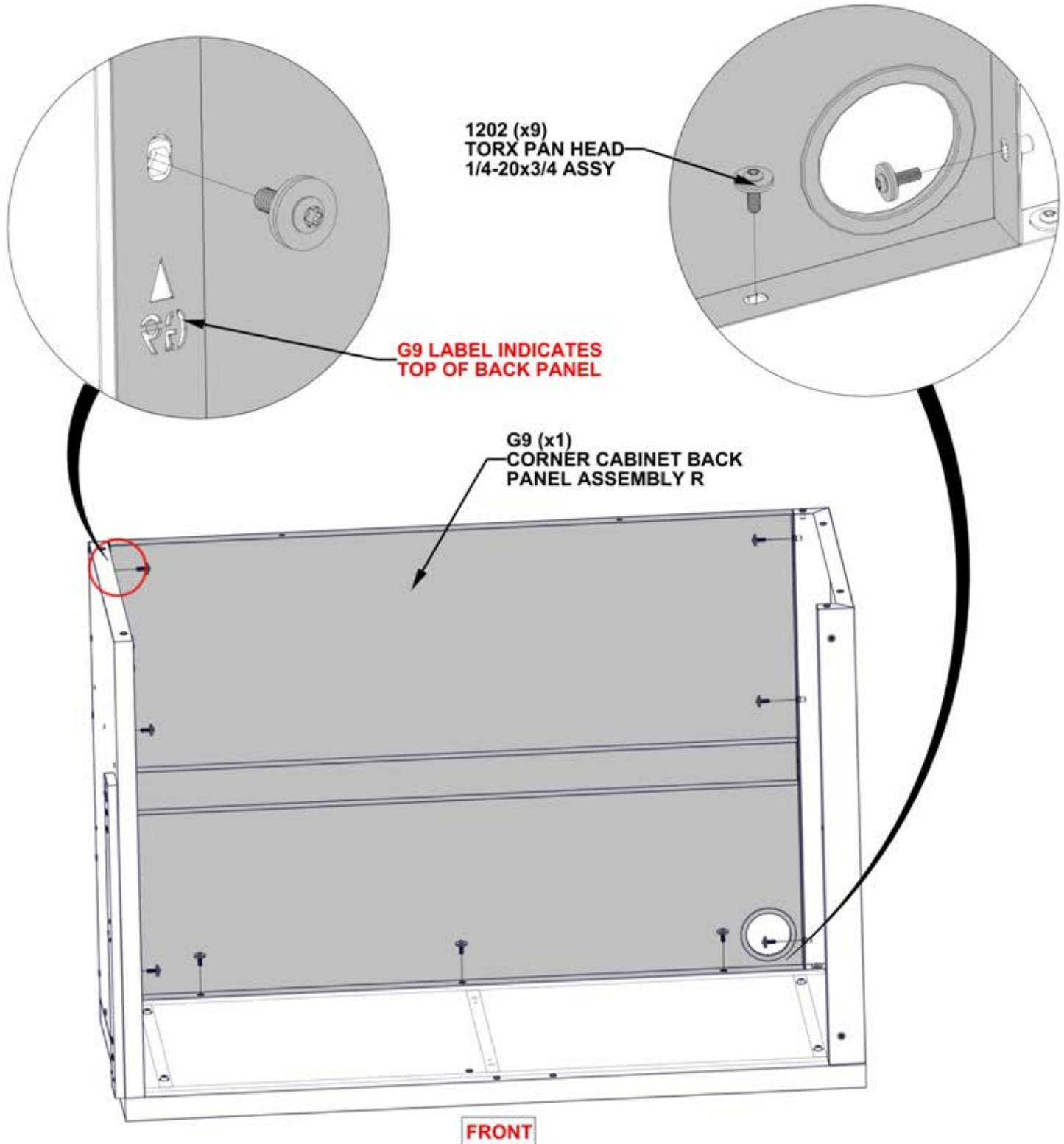

STEP 47 - GRILL CABINET ASSEMBLY

Qty	PartNo	Description
3	H101202	TORX PAN HEAD 1/4-20x3/4 ASSY



G8 RIGHT CORNER CABINET SIDE WALL ASSEMBLY M - A4M03042
(x1) 3 1/8"x7 1/16"x33 3/8" (80x180x848)

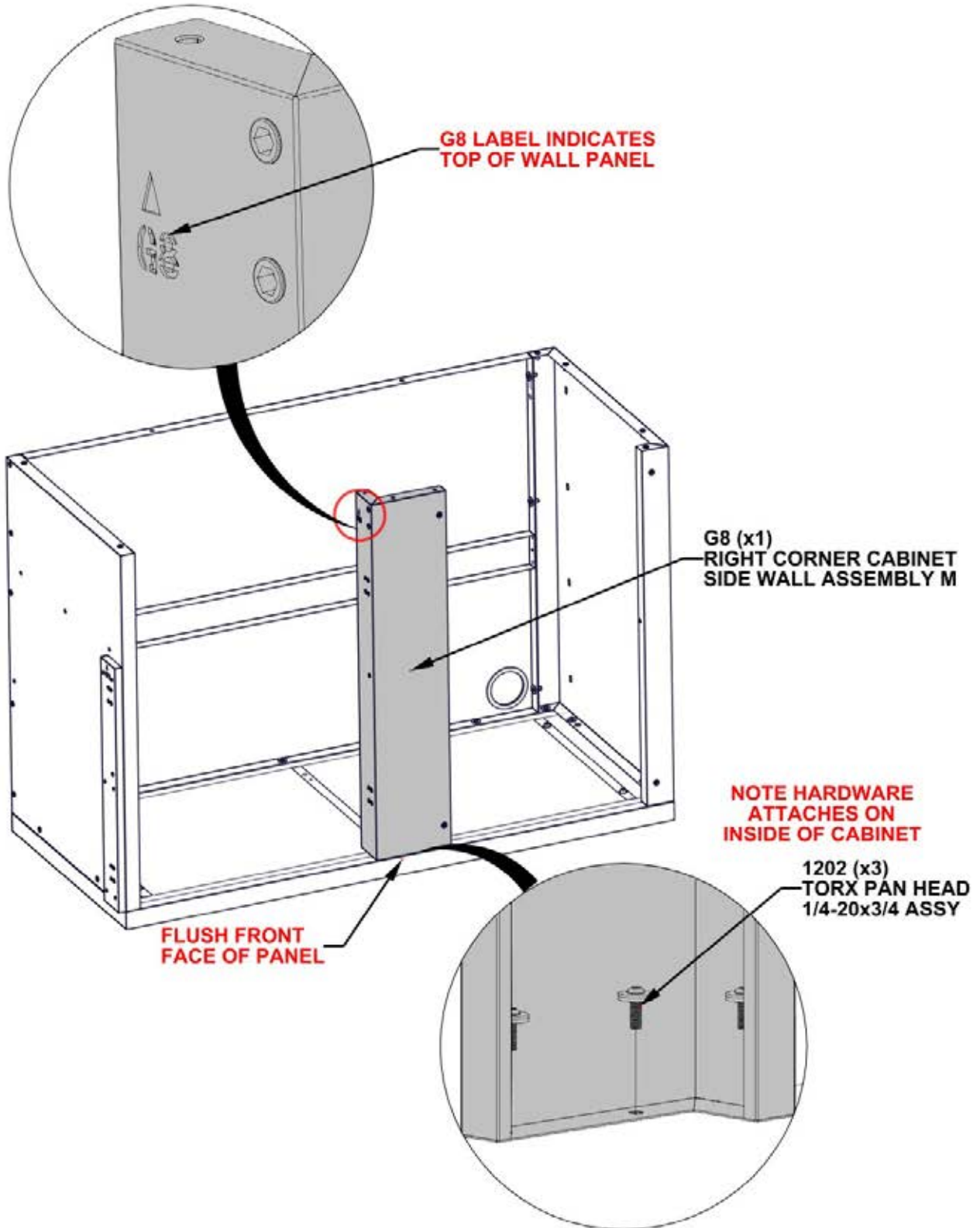

STEP 48 - GRILL CABINET ASSEMBLY

Qty	PartNo	Description
2	H101289	PAN HEAD SCREW 8-32x1/2" SS

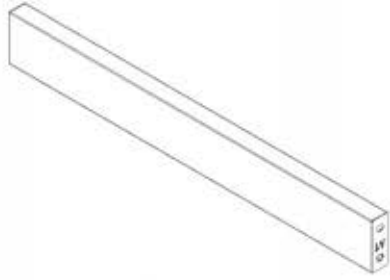

A1 CORNER CABINET HORIZONTAL BEAM ASSEMBLY - A4M03032
(x1) 1"x2 3/4"x22 1/4" (25x70x565)



A2 MAGNET BRACKET - A4M03026
(x1) 1"x1 1/4"x3 1/8" (25x31x80)

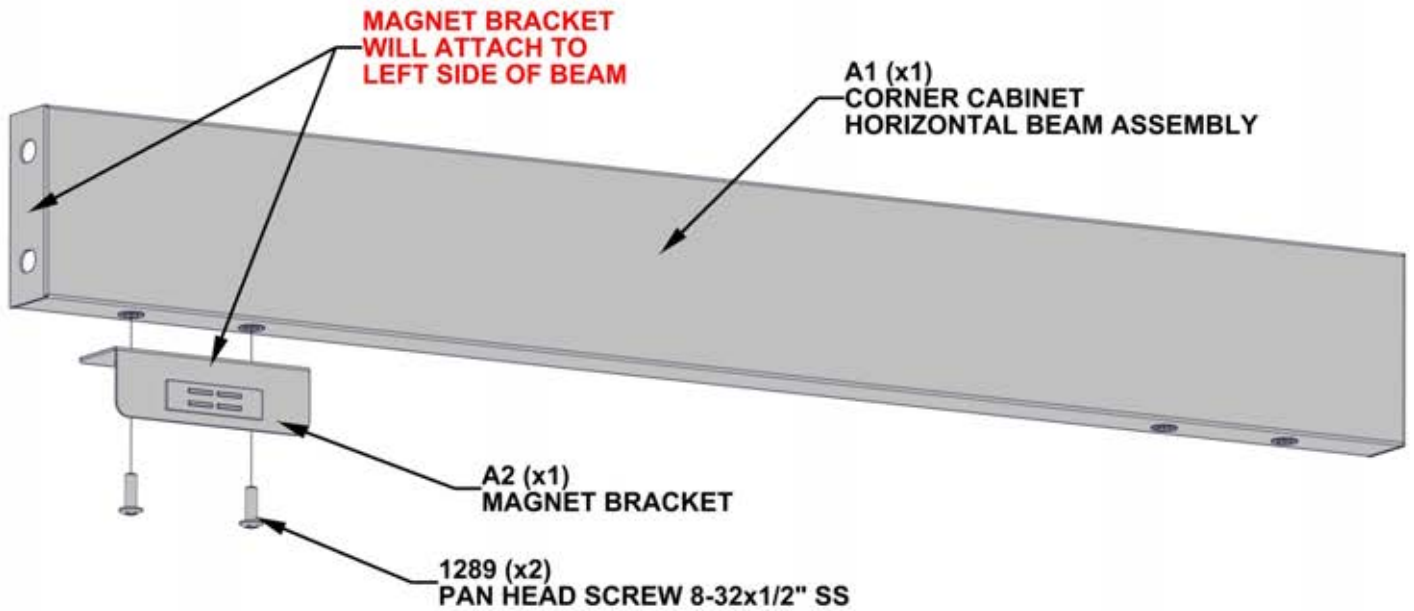

STEP 49 - GRILL CABINET ASSEMBLY



HORIZONTAL BEAM
ASSEMBLY FROM STEP 48

Qty	PartNo	Description
4	H101202	TORX PAN HEAD 1/4-20x3/4 ASSY

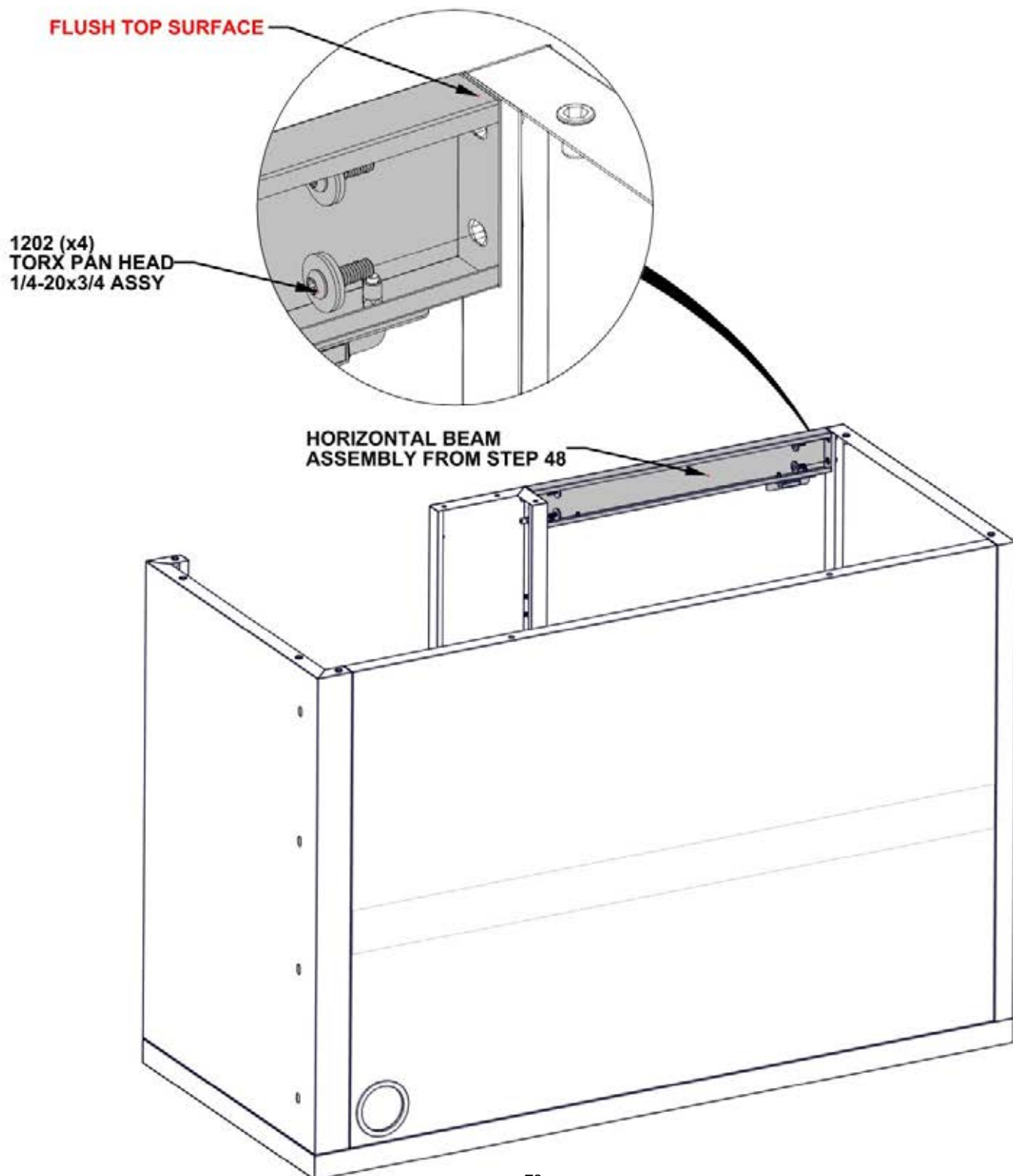

FLUSH TOP SURFACE

1202 (x4)
TORX PAN HEAD
1/4-20x3/4 ASSY

HORIZONTAL BEAM
ASSEMBLY FROM STEP 48

STEP 50A - GRILL CABINET ASSEMBLY

Qty	PartNo	Description
8	H101103	TORX SOCKET SCREW 1/4-20



T3 CORNER CABINET MARBLE PANEL ASSEMBLY R - A4M03044
(x1) 1 1/4"x24 1/8"x51 7/8" (32x612x1317)

- FLUSH BACK AND SIDES OF PANEL ASSEMBLY.
- SQUARE ALL SIDES OF CABINET BEFORE TIGHTENING HARDWARE.

1103 (x8)
TORX SOCKET SCREW 1/4-20

FLUSH BACK AND
SIDES OF PANEL

T3 LABEL ON BOTTOM
SIDE INDICATES
BACK OF PANEL

T3 (x1)
CORNER CABINET MARBLE
PANEL ASSEMBLY R

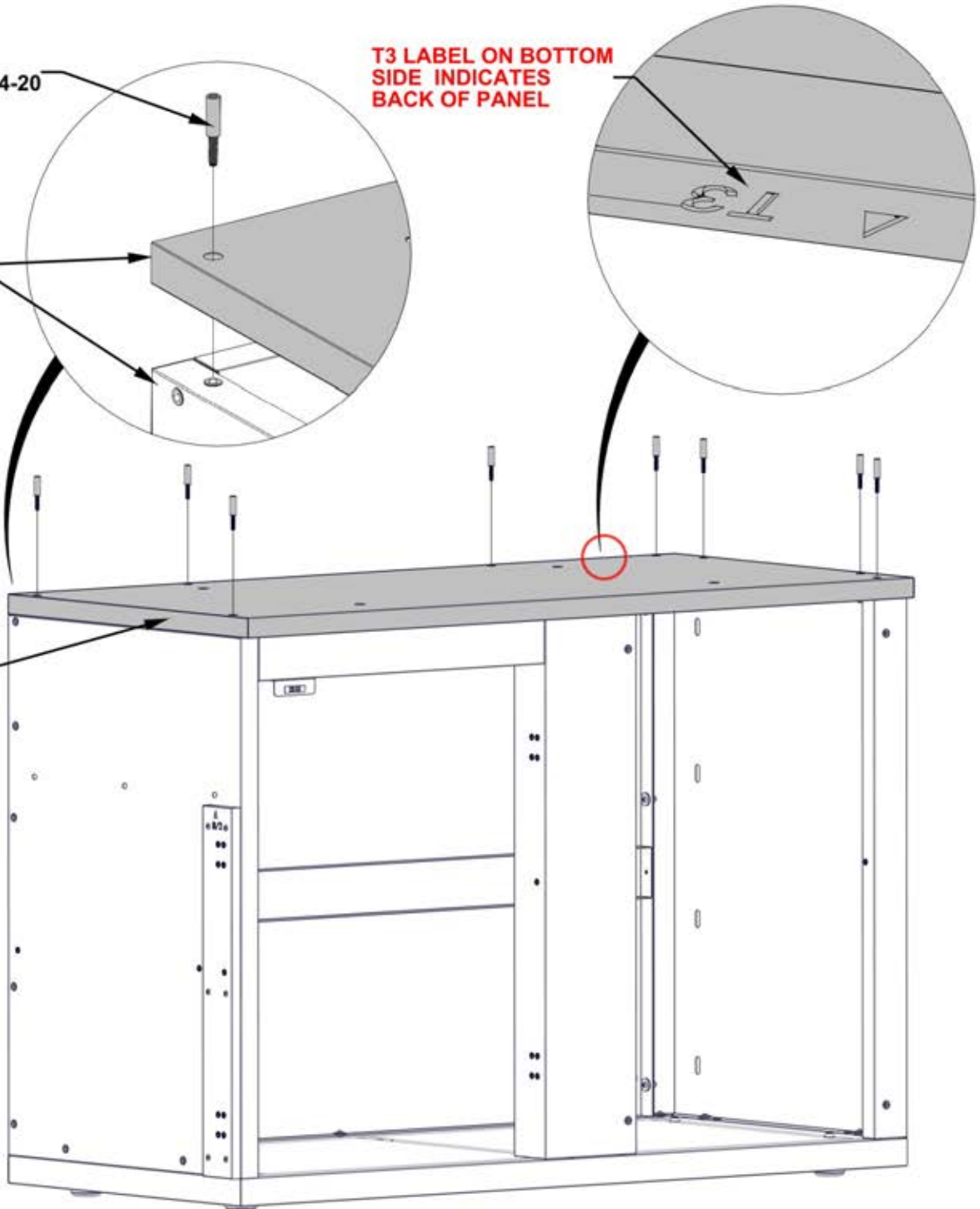

STEP 50B - GRILL CABINET ASSEMBLY

Qty	PartNo	Description
3	H101202	TORX PAN HEAD 1/4-20x3/4 ASSY

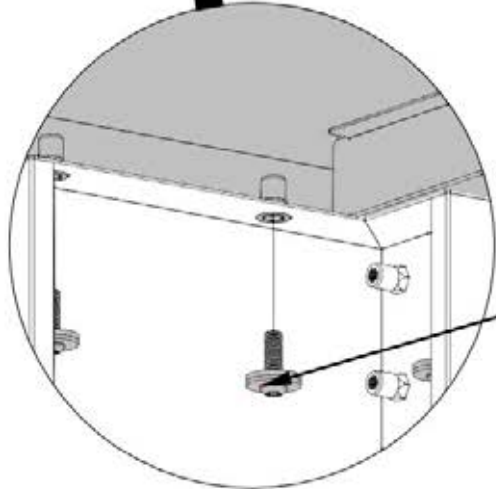
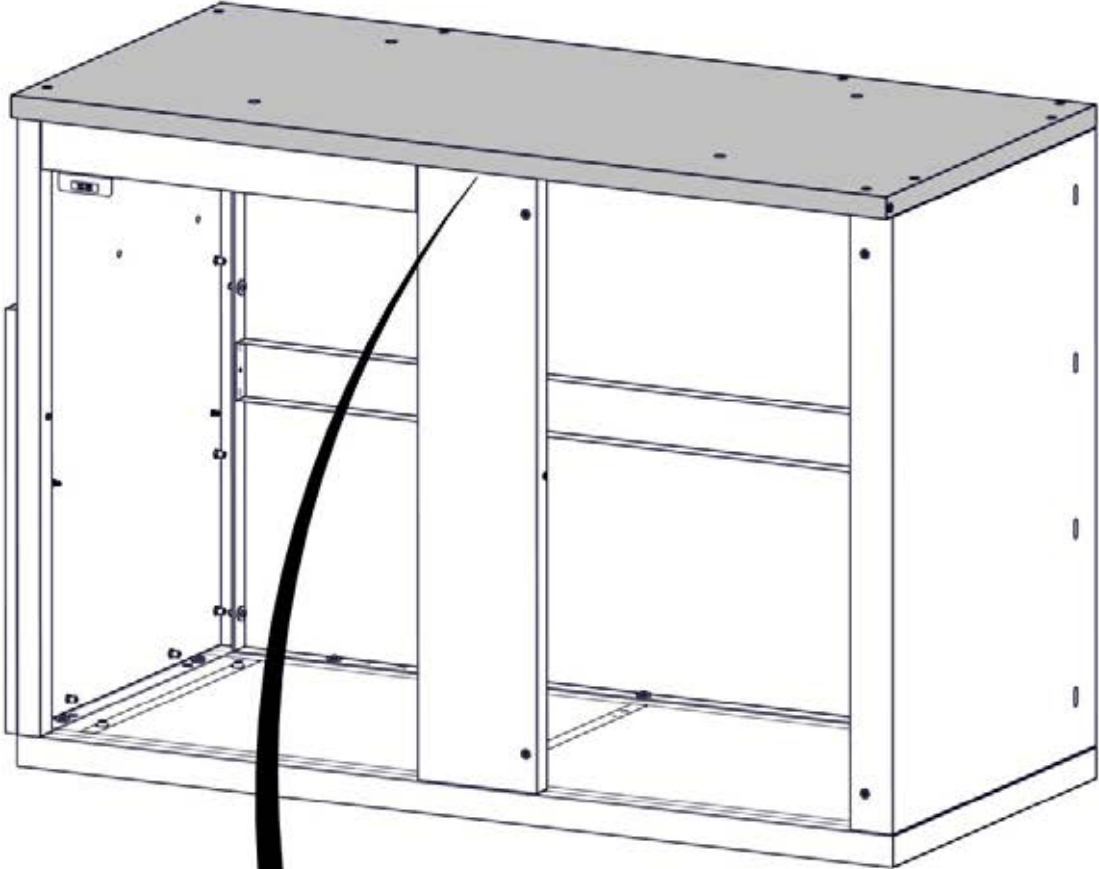

**NOTE HARDWARE
ATTACHES ON
INSIDE OF CABINET**

**1202 (x3)
TORX PAN HEAD 1/4-20x3/4 ASSY**

STEP 51 - GRILL CABINET INSTALLATION



GRILL CABINET FROM PREVIOUS STEPS

Qty	PartNo	Description
4	H101202	TORX PAN HEAD 1/4-20x3/4 ASSY

- POSITION GRILL CABINET ASSEMBLY UNDERNEATH FUSION FIRE STRUCTURE.
- SIDE OF GRILL CABINET WILL SIT AGAINST THE INSIDE OF BACK RIGHT POST.
- BACKSIDE OF GRILL CABINET WILL SIT FLUSH WITH BACKSIDE OF POST.
- **BEFORE TIGHTENING HARDWARE, ADJUST CABINET FEET AS NEEDED UNTIL GRILL CABINET IS LEVEL**

ALIGN SLOTS ON INSIDE OF CABINET WITH THREADED INSERTS IN BACK POST

1202 (x4)
TORX PAN HEAD
1/4-20x3/4 ASSY

FLUSH BACK SIDE OF GRILL CABINET WITH BACKSIDE OF POST

BACK VIEW

GRILL CABINET FROM PREVIOUS STEPS

STEP 52 - GRILL CABINET ASSEMBLY

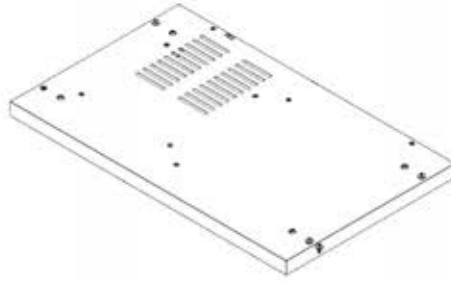

F2 GRILL CABINET FLOOR PANEL ASSEMBLY - A4M03048
(x1) 2 5/8"x23 3/8"x38 1/4" (66x594x972)

- ONLY KITCHEN GRILL CABINETS ARE SHOWN FOR DETAIL.
- **LOOKING AT THE BACKSIDE OF THE CABINETS, SLIDE FLOOR PANEL IN BETWEEN GRILL CABINETS.**

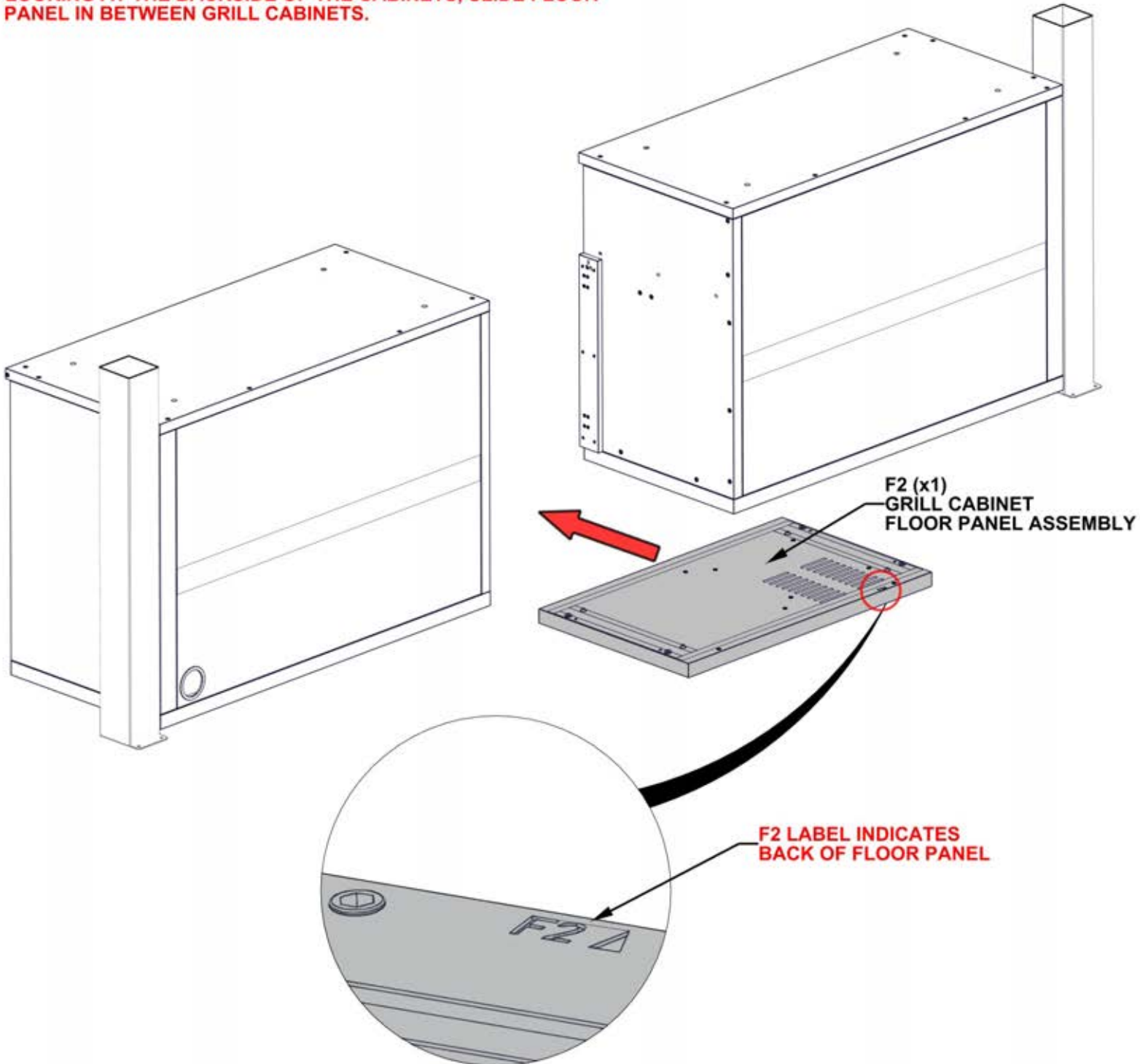

STEP 53 - GRILL CABINET ASSEMBLY

- ONLY KITCHEN GRILL CABINETS ARE SHOWN FOR DETAIL.
- POSITION FLOOR PANEL AS SHOWN BELOW.
- EACH FLOOR PANEL HAS FACTORY INSTALLED ADJUSTABLE FEET. USE PROVIDED HEX DRIVER TO ADJUST EACH FOOT UNTIL PANEL IS LEVEL.
- ADJUST LEFT AND RIGHT CORNER CABINET TO ELIMINATE ANY GAPS BETWEEN FLOOR PANEL AND CABINETS.

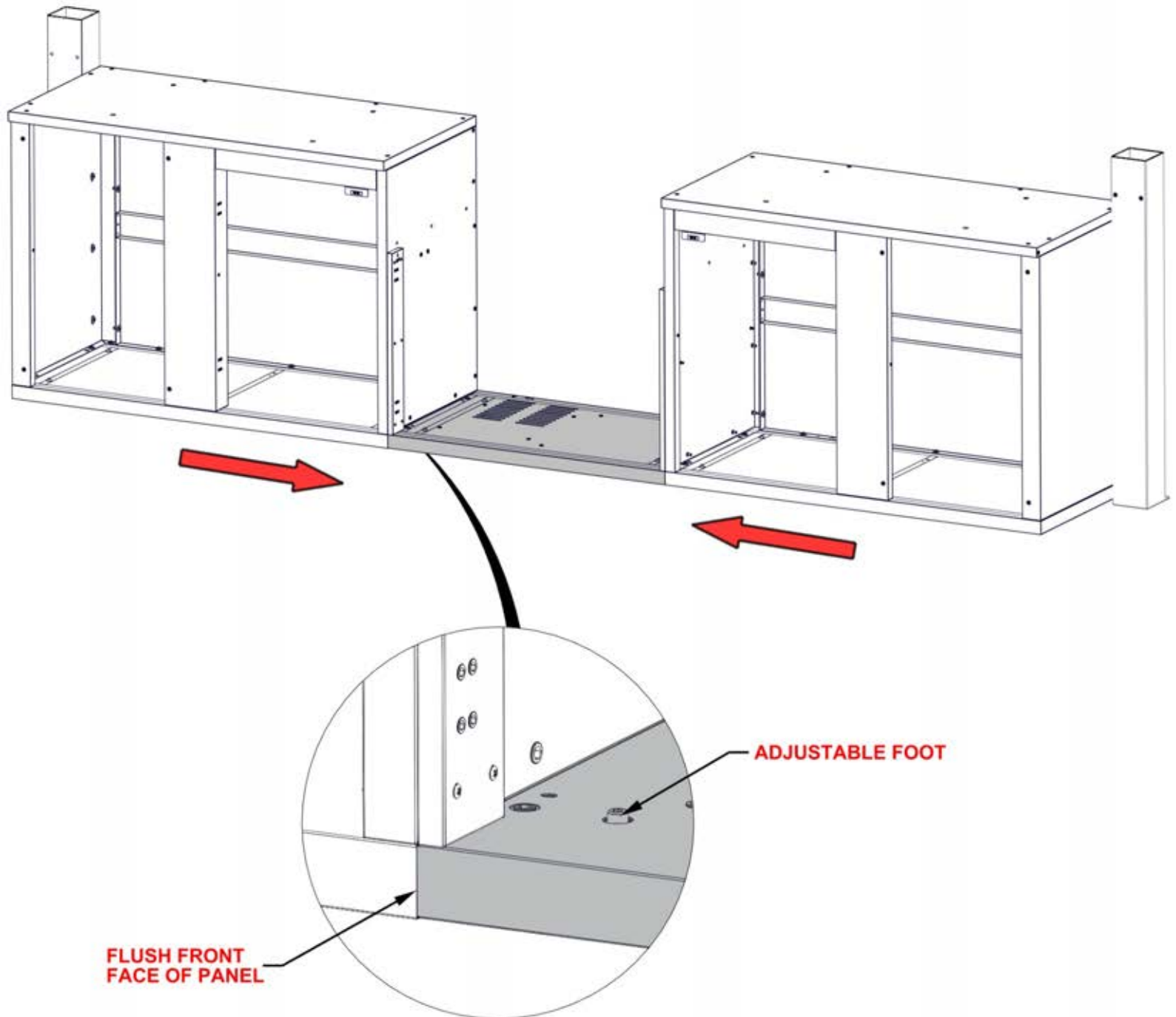

STEP 54 - GRILL CABINET ASSEMBLY

Qty	PartNo	Description
4	H101202	TORX PAN HEAD 1/4-20x3/4 ASSY

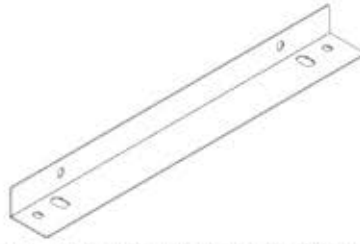

A6 ANGLED BRACKET - A4M03053
(x1) 1 3/8"x1 15/16"x17 1/8" (35x50x435)

- ONLY KITCHEN GRILL CABINETS ARE SHOWN FOR DETAIL.

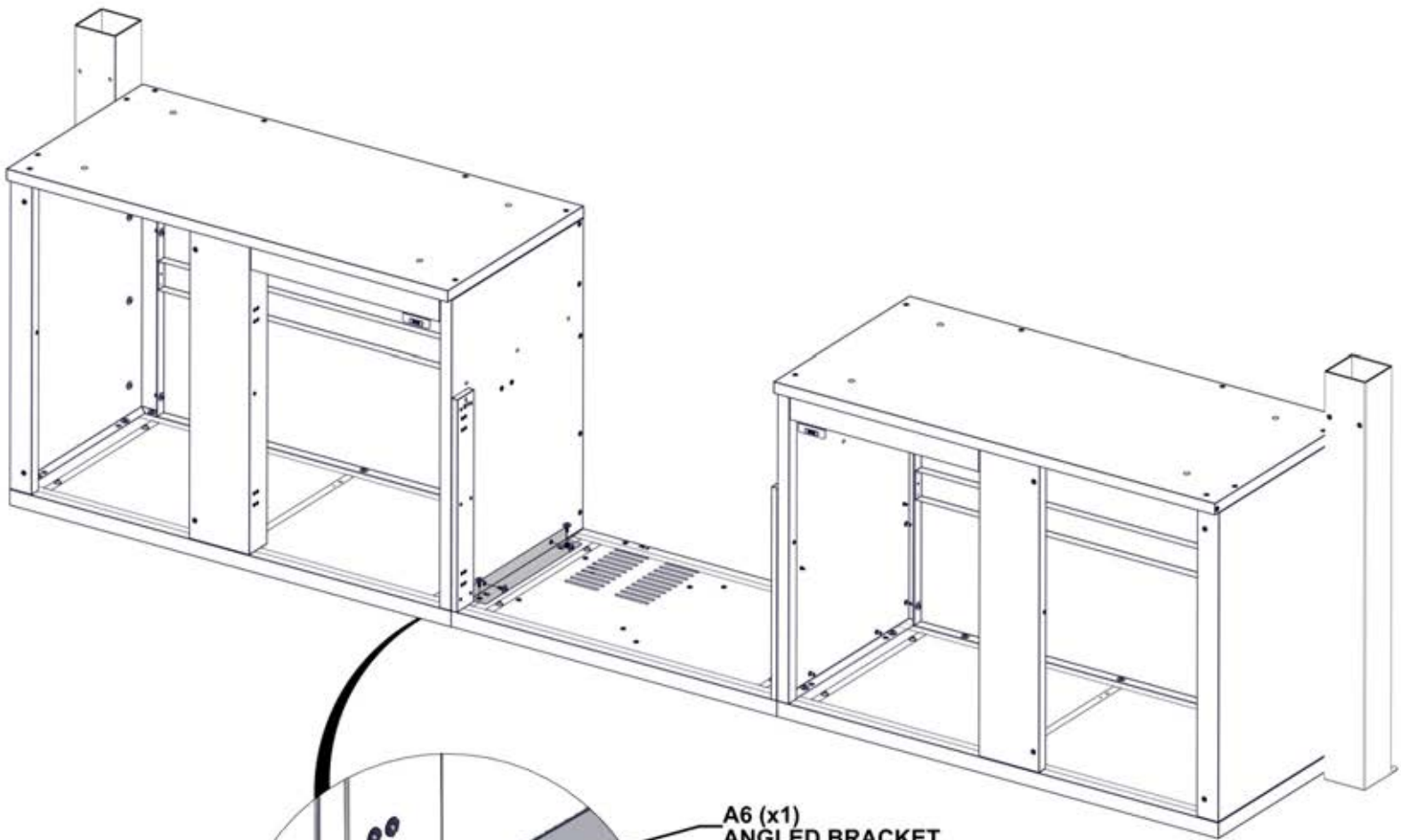

A6 (x1)
ANGLED BRACKET

1202 (x4)
TORX PAN HEAD 1/4-20x3/4 ASSY

**MAKE SURE FRONT
FACE OF FLOOR
PANELS ARE FLUSH**

STEP 55 - GRILL CABINET ASSEMBLY

Qty	PartNo	Description
4	H101202	TORX PAN HEAD 1/4-20x3/4 ASSY

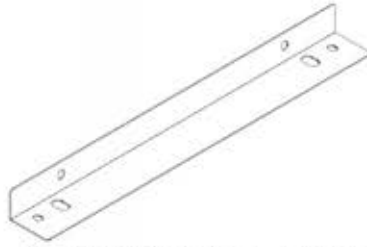

A6 ANGLED BRACKET - A4M03053
(x1) 1 3/8"x1 15/16"x17 1/8" (35x50x435)

- ONLY KITCHEN GRILL CABINETS ARE SHOWN FOR DETAIL.

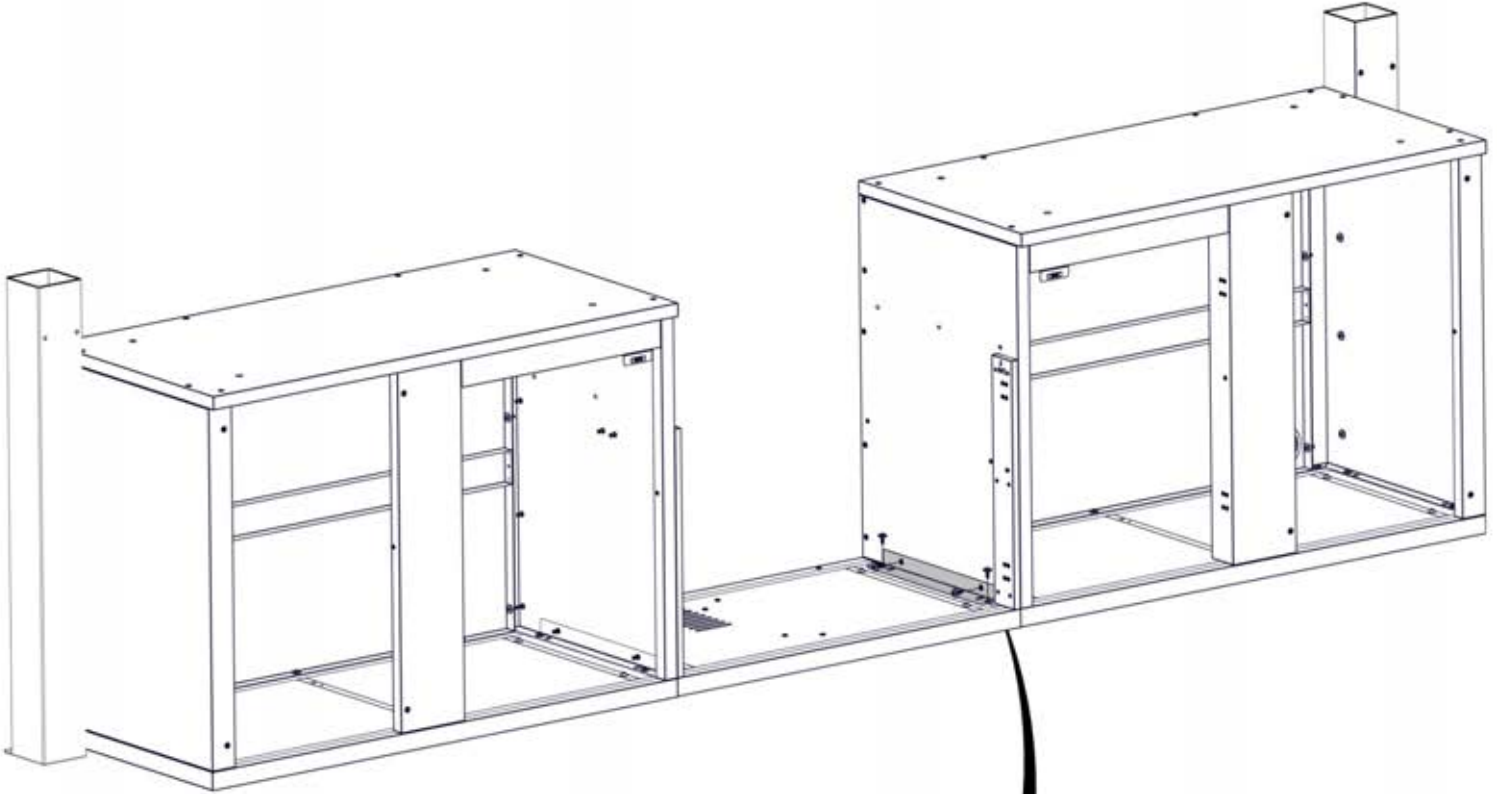

A6 (x1)
ANGLED BRACKET

1202 (x4)
TORX PAN HEAD 1/4-20x3/4 ASSY

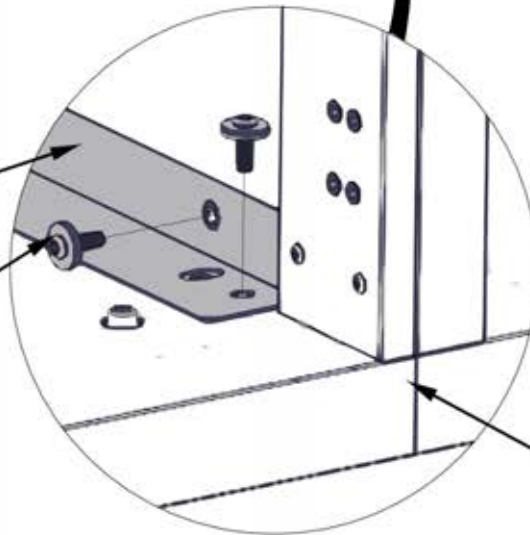

**MAKE SURE FRONT
FACE OF FLOOR
PANELS ARE FLUSH**

STEP 56 - GRILL CABINET ASSEMBLY

Qty	PartNo	Description
8	H101202	TORX PAN HEAD 1/4-20x3/4 ASSY

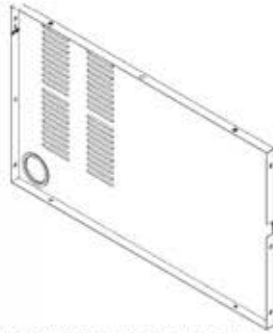

G10 GRILL CABINET BACK PANEL ASSEMBLY - A4M03055
(x1) 1 3/16"x22 7/8"x38 3/16" (30x581x970)

- ONLY KITCHEN GRILL CABINETS ARE SHOWN FOR DETAIL.

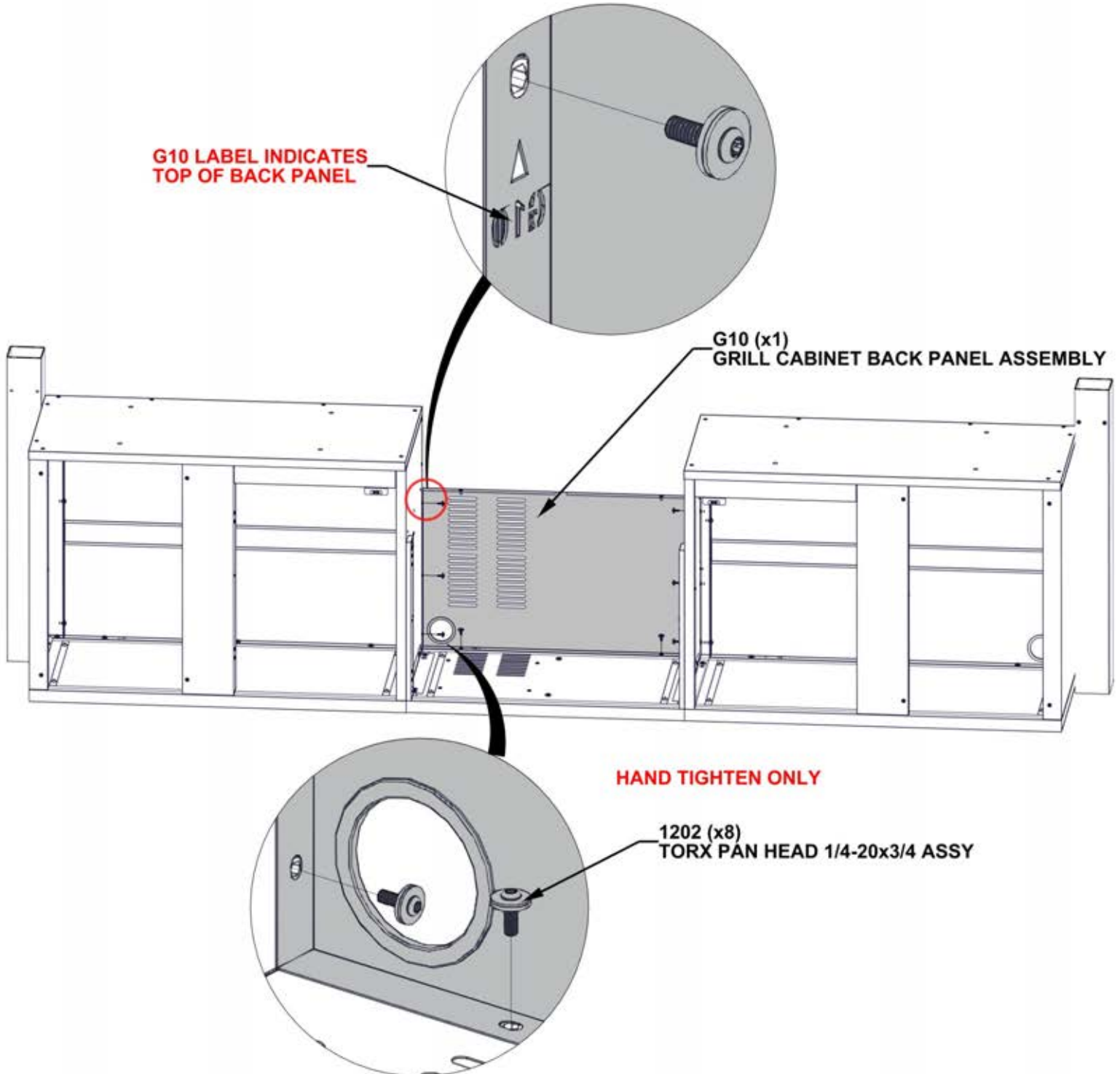

STEP 57 - GRILL CABINET ASSEMBLY

Qty	PartNo	Description
2	H101202	TORX PAN HEAD 1/4-20x3/4 ASSY



G5 GRILL CABINET SIDE WALL ASSEMBLY M - A4M03050
(x1) 1 3/4"x22 13/16"x23 1/4" (44x579x591)

- ONLY KITCHEN GRILL CABINETS ARE SHOWN FOR DETAIL.

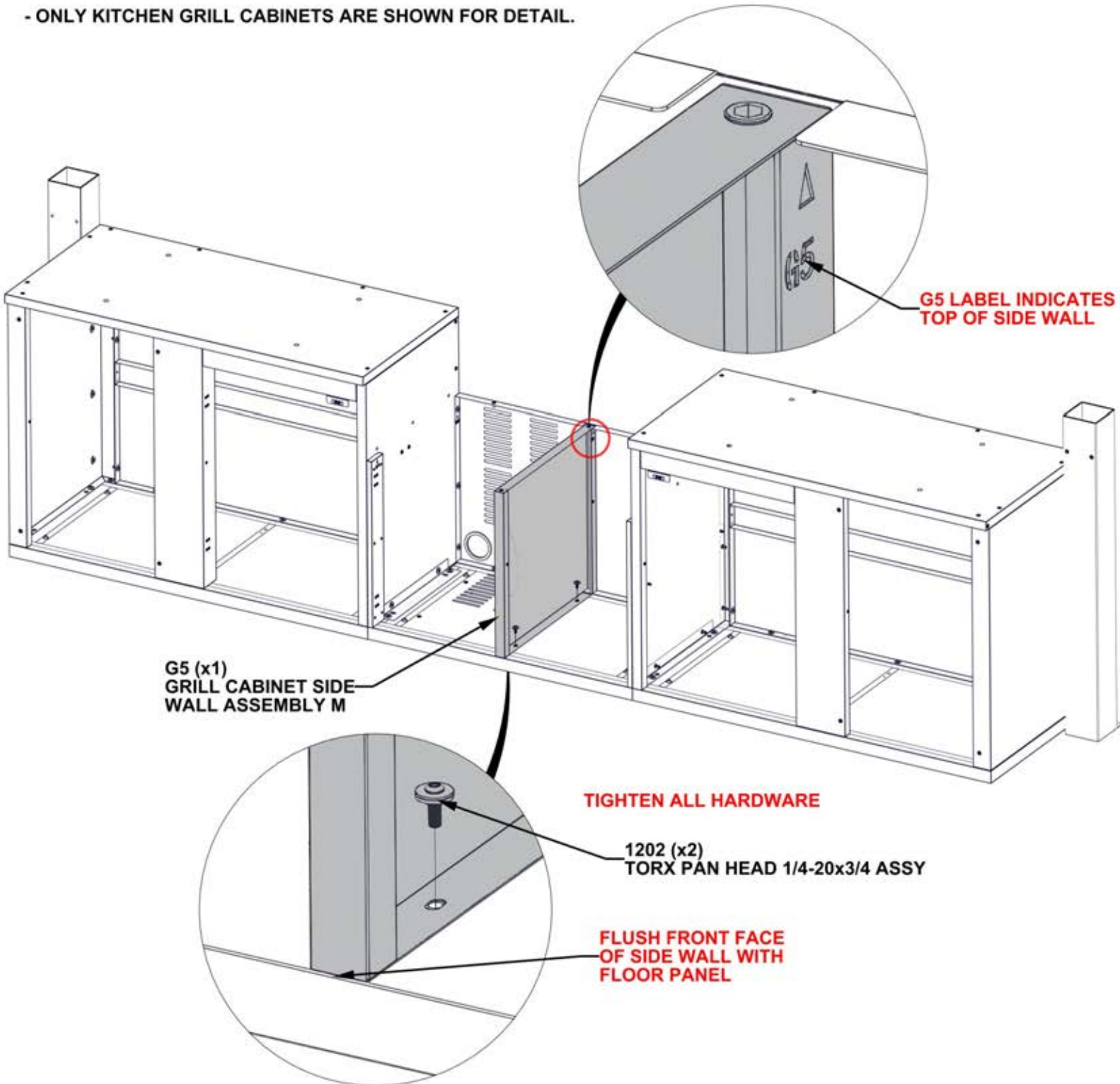

STEP 58 - GRILL CABINET ASSEMBLY

Qty	PartNo	Description
5	H101289	PAN HEAD SCREW 8-32x1/2" SS

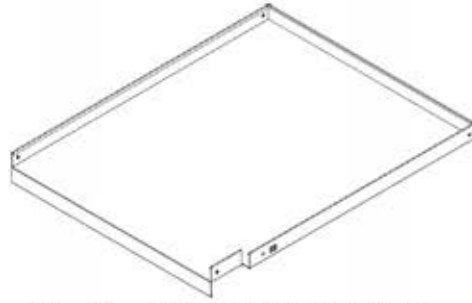

C3 GRILL CABINET SHELF - A4M03054
(x1) 2 5/16"x18 1/4"x22 11/16" (59x464x577)

- ONLY KITCHEN GRILL CABINETS ARE SHOWN FOR DETAIL.

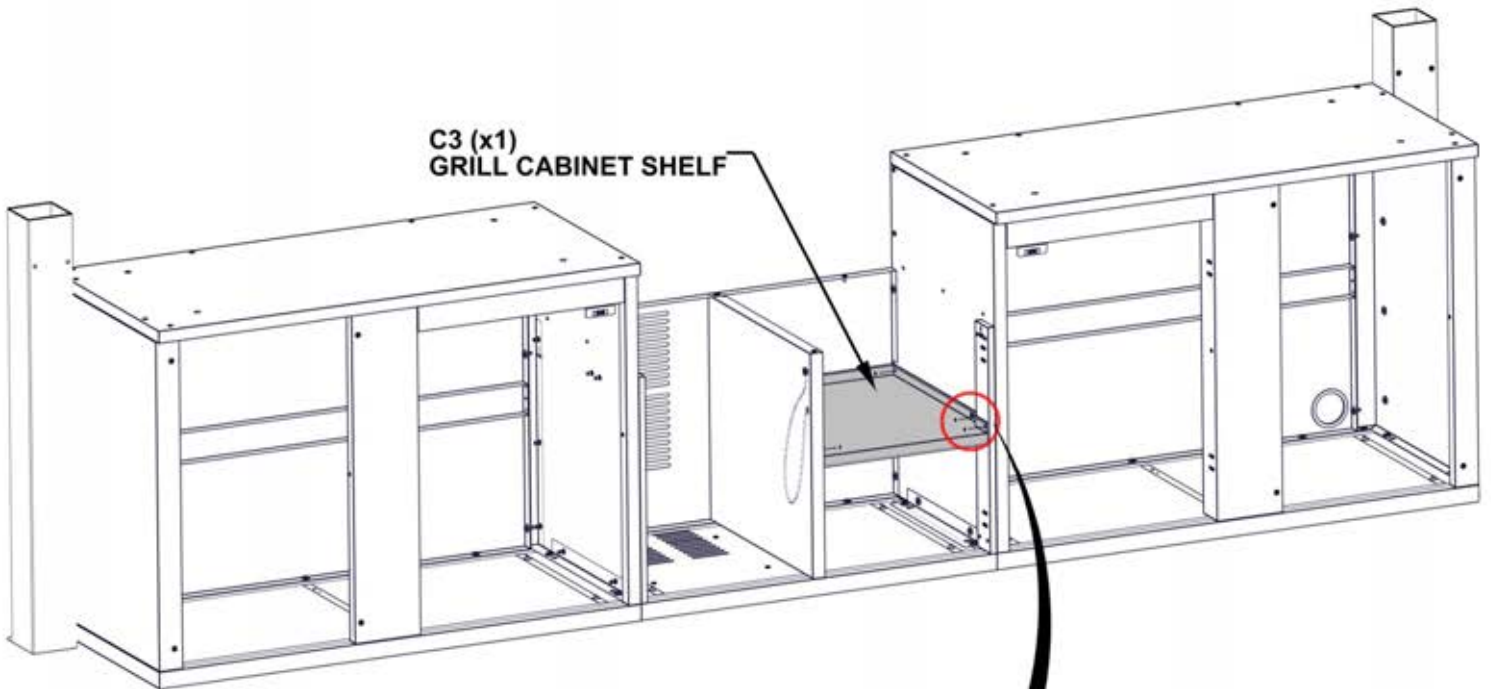

C3 (x1)
GRILL CABINET SHELF

C3 LABEL INDICATES
FRONT OF SHELF

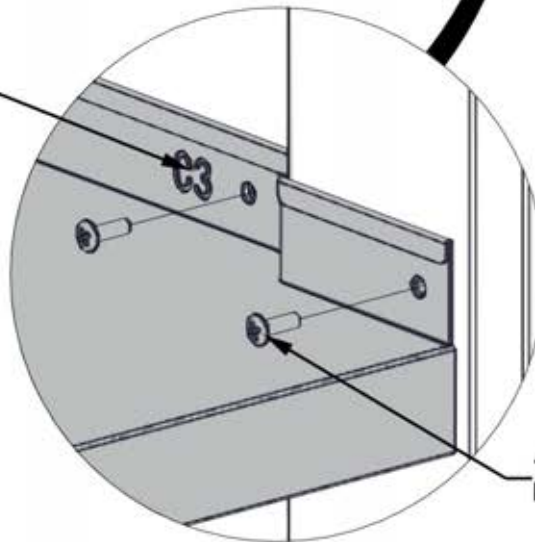

1289 (x5)
PAN HEAD SCREW 8-32x1/2" SS

STEP 59 - GRILL CABINET ASSEMBLY

Qty	PartNo	Description
2	H101202	TORX PAN HEAD 1/4-20x3/4 ASSY



A9 HOSE BRACKET ASSEMBLY - A4M03060
(x1) 1 1/4"x1 7/16"x2 9/16" (31.5x36.5x65)

- ONLY KITCHEN GRILL CABINETS ARE SHOWN FOR DETAIL.

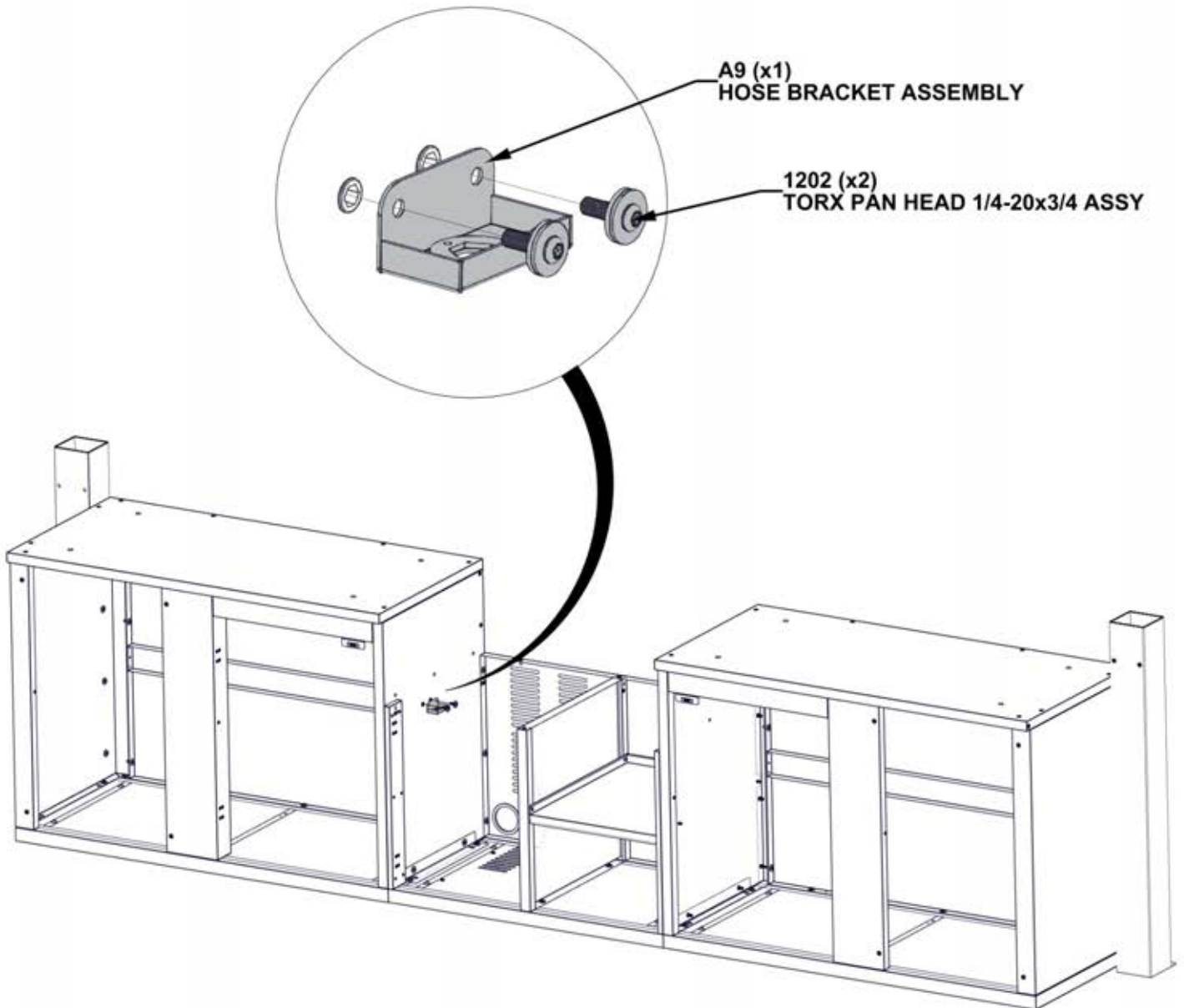

STEP 60 - GRILL CABINET ASSEMBLY

Qty	PartNo	Description
4	H101292	TORX PAN HEAD 1/4-20x13/32"

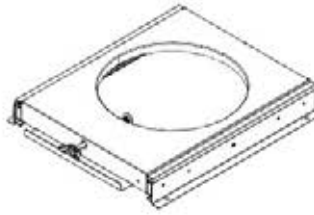

A13 GAS TANK HOLDER ASSEMBLY - A4M03047
(x1) 1 15/16"x12 7/8"x14 3/4" (49x327x374)

- ONLY KITCHEN GRILL CABINETS ARE SHOWN FOR DETAIL.

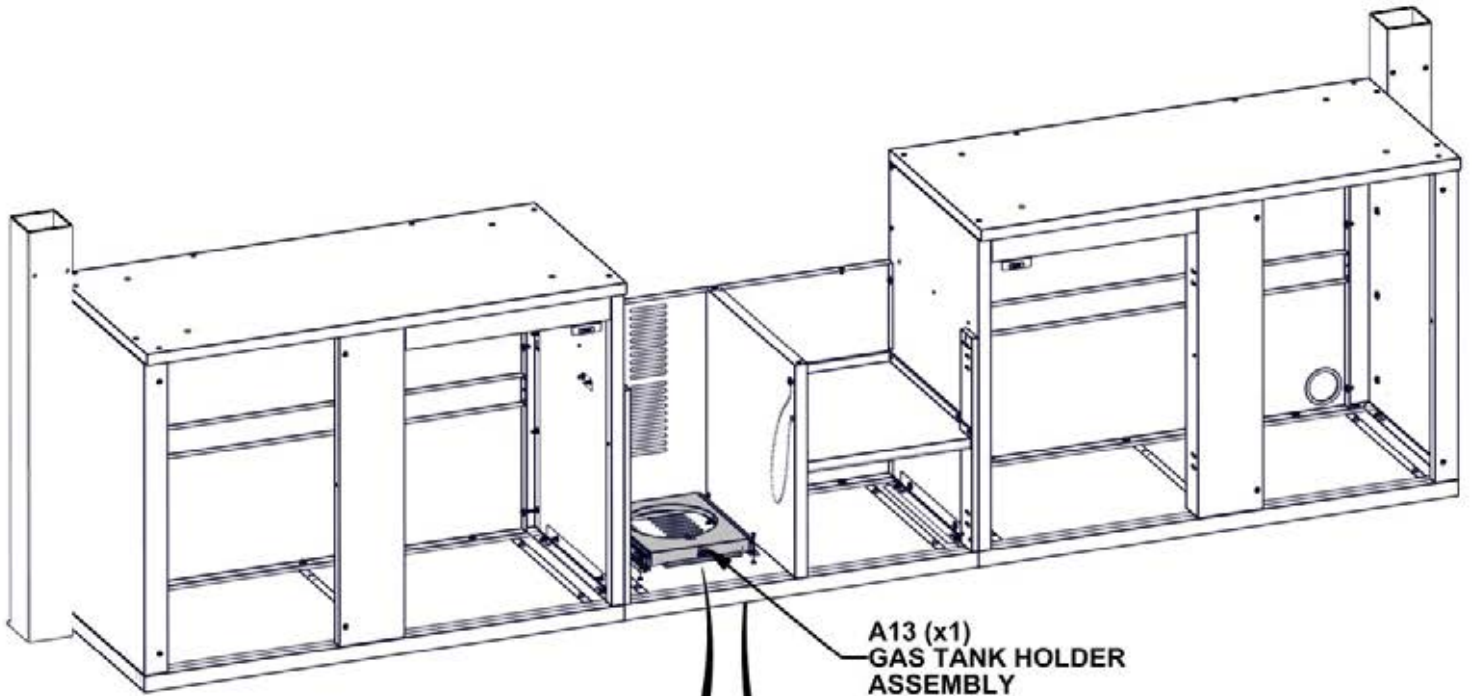

A13 (x1)
GAS TANK HOLDER
ASSEMBLY

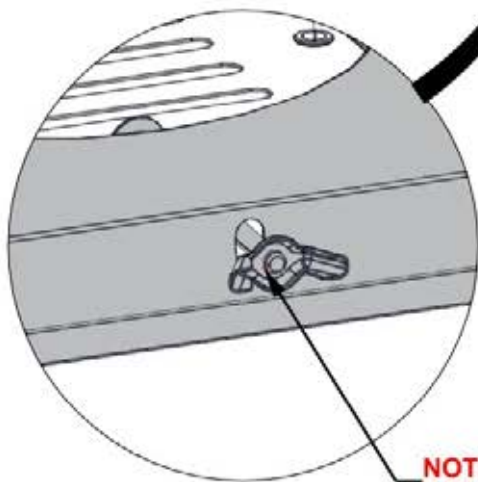

**NOTE ORIENTATION OF
WING NUT TOWARDS FRONT**

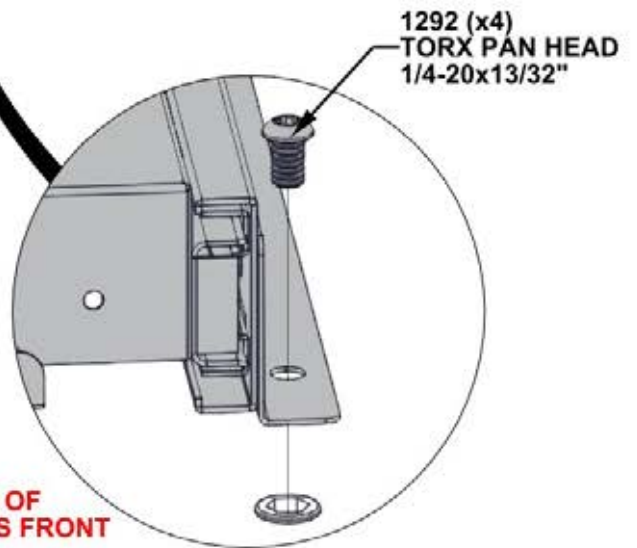

1292 (x4)
TORX PAN HEAD
1/4-20x13/32"

STEP 61 - GRILL CABINET ASSEMBLY

Qty	PartNo	Description
4	H101289	PAN HEAD SCREW 8-32x1/2" SS

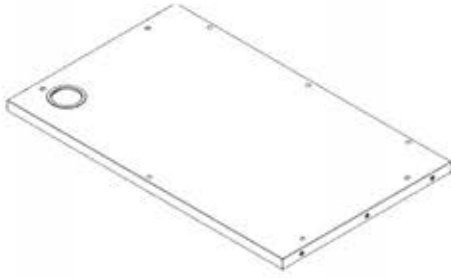

T2 GRILL TABLETOP ASSEMBLY - A4M03057
(x1) 1 1/4"x23 3/8"x38 3/16" (32x594x970)



A2 MAGNET BRACKET - A4M03026
(x2) 1"x1 1/4"x3 1/8" (25x31x80)

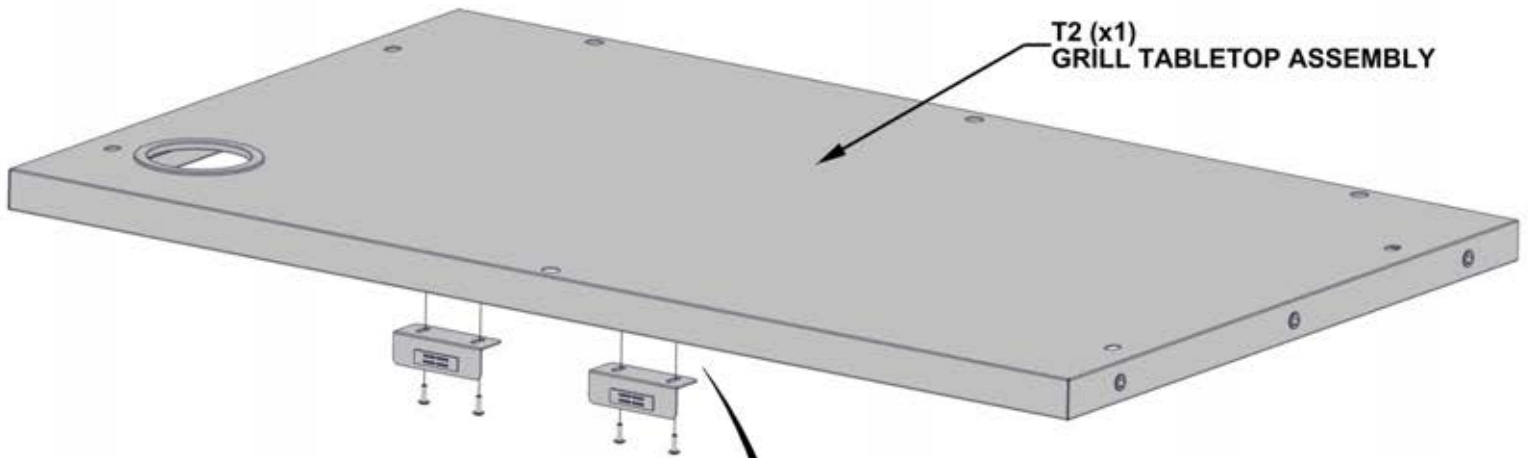

T2 (x1)
GRILL TABLETOP ASSEMBLY

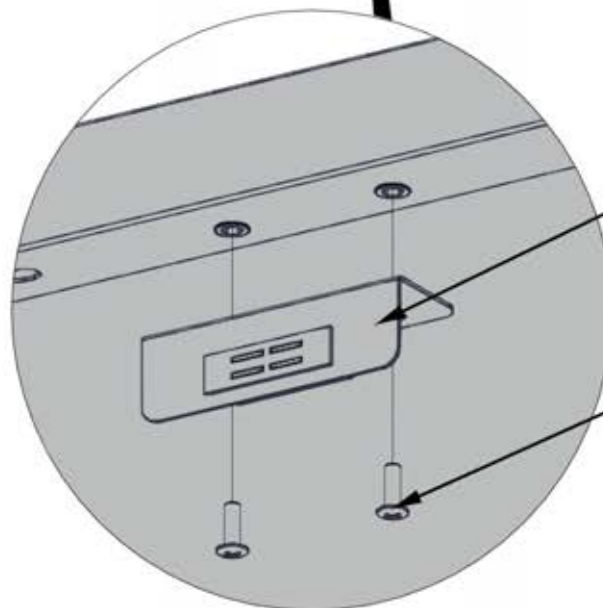

A2 (x2)
MAGNET BRACKET

1289 (x4)
PAN HEAD SCREW 8-32x1/2" SS

STEP 62A - GRILL CABINET ASSEMBLY

Qty	PartNo	Description
6	H101202	TORX PAN HEAD 1/4-20x3/4 ASSY

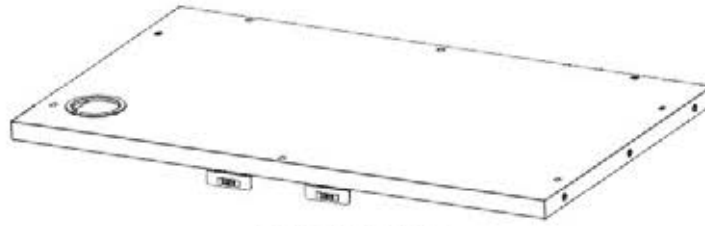

GRILL TABLETOP
ASSEMBLY FROM STEP 61

- ONLY KITCHEN GRILL CABINETS ARE SHOWN FOR DETAIL.

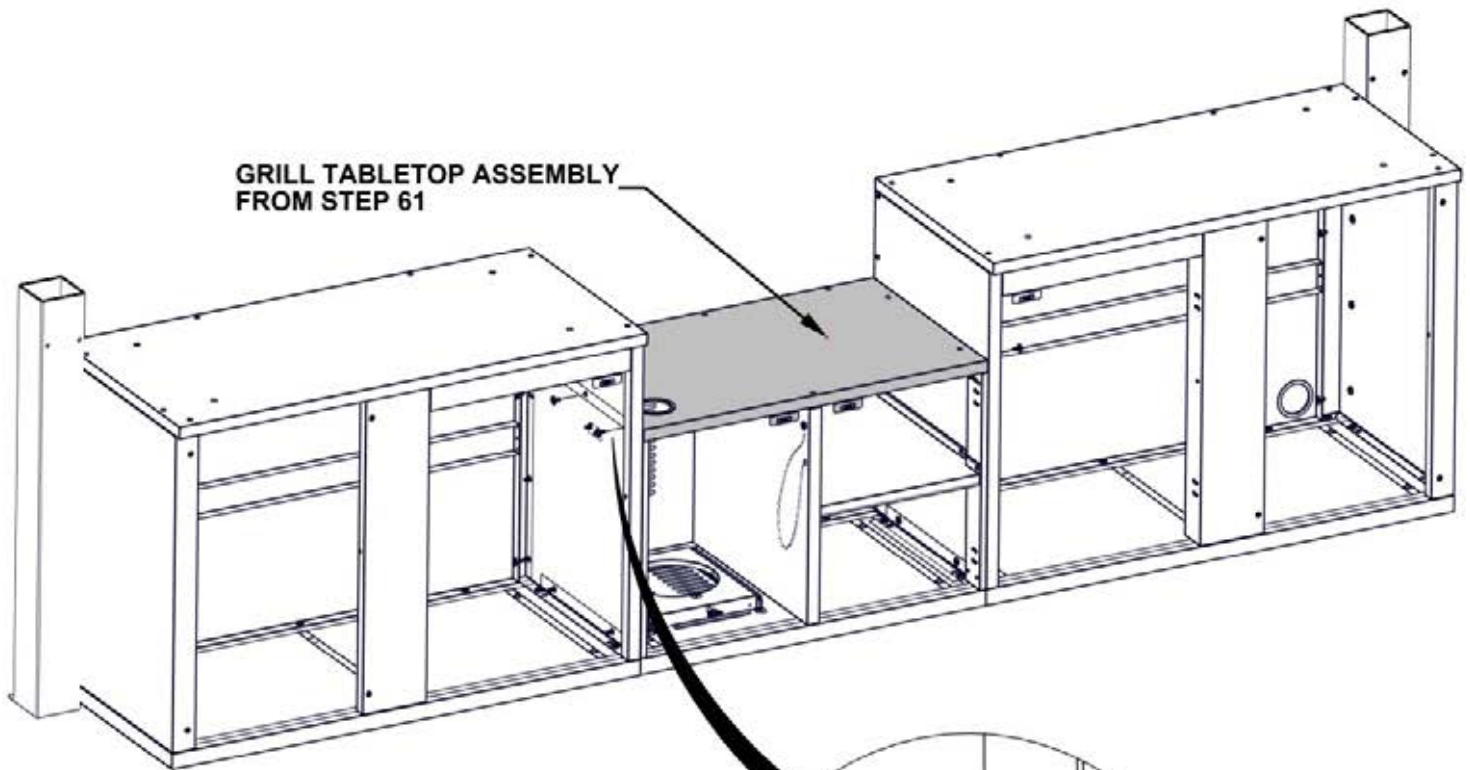

GRILL TABLETOP ASSEMBLY
FROM STEP 61

**NOTE HARDWARE
ATTACHES ON
INSIDE OF CABINETS**

1202 (x6)
TORX PAN HEAD 1/4-20x3/4 ASSY

HAND TIGHTEN ONLY

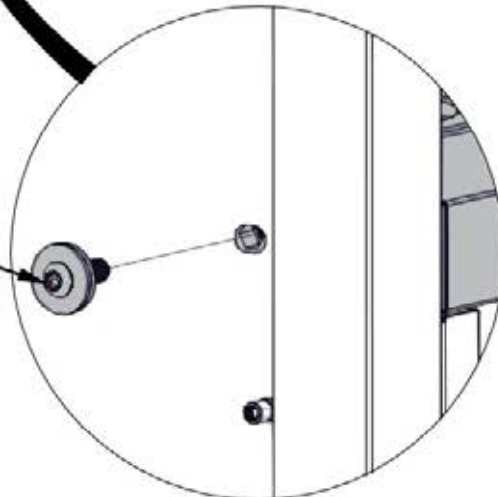

STEP 62B - GRILL CABINET ASSEMBLY

Qty	PartNo	Description
4	H101103	TORX SOCKET SCREW 1/4-20

- ONLY KITCHEN GRILL CABINETS ARE SHOWN FOR DETAIL.

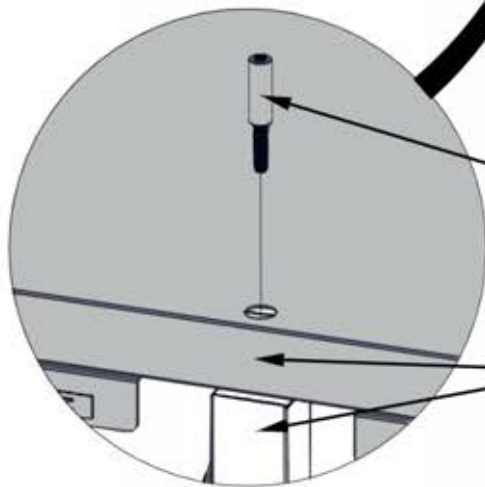
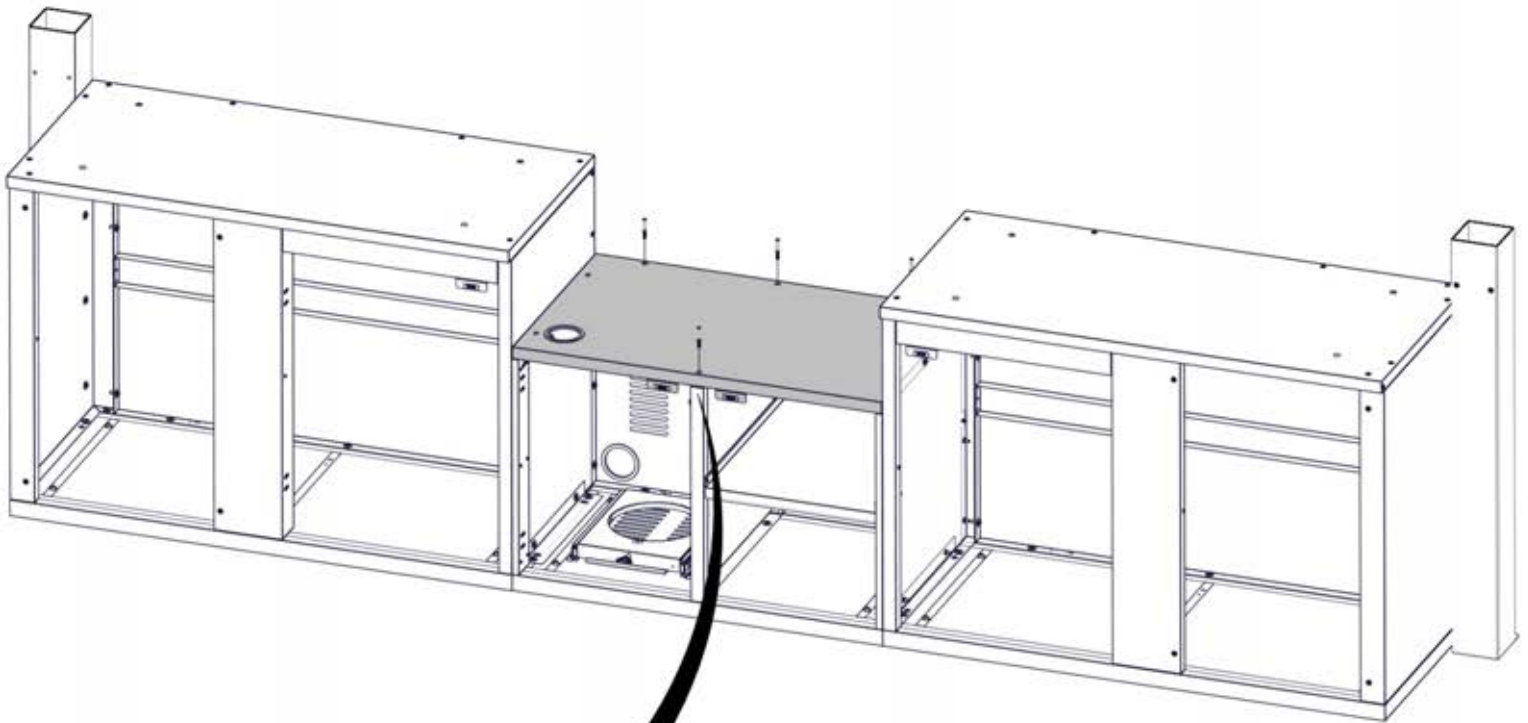

TIGHTEN ALL HARDWARE

1103 (x4)
TORX SOCKET SCREW 1/4-20

**MAKE SURE FRONT
FACE OF TABLETOP
IS FLUSH WITH
UPRIGHT PANEL**

STEP 63 - GRILL CABINET ASSEMBLY

Qty	PartNo	Description
4	H101202	TORX PAN HEAD 1/4-20x3/4 ASSY

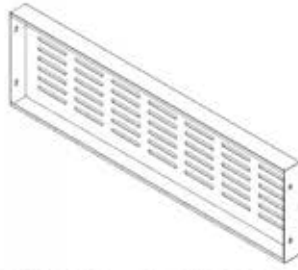

G11 GRILL VENTILATION PANEL - A4M03056
(x1) 1 5/16"x11 3/16"x38 3/16" (33x284x970)

- ONLY KITCHEN GRILL CABINETS ARE SHOWN FOR DETAIL.

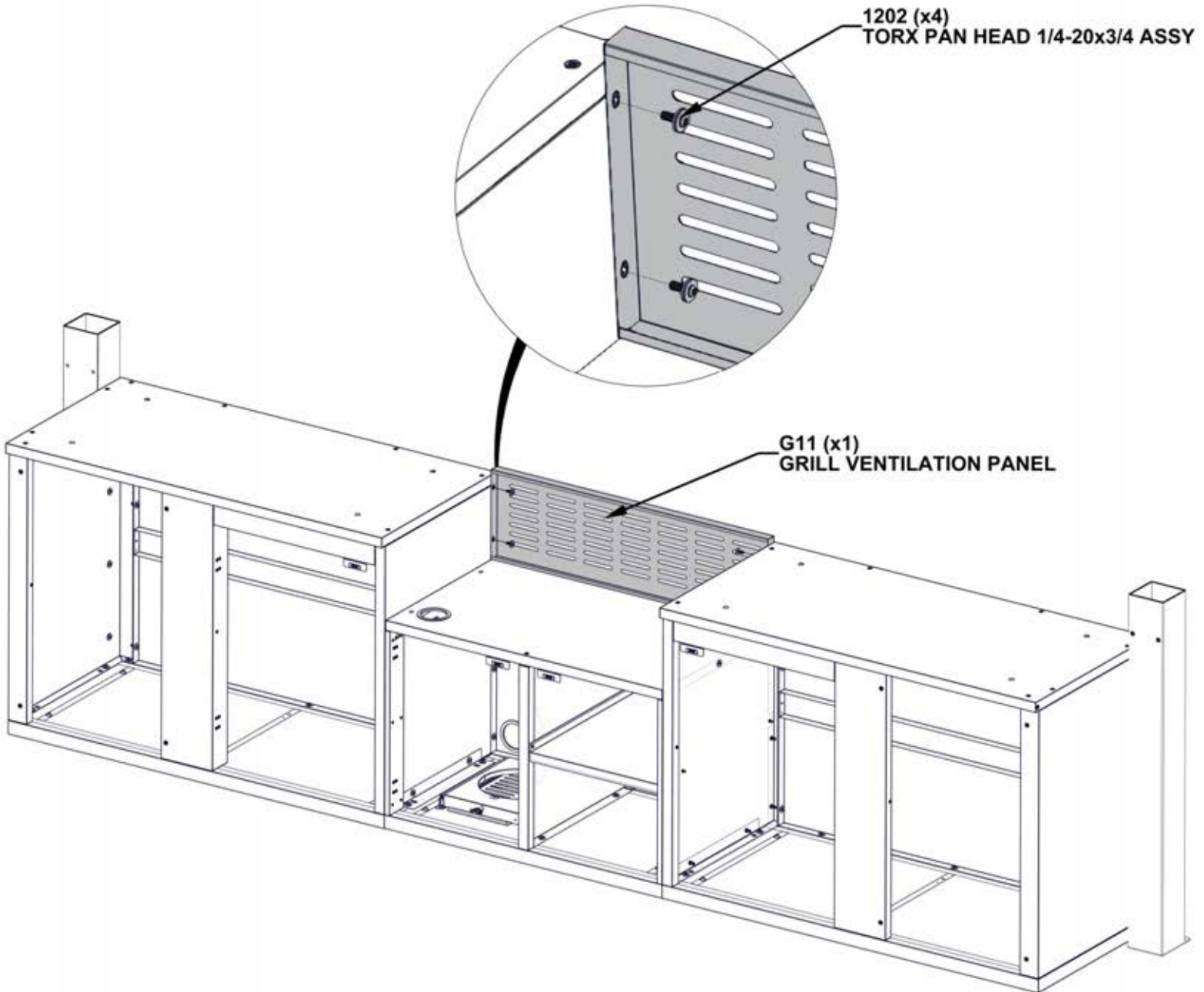

STEP 64A - GRILL CABINET ASSEMBLY

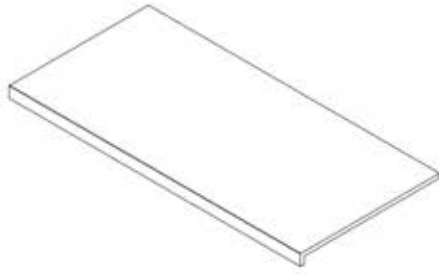

M1 CORNER CABINET MARBLE - A4M03035
(x1) 1 15/16"x24 13/16"x51 7/8" (50x630x1317)

- ONLY KITCHEN CABINETS ARE SHOWN FOR DETAIL.
- IT IS RECOMMENDED TO HAVE AT LEAST TWO PEOPLE SET MARBLE COUNTERTOP IN PLACE.
- SLIDE IN PLACE UNTIL MARBLE IS TIGHT AGAINST PANEL, AND FLUSH ON ALL SIDES.
- **WHEN SETTING MARBLE IN PLACE, MAKE SURE YOUR FINGERS ARE CLEAR AND NOT UNDERNEATH MARBLE.**

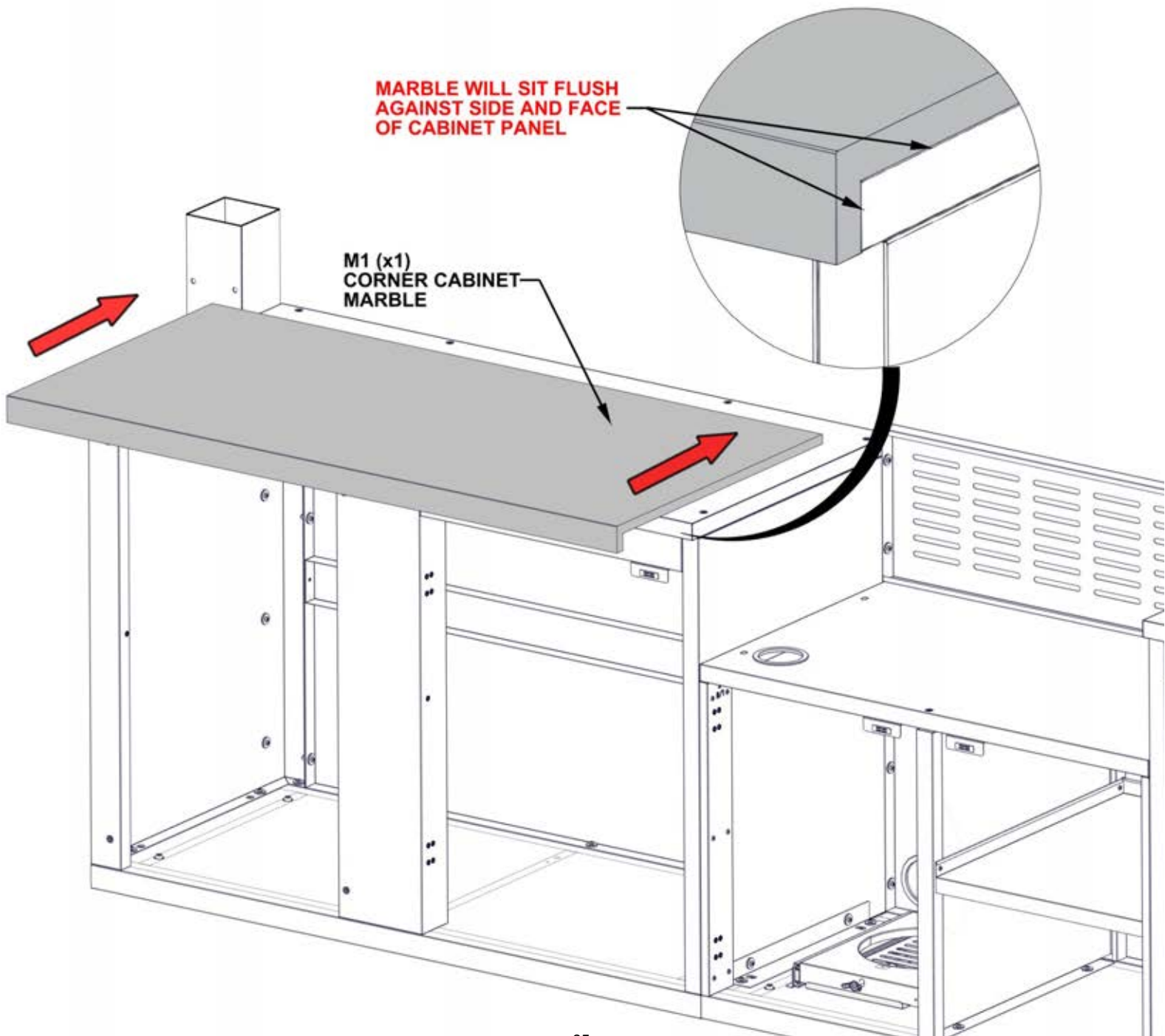

STEP 64B - GRILL CABINET ASSEMBLY

Qty	PartNo	Description
4	H101292	TORX PAN HEAD 1/4-20x13/32"
4	H101053	STEEL WASHER 6x20
4	H101054	SEALANT WASHER

- ONLY KITCHEN GRILL CABINETS ARE SHOWN FOR DETAIL.
- MAKE SURE YOU ARE USING THE CORRECT HARDWARE FOR THIS STEP.
- ONCE MARBLE IS IN PLACE, IT IS RECOMMENDED TO COVER WITH A PIECE OF CARDBOARD OR FOAM UNTIL ASSEMBLY IS FINISHED TO PREVENT DAMAGE.
- DO NOT USE MARBLE SURFACE AS A WORK BENCH.

MAKE SURE ALL SIDES OF MARBLE ARE FLUSH BEFORE TIGHTENING HARDWARE

DO NOT OVERTIGHTEN HARDWARE

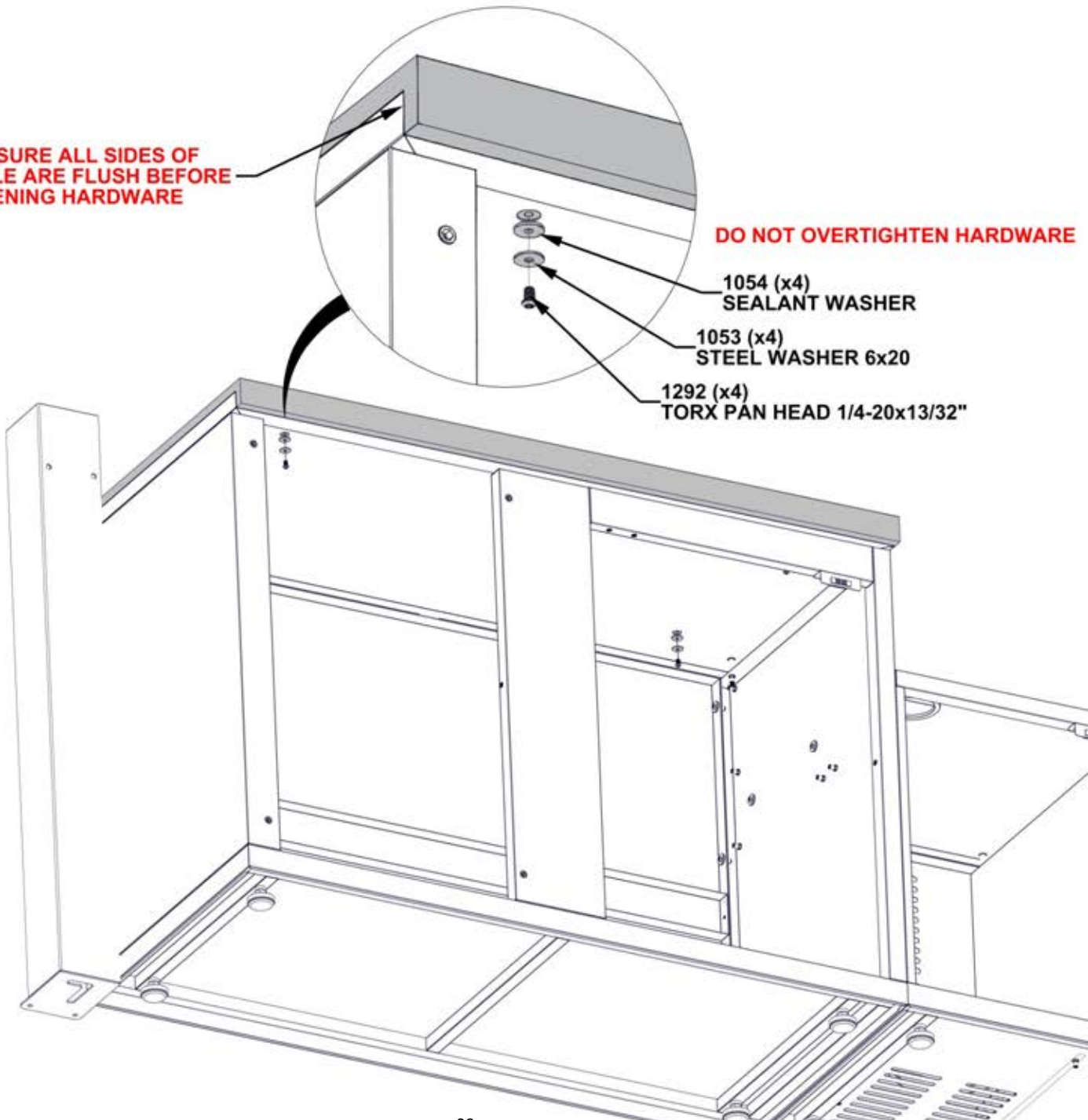

STEP 65A - GRILL CABINET ASSEMBLY

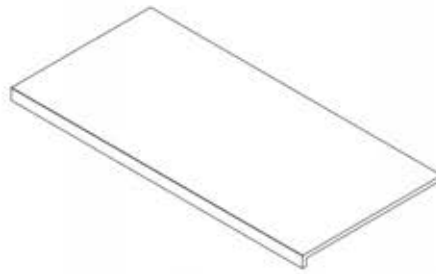

M1 CORNER CABINET MARBLE - A4M03035
(x1) 1 15/16"x24 13/16"x51 7/8" (50x630x1317)

- ONLY KITCHEN CABINETS ARE SHOWN FOR DETAIL.
- IT IS RECOMMENDED TO HAVE AT LEAST TWO PEOPLE SET MARBLE COUNTERTOP IN PLACE.
- SLIDE IN PLACE UNTIL MARBLE IS TIGHT AGAINST PANEL, AND FLUSH ON ALL SIDES.
- **WHEN SETTING MARBLE IN PLACE, MAKE SURE YOUR FINGERS ARE CLEAR AND NOT UNDERNEATH MARBLE.**

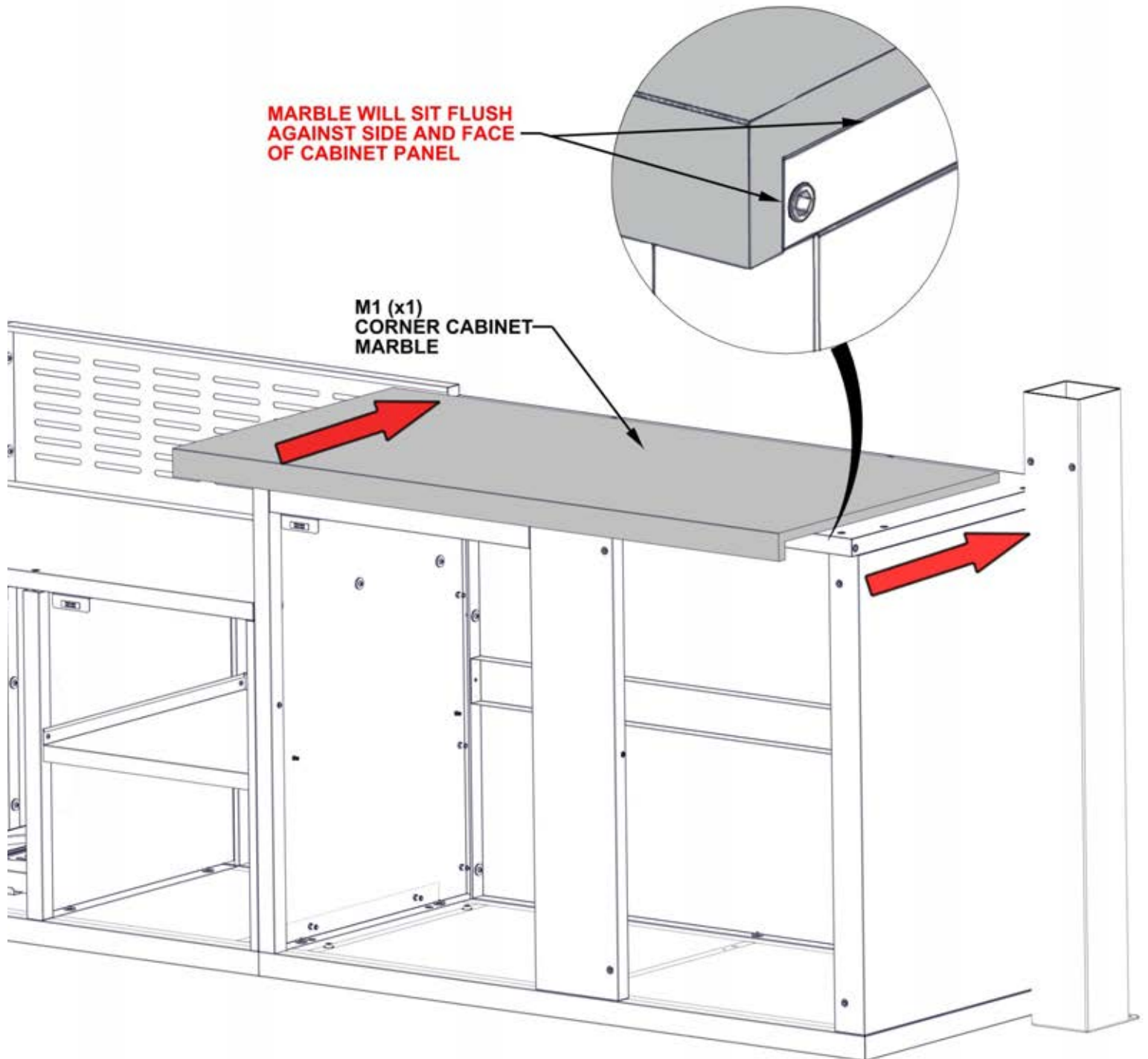

STEP 65B - GRILL CABINET ASSEMBLY

Qty	PartNo	Description
4	H101292	TORX PAN HEAD 1/4-20x13/32"
4	H101053	STEEL WASHER 6x20
4	H101054	SEALANT WASHER

- ONLY KITCHEN GRILL CABINETS ARE SHOWN FOR DETAIL.

- MAKE SURE YOU ARE USING THE CORRECT HARDWARE FOR THIS STEP.

- ONCE MARBLE IS IN PLACE, IT IS RECOMMENDED TO COVER WITH A PIECE OF CARDBOARD OR FOAM UNTIL ASSEMBLY IS FINISHED TO PREVENT DAMAGE.

- DO NOT USE MARBLE SURFACE AS A WORK BENCH.

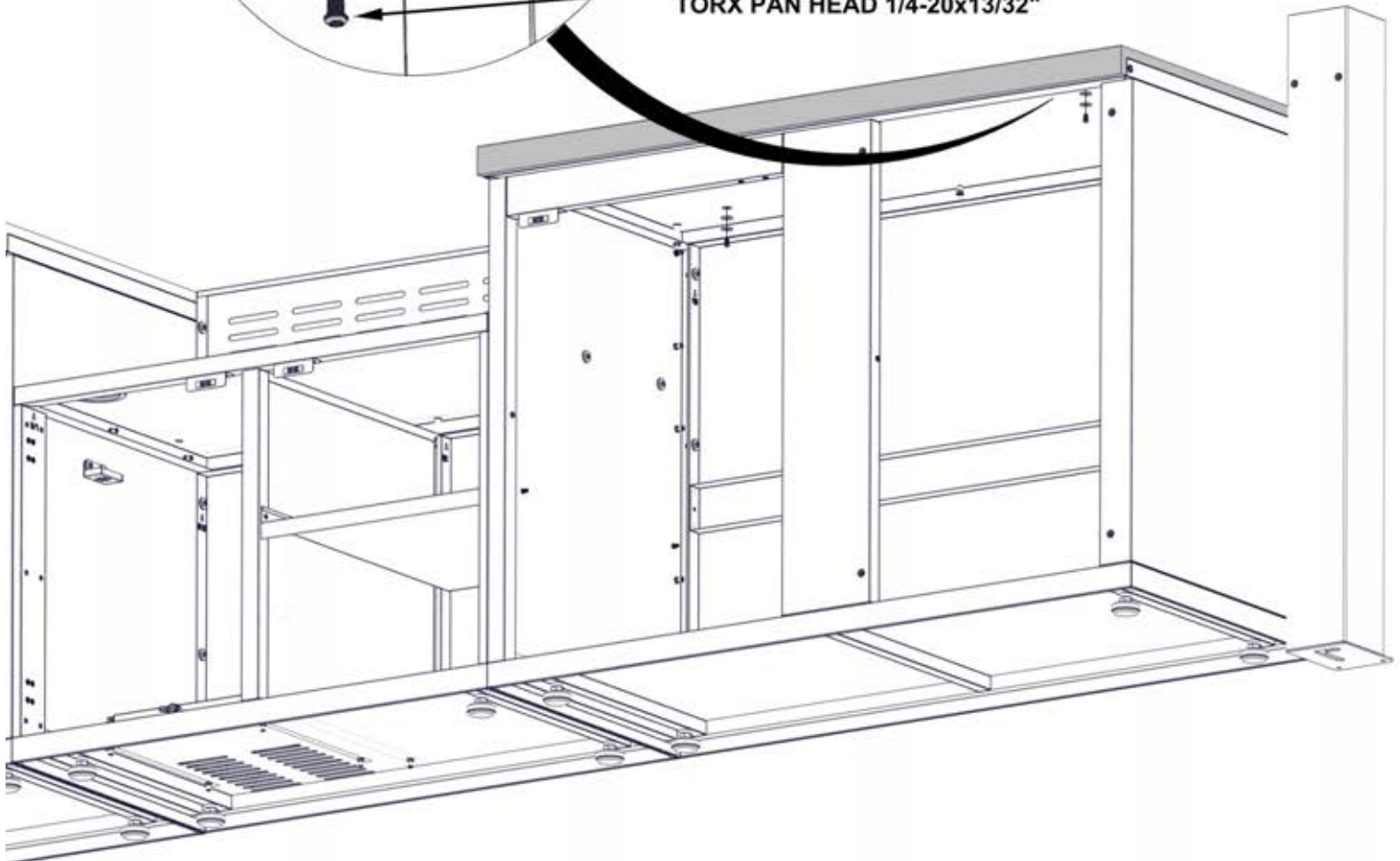
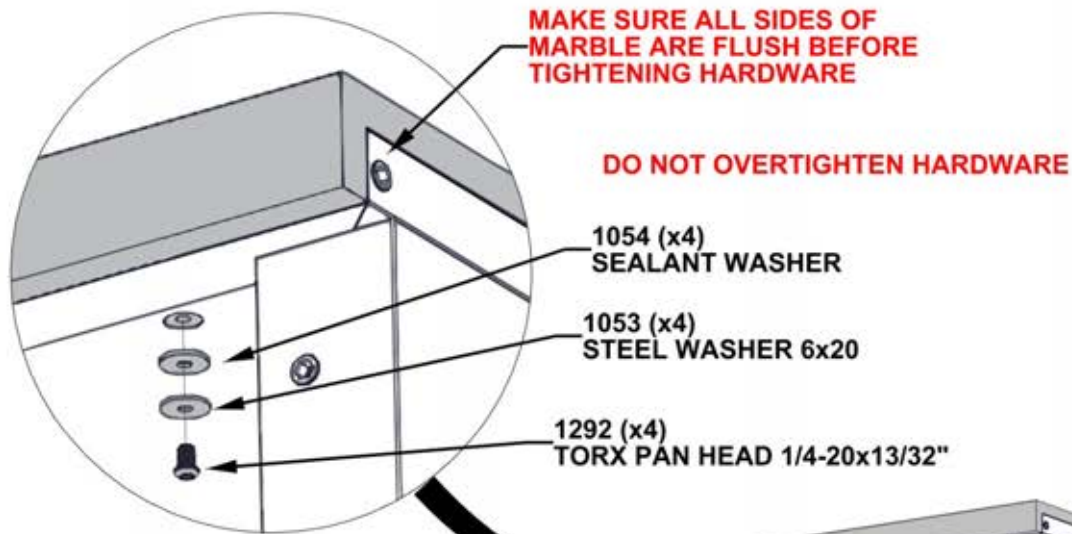

STEP 66 - GRILL CABINET ASSEMBLY

Qty	PartNo	Description
3	H101289	PAN HEAD SCREW 8-32x1/2" SS

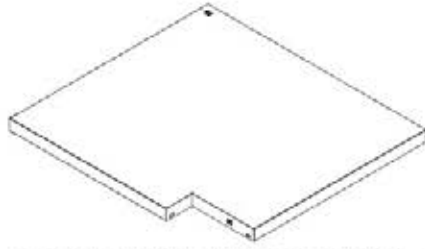

C2 CORNER CABINET SHELF ASSEMBLY L - A4M03038
(x1) 1 1/4"x23 1/8"x25 7/16" (32x588x646)

- ONLY KITCHEN GRILL CABINETS ARE SHOWN FOR DETAIL.

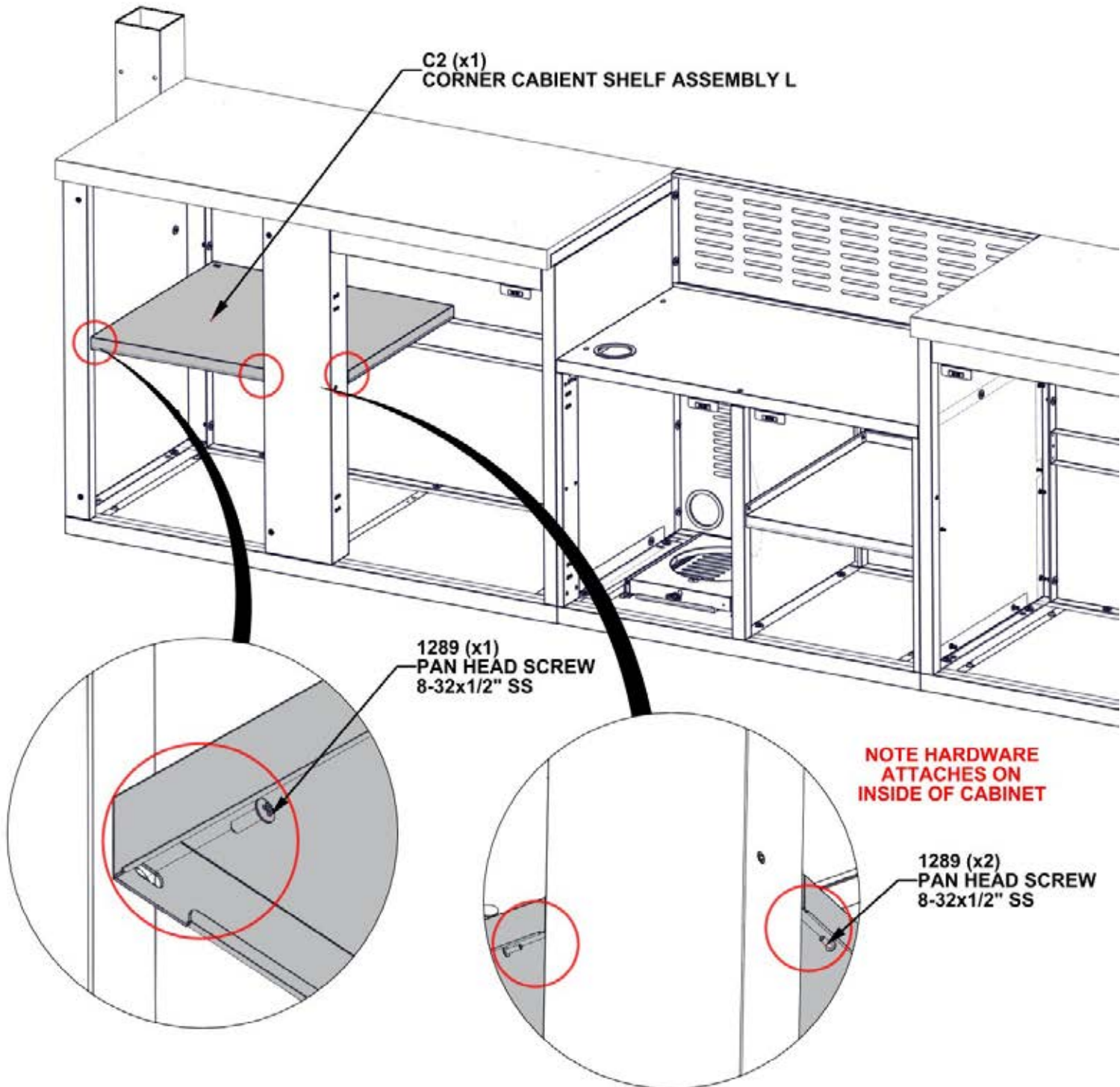

STEP 67 - GRILL CABINET ASSEMBLY

Qty	PartNo	Description
2	H101289	PAN HEAD SCREW 8-32x1/2" SS

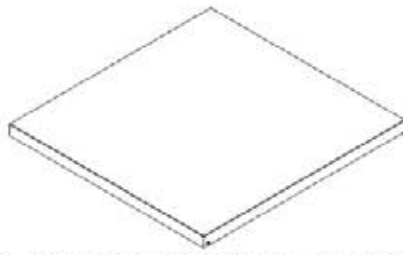

C1 CORNER CABINET SHELF - A4M03037
(x1) 1 3/16"x22 3/16"x23" (30x564x584)

- ONLY KITCHEN GRILL CABINETS ARE SHOWN FOR DETAIL.

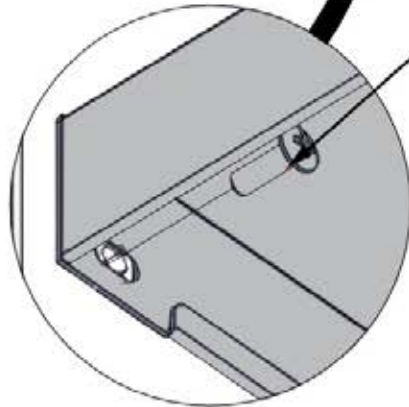
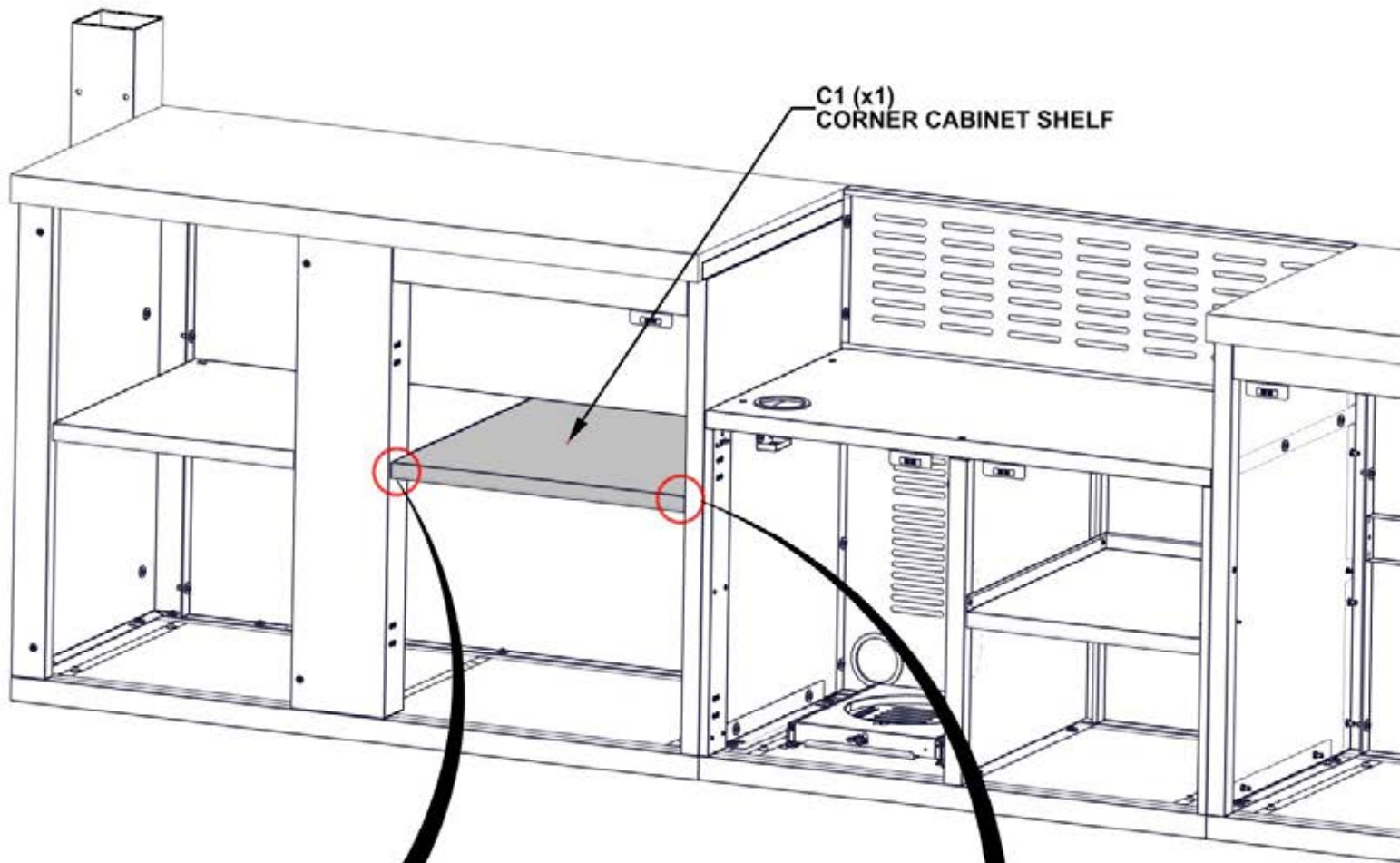

1289 (x1)
PAN HEAD SCREW
8-32x1/2" SS

**NOTE HARDWARE
ATTACHES ON
INSIDE OF CABINET**

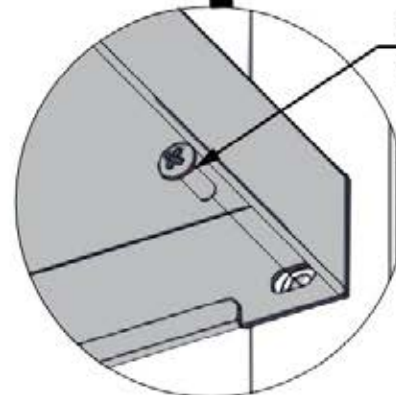

1289 (x1)
PAN HEAD SCREW
8-32x1/2" SS

STEP 68 - GRILL CABINET ASSEMBLY

Qty	PartNo	Description
3	H101289	PAN HEAD SCREW 8-32x1/2" SS

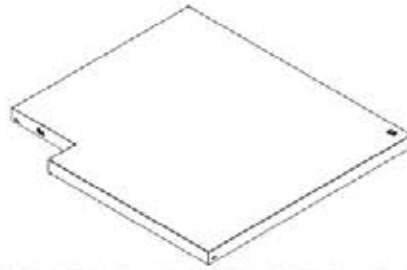

C4 CORNER CABINET SHELF ASSEMBLY R - A4M03046
(x1) 1 1/4"x23 1/8"x25 7/16" (32x588x646)

- ONLY KITCHEN GRILL CABINETS ARE SHOWN FOR DETAIL.

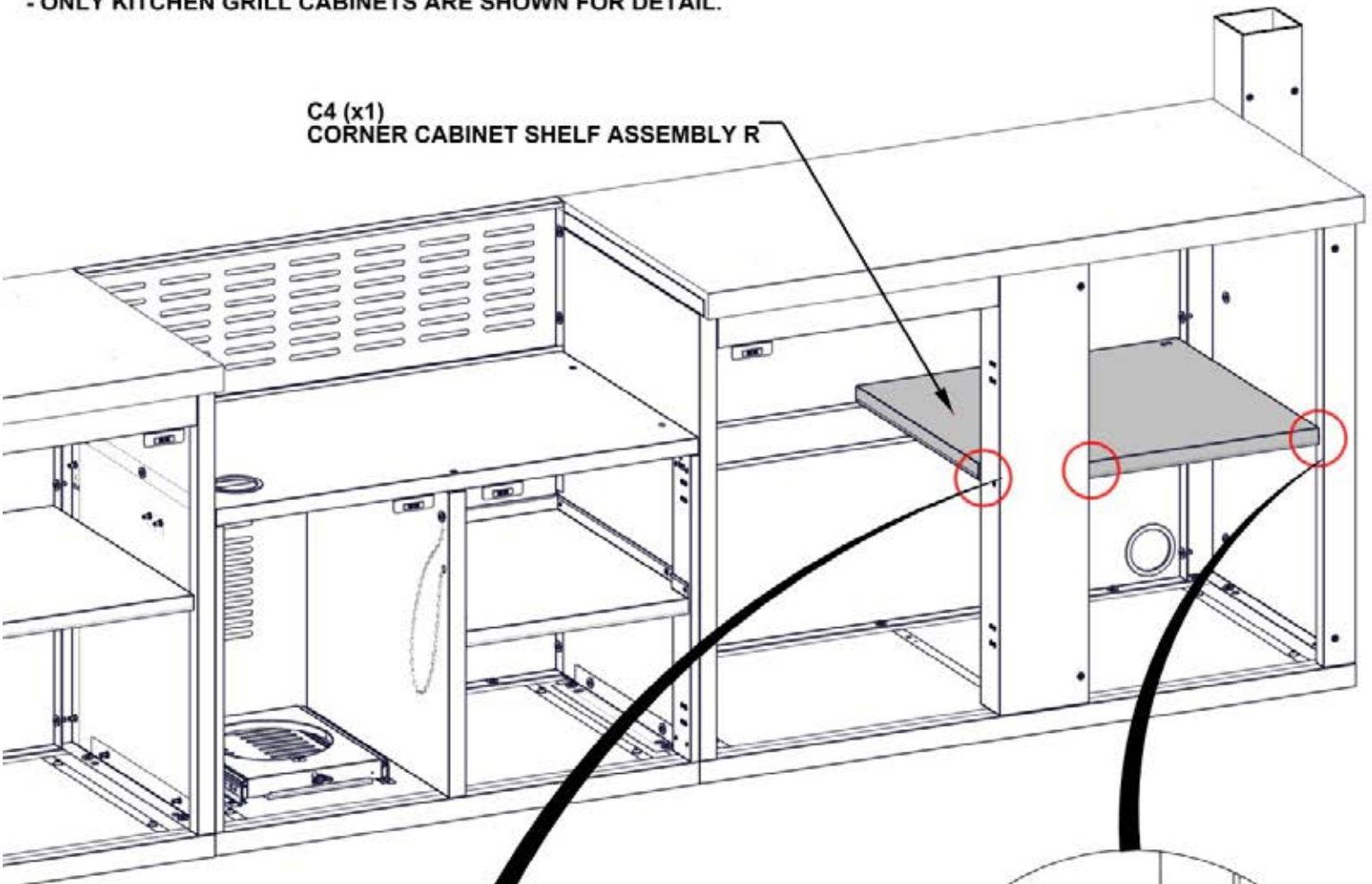

C4 (x1)
CORNER CABINET SHELF ASSEMBLY R

1289 (x1)
PAN HEAD SCREW
8-32x1/2" SS

**NOTE HARDWARE
ATTACHES ON
INSIDE OF CABINET**

1289 (x2)
PAN HEAD SCREW
8-32x1/2" SS

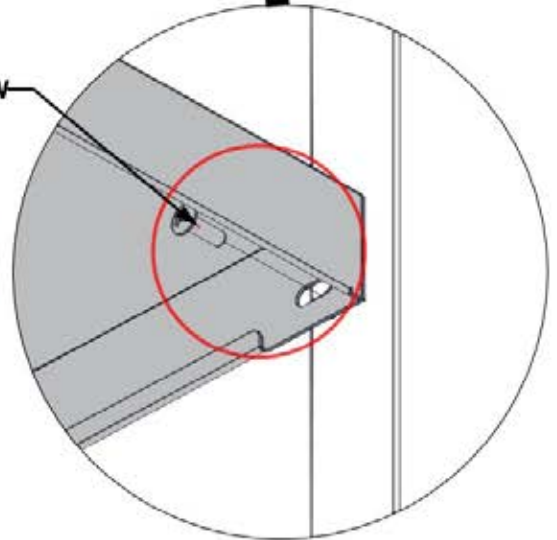
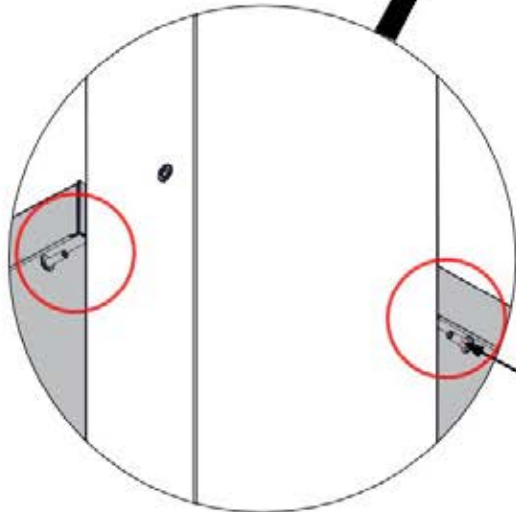

STEP 69 - GRILL CABINET ASSEMBLY

Qty	PartNo	Description
2	H101289	PAN HEAD SCREW 8-32x1/2" SS

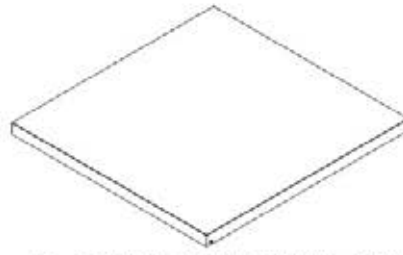

C1 CORNER CABINET SHELF - A4M03037
(x1) 1 3/16"x22 3/16"x23" (30x564x584)

- ONLY KITCHEN GRILL CABINETS ARE SHOWN FOR DETAIL.

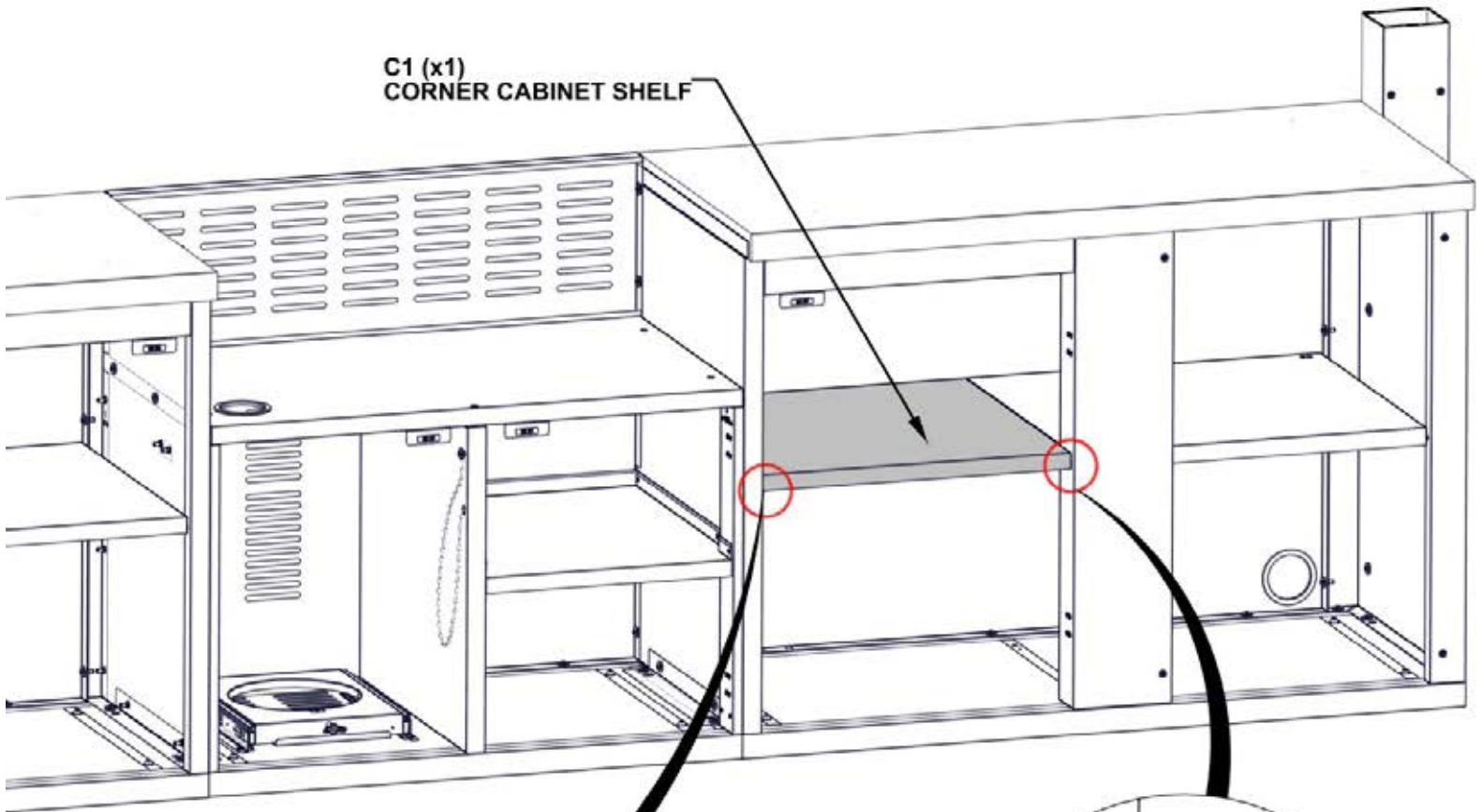

C1 (x1)
CORNER CABINET SHELF

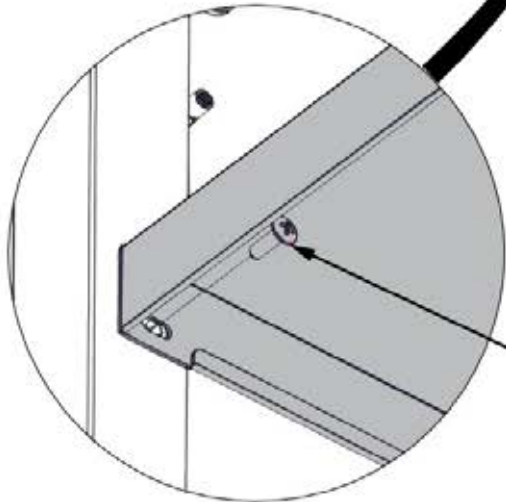

1289 (x1)
PAN HEAD SCREW
8-32x1/2" SS

**NOTE HARDWARE
ATTACHES ON
INSIDE OF CABINET**

1289 (x1)
PAN HEAD SCREW
8-32x1/2" SS

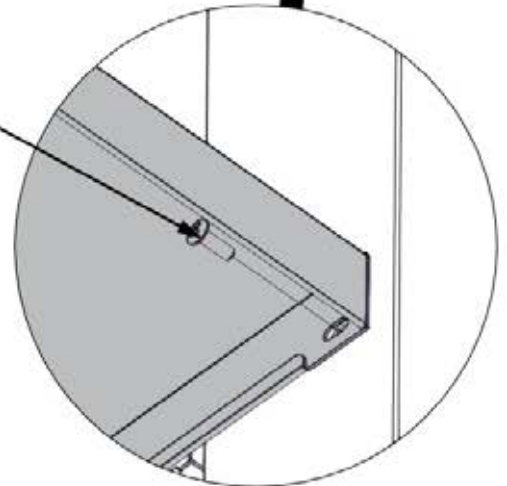

STEP 70 - SINK CABINET ASSEMBLY

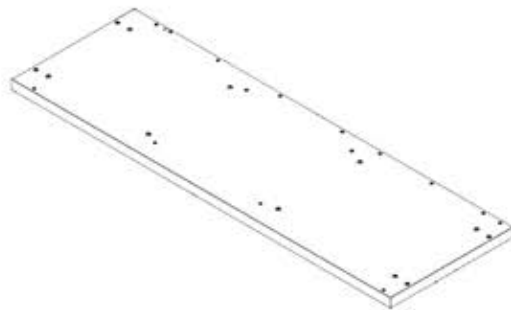

F5 SINK CABINET FLOOR PANEL ASSEMBLY - A4M03092
(x1) 2 5/8"x23 3/8"x72 3/16" (66x594x1834)

- ONLY KITCHEN CABINETS ARE SHOWN FOR DETAIL.
- POSITION FLOOR PANEL AS SHOWN BELOW.
- EACH FLOOR PANEL HAS FACTORY INSTALLED ADJUSTABLE FEET. USE PROVIDED HEX DRIVER TO ADJUST EACH FOOT UNTIL PANEL IS LEVEL.

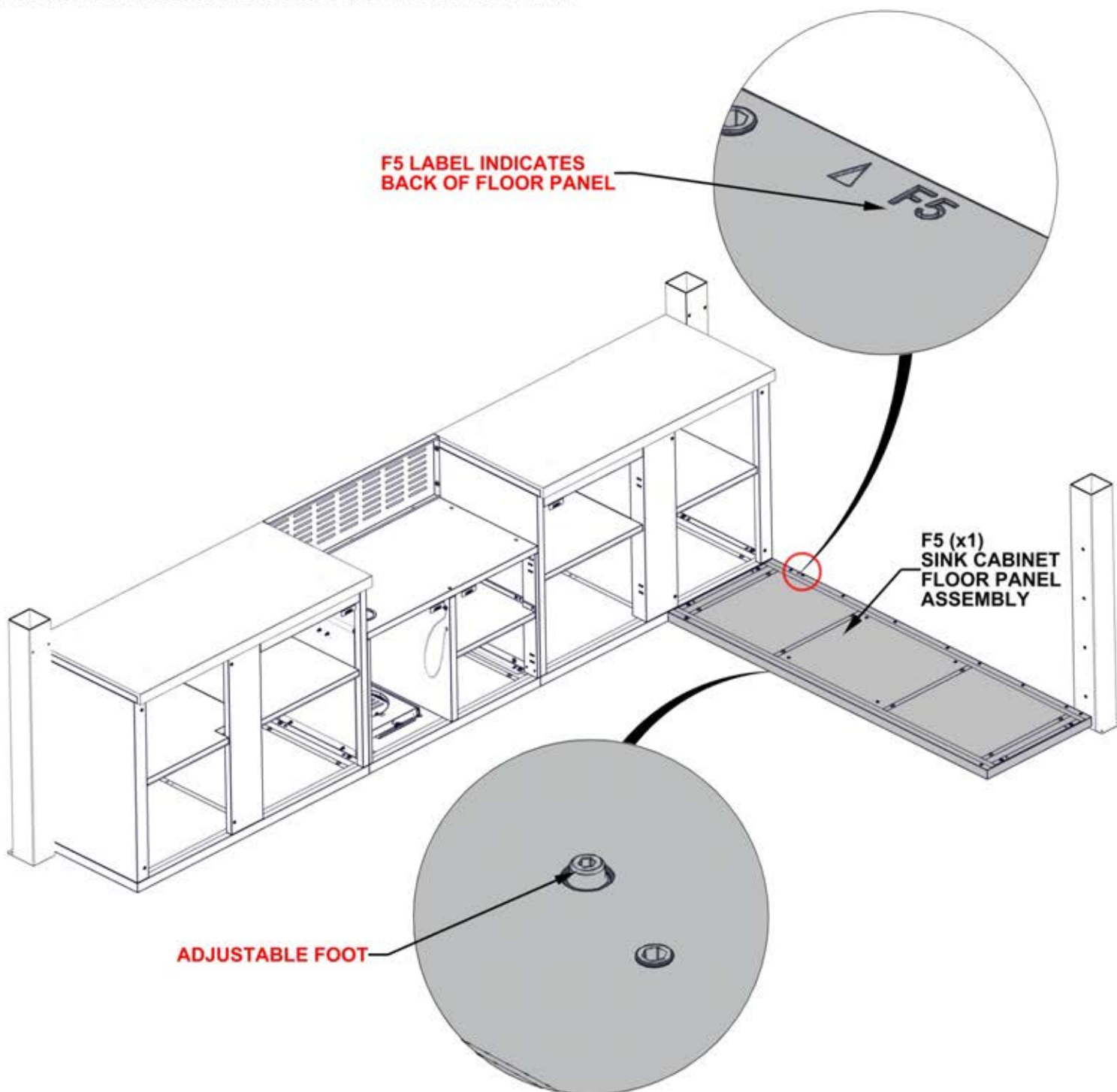

STEP 71A - SINK CABINET ASSEMBLY

Qty	PartNo	Description
3	H101202	TORX PAN HEAD 1/4-20x3/4 ASSY



S1 SINK CABINET SIDE PANEL ASSEMBLY L - A4M03094
(x1) 4 3/4"x23 3/8"x33 3/8" (121x594x848)

- ONLY KITCHEN CABINETS ARE SHOWN FOR DETAIL.
- SIDE PANEL WILL SIT UNDERNEATH THE FRONT MARBLE LIP.
- IF TOP OF SIDE PANEL INTERFERES WITH MARBLE, ADJUST FLOOR PANEL FEET DOWN UNTIL THERE IS ENOUGH ROOM FOR PANEL TO FIT.

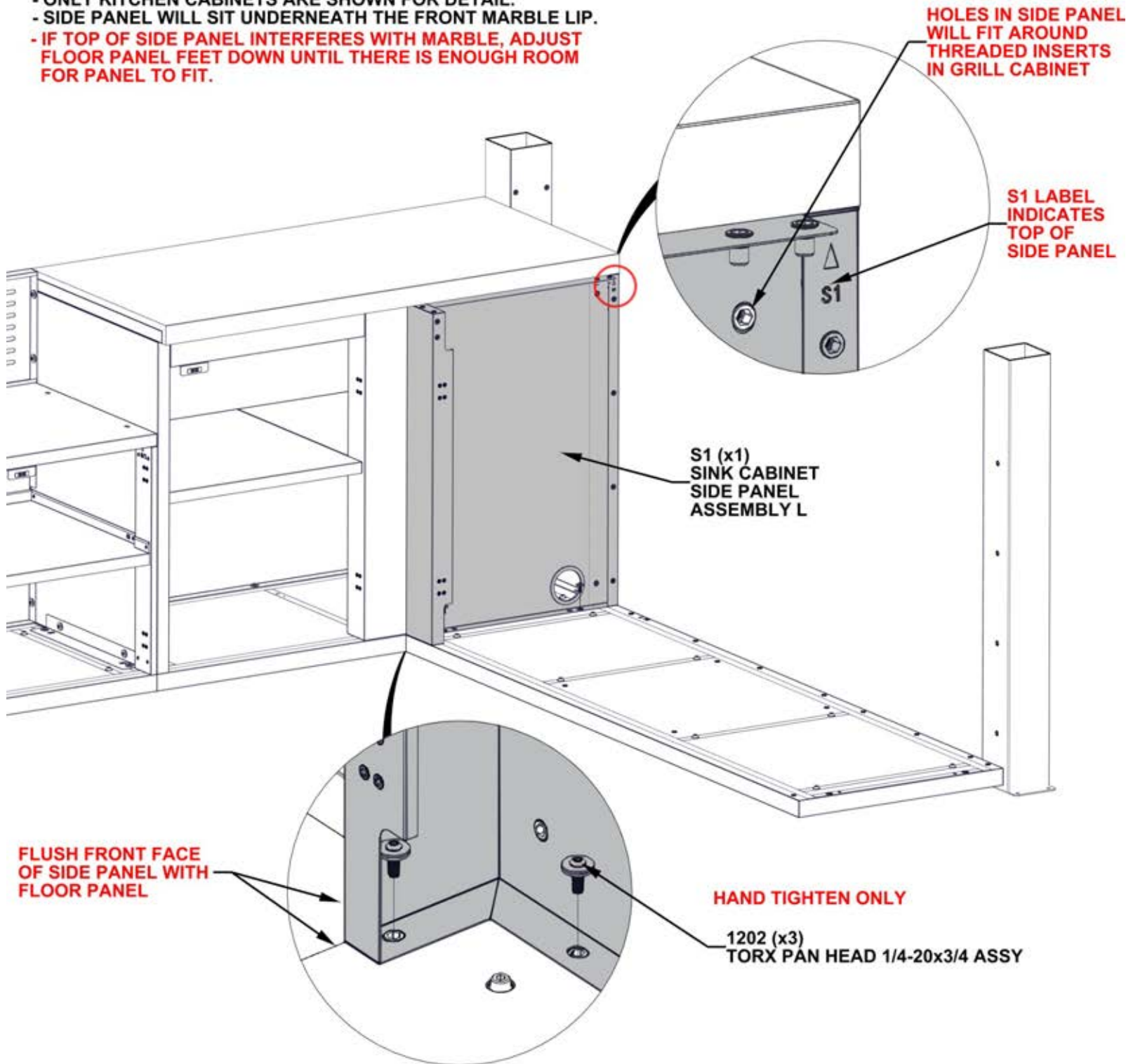

STEP 71B - SINK CABINET ASSEMBLY

Qty	PartNo	Description
4	H101202	TORX PAN HEAD 1/4-20x3/4 ASSY

- ONLY KITCHEN CABINETS ARE SHOWN FOR DETAIL.

- ADJUST FLOOR FEET UNTIL TOP SIDE OF S1 PANEL TOUCHES BOTTOM OF PANEL

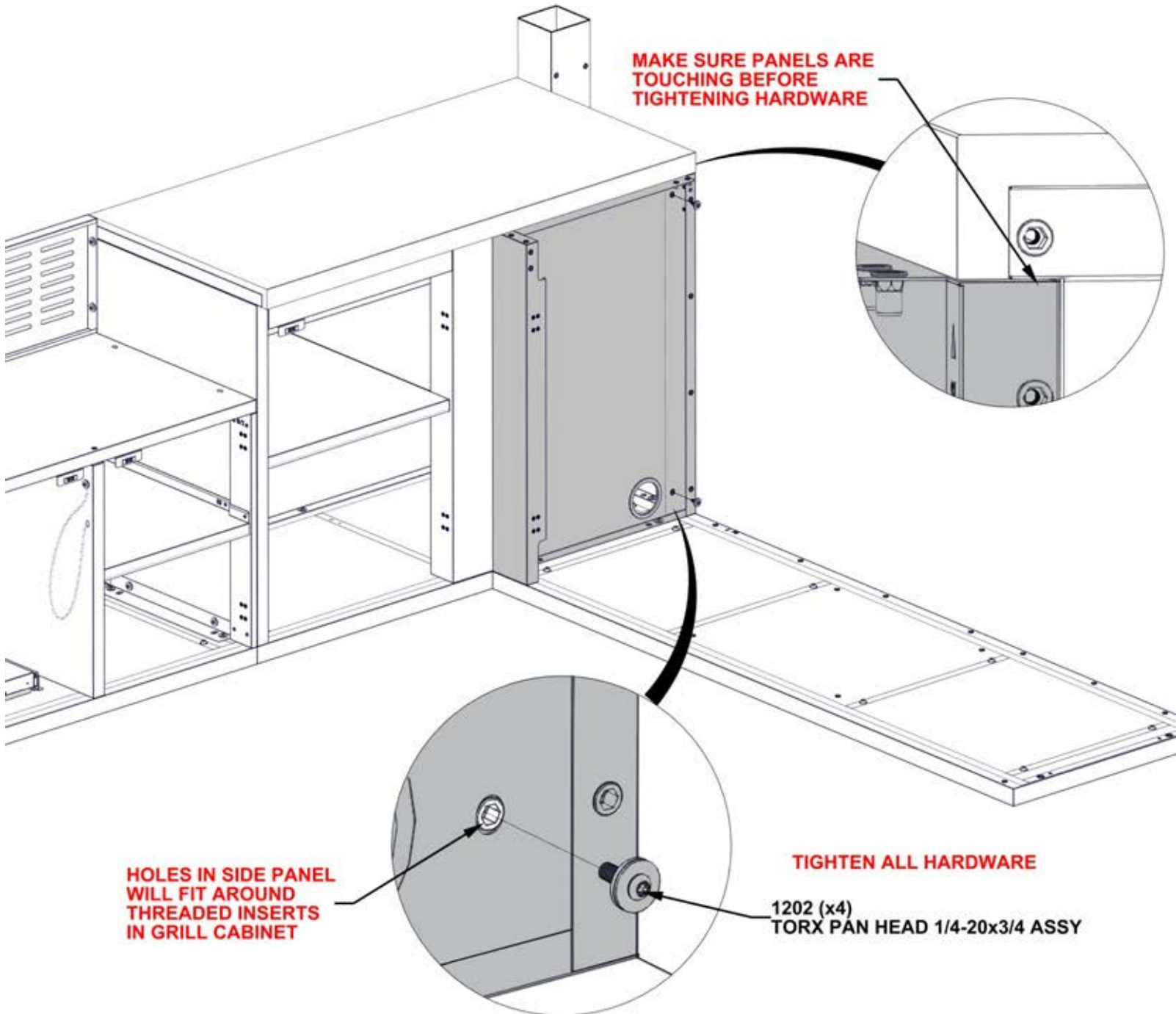

STEP 72A - SINK CABINET ASSEMBLY

Qty	PartNo	Description
4	H101202	TORX PAN HEAD 1/4-20x3/4 ASSY

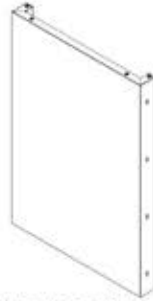

S4 SINK CABINET SIDE PANEL ASSEMBLY R - A4M03093
(x1) 2 5/8"x23 3/8"x33 3/8" (67x594x848)

- ONLY KITCHEN CABINETS ARE SHOWN FOR DETAIL.

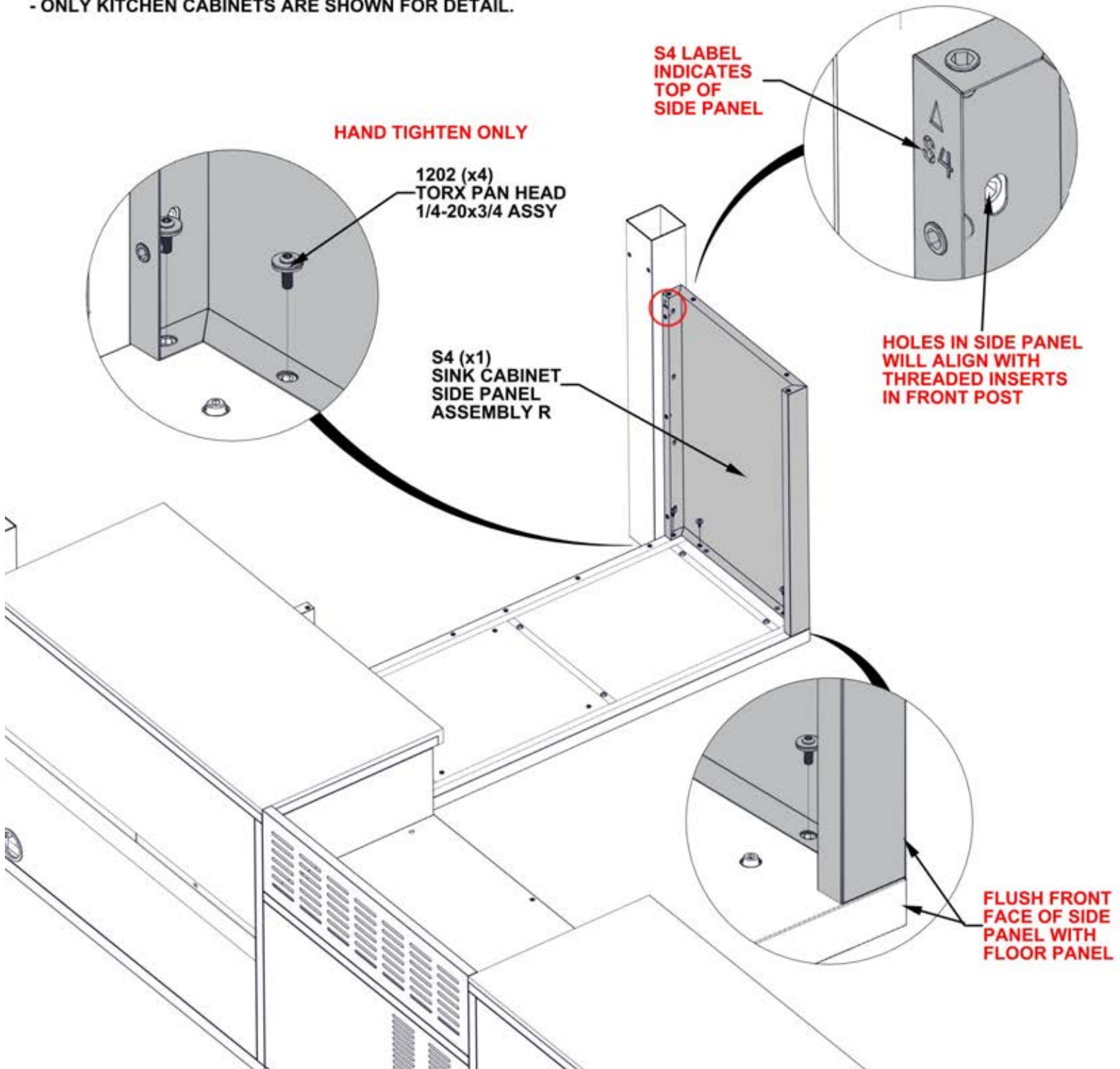

STEP 72B - SINK CABINET ASSEMBLY

Qty	PartNo	Description
4	H101202	TORX PAN HEAD 1/4-20x3/4 ASSY

- ONLY KITCHEN CABINETS ARE SHOWN FOR DETAIL.

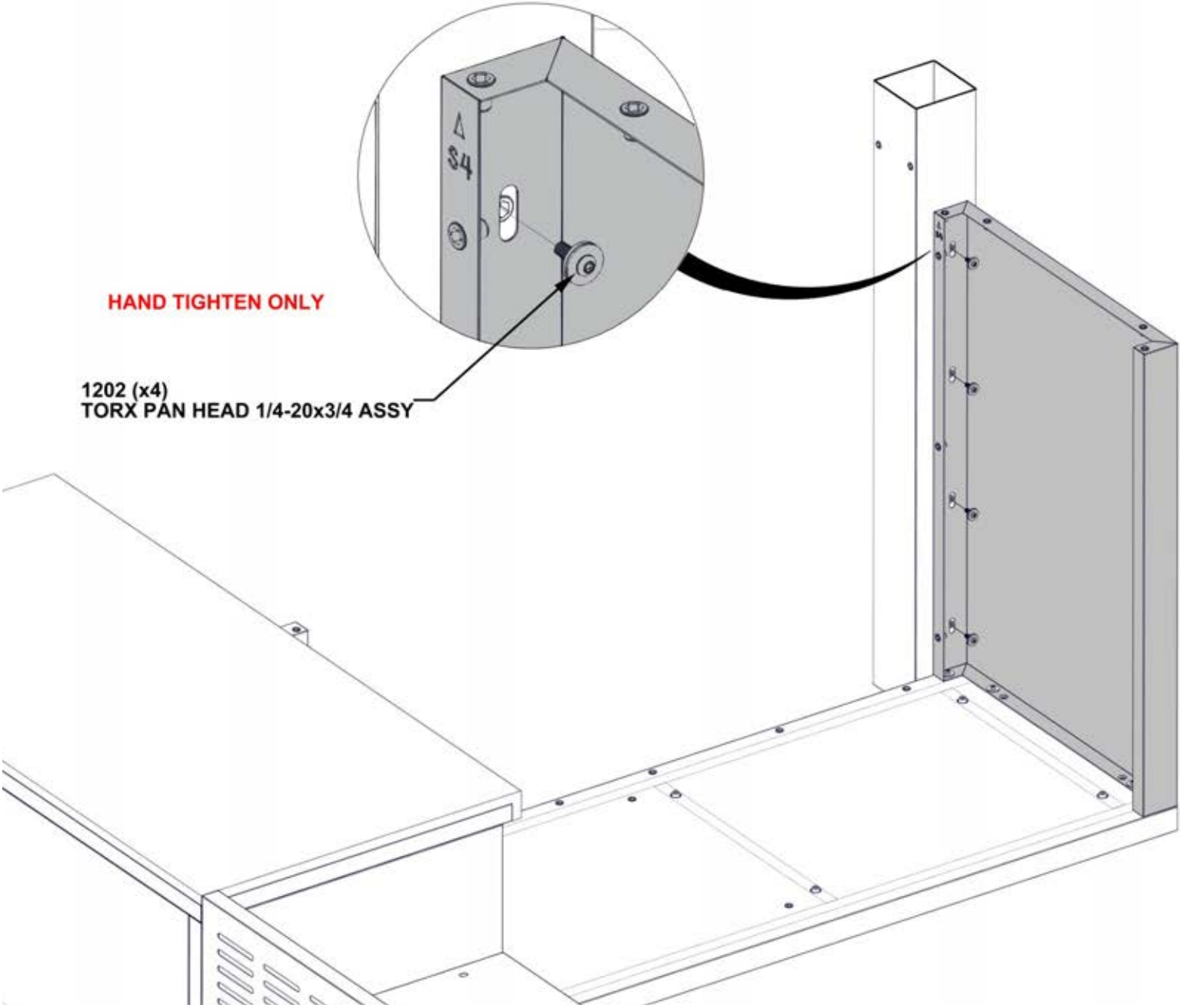

STEP 73 - SINK CABINET ASSEMBLY

Qty	PartNo	Description
6	H101202	TORX PAN HEAD 1/4-20x3/4 ASSY



S6 FRIDGE BACK PANEL ASSEMBLY - A4M03099
(x1) 1 3/16"x24 1/2"x33 3/8" (30x623x848)

- ONLY KITCHEN CABINETS ARE SHOWN FOR DETAIL.

S6 LABEL INDICATES
TOP OF BACK PANEL

HAND TIGHTEN ONLY

1202 (x6)
TORX PAN HEAD
1/4-20x3/4 ASSY

S6 (x1)
FRIDGE BACK
PANEL ASSEMBLY

STEP 74 - SINK CABINET ASSEMBLY

Qty	PartNo	Description
2	H101202	TORX PAN HEAD 1/4-20x3/4 ASSY

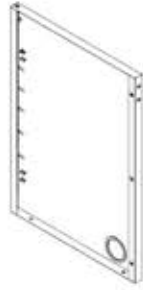

S3 SINK CABINET SIDE PANEL MR - A4M03095
(x1) 1 3/8"x23 3/8"x33 3/8" (35x594x848)

- ONLY KITCHEN CABINETS ARE SHOWN FOR DETAIL.

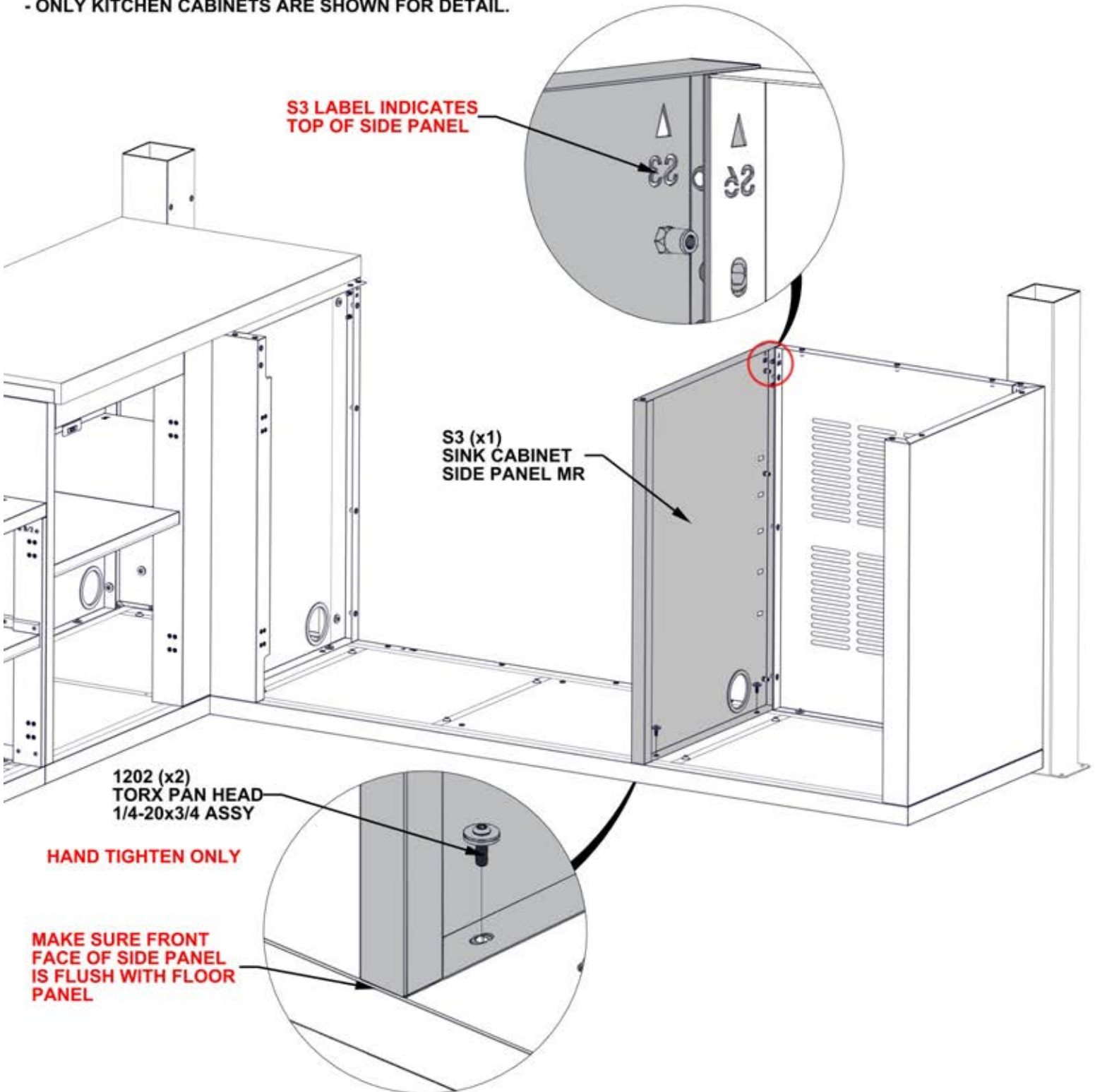

STEP 75 - SINK CABINET ASSEMBLY

Qty	PartNo	Description
3	H101202	TORX PAN HEAD 1/4-20x3/4 ASSY

- ONLY KITCHEN CABINETS ARE SHOWN FOR DETAIL.

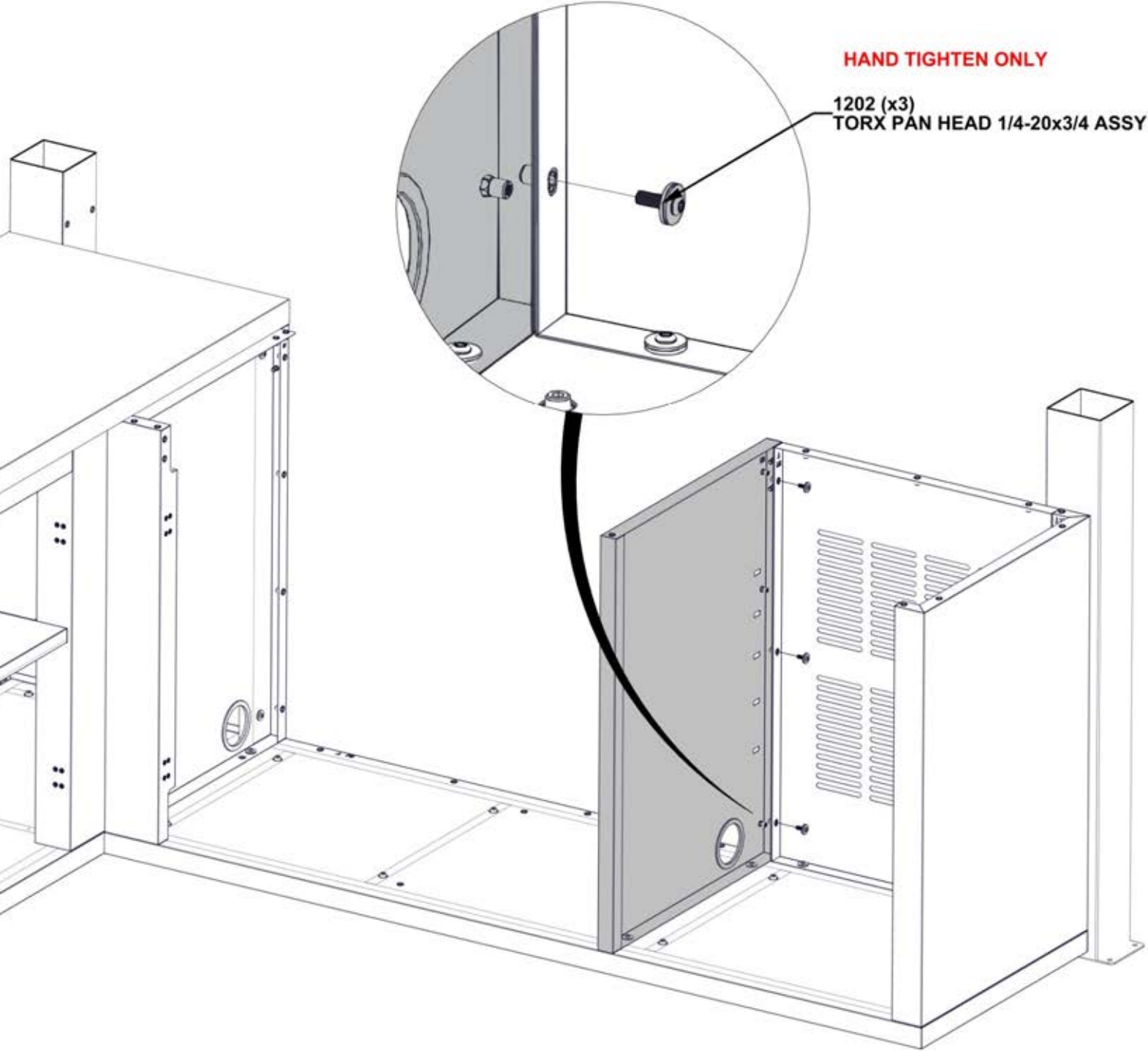

STEP 76 - SINK CABINET ASSEMBLY

Qty	PartNo	Description
11	H101202	TORX PAN HEAD 1/4-20x3/4 ASSY



S5 SINK CABINET BACK PANEL ASSEMBLY - A4M03098
(x1) 1 3/16"x33 3/8"x42 1/8" (30x848x1070)

- ONLY KITCHEN CABINETS ARE SHOWN FOR DETAIL.

S5 LABEL INDICATES
TOP OF BACK PANEL

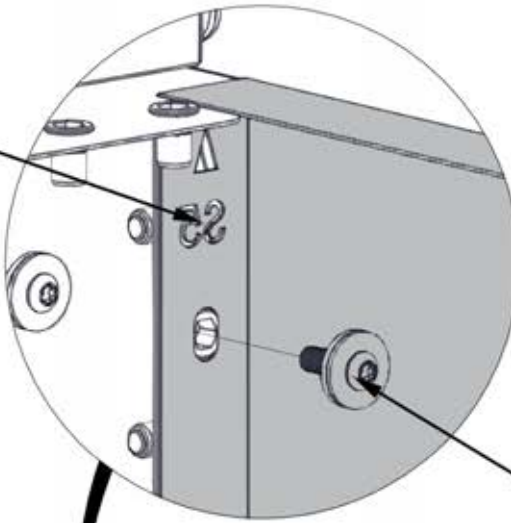

HAND TIGHTEN ONLY

1202 (x11)
TORX PAN HEAD 1/4-20x3/4 ASSY

S5 (x1)
SINK CABINET BACK
PANEL ASSEMBLY

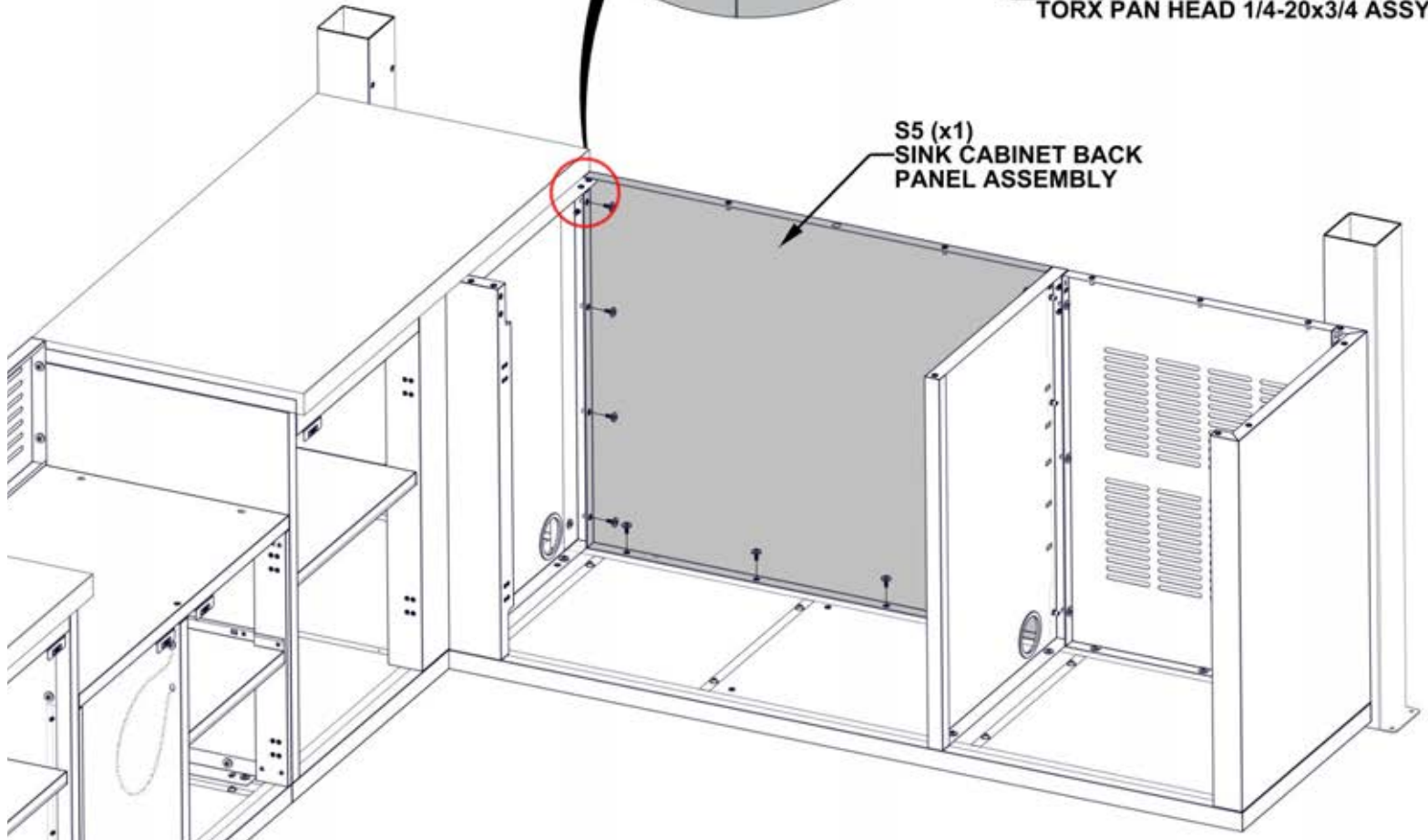

STEP 77 - SINK CABINET ASSEMBLY

Qty	PartNo	Description
2	H101202	TORX PAN HEAD 1/4-20x3/4 ASSY

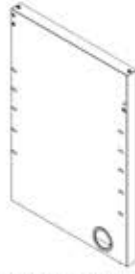

S2 SINK CABINET SIDE PANEL ASSEMBLY ML - A4M03096
(x1) 1 15/16"x23 5/16"x33 3/8" (50x593x847)

- ONLY KITCHEN CABINETS ARE SHOWN FOR DETAIL.

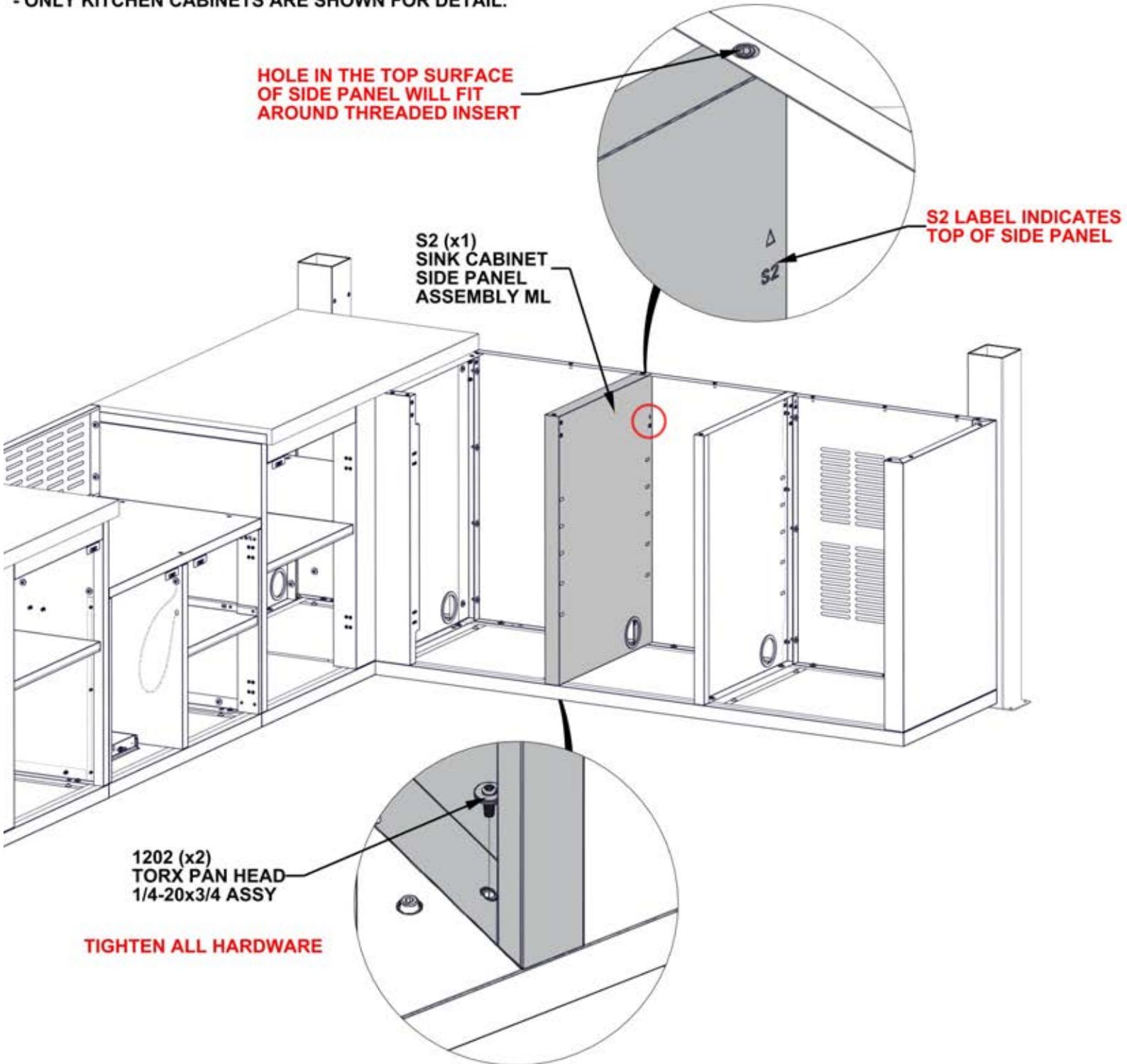

STEP 78 - SINK CABINET ASSEMBLY

Qty	PartNo	Description
2	H101289	PAN HEAD SCREW 8-32x1/2" SS

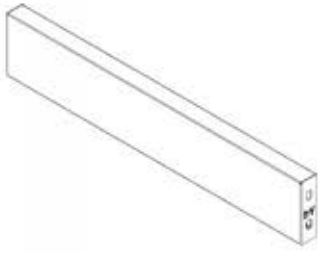

A4 SINK CABINET HORIZONTAL CHANNEL - A4M03097
(x1) 1"x3 3/8"x18 3/8" (25x85x466)



A2 MAGNET BRACKET - A4M03026
(x1) 1"x1 1/4"x3 1/8" (25x31x80)

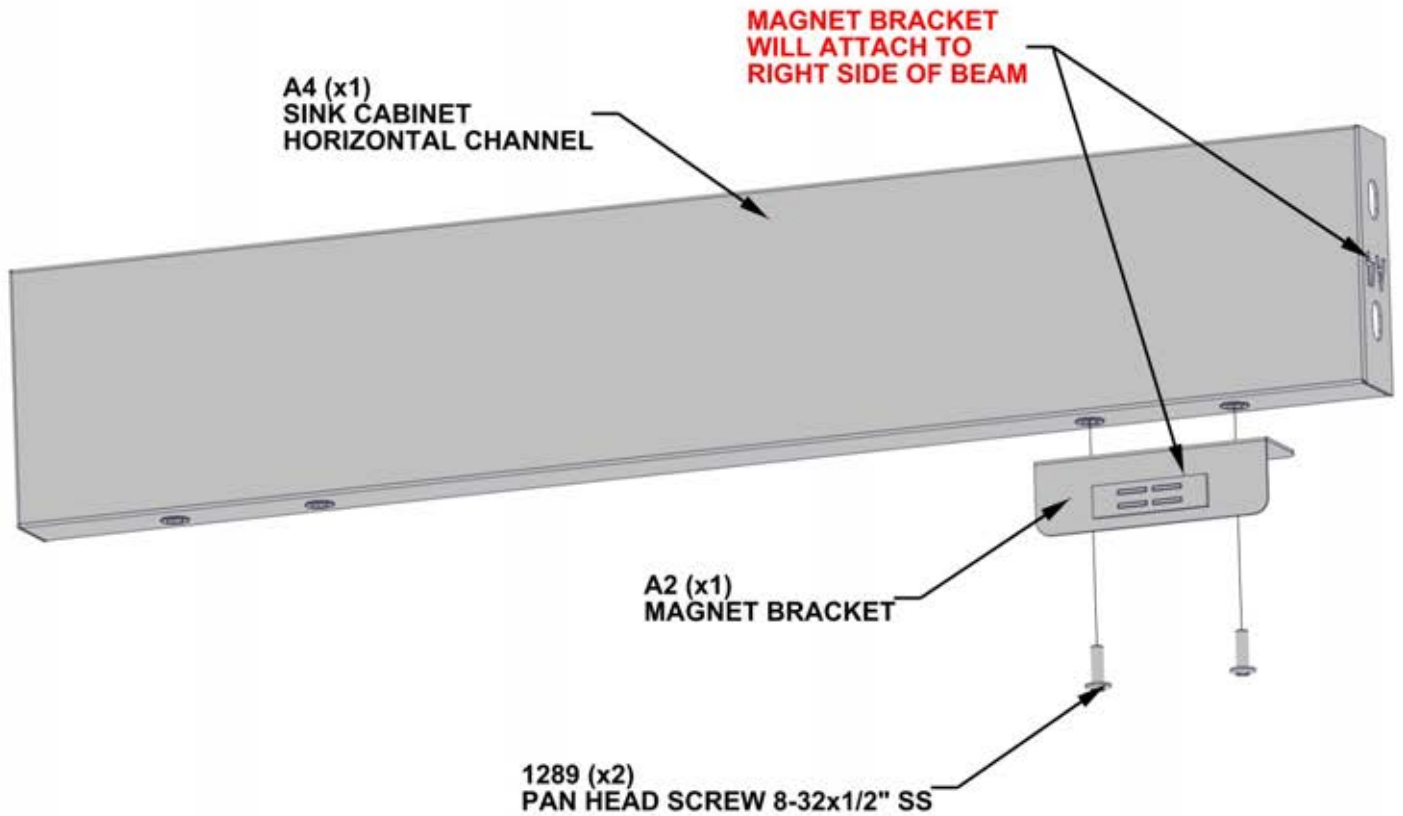

STEP 79 - SINK CABINET ASSEMBLY

Qty	PartNo	Description
4	H101202	TORX PAN HEAD 1/4-20x3/4 ASSY



HORIZONTAL BEAM
ASSEMBLY FROM STEP 78

- ONLY KITCHEN CABINETS ARE SHOWN FOR DETAIL.

FLUSH TOP SURFACE

1202 (x4)
TORX PAN HEAD 1/4-20x3/4 ASSY

**NOTE HARDWARE
ATTACHES ON
INSIDE OF CABINET**

HORIZONTAL BEAM
ASSEMBLY FROM STEP 78

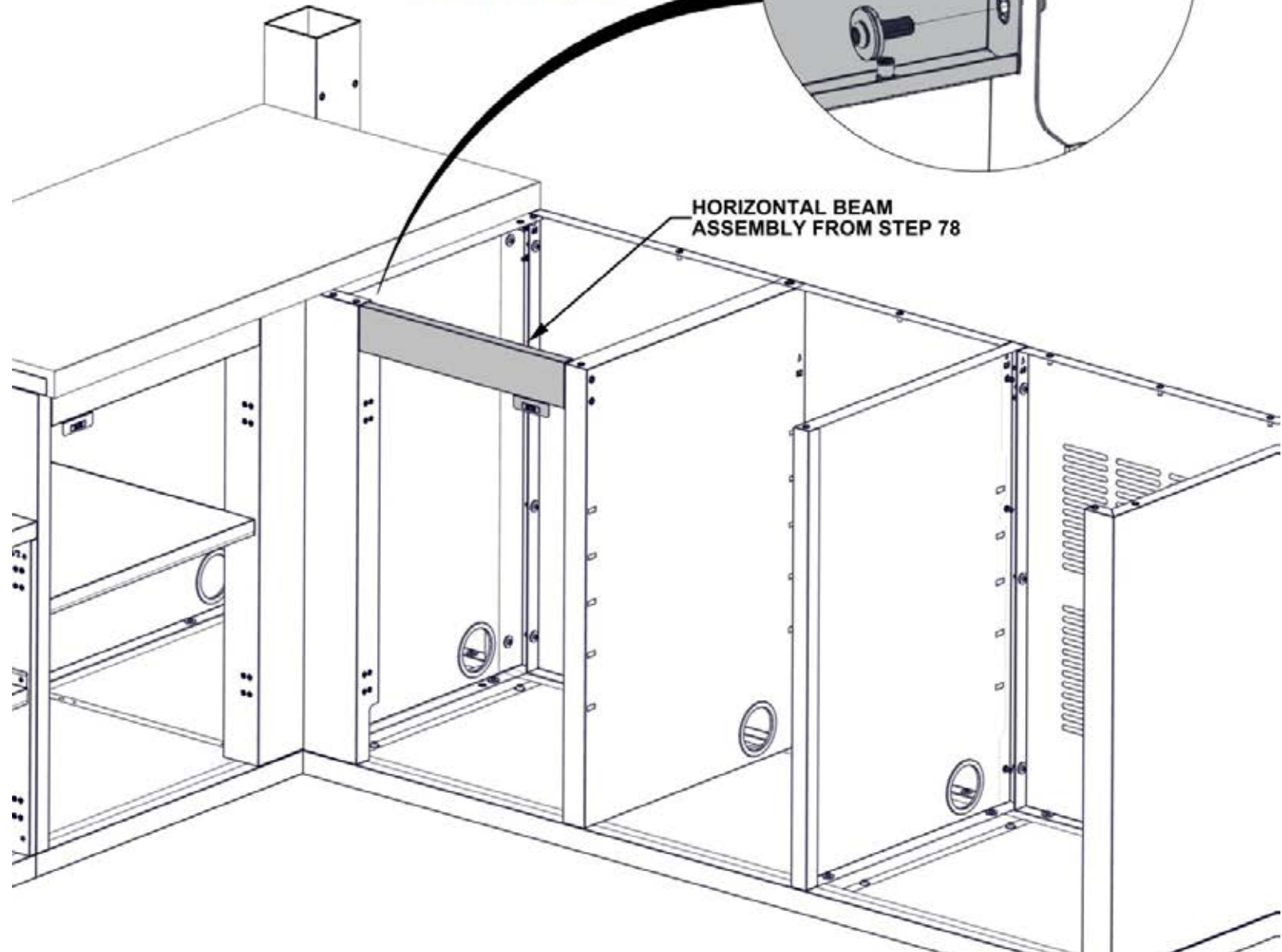
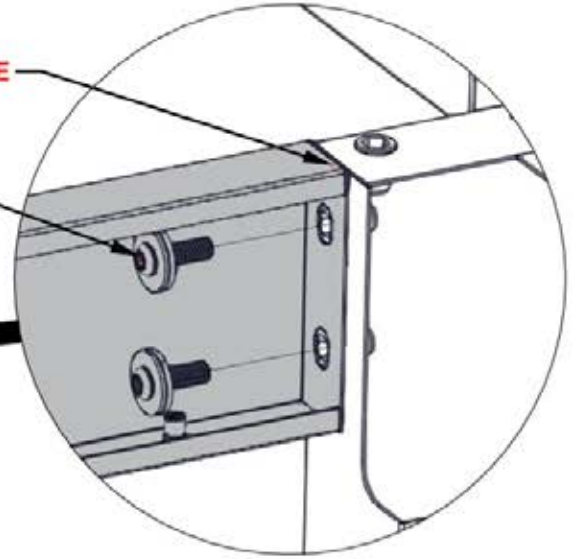

STEP 80 - SINK CABINET ASSEMBLY

Qty	PartNo	Description
2	H101289	PAN HEAD SCREW 8-32x1/2" SS

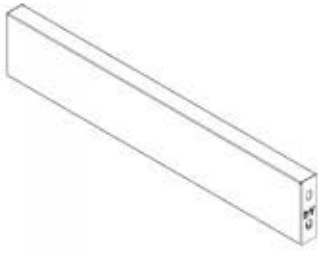

A4 SINK CABINET HORIZONTAL CHANNEL - A4M03097
(x1) 1"x3 3/8"x18 3/8" (25x85x466)



A2 MAGNET BRACKET - A4M03026
(x1) 1"x1 1/4"x3 1/8" (25x31x80)

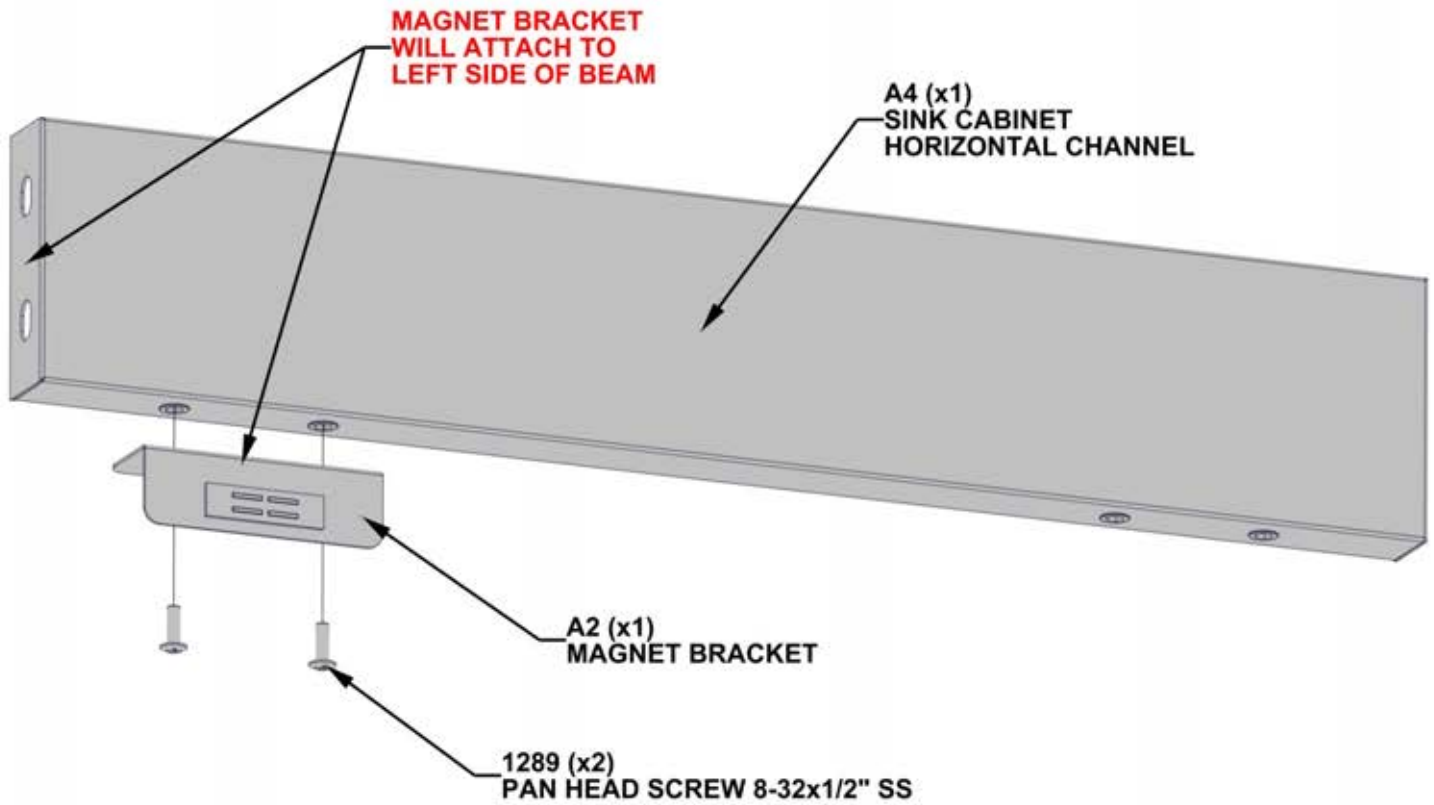

STEP 81 - SINK CABINET ASSEMBLY

Qty	PartNo	Description
4	H101202	TORX PAN HEAD 1/4-20x3/4 ASSY

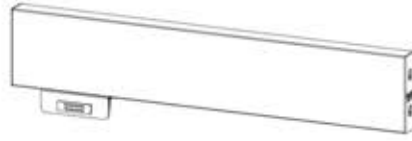

HORIZONTAL BEAM
ASSEMBLY FROM STEP 80

- ONLY KITCHEN CABINETS ARE SHOWN FOR DETAIL.

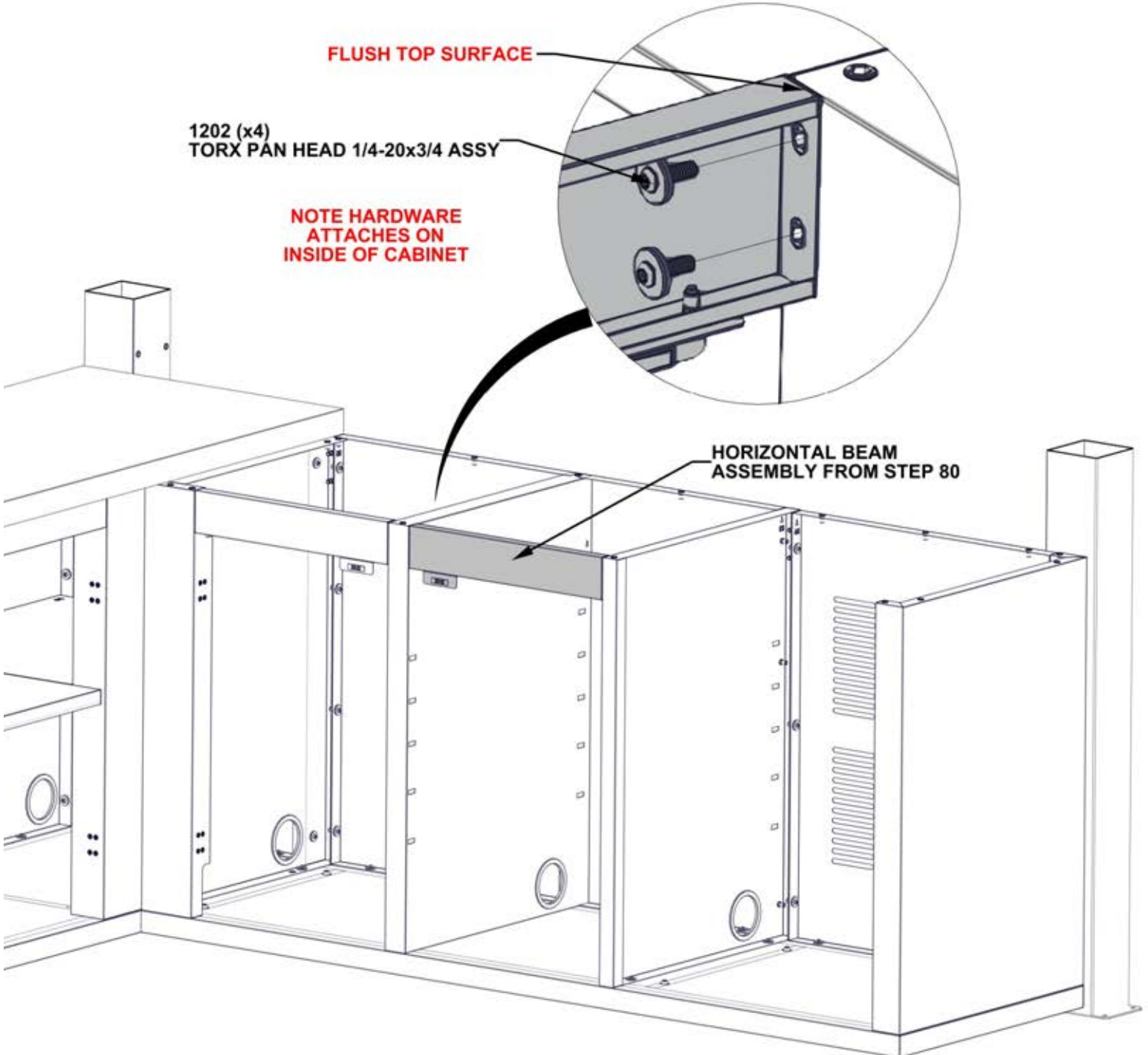

STEP 82 - SINK CABINET ASSEMBLY

Qty	PartNo	Description
16	H101103	TORX SOCKET SCREW 1/4-20

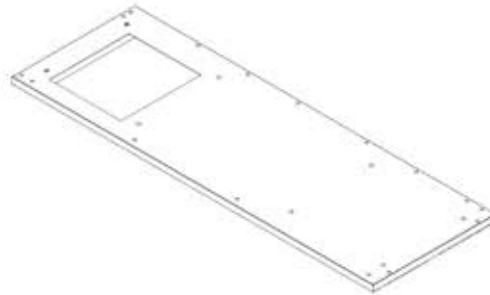

T7 SINK CABINET MARBLE PANEL ASSEMBLY - A4M03142
(x1) 1 1/4"x24 1/8"x70 13/16" (32x612x1798)

- ONLY KITCHEN CABINETS ARE SHOWN FOR DETAIL.
- FLUSH BACK AND SIDES OF PANEL ASSEMBLY.
- **SQUARE ALL SIDES OF CABINET BEFORE TIGHTENING HARDWARE.**

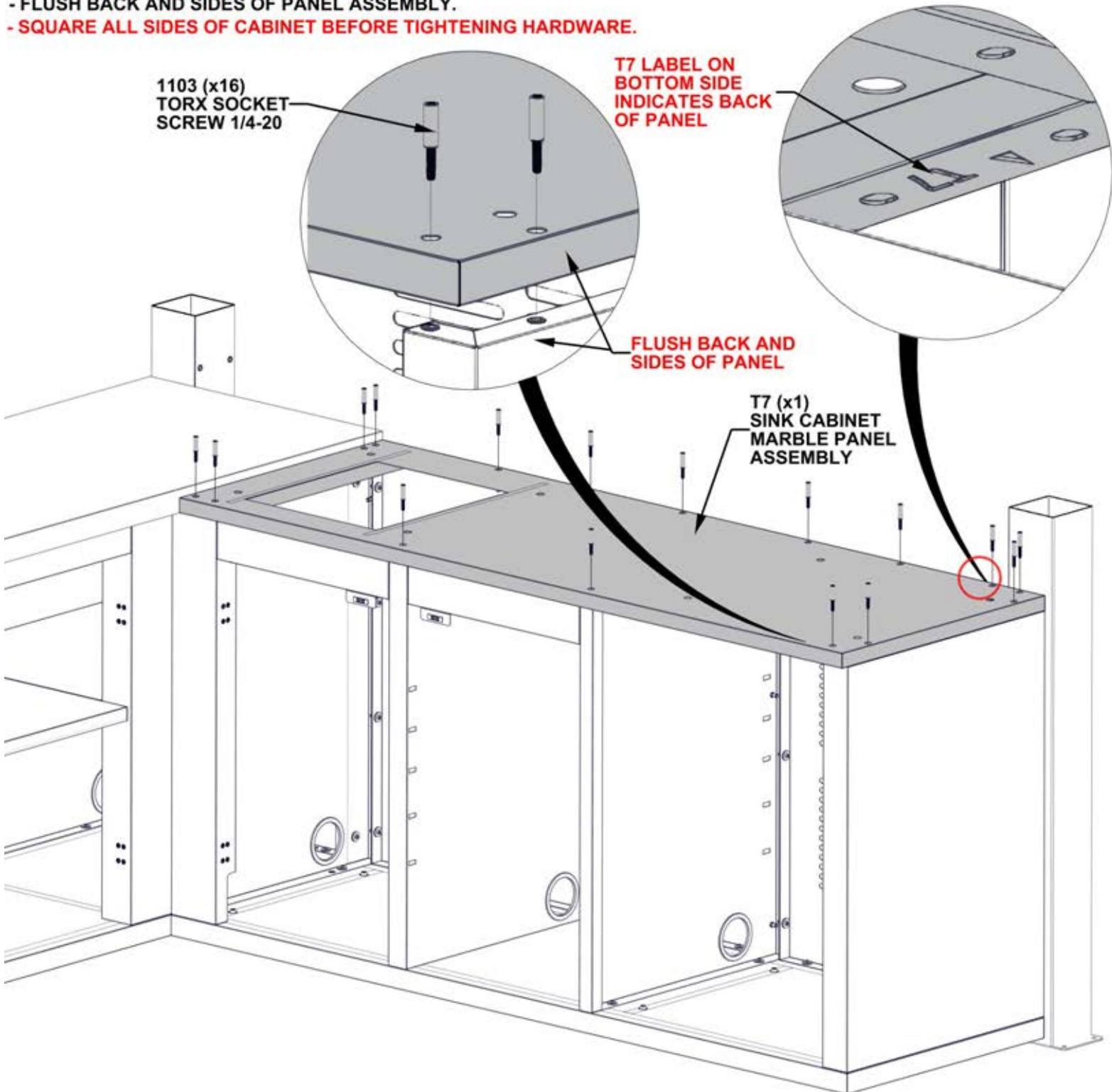

STEP 83 - SINK CABINET ASSEMBLY

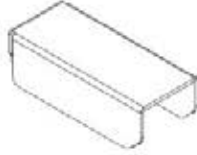

A5 SHELF BRACKET - A4M03141
(x8) 5/8"x7/8"x2 1/16" (16x22x53)

- ONLY KITCHEN CABINETS ARE SHOWN FOR DETAIL.
- ATTACH SHELF BRACKETS ON BOTH SIDES OF CENTER CABINET.

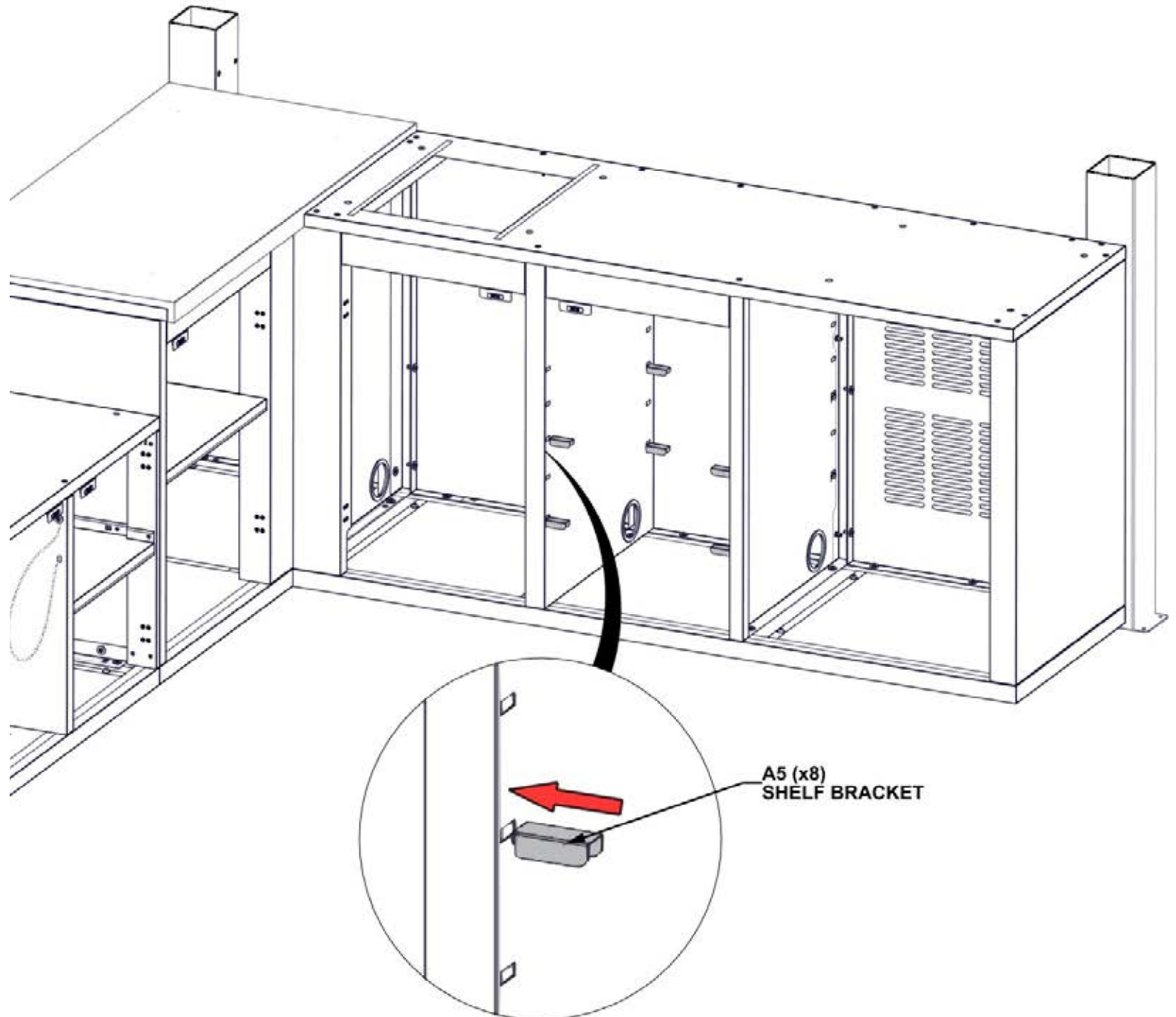

STEP 84 - SINK CABINET ASSEMBLY

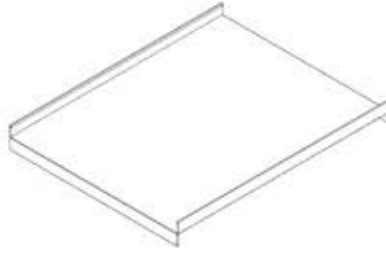

C6 SINK CABINET SHELF - A4M03100
(x2) 2 5/16"x18 1/4"x23 1/8" (59x464x587)

- ONLY KITCHEN CABINETS ARE SHOWN FOR DETAIL.
- INSTALL CABINET SHELVES IN CENTER CABINET.
- SHELVES WILL REST ON SHELF BRACKETS FROM PREVIOUS STEP AND CAN BE POSITIONED AS DESIRED.

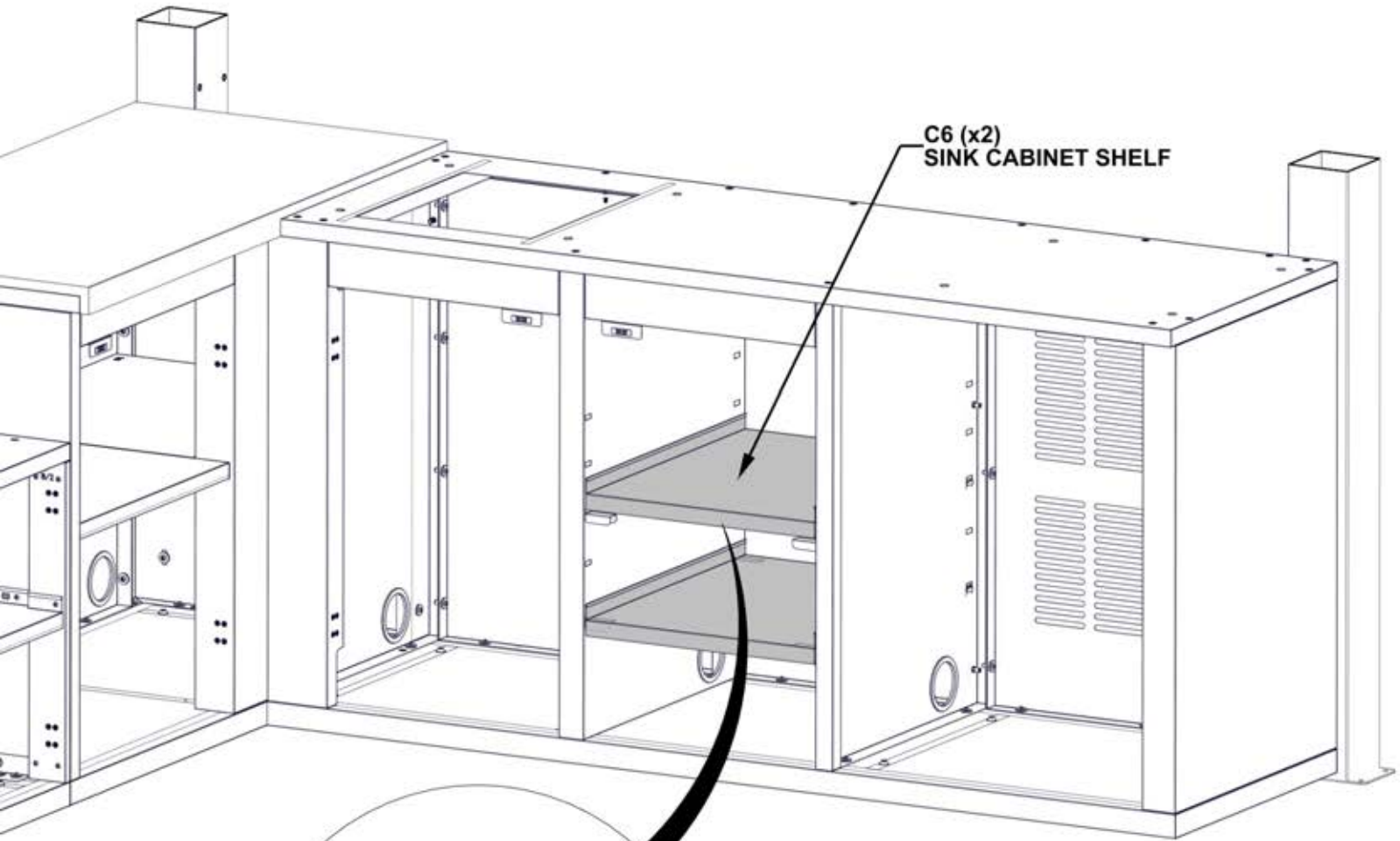

C6 (x2)
SINK CABINET SHELF

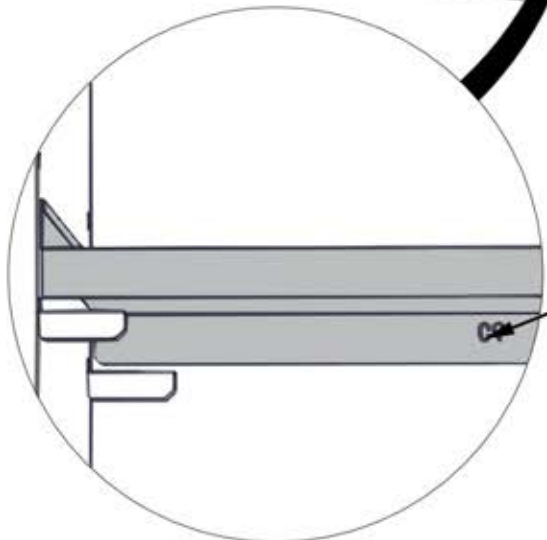

C6 LABEL ON
INDICATES BACK
OF CABINET SHELF

STEP 85A - SINK PRE-ASSEMBLY

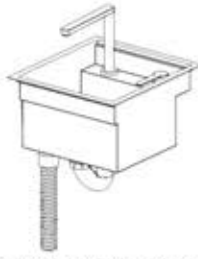

A16 SINK ASSEMBLY - A4M03143
(x1) 15 1/8"x15 5/16"x16 7/8" (384x389x429)

1. INSTALLING THE SINK DRAIN

- SET DRAIN INSIDE OF SINK BODY, PLACING FOAM GASKET BETWEEN SURFACES.
- FASTEN IN PLACE USING RUBBER GASKET AND DRAIN NUT FROM BOTTOM SIDE.

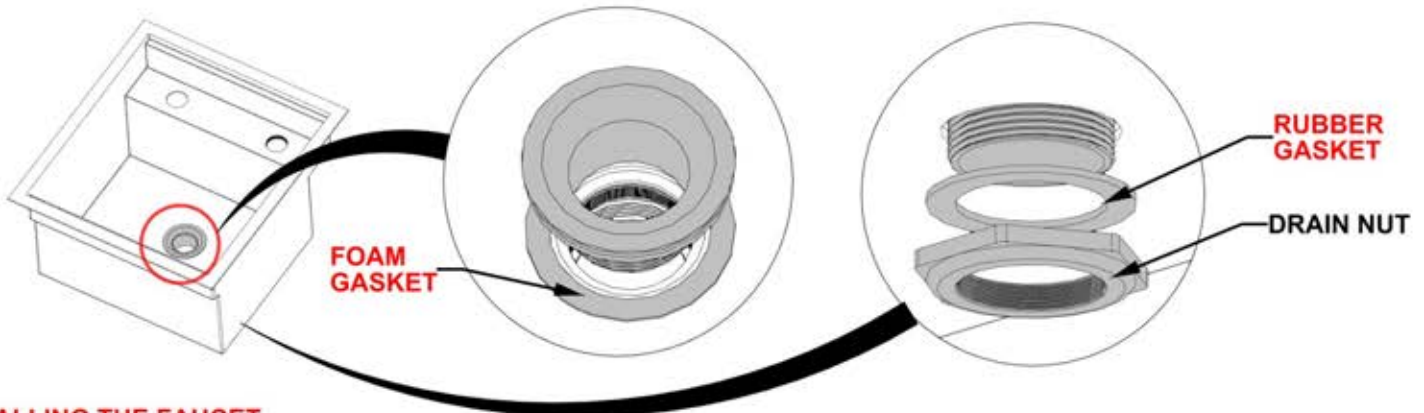

2. INSTALLING THE FAUCET

- INSTALL FAUCET BY PLACING HANDLE AND SPOUT INTO SINK OPENINGS AND SECURING IN PLACE VIA NUT.
- INSERT SCREWS TO LOCK.
- CONNECT WATER FAUCET LINES TOGETHER.

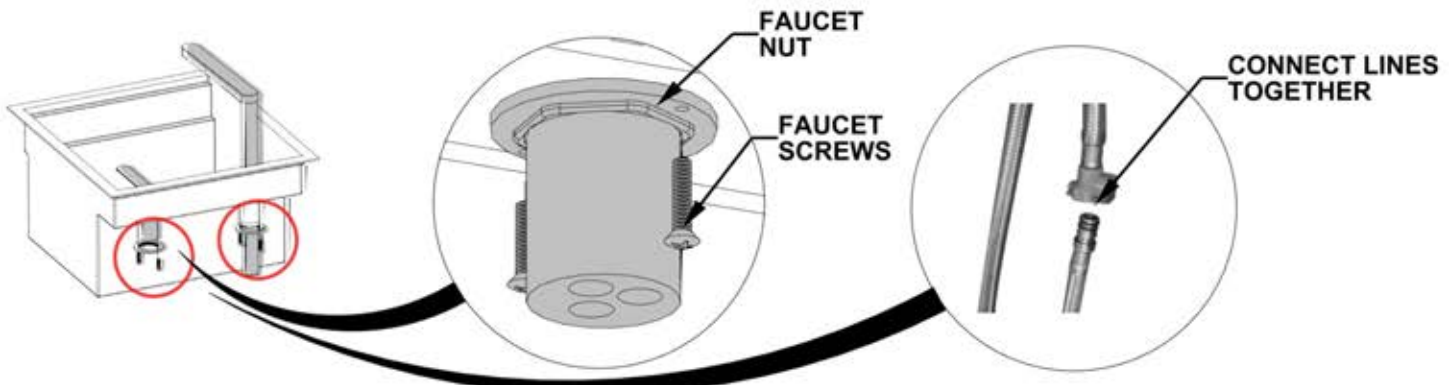

2. INSTALLING THE DRAIN FITTING

- ATTACH DRAIN FITTING TO SINK DRAIN.

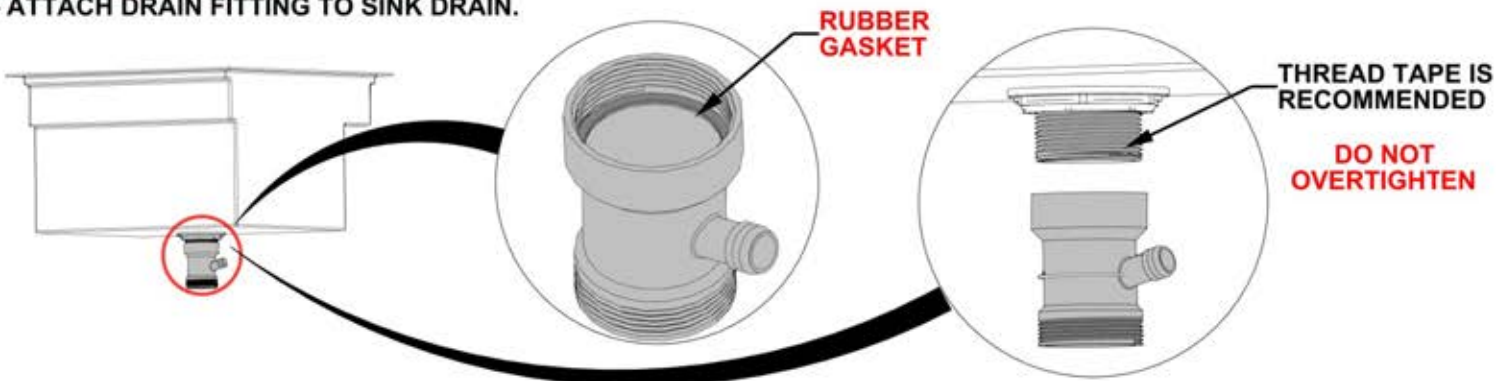

STEP 85B - SINK PRE-ASSEMBLY

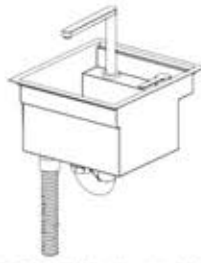

A16 SINK ASSEMBLY - A4M03143
(x1) 15 1/8"x15 5/16"x16 7/8" (384x389x429)

4. INSTALLING THE OVERFLOW DRAIN

- MAKE SURE RUBBER GASKET IS INSTALLED IN OVERFLOW DRAIN.
- INSERT DRAIN SCREW TO HOLD IN PLACE.

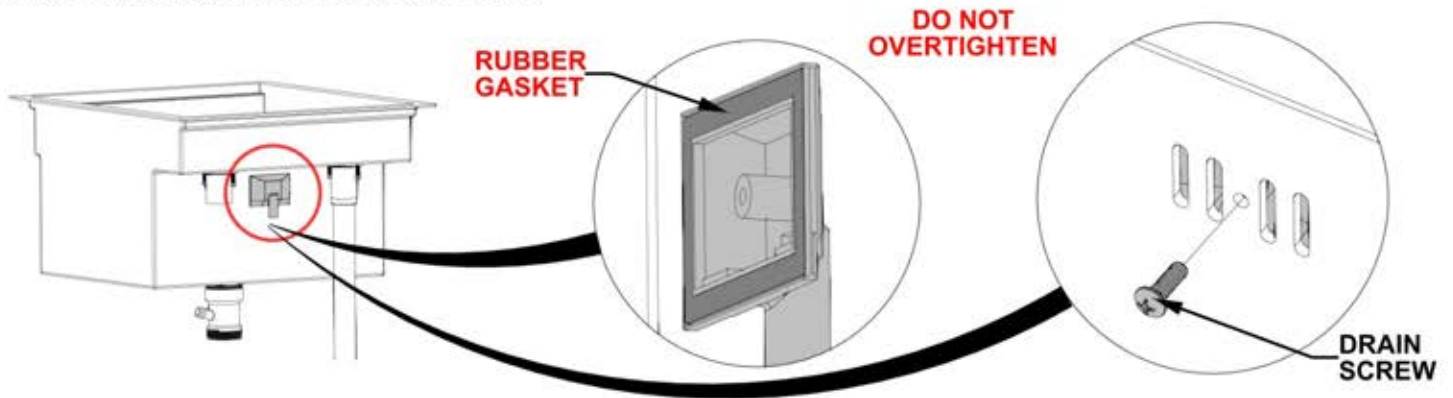

5. INSTALLING THE OVERFLOW DRAIN

- ATTACH OVERFLOW DRAIN BY CONNECTING EACH END AS SHOWN.

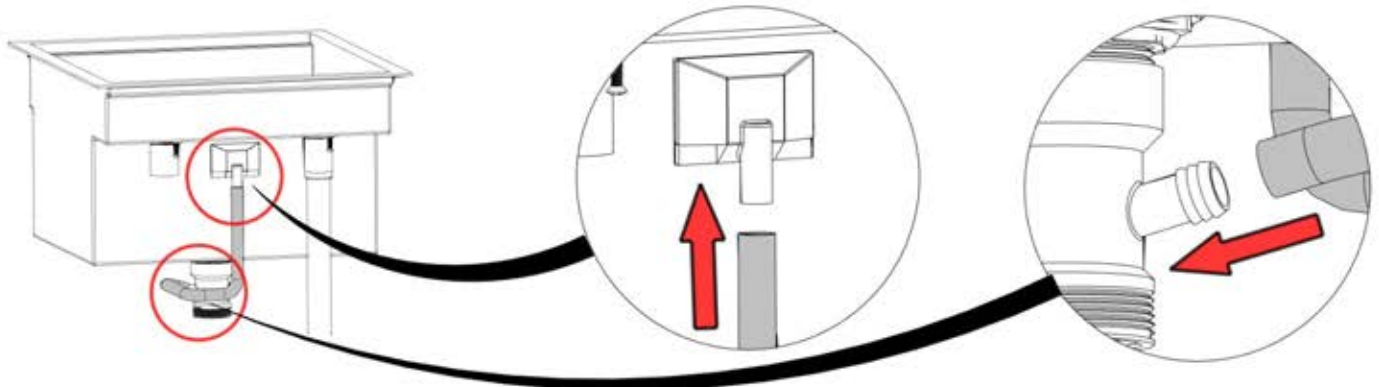

6. INSTALLING THE MAIN DRAIN AND TRAP

- ATTACH TRAP AND CORRUGATED DRAIN HOSE TO DRAIN FITTING.

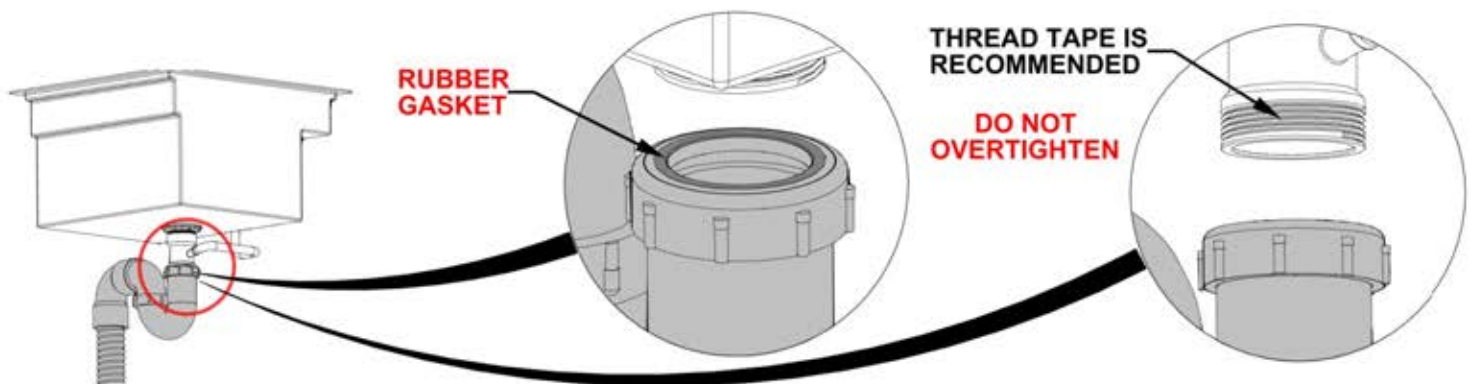

STEP 85C - SINK CABINET ASSEMBLY

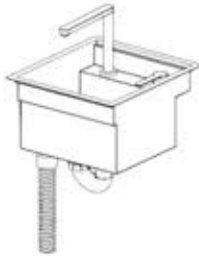

A16 SINK ASSEMBLY - A4M03143
(x1) 15 1/8"x15 5/16"x16 7/8" (384x389x429)



A4M03151 GARDEN HOSE ADAPTER
(x1)

- DRAIN STRAINER MUST BE USED WHEN DISCARDING FOOD INSIDE OF SINK.
- DO NOT LET SOLID MATERIAL ENTER SINK BASIN.

OPTIONS FOR WATER INLET SUPPLY HOOKUP:

- GARDEN HOSE ATTACHMENT USING PROVIDED ADAPTER
- WATER INLET SUPPLY LINE

**ATTACH ADAPTER
TO INLET LINE AND
TIGHTEN WITH WRENCH**

OPTIONS FOR DRAIN DISCHARGE:

- BUCKET OR GREY WATER CONTAINER
- FRENCH DRAIN OR DRY BASIN
- INTEGRATED SEWER SYSTEM
- CHECK YOUR LOCAL REQUIRMENTS.

**IT IS RECOMMENDED TO
APPLY A FINE BEAD OF
SILICONE, TO UNDERNEATH
SIDE OF ALL SINK FLANGES
BEFORE INSTALLING**

A4M03151 (x1)
GARDEN HOSE
ADAPTER

A16 (x1)
SINK ASSEMBLY

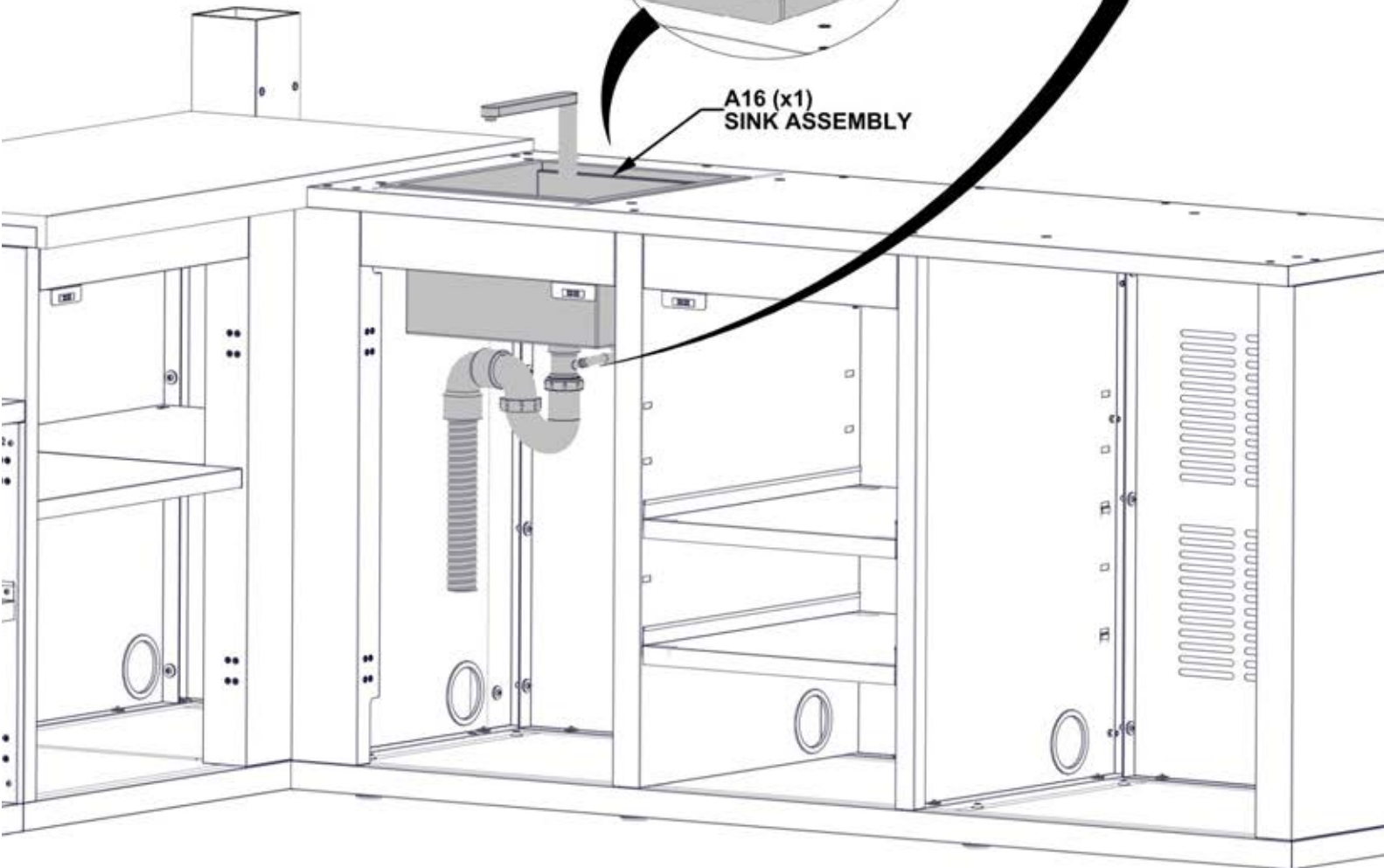

STEP 86A - SINK CABINET ASSEMBLY

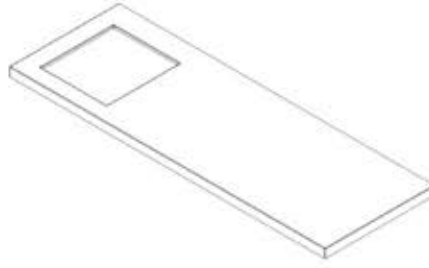

M4 SINK CABINET MARBLE - A4M03146
(x1) 1 15/16"x24 13/16"x71 1/2" (50x630x1816)

- ONLY KITCHEN CABINETS ARE SHOWN FOR DETAIL.
- IT IS RECOMMENDED TO HAVE AT LEAST TWO PEOPLE SET MARBLE COUNTERTOP IN PLACE.
- SLIDE IN PLACE UNTIL MARBLE IS TIGHT AGAINST BACK POST AND OPPOSITE COUNTERTOP.
- **WHEN SETTING MARBLE IN PLACE, MAKE SURE YOUR FINGERS ARE CLEAR AND NOT UNDERNEATH MARBLE.**

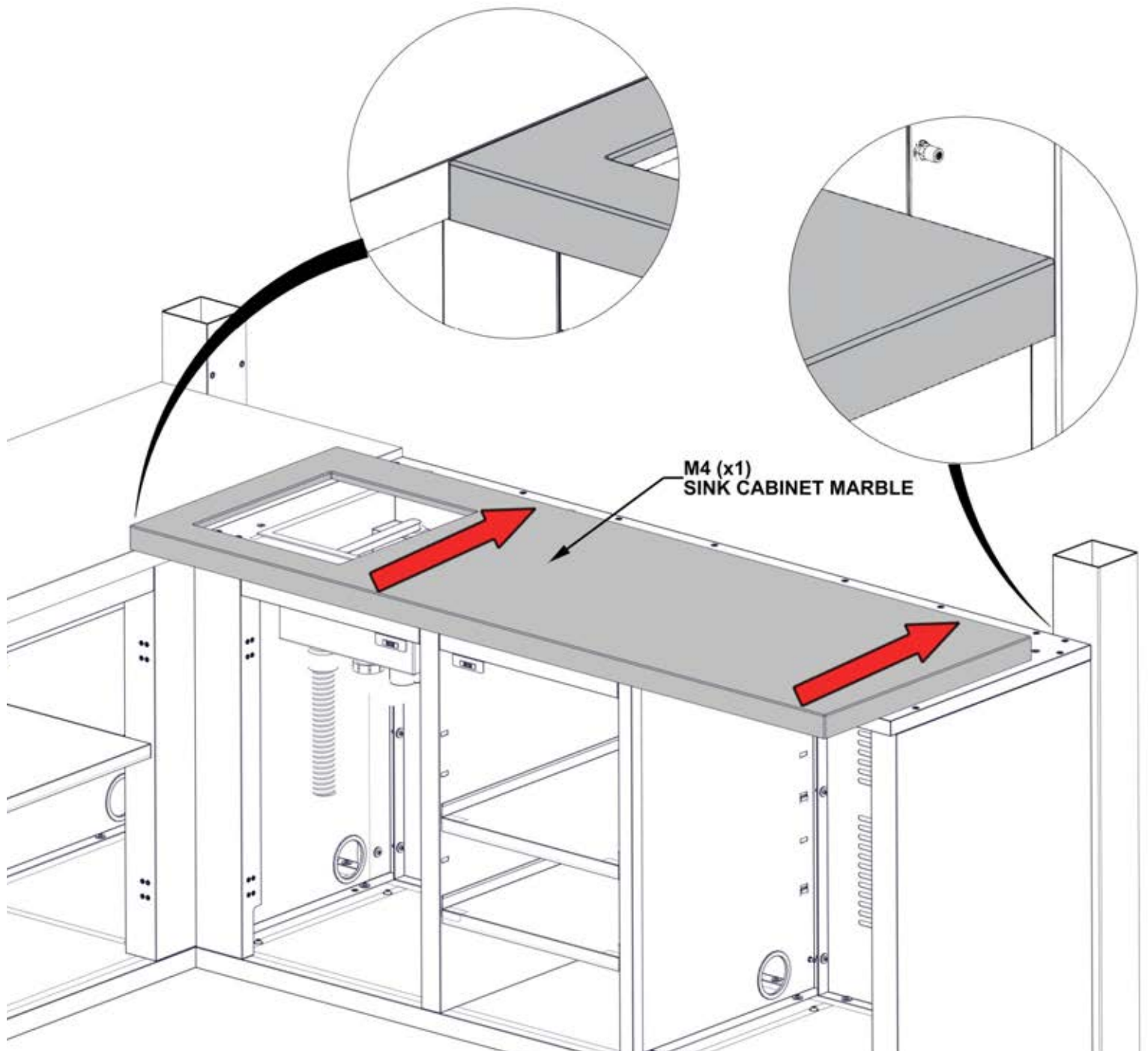

STEP 86B - SINK CABINET ASSEMBLY

Qty	PartNo	Description
8	H101292	TORX PAN HEAD 1/4-20x13/32"
8	H101054	SEALANT WASHER
8	H101053	STEEL WASHER 6x20

- ONLY KITCHEN GRILL CABINETS ARE SHOWN FOR DETAIL.

- MAKE SURE YOU ARE USING THE CORRECT HARDWARE FOR THIS STEP.

- ONCE MARBLE IS IN PLACE, IT IS RECOMMENDED TO COVER WITH A PIECE OF CARDBOARD OR FOAM UNTIL ASSEMBLY IS FINISHED TO PREVENT DAMAGE.

- DO NOT USE MARBLE SURFACE AS A WORK BENCH.

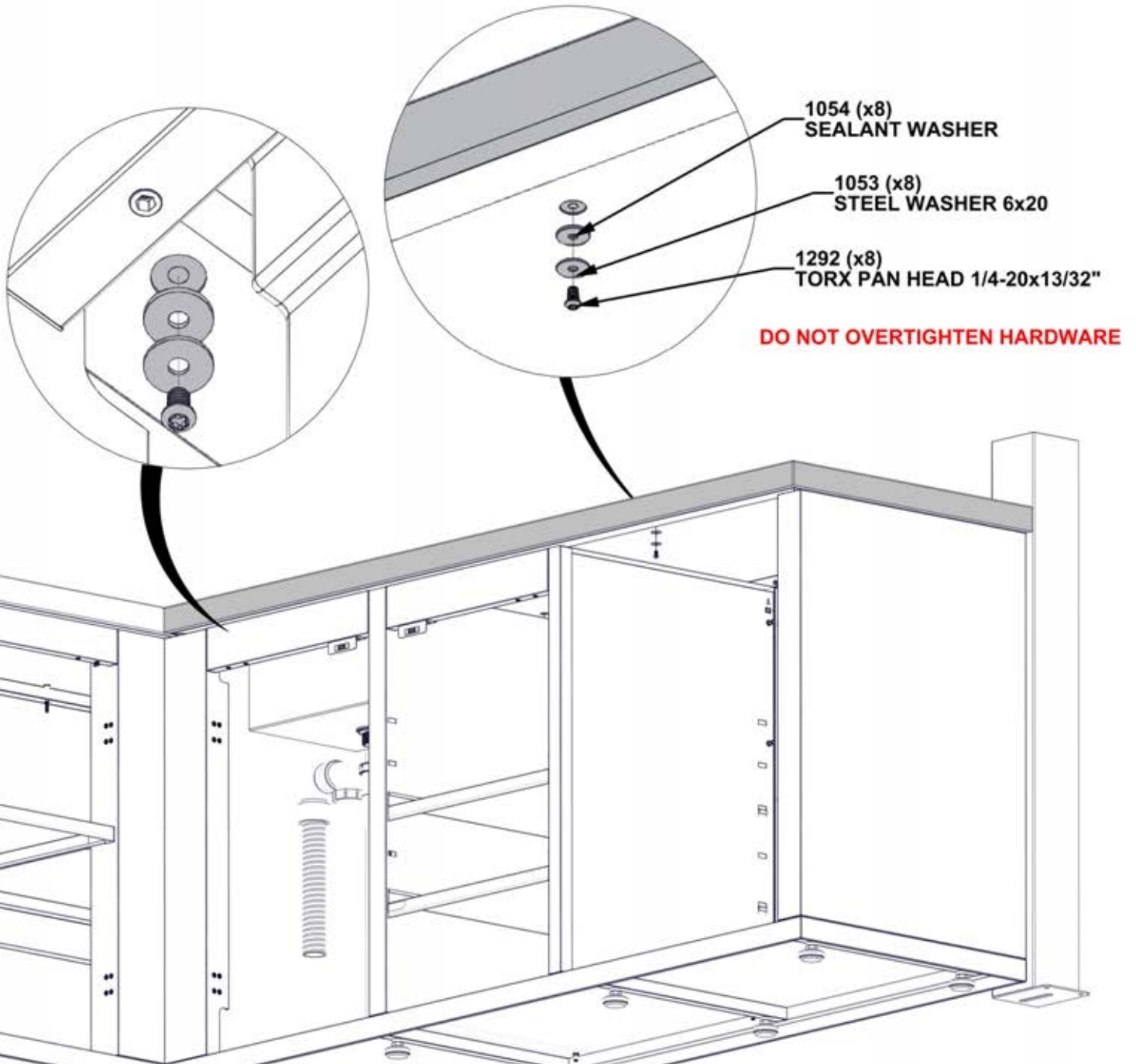

STEP 87 - SINK CABINET ASSEMBLY

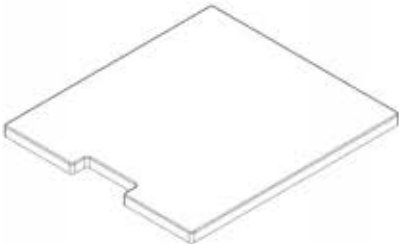

M5 SINK COVER MARBLE - A4M03147
(x1) 11/16"x14 3/4"x16 5/16" (18x375x415)

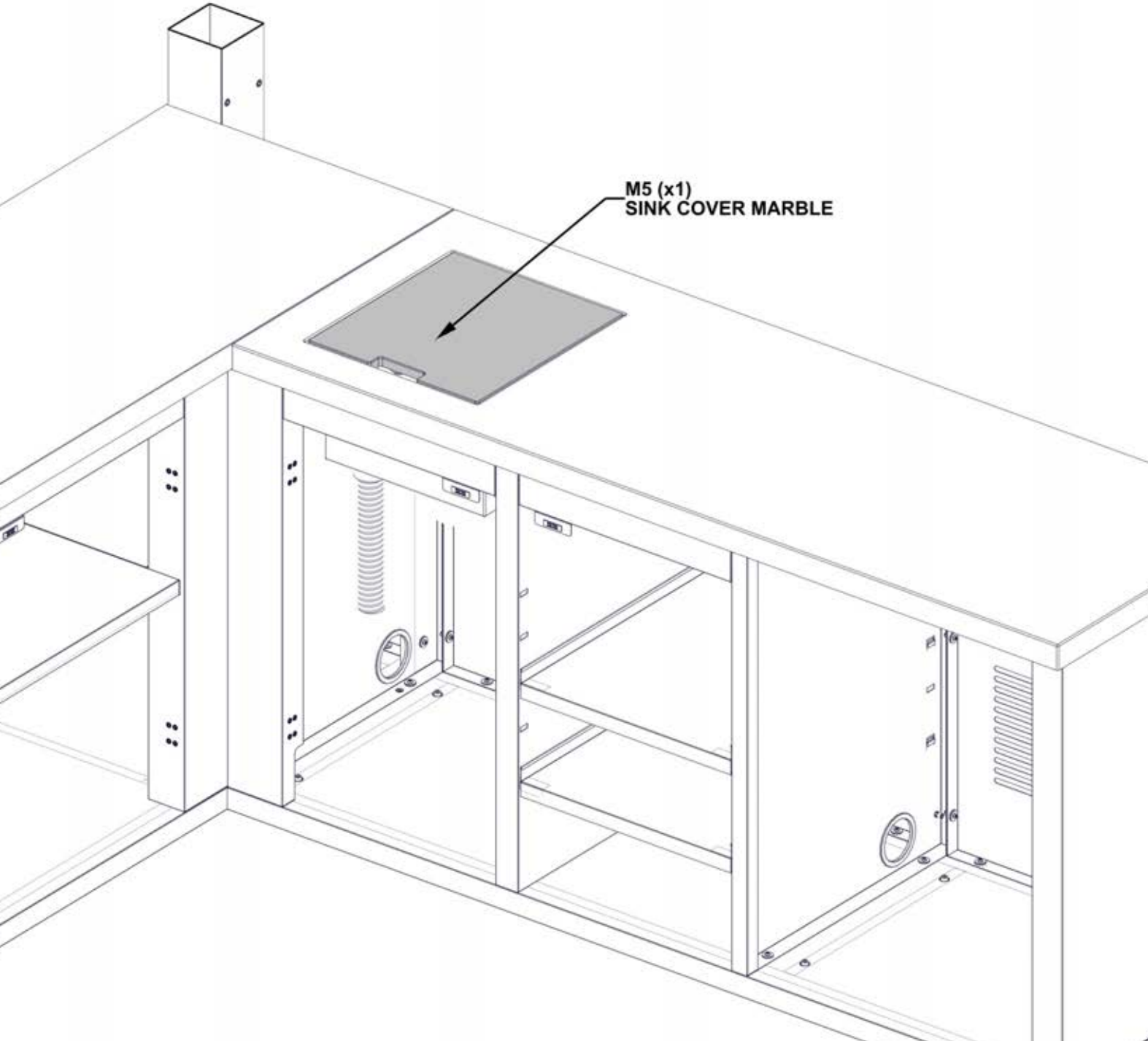

STEP 88 - BAR TABLETOP ASSEMBLY

Qty	PartNo	Description
6	H101202	TORX PAN HEAD 1/4-20x3/4 ASSY



A12 BAR TABLE BRACKET - A4M03022
(x2) 3 3/4"x7 7/8"x8 7/8" (95x200x225)

- ONLY KITCHEN CABINETS ARE SHOWN FOR DETAIL.

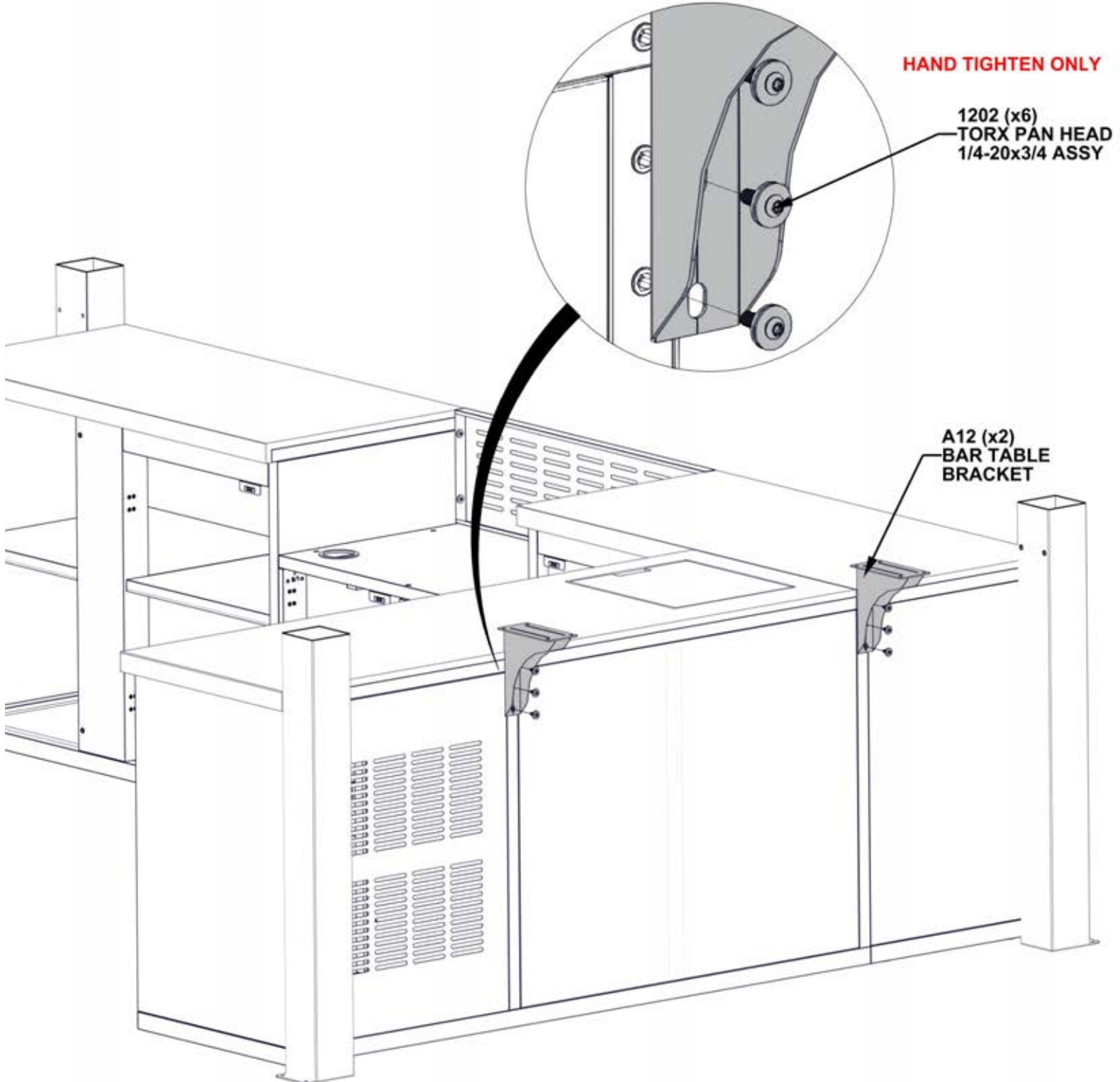

STEP 89 - BAR TABLETOP ASSEMBLY

Qty	PartNo	Description
4	H101202	TORX PAN HEAD 1/4-20x3/4 ASSY



A7 TABLE BRACKET - A4M03148
(x1) 1 15/16"x1 15/16"x7 1/2" (50x50x191)



A8 TABLE BRACKET - A4M03149
(x1) 1 15/16"x1 15/16"x7 1/2" (50x50x191)

- ONLY KITCHEN CABINETS ARE SHOWN FOR DETAIL.

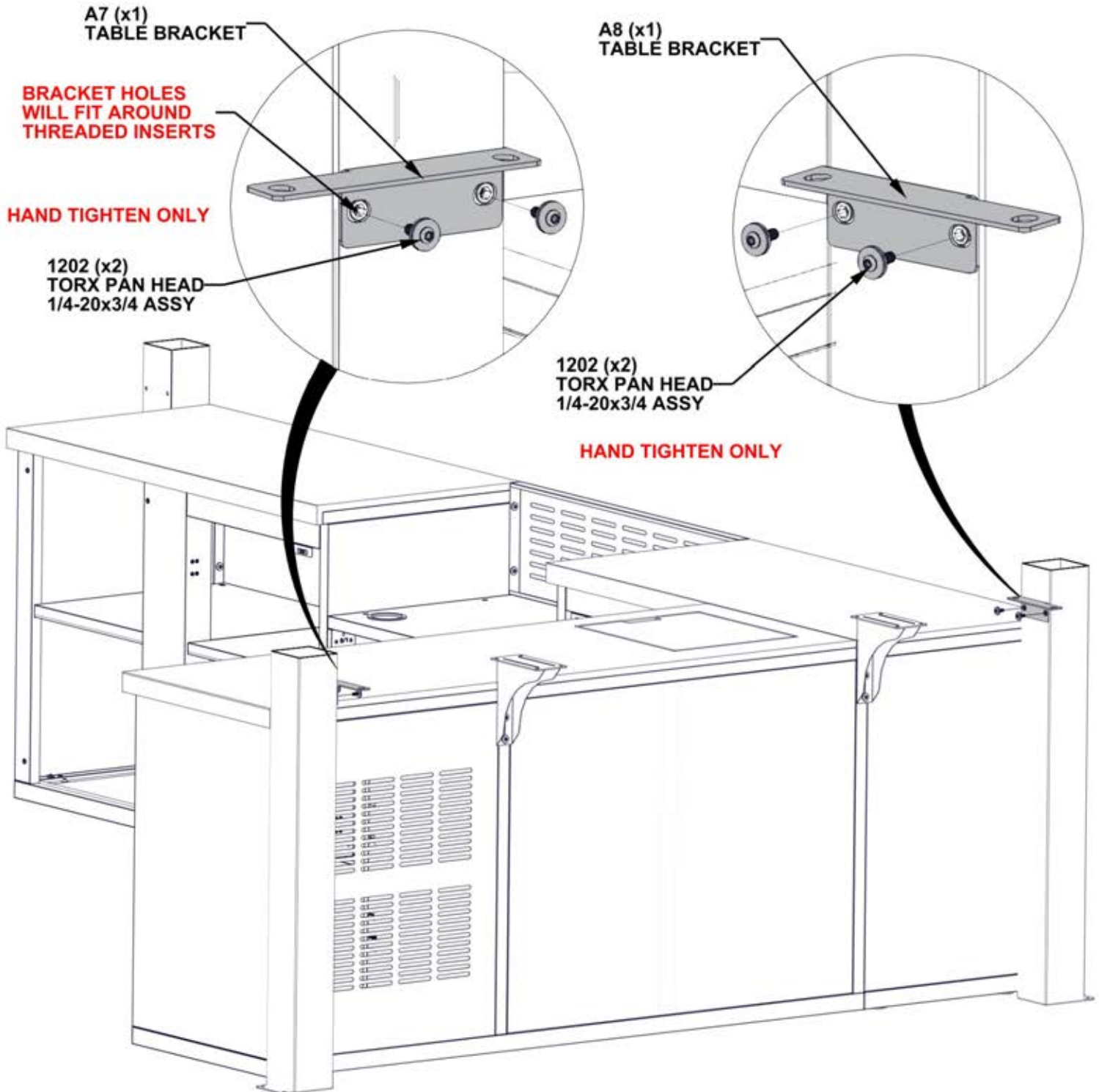

STEP 90 - BAR TABLETOP ASSEMBLY

Qty	PartNo	Description
12	H101202	TORX PAN HEAD 1/4-20x3/4 ASSY

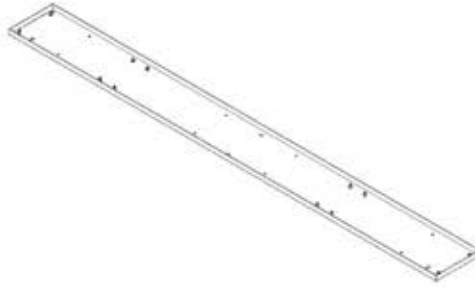

T8 BAR TABLE PAN ASSEMBLY - A4M03023
(x1) 1"x8 7/8"x86 1/4" (25x225x2190)

- ONLY KITCHEN CABINETS ARE SHOWN FOR DETAIL.

- BEFORE TIGHTENING HARDWARE, MAKE SURE BAR TABLETOP IS LEVEL.

TIGHTEN ALL HARDWARE

1202 (x12)
TORX PAN HEAD
1/4-20x3/4 ASSY

**ARROWS WILL FACE
TOWARD CABINETS**

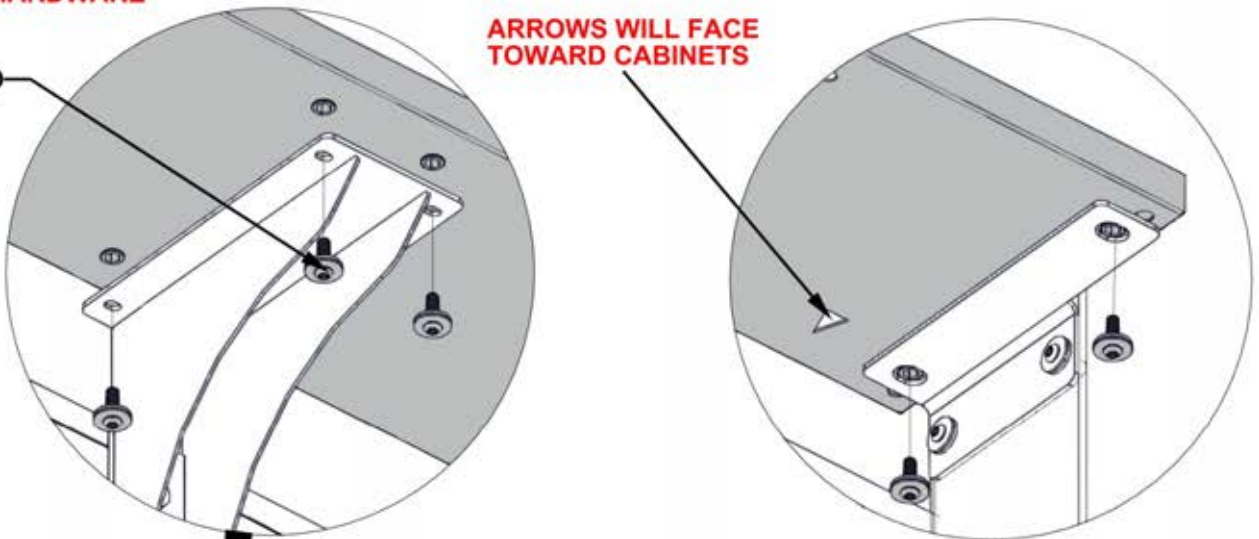

T8 (x1)
BAR TABLE PAN
ASSEMBLY

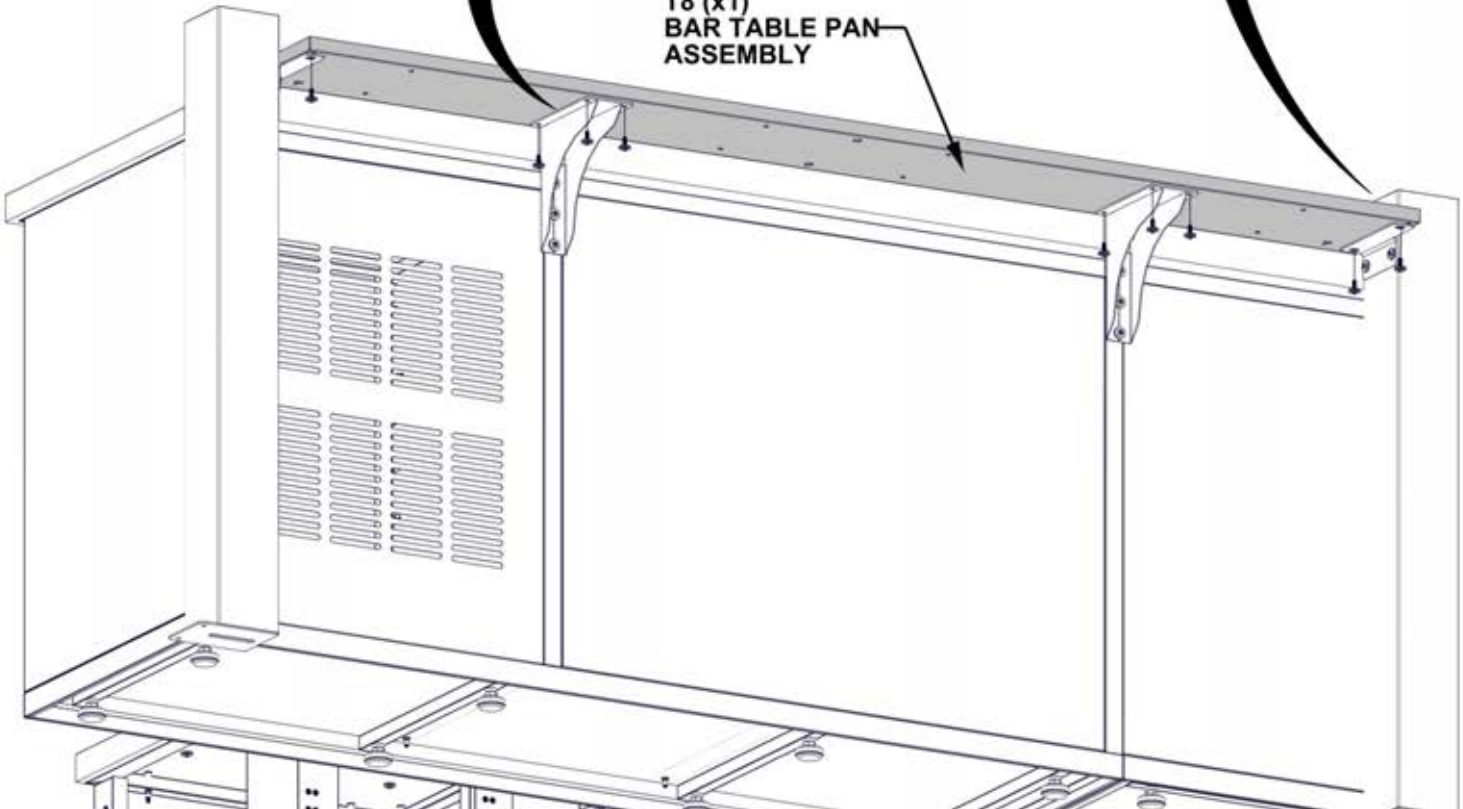

STEP 91A - BAR TABLETOP ASSEMBLY

Qty	PartNo	Description
4	H101293	TORX PAN HEAD 1/4-20x1 3/8"
4	H101054	SEALANT WASHER
4	H101053	STEEL WASHER 6x20



M6 BAR MARBLE RIGHT - A4M03020
(x1) 11/16"x14 1/16"x43 7/16" (18x358x1103)

- ONLY KITCHEN CABINETS ARE SHOWN FOR DETAIL.
- ONCE MARBLE IS IN PLACE, IT IS RECOMMENDED TO COVER WITH A PIECE OF CARDBOARD OR FOAM UNTIL ASSEMBLY IS FINISHED TO PREVENT DAMAGE.
- DO NOT USE MARBLE SURFACE AS A WORK BENCH.

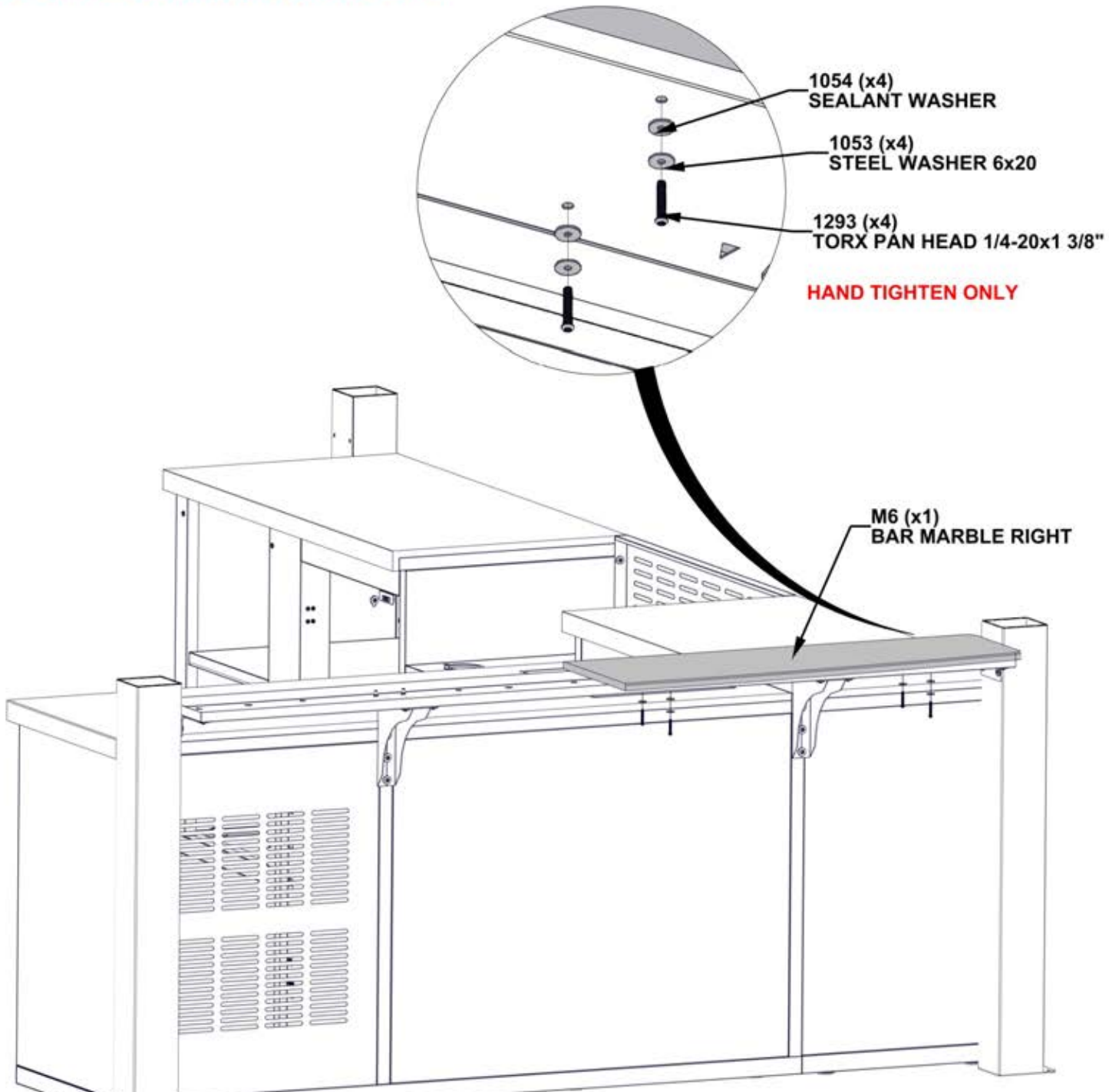

STEP 91B - BAR TABLETOP ASSEMBLY

Qty	PartNo	Description
4	H101293	TORX PAN HEAD 1/4-20x1 3/8"
4	H101054	SEALANT WASHER
4	H101053	STEEL WASHER 6x20



M7 BAR MARBLE LEFT - A4M03021
(x1) 11/16"x14 1/16"x43 7/16" (18x358x1103)

- ONLY KITCHEN CABINETS ARE SHOWN FOR DETAIL.
- ONCE MARBLE IS IN PLACE, IT IS RECOMMENDED TO COVER WITH A PIECE OF CARDBOARD OR FOAM UNTIL ASSEMBLY IS FINISHED TO PREVENT DAMAGE.
- DO NOT USE MARBLE SURFACE AS A WORK BENCH.
- CENTER BOTH LEFT AND RIGHT MARBLE COUNTERTOPS BETWEEN POST BEFORE TIGHTENING HARDWARE.

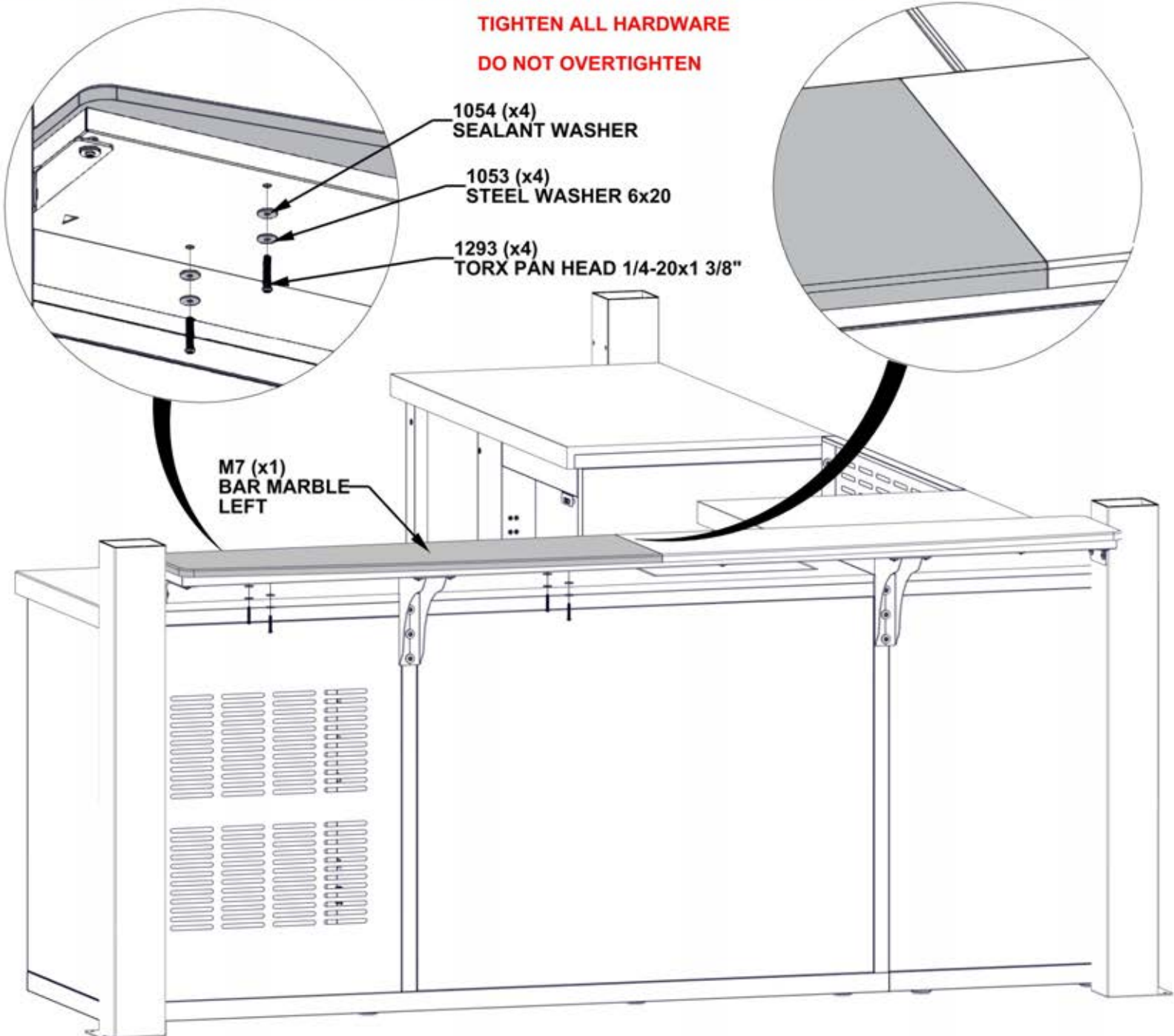

STEP 92 - PIZZA OVEN CABINET ASSEMBLY

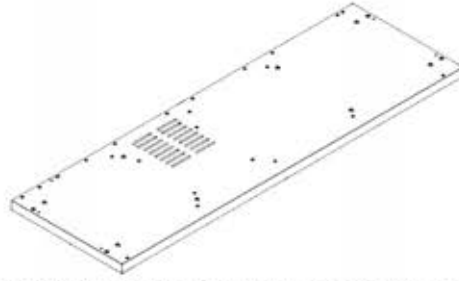

F4 PIZZA OVEN CABINET FLOOR PANEL ASSEMBLY - A4M03062
(x1) 2 5/8"x23 3/8"x72 3/16" (66x594x1834)

- ONLY KITCHEN CABINETS ARE SHOWN FOR DETAIL.
- POSITION FLOOR PANEL AS SHOWN BELOW.
- EACH FLOOR PANEL HAS FACTORY INSTALLED ADJUSTABLE FEET. USE PROVIDED HEX DRIVER TO ADJUST EACH FOOT UNTIL PANEL IS LEVEL.

**F4 LABEL INDICATES
BACK OF FLOOR PANEL**

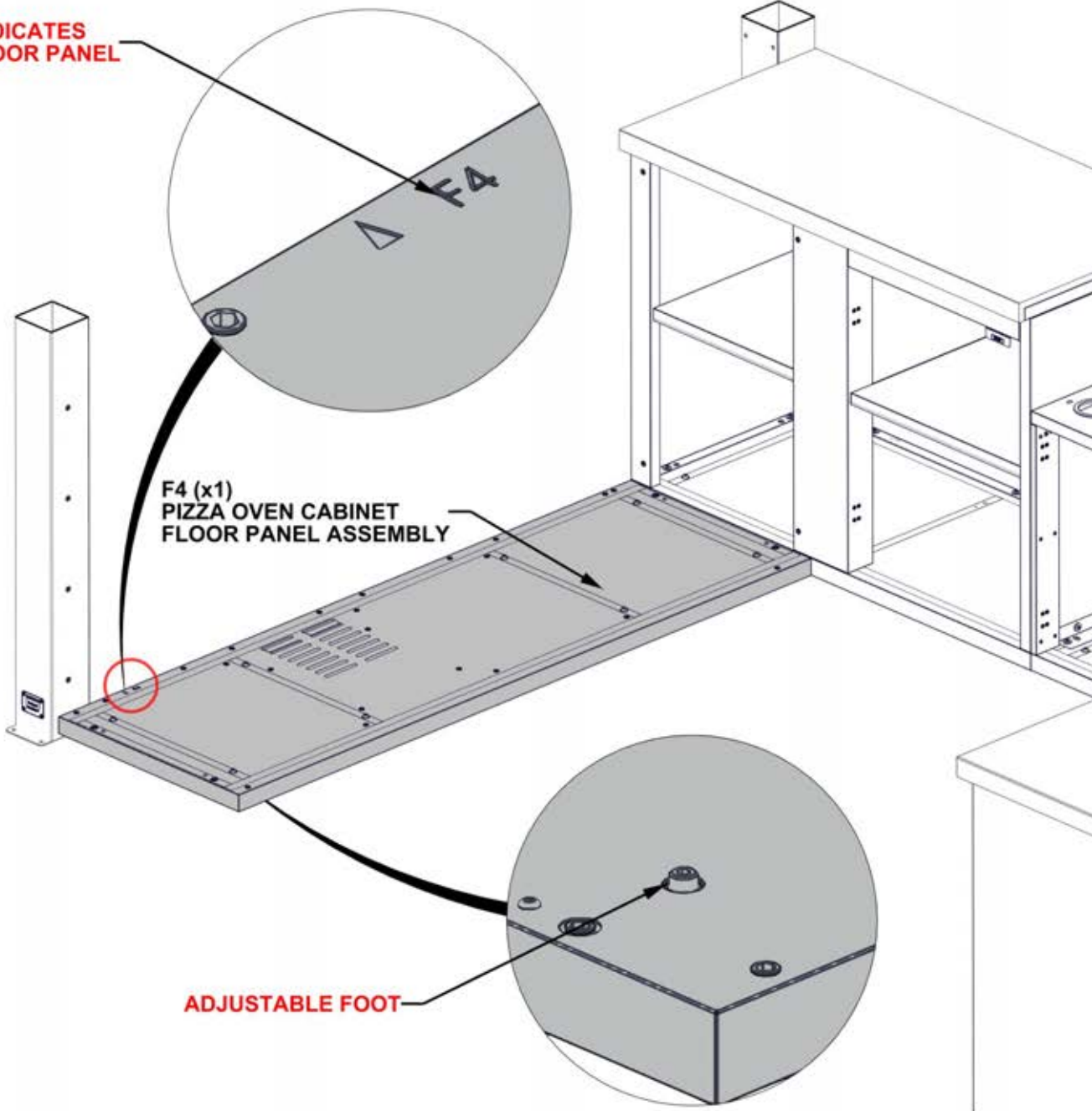

F4 (x1)
PIZZA OVEN CABINET
FLOOR PANEL ASSEMBLY

ADJUSTABLE FOOT

STEP 93A - PIZZA OVEN CABINET ASSEMBLY

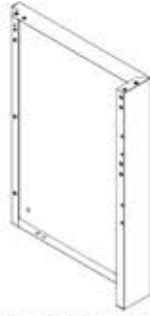

Qty	PartNo	Description
3	H101202	TORX PAN HEAD 1/4-20x3/4 ASSY

O1 PIZZA OVEN CABINET SIDE PANEL ASSEMBLY R - A4M03064
 (x1) 4 3/4"x23 3/8"x33 3/8" (121x594x848)

- ONLY KITCHEN CABINETS ARE SHOWN FOR DETAIL.
- SIDE PANEL WILL SIT UNDERNEATH THE FRONT MARBLE LIP.
- IF TOP OF SIDE PANEL INTERFERES WITH MARBLE, ADJUST FLOOR PANEL FEET DOWN UNTIL THERE IS ENOUGH ROOM FOR PANEL TO FIT.

HOLES IN SIDE PANEL WILL FIT AROUND THREADED INSERTS IN GRILL CABINET

O1 LABEL INDICATES TOP OF SIDE PANEL

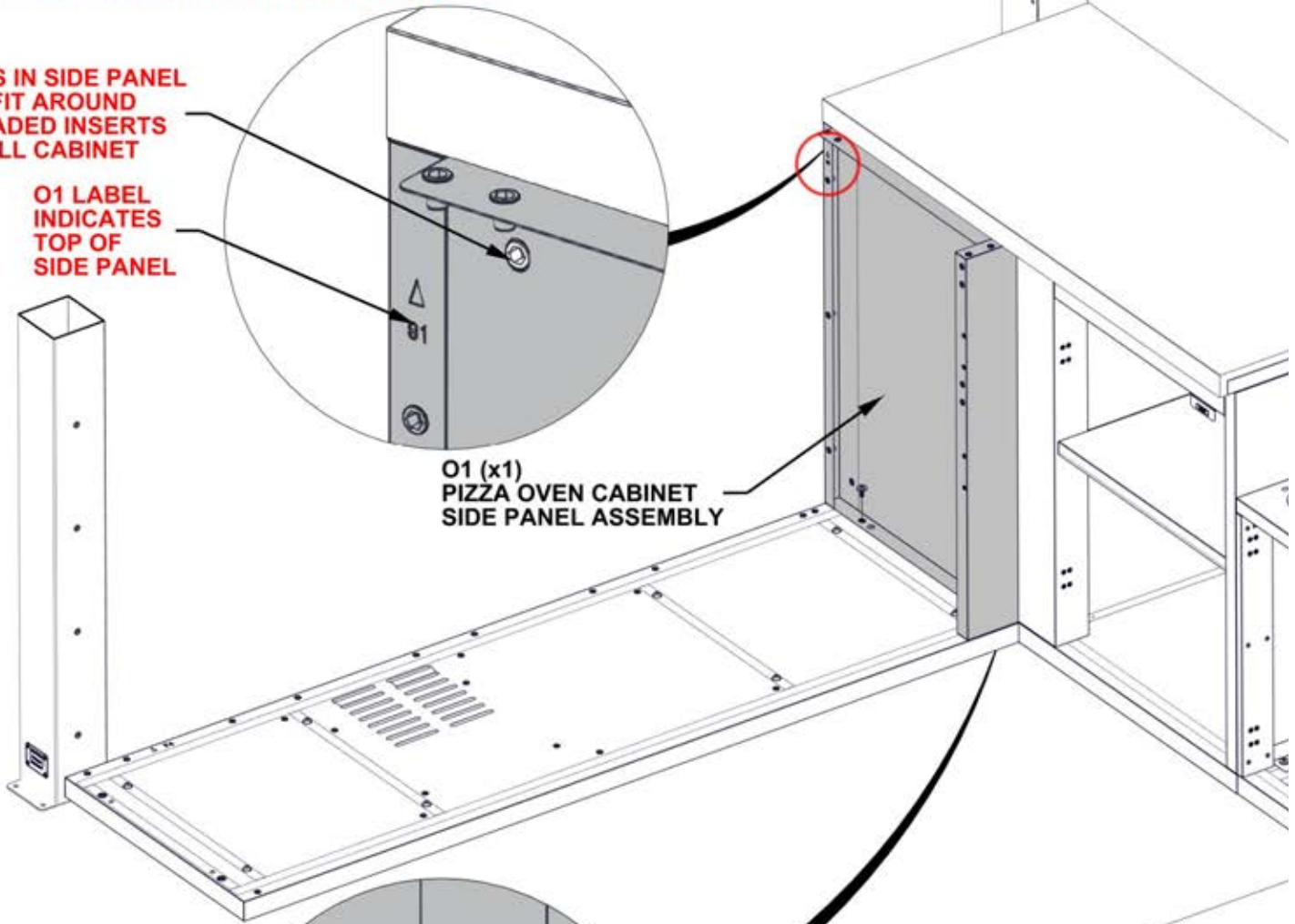

O1 (x1)
 PIZZA OVEN CABINET
 SIDE PANEL ASSEMBLY

1202 (x3)
 TORX PAN HEAD
 1/4-20x3/4 ASSY

HAND TIGHTEN ONLY

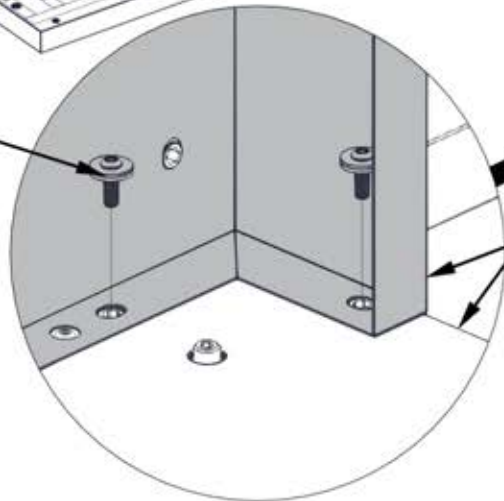

FLUSH FRONT FACE OF SIDE PANEL WITH FLOOR PANEL

STEP 93B - PIZZA OVEN CABINET ASSEMBLY

Qty	PartNo	Description
4	H101202	TORX PAN HEAD 1/4-20x3/4 ASSY

- ONLY KITCHEN CABINETS ARE SHOWN FOR DETAIL.

- ADJUST FLOOR FEET UNTIL TOP SIDE OF O1 PANEL TOUCHES BOTTOM OF PANEL

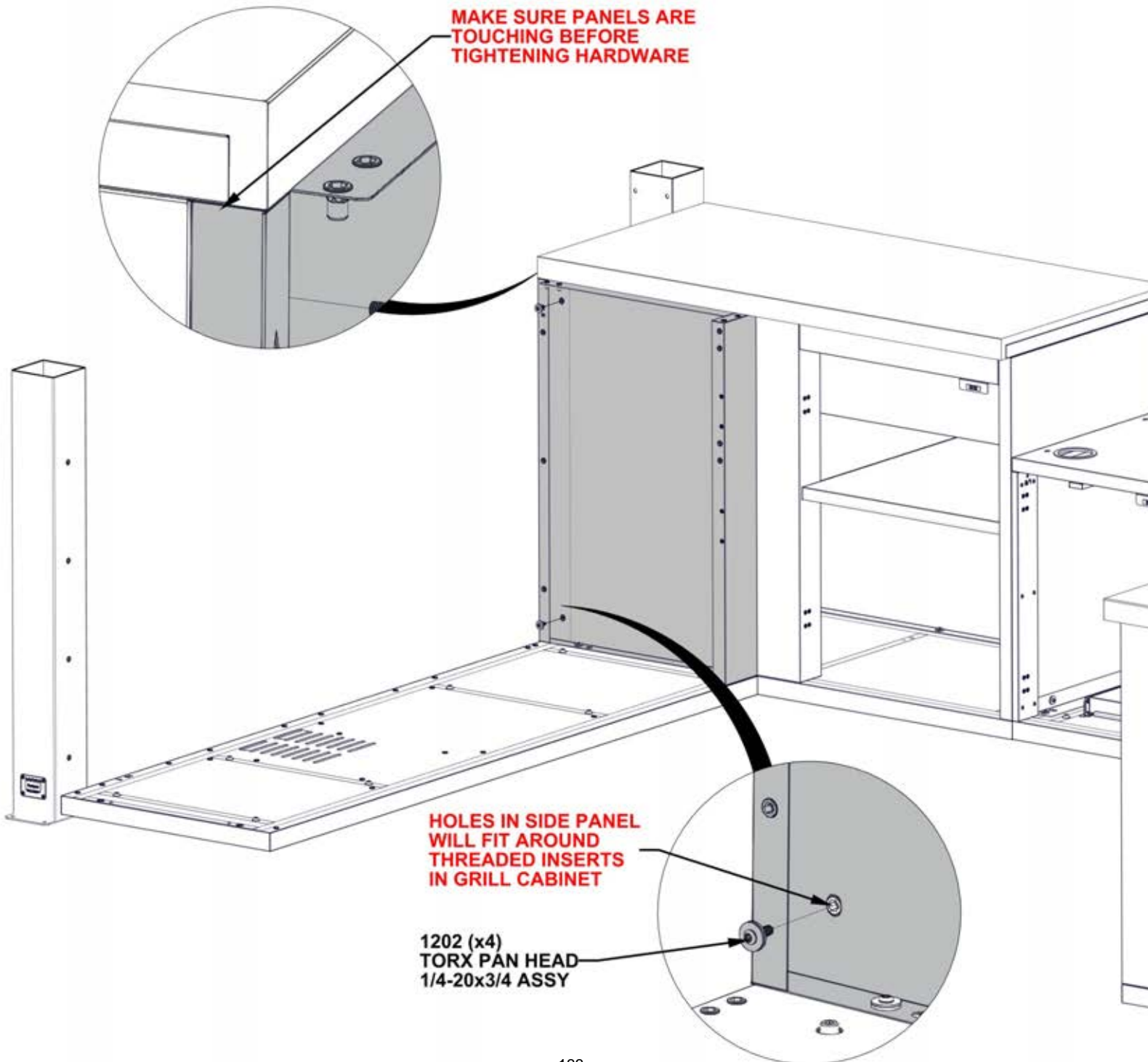

STEP 94A - PIZZA OVEN CABINET ASSEMBLY



Qty	PartNo	Description
4	H101202	TORX PAN HEAD 1/4-20x3/4 ASSY

O5 PIZZA OVEN CABINET SIDE PANEL ASSEMBLY L - A4M03063
 (x1) 2 5/8"x23 3/8"x33 3/8" (67x594x848)

- ONLY KITCHEN CABINETS ARE SHOWN FOR DETAIL.

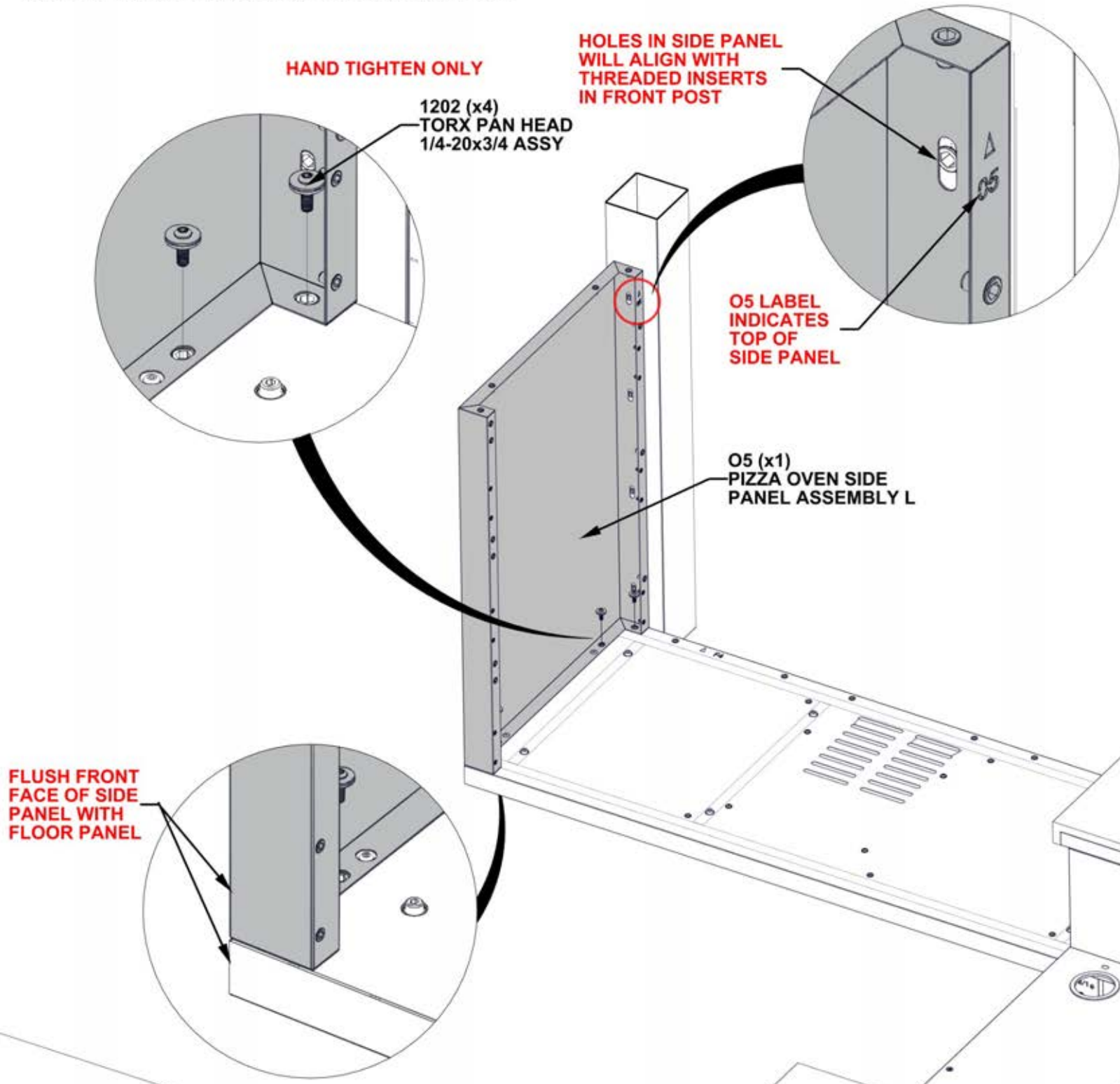

STEP 94B - PIZZA OVEN CABINET ASSEMBLY

Qty	PartNo	Description
4	H101202	TORX PAN HEAD 1/4-20x3/4 ASSY

- ONLY KITCHEN CABINETS ARE SHOWN FOR DETAIL.

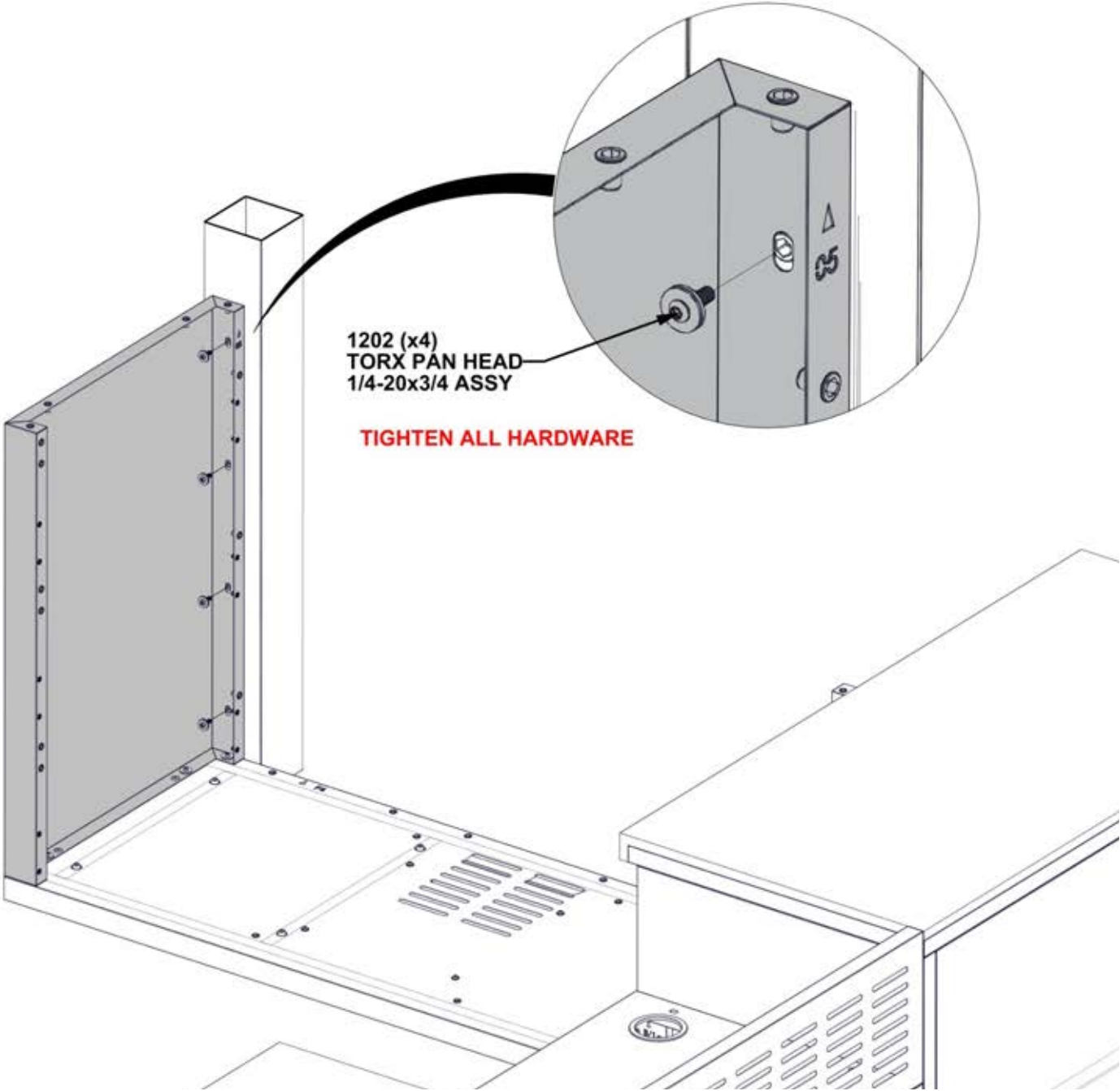

STEP 95 - PIZZA OVEN CABINET ASSEMBLY



Qty	PartNo	Description
5	H101202	TORX PAN HEAD 1/4-20x3/4 ASSY

O9 PIZZA OVEN CABINET LEFT BACK PANEL - A4M03065
(x1) 1 3/16"x15 3/16"x33 3/8" (30x386x848)

- ONLY KITCHEN CABINETS ARE SHOWN FOR DETAIL.

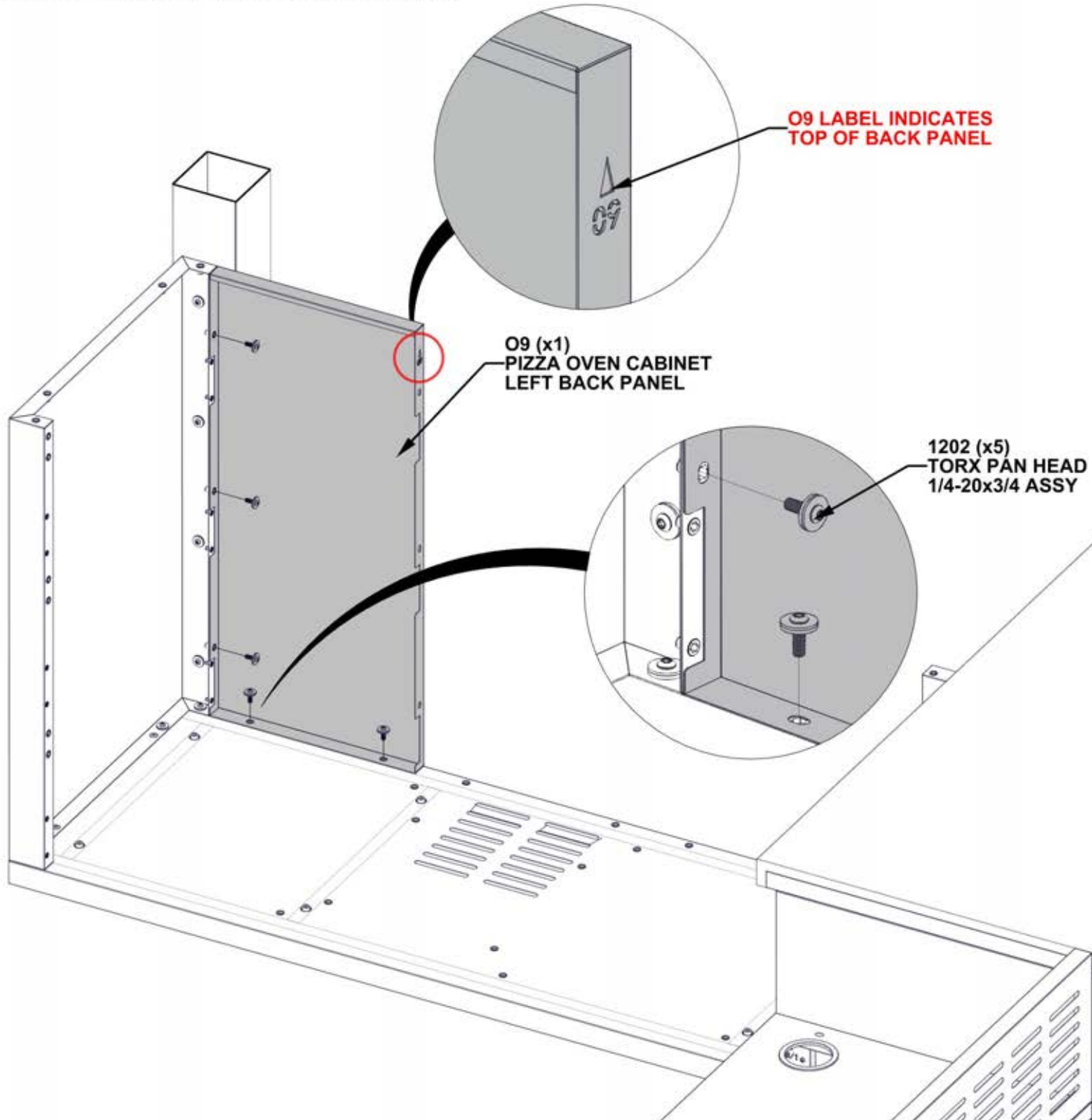

STEP 96 - PIZZA OVEN CABINET ASSEMBLY



A10 SLIDE BRACKET ASSEMBLY - A4M03083
(x3) 15/16"x3 3/8"x22 5/8" (23x85x575)

Qty	PartNo	Description
12	H101289	PAN HEAD SCREW 8-32x1/2" SS

- ONLY KITCHEN CABINETS ARE SHOWN FOR DETAIL.

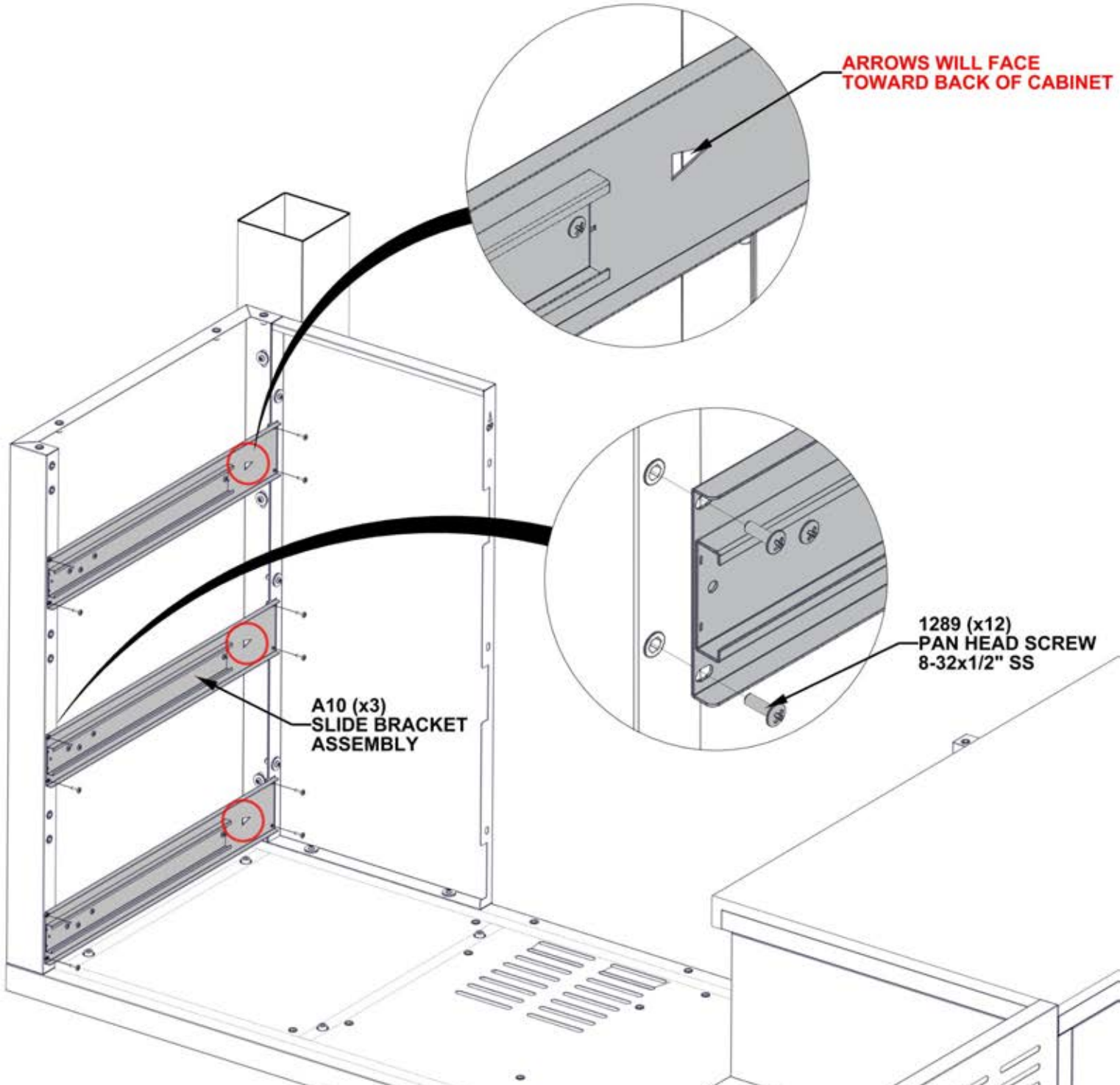

STEP 97 - PIZZA OVEN CABINET ASSEMBLY



Qty	PartNo	Description
2	H101202	TORX PAN HEAD 1/4-20x3/4 ASSY

O4 PIZZA OVEN CABINET SIDE PANEL ASSEMBLY ML - A4M03066
 (x1) 2 5/8"x23 3/8"x33 3/8" (67x594x848)

- ONLY KITCHEN CABINETS ARE SHOWN FOR DETAIL.

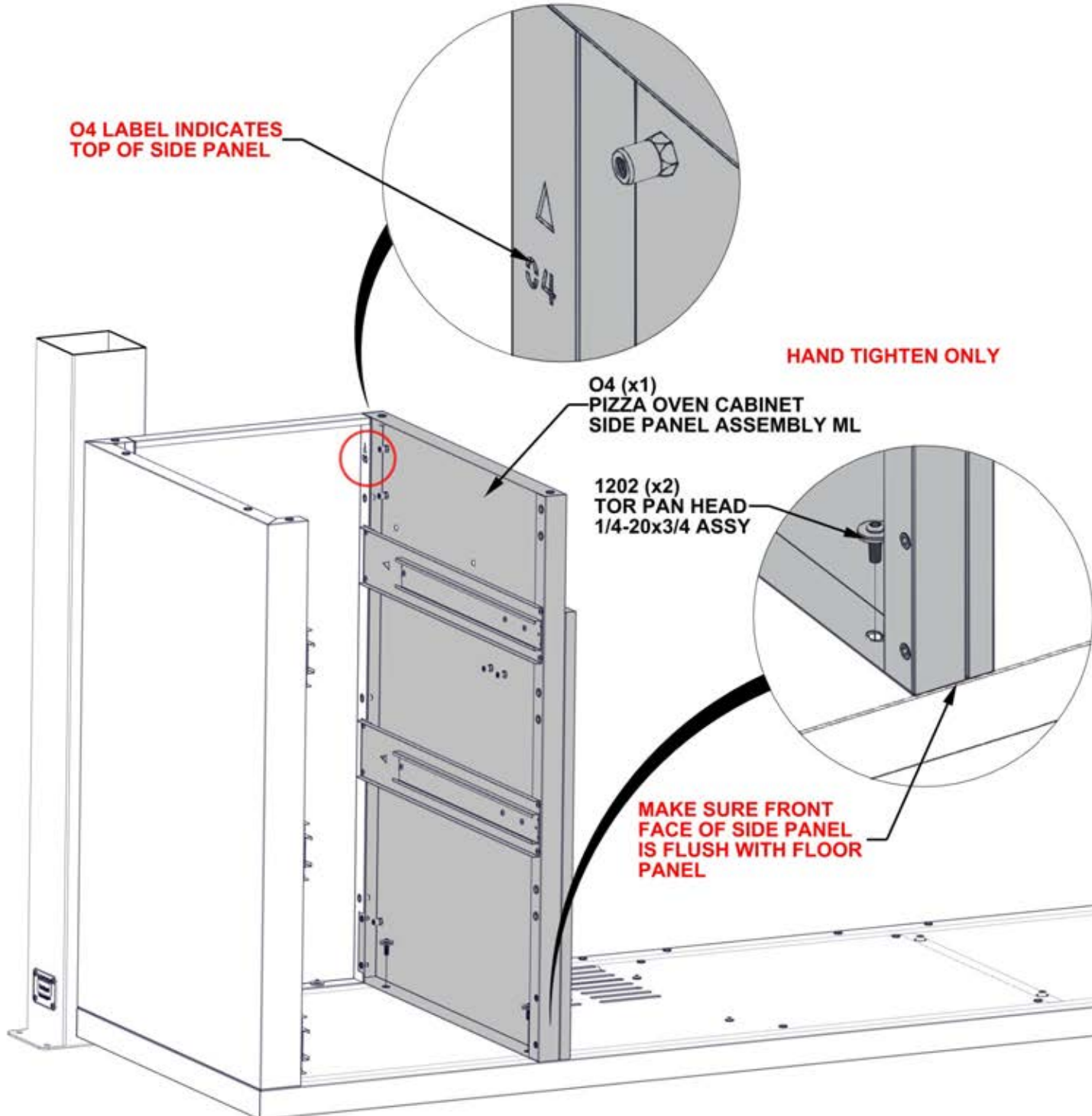

STEP 98 - PIZZA OVEN CABINET ASSEMBLY

Qty	PartNo	Description
3	H101202	TORX PAN HEAD 1/4-20x3/4 ASSY

- ONLY KITCHEN CABINETS ARE SHOWN FOR DETAIL.

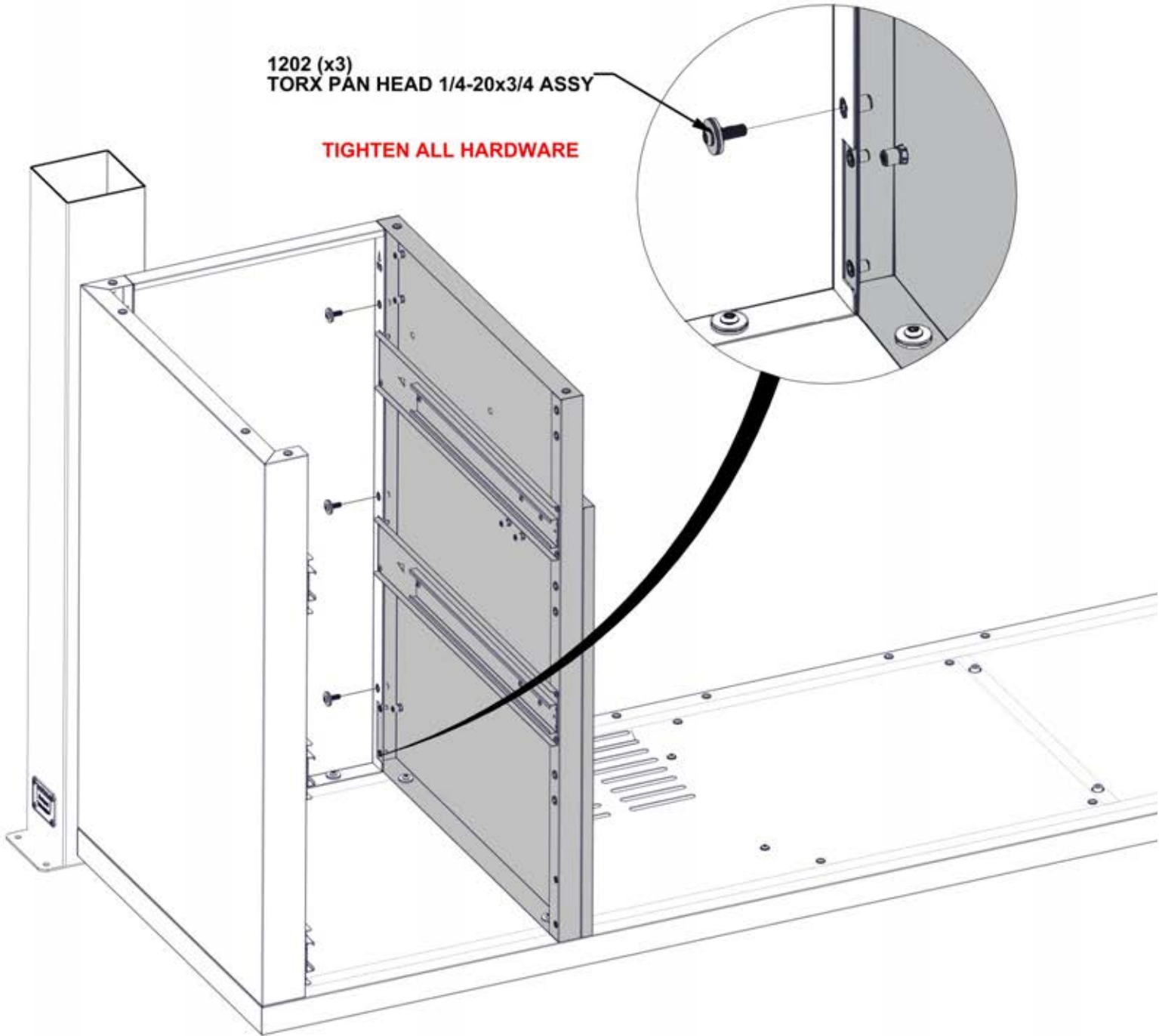

STEP 99 - PIZZA OVEN CABINET ASSEMBLY



Qty	PartNo	Description
4	H101289	PAN HEAD SCREW 8-32x1/2" SS

A10 SLIDE BRACKET ASSEMBLY - A4M03083
(x1) 15/16"x3 3/8"x22 5/8" (23x85x575)

- ONLY KITCHEN CABINETS ARE SHOWN FOR DETAIL.

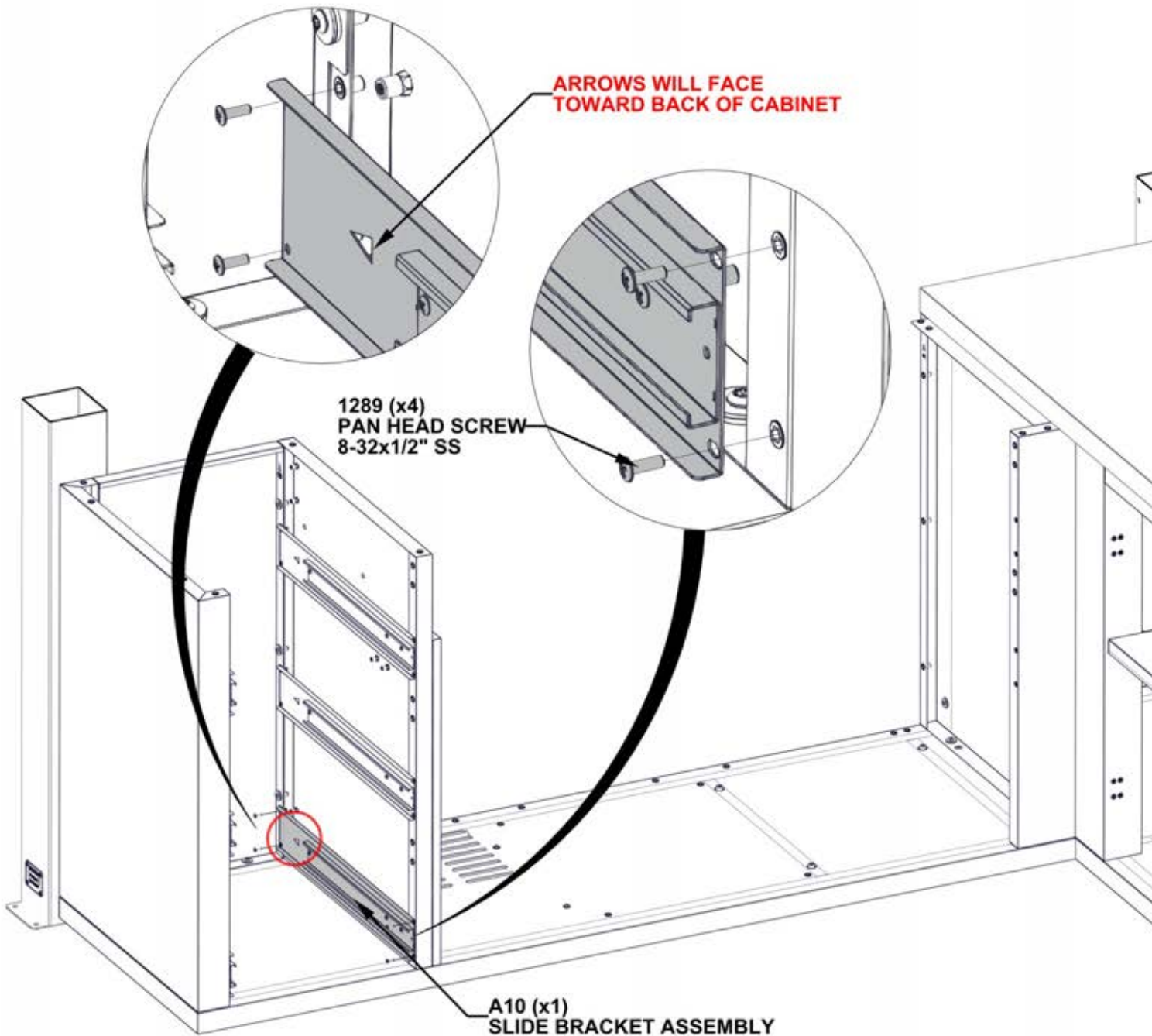

STEP 100 - PIZZA OVEN CABINET ASSEMBLY

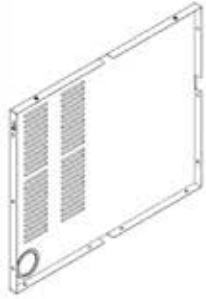

Qty	PartNo	Description
7	H101202	TORX PAN HEAD 1/4-20x3/4 ASSY

O7 PIZZA OVEN CABINET BACK PANEL ASSEMBLY M - A4M03075
(x1) 1 3/16"x26 7/16"x31 7/16" (30x672x798)

- ONLY KITCHEN CABINETS ARE SHOWN FOR DETAIL.

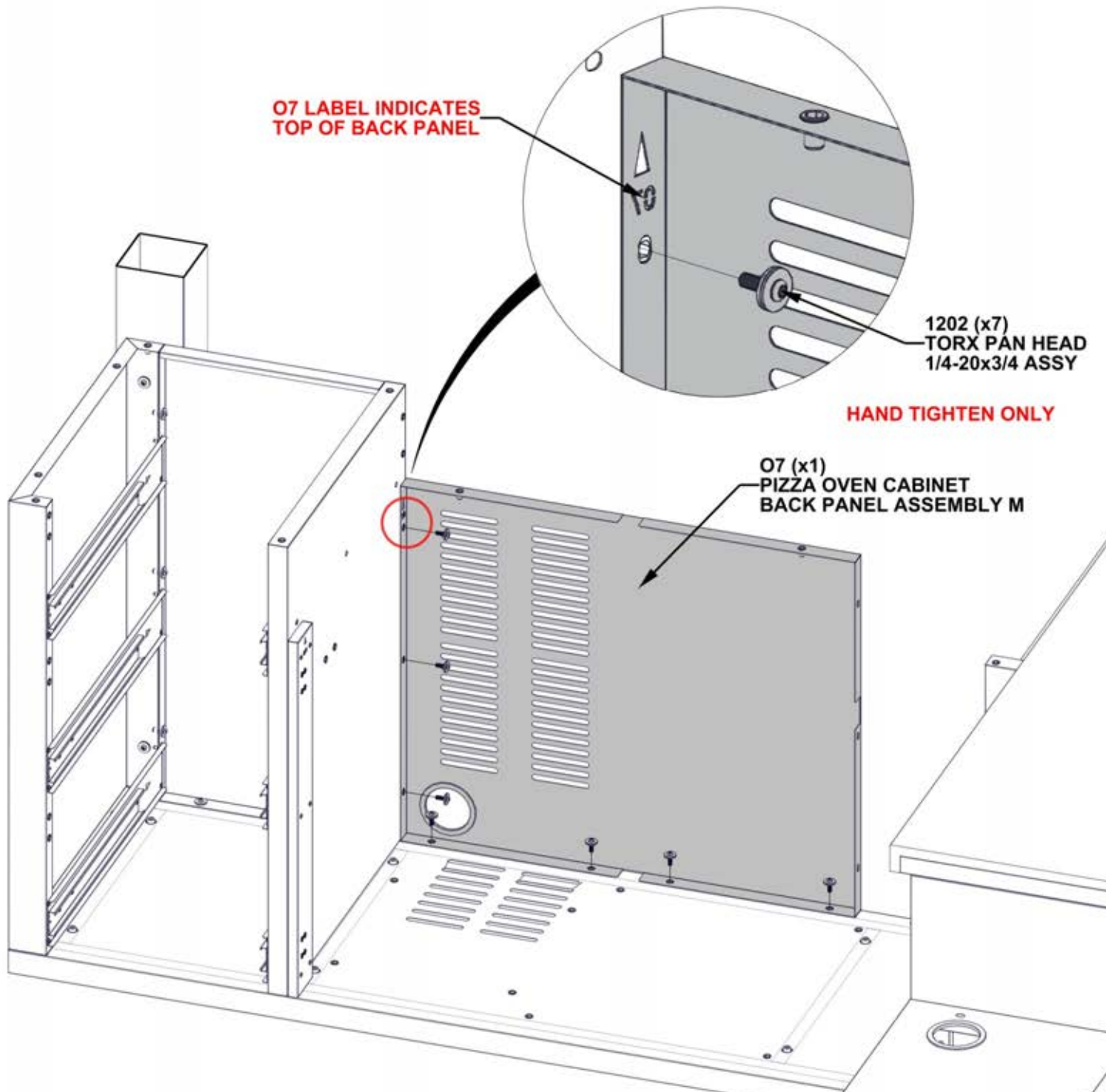

STEP 101 - PIZZA OVEN CABINET ASSEMBLY



Qty	PartNo	Description
2	H101202	TORX PAN HEAD 1/4-20x3/4 ASSY

O2 PIZZA OVEN CABINET SIDE PANEL ASSEMBLY MR - A4M03067
 (x1) 2 5/8"x23 3/8"x33 3/8" (67x594x848)

- ONLY KITCHEN CABINETS ARE SHOWN FOR DETAIL.

HAND TIGHTEN ONLY

1202 (x2)
 TORX PAN HEAD
 1/4-20x3/4 ASSY

**MAKE SURE FRONT
 FACE OF SIDE PANEL
 IS FLUSH WITH FLOOR
 PANEL**

**O2 LABEL INDICATES
 TOP OF SIDE PANEL**

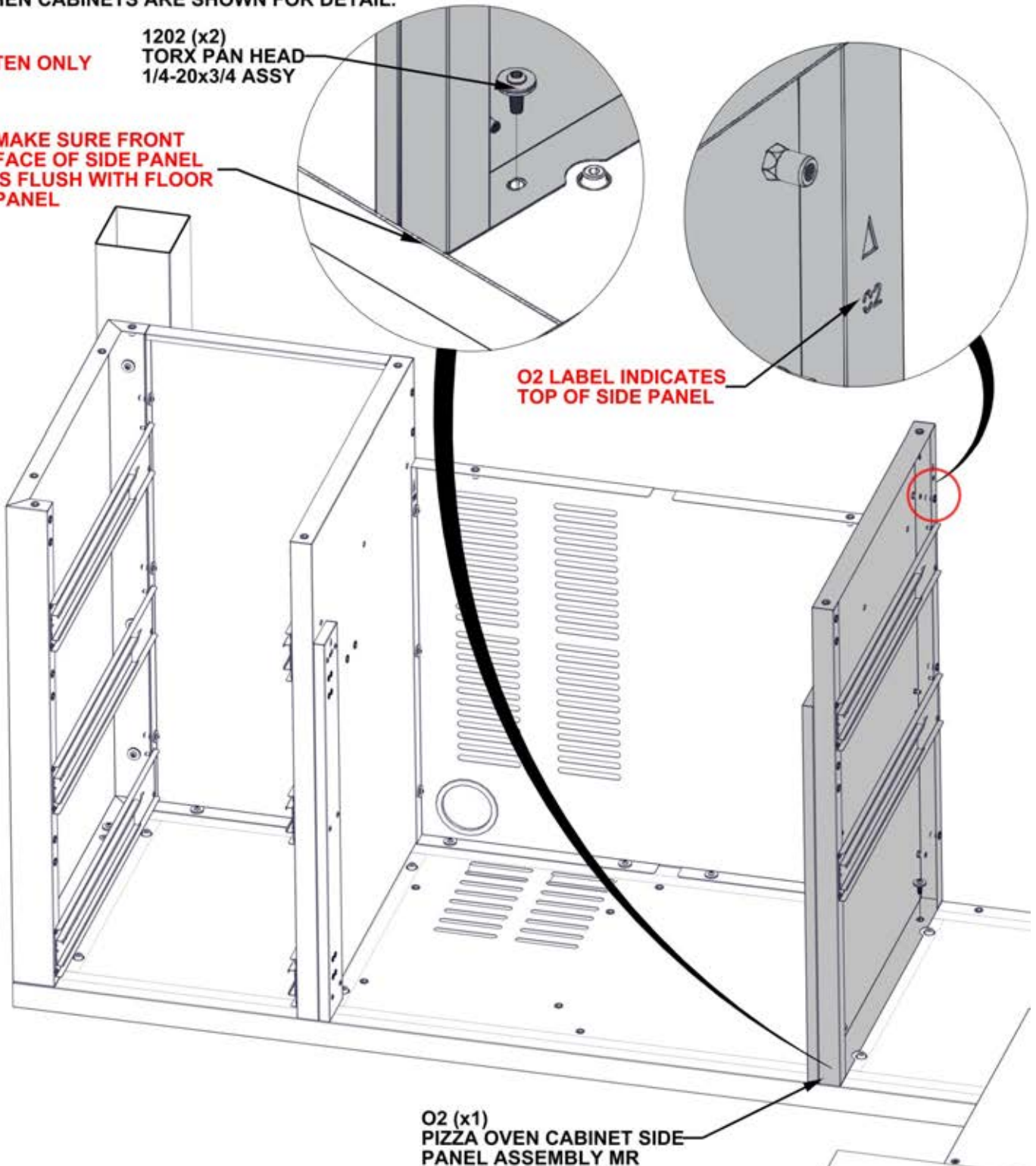

O2 (x1)
 PIZZA OVEN CABINET SIDE
 PANEL ASSEMBLY MR

STEP 102 - PIZZA OVEN CABINET ASSEMBLY

Qty	PartNo	Description
3	H101202	TORX PAN HEAD 1/4-20x3/4 ASSY

- ONLY KITCHEN CABINETS ARE SHOWN FOR DETAIL.

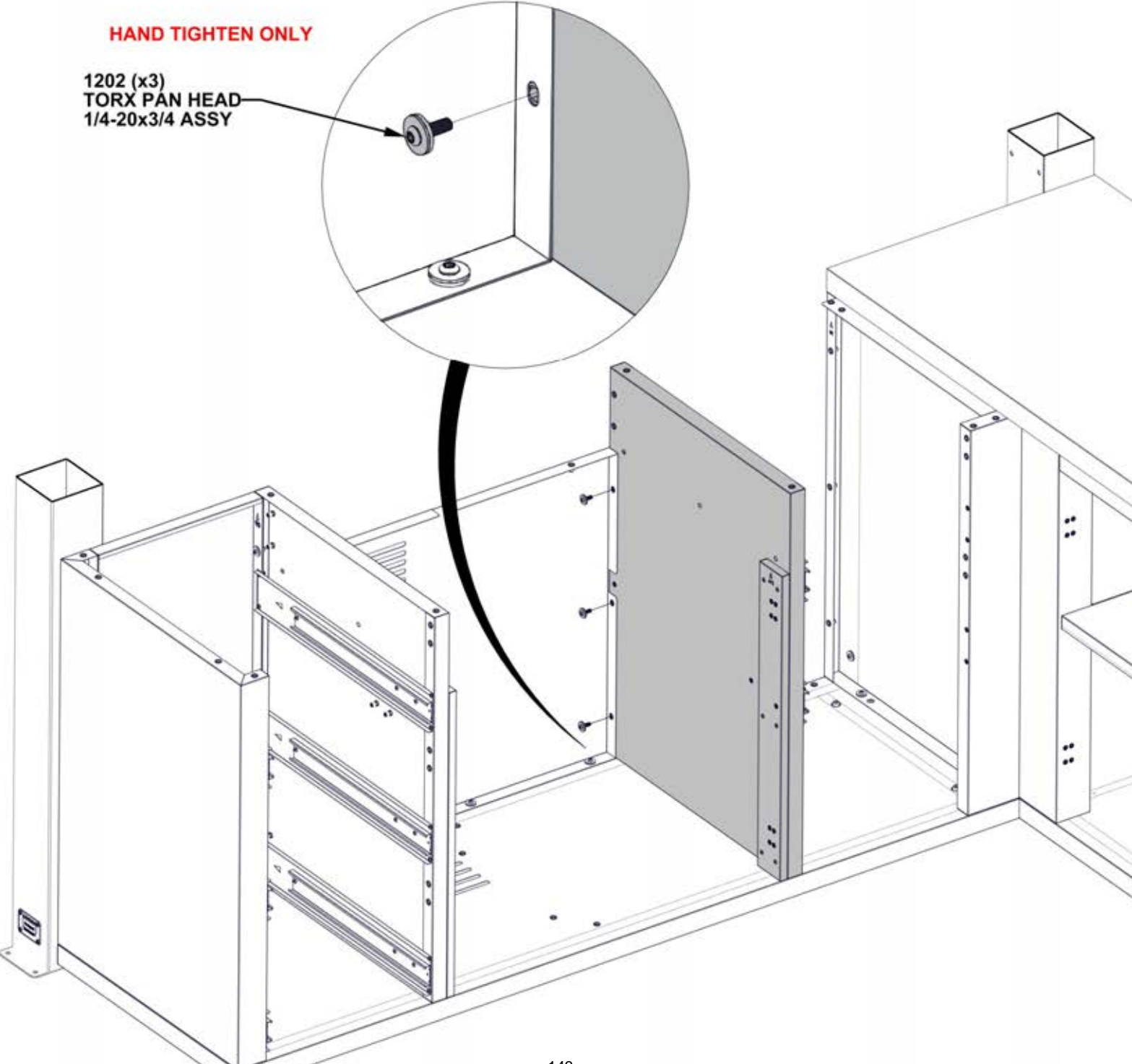

STEP 103 - PIZZA OVEN CABINET ASSEMBLY



Qty	PartNo	Description
7	H101202	TORX PAN HEAD 1/4-20x3/4 ASSY

O6 PIZZA OVEN CABINET BACK PANEL R - A4M03076
(x1) 1 3/16"x18 9/16"x33 3/8" (30x472x848)

- ONLY KITCHEN CABINETS ARE SHOWN FOR DETAIL.

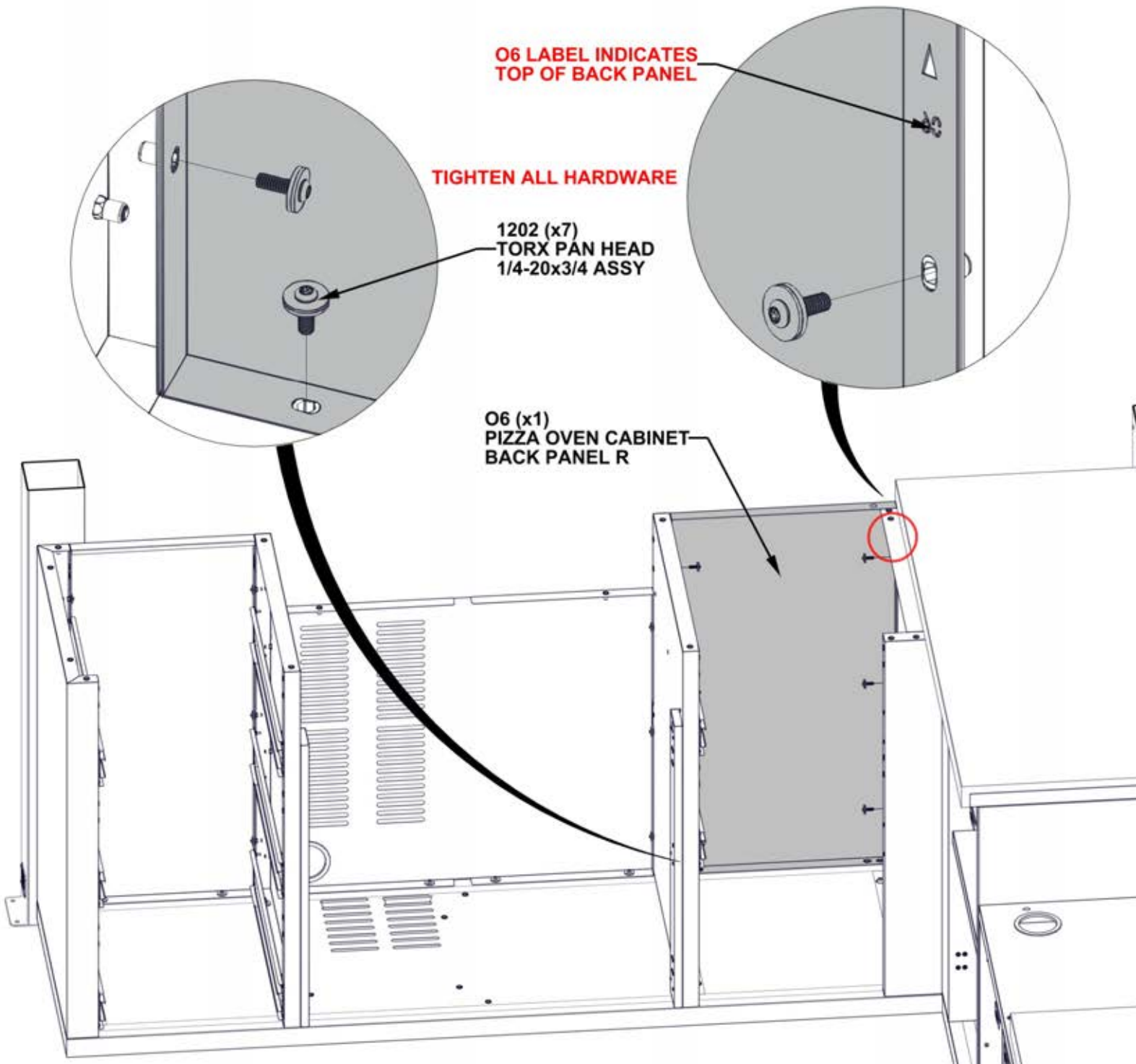

STEP 104 - PIZZA OVEN CABINET ASSEMBLY



Qty	PartNo	Description
2	H101202	TORX PAN HEAD 1/4-20x3/4 ASSY

O10 PIZZA OVEN SLIDE UPRIGHT ASSEMBLY - A4M03079
(x1) 1 3/16"x2 15/16"x33 1/4" (30x75x844)

- ONLY KITCHEN CABINETS ARE SHOWN FOR DETAIL.

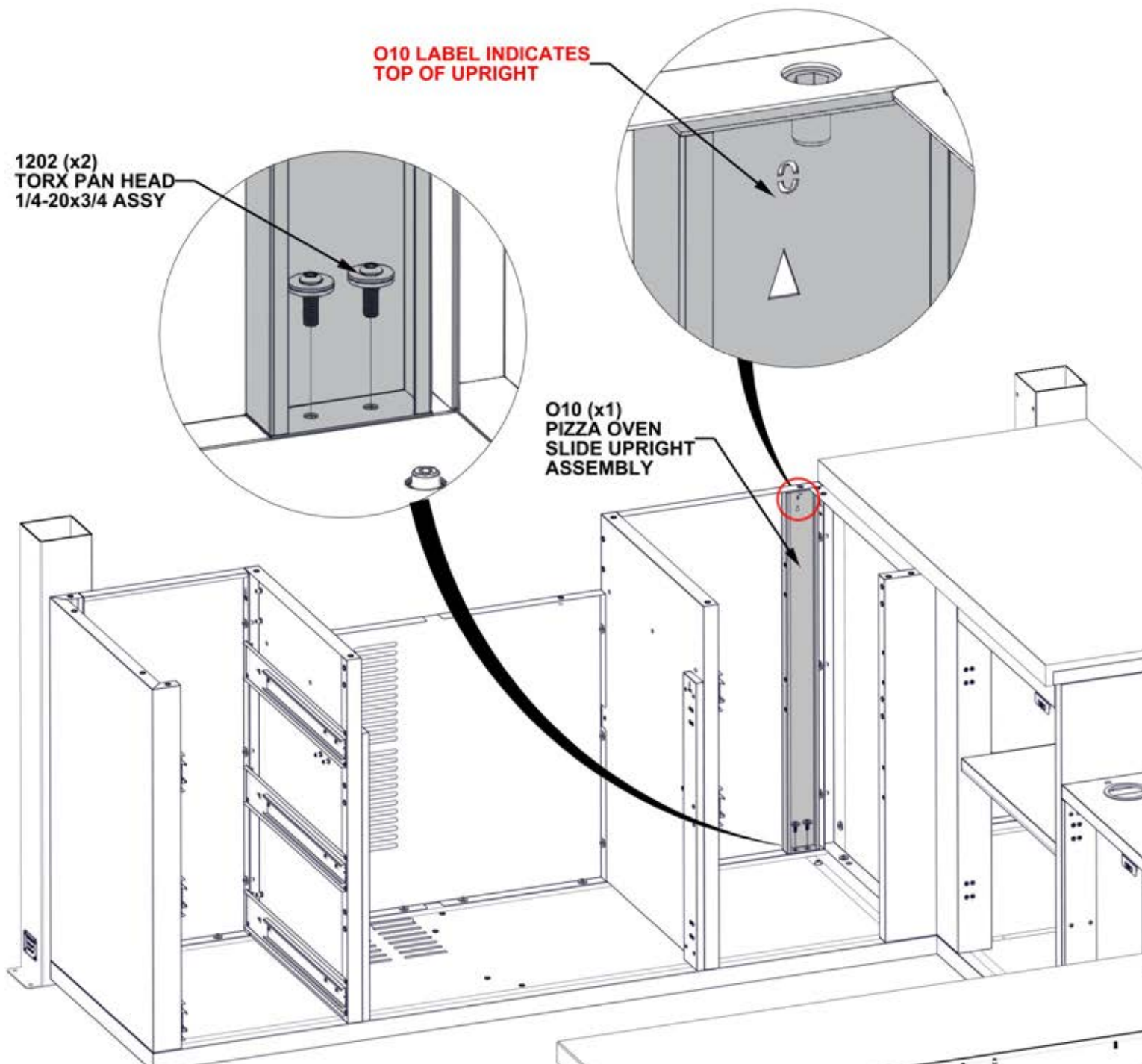

STEP 105 - PIZZA OVEN CABINET ASSEMBLY



Qty	PartNo	Description
8	H101289	PAN HEAD SCREW 8-32x1/2" SS

A10 SLIDE BRACKET ASSEMBLY - A4M03083
(x2) 15/16"x3 3/8"x22 5/8" (23x85x575)

- ONLY KITCHEN CABINETS ARE SHOWN FOR DETAIL.

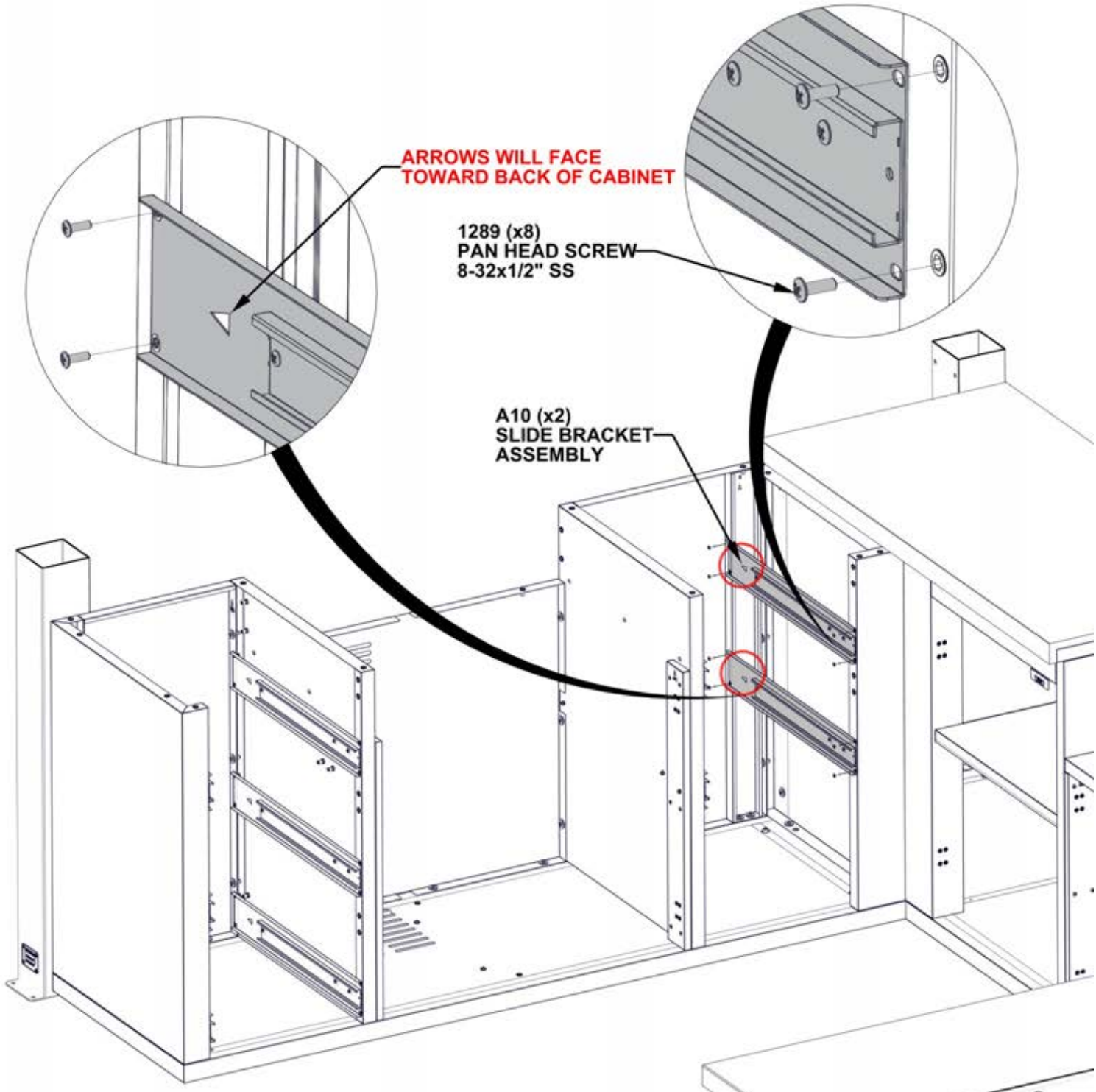

STEP 106 - PIZZA OVEN CABINET ASSEMBLY



A9 HOSE BRACKET ASSEMBLY - A4M03060
(x1) 1 1/4"x1 7/16"x2 9/16" (31.5x36.5x65)

Qty	PartNo	Description
2	H101202	TORX PAN HEAD 1/4-20x3/4 ASSY

- ONLY KITCHEN CABINETS ARE SHOWN FOR DETAIL.

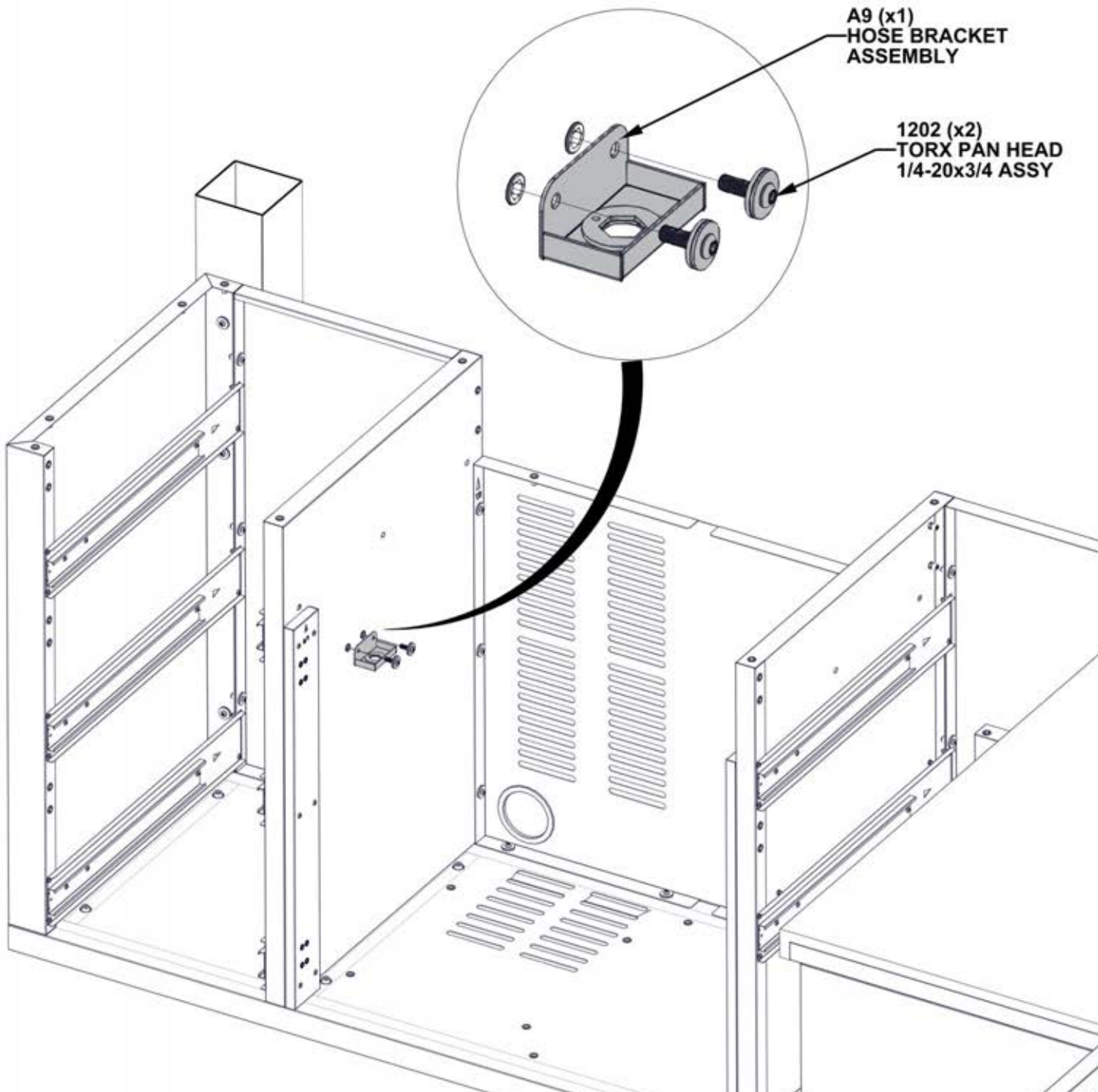

A9 (x1)
HOSE BRACKET
ASSEMBLY

1202 (x2)
TORX PAN HEAD
1/4-20x3/4 ASSY

STEP 107 - PIZZA OVEN CABINET ASSEMBLY



Qty	PartNo	Description
4	H101292	TORX PAN HEAD 1/4-20x13/32"

A13 GAS TANK HOLDER ASSEMBLY - A4M03047
(x1) 1 15/16"x12 7/8"x14 3/4" (49x327x374)

- ONLY KITCHEN CABINETS ARE SHOWN FOR DETAIL.

NOTE ORIENTATION OF WING NUT TOWARDS FRONT

1292 (x4)
TORX PAN HEAD
1/4-20x13/32"

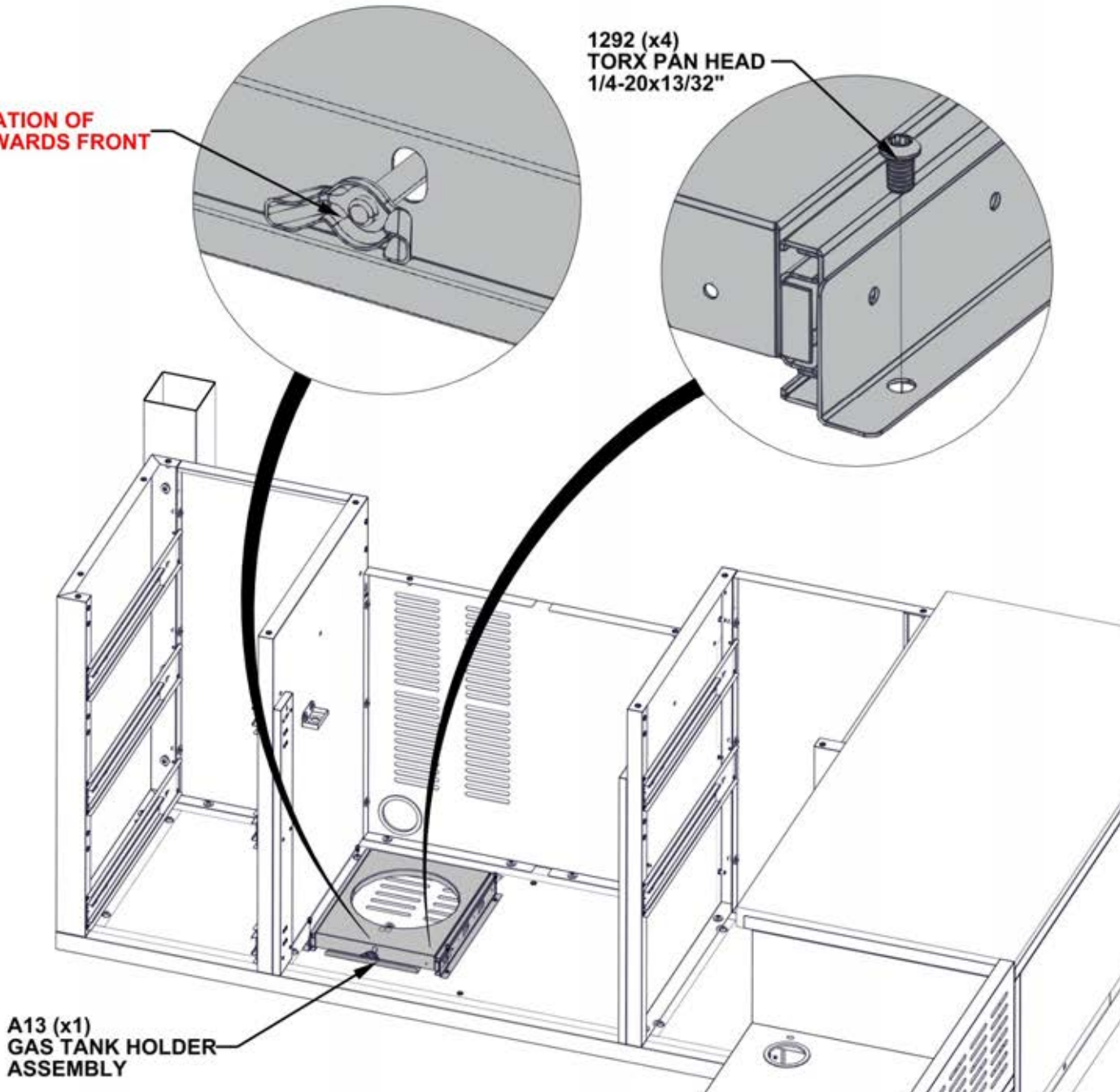

A13 (x1)
GAS TANK HOLDER
ASSEMBLY

STEP 108 - PIZZA OVEN CABINET ASSEMBLY



Qty	PartNo	Description
2	H101202	TORX PAN HEAD 1/4-20x3/4 ASSY

O3 PIZZA OVEN CABINET SIDE PANEL ASSEMBLY M - A4M03077
(x1) 1 3/4"x23 5/16"x26 7/16" (44x592x672)

- ONLY KITCHEN CABINETS ARE SHOWN FOR DETAIL.

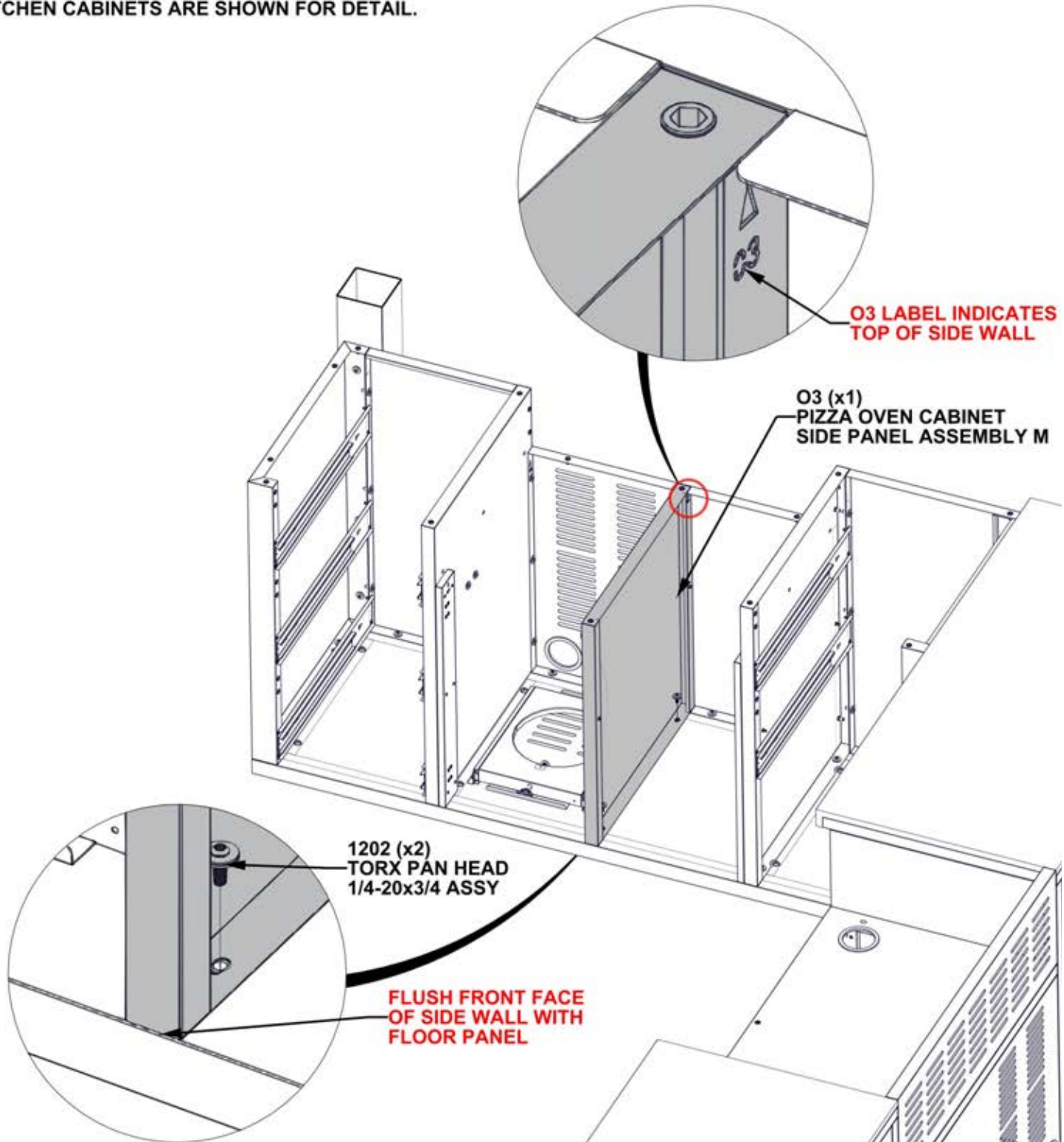

STEP 109 - PIZZA OVEN CABINET ASSEMBLY

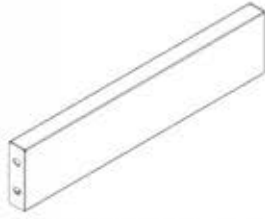

A3 HORIZONTAL CHANNEL - A4M03071
(x3) 1"x3 3/8"x15 3/16" (25x85x386)

Qty	PartNo	Description
12	H101202	TORX PAN HEAD 1/4-20x3/4 ASSY

- ONLY KITCHEN CABINETS ARE SHOWN FOR DETAIL.
- **INSTALL HORIZONTAL CHANNELS IN THE ORDER SHOWN BELOW.**

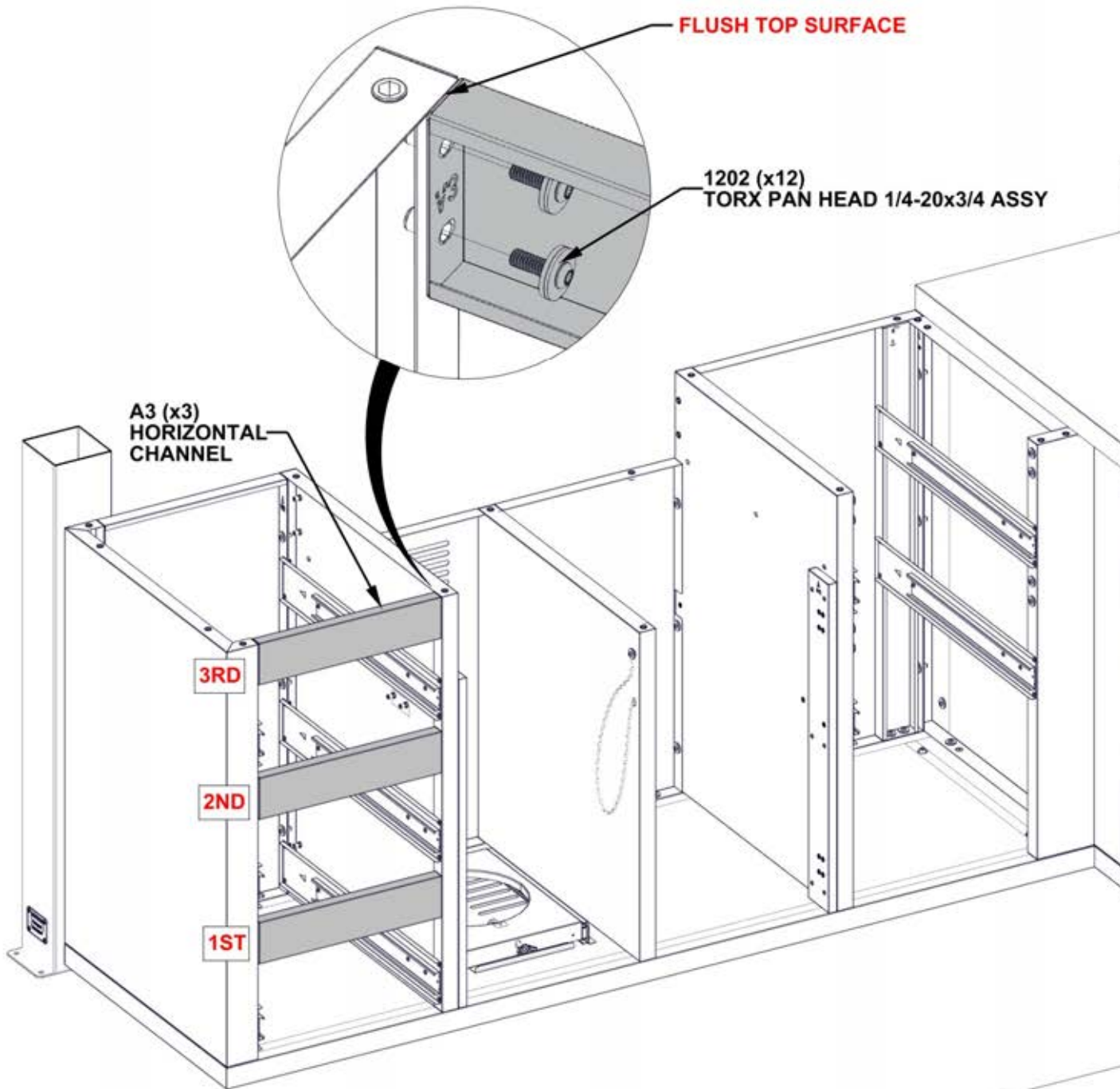

STEP 110 - PIZZA OVEN CABINET ASSEMBLY

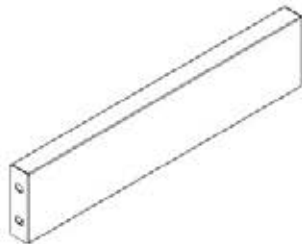

A3 HORIZONTAL CHANNEL - A4M03071
(x2) 1"x3 3/8"x15 3/16" (25x85x386)

Qty	PartNo	Description
8	H101202	TORX PAN HEAD 1/4-20x3/4 ASSY

- ONLY KITCHEN CABINETS ARE SHOWN FOR DETAIL.
- **INSTALL HORIZONTAL CHANNELS IN THE ORDER SHOWN BELOW.**

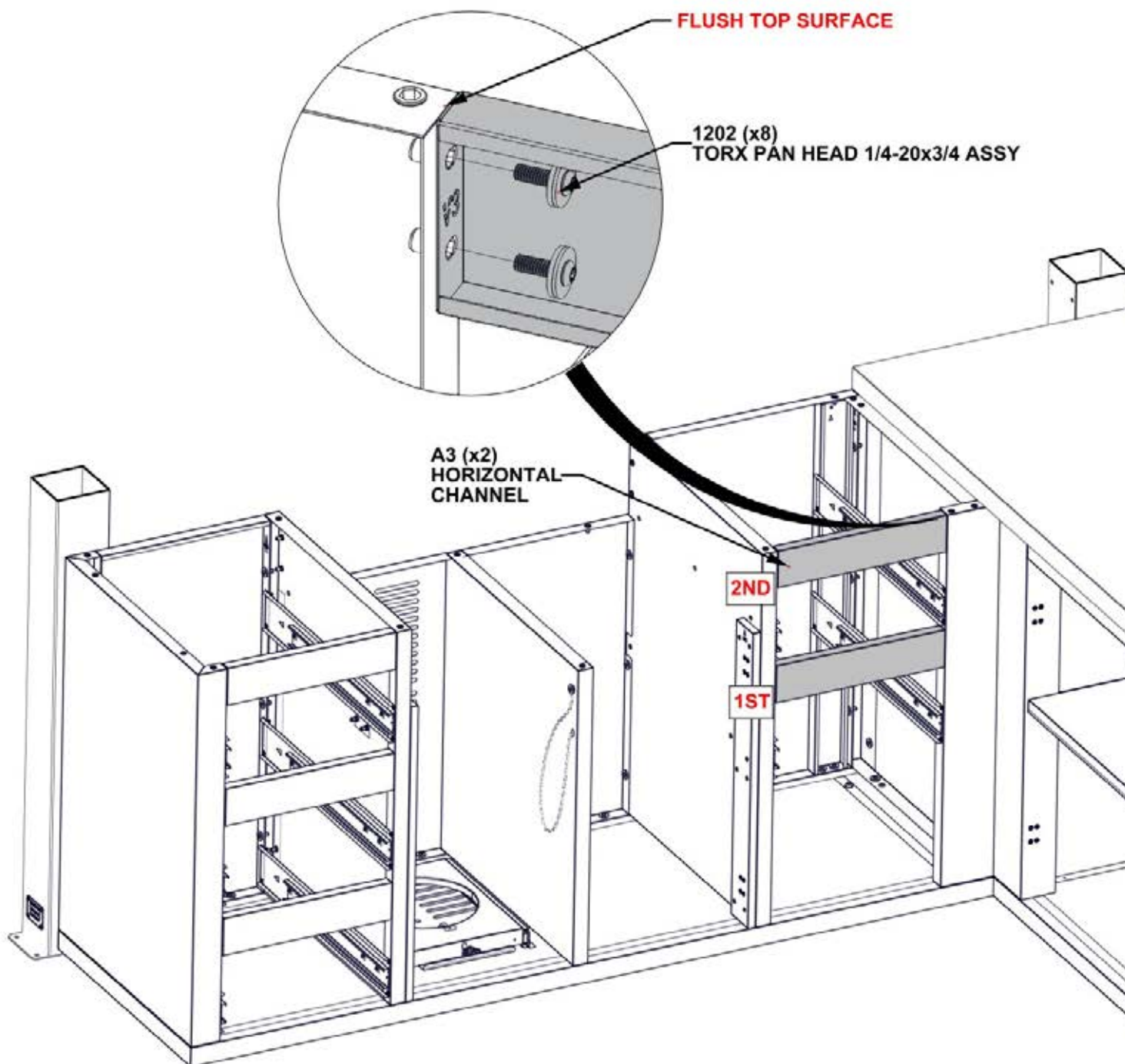

STEP 111 - PIZZA OVEN CABINET ASSEMBLY



Qty	PartNo	Description
5	H101289	PAN HEAD SCREW 8-32x1/2" SS

C5 PIZZA OVEN CABINET SHELF - A4M03074
(x1) 2 3/8"x14 7/8"x23 1/16" (60x378x585)

- ONLY KITCHEN CABINETS ARE SHOWN FOR DETAIL.

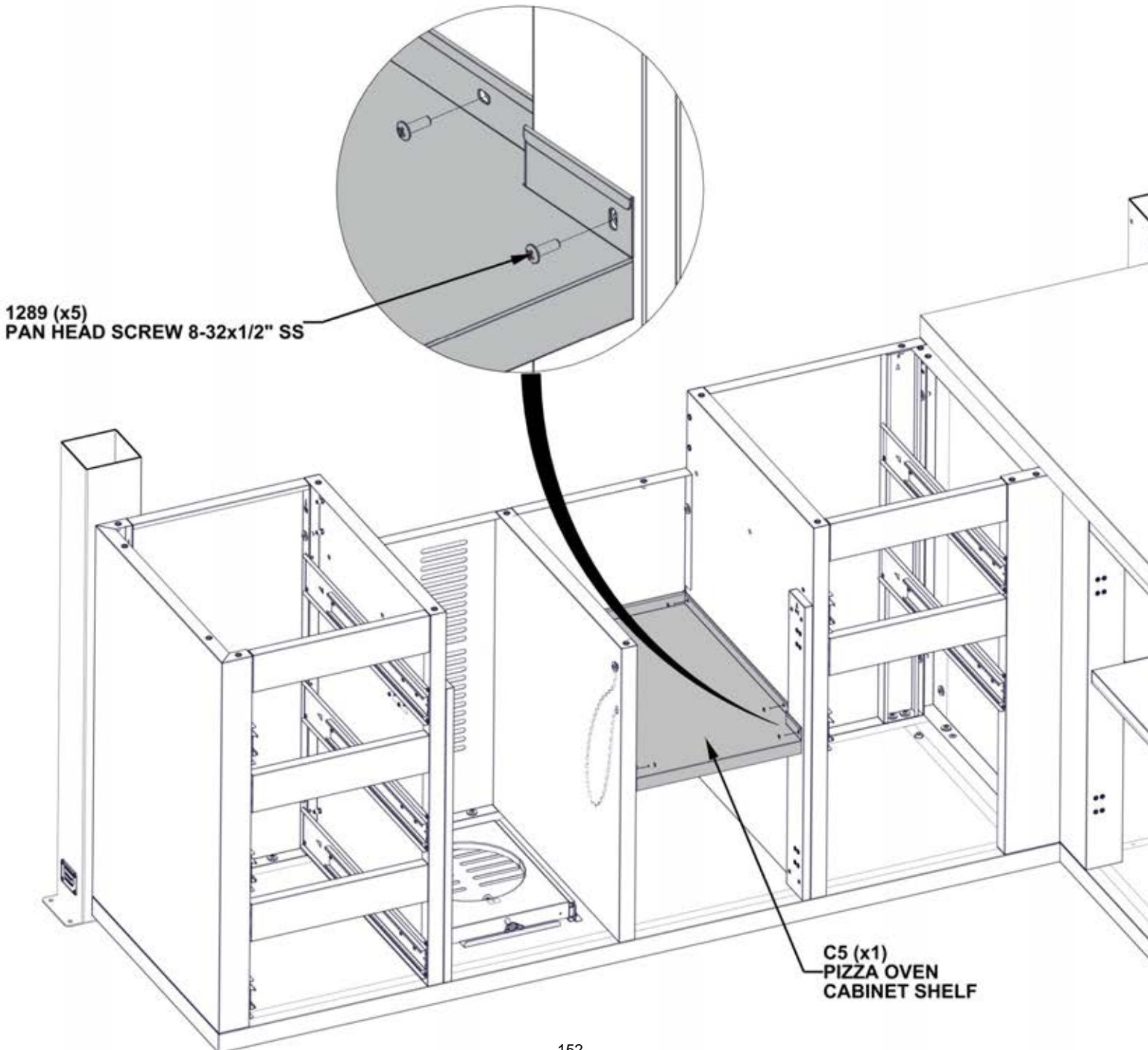

STEP 112 - PIZZA OVEN CABINET ASSEMBLY

Qty	PartNo	Description
4	H101289	PAN HEAD SCREW 8-32x1/2" SS

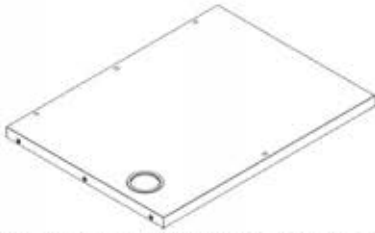

T6 PIZZA OVEN TABLETOP ASSEMBLY - A4M03070
(x1) 1 3/8"x23 3/8"x31 7/16" (35x594x798)



A2 MAGNET BRACKET - A4M03026
(x2) 1"x1 1/4"x3 1/8" (25x31x80)

T6 (x1)
PIZZA OVEN TABLETOP ASSEMBLY

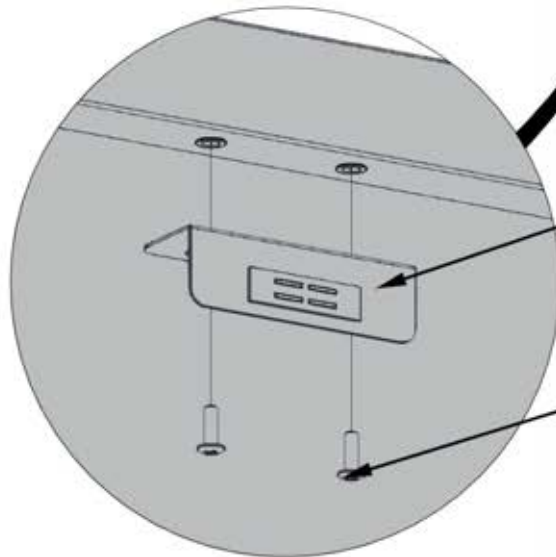
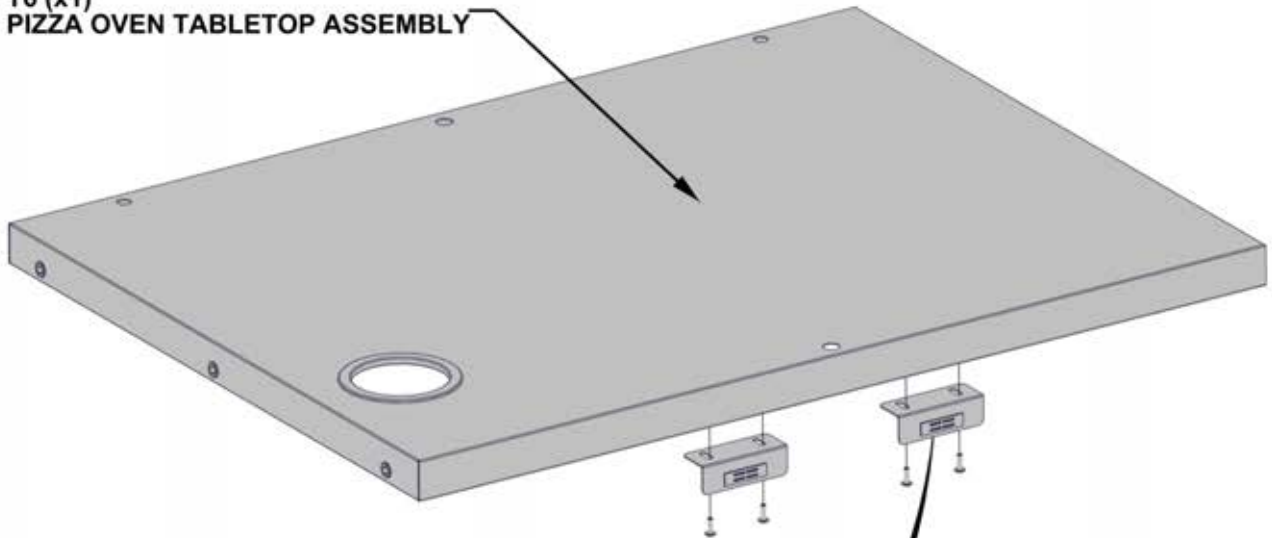

A2 (x2)
MAGNET BRACKET

1289 (x4)
PAN HEAD SCREW 8-32x1/2" SS

STEP 113A - PIZZA OVEN CABINET ASSEMBLY



OVEN TABLETOP
ASSEMBLY FROM STEP 112

Qty	PartNo	Description
6	H101202	TORX PAN HEAD 1/4-20x3/4 ASSY

- ONLY KITCHEN CABINETS ARE SHOWN FOR DETAIL.

HAND TIGHTEN ONLY

1202 (x6)
TORX PAN HEAD 1/4-20x3/4 ASSY

**NOTE HARDWARE
ATTACHES ON
INSIDE OF CABINETS**

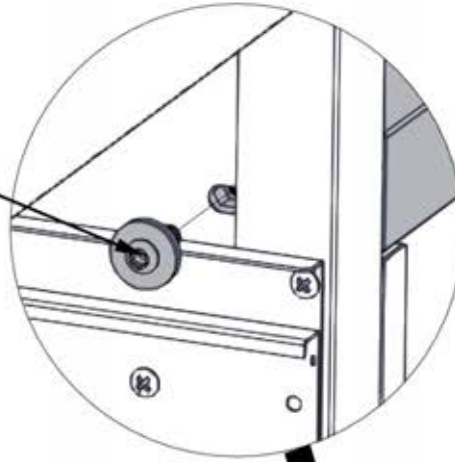

GRILL TABLETOP ASSEMBLY
FROM STEP 112

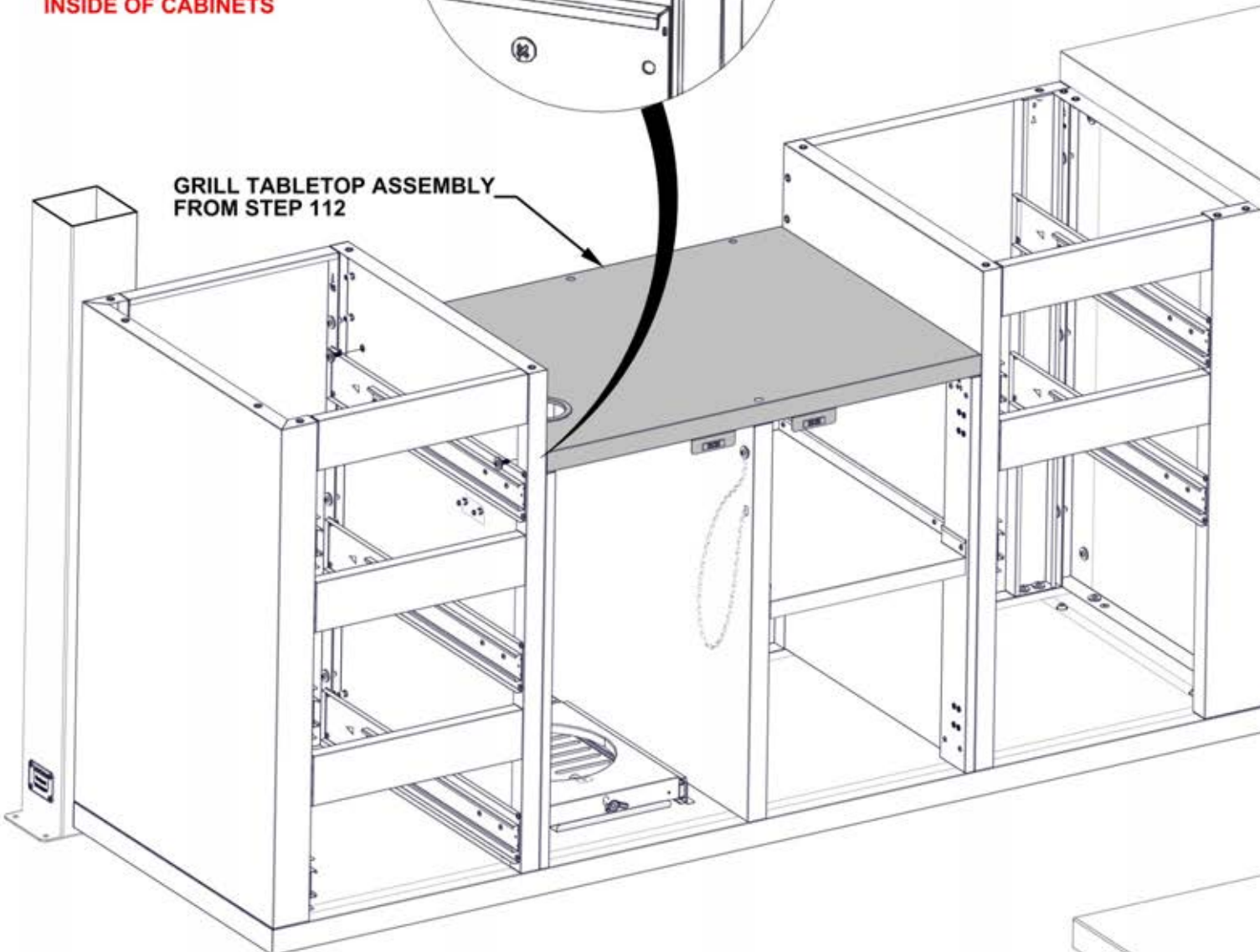

STEP 113B - PIZZA OVEN CABINET ASSEMBLY

Qty	PartNo	Description
4	H101103	TORX SOCKET SCREW 1/4-20

- ONLY KITCHEN CABINETS ARE SHOWN FOR DETAIL.

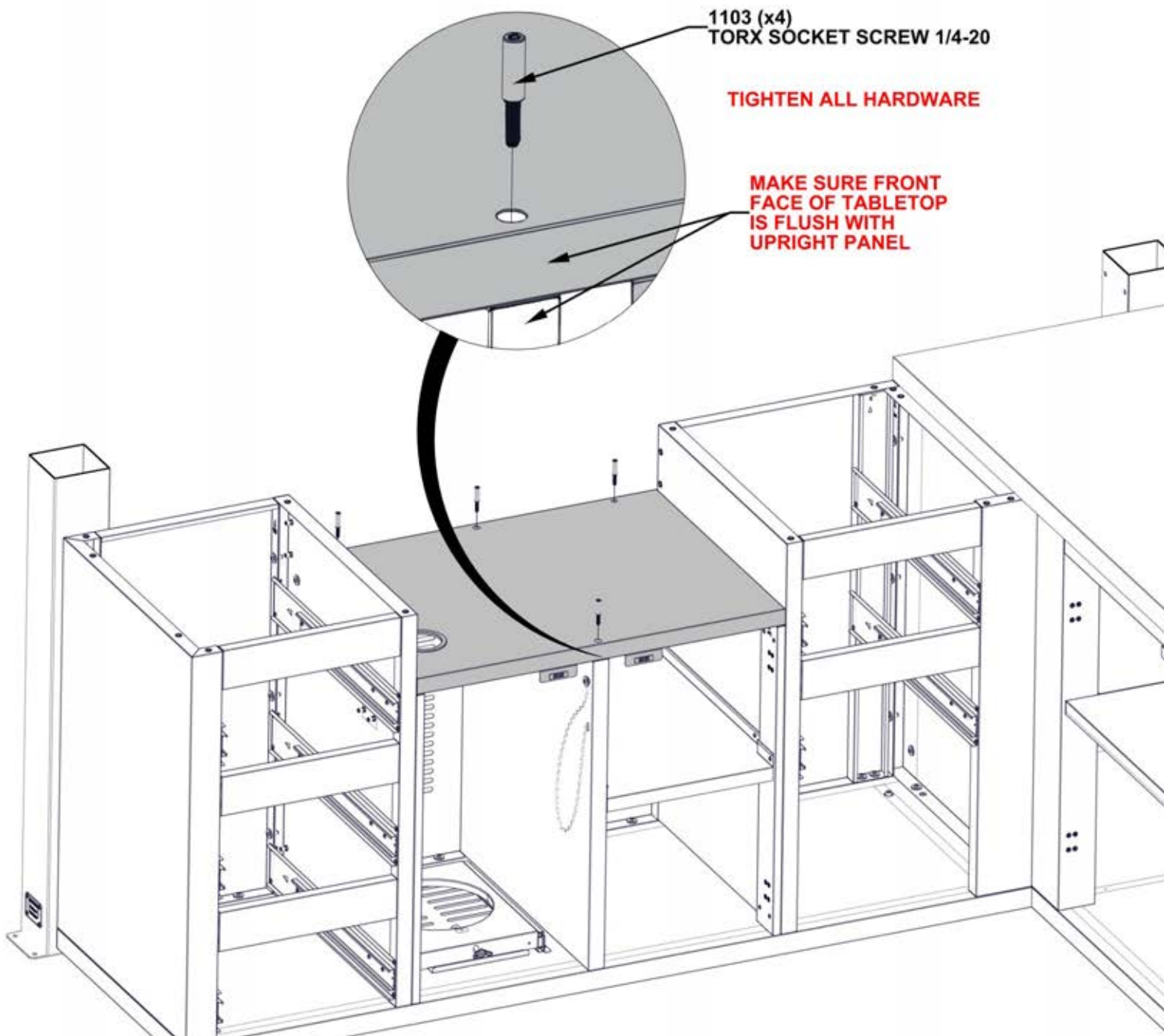

STEP 114 - PIZZA OVEN CABINET ASSEMBLY

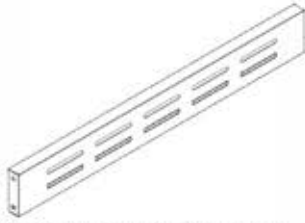

Qty	PartNo	Description
4	H101202	TORX PAN HEAD 1/4-20x3/4 ASSY

O8 PIZZA OVEN VENTILATION PANEL - A4M03078
(x1) 1 3/16"x4"x31 7/16" (30x102x798)

- ONLY KITCHEN CABINETS ARE SHOWN FOR DETAIL.

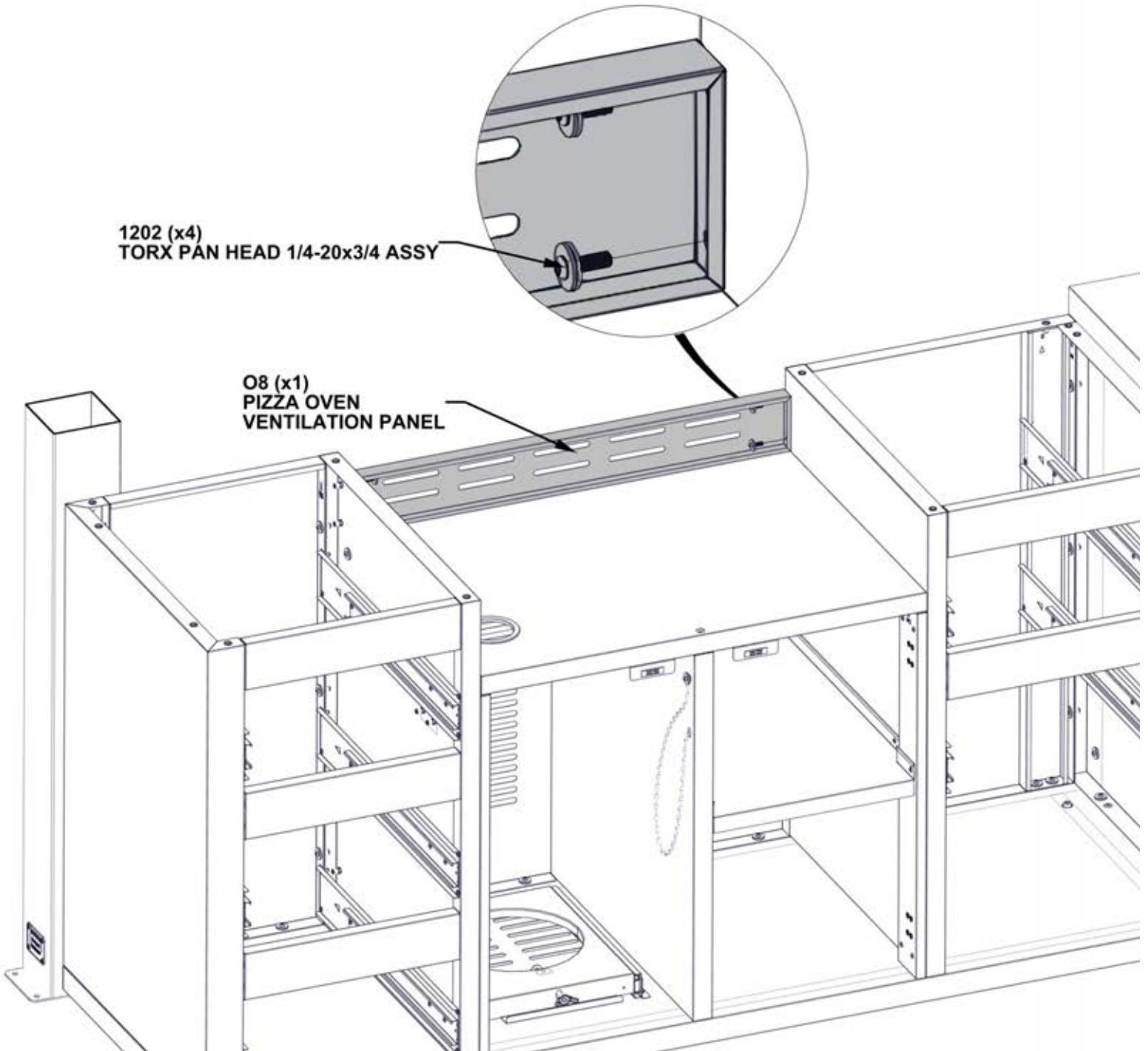

STEP 115 - PIZZA OVEN CABINET ASSEMBLY

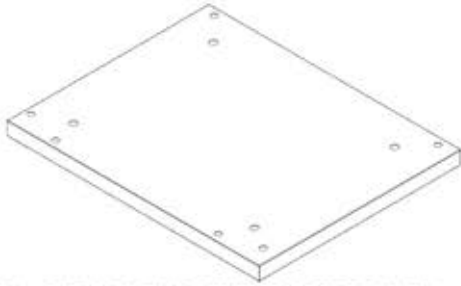

Qty	PartNo	Description
6	H101103	TORX SOCKET SCREW 1/4-20

T4 PIZZA OVEN CABINET MARBLE PANEL L - A4M03068
 (x1) 1 1/4"x19 5/16"x24 1/8" (32x490x612)

- ONLY KITCHEN CABINETS ARE SHOWN FOR DETAIL.
- FLUSH BACK AND SIDES OF PANEL ASSEMBLY.
- **SQUARE ALL SIDES OF CABINET BEFORE TIGHTENING HARDWARE.**

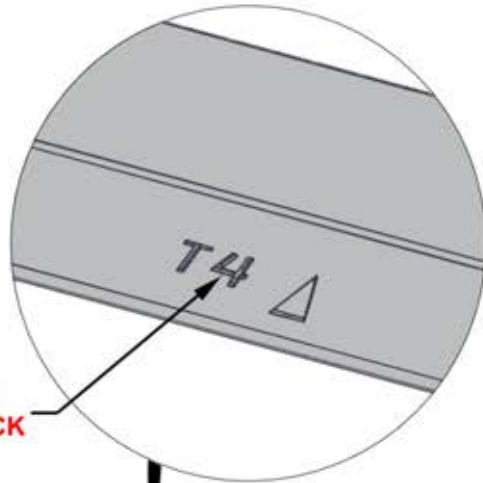

T4 LABEL ON
 BOTTOM SIDE
 INDICATES BACK
 OF PANEL

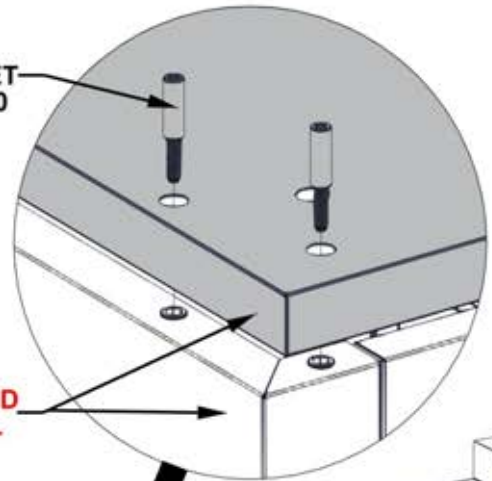

1103 (x6)
 TORX SOCKET
 SCREW 1/4-20

FLUSH BACK AND
 SIDES OF PANEL

T4 (x1)
 PIZZA OVEN
 CABINET MARBLE
 PANEL L

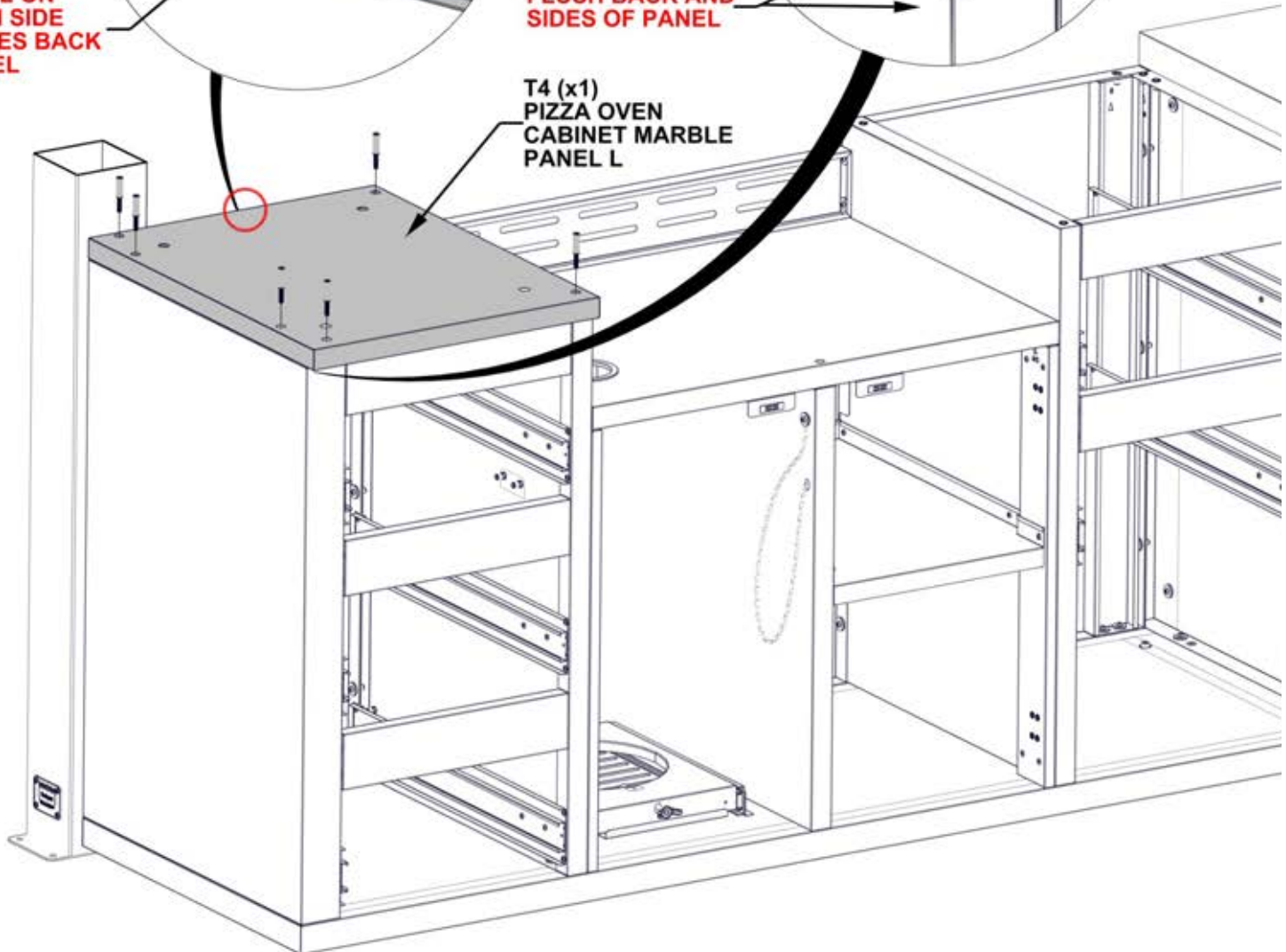

STEP 116 - PIZZA OVEN CABINET ASSEMBLY

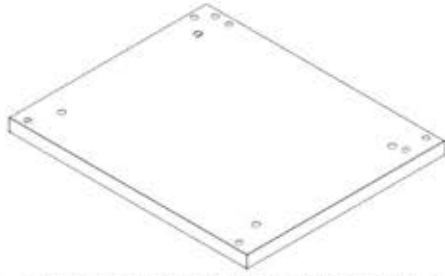

Qty	PartNo	Description
7	H101103	TORX SOCKET SCREW 1/4-20

T5 PIZZA OVEN CABINET MARBLE PANEL R - A4M03069
 (x1) 1 1/4"x20"x24 1/8" (32x508x612)

- ONLY KITCHEN CABINETS ARE SHOWN FOR DETAIL.
- FLUSH BACK AND SIDES OF PANEL ASSEMBLY.
- **SQUARE ALL SIDES OF CABINET BEFORE TIGHTENING HARDWARE.**

1103 (x7)
 TORX SOCKET
 SCREW 1/4-20

**FLUSH BACK
 AND SIDES
 OF PANEL**

**T5 LABEL ON
 BOTTOM SIDE
 INDICATES BACK
 OF PANEL**

T5 (x1)
 PIZZA OVEN
 CABINET MARBLE
 PANEL R

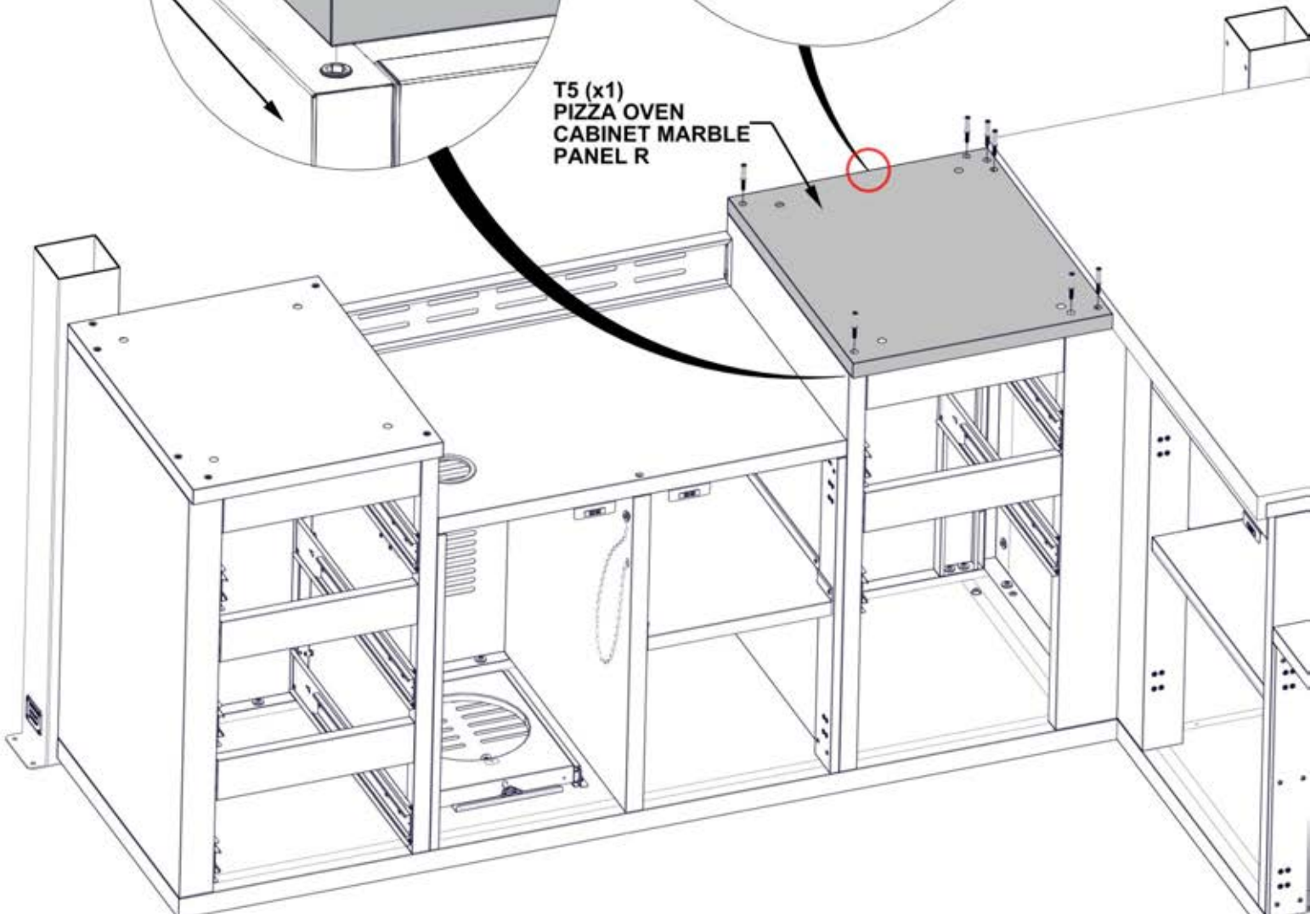

STEP 117A - PIZZA OVEN CABINET ASSEMBLY

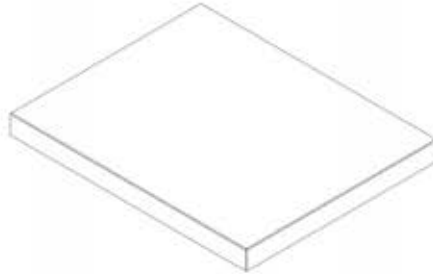

M2 PIZZA OVEN CABINET MARBLE L - A4M03089
(x1) 1 15/16"x20 1/16"x24 13/16" (50x509x630)

- ONLY KITCHEN CABINETS ARE SHOWN FOR DETAIL.
- IT IS RECOMMENDED TO HAVE AT LEAST TWO PEOPLE SET MARBLE COUNTERTOP IN PLACE.
- SLIDE IN PLACE UNTIL MARBLE IS TIGHT AGAINST POST AND SIDES ARE FLUSH WITH PANEL.
- **WHEN SETTING MARBLE IN PLACE, MAKE SURE YOUR FINGERS ARE CLEAR AND NOT UNDERNEATH MARBLE.**

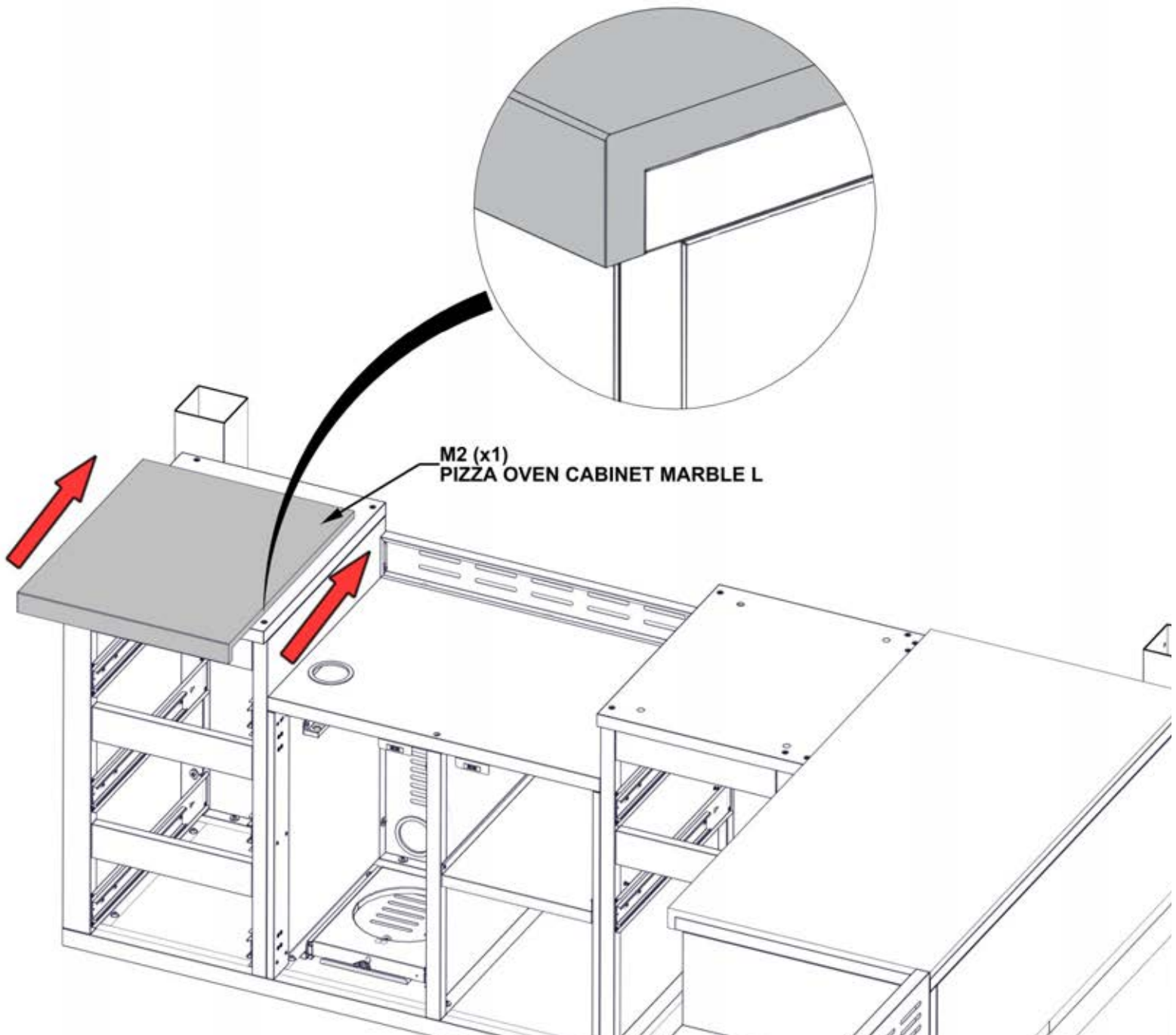

STEP 117B - PIZZA OVEN CABINET ASSEMBLY

Qty	PartNo	Description
4	H101292	TORX PAN HEAD 1/4-20x13/32"
4	H101053	STEEL WASHER 6x20
4	H101054	SEALANT WASHER

- ONLY KITCHEN CABINETS ARE SHOWN FOR DETAIL.
- MAKE SURE YOU ARE USING THE CORRECT HARDWARE FOR THIS STEP.
- ONCE MARBLE IS IN PLACE, IT IS RECOMMENDED TO COVER WITH A PIECE OF CARDBOARD OR FOAM UNTIL ASSEMBLY IS FINISHED TO PREVENT DAMAGE.
- DO NOT USE MARBLE SURFACE AS A WORK BENCH.

DO NOT OVERTIGHTEN HARDWARE

1054 (x4)
SEALANT WASHER

1053 (x4)
STEEL WASHER 6x20

1292 (x4)
TORX PAN HEAD 1/4-20x13/32"

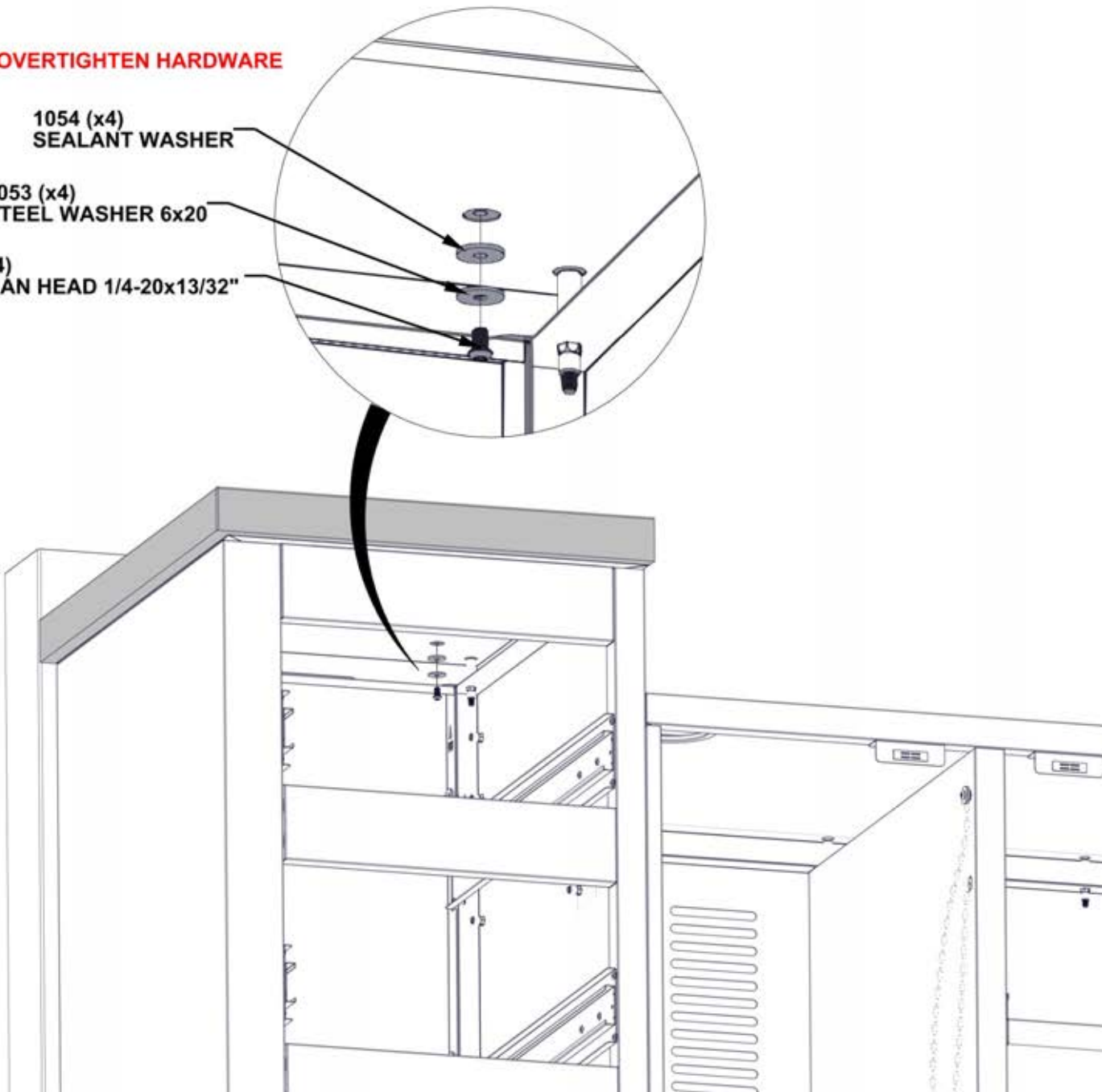

STEP 118A - PIZZA OVEN CABINET ASSEMBLY

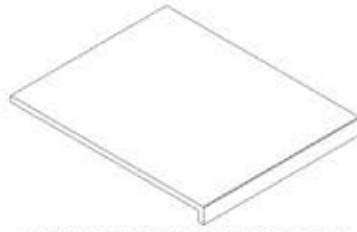

M3 PIZZA OVEN CABINET MARBLE R - A4M03090
(x1) 1 15/16"x20"x24 13/16" (50x508x630)

- ONLY KITCHEN CABINETS ARE SHOWN FOR DETAIL.
- IT IS RECOMMENDED TO HAVE AT LEAST TWO PEOPLE SET MARBLE COUNTERTOP IN PLACE.
- SLIDE IN PLACE UNTIL MARBLE IS TIGHT AGAINST POST AND SIDES ARE FLUSH WITH PANEL.
- **WHEN SETTING MARBLE IN PLACE, MAKE SURE YOUR FINGERS ARE CLEAR AND NOT UNDERNEATH MARBLE.**

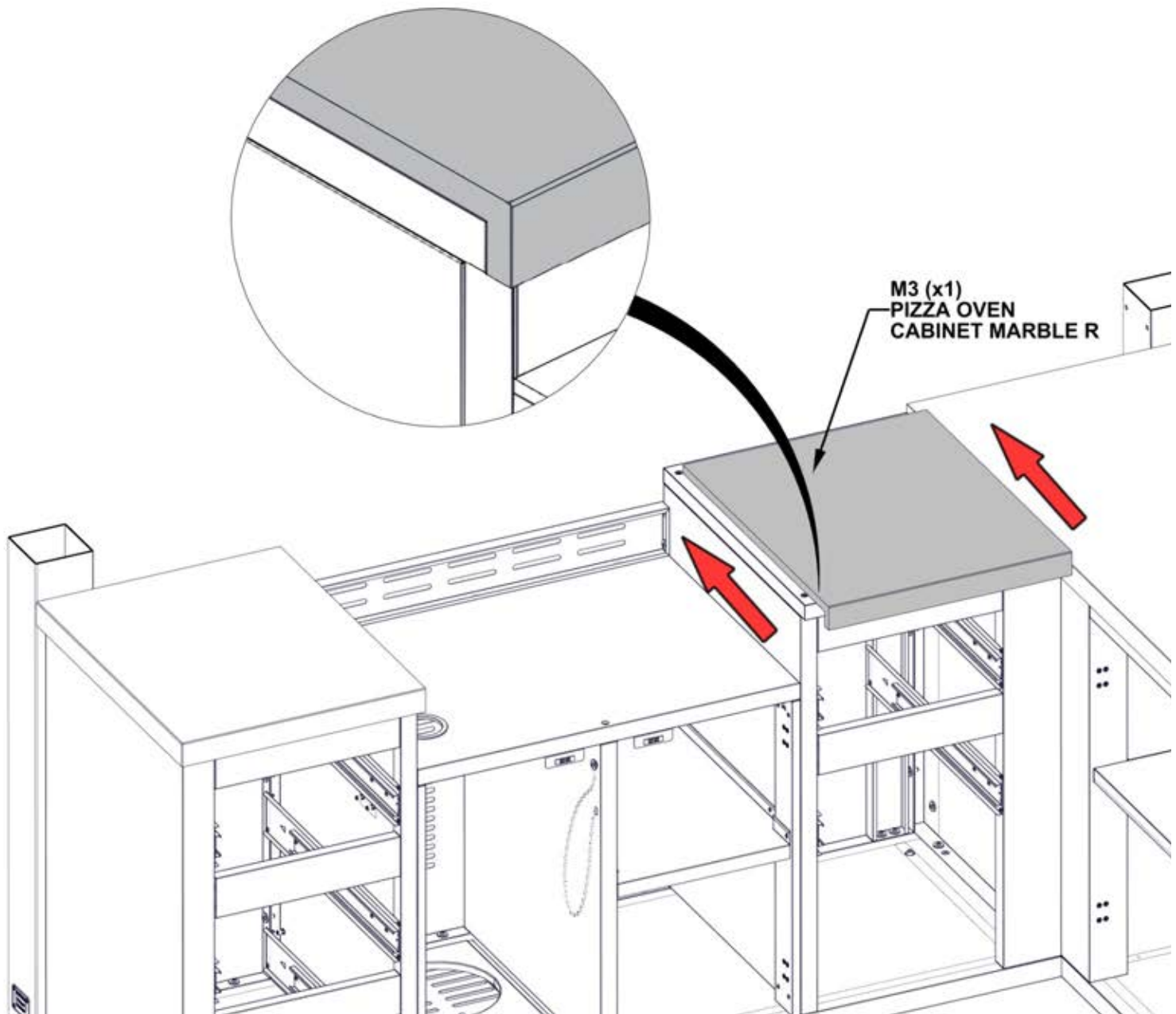

STEP 118B - PIZZA OVEN CABINET ASSEMBLY

Qty	PartNo	Description
4	H101292	TORX PAN HEAD 1/4-20x13/32"
4	H101053	STEEL WASHER 6x20
4	H101054	SEALANT WASHER

- ONLY KITCHEN CABINETS ARE SHOWN FOR DETAIL.

- **MAKE SURE YOU ARE USING THE CORRECT HARDWARE FOR THIS STEP.**

- **ONCE MARBLE IS IN PLACE, IT IS RECOMMENDED TO COVER WITH A PIECE OF CARDBOARD OR FOAM UNTIL ASSEMBLY IS FINISHED TO PREVENT DAMAGE.**

- **DO NOT USE MARBLE SURFACE AS A WORK BENCH.**

DO NOT OVERTIGHTEN HARDWARE

1054 (x4)
SEALANT WASHER

1053 (x4)
STEEL WASHER 6x20

1292 (x4)
TORX PAN HEAD 1/4-20x13/32"

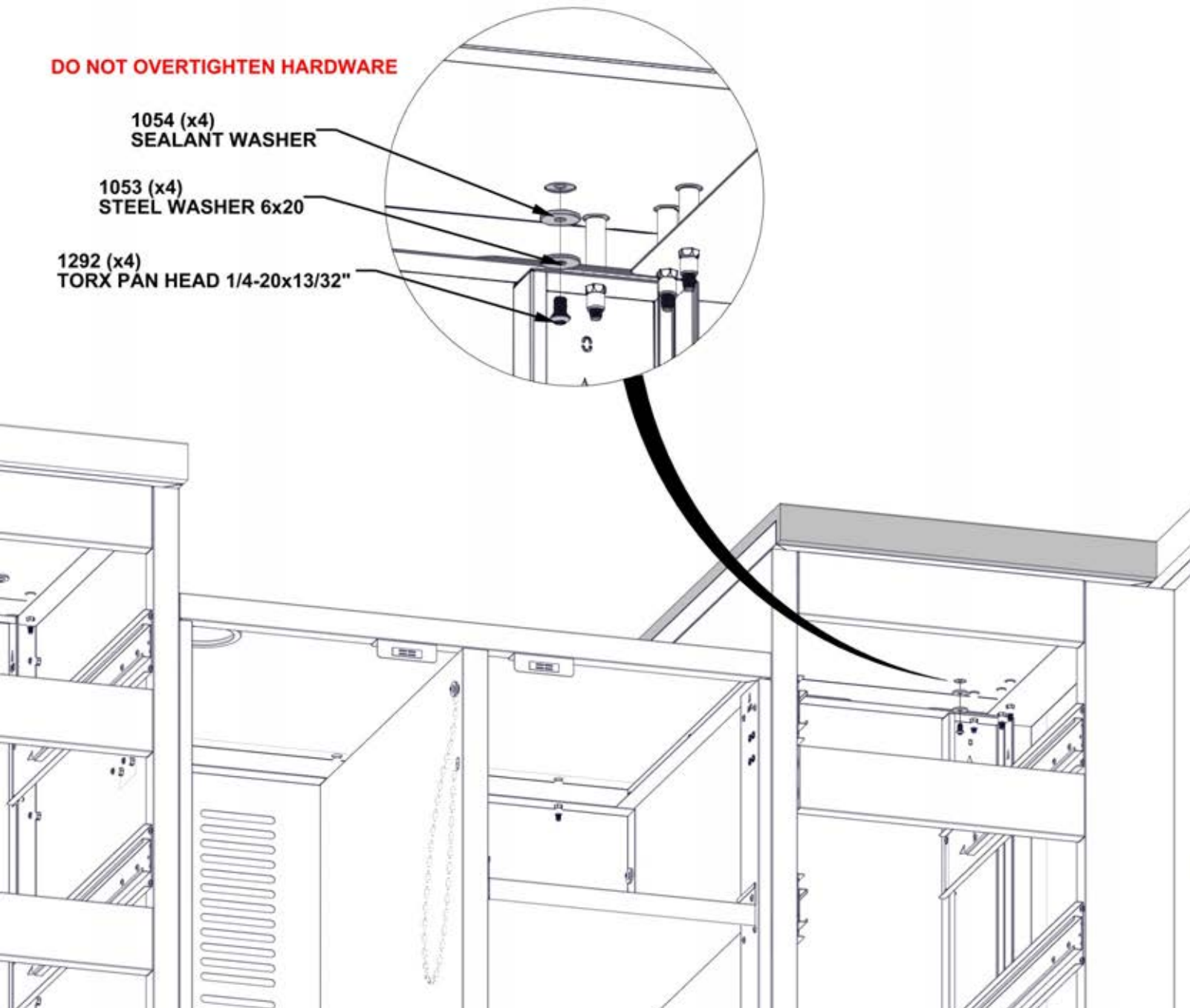

STEP 119A - KITCHEN TRASH CAN ASSEMBLY

Qty	PartNo	Description
6	H101289	PAN HEAD SCREW 8-32x1/2" SS

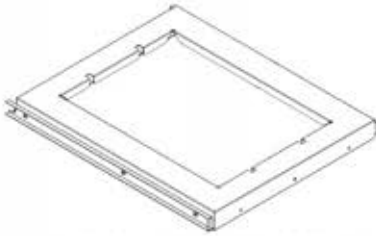

A15 TRASH CAN BRACKET ASSEMBLY - A4M03085
(x1) 1 3/8"x14 11/16"x450.00 (35x373x455)



A11 TRIANGLE PANEL - A4M03086
(x2) 13/16"x13 3/4"x13 3/4" (20x350x350)

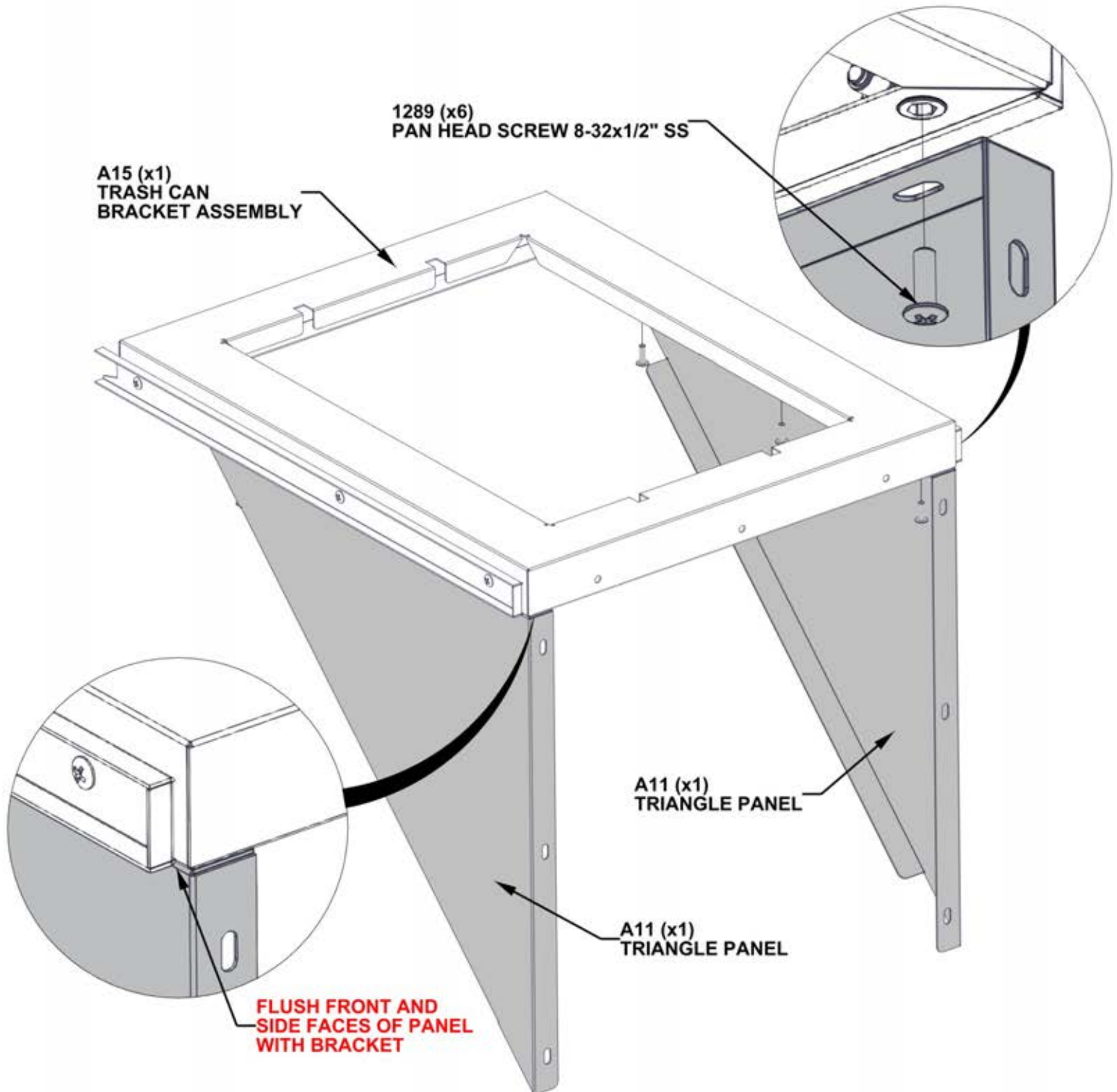

STEP 119B - KITCHEN TRASH CAN ASSEMBLY

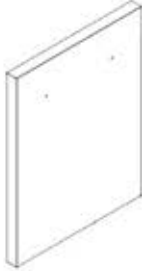

Qty	PartNo	Description
9	H101289	PAN HEAD SCREW 8-32x1/2" SS

D11 TRASH CAN PANEL ASSEMBLY - A4M03084
(x1) 1 5/16"x16 1/2"x21 5/8" (34x419x550)

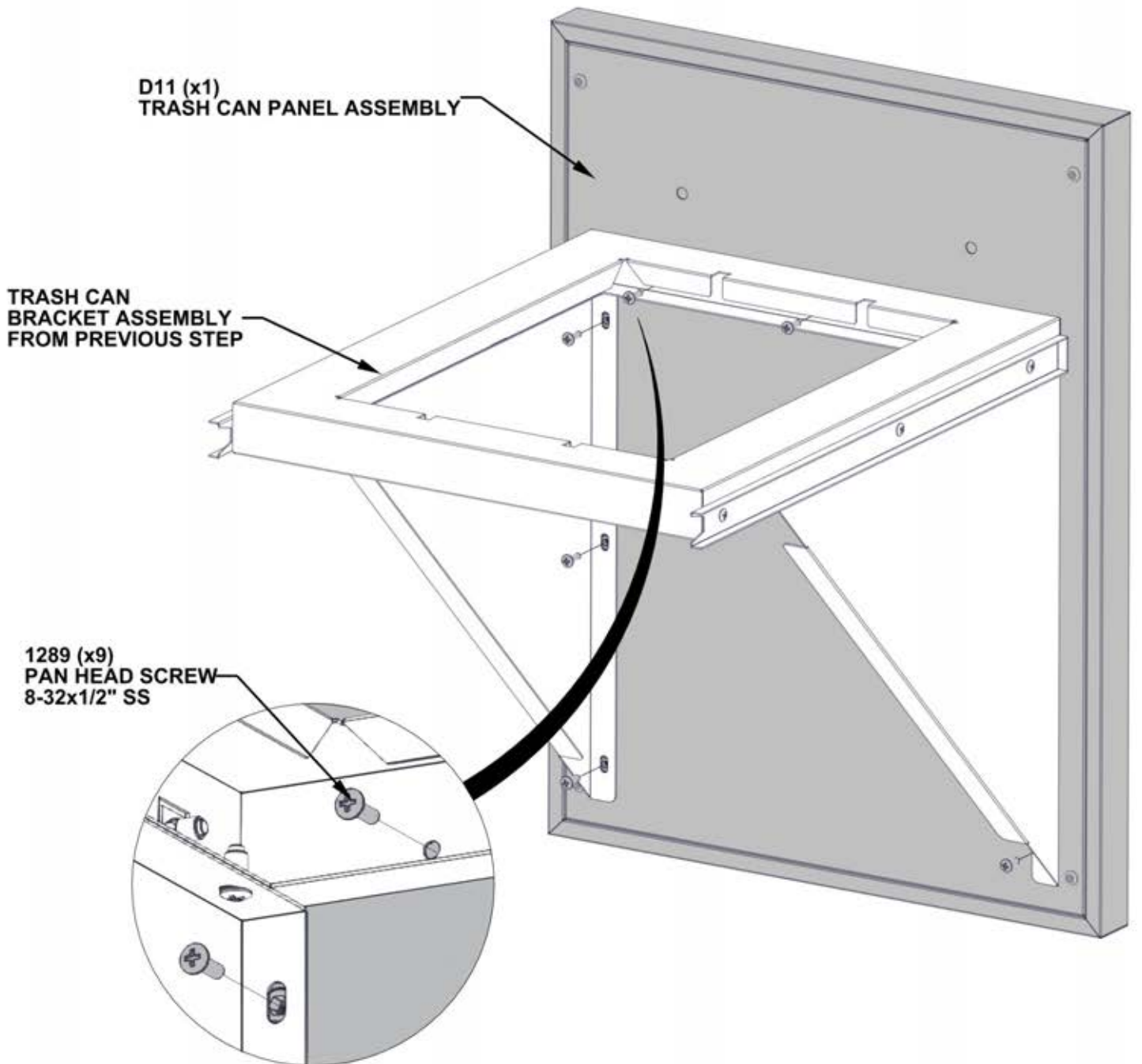

STEP 119C - KITCHEN TRASH CAN ASSEMBLY

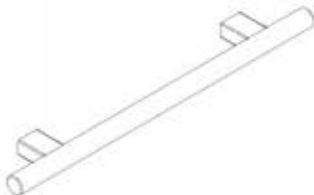

Qty	PartNo	Description
2	H101288	SHOULDER BOLT 8-32x42mm SS

H2 STAINLESS STEEL HANDLE - A4M03024
(x1) 5/8"x1 9/16"x11 13/16" (16x40x300)

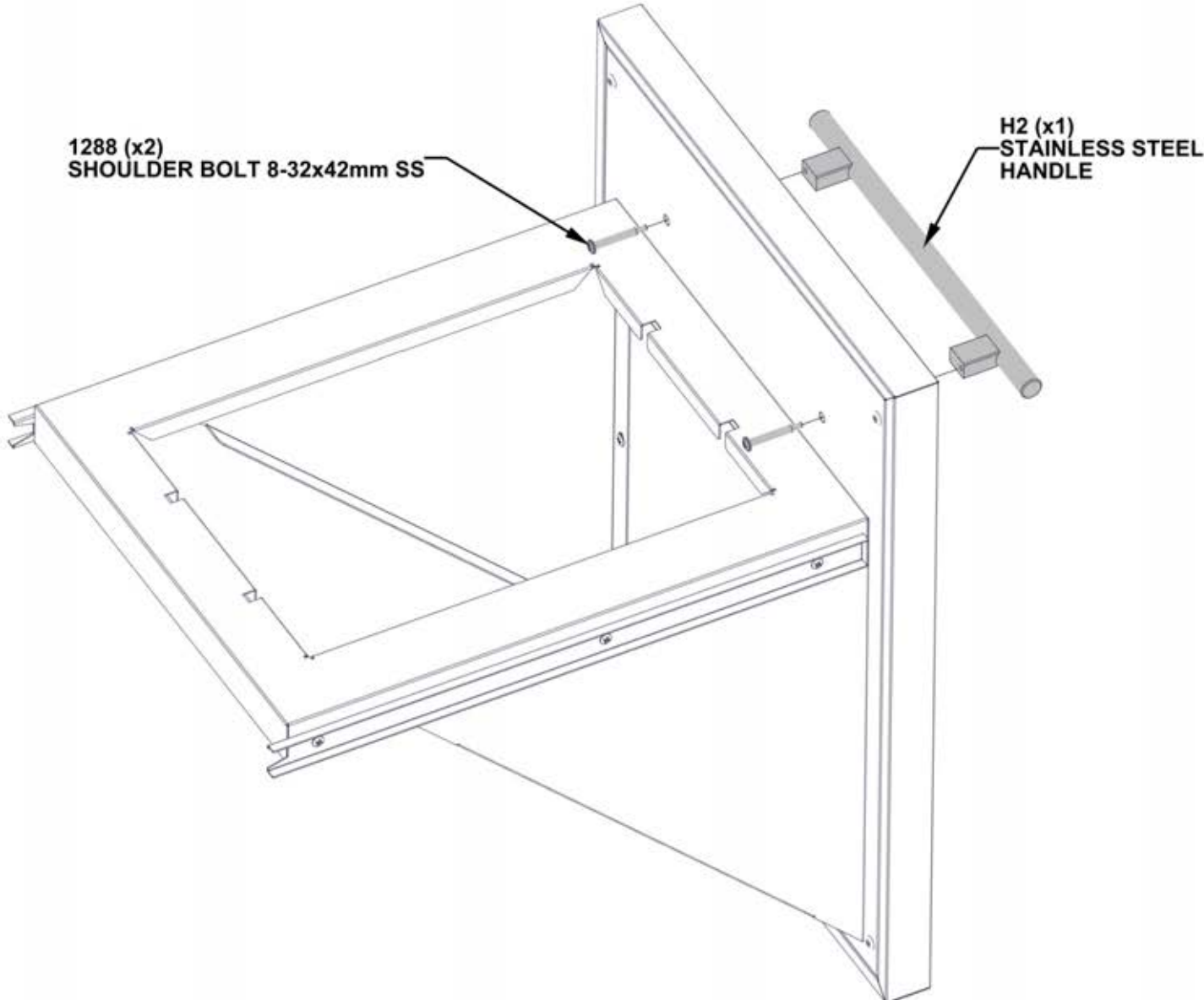

STEP 120 - KITCHEN TRASH CAN INSTALLATION



TRASH CAN ASSEMBLY
STEPS 119A - 119C

- ONLY KITCHEN CABINETS ARE SHOWN FOR DETAIL.
- ATTACH TRASH CAN ASSEMBLY BY ALIGNING BOTH ENDS OF FACTORY ASSEMBLED DRAWER SLIDES WITH ONE ANOTHER.
- PRESS TOGETHER UNTIL DRAWER SLIDES CONNECT.

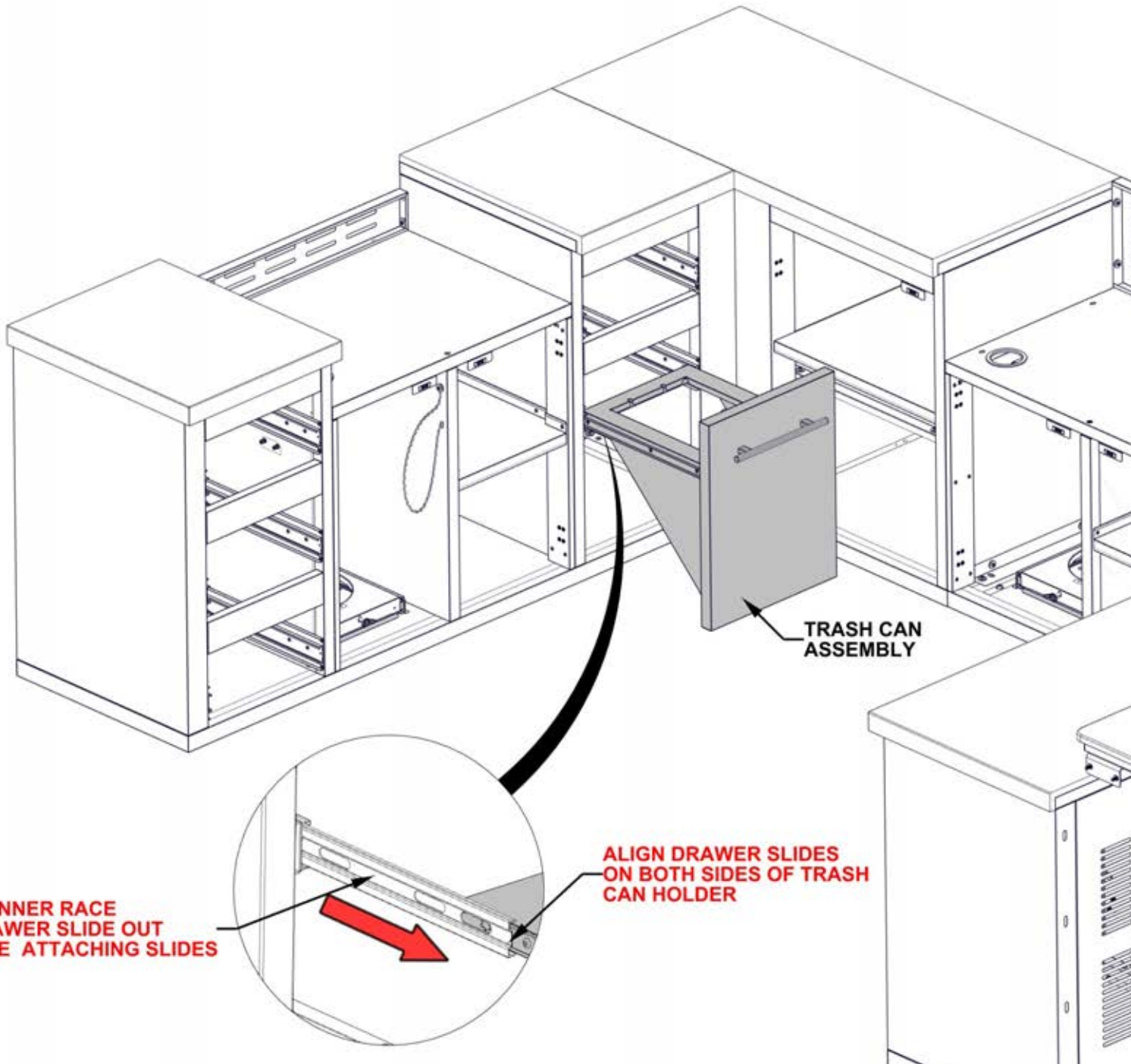

STEP 121A - KITCHEN DRAWER ASSEMBLY

Qty	PartNo	Description
36	H101289	PAN HEAD SCREW 8-32x1/2" SS



D10 DRAWER ASSEMBLY - A4M03081
(x4) 5 11/16"x14 5/8"x22 1/4" (145x372x565)

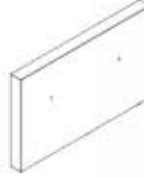

D9 DRAWER PANEL ASSEMBLY - A4M03080
(x4) 1 5/16"x10 1/4"x16 1/2" (34x260x419)

- REPEAT THIS STEP FOUR TIMES

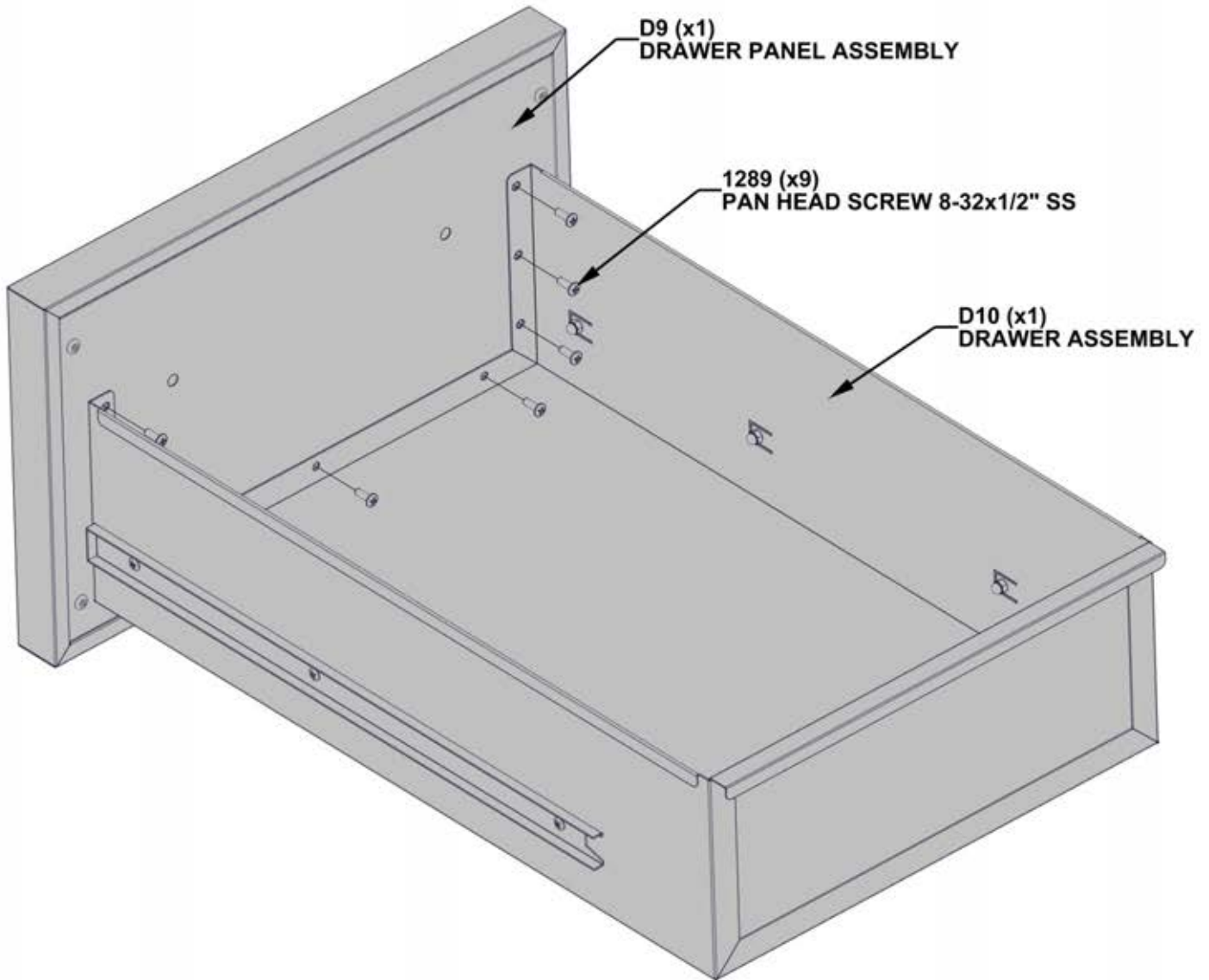

STEP 121B - KITCHEN DRAWER ASSEMBLY

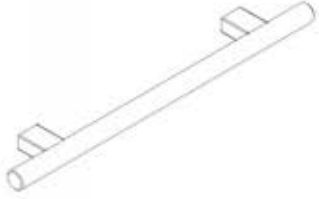

H2 STAINLESS STEEL HANDLE - A4M03024
(x4) 5/8"x1 9/16"x11 13/16" (16x40x300)

Qty	PartNo	Description
8	H101288	SHOULDER BOLT 8-32x42mm SS

- REPEAT THIS STEP FOUR TIMES

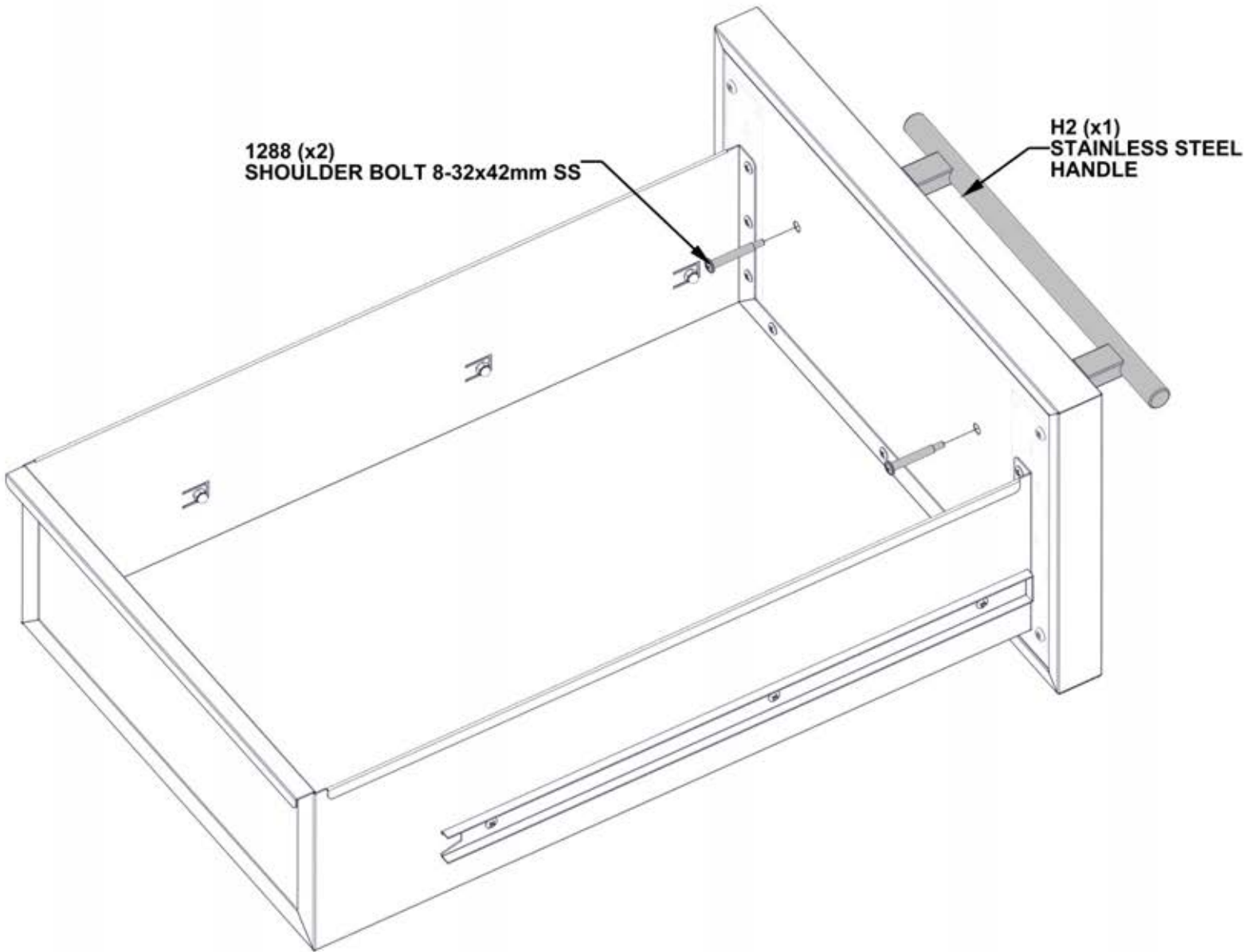

STEP 122A - KITCHEN DRAWER INSTALLATION

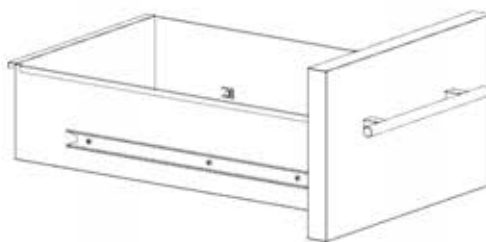

DRAWER ASSEMBLY
STEPS 121A - 121B

- ONLY KITCHEN CABINETS ARE SHOWN FOR DETAIL.
- ATTACH DRAWER ASSEMBLY BY ALIGNING BOTH ENDS OF FACTORY ASSEMBLED DRAWER SLIDES WITH ONE ANOTHER.
- PRESS TOGETHER UNTIL DRAWER SLIDES CONNECT.

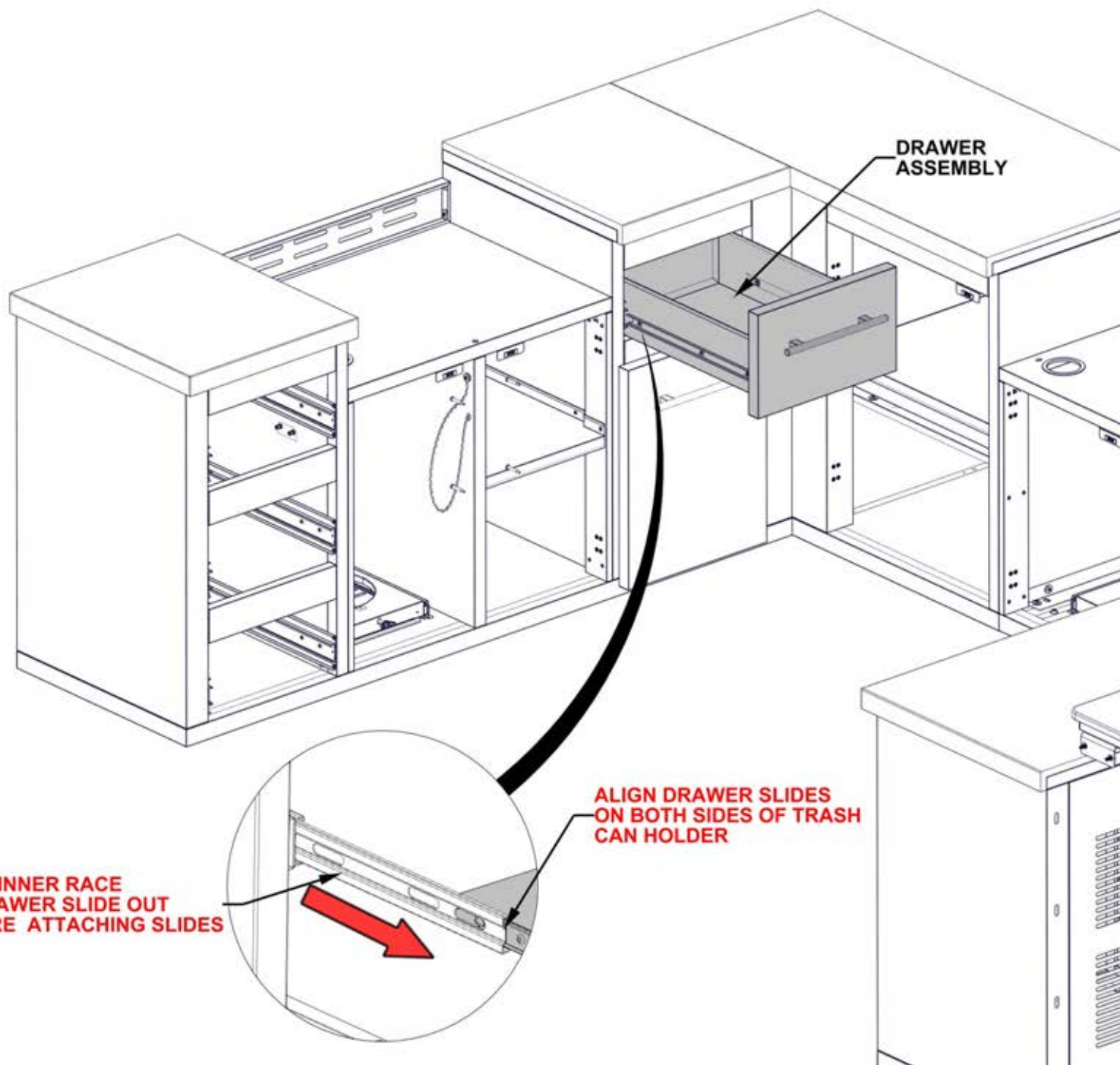

STEP 122B - KITCHEN DRAWER ASSEMBLY

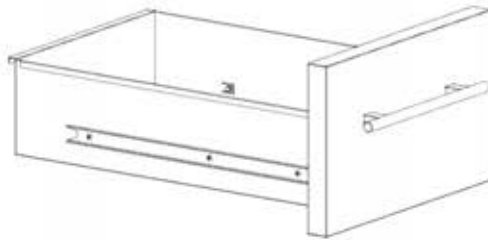

DRAWER ASSEMBLY
STEPS 121A - 121B

- ONLY KITCHEN CABINETS ARE SHOWN FOR DETAIL.
- REPEAT STEP 122A TO INSTALL REMAINING THREE DRAWERS.

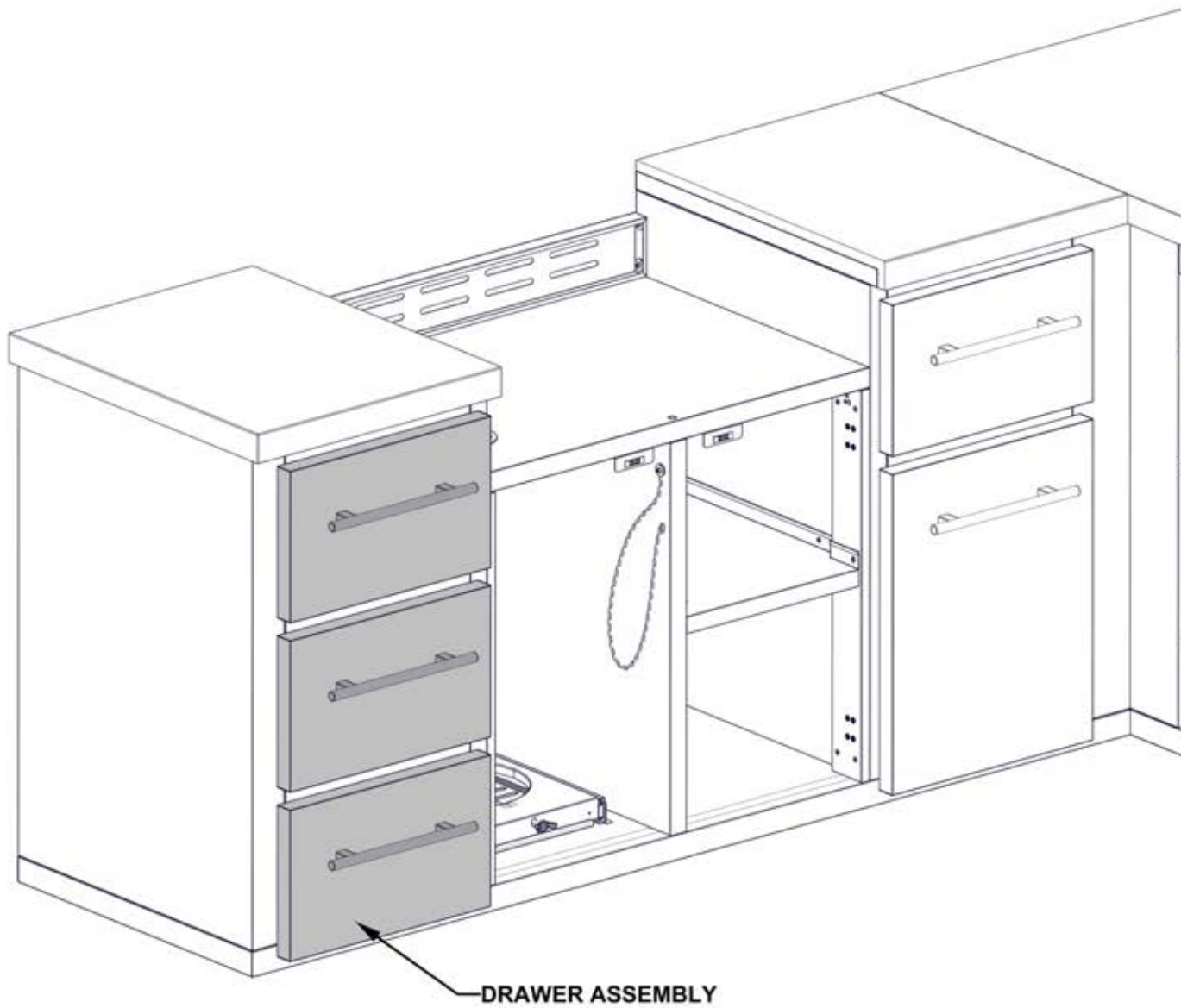

DRAWER ASSEMBLY

STEP 123A - DOOR ASSEMBLY

Qty	PartNo	Description
32	H101185	PHILLIPS FLAT HEAD 8-32x.5 SCREW

 D1 LEFT CORNER CABINET DOOR ASSEMBLY - A4M03036
(x1) 1 5/16"x23 5/8"x33 1/16" (34x600x840)

 D2 RIGHT CORNER CABINET DOOR ASSEMBLY - A4M03045
(x1) 1 5/16"x23 5/8"x33 1/16" (34x600x840)

 D3 GRILL CABINET DOOR ASSEMBLY L - A4M03058
(x1) 1 5/16"x19"x25 3/16" (34x483x639)

 D4 GRILL CABINET DOOR ASSEMBLY R - A4M03059
(x1) 1 5/16"x19"x25 3/16" (34x483x639)

 D5 PIZZA OVEN CABINET DOOR ASSEMBLY L - A4M03087
(x1) 1 5/16"x15 9/16"x28 1/8" (34x396x715)

 D6 PIZZA OVEN CABINET DOOR ASSEMBLY R - A4M03088
(x1) 1 5/16"x15 9/16"x28 1/8" (34x396x715)

 D7 SINK CABINET DOOR ASSEMBLY L - A4M03144
(x1) 1 5/16"x20"x33 1/16" (34x508x840)

 D8 SINK CABINET DOOR ASSEMBLY R - A4M03145
(x1) 1 5/16"x20"x33 1/16" (34x508x840)

 A4M03025 FULL OVERLAY HINGE
(x16)

- INSTALL CABINET HINGES TO ALL DOORS.

DO NOT OVERTIGHTEN HARDWARE.

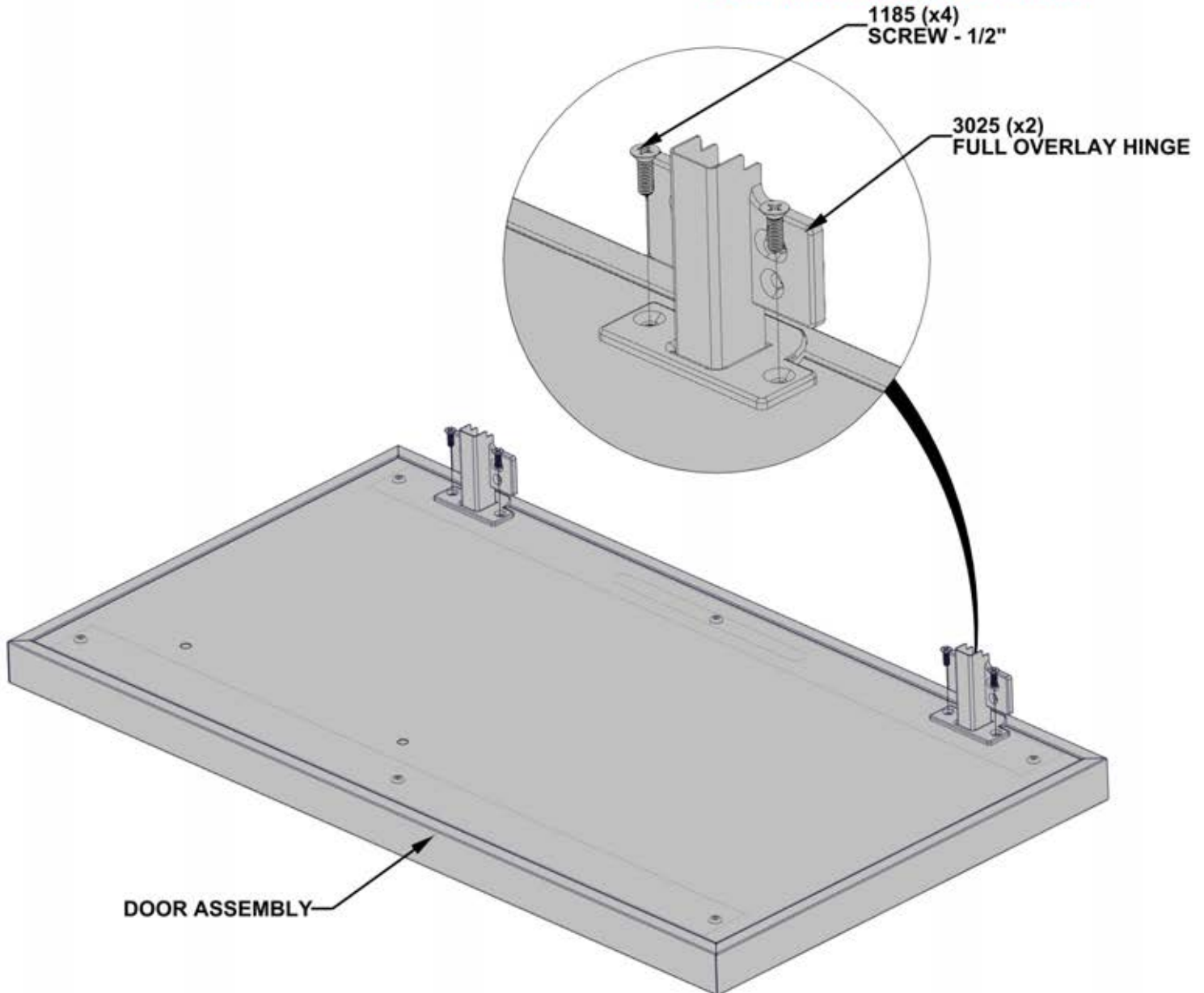

STEP 123B - DOOR ASSEMBLY

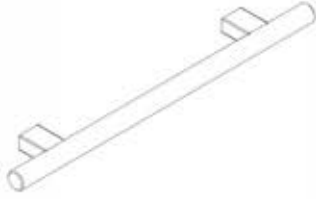

H2 STAINLESS STEEL HANDLE - A4M03024
(x8) 5/8"x1 9/16"x11 13/16" (16x40x300)

Qty	PartNo	Description
16	H101288	SHOULDER BOLT 8-32x42mm SS

- INSTALL CABINET HANDLES TO ALL DOORS.

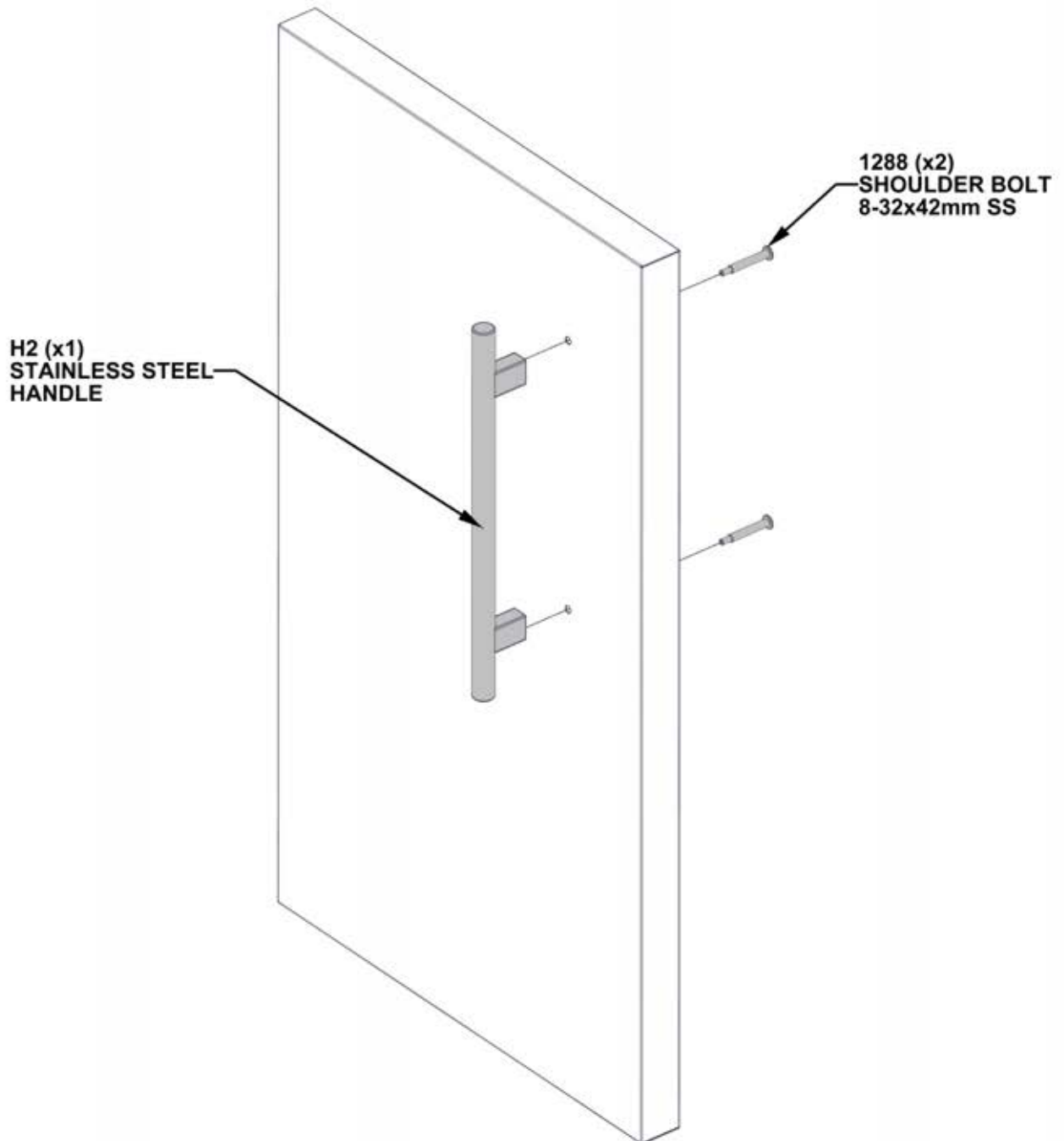

STEP 124 - CABINET DOOR ATTACHMENT



Qty	PartNo	Description
8	H101185	PHILLIPS FLAT HEAD 8-32x.5 SCREW

D5 PIZZA OVEN CABINET DOOR ASSEMBLY L - A4M03087
(x1) 1 5/16"x15 9/16"x28 1/8" (34x396x715)

- ONLY KITCHEN CABINETS ARE SHOWN FOR DETAIL.
- FOR THIS STEP IT IS HELPFUL TO HAVE AN ADDITIONAL PERSON HELP HOLD DOOR IN PLACE.
- WITH CABINET HINGES ATTACHED TO DOOR, ALIGN HOLES IN HINGE BRACKET WITH THREADED INSERTS IN SIDE OF CABINET PANEL.

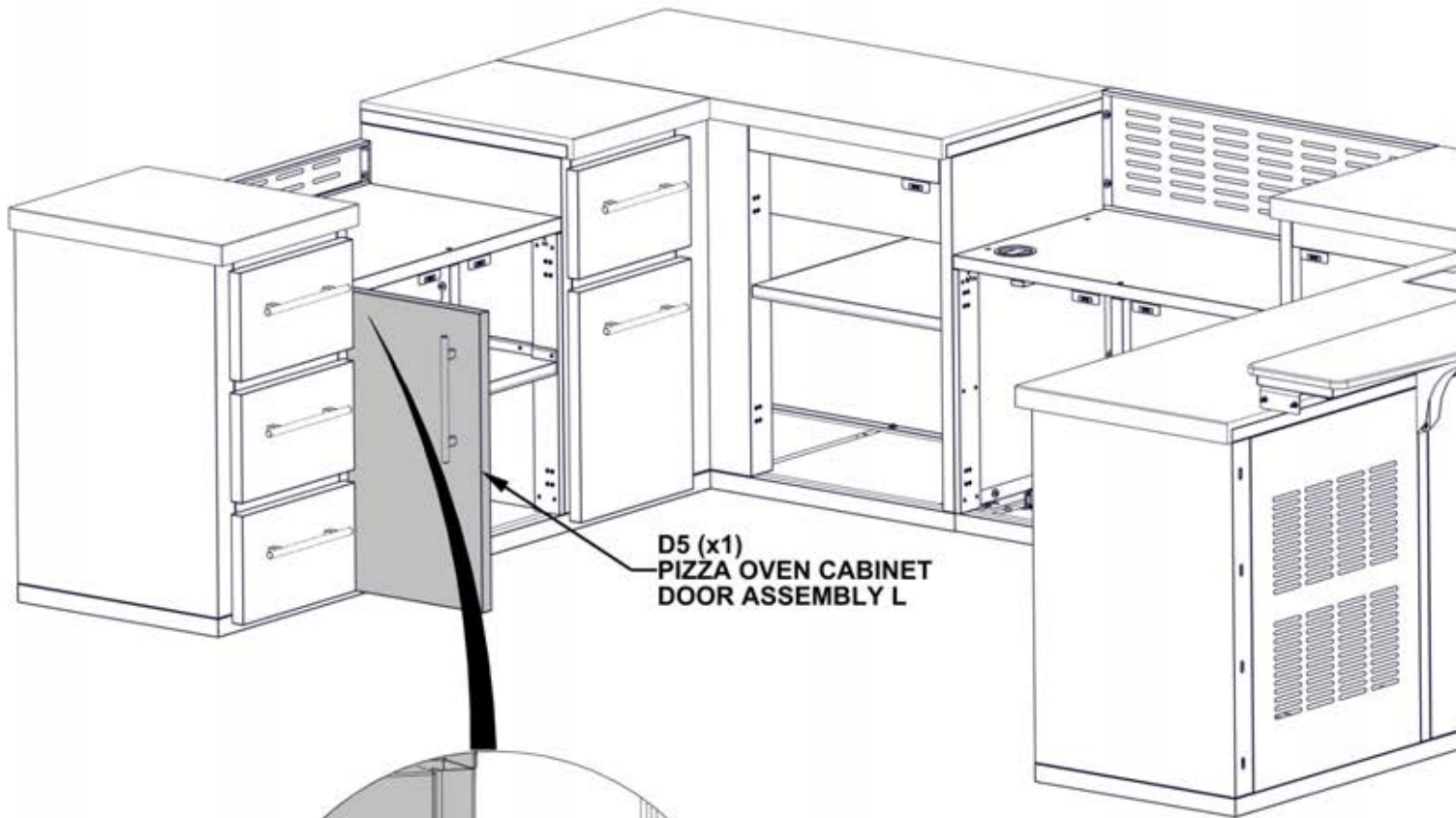

D5 (x1)
PIZZA OVEN CABINET
DOOR ASSEMBLY L

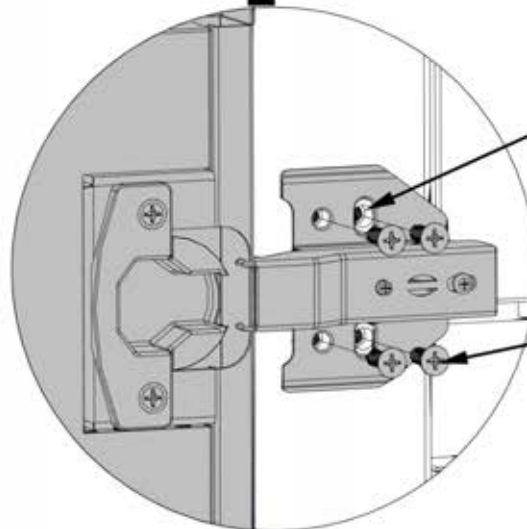

**ALIGN HINGE BRACKET WITH
THREADED INSERTS IN PANEL**

DO NOT OVERTIGHTEN HARDWARE

1185 (x8)
SCREW - 1/2"

STEP 125 - CABINET DOOR ATTACHMENT



Qty	PartNo	Description
8	H101185	PHILLIPS FLAT HEAD 8-32x.5 SCREW

D6 PIZZA OVEN CABINET DOOR ASSEMBLY R - A4M03088
(x1) 1 5/16"x15 9/16"x28 1/8" (34x396x715)

- ONLY KITCHEN CABINETS ARE SHOWN FOR DETAIL.
- FOR THIS STEP IT IS HELPFUL TO HAVE AN ADDITIONAL PERSON HELP HOLD DOOR IN PLACE.
- WITH CABINET HINGES ATTACHED TO DOOR, ALIGN HOLES IN HINGE BRACKET WITH THREADED INSERTS IN SIDE OF CABINET PANEL.

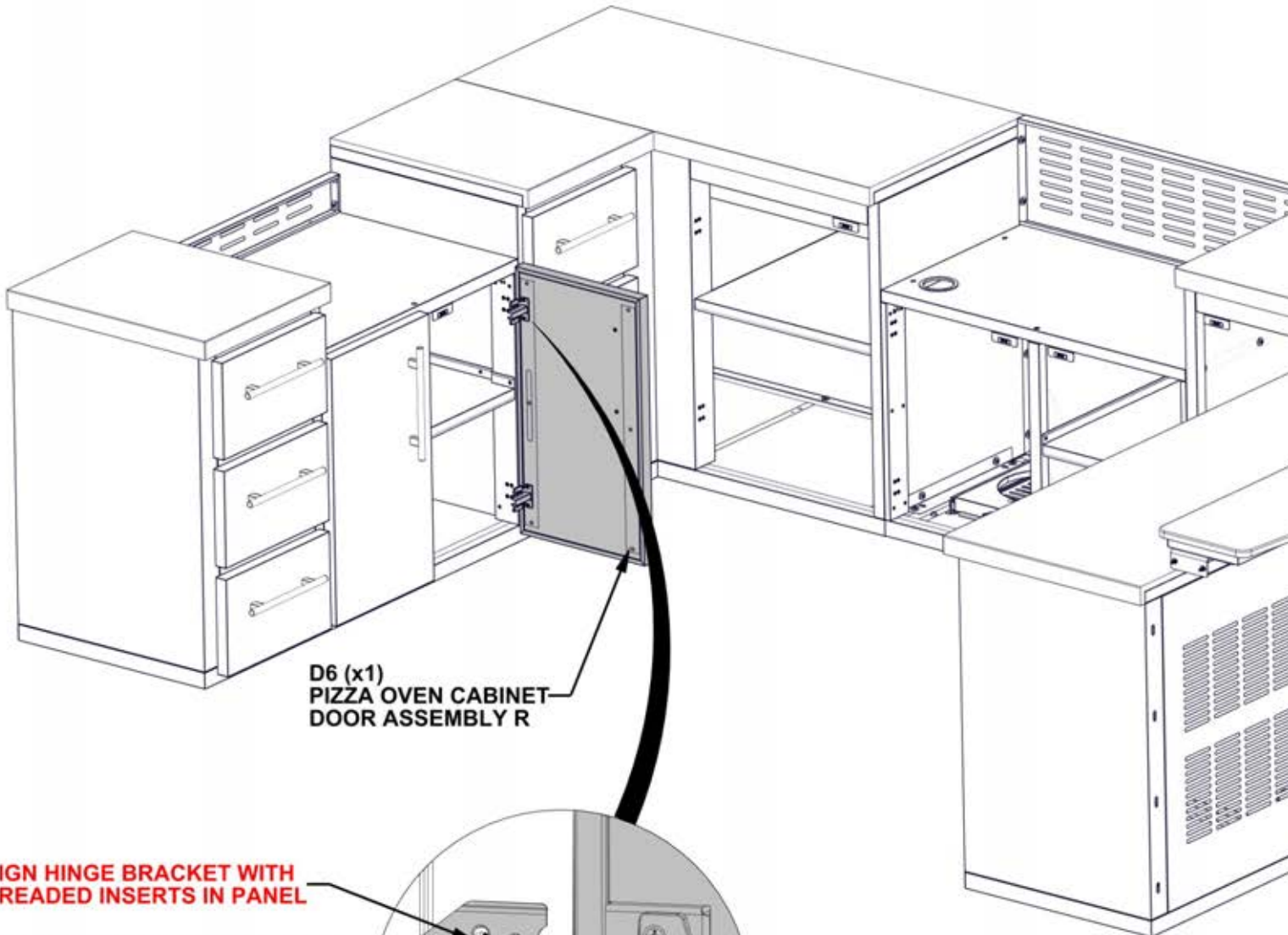

D6 (x1)
PIZZA OVEN CABINET
DOOR ASSEMBLY R

**ALIGN HINGE BRACKET WITH
THREADED INSERTS IN PANEL**

DO NOT OVERTIGHTEN HARDWARE

1185 (x8)
SCREW - 1/2"

STEP 126 - CABINET DOOR ATTACHMENT



Qty	PartNo	Description
8	H101185	PHILLIPS FLAT HEAD 8-32x.5 SCREW

D1 LEFT CORNER CABINET DOOR ASSEMBLY - A4M03036
(x1) 1 5/16"x23 5/8"x33 1/16" (34x600x840)

- ONLY KITCHEN CABINETS ARE SHOWN FOR DETAIL.
- FOR THIS STEP IT IS HELPFUL TO HAVE AN ADDITIONAL PERSON HELP HOLD DOOR IN PLACE.
- WITH CABINET HINGES ATTACHED TO DOOR, ALIGN HOLES IN HINGE BRACKET WITH THREADED INSERTS IN SIDE OF CABINET PANEL.

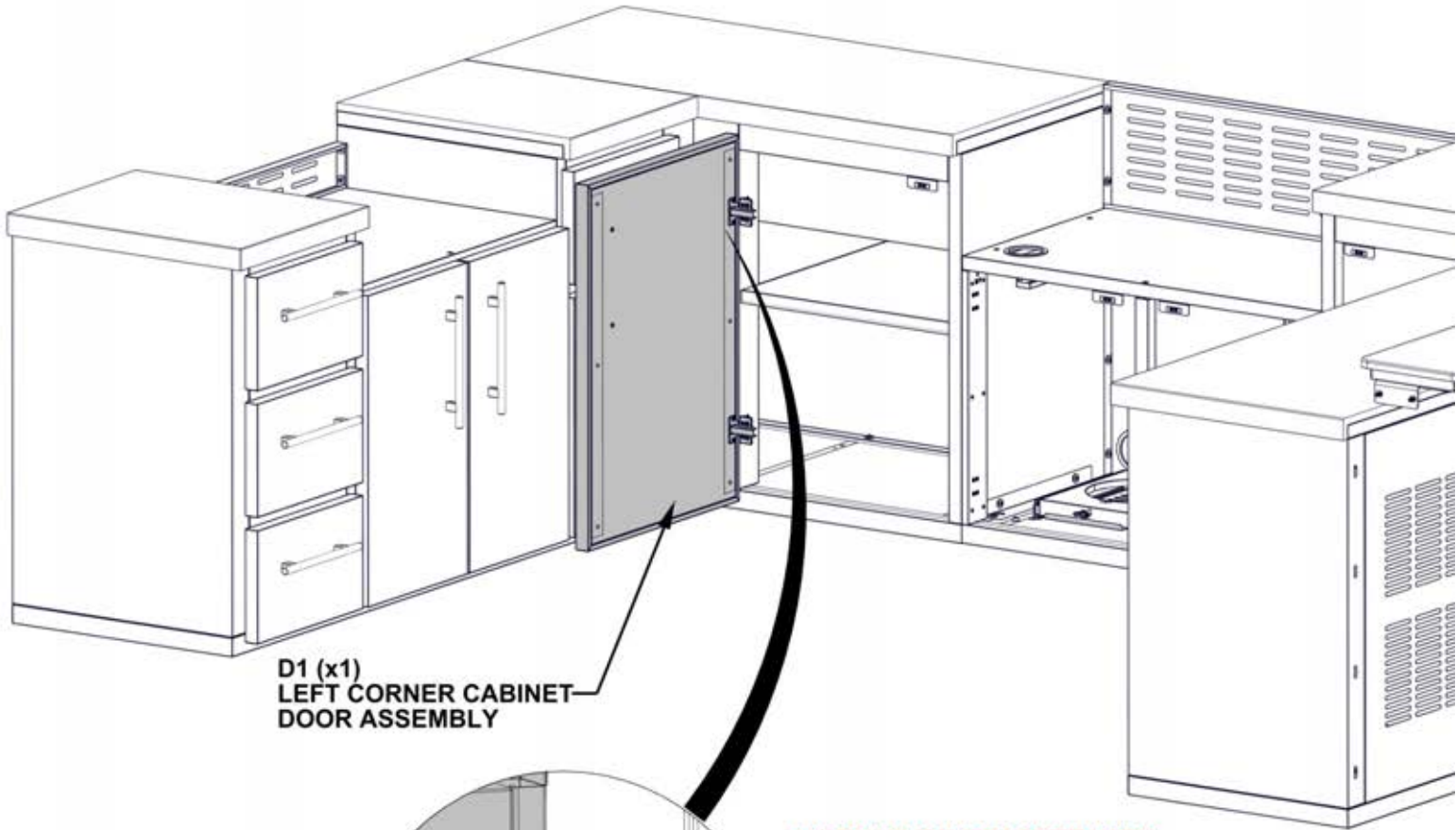

D1 (x1)
LEFT CORNER CABINET
DOOR ASSEMBLY

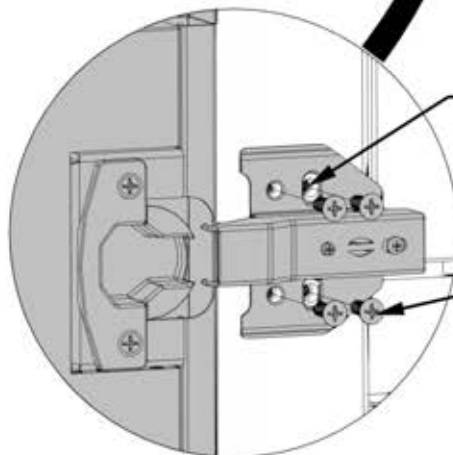

**ALIGN HINGE BRACKET WITH
THREADED INSERTS IN PANEL**

DO NOT OVERTIGHTEN HARDWARE

1185 (x8)
SCREW - 1/2"

STEP 127 - CABINET DOOR ATTACHMENT



Qty	PartNo	Description
8	H101185	PHILLIPS FLAT HEAD 8-32x.5 SCREW

D3 GRILL CABINET DOOR ASSEMBLY L - A4M03058
(x1) 1 5/16"x19"x25 3/16" (34x483x639)

- ONLY KITCHEN CABINETS ARE SHOWN FOR DETAIL.
- FOR THIS STEP IT IS HELPFUL TO HAVE AN ADDITIONAL PERSON HELP HOLD DOOR IN PLACE.
- WITH CABINET HINGES ATTACHED TO DOOR, ALIGN HOLES IN HINGE BRACKET WITH THREADED INSERTS IN SIDE OF CABINET PANEL.

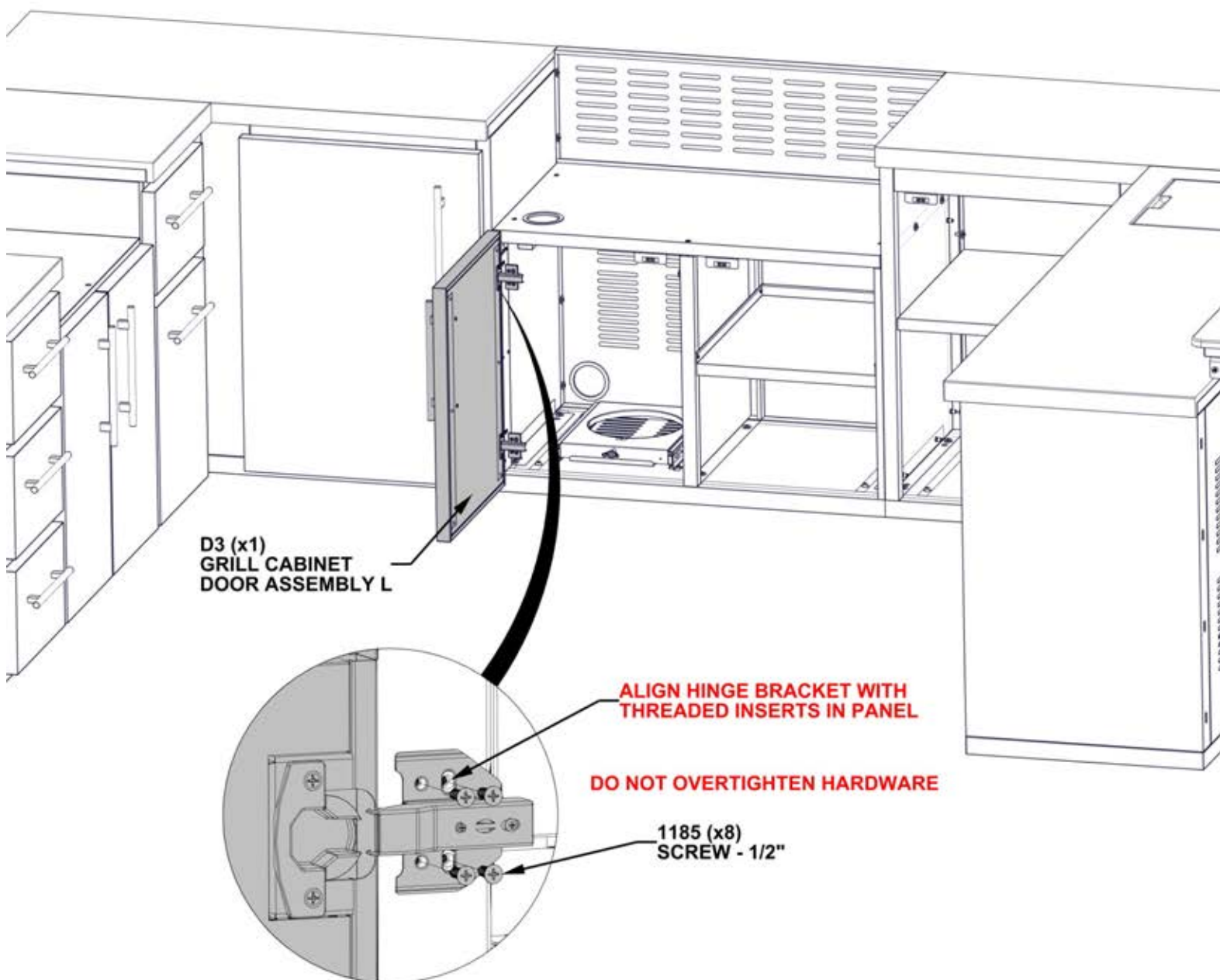

STEP 128 - CABINET DOOR ATTACHMENT



Qty	PartNo	Description
8	H101185	PHILLIPS FLAT HEAD 8-32x.5 SCREW

D4 GRILL CABINET DOOR ASSEMBLY R - A4M03059
(x1) 1 5/16"x19"x25 3/16" (34x483x639)

- ONLY KITCHEN CABINETS ARE SHOWN FOR DETAIL.
- FOR THIS STEP IT IS HELPFUL TO HAVE AN ADDITIONAL PERSON HELP HOLD DOOR IN PLACE.
- WITH CABINET HINGES ATTACHED TO DOOR, ALIGN HOLES IN HINGE BRACKET WITH THREADED INSERTS IN SIDE OF CABINET PANEL.

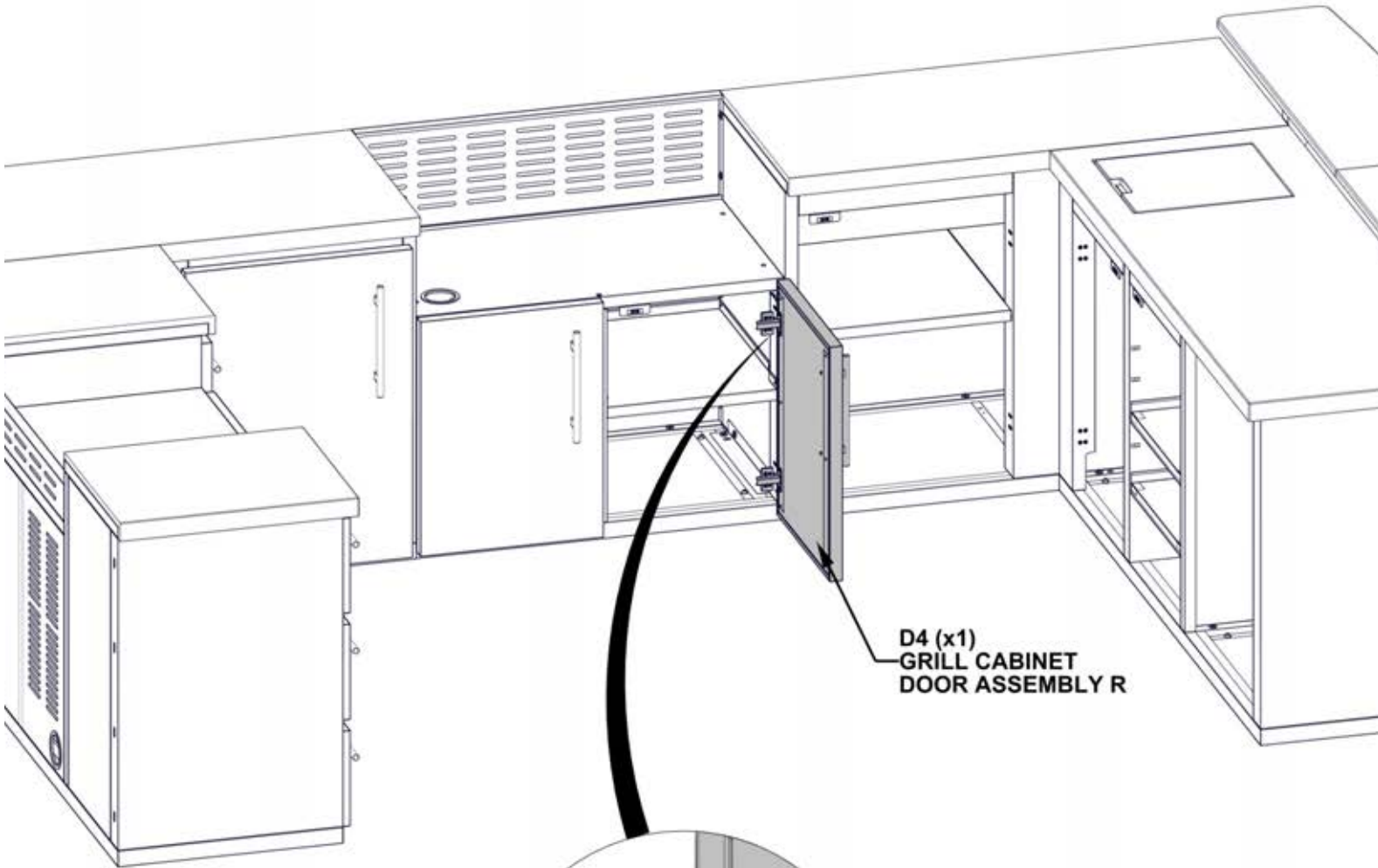

D4 (x1)
GRILL CABINET
DOOR ASSEMBLY R

**ALIGN HINGE BRACKET WITH
THREADED INSERTS IN PANEL**

DO NOT OVERTIGHTEN HARDWARE

1185 (x8)
SCREW - 1/2"

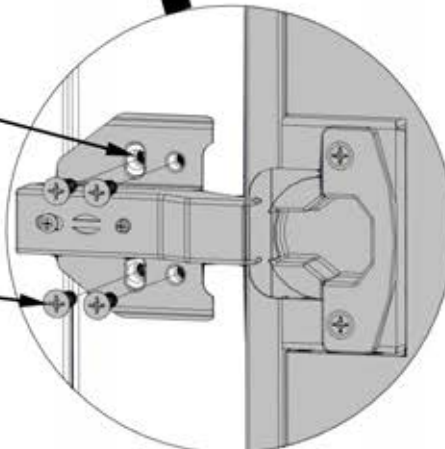

STEP 129 - CABINET DOOR ATTACHMENT



Qty	PartNo	Description
8	H101185	PHILLIPS FLAT HEAD 8-32x.5 SCREW

D2 RIGHT CORNER CABINET DOOR ASSEMBLY - A4M03045
(x1) 1 5/16"x23 5/8"x33 1/16" (34x600x840)

- ONLY KITCHEN CABINETS ARE SHOWN FOR DETAIL.
- FOR THIS STEP IT IS HELPFUL TO HAVE AN ADDITIONAL PERSON HELP HOLD DOOR IN PLACE.
- WITH CABINET HINGES ATTACHED TO DOOR, ALIGN HOLES IN HINGE BRACKET WITH THREADED INSERTS IN SIDE OF CABINET PANEL.

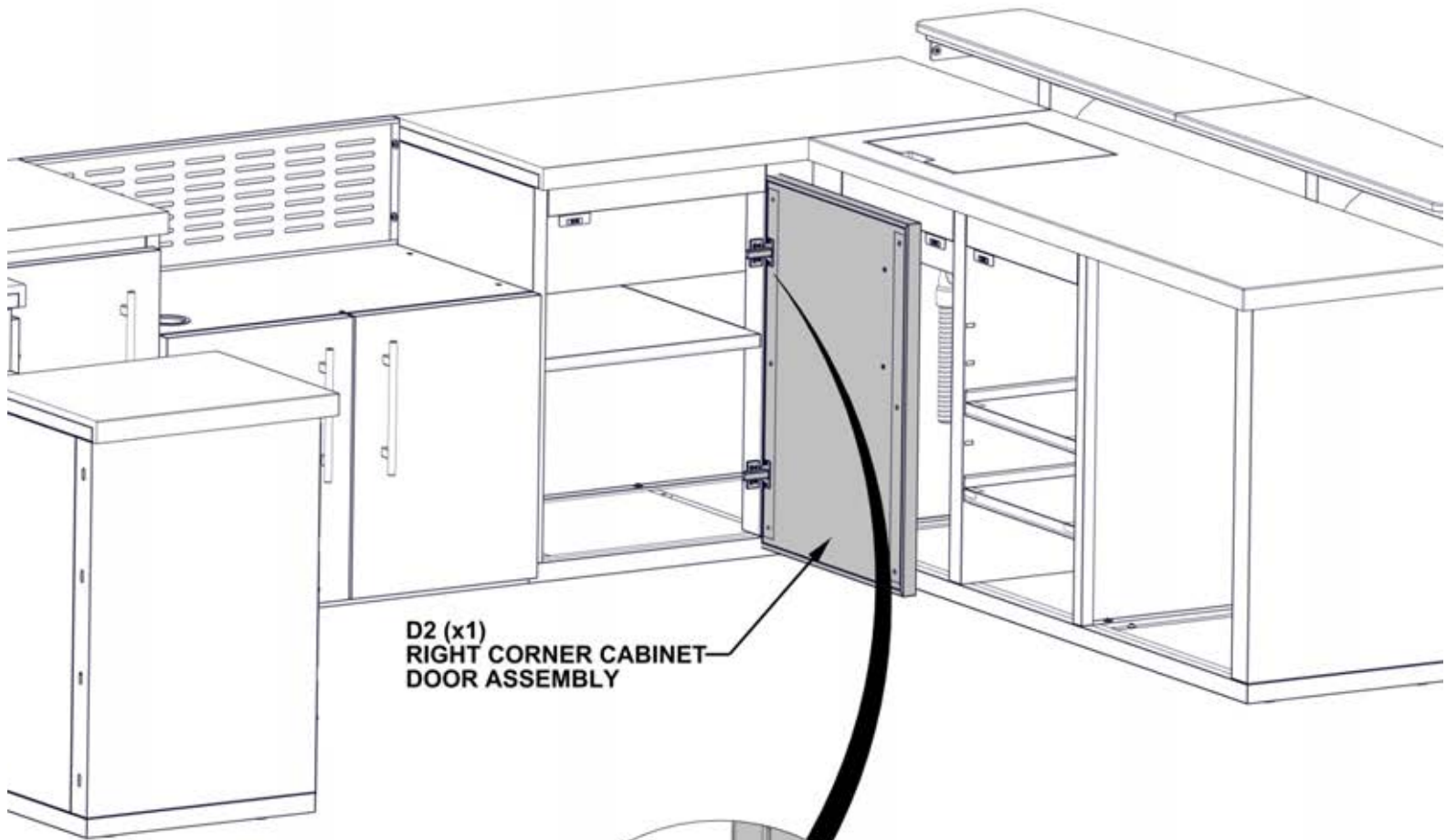

D2 (x1)
RIGHT CORNER CABINET
DOOR ASSEMBLY

**ALIGN HINGE BRACKET WITH
THREADED INSERTS IN PANEL**

DO NOT OVERTIGHTEN HARDWARE

1185 (x8)
SCREW - 1/2"

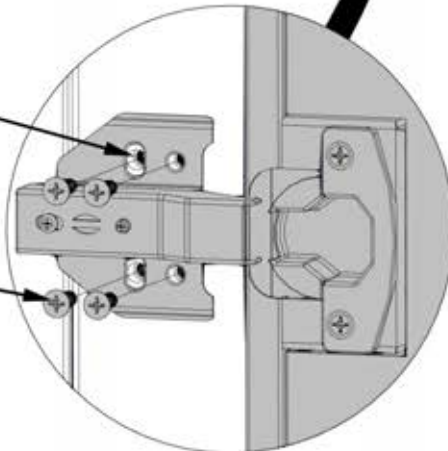

STEP 130 - CABINET DOOR ATTACHMENT



Qty	PartNo	Description
8	H101185	PHILLIPS FLAT HEAD 8-32x.5 SCREW

D7 SINK CABINET DOOR ASSEMBLY L - A4M03144
(x1) 1 5/16"x20"x33 1/16" (34x508x840)

- ONLY KITCHEN CABINETS ARE SHOWN FOR DETAIL.
- FOR THIS STEP IT IS HELPFUL TO HAVE AN ADDITIONAL PERSON HELP HOLD DOOR IN PLACE.
- WITH CABINET HINGES ATTACHED TO DOOR, ALIGN HOLES IN HINGE BRACKET WITH THREADED INSERTS IN SIDE OF CABINET PANEL.

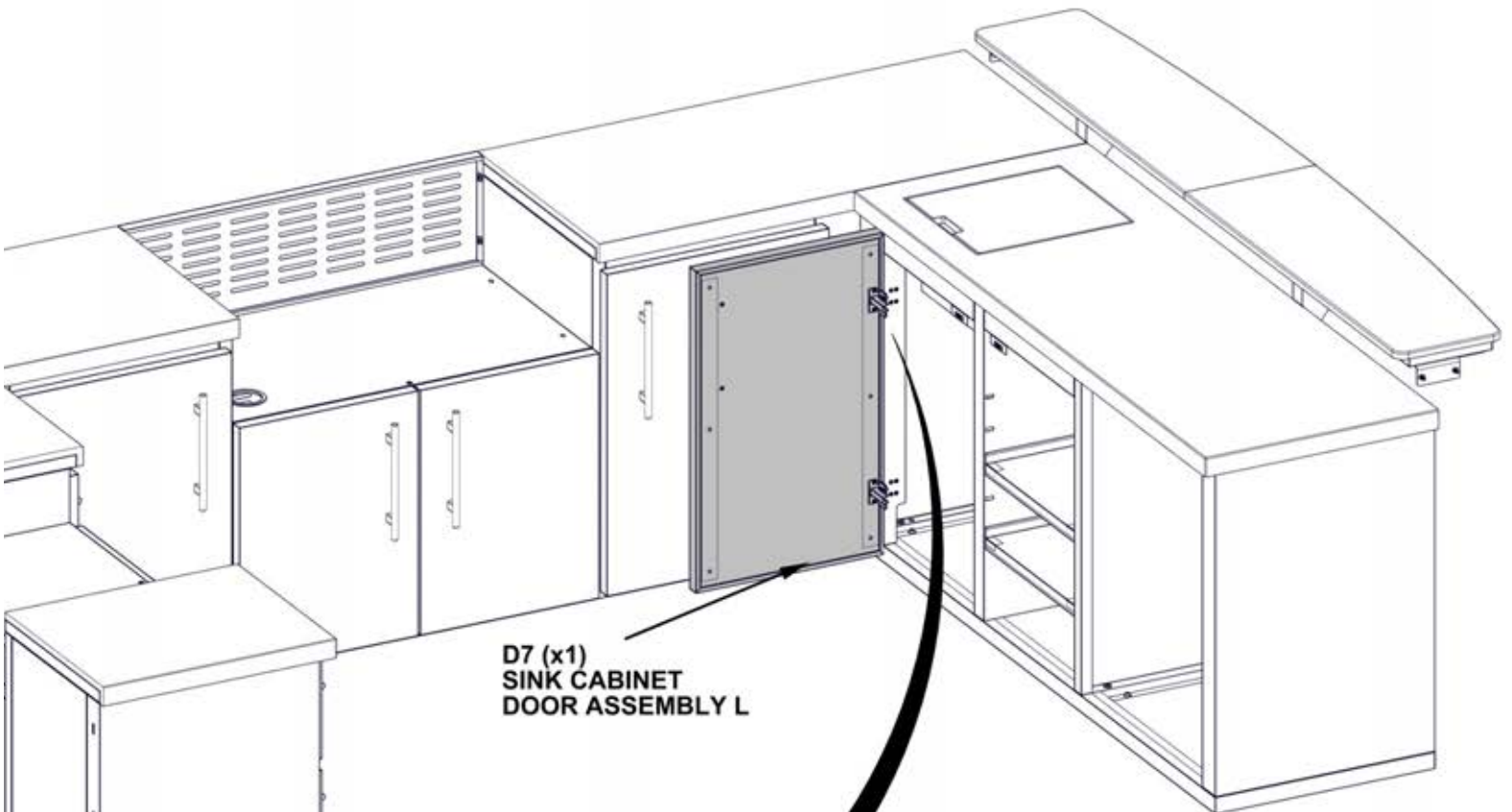

D7 (x1)
SINK CABINET
DOOR ASSEMBLY L

**ALIGN HINGE BRACKET WITH
THREADED INSERTS IN PANEL**

DO NOT OVERTIGHTEN HARDWARE

1185 (x8)
SCREW - 1/2"

STEP 131 - CABINET DOOR ATTACHMENT



Qty	PartNo	Description
8	H101185	PHILLIPS FLAT HEAD 8-32x.5 SCREW

D8 SINK CABINET DOOR ASSEMBLY R - A4M03145
(x1) 1 5/16"x20"x33 1/16" (34x508x840)

- ONLY KITCHEN CABINETS ARE SHOWN FOR DETAIL.
- FOR THIS STEP IT IS HELPFUL TO HAVE AN ADDITIONAL PERSON HELP HOLD DOOR IN PLACE.
- WITH CABINET HINGES ATTACHED TO DOOR, ALIGN HOLES IN HINGE BRACKET WITH THREADED INSERTS IN SIDE OF CABINET PANEL.

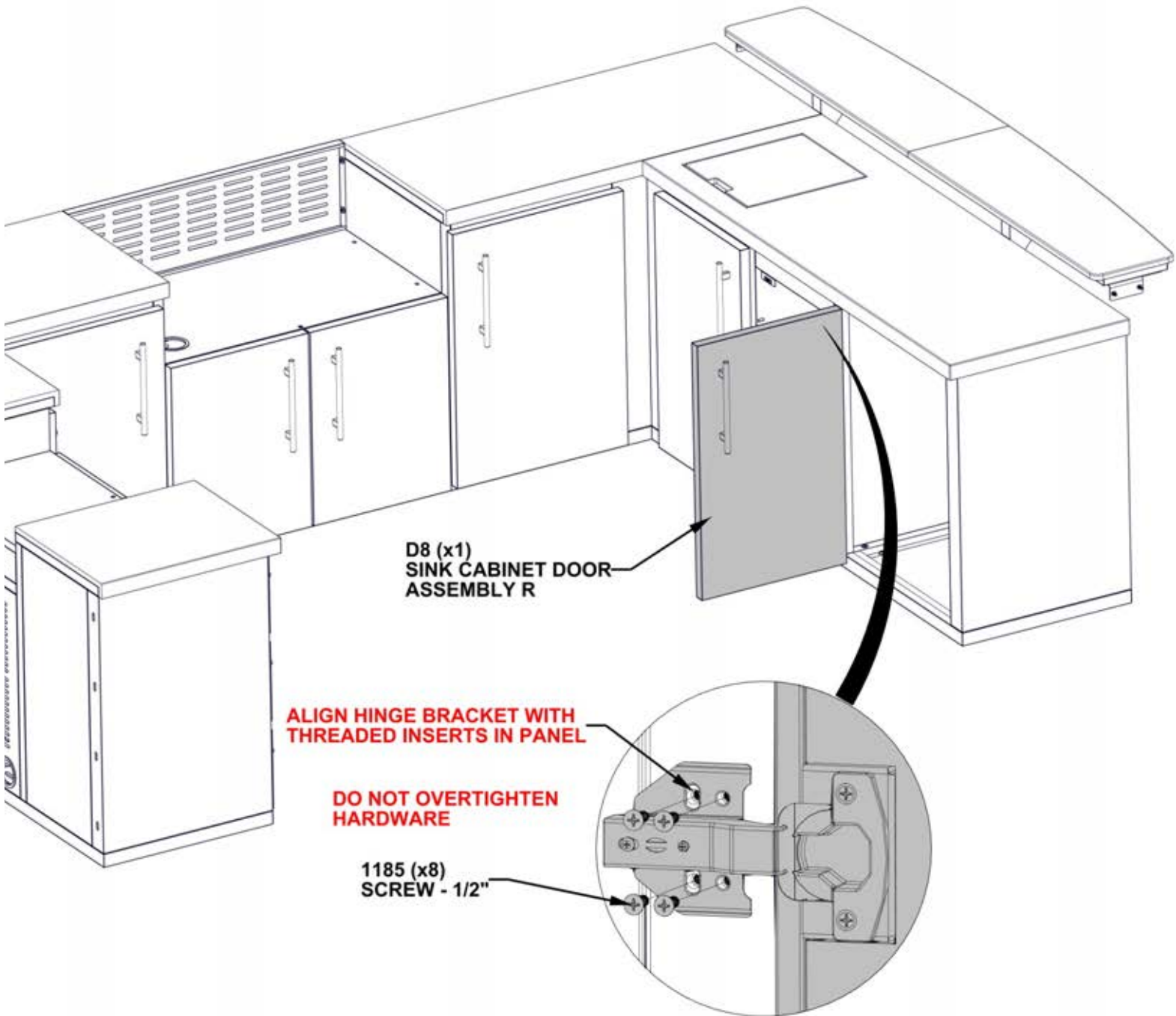

STEP 132 - CABINET DOOR ADJUSTMENT (AS NEEDED)

- ONLY KITCHEN CABINETS ARE SHOWN FOR DETAIL.
- ADJUST HINGES (AS NEEDED) SO THAT THE GAP AROUND ALL DOORS IS THE SAME AND THERE IS NO INTERFERENCE BETWEEN DOORS AND CABINETS.
- ADJUST MAGNET CATCH BRACKETS AS NEEDED.

**LOOSEN SCREWS TO ADJUST
MAGNET BRACKET, UNTIL IT
COMES IN CONTACT WITH
DOOR IN THE SHUT POSITION**

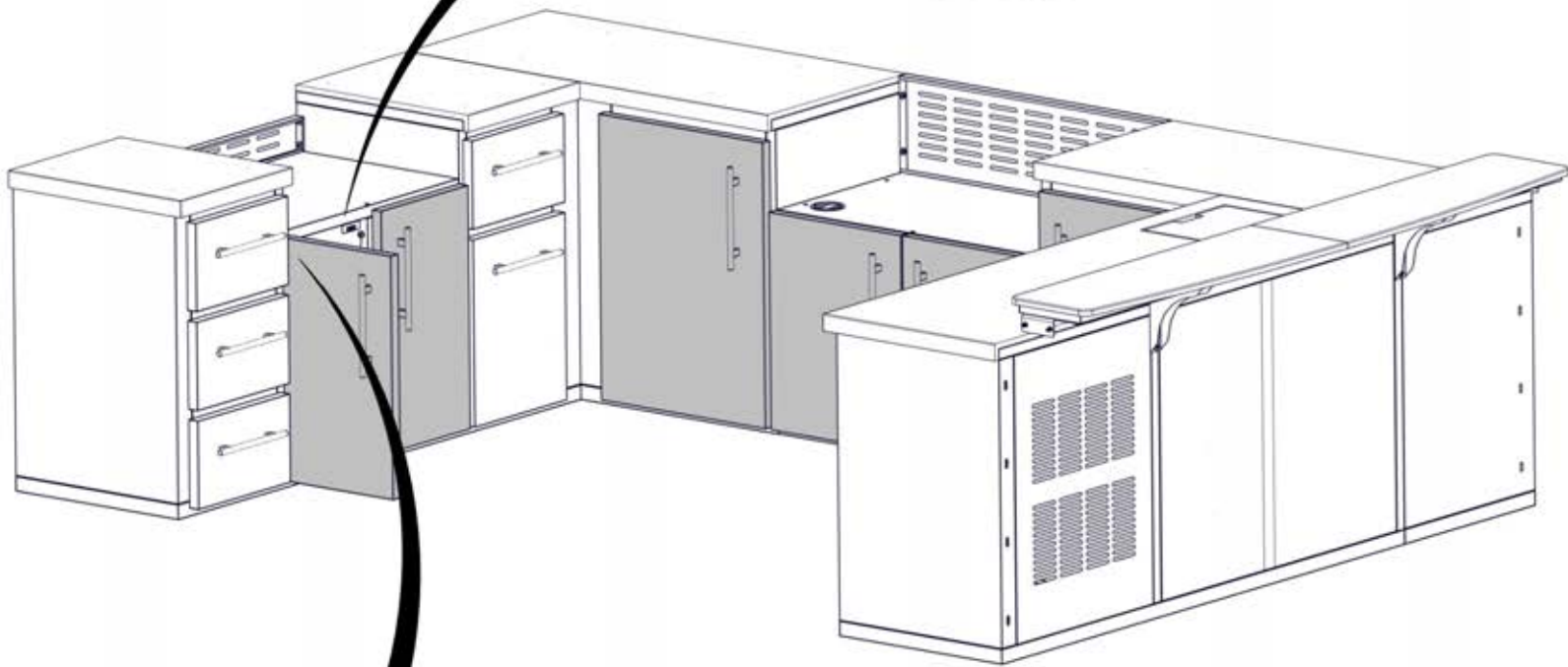
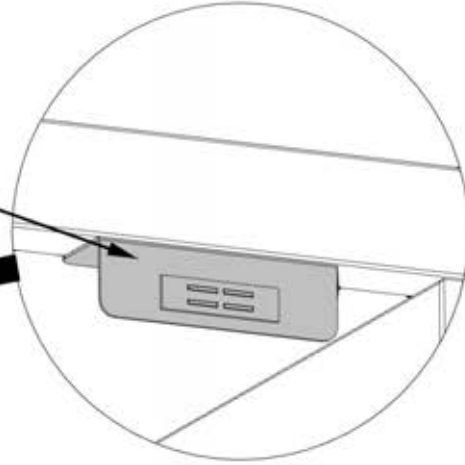

**SCREW #1:
SCREW CLOCKWISE TO BRING EDGE OF DOOR AWAY FROM
CABINET. SCREW COUNTER CLOCKWISE TO BRING EDGE OF DOOR
CLOSER TO CABINET**

**SCREW #2:
LOOSEN THESE SCREWS TO SLIDE DOOR TOWARD CABINET OR
AWAY FROM CABINET**

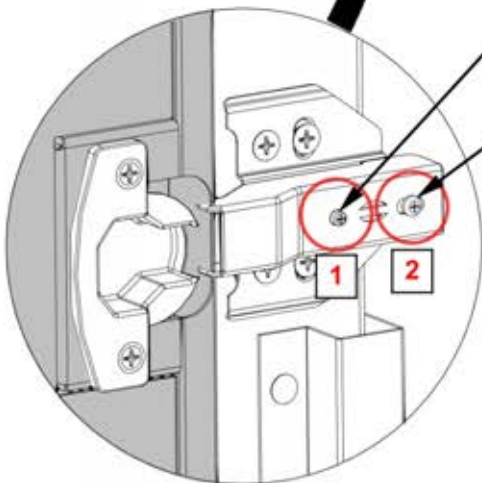

STEP 133 - KITCHEN ACCESSORY

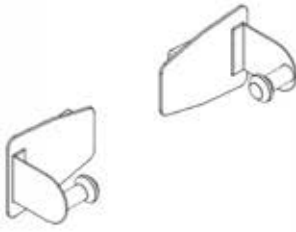

A4M02290 MAGNETIC PAPER TOWEL HOLDER
(x1)

- ONLY KITCHEN CABINETS ARE SHOWN FOR DETAIL.
- MAGNETIC PAPER TOWEL HOLDER CAN BE ATTACHED TO ANY METAL SURFACE ON KITCHEN.
- WE RECOMMEND ATTACHING TO THE INSIDE OF GRILL CABINET DOOR.
- **MAKE SURE TO KEEP PAPER TOWEL HOLDER AT A SAFE DISTANCE FROM GRILLING SURFACE.**

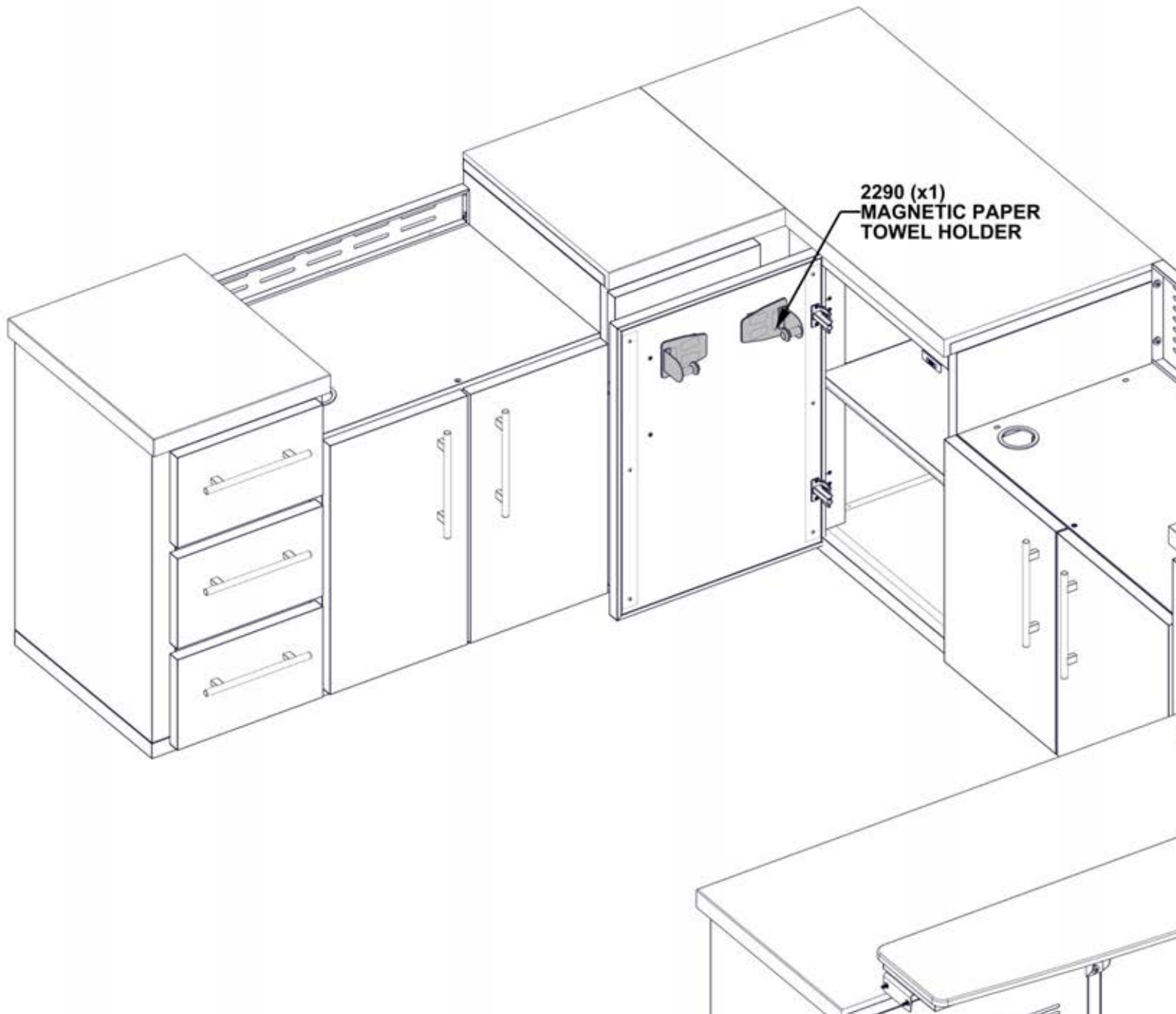

STEP 134 - KITCHEN ANCHORING

Qty	PartNo	Description
8	H100630	WASHER FLAT 8x19 BLK
8	H100120	CONCRETE ANCHOR 1/4"x2"

- MANUFACTURER RECOMMENDS INSTALLATION ON CONCRETE SURFACE OR CONCRETE POST PADS AS SHOWN BELOW.
- FOR INSTALLATION ON WOOD DECK, YOU MUST ENSURE THERE IS AMPLE STRUCTURAL SUPPORT UNDER THE DECK. HARDWARE NOT INCLUDED FOR DECK ATTACHMENT.

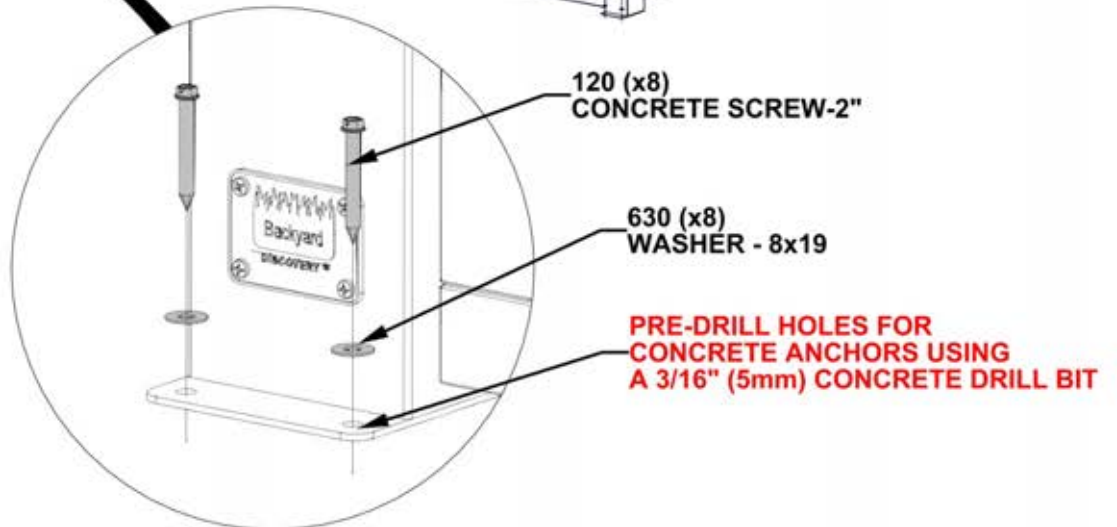
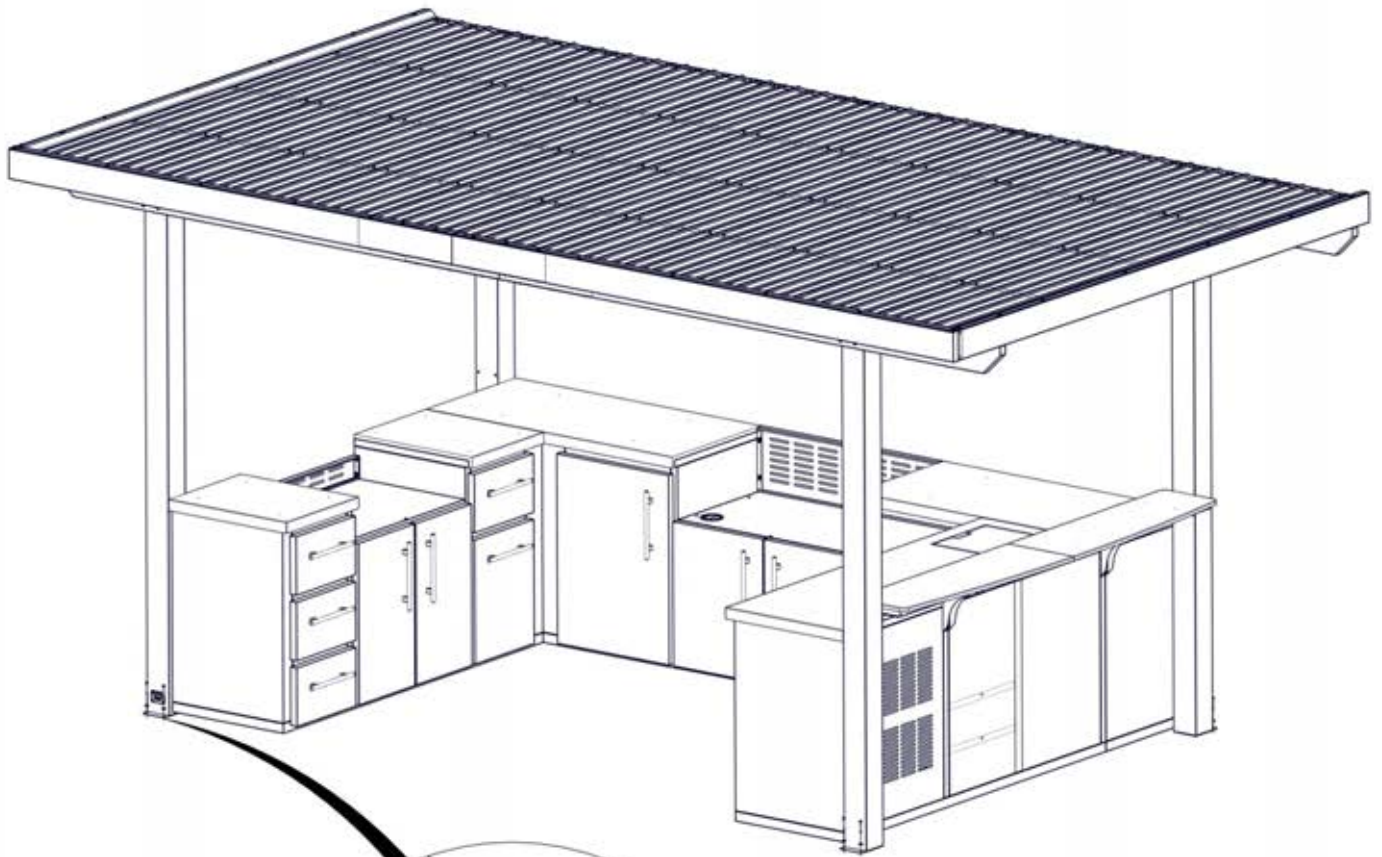

OUTDOOR KITCHEN GRILL KIT



9240025 OUTDOOR KITCHEN GRILL KIT
(x1)

-
- FOR INSTALLATION AND DETAILED INFORMATION OF OUTDOOR KITCHEN GRILL KIT, REFER TO ASSEMBLY INSTRUCTIONS THAT COME PACKAGED WITH THE OUTDOOR KITCHEN GRILL KIT.
 - FOLLOW DIRECTIONS FOR PROPER CARE AND USE.

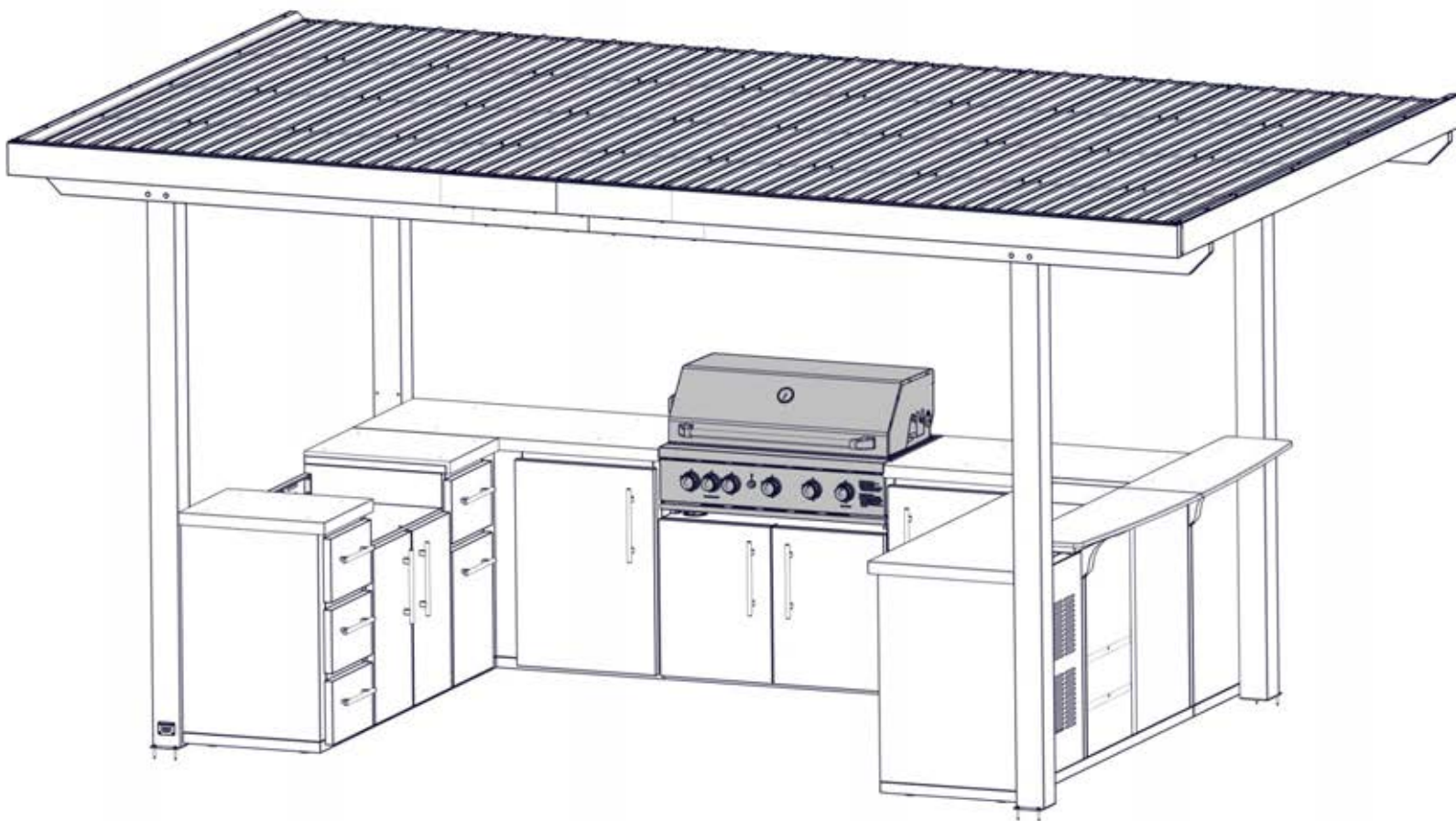

**NATURAL GAS CONVERSION KIT AVAILABLE BY CONTACTING BACKYARD DISCOVERY AT
www.backyarddiscovery.com 1-800-856-4445**

OUTDOOR KITCHEN PIZZA OVEN



9240018 OUTDOOR KITCHEN PIZZA OVEN
(x1)

- FOR INSTALLATION AND DETAILED INFORMATION OF OUTDOOR KITCHEN PIZZA OVEN, REFER TO ASSEMBLY INSTRUCTIONS THAT COME PACKAGED WITH THE OUTDOOR KITCHEN PIZZA OVEN.
- FOLLOW DIRECTIONS FOR PROPER CARE AND USE.

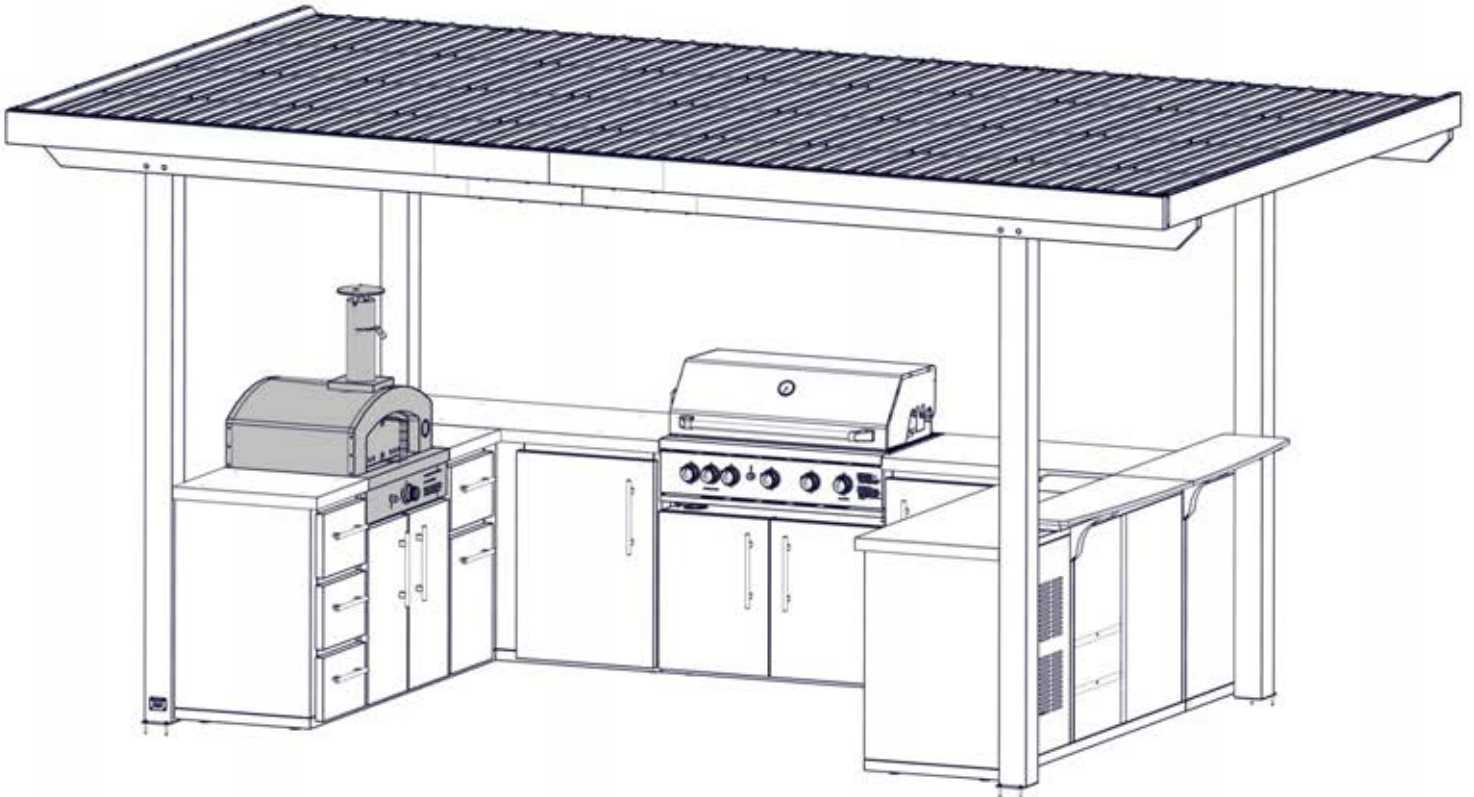

**NATURAL GAS CONVERSION KIT AVAILABLE BY CONTACTING BACKYARD DISCOVERY AT
www.backyarddiscovery.com 1-800-856-4445**

OUTDOOR KITCHEN FRIDGE



9240162 OUTDOOR KITCHEN FRIDGE - RIGHT OPEN
(x1)

- FOR INSTALLATION OF OUTDOOR KITCHEN FRIDGE, REFER TO PAGES IN THIS INSTRUCTION MANUAL.
- FOR DETAILED INFORMATION OF OUTDOOR KITCHEN FRIDGE, REFER TO ASSEMBLY INSTRUCTIONS THAT COME PACKAGED WITH THE OUTDOOR KITCHEN FRIDGE.
- FOLLOW DIRECTIONS FOR PROPER CARE AND USE.

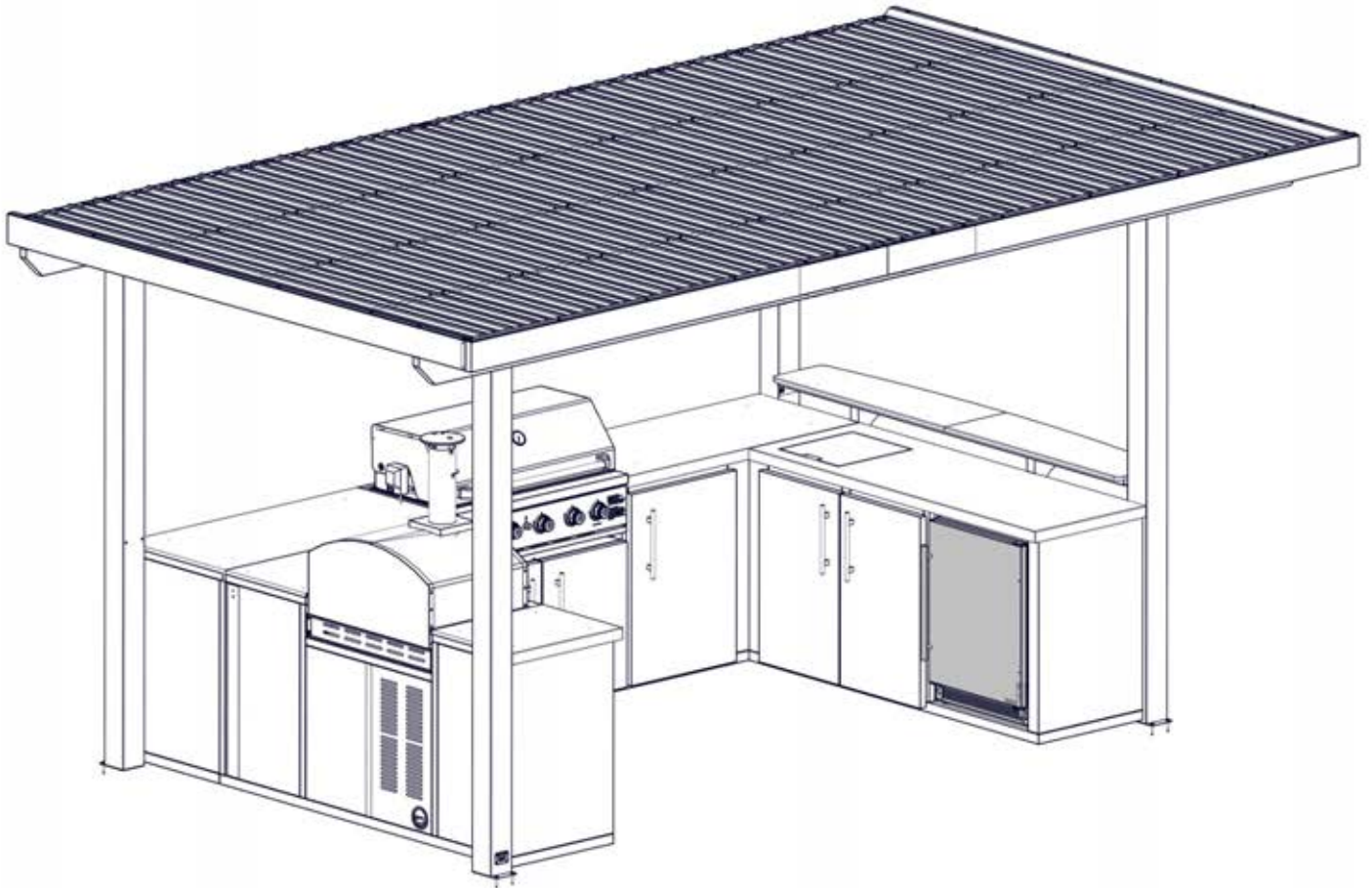

OUTDOOR KITCHEN FRIDGE

- CAREFULLY SLIDE FRIDGE INTO CABINET OPENING MAKING SURE THAT THE ELECTRICAL CORD IS ROUTED THROUGH THE HOLES IN THE SIDE PANELS OF THE CABINET.
- IF FRIDGE IS NOT IN UPRIGHT POSITION, PLEASE LET SIT FOR 24 HRS BEFORE PLUGGING INTO RECEPTACLE.
- FRIDGE CANNOT BE CONNECTED TO ELECTRICAL ENCLOSURE ATTACHED TO OUTDOOR STRUCTURE.

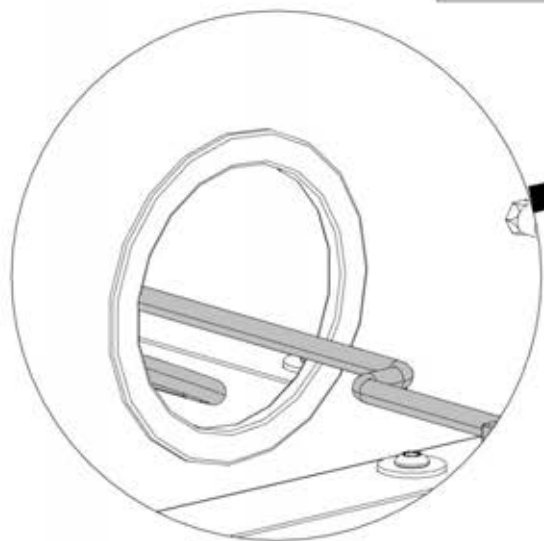
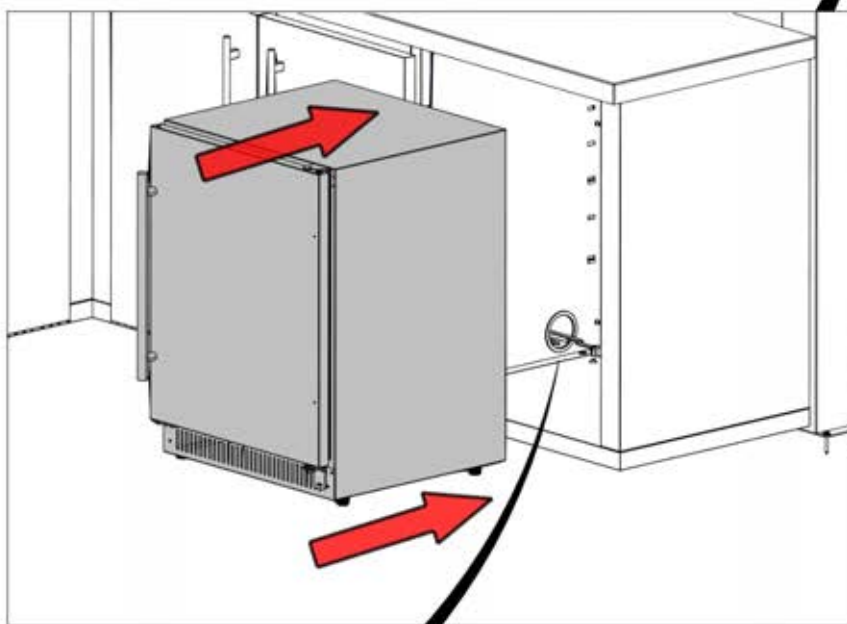
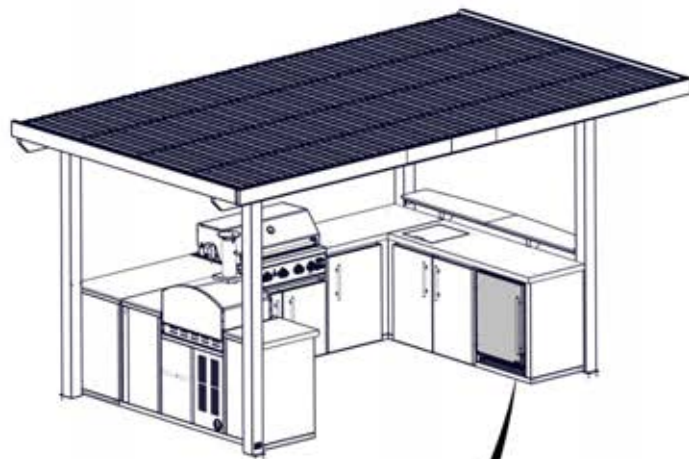

OUTDOOR KITCHEN FRIDGE

- ALIGN FEET ON FRIDGE UNIT SO THAT IT IS LEVEL AND DOES NOT TILT.
- TURN FEET CLOCKWISE TO EXTEND THEM AND COUNTERCLOCKWISE TO SHORTEN. REPEAT THIS FOR ALL FOUR FRIDGE FEET AS NEEDED TO LEVEL.

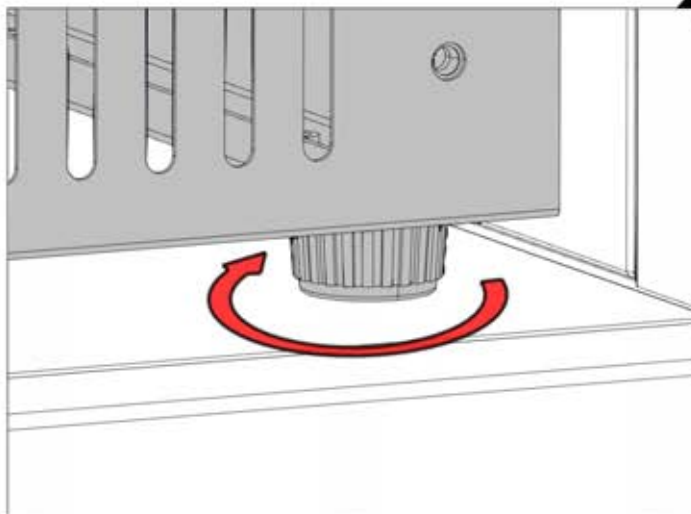
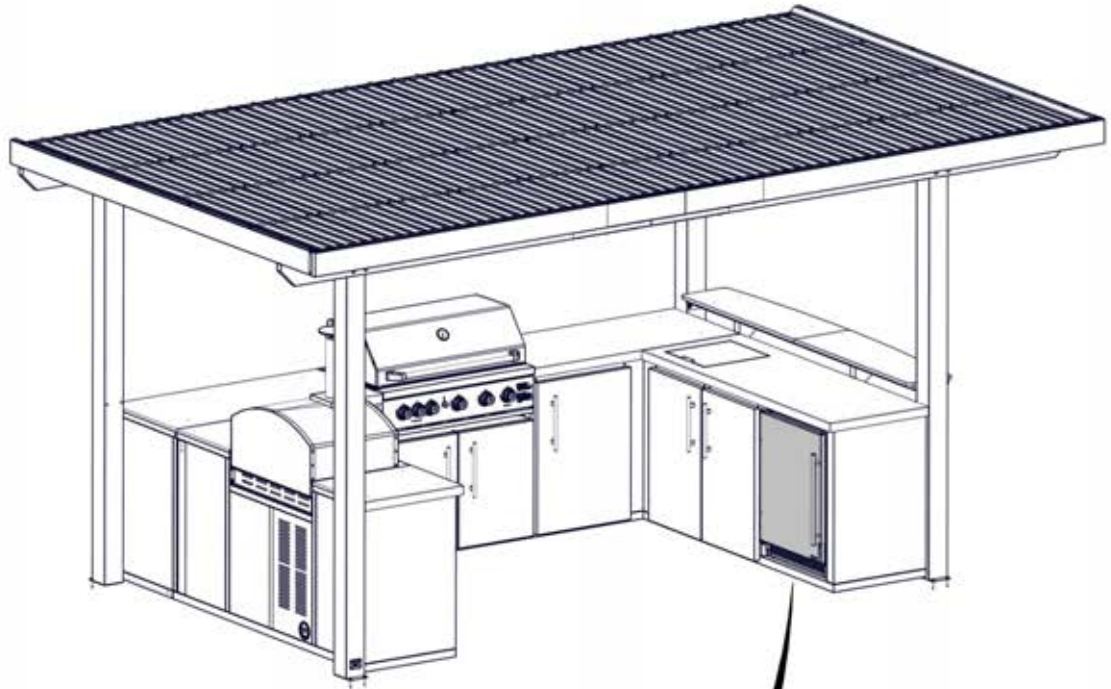

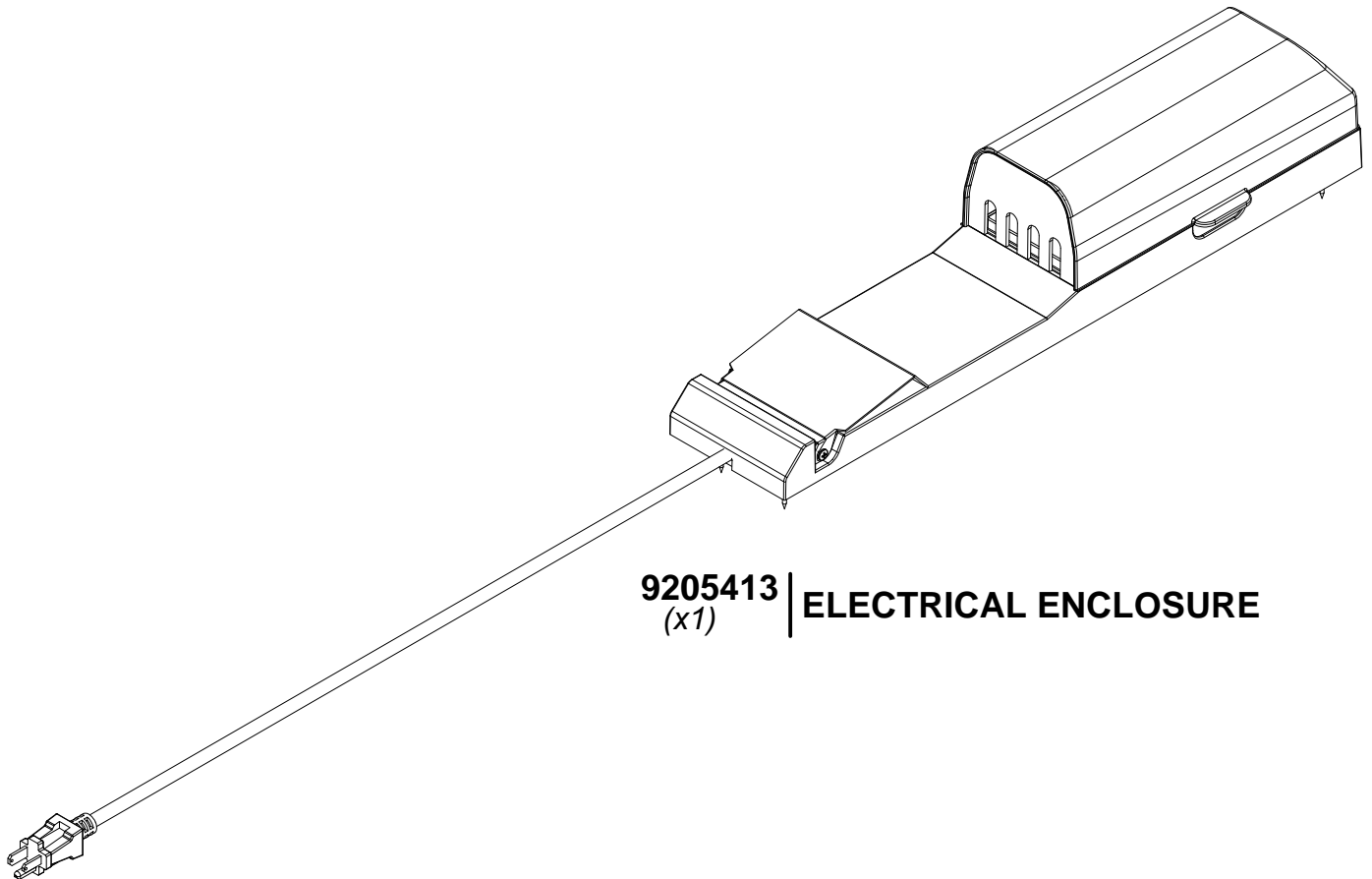

9205413 | **ELECTRICAL ENCLOSURE**
(x1)

FOR POWERPORT INSTALLATION REFER TO ASSEMBLY INSTRUCTIONS THAT COME PACKAGED WITH THE POWERPORT KIT. INSTALL ON ANY EXTERIOR POST THAT IS DESIRED. FOLLOW DIRECTIONS FOR PROPER INSTALLATION.