



Manufactured by:
Backyard Discovery
3305 Airport Drive, Pittsburg, KS
66762 800-856-4445

Basepoint Business Centre: Rivermead Drive, Westlea, Swindon SN5 7EX Phone: 0800-118-2476
J.P. Coenstraat 7, The Bridge, The Hague, 2595 WP, Netherlands Phone: 08005678990

WHITE WILLOW GREENHOUSE

MODEL # : 2304178

For Horticulture Use Only



WARNING

Cancer and Reproductive Harm
www.P65Warnings.ca.gov



Please visit www.backyarddiscovery.com

For the most up to date assembly manual, to register your product, or to order replacement parts *Para obtener instrucciones en español, visite* www.backyarddiscovery.com



EASY STEP-BY-STEP

3D INTERACTIVE INSTRUCTIONS

DOWNLOAD THE FREE APP



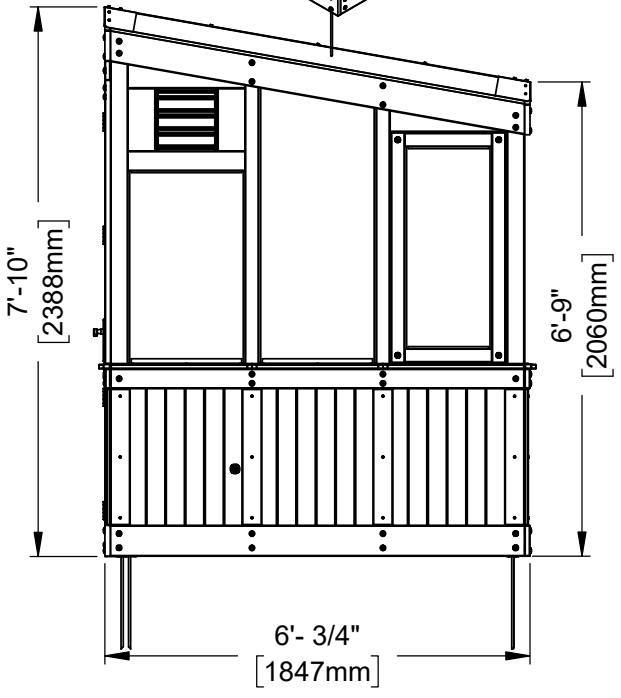
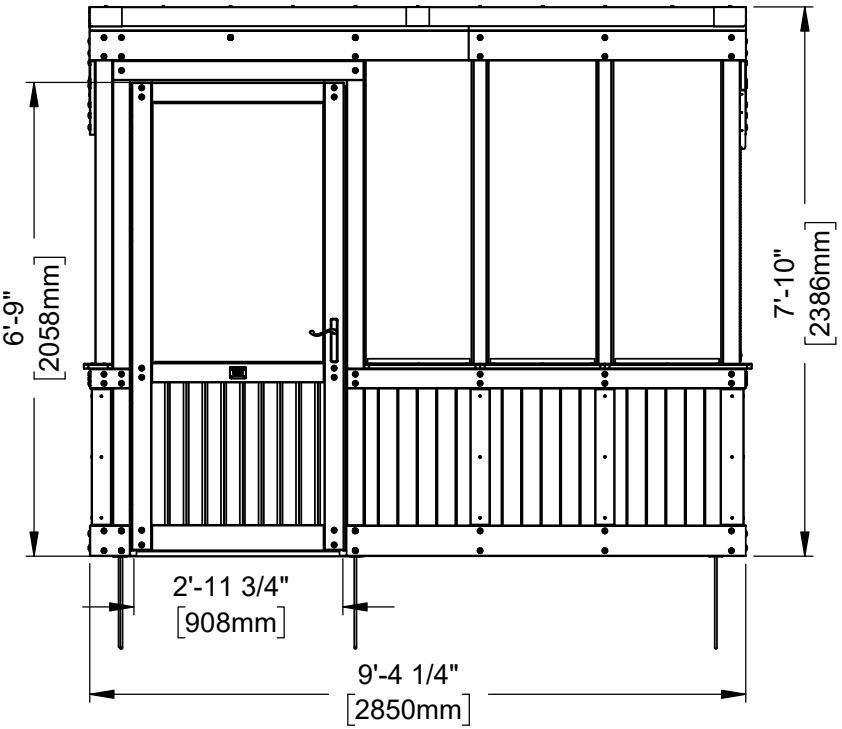
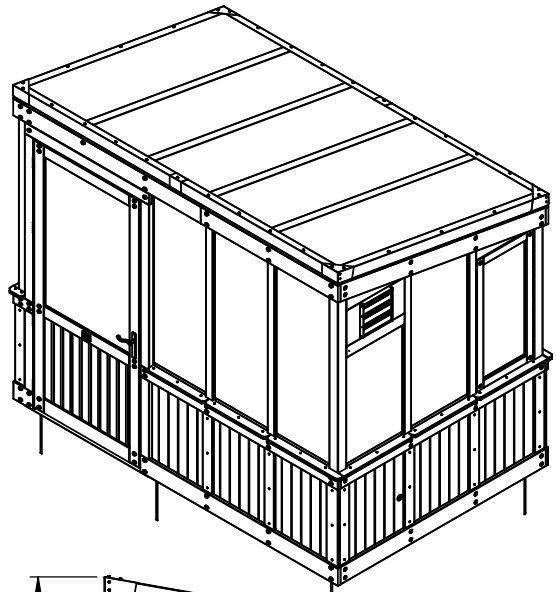
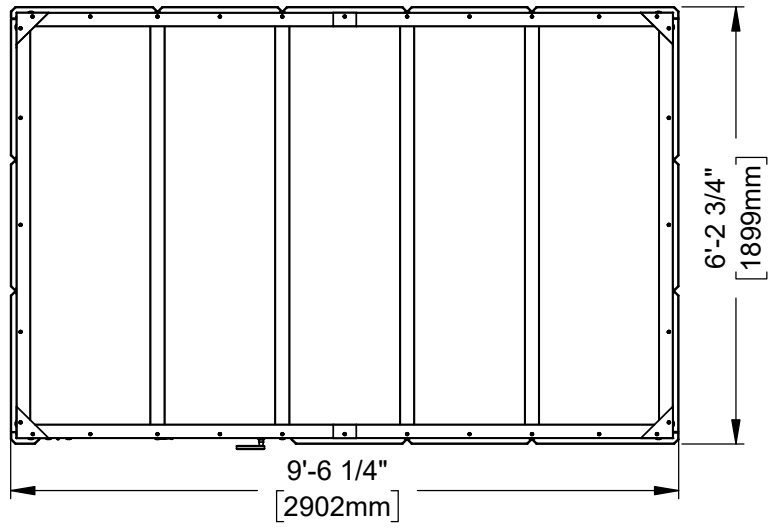
Made in China

INS-2304178-A- WHITE WILLOW GREENHOUSE-ENG 2-29-2024

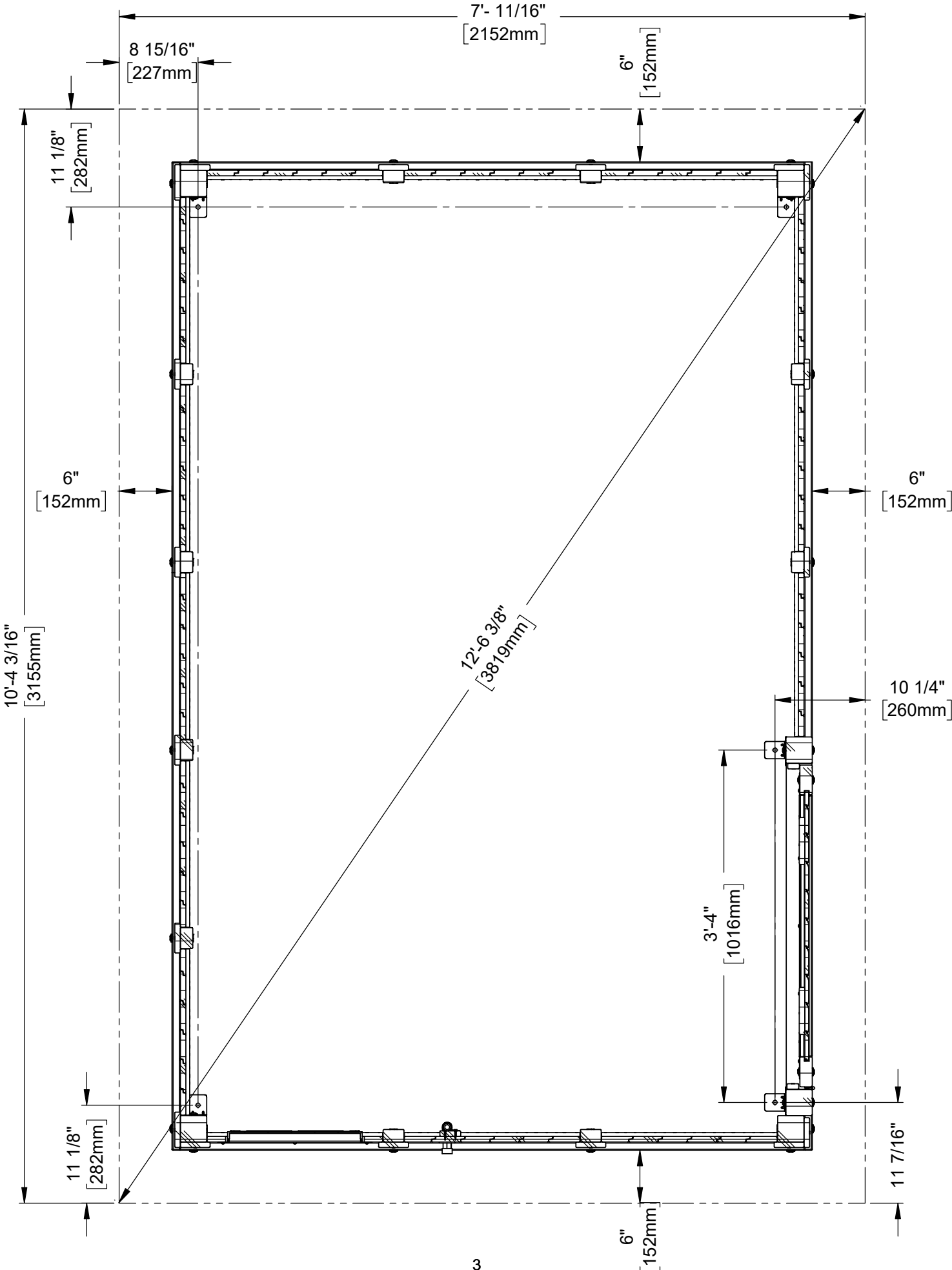
OWNER'S MANUAL - BASIC SETUP DIMENSIONS & ASSEMBLY NOTES

It is critically important that you start with square and level footings or concrete pad to attach your structure

- Pay close attention to the items needed for each step. Make sure you are using the correct hardware for each step. Using incorrect hardware may result in improper assembly
- Remember to double check for underground utilities and overhead electrical lines
- The hardware to attach the post mounts to the structure is included.
- The hardware to mount the structure permanently to a concrete surface is included.



OWNER'S MANUAL - ANCHORING LAYOUT

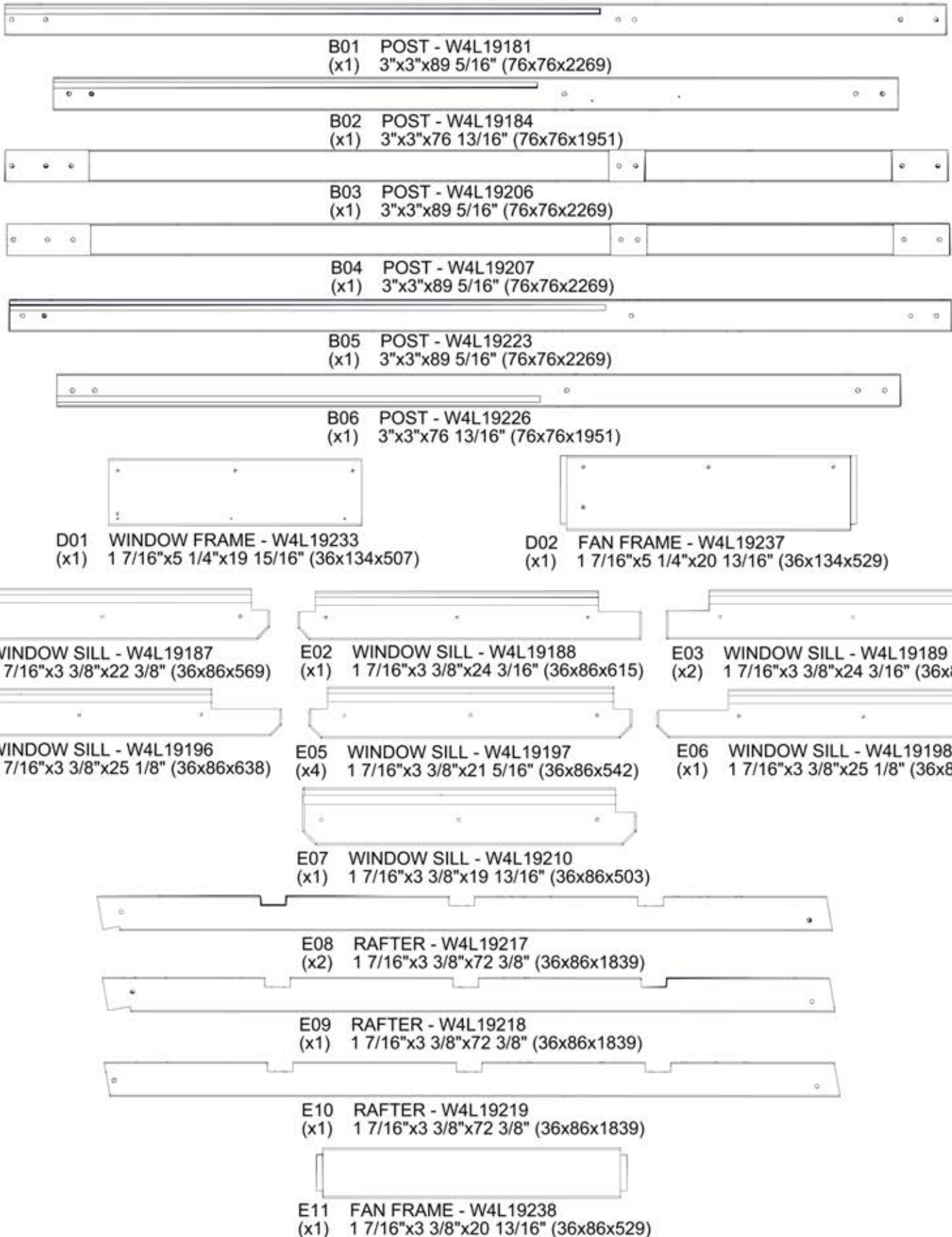


OWNER'S MANUAL - SITE LOCATION AND PREPARATION

- A. Check your local building and city codes for permit requirements or restrictions, including any HOA restrictions.
- B. Select a location with lots of sun, good drainage, and the ability to create a level firm surface for your greenhouse.
 - A firm, level surface is critically important to the longevity of your greenhouse.
 - Ensure it is accessible on all sides to clean and conduct annual maintenance
 - Consider a site location with a close proximity to both water and electrical sources
 - Make sure site drains well and avoid low lying areas.
 - Recommended area for site preparation of the White Willow Greenhouse is 10'-4 3/16" x 7'-11/16" x 7'-10" (3155mm x 2152mm x 2386mm).
- C. Before preparing your surface – double check for possibility of any underground utilities (example: gas, cable, or sprinkler lines)
 - Remove any grass, dirt, landscaping to create a level, hard-packed surface
 - This may involve some digging to create a level spot, dependent on your site location.
- D. Determine your preferred site pad materials for your greenhouse
 - It is NOT recommended to set the greenhouse directly on soil or grass. This will shorten the lifespan of your greenhouse.
 - Site pad options include gravel, patio or brick pavers, concrete pad.
 - Anchors are included for either natural surface, such as gravel, or for a concrete foundation.
 - Manufacturer recommends installation on concrete surface or concrete post pads.

OWNER'S MANUAL - PARTS IDENTIFICATION

WOOD COMPONENTS (NOT TO SCALE)



OWNER'S MANUAL - PARTS IDENTIFICATION

WOOD COMPONENTS (NOT TO SCALE)




F01 SIDE UPRIGHT - W4L19182
(x1) 1 7/16"x2 3/8"x85 3/8" (36x60x2168)




F02 SIDE UPRIGHT - W4L19183
(x1) 1 7/16"x2 3/8"x81 3/8" (36x60x2068)




F03 BACK UPRIGHT - W4L19191
(x4) 1 7/16"x2 3/8"x76 13/16" (36x60x1951)




F04 ANGLE BRACE - W4L19200
(x6) 1 7/16"x2 3/8"x15 3/16" (36x60x385)




F05 ANGLE BRACE - W4L19203
(x3) 1 7/16"x2 3/8"x16 1/4" (36x60x412)




F06 FRONT UPRIGHT - W4L19205
(x2) 1 7/16"x2 3/8"x89 5/16" (36x60x2269)




F07 DOOR TRIM - W4L19215
(x1) 1 7/8"x1 15/16"x37" (47x50x940)




F08 SIDE UPRIGHT - W4L19224
(x1) 1 7/16"x2 3/8"x85 3/8" (36x60x2168)




F09 SIDE UPRIGHT - W4L19225
(x1) 1 7/16"x2 3/8"x81 3/8" (36x60x2068)




G01 BASE BOARD - W4L19185
(x2) 15/16"x5 1/4"x70 13/16" (24x134x1799)




G02 BASE BOARD - W4L19194
(x1) 15/16"x5 1/4"x67 15/16" (24x134x1726)



G03 BASE BOARD - W4L19195
(x1) 15/16"x5 1/4"x46 5/8" (24x134x1184)



G04 BASE BOARD - W4L19208
(x1) 15/16"x5 1/4"x68 1/4" (24x134x1734)



G05 BASE BOARD - W4L19212
(x1) 15/16"x5 1/4"x6 15/16" (24x134x176)



H01 RUNNING BOARD - W4L19186
(x2) 15/16"x3 3/8"x70 13/16" (24x86x1799)



H02 RUNNING BOARD - W4L19192
(x1) 15/16"x3 3/8"x68 3/4" (24x86x1746)



H03 RUNNING BOARD - W4L19193
(x1) 15/16"x3 3/8"x47 3/8" (24x86x1204)

OWNER'S MANUAL - PARTS IDENTIFICATION

WOOD COMPONENTS (NOT TO SCALE)



H04 RUNNING BOARD - W4L19209
(x1) 15/16"x3 3/8"x68 1/4" (24x86x1734)



H05 RUNNING BOARD - W4L19211
(x1) 15/16"x3 3/8"x6 15/16" (24x86x176)



H06 DOOR TRIM - W4L19213
(x1) 15/16"x3 3/8"x43" (24x86x1092)



J01 PURLIN - W4L19220
(x3) 15/16"x2 3/8"x66 7/16" (24x60x1688)



J02 PURLIN - W4L19221
(x3) 15/16"x2 3/8"x45 1/8" (24x60x1146)



J03 CORNER BOARD - W4L19222
(x1) 7/8"x1 15/16"x4 15/16" (24x50x125)



M01 COVER BOARD - W4L19227
(x15) 5/8"x3 3/8"x23 5/16" (16x86x592)



N01 TABLE TRIM - W4L19201
(x1) 5/8"x2 3/8"x89 1/2" (16x60x2274)



N02 TABLE TRIM - W4L19230
(x1) 5/8"x2 3/8"x67 5/8" (16x60x1717)



N03 WINDOW FRAME - W4L19234
(x1) 5/8"x2 3/8"x19 5/16" (16x60x491)



N04 SLAT UPRIGHT - W4L19236
(x1) 5/8"x2 3/8"x49 7/16" (16x60x1256)



N05 SLAT - W4L19240
(x11) 5/8"x2 3/8"x25 3/8" (16x60x645)



N06 SPIGOT BOARD - W4L19242
(x1) 5/8"x2 3/8"x20 11/16" (16x60x526)



O01 DOOR TRIM - W4L19214
(x2) 5/8"x1 5/16"x79 3/8" (16x34x2016)



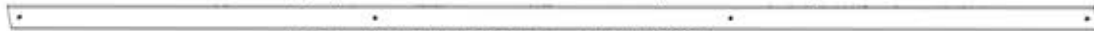
P01 WINDOW CAP - W4L19190
(x4) 1 7/16"x1 7/16"x20 1/2" (36x36x520)



P02 WINDOW CAP - W4L19199
(x7) 1 7/16"x1 7/16"x18 7/8" (36x36x480)



P03 TABLE CLEAT - W4L19202
(x1) 1 7/16"x1 7/16"x88 1/8" (36x36x2238)



P04 PURLIN CLEAT - W4L19204
(x2) 1 7/16"x1 7/16"x64 1/2" (36x36x1638)



P05 WINDOW CAP - W4L19216
(x1) 1 7/16"x1 7/16"x18 9/16" (36x36x472)



P06 TABLE CLEAT - W4L19229
(x4) 1 7/16"x1 7/16"x13 3/16" (36x36x335)



P07 TABLE CLEAT - W4L19231
(x1) 1 7/16"x1 7/16"x64 3/4" (36x36x1645)



V01 LATCH BLOCK - W4L19241
(x1) 1 1/4"x1 1/4"x2 3/8" (32x32x60)



Y01 COVER BOARD - W4L19228
(x3) 5/8"x4"x23 5/16" (16x102x592)

OWNER'S MANUAL - PARTS IDENTIFICATION

WOOD COMPONENTS (NOT TO SCALE)



AJ01 WINDOW SILL - W4L19232
(x1) 1 7/16"x4"x24 3/16" (36x102x615)



CB01 WINDOW FRAME UPRIGHT - W4L19235
(x1) 5/8"x3"x49 7/16" (16x76x1256)



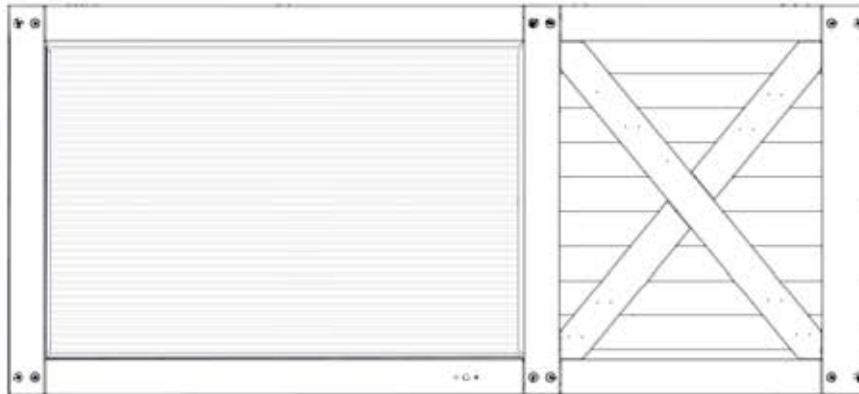
FF01 FAN FRAME - W4L19239
(x2) 1 7/16"x5 1/8"x11 1/2" (36x130x292)



FB01 FRONT BEAM - W2A04070
(x1) 15/16"x8 7/16"x68 3/4" (24x214x1746)



FB02 FRONT BEAM - W2A04071
(x1) 15/16"x8 7/16"x47 3/8" (24x214x1204)



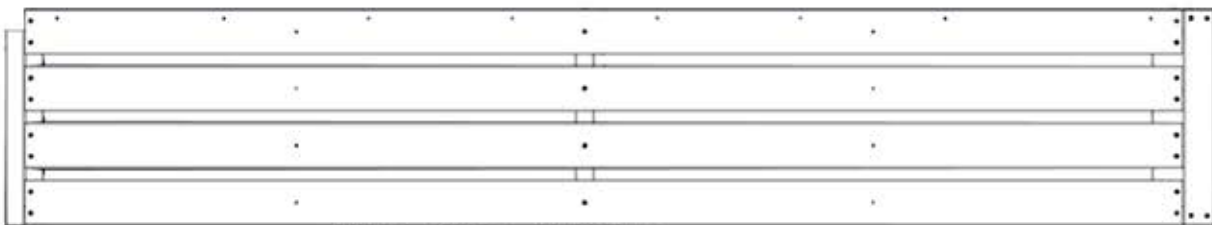
DA01 DOOR ASSEMBLY - W2A04072
(x1) 1 7/8"x36 9/16"x80" (48x928x2032)



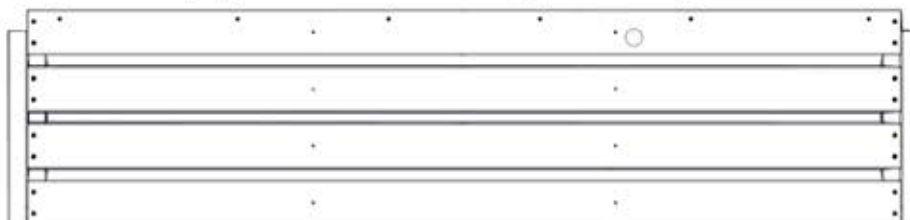
BB01 BACK BEAM - W2A04064
(x1) 15/16"x8 7/16"x68 3/4" (24x214x1746)



BB02 BACK BEAM - W2A04065
(x1) 15/16"x8 7/16"x47 3/8" (24x214x1204)



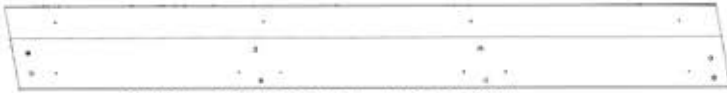
TB01 TABLE - W2A04066
(x1) 2 1/16"x16"x89 1/2" (52x407x2274)



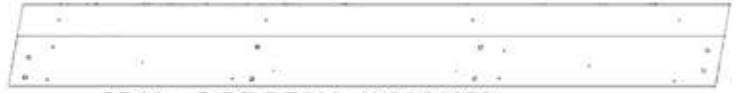
TB02 TABLE - W2A04068
(x1) 2 1/16"x16"x67 5/8" (52x407x1717)

OWNER'S MANUAL - PARTS IDENTIFICATION

WOOD COMPONENTS (NOT TO SCALE)



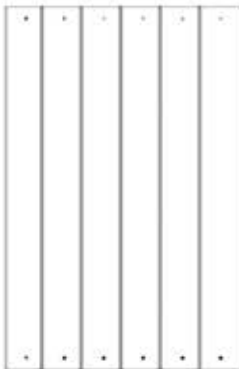
SB01 SIDE BEAM - W2A04061
(x1) 15/16"x8 7/16"x73 3/8" (24x214x1865)



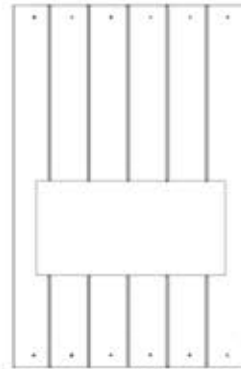
SB02 SIDE BEAM - W2A04073
(x1) 15/16"x8 7/16"x73 3/8" (24x214x1865)



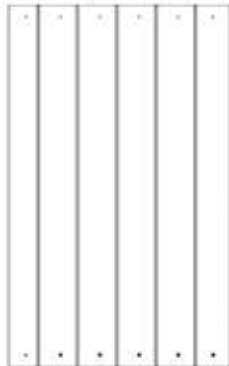
WA01 WINDOW ASSEMBLY - W2A04074
(x1) 1 7/8"x19 5/8"x39 3/16" (48x498x996)



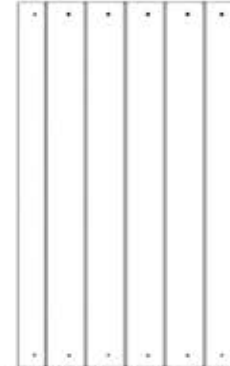
WP01 WALL PANEL - W2A04060
(x3) 1 1/16"x19 15/16"x30 9/16" (27x507x777)



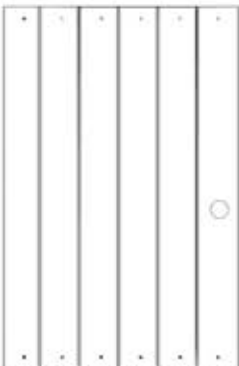
WP02 WALL PANEL - W2A04062
(x1) 1 1/16"x19 15/16"x30 9/16" (27x507x777)



WP03 WALL PANEL - W2A04063
(x7) 1 1/16"x18 7/8"x30 9/16" (27x480x777)



WP04 WALL PANEL - W2A04069
(x1) 1 1/16"x18 9/16"x30 9/16" (27x472x777)



WP05 WALL PANEL - W2A04075
(x1) 1 1/16"x19 15/16"x30 9/16" (27x507x777)



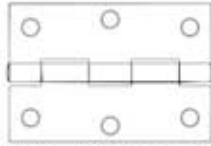
WP06 WALL PANEL - W2A04076
(x1) 1 1/16"x19 15/16"x30 9/16" (27x507x777)

OWNER'S MANUAL - PARTS IDENTIFICATION

ACCESSORY COMPONENTS (NOT TO SCALE)



A4M00555 L BRACKET BLK
(x4)



A4M00557 HINGE ASSEMBLY
(x4)



A6P00692 CORD GROMMET
(x1)



A4M02158 BYD ID TAG PATIO
(x1)



A4M00997 METAL CLEAT
(x1)



A4M02093 RAFTER BRACKET
(x8)



A4M02096 BRACKET
(x2)



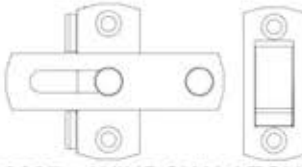
A4M02091 GROUND STAKE REBAR
(x5)



A4M02410 STORM DOOR HANDLE
(x1)



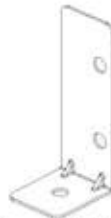
A4M02411 DOOR PROTECTOR CHAIN
(x1)



A4M02607 WINDOW LATCH LOCK
(x1)



A4M02502 ANCHOR BRACKET
(x1)



A4M02503 ANCHOR BRACKET
(x2)



A4M02526 DOOR BRACKET
(x1)



A4M02532 DOOR SWEEP
(x1)



A4M02533 SUPPORT HINGE
(x1)



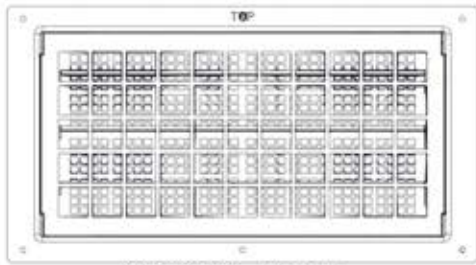
A6P00690 DUST SEAL TAPE
(x1)



A6P00813 DOUBLE SIDED TAPE
(x1)

OWNER'S MANUAL - PARTS IDENTIFICATION

ACCESSORY COMPONENTS (NOT TO SCALE)



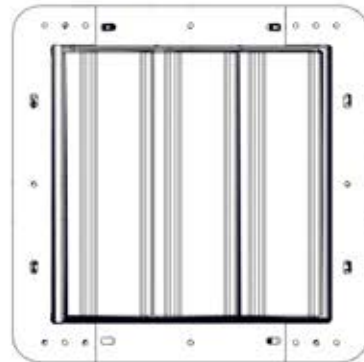
A6P00730 VENT
(x1)



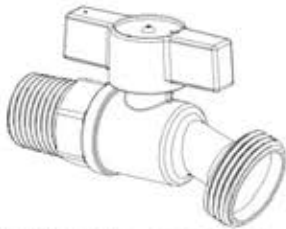
9205413 ELECTRICAL ENCLOSURE
(x1)



A6P00754 THERMOSTAT
(x1)



A4M02383 EXHAUST FAN
(x1)



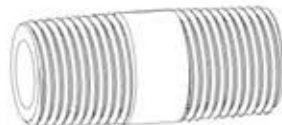
A4M02384 SPIGOT
(x1)



A6P00645 PIPE 1/2" SCH40 X 24"
(x1)



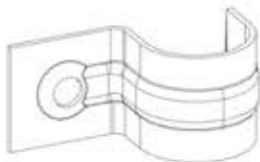
A6P00646 ELBOW 1/2" NPT
(x2)



A6P00649 THREADED PIPE
CONNECTOR
(x1)



A6P00809 PLUMBERS TAPE
(x1)



A4M02385 PIPE CLAMP
(x2)



A6P00648 THREADED HOSE FITTING
(x1)



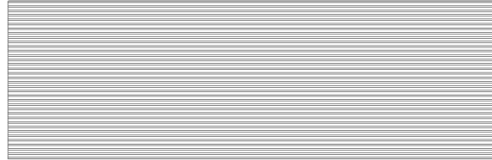
A6P00577 RUBBER GROMMET
(x1)

OWNER'S MANUAL - PARTS IDENTIFICATION

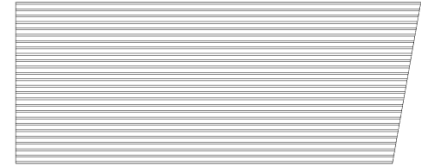
ACCESSORY COMPONENTS (NOT TO SCALE)



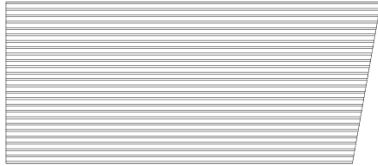
A6P00755 POLY SHEET
(x3)



A6P00758 POLY SHEET
(x2)



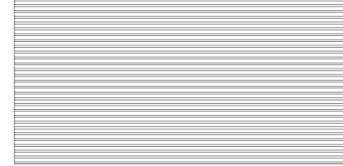
A6P00759 POLY SHEET
(x1)



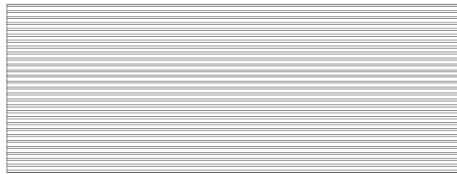
A6P00768 POLY SHEET
(x1)



A6P00769 POLY SHEET
(x1)



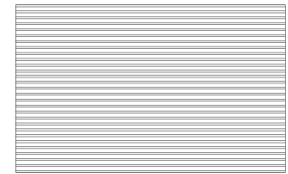
A6P00770 POLY SHEET
(x5)



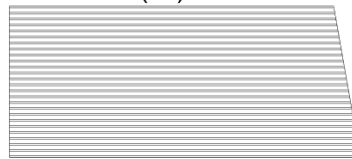
A6P00774 POLY SHEET
(x2)



A6P00777 POLY SHEET
(x1)



A6P00784 POLY SHEET
(x1)



A6P00798 POLY SHEET
(x1)



A6P00757 POLY SHEET SPLICE
(x4)



A6P00760 POLY CHANNEL
(x10)



A6P00766 POLY CHANNEL
(x14)



A6P00761 POLY CHANNEL
(x1)



A6P00762 POLY CHANNEL
(x3)



A6P00763 POLY CHANNEL
(x3)



A6P00764 POLY CHANNEL
(x1)



A6P00765 POLY CHANNEL
(x10)



A6P00767 POLY CHANNEL
(x2)



A6P00775 POLY CHANNEL
(x6)



A6P00778 POLY CHANNEL
(x2)



A6P00779 POLY CHANNEL
(x4)



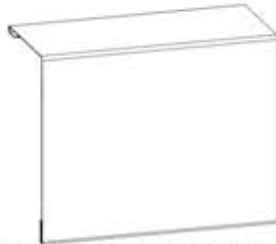
A6P00783 POLY CHANNEL
(x2)

OWNER'S MANUAL - PARTS IDENTIFICATION

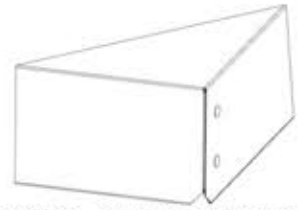
ACCESSORY COMPONENTS (NOT TO SCALE)



A4M02516 EDGE TRIM SPLICE
(x1)



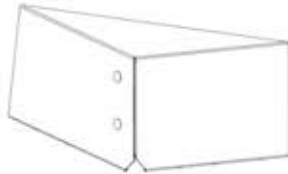
A4M02521 EDGE TRIM SPLICE
(x1)



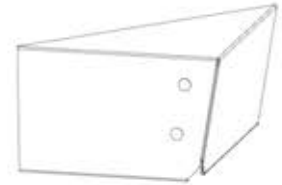
A4M02522 CORNER SPLICE TRIM
(x1)



A4M02523 CORNER SPLICE TRIM
(x1)



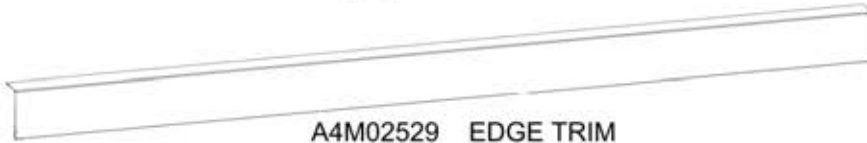
A4M02524 CORNER SPLICE TRIM
(x1)



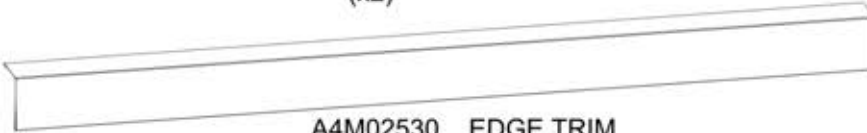
A4M02525 CORNER SPLICE TRIM
(x1)



A4M02528 EDGE TRIM
(x2)



A4M02529 EDGE TRIM
(x2)

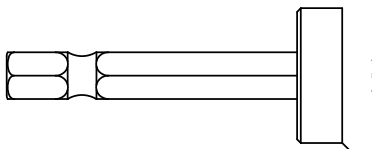


A4M02530 EDGE TRIM
(x2)

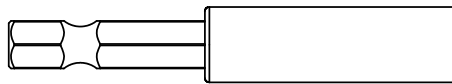


A4M02527 SPLICE COVER
(x4)

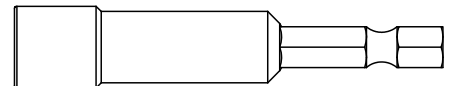
HARDWARE COMPONENTS (NOT TO SCALE)



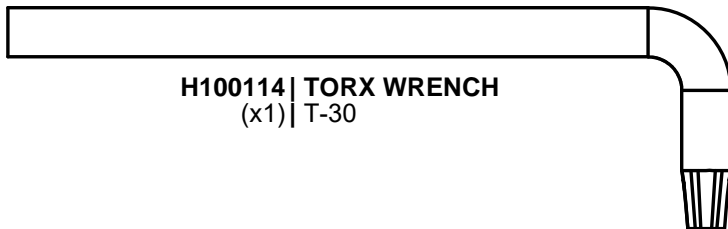
H100764 | SCREW SETTER
(x1)



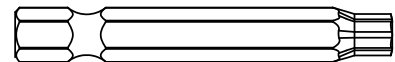
H101100 | MAGNETIC DRIVER
(x1)



H101106 | SOCKET DRIVER
(x1)



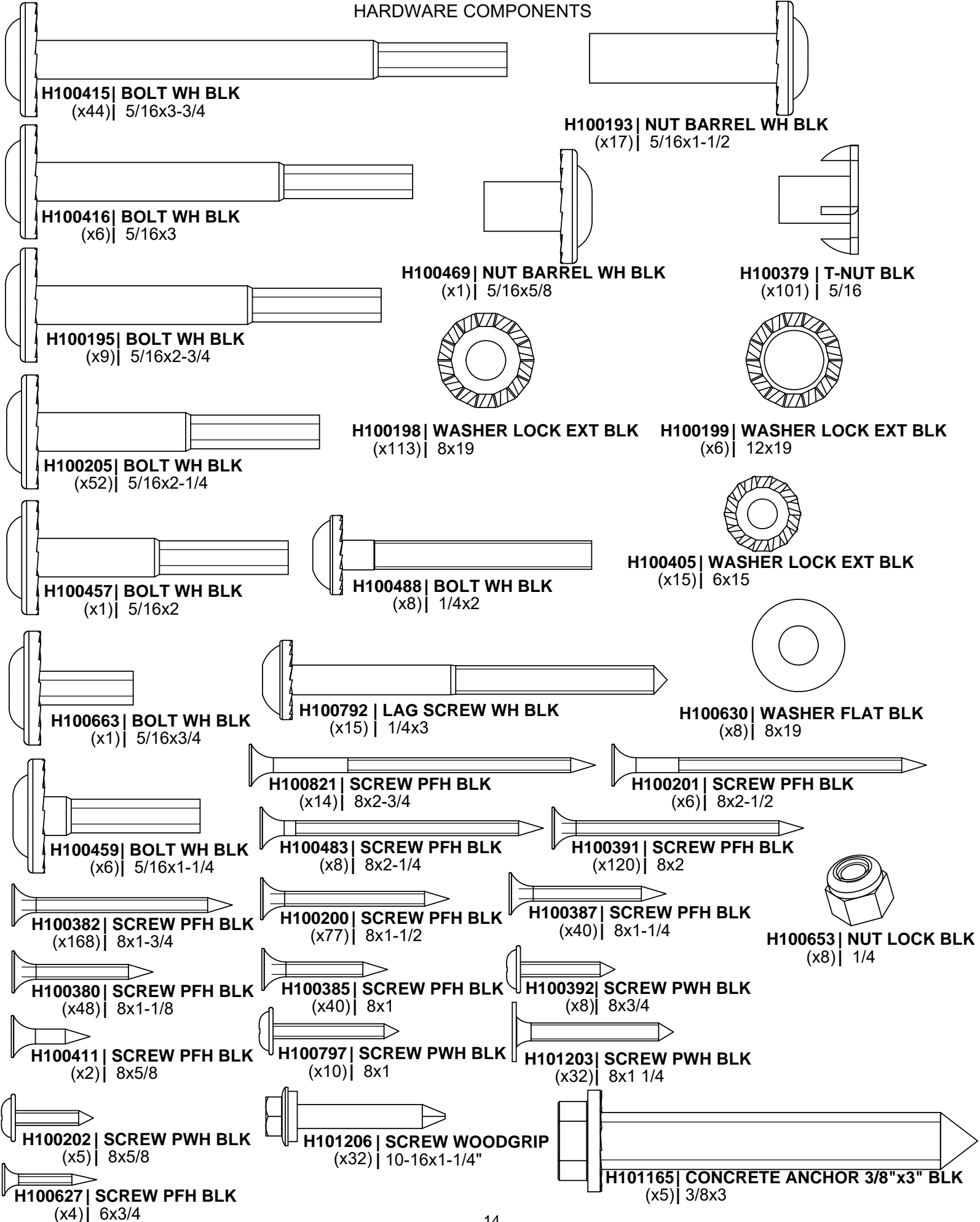
H100114 | TORX WRENCH
(x1) | T-30



H100147 | TORX BIT
(x1) | T-30

OWNER'S MANUAL - PARTS IDENTIFICATION

HARDWARE COMPONENTS



PRE-ASSEMBLY STEP 1 - SORTING PARTS

It is critical for ease of assembly that you take the time to sort and organize the wood and hardware.

WOOD PARTS:

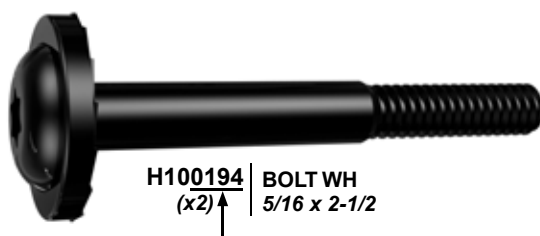
- Organize wood parts by the three-digit, alpha-numeric number stamped on each board (ex. P01).
- If there are multiple boards with the same stamped number, stack those pieces together.
- Stamps can be found on the flat surface of the boards or on the end of the boards.
- Allow yourself plenty of room - the wood pieces can take up a significant amount of space.

NOTE: CARTONS ARE NOT ORGANIZED BY BOARD NUMBER.



HARDWARE PARTS:

- We recommend that you have a separate table to organize the hardware.
- Hardware bags are printed with a seven-digit, alpha-numeric part number.
- You can organize your hardware by part number or group by hardware type (i.e. bolts, nuts, etc.).
- During assembly you only need to reference the last four digits of the number.



H100194 | BOLT WH
(x2) ↑ 5/16 x 2-1/2

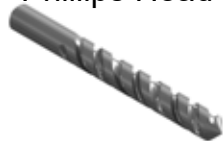
PRE-ASSEMBLY STEP 2 - TOOLS REQUIRED



Cordless Drill
or Electric Drill



Drill
Attachments:
Phillips Head



1/8", 3/16", 3/8" &
7/16" Drill Bits



Phillips Screw Driver



Open End
Wrenches 1/2" &
9/16"



3/8" Drive Ratchet, 1/2" &
7/16" STD Sockets 1/2" & 7/16"
Deep Sockets



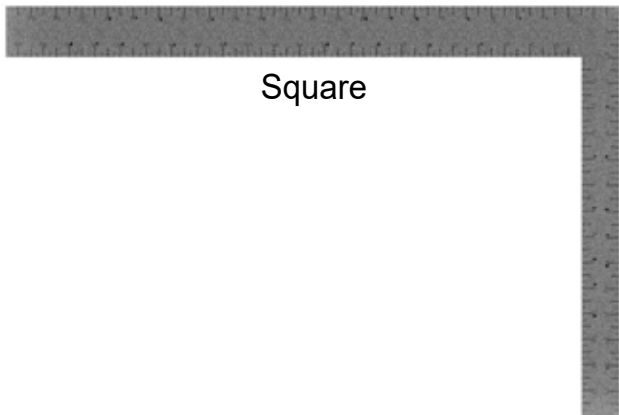
Claw Hammer



Rubber Mallet
- Optional



Tape Measure



Square




Level 24"

PRE-ASSEMBLY STEP 3 - CHOOSE YOUR ASSEMBLY METHOD

There are several types of assembly instructions available to you.

1. Printed Assembly Manual included with your set
2. BILT APP - 3D interactive instructions
3. Combination of the Printed Manual and BILT APP (Note: Step numbers can differ between the two methods)



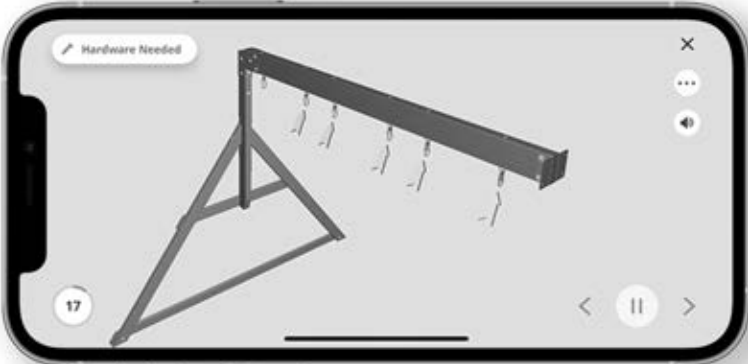
BILT.

Scan for easy
3D instructions

Download the BILT app
before you begin

Download on the
App Store

GET IT ON
Google Play



The image shows a smartphone screen displaying a 3D assembly instruction. The screen features a 3D model of a metal frame with a horizontal beam and several hanging components. A 'Hardware Needed' button is visible in the top left corner of the app interface. The number '17' is shown in a small circle in the bottom left corner. Navigation icons for back, play/pause, and forward are visible at the bottom of the screen.

STEP 4A - SIDE WALL ASSEMBLY

QTY	PART NUMBER	DESCRIPTION
20	H100198	WASHER LOCK EXT 8x19
12	H100205	BOLT WH 5/16x2 1/4 BLK
20	H100379	TNUT-5/16" BLK
8	H100415	BOLT WH 5/16x3 3/4 BLK

B01 POST - W4L19181
(x1) 3"x3"x89 5/16" (76x76x2269)

B02 POST - W4L19184
(x1) 3"x3"x76 13/16" (76x76x1951)

F01 SIDE UPRIGHT - W4L19182
(x1) 1 7/16"x2 3/8"x85 3/8" (36x60x2168)

F02 SIDE UPRIGHT - W4L19183
(x1) 1 7/16"x2 3/8"x81 3/8" (36x60x2068)

SB01 SIDE BEAM - W2A04061
(x1) 15/16"x8 7/16"x73 3/8" (24x214x1865)

G01 BASE BOARD - W4L19185
(x1) 15/16"x5 1/4"x70 13/16" (24x134x1799)

H01 RUNNING BOARD - W4L19186
(x1) 15/16"x3 3/8"x70 13/16" (24x86x1799)

ENSURE CORRECT ORIENTATION OF B01 AND B02 AS SHOWN.

INSERT T-NUTS FIRST. HAND TIGHTEN ONLY.

ENSURE CORRECT ORIENTATION OF F01 AND F02.

SB01 (x1)
SIDE BEAM

F02 (x1)
SIDE UPRIGHT

B02 (x1)
POST

415 (x8)
BOLT - 3 3/4"

198 (x20)
WASHER - 8x19

379 (x20)
TNUT-5/16"

**PILOT HOLES ON H01
FACE UP AS SHOWN.**

B01 (x1)
POST

F01 (x1)
SIDE UPRIGHT

205 (x12)
BOLT - 2 1/4"

H01 (x1)
RUNNING BOARD

G01 (x1)
BASE BOARD

STEP 4B - SIDE WALL ASSEMBLY

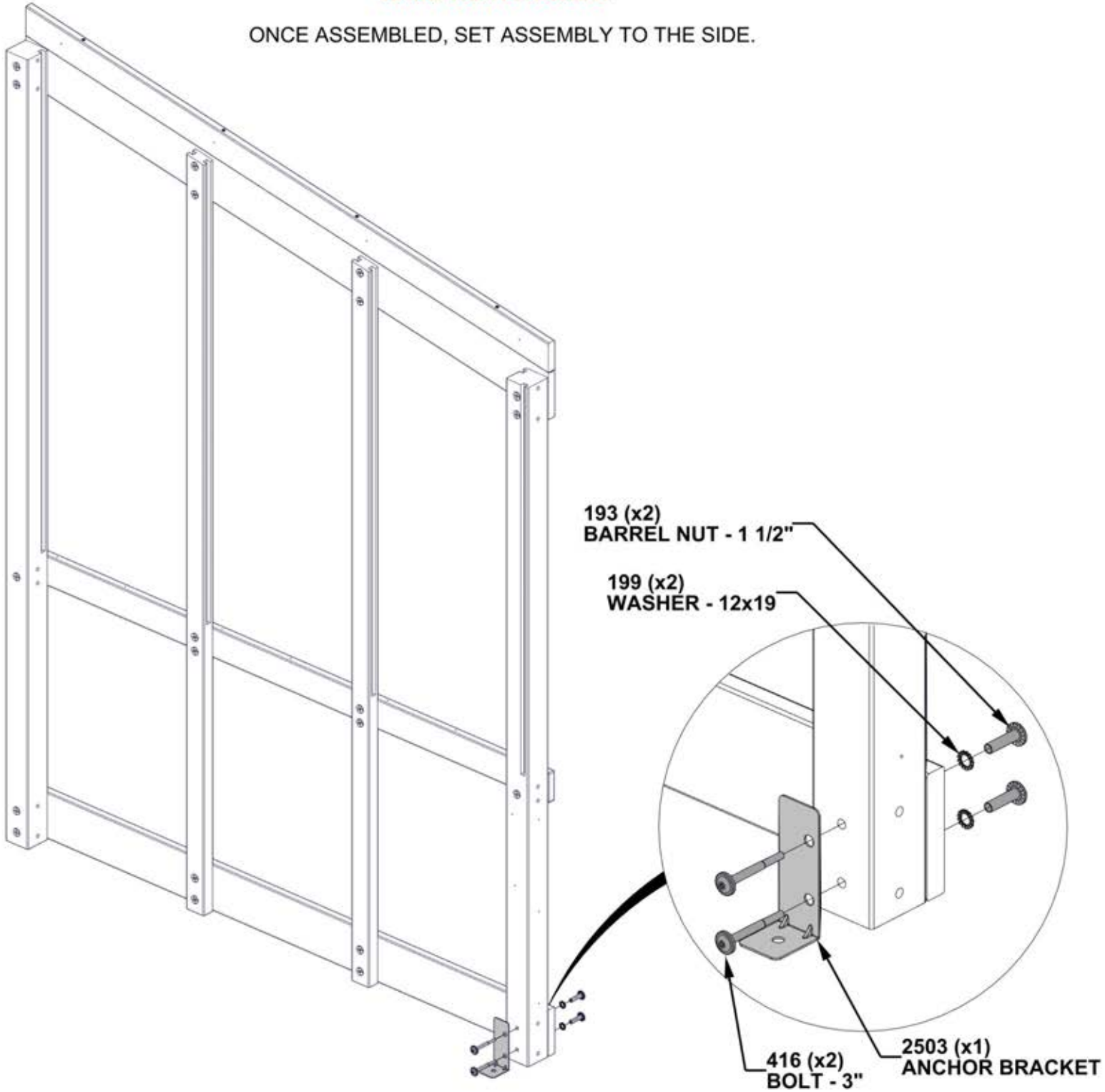
QTY	PART NUMBER	DESCRIPTION
2	H100193	NUT BARREL WH 5/16 X 1 1/2 BLK
2	H100199	WASHER LOCK EXT 12x19
2	H100416	BOLT WH 5/16x3 BLK



A4M02503 ANCHOR BRACKET
(x1)

HAND TIGHTEN ONLY.

ONCE ASSEMBLED, SET ASSEMBLY TO THE SIDE.



193 (x2)
BARREL NUT - 1 1/2"

199 (x2)
WASHER - 12x19

416 (x2)
BOLT - 3"

2503 (x1)
ANCHOR BRACKET

STEP 5A - BACK WALL ASSEMBLY

QTY	PART NUMBER	DESCRIPTION
16	H100198	WASHER LOCK EXT 8x19
16	H100205	BOLT WH 5/16x2 1/4 BLK
16	H100379	TNUT-5/16" BLK

BB01 BACK BEAM - W2A04064
(x1) 15/16"x8 7/16"x68 3/4" (24x214x1746)

BB02 BACK BEAM - W2A04065
(x1) 15/16"x8 7/16"x47 3/8" (24x214x1204)

G02 BASE BOARD - W4L19194
(x1) 15/16"x5 1/4"x67 15/16" (24x134x1726)

G03 BASE BOARD - W4L19195
(x1) 15/16"x5 1/4"x46 5/8" (24x134x1184)

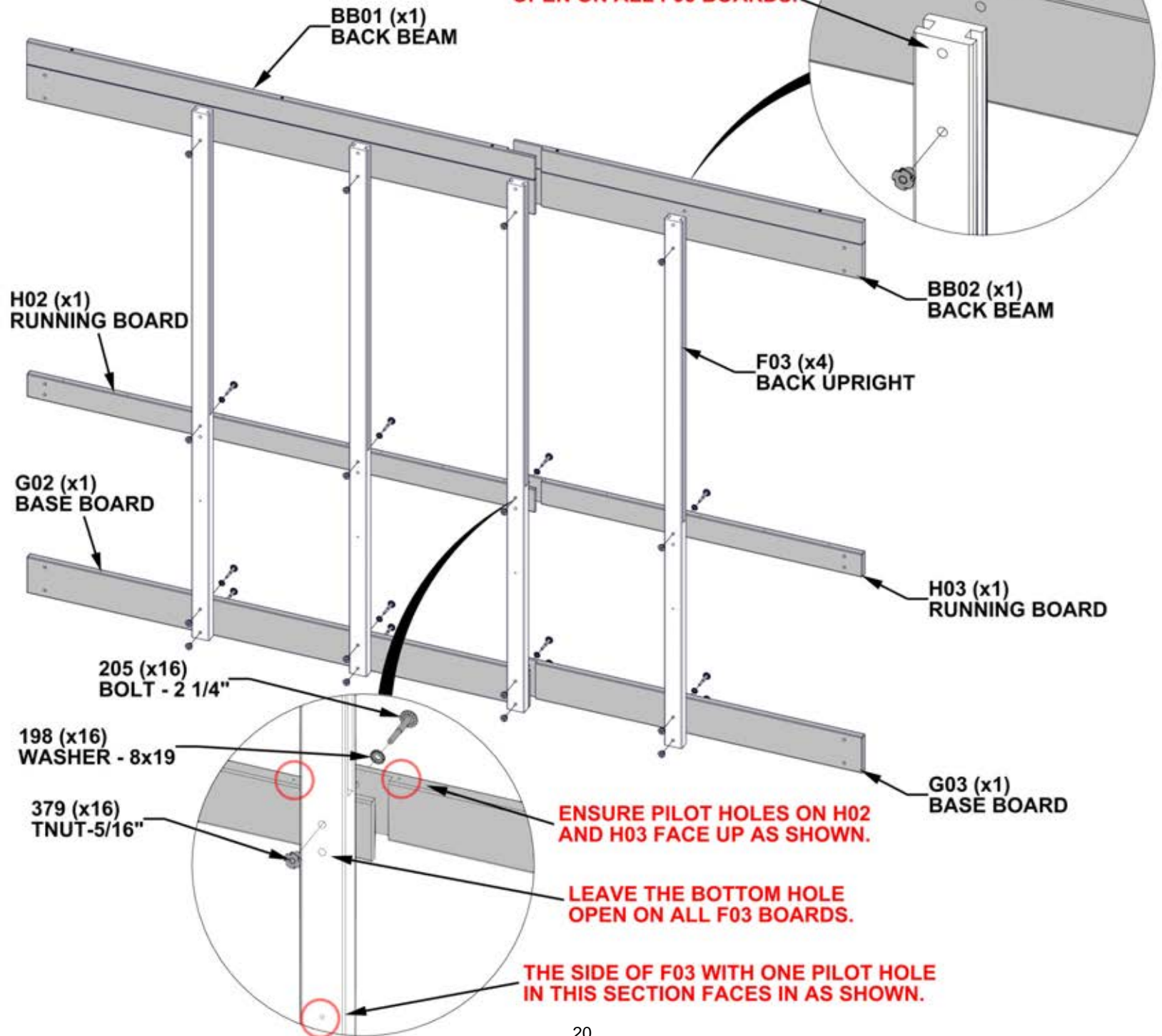
F03 BACK UPRIGHT - W4L19191
(x4) 1 7/16"2 3/8"x76 13/16" (36x60x1951)

H02 RUNNING BOARD - W4L19192
(x1) 15/16"x3 3/8"x68 3/4" (24x86x1746)

H03 RUNNING BOARD - W4L19193
(x1) 15/16"x3 3/8"x47 3/8" (24x86x1204)

INSERT T-NUTS FIRST. HAND TIGHTEN ONLY.

LEAVE THE TOP HOLE OPEN ON ALL F03 BOARDS.

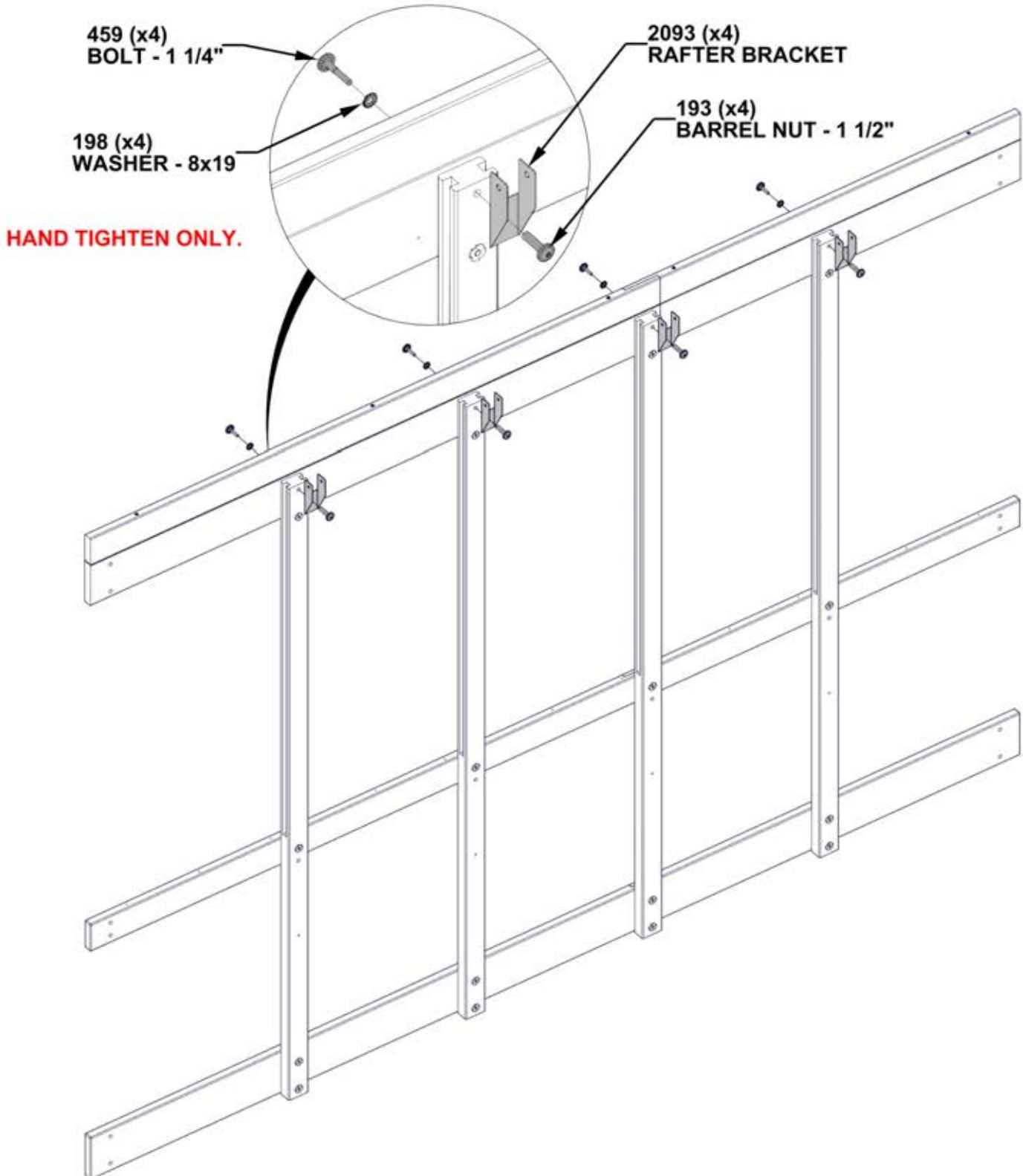


STEP 5B - BACK WALL ASSEMBLY

QTY	PART NUMBER	DESCRIPTION
4	H100193	NUT BARREL WH 5/16 X 1 1/2 BLK
4	H100198	WASHER LOCK EXT 8x19
4	H100459	BOLT WH 5/16x1 1/4 BLK



A4M02093 RAFTER BRACKET
(x4)

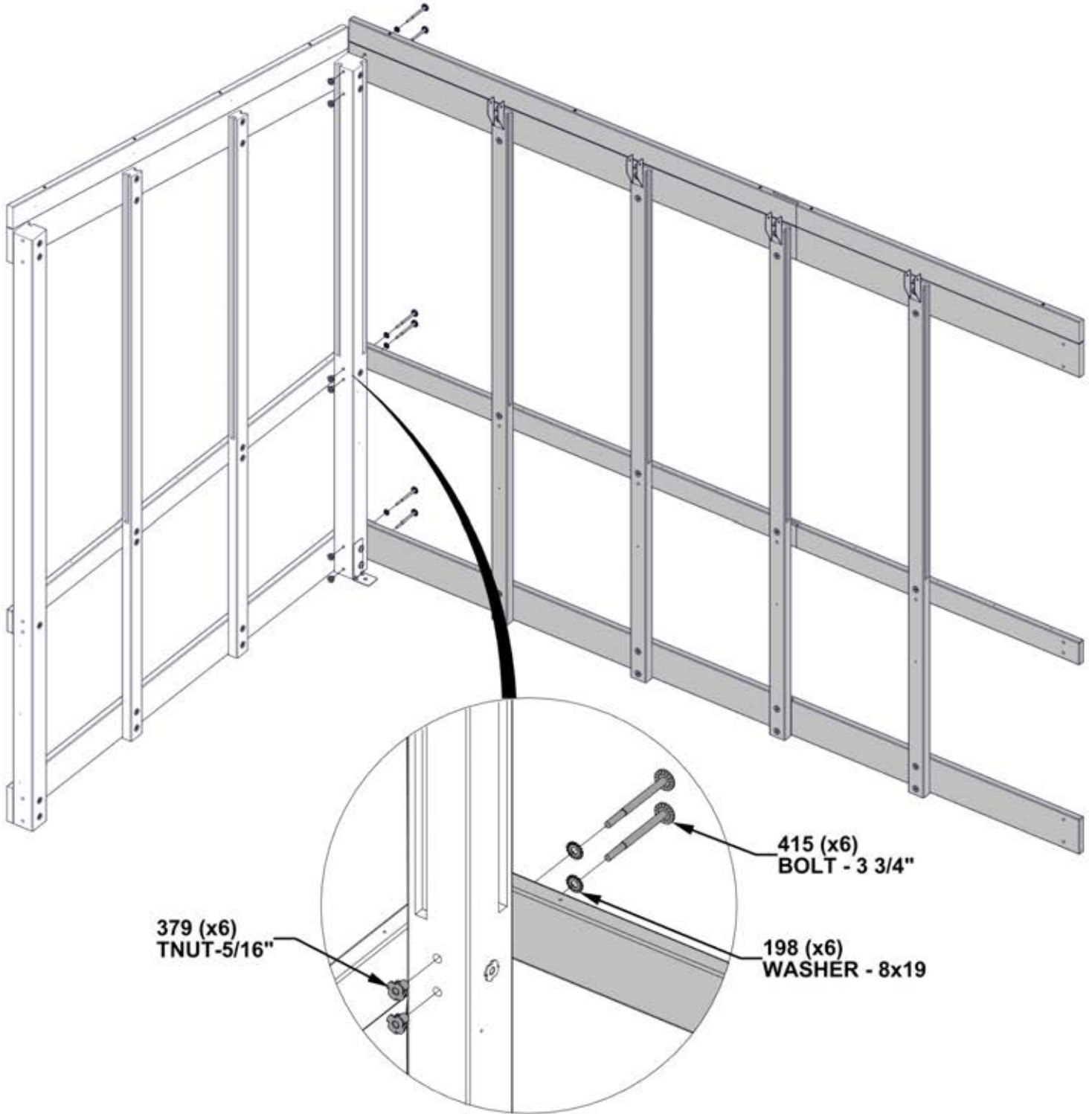


STEP 6 - GREENHOUSE ASSEMBLY

QTY	PART NUMBER	DESCRIPTION
6	H100198	WASHER LOCK EXT 8x19
6	H100379	TNUT-5/16" BLK
6	H100415	BOLT WH 5/16x3 3/4 BLK

HAND TIGHTEN ONLY.

STAND UP THE SIDE AND BACK ASSEMBLIES AND BOLT TOGETHER.



STEP 7A - SIDE WALL ASSEMBLY

QTY	PART NUMBER	DESCRIPTION
16	H100198	WASHER LOCK EXT 8x19
10	H100205	BOLT WH 5/16x2 1/4 BLK
16	H100379	TNUT-5/16" BLK
6	H100415	BOLT WH 5/16x3 3/4 BLK

B05 POST - W4L19223
(x1) 3"x3"x89 5/16" (76x76x2269)

B06 POST - W4L19226
(x1) 3"x3"x76 13/16" (76x76x1951)

F08 SIDE UPRIGHT - W4L19224
(x1) 1 7/16"x2 3/8"x85 3/8" (36x60x2168)

F09 SIDE UPRIGHT - W4L19225
(x1) 1 7/16"x2 3/8"x81 3/8" (36x60x2068)

SB02 SIDE BEAM - W2A04073
(x1) 15/16"x8 7/16"x73 3/8" (24x214x1865)

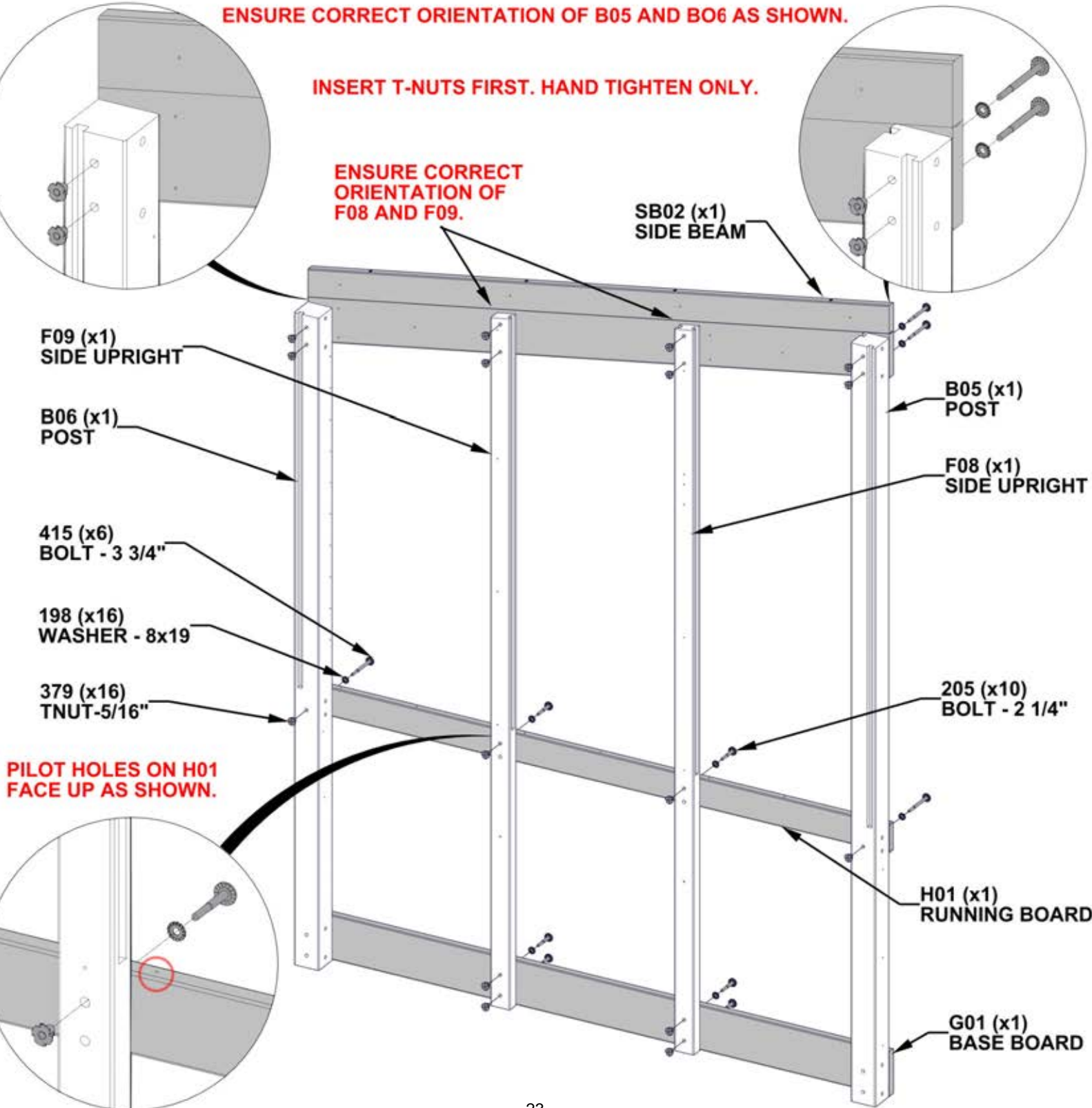
G01 BASE BOARD - W4L19185
(x1) 15/16"x5 1/4"x70 13/16" (24x134x1799)

H01 RUNNING BOARD - W4L19186
(x1) 15/16"x3 3/8"x70 13/16" (24x86x1799)

ENSURE CORRECT ORIENTATION OF B05 AND B06 AS SHOWN.

INSERT T-NUTS FIRST. HAND TIGHTEN ONLY.

ENSURE CORRECT ORIENTATION OF F08 AND F09.



PILOT HOLES ON H01 FACE UP AS SHOWN.

STEP 7B - SIDE WALL ASSEMBLY

QTY	PART NUMBER	DESCRIPTION
4	H100193	NUT BARREL WH 5/16 X 1 1/2 BLK
4	H100199	WASHER LOCK EXT 12x19
4	H100416	BOLT WH 5/16x3 BLK

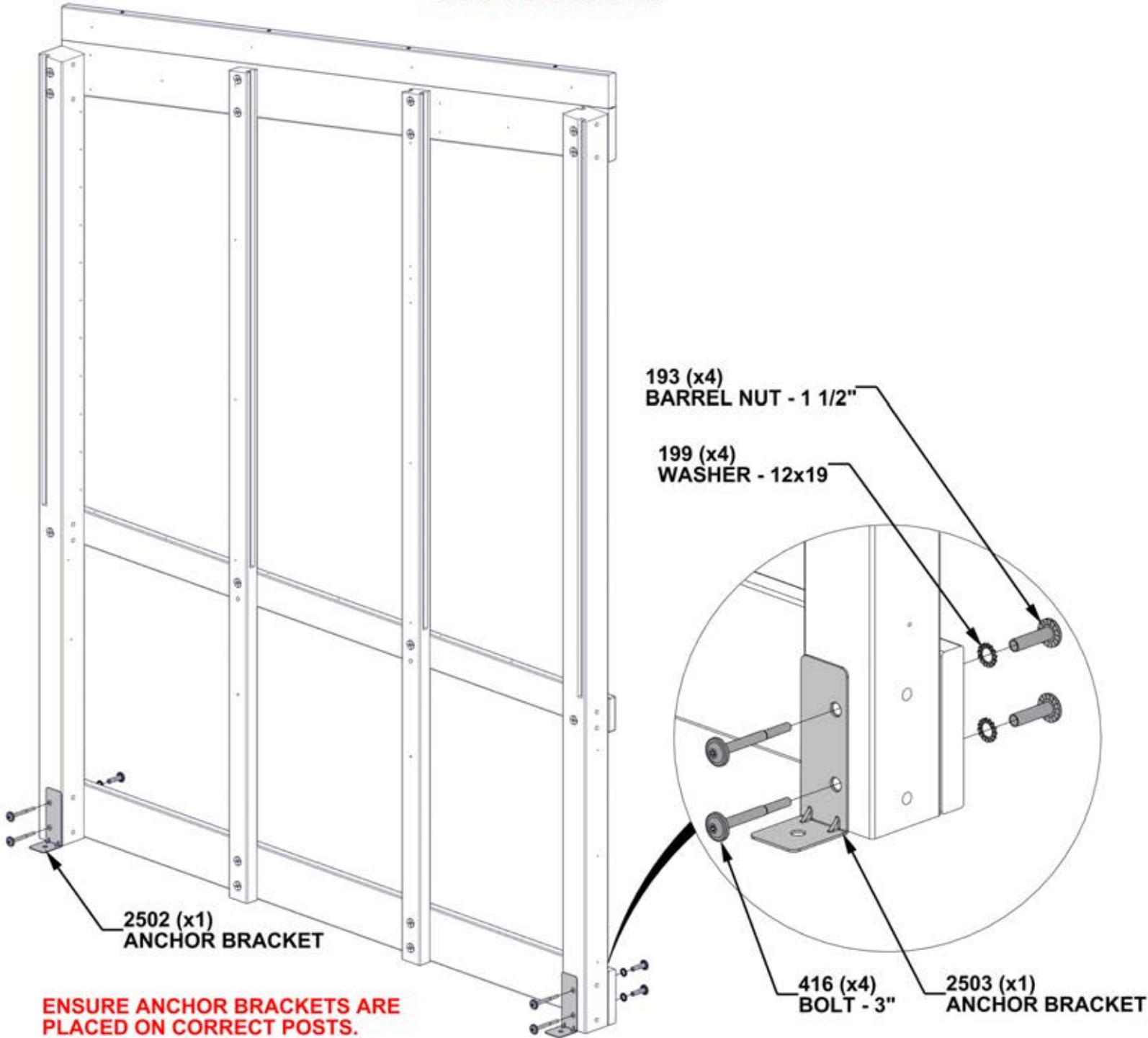


A4M02502 ANCHOR BRACKET (x1)



A4M02503 ANCHOR BRACKET (x1)

HAND TIGHTEN ONLY.

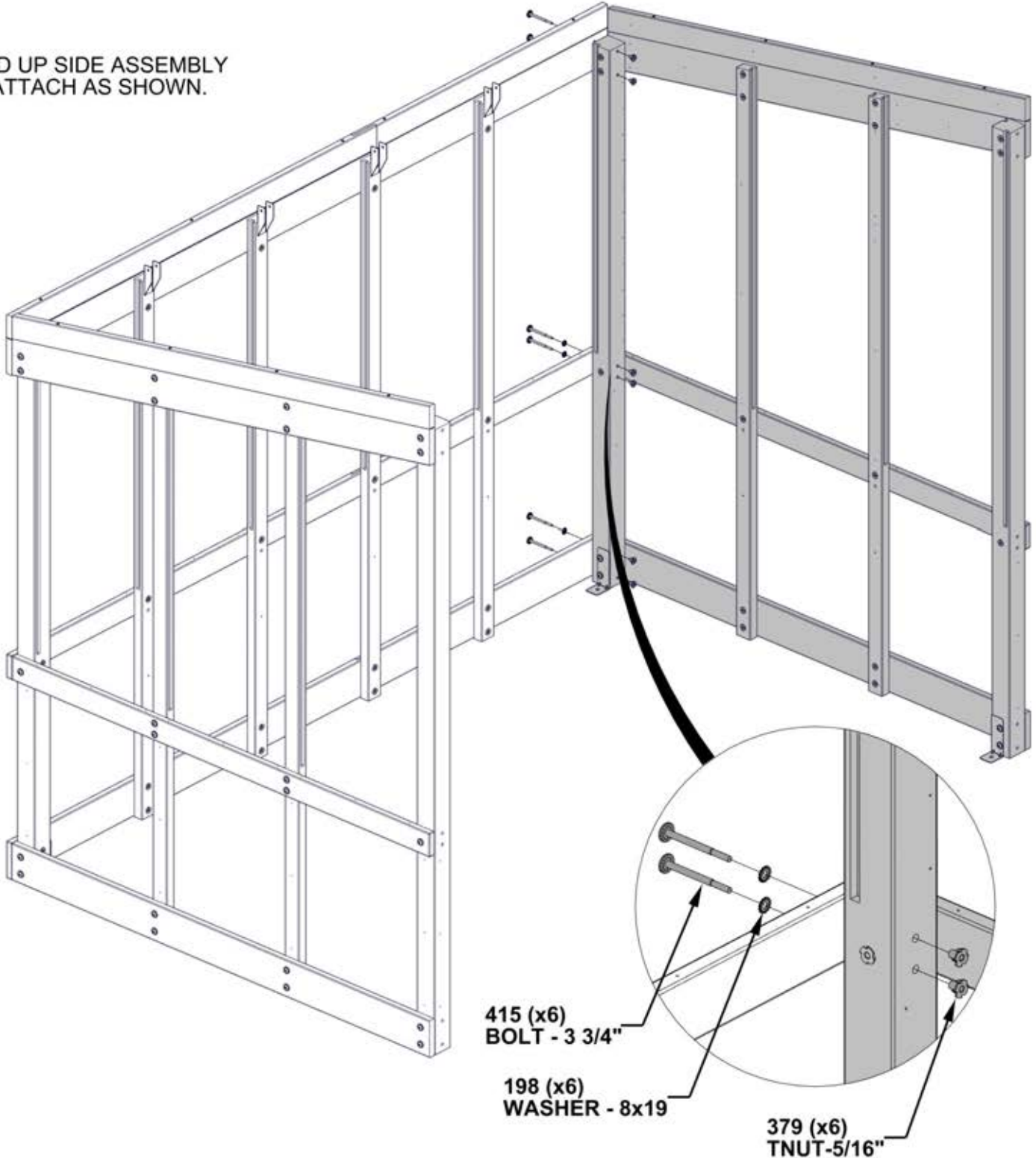


STEP 8 - GREENHOUSE ASSEMBLY

QTY	PART NUMBER	DESCRIPTION
6	H100198	WASHER LOCK EXT 8x19
6	H100379	TNUT-5/16" BLK
6	H100415	BOLT WH 5/16x3 3/4 BLK

HAND TIGHTEN ONLY.

STAND UP SIDE ASSEMBLY
AND ATTACH AS SHOWN.



STEP 9A - FRONT WALL ASSEMBLY

QTY	PART NUMBER	DESCRIPTION
2	H100195	BOLT WH 5/16x2 3/4 BLK
10	H100198	WASHER LOCK EXT 8x19
8	H100205	BOLT WH 5/16x2 1/4 BLK
10	H100379	TNUT-5/16" BLK



B03 POST - W4L19206
(x1) 3"x3"x89 5/16" (76x76x2269)



F06 FRONT UPRIGHT - W4L19205
(x2) 1 7/16"x2 3/8"x89 5/16" (36x60x2269)



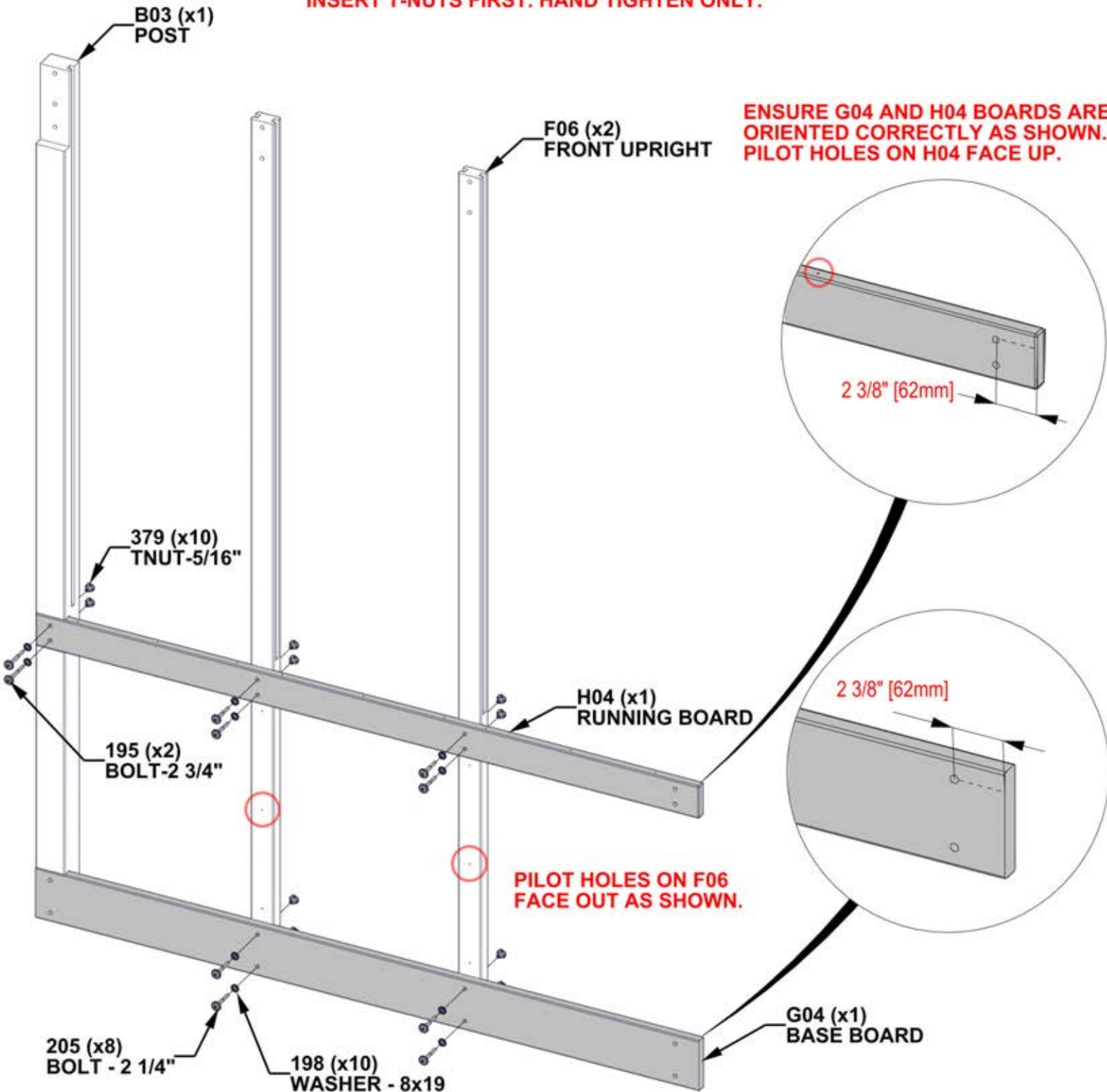
G04 BASE BOARD - W4L19208
(x1) 15/16"x5 1/4"x68 1/4" (24x134x1734)



H04 RUNNING BOARD - W4L19209
(x1) 15/16"x3 3/8"x68 1/4" (24x86x1734)

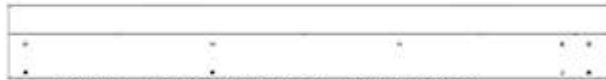
INSERT T-NUTS FIRST. HAND TIGHTEN ONLY.

ENSURE G04 AND H04 BOARDS ARE ORIENTED CORRECTLY AS SHOWN. PILOT HOLES ON H04 FACE UP.



STEP 9B - FRONT WALL ASSEMBLY

QTY	PART NUMBER	DESCRIPTION
1	H100195	BOLT WH 5/16x2 3/4 BLK
3	H100198	WASHER LOCK EXT 8x19
2	H100205	BOLT WH 5/16x2 1/4 BLK
3	H100379	TNUT-5/16" BLK

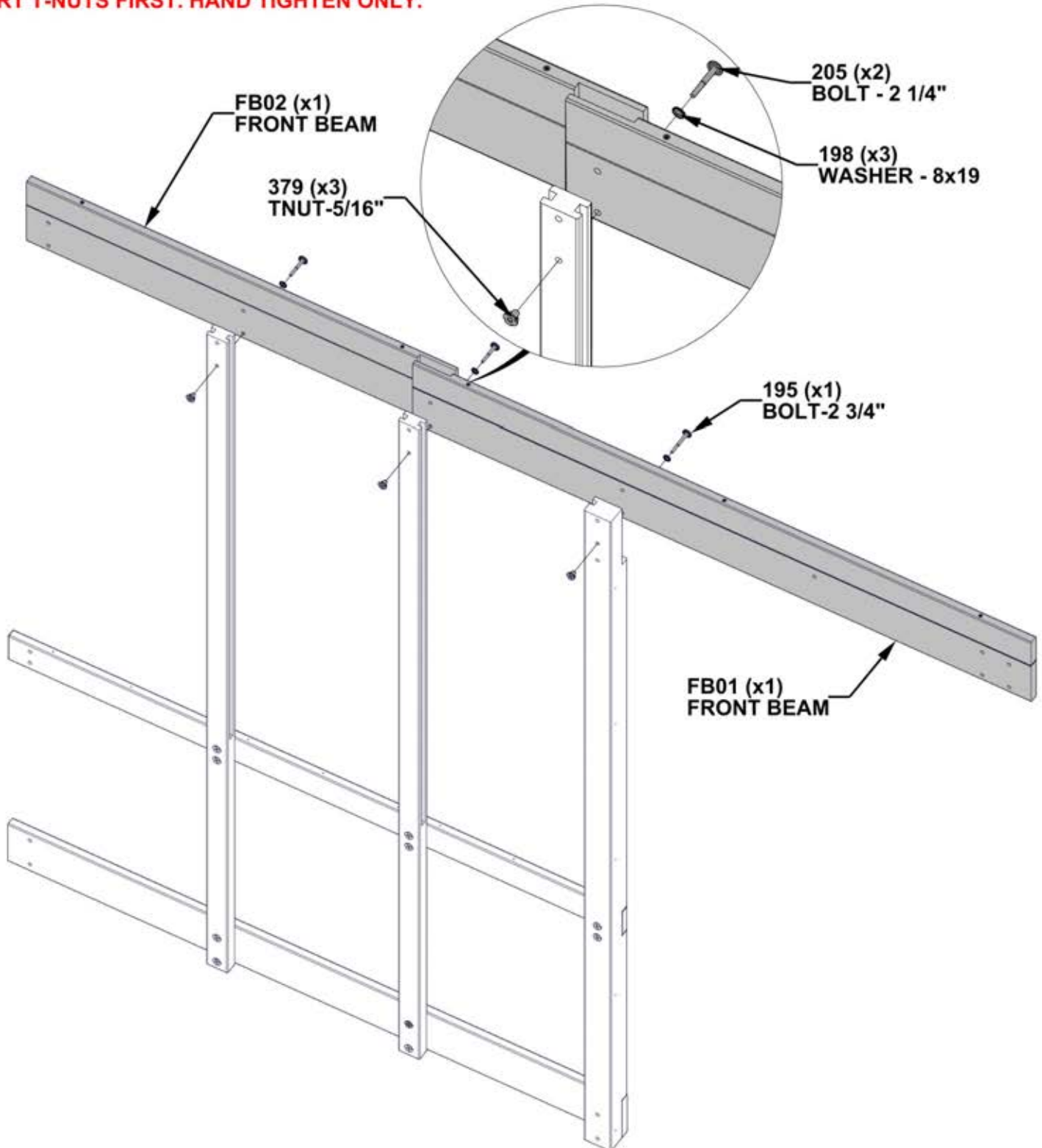


FB01 FRONT BEAM - W2A04070
(x1) 15/16"x8 7/16"x68 3/4" (24x214x1746)



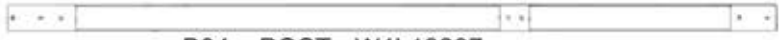
FB02 FRONT BEAM - W2A04071
(x1) 15/16"x8 7/16"x47 3/8" (24x214x1204)

INSERT T-NUTS FIRST. HAND TIGHTEN ONLY.



STEP 9C - FRONT WALL ASSEMBLY

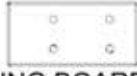
QTY	PART NUMBER	DESCRIPTION
4	H100193	NUT BARREL WH 5/16 X 1 1/2 BLK
4	H100195	BOLT WH 5/16x2 3/4 BLK
8	H100198	WASHER LOCK EXT 8x19
4	H100205	BOLT WH 5/16x2 1/4 BLK
4	H100379	TNUT-5/16" BLK



B04 POST - W4L19207
(x1) 3"x3"x89 5/16" (76x76x2269)



G05 BASE BOARD - W4L19212
(x1) 15/16"x5 1/4"x6 15/16" (24x134x176)



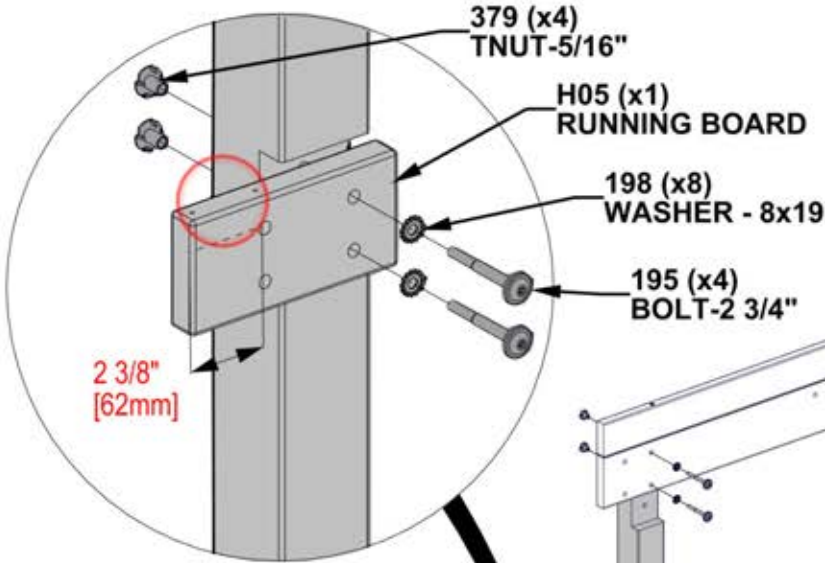
H05 RUNNING BOARD - W4L19211
(x1) 15/16"x3 3/8"x6 15/16" (24x86x176)



A4M02526 DOOR BRACKET
(x1)

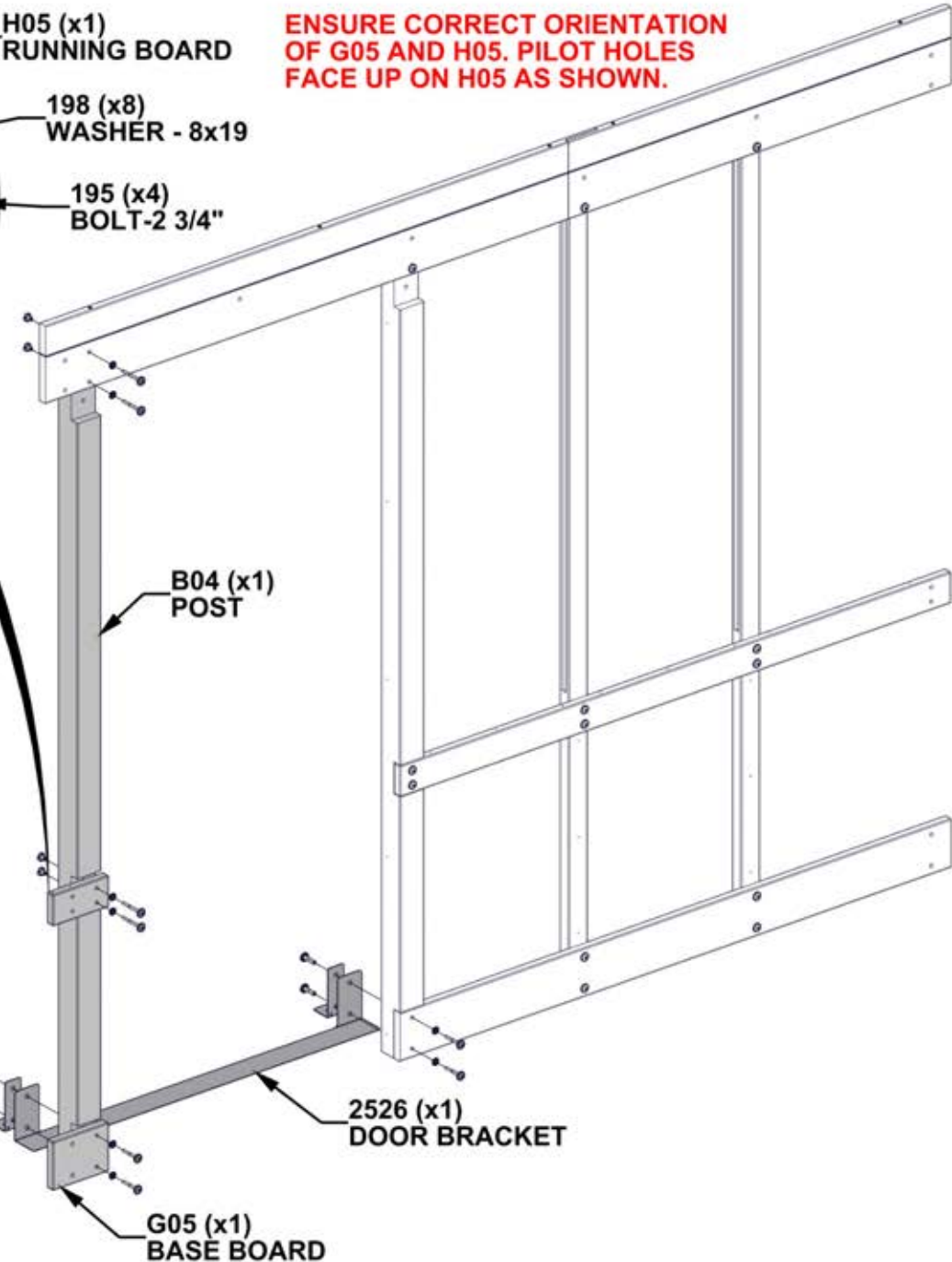
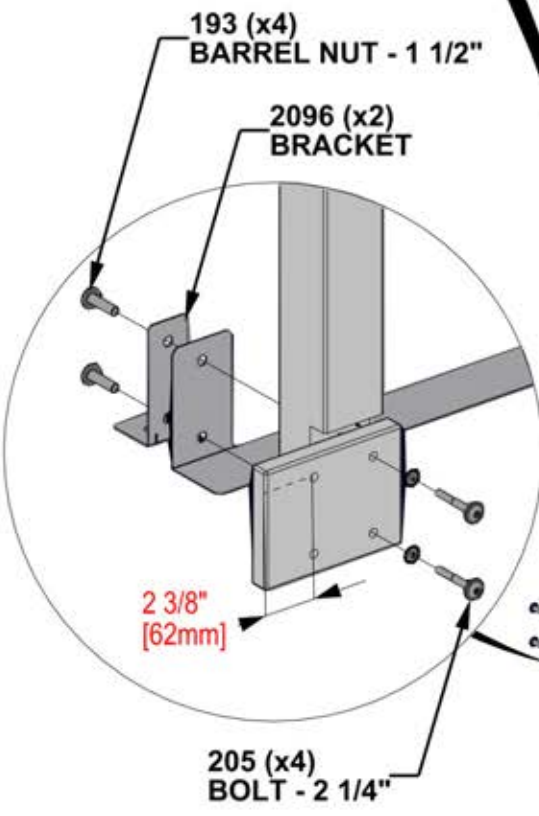


A4M02096 BRACKET
(x2)



INSERT T-NUTS FIRST. HAND TIGHTEN ONLY.

ENSURE CORRECT ORIENTATION OF G05 AND H05. PILOT HOLES FACE UP ON H05 AS SHOWN.



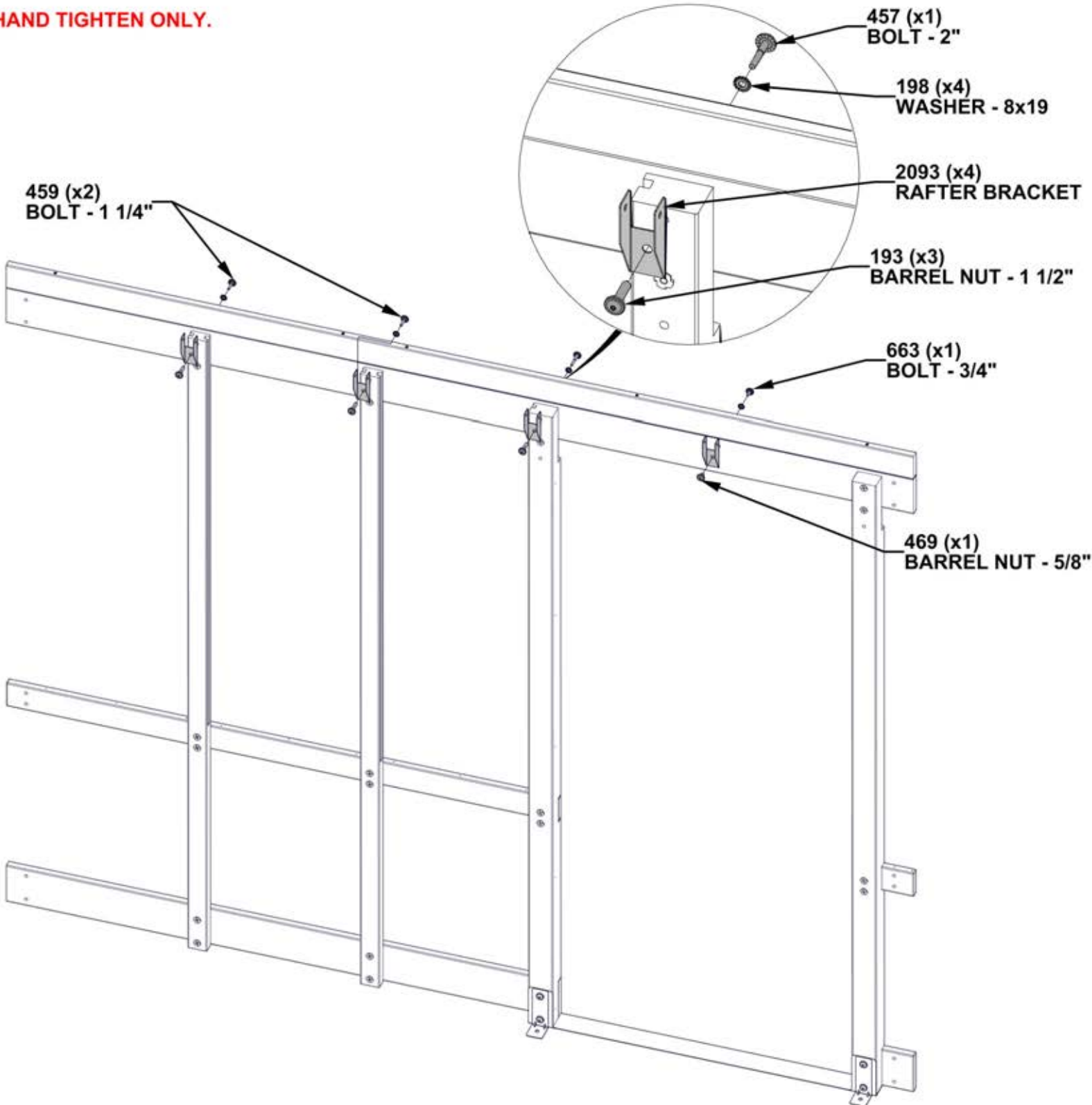
STEP 9D - FRONT WALL ASSEMBLY

QTY	PART NUMBER	DESCRIPTION
3	H100193	NUT BARREL WH 5/16 X 1 1/2 BLK
4	H100198	WASHER LOCK EXT 8x19
1	H100457	BOLT WH 5/16x2 BLK
2	H100459	BOLT WH 5/16x1 1/4 BLK
1	H100469	NUT BARREL WH 5/16X5/8 BLK
1	H100663	BOLT WH 5/16x3/4 BLK



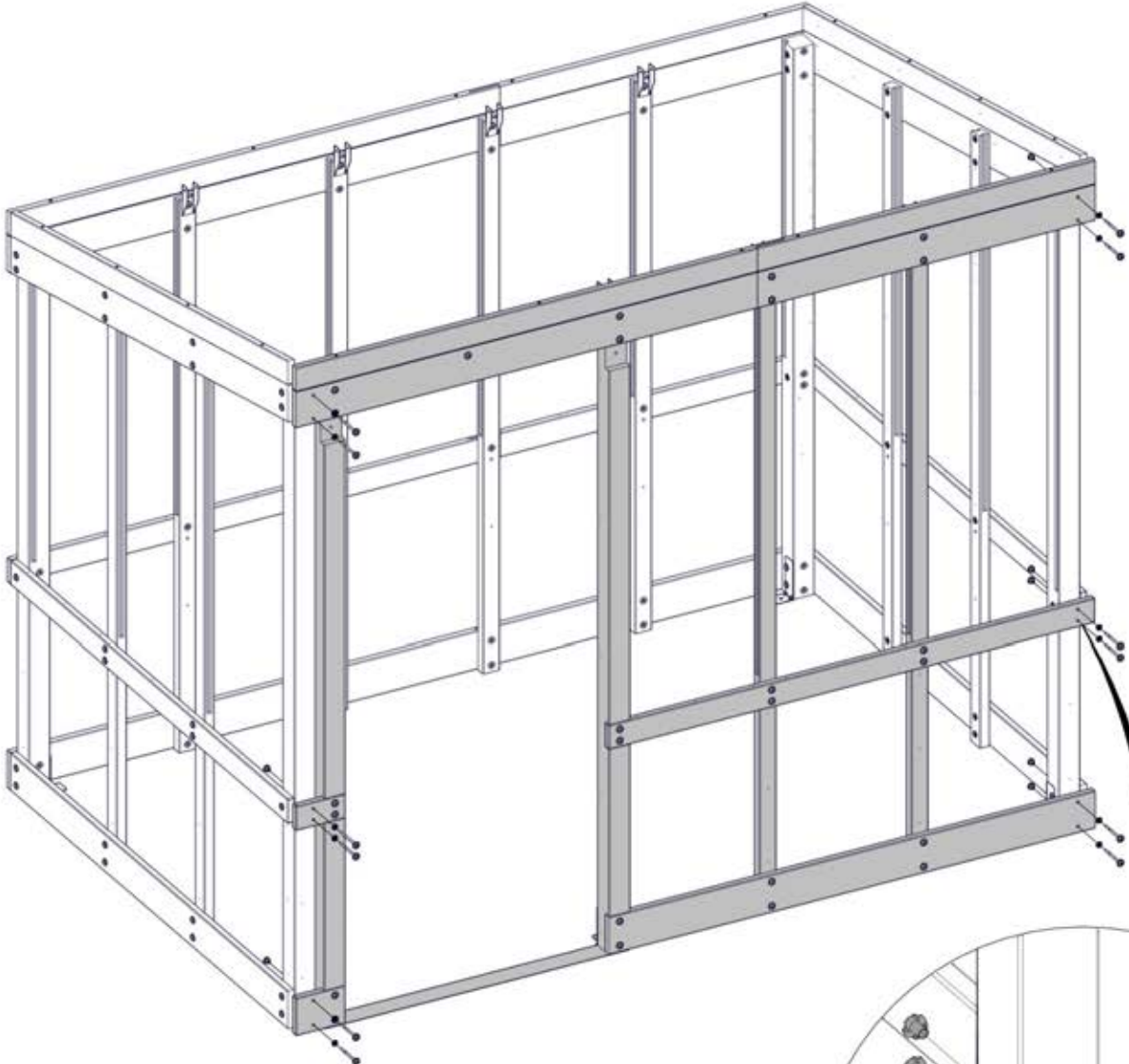
A4M02093 (x4) RAFTER BRACKET

HAND TIGHTEN ONLY.



STEP 10 - GREENHOUSE ASSEMBLY

QTY	PART NUMBER	DESCRIPTION
12	H100198	WASHER LOCK EXT 8x19
12	H100379	TNUT-5/16" BLK
12	H100415	BOLT WH 5/16x3 3/4 BLK



INSERT T-NUTS FIRST. HAND TIGHTEN ONLY.

379 (x12)
TNUT-5/16"

198 (x12)
WASHER - 8x19

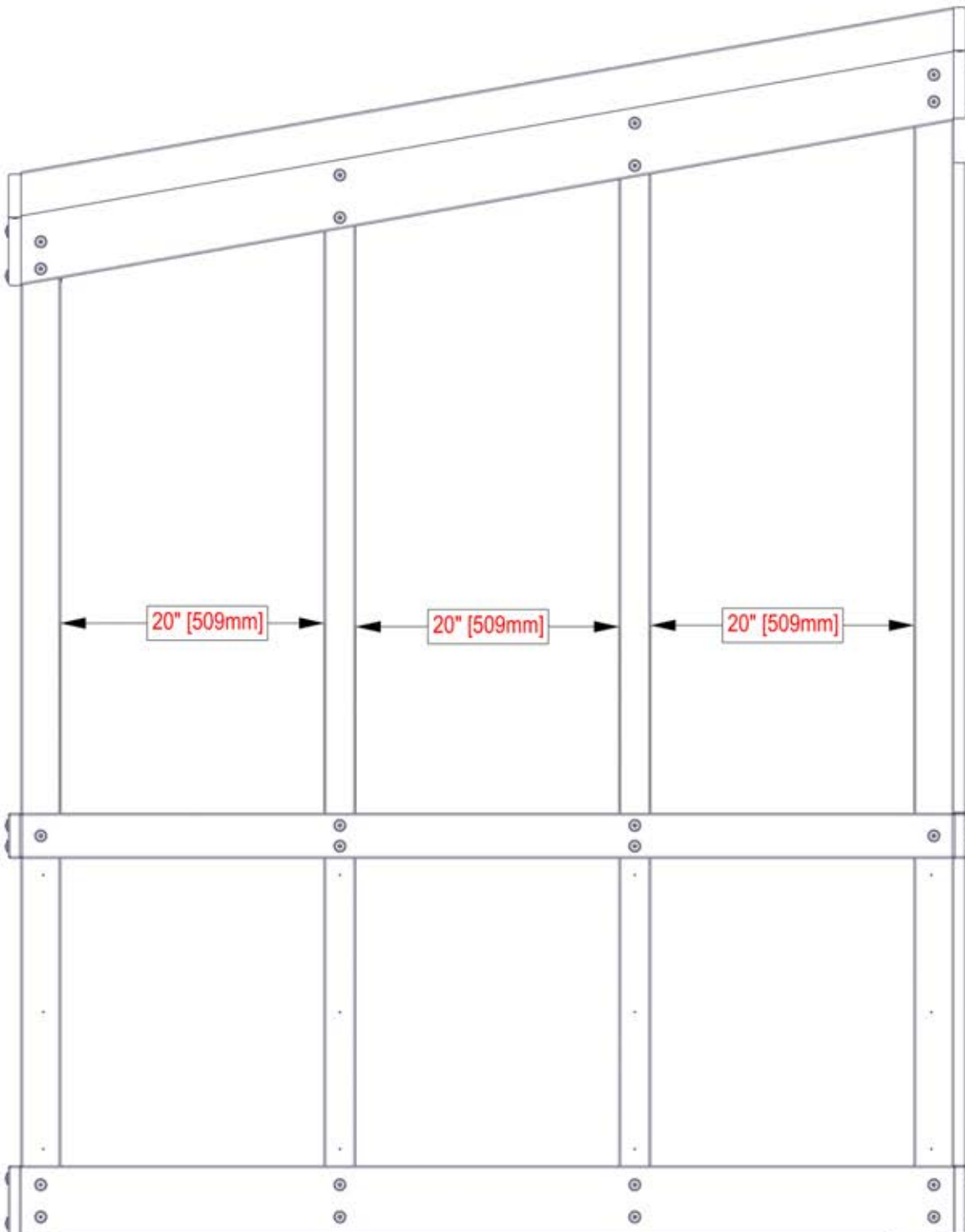
415 (x12)
BOLT - 3 3/4"

STEP 11A - GREENHOUSE ASSEMBLY

IMPORTANT!

STARTING WITH THIS SIDE, ENSURE THAT:

- POSTS AND UPRIGHTS ARE PLUMB (STRAIGHT UP AND DOWN) WITH A LEVEL.
- MEASUREMENTS BETWEEN POSTS AND UPRIGHTS ARE 20" [509mm] AS SHOWN.
- RUNNING AND BASE BOARDS ARE SQUARED TO THE UPRIGHTS.
- ALL HARDWARE ON THIS SIDE IS FULLY TIGHTENED.

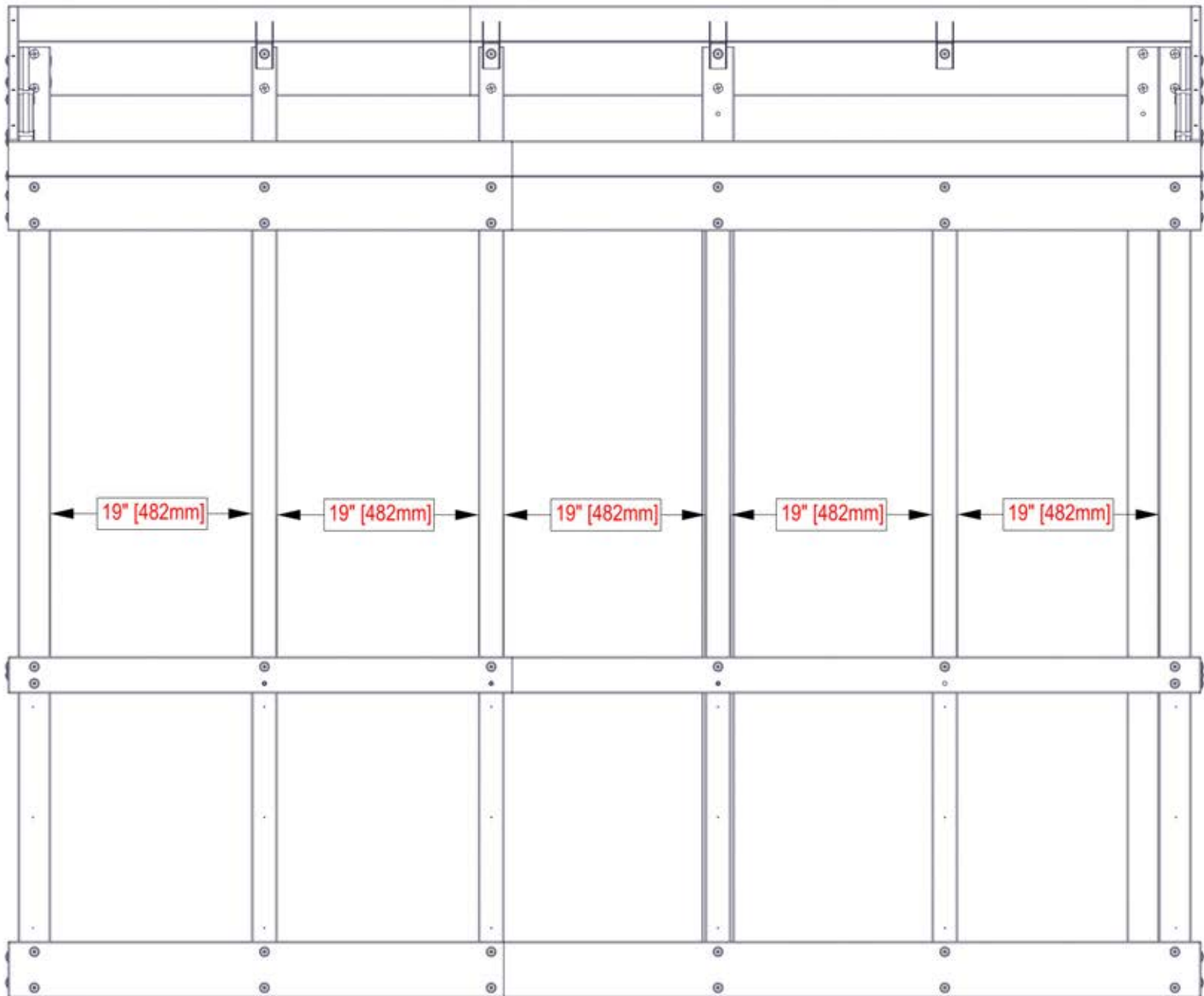


STEP 11B - GREENHOUSE ASSEMBLY

IMPORTANT!

GOING TO THE BACK SIDE, ENSURE THAT:

- POSTS AND UPRIGHTS ARE PLUMB (STRAIGHT UP AND DOWN) WITH A LEVEL.
- MEASUREMENTS BETWEEN POSTS AND UPRIGHTS ARE 19" [482mm] AS SHOWN.
- RUNNING AND BASE BOARDS ARE SQUARED TO THE UPRIGHTS.
- ALL HARDWARE ON THIS SIDE IS FULLY TIGHTENED.

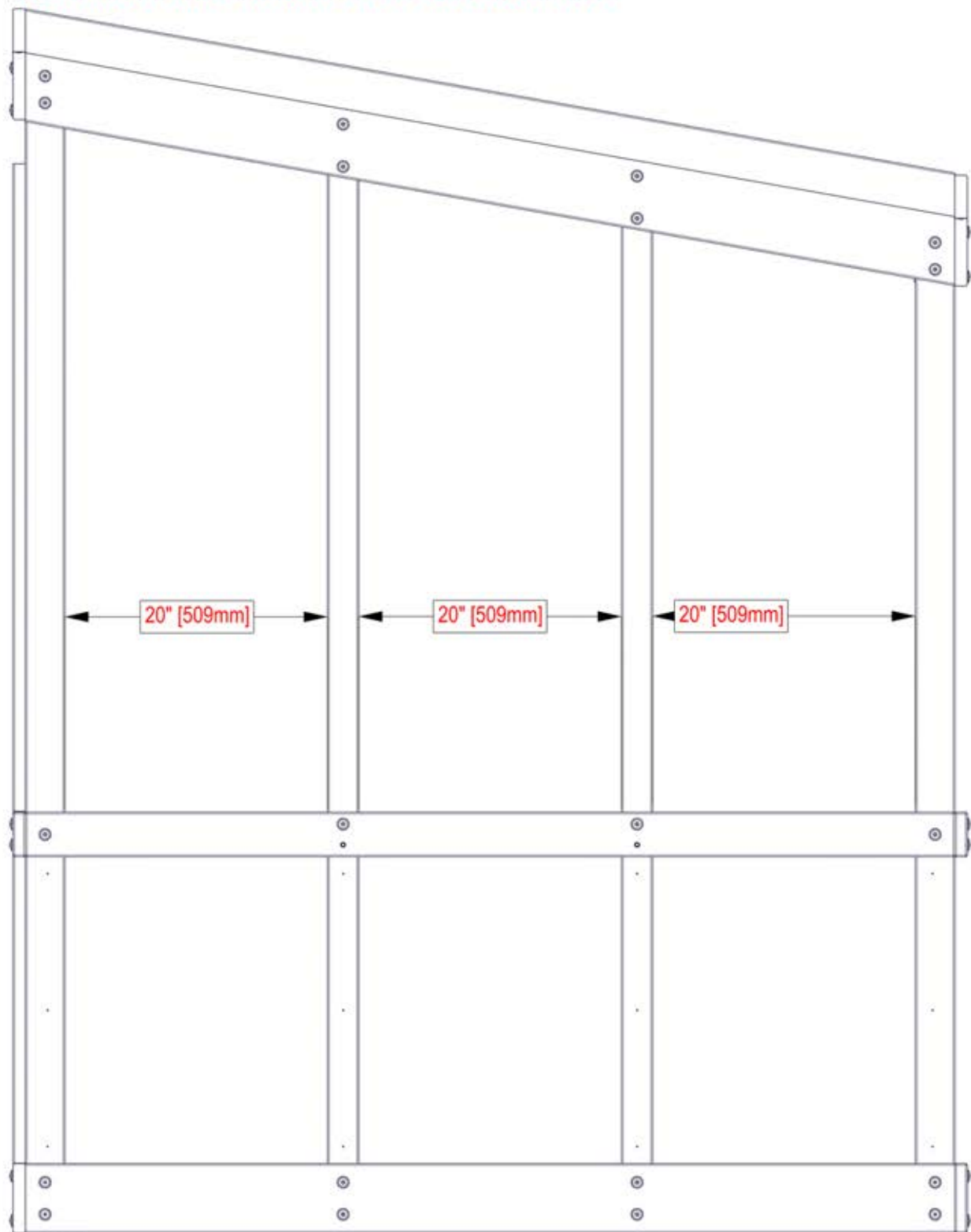


STEP 11C - GREENHOUSE ASSEMBLY

IMPORTANT!

GOING TO THE NEXT SIDE, ENSURE THAT:

- POSTS AND UPRIGHTS ARE PLUMB (STRAIGHT UP AND DOWN) WITH A LEVEL.
- MEASUREMENTS BETWEEN POSTS AND UPRIGHTS ARE 20" [509mm] AS SHOWN.
- RUNNING AND BASE BOARDS ARE SQUARED TO THE UPRIGHTS.
- ALL HARDWARE ON THIS SIDE IS FULLY TIGHTENED.

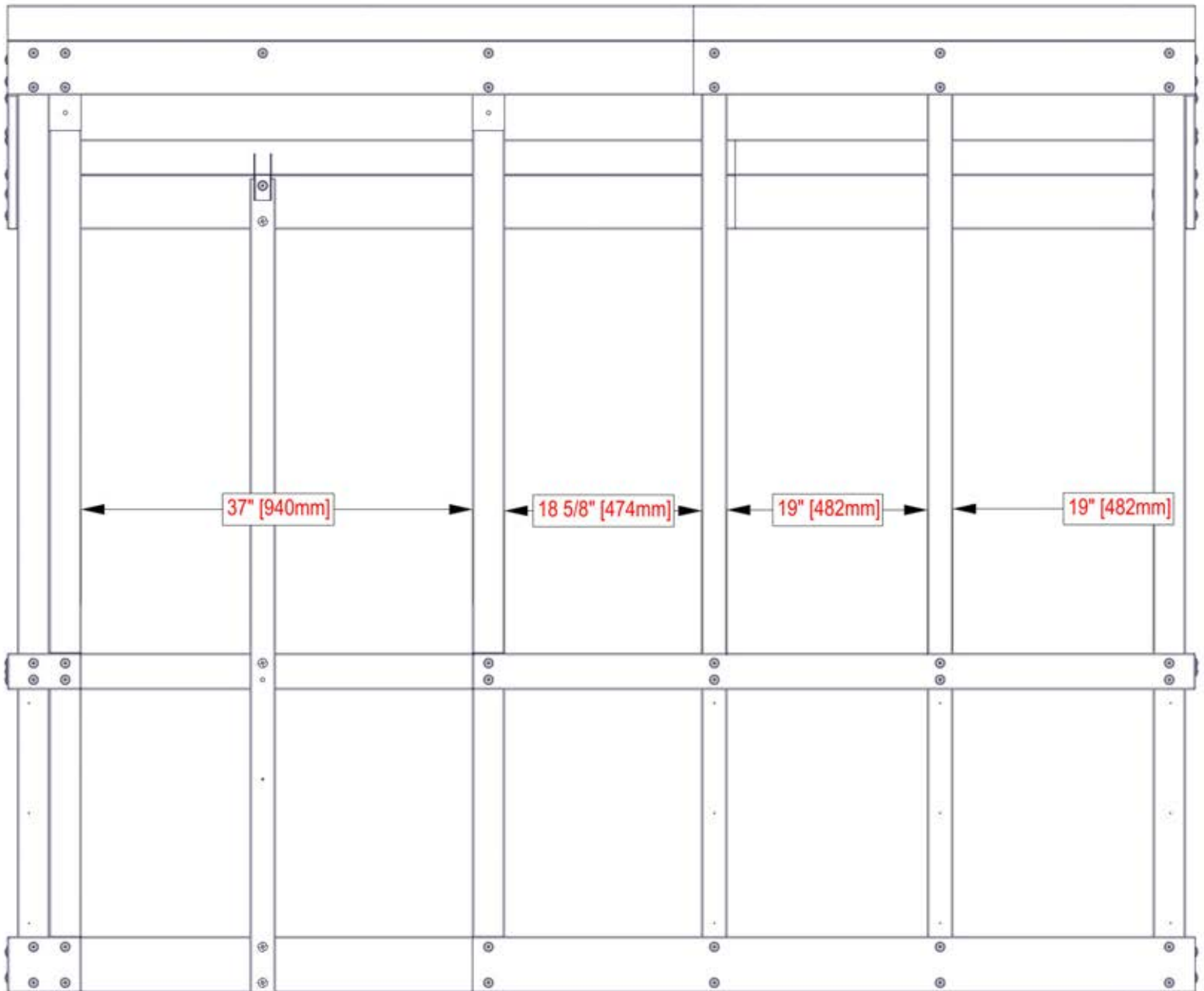


STEP 11D - GREENHOUSE ASSEMBLY

IMPORTANT!

GOING TO THE FRONT SIDE, ENSURE THAT:

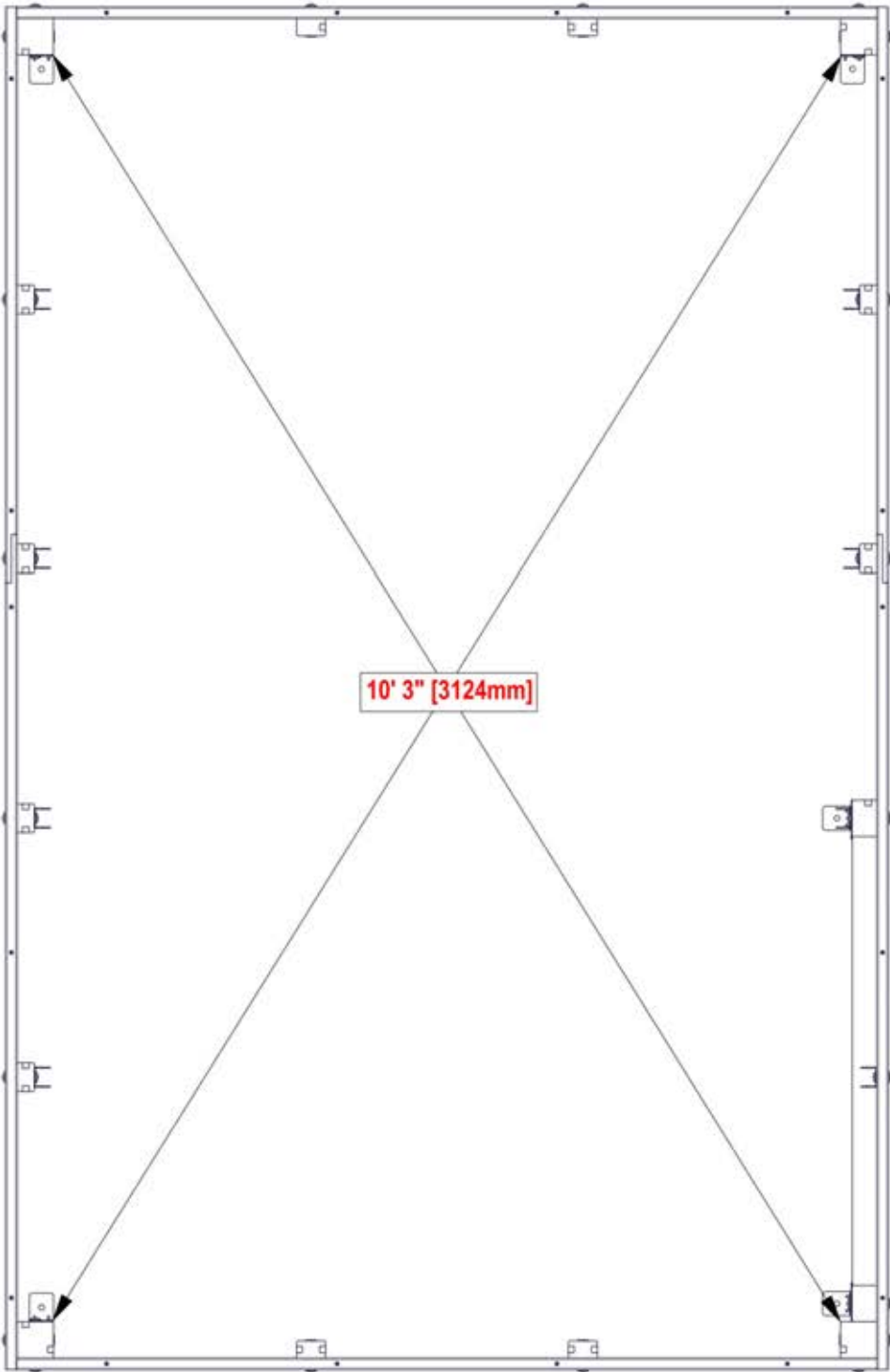
- POSTS AND UPRIGHTS ARE PLUMB (STRAIGHT UP AND DOWN) WITH A LEVEL.
- MEASUREMENTS BETWEEN POSTS AND UPRIGHTS ARE AS SHOWN.
- RUNNING AND BASE BOARDS ARE SQUARED TO THE UPRIGHTS.
- ALL HARDWARE ON THIS SIDE IS FULLY TIGHTENED.



STEP 12 - GREENHOUSE ASSEMBLY

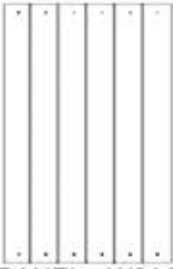
CRITICAL: SQUARE ASSEMBLY BEFORE PROCEEDING TO NEXT STEPS.

WARNING: THERE WILL BE ALIGNMENT ISSUES IF THE STRUCTURE IS NOT PROPERLY SQUARED.

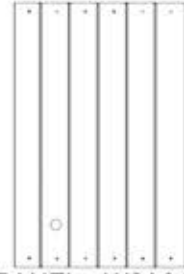
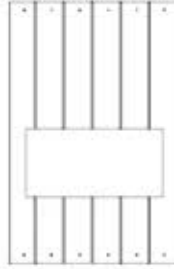


STEP 13 - SIDE WALL ASSEMBLY

QTY	PART NUMBER	DESCRIPTION
36	H100382	SCREW PFH 8x1 3/4 BLK



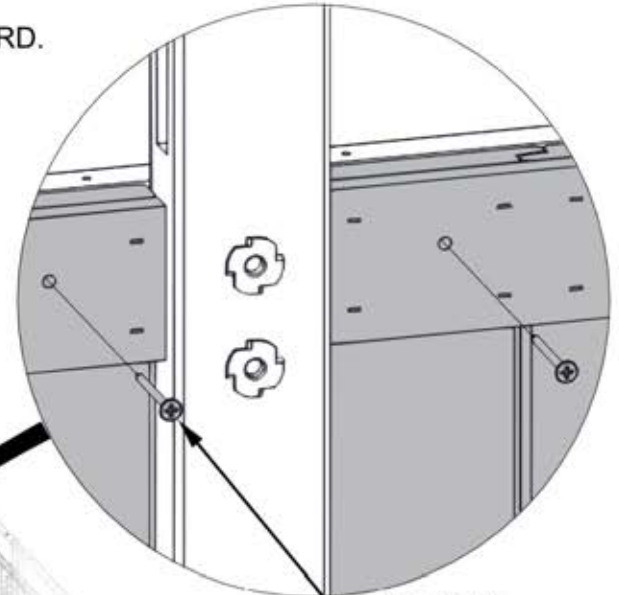
WP02 WALL PANEL - W2A04062
(x1) 1 1/16"x19 15/16"x30 9/16" (27x507x777)



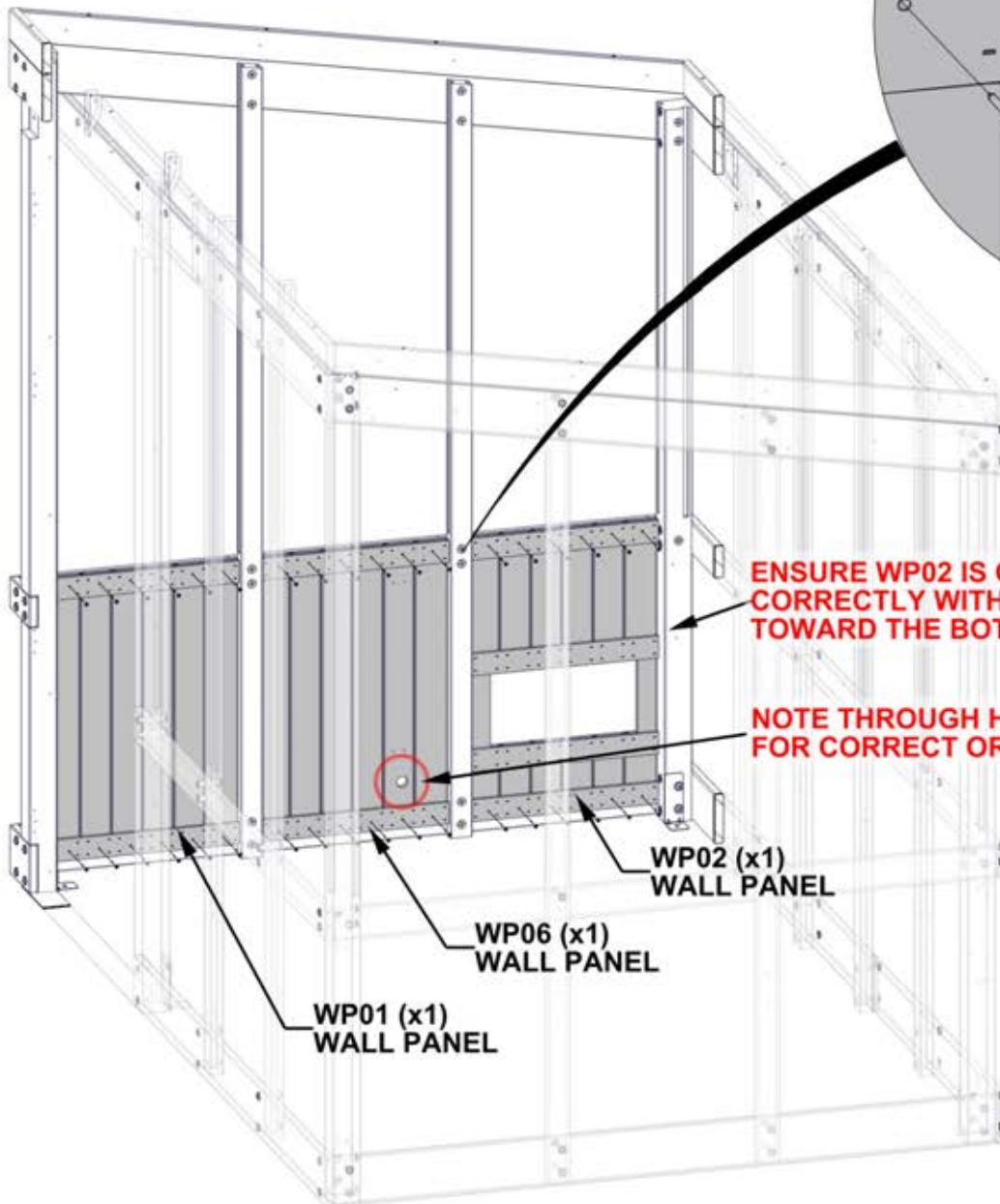
WP06 WALL PANEL - W2A04076
(x1) 1 1/16"x19 15/16"x30 9/16" (27x507x777)

WP01 WALL PANEL - W2A04060
(x1) 1 1/16"x19 15/16"x30 9/16" (27x507x777)

- TOP OF PANELS SHOULD BE FLUSH WITH TOP OF RUNNING BOARD.
- CENTER BETWEEN POSTS AND UPRIGHTS.
- ATTACH AS SHOWN.



382 (x36)
SCREW - 1 3/4"



ENSURE WP02 IS ORIENTED CORRECTLY WITH OPENING TOWARD THE BOTTOM.

NOTE THROUGH HOLE IN WP06 FOR CORRECT ORIENTATION.

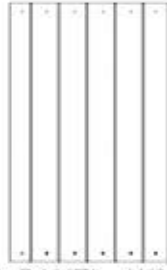
WP02 (x1)
WALL PANEL

WP06 (x1)
WALL PANEL

WP01 (x1)
WALL PANEL

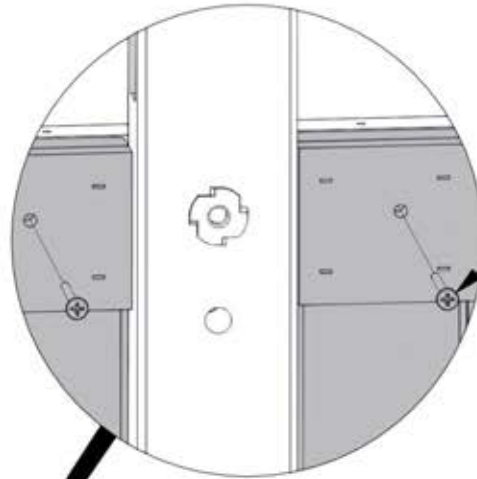
STEP 14 - BACK WALL ASSEMBLY

QTY	PART NUMBER	DESCRIPTION
60	H100382	SCREW PFH 8x1 3/4 BLK

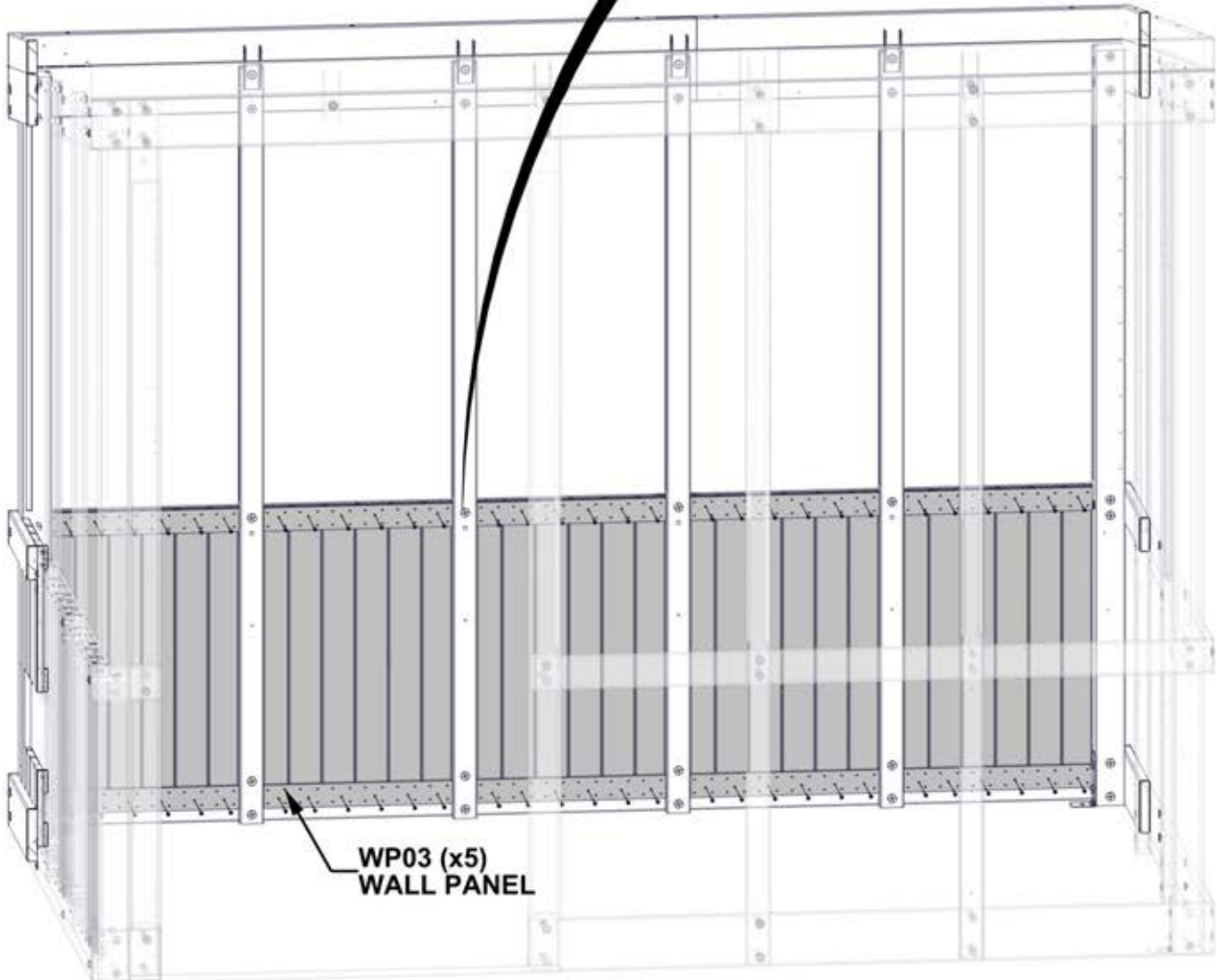


WP03 WALL PANEL - W2A04063
(x5) 1 1/16"x18 7/8"x30 9/16" (27x480x777)

- TOP OF PANELS SHOULD BE FLUSH WITH TOP OF RUNNING BOARD.
- CENTER BETWEEN POSTS AND UPRIGHTS.
- ATTACH AS SHOWN.



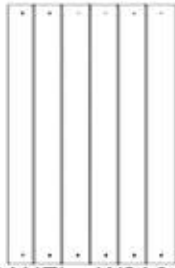
382 (x60)
SCREW - 1 3/4"



WP03 (x5)
WALL PANEL

STEP 15 - SIDE WALL ASSEMBLY

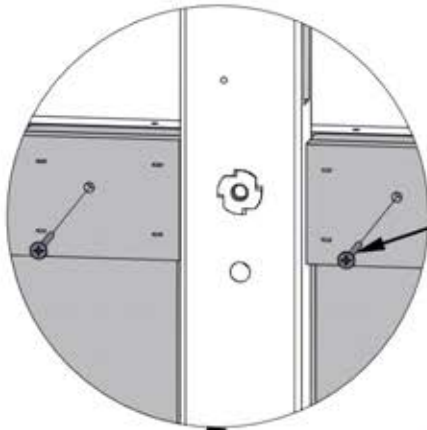
QTY	PART NUMBER	DESCRIPTION
36	H100382	SCREW PFH 8x1 3/4 BLK



WP01 WALL PANEL - W2A04060
(x2) 1 1/16"x19 15/16"x30 9/16" (27x507x777)

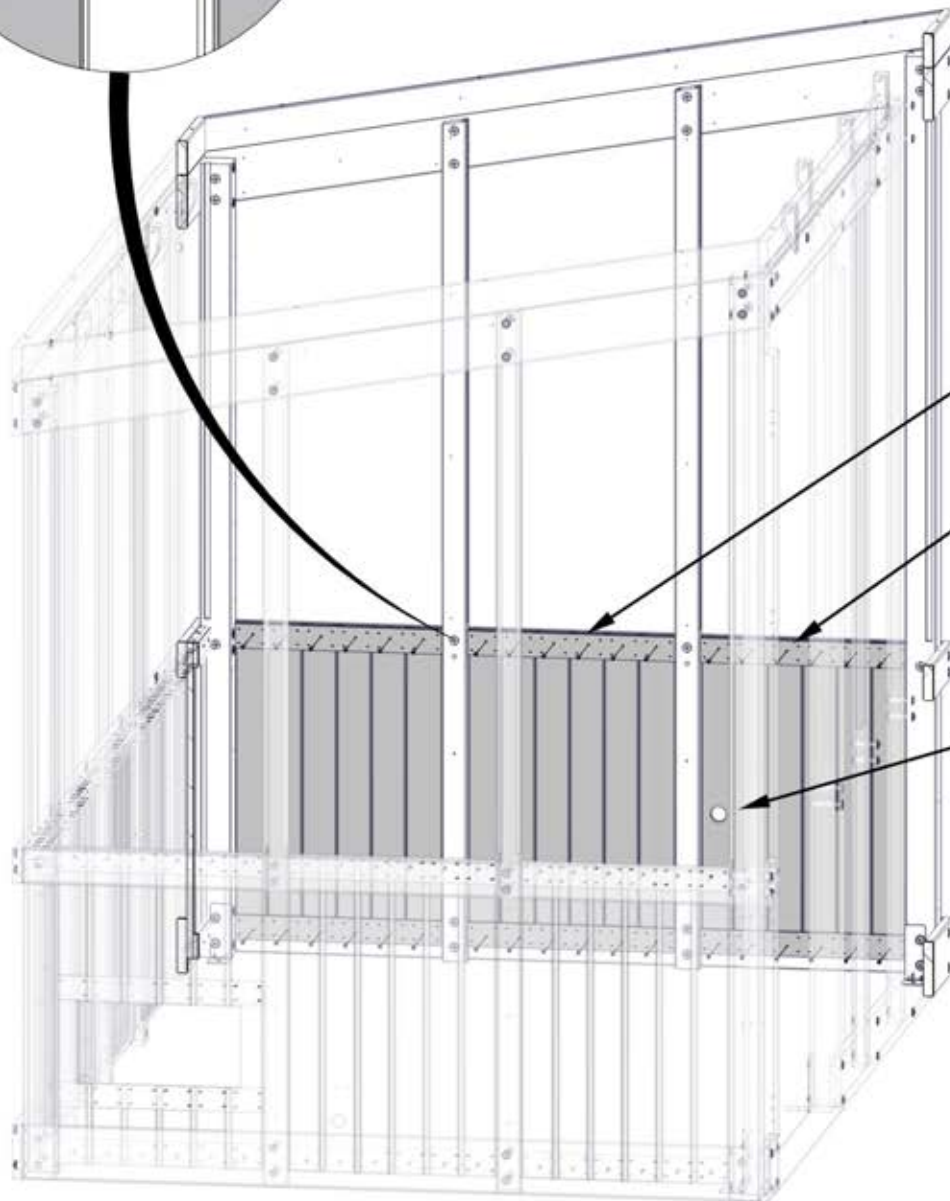


WP05 WALL PANEL - W2A04075
(x1) 1 1/16"x19 15/16"x30 9/16" (27x507x777)



- TOP OF PANELS SHOULD BE FLUSH WITH TOP OF RUNNING BOARD.
- CENTER BETWEEN POSTS AND UPRIGHTS.
- ATTACH AS SHOWN.

382 (x36)
SCREW - 1 3/4"



WP01 (x2)
WALL PANEL

WP05 (x1)
WALL PANEL

**ENSURE WP05 IS ORIENTED
CORRECTLY WITH THE
HOLE IN THE CORRECT
POSITION AS SHOWN.**

STEP 16 - FRONT WALL ASSEMBLY

QTY	PART NUMBER	DESCRIPTION
36	H100382	SCREW PFH 8x1 3/4 BLK

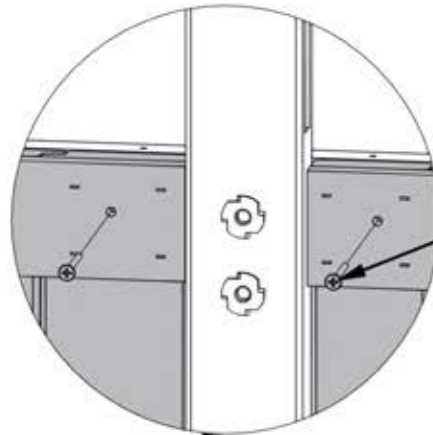


WP03 WALL PANEL - W2A04063
(x2) 1 1/16"x18 7/8"x30 9/16" (27x480x777)



WP04 WALL PANEL - W2A04069
(x1) 1 1/16"x18 9/16"x30 9/16" (27x472x777)

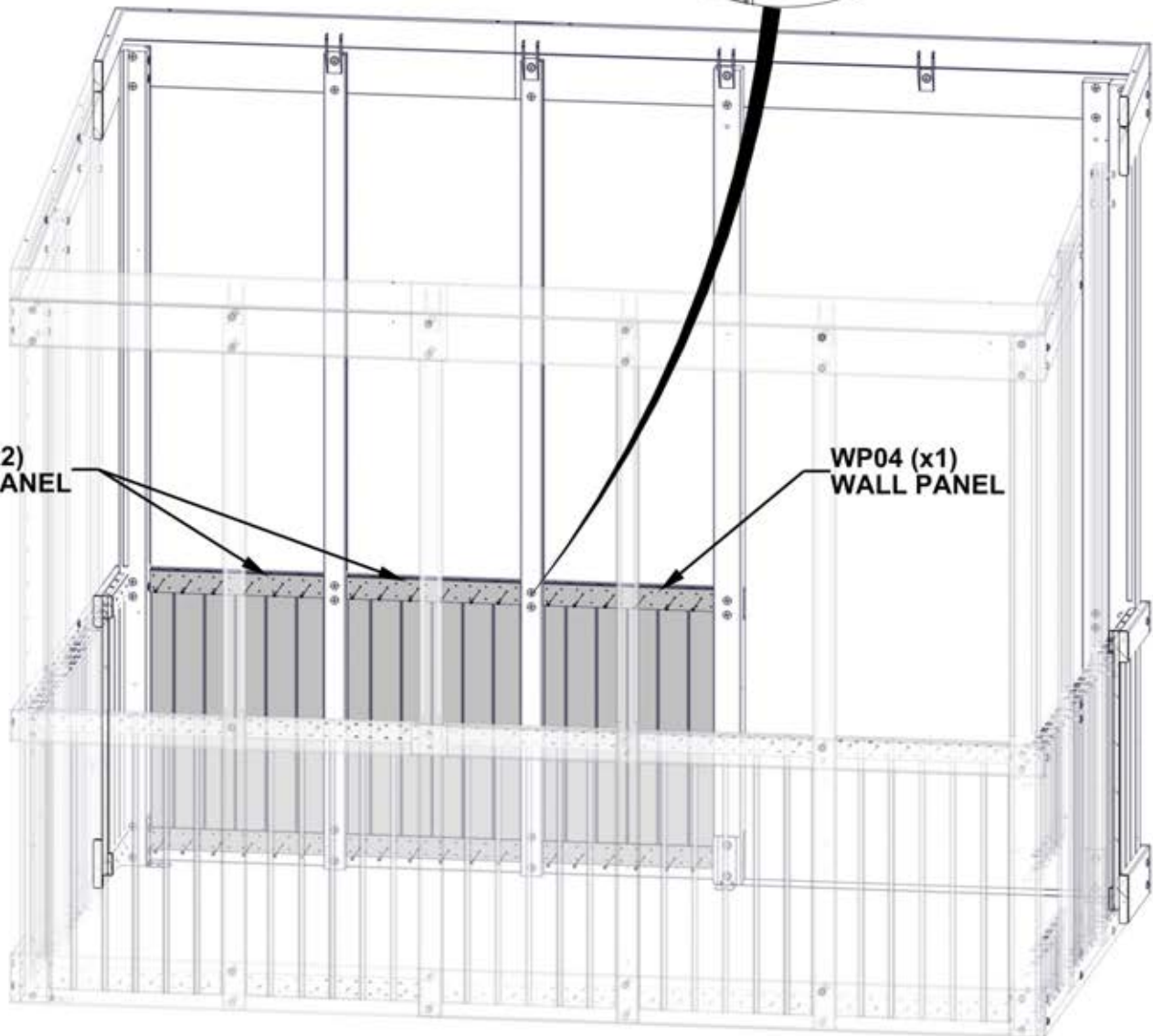
- TOP OF PANELS SHOULD BE FLUSH WITH TOP OF RUNNING BOARD.
- CENTER BETWEEN POSTS AND UPRIGHTS.
- ATTACH AS SHOWN.



382 (x36)
SCREW - 1 3/4"

WP03 (x2)
WALL PANEL

WP04 (x1)
WALL PANEL



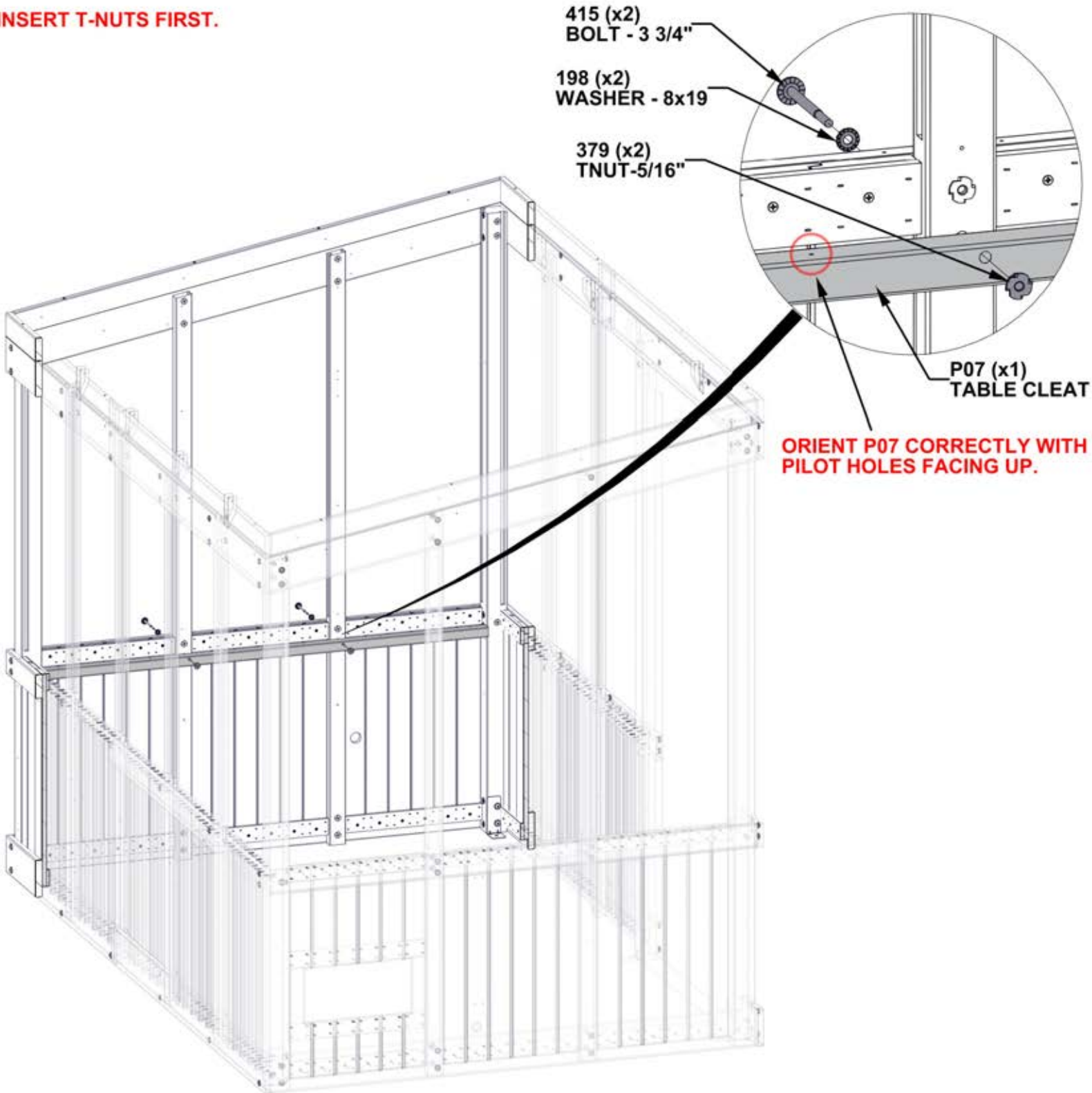
STEP 17 - TABLE ASSEMBLY

QTY	PART NUMBER	DESCRIPTION
2	H100198	WASHER LOCK EXT 8x19
2	H100379	TNUT-5/16" BLK
2	H100415	BOLT WH 5/16x3 3/4 BLK



P07 TABLE CLEAT - W4L19231
(x1) 1 7/16"x1 7/16"x64 3/4" (36x36x1645)

INSERT T-NUTS FIRST.



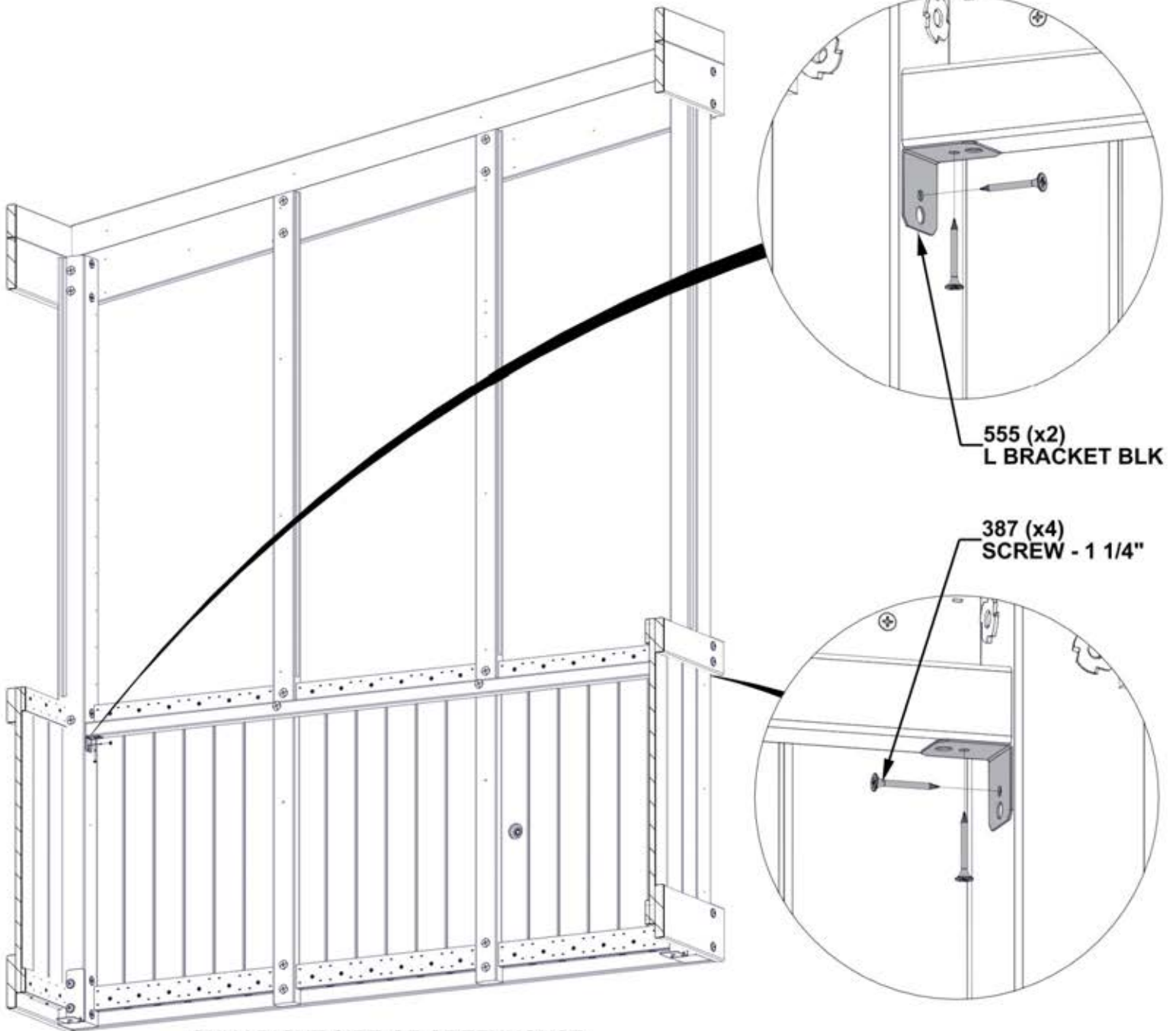
STEP 18 - TABLE ASSEMBLY

QTY	PART NUMBER	DESCRIPTION
4	H100387	SCREW PFH 8x1 1/4 BLK



A4M00555 L BRACKET BLK
(x2)

ATTACH BRACKETS USING PILOT HOLES IN POSTS AND TABLE CLEAT.



ONLY RIGHT SIDE OF GREENHOUSE SHOWN FOR DETAIL.

STEP 19 - TABLE ASSEMBLY

QTY	PART NUMBER	DESCRIPTION
8	H100387	SCREW PFH 8x1 1/4 BLK
4	H100483	SCREW PFH 8x2 1/4 BLK



TB02 TABLE - W2A04068
(x1) 2 1/16"x16"x67 5/8" (52x407x1717)



P06 TABLE CLEAT - W4L19229
(x2) 1 7/16"x1 7/16"x13 3/16" (36x36x335)

ENSURE P06 IS ORIENTED CORRECTLY WITH PILOT HOLE ON BOTTOM AND TOWARDS THE FRONT AS SHOWN.

483 (x4)
SCREW - 2 1/4"

387 (x8)
SCREW - 1 1/4"

TB02 (x1)
TABLE

P06 (x2)
TABLE CLEAT

NOTE PILOT HOLES ON THE FRONT OF TABLE FOR ORIENTATION OF TABLE CLEATS.

STEP 20 - TABLE ASSEMBLY

QTY	PART NUMBER	DESCRIPTION
6	H100821	SCREW PFH 8x2 3/4 BLK



TABLE ASSEMBLY - FROM PREVIOUS STEP

DO NOT LEAN ON OR PUT ANY WEIGHT ON TABLE UNTIL ANGLE BRACES ARE INSTALLED IN NEXT STEP.

ATTACH TABLE USING PILOT HOLES
IN PREVIOUSLY INSTALLED CLEAT.

821 (x6)
SCREW - 2 3/4"

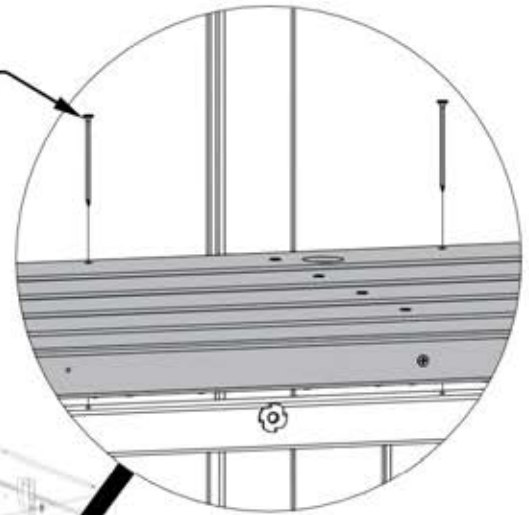
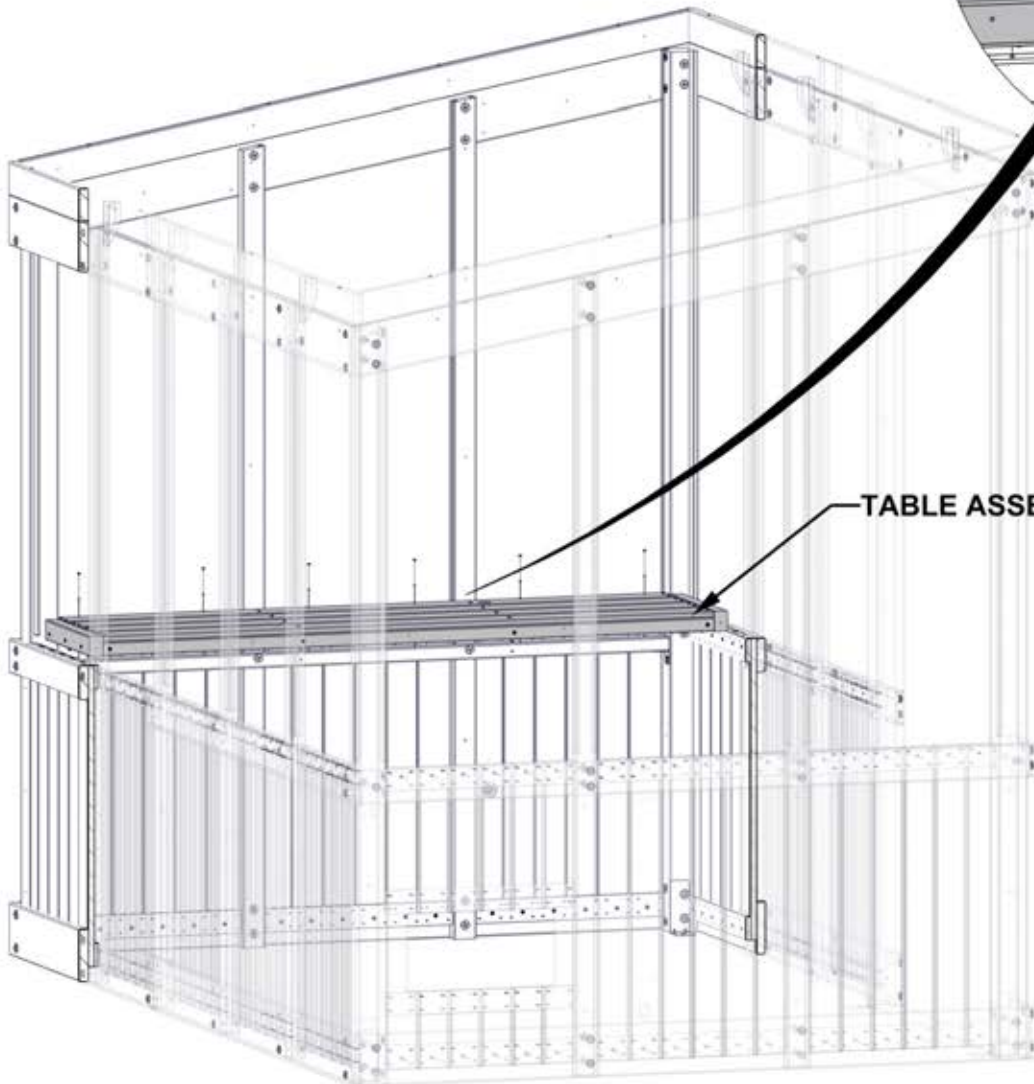


TABLE ASSEMBLY



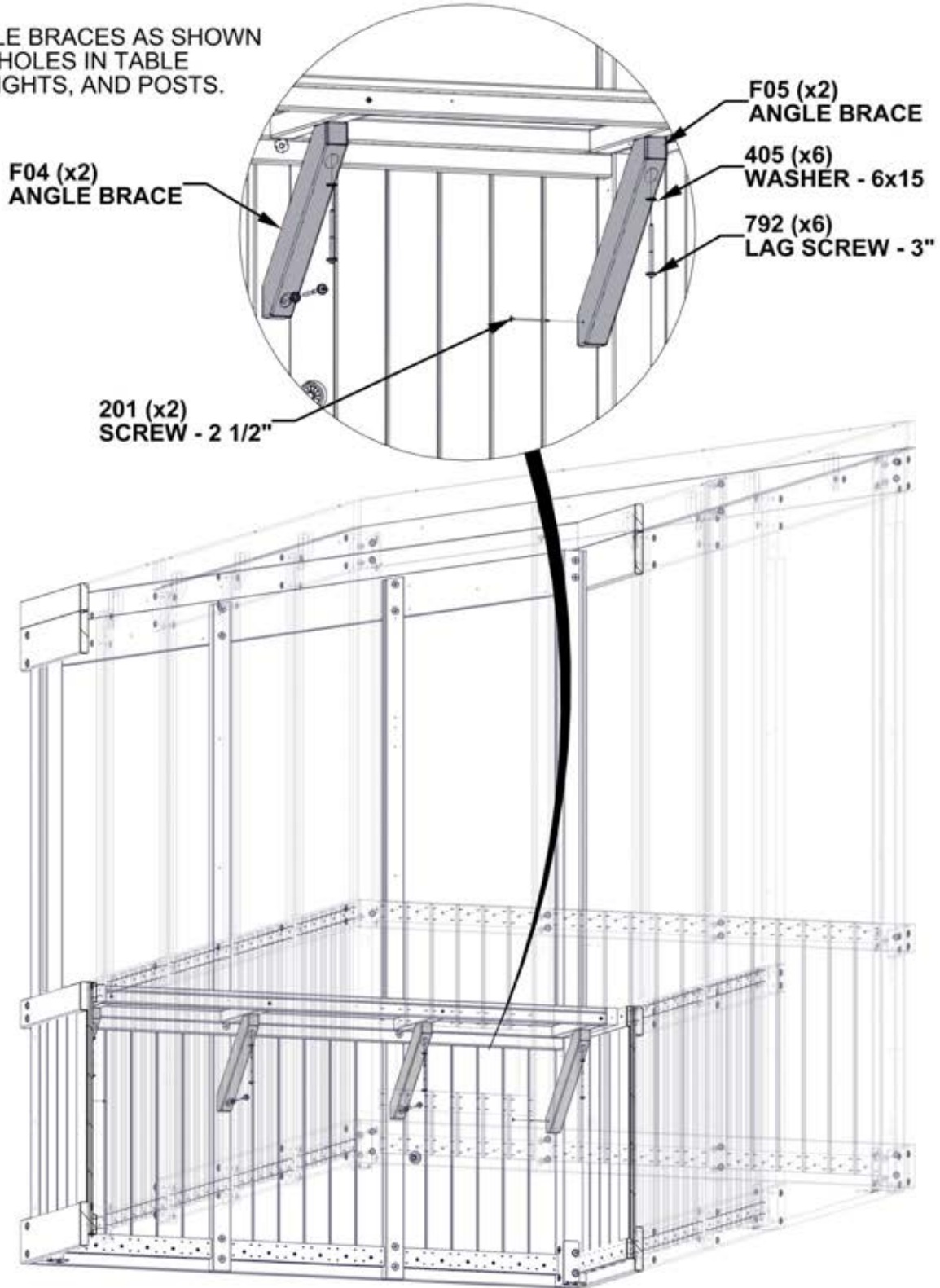
STEP 21 - TABLE ASSEMBLY

QTY	PART NUMBER	DESCRIPTION
2	H100201	SCREW PFH 8x2 1/2 BLK
6	H100405	WASHER LOCK EXT 6x15
6	H100792	LAG SCREW WH 1/4x3 BLK

F04 ANGLE BRACE - W4L19200
(x2) 1 7/16"x2 3/8"x15 3/16" (36x60x385)

F05 ANGLE BRACE - W4L19203
(x2) 1 7/16"x2 3/8"x16 1/4" (36x60x412)

ATTACH ANGLE BRACES AS SHOWN
USING PILOT HOLES IN TABLE
CLEATS, UPRIGHTS, AND POSTS.



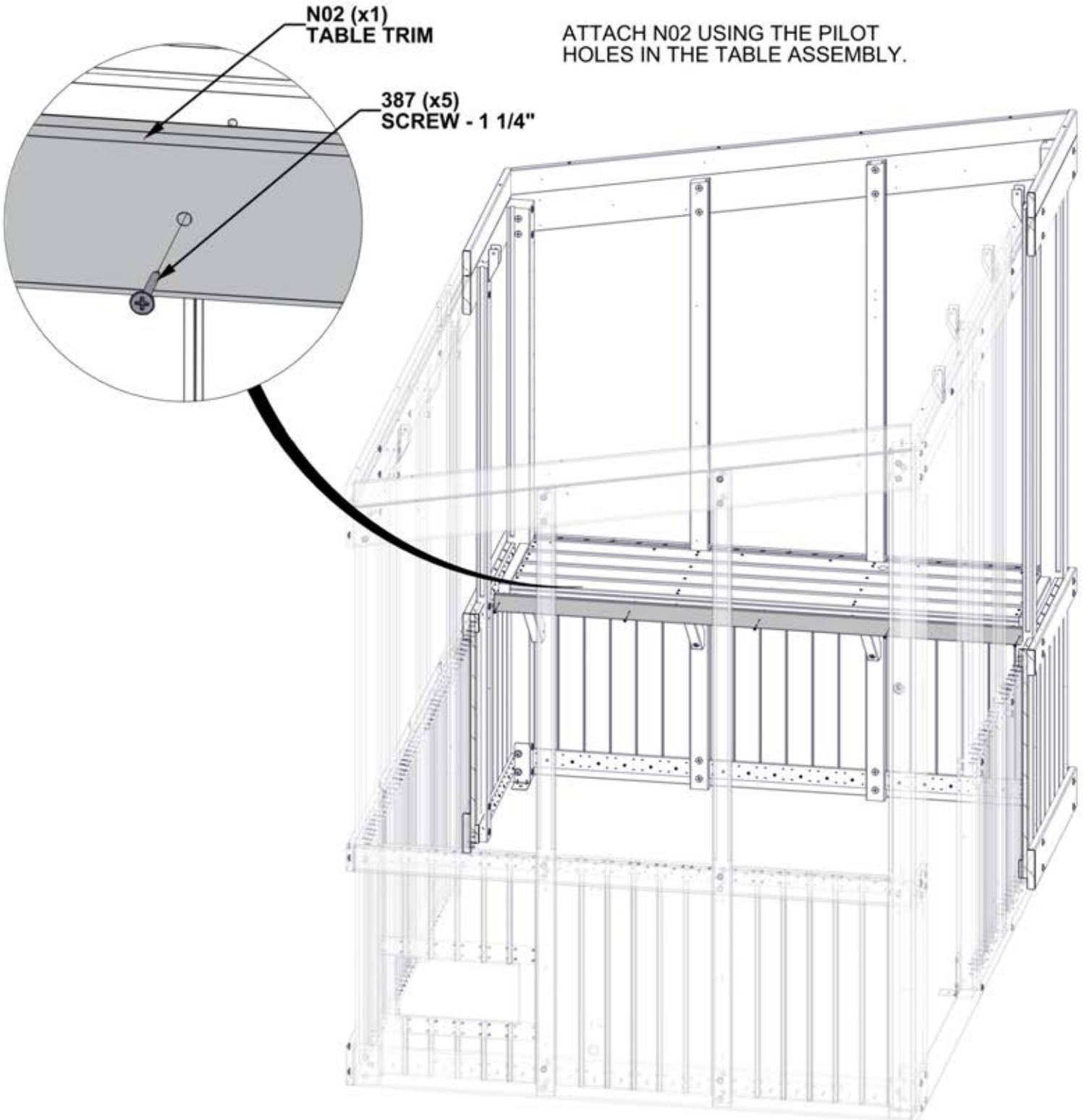
STEP 22 - TABLE ASSEMBLY

QTY	PART NUMBER	DESCRIPTION
5	H100387	SCREW PFH 8x1 1/4 BLK



N02 TABLE TRIM - W4L19230
(x1) 5/8"x2 3/8"x67 5/8" (16x60x1717)

ATTACH N02 USING THE PILOT HOLES IN THE TABLE ASSEMBLY.

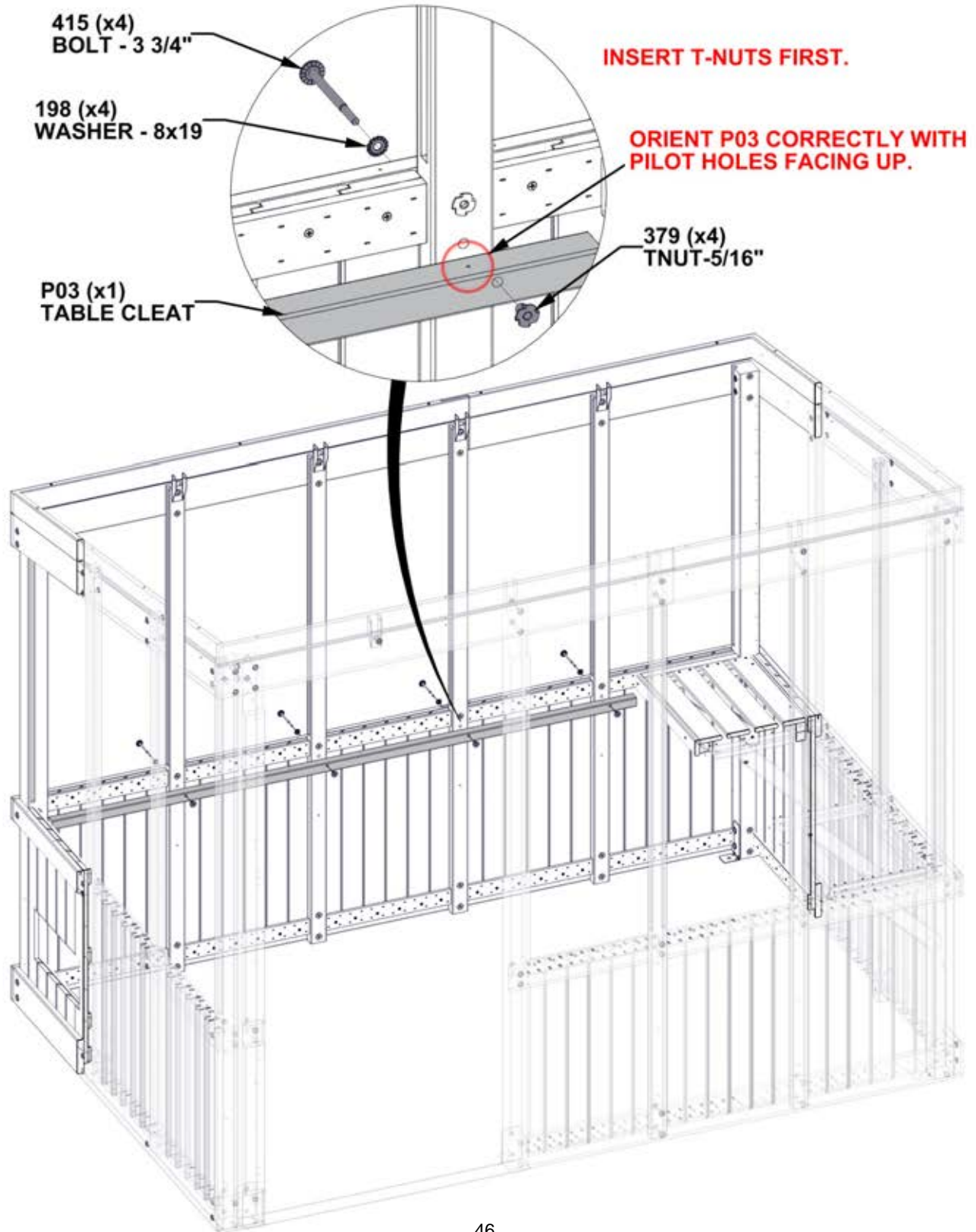


STEP 23 - TABLE ASSEMBLY

QTY	PART NUMBER	DESCRIPTION
4	H100198	WASHER LOCK EXT 8x19
4	H100379	TNUT-5/16" BLK
4	H100415	BOLT WH 5/16x3 3/4 BLK

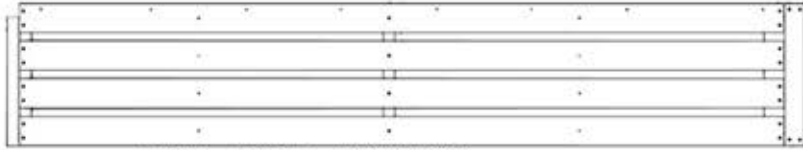


P03 TABLE CLEAT - W4L19202
 (x1) 1 7/16"x1 7/16"x88 1/8" (36x36x2238)



STEP 24 - TABLE ASSEMBLY

QTY	PART NUMBER	DESCRIPTION
8	H100387	SCREW PFH 8x1 1/4 BLK
4	H100483	SCREW PFH 8x2 1/4 BLK

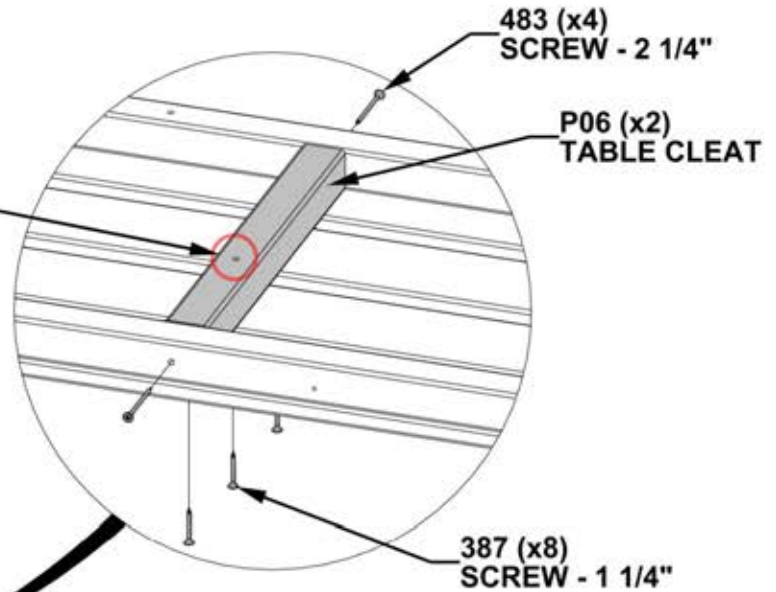


TB01 TABLE - W2A04066
(x1) 2 1/16"x16"x89 1/2" (52x407x2274)



P06 TABLE CLEAT - W4L19229
(x2) 1 7/16"x1 7/16"x13 3/16" (36x36x335)

ENSURE P06 IS ORIENTED CORRECTLY WITH PILOT HOLE ON BOTTOM AND TOWARDS THE FRONT AS SHOWN.



483 (x4)
SCREW - 2 1/4"

P06 (x2)
TABLE CLEAT

387 (x8)
SCREW - 1 1/4"

TB01 (x1)
TABLE

NOTE PILOT HOLES ON THE FRONT OF TABLE FOR ORIENTATION OF TABLE CLEATS.

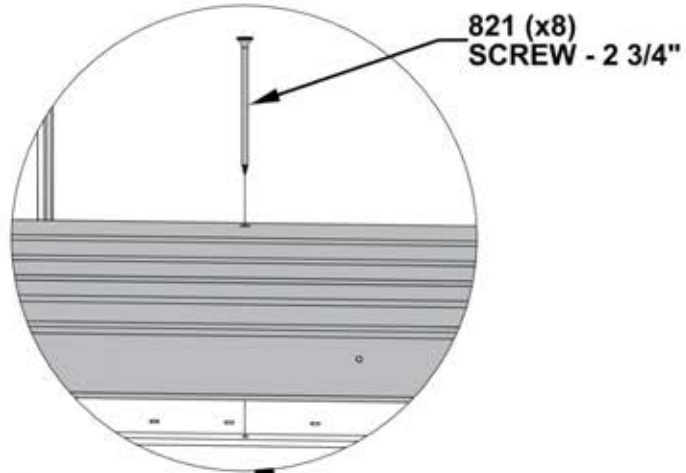
STEP 25 - TABLE ASSEMBLY

QTY	PART NUMBER	DESCRIPTION
8	H100821	SCREW PFH 8x2 3/4 BLK

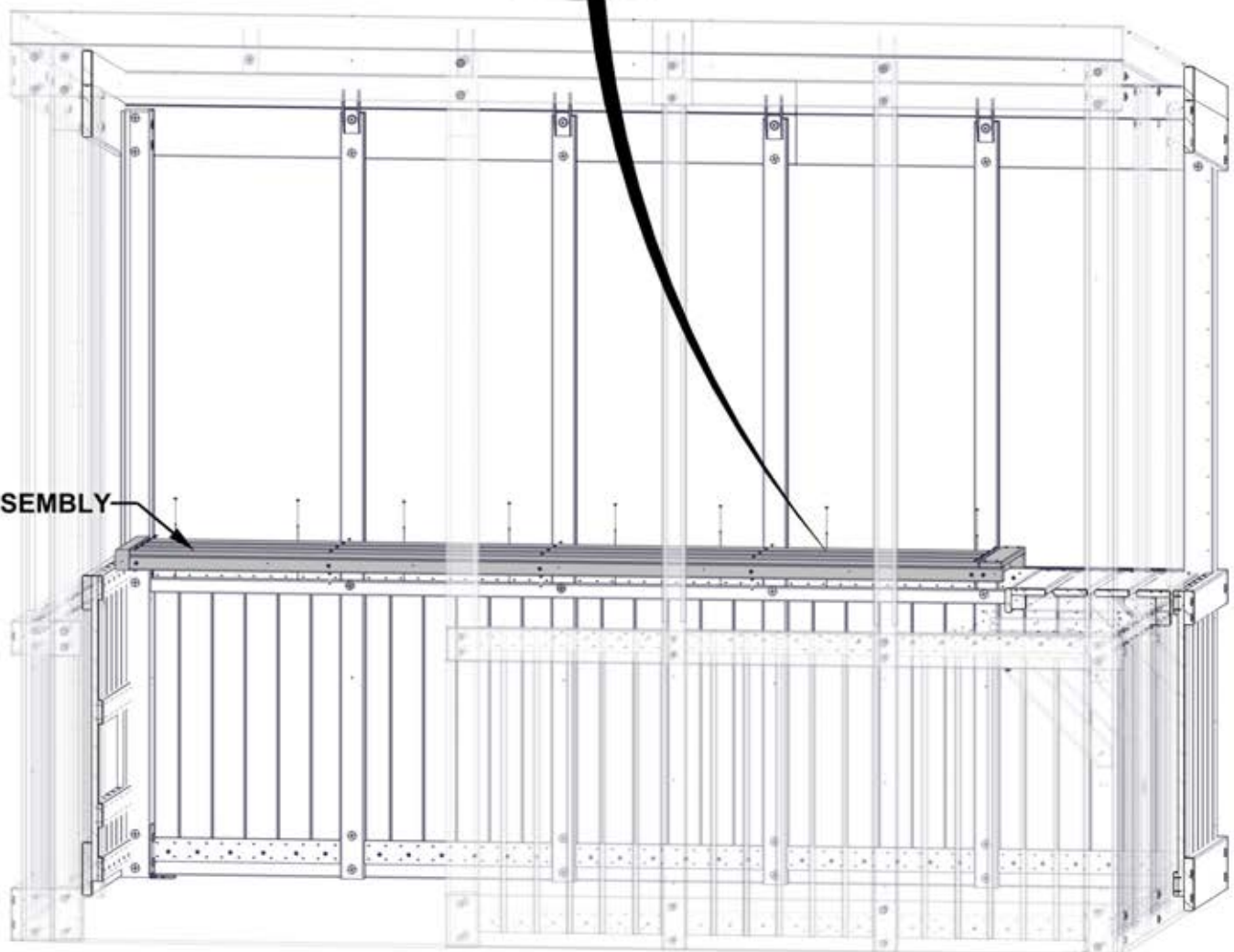


TABLE ASSEMBLY - FROM PREVIOUS STEP

DO NOT LEAN ON OR PUT ANY WEIGHT ON TABLE UNTIL ANGLE BRACES ARE INSTALLED IN NEXT STEPS.



ATTACH TABLE USING PILOT HOLES IN PREVIOUSLY INSTALLED CLEAT.

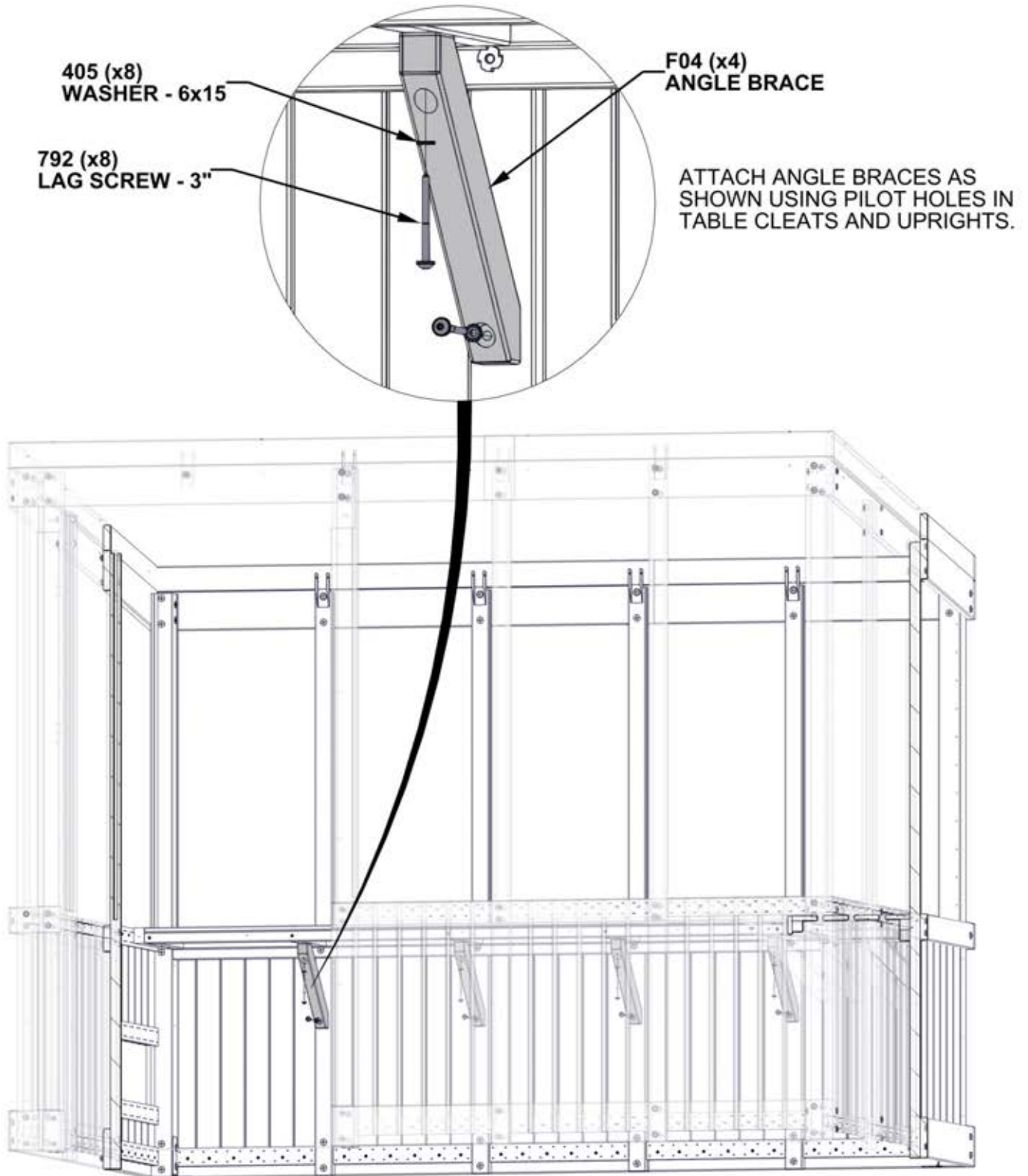


STEP 26 - TABLE ASSEMBLY

QTY	PART NUMBER	DESCRIPTION
8	H100405	WASHER LOCK EXT 6x15
8	H100792	LAG SCREW WH 1/4x3 BLK



F04 ANGLE BRACE - W4L19200
(x4) 1 7/16"x2 3/8"x15 3/16" (36x60x385)



STEP 27 - TABLE ASSEMBLY

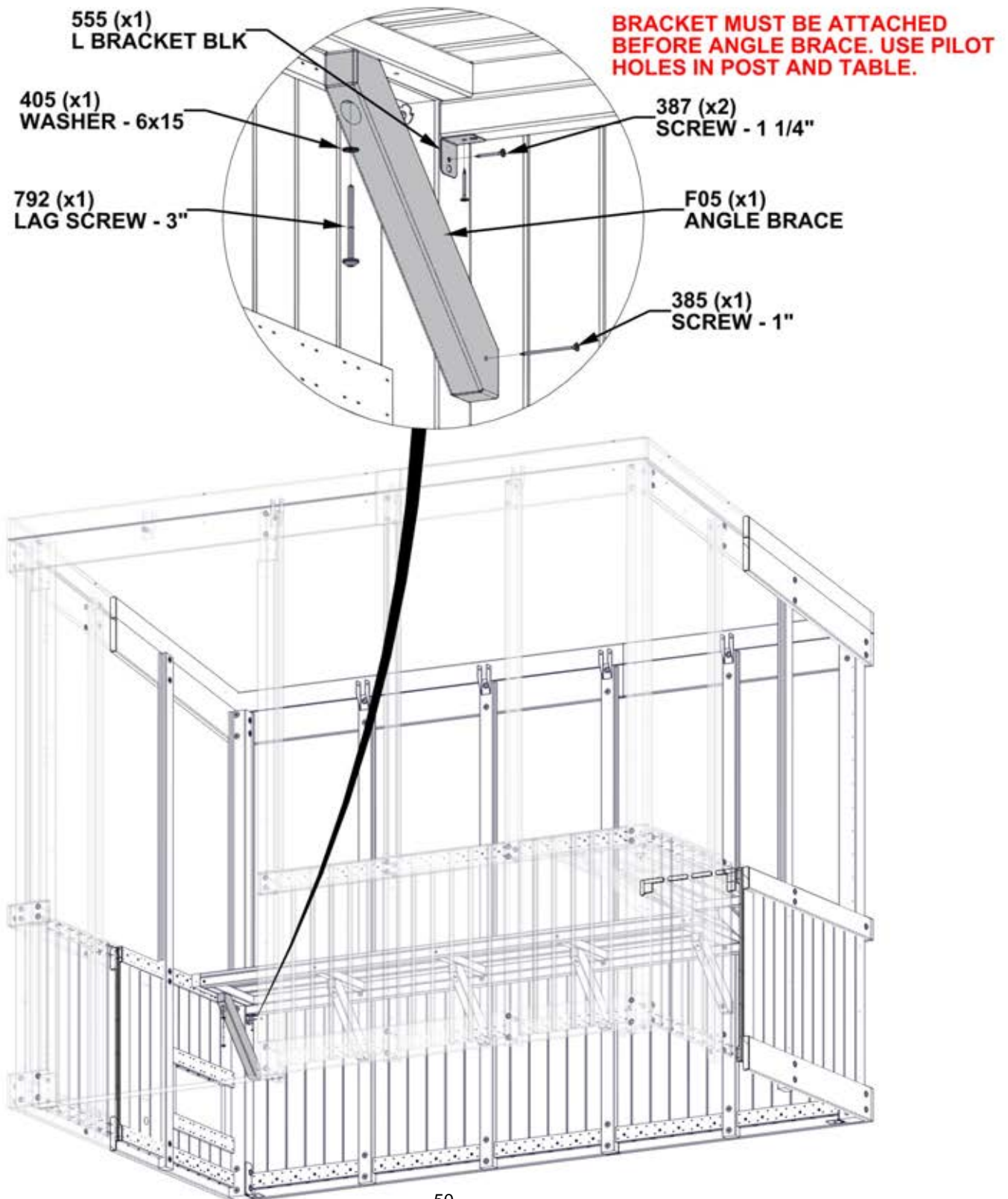
QTY	PART NUMBER	DESCRIPTION
1	H100201	SCREW PFH 8x2 1/2 BLK
2	H100387	SCREW PFH 8x1 1/4 BLK
1	H100405	WASHER LOCK EXT 6x15
1	H100792	LAG SCREW WH 1/4x3 BLK



F05 ANGLE BRACE - W4L19203
(x1) 1 7/16"x2 3/8"x16 1/4" (36x60x412)



A4M00555 L BRACKET BLK
(x1)



STEP 28 - TABLE ASSEMBLY

QTY	PART NUMBER	DESCRIPTION
7	H100387	SCREW PFH 8x1 1/4 BLK

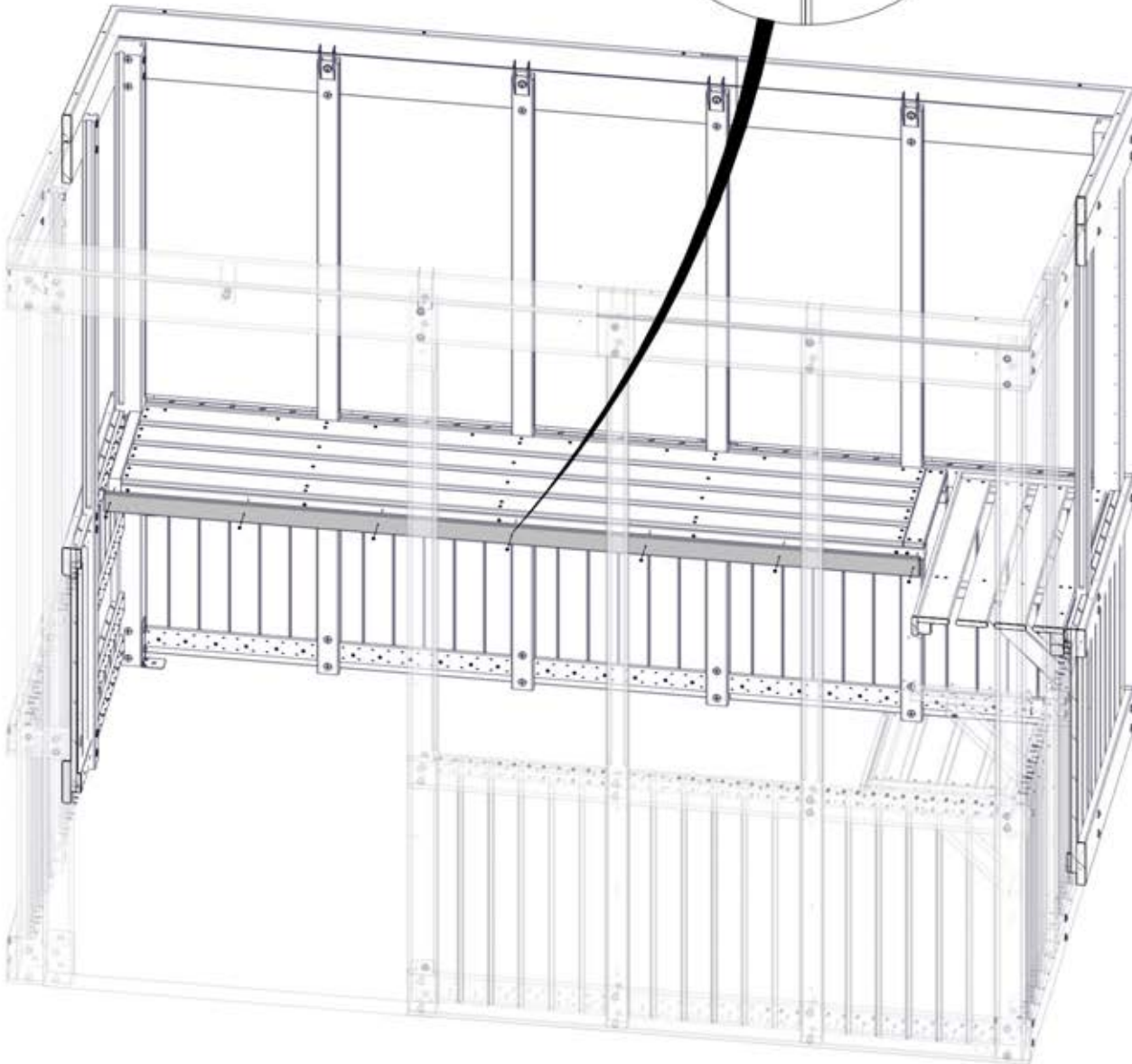
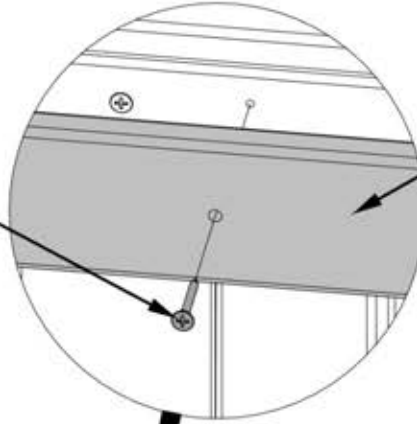


N01 TABLE TRIM - W4L19201
(x1) 5/8"x2 3/8"x89 1/2" (16x60x2274)

ATTACH N01 USING THE PILOT HOLES IN THE TABLE ASSEMBLY.

387 (x7)
SCREW - 1 1/4"

N01 (x1)
TABLE TRIM



STEP 29 - WINDOW SILL ASSEMBLY

QTY	PART NUMBER	DESCRIPTION
9	H100391	SCREW PFH 8x2 BLK



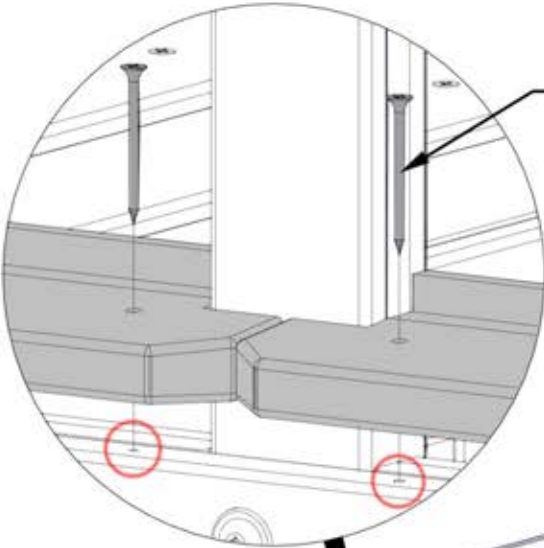
E01 WINDOW SILL - W4L19187
(x1) 1 7/16"x3 3/8"x22 3/8" (36x86x569)



E02 WINDOW SILL - W4L19188
(x1) 1 7/16"x3 3/8"x24 3/16" (36x86x615)

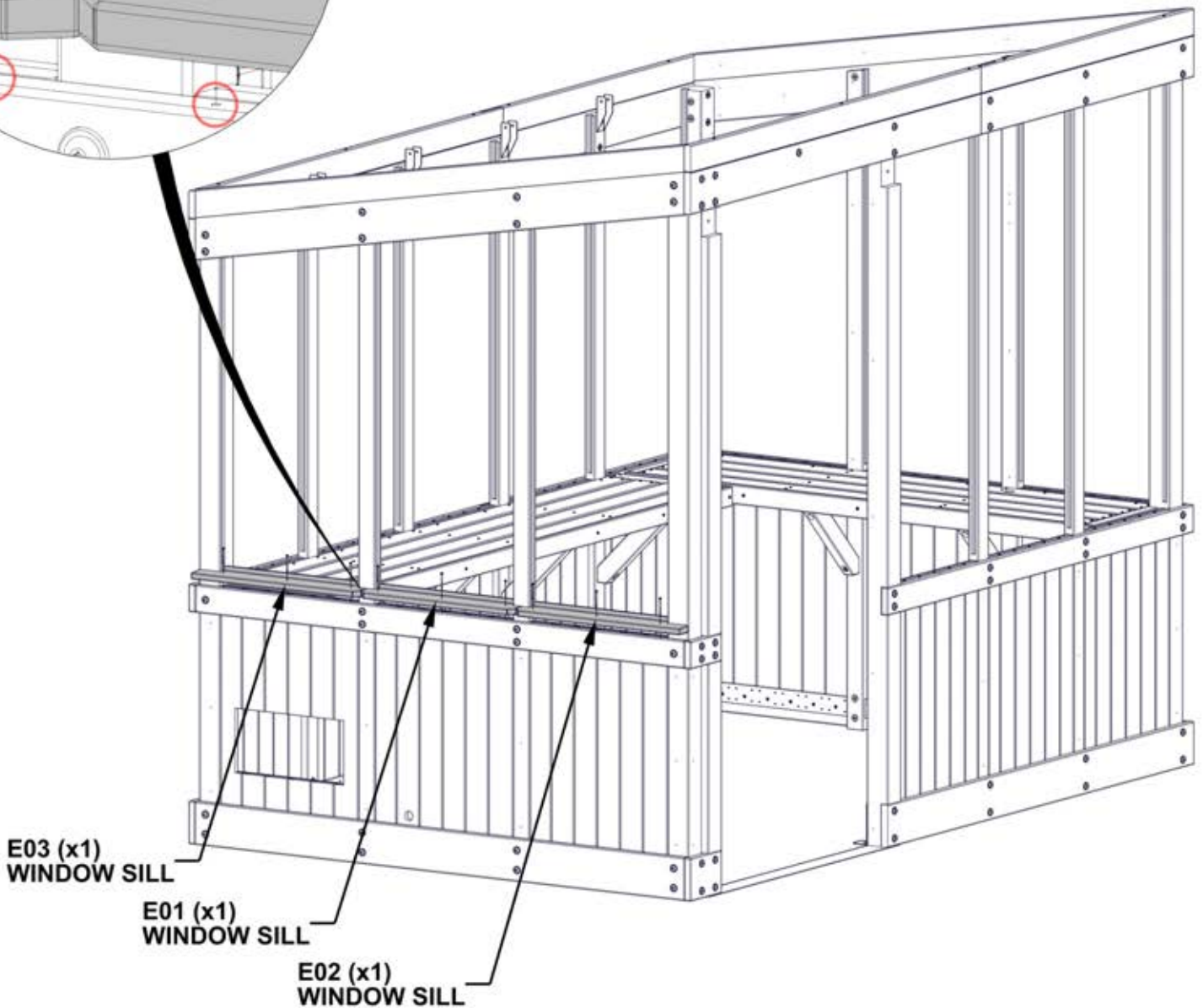


E03 WINDOW SILL - W4L19189
(x1) 1 7/16"x3 3/8"x24 3/16" (36x86x614)



391 (x9)
SCREW - 2"

ATTACH WINDOW SILLS USING
PILOT HOLES IN RUNNING BOARD.



STEP 30 - WINDOW SILL ASSEMBLY

QTY	PART NUMBER	DESCRIPTION
15	H100391	SCREW PFH 8x2 BLK



E04 WINDOW SILL - W4L19196
(x1) 1 7/16"x3 3/8"x25 1/8" (36x86x638)

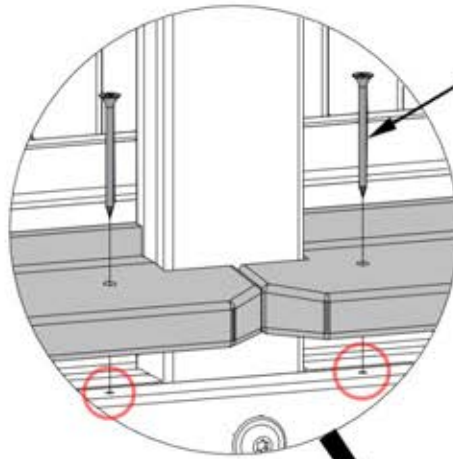


E05 WINDOW SILL - W4L19197
(x3) 1 7/16"x3 3/8"x21 5/16" (36x86x542)

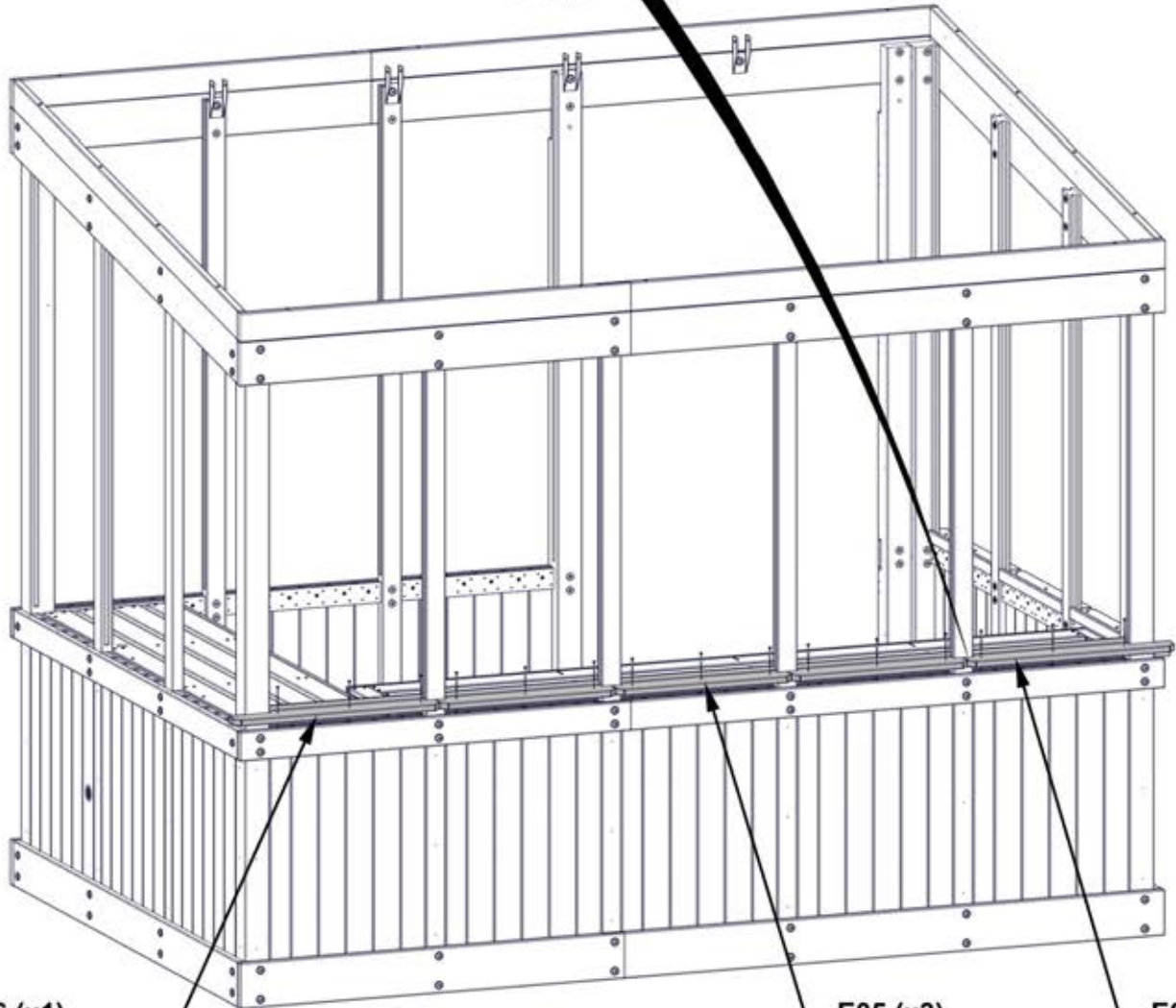


E06 WINDOW SILL - W4L19198
(x1) 1 7/16"x3 3/8"x25 1/8" (36x86x638)

ATTACH WINDOW SILLS USING
PILOT HOLES IN RUNNING BOARD.



391 (x15)
SCREW - 2"



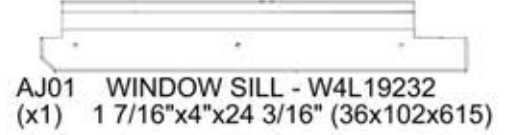
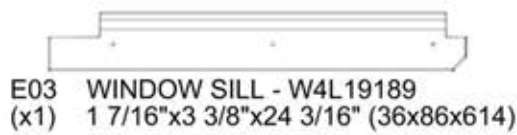
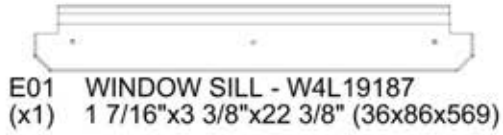
E06 (x1)
WINDOW SILL

E05 (x3)
WINDOW SILL

E04 (x1)
WINDOW SILL

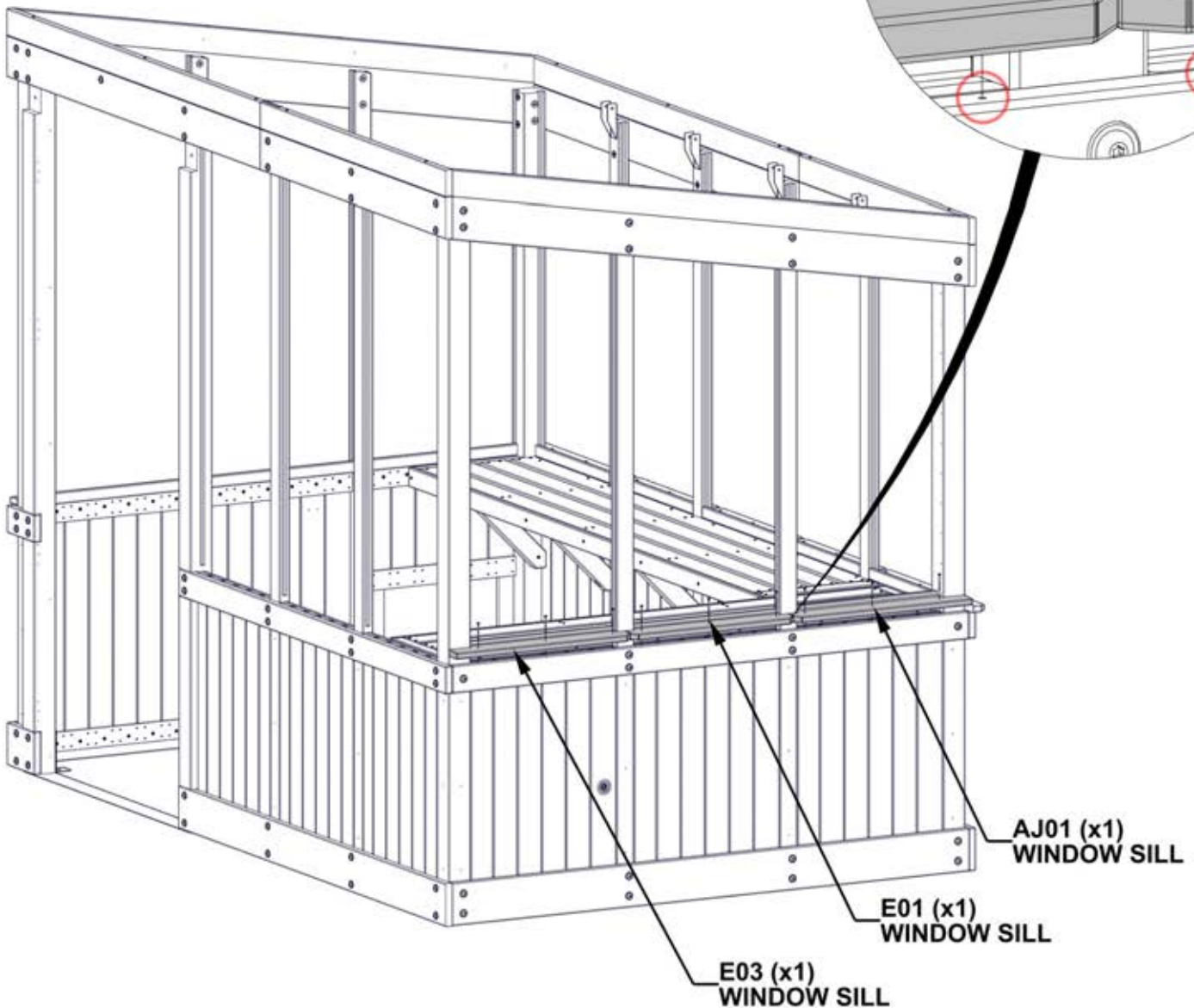
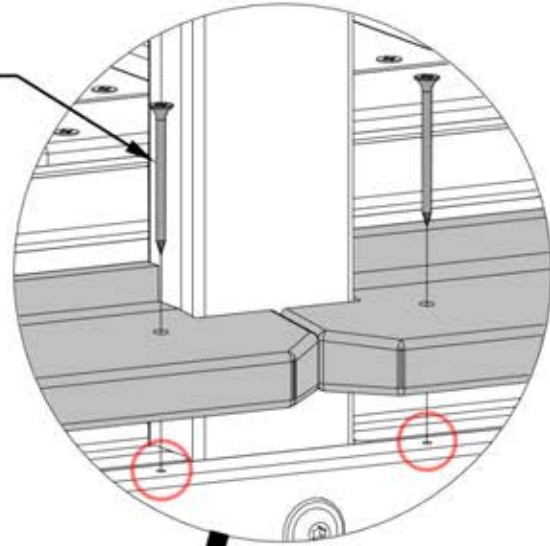
STEP 31 - WINDOW SILL ASSEMBLY

QTY	PART NUMBER	DESCRIPTION
9	H100391	SCREW PFH 8x2 BLK



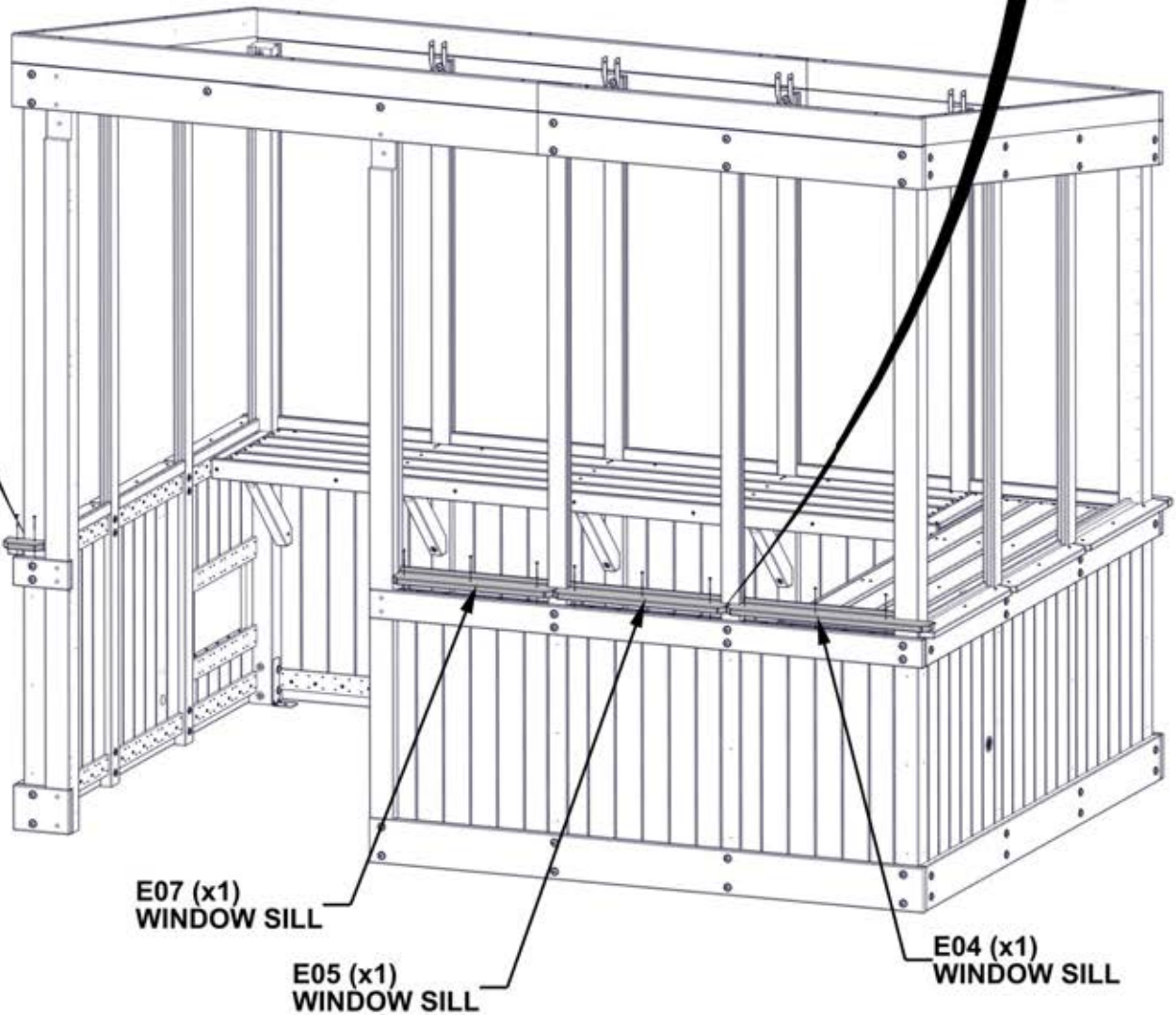
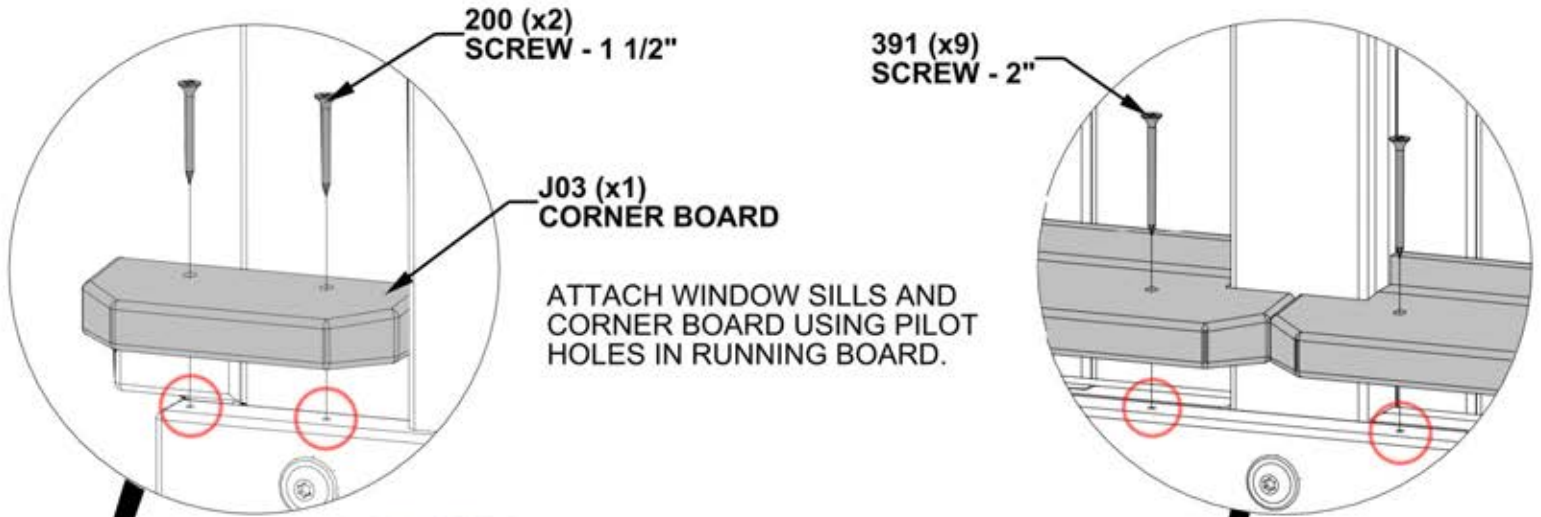
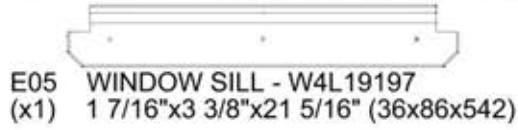
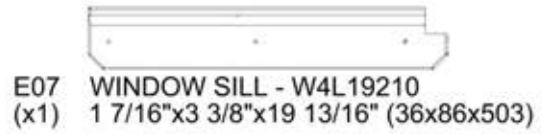
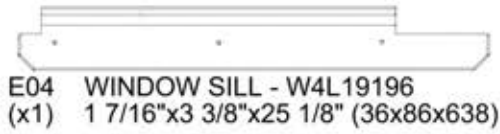
ATTACH WINDOW SILLS USING PILOT HOLES IN RUNNING BOARD.

391 (x9)
SCREW - 2"



STEP 32 - WINDOW SILL ASSEMBLY

QTY	PART NUMBER	DESCRIPTION
2	H100200	SCREW PFH 8x1 1/2 BLK
9	H100391	SCREW PFH 8x2 BLK

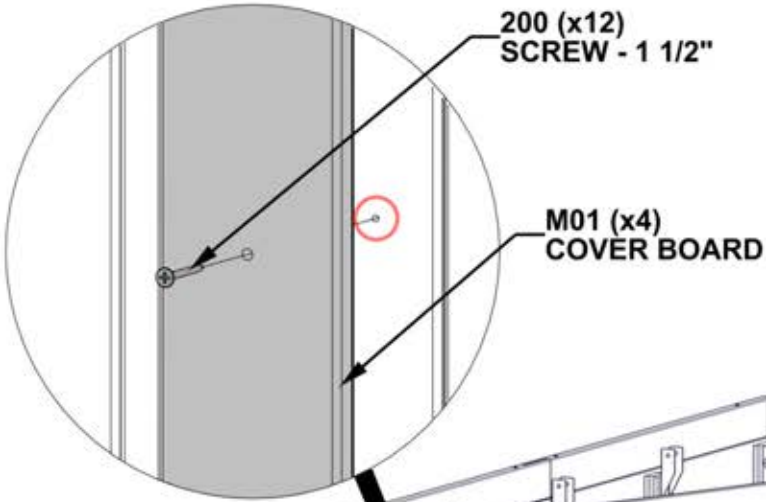


STEP 33 - COVER BOARD ASSEMBLY

QTY	PART NUMBER	DESCRIPTION
12	H100200	SCREW PFH 8x1 1/2 BLK



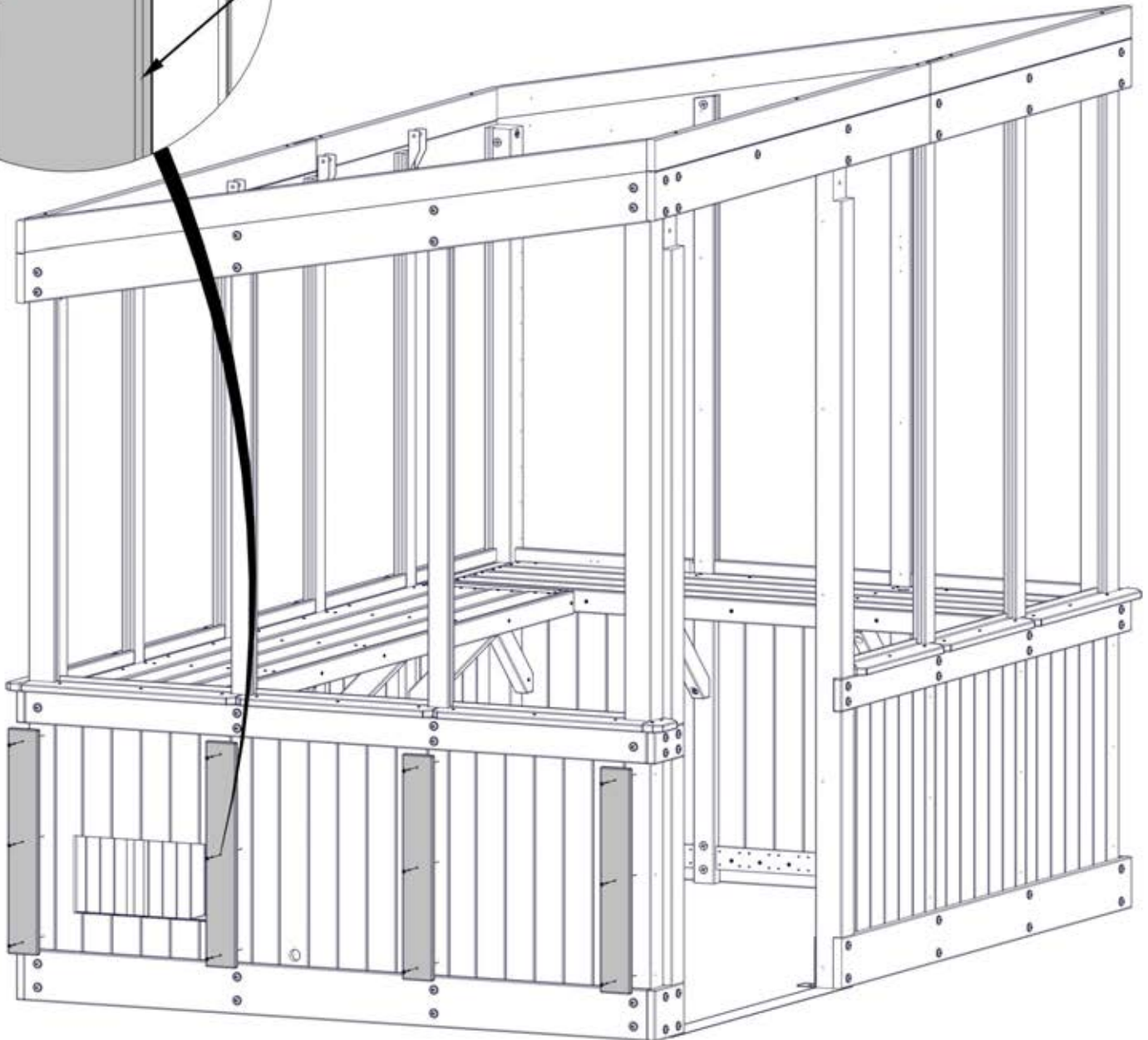
M01 COVER BOARD - W4L19227
(x4) 5/8"x3 3/8"x23 5/16" (16x86x592)



200 (x12)
SCREW - 1 1/2"

M01 (x4)
COVER BOARD

ATTACH COVER BOARDS USING PILOT HOLES IN UPRIGHTS AND POSTS.



STEP 34 - COVER BOARD ASSEMBLY

QTY	PART NUMBER	DESCRIPTION
18	H100200	SCREW PFH 8x1 1/2 BLK

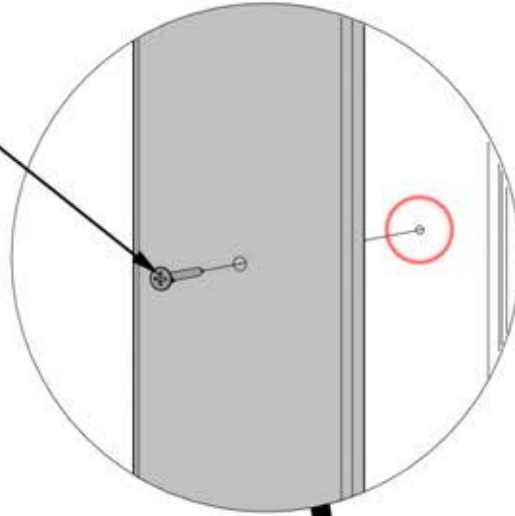


M01 COVER BOARD - W4L19227
(x4) 5/8"x3 3/8"x23 5/16" (16x86x592)

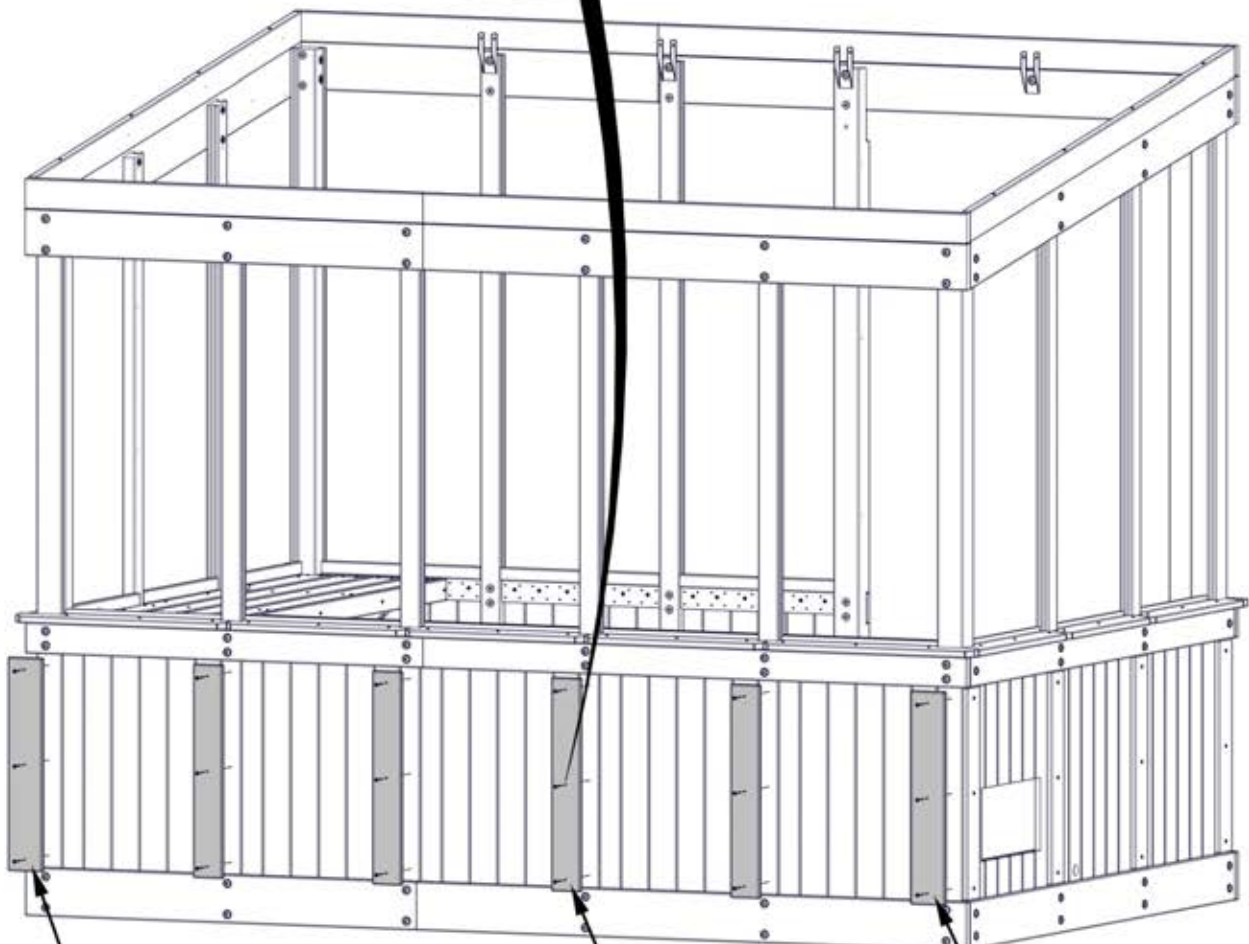


Y01 COVER BOARD - W4L19228
(x2) 5/8"x4"x23 5/16" (16x102x592)

200 (x18)
SCREW - 1 1/2"



ATTACH COVER BOARDS USING PILOT HOLES IN UPRIGHTS AND POSTS.



Y01 (x1)
COVER BOARD

M01 (x4)
COVER BOARD

Y01 (x1)
COVER BOARD

STEP 35 - COVER BOARD ASSEMBLY

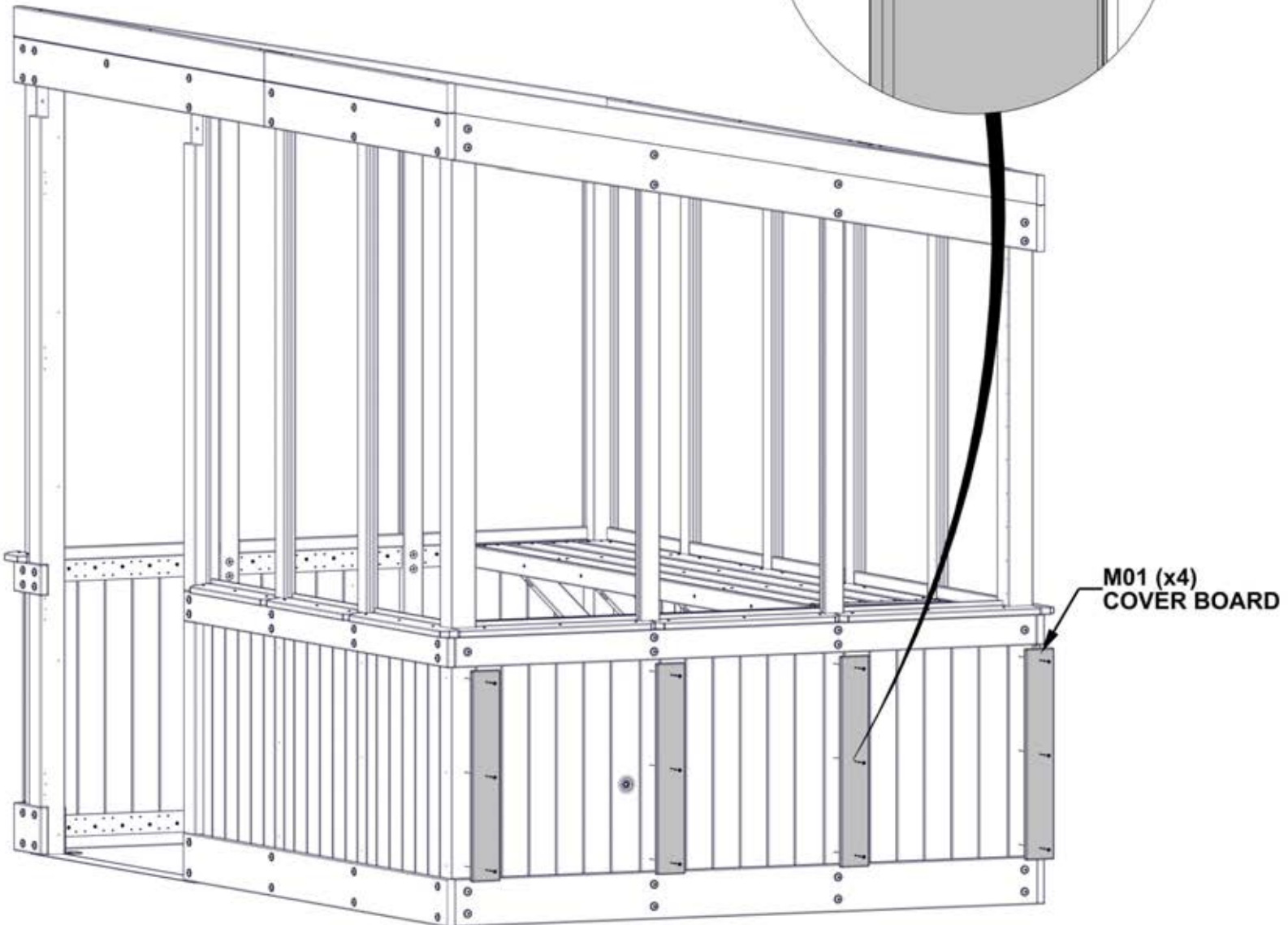
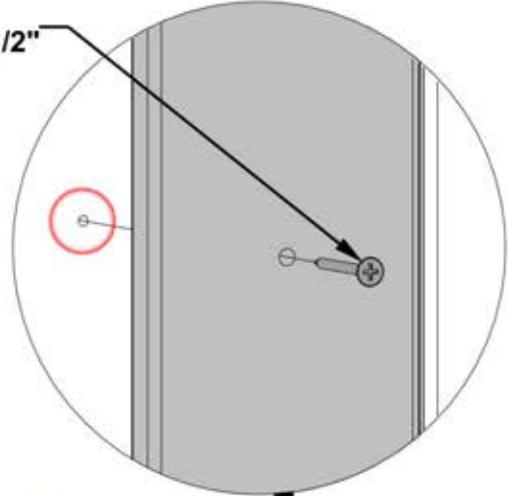
QTY	PART NUMBER	DESCRIPTION
12	H100200	SCREW PFH 8x1 1/2 BLK



M01 COVER BOARD - W4L19227
(x4) 5/8"x3 3/8"x23 5/16" (16x86x592)

ATTACH COVER BOARDS USING PILOT HOLES IN UPRIGHTS AND POSTS.

200 (x12)
SCREW - 1 1/2"



STEP 36 - COVER BOARD ASSEMBLY

QTY	PART NUMBER	DESCRIPTION
12	H100200	SCREW PFH 8x1 1/2 BLK

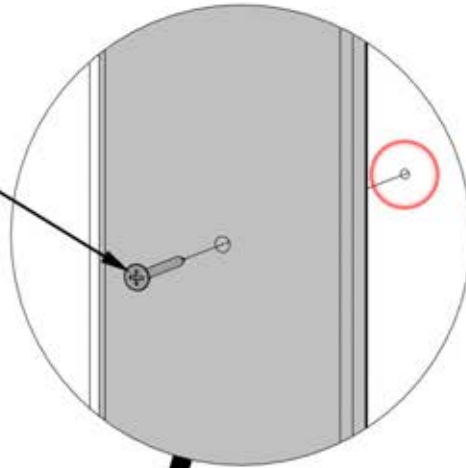


M01 COVER BOARD - W4L19227
(x3) 5/8"x3 3/8"x23 5/16" (16x86x592)

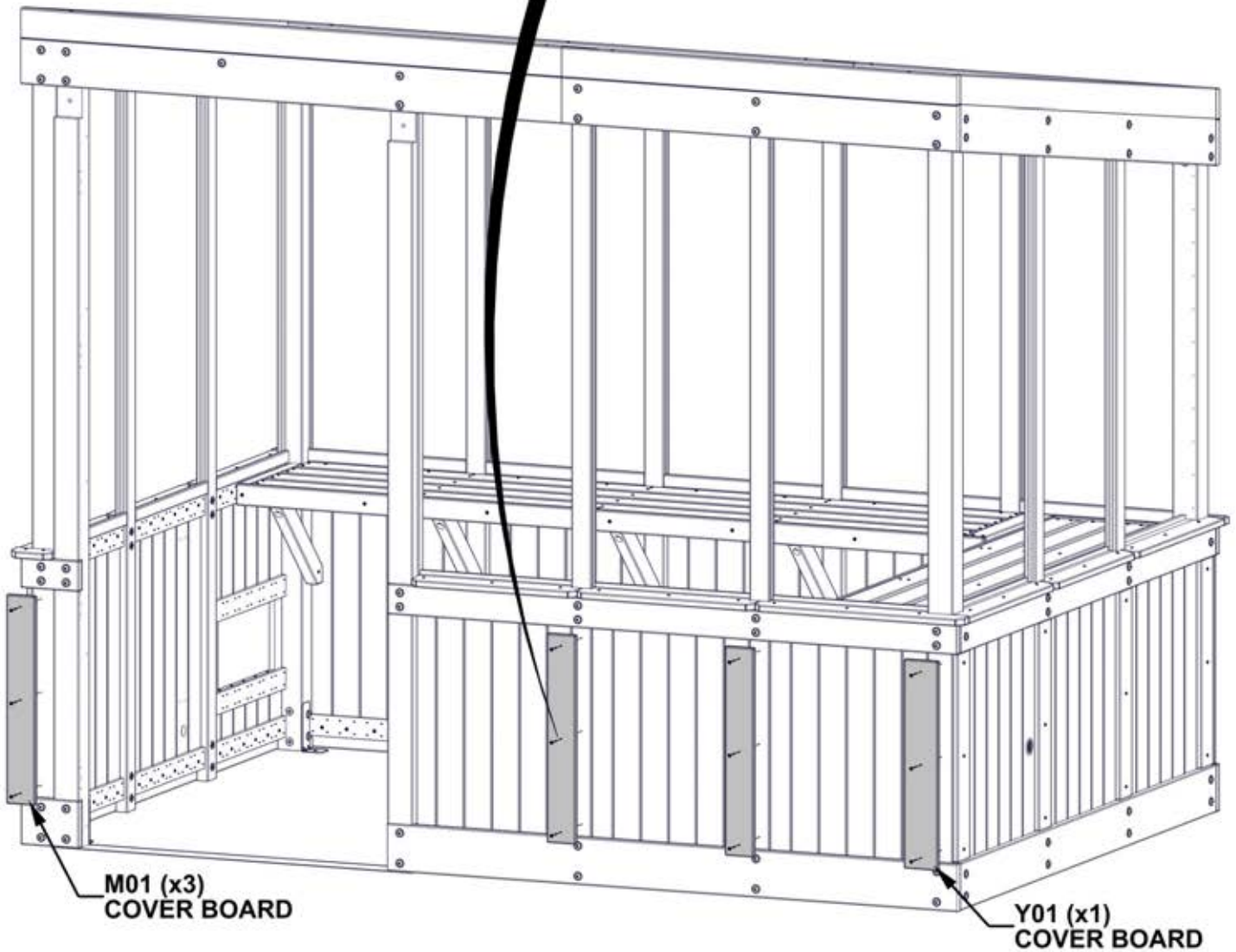


Y01 COVER BOARD - W4L19228
(x1) 5/8"x4"x23 5/16" (16x102x592)

200 (x12)
SCREW - 1 1/2"



ATTACH COVER BOARDS USING PILOT HOLES IN UPRIGHTS AND POSTS.



M01 (x3)
COVER BOARD

Y01 (x1)
COVER BOARD

STEP 37 - DOOR TRIM ASSEMBLY

QTY	PART NUMBER	DESCRIPTION
2	H100195	BOLT WH 5/16x2 3/4 BLK
2	H100198	WASHER LOCK EXT 8x19
2	H100379	TNUT-5/16" BLK



H06 DOOR TRIM - W4L19213
(x1) 15/16"x3 3/8"x43" (24x86x1092)

INSERT T-NUTS FIRST.

ENSURE H06 IS ORIENTED AS SHOWN. PILOT HOLES ARE TO THE BOTTOM OF BOARD AND FACING IN.

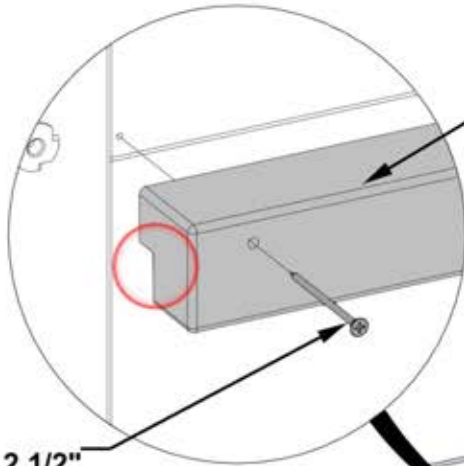


STEP 38 - DOOR TRIM ASSEMBLY

QTY	PART NUMBER	DESCRIPTION
3	H100201	SCREW PFH 8x2 1/2 BLK



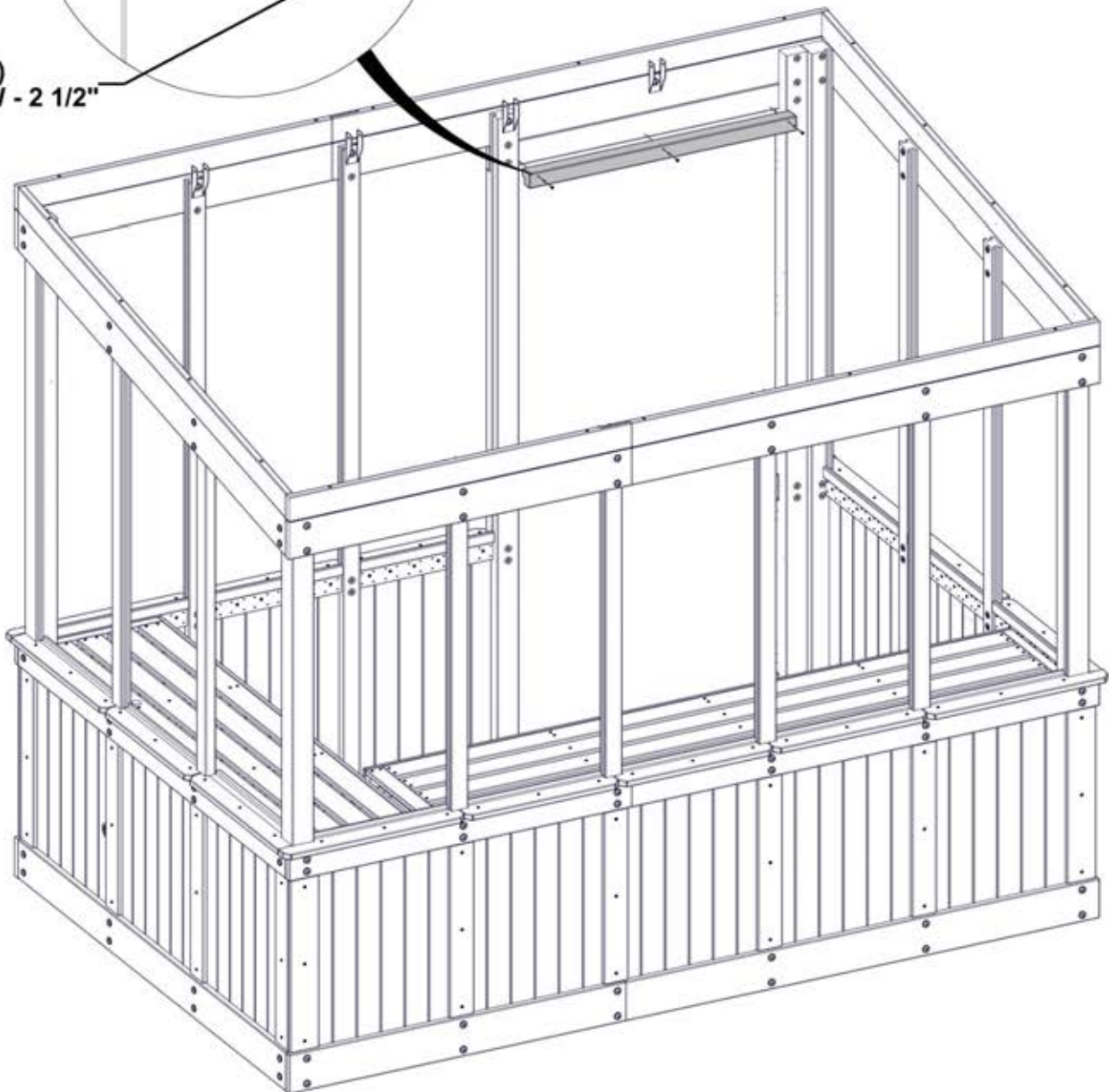
F07 DOOR TRIM - W4L19215
(x1) 1 7/8"x1 15/16"x37" (47x50x940)



F07 (x1)
DOOR TRIM

- ENSURE CORRECT ORIENTATION OF F07 WITH NOTCH FACING DOWN AND OUT.
- ALIGN WITH PILOT HOLES.
- ATTACH AS SHOWN.

201 (x3)
SCREW - 2 1/2"



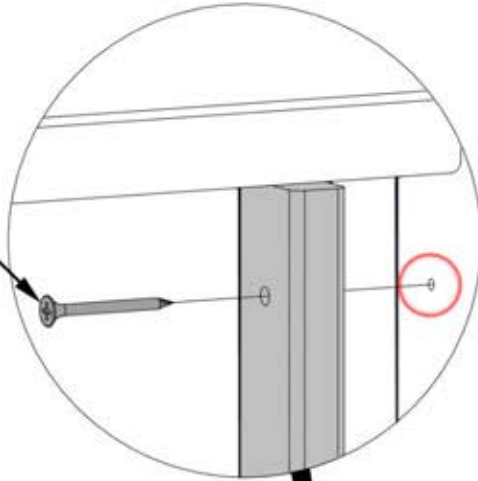
STEP 39 - DOOR TRIM ASSEMBLY

QTY	PART NUMBER	DESCRIPTION
10	H100200	SCREW PFH 8x1 1/2 BLK

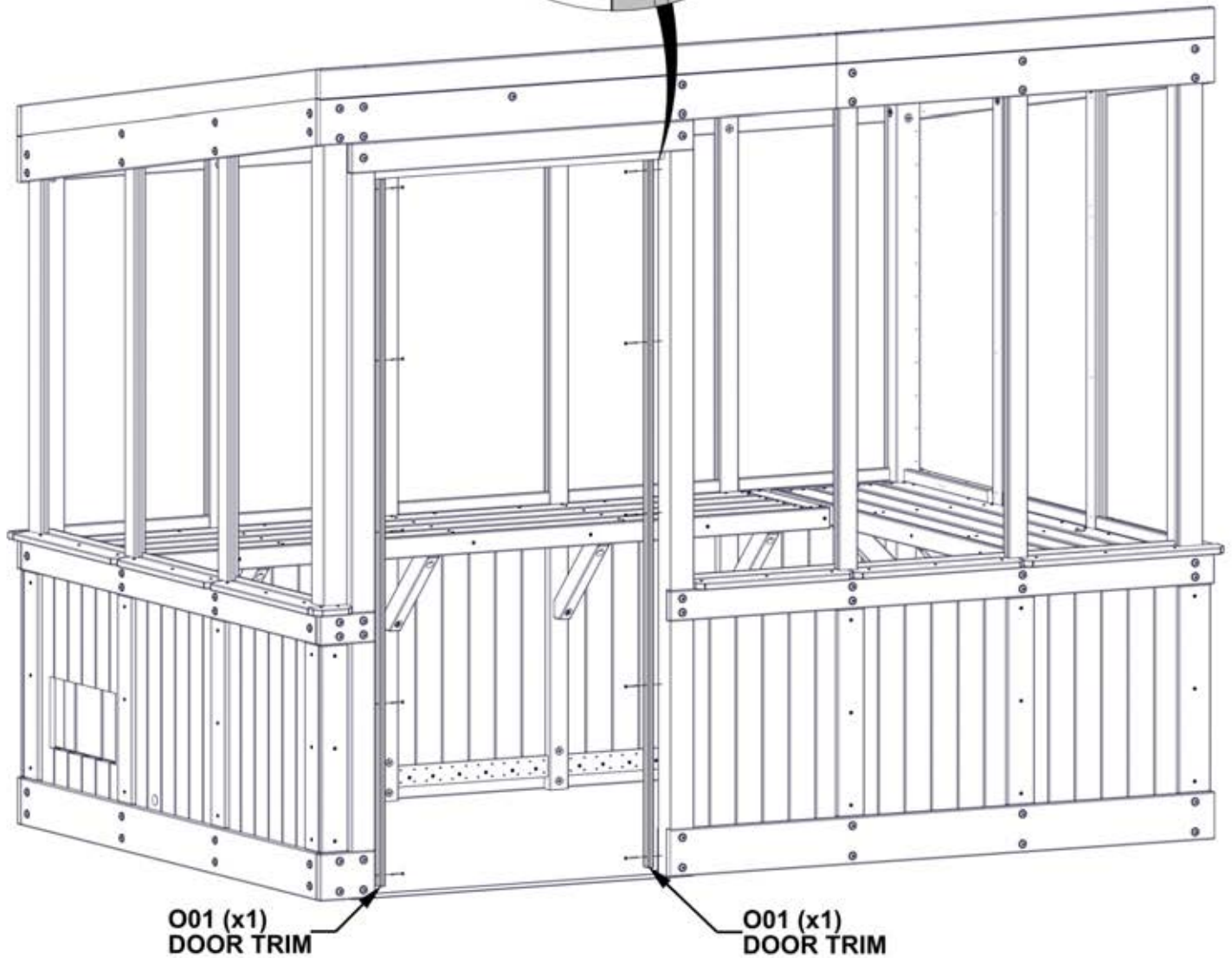


O01 DOOR TRIM - W4L19214
(x2) 5/8"x1 5/16"x79 3/8" (16x34x2016)

200 (x10)
SCREW - 1 1/2"



ATTACH O01 BOARDS USING
PILOT HOLES IN POSTS.



STEP 40 - WINDOW ASSEMBLY

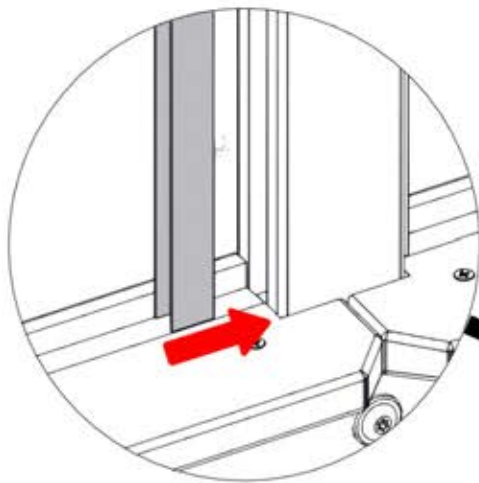
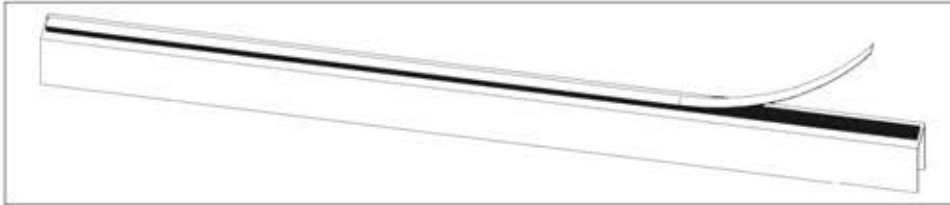
A6P00761 POLY CHANNEL
(x1)

A6P00762 POLY CHANNEL
(x2)

A6P00763 POLY CHANNEL
(x2)

A6P00764 POLY CHANNEL
(x1)

REMOVE TAPE LINER ON POLY CHANNELS BEFORE INSTALLING.



POLY SHEET SITS ON WINDOW SILL AND SLIDES INTO GROOVES IN UPRIGHTS AND POSTS. FIRMLY PRESS CHANNEL INTO GROOVE TO ENSURE TAPE ADHESION.

0764 (x1)
POLY CHANNEL

0763 (x1)
POLY CHANNEL

0762 (x1)
POLY CHANNEL

0761 (x1)
POLY CHANNEL

ENSURE CORRECT PLACEMENT OF EACH CHANNEL AS SHOWN.

POLYCARBONATE SHEETING INFORMATION - IMPORTANT!

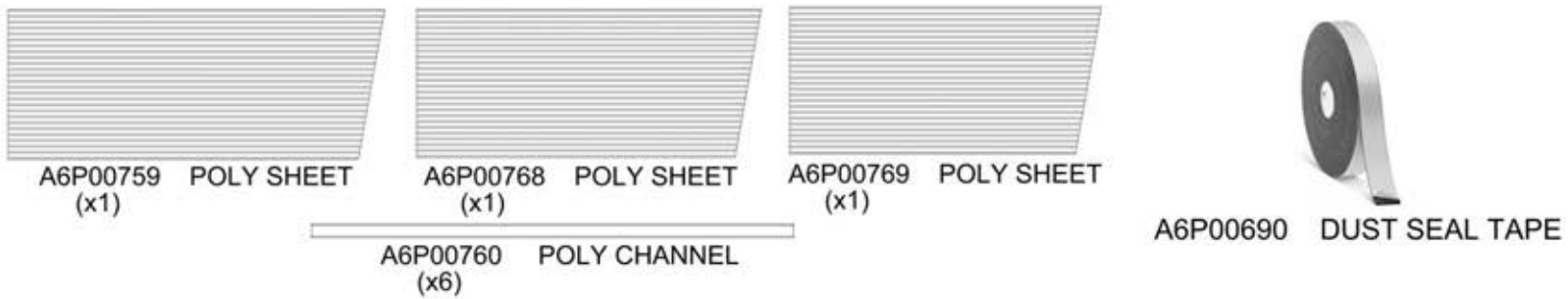
The Polycarbonate Sheeting has UV protection on ONE (1) SIDE.

CRITICAL to install with the UV protection facing the OUTSIDE

- Wear safety gloves to protect against any sharp edges during handling or install.
- Do NOT use knife or sharp object to remove protective film as it may result in damage to polycarbonate sheeting
- Leave film on during install to ensure UV side is facing outside.
- Peel protective film back from edges approximately 2" (5cm) during installation.
- Remove film completely after installation.

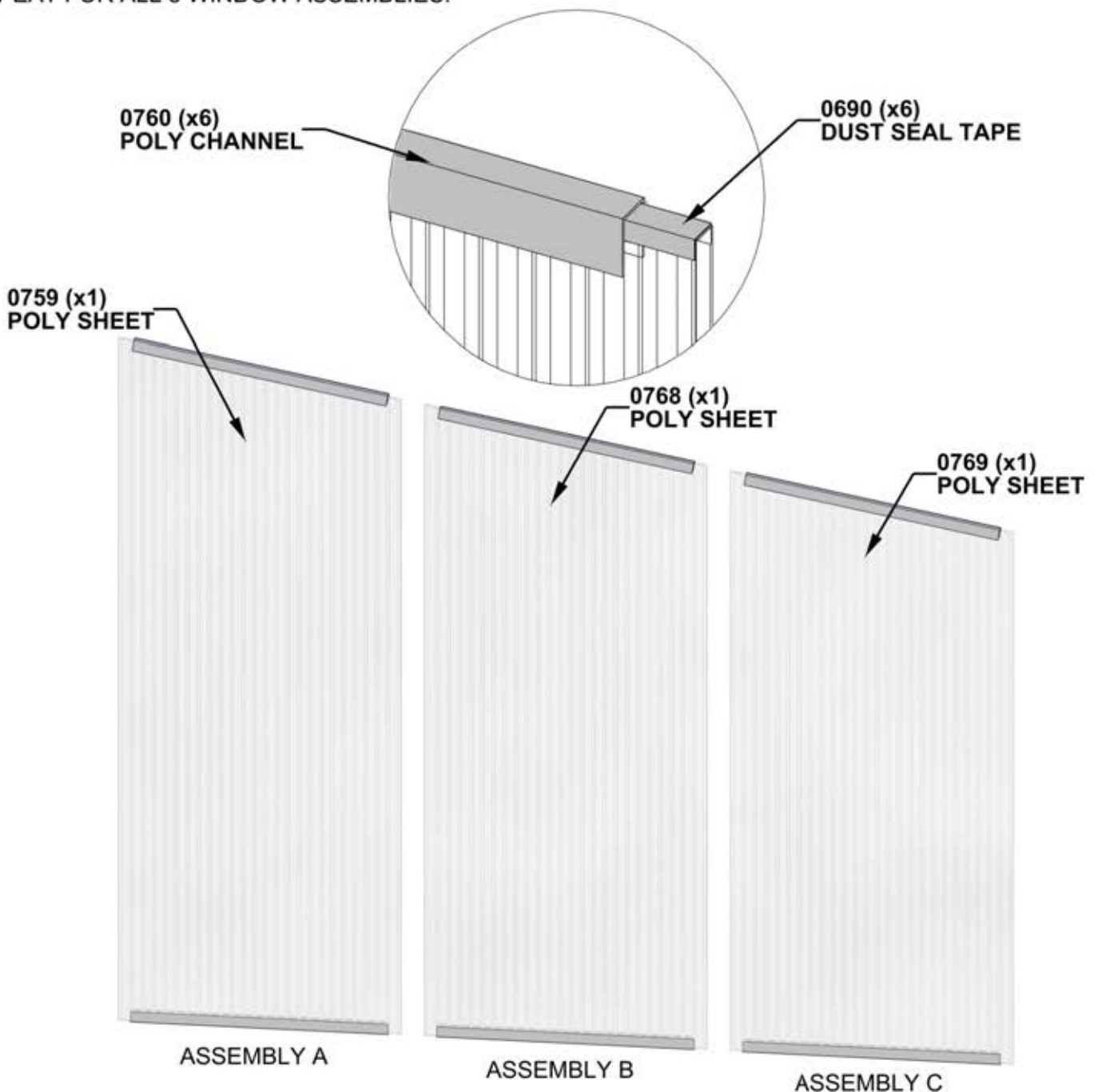
NOTE: Do not store polycarbonate sheeting with film outside in direct sunlight or rain. It may make removal of film more difficult.

STEP 41 - WINDOW ASSEMBLY



TO APPLY DUST SEAL TAPE AND POLY CHANNEL:

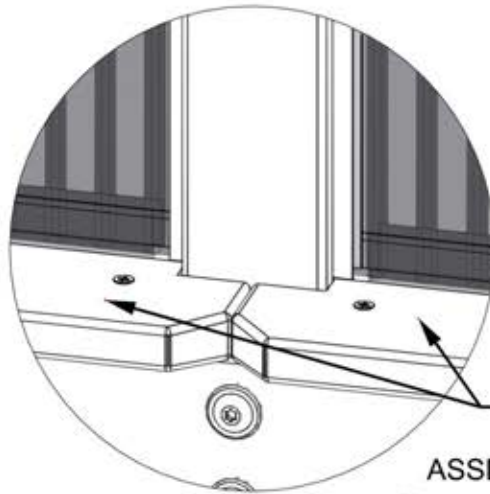
- CUT 2 STRIPS OF DUST SEAL TAPE THE SAME WIDTH AS THE POLY SHEET.
- WRAP DUST SEAL TAPE ALONG EDGE OF POLY SHEET WIDTH.
- AFTER TAPE IS SECURE, PUSH CHANNEL ON OVER THE TAPE, CENTERING ON THE POLY SHEET.
- REPEAT ON THE BOTTOM SIDE OF POLY SHEET.
- REPEAT FOR ALL 3 WINDOW ASSEMBLIES.



STEP 42 - WINDOW ASSEMBLY

IMPORTANT!

- ENSURE UV SIDE OF WINDOWS ARE FACING OUTSIDE.
- ONCE WINDOWS ARE INSTALLED, IT IS SAFE TO REMOVE THE PROTECTIVE FILM.

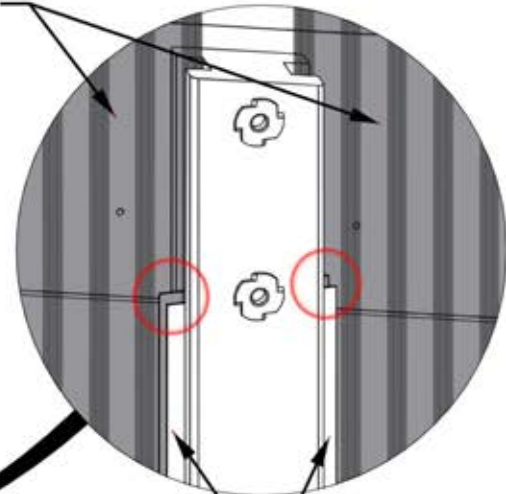


WINDOW SILLS

OUTSIDE VIEW

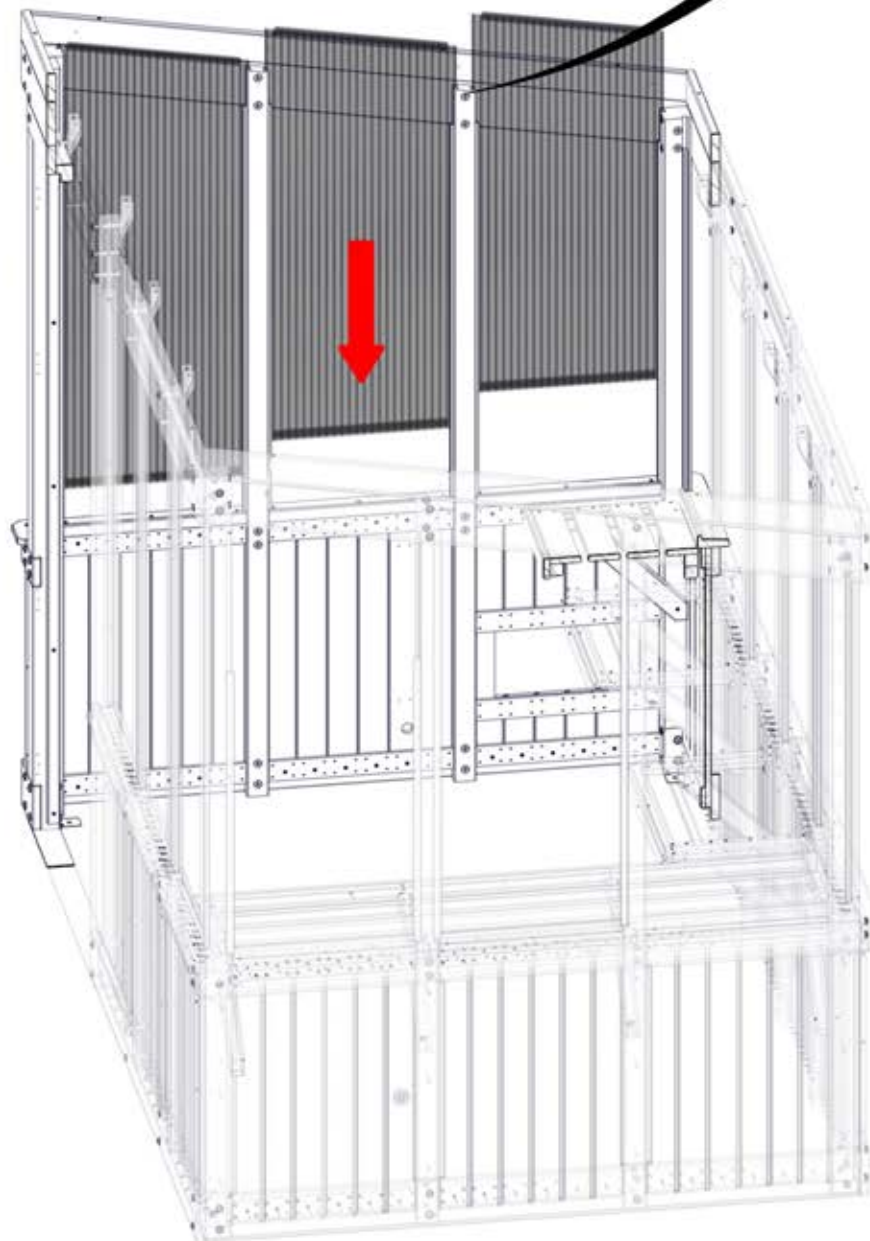
WINDOW ASSEMBLIES FROM STEP 41

INSERT WINDOW POLY SHEET INTO POLY CHANNEL ON BOTH SIDES OF WINDOW. GENTLY SLIDE WINDOW DOWN UNTIL IT IS EVENLY SEATED ON WINDOW SILL.

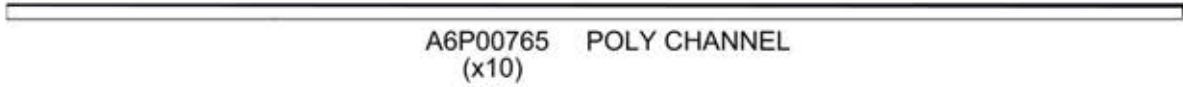


POLY CHANNEL FROM STEP 40

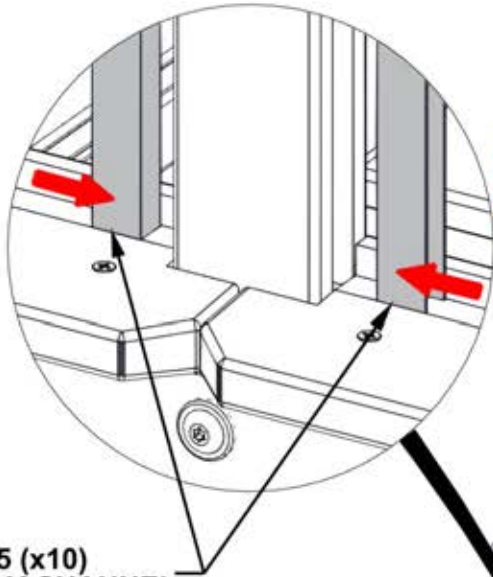
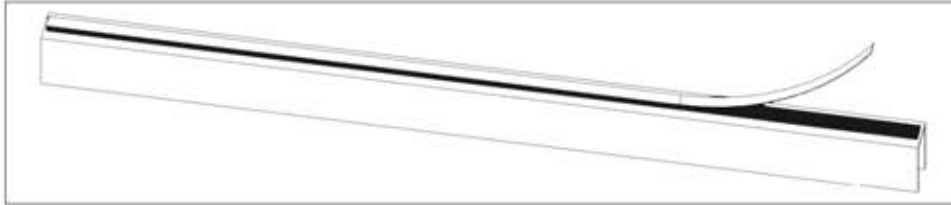
ASSEMBLY A ASSEMBLY B ASSEMBLY C



STEP 43 - WINDOW ASSEMBLY

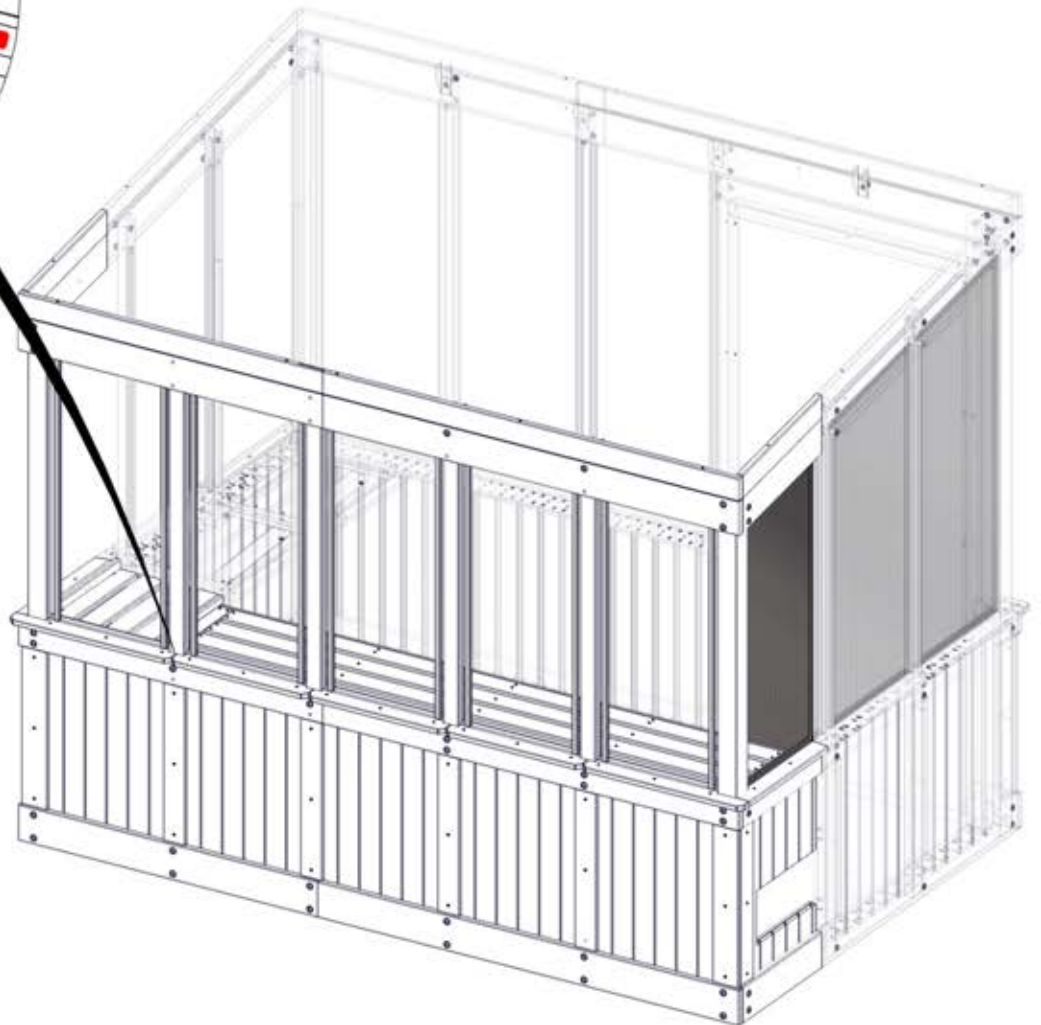


REMOVE TAPE LINER ON POLY CHANNELS BEFORE INSTALLING.



POLY CHANNEL SITS ON WINDOW SILL AND SLIDES INTO GROOVES IN UPRIGHTS AND POSTS. FIRMLY PRESS CHANNEL INTO GROOVE TO ENSURE TAPE ADHESION.

**0765 (x10)
POLY CHANNEL**



STEP 44 - WINDOW ASSEMBLY



A6P00770 POLY SHEET
(x5)



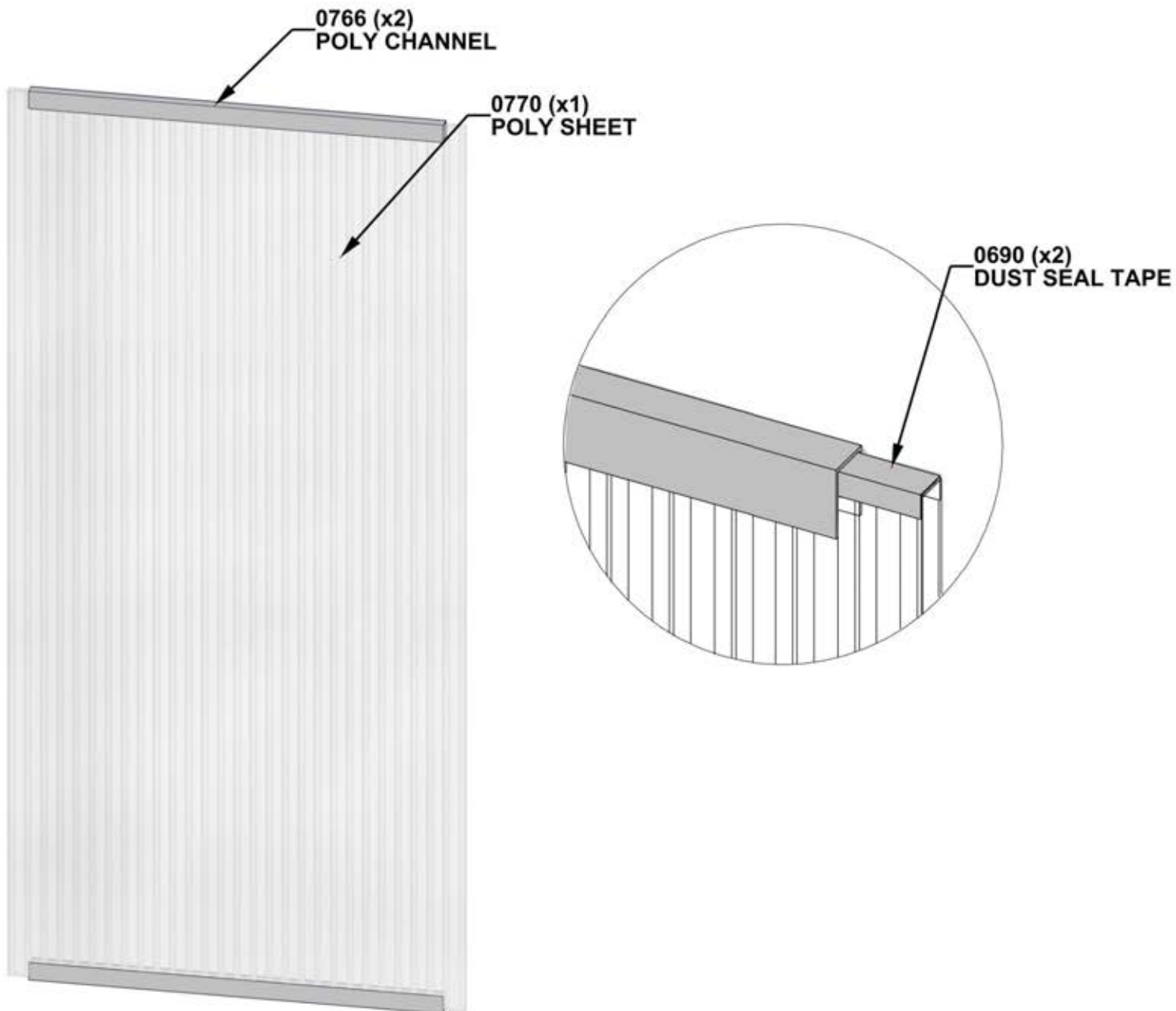
A6P00766 POLY CHANNEL
(x10)



A6P00690 DUST SEAL TAPE

TO APPLY DUST SEAL TAPE AND POLY CHANNEL:

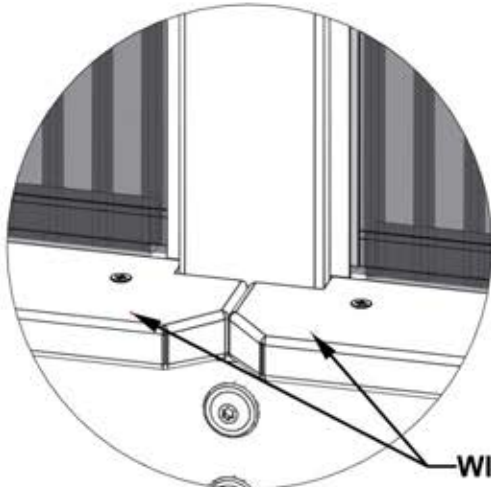
- CUT 2 STRIPS OF DUST SEAL TAPE THE SAME WIDTH AS THE POLY SHEET.
- WRAP DUST SEAL TAPE ALONG EDGE OF POLY SHEET WIDTH.
- AFTER TAPE IS SECURE, PUSH CHANNEL ON OVER THE TAPE, CENTERING ON THE POLY SHEET.
- REPEAT ON THE BOTTOM SIDE OF POLY SHEET.
- REPEAT FOR ALL 5 WINDOW ASSEMBLIES.



STEP 45 - WINDOW ASSEMBLY

IMPORTANT!

- ENSURE UV SIDE OF WINDOWS ARE FACING OUTSIDE.
- ONCE WINDOWS ARE INSTALLED, IT IS SAFE TO REMOVE THE PROTECTIVE FILM.

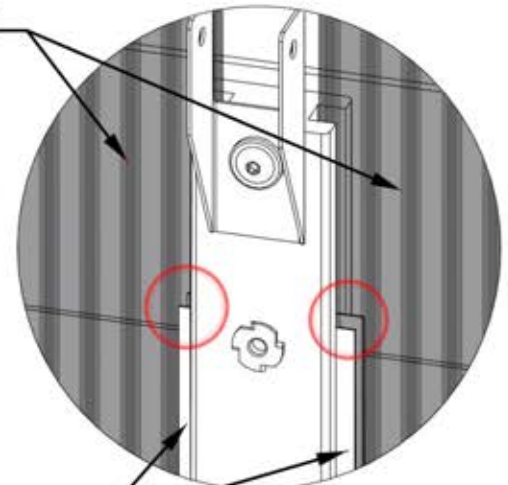


OUTSIDE VIEW

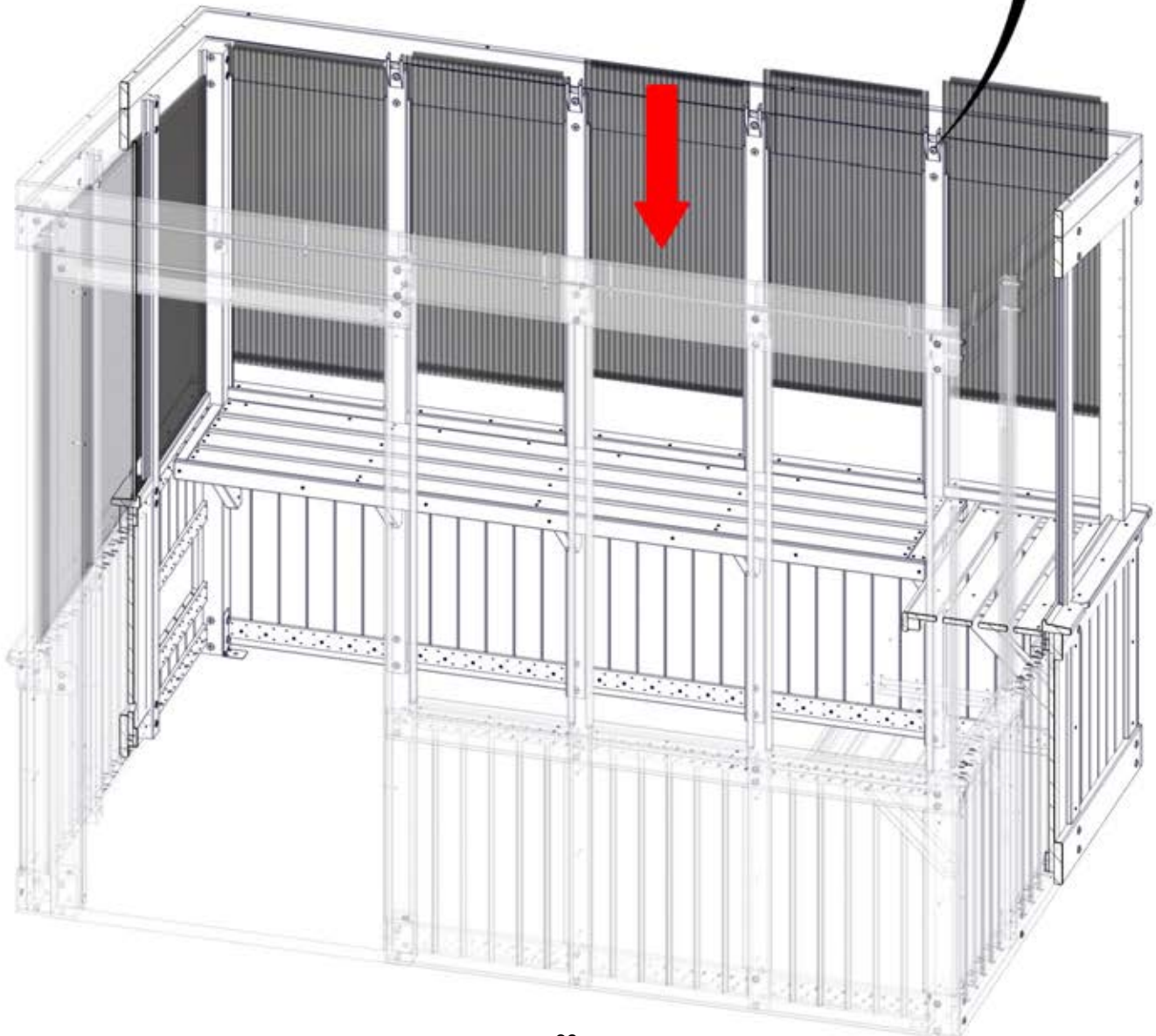
WINDOW SILLS

WINDOW ASSEMBLIES FROM STEP 44

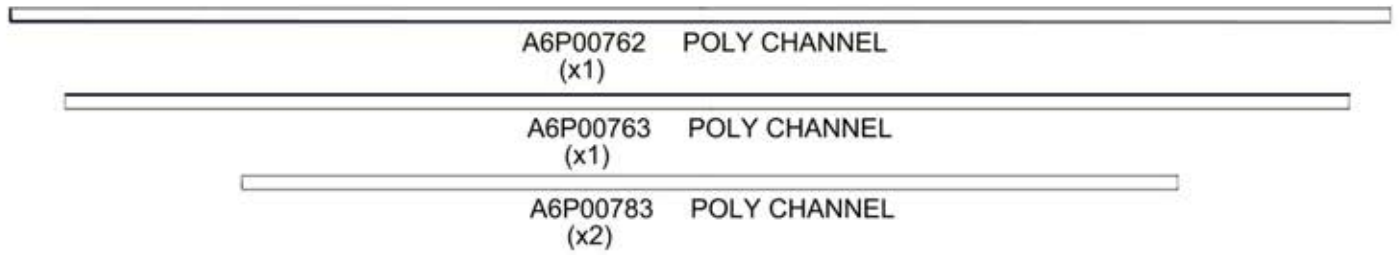
INSERT WINDOW POLY SHEET INTO POLY CHANNEL ON BOTH SIDES OF WINDOW. GENTLY SLIDE WINDOW DOWN UNTIL IT IS EVENLY SEATED ON WINDOW SILL.



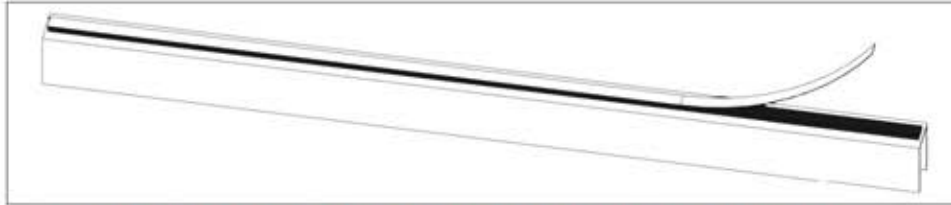
POLY CHANNEL FROM STEP 43



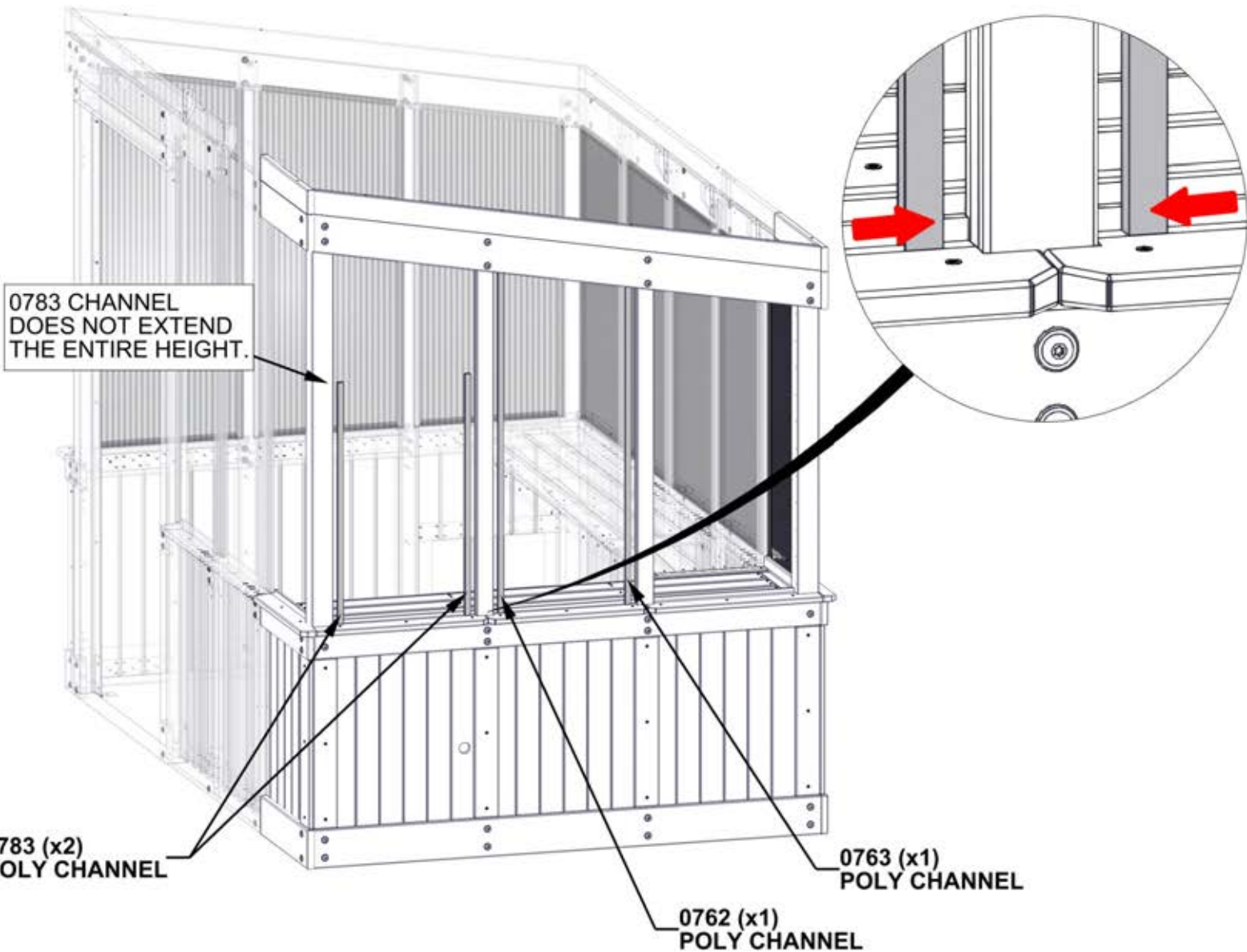
STEP 46 - WINDOW ASSEMBLY



REMOVE TAPE LINER ON POLY CHANNELS BEFORE INSTALLING.



POLY CHANNEL SITS ON WINDOW SILL AND SLIDES INTO GROOVES IN UPRIGHTS AND POSTS. FIRMLY PRESS CHANNEL INTO GROOVE TO ENSURE TAPE



STEP 47 - WINDOW ASSEMBLY



A6P00798 POLY SHEET
(x1)



A6P00784 POLY SHEET
(x1)



A6P00690 DUST SEAL TAPE

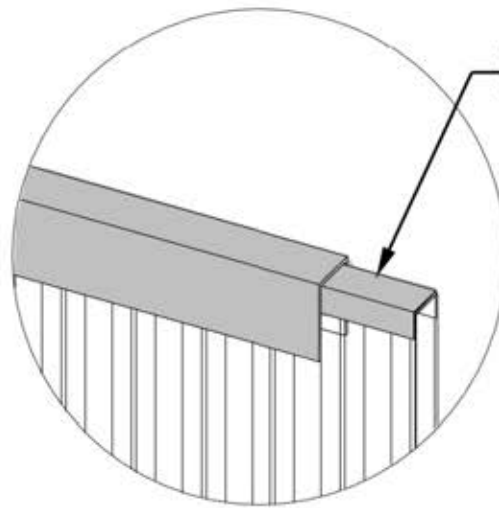


A6P00760 POLY CHANNEL
(x4)

TO APPLY DUST SEAL TAPE AND POLY CHANNEL:

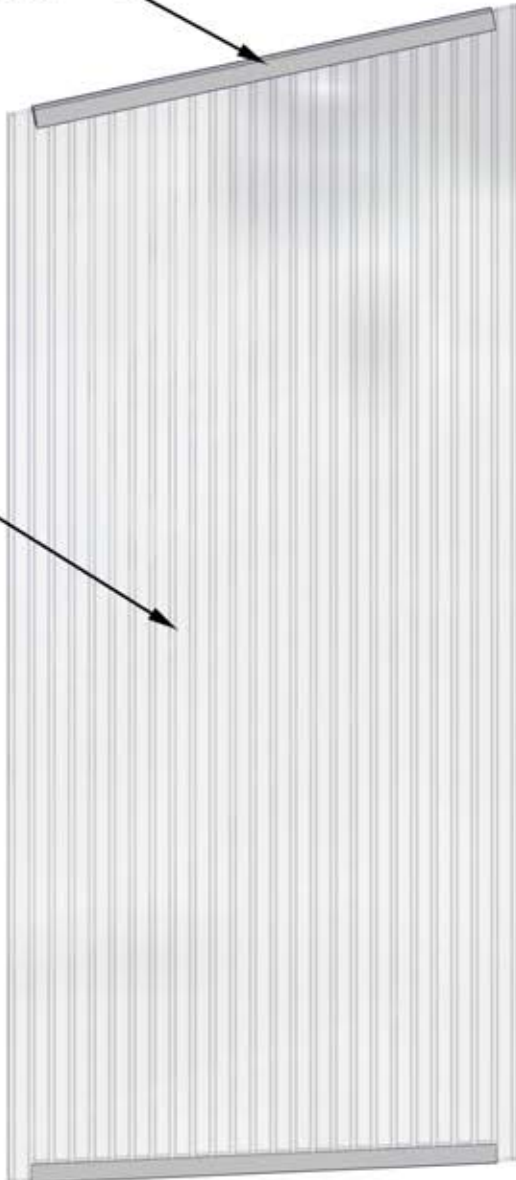
- CUT 2 STRIPS OF DUST SEAL TAPE THE SAME WIDTH AS THE POLY SHEET.
- WRAP DUST SEAL TAPE ALONG EDGE OF POLY SHEET WIDTH.
- AFTER TAPE IS SECURE, PUSH CHANNEL ON OVER THE TAPE, CENTERING ON THE POLY SHEET.
- REPEAT ON THE BOTTOM SIDE OF POLY SHEET.
- REPEAT FOR BOTH WINDOW ASSEMBLIES.

0760 (x4)
POLY CHANNEL

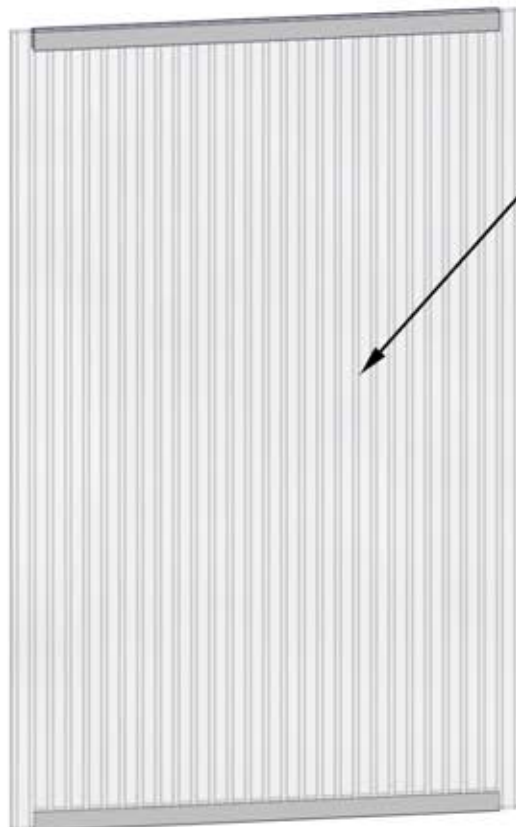


0690 (x4)
DUST SEAL TAPE

0798 (x1)
POLY SHEET



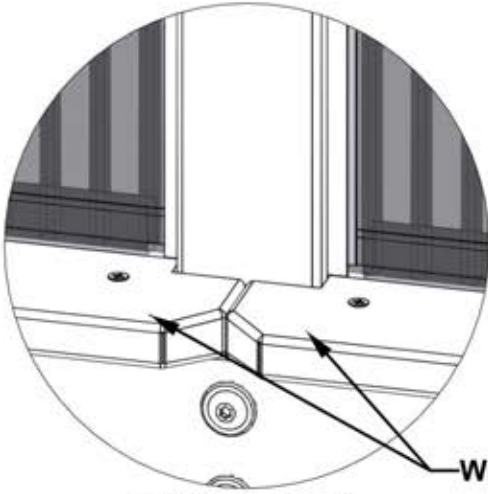
0784 (x1)
POLY SHEET



STEP 48 - WINDOW ASSEMBLY

IMPORTANT!

- ENSURE UV SIDE OF WINDOWS ARE FACING OUTSIDE.
- ONCE WINDOWS ARE INSTALLED, IT IS SAFE TO REMOVE THE PROTECTIVE FILM.



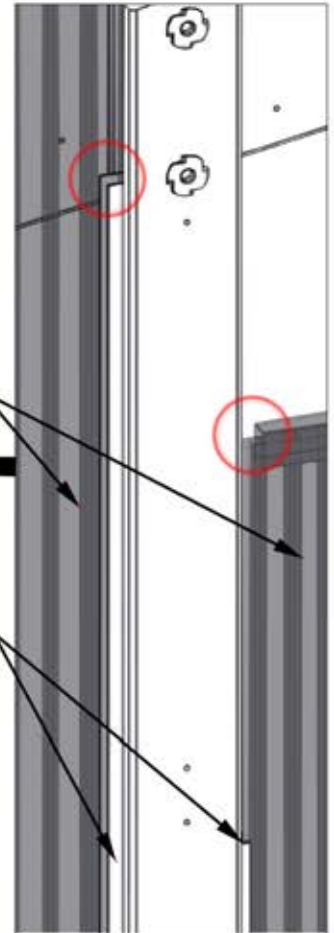
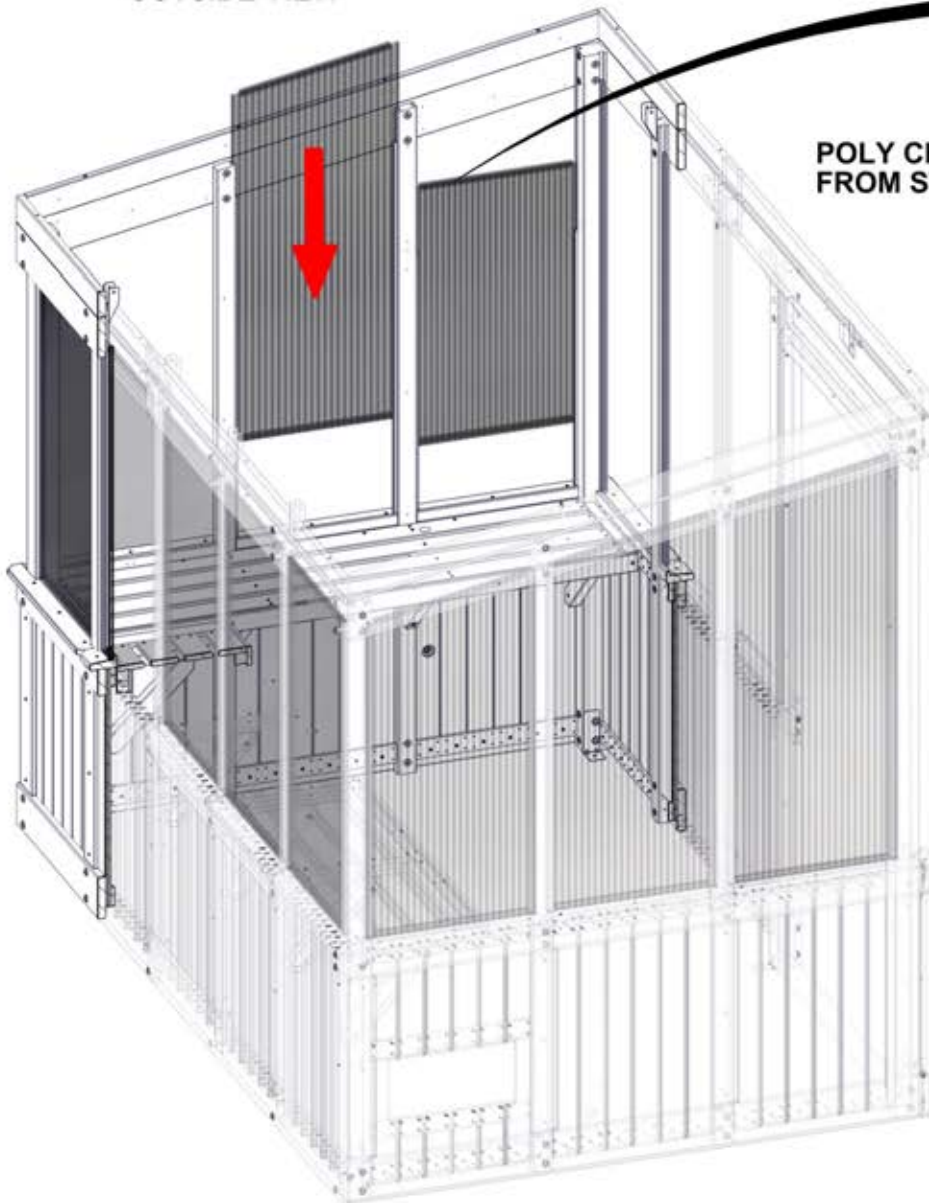
OUTSIDE VIEW

INSERT WINDOW POLY SHEET INTO POLY CHANNEL ON BOTH SIDES OF WINDOW. GENTLY SLIDE WINDOW DOWN UNTIL IT IS EVENLY SEATED ON WINDOW SILL.

WINDOW SILLS

WINDOW ASSEMBLIES FROM STEP 47

POLY CHANNEL FROM STEP 46



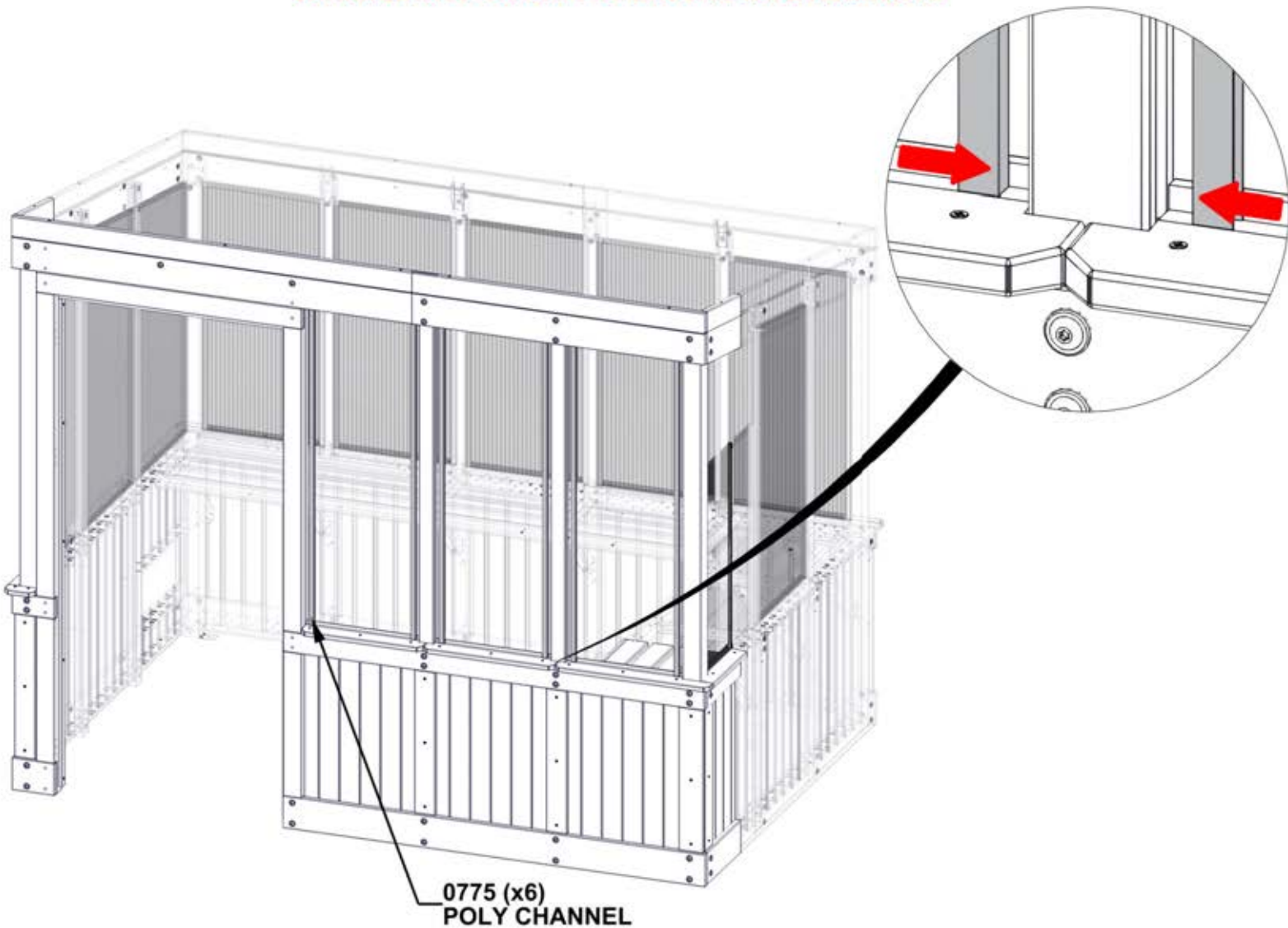
STEP 49 - WINDOW ASSEMBLY

A6P00775 POLY CHANNEL
(x6)

REMOVE TAPE LINER ON POLY CHANNELS BEFORE INSTALLING.



POLY CHANNEL SITS ON WINDOW SILL AND SLIDES INTO GROOVES IN UPRIGHTS AND POSTS. FIRMLY PRESS CHANNEL INTO GROOVE TO ENSURE TAPE ADHESION.



STEP 50 - WINDOW ASSEMBLY



A6P00774 POLY SHEET
(x2)



A6P00777 POLY SHEET
(x1)



A6P00690 DUST SEAL
TAPE



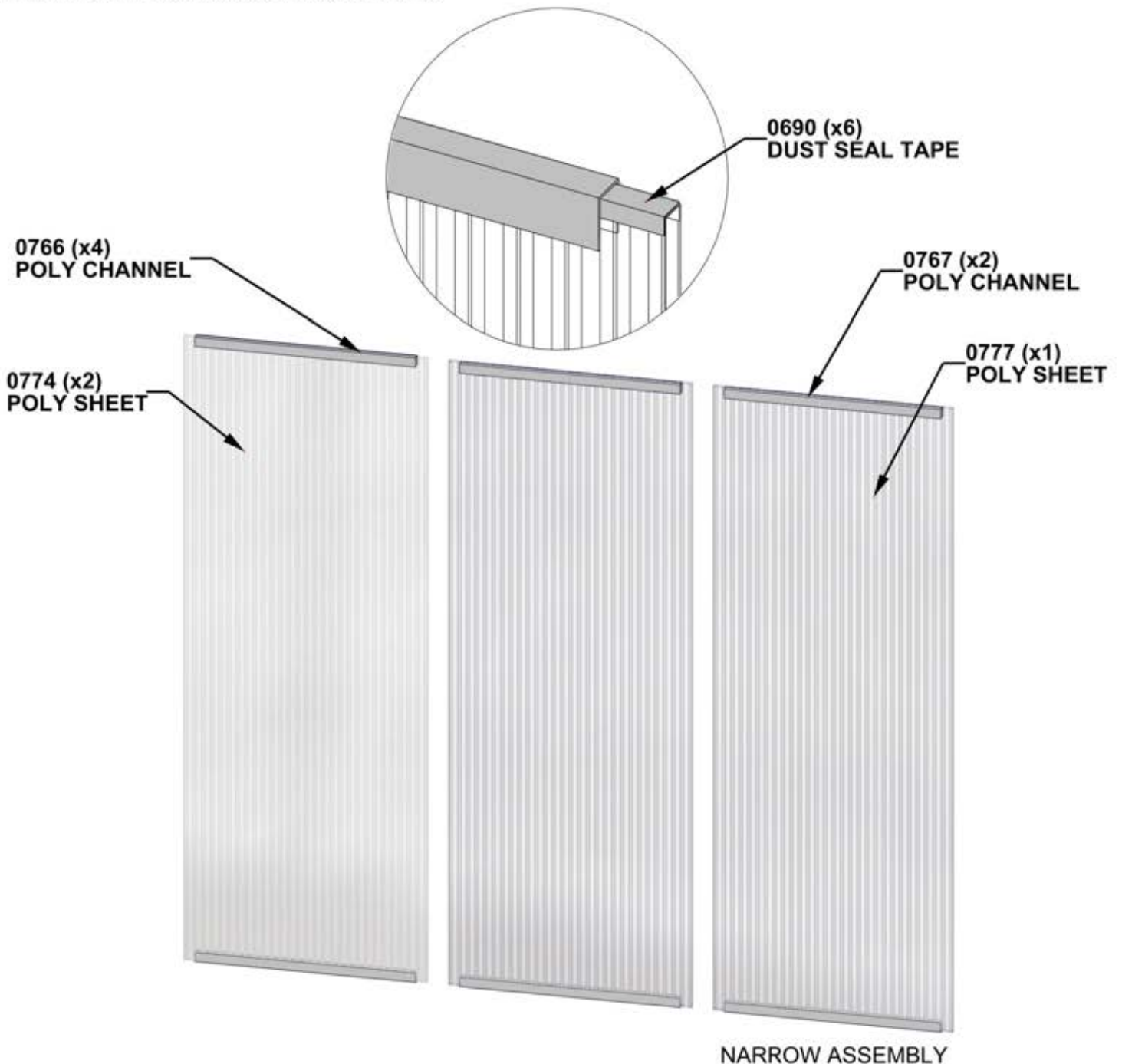
A6P00766 POLY CHANNEL
(x4)



A6P00767 POLY CHANNEL
(x2)

TO APPLY DUST SEAL TAPE AND POLY CHANNEL:

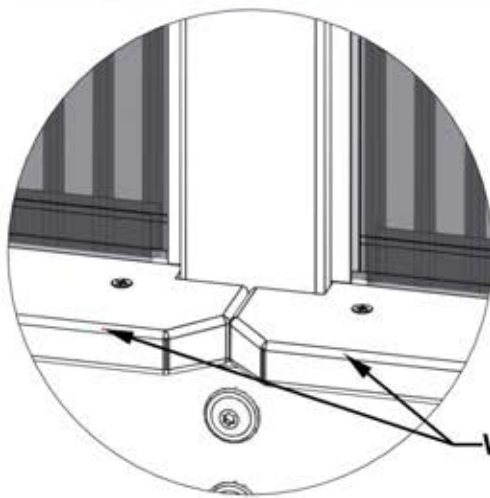
- CUT 2 STRIPS OF DUST SEAL TAPE THE SAME WIDTH AS THE POLY SHEET.
- WRAP DUST SEAL TAPE ALONG EDGE OF POLY SHEET WIDTH.
- AFTER TAPE IS SECURE, PUSH CHANNEL ON OVER THE TAPE, CENTERING ON THE POLY SHEET.
- REPEAT ON THE BOTTOM SIDE OF POLY SHEET.
- REPEAT FOR ALL 3 WINDOW ASSEMBLIES.



STEP 51 - WINDOW ASSEMBLY

IMPORTANT!

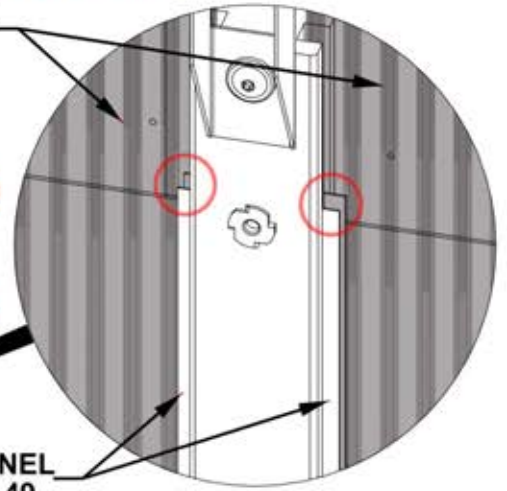
- ENSURE UV SIDE OF WINDOWS ARE FACING OUTSIDE.
- ONCE WINDOWS ARE INSTALLED, IT IS SAFE TO REMOVE THE PROTECTIVE FILM.



OUTSIDE VIEW

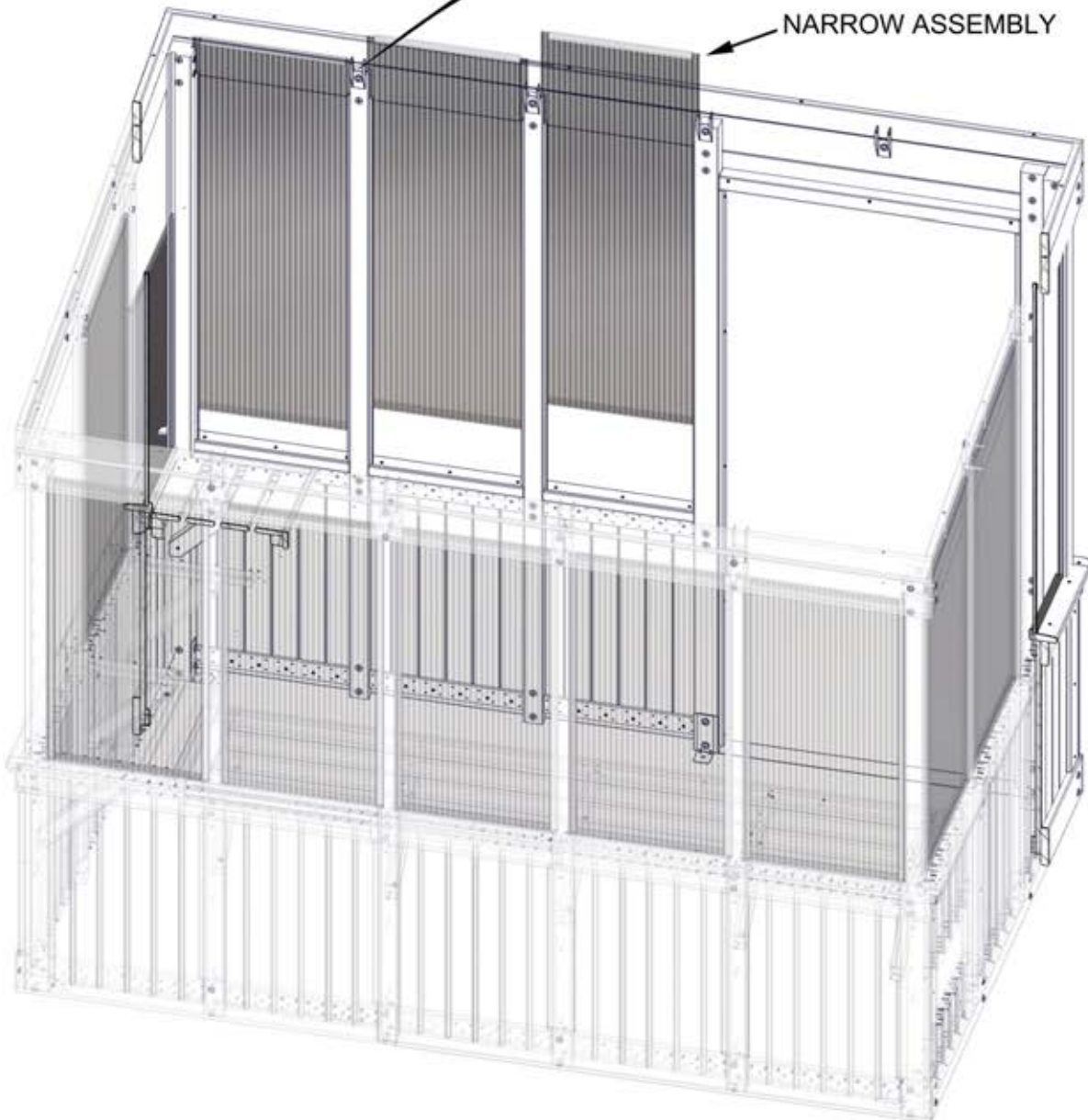
INSERT WINDOW POLY SHEET INTO POLY CHANNEL ON BOTH SIDES OF WINDOW. GENTLY SLIDE WINDOW DOWN UNTIL IT IS EVENLY SEATED ON WINDOW SILL.

WINDOW ASSEMBLIES FROM STEP 50



POLY CHANNEL FROM STEP 49

NARROW ASSEMBLY



STEP 52 - WINDOW ASSEMBLY

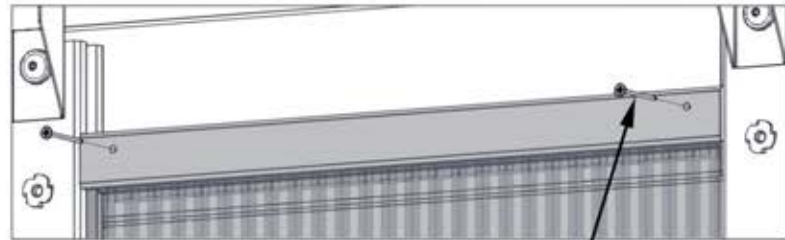
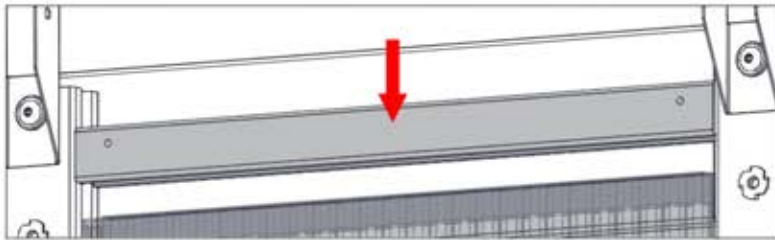
QTY	PART NUMBER	DESCRIPTION
6	H100391	SCREW PFH 8x2 BLK



P02 WINDOW CAP - W4L19199
(x2) 1 7/16"x1 7/16"x18 7/8" (36x36x480)



P05 WINDOW CAP - W4L19216
(x1) 1 7/16"x1 7/16"x18 9/16" (36x36x472)

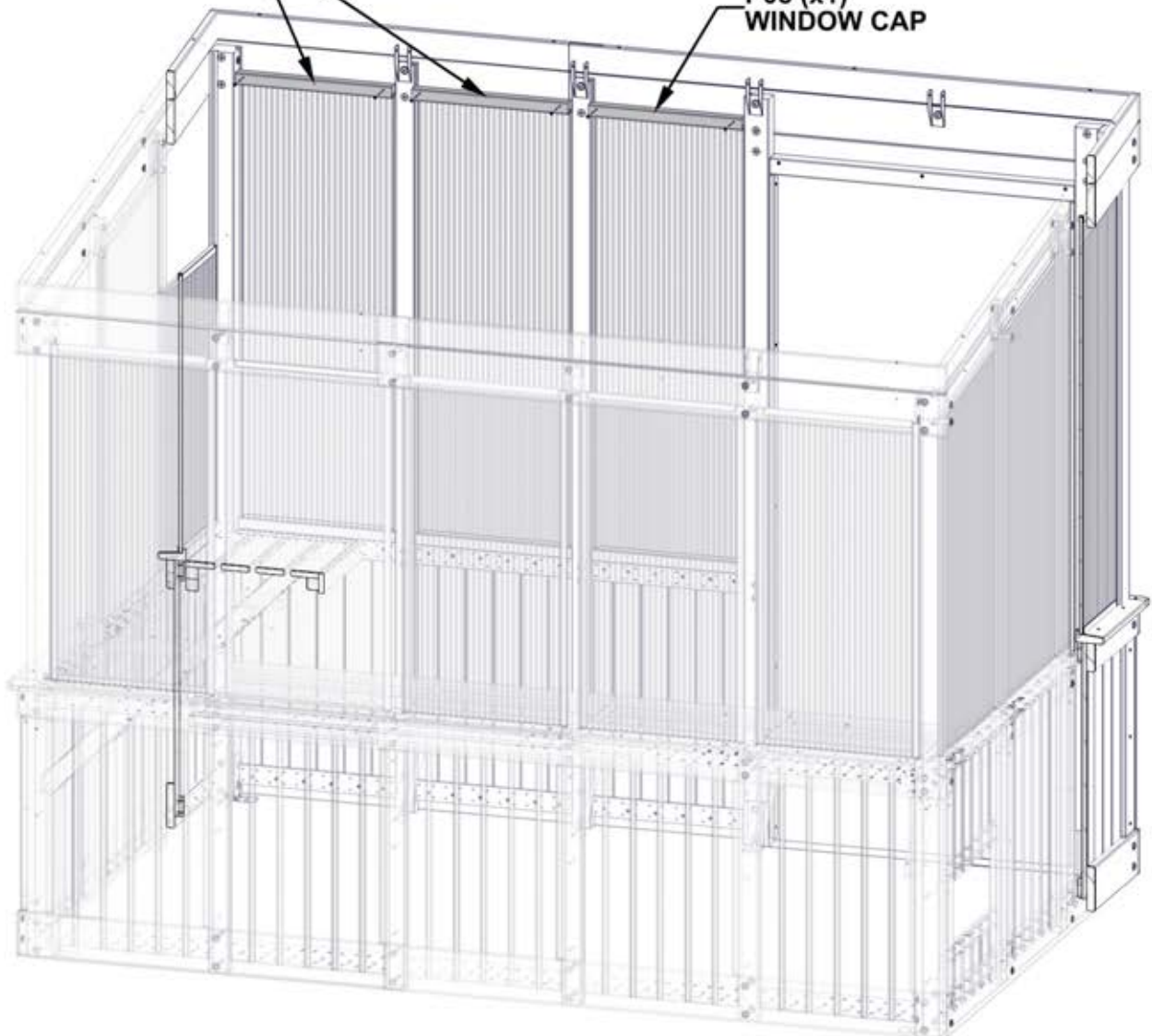


FIRST, SLIDE DOWN WINDOW CAPS WITH THE WINDOW ASSEMBLY FITTING INTO THE GROOVE, THEN SCREW INTO PLACE.

P02 (x2)
WINDOW CAP

391 (x6)
SCREW - 2"

P05 (x1)
WINDOW CAP

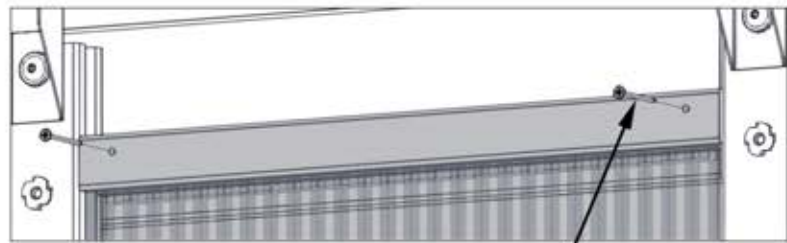
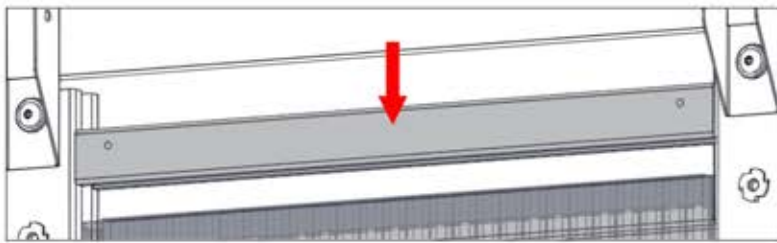


STEP 53 - WINDOW ASSEMBLY

QTY	PART NUMBER	DESCRIPTION
6	H100391	SCREW PFH 8x2 BLK



P01 WINDOW CAP - W4L19190
(x3) 1 7/16"x1 7/16"x20 1/2" (36x36x520)



FIRST, SLIDE DOWN WINDOW CAPS WITH THE WINDOW ASSEMBLY FITTING INTO THE GROOVE, THEN SCREW INTO PLACE.

P01 (x3)
WINDOW CAP

391 (x6)
SCREW - 2"

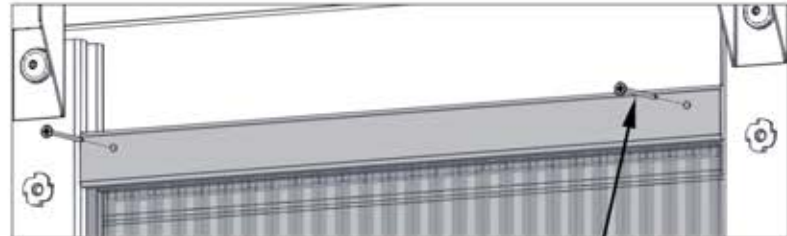
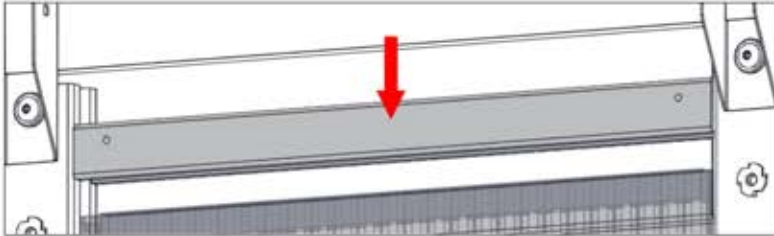


STEP 54 - WINDOW ASSEMBLY

QTY	PART NUMBER	DESCRIPTION
10	H100391	SCREW PFH 8x2 BLK



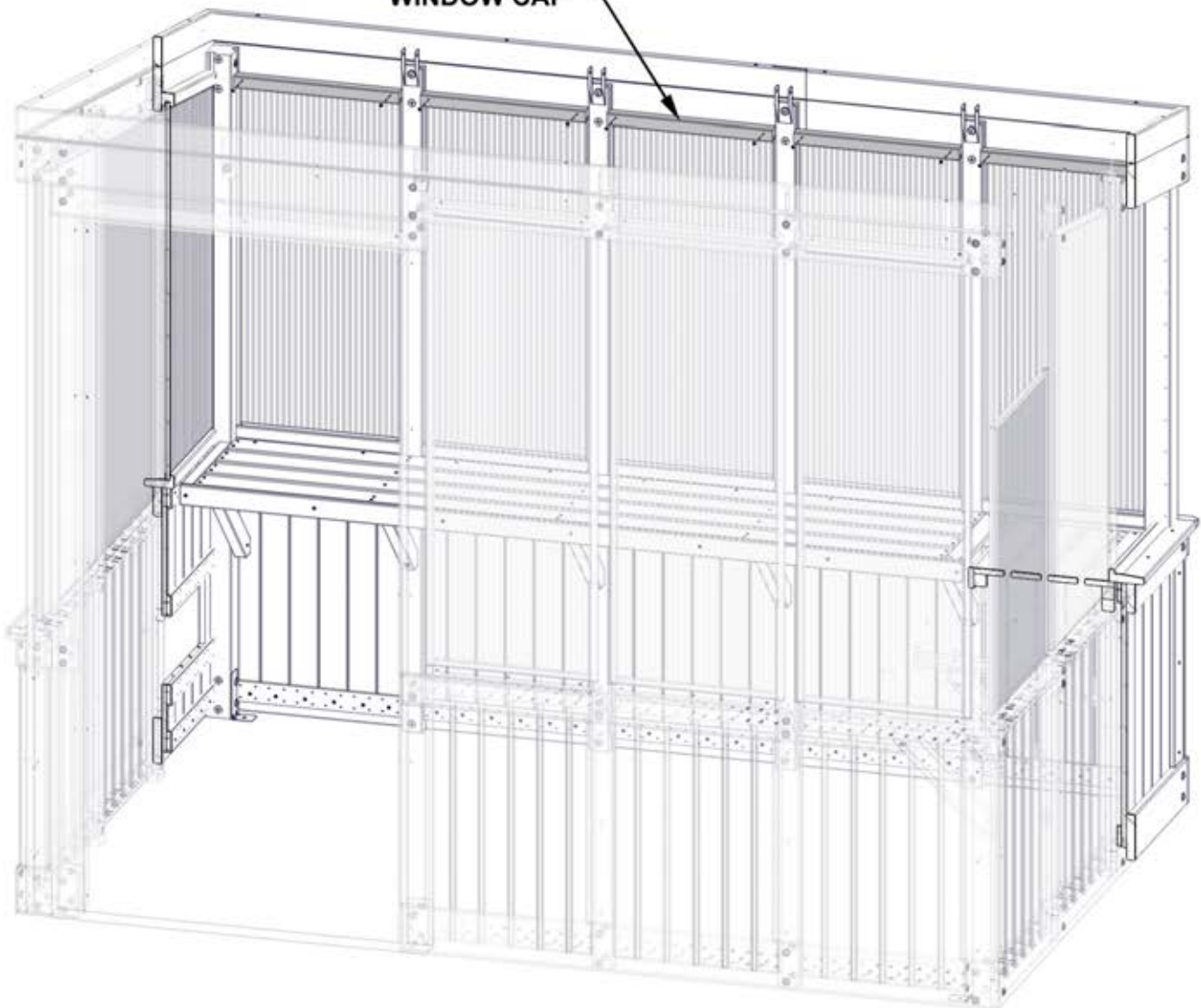
P02 WINDOW CAP - W4L19199
(x5) 1 7/16"x1 7/16"x18 7/8" (36x36x480)



FIRST, SLIDE DOWN WINDOW CAPS WITH THE WINDOW ASSEMBLY FITTING INTO THE GROOVE, THEN SCREW INTO PLACE.

391 (x10)
SCREW - 2"

P02 (x5)
WINDOW CAP

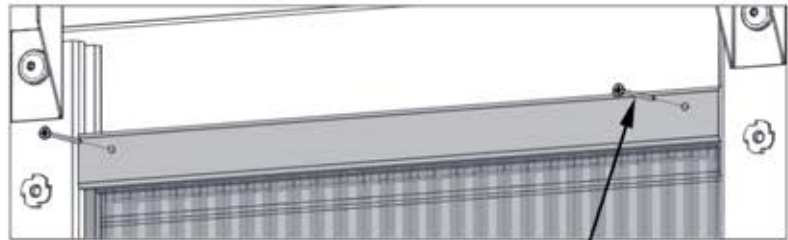
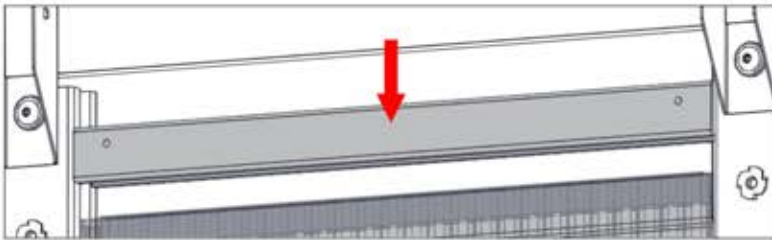


STEP 55 - WINDOW ASSEMBLY

QTY	PART NUMBER	DESCRIPTION
2	H100391	SCREW PFH 8x2 BLK

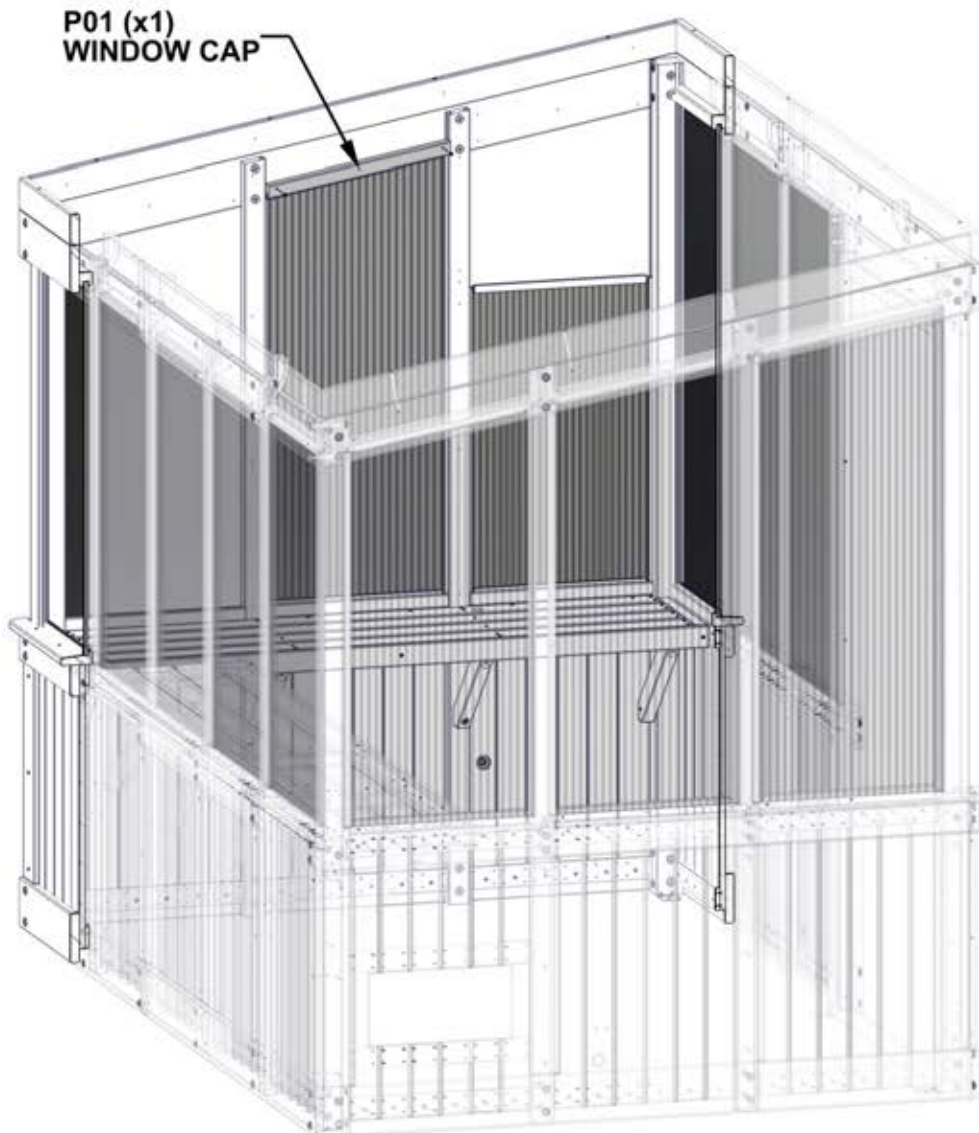


P01 WINDOW CAP - W4L19190
(x1) 1 7/16"x1 7/16"x20 1/2" (36x36x520)



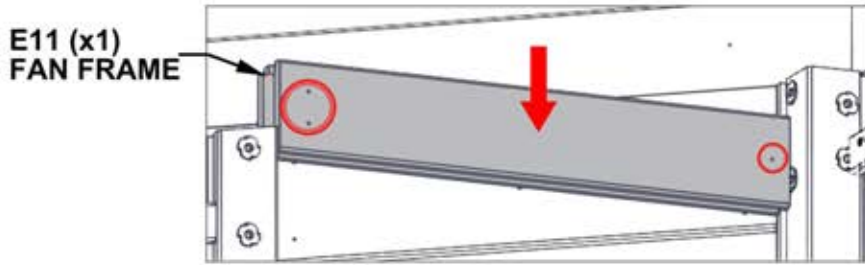
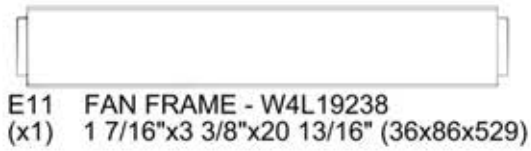
FIRST, SLIDE DOWN WINDOW CAPS WITH THE WINDOW ASSEMBLY FITTING INTO THE GROOVE, THEN SCREW INTO PLACE.

391 (x2)
SCREW - 2"



STEP 56 - WINDOW ASSEMBLY

QTY	PART NUMBER	DESCRIPTION
6	H100387	SCREW PFH 8x1 1/4 BLK

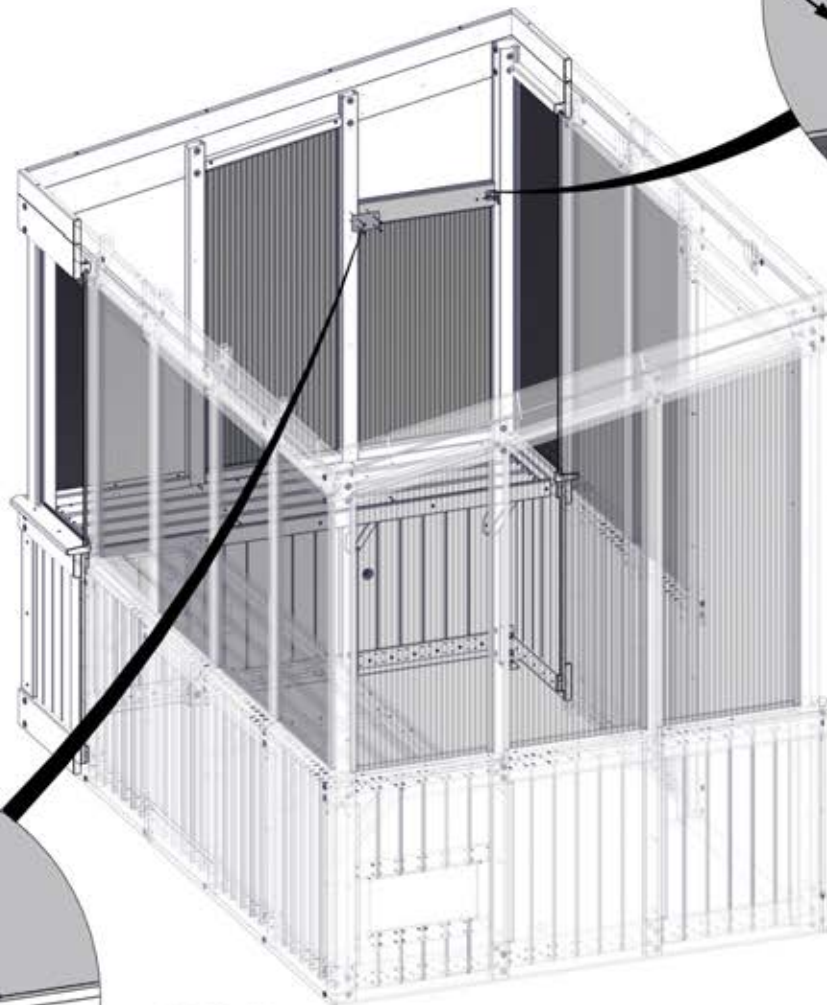
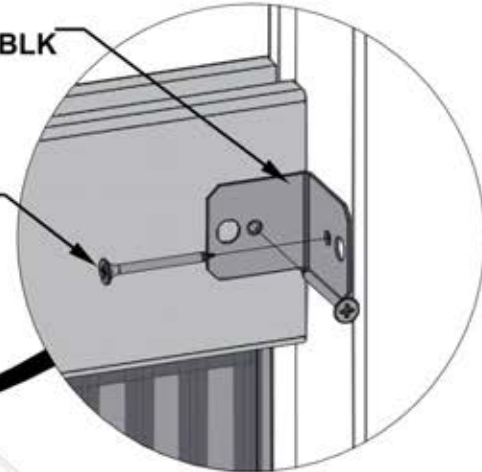


SLIDE E11 INTO PLACE USING GROOVES IN UPRIGHT AND POST.

NOTE PILOT HOLES FOR CORRECT INSTALLATION.

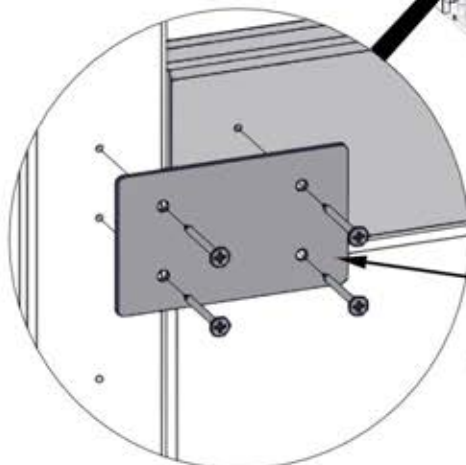
555 (x1) L BRACKET BLK

387 (x6) SCREW - 1 1/4"



997 (x1) METAL CLEAT

ATTACH METAL CLEAT BY ALIGNING WITH PILOT HOLES IN UPRIGHT AND E11.



STEP 57 - WINDOW ASSEMBLY

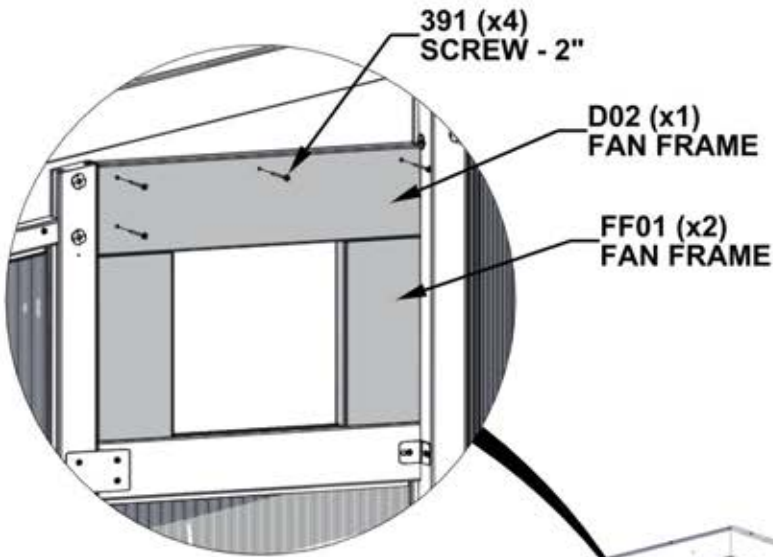
QTY	PART NUMBER	DESCRIPTION
4	H100391	SCREW PFH 8x2 BLK



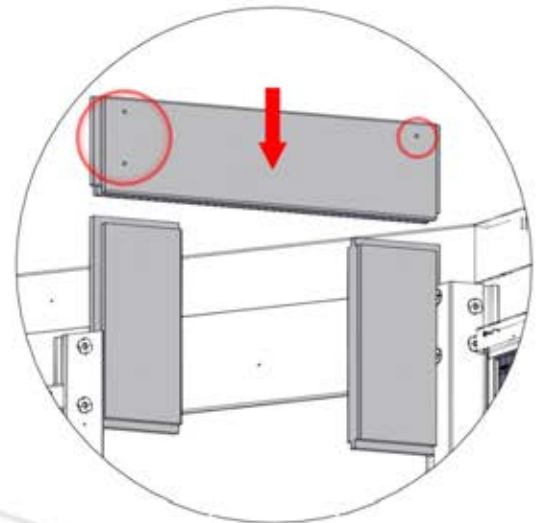
D02 FAN FRAME - W4L19237
(x1) 1 7/16"x5 1/4"x20 13/16" (36x134x529)



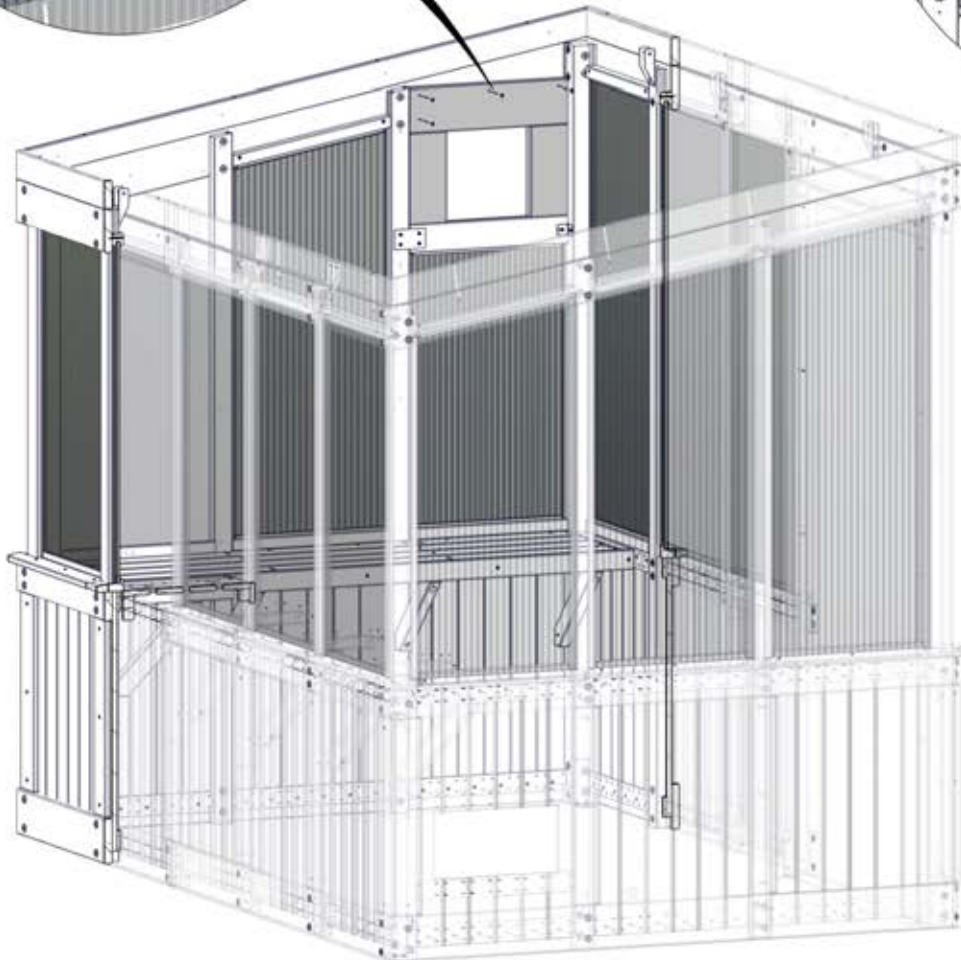
FF01 FAN FRAME - W4L19239
(x2) 1 7/16"x5 1/8"x11 1/2" (36x130x292)



NOTE PILOT HOLES FOR CORRECT INSTALLATION.



D02 AND FF01 SLIDE INTO PLACE USING GROOVES IN POST AND UPRIGHT. BOTTOM OF FF01 SLIDES INTO E11 FROM PREVIOUS STEP.



STEP 58 - WINDOW ASSEMBLY

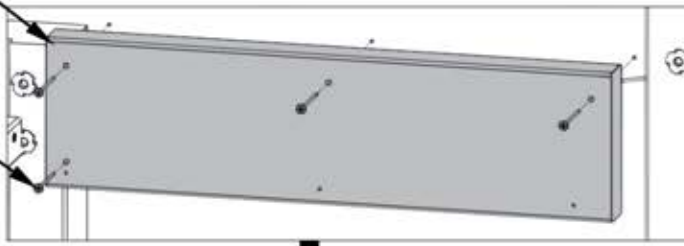
QTY	PART NUMBER	DESCRIPTION
4	H100391	SCREW PFH 8x2 BLK



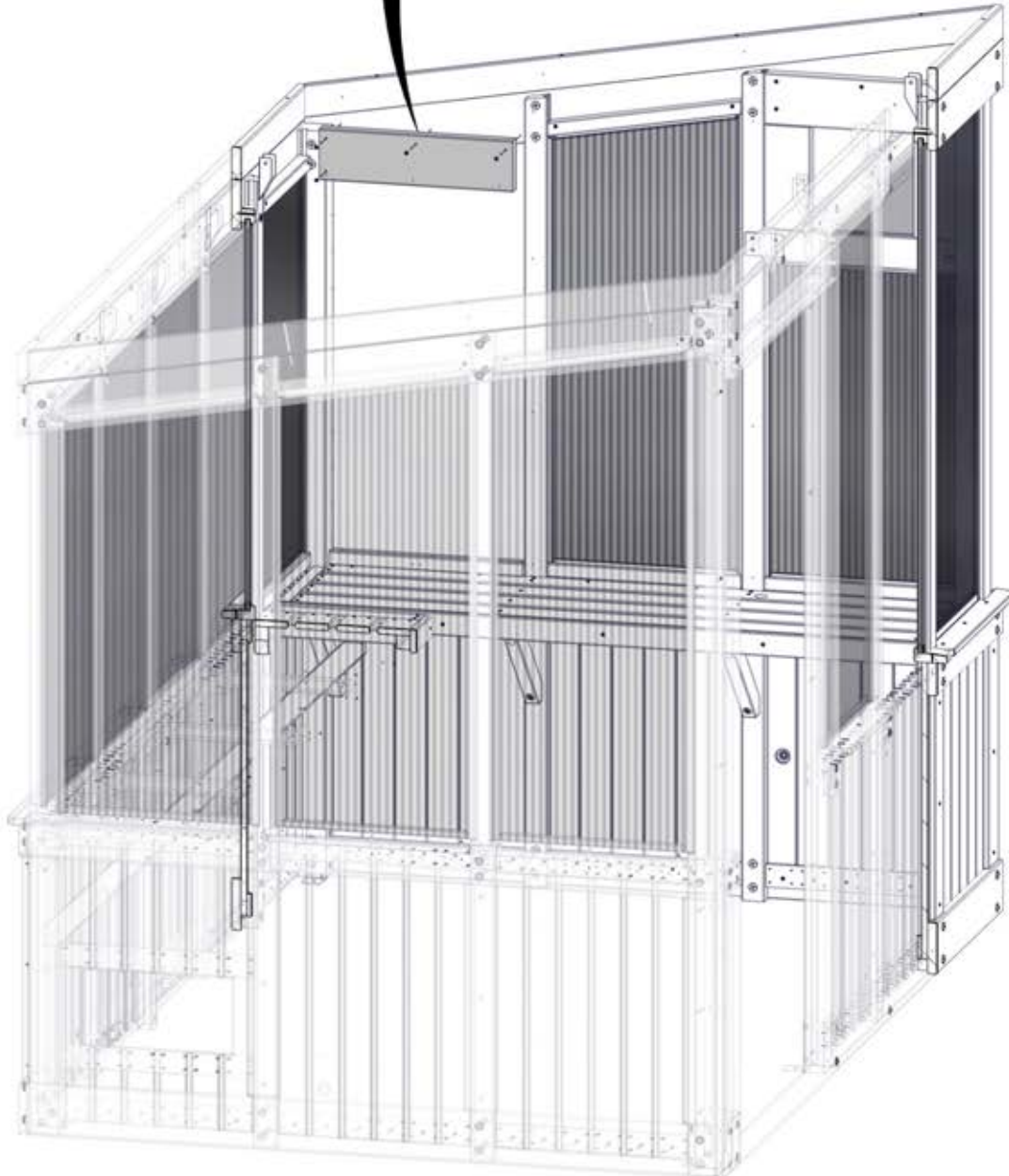
D01 WINDOW FRAME - W4L19233
(x1) 1 7/16"x5 1/4"x19 15/16" (36x134x507)

D01 (x1)
WINDOW FRAME

391 (x4)
SCREW - 2"



**NOTE PILOT HOLES FOR
CORRECT ORIENTATION OF
D01. ATTACH USING PILOT
HOLES IN SIDE BEAM.**



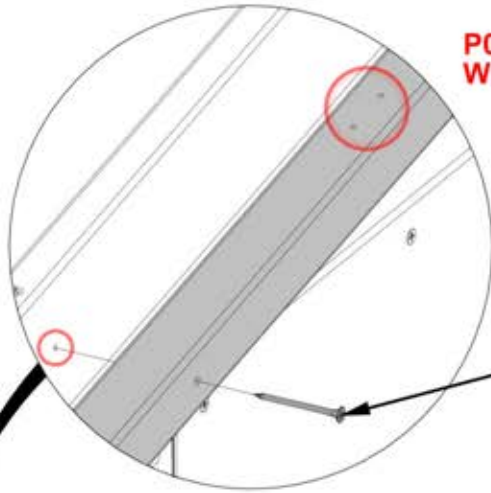
STEP 59 - ROOF ASSEMBLY

QTY	PART NUMBER	DESCRIPTION
8	H100391	SCREW PFH 8x2 BLK



P04 PURLIN CLEAT - W4L19204
(x2) 1 7/16"x1 7/16"x64 1/2" (36x36x1638)

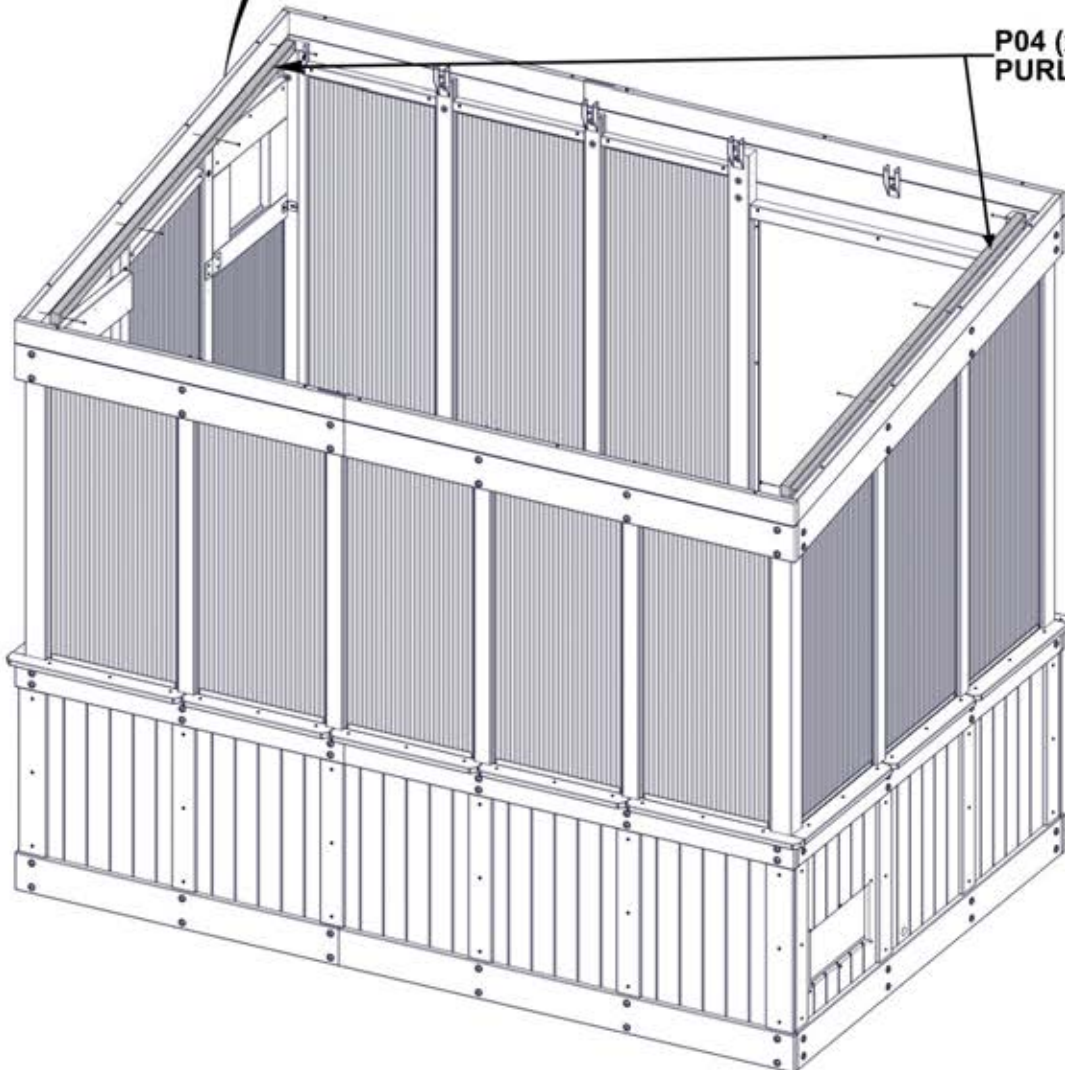
ATTACH P04 BOARDS BY ALIGNING PILOT HOLES WITH PILOT HOLES IN SIDE BEAMS AS SHOWN.



P04 BOARDS ARE ORIENTED WITH PILOT HOLES FACING UP.

391 (x8)
SCREW - 2"

P04 (x2)
PURLIN CLEAT

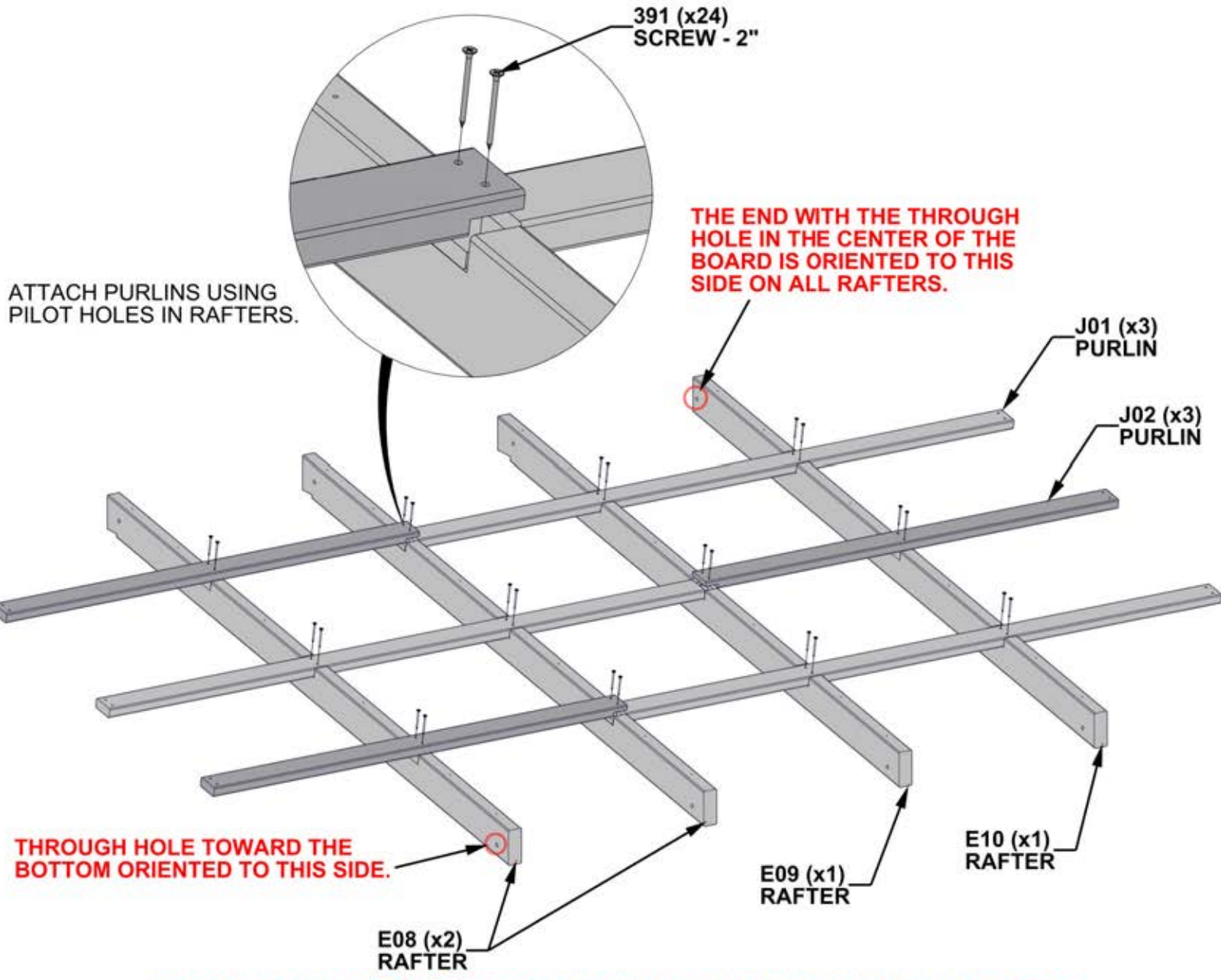


STEP 60A - ROOF ASSEMBLY

QTY	PART NUMBER	DESCRIPTION
24	H100391	SCREW PFH 8x2 BLK

- E08 RAFTER - W4L19217
(x2) 1 7/16"x3 3/8"x72 3/8" (36x86x1839)
- E09 RAFTER - W4L19218
(x1) 1 7/16"x3 3/8"x72 3/8" (36x86x1839)
- E10 RAFTER - W4L19219
(x1) 1 7/16"x3 3/8"x72 3/8" (36x86x1839)

- J01 PURLIN - W4L19220
(x3) 15/16"x2 3/8"x66 7/16" (24x60x1688)
- J02 PURLIN - W4L19221
(x3) 15/16"x2 3/8"x45 1/8" (24x60x1146)



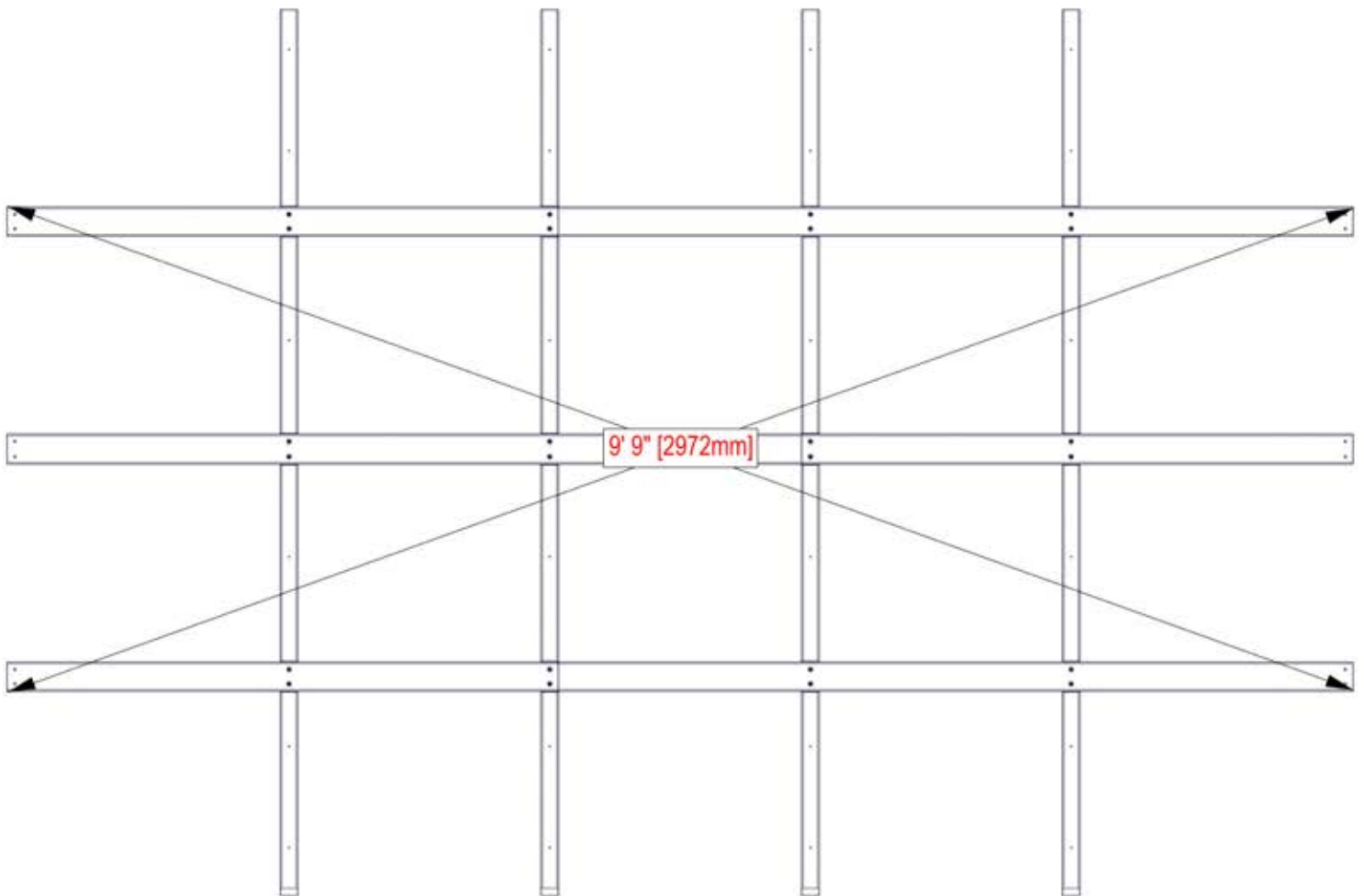
IT IS CRITICAL FOR LATER STEPS TO ENSURE CORRECT PLACEMENT OF RAFTERS.

STEP 60B - ROOF ASSEMBLY

IMPORTANT!

BEFORE PROCEEDING:

- ENSURE UNIT IS SQUARE.
- THE BELOW DIMENSIONS ARE CRITICAL TO THE FINAL ROOF ASSEMBLY.
- MEASUREMENTS SHOULD BE HELD WITHIN +/- 1/4" [6mm].
- MEASUREMENTS OUTSIDE OF TOLERANCE WILL LEAD TO INABILITY TO ASSEMBLY THE ROOF.



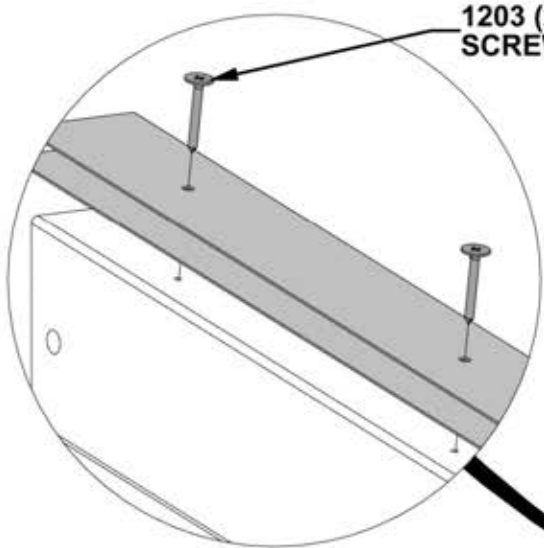
LOOSEN HARDWARE TO ADJUST FOR SQUARING IF NEEDED.

STEP 61 - ROOF ASSEMBLY

QTY	PART NUMBER	DESCRIPTION
24	H101203	SCREW PWH 8x15x1 1/4 BLK



A6P00757 POLY SHEET SPLICE
(x4)



1203 (x24)
SCREW - 1 1/4"

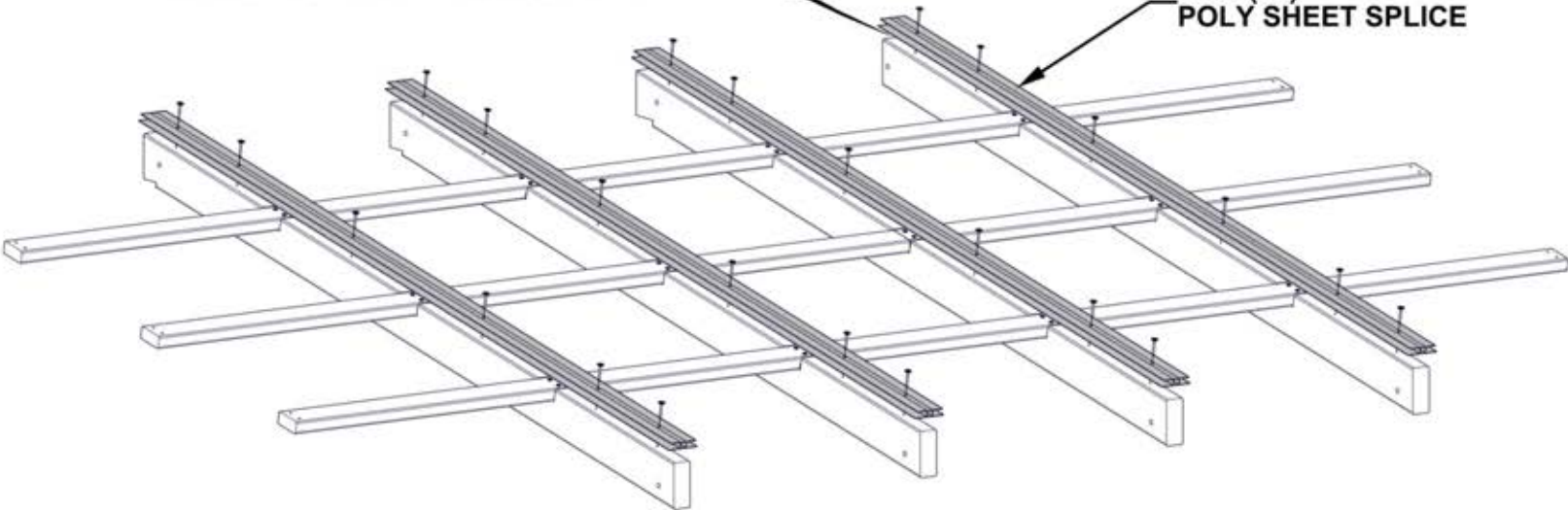
**ENSURE THE NARROWER SIDE
OF POLY SPLICE FACES UP.**



END VIEW OF POLY SPLICE

ALIGN POLY SHEET SPLICE WITH
PILOT HOLES IN RAFTERS AS SHOWN.

0757 (x4)
POLY SHEET SPLICE



STEP 62 - ROOF ASSEMBLY

QTY	PART NUMBER	DESCRIPTION
8	H100488	BOLT WH 1/4x2 BLK
8	H100630	WASHER FLAT 8x19 BLK
8	H100653	NUT LOCK 1/4 BLK

WITH AT LEAST TWO PEOPLE, LIFT ROOF ASSEMBLY AND PLACE INTO RAFTER BRACKETS.

ALIGN HOLES ON RAFTERS WITH RAFTER BRACKETS.

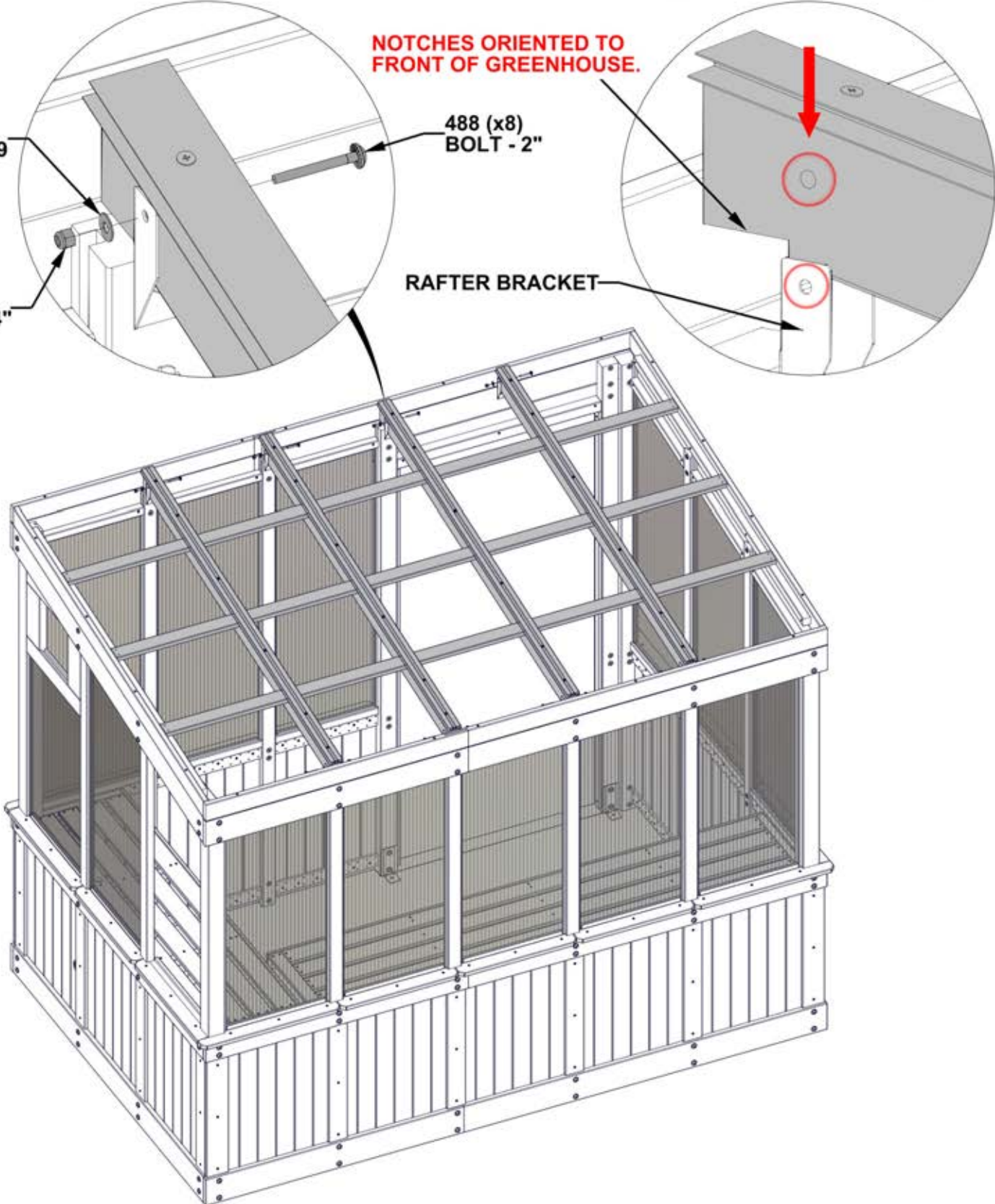
NOTCHES ORIENTED TO FRONT OF GREENHOUSE.

630 (x8)
WASHER - 8x19

488 (x8)
BOLT - 2"

653 (x8)
LOCK NUT - 1/4"

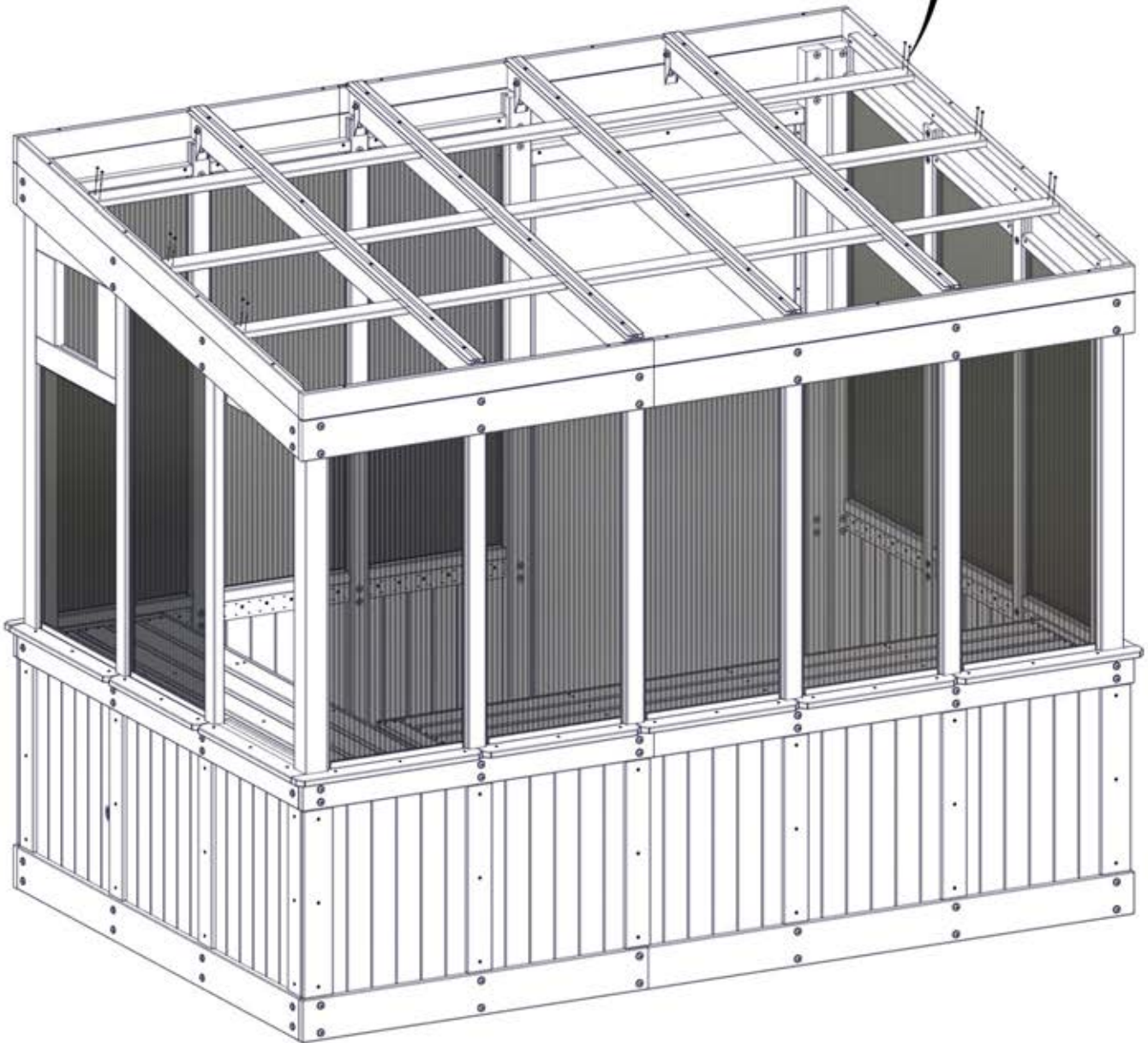
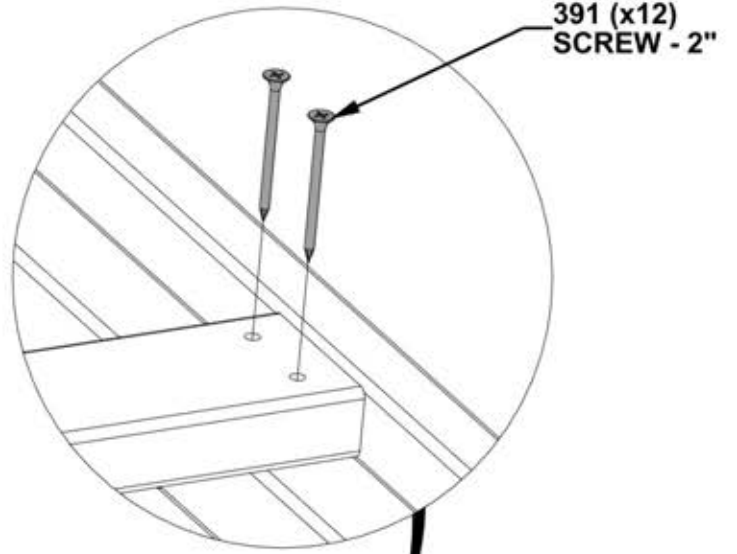
RAFTER BRACKET



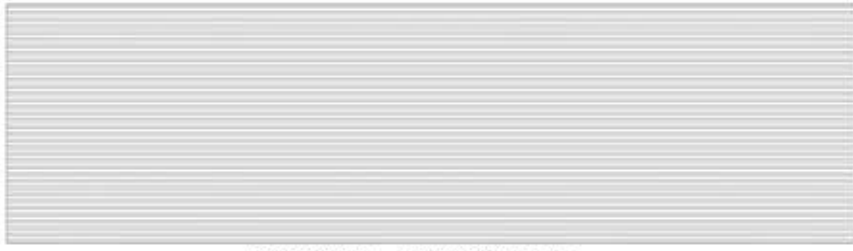
STEP 63 - ROOF ASSEMBLY

QTY	PART NUMBER	DESCRIPTION
12	H100391	SCREW PFH 8x2 BLK

INSERT SCREWS THROUGH PILOT HOLES IN PURLINS INTO PURLIN CLEATS AS SHOWN.



STEP 64 - ROOF ASSEMBLY



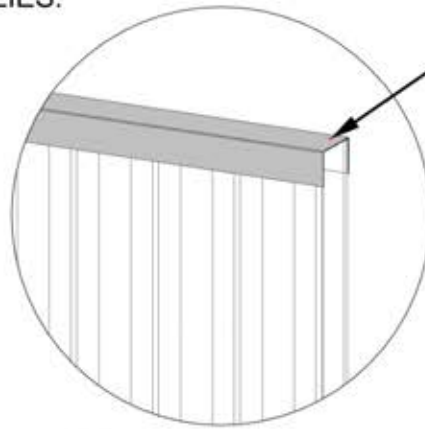
A6P00755 POLY SHEET
(x3)



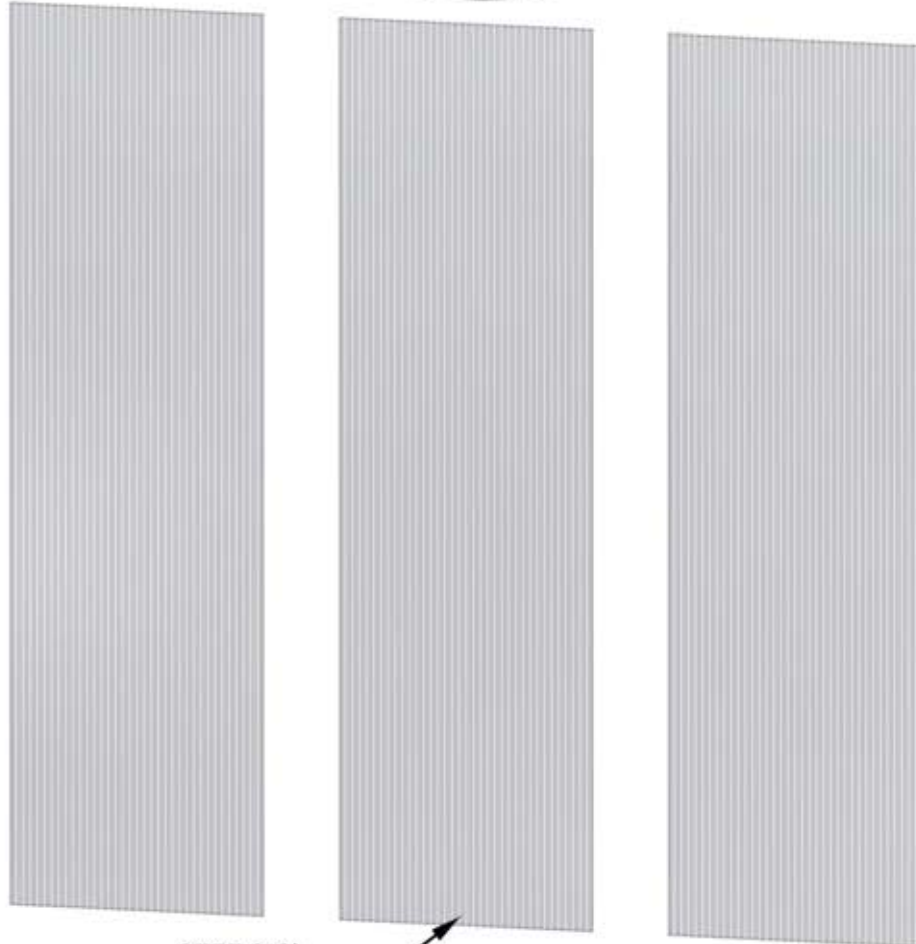
A6P00690 DUST SEAL TAPE

TO APPLY DUST SEAL TAPE AND POLY CHANNEL:

- CUT 2 STRIPS OF DUST SEAL TAPE THE SAME WIDTH AS THE POLY SHEET.
- WRAP DUST SEAL TAPE ALONG EDGE OF POLY SHEET WIDTH.
- REPEAT ON THE BOTTOM SIDE OF POLY SHEET.
- REPEAT FOR ALL 3 WINDOW ASSEMBLIES.



690 (x6)
DUST SEAL TAPE



0755 (x3)
POLY SHEET

STEP 65 - ROOF ASSEMBLY

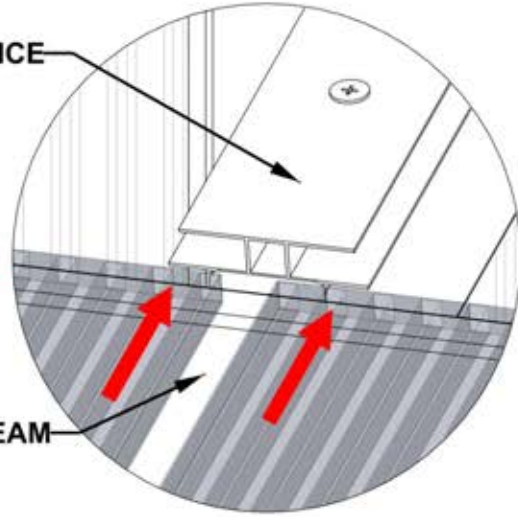
IMPORTANT!

- ENSURE UV SIDE OF WINDOWS ARE FACING OUTSIDE.
- REMOVE THE PROTECTIVE FILM PRIOR TO INSTALLATION OF ROOF PANELS.

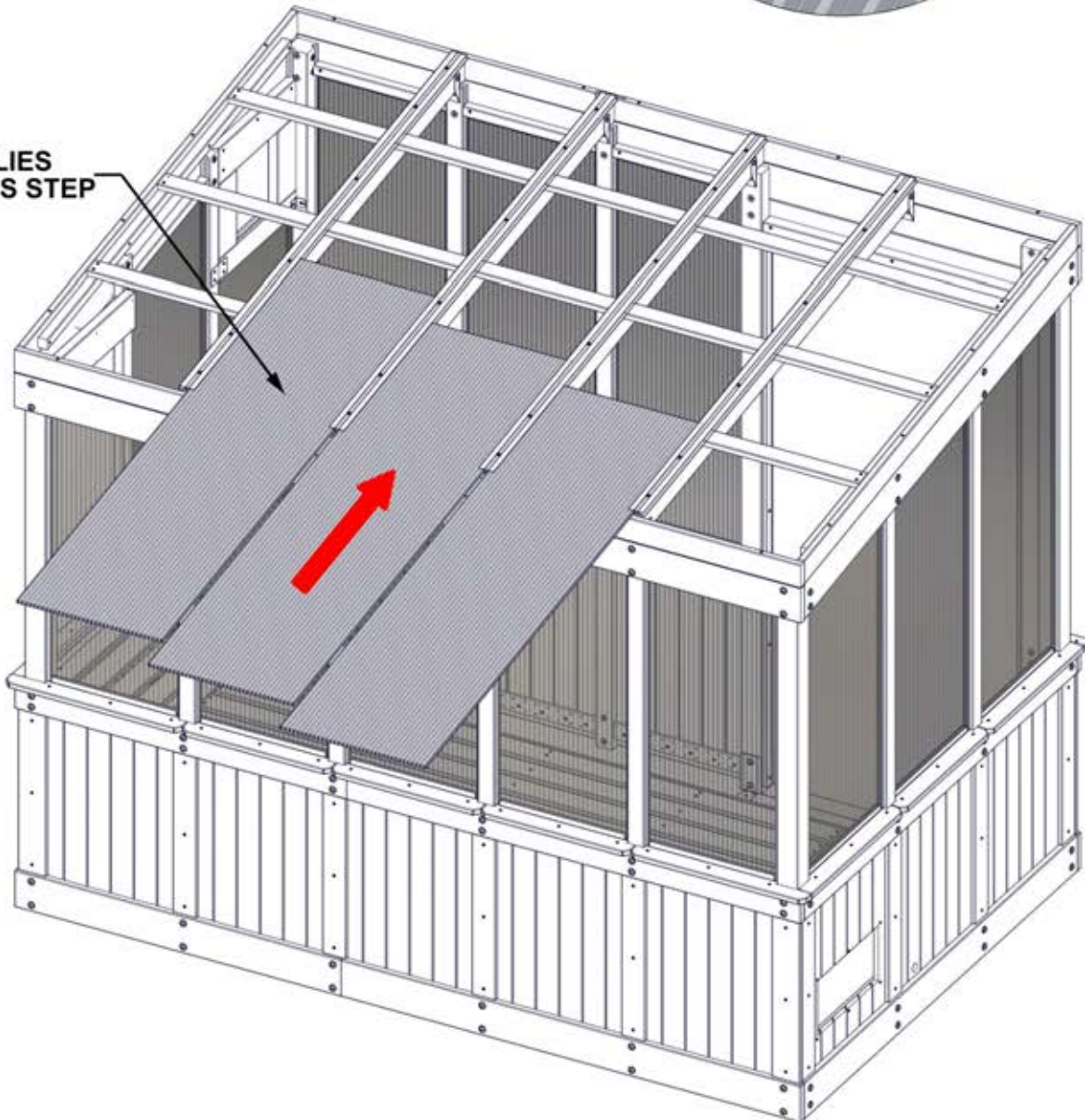
SLIDE POLY SHEETS INTO POLY SHEET SPLICES. PUSH THE SHEETS UNTIL BOTTOM OF SHEET IS FLUSH WITH OUTSIDE OF BEAM.

POLY SHEET SPLICE

OUTSIDE BEAM



ROOF ASSEMBLIES FROM PREVIOUS STEP



STEP 66 - ROOF ASSEMBLY



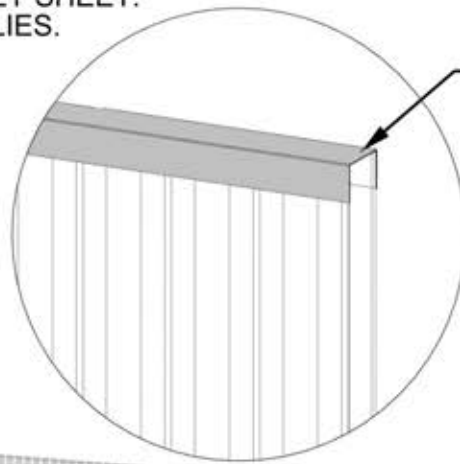
A6P00758 POLY SHEET
(x2)



A6P00690 DUST SEAL TAPE

TO APPLY DUST SEAL TAPE AND POLY CHANNEL:

- CUT 2 STRIPS OF DUST SEAL TAPE THE SAME WIDTH AS THE POLY SHEET.
- WRAP DUST SEAL TAPE ALONG EDGE OF POLY SHEET WIDTH.
- REPEAT ON THE BOTTOM SIDE OF POLY SHEET.
- REPEAT FOR BOTH WINDOW ASSEMBLIES.



690 (x4)
DUST SEAL TAPE

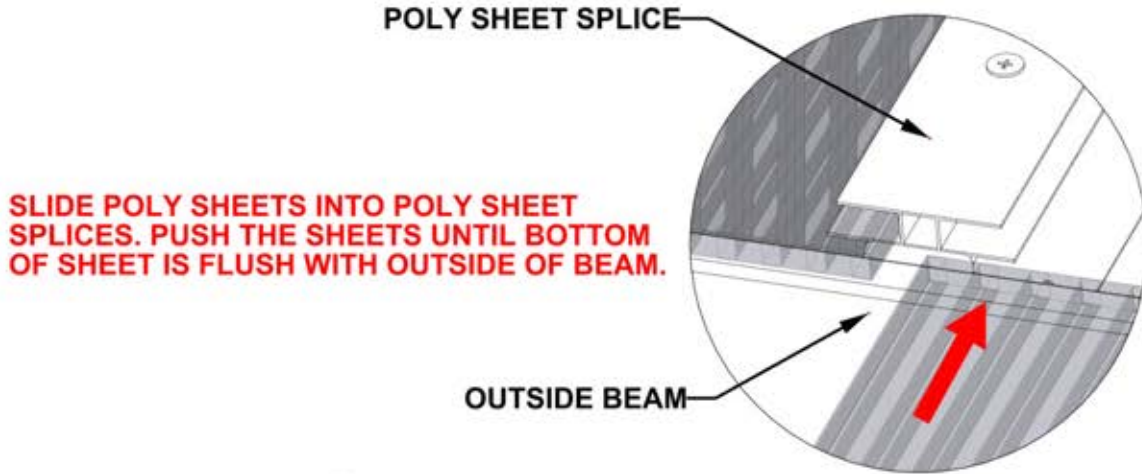


0758 (x2)
POLY SHEET

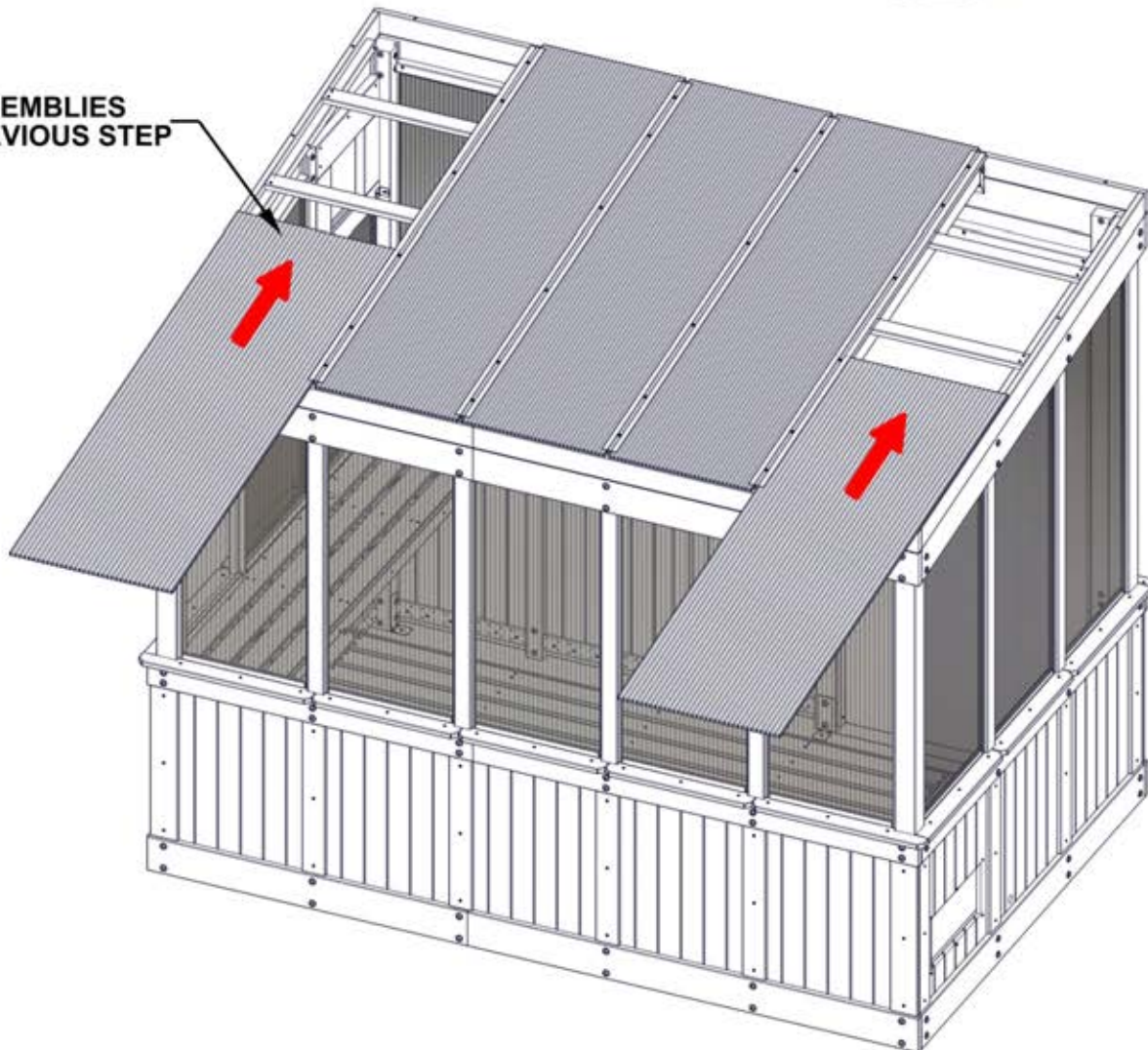
STEP 67 - ROOF ASSEMBLY

IMPORTANT!

- ENSURE UV SIDE OF WINDOWS ARE FACING OUTSIDE.
- REMOVE THE PROTECTIVE FILM PRIOR TO INSTALLATION OF ROOF PANELS.



ROOF ASSEMBLIES FROM PREVIOUS STEP



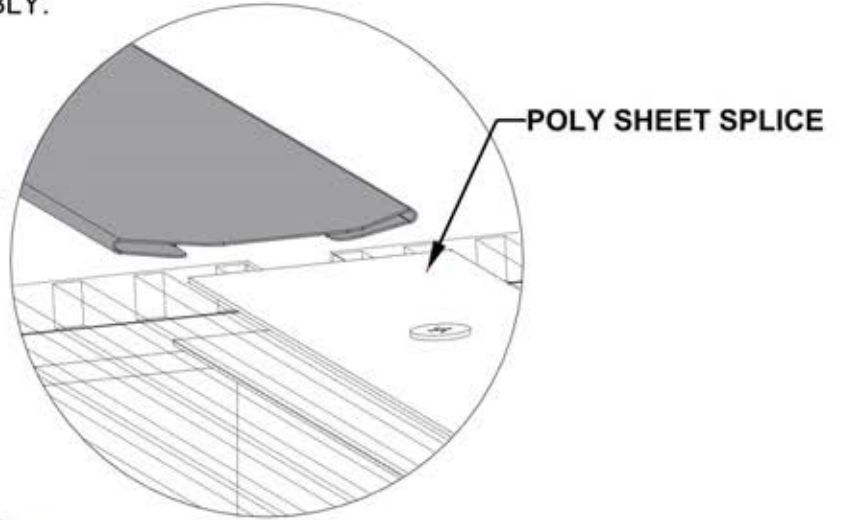
STEP 68 - ROOF ASSEMBLY



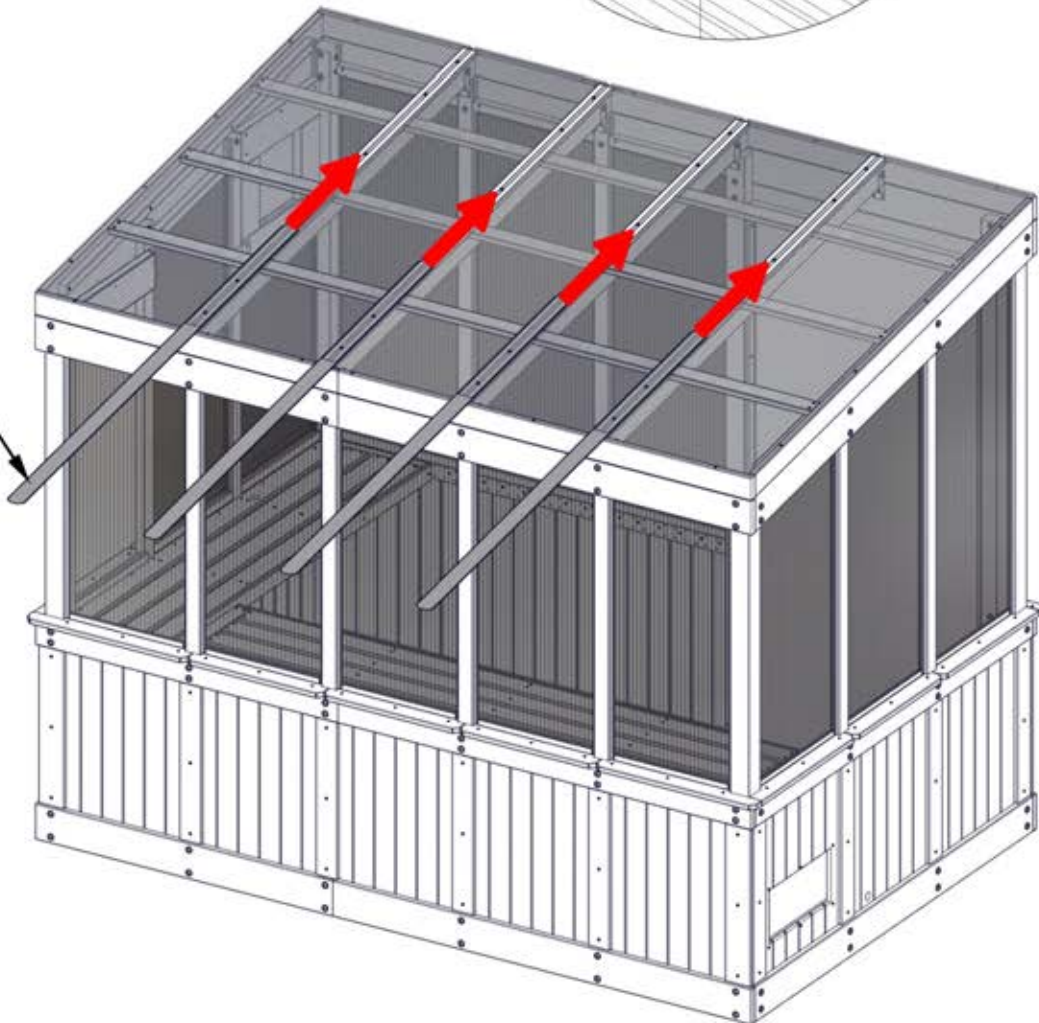
A4M02527 SPLICE COVER
(x4)

TIP: MAY NEED TO PUT A SLIGHT BEND IN THE LEADING EDGE OF THE SPLICE COVER TO EASE IN ASSEMBLY.

SLIDE TABS ON SPLICE COVERS OVER THE TABS ON THE POLY CHANNEL AND SLIDE UP UNTIL THE BOTTOM OF THE SPLICE IS FLUSH WITH BOTTOM OF THE CHANNEL.



2527 (x4)
SPLICE COVER

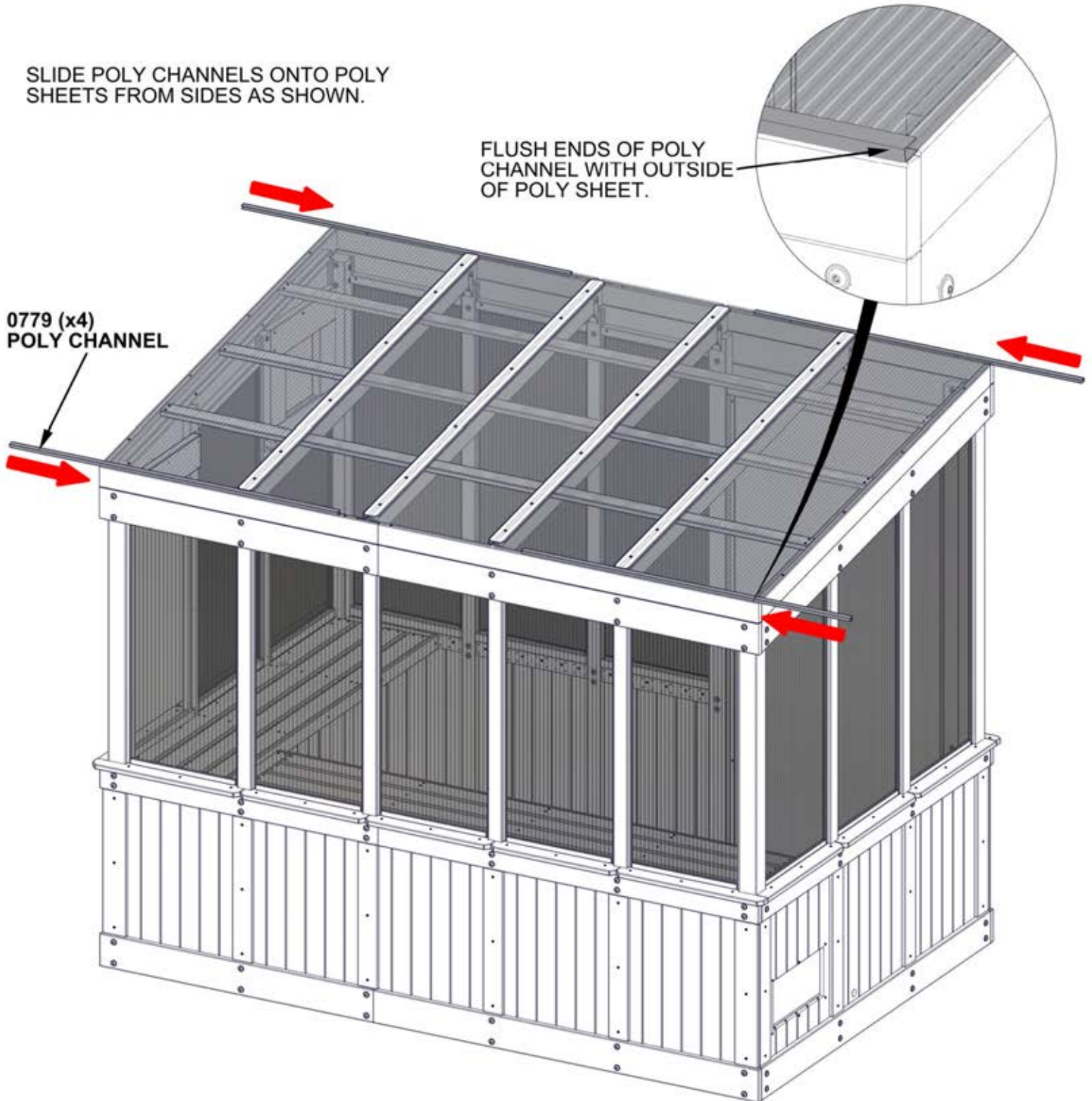


STEP 69 - ROOF ASSEMBLY

A6P00779 POLY CHANNEL
(x4)

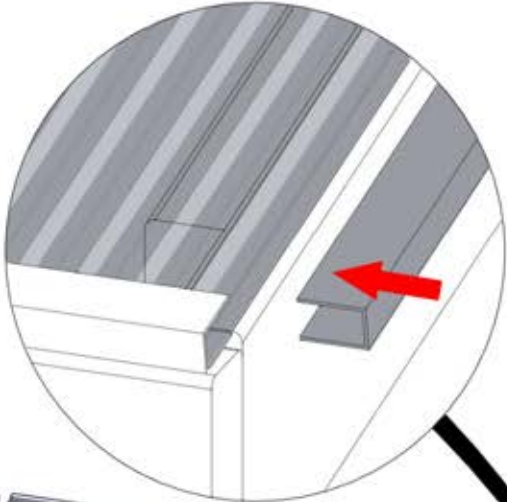
SLIDE POLY CHANNELS ONTO POLY SHEETS FROM SIDES AS SHOWN.

FLUSH ENDS OF POLY CHANNEL WITH OUTSIDE OF POLY SHEET.



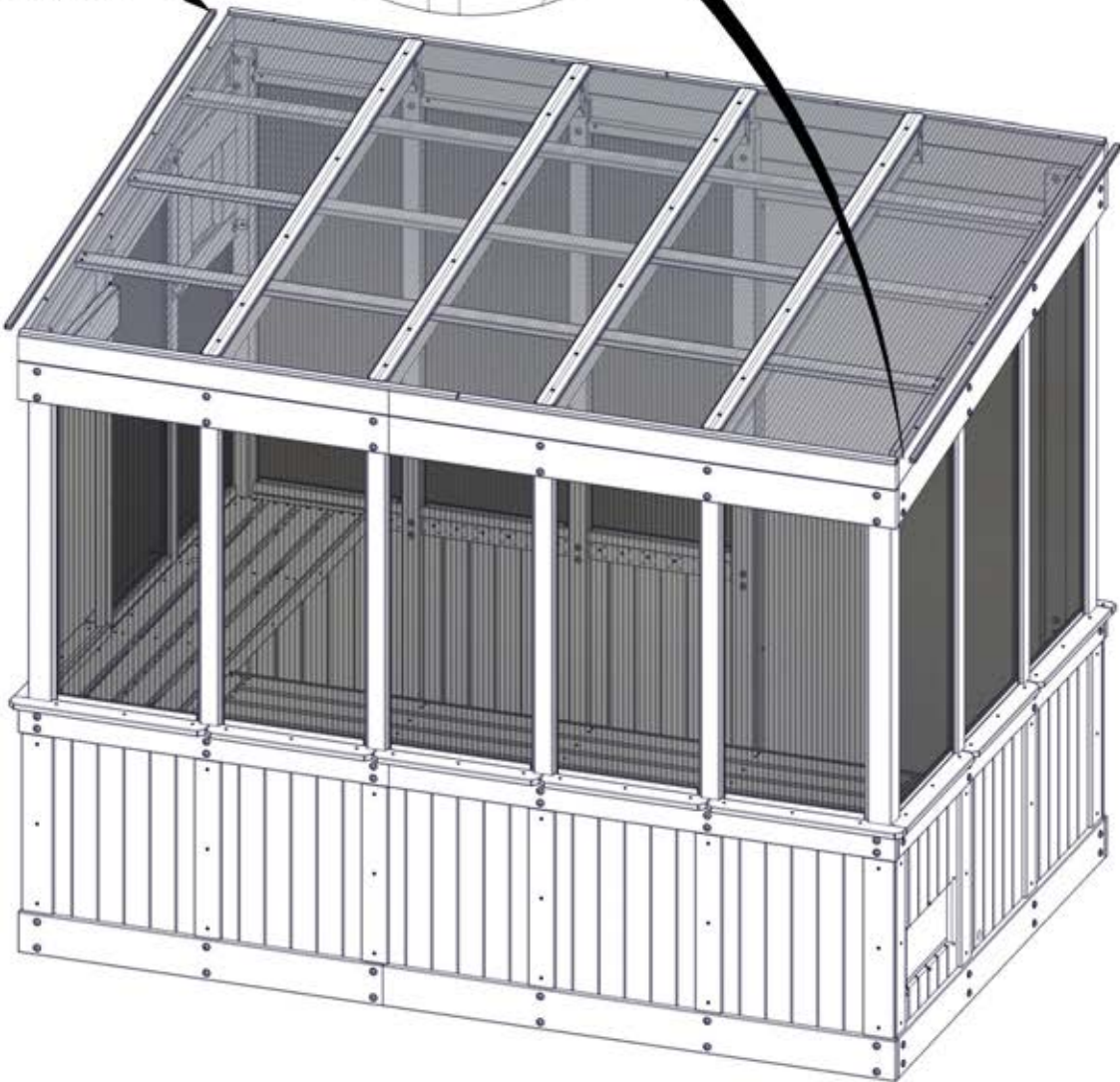
STEP 70 - ROOF ASSEMBLY

A6P00778 POLY CHANNEL
(x2)



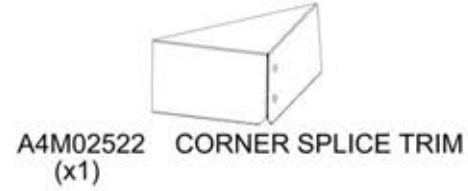
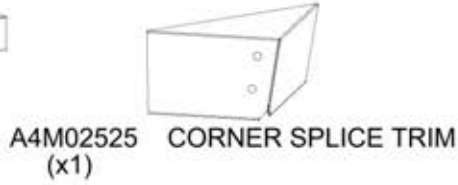
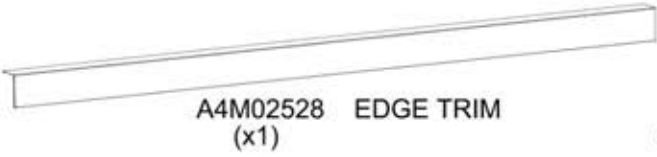
SLIDE POLY CHANNEL ON EACH SIDE OF ROOF. CENTER EACH CHANNEL ON THE POLY SHEET EDGE.

0778 (x2)
POLY CHANNEL



STEP 71 - ROOF ASSEMBLY

QTY	PART NUMBER	DESCRIPTION
3	H101206	SCREW WOODGRIP 10-16X1-1/4"



WARNING: GLOVES ARE RECOMMENDED WHEN HANDLING STEEL.

SHORT SIDE RESTS ON THE TOP, THE LONG SIDE IS PRESSED AGAINST THE SIDE BEAM AS SHOWN.

NOTE: REMOVE BLUE FILM FROM EDGE TRIM AND CORNER SPLICE TRIM.

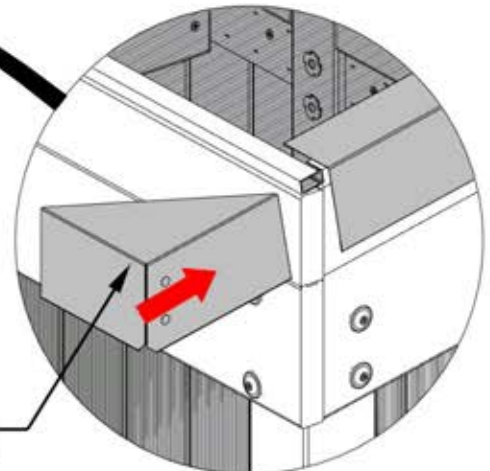
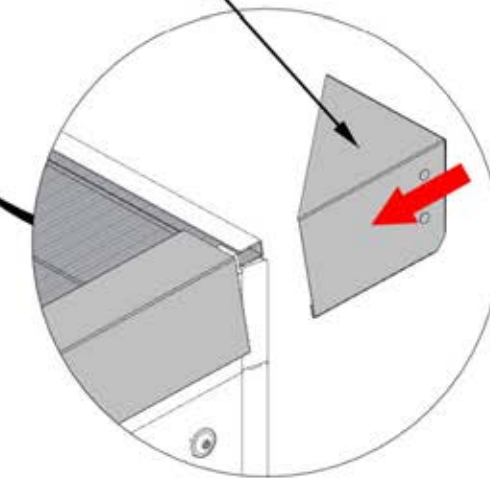
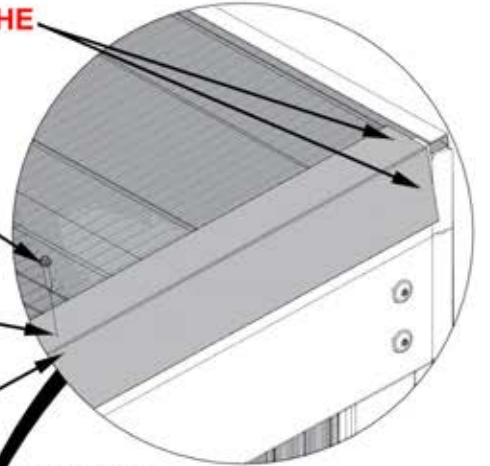
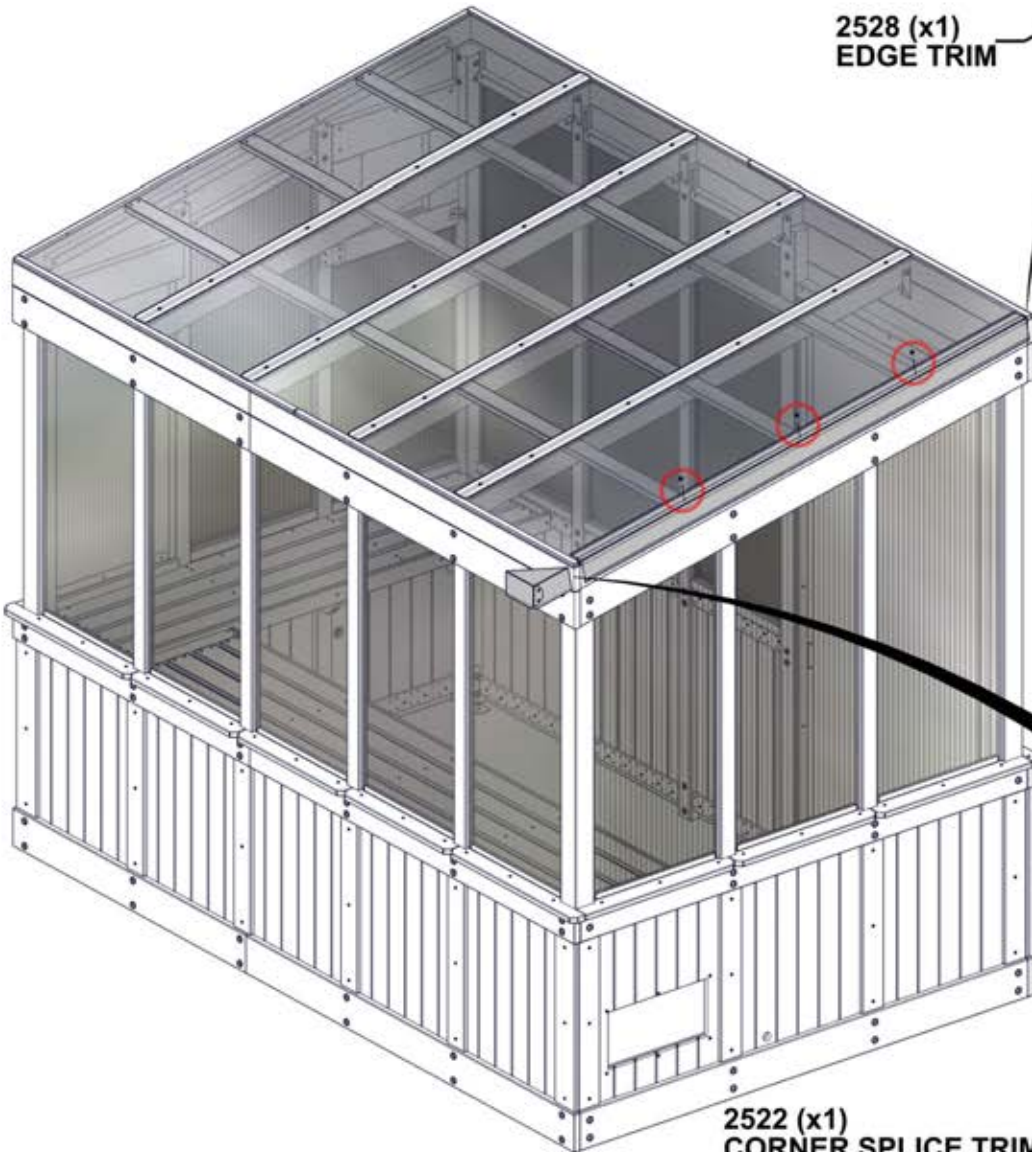
1206 (x3)
SCREW WOODGRIP 10-16x1-1/4"

ATTACH SCREWS IN THE PURLINS 3/4" [19mm] FROM THE EDGE OF EDGE TRIM.

2528 (x1)
EDGE TRIM

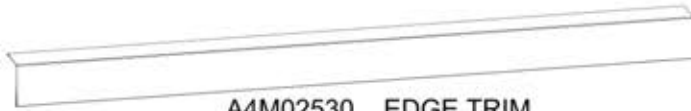
2525 (x1)
CORNER SPLICE TRIM LH

2522 (x1)
CORNER SPLICE TRIM RH



STEP 72 - ROOF ASSEMBLY

QTY	PART NUMBER	DESCRIPTION
9	H101206	SCREW WOODGRIP 10-16X1-1/4"



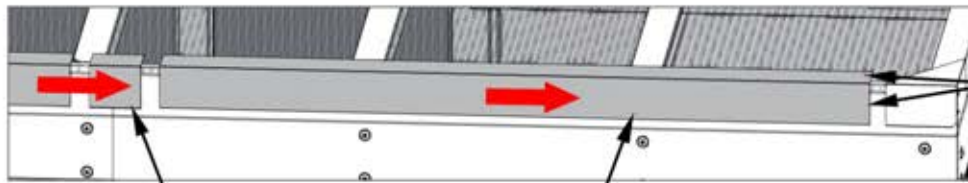
A4M02530 EDGE TRIM
(x2)



A4M02516 EDGE TRIM SPLICE
(x1)

WARNING: GLOVES ARE RECOMMENDED WHEN HANDLING STEEL.

NOTE: REMOVE BLUE FILM FROM EDGE TRIM AND CORNER SPLICE TRIM.



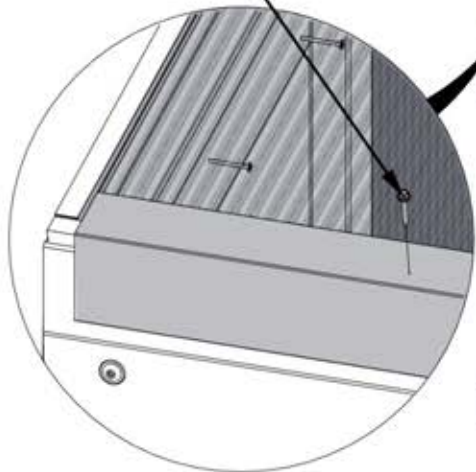
THE SHORT SIDE RESTS ON THE TOP, THE LONG SIDE IS PRESSED AGAINST THE BACK BEAM AS SHOWN.

2530 (x2)
EDGE TRIM

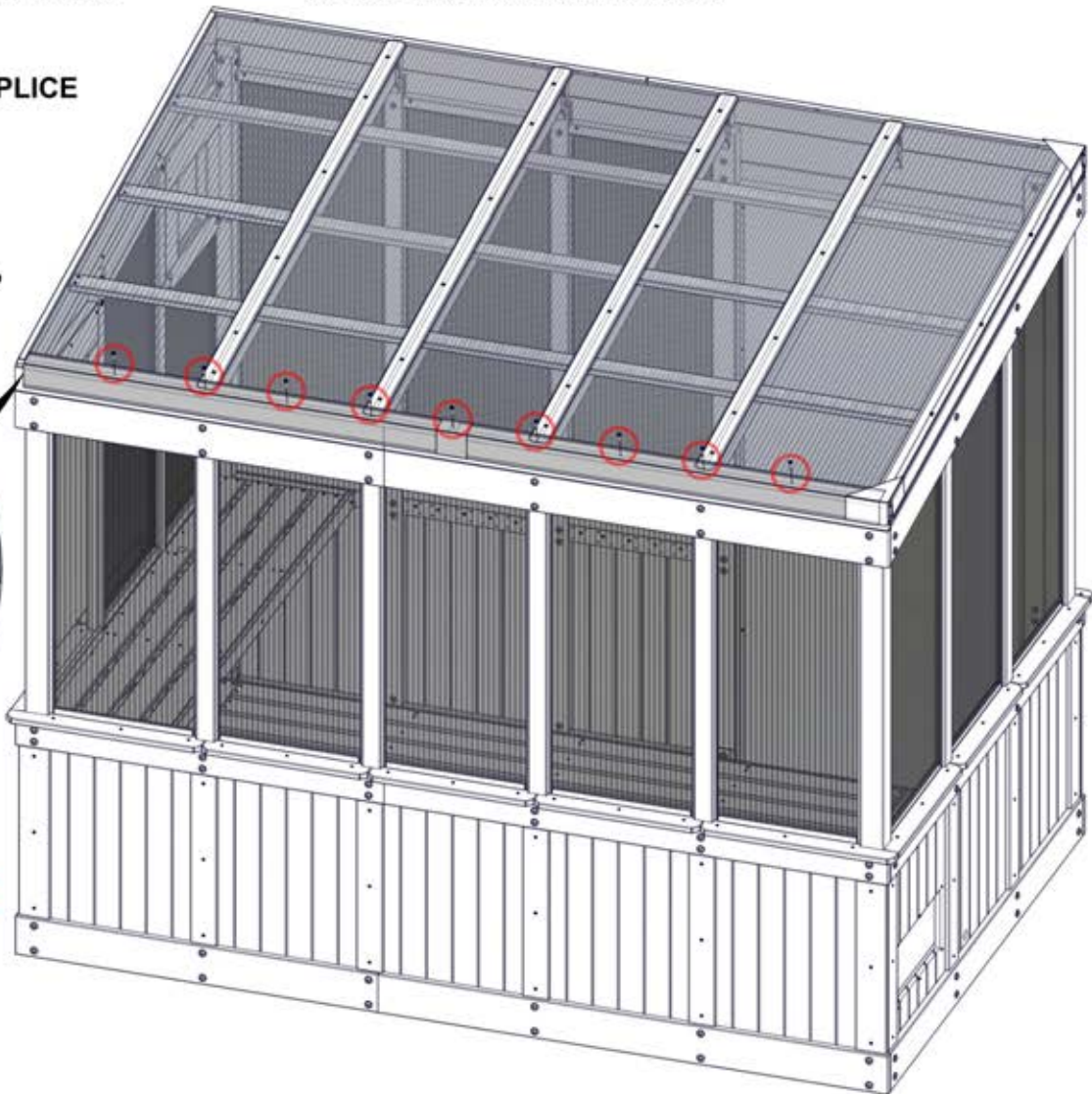
EDGE TRIM PIECES SLIDE INTO SPLICE AND CORNER SPLICE.

2516 (x1)
EDGE TRIM SPLICE

1206 (x9)
SCREW WOODGRIP 10-16x1-1/4"

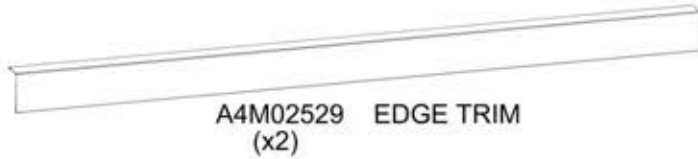


ONCE EDGE TRIM IS SLID INTO PLACE, INSERT SCREWS AS SHOWN PLACED 1/2" [12mm] FROM OUTSIDE EDGE OF EDGE TRIM.

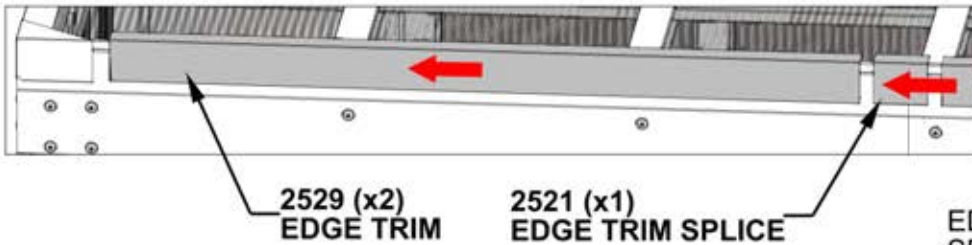


STEP 73 - ROOF ASSEMBLY

QTY	PART NUMBER	DESCRIPTION
9	H101206	SCREW WOODGRIP 10-16X1-1/4"



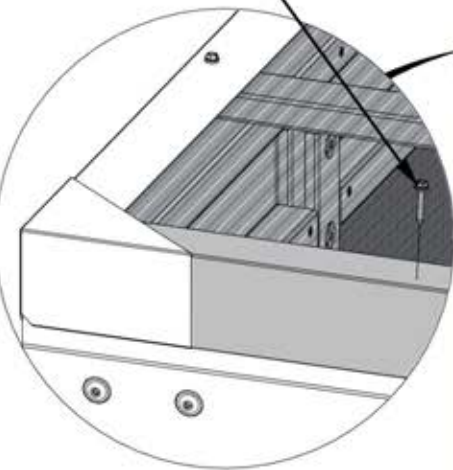
WARNING: GLOVES ARE RECOMMENDED WHEN HANDLING STEEL.
NOTE: REMOVE BLUE FILM FROM EDGE TRIM AND CORNER SPLICE TRIM.



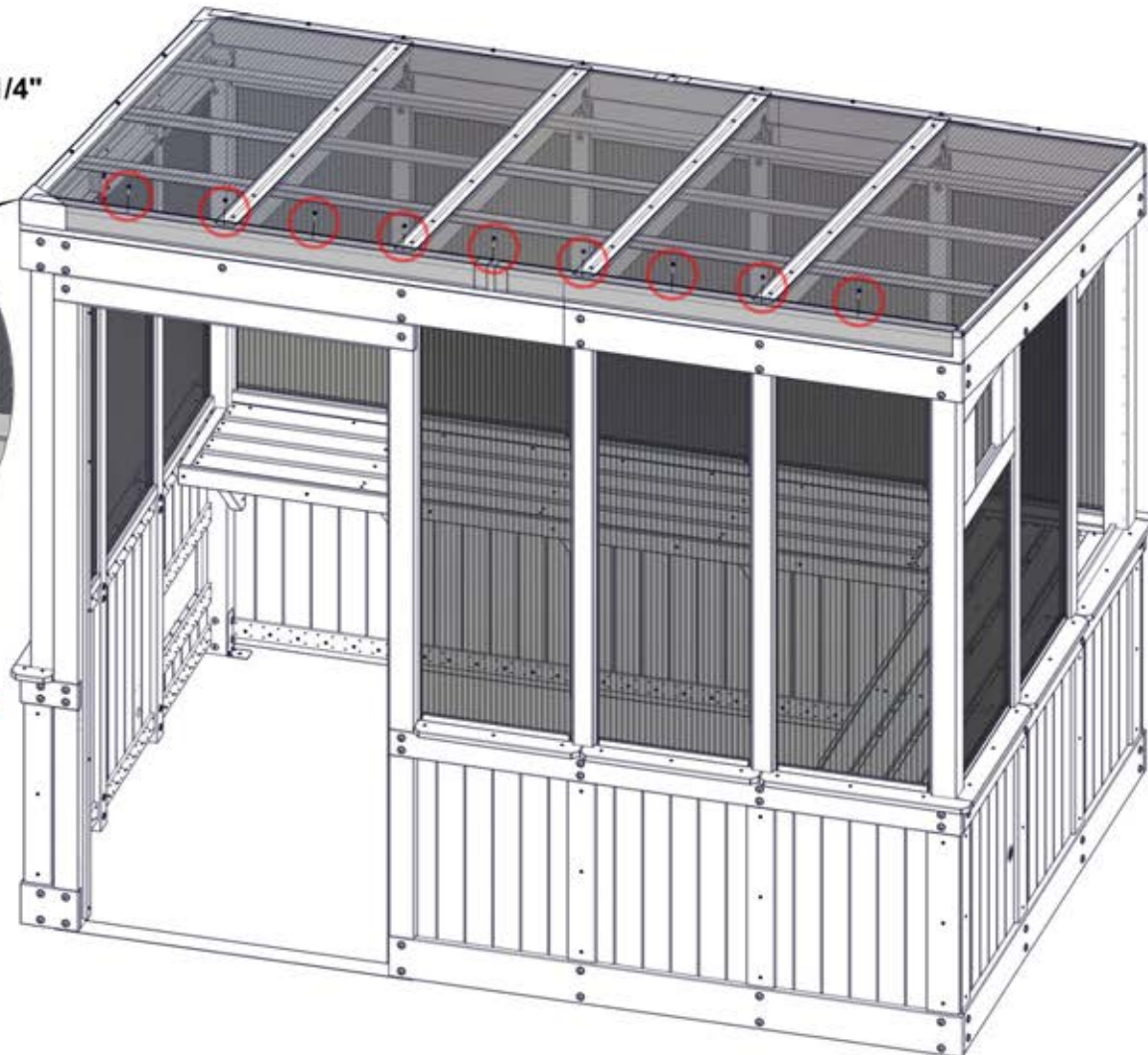
THE SHORT SIDE RESTS ON THE TOP, THE LONG SIDE IS PRESSED AGAINST THE FRONT BEAM AS SHOWN.

EDGE TRIM PIECES SLIDE INTO SPLICE AND CORNER SPLICE.

1206 (x9)
SCREW WOODGRIP 10-16x1-1/4"

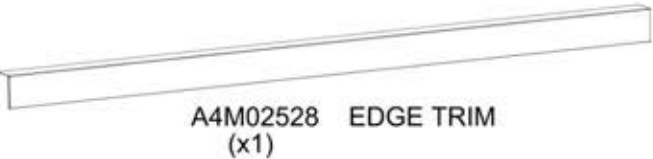


ONCE EDGE TRIM IS SLID INTO PLACE, INSERT SCREWS AS SHOWN PLACED 1/2" [12mm] FROM OUTSIDE EDGE OF EDGE TRIM.



STEP 74 - ROOF ASSEMBLY

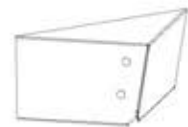
QTY	PART NUMBER	DESCRIPTION
3	H101206	SCREW WOODGRIP 10-16X1-1/4"



A4M02528 EDGE TRIM (x1)

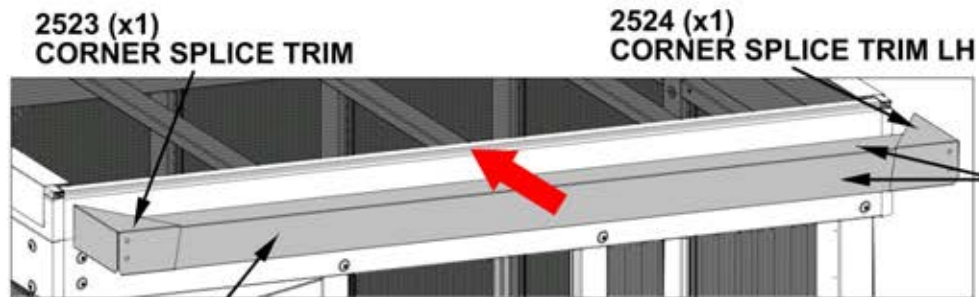


A4M02523 CORNER SPLICE TRIM (x1)



A4M02524 CORNER SPLICE TRIM (x1)

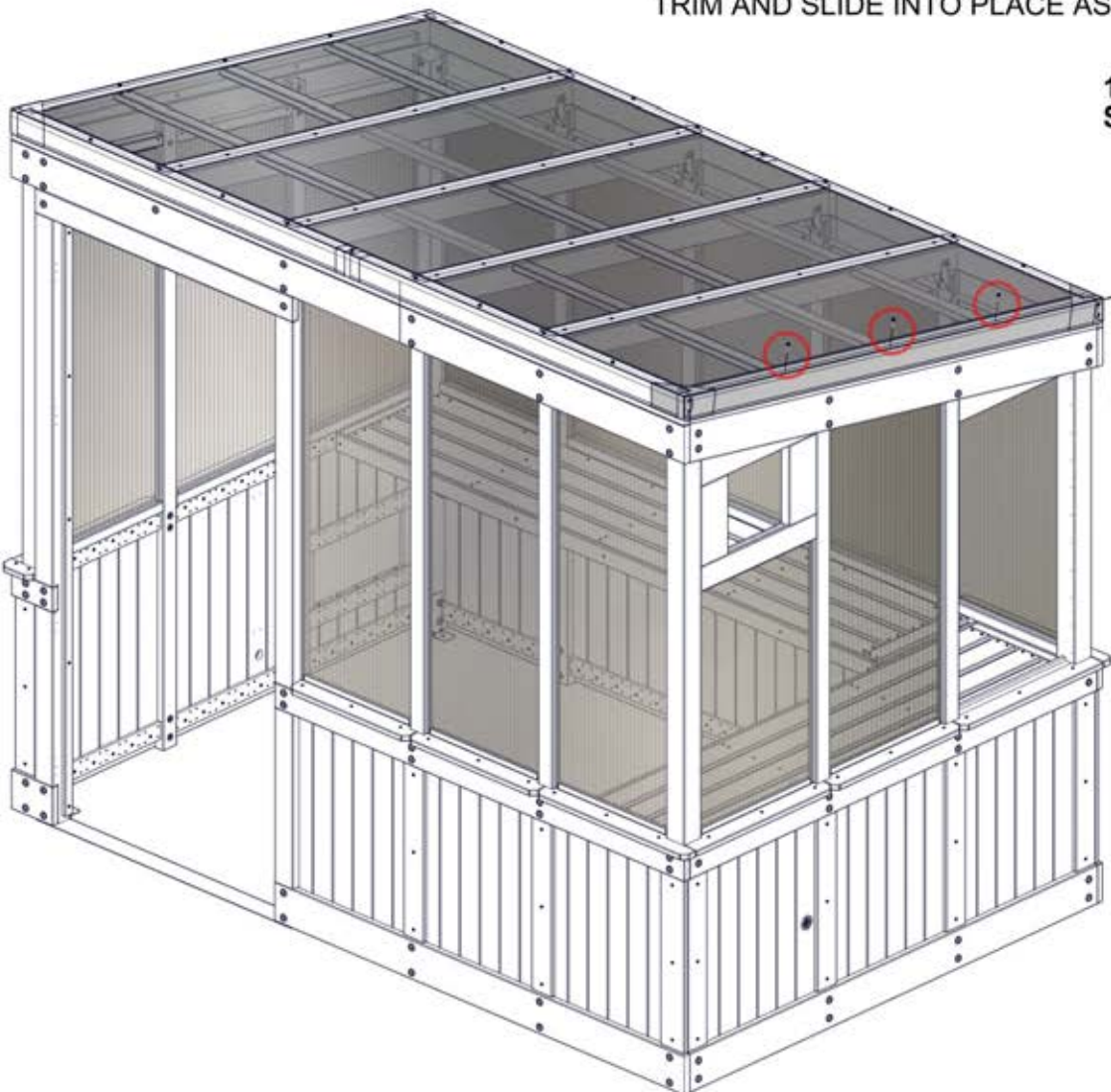
WARNING: GLOVES ARE RECOMMENDED WHEN HANDLING STEEL.
NOTE: REMOVE BLUE FILM FROM EDGE TRIM AND CORNER SPLICE TRIM.



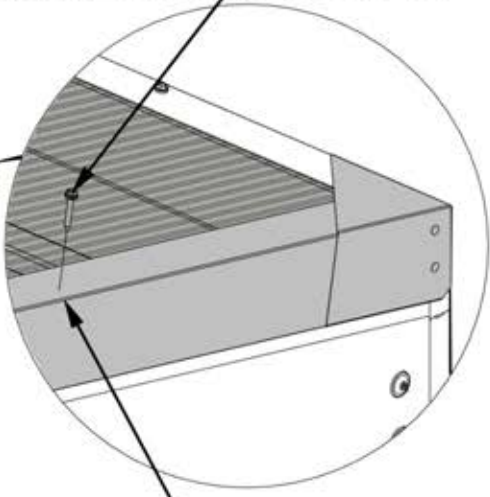
THE SHORT SIDE RESTS ON THE TOP, THE LONG SIDE IS PRESSED AGAINST THE SIDE BEAM AS SHOWN.

2528 (x1) EDGE TRIM

SLIDE EACH CORNER SPLICE ONTO EDGE TRIM AND SLIDE INTO PLACE AS SHOWN.



1206 (x3) SCREW WOODGRIP 10-16x1-1/4"



ATTACH SCREWS IN THE PURLINS 3/4" [19mm] FROM THE EDGE OF EDGE TRIM.

STEP 75 - ROOF ASSEMBLY

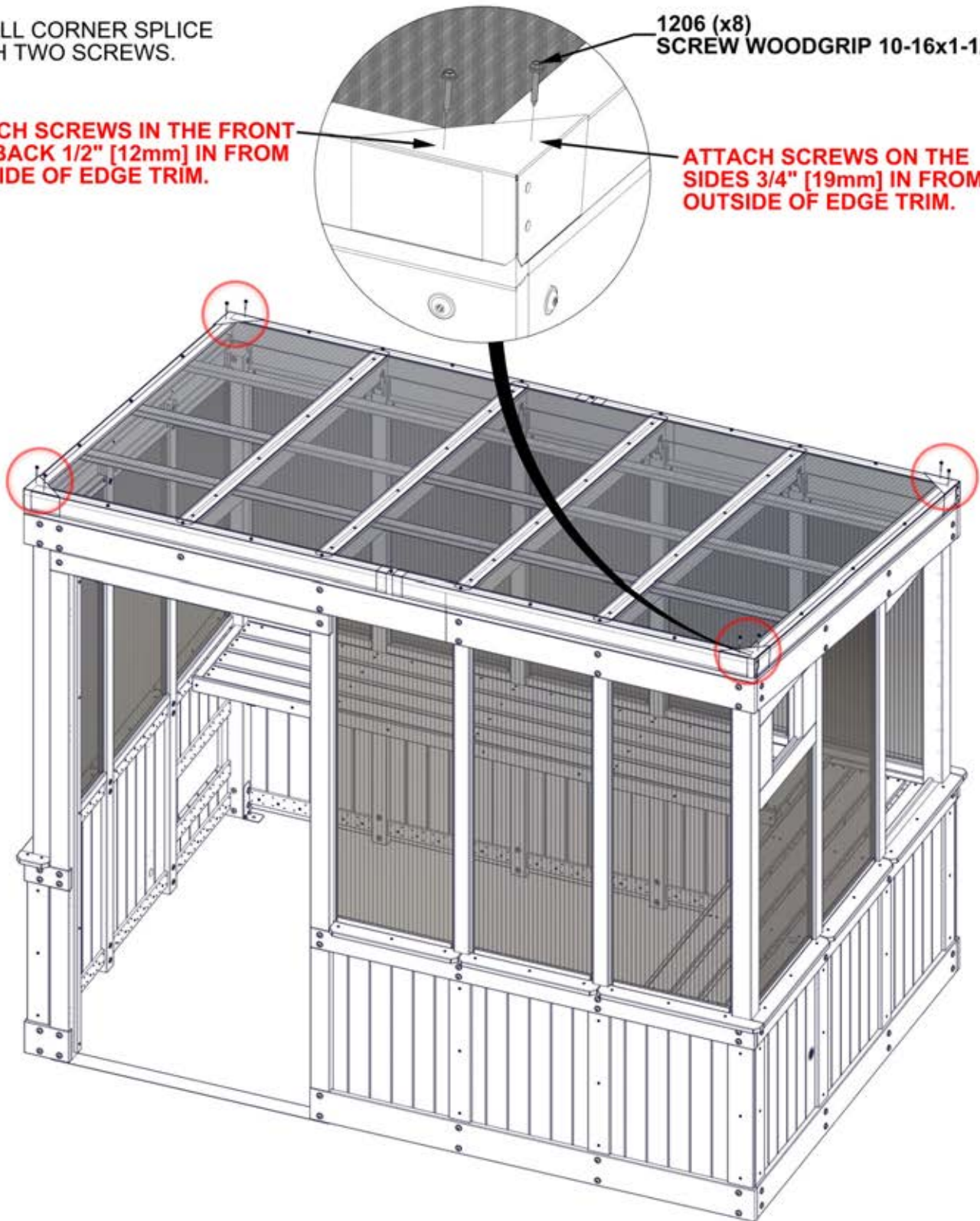
QTY	PART NUMBER	DESCRIPTION
8	H101206	SCREW WOODGRIP 10-16X1-1/4"

ATTACH ALL CORNER SPLICE TRIM WITH TWO SCREWS.

ATTACH SCREWS IN THE FRONT AND BACK 1/2" [12mm] IN FROM OUTSIDE OF EDGE TRIM.

1206 (x8)
SCREW WOODGRIP 10-16x1-1/4"

ATTACH SCREWS ON THE SIDES 3/4" [19mm] IN FROM OUTSIDE OF EDGE TRIM.



STEP 76A - WINDOW ASSEMBLY

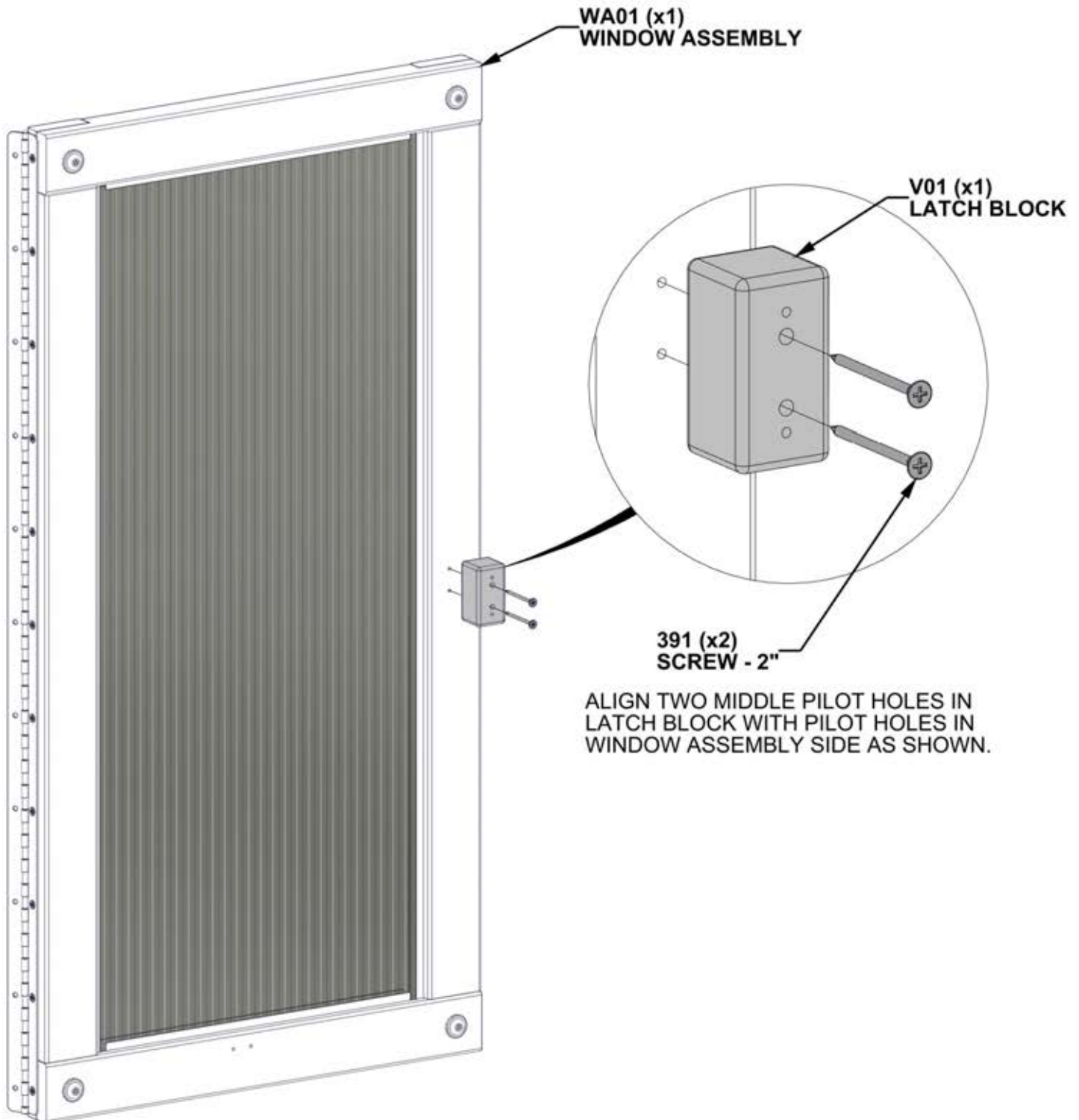
QTY	PART NUMBER	DESCRIPTION
2	H100391	SCREW PFH 8x2 BLK



WA01 WINDOW ASSEMBLY - W2A04074
(x1) 1 7/8"x19 5/8"x39 3/16" (48x498x996)

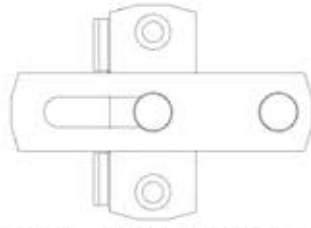


V01 LATCH BLOCK - W4L19241
(x1) 1 1/4"x1 1/4"x2 3/8" (32x32x60)



STEP 76B - WINDOW ASSEMBLY

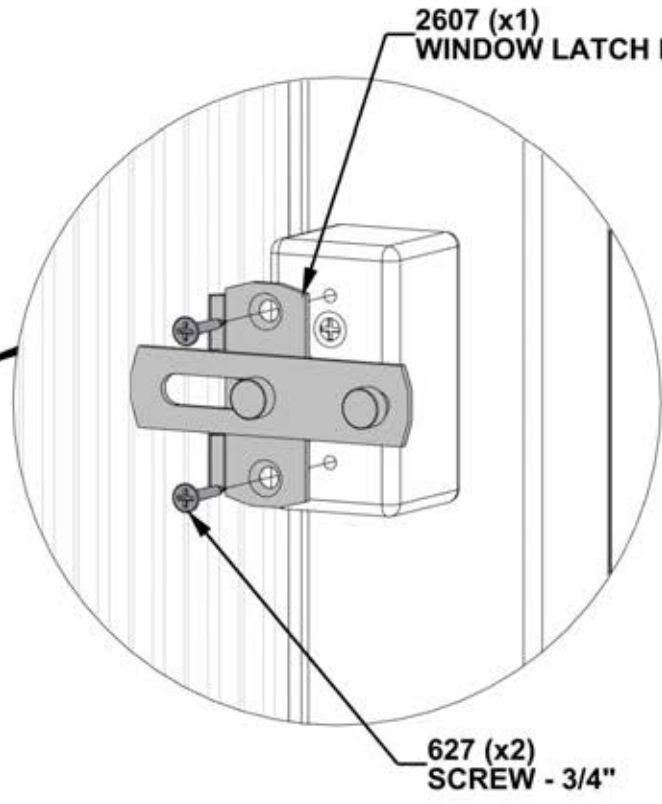
QTY	PART NUMBER	DESCRIPTION
2	H100627	SCREW PFH 6x3/4 BLK



A4M02607 WINDOW LATCH LOCK
(x1)



ENSURE CORRECT ORIENTATION OF WINDOW LATCH LOCK AS SHOWN.

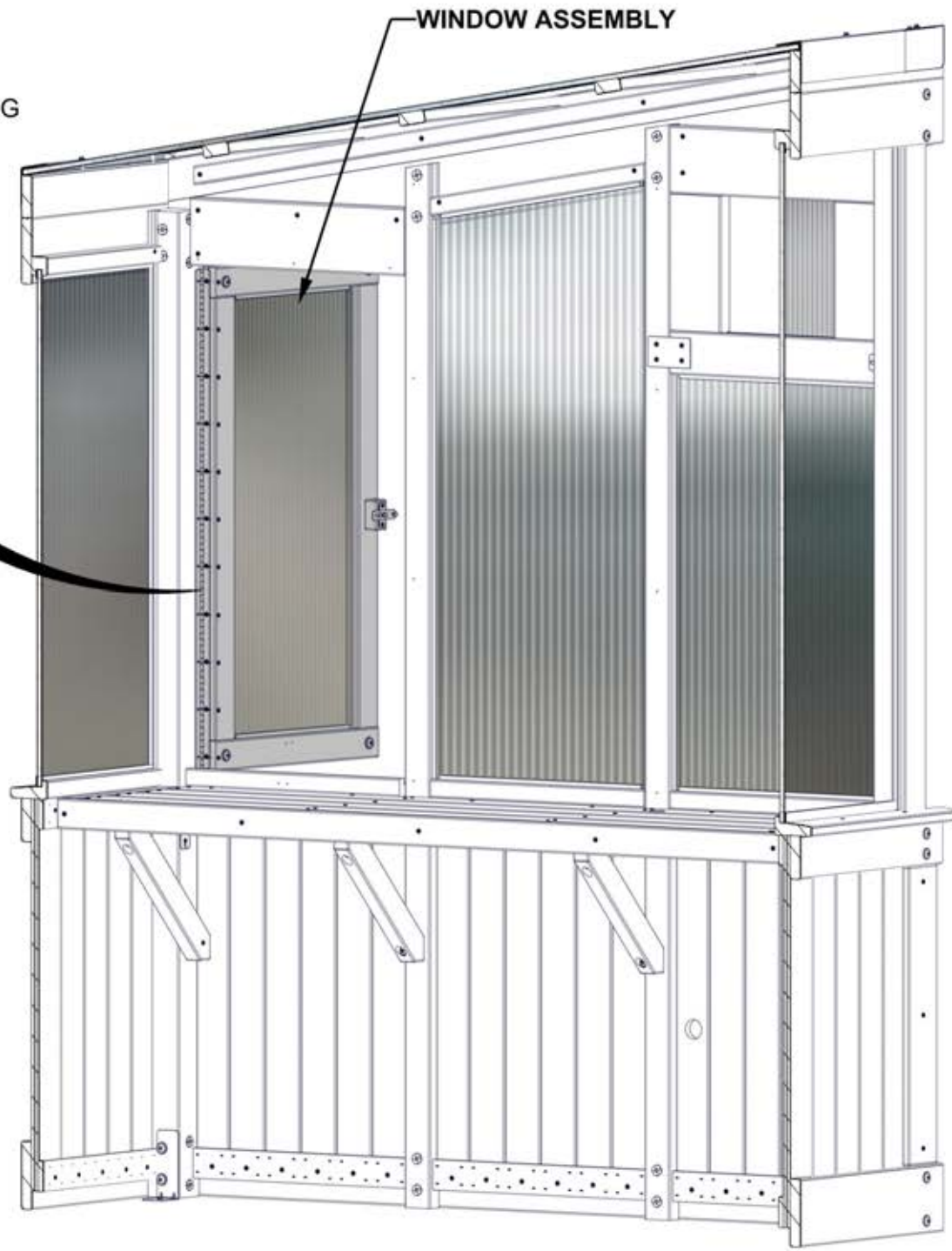
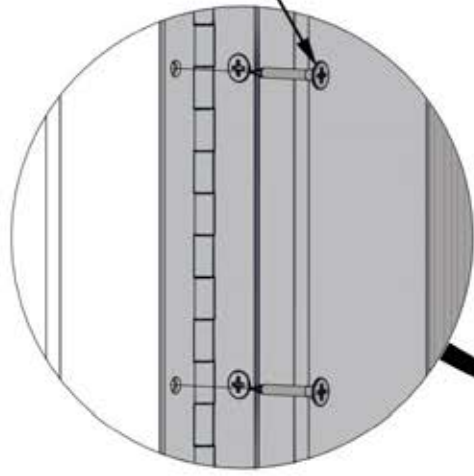


STEP 77 - WINDOW ASSEMBLY

QTY	PART NUMBER	DESCRIPTION
11	H100385	SCREW PFH 8x1 BLK

ATTACH WINDOW ASSEMBLY USING PILOT HOLES IN POST AS SHOWN.

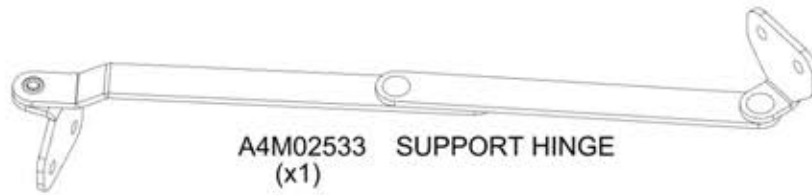
385 (x11)
SCREW - 1"



ONLY RIGHT SIDE OF GREENHOUSE SHOWN FOR DETAIL.

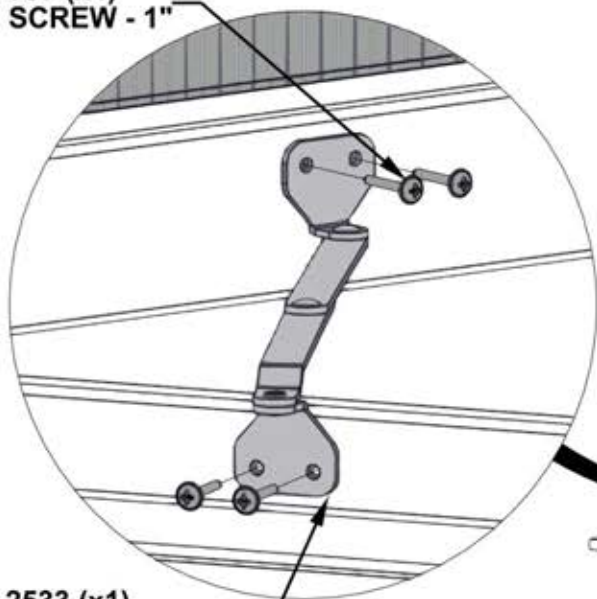
STEP 78 - WINDOW ASSEMBLY

QTY	PART NUMBER	DESCRIPTION
4	H100797	SCREW PWH 8x1 BLK

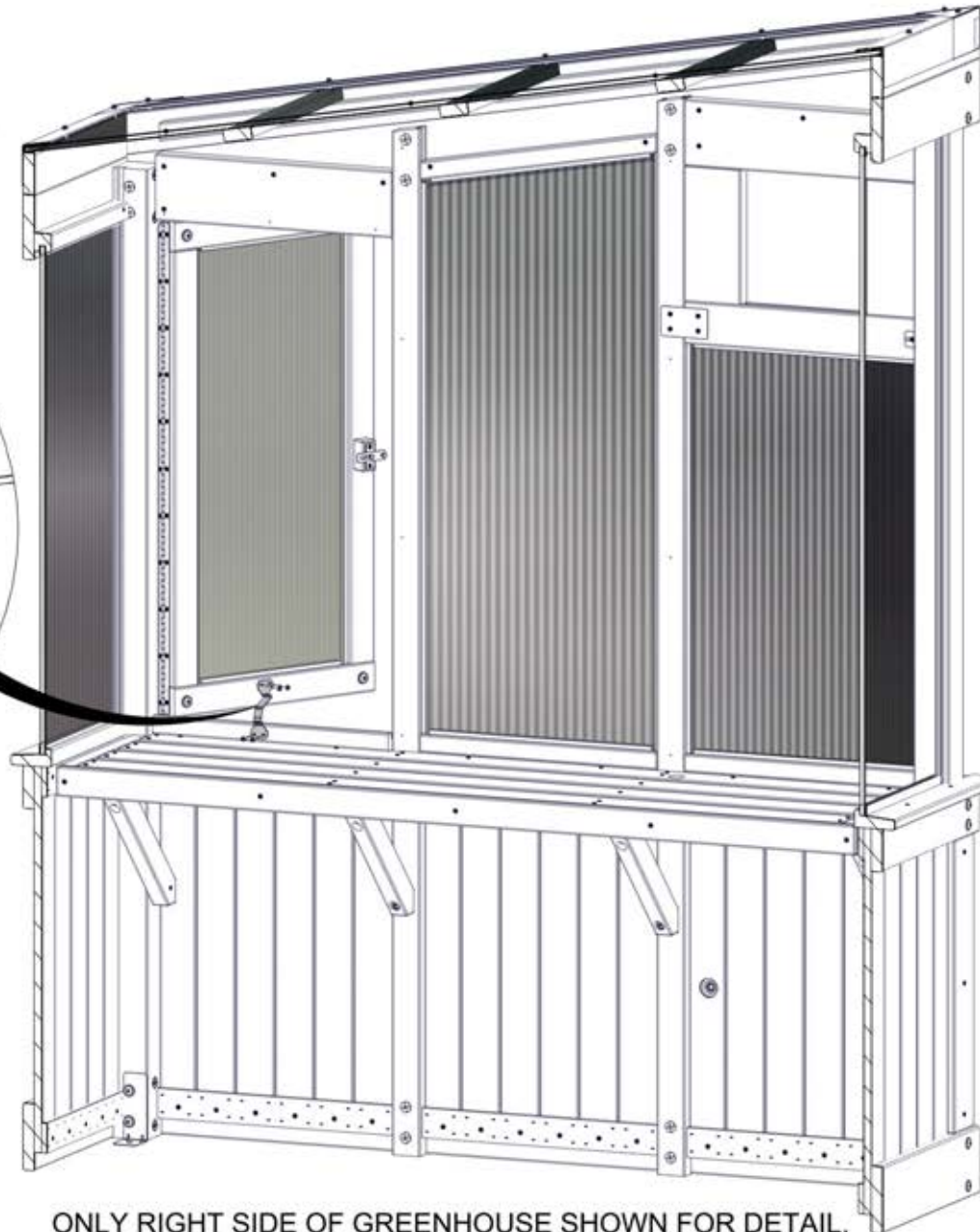


ATTACH SUPPORT HINGE USING PILOT HOLES IN WINDOW ASSEMBLY AND WINDOW SILL AS SHOWN.

797 (x4)
SCREW - 1"



2533 (x1)
SUPPORT HINGE



STEP 79 - SIDE WALL ASSEMBLY

QTY	PART NUMBER	DESCRIPTION
11	H100200	SCREW PFH 8x1 1/2 BLK



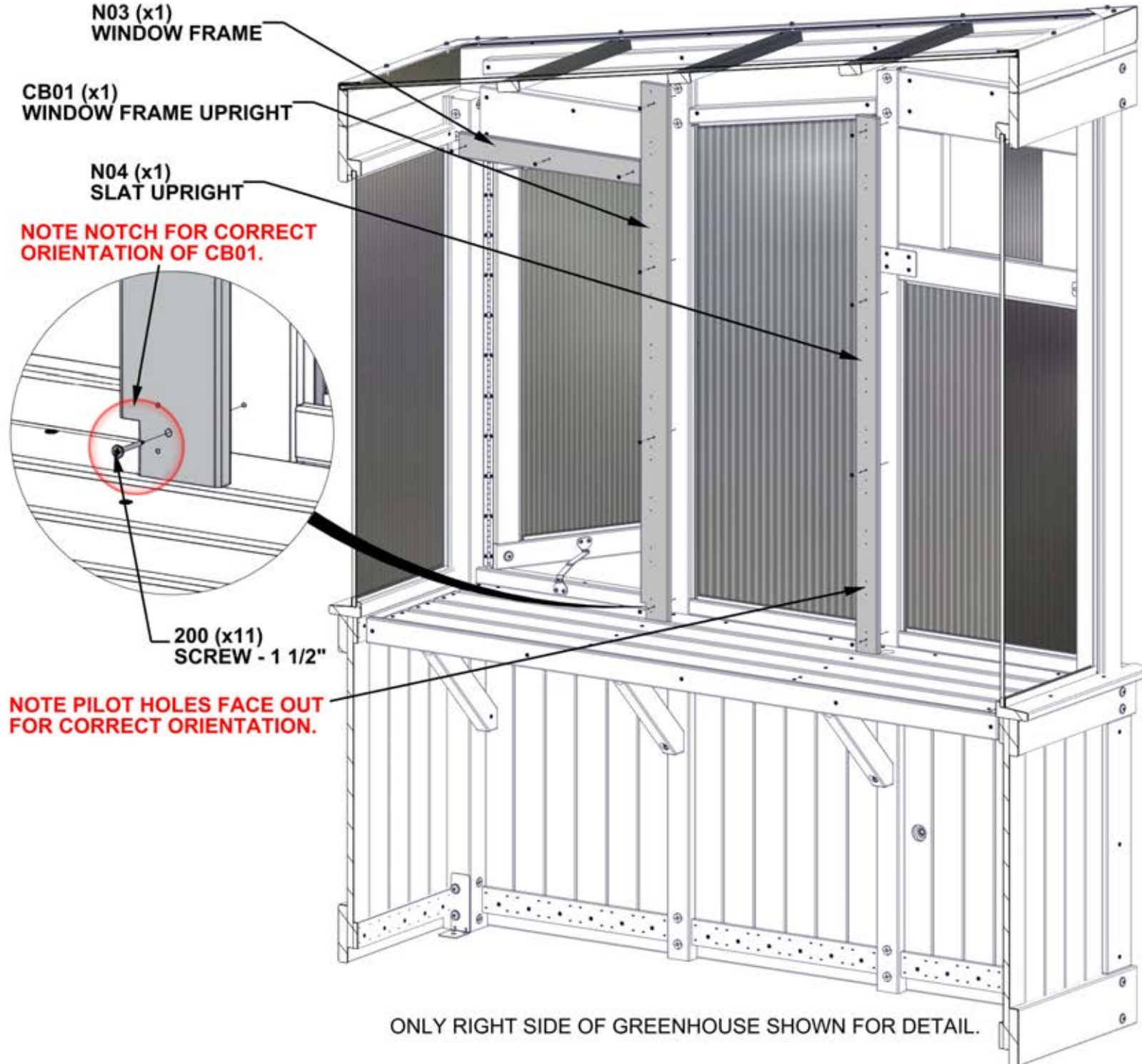
CB01 WINDOW FRAME UPRIGHT - W4L19235
(x1) 5/8"x3"x49 7/16" (16x76x1256)



N03 WINDOW FRAME - W4L19234
(x1) 5/8"x2 3/8"x19 5/16" (16x60x491)

N04 SLAT UPRIGHT - W4L19236
(x1) 5/8"x2 3/8"x49 7/16" (16x60x1256)

ALIGN PILOT HOLES TO ATTACH BOARDS.

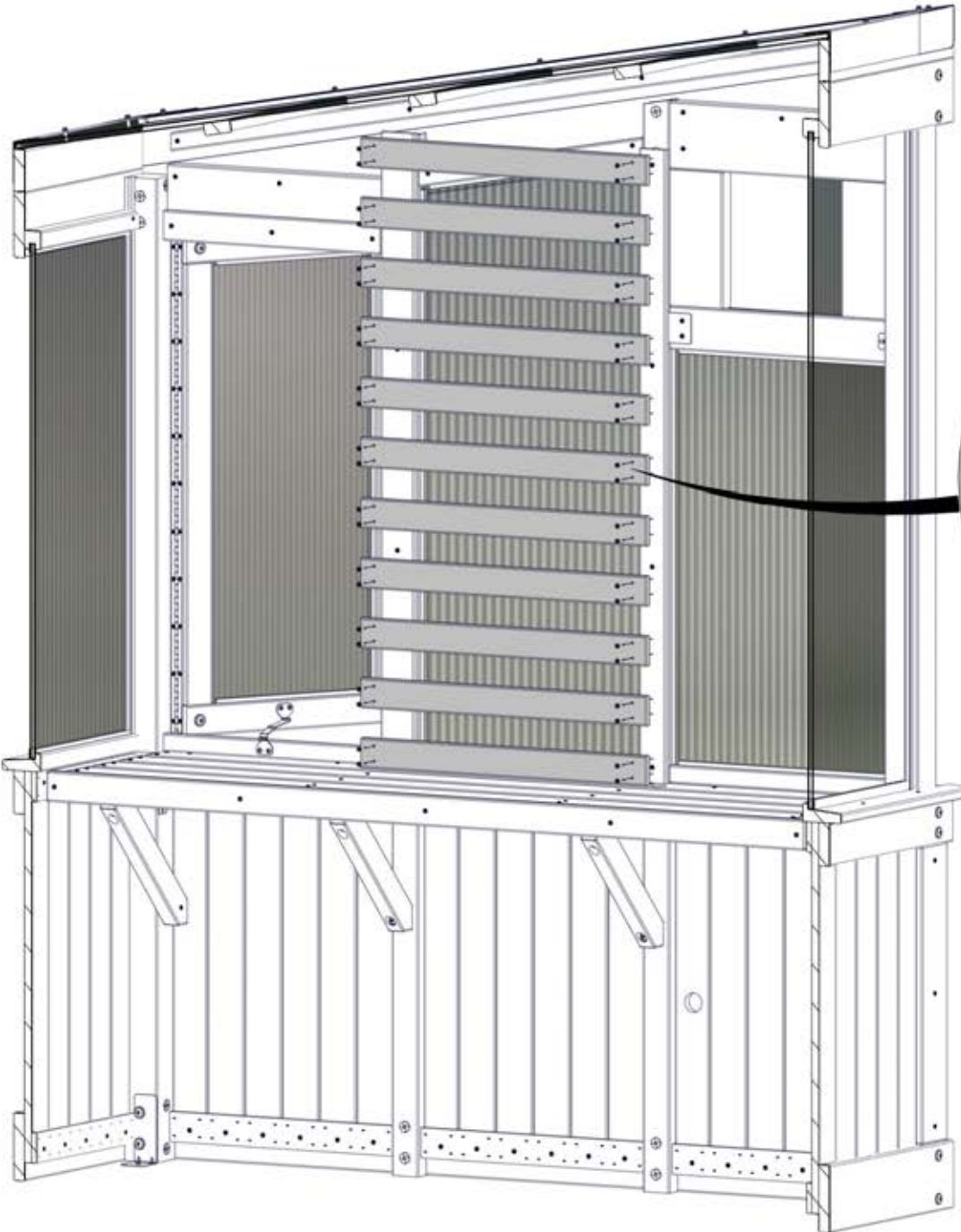


STEP 80 - SIDE WALL ASSEMBLY

QTY	PART NUMBER	DESCRIPTION
44	H100380	SCREW PFH 8x1 1/8 BLK

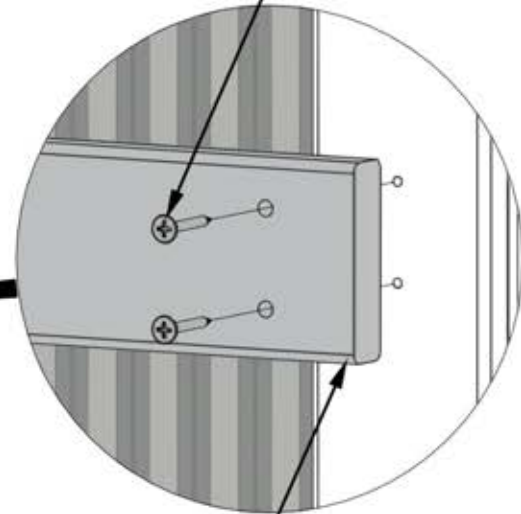


N05 SLAT - W4L19240
(x11) 5/8"x2 3/8"x25 3/8" (16x60x645)



ALIGN PILOT HOLES
TO ATTACH SLATS.

380 (x44)
SCREW - 1 1/8"



N05 (x11)
SLAT

ONLY RIGHT SIDE OF GREENHOUSE SHOWN FOR DETAIL.

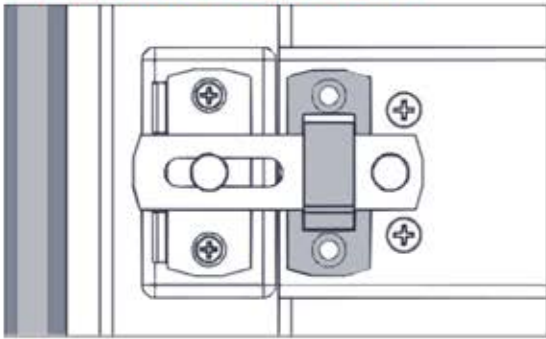
STEP 81 - SIDE WALL ASSEMBLY

QTY	PART NUMBER	DESCRIPTION
2	H100627	SCREW PFH 6x3/4 BLK

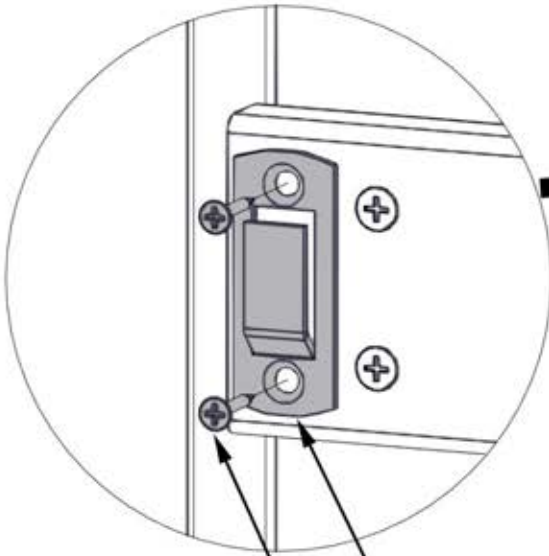


A4M02607 WINDOW LATCH LOCK (x1)

WITH WINDOW CLOSED, ALIGN LATCH LOCK AS SHOWN. MARK HOLE LOCATIONS AND PRE-DRILL WITH 1/8" [3mm] DRILL BIT.

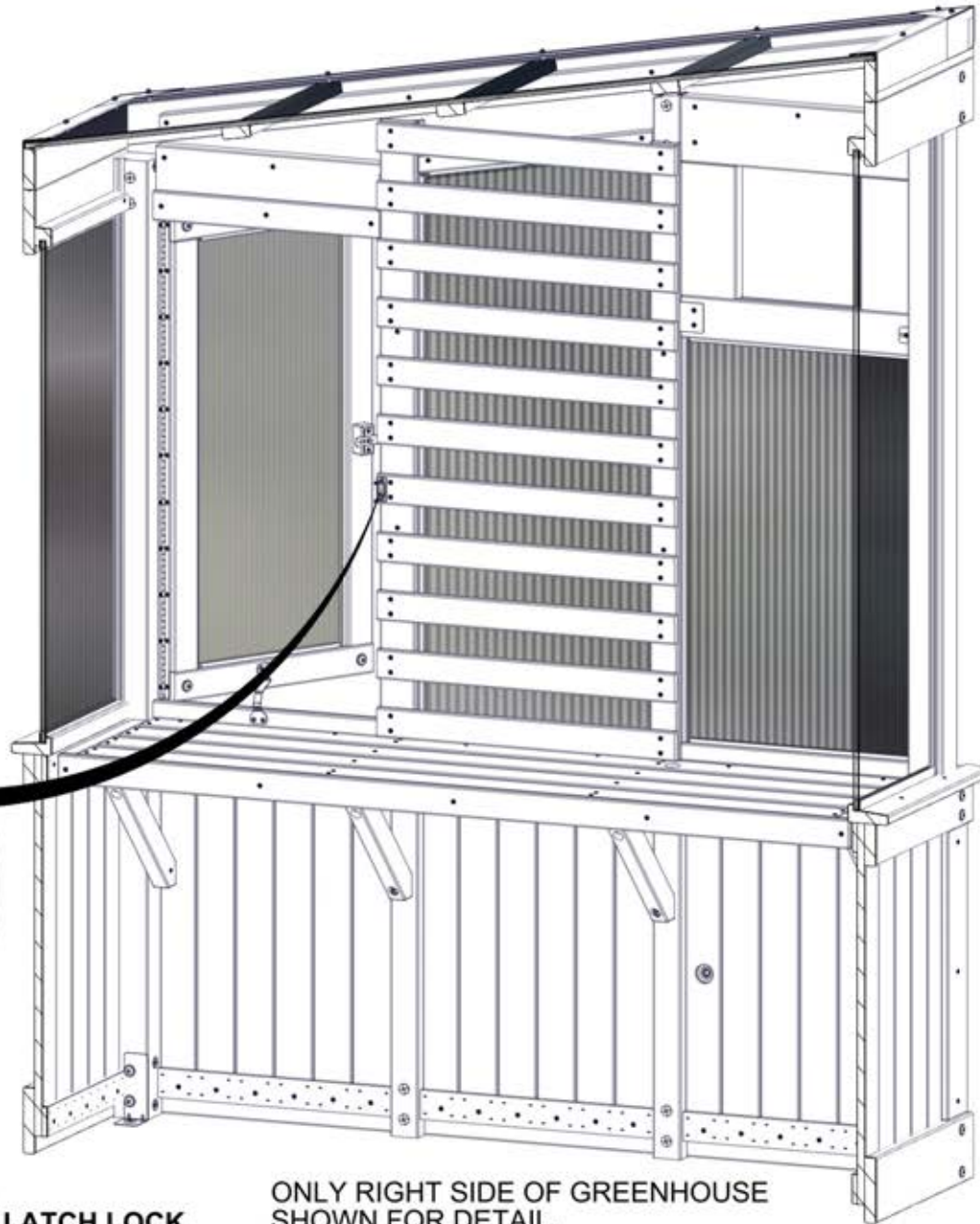


ATTACH LATCH LOCK USING PRE-DRILLED HOLES.



2607 (x1) WINDOW LATCH LOCK

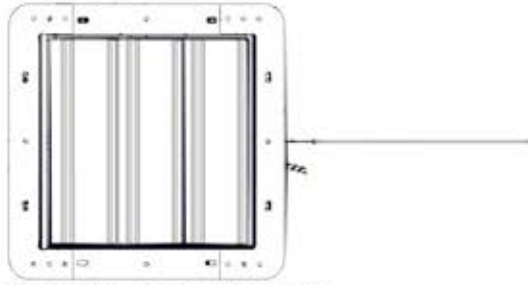
627 (x2) SCREW - 3/4"



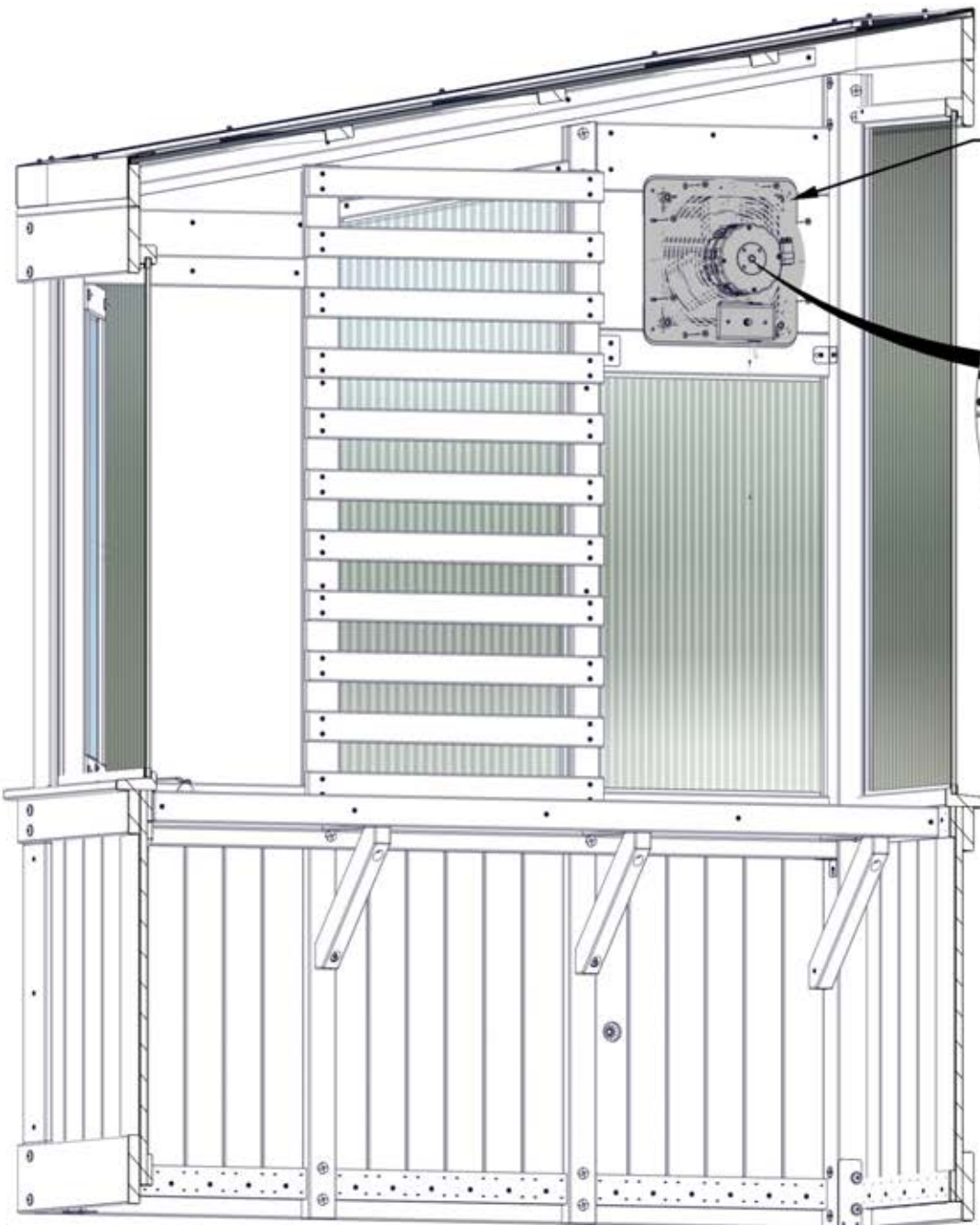
ONLY RIGHT SIDE OF GREENHOUSE SHOWN FOR DETAIL.

STEP 82 - SIDE WALL ASSEMBLY

QTY	PART NUMBER	DESCRIPTION
8	H101203	SCREW PWH 8x15x1 1/4 BLK



A4M02383 EXHAUST FAN
(x1)



CENTER EXHAUST FAN
IN THE OPENING AND
ATTACH AS SHOWN.

2383 (x1)
EXHAUST FAN

1203 (x8)
SCREW - 1 1/4"

ONLY RIGHT SIDE OF GREENHOUSE SHOWN FOR DETAIL.

STEP 83A - SIDE WALL ASSEMBLY

QTY	PART NUMBER	DESCRIPTION
2	H100385	SCREW PFH 8x1 BLK
2	H100411	SCREW PFH 8x5/8 BLK



INCLUDED WITH THE ELECTRICAL ENCLOSURE

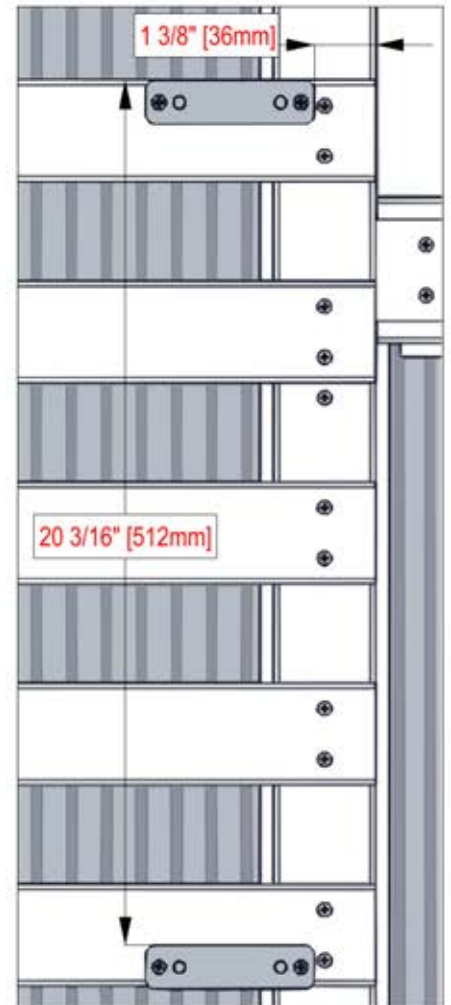
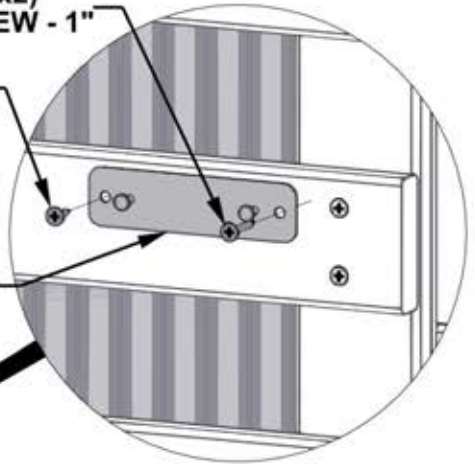
NOTES:
 DRILL PILOT HOLES USING AN 1/8" [3mm] DRILL BIT.
 USE MOUNTING BRACKETS & DIMENSIONS AS A GUIDE.

LONGER SCREWS ATTACH TO UPRIGHT ON BOTH BRACKETS.

385 (x2)
 SCREW - 1"

411 (x2)
 SCREW - 5/8"

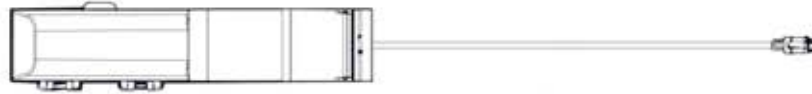
1292 (x2)
 MOUNTING BRACKET



ATTACH BRACKETS USING DIMENSIONS GIVEN.

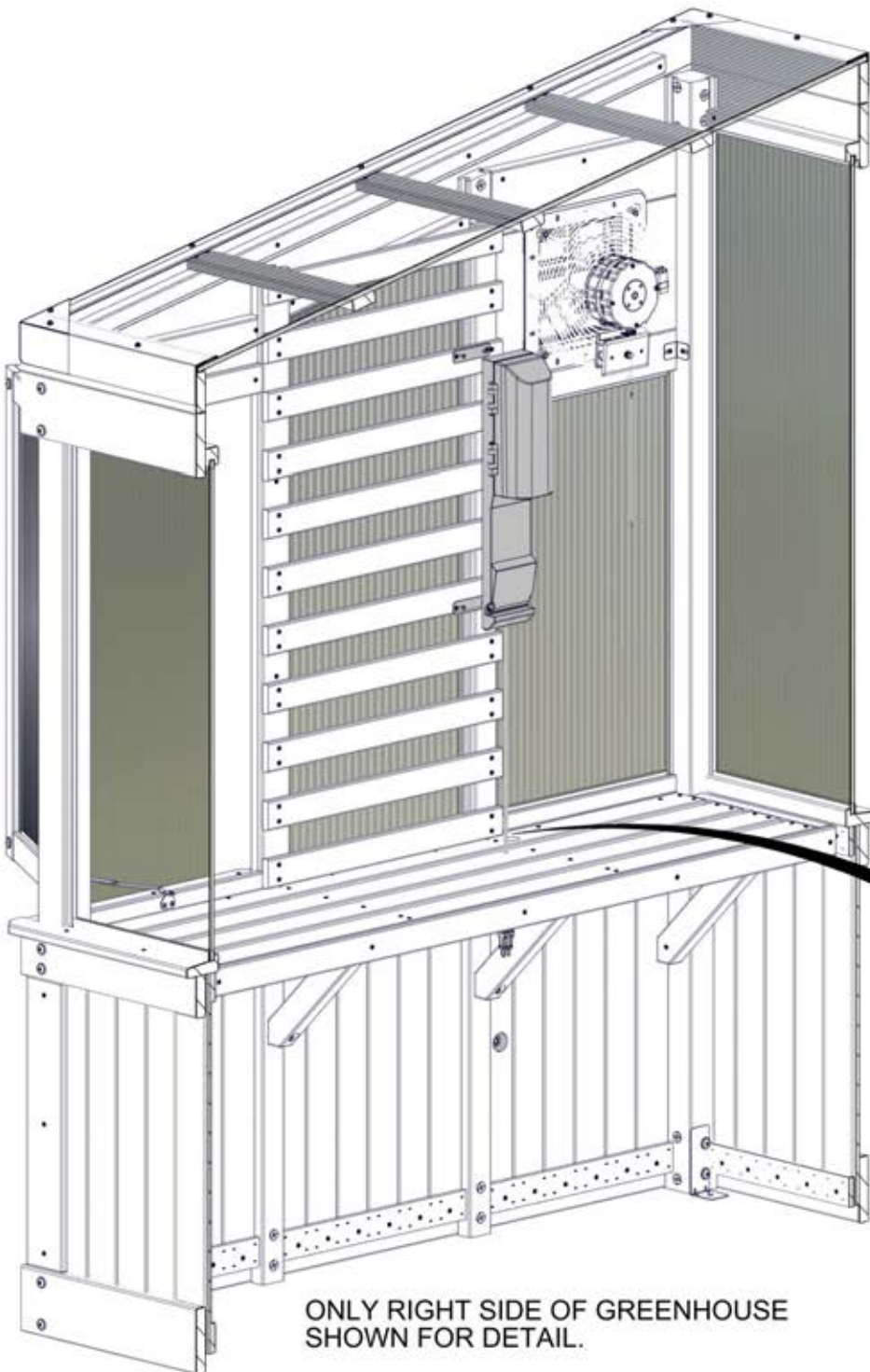
ONLY RIGHT SIDE OF GREENHOUSE SHOWN FOR DETAIL.

STEP 83B - SIDE WALL ASSEMBLY

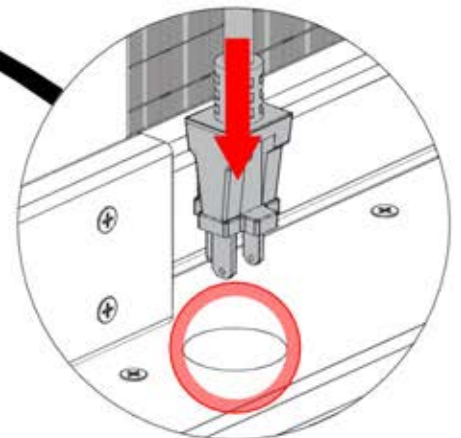
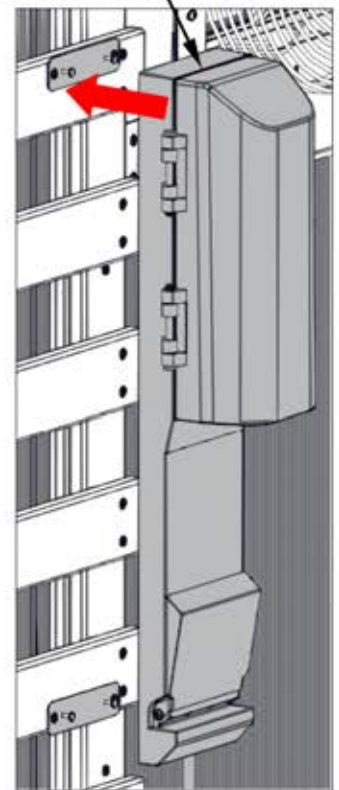


9205413 ELECTRICAL ENCLOSURE
(x1)

HANG ELECTRICAL ENCLOSURE ON THE MOUNTING BRACKETS,
THEN RUN ELECTRICAL CORD THROUGH HOLE IN TABLE AS SHOWN.



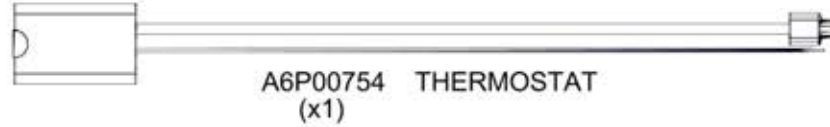
413 (x1)
ELECTRICAL ENCLOSURE



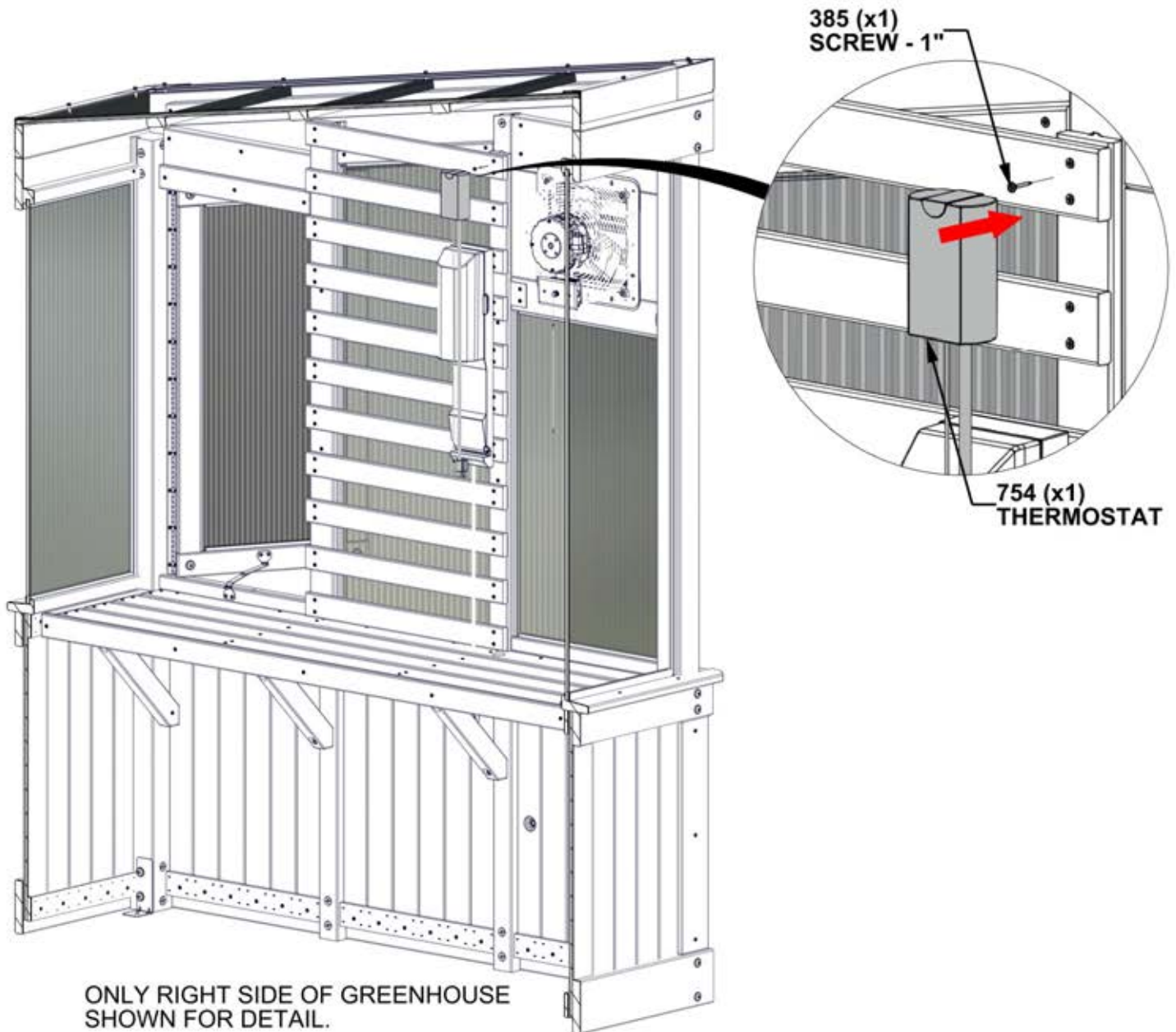
ONLY RIGHT SIDE OF GREENHOUSE
SHOWN FOR DETAIL.

STEP 84 - SIDE WALL ASSEMBLY

QTY	PART NUMBER	DESCRIPTION
1	H100385	SCREW PFH 8x1 BLK

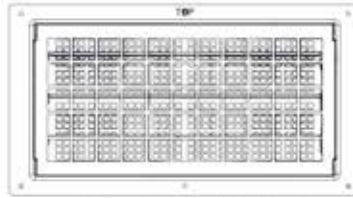


- NOTES:
- LOCATE THERMOSTAT IN A DESIRED LOCATION CLOSE TO THE ELECTRICAL ENSLOSURE.
 - INSTALL SCREW LEAVING IT PARTIALLY STICKING OUT AND HANG ON THERMOSTAT.
 - HANG THE PROBE IN AN ELEVATED LOCATION.



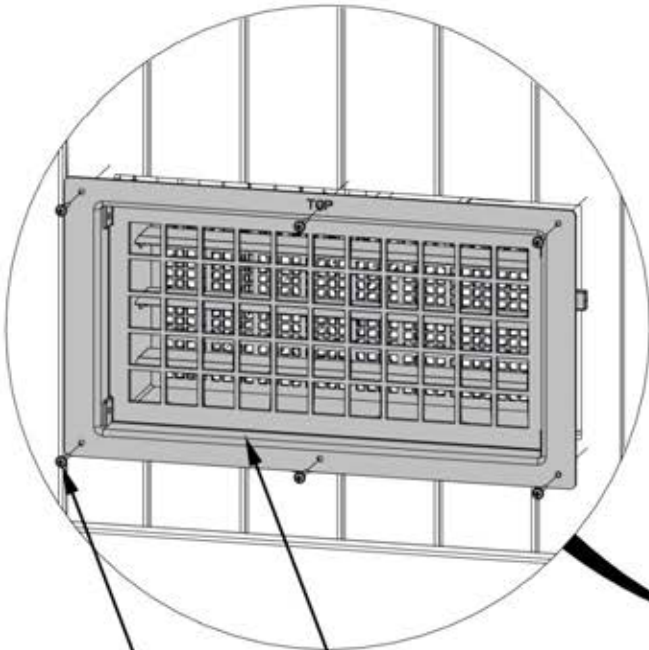
STEP 85 - VENT ASSEMBLY

QTY	PART NUMBER	DESCRIPTION
6	H100797	SCREW PWH 8x1 BLK



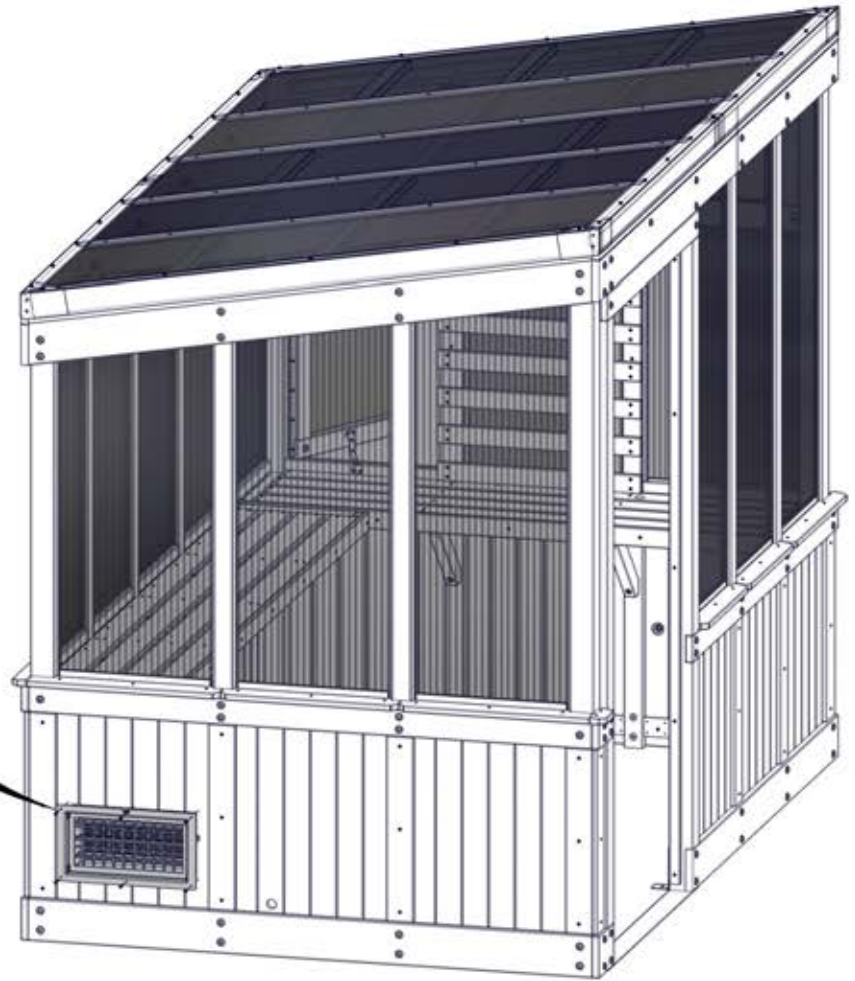
A6P00730 VENT
(x1)

USE VENT CENTERED IN OPENING AS A TEMPLATE TO PRE-DRILL PILOT HOLES WITH AN 1/8" [3mm] DRILL BIT BEFORE SCREWS ARE INSTALLED. DO NOT DRILL ALL THE WAY THROUGH WALL PANEL.

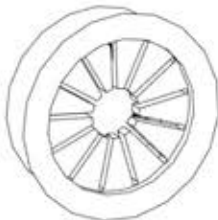


730 (x1)
VENT

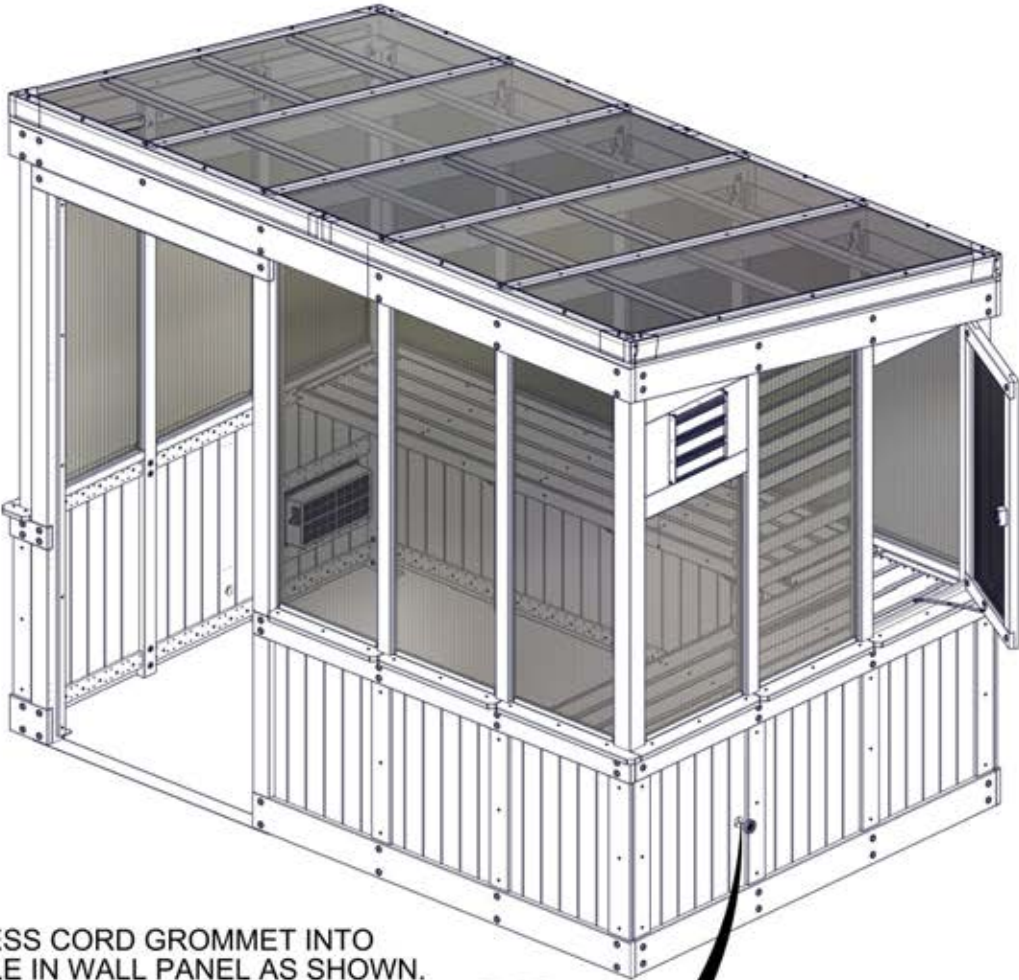
797 (x6)
SCREW - 1"



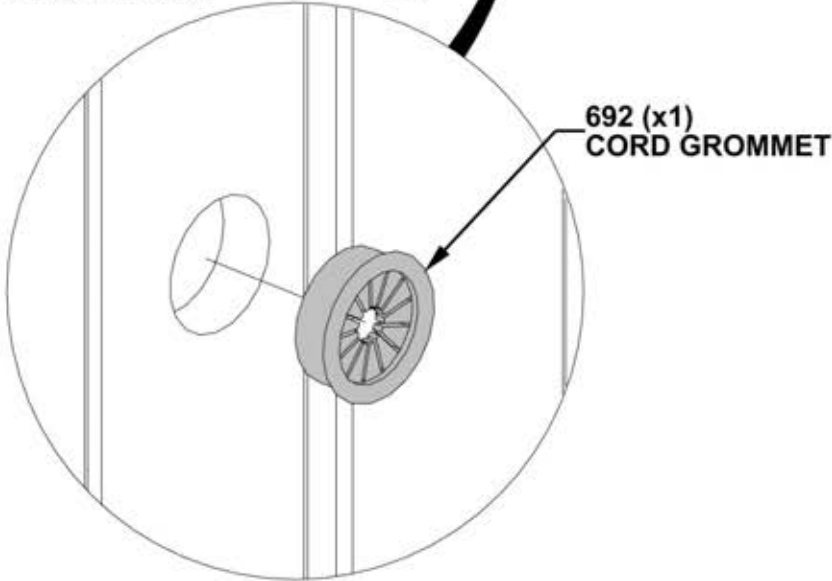
STEP 86 - SIDE WALL ASSEMBLY



A6P00692 CORD GROMMET
(x1)

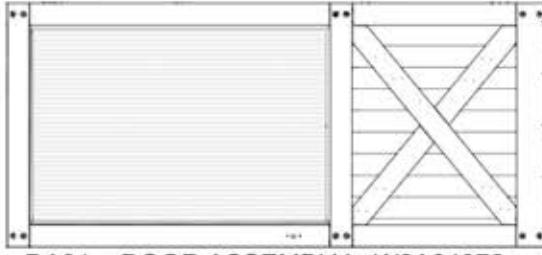


PRESS CORD GROMMET INTO HOLE IN WALL PANEL AS SHOWN.

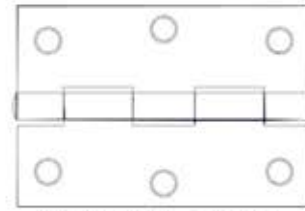


STEP 87 - DOOR ASSEMBLY

QTY	PART NUMBER	DESCRIPTION
12	H100385	SCREW PFH 8x1 BLK



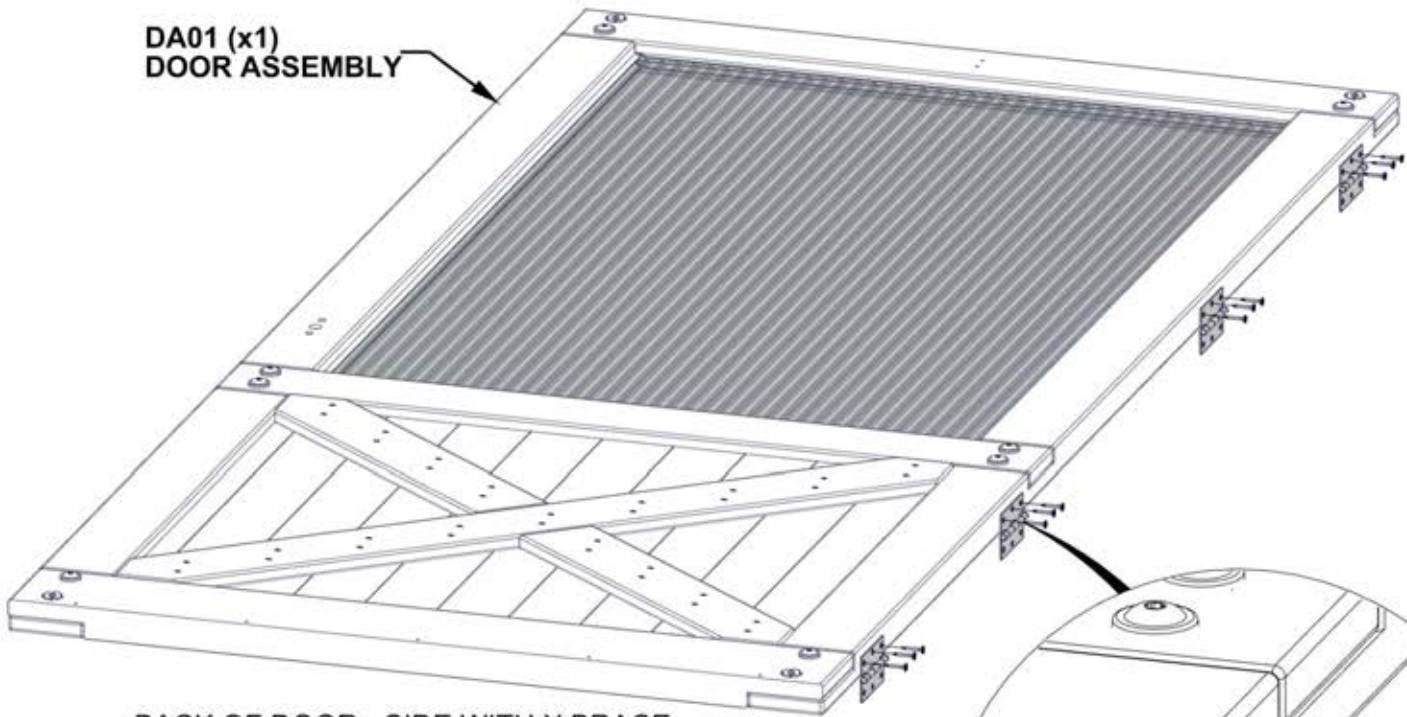
DA01 DOOR ASSEMBLY - W2A04072
(x1) 1 7/8"x36 9/16"x80" (48x928x2032)



A4M00557 HINGE
(x4)

ALIGN PILOT HOLES IN HINGES WITH PILOT HOLES ON DOOR.

DA01 (x1)
DOOR ASSEMBLY



BACK OF DOOR - SIDE WITH X BRACE

WITH THE DOOR LAYING WITH THE BACK FACING UP AS SHOWN, ATTACH HINGES. CORRECT ORIENTATION OF HINGES IS CRITICAL.

NOTE DIRECTION OF BARREL ON HINGES.

557 (x4)
HINGE ASSEMBLY

385 (x12)
SCREW - 1"

STEP 88 - DOOR ASSEMBLY

QTY	PART NUMBER	DESCRIPTION
12	H100385	SCREW PFH 8x1 BLK

LIFT DOOR INTO PLACE AND ATTACH AS SHOWN.



ONLY FRONT OF GREENHOUSE SHOWN FOR DETAIL.

STEP 89 - DOOR ASSEMBLY

QTY	PART NUMBER	DESCRIPTION
2	H101259	SCREW POH 8x1 3/4 BLK



A4M02410 STORM DOOR HANDLE
(x1)



2410 (x1)
STORM DOOR HANDLE

1259 (x2)
SCREW - 1 3/4"

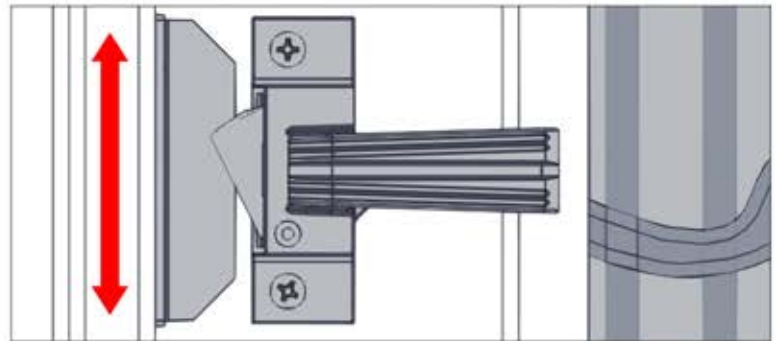
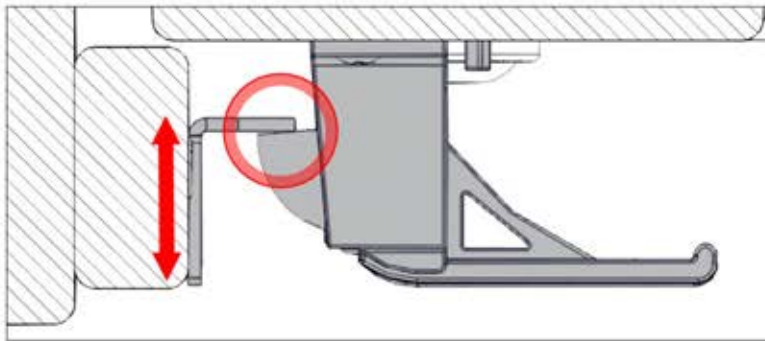
**ENSURE CORRECT ORIENTATION
OF HANDLE AS SHOWN.**

STEP 90 - DOOR ASSEMBLY

QTY	PART NUMBER	DESCRIPTION
2	H101260	SCREW PRH 8x1 1/4 SS



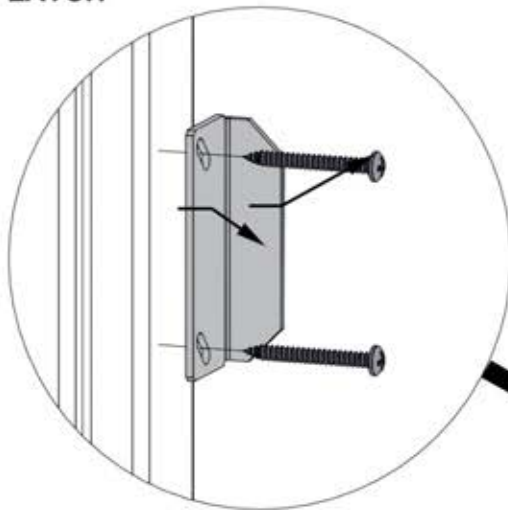
A4M02410 STORM DOOR HANDLE LATCH
(x1)



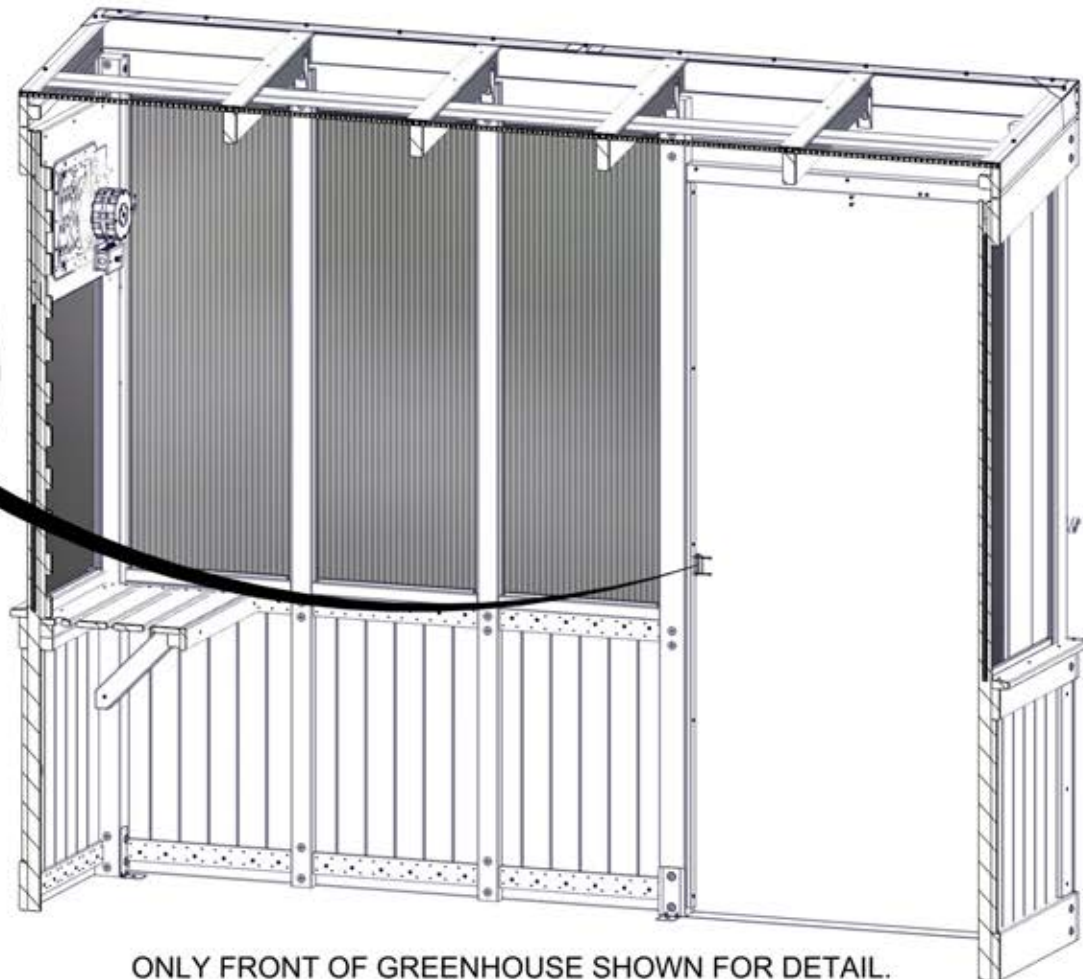
WITH THE DOOR SHUT, POSITION THE DOOR LATCH AS SHOWN. ADJUST FRONT TO BACK TO ENSURE THE LATCH MAKES CONTACT AS SHOWN. ADJUST UP AND DOWN TO ENSURE THE LATCH IS CENTERED WITH THE HANDLE AS SHOWN. MARK THE SLOTTED HOLE LOCATIONS AND PRE-DRILL WITH AN 1/8" [3mm] DRILL BIT.

1260 (x2)
SCREW - 1 1/4"

2410 (x1)
LATCH



ATTACH USING PILOT HOLES.



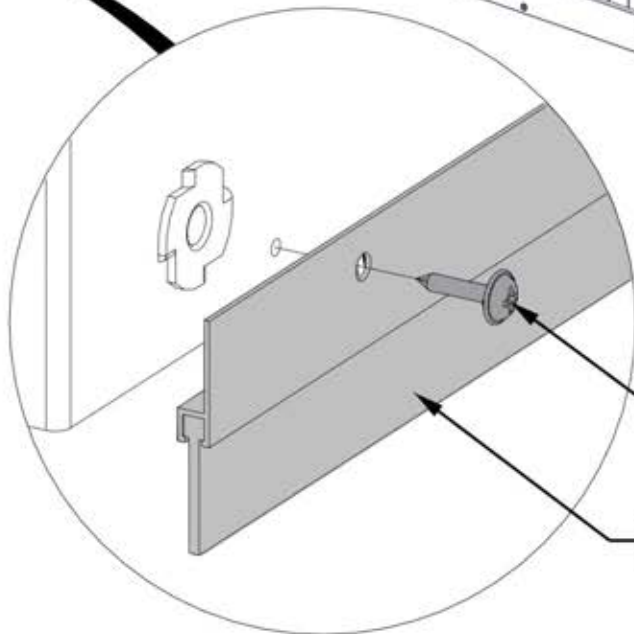
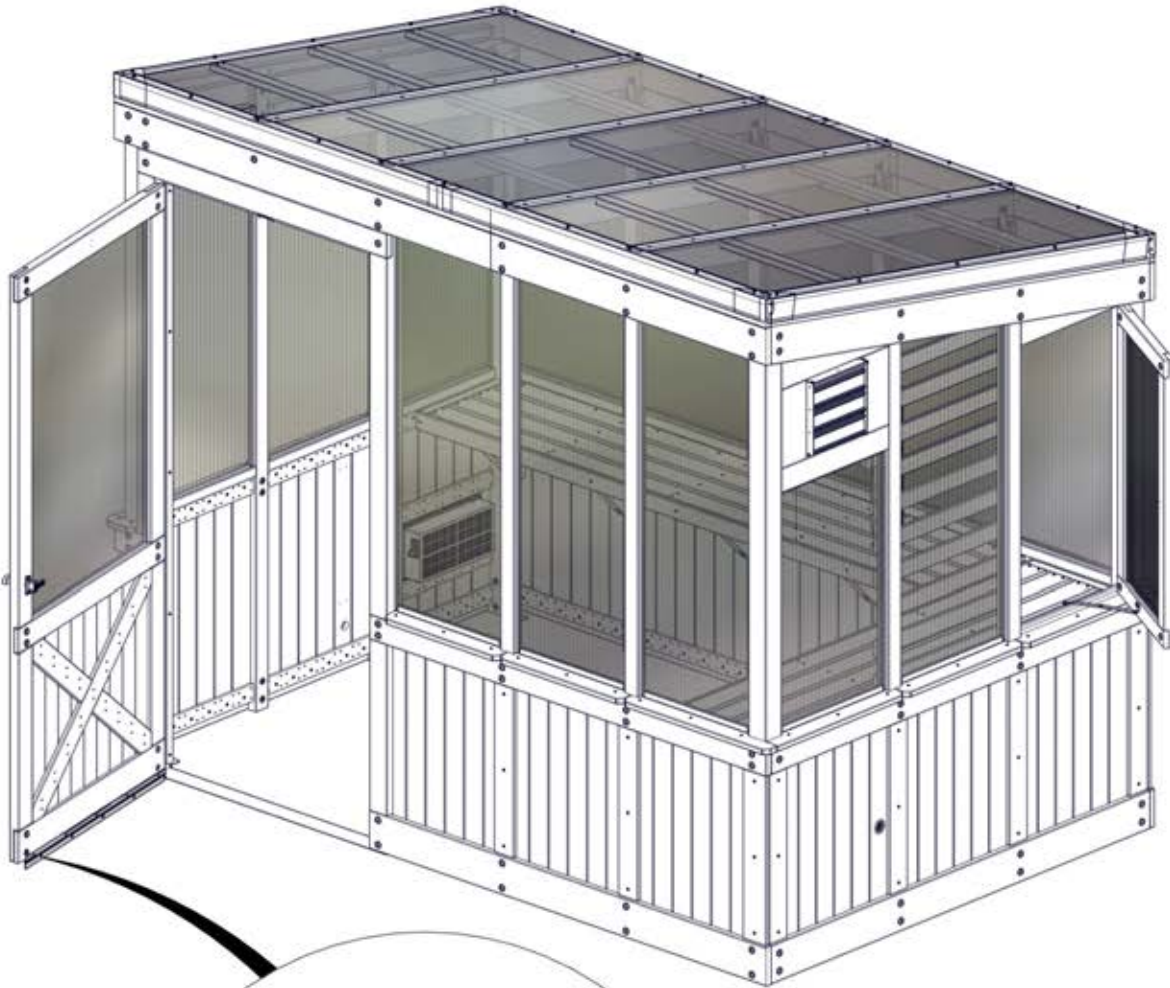
ONLY FRONT OF GREENHOUSE SHOWN FOR DETAIL.

STEP 91 - DOOR ASSEMBLY

QTY	PART NUMBER	DESCRIPTION
5	H100202	SCREW PWH 8x5/8 BLK



A4M02532 DOOR SWEEP
(x1)



ATTACH DOOR SWEEP USING PILOT HOLES IN DOOR ASSEMBLY AS SHOWN.

202 (x5)
SCREW - 5/8"

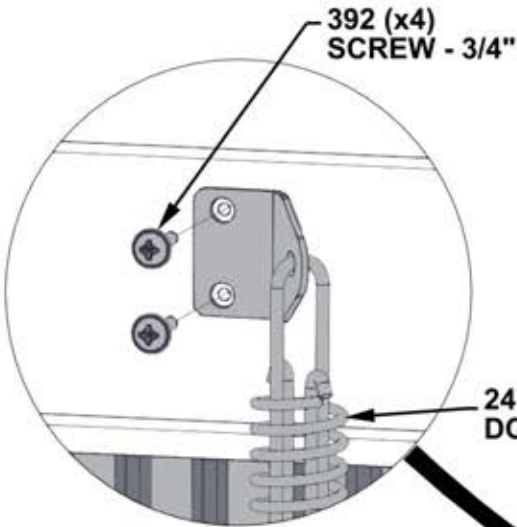
2532 (x1)
DOOR SWEEP

STEP 92 - DOOR ASSEMBLY

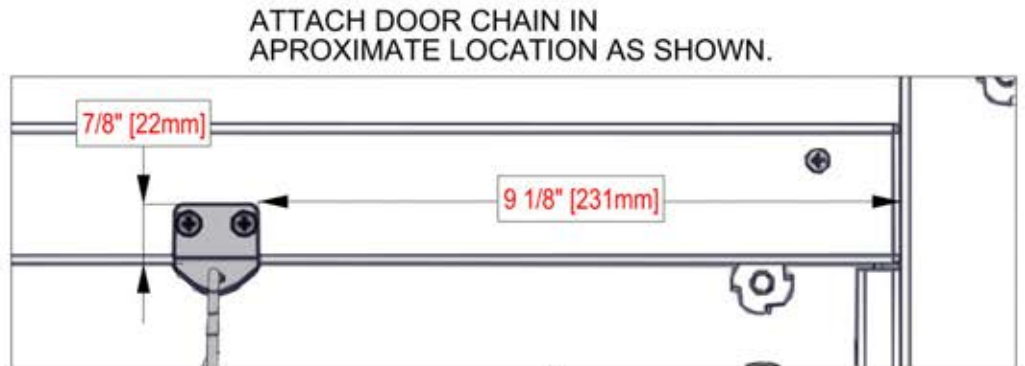
QTY	PART NUMBER	DESCRIPTION
4	H100392	SCREW PWH 8x3/4 BLK



A4M02411 DOOR PROTECTOR CHAIN
(x1)

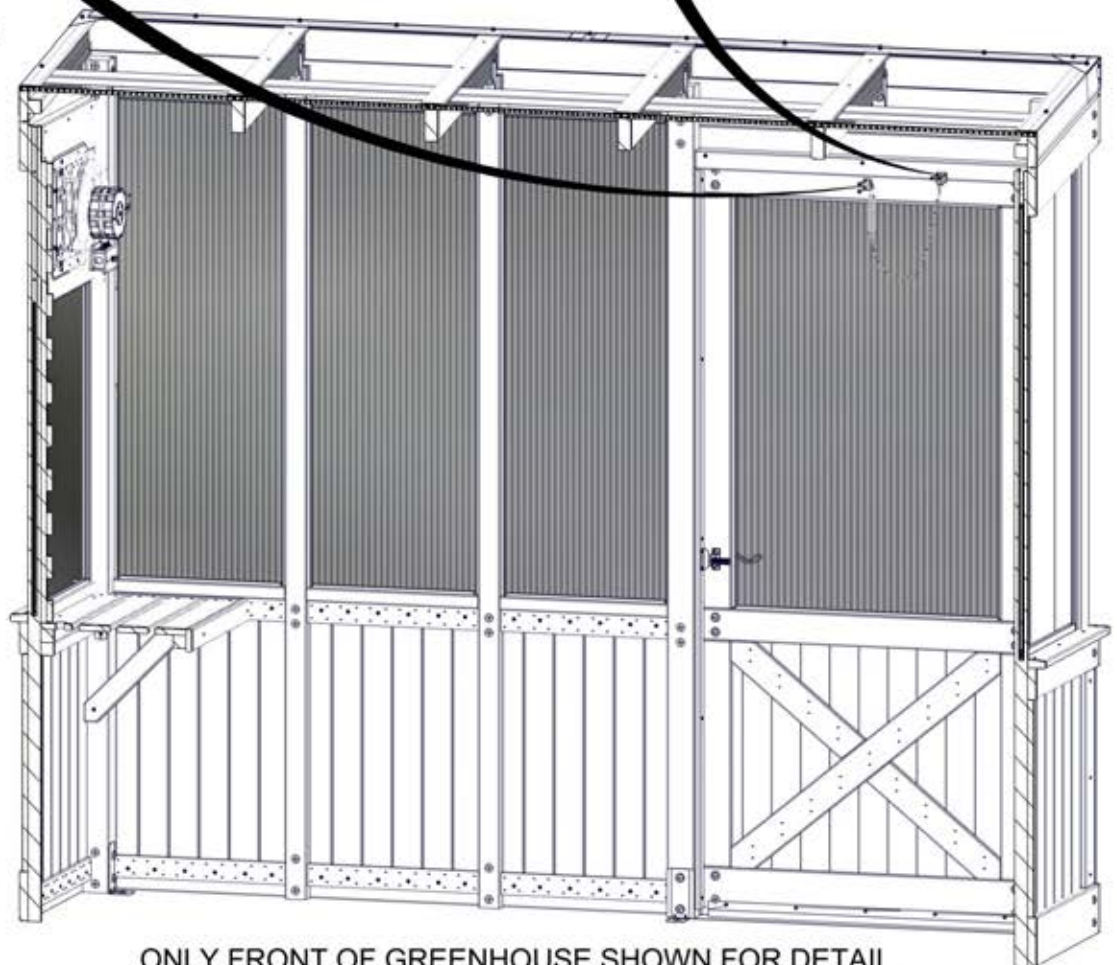


ATTACH SPRING SIDE BRACKET TO DOOR USING PILOT HOLES AS SHOWN.



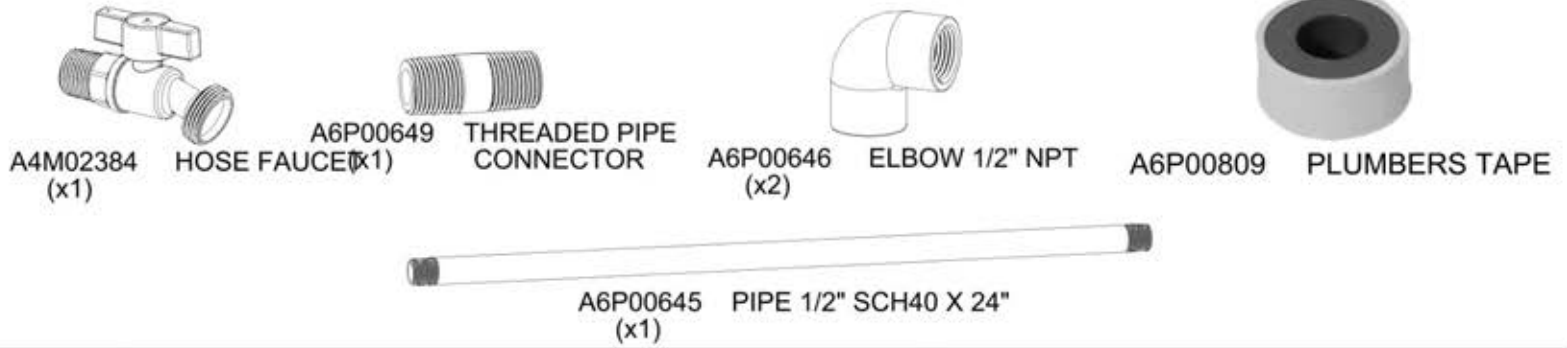
ATTACH DOOR CHAIN IN APPROXIMATE LOCATION AS SHOWN.

2411 (x1)
DOOR PROTECTOR CHAIN

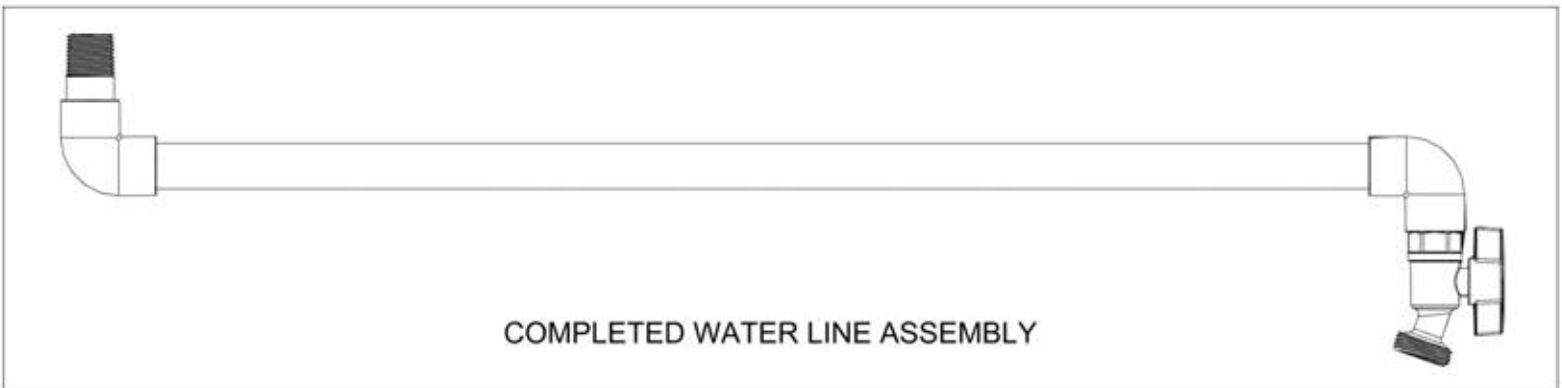
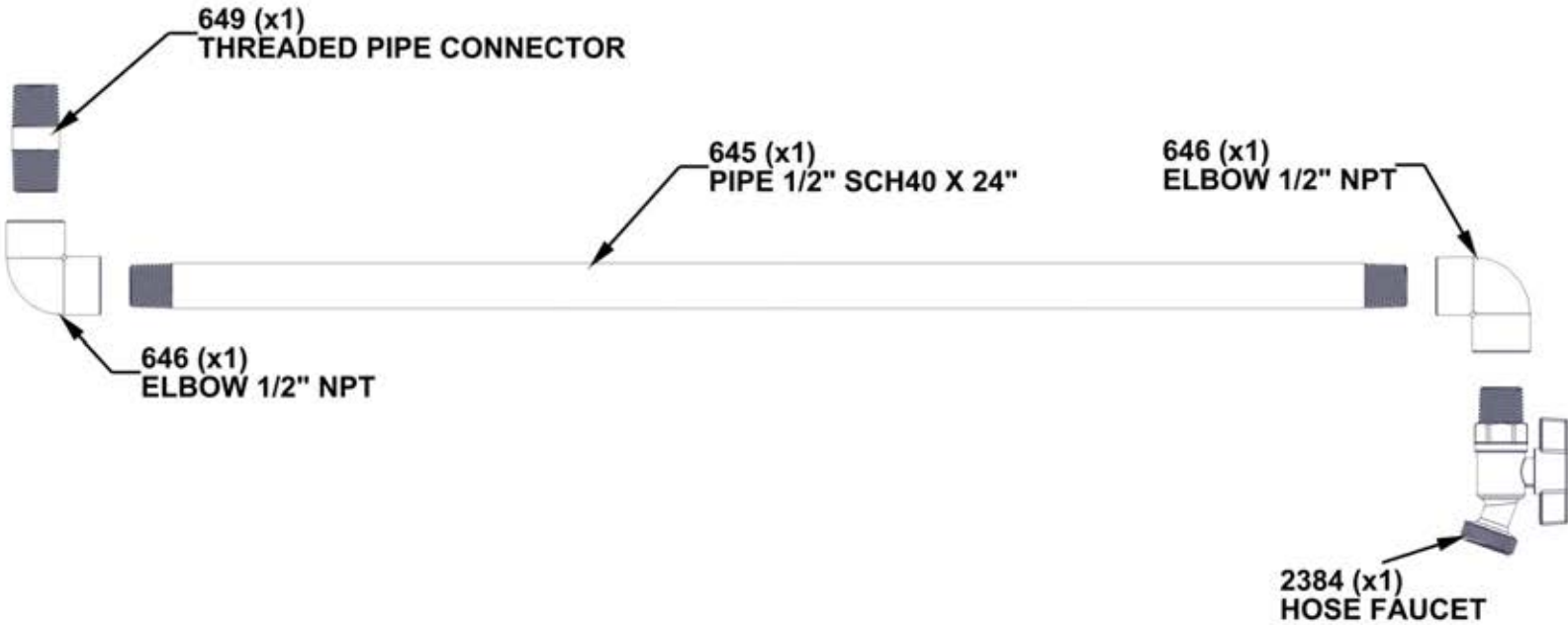


ONLY FRONT OF GREENHOUSE SHOWN FOR DETAIL.

STEP 93A - WATER LINE ASSEMBLY



- USE PLUMBERS TAPE AND WRAP THREADS OF MALE FITTINGS.
- FASTEN FITTINGS TO FORM THE COMPLETED WATER LINE ASSEMBLY BELOW.



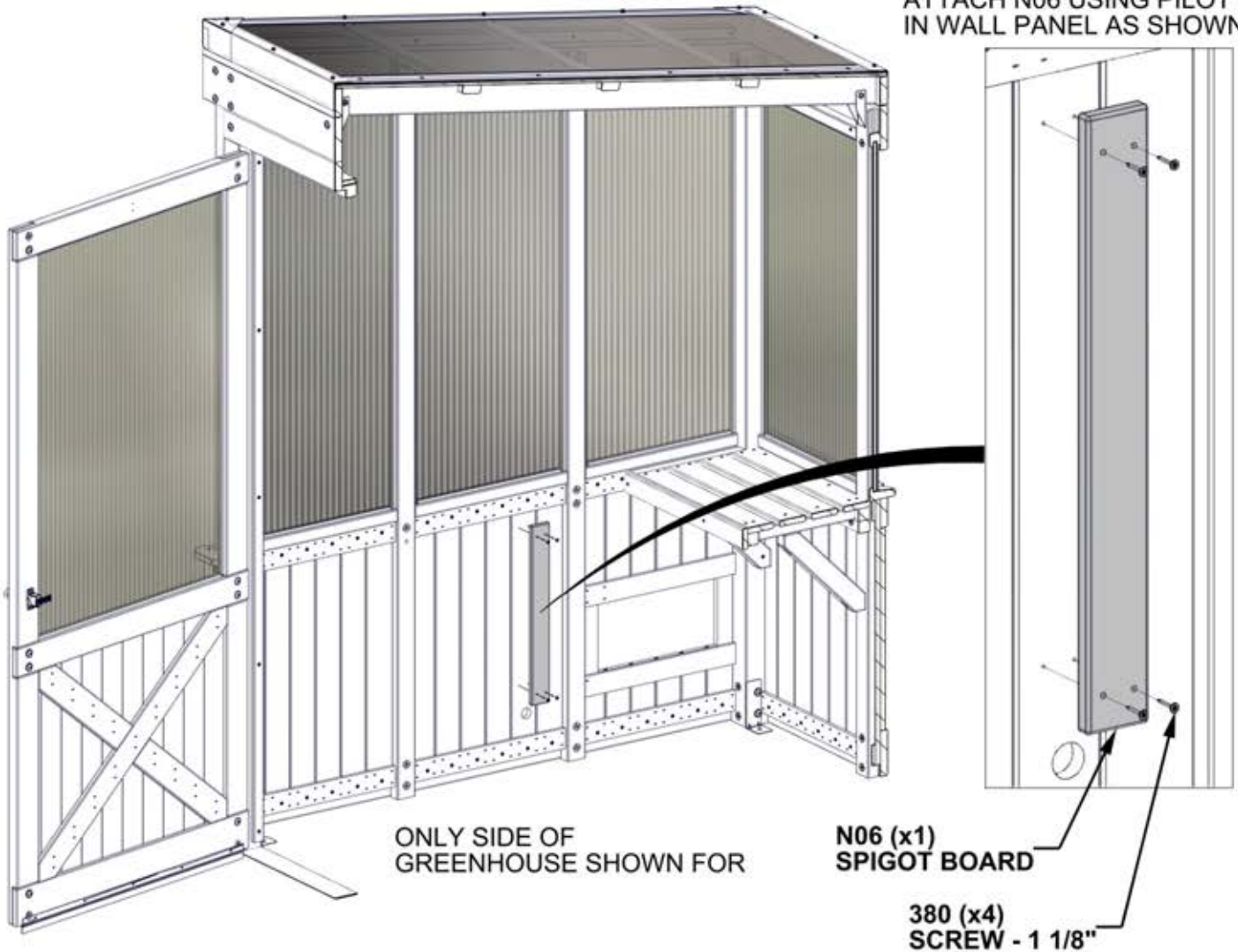
STEP 93B - WATER LINE ASSEMBLY

QTY	PART NUMBER	DESCRIPTION
4	H100380	SCREW PFH 8x1 1/8 BLK



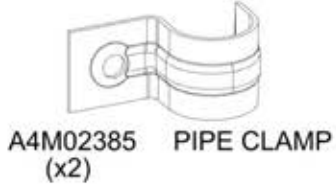
N06 SPIGOT BOARD - W4L19242
(x1) 5/8"x2 3/8"x20 11/16" (16x60x526)

ATTACH N06 USING PILOT HOLES IN WALL PANEL AS SHOWN.

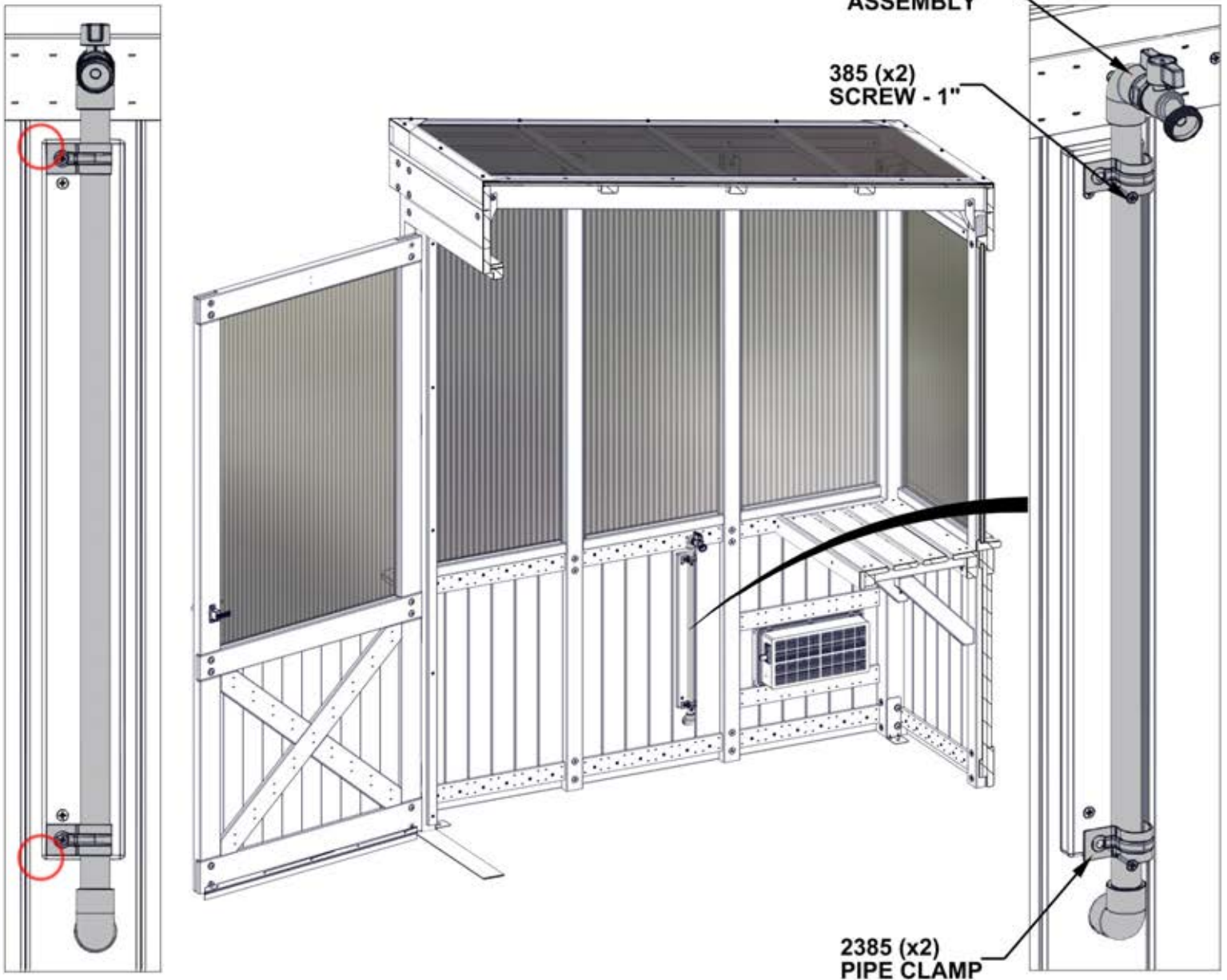


STEP 93C - WATER LINE ASSEMBLY

QTY	PART NUMBER	DESCRIPTION
2	H100385	SCREW PFH 8x1 BLK



- INSERT WATER LINE ASSEMBLY THROUGH HOLE IN WALL PANEL.
- SECURE WATER LINE TO BOARD FROM PREVIOUS STEP WITH PIPE CLAMPS.
- PRE-DRILL WITH AN 1/8" [3mm] DRILL BIT WITH CLAMPS LINED UP IN POSITION.
- FASTEN CLAMPS FLUSH TO OUTSIDE CORNERS AS SHOWN.



STEP 93D - WATER LINE ASSEMBLY



A6P00648 THREADED HOSE FITTING
(x1)



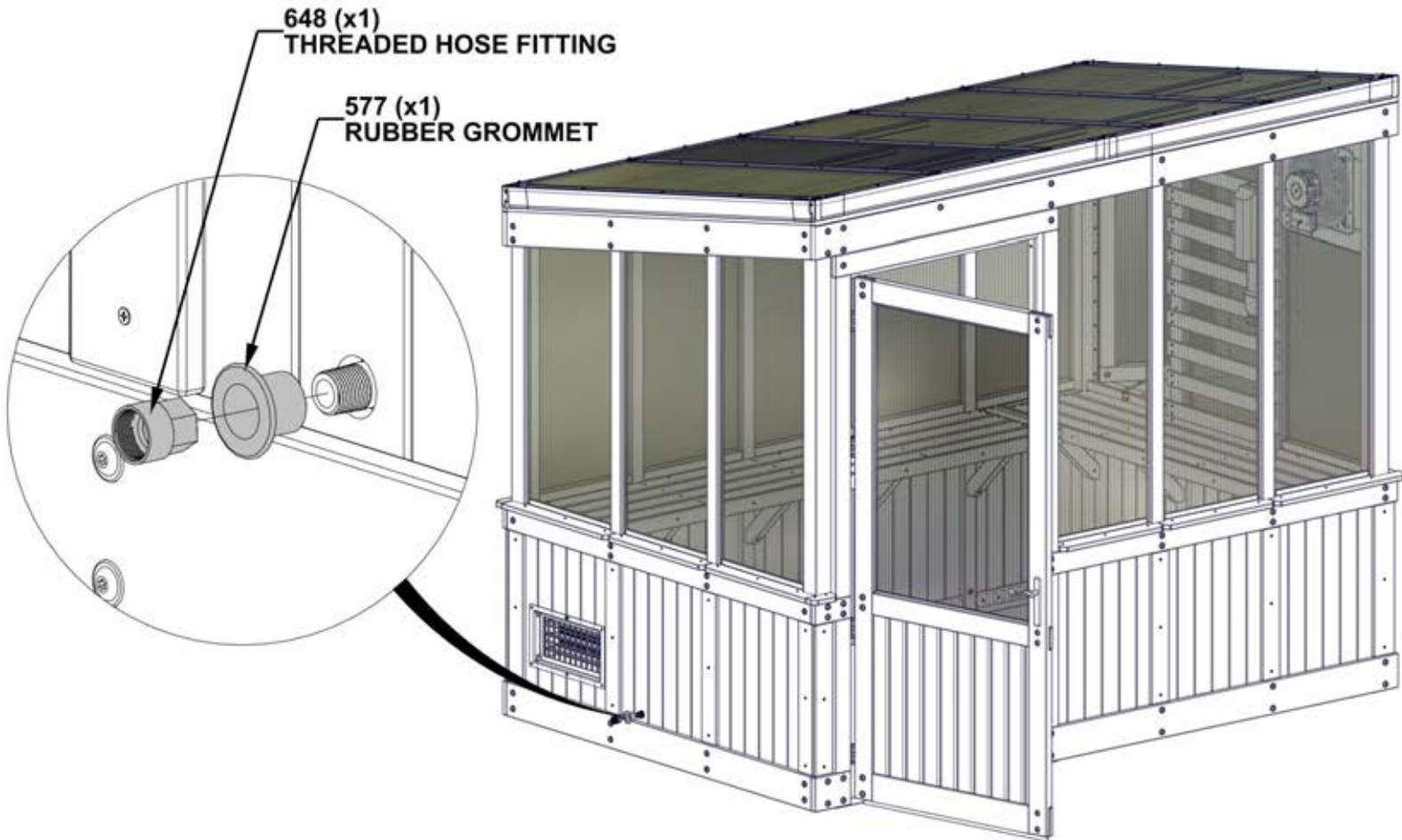
A6P00577 RUBBER GROMMET
(x1)



A6P00809 PLUMBERS TAPE

- PUSH RUBBER GROMMET IN HOLE AROUND THE WATER LINE ASSEMBLY FROM PREVIOUS STEPS.
- USE PLUMBERS TAPE AND WRAP THREADS OF MALE FITTINGS.
- FASTEN THREADED HOSE FITTING.

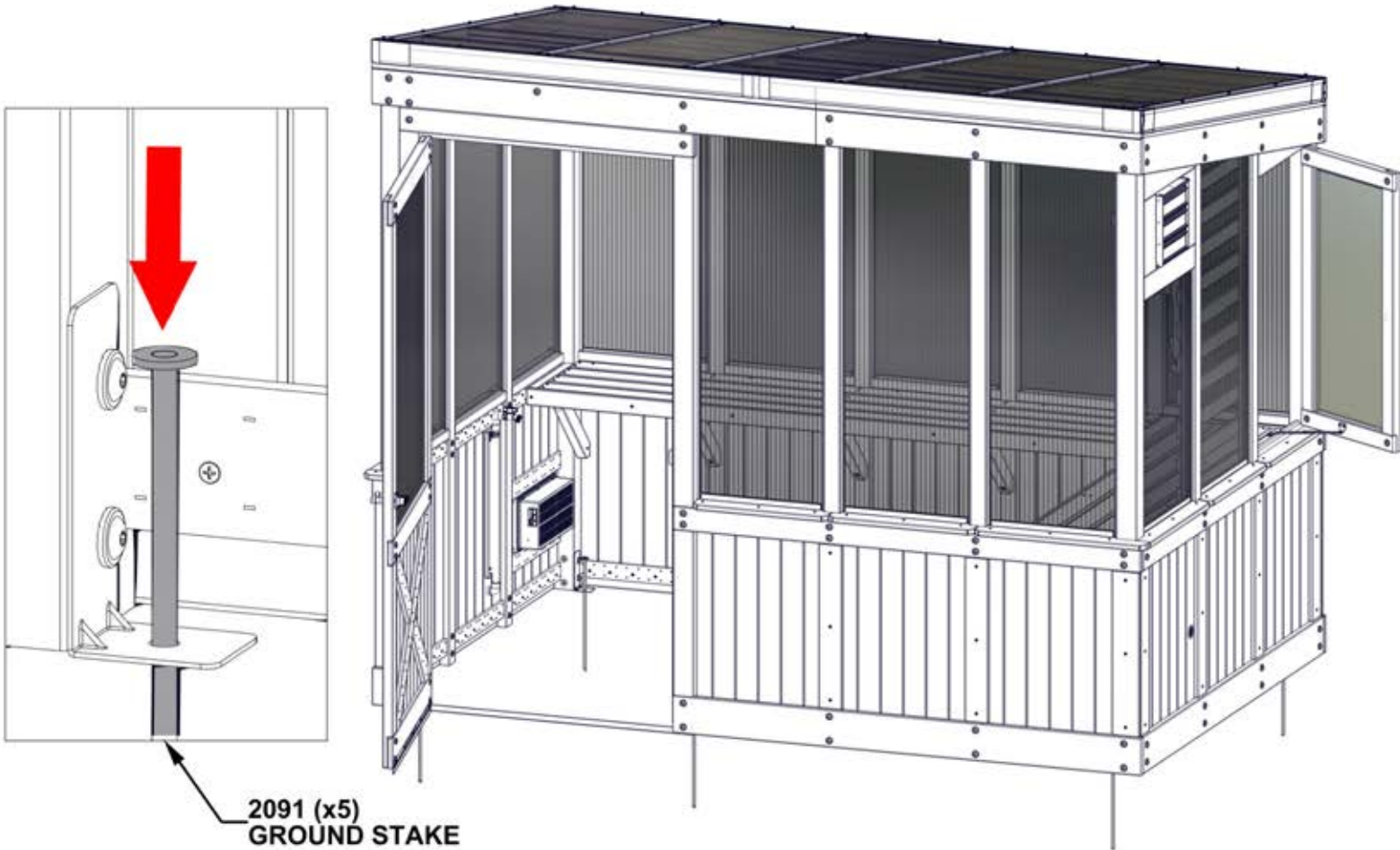
**INSTALL RUBBER GROMMET
BEFORE THREADED HOSE FITTING.**



STEP 94A - ANCHORING



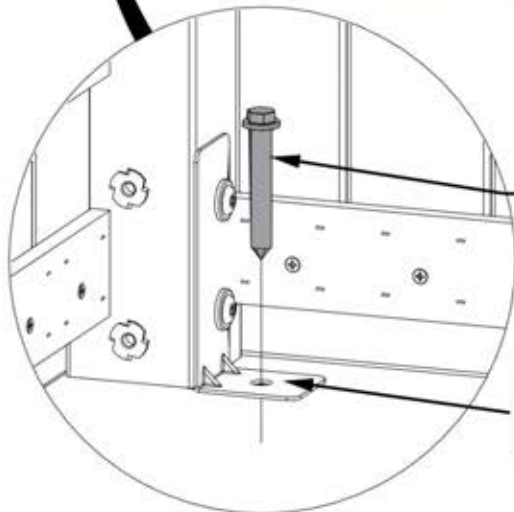
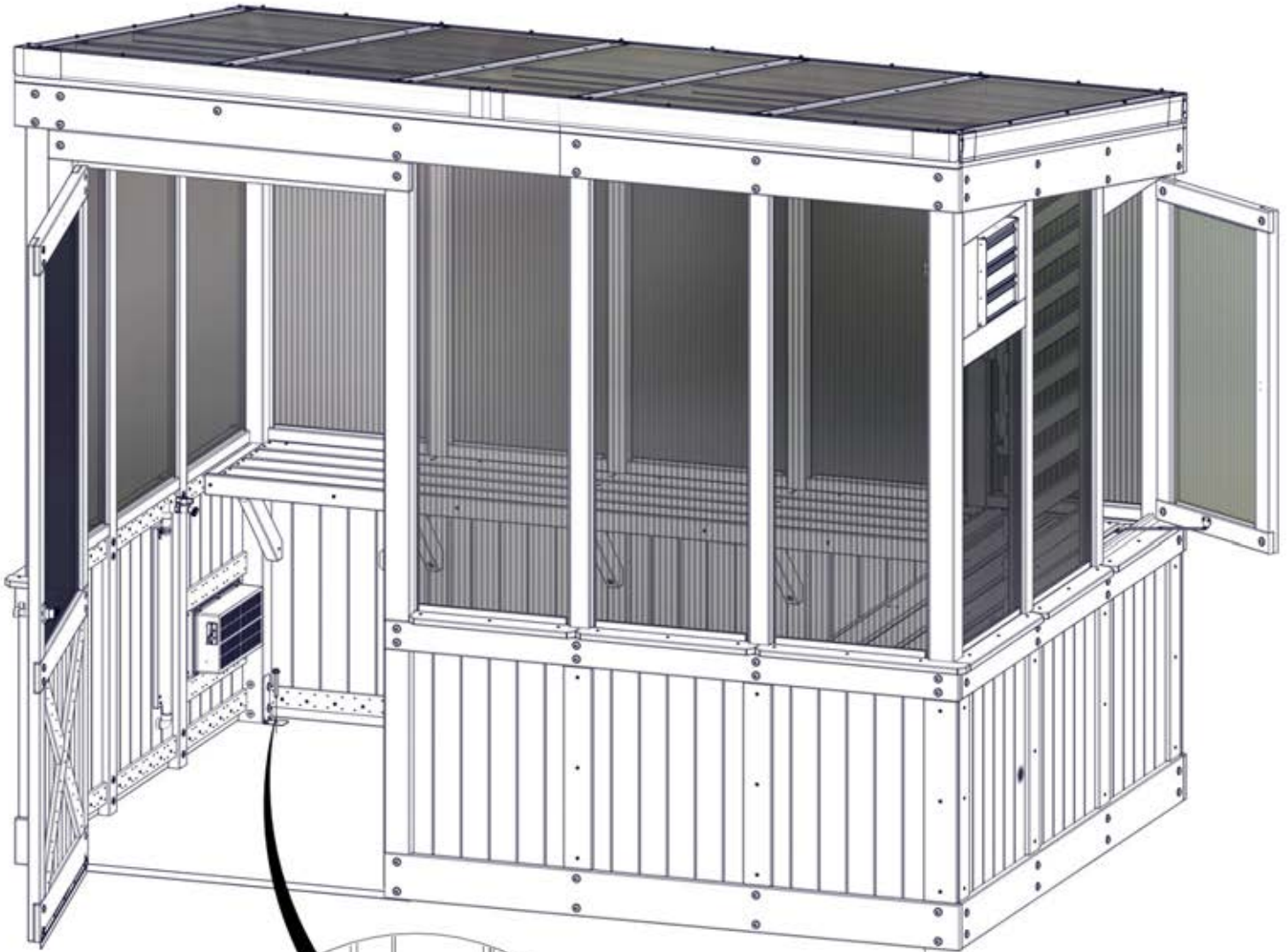
IF GREENHOUSE IS ON A CONCRETE SURFACE, SEE STEP 94B FOR ANCHORING STRUCTURE.



STEP 94B - ANCHORING

QTY	PART NUMBER	DESCRIPTION
5	H101165	CONCRETE ANCHOR 3/8x3" BLK

IF GREENHOUSE IS NOT ON A CONCRETE SURFACE, SEE STEP 94A FOR ANCHORING STRUCTURE.



1165 (x5)
CONCRETE ANCHOR-3"

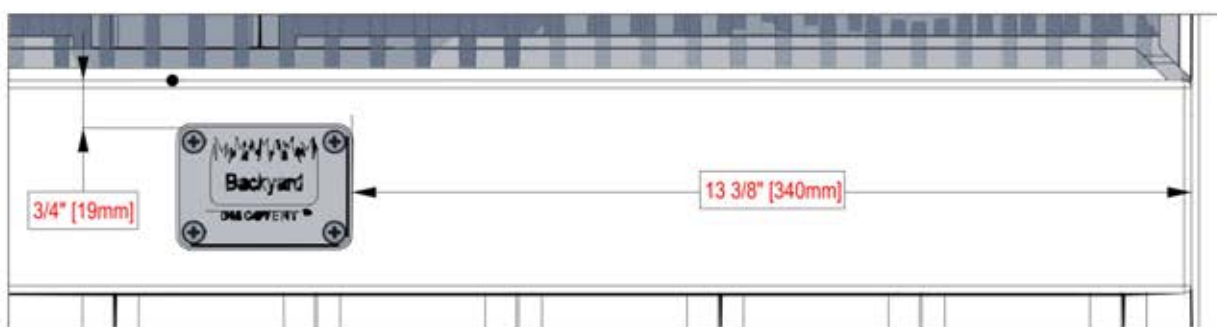
PRE-DRILL HOLES FOR CONCRETE ANCHORS USING A 5/16" [8mm] CONCRETE DRILL BIT.

STEP 95 - DOOR ASSEMBLY

QTY	PART NUMBER	DESCRIPTION
4	H100392	SCREW PWH 8x3/4 BLK



A4M02158 BYD ID TAG PATIO
(x1)



CENTER ID TAG ON BOARD WITH MEASUREMENTS GIVEN.

