



Manufactured by:
 Backyard Discovery
 3305 Airport Drive, Pittsburg, KS 66762
 800-856-4445

Basepoint Business Centre: Rivermead Drive, Westlea, Swindon SN5 7EX Phone: 0800-118-2476
 J.P. Coenstraat 7, The Bridge, The Hague, 2595 WP, Netherlands Phone: 08005678990

121 - ") '5 fWUXJU Gazebo

MODEL # : 2306073B



Please visit www.backyarddiscovery.com
 For the most up to date assembly manual, to register your product, or to order replacement parts *Para obtener instrucciones en español, visite* www.backyarddiscovery.com



EASY STEP-BY-STEP
3D INTERACTIVE INSTRUCTIONS
 DOWNLOAD THE FREE APP



OWNER'S MANUAL - BASIC SETUP DIMENSIONS & ASSEMBLY NOTES

It is critically important that you start with square and level footings, concrete pad or deck to attach your structure

- Pay close attention to the items needed for each step. Make sure you are using the correct hardware for each step. Using incorrect hardware may result in improper assembly
- Remember to double check for underground utilities and overhead electrical lines

Post mounts are provided with your structure which allows you to permanently install your structure to a pre-existing or new wood or concrete surface. See Anchor Instructions for further details and recommendations.

- The hardware to attach the post mounts to the structure is included.
- The hardware to mount the structure permanently to a concrete surface is included.
- The hardware to mount the structure permanently to a wood deck is NOT included and will need to be purchased separately. You must ensure there is ample structural support under the deck before permanently attaching.

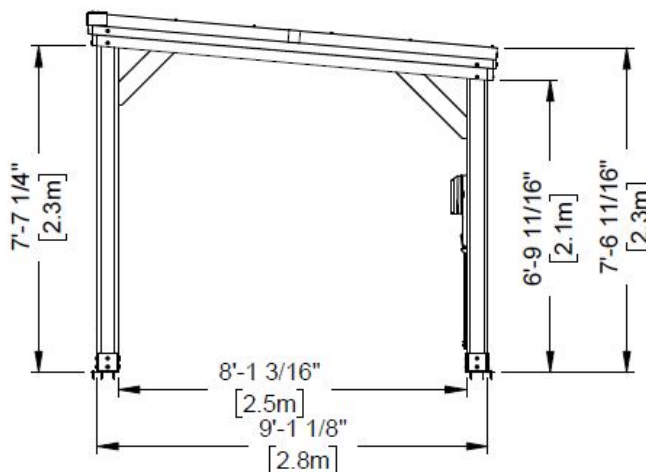
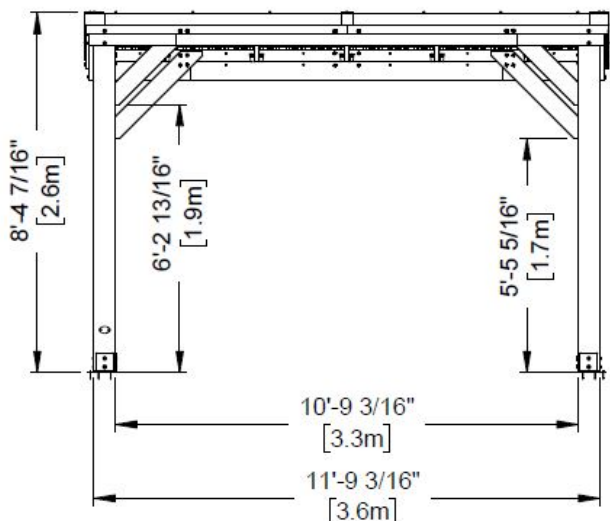
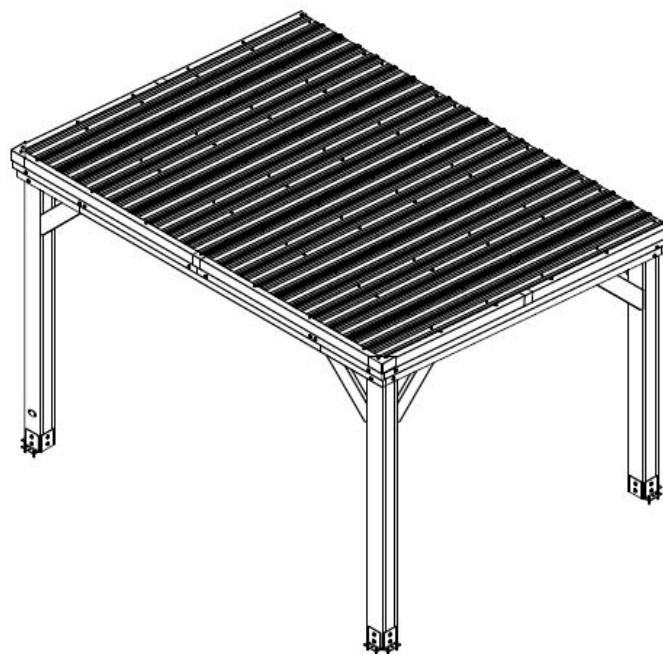
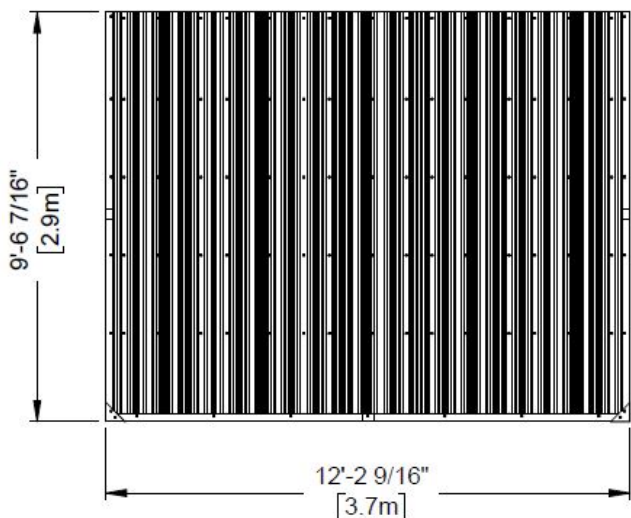

OWNER'S MANUAL - ANCHORING LAYOUT

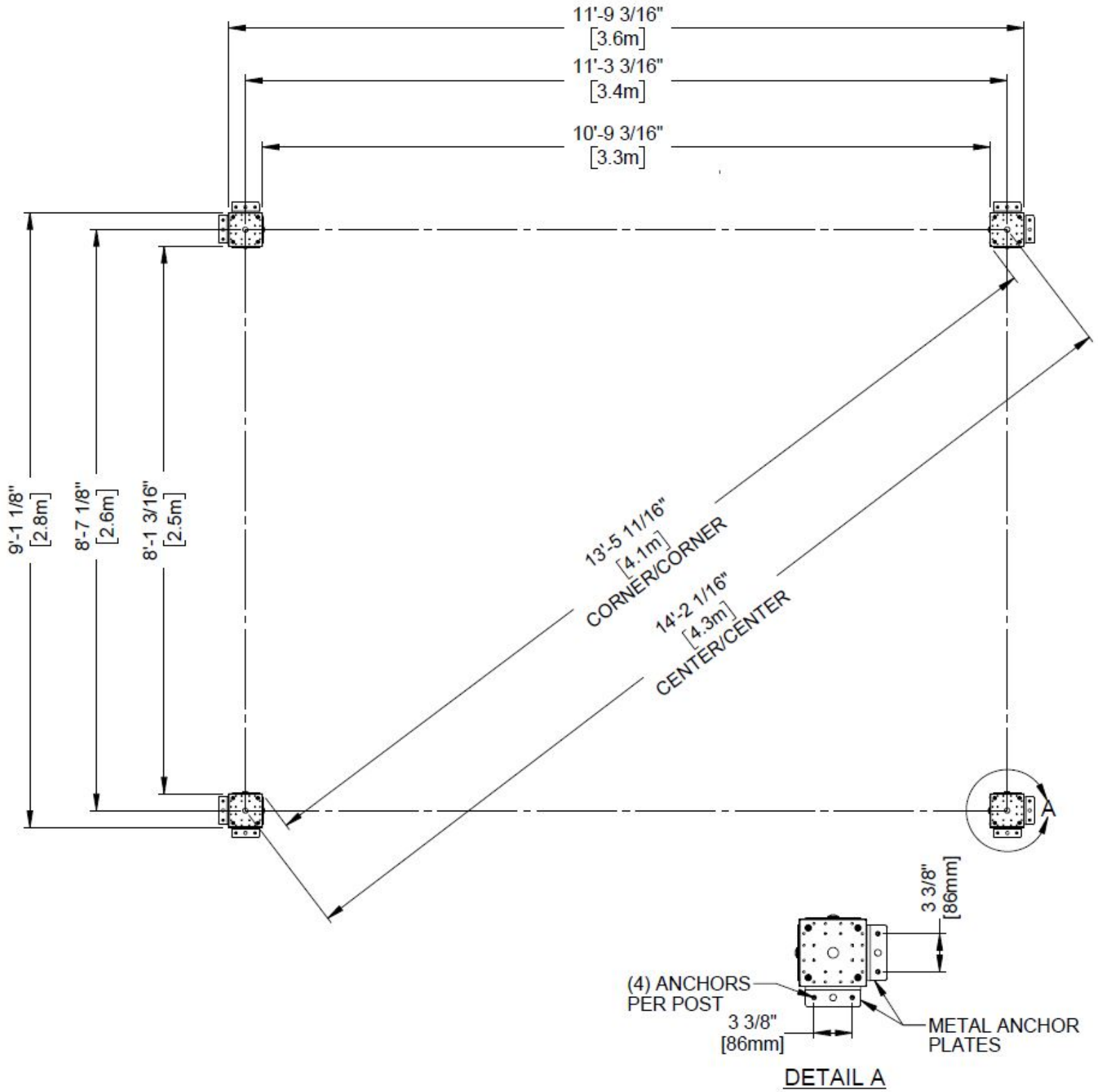

OWNER'S MANUAL - PARTS IDENTIFICATION

Wood Components (Not to Scale)

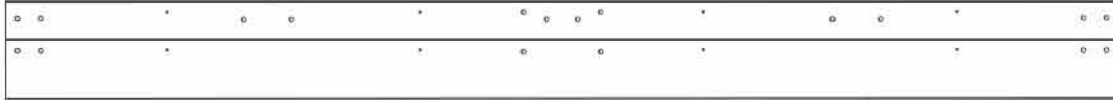

J05 JOIST ASSEMBLY - W2A04170
(x1) 1 7/16"x8 7/16"x95 1/16" (36x214x2414)



J06 JOIST ASSEMBLY - W2A03552
(x1) 1 7/16"x8 7/16"x28 7/16" (36x214x722)

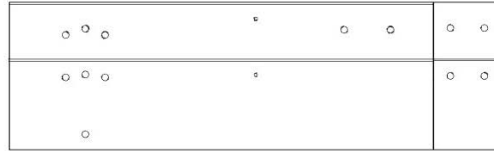

J04 JOIST ASSEMBLY - W2A03551
(x1) 1 7/16"x8 7/16"x28 7/16" (36x214x722)



J09 CLEAT - W4L17306
(x2) 15/16"x2 3/8"x97 9/16" (24x60x2479)



G04 FASCIA - W4L17304
(x2) 15/16"x5 1/4"x112 13/16" (24x134x2866)



E02 RAFTER - W4L19577
(x4) 1 7/16"x3 3/8"x109 3/4" (36x86x2787)



D03 CORBEL - W4L17297
(x2) 1 3/8"x5 1/4"x27 1/4" (36x134x692)



D04 CORBEL - W4L17299
(x2) 1 3/8"x5 1/4"x33 7/8" (36x134x860)

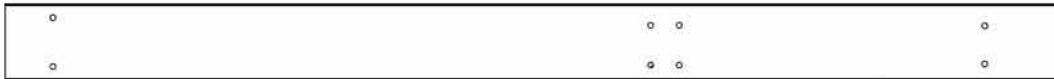

G05 FASCIA - W4L17303
(x2) 15/16"x5 1/4"x72 15/16" (24x134x1853)



J07 JOIST ASSEMBLY - W2A03547
(x1) 1 7/16"x8 7/16"x110 5/16" (36x214x2801)



J08 JOIST ASSEMBLY - W2A03548
(x1) 1 7/16"x8 7/16"x110 5/16" (36x214x2801)

OWNER'S MANUAL - PARTS IDENTIFICATION

Wood Components (Not to Scale)



J01 JOIST ASSEMBLY - W2A03549
(x1) 1 7/16"x8 7/16"x28 7/16" (36x214x722)

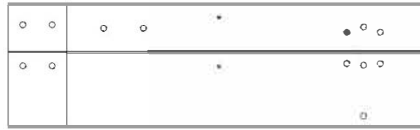

J03 JOIST ASSEMBLY - W2A03550
(x1) 1 7/16"x8 7/16"x28 7/16" (36x214x722)



G01 FASCIA - W4L17307
(x2) 15/16"x5 1/4"x72 15/16" (24x134x1853)



H02 PURLIN - W4L19579
(x4) 15/16"x3 3/8"x45 13/16" (24x86x1163)



E01 RAFTER - W4L17300
(x3) 1 7/16"x3 3/8"x109 3/4" (36x86x2787)



D02 CORBEL W/TAG - W2A03544
(x1) 1 7/16"x5 1/4"x34 7/16" (36x134x874)



D01 CORBEL - W4L17290
(x3) 1 7/16"x5 1/4"x34 7/16" (36x134x874)



J02 JOIST ASSEMBLY - W2A04171
(x1) 1 7/16"x8 7/16"x95 1/16" (36x214x2414)



H01 PURLIN - W4L19578
(x4) 15/16"x3 3/8"x97 5/8" (24x86x2479)



P01 POST - W2A03540
(x1) 6"x6"x98 1/2" (152x152x2502)



P03 POST - W2A03541
(x1) 6"x6"x98 1/2" (152x152x2502)



P02 POST - W2A03542
(x1) 6"x6"x89 1/16" (152x152x2262)



P04 POST - W2A03543
(x1) 6"x6"x89 1/16" (152x152x2262)

OWNER'S MANUAL - PARTS IDENTIFICATION

Hardware Components

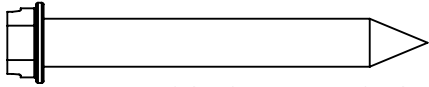

H100120 | CONCRETE ANCHOR
(x16) | 1/4x2

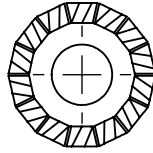

H100198 | WASHER LOCK EXT BLK
(x94) | 8x19

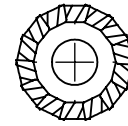

H100405 | WASHER LOCK EXT BLK
(x8) | 6x15

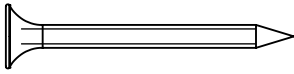

H100200 | SCREW PFH BLK
(x16) | 8x1-1/2

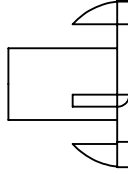

H100379 | T-NUT BLK
(x84) | 5/16

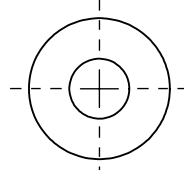

H100630 | WASHER FLAT BLK
(x32) | 8x19

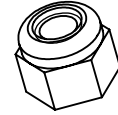

H100653 | NUT LOCK BLK
(x10) | 1/4

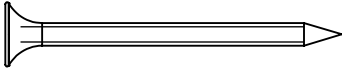

H100382 | SCREW PFH BLK
(x56) | 8x1-3/4

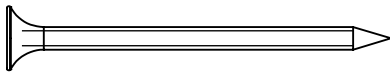

H100391 | SCREW PFH BLK
(x56) | 8x2

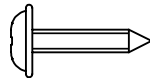

H100202 | SCREW PWH BLK
(x4) | 8x5/8

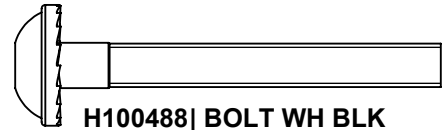

H100488 | BOLT WH BLK
(x6) | 1/4x2

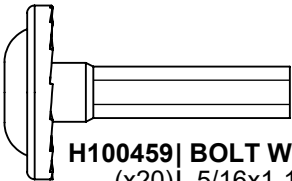

H100459 | BOLT WH BLK
(x20) | 5/16x1-1/4

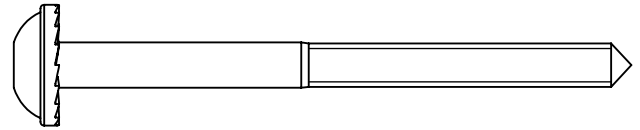

H100792 | LAG SCREW WH BLK
(x8) | 1/4x3

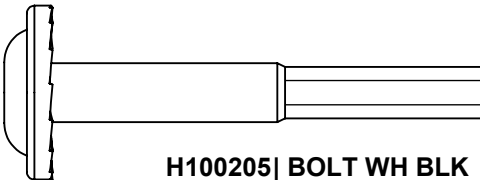

H100205 | BOLT WH BLK
(x8) | 5/16x2-1/4

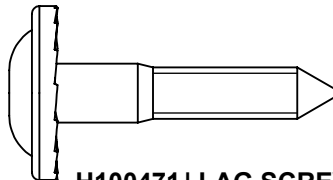

H100471 | LAG SCREW WH BLK
(x32) | 5/16x1-1/2

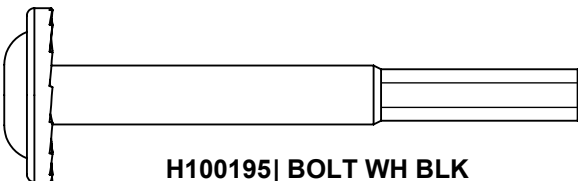

H100195 | BOLT WH BLK
(x8) | 5/16x2-3/4

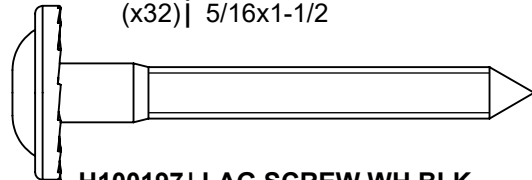

H100197 | LAG SCREW WH BLK
(x8) | 5/16x2-1/2

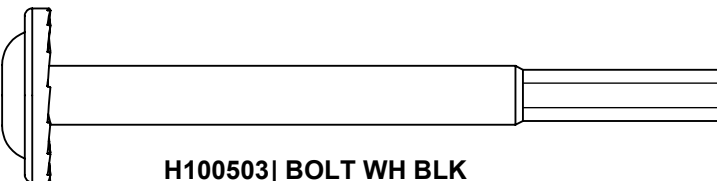

H100503 | BOLT WH BLK
(x6) | 5/16x3-1/2

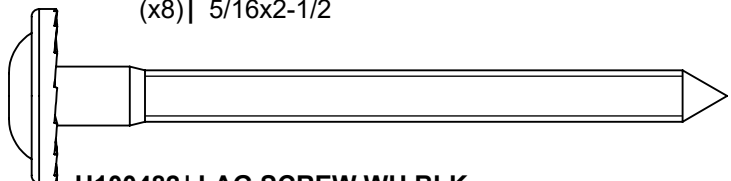

H100482 | LAG SCREW WH BLK
(x16) | 5/16x3-1/2

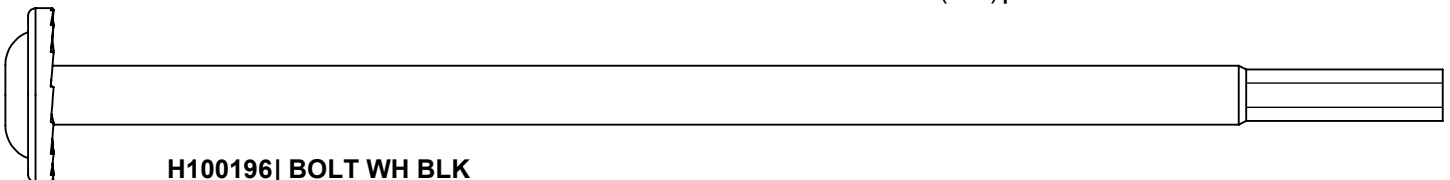

H100196 | BOLT WH BLK
(x32) | 5/16x7-1/4

OWNER'S MANUAL - PARTS IDENTIFICATION

Hardware Components



H101116 | SCREW TAPPING
(x21) | 1/4 x 1

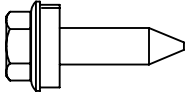

H101117 | SCREW WOODGRIP
(x120) | 10x3/4

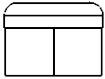

H100479 | NUT LOCK BLK
(x6) | 5/16

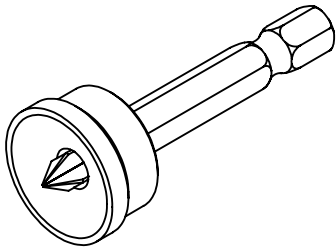

H100764 | SCREW SETTER
(x1) |

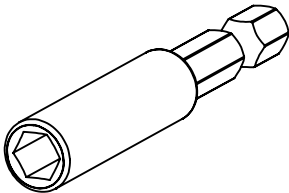

H101100 | MAGNETIC DRIVER
(x1) |



H101127 | BOLT WH BLK
(x4) | 1/4x3-1/2

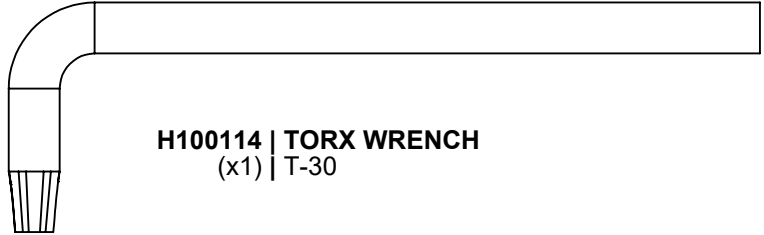

H100114 | TORX WRENCH
(x1) | T-30



H100415 | BOLT WH BLK
(x16) | 5/16x3-3/4

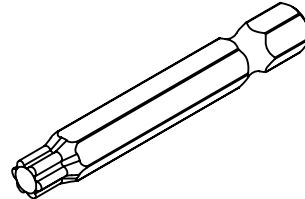

H100147 | TORX BIT
(x1) | T-30

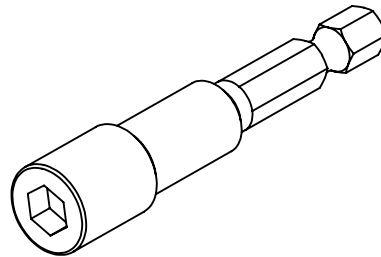

H101106 | SOCKET DRIVER
(x1) |

OWNER'S MANUAL - PARTS IDENTIFICATION

Accessory Components (Not to Scale)

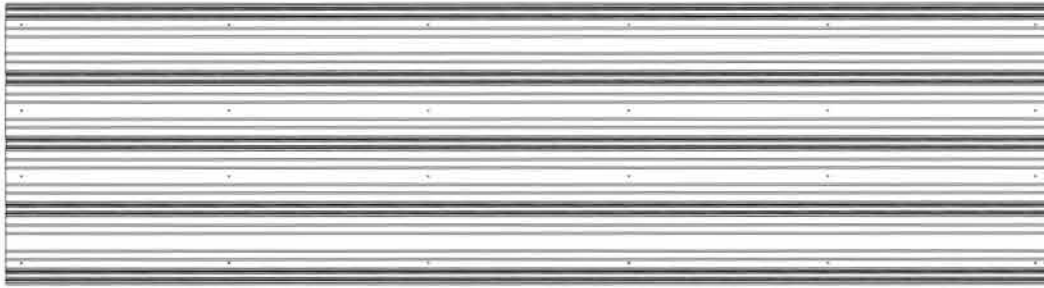

A4M02738 29GA SHEETING
(x4)

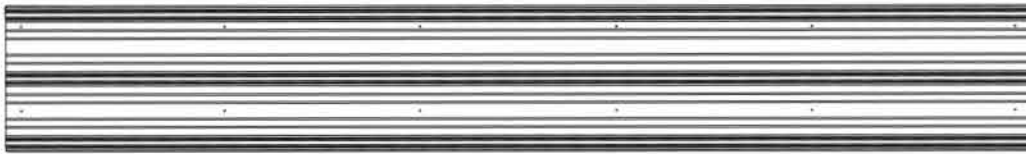

A4M02739 29GA SHEETING
(x2)

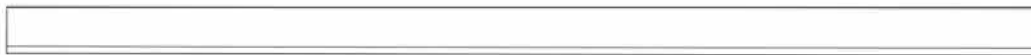

A4M02793 DRIP EDGE
(x2)



A4M02763 RAFTER BRACE
(x2)



9205413 ELECTRICAL ENCLOSURE
(x1)

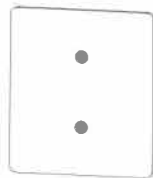

A4M00978 POST PLATE
(x8)

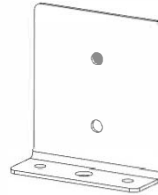

A4M00977 POST ANCHORING PLATE
(8x)

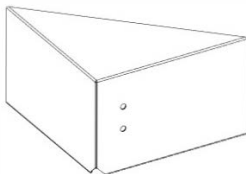

A4M02735 CORNER SPLICE TRIM RH
(x1)

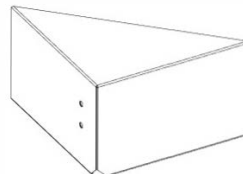

A4M02736 CORNER SPLICE TRIM LH
(x1)



A4M02733 TRIM SHORT
(x4)



A4M02740 TRIM LONG
(x2)



A4M02794 DRIP EDGE TRIM
(x1)

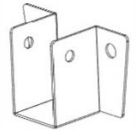

A4M01787 RAFTER BRACKET
(x6)

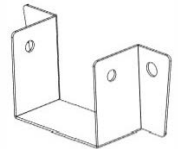

A4M02764 RAFTER BRACKET
(x4)

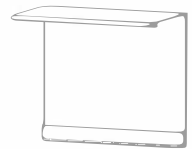

A4M02734 TRIM SPLICE
(x3)

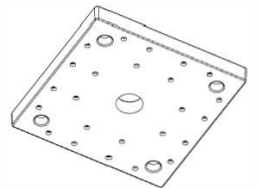

A6P00308 6x6 POST FOOT
(x4)

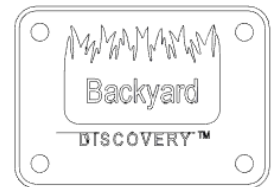

A4M02158 BYD ID TAG PATIO
(x1)

PRE-ASSEMBLY STEP 1 - SORTING PARTS

It is critical for ease of assembly that you take the time to sort and organize the wood and hardware.

WOOD PARTS:

- Organize wood parts by the three-digit, alpha-numeric number stamped on each board (ex. P01).
- If there are multiple boards with the same stamped number, stack those pieces together.
- Stamps can be found on the flat surface of the boards or on the end of the boards.
- Allow yourself plenty of room - the wood pieces can take up a significant amount of space.

NOTE: CARTONS ARE NOT ORGANIZED BY BOARD NUMBER.



HARDWARE PARTS:

- We recommend that you have a separate table to organize the hardware.
- Hardware bags are printed with a seven-digit, alpha-numeric part number.
- You can organize your hardware by part number or group by hardware type (i.e. bolts, nuts, etc.).
- During assembly you only need to reference the last four digits of the number.

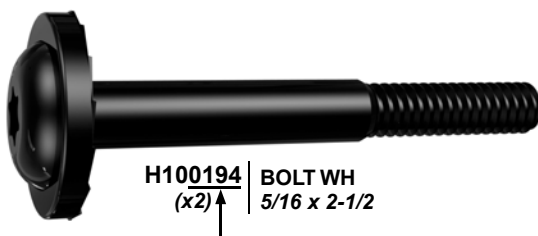

PRE-ASSEMBLY STEP 2 - TOOLS REQUIRED



Cordless Drill or Electric Drill



Drill Attachments:
Phillips Head

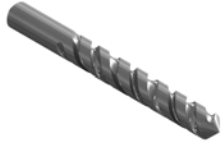

1/8", 3/16", 3/8" &
7/16" Drill Bits



Phillips Screw Driver



Open End
Wrenches 1/2" &
7/16"



3/8" Drive Ratchet, 1/2" &
7/16" STD Sockets, 1/2" &
7/16" Deep Sockets



Tape Measure



Claw Hammer



3/8 & 5/16" Nut Drivers

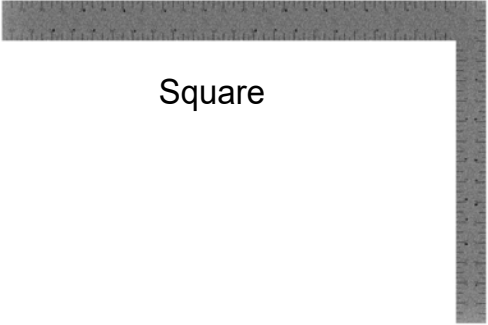

Square



Level 24"

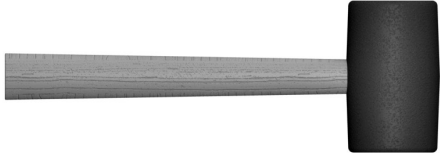

Rubber Mallet -
Optional

PRE-ASSEMBLY STEP 3 - CHOOSE YOUR ASSEMBLY METHOD

There are several types of assembly instructions available to you.

1. Printed Assembly Manual included with your set
2. BILT APP - 3D interactive instructions
3. Combination of the Printed Manual and BILT APP (Note: Step numbers can differ between the two methods)



STEP 1 - GAZEBO ASSEMBLY

QTY	PART NUMBER	DESCRIPTION
16	H100200	SCREW PFH 8x1 1/2 BLK



P01 POST - W2A03540
(x1) 6"x6"x98 1/2" (152x152x2502)



P02 POST - W2A03542
(x1) 6"x6"x89 1/16" (152x152x2262)



P03 POST - W2A03541
(x1) 6"x6"x98 1/2" (152x152x2502)



P04 POST - W2A03543
(x1) 6"x6"x89 1/16" (152x152x2262)

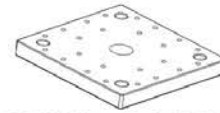

A6P00308 6x6 POST FOOT
(x4)

**REPEAT FOR THE (2) OTHER
POST LABELED P02 & P04**

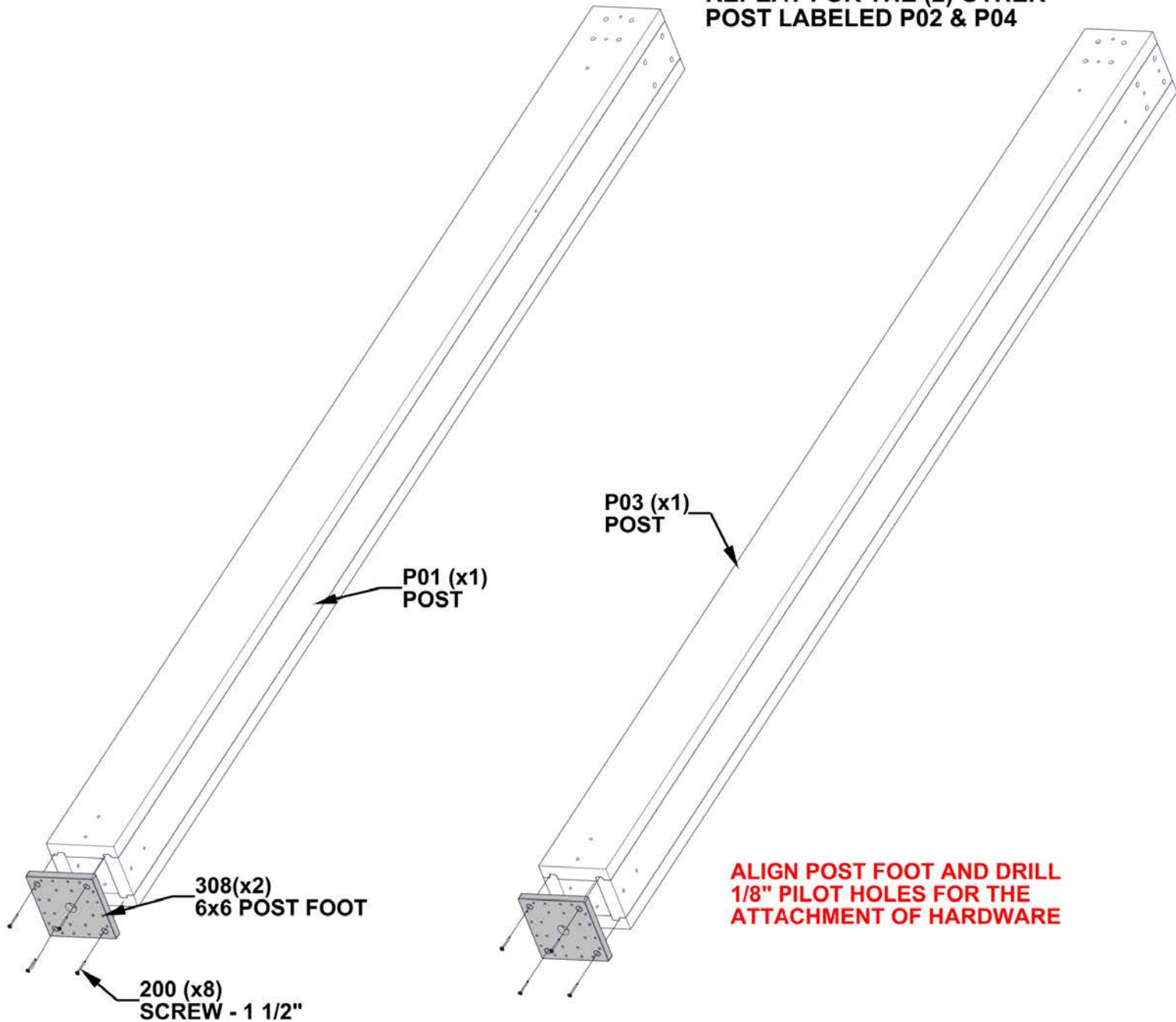

**ALIGN POST FOOT AND DRILL
1/8" PILOT HOLES FOR THE
ATTACHMENT OF HARDWARE**

STEP 2 - GAZEBO ASSEMBLY

QTY	PART NUMBER	DESCRIPTION
4	H100195	BOLT WH 5/16x2 3/4 BLK
4	H100198	WASHER LOCK EXT 8x19
4	H100379	TNUT-5/16" BLK



D03 CORBEL - W4L17297
(x1) 1 3/8"x5 1/4"x27 1/4" (36x134x692)

D04 CORBEL - W4L17299
(x1) 1 3/8"x5 1/4"x33 7/8" (36x134x860)



J07 JOIST ASSEMBLY - W2A03547
(x1) 1 7/16"X8 7/16"X110 5/16" (36x214x2801)

HAND TIGHTEN

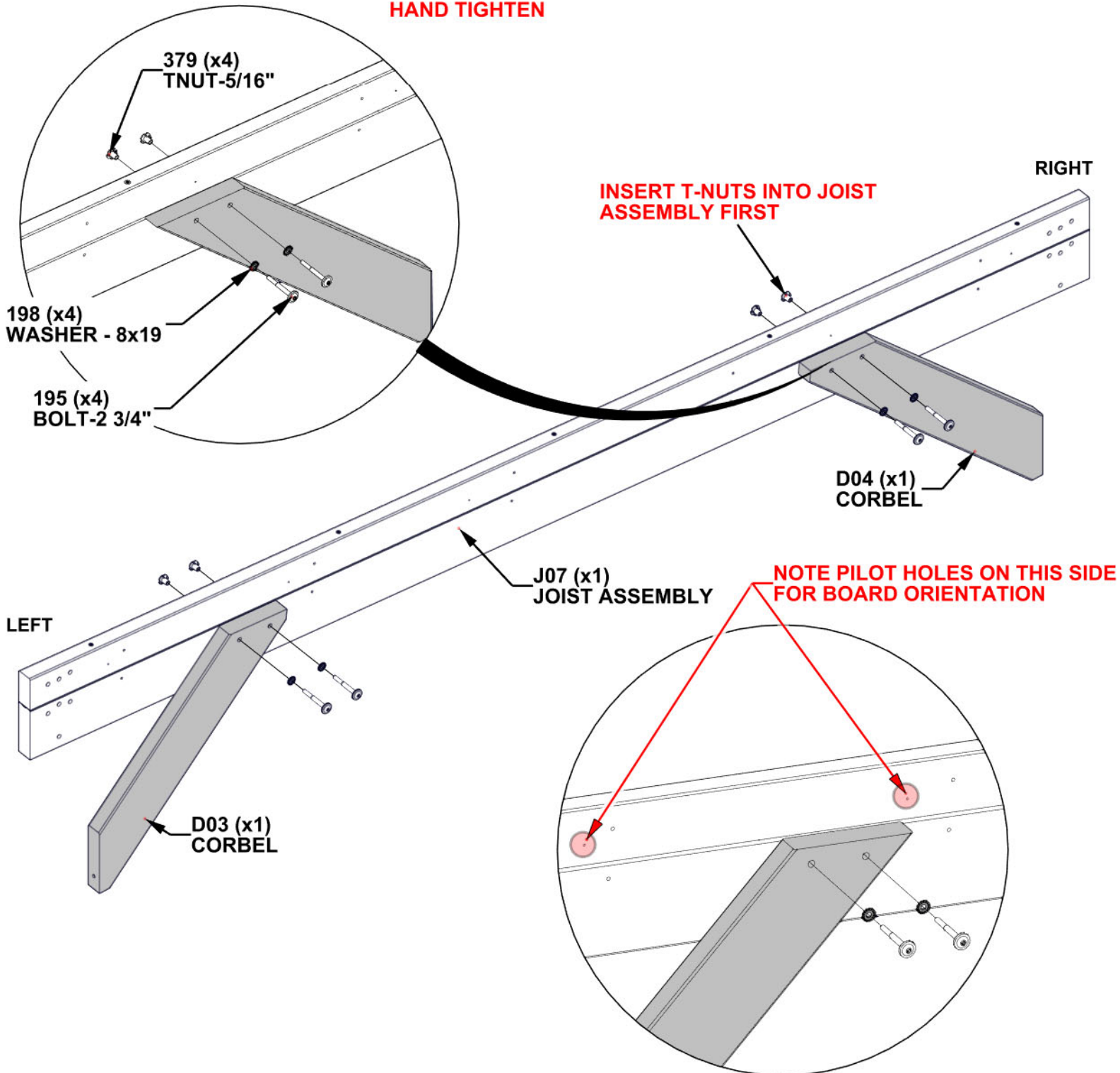

STEP 3 - GAZEBO ASSEMBLY

QTY	PART NUMBER	DESCRIPTION
8	H100196	BOLT WH 5/16x7 1/4 BLK
8	H100198	WASHER LOCK EXT 8x19
8	H100379	T-NUT 5/16 BLK
2	H100405	WASHER LOCK EXT 6x15
2	H100792	LAG SCREW WH 1/4x3 BLK

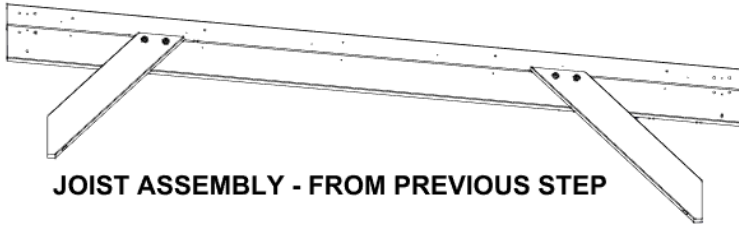

- NOTES:**
- TO AVOID SPLITTING, MAKE SURE LAG SCREWS GO INTO PILOT HOLES.
 - IF BOLT DOES NOT ENGAGE WITH T-NUT, CHECK FOR SAWDUST BUILD UP IN HOLES. CLEAN WITH A LONG SCREWDRIVER IF NEEDED.
 - SQUARE LEGS BEFORE TIGHTENING.
 - TIGHTEN CORBELS AT END OF STEP

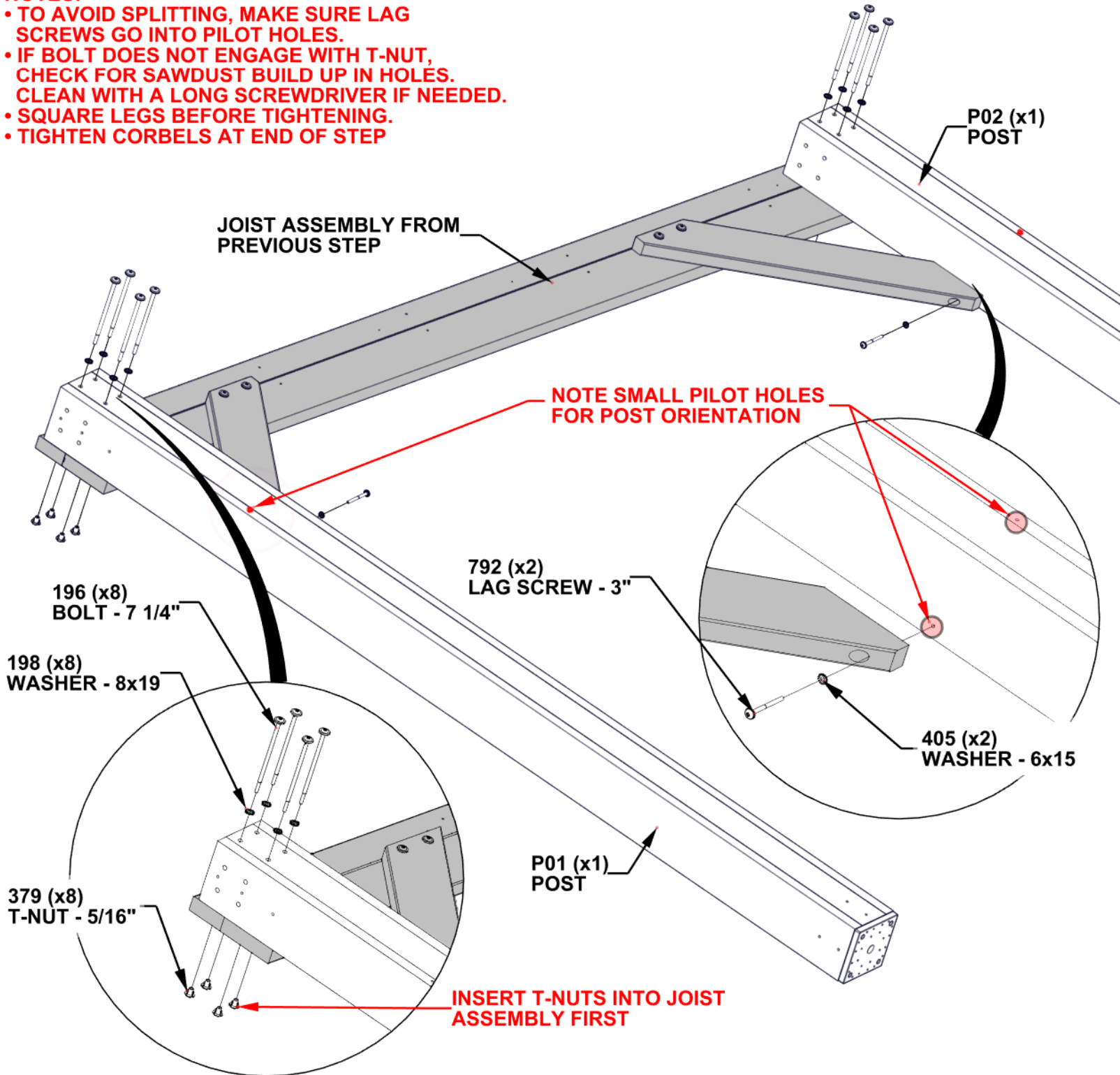

STEP 4 - GAZEBO ASSEMBLY

QTY	PART NUMBER	DESCRIPTION
4	H100195	BOLT WH 5/16x2 3/4 BLK
4	H100198	WASHER LOCK EXT 8x19
4	H100379	TNUT-5/16" BLK



D03 CORBEL - W4L17297
(x1) 1 3/8"x5 1/4"x27 1/4" (36x134x692)

D04 CORBEL - W4L17299
(x1) 1 3/8"x5 1/4"x33 7/8" (36x134x860)



J08 JOIST ASSEMBLY - W2A03548
(x1) 1 7/16"x8 7/16"x110 5/16" (36x214x2801)

HAND TIGHTEN

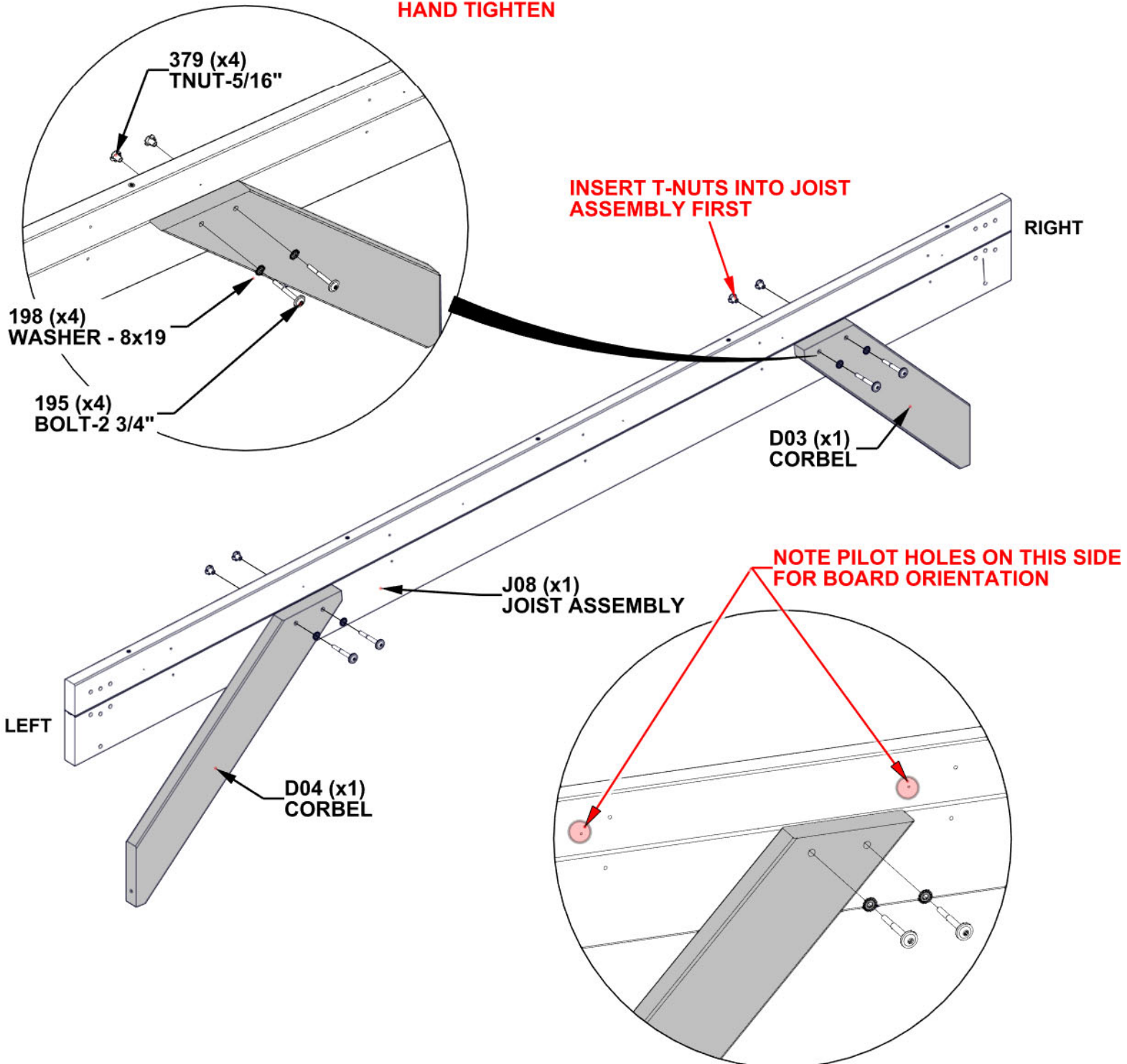

STEP 5 - GAZEBO ASSEMBLY

QTY	PART NUMBER	DESCRIPTION
8	H100196	BOLT WH 5/16x7 1/4 BLK
8	H100198	WASHER LOCK EXT 8x19
8	H100379	T-NUT 5/16 BLK
2	H100405	WASHER LOCK EXT 6x15
2	H100792	LAG SCREW WH 1/4x3 BLK

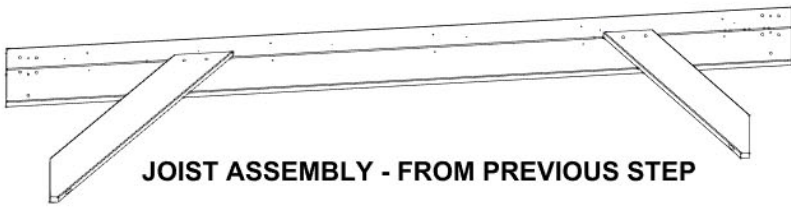

- NOTES:**
- TO AVOID SPLITTING, MAKE SURE LAG SCREWS GO INTO PILOT HOLES.
 - IF BOLT DOES NOT ENGAGE WITH T-NUT, CHECK FOR SAWDUST BUILD UP IN HOLES. CLEAN WITH A LONG SCREW DRIVER IF NEEDED.
 - SQUARE LEGS BEFORE TIGHTENING.
 - TIGHTEN CORBLES AT END OF STEP.

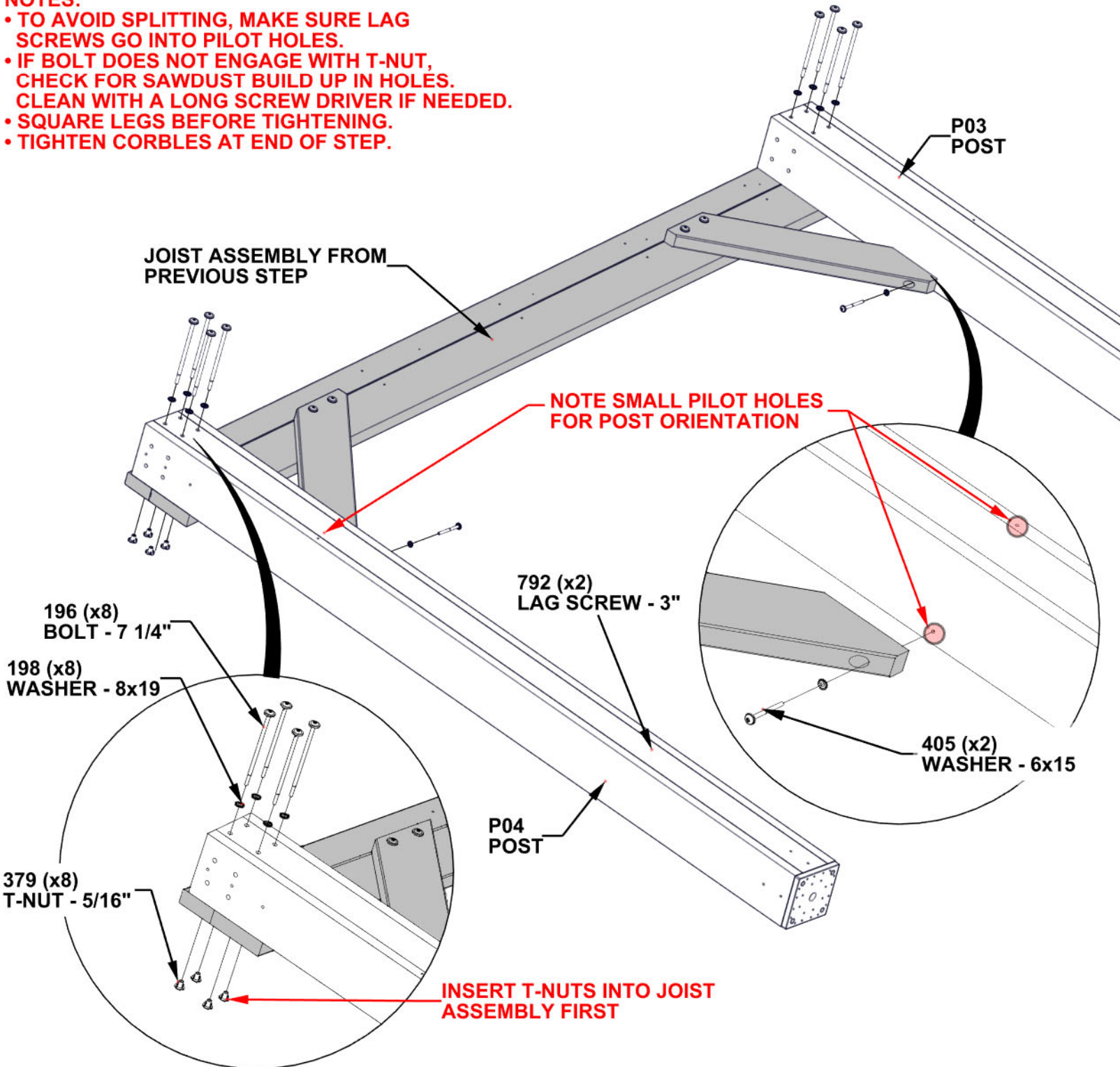

STEP 6A - FRONT JOIST ASSEMBLY

QTY	PART NUMBER	DESCRIPTION
12	H100379	T-NUT 5/16 BLK



J01 JOIST ASSEMBLY - W2A03549
(x1) 1 7/16"x8 7/16"x28 7/16" (36x214x722)

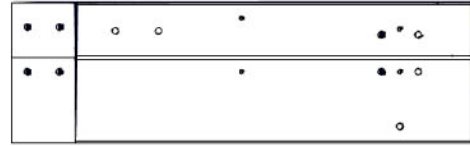

J03 JOIST ASSEMBLY - W2A03550
(x1) 1 7/16"x8 7/16"x28 7/16" (36x214x722)

NOTES:

- NOTE NOTCH IN JOIST FOR LOCATION OF T-NUTS.
- ONCE COMPLETE SET ASIDE FOR LATER IN THIS STEP

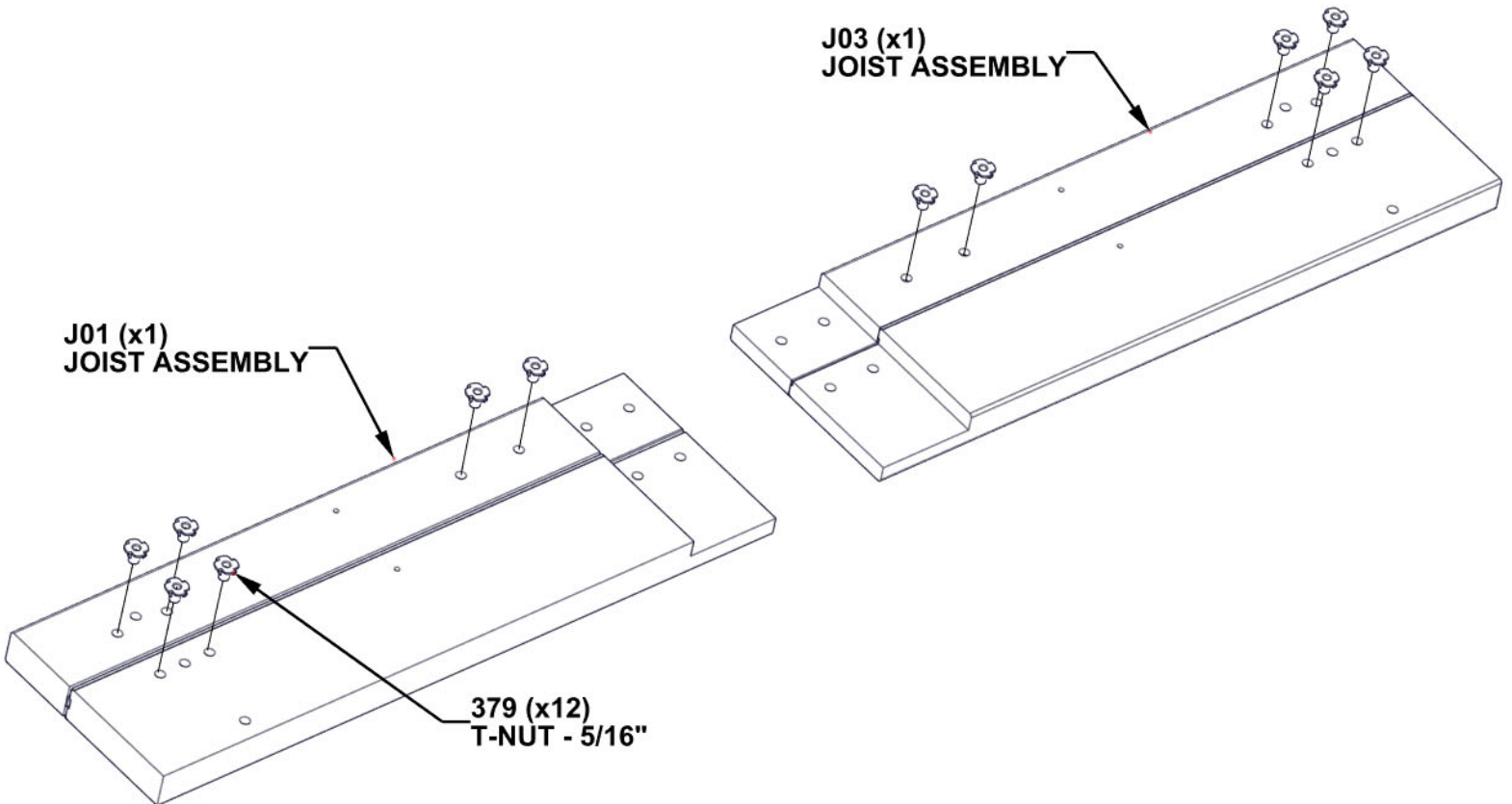

STEP 6B - FRONT JOIST ASSEMBLY

QTY	PART NUMBER	DESCRIPTION
6	H100379	T-NUT 5/16 BLK



J02 JOIST ASSEMBLY - W2A04171
(x1) 1 7/16"x8 7/16"x95 1/16" (36x214x2414)

NOTE:
-NOTE NOTCH IN JOIST FOR LOCATION OF T-NUTS.

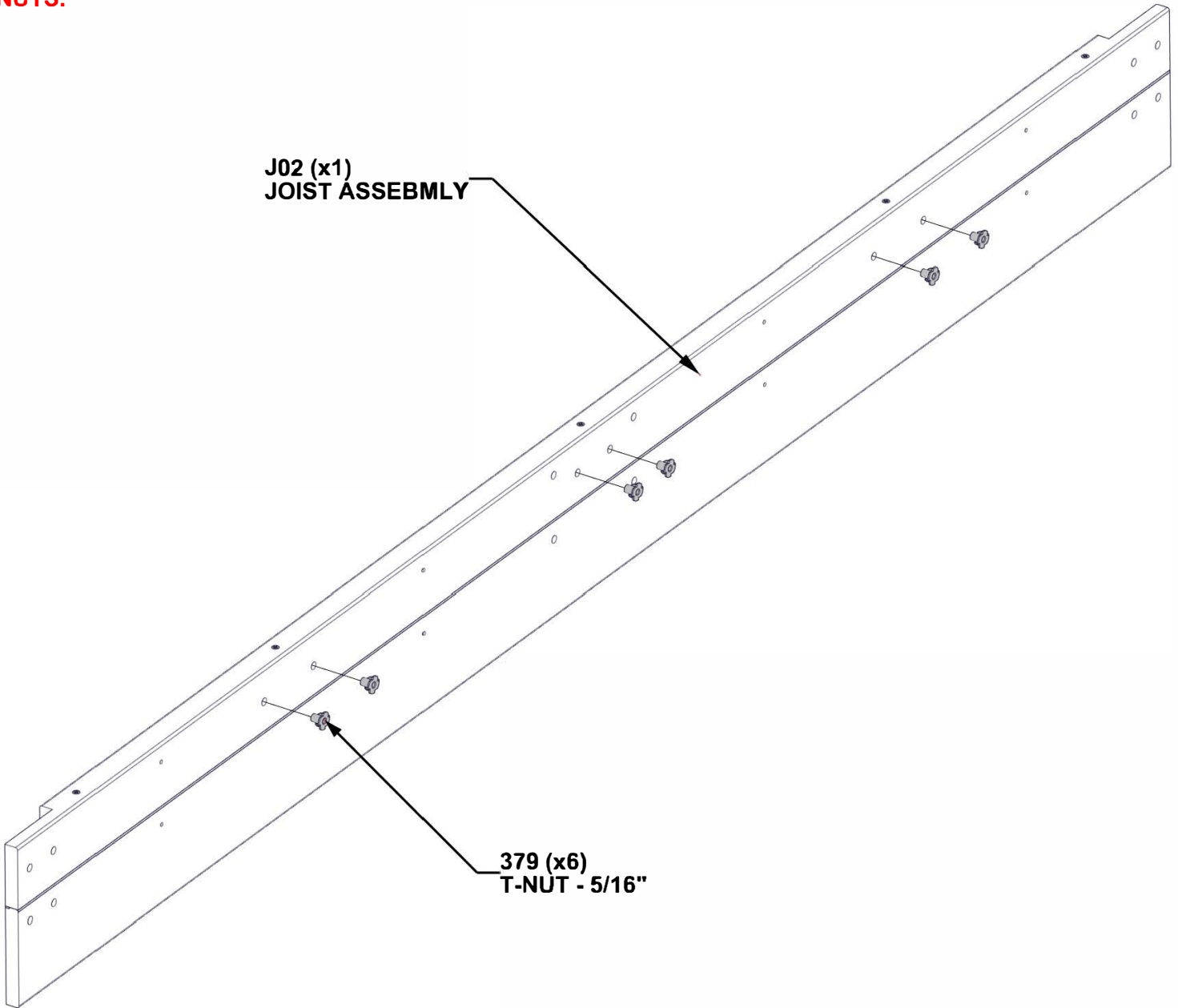

STEP 6C - FRONT JOIST ASSEMBLY



G01 FASCIA - W4L17307
(x2) 15/16"x5 1/4"x72 15/16" (24x134x1853)



JOIST ASSEMBLY FROM PREVIOUS STEP

QTY	PART NUMBER	DESCRIPTION
4	H100379	TNUT-5/16" BLK
4	H100205	BOLT WH 5/16x2 1/4 BLK
4	H100198	WASHER LOCK EXT 8x19

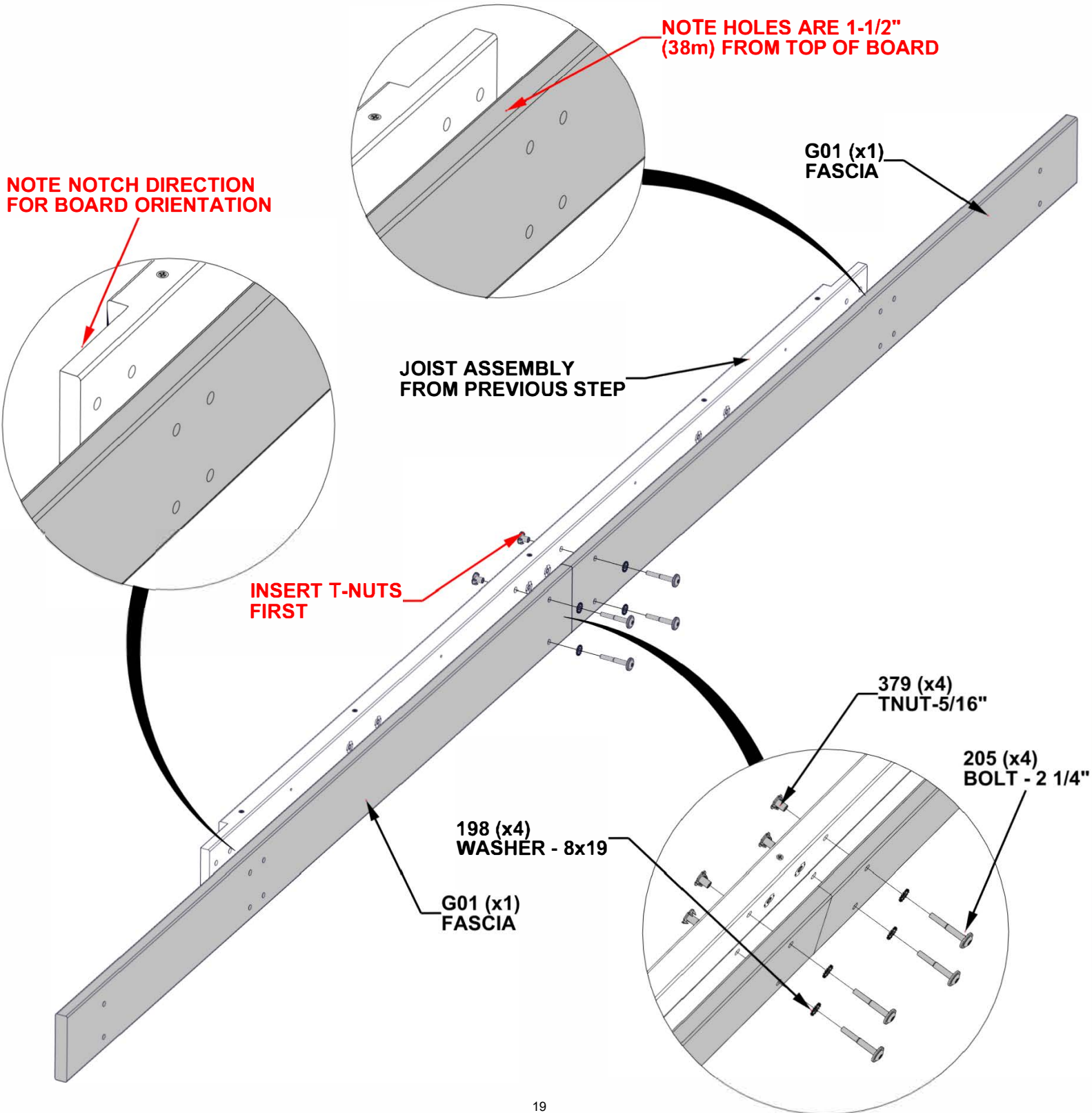

STEP 6D - FRONT JOIST ASSEMBLY

QTY	PART NUMBER	DESCRIPTION
8	H100379	TNUT-5/16" BLK
8	H100415	BOLT WH 5/16x3 3/4 BLK
8	H100198	WASHER LOCK EXT 8x19

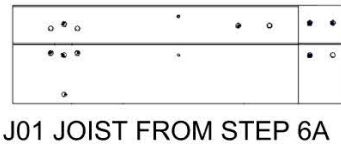
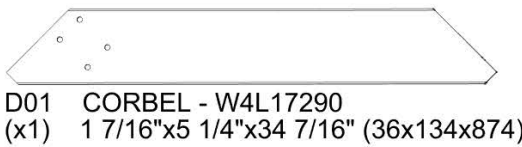
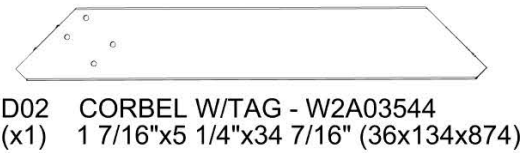

CORBELS ARE TO BE HAND TIGHTENED ONLY

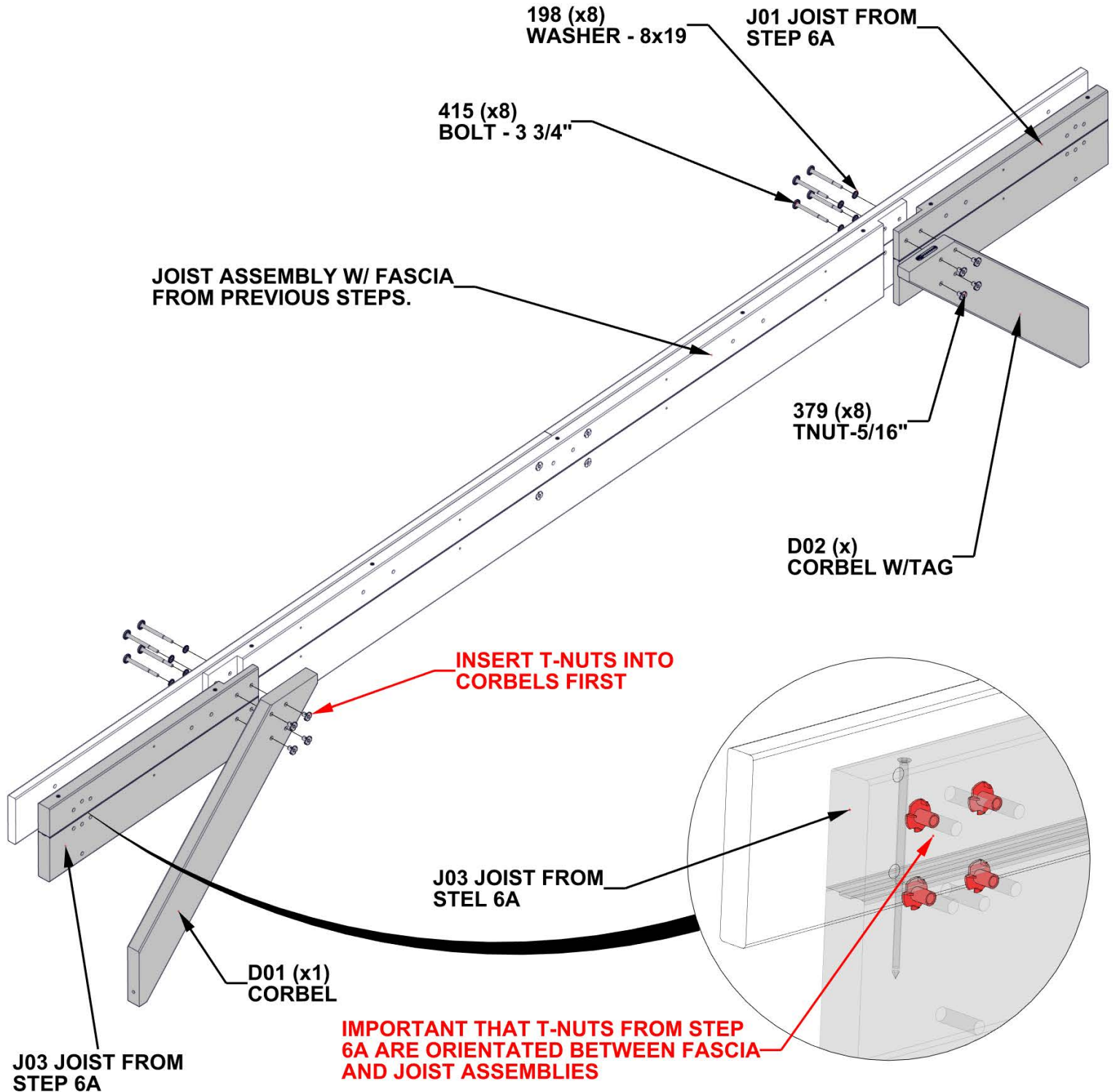

STEP 7A - REAR JOIST ASSEMBLY

QTY	PART NUMBER	DESCRIPTION
12	H100379	T-NUT 5/16 BLK

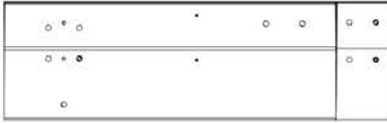

J04 JOIST ASSEMBLY - W2A03551
 (x1) 1 7/16"x8 7/16"x28 7/16" (36x214x722)

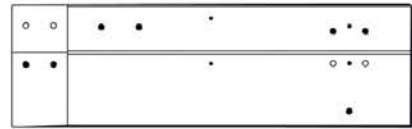

J06 JOIST ASSEMBLY - W2A03552
 (x1) 1 7/16"x8 7/16"x28 7/16" (36x214x722)

NOTES:

- NOTE NOTCH IN JOIST FOR LOCATION OF T-NUTS.
- ONCE COMPLETE SET ASIDE FOR LATER IN THIS STEP

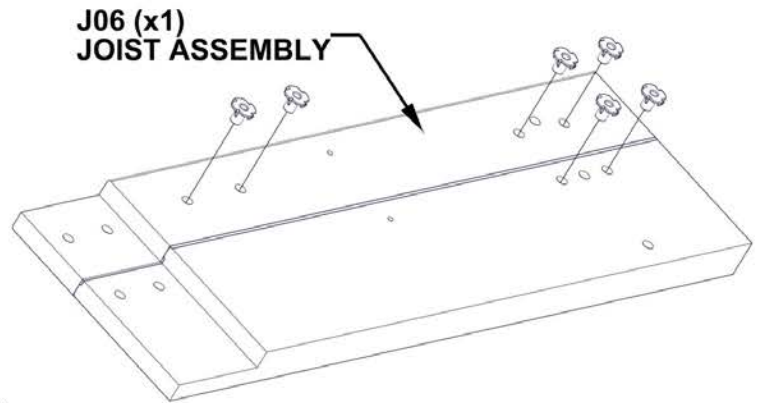
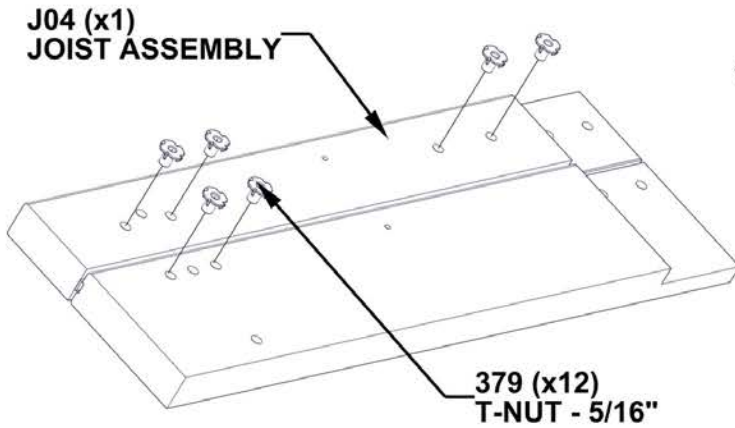

STEP 7B - REAR JOIST ASSEMBLY

QTY	PART NUMBER	DESCRIPTION
6	H100379	T-NUT 5/16 BLK



J05 JOIST ASSEMBLY - W2A04170
(x1) 1 7/16"x8 7/16"x95 1/16" (36x214x2414)

NOTE:
-NOTE NOTCH IN JOIST FOR LOCATION OF T-NUTS.

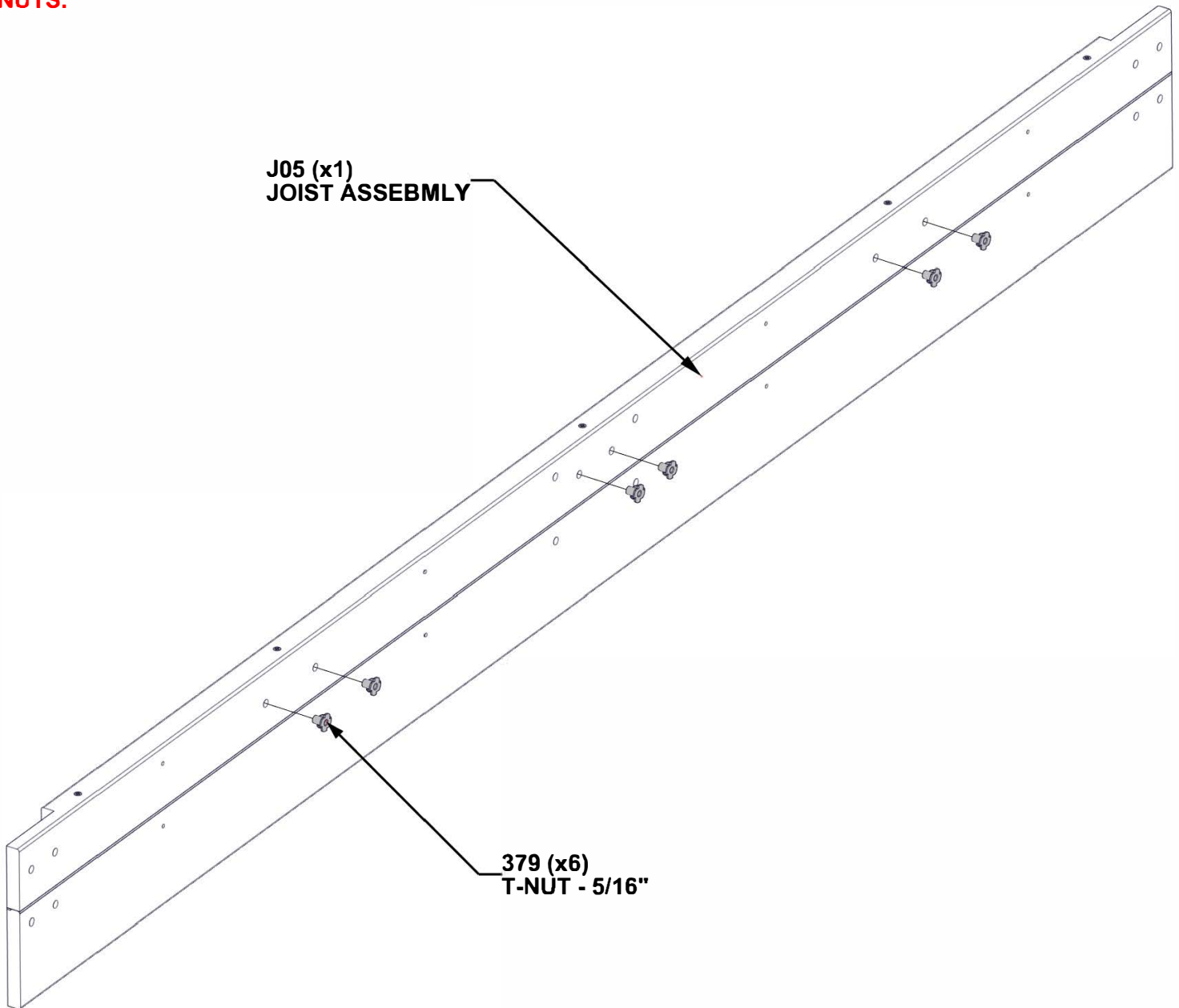

STEP 7C - REAR JOIST ASSEMBLY



G05 FASCIA - W4L17303
(x2) 15/16"x5 1/4"x72 15/16" (24x134x1853)



JOIST ASSEMBLY FROM PREVIOUS STEP

QTY	PART NUMBER	DESCRIPTION
4	H100379	TNUT-5/16" BLK
4	H100205	BOLT WH 5/16x2 1/4 BLK
4	H100198	WASHER LOCK EXT 8x19

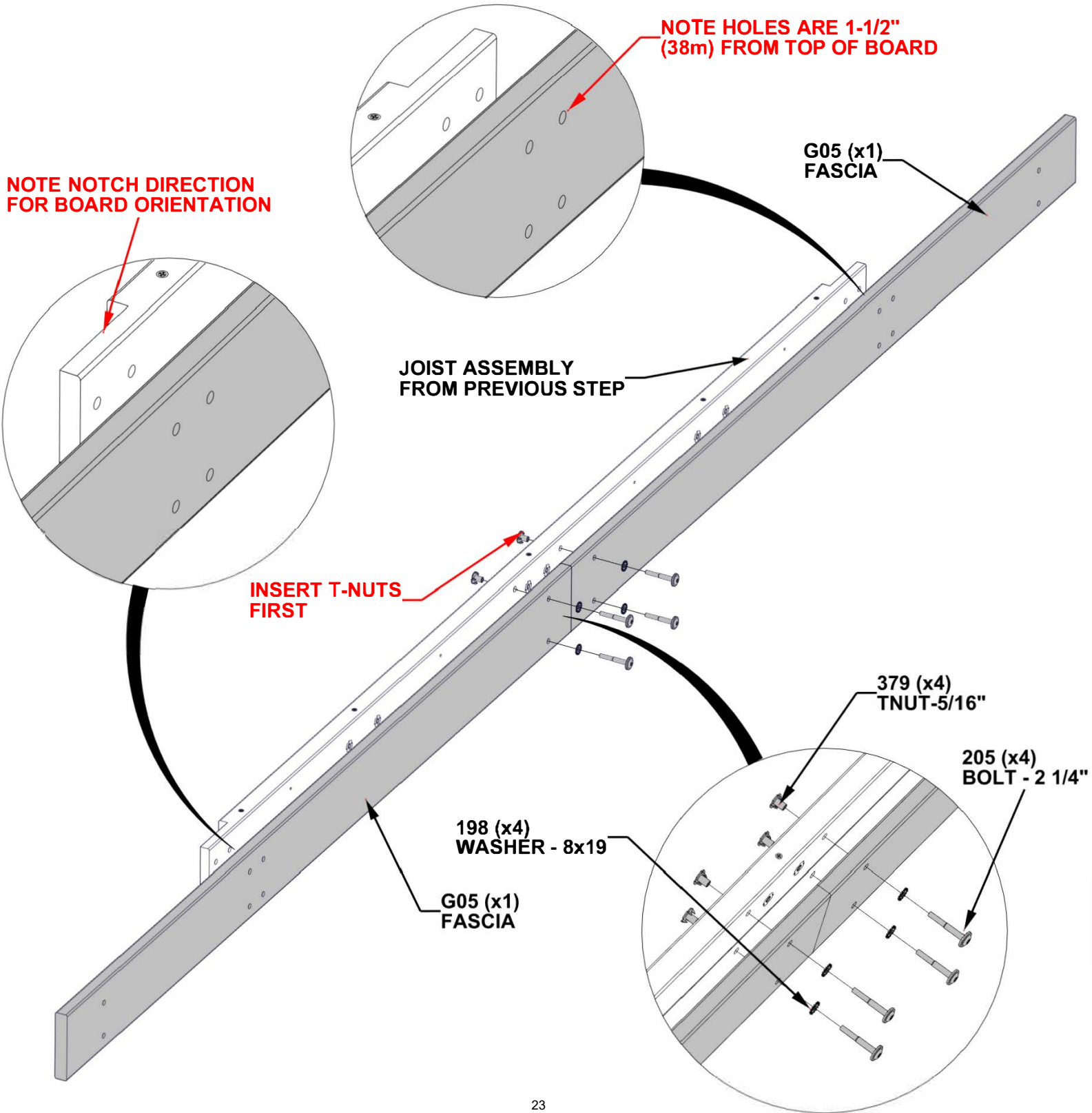

STEP 7D - REAR JOIST ASSEMBLY

QTY	PART NUMBER	DESCRIPTION
8	H100379	TNUT-5/16" BLK
8	H100415	BOLT WH 5/16x3 3/4 BLK
8	H100198	WASHER LOCK EXT 8x19



D01 CORBEL - W4L17290
(x2) 1 7/16"x5 1/4"x34 7/16" (36x134x874)

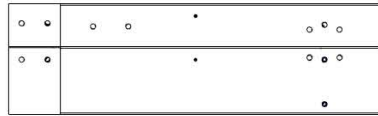

J04 JOIST FROM STEP 7A



J06 JOIST FROM STEP 7A

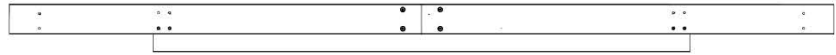

JOIST ASSEMBLY W/FASCIA FROM PREVIOUS STEPS

CORBELS ARE TO BE HAND TIGHTENED ONLY

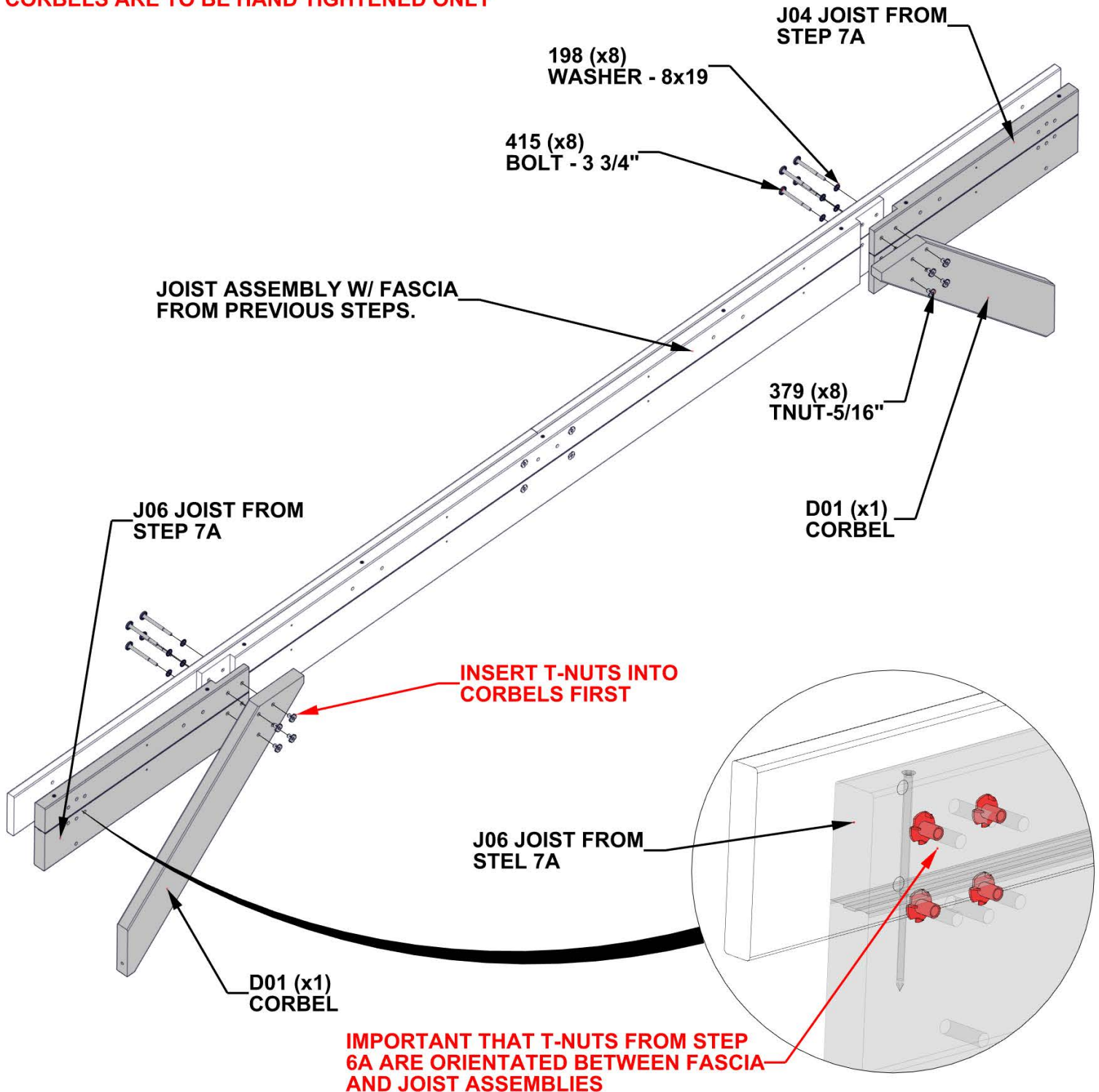

STEP 8A - GAZEBO ASSEMBLY

QTY	PART NUMBER	DESCRIPTION
8	H100196	BOLT WH 5/16x7 1/4 BLK
8	H100198	WASHER LOCK EXT 8x19

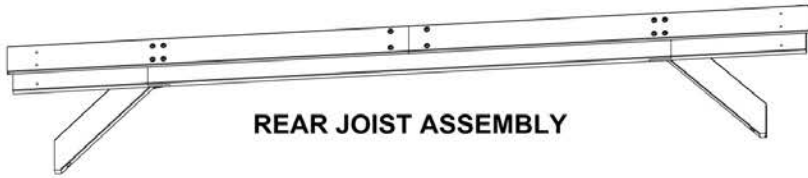

- NOTES:**
- **ALIGN JOIST ASSEMBLY WITH HOLES IN POST.**
 - **IF BOLTS DO NOT ENGAGE WITH T-NUTS INSTALLED IN JOIST ASSEMBLY, CHECK FOR SAWDUST BUILD UP IN HOLES. CLEAN WITH A LONG SCREWDRIVER IF NEEDED.**

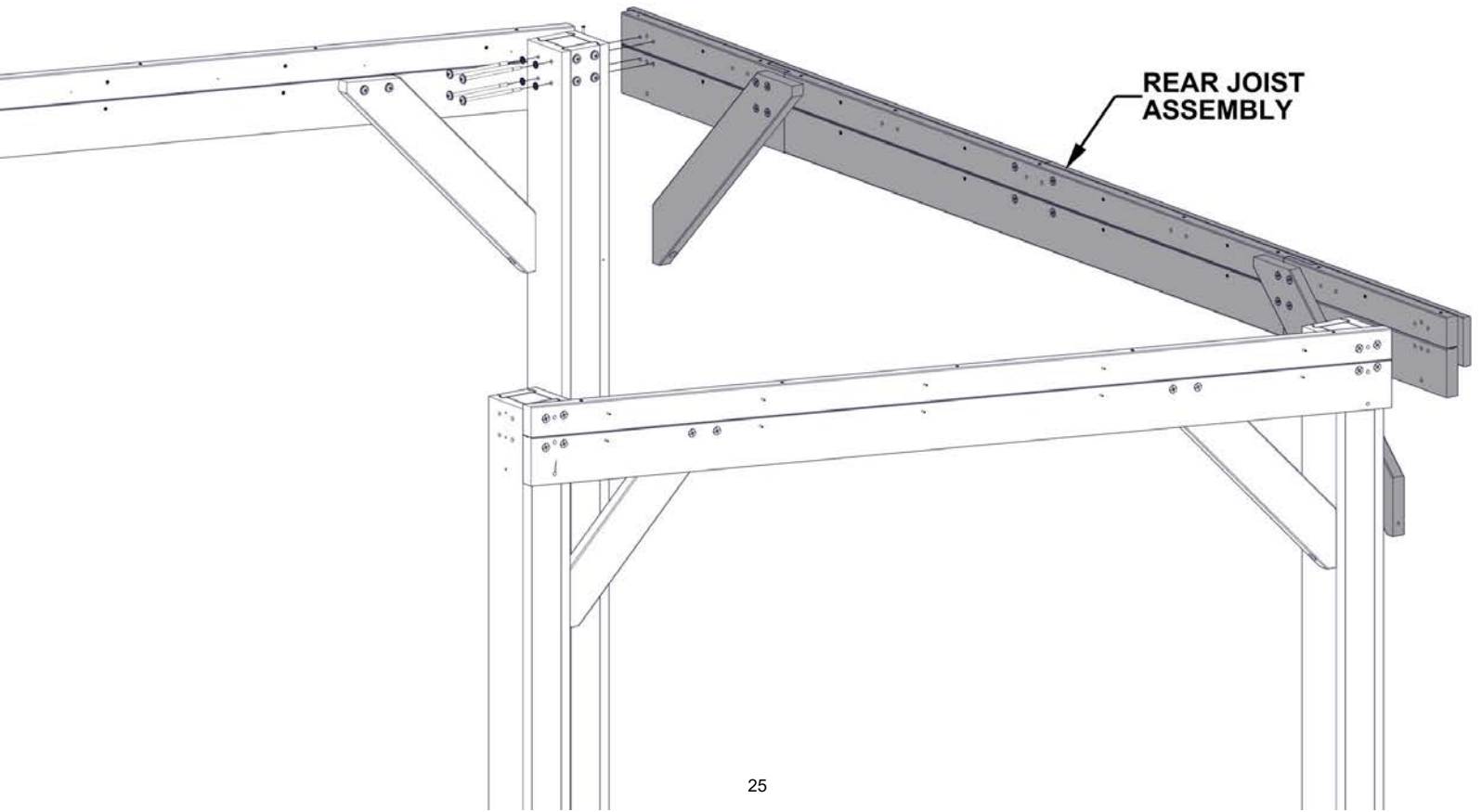
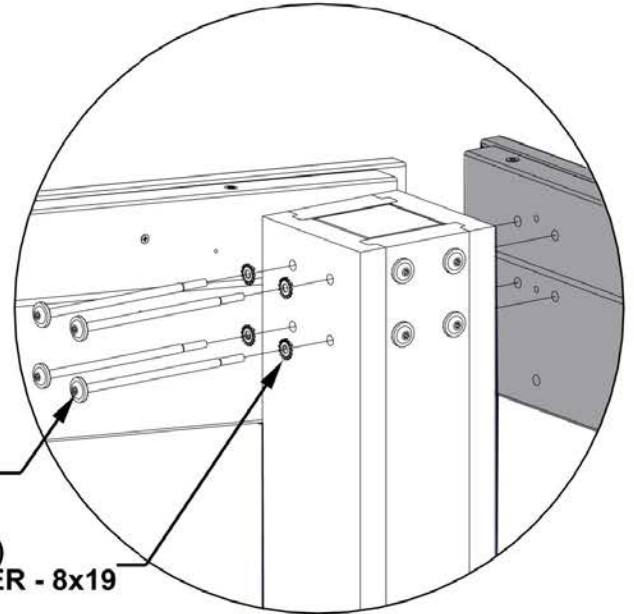
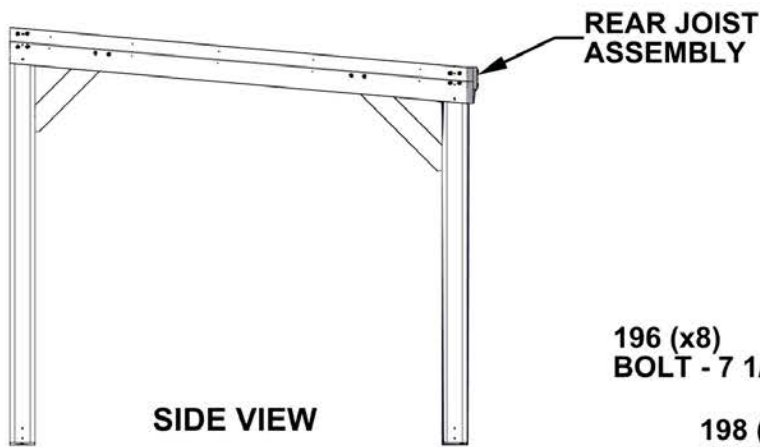

STEP 8B - GAZEBO ASSEMBLY

QTY	PART NUMBER	DESCRIPTION
2	H100197	LAG SCREW WH 5/16x2 1/2 BLK
6	H100198	WASHER LOCK EXT 8x19
2	H100405	WASHER LOCK EXT 6x15
4	H100482	LAG SCREW WH 5/16x3 1/2 BLK
2	H100792	LAG SCREW WH 1/4x3 BLK

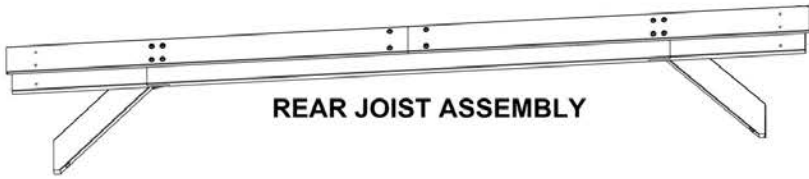

NOTES:
 • TO AVOID SPLITTING, MAKE SURE LAG SCREWS GO INTO PILOT HOLES.

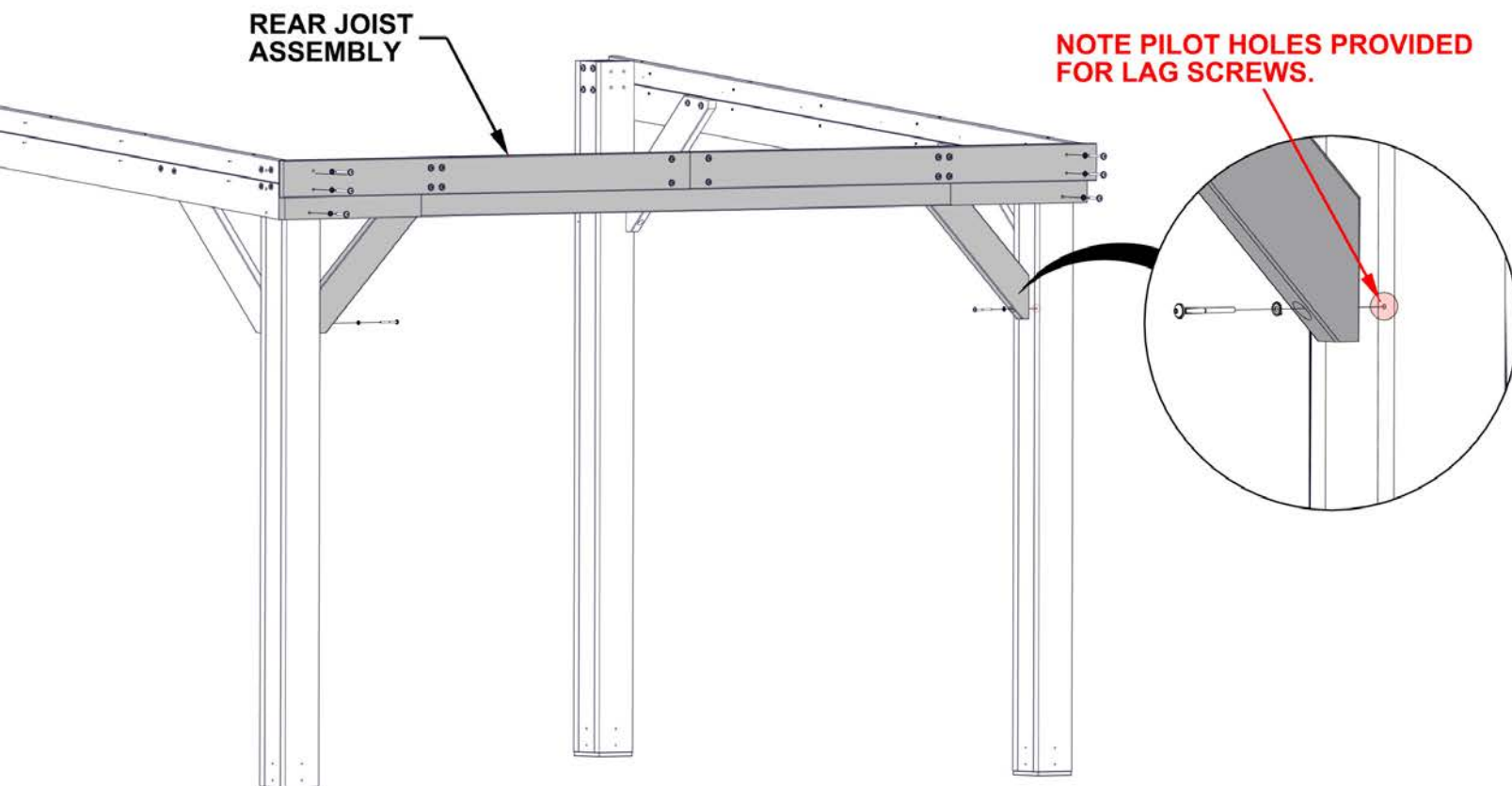
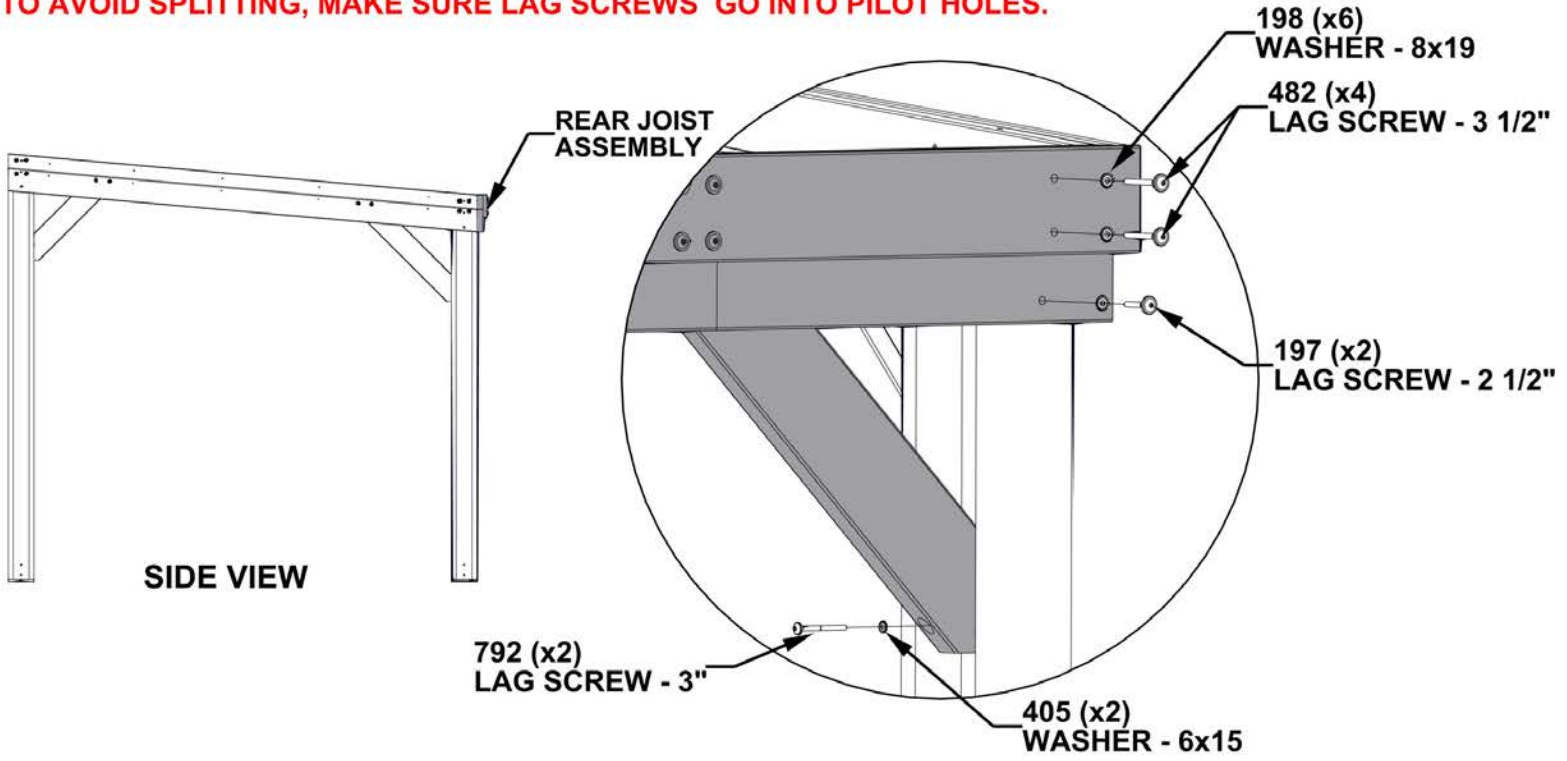

STEP 9A - GAZEBO ASSEMBLY

QTY	PART NUMBER	DESCRIPTION
8	H100196	BOLT WH 5/16x7 1/4 BLK
8	H100198	WASHER LOCK EXT 8x19

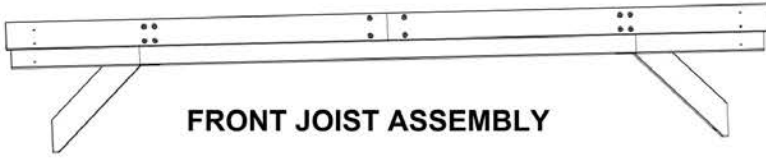

- NOTES:**
- ALIGN JOIST ASSEMBLY WITH HOLES IN POST.
 - IF BOLTS DO NOT ENGAGE WITH T-NUTS INSTALLED IN JOIST ASSEMBLY, CHECK FOR SAWDUST BUILD UP IN HOLES. CLEAN WITH A LONG SCREWDRIVER IF NEEDED.

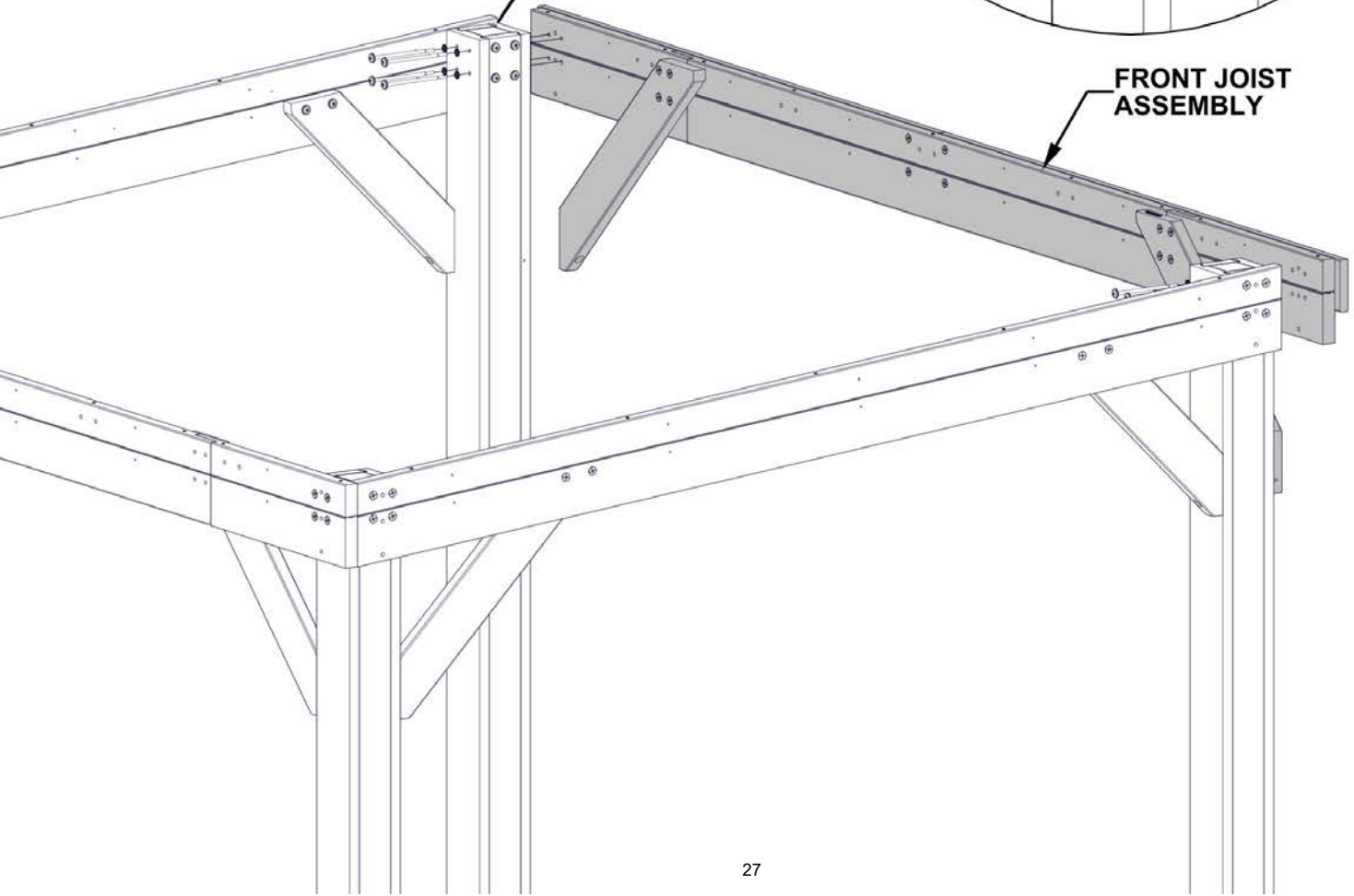
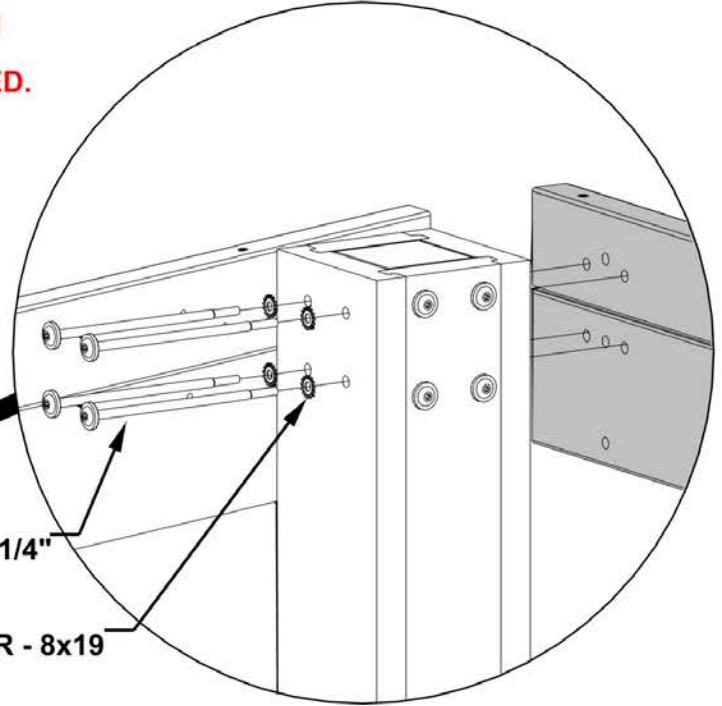
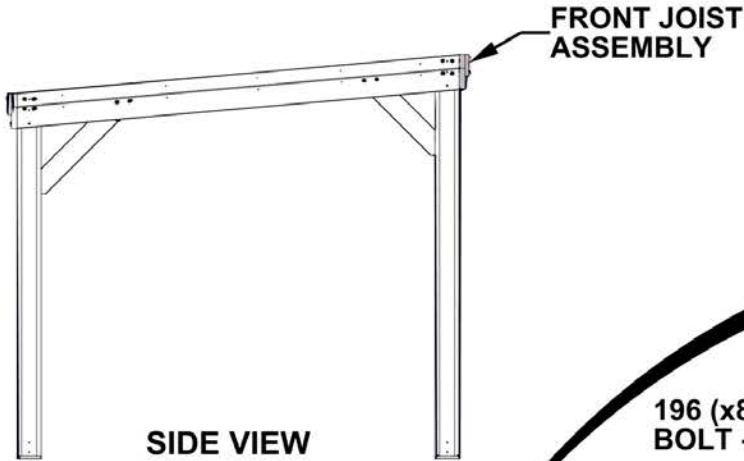

STEP 9B - GAZEBO ASSEMBLY

QTY	PART NUMBER	DESCRIPTION
2	H100197	LAG SCREW WH 5/16x2 1/2 BLK
6	H100198	WASHER LOCK EXT 8x19
2	H100405	WASHER LOCK EXT 6x15
4	H100482	LAG SCREW WH 5/16x3 1/2 BLK
2	H100792	LAG SCREW WH 1/4x3 BLK

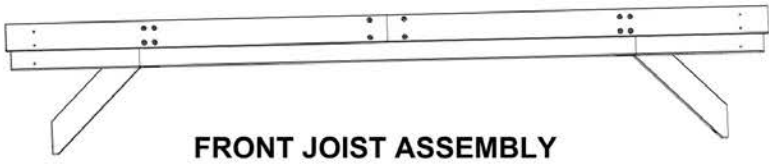

FRONT JOIST ASSEMBLY

NOTES:
 • TO AVOID SPLITTING, MAKE SURE LAG SCREWS GO INTO PILOT HOLES.

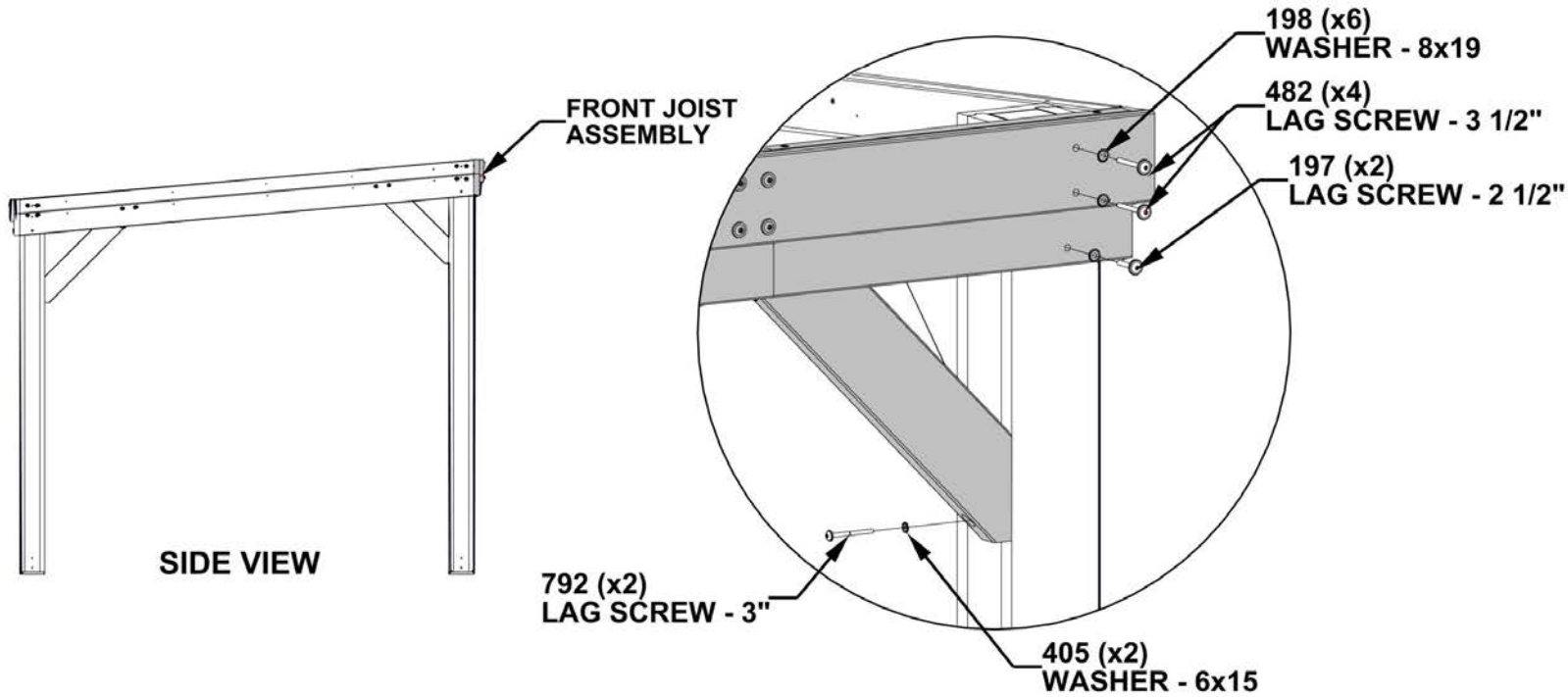

NOTE PILOT HOLES PROVIDED FOR LAG SCREWS.

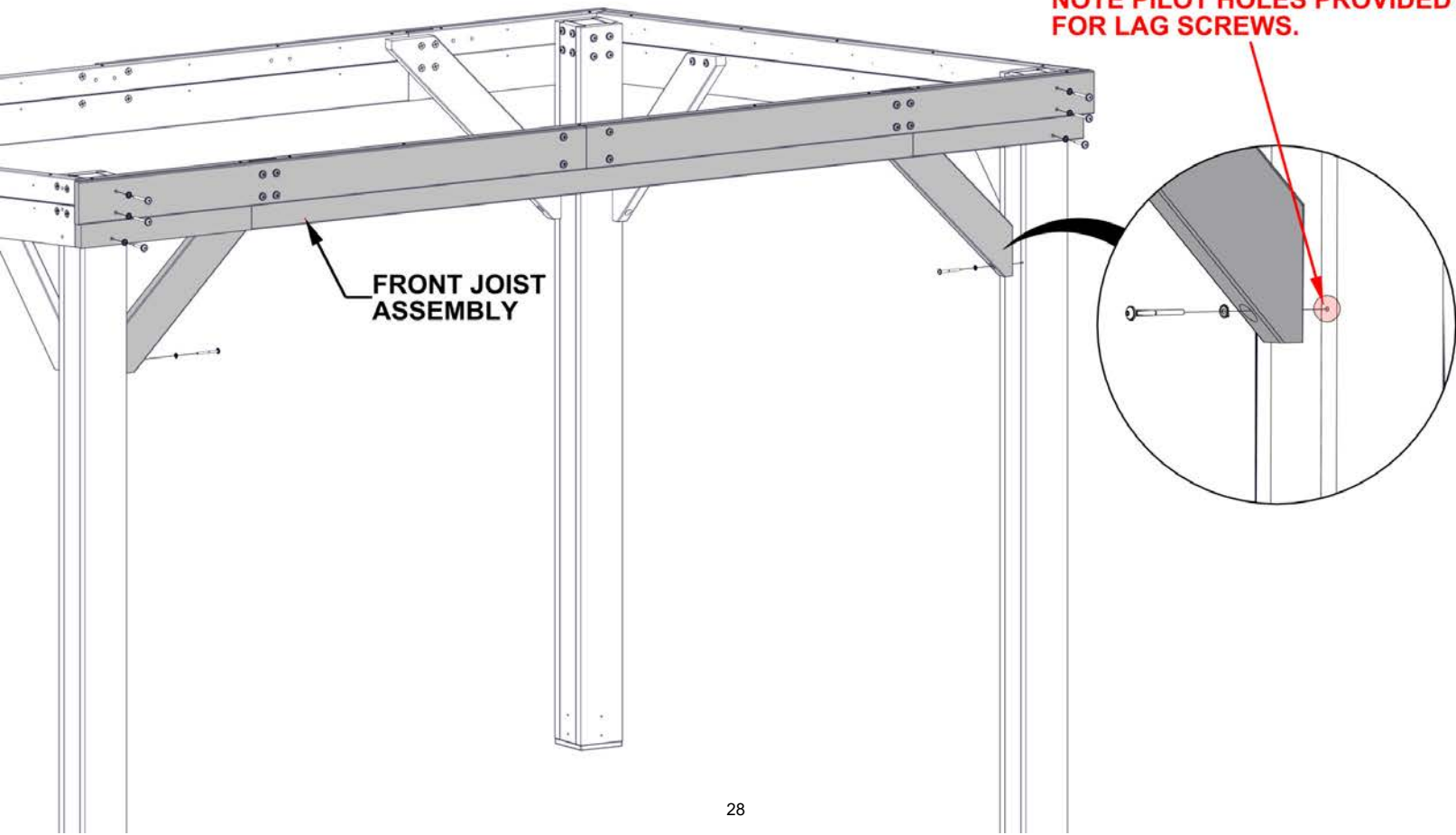

STEP 9C - GAZEBO ASSEMBLY

**CRITICAL: SQUARE ASSEMBLY BEFORE PROCEEDING TO NEXT STEPS.
ONCE ASSEMBLY IS SQUARED, FULLY TIGHTEN ALL HARDWARE**

MEASUREMENTS TAKE FROM INSIDE POST CORNER TO INSIDE POST CORNER

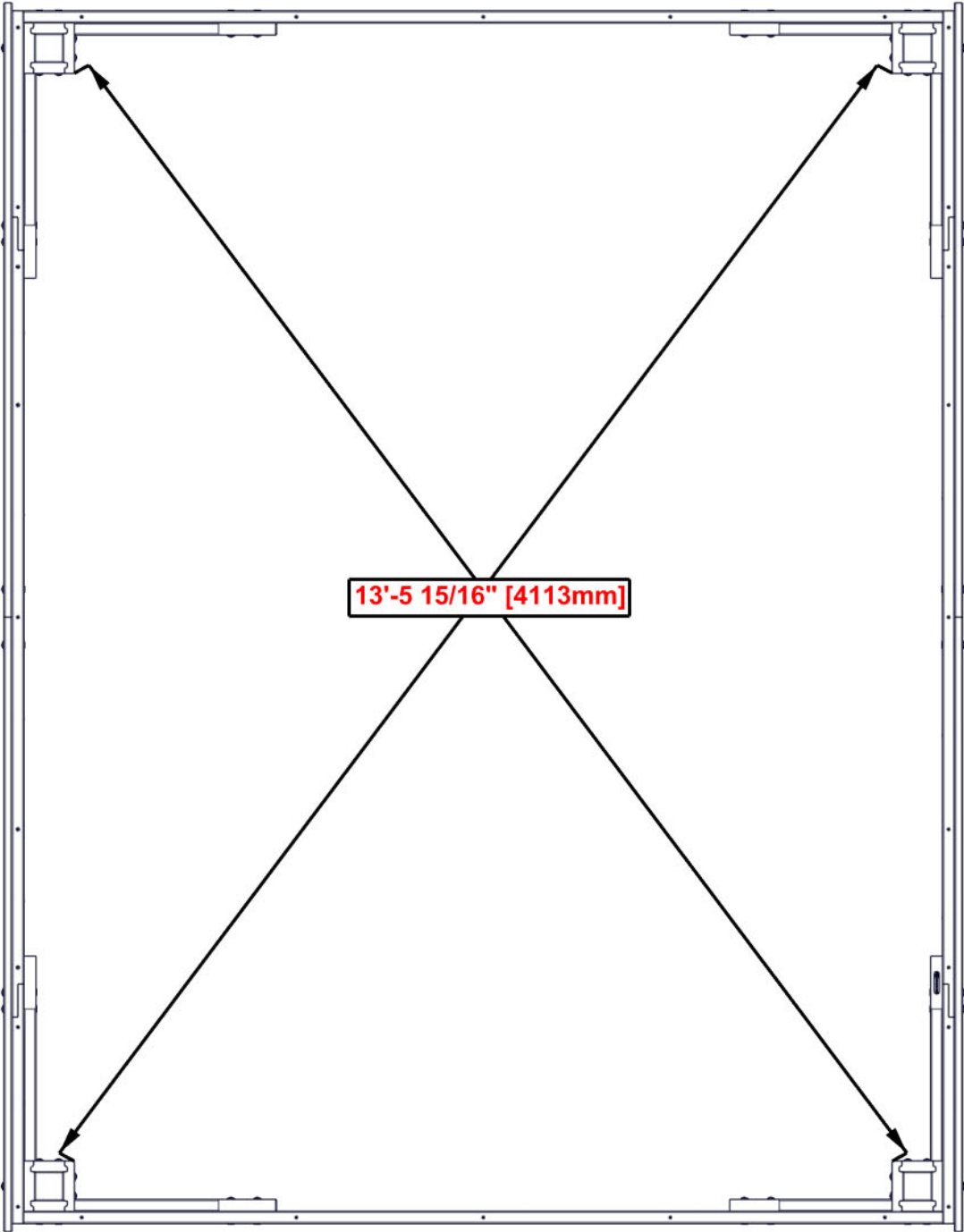

STEP 10 - GAZEBO ASSEMBLY

QTY	PART NUMBER	DESCRIPTION
4	H100197	LAG SCREW WH 5/16x2 1/2 BLK
12	H100198	WASHER LOCK EXT 8x19
8	H100482	LAG SCREW WH 5/16x3 1/2 BLK



G04 FASCIA - W4L17304
 (x2) 15/16"x5 1/4"x112 13/16" (24x134x2866)

NOTES:
 • TO AVOID SPLITTING, MAKE SURE LAG SCREWS GO INTO PILOT HOLES.

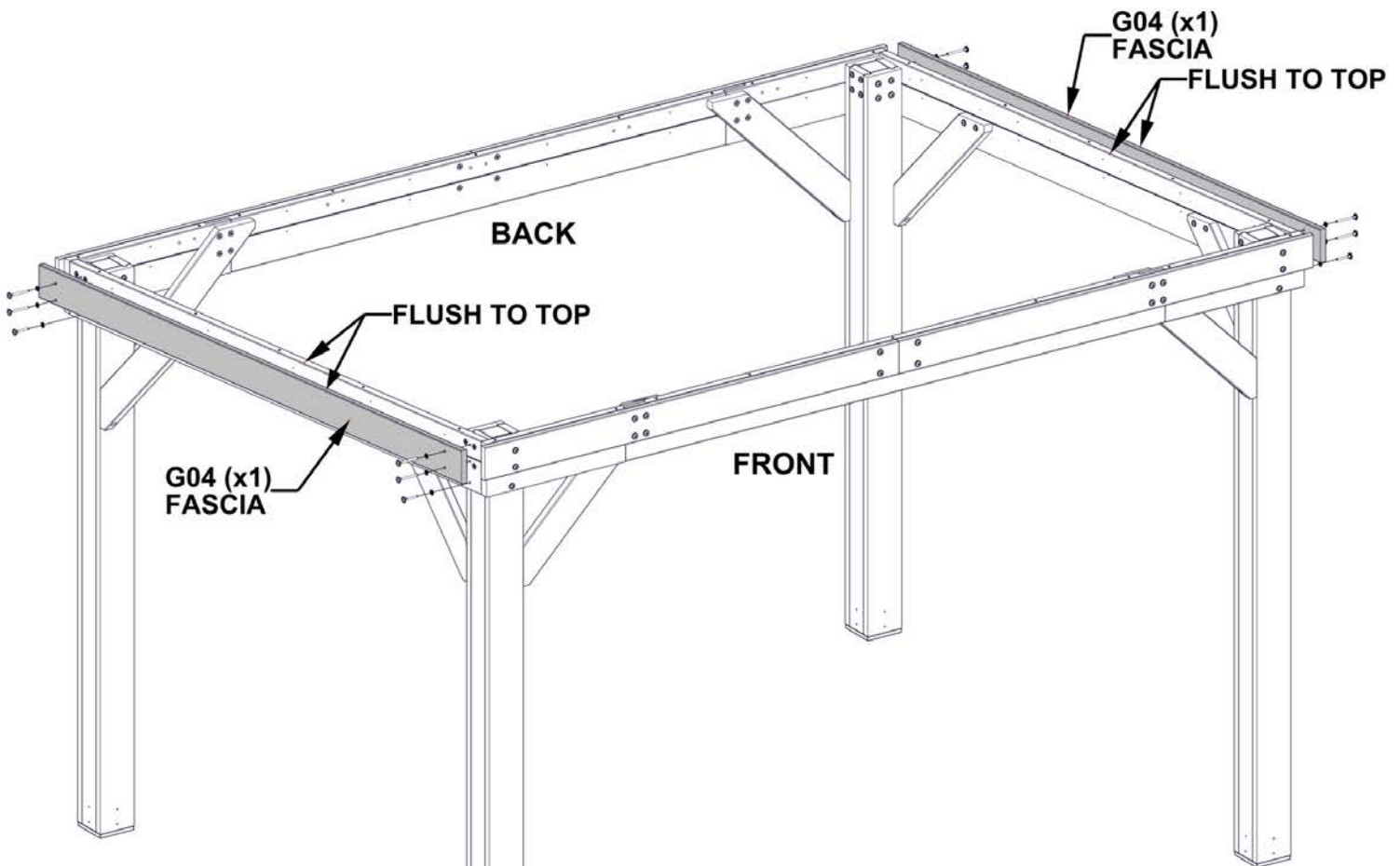
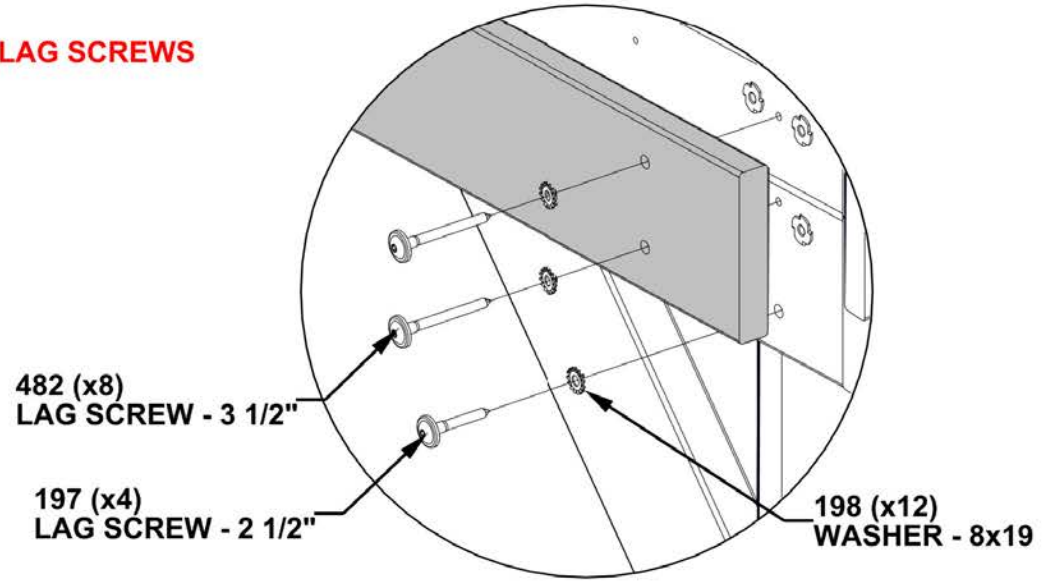

STEP 11 - GAZEBO ASSEMBLY

QTY	PART NUMBER	DESCRIPTION
44	H100391	SCREW PFH 8x2 BLK

INSTALL SCREWS INTO PILOT HOLES. THE PILOT HOLES TO USE ARE THE TWO HOLES THAT ALIGN VERTICALLY. WORK AROUND THE ASSEMBLY INSTALLING SCREWS INTO THE SIDES, FRONT AND BACK.

391 (x44)
SCREW - 2"

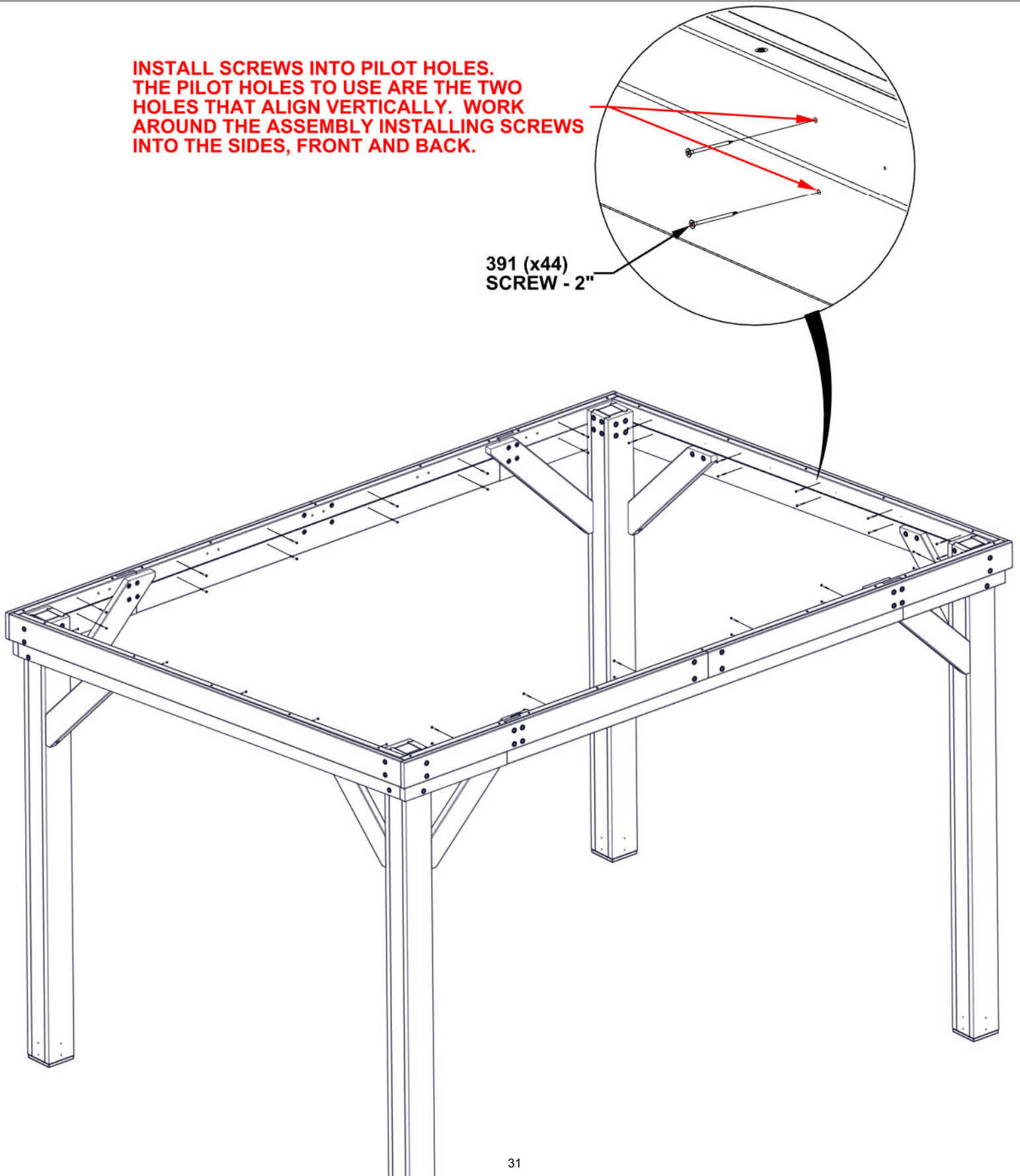

STEP 12 - GAZEBO ASSEMBLY

QTY	PART NUMBER	DESCRIPTION
12	H100391	SCREW PFH 8x2 BLK



J09 CLEAT - W4L17306
(x2) 15/16"x2 3/8"x97 9/16" (24x60x2479)

NOTE:
• REPEAT CONNECTION ON OTHER SIDE

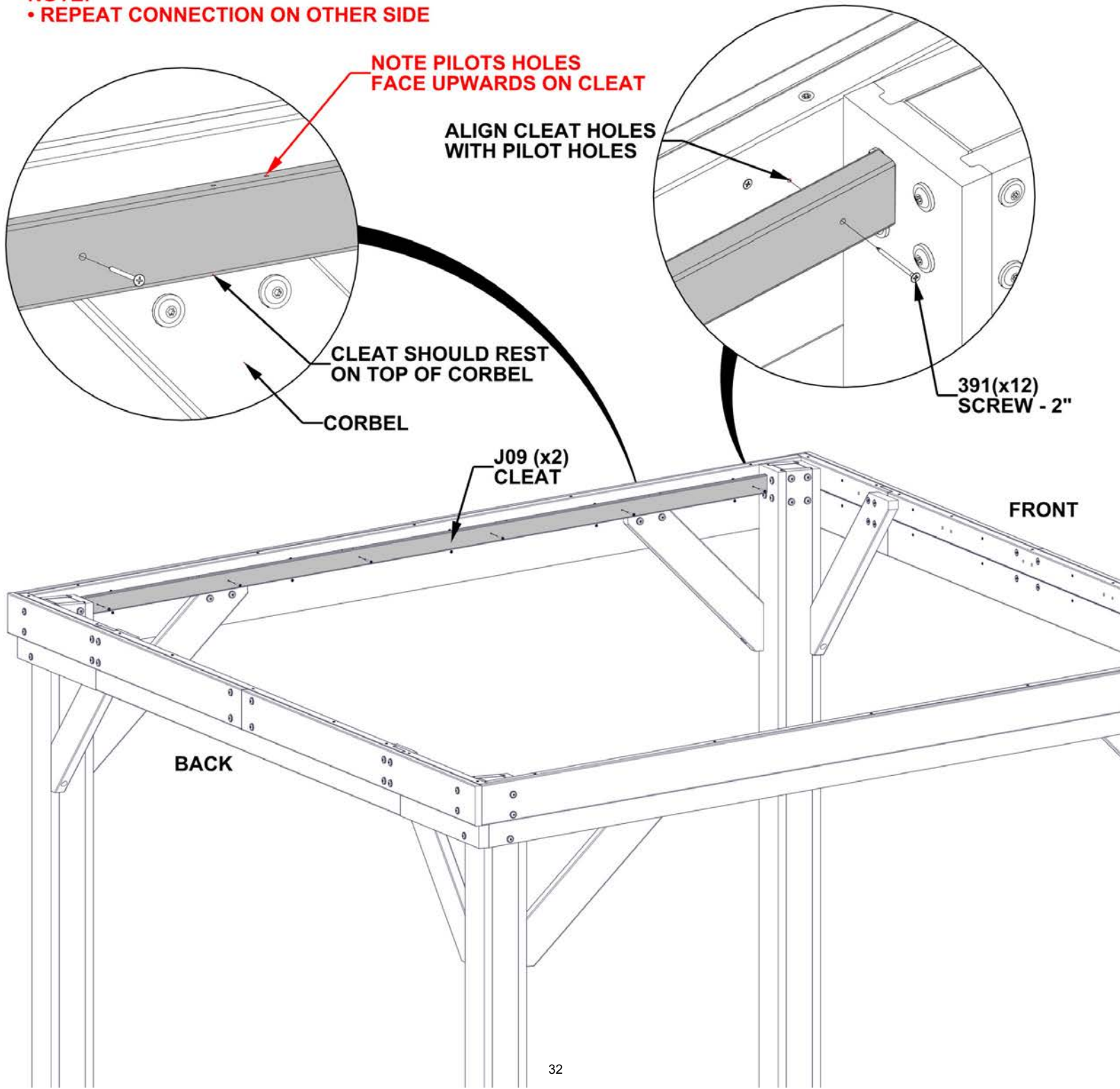

STEP 13 - GAZEBO ASSEMBLY

QTY	PART NUMBER	DESCRIPTION
20	H100459	BOLT WH 5/16x1 1/4 BLK

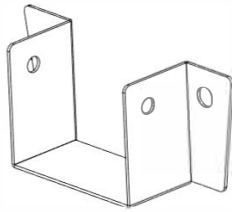

2764 RAFTER BRACKET - A4M02764
(x4) 1 5/8"x2 7/16"x5 1/4" (42x62x133)

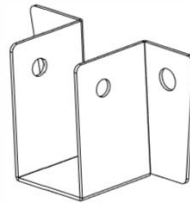

1787 RAFTER BRACKET - A4M01787
(x6) 1 5/8"x2 7/16"x4" (42x62x101)

NOTE:
- BRACKETS ALTERNATE STARTING WITH A4M01787.
- REPEAT ON BOTH SIDES.

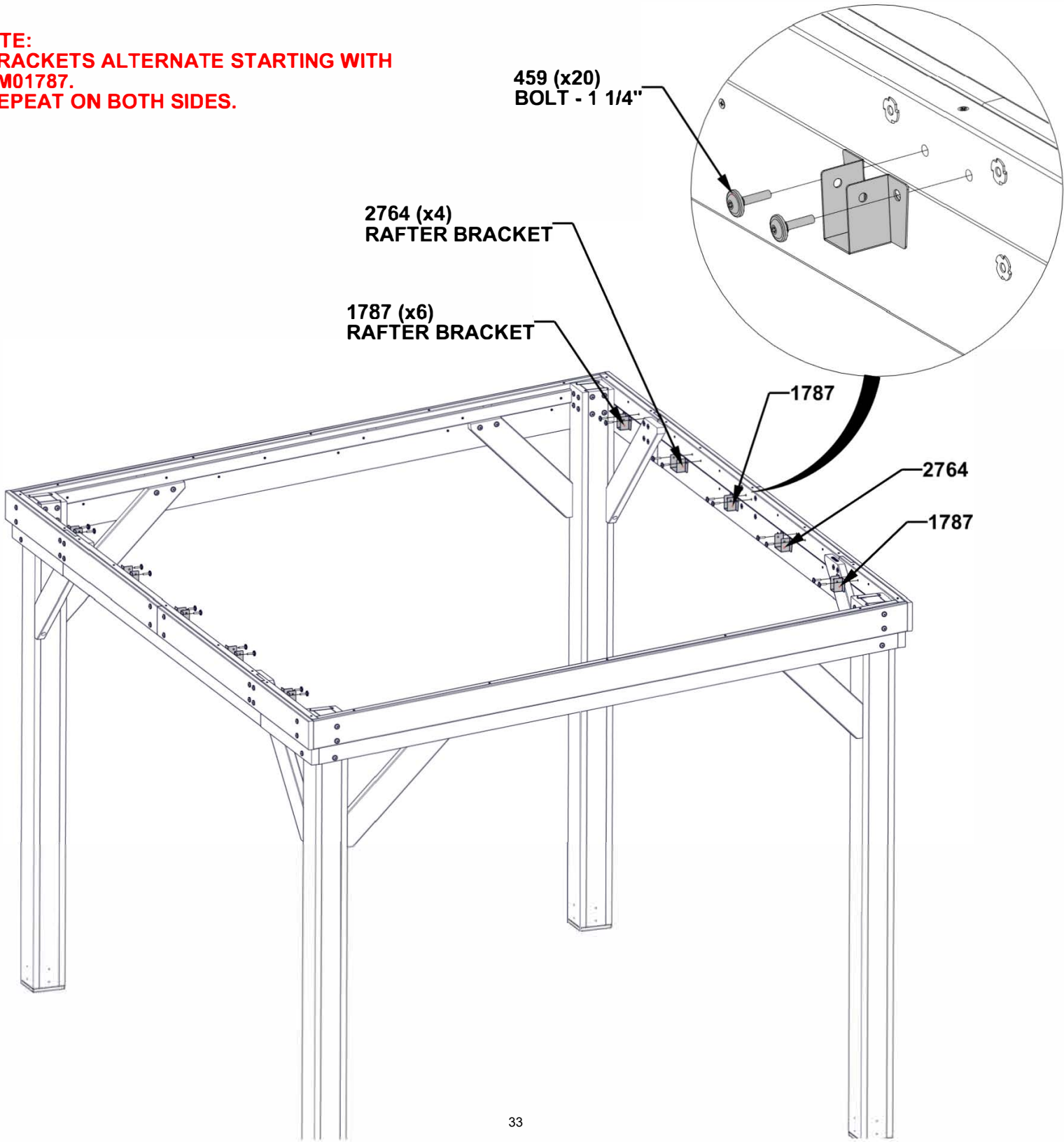

STEP 14A - GAZEBO ASSEMBLY



E02 RAFTER - W4L19577
(x4) 1 7/16"x3 3/8"x109 3/4" (36x86x2787)



2763 RAFTER BRACE - A4M02763
(x2) 1/16"x3 1/8"x109 1/2" (1.5x80x2781)

QTY	PART NUMBER	DESCRIPTION
6	H100479	NUT LOCK 5/16 BLK
6	H100503	BOLT WH 5/16x3 1/2 BLK
6	H100198	WASHER LOCK EXT 8x19
6	H100630	WASHER FLAT 8x19 BLK

NOTE:
- INSERT HARDWARE AS SHOWN, DO NOT TIGHTEN UNTIL NEXT STEP.
- REPEAT THIS STEP TWICE.

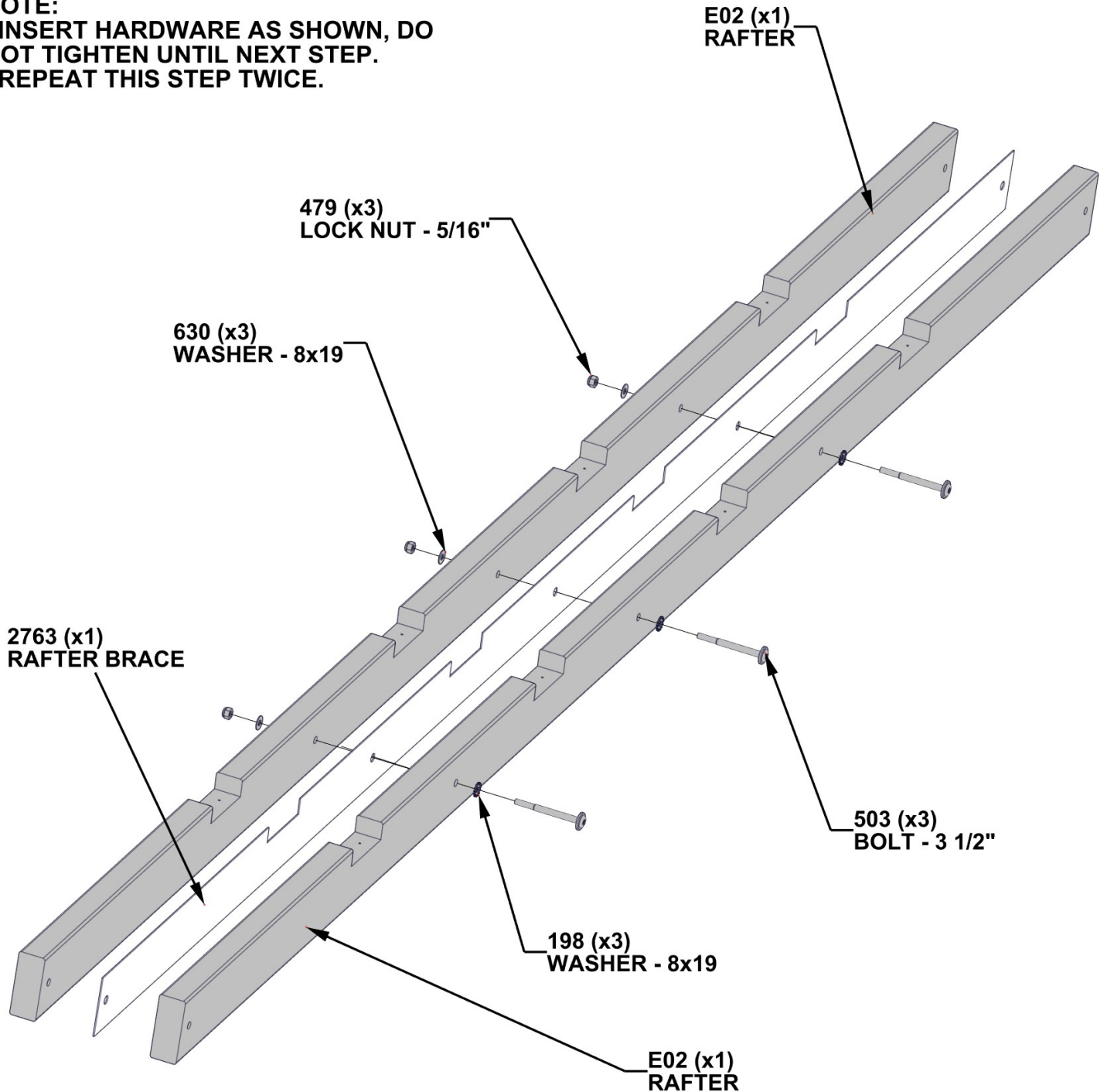

STEP 14B - GAZEBO ASSEMBLY



E01 RAFTER - W4L17300
(x3) 1 7/16"x3 3/8"x109 3/4" (36x86x2787)



(x2) RAFTER ASSEMBLY FROM STEP 14A

QTY	PART NUMBER	DESCRIPTION
10	H100653	NUT LOCK 1/4 BLK
6	H100488	BOLT WH 1/4x2 BLK
4	H101127	BOLT WH 1/4x3-1/2 BLK
10	H100630	WASHER FLAT 8x19 BLK

NOTES:

- INSERT RAFTERS INTO BRACKETS
- ATTACH E01 RAFTERS TO BRACKETS USING 2" BOLTS, FLAT WASHERS, AND LOCK NUTS.
- ATTACH RAFTER ASSEMBLY FROM PREVIOUS STEP USING 3-1/2" BOLTS, FLAT WASHERS, AND LOCK NUTS
- NOTCHES IN ALL RAFTERS WILL FACE UPWARDS.
- TIGHTEN HARDWARE FROM PREVIOUS STEP.

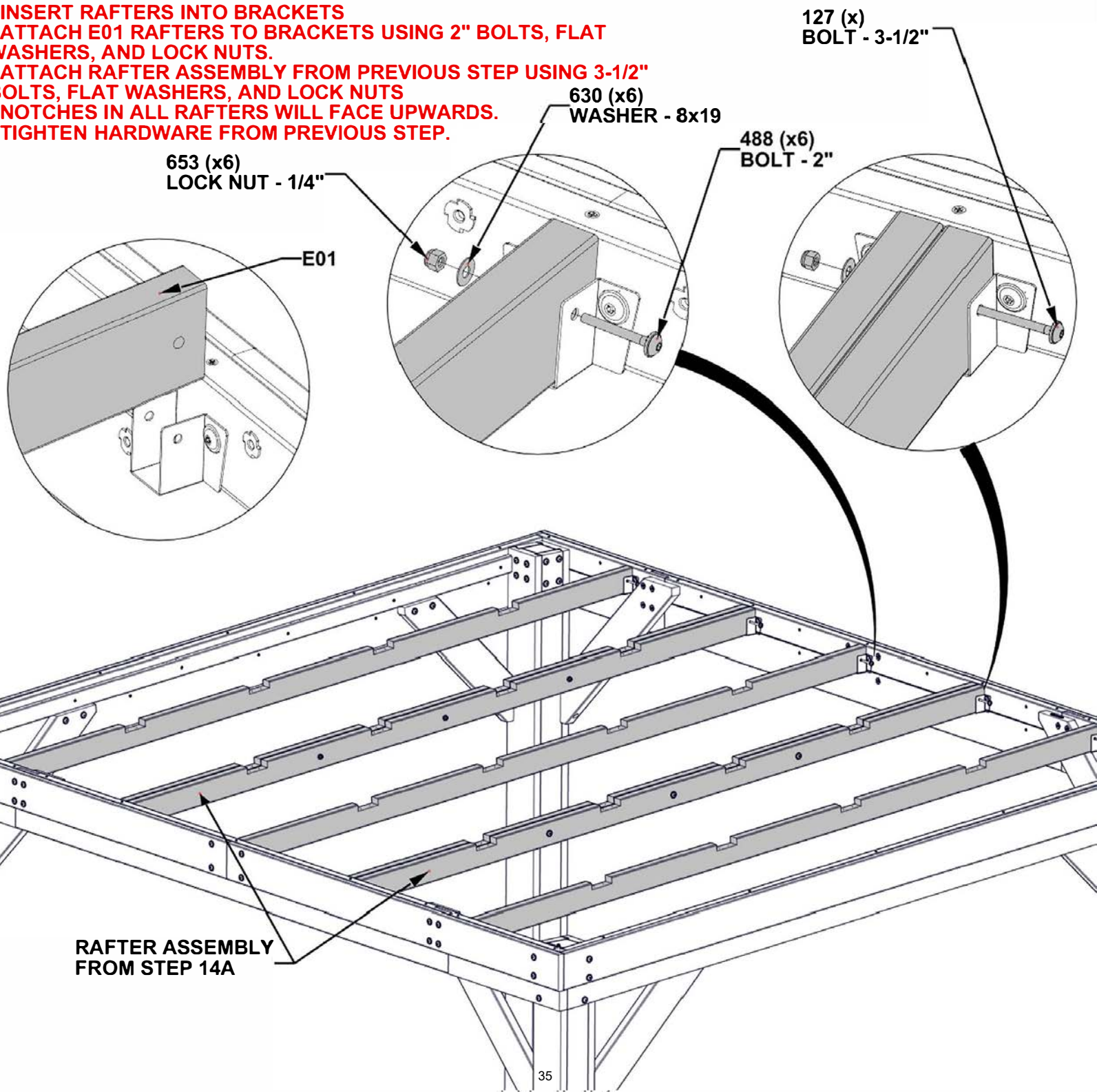

STEP 15 - GAZEBO ASSEMBLY



H01 PURLIN - W4L19578
(x4) 15/16"x3 3/8"x97 5/8" (24x86x2479)

NOTE:
- POSITION H01 PURLINS AS SHOWN.

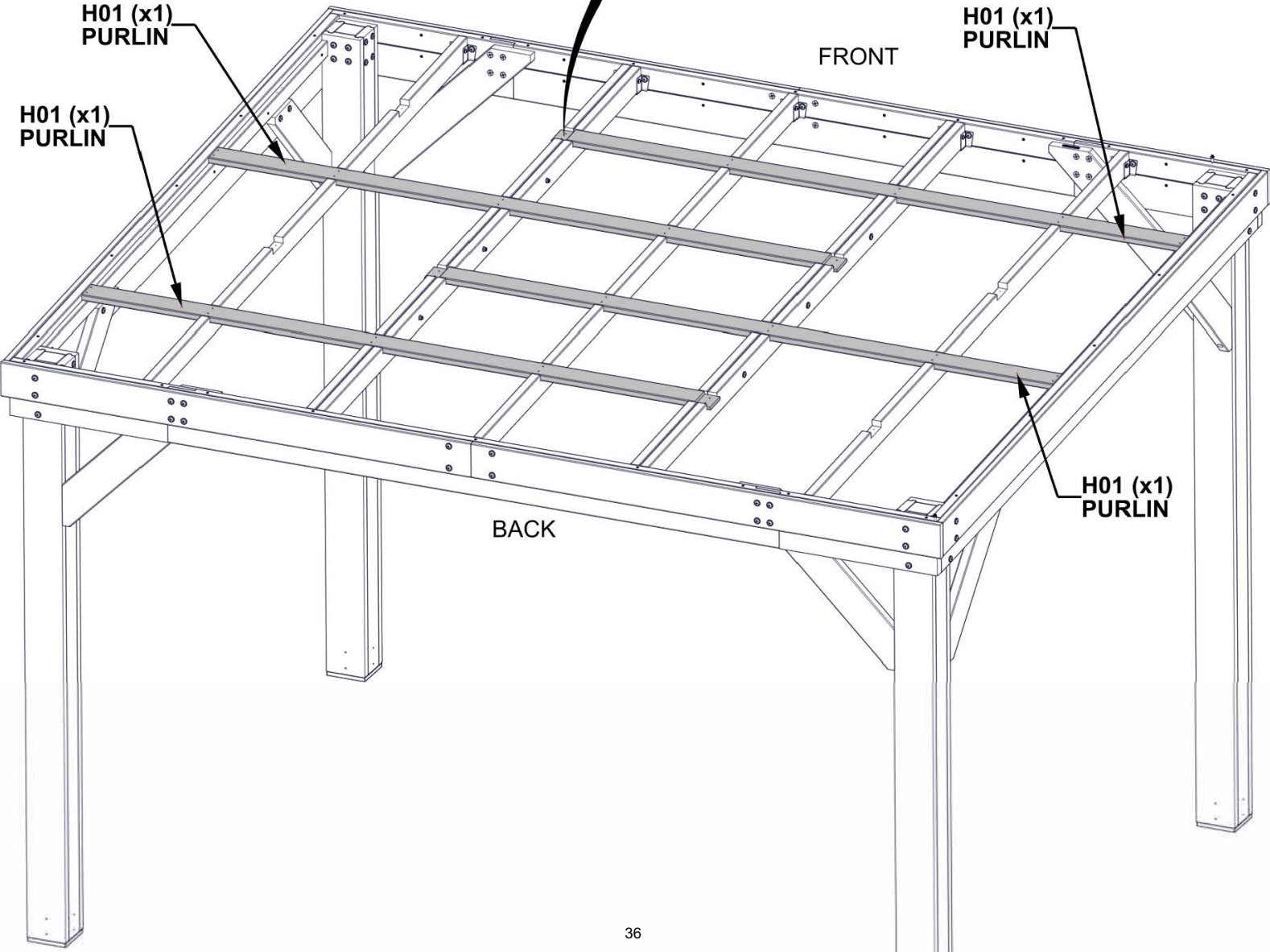
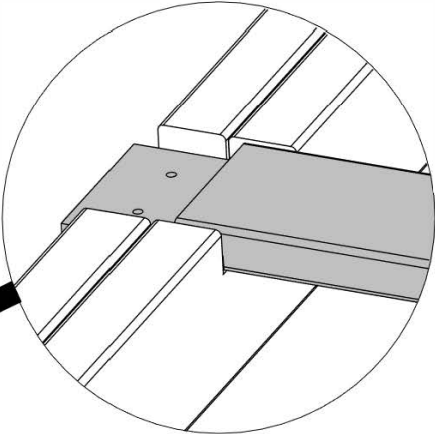

STEP 16 - GAZEBO ASSEMBLY

QTY	PART NUMBER	DESCRIPTION
56	H100382	SCREW PFH 8x1 3/4 BLK



H02 PURLIN - W4L19579
 (x4) 15/16"x3 3/8"x45 13/16" (24x86x1163)

NOTE:
 - ALIGN PURLIN HOLES WITH RAFTER PILOT HOLES.
 - ATTACH SCREWS FROM CENTER AND WORK OUTWARDS.

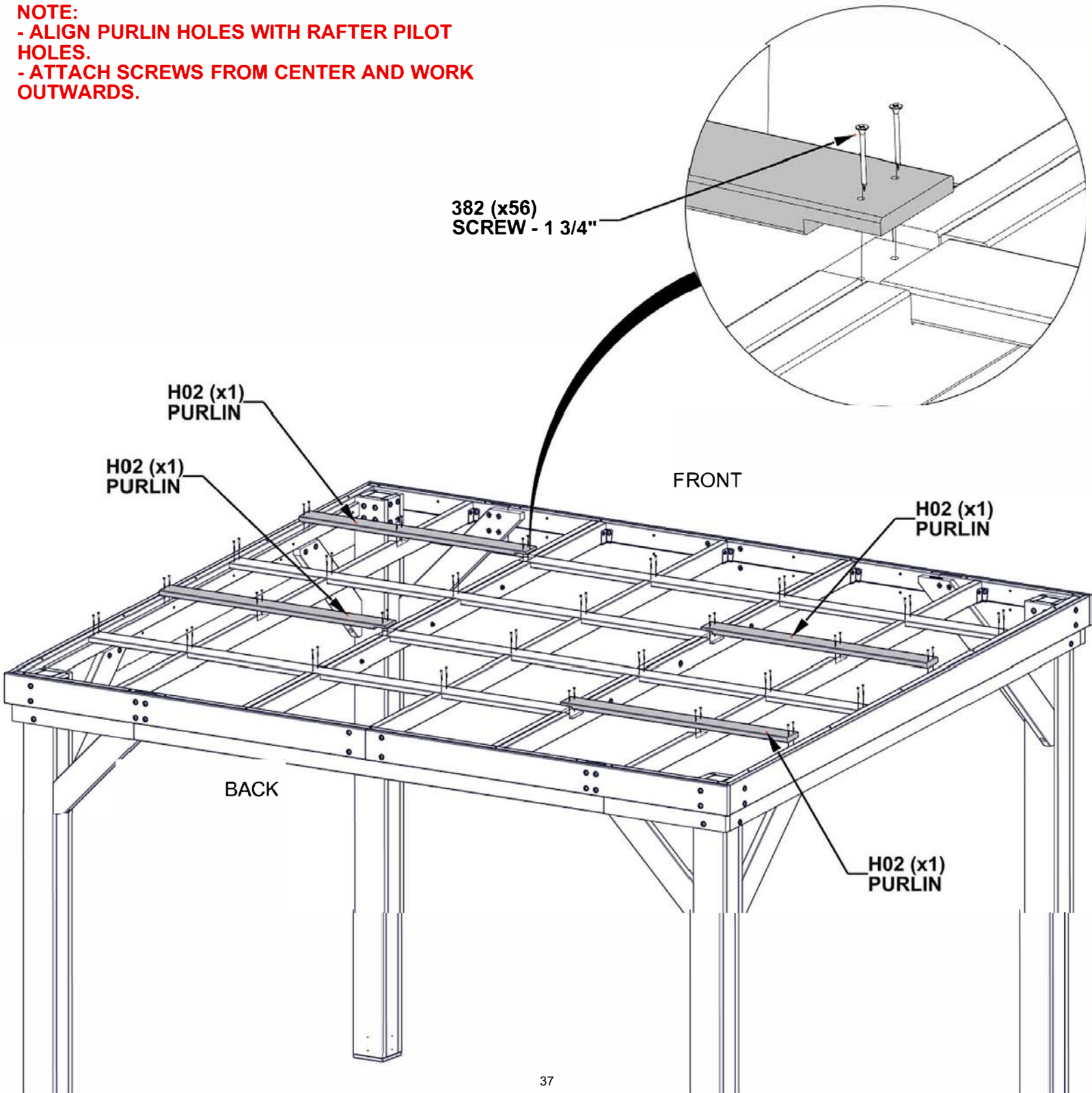

STEP 17A - GAZEBO ASSEMBLY



A4M02739 29GA SHEETING
(x1)

WARNING: GLOVES ARE RECOMMENDED WHEN HANDLING STEEL ROOF PIECES.

NOTES:

- REMOVE BLUE FILM FROM ROOF PANELS.
- IT IS IMPORTANT THAT YOU POSITION THE ROOF PANELS AS SHOWN SO THE TRIM PIECES WILL FIT CORRECTLY IN FUTURE STEPS.
- STARTING AT THE BACK OF THE GAZEBO, POSITION THE FIRST ROOF PANEL WITH A 1/4" OVERHANG OFF THE BACK SIDE AND A 1/4" GAP AT THE SIDE.
- IT IS IMPORTANT TO MAINTAIN THE 1/4" SIDE GAP FROM THE BACK OF THE GAZEBO TO THE FRONT.
- ATTACH PANEL AS SHOWN.
- DO NOT GET ON THE ROOF TO ATTACH SCREWS.

ORIENT FIRST PANEL WITH A 1/4" OVERHANG OFF OF THE BACK SIDE AS SHOWN. SEE STEP 17B FOR FASTENING REQUIREMENTS.

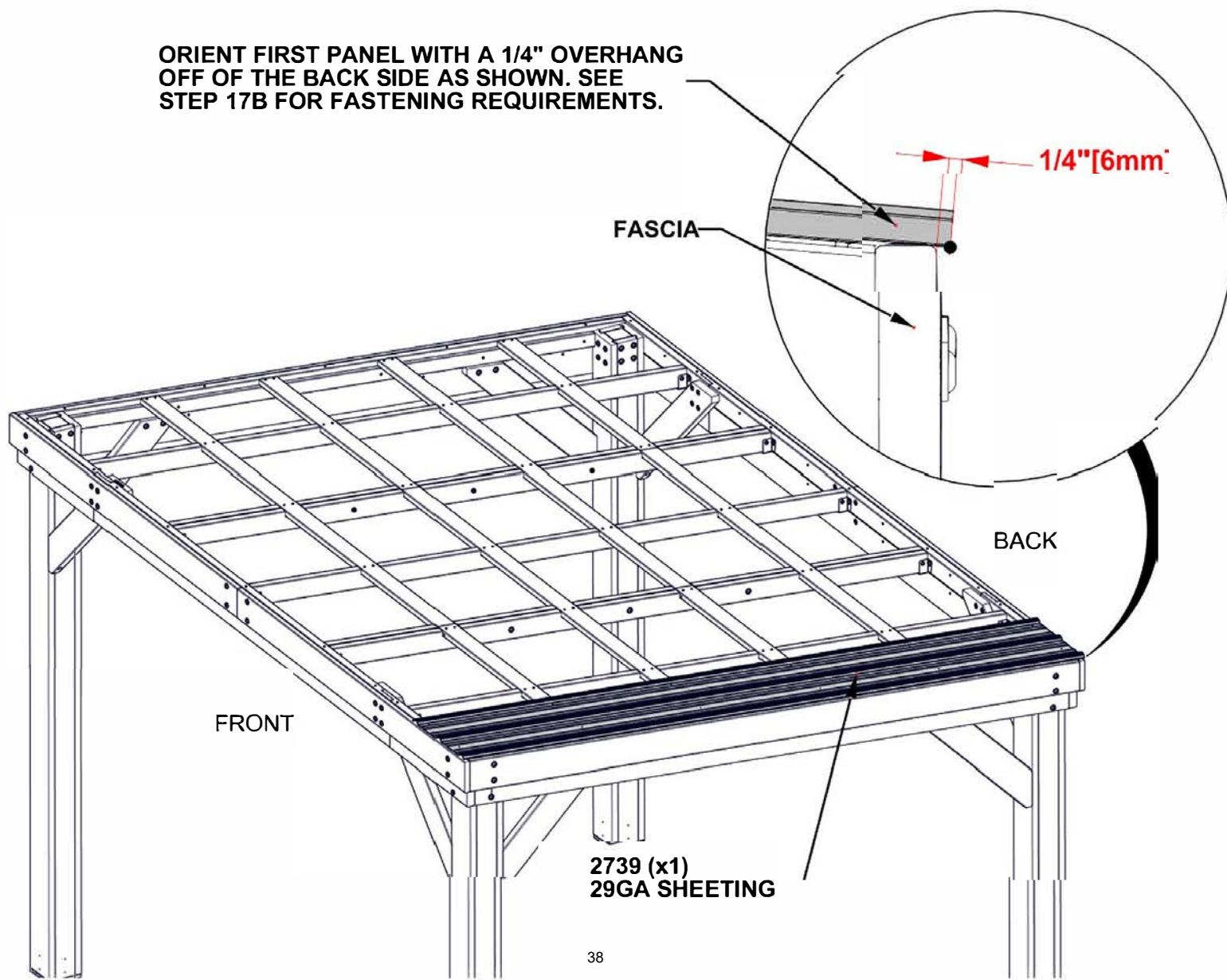

STEP 17B - GAZEBO ASSEMBLY

QTY	PART NUMBER	DESCRIPTION
10	H101117	SCREW WOODGRIP 10-16x3/4" BLK

WARNING: GLOVES ARE RECOMMENDED WHEN HANDLING STEEL ROOF PIECES.

NOTES:

- REMOVE BLUE FILM FROM ROOF PANELS.
- IT IS IMPORTANT THAT YOU POSITION THE ROOF PANELS AS SHOWN SO THE TRIM PIECES WILL FIT CORRECTLY IN FUTURE STEPS.
- STARTING AT THE BACK OF THE GAZEBO, POSITION THE FIRST ROOF PANEL WITH A 1/4" OVERHANG OFF THE BACK SIDE AND A 1/4" GAP AT THE SIDE.
- IT IS IMPORTANT TO MAINTAIN THE 1/4" SIDE GAP FROM THE BACK OF THE GAZEBO TO THE FRONT.
- ATTACH PANEL AS SHOWN.
- DO NOT GET ON THE ROOF TO ATTACH SCREWS.
- DO NOT ATTACH BACK ROW OF SCREWS.

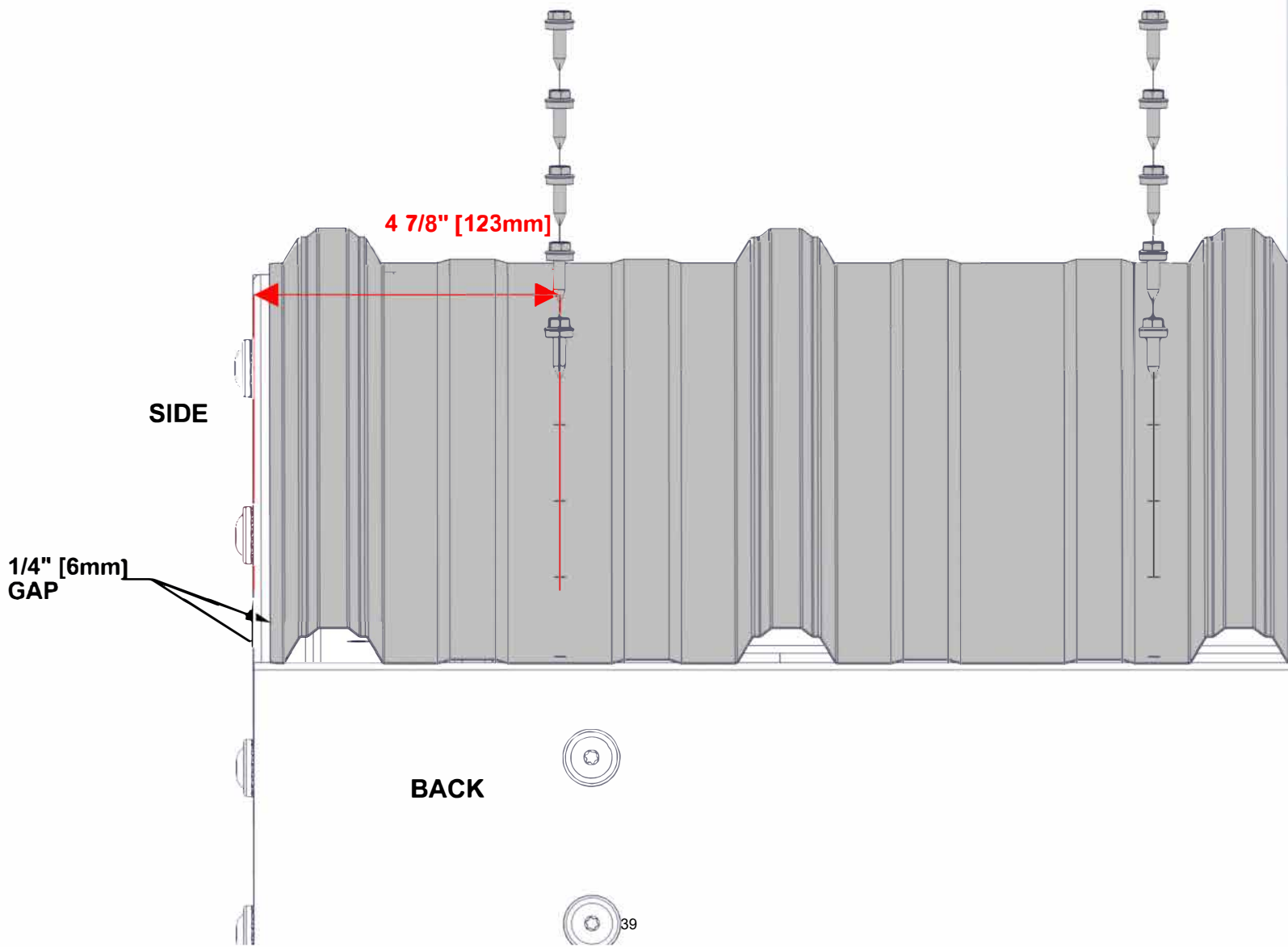

STEP 18 - GAZEBO ASSEMBLY

QTY	PART NUMBER	DESCRIPTION
80	H101117	SCREW WOODGRIP 10-16x3/4" BLK

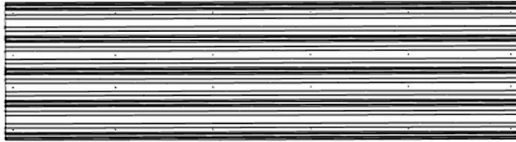

A4M02738 29GA SHEETING
(x4)

- NOTES:**
- REMOVE BLUE FILM FROM ROOF PANELS.
 - IT IS IMPORTANT THAT YOU POSITION THE ROOF PANELS AS SHOWN SO THE TRIM PIECES WILL FIT CORRECTLY IN FUTURE STEPS.
 - STARTING AT THE BACK OF THE GAZEBO, POSITION THE FIRST ROOF PANEL WITH A 1/4" OVERHANG OFF THE BACK SIDE AND A 1/4" GAP AT THE SIDE.
 - IT IS IMPORTANT TO MAINTAIN THE 1/4" SIDE GAP FROM THE BACK OF THE GAZEBO TO THE FRONT.
 - ATTACH PANEL AS SHOWN.
 - DO NOT GET ON THE ROOF TO ATTACH SCREWS.
 - DO NOT ATTACH THE BACK ROW OF SCREWS.

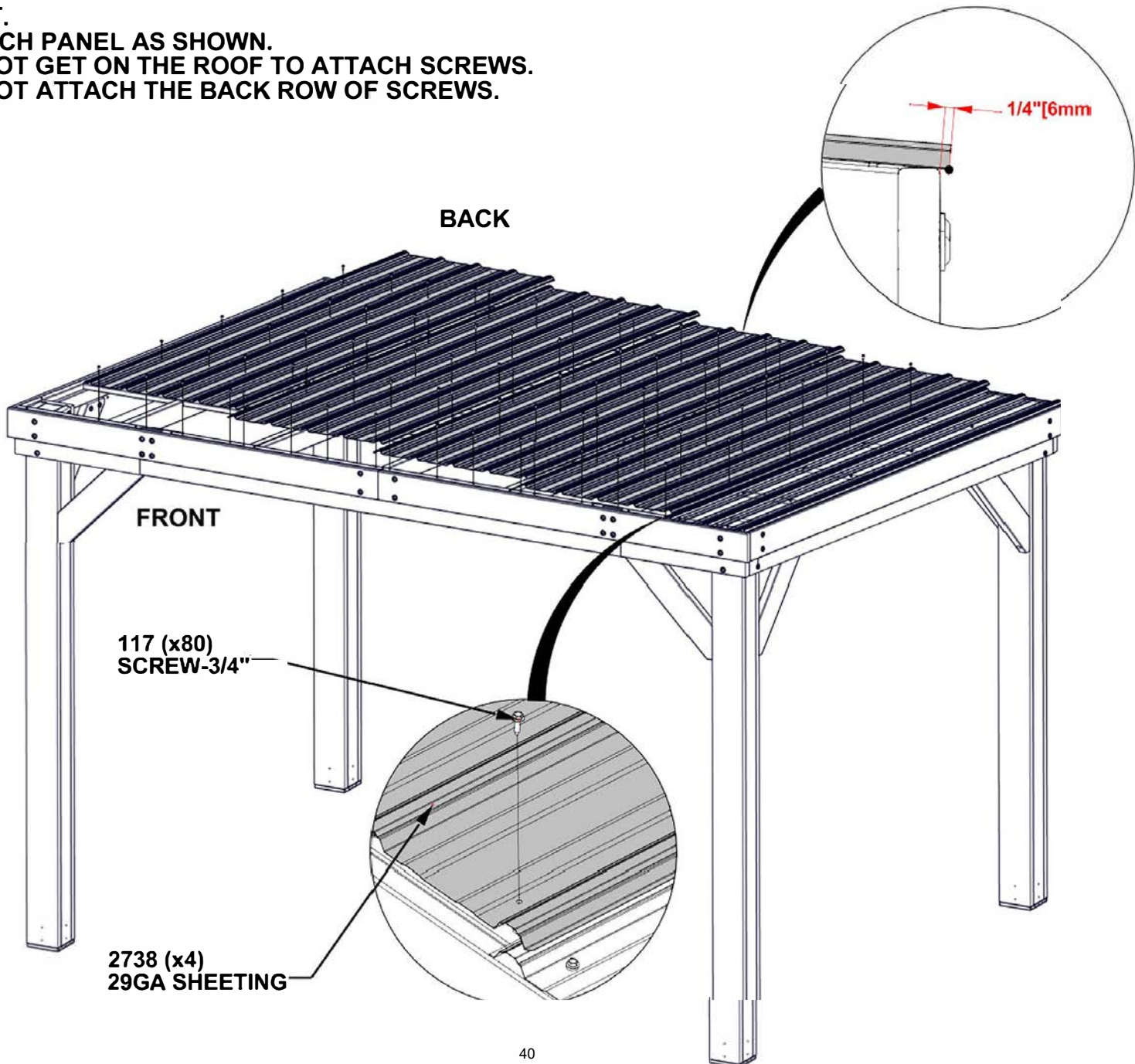

STEP 19 - GAZEBO ASSEMBLY

QTY	PART NUMBER	DESCRIPTION
10	H101117	SCREW WOODGRIP 10-16x3/4" BLK



A4M02739 29GA SHEETING
(x1)

NOTES:

- ENSURE PANEL OVERHANGS THE BACK SIDE OF THE GAZEBO BY 1/4".
- OVERLAB PANEL BY ONE RIB AS SHOWN BELOW.
- DO NOT GET ON THE ROOF TO ATTACH SCREWS.
- DO NOT ATTACH BACK ROW OF SCREWS.

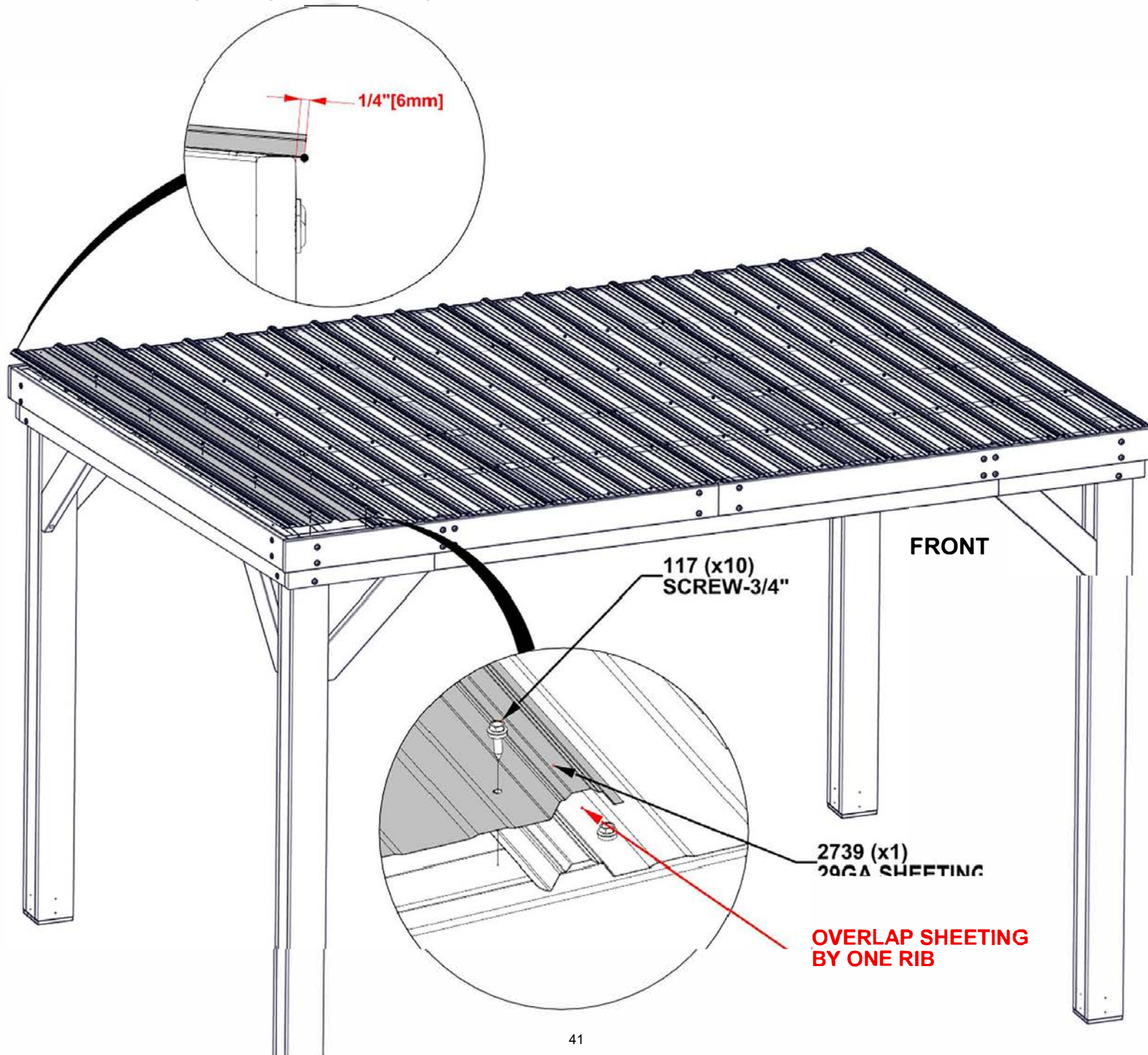

STEP 20 - GAZEBO ASSEMBLY

QTY	PART NUMBER	DESCRIPTION
7	H101116	SCREW SELF TAPPING 1/4x1 BLK



A4M02736 CORNER SPLICE TRIM LH
(x1)

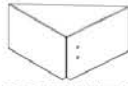

A4M02735 CORNER SPLICE TRIM RH
(x1)



A4M02734 EDGE TRIM SPLICE
(x1)



A4M02740 EDGE TRIM LONG
(x2)

LAYOUT EDGE TRIM, EDGE TRIM SPLICE AND CORNER SPLICE TRIM AS SHOWN BELOW. SLIDE TRIM PIECES INTO SPLICE. ATTACH CORNER SPLICES BY SLIDING ONTO EDGE TRIM. SCREW AS NOTED IN DETAIL

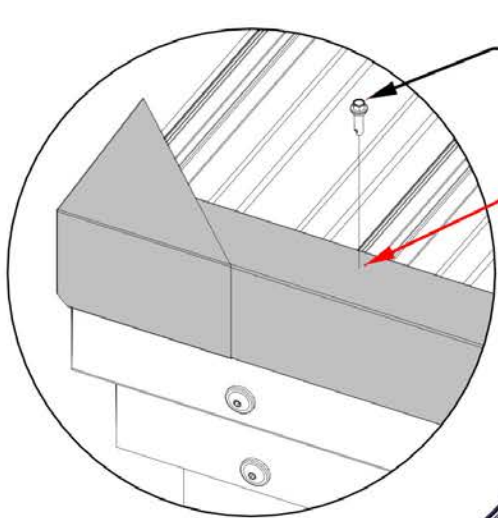

116 (x7)
SCREW - 1"

ATTACH THIS SCREW THROUGH THE TRIM AND INTO THE 2ND RIB OF TIN, SKIP TWO RIBS AND REPEAT.

2736 (x1)
CORNER SPLICE TRIM LH

2740(x1)
EDGE TRIM LONG

2734 (x1)
EDGE TRIM SPLICE

2740(x1)
EDGE TRIM LONG

2735(x1)
CORNER SPLICE TRIM RH

FRONT

STEP 21 - GAZEBO ASSEMBLY

QTY	PART NUMBER	DESCRIPTION
12	H101116	SCREW SELP TAPPING 1/4x1" BLK

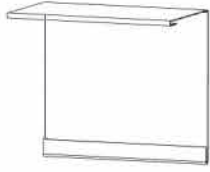

A4M02733 TRIM SHORT
(x2)



A4M02734 TRIM SPLICE
(x4)

LAY EDGE TRIM ON SIDE OF ROOF AS SHOWN BELOW, SLIDE EACH PIECE INTO ONE ANOTHER. FLUSH LAST PIECE WITH THE REAR EDGE OF SHEETING. SCREWS GO THOUGH EDGE TRIM INTO RIB AT THE APPROXIMATE LOCATIONS SHOWN. REPEAT ON OPPOSITE SIDE. DO NOT ATTACH REAR MOST SCREW UNTIL NEXT STEP.

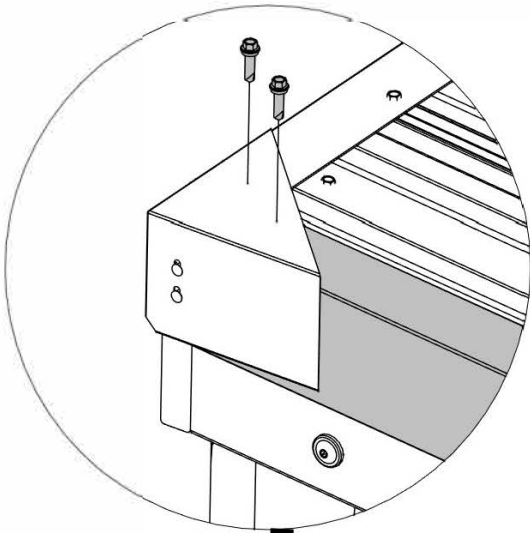

FRONT

116 (x6)
SCREW-1"

2733 (x1)
TRIM SHORT

2734 (x1)
TRIM SPLICE

2733 (x1)
TRIM SHORT

STEP 22 - GAZEBO ASSEMBLY

QTY	PART NUMBER	DESCRIPTION
2	H101116	SCREW TAPPING 1/4x1" BLK
20	H101117	SCREW WOODGRIP 10-16x3/4" BLK

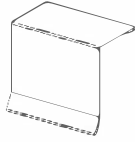

A4M02794 DRIP EDGE TRIM
(x1)



A4M02793 DRIP EDGE
(x2)

NOTE:

- DRIP EDGES ARE FLUSH WITH THE EDGES OF THE GAZEBO AS SHOWN.
- GENTLY LIFT ROOF SHEETS TO SLIDE DRIP EDGE UNDER.
- SLIDE EACH PIECE INTO ONE ANOTHER, MAKE SURE END PIECES ARE FLUSH WITH EDGE.
- DRIP EDGE WILL COVER BOLTS PREVIOUSLY INSTALLED.
- H101117 SCREWS GO THROUGH THE HOLES ON THE ROOF SHEETS TO FASTEN DRIP EDGE DOWN.
- H101116 SCREWS ARE ATTACHED IN LINE AS PREVIOUS STEPS

DRIP EDGE IS
FLUSH WITH EDGE
ON BOTH SIDES

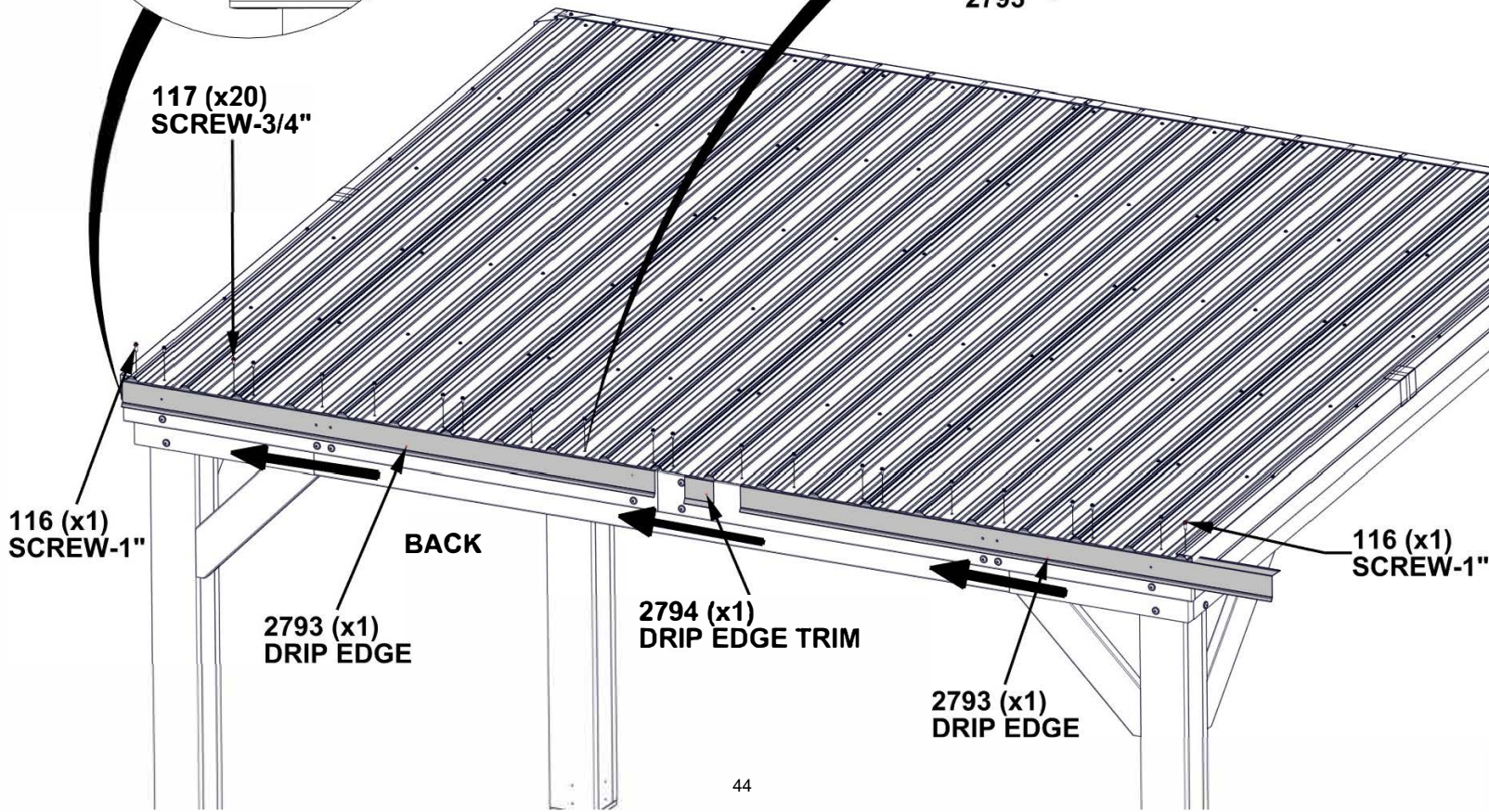
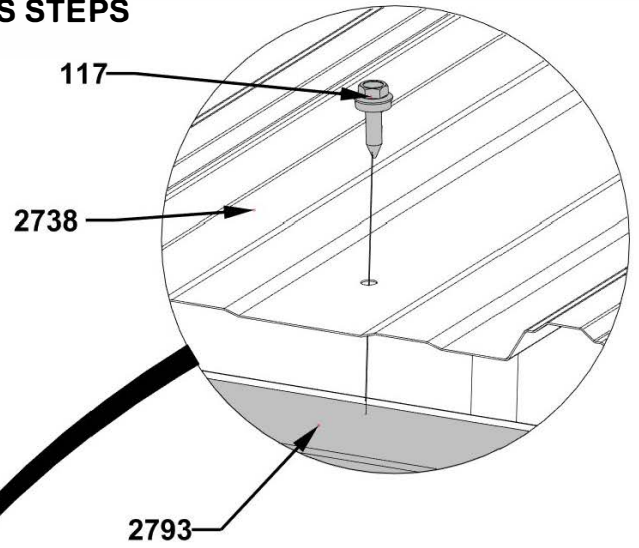
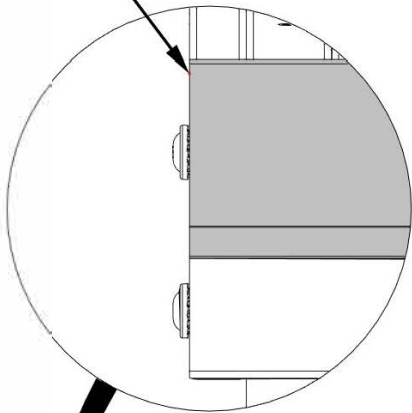

STEP 23 - GAZEBO ASSEMBLY

QTY	PART NUMBER	DESCRIPTION
32	H100471	LAG SCREW WH 5/16x1 1/2 BLK

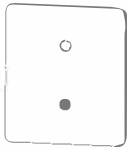

A4M00978 POST PLATE
(x8)

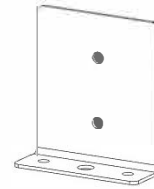

A4M00977 POST ANCHORING PLATE WITH FLANGE
(x8)

- NOTES:**
- 977 POST ANCHORING PLATES MOUNT ON OUTSIDE OF POST AS SHOWN.
 - 978 POST PLATES GO ON INSIDE OF POST AS SHOWN.

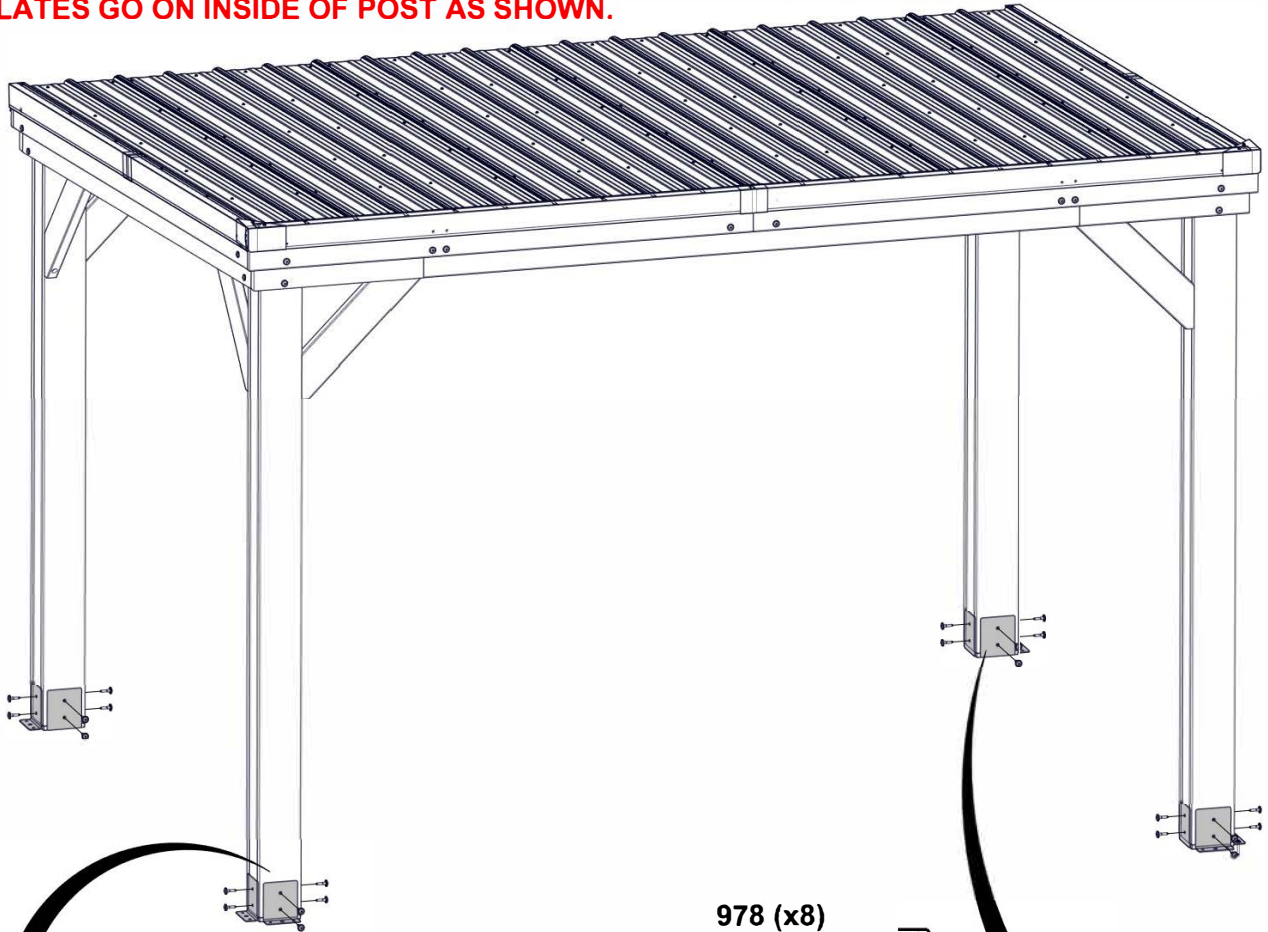

978 (x8)
POST PLATE

977 (x8)
POST ANCHORING PLATE
WITH FLANGE

471 (x32)
LAG SCREW - 1 1/2"

STEP 24 - GAZEBO ASSEMBLY

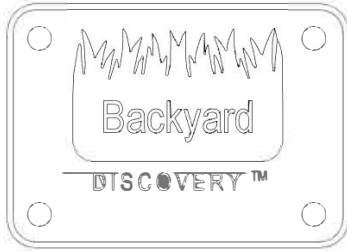

QTY	PART NUMBER	DESCRIPTION
4	H100202	SCREW PWH 8x5/8 BLK

A4M02158 BYD ID TAG PATIO
(x1)

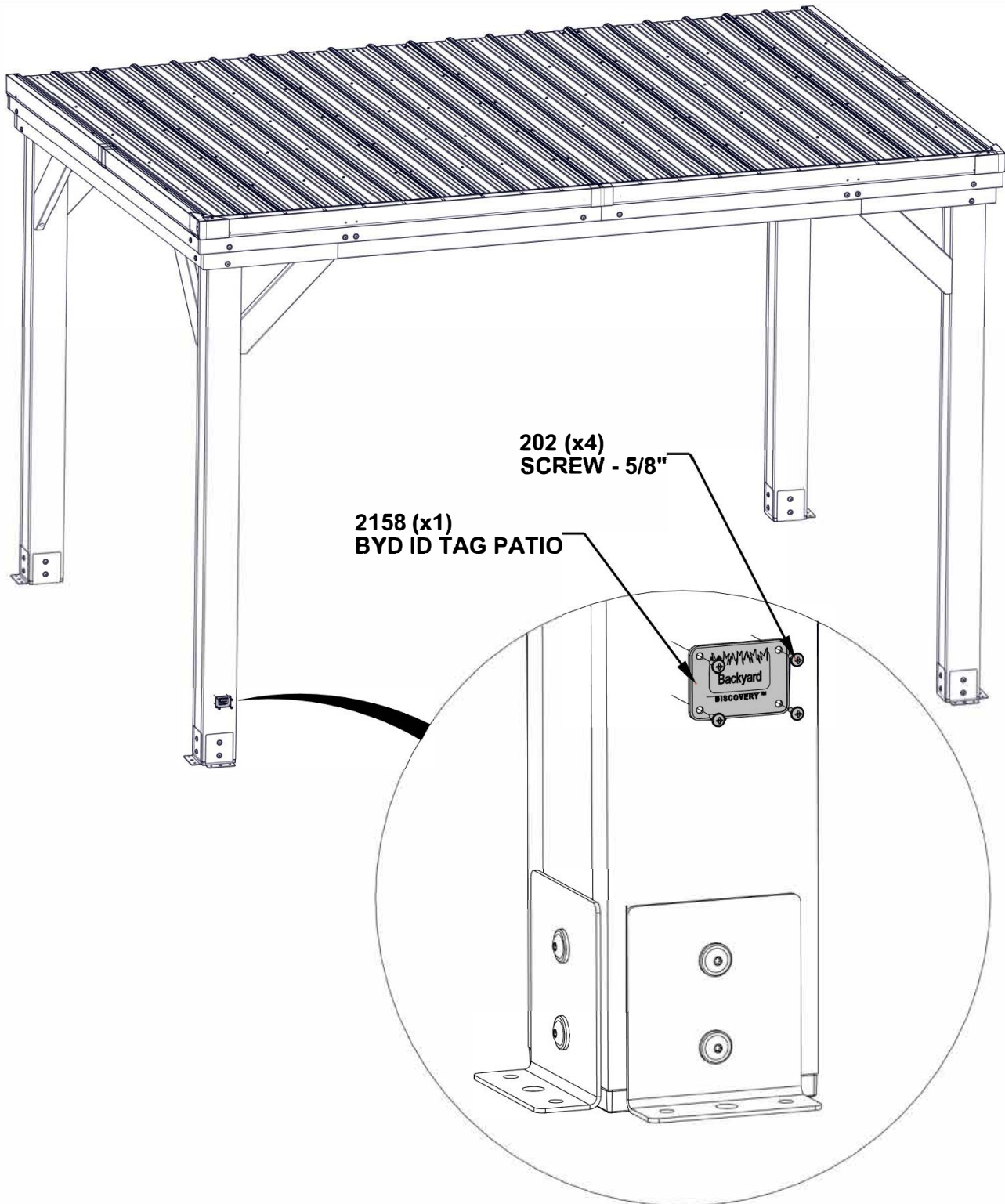

STEP 25 - GAZEBO ASSEMBLY

QTY	PART NUMBER	DESCRIPTION
16	H100120	CONCRETE SCREW
16	H100630	WASHER FLAT 8x19 BLK

MANUFACTURER RECOMMENDS INSTALLATION ON CONCRETE SURFACE OR CONCRETE POST PAD AS SHOWN BELOW.

FOR INSTALLATION ON WOOD DECK, YOU MUST ENSURE THERE IS AMPLE STRUCTURAL SUPPORT UNDER THE DECK. HARDWARE NOT INCLUDED FOR DECK ATTACHMENT.

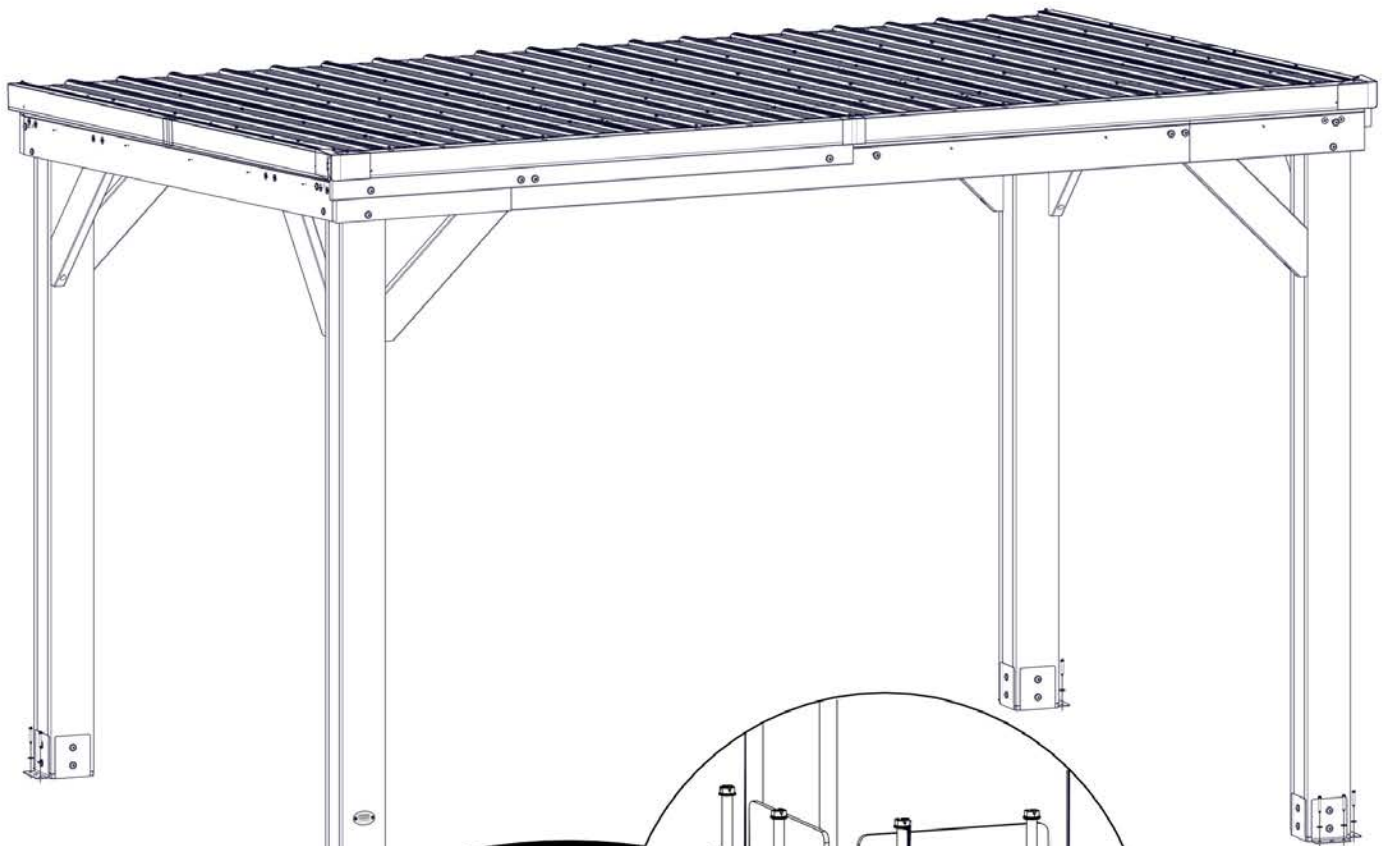

120 (x16)
CONCRETE SCREW

630 (x16)
WASHER - 8x19

**PRE-DRILL HOLES FOR CONCRETE ANCHORS
USING A 3/16" CONCRETE DRILL BIT.**

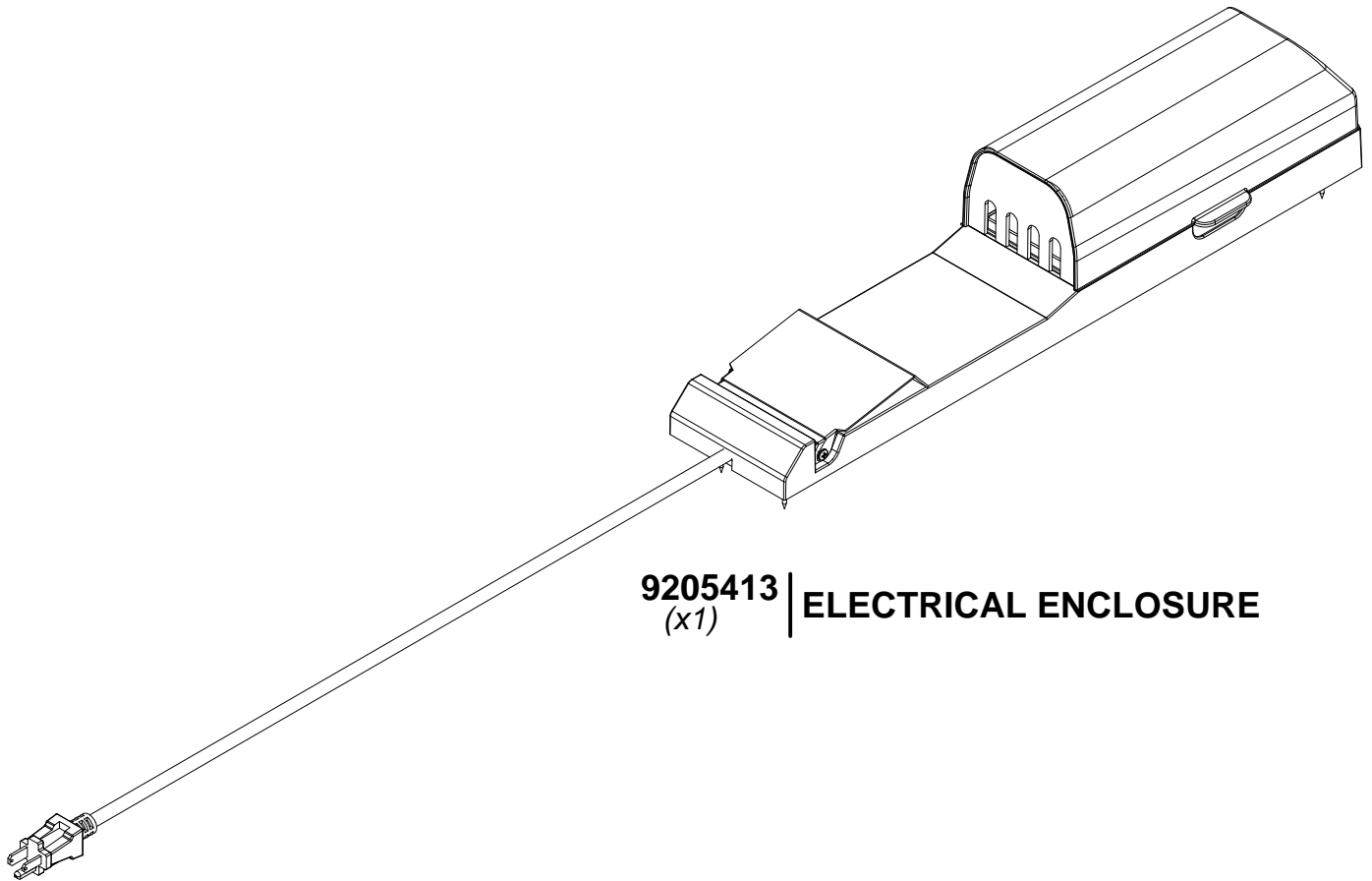

9205413 | **ELECTRICAL ENCLOSURE**
(x1)

FOR POWERPORT INSTALLATION REFER TO ASSEMBLY INSTRUCTIONS THAT COME PACKAGED WITH THE POWERPORT KIT. INSTALL ON ANY POST THAT IS DESIRED. FOLLOW DIRECTIONS FOR PROPER INSTALLATION.