



Manufactured by:  
Backyard Discovery  
3305 Airport Drive, Pittsburg,  
KS 66762 800-856-4445

BBackyard Discovery Australia Pty Ltd 2/7 Hood Street, Hampton VIC 3188, Phone: 1800-087-941

# SAXONY XL AUS

## MODEL # : 2306097B

THE ASSEMBLY MANUAL MUST BE RETAINED  
SINCE IT CONTAINS IMPORTANT INFORMATION

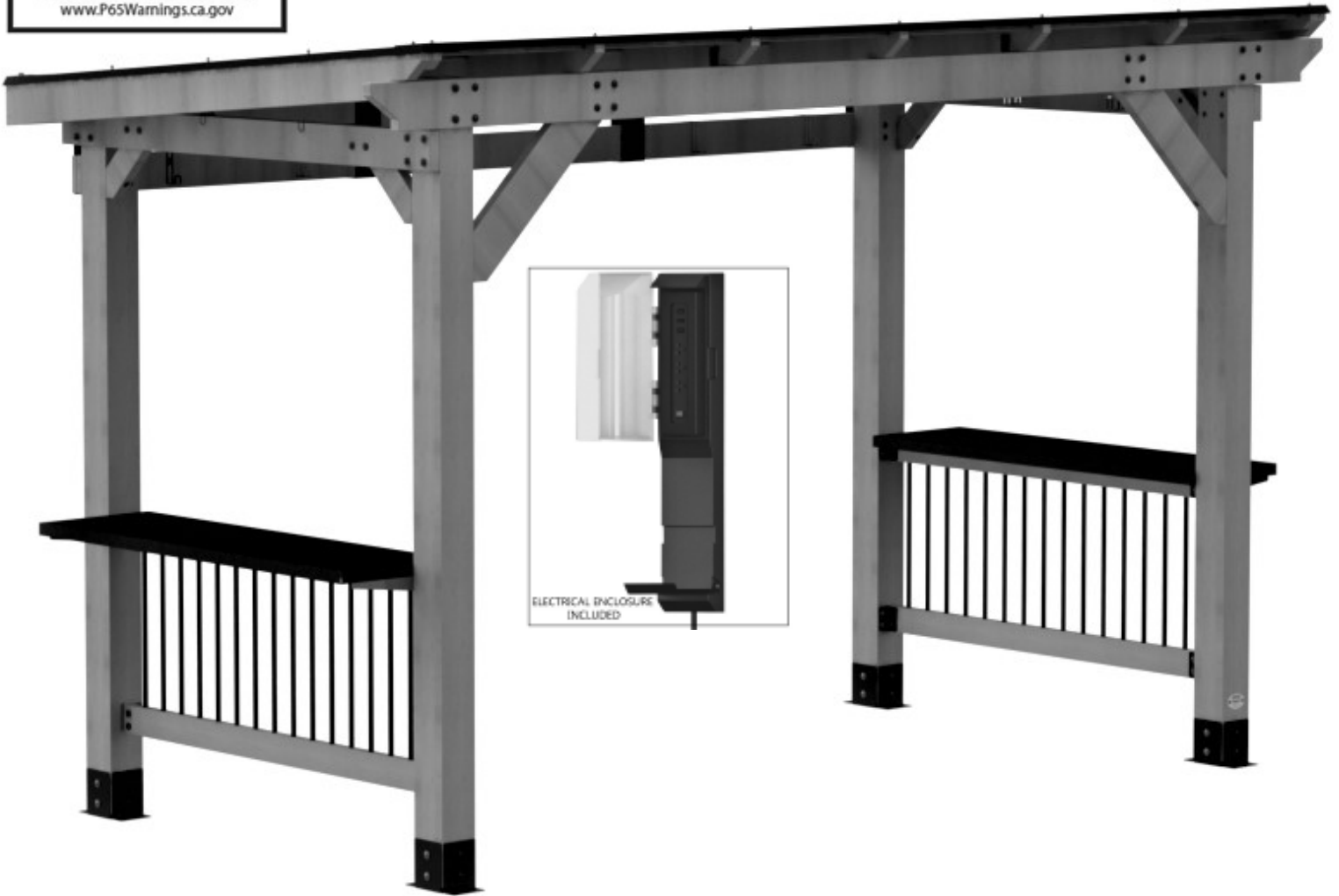

Please visit [www.backyarddiscovery.com](http://www.backyarddiscovery.com)  
For the most up to date assembly manual, to register your product, or to order  
replacement parts *Para obtener instrucciones en español, visite*  
[www.backyarddiscovery.com](http://www.backyarddiscovery.com)



EASY STEP-BY-STEP  
3D INTERACTIVE INSTRUCTIONS  
DOWNLOAD THE FREE APP



# OWNER'S MANUAL - BASIC SETUP DIMENSIONS & ASSEMBLY NOTES

It is critically important that you start with square and level footings, concrete pad or deck to attach your structure

- Pay close attention to the items needed for each step. Make sure you are using the correct hardware for each step. Using incorrect hardware may result in improper assembly
- Remember to double check for underground utilities and overhead electrical lines

**Post mounts are provided with your structure which allows you to permanently install your structure to a pre-existing or new wood or concrete surface. See Anchor Instructions for further details and recommendations.**

- The hardware to attach the post mounts to the structure is included.
- The hardware to mount the structure permanently to a concrete surface is included.
- The hardware to mount the structure permanently to a wood deck is NOT included and will need to be purchased separately. You must ensure there is ample structural support under the deck before permanently attaching.

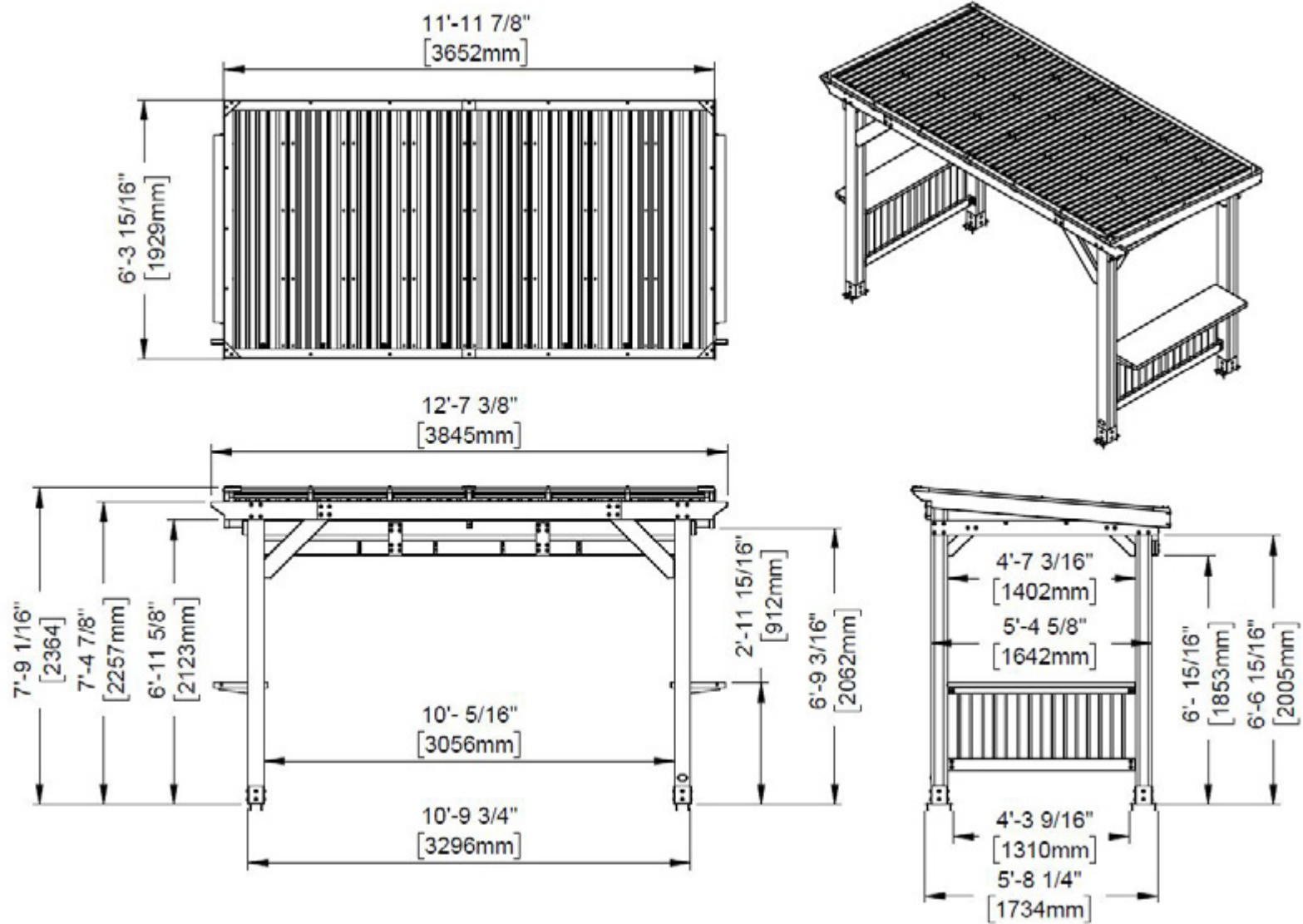

# OWNER'S MANUAL - ANCHORING LAYOUT

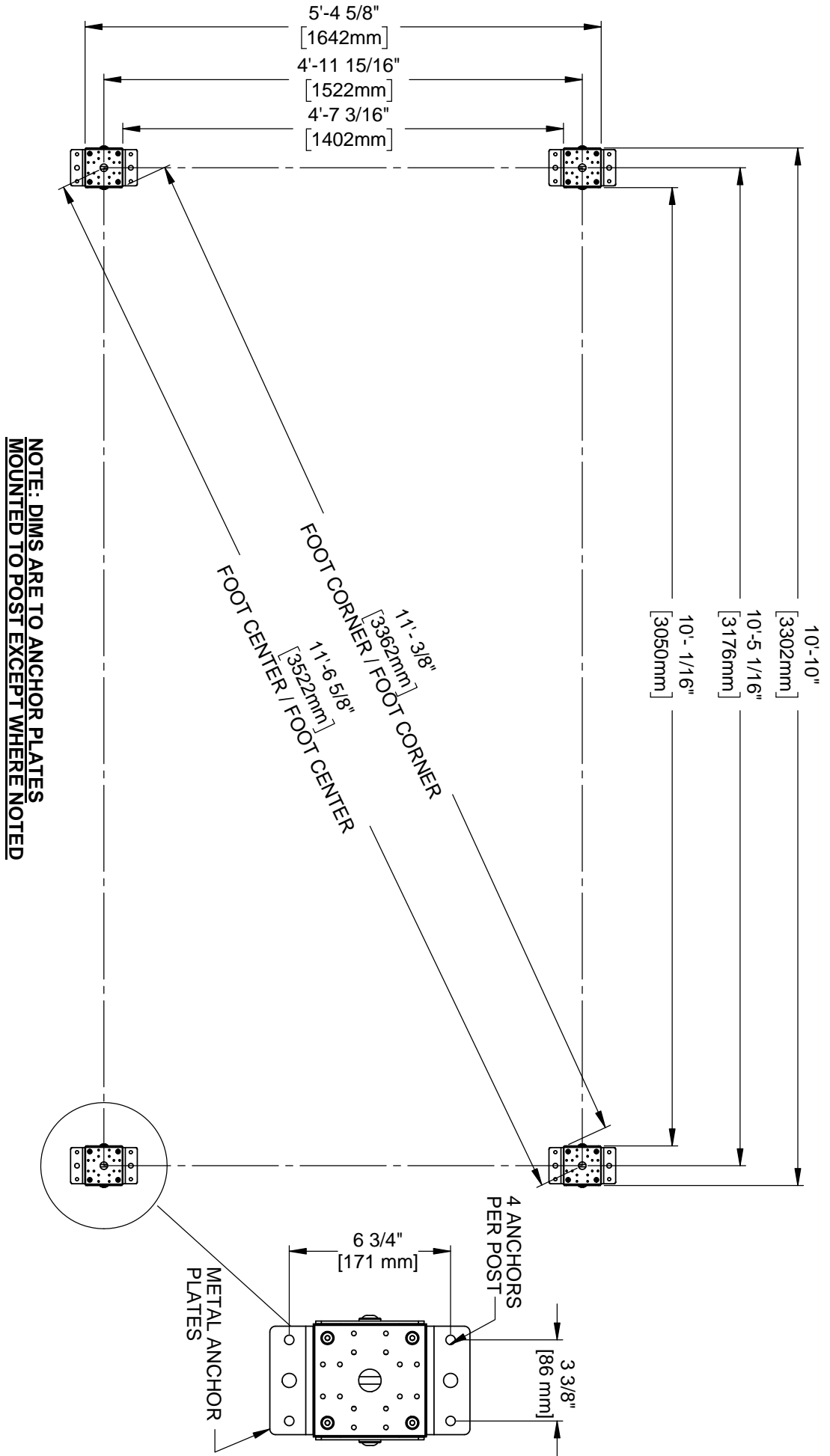

# OWNER'S MANUAL - PARTS IDENTIFICATION

## Wood Components (Not to Scale)

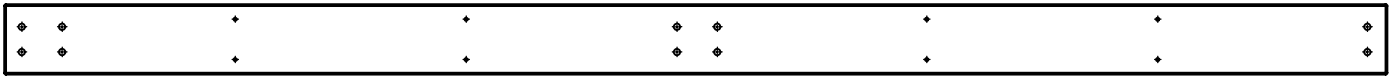

**Q1 | RAIL-W4L16185**  
(x2) | 15/16"x4 7/16"x86 7/16" (24x112x2196)



**Q2 | RAIL-W4L16186**  
(x2) | 15/16"x4 7/16"x43 5/16" (24x112x1100)

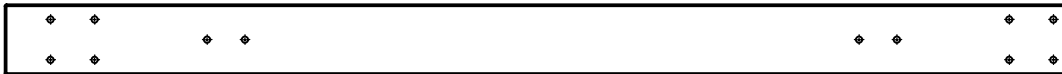

**Q3 | RAIL-W4L16187**  
(x2) | 1 7/16"x4 7/16"x66 9/16" (36x112x1690)



**D1 | JOIST END-W4L16188**  
(x1) | 1 7/16"x5 1/4"x35 13/16" (36x134x910)



**D3 | JOIST END-W4L16190**  
(x1) | 1 7/16"x5 1/4"x35 13/16" (36x134x910)

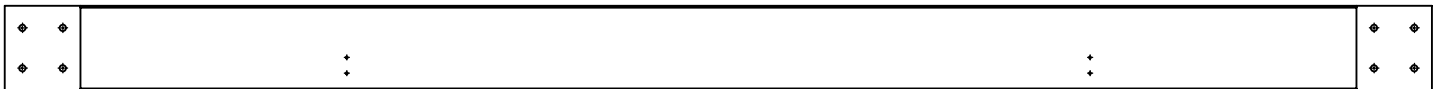

**D2 | JOIST-W4L16189**  
(x1) | 1 7/16"x5 1/4"x89 3/16" (36x134x2266)



**D4 | CORBEL-W4L16191**  
(x1) | 1 7/16"x5 1/4"x32 7/8" (36x134x835)



**E1 | CORBEL-W4L16192**  
(x4) | 1 7/16"x3 3/8"x15 3/4" (36x86x400)

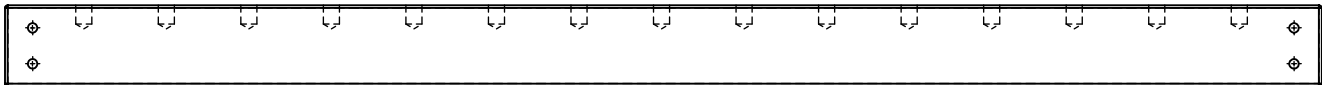

**E2 | RAIL-W4L16193**  
(x4) | 1 7/16"x3 3/8"x54 7/8" (36x86x1394)



**E3 | RAFTER-W4L16194**  
(x3) | 1 7/16"x3 3/8"x74 3/16" (36x86x1884)

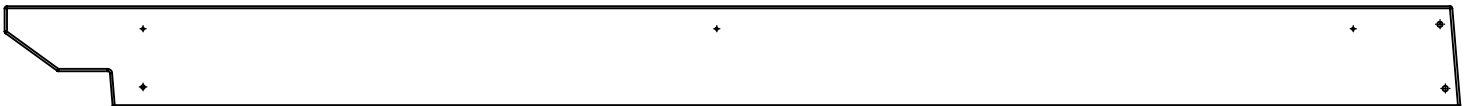

**D5 | BEAM-W4L16195**  
(x1) | 1 7/16"x5 1/4"x75 13/16" (36x134x1926)



**D6 | JOIST-W4L16196**  
(x2) | 1 7/16"x5 1/4"x72 3/4" (36x134x1848)

# OWNER'S MANUAL - PARTS IDENTIFICATION

## Wood Components (Not to Scale)



**F1 | RAFTER-W4L16197**  
(x2) | 1 7/16"x2 3/8"x74 3/16" (36x60x1884)



**H1 | PURLIN-W4L16198**  
(x8) | 15/16"x3 3/8"x71 7/8" (24x86x1826)

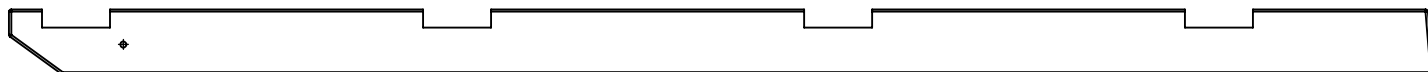

**E4 | RAFTER-W4L16199**  
(x2) | 1 7/16"x3 3/8"x74 3/16" (36x86x1884)



**Q4 | RAIL-W4L16200**  
(x1) | 15/16"x4 7/16"x86 7/16" (24x112x2196)



**Q5 | RAIL-W4L16201**  
(x1) | 15/16"x4 7/16"x43 5/16" (24x112x1100)



**D7 | BEAM-W4L16202**  
(x1) | 1 7/16"x5 1/4"x75 13/16" (36x134x1926)



**Q8 | RAIL-W4L16205**  
(x1) | 15/16"x4 7/16"x86 7/16" (24x112x2196)



**Q9 | RAIL-W4L16206**  
(x1) | 15/16"x4 7/16"x43 5/16" (24x112x1100)

# OWNER'S MANUAL - PARTS IDENTIFICATION

## Wood Components (Not to Scale)

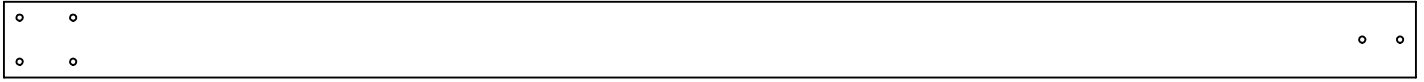

**P1 | POST-W2A03364**  
(x1) | 4 3/4"x4 3/4"x88 1/4" (120x120x2242)



**P2 | POST-W2A03365**  
(x1) | 4 3/4"x4 3/4"x82 3/4" (120x120x2102)



**P3 | POST-W2A03366**  
(x1) | 4 3/4"x4 3/4"x88 1/4" (120x120x2242)

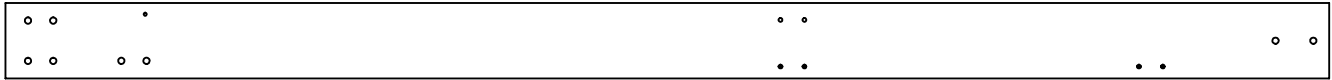

**P4 | POST-W2A03367**  
(x1) | 4 3/4"x4 3/4"x82 3/4" (120x120x2102)



**C1 | CORBEL W/ TAG-W2A03369**  
(x1) | 1 7/16"x5 1/4"x32 7/8" (36x134x835)

# OWNER'S MANUAL - PARTS IDENTIFICATION

## Hardware Components (Not to Scale)

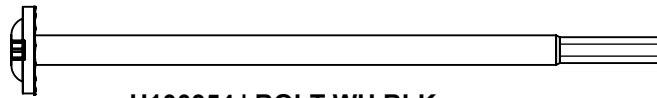

**H100354 | BOLT WH BLK**  
(x15) | 5/16 x 6 1/2



**H100653 | NUT LOCK BLK**  
(x10) | 1/4



**H100630 | WASHER FLAT BLK**  
(x27) | 8 x 19

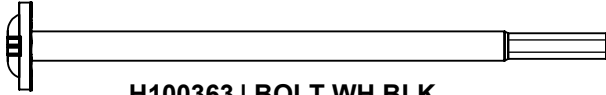

**H100363 | BOLT WH BLK**  
(x26) | 5/16 x 6



**H100379 | T-NUT BLK**  
(x60) | 5/16



**H100198 | WASHER LOCK EXT BLK**  
(x48) | 8 x 19

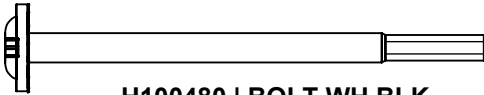

**H100480 | BOLT WH BLK**  
(x9) | 5/16 x 4 3/4



**H100469 | NUT BARREL WH BLK**  
(x42) | 5/16 x 5/8



**H100199 | WASHER LOCK EXT BLK**  
(x9) | 12 x 19

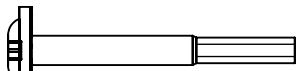

**H100195 | BOLT WH BLK**  
(x18) | 5/16 x 2 3/4



**H100405 | WASHER LOCK EXT BLK**  
(x7) | 6 x 15



**H100378 | BOLT WH BLK**  
(x18) | 5/16 x 1 3/4

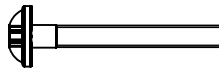

**H100488 | BOLT WH BLK**  
(x6) | 1/4 x 2

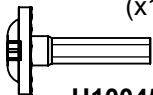

**H100459 | BOLT WH BLK**  
(x22) | 5/16 x 1 1/4



**H100486 | BOLT WH BLK**  
(x4) | 1/4 x 5/8



**H100392 | SCREW PWH BLK**  
(x13) | 8 x 3/4



**H100120 | SCREW CONCRETE ANCHOR**  
(x18) | 1/4 x 2"

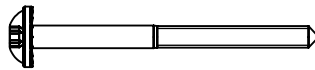

**H100792 | LAG SCREW WH BLK**  
(x7) | 1/4 x 3



**H100536 | SCREW PWH BLK**  
(x11) | 8 x 1 1/4

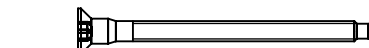

**H101008 | SCREW CONFIRMAT BLK**  
(x17) | 7 x 3

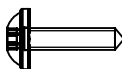

**H100460 | LAG SCREW WH BLK**  
(x4) | 1/4 x 1



**H100200 | SCREW PFH BLK**  
(x17) | 8 x 1 1/2



**H101117 | SCREW WOODGRIP**  
(x84) | 10 x 3/4

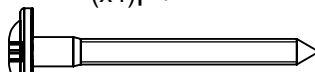

**H100206 | LAG SCREW WH BLK**  
(x2) | 5/16 x 3

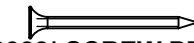

**H100382 | SCREW PFH BLK**  
(x84) | 8 x 1 3/4



**H101116 | SCREW TAPPING**  
(x26) | 1/4 x 3/4

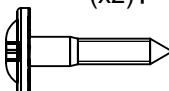

**H100471 | LAG SCREW WH BLK**  
(x42) | 5/16 x 1 1/2



**H100201 | SCREW PFH BLK**  
(x7) | 8 x 2 1/2

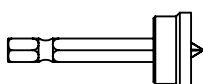

**H100764 | SCREW SETTER**  
(x1) |

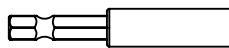

**H101100 | MAGNETIC DRIVER**  
(x1) |

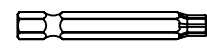

**H100147 | TORX BIT**  
(x1) | T-30

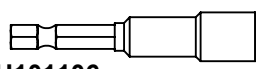

**H101106 | SOCKET DRIVER**  
(x1) |

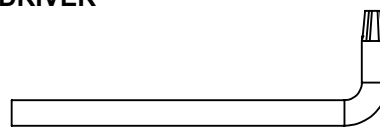

**H100114 | TORX WRENCH**  
(x1) | T-30

# OWNER'S MANUAL - PARTS IDENTIFICATION

## Accessory Components (Not to Scale)



**A4M02694**  
(x2) | ROOF EDGE TRIM



**A4M02695**  
(x4) | ROOF EDGE TRIM

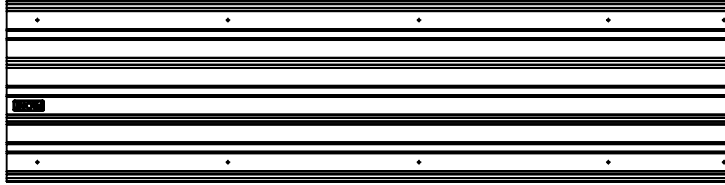

**A4M02666**  
(x8) | 29GA STEEL SHEETING

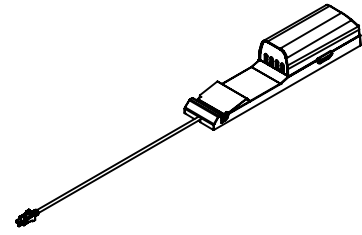

**9220409** | AUSTRALIA ELECTRICAL ENCLOSURE  
(x1)

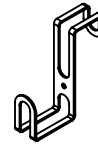

**A4M01591** | HOOK  
(x10)

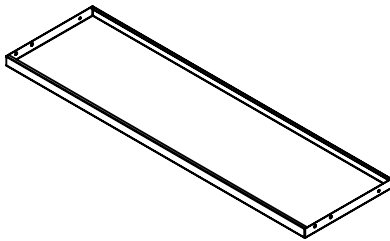

**A4M01488** | TABLE  
(x2)



**A4M02697** | ROOF EDGE TRIM SPLICE  
(x2)

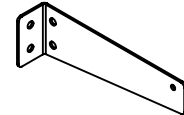

**A4M01487** | L BRACKET  
(x2)



**A4M02696** | CORNER SPLICE TRIM  
(x4)

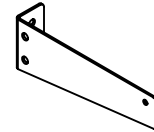

**A4M01486** | L BRACKET  
(x2)

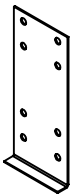

**A4M01490** | SPLICE BRACKET  
(x6)

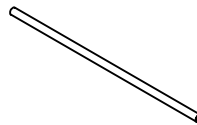

**A4M01225** | METAL TUBE  
(x30)



**A4M01478** | POST ANCHORING PLATE  
(x8)



**A4M01228** | RAFTER CLIP  
(x5)



**A4M01047** | L BRACKET 2.5x38x55  
(x2)

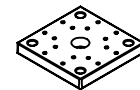

**A6P00500** | PLASTIC POST FOOT  
(x4)



**A4M00855** | L BRACKET  
(x8) | 51x32x82x3.175



**A4M01477** | POST PLATE  
(x8)



**A100241** | BYD ID TAG (SMALL) WITHOUT AGES  
(x1)



# PRE-ASSEMBLY STEP 1 - TOOLS REQUIRED



Cordless Drill  
or Electric Drill



Drill  
Attachments:  
Phillips Head



Open End  
Wrenches  
1/2" & 7/16"



1/8", 3/16", 3/8" &  
7/16" Drill Bits



3/8" Drive Ratchet, 1/2" &  
7/16" STD Sockets, 1/2" &  
7/16" Deep Sockets



Tape Measure



Claw Hammer



Phillips Screw Driver

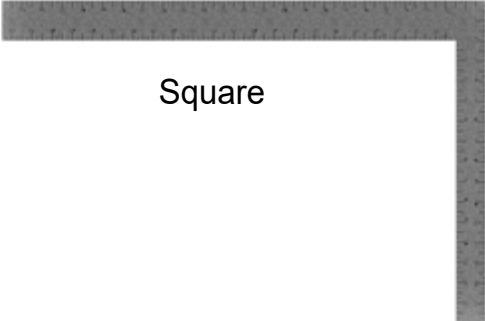

Square



Level 24"



Rubber Mallet  
- Optional

## PRE-ASSEMBLY STEP 2 - SORTING PARTS

It is critical for ease of assembly that you take the time to sort and organize the wood and hardware.

---

### WOOD PARTS:

- Organize wood parts by the three-digit, alpha-numeric number stamped on each board (ex. P01).
- If there are multiple boards with the same stamped number, stack those pieces together.
- Stamps can be found on the flat surface of the boards or on the end of the boards.
- Allow yourself plenty of room - the wood pieces can take up a significant amount of space.

**NOTE: CARTONS ARE NOT ORGANIZED BY BOARD NUMBER.**



### HARDWARE PARTS:

- We recommend that you have a separate table to organize the hardware.
- Hardware bags are printed with a seven-digit, alpha-numeric part number.
- You can organize your hardware by part number or group by hardware type (i.e. bolts, nuts, etc.).
- During assembly you only need to reference the last four digits of the number.

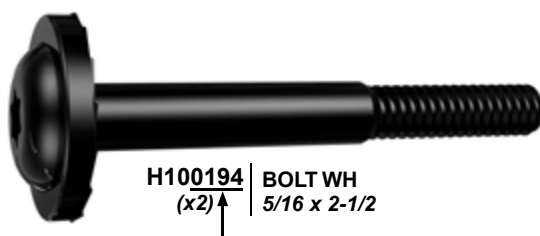

# PRE-ASSEMBLY STEP 3 - CHOOSE YOUR ASSEMBLY METHOD

There are several types of assembly instructions available to you.

1. Printed Assembly Manual included with your set
2. BILT APP - 3D interactive instructions
3. Combination of the Printed Manual and BILT APP (Note: Step numbers can differ between the two methods)

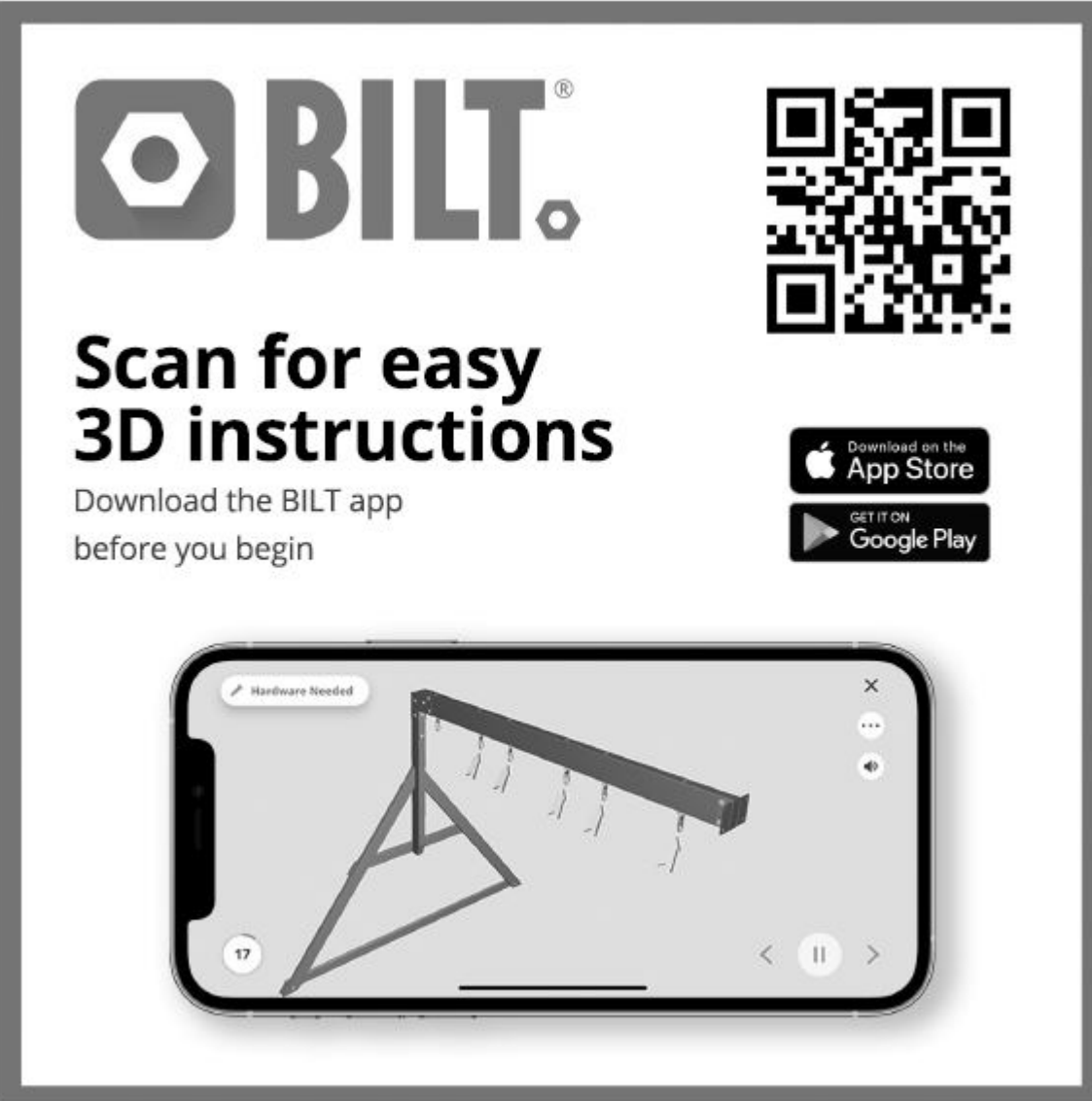

The graphic is a rectangular advertisement for the BILT app. At the top left is the BILT logo, which consists of a stylized hexagonal bolt head icon followed by the word "BILT." in a bold, sans-serif font. To the right of the logo is a large QR code. Below the logo and QR code, the text "Scan for easy 3D instructions" is written in a large, bold, black font. Underneath this, in a smaller font, it says "Download the BILT app before you begin". To the right of this text are two buttons: "Download on the App Store" with the Apple logo and "GET IT ON Google Play" with the Google Play logo. At the bottom of the graphic is a smartphone displaying the BILT app interface. The screen shows a 3D model of a metal truss structure with a horizontal beam and several hanging components. The app interface includes a "Hardware Needed" button at the top left, a close button (X) at the top right, a menu button (three dots) below the close button, a back button (left arrow) at the bottom left, a play/pause button (two vertical bars) at the bottom center, and a forward button (right arrow) at the bottom right. A small circle with the number "17" is visible in the bottom left corner of the phone screen.

# STEP 1 - GAZEBO ASSEMBLY

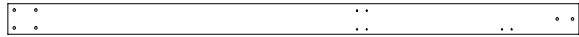

**P1 | POST-W2A03364**  
 (x1) | 4 3/4"x4 3/4"x88 1/4" (120x120x2242)



**P2 | POST-W2A03365**  
 (x1) | 4 3/4"x4 3/4"x82 3/4" (120x120x2102)

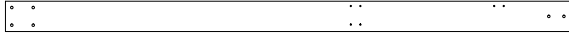

**P3 | POST-W2A03366**  
 (x1) | 4 3/4"x4 3/4"x88 1/4" (120x120x2242)



**P4 | POST-W2A03367**  
 (x1) | 4 3/4"x4 3/4"x82 3/4" (120x120x2102)

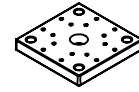

**A6P00500**  
 (x4) | PLASTIC POST FOOT

QTY.	PART NUMBER	DESCRIPTION
16	H100200	SCREW PFH 8 X 1 1/2 BLK

**NOTE: PILOT HOLE ORIENTATION ON EACH POST.**

**REPEAT FOR THE (2) OTHER POST LABELED P1 & P2.**

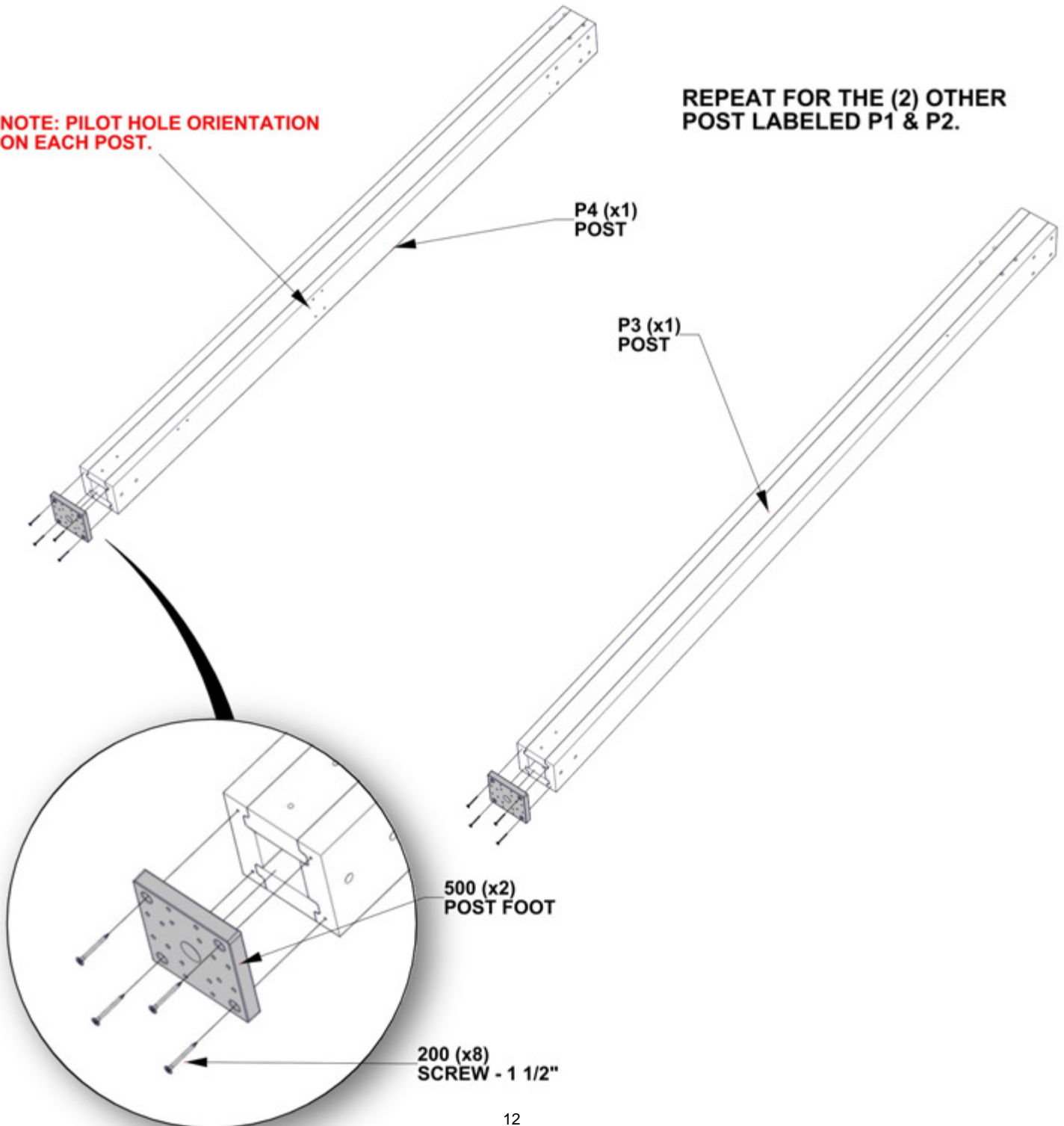

# STEP 2 - GAZEBO ASSEMBLY



**Q3 | RAIL-W4L16187**  
 (x1) | 1 7/16"x4 7/16"x66 9/16" (36x112x1690)

QTY.	PART NUMBER	DESCRIPTION
8	H100379	T-NUT 5/16 BLK
8	H100363	BOLT 5/16 X 6 BLK
8	H100198	WASHER LOCK EXT 8X19 BLK

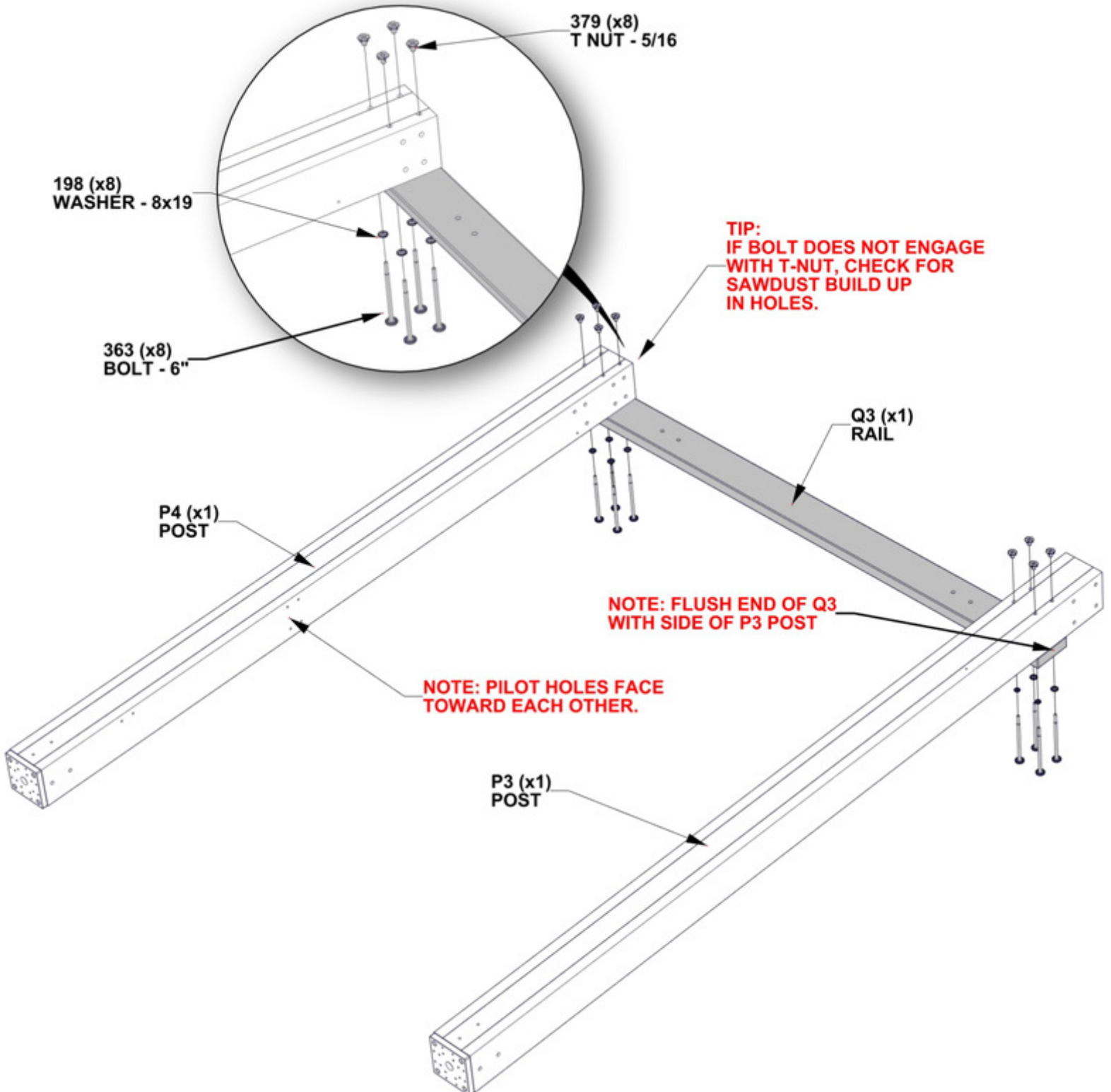

# STEP 3 - GAZEBO ASSEMBLY

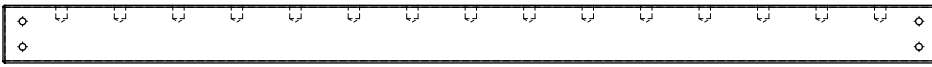

**E2 | RAIL-W4L16193**  
(x1) | 1 7/16"x3 3/8"x55" (36x86x1394)



**A4M00855 | L BRACKET**  
(x2) | 51x32x82x3.175

QTY.	PART NUMBER	DESCRIPTION
4	H100471	LAG SCREW WH 5/16 X 1 1/2 BLK
4	H100459	BOLT WH 5/16 X 1 1/4 BLK
4	H100199	WASHER LOCK EXT 12X19 BLK
4	H100469	NUT BARREL WH 5/16 X 5/8 BLK

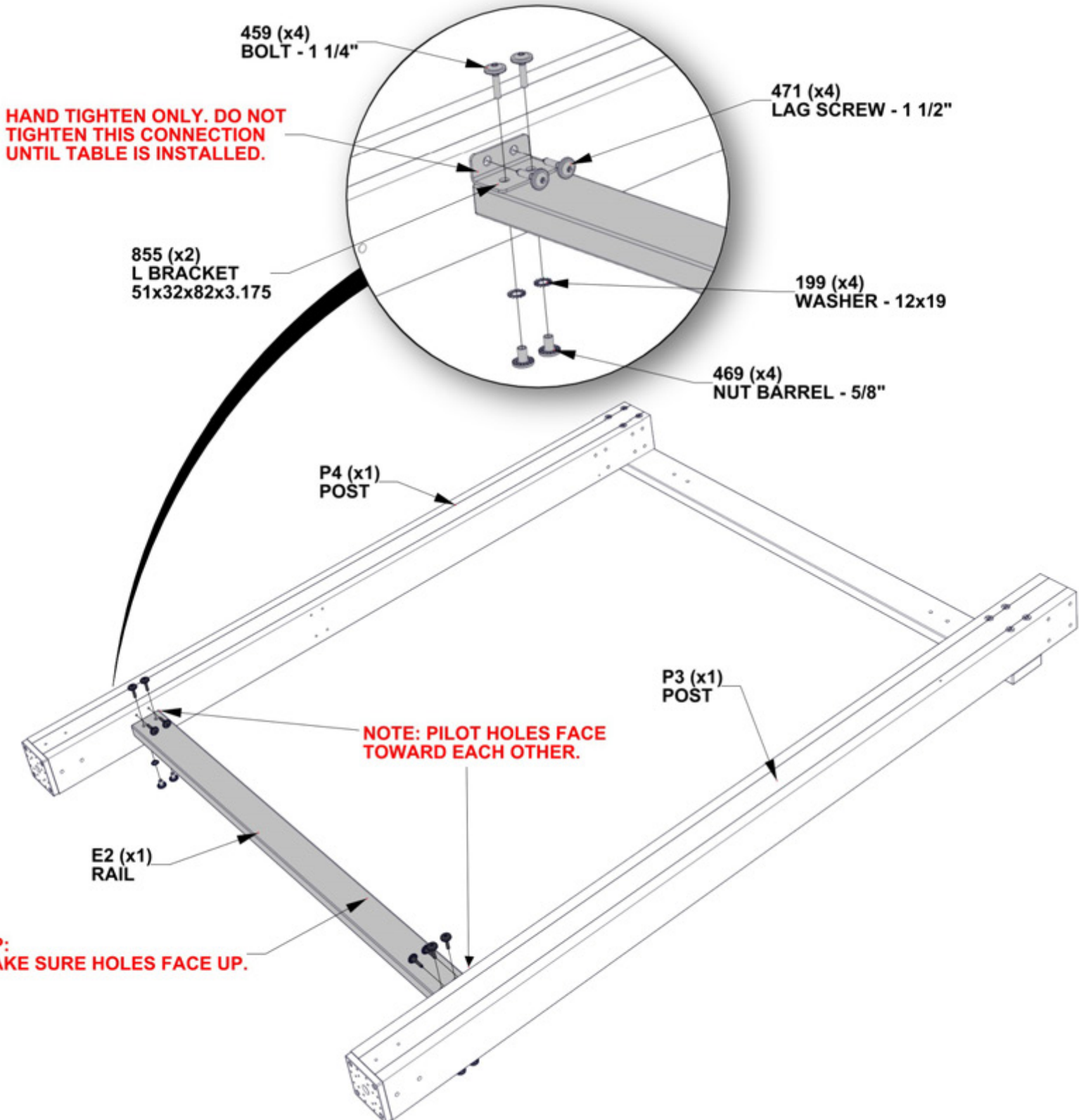

# STEP 4 - GAZEBO ASSEMBLY



**Q3 | RAIL-W4L16187**  
 (x1) | 1 7/16"x4 7/16"x66 9/16" (36x112x1690)

QTY.	PART NUMBER	DESCRIPTION
8	H100379	T-NUT 5/16 BLK
8	H100198	WASHER LOCK EXT 8X19 BLK
8	H100363	BOLT 5/16 X 6 BLK

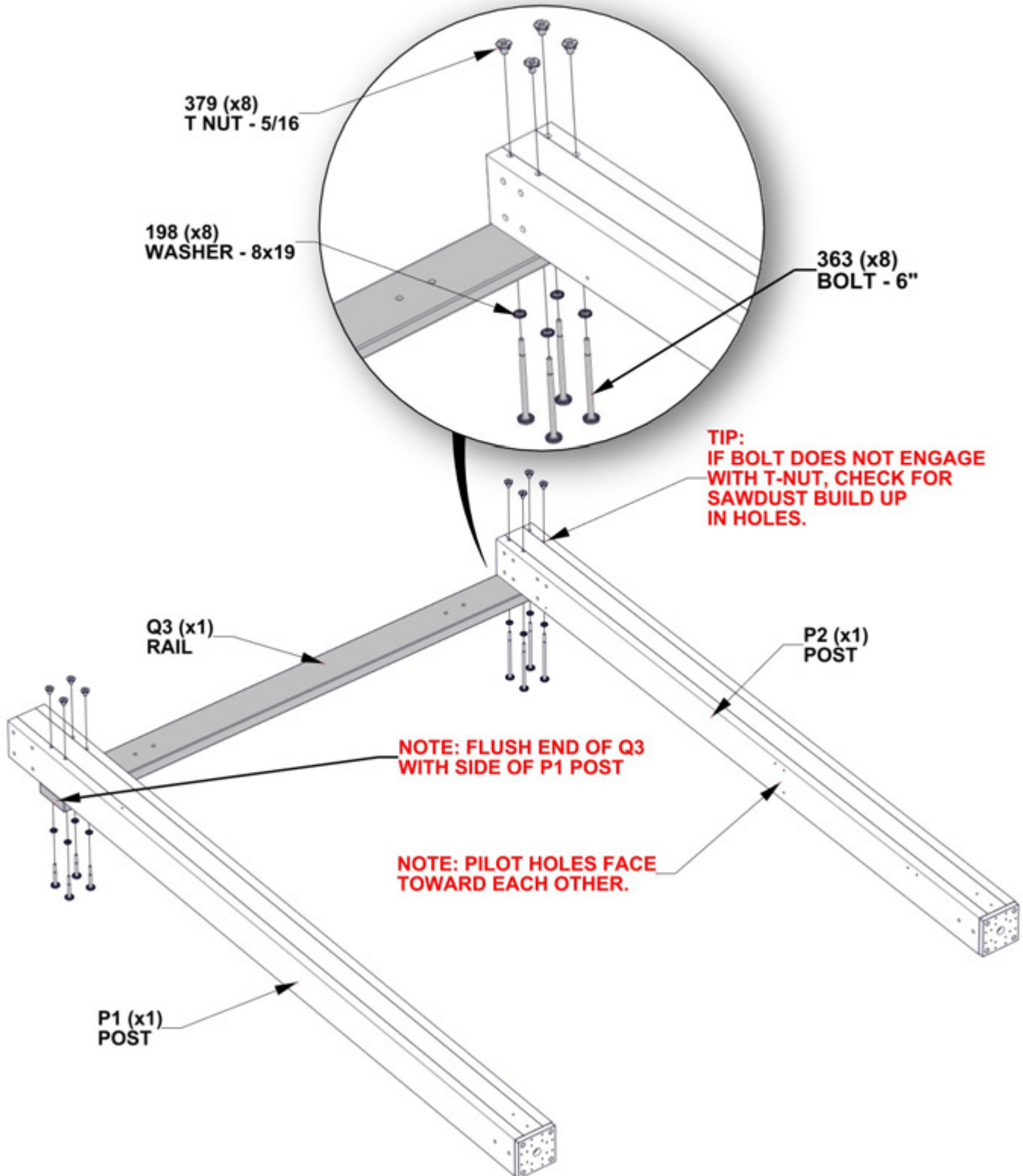

# STEP 5 - GAZEBO ASSEMBLY

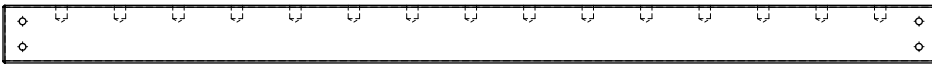

**E2 | RAIL-W4L16193**  
(x1) | 1 7/16"x3 3/8"x55" (36x86x1394)



**A4M00855 | L BRACKET**  
(x2) | 51x32x82x3.175

QTY.	PART NUMBER	DESCRIPTION
4	H100199	WASHER LOCK EXT 12X19 BLK
4	H100471	LAG SCREW WH 5/16 X 1 1/2 BLK
4	H100469	NUT BARREL WH 5/16 X 5/8 BLK
4	H100459	BOLT WH 5/16 X 1 1/4 BLK

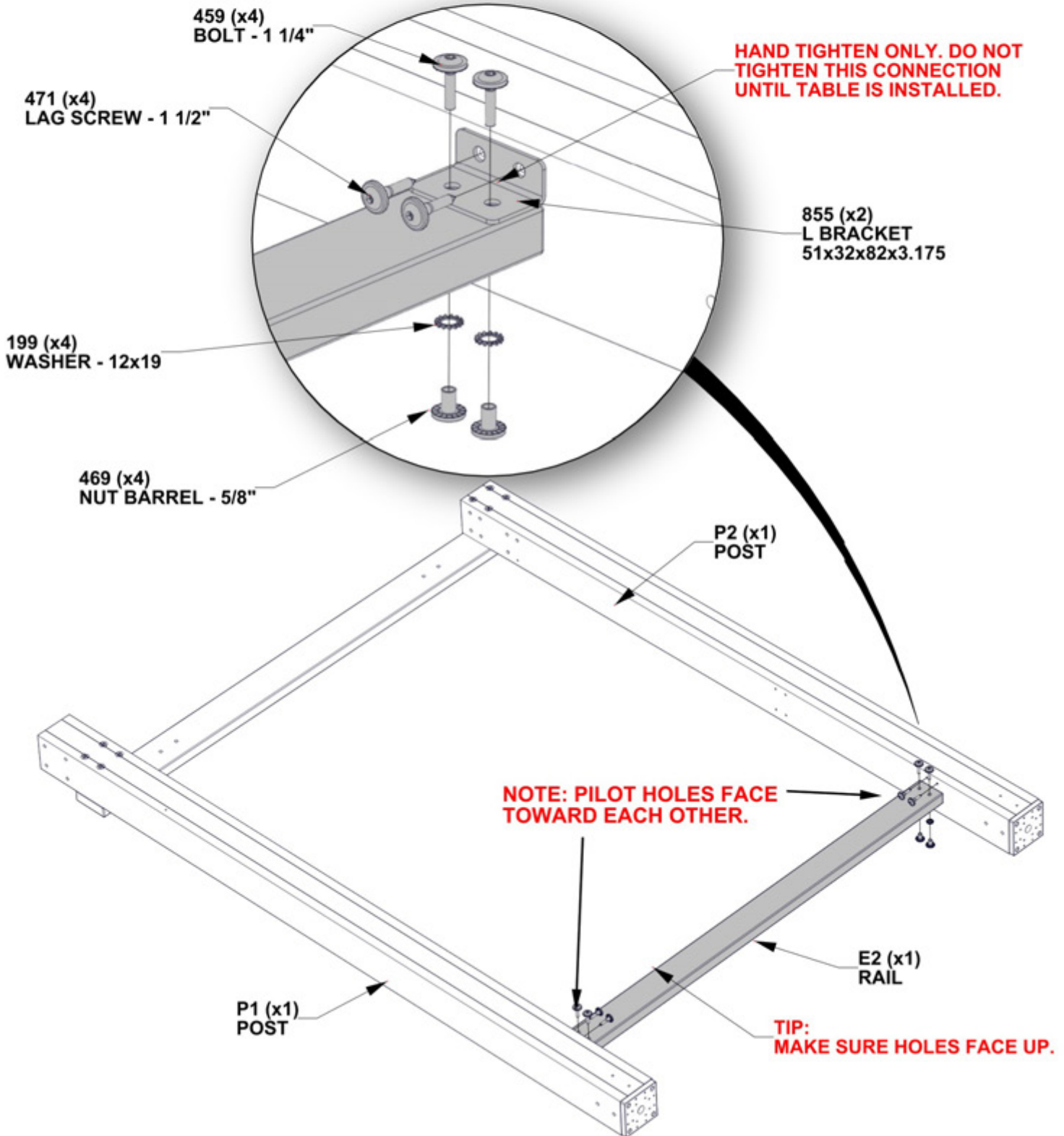



# STEP 6 - GAZEBO ASSEMBLY

QTY.	PART NUMBER	DESCRIPTION
8	H100379	T-NUT 5/16 BLK
8	H100195	BOLT WH 5/16 X 2 3/4 BLK
8	H100198	WASHER LOCK EXT 8X19 BLK



**D1 | JOIST END-W4L16188**  
(x1) | 1 7/16"x5 1/4"x36 13/16" (36x134x910)

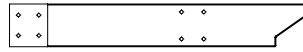

**D3 | JOIST END-W4L16190**  
(x1) | 1 7/16"x5 1/4"x36 13/16" (36x134x910)

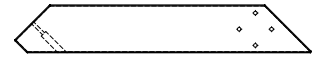

**D4 | CORBEL-W4L16191**  
(x1) | 1 7/16"x5 1/4"x32 7/8" (36x134x835)

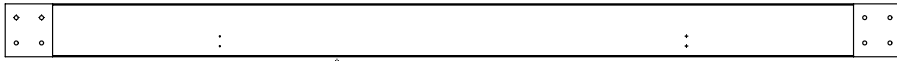

**D2 | JOIST-W4L16189**  
(x1) | 1 7/16"x5 1/4"x89 3/16" (36x134x2266)

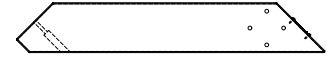

**C1 | CORBEL W/ TAG-W2A03369**  
(x1) | 1 7/16"x5 1/4"x32 7/8" (36x134x835)

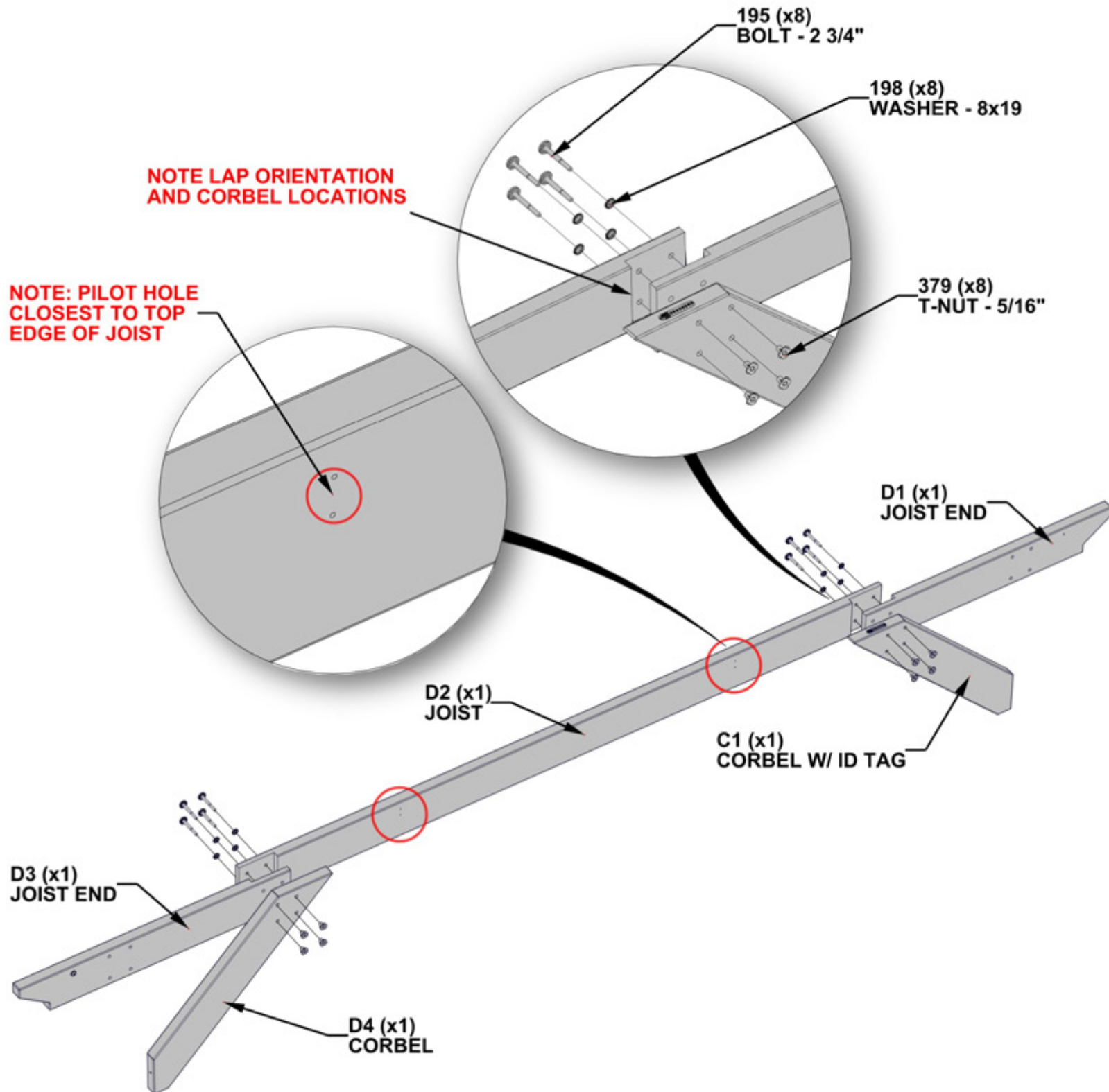

# STEP 7 - GAZEBO ASSEMBLY



QTY.	PART NUMBER	DESCRIPTION
2	H100792	LAG SCREW WH 1/4 X 3 BLK
2	H100405	WASHER LOCK EXT 6X15 BLK
8	H100379	T-NUT 5/16 BLK
8	H100363	BOLT 5/16 X 6 BLK
8	H100198	WASHER LOCK EXT 8X19 BLK

**NOTE: ALIGN JOIST ASSEMBLY FROM PREVIOUS STEP, WITH HOLES IN POST. TALLER POST INDICATE FRONT OF ASSEMBLY.**

**TIP: IF BOLT DOES NOT ENGAGE WITH T-NUT, CHECK FOR SAWDUST BUILD UP IN HOLES.**

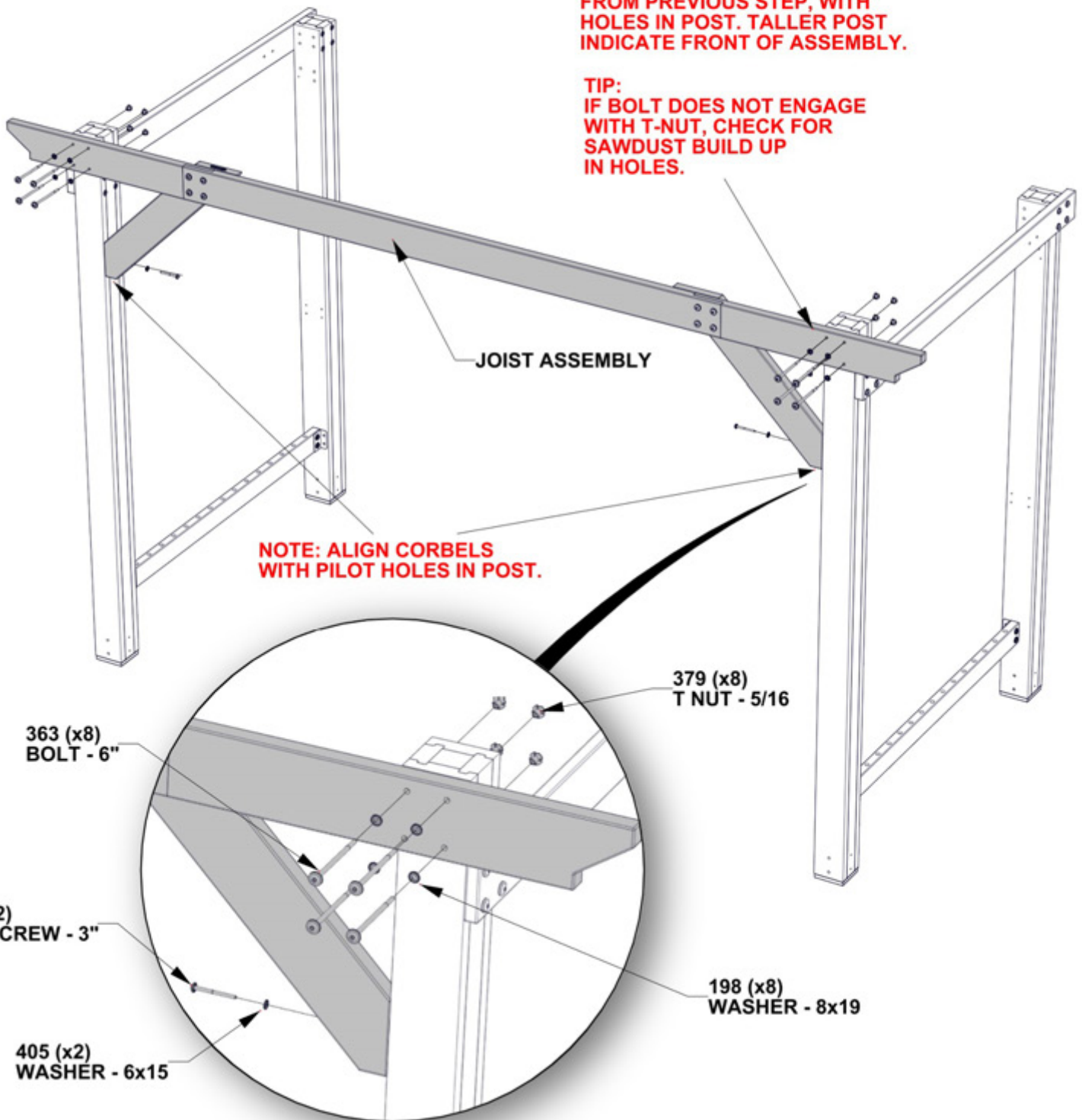

# STEP 8 - GAZEBO ASSEMBLY

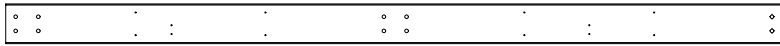

**Q8 | RAIL-W4L16205**  
 (x1) | 15/16"x4 7/16"x86 7/16" (24x112x2196)



**Q1 | RAIL-W4L16185**  
 (x1) | 15/16"x4 7/16"x86 7/16" (24x112x2196)

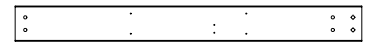

**Q9 | RAIL-W4L16206**  
 (x1) | 15/16"x4 7/16"x43 5/16" (24x112x1100)

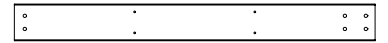

**Q2 | RAIL-W4L16186**  
 (x1) | 15/16"x4 7/16"x43 5/16" (24x112x1100)

QTY.	PART NUMBER	DESCRIPTION
12	H100382	SCREW PFH 8 X 1 3/4 BLK

**ALIGN Q1 & Q2 WITH PILOT HOLES IN Q9 & Q8.  
 ALL EDGES SHOULD BE FLUSH.**

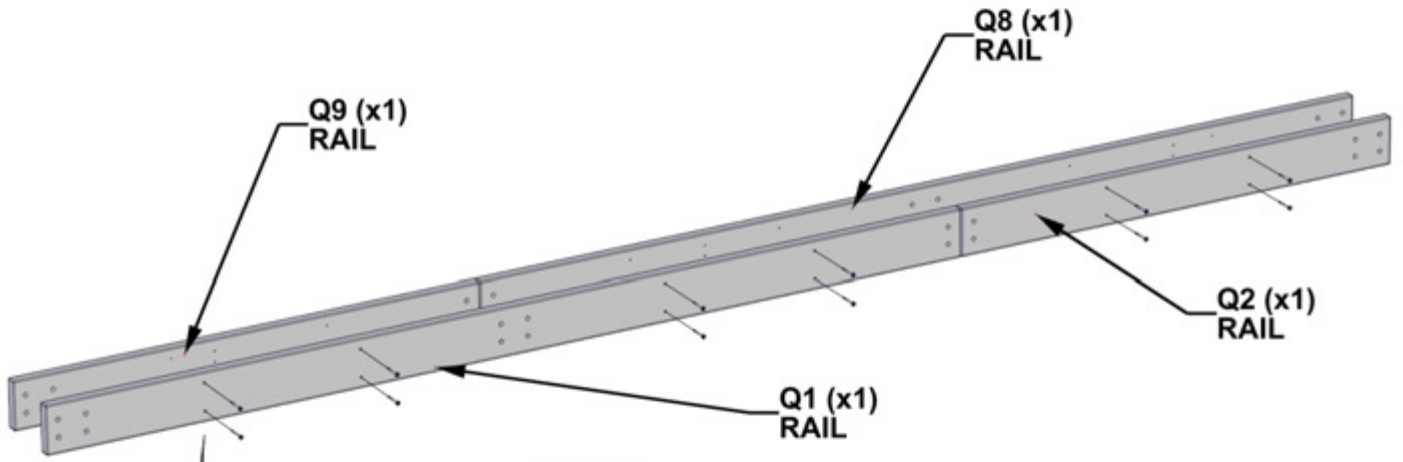

**NOTE:  
 TWO PILOT HOLES ON Q9 & Q8  
 CLOSEST TO TOP OF BOARDS**

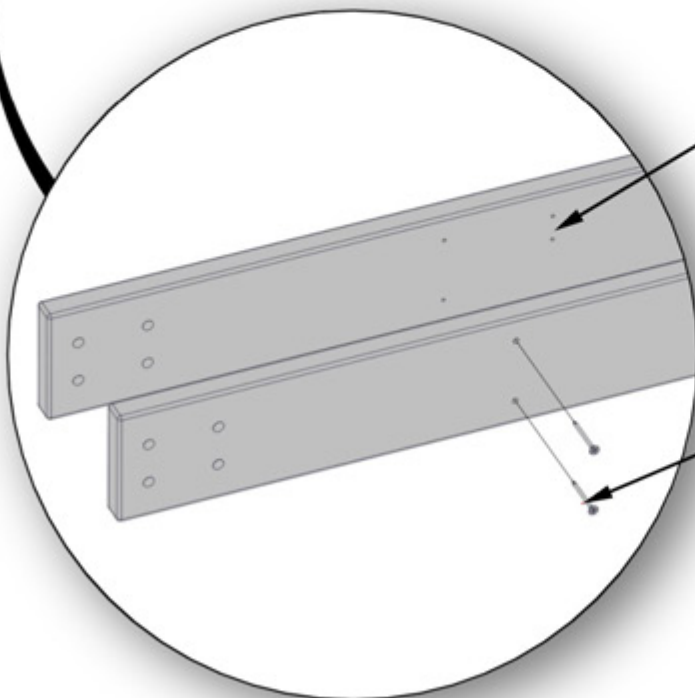

**382 (x12)  
 SCREW - 1 3/4"**

# STEP 9 - GAZEBO ASSEMBLY

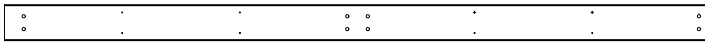

**Q4 | RAIL-W4L16200**  
 (x1) | 15/16"x4 7/16"x86 7/16" (24x112x2196)

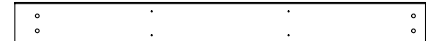

**Q5 | RAIL-W4L16201**  
 (x1) | 15/16"x4 7/16"x43 5/16" (24x112x1100)



**Q1 | RAIL-W4L16185**  
 (x1) | 15/16"x4 7/16"x86 7/16" (24x112x2196)

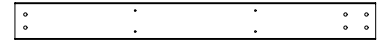

**Q2 | RAIL-W4L16186**  
 (x1) | 15/16"x4 7/16"x43 5/16" (24x112x1100)

QTY.	PART NUMBER	DESCRIPTION
12	H100382	SCREW PFH 8 X 1 3/4 BLK

**ALIGN Q1 & Q2 WITH PILOT HOLES IN Q4 & Q5.  
 ALL EDGES SHOULD BE FLUSH.**

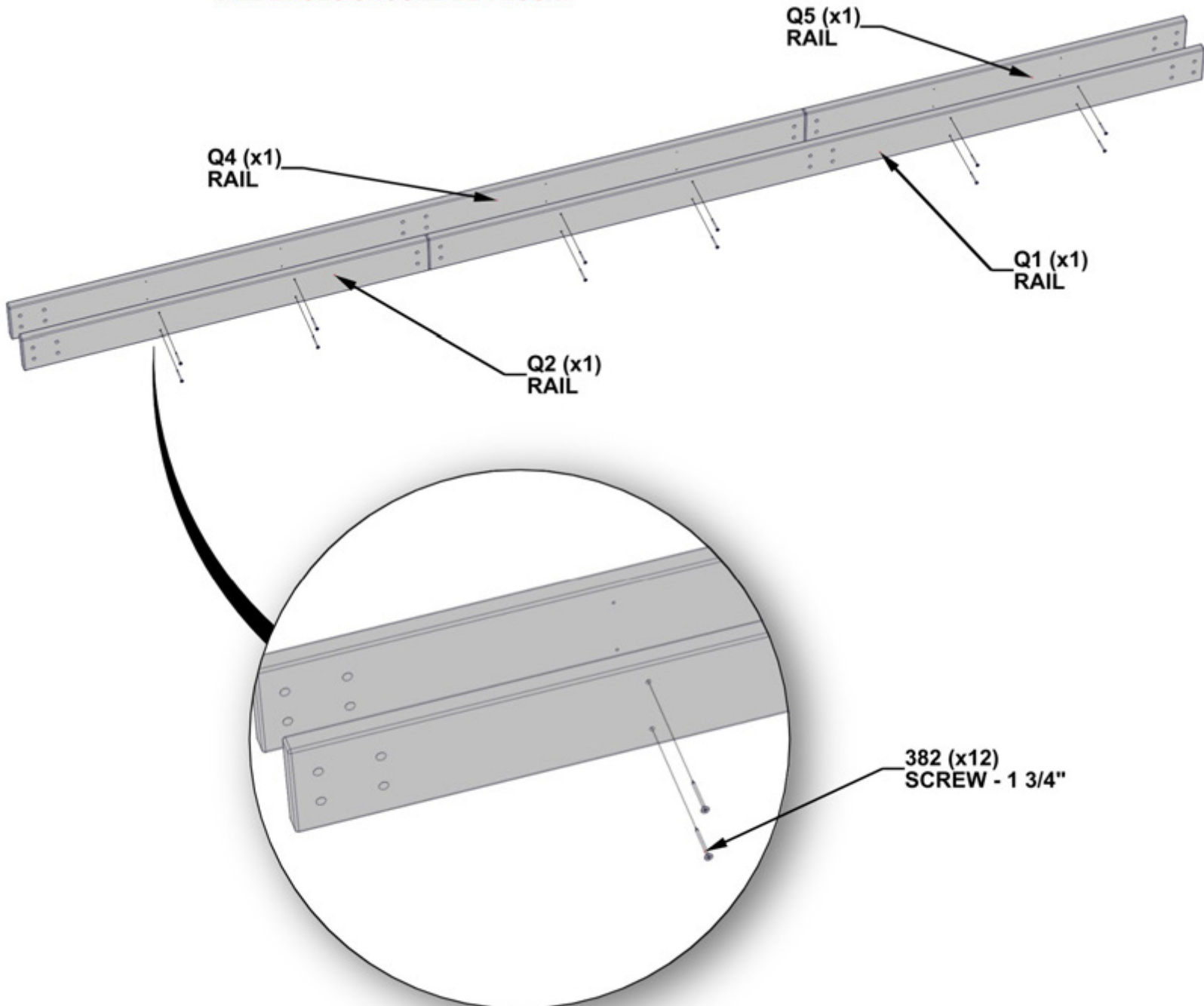

# STEP 10 - GAZEBO ASSEMBLY



RAIL ASSEMBLY - STEP 9

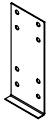

A4M01490  
(x4) | SPLICE BRACKET

QTY.	PART NUMBER	DESCRIPTION
8	H100469	NUT BARREL WH 5/16 X 5/8 BLK
8	H100378	BOLT WH 5/16 X 1 3/4 BLK

**NOTE: ATTACH RAIL ASSEMBLY FROM STEP 9 TO SPLICE BRACKETS. HAND TIGHTEN BOLTS ONLY.**

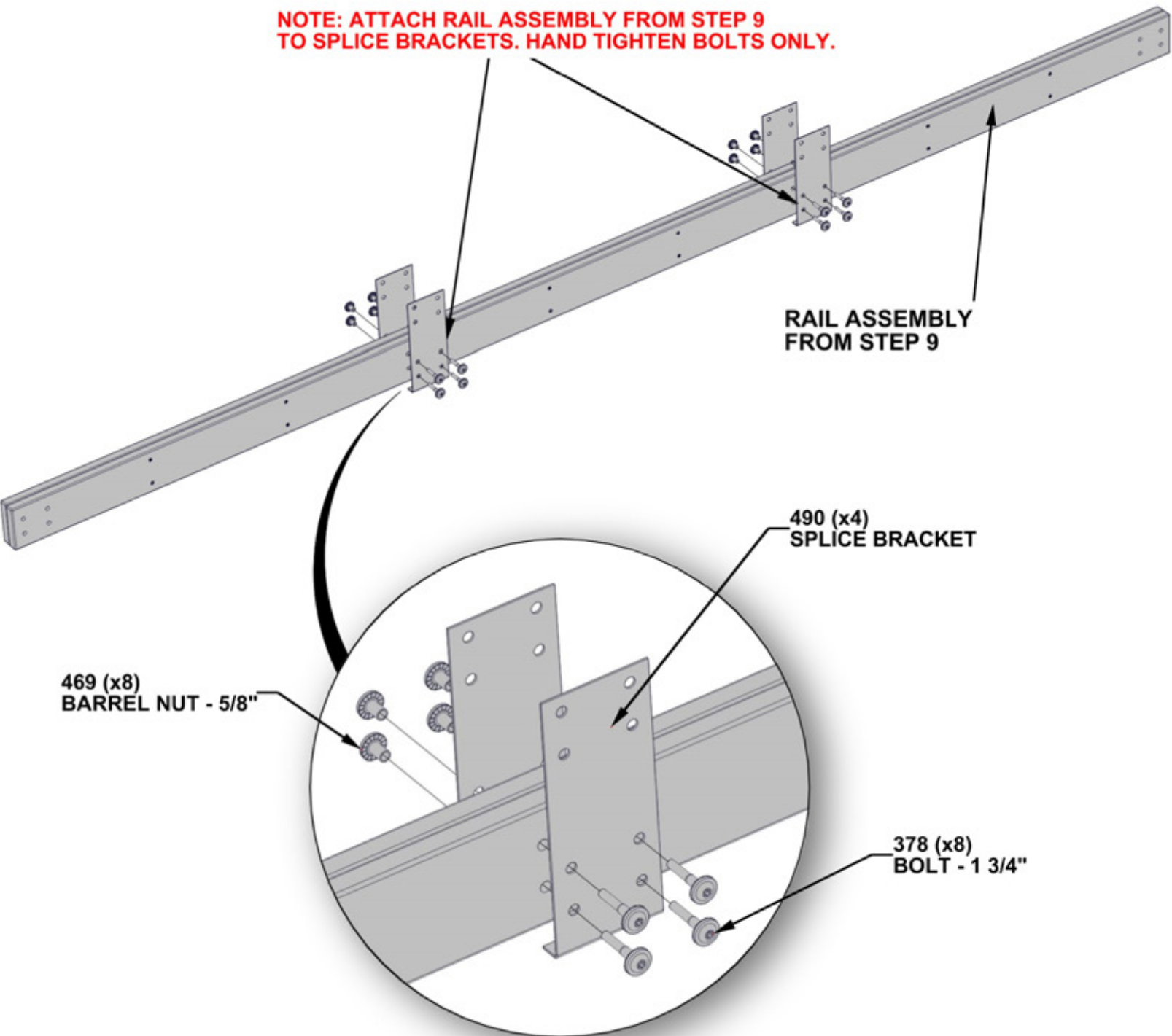

# STEP 11 - GAZEBO ASSEMBLY



RAIL ASSEMBLY - STEP 8

QTY.	PART NUMBER	DESCRIPTION
8	H100469	NUT BARREL WH 5/16 X 5/8 BLK
8	H100378	BOLT WH 5/16 X 1 3/4 BLK

**NOTE: ROTATE ASSEMBLY TO WHERE ALL SCREWS ARE ON BACKSIDE OF BOARDS**

**NOTE: ATTACH RAIL ASSEMBLY FROM STEP 8 TO SPLICE BRACKETS. HAND TIGHTEN BOLTS ONLY.**

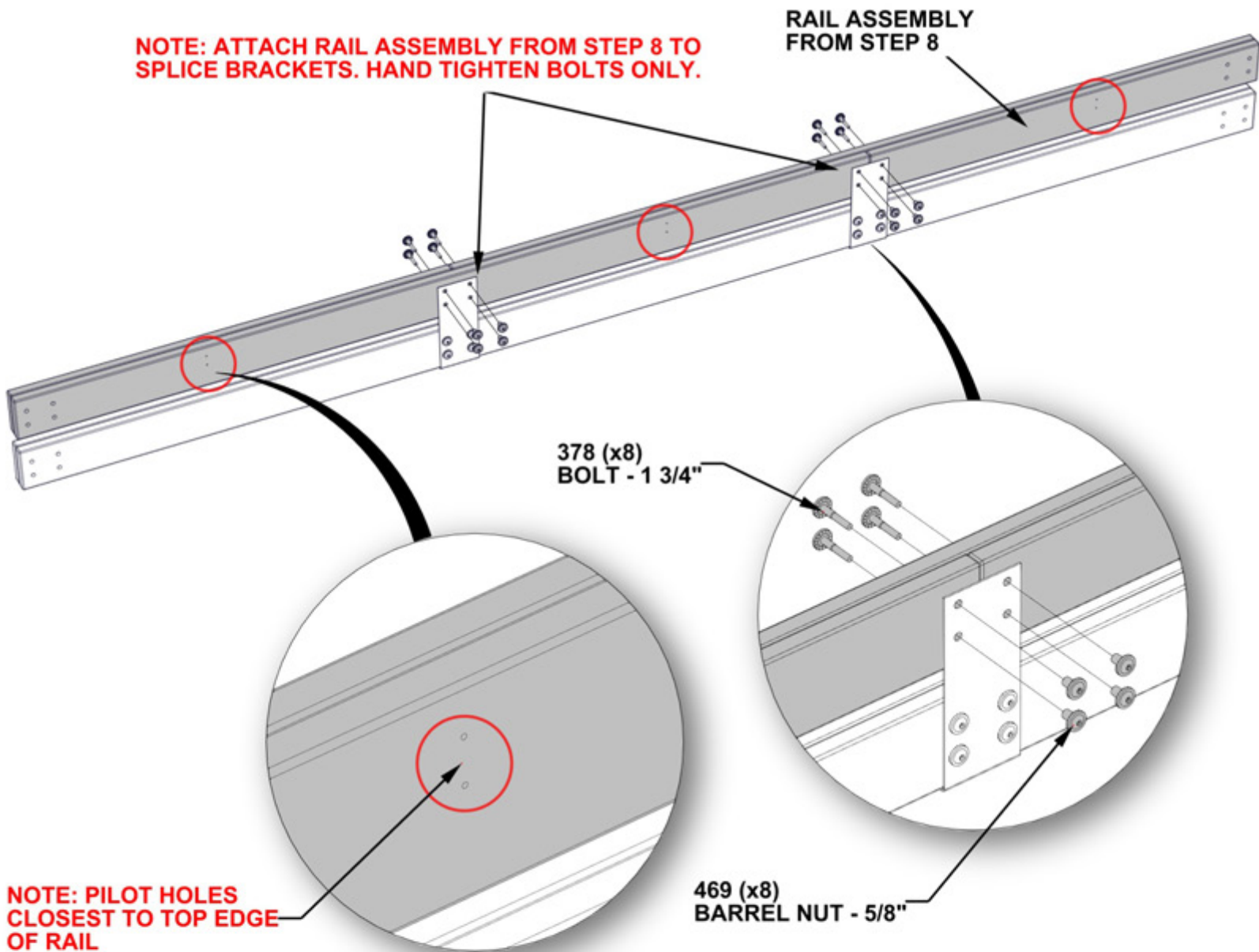

# STEP 12 - GAZEBO ASSEMBLY

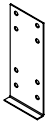

**A4M01490**  
(x2) | SPLICE BRACKET

QTY.	PART NUMBER	DESCRIPTION
2	H100206	LAG SCREW WH 5/16 X 3 BLK
14	H100379	T-NUT 5/16 BLK
14	H100354	BOLT WH 5/16 X 6 1/2 BLK

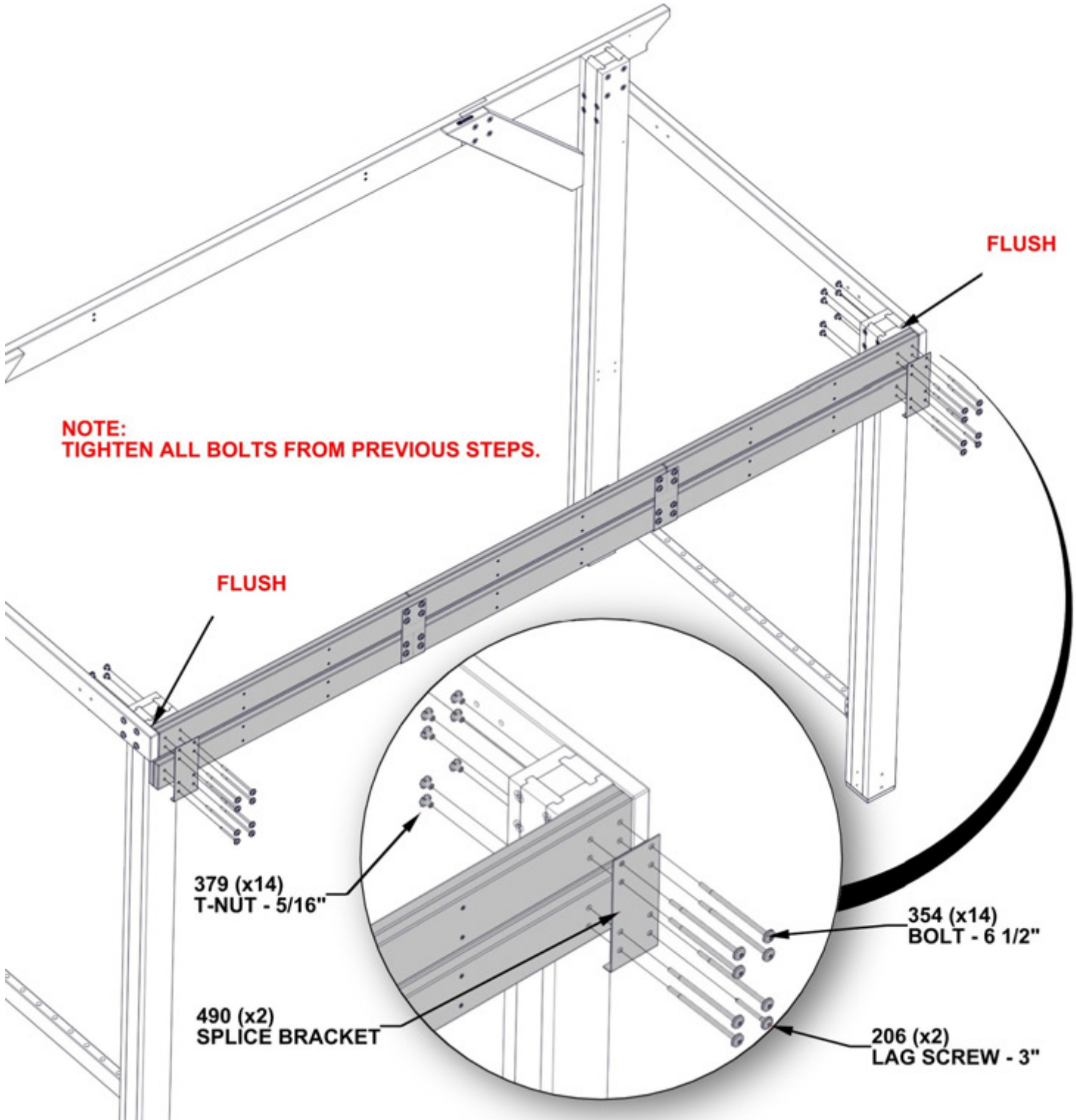

# STEP 13 - GAZEBO ASSEMBLY



**E1 | CORBEL-W4L16192**  
 (x2) | 1 7/16"x3 3/8"x15 3/4" (36x86x400)

QTY.	PART NUMBER	DESCRIPTION
2	H100792	LAG SCREW WH 1/4 X 3 BLK
2	H100405	WASHER LOCK EXT 6X15 BLK
4	H100379	T-NUT 5/16 BLK
4	H100195	BOLT WH 5/16 X 2 3/4 BLK
4	H100198	WASHER LOCK EXT 8X19 BLK

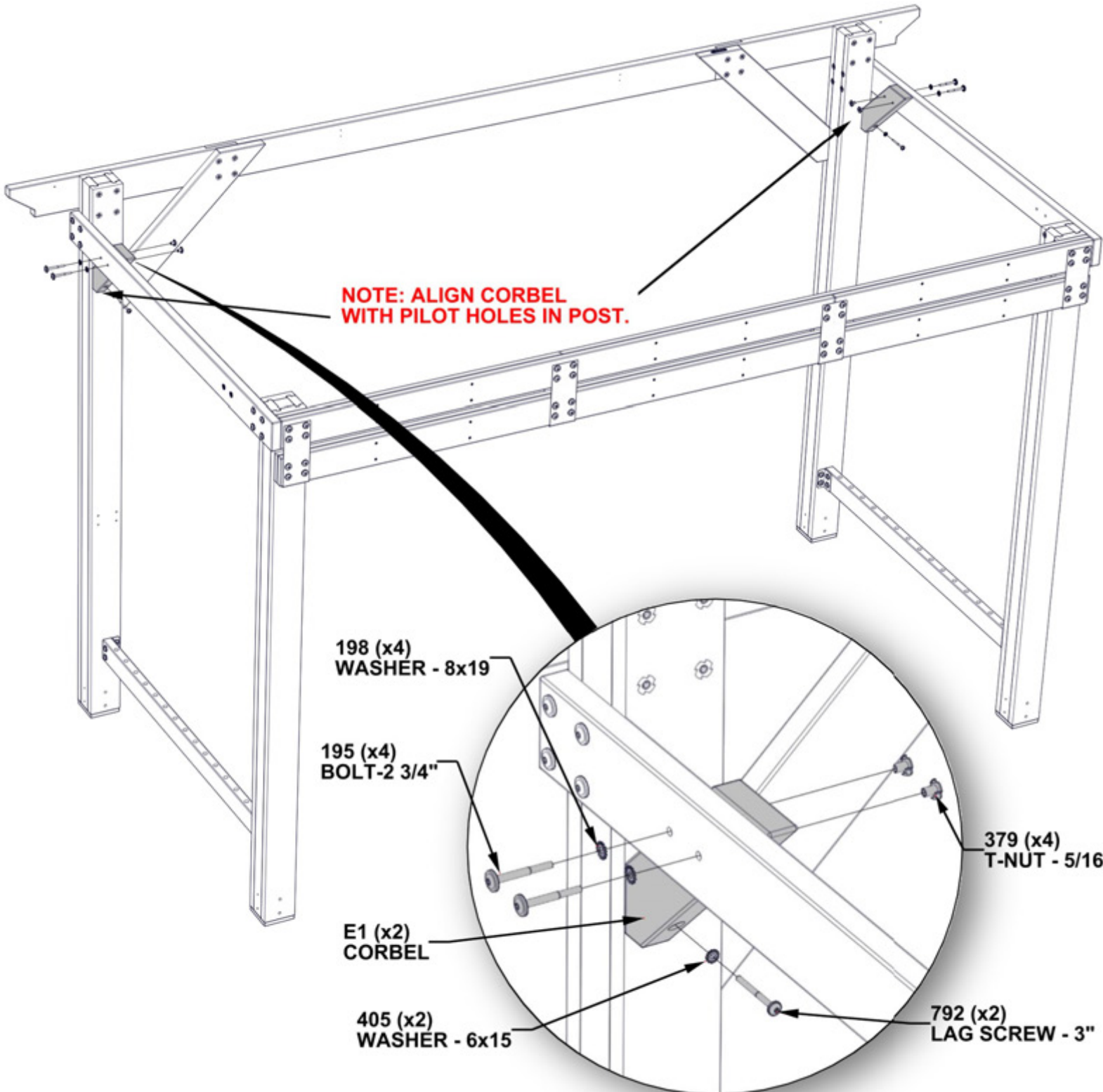



# STEP 14 - GAZEBO ASSEMBLY



**E1 | CORBEL-W4L16192**  
 (x2) | 1 7/16"x3 3/8"x15 3/4" (36x86x400)

QTY.	PART NUMBER	DESCRIPTION
2	H100792	LAG SCREW WH 1/4 X 3 BLK
2	H100405	WASHER LOCK EXT 6X15 BLK
4	H100379	T-NUT 5/16 BLK
4	H100195	BOLT WH 5/16 X 2 3/4 BLK
4	H100198	WASHER LOCK EXT 8X19 BLK

**NOTE: ALIGN CORBEL WITH PILOT HOLES IN POST.**

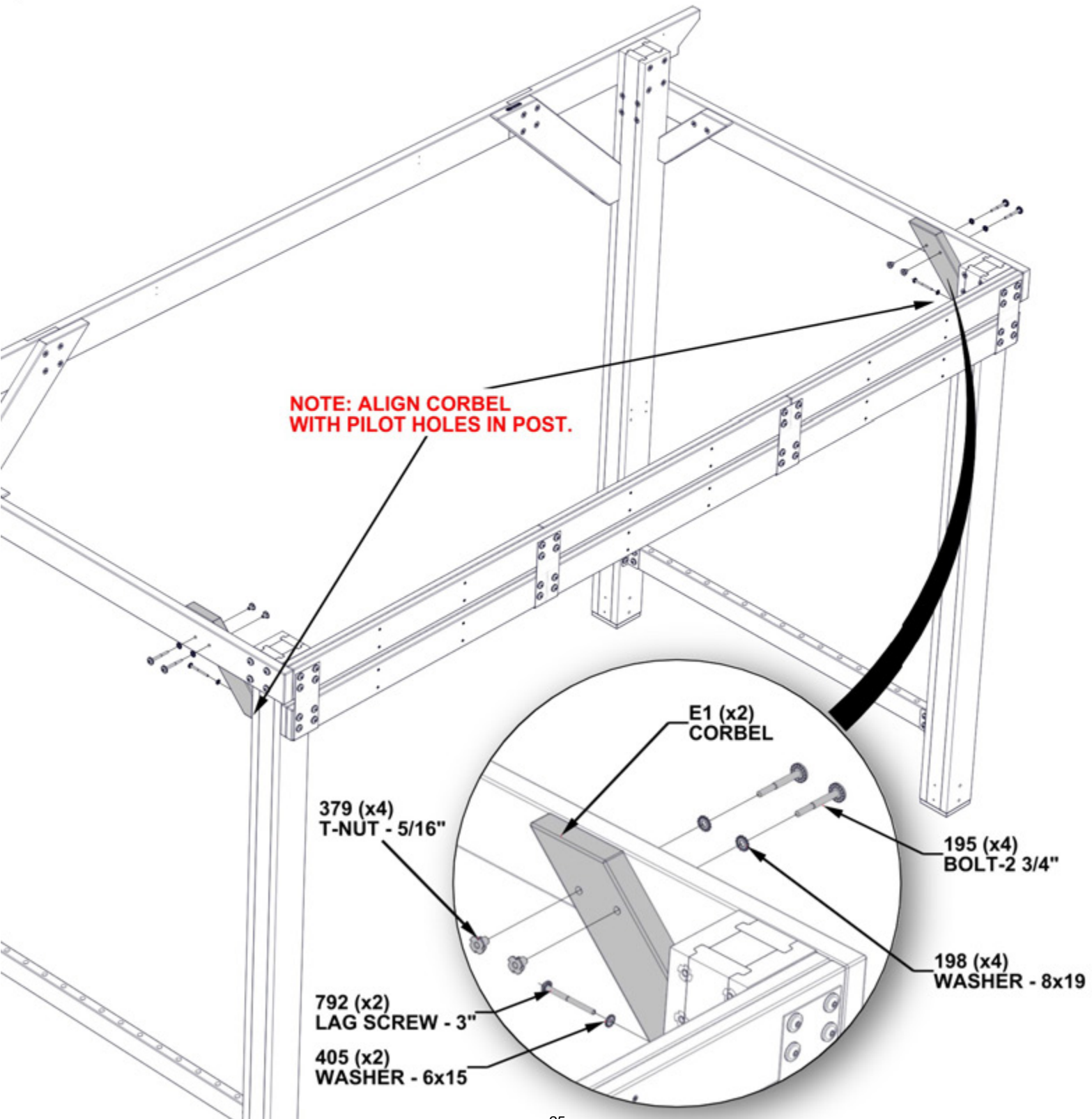

# STEP 15 - GAZEBO ASSEMBLY

QTY.	PART NUMBER	DESCRIPTION
8	H100469	NUT BARREL WH 5/16 X 5/8 BLK
8	H100459	BOLT WH 5/16 X 1 1/4 BLK



**E2 | RAIL-W4L16193**  
(x2) | 1 7/16"x3 3/8"x55" (36x86x1394)

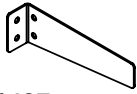

**A4M01487**  
(x2) | L BRACKET



**A4M01486**  
(x2) | L BRACKET

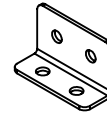

**A4M00855**  
(x4) | L BRACKET 51x32x82x3.175

**REPEAT THIS STEP TWICE**

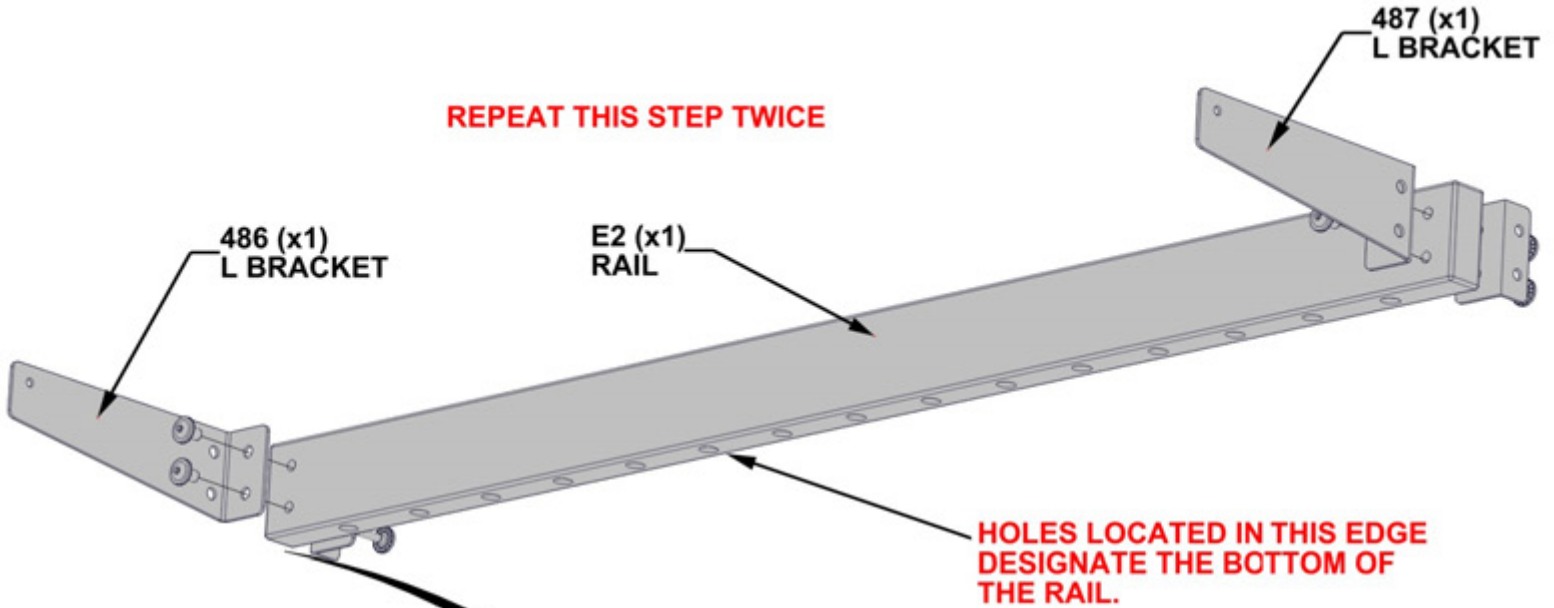

**NOTE:  
FLAT SIDE OF L BRACKET UP.**

**459 (x4)  
BOLT - 1 1/4"**

**855 (x2)  
L BRACKET  
51x32x82x3.175**

**469 (x4)  
BARREL NUT - 5/8"**

# STEP 16 - GAZEBO ASSEMBLY



(2) | RAIL ASSEMBLY

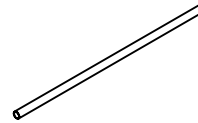

A4M01225  
(x30) | METAL TUBE

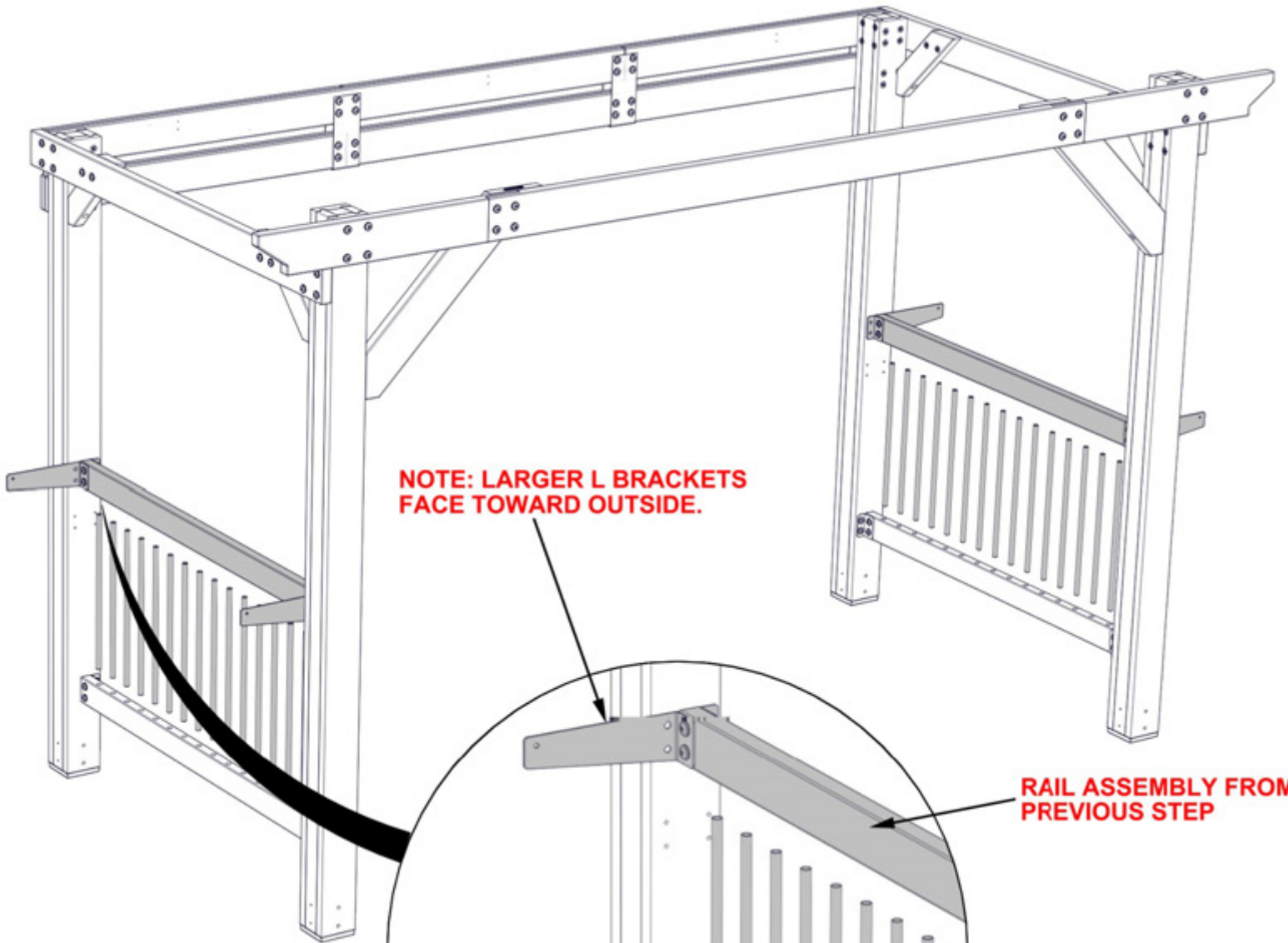

**NOTE: LARGER L BRACKETS  
FACE TOWARD OUTSIDE.**

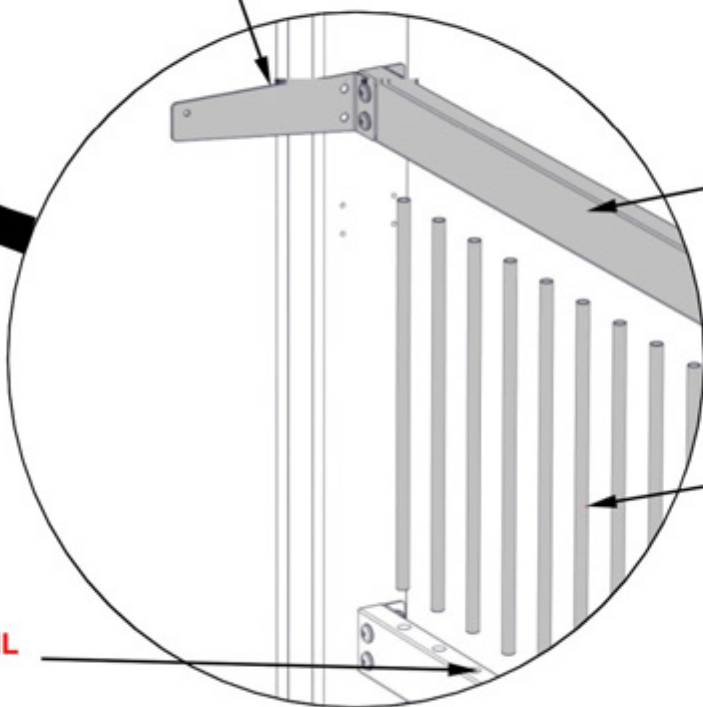

**RAIL ASSEMBLY FROM  
PREVIOUS STEP**

**225 (x30)  
METAL TUBE**

**PLACE RODS INTO BOTTOM  
BOARD ON UPRIGHT. PLACE RAIL  
ASSEMBLY ON TOP. SECURE  
BETWEEN BOARDS.**

# STEP 17 - GAZEBO ASSEMBLY

QTY.	PART NUMBER	DESCRIPTION
8	H100471	LAG SCREW WH 5/16 X 1 1/2 BLK

**REPEAT THIS STEP FOR OPPOSITE SIDE**

**ATTACH BOTTOM TWO SCREWS ON TOP RAIL ONLY, BUT DO NOT TIGHTEN COMPLETELY. TABLE TOP WILL ATTACH TO TOP HOLES IN NEXT STEP. REPEAT ON BOTH ENDS OF RAIL.**

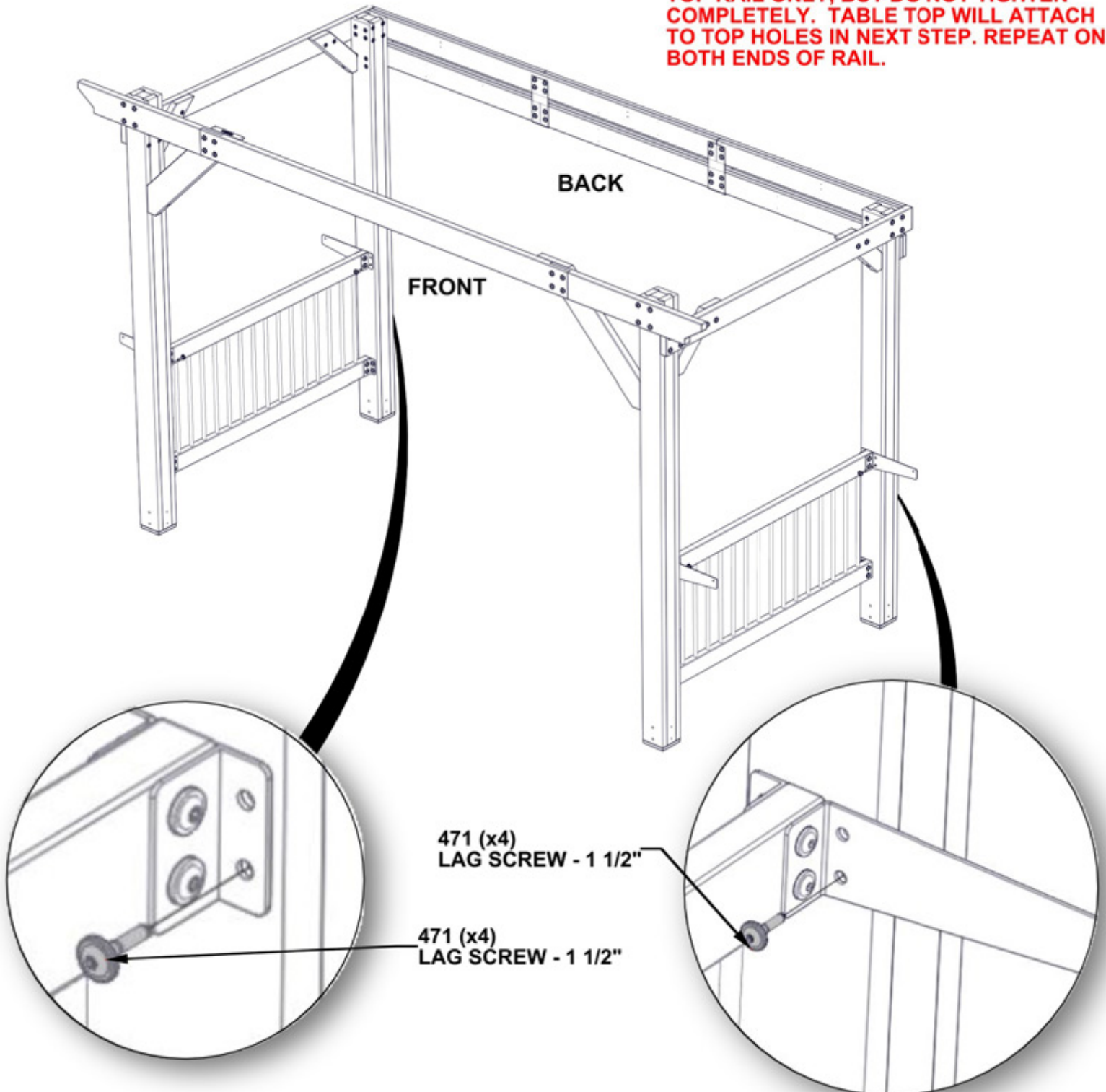

# STEP 18 - GAZEBO ASSEMBLY

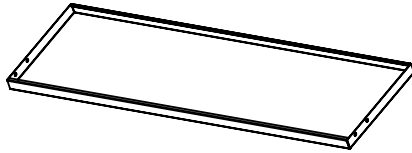

**A4M01488** | TABLE  
(x2)

QTY.	PART NUMBER	DESCRIPTION
4	H100653	NUT LOCK 1/4 BLK
4	H100486	BOLT WH 1/4 X 5/8
4	H100630	WASHER FLAT 8x19 BLK
8	H100471	LAG SCREW WH 5/16 X 1 1/2 BLK

**REPEAT THIS STEP FOR OPPOSITE SIDE**

**AFTER TABLE IS ATTACHED,  
TIGHTEN ALL CONNECTIONS,  
TOP AND BOTTOM BOTH SIDES.**

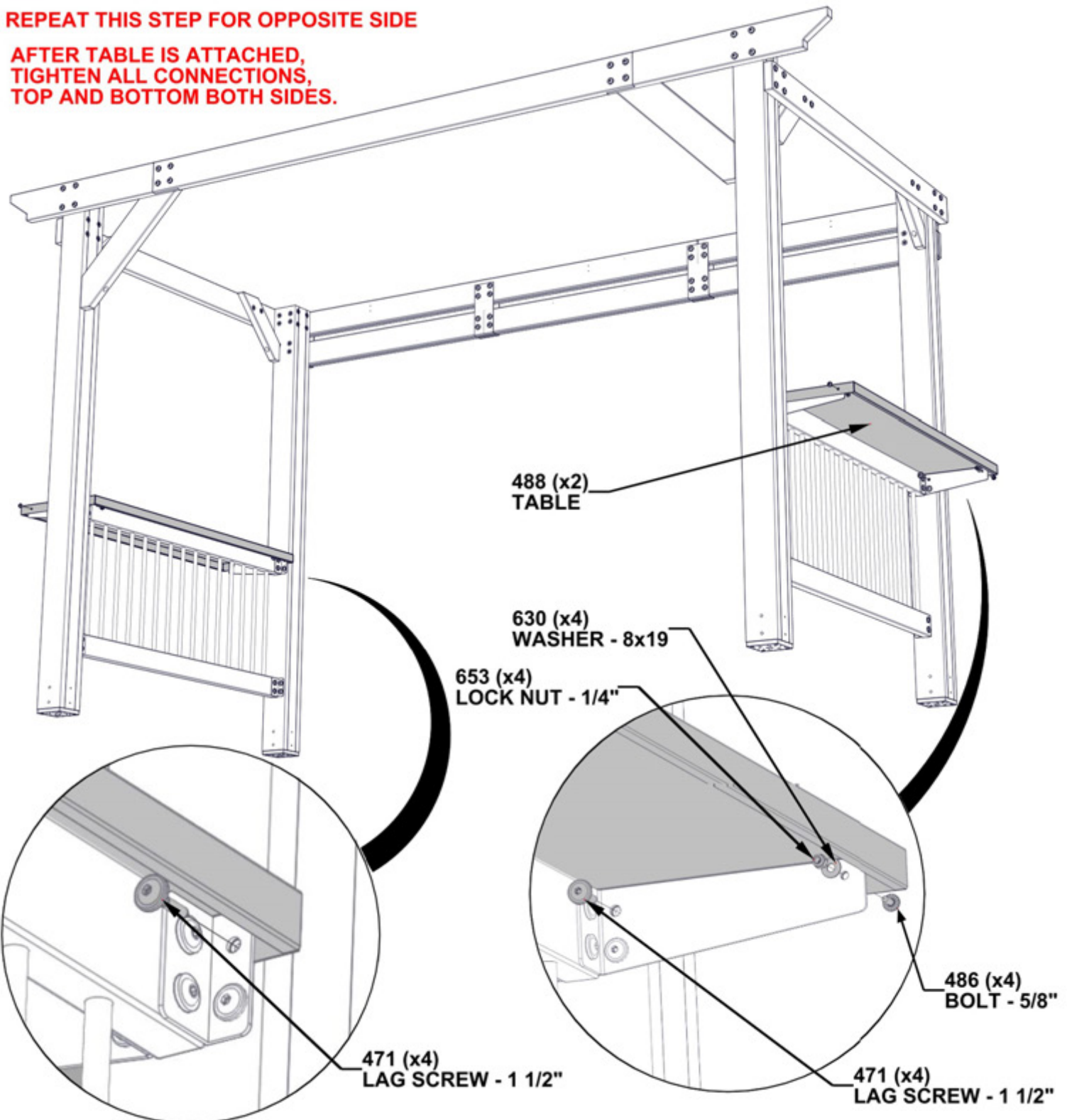

# STEP 19 - GAZEBO ASSEMBLY

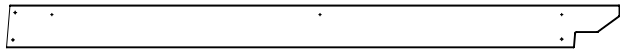

**D7 | BEAM-W4L16202**  
(x1) | 1 7/16"x5 1/4"x75 13/16" (36x134x1926)

QTY.	PART NUMBER	DESCRIPTION
6	H100201	SCREW PFH 8 X 2 1/2 BLK

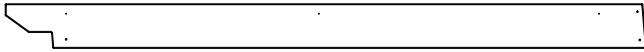

**D5 | BEAM-W4L16195**  
(x1) | 1 7/16"x5 1/4"x75 13/16" (36x134x1926)

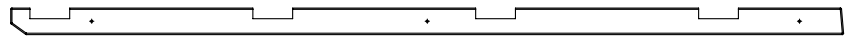

**F1 | RAFTER-W4L16197**  
(x2) | 1 7/16"x2 3/8"x74 3/16" (36x60x1884)

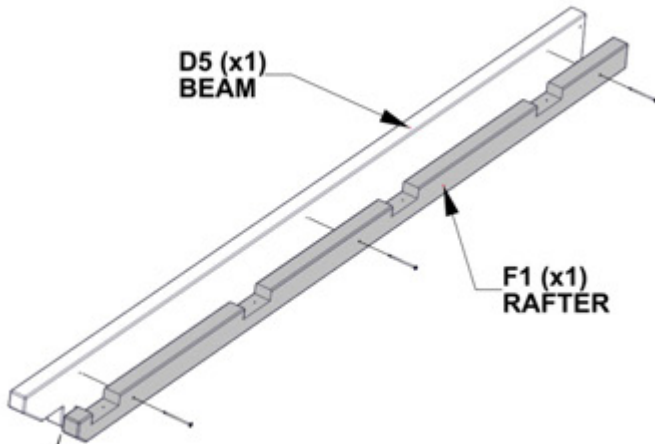

**ALIGN RAFTER WITH PILOT HOLES ON BEAM.**

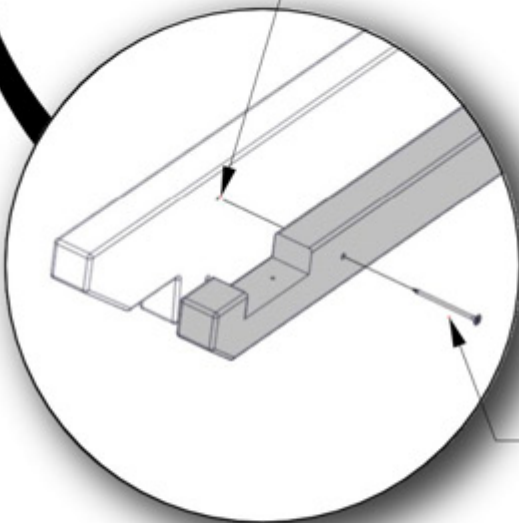

201 (x6) SCREW - 2 1/2"

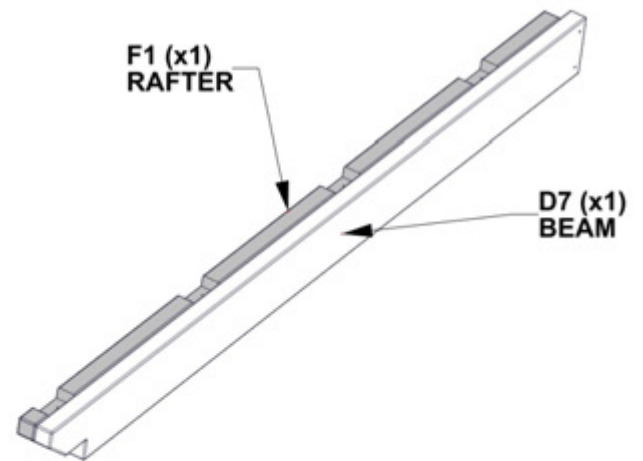

**FRONT AND TOP EDGE OF BEAM & RAFTER TO BE FLUSH**

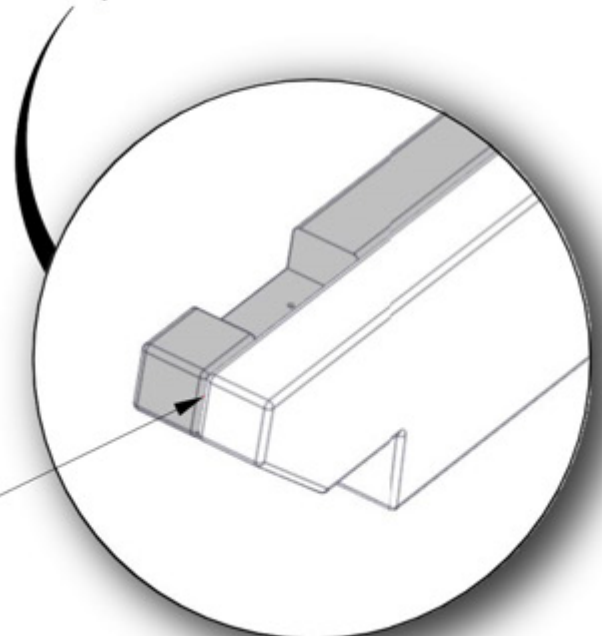

# STEP 20 - GAZEBO ASSEMBLY



**D6 | JOIST-W4L16196**  
 (x2) | 1 7/16"x5 1/4"x72 3/4" (36x134x1848)

QTY.	PART NUMBER	DESCRIPTION
4	H100379	T-NUT 5/16 BLK
4	H100459	BOLT WH 5/16 X 1 1/4 BLK
4	H100198	WASHER LOCK EXT 8X19 BLK

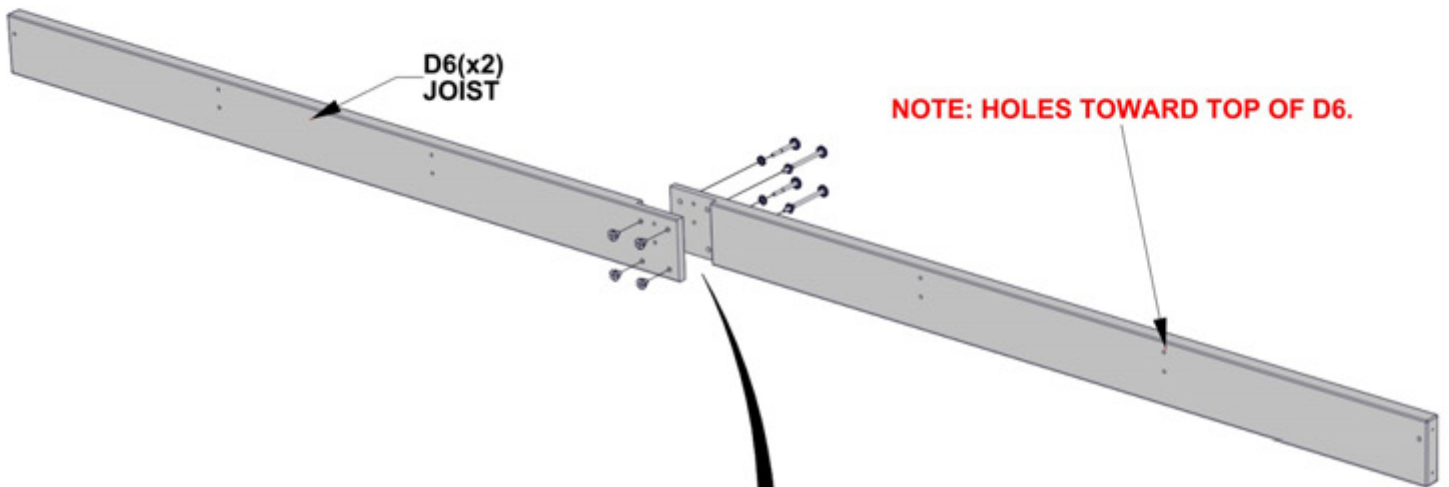

**NOTE: LAP ORIENTATION**

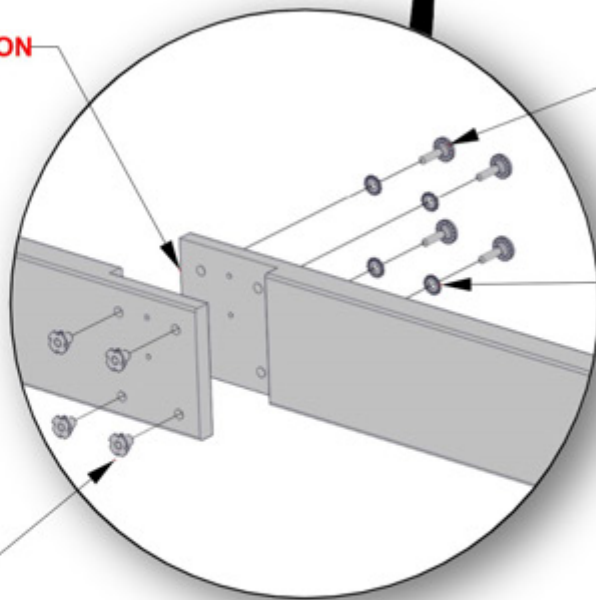

**459 (x4)  
BOLT - 1 1/4"**

**198 (x4)  
WASHER - 8x19**

**379 (x4)  
T NUT - 5/16**

# STEP 21 - GAZEBO ASSEMBLY

QTY.	PART NUMBER	DESCRIPTION
6	H101008	SCREW CONFIRMAT 7 X 3 BLK

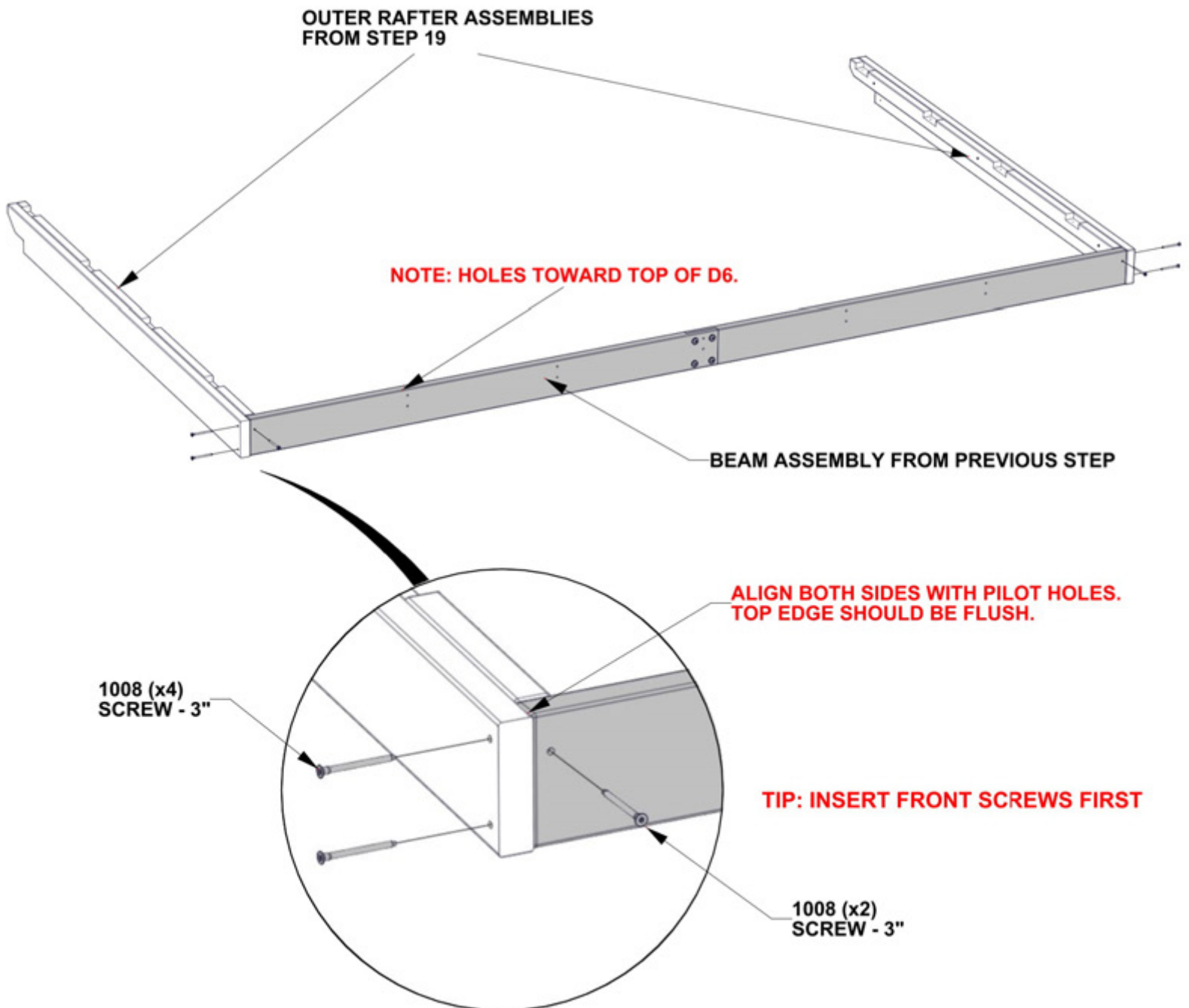



# STEP 22 - GAZEBO ASSEMBLY

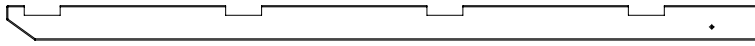

**E3 | RAFTER-W4L16194**  
(x3) | 1 7/16"x3 3/8"x74 3/16" (36x86x1884)

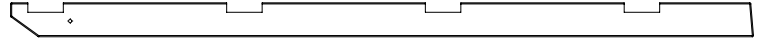

**E4 | RAFTER-W4L16199**  
(x2) | 1 7/16"x3 3/8"x74 3/16" (36x86x1884)

QTY.	PART NUMBER	DESCRIPTION
10	H101008	SCREW CONFIRMAT 7 X 3 BLK

**FLIP ASSEMBLY FROM PREVIOUS STEP OVER. LAY RAFTERS FLAT, ALIGNING PILOT HOLES WITH HOLES IN D6 BOARDS. BOTTOM EDGE WILL BE FLUSH.**

**NOTCHES IN RAFTERS SHOULD FACE DOWN.**

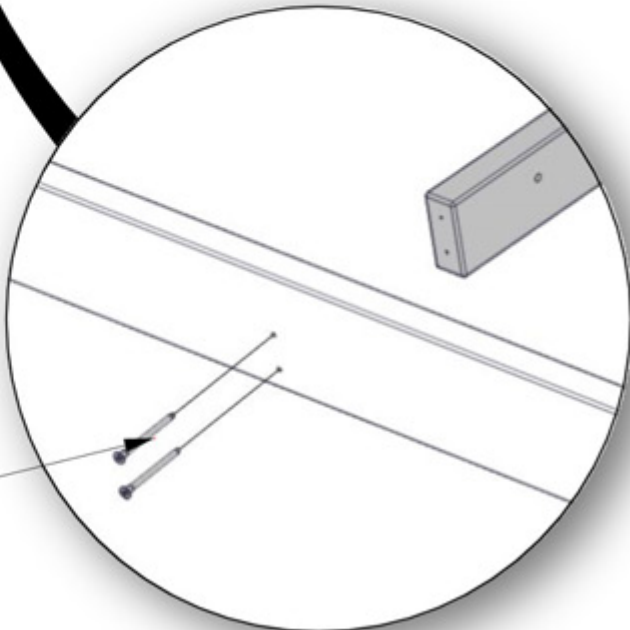
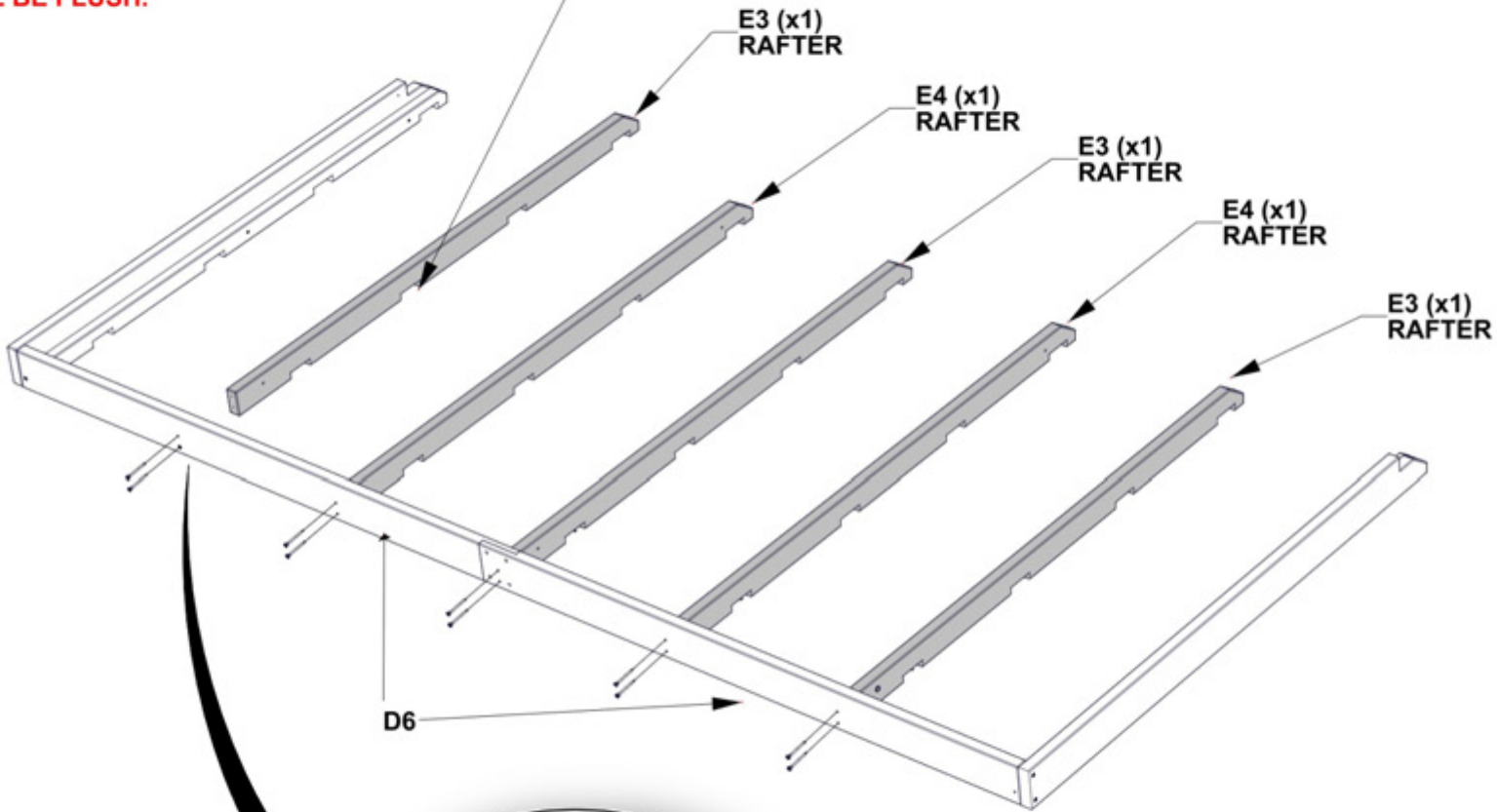

**1008 (x10) SCREW - 3"**

# STEP 23 - GAZEBO ASSEMBLY



**H1 | PURLIN-W4L16198**  
 (x2) | 15/16"x3 3/8"x71 7/8" (24x86x1826)

QTY.	PART NUMBER	DESCRIPTION
14	H100382	SCREW PFH 8 X 1 3/4 BLK

**FLIP ASSEMBLY FROM PREVIOUS STEP OVER.  
 POSITION H1 PURLIN IN PLACE. MEASURE  
 DIAGONALLY AND SQUARE AS NEEDED.  
 MEASUREMENT SHOULD BE 162 1/8 in [4118 mm].**

**ONCE SQUARE, INSERT SCREWS.  
 RE-MEASURE CORNER TO CORNER.**

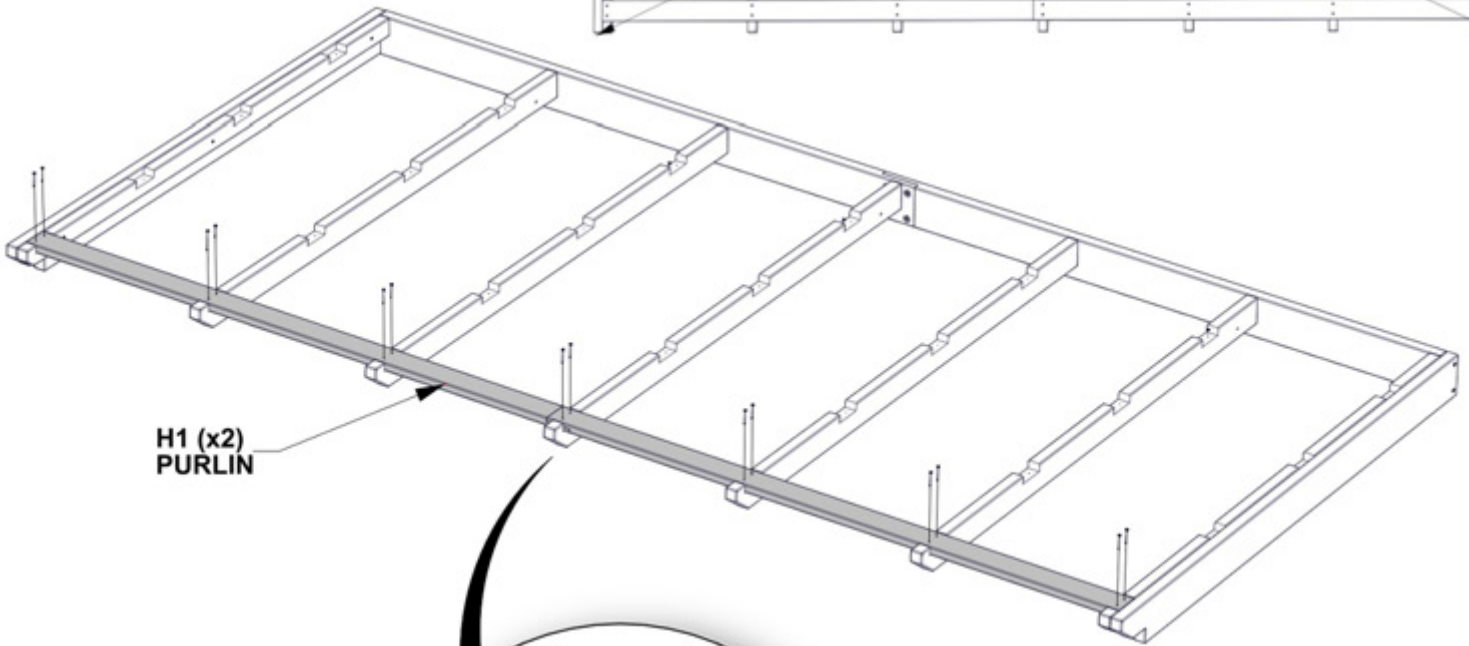
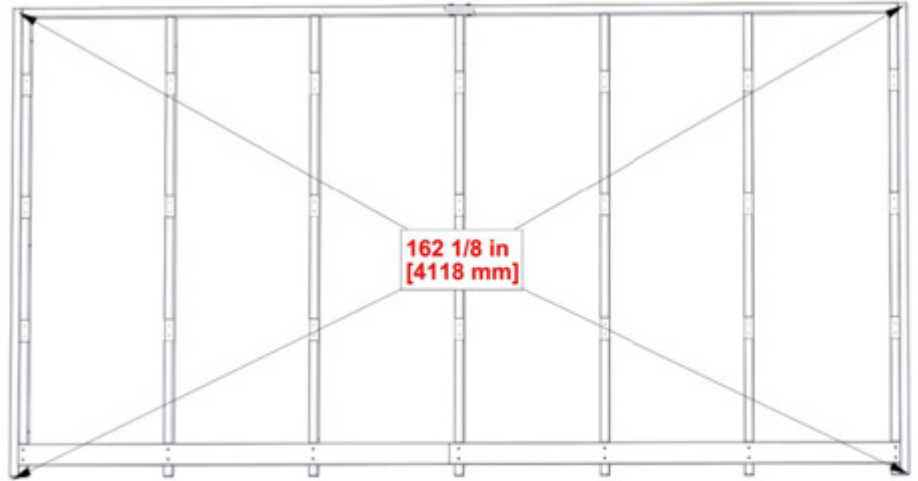

**NOTE: LAP ORIENTATION**

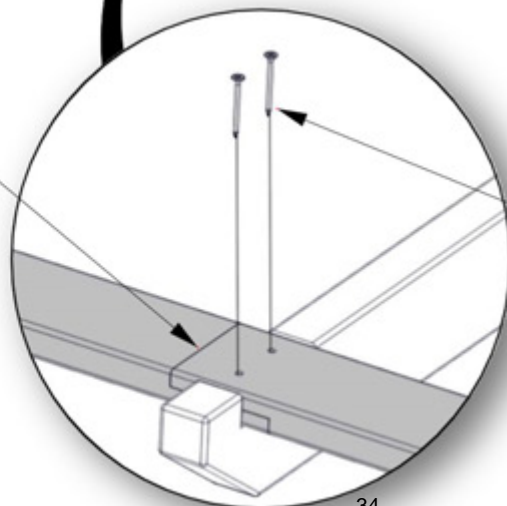

**382 (x14)  
 SCREW - 1 3/4"**

# STEP 24 - GAZEBO ASSEMBLY



**H1 | PURLIN-W4L16198**  
(x6) | 15/16"x3 3/8"x71 7/8" (24x86x1826)

QTY.	PART NUMBER	DESCRIPTION
42	H100382	SCREW PFH 8 X 1 3/4 BLK

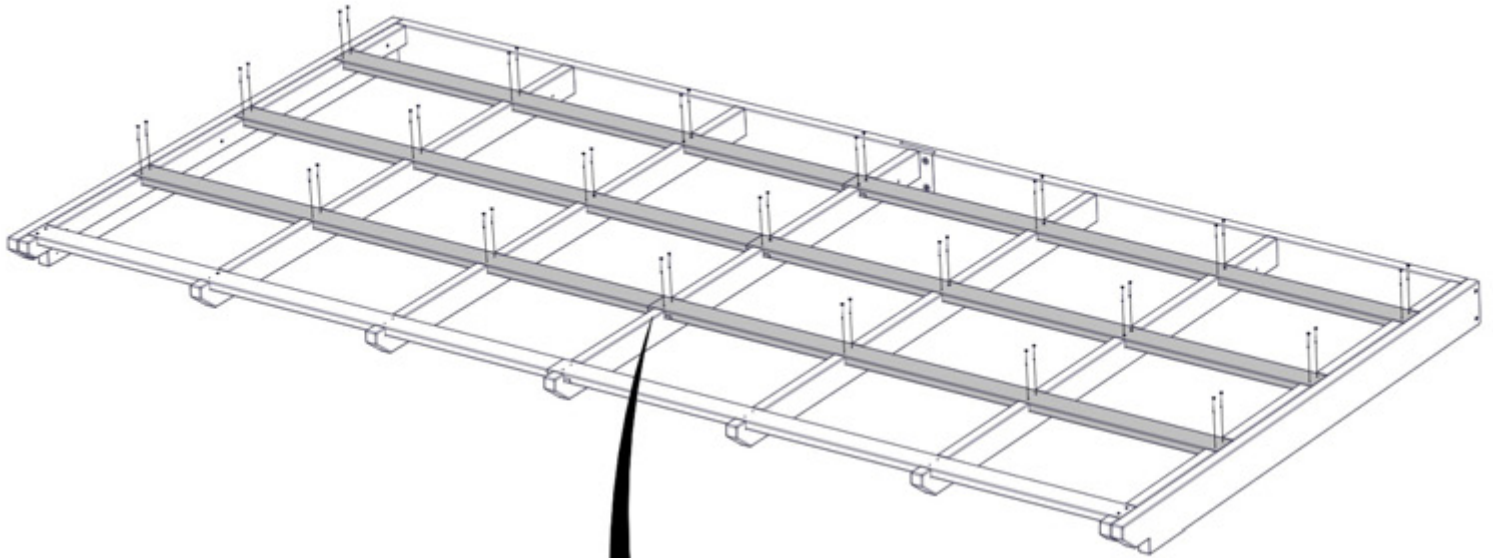

382 (x42)  
SCREW - 1 3/4"

**NOTE: LAP ORIENTATION**

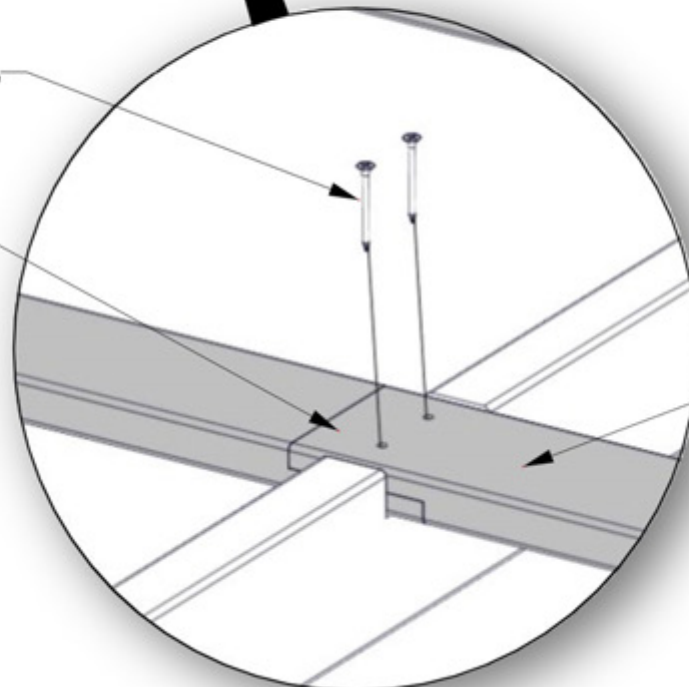

H1 (x6)  
PURLIN

# STEP 25 - GAZEBO ASSEMBLY

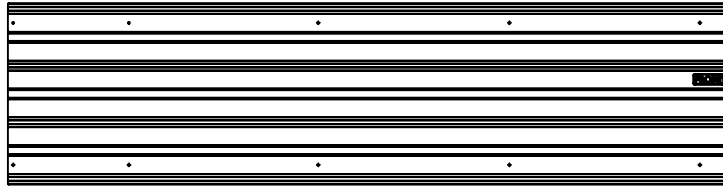

A4M02666 | 29GA STEEL SHEETING  
(x8)

QTY.	PART NUMBER	DESCRIPTION
80	H101117	SCREW WOODGRIP 10-16x3/4" BLK

**NOTE:**  
**WARNING:**  
GLOVES SHOULD BE WORN WHEN HANDLING ROOF PANELS. EDGES ARE SHARP. REMOVE BLUE FILM FROM EACH SHEET.

1. LOOKING AT THE BACK OF THE UNIT AS PICTURED BELOW, PLACE TIN SHEETS DOWN.
2. STARTING AT THE RIGHT SIDE AND WORKING TOWARD THE LEFT SIDE OVER LAPPING BY ONE RIB.
3. CENTER SHEETS ON ROOF AND LEAVE EQUAL GAPS ON BOTH LEFT AND RIGHT SIDES. SCREW IN PLACE.

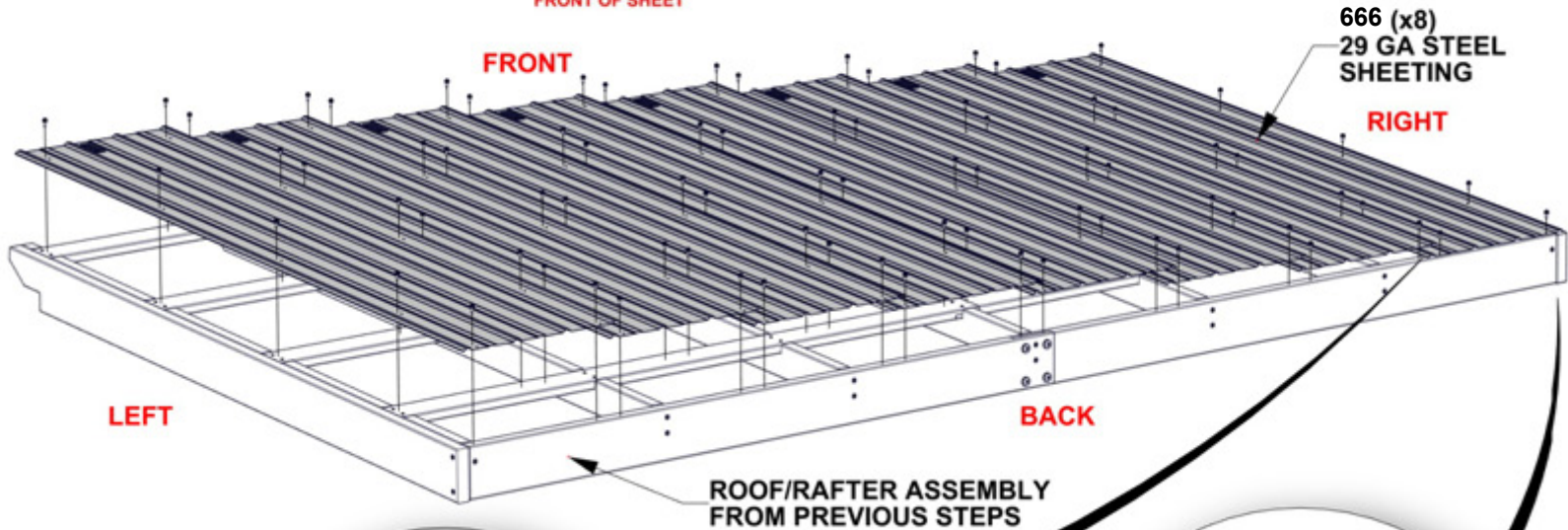
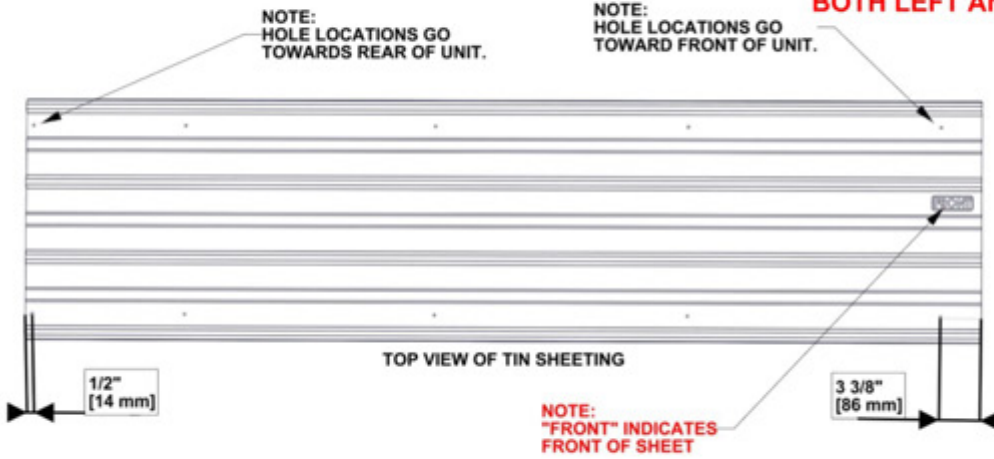

117 (x80)  
SCREW - 3/4"

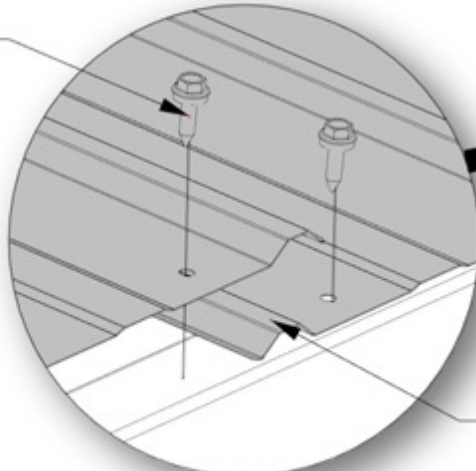

ALIGN EDGE OF ALL SHEETS FLUSH WITH JOIST

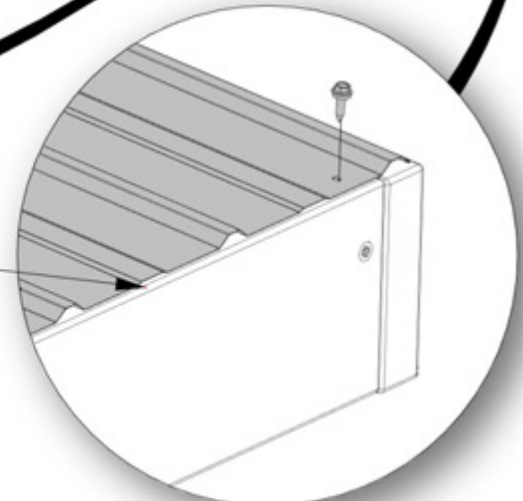

NOTE: SHEETS OVERLAP BY (1) RIB

# STEP 26 - GAZEBO ASSEMBLY

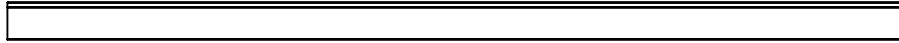

A4M02695 | ROOF EDGE TRIM  
(x2)

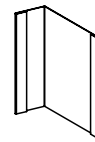

A4M02697 | ROOF EDGE TRIM SPLICE  
(x1)

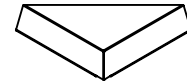

A4M02696 CORNER SPLICE TRIM  
(x2)

QTY.	PART NUMBER	DESCRIPTION
7	H101116	SCREW SELF TAPPING 1/4x1 BLK

LAYOUT ROOF EDGE TRIM, TRIM SPLICE, AND CORNER SPLICE AS SHOWN BELOW. SLIDE TRIM PIECE INTO SPLICE. ATTACH CORNER SPLICES BY PRESSING INTO EDGE TRIM. SCREWS GO THROUGH EDGE TRIM INTO THE TOP OF THE RIBS IN THE APPROXIMATE LOCATIONS SHOW.

116 (x7)  
SCREW - 1"

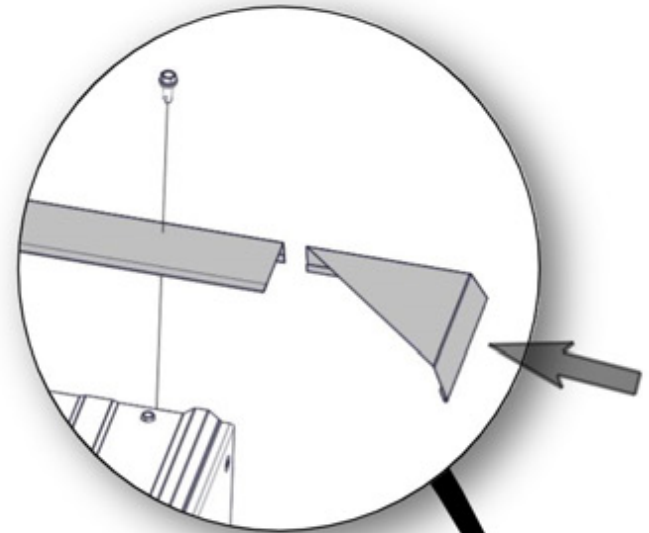
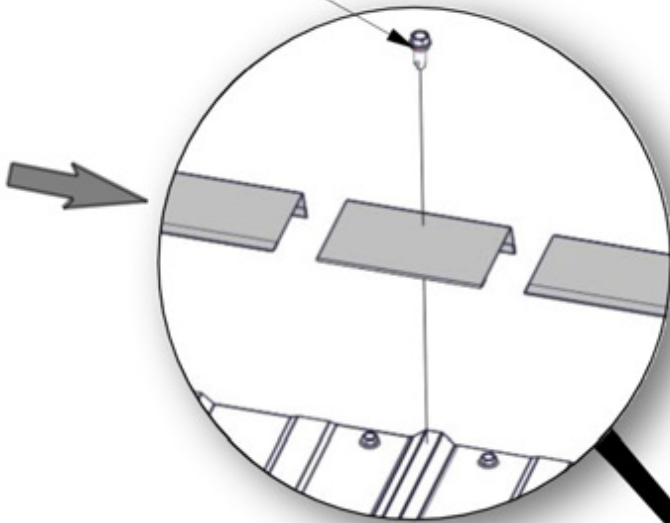

696 (x2)  
CORNER SPLICE TRIM

695(x1)  
ROOF EDGE TRIM

BACK

697 (x1)  
ROOF EDGE TRIM SPLICE

695 (x1)  
ROOF EDGE TRIM

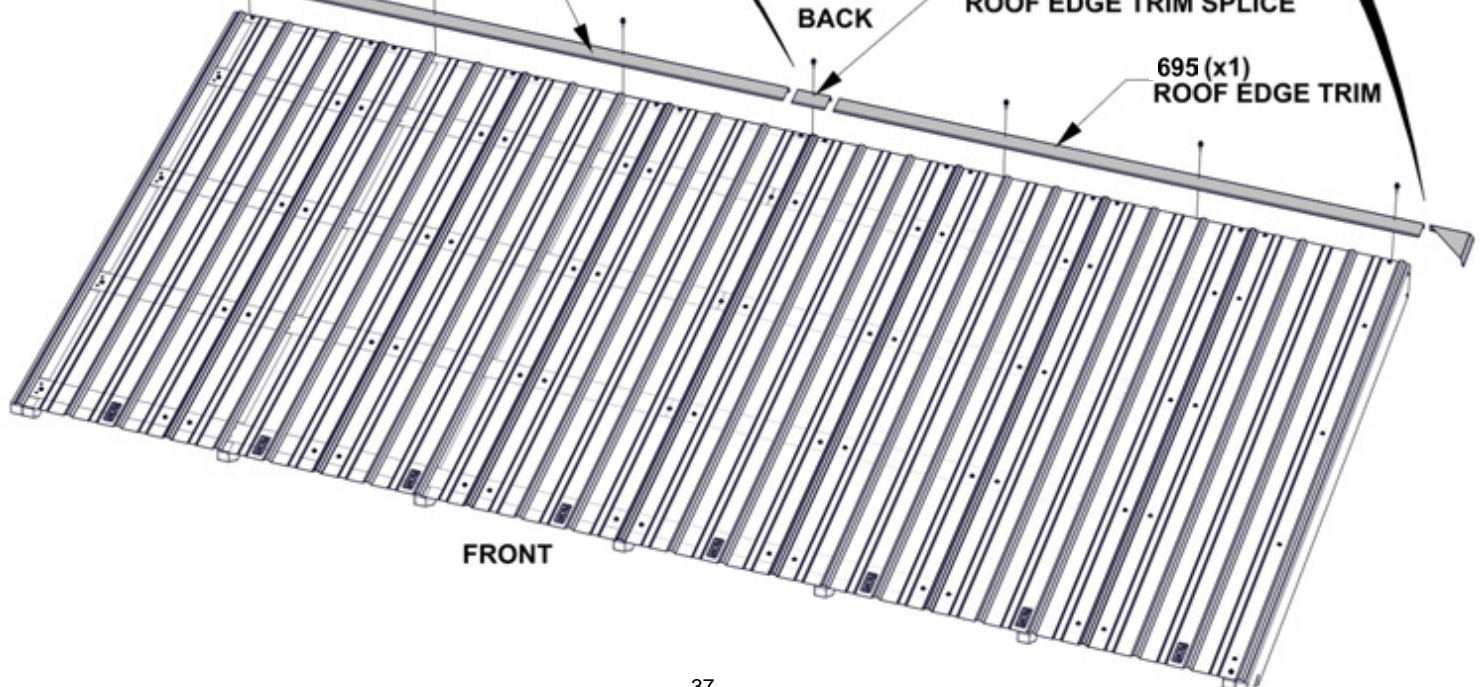

# STEP 27 - GAZEBO ASSEMBLY

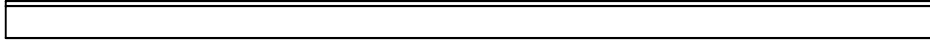

A4M02694 | ROOF EDGE TRIM  
(x1)

QTY.	PART NUMBER	DESCRIPTION
4	H101116	SCREW SELF TAPPING 1/4x1 BLK

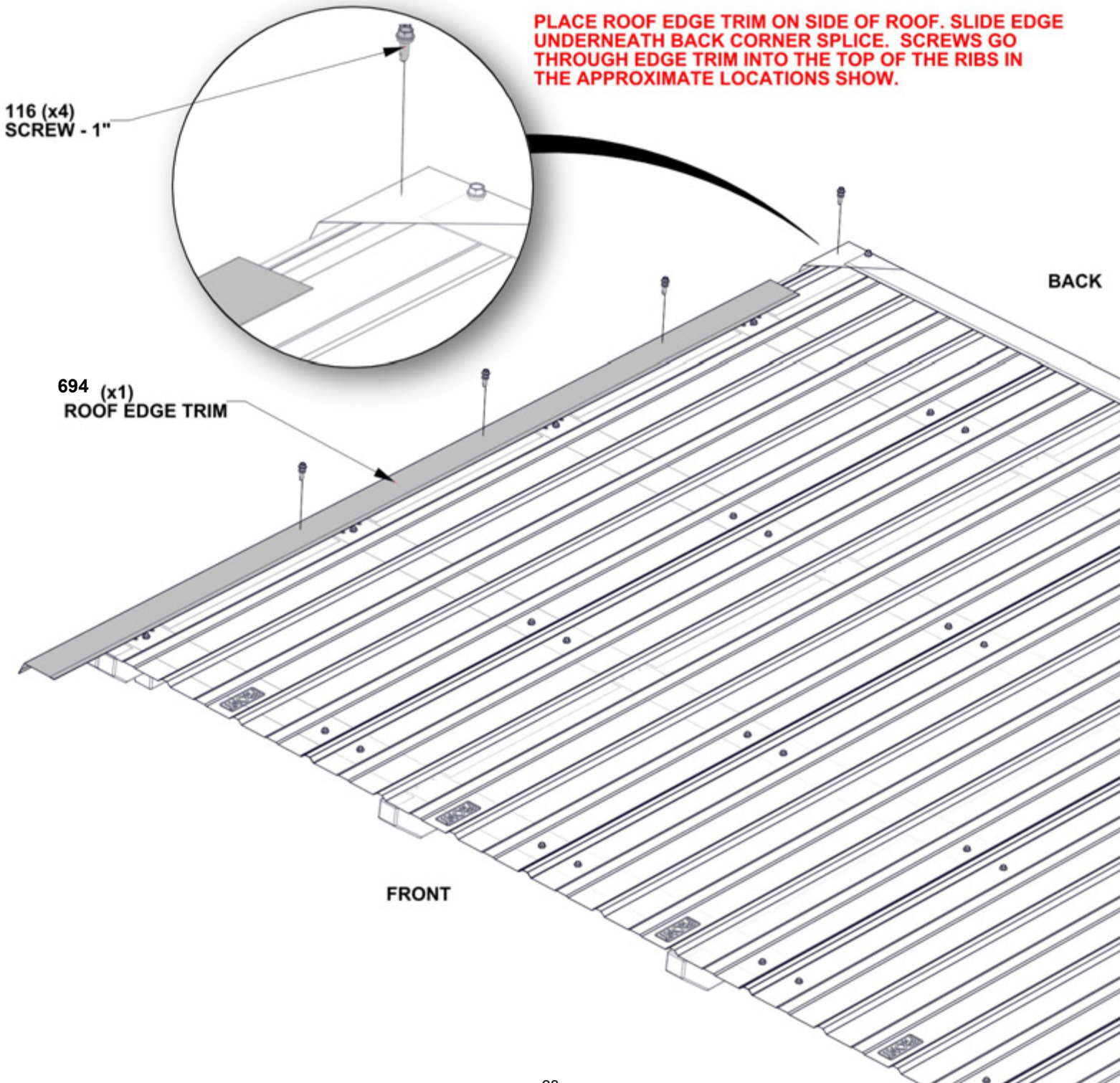

# STEP 28 - GAZEBO ASSEMBLY

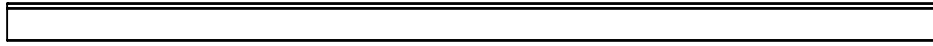

A4M02694 | ROOF EDGE TRIM  
(x1)

QTY.	PART NUMBER	DESCRIPTION
4	H101116	SCREW SELF TAPPING 1/4x1 BLK

PLACE ROOF EDGE TRIM ON SIDE OF ROOF. SLIDE EDGE UNDERNEATH BACK CORNER SPLICE. SCREWS GO THROUGH EDGE TRIM INTO THE TOP OF THE RIBS IN THE APPROXIMATE LOCATIONS SHOW.

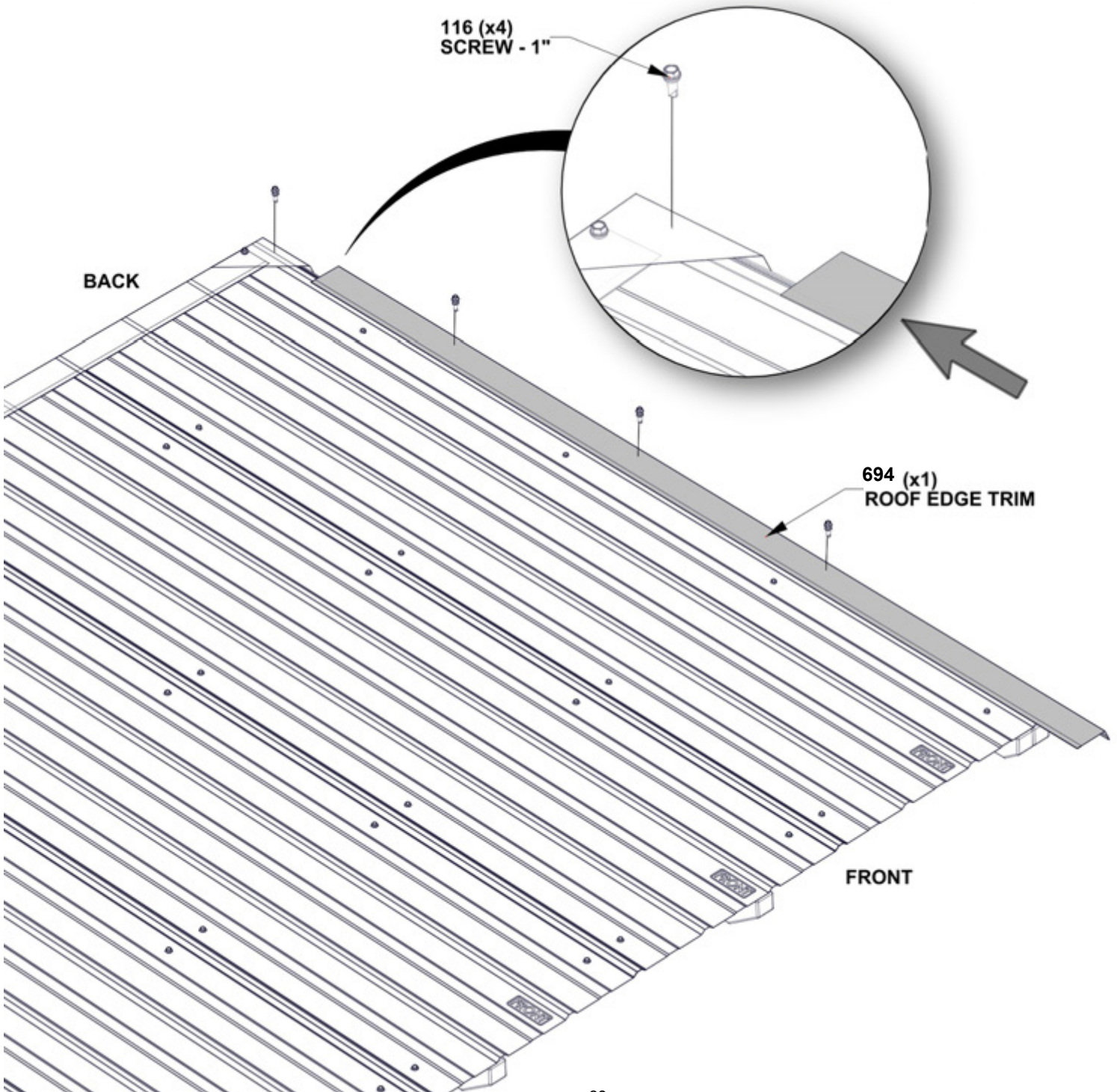

# STEP 29 - GAZEBO ASSEMBLY

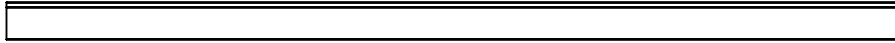

A4M02695 | ROOF EDGE TRIM  
(x2)

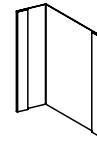

A4M02697 | ROOF EDGE TRIM SPLICE  
(x1)

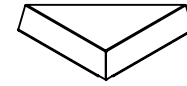

A4M02696 | CORNER SPLICE  
TRIM  
(x2)

QTY.	PART NUMBER	DESCRIPTION
9	H101116	SCREW SELF TAPPING 1/4x1 BLK

**LAYOUT ROOF EDGE TRIM, TRIM SPLICE, AND CORNER SPLICE AS SHOWN BELOW. SLIDE TRIM PIECE INTO SPLICE. ATTACH CORNER SPLICES BY PRESSING INTO EDGE TRIM. SCREWS GO THROUGH EDGE TRIM INTO THE TOP OF THE RIBS IN THE APPROXIMATE LOCATIONS SHOW.**

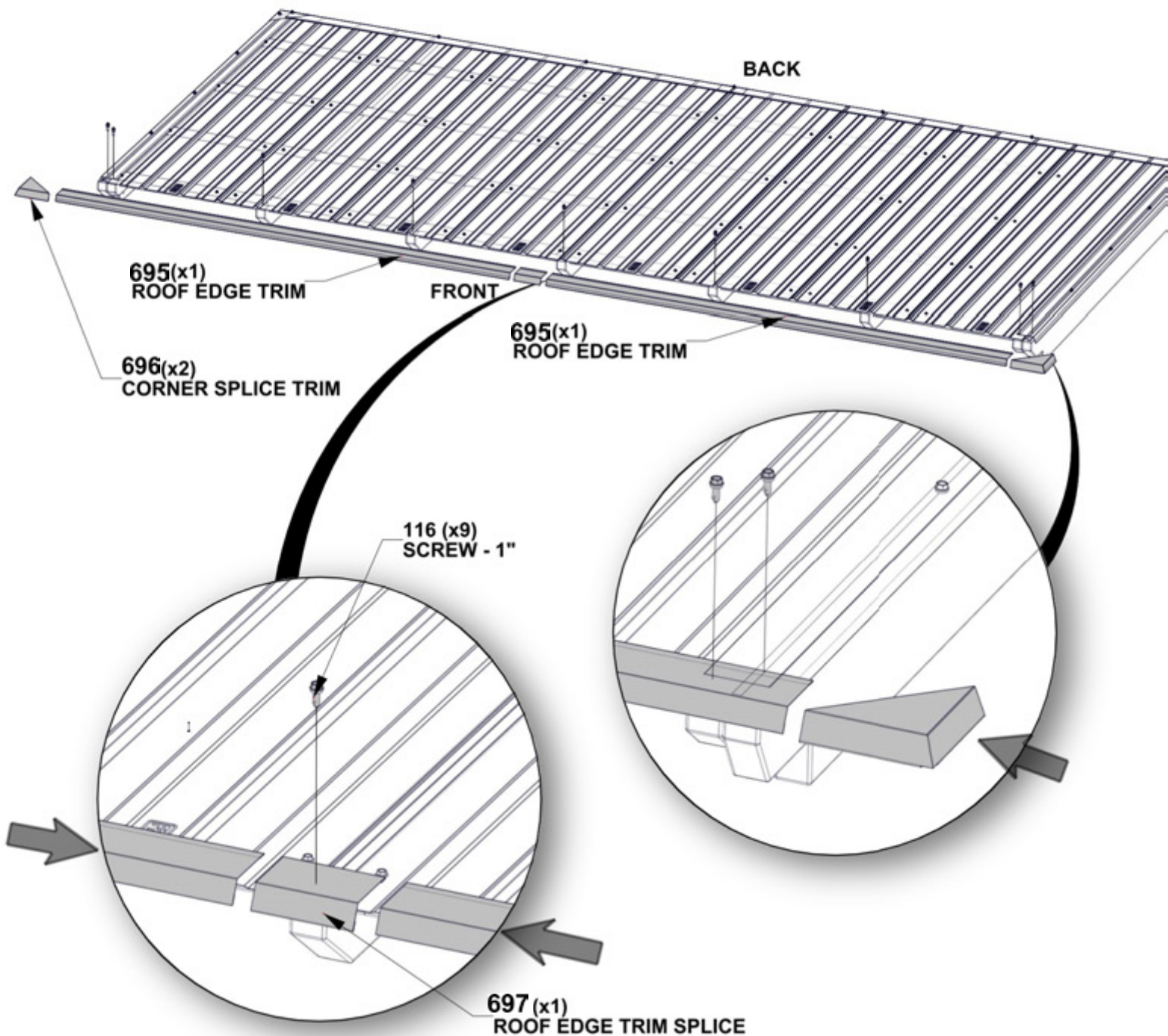



# STEP 30 - GAZEBO ASSEMBLY



A4M01047  
(x2) | L BRACKET 2.5x38x55

QTY.	PART NUMBER	DESCRIPTION
2	H100460	LAG SCREW WH 1/4 X 1 BLK

**NOTE:**  
ATTACH L BRACKET TO FRONT LEFT  
AND RIGHT EDGE USING PILOT HOLES.  
BRACKET MUST BE ATTACHED TO OUTSIDE  
BEAM BEFORE ROOF IS ATTACHED TO ASSEMBLY.

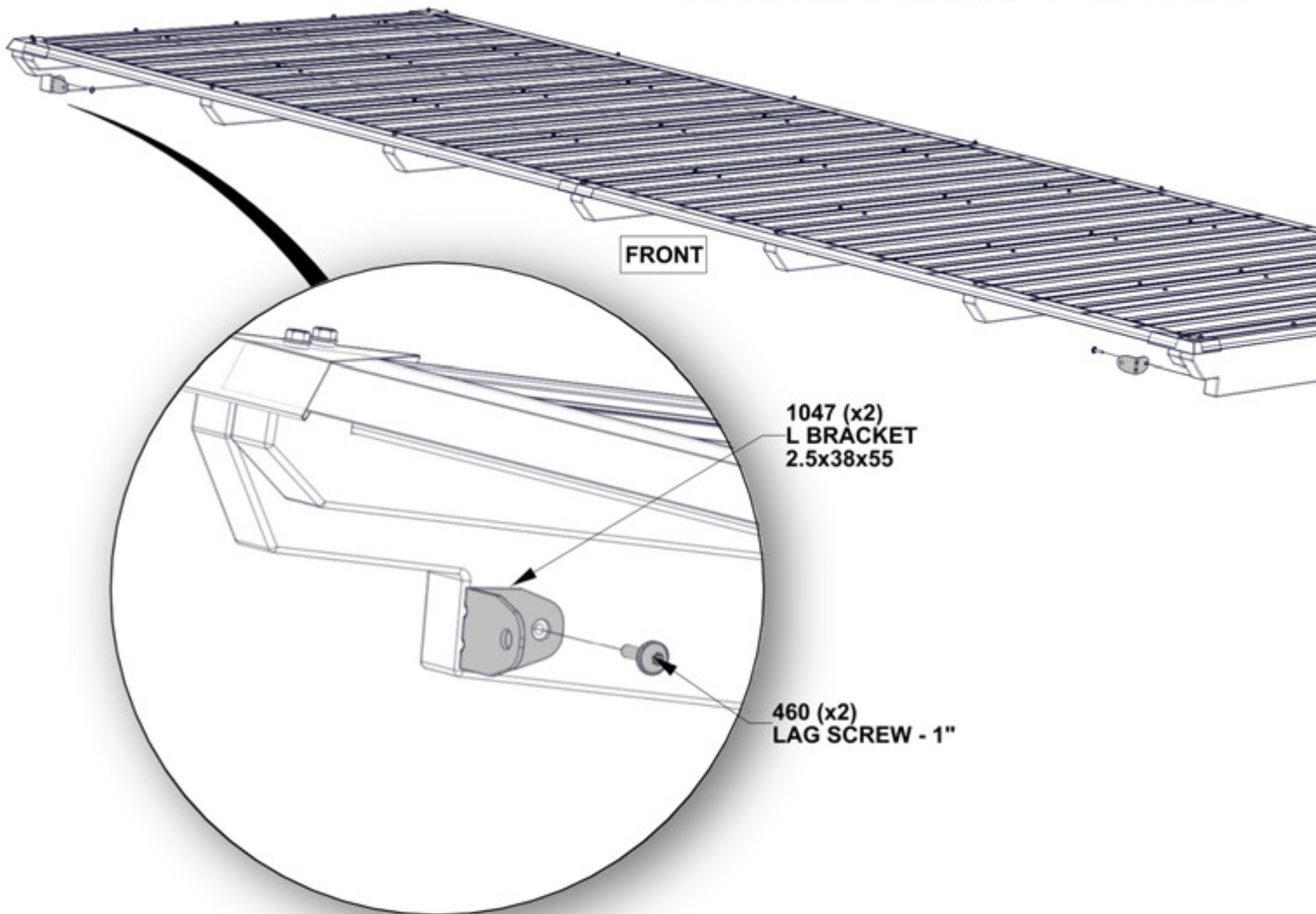

# STEP 31 - GAZEBO ASSEMBLY

**WARNING: GLOVES SHOULD BE WORN WHEN HANDLING METAL PIECES.**

## TIPS:

- ROOF ASSEMBLY WILL WEIGH APPROXIMATELY 150-180LBS.
- THREE PEOPLE ARE HELPFUL FOR THIS STEP.
- PLACE A PERSON ON A LADDER IN THE CENTER OF THE GAZEBO TO HELP SUPPORT THE ROOF PANEL.
- WITH TWO PEOPLE, CAREFULLY WORK THE PANEL UP FROM THE BACKSIDE OF THE GAZEBO UNTIL THE OUTER RAFTER NOTCH RESTS ON FRONT BEAM.

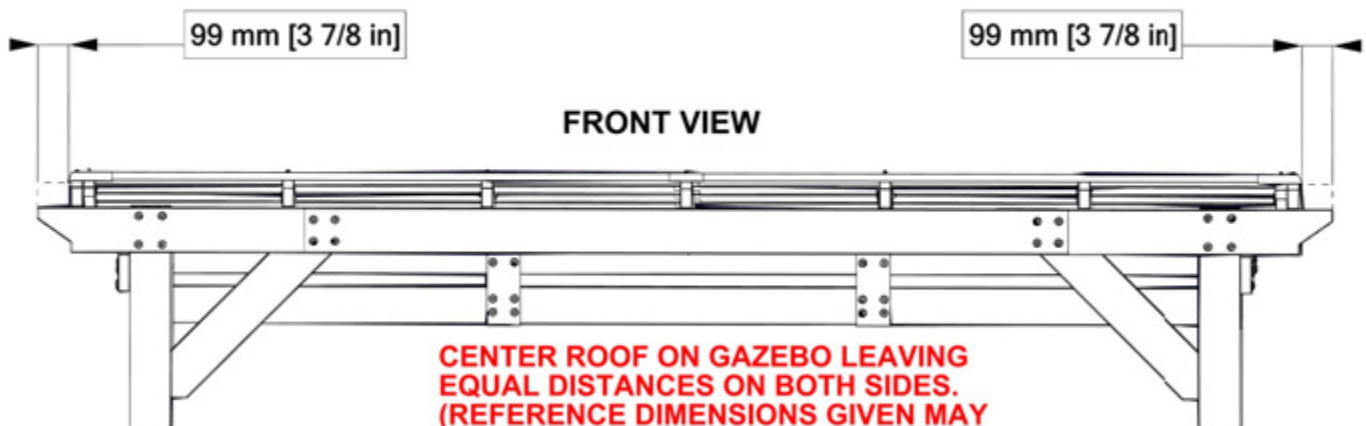
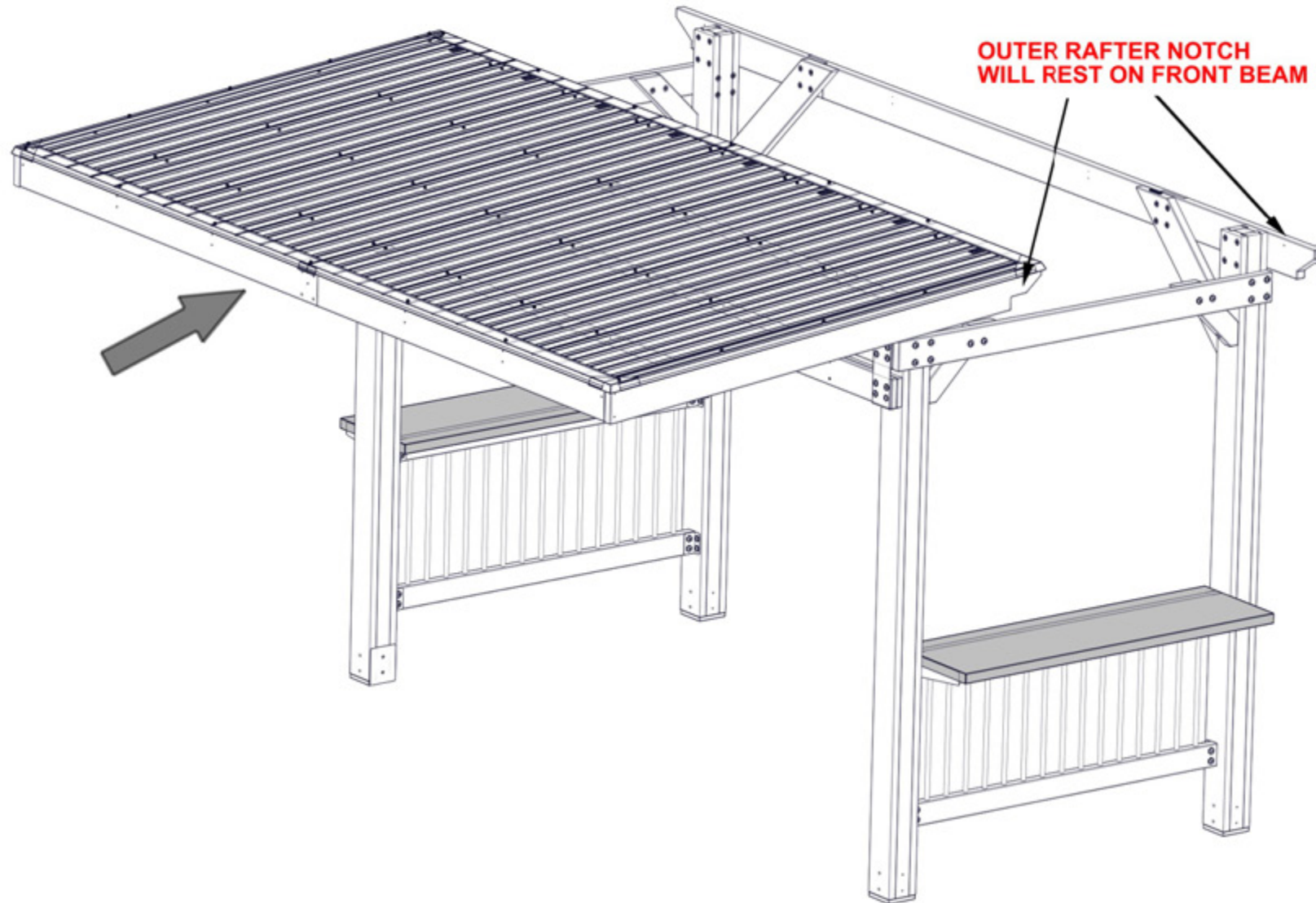

**CENTER ROOF ON GAZEBO LEAVING EQUAL DISTANCES ON BOTH SIDES. (REFERENCE DIMENSIONS GIVEN MAY CHANGE ACCORDINGLY)**

# STEP 32 - GAZEBO ASSEMBLY



A4M01228  
(x3) | RAFTER BRACKET

QTY.	PART NUMBER	DESCRIPTION
3	H100488	BOLT WH 1/4 X 2 BLK
3	H100630	WASHER FLAT 8x19 BLK
3	H100653	NUT LOCK 1/4 BLK
6	H100536	SCREW PWH 8 X 1 1/4 BLK

**REPEAT STEP TO FASTEN  
OTHER 2 RAFTER BRACKETS**

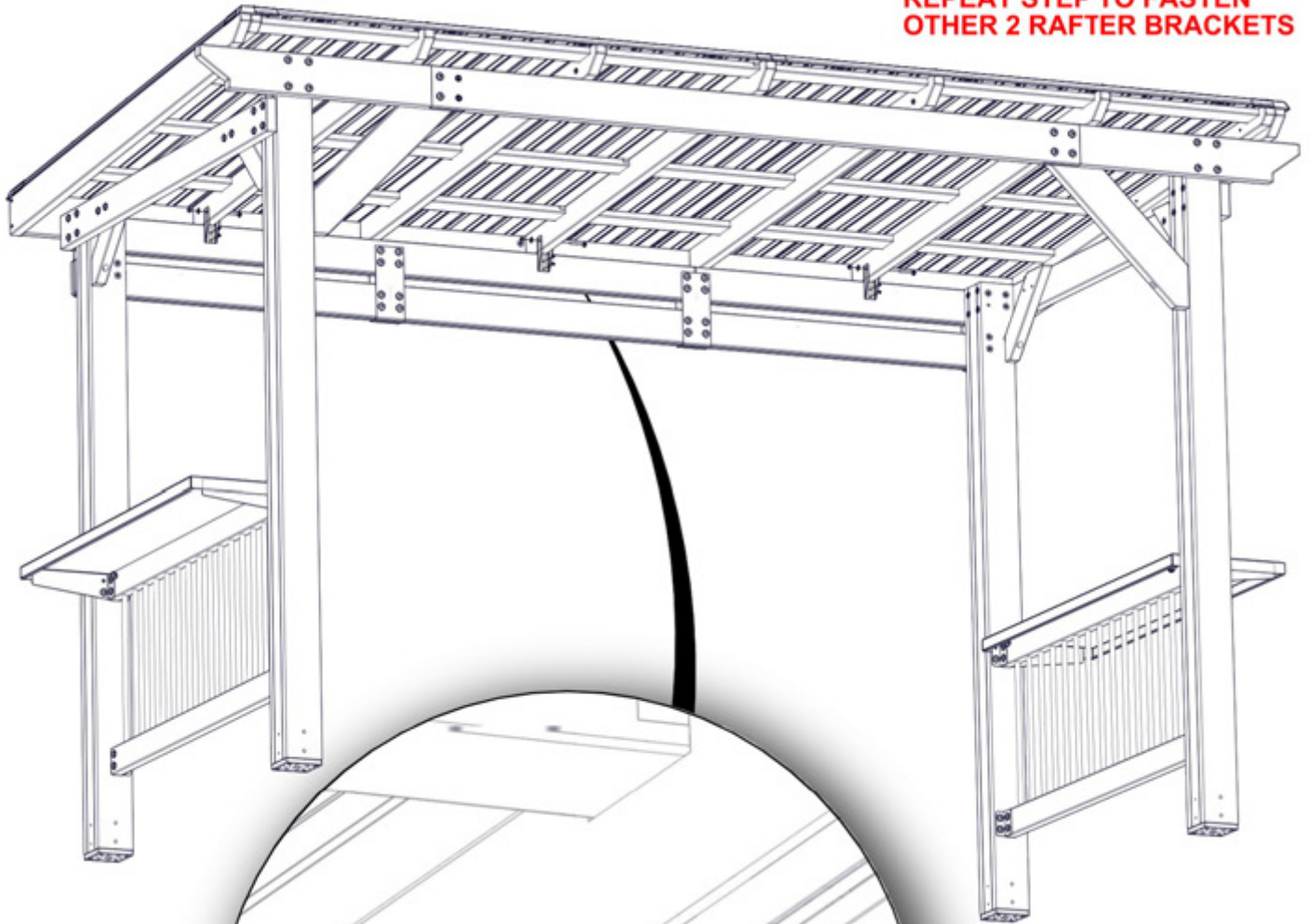

653 (x3)  
LOCK NUT - 1/4"

630 (x3)  
WASHER - 8x19

228 (x3)  
RAFTER CLIP

488 (x3)  
BOLT - 2"

536 (x6)  
SCREW - 1 1/4"

# STEP 33 - GAZEBO ASSEMBLY



A4M01228  
(x2) | RAFTER BRACKET

QTY.	PART NUMBER	DESCRIPTION
2	H100488	BOLT WH 1/4 X 2 BLK
2	H100630	WASHER FLAT 8x19 BLK
2	H100653	NUT LOCK 1/4 BLK
4	H100536	SCREW PWH 8 X 1 1/4 BLK

**REPEAT STEP TO FASTEN  
OTHER RAFTER BRACKET.**

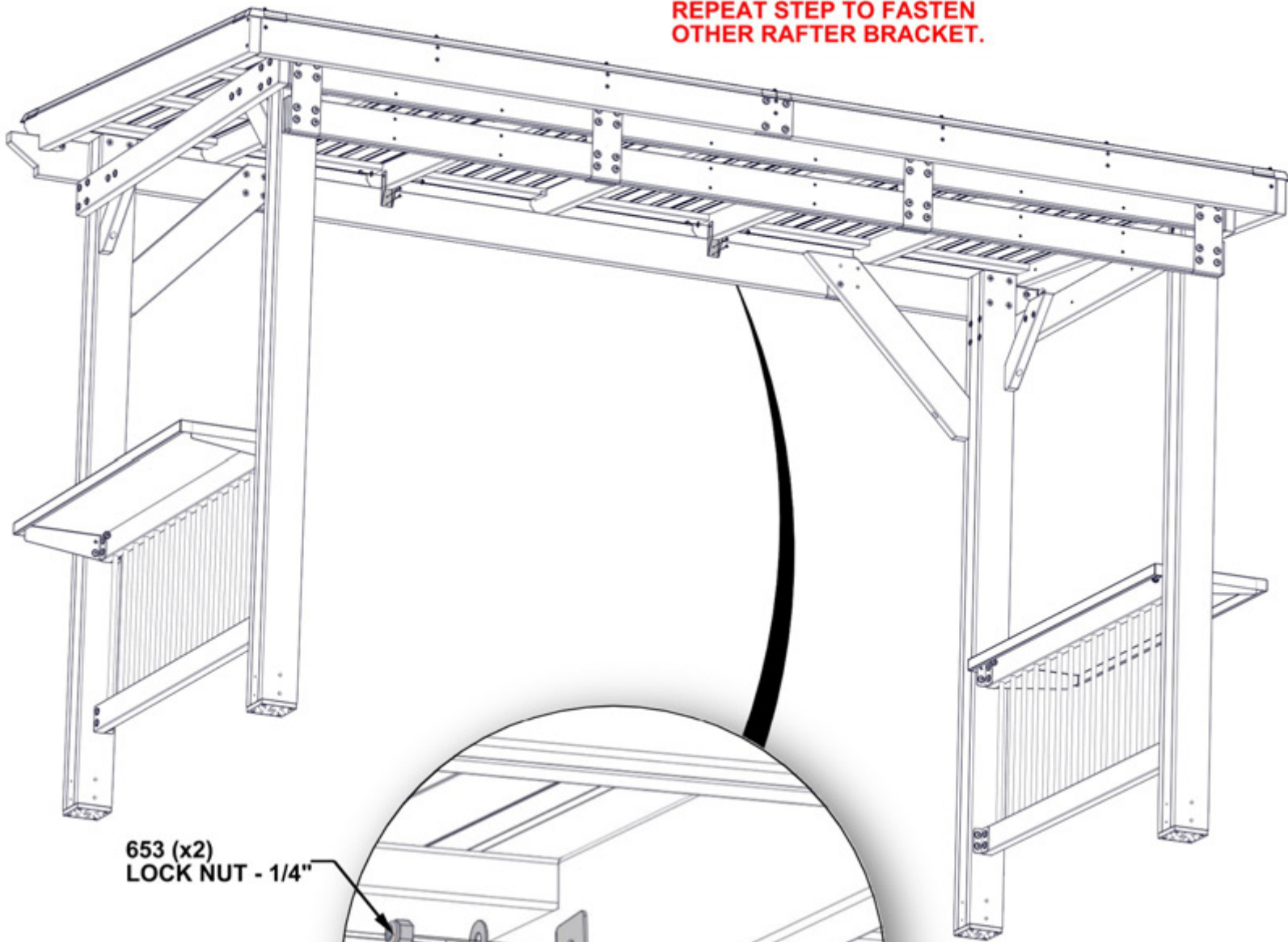

653 (x2)  
LOCK NUT - 1/4"

630 (x2)  
WASHER - 8x19

228 (x2)  
RAFTER CLIP

488 (x2)  
BOLT - 2"

536 (x4)  
SCREW - 1 1/4"

# STEP 34 - GAZEBO ASSEMBLY

QTY.	PART NUMBER	DESCRIPTION
2	H100460	LAG SCREW WH 1/4 X 1 BLK

460 (x2)  
LAG SCREW - 1"

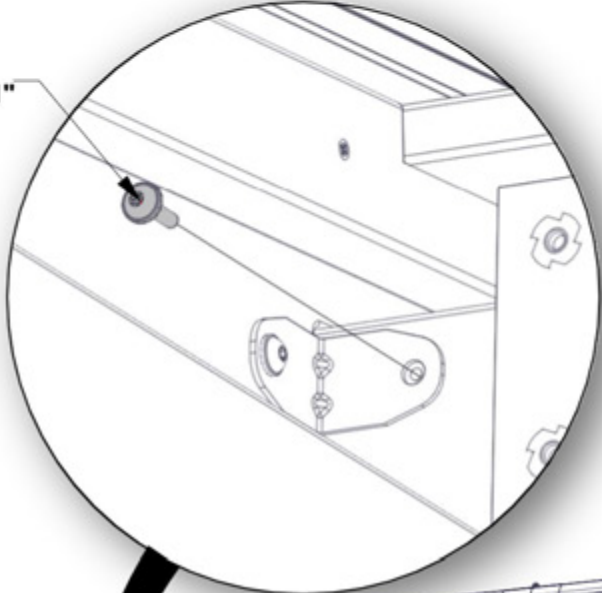

**NOTE:**  
FASTEN BOTH L BRACKETS ON ROOF  
ASSEMBLY, TO FRONT JOIST  
USING PILOT HOLE.

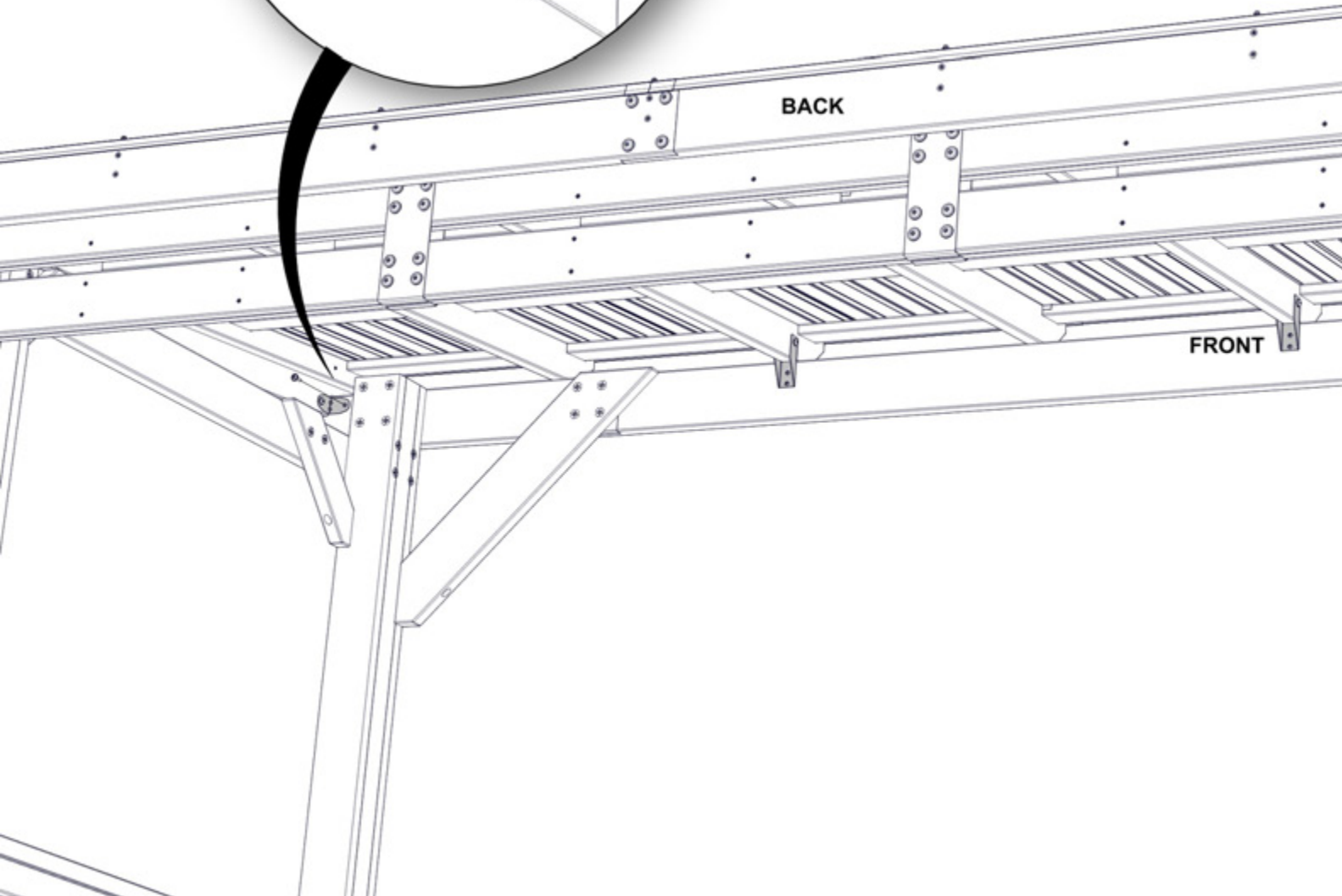

# STEP 35 - GAZEBO ASSEMBLY

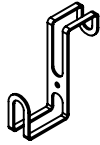

A4M01591  
(x10) | HOOK

QTY.	PART NUMBER	DESCRIPTION
10	H100392	SCREW PWH 8 X 3/4 BLK

**NOTE:**  
GAZEBO INCLUDES 10 UNIVERSAL HOOKS THAT CAN BE  
INSTALLED ANYWHERE THE CONSUMER DESIRES ALONG  
THE BACK PANEL OR SIDE RAILS OF THE GAZEBO.

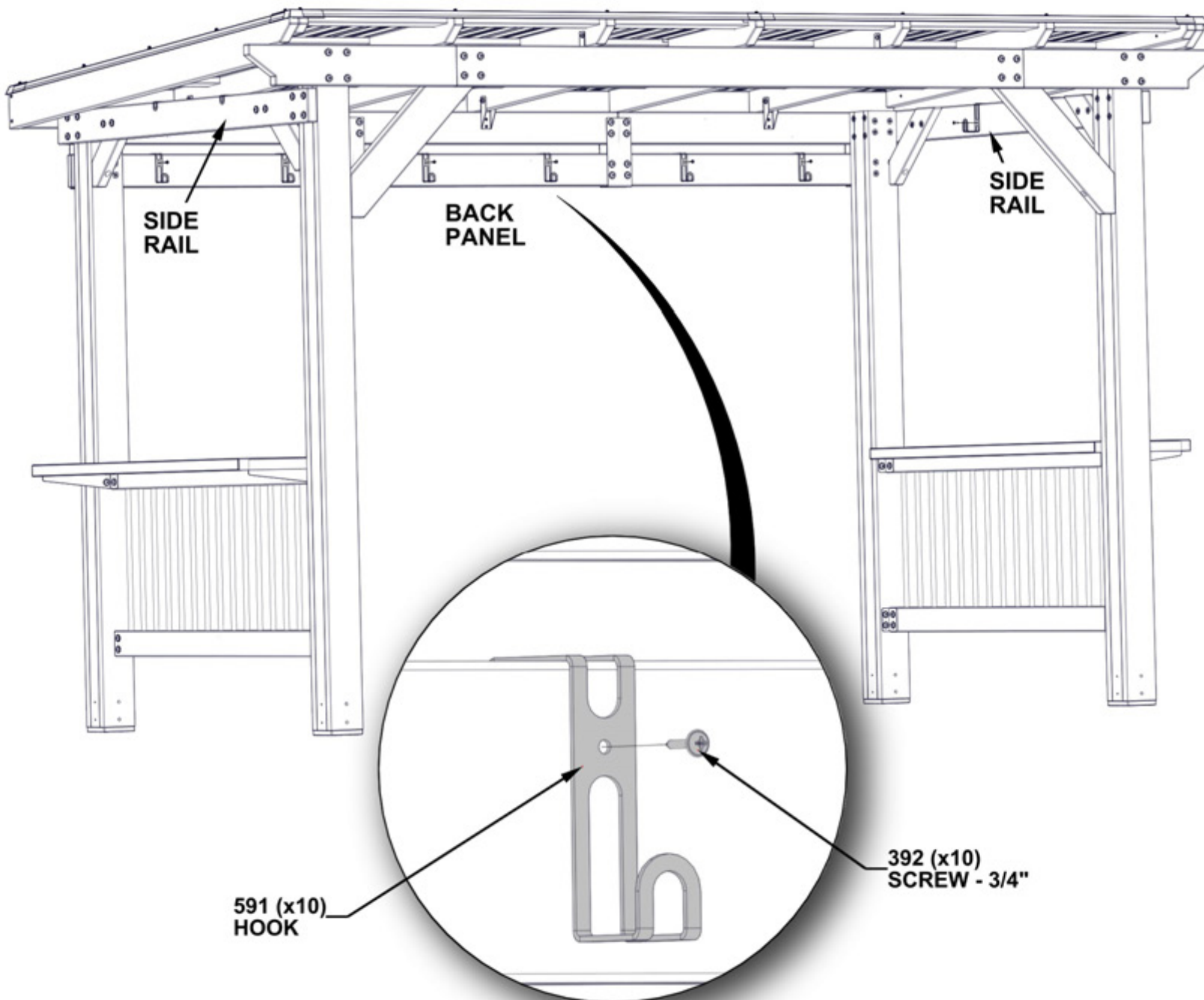

# STEP 36 - GAZEBO ASSEMBLY

QTY.	PART NUMBER	DESCRIPTION
8	H100469	NUT BARREL WH 5/16 X 5/8 BLK
8	H100480	BOLT WH 5/16 X 4 3/4 BLK
16	H100471	LAG SCREW WH 5/16 X 1 1/2 BLK



A4M01478 (x8) | POST ANCHORING PLATE

A4M01477 (x8) | POST PLATE

**NOTES:**  
**477 POST PLATES MOUNT ON LEFT AND RIGHT SIDE OF POST.**  
**478 POST ANCHORING PLATES MOUNT ON FRONT AND BACK OF POST.**

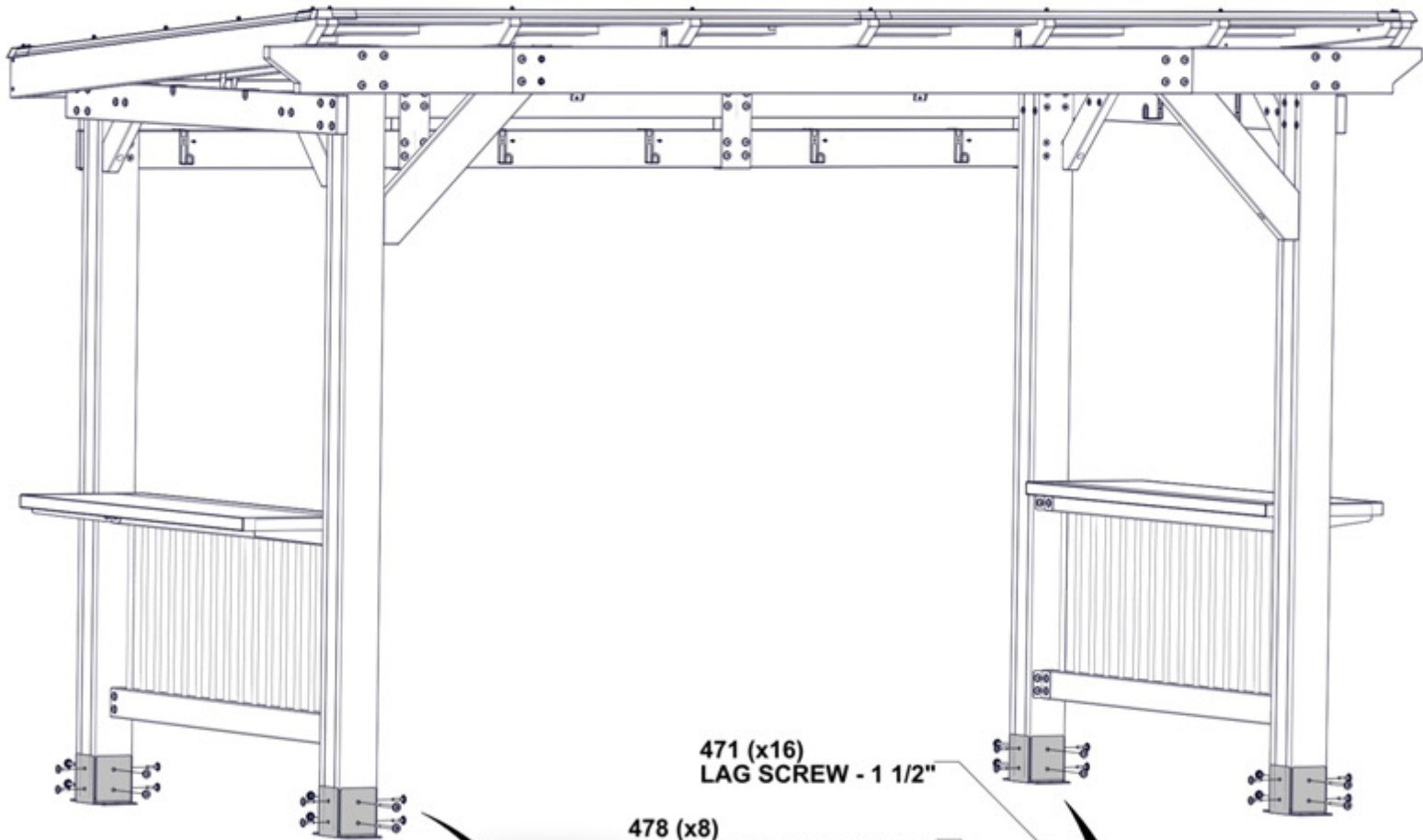

471 (x16)  
LAG SCREW - 1 1/2"

478 (x8)  
POST ANCHORING PLATE

469 (x8)  
NUT BARREL - 5/8"

480 (x8)  
BOLT - 4 3/4"

477 (x8)  
POST PLATE

# STEP 37 - GAZEBO ASSEMBLY



A100241 (x1) | BYD ID TAG (SMALL) WITHOUT AGES

QTY.	PART NUMBER	DESCRIPTION
2	H100392	SCREW PWH 8 X 3/4 BLK

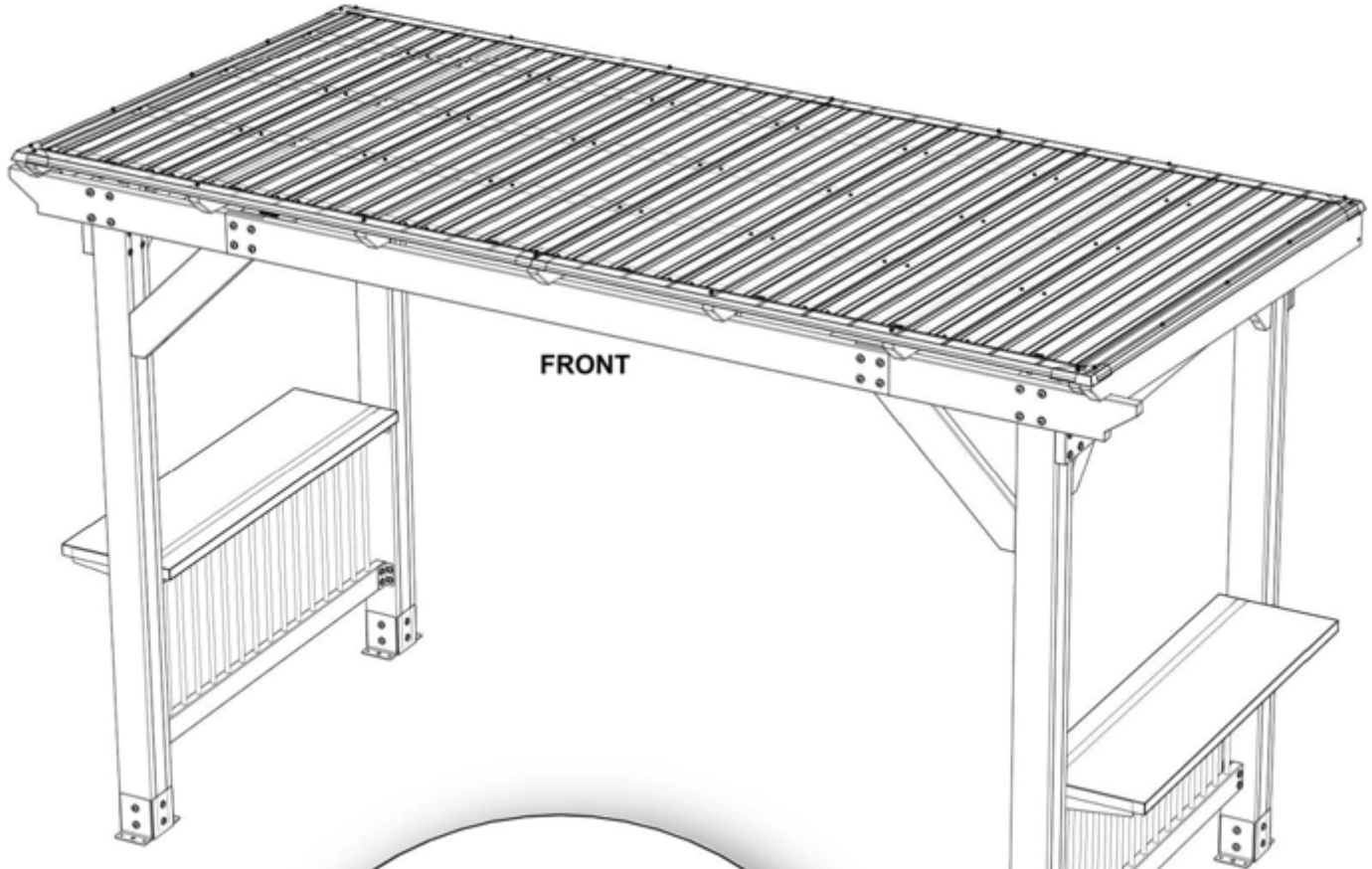

241 (x1)  
BYD ID TAG  
(SMALL) WITHOUT AGES

392 (x2)  
SCREW -3/4"

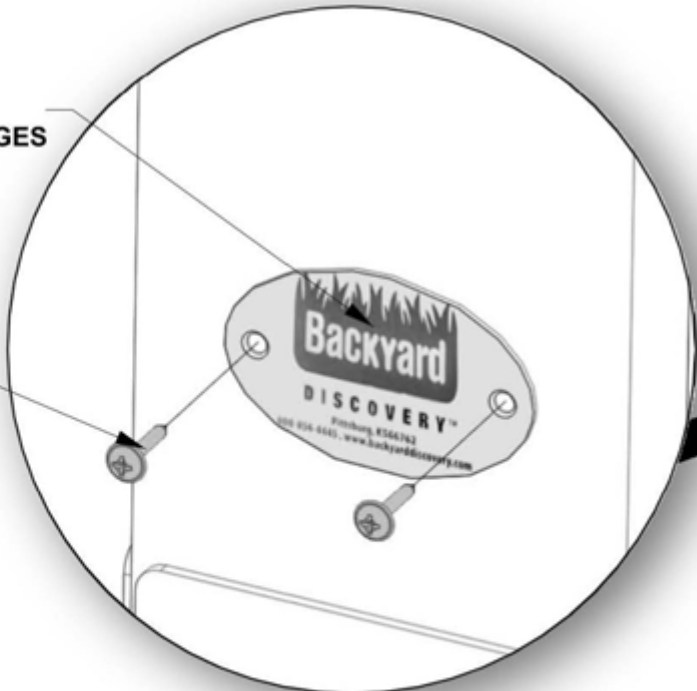



# STEP 38 - GAZEBO ASSEMBLY

QTY.	PART NUMBER	DESCRIPTION
16	H100630	WASHER FLAT 8x19 BLK
16	H100120	CONCRETE ANCHOR 1/4"x2"

**NOTES:**  
MANUFACTURER RECOMMENDS INSTALLATION ON CONCRETE SURFACE OR CONCRETE POST PADS. SEE BELOW.

**FOR INSTALLATION ON WOOD DECKS, YOU MUST ENSURE THERE IS AMPLE STRUCTURAL SUPPORT UNDER DECK.**

**NOTES:**  
PRE-DRILL HOLES FOR CONCRETE ANCHORS USING A 3/16" CONCRETE DRILL BIT.



630 (x16)  
WASHER - 8x19

120 (x16)  
SCREW - 2"

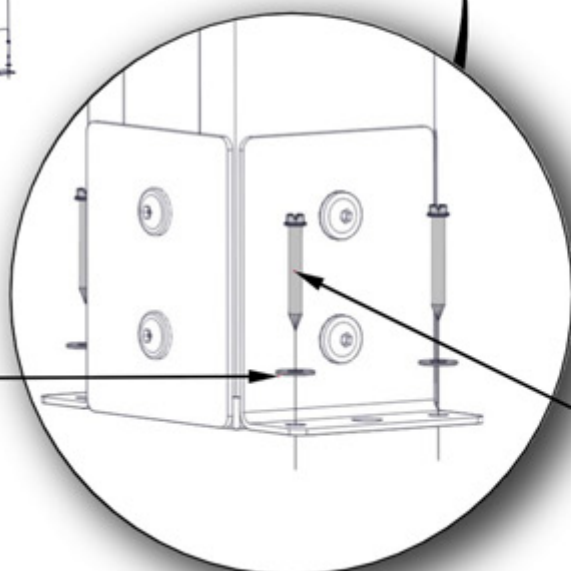

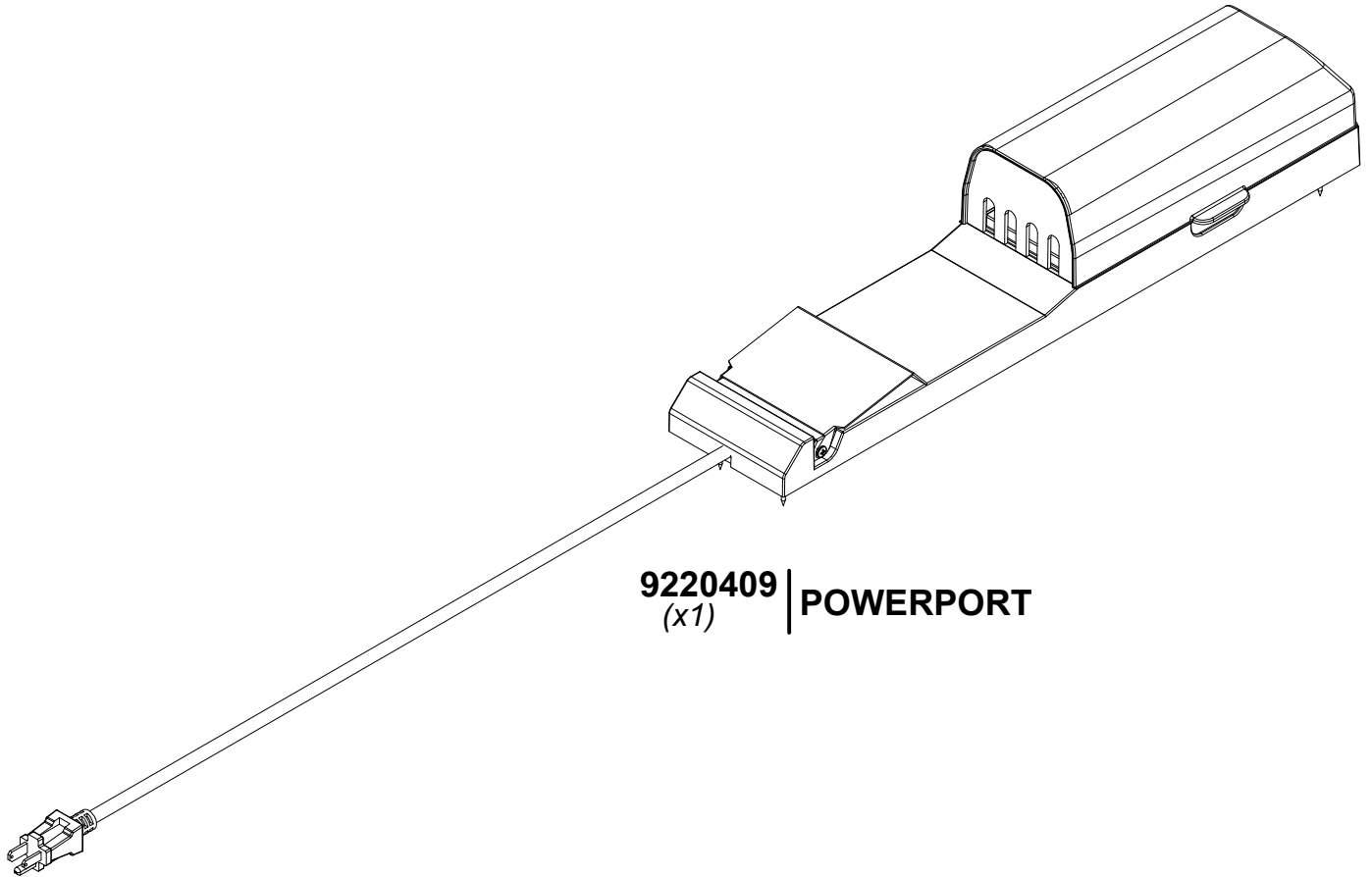

**9220409** | **POWERPORT**  
*(x1)*

FOR POWERPORT INSTALLATION REFER TO ASSEMBLY INSTRUCTIONS THAT COME PACKAGED WITH THE POWERPORT KIT. INSTALL ON ANY POST THAT IS DESIRED. FOLLOW DIRECTIONS FOR PROPER INSTALLATION.