



Manufactured by:
Backyard Discovery
3305 Airport Drive, Pittsburg, KS 66762
800-856-4445

Basepoint Business Centre: Rivermead Drive, Westlea, Swindon SN5 7EX Phone: 0800-118-2476
J.P. Coenstraat 7, The Bridge, The Hague, 2595 WP, Netherlands Phone: 08005678990

16x12 NORWOOD GAZEBO

MODEL # : 2306134B



Please visit www.backyarddiscovery.com
For the most up to date assembly manual, to register your product, or to order replacement parts *Para obtener instrucciones en español, visite*
www.backyarddiscovery.com



EASY STEP-BY-STEP
3D INTERACTIVE INSTRUCTIONS
DOWNLOAD THE FREE APP



OWNER'S MANUAL - BASIC SETUP DIMENSIONS & ASSEMBLY NOTES

It is critically important that you start with square and level footings, concrete pad or deck to attach your structure

- Pay close attention to the items needed for each step. Make sure you are using the correct hardware for each step. Using incorrect hardware may result in improper assembly
- Remember to double check for underground utilities and overhead electrical lines

Post mounts are provided with your structure which allows you to permanently install your structure to a pre-existing or new wood or concrete surface. See Anchor Instructions for further details and recommendations.

- The hardware to attach the post mounts to the structure is included.
- The hardware to mount the structure permanently to a concrete surface is included.
- The hardware to mount the structure permanently to a wood deck is NOT included and will need to be purchased separately. You must ensure there is ample structural support under the deck before permanently attaching.

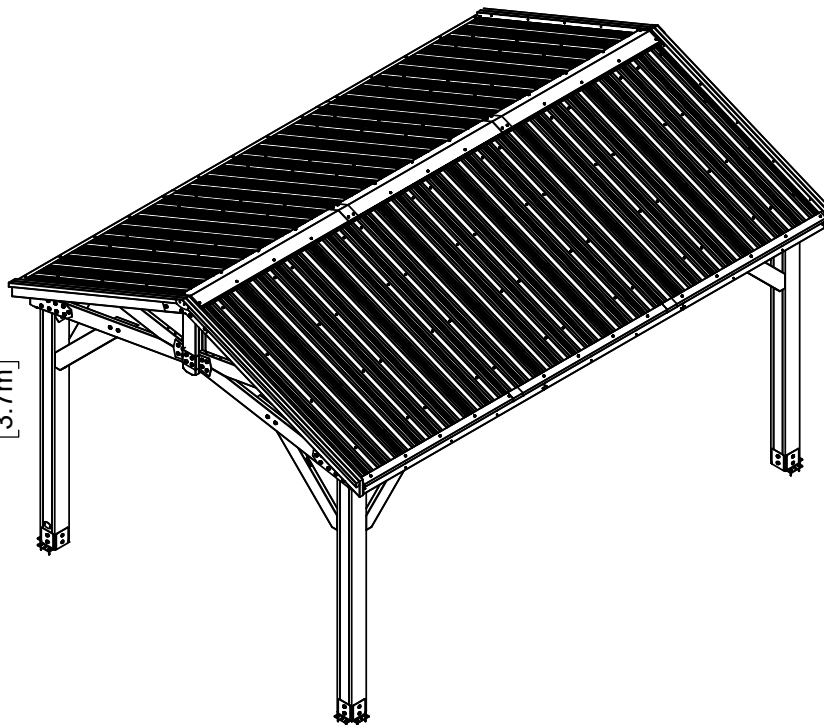
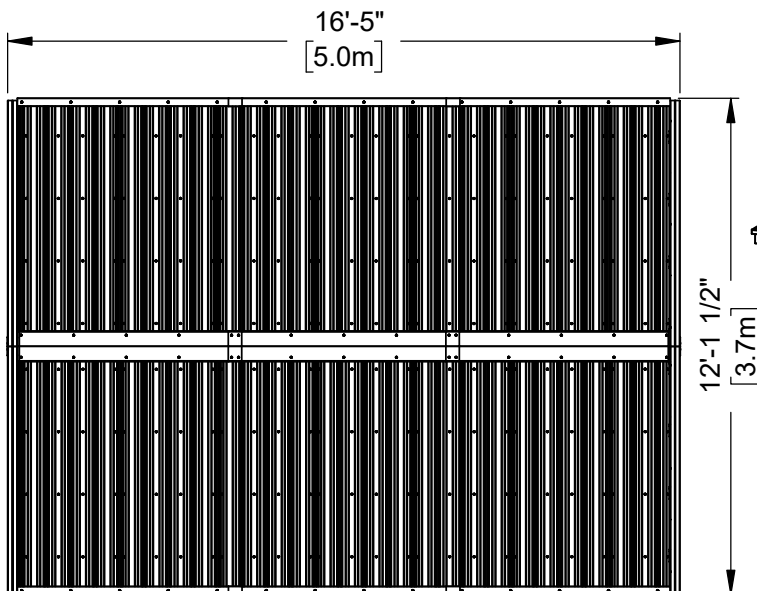
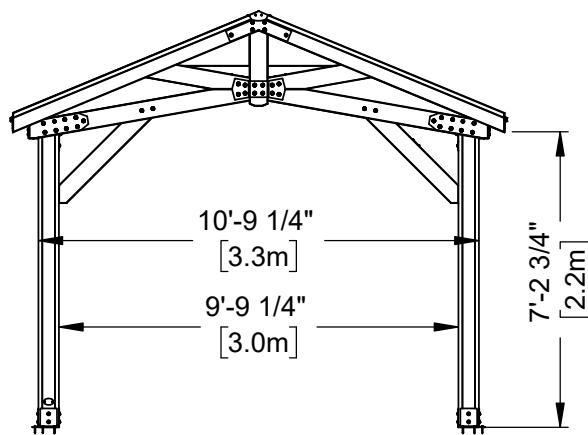
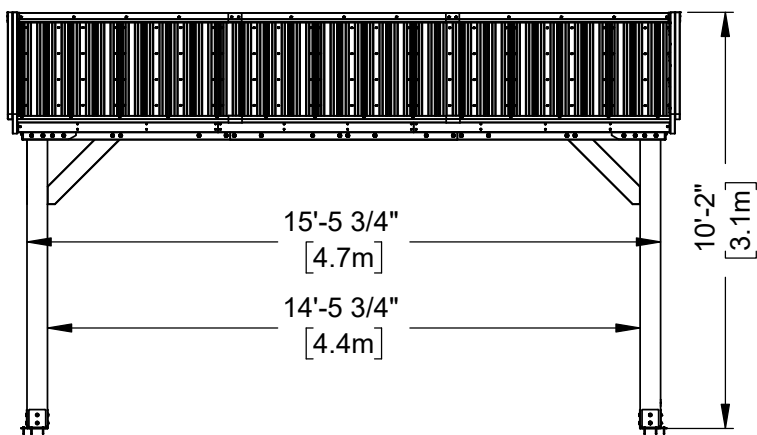

OWNER'S MANUAL - ANCHORING LAYOUT

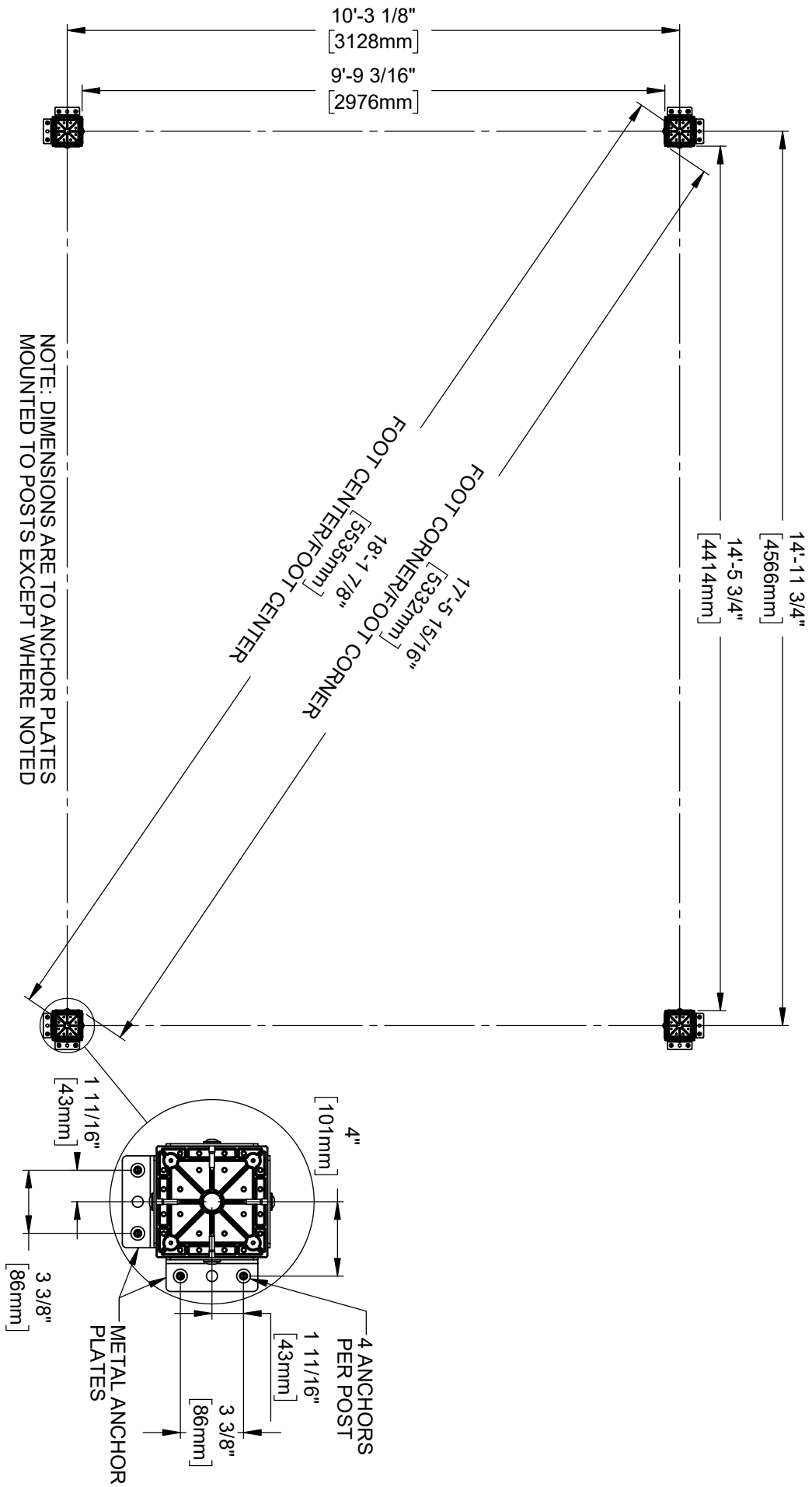

OWNER'S MANUAL - PARTS IDENTIFICATION

Wood Components (Not to Scale)

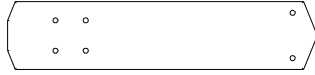

D01 | GABLE BOARD - W4L19640
(x4) | 1 3/8"x5 1/4"x24 5/8" (36x134x626)

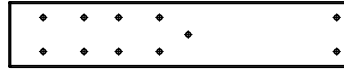

D02 | TOP RAIL - W4L16851
(x4) | 1 3/8"x5 1/4"x27 5/8" (36x134x703)

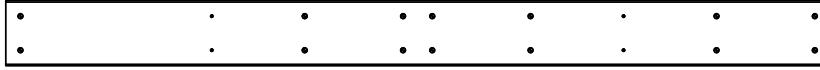

D03 | TOP RAIL - W4L16852
(x4) | 1 3/8"x5 1/4"x66 5/8" (36x134x1692)

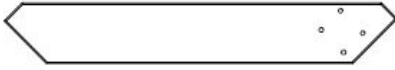

D04 | CORBEL - W4L16853
(x4) | 1 3/8"x5 1/4"x34 7/16" (36x134x875)



D05 | GABLE BOARD - W4L16854
(x2) | 1 3/8"x1 1/2"x5 1/4" (36x38x134)



D06 | CORBEL - W4L16375
(x3) | 1 3/8"x5 1/4"x44 1/16" (36x134x1119)



D07 | TOP RAIL - W4L16856
(x4) | 1 3/8"x5 1/4"x61" (36x134x1549)

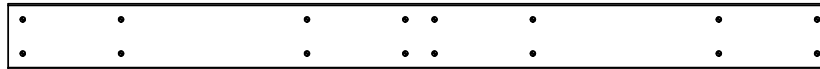

D08 | TOP RAIL - W4L16857
(x2) | 1 3/8"x5 1/4"x66 5/8" (36x134x1692)

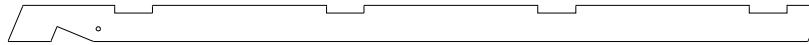

E01 | RAFTER - W4L19638
(x8) | 1 3/8"x3 3/8"x76 3/8" (36x86x1941)

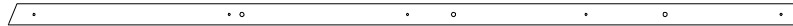

E02 | TRUSS - W4L19639
(x4) | 1 3/8"x2 3/8"x74 15/16" (36x60x1910)



E05 | RAFTER - W4L19637
(x8) | 1 3/8"x3 3/8"x76 3/8" (36x86x1941)



E06 | ACCESSORY TRUSS - W4L16863
(x8) | 1 3/8"x3 3/8"x73 13/16" (36x86x1875)

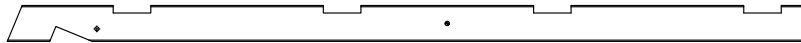

E08 | RAFTER - W4L19641
(x6) | 1 3/8"x3 3/8"x76 3/8" (36x86x1941)



G01 | COVER BOARD - W4L16917
(x2) | 1"x5 1/4"x89 1/2" (24x134x2274)

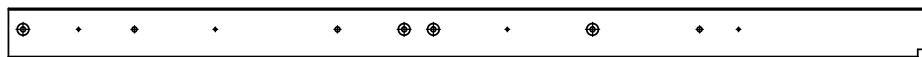

AD01 | RAFTER - W4L16866
(x2) | 1"x4"x74 3/4" (24x102x1900)



AD02 | RAFTER - W4L16867
(x2) | 1"x4"x66 3/8" (24x102x1686)

OWNER'S MANUAL - PARTS IDENTIFICATION

Wood Components (Not to Scale)



AD03 | RAFTER - W4L16868
(x2) | 1"x4"x41 5/8" (24x102x1057)



H01 | FASCIA - W4L16869
(x2) | 1"x3 3/8"x57 3/8" (24x86x1458)



H02 | FASCIA - W4L16870
(x2) | 1"x3 3/8"x58 5/8" (24x86x1490)



H03 | FASCIA - W4L16871
(x2) | 1"x3 3/8"x58 3/8" (24x86x1482)



H04 | FASCIA - W4L16872
(x1) | 1"x3 3/8"x57 3/8" (24x86x1458)



H05 | FASCIA - W4L16873
(x2) | 1"x3 3/8"x75 1/8" (24x86x1907)



H06 | FASCIA - W4L16874
(x2) | 1"x3 3/8"x41 7/8" (24x86x1064)



H07 | FASCIA - W4L16875
(x1) | 1"x3 3/8"x57 3/8" (24x86x1458)

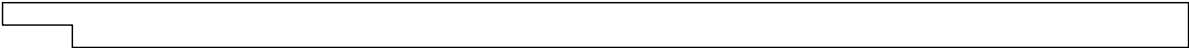

H08 | NOTCHED SUPPORT BOARD - W4L16915
(x2) | 1"x3 3/8"x89 1/2" (24x86x2274)



H09 | SHEATHING BOARD - W4L19642
(x8) | 15/16"x3 3/8"x75 1/16" (24x86x1907)



H10 | SHEATHING BOARD - W4L19643
(x8) | 15/16"x3 3/8"x57 3/8" (24x86x1458)

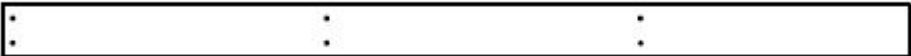

H11 | SHEATHING BOARD - W4L19644
(x8) | 15/16"x3 3/8"x58 11/16" (24x86x1490)

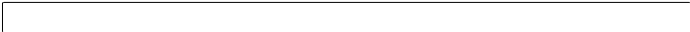

J09 | RIDGE CAP STIFFENER - W4L16876
(x4) | 1"x2 3/8"x53 7/8" (24x60x1367)

OWNER'S MANUAL - PARTS IDENTIFICATION

Wood Components (Not to Scale)



J10 | RIDGE CAP STIFFENER - W4L16877
(x2) | 1"x2 3/8"x83 1/2" (24x60x2121)



P01 | POST - W2A03501
(x2) | 6"x6"x89 1/2" (152x152x2274)



P02 | POST - W2A03502
(x2) | 6"x6"x89 1/2" (152x152x2274)

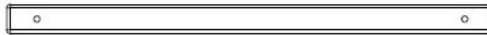

S01 | SPACER BOARD - W4L19291
(x2) | 5/8"x15/16"x16" (12x24x406)

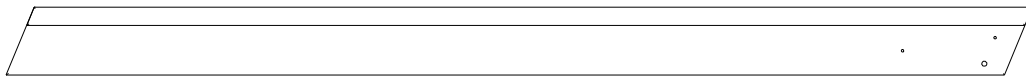

GP1 | GABLE PANEL - W2A04177
(x2) | 2 7/8"x5 1/4"x80 3/16" (72x134x2037)

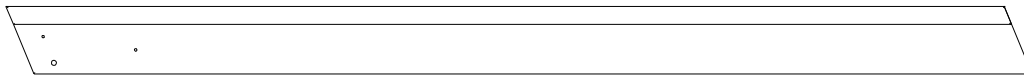

GP2 | GABLE PANEL - W2A04178
(x2) | 2 7/8"x5 1/4"x80 3/16" (72x134x2037)



CA01 | CORBEL - W2A03461
(x1) | 1 7/16"x5 3/8"x44 1/16" (36x136x1119)

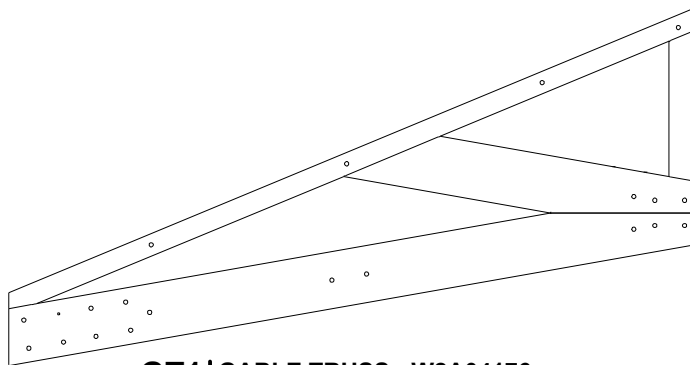

GT1 | GABLE TRUSS - W2A04176
(x4) | 1 7/16"x34"x64 9/16" (36x864x1640)

OWNER'S MANUAL - PARTS IDENTIFICATION

Hardware Components

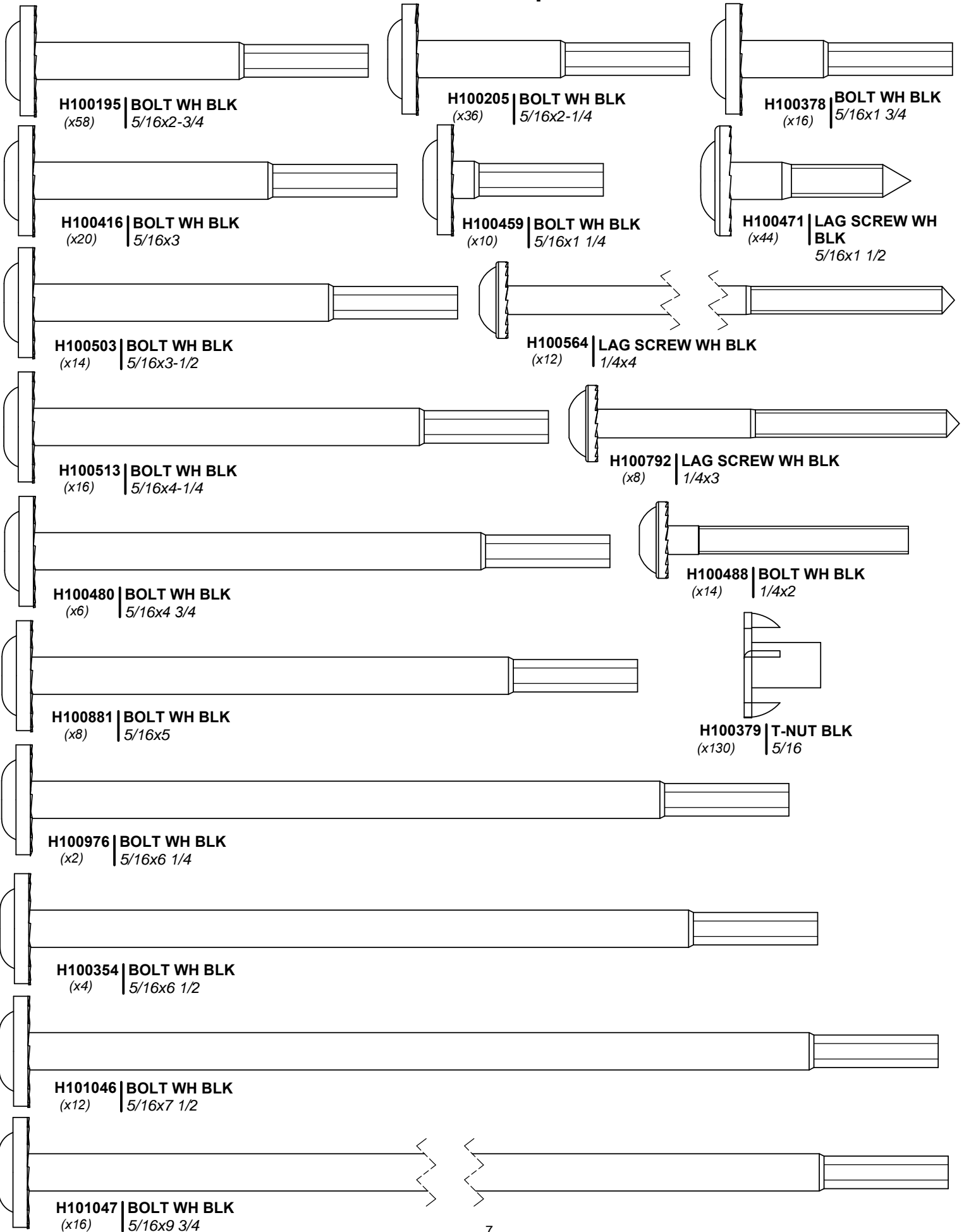

OWNER'S MANUAL - PARTS IDENTIFICATION

Hardware Components

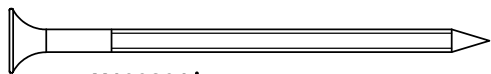

H100201 | SCREW PFH BLK
(60) | 8x2-1/2

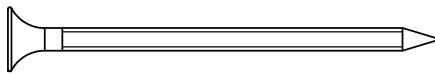

H100483 | SCREW PFH BLK
(x4) | 8x2 1/4

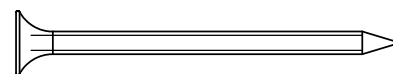

H100391 | SCREW PFH BLK
(x268) | 8x2

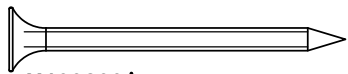

H100200 | SCREW PFH BLK
(x20) | 8x1 1/2

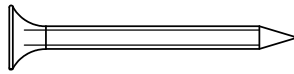

H100382 | SCREW PFH BLK
(x16) | 8x1 3/4

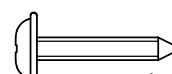

H100392 | SCREW PWH BLK
(x26) | 8x3/4

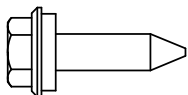

H100833 | SCREW WOODGRIP
(x262) | 10x3/4

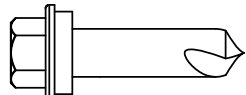

H100759 | SCREW TAPPING
(x28) | 1/4x3/4

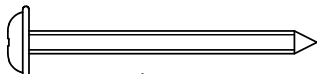

H100823 | SCREW PWH BLK
(x28) | 8x1-1/2

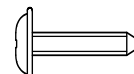

H100202 | SCREW PWH BLK
(x4) | 8x5/8

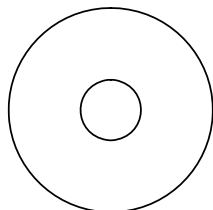

H100478 | WASHER FLAT BLK
(92) | 8x27

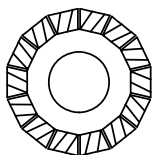

H100198 | WASHER LOCK EXT BLK
(x128) | 8x19

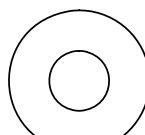

H100630 | WASHER FLAT BLK
(x30) | 8x19

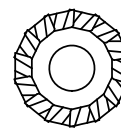

H100405 | WASHER LOCK EXT BLK
(x20) | 6x15

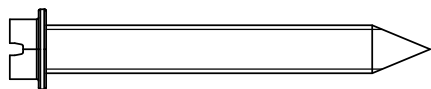

H100120 | SCREW CONCRETE ANCHOR
(x16) | 1/4x2

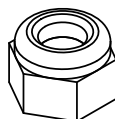

H100479 | NUT LOCK BLK
(x88) | 5/16



H100653 | NUT LOCK BLK
(x14) | 1/4

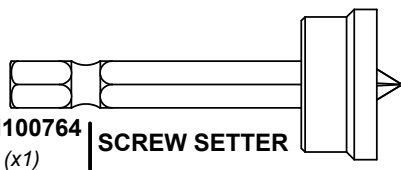

H100764 | SCREW SETTER
(x1)

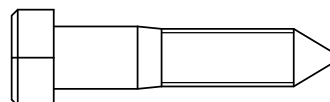

H100659 | LAG SCREW BLK
(x4) | 5/16x1 1/2

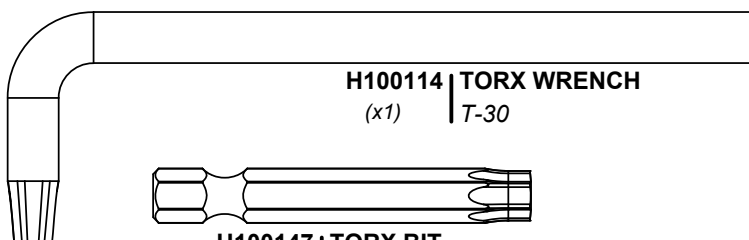

H100114 | TORX WRENCH
(x1) | T-30

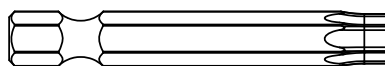

H100147 | TORX BIT
(x1) | T-30

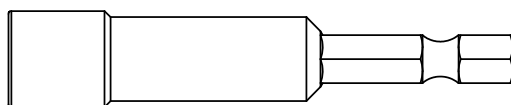

H101106 | HEX DRIVER
(x1) | 5/16

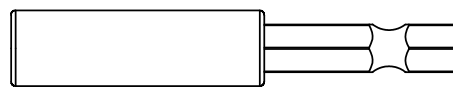

H101100 | MAGNETIC DRIVER
(x1)

OWNER'S MANUAL - PARTS IDENTIFICATION

Accessory Components (Not to Scale)

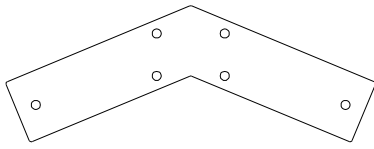

A4M01130 | GABLE BRACKET
(x2)

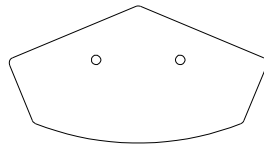

A4M01147 | PEAK SEAM BRACKET
(x2)

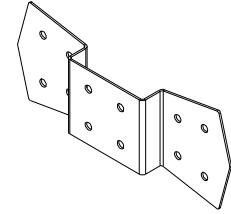

A4M01129 | GABLE BRACKET
(x4)

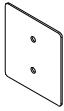

A4M00978 | POST PLATE
(x8)

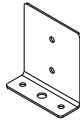

A4M00977 | POST ANCHORING PLATE
(x8)

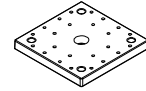

A6P00308 | 6x6 POST FOOT
(x4)

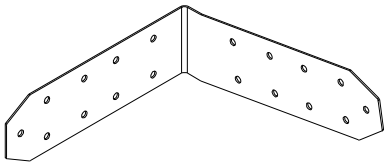

A4M01301 | RIGHT OUTSIDE BRACKET
(x2)

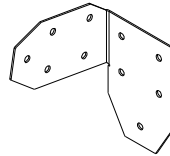

A4M01232 | LEFT ANGLE BRACKET
(x2)

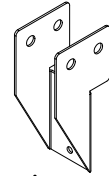

A4M01752 | RAFTER CLIP
(x14)

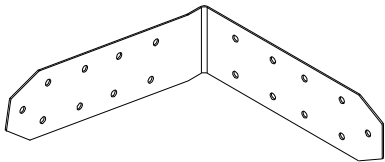

A4M01302 | LEFT OUTSIDE BRACKET
(x2)

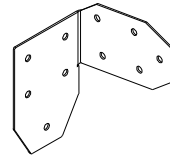

A4M01233 | RIGHT ANGLE BRACKET
(x2)

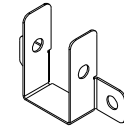

A4M01148 | TRUSS BRACKET
(x2)



A4M02158 | BYD ID TAG PATIO
(x1)

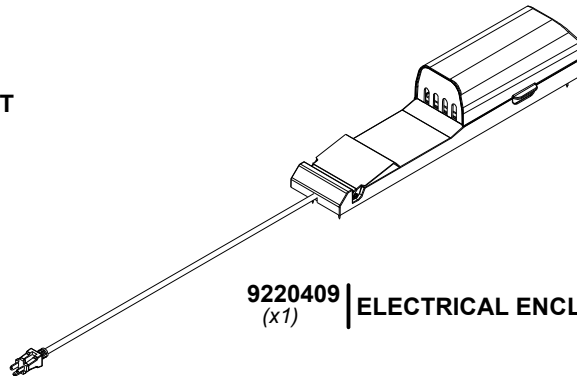

9220409 | ELECTRICAL ENCLOSURE
(x1)

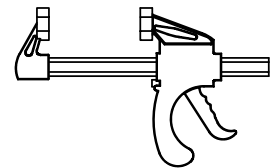

A6P00460 | 6" QUICK RELEASE BAR CLAMP
(x2)

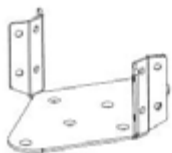

A4M02501 | FAN MOUNT BRACKET
(x1)



A4M02679 | ROOF END TRIM
(x1)

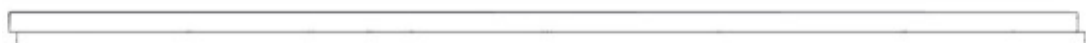

A4M02680 | ROOF END TRIM
(x1)



A4M03426 | ROOF END TRIM
(x1)



A4M03427 | ROOF END TRIM
(x1)

OWNER'S MANUAL - PARTS IDENTIFICATION

Accessory Components (Not to Scale)



A4M02646 29 GA STEEL SHEETING
(x2)

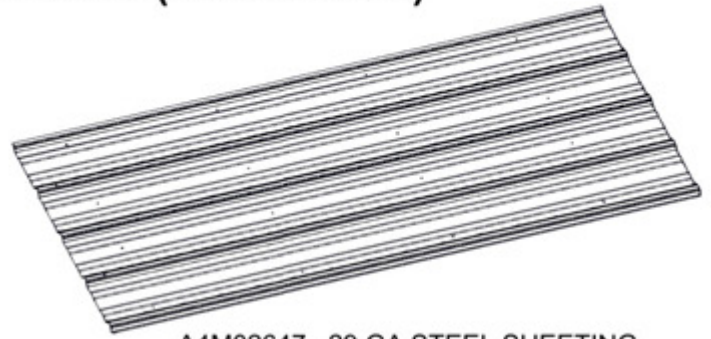

A4M02647 29 GA STEEL SHEETING
(x2)

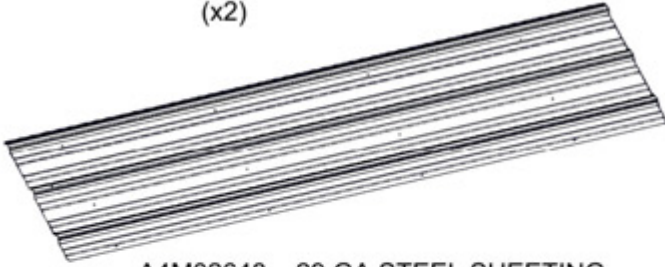

A4M02648 29 GA STEEL SHEETING
(x1)

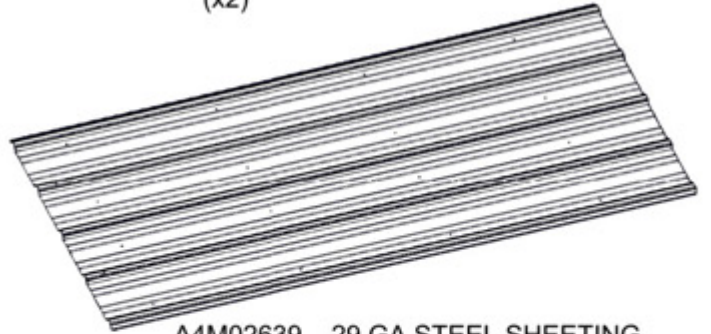

A4M02639 29 GA STEEL SHEETING
(x4)

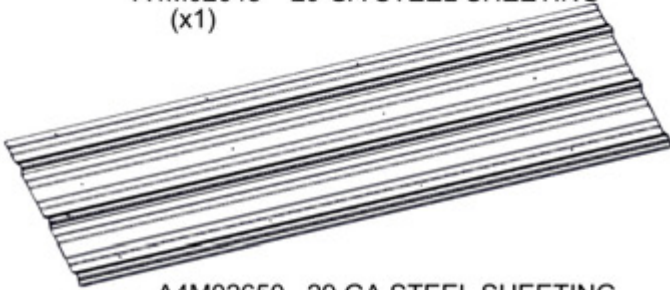

A4M02650 29 GA STEEL SHEETING
(x1)

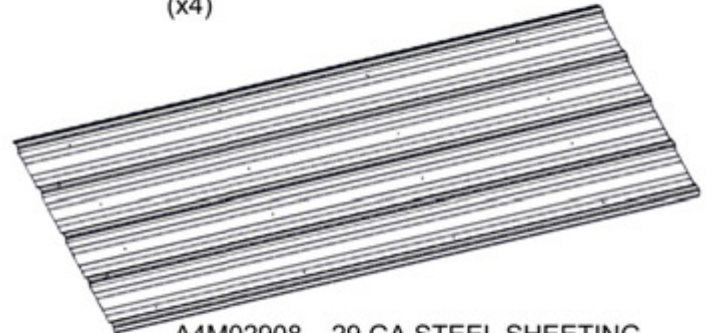

A4M02908 29 GA STEEL SHEETING
(x2)



A4M02653 16 FOOT ROOF EDGE TRIM
(x6)



A4M02654 16 FOOT RIDGE CAP 29 GA
(x3)

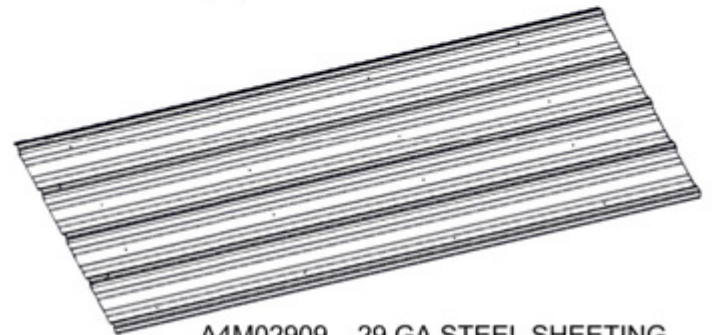

A4M02909 29 GA STEEL SHEETING
(x2)



A4M02377 GAZEBO BRACE
METAL
(x2)

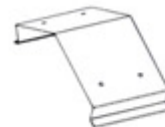

A4M02640 RIDGE CAP SPLICE
(x2)

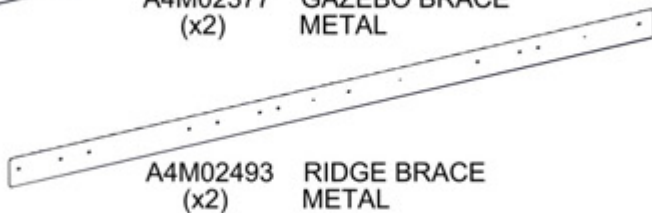

A4M02493 RIDGE BRACE
METAL
(x2)



A4M02638 ROOF EDGE TRIM SPLICE
(x4)

A6P00398 RIDGE CAP PROTECTOR
(x2)

PRE-ASSEMBLY STEP 1 - SORTING PARTS

It is critical for ease of assembly that you take the time to sort and organize the wood and hardware.

WOOD PARTS:

- Organize wood parts by the three-digit, alpha-numeric number stamped on each board (ex. P01).
- If there are multiple boards with the same stamped number, stack those pieces together.
- Stamps can be found on the flat surface of the boards or on the end of the boards.
- Allow yourself plenty of room - the wood pieces can take up a significant amount of space.

NOTE: CARTONS ARE NOT ORGANIZED BY BOARD NUMBER.



HARDWARE PARTS:

- We recommend that you have a separate table to organize the hardware.
- Hardware bags are printed with a seven-digit, alpha-numeric part number.
- You can organize your hardware by part number or group by hardware type (i.e. bolts, nuts, etc.).
- During assembly you only need to reference the last four digits of the number.

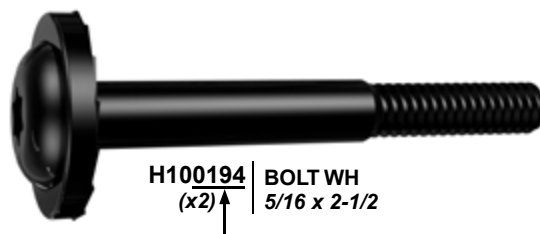

PRE-ASSEMBLY STEP 2 - TOOLS REQUIRED



Cordless Drill or Electric Drill



Drill Attachments:
Phillips Head



1/8", 3/16", 3/8" &
7/16" Drill Bits



Phillips Screw Driver



Open End Wrenches
1/2" & 9/16"



3/8" Drive Ratchet, 1/2" &
7/16" STD Sockets 1/2" & 7/16"
Deep Sockets



Claw Hammer



Rubber Mallet -
Optional

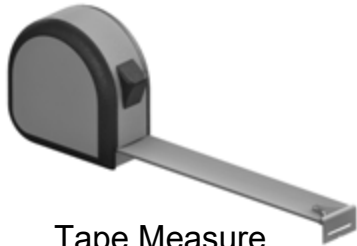

Tape Measure

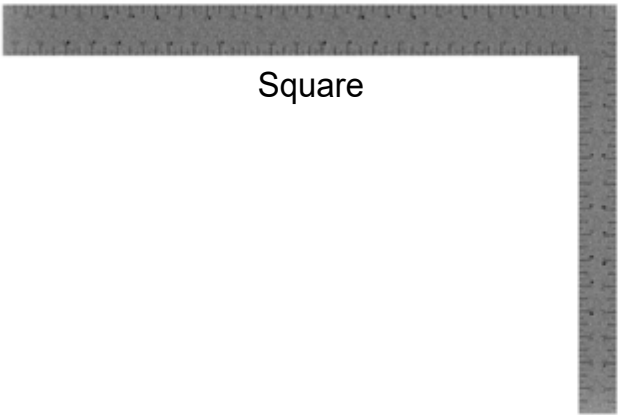

Square



Level 24"

PRE-ASSEMBLY STEP 3 - CHOOSE YOUR ASSEMBLY METHOD

There are several types of assembly instructions available to you.

1. Printed Assembly Manual included with your set
2. BILT APP - 3D interactive instructions
3. Combination of the Printed Manual and BILT APP (Note: Step numbers can differ between the two methods)

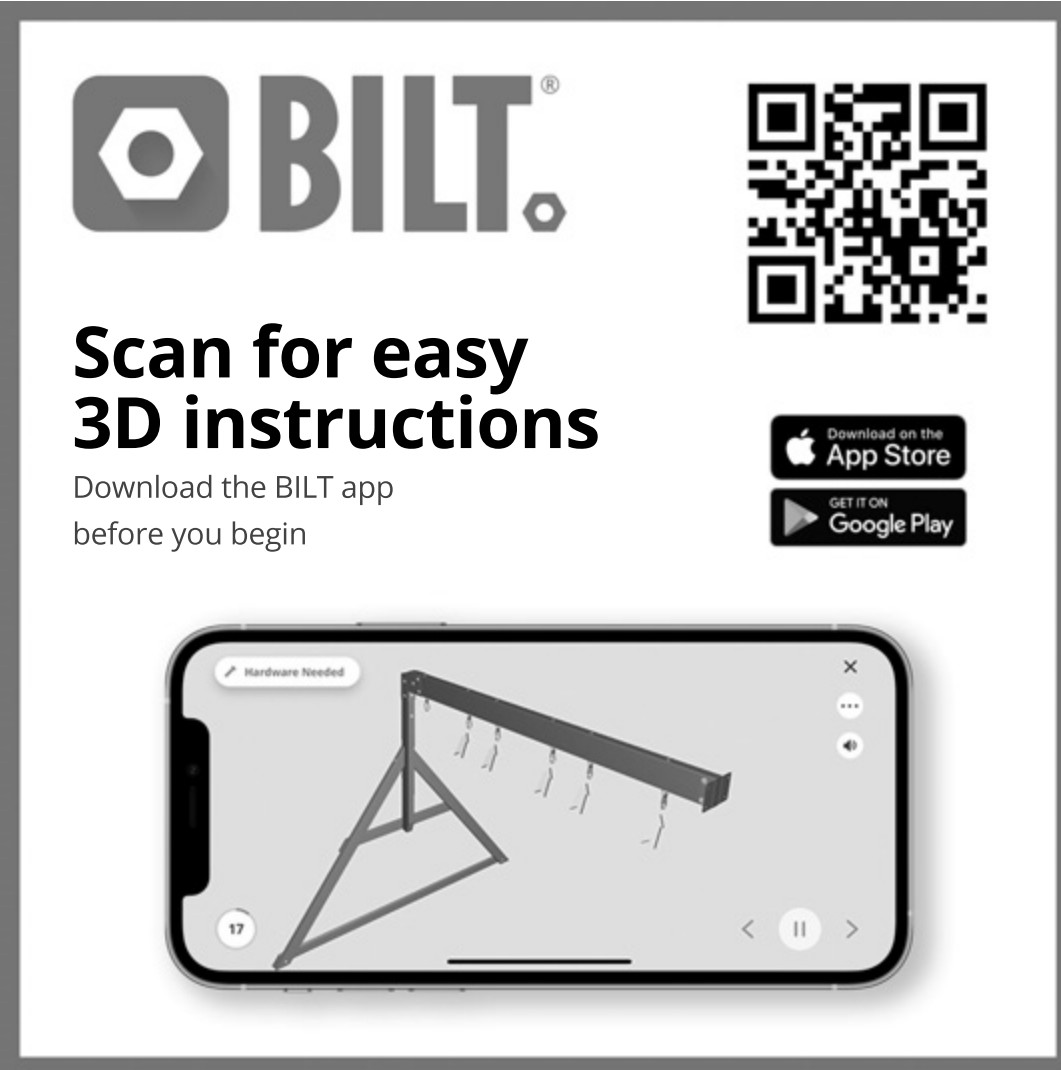

The graphic features the BILT logo (a hexagon with a bolt head inside) and the word "BILT." in a bold, sans-serif font. To the right is a large QR code. Below the logo, the text "Scan for easy 3D instructions" is written in a large, bold font. Underneath this, it says "Download the BILT app before you begin". To the right of the text are two buttons: "Download on the App Store" and "GET IT ON Google Play". At the bottom, a smartphone screen displays a 3D assembly instruction for step 17, showing a metal frame with a horizontal bar and several bolts being attached. The screen includes a "Hardware Needed" list, a close button (X), a menu button (three dots), a back button (left arrow), a play/pause button (II), and a forward button (right arrow).

STEP 4 - POST ASSEMBLY

QTY	PART NUMBER	DESCRIPTION
8	H100200	SCREW PFH 8 X 1 1/2 BLK



P01 POST - W2A03501
(x1) 6"x6"x89 1/2" (152x152x2274)

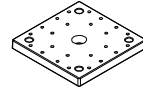

A6P00308 6x6 POST FOOT
(x2)

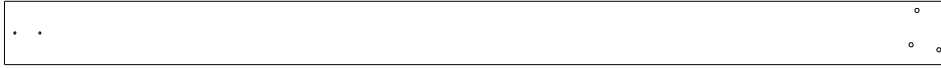

P02 POST - W2A03502
(x1) 6"x6"x89 1/2" (152x152x2274)

- FOR EASE OF ASSEMBLY, WE RECOMMEND USING SAW HORSES FOR STEPS 4 - 11.

P01 (x1)
POST

P02 (x1)
POST

ALIGN POST FOOT AND DRILL 1/8" PILOT HOLES FOR THE ATTACHMENT OF HARDWARE.

200 (x8)
SCREW - 1 1/2"

308 (x2)
6x6 POST FOOT

STEP 5 - END GABLE ASSEMBLY

QTY	PART NUMBER	DESCRIPTION
2	H100483	SCREW PFH 8 X 2 1/4 BLK



D01 GABLE BOARD - W4L19640
(x1) 1 3/8"x5 1/4"x24 1/4" (36x134x626)



D05 GABLE BOARD - W4L16854
(x1) 1 3/8"x1 1/2"x5 1/4" (36x38x134)

- ALIGN D05 WITH D01 ENSURING THAT BOTTOM FACES ARE FLUSH.
- DRILL 1/8" PILOT HOLES IN D01 USING D05 AS TEMPLATE.

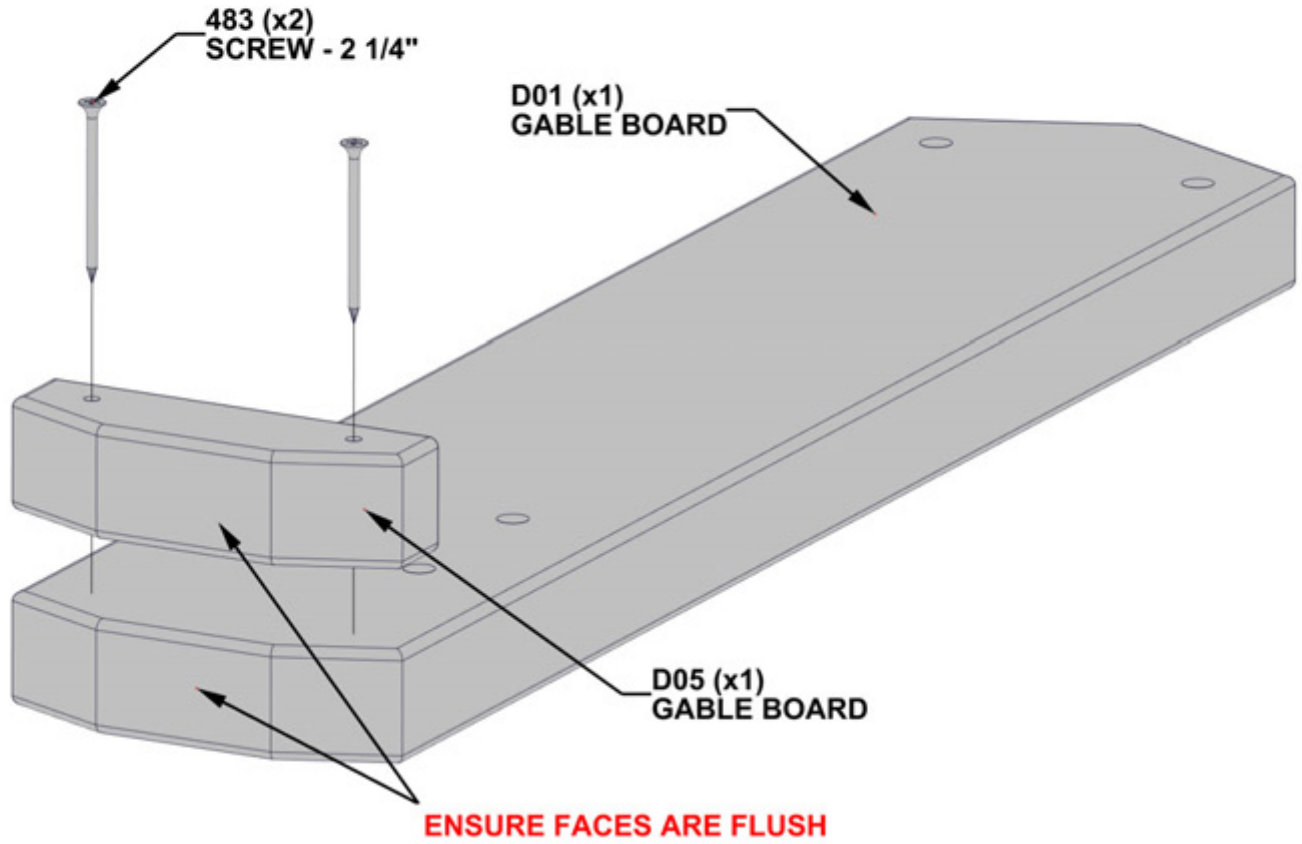

STEP 6 - END GABLE ASSEMBLY

QTY	PART NUMBER	DESCRIPTION
4	H100478	WASHER FLAT 8X27 BLK
4	H100479	NUT LOCK 5/16 BLK
4	H100881	BOLT WH 5/16 X 5 BLK

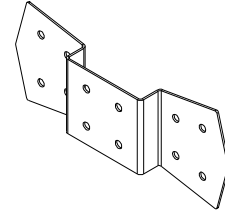
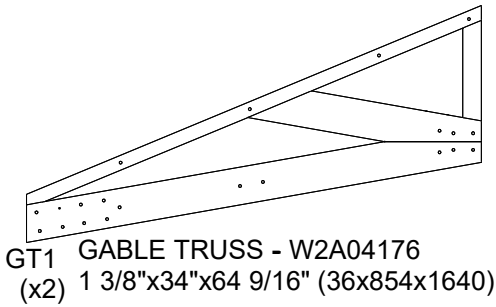

- IF HOLES DO NOT ALIGN, USE METAL BRACKET AS A GUIDE AND DRILL THROUGH USING A 7/16" - (10mm) DRILL BIT, THEN ASSEMBLE.

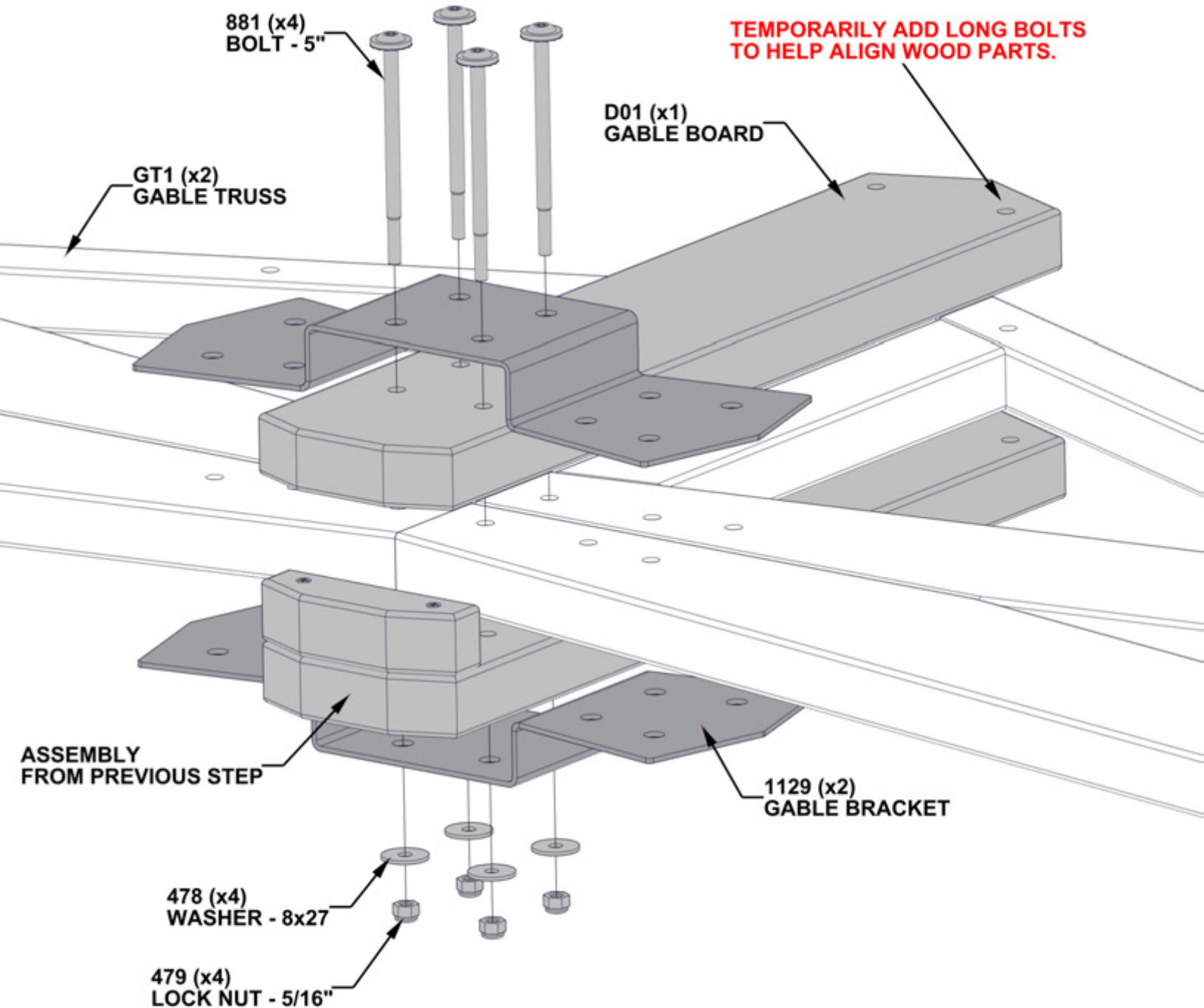

STEP 7 - END GABLE ASSEMBLY

QTY	PART NUMBER	DESCRIPTION
8	H100205	BOLT WH 5/16 X 2 1/4 BLK
8	H100478	WASHER FLAT 8X27 BLK
8	H100479	NUT LOCK 5/16 BLK

- IF HOLES DO NOT ALIGN, USE METAL BRACKET AS A GUIDE AND DRILL THROUGH USING A 7/16" - (10mm) DRILL BIT, THEN ASSEMBLE.

ENSURE THAT ALL BOLT HEADS ARE ON THE SAME SIDE.

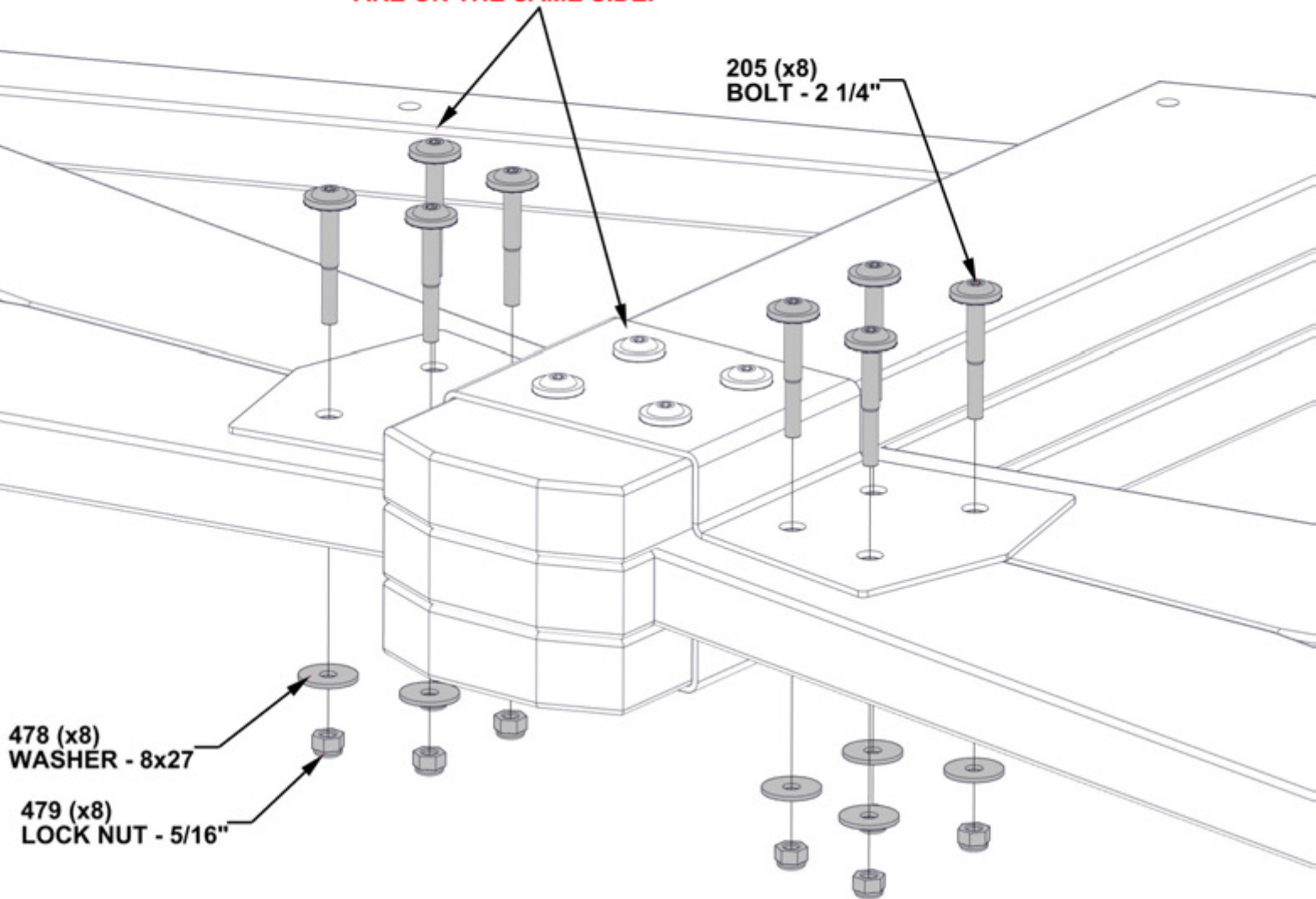

STEP 8A - END GABLE ASSEMBLY

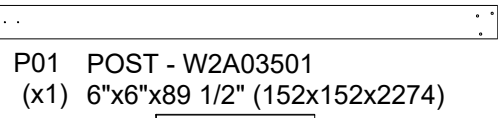

P01 POST - W2A03501
(x1) 6"x6"x89 1/2" (152x152x2274)

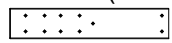

D02 TOP RAIL - W4L16851
(x1) 1 3/8"x5 1/4"x27 5/8" (36x134x703)

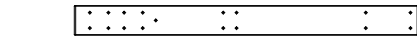

D07 TOP RAIL - W4L16856
(x1) 1 3/8"x5 1/4"x61" (36x134x1549)

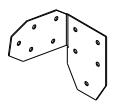

A4M01232 LEFT ANGLE BRACKET
(x1)

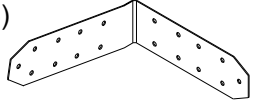

A4M01302 LEFT OUTSIDE BRACKET
(x1)

QTY	PART NUMBER	DESCRIPTION
5	H100205	BOLT WH 5/16 X 2 1/4 BLK
8	H100379	T-NUT 5/16 BLK
5	H100416	BOLT WH 5/16 X 3 BLK
1	H100471	LAG SCREW WH 5/16 X 1 1/2 BLK
10	H100478	WASHER FLAT 8X27 BLK
9	H100479	NUT LOCK 5/16 BLK
1	H100659	LAG SCREW HEX 5/16x1 1/2 BLK
3	H101046	BOLT WH 5/16 X 7 1/2 BLK
4	H101047	BOLT WH 5/16 X 9 3/4 BLK

- INSERT T-NUTS FIRST

ENSURE CORRECT ORIENTATION OF POST.

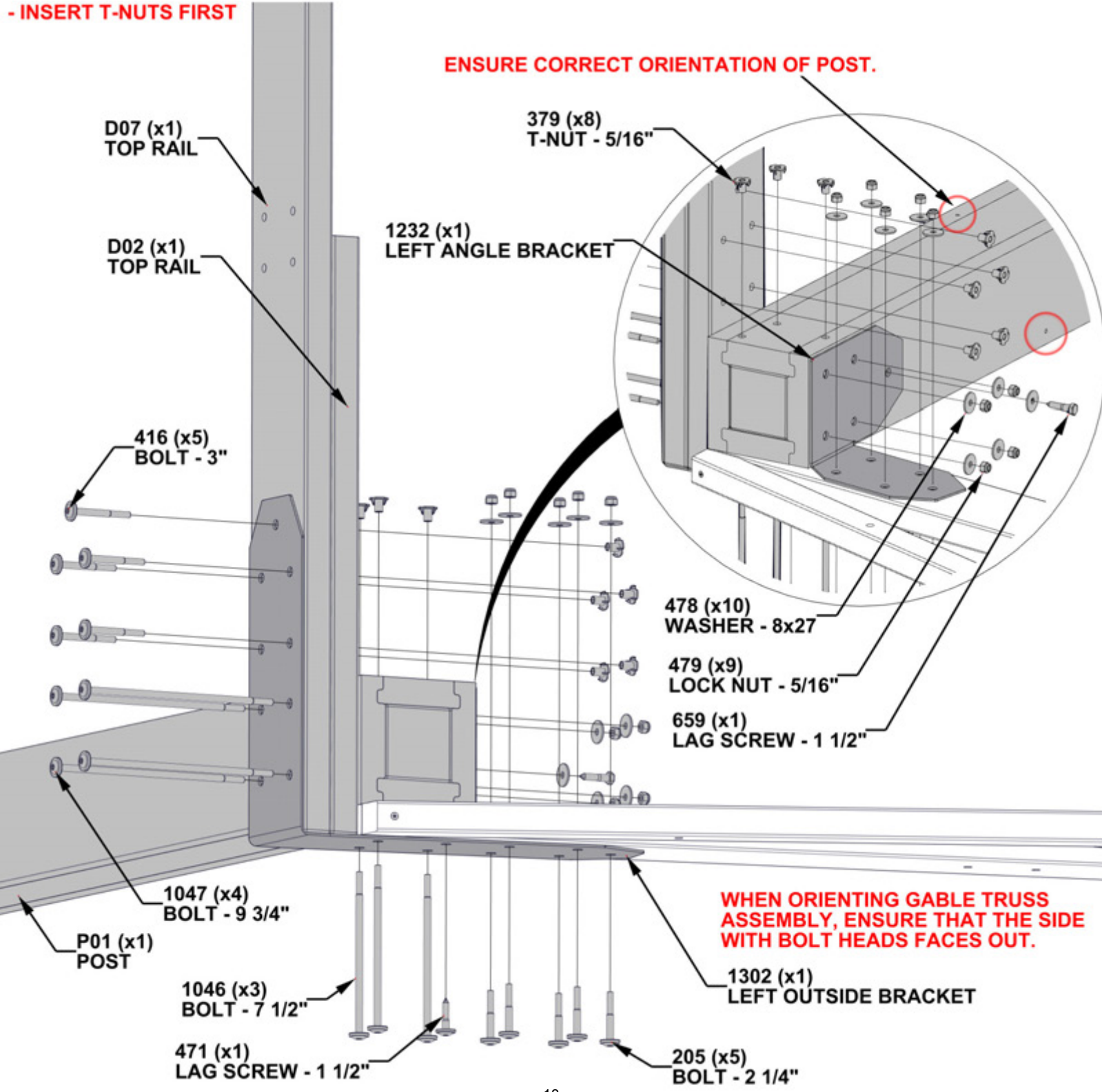

STEP 8B - END GABLE ASSEMBLY

QTY	PART NUMBER	DESCRIPTION
5	H100205	BOLT WH 5/16 X 2 1/4 BLK
8	H100379	T-NUT 5/16 BLK
5	H100416	BOLT WH 5/16 X 3 BLK
1	H100471	LAG SCREW WH 5/16 X 1 1/2 BLK
10	H100478	WASHER FLAT 8X27 BLK
9	H100479	NUT LOCK 5/16 BLK
1	H100659	LAG SCREW HEX 5/16x1 1/2 BLK
3	H101046	BOLT WH 5/16 X 7 1/2 BLK
4	H101047	BOLT WH 5/16 X 9 3/4 BLK

P02 POST - W2A03502
(x1) 6"x6"x89 1/2" (152x152x2274)



D02 TOP RAIL - W4L16851
(x1) 1 3/8"x5 1/4"x27 5/8" (36x134x703)

D07 TOP RAIL - W4L16856
(x1) 1 3/8"x5 1/4"x61" (36x134x1549)

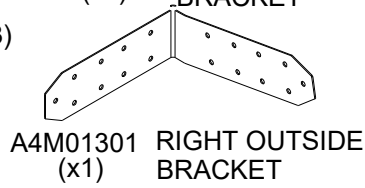

- INSERT T-NUTS FIRST

ENSURE CORRECT ORIENTATION OF POST.

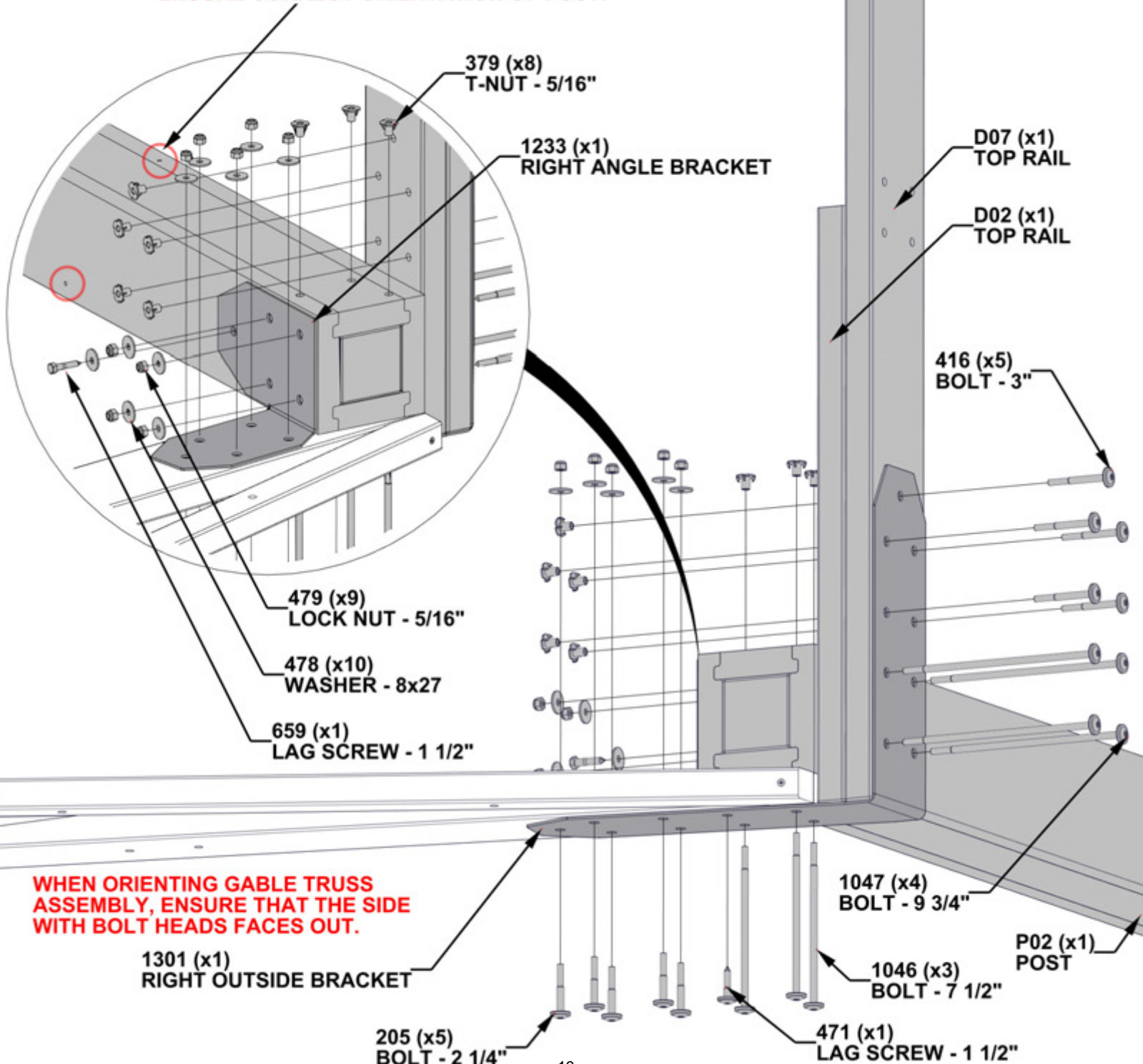

STEP 9 - GAZEBO ASSEMBLY

QTY	PART NUMBER	DESCRIPTION
4	H100195	BOLT WH 5/16x2 3/4 BLK
4	H100198	WASHER LOCK EXT 8x19
4	H100379	T-NUT 5/16 BLK
2	H100405	WASHER LOCK EXT 6x15
2	H100792	LAG SCREW WH 1/4x3 BLK

CA01 CORBEL WITH TAG - W2A03461
 (x1) 1 3/8"x5 1/4"x44 1/16" (36x134x1119)

D06 CORBEL - W4L16375
 (x3) 1 3/8"x5 1/4"x44 1/16" (36x134x1119)

- WHEN BUILDING THE SECOND END GABLE, TWO D06 BOARDS WILL BE USED.
- INSERT T-NUTS FIRST

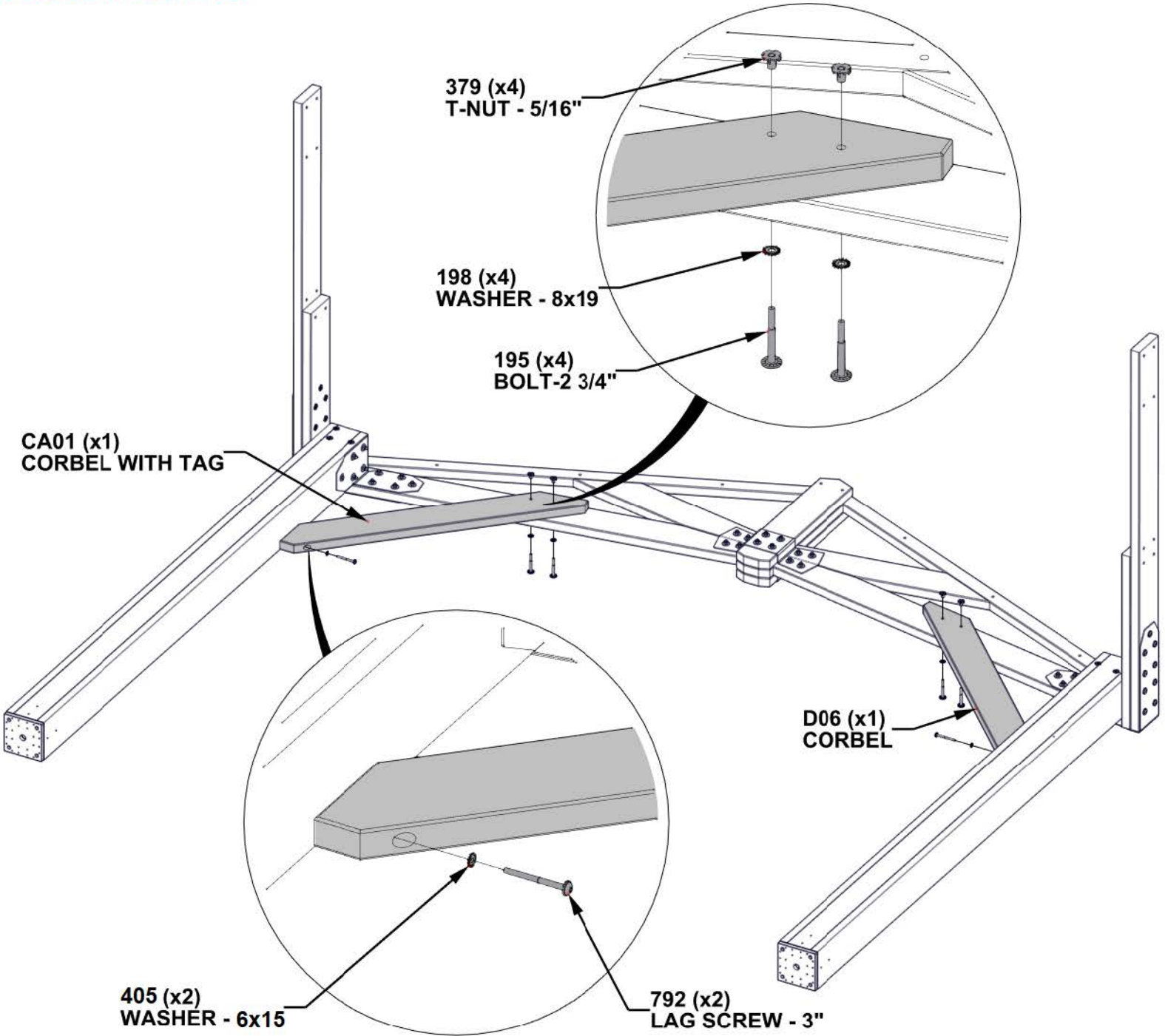

STEP 10 - GAZEBO ASSEMBLY

QTY	PART NUMBER	DESCRIPTION
4	H100195	BOLT WH 5/16x2 3/4 BLK
12	H100198	WASHER LOCK EXT 8x19
4	H100201	SCREW PFH 8x2 1/2 BLK
32	H100379	T-NUT 5/16 BLK
2	H100405	WASHER LOCK EXT 6x15
8	H100513	BOLT WH 5/16x4 1/4 BLK
2	H100792	LAG SCREW WH 1/4x3 BLK



D03 TOP RAIL - W4L16852
(x2) 1 3/8"X5 1/4"X66 5/8" (36x134x1692)



D04 CORBEL - W4L16853
(x2) 1 3/8"X5 1/4"X34 7/16" (36x134x875)

- INSERT T-NUTS FIRST

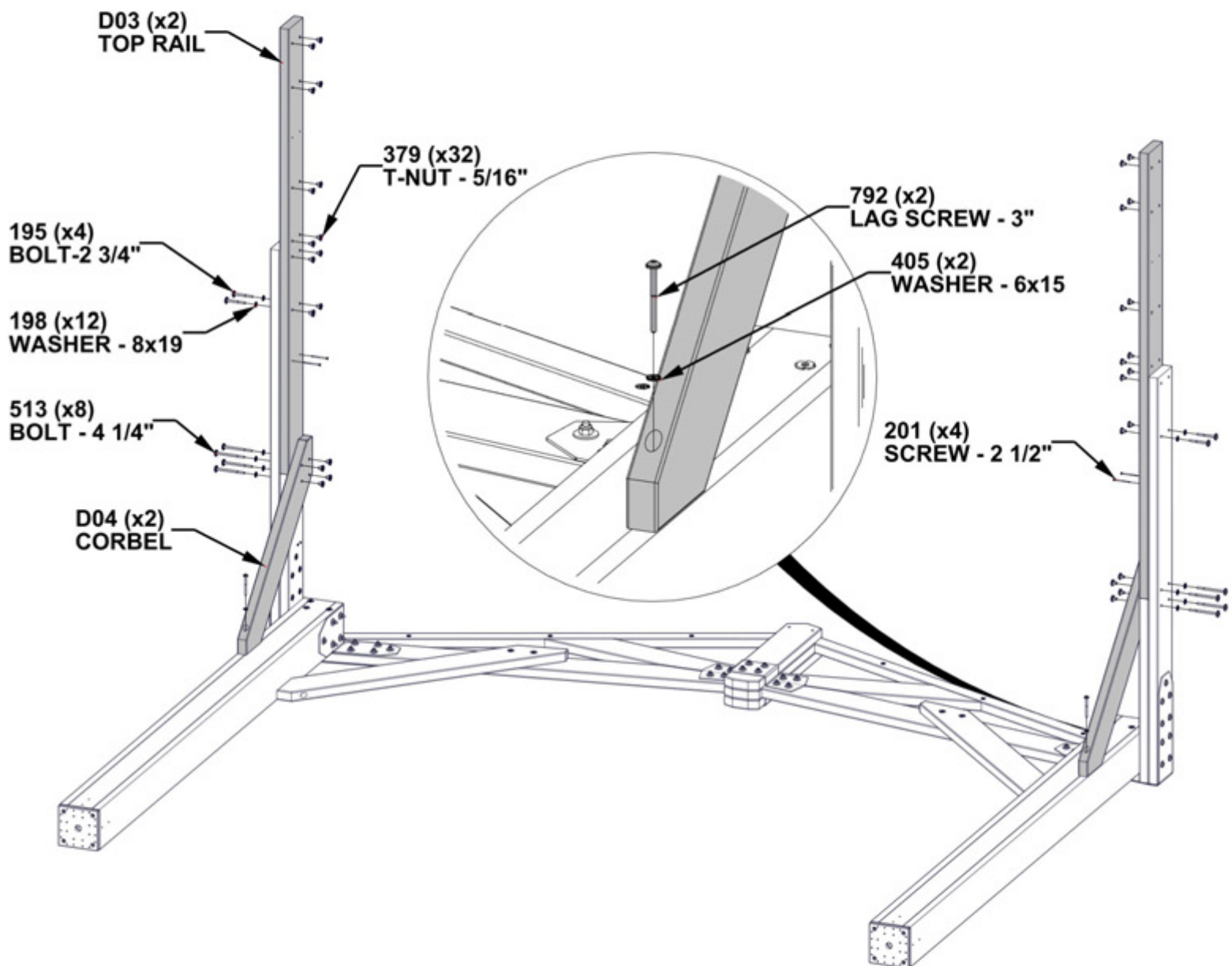

**REPEAT POST AND GABLE ASSEMBLY
STEPS 4 THROUGH 10**

STEP 11 - GAZEBO ASSEMBLY



H08 NOTCHED SUPPORT BOARD - W4L16915
(x2) 1"X3 3/8"X89 1/2" (24x86x2274)

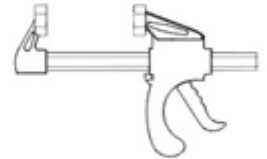

A6P00460 6" QUICK RELEASE
(x2) BAR CLAMP

- ADDITIONAL HELPERS ARE RECOMMENDED FOR THIS STEP.
- USING THE INCLUDED CLAMPS AND H08 BOARDS, STAND UP ONE GABLE END AND SECURELY CLAMP AS SHOWN.

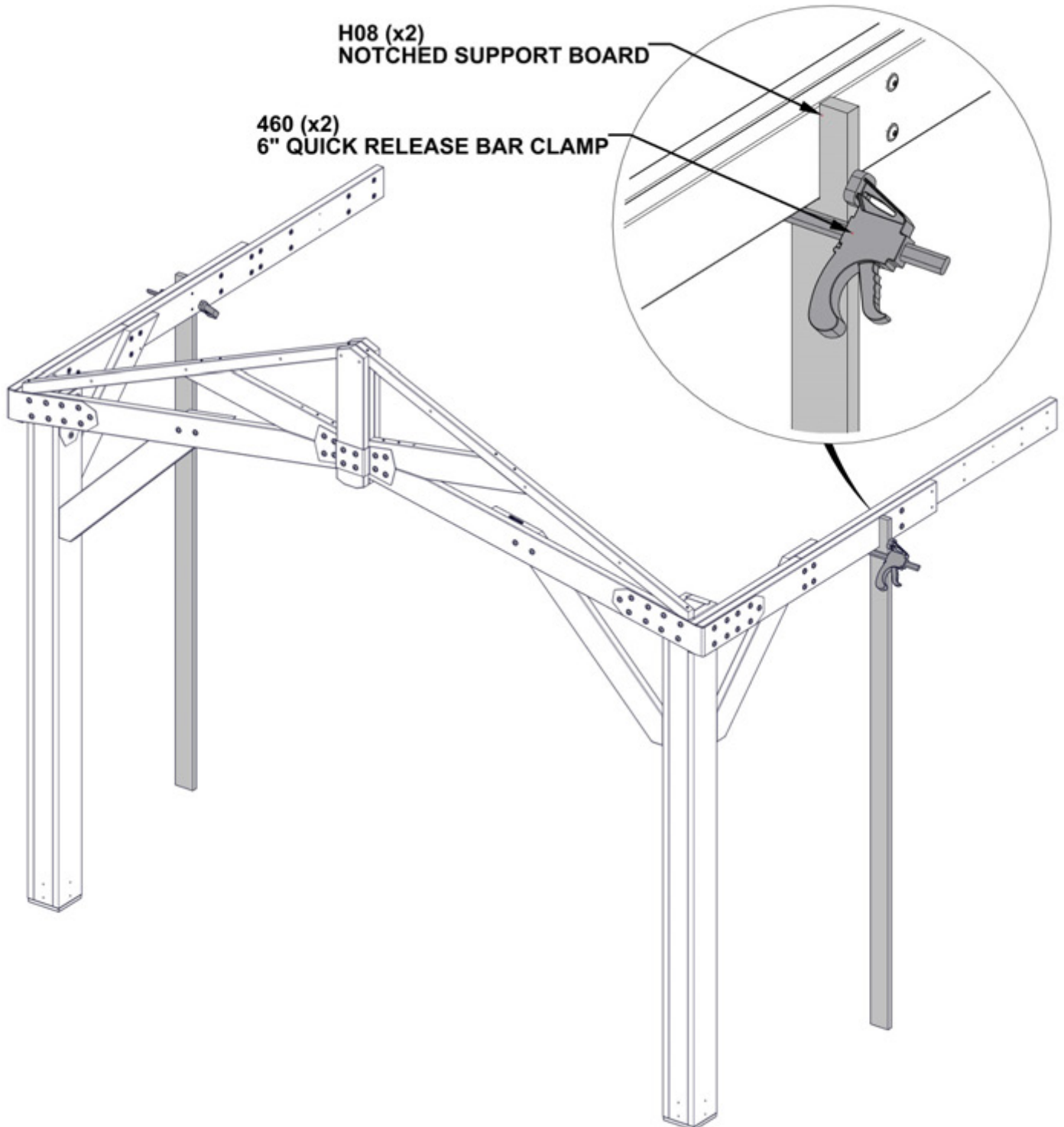

STEP 12A GAZEBO ASSEMBLY

QTY	PART NUMBER	DESCRIPTION
4	H100195	BOLT WH 5/16 X 2 3/4 BLK
4	H100198	WASHER LOCK EXT 8X19 BLK



A4M02377 GAZEBO BRACE
(x2) METAL

- ATTACH 2377 BRACE BY SLIDING IT IN BETWEEN WOOD TO FIRST SET OF BOLT HOLES.

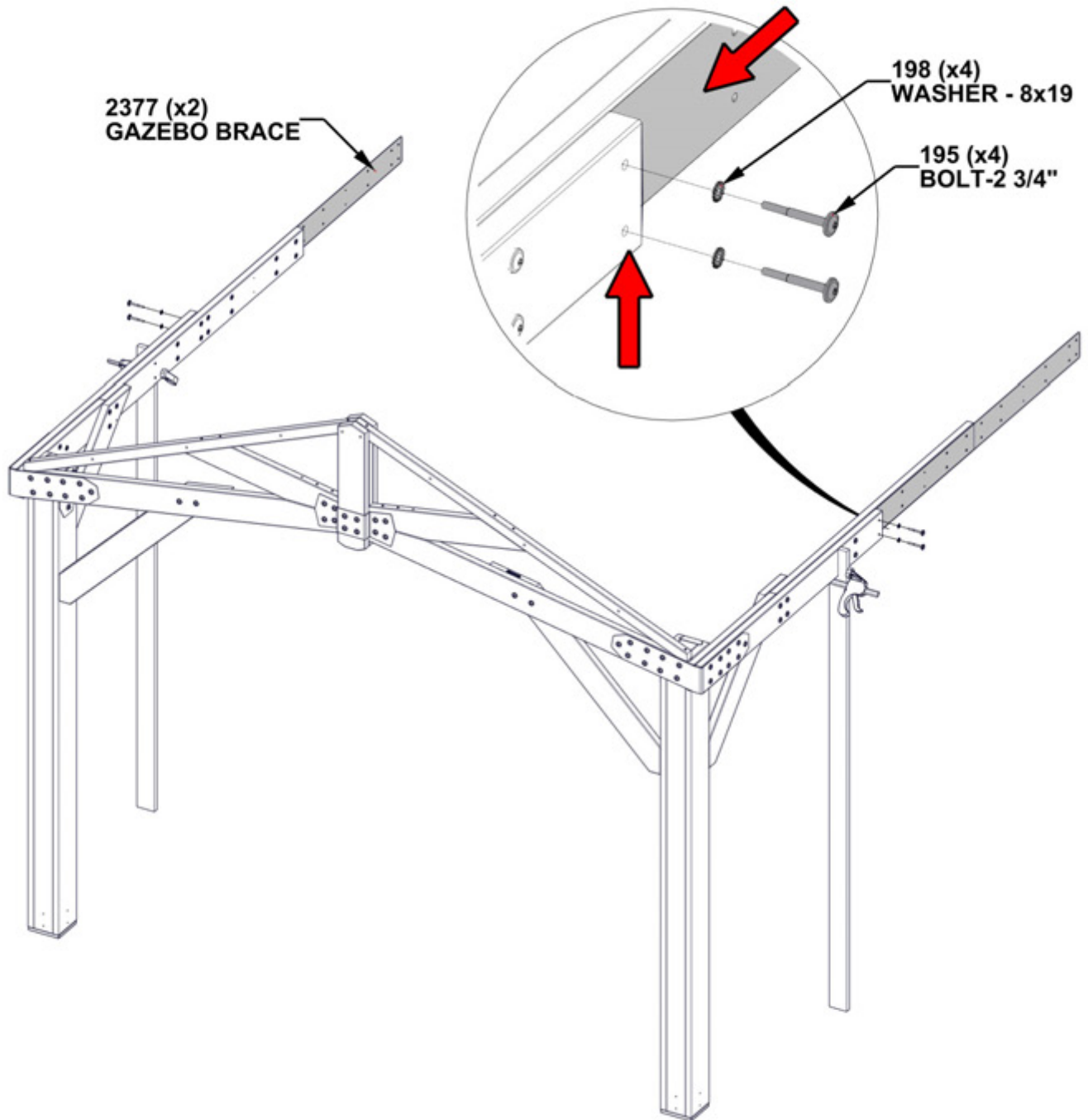

STEP 12B GAZEBO ASSEMBLY

QTY	PART NUMBER	DESCRIPTION
16	H100195	BOLT WH 5/16 X 2 3/4 BLK
16	H100198	WASHER LOCK EXT 8X19 BLK
4	H100201	SCREW PFH 8 X 2 1/2 BLK



D08 TOP RAIL - W4L16857
 (x2) 1 3/8"X5 1/4"X66 5/8" (36x134x1692)

- WITH THE GABLE END STANDING UP, ATTACH D08 BOARDS.

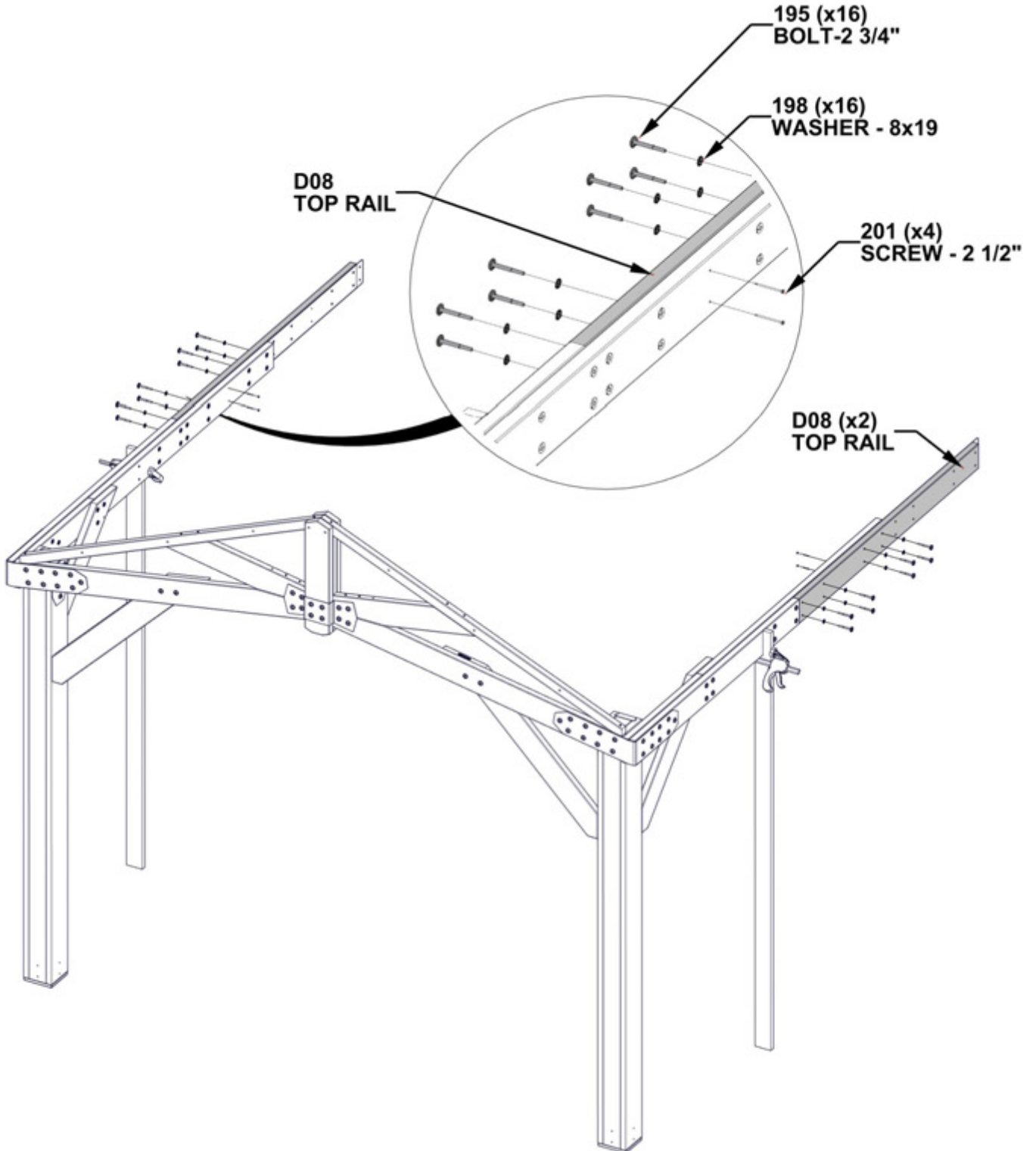

STEP 13 - GAZEBO ASSEMBLY

QTY	PART NUMBER	DESCRIPTION
20	H100195	BOLT WH 5/16 X 2 3/4 BLK
20	H100198	WASHER LOCK EXT 8X19 BLK
4	H100201	SCREW PFH 8 X 2 1/2 BLK

- INSERT T-NUTS FIRST

- STAND UP OTHER GABLE END AND ATTACH HARDWARE AS SHOWN.

- ONCE ALL HARDWARE IS SECURELY ATTACHED, REMOVE CLAMPS AND H08 BOARDS.

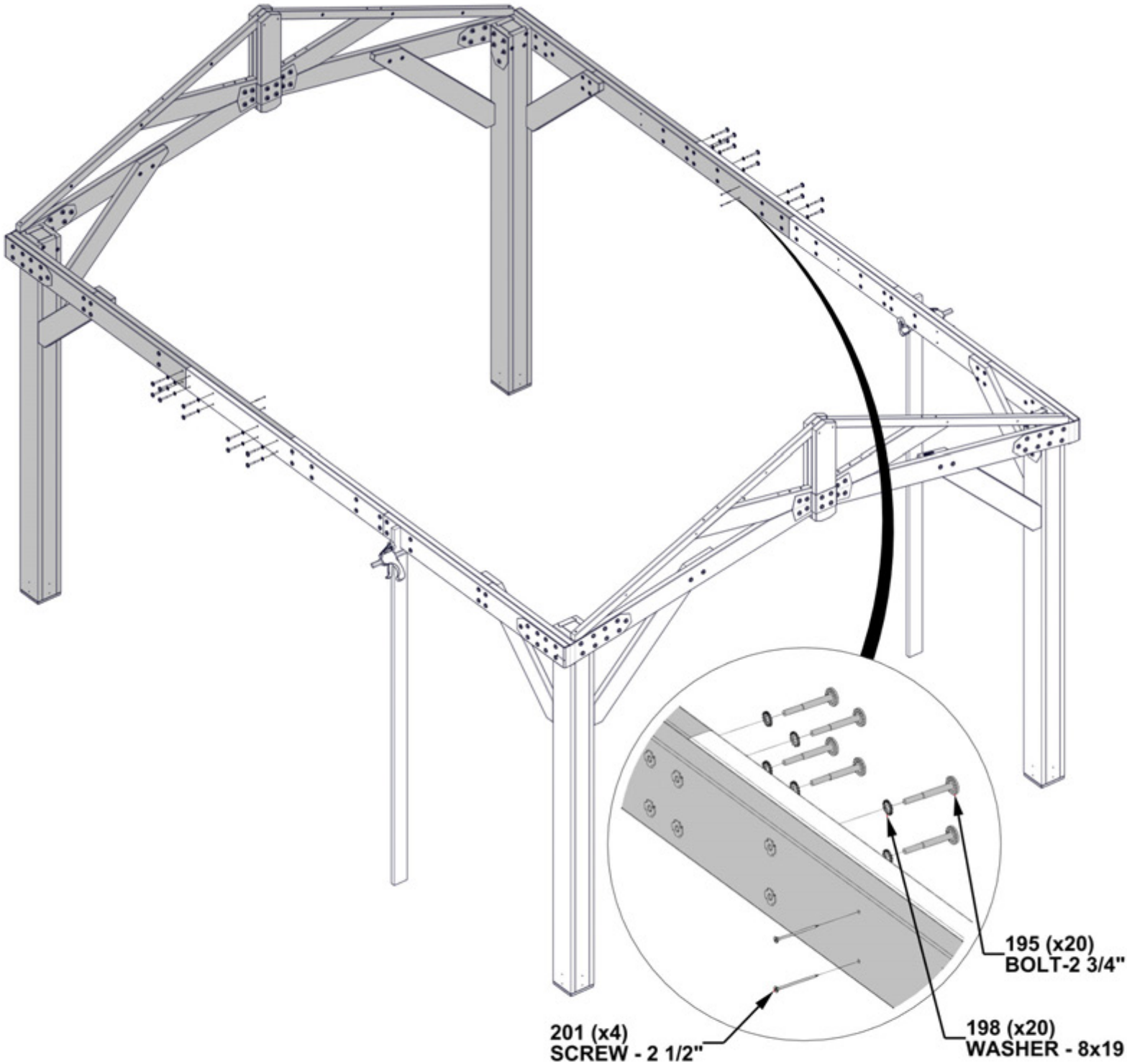

STEP 14 - GAZEBO ASSEMBLY

QTY	PART NUMBER	DESCRIPTION
16	H100201	SCREW PFH 8 X 2 1/2 BLK

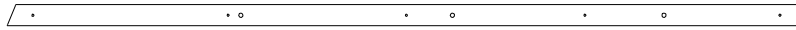

E02 TRUSS - W4L19639
(x4) 1 3/8"x2 3/8"x75 3/16" (36x60x1910)

- COMPLETE THIS STEP TWICE FOR OPPOSITE SIDE.

**ALIGN HOLES FOR
CORRECT ORIENTATION.**

FLUSH TOPS

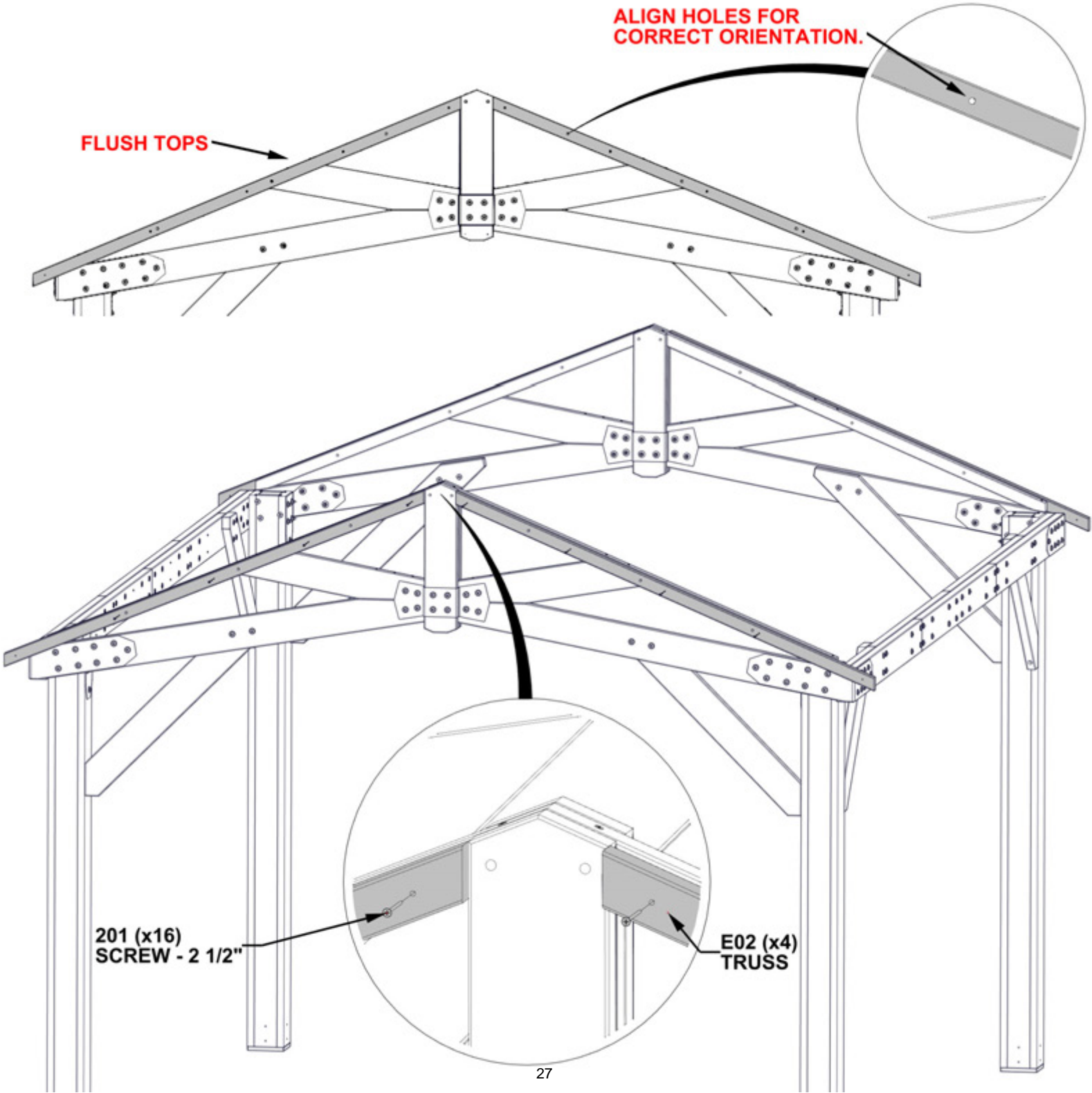

STEP 15 - GAZEBO ASSEMBLY

QTY	PART NUMBER	DESCRIPTION
4	H100201	SCREW PFH 8 X 2 1/2 BLK
12	H100405	WASHER LOCK EXT 6X15 BLK
12	H100564	LAG SCREW WH 1/4 X 4 BLK

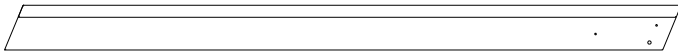

GP1 GABLE PANEL - W2A04177
(x2) 2 13/16"x5 1/4"x80 3/16" (72x134x2037)

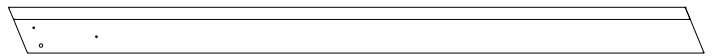

GP2 GABLE PANEL - W2A04178
(x2) 2 13/16"x5 1/4"x80 3/16" (72x134x2037)

- ALIGN LAG SCREWS WITH PILOT HOLES IN GABLE PANELS.

TEMPORARILY INSERT 354 BOLTS TO ALIGN GABLE PANEL WITH GABLE.

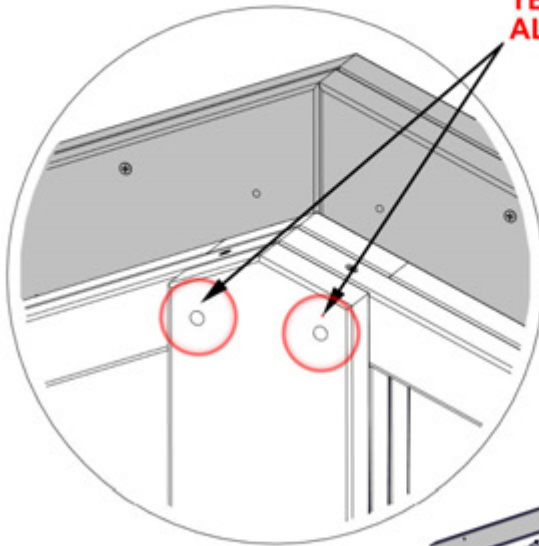

405 (x12)
WASHER - 6x15

564 (x12)
LAG SCREW - 4"

201 (x4)
SCREW - 2 1/2"

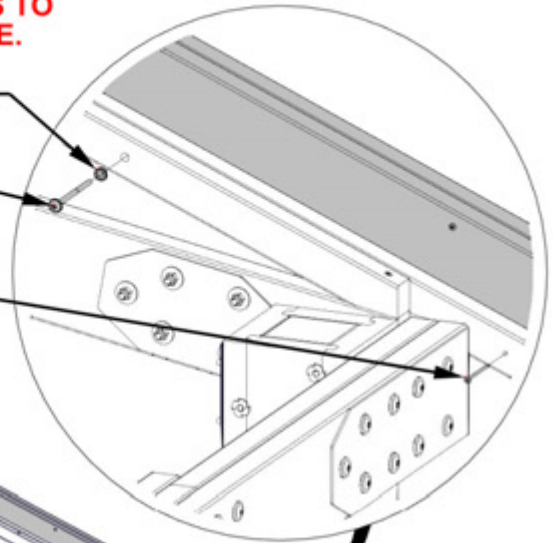

GP1 (x2)
GABLE PANEL

GP2 (x2)
GABLE PANEL

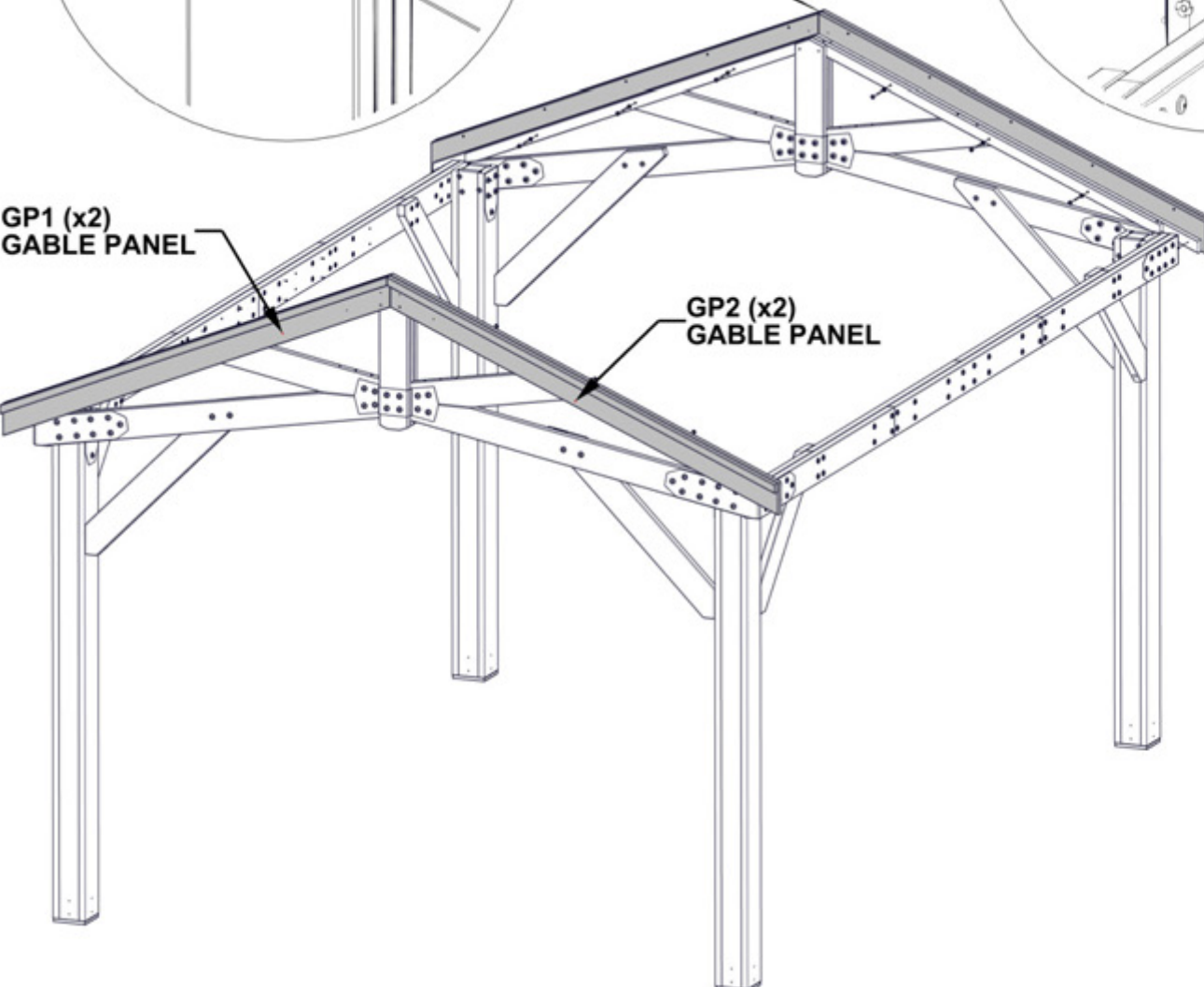

STEP 16 - GAZEBO ASSEMBLY

QTY	PART NUMBER	DESCRIPTION
4	H100200	SCREW PFH 8 X 1 1/2 BLK
4	H100354	BOLT WH 5/16 X 6 1/2 BLK
8	H100471	LAG SCREW WH 5/16 X 1 1/2 BLK
4	H100478	WASHER FLAT 8X27 BLK
4	H100479	NUT LOCK 5/16 BLK

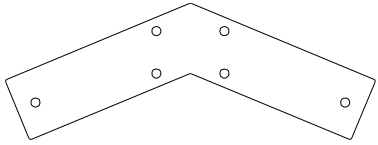

A4M01130 GABLE BRACKET
(x2)

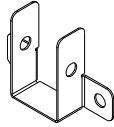

A4M01148 TRUSS
BRACKET
(x2)

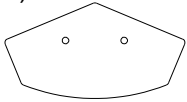

A4M01147 PEAK SEAM BRACKET
(x2)

- COMPLETE THIS STEP TWICE FOR OPPOSITE SIDE.

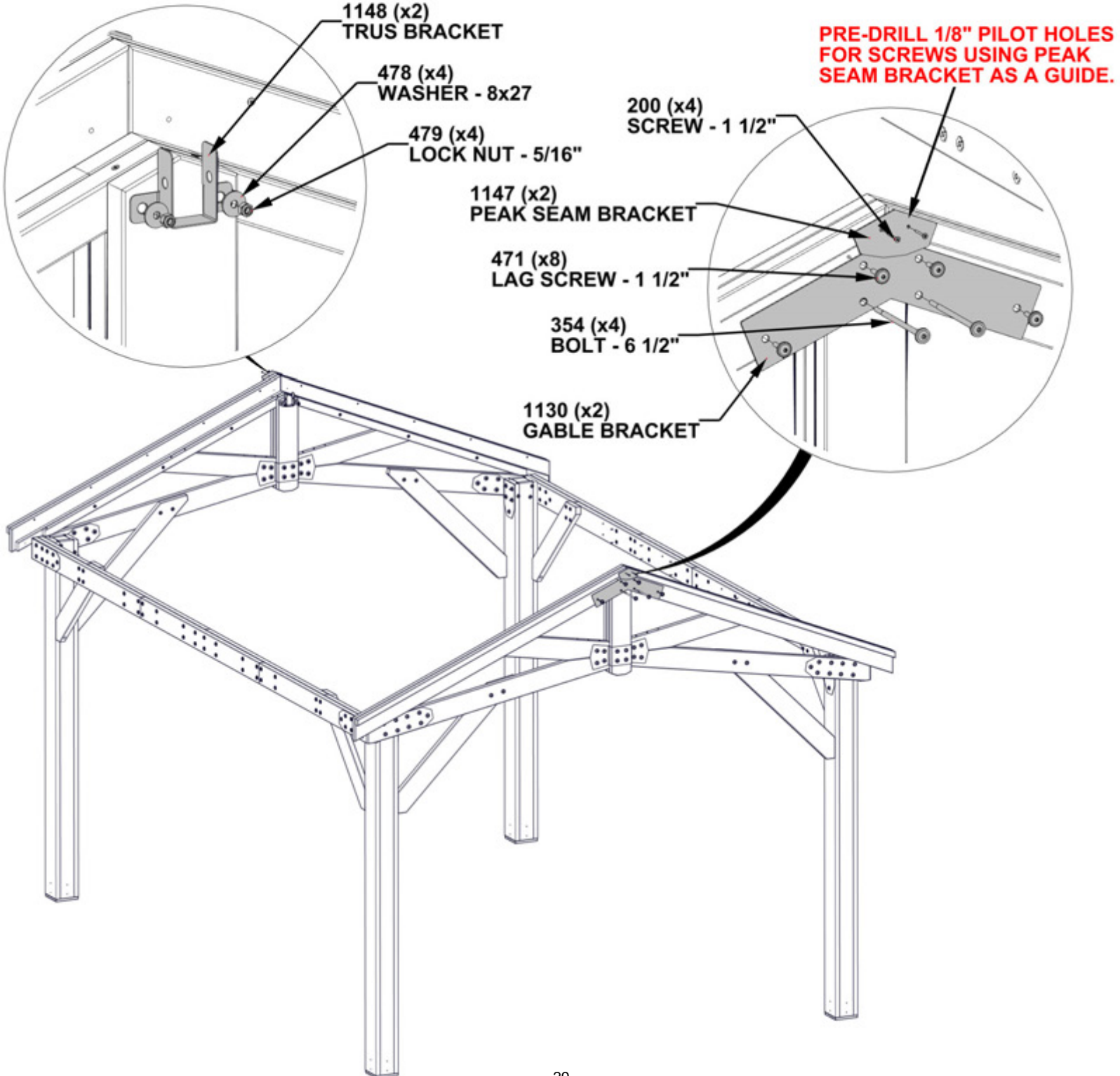

STEP 17 RAFTER ASSEMBLY

QTY	PART NUMBER	DESCRIPTION
10	H100198	WASHER LOCK EXT 8X19 BLK
26	H100379	T-NUT 5/16 BLK
8	H100382	SCREW PFH 8 X 1 3/4 BLK
10	H100459	BOLT WH 5/16 X 1 1/4 BLK

AD01 RAFTER - W4L16866
(x2) 1"X4"X74 3/4" (24x102x1900)

AD02 RAFTER - W4L16867
(x2) 1"X4"X66 3/8" (24x102x1686)

A4M02493 RIDGE BRACE
(x2) METAL

AD03 RAFTER - W4L16868
(x2) 1"X4"X41 5/8" (24x102x1057)

- INSERT T-NUTS FIRST

INSERT INTERIOR T-NUTS BEFORE ANY OTHER HARDWARE IS ATTACHED.

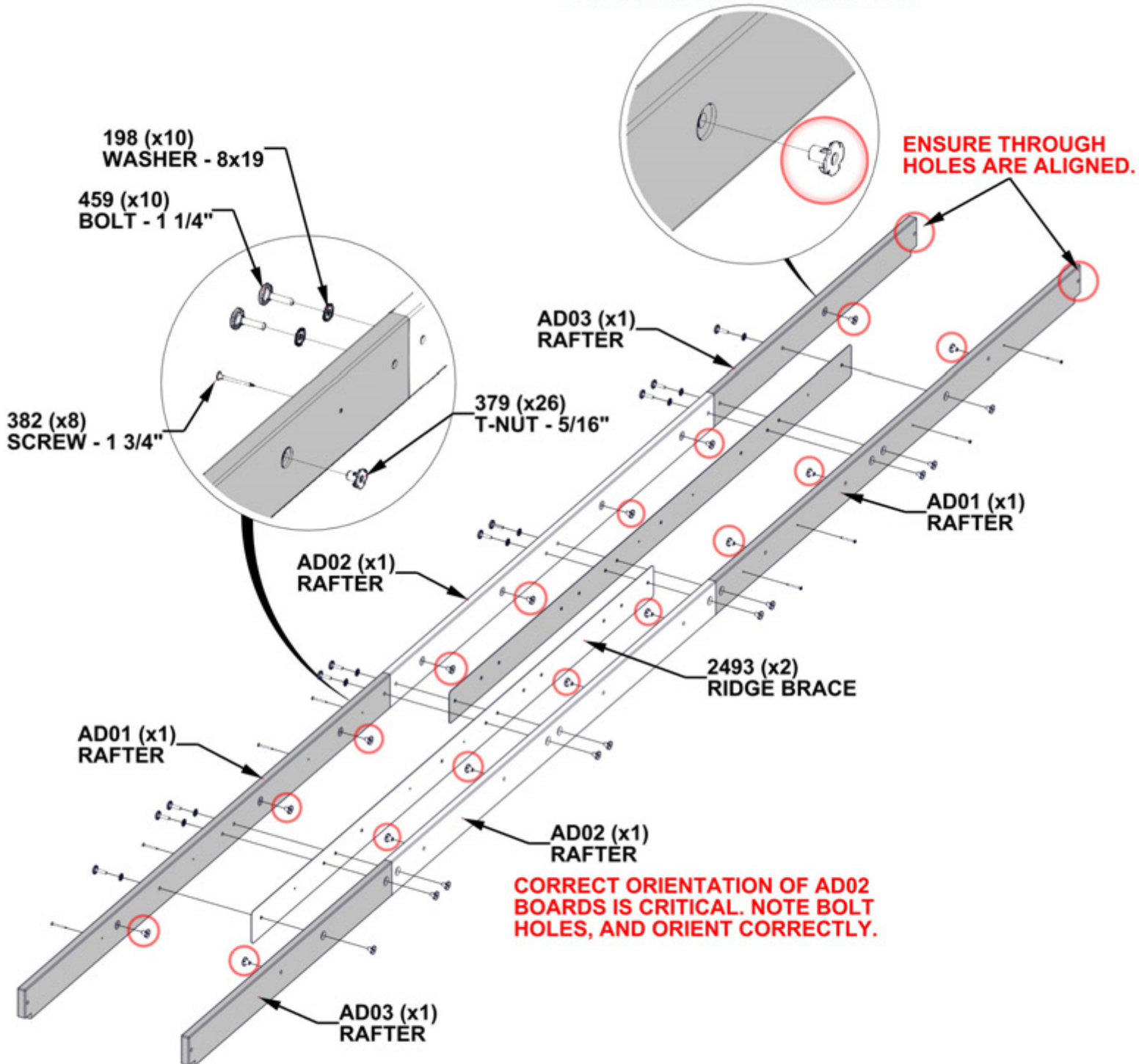

STEP 18 - GAZEBO ASSEMBLY

QTY	PART NUMBER	DESCRIPTION
2	H100195	BOLT WH 5/16 X 2 3/4 BLK
2	H100478	WASHER FLAT 8X27 BLK
2	H100479	NUT LOCK 5/16 BLK

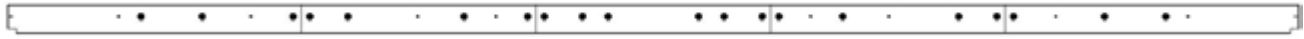

RAFTER ASSEMBLY FROM PREVIOUS STEP

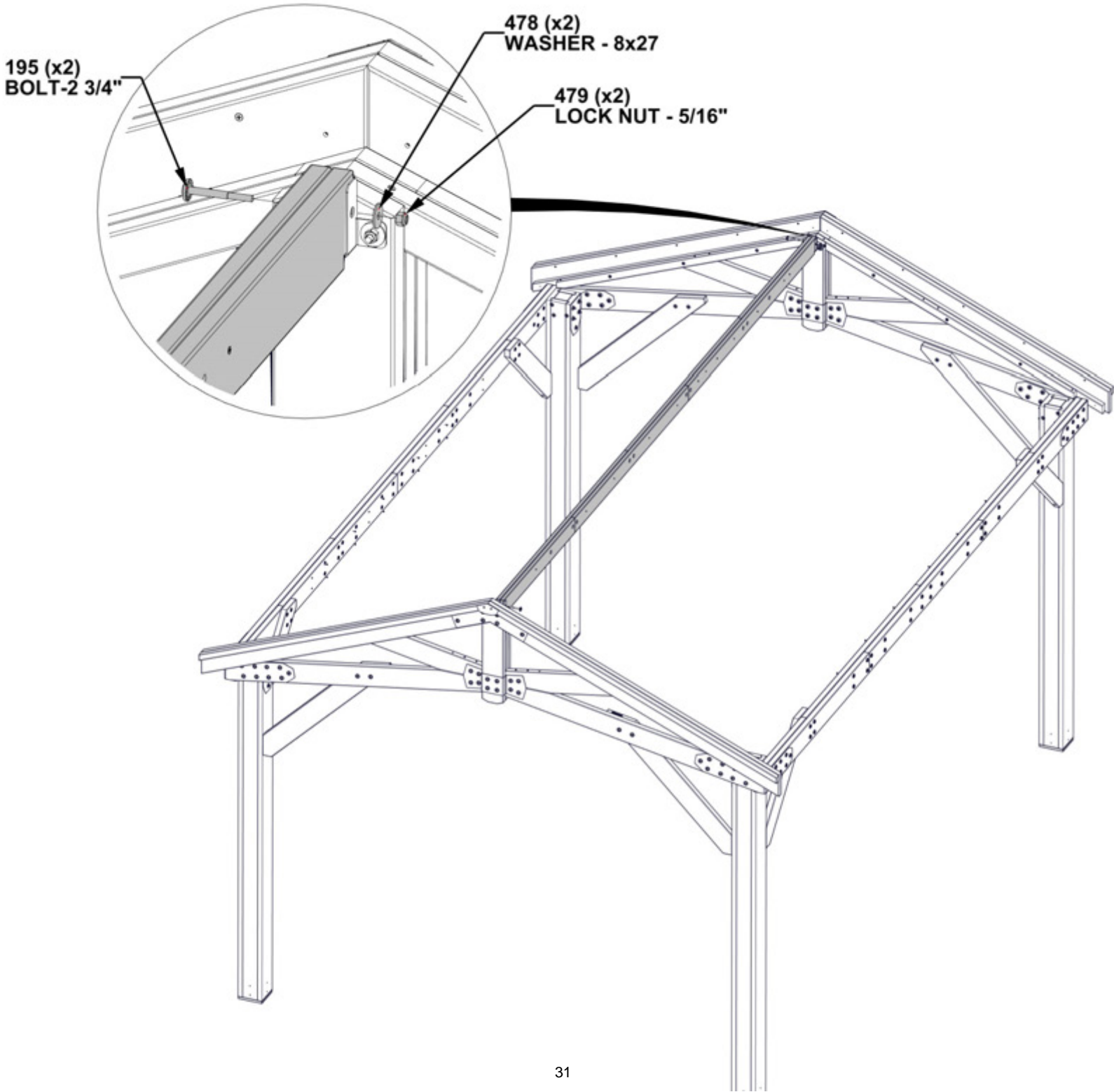

STEP 19 - ROOF PANEL ASSEMBLY

QTY	PART NUMBER	DESCRIPTION
4	H100198	WASHER LOCK EXT 8X19 BLK
44	H100391	SCREW PFH 8 X 2 BLK
4	H100478	WASHER FLAT 8X27 BLK
4	H100479	NUT LOCK 5/16 BLK
4	H100503	BOLT WH 5/16 X 3 1/2 BLK

- H01 FASCIA - W4L16869
(x1) 1"x3 3/8"x57 3/8" (24x86x1458)
- H02 FASCIA - W4L16870
(x1) 1"x3 3/8"x58 5/8" (24x86x1490)
- H03 FASCIA - W4L16871
(x1) 1"x3 3/8"x58 3/8" (24x86x1482)
- H04 FASCIA - W4L16872
(x1) 1"x3 3/8"x57 3/8" (24x86x1458)
- H05 FASCIA - W4L16873
(x1) 1"x3 3/8"x75 1/8" (24x86x1907)
- H06 FASCIA - W4L16874
(x1) 1"x3 3/8"x41 7/8" (24x86x1064)
- E01 RAFTER - W4L19638
(x4) 1 3/8"x3 3/8"x76 3/8" (36x86x1941)

- E05 RAFTER - W4L19637
(x4) 1 3/8"x3 3/8"x76 3/8" (36x86x1941)
- E08 RAFTER - W4L19641
(x3) 1 3/8"x3 3/8"x76 3/8" (36x86x1941)

ROOF PANEL A

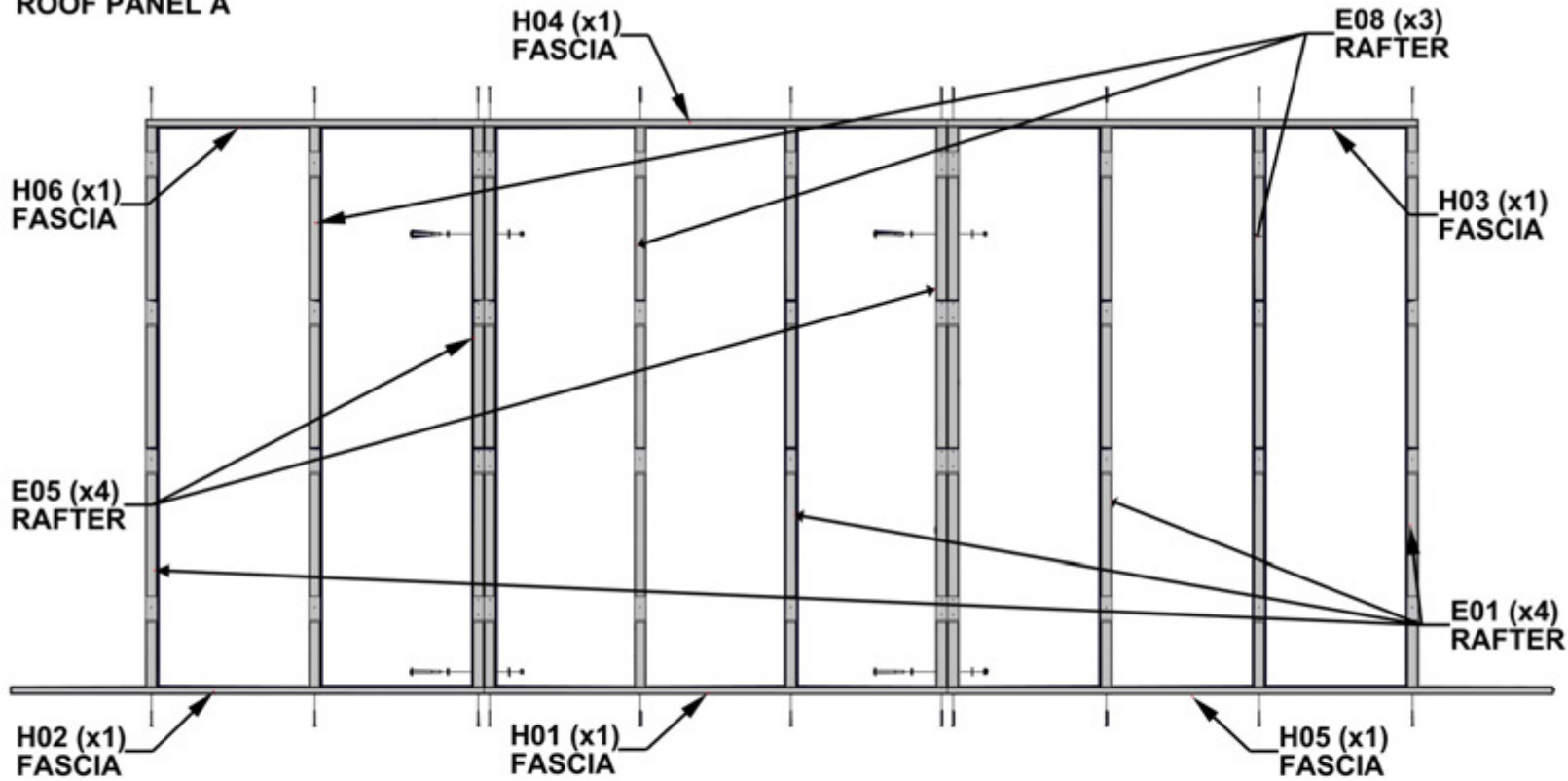

ENSURE ALL RAFTERS ARE PLACED CORRECTLY.

ENSURE H04 IS ORIENTED CORRECTLY. CHECK MEASUREMENTS FROM BOLT HOLE TO END OF BOARD AND ORIENT AS SHOWN.

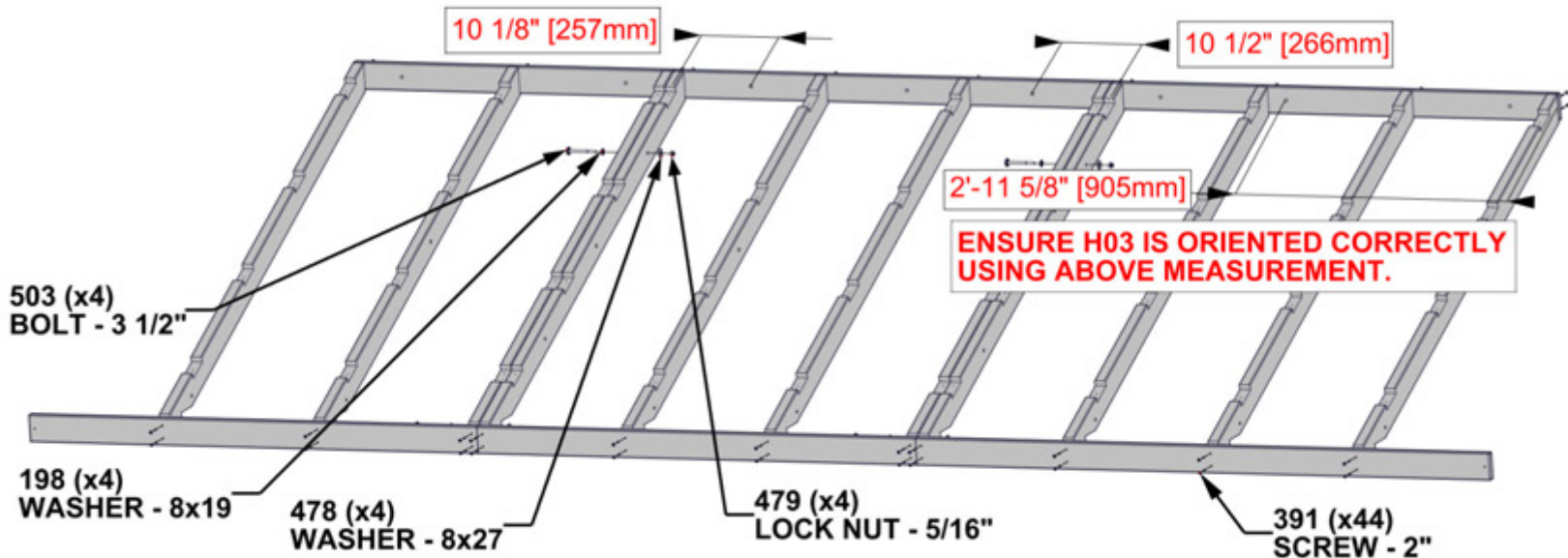

STEP 20A - ROOF PANEL ASSEMBLY

QTY	PART NUMBER	DESCRIPTION
88	H100391	SCREW PFH 8x2 BLK



H09 SHEATHING BOARD - W4L19642
 (x4) 5/16"x3 3/8"x75 1/16" (24x86x1907)



H10 SHEATHING BOARD - W4L19643
 (x4) 15/16"x3 3/8"x57 3/8" (24x86x1458)



H11 SHEATHING BOARD - W4L19644
 (x4) 15/16"x3 3/8"x58 11/16" (24x86x1490)

ROOF PANEL A

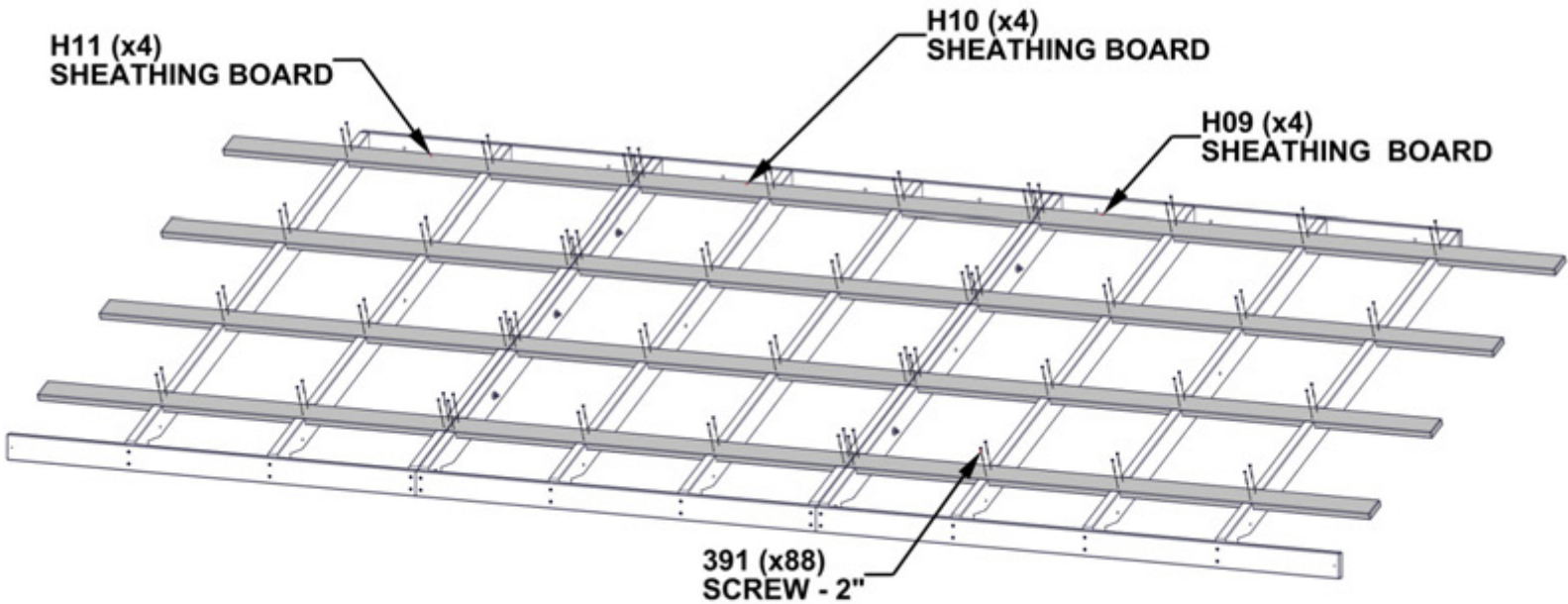

STEP 20B - ROOF PANEL ASSEMBLY

ROOF PANEL A

CRITICAL:

- SQUARE UNIT BEFORE PROCEEDING TO NEXT STEPS.
- THE BELOW DIMENSIONS ARE CRITICAL TO THE FINAL ROOF ASSEMBLY.
- MEASUREMENTS SHOULD BE HELD WITHIN +/- 1/4" (6mm).
- MEASUREMENTS OUTSIDE OF TOLERANCE WILL LEAD TO THE INABILITY TO ASSEMBLY THE ROOF.

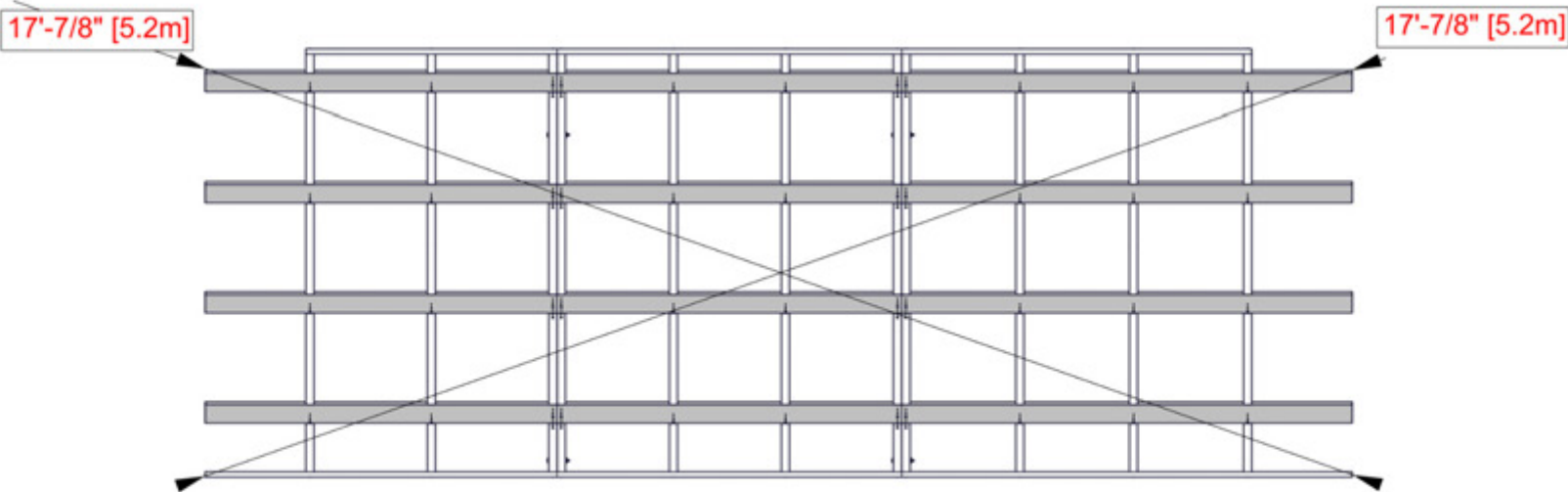

STEP 21 - ROOF PANEL ASSEMBLY

ROOF PANEL A

- USE THIS PAGE TO FAMILIARIZE YOURSELF WITH THE ROOF PANEL AND ASSIST YOU IN STEPS 22-24.
- REMOVE PROTECTIVE BLUE FILM.
- START AT THE END INDICATED AND ASSEMBLE IN THE DIRECTION OF THE ARROW.
- **GLOVES SHOULD BE WORN WHEN HANDLING ROOF PANELS. EDGES ARE SHARP.**

THE PRE-DRILLED HOLES ON EACH PANEL SHOULD ALWAYS BE POSITIONED ON THE RIDGE SIDE.

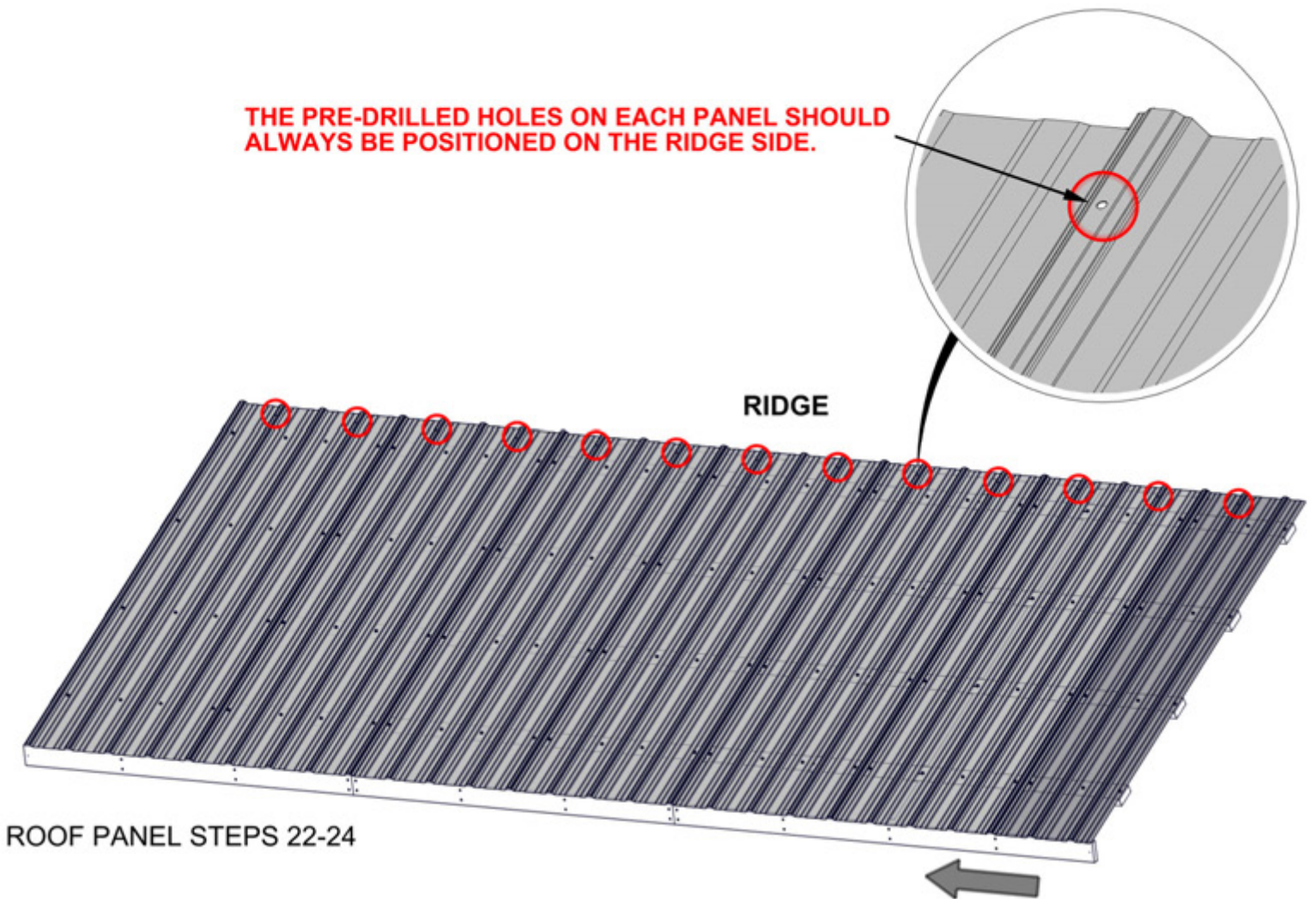

STEP 22 - ROOF PANEL ASSEMBLY

QTY	PART NUMBER	DESCRIPTION
44	H100833	SCREW WOODGRIP 10-16 x 3/4

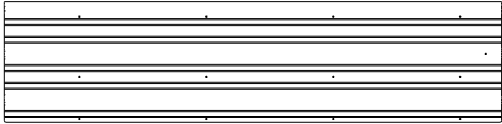

A4M02650 29 GA STEEL SHEETING
(x1)

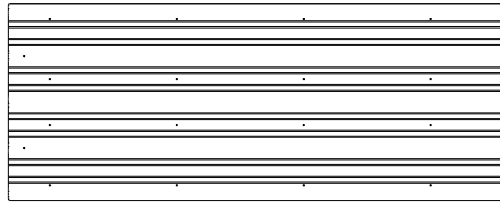

A4M02639 29 GA STEEL SHEETING
(x1)



A4M02646 29 GA STEEL SHEETING
(x1)

ROOF PANEL A

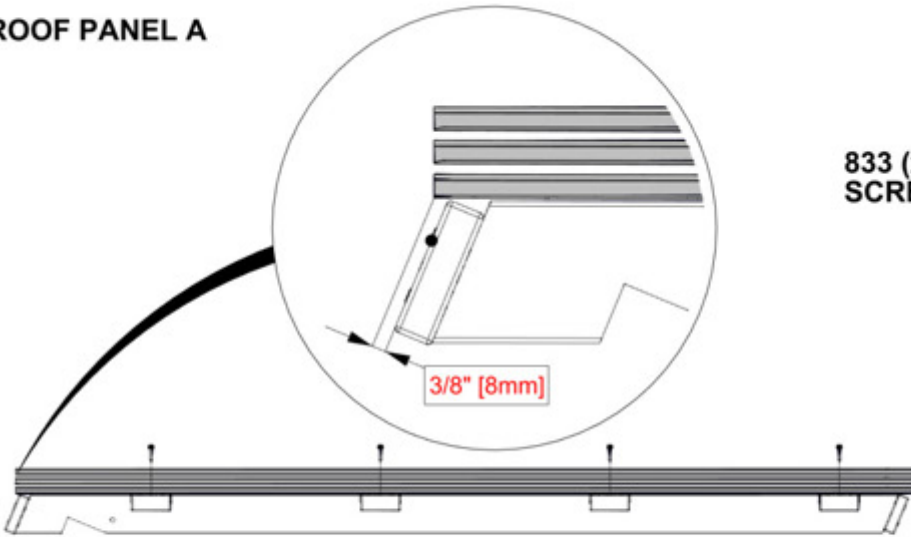

3/8" [8mm]

833 (x44)
SCREW - 3/4"

NOTE RIB OVERLAP

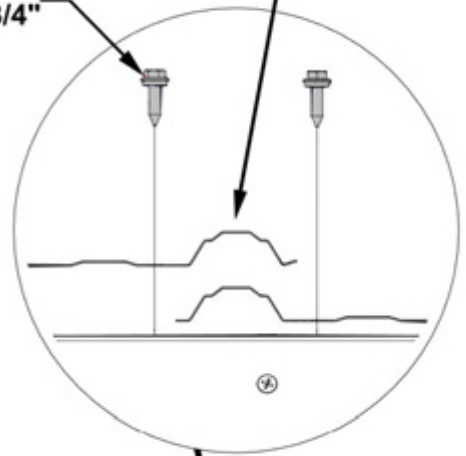

MAKE SURE YOUR ROOF PANEL IS SQUARE BEFORE MOVING ON.

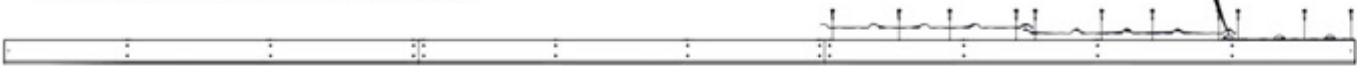

2650 (x1)
29 GA STEEL SHEETING

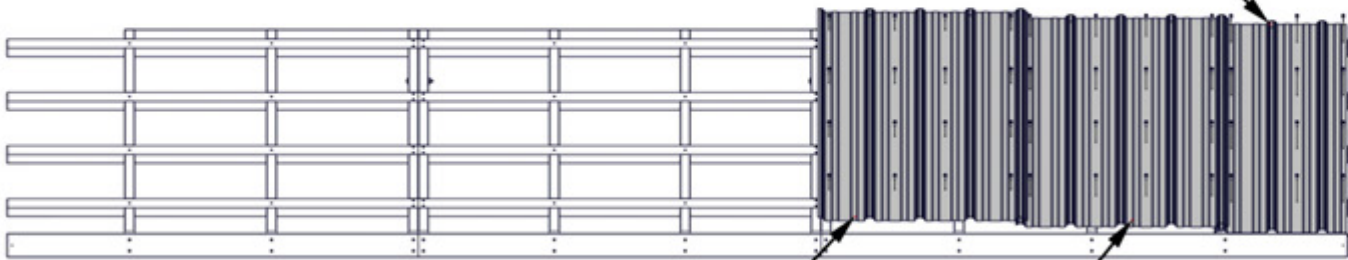

2646 (x1)
29 GA STEEL SHEETING

ENSURE CORRECT PLACEMENT OF STEEL SHEETING.

2639 (x1)
29 GA STEEL SHEETING

PLACE SHEETING ON ROOF PANEL, ALIGNING EDGE OF RIB 2 7/8" (72mm) FROM END OF H BOARD.

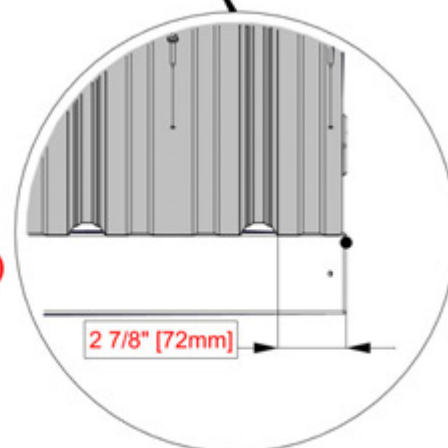

2 7/8" [72mm]

STEP 23 - ROOF PANEL ASSEMBLY

QTY	PART NUMBER	DESCRIPTION
32	H100833	SCREW WOODGRIP 10-16 x 3/4



A4M02646 29 GA STEEL SHEETING (x1)

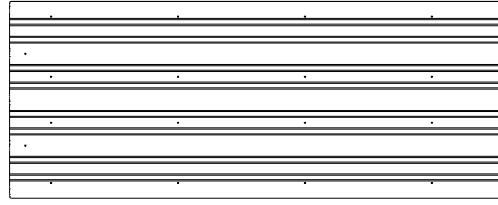

A4M02908 29 GA STEEL SHEETING (x1)

ROOF PANEL A

833 (x32)
SCREW - 3/4"

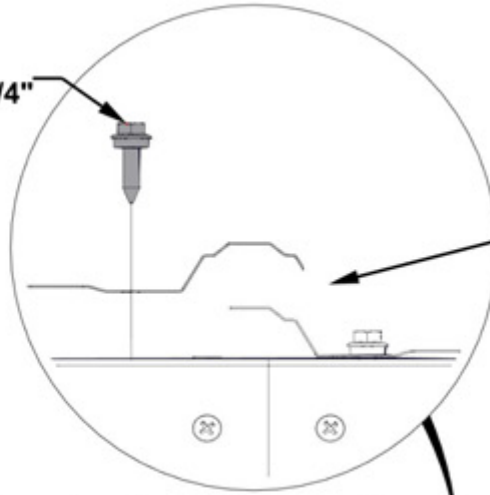

NOTE RIB OVERLAP

ENSURE CORRECT PLACEMENT OF STEEL SHEETING.

2646 (x1)
29 GA STEEL SHEETING

2908 (x1)
29 GA STEEL SHEETING

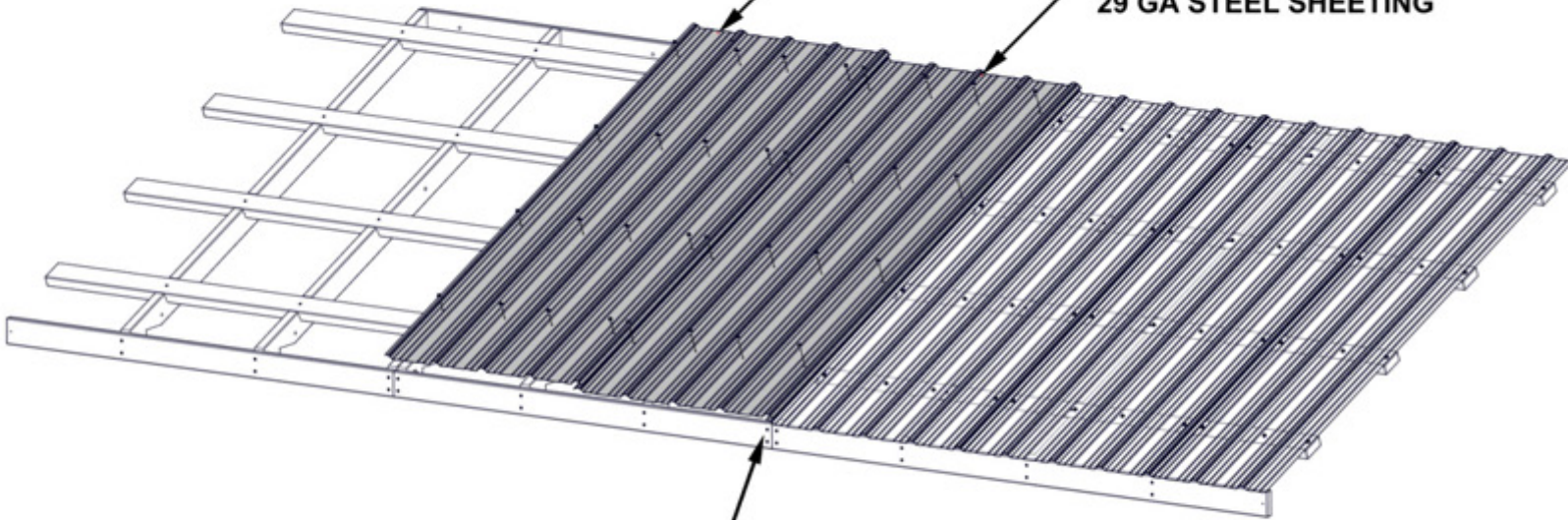

FLUSH ENDS OF ALL SHEETS

STEP 24 - ROOF PANEL ASSEMBLY

QTY	PART NUMBER	DESCRIPTION
32	H100833	SCREW WOODGRIP 10-16 x 3/4"



A4M02639 29 GA STEEL SHEETING
(x1)

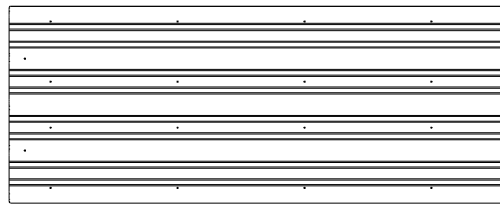

A4M02908 29 GA STEEL SHEETING
(x1)

ROOF PANEL A

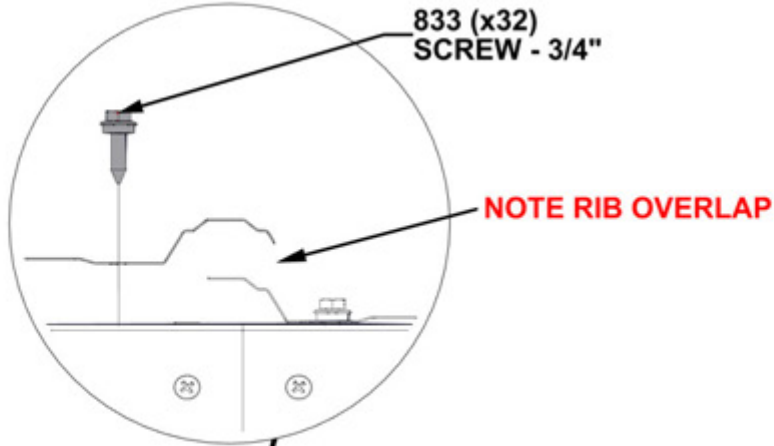

STEP 25 - ROOF PANEL ASSEMBLY

ROOF PANEL A

- SEPARATE THE ROOF PANEL AT THIS TIME FOR EASE OF ASSEMBLING.
- REMOVE HARDWARE AND SET TO THE SIDE AS IT WILL BE USED AGAIN AFTER BOTH ROOF

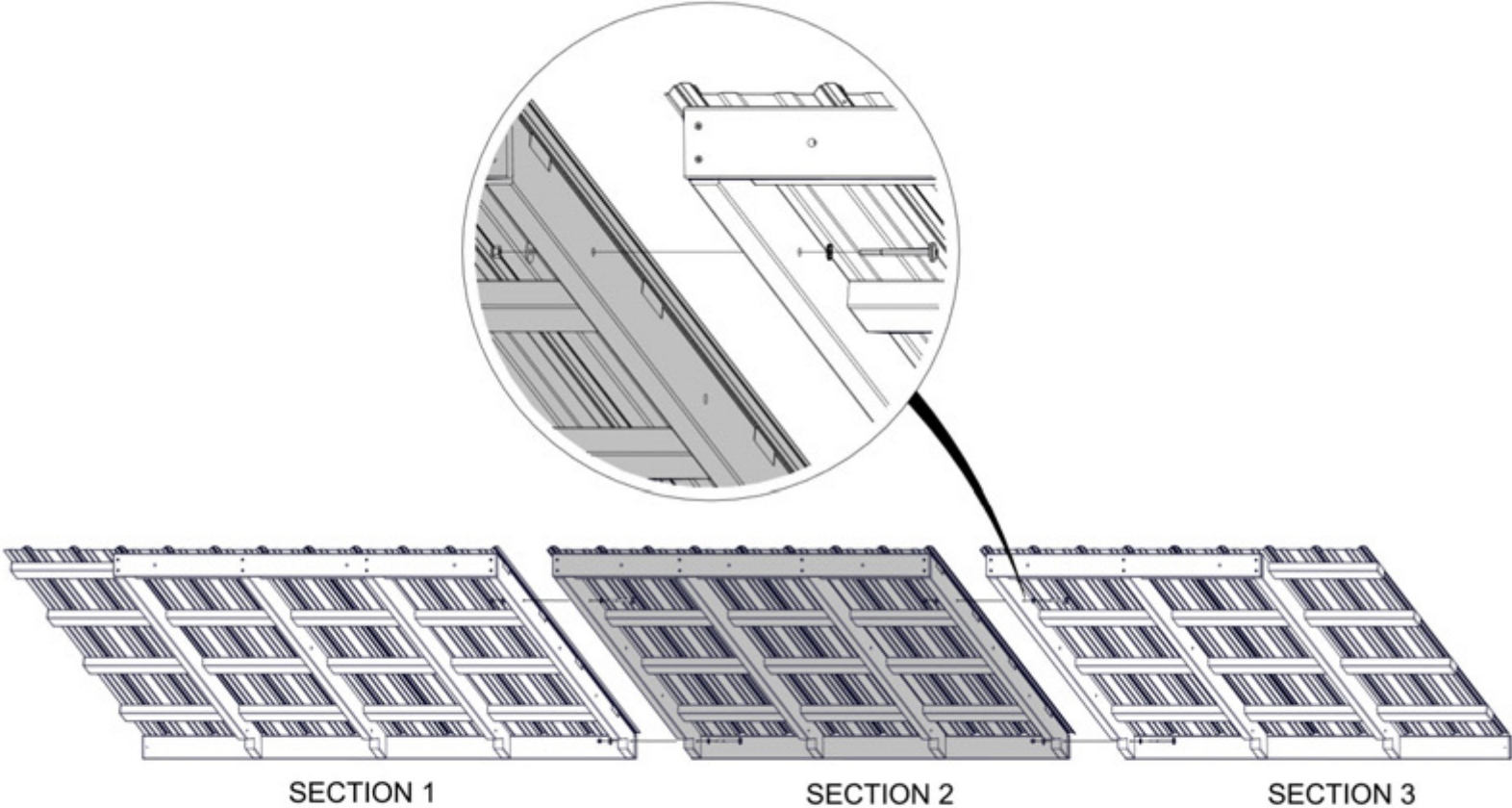

STEP 26 - ROOF PANEL ASSEMBLY

QTY	PART NUMBER	DESCRIPTION
4	H100198	WASHER LOCK EXT 8X19 BLK
44	H100391	SCREW PFH 8 X 2 BLK
4	H100478	WASHER FLAT 8X27 BLK
4	H100479	NUT LOCK 5/16 BLK
4	H100503	BOLT WH 5/16 X 3 1/2 BLK

- H01 FASCIA - W4L16869
(x1) 1"x3 3/8"x57 3/8" (24x86x1458)
- H02 FASCIA - W4L16870
(x1) 1"x3 3/8"x58 5/8" (24x86x1490)
- H03 FASCIA - W4L16871
(x1) 1"x3 3/8"x58 3/8" (24x86x1482)
- H05 FASCIA - W4L16873
(x1) 1"x3 3/8"x75 1/8" (24x86x1907)
- H06 FASCIA - W4L16874
(x1) 1"x3 3/8"x41 7/8" (24x86x1064)
- H07 FASCIA - W4L16875
(x1) 1"x3 3/8"x57 3/8" (24x86x1458)
- E01 RAFTER - W4L19638
(x4) 1 3/8"x3 3/8"x76 3/8" (36x86x1941)

- E05 RAFTER - W4L19637
(x4) 1 3/8"x3 3/8"x76 3/8" (36x86x1941)
- E08 RAFTER - W4L19641
(x3) 1 3/8"x3 3/8"x76 3/8" (36x86x1941)

ROOF PANEL B

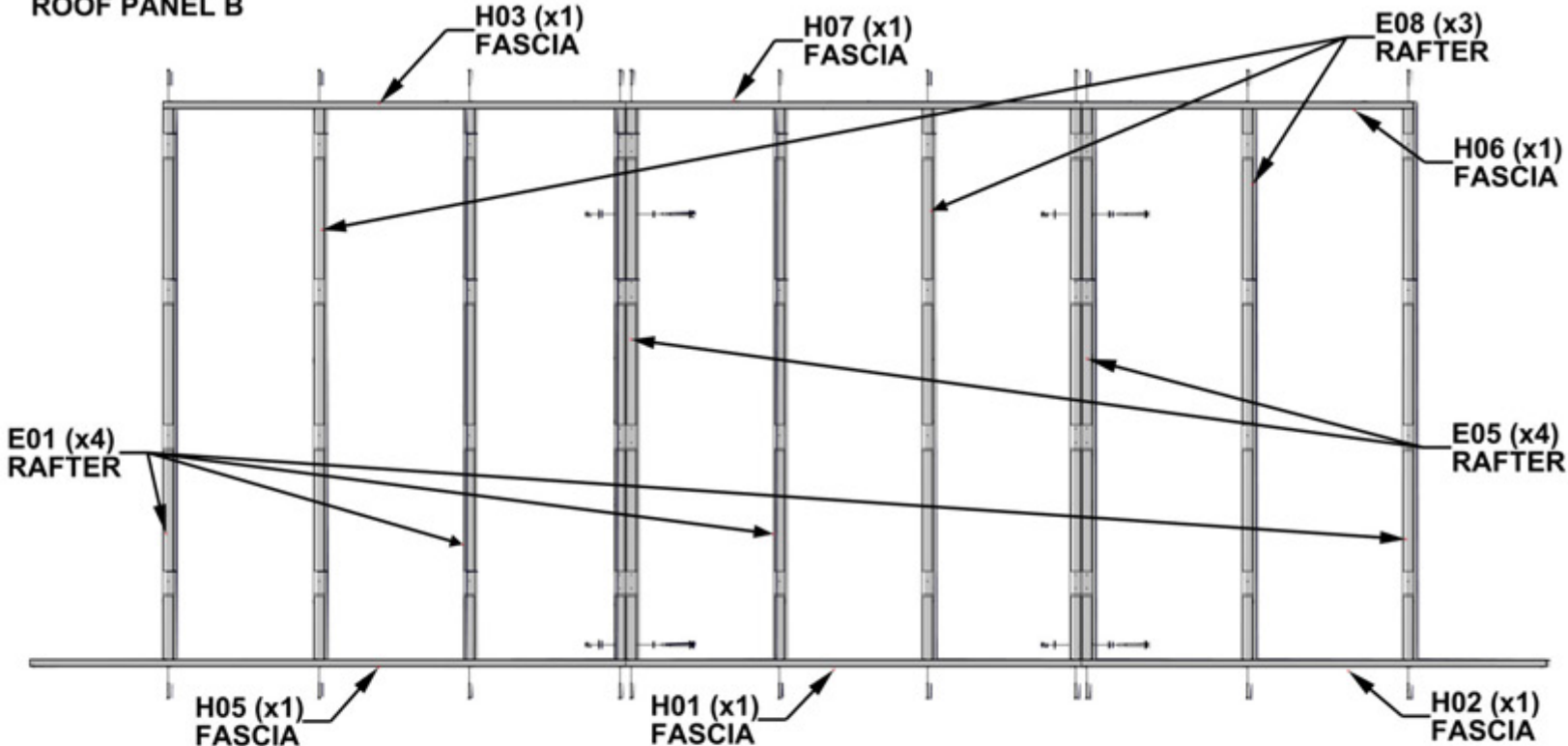

ENSURE ALL RAFTERS ARE PLACED CORRECTLY.

ENSURE H07 IS ORIENTED CORRECTLY. CHECK MEASUREMENTS FROM BOLT HOLE TO END OF BOARD AND ORIENT AS SHOWN.

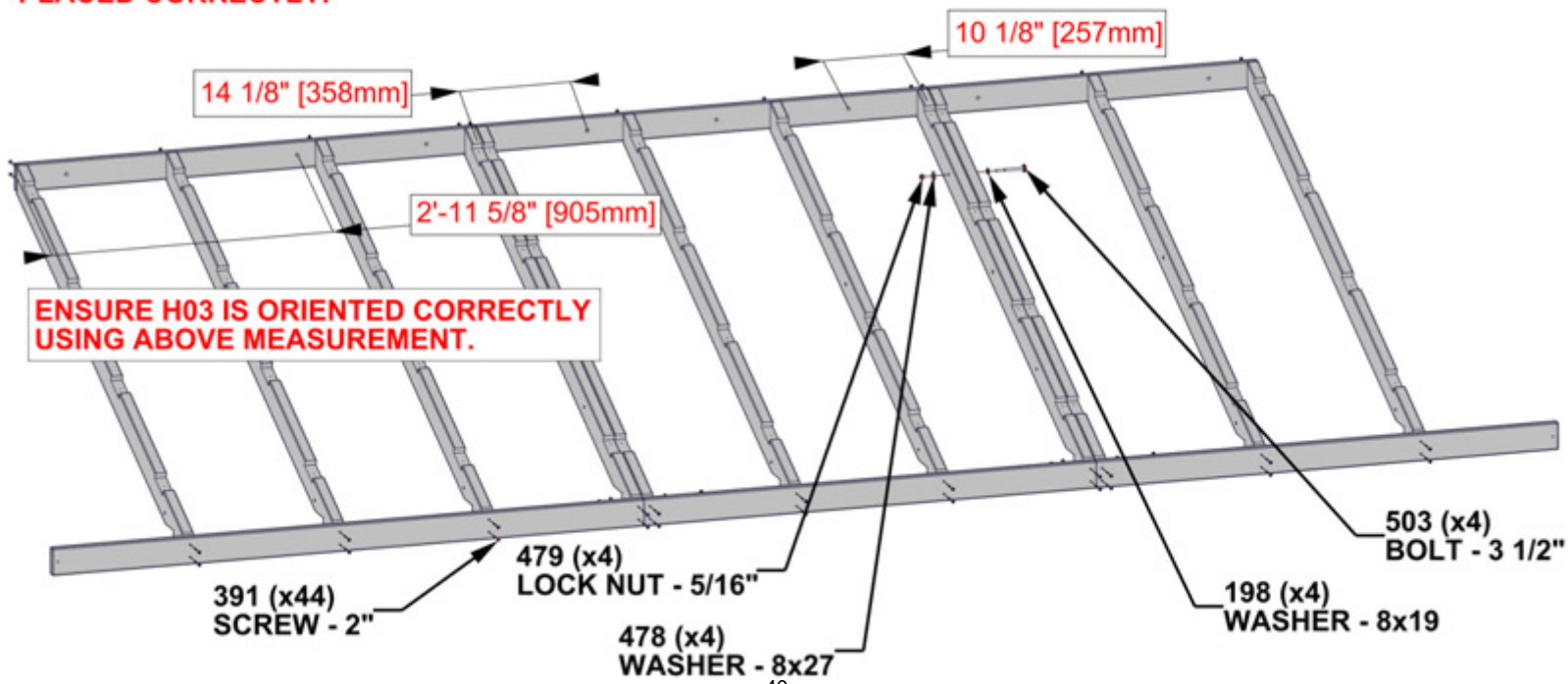

ENSURE H03 IS ORIENTED CORRECTLY USING ABOVE MEASUREMENT.

STEP 27A - ROOF PANEL ASSEMBLY

QTY	PART NUMBER	DESCRIPTION
88	H100391	SCREW PFH 8x2 BLK



H09 SHEATHING BOARD - W4L19642
(x4) 15/16"x3 3/8"x75 1/16" (24x86x1907)



H10 SHEATHING BOARD - W4L19643
(x4) 15/16"x3 3/8"x57 3/8" (24x86x1458)



H11 SHEATHING BOARD - W4L19644
(x4) 15/16"x3 3/8"x58 11/16" (24x86x1490)

ROOF PANEL B

H09 (x4)
SHEATHING BOARD

H10 (x4)
SHEATHING BOARD

H11 (x4)
SHEATHING BOARD

391 (x88)
SCREW - 2"

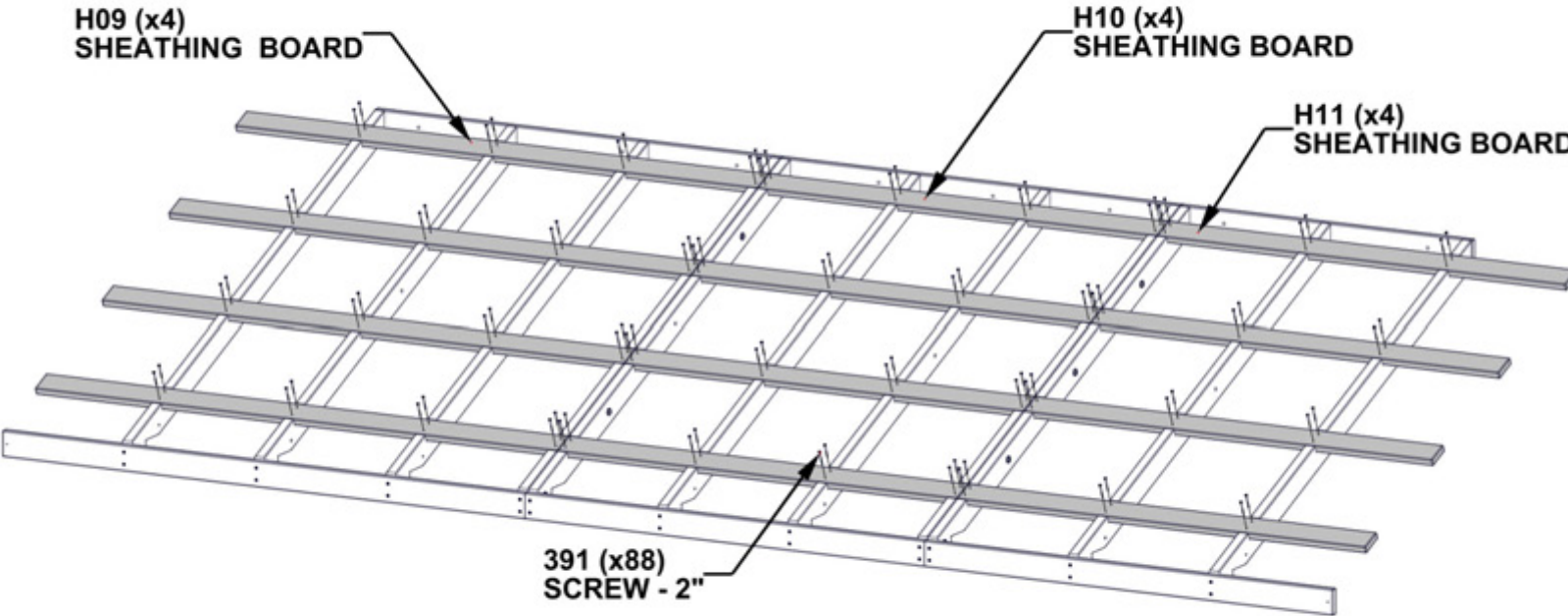

STEP 27B - ROOF PANEL ASSEMBLY

ROOF PANEL B

CRITICAL:

- SQUARE UNIT BEFORE PROCEEDING TO NEXT STEPS.
- THE BELOW DIMENSIONS ARE CRITICAL TO THE FINAL ROOF ASSEMBLY.
- MEASUREMENTS SHOULD BE HELD WITHIN $\pm 1/4"$.
- MEASUREMENTS OUTSIDE OF TOLERANCE WILL LEAD TO THE INABILITY TO ASSEMBLY THE ROOF.

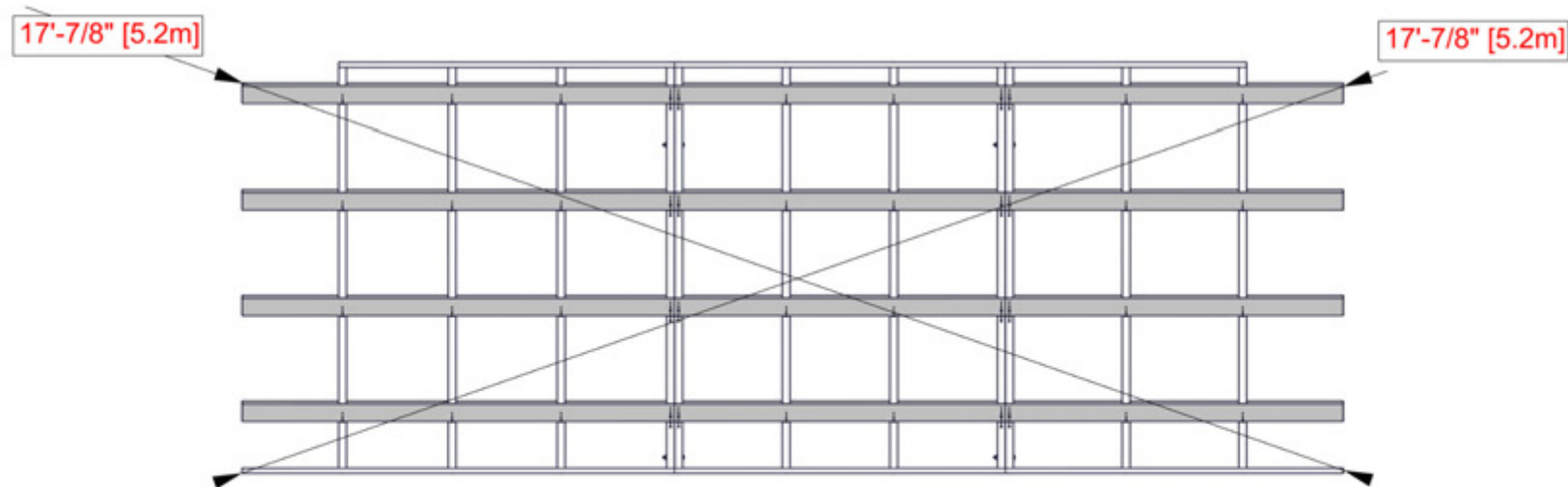

STEP 28 - ROOF PANEL ASSEMBLY

ROOF PANEL B

- USE THIS PAGE TO FAMILIARIZE YOURSELF WITH THE ROOF PANEL AND ASSIST YOU IN STEPS 29-31.
- REMOVE PROTECTIVE BLUE FILM.
- START AT THE END INDICATED AND ASSEMBLE IN THE DIRECTION OF THE ARROW.
- **GLOVES SHOULD BE WORN WHEN HANDLING ROOF PANELS. EDGES ARE SHARP.**

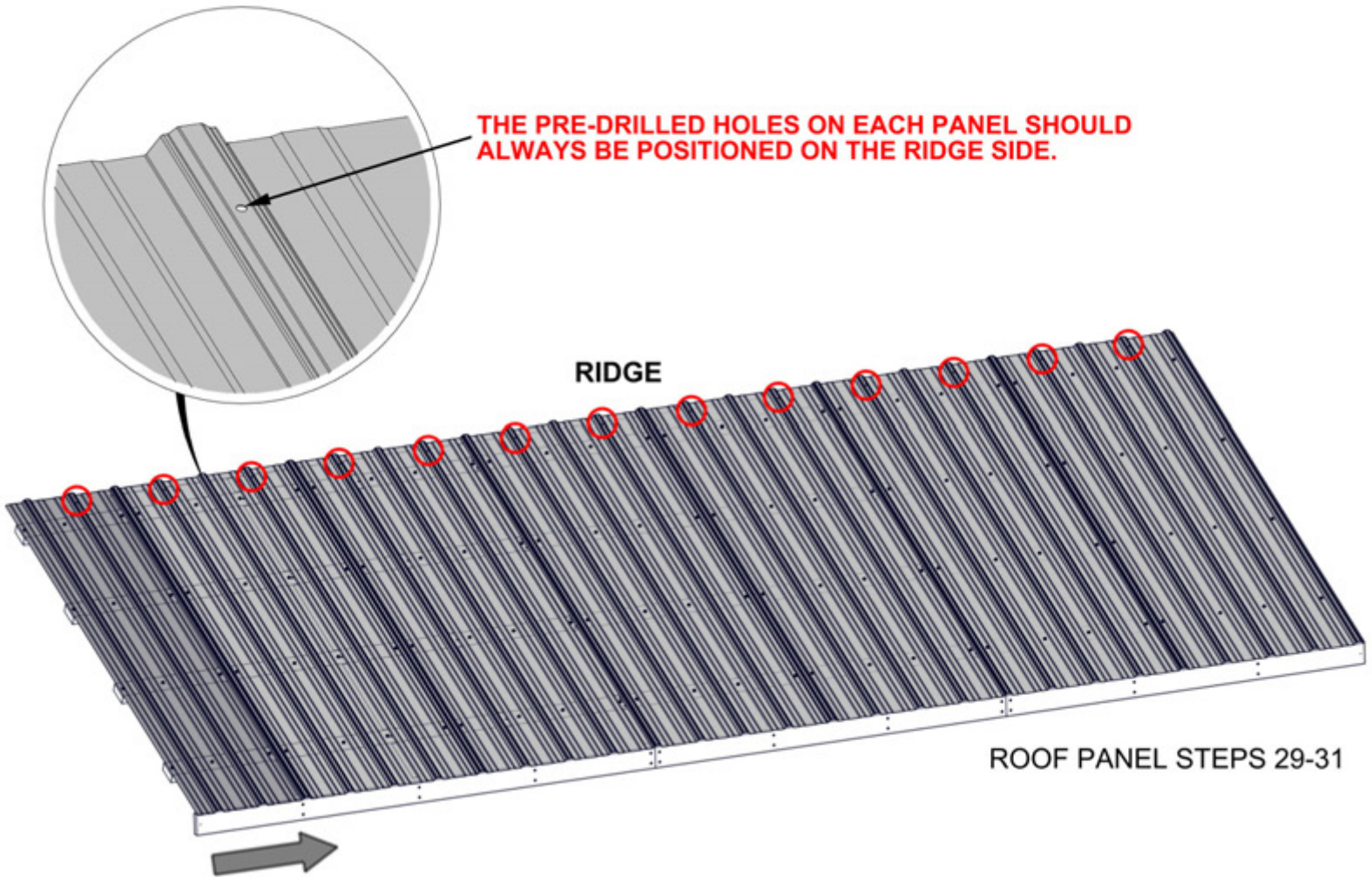

STEP 29 - ROOF PANEL ASSEMBLY

QTY	PART NUMBER	DESCRIPTION
44	H100833	SCREW WOODGRIP 10-16 x 3/4

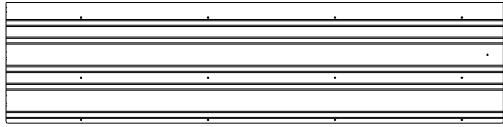

A4M02648 29 GA STEEL SHEETING (x1)

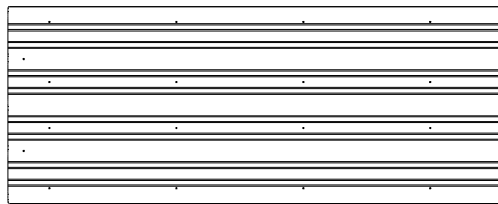

A4M02639 29 GA STEEL SHEETING (x1)

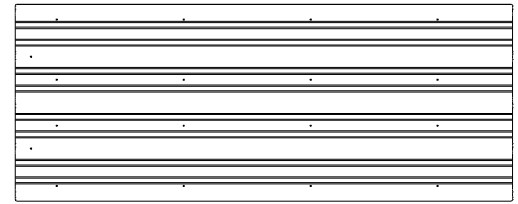

A4M02647 29 GA STEEL SHEETING (x1)

ROOF PANEL B

NOTE RIB OVERLAP

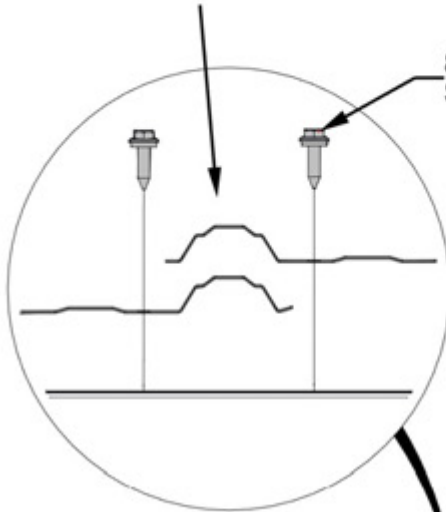

833 (x44)
SCREW - 3/4"

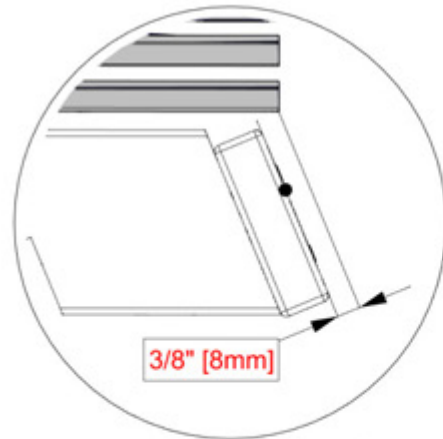

3/8" [8mm]

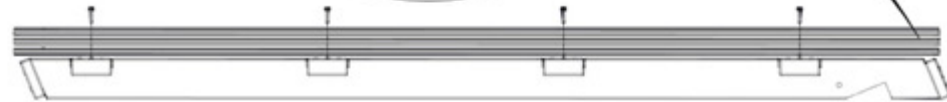

MAKE SURE YOUR ROOF PANEL IS SQUARE BEFORE MOVING ON.



2648 (x1)
29 GA STEEL SHEETING

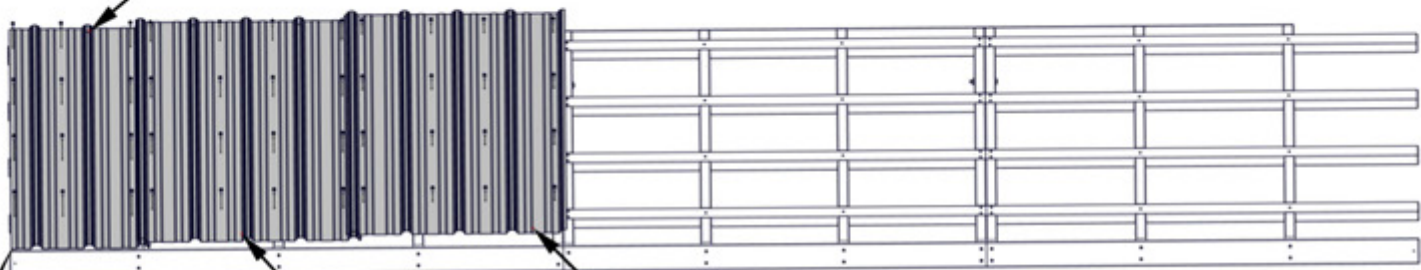

2647 (x1)
29 GA STEEL SHEETING

2639 (x1)
29 GA STEEL SHEETING

ENSURE CORRECT PLACEMENT OF STEEL SHEETING.

PLACE SHEETING ON ROOF PANEL, ALIGNING EDGE OF RIB 2 7/8" (72mm) FROM END OF H BOARD.

2 7/8" [72mm]

STEP 30 - ROOF PANEL ASSEMBLY

QTY	PART NUMBER	DESCRIPTION
32	H100833	SCREW WOODGRIP 10-16x3/4"



A4M02909 29 GA STEEL SHEETING
(x1)

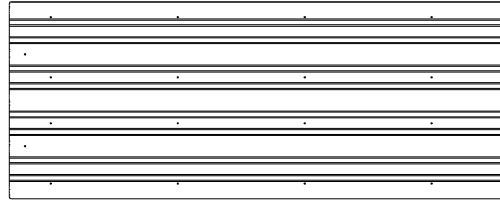

A4M02647 29 GA STEEL SHEETING
(x1)

ROOF PANEL B

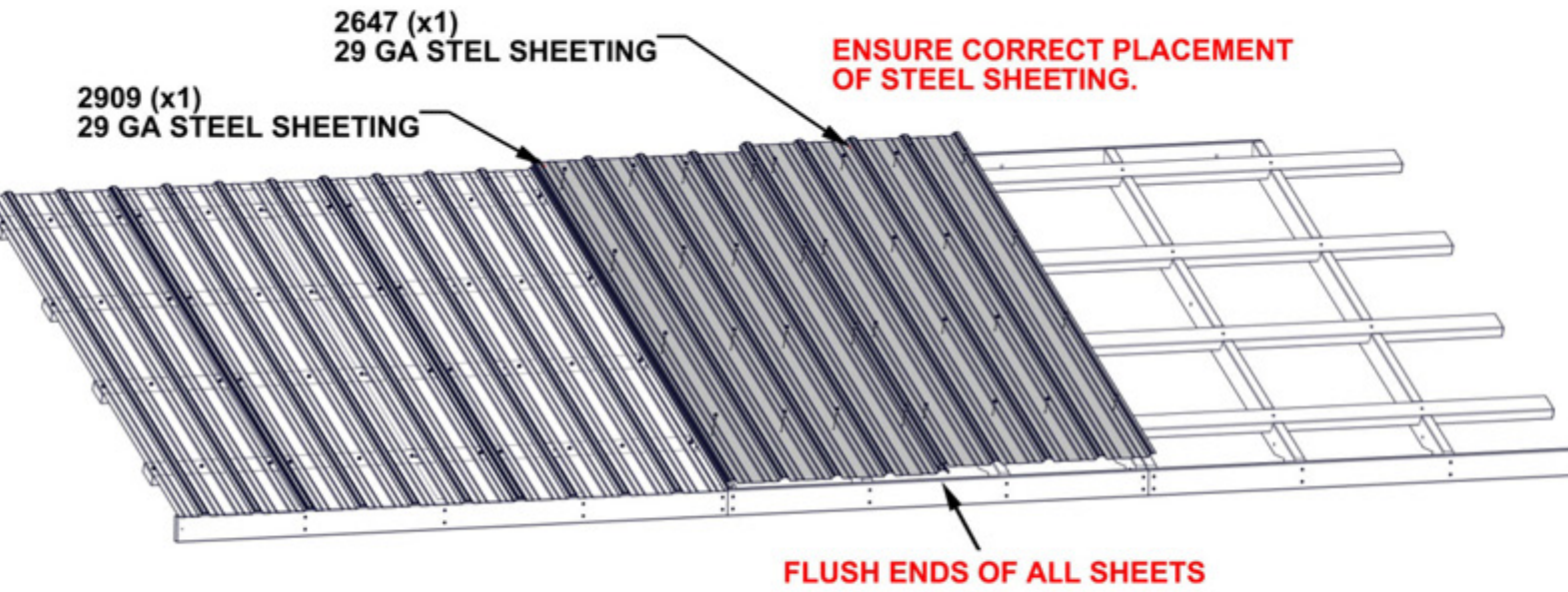
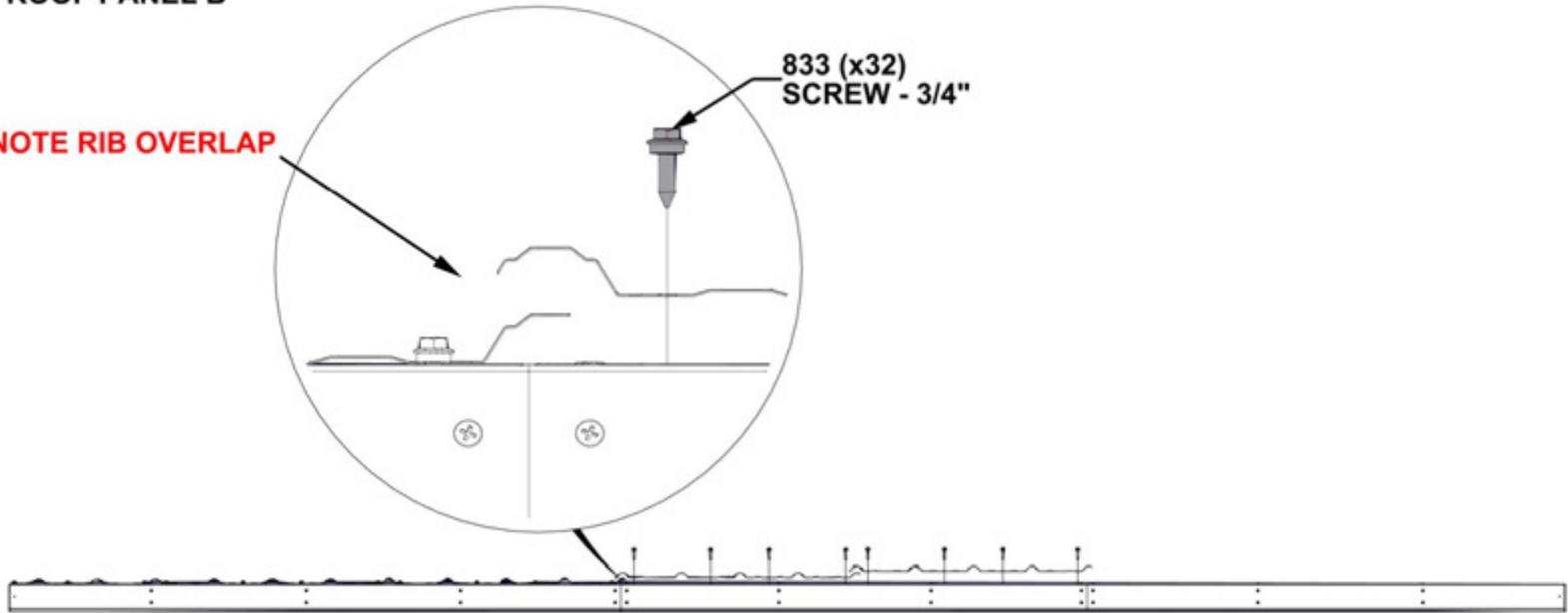

STEP 31 - ROOF PANEL ASSEMBLY

QTY	PART NUMBER	DESCRIPTION
32	H100833	SCREW WOODGRIP 10-16x3/4"



A4M02639 29 GA STEEL SHEETING
(x1)

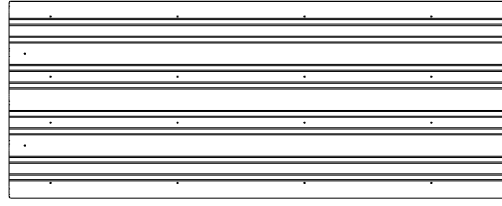

A4M02909 29 GA STEEL SHEETING
(x1)

ROOF PANEL B

NOTE RIB OVERLAP

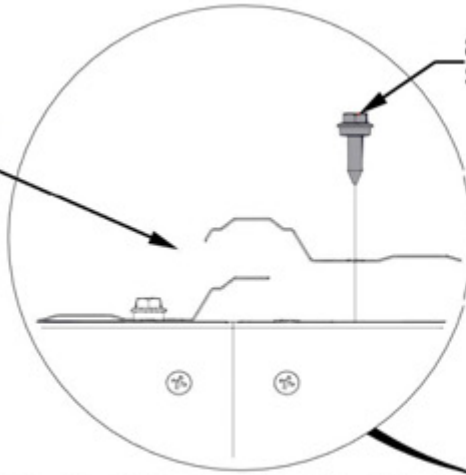

833 (x32)
SCREW - 3/4"



2639 (x1)
29 GA STEEL SHEETING

2909 (x1)
29 GA STEEL SHEETING



FLUSH ENDS OF ALL SHEETS

STEP 32 - ROOF PANEL ASSEMBLY

ROOF PANEL B

- SEPARATE THE ROOF PANEL AT THIS TIME FOR EASE OF ASSEMBLING.
- REMOVE HARDWARE AND SET TO THE SIDE AS IT WILL BE USED AGAIN AFTER BOTH ROOF PANELS ARE INSTALLED.

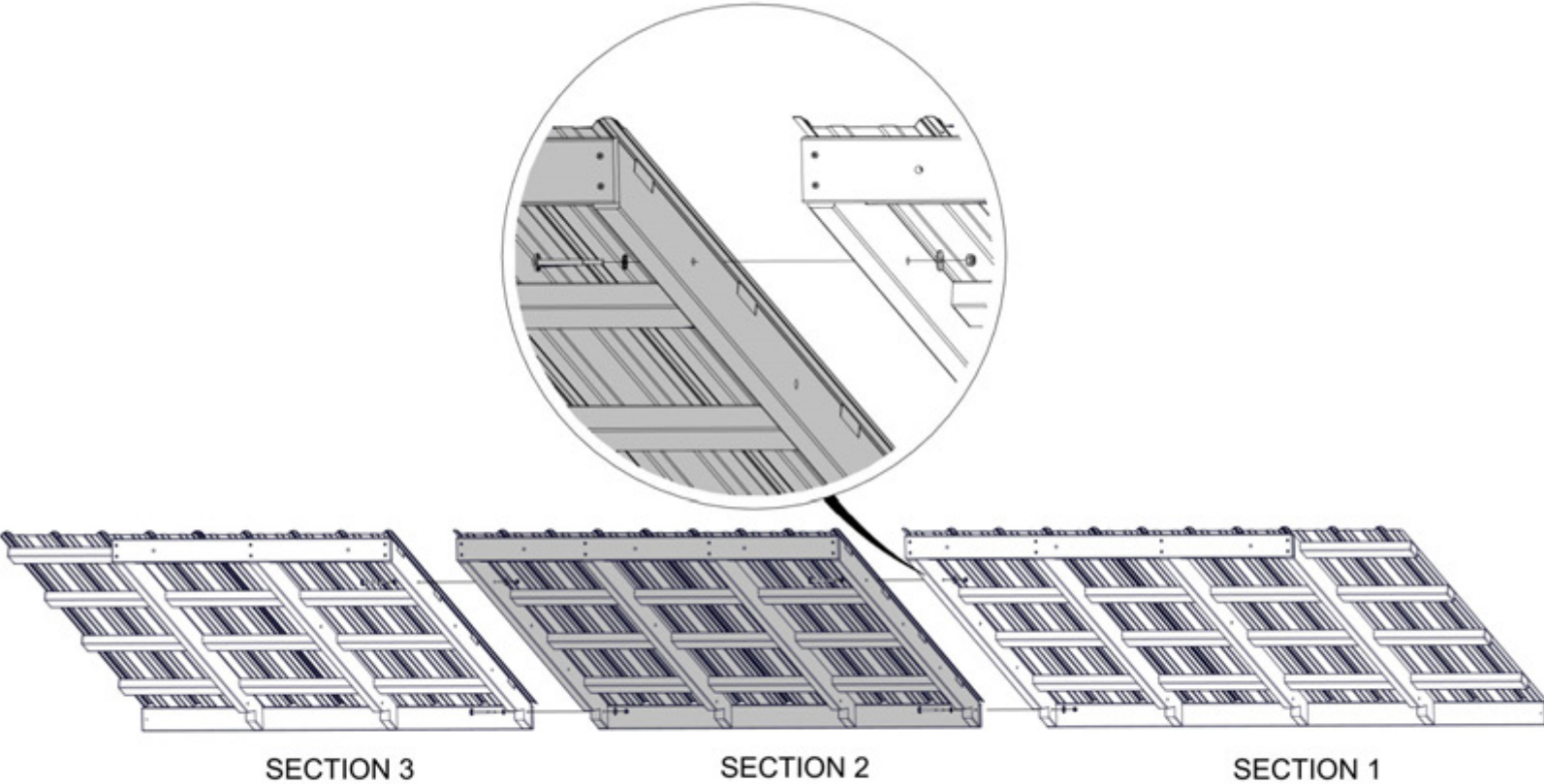

STEP 33 - ROOF ASSEMBLY

QTY	PART NUMBER	DESCRIPTION
3	H100198	WASHER LOCK EXT 8X19 BLK
3	H100378	BOLT WH 5/16 X 1 3/4 BLK
1	H100391	SCREW PFH 8 X 2 BLK

INSTALL ROOF PANEL A, SECTION 1

- WITH AT LEAST TWO PEOPLE, LIFT ASSEMBLED ROOF PANEL AND SLIDE IT INTO THE TRACKS ON THE RAFTERS.
- ONCE IN PLACE, INSTALL ATTACHMENT HARDWARE AS SHOWN.
- A THIRD PERSON IS HELPFUL TO ATTACH THE ROOF ONCE IN PLACE.

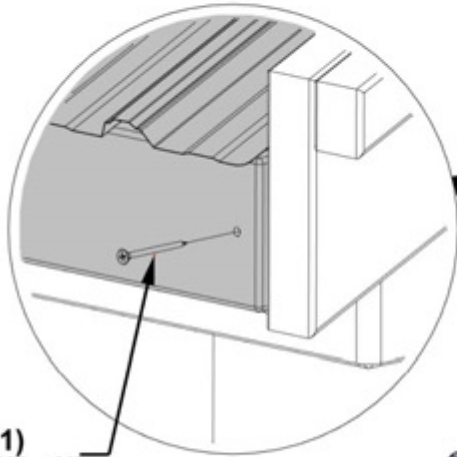
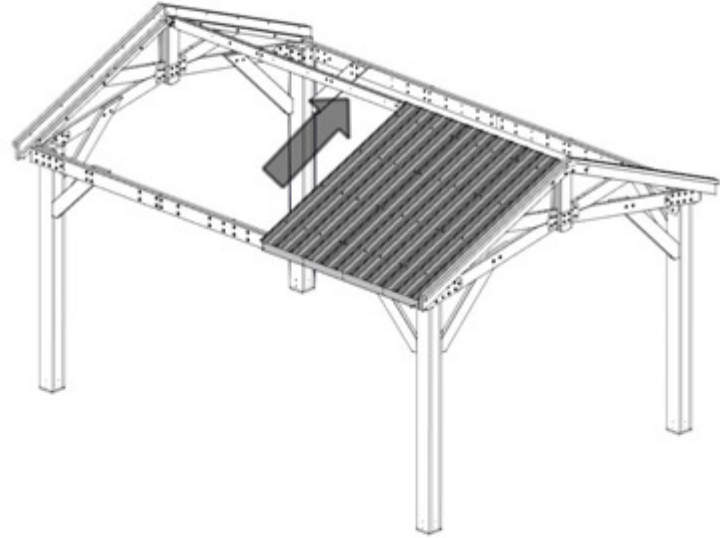

391 (x1)
SCREW - 2"

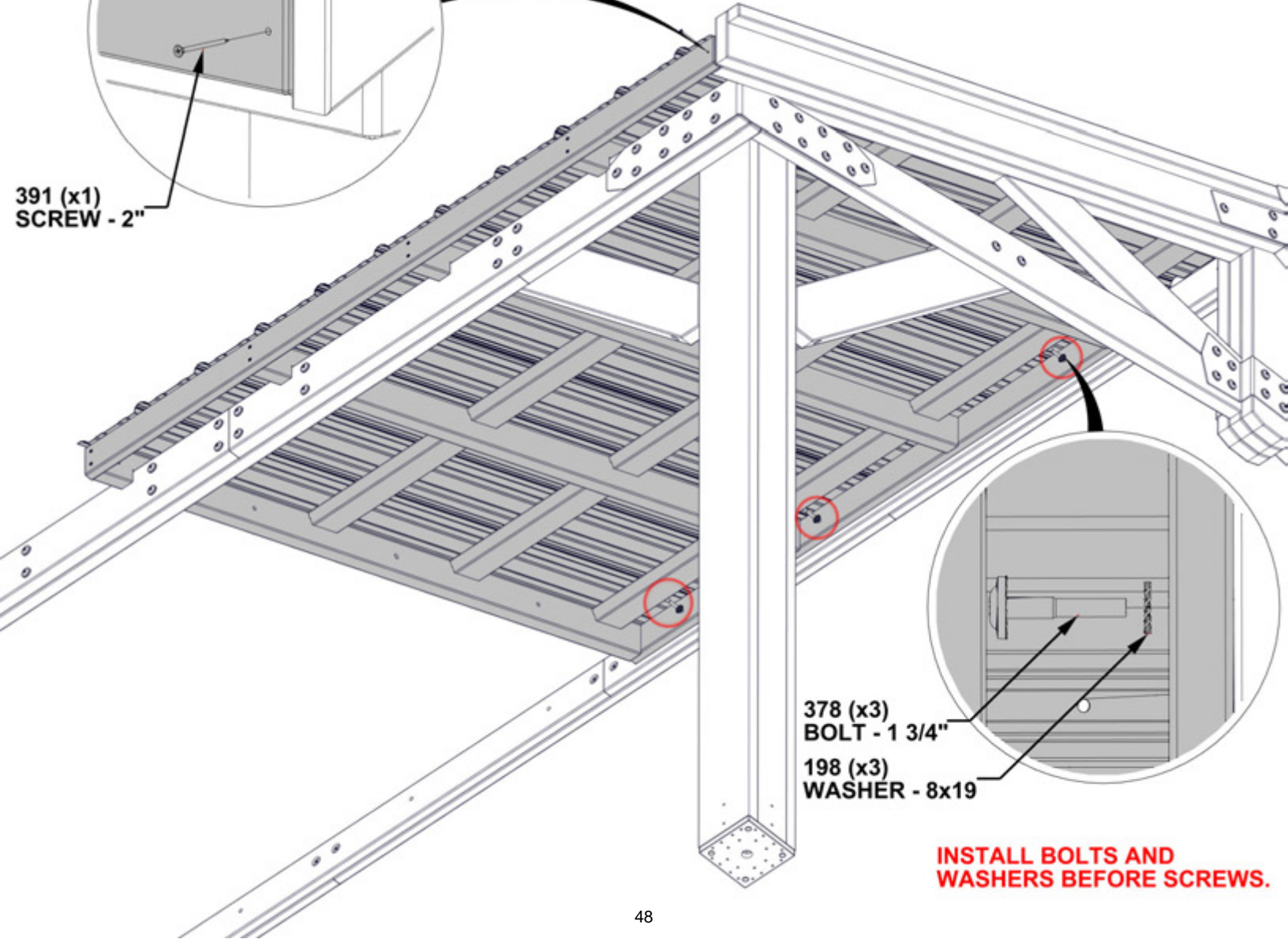

378 (x3)
BOLT - 1 3/4"
198 (x3)
WASHER - 8x19

**INSTALL BOLTS AND
WASHERS BEFORE SCREWS.**

STEP 34 - ROOF ASSEMBLY

QTY	PART NUMBER	DESCRIPTION
3	H100198	WASHER LOCK EXT 8X19 BLK
3	H100378	BOLT WH 5/16 X 1 3/4 BLK
1	H100391	SCREW PFH 8 X 2 BLK

- WITH AT LEAST TWO PEOPLE, LIFT ASSEMBLED ROOF PANEL AND SLIDE IT INTO THE TRACKS ON THE RAFTERS.
- ONCE IN PLACE, INSTALL ATTACHMENT HARDWARE AS SHOWN.
- A THIRD PERSON IS HELPFUL TO ATTACH THE ROOF ONCE IN PLACE.

INSTALL ROOF PANEL B, SECTION 1

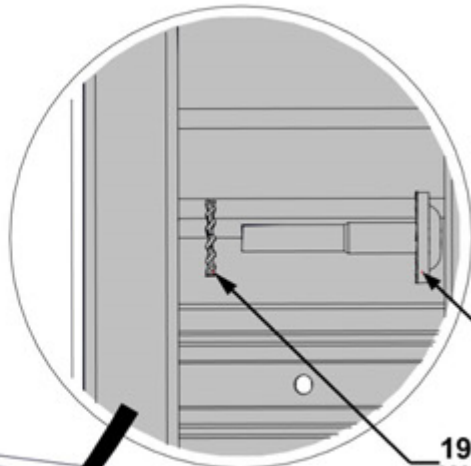
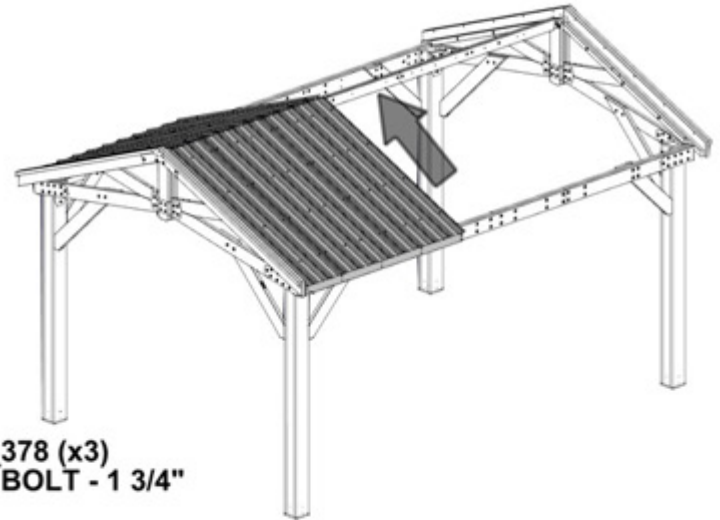

378 (x3)
BOLT - 1 3/4"

198 (x3)
WASHER - 8x19

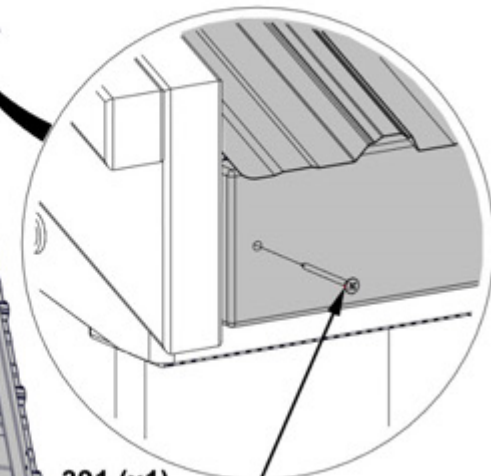
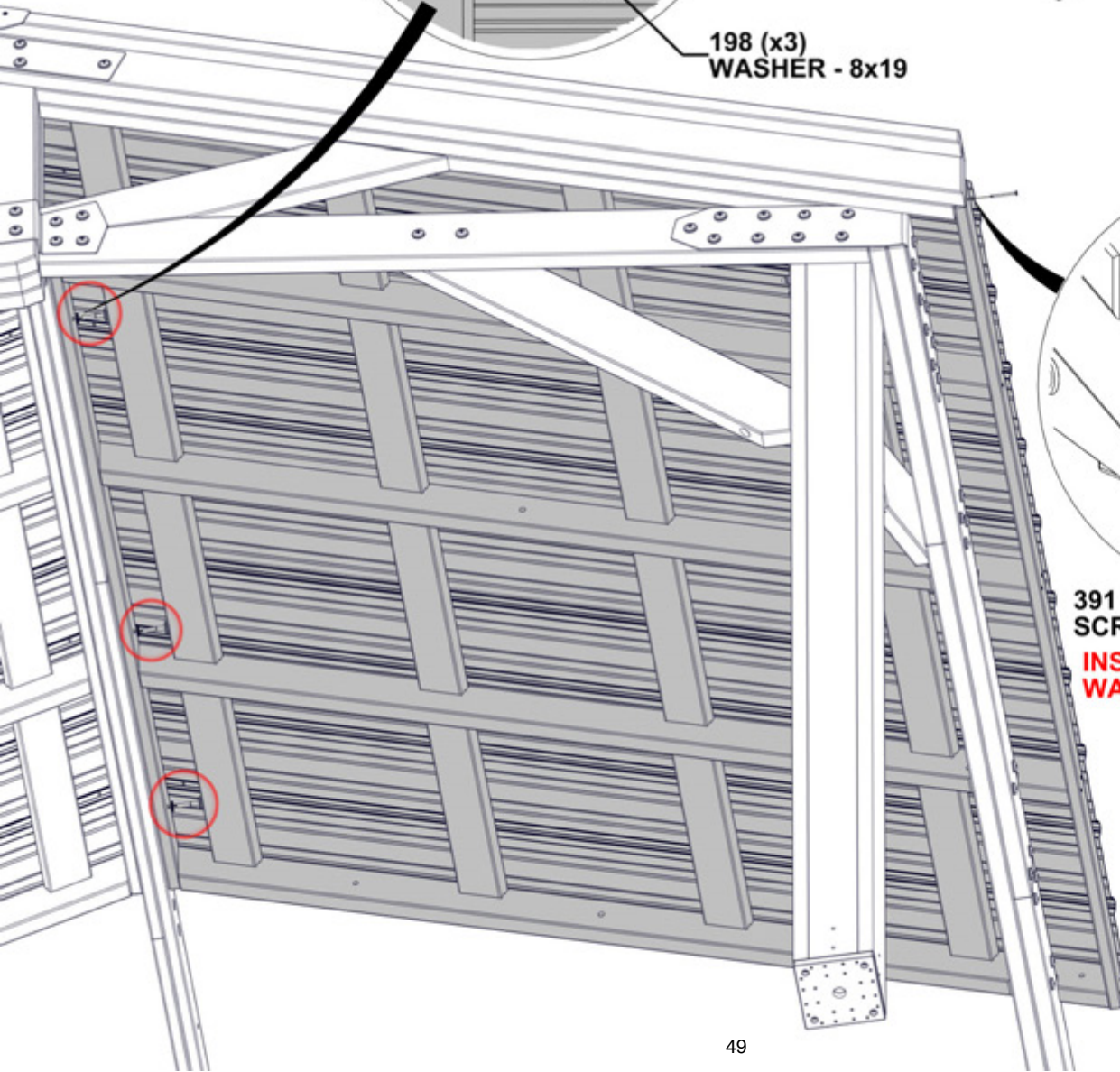

391 (x1)
SCREW - 2"

INSTALL BOLTS AND WASHERS BEFORE SCREWS.

STEP 35 - ROOF ASSEMBLY

QTY	PART NUMBER	DESCRIPTION
2	H100198	WASHER LOCK EXT 8X19 BLK
2	H100478	WASHER FLAT 8X27 BLK
2	H100479	NUT LOCK 5/16 BLK
2	H100480	BOLT WH 5/16 X 4 3/4 BLK

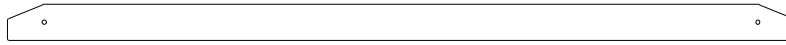

E06 ACCESSORY TRUSS - W4L16863
 (x2) 1 3/8"x3 3/8"x73 13/16" (36x86x1875)

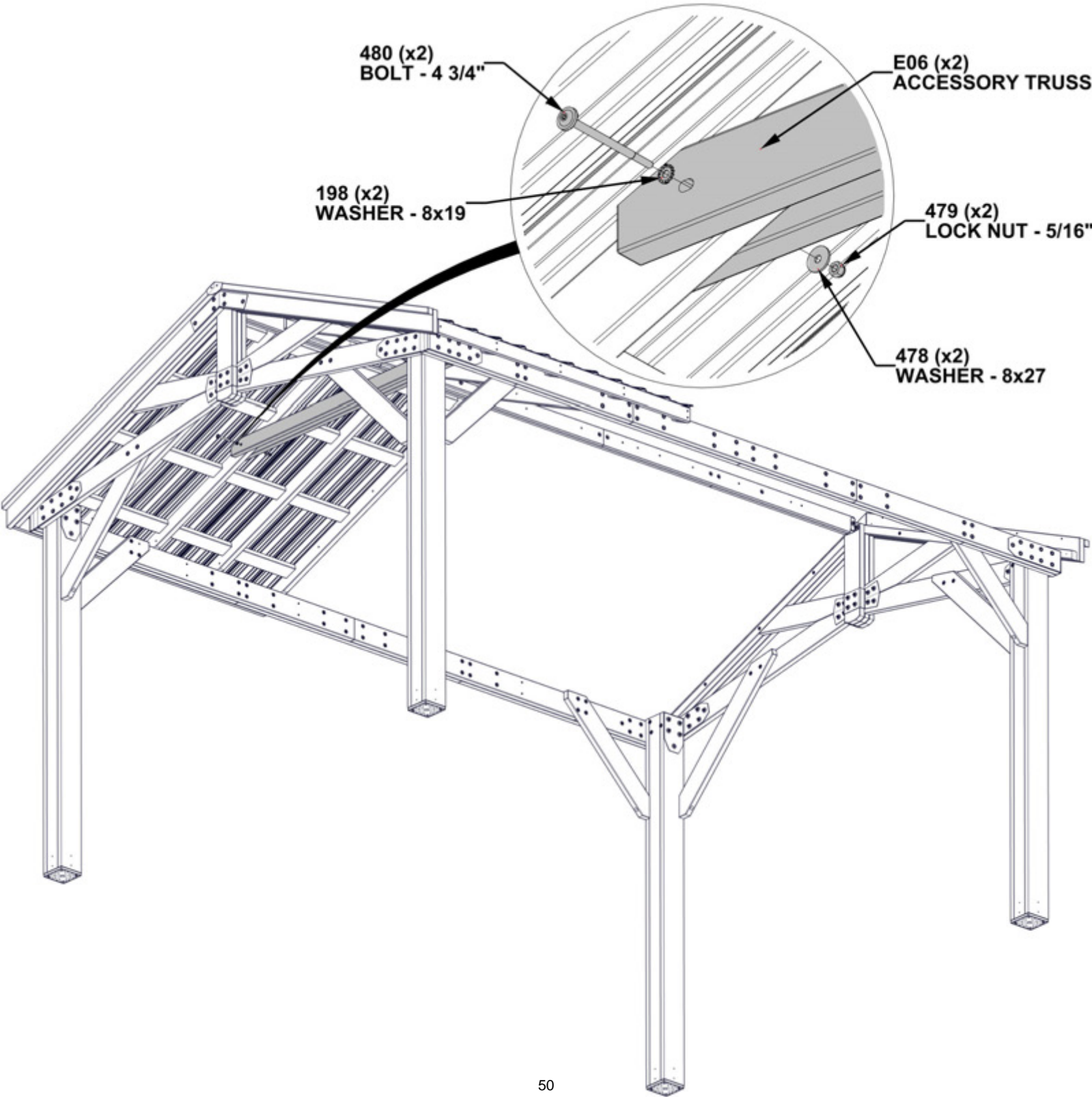

STEP 36 - ROOF ASSEMBLY

- THE CORNER OF EXISTING PANEL MAY NEED TO BE LIFTED TO GET THE PANEL STARTED SLIDING UP.
- WITH AT LEAST TWO PEOPLE, LIFT ASSEMBLED ROOF PANEL AND SLIDE IT INTO THE TRACKS ON THE RAFTERS.
- ONCE IN PLACE, INSTALL ATTACHMENT HARDWARE AS SHOWN.
- A THIRD PERSON IS HELPFUL TO ATTACH THE ROOF ONCE IN PLACE.

QTY	PART NUMBER	DESCRIPTION
6	H100198	WASHER LOCK EXT 8X19 BLK
3	H100378	BOLT WH 5/16 X 1 3/4 BLK
3	H100478	WASHER FLAT 8X27 BLK
3	H100479	NUT LOCK 5/16 BLK
3	H100503	BOLT WH 5/16 X 3 1/2 BLK

INSTALL ROOF PANEL A, SECTION 2

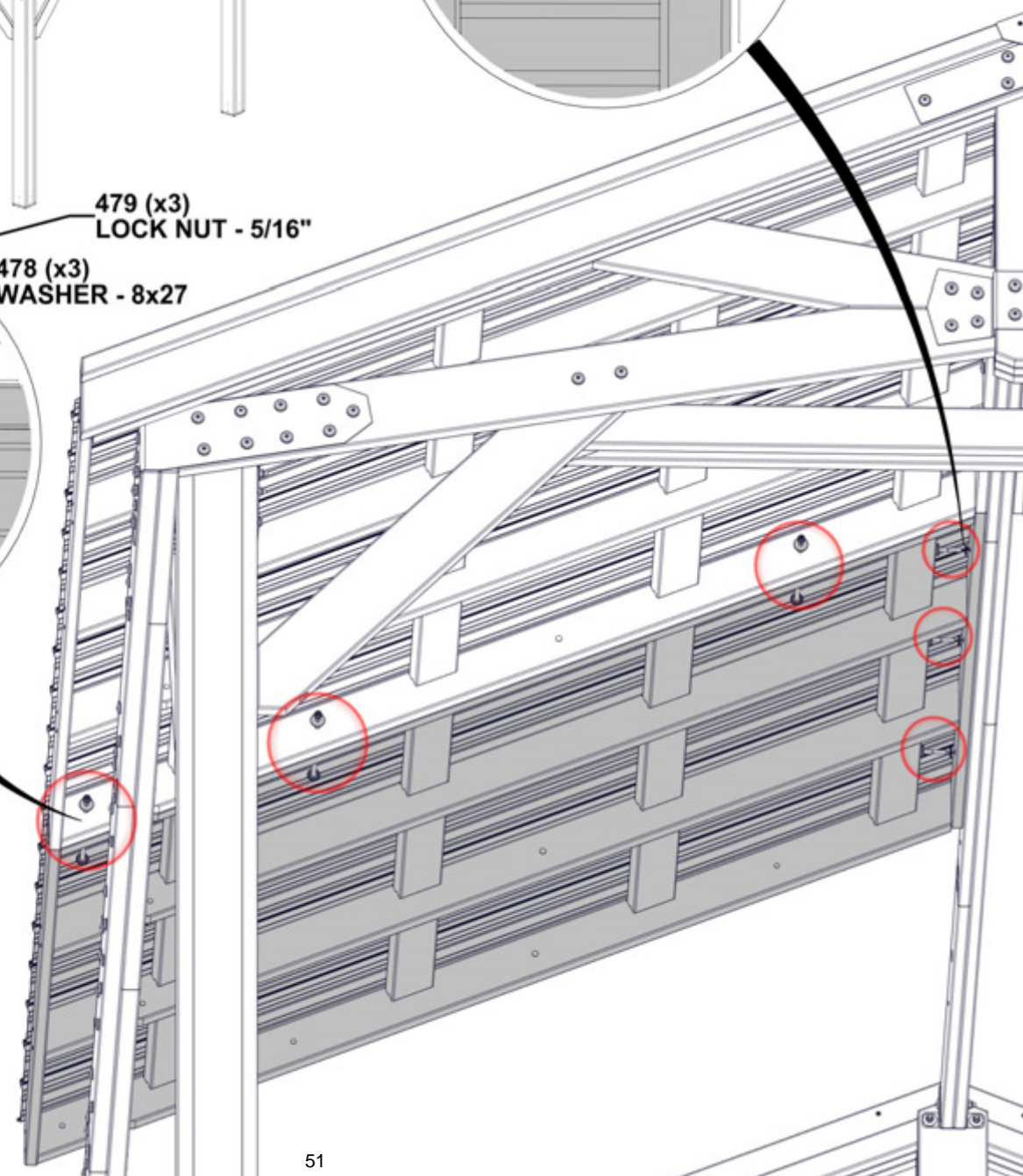
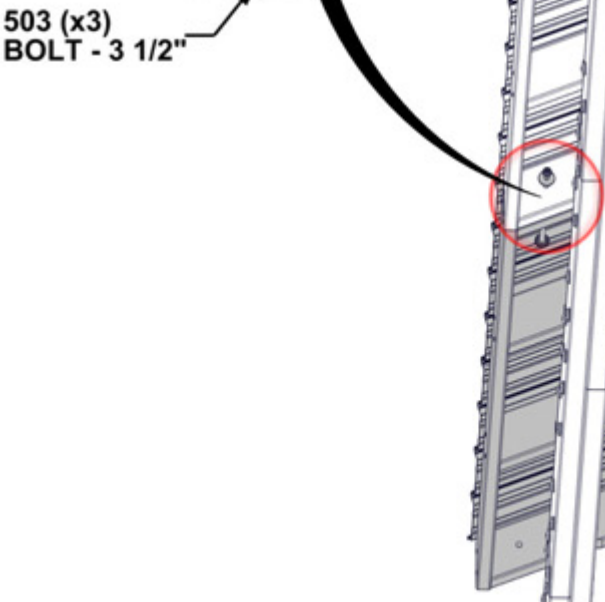
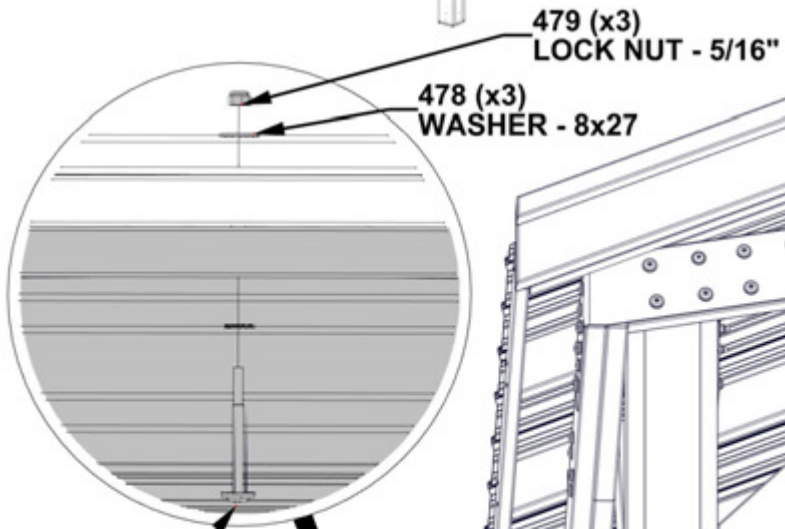
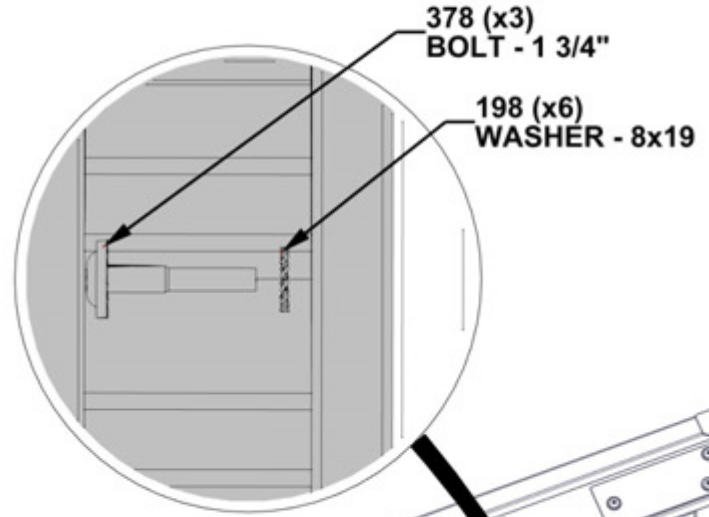
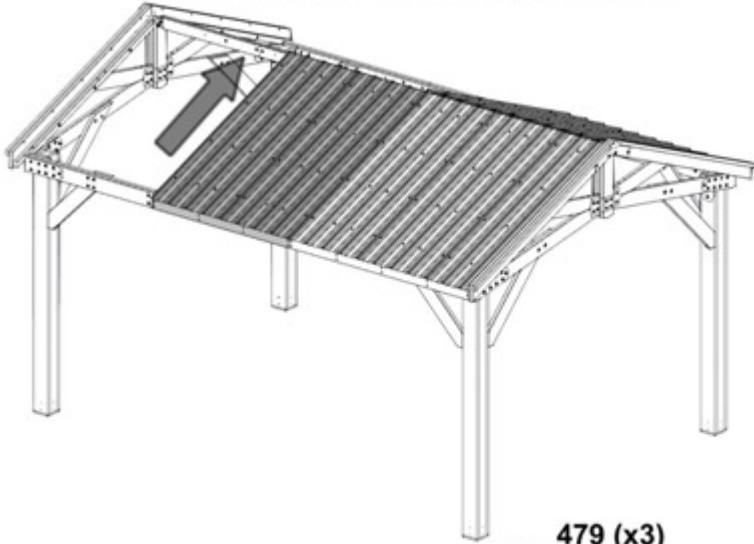

STEP 37 - ROOF ASSEMBLY

QTY	PART NUMBER	DESCRIPTION
6	H100198	WASHER LOCK EXT 8X19 BLK
3	H100378	BOLT WH 5/16 X 1 3/4 BLK
3	H100478	WASHER FLAT 8X27 BLK
3	H100479	NUT LOCK 5/16 BLK
3	H100503	BOLT WH 5/16 X 3 1/2 BLK

- THE CORNER OF EXISTING PANEL MAY NEED TO BE LIFTED TO GET THE PANEL STARTED SLIDING UP.
- WITH AT LEAST TWO PEOPLE, LIFT ASSEMBLED ROOF PANEL AND SLIDE IT INTO THE TRACKS ON THE RAFTERS.
- ONCE IN PLACE, INSTALL ATTACHMENT HARDWARE AS SHOWN.
- A THIRD PERSON IS HELPFUL TO ATTACH THE ROOF ONCE IN PLACE.

INSTALL ROOF PANEL B, SECTION 2

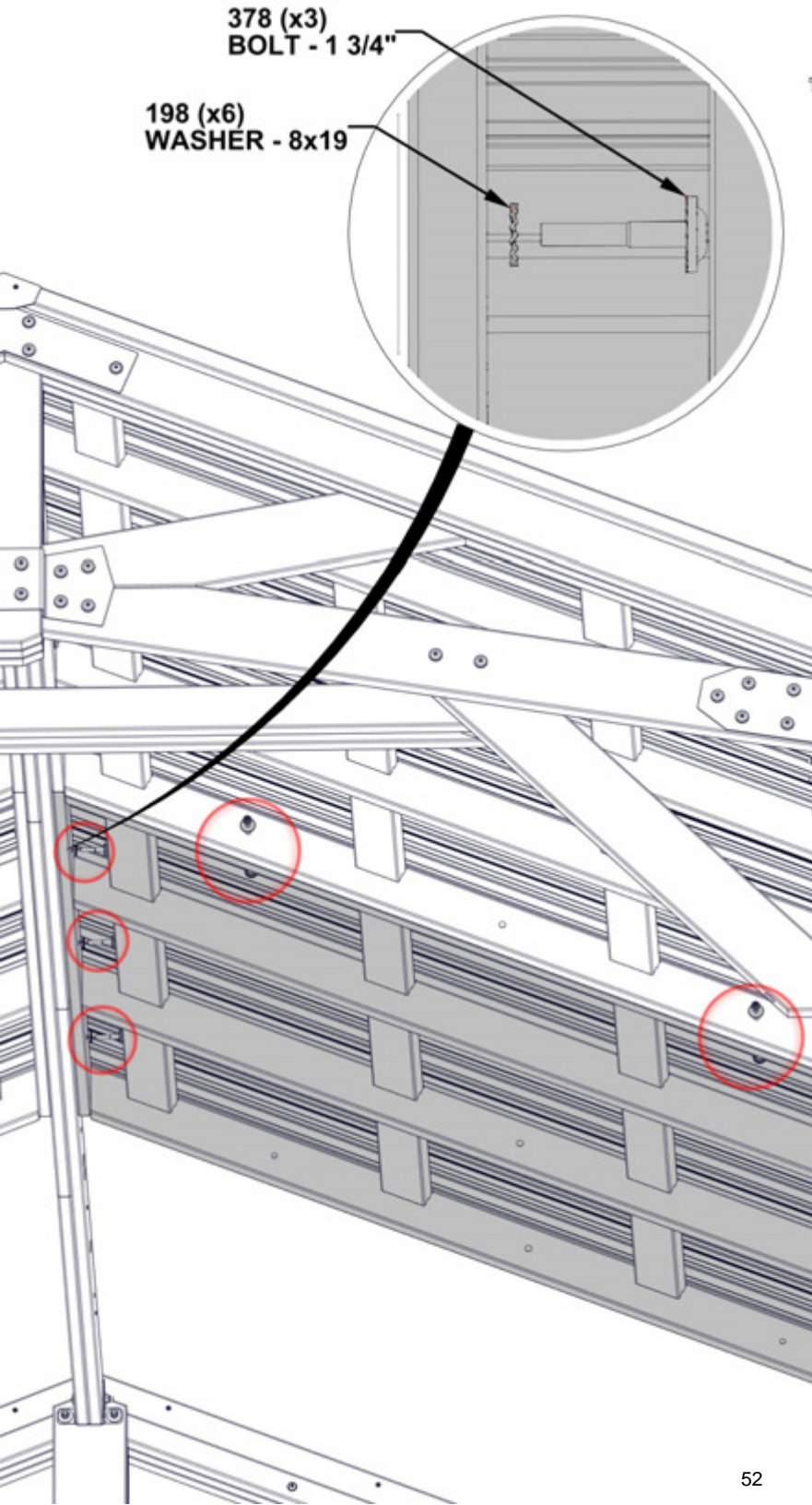
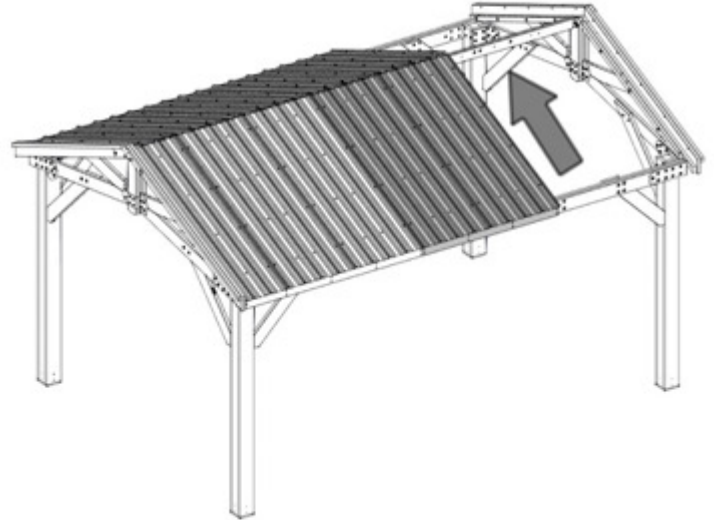

479 (x3)
LOCK NUT - 5/16"

478 (x3)
WASHER - 8x27

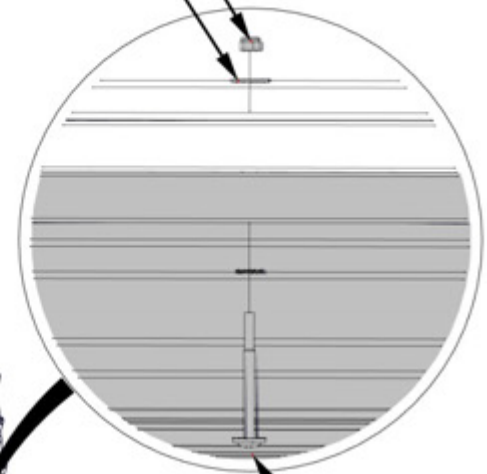

503 (x3)
BOLT - 3 1/2"

STEP 38 - ROOF ASSEMBLY

QTY	PART NUMBER	DESCRIPTION
4	H100198	WASHER LOCK EXT 8X19 BLK
4	H100478	WASHER FLAT 8X27 BLK
4	H100479	NUT LOCK 5/16 BLK
2	H100480	BOLT WH 5/16 X 4 3/4 BLK
2	H100976	BOLT WH 5/16 X 6 1/4 BLK



E06 ACCESSORY TRUSS - W4L16863
 (x4) 1 3/8"x3 3/8"x73 13/16" (36x86x1875)

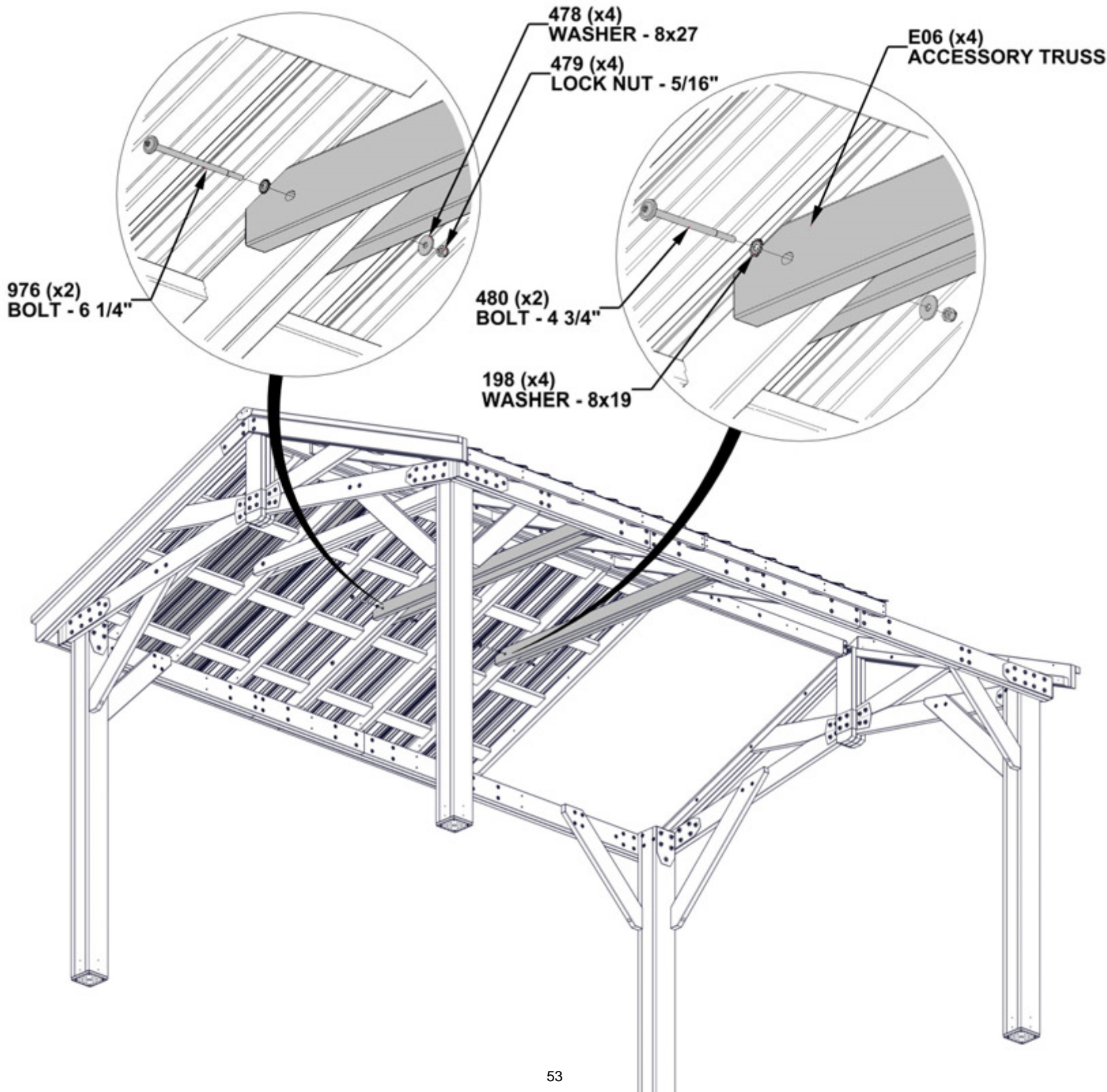

STEP 39 - ROOF ASSEMBLY

QTY	PART NUMBER	DESCRIPTION
6	H100198	WASHER LOCK EXT 8X19 BLK
2	H100378	BOLT WH 5/16 X 1 3/4 BLK
1	H100391	SCREW PFH 8 X 2 BLK
4	H100478	WASHER FLAT 8X27 BLK
4	H100479	NUT LOCK 5/16 BLK
4	H100503	BOLT WH 5/16 X 3 1/2 BLK

- THE CORNER OF EXISTING PANEL MAY NEED TO BE LIFTED TO GET THE PANEL STARTED SLIDING UP.
- WITH AT LEAST TWO PEOPLE, LIFT ASSEMBLED ROOF PANEL AND SLIDE IT INTO THE TRACKS ON THE RAFTERS.
- ONCE IN PLACE, INSTALL ATTACHMENT HARDWARE AS SHOWN.
- A THIRD PERSON IS HELPFUL TO ATTACH THE ROOF ONCE IN PLACE.

INSTALL ROOF PANEL A, SECTION 3

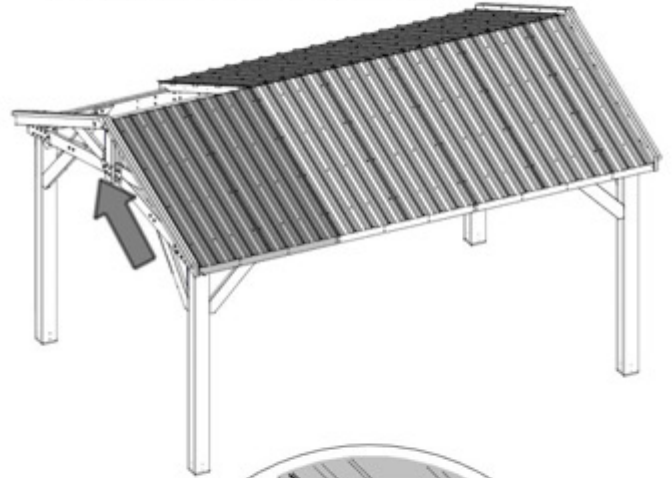

INSTALL BOLTS AND WASHERS BEFORE SCREWS.

198 (x6)
WASHER - 8x19

378 (x2)
BOLT - 1 3/4"

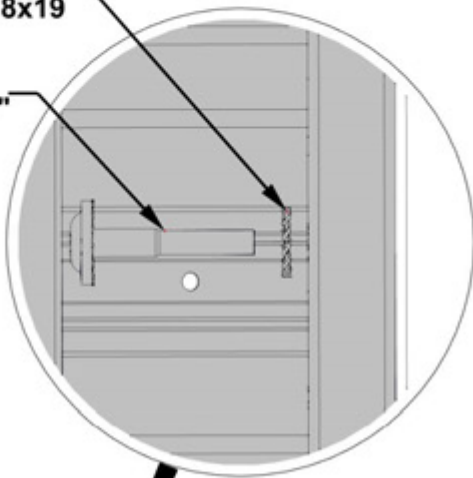

391 (x1)
SCREW - 2"

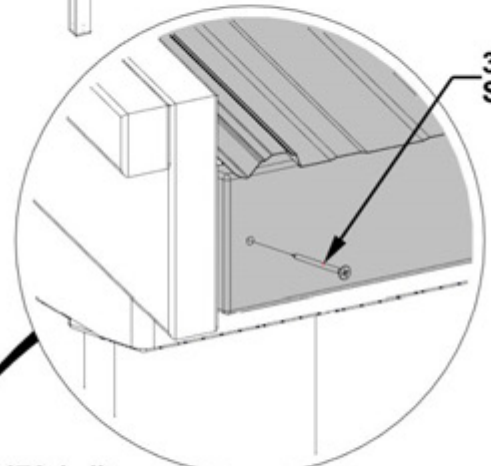

479 (x4)
LOCK NUT - 5/16"

478 (x4)
WASHER - 8x27

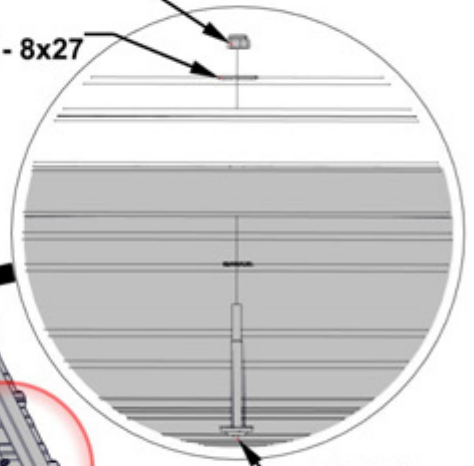

503 (x4)
BOLT - 3 1/2"

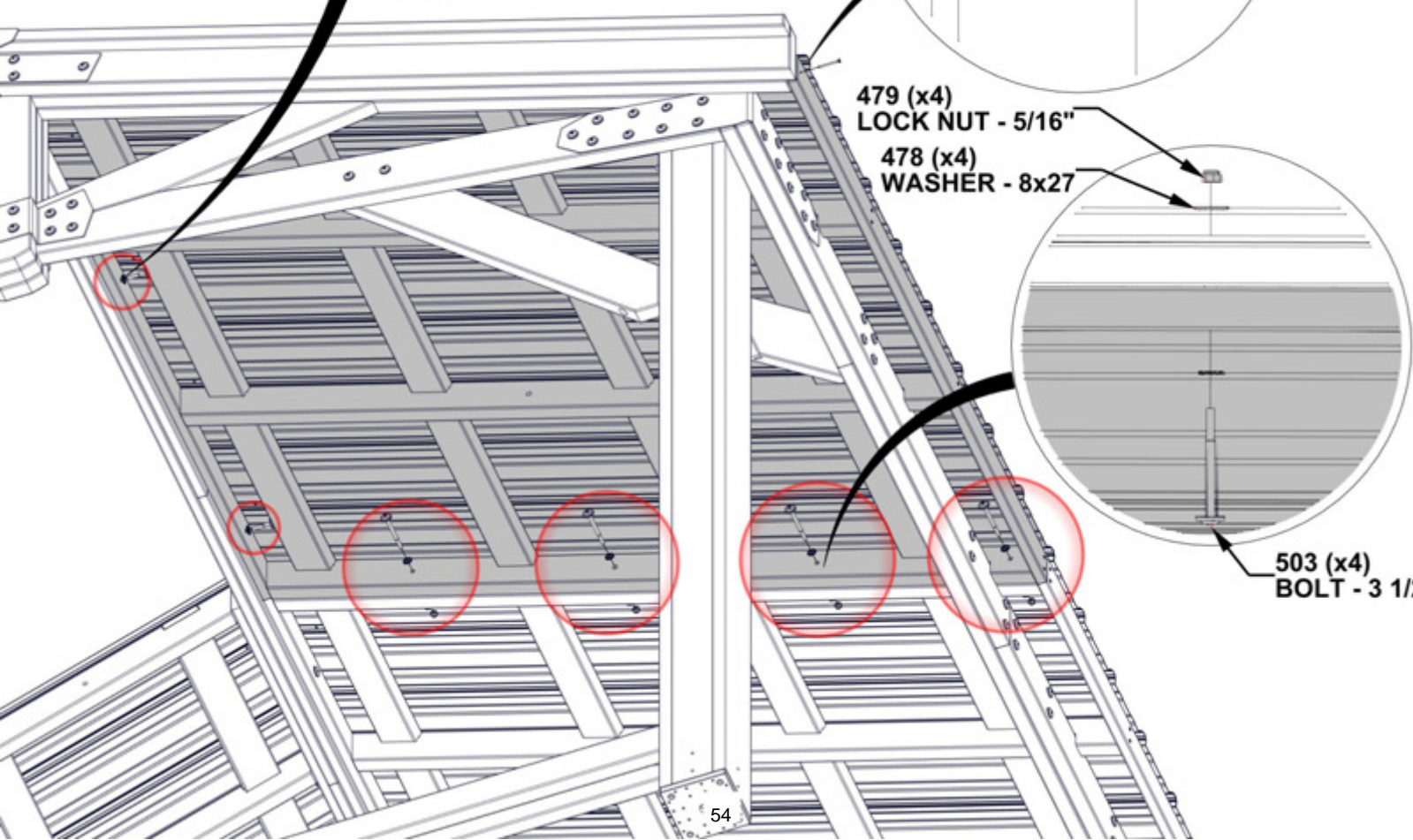

STEP 40 - ROOF ASSEMBLY

QTY	PART NUMBER	DESCRIPTION
6	H100198	WASHER LOCK EXT 8X19 BLK
2	H100378	BOLT WH 5/16 X 1 3/4 BLK
1	H100391	SCREW PFH 8 X 2 BLK
4	H100478	WASHER FLAT 8X27 BLK
4	H100479	NUT LOCK 5/16 BLK
4	H100503	BOLT WH 5/16 X 3 1/2 BLK

- THE CORNER OF EXISTING PANEL MAY NEED TO BE LIFTED TO GET THE PANEL STARTED SLIDING UP.
- WITH AT LEAST TWO PEOPLE, LIFT ASSEMBLED ROOF PANEL AND SLIDE IT INTO THE TRACKS ON THE RAFTERS.
- ONCE IN PLACE, INSTALL ATTACHMENT HARDWARE AS SHOWN.
- A THIRD PERSON IS HELPFUL TO ATTACH THE ROOF ONCE IN PLACE.

INSTALL ROOF PANEL B. SECTION 3

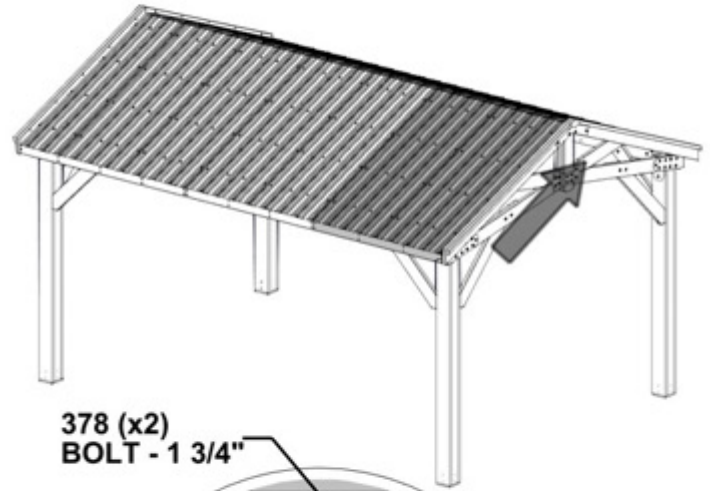

INSTALL BOLTS AND WASHERS BEFORE SCREWS.

391 (x1)
SCREW - 2"

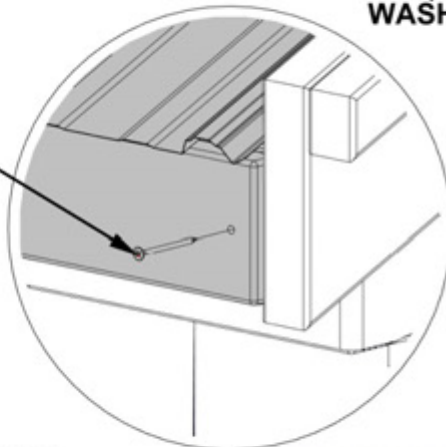

378 (x2)
BOLT - 1 3/4"

198 (x6)
WASHER - 8x19

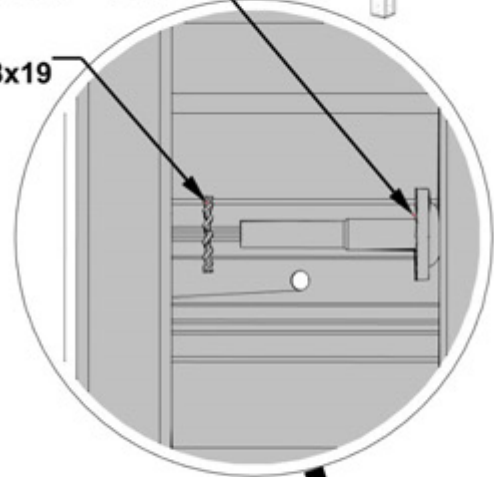

479 (x4)
LOCK NUT - 5/16"

478 (x4)
WASHER - 8x27

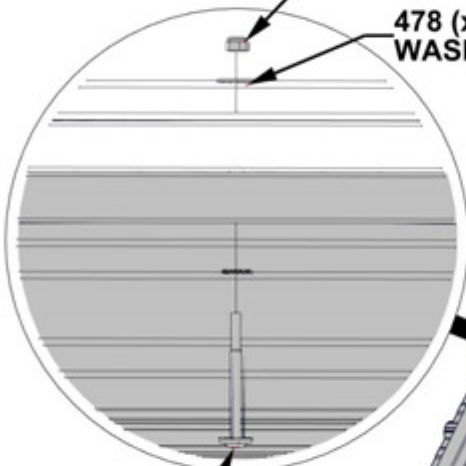

503 (x4)
BOLT - 3 1/2"

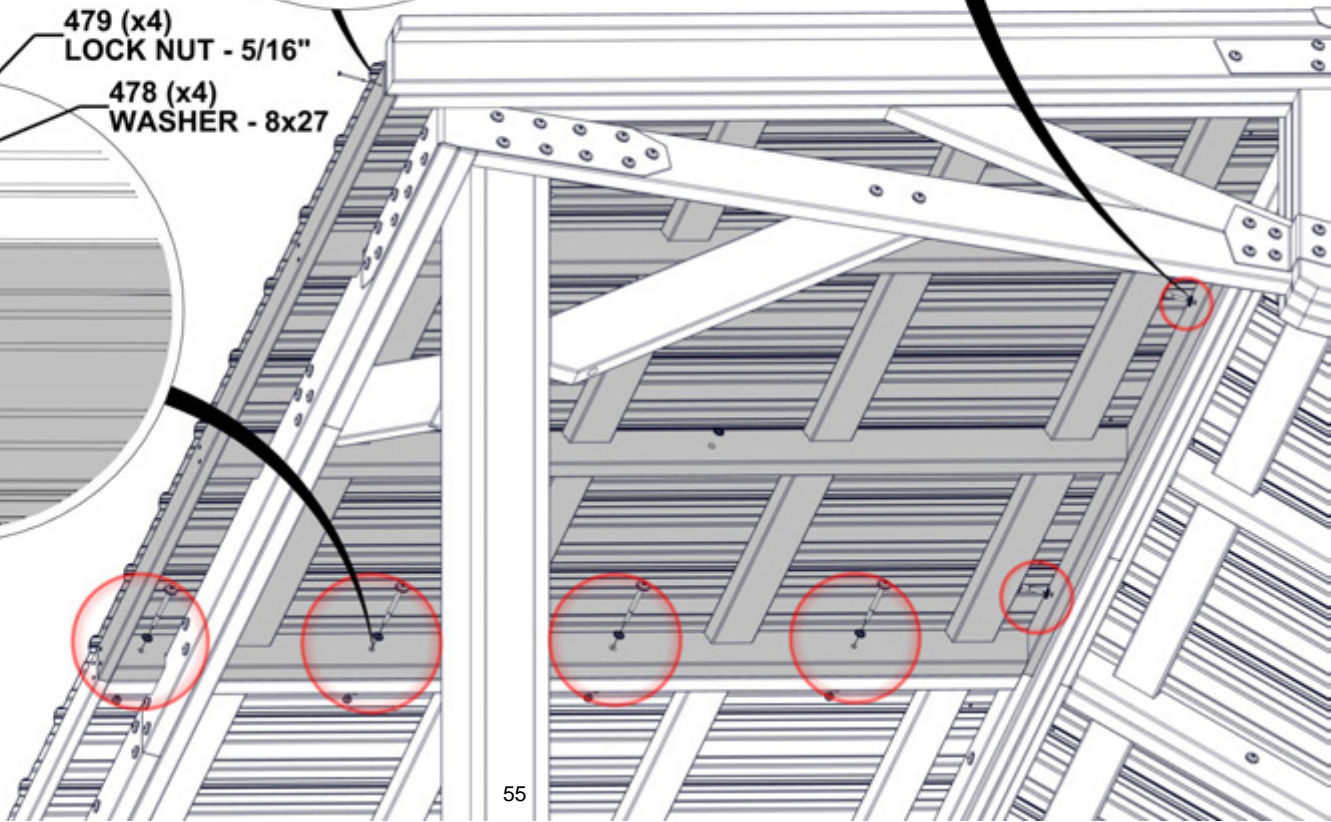

STEP 41 - ROOF ASSEMBLY

QTY	PART NUMBER	DESCRIPTION
2	H100198	WASHER LOCK EXT 8X19 BLK
2	H100478	WASHER FLAT 8X27 BLK
2	H100479	NUT LOCK 5/16 BLK
2	H100480	BOLT WH 5/16 X 4 3/4 BLK

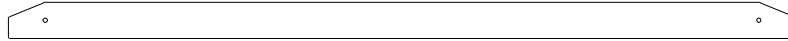

E06 ACCESSORY TRUSS - W4L16863
(x2) 1 3/8"x3 3/8"x73 13/16" (36x86x1875)

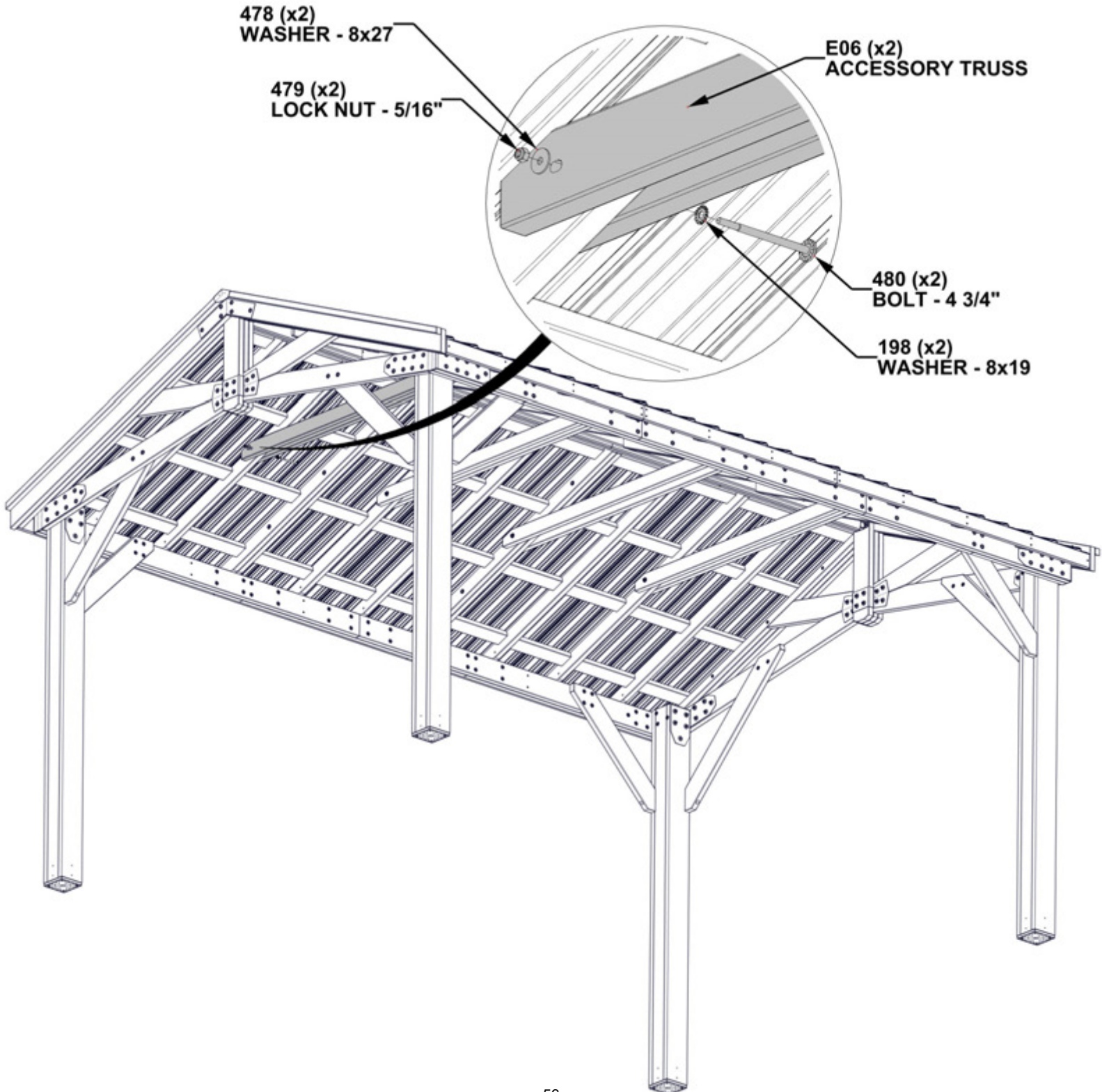

STEP 42 - GAZEBO ASSEMBLY

QTY	PART NUMBER	DESCRIPTION
24	H100201	SCREW PFH 8 X 2 1/2 BLK



G01 COVER BOARD - W4L16917
 (x2) 1"x5 1/4"x89 1/2" (24x134x2274)

- REPEAT FOR OTHER SIDE OF GAZEBO.

FOR BOARD PLACEMENT, MEASURE AS SHOWN FROM END OF CORBEL. USE PILOT HOLES TO ATTACH BOARD.

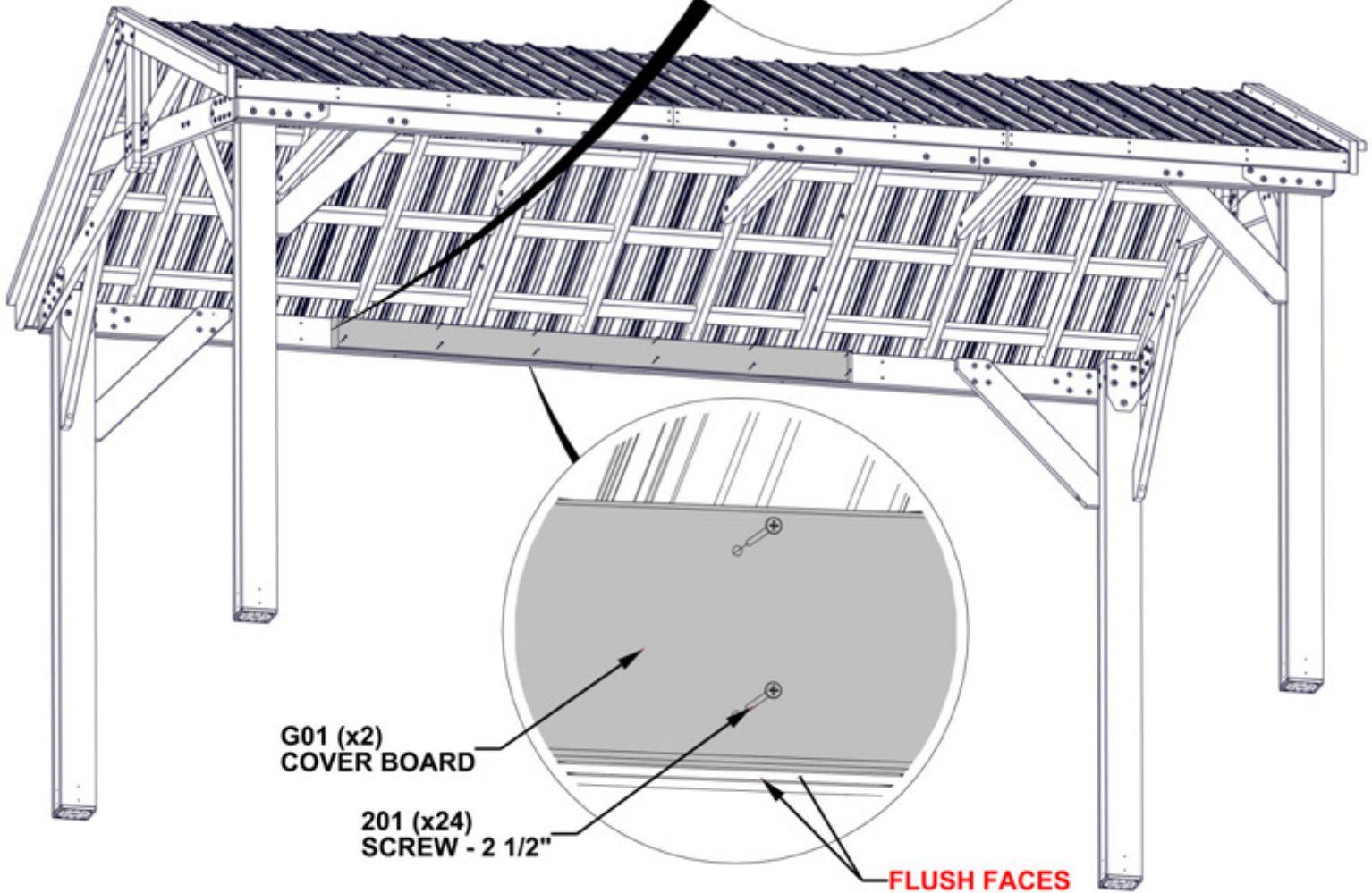
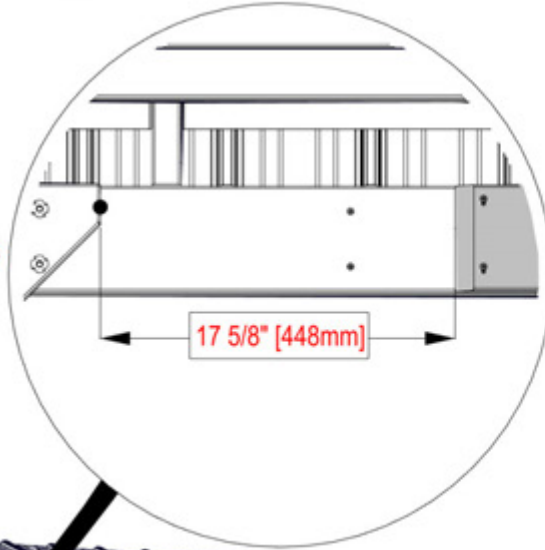

STEP 43 - ROOF ASSEMBLY

QTY	PART NUMBER	DESCRIPTION
14	H100488	BOLT WH 1/4 X 2 BLK
14	H100630	WASHER FLAT 8x19 BLK
14	H100653	NUT LOCK 1/4 BLK
28	H100823	SCREW PWH 8 X 1 1/2 BLK

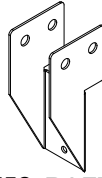

A4M01752 RAFTER CLIP
(x14)

630 (x14)
WASHER - 8x19

653 (x14)
LOCK NUT - 1/4"

823 (x28)
SCREW - 1 1/2"

488 (x14)
BOLT - 2"

**USE THIS BOLT HOLE FOR
CENTER THREE RAFTER CLIPS.**

1752 (x14)
RAFTER CLIP

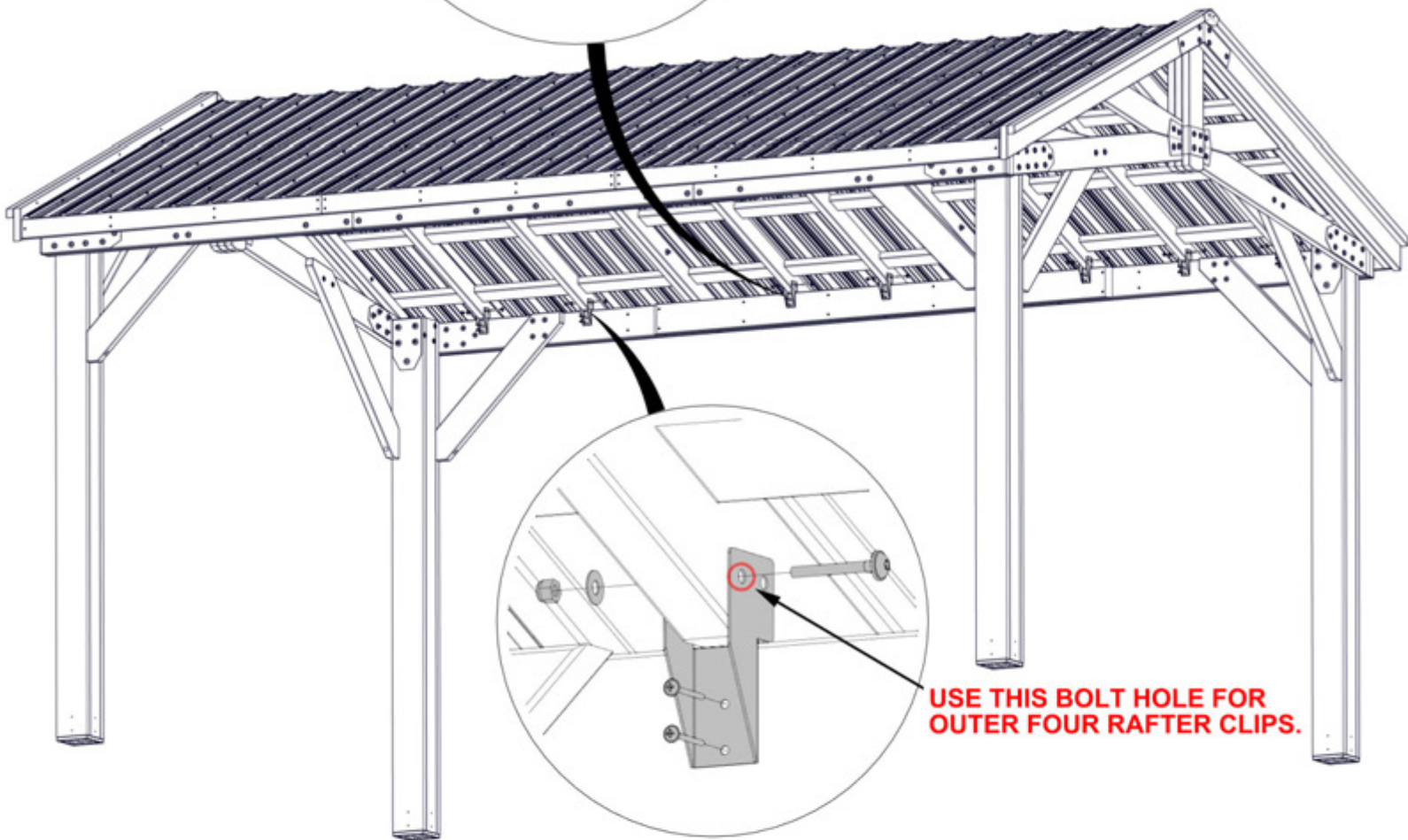

**USE THIS BOLT HOLE FOR
OUTER FOUR RAFTER CLIPS.**

STEP 44A - ROOF ASSEMBLY

QTY	PART NUMBER	DESCRIPTION
8	H100833	SCREW WOODGRIP 10-16x3/4"

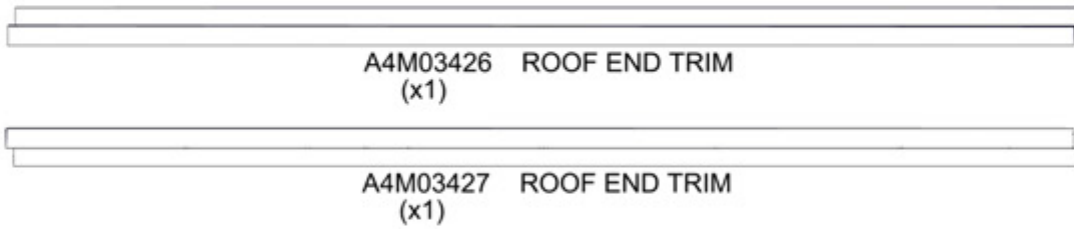

- ATTACH SCREWS IN LINE WITH ROOF PANEL SCREWS.

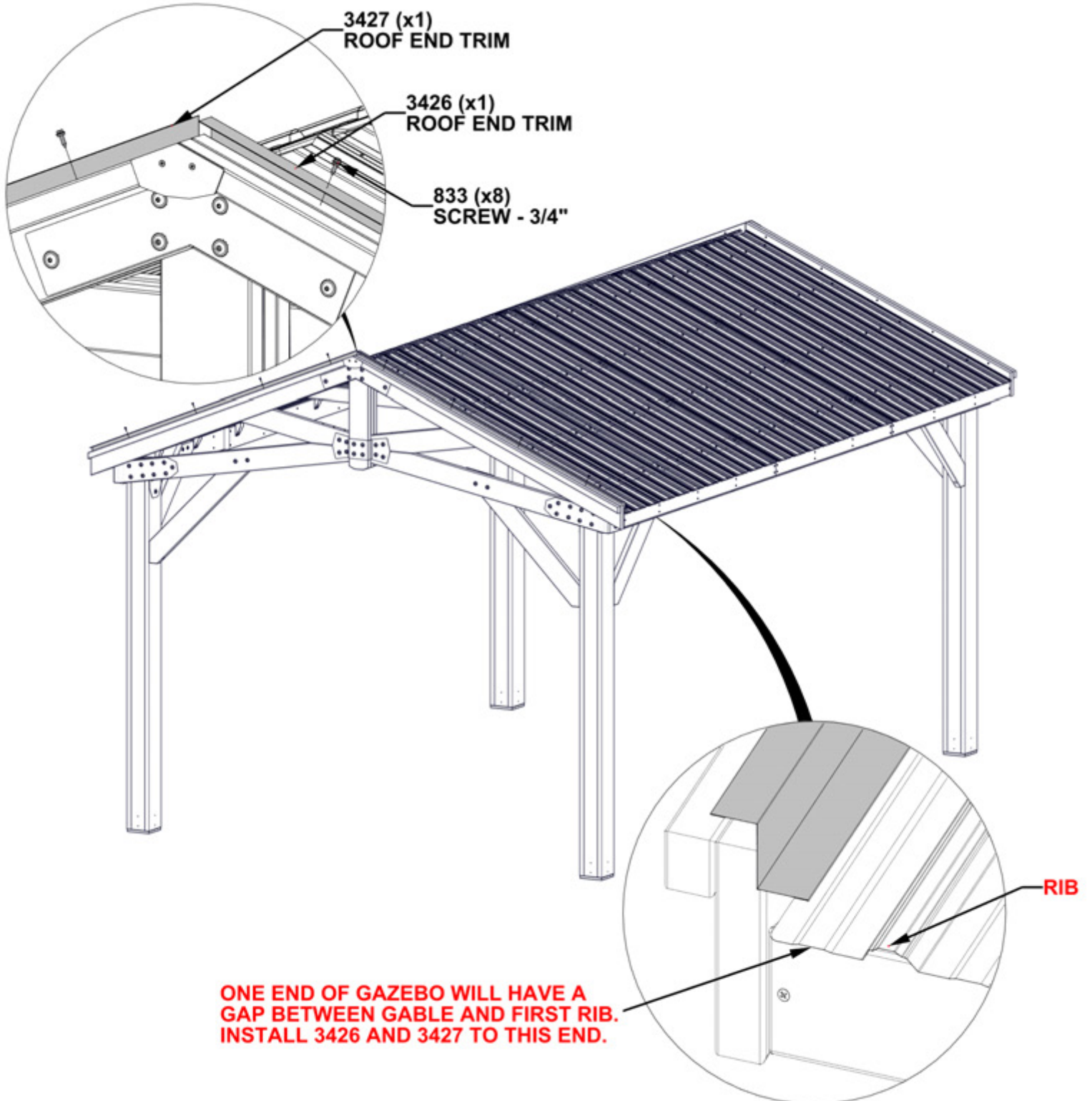

STEP 44B - ROOF ASSEMBLY

QTY	PART NUMBER	DESCRIPTION
8	H100833	SCREW WOODGRIP 10-16x3/4"

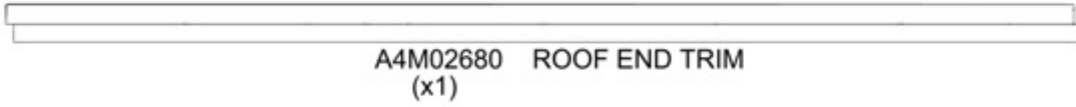
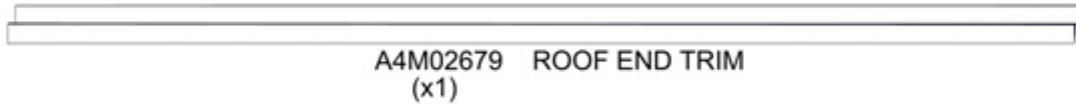

- ATTACH SCREWS IN LINE WITH ROOF PANEL SCREWS.

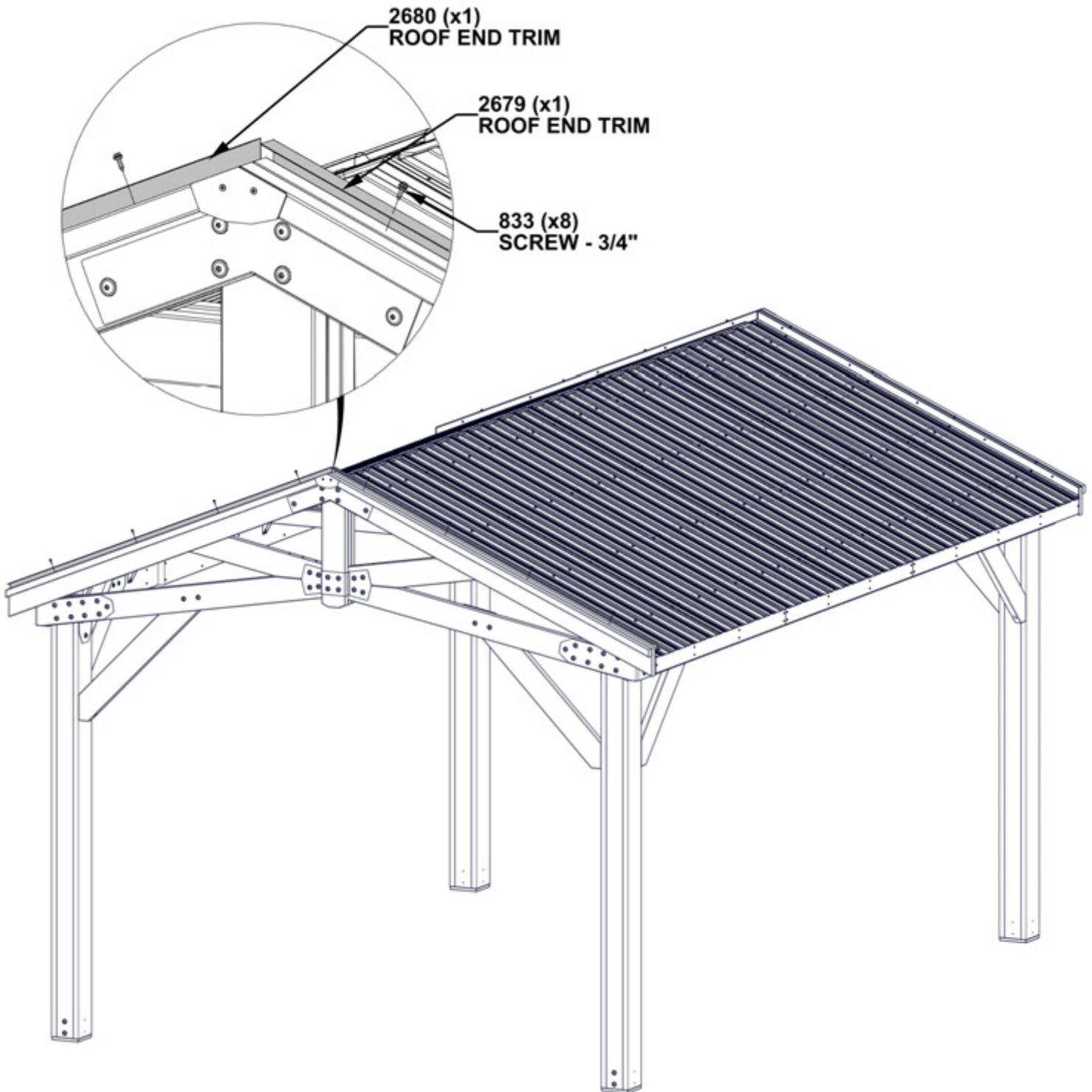

STEP 45 - ROOF ASSEMBLY

QTY	PART NUMBER	DESCRIPTION
14	H100759	SCREW SELF TAPPING 1/4x1

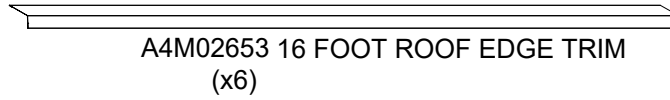

A4M02653 16 FOOT ROOF EDGE TRIM
(x6)



A4M02638 ROOF EDGE TRIM SPLICE
(x4)

- COMPLETE THIS STEP FOR OPPOSITE SIDE.
- DUE TO MULTIPLE LAYERS OF METAL ON THE EDGE TRIM, IT IS RECOMMENDED THAT A 1/8" (3mm) DRILL BIT IS USED TO CREATE STARTER HOLES.
- REMOVE PROTECTIVE BLUE FILM.
- GLOVES SHOULD BE WORN WHEN HANDLING ROOF METAL. EDGES ARE SHARP.
- START FIRST SCREW AT THE FIRST RIB FROM END.
- ATTACH SCREWS ON EVERY OTHER RIB.

SCREWS GO THROUGH EDGE TRIM INTO THE TOP OF THE RIBS IN THE APPROXIMATE LOCATIONS SHOWN.

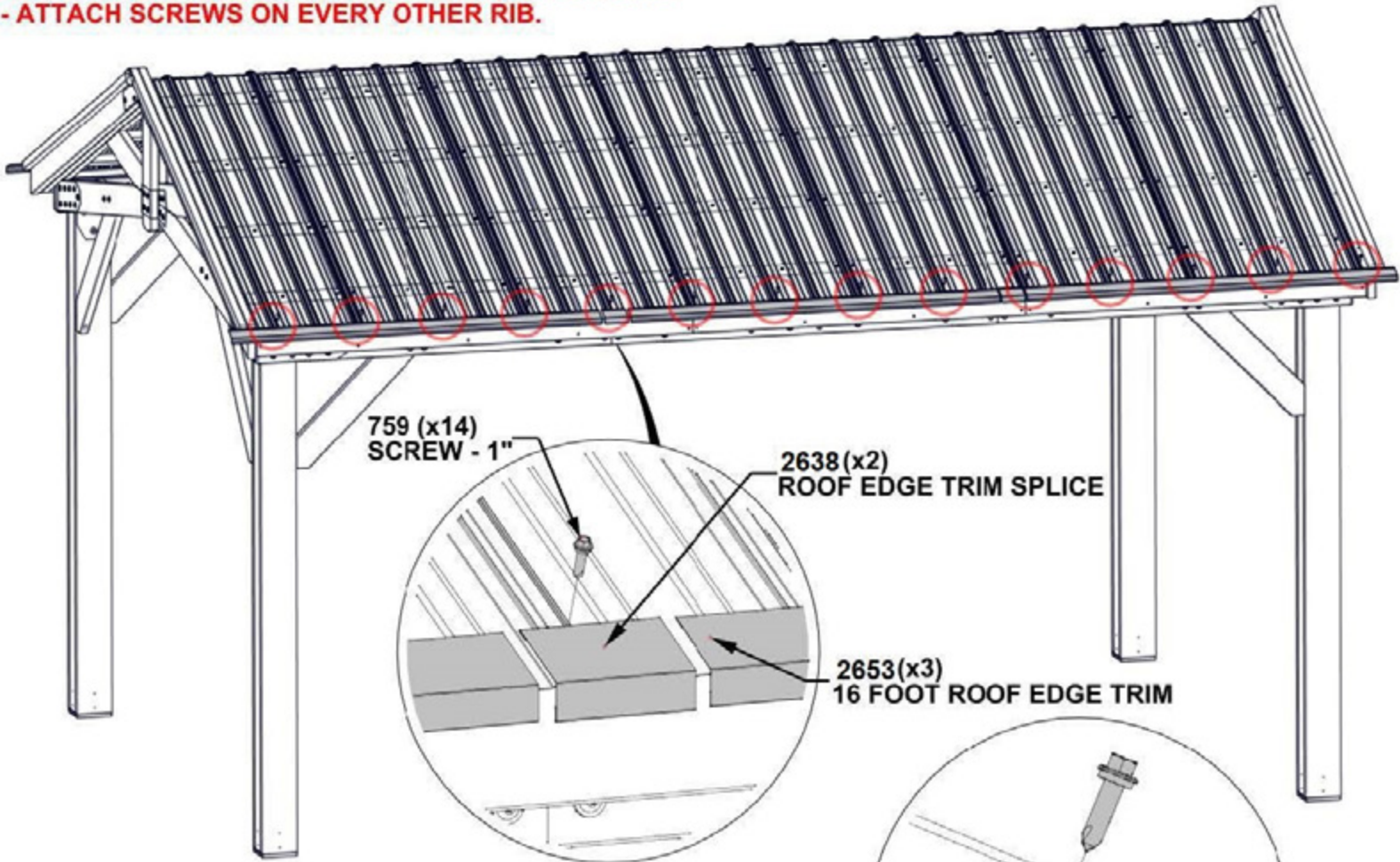

759 (x14)
SCREW - 1"

2638 (x2)
ROOF EDGE TRIM SPLICE

2653 (x3)
16 FOOT ROOF EDGE TRIM

SLIDE TRIM INTO SPLICE ENSURING THAT BOTH ENDS ARE FLUSH WITH THE EDGES OF ROOF PANELS.



SIDE VIEW

STEP 46 - ROOF ASSEMBLY

A4M02640
(x2)



RIDGE CAP SPLICE

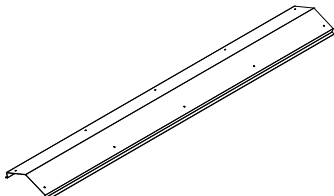

A4M02654 16 FOOT RIDGE CAP 29 GA
(x3)

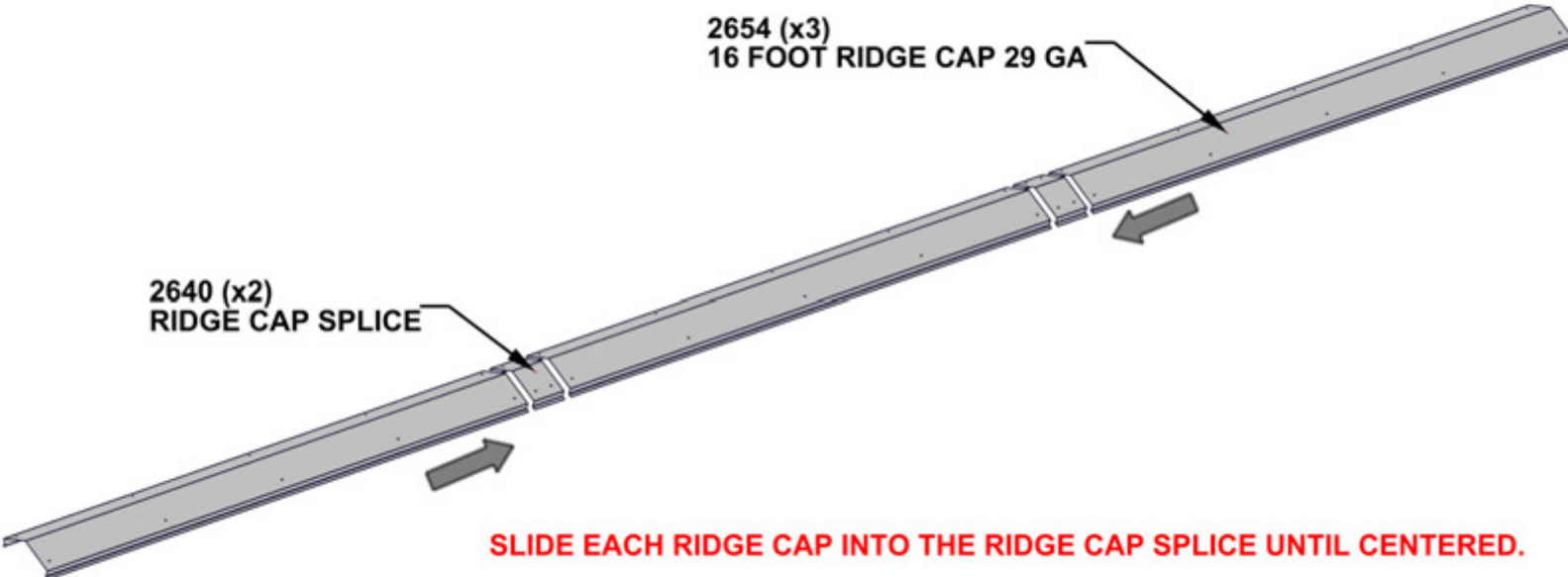

STEP 47 - ROOF ASSEMBLY

QTY	PART NUMBER	DESCRIPTION
30	H100833	SCREW WOODGRIP 10-16 x 3/4



J09 RIDGE CAP STIFFENER - W4L16876
(x4) 1"x2 3/8"x53 7/8" (24x60x1367)

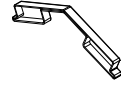

J10 RIDGE CAP STIFFENER - W4L16877
(x2) 1"x2 3/8"x83 1/2" (24x60x2121)

A6P00398 RIDGE CAP PROTECTOR
(x2)

- ASSEMBLE BY ALIGNING THE HOLES ON EACH RIDGE CAP TO THE HOLES IN THE RIDGE CAP SPLICE.
- REMOVE SPACERS FROM RIDGE CAP PROTECTORS BEFORE INSTALLING.
- **FINAL LENGTH - 15'-11 5/16" [4859mm]**

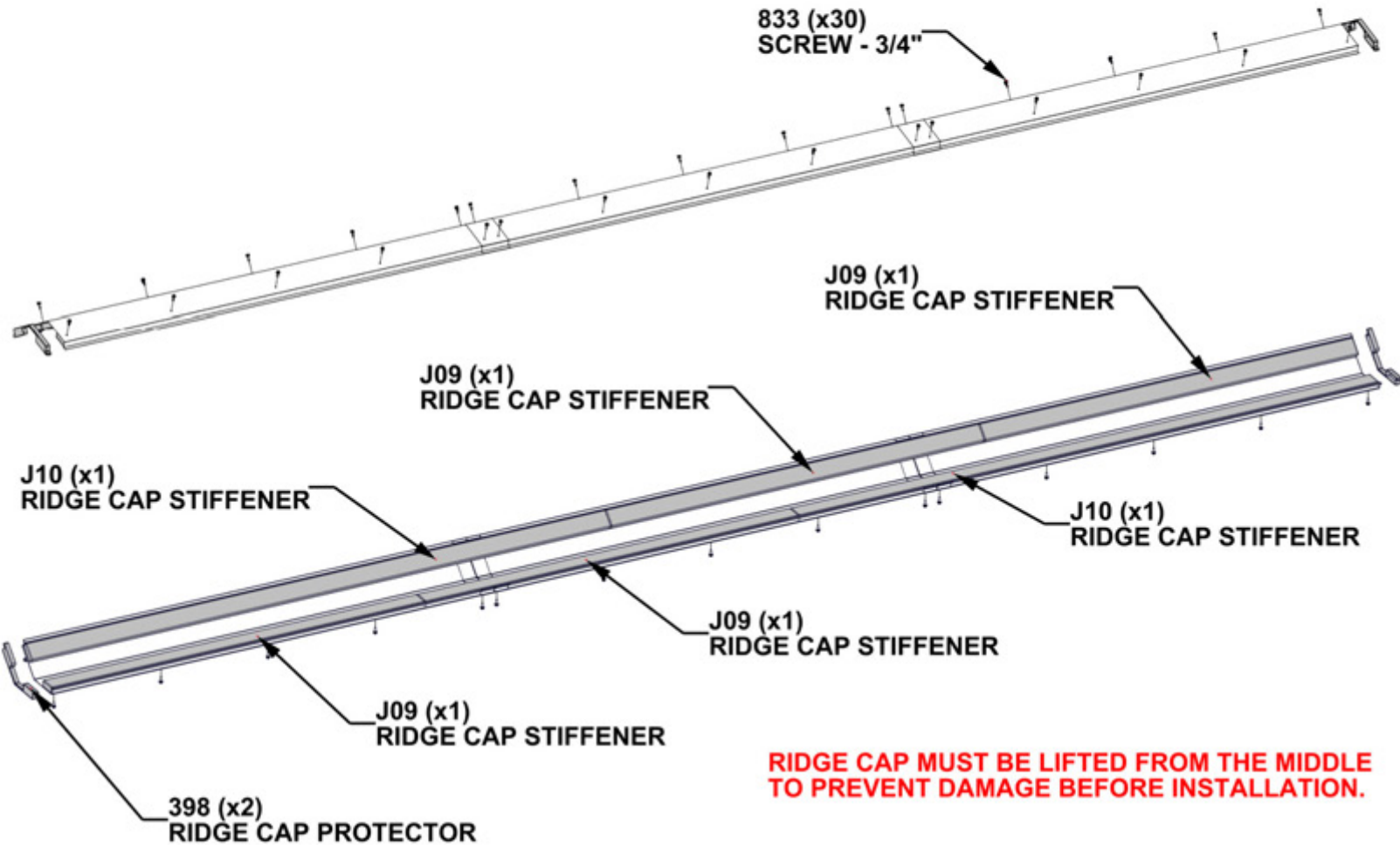

STEP 48 - ROOF ASSEMBLY

QTY	PART NUMBER	DESCRIPTION
26	H100392	SCREW PWH 8 X 3/4 BLK



RIDGE CAP ASSEMBLY FROM PREVIOUS STEP

- **DO NOT CLIMB ON ROOF TO INSTALL. ROOF CAP HAS BEEN DESIGNED TO INSTALL FROM A LADDER.**
- **FOR PROPER INSTALLATION, USE AN ADULT HELPER TO KEEP DOWNWARD PRESSURE ON THE RIDGE CAP WHILE SCREWING IN SCREWS.**

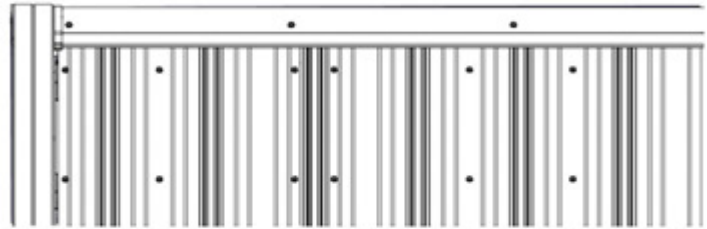
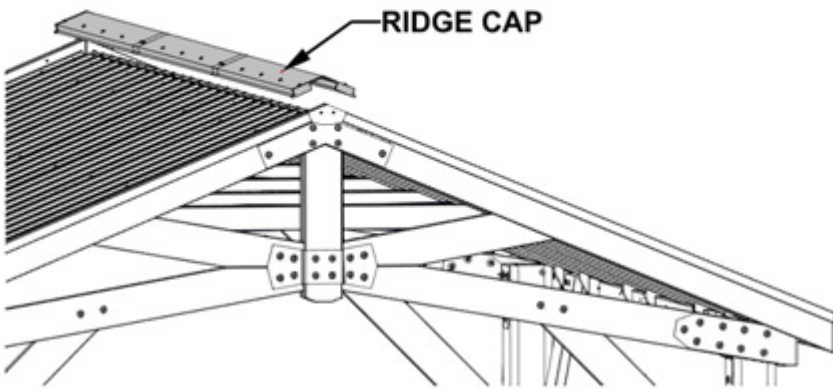

INSTALL SCREWS THROUGH PILOT HOLES IN ROOF PANELS INTO RIDGE CAP STIFFENER BOARDS.

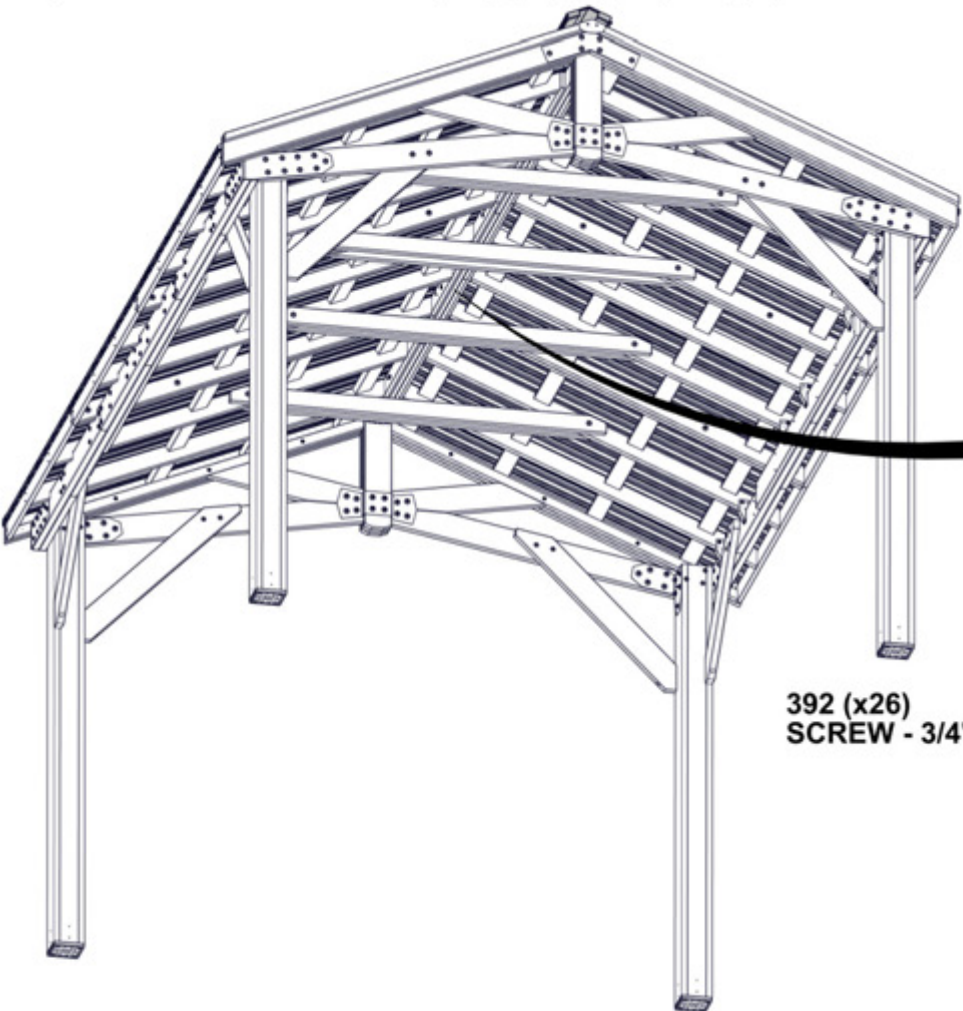

392 (x26)
SCREW - 3/4"

STEP 49 - GAZEBO ASSEMBLY

QTY	PART NUMBER	DESCRIPTION
8	H100382	SCREW PFH 8x1 3/4 BLK



A4M02501 FAN MOUNT BRACKET
(x1)



S01 SPACER BOARD - W4L19291
(x2) 5/8"x15/16"x16" (16x24x406)

- ATTACH YOUR ELECTRICAL BOX (SOLD SEPARATELY) WITH THE PROVIDED HOLES IN FAN MOUNT BRACKET.
- PLACE FAN MOUNT BRACKET & SPACER BOARDS ON RIDGE BEAMS AND MOVE TO DESIRED LOCATION.
- ROTATE BRACKET UNTIL MOUNTING FLANGES ALIGN BEST WITH REIDGE BEAMS.
- USE AN 1/8" (3mm) DRILL BIT AND DRILL PILOT HOLES AND ATTACH AS SHOWN.

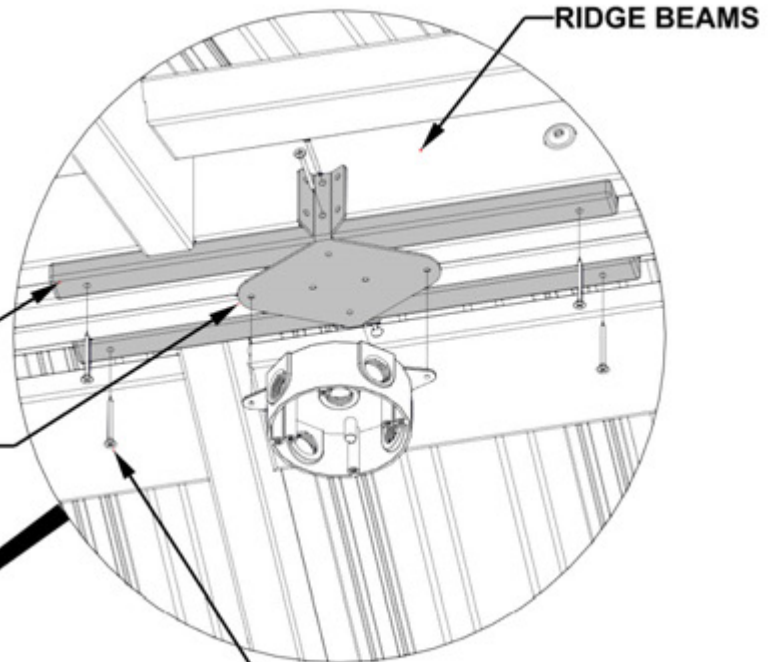

S01 (x2)
SPACER BOARD
2501 (x1)
FAN MOUNT BRACKET

RIDGE BEAMS

382 (x8)
SCREW - 1 3/4"

HARDWARE
NOT INCLUDED

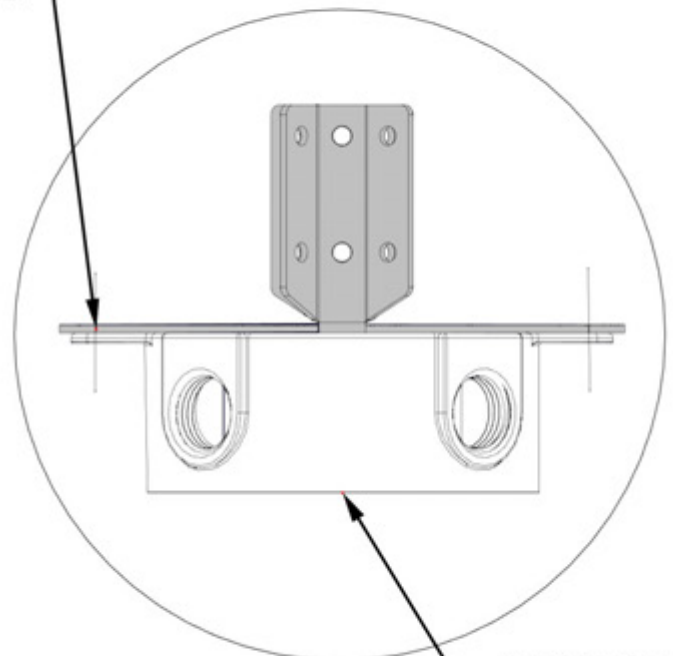
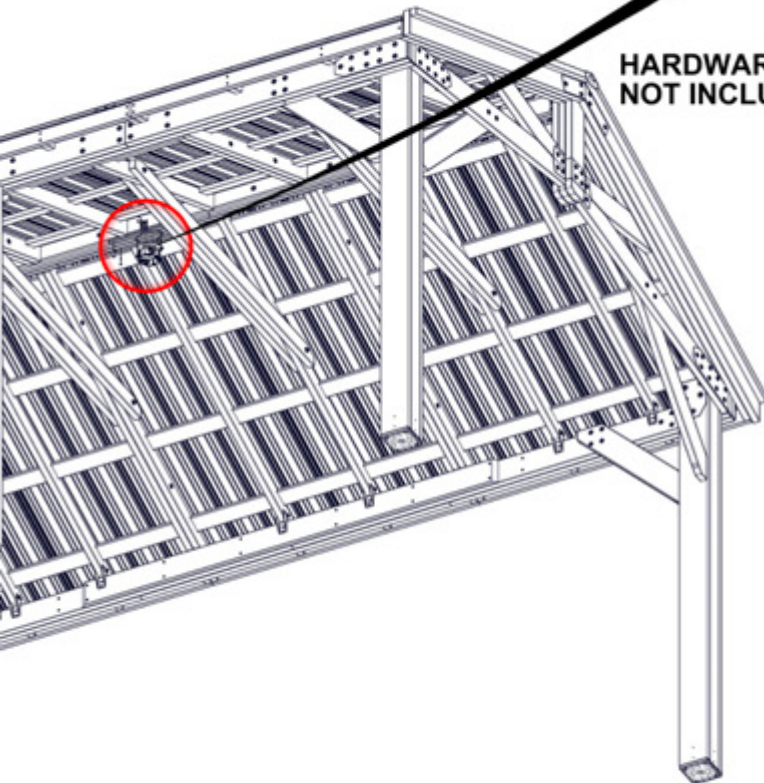

ELECTRICAL BOX
NOT INCLUDED

STEP 50 - GAZEBO ASSEMBLY

QTY	PART NUMBER	DESCRIPTION
32	H100471	LAG SCREW WH 5/16 X 1 1/2 BLK

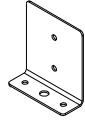

A4M00977 POST ANCHORING
(x8) PLATE



A4M00978 POST PLATE
(x8)

- USE PILOT HOLES IN POST TO INSTALL LAG SCREWS.

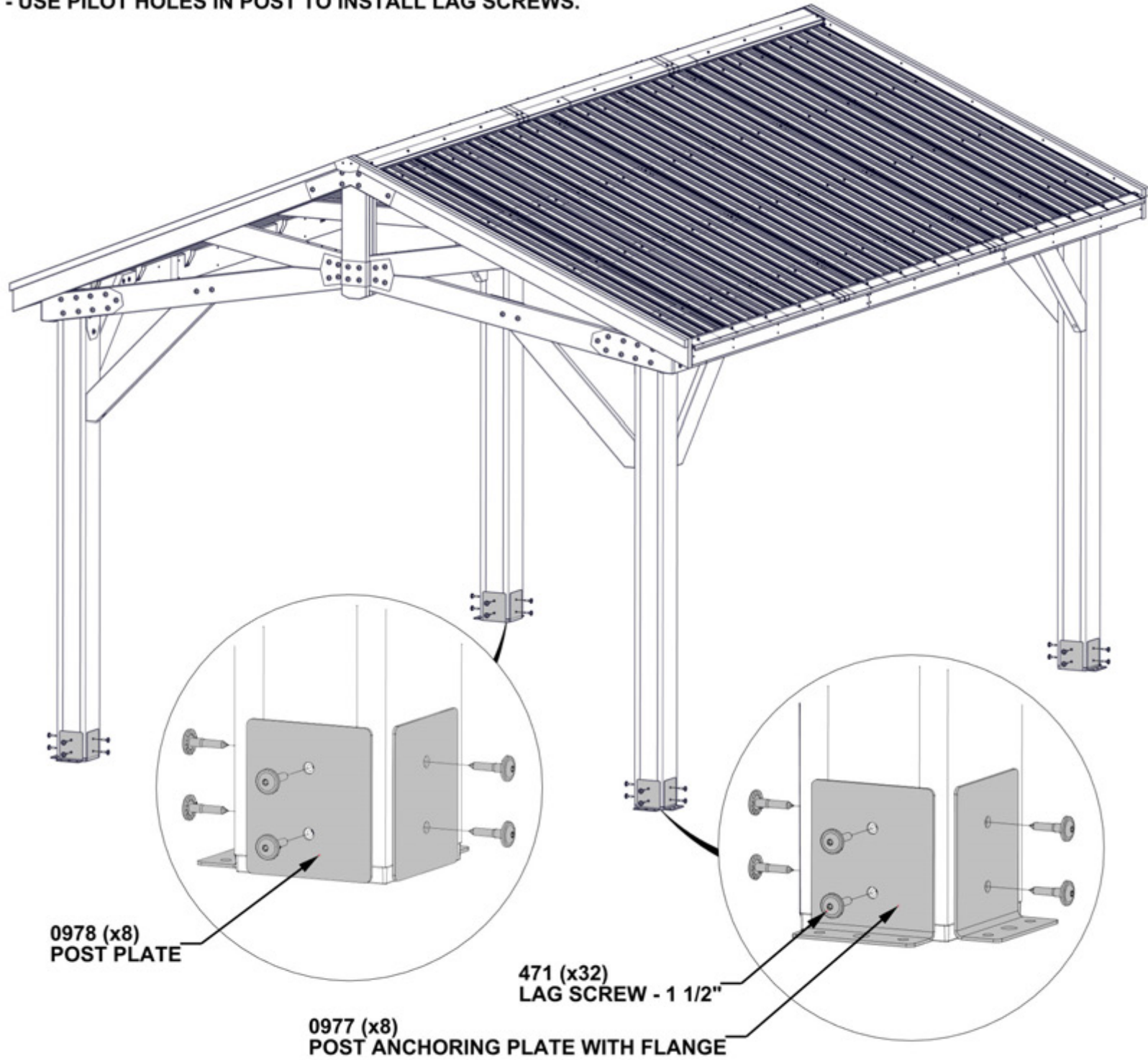

STEP 51 - GAZEBO ASSEMBLY

QTY	PART NUMBER	DESCRIPTION
4	H100202	SCREW PWH 8x5/8 BLK



A4M02158 BYD ID TAG PATIO
(x1)

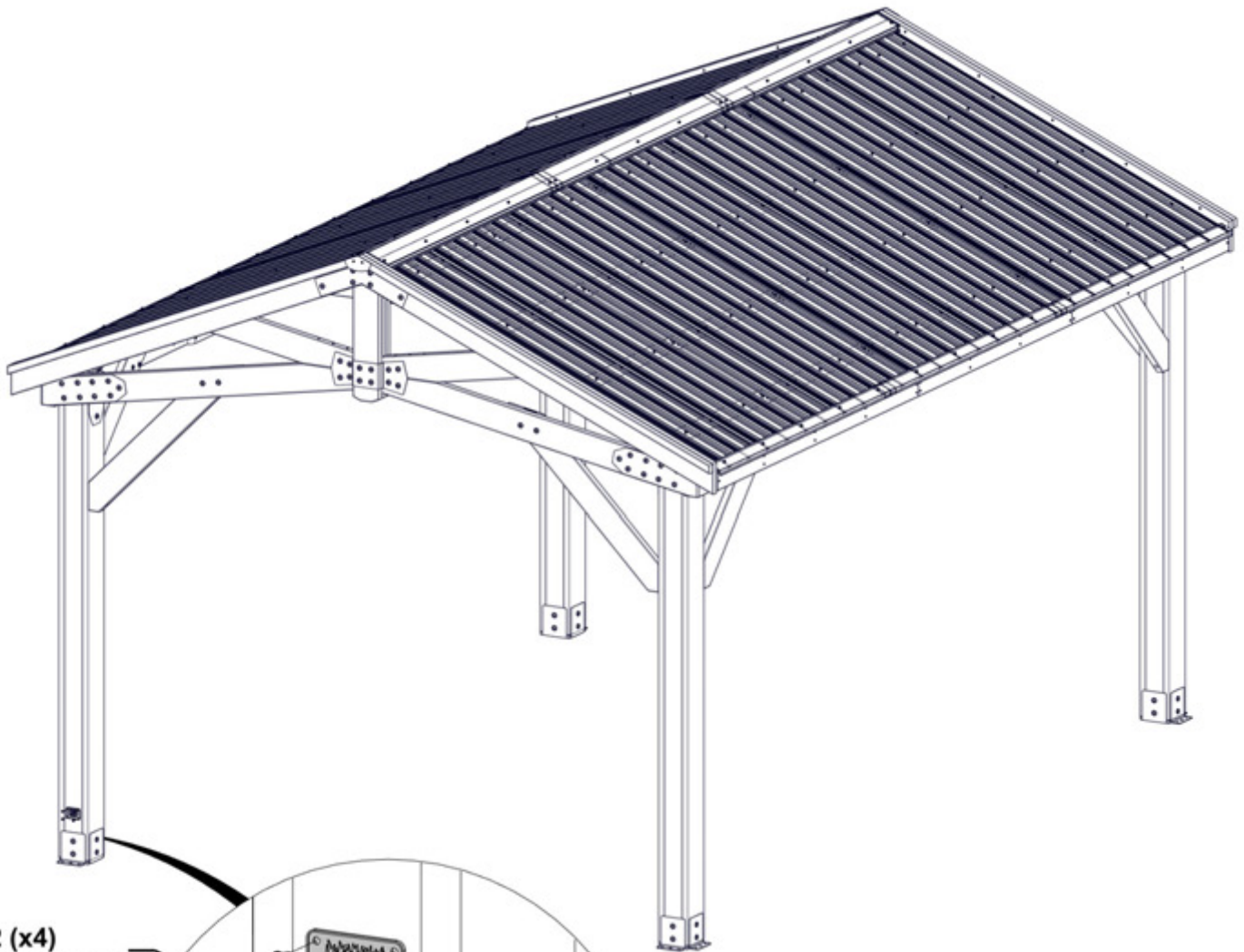

202 (x4)
SCREW - 5/8"

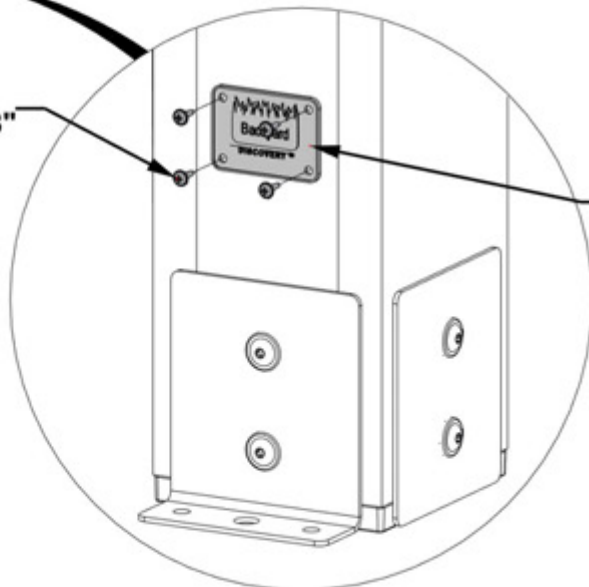

2158 (x1)
BYD ID TAG PATIO

STEP 52 - GAZEBO ASSEMBLY

QTY	PART NUMBER	DESCRIPTION
16	H100120	CONCRETE ANCHOR 1/4"x2"
16	H100630	WASHER FLAT 8x19 BLK

- MANUFACTURER RECOMMENDS INSTALLATION ON CONCRETE SURFACE OR CONCRETE POST PAD AS SHOWN BELOW.
- FOR INSTALLATION ON WOOD DECK, YOU MUST ENSURE THERE IS AMPLE STRUCTURAL SUPPORT UNDER THE DECK. HARDWARE NOT INCLUDED FOR DECK ATTACHMENT.

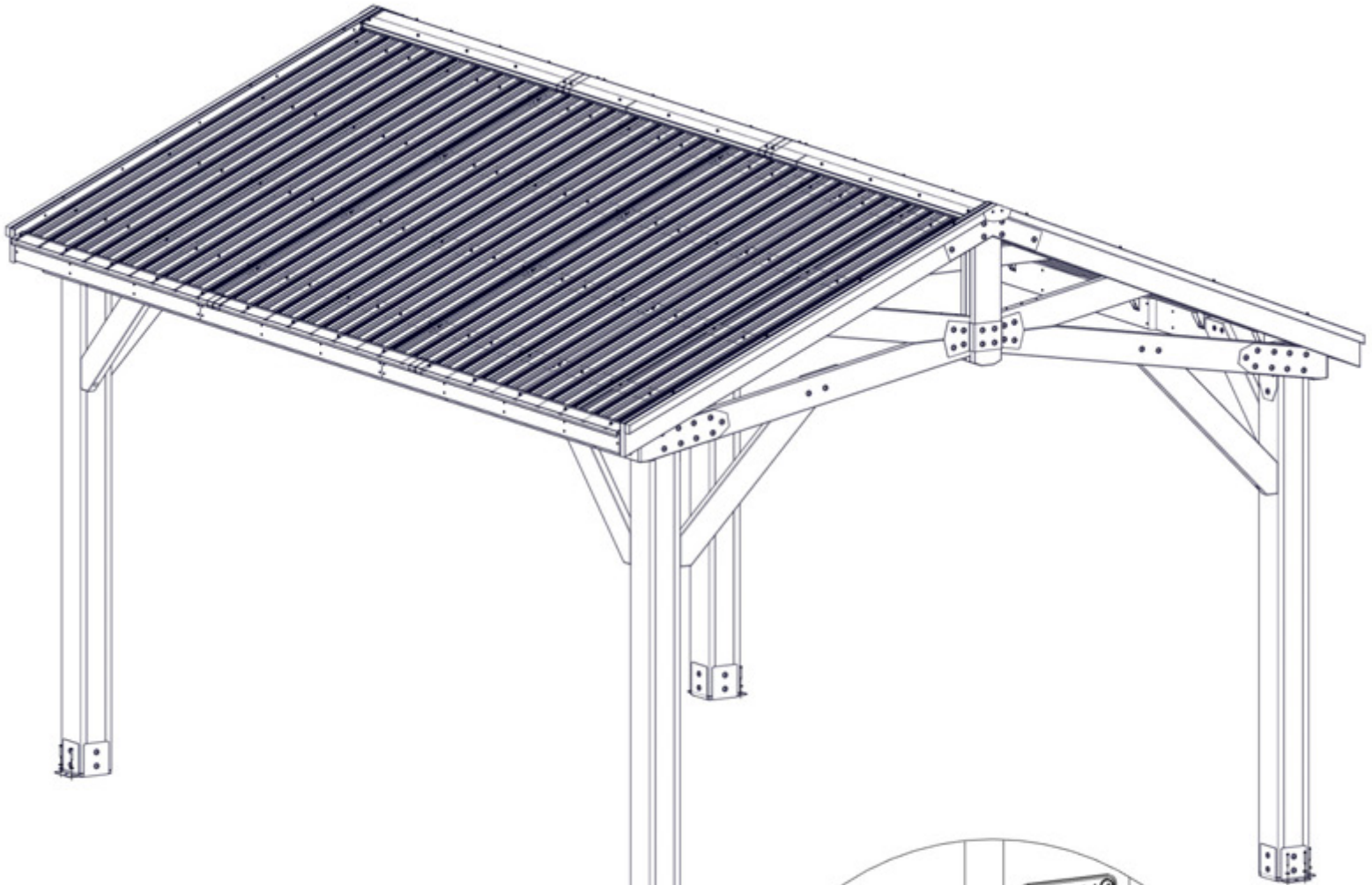

120 (x16)
CONCRETE SCREW-2"

630 (x16)
WASHER - 8x19

PRE-DRILL HOLES FOR CONCRETE ANCHORS
USING A 3/16" CONCRETE DRILL BIT.

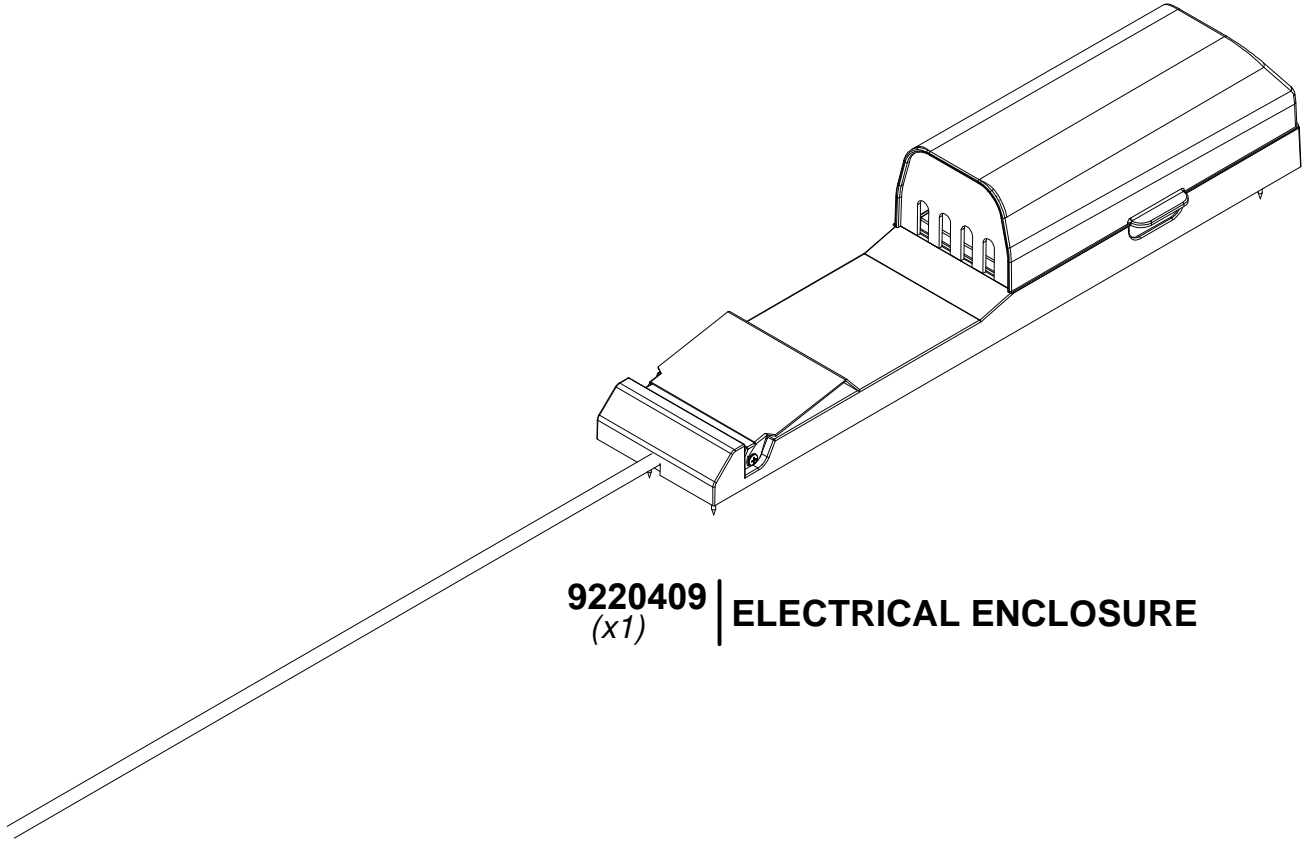

9220409 | **ELECTRICAL ENCLOSURE**
(x1)

FOR POWERPORT INSTALLATION REFER TO ASSEMBLY INSTRUCTIONS THAT COME PACKAGED WITH THE POWERPORT KIT. INSTALL ON ANY POST THAT IS DESIRED. FOLLOW DIRECTIONS FOR PROPER INSTALLATION.