



Manufactured by:  
Backyard Discovery  
3305 Airport Drive, Pittsburg, KS 66762  
800-856-4445

Basepoint Business Centre: Rivermead Drive, Westlea, Swindon SN5 7EX Phone: 0800-118-2476  
J.P. Coenstraat 7, The Bridge, The Hague, 2595 WP, Netherlands Phone: 08005678990

# 20x20 Kingsport Carport

## MODEL # : 2306196



Please visit [www.backyarddiscovery.com](http://www.backyarddiscovery.com)  
For the most up to date assembly manual, to register your product, or to order  
replacement parts *Para obtener instrucciones en español, visite*  
[www.backyarddiscovery.com](http://www.backyarddiscovery.com)



EASY STEP-BY-STEP  
3D INTERACTIVE INSTRUCTIONS  
DOWNLOAD THE FREE APP



# OWNER'S MANUAL - BASIC SETUP DIMENSIONS & ASSEMBLY NOTES

It is critically important that you start with square and level footings or concrete pad to attach your structure

- Pay close attention to the items needed for each step. Make sure you are using the correct hardware for each step. Using incorrect hardware may result in improper assembly
- Remember to double check for underground utilities and overhead electrical lines

Post mounts are provided with your structure which allows you to permanently install your structure to a pre-existing or concrete surface. See Anchor Instructions for further details and recommendations.

- The hardware to attach the post mounts to the structure is included.
- The hardware to mount the structure permanently to a concrete surface is included.

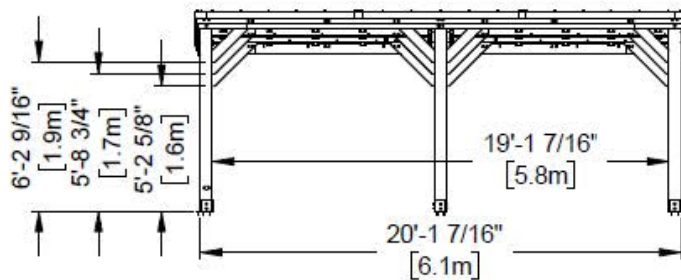
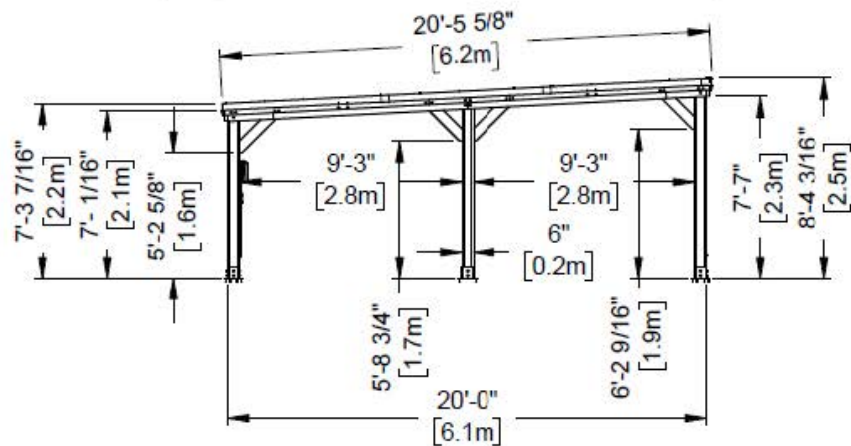
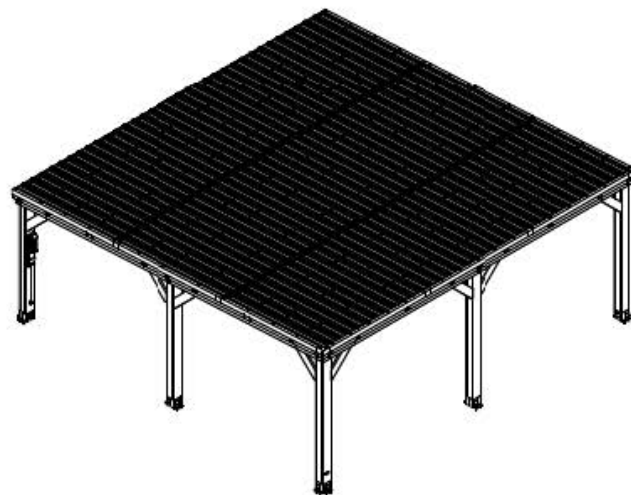
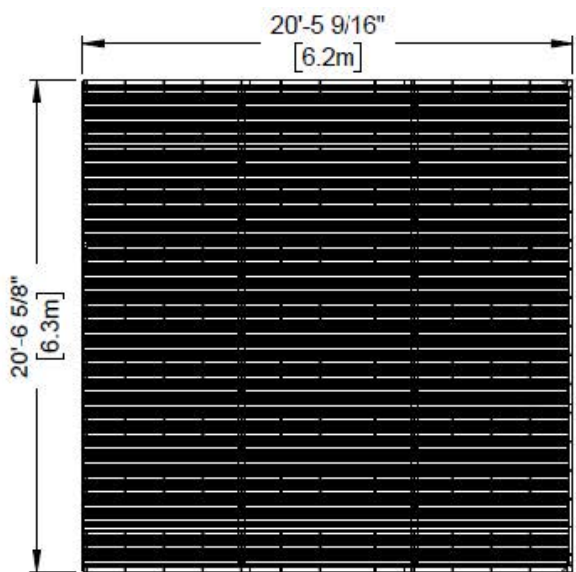

# OWNERS MANUAL - ANCHORING LAYOUT

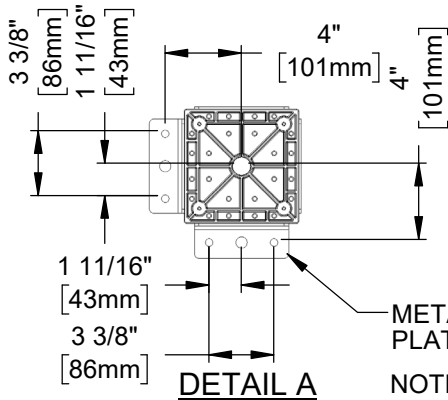
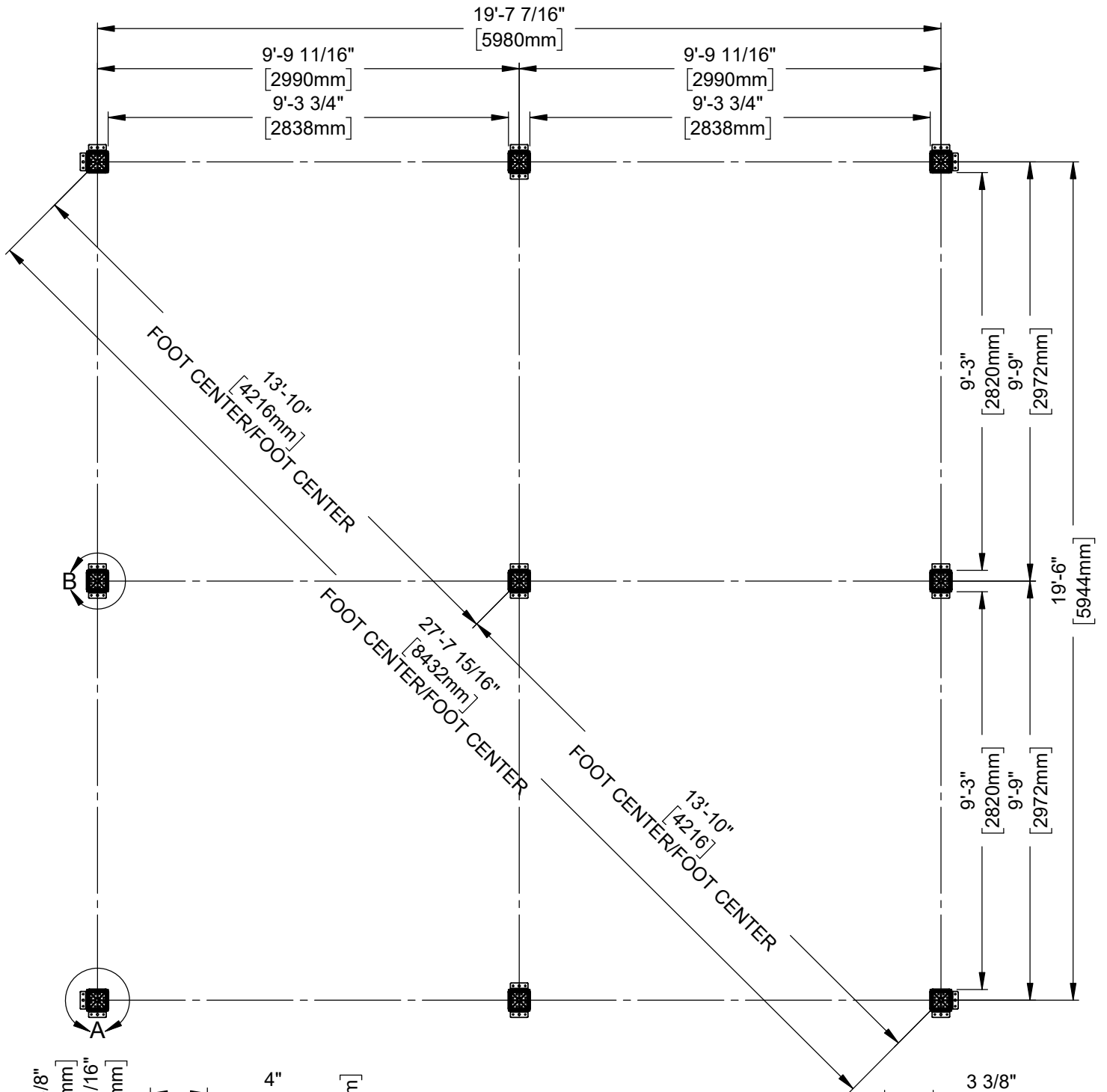

**DETAIL A**

NOTES: DIMENSIONS ARE TO ANCHOR PLATES MOUNTED TO POST, EXCEPT WHERE NOTED.

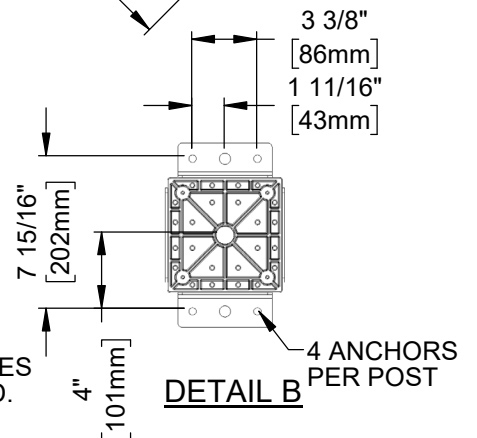

**DETAIL B**

# OWNER'S MANUAL - PARTS IDENTIFICATION

## Wood Components (Not to Scale)

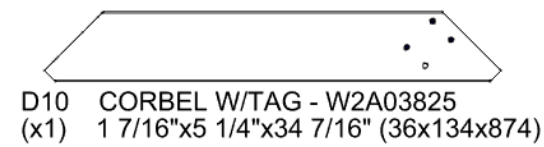
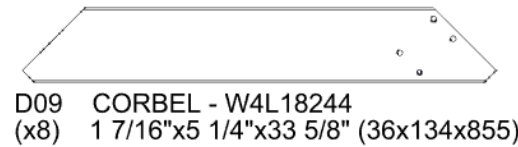
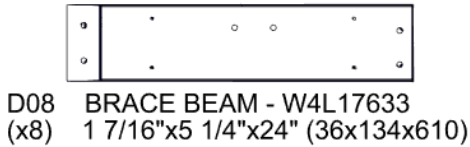
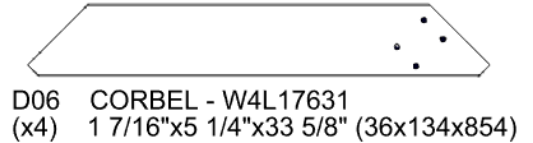
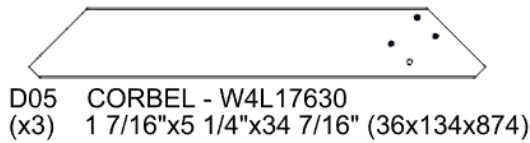
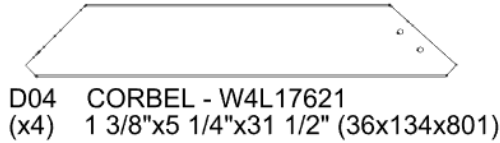
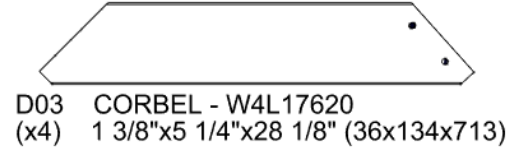
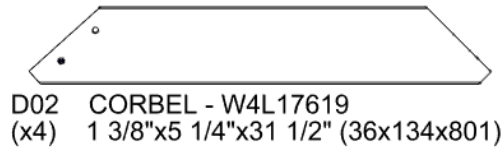
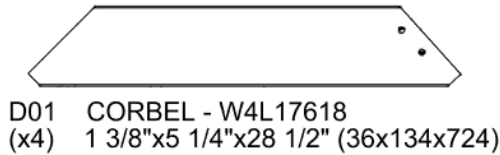

# OWNER'S MANUAL - PARTS IDENTIFICATION

## Wood Components (Not to Scale)



G07 FASCIA - W4L17634  
(x2) 15/16"x5 1/4"x66 3/8" (24x134x1686)



G09 FASCIA - W4L17636  
(x1) 15/16"x5 1/4"x113 3/8" (24x134x2880)



G10 BRACE BEAM - W4L17666  
(x2) 15/16"x5 1/4"x100 1/2" (24x134x2553)



G12 BRACE BEAM - W4L17668  
(x2) 15/16"x5 1/4"x93 1/8" (24x134x2365)

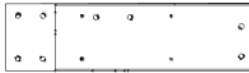

G11 BRACE BEAM - W4L17667  
(x2) 15/16"x5 1/4"x19 1/2" (24x134x495)



G13 BRACE BEAM - W4L17669  
(x2) 15/16"x5 1/4"x26 7/8" (24x134x683)



G14 BRACE BEAM - W4L17670  
(x2) 15/16"x5 1/4"x100 1/2" (24x134x2553)

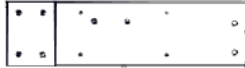

G15 BRACE BEAM - W4L17801  
(x2) 15/16"x5 1/4"x19 1/2" (24x134x495)

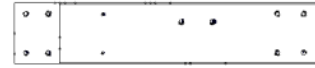

G17 BRACE BEAM - W4L17803  
(x2) 15/16"x5 1/4"x26 7/8" (24x134x683)



G16 BRACE BEAM - W4L17802  
(x2) 15/16"x5 1/4"x93 1/8" (24x134x2365)



H01 PURLIN - W4L17804  
(x16) 15/16"x3 3/8"x82 3/4" (24x86x2102)



H02 PURLIN - W4L17805  
(x16) 15/16"x3 3/8"x35 3/4" (24x86x908)



J01 JOIST ASSEMBLY - W2A03806  
(x1) 1 7/16"x8 7/16"x100" (36x214x2600)

# OWNER'S MANUAL - PARTS IDENTIFICATION

## Wood Components (Not to Scale)

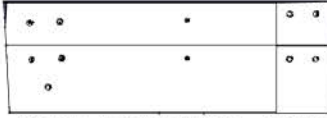

J02 JOIST ASSEMBLY - W2A03811  
(x1) 36X8 7/16"X24 9/16" (36x214x624)

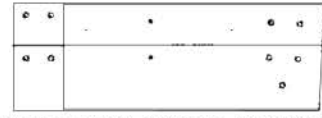

J03 JOIST ASSEMBLY - W2A03807  
(x1) 1 7/16"x8 7/16"x24 9/16" (36x214x624)

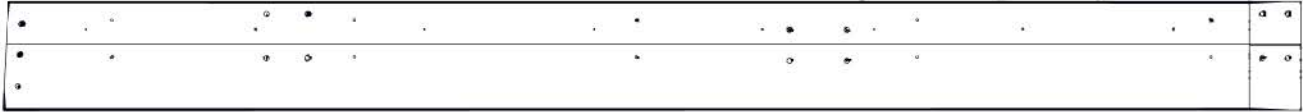

J04 JOIST ASSEMBLY - W2A03810  
(x1) 1 7/16"x8 7/16"x100" (36x214x2600)



J05 JOIST ASSEMBLY - W2A03814  
(x1) 1 7/16"x8 7/16"x28 7/16" (36x214x722)



J07 JOIST ASSEMBLY - W2A03815  
(x1) 1 7/16"x8 7/16"x28 7/16" (36x214x722)



J06 JOIST ASSEMBLY - W2A03816  
(x1) 1 7/16"x8 7/16"x97 5/8" (36x214x2480)

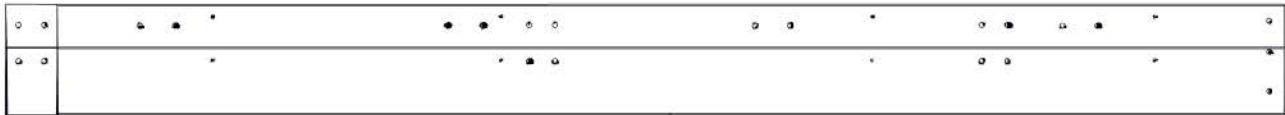

J08 JOIST ASSEMBLY - W2A03817  
(x1) 1 7/16"x8 7/16"x97 5/8" (36x214x2480)



J09 JOIST ASSEMBLY - W2A03819  
(x1) 1 7/16"x8 7/16"x28 7/16" (36x214x722)



J10 JOIST ASSEMBLY - W2A03820  
(x1) 1 7/16"x8 7/16"x28 7/16" (36x214x722)

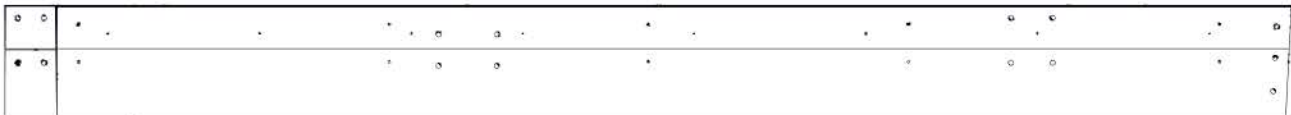

J11 JOIST ASSEMBLY - W2A03812  
(x1) 1 7/16"x8 7/16"x97 11/16" (36x214x2481)

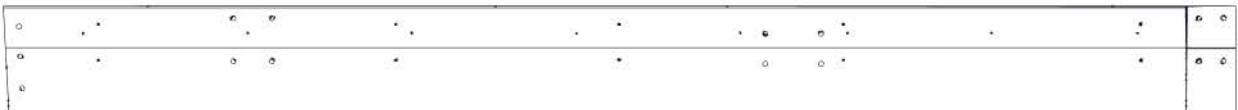

J12 JOIST ASSEMBLY - W2A03808  
(x1) 1 7/16"x8 7/16"x97 11/16" (36x214x2481)

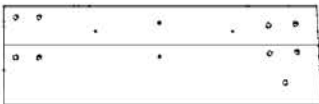

J13 JOIST ASSEMBLY - W2A03809  
(x1) 1 7/16"x8 7/16"x26 7/8" (36x214x682)

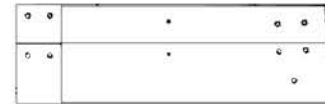

J14 JOIST ASSEMBLY - W2A03813  
(x1) 1 7/16"x8 7/16"x26 7/8" (36x214x682)

# OWNER'S MANUAL - PARTS IDENTIFICATION

## Wood Components (Not to Scale)



J15 JOIST ASSEMBLY - W2A03821  
(x1) 1 7/16"x8 7/16"x97 5/8" (36x214x2480)



J16 JOIST ASSEMBLY - W2A03822  
(x1) 1 7/16"x8 7/16"x97 5/8" (36x214x2480)



J17 JOIST ASSEMBLY - W2A03826  
(x1) 36X8 7/16"X24 9/16" (36x214x624)

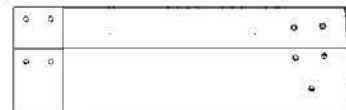

J20 JOIST ASSEMBLY - W2A03829  
(x1) 1 7/16"x8 7/16"x26 7/8" (36x214x682)



J18 JOIST ASSEMBLY - W2A03827  
(x1) 1 7/16"x8 7/16"x100" (36x214x2600)



J19 JOIST ASSEMBLY - W2A03828  
(x1) 1 7/16"x8 7/16"x97 11/16" (36x214x2481)



J21 JOIST ASSEMBLY - W2A03830  
(x1) 1 7/16"x8 7/16"x24 9/16" (36x214x624)



J24 JOIST ASSEMBLY - W2A03833  
(x1) 1 7/16"x8 7/16"x26 7/8" (36x214x682)



J22 JOIST ASSEMBLY - W2A03831  
(x1) 1 7/16"x8 7/16"x100" (36x214x2600)



J23 JOIST ASSEMBLY - W2A03832  
(x1) 1 7/16"x8 7/16"x97 11/16" (36x214x2481)



J25 CLEAT - W4L17622  
(x8) 15/16"x2 3/8"x48 1/8" (24x60x1223)



J26 CLEAT - W4L17623  
(x4) 15/16"x2 3/8"x52 3/4" (24x60x1340)



J27 CLEAT - W4L18290  
(x4) 15/16"x2 3/8"x54 1/4" (24x60x1378)

# OWNER'S MANUAL - PARTS IDENTIFICATION

## Wood Components (Not to Scale)



P01 POST - W2A03800  
(x1) 6"x6"x98 1/2" (152x152x2502)

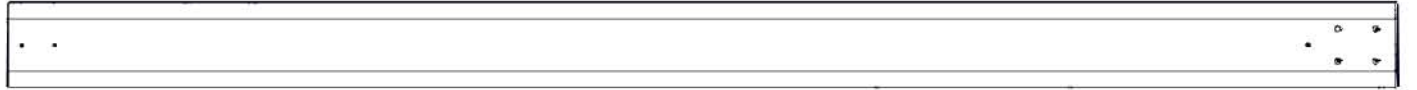

P02 POST - W2A03801  
(x1) 6"x6"x98 1/2" (152x152x2502)



P03 POST - W2A03802  
(x1) 6"x6"x92 5/16" (152x152x2344)



P04 POST - W2A03803  
(x1) 6"x6"x92 5/16" (152x152x2344)



P05 POST - W2A03804  
(x1) 6"x6"x86 1/4" (152x152x2190)

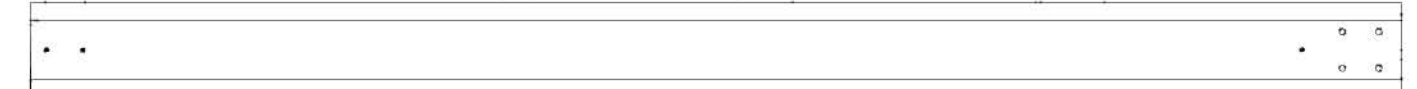

P06 POST - W2A03805  
(x1) 6"x6"x86 1/4" (152x152x2190)



P07 POST - W2A03818  
(x1) 6"x6"x98 1/2" (152x152x2502)



P08 POST - W2A03823  
(x1) 6"x6"x86 1/4" (152x152x2190)



P09 POST - W2A03824  
(x1) 6"x6"x92 5/16" (152x152x2344)



# OWNER'S MANUAL - PARTS IDENTIFICATION

## Hardware Components

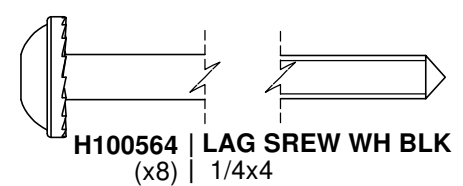
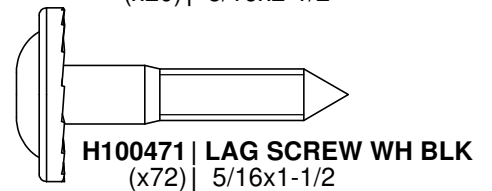
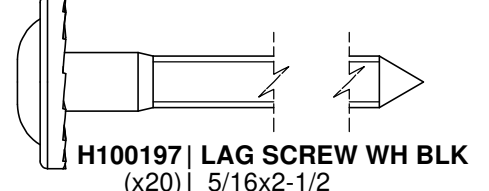
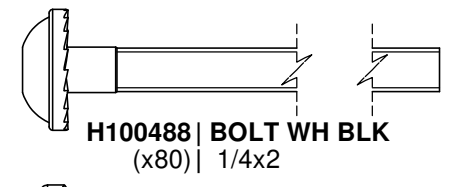
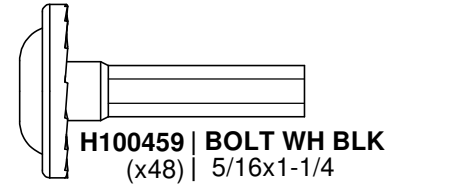
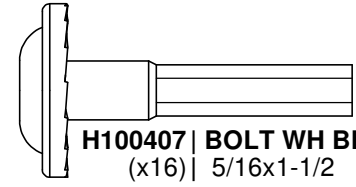
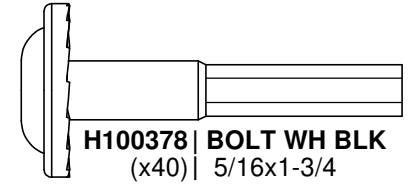
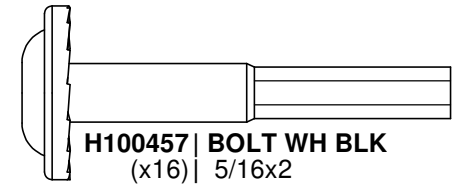
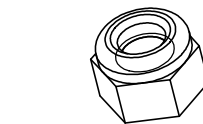
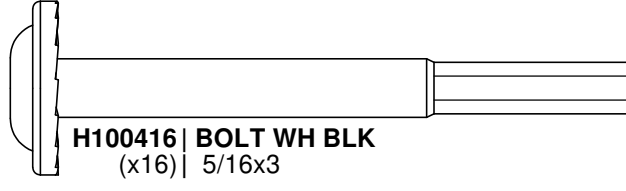
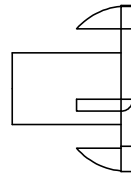
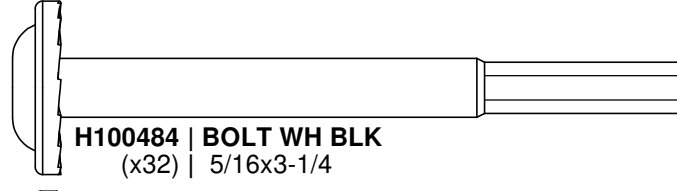
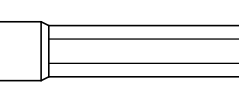
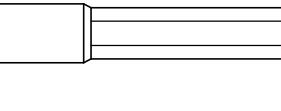
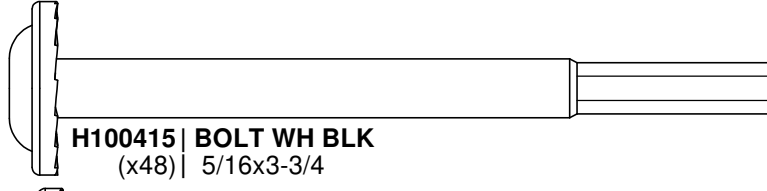
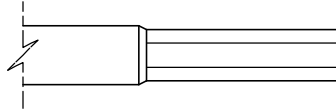
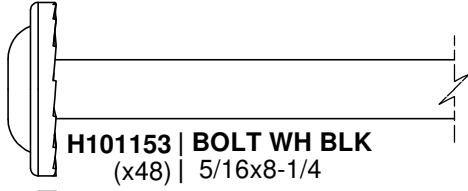
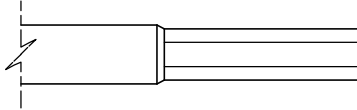
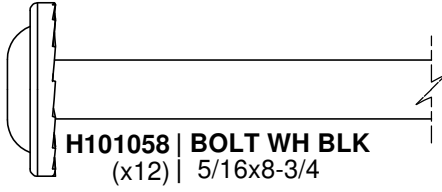
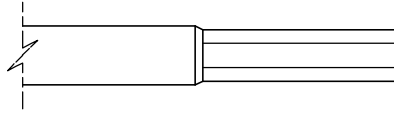
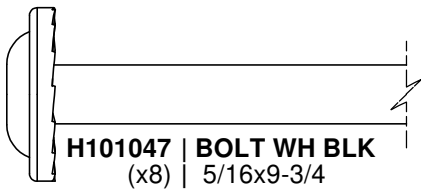

# OWNER'S MANUAL - PARTS IDENTIFICATION

## Hardware Components



**H100483 | SCREW PFH BLK**  
(x96) | 8x2-1/4

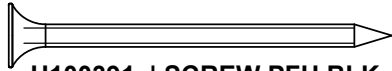

**H100391 | SCREW PFH BLK**  
(x168) | 8x2

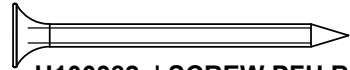

**H100382 | SCREW PFH BLK**  
(x224) | 8x1-3/4

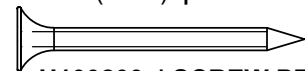

**H100200 | SCREW PFH BLK**  
(x128) | 8x1-1/2

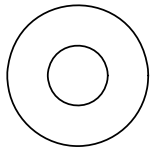

**H100630 | WASHER FLAT BLK**  
(x212) | 8x19

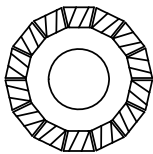

**H100198 | WASHER LOCK EXT BLK**  
(x273) | 8x19

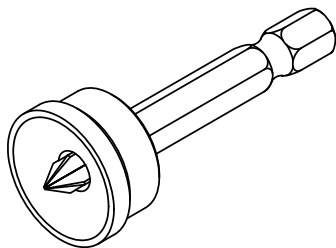

**H100764 | SCREW SETTER**  
(x1)

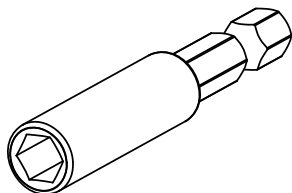

**H101100 | MAGNETIC DRIVER**  
(x1)

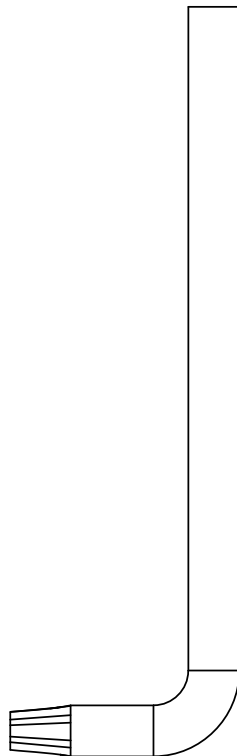

**H100114 | TORX WRENCH**  
(x1) | T-30

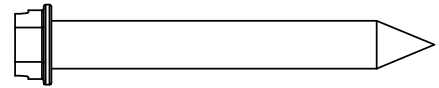

**H100120 | CONCRETE ANCHOR**  
(x36) | 1/4x2

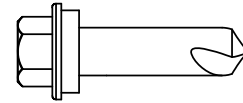

**H101116 | SCREW TAPPING**  
(x45) | 1/4 x 1

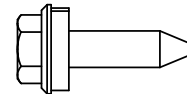

**H101117 | SCREW WOODGRIP**  
(x443) | 10x3/4

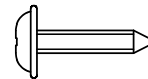

**H100202 | SCREW PWH BLK**  
(x2) | 8x5/8

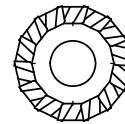

**H100405 | WASHER LOCK EXT BLK**  
(x32) | 6x15

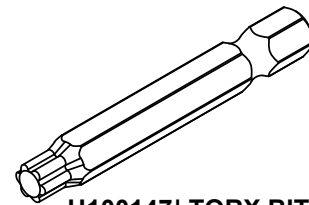

**H100147 | TORX BIT**  
(x1) | T-30

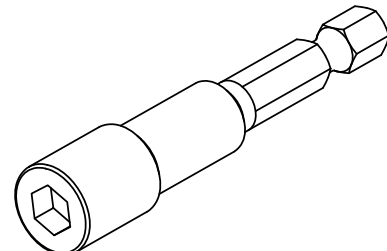

**H101106 | SOCKET DRIVER**  
(x1)

# OWNER'S MANUAL - PARTS IDENTIFICATION

## Accessory Components (Not to Scale)

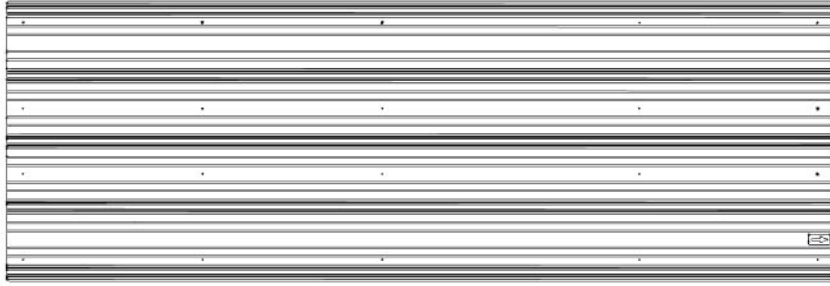

A4M01911 29GA SHEETING  
(x8)



A4M01910 29GA SHEETING  
(x16)



A4M02240 29GA SHEETING  
(x2)



A4M02241 29GA SHEETING  
(x1)



A6P00556 WEATHER TAPE  
(x4)



A100241 ID TAG  
(x1)

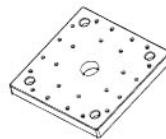

A6P00308 6x6 POST FOOT  
(x9)



A4M00977 POST ANCHORING PLATE  
(x18)

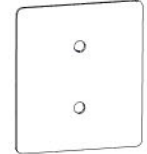

A4M00978 POST PLATE  
(x18)

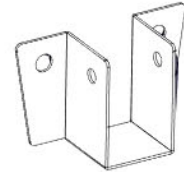

A4M01787 RAFTER BRACKET  
(x80)

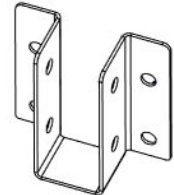

A4M02211 JOIST HANGER 90°  
(x4)



A4M02103 JOIST HANGER 90°  
(x8)

# OWNER'S MANUAL - PARTS IDENTIFICATION

## Accessory Components (Not to Scale)

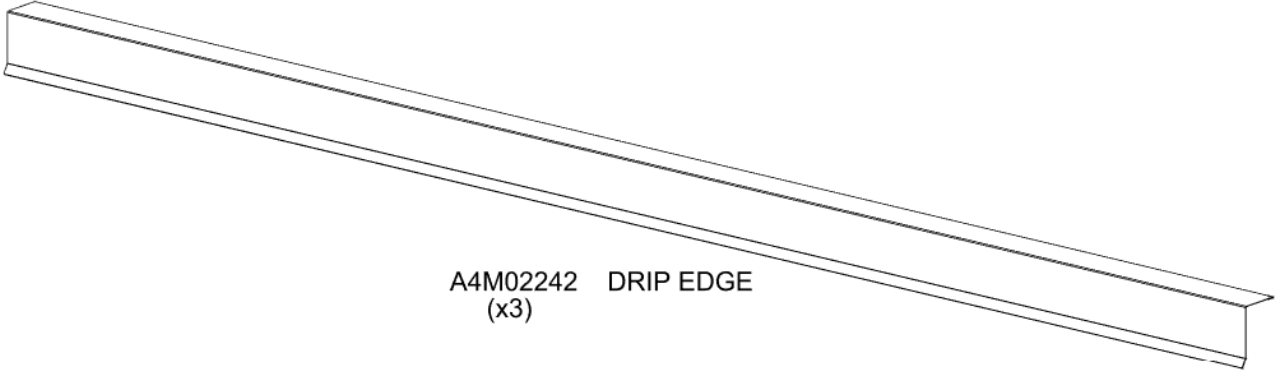

A4M02242 DRIP EDGE  
(x3)

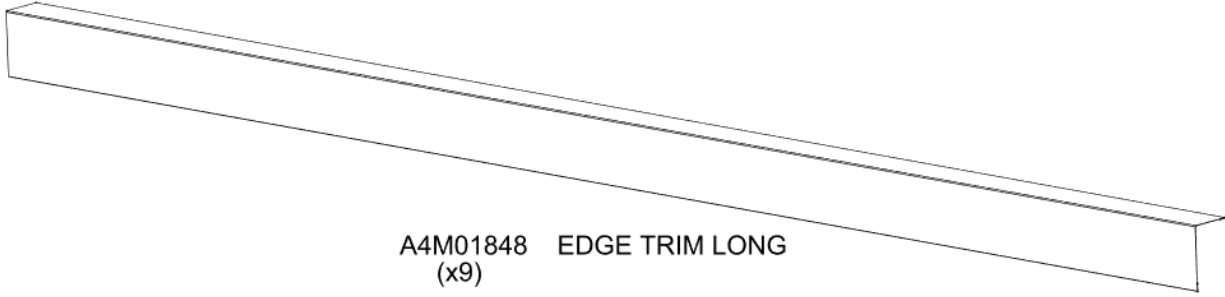

A4M01848 EDGE TRIM LONG  
(x9)



A4M01799 EDGE TRIM SPLICE  
(x6)



A4M01916 DRIP EDGE SPLICE  
(x2)

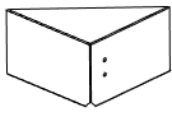

A4M01800 CORNER SPLICE TRIM RH  
(x1)

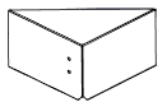

A4M01893 CORNER SPLICE TRIM LH  
(x1)



9205413 ELECTRICAL ENCLOSURE  
(x1)

# PRE-ASSEMBLY STEP 1 - SORTING PARTS

It is critical for ease of assembly that you take the time to sort and organize the wood and hardware.

---

## WOOD PARTS:

- Organize wood parts by the three-digit, alpha-numeric number stamped on each board (ex. P01).
- If there are multiple boards with the same stamped number, stack those pieces together.
- Stamps can be found on the flat surface of the boards or on the end of the boards.
- Allow yourself plenty of room - the wood pieces can take up a significant amount of space.

**NOTE: CARTONS ARE NOT ORGANIZED BY BOARD NUMBER.**



## HARDWARE PARTS:

- We recommend that you have a separate table to organize the hardware.
- Hardware bags are printed with a seven-digit, alpha-numeric part number.
- You can organize your hardware by part number or group by hardware type (i.e. bolts, nuts, etc.).
- During assembly you only need to reference the last four digits of the number.

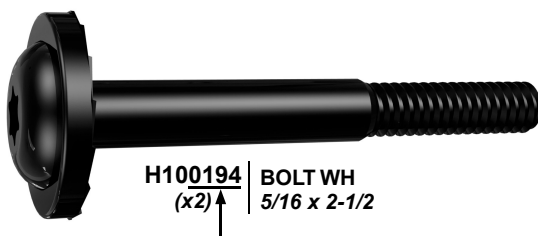

# PRE-ASSEMBLY STEP 2 - TOOLS REQUIRED



Cordless Drill or  
Electric Drill



Drill Attachments:  
Phillips Head

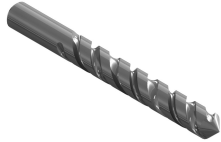

1/8", 3/16", 3/8" &  
7/16" Drill Bits



Phillips Screw Driver



Open End  
Wrenches 1/2" &  
7/16"



3/8" Drive Ratchet, 1/2" &  
7/16" STD Sockets, 1/2" &  
7/16" Deep Sockets



Tape Measure



Claw Hammer



3/8 & 5/16" Nut Drivers

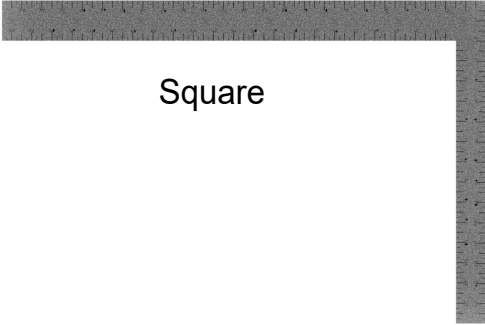

Square



Level 24"

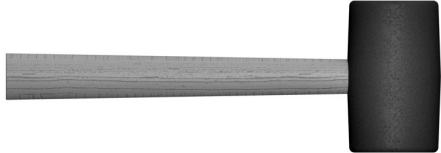

Rubber Mallet -  
Optional

# PRE-ASSEMBLY STEP 3 - CHOOSE YOUR ASSEMBLY METHOD

There are several types of assembly instructions available to you.

1. Printed Assembly Manual included with your set
2. BILT APP - 3D interactive instructions
3. Combination of the Printed Manual and BILT APP (Note: Step numbers can differ between the two methods)



# STEP 1 - RIGHT FRONT ASSEMBLY

QTY	PART NUMBER	DESCRIPTION
8	H100200	SCREW PFH 8x1 1/2 BLK



P02 FRONT POST - W2A03801  
(x1) 6"x6"x98 1/2" (152x152x2502)

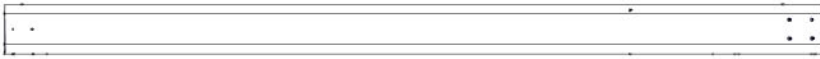

P07 FRONT POST - W2A03818  
(x1) 6"x6"x98 1/2" (152x152x2502)

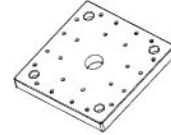

A6P00308 6x6 POST FOOT  
(x2)

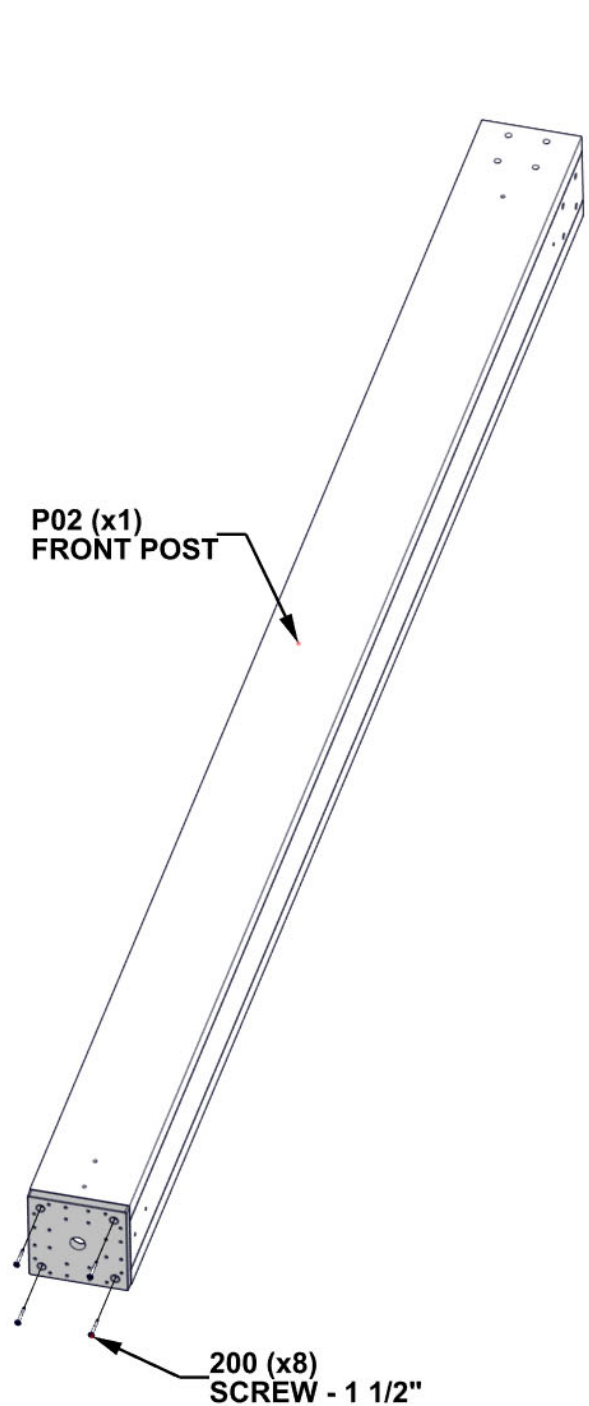
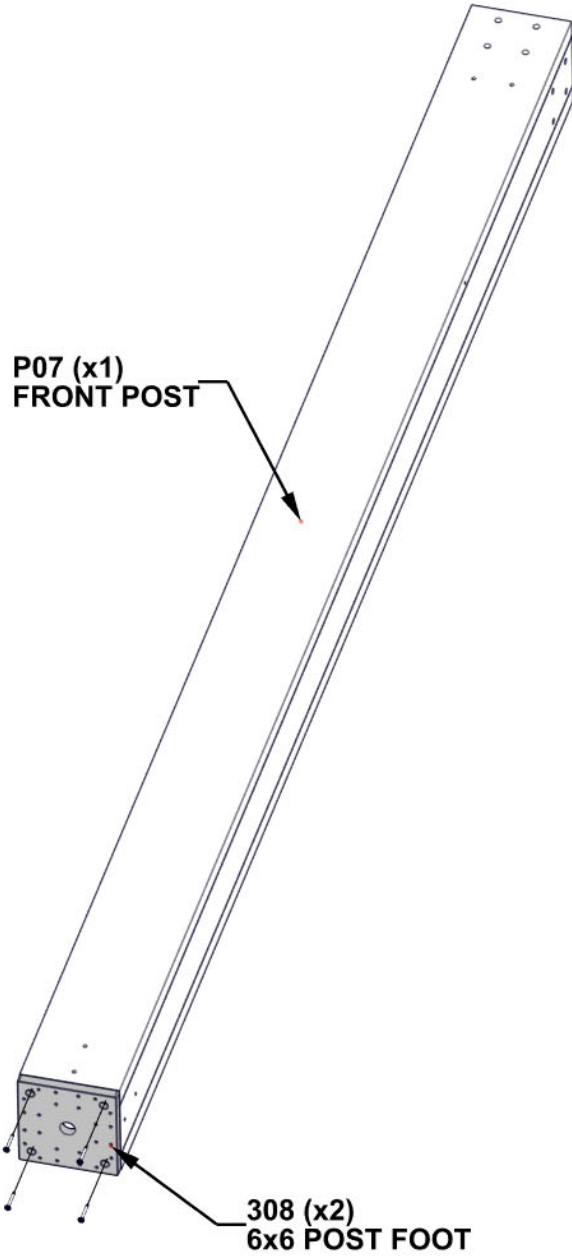

**ALIGN POST FOOT AND DRILL 1/8" PILOT HOLES FOR THE ATTACHMENT OF HARDWARE.**



**SET FRONT POST  
ASSEMBLIES TO THE SIDE**

# STEP 2 - RIGHT FRONT ASSEMBLY

QTY	PART NUMBER	DESCRIPTION
8	H100379	T-NUT 5/16 BLK



J08 JOIST ASSEMBLY - W2A03817  
(x1) 1 7/16"x8 7/16"x97 5/8" (36x214x2480)

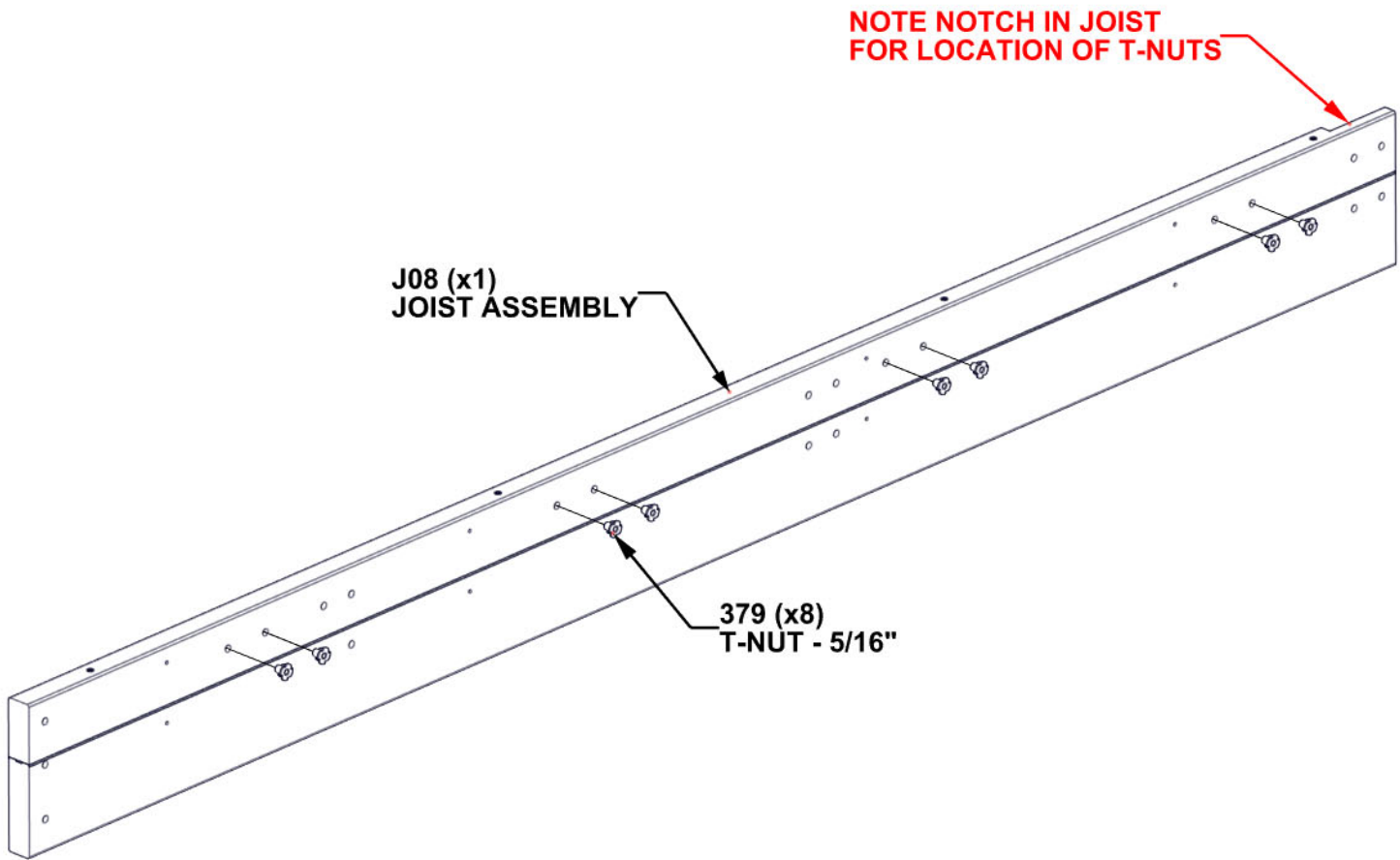

# STEP 3 - RIGHT FRONT ASSEMBLY

QTY	PART NUMBER	DESCRIPTION
2	H100379	T-NUT 5/16 BLK



J07 JOIST ASSEMBLY - W2A03815  
(x1) 1 7/16"x8 7/16"x28 7/16" (36x214x722)

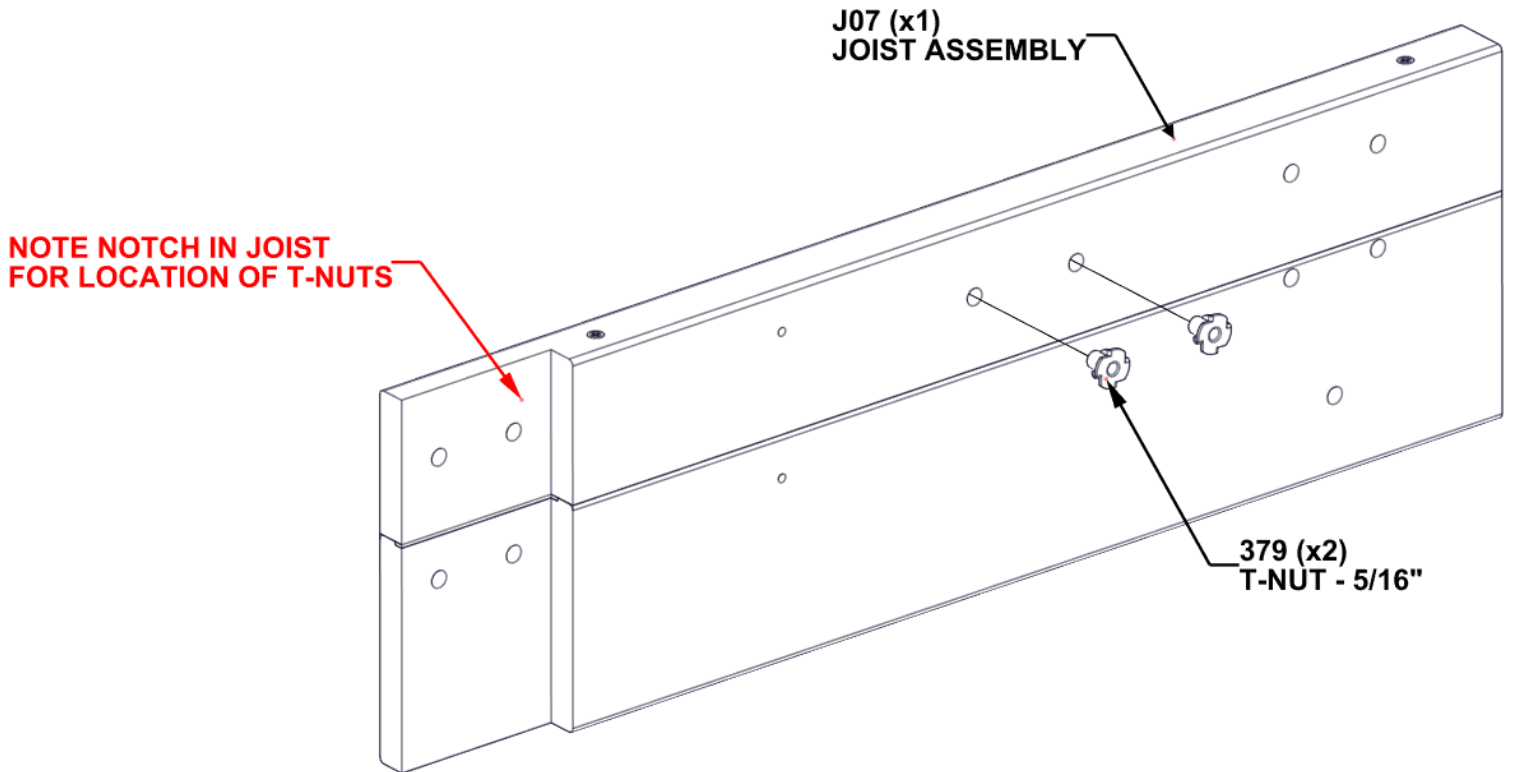

# STEP 4A - RIGHT FRONT ASSEMBLY

QTY	PART NUMBER	DESCRIPTION
4	H100198	WASHER LOCK EXT 8x19
4	H100205	BOLT WH 5/16x2 1/4 BLK
4	H100379	TNUT-5/16" BLK



G04 FASCIA - W4L17624  
 (x1) 15/16"x5 1/4"x66 3/8" (24x134x1686)

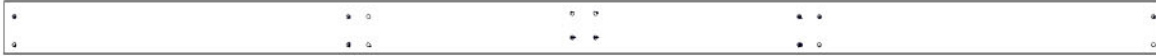

G06 FASCIA - W4L17629  
 (x1) 15/16"x5 1/4"x113 3/8" (24x134x2880)

**NOTES:**  
 • INSERT T-NUTS FIRST.

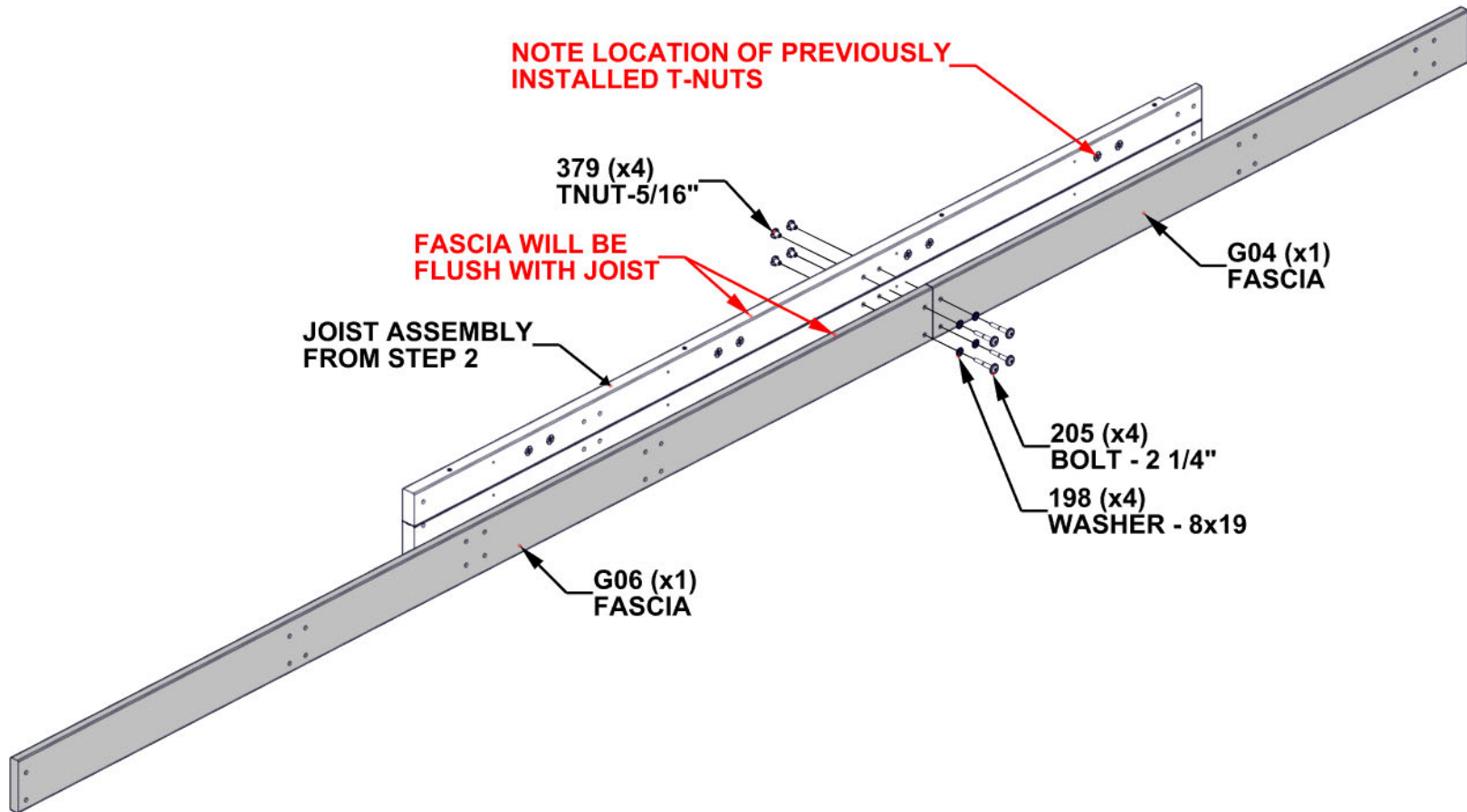

# STEP 4B - RIGHT FRONT ASSEMBLY

QTY	PART NUMBER	DESCRIPTION
8	H100198	WASHER LOCK EXT 8x19
8	H100379	TNUT-5/16" BLK
8	H100415	BOLT WH 5/16x3 3/4 BLK



D05 CORBEL - W4L17630  
 (x2) 1 7/16"x5 1/4"x34 7/16" (36x134x874)

**NOTES:**  
 • INSERT T-NUTS FIRST.

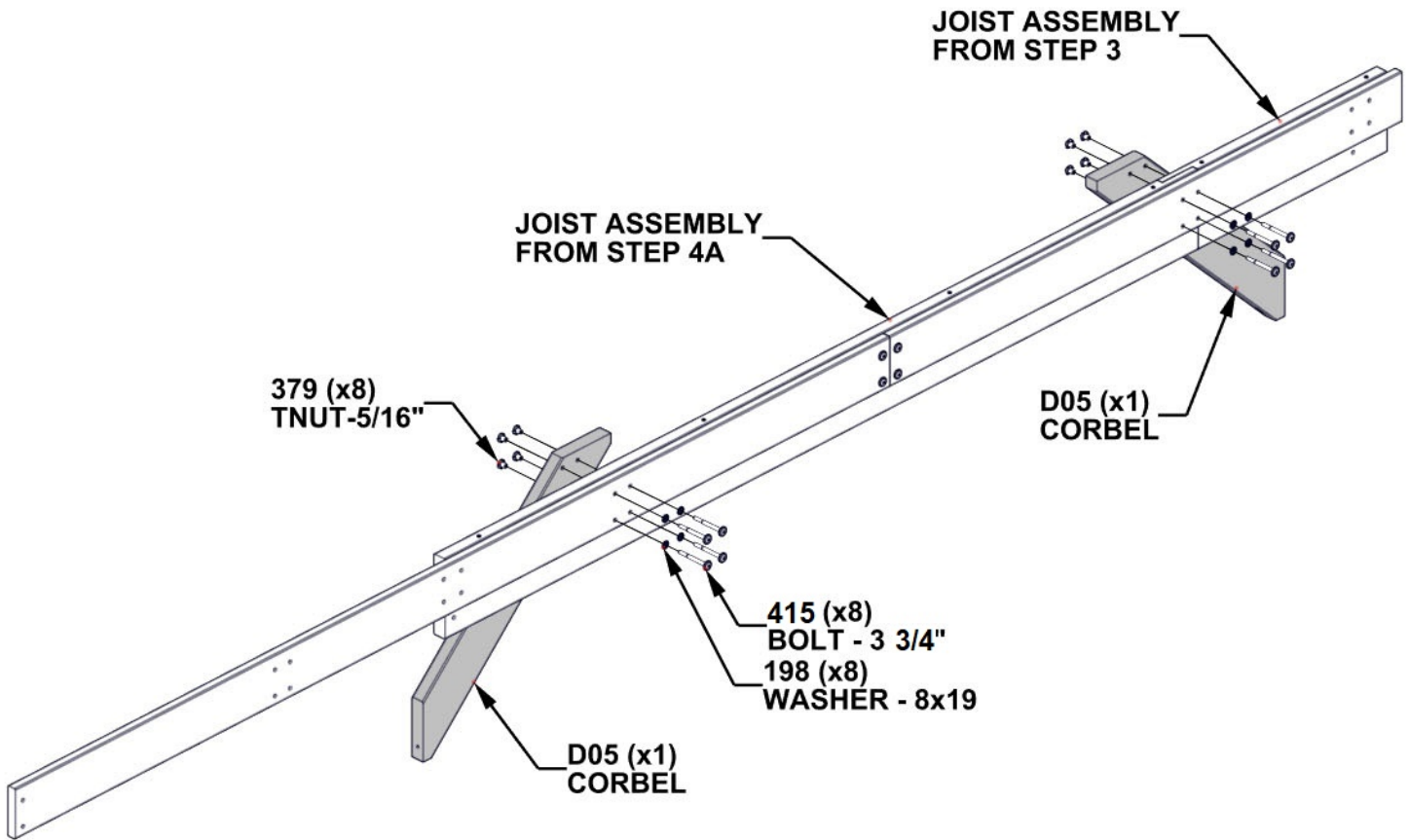

# STEP 4C - RIGHT FRONT ASSEMBLY

QTY	PART NUMBER	DESCRIPTION
10	H100391	SCREW PFH 8x2 BLK

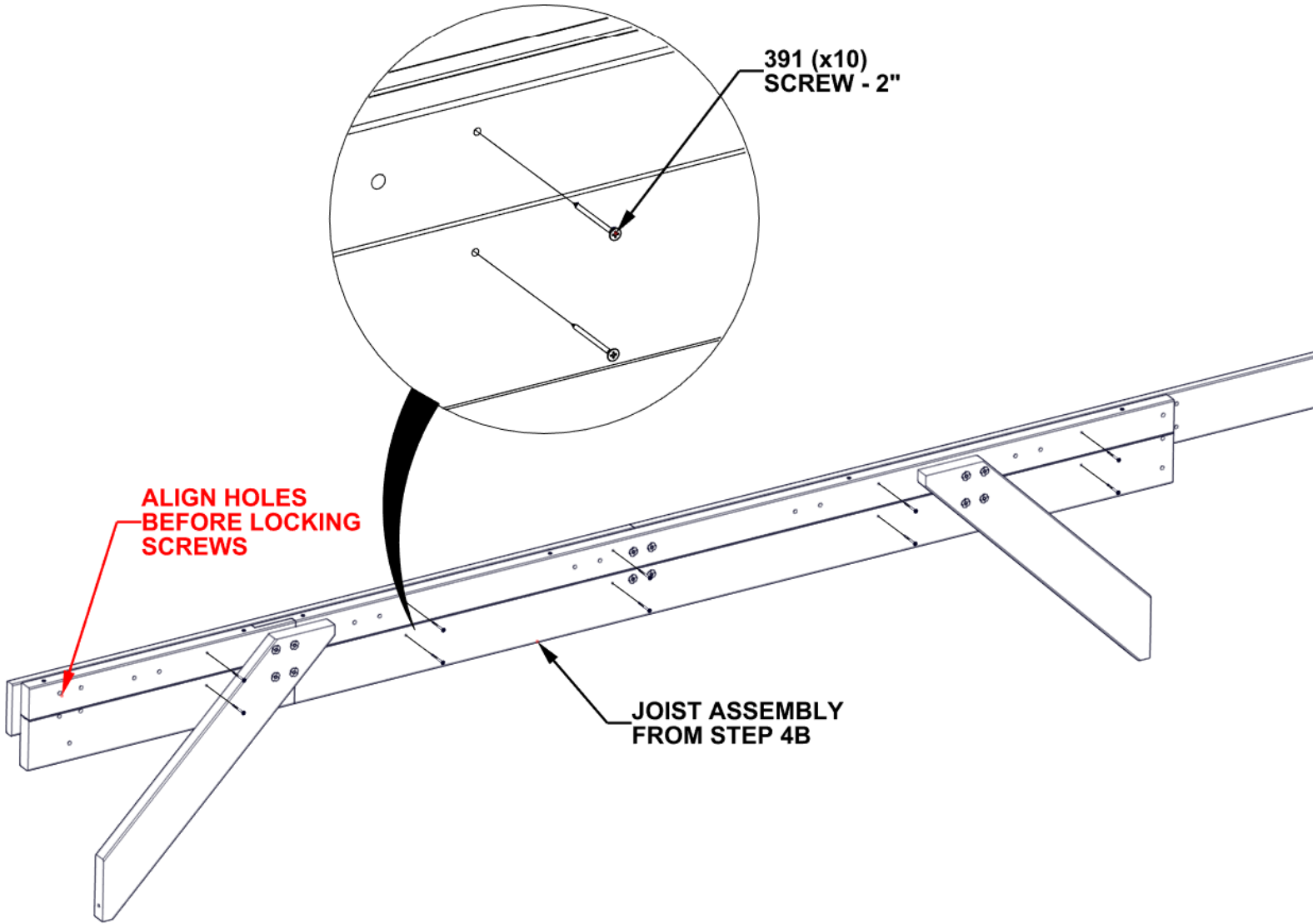

# STEP 4D - RIGHT FRONT ASSEMBLY

QTY	PART NUMBER	DESCRIPTION
10	H100459	BOLT WH 5/16x1 1/4 BLK

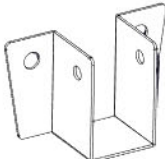

A4M01787 RAFTER BRACKET  
(x5)

**NOTE:**  
ALIGN RAFTER BRACKETS WITH HOLES  
IN BEAM AND ATTACH AS SHOWN

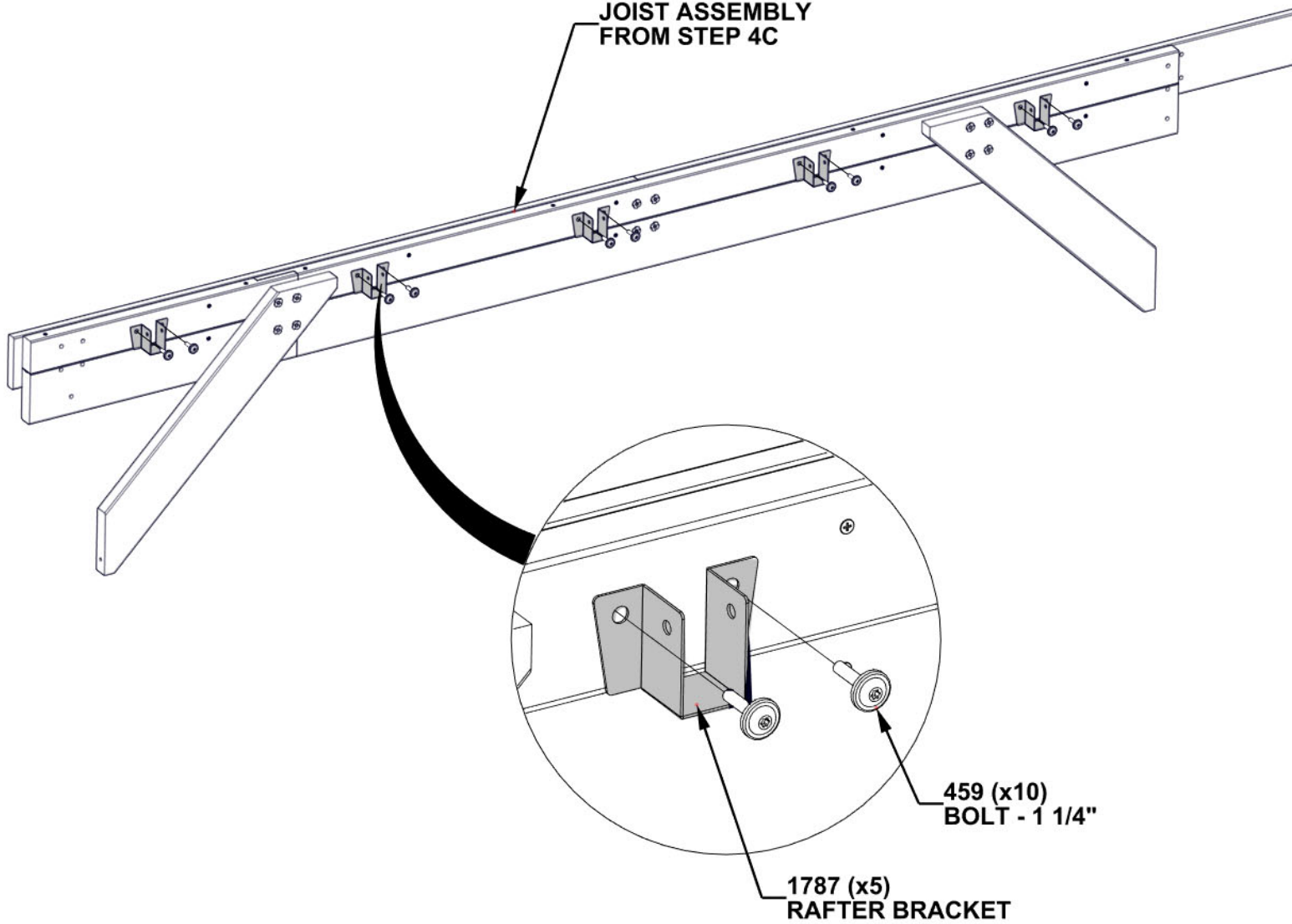

# STEP 5 - RIGHT FRONT ASSEMBLY

QTY	PART NUMBER	DESCRIPTION
2	H100197	LAG SCREW WH 5/16x2 1/2 BLK
8	H100198	WASHER LOCK EXT 8x19
6	H100379	TNUT-5/16" BLK
2	H100405	WASHER LOCK EXT 6x15
2	H100792	LAG SCREW WH 1/4x3 BLK
6	H101153	BOLT WH 5/16x8 1/4 BLK

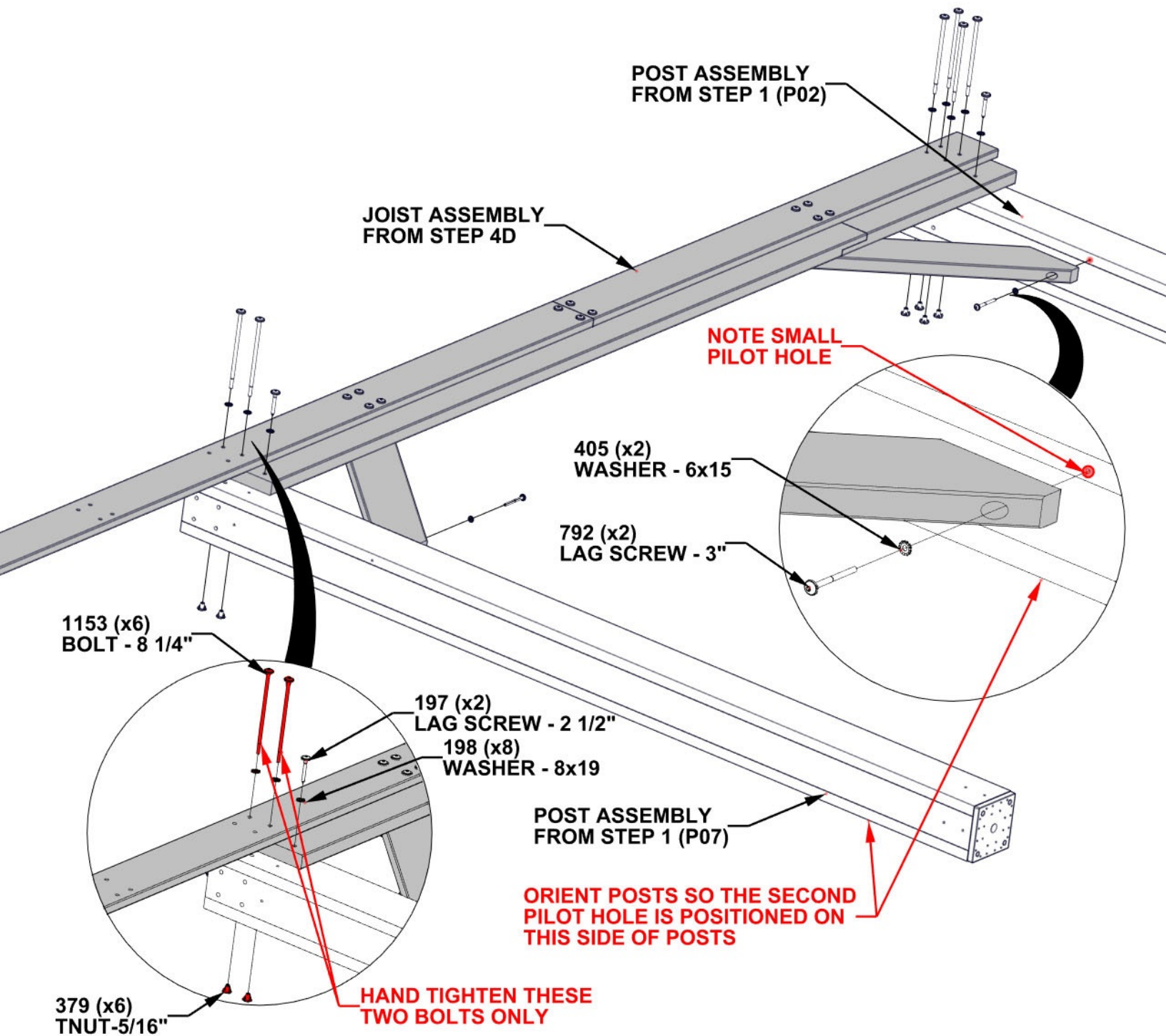



**SET RIGHT FRONT  
ASSEMBLY TO THE SIDE**

# STEP 6A - LEFT JOIST ASSEMBLY

QTY	PART NUMBER	DESCRIPTION
4	H100379	TNUT-5/16" BLK

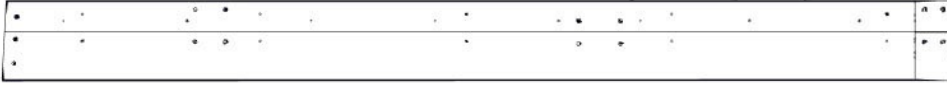

J04 JOIST ASSEMBLY - W2A03810  
(x1) 1 7/16"x8 7/16"x100" (36x214x2600)

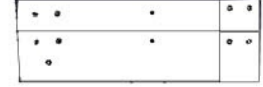

J02 JOIST ASSEMBLY - W2A03811  
(x1) 36X8 7/16"X24 9/16" (36x214x624)

**NOTES:**

- POSITION JOIST ASSEMBLIES AS SHOWN BELOW.
- ADD T-NUTS IN THE TOP FOUR HOLES AS SHOWN.

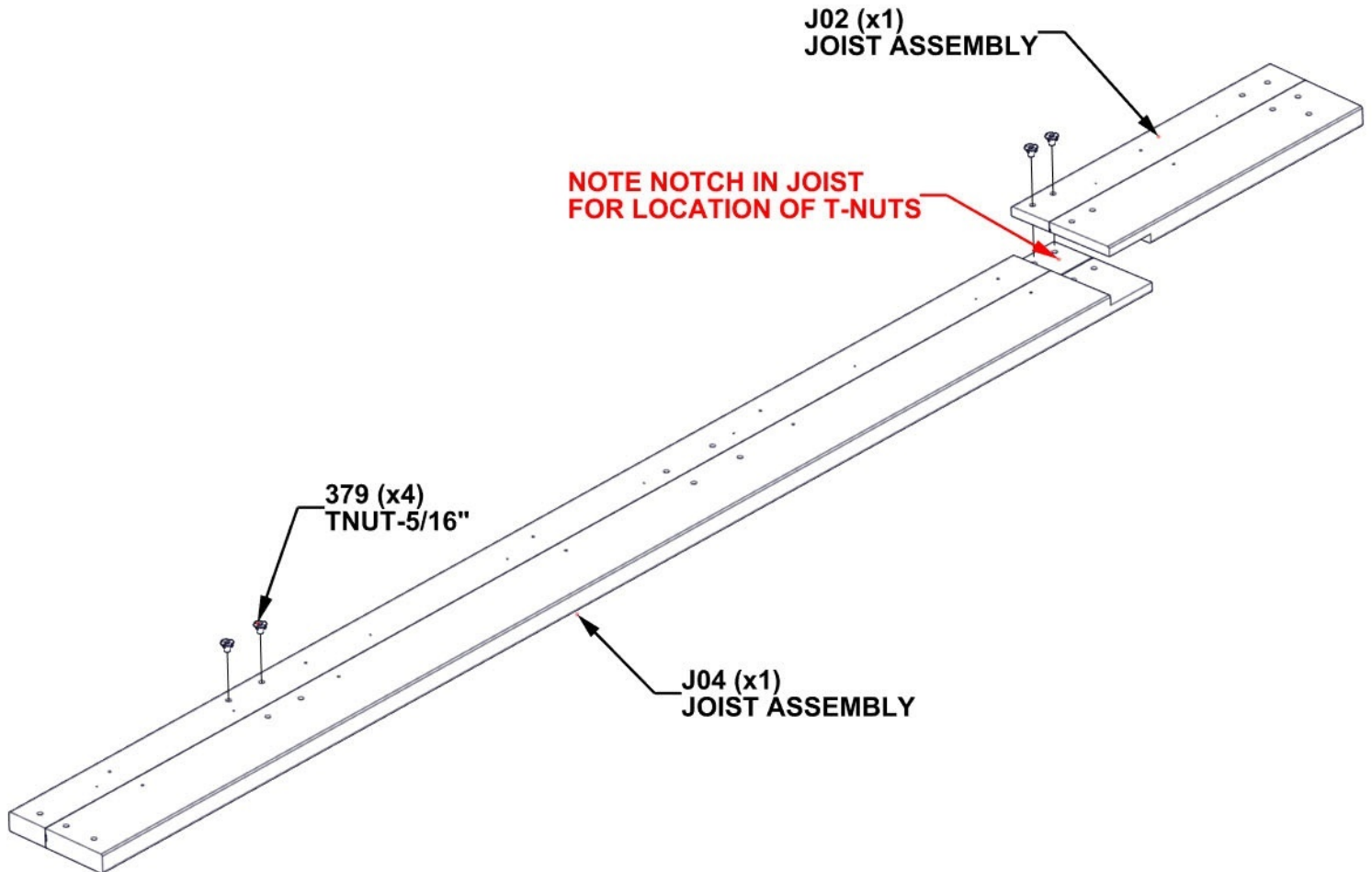

# STEP 6B - LEFT JOIST ASSEMBLY

QTY	PART NUMBER	DESCRIPTION
4	H100198	WASHER LOCK EXT 8x19
4	H100205	BOLT WH 5/16x2 1/4 BLK



G02 FASCIA - W4L17616  
(x1) 15/16"x5 1/4"x41 3/16" (24x134x1046)



G01 FASCIA - W4L17615  
(x1) 15/16"x5 1/4"x100 1/8" (24x134x2543)

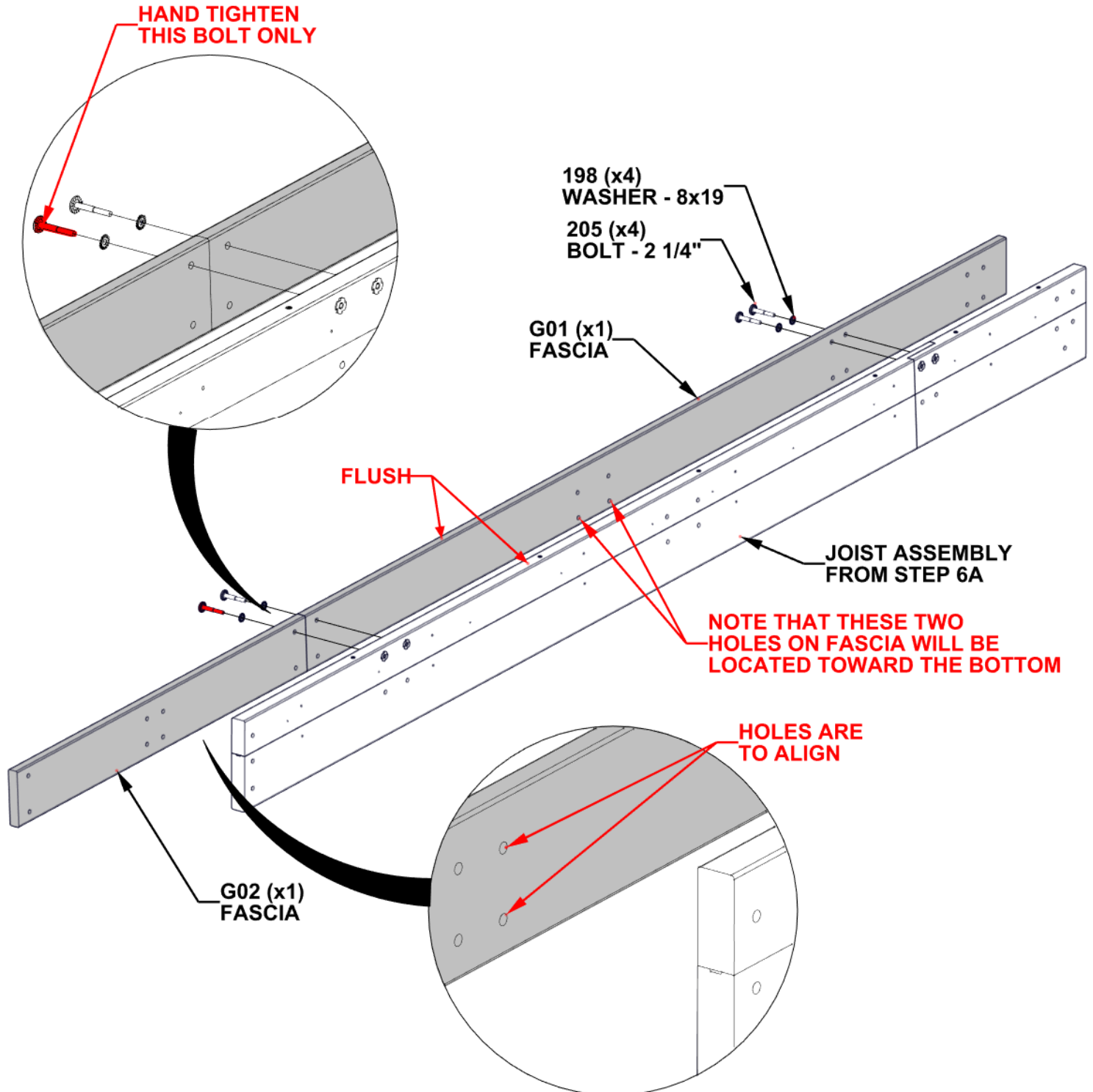

# STEP 6C - LEFT JOIST ASSEMBLY

QTY	PART NUMBER	DESCRIPTION
4	H100198	WASHER LOCK EXT 8x19
4	H100379	TNUT-5/16" BLK
4	H100415	BOLT WH 5/16x3 3/4 BLK

D01 CORBEL - W4L17618  
 (x1) 1 3/8"x5 1/4"x28 1/2" (36x134x724)

D02 CORBEL - W4L17619  
 (x1) 1 3/8"x5 1/4"x31 1/2" (36x134x801)

NOTES:  
 • INSERT T-NUTS FIRST.

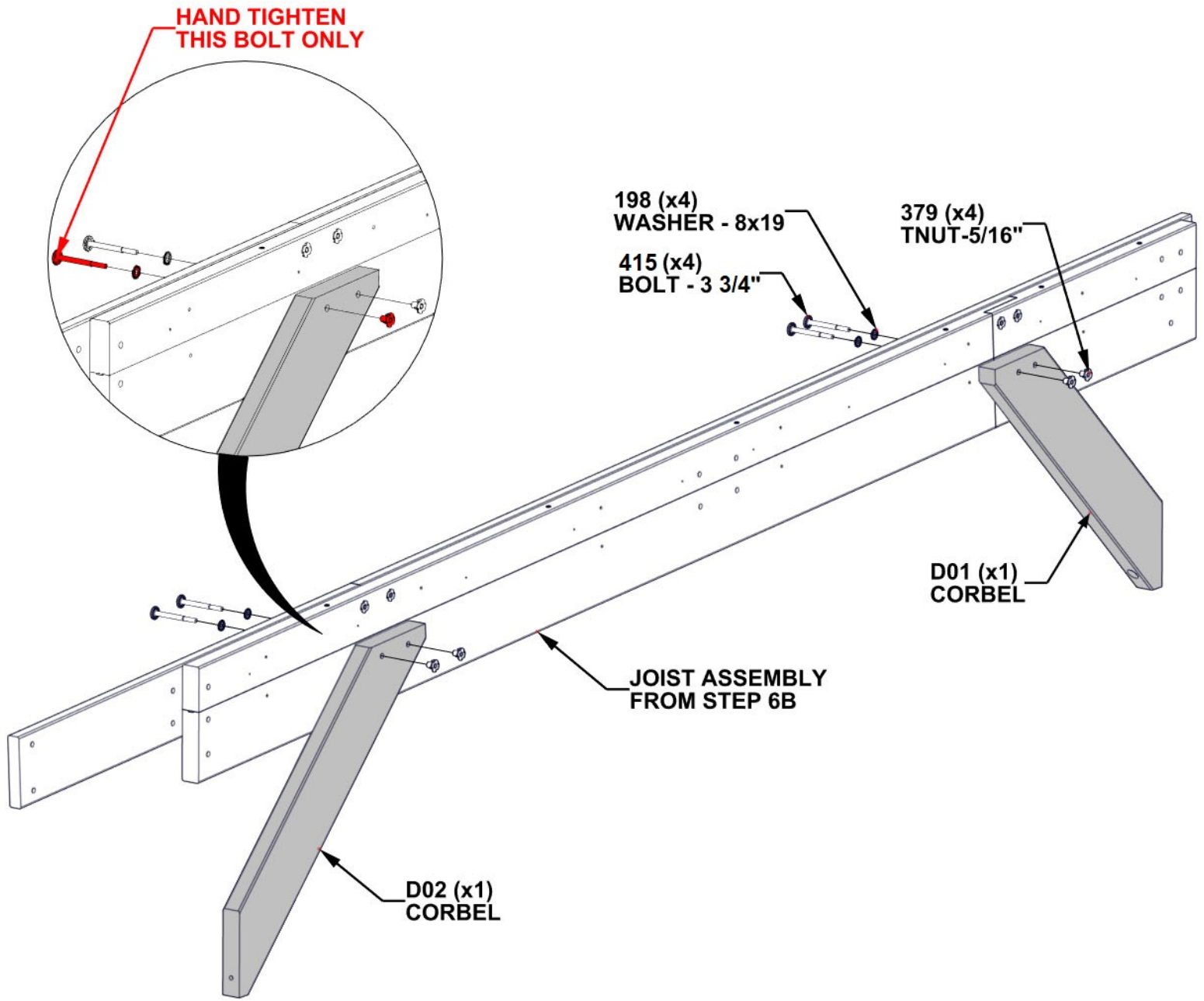

# STEP 6D - LEFT JOIST ASSEMBLY

QTY	PART NUMBER	DESCRIPTION
4	H100198	WASHER LOCK EXT 8x19
4	H100416	BOLT WH 5/16x3 BLK
4	H100479	NUT LOCK 5/16 BLK
4	H100630	WASHER FLAT 8x19 BLK



A4M02103 JOIST HANGER 90°  
(x1)

**NOTE:**  
ALIGN JOIST HANGER WITH HOLES  
IN BEAM AND ATTACH AS SHOWN

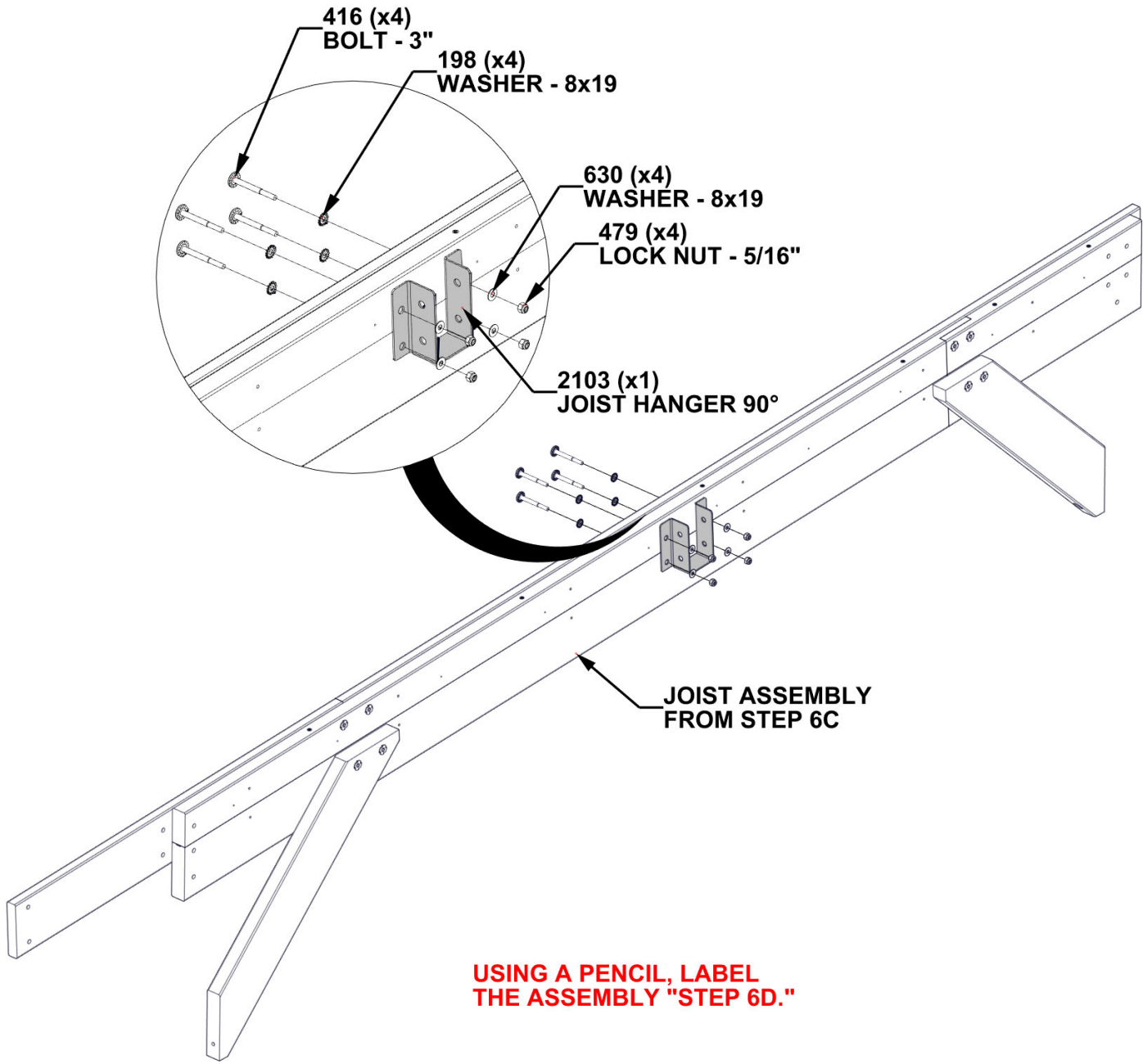

**SET LEFT JOIST  
ASSEMBLY TO THE SIDE**

# STEP 7A - LEFT CENTER JOIST ASSEMBLY

QTY	PART NUMBER	DESCRIPTION
2	H100198	WASHER LOCK EXT 8x19
2	H100379	TNUT-5/16" BLK
2	H100459	BOLT WH 5/16x1 1/4 BLK



J22 JOIST ASSEMBLY - W2A03831  
(x1) 1 7/16"x8 7/16"x100" (36x214x2600)



J21 JOIST ASSEMBLY - W2A03830  
(x1) 1 7/16"x8 7/16"x24 9/16" (36x214x624)

- NOTES:**
- POSITION JOIST ASSEMBLIES AS SHOWN BELOW.
  - INSERT T-NUTS FIRST

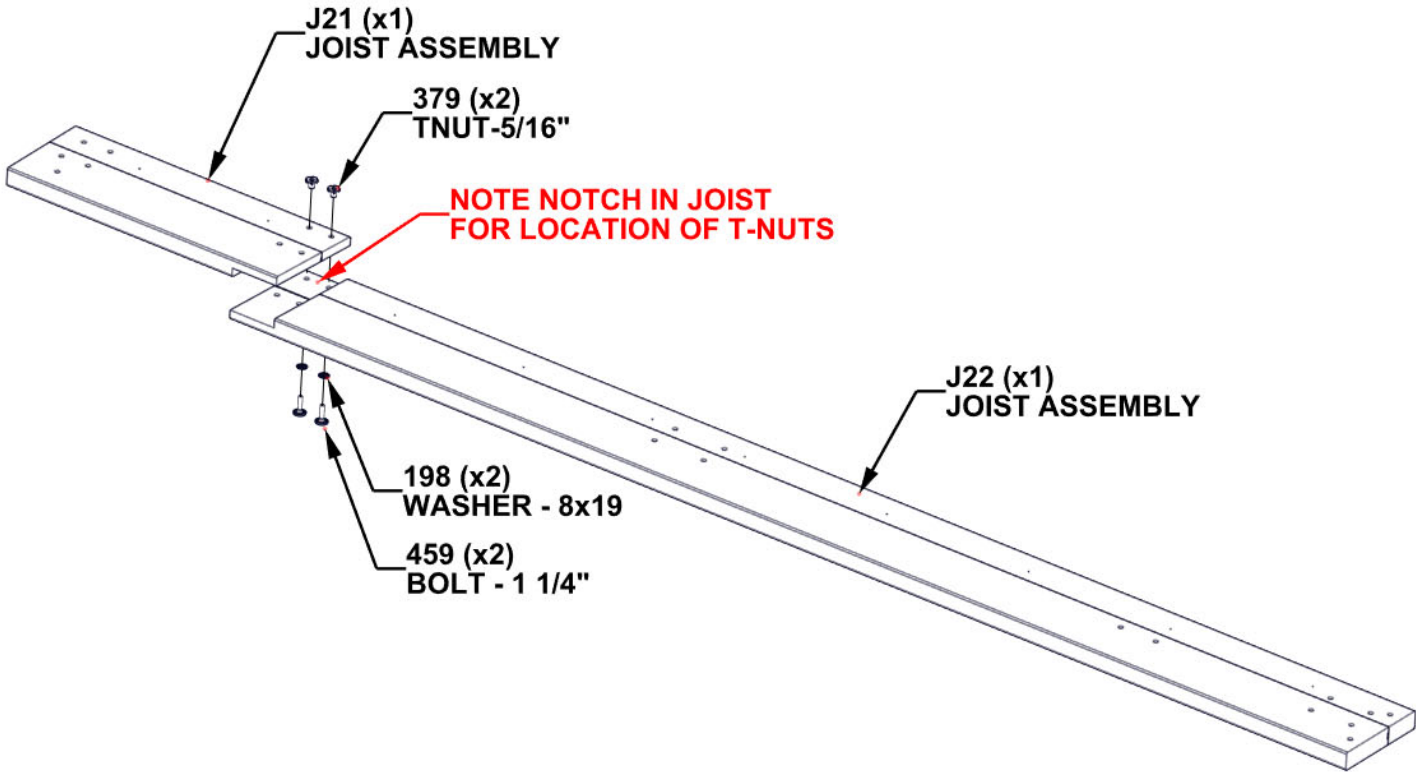

# STEP 7B - LEFT CENTER JOIST ASSEMBLY

QTY	PART NUMBER	DESCRIPTION
4	H100195	BOLT WH 5/16x2 3/4 BLK
4	H100198	WASHER LOCK EXT 8x19
4	H100379	TNUT-5/16" BLK



D01 CORBEL - W4L17618  
(x1) 1 3/8"x5 1/4"x28 1/2" (36x134x724)



D02 CORBEL - W4L17619  
(x1) 1 3/8"x5 1/4"x31 1/2" (36x134x801)

**NOTES:**  
• INSERT T-NUTS FIRST.

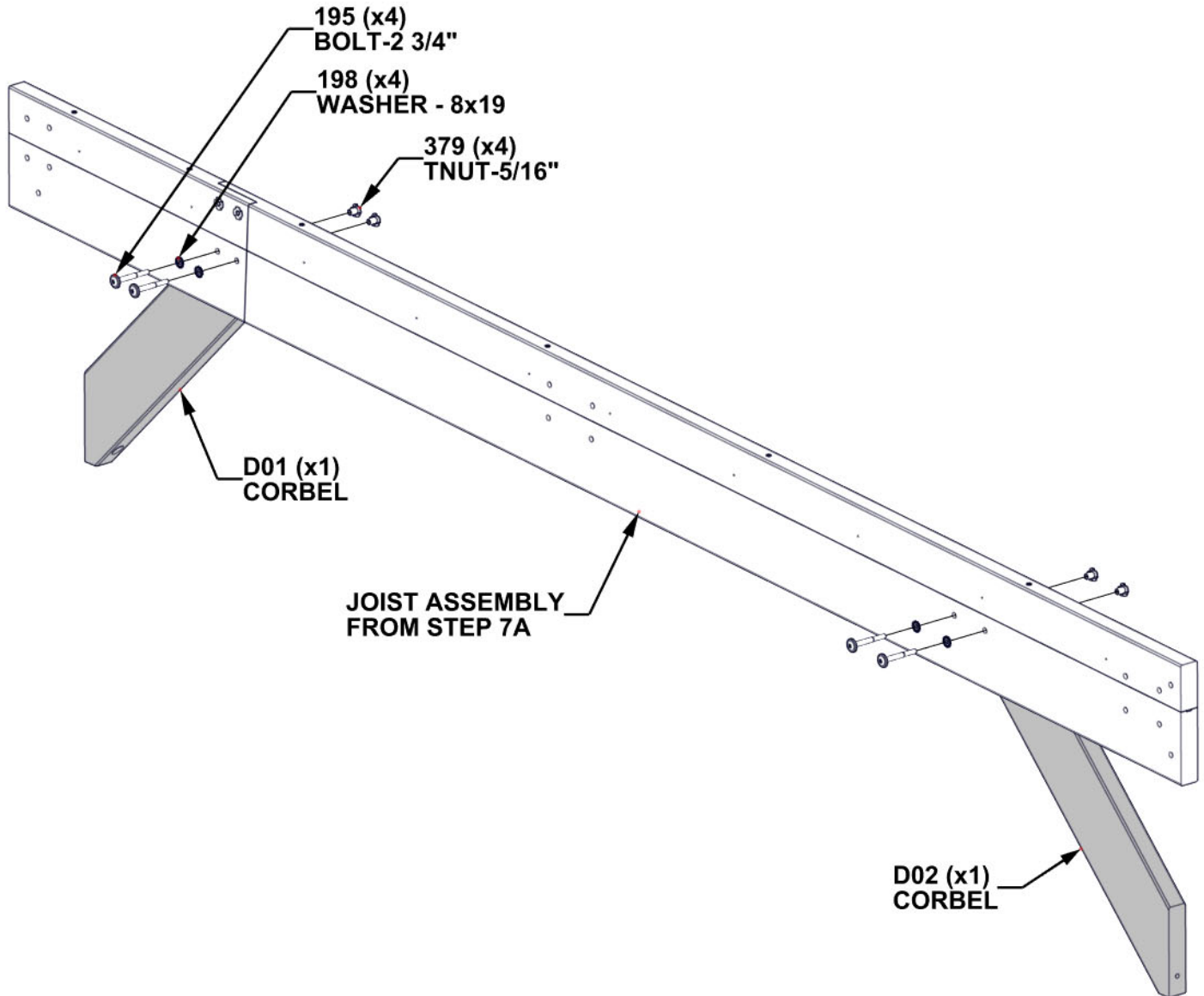



# STEP 7C - LEFT CENTER JOIST ASSEMBLY

QTY	PART NUMBER	DESCRIPTION
4	H100198	WASHER LOCK EXT 8x19
4	H100457	BOLT WH 5/16x2 BLK
4	H100479	NUT LOCK 5/16 BLK
4	H100630	WASHER FLAT 8x19 BLK



A4M02103 JOIST HANGER 90°  
(x1)

**NOTE:**  
ALIGN JOIST HANGER WITH HOLES  
IN BEAM AND ATTACH AS SHOWN

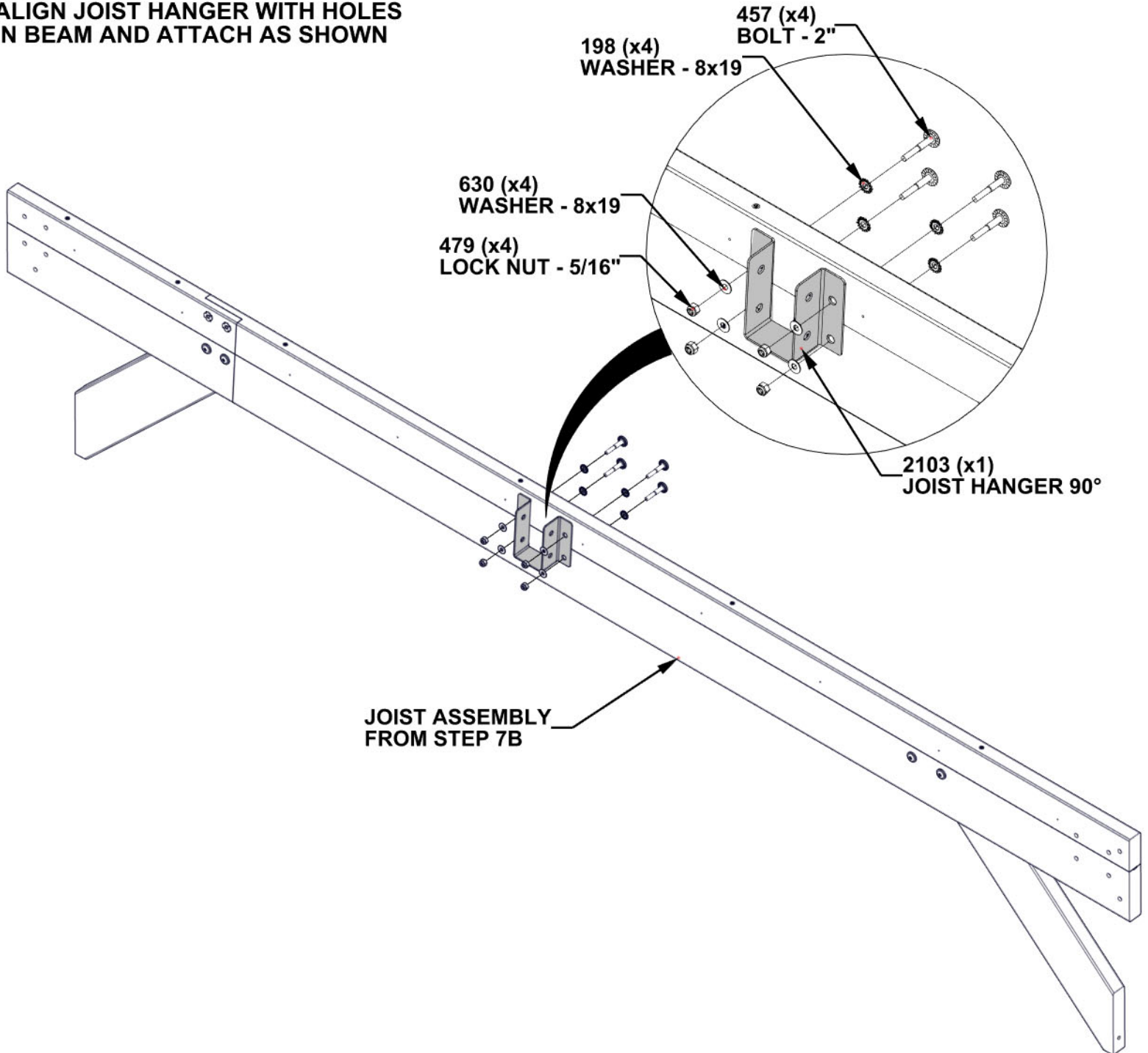

# STEP 7D - LEFT CENTER JOIST ASSEMBLY

QTY	PART NUMBER	DESCRIPTION
4	H100379	T-NUT 5/16 BLK
4	H100407	BOLT WH 5/16x1 1/2 BLK

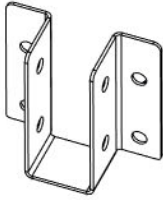

A4M02211 JOIST HANGER 90°  
(x1)

**NOTE:**  
ALIGN JOIST HANGER WITH HOLES  
IN BEAM AND ATTACH AS SHOWN

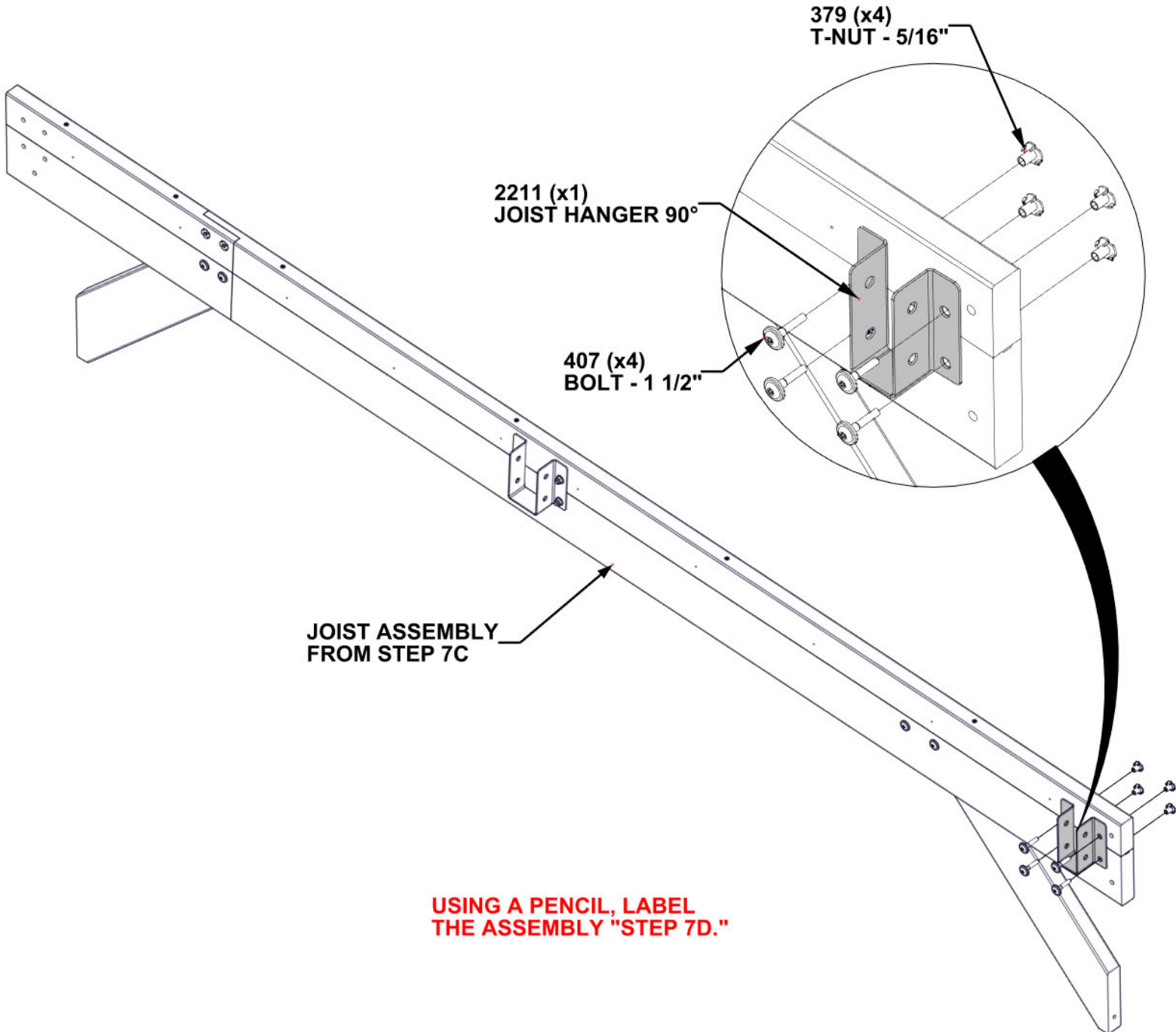

**SET LEFT CENTER JOIST  
ASSEMBLY TO THE SIDE**

# STEP 8A - RIGHT CENTER JOIST ASSEMBLY

QTY	PART NUMBER	DESCRIPTION
2	H100198	WASHER LOCK EXT 8x19
2	H100379	TNUT-5/16" BLK
2	H100459	BOLT WH 5/16x1 1/4 BLK

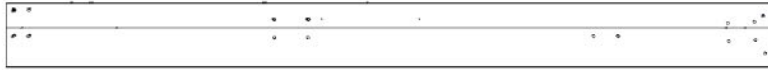

J18 JOIST ASSEMBLY - W2A03827  
(x1) 1 7/16"x8 7/16"x100" (36x214x2600)



J17 JOIST ASSEMBLY - W2A03826  
(x1) 36X8 7/16"X24 9/16" (36x214x624)

- NOTES:**
- POSITION JOIST ASSEMBLIES AS SHOWN BELOW.
  - INSERT T-NUTS FIRST

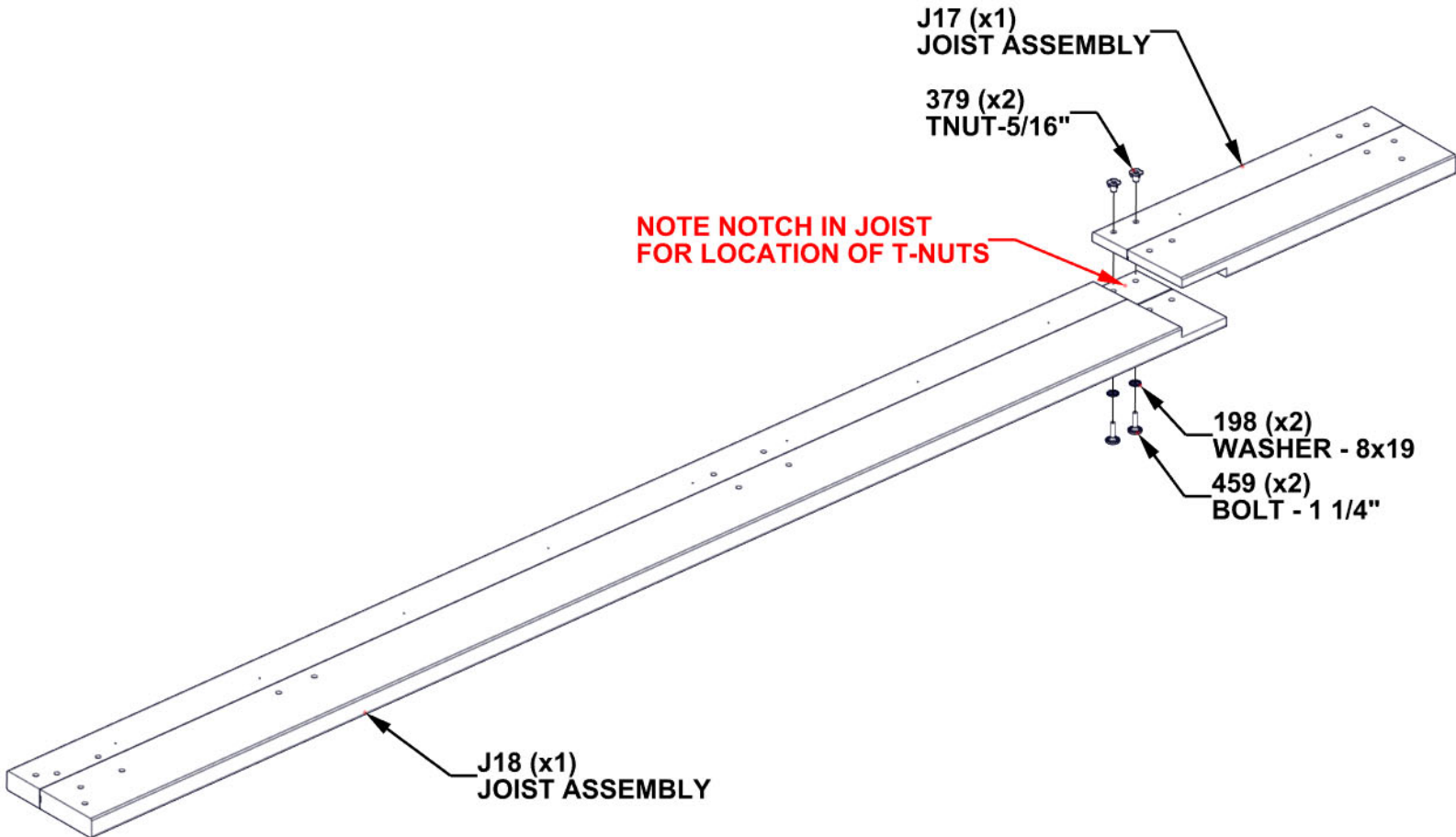

# STEP 8B - RIGHT CENTER JOIST ASSEMBLY

QTY	PART NUMBER	DESCRIPTION
4	H100195	BOLT WH 5/16x2 3/4 BLK
4	H100198	WASHER LOCK EXT 8x19
4	H100379	TNUT-5/16" BLK



D01 CORBEL - W4L17618  
(x1) 1 3/8"x5 1/4"x28 1/2" (36x134x724)



D02 CORBEL - W4L17619  
(x1) 1 3/8"x5 1/4"x31 1/2" (36x134x801)

**NOTES:**  
• INSERT T-NUTS FIRST.

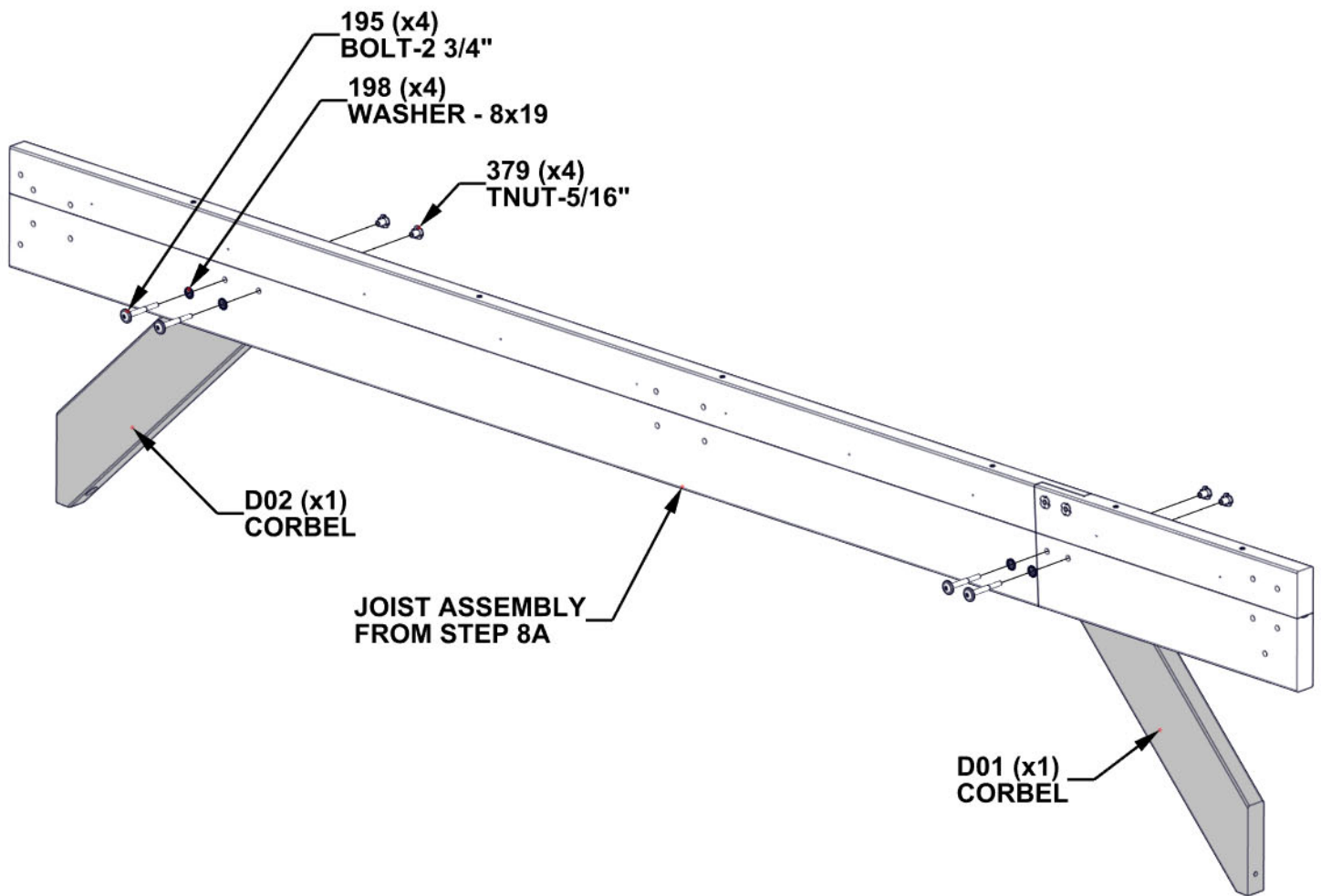

# STEP 8C - RIGHT CENTER JOIST ASSEMBLY

QTY	PART NUMBER	DESCRIPTION
4	H100198	WASHER LOCK EXT 8x19
4	H100457	BOLT WH 5/16x2 BLK
4	H100479	NUT LOCK 5/16 BLK
4	H100630	WASHER FLAT 8x19 BLK

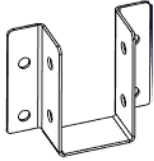

A4M02103 JOIST HANGER 90°  
(x1)

**NOTE:**  
ALIGN JOIST HANGER WITH HOLES  
IN BEAM AND ATTACH AS SHOWN

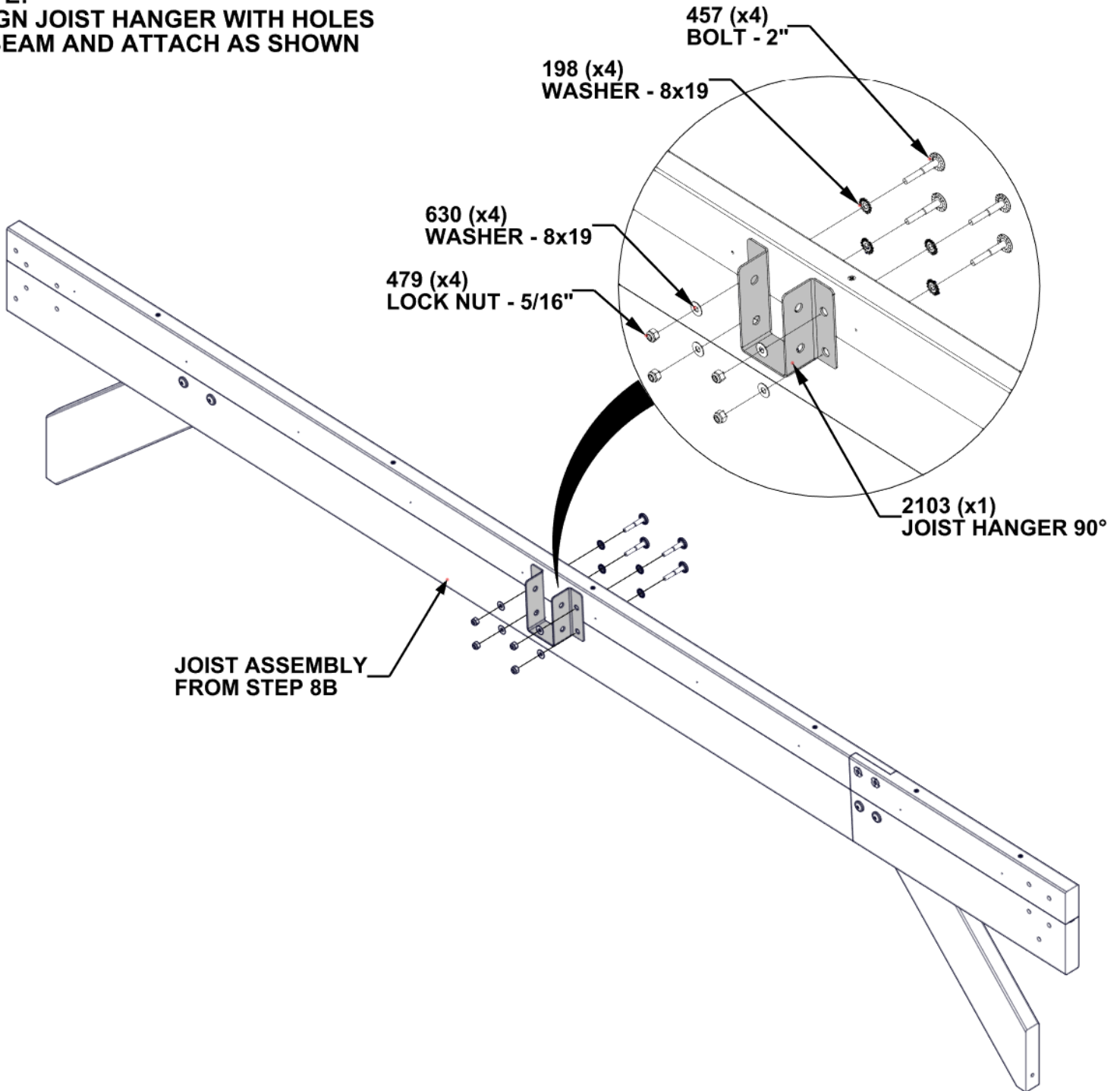

# STEP 8D - RIGHT CENTER JOIST ASSEMBLY

QTY	PART NUMBER	DESCRIPTION
4	H100379	T-NUT 5/16 BLK
4	H100407	BOLT WH 5/16x1 1/2 BLK

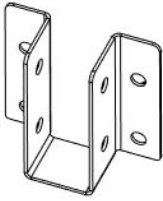

A4M02211 JOIST HANGER 90°  
(x1)

**NOTE:**  
ALIGN JOIST HANGER WITH HOLES  
IN BEAM AND ATTACH AS SHOWN

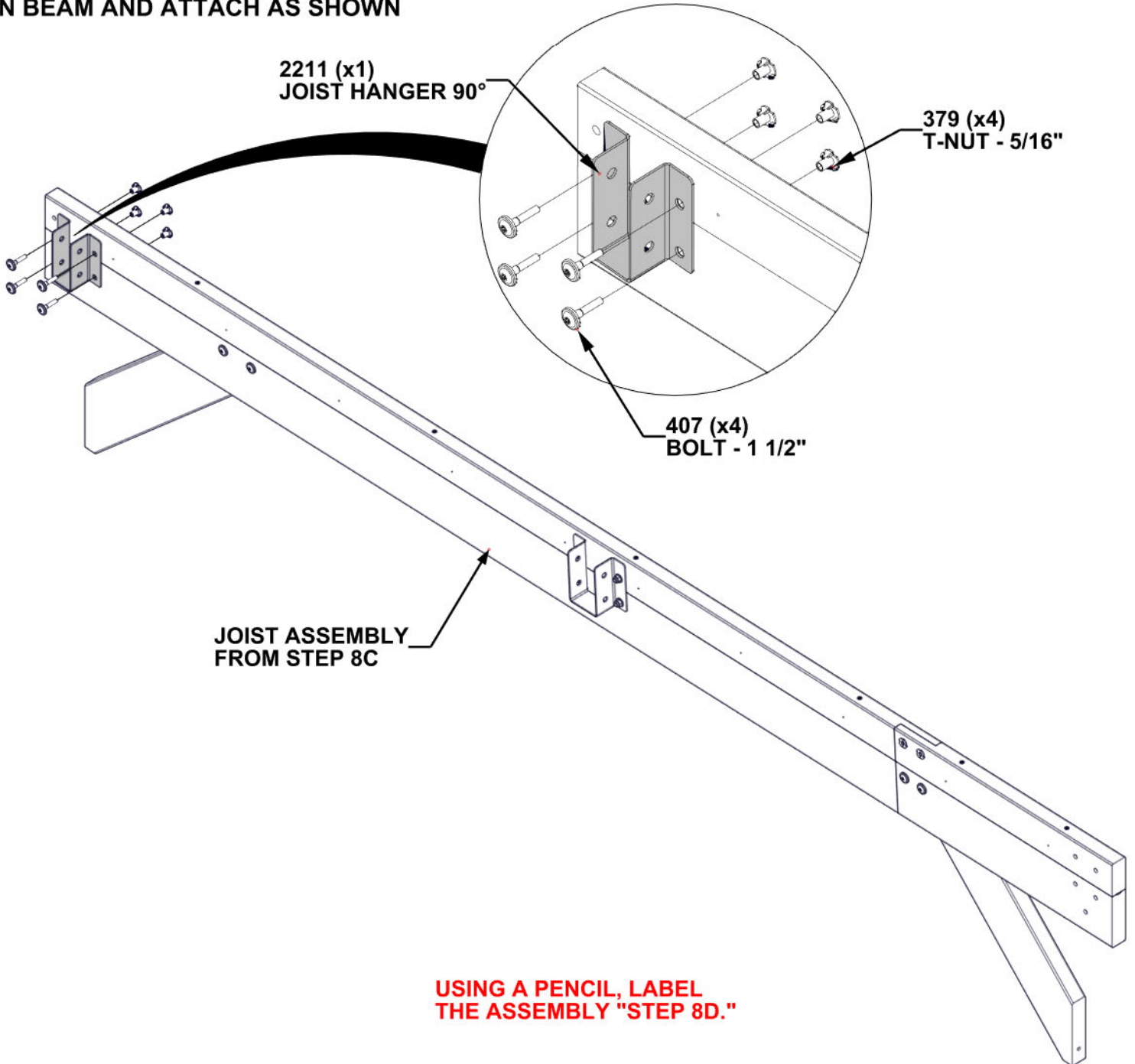

**SET RIGHT CENTER JOIST  
ASSEMBLY TO THE SIDE**



# STEP 9 - CENTER POST ASSEMBLY

QTY	PART NUMBER	DESCRIPTION
8	H100200	SCREW PFH 8x1 1/2 BLK



P04 CENTER POST - W2A03803  
(x1) 6"x6"x92 5/16" (152x152x2344)



P09 CENTER POST - W2A03824  
(x1) 6"x6"x92 5/16" (152x152x2344)

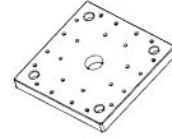

A6P00308 6x6 POST FOOT  
(x2)

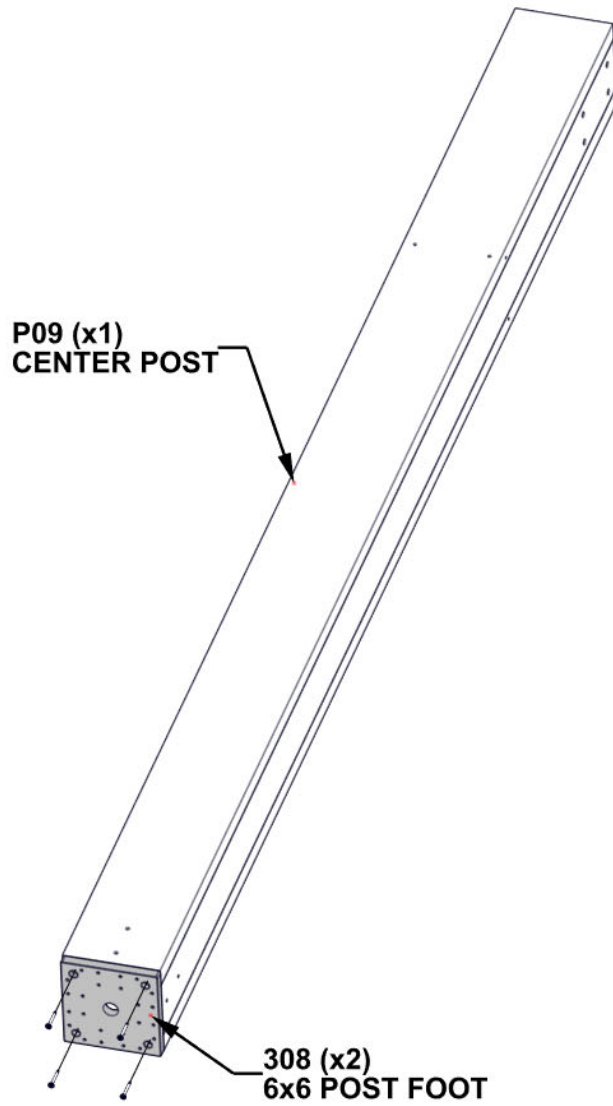

**ALIGN POST FOOT AND DRILL 1/8" PILOT HOLES FOR THE ATTACHMENT OF HARDWARE.**

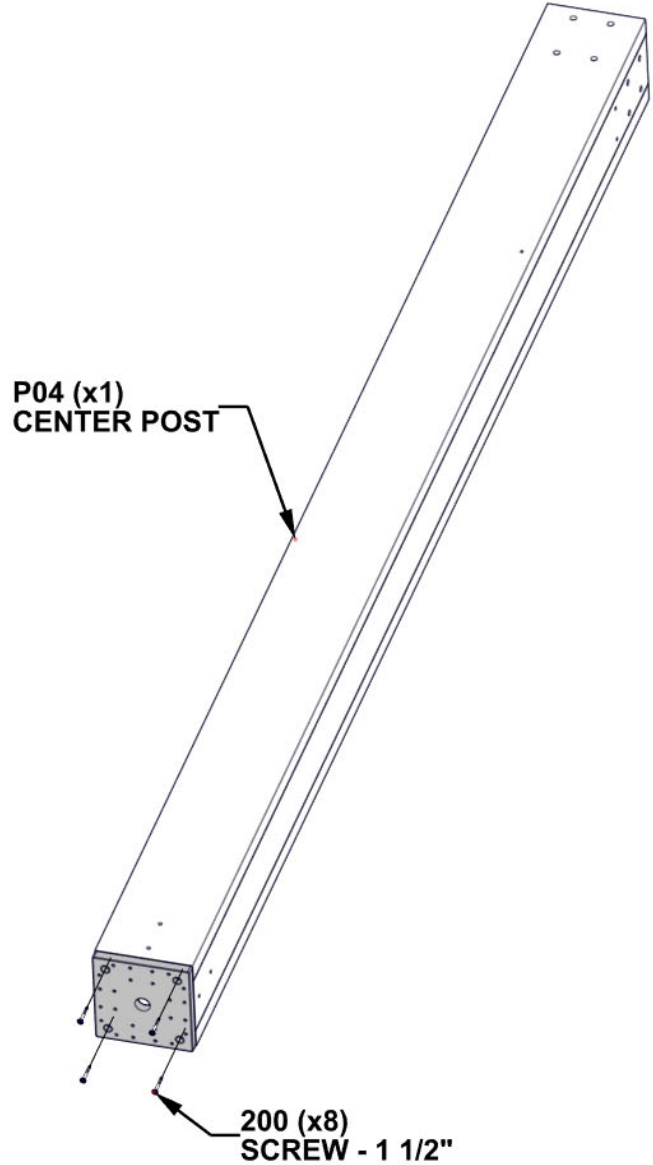

# STEP 10 - CARPORT ASSEMBLY

QTY	PART NUMBER	DESCRIPTION
2	H100197	LAG SCREW WH 5/16x2 1/2 BLK
8	H100198	WASHER LOCK EXT 8x19
6	H100379	TNUT-5/16" BLK
2	H100405	WASHER LOCK EXT 6x15
2	H100792	LAG SCREW WH 1/4x3 BLK
6	H101153	BOLT WH 5/16x8 1/4 BLK

**NOTE:**

- EXTRA PEOPLE ARE HELPFUL FOR THIS STEP.
- THE FRONT OF THE UNIT IS DETERMINED BY THE TALLER POST.

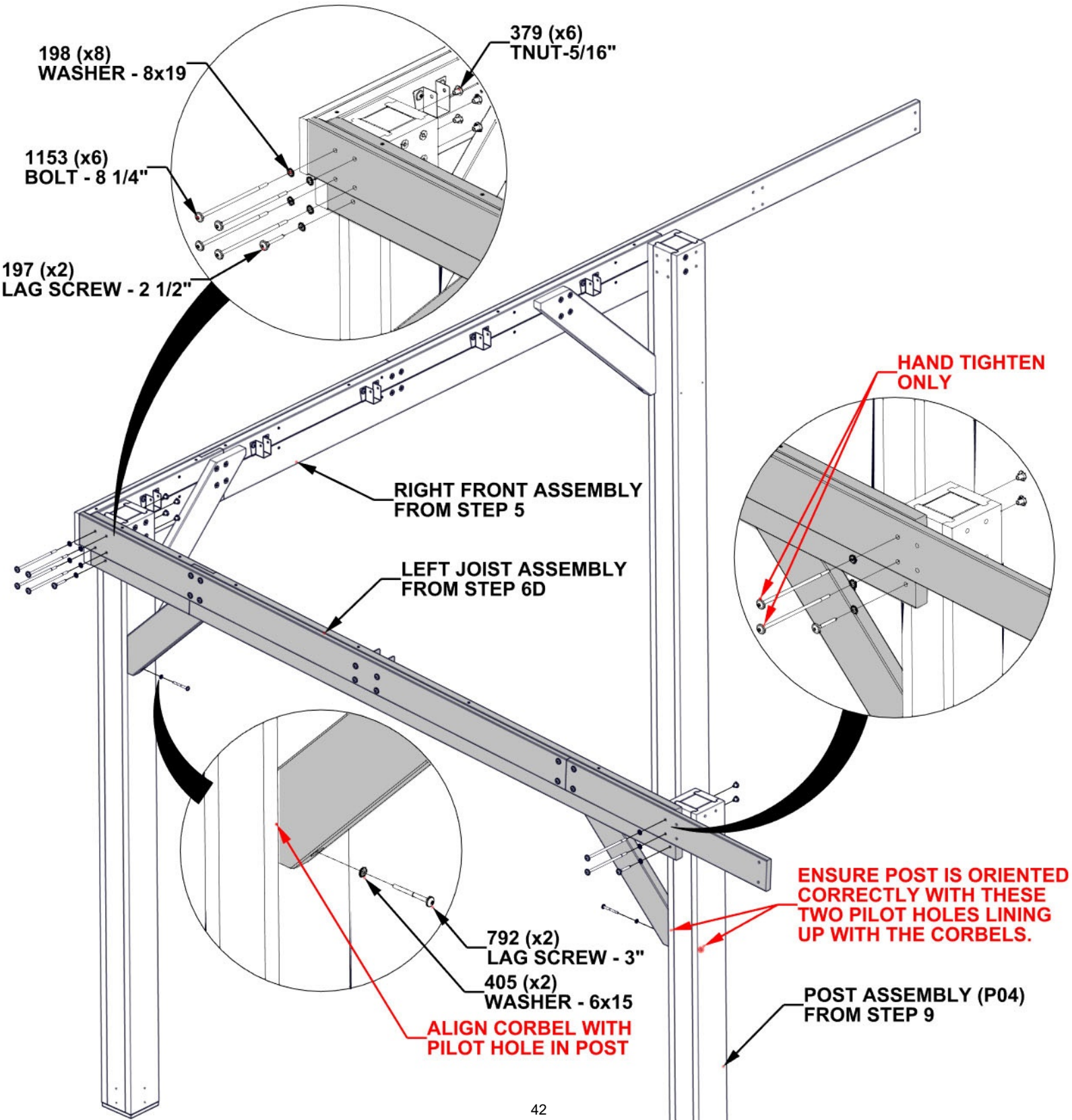

# STEP 11 - CARPORT ASSEMBLY

QTY	PART NUMBER	DESCRIPTION
2	H100197	LAG SCREW WH 5/16x2 1/2 BLK
8	H100198	WASHER LOCK EXT 8x19
6	H100379	TNUT-5/16" BLK
4	H100405	WASHER LOCK EXT 6x15
4	H100792	LAG SCREW WH 1/4x3 BLK
6	H101058	BOLT WH 5/16x8 3/4 BLK

**NOTE:**

- EXTRA PEOPLE ARE HELPFUL FOR THIS STEP.
- THE FRONT OF THE UNIT IS DETERMINED BY THE TALLER POST.

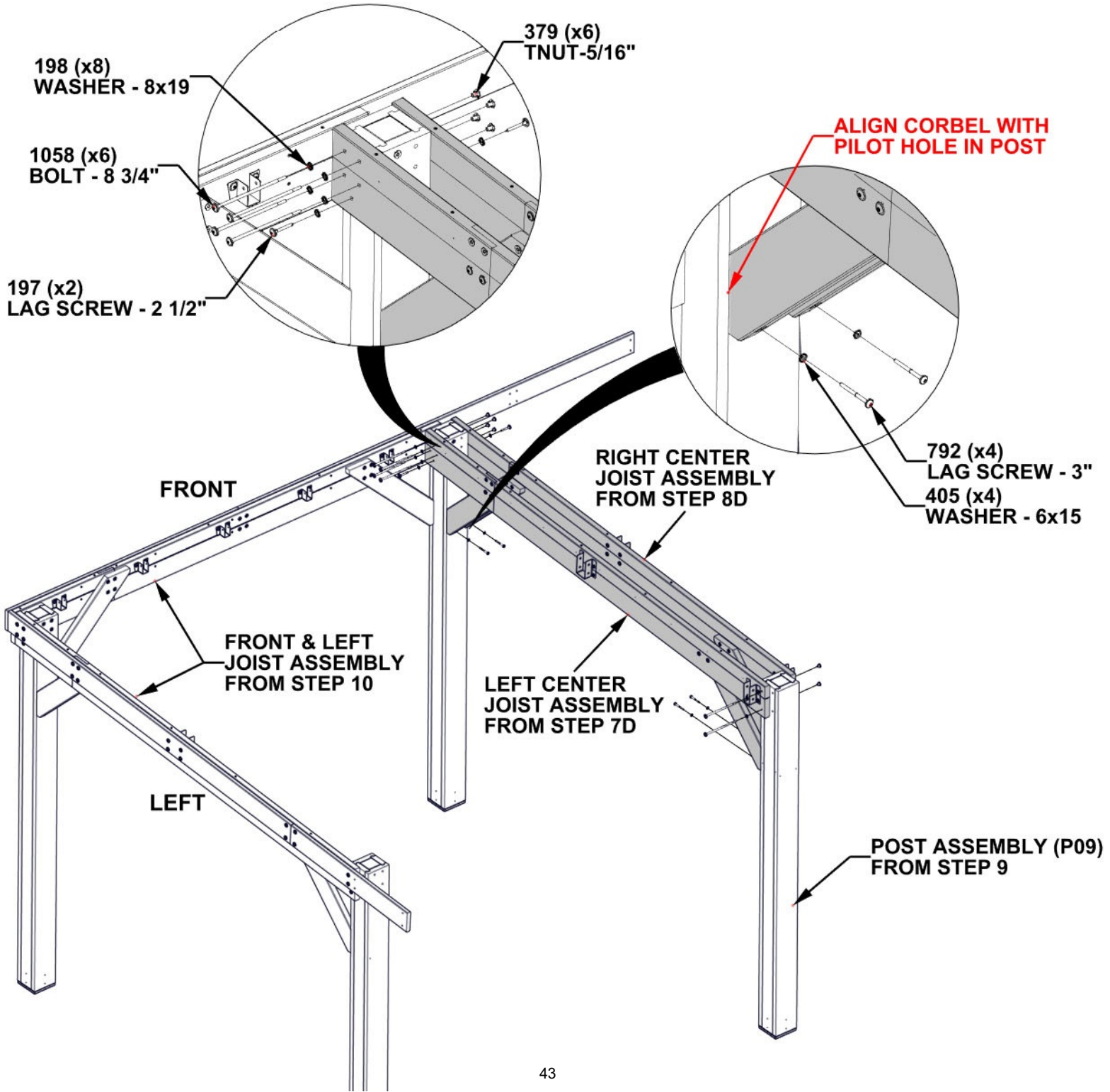

# STEP 12 - RIGHT REAR ASSEMBLY

QTY	PART NUMBER	DESCRIPTION
8	H100200	SCREW PFH 8x1 1/2 BLK



P08 REAR POST - W2A03823  
(x1) 6"x6"x86 1/4" (152x152x2190)



P06 REAR POST - W2A03805  
(x1) 6"x6"x86 1/4" (152x152x2190)

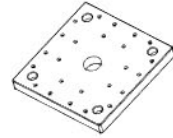

A6P00308 6x6 POST FOOT  
(x2)

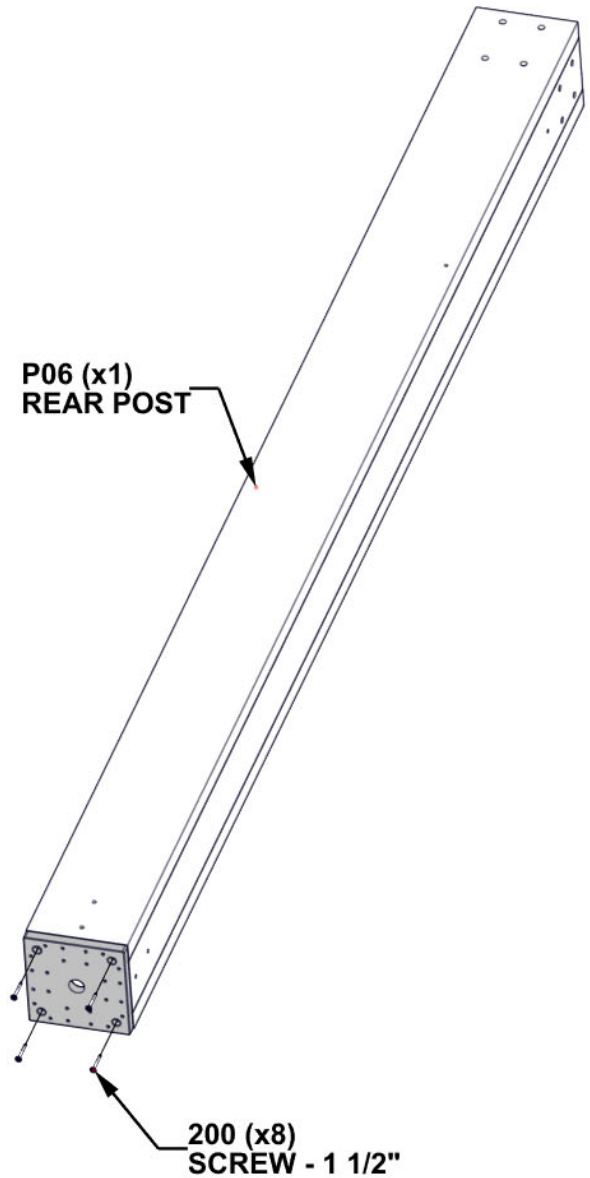
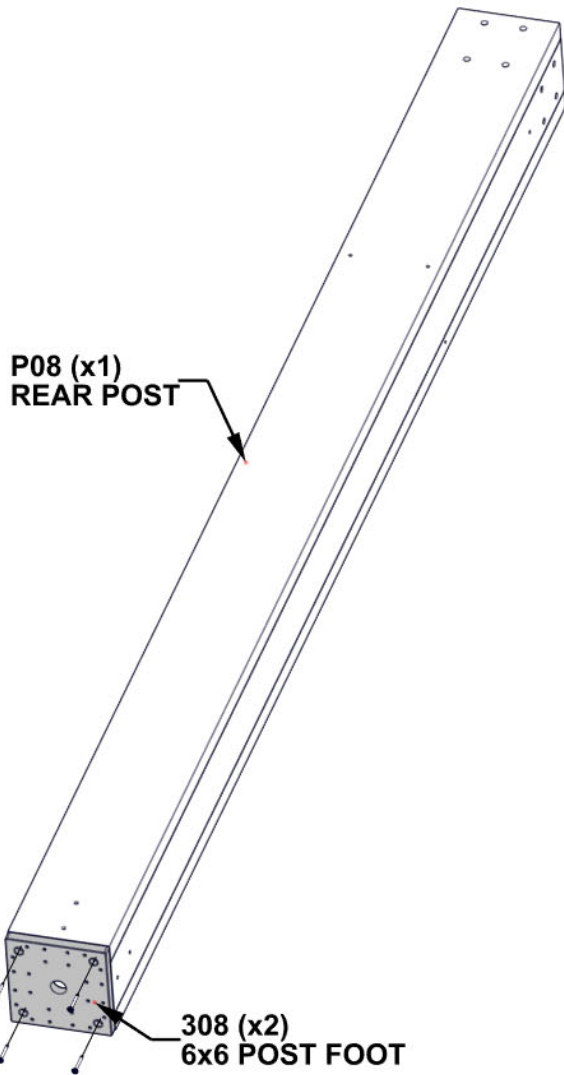

**ALIGN POST FOOT AND DRILL 1/8" PILOT HOLES FOR THE ATTACHMENT OF HARDWARE.**

**SET REAR POST  
ASSEMBLIES TO THE SIDE**

# STEP 13 - RIGHT REAR ASSEMBLY

QTY	PART NUMBER	DESCRIPTION
8	H100379	T-NUT 5/16 BLK

○	.	○	○	○	.	○	○	○	○	.	○	○	.	○	○
○	.	○	○	.	○	○	.	○	○	.	○	○	.	○	○
○															

J15 JOIST ASSEMBLY - W2A03821  
 (x1) 1 7/16"x8 7/16"x97 5/8" (36x214x2480)

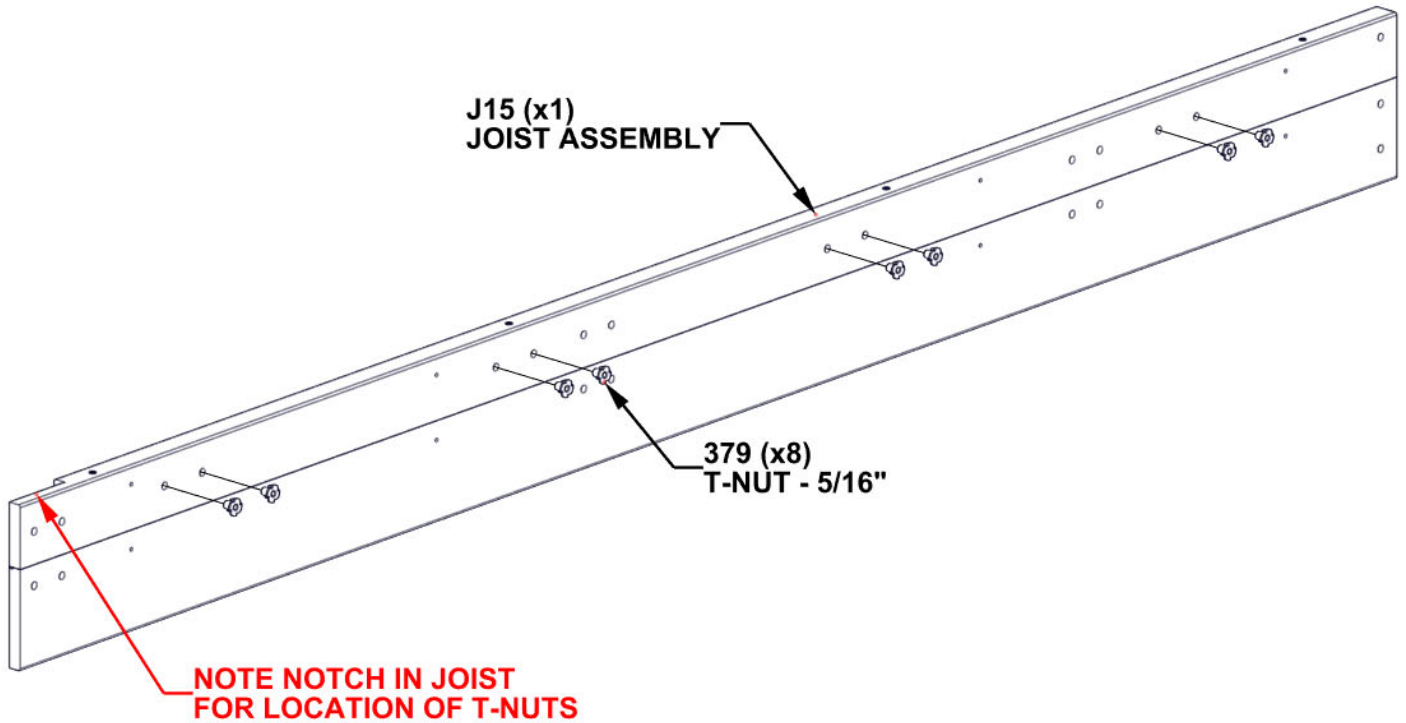

# STEP 14 - RIGHT REAR ASSEMBLY

QTY	PART NUMBER	DESCRIPTION
2	H100379	T-NUT 5/16 BLK



J09 JOIST ASSEMBLY - W2A03819  
(x1) 1 7/16"x8 7/16"x28 7/16" (36x214x722)

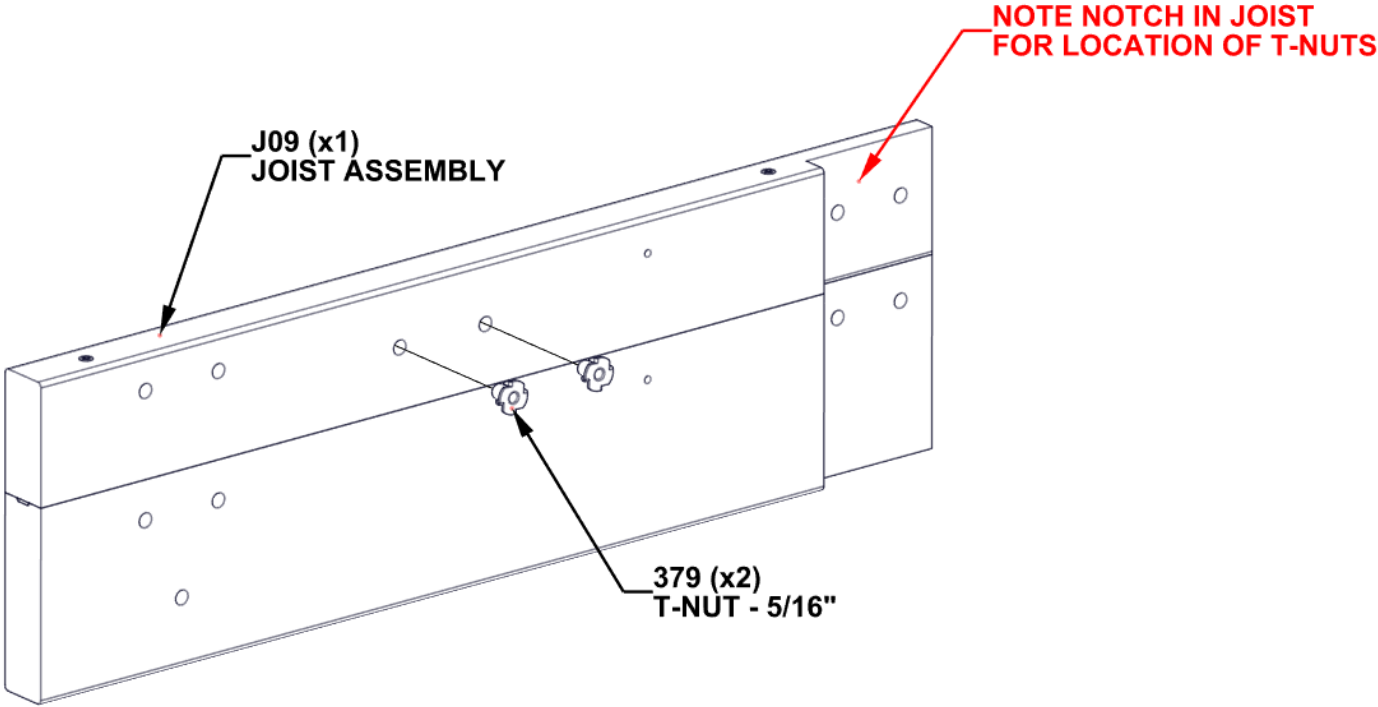

# STEP 15A - RIGHT REAR ASSEMBLY

QTY	PART NUMBER	DESCRIPTION
4	H100198	WASHER LOCK EXT 8x19
4	H100205	BOLT WH 5/16x2 1/4 BLK
4	H100379	TNUT-5/16" BLK



G07 FASCIA - W4L17634  
 (x1) 15/16"x5 1/4"x66 3/8" (24x134x1686)



G09 FASCIA - W4L17636  
 (x1) 15/16"x5 1/4"x113 3/8" (24x134x2880)

**NOTES:**  
 • INSERT T-NUTS FIRST.

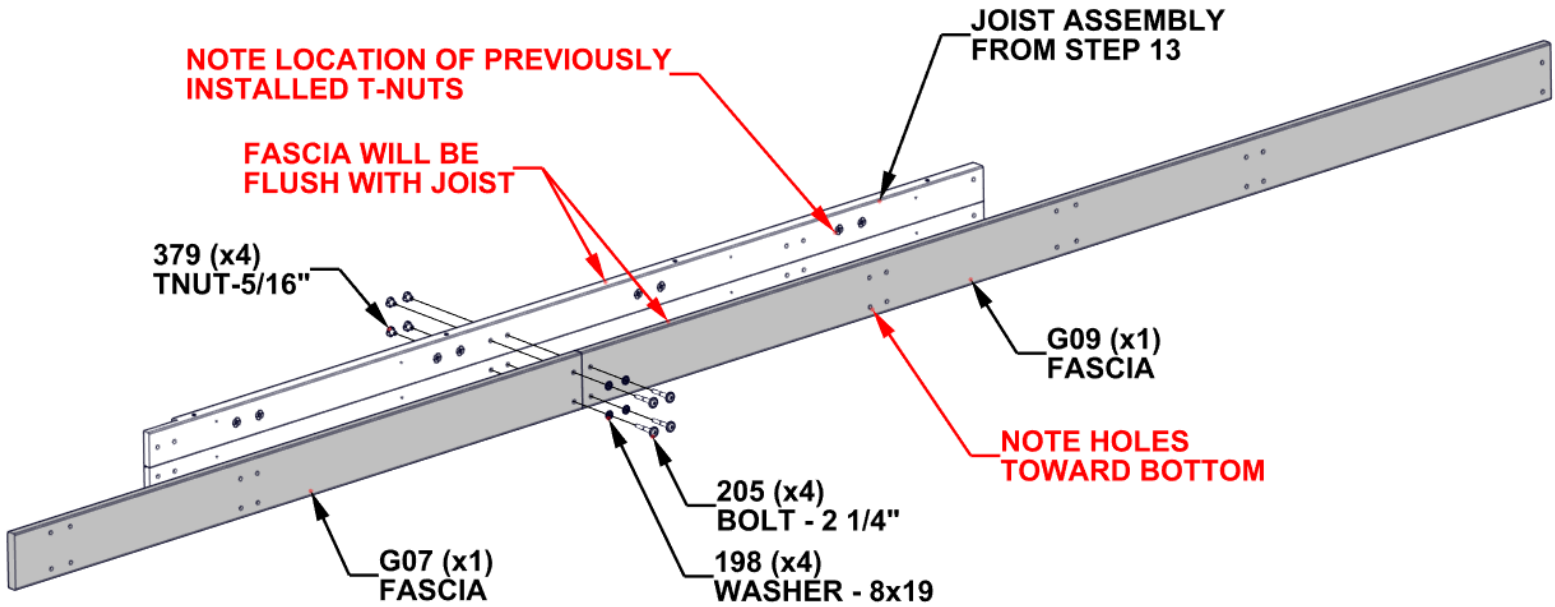



# STEP 15B - RIGHT REAR ASSEMBLY

QTY	PART NUMBER	DESCRIPTION
8	H100198	WASHER LOCK EXT 8x19
8	H100379	TNUT-5/16" BLK
8	H100415	BOLT WH 5/16x3 3/4 BLK



D06 CORBEL - W4L17631  
 (x2) 1 7/16"x5 1/4"x33 5/8" (36x134x854)

**NOTES:**  
 • INSERT T-NUTS FIRST.

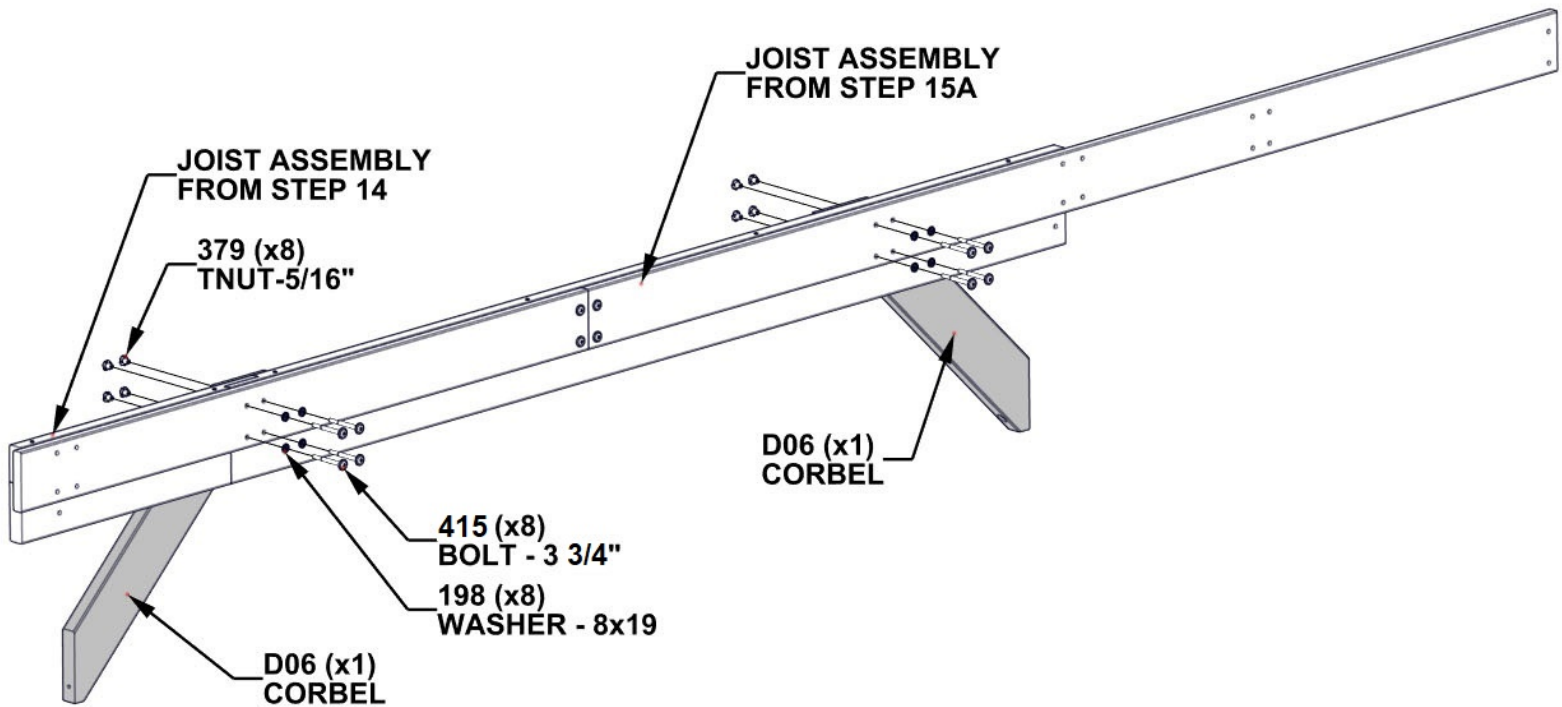

# STEP 15C - RIGHT REAR ASSEMBLY

QTY	PART NUMBER	DESCRIPTION
10	H100391	SCREW PFH 8x2 BLK

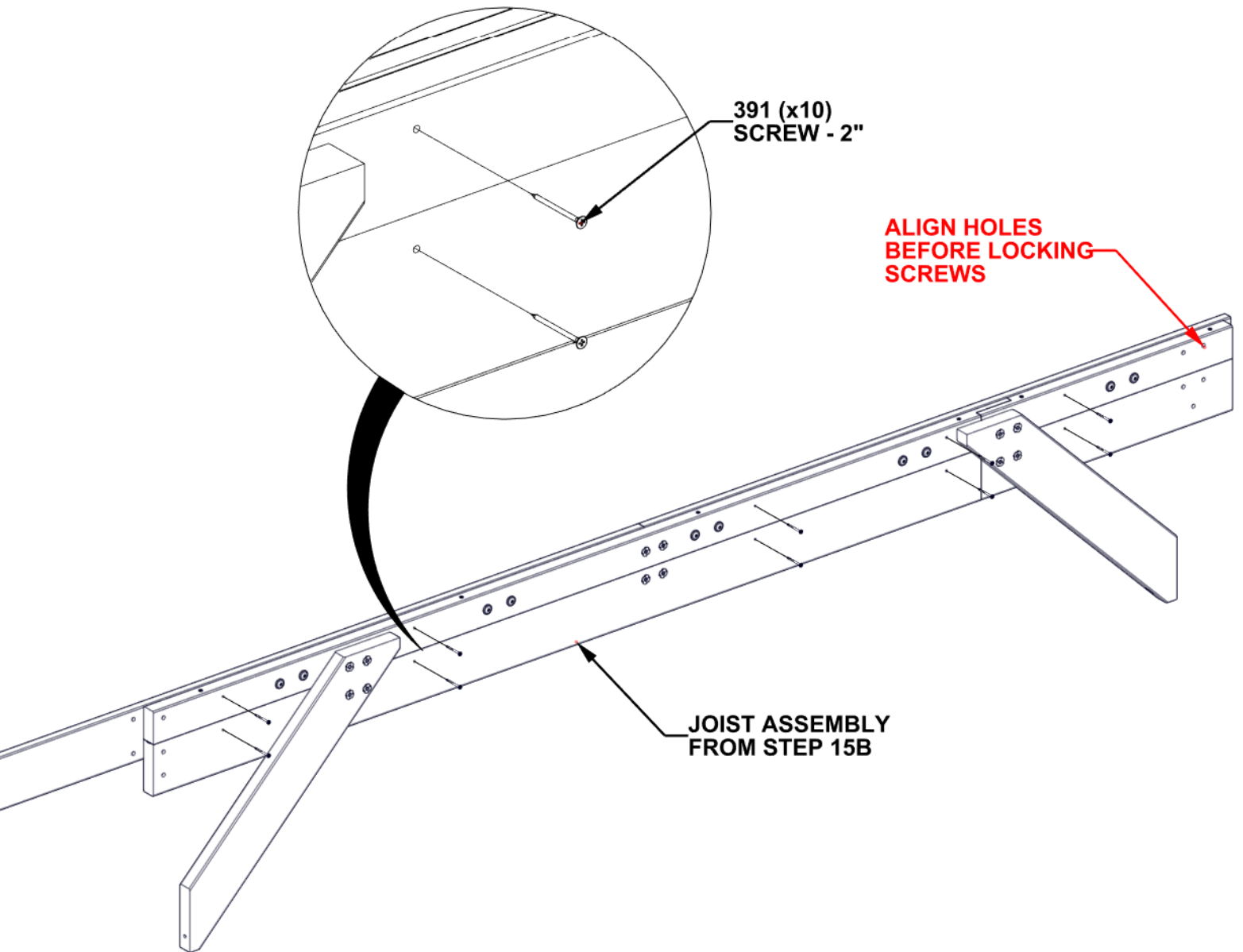

# STEP 15D - RIGHT REAR ASSEMBLY

QTY	PART NUMBER	DESCRIPTION
10	H100459	BOLT WH 5/16x1 1/4 BLK

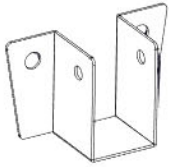

A4M01787 RAFTER BRACKET  
(x5)

**NOTE:**  
ALIGN RAFTER BRACKETS WITH HOLES  
IN BEAM AND ATTACH AS SHOWN

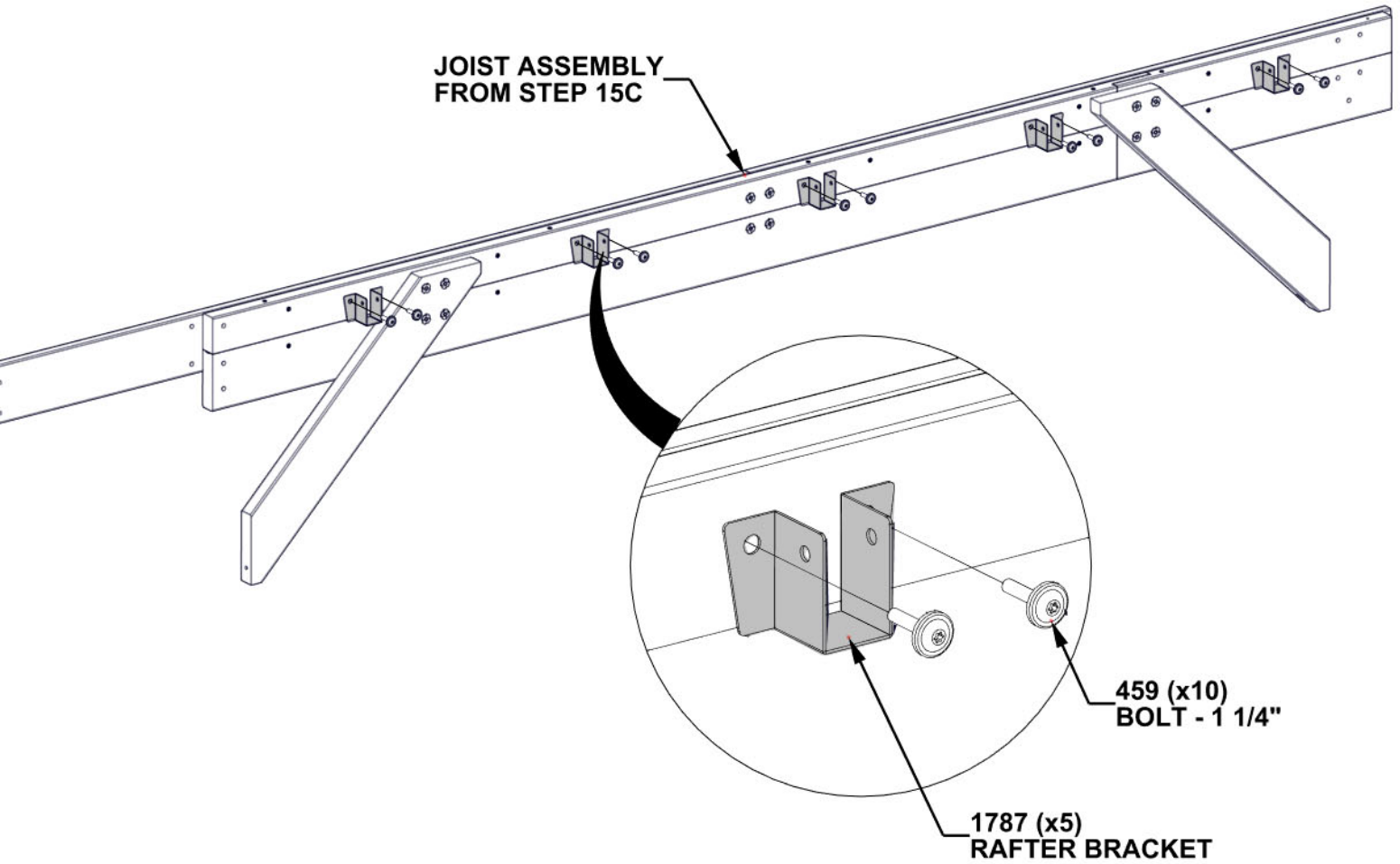

# STEP 16 - RIGHT REAR ASSEMBLY

QTY	PART NUMBER	DESCRIPTION
2	H100197	LAG SCREW WH 5/16x2 1/2 BLK
8	H100198	WASHER LOCK EXT 8x19
6	H100379	TNUT-5/16" BLK
2	H100405	WASHER LOCK EXT 6x15
2	H100792	LAG SCREW WH 1/4x3 BLK
6	H101153	BOLT WH 5/16x8 1/4 BLK

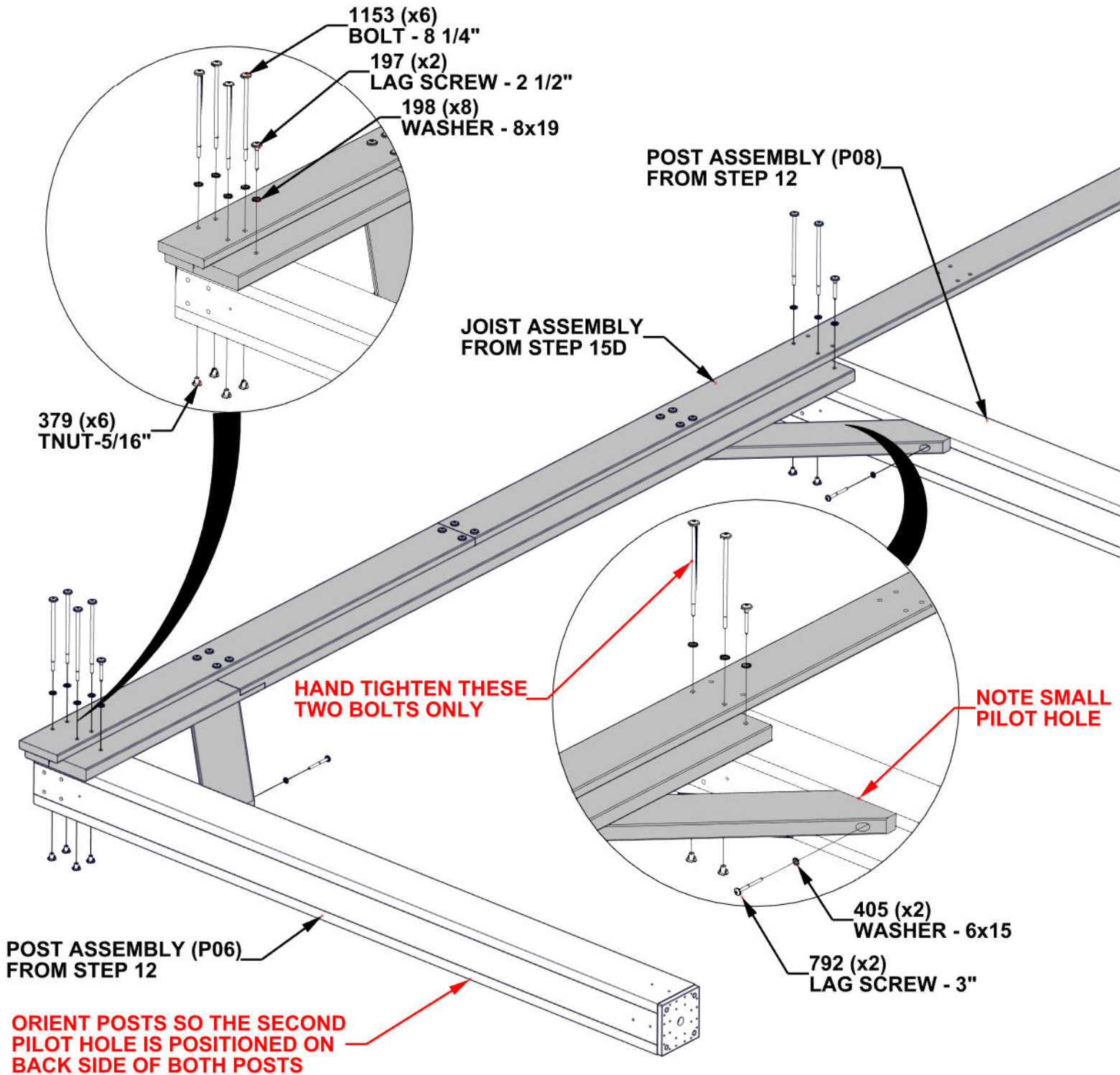

**SET RIGHT REAR  
ASSEMBLY TO THE SIDE**

# STEP 17A - RIGHT JOIST ASSEMBLY

QTY	PART NUMBER	DESCRIPTION
3	H100379	TNUT-5/16" BLK

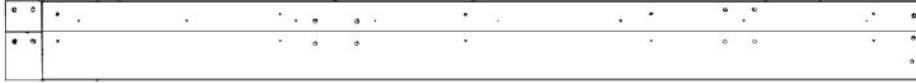

J11 JOIST ASSEMBLY - W2A03812  
(x1) 1 7/16"x8 7/16"x97 11/16" (36x214x2481)

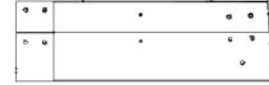

J14 JOIST ASSEMBLY - W2A03813  
(x1) 1 7/16"x8 7/16"x26 7/8" (36x214x682)

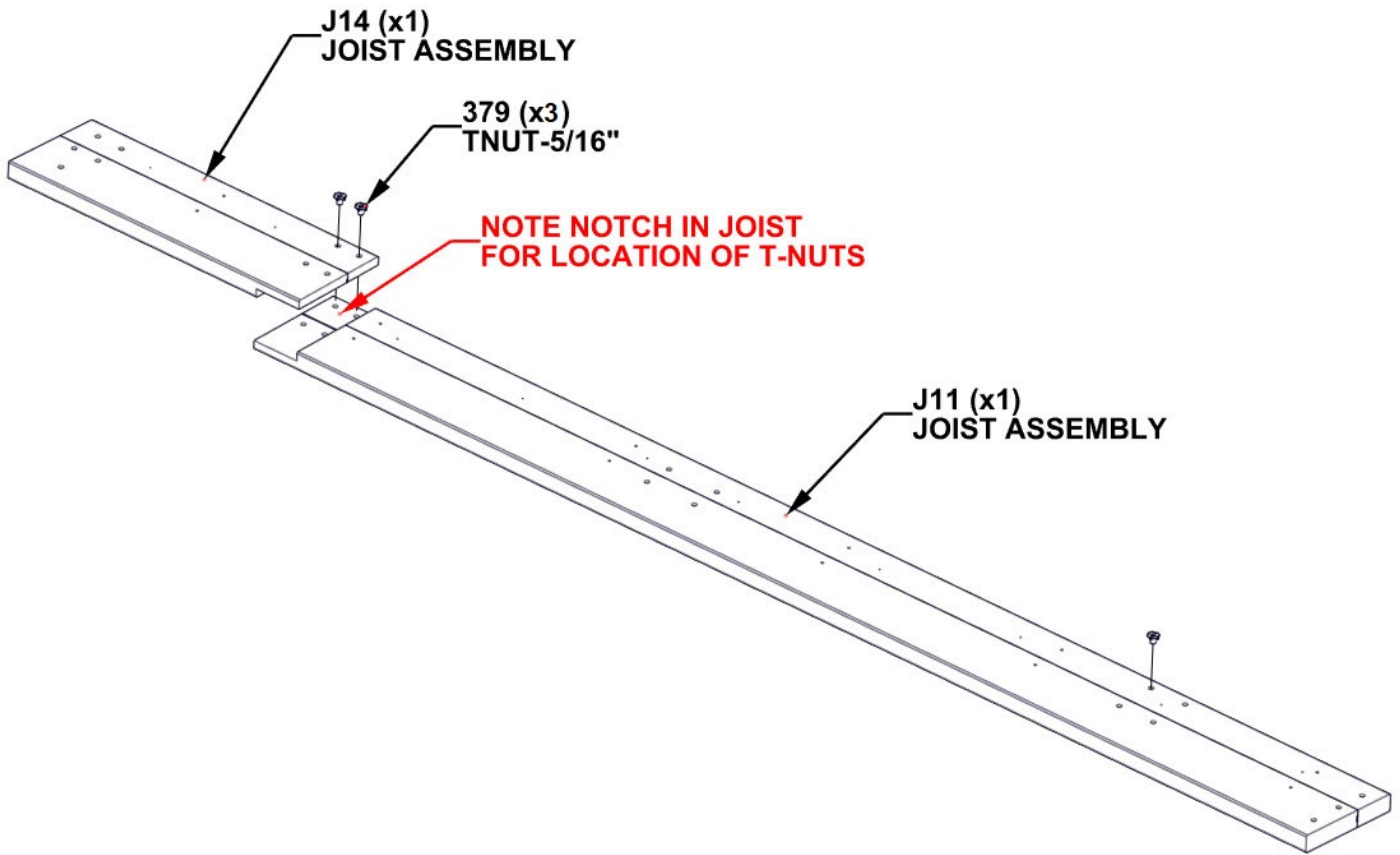

# STEP 17B - RIGHT JOIST ASSEMBLY

QTY	PART NUMBER	DESCRIPTION
3	H100198	WASHER LOCK EXT 8x19
3	H100205	BOLT WH 5/16x2 1/4 BLK



G03 FASCIA - W4L17617  
 (x1) 15/16"x5 1/4"x102 1/8" (24x134x2594)

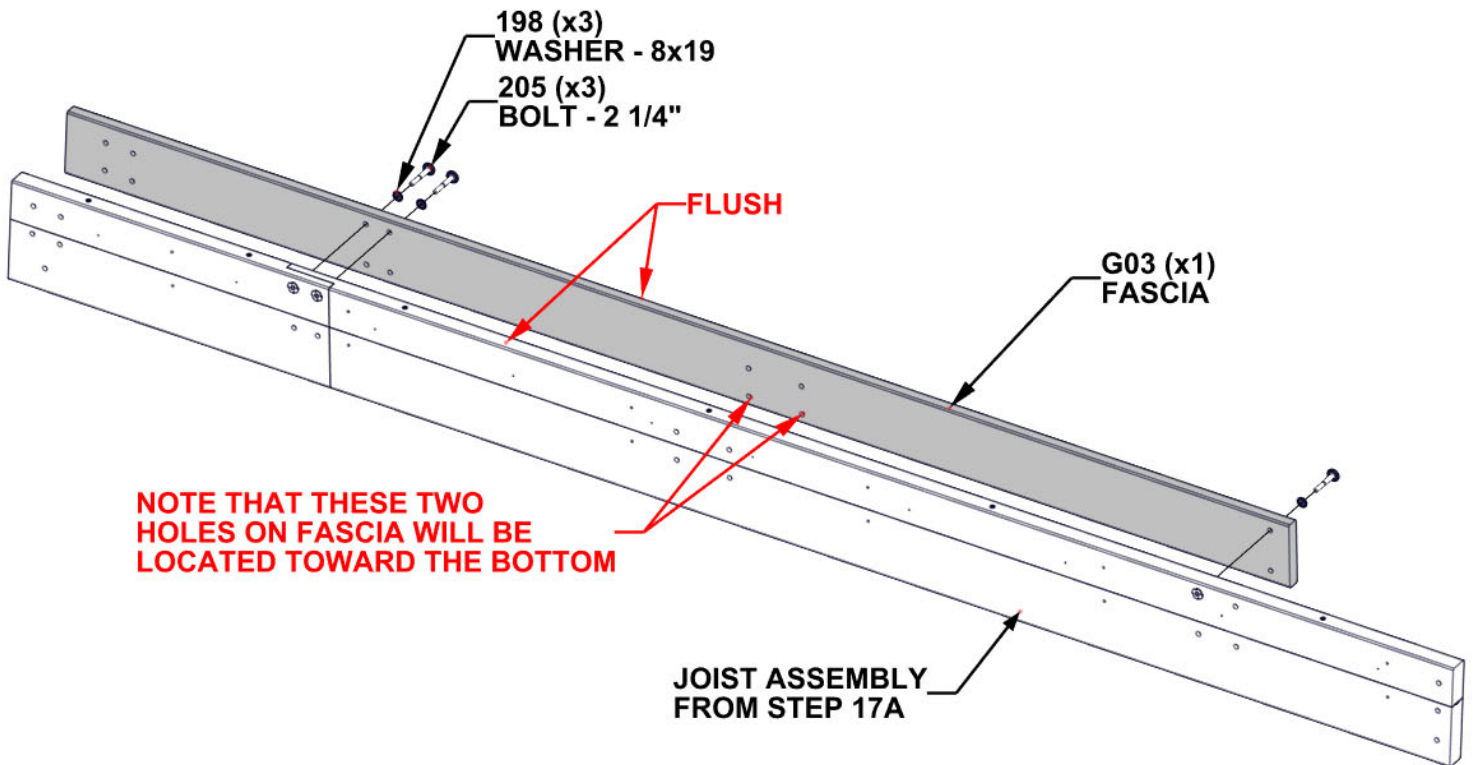

# STEP 17C - RIGHT JOIST ASSEMBLY

QTY	PART NUMBER	DESCRIPTION
2	H100198	WASHER LOCK EXT 8x19
2	H100379	TNUT-5/16" BLK
2	H100415	BOLT WH 5/16x3 3/4 BLK



D04 CORBEL - W4L17621  
(x1) 1 3/8"x5 1/4"x31 1/2" (36x134x801)

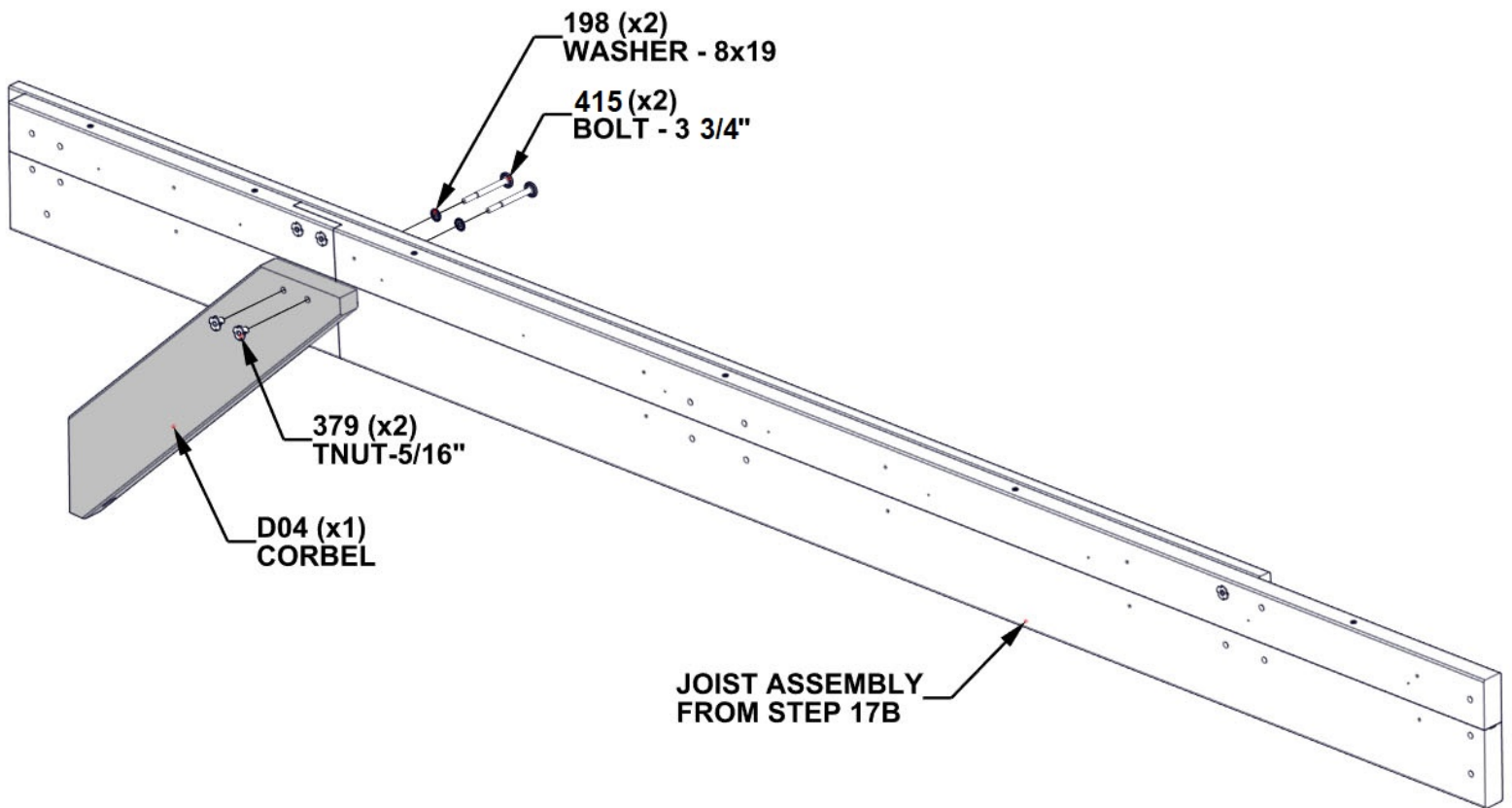



# STEP 17D - RIGHT JOIST ASSEMBLY

QTY	PART NUMBER	DESCRIPTION
4	H100198	WASHER LOCK EXT 8x19
4	H100416	BOLT WH 5/16x3 BLK
4	H100479	NUT LOCK 5/16 BLK
4	H100630	WASHER FLAT 8x19 BLK



A4M02103 JOIST HANGER 90°  
(x1)

**NOTE:**  
ALIGN JOIST HANGER WITH HOLES  
IN BEAM AND ATTACH AS SHOWN

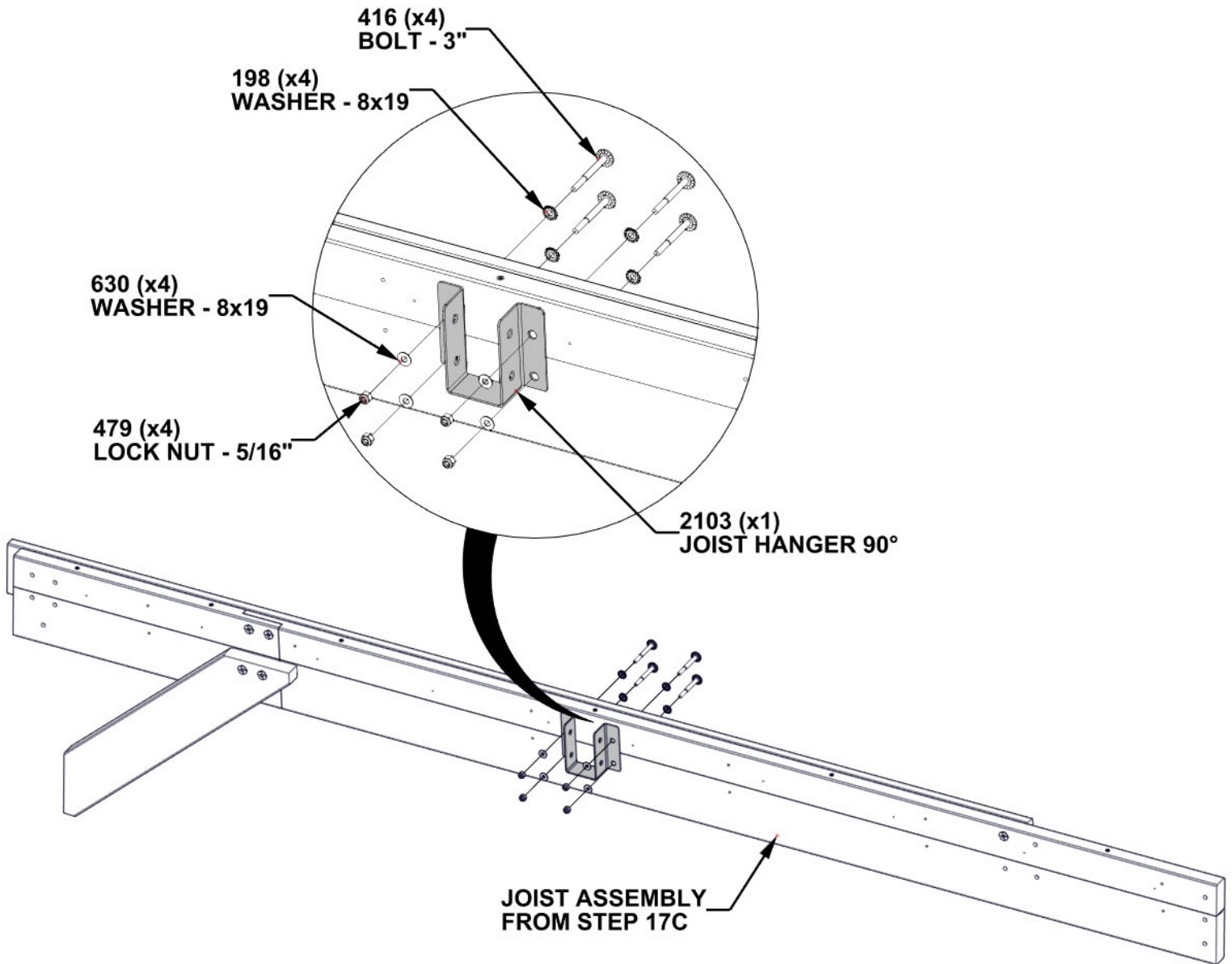

**USING A PENCIL, LABEL  
THE ASSEMBLY "STEP 17D."**

**SET RIGHT JOIST  
ASSEMBLY TO THE SIDE**

# STEP 18A - RIGHT CENTER JOIST ASSEMBLY

QTY	PART NUMBER	DESCRIPTION
2	H100198	WASHER LOCK EXT 8x19
2	H100379	TNUT-5/16" BLK
2	H100459	BOLT WH 5/16x1 1/4 BLK



J23 JOIST ASSEMBLY - W2A03832  
(x1) 1 7/16"x8 7/16"x97 11/16" (36x214x2481)



J24 JOIST ASSEMBLY - W2A03833  
(x1) 1 7/16"x8 7/16"x26 7/8" (36x214x682)

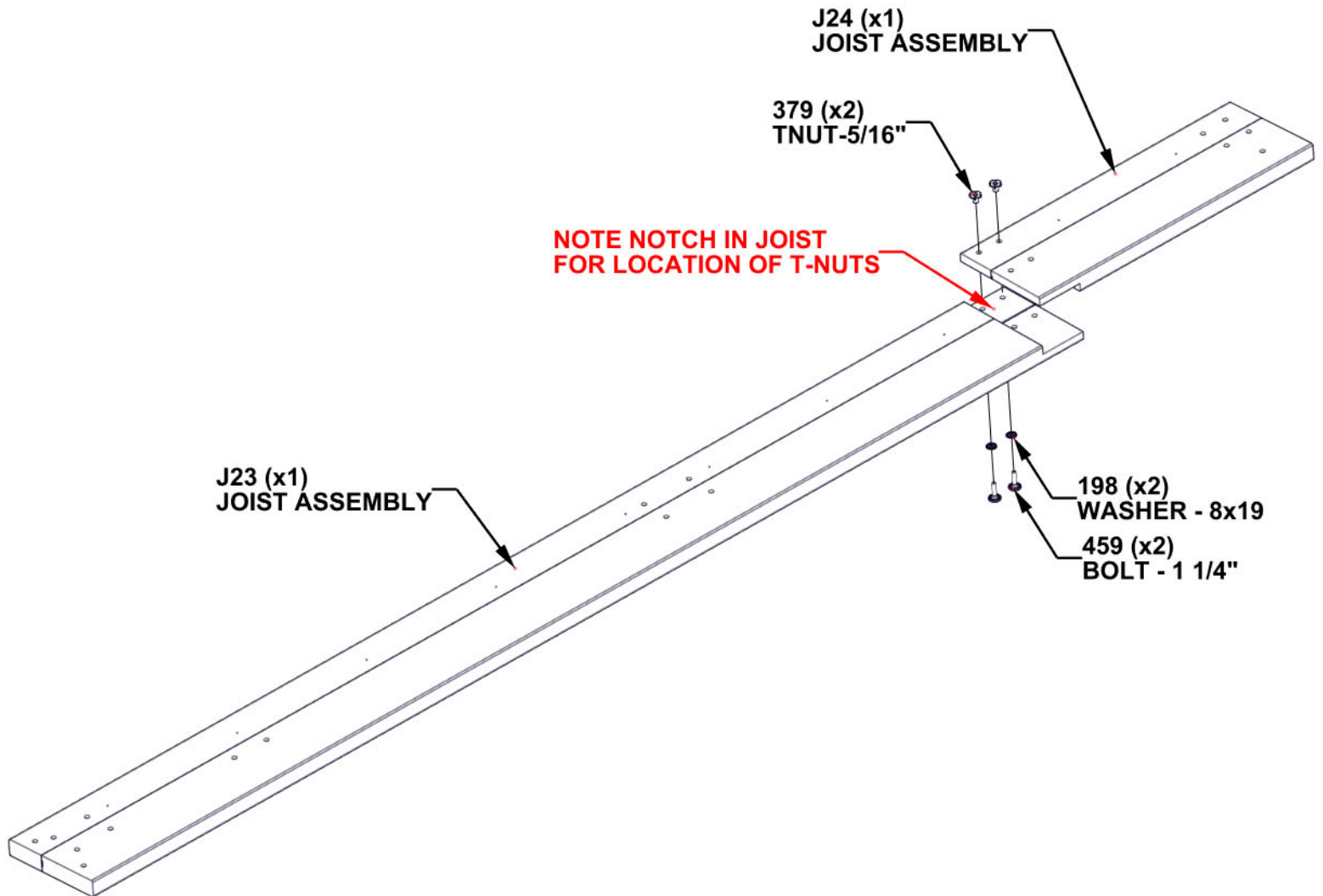

# STEP 18B - RIGHT CENTER JOIST ASSEMBLY

QTY	PART NUMBER	DESCRIPTION
4	H100195	BOLT WH 5/16x2 3/4 BLK
4	H100198	WASHER LOCK EXT 8x19
4	H100379	TNUT-5/16" BLK



D04 CORBEL - W4L17621  
(x1) 1 3/8"x5 1/4"x31 1/2" (36x134x801)



D03 CORBEL - W4L17620  
(x1) 1 3/8"x5 1/4"x28 1/8" (36x134x713)

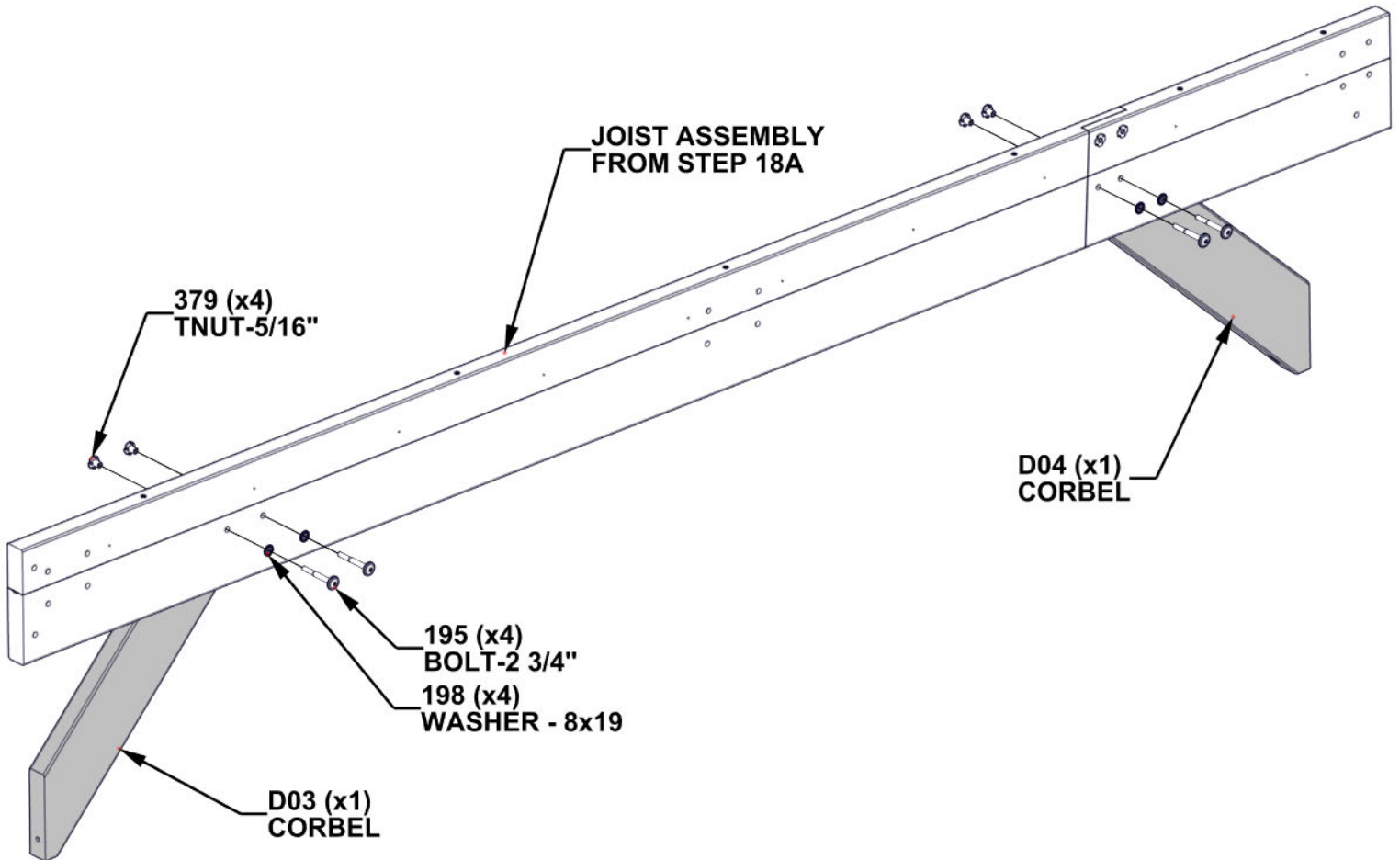

# STEP 18C - RIGHT CENTER JOIST ASSEMBLY

QTY	PART NUMBER	DESCRIPTION
4	H100198	WASHER LOCK EXT 8x19
4	H100457	BOLT WH 5/16x2 BLK
4	H100479	NUT LOCK 5/16 BLK
4	H100630	WASHER FLAT 8x19 BLK



A4M02103 JOIST HANGER 90°  
(x1)

**NOTE:**  
ALIGN JOIST HANGER WITH HOLES  
IN BEAM AND ATTACH AS SHOWN

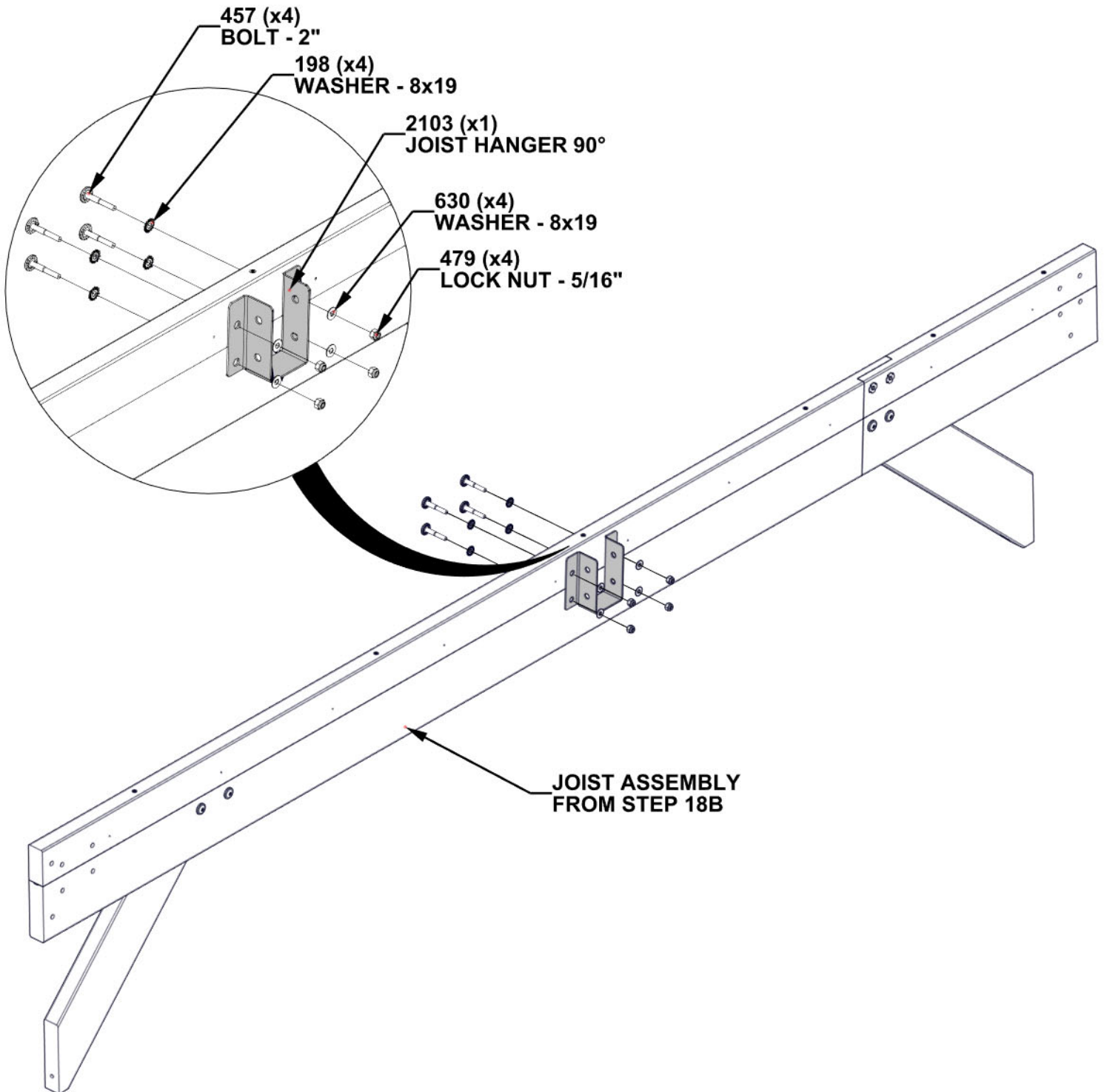

# STEP 18D - RIGHT CENTER JOIST ASSEMBLY

QTY	PART NUMBER	DESCRIPTION
4	H100379	T-NUT 5/16 BLK
4	H100407	BOLT WH 5/16x1 1/2 BLK

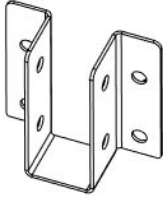

A4M02211 JOIST HANGER 90°  
(x1)

**NOTE:**  
ALIGN JOIST HANGER WITH HOLES  
IN BEAM AND ATTACH AS SHOWN

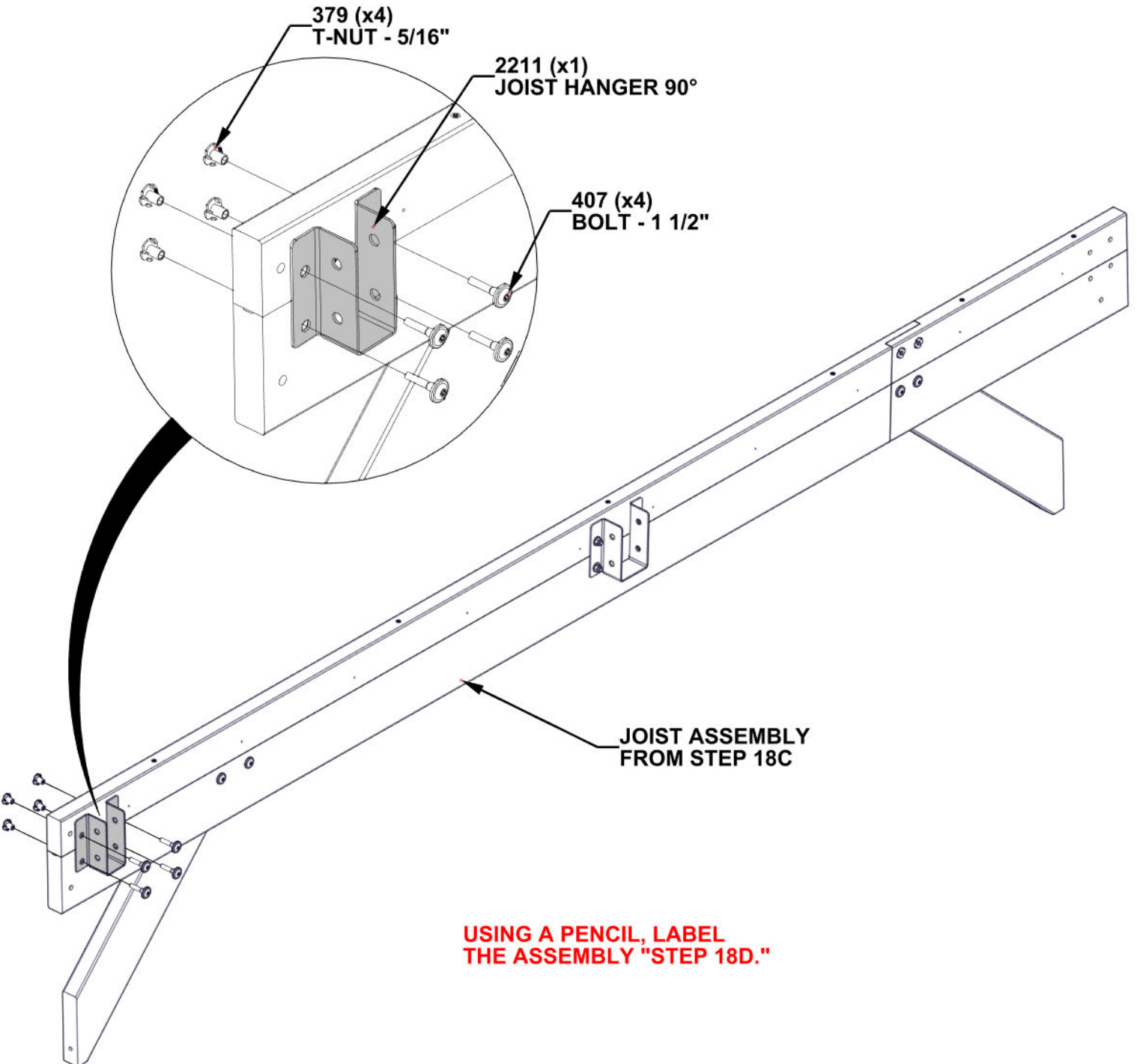

**USING A PENCIL, LABEL  
THE ASSEMBLY "STEP 18D."**

**SET RIGHT CENTER JOIST  
ASSEMBLY TO THE SIDE**

# STEP 19A - LEFT CENTER JOIST ASSEMBLY

QTY	PART NUMBER	DESCRIPTION
2	H100198	WASHER LOCK EXT 8x19
2	H100379	TNUT-5/16" BLK
2	H100459	BOLT WH 5/16x1 1/4 BLK



J19 JOIST ASSEMBLY - W2A03828  
(x1) 1 7/16"x8 7/16"x97 11/16" (36x214x2481)

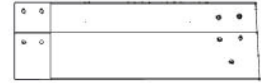

J20 JOIST ASSEMBLY - W2A03829  
(x1) 1 7/16"x8 7/16"x26 7/8" (36x214x682)

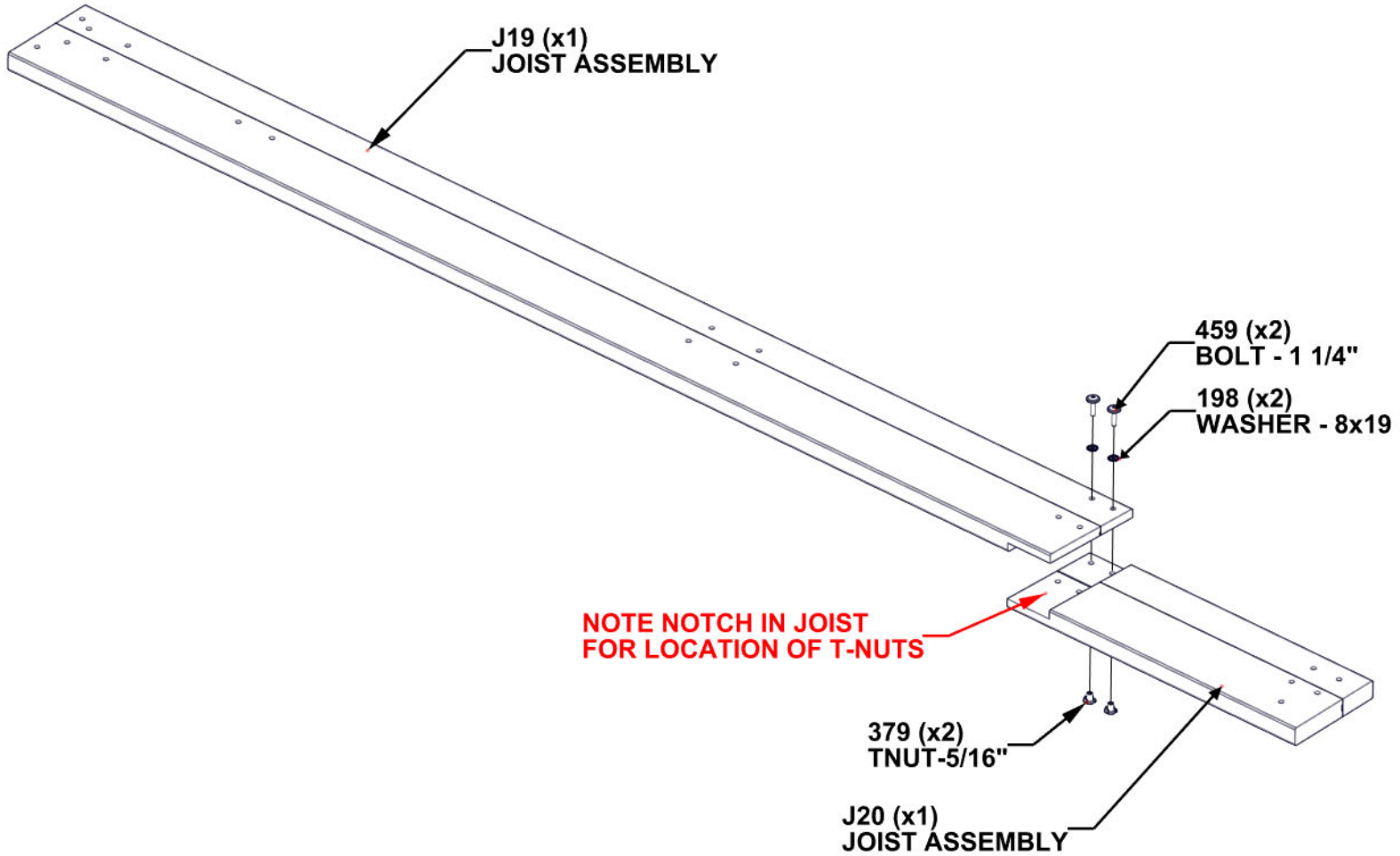



# STEP 19B - LEFT CENTER JOIST ASSEMBLY

QTY	PART NUMBER	DESCRIPTION
4	H100195	BOLT WH 5/16x2 3/4 BLK
4	H100198	WASHER LOCK EXT 8x19
4	H100379	TNUT-5/16" BLK



D04 CORBEL - W4L17621  
(x1) 1 3/8"x5 1/4"x31 1/2" (36x134x801)



D03 CORBEL - W4L17620  
(x1) 1 3/8"x5 1/4"x28 1/8" (36x134x713)

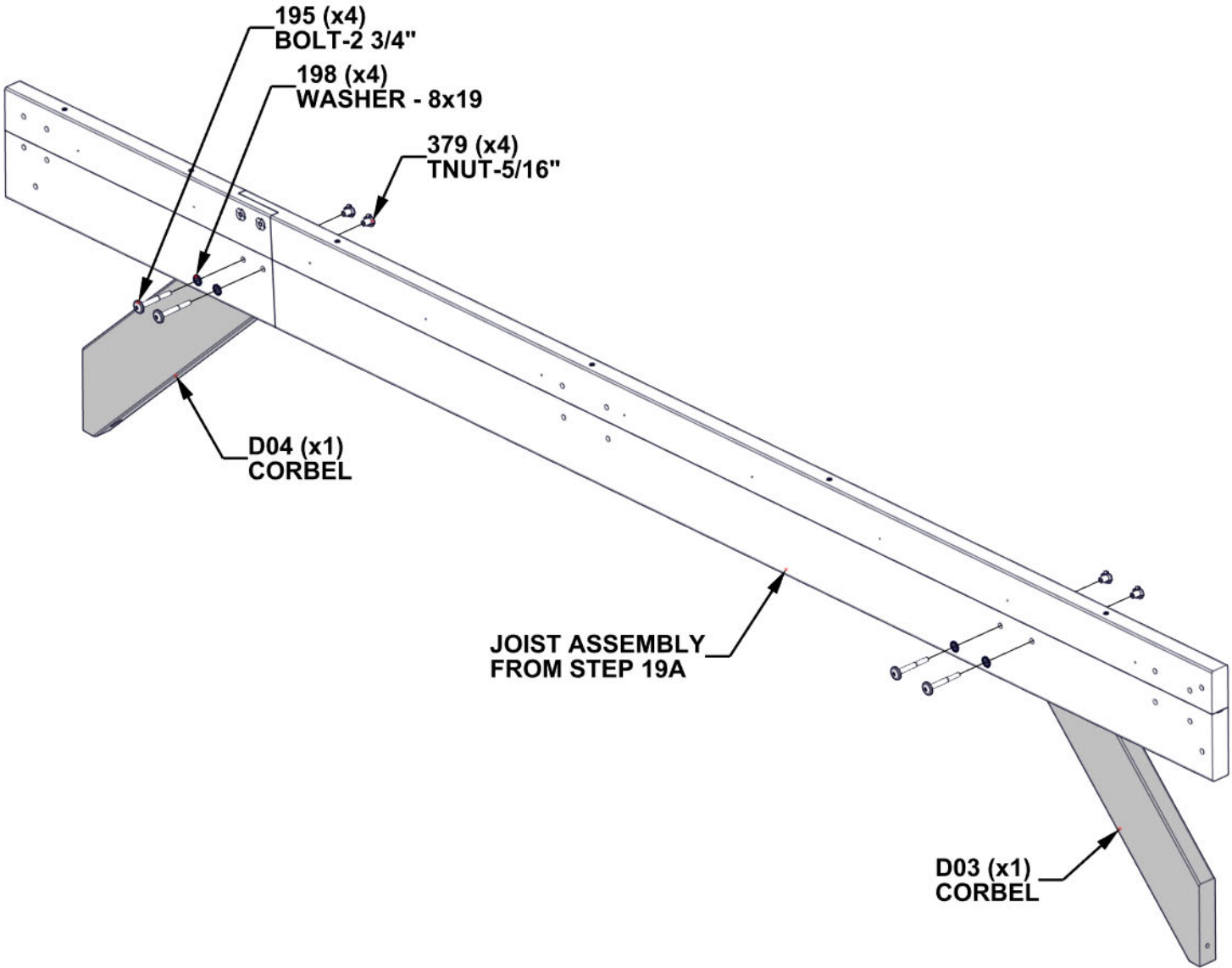

# STEP 19C - LEFT CENTER JOIST ASSEMBLY

QTY	PART NUMBER	DESCRIPTION
4	H100198	WASHER LOCK EXT 8x19
4	H100457	BOLT WH 5/16x2 BLK
4	H100479	NUT LOCK 5/16 BLK
4	H100630	WASHER FLAT 8x19 BLK



A4M02103 JOIST HANGER 90°  
(x1)

**NOTE:**  
ALIGN JOIST HANGER WITH HOLES  
IN BEAM AND ATTACH AS SHOWN

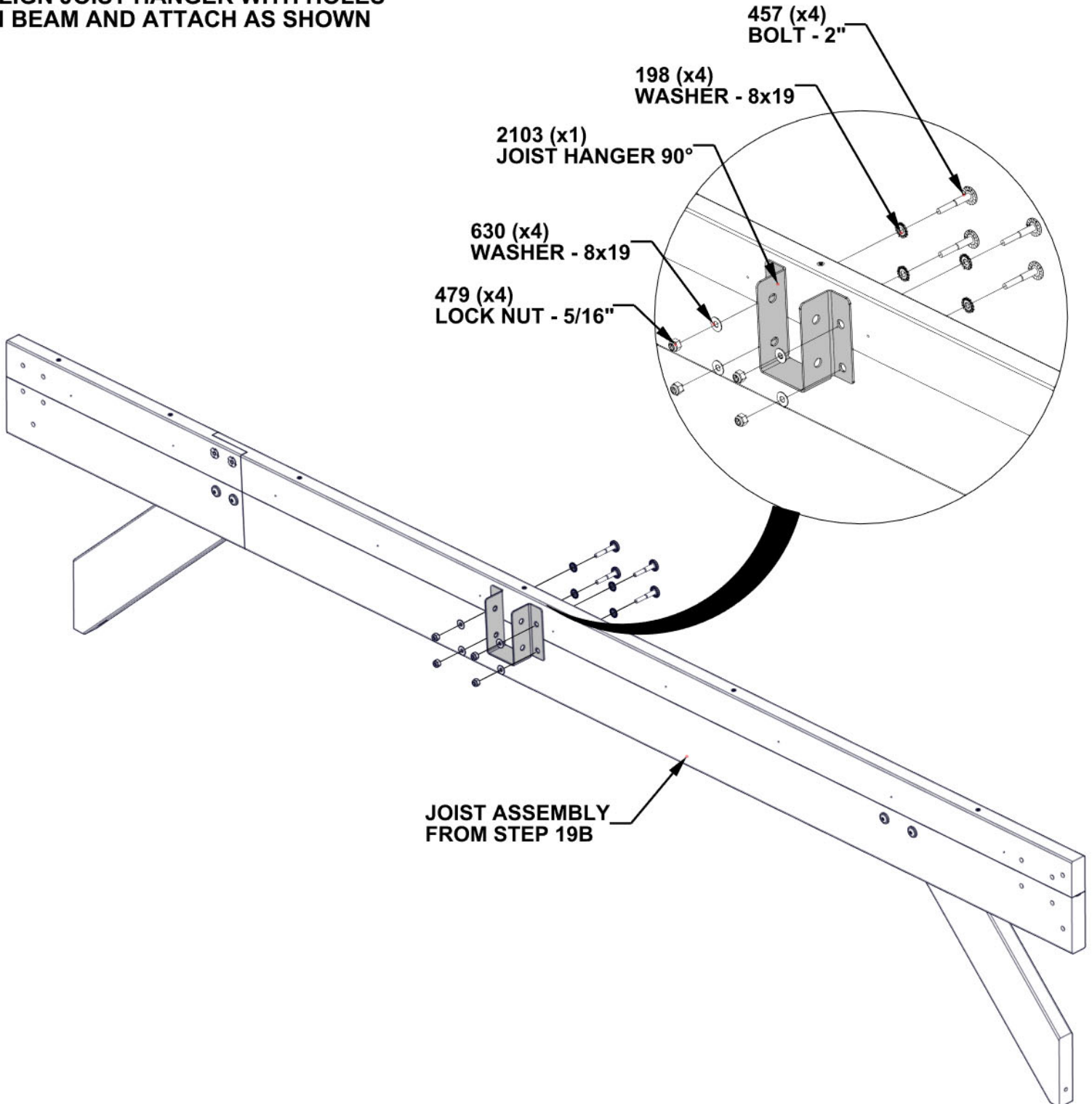

# STEP 19D - LEFT CENTER JOIST ASSEMBLY

QTY	PART NUMBER	DESCRIPTION
4	H100379	T-NUT 5/16 BLK
4	H100407	BOLT WH 5/16x1 1/2 BLK

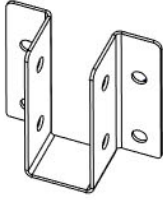

A4M02211 JOIST HANGER 90°  
(x1)

**NOTE:**  
ALIGN JOIST HANGER WITH HOLES  
IN BEAM AND ATTACH AS SHOWN

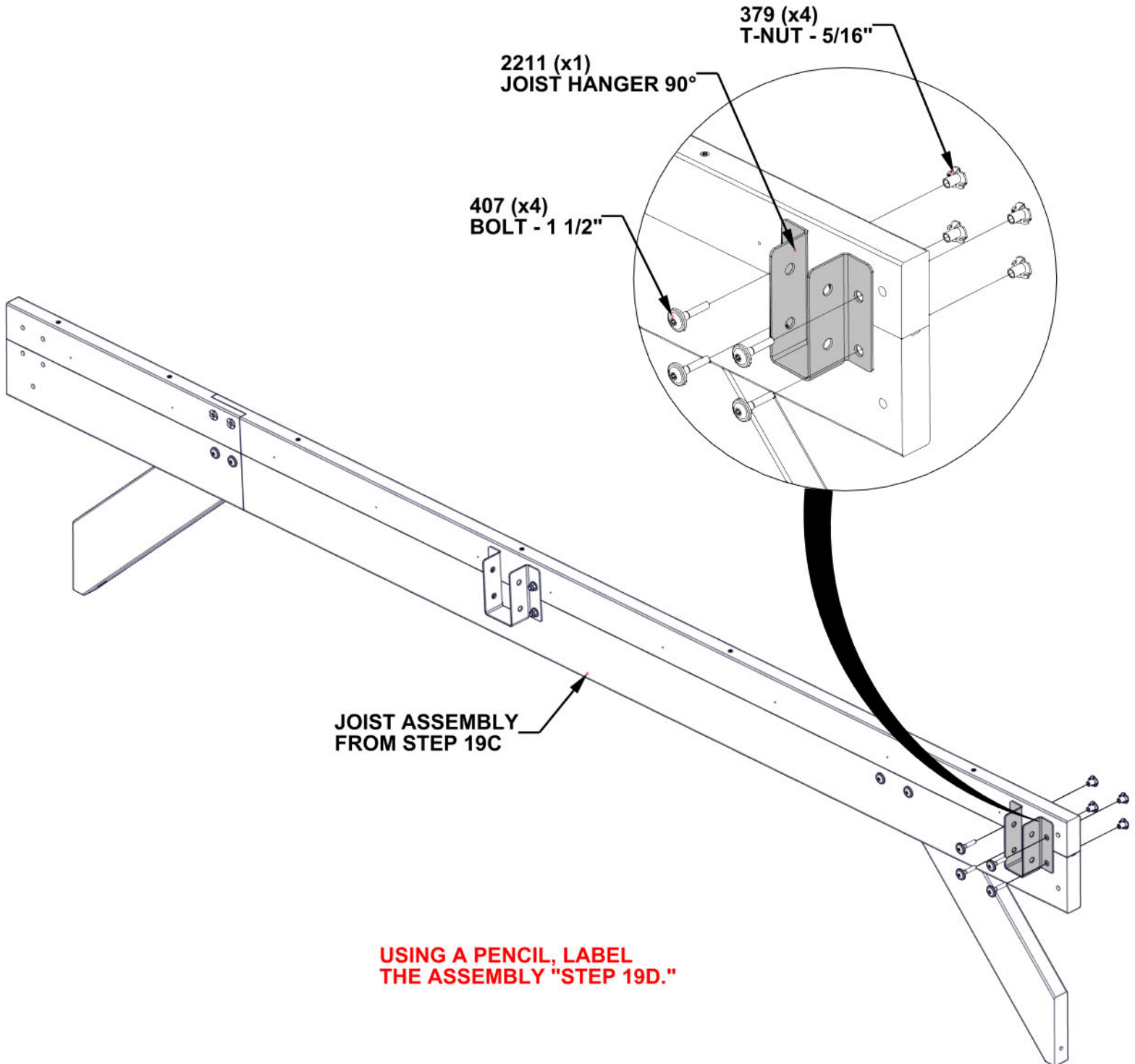

**SET LEFT CENTER JOIST  
ASSEMBLY TO THE SIDE**

# STEP 20 - CARPORT ASSEMBLY

QTY	PART NUMBER	DESCRIPTION
2	H100197	LAG SCREW WH 5/16x2 1/2 BLK
8	H100198	WASHER LOCK EXT 8x19
6	H100379	TNUT-5/16" BLK
1	H100405	WASHER LOCK EXT 6x15
1	H100792	LAG SCREW WH 1/4x3 BLK
6	H101153	BOLT WH 5/16x8 1/4 BLK

- NOTE:**
- EXTRA PEOPLE ARE HELPFUL FOR THIS STEP.
  - THE FRONT OF THE UNIT IS DETERMINED BY THE TALLER POST.
  - INSERT T-NUTS FIRST.

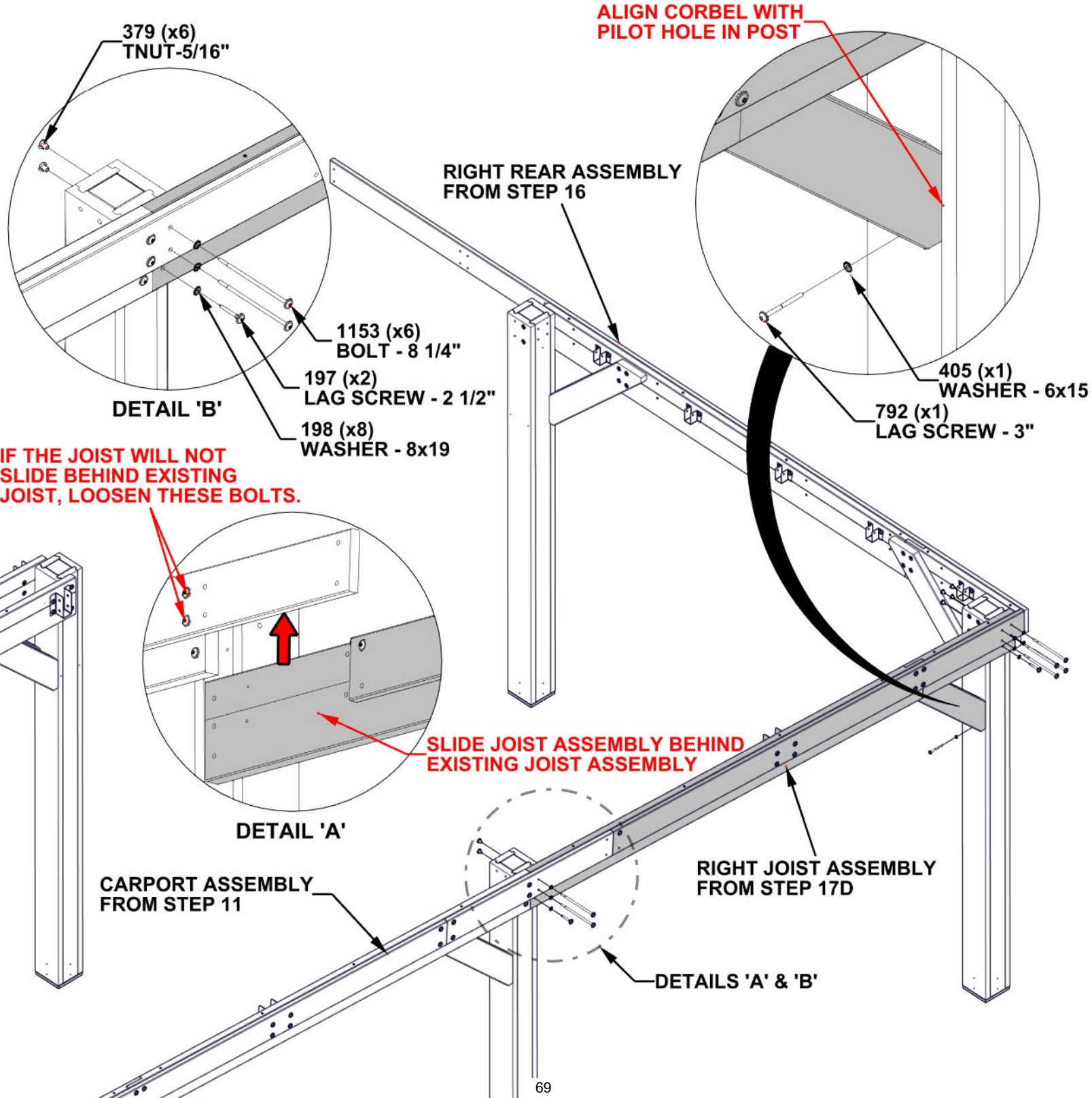

# STEP 21 - CARPORT ASSEMBLY



D03 CORBEL - W4L17620  
 (x1) 1 3/8"x5 1/4"x28 1/8" (36x134x713)

QTY	PART NUMBER	DESCRIPTION
3	H100198	WASHER LOCK EXT 8x19
1	H100205	BOLT WH 5/16x2 1/4 BLK
3	H100379	TNUT-5/16" BLK
1	H100405	WASHER LOCK EXT 6x15
2	H100415	BOLT WH 5/16x3 3/4 BLK
1	H100792	LAG SCREW WH 1/4x3 BLK

**NOTE:**  
 • INSERT T-NUTS FIRST.

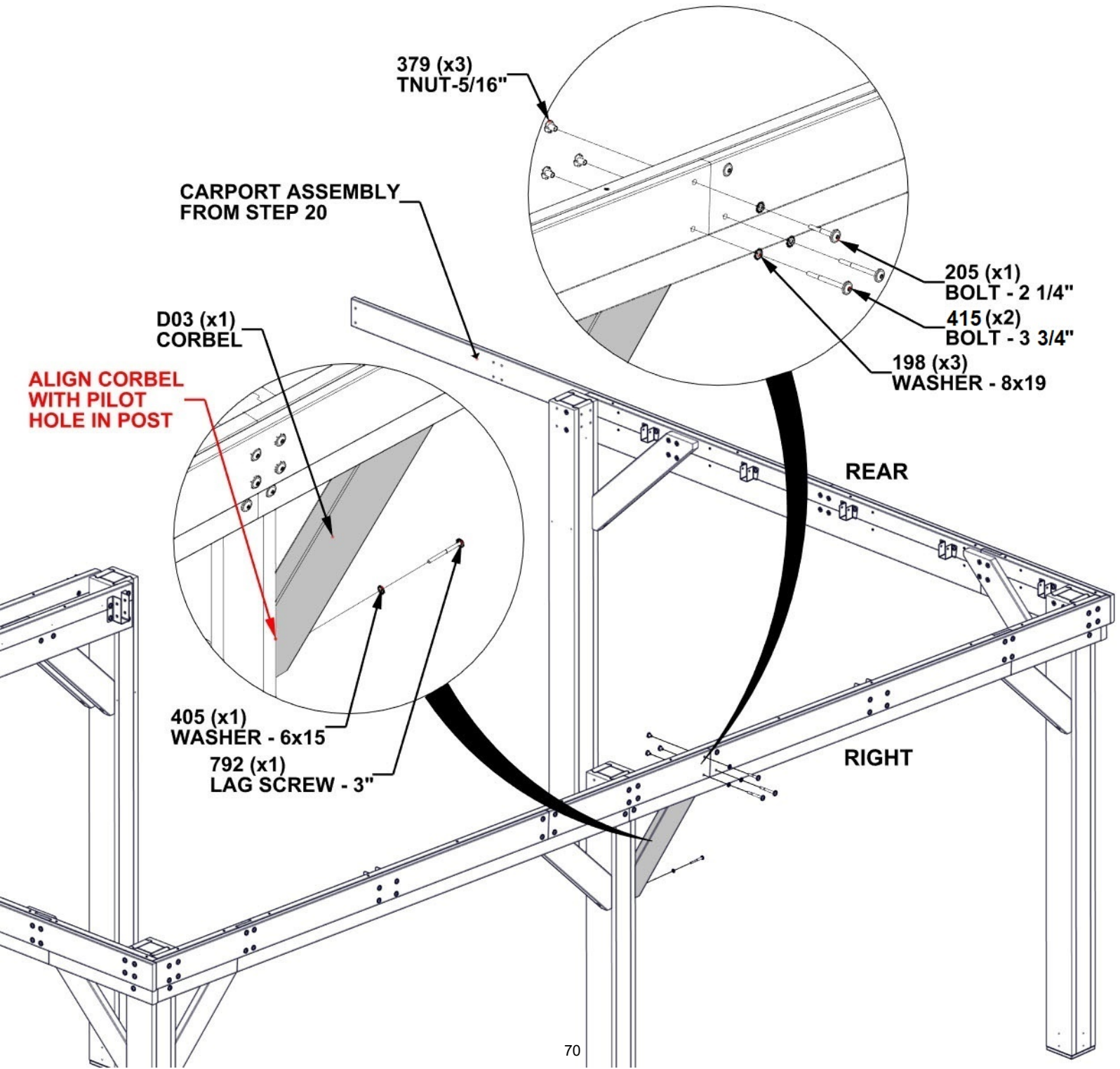

# STEP 22 - CARPORT ASSEMBLY

QTY	PART NUMBER	DESCRIPTION
2	H100197	LAG SCREW WH 5/16x2 1/2 BLK
8	H100198	WASHER LOCK EXT 8x19
6	H100379	TNUT-5/16" BLK
4	H100405	WASHER LOCK EXT 6x15
4	H100792	LAG SCREW WH 1/4x3 BLK
6	H101058	BOLT WH 5/16x8 3/4 BLK

**NOTE:**

- EXTRA PEOPLE ARE HELPFUL FOR THIS STEP.
- THE FRONT OF THE UNIT IS DETERMINED BY THE TALLER POST.
- INSERT T-NUTS FIRST.

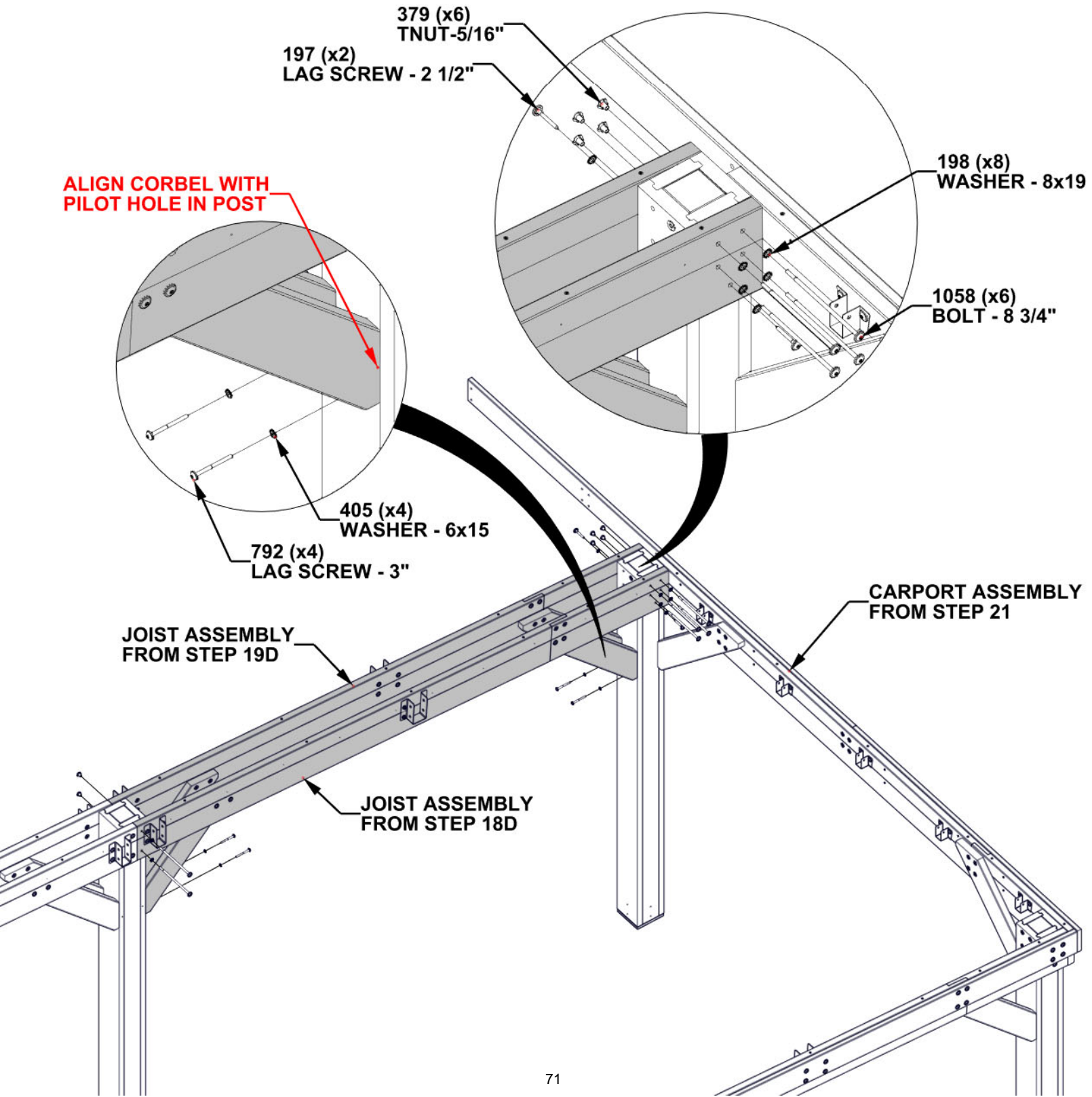

# STEP 23A - CENTER BEAM ASSEMBLY

QTY	PART NUMBER	DESCRIPTION
8	H100198	WASHER LOCK EXT 8x19
8	H100379	T-NUT 5/16 BLK
8	H100484	BOLT WH 5/16x3 1/4 BLK

- G11 BRACE BEAM - W4L17667  
(x1) 15/16"x5 1/4"x19 1/2" (24x134x495)
- G13 BRACE BEAM - W4L17669  
(x1) 15/16"x5 1/4"x26 7/8" (24x134x683)



- G10 BRACE BEAM - W4L17666  
(x1) 15/16"x5 1/4"x100 1/2" (24x134x2553)



- G12 BRACE BEAM - W4L17668  
(x1) 15/16"x5 1/4"x93 1/8" (24x134x2365)



- D09 CORBEL - W4L18244  
(x2) 1 7/16"x5 1/4"x33 5/8" (36x134x855)

- NOTES:**
- HAND TIGHTEN ONLY.
  - INSERT T-NUTS FIRST.

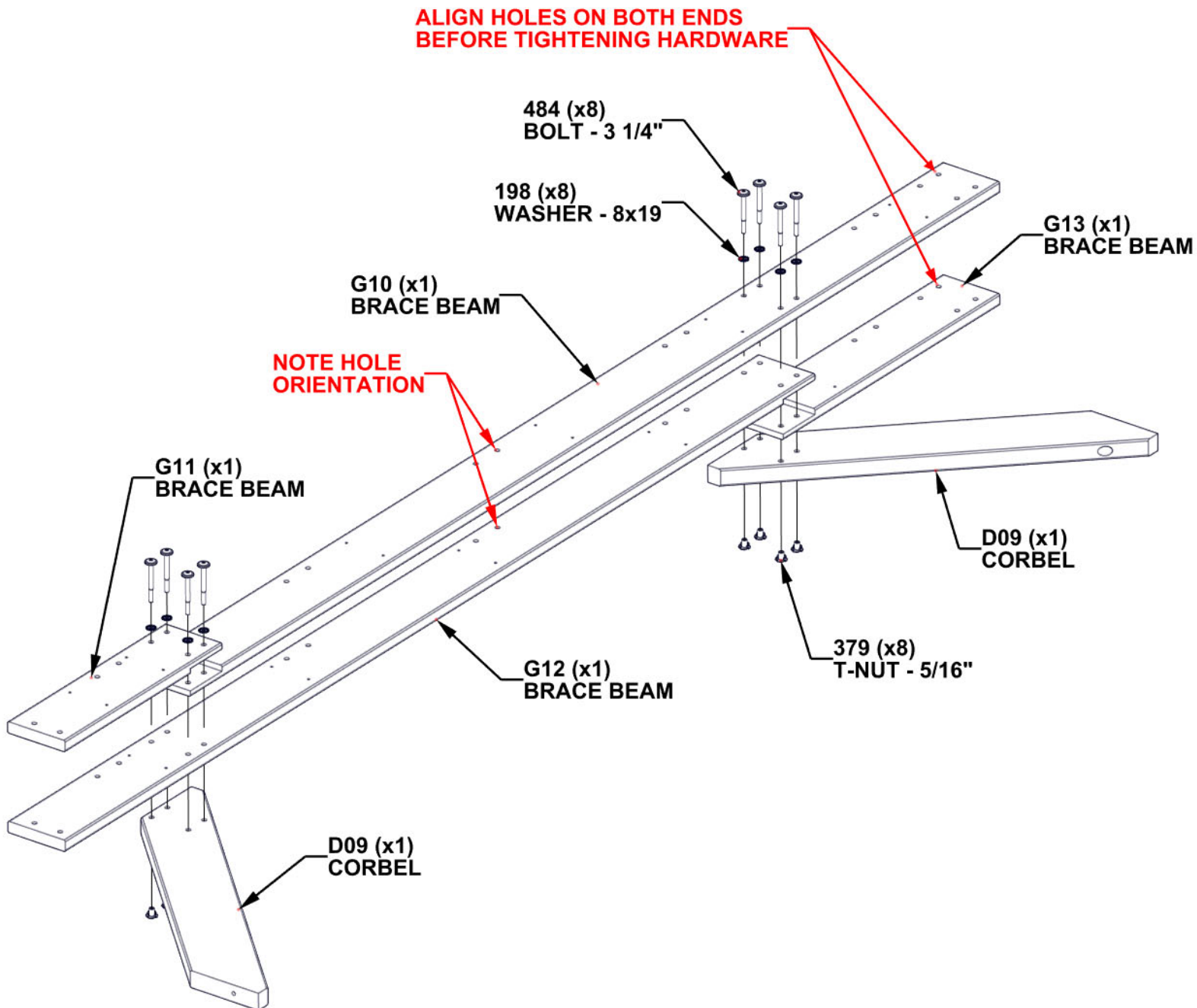



# STEP 23B - CENTER BEAM ASSEMBLY

QTY	PART NUMBER	DESCRIPTION
22	H100200	SCREW PFH 8x1 1/2 BLK

## NOTES:

- BEFORE ATTACHING SCREWS, MAKE SURE ALL BOARDS ARE FLUSH AT TOP, SIDES, & BOTTOMS.
- AFTER SCREWS ARE TIGHTENED, TIGHTEN ALL OTHER HARDWARE.

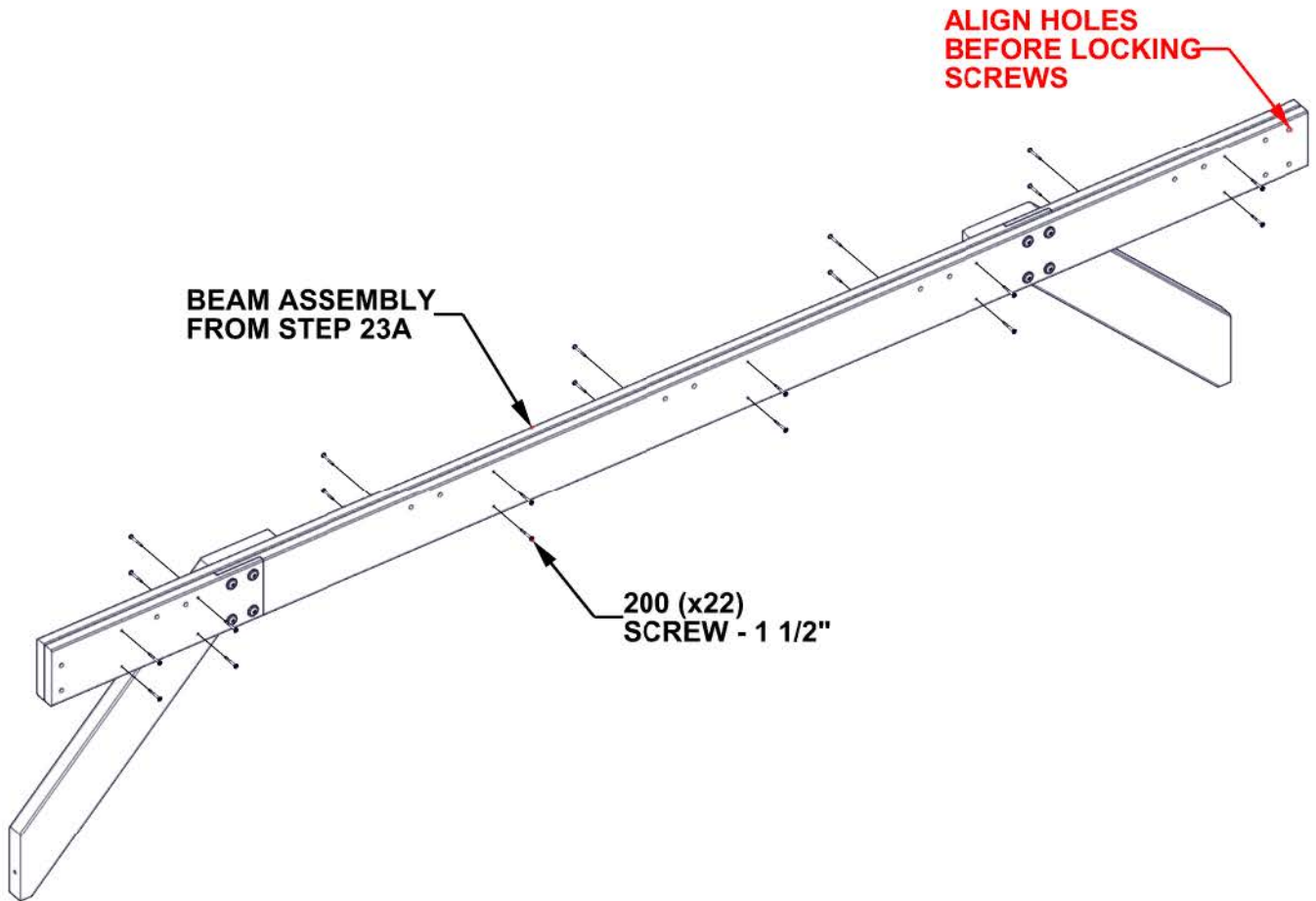

# STEP 23C - CENTER BEAM ASSEMBLY

QTY	PART NUMBER	DESCRIPTION
10	H100378	BOLT WH 5/16x1 3/4 BLK
10	H100379	T-NUT 5/16 BLK

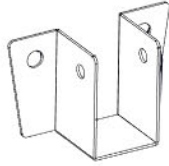

A4M01787 RAFTER BRACKET  
(x5)

**NOTE:**  
ALIGN RAFTER BRACKETS WITH HOLES  
IN BEAM AND ATTACH AS SHOWN

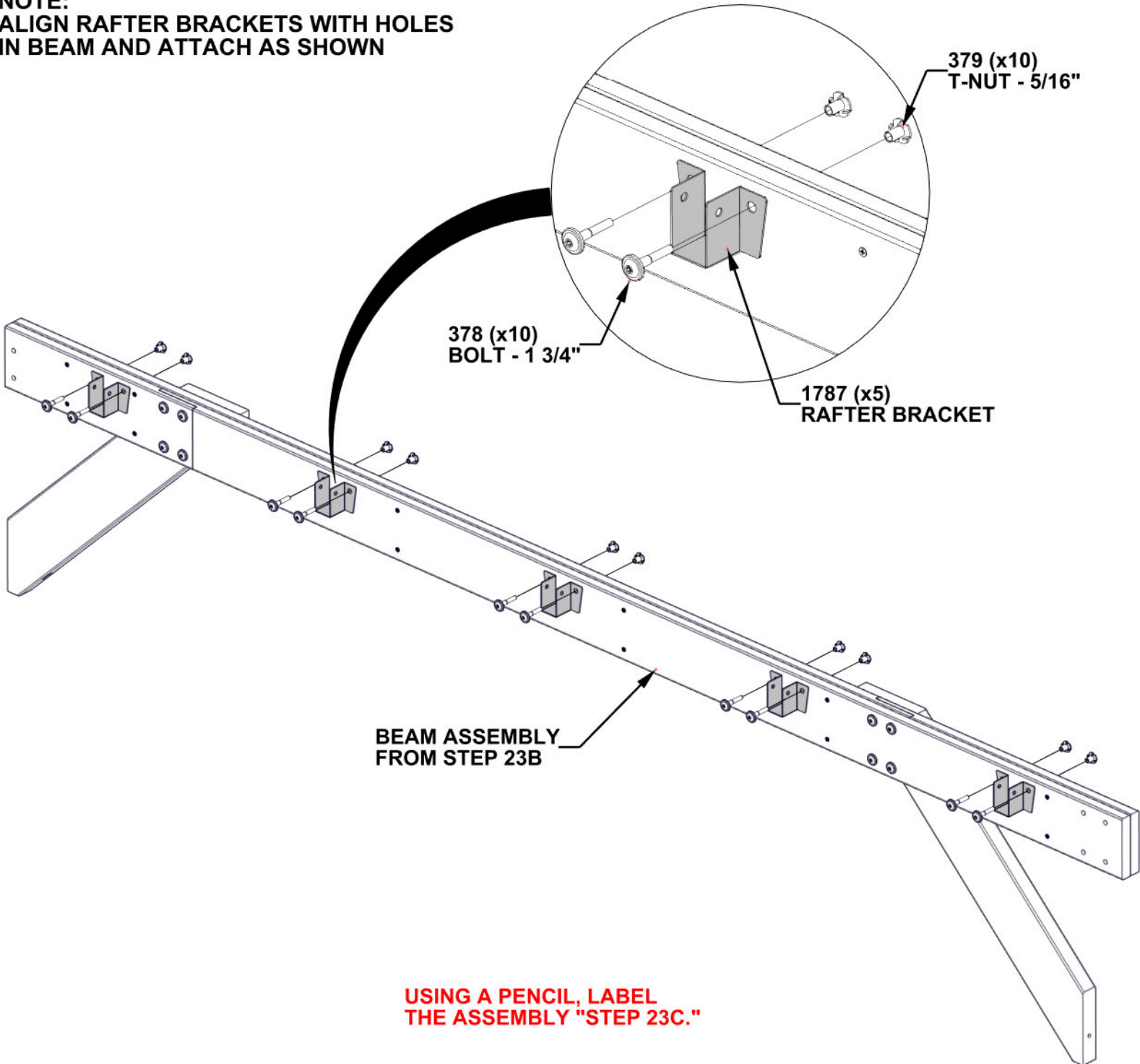

**SET CENTER BEAM  
ASSEMBLIES TO THE SIDE**

# STEP 24A - CENTER BEAM ASSEMBLY

QTY	PART NUMBER	DESCRIPTION
8	H100198	WASHER LOCK EXT 8x19
8	H100379	T-NUT 5/16 BLK
8	H100484	BOLT WH 5/16x3 1/4 BLK

G15 BRACE BEAM - W4L17801 (x1) 15/16"x5 1/4"x19 1/2" (24x134x495)      G17 BRACE BEAM - W4L17803 (x1) 15/16"x5 1/4"x26 7/8" (24x134x683)



G16 BRACE BEAM - W4L17802 (x1) 15/16"x5 1/4"x93 1/8" (24x134x2365)

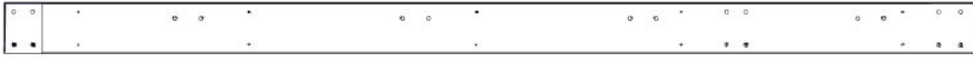

G14 BRACE BEAM - W4L17670 (x1) 15/16"x5 1/4"x100 1/2" (24x134x2553)

D09 CORBEL - W4L18244 (x2) 1 7/16"x5 1/4"x33 5/8" (36x134x855)



- NOTES:**
- HAND TIGHTEN ONLY.
  - INSERT T-NUTS FIRST.

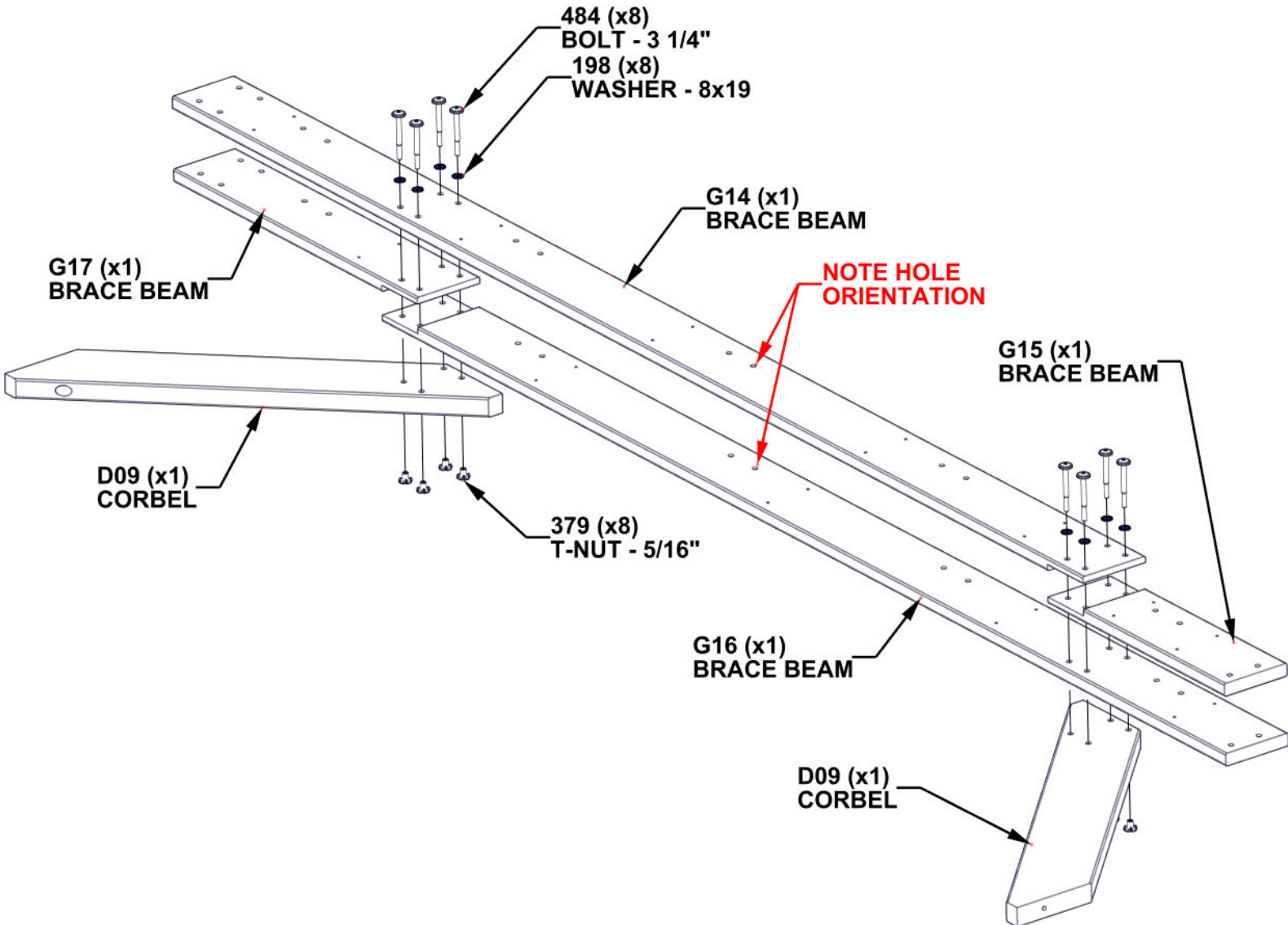

# STEP 24B - CENTER BEAM ASSEMBLY

QTY	PART NUMBER	DESCRIPTION
24	H100200	SCREW PFH 8x1 1/2 BLK

## NOTES:

- BEFORE ATTACHING SCREWS, MAKE SURE ALL BOARDS ARE FLUSH AT TOP, SIDES, & BOTTOMS.
- AFTER SCREWS ARE TIGHTENED, TIGHTEN ALL OTHER HARDWARE.

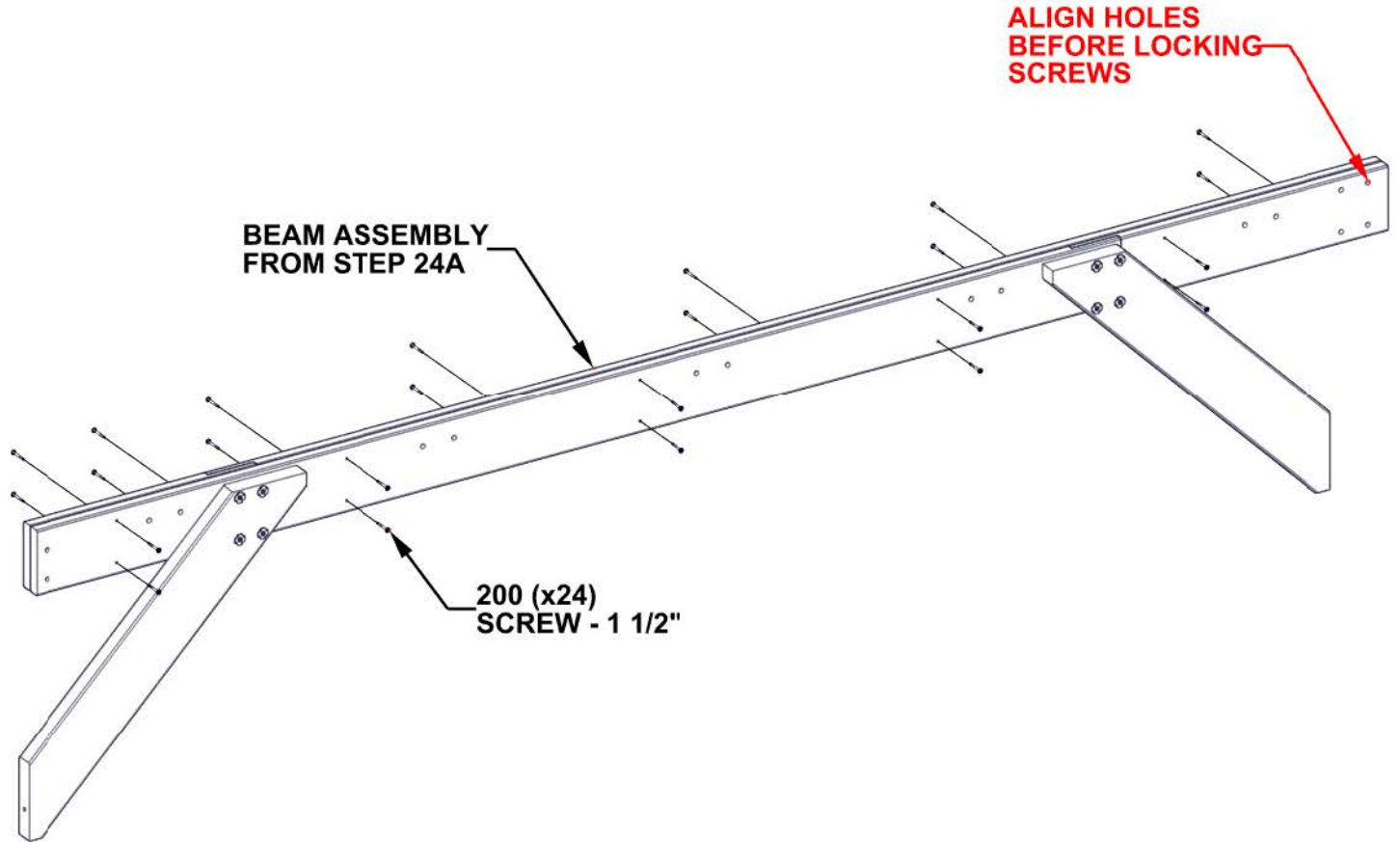

# STEP 24C - CENTER BEAM ASSEMBLY

QTY	PART NUMBER	DESCRIPTION
10	H100378	BOLT WH 5/16x1 3/4 BLK
10	H100379	T-NUT 5/16 BLK

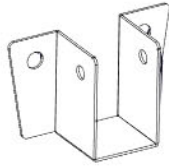

A4M01787 RAFTER BRACKET  
(x5)

**NOTE:**  
ALIGN RAFTER BRACKETS WITH HOLES  
IN BEAM AND ATTACH AS SHOWN

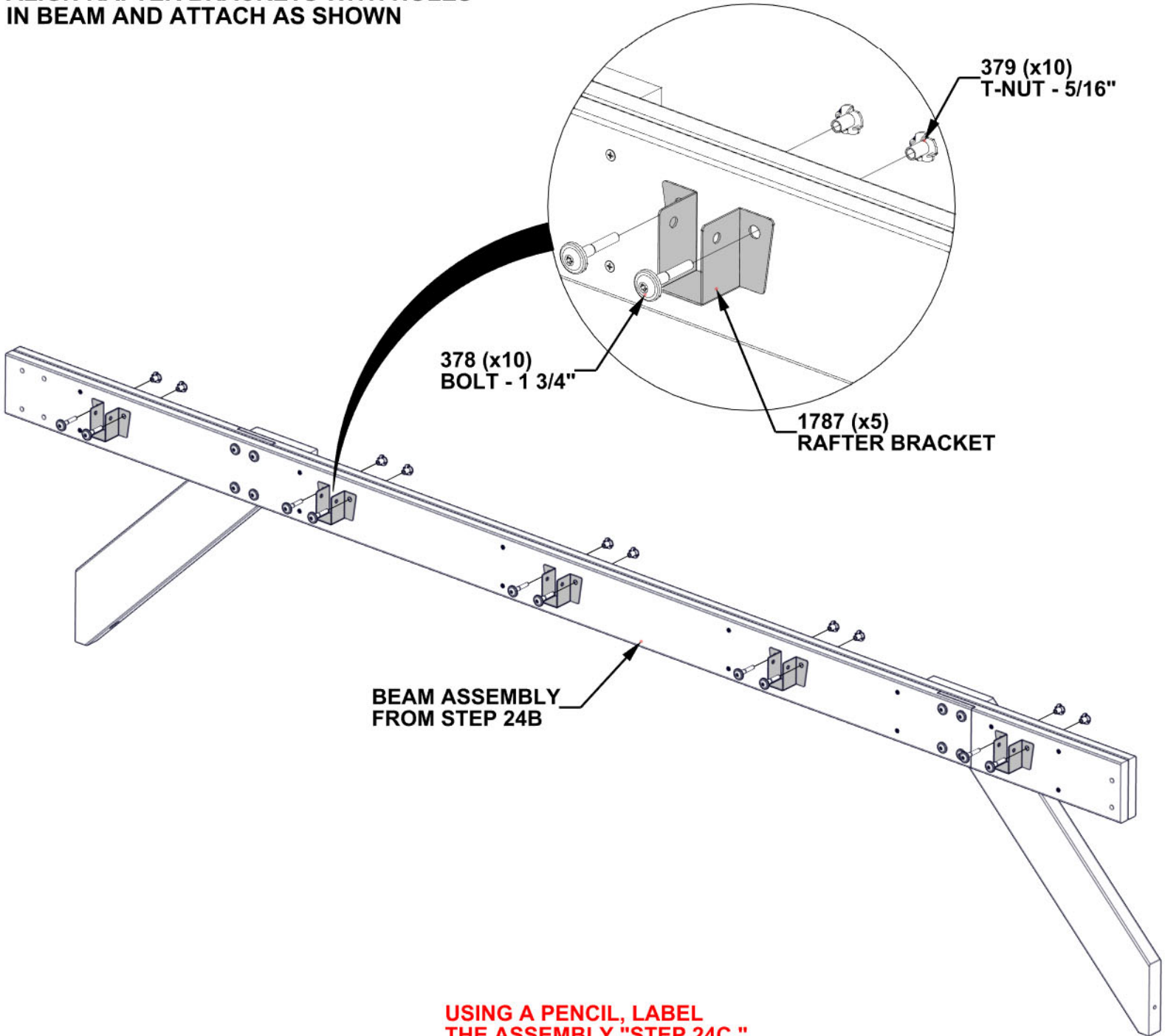

**USING A PENCIL, LABEL  
THE ASSEMBLY "STEP 24C."**

# STEP 25A - CARPORT ASSEMBLY

QTY	PART NUMBER	DESCRIPTION
4	H100194	BOLT WH 5/16x2 1/2 BLK
4	H100198	WASHER LOCK EXT 8x19
4	H100379	TNUT-5/16" BLK
4	H100479	NUT LOCK 5/16 BLK
4	H100630	WASHER FLAT 8x19 BLK
4	H101047	BOLT WH 5/16x9 3/4 BLK

**NOTE:**

- EXTRA PEOPLE ARE HELPFUL FOR THIS STEP.
- INSERT T-NUTS FIRST.

**1. INSERT JOIST ASSEMBLIES INTO BRACKETS.**

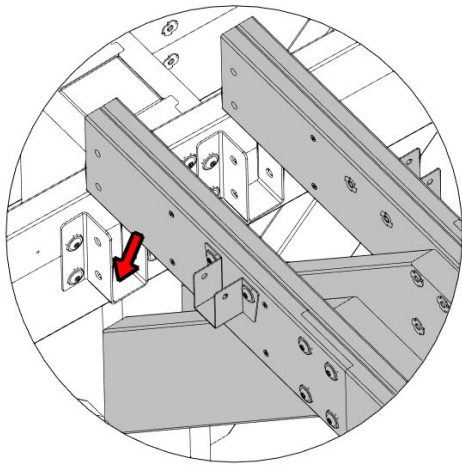

**3. ATTACH JOISTS TO BRACKETS.**

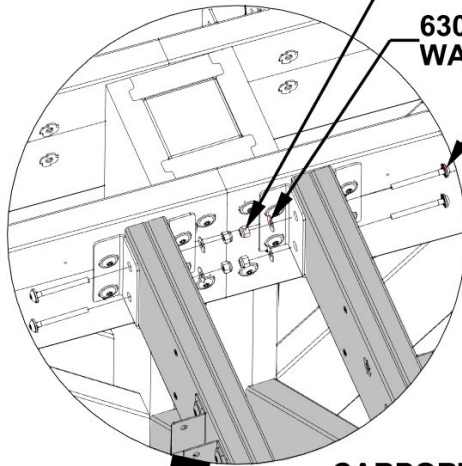

- 479 (x4) LOCK NUT - 5/16"
- 630 (x4) WASHER - 8x19
- 194 (x4) BOLT - 2 1/2"

**2. ATTACH JOISTS TO POST.**

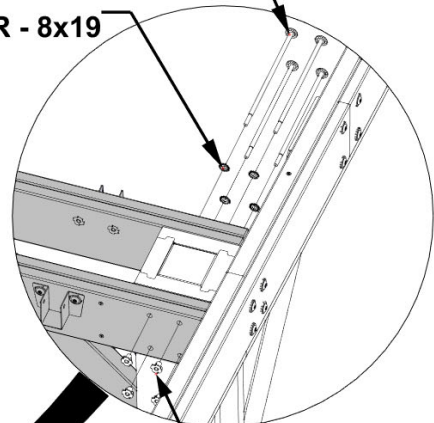

- 1047 (x4) BOLT - 9 3/4"
- 198 (x4) WASHER - 8x19

- 379 (x4) TNUT-5/16"

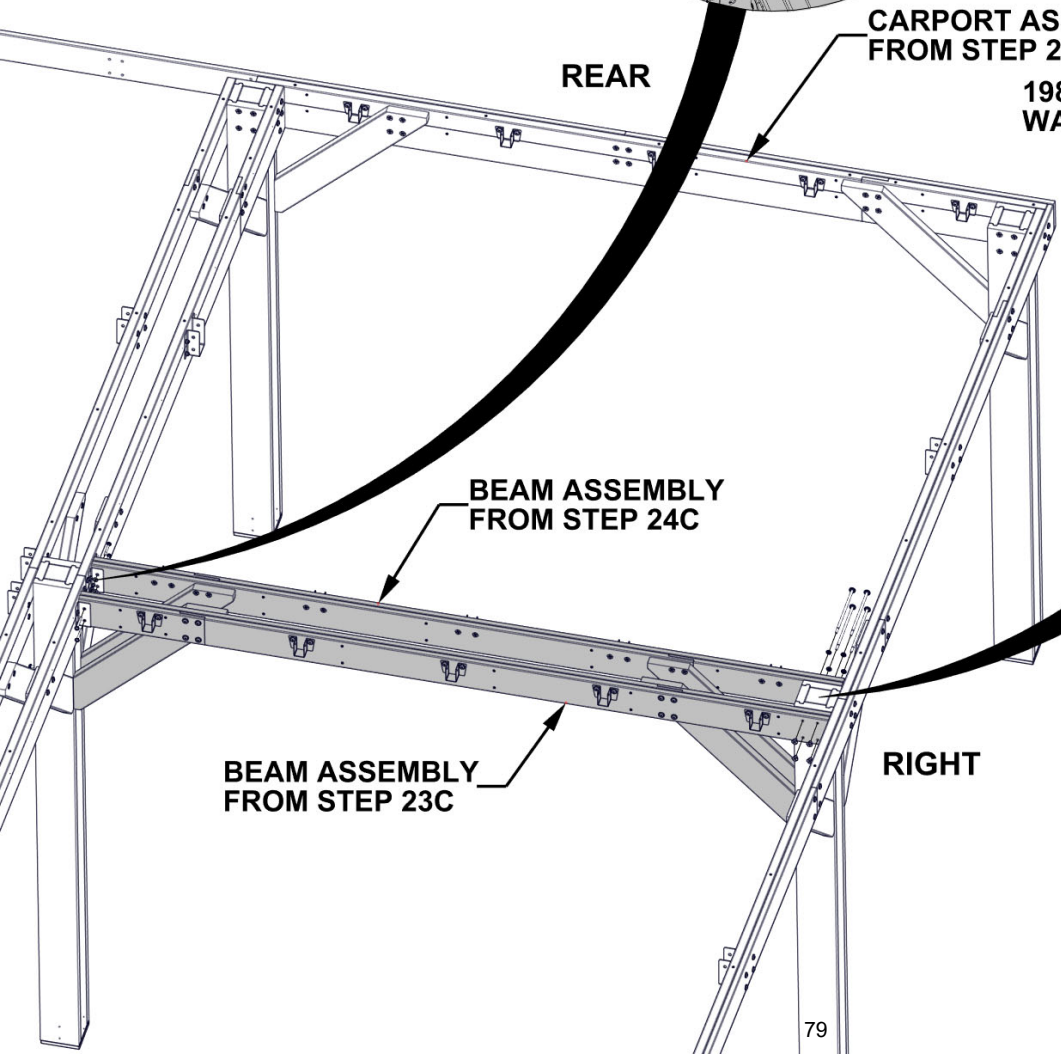

CARPORT ASSEMBLY FROM STEP 22

RIGHT

# STEP 25B - CARPORT ASSEMBLY

QTY	PART NUMBER	DESCRIPTION
4	H100405	WASHER LOCK EXT 6x15
4	H100564	LAG SCREW WH 1/4x4 BLK

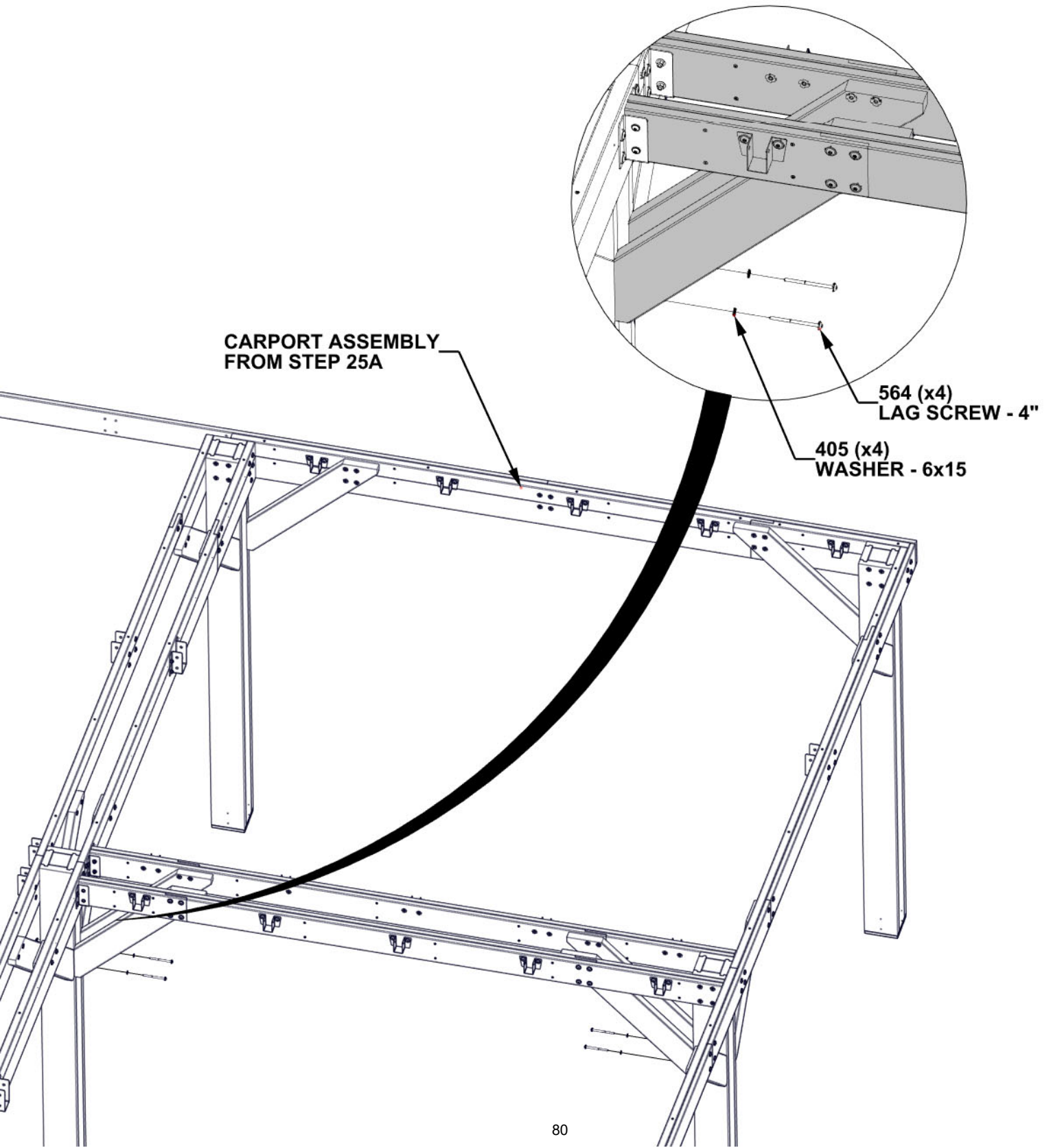



# STEP 26 - LEFT FRONT POST ASSEMBLY

QTY	PART NUMBER	DESCRIPTION
4	H100200	SCREW PFH 8x1 1/2 BLK
2	H100202	SCREW PWH 8x5/8 BLK

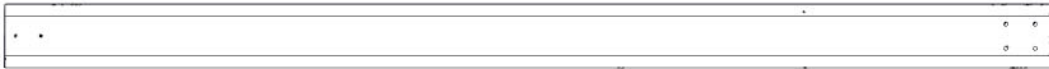

P01 FRONT POST - W2A03800  
(x1) 6"x6"x98 1/2" (152x152x2502)

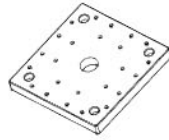

A100241 ID TAG  
(x1)

A6P00308 6x6 POST FOOT  
(x1)

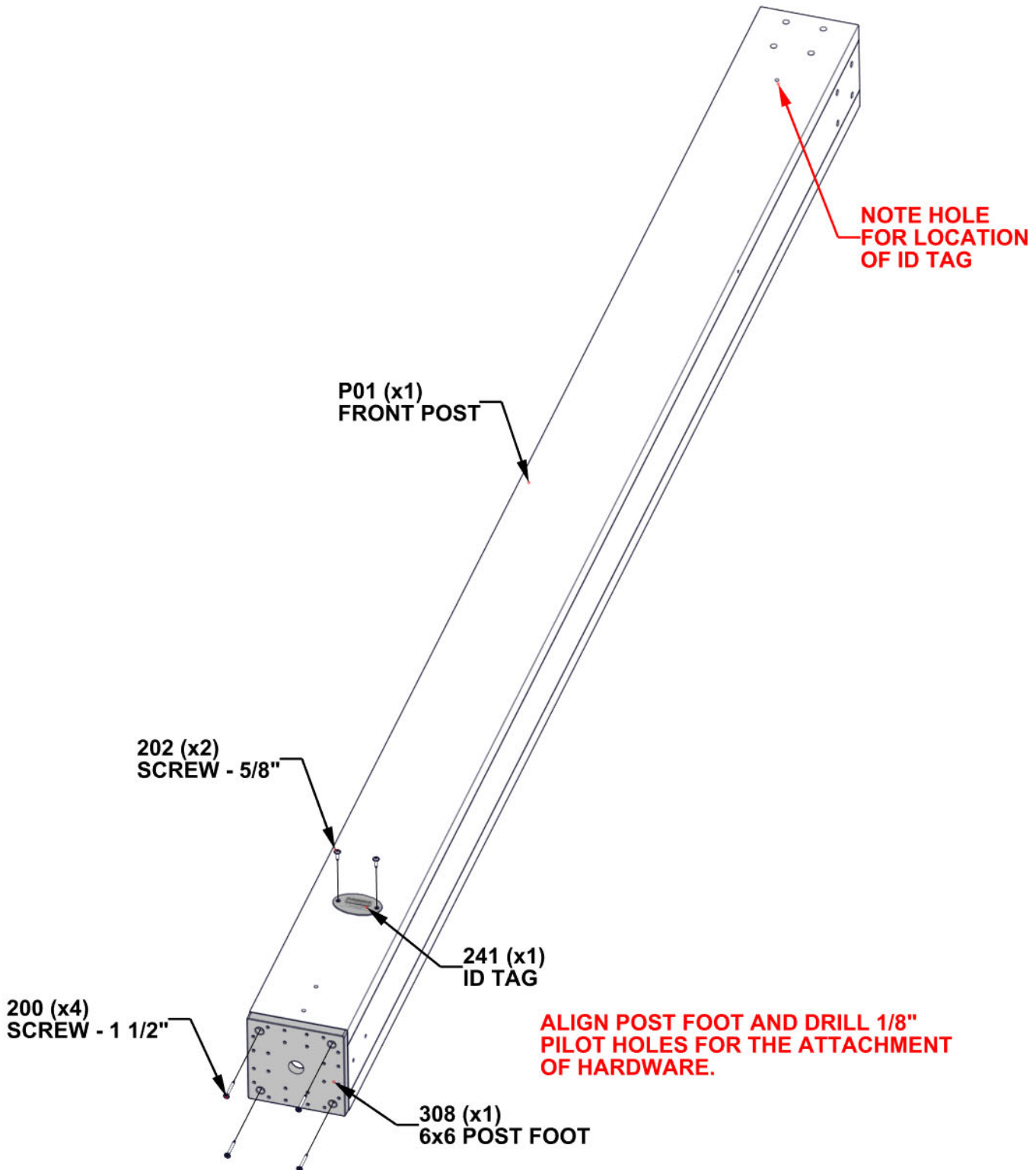

**SET LEFT FRONT POST  
ASSEMBLY TO THE SIDE**

# STEP 27 - LEFT FRONT JOIST ASSEMBLY

QTY	PART NUMBER	DESCRIPTION
8	H100379	T-NUT 5/16 BLK

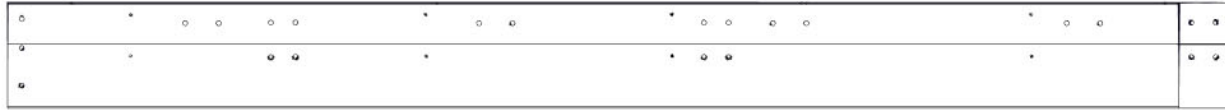

J06 JOIST ASSEMBLY - W2A03816  
 (x1) 1 7/16"x8 7/16"x97 5/8" (36x214x2480)

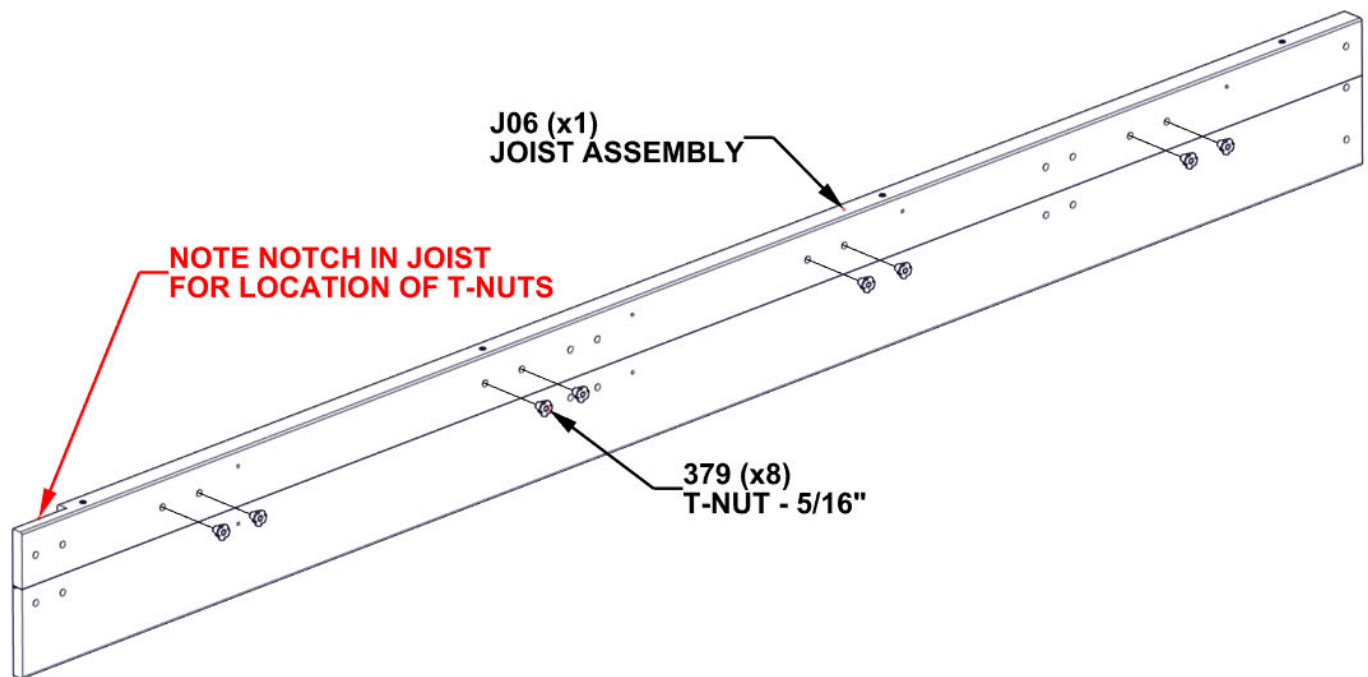

# STEP 28 - LEFT FRONT JOIST ASSEMBLY

QTY	PART NUMBER	DESCRIPTION
2	H100379	T-NUT 5/16 BLK



J05 JOIST ASSEMBLY - W2A03814  
(x1) 1 7/16"x8 7/16"x28 7/16" (36x214x722)

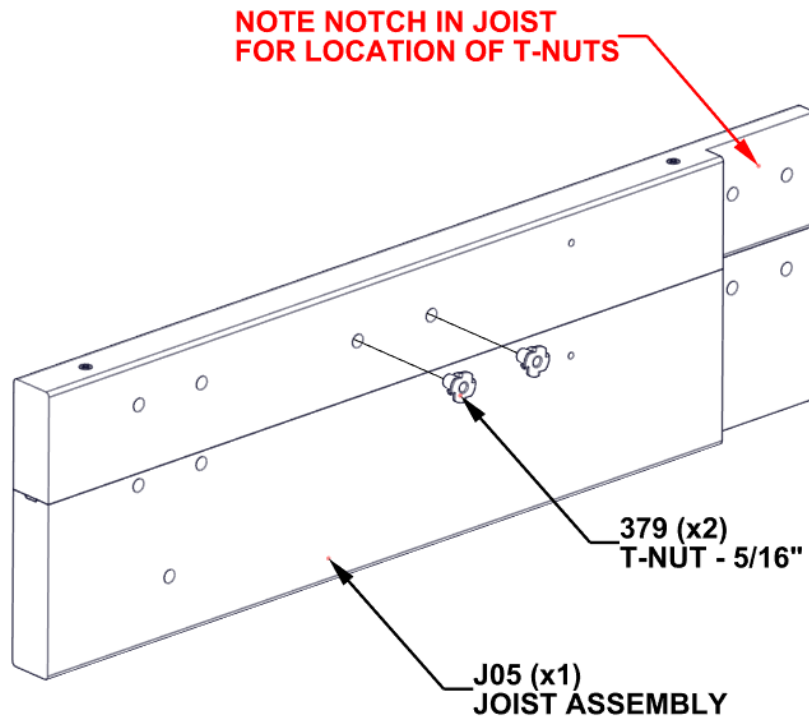

# STEP 29A - LEFT FRONT JOIST ASSEMBLY

QTY	PART NUMBER	DESCRIPTION
2	H100198	WASHER LOCK EXT 8x19
2	H100205	BOLT WH 5/16x2 1/4 BLK
2	H100379	TNUT-5/16" BLK



G04 FASCIA - W4L17624  
 (x1) 15/16"x5 1/4"x66 3/8" (24x134x1686)

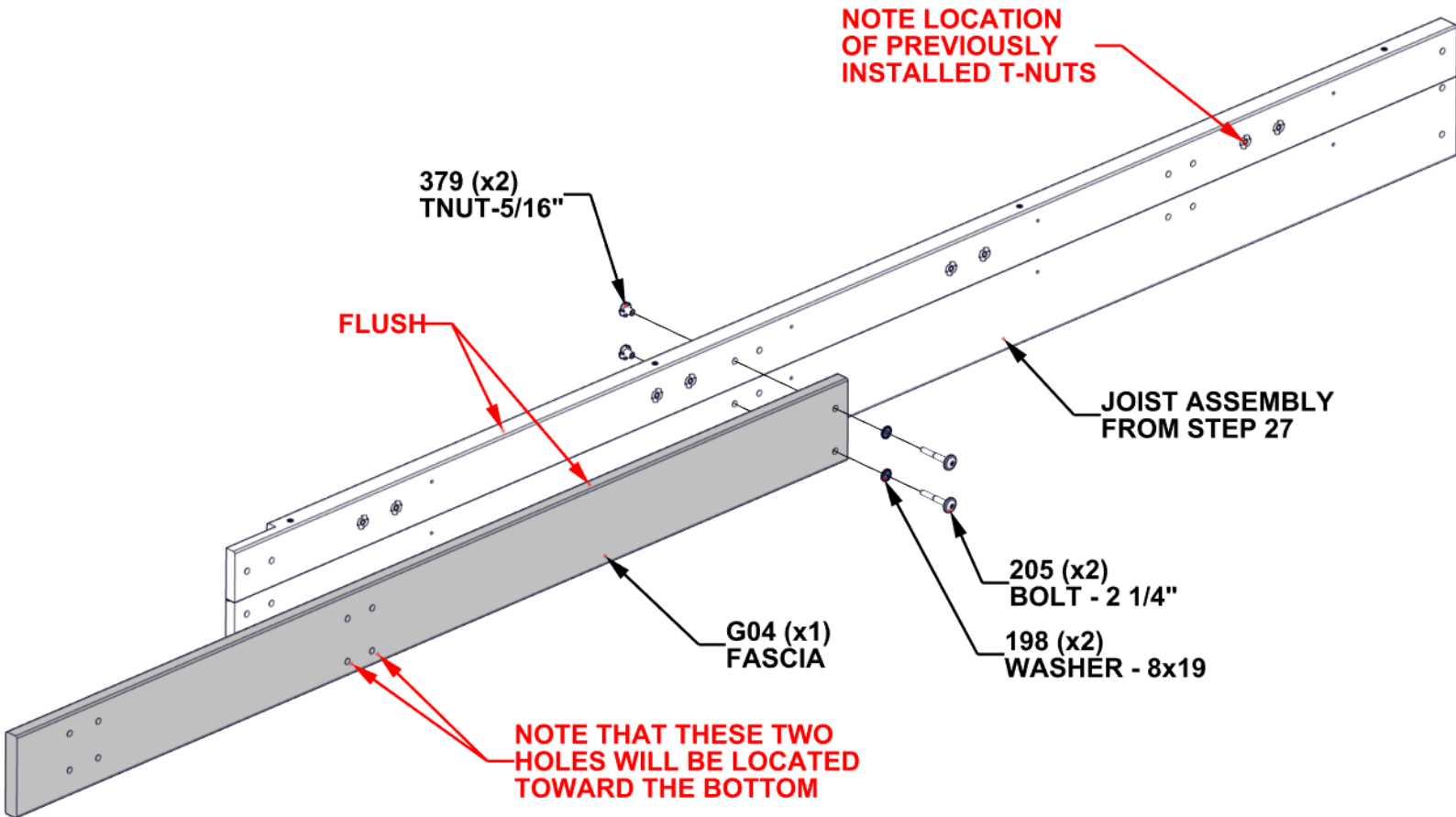

# STEP 29B - LEFT FRONT JOIST ASSEMBLY

QTY	PART NUMBER	DESCRIPTION
4	H100198	WASHER LOCK EXT 8x19
4	H100379	TNUT-5/16" BLK
4	H100415	BOLT WH 5/16x3 3/4 BLK



D10 CORBEL W/TAG - W2A03825  
(x1) 1 7/16"x5 1/4"x34 7/16" (36x134x874)

**NOTES:**  
• INSERT T-NUTS FIRST.

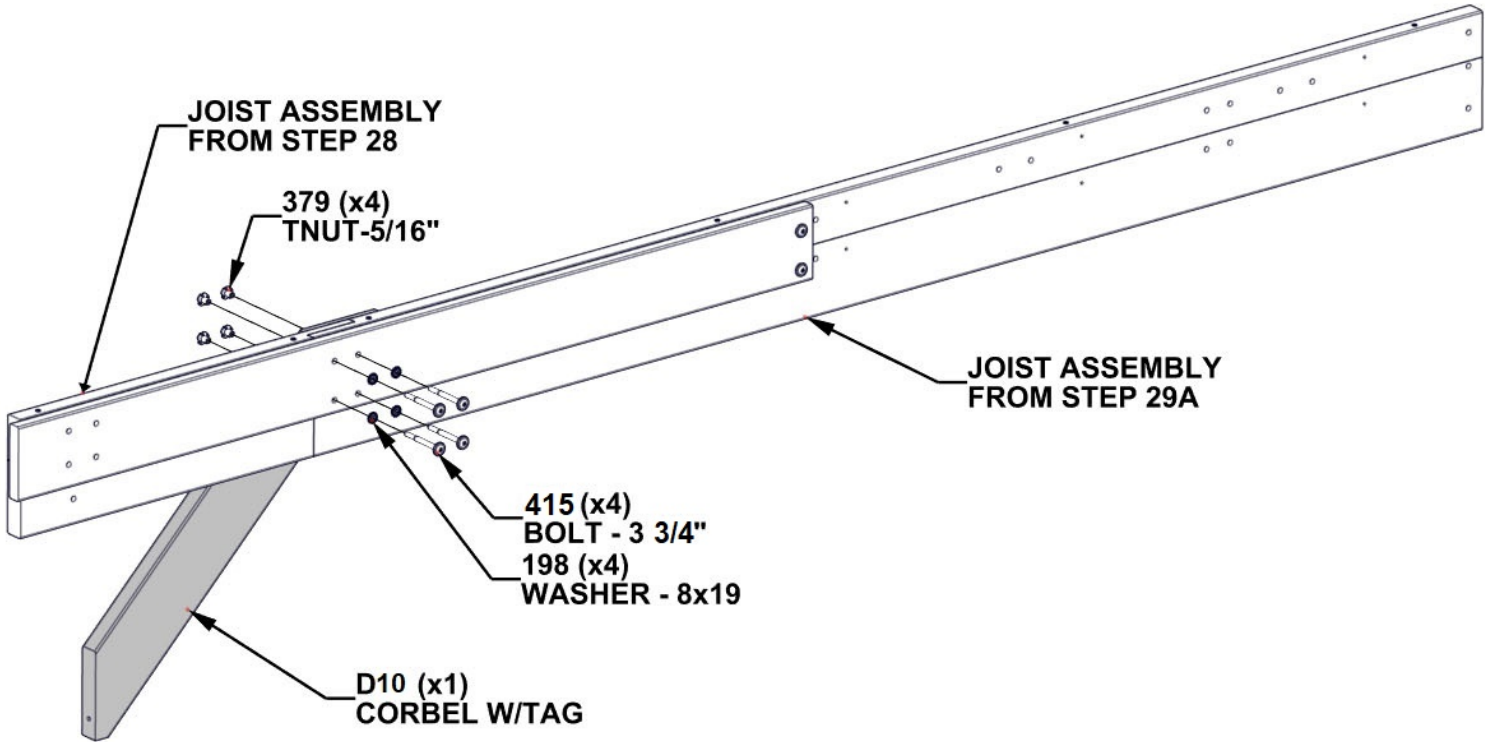

# STEP 29C - LEFT FRONT JOIST ASSEMBLY

QTY	PART NUMBER	DESCRIPTION
10	H100459	BOLT WH 5/16x1 1/4 BLK



A4M01787 RAFTER BRACKET  
(x5)

**NOTE:**  
ALIGN RAFTER BRACKETS WITH HOLES  
IN BEAM AND ATTACH AS SHOWN

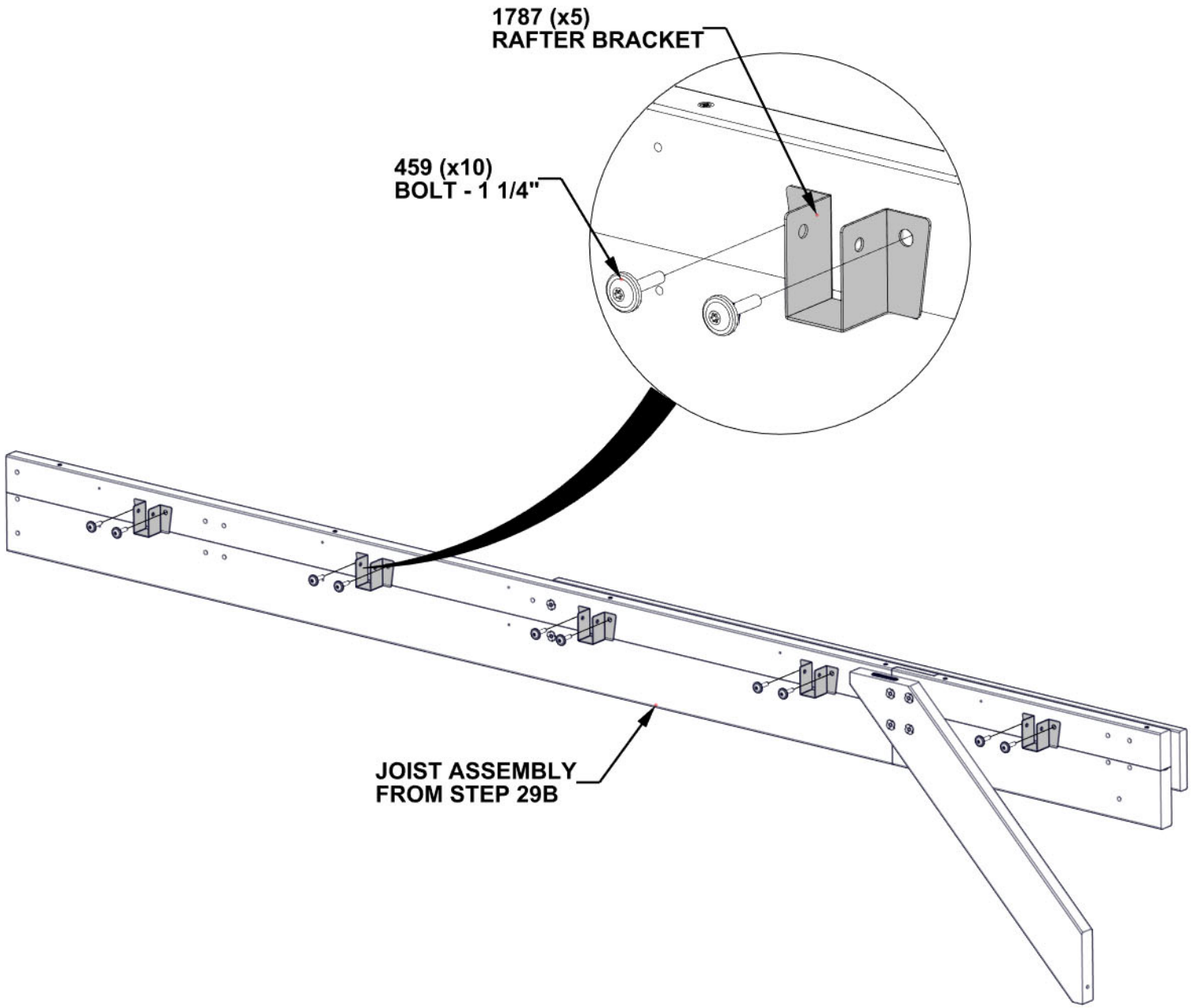

# STEP 30A - CARPORT ASSEMBLY

QTY	PART NUMBER	DESCRIPTION
2	H100197	LAG SCREW WH 5/16x2 1/2 BLK
8	H100198	WASHER LOCK EXT 8x19
6	H100379	TNUT-5/16" BLK
1	H100405	WASHER LOCK EXT 6x15
1	H100792	LAG SCREW WH 1/4x3 BLK
6	H101153	BOLT WH 5/16x8 1/4 BLK

- NOTE:**
- EXTRA PEOPLE ARE HELPFUL FOR THIS STEP.
  - INSERT T-NUTS FIRST.

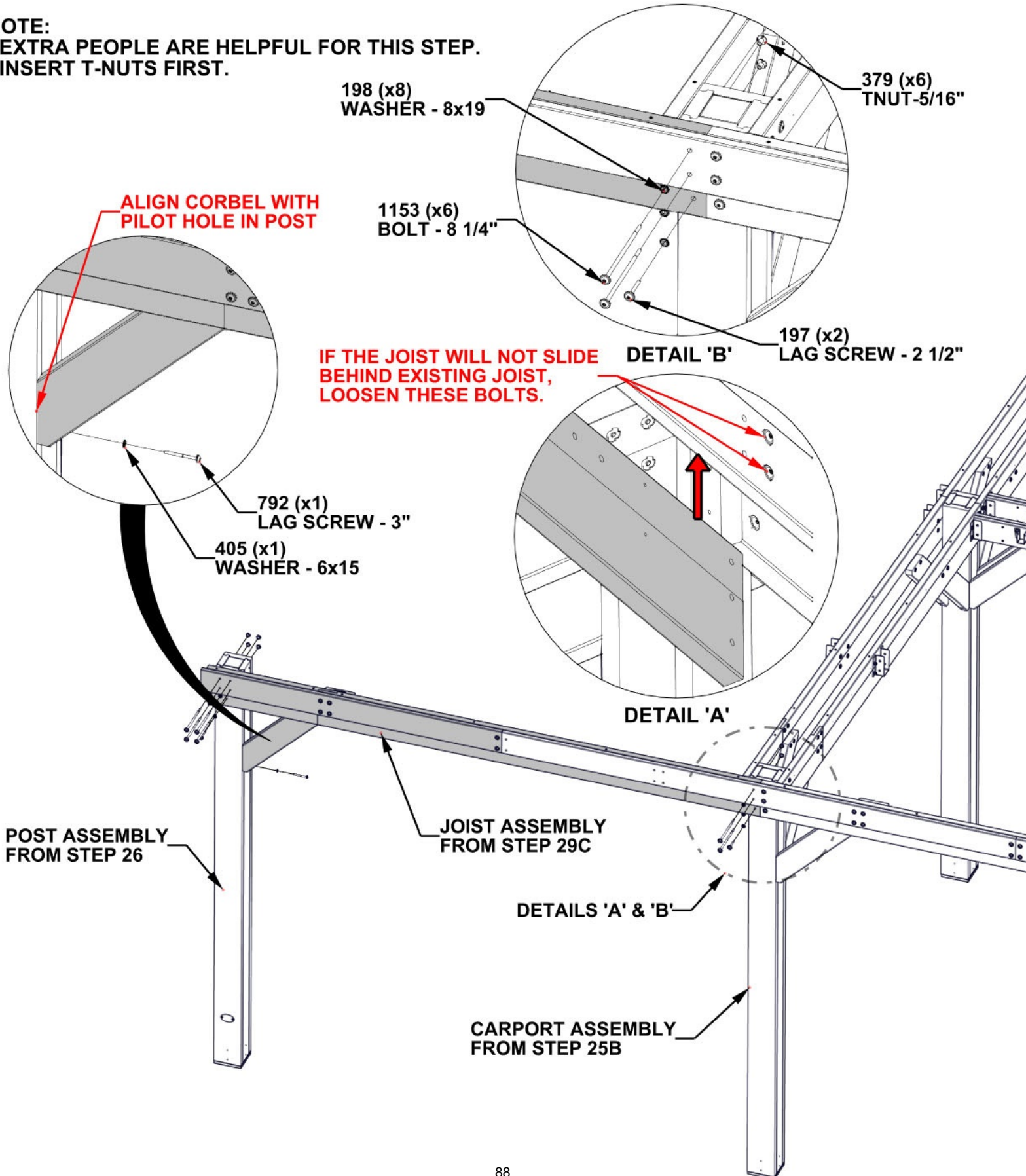

198 (x8)  
WASHER - 8x19

379 (x6)  
TNUT-5/16"

**ALIGN CORBEL WITH  
PILOT HOLE IN POST**

1153 (x6)  
BOLT - 8 1/4"

**IF THE JOIST WILL NOT SLIDE  
BEHIND EXISTING JOIST,  
LOOSEN THESE BOLTS.**

DETAIL 'B'

197 (x2)  
LAG SCREW - 2 1/2"

792 (x1)  
LAG SCREW - 3"

405 (x1)  
WASHER - 6x15

DETAIL 'A'

POST ASSEMBLY  
FROM STEP 26

JOIST ASSEMBLY  
FROM STEP 29C

DETAILS 'A' & 'B'

CARPORT ASSEMBLY  
FROM STEP 25B



# STEP 30B - CARPORT ASSEMBLY

QTY	PART NUMBER	DESCRIPTION
10	H100391	SCREW PFH 8x2 BLK

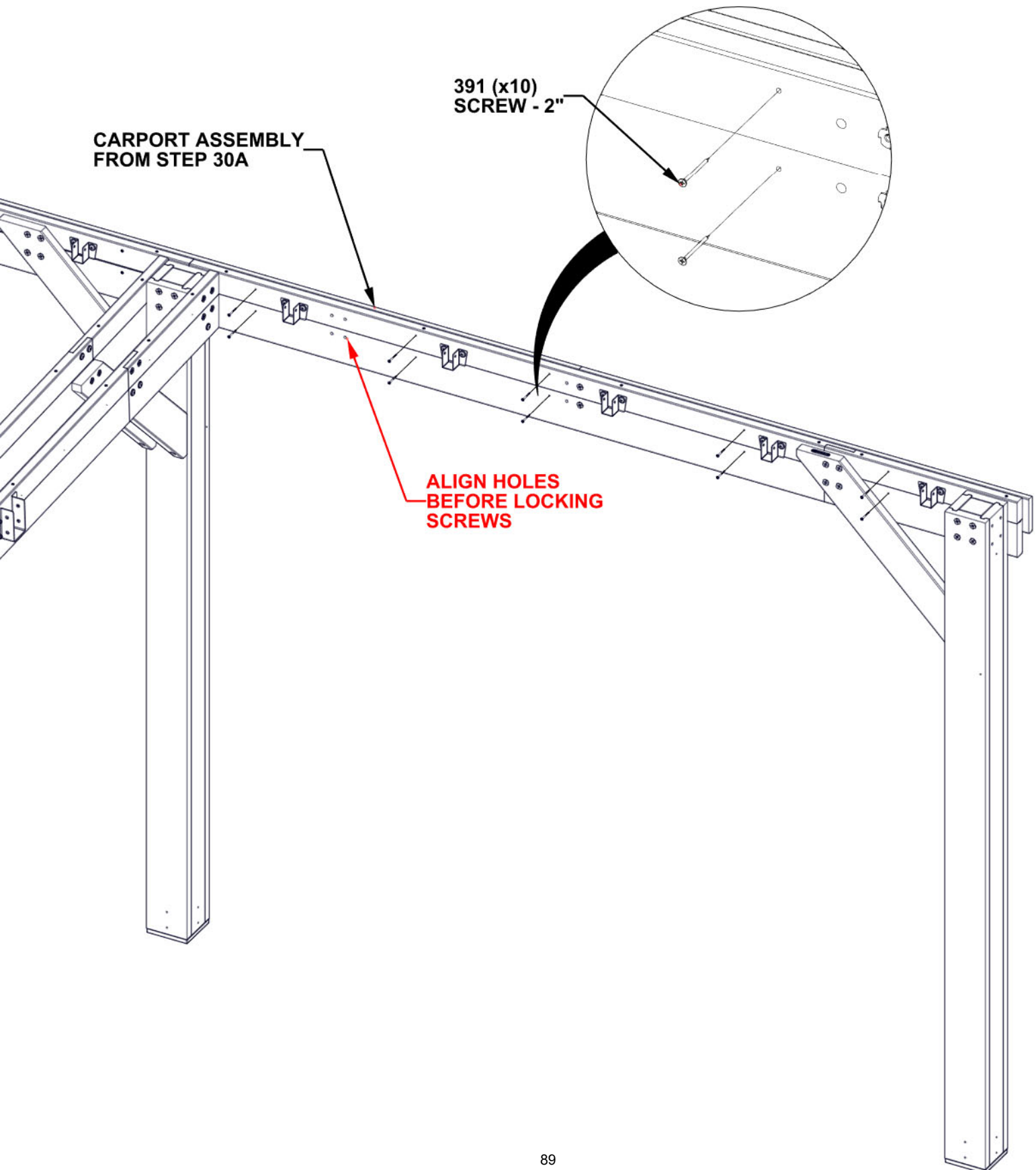

# STEP 30C - CARPORT ASSEMBLY



D05 CORBEL - W4L17630  
 (x1) 1 7/16"x5 1/4"x34 7/16" (36x134x874)

QTY	PART NUMBER	DESCRIPTION
6	H100198	WASHER LOCK EXT 8x19
2	H100205	BOLT WH 5/16x2 1/4 BLK
6	H100379	TNUT-5/16" BLK
1	H100405	WASHER LOCK EXT 6x15
4	H100415	BOLT WH 5/16x3 3/4 BLK
1	H100792	LAG SCREW WH 1/4x3 BLK

**NOTE:**  
 • INSERT T-NUTS FIRST.

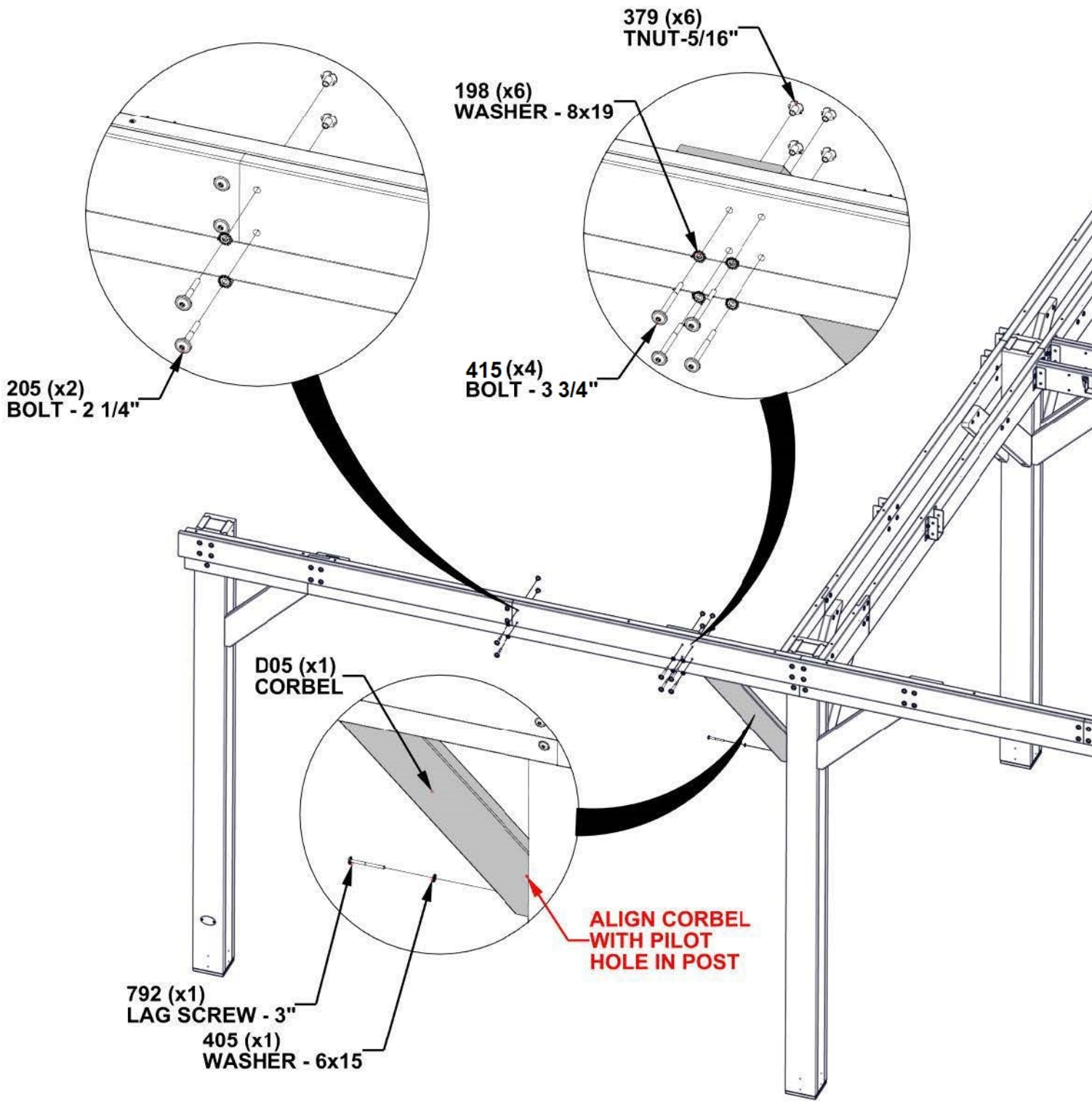

# STEP 31 - LEFT CENTER POST ASSEMBLY

QTY	PART NUMBER	DESCRIPTION
4	H100200	SCREW PFH 8x1 1/2 BLK



P03 CENTER POST - W2A03802  
(x1) 6"x6"x92 5/16" (152x152x2344)

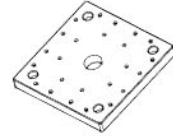

A6P00308 6x6 POST FOOT  
(x1)

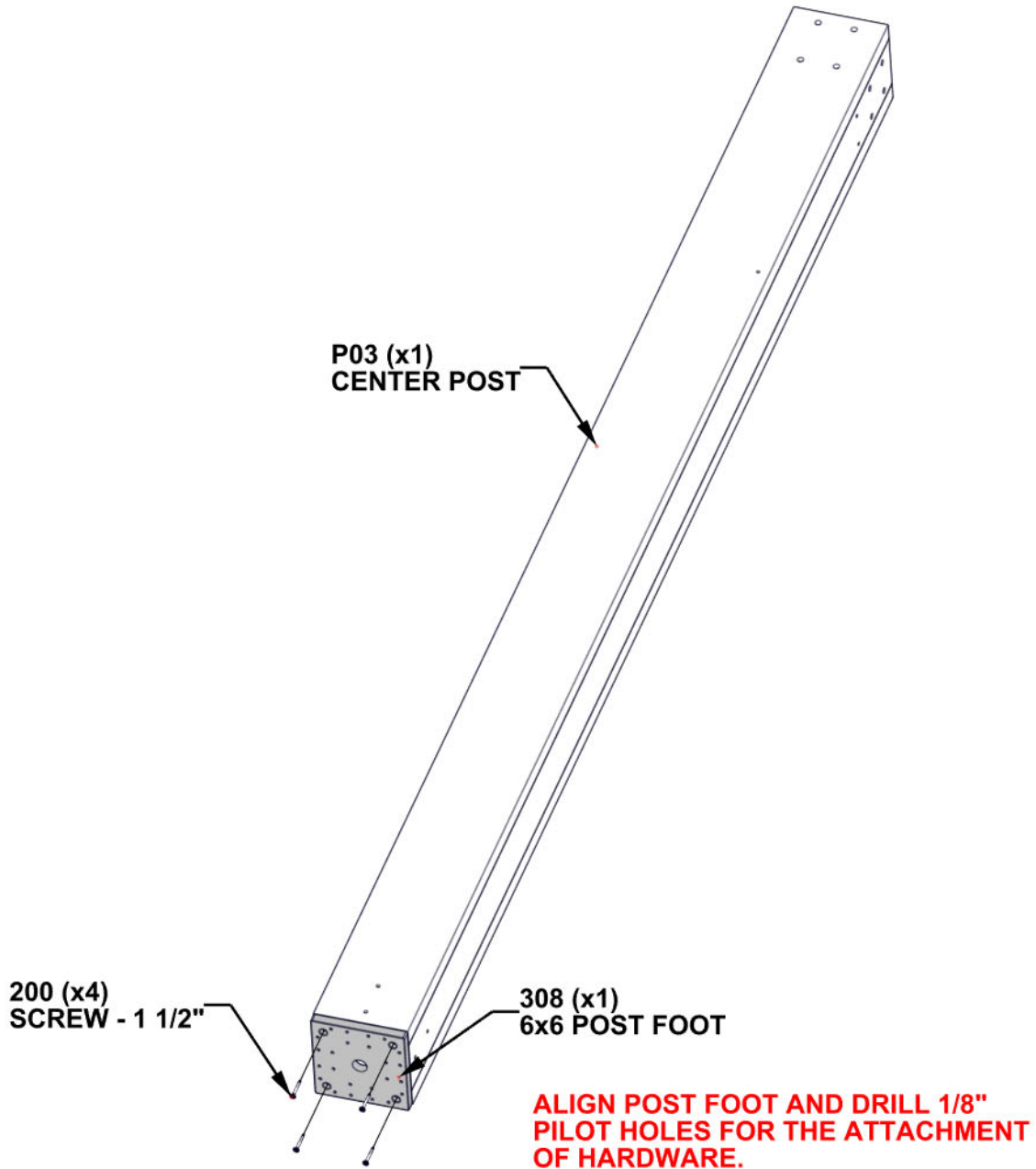

**SET LEFT CENTER POST  
ASSEMBLY TO THE SIDE**

# STEP 32A - RIGHT JOIST ASSEMBLY

QTY	PART NUMBER	DESCRIPTION
4	H100379	TNUT-5/16" BLK

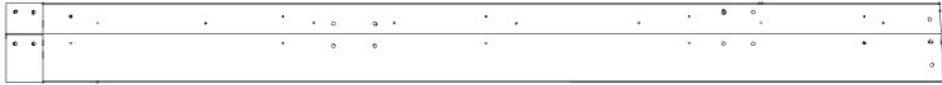

J01 JOIST ASSEMBLY - W2A03806  
 (x1) 1 7/16"x8 7/16"x100" (36x214x2600)

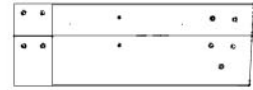

J03 JOIST ASSEMBLY - W2A03807  
 (x1) 1 7/16"x8 7/16"x24 9/16" (36x214x624)

- NOTES:**
- POSITION JOIST ASSEMBLIES AS SHOWN BELOW.
  - ADD T-NUTS IN THE TOP TWO HOLES AS SHOWN.
  - NOTE NOTCH DIRECTION IN ASSEMBLIES FOR T-NUT LOCATION

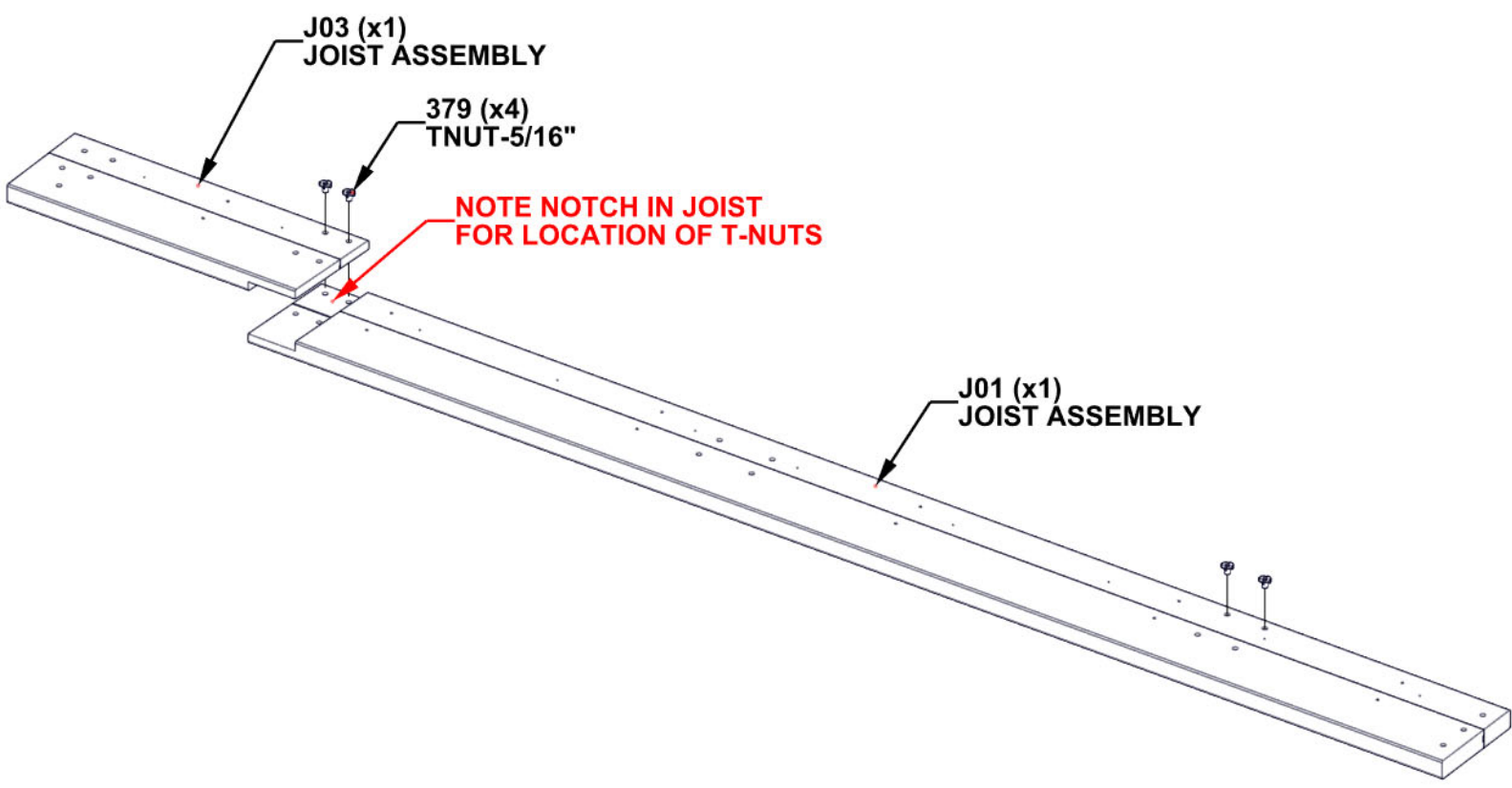

# STEP 32B - RIGHT JOIST ASSEMBLY

QTY	PART NUMBER	DESCRIPTION
4	H100198	WASHER LOCK EXT 8x19
4	H100205	BOLT WH 5/16x2 1/4 BLK



G02 FASCIA - W4L17616  
 (x1) 15/16"x5 1/4"x41 3/16" (24x134x1046)



G01 FASCIA - W4L17615  
 (x1) 15/16"x5 1/4"x100 1/8" (24x134x2543)

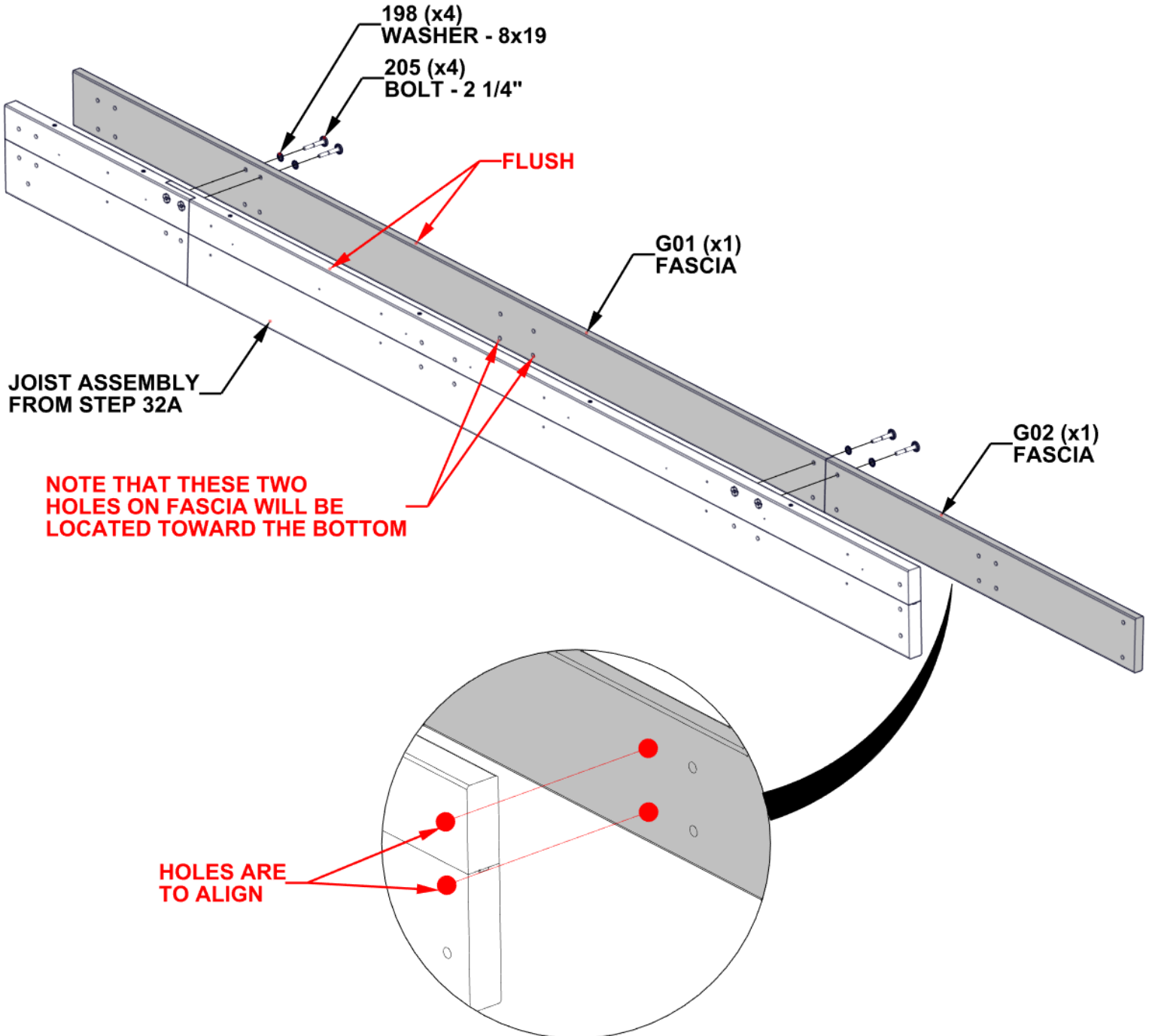

# STEP 32C - RIGHT JOIST ASSEMBLY

QTY	PART NUMBER	DESCRIPTION
4	H100198	WASHER LOCK EXT 8x19
4	H100379	TNUT-5/16" BLK
4	H100415	BOLT WH 5/16x3 3/4BLK



D01 CORBEL - W4L17618  
(x1) 1 3/8"x5 1/4"x28 1/2" (36x134x724)



D02 CORBEL - W4L17619  
(x1) 1 3/8"x5 1/4"x31 1/2" (36x134x801)

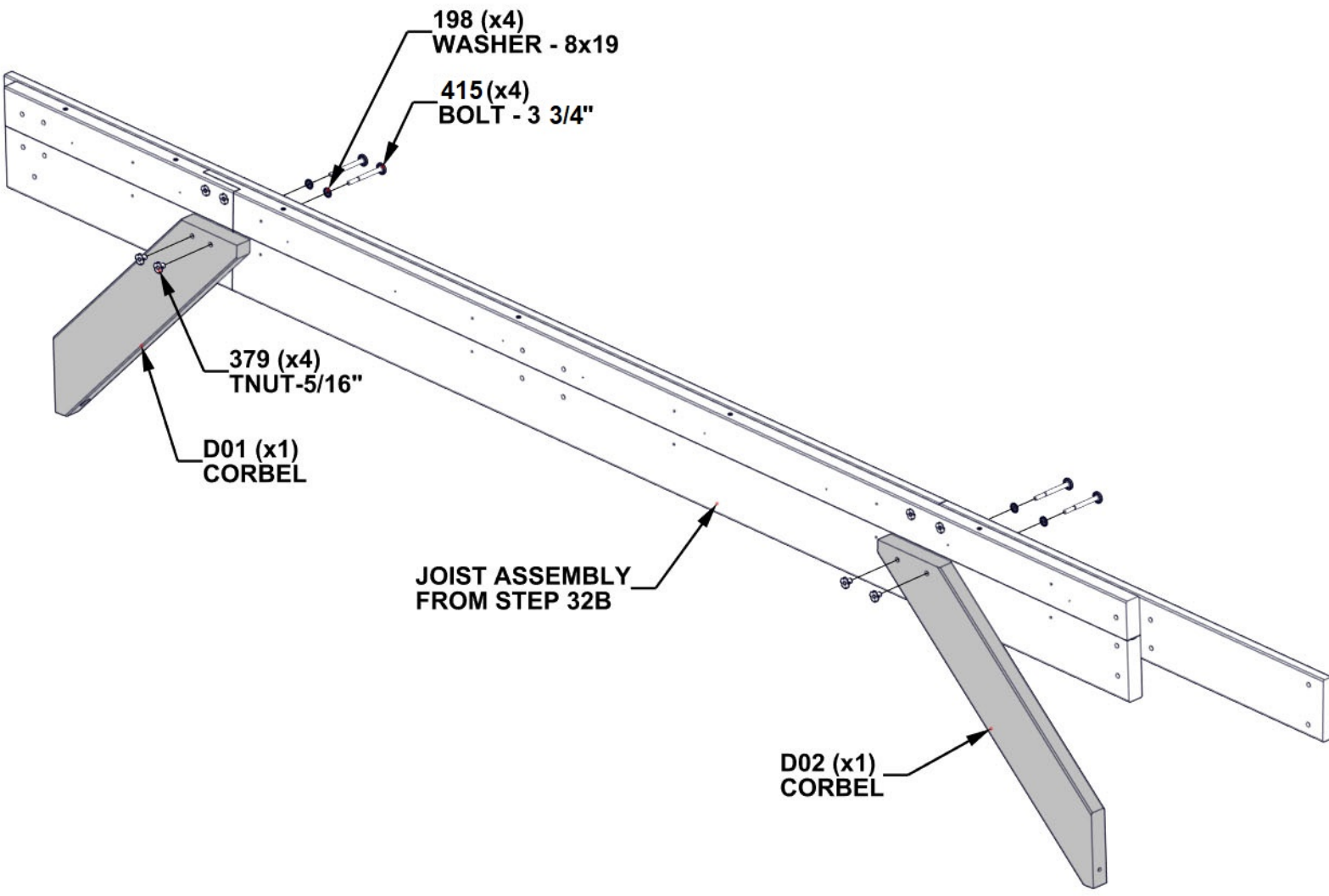

# STEP 32D - RIGHT JOIST ASSEMBLY

QTY	PART NUMBER	DESCRIPTION
4	H100198	WASHER LOCK EXT 8x19
4	H100416	BOLT WH 5/16x3 BLK
4	H100479	NUT LOCK 5/16 BLK
4	H100630	WASHER FLAT 8x19 BLK

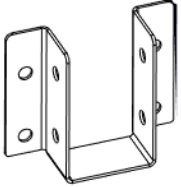

A4M02103 JOIST HANGER 90°  
(x1)

**NOTE:**  
ALIGN JOIST HANGER WITH HOLES  
IN BEAM AND ATTACH AS SHOWN

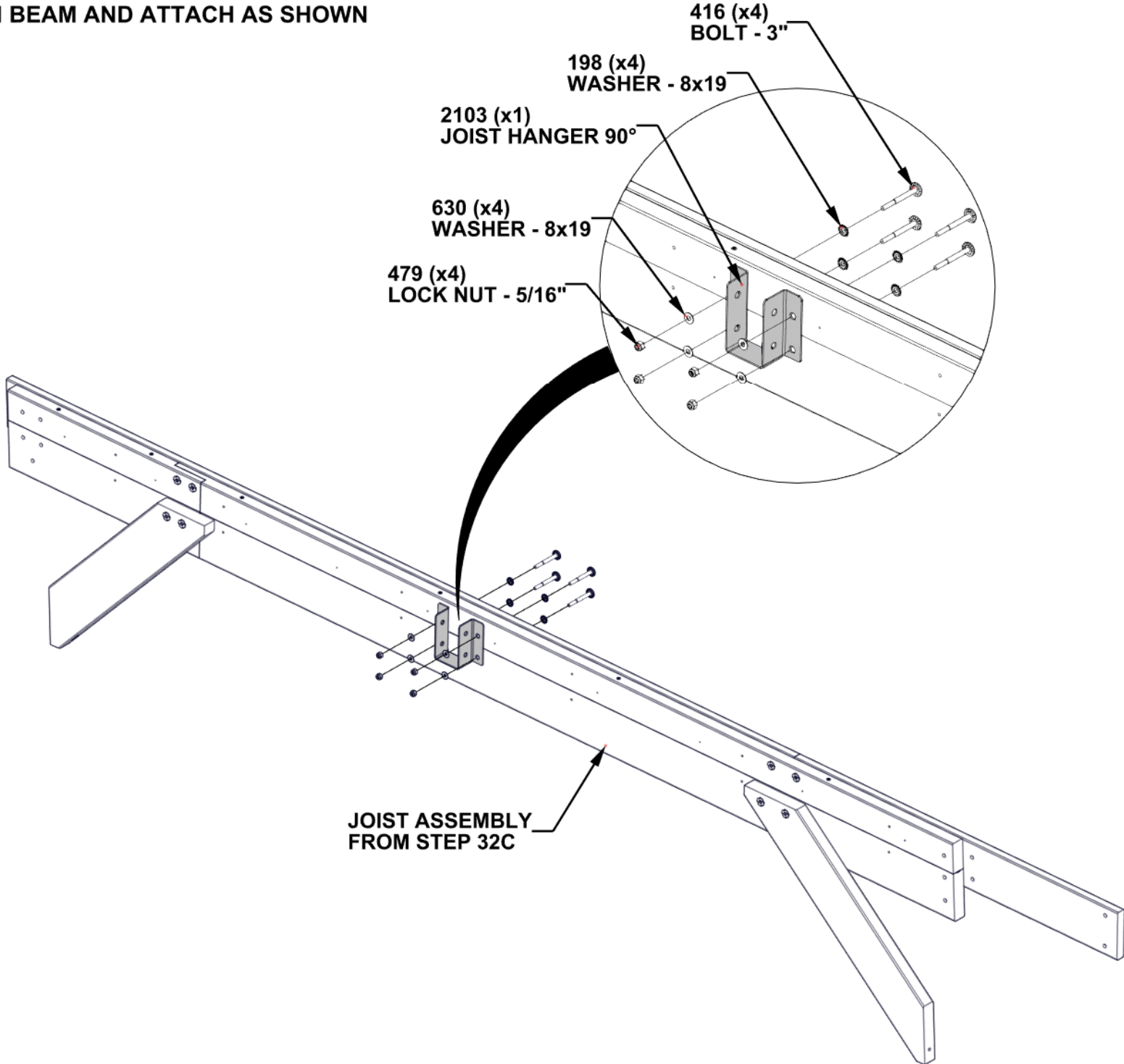



# STEP 33 - CARPORT ASSEMBLY

QTY	PART NUMBER	DESCRIPTION
2	H100197	LAG SCREW WH 5/16x2 1/2 BLK
8	H100198	WASHER LOCK EXT 8x19
6	H100379	TNUT-5/16" BLK
2	H100405	WASHER LOCK EXT 6x15
2	H100792	LAG SCREW WH 1/4x3 BLK
6	H101153	BOLT WH 5/16x8 1/4 BLK

- NOTE:**
- EXTRA PEOPLE ARE HELPFUL FOR THIS STEP.
  - INSERT T-NUTS FIRST.

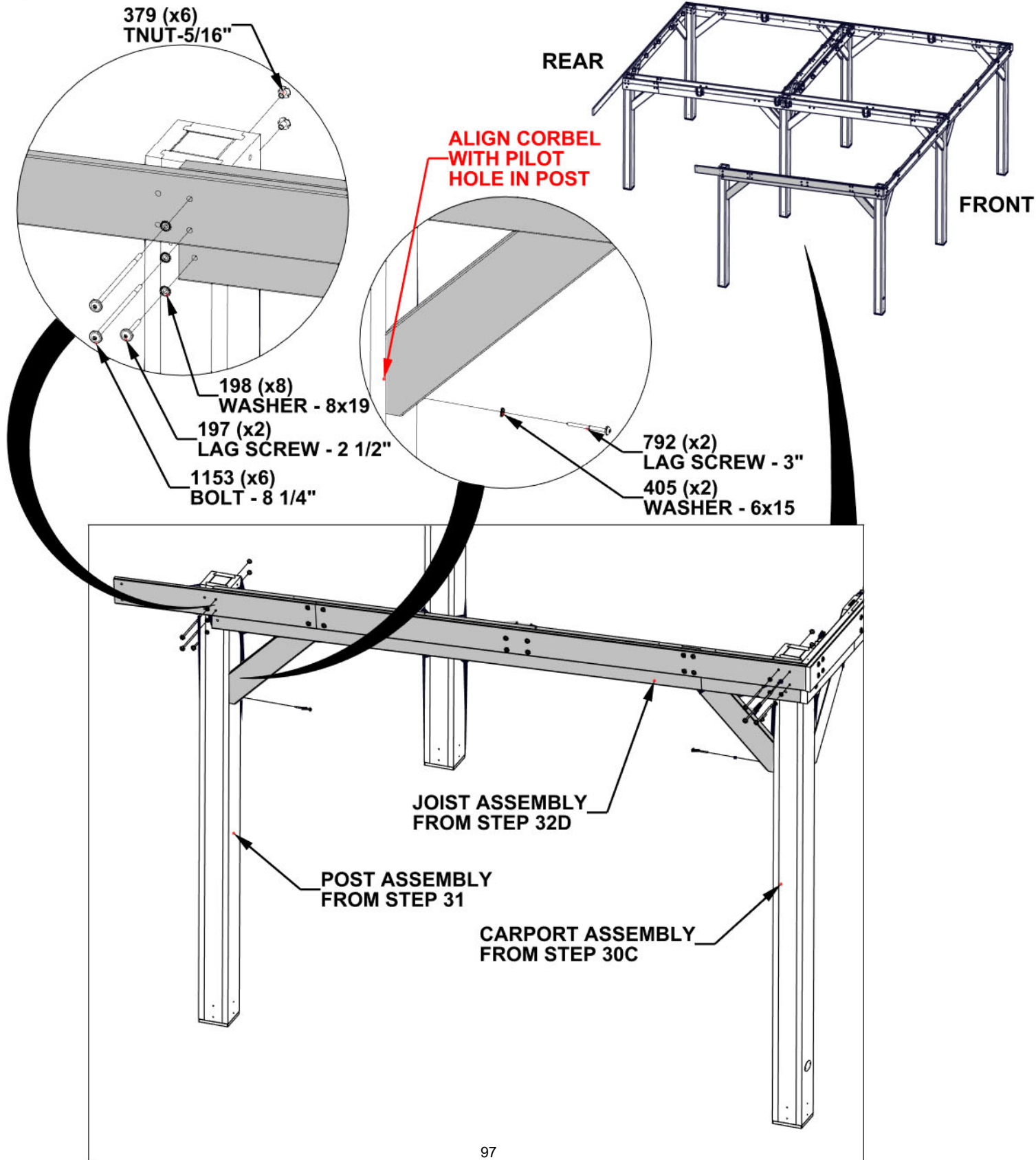

# STEP 34 - LEFT REAR POST ASSEMBLY

QTY	PART NUMBER	DESCRIPTION
4	H100200	SCREW PFH 8x1 1/2 BLK



P05 REAR POST - W2A03804  
(x1) 6"x6"x86 1/4" (152x152x2190)

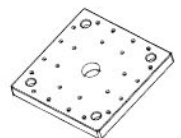

A6P00308 6x6 POST FOOT  
(x1)

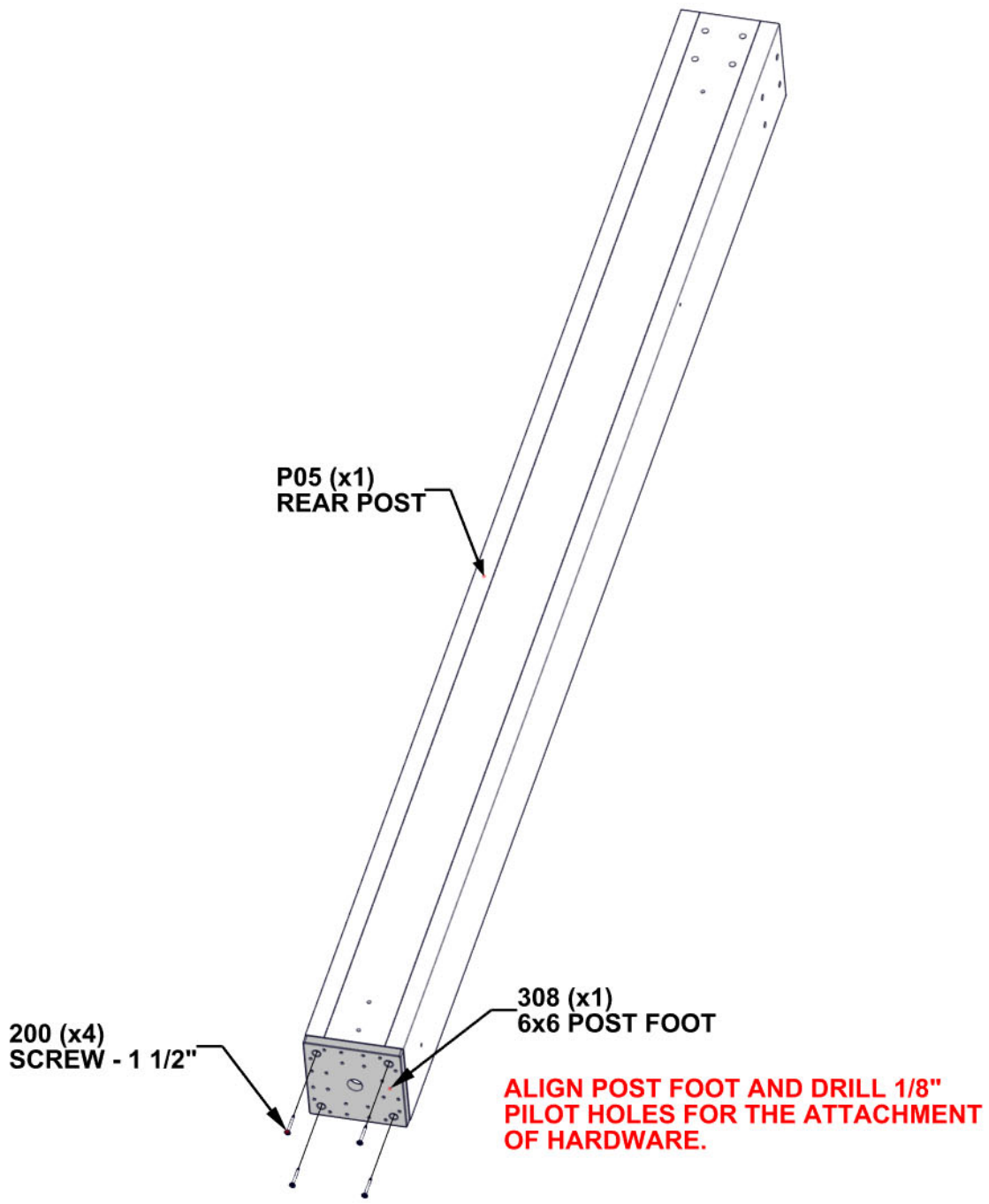

**SET LEFT REAR POST  
ASSEMBLY TO THE SIDE**

# STEP 35A - LEFT JOIST ASSEMBLY

QTY	PART NUMBER	DESCRIPTION
3	H100379	TNUT-5/16" BLK



J12 JOIST ASSEMBLY - W2A03808  
(x1) 1 7/16"x8 7/16"x97 11/16" (36x214x2481)

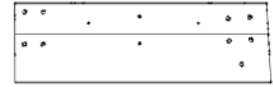

J13 JOIST ASSEMBLY - W2A03809  
(x1) 1 7/16"x8 7/16"x26 7/8" (36x214x682)

**NOTES:**

- POSITION JOIST ASSEMBLIES AS SHOWN BELOW.
- ADD T-NUTS IN THE TOP THREE HOLES AS SHOWN.
- NOTE NOTCH DIRECTION IN ASSEMBLIES FOR T-NUT LOCATION

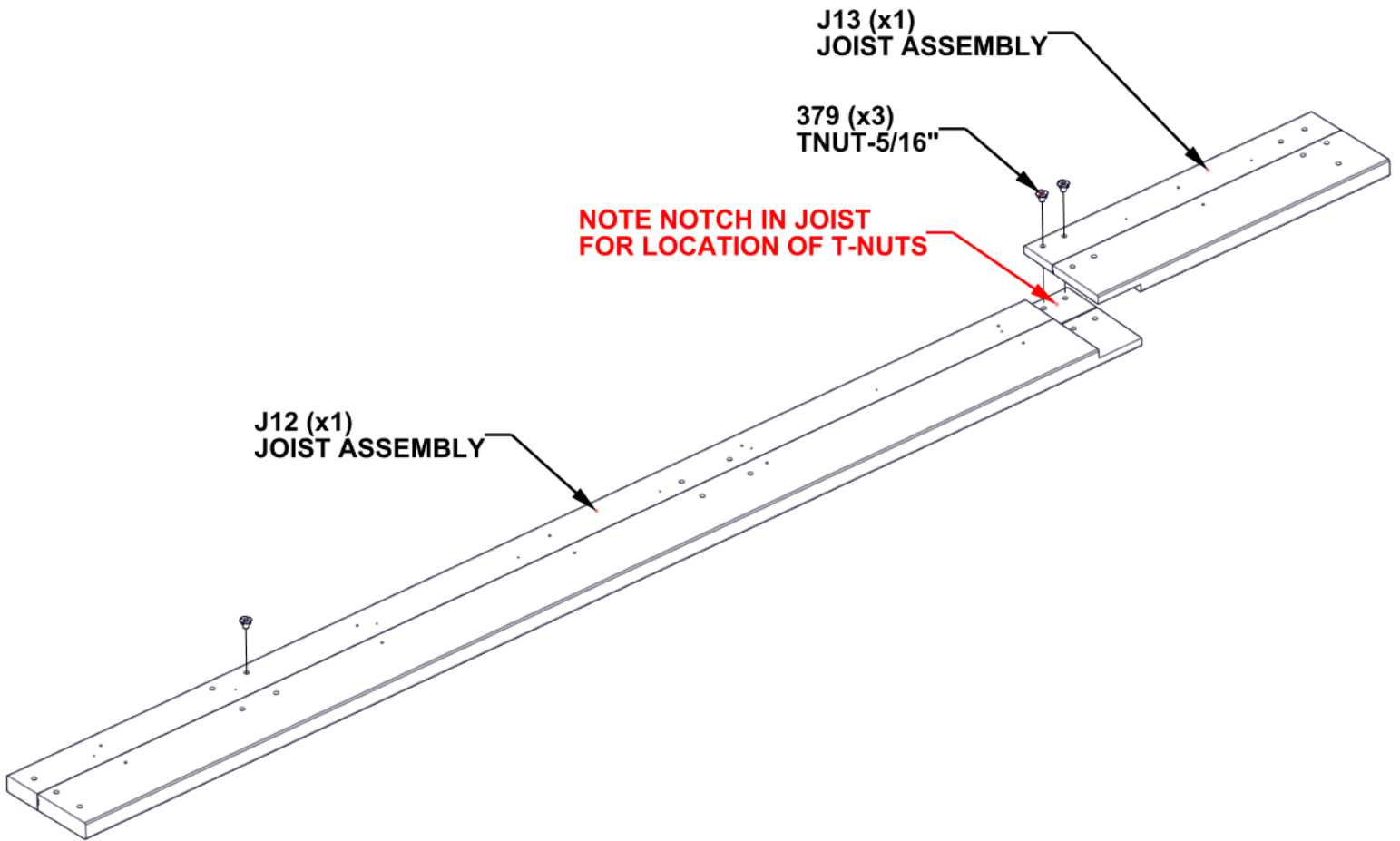

# STEP 35B - LEFT JOIST ASSEMBLY

QTY	PART NUMBER	DESCRIPTION
3	H100198	WASHER LOCK EXT 8x19
3	H100205	BOLT WH 5/16x2 1/4 BLK



G03 FASCIA - W4L17617  
(x1) 15/16"x5 1/4"x102 1/8" (24x134x2594)

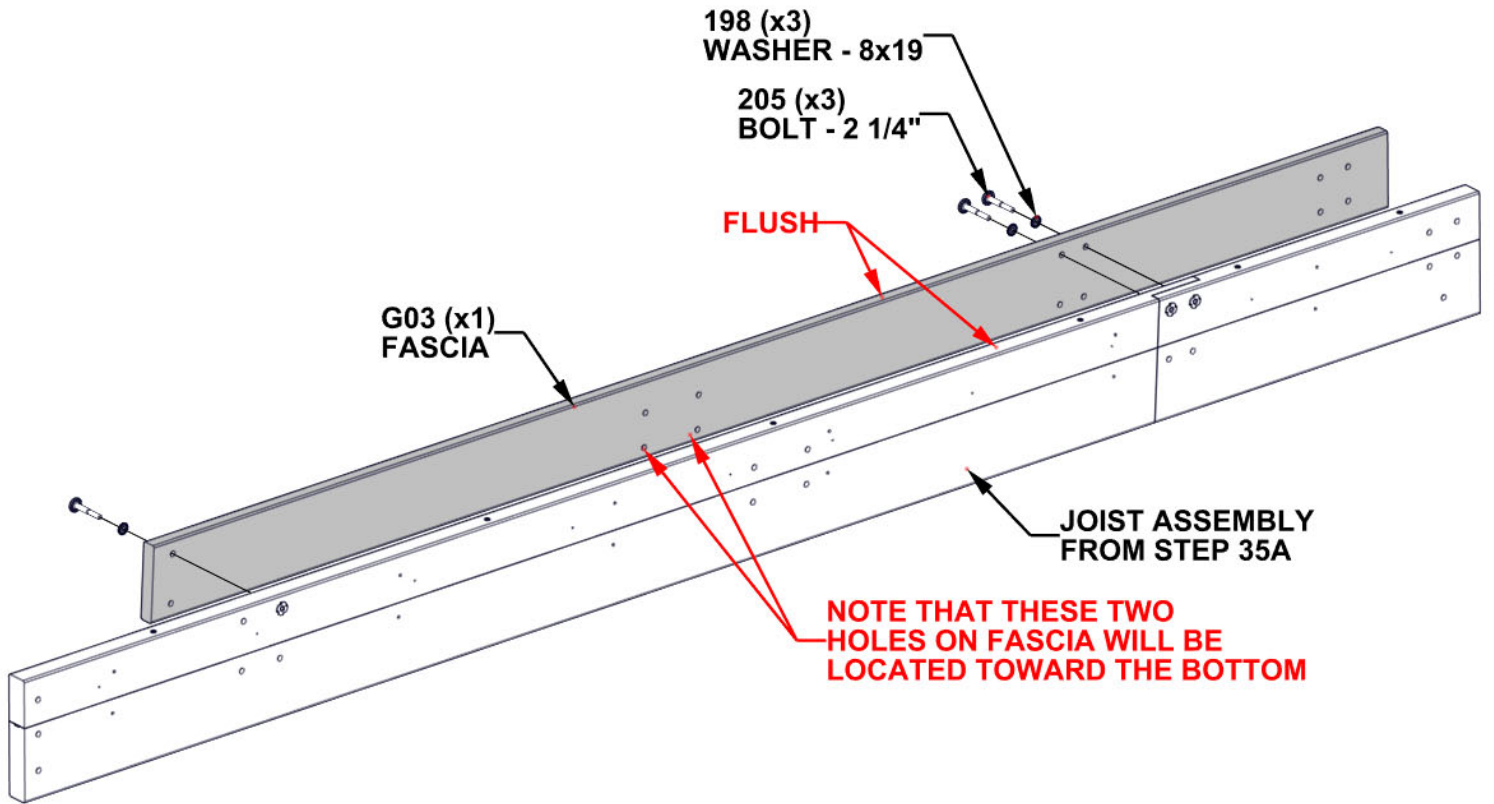

# STEP 35C - LEFT JOIST ASSEMBLY

QTY	PART NUMBER	DESCRIPTION
2	H100198	WASHER LOCK EXT 8x19
2	H100379	TNUT-5/16" BLK
2	H100415	BOLT WH 5/16x3 3/4 BLK



D04 CORBEL - W4L17621  
 (x1) 1 3/8"x5 1/4"x31 1/2" (36x134x801)

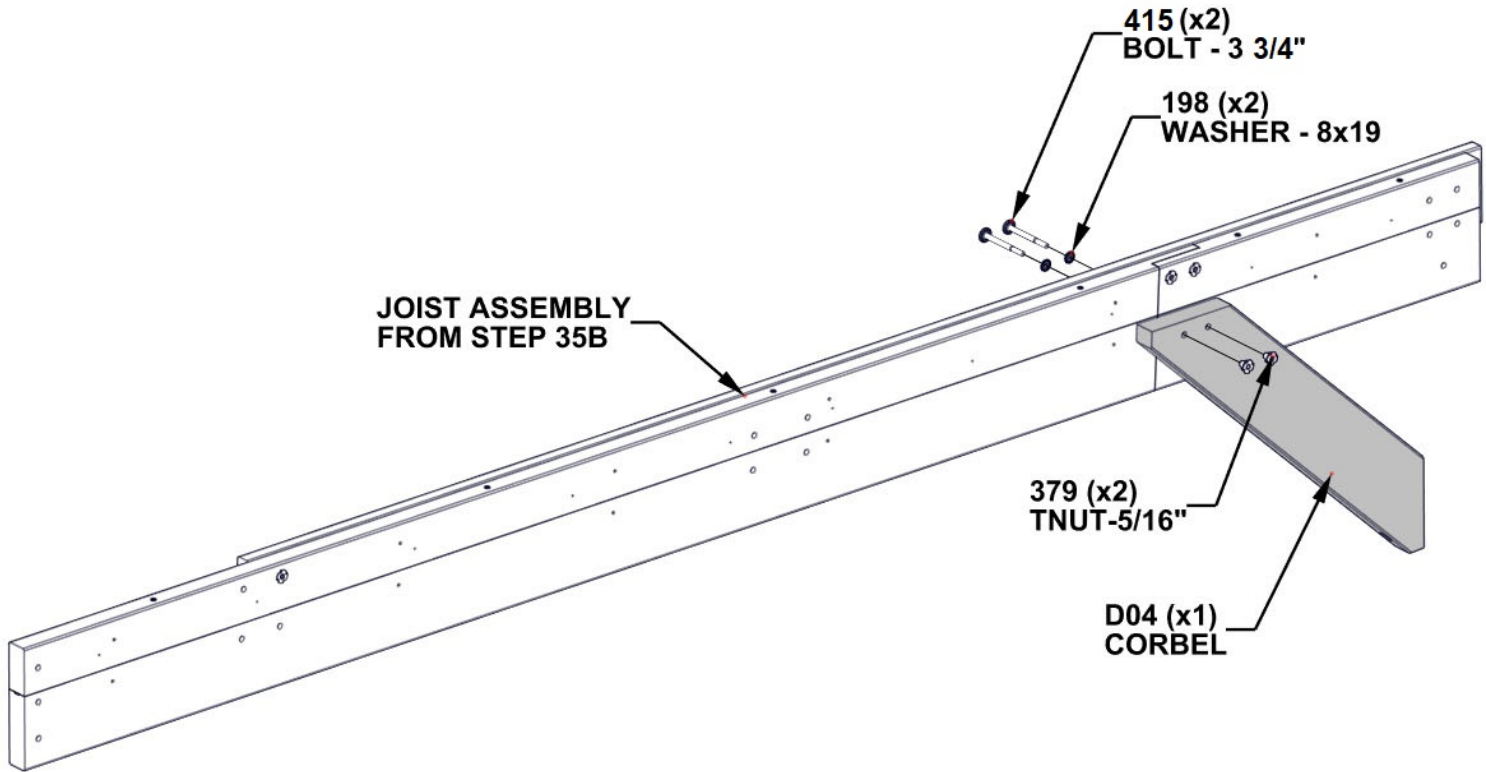

# STEP 35D - LEFT JOIST ASSEMBLY

QTY	PART NUMBER	DESCRIPTION
4	H100198	WASHER LOCK EXT 8x19
4	H100416	BOLT WH 5/16x3 BLK
4	H100479	NUT LOCK 5/16 BLK
4	H100630	WASHER FLAT 8x19 BLK

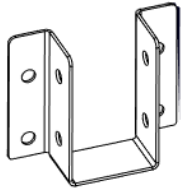

A4M02103 JOIST HANGER 90°  
(x1)

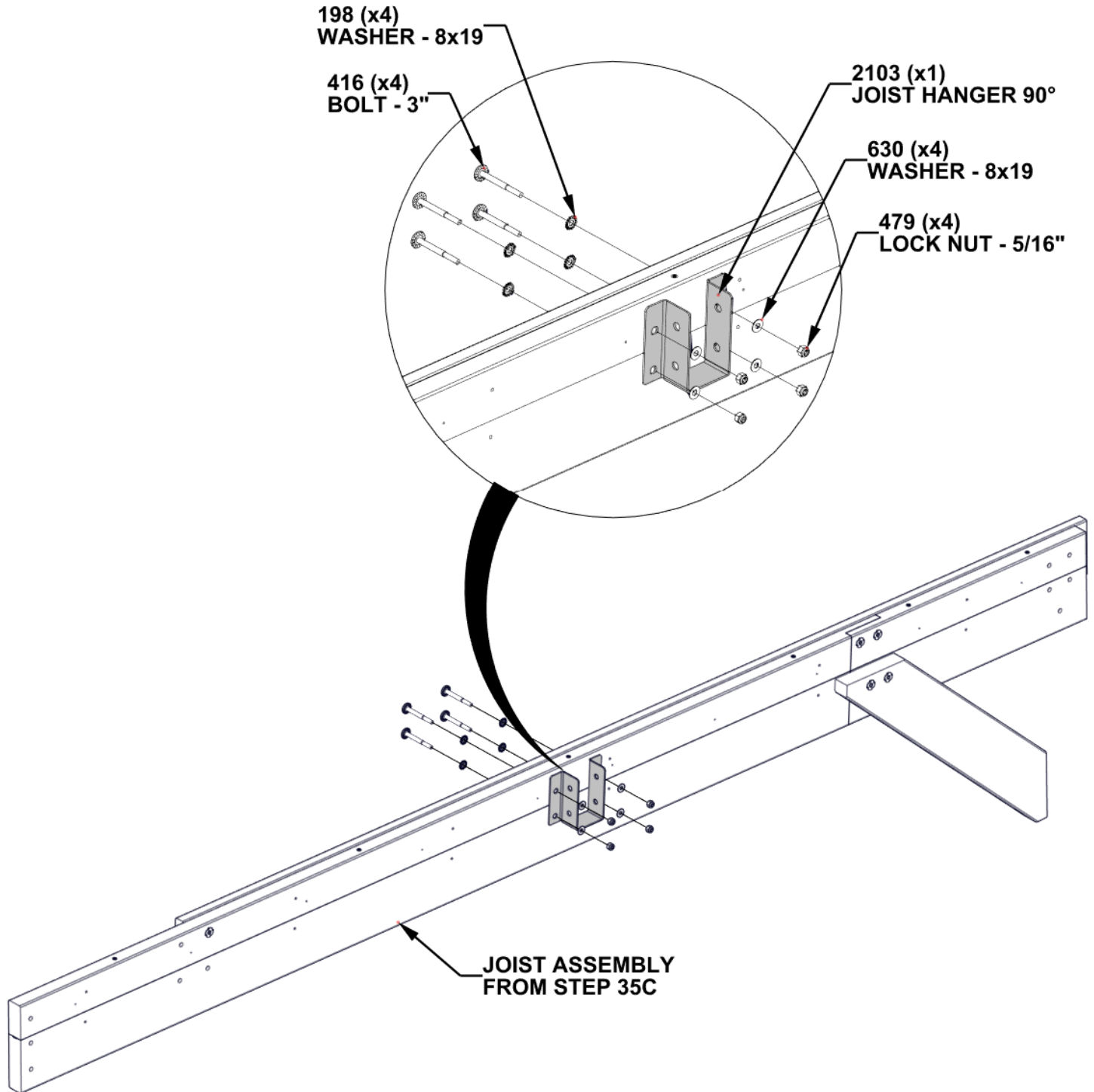

# STEP 36A - CARPORT ASSEMBLY

QTY	PART NUMBER	DESCRIPTION
2	H100197	LAG SCREW WH 5/16x2 1/2 BLK
8	H100198	WASHER LOCK EXT 8x19
6	H100379	TNUT-5/16" BLK
1	H100405	WASHER LOCK EXT 6x15
1	H100792	LAG SCREW WH 1/4x3 BLK
6	H101153	BOLT WH 5/16x8 1/4 BLK

**NOTE:**  
 • EXTRA PEOPLE ARE HELPFUL FOR THIS STEP.  
 • INSERT T-NUTS FIRST.

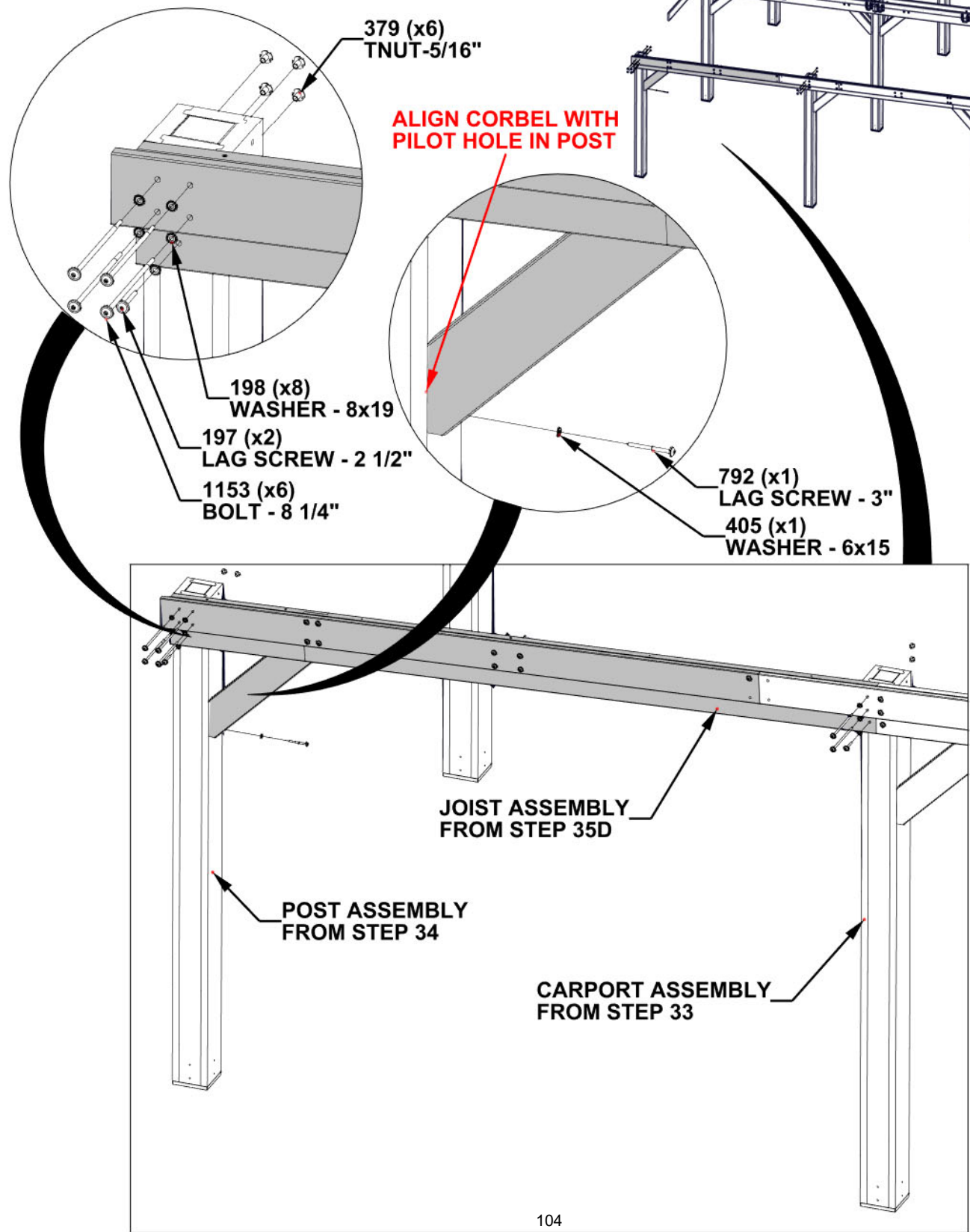
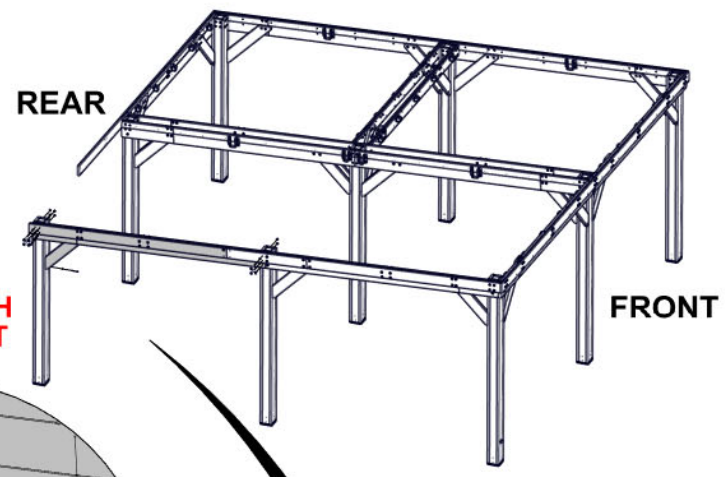



# STEP 36B - CARPORT ASSEMBLY

QTY	PART NUMBER	DESCRIPTION
3	H100198	WASHER LOCK EXT 8x19
1	H100205	BOLT WH 5/16x2 1/4 BLK
3	H100379	TNUT-5/16" BLK
1	H100405	WASHER LOCK EXT 6x15
2	H100415	BOLT WH 5/16x3 3/4 BLK
1	H100792	LAG SCREW WH 1/4x3 BLK



D03 CORBEL - W4L17620  
 (x1) 1 3/8"x5 1/4"x28 1/8" (36x134x713)

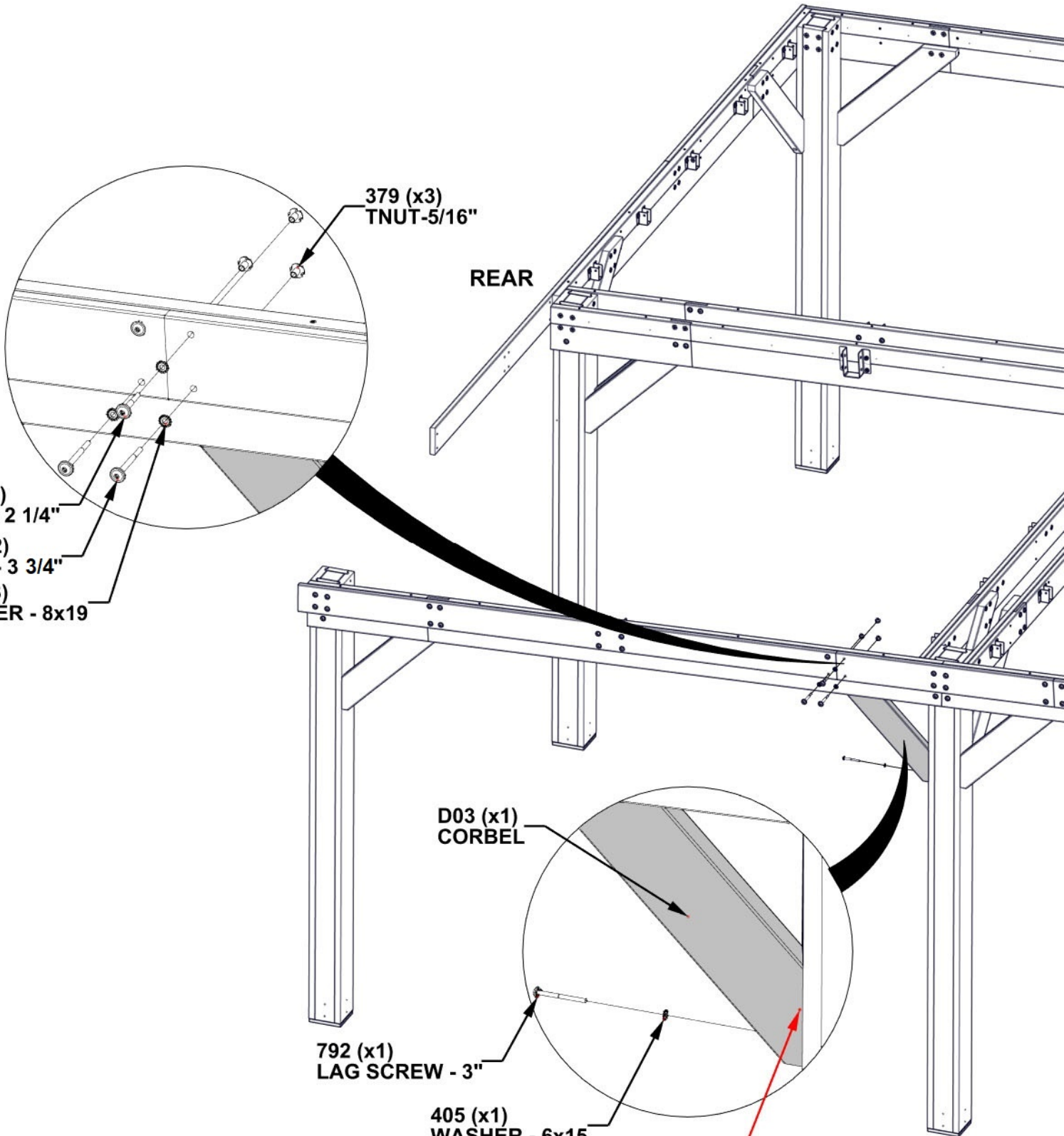

**ALIGN CORBEL WITH  
PILOT HOLE IN POST**

# STEP 37 - LEFT REAR JOIST ASSEMBLY

QTY	PART NUMBER	DESCRIPTION
8	H100379	T-NUT 5/16 BLK



J16 JOIST ASSEMBLY - W2A03822  
(x1) 1 7/16"x8 7/16"x97 5/8" (36x214x2480)

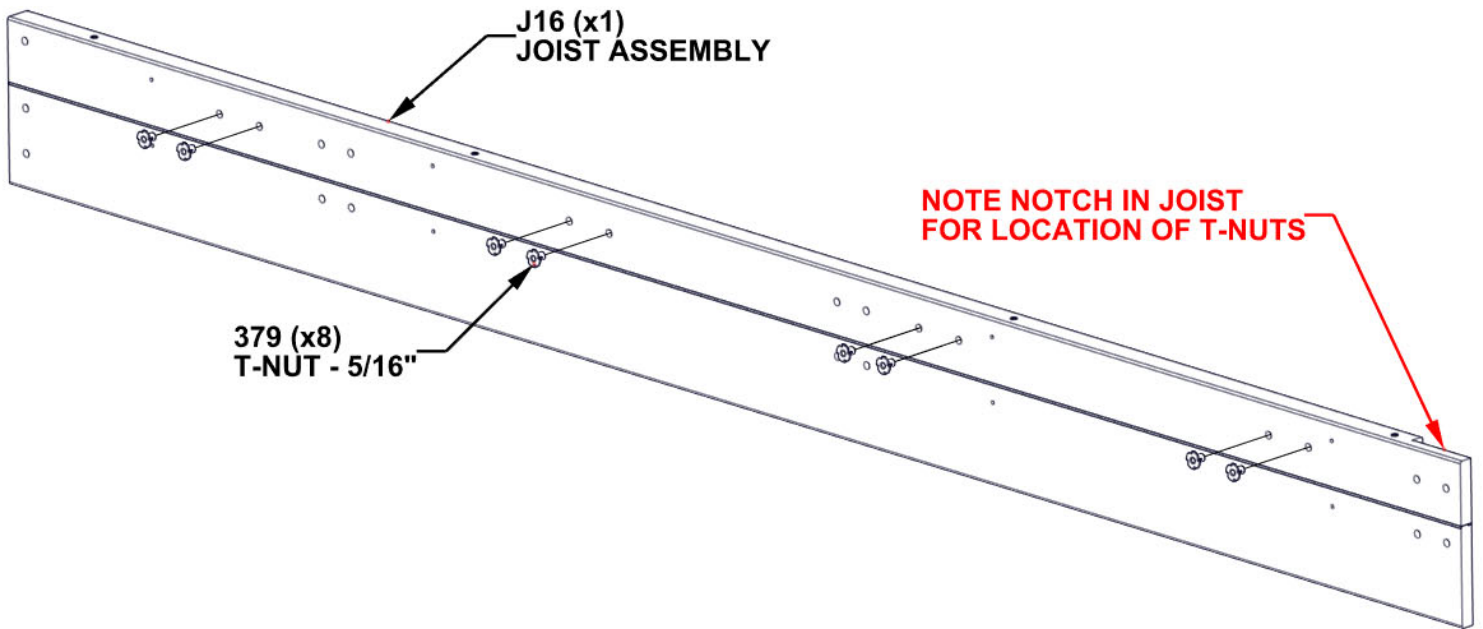

# STEP 38 - LEFT REAR JOIST ASSEMBLY

QTY	PART NUMBER	DESCRIPTION
2	H100379	T-NUT 5/16 BLK



J10 JOIST ASSEMBLY - W2A03820  
(x1) 1 7/16"x8 7/16"x28 7/16" (36x214x722)

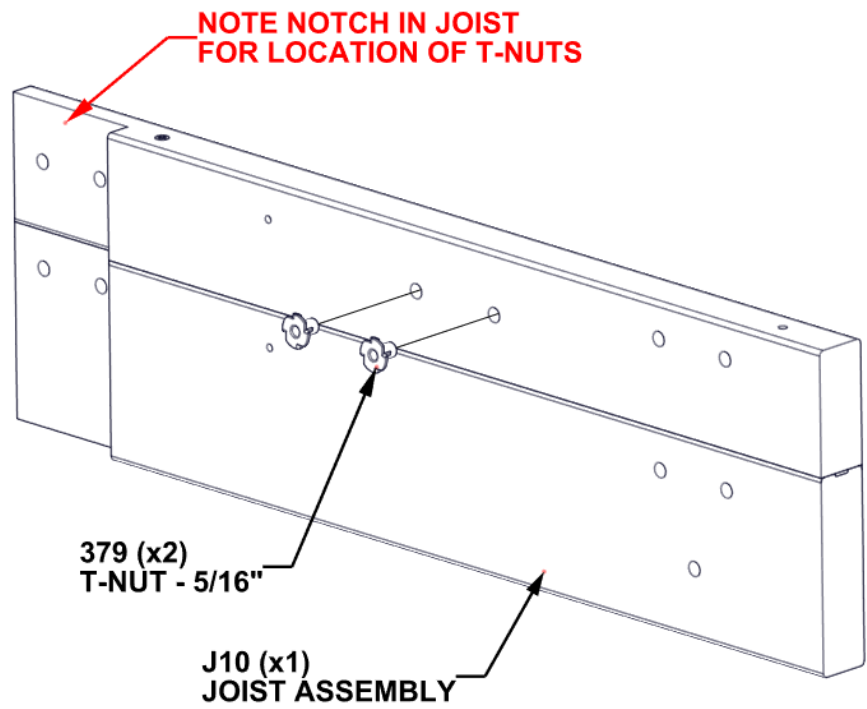

# STEP 39A - LEFT REAR JOIST ASSEMBLY

QTY	PART NUMBER	DESCRIPTION
2	H100198	WASHER LOCK EXT 8x19
2	H100205	BOLT WH 5/16x2 1/4 BLK
2	H100379	TNUT-5/16" BLK



G07 FASCIA - W4L17634  
 (x1) 15/16"x5 1/4"x66 3/8" (24x134x1686)

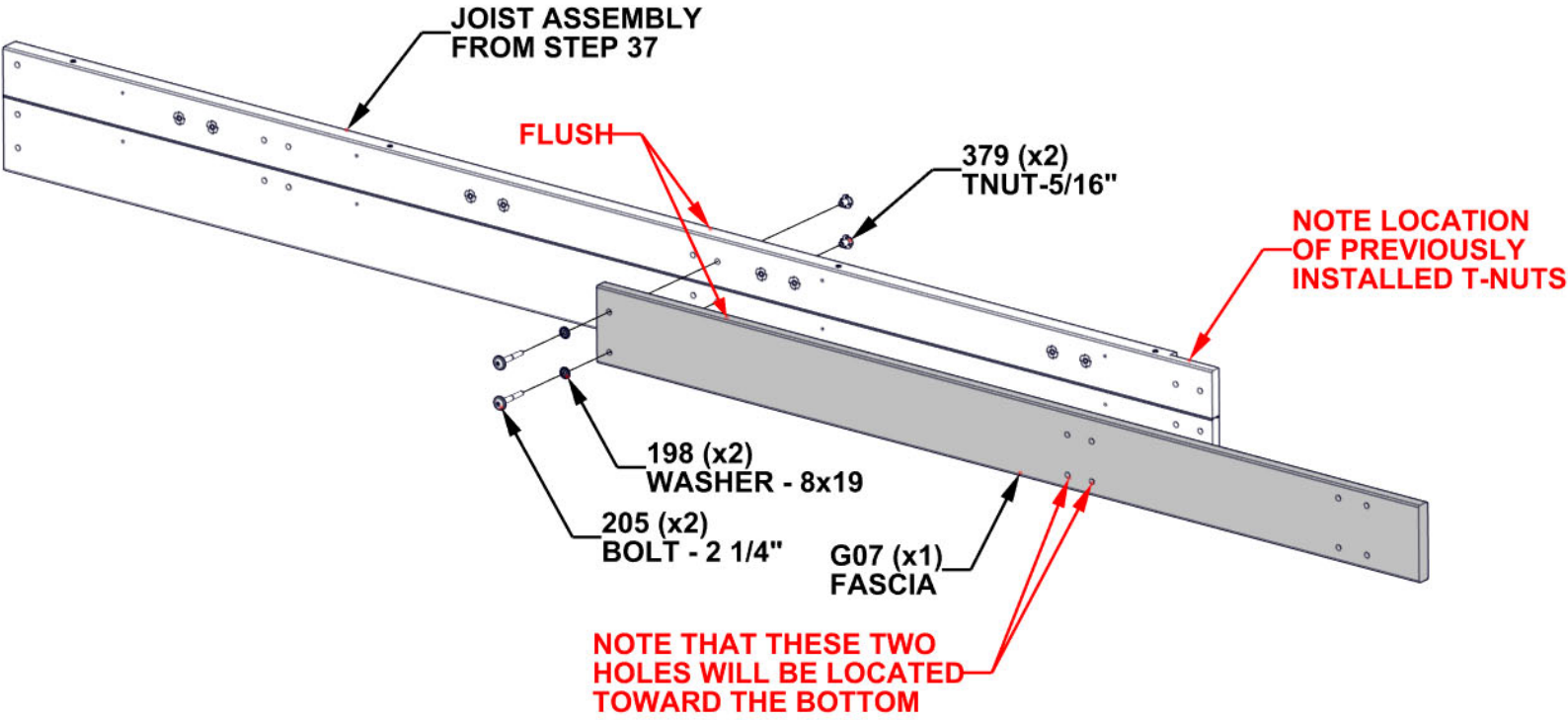

# STEP 39B - LEFT REAR JOIST ASSEMBLY

QTY	PART NUMBER	DESCRIPTION
4	H100198	WASHER LOCK EXT 8x19
4	H100379	TNUT-5/16" BLK
4	H100415	BOLT WH 5/16x3 3/4 BLK



D06 CORBEL - W4L17631  
(x1) 1 7/16"x5 1/4"x33 5/8" (36x134x854)

**NOTES:**  
• INSERT T-NUTS FIRST.

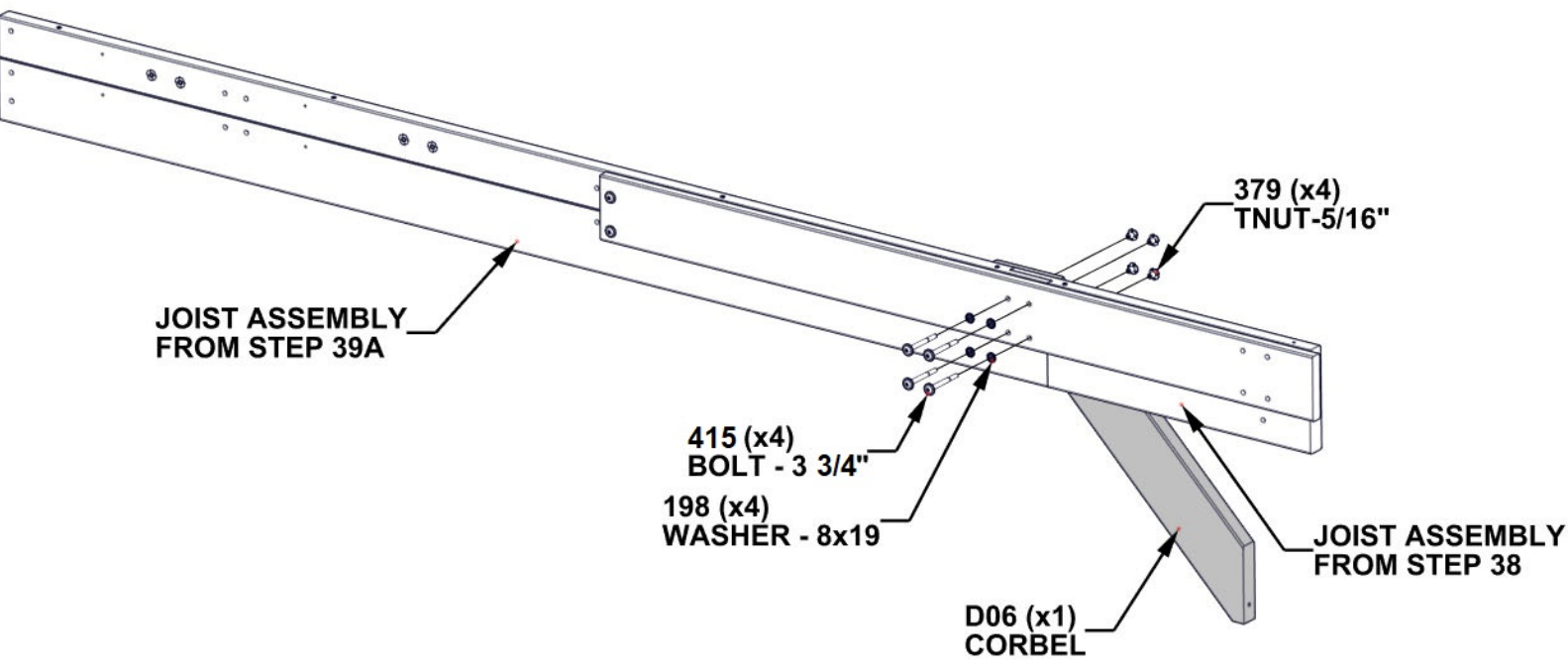

# STEP 39C - LEFT REAR JOIST ASSEMBLY

QTY	PART NUMBER	DESCRIPTION
10	H100459	BOLT WH 5/16x1 1/4 BLK

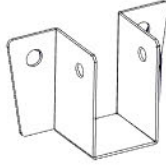

A4M01787 RAFTER BRACKET  
(x5)

**NOTE:**  
ALIGN RAFTER BRACKETS WITH HOLES  
IN BEAM AND ATTACH AS SHOWN

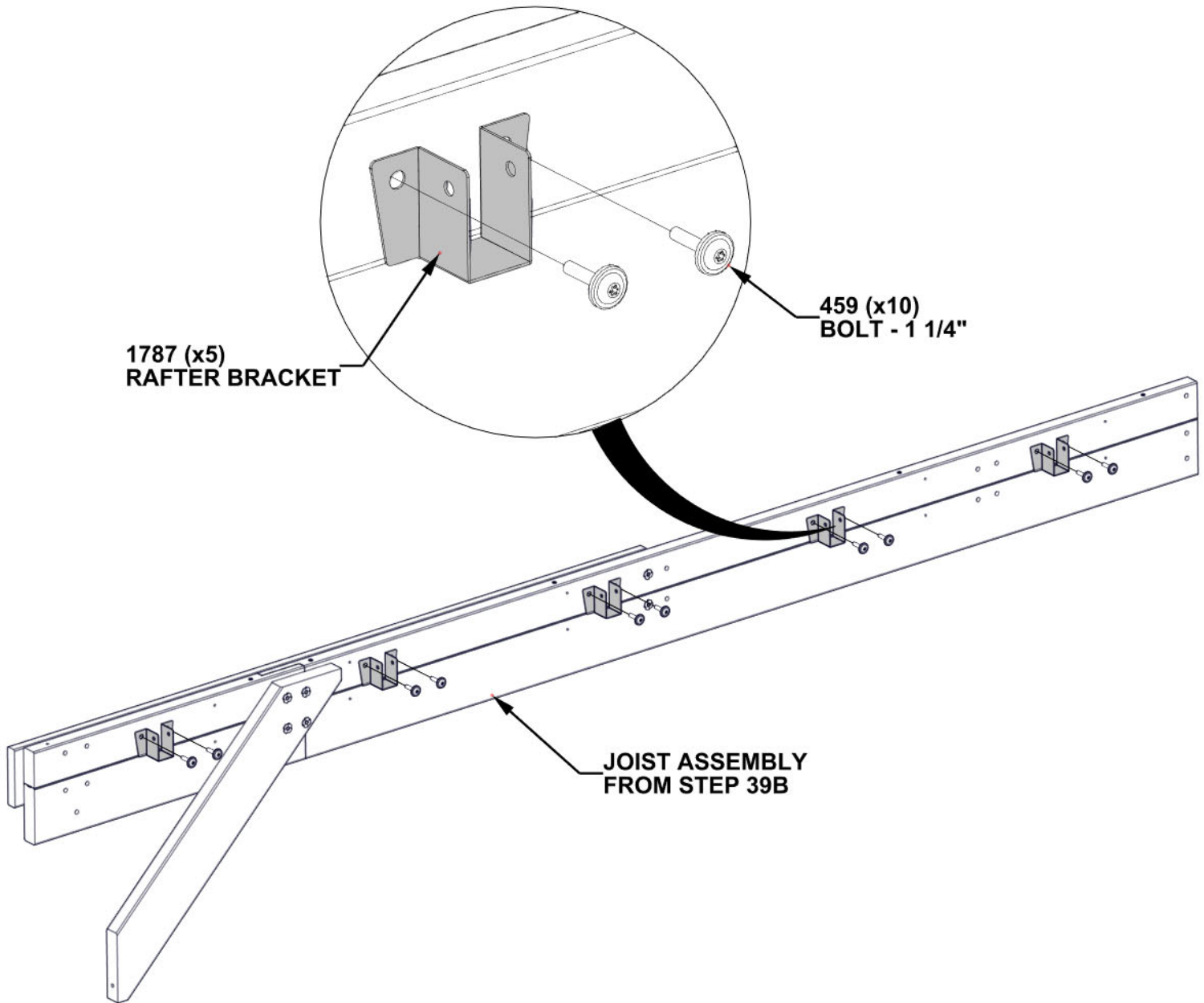

# STEP 40A - CARPORT ASSEMBLY

QTY	PART NUMBER	DESCRIPTION
2	H100197	LAG SCREW WH 5/16x2 1/2 BLK
8	H100198	WASHER LOCK EXT 8x19
6	H100379	TNUT-5/16" BLK
6	H101153	BOLT WH 5/16x8 1/4 BLK

- NOTE:**
- EXTRA PEOPLE ARE HELPFUL FOR THIS STEP.
  - INSERT T-NUTS FIRST.

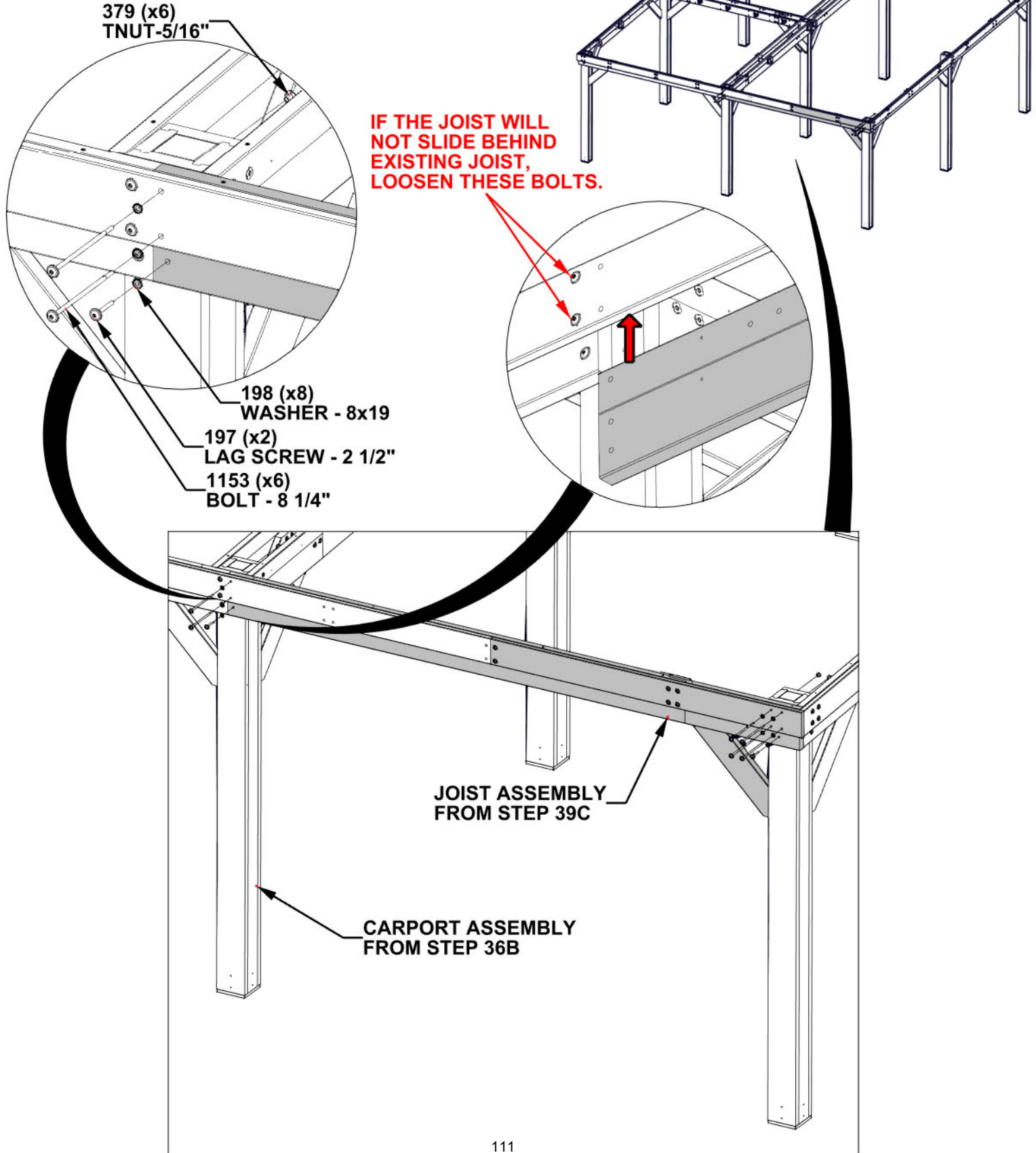

# STEP 40B - CARPORT ASSEMBLY

QTY	PART NUMBER	DESCRIPTION
10	H100391	SCREW PFH 8x2 BLK

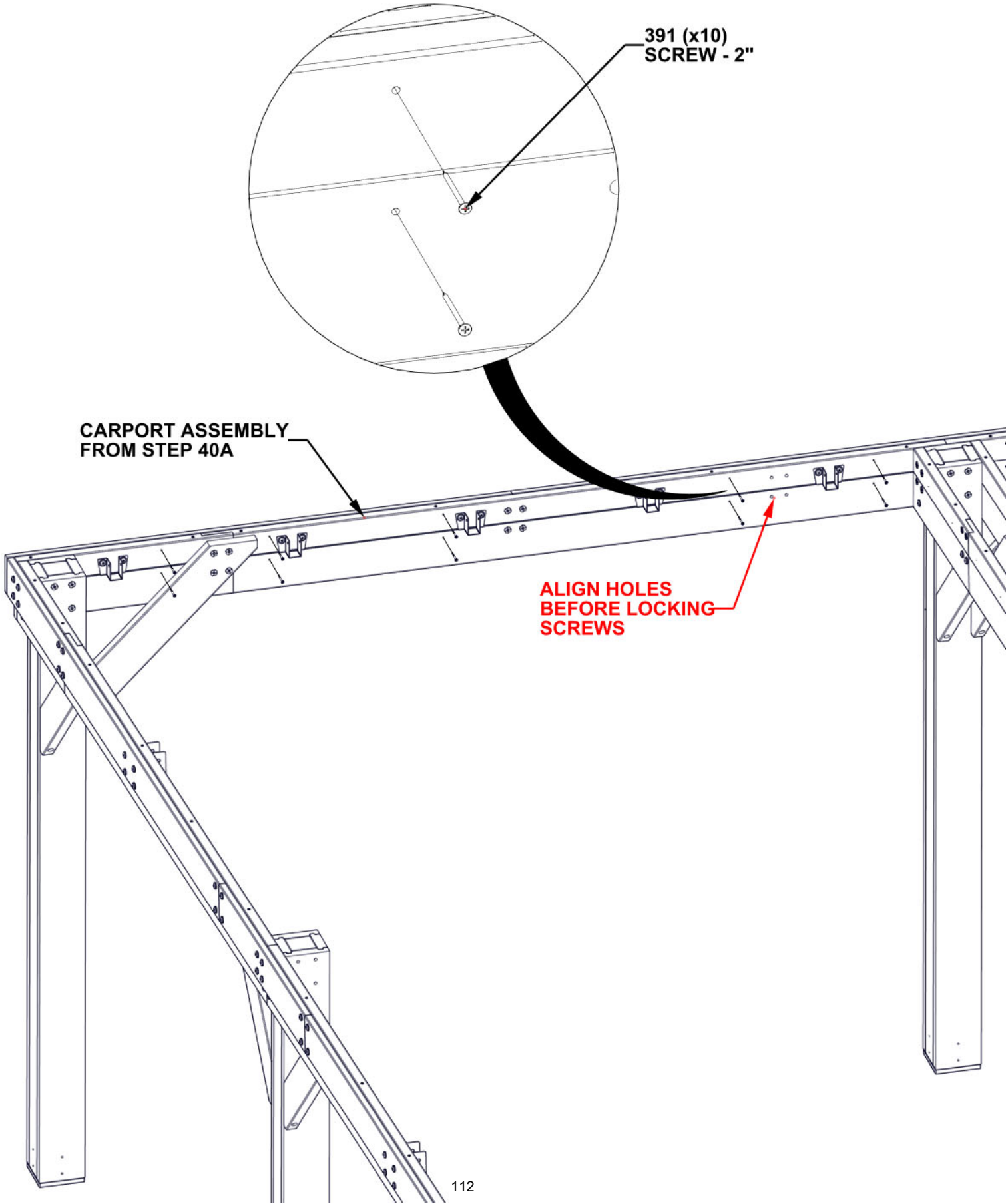

CARPORT ASSEMBLY  
FROM STEP 40A

391 (x10)  
SCREW - 2"

ALIGN HOLES  
BEFORE LOCKING  
SCREWS



# STEP 40C - CARPORT ASSEMBLY

QTY	PART NUMBER	DESCRIPTION
6	H100198	WASHER LOCK EXT 8x19
2	H100205	BOLT WH 5/16x2 1/4 BLK
6	H100379	TNUT-5/16" BLK
2	H100405	WASHER LOCK EXT 6x15
4	H100415	BOLT WH 5/16x3 3/4 BLK
2	H100792	LAG SCREW WH 1/4x3 BLK



D06 CORBEL - W4L17631  
 (x1) 1 7/16"x5 1/4"x33 5/8" (36x134x854)

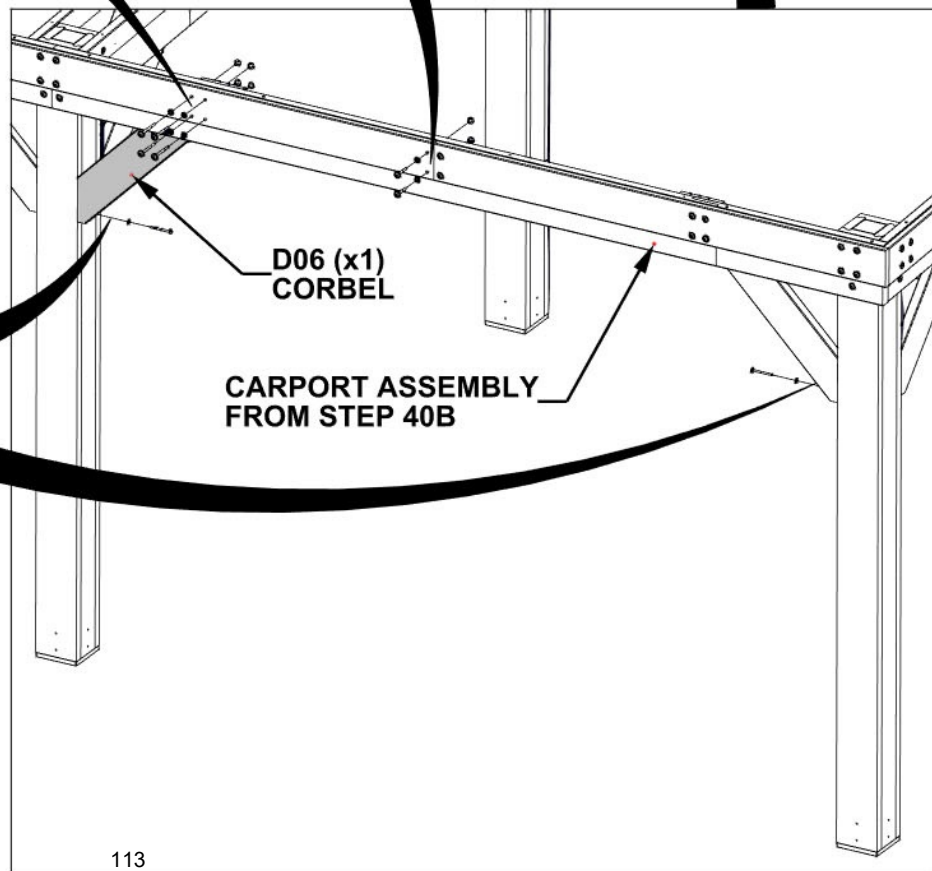
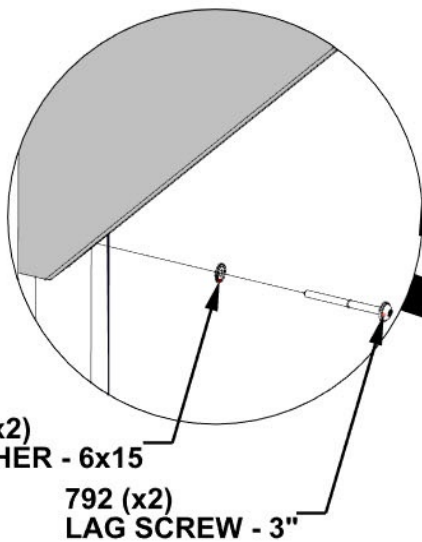
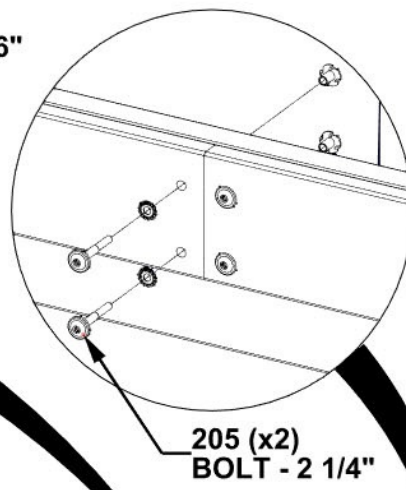
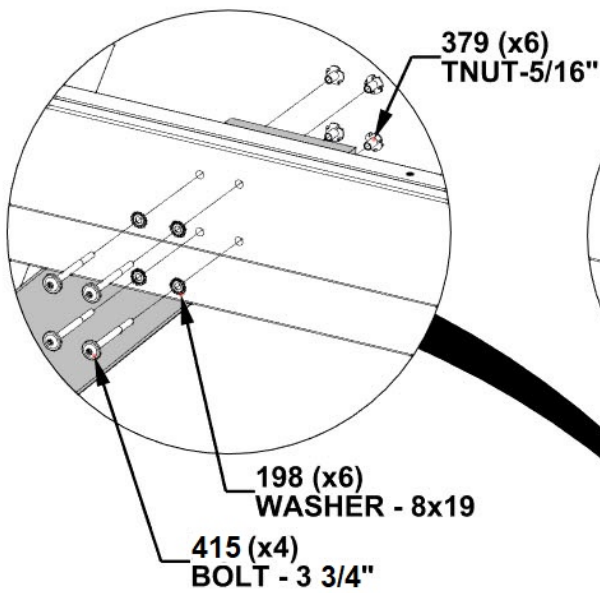
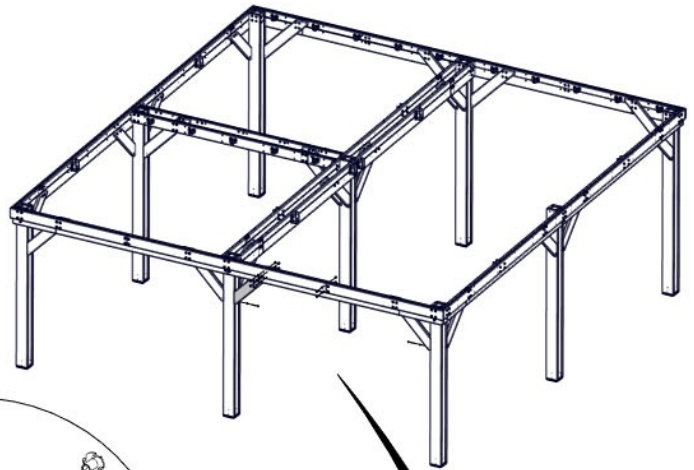

# STEP 41A - CENTER BEAM ASSEMBLY

QTY	PART NUMBER	DESCRIPTION
8	H100198	WASHER LOCK EXT 8x19
8	H100379	T-NUT 5/16 BLK
8	H100484	BOLT WH 5/16x3 1/4 BLK

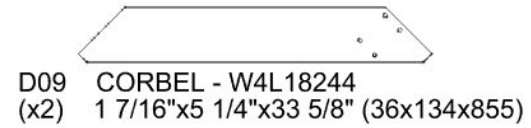
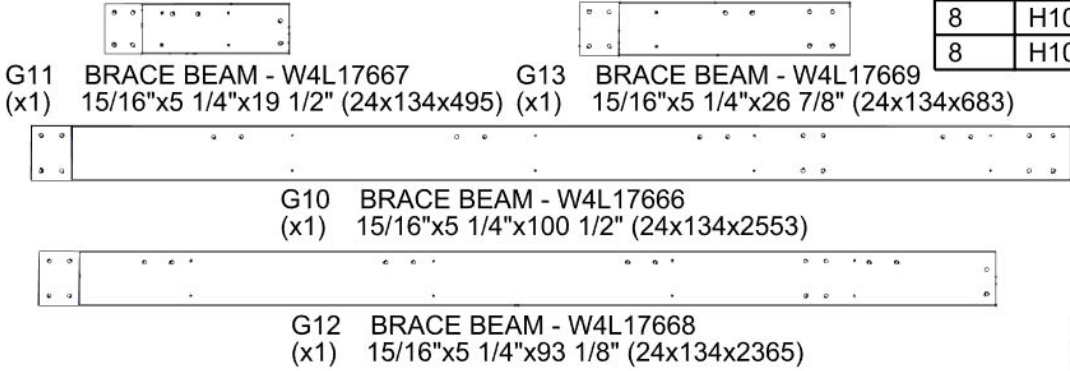

- NOTES:**
- HAND TIGHTEN ONLY.
  - INSERT T-NUTS FIRST.

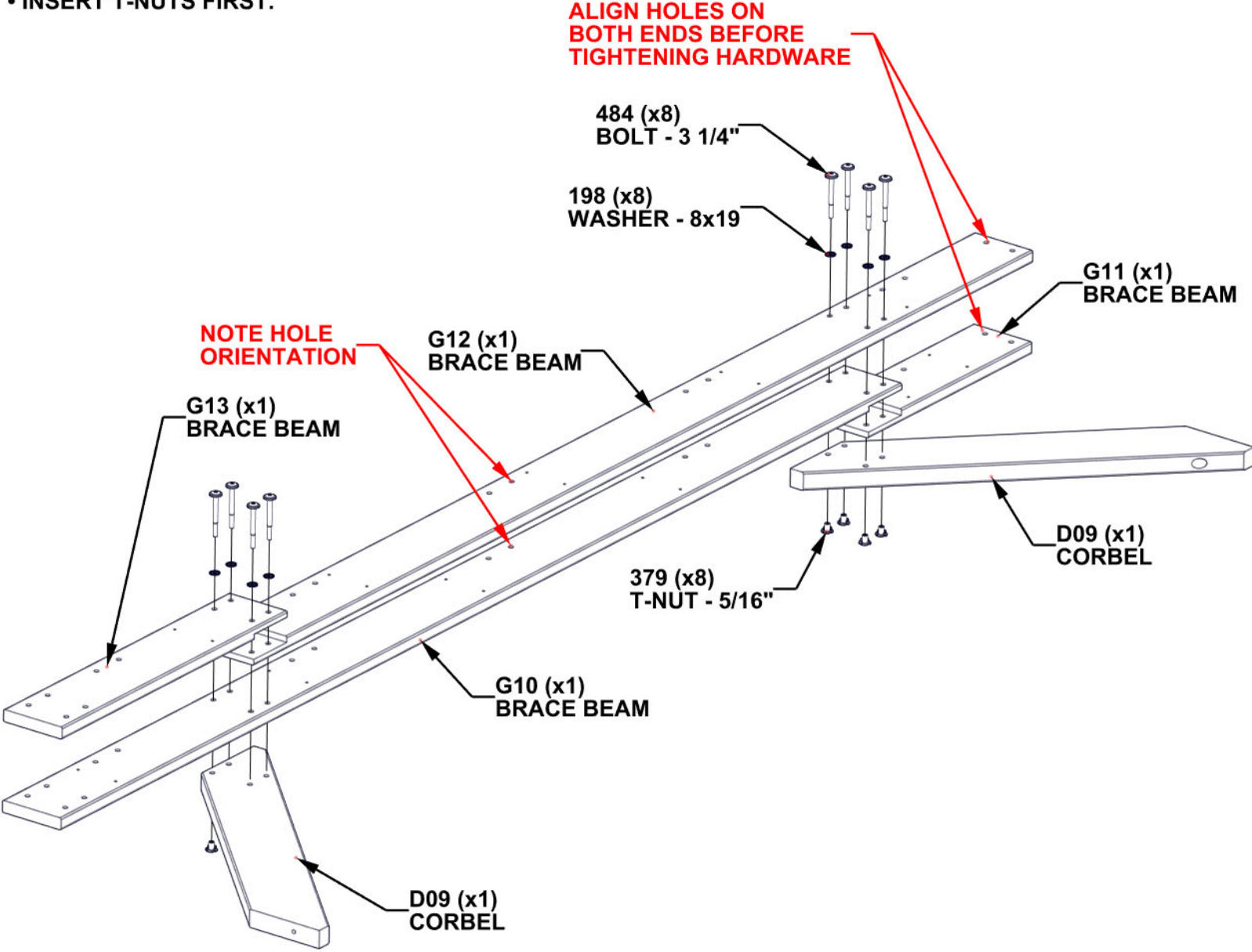

# STEP 41B - CENTER BEAM ASSEMBLY

QTY	PART NUMBER	DESCRIPTION
22	H100200	SCREW PFH 8x1 1/2 BLK

- NOTES:**
- BEFORE ATTACHING SCREWS, MAKE SURE ALL BOARDS ARE FLUSH AT TOP, SIDES, & BOTTOMS.
  - AFTER SCREWS ARE TIGHTENED, TIGHTEN ALL OTHER HARDWARE.

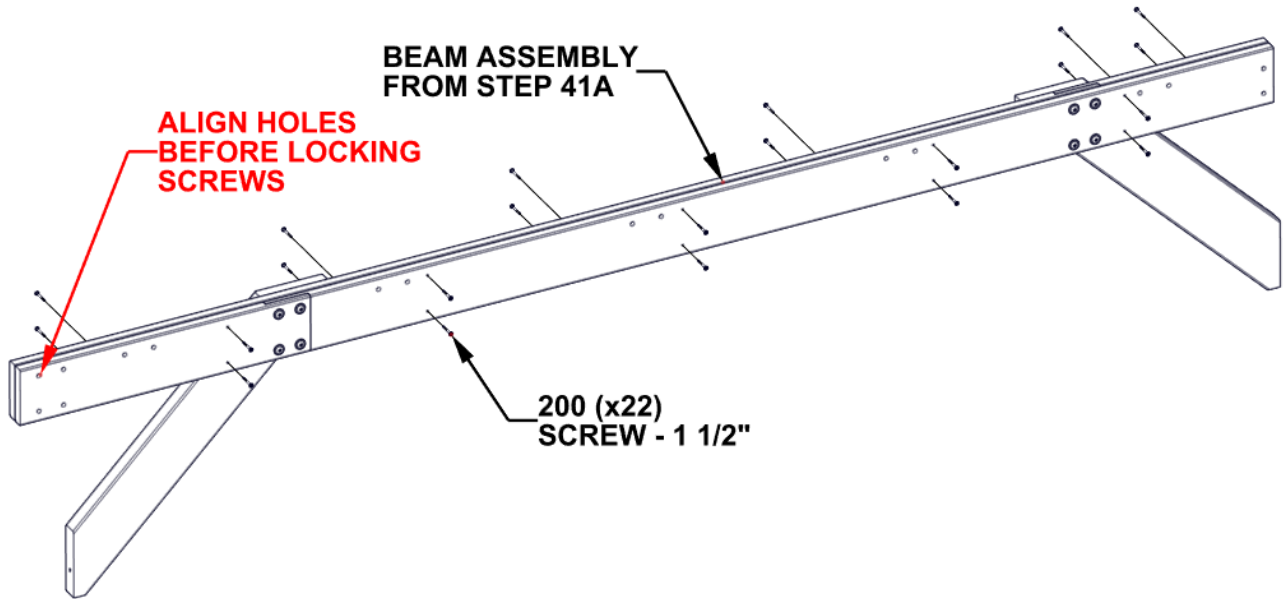

# STEP 41C - CENTER BEAM ASSEMBLY

QTY	PART NUMBER	DESCRIPTION
10	H100378	BOLT WH 5/16x1 3/4 BLK
10	H100379	T-NUT 5/16 BLK



A4M01787 RAFTER BRACKET  
(x5)

**NOTE:**  
ALIGN RAFTER BRACKETS WITH HOLES  
IN BEAM AND ATTACH AS SHOWN

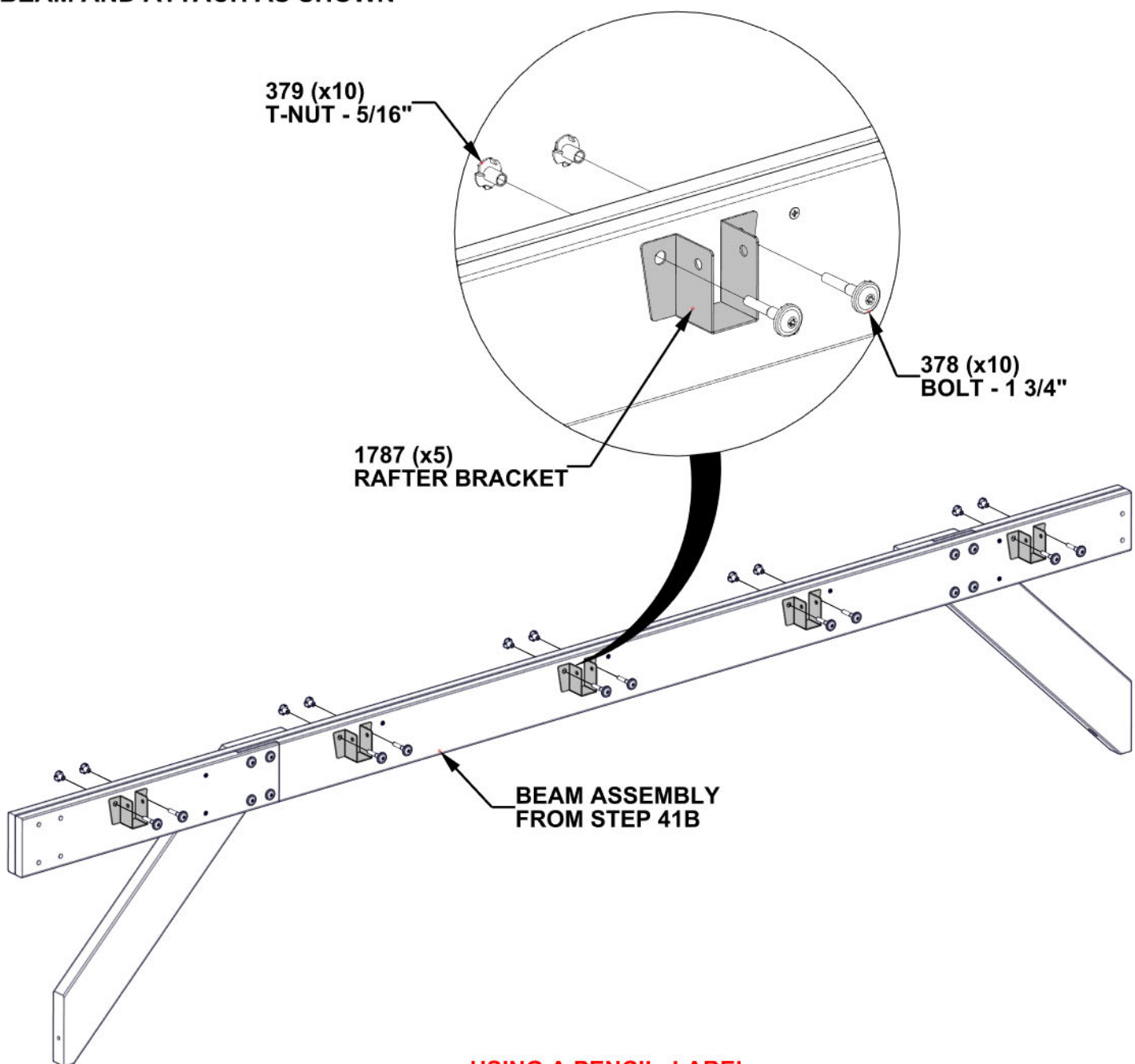

**USING A PENCIL, LABEL  
THE ASSEMBLY "STEP 41C."**

**SET CENTER BEAM  
ASSEMBLY TO THE SIDE**

# STEP 42A - CENTER BEAM ASSEMBLY

QTY	PART NUMBER	DESCRIPTION
8	H100198	WASHER LOCK EXT 8x19
8	H100379	T-NUT 5/16 BLK
8	H100484	BOLT WH 5/16x3 1/4 BLK

G15 BRACE BEAM - W4L17801 (x1) 15/16"x5 1/4"x19 1/2" (24x134x495)      G17 BRACE BEAM - W4L17803 (x1) 15/16"x5 1/4"x26 7/8" (24x134x683)



G16 BRACE BEAM - W4L17802 (x1) 15/16"x5 1/4"x93 1/8" (24x134x2365)



G14 BRACE BEAM - W4L17670 (x1) 15/16"x5 1/4"x100 1/2" (24x134x2553)



D09 CORBEL - W4L18244 (x2) 1 7/16"x5 1/4"x33 5/8" (36x134x855)

- NOTES:**
- HAND TIGHTEN ONLY.
  - INSERT T-NUTS FIRST.

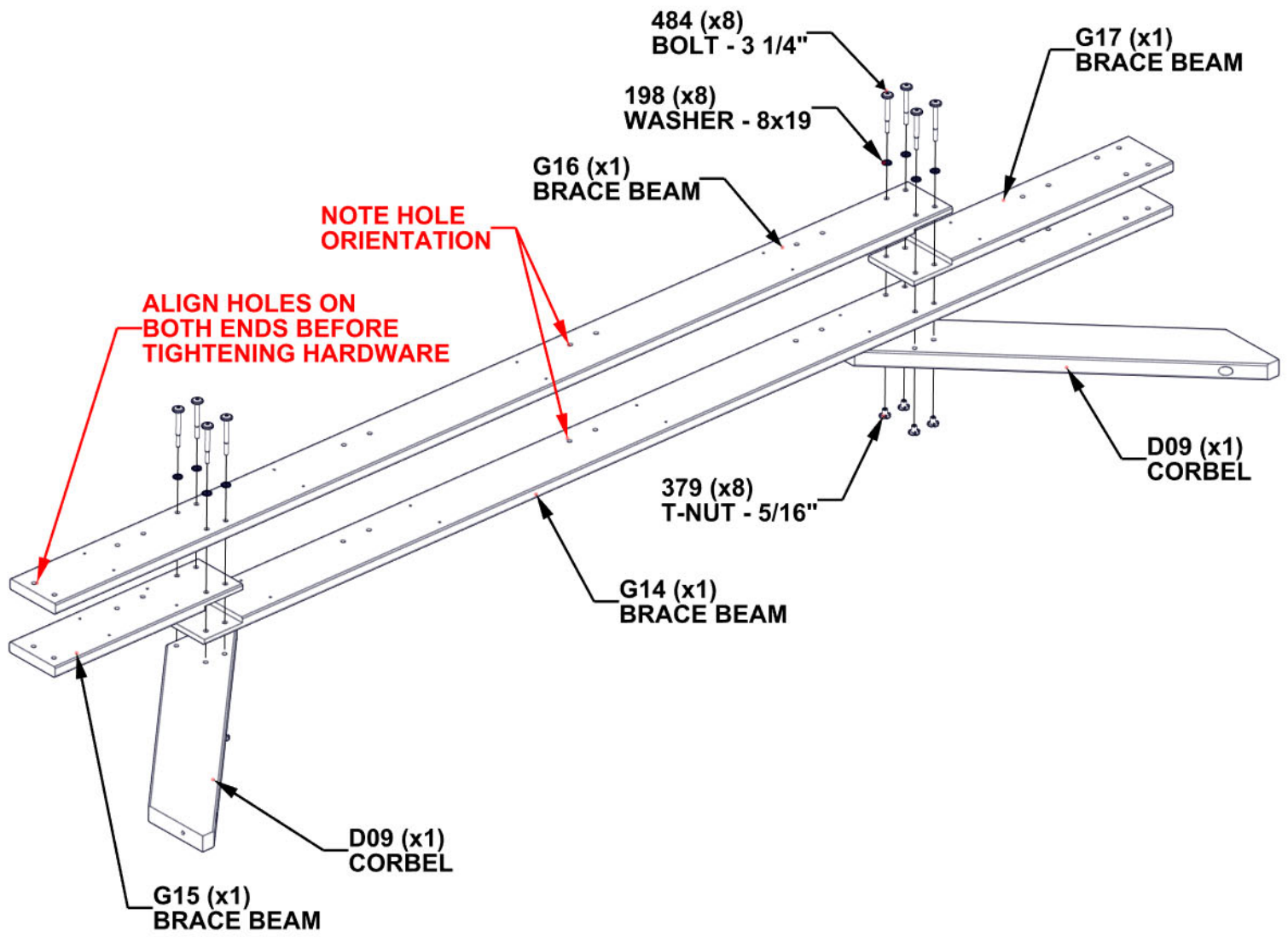

# STEP 42B - CENTER BEAM ASSEMBLY

QTY	PART NUMBER	DESCRIPTION
24	H100200	SCREW PFH 8x1 1/2 BLK

## NOTES:

- BEFORE ATTACHING SCREWS, MAKE SURE ALL BOARDS ARE FLUSH AT TOP, SIDES, & BOTTOMS.
- AFTER SCREWS ARE TIGHTENED, TIGHTEN ALL OTHER HARDWARE.

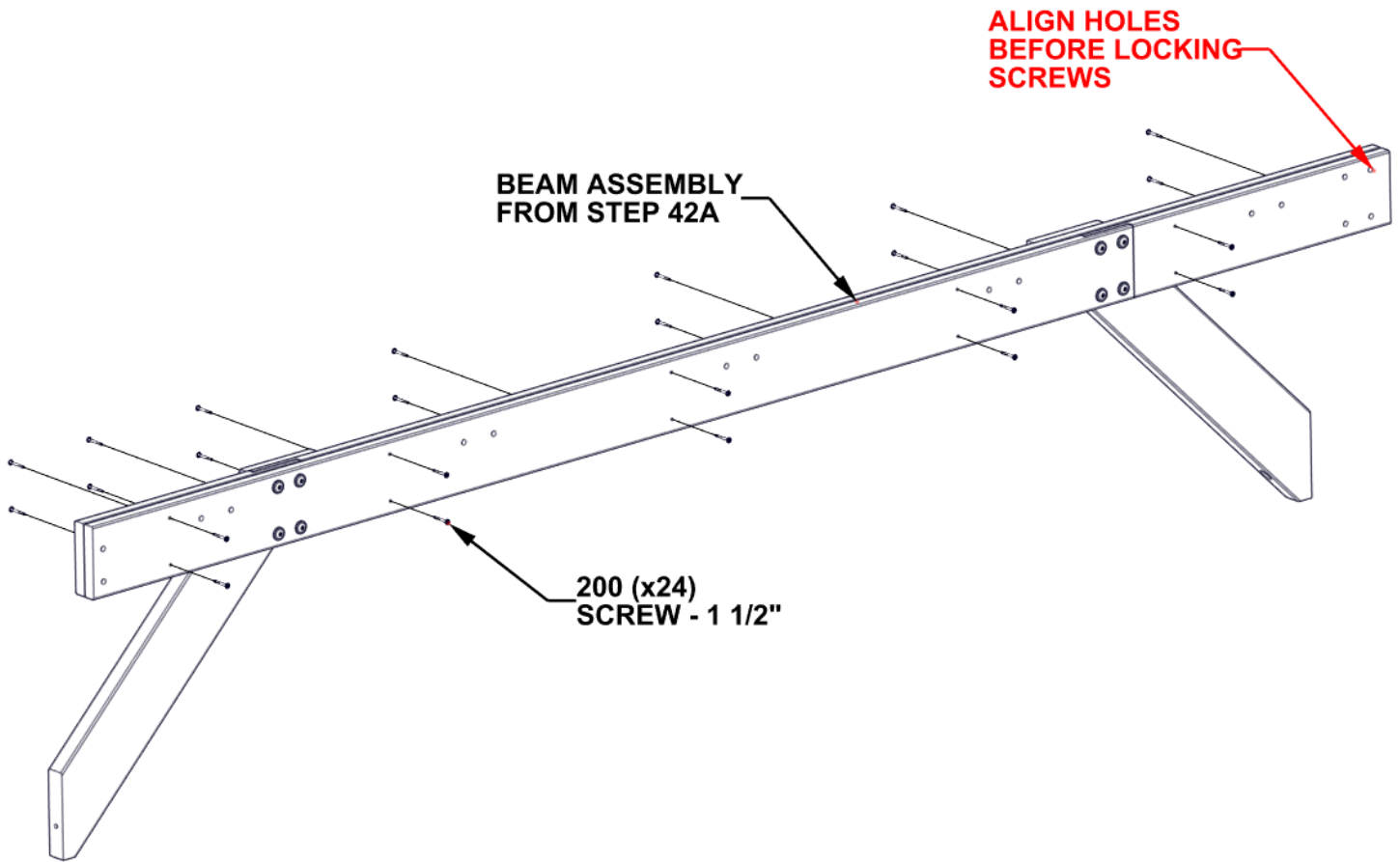

# STEP 42C - CENTER BEAM ASSEMBLY

QTY	PART NUMBER	DESCRIPTION
10	H100378	BOLT WH 5/16x1 3/4 BLK
10	H100379	T-NUT 5/16 BLK

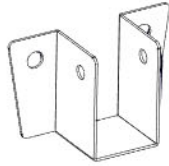

A4M01787 RAFTER BRACKET  
(x5)

**NOTE:**  
ALIGN RAFTER BRACKETS WITH HOLES  
IN BEAM AND ATTACH AS SHOWN

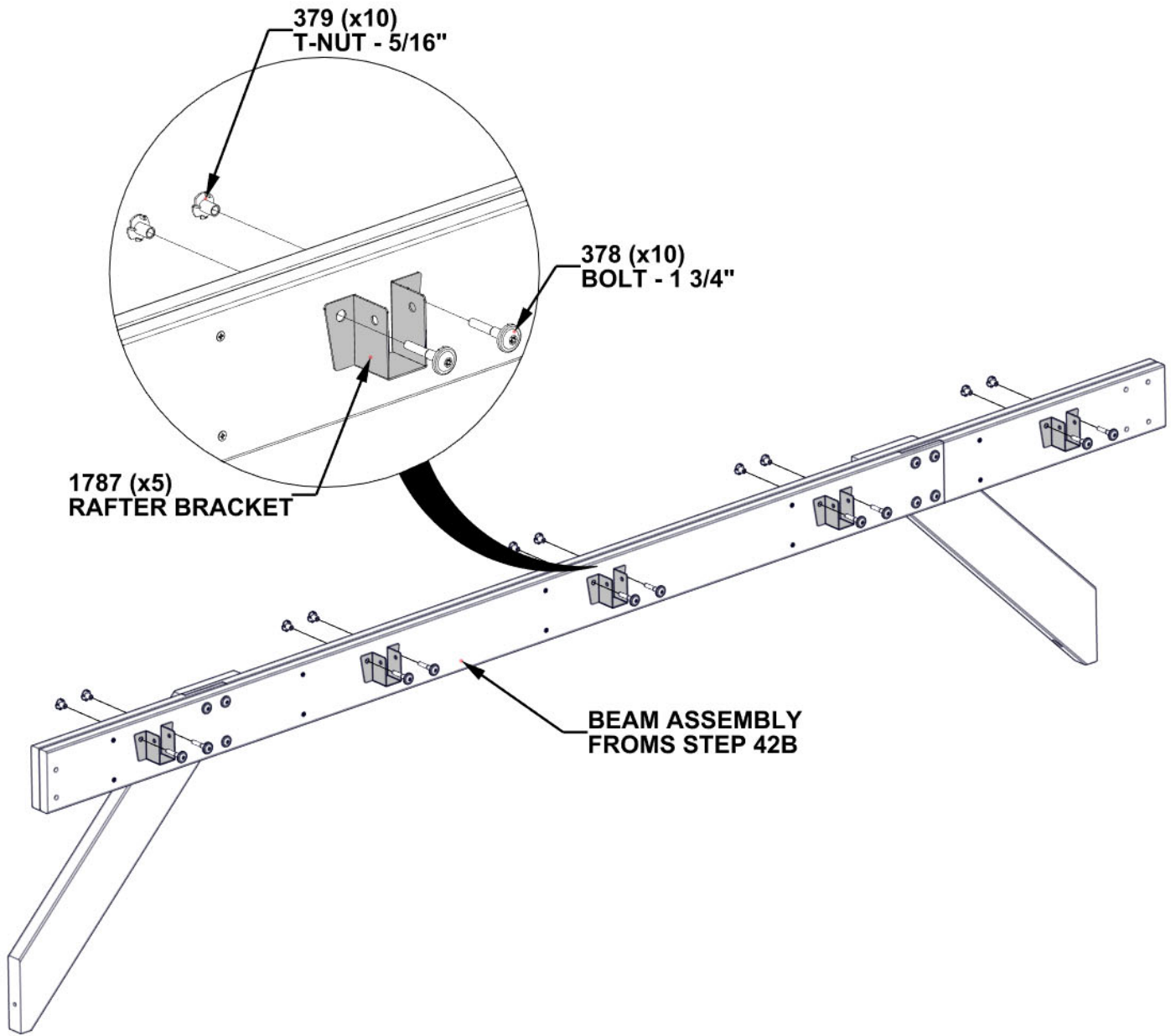

**USING A PENCIL, LABEL  
THE ASSEMBLY "STEP 42C."**



# STEP 43A - CARPORT ASSEMBLY

QTY	PART NUMBER	DESCRIPTION
4	H100194	BOLT WH 5/16x2 1/2 BLK
4	H100198	WASHER LOCK EXT 8x19
4	H100379	TNUT-5/16" BLK
4	H100479	NUT LOCK 5/16 BLK
4	H100630	WASHER FLAT 8x19 BLK
4	H101047	BOLT WH 5/16x9 3/4 BLK

**NOTE:**

- EXTRA PEOPLE ARE HELPFUL FOR THIS STEP.
- INSERT T-NUTS FIRST.

**3. ATTACH JOISTS TO BRACKETS.**

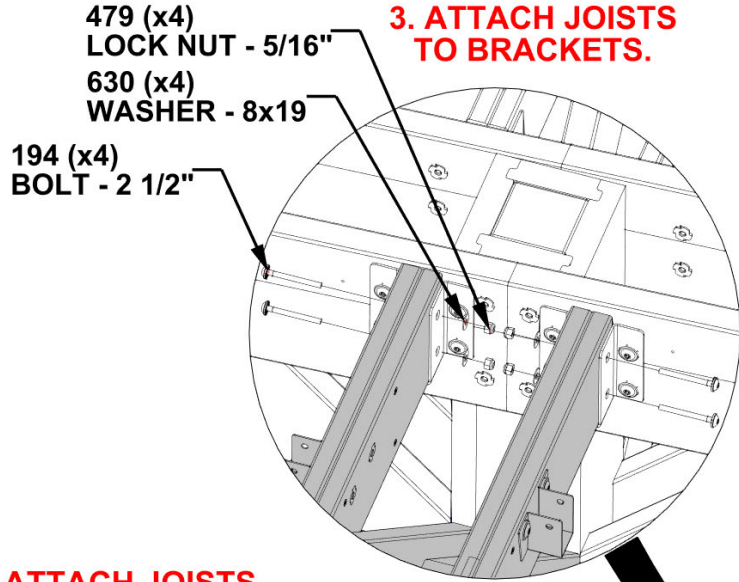

**1. INSERT JOIST ASSEMBLIES INTO BRACKETS.**

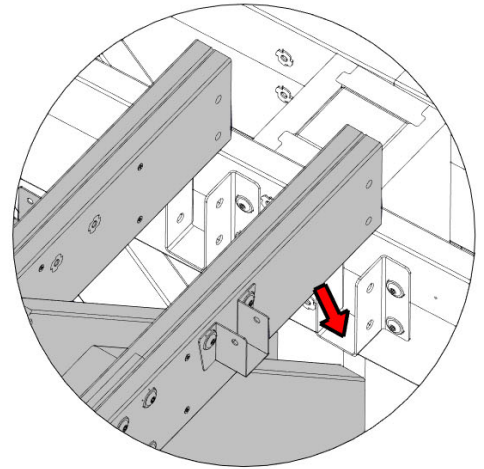

**2. ATTACH JOISTS TO POST.**

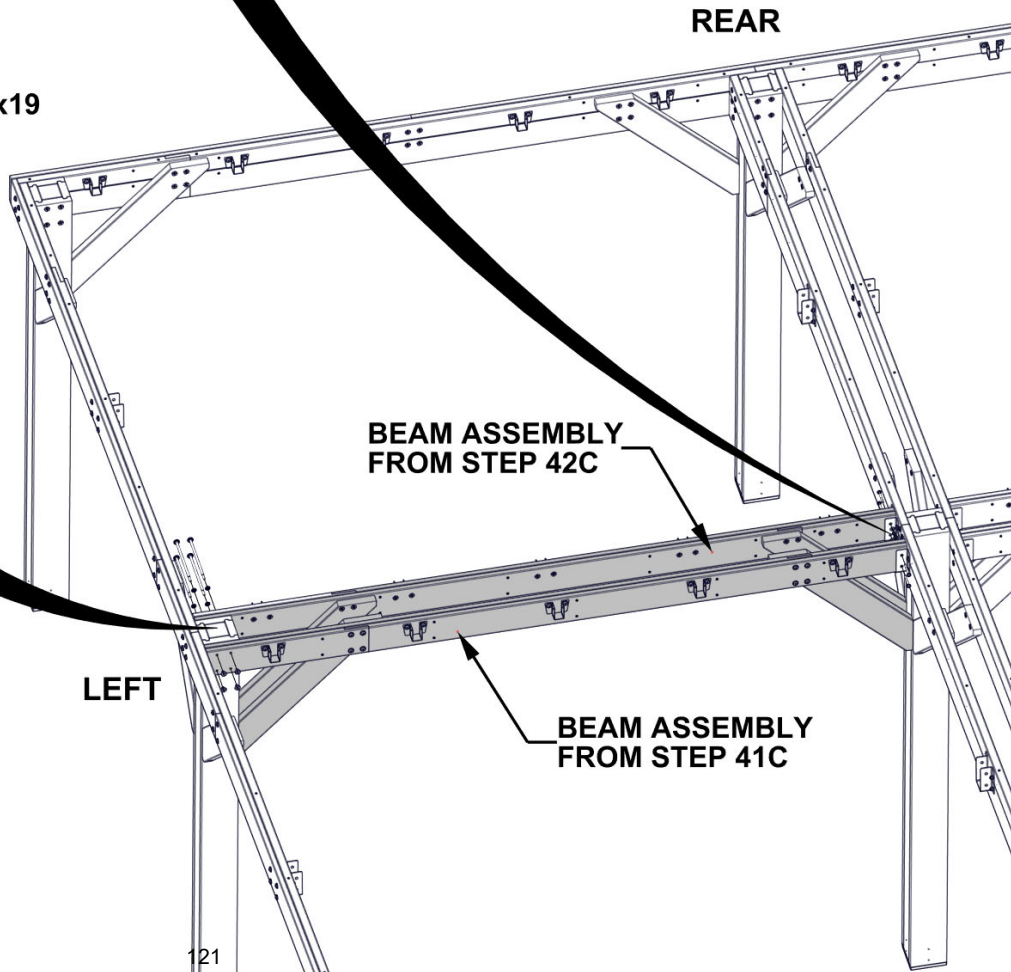
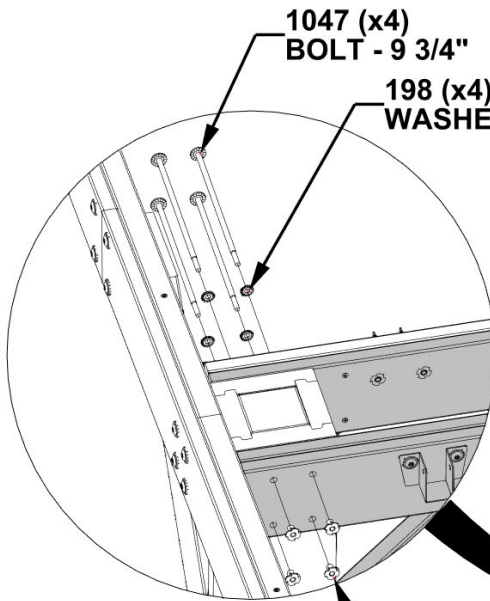

379 (x4)  
TNUT-5/16"

LEFT

BEAM ASSEMBLY FROM STEP 41C

# STEP 43B - CARPORT ASSEMBLY

QTY	PART NUMBER	DESCRIPTION
4	H100405	WASHER LOCK EXT 6x15
4	H100564	LAG SCREW WH 1/4x4 BLK

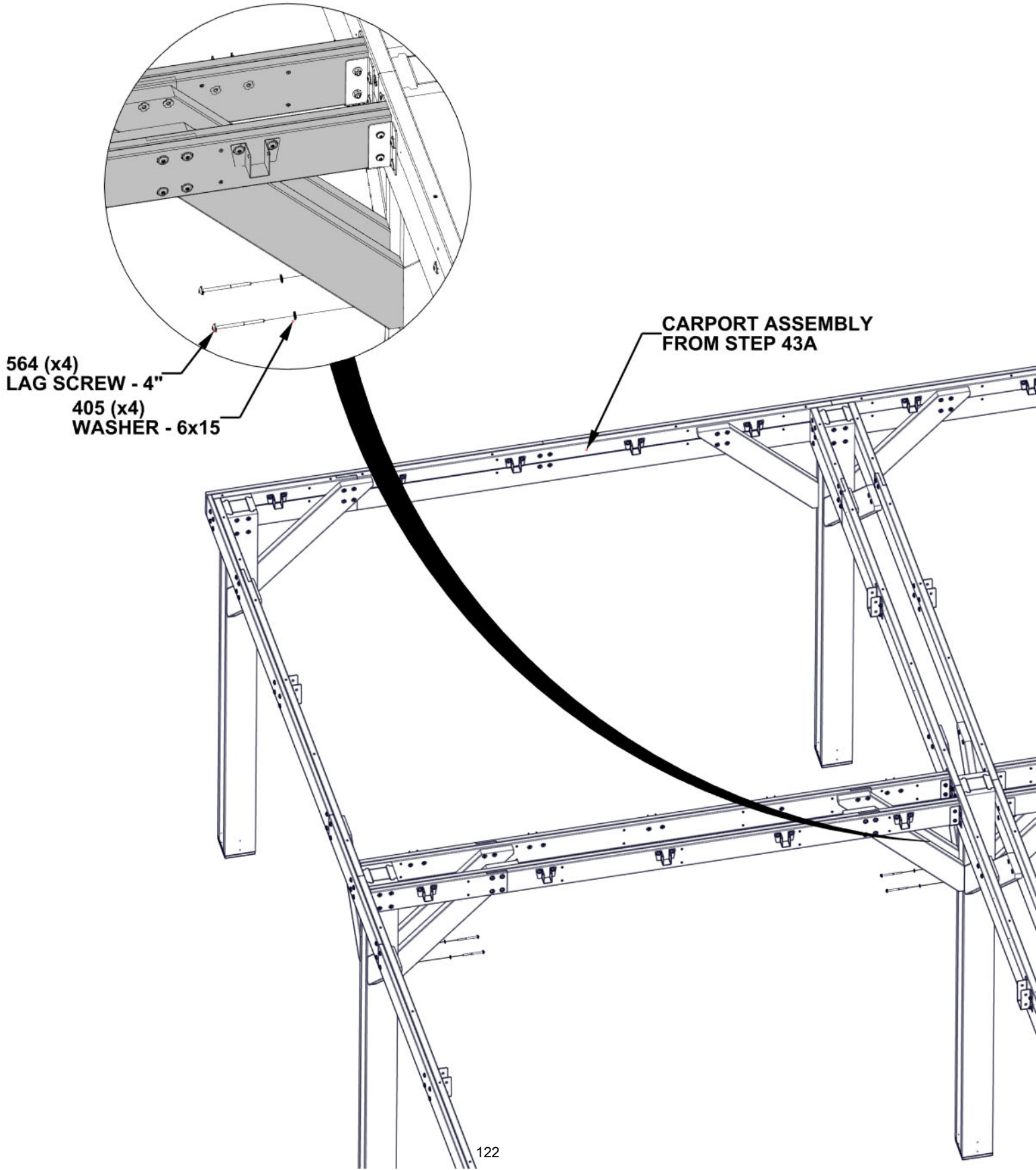

# STEP 44 - CARPORT ASSEMBLY

QTY	PART NUMBER	DESCRIPTION
48	H100391	SCREW PFH 8x2 BLK

**INSTALL SCREWS INTO PILOT HOLES. THE PILOT HOLES TO USE ARE THE TWO HOLES THAT ALIGN VERTICALLY. WORK AROUND THE ASSEMBLY INSTALLING SCREWS INTO BOTH LEFT AND RIGHT SIDES.**

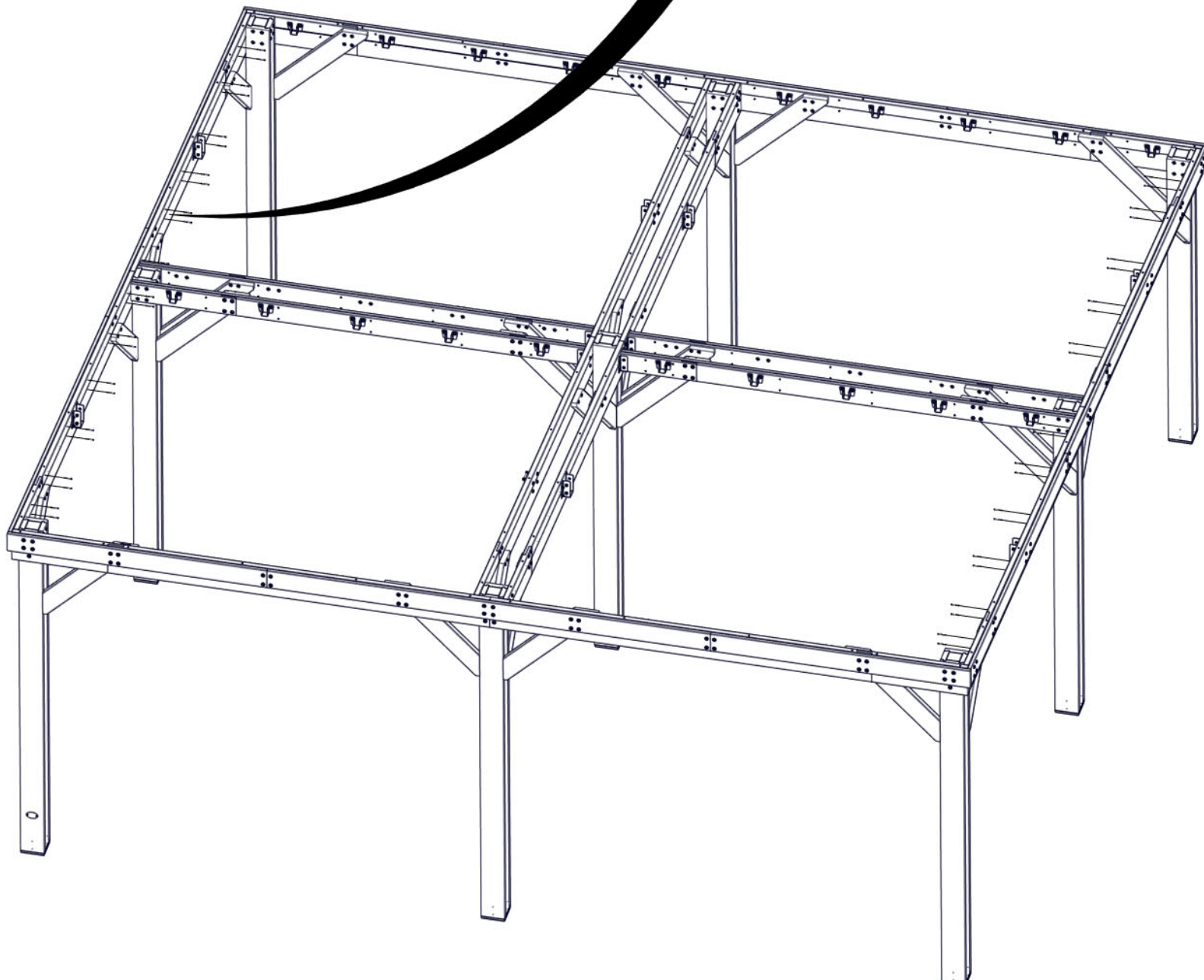
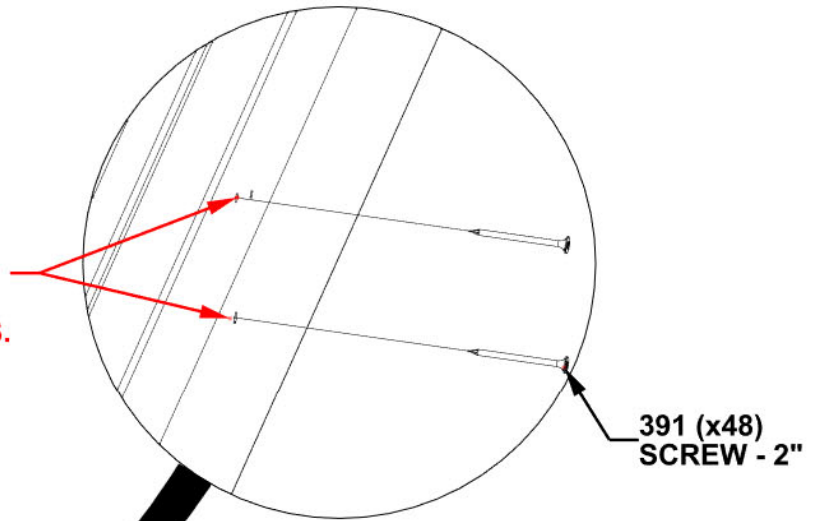

# STEP 45A - BRACE BEAM ASSEMBLY

QTY	PART NUMBER	DESCRIPTION
16	H100195	BOLT WH 5/16x2 3/4 BLK
16	H100198	WASHER LOCK EXT 8x19
16	H100379	TNUT-5/16" BLK



D08 BRACE BEAM - W4L17633  
(x8) 1 7/16"x5 1/4"x24 1/8" (36x134x612)



D07 BRACE BEAM - W4L17632  
(x8) 1 7/16"x5 1/4"x94 1/2" (36x134x2400)

- NOTE:**
- INSERT T-NUTS FIRST.
  - HAND TIGHTEN ONLY.
  - REPEAT THIS STEP 4 TIMES.

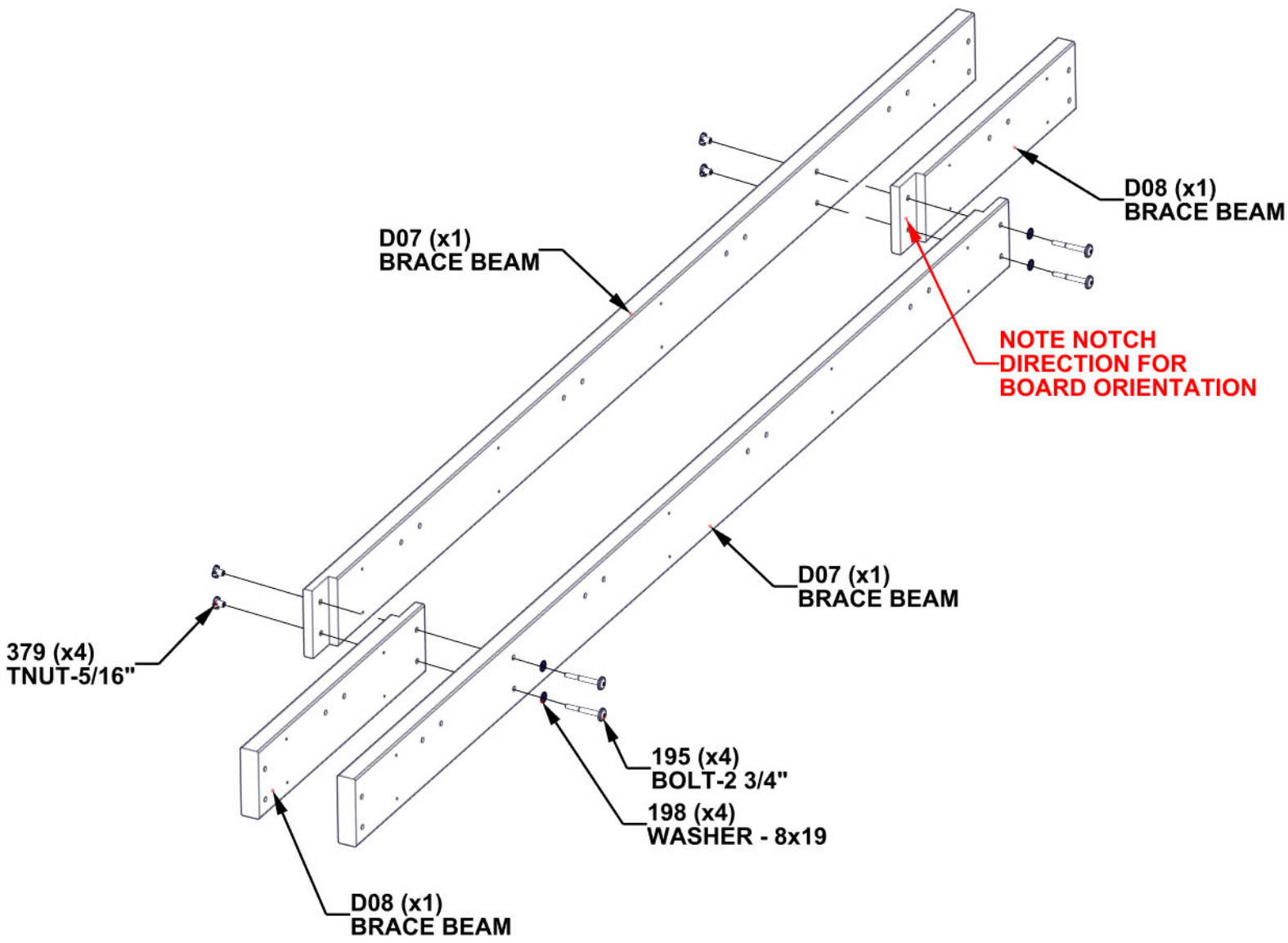

# STEP 45B - BRACE BEAM ASSEMBLY

QTY	PART NUMBER	DESCRIPTION
96	H100483	SCREW PFH 8x2 1/4 BLK

- NOTE:**
- MAKE SURE THE TOP, BOTTOM, AND ENDS OF ALL BOARDS ARE FLUSH.
  - MAKE SURE ALL HOLES ARE ALIGNED WHEREAS BOLTS CAN PASS THROUGH.
  - INSTALL SCREWS AS SHOWN BELOW AND TIGHTEN ALL HARDWARE.
  - **REPEAT THIS STEP 4 TIMES.**

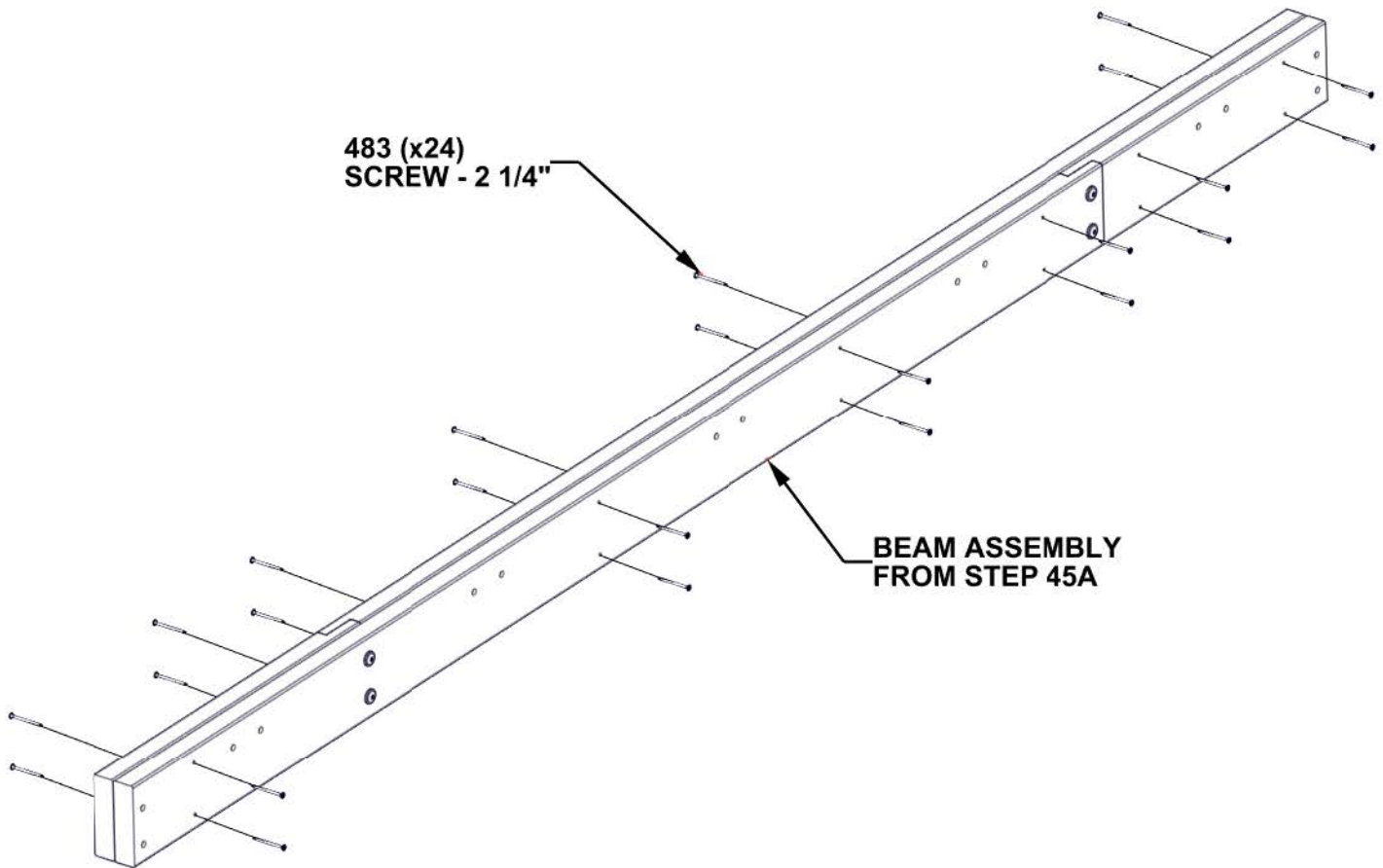

# STEP 45C - BRACE BEAM ASSEMBLY

QTY	PART NUMBER	DESCRIPTION
40	H100479	NUT LOCK 5/16 BLK
40	H100503	BOLT WH 5/16x3 1/2 BLK
40	H100630	WASHER FLAT 8x19 BLK

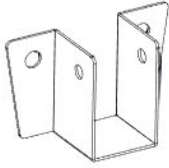

A4M01787 RAFTER BRACKET  
(x40)

- NOTE:**
- ALIGN RAFTER BRACKETS WITH HOLES IN BEAM AND ATTACH AS SHOWN.
  - **REPEAT THIS STEP 4 TIMES.**

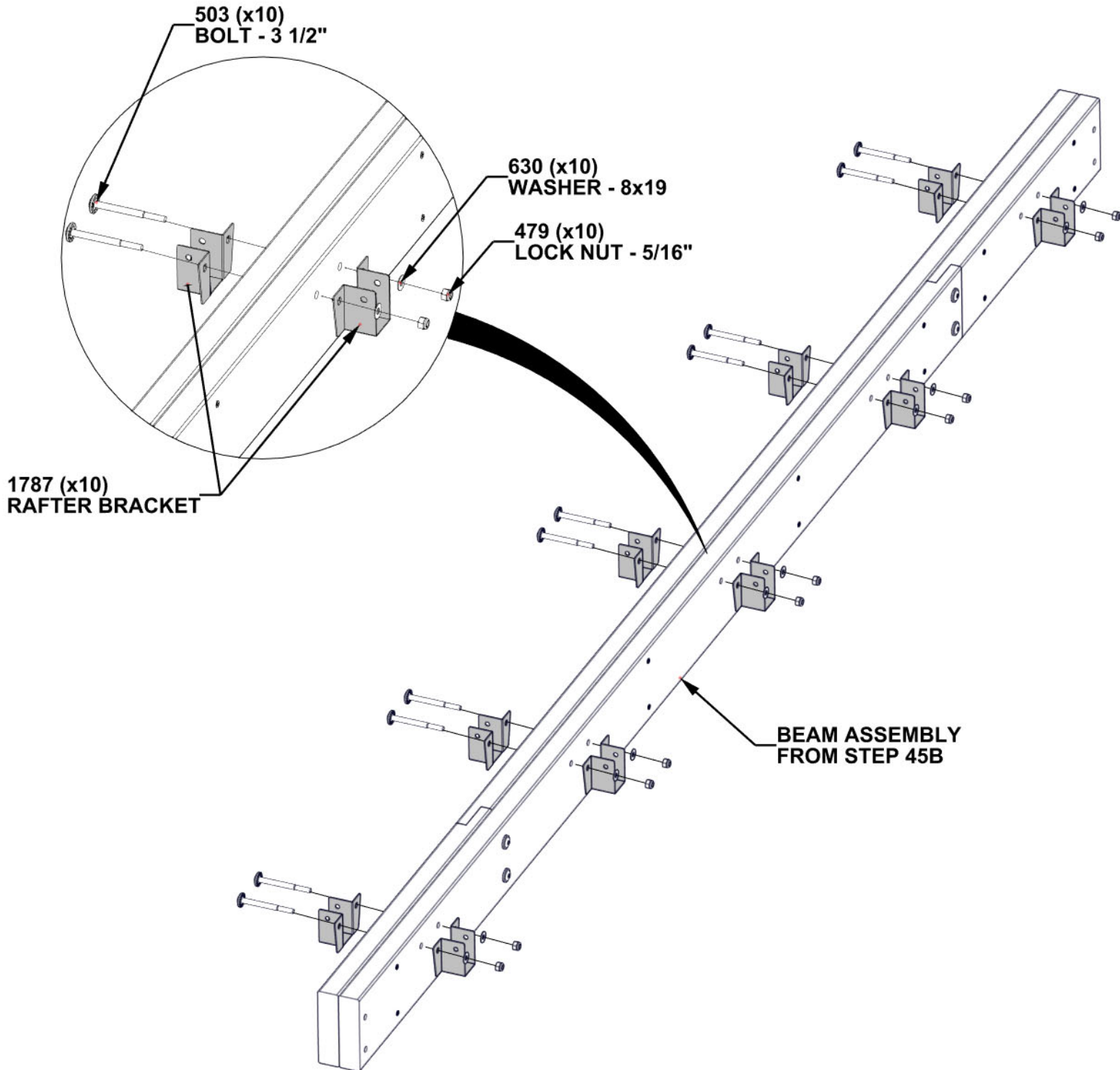

# STEP 46 - CARPORT ASSEMBLY

QTY	PART NUMBER	DESCRIPTION
16	H100630	WASHER FLAT 8x19 BLK
16	H100479	NUT LOCK 5/16 BLK
16	H100503	BOLT WH 5/16x3-1/2 BLK

## NOTE:

- EXTRA PEOPLE ARE HELPFUL FOR THIS STEP.
- HAND TIGHTEN ONLY.

### 2. ATTACH JOISTS TO BRACKETS.

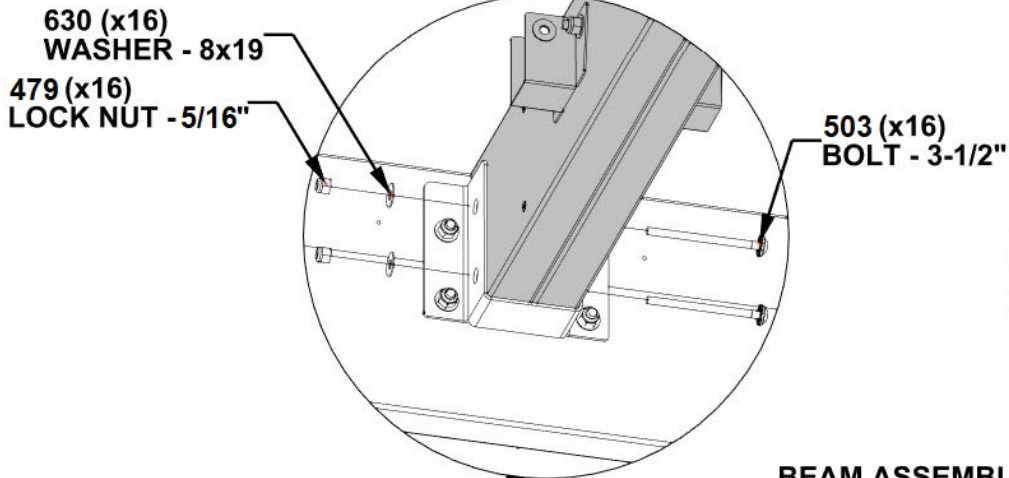

### 1. INSERT JOIST ASSEMBLIES INTO BRACKETS.

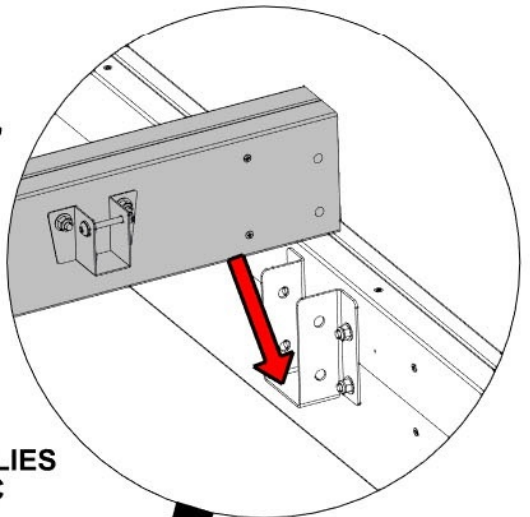

BEAM ASSEMBLIES  
FROM STEP 45C

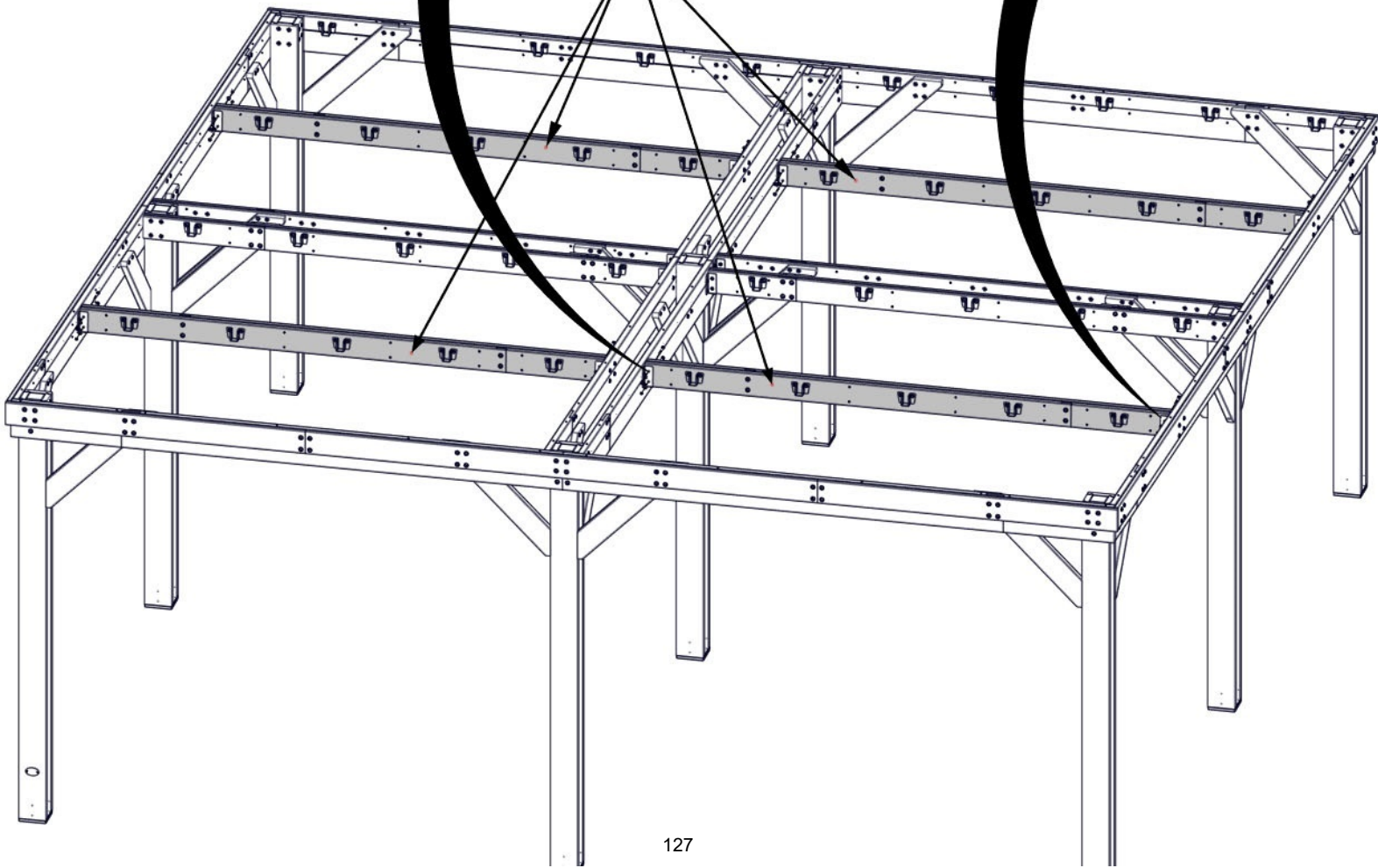

# STEP 47 - SQUARE ASSEMBLY

**CRITICAL: SQUARE ASSEMBLY BEFORE PROCEEDING TO NEXT STEPS.  
ONCE SQUARE, ENSURE ALL HARDWARE IS FULLY TIGHTENED.**

MEASUREMENTS TAKEN FROM INSIDE OF POST TO INSIDE OF POST.

**WARNING: IF IT ISN'T SQUARE, THERE WILL BE ALIGNMENT ISSUES.**

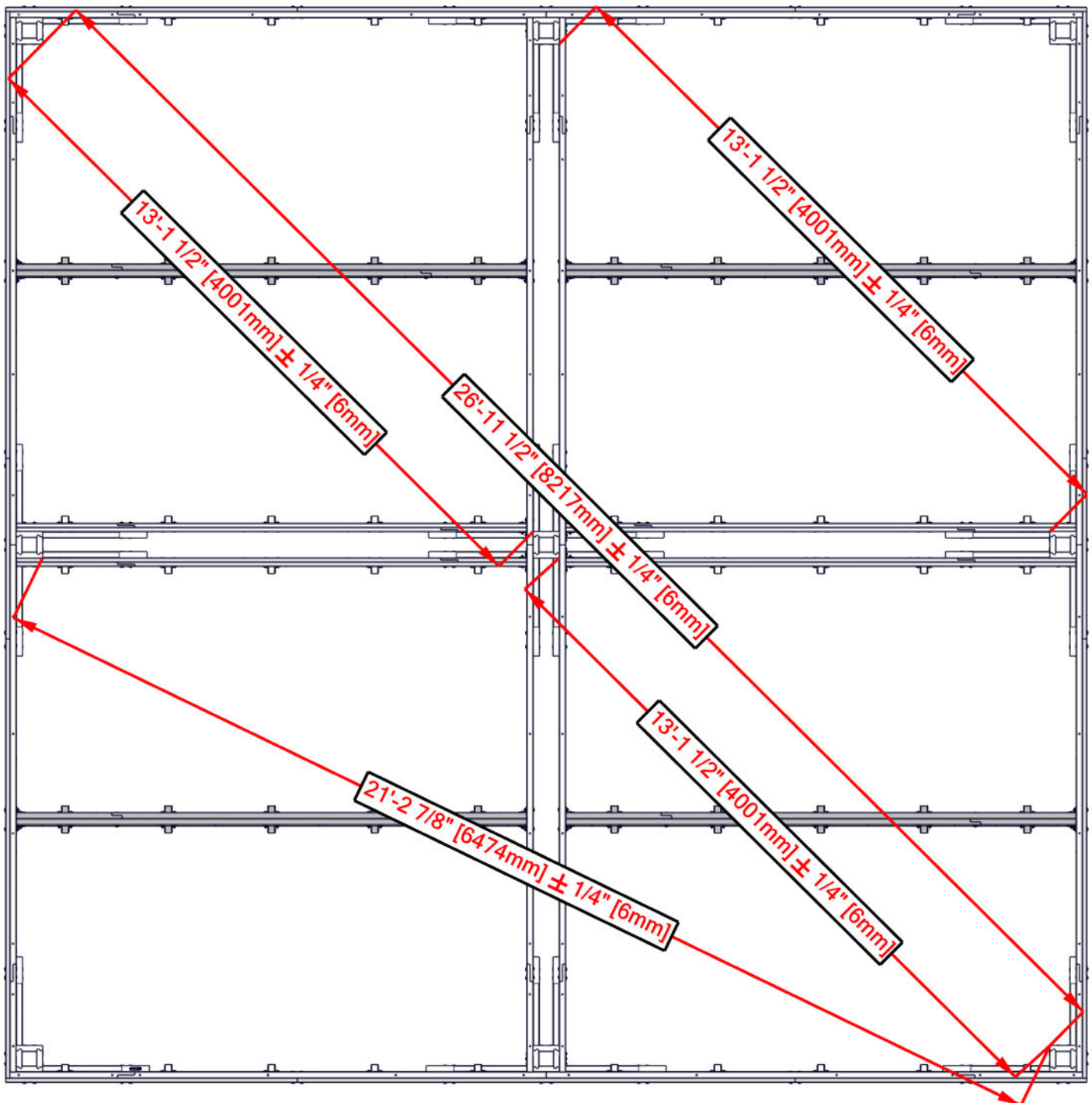



# STEP 48 - CARPORT ASSEMBLY

QTY	PART NUMBER	DESCRIPTION
80	H100488	BOLT WH 1/4x2 BLK
80	H100630	WASHER FLAT 8x19 BLK
80	H100653	NUT LOCK 1/4 BLK

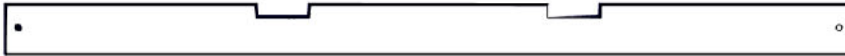

E01 RAFTER - W4L17637  
(x40) 1 7/16"x36x55 11/16" (36x86x1415)

## 2. ATTACH JOISTS TO BRACKETS USING PROVIDED HARDWARE.

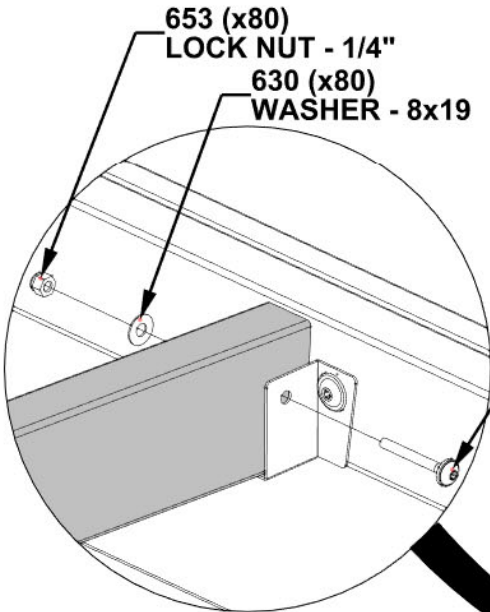

**NOTE:**  
NOTCHES IN ALL RAFTERS  
WILL FACE UPWARDS.

488 (x80)  
BOLT - 2"

## 1. INSERT RAFTERS INTO BRACKETS.

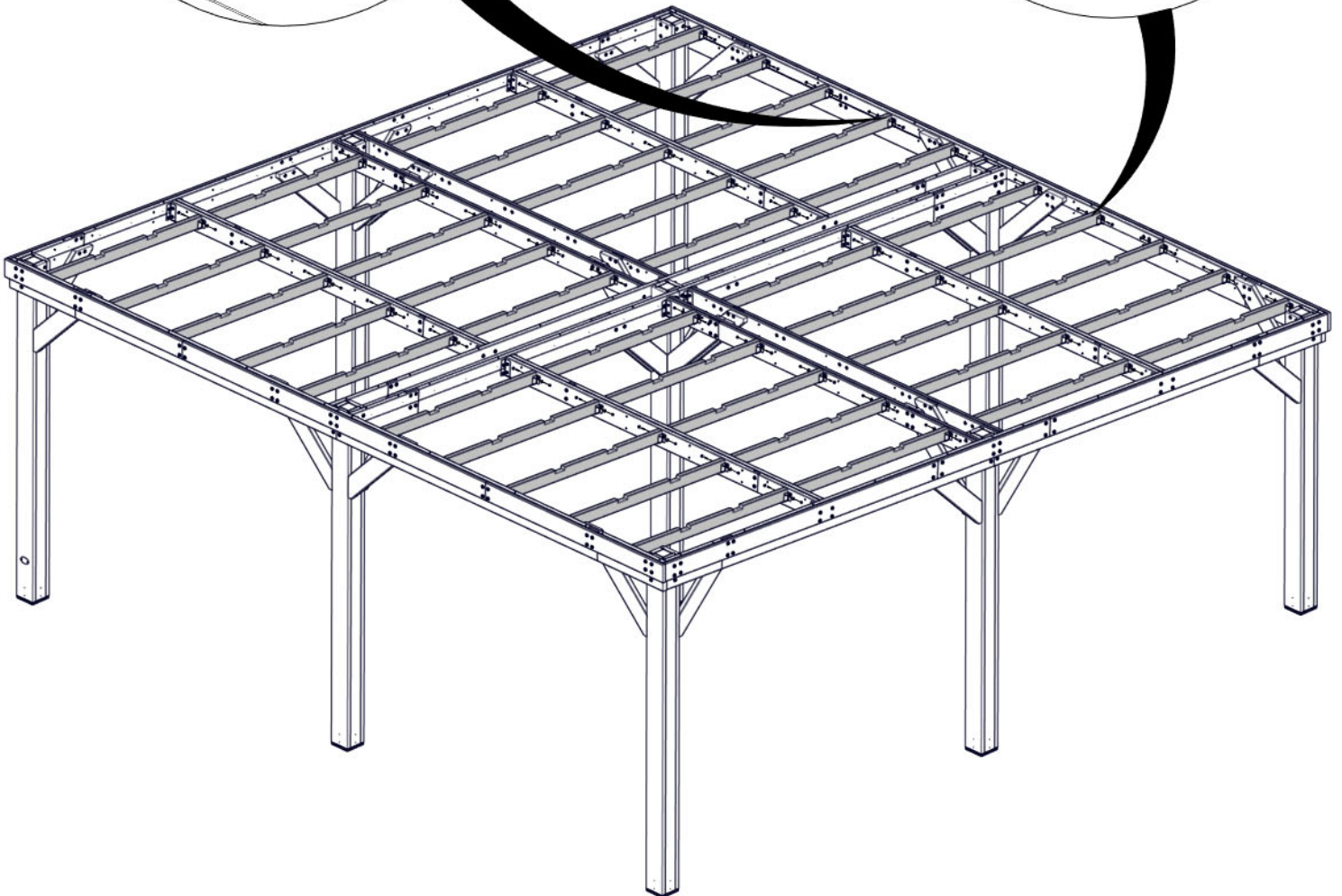
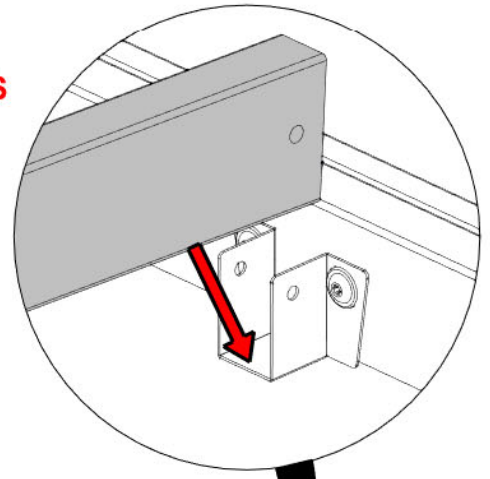

# STEP 49A - CARPORT ASSEMBLY

QTY	PART NUMBER	DESCRIPTION
40	H100391	SCREW PFH 8x2 BLK



J25 CLEAT - W4L17622  
(x4) 15/16"x2 3/8"x48 1/8" (24x60x1223)



J27 CLEAT - W4L18290  
(x4) 15/16"x2 3/8"x54 1/4" (24x60x1378)

**NOTE:**  
• REPEAT CLEAT INSTALLATION ON OPPOSITE SIDE OF CARPORT.

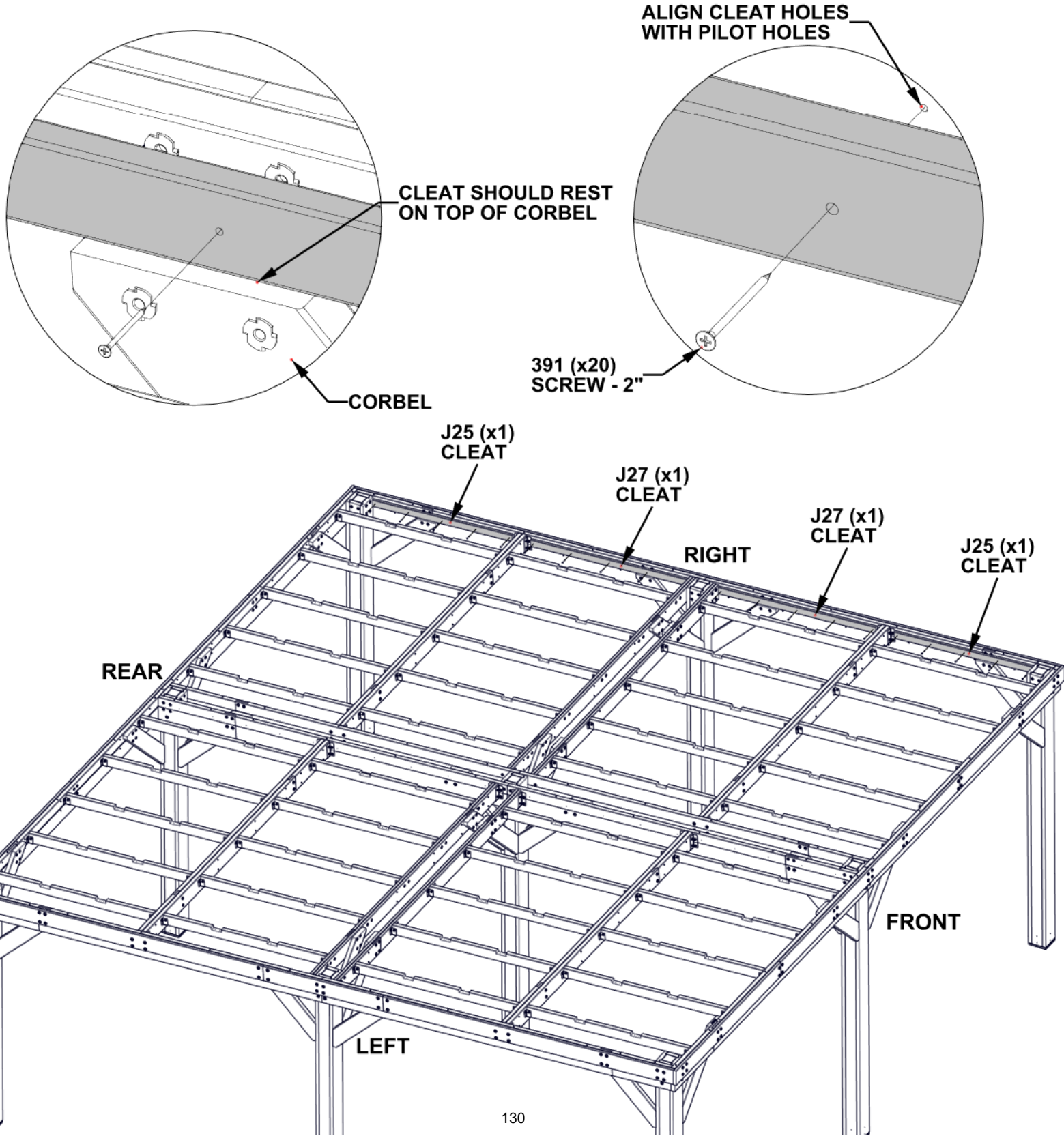

# STEP 49B - CARPORT ASSEMBLY

QTY	PART NUMBER	DESCRIPTION
40	H100391	SCREW PFH 8x2 BLK



J25 CLEAT - W4L17622  
 (x4) 15/16"x2 3/8"x48 1/8" (24x60x1223)



J26 CLEAT - W4L17623  
 (x4) 15/16"x2 3/8"x52 3/4" (24x60x1340)

**NOTE:**

- REPEAT CLEAT INSTALLATION ON OPPOSITE SIDE OF CENTER BEAMS.

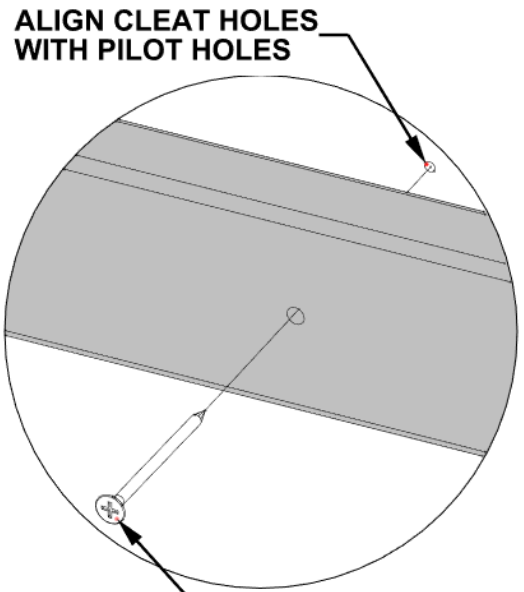

391 (x40)  
 SCREW - 2"

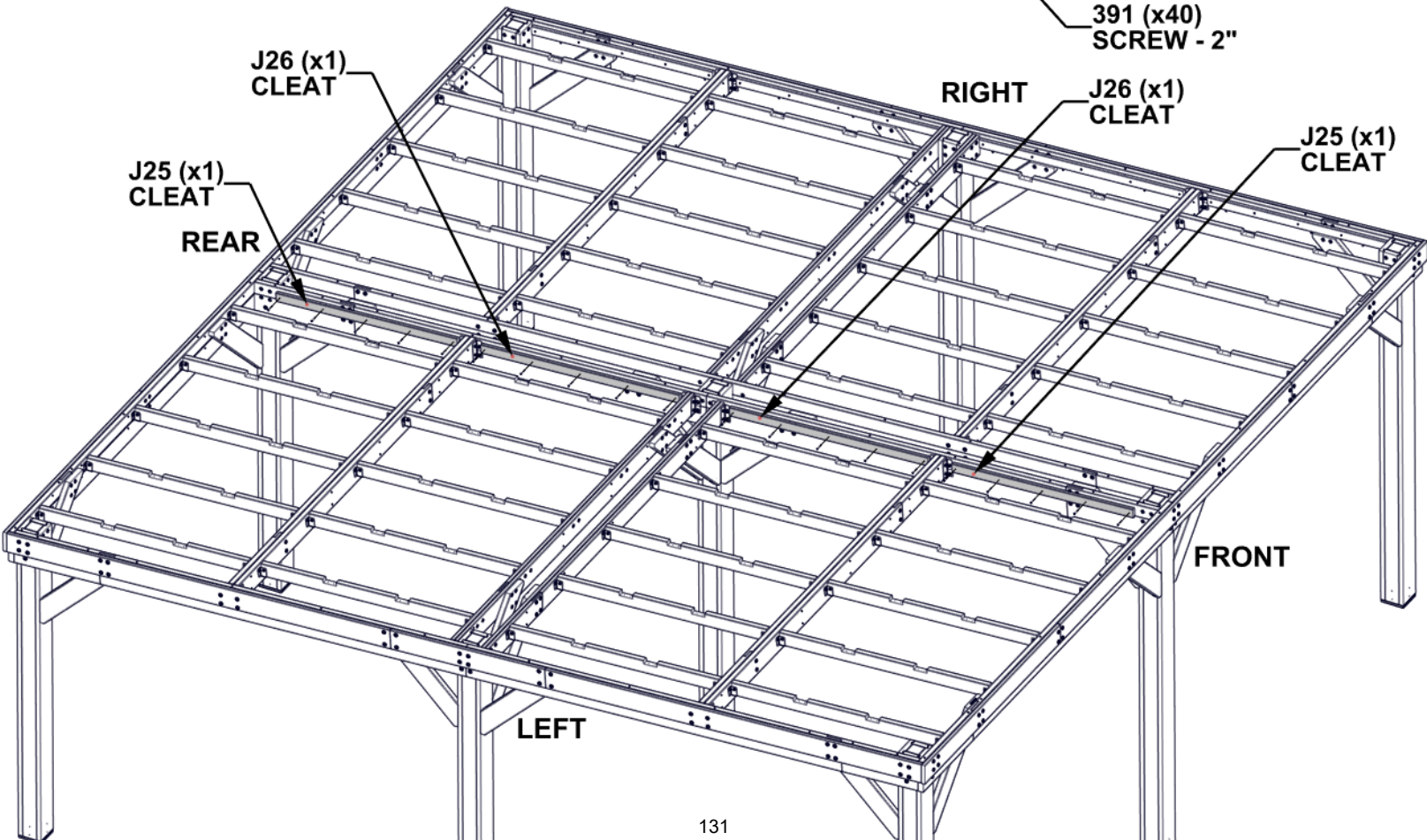

# STEP 50A - CARPORT ASSEMBLY

QTY	PART NUMBER	DESCRIPTION
64	H100382	SCREW PFH 8x1 3/4 BLK



H02 PURLIN - W4L17805  
(x16) 15/16"x3 3/8"x35 13/16" (24x86x909)

## NOTES:

- POSITION PURLINS AS SHOWN BELOW.
- START WITH SHORT PURLINS IN FRONT CORNERS, THEN REPEAT PATTERN AS SHOWN.
- **REPEAT THIS STEP 4 TIMES.**

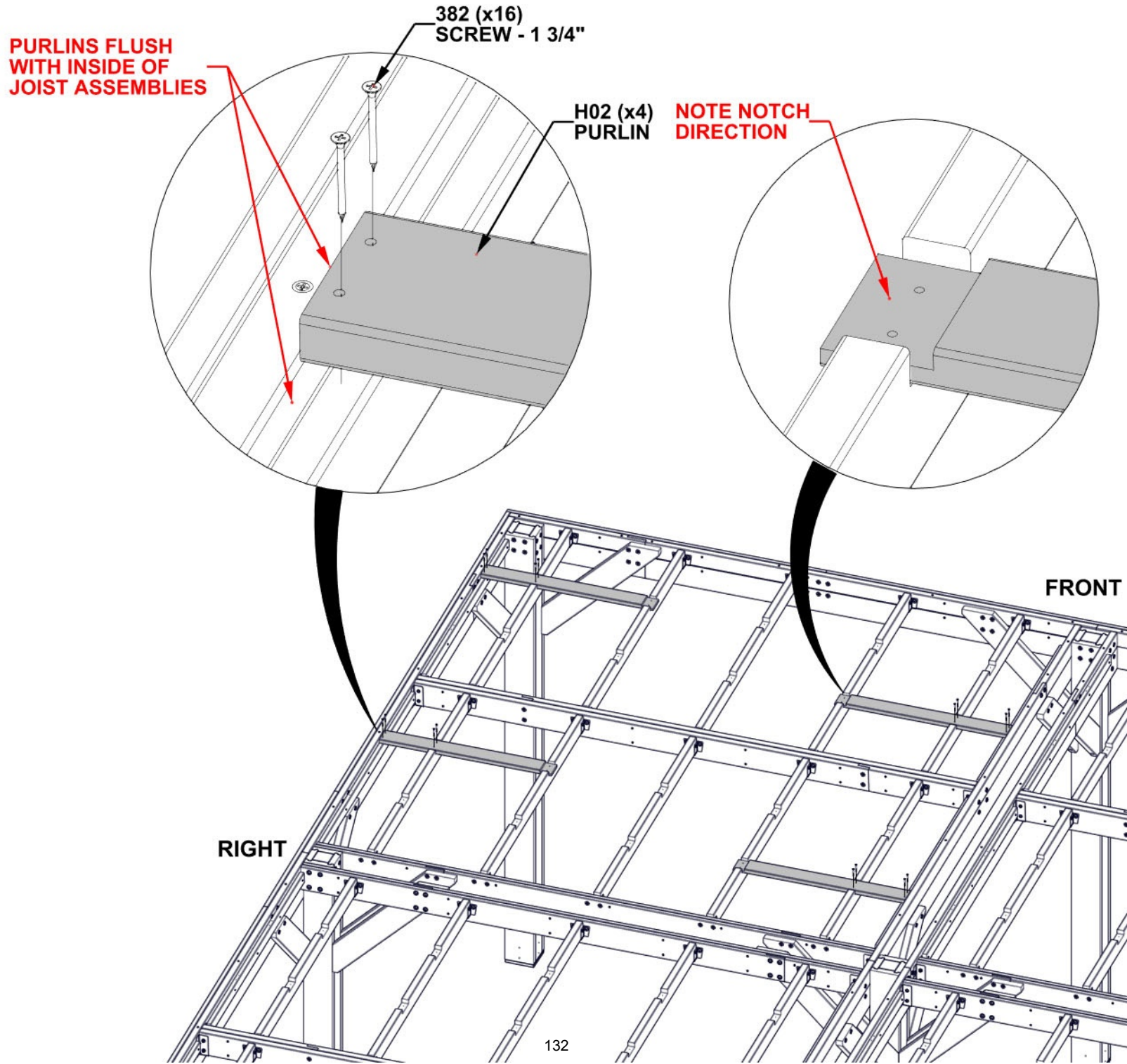

# STEP 50B - CARPORT ASSEMBLY

QTY	PART NUMBER	DESCRIPTION
160	H100382	SCREW PFH 8x1 3/4 BLK



H01 PURLIN - W4L17804  
(x16) 15/16"x3 3/8"x82 13/16" (24x86x2103)

## NOTES:

- POSITION PURLINS AS SHOWN BELOW.
- REPEAT THIS STEP 4 TIMES.

PURLINS FLUSH WITH INSIDE OF JOIST ASSEMBLIES

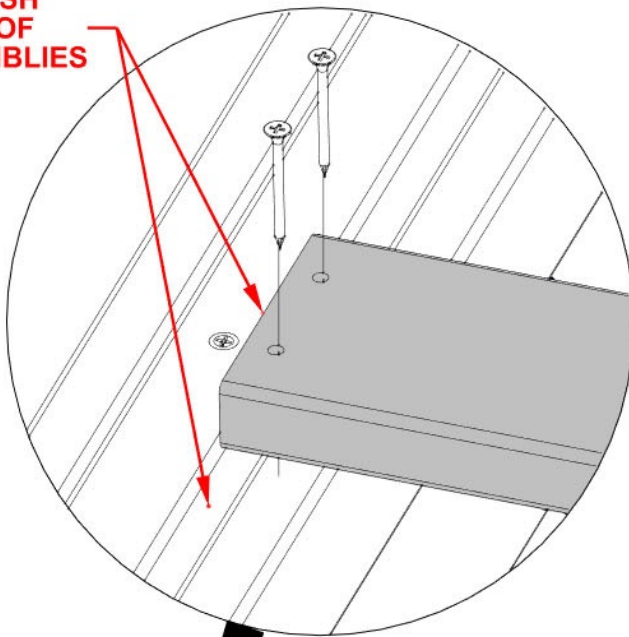

382 (x40)  
SCREW - 1 3/4"

H01 (x4)  
PURLIN

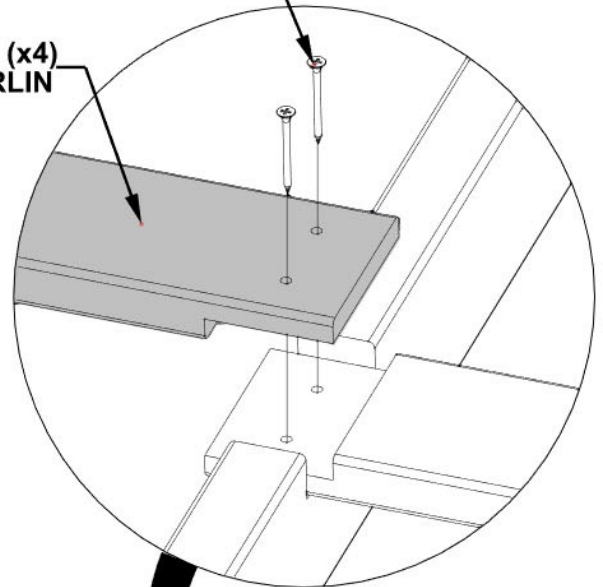

RIGHT

FRONT

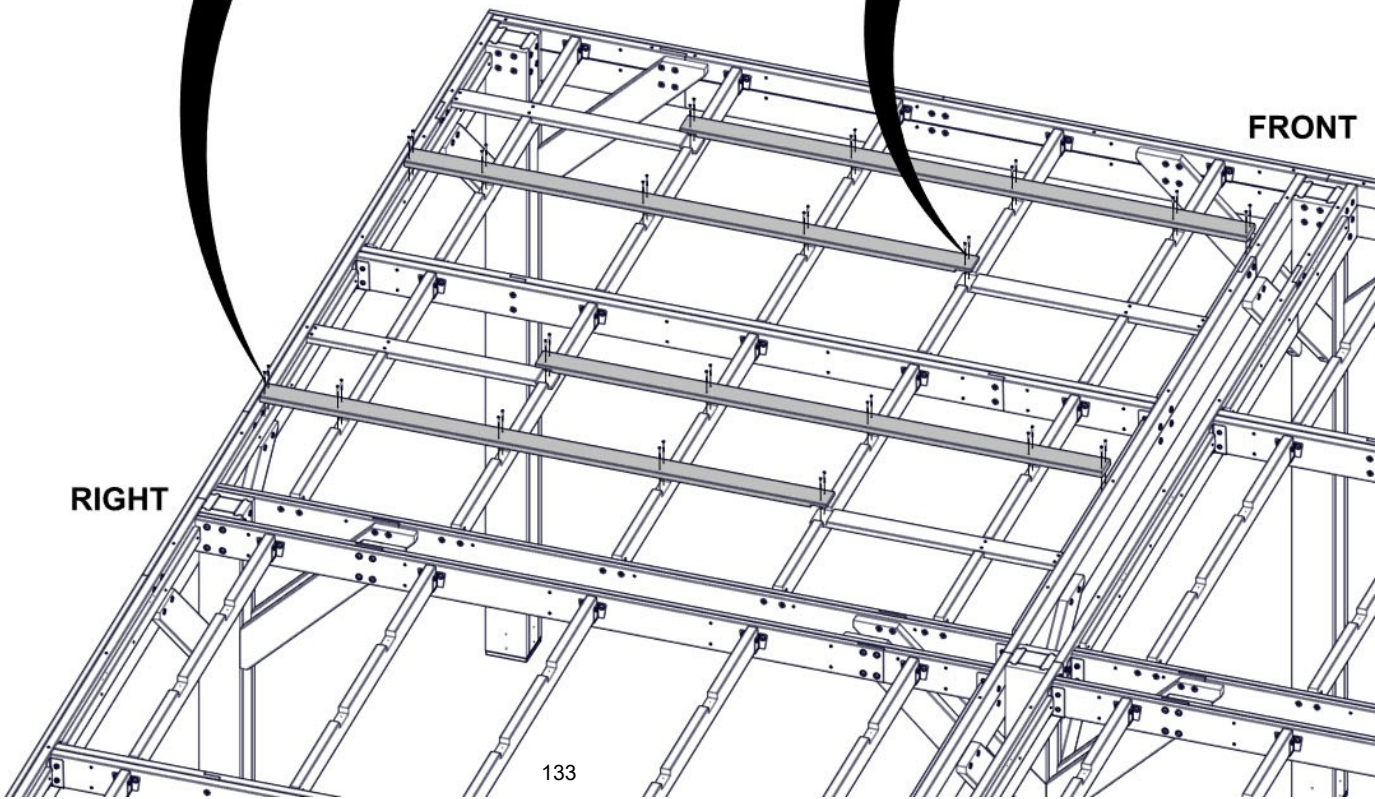

# STEP 51A - CARPORT ASSEMBLY

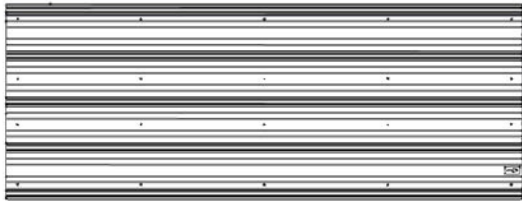

A4M01910 29GA SHEETING  
(x8)

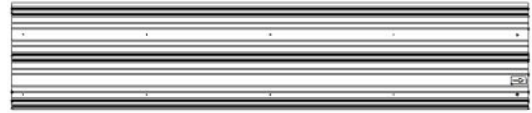

A4M02240 29GA SHEETING  
(x1)

**WARNING: GLOVES ARE RECOMMENDED WHEN HANDLING STEEL ROOF SHEETS.**

**NOTES:**

- REMOVE BLUE FILM FROM ROOF PANELS.
- ORIENT ROOF PANELS AS SHOWN BELOW.
- **START BY FLUSHING THE FIRST SHEET WITH THE SIDE OF THE BEAM, THEN MARK WHERE EVERY OTHER SHEET WILL LAND AS SHOWN BELOW TO ENSURE THE PANELS WILL ALIGN CORRECTLY. THE LAST SHEET SHOULD ALIGN CLOSE TO THE EDGE OF THE BEAM.**
- IT IS IMPORTANT TO HOLD THE 1/4" OVERHANG AT THE BACK OF THE UNIT SO TRIM PIECES WILL FIT CORRECTLY IN FUTURE STEPS.
- ATTACH ONE SHEET AT A TIME, DO NOT GET ON THE ROOF TO ATTACH SCREWS.
- SEE NEXT STEP FOR FASTENING REQUIREMENTS.

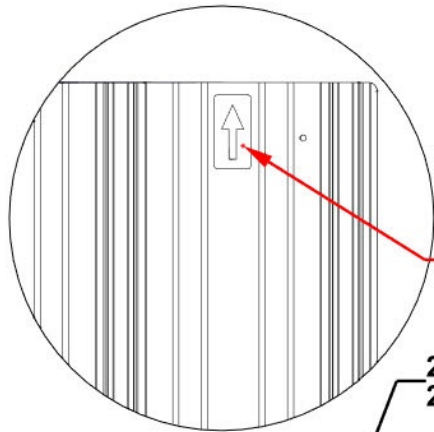

**NOTE DIRECTION ARROW. THIS WILL FACE TOWARD THE FRONT OF THE UNIT.**

1/4" [7mm]

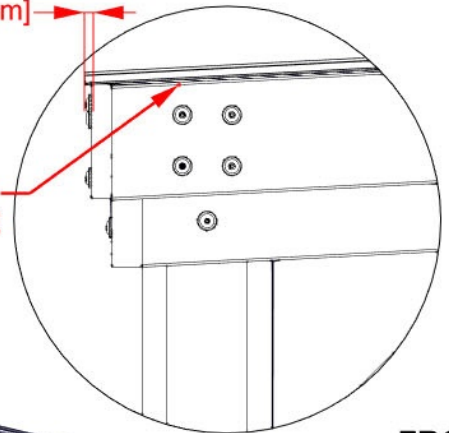

**FIRST SHEET TO BE FLUSH WITH THE SIDE**

**FRONT**

2240 (x1)  
29GA SHEETING  
1910 (x8)  
29GA SHEETING

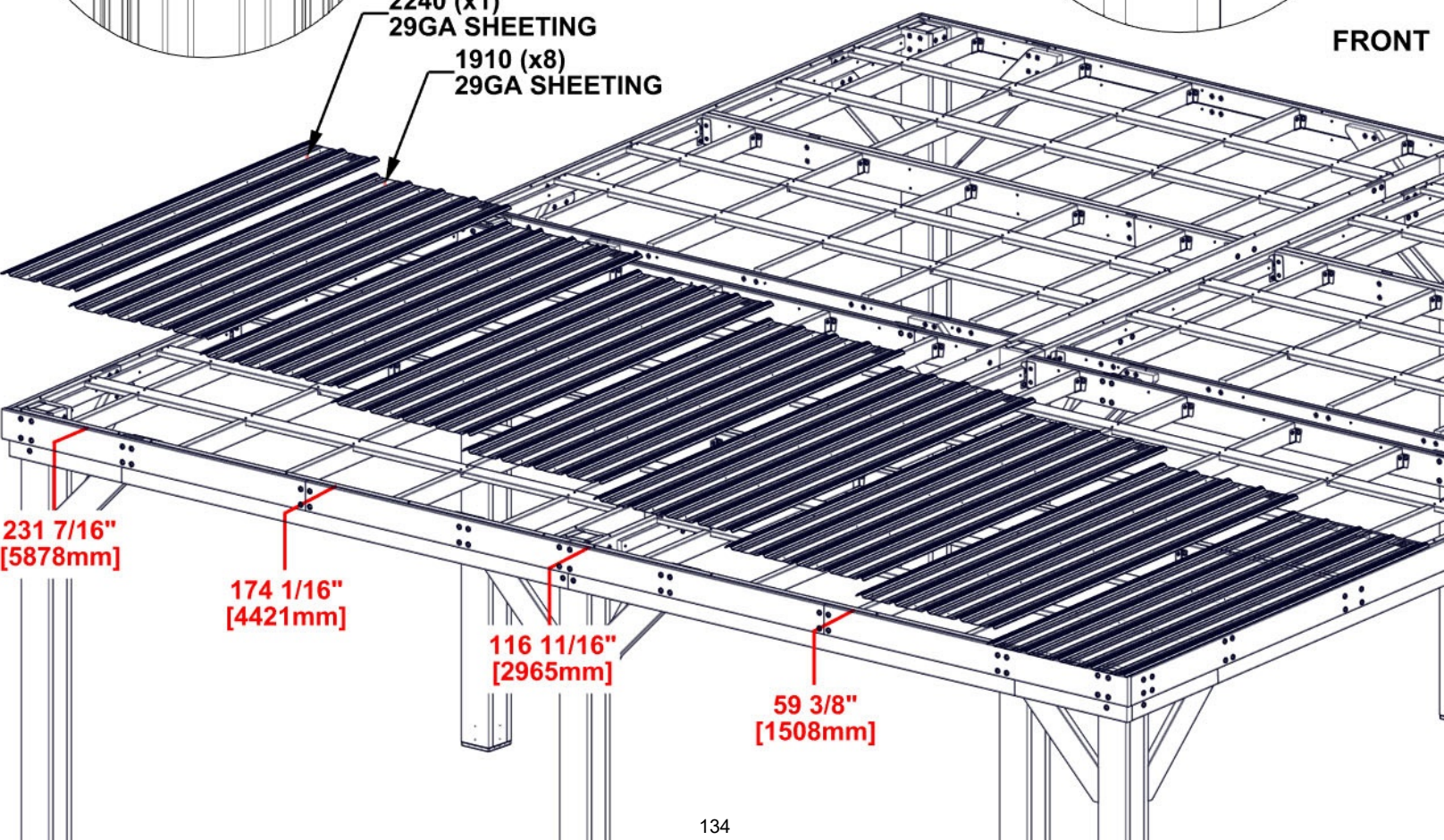

# STEP 51B - CARPORT ASSEMBLY

QTY	PART NUMBER	DESCRIPTION
102	H101117	SCREW WOODGRIP 10-16x3/4" BLK

**WARNING: GLOVES ARE RECOMMENDED WHEN HANDLING STEEL ROOF SHEETS.**

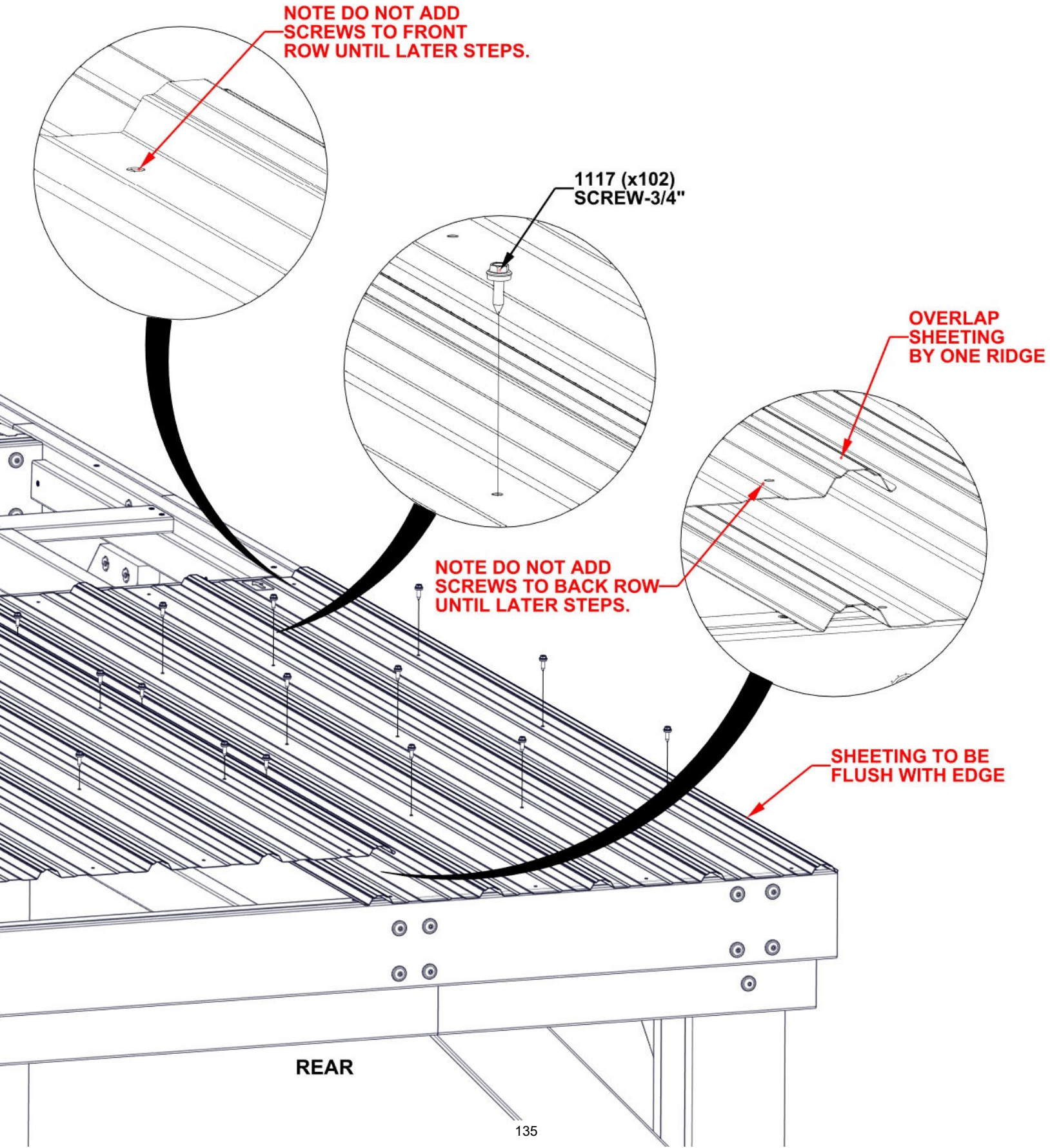

# STEP 52 - CARPORT ASSEMBLY

QTY	PART NUMBER	DESCRIPTION
34	H101117	SCREW WOODGRIP 10-16x3/4" BLK

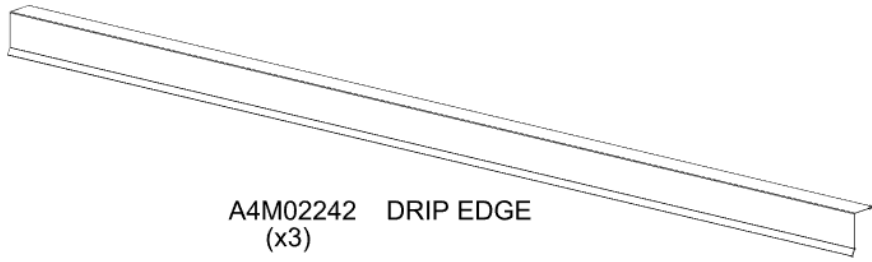

A4M01916 DRIP EDGE SPLICE (x2)

**WARNING: GLOVES ARE RECOMMENDED WHEN HANDLING STEEL.**

**NOTES:**

- REMOVE BLUE FILM FROM DRIP EDGE AND DRIP EDGE SPLICE.
- ORIENT DRIP EDGE AND DRIP EDGE SPLICE AS SHOWN BELOW.
- ATTACH USING HOLES IN SHEETING. DO NOT GET ON ROOF TO ATTACH SCREWS.

**SLIDE DRIP EDGE UNDERNEATH SHEETING. PUSH ALL THE WAY BACK UNTIL IT IS FLUSH WITH BACKSIDE OF SHEETING.**

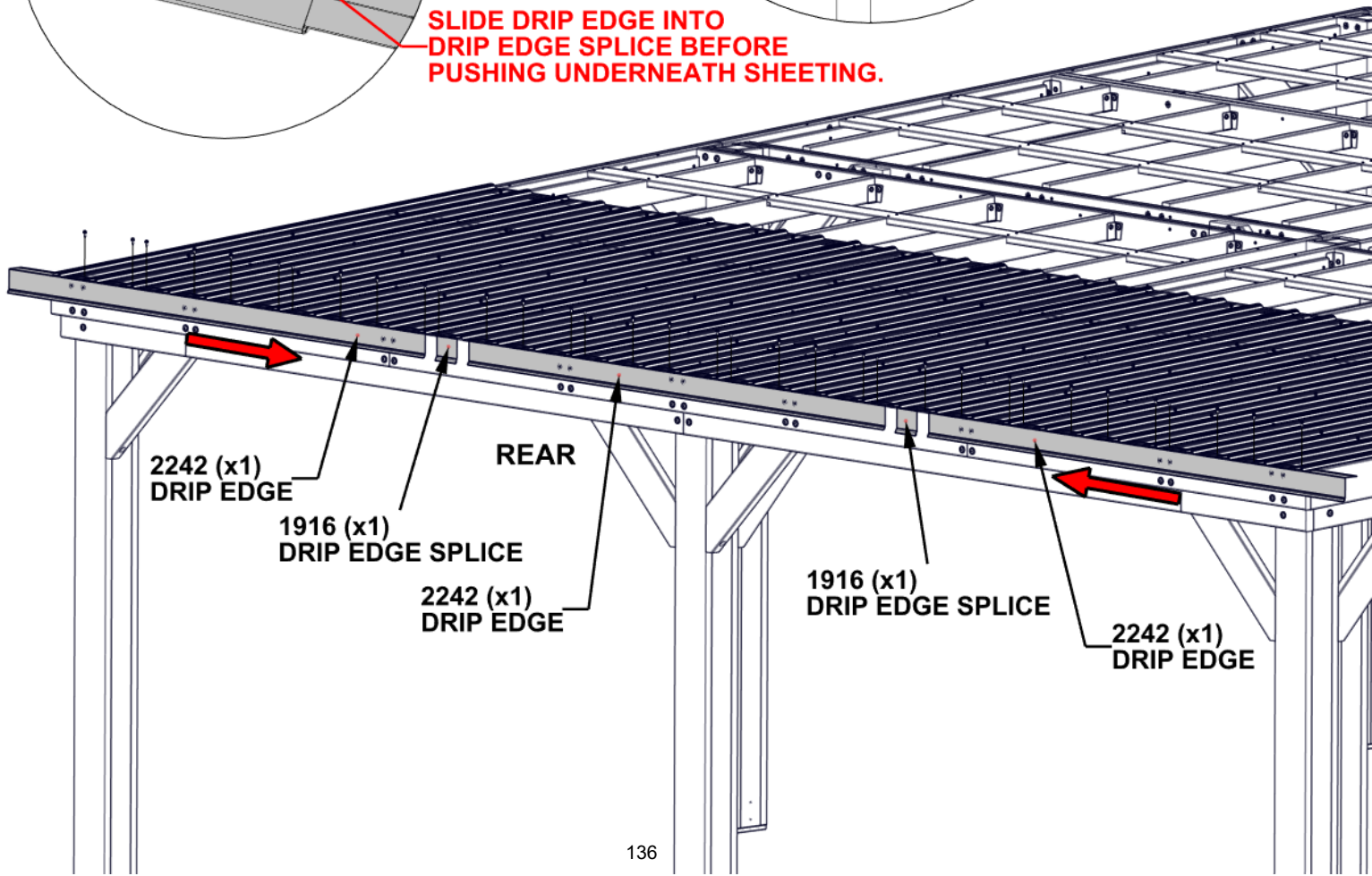
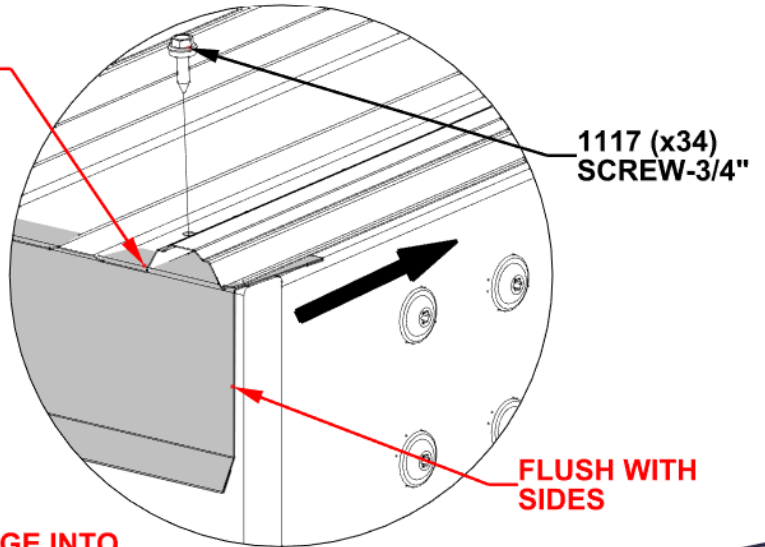
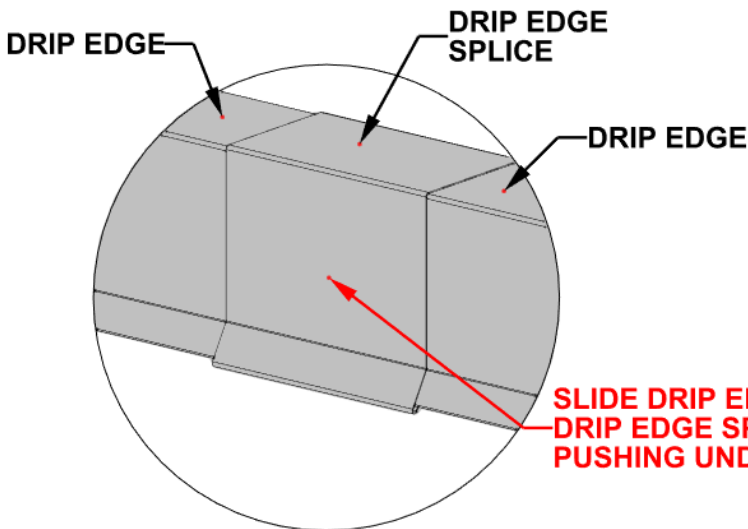



# STEP 53A - CARPORT ASSEMBLY



A6P00556 WEATHER TAPE  
(x2)

**APPLY WEATHER TAPE APPROXIMATE 1" [24mm] FROM EDGE AS SHOWN. APPLY ACROSS ALL SHEETS BEFORE INSTALLING NEXT ROW OF SHEETING.**

556 (x2)  
WEATHER TAPE

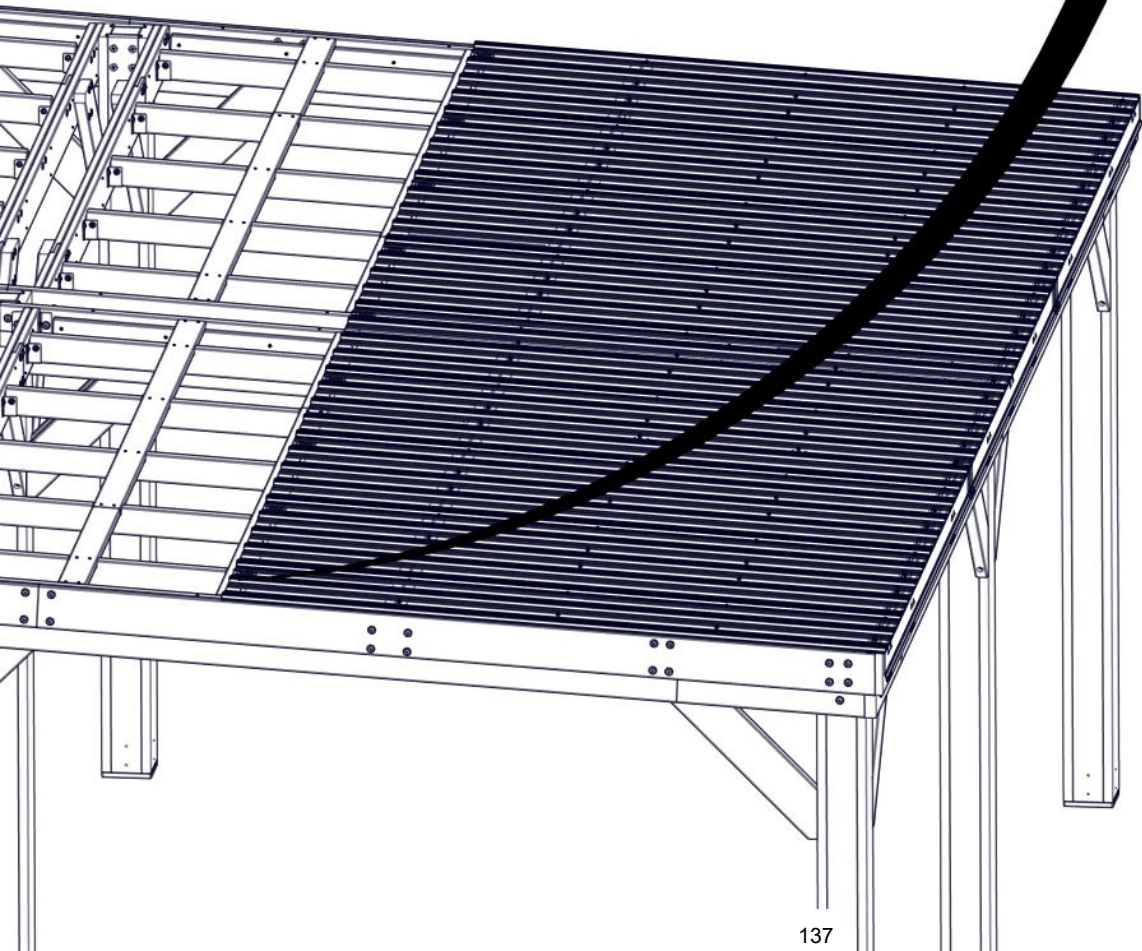
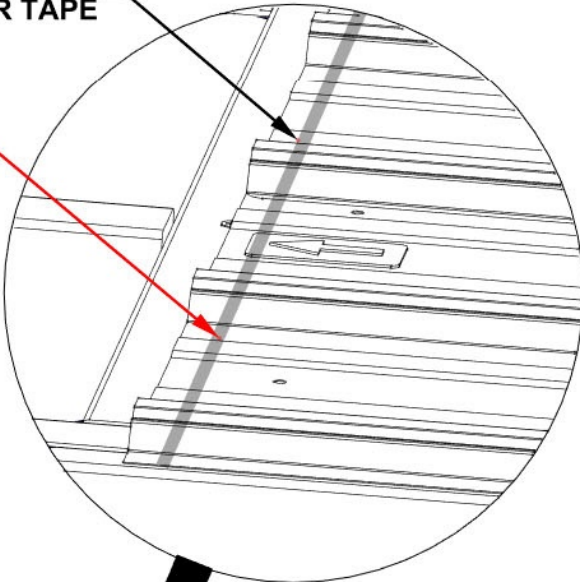

# STEP 53B - CARPORT ASSEMBLY

QTY	PART NUMBER	DESCRIPTION
136	H101117	SCREW WOODGRIP 10-16x3/4" BLK

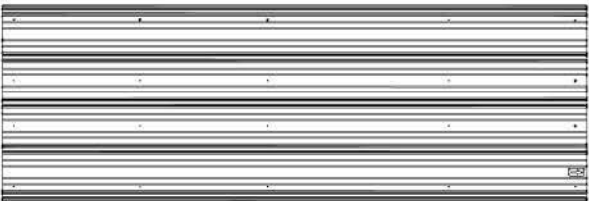

A4M01911 29GA SHEETING (x8)



A4M02241 29GA SHEETING (x1)

**WARNING: GLOVES ARE RECOMMENDED WHEN HANDLING STEEL ROOF SHEETS.**

**NOTES:**

- REMOVE BLUE FILM FROM ROOF PANELS.
- ORIENT ROOF PANELS AS SHOWN BELOW.
- **START BY FLUSHING THE FIRST SHEET WITH THE SIDE OF THE BEAM, THEN MARK WHERE EVERY OTHER SHEET WILL LAND AS SHOWN BELOW TO ENSURE THE PANELS WILL ALIGN CORRECTLY. THE LAST SHEET SHOULD ALIGN CLOSE TO THE EDGE OF THE BEAM.**
- ATTACH ONE SHEET AT A TIME, DO NOT GET ON THE ROOF TO ATTACH SCREWS.

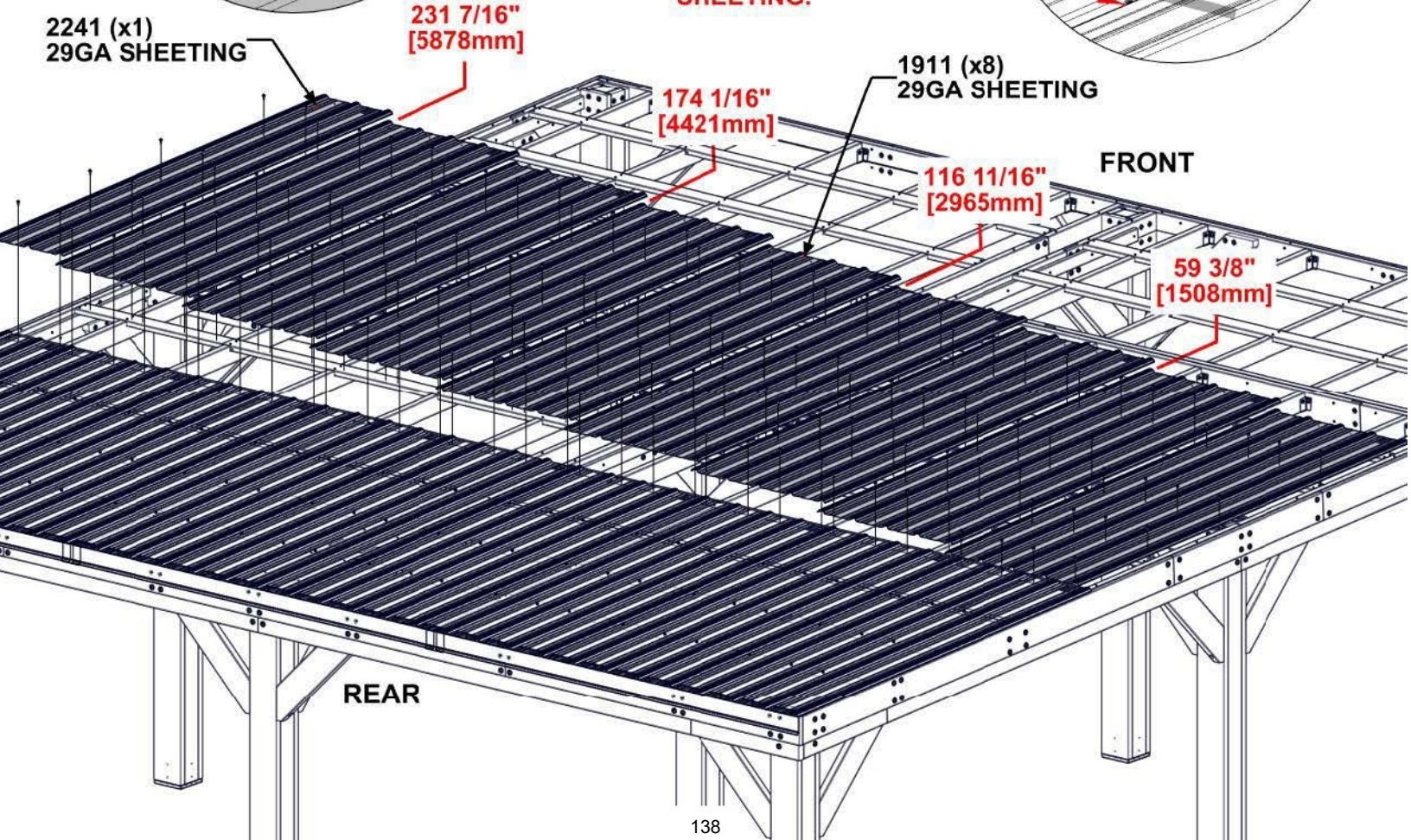
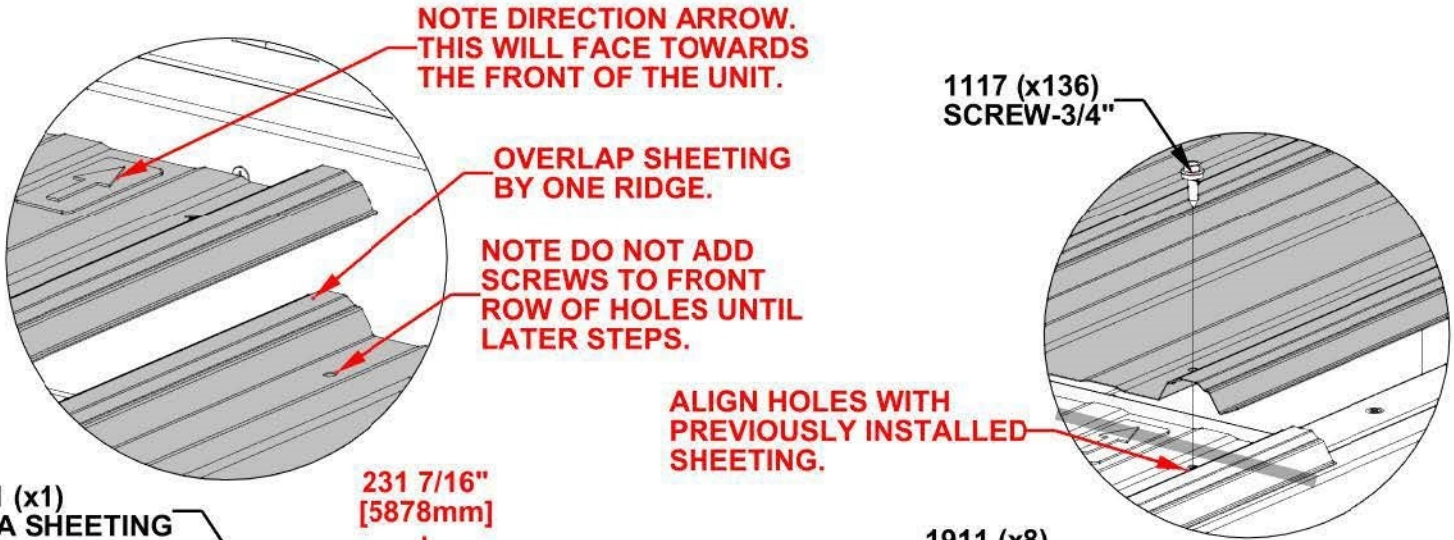

# STEP 54A - CARPORT ASSEMBLY



A6P00556 WEATHER TAPE  
(x2)

**APPLY WEATHER TAPE APPROXIMATE 1" [24mm] FROM EDGE AS SHOWN. APPLY ACROSS ALL SHEETS BEFORE INSTALLING NEXT ROW OF SHEETING.**

556 (x2)  
WEATHER TAPE

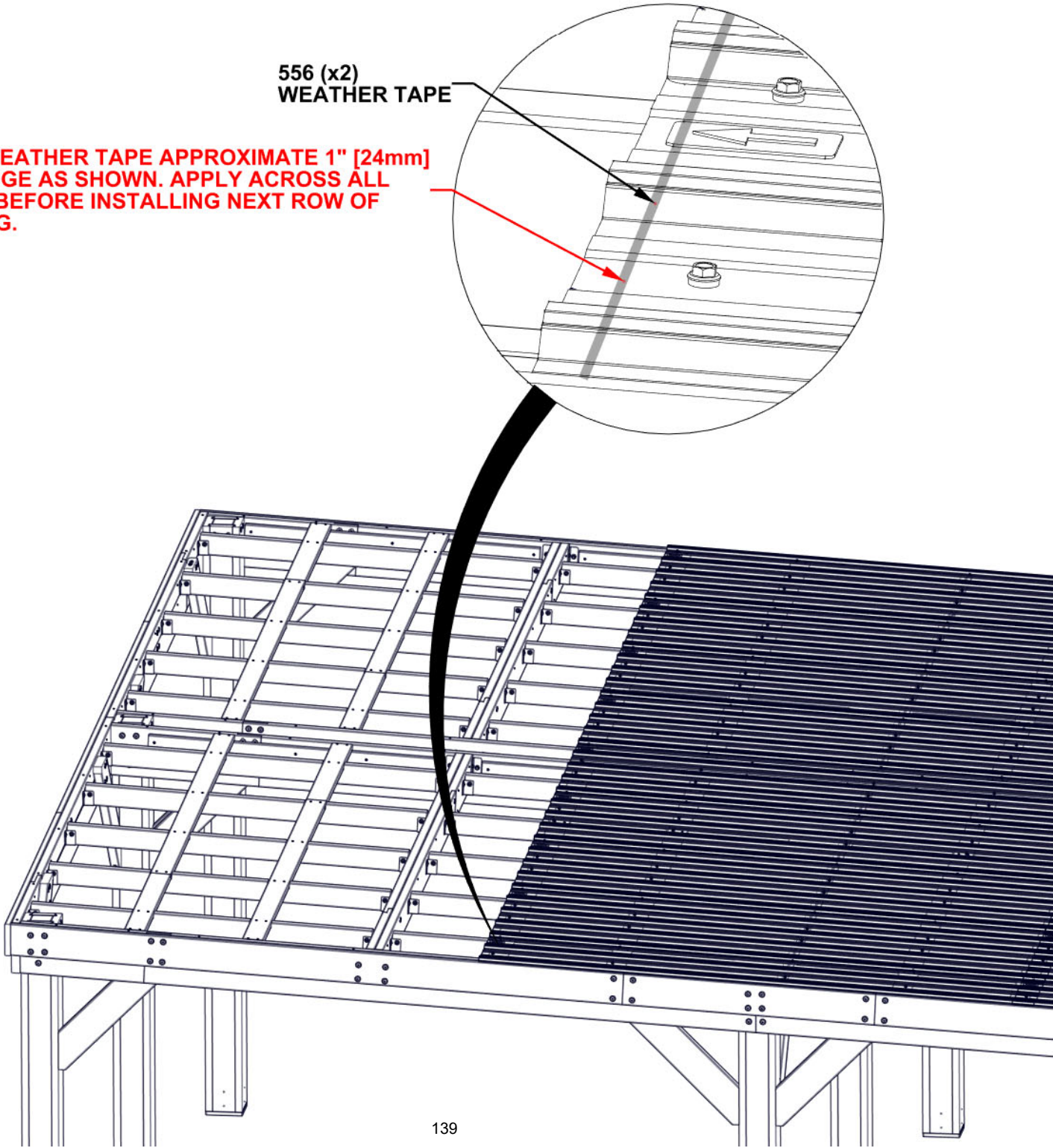

# STEP 54B - CARPORT ASSEMBLY

QTY	PART NUMBER	DESCRIPTION
170	H101117	SCREW WOODGRIP 10-16x3/4" BLK

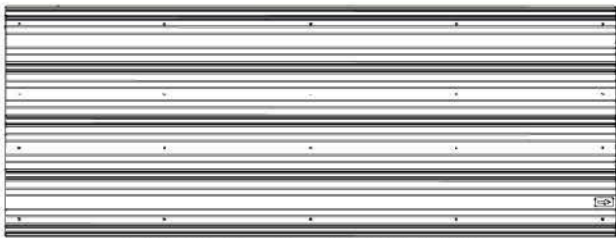

A4M01910 29GA SHEETING  
(x8)

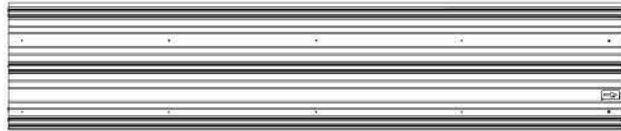

A4M02240 29GA SHEETING  
(x1)

**WARNING: GLOVES ARE RECOMMENDED WHEN HANDLING STEEL ROOF SHEETS.**

**NOTES:**

- REMOVE BLUE FILM FROM ROOF PANELS.
- ORIENT ROOF PANELS AS SHOWN BELOW.
- **START BY FLUSHING THE FIRST SHEET WITH THE SIDE OF THE BEAM, THEN MARK WHERE EVERY OTHER SHEET WILL LAND AS SHOWN BELOW TO ENSURE THE PANELS WILL ALIGN CORRECTLY. THE LAST SHEET SHOULD ALIGN CLOSE TO THE EDGE OF THE BEAM.**
- ATTACH ONE SHEET AT A TIME, DO NOT GET ON THE ROOF TO ATTACH SCREWS.

NOTE DIRECTION ARROW. THIS WILL FACE TOWARDS THE FRONT OF THE UNIT.

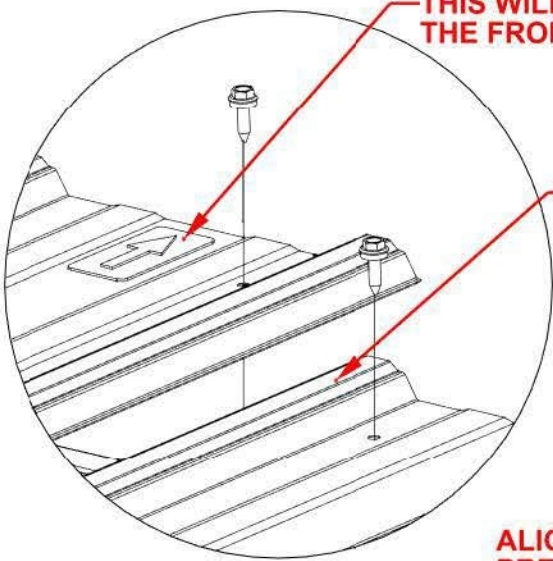

OVERLAP SHEETING BY ONE RIDGE.

1117 (x170)  
SCREW-3/4"

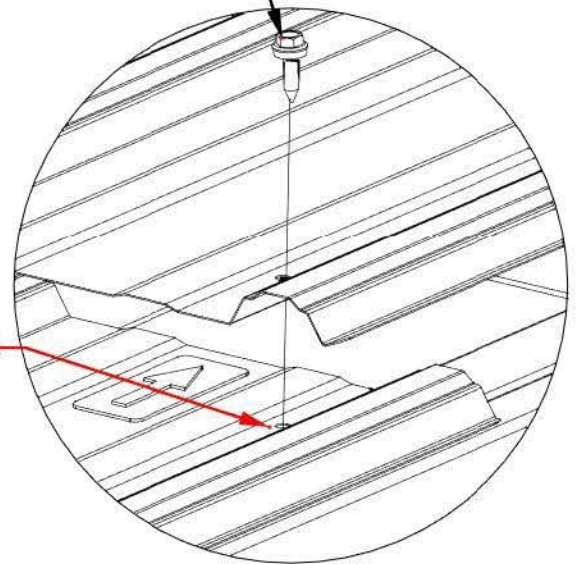

ALIGN HOLES WITH PREVIOUSLY INSTALLED SHEETING.

2240 (x1)  
29GA SHEETING

231 7/16"  
[5878mm]

1910 (x8)  
29GA SHEETING

174 1/16"  
[4421mm]

FRONT

116 11/16"  
[2965mm]

59 3/8"  
[1508mm]

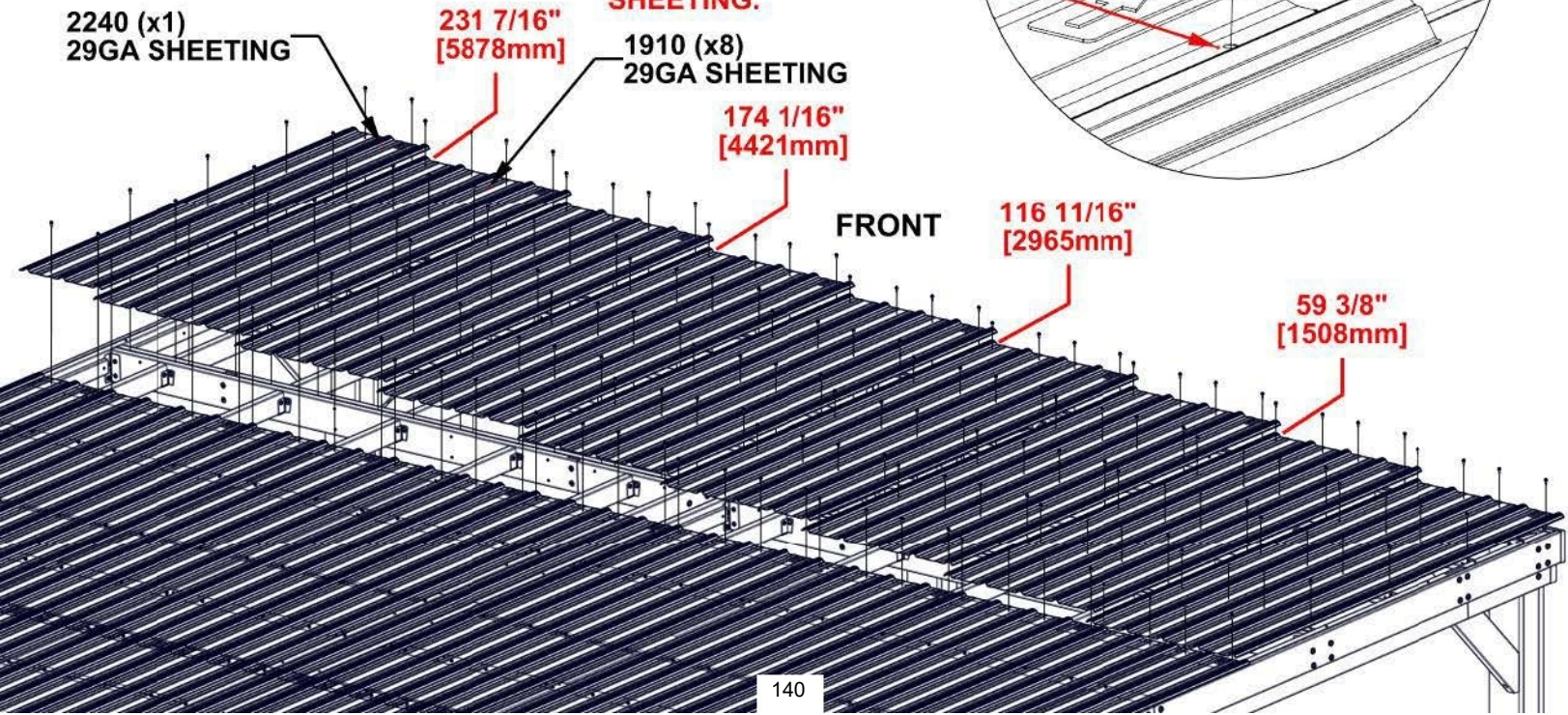

# STEP 55 - CARPORT ASSEMBLY

QTY	PART NUMBER	DESCRIPTION
17	H101116	SCREW SELF TAPPING 1/4x1 BLK

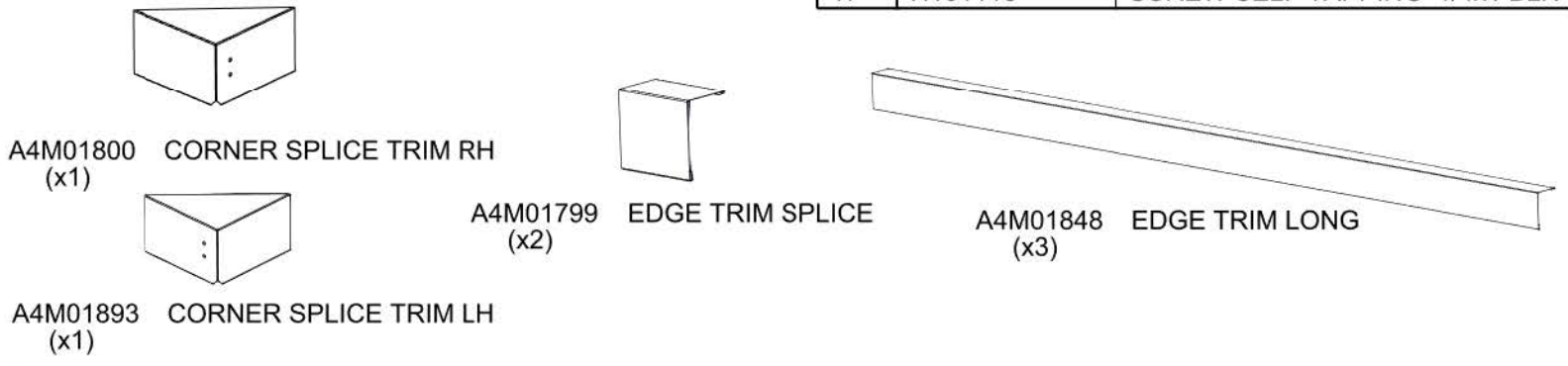

**WARNING: GLOVES ARE RECOMMENDED WHEN HANDLING STEEL.**

**NOTES:**

- REMOVE BLUE FILM FROM EDGE TRIM, EDGE TRIM SPLICE, AND CORNER SPLICE TRIM.
- ORIENT EDGE TRIM, EDGE TRIM SPLICE, AND CORNER SPLICE TRIM AS SHOWN BELOW.
- SLIDE TRIM PIECES INTO SPLICES. ATTACH CORNER SPLICES BY SLIDING ONTO EDGE TRIM. SCREW AS NOTED IN DETAIL.

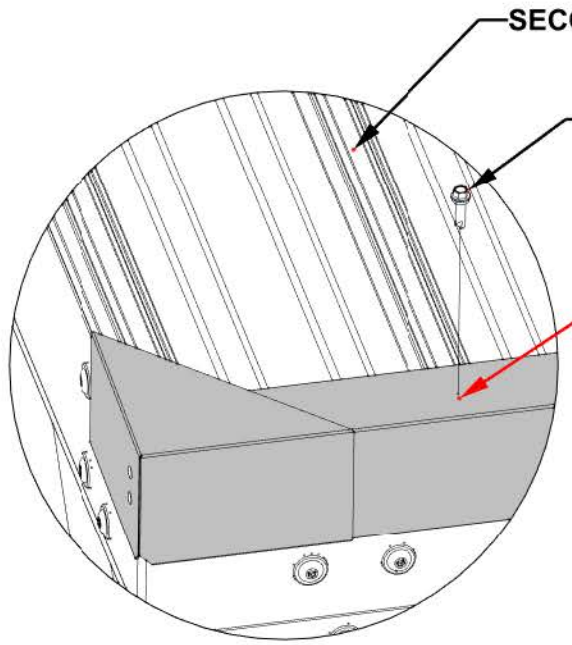

**ATTACH THIS SCREW THROUGH THE TRIM AND INTO THE 2ND RIB OF THE SHEETING. SKIP ONE RIB AND REPEAT.**

**NOTE: TRIM WILL ONLY BE INSTALLED ON THE FRONT AND SIDES OF UNIT, NO TRIM WILL BE INSTALLED ON BACKSIDE TO ALLOW FOR DRAINAGE.**

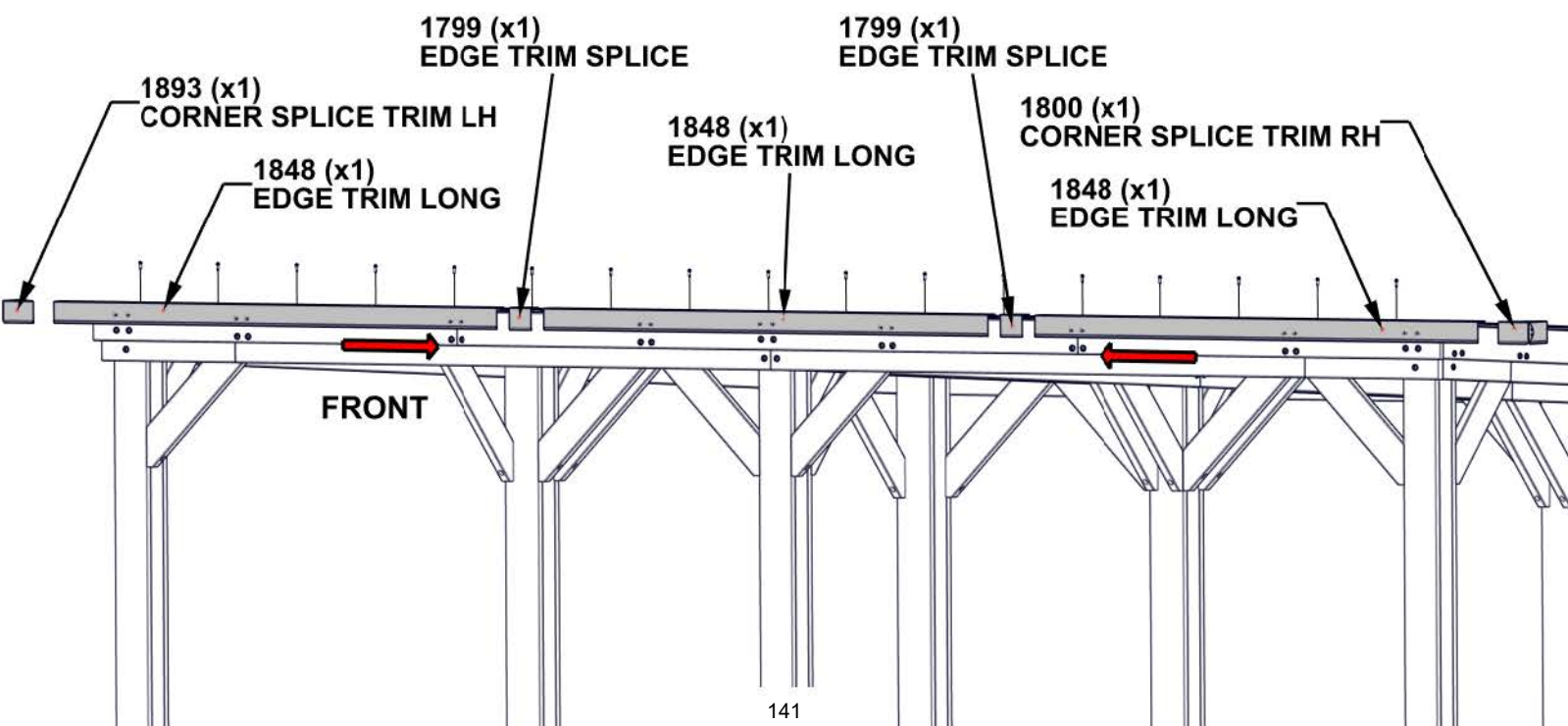

# STEP 56 - CARPORT ASSEMBLY

QTY	PART NUMBER	DESCRIPTION
28	H101116	SCREW SELF TAPPING 1/4x1 BLK



A4M01848 EDGE TRIM LONG  
(x6)



A4M01799 EDGE TRIM SPLICE  
(x4)

**WARNING: GLOVES ARE RECOMMENDED WHEN HANDLING STEEL.**

- NOTES:**
- REMOVE BLUE FILM FROM EDGE TRIM, EDGE TRIM SPLICE, AND CORNER SPLICE TRIM.
  - ORIENT EDGE TRIM AND EDGE TRIM SPLICE AS SHOWN BELOW. SLIDE EDGE TRIM INTO SPLICES.
  - FLUSH LAST PIECE WITH THE REAR DRIP EDGE. SCREWS GO THROUGH EDGE TRIM INTO RIB AT THE APPROXIMATE LOCATIONS SHOWN.
  - REPEAT ON OPPOSITE SIDE.

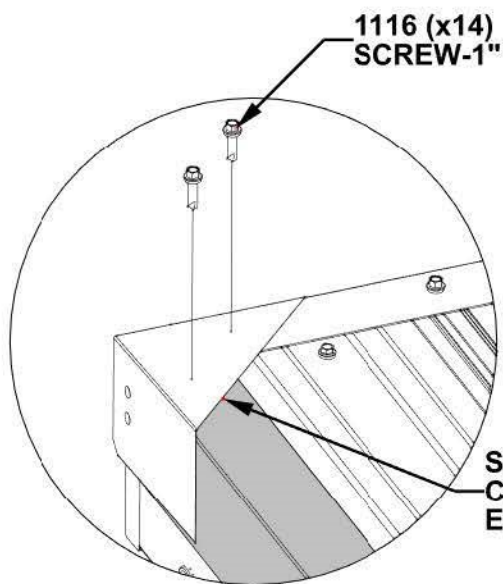

1116 (x14)  
SCREW-1"

SLIDE EDGE TRIM INTO  
CORNER SPLICE. FASTEN  
EDGE TRIM USING H101116 SCREWS.

FRONT

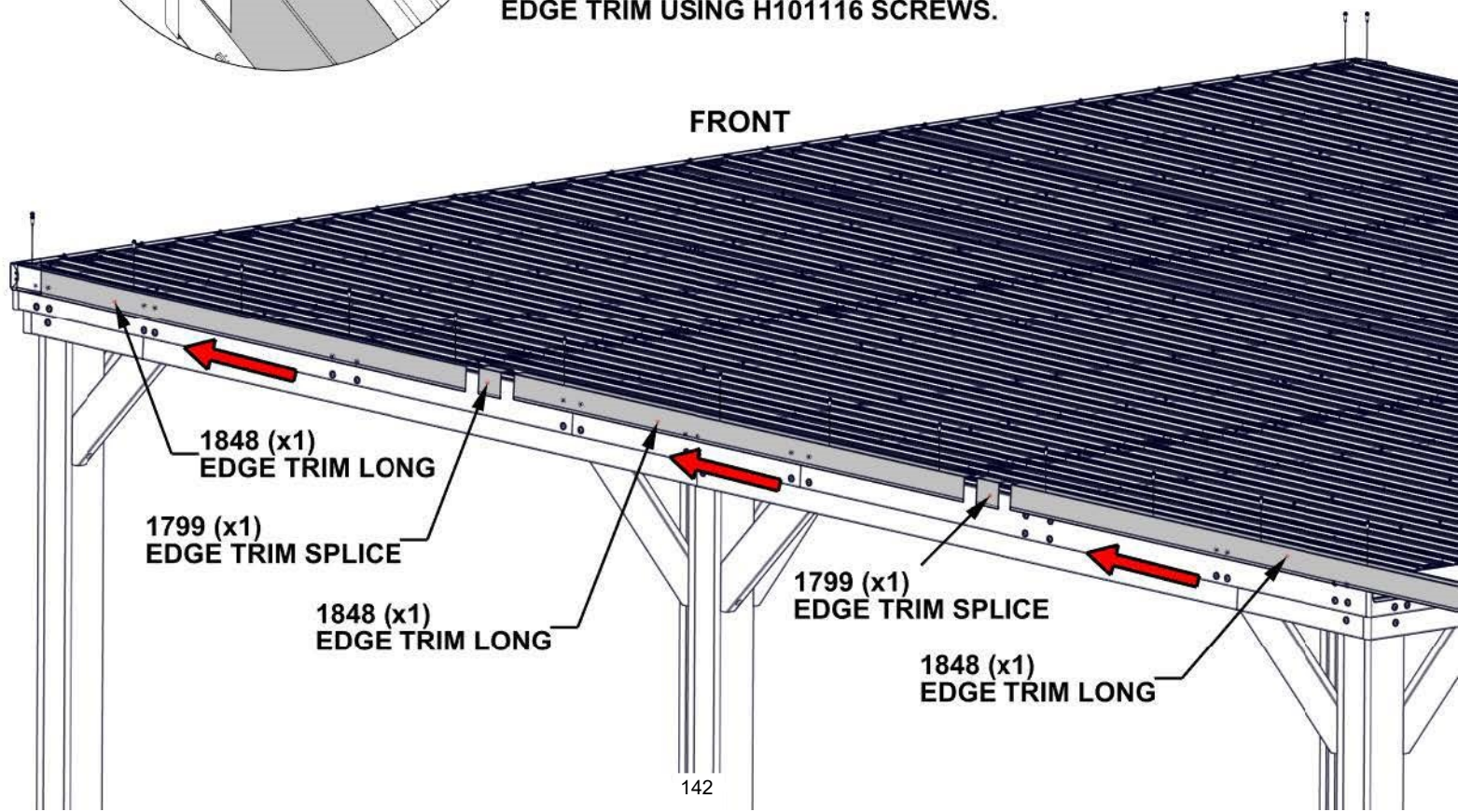

1848 (x1)  
EDGE TRIM LONG

1799 (x1)  
EDGE TRIM SPLICE

1848 (x1)  
EDGE TRIM LONG

1799 (x1)  
EDGE TRIM SPLICE

1848 (x1)  
EDGE TRIM LONG

# STEP 57 - CARPORT ASSEMBLY

QTY	PART NUMBER	DESCRIPTION
72	H100471	LAG SCREW WH 5/16x1 1/2 BLK

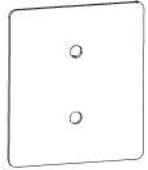

A4M00978 POST PLATE (x18)

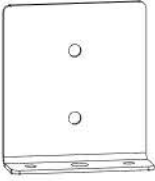

A4M00977 POST ANCHORING PLATE (x18)

- NOTE:**
- 977 POST ANCHORING PLATES MOUNT ON OUTSIDE OF POST AS SHOWN EXCEPT THE CENTER POST.
  - 978 POST PLATES GO ON INSIDE OF POST AS SHOWN EXCEPT CENTER POST, THESE WILL ALSO BE ON THE FRONT FACE OF POST AS SHOWN IN DETAIL BELOW.

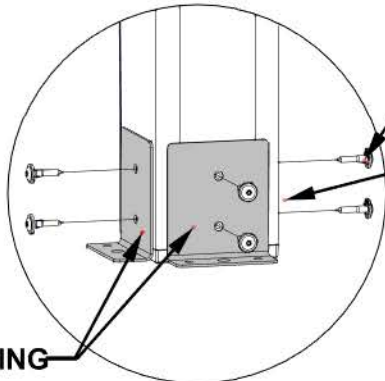
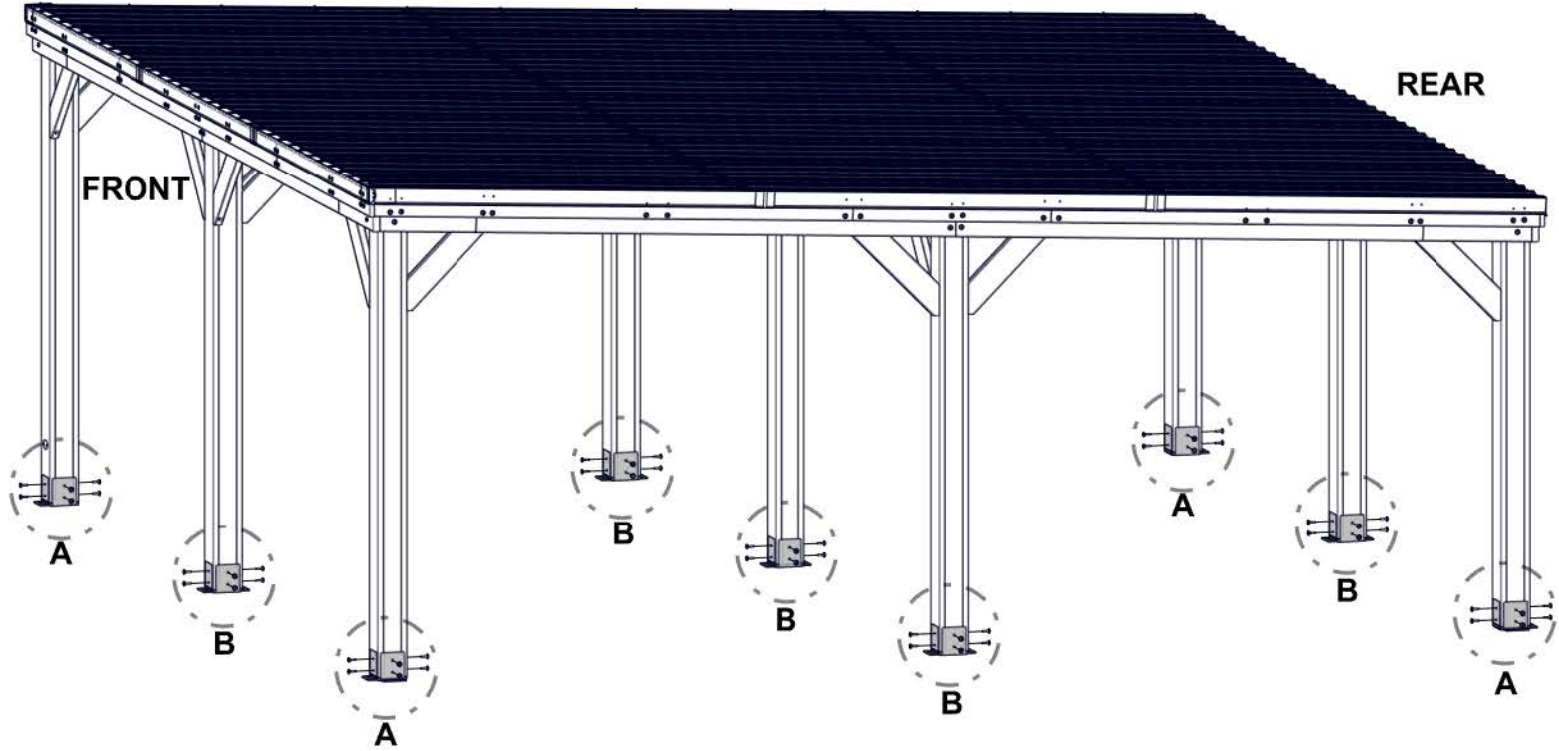

977 (x18) POST ANCHORING PLATE

DETAIL 'A'

471 (x72) LAG SCREW - 1 1/2"

978 POST PLATE

977 POST ANCHORING PLATE (FRONT AND REAR)

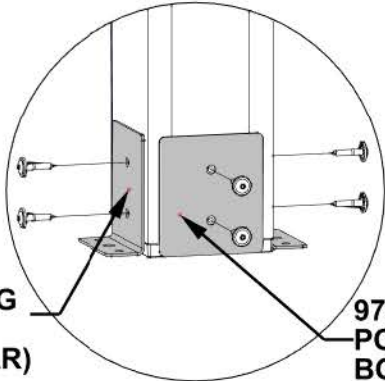

978 (x18) POST PLATE BOTH SIDES

DETAIL 'B'

**USE PILOT HOLES IN POST TO INSTALL THE ANCHORING LAGS**

# STEP 58 - CARPORT ASSEMBLY

QTY	PART NUMBER	DESCRIPTION
36	H100120	CONCRETE ANCHOR 1/4"x2"
36	H100630	WASHER FLAT 8x19 BLK

MANUFACTURER RECOMMENDS INSTALLATION ON CONCRETE SURFACE OR CONCRETE POST PADS.

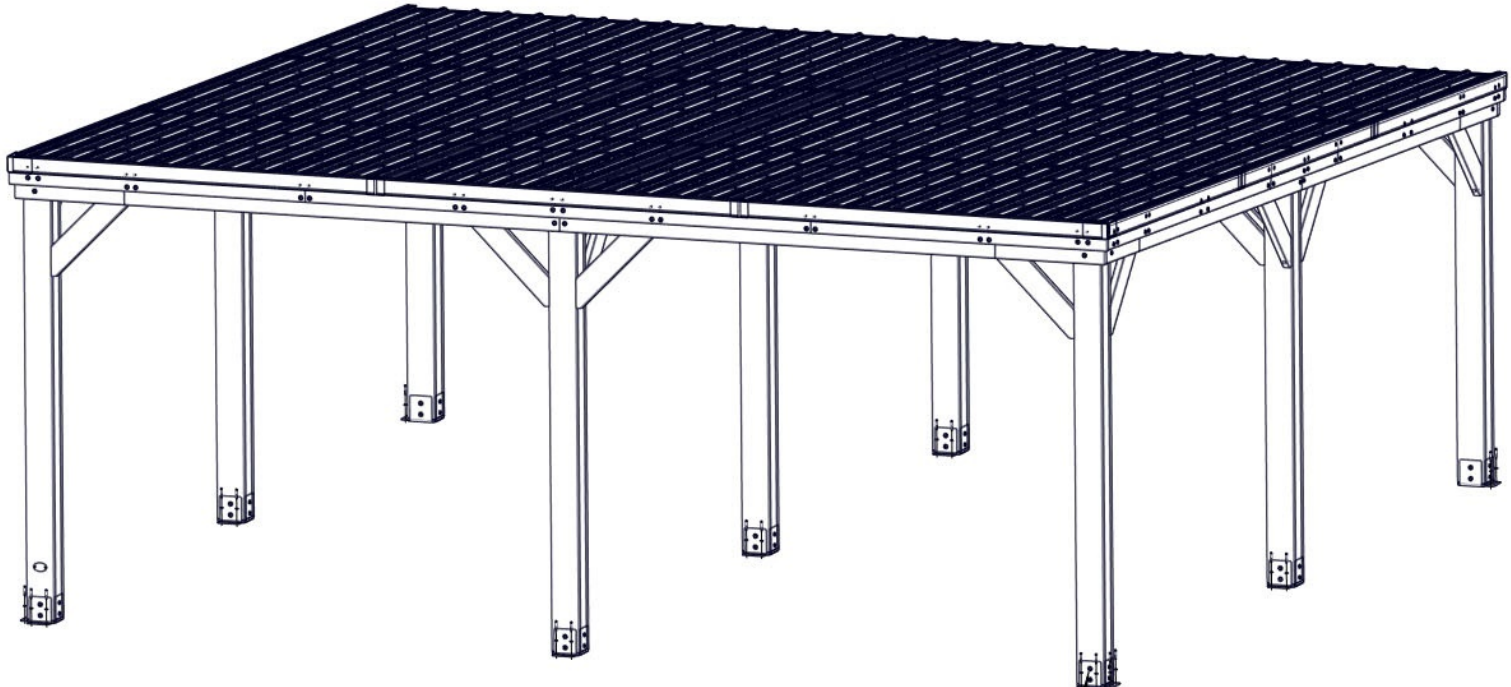

120 (x36)  
CONCRETE SCREW-2"

630 (x36)  
WASHER - 8x19

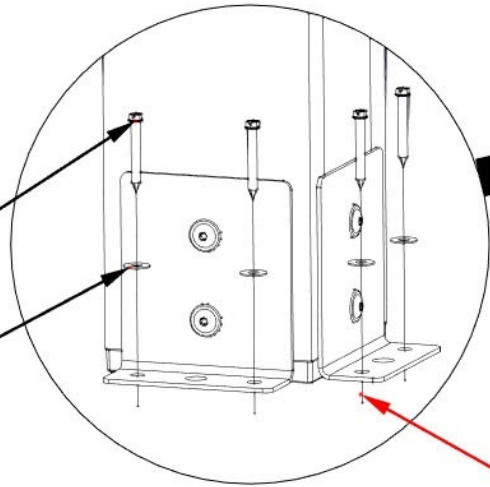

**PRE-DRILL HOLES FOR CONCRETE ANCHORS USING A 3/16"**



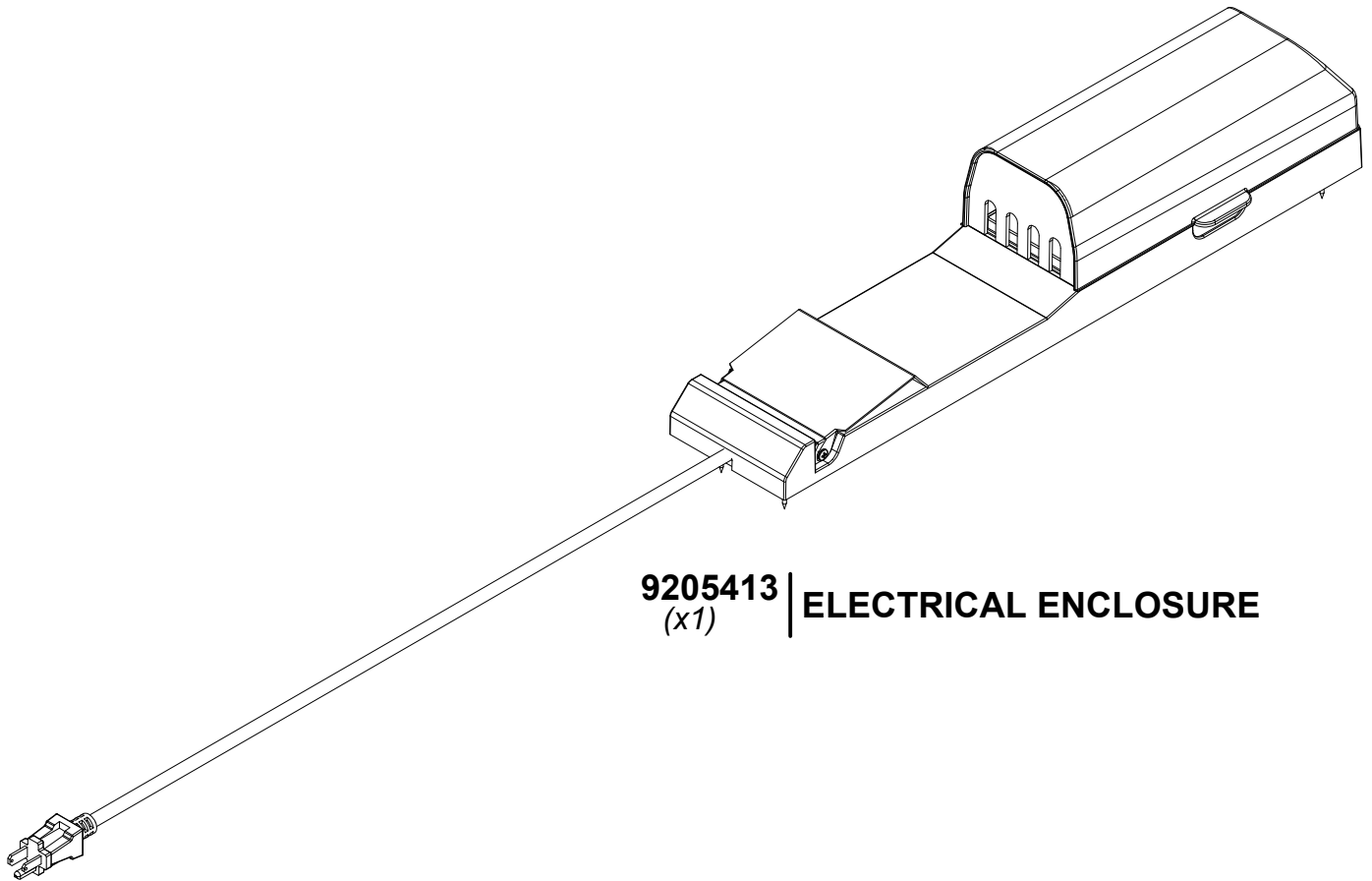

**9205413** | **ELECTRICAL ENCLOSURE**  
(x1)

FOR POWERPORT INSTALLATION REFER TO ASSEMBLY INSTRUCTIONS THAT COME PACKAGED WITH THE POWERPORT KIT. INSTALL ON ANY POST THAT IS DESIRED. FOLLOW DIRECTIONS FOR PROPER INSTALLATION.