



Manufactured by: Backyard  
Discovery  
3305 Airport Drive, Pittsburg,  
KS 66762 800-856-4445

Basepoint Business Centre: Rivermead Drive, Westlea, Swindon SN5 7EX Phone:  
0800-118-2476 J.P. Coenstraat 7, The Bridge, The Hague, 2595 WP, Netherlands Phone: 08005678990

# 12x12 BARRINGTON GAZEBO

## MODEL # : 2306226



Please visit [www.backyarddiscovery.com](http://www.backyarddiscovery.com)  
For the most up to date assembly manual, to register your product, or to order  
replacement parts *Para obtener instrucciones en español, visite*  
[www.backyarddiscovery.com](http://www.backyarddiscovery.com)



EASY STEP-BY-STEP  
3D INTERACTIVE INSTRUCTIONS  
DOWNLOAD THE FREE APP



Made in China

INS-2306226-A-12X12 BARRINGTON GAZEBO-ENG 9-23-2024

# OWNER'S MANUAL - BASIC SETUP DIMENSIONS & ASSEMBLY NOTES

It is critically important that you start with square and level footings or concrete pad to attach your structure.

- Pay close attention to the items needed for each step. Make sure you are using the correct hardware for each step. using incorrecdt hardware may result in improper assembly
- Remember to double check for underground utilities and overhead electrical lines

Post mounts are provided with your structure which allows you to permanently install your structure to a pre-existing or new wood concrete surface. See Anchor Instructions for further details and recommendations.

- The hardware to attach the post mounts to the structure is included.
- The hardware to mount the structure permanently to a concrete surface is included
- The hardware to mount the sctructure permanently to a wood deck is NOT included and will need to be purchased separately. You must ensure there is ample structural support under the deck before permanently attaching.

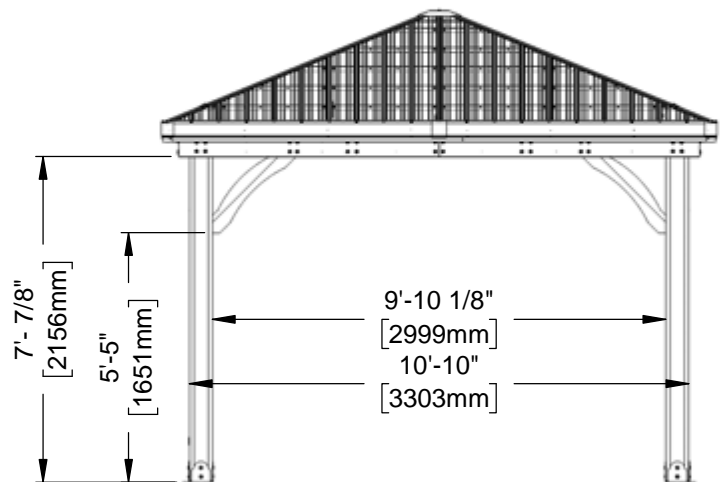
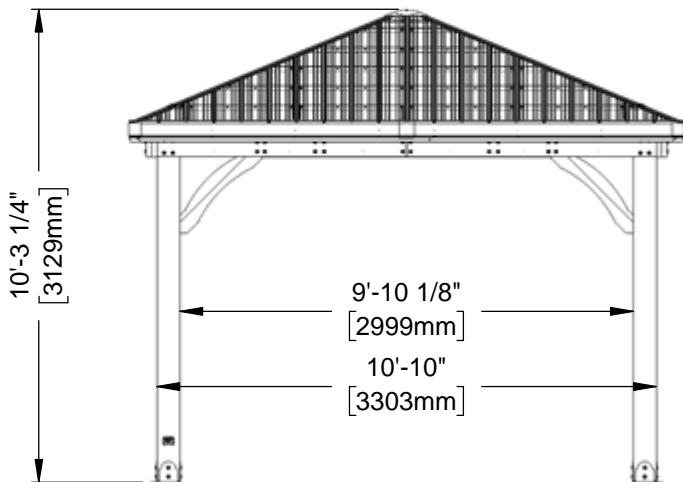
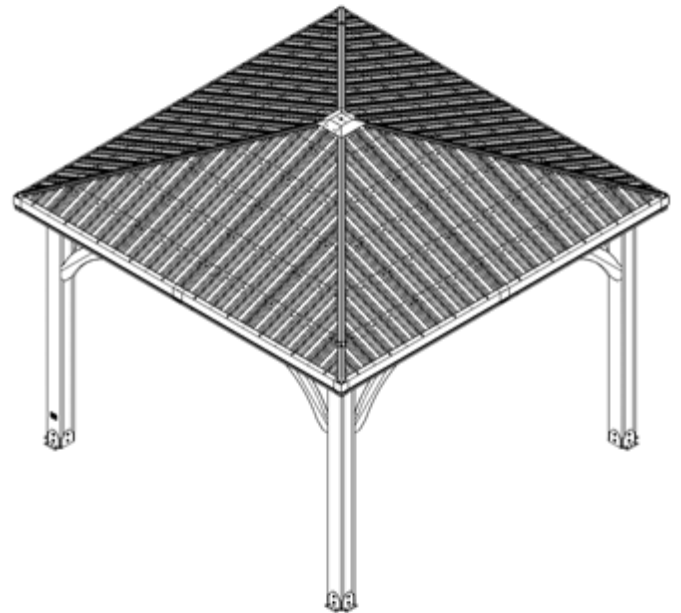
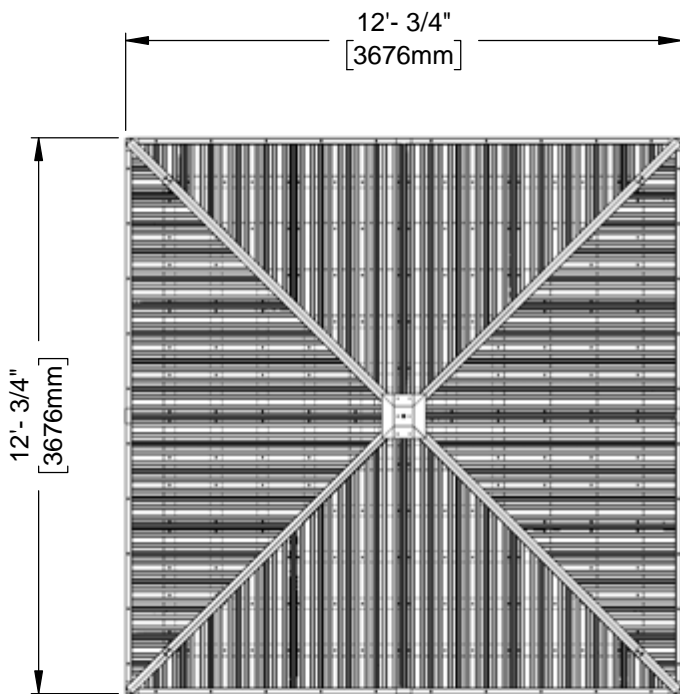

# OWNER'S MANUAL - ANCHORING LAYOUT

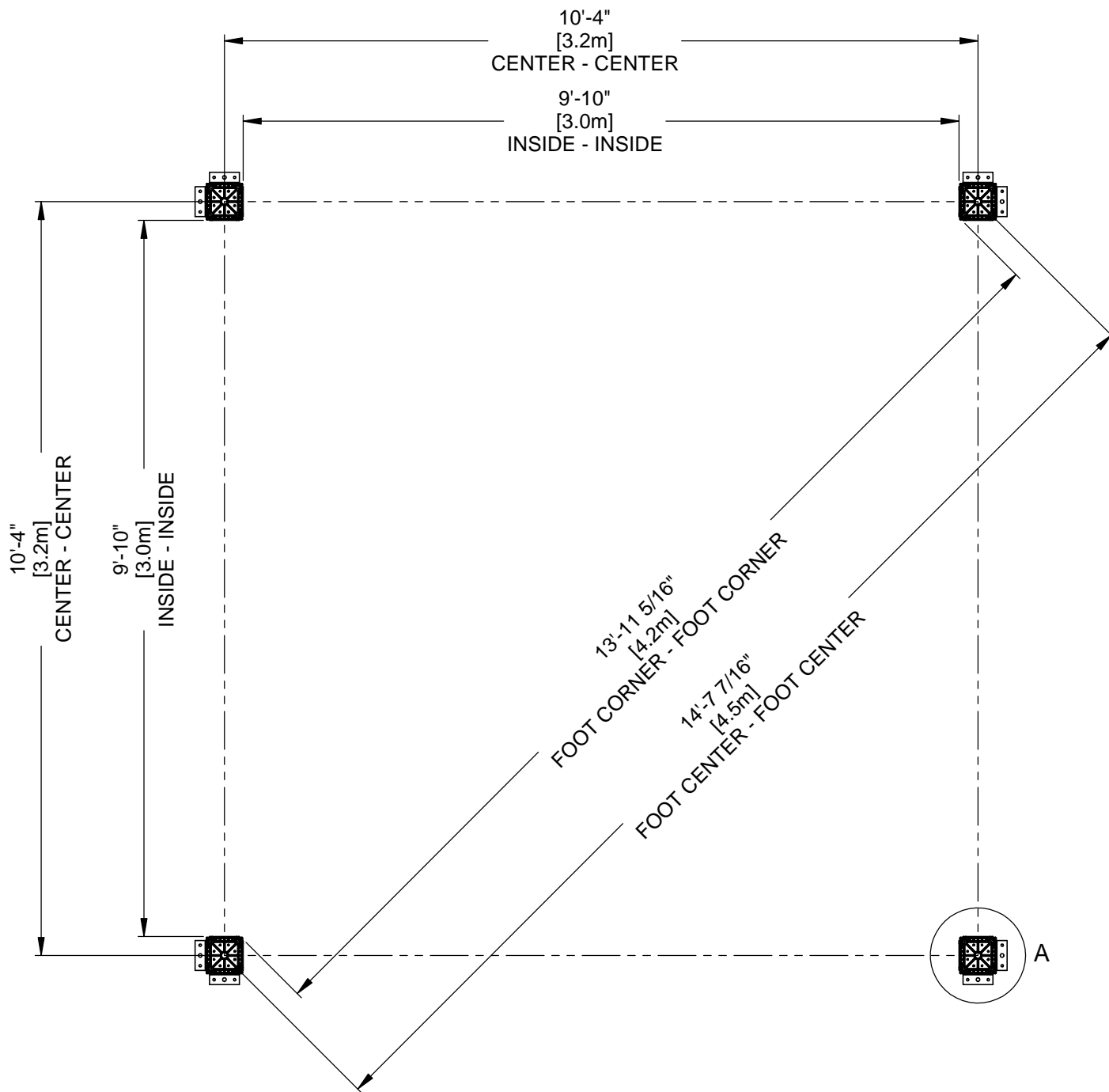

NOTE: DIMENSIONS ARE TO ANCHOR PLATES MOUNTED TO POSTS EXCEPT WHERE NOTED.

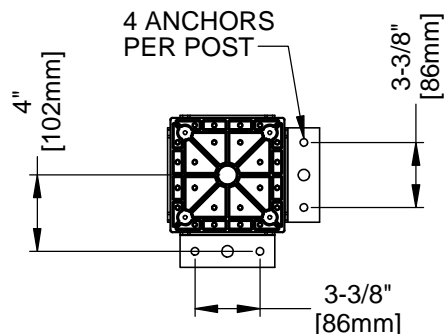

**DETAIL A**

# OWNER'S MANUAL - PARTS IDENTIFICATION

## Wood Components (Not to Scale)



**C01 | CORBEL-W2A03198**  
(x7) | 1 7/16"x6 7/16"x35 1/8" (36x163x893)



**C02 | CORBEL-W2A03198**  
(x1) | 1 7/16"x6 7/16"x35 1/8" (36x163x893)



**D01 | BEAM-W4L20737**  
(x4) | 1 7/16"x5 1/4"x29 15/16" (36x134x760)



**D02 | BEAM-W4L17576**  
(x4) | 1 7/16"x5 1/4"x1 7/16" (36x134x688)



**D03 | BEAM-W4L17577**  
(x4) | 1 7/16"x5 1/4"x65" (36x134x1651)

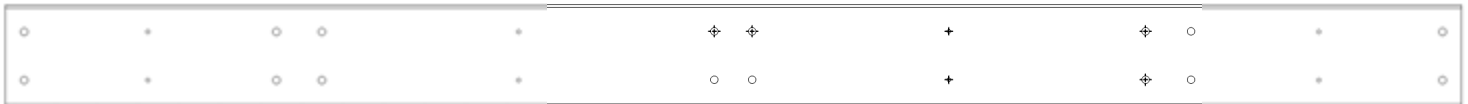

**D05 | BEAM-W4L20738**  
(x4) | 1 7/16"x5 1/4"x75 7/8" (36x134x1927)



**D06 | BEAM-W4L15241**  
(x4) | 1 7/16"x5 1/4"x67 13/16" (36x134x1723)



**E05 | RAFTER-W4L15207**  
(x4) | 1 7/16"x3 3/8"x69" (36x86x1752)



**E06 | RAFTER-W4L15208**  
(x4) | 1 7/16"x3 3/8"x45 7/16" (36x86x1155)



**E07 | RAFTER-W4L15209**  
(x4) | 1 3/8"x3 3/8"x22" (36x86x557)



**E11 | RAFTER-W4L15217**  
(x4) | 1 7/16"x3 3/8"x69" (36x86x1752)



# OWNER'S MANUAL - PARTS IDENTIFICATION

## Wood Components (Not to Scale)

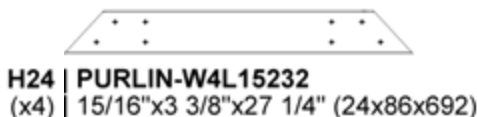
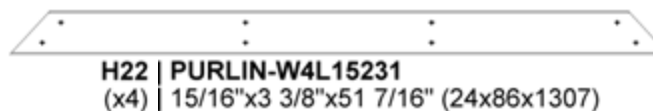
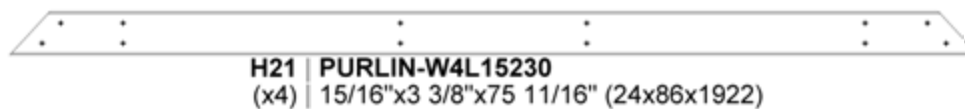
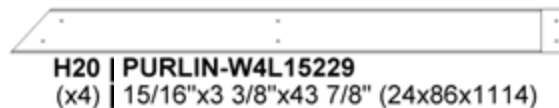
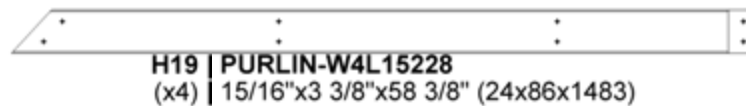
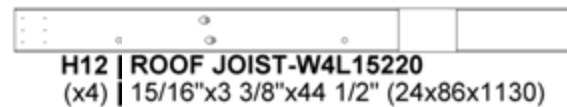
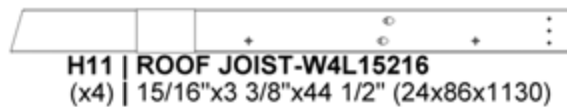
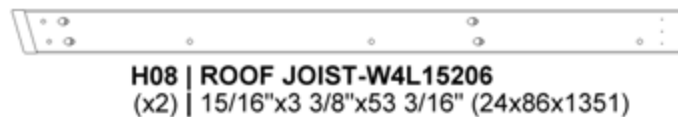
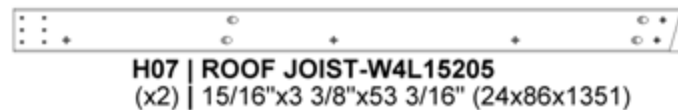
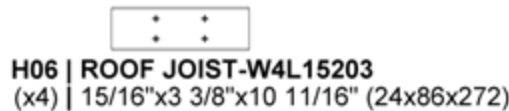
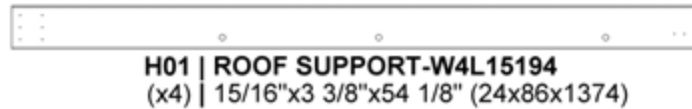
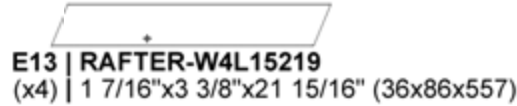
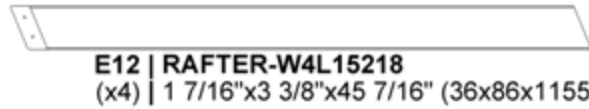

# OWNER'S MANUAL - PARTS IDENTIFICATION

## Wood Components (Not to Scale)



**H27 | PURLIN-W4L15237**  
(x4) | 15/16"x3 3/8"x56" (24x86x1422)

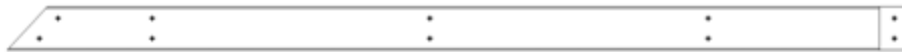

**H28 | PURLIN-W4L15238**  
(x4) | 15/16"x3 3/8"x70 1/2" (24x86x1791)



**H30 | TOP JOIST-W4L20292**  
(x4) | 15/16"x3 3/8"x38 13/16" (24x86x986)



**H31 | SIDE PANEL ROOF JOIST-W4L20290**  
(x2) | 15/16"x3 3/8"x53 3/16" (24x86x1351)



**H32 | SIDE PANEL ROOF JOIST-W4L20291**  
(x2) | 15/16"x3 3/8"x53 3/16" (24x86x1351)



**P01 | POST-W2A03202**  
(x2) | 6"x6"x89 1/2" (152x152x2274)



**P02 | POST-W2A03203**  
(x2) | 6"x6"x89 1/2" (152x152x2274)



**Q01 | ROOF JOIST-W4L15204**  
(x2) | 15/16"x4 7/16"x65 15/16" (24x112x1675)



**Q02 | ROOF JOIST-W4L17579**  
(x2) | 15/16"x4 7/16"x64 15/16" (24x112x1649)

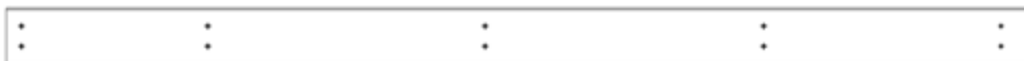

**Q03 | ROOF JOIST-W4L15221**  
(x2) | 24x4 7/16"x80 1/2" (24x112x2044)



**Q04 | ROOF JOIST-W4L17578**  
(x2) | 24x4 7/16"x79 7/16" (24x112x2018)



**T02 | PURLIN-W4L15239**  
(x4) | 15/16"x1 5/16"x12 7/8" (24x34x327)

# OWNER'S MANUAL - PARTS IDENTIFICATION

## Hardware Components (Not to Scale)



**H100764 | SCREW SETTER**  
(x1) |



**H100147 | TORX BIT**  
(x1) | T-30

**H101058 | BOLT WH BLK**  
(x32) | 5/16 X 8 3/4

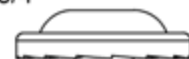

**H100114 | TORX WRENCH**  
(x1) | T-30



**H100120 | CONCRETE ANCHOR**  
(x16) | 1/4"X2"

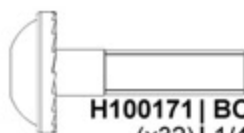

**H100171 | BOLT WH BLK**  
(x32) | 1/4 X 1

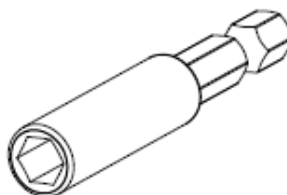

**H101100 | MAGNETIC DRIVER**  
(x1) |

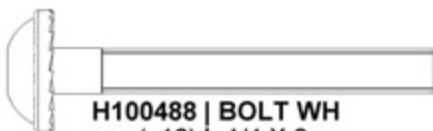

**H100488 | BOLT WH**  
(x16) | 1/4 X 2

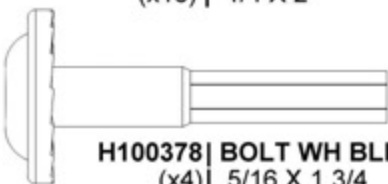

**H100378 | BOLT WH BLK**  
(x4) | 5/16 X 1 3/4

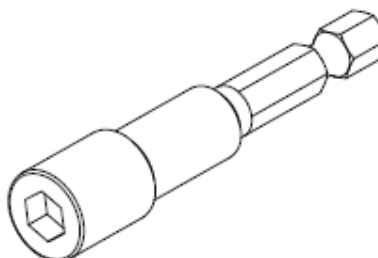

**H101106 | SOCKET DRIVER**  
(x1) |



**H100195 | BOLT WH BLK**  
(x48) | 5/16 X 2 3/4



**H100415 | BOLT WH BLK**  
(x20) | 5/16 X 3 3/4



**H100513 | BOLT WH BLK**  
(x32) | 5/16 X 4 1/4



**H100354 | BOLT WH BLK**  
(x1) | 5/16 X 6 1/2

# OWNER'S MANUAL - PARTS IDENTIFICATION

## Hardware Components (Not to Scale)

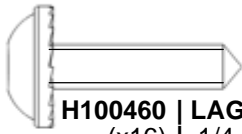

**H100460 | LAG SCREW WH BLK**  
(x16) | 1/4 X 1

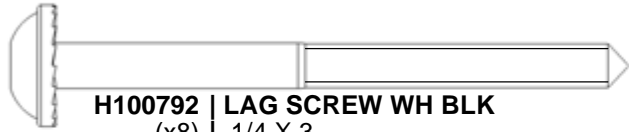

**H100792 | LAG SCREW WH BLK**  
(x8) | 1/4 X 3

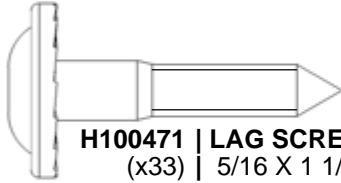

**H100471 | LAG SCREW WH BLK**  
(x33) | 5/16 X 1 1/2



**H100653 | NUT LOCK BLK**  
(x16) | 1/4

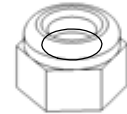

**H100479 | NUT LOCK BLK**  
(x20) | 5/16

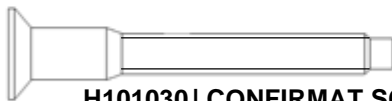

**H101030 | CONFIRMAT SCREW**  
(x96) | 2

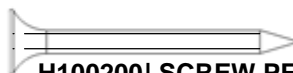

**H100200 | SCREW PFH BLK**  
(x16) | 8 X 1 1/2

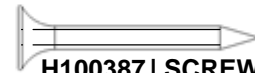

**H100387 | SCREW PFH BLK**  
(x4) | 8 X 1 1/4

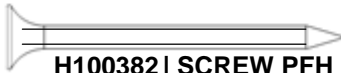

**H100382 | SCREW PFH BLK**  
(x16) | 8 X 1 3/4

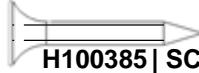

**H100385 | SCREW PFH BLK**  
(x172) | 8 X 1



**H100483 | SCREW PFH BLK**  
(x48) | 8 X 2 1/4

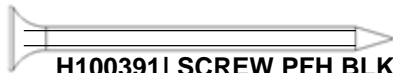

**H100391 | SCREW PFH BLK**  
(x232) | 8 X 2

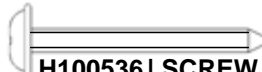

**H100536 | SCREW PWH BLK**  
(x32) | 8 X 1 1/4

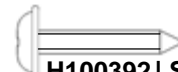

**H100392 | SCREW PWH BLK**  
(x16) | 8 X 3/4

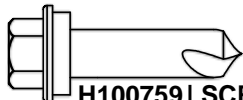

**H100759 | SCREW TAPPING**  
(x52) | 1/4X1

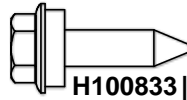

**H100833 | SCREW WOODGRIP**  
(x224) | 10-16X3/4"



**H100198 | WASHER LOCK EXT BLK**  
(x136) | 8X19



**H100398 | T-NUT BLK**  
(x32) | 1/4X1



**H100379 | T-NUT BLK**  
(x116) | 5/16



**H100630 | WASHER FLAT BLK**  
(x32) | 8X19



**H100770 | WASHER FLAT BLK**  
(x20) | 9.5 X 22



**H100405 | WASHER LOCK EXT BLK**  
(x8) | 6X15

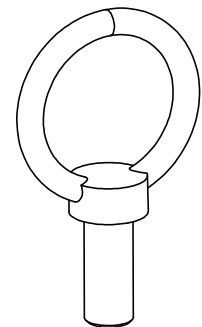

**H101285 | EYE NUT**  
(x1) | 5/16-18 X 3/4" DIA.

# OWNER'S MANUAL - PARTS IDENTIFICATION

## Accessory Components (Not to Scale)

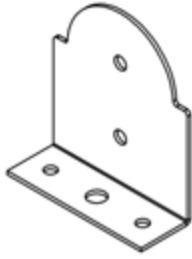

**A4M01793 | POST ANCHOR PLATE**  
(x8)



**A4M01794 | POST PLATE**  
(x8)

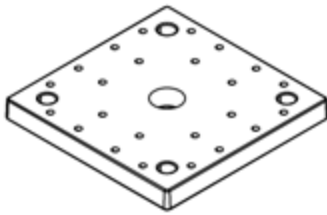

**A6P00308 | 6x6 POST FOOT**  
(x4)

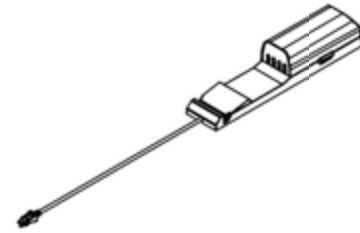

**9205413 | ELECTRICAL ENCLOSURE**  
(x1)

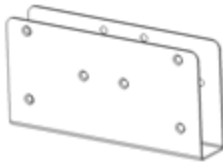

**A4M01237 | ROOF SUPPORT SPLICE CLIP**  
(x12)

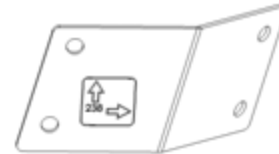

**A4M01238 | PANEL BRACKET**  
(x4)

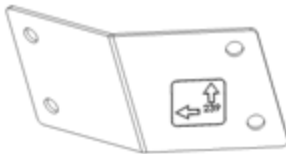

**A4M01239 | PANEL BRACKET**  
(x4)



**A4M02850 | RIDGE CAP CHANNEL SHORT**  
(x8)



**A4M02158 | BYD ID TAG PATIO**  
(x1)

# OWNER'S MANUAL - PARTS IDENTIFICATION

## Accessory Components (Not to Scale)

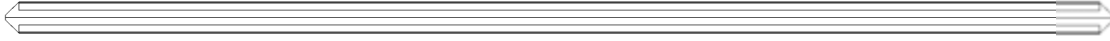

**A4M02826 | CORNER RIDGE CAP LONG**  
(x4) |

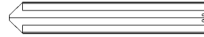

**A4M02867 | CORNER RIDGE CAP SHORT**  
(x4) |

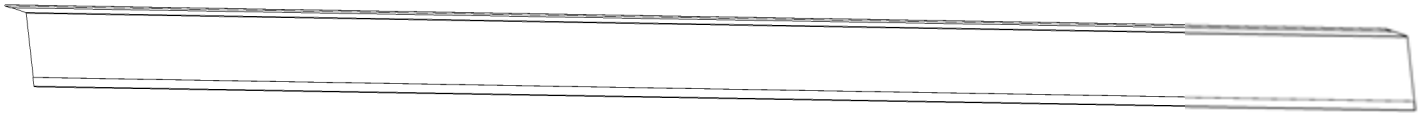

**A4M02821 | EDGE TRIM**  
(x8) |



**A4M02847 | RIDGE CAP CHANNEL LONG**  
(x8) |

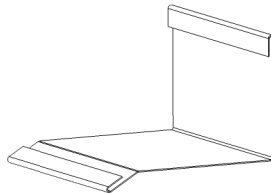

**A4M03410 | DRIP EDGE SPLICE**  
(x4) |

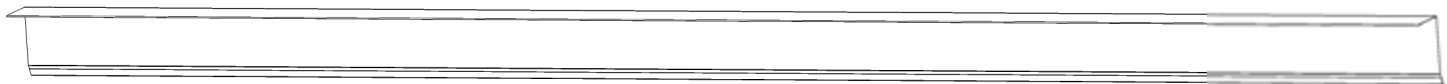

**A4M03411 | DRIP EDGE**  
(x8) |

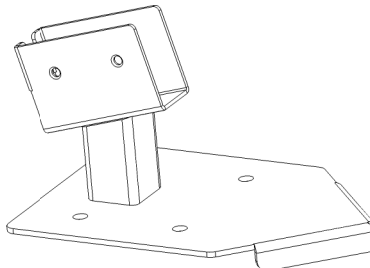

**A4M01234 | POST CLIP ASSY**  
(x4) |

# OWNER'S MANUAL - PARTS IDENTIFICATION

## Accessory Components (Not to Scale)



**A4M01185 | CORNER BRACKET**  
(x4)

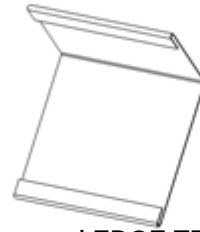

**A4M02822 | EDGE TRIM SPLICE**  
(x4)

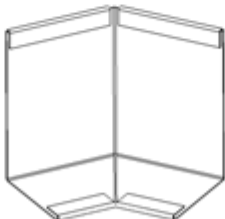

**A4M02825 | EDGE TRIM CORNER SPLICE**  
(x4)

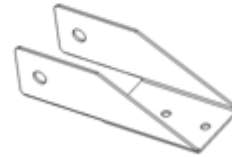

**A4M01228 | RAFTER CLIP**  
(x16)

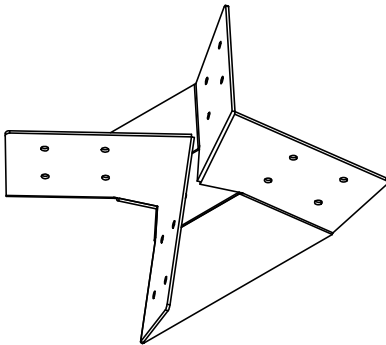

**A4M01901 | PANEL SUPPORT BRACKET**  
(x1)

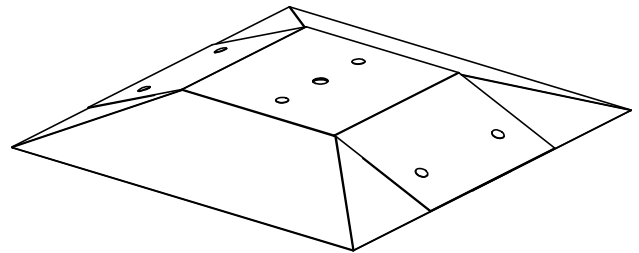

**A4M01907 | PEAK RIDGE CAP**  
(x1)



**A4M01908 | METAL SPACER**  
(x1)

# OWNER'S MANUAL - PARTS IDENTIFICATION

## Accessory Components (Not to Scale)

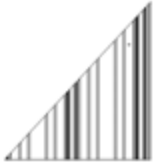

**A4M01924-2** | 29GA STEEL SHEETING  
(x4)

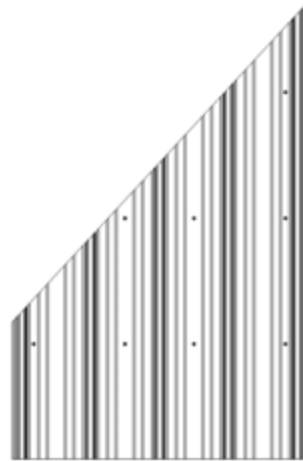

**A4M01923-1** | 29GA STEEL SHEETING  
(x4)

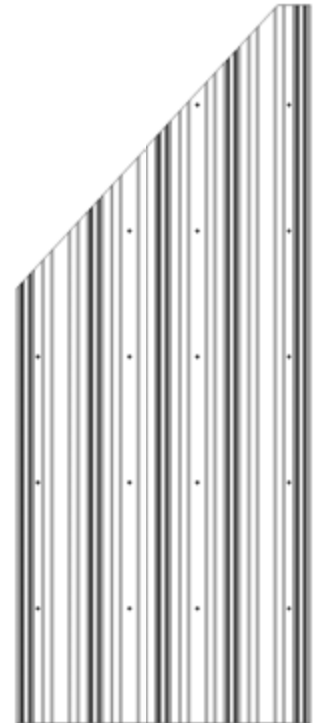

**A4M01923-2** | 29GA STEEL SHEETING  
(x4)



**A4M01922-2** | 29GA STEEL SHEETING  
(x4)



**A4M01922-1** | 29GA STEEL SHEETING  
(x4)

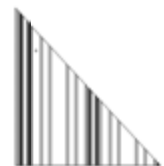

**A4M01924-1** | 29GA STEEL SHEETING  
(x4)



# PRE-ASSEMBLY STEP 1 - SORTING PARTS

It is critical for ease of assembly that you take the time to sort and organize the wood and hardware.

---

## WOOD PARTS:

- Organize wood parts by the three-digit, alpha-numeric number stamped on each board (ex. P01).
- If there are multiple boards with the same stamped number, stack those pieces together.
- Stamps can be found on the flat surface of the boards or on the end of the boards.
- Allow yourself plenty of room - the wood pieces can take up a significant amount of space.

**NOTE: CARTONS ARE NOT ORGANIZED BY BOARD OR STEP NUMBER.**



## HARDWARE PARTS:

- We recommend that you have a separate table to organize the hardware.
- Hardware bags are printed with a seven-digit, alpha-numeric part number.
- You can organize your hardware by part number or group by hardware type (e.g. bolts, nuts, etc.).
- During assembly you only need to reference the last four digits of the number.

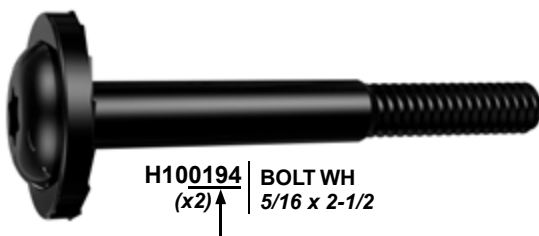

H100194 | BOLT WH  
(x2) ↑ 5/16 x 2-1/2

# PRE-ASSEMBLY STEP 2 - TOOLS REQUIRED



Cordless Drill or Electric Drill



Drill Attachments:  
Phillips Head



1/8" & 3/8" Drill Bits



Phillips Screw Driver



Open End Wrenches 1/2" & 7/16"



3/8" Drive Ratchet, 1/2" & 7/16" STD Sockets, 1/2" & 7/16" Deep Sockets



Tape Measure



Claw Hammer



Rubber Mallet - Optional

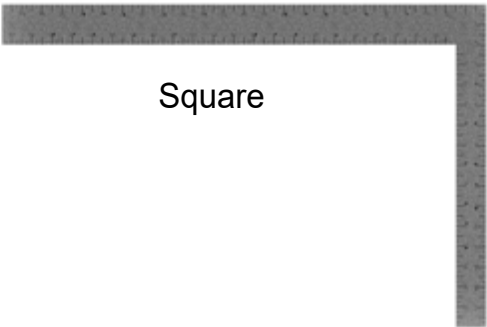

Square



Level 24"

# PRE-ASSEMBLY STEP 3 - CHOOSE YOUR ASSEMBLY METHOD

There are several types of assembly instructions available to you.

1. Printed Assembly Manual included with your set
2. BILT APP - 3D interactive instructions
3. Combination of the Printed Manual and BILT APP (Note: Step numbers can differ between the two methods)



# STEP 1 - POST ASSEMBLY

QTY	PART NUMBER	DESCRIPTION
8	H100200	SCREW PFH 8x1 1/2 BLK



P01 POST - W2A03202-1  
(x1) 1 1/4"x6"x89 1/2" (152x152x2274)



P02 POST - W2A03202-1  
(x1) 1 1/4"x6"x89 1/2" (152x152x2274)

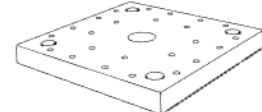

A6P00308 - 6x6 POST FOOT  
(x2)

- FOR EASE OF ASSEMBLY, SAW HORSES ARE RECOMMENDED FOR POST AND BEAM ASSEMBLIES
- ALIGN FEET WITH POSTS AND PRE-DRILL HOLES WITH 1/8" DRILL BIT PRIOR TO ATTACHMENT

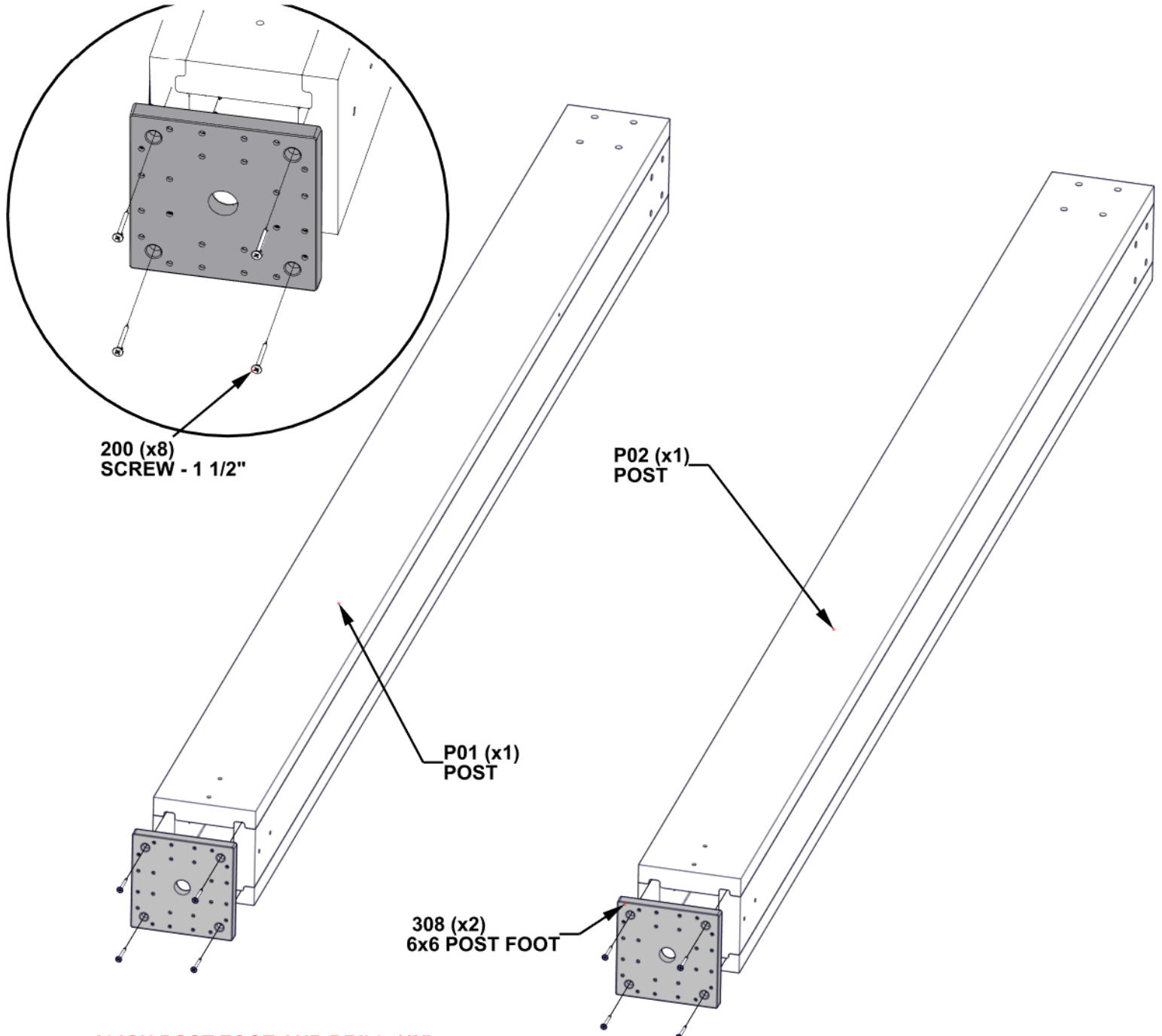

**ALIGN POST FOOT AND DRILL 1/8"  
[3mm] PILOT HOLES FOR THE  
ATTACHMENT HARDWARE.**

# STEP 2 - 130" BEAM ASSEMBLY



D05 BEAM - W4L20738  
(x1) 1 7/16"x5 1/4"x75 7/8" (36x134x1927)



D03 BEAM - W4L17577  
(x2) 1 7/16"x5 1/4"x65" (36x134x1651)

QTY	PART NUMBER	DESCRIPTION
12	H100195	BOLT WH 5/16x2 3/4 BLK
12	H100198	WASHER LOCK EXT 8x19
12	H100379	TNUT-5/16" BLK

**- INSERT T-NUTS FIRST**

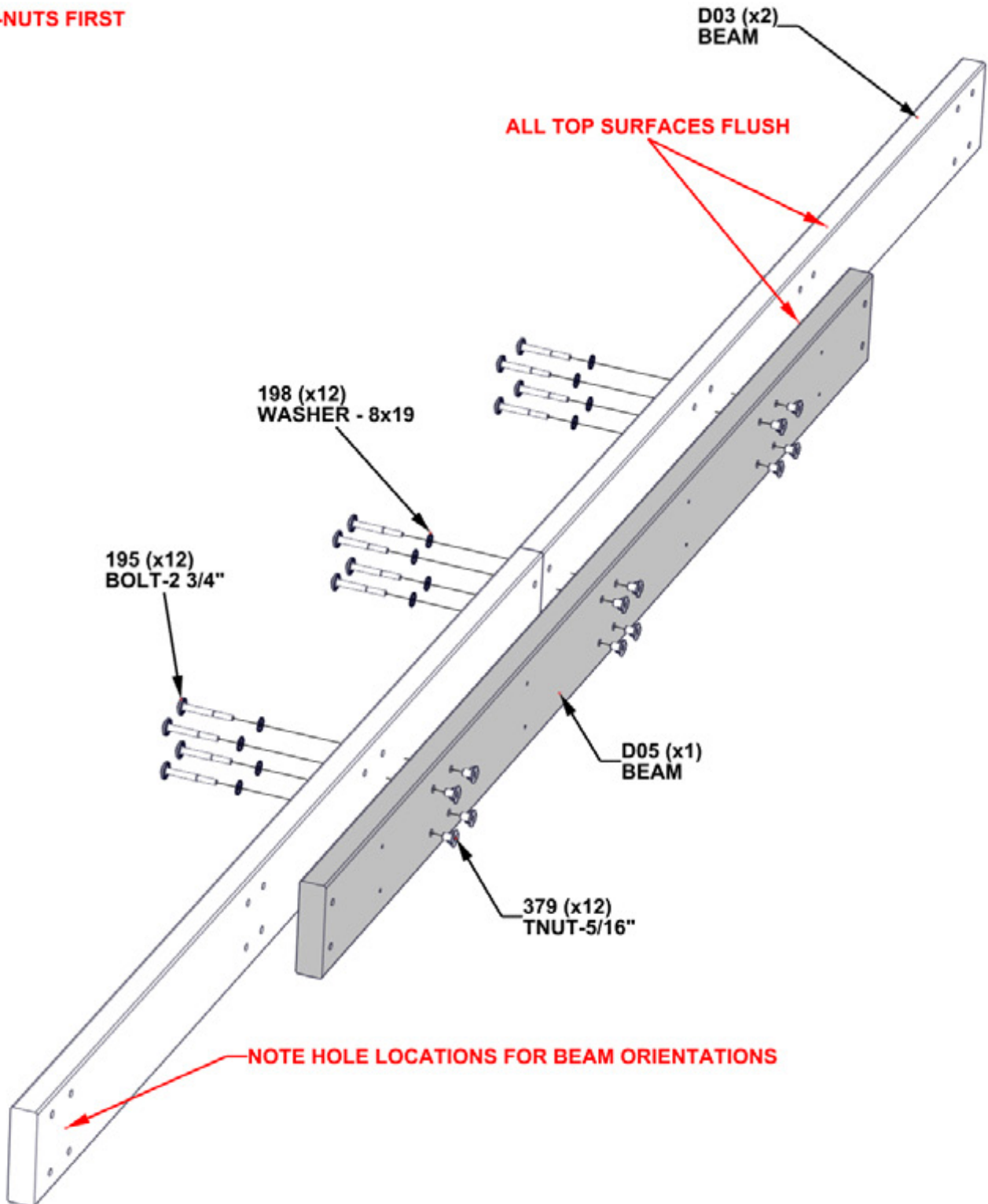

# STEP 3 - 130" BEAM ASSEMBLY



D02 BEAM - W4L17576  
(x2) 27 1/16"x5 1/4"x1 7/16" (688x134x36)

QTY	PART NUMBER	DESCRIPTION
12	H100483	SCREW PFH 8x2 1/4 BLK

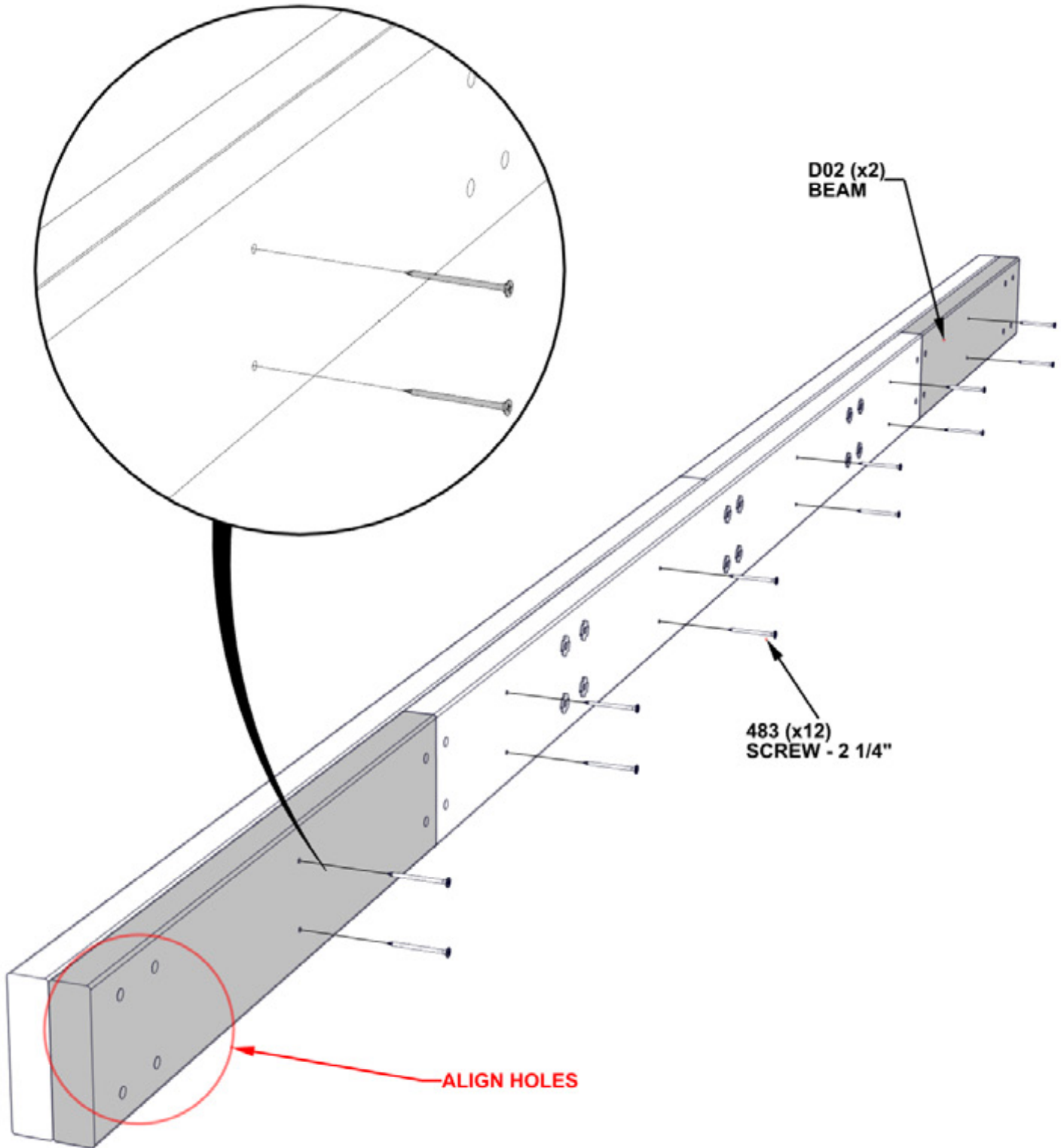

# STEP 4 - 130" BEAM & POST ASSEMBLY

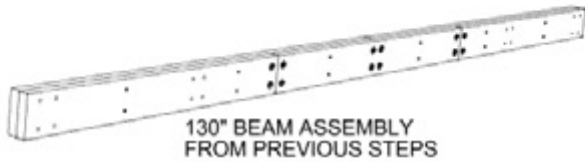

QTY	PART NUMBER	DESCRIPTION
8	H100198	WASHER LOCK EXT 8x19
8	H100379	TNUT-5/16" BLK
8	H101058	BOLT WH 5/16x8 3/4 BLK

**- INSERT T-NUTS FIRST**

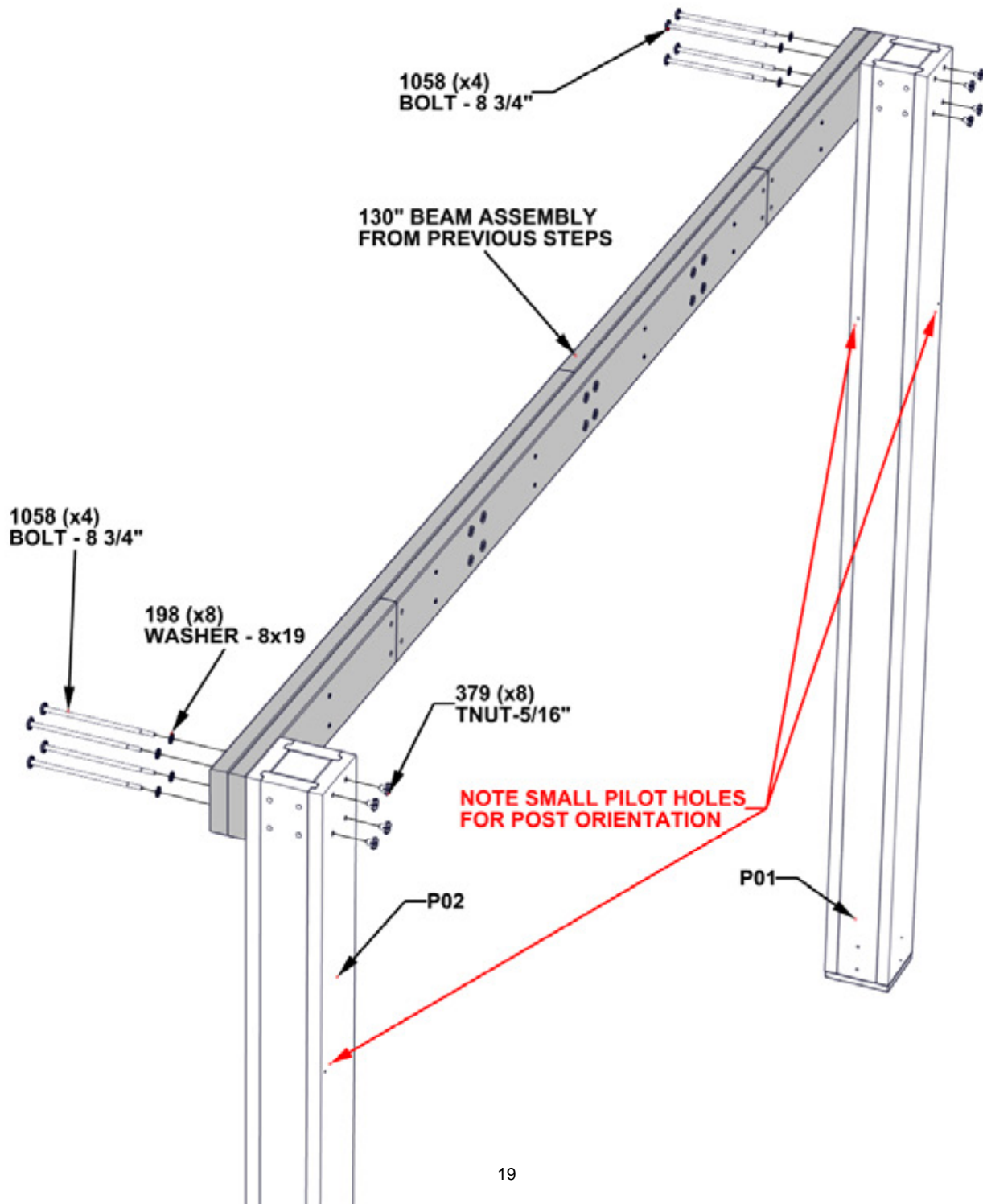



# STEP 5 - 130" BEAM & POST ASSEMBLY



C01 CORBEL - W2A03198-1  
(x2) 1 7/16"x3 3/8"x35 1/8" (36x86x893)

QTY	PART NUMBER	DESCRIPTION
8	H100198	WASHER LOCK EXT 8x19
8	H100379	TNUT-5/16" BLK
2	H100405	WASHER LOCK EXT 6x15
8	H100513	BOLT WH 5/16x4 1/4 BLK
2	H100792	LAG SCREW WH 1/4x3 BLK

## - INSERT T-NUTS FIRST

- INSERT BOLTS BEFORE LAG SCREWS

-TO AVOID SPLITTING, MAKE SURE LAG SCREWS GO INTO PILOT HOLES

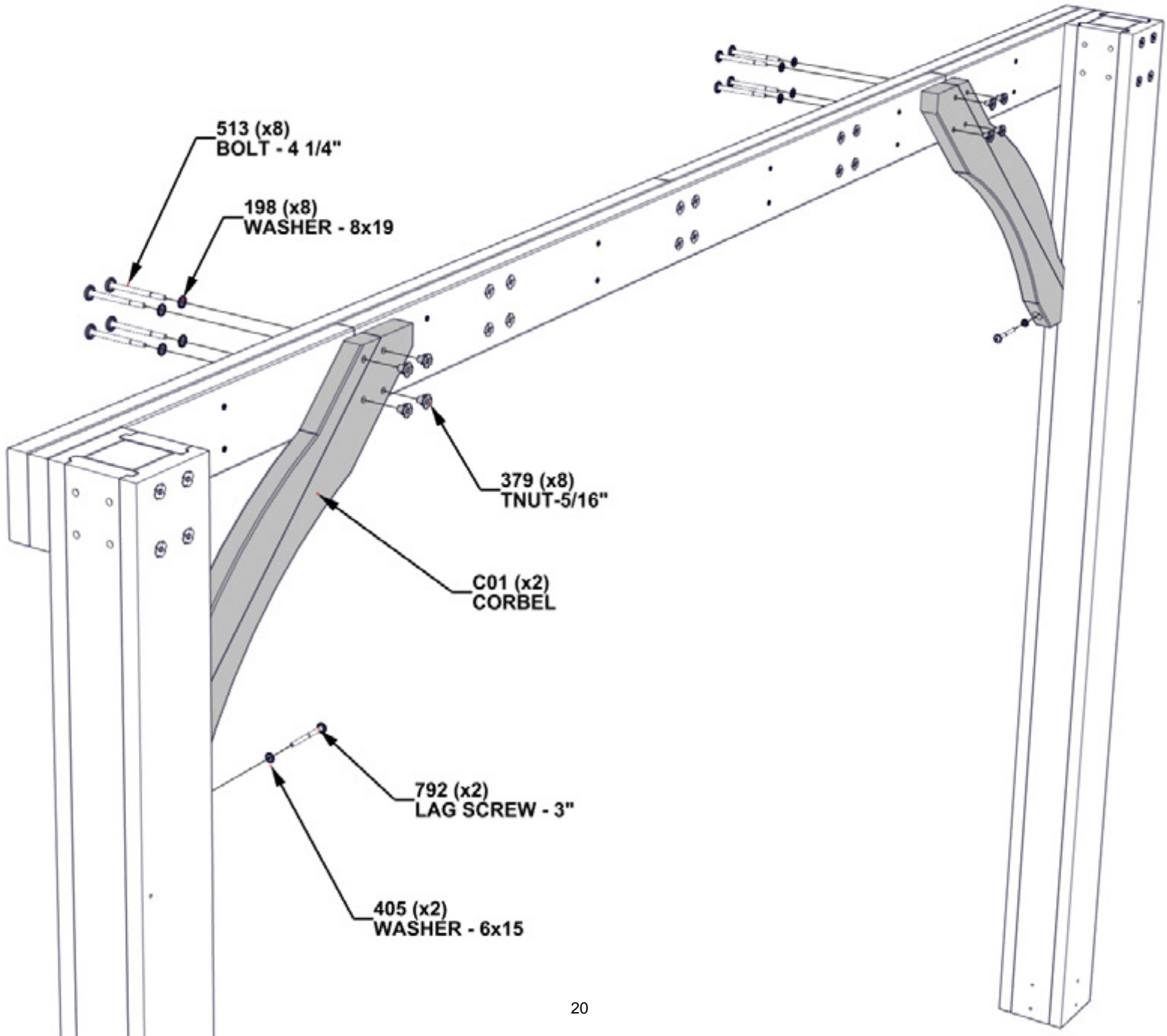



**REPEAT 130" BEAM & POST  
ASSEMBLY STEPS 1 THROUGH 5**

# STEP 6 - 135-3/4" BEAM ASSEMBLY



D06 BEAM - W4L15241  
(x2) 1 7/16"x5 1/4"x67 13/16" (36x134x1723)



D05 BEAM - W4L20738  
(x1) 1 7/16"x5 1/4"x75 7/8" (36x134x1927)

QTY	PART NUMBER	DESCRIPTION
12	H100195	BOLT WH 5/16x2 3/4 BLK
12	H100198	WASHER LOCK EXT 8x19
12	H100379	TNUT-5/16" BLK

**- INSERT T-NUTS FIRST**

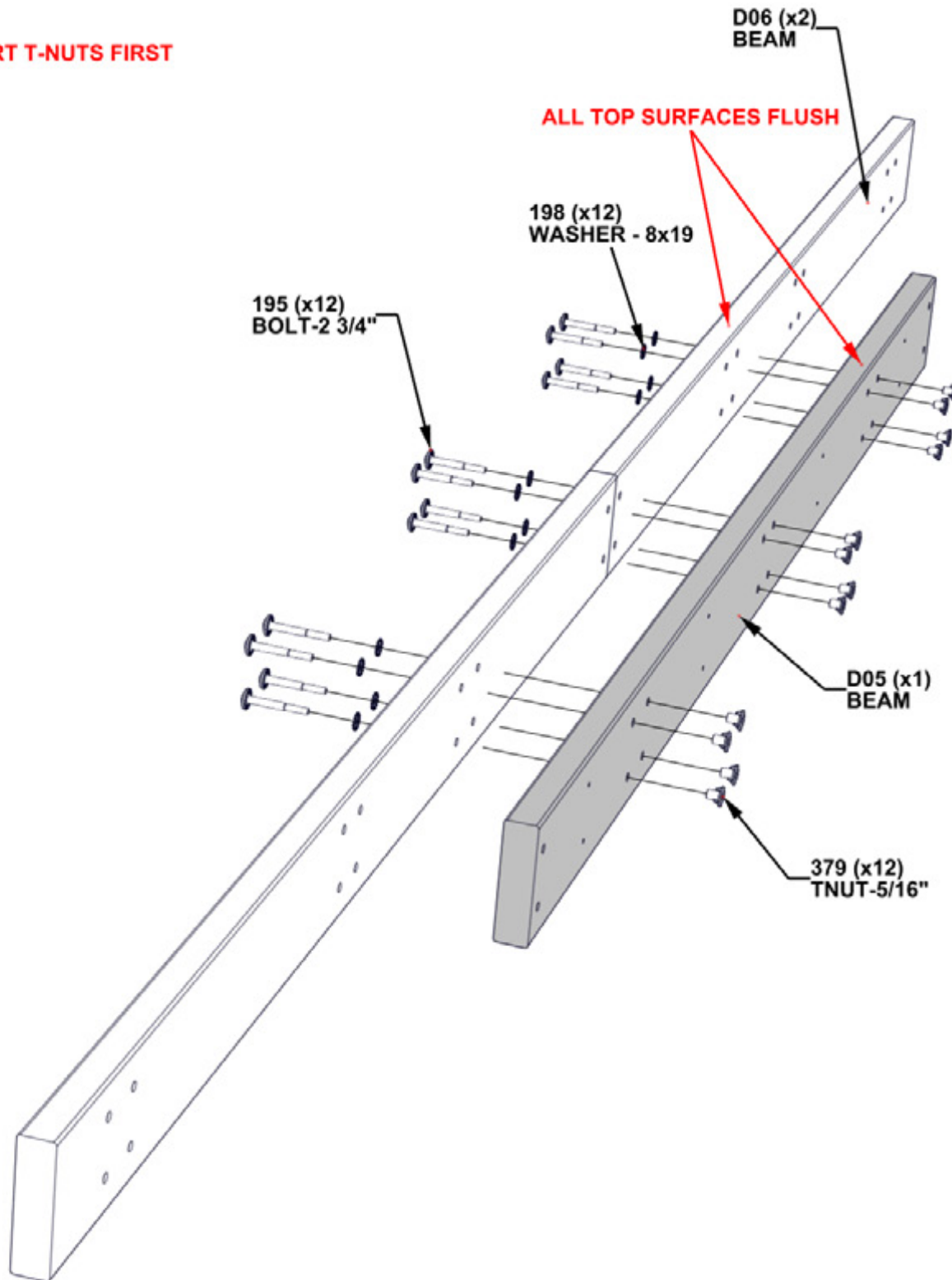

# STEP 7 - 135-3/4" BEAM ASSEMBLY

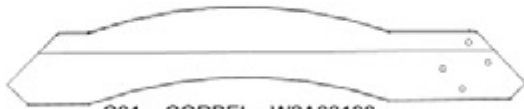

C01 CORBEL - W2A03198  
(x1) 1 7/16"x6 7/16"x35 1/8" (36x163x893)

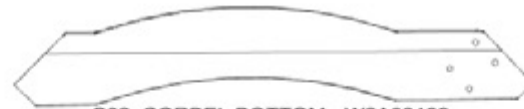

C02 CORBEL BOTTOM - W2A03199  
(x1) 1 7/16"x6 7/16"x35 1/8" (36x163x893)

QTY	PART NUMBER	DESCRIPTION
8	H100198	WASHER LOCK EXT 8x19
8	H100379	TNUT-5/16" BLK
8	H100513	BOLT WH 5/16x4 1/4 BLK



D01 BEAM - W4L20737  
(x2) 1 7/16"x5 1/4"x29 15/16" (36x134x760)

**- INSERT T-NUTS FIRST**

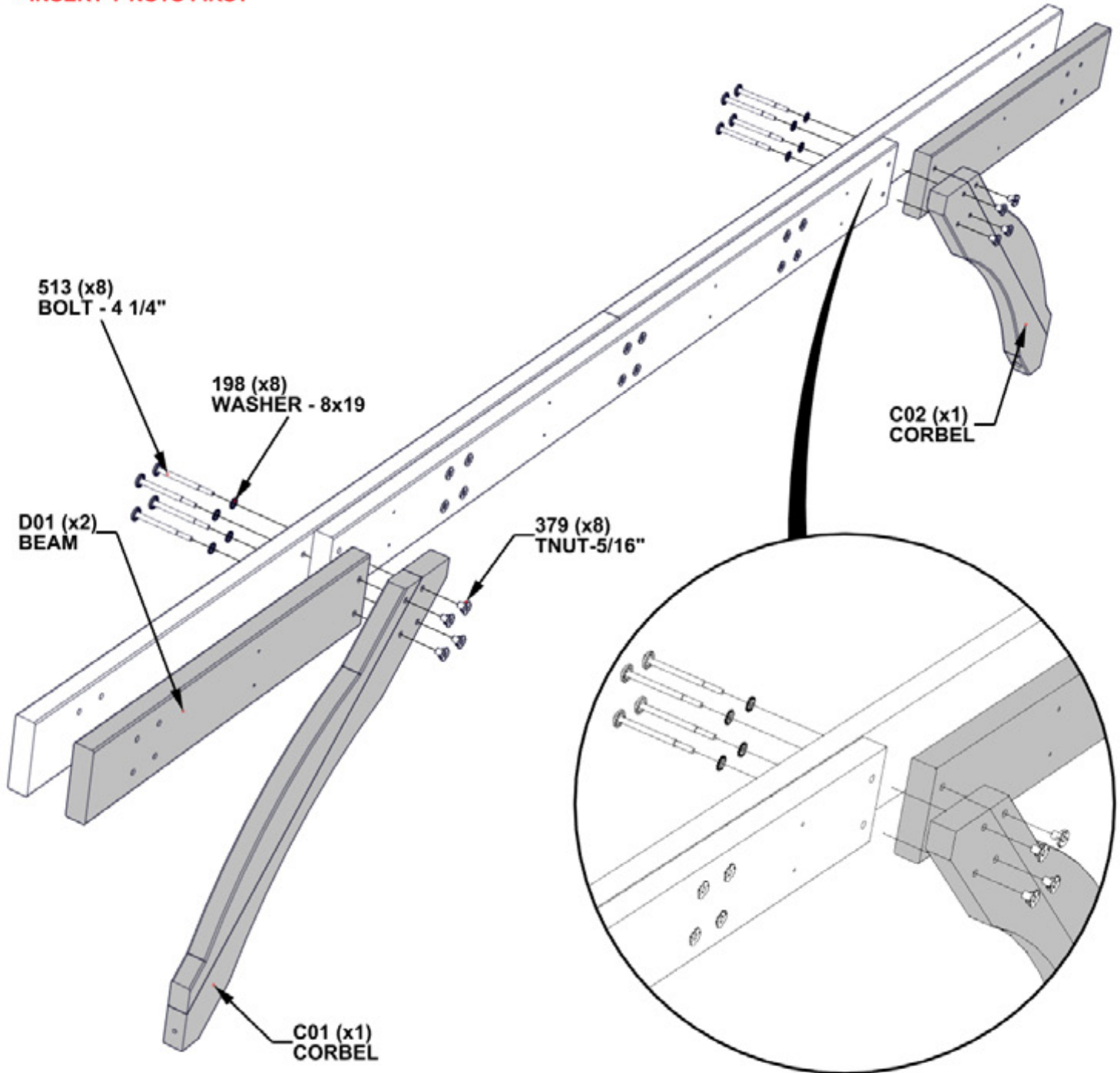

# STEP 8 - 135-3/4" BEAM ASSEMBLY

QTY	PART NUMBER	DESCRIPTION
12	H100483	SCREW PFH 8x2 1/4 BLK

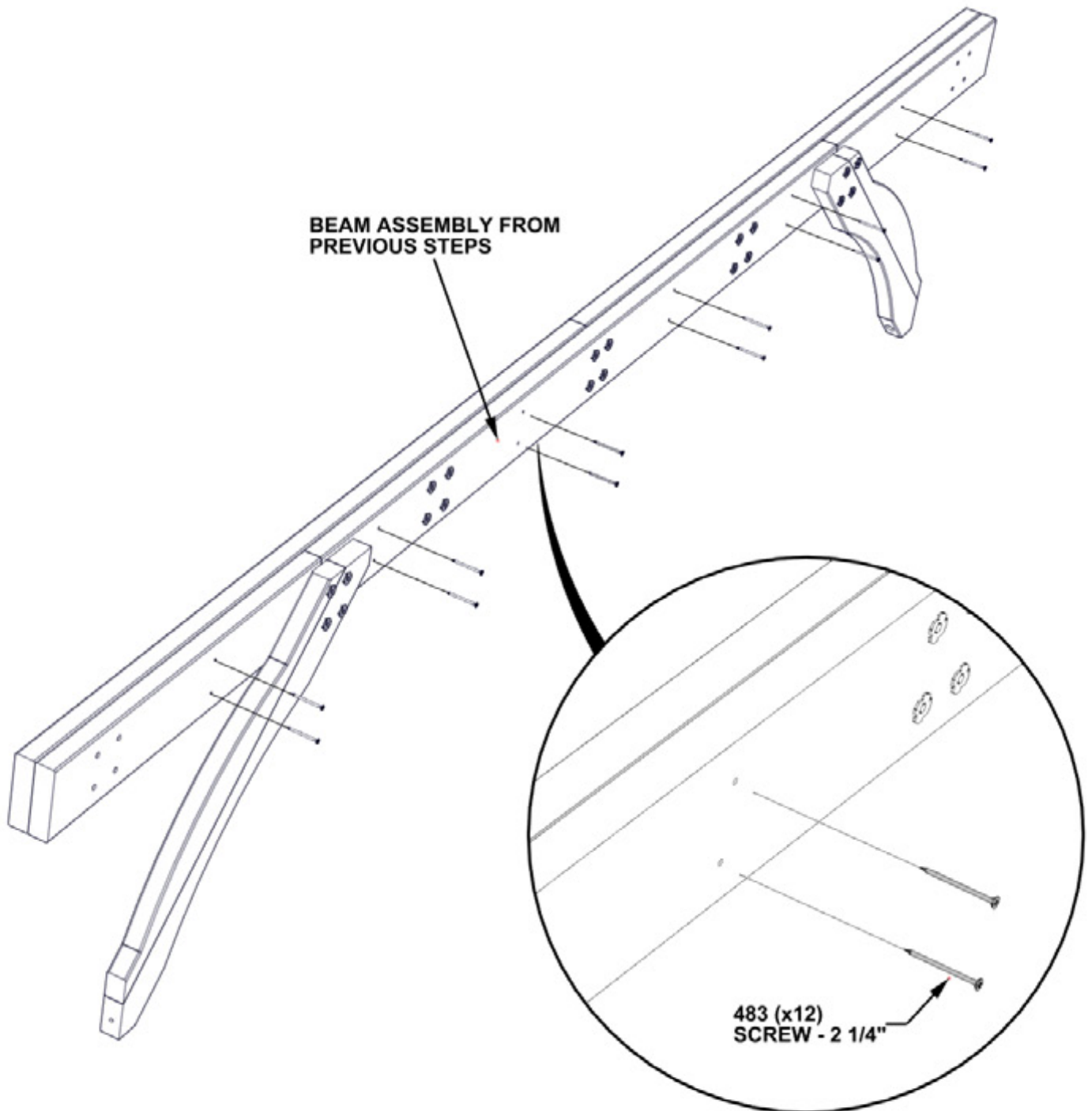

**REPEAT 135-3/4" BEAM  
ASSEMBLY STEPS 6 THROUGH 8**



# STEP 9 - STRUCTURE ASSEMBLY

QTY	PART NUMBER	DESCRIPTION
8	H100198	WASHER LOCK EXT 8x19
8	H100379	TNUT-5/16" BLK
2	H100405	WASHER LOCK EXT 6x15
2	H100792	LAG SCREW WH 1/4x3 BLK
8	H101058	BOLT WH 5/16x8 3/4 BLK

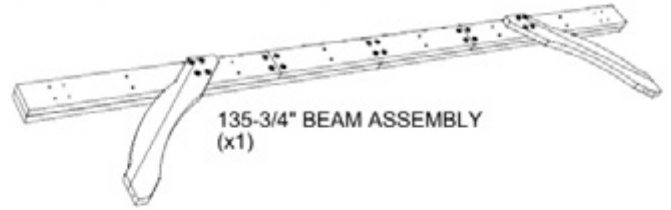
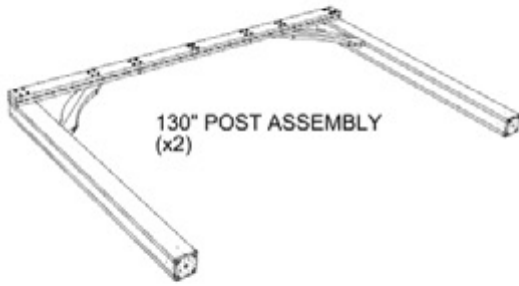

**- INSERT T-NUTS FIRST**

- 3 PEOPLE ARE HELPFUL FOR THIS STEP.

- MOVE THE POST ASSEMBLIES TO THEIR FINAL LOCATION WITH SOMEONE HOLDING EACH ASSEMBLY UPRIGHT.

- USING A THIRD PERSON, CONNECT THE 135-3/4" BEAM ASSEMBLY TO THE POSTS TO MAKE THE GAZEBO FRAME.

**- HAND TIGHTEN ONLY**

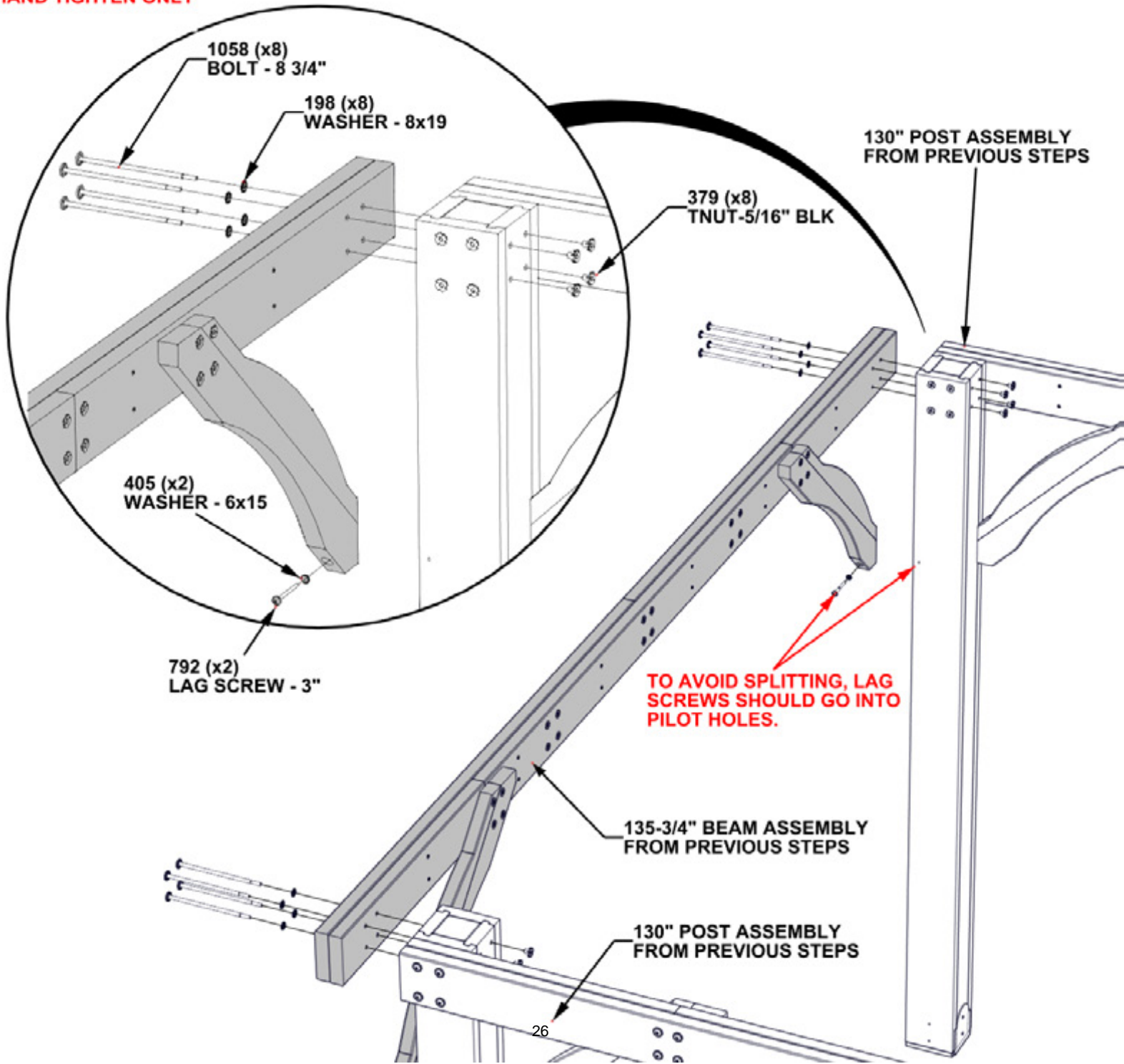

**REPEAT 135-3/4" BEAM TO POST  
ASSEMBLY STEP 9**

# STEP 10 - SQUARE STRUCTURE

**CRITICAL: SQUARE UNIT BEFORE PROCEEDING TO NEXT STEPS.  
ONCE SQUARE, TIGHTEN ALL HARDWARE.**

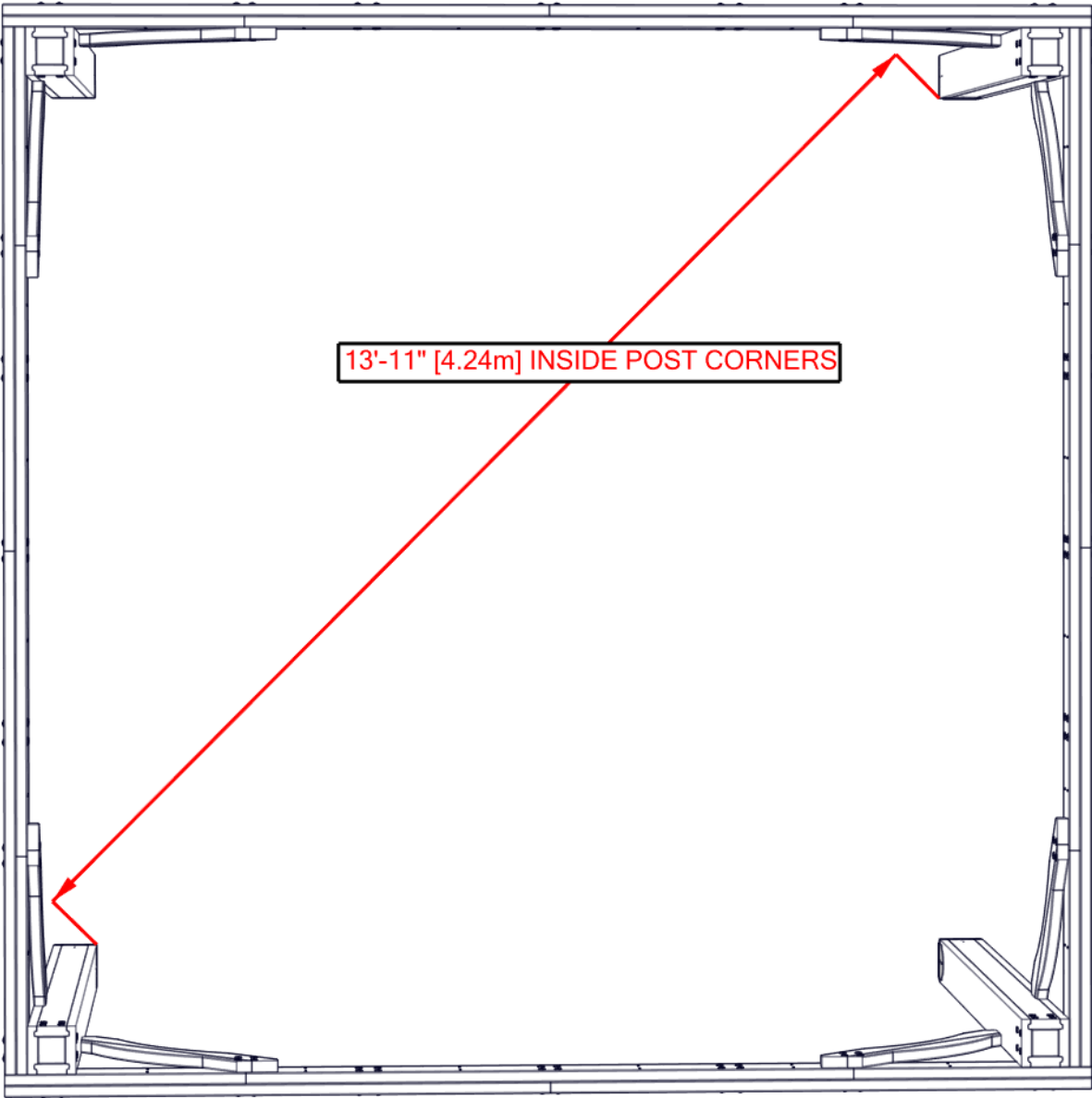



# STEP 11 - ROOF SUPPORT ASSEMBLY

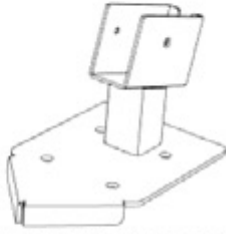

A4M01234 - 1234 POST CLIP ASSY  
(x4)

QTY	PART NUMBER	DESCRIPTION
16	H100460	LAG SCREW WH 1/4x1 BLK

- REPEAT ON ALL 4 POSTS
- DO NOT OVERTIGHTEN

460 (x4)  
LAG SCREW - 1"

1234 (x1)  
POST CLIP ASSY

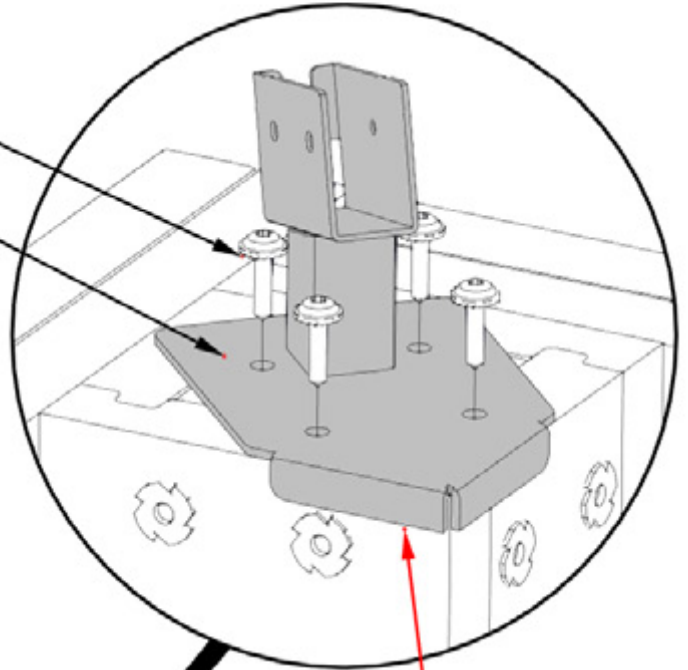

POST CLIPS MUST BE  
FLUSH TO POST BEFORE  
ATTACHING SCREWS

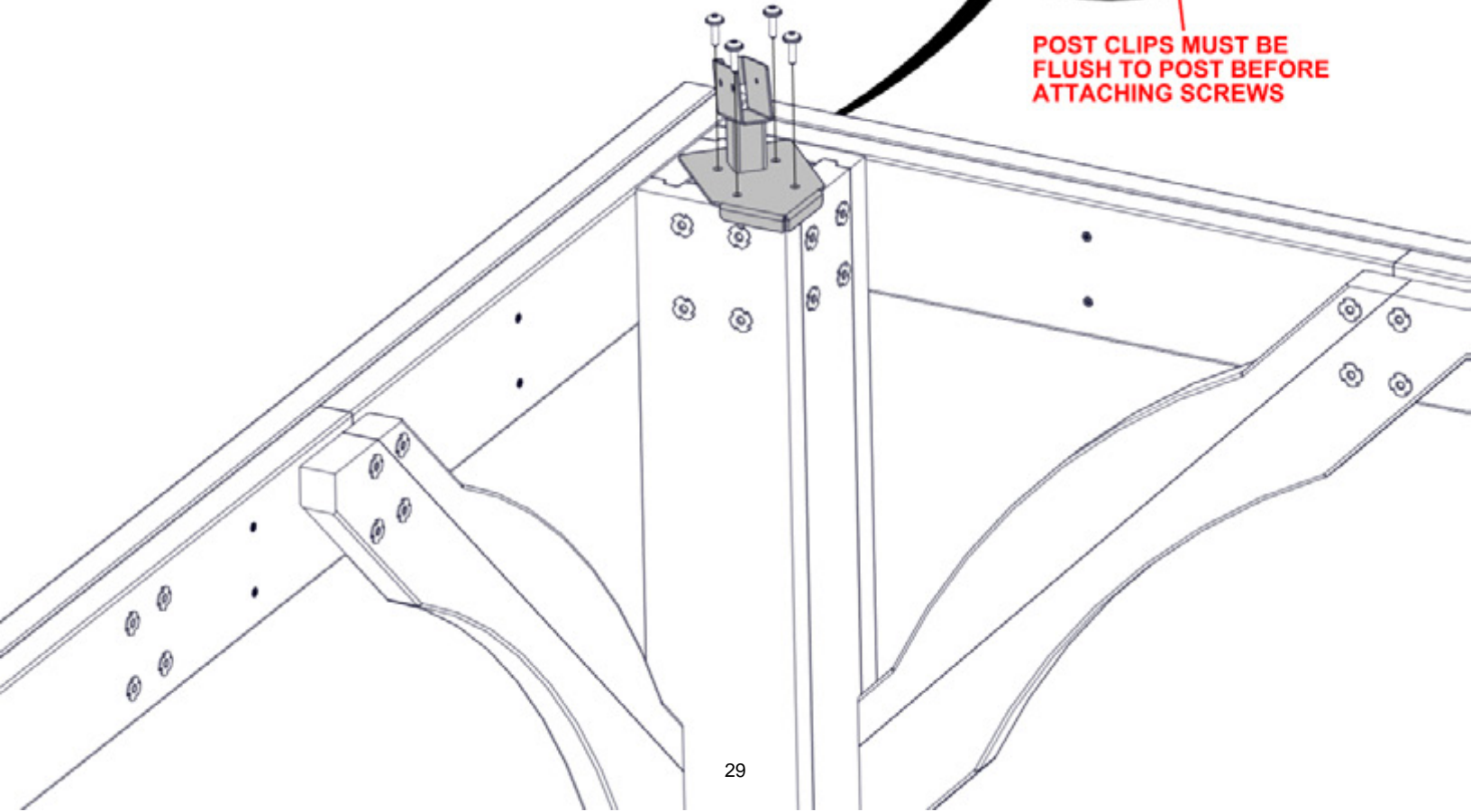

# STEP 12 - ROOF SUPPORT ASSEMBLY

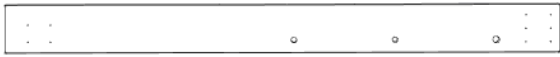

H30 TOP JOIST - W4L20292  
(x4) 15/16"x3 3/8"x38 13/16" (24x86x986)

QTY	PART NUMBER	DESCRIPTION
48	H100385	SCREW PFH 8x1 BLK

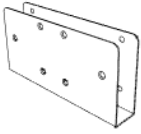

A4M01237 - ROOF SUPPORT SPLICE CLIP  
(x4)



H01 ROOF SUPPORT - W4L15194  
(x4) 15/16"x3 3/8"x54 1/8" (24x86x1374)

- USE PILOT HOLES TO ATTACH SPLICE CLIP TO H01 & H30

**- REPEAT THIS STEP 3 MORE TIMES**

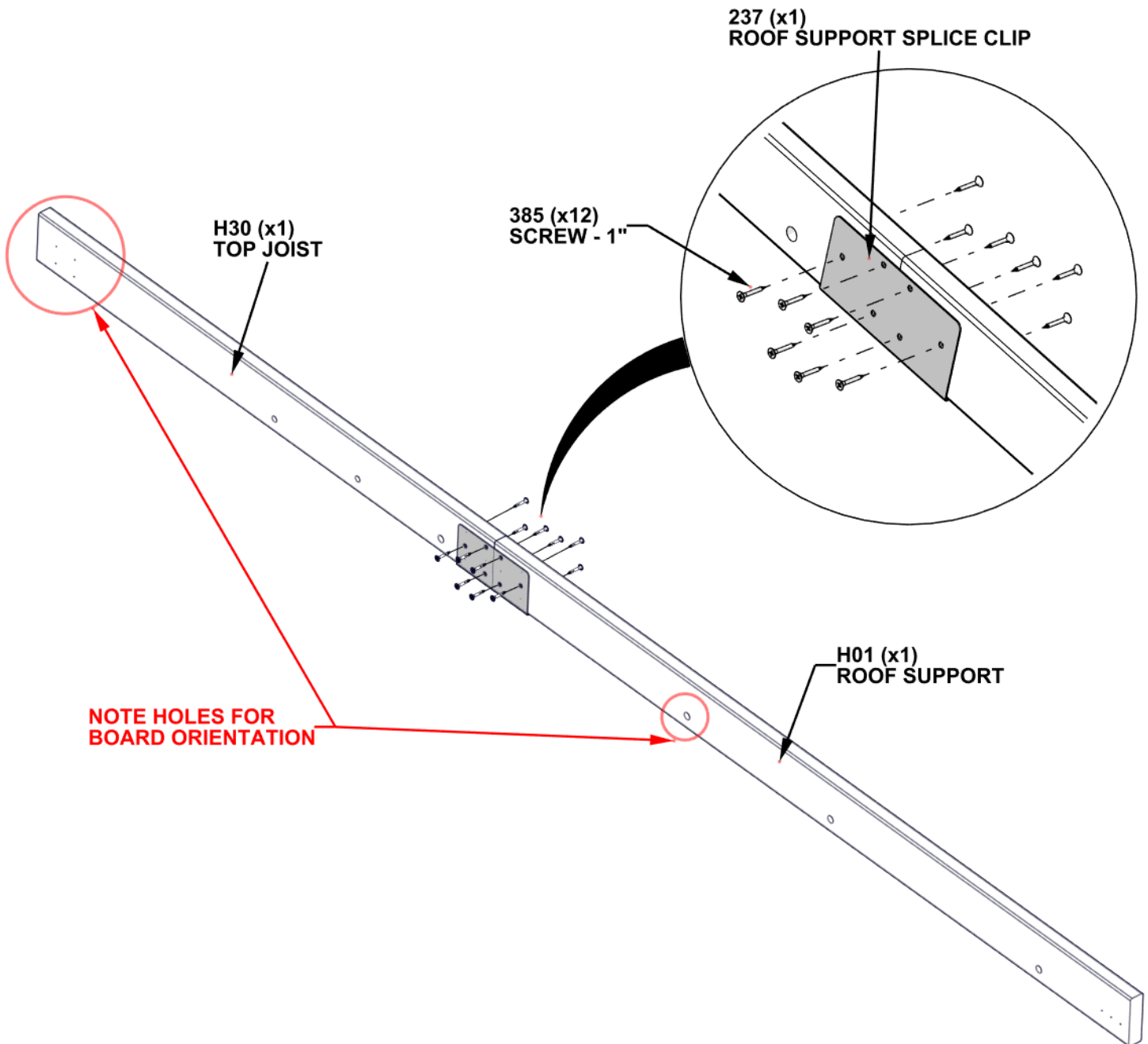

# STEP 13 - ROOF SUPPORT ASSEMBLY

QTY	PART NUMBER	DESCRIPTION
16	H100385	SCREW PFH 8 X 1 BLK

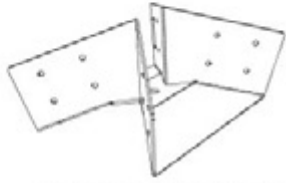

A4M01901 BROKE PLATE  
(x1)

**- REPEAT THIS STEP**

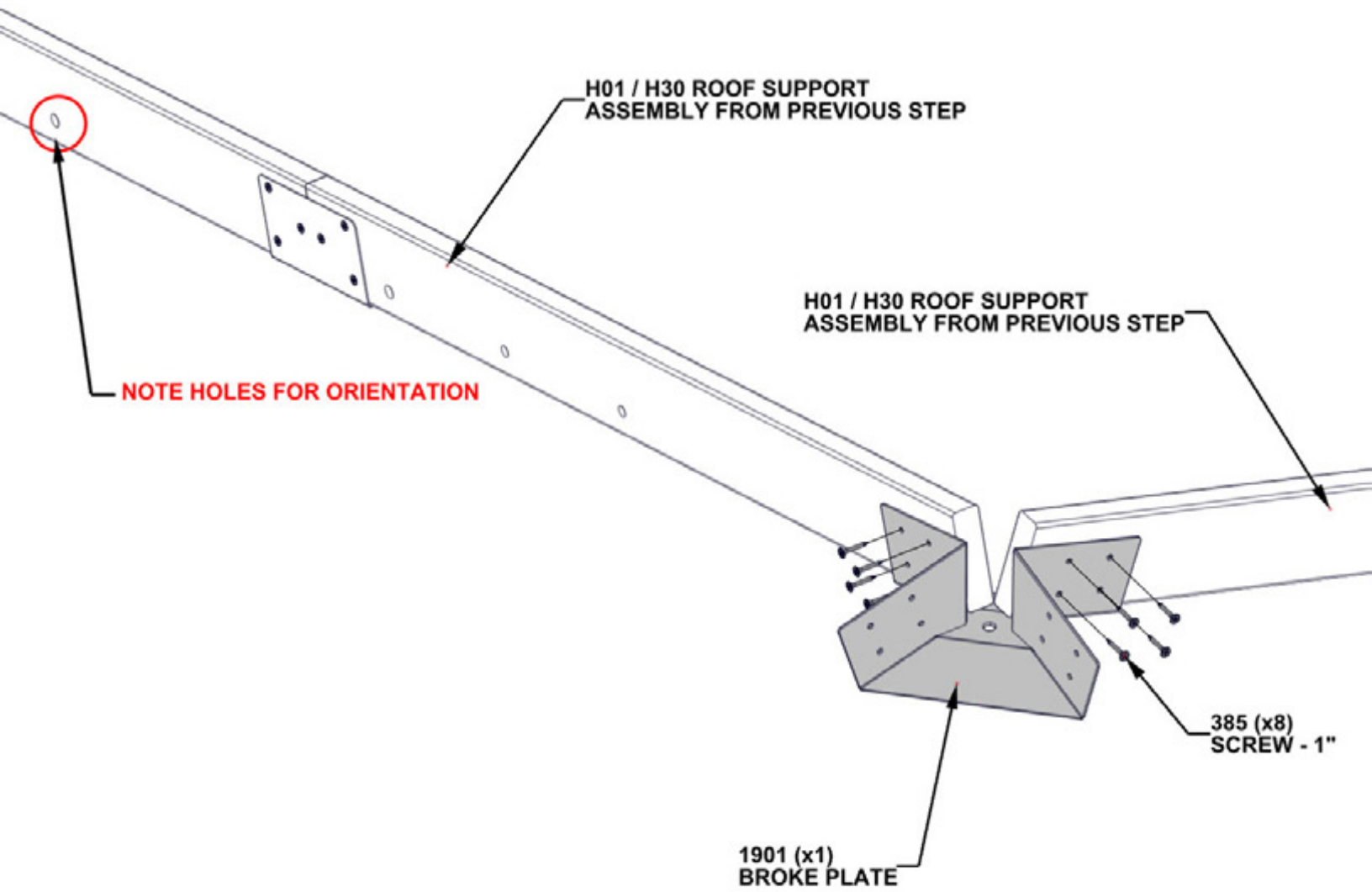

# STEP 14 - ROOF SUPPORT ASSEMBLY

QTY	PART NUMBER	DESCRIPTION
1	H100354	BOLT WH 5/16 X 6 1/2 BLK
1	H101285	EYE NUT

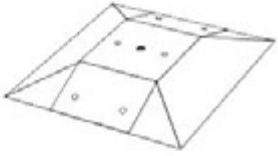

A4M01907 PEAK RIDGE CAP PLATE  
(x1)



A4M01908 METAL SPACER  
(x1)

- REMOVE PROTECTIVE BLUE FILM BEFORE ASSEMBLY.
- GLOVES ARE RECOMMENDED WHEN HANDLING STEEL ROOF PIECES.

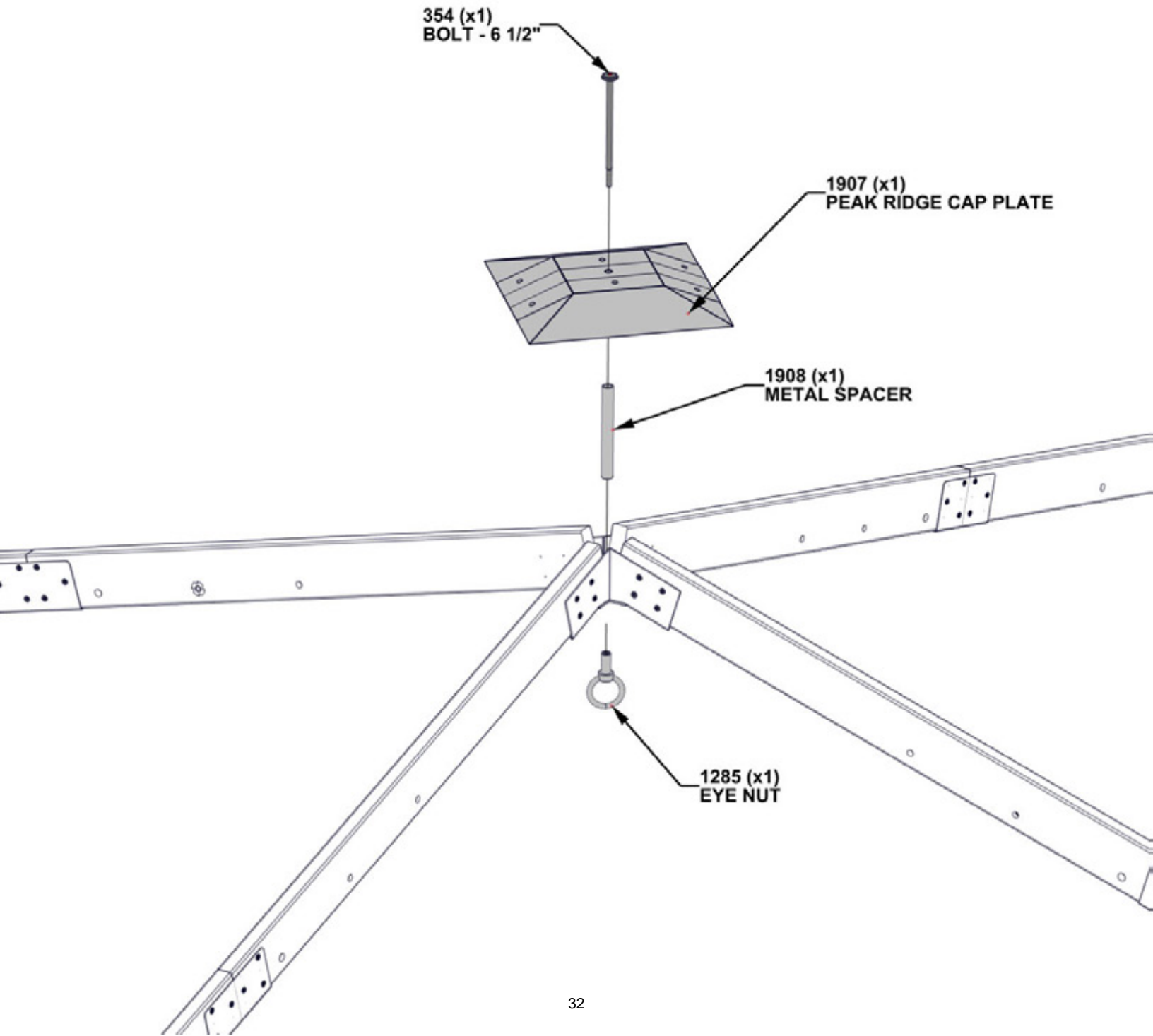

## STEP 15 - ROOF SUPPORT ASSEMBLY

- 3 PEOPLE ARE RECOMMENDED FOR THIS STEP.
- POSITION 1 PERSON ON A LADDER IN THE CENTER.
- LIFT ROOF SUPPORT UP AND OVER BEAMS AND INSERT INTO CORNER POST CLIPS.

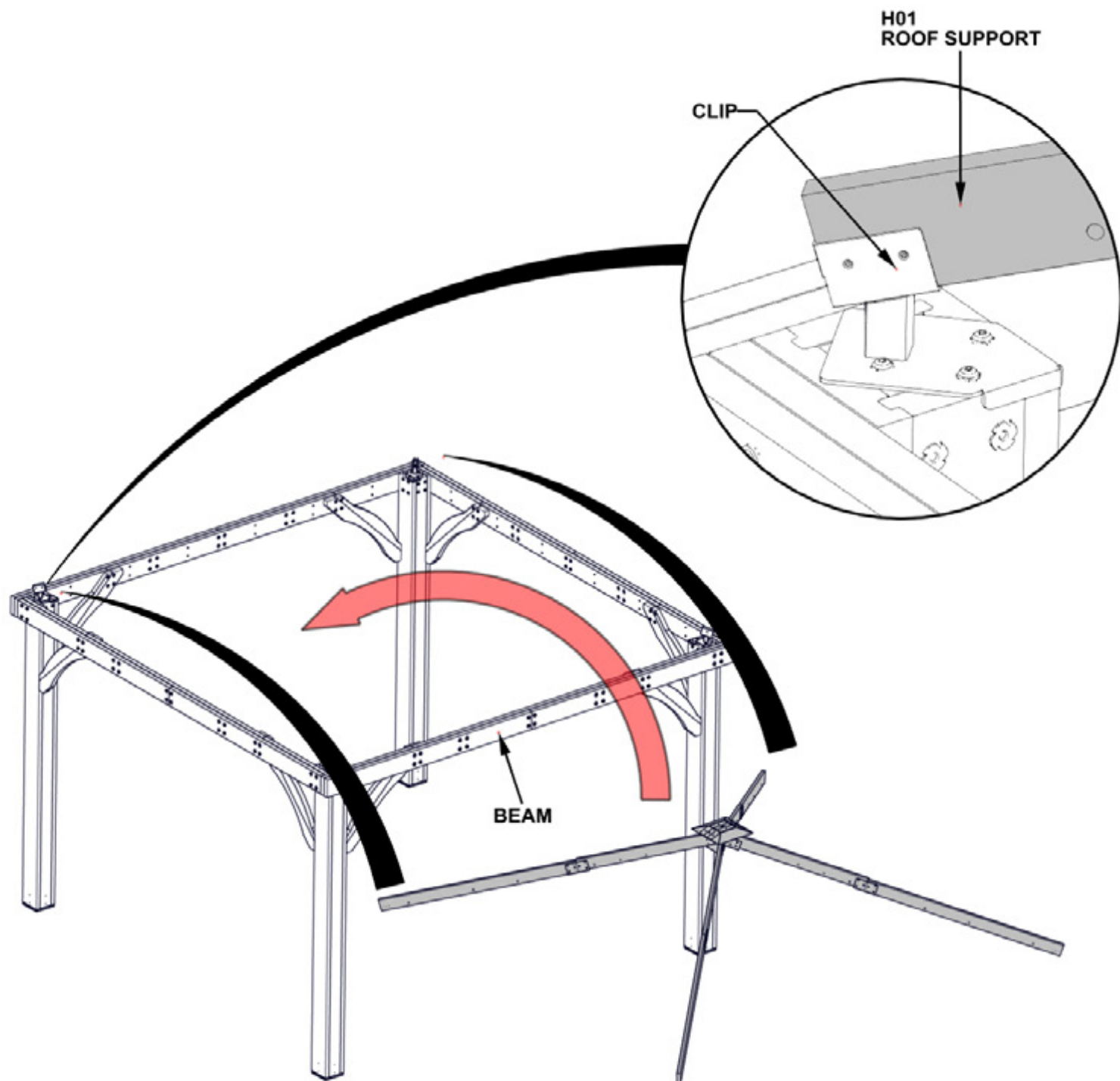



# STEP 16 - ROOF SUPPORT ASSEMBLY

QTY	PART NUMBER	DESCRIPTION
12	H100385	SCREW PFH 8x1 BLK

- REPEAT ON ALL POSTS

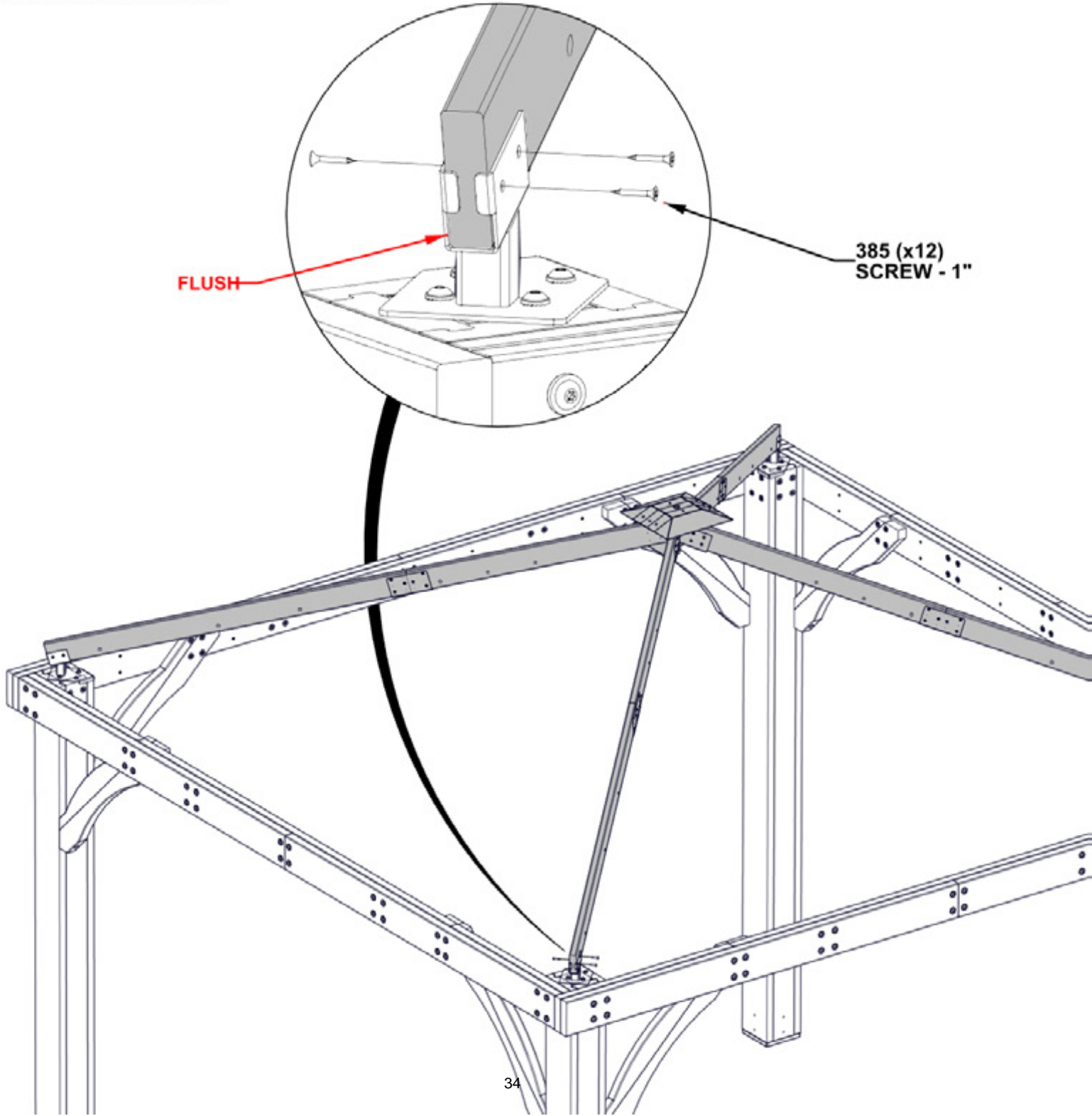

# STEP 17 - SIDE ROOF PANEL ASSEMBLY



H31 TOP JOIST - W4L20290  
(x1) 15/16"x3 3/8"x53 3/16" (24x86x1351)



H32 TOP JOIST - W4L20291  
(x1) 15/16"x3 3/8"x53 3/16" (24x86x1351)

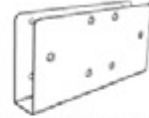

A4M01237- ROOF SUPPORT SPLICE CLIP  
(x2)

QTY	PART NUMBER	DESCRIPTION
24	H100385	SCREW PFH 8x1 BLK



H11 ROOF JOIST - W4L15216  
(x1) 15/16"x3 3/8"x44 1/2" (24x86x1130)



H12 ROOF JOIST - W4L15220  
(x1) 15/16"x3 3/8"x44 1/2" (24x86x1130)

- INSERT BOARDS INTO EACH SIDE OF THE BRACKETS AS SHOWN
- INSERT SCREWS THROUGH EACH OF THE BRACKET HOLES ON BOTH SIDES

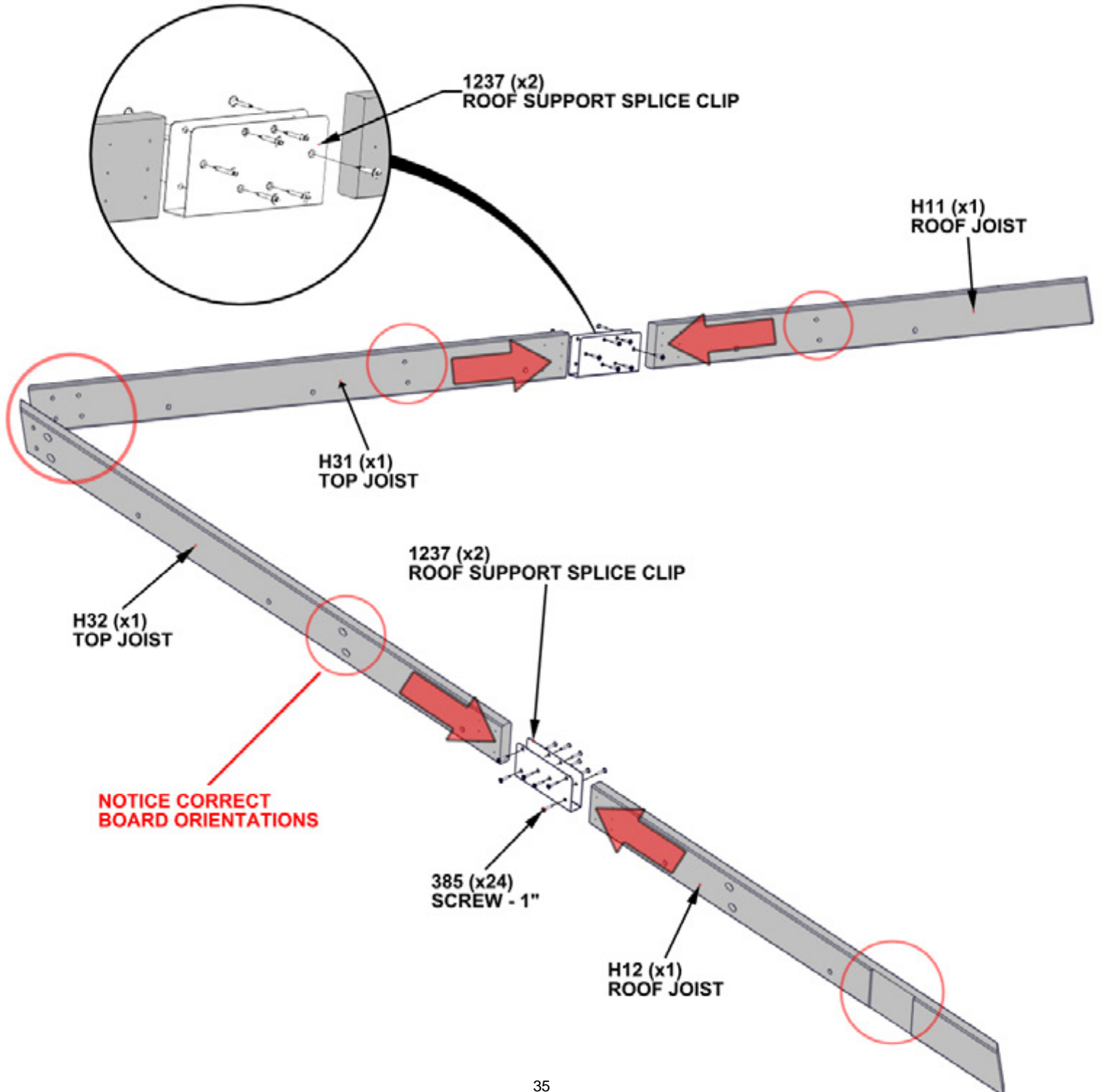

# STEP 18 - SIDE ROOF PANEL ASSEMBLY

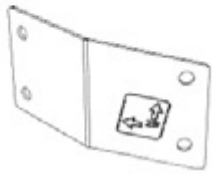

A4M01239 PANEL BRACKET  
(x1)

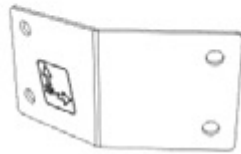

A4M01238 PANEL BRACKET  
(x1)

QTY	PART NUMBER	DESCRIPTION
4	H100171	BOLT WH 1/4x1 BLK
4	H100398	T-NUT 1/4 BLK



H06 ROOF JOIST - W4L15203  
(x1) 15/16"x3 3/8"x10 11/16" (24x86x272)

**- INSERT T-NUTS FIRST**

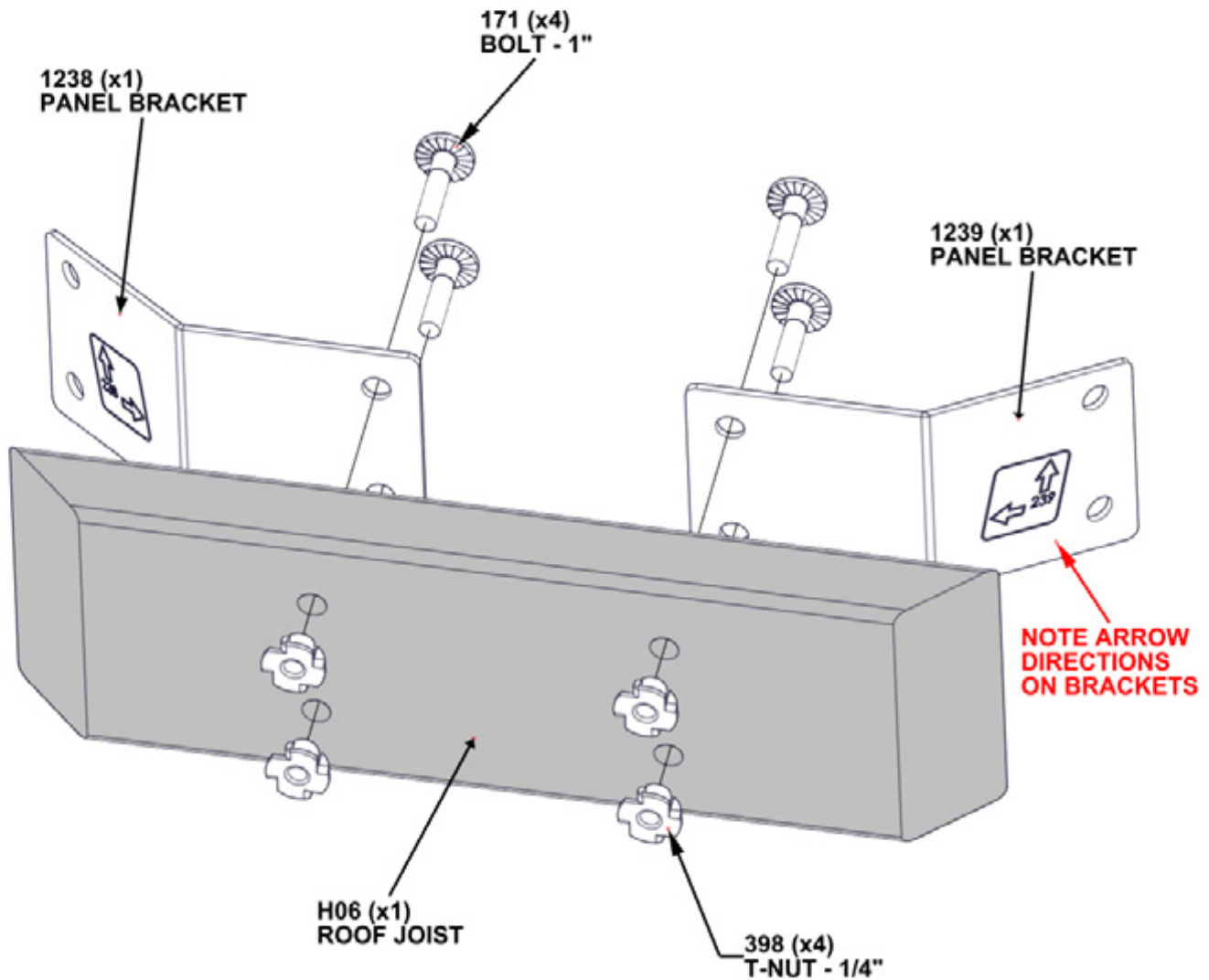



# STEP 19 - SIDE ROOF PANEL ASSEMBLY

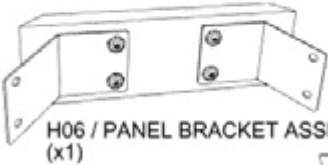

QTY	PART NUMBER	DESCRIPTION
4	H100171	BOLT WH 1/4x1 BLK
4	H100398	T-NUT 1/4 BLK

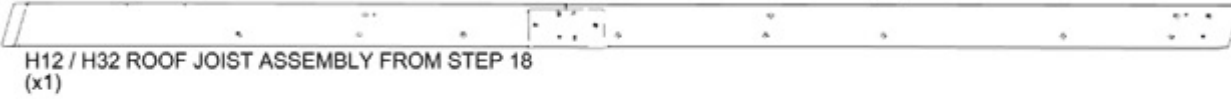
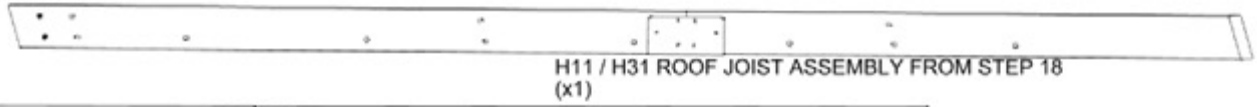

**- INSERT T-NUTS FIRST**

H06 / PANEL BRACKET ASSEMBLY

H11 / H31 ROOF JOIST ASSEMBLY

H12 / H32 ROOF JOIST ASSEMBLY

COMPLETED VIEW

H06 (x1) ROOF JOIST

398 (x4) T-NUT - 1/4"

171 (x4) BOLT - 1"

# STEP 20 - SIDE ROOF PANEL ASSEMBLY



E13 RAFTER - W4L15219  
(x1) 1 7/16"x3 3/8"x21 15/16" (36x86x557)



E07 RAFTER - W4L15209  
(x1) 1 3/8"x3 3/8"x22" (36x86x557)

QTY	PART NUMBER	DESCRIPTION
12	H101030	CONFIRMAT - SCREW 2"



E11 RAFTER - W4L15217  
(x1) 1 7/16"x3 3/8"x69" (36x86x1752)

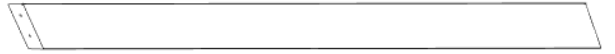

E12 RAFTER - W4L15218  
(x1) 1 7/16"x3 3/8"x45 7/16" (36x86x1155)

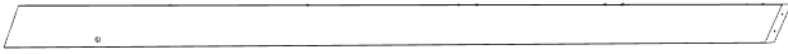

E05 RAFTER - W4L15207  
(x1) 1 7/16"x3 3/8"x69" (36x86x1752)



E06 RAFTER - W4L15208  
(x1) 1 7/16"x3 3/8"x45 7/16" (36x86x1155)

**NOTE PILOT HOLES ARE FACE UP ON ALL RAFTERS**

1030 (x12)  
CONFIRMAT SCREW - 2"

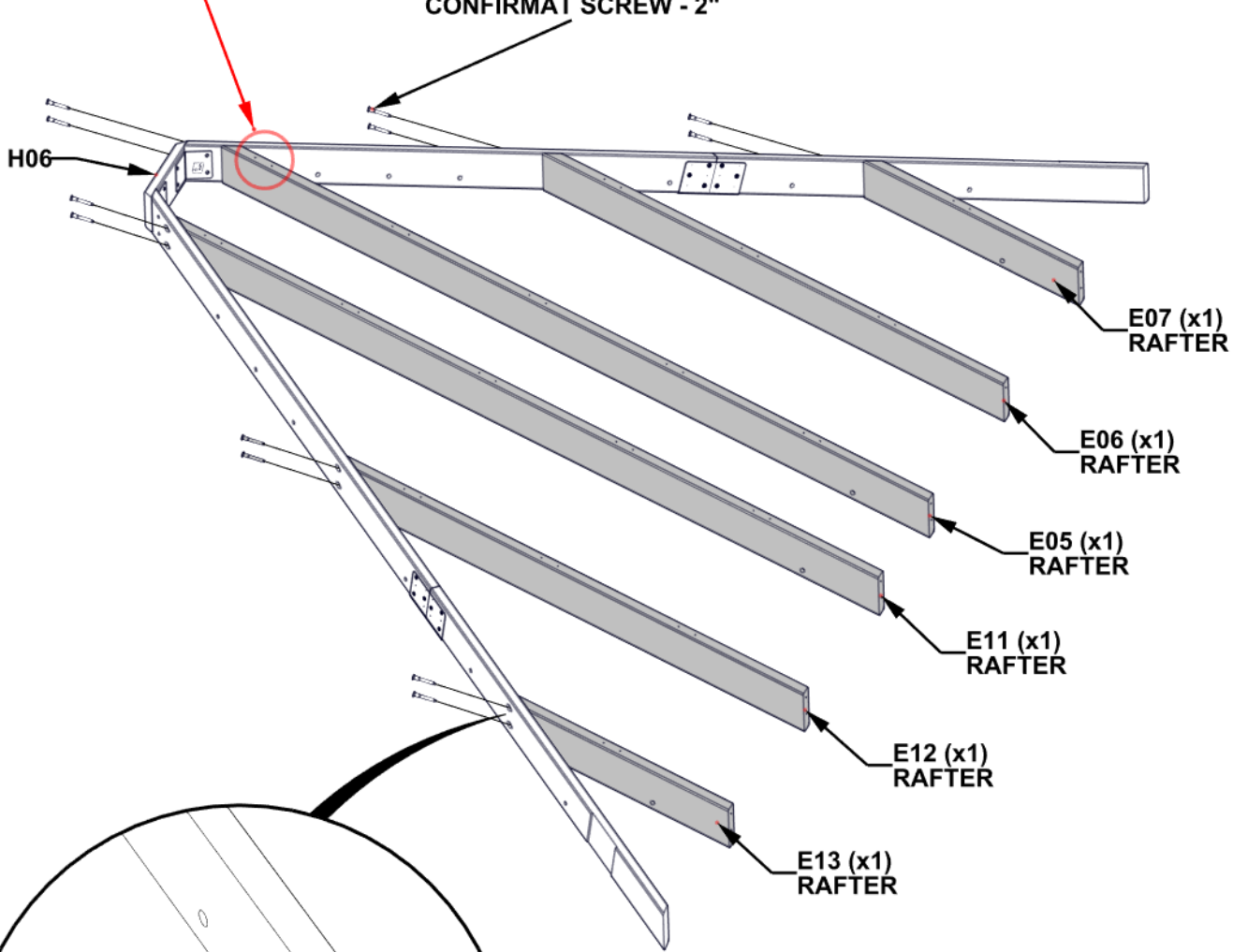

# STEP 21 - SIDE ROOF PANEL ASSEMBLY



Q04 ROOF JOIST - W4L17578  
(x1) 24x4 7/16"x79 7/16" (24x112x2018)

QTY	PART NUMBER	DESCRIPTION
4	H100382	SCREW PFH 8x1 3/4 BLK
12	H101030	CONFIRMAT - SCREW 2"



Q02 ROOF JOIST - W4L17579  
(x1) 15/16"x4 7/16"x64 15/16" (24x112x1649)

- USE Q04/Q02 BOARDS AS GUIDES, & A 1/8" DRILL BIT, TO DRILL PILOT HOLES INTO THE H12/11 BOARDS
- RAFTERS MAY NEED TO BE LOOSENED TO ATTACH Q04 & Q02 TO H12/11

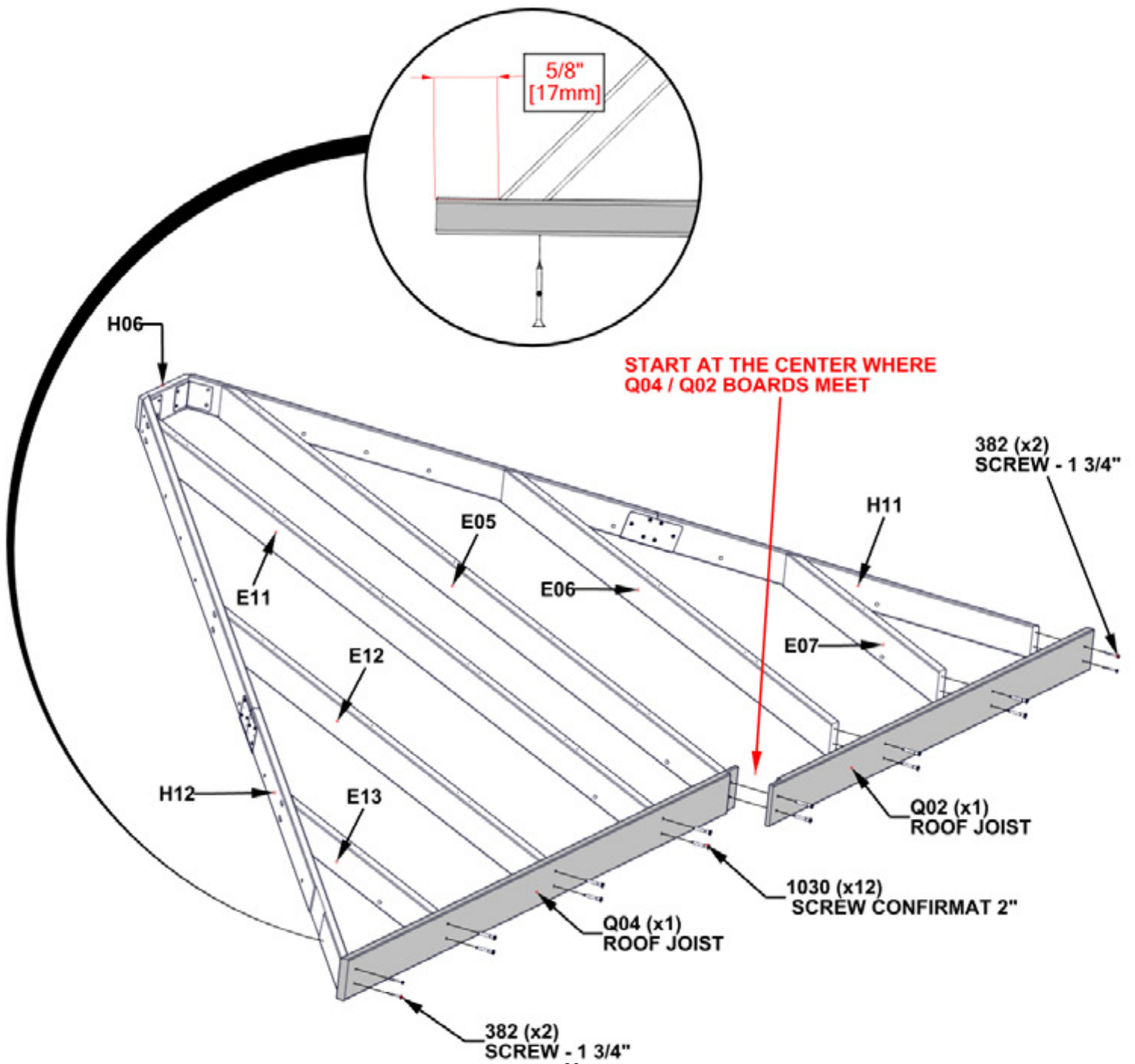
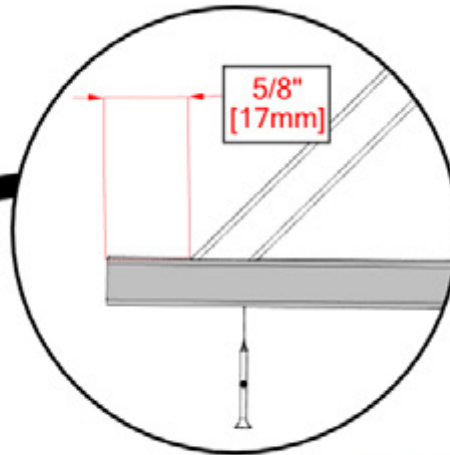

## STEP 22 - SIDE ROOF PANEL ASSEMBLY

### CRITICAL

- SQUARE UNIT BEFORE PROCEEDING TO NEXT STEPS.
- THE BELOW DIMENSIONS ARE CRITICAL TO THE FINAL ROOF ASSEMBLY.
- MEASUREMENTS SHOULD BE WITHIN  $\pm 1/4"$ .
- MEASUREMENTS OUTSIDE OF TOLERANCE WILL LEAD TO THE INABILITY TO ASSEMBLE THE ROOF

- LOOSEN HARDWARE TO ADJUST FOR SQUARING IF NEEDED

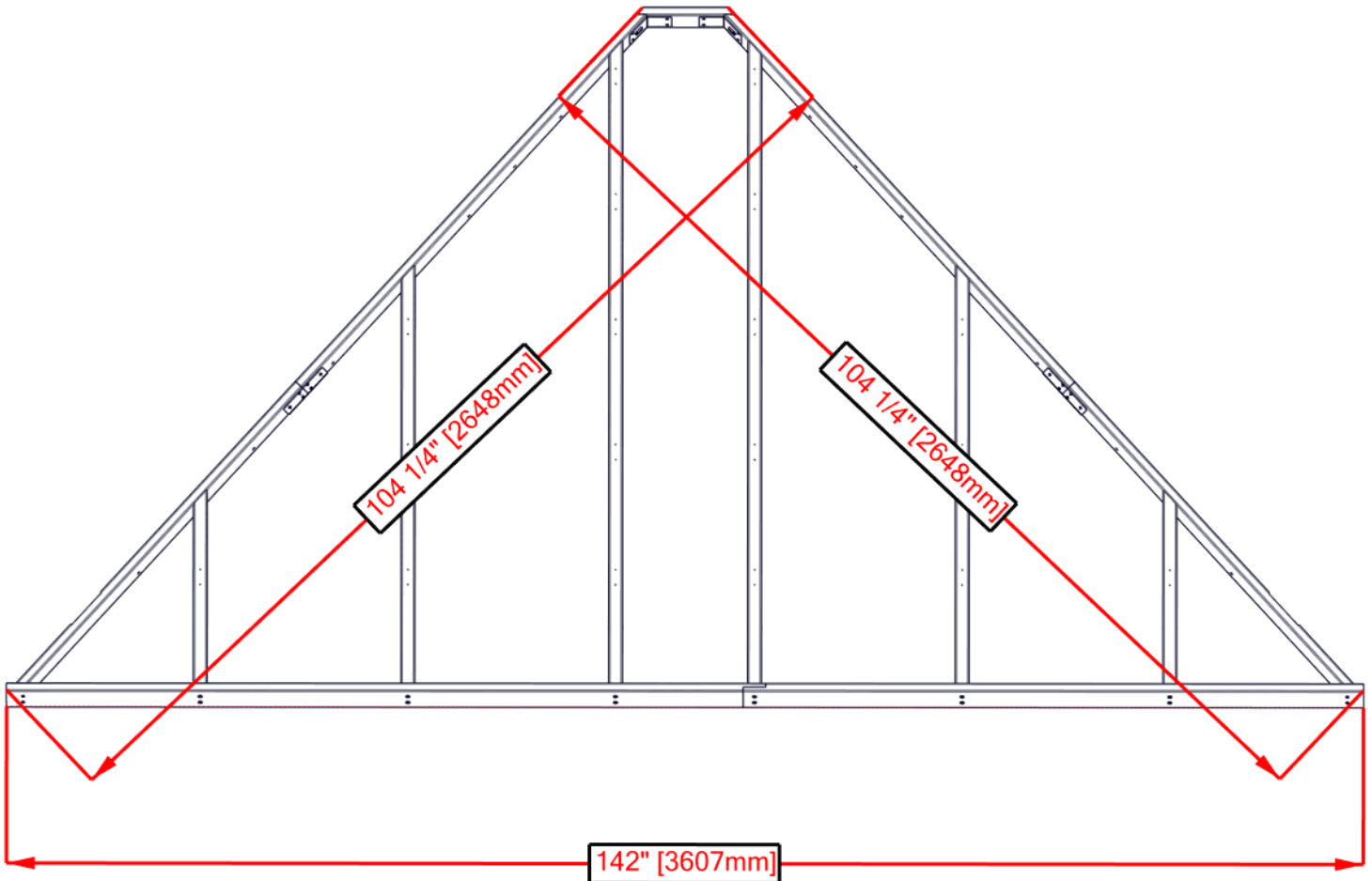



# STEP 23 - SIDE ROOF PANEL ASSEMBLY

QTY	PART NUMBER	DESCRIPTION
36	H100391	SCREW PFH 8x2 BLK

H24 PURLIN - W4L15232  
(x1) 15/16"x3 3/8"x27 1/4" (24x86x692)

H21 PURLIN - W4L15230  
(x1) 15/16"x3 3/8"x75 11/16" (24x86x1922)

H19 PURLIN - W4L15228  
(x1) 15/16"x3 3/8"x58 3/8" (24x86x1483)

H20 PURLIN - W4L15229  
(x1) 15/16"x3 3/8"x43 7/8" (24x86x1114)

H28 PURLIN - W4L15238  
(x1) 15/16"x3 3/8"x70 1/2" (24x86x1791)

H27 PURLIN - W4L15237  
(x1) 15/16"x3 3/8"x56" (24x86x1422)

H22 PURLIN - W4L15231  
(x1) 15/16"x3 3/8"x51 7/16" (24x86x1307)

- ALIGN PURLIN PILOT HOLES WITH RAFTER PILOT HOLES
- ATTACH SCREWS FROM THE CENTER AND WORK OUTWARD

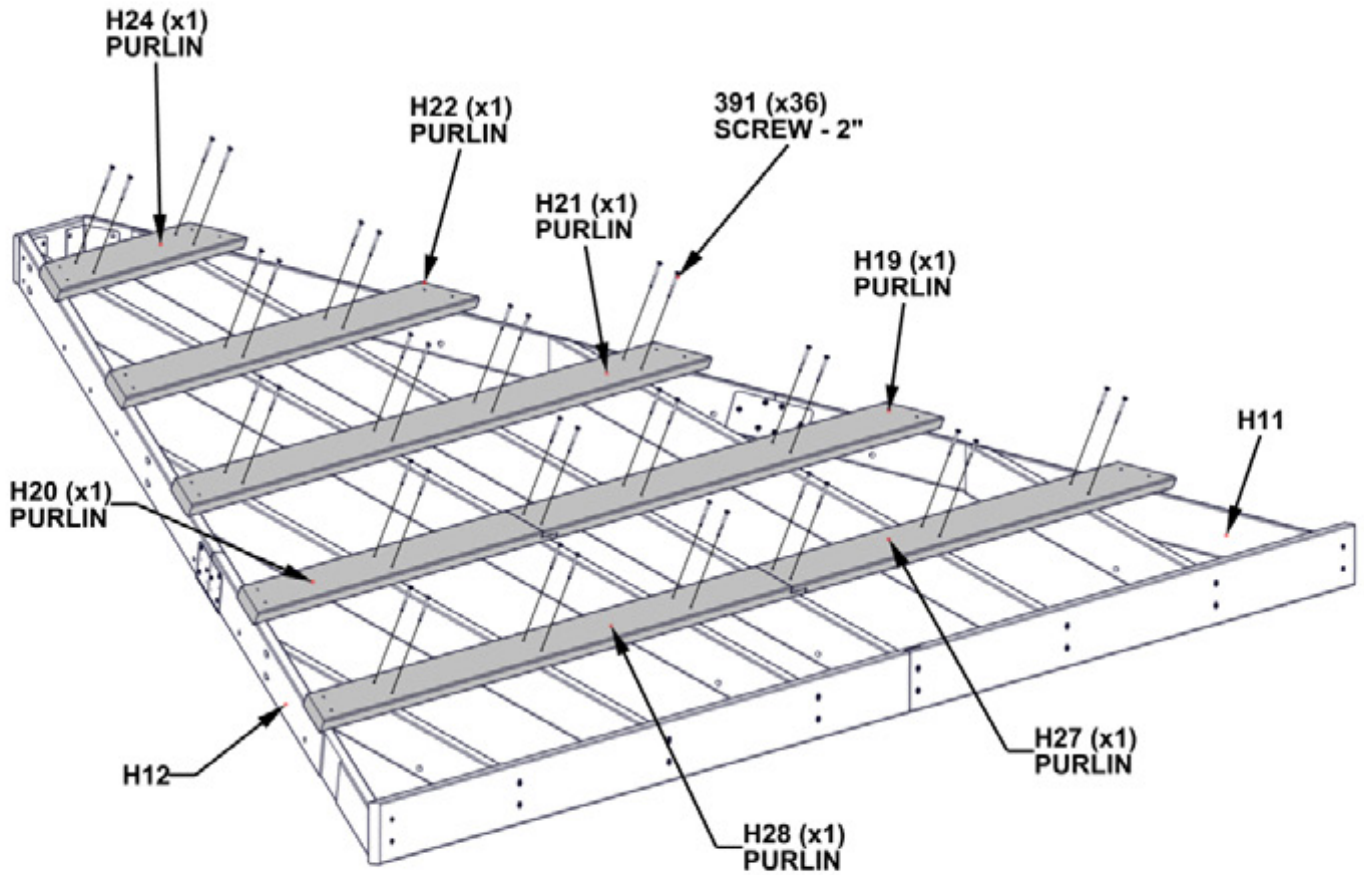

# STEP 24 - SIDE ROOF PANEL ASSEMBLY



T02 PURLIN - W4L15239  
(x1) 15/16"x1 5/16"x12 7/8" (24x34x327)

QTY	PART NUMBER	DESCRIPTION
22	H100391	SCREW PFH 8x2 BLK

- H07, H08, H11, & H12 BOARDS DO NOT HAVE PILOT HOLES FOR OUTSIDE EDGE SCREWS
- USING THE PURLINS AS A GUIDE AND A 1/8" DRILL BIT, DRILL PILOT HOLES INTO H12/H08/H11/H07 BOARDS

**- IF PURLINS OVERHANG MORE THAN 5/8" CUT DOWN TO 5/8"**

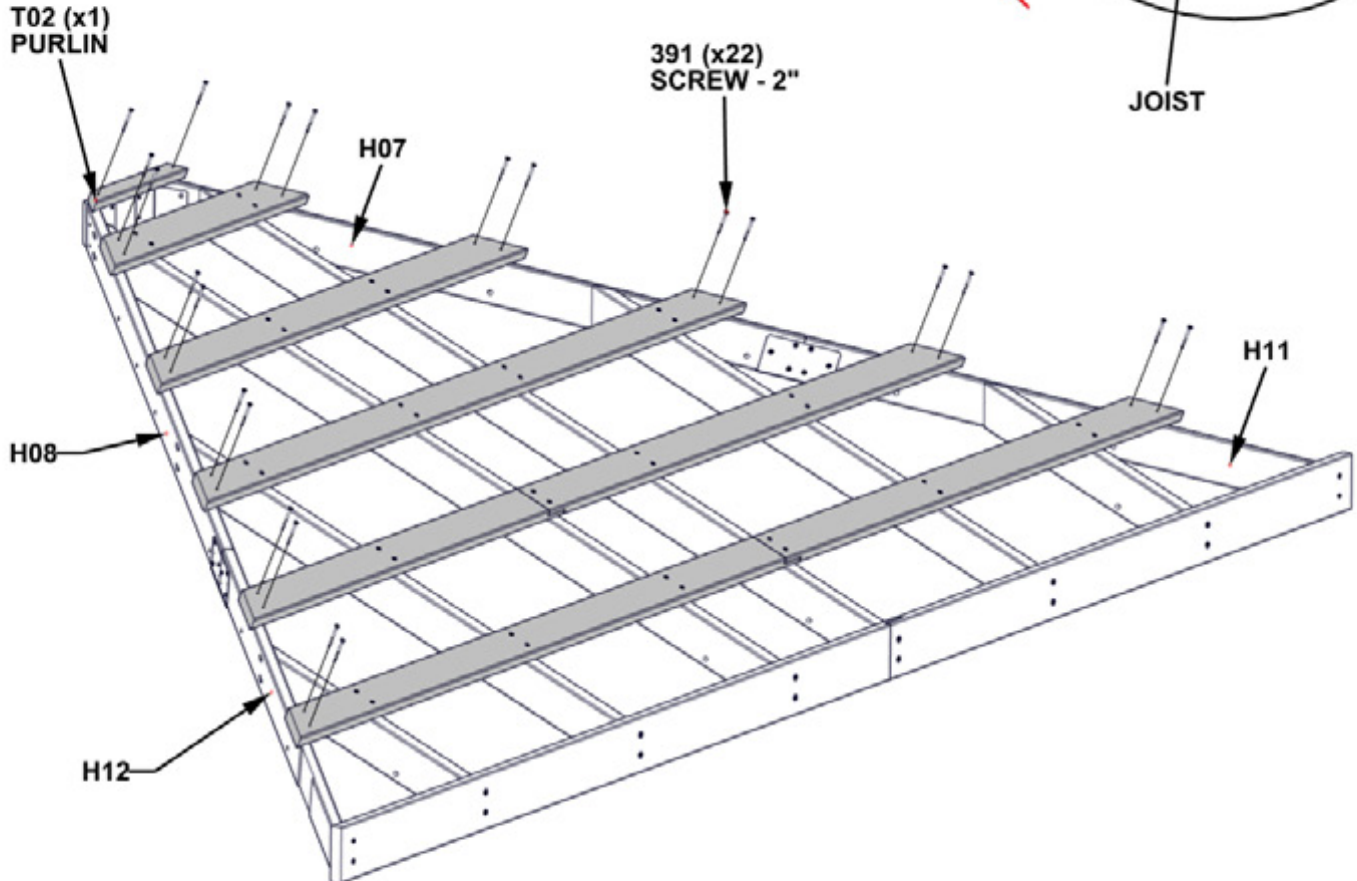
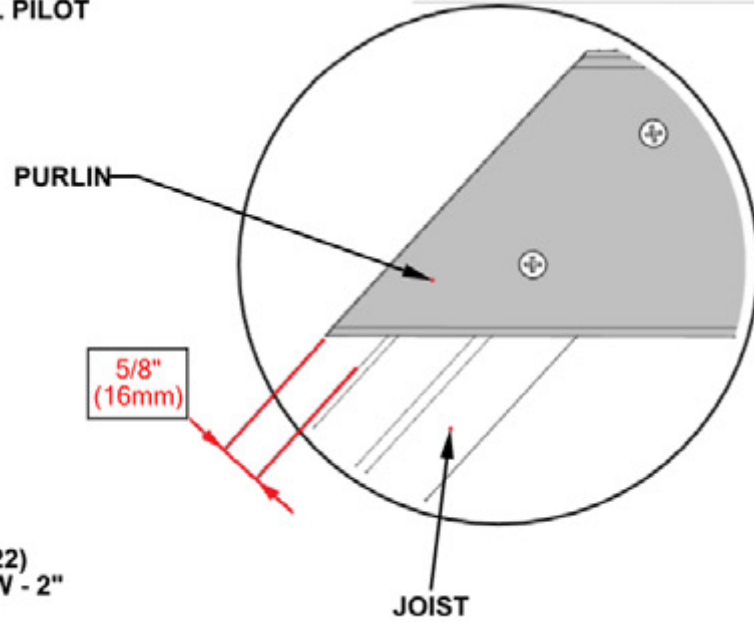



# STEP 25 - SIDE ROOF PANEL ASSEMBLY

29GA STEEL SHEETING - A4M01923-1  
(x1) 0.02x30 11/16"x14 1/4"

29GA STEEL SHEETING - A4M01922-2  
(x1) 0.02x30 11/16"x45 5/16"

29GA STEEL SHEETING - A4M01922-1  
(x1) 0.02x30 11/16"x45 5/16"

29GA STEEL SHEETING - A4M01924-2  
(x1) 0.02x30 11/16"x32 15/16"

29GA STEEL SHEETING - A4M01923-2  
(x1) 0.02x30 11/16"x14 1/4"

29GA STEEL SHEETING - A4M01924-1  
(x1) 0.02x30 11/16"x32 15/16"

- REMOVE PROTECTIVE BLUE FILM. THIS SIDE WILL FACE UP.
- STARTING IN THE CENTER, PLACE PANELS AS SHOWN BELOW.
- OVERLAP PANELS BY ONE RIDGE.
- PANELS SHOULD BE FLUSH WITH PURLIN ENDS AND ROOF JOIST.

**WARNING: GLOVES ARE RECOMMENDED WHEN HANDLING STEEL ROOF SHEETING**

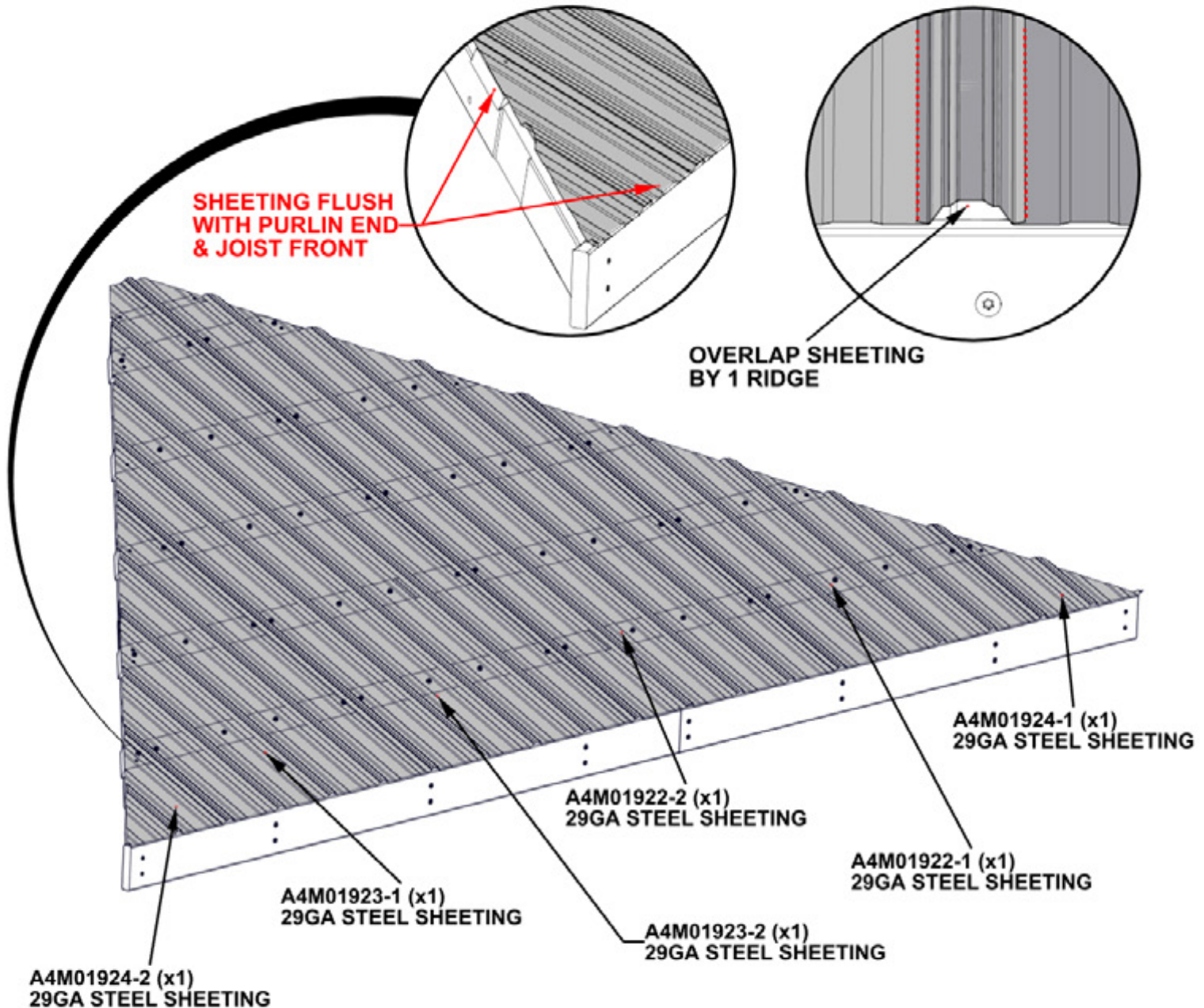

# STEP 26 - SIDE ROOF PANEL ASSEMBLY

QTY	PART NUMBER	DESCRIPTION
46	H100833	SCREW WOODGRIP 10-16x3/4

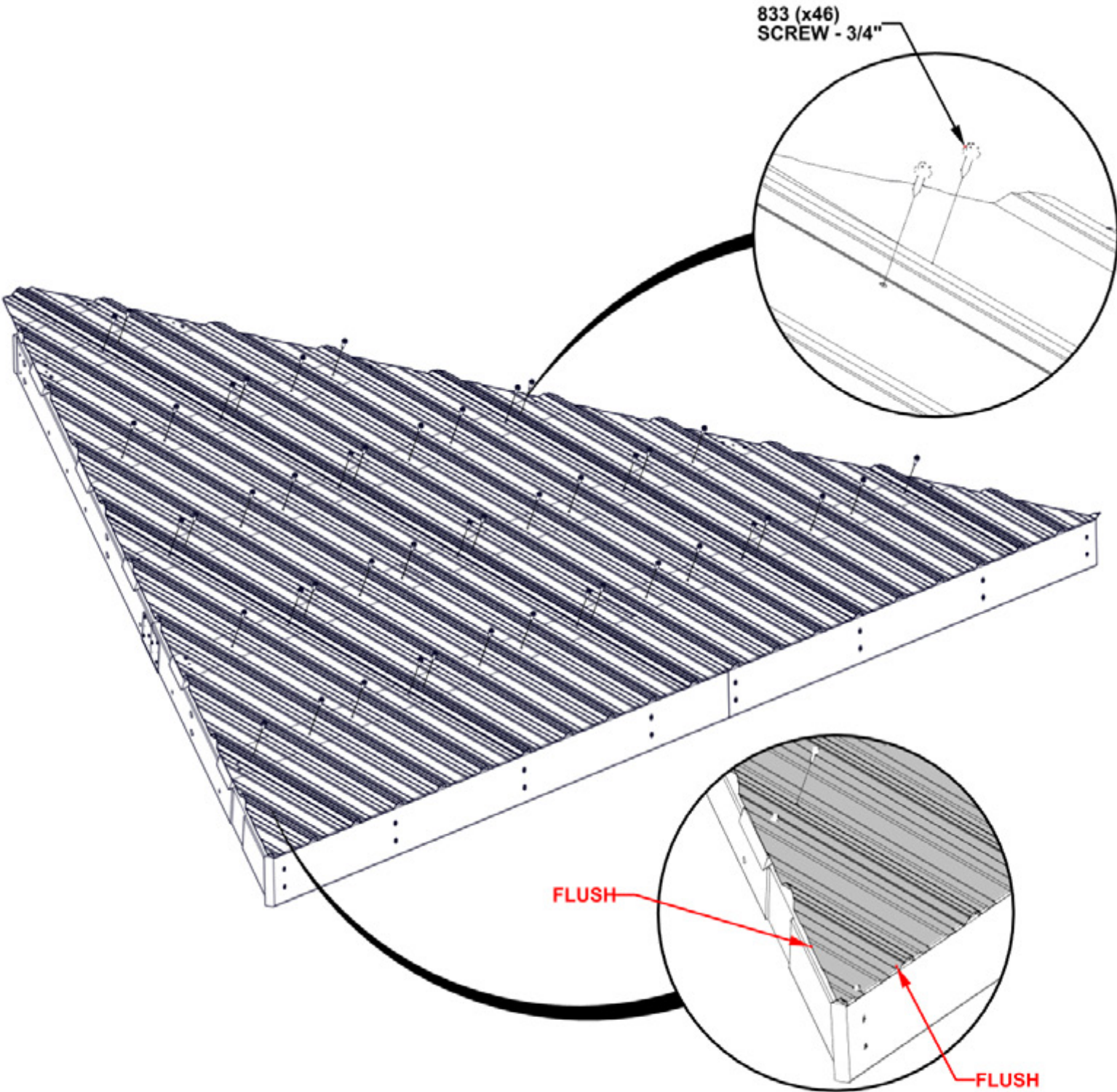



# STEP 27 - SIDE ROOF PANEL ASSEMBLY

QTY	PART NUMBER	DESCRIPTION
6	H100833	SCREW WOODGRIP 10-16x3/4"



A4M02847 - RIDGE CAP CHANNEL LONG  
(x2)

A4M02850 - RIDGE CAP CHANNEL SHORT  
(x2)

- POSITION THE RIDGE CAP CHANNEL OVER THE EDGE OF THE ROOF PANELS WITH THE WIDER SIDE OF THE CHANNEL ON THE BOTTOM
- MAKE SURE THE PANELS ARE FULLY SEATED INTO THE CHANNEL.
- FLUSH THE TOP OF THE CHANNEL WITH THE TOP OF THE METAL PANELS
- NOTE IT MAY BE NECESSARY TO LOOSEN SOME OF THE OUTSIDE SCREWS FROM STEP 26

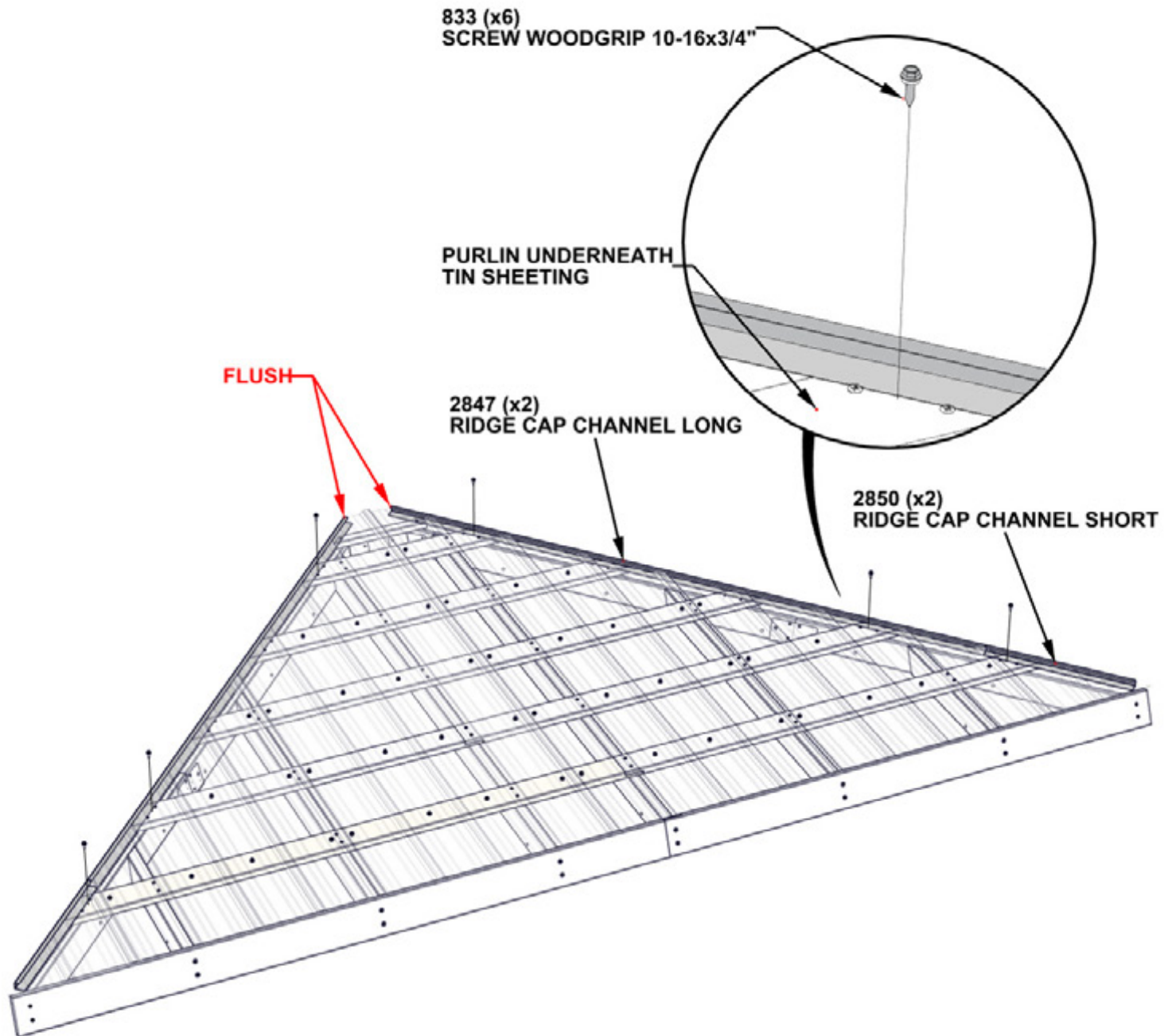

**REPEAT ROOF PANEL ASSEMBLY  
STEPS 17 THROUGH 27**

# STEP 28 - ROOF PANEL ATTACHMENT

QTY	PART NUMBER	DESCRIPTION
4	H100379	T-NUT 5/16 BLK

- INSERT T-NUTS AS SHOWN
- CORRECT T-NUT PLACEMENT IS CRITICAL TO REMAINING STEPS

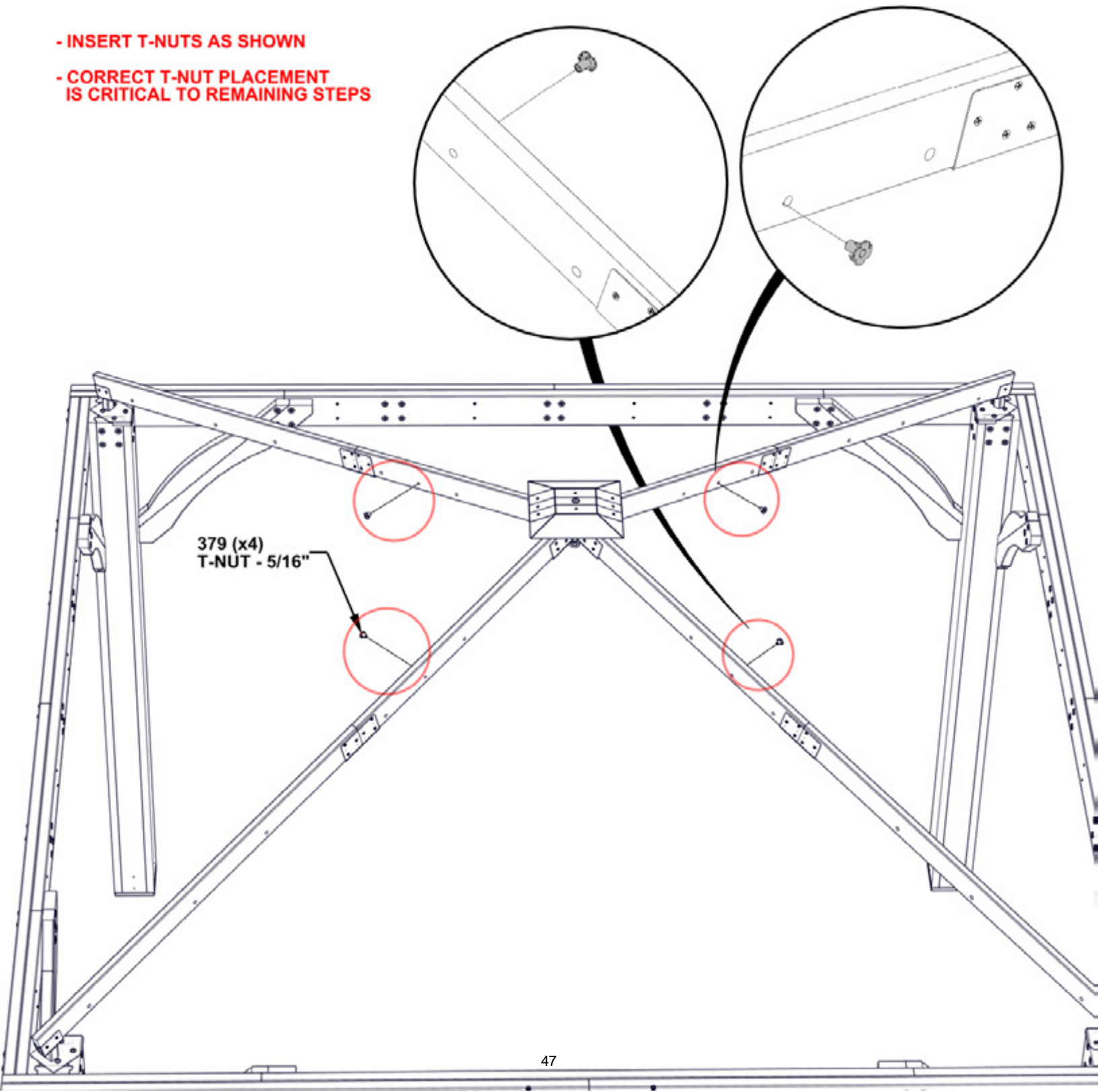

# STEP 29 - ROOF PANEL ATTACHMENT

QTY	PART NUMBER	DESCRIPTION
4	H100198	WASHER LOCK EXT 8x19
4	H100378	BOLT WH 5/16x1 3/4 BLK

- 3 PEOPLE ARE RECOMMENDED FOR THIS STEP.
- POSITION A PERSON ON A LADDER IN THE CENTER OF THE GAZEBO TO HELP SUPPORT THE ROOF PANEL
- WITH 2 PEOPLE, WORK THE PANEL UP WITHOUT SLIDING OR DRAGGING, UNTIL IT MEETS THE ROOF SUPPORT FRAME.
- MAKE SURE THE ROOF PANEL SLIDES UNDERNEATH THE RIDGE CAP.
- PLACE BOLTS WITH WASHER INTO THE T-NUTS INSTALLED DURING THE PREVIOUS STEP ON BOTH SIDES.

**- REPEAT THIS STEP FOR THE OTHER SIDE ROOF PANEL ON THE OPPOSITE SIDE.**

VIEW FROM BELOW ROOF PANEL

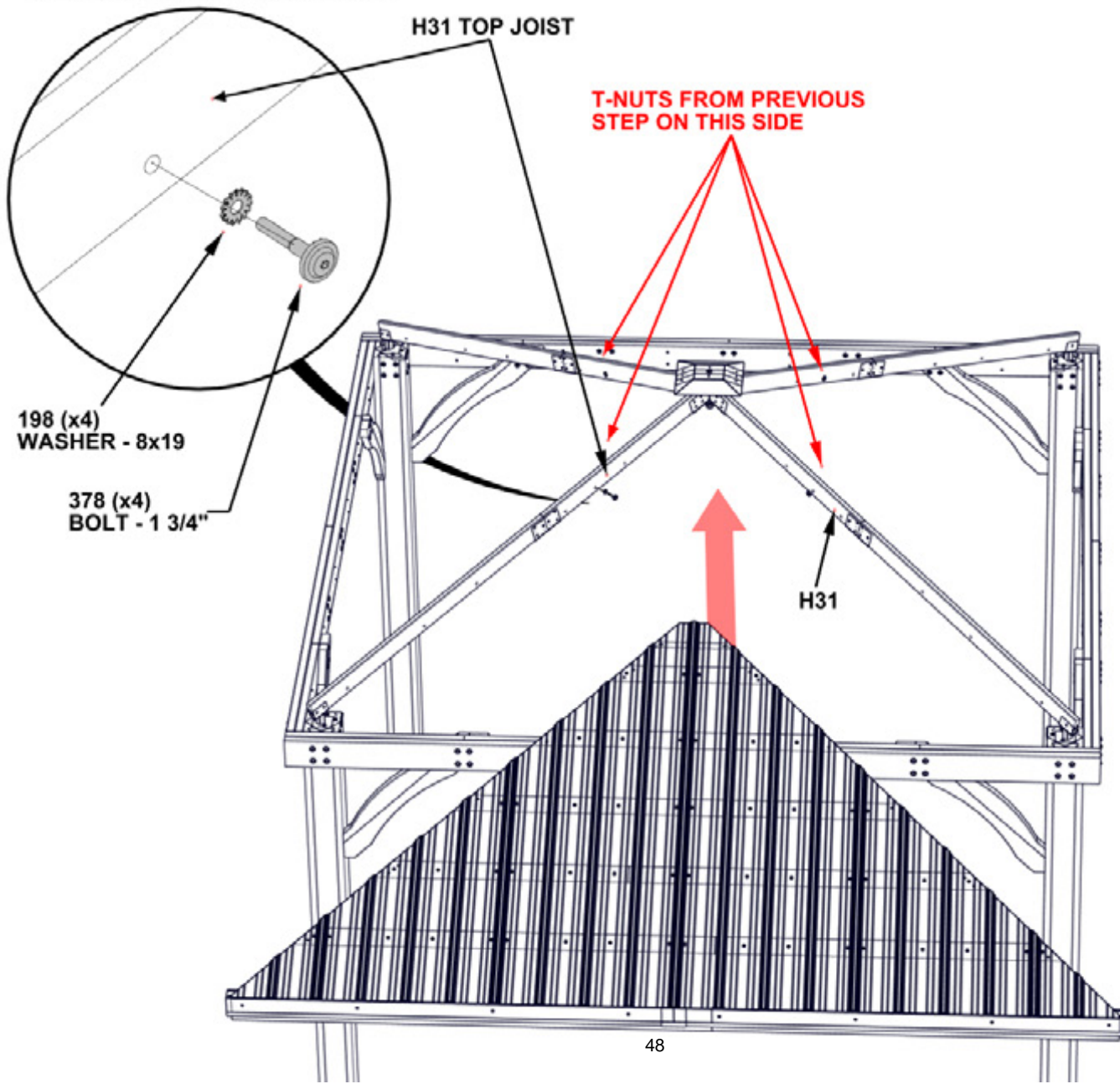



# STEP 30 - FRONT / BACK ROOF PANEL ASSEMBLY



H07 ROOF JOIST - W4L15205  
(x1) 15/16"x3 3/8"x53 3/16" (24x86x1351)

QTY	PART NUMBER	DESCRIPTION
24	H100385	SCREW PFH 8x1 BLK



H08 ROOF JOIST - W4L15206  
(x1) 15/16"x3 3/8"x53 3/16" (24x86x1351)



H11 ROOF JOIST - W4L15216  
(x1) 15/16"x3 3/8"x44 1/2" (24x86x1130)

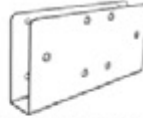

A4M01237 - ROOF SUPPORT SPLICE CLIP  
(x2)



H12 ROOF JOIST - W4L15220  
(x1) 15/16"x3 3/8"x44 1/2" (24x86x1130)

- INSERT BOARDS INTO EACH SIDE OF THE BRACKETS AS SHOWN
- INSERT SCREWS THROUGH EACH OF THE BRACKET HOLES ON BOTH SIDES

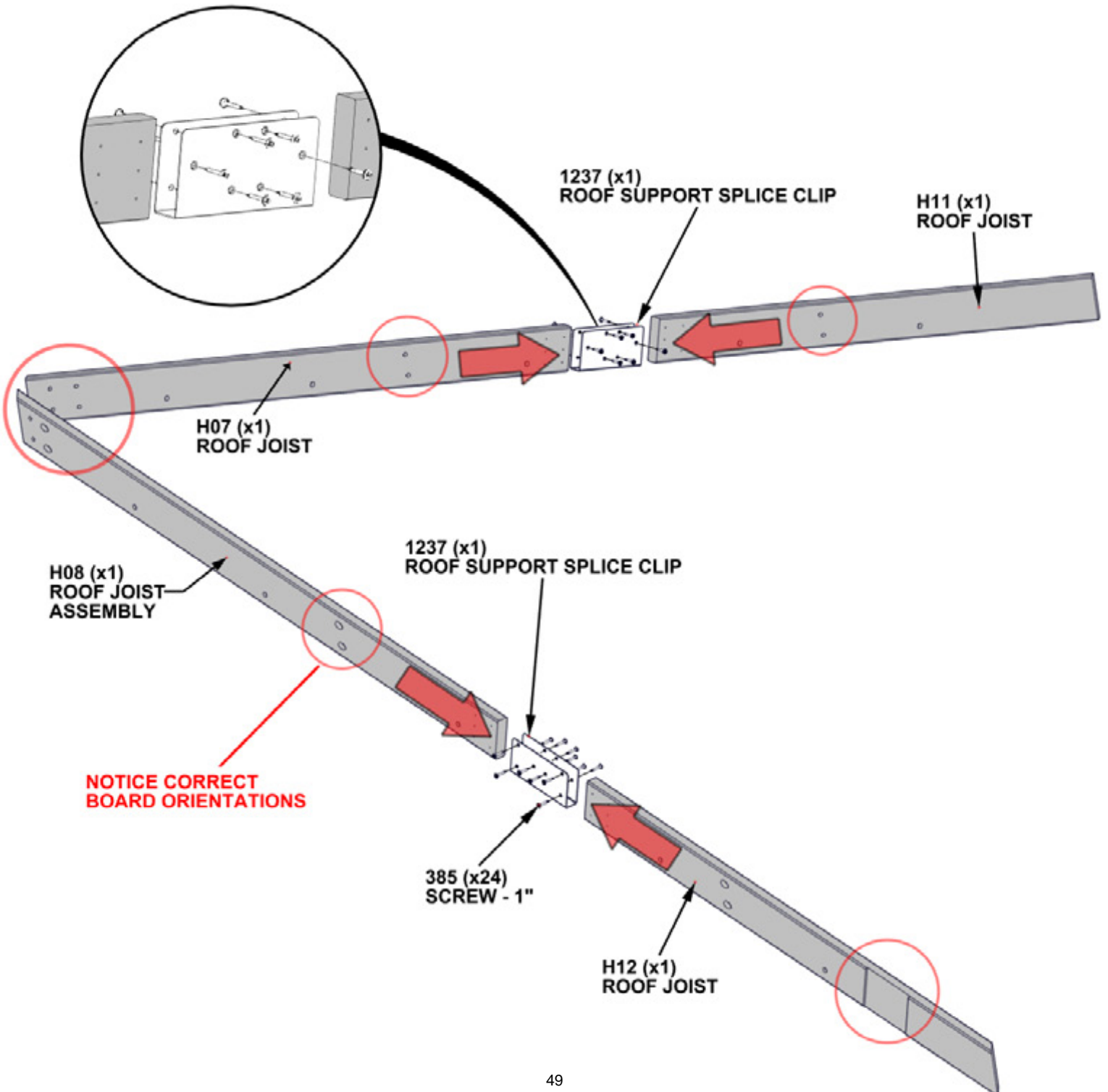

# STEP 31 - FRONT / BACK ROOF PANEL ASSEMBLY

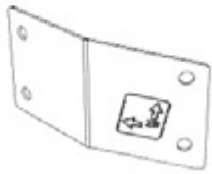

A4M01239 - PANEL BRACKET  
(x1)

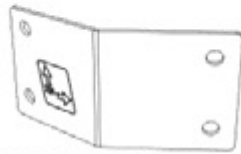

A4M01238 - PANEL BRACKET  
(x1)

QTY	PART NUMBER	DESCRIPTION
4	H100171	BOLT WH 1/4x1 BLK
4	H100398	T-NUT 1/4 BLK



H06 ROOF JOIST - W4L15203  
(x1) 15/16"x3 3/8"x10 11/16" (24x86x272)

**- INSERT T-NUTS FIRST**

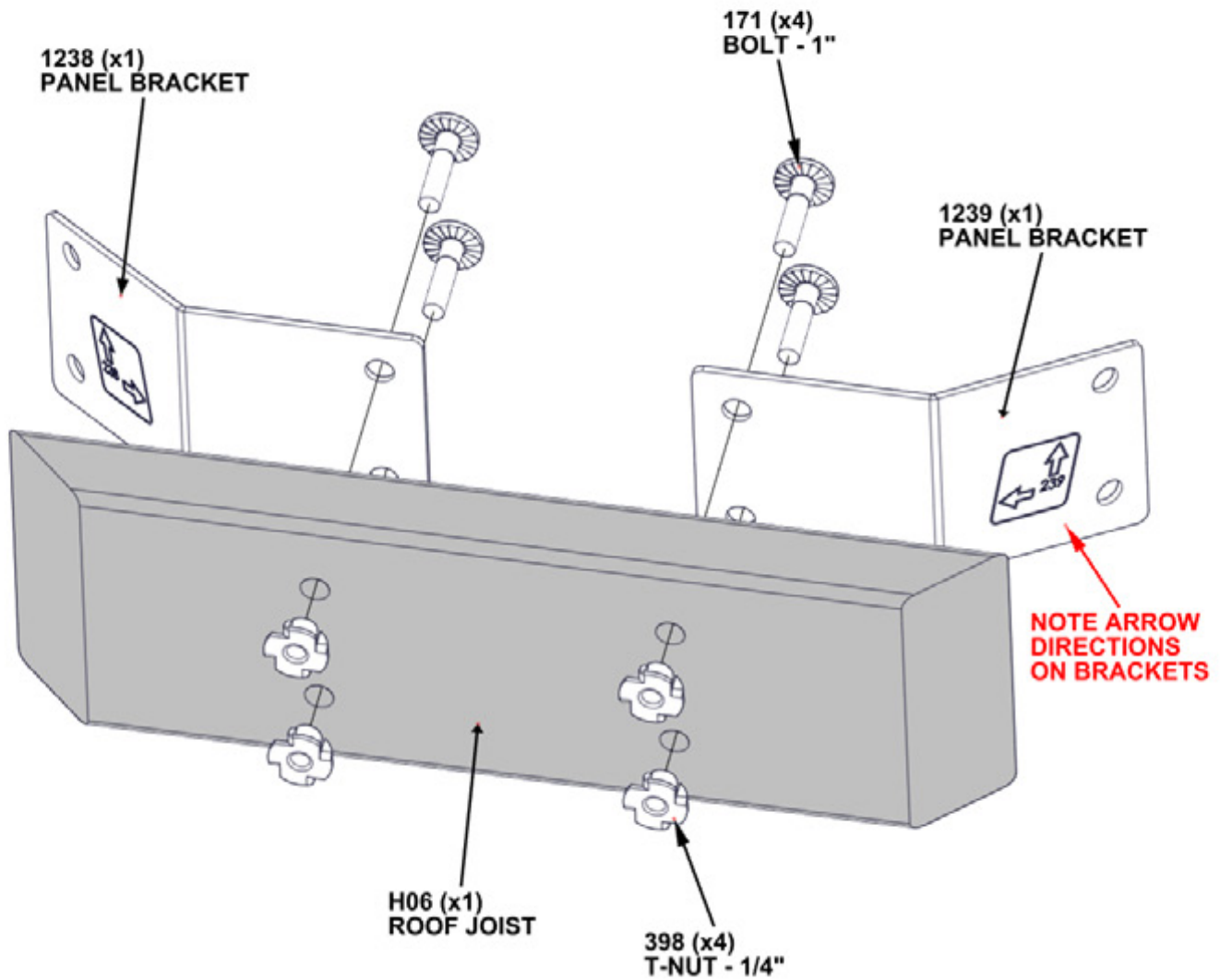

# STEP 32 - FRONT / BACK ROOF PANEL ASSEMBLY

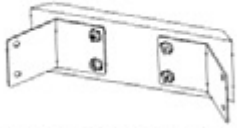

H06 / PANEL BRACKET ASSEMBLY  
(x1)

QTY	PART NUMBER	DESCRIPTION
4	H100171	BOLT WH 1/4x1 BLK
4	H100398	T-NUT 1/4 BLK

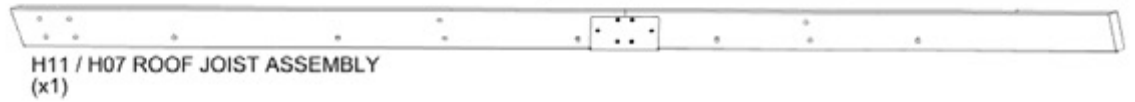

H11 / H07 ROOF JOIST ASSEMBLY  
(x1)



H12 / H08 ROOF JOIST ASSEMBLY  
(x1)

## - INSTALL T-NUTS FIRST

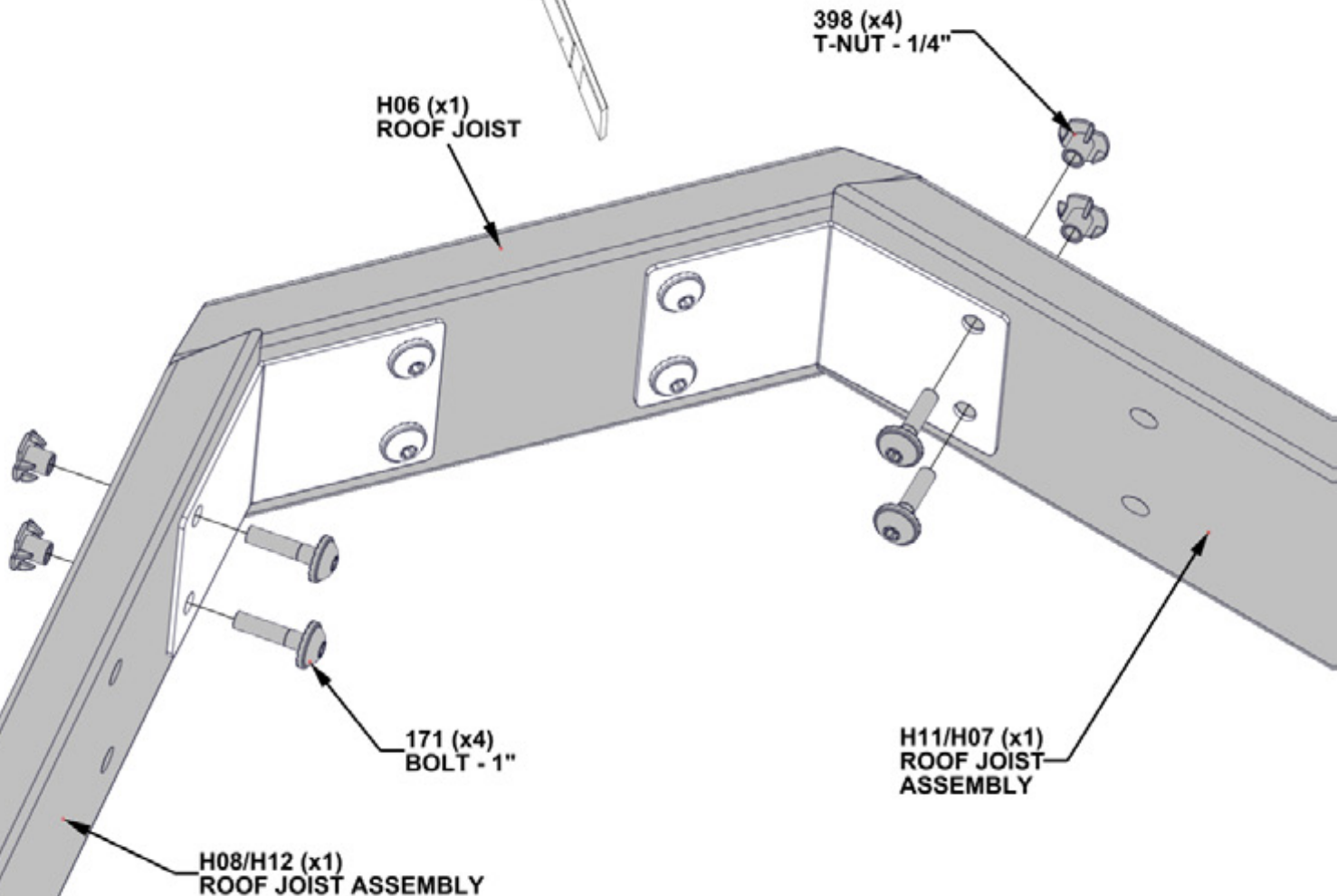
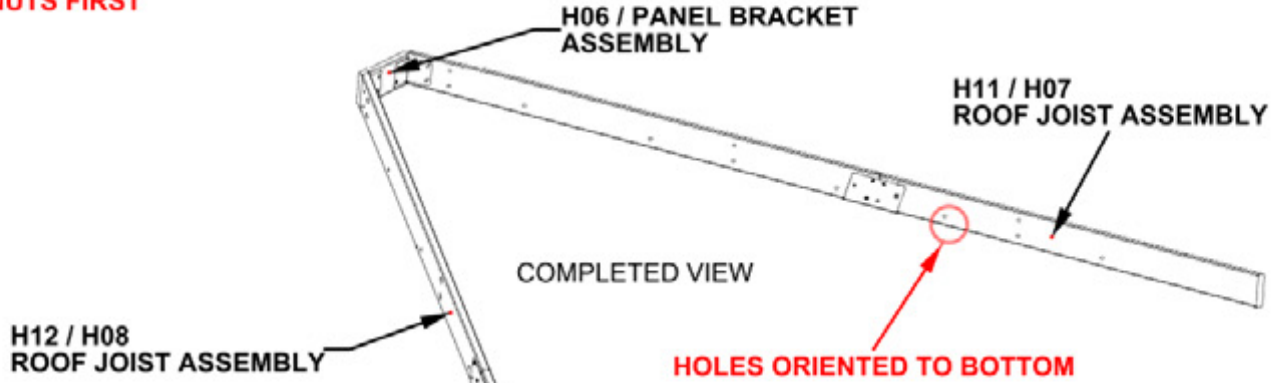

# STEP 33 - FRONT / BACK ROOF PANEL ASSEMBLY

E07 RAFTER - W4L15209  
(x1) 1 3/8"x3 3/8"x22" (36x86x557)

E13 RAFTER - W4L15219  
(x1) 1 7/16"x3 3/8"x21 15/16" (36x86x557)

QTY	PART NUMBER	DESCRIPTION
12	H101030	CONFIRMAT - SCREW 2"

E11 RAFTER - W4L15217  
(x1) 1 7/16"x3 3/8"x69" (36x86x1752)

E12 RAFTER - W4L15218  
(x1) 1 7/16"x3 3/8"x45 7/16" (36x86x1155)

E05 RAFTER - W4L15207  
(x1) 1 7/16"x3 3/8"x69" (36x86x1752)

E06 RAFTER - W4L15208  
(x1) 1 7/16"x3 3/8"x45 7/16" (36x86x1155)

**NOTE PILOT HOLES ARE  
FACE UP ON ALL RAFTERS**

1030 (x12)  
CONFIRMAT SCREW - 2"

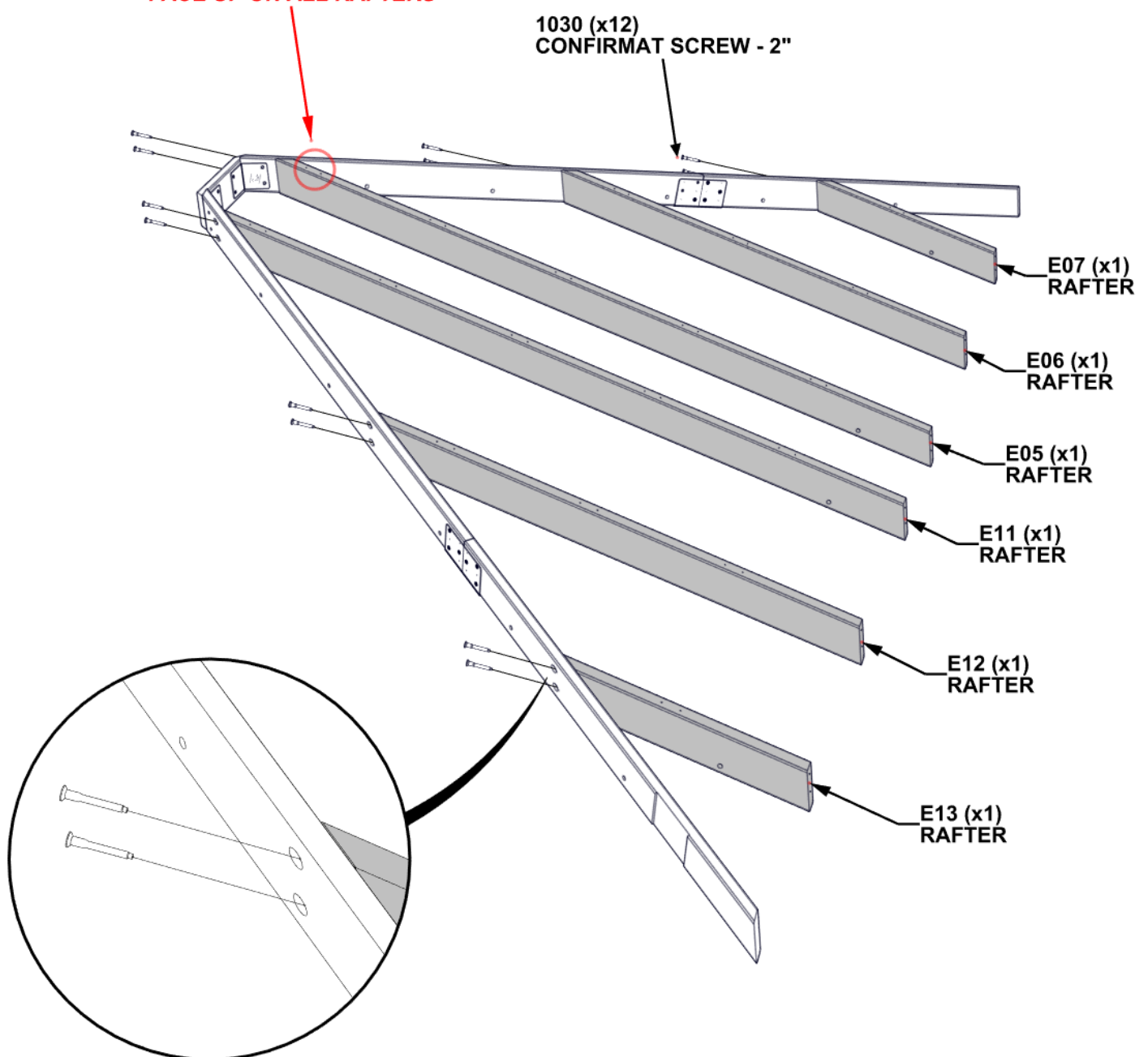



# STEP 34 - FRONT / BACK ROOF PANEL ASSEMBLY



Q03 ROOF JOIST - W4L15221  
(x1)



Q01 ROOF JOIST - W4L15204  
(x1)

QTY	PART NUMBER	DESCRIPTION
4	H100382	SCREW PFH 8x1 3/4 BLK
12	H101030	CONFIRMAT - SCREW 2"

- USE Q01/Q03 BOARDS AS GUIDES, & A 1/8" DRILL BIT, DRILL PILOT HOLES INTO H12/H11 BOARDS
- RAFTERS MAY NEED TO BE LOOSENED TO ATTACH Q01/Q03 BOARDS

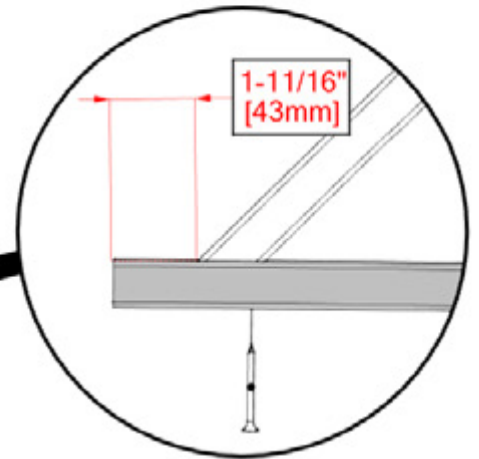

**START AT THE CENTER WHERE Q03/Q01 BOARDS MEET**

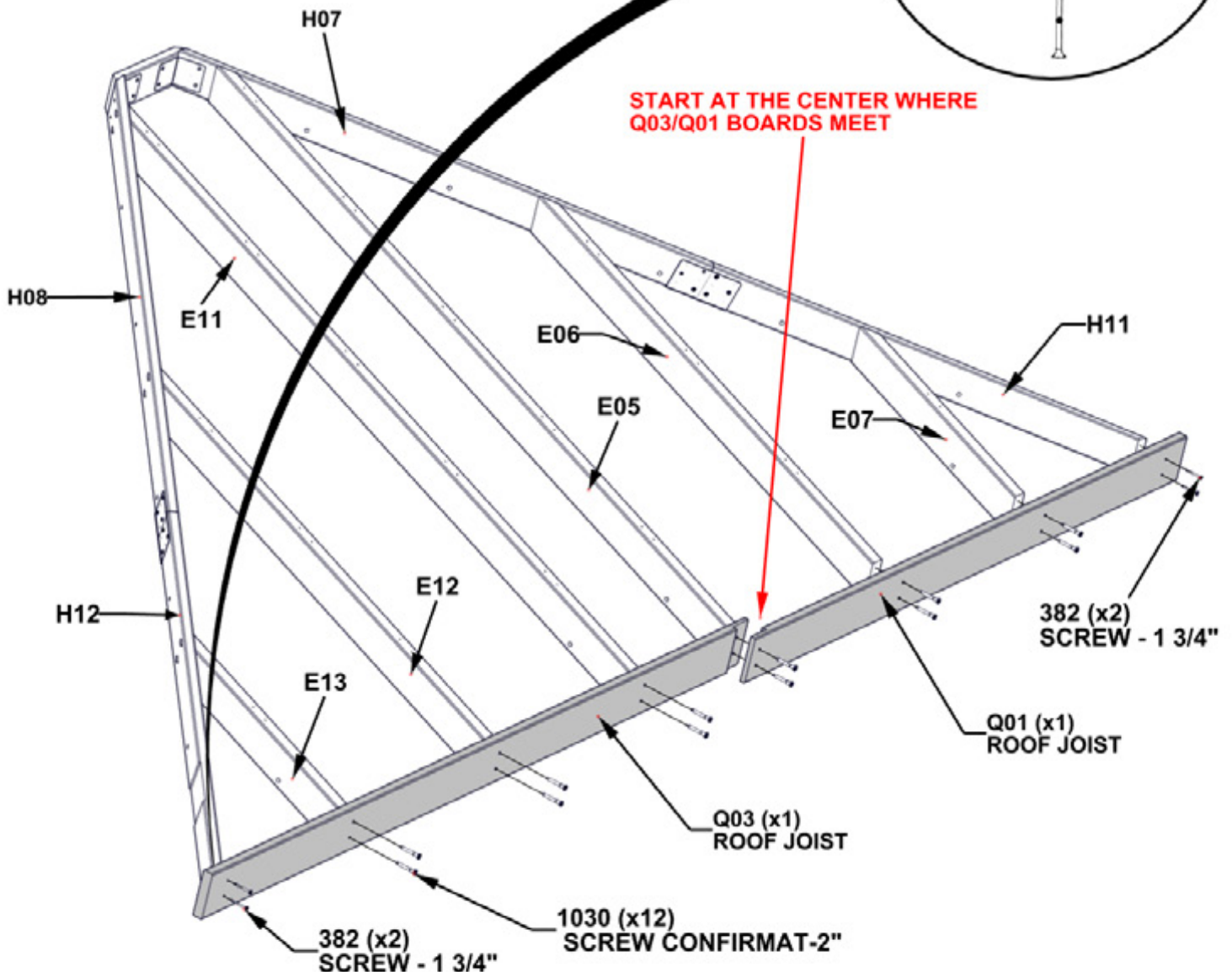

# STEP 35 - FRONT / BACK ROOF PANEL ASSEMBLY

**CRITICAL**

- SQUARE UNIT BEFORE PROCEEDING TO NEXT STEPS.
- THE BELOW DIMENSIONS ARE CRITICAL TO THE FINAL ROOF ASSEMBLY.
- MEASUREMENTS SHOULD BE WITHIN  $\pm 1/4"$ .
- MEASUREMENTS OUTSIDE OF TOLERANCE WILL LEAD TO THE INABILITY TO ASSEMBLE THE ROOF

- LOOSEN HARDWARE TO ADJUST FOR SQUARING IF NEEDED

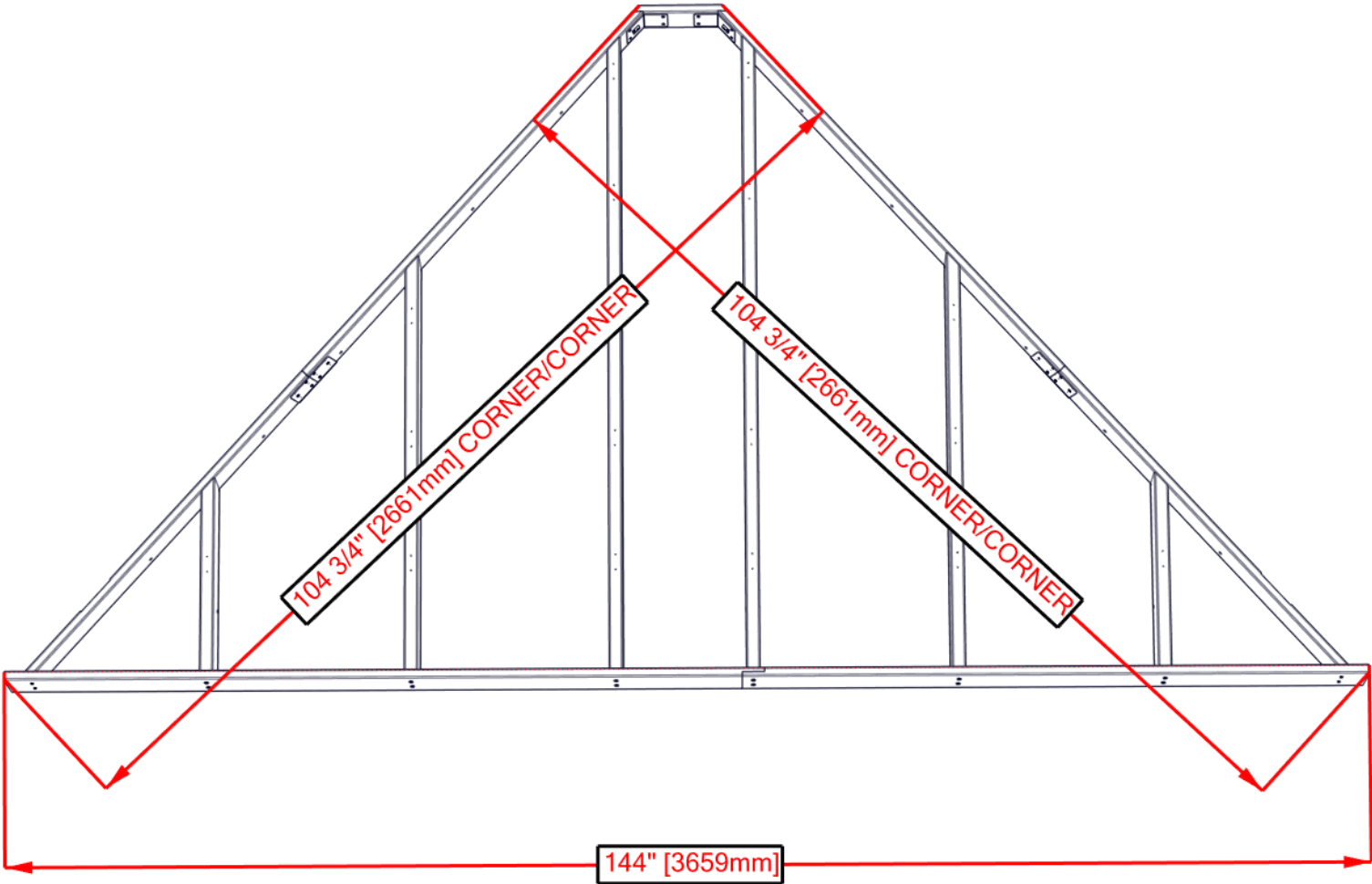

# STEP 36 - FRONT / BACK ROOF PANEL ASSEMBLY

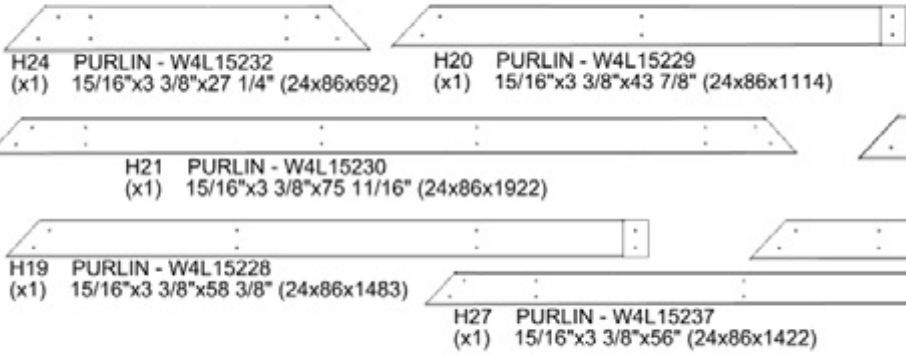

QTY	PART NUMBER	DESCRIPTION
36	H100391	SCREW PFH 8x2 BLK

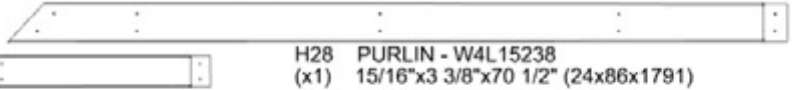
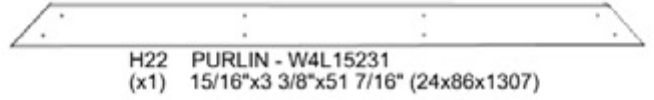

- ALIGN PURLIN PILOT HOLES WITH RAFTER PILOT HOLES
- ATTACH SCREWS FROM THE CENTER AND WORK OUTWARD

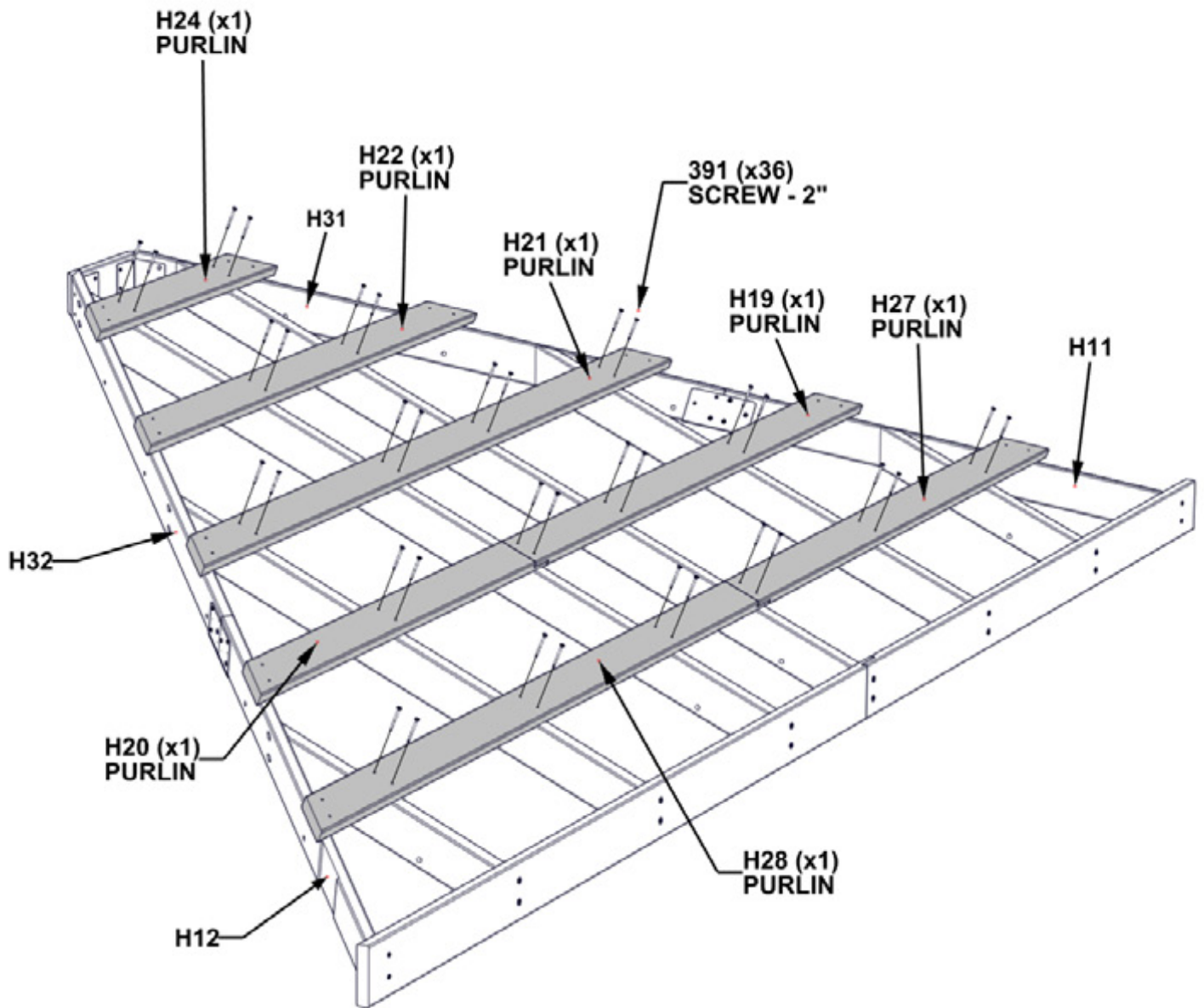



# STEP 37 - FRONT / BACK ROOF PANEL ASSEMBLY



T02 PURLIN - W4L15239  
 (x1) 15/16"x1 5/16"x12 7/8" (24x34x327)

QTY	PART NUMBER	DESCRIPTION
22	H100391	SCREW PFH 8x2 BLK

- H11, H12, H31, & H32 BOARDS DO NOT HAVE PILOT HOLES FOR OUTSIDE EDGE SCREWS
- USING THE PURLINS AS A GUIDE AND A 1/8" DRILL BIT, DRILL PILOT HOLES INTO H12/H08/H11/H07 BOARDS

**- IF PURLINS OVERHANG MORE THAN 5/8" CUT DOWN TO 5/8"**

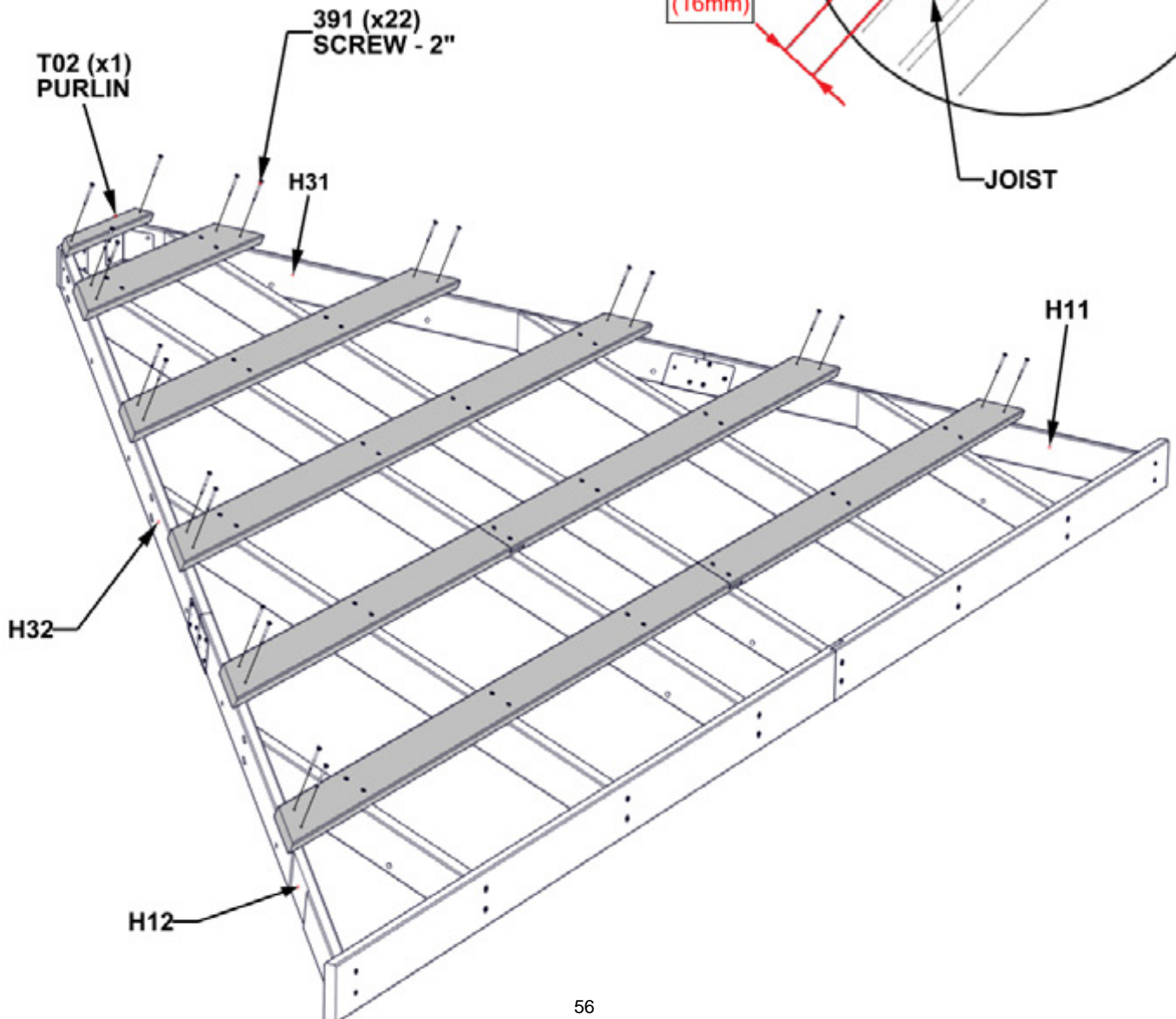
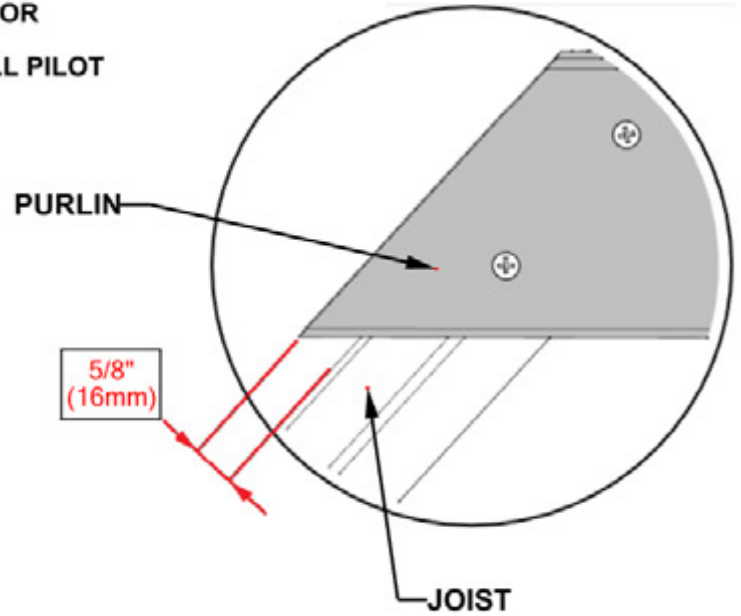

# STEP 38 - FRONT / BACK ROOF PANEL ASSEMBLY

29GA STEEL SHEETING - A4M01923-1  
(x1) 0.02x30 11/16"x14 1/4"



29GA STEEL SHEETING - A4M01924-2  
(x1) 0.02x30 11/16"x32 15/16"



29GA STEEL SHEETING - A4M01923-2  
(x1) 0.02x30 11/16"x14 1/4"



29GA STEEL SHEETING - A4M01922-2  
(x1) 0.02x30 11/16"x45 5/16"



29GA STEEL SHEETING - A4M01922-1  
(x1) 0.02x30 11/16"x45 5/16"

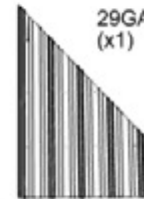

29GA STEEL SHEETING - A4M01924-1  
(x1) 0.02x30 11/16"x32 15/16"



- REMOVE PROTECTIVE BLUE FILM. THIS SIDE WILL FACE UP.
- STARTING IN THE CENTER, PLACE PANELS AS SHOWN BELOW.
- OVERLAP PANELS BY ONE RIDGE.
- PANELS SHOULD BE FLUSH WITH PURLIN ENDS AND ROOF JOIST.

**WARNING: GLOVES ARE RECOMMENDED WHEN HANDLING STEEL ROOF SHEETING**

SHEETING EXTENDS BEYOND FRAME

SHEETING FLUSH WITH PURLIN END & JOIST FRONT

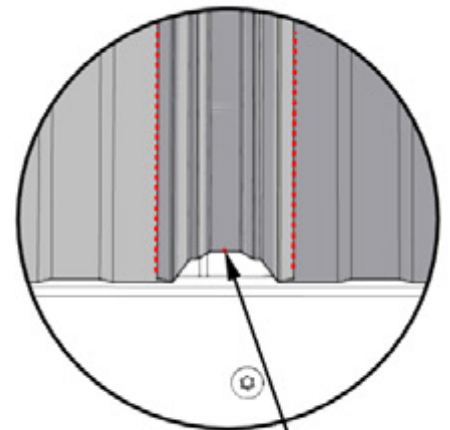
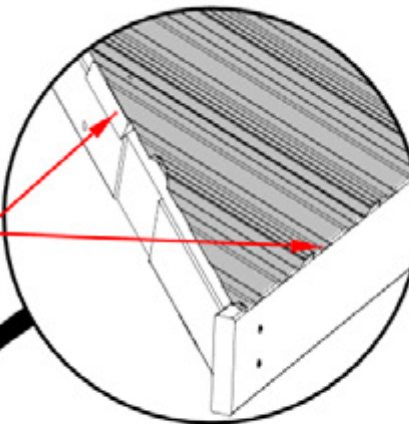

OVERLAP SHEETING BY 1 RIDGE

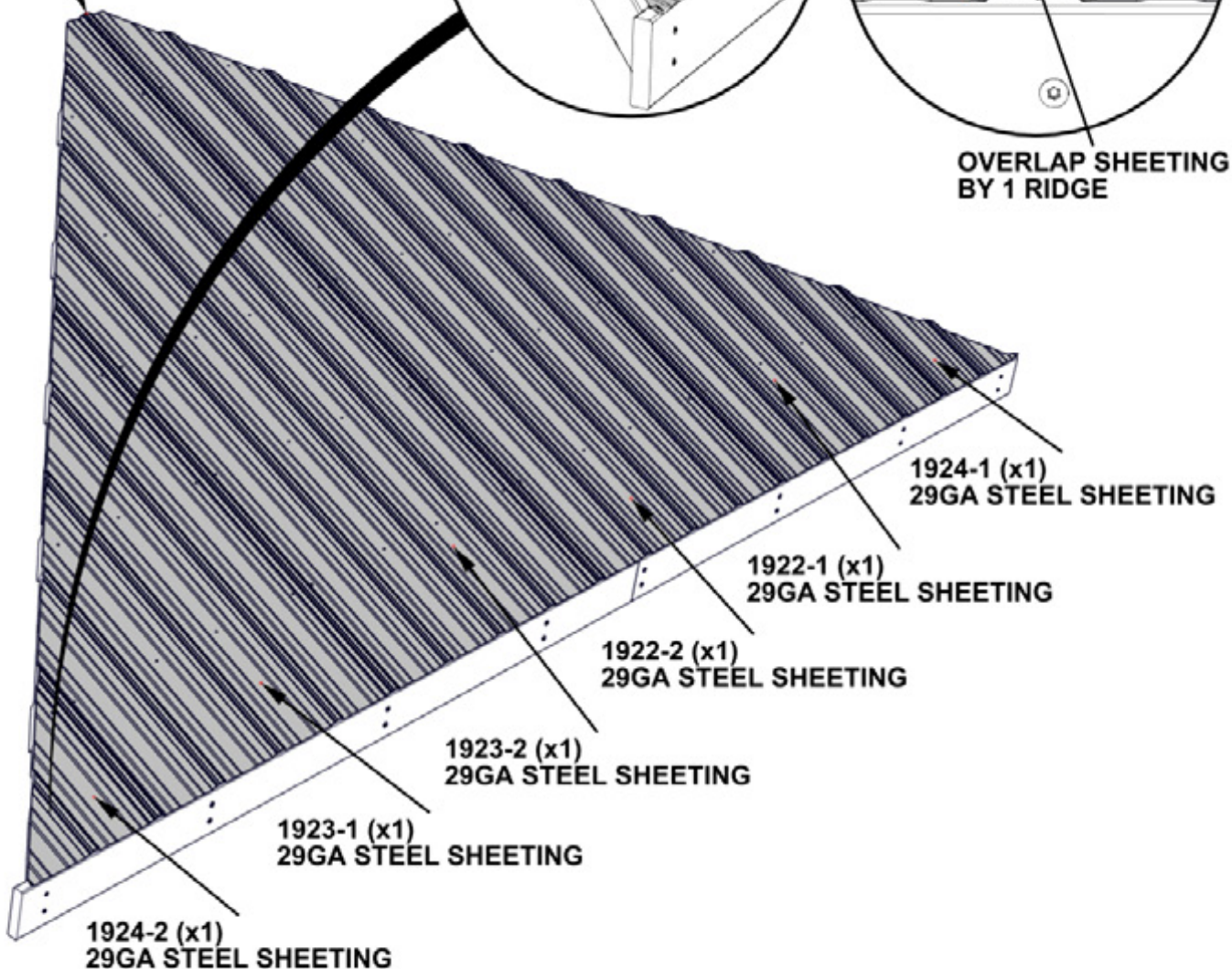



# STEP 39 - FRONT / BACK ROOF PANEL ASSEMBLY

QTY	PART NUMBER	DESCRIPTION
46	H100833	SCREW WOODGRIP 10-16x3/4

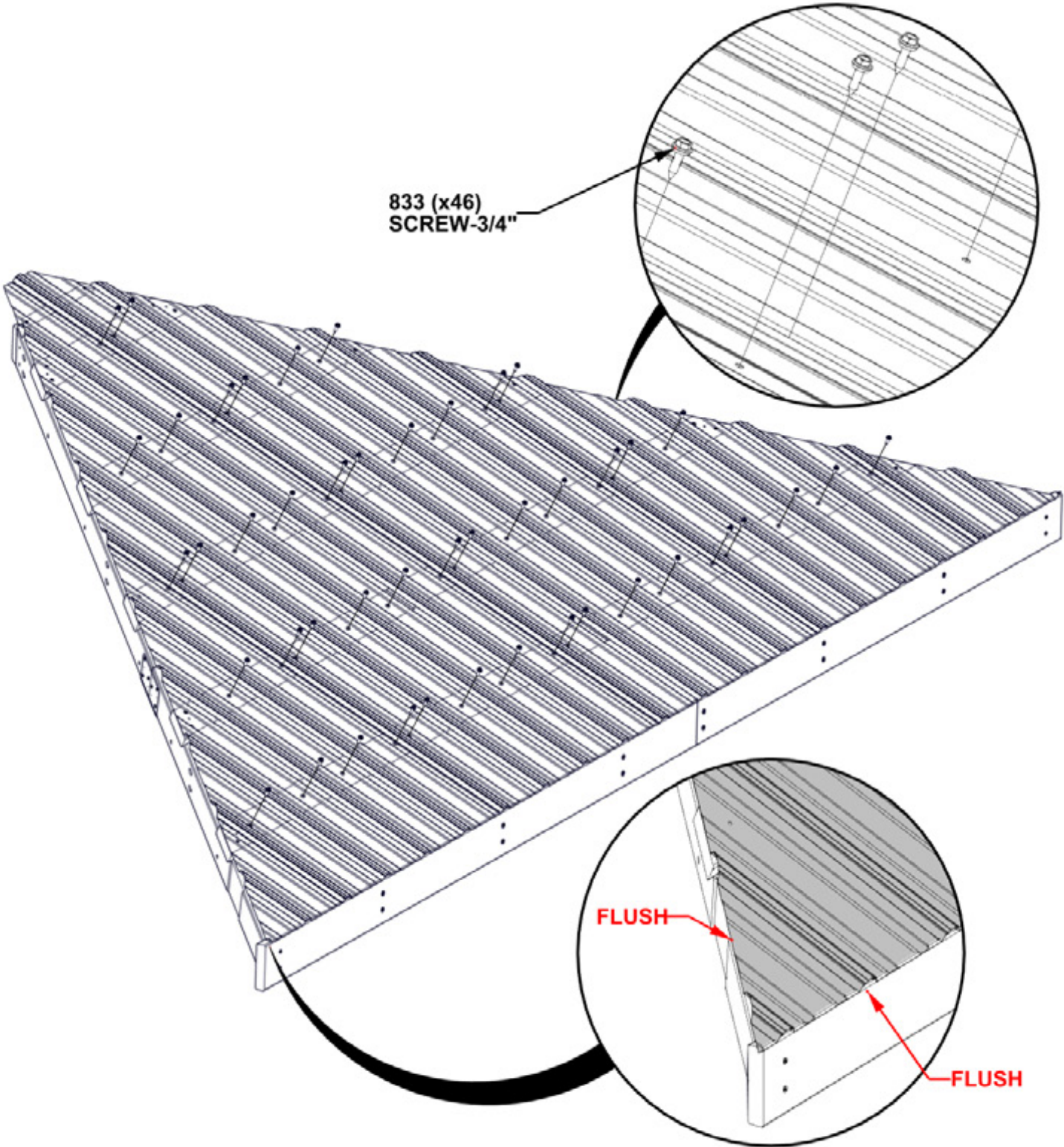

# STEP 40 - FRONT / BACK ROOF PANEL ASSEMBLY

QTY	PART NUMBER	DESCRIPTION
6	H100833	SCREW WOODGRIP 10-16x3/4"



A4M02847 - RIDGE CAP CHANNEL LONG (x2)



A4M02850 - RIDGE CAP CHANNEL SHORT (x2)

- POSITION THE RIDGE CAP CHANNEL OVER THE EDGE OF THE ROOF PANELS WITH THE WIDER SIDE OF THE CHANNEL ON THE BOTTOM.
- MAKE SURE THE PANELS ARE FULLY SEATED INTO THE CHANNEL.
- FLUSH THE TOP OF THE CHANNEL WITH THE TOP OF THE METAL PANELS.

833 (x6)  
SCREW WOODGRIP 10-16x3/4"

PURLIN UNDERNEATH  
TIN SHEETING

2847 (x2)  
RIDGE CAP CHANNEL LONG

FLUSH

2850 (x2)  
RIDGE CAP CHANNEL SHORT

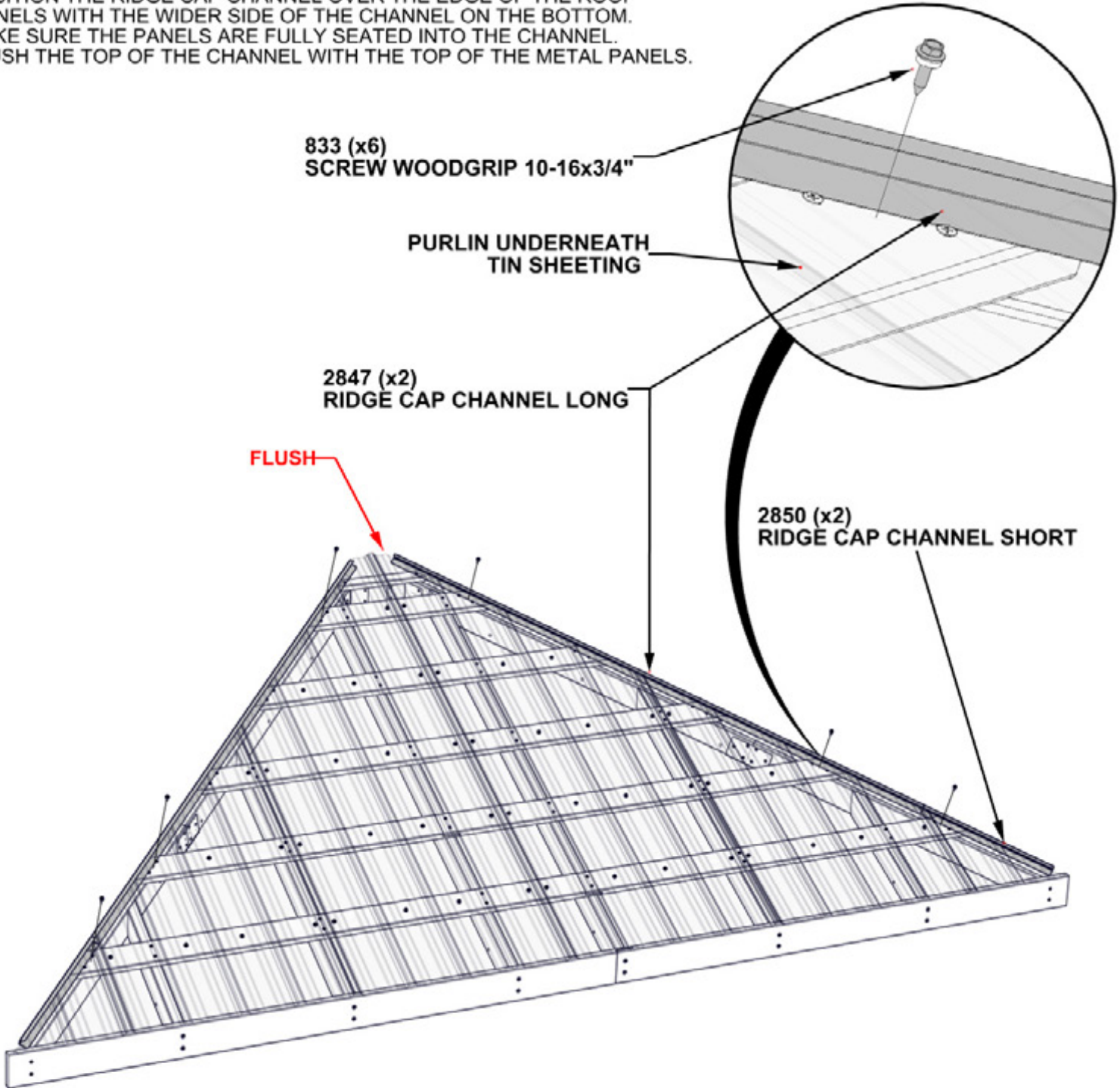

**REPEAT FRONT/BACK ROOF  
PANEL ASSEMBLY STEPS 30  
THROUGH 40**



## STEP 41 - ROOF PANEL ATTACHMENT

- 3 PEOPLE ARE RECOMMENDED FOR THIS STEP.
- POSITION A PERSON ON A LADDER IN THE CENTER OF THE GAZEBO TO HELP SUPPORT THE ROOF PANEL.
- WITH 2 PEOPLE, WORK THE PANEL UP WITHOUT SLIDING OR DRAGGING, UNTIL IT MEETS THE ROOF SUPPORT FRAME.
- MAKE SURE THE ROOF PANEL SLIDES UNDERNEATH THE RIDGE CAP.

**SEE NEXT STEP FOR ROOF PANEL HARDWARE ATTACHMENT**

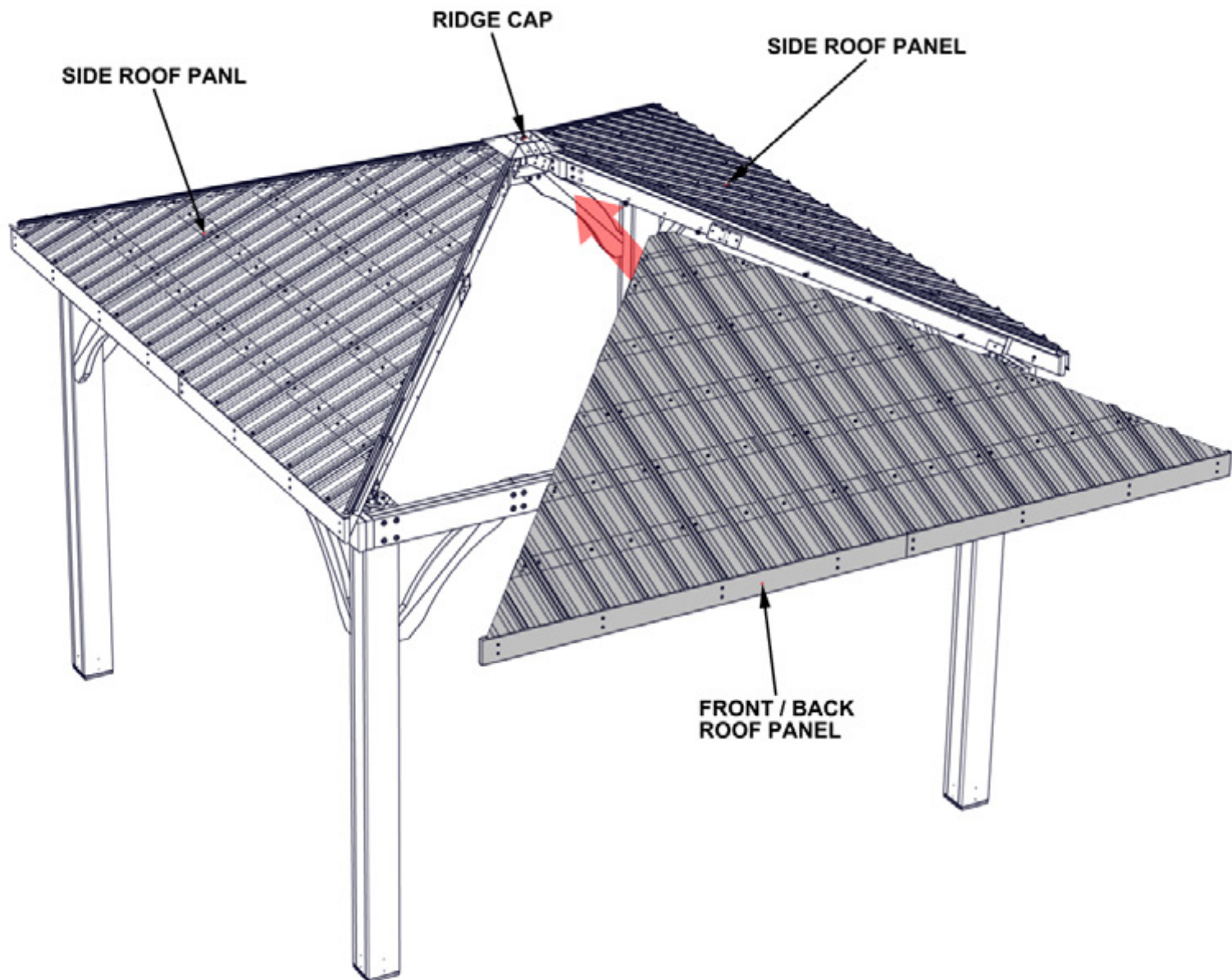

# STEP 42 - ROOF PANEL ATTACHMENT

QTY	PART NUMBER	DESCRIPTION
20	H100198	WASHER LOCK EXT 8x19
20	H100415	BOLT WH 5/16x3 3/4 BLK
20	H100479	NUT LOCK 5/16 BLK
20	H100770	WASHER FLAT 5/16 BLK

- HAND TIGHTEN ONLY
- REPEAT ON ALL PANEL EDGES

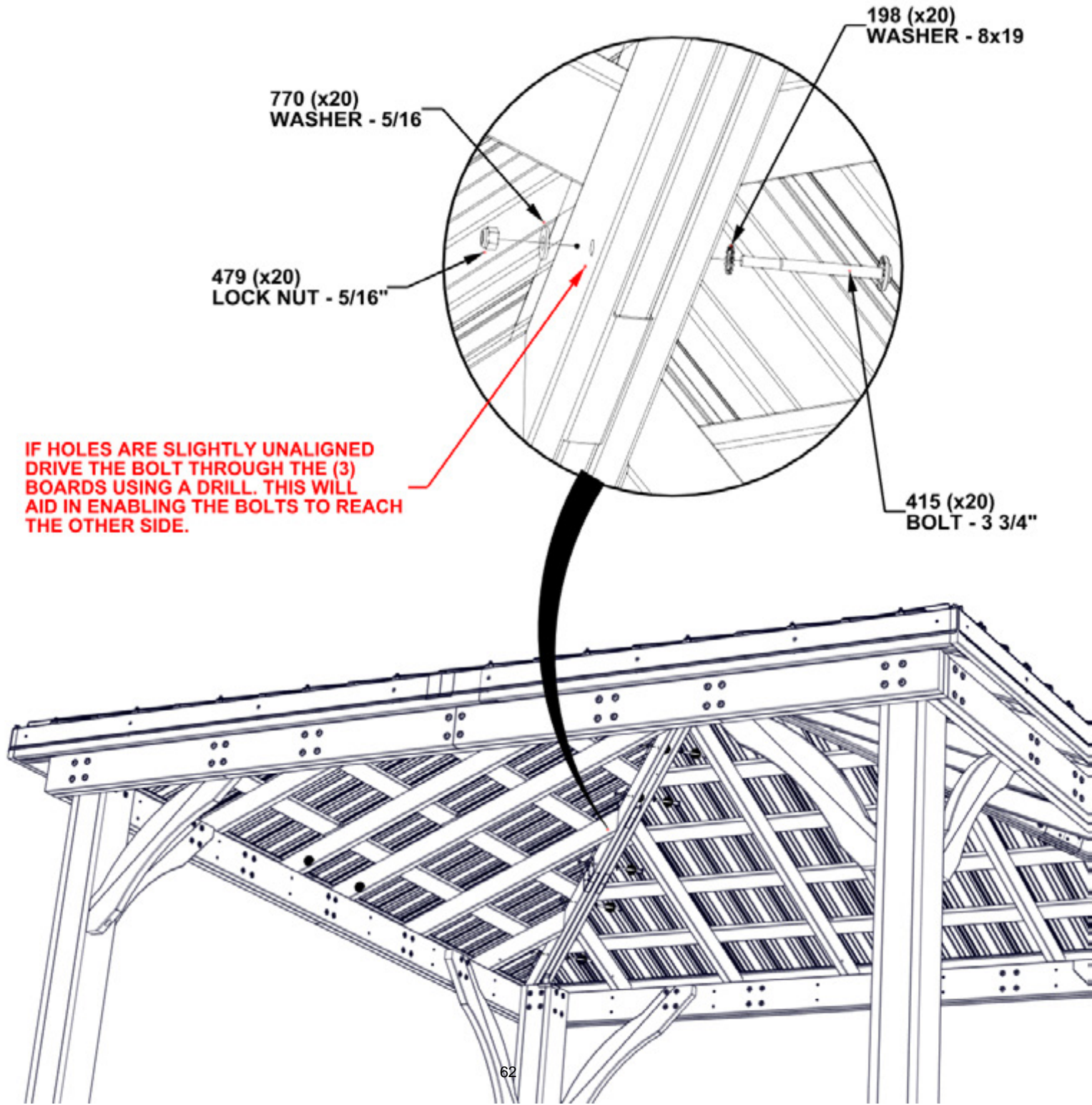

770 (x20)  
WASHER - 5/16

479 (x20)  
LOCK NUT - 5/16"

198 (x20)  
WASHER - 8x19

IF HOLES ARE SLIGHTLY UNALIGNED  
DRIVE THE BOLT THROUGH THE (3)  
BOARDS USING A DRILL. THIS WILL  
AID IN ENABLING THE BOLTS TO REACH  
THE OTHER SIDE.

415 (x20)  
BOLT - 3 3/4"



# STEP 43 - ROOF PANEL ASSEMBLY

**TIGHTEN ALL THE HARDWARE IN THE ORDER SHOWN BELOW.  
START AT THE TOP AND WORK YOUR WAY DOWN.**

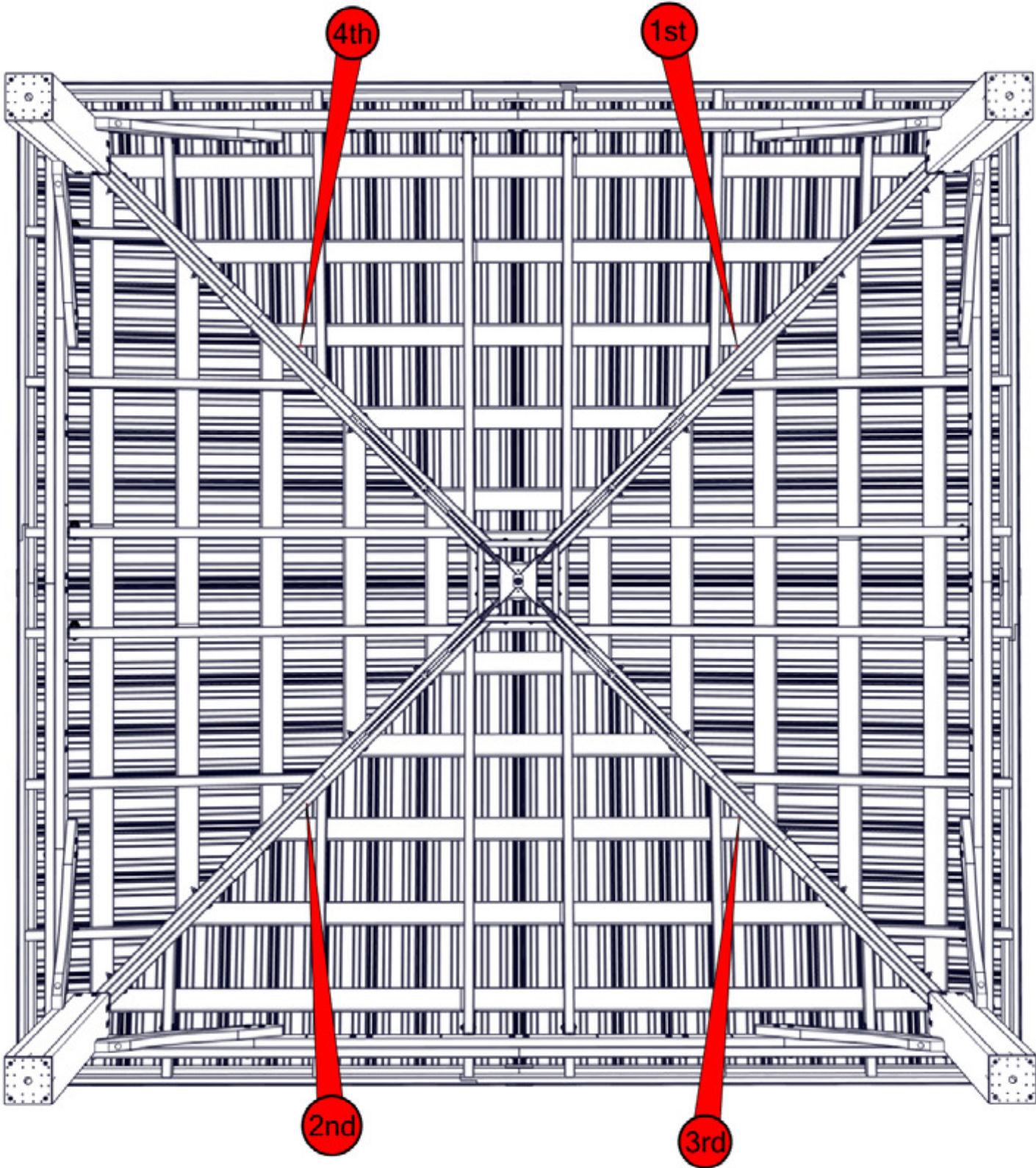



# STEP 44 - ROOF TRIM ASSEMBLY



A4M01228 - RAFTER CLIP-  
(x16)

QTY	PART NUMBER	DESCRIPTION
16	H100488	BOLT WH 1/4x2 BLK
32	H100536	SCREW PWH 8x1 1/4 BLK
16	H100630	WASHER FLAT 8x19 BLK
16	H100653	NUT LOCK 1/4 BLK

- ATTACH RAFTER CLIPS FIRST WITH 2" BOLTS
- USING THE BRACKET AS A TEMPLATE & A 1/8" DRILL BIT, DRILL PILOT HOLES FOR THE H100536 SCREWS.
- DRILL PILOT HOLES APPROXIMATELY 1/2" DEEP.

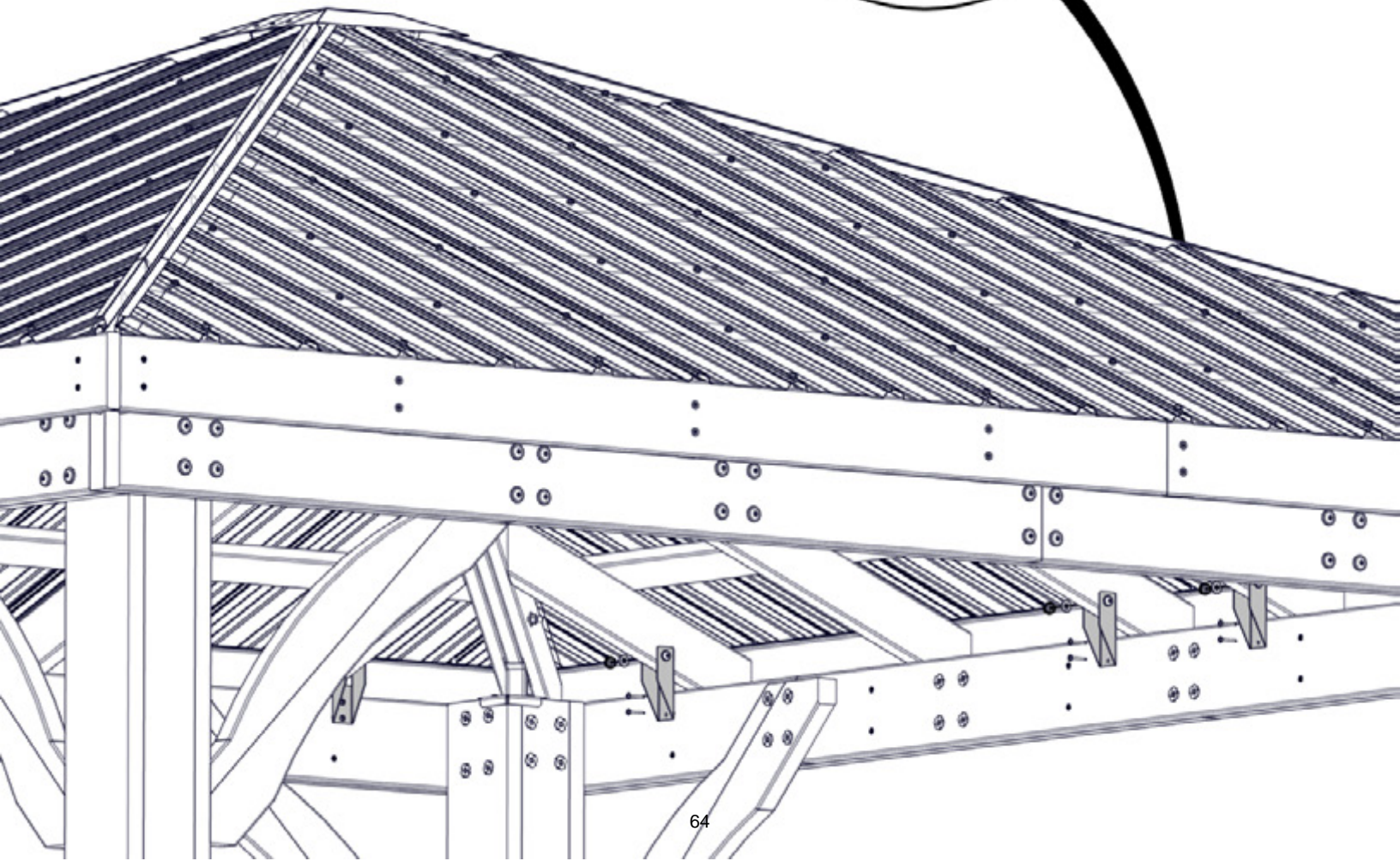
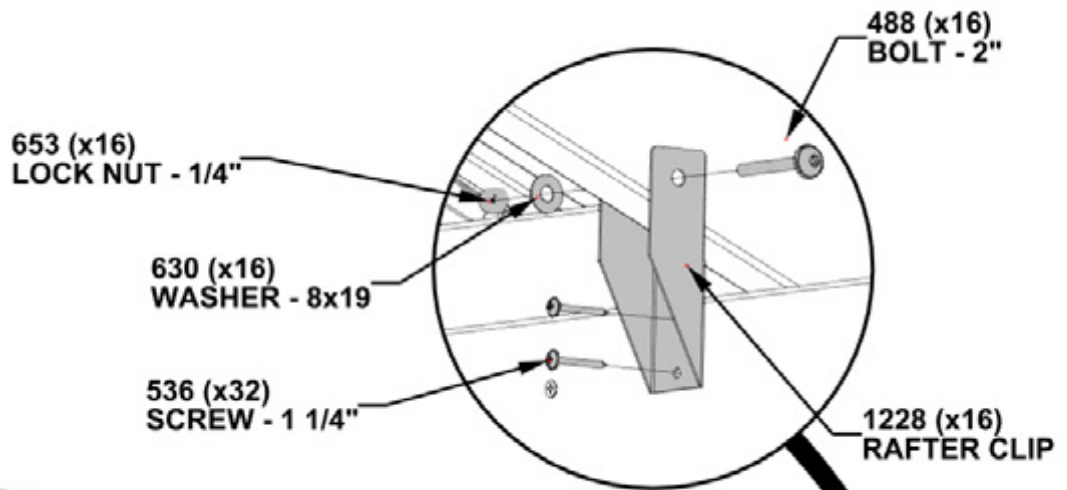



# STEP 45 - ROOF TRIM ASSEMBLY

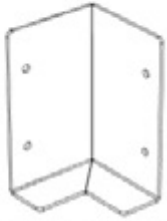

A4M01185 - CORNER BRACKET  
(x4)

QTY	PART NUMBER	DESCRIPTION
16	H100392	SCREW PWH 8x3/4 BLK

- USING THE CORNER BRACKETS AS A GUIDE & A 1/8" DRILL BIT, PREDRILL HOLES AT EACH BRACKET LOCATION

- REPEAT THIS STEP ON THE 3 REMAINING CORNERS

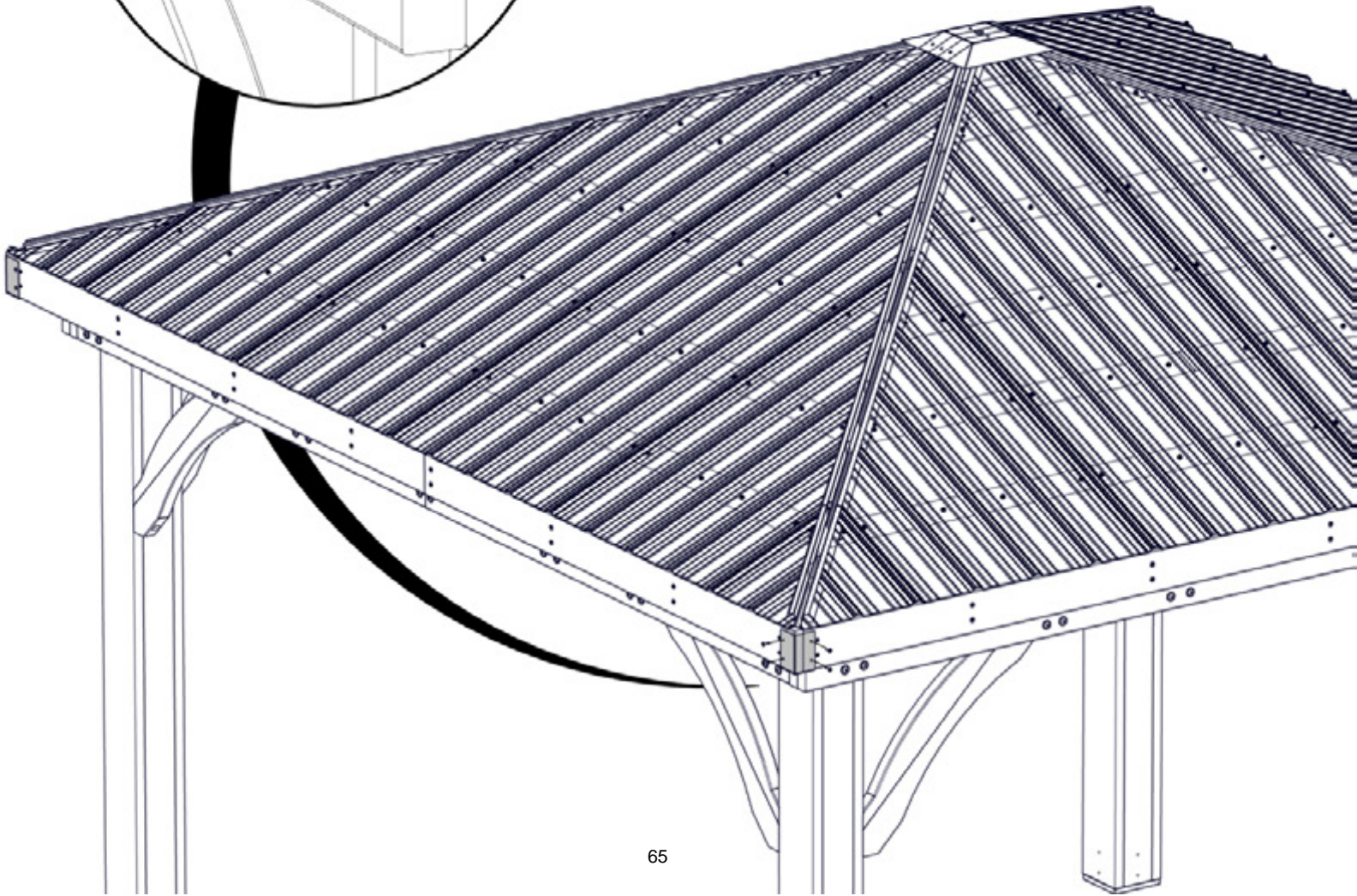
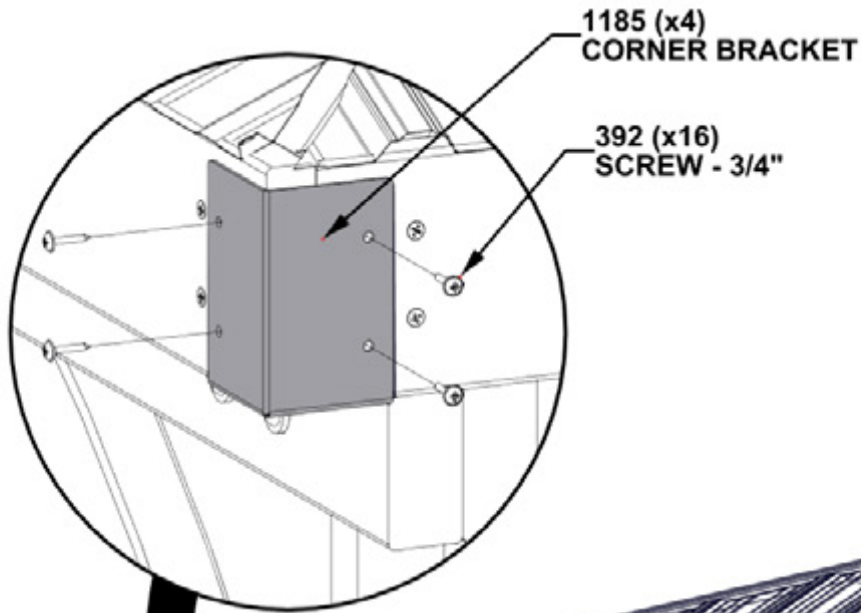



## STEP 46 - DRIP EDGE ASSEMBLY

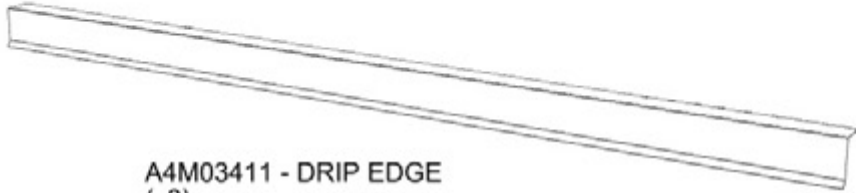

A4M03411 - DRIP EDGE  
(x8)

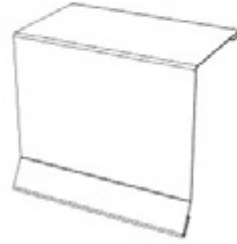

A4M03410 - DRIP EDGE SPLICE  
(x4)

- INSERT 1 DRIP EDGE INTO EACH SIDE OF THE SPLICE SO THEY MEET IN THE CENTER.
- INSERT THE DRIP EDGE ASSEMBLY UNDER THE ROOF SHEETING, AND ON TOP OF THE ROOF JOIST.
- SEE THE DETAIL BELOW

**- REPEAT THIS STEP FOR ALL 4 SIDES**

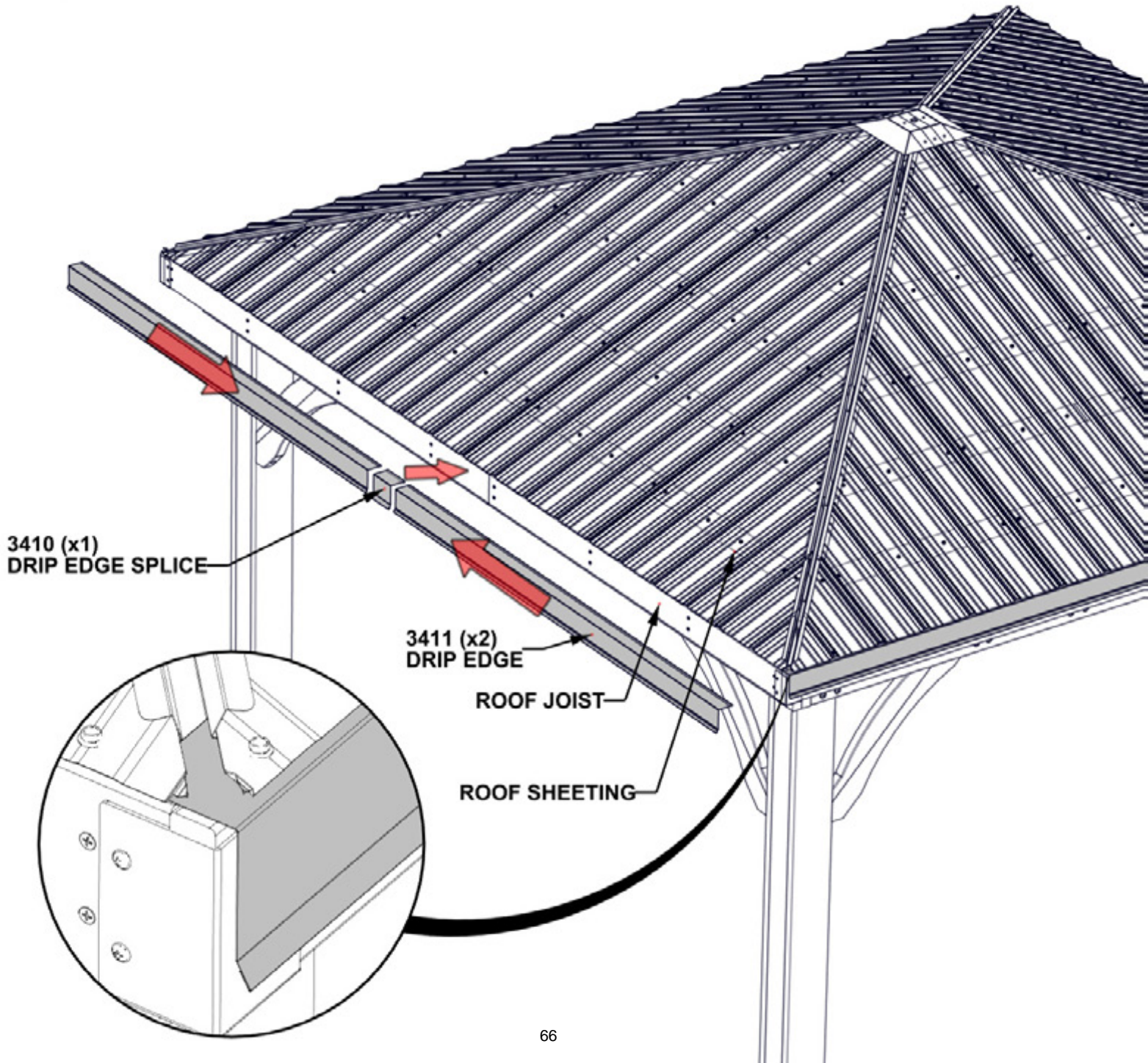



# STEP 47 - ROOF TRIM ASSEMBLY



A4M02821 - EDGE TRIM  
(x8)



A4M02825 - EDGE TRIM CORNER SPLICE -  
(x4)



A4M02822 - EDGE TRIM SPLICE -  
(x4)

QTY	PART NUMBER	DESCRIPTION
40	H100759	SCREW SELF TAPPING 1/4x1

- SLIDE EDGE TRIM PIECES INTO EACH SIDE OF THE EDGE TRIM SPLICE AND CORNER SPLICE.
- CENTER THE EDGE TRIM ASSEMBLY OVER THE EDGE OF THE ROOF.
- BE SURE ALL ROOF PANELS ARE COVERED BEFORE INSTALLING SCREWS.
- START SCREWS AT THE FIRST HIGH RIDGE OF THE ROOF SHEETING.
- BE SURE TO INSERT SCREWS THROUGH TRIM PIECES AND DRIP EDGE PIECES.
- PROCEED TO INSTALL A SCREW AT EVERY OTHER HIGH RIDGE (10 PER SIDE).

**REPEAT THIS STEP ON ALL 4 SIDES**

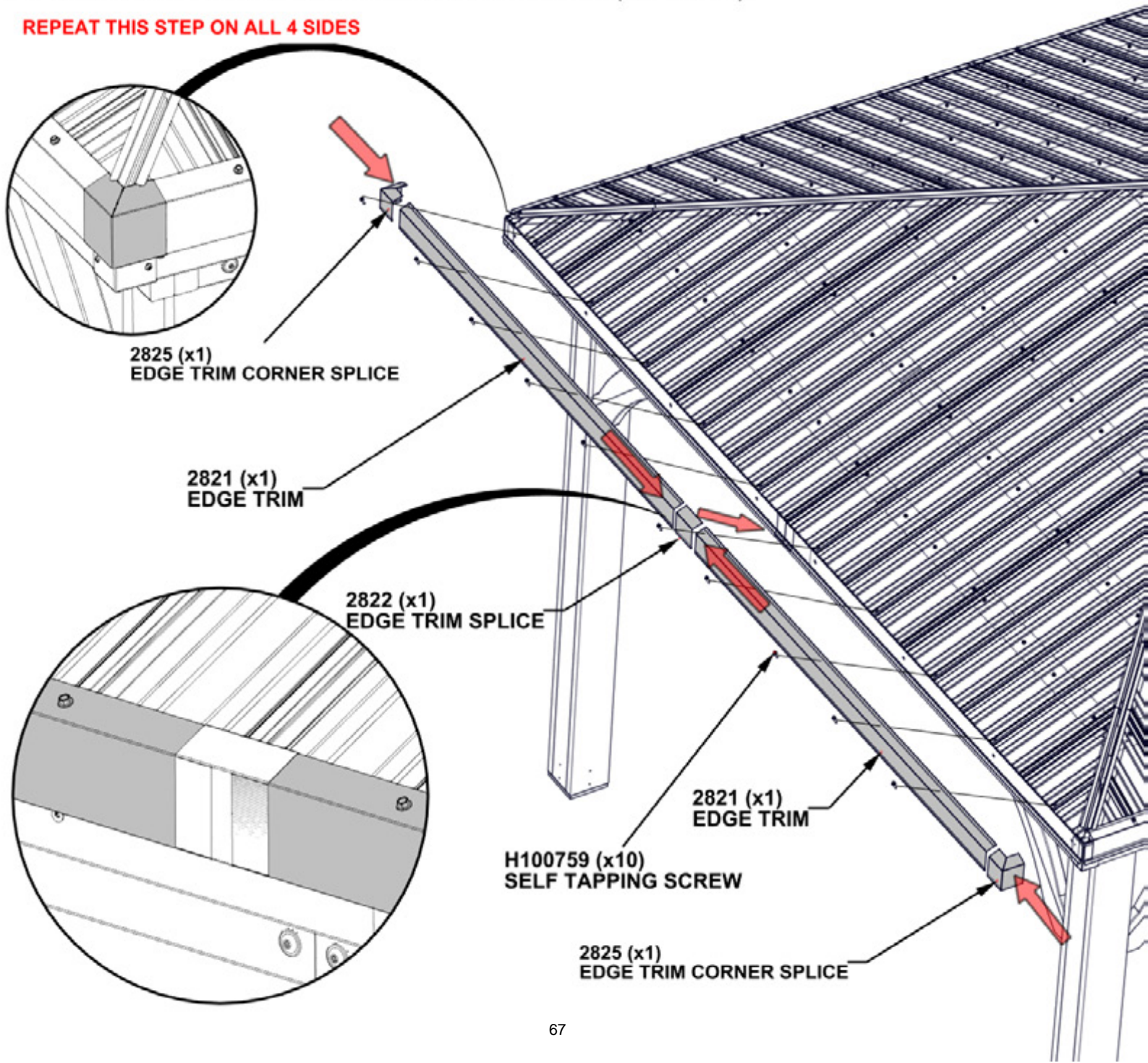



## STEP 48 - ROOF ASSEMBLY



A4M02826 - CORNER RIDGE CAP LONG  
(x4)

- SLIDE LONG CORNER RIDGE CAP ONTO ROOF RIDE CAP CHANNEL AS SHOWN.
- SLIDE THE END UNDER THE PEAK RIDGE CAP PLATE.
- THIS PIECE WILL BE SECURED INTO PLACE DURING THE NEXT STEP.
- IF NEEDED, THE PEAK RIDGE CAP CAN BE LOOSENED WITH THE EYE NUT TO MAKE ROOM FOR 248 RIDGE CAP.

**REPEAT THIS STEP FOR ALL 4 CORNERS**

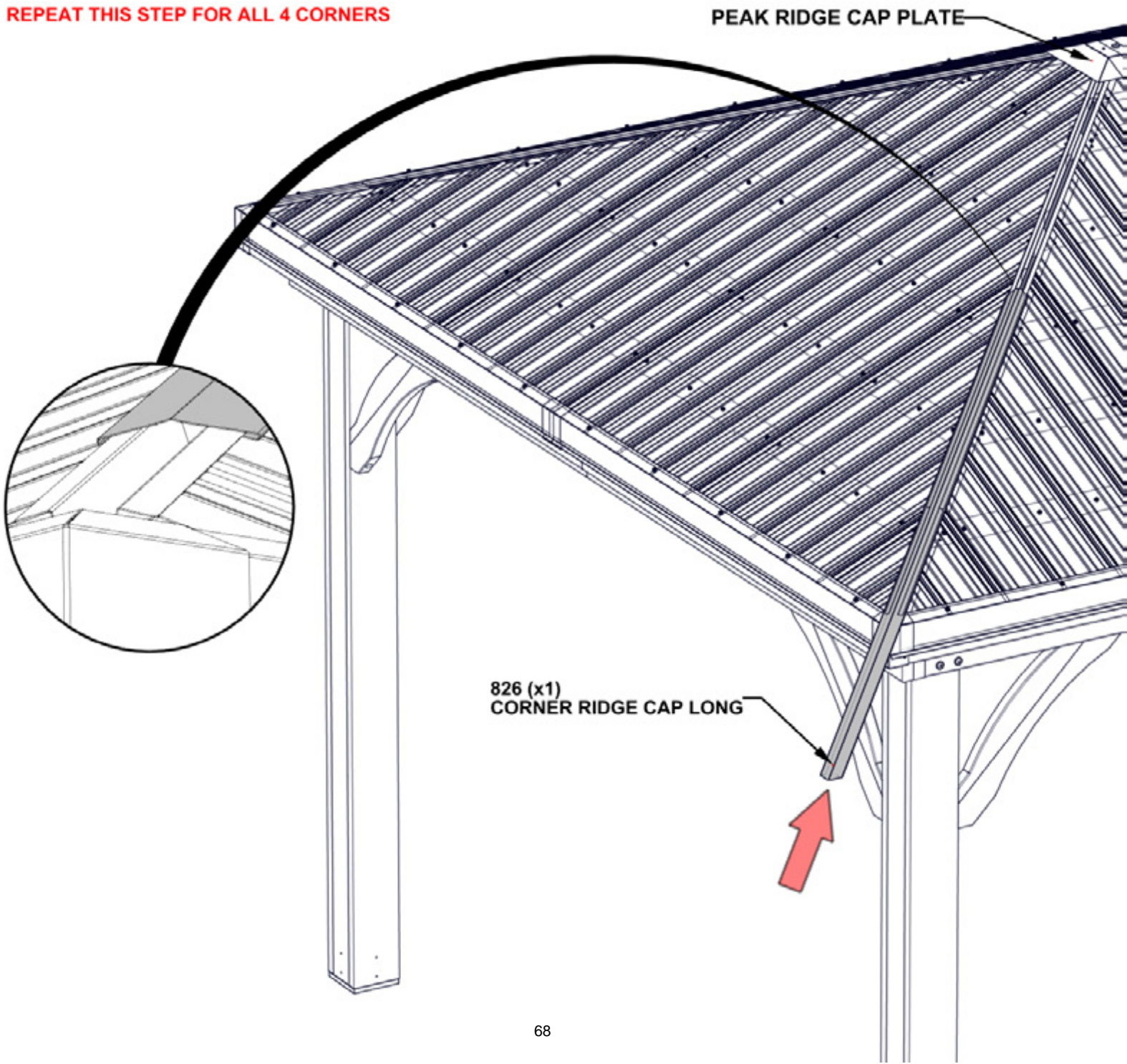

# STEP 49 - ROOF ASSEMBLY



CORNER RIDGE CAP SHORT - A4M02867  
(x4)

QTY	PART NUMBER	DESCRIPTION
12	H100759	SCREW SELF TAPPING 1/4x1

- SLIDE CORNER RIDGE CAP ONTO THE ROOF RIDGE CAP CHANNEL SAME AS (PREVIOUS STEP 48).
- SLIDE THE SHORT RIDGE CAP SPLICE OVER THE END OF THE LONG RIDGE CAP.
- SECURE THE CORNER RIDGE CAP WITH 2 SCREWS AS SHOWN.
- SECURE THE RIDGE CAP SPLICE WITH 1 SCREW THROUGH SPLICE AND LONG RIDGE CAP.

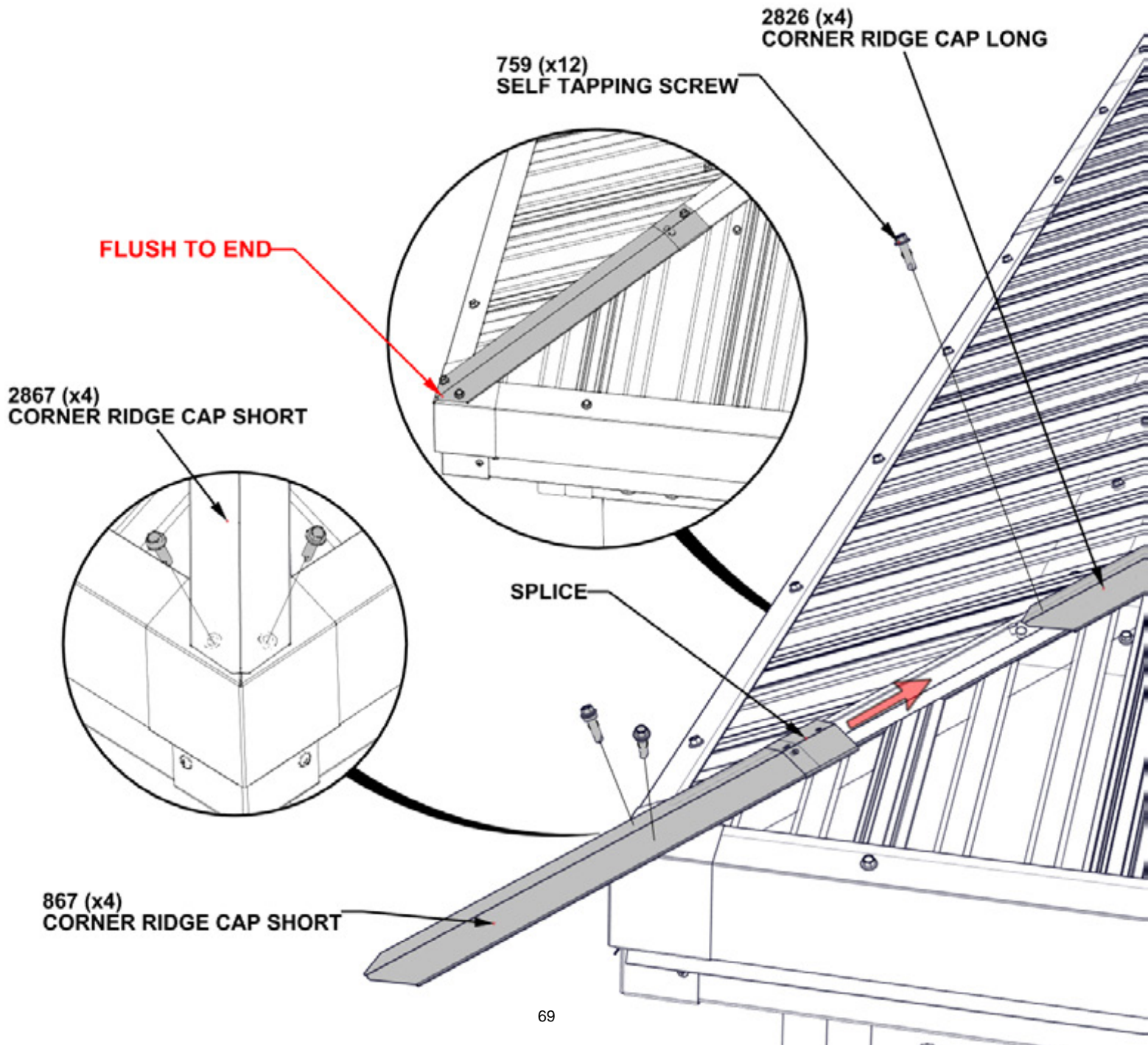



# STEP 50 - ANCHORING HARDWARE



A4M01793 - POST ANCHORING PLATE  
(x8)



A4M01794 - POST PLATE  
(x8)

QTY	PART NUMBER	DESCRIPTION
32	H100471	LAG SCREW WH 5/16x1 1/2 BLK

- ALIGN PLATE HOLES WITH POST PILOT HOLES
- ALL POST PLATES GO ON THE INSIDES OF THE POSTS AS SHOWN
- ALL POST ANCHORING PLATES GO ON THE OUTSIDE OF THE POSTS AS SHOWN

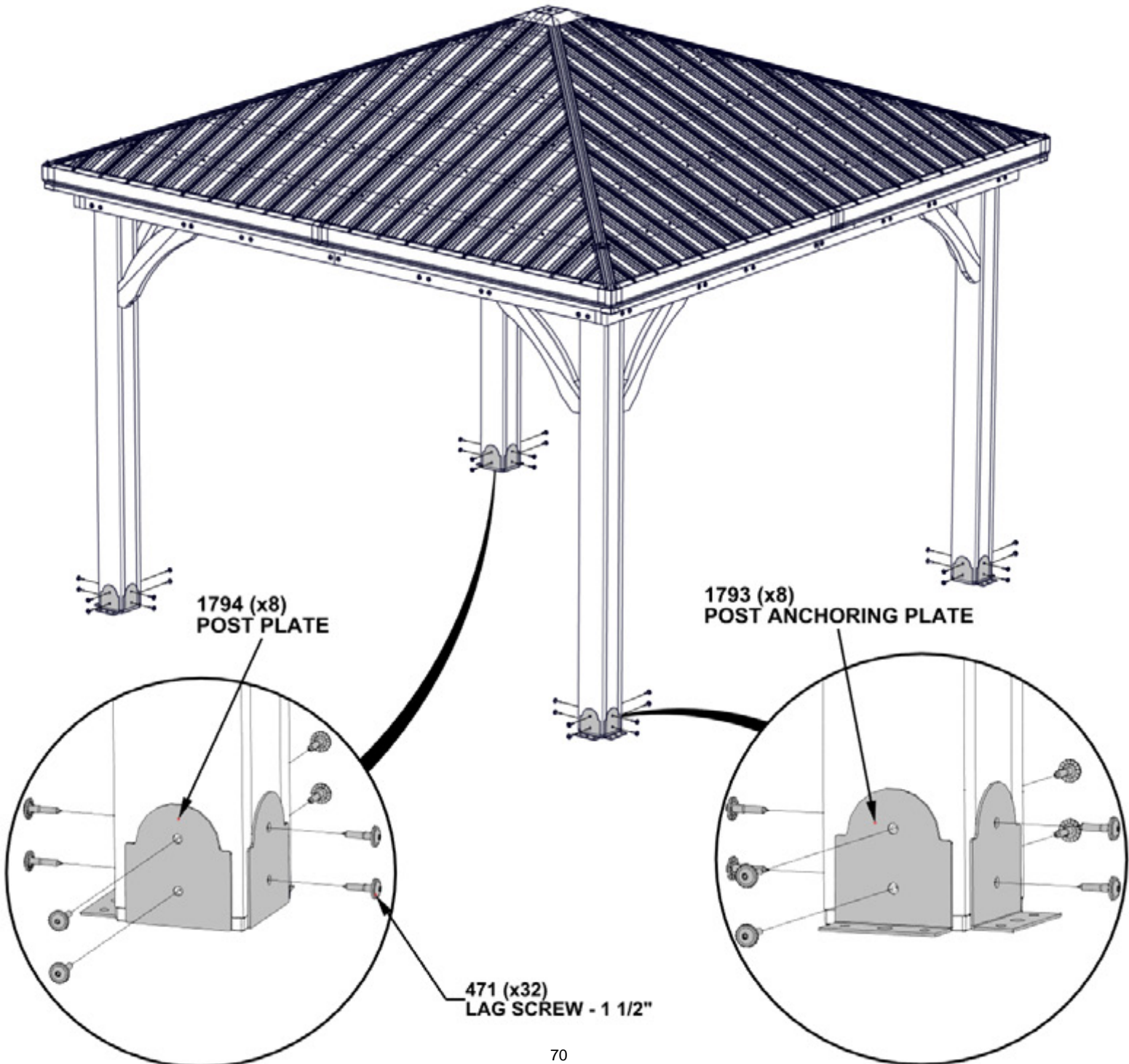

# STEP 51 - ID TAG ATTACHMENT



QTY	PART NUMBER	DESCRIPTION
4	H100387	SCREW PFH 8x1 1/4 BLK

A4M02158  
BYD ID TAG PATIO  
(x1)

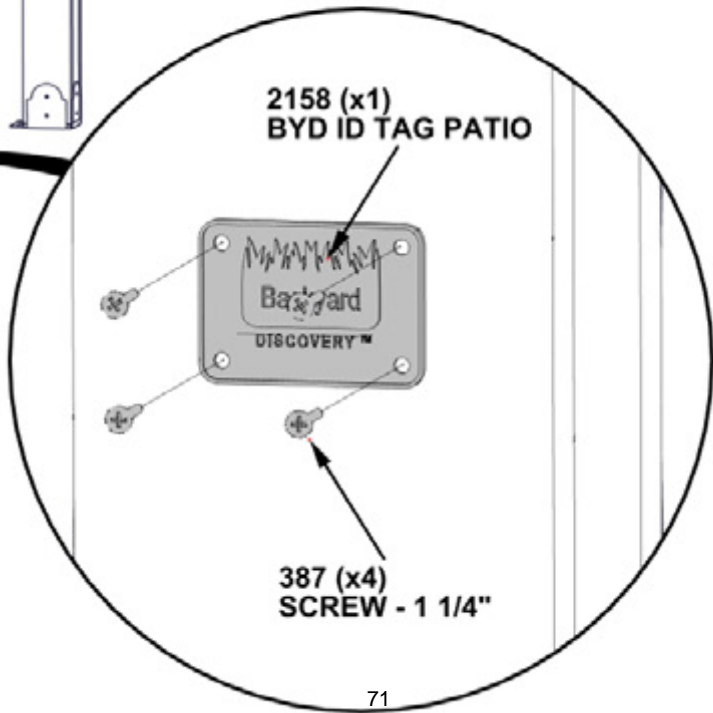
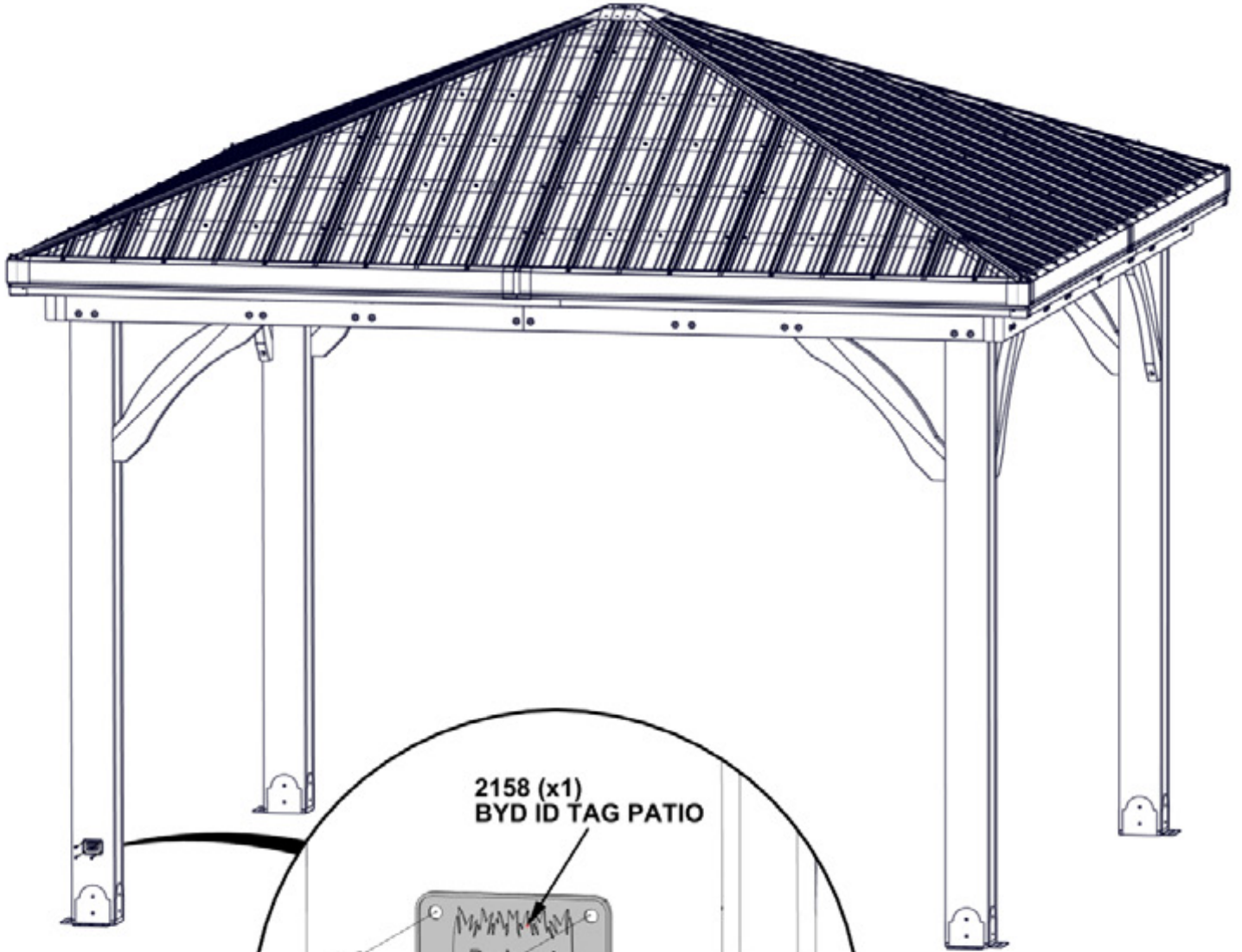

2158 (x1)  
BYD ID TAG PATIO

387 (x4)  
SCREW - 1 1/4"



## STEP 52 - ANCHORING

QTY	PART NUMBER	DESCRIPTION
16	H100120	CONCRETE ANCHOR 1/4"x2"
16	H100630	WASHER FLAT 8x19 BLK

- MANUFACTURER RECOMMENDS INSTALLATION ON CONCRETE SURFACE OR CONCRETE POST PADS AS SHOWN BELOW.
- FOR INSTALLATION ON A WOOD DECK, YOU MUST ENSURE THERE IS AMPLE STRUCTURAL SUPPORT UNDER DECK. HARDWARE NOT PROVIDED FOR DECK ATTACHMENT.

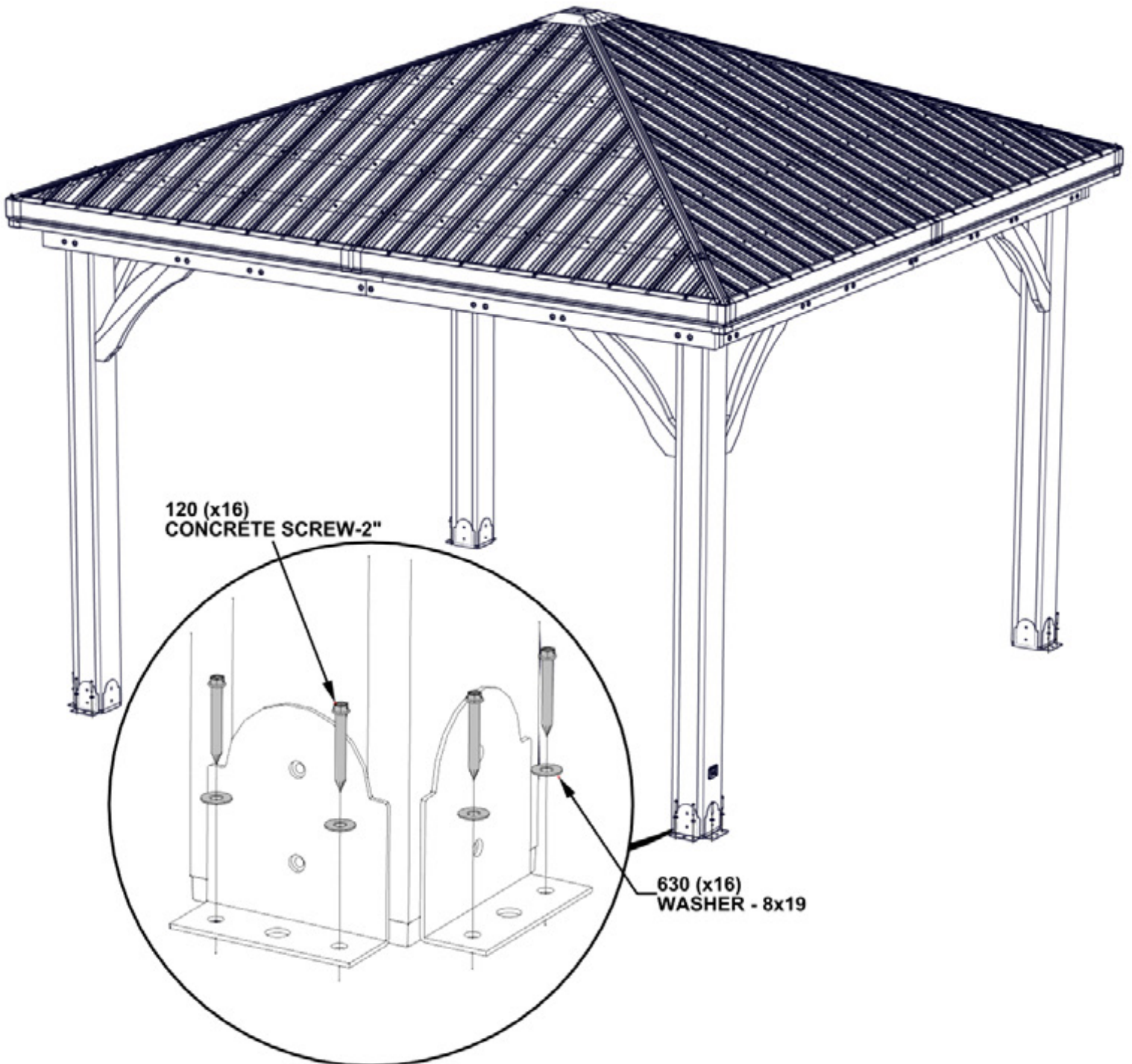

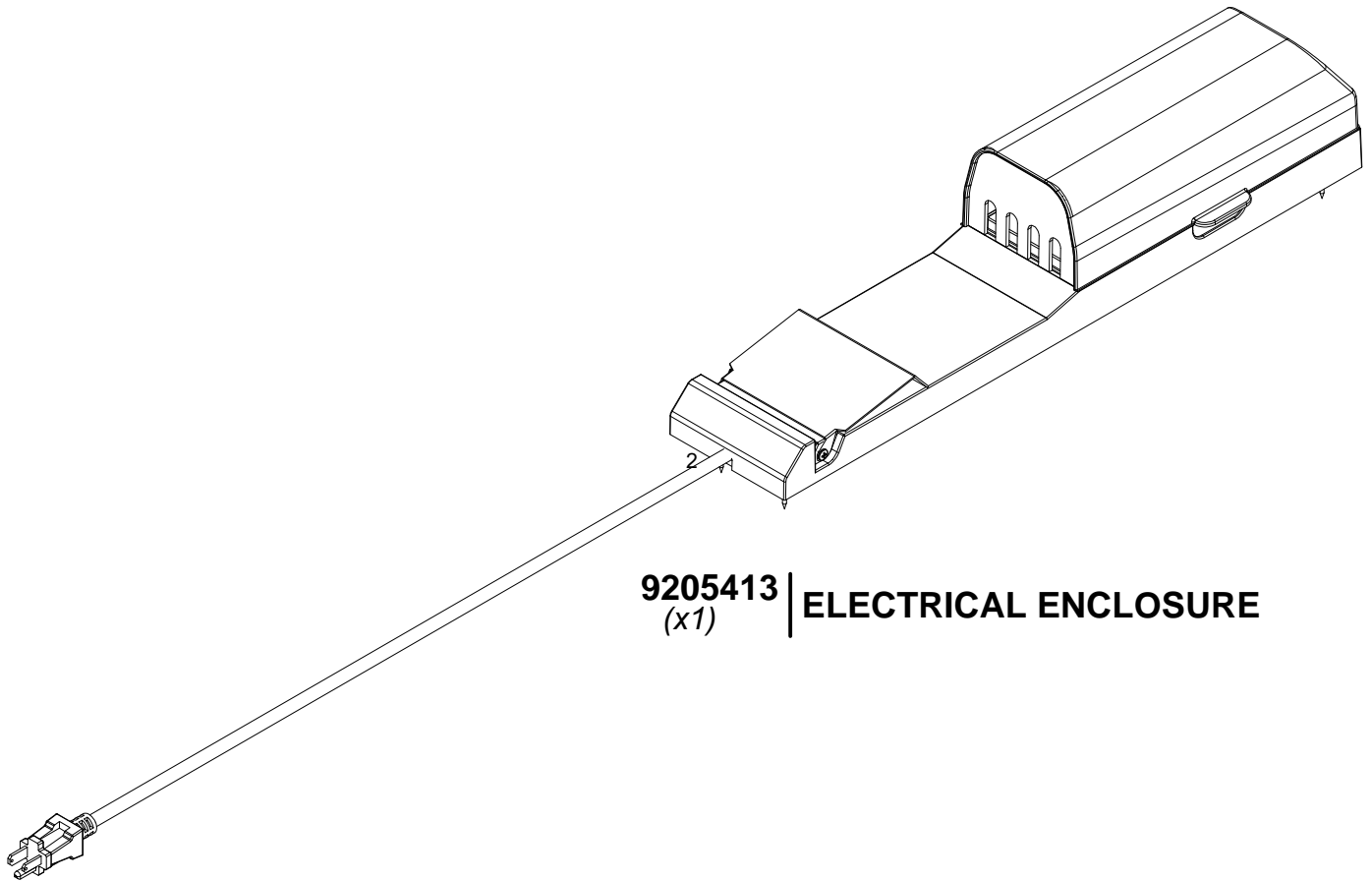

**9205413** | **ELECTRICAL ENCLOSURE**  
*(x1)*

FOR POWERPORT INSTALLATION REFER TO ASSEMBLY INSTRUCTIONS THAT COME PACKAGED WITH THE POWERPORT KIT. INSTALL ON ANY POST THAT IS DESIRED. FOLLOW DIRECTIONS FOR PROPER INSTALLATION.