



Manufactured by:
Backyard Discovery
3305 Airport Drive, Pittsburg, KS
66762 800-856-4445

Basepoint Business Centre: Rivermead Drive, Westlea, Swindon SN5 7EX Phone: 0800-118-2476
J.P. Coenstraat 7, The Hague, 2595 WP, Netherlands Phone: 08005678990

WAGGIN' RETREAT DOG KENNEL

MODEL # : 2308015



Please visit www.backyarddiscovery.com
For the most up to date assembly manual, to register your product, or to order
replacement parts *Para obtener instrucciones en español, visite*
www.backyarddiscovery.com



EASY STEP-BY-STEP
3D INTERACTIVE INSTRUCTIONS
DOWNLOAD THE FREE APP



OWNER'S MANUAL - BASIC SETUP DIMENSIONS & ASSEMBLY NOTES

It is critically important that you start with a square and level surface. A concrete pad is recommended to avoid digging and for easy cleaning.

- Pay close attention to items needed for each step and make sure you are using the correct hardware. Incorrect hardware may result in improper assembly.
- Double check for underground utilities and overhead lines.
- While determining location, keep in mind the kennel door position is customizable. See "Choosing a Door Location" in this manual.
- Before building, make sure your location is not too exposed to wind and direct sun.
- Waggin' Retreat is recommended for small to medium sized dogs.
- Post mounts are provided with your structure which allows you to permanently install your structure to a concrete or dirt surface. See Anchor Instructions for further details and recommendations.

Consider the breed and individual needs of your dog before leaving them outside in hot or cold weather for long periods of time.

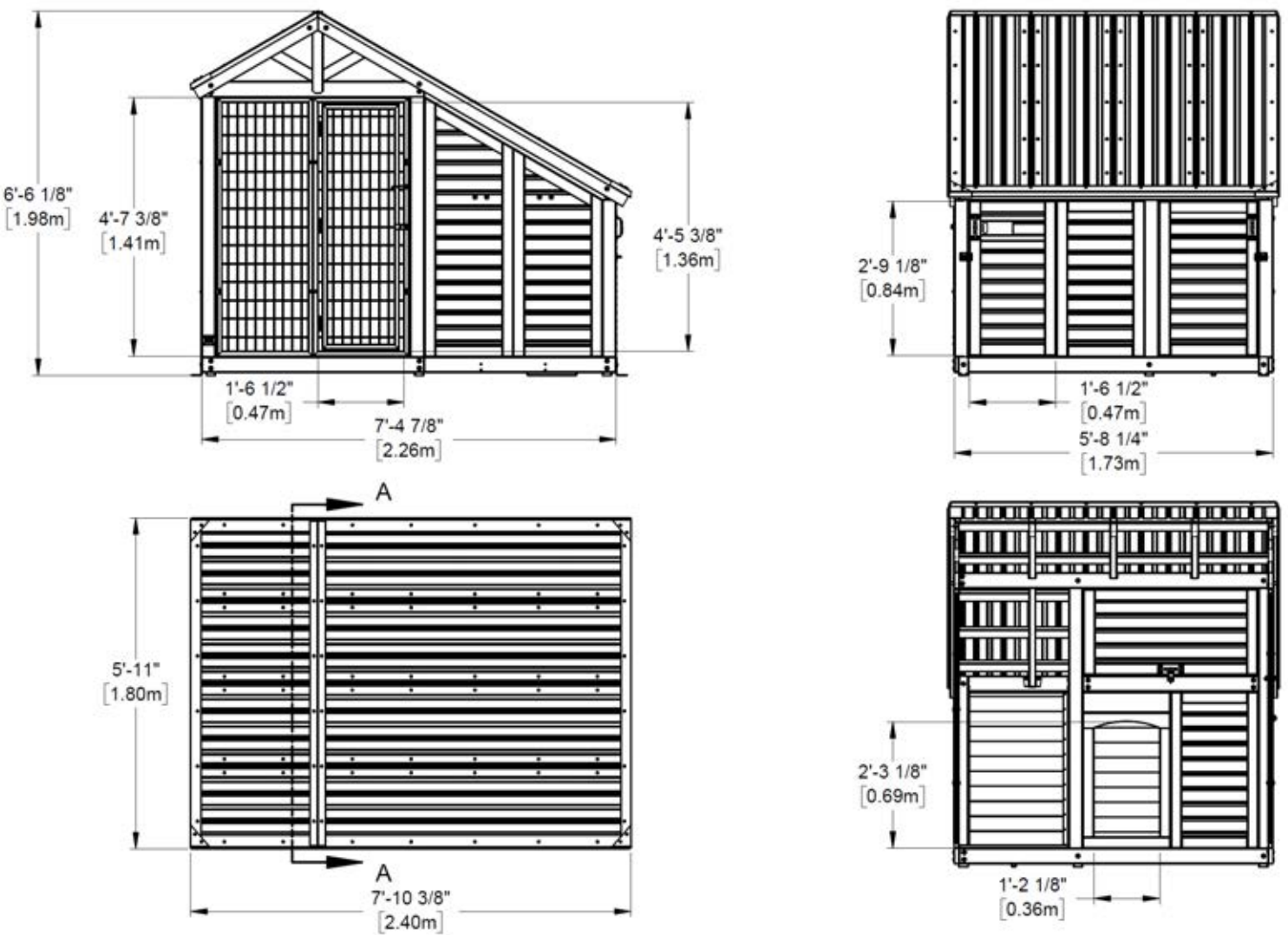

OWNER'S MANUAL - ANCHORING LAYOUT

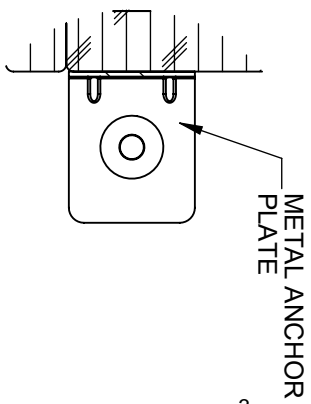
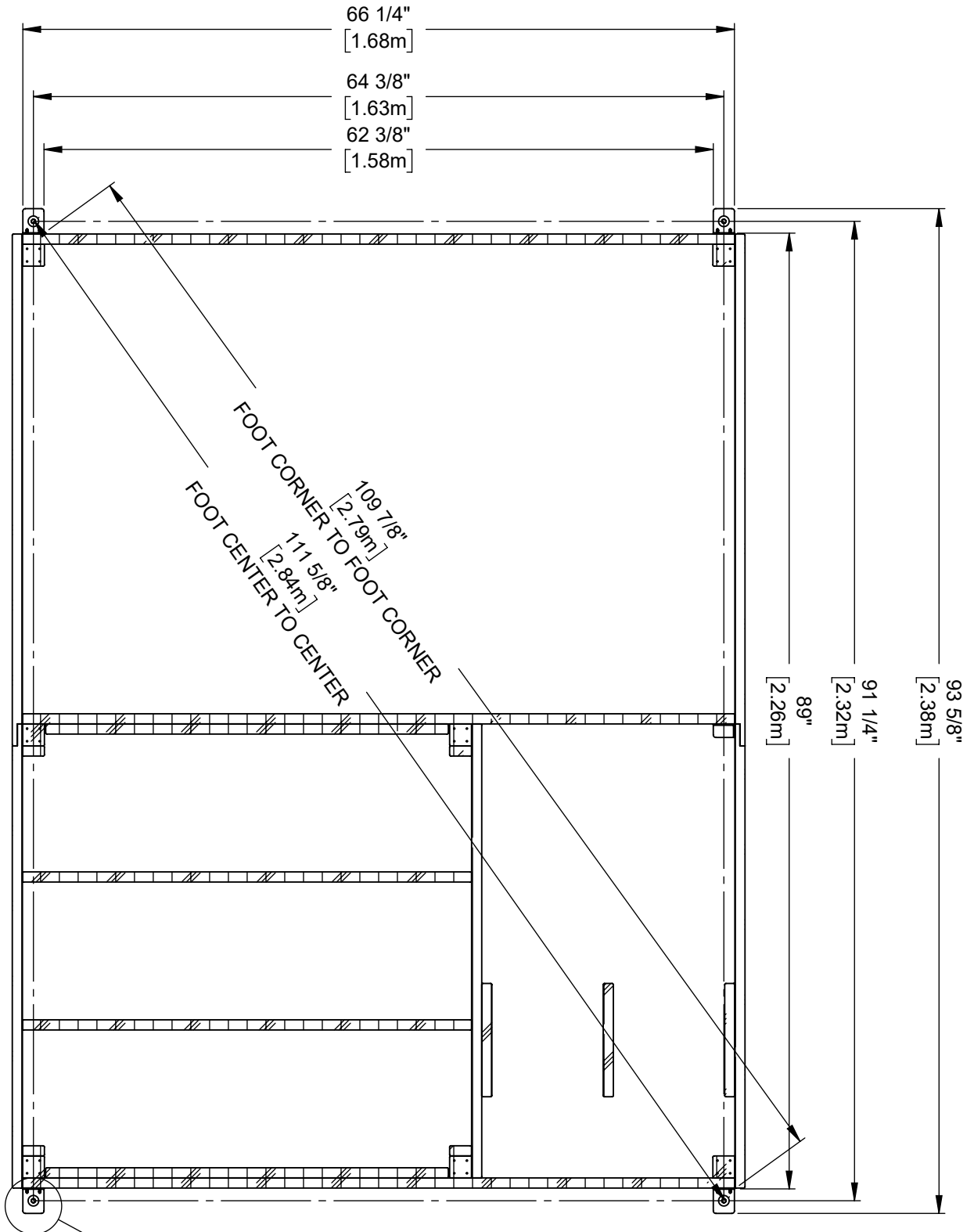

OWNER'S MANUAL - SITE LOCATION AND PREPARATION

- A. Check your local building and city codes for permit requirements or restrictions, including any HOA restrictions.
- B. Select a location with good drainage, and the ability to create a level firm surface for your dog kennel.
 - A firm, level surface is critically important to the longevity of your dog kennel.
 - Ensure it is accessible on all sides to clean and conduct annual maintenance
 - Make sure site drains well and avoid low lying areas.
 - Recommended area for site preparation of the Waggin' Retreat Dog Kennel is 9'-10 3/8" x 7'-11" x 6' 6" (3008mm x 2414mm x 1981mm).
- C. Before preparing your surface – double check for possibility of any underground utilities (example: gas, cable, or sprinkler lines)
 - Remove any grass, dirt, landscaping to create a level, hard-packed surface
 - This may involve some digging to create a level spot, dependent on your site location.
- D. Determine your preferred site pad materials for your dog kennel
 - It is NOT recommended to put the dog kennel directly on soil or grass. This will shorten the lifespan of your kennel.
 - Site pad options include gravel, or concrete surface.
 - Anchors are included for either natural surface, such as gravel, or for a concrete foundation.
 - Manufacturer recommends installation on concrete surface.

Owner's Manual - Parts Identification

Wood Components (Not to Scale)



B1 POST - W4L19156
(x1) 3"X3"X62 7/16" (76x76x1586)

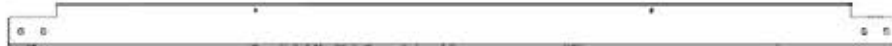

B2 POST - W4L19158
(x1) 3"X3"X62 7/16" (76x76x1586)



B3 POST - W4L19161
(x1) 3"X3"X62 7/16" (76x76x1586)



B4 POST - W4L19164
(x1) 3"X3"X40 5/16" (76x76x1024)



B5 POST - W4L19167
(1x) 3"X3"X40 5/16" (76x76x1024)



B6 POST - W4L19172
(x1) 3"X3"X62 7/16" (76x76x1586)



B7 POST - W4L19460
(x1) 3"X3"X40 5/16" (76x76x1024)



E1 RAFTER - W4L19467
(x3) 1 7/16"x3 3/8"x28 1/4" (36x86x716)

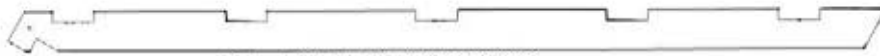

E2 RAFTER - W4L19468
(x2) 1 7/16"x3 3/8"x73 1/8" (36x86x1857)

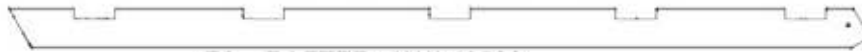

E3 RAFTER - W4L19529
(x1) 1 7/16"x3 3/8"x73 1/8" (36x86x1857)



H1 TOP BOARD - W4L19157
(x1) 15/16"X3 3/8"X66 3/8" (24x86x1686)

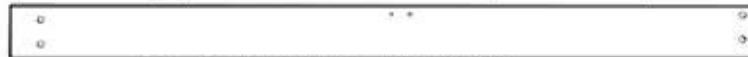

H2 TOP BOARD - W4L19159
(x1) 15/16"X3 3/8"X47 11/16" (24x86x1211)



H3 GROUNDBOARD - W4L19160
(x1) 15/16"X3 3/8"X47 11/16" (24x86x1211)

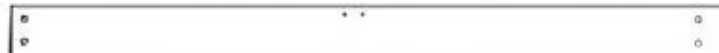

H4 TOP BOARD - W4L19162
(x1) 15/16"X3 3/8"X47 11/16" (24x86x1211)

Owner's Manual - Parts Identification

Wood Components (Not to Scale)



H5 TOP BOARD - W4L19163
(x1) 15/16"X3 3/8"X50 3/16" (24x86x1275)

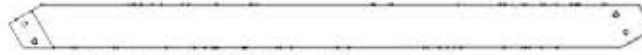

H6 TOP BOARD - W4L19165
(x1) 15/16"X3 3/8"X50 3/16" (24x86x1275)



H7 GROUNDBOARD - W4L19166
(x1) 15/16"X3 3/8"X47 11/16" (24x86x1211)



H8 GROUNDBOARD - W4L19168
(x1) 15/16"X3 3/8"X43 1/4" (24x86x1098)



H9 GROUNDBOARD - W4L19169
(x1) 15/16"X3 3/8"X43 1/4" (24x86x1098)



H10 GROUNDBOARD - W4L19170
(x1) 15/16"X3 3/8"X66 3/8" (24x86x1686)



H11 GROUNDBOARD - W4L19171
(x1) 15/16"X3 3/8"X42 5/16" (24x86x1074)



H12 GROUNDBOARD - W4L19173
(x1) 15/16"X3 3/8"X66 3/8" (24x86x1686)



H13 TOP BOARD - W4L19174
(x1) 15/16"X3 3/8"X49 3/8" (24x86x1254)



H14 FLOOR BOARD - W4L19178
(x11) 15/16"X3 3/8"X42 3/16" (24x86x1072)



H15 WALL BOARD - W4L19180
(x1) 15/16"X3 3/8"X37 3/4" (24x86x959)



M4 FLOOR BOARD - W4L19456
(x5) 5/8"x3 3/8"x42 3/16" (16x86x1072)

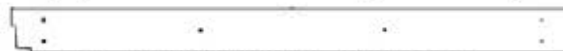

M1 FLOORBOARD - W4L19457
(x2) 5/8"x3 3/8"x42 3/16" (16x86x1072)

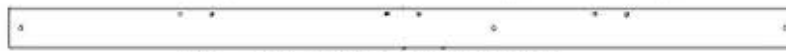

H18 TOP BOARD - W4L19459
(x1) 15/16"X3 3/8"X66 3/8" (24x86x1686)



H19 TOP BOARD - W4L19461
(x1) 15/16"X3 3/8"X66 3/8" (24x86x1686)

Owner's Manual - Parts Identification

Wood Components (Not to Scale)



H20 FASCIA BOARD - W4L19463
(x1) 15/16"x3 3/8"x31 5/16" (24x86x795)



H21 FASCIA BOARD - W4L19464
(x1) 15/16"x3 3/8"x77 3/8" (24x86x1966)



H22 RIDGE BEAM - W4L19466
(x2) 15/16"x3 3/8"x68 1/4" (24x86x1734)



M2 FLOOR BOARD - W4L19469
(x1) 5/8"x3 3/8"x40 3/16" (16x86x1021)



M3 FLOOR BOARD - W4L19470
(x3) 5/8"x3 3/8"x40 3/16" (16x86x1021)



H25 FASCIA BOARD - W4L19522
(x1) 15/16"x3 3/8"x31 5/16" (24x86x795)



H26 FASCIA BOARD - W4L19523
(x1) 15/16"x3 3/8"x77 3/8" (24x86x1966)



H27 SHEATHING BOARD - W4L19524
(x7) 15/16"x3 3/8"x68 1/4" (24x86x1734)



H28 DOG BOWL CLEAT - W4L19525
(x2) 15/16"x3 3/8"x10 9/16" (24x86x268)



AD01 DOG BOWL CLEAT - W4L19526
(x1) 15/16"x4"x10 9/16" (24x102x268)

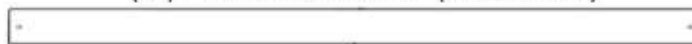

H30 GROUNDBOARD - W4L19530
(x1) 15/16"x3 3/8"x66 3/8" (24x86x1686)



J1 FLOOR JOIST - W4L19175
(x2) 15/16"x2 3/8"x37 1/2" (24x60x953)



J2 FLOOR JOIST - W4L19176
(x2) 15/16"x2 3/8"x41 7/8" (24x60x1063)



J3 FLOOR BOARD - W4L19177
(x2) 15/16"x2 1/16"x38 1/8" (24x52x968)



J4 FLOOR CLEAT - W4L19179
(x4) 15/16"x2 1/16"x2 3/8" (24x52x60)

Owner's Manual - Parts Identification

Wood Components (Not to Scale)



J5 FLOOR JOIST - W4L19454
(x2) 15/16"X2 3/8"X41 9/16" (24x60x1055)



J6 FLOOR JOIST - W4L19455
(x2) 15/16"X2 3/8"X41 9/16" (24x60x1055)

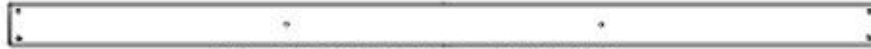

N2 FLOOR BOARD - W4L19458
(x2) 5/8"x1 7/8"x38 1/8" (16x48x968)



J8 GABLE BOARD - W4L19462
(x2) 15/16"X2 3/8"X13 7/16" (24x60x341)



J9 GABLE BOARD - W4L19465
(x4) 15/16"X2 3/8"X12 5/8" (24x60x320)



J10 CLEAT - W4L19527
(x1) 15/16"x2 3/8" X6 7/8" (24x60x175)



S1 CLEAT - W4L19521
(x4) 15/16"x15/16"x17 11/16" (24x24x450)

Owner's Manual - Parts Identification

Wood Components (Not to Scale)

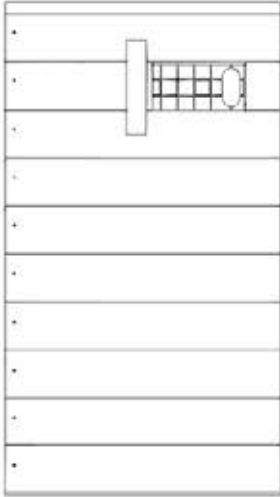

DP1 DOG HOUSE DOOR - W2A04051
(x1) 1 1/4"X18 7/16"X33 1/16" (32x469x840)

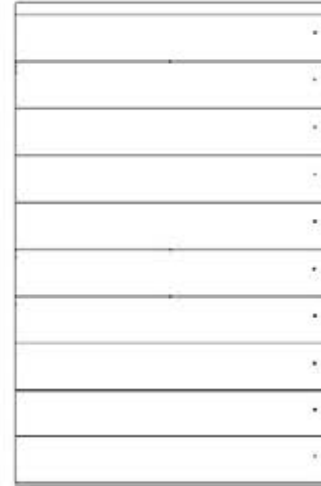

DP2 DOOR PANEL - W2A04052
(x1) 1 1/16"X21 1/16"X33 1/16" (27x535x840)



DP3 STORAGE DOOR - W2A04053
(x1) 1 1/16"X18 1/4"X37 5/16" (27x464x947)

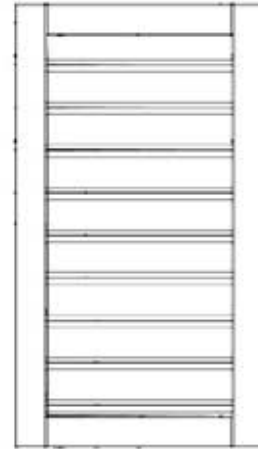

WP1 WALL PANEL - W2A04044
(x1) 1 1/16"X18 3/4"X33 1/2" (27x477x850)

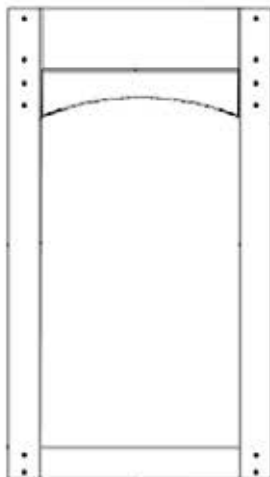

WP2 DOOR FRAME - W2A04045
(x1) 1 7/16"X18 13/16"X29 1/16" (36x478x738)



WP3 WALL PANEL - W2A04046
(x1) 1 1/16"X19 1/16"X55 5/8" (27x484x1412)

Owner's Manual - Parts Identification

Wood Components (Not to Scale)



WP4 WALL PANEL - W2A04047
(x1) 1 1/16"X19 1/16"X44 9/16" (27x484x1133)

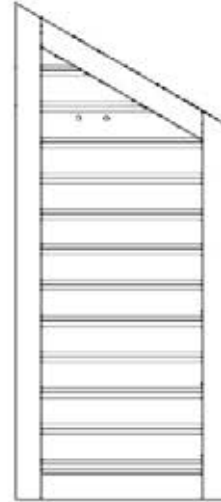

WP5 WALL PANEL - W2A04048
(x1) 1 1/16"X19 1/16"X55 5/8" (27x484x1412)

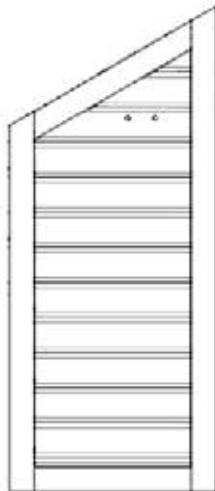

WP6 WALL PANEL - W2A04049
(x1) 1 1/16"X19 1/16"X44 9/16" (27x484x1133)

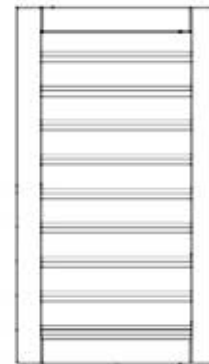

WP7 WALL PANEL - W2A04050
(x1) 1 1/16"X18 3/4"X33 1/2" (27x477x850)

Owner's Manual - Parts Identification

Accessory Components (Not to Scale)



MP01 METAL PANEL - A4M02614
(x6) 1 1/16"X20 1/2"X58 9/16" (27.4x520x1488)

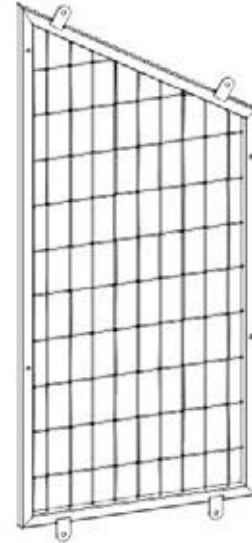

MP02 METAL PANEL - A4M02618
(x1) 1 1/16"X20 1/2"X46 15/16" (27x520x1192)

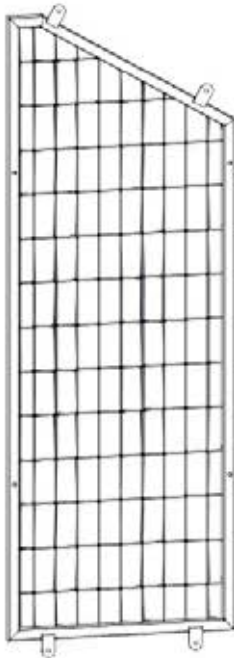

MP03 METAL PANEL - A4M02617
(x1) 1 1/16"X20 1/2"X57 15/16" (27.4x520x1472)

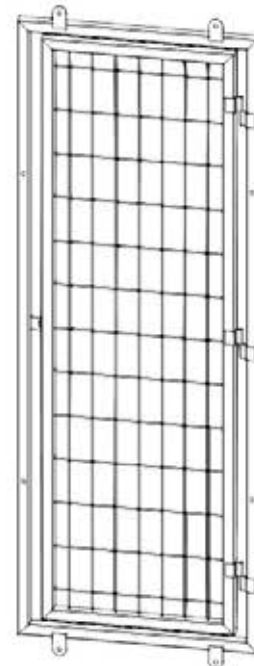

MP04 METAL DOOR PANEL ASSEMBLY - A4M02619
(x1) 1 1/16"X20 1/2"X58 9/16" (27x520x1488)

Owner's Manual - Parts Identification

Accessory Components (Not to Scale)

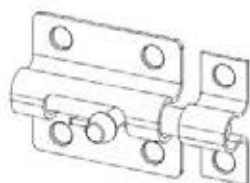

A100266 DEAD BOLT
(x2)

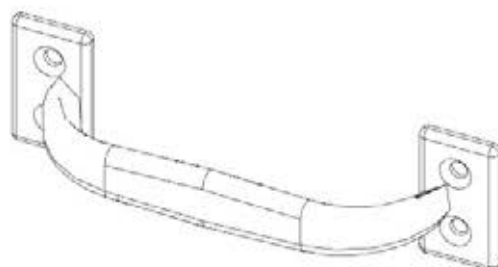

A4M00559 PULL HANDLE
(x3)

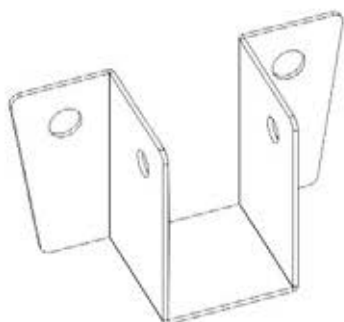

A4M01787 RAFTER BRACKET
(x6)

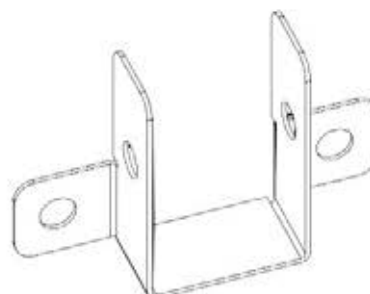

A4M01148 TRUSS BRACKET
(x2)

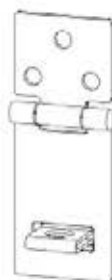

A4M02627 HASP LOCK
(x1)



A4M00997 METAL CLEAT
(x10)



A4M02616 METAL PANEL FLAT BRACKET
(x12)

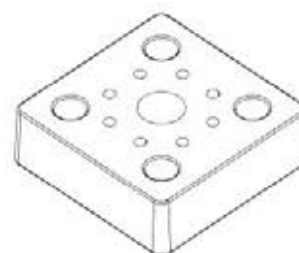

A6P00651 2x2 POST FOOT
(x7)

Owner's Manual - Parts Identification

Accessory Components (Not to Scale)



A4M02726 HINGE 832mm
(x2)

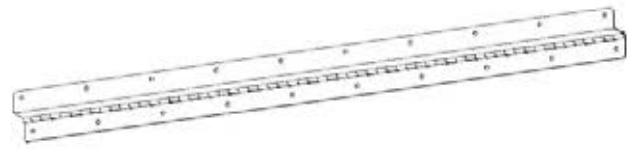

A4M02289 HINGE 832mm
(x1)

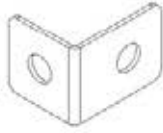

A4M02615 METAL PANEL BRACKET
(x12)

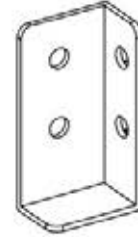

A4M02633 BRACKET FOOT
(x1)

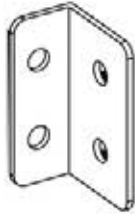

A4M00855 L BRACKET 51x32x82x3.175
(x3)

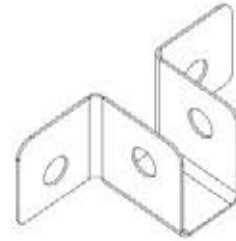

A4M02606 JOIST HANGER 90°
(x4)

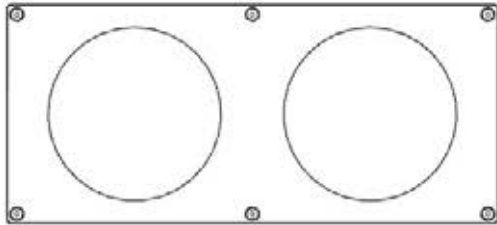

A6P00678 DOG BOWL FRAME
(x1)



A4M02632 METAL STRAP 118mm
(x2)



A4M02622 29 GA SHEETING
(x2)



A4M02623 29 GA SHEETING
(x2)

Owner's Manual - Parts Identification

Accessory Components (Not to Scale)



A4M02620 29 GA SHEETING
(x2)

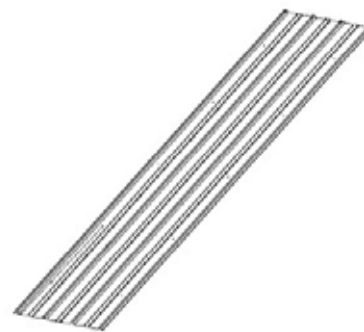

A4M02621 29 GA SHEETING
(x2)



A4M02630 ROOF EDGE TRIM
(x1)



A4M02631 ROOF EDGE TRIM
(x1)

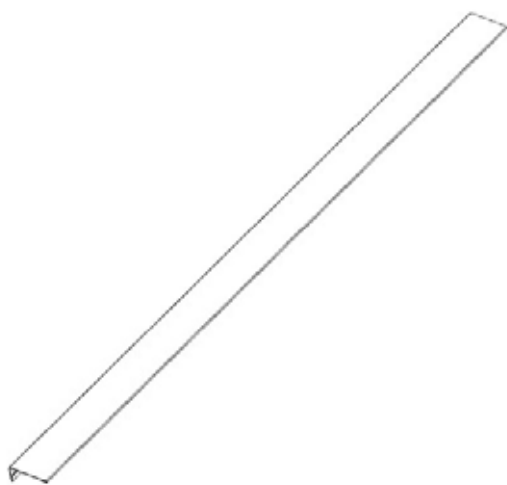

A4M02628 ROOF EDGE TRIM
(x1)

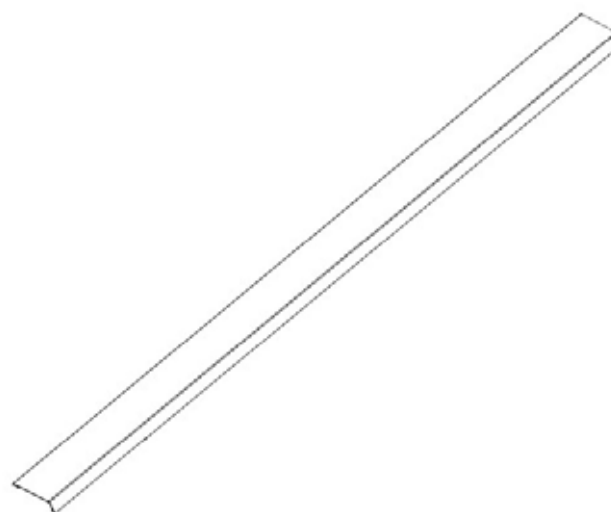

A4M02629 ROOF EDGE TRIM
(x1)

Owner's Manual - Parts Identification

Accessory Components (Not to Scale)

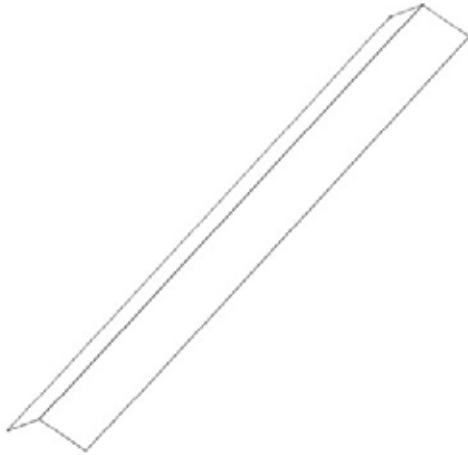

A4M02624 RIDGE CAP
(x1)

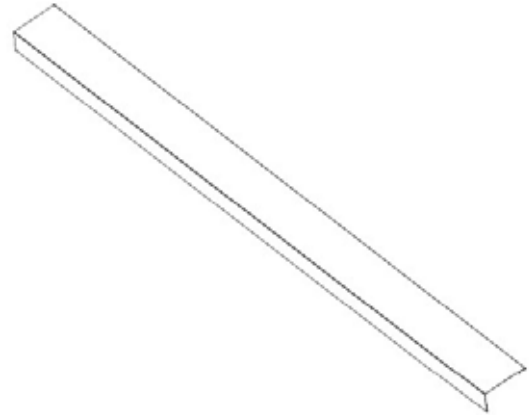

A4M02625 ROOF EDGE TRIM
(x2)

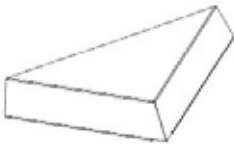

A4M02696 CORNER CAP
(x4)



A4M02941 ANCHORING BRACKET
(x4)

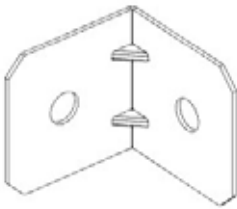

A4M01785 ANGLE BRACKET
(x37)

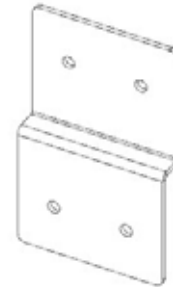

A4M01846 Z TIE BRACKET
(x2)

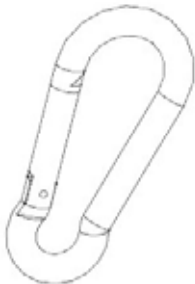

A4M02971 CARABINER
(x2)



A4M02158 BYD ID TAG PATIO
(x1)

Owner's Manual - Parts Identification

Accessory Components (Not to Scale)

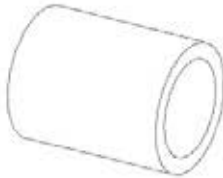

A6P00964 A6P00964
(x2)

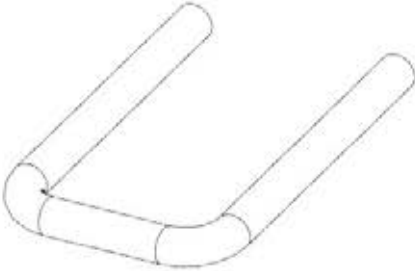

A4M03140 U-BAR
(x1)



A4M02091 GROUND STAKE
(x4)



A4M03459 SWING HOOK LATCH
(x1)

Owner's Manual - Parts Identification

Hardware Components

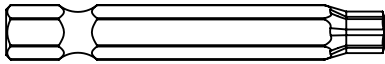

H100147 | TORX BIT
(x1) T-30

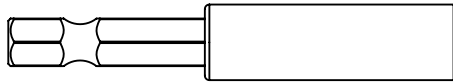

H101100 | MAGNETIC DRIVER
(x1)

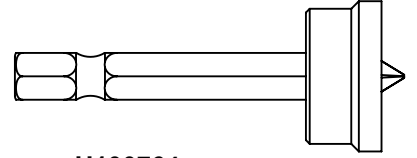

H100764 | SCREW SETTER
(x1)

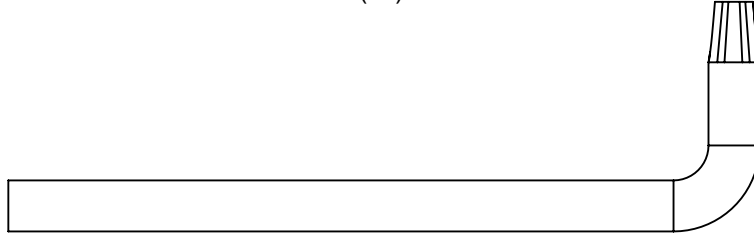

H100114 | TORX WRENCH
(x1) T-30

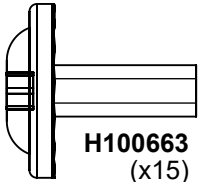

H100663 | BOLT WH BLK
(x15) | 5/16 x 3/4

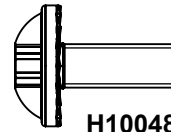

H100486 | BOLT WH BLK
(x48) | 1/4 x 5/8

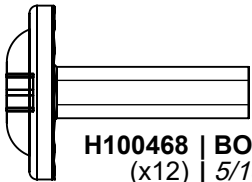

H100468 | BOLT WH BLK
(x12) | 5/16 x 1

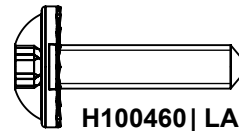

H100460 | LAG SCREW WH BLK
(x48) | 1/4 x 1

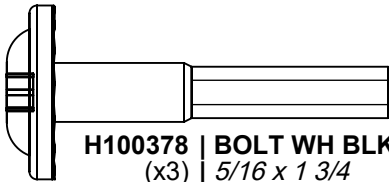

H100378 | BOLT WH BLK
(x3) | 5/16 x 1 3/4

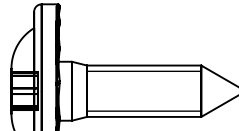

H100854 | LAG SCREW WH BLK
(x4) | 5/16 x 1

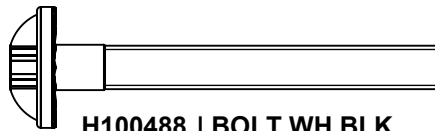

H100488 | BOLT WH BLK
(x7) | 1/4 x 2

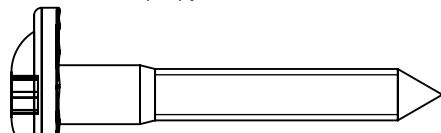

H100458 | LAG SCREW WH BLK
(x2) | 5/16 x 2

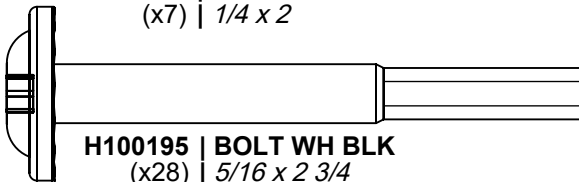

H100195 | BOLT WH BLK
(x28) | 5/16 x 2 3/4



H100416 | BOLT WH BLK
(x3) | 5/16 x 3

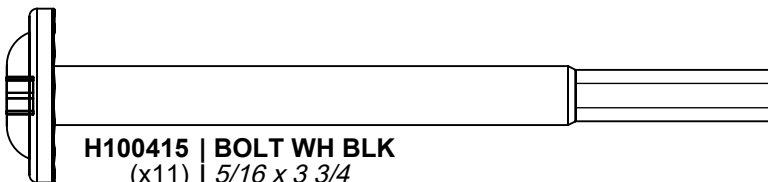

H100415 | BOLT WH BLK
(x11) | 5/16 x 3 3/4

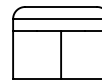

H100479 | NUT LOCK BLK
(x8) | 5/16

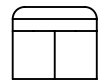

H100653 | NUT LOCK BLK
(x6) | 1/4

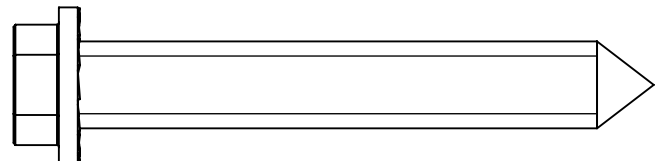

H101165 | CONCRETE ANCHOR 3/8"x3" BLK
(x4)

Owner's Manual - Parts Identification

Hardware Components

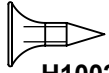

H100203 | SCREW PFH BLK
(x12) | 8 x 1/2

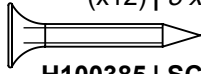

H100385 | SCREW PFH BLK
(x12) | 8 x 1

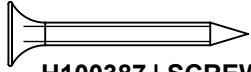

H100387 | SCREW PFH BLK
(x78) | 8 x 1 1/4

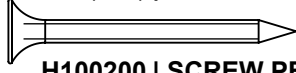

H100200 | SCREW PFH BLK
(x82) | 8 x 1 1/2

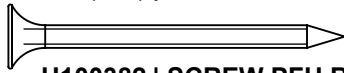

H100382 | SCREW PFH BLK
(x49) | 8 x 1 3/4



H100391 | SCREW PFH BLK
(x98) | 8 x 2

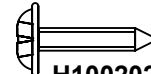

H100202 | SCREW PWH BLK
(x5) | 8 x 5/8

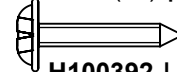

H100392 | SCREW PWH BLK
(x94) | 8 x 3/4

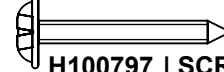

H100797 | SCREW PWH BLK
(x38) | 8 x 1

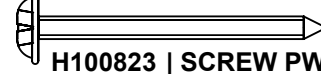

H100823 | SCREW PWH BLK
(x6) | 8 x 1 1/2

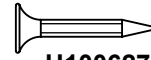

H100627 | SCREW PFH BLK
(x66) | 6 x 3/4

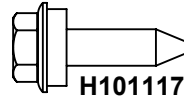

H101117 | SCREW WOODGRIP
(x88) | 10 - 16 x 3/4

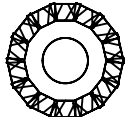

H100405 | WASHER LOCK EXT BLK
(x12) | 6 x 15

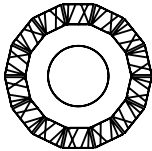

H100198 | WASHER LOCK EXT BLK
(x56) | 8 x 19

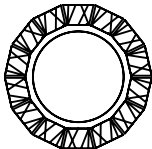

H100199 | WASHER LOCK EXT BLK
(x2) | 12 x 19

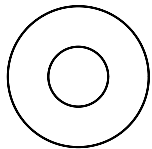

H100630 | WASHER FLAT BLK
(x8) | 8 x 19

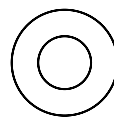

H101133 | WASHER FLAT BLK
(x6) | 7 x 14

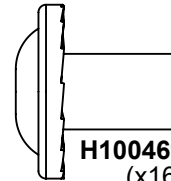

H100469 | NUT BARREL WH BLK
(x16) | 5/16 X 5/8

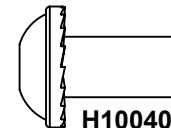

H100404 | NUT BARREL WH BLK
(x49) | 1/4 x 5/8

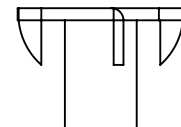

H100379 | T-NUT BLK
(x48) | 5/16

PRE-ASSEMBLY STEP 1 - SORTING PARTS

It is critical for ease of assembly that you take the time to sort and organize the wood and hardware.

WOOD PARTS:

- Organize wood parts by the three-digit, alpha-numeric number stamped on each board (ex. P01).
- If there are multiple boards with the same stamped number, stack those pieces together.
- Stamps can be found on the flat surface of the boards or on the end of the boards.
- Allow yourself plenty of room - the wood pieces can take up a significant amount of space.

NOTE: CARTONS ARE NOT ORGANIZED BY BOARD NUMBER.

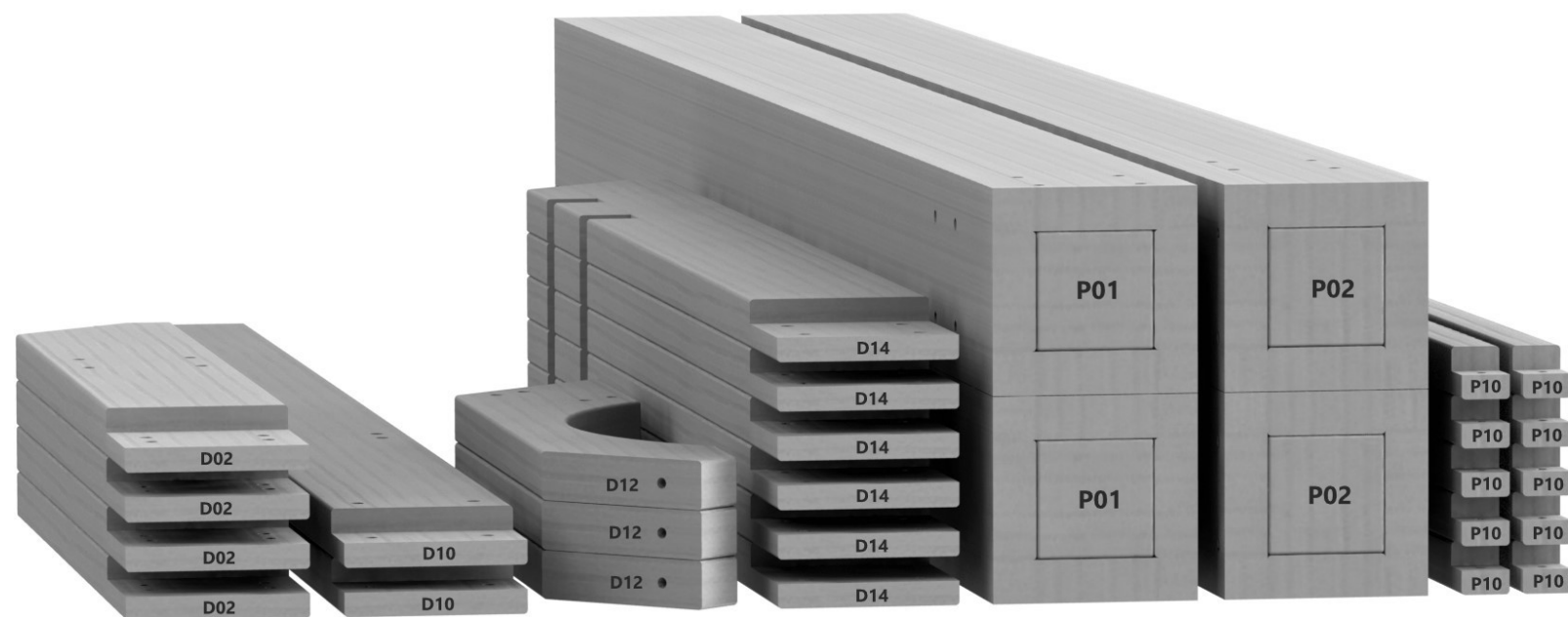

HARDWARE PARTS:

- We recommend that you have a separate table to organize the hardware.
- Hardware bags are printed with a seven-digit, alpha-numeric part number.
- You can organize your hardware by part number or group by hardware type (i.e. bolts, nuts, etc.).
- During assembly you only need to reference the last four digits of the number.

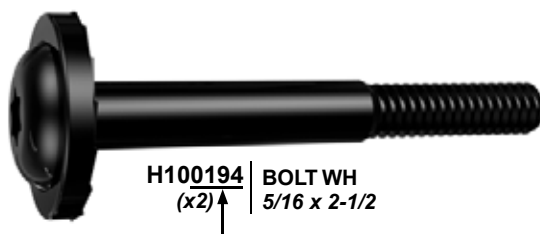

H100194 | BOLT WH
(x2) ↑ 5/16 x 2-1/2

PRE-ASSEMBLY STEP 2 - TOOLS REQUIRED



Cordless Drill
or Electric Drill

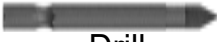

Drill
Attachments:
Phillips Head



1/8", 3/16", 3/8" &
7/16" Drill Bits



Phillips Screw Driver



Open End
Wrenches 1/2" &
9/16"



3/8" Drive Ratchet, 1/2" &
7/16" STD Sockets 1/2" & 7/16"
Deep Sockets



Claw Hammer



Rubber Mallet
- Optional

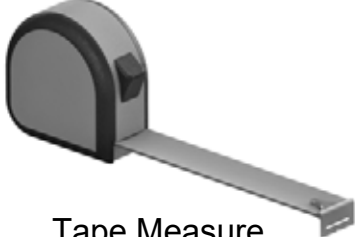

Tape Measure

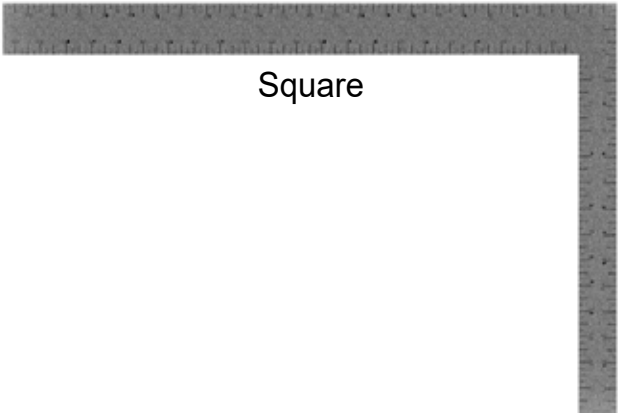

Square



Level 24"

PRE-ASSEMBLY STEP 3 - CHOOSE YOUR ASSEMBLY METHOD

There are several types of assembly instructions available to you.

1. Printed Assembly Manual included with your set
2. BILT APP - 3D interactive instructions
3. Combination of the Printed Manual and BILT APP (Note: Step numbers can differ between the two methods)

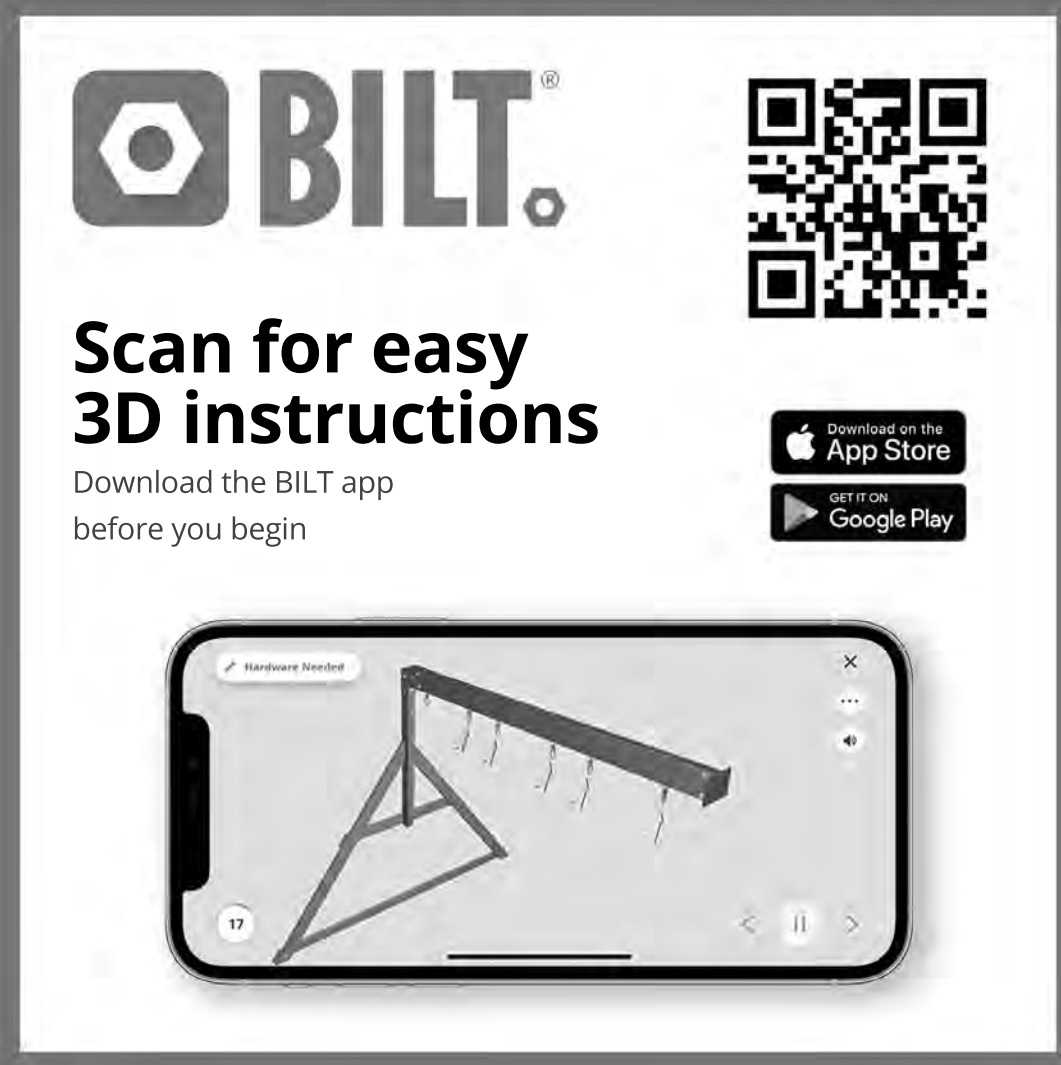

BILT.

**Scan for easy
3D instructions**

Download the BILT app
before you begin

Download on the
App Store

GET IT ON
Google Play

Hardware Needed

17

The advertisement is enclosed in a grey border. It features the BILT logo at the top left, a QR code at the top right, and two app store download buttons. Below the text is a smartphone displaying a 3D assembly instruction for a step numbered 17. The instruction shows a metal frame with a horizontal bar being attached to a vertical support.

STEP 1 - B1 POST ASSEMBLY

Qty	PART NUMBER	DESCRIPTION
4	H100200	SCREW PFH 8x1 1/2 BLK
4	H100460	LAG SCREW WH 1/4x1 BLK
5	H100379	TNUT-5/16" BLK



B1 POST - W4L19156
(x1) 3"X3"X62 7/16" (76x76x1586)



A6P00651 2x2 POST FOOT
(x1)

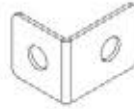

A4M02615 METAL PANEL BRACKET
(x4)

- INSTALL T-NUTS FIRST

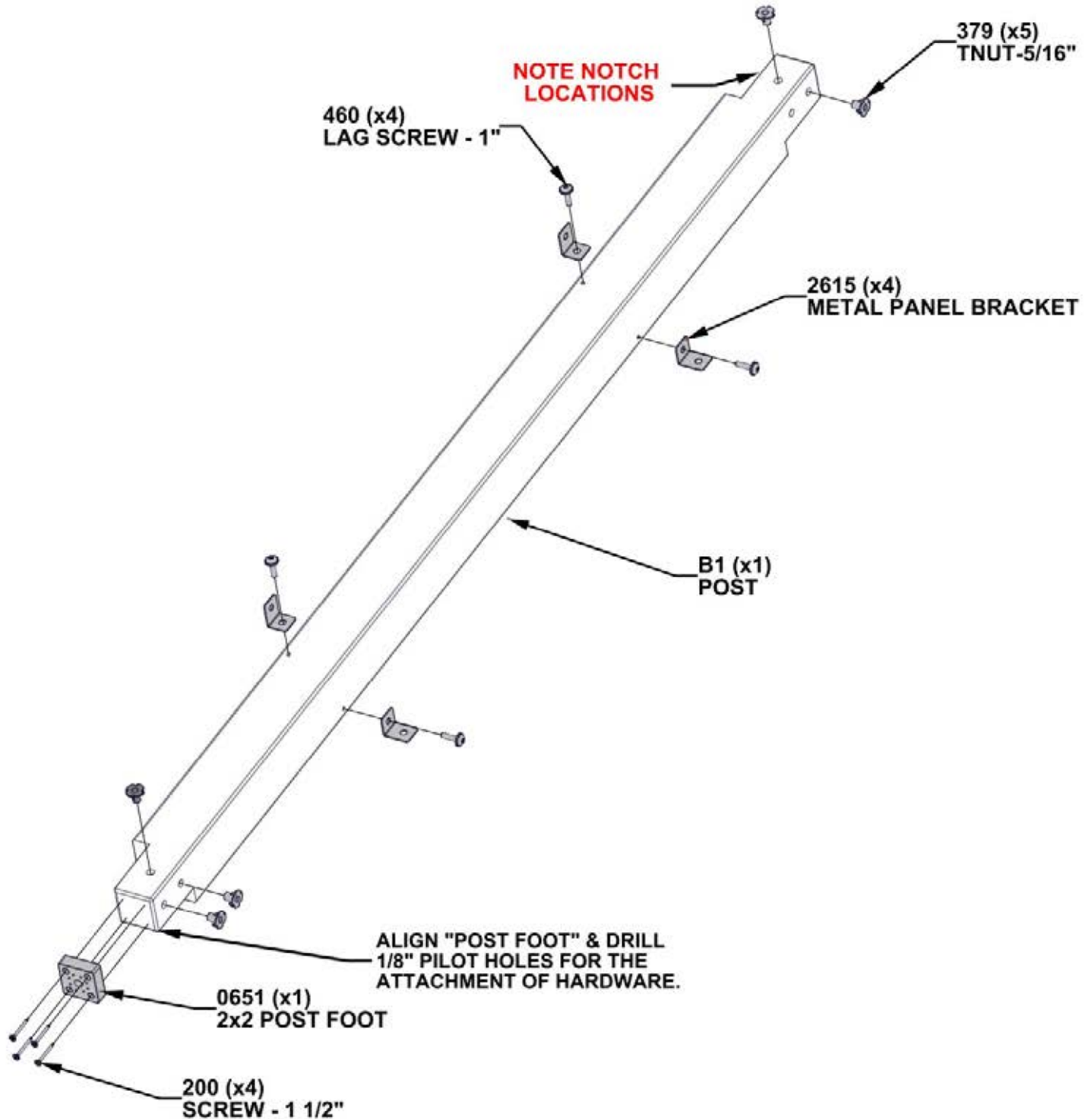

STEP 2 - B2 POST ASSEMBLY

Qty	PART NUMBER	DESCRIPTION
4	H100460	LAG SCREW WH 1/4x1 BLK
4	H100200	SCREW PFH 8x1 1/2 BLK
5	H100379	TNUT-5/16" BLK



B2 POST - W4L19158
(x1) 3"X3"X62 7/16" (76x76x1586)



A6P00651 2x2 POST FOOT
(x1)

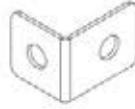

A4M02615 METAL PANEL BRACKET
(x4)

- INSTALL T-NUTS FIRST

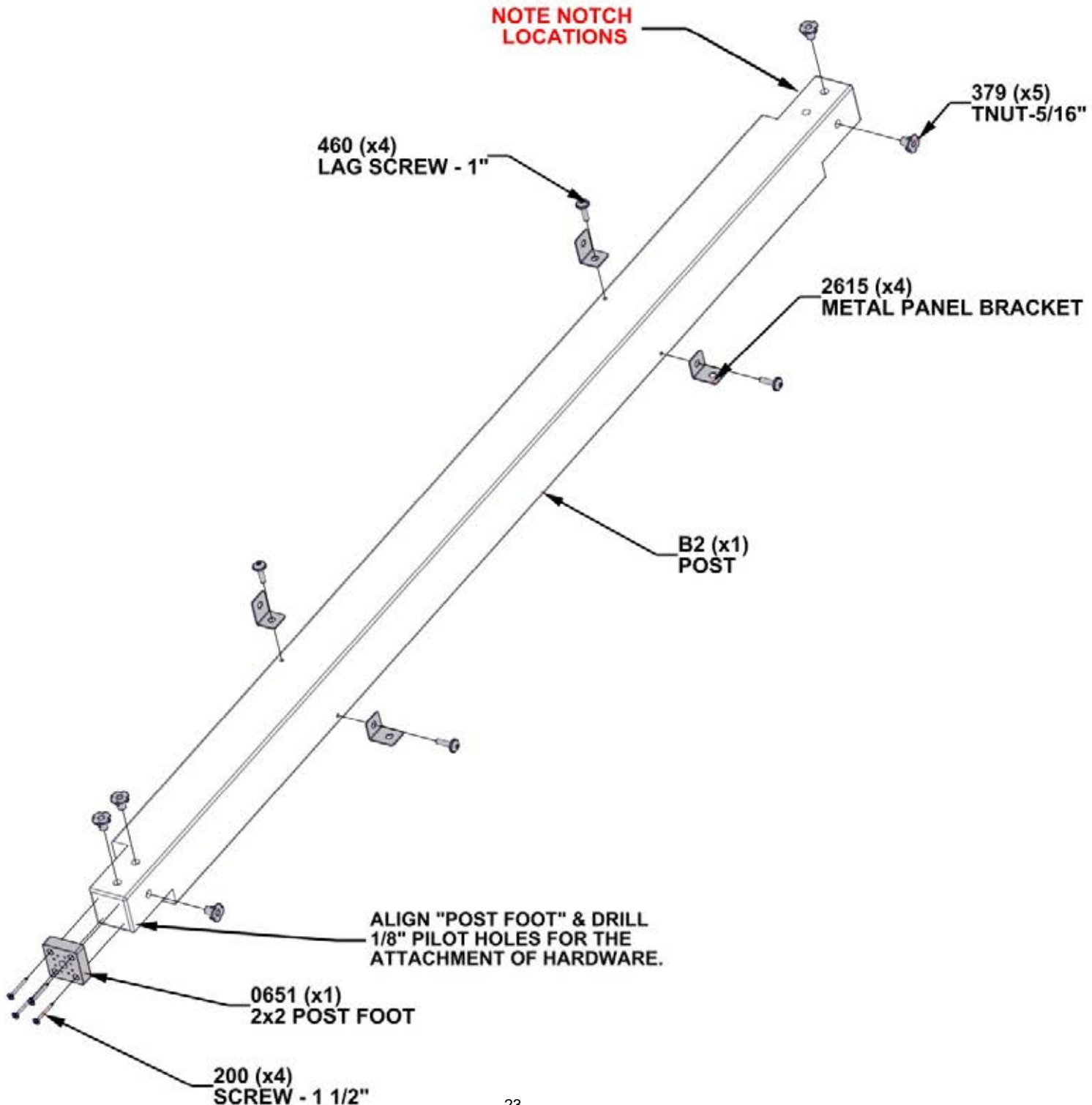

STEP 3 - DOG KENNEL ASSEMBLY



B1 POST ASSEMBLY
(x1) (FROM STEP 1)

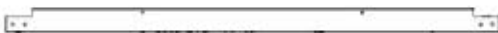

B2 POST ASSEMBLY
(x1) (FROM STEP 2)

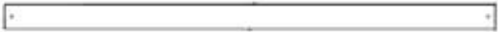

H30 GROUNDBOARD - W4L19530
(x1) 15/16"X3 3/8"X66 3/8" (24x86x1686)



A4M02941 ANCHORING BRACKET
(x2)



H1 TOP BOARD - W4L19157
(x1) 15/16"X3 3/8"X66 3/8" (24x86x1686)

Qty	PART NUMBER	DESCRIPTION
2	H100195	BOLT WH 5/16x2 3/4 BLK
2	H100198	WASHER LOCK EXT 8x19
2	H100416	BOLT WH 5/16x3 BLK

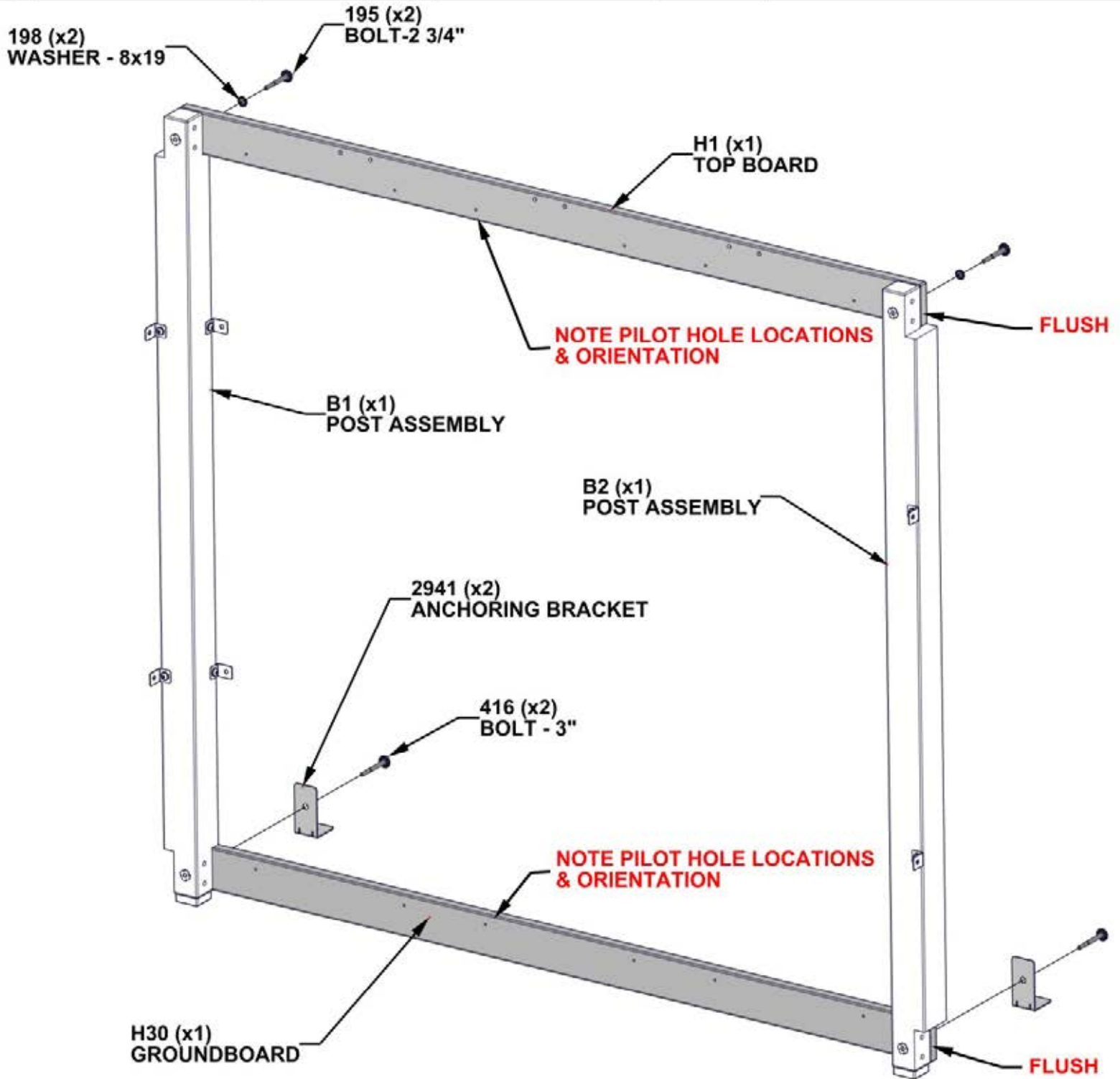

STEP 4 - B3 POST ASSEMBLY

Qty	PART NUMBER	DESCRIPTION
2	H100460	LAG SCREW WH 1/4x1 BLK
4	H100200	SCREW PFH 8x1 1/2 BLK
5	H100379	TNUT-5/16" BLK



B3 POST - W4L19161
(x1) 3"X3"X62 7/16" (76x76x1586)



A6P00651 2x2 POST FOOT
(x1)

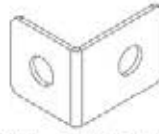

A4M02615 METAL PANEL BRACKET
(x2)

- INSTALL T-NUTS FIRST

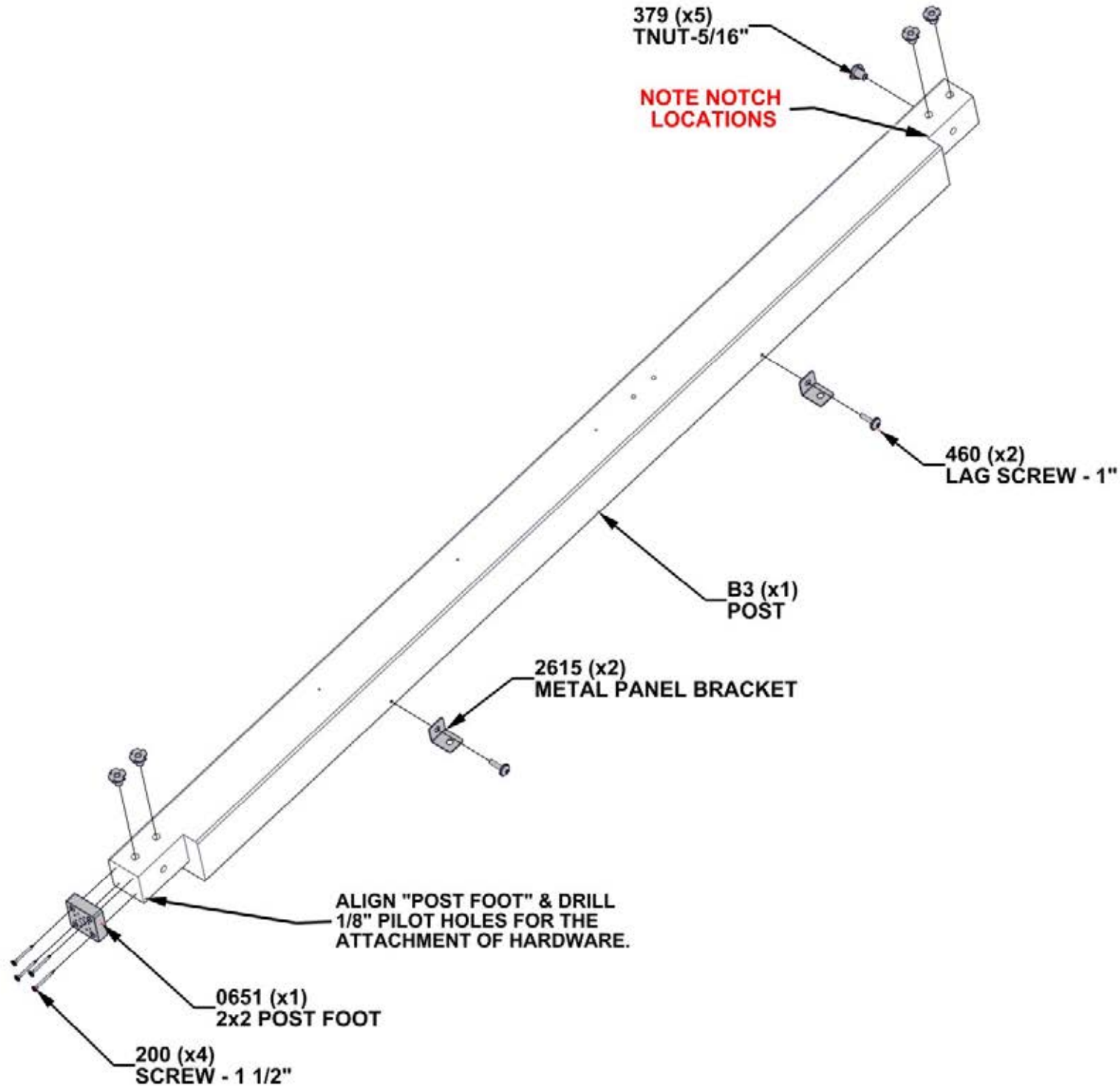

STEP 5 - B6 POST ASSEMBLY

Qty	PART NUMBER	DESCRIPTION
4	H100200	SCREW PFH 8x1 1/2 BLK
5	H100379	TNUT-5/16" BLK



B6 POST - W4L19172
(x1) 3"X3"X62 7/16" (76x76x1586)



A6P00651 2x2 POST FOOT
(x1)

- INSTALL T-NUTS FIRST

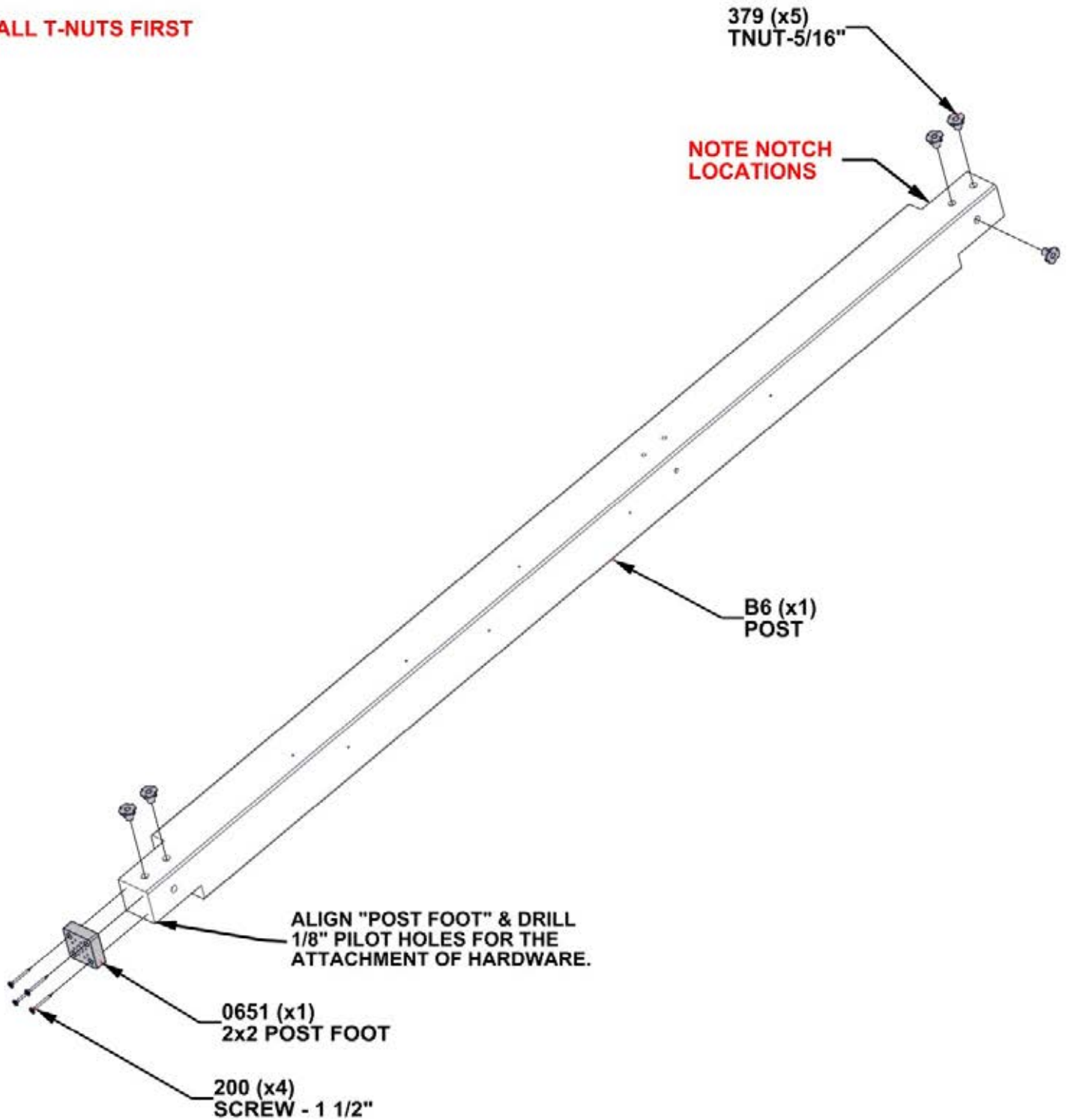

STEP 6 - DOG KENNEL ASSEMBLY

Qty	PART NUMBER	DESCRIPTION
2	H100379	TNUT-5/16" BLK
2	H100415	BOLT WH 5/16x3 3/4 BLK
2	H100195	BOLT WH 5/16x2 3/4 BLK
4	H100198	WASHER LOCK EXT 8x19



B3 POST ASSEMBLY
(x1) (FROM STEP 4)

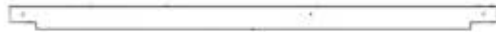

B6 POST ASSEMBLY
(x1) (FROM STEP 5)



H12 GROUNDBOARD - W4L19173
(x1) 15/16"X3 3/8"X66 3/8" (24x86x1686)



J4 FLOOR CLEAT - W4L19179
(x2) 15/16"X2 1/16"X2 3/8" (24x52x60)



H19 TOP BOARD - W4L19461
(x1) 15/16"X3 3/8"X66 3/8" (24x86x1686)

- INSTALL T-NUTS FIRST

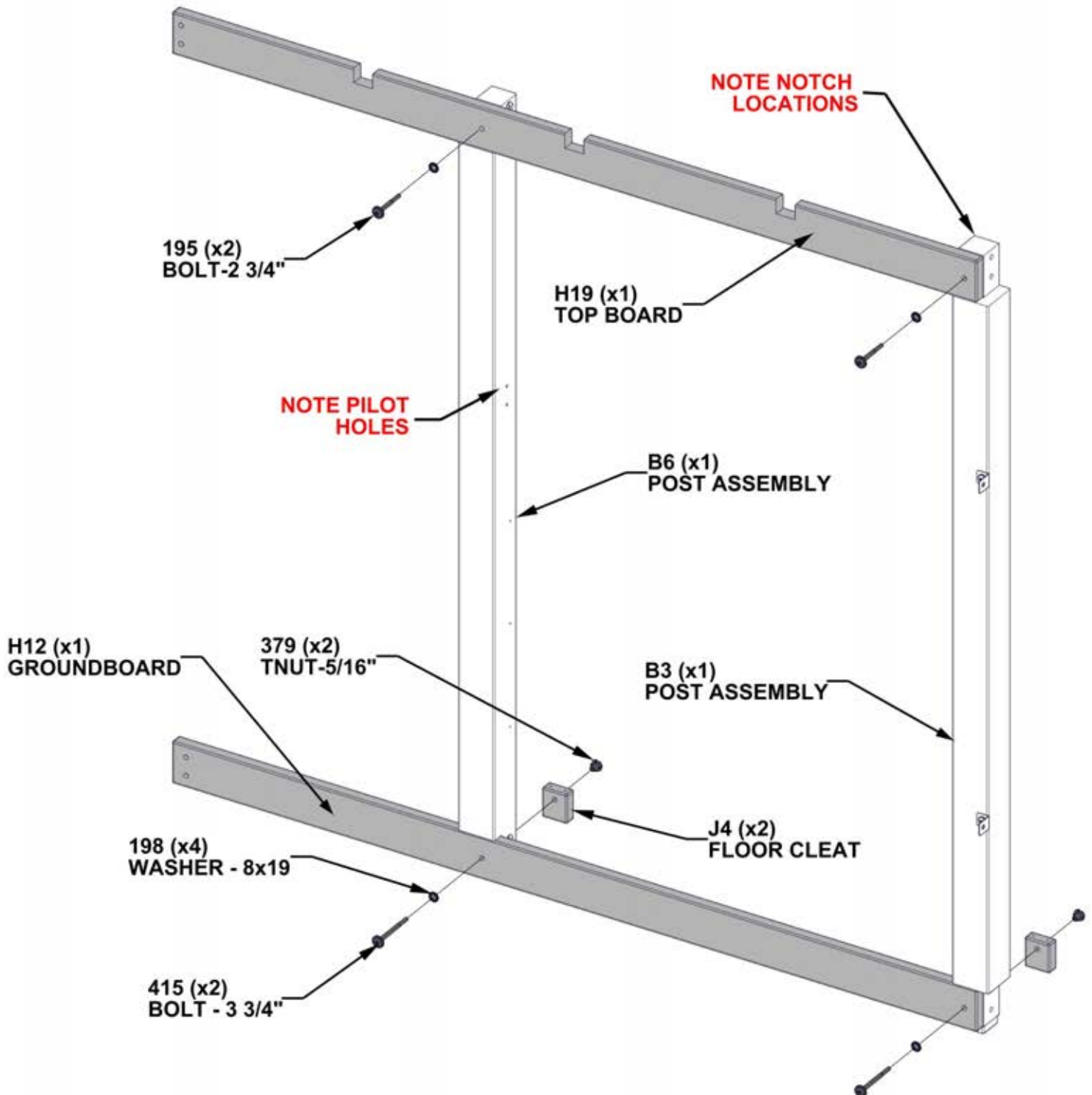

STEP 7 - DOG KENNEL ASSEMBLY

Qty	PART NUMBER	DESCRIPTION
4	H100379	TNUT-5/16" BLK
4	H100468	BOLT WH 5/16x1 BLK



A4M00855 L BRACKET
(x1)



A4M02633 BRACKET FOOT
(x1)

- INSTALL T-NUTS FIRST

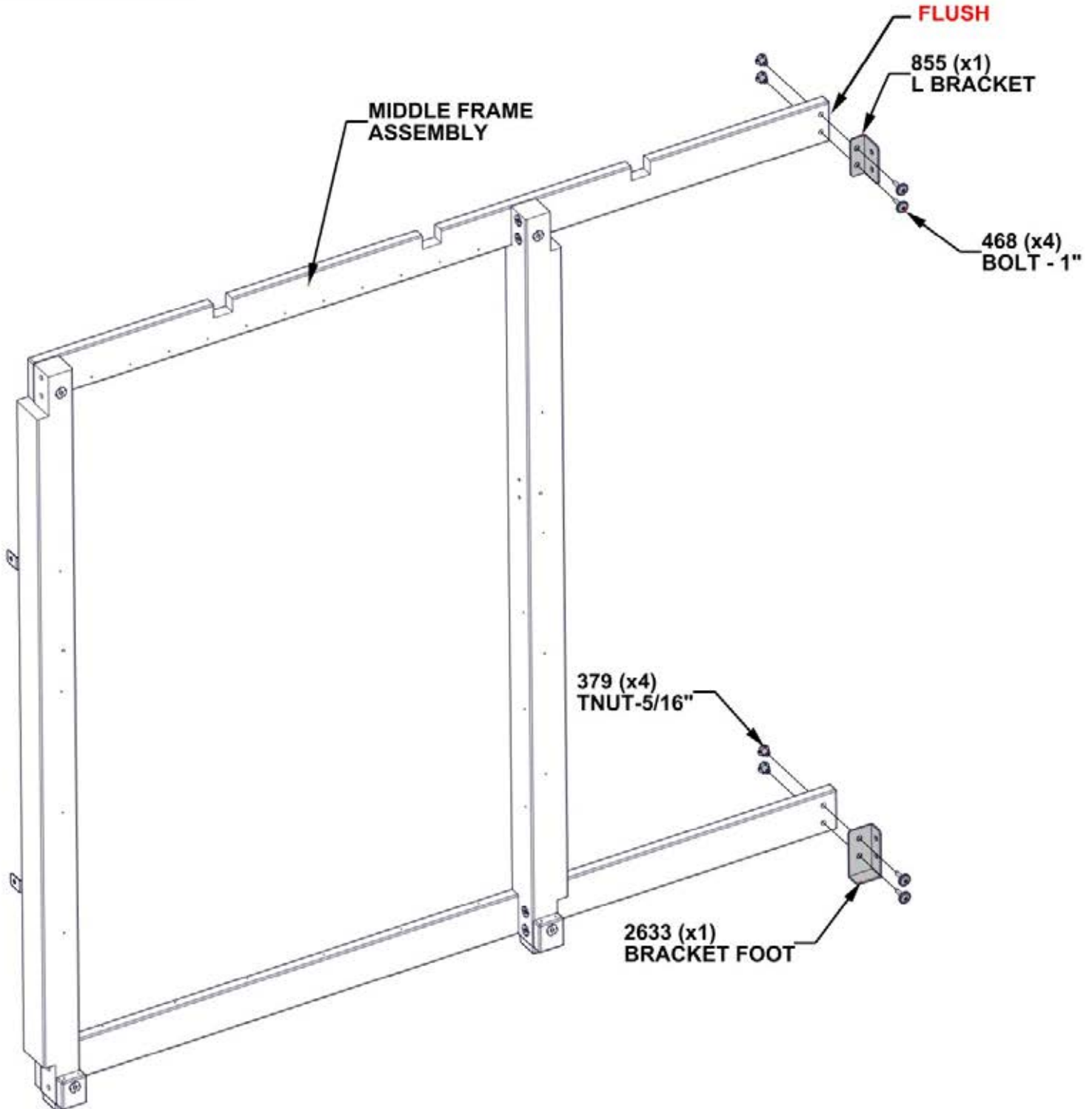

STEP 8 - B5 POST ASSEMBLY

Qty	PART NUMBER	DESCRIPTION
3	H100379	TNUT-5/16" BLK
4	H100200	SCREW PFH 8x1 1/2 BLK

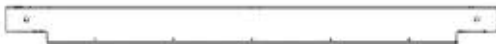

B5 POST - W4L19167
(x1) 3"X3"X40 5/16" (76x76x1024)

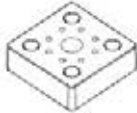

A6P00651 2x2 POST FOOT
(x1)

- INSTALL T-NUTS FIRST

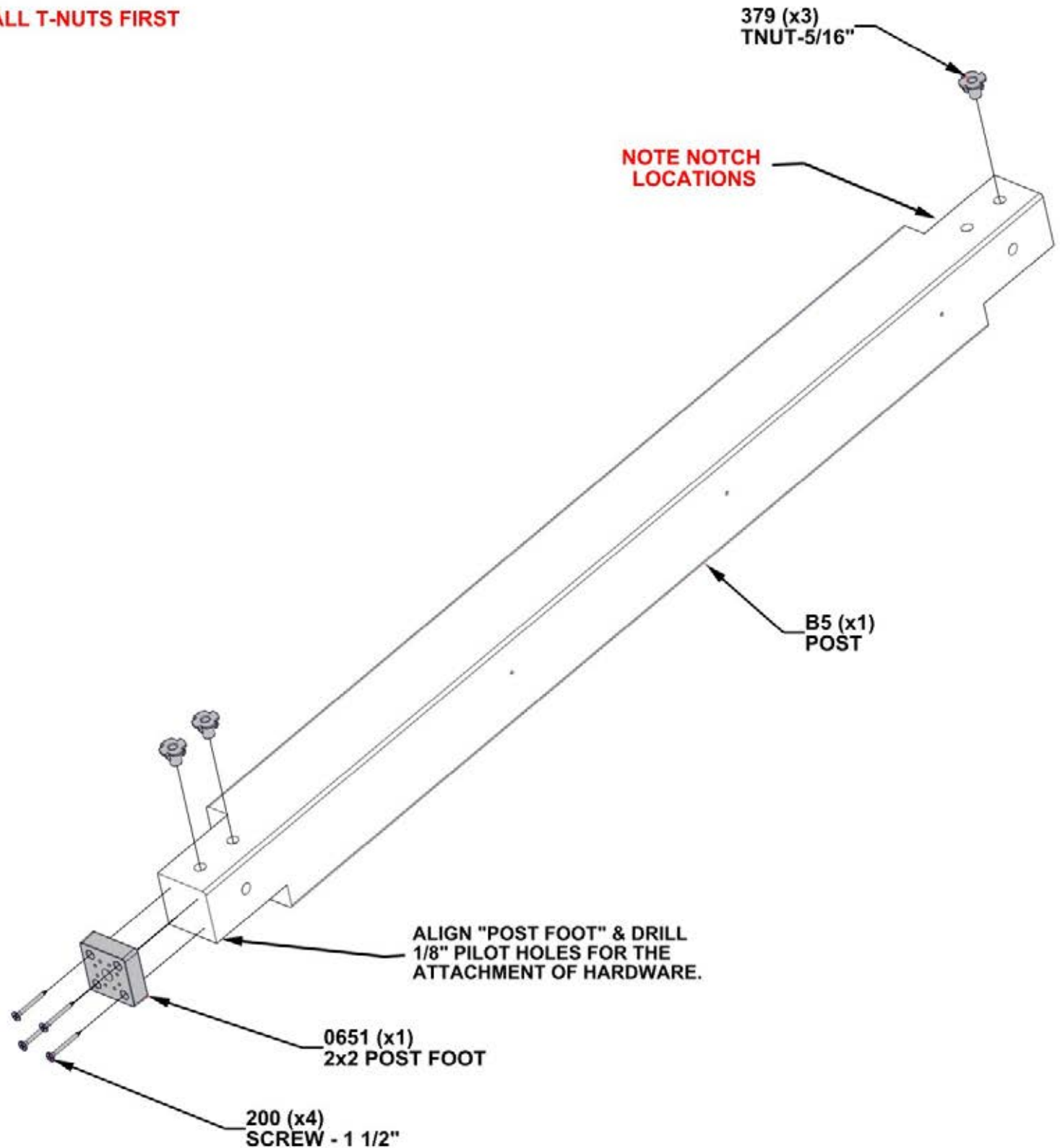

STEP 9 - B7 POST ASSEMBLY

Qty	PART NUMBER	DESCRIPTION
4	H100379	TNUT-5/16" BLK
4	H100200	SCREW PFH 8x1 1/2 BLK



B7 POST - W4L19460
(x1) 3"X3"X40 5/16" (76x76x1024)

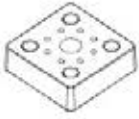

A6P00651 2x2 POST FOOT
(x1)

- INSTALL T-NUTS FIRST

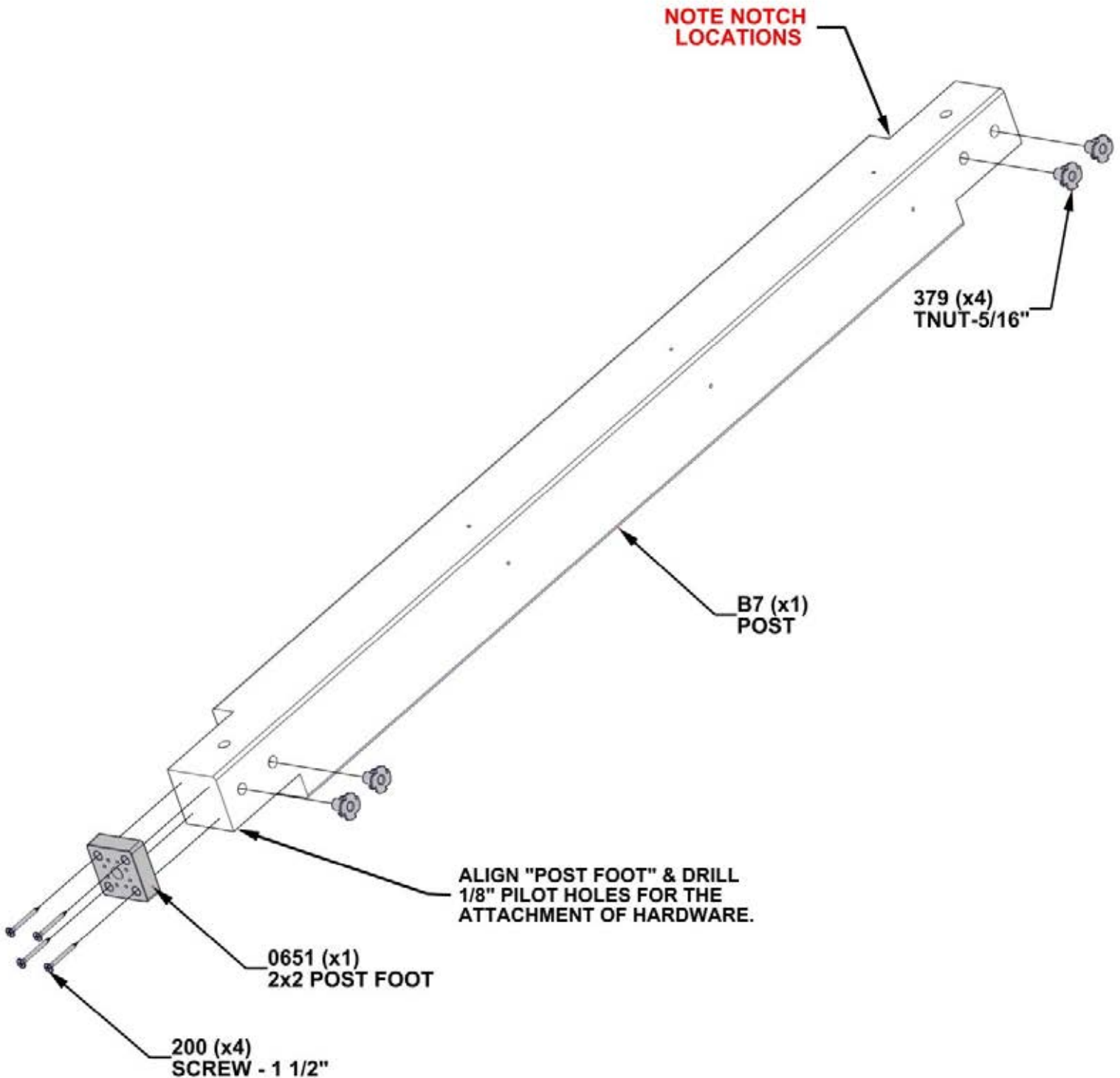

STEP 10 - B4 POST ASSEMBLY

Qty	PART NUMBER	DESCRIPTION
2	H100460	LAG SCREW WH 1/4x1 BLK
4	H100200	SCREW PFH 8x1 1/2 BLK
5	H100379	TNUT-5/16" BLK



B4 POST - W4L19164
(x1) 3"x3"x40 5/16" (76x76x1024)

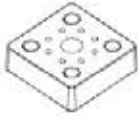

A6P00651 2x2 POST FOOT
(x1)

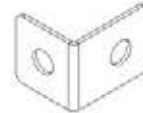

A4M02615 METAL PANEL BRACKET
(x2)

- INSTALL T-NUTS FIRST

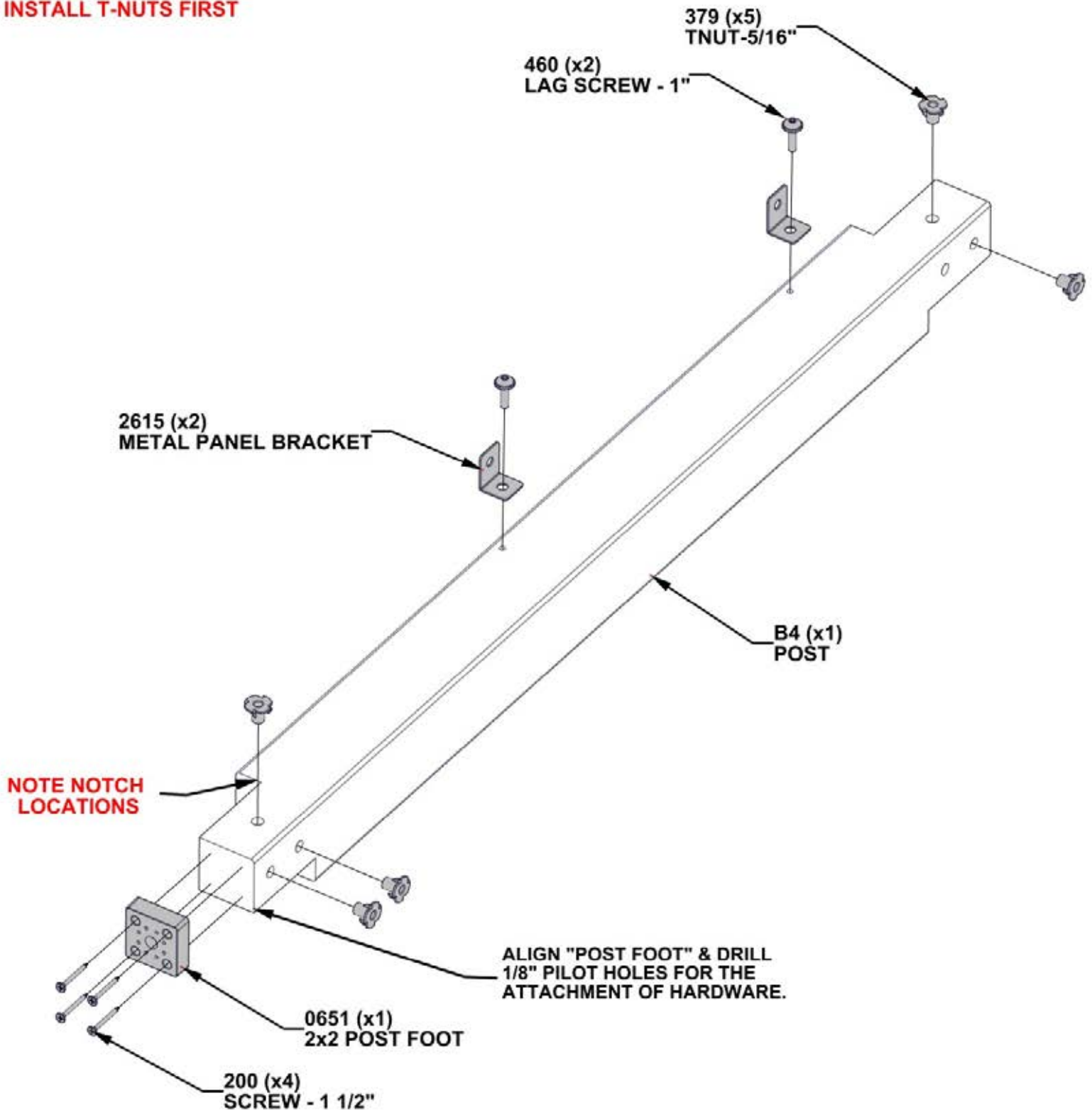

STEP 11 - DOG KENNEL ASSEMBLY

Qty	PART NUMBER	DESCRIPTION
1	H100198	WASHER LOCK EXT 8x19
1	H100416	BOLT WH 5/16x3 BLK
2	H100379	T-NUT 5/16 BLK
2	H100415	BOLT WH 5/16x3 3/4 BLK

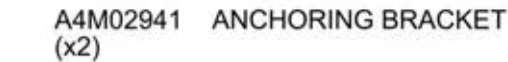
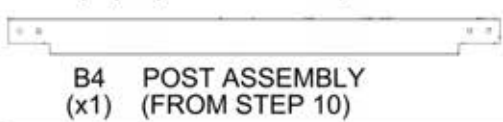
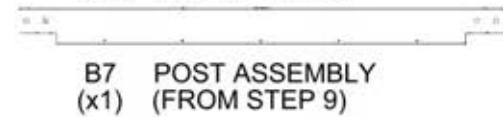
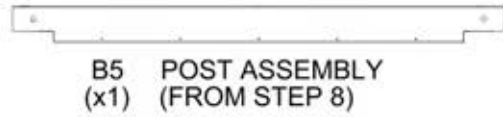

- INSTALL T-NUTS FIRST

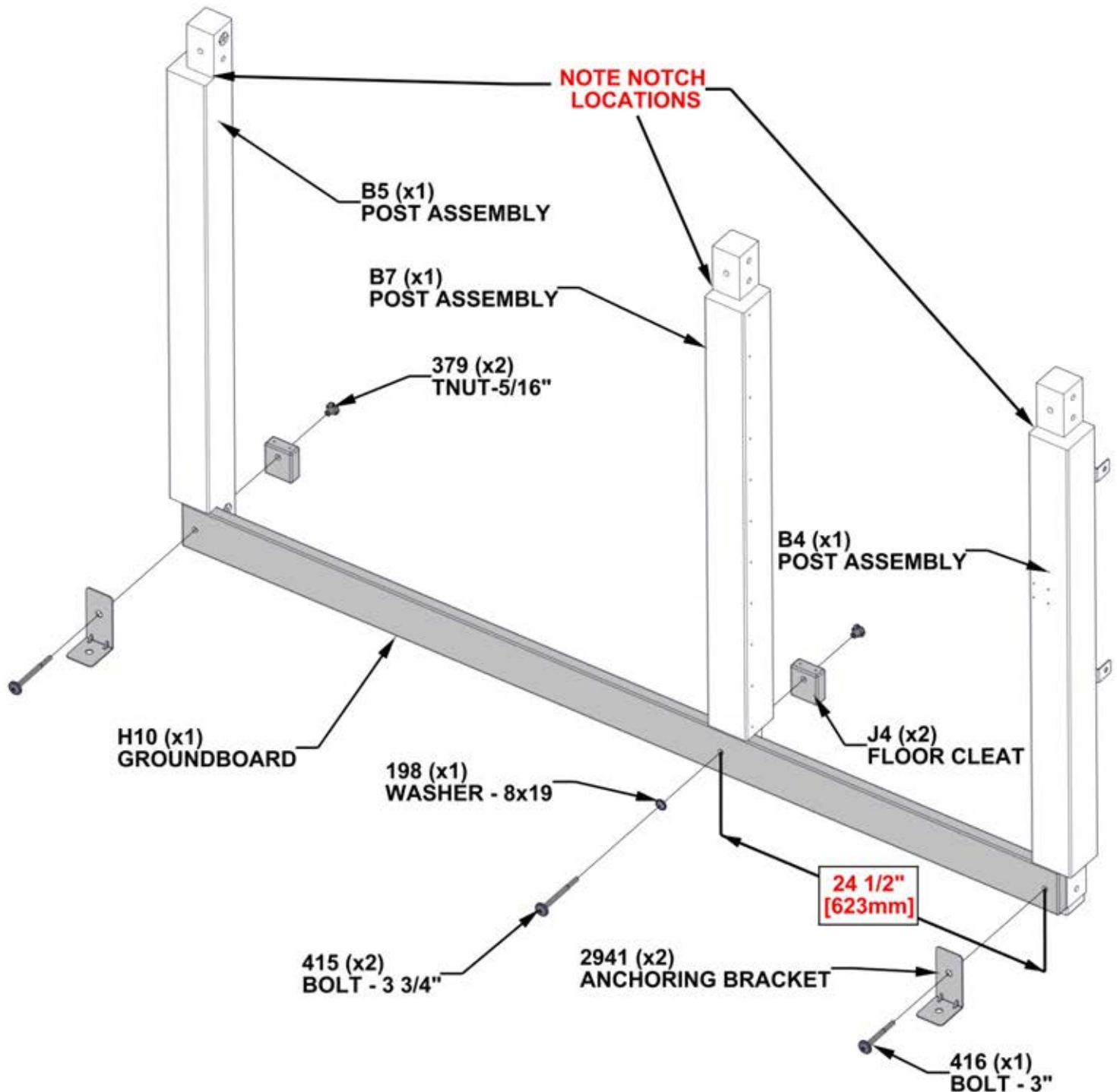

STEP 12 - DOG KENNEL ASSEMBLY

Qty	PART NUMBER	DESCRIPTION
12	H100195	BOLT WH 5/16x2 3/4 BLK
12	H100198	WASHER LOCK EXT 3x19

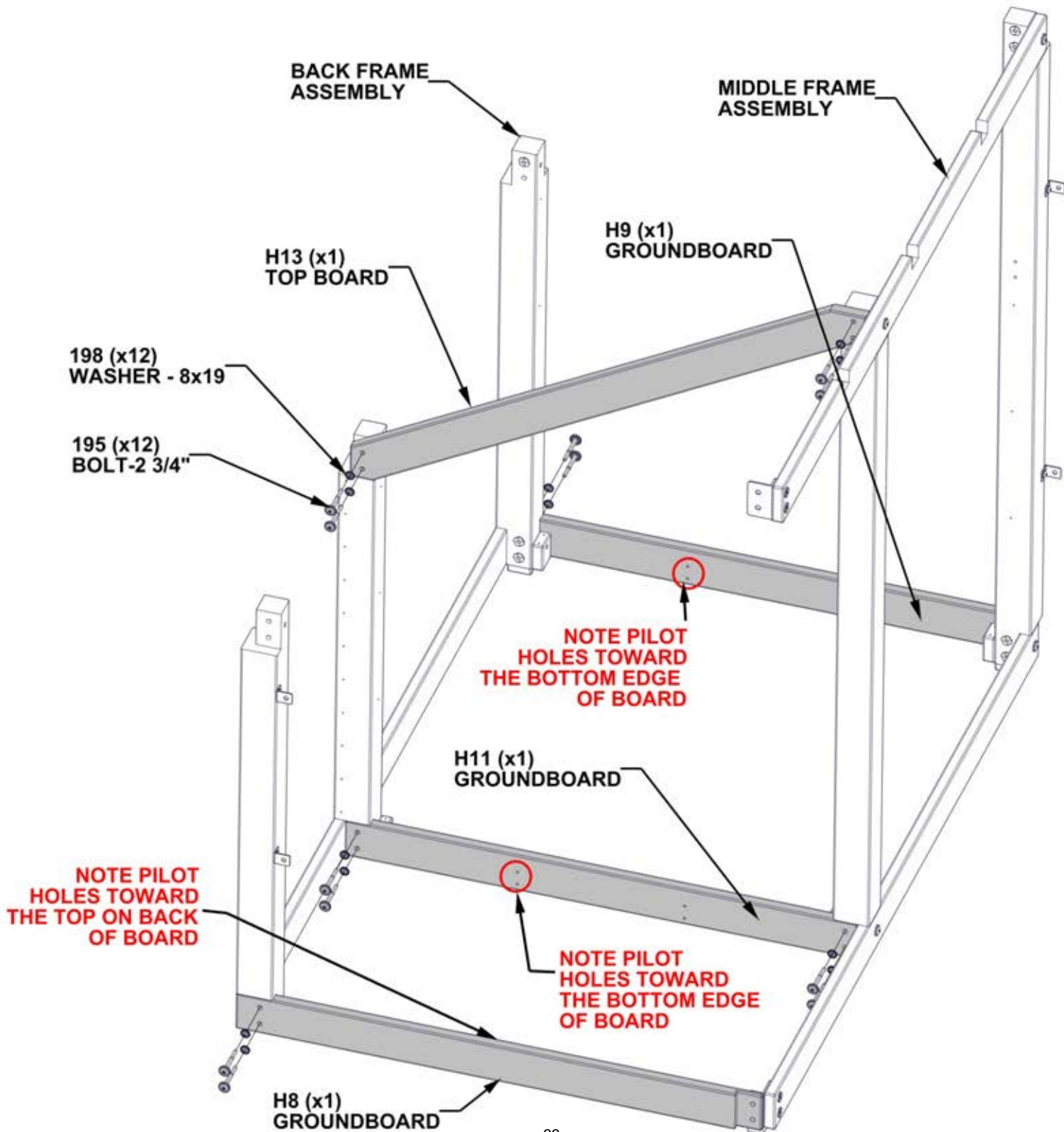
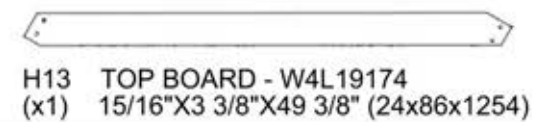
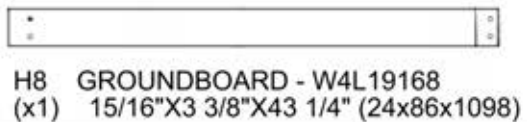
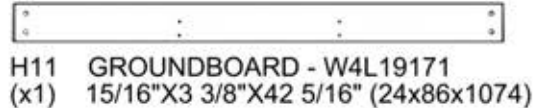

STEP 13 A - DOG KENNEL ASSEMBLY

Qty	PART NUMBER	DESCRIPTION
4	H100195	BOLT WH 5/16x2 3/4 BLK
4	H100198	WASHER LOCK EXT 8x19



H3 GROUNDBOARD - W4L19160
(x1) 15/16"X3 3/8"X47 11/16" (24x86x1211)



BACK & MIDDLE FRAME ASSEMBLY
(x1) (FROM STEP 12)



FRONT FRAME ASSEMBLY
(x1) (FROM STEP 3)

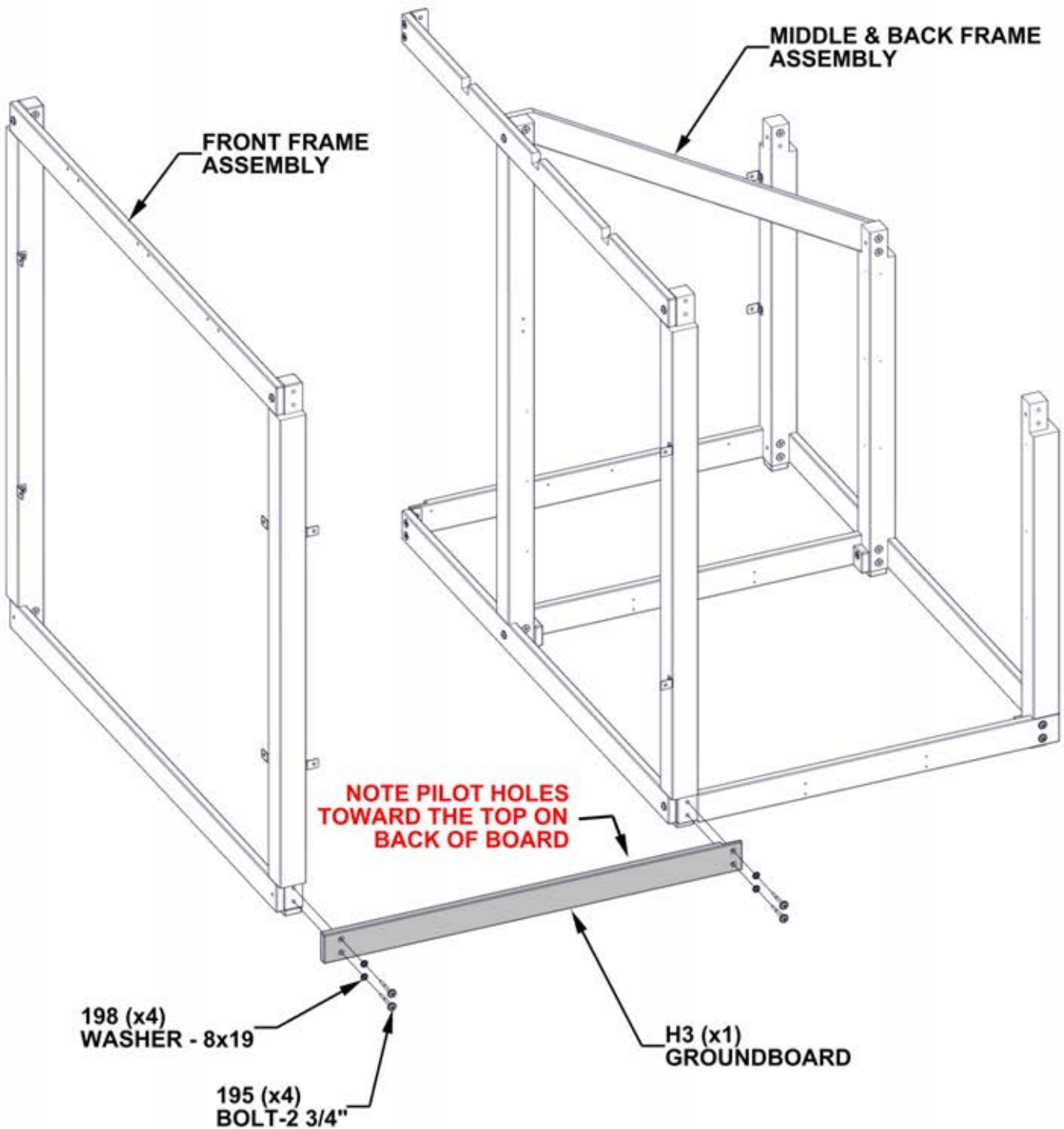

STEP 13 B - DOG KENNEL ASSEMBLY

Qty	PART NUMBER	DESCRIPTION
2	H100195	BOLT WH 5/16x2 3/4 BLK
2	H100198	WASHER LOCK EXT 8x19
2	H100379	TNUT-5/16" BLK
2	H100663	BOLT WH 5/16x3/4 BLK

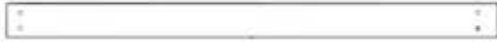

H7 GROUNDBOARD - W4L19166
 (x1) 15/16"X3 3/8"X47 11/16" (24x86x1211)

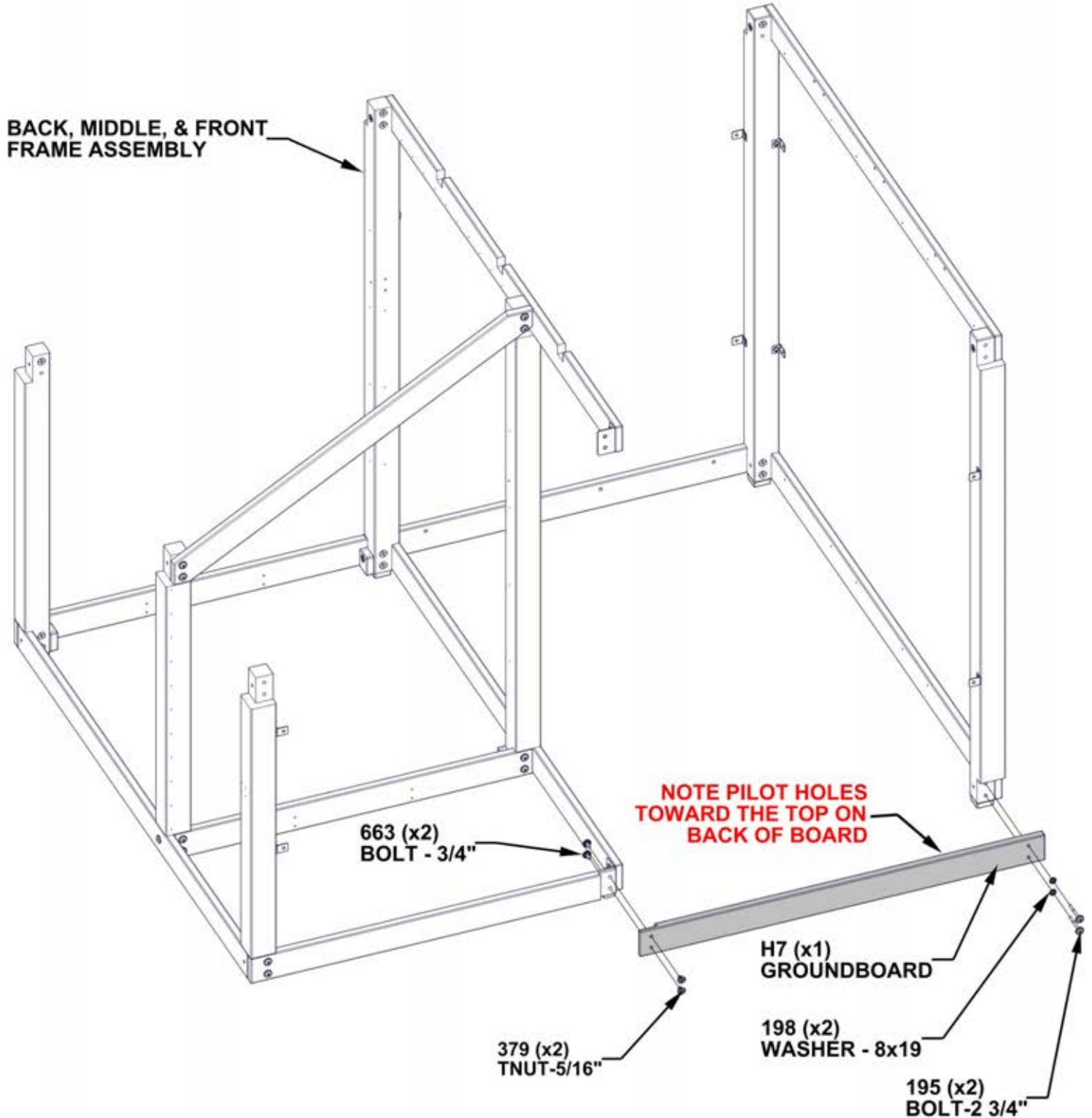

STEP 14 A - DOG KENNEL ASSEMBLY

Qty	PART NUMBER	DESCRIPTION
2	H100379	TNUT-5/16" BLK
3	H100195	BOLT WH 5/16x2 3/4 BLK
3	H100198	WASHER LOCK EXT 8x19

H2 TOP BOARD - W4L19159
 (x1) 15/16"X3 3/8"X47 11/16" (24x86x1211)

H6 TOP BOARD - W4L19165
 (x1) 15/16"X3 3/8"X50 3/16" (24x86x1275)

- INSTALL T-NUTS FIRST
- USE PILOT HOLES TO ALIGN HARDWARE IN BOTTOM HOLES

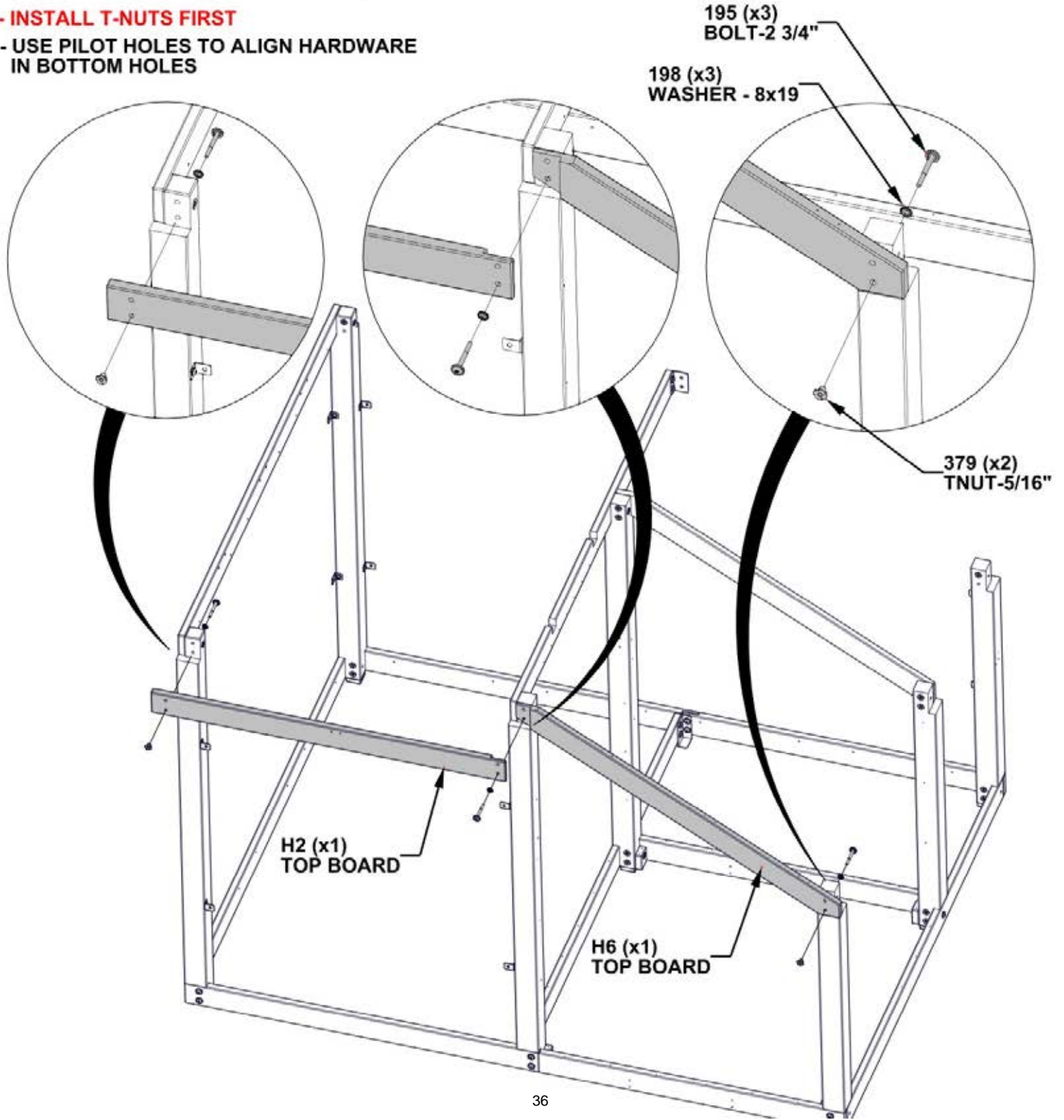

STEP 14 B - DOG KENNEL ASSEMBLY

Qty	PART NUMBER	DESCRIPTION
1	H100469	NUT BARREL WH 5/16X5/8 BLK
1	H100663	BOLT WH 5/16X3/4 BLK
1	H100199	WASHER LOCK EXT 12x19
2	H100379	TNUT-5/16" BLK
2	H100195	BOLT WH 5/16X2 3/4 BLK
2	H100198	WASHER LOCK EXT 8x19



H4 TOP BOARD - W4L19162
(x1) 15/16"X3 3/8"X47 11/16" (24x86x1211)

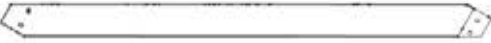

H5 TOP BOARD - W4L19163
(x1) 15/16"X3 3/8"X50 3/16" (24x86x1275)

- INSTALL T-NUTS IN WOOD FIRST
- USE PILOT HOLES TO ALIGN HARDWARE IN BOTTOM HOLES

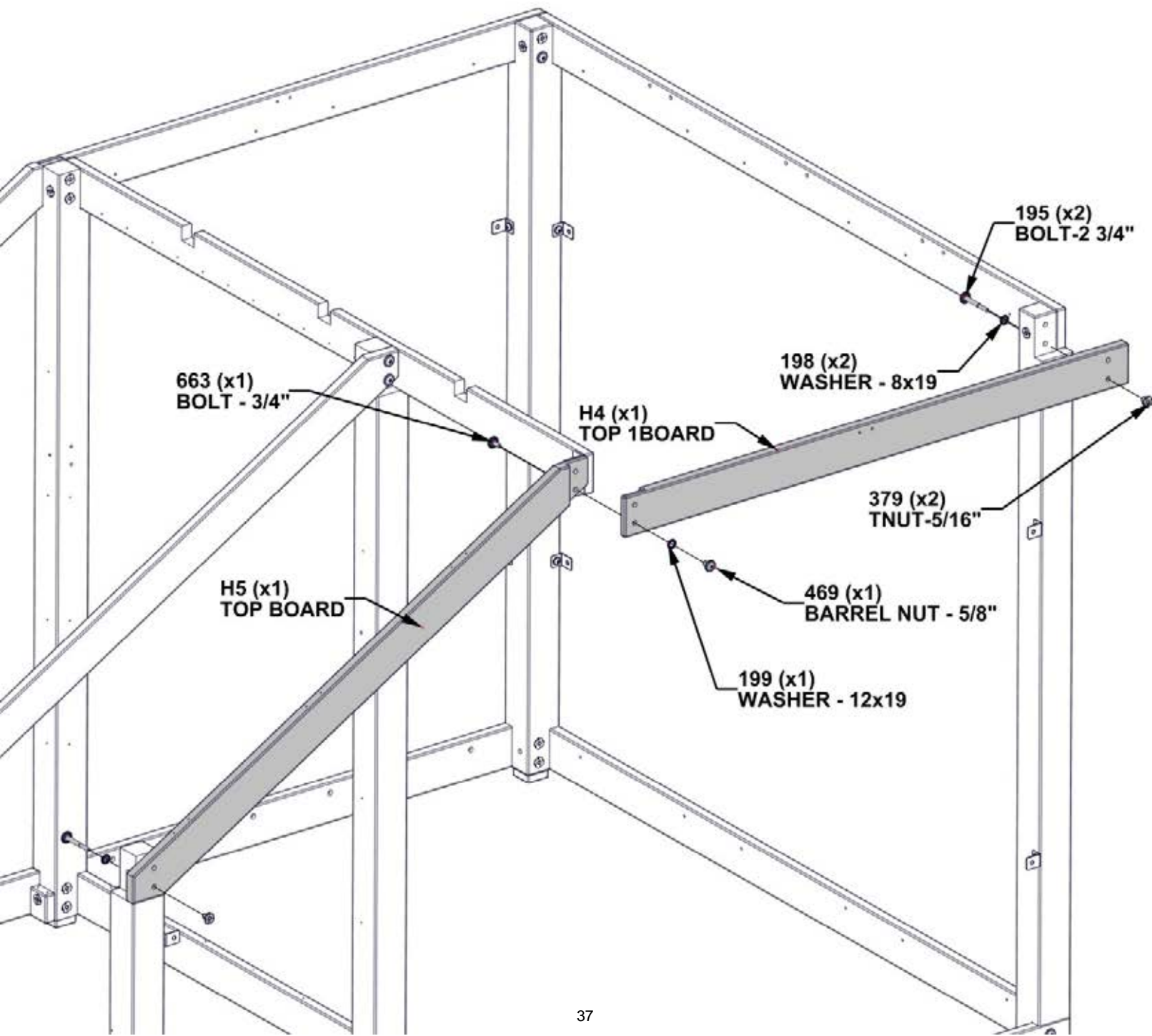

STEP 15 A - H18 ASSEMBLY

Qty	PART NUMBER	DESCRIPTION
2	H100392	SCREW PWH 8x3/4 BLK



H18 TOP BOARD - W4L19459
(x1) 15/16"X3 3/8"X66 3/8" (24x86x1686)



A4M00997 METAL CLEAT
(x1)

- USE PILOT HOLES TO ALIGN SCREWS

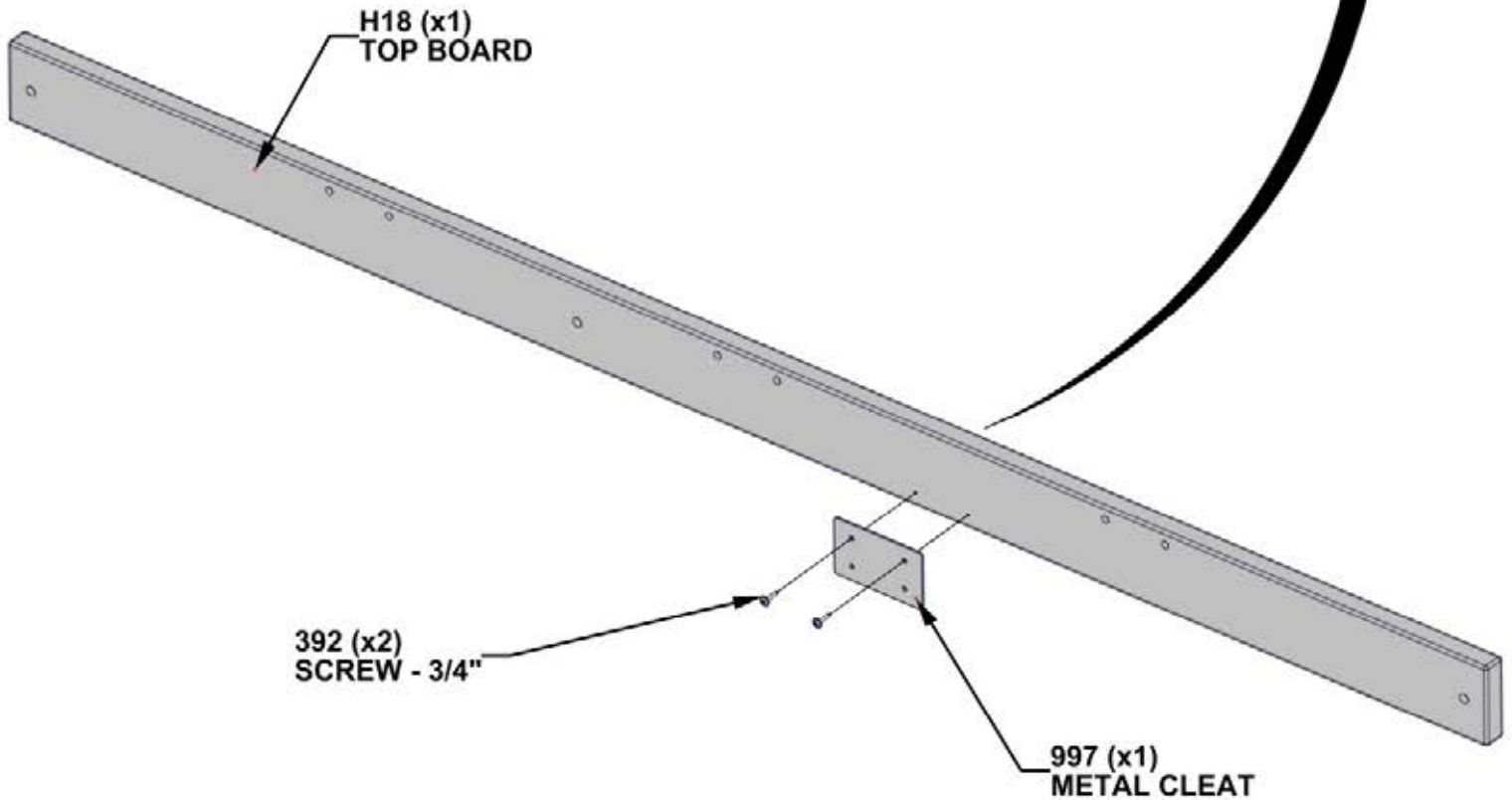
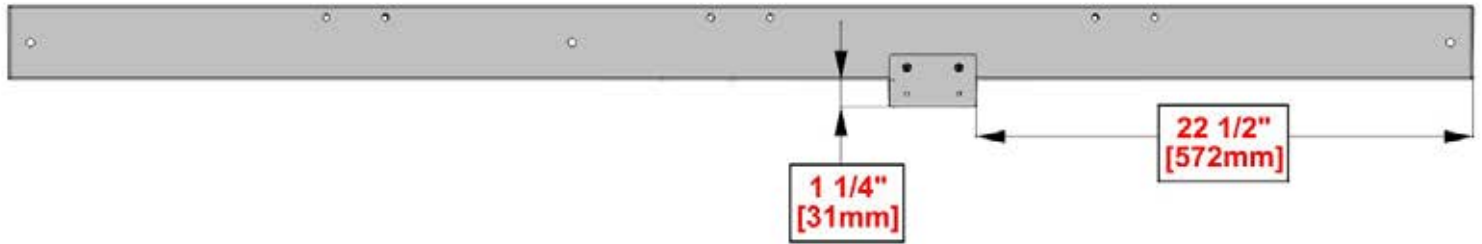

STEP 15 B - DOG KENNEL ASSEMBLY

Qty	PART NUMBER	DESCRIPTION
1	H100195	BOLT WH 5/16x2 3/4 BLK
2	H100379	TNUT-5/16" BLK
2	H100415	BOLT WH 5/16x3 3/4 BLK
3	H100198	WASHER LOCK EXT 8x19



H18 BOARD ASSEMBLY
(x1) (FROM STEP 15A)



J5 FLOOR JOIST - W4L19454
(x1) 15/16"X2 3/8"X41 9/16" (24x60x1055)

- INSTALL T-NUTS FIRST

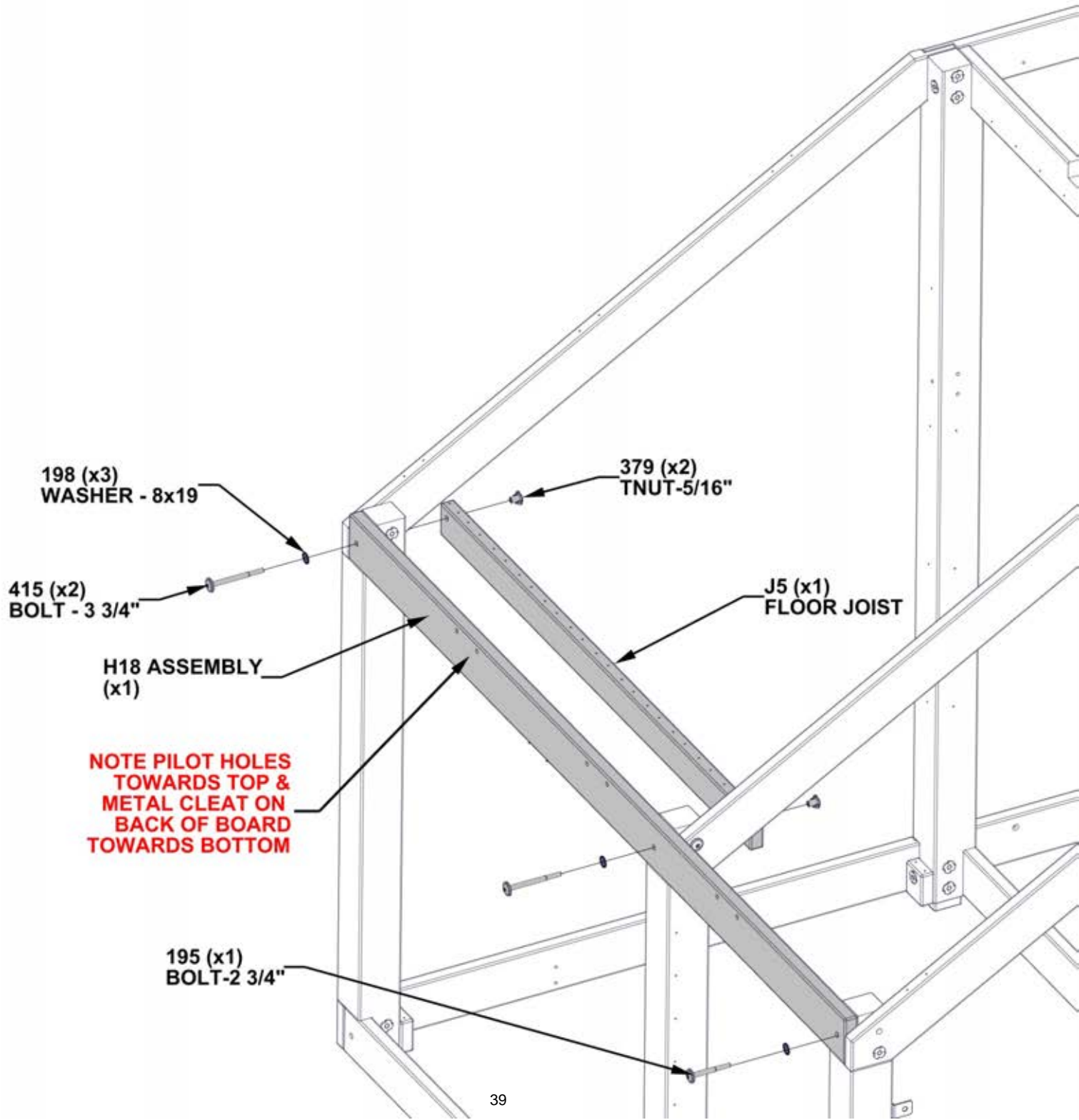

**NOTE PILOT HOLES
TOWARDS TOP &
METAL CLEAT ON
BACK OF BOARD
TOWARDS BOTTOM**

STEP 16 - DOG KENNEL ASSEMBLY

Qty	PART NUMBER	DESCRIPTION
8	H100391	SCREW PFH 8x2 BLK
14	H100200	SCREW PFH 8x1 1/2 BLK



J1 FLOOR JOIST - W4L19175
(x2) 15/16"X2 3/8"X37 1/2" (24x60x953)



J2 FLOOR JOIST - W4L19176
(x2) 15/16"X2 3/8"X41 7/8" (24x60x1063)

- USE PILOT HOLES TO ALIGN SCREWS

200 (x14)
SCREW - 1 1/2"

391 (x8)
SCREW - 2"

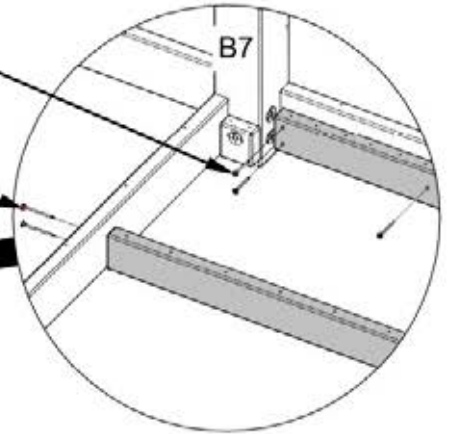

B7

J2 (x2)
FLOOR JOIST

J1 (x2)
FLOOR JOIST

NOTE PILOT HOLES UPWARD & BOARDS ARE FLUSH WITH BOTTOM

STEP 17 - DOG KENNEL ASSEMBLY

Qty	PART NUMBER	DESCRIPTION
78	H100391	SCREW PFH 8x2 BLK



H14 FLOOR BOARD - W4L19178
(x11) 15/16"X3 3/8"X42 3/16" (24x86x1072)

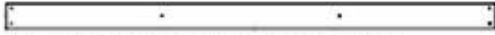

J3 FLOOR BOARD - W4L19177
(x2) 15/16"X2 1/16"X38 1/8" (24x52x968)

- USE PILOT HOLES TO ALIGN SCREWS

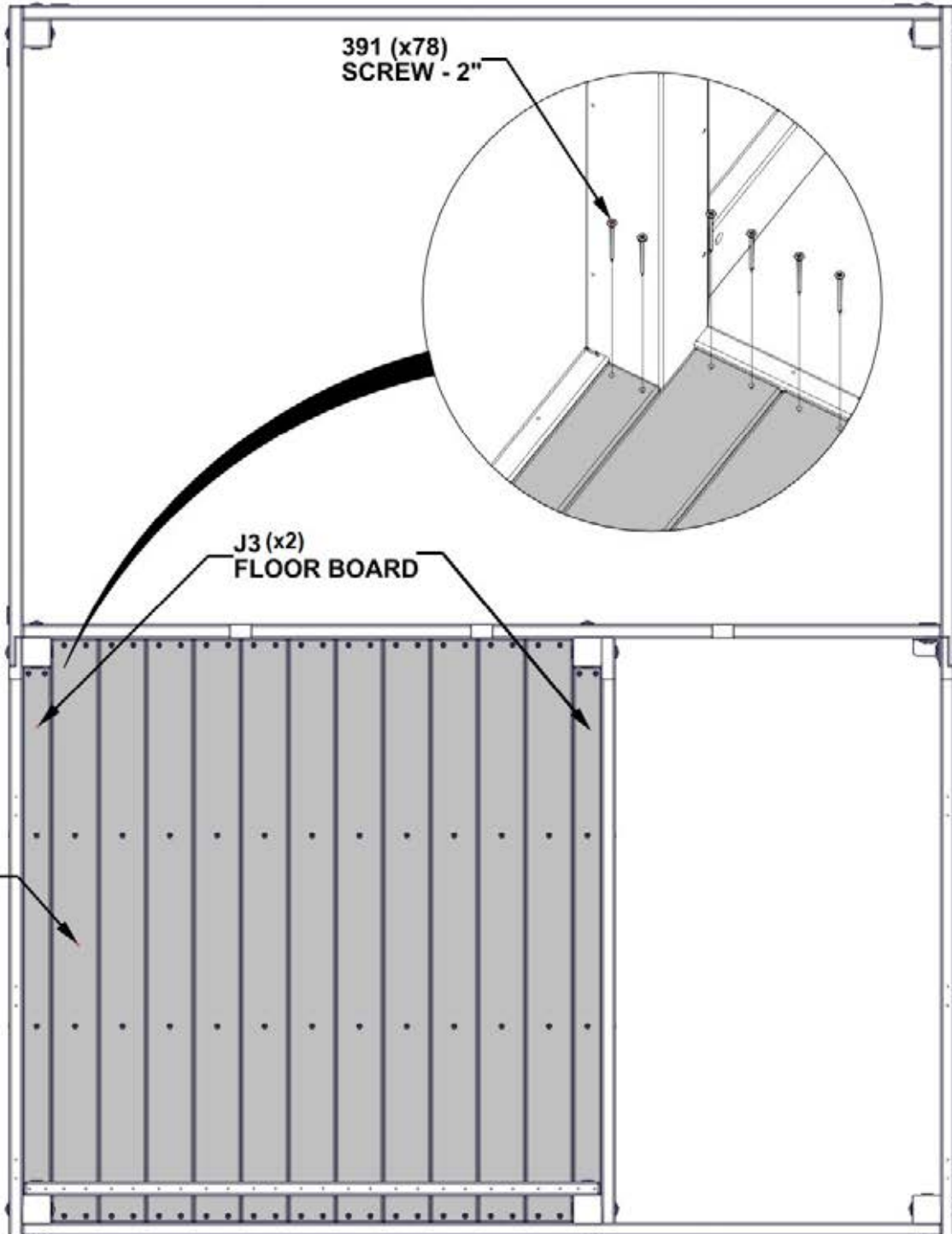

STEP 18 A - WP6 ASSEMBLY

Qty	PART NUMBER	DESCRIPTION
5	H100392	SCREW PWH 8x3/4 BLK

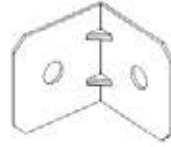

WP6 WALL PANEL - W2A04049
 (x1) 1 1/16"X19 1/16"X44 9/16" (27x484x1133)

A4M01785 ANGLE BRACKET
 (x5)

- USE PILOT HOLES TO ALIGN SCREWS

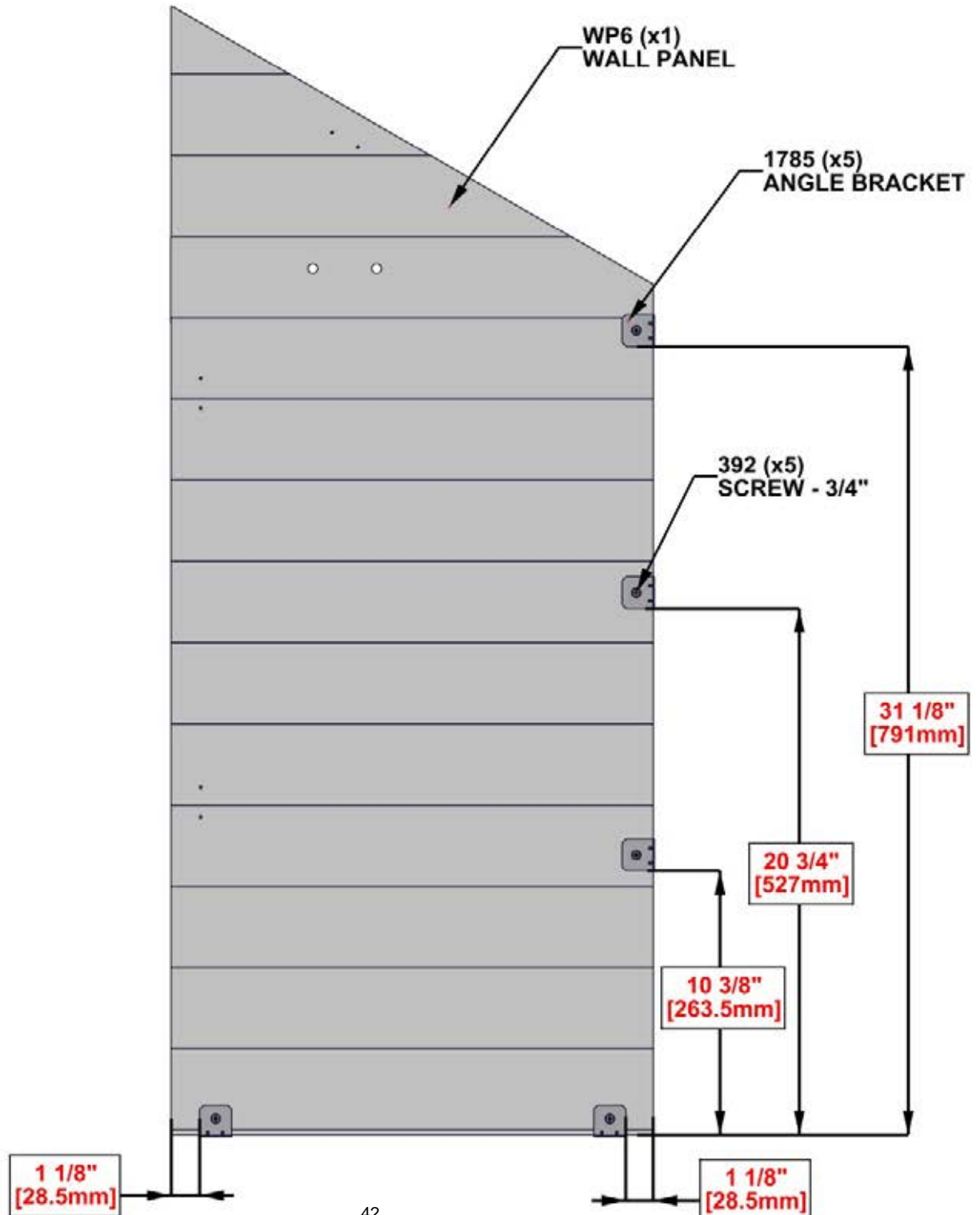

STEP 18 B - WP5 ASSEMBLY



Qty	PART NUMBER	DESCRIPTION
6	H100392	SCREW PWH 8x3/4 BLK

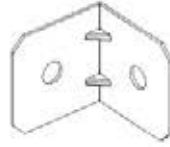

WP5 WALL PANEL - W2A04048
 (x1) 1 1/16"X19 1/16"X55 5/8" (27x484x1412)

A4M01785 ANGLE BRACKET
 (x6)

- USE PILOT HOLES TO ALIGN SCREWS

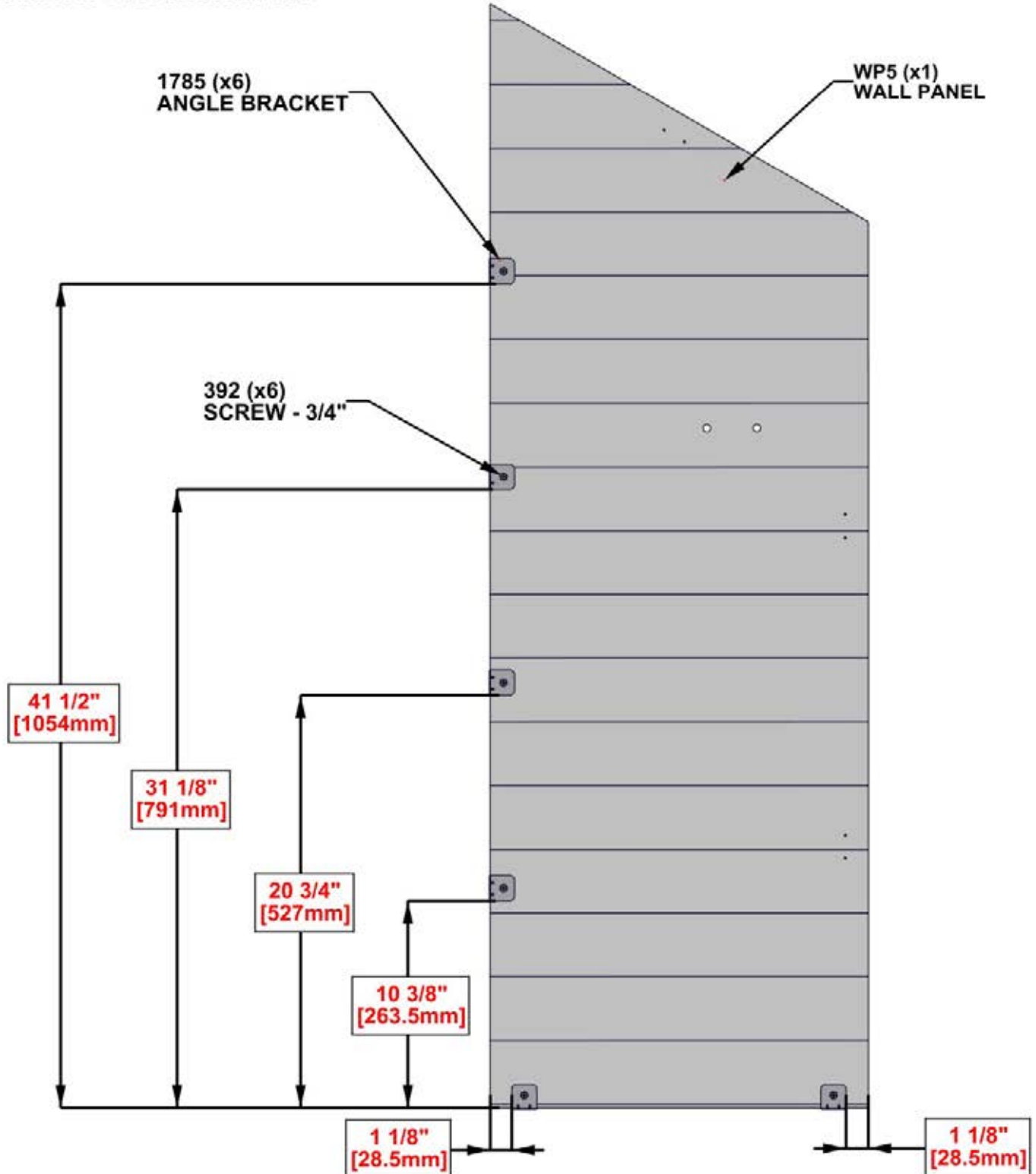

STEP 18 C - WP5 & WP6 ASSEMBLY



WP6 ASSEMBLY
(x1) (FROM STEP 18 A)



WP5 ASSEMBLY
(x1) (FROM STEP 18 B)

Qty	PART NUMBER	DESCRIPTION
12	H100797	SCREW PWH 8x1 BLK



A4M00997 METAL CLEAT
(x4)

- USE PILOT HOLES TO ALIGN SCREWS

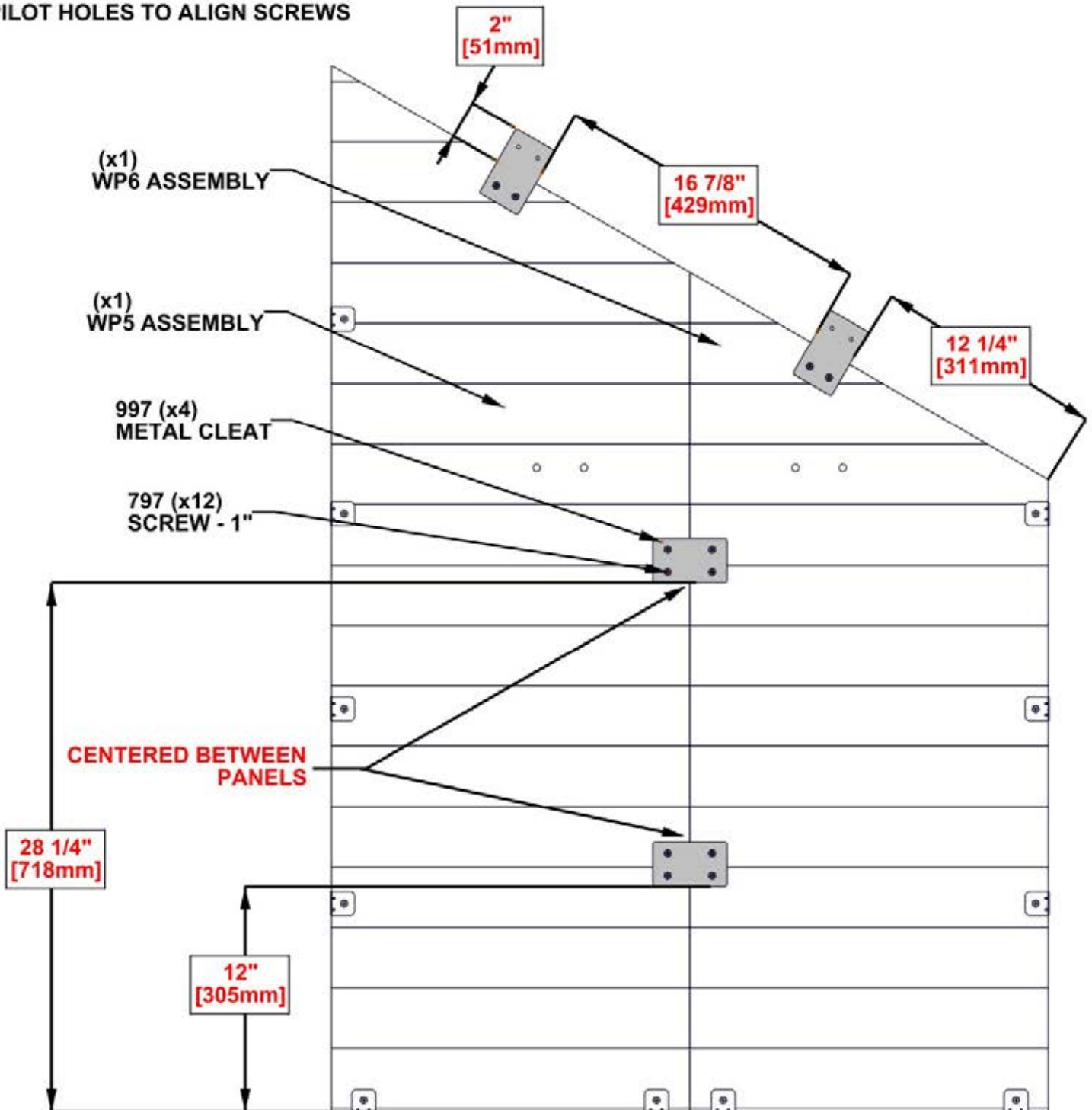

STEP 18 D - DOG KENNEL ASSEMBLY

Qty	PART NUMBER	DESCRIPTION
4	H100797	SCREW PWH 8x1 BLK
11	H100392	SCREW PWH 8x3/4 BLK

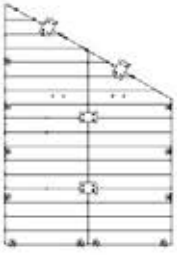

WP5 & WP6 ASSEMBLY
(x1) (FROM STEPS 18 C)

- PREDRILL 1/8" [3mm] PILOT HOLES FOR THE ATTACHMENT OF HARDWARE ON FLOORING BOARDS
- USE PILOT HOLES TO ALIGN SCREWS

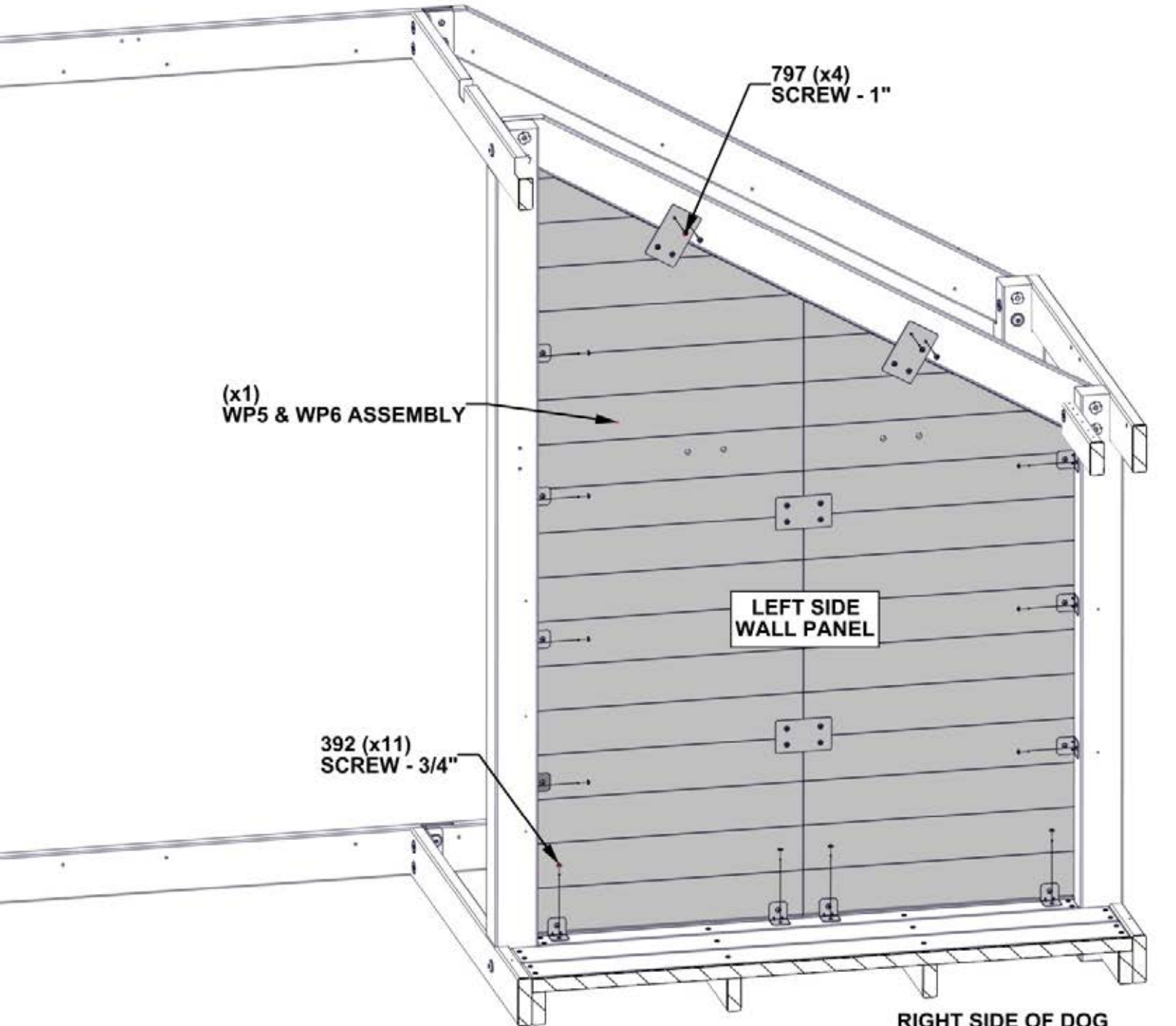

RIGHT SIDE OF DOG KENNEL IS HIDDEN FOR DETAIL

STEP 19 A - WP4 ASSEMBLY



Qty	PART NUMBER	DESCRIPTION
5	H100392	SCREW PWH 8x3/4 BLK

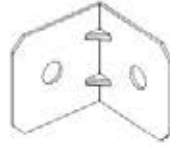

WP4 WALL PANEL - W2A04047
 (x1) 1 1/16"X19 1/16"X44 9/16" (27x484x1133)

A4M01785 ANGLE BRACKET
 (x5)

- USE PILOT HOLES TO ALIGN SCREWS

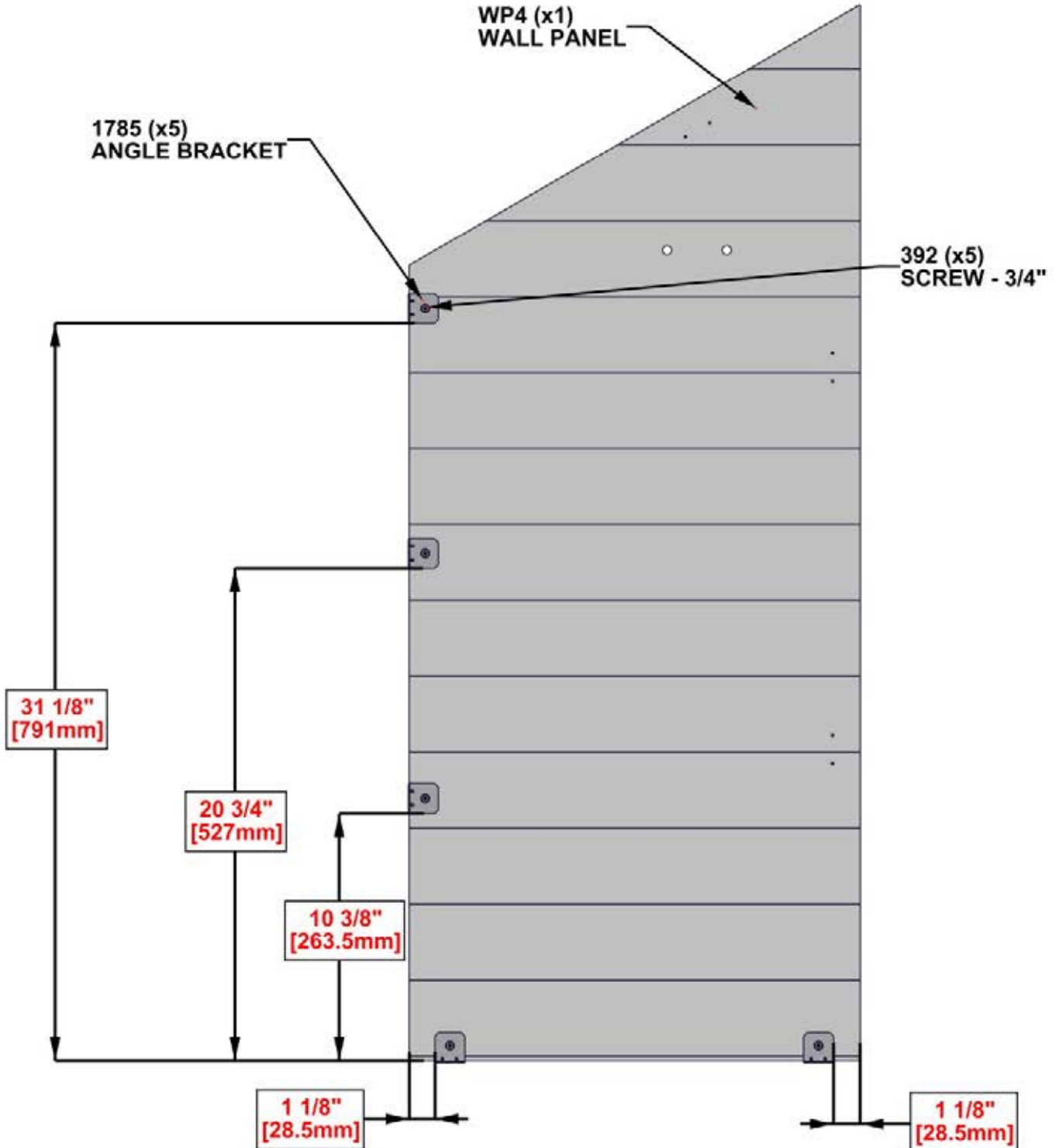

STEP 19 B - WP3 ASSEMBLY

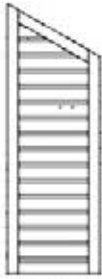

Qty	PART NUMBER	DESCRIPTION
6	H100392	SCREW PWH 8x3/4 BLK

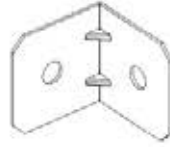

WP3 WALL PANEL - W2A04046
 (x1) 1 1/16"X19 1/16"X55 5/8" (27x484x1412)

A4M01785 ANGLE BRACKET
 (x6)

- USE PILOT HOLES TO ALIGN SCREWS

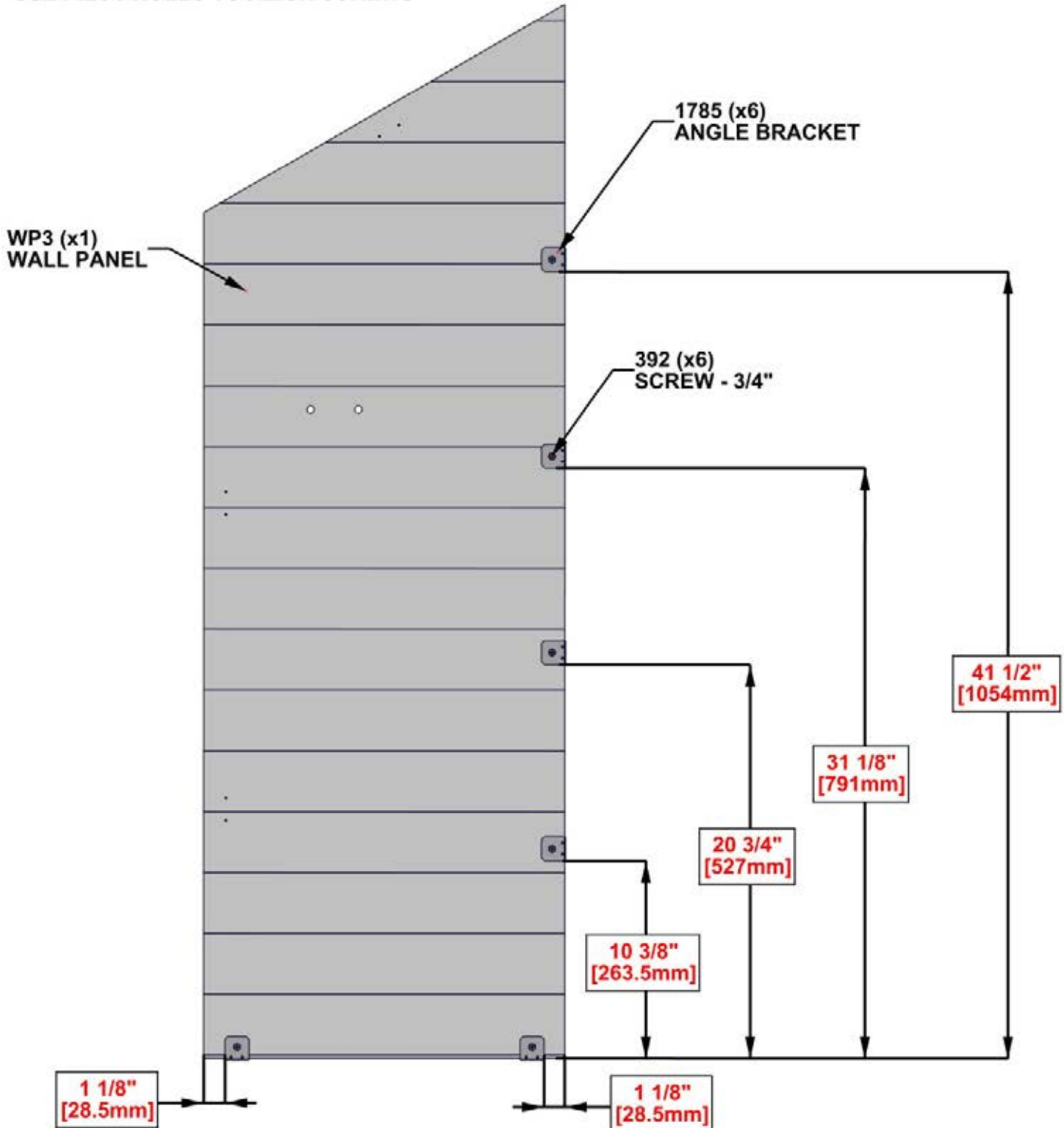

STEP 19 C - WP3 & WP4 ASSEMBLY

Qty	PART NUMBER	DESCRIPTION
12	H100797	SCREW PWH 8x1 BLK



WP4 ASSEMBLY
(x1) (FROM STEP 19 A)

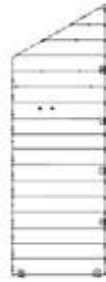

WP3 ASSEMBLY
(x1) (FROM STEP 19 B)



A4M00997 METAL CLEAT
(x4)

- USE PILOT HOLES TO ALIGN SCREWS

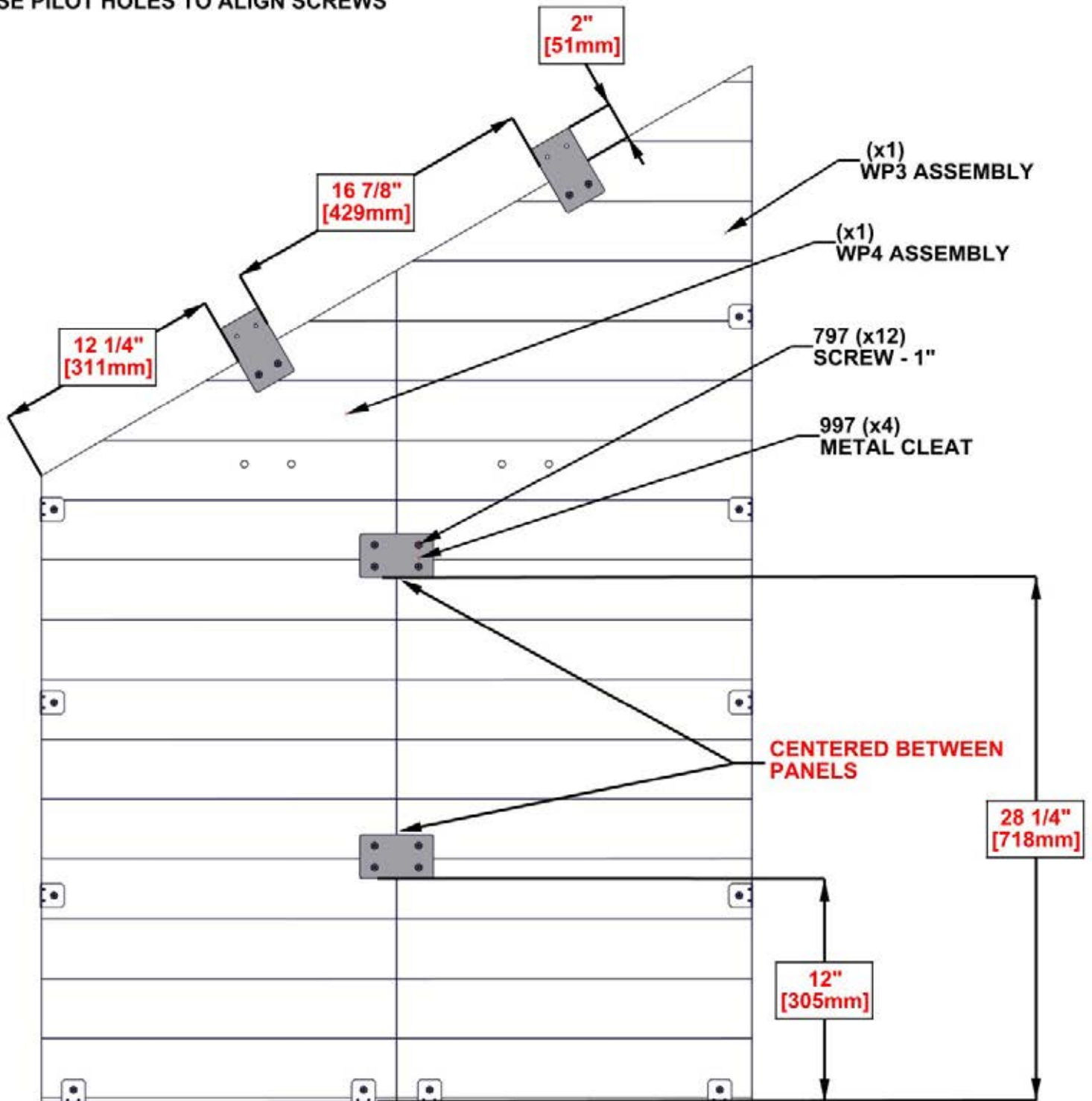

STEP 19 D - DOG KENNEL ASSEMBLY

Qty	PART NUMBER	DESCRIPTION
4	H100797	SCREW PWH 8x1 BLK
11	H100392	SCREW PWH 8x3/4 BLK

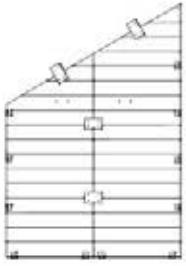

WP3 & WP4 ASSEMBLY
(x1) (FROM STEPS 19 C)

- PREDRILL 1/8" [3mm] PILOT HOLES FOR THE ATTACHMENT OF HARDWARE ON FLOORING BOARDS
- USE PILOT HOLES TO ALIGN SCREWS

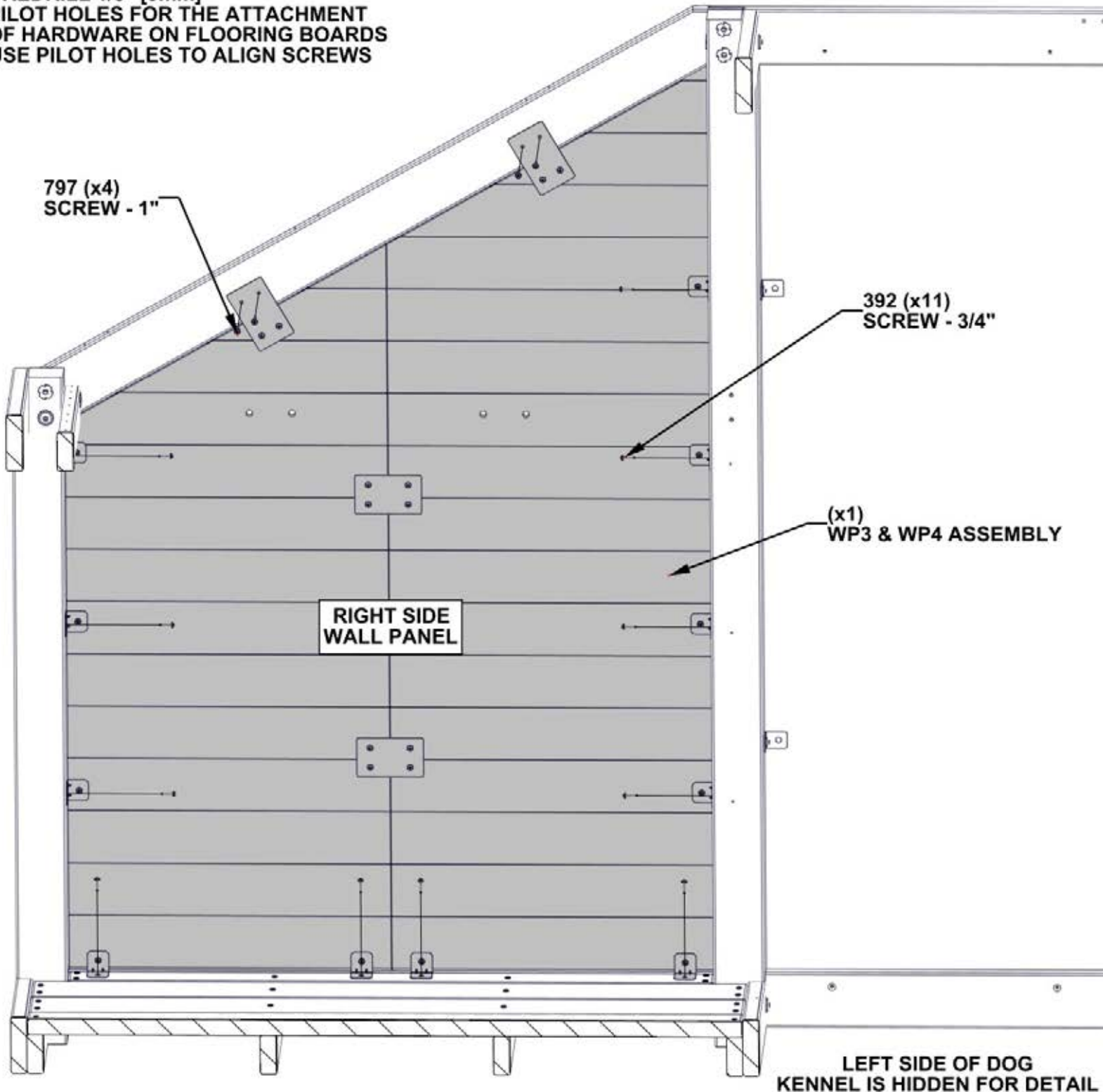

STEP 20 A - DP2 DOOR PANEL ASSEMBLY



Qty	PART NUMBER	DESCRIPTION
11	H100627	SCREW PFH 6x3/4 BLK



DP2 DOOR PANEL - W2A04052
 (x1) 1 1/16"X21 1/16"X33 1/16" (27x535x840)

A4M02289 PIANO HINGE 832mm
 (x1)

- USE PILOT HOLES TO ALIGN HINGE

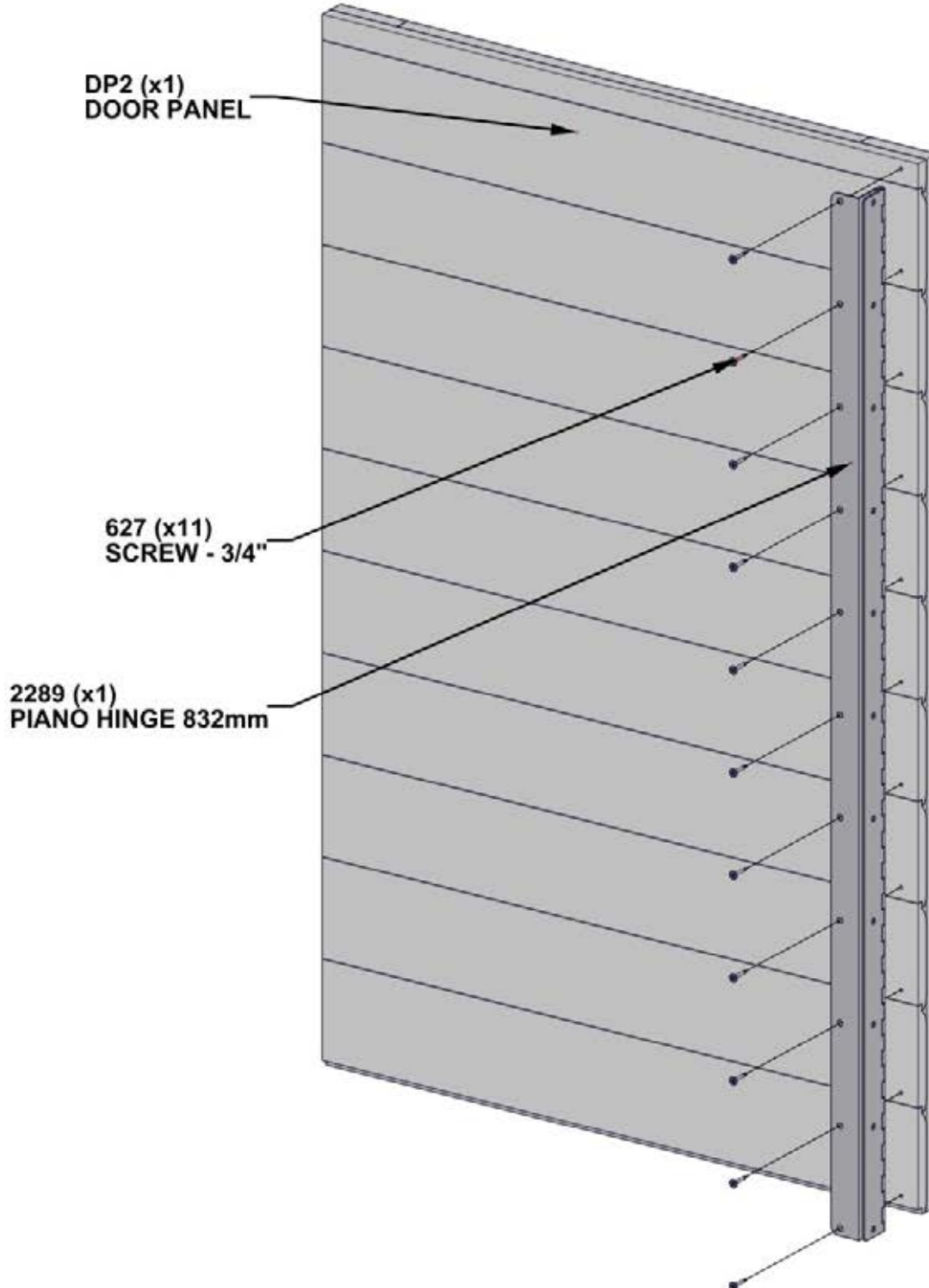

STEP 20 B - DOG KENNEL ASSEMBLY

Qty	PART NUMBER	DESCRIPTION
11	H100627	SCREW PFH 6x3/4 BLK

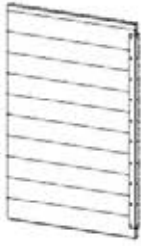

DOOR PANEL & PIANO HINGE ASSEMBLY
(x1) (FROM STEP 20 A)

- USE PILOT HOLES TO ALIGN SCREWS

(x1)
DOOR PANEL & PIANO
HINGE ASSEMBLY

627 (x11)
SCREW - 3/4"

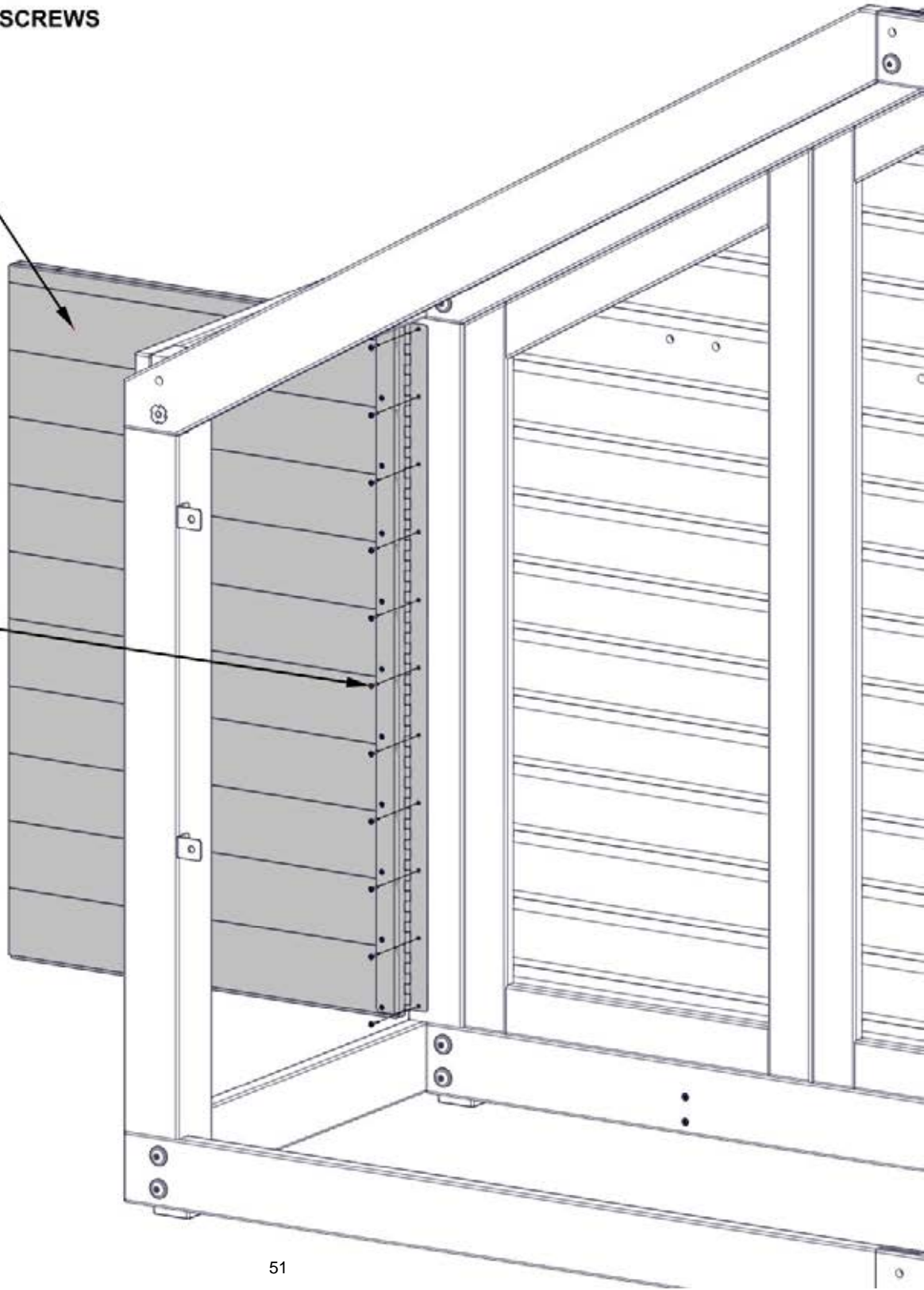

STEP 21 A - WP7 ASSEMBLY

Qty	PART NUMBER	DESCRIPTION
5	H100392	SCREW PWH 8x3/4 BLK



WP7 WALL PANEL - W2A04050
(x1) 1 1/16"X18 3/4"X33 1/2" (27x477x850)

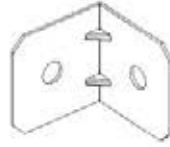

A4M01785 ANGLE BRACKET
(x5)

- USE PILOT HOLES TO ALIGN SCREWS

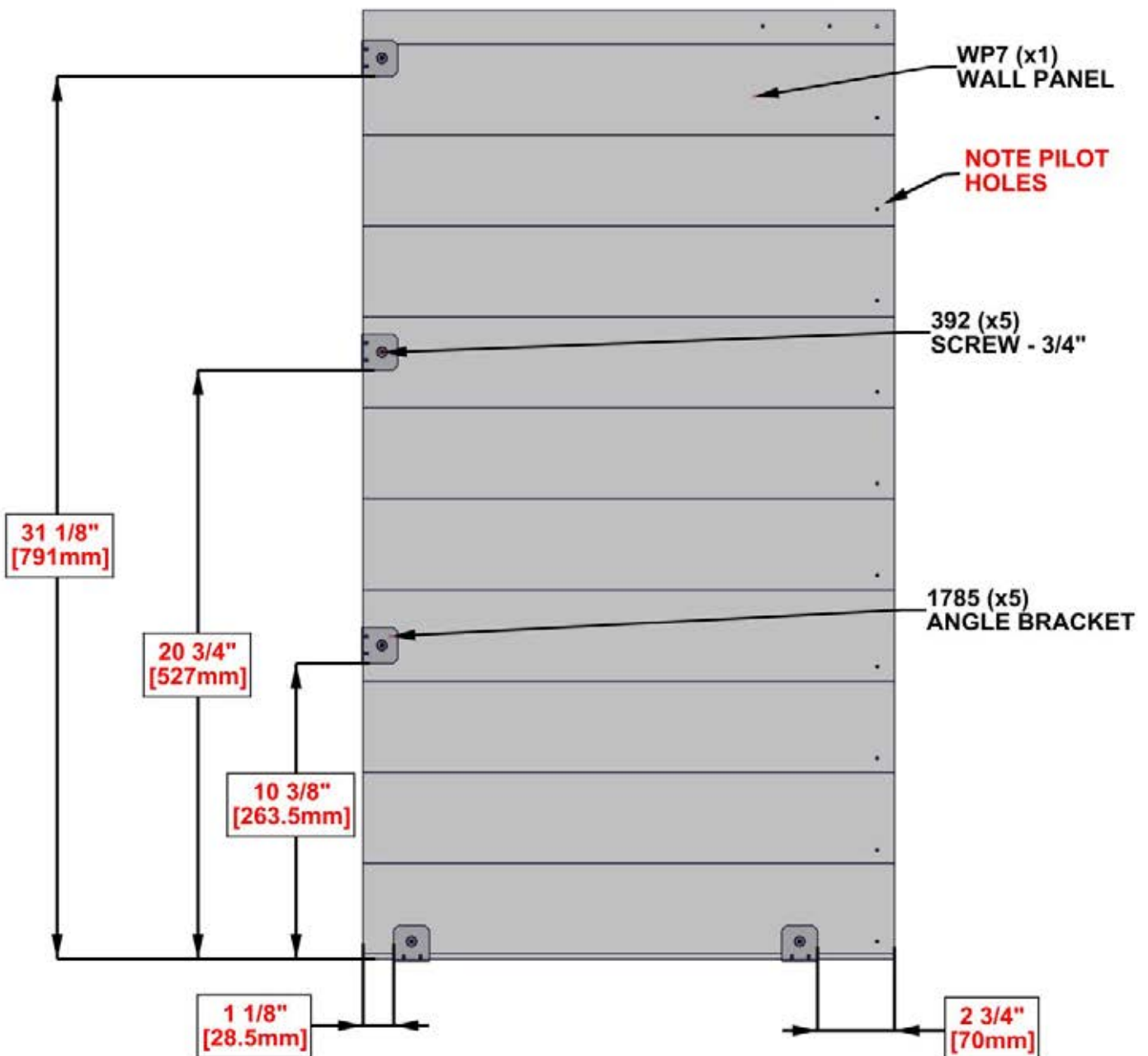

STEP 21 B - DOG KENNEL ASSEMBLY



Qty	PART NUMBER	DESCRIPTION
7	H100392	SCREW PWH 8x3/4 BLK

WP7 ASSEMBLY
(x1) (FROM STEP 21 A)

- PREDRILL 1/8" [3mm] PILOT HOLES FOR THE ATTACHMENT OF HARDWARE ON FLOORING BOARDS
- USE PILOT HOLES TO ALIGN SCREWS

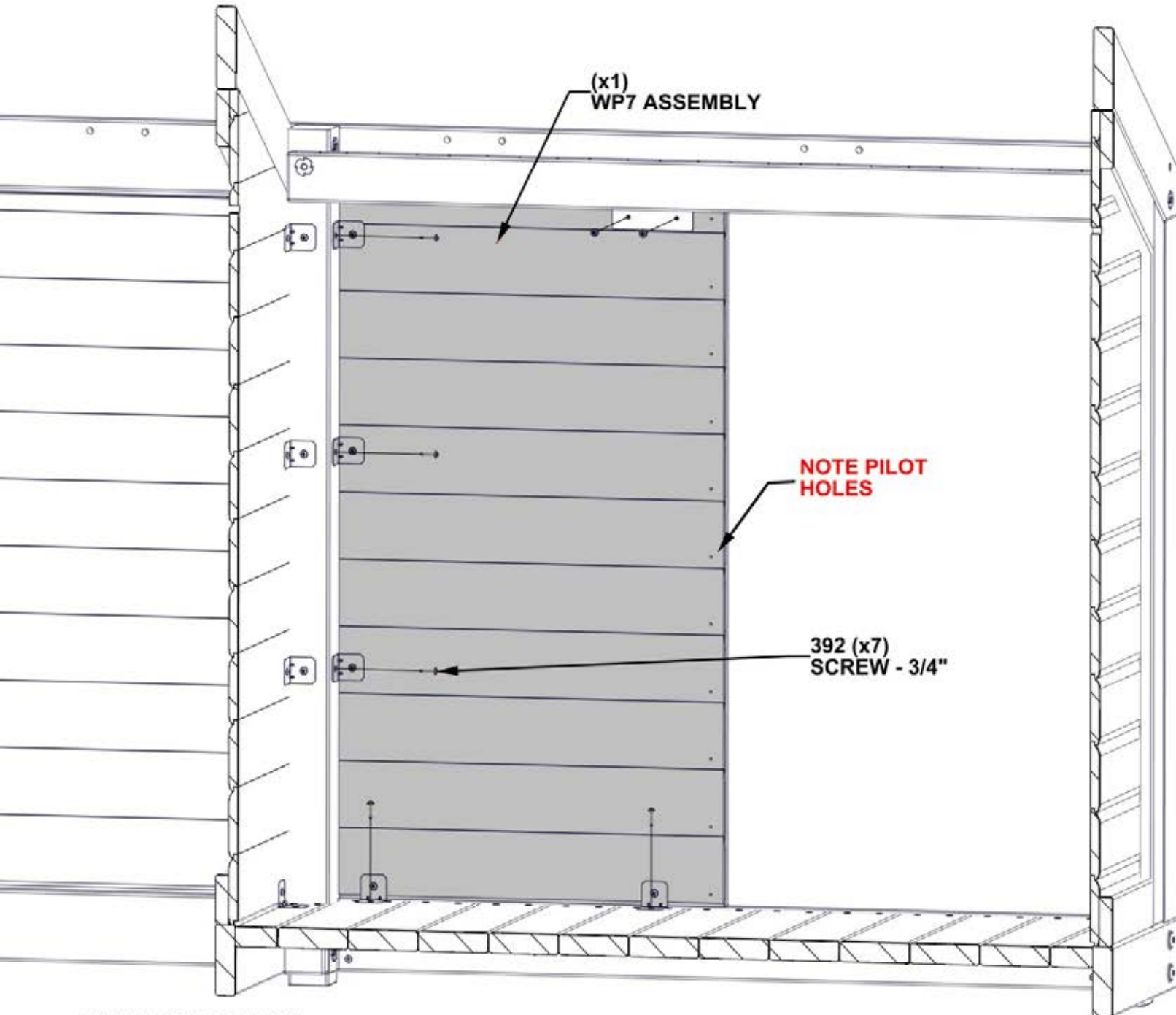

FRONT SIDE OF DOG
KENNEL IS HIDDEN FOR DETAIL

STEP 22 A - DP1 DOOR ASSEMBLY

Qty	PART NUMBER	DESCRIPTION
11	H100627	SCREW PFH 6x3/4 BLK

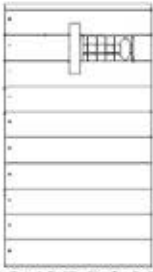

DP1 DOG HOUSE DOOR - W2A04051
 (x1) 1 1/4"X18 7/16"X33 1/16" (32x469x840)



A4M02726 HINGE 832mm
 (x1)

- USE PILOT HOLES TO ALIGN HINGE

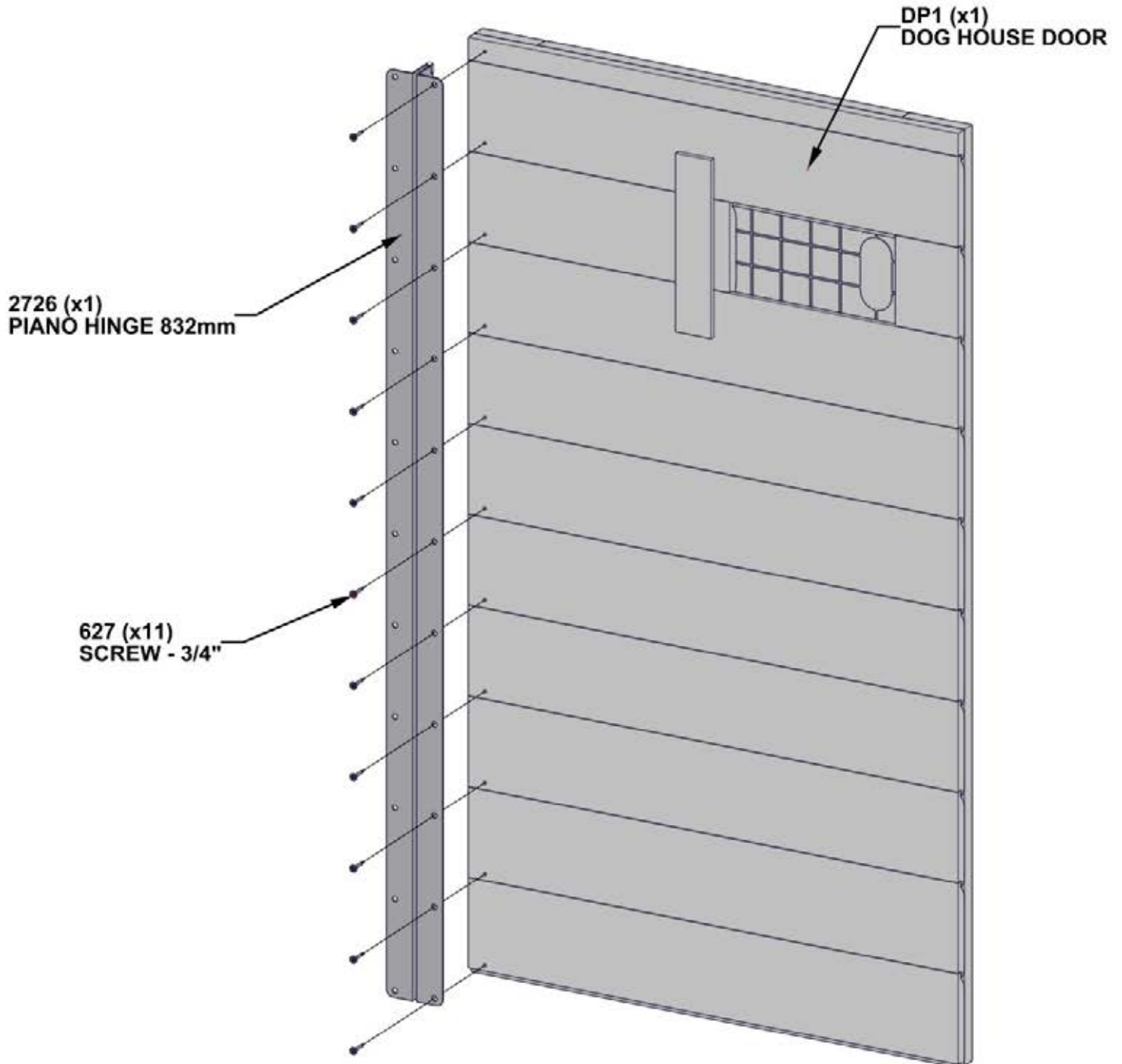

STEP 22 B - DOG KENNEL ASSEMBLY

Qty	PART NUMBER	DESCRIPTION
11	H100627	SCREW PFH 6x3/4 BLK

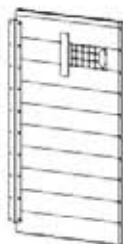

DP1 DOOR PANEL & PIANO HINGE ASSEMBLY
(x1) (FROM STEP 22 A)

- USE PILOT HOLES TO ALIGN SCREWS

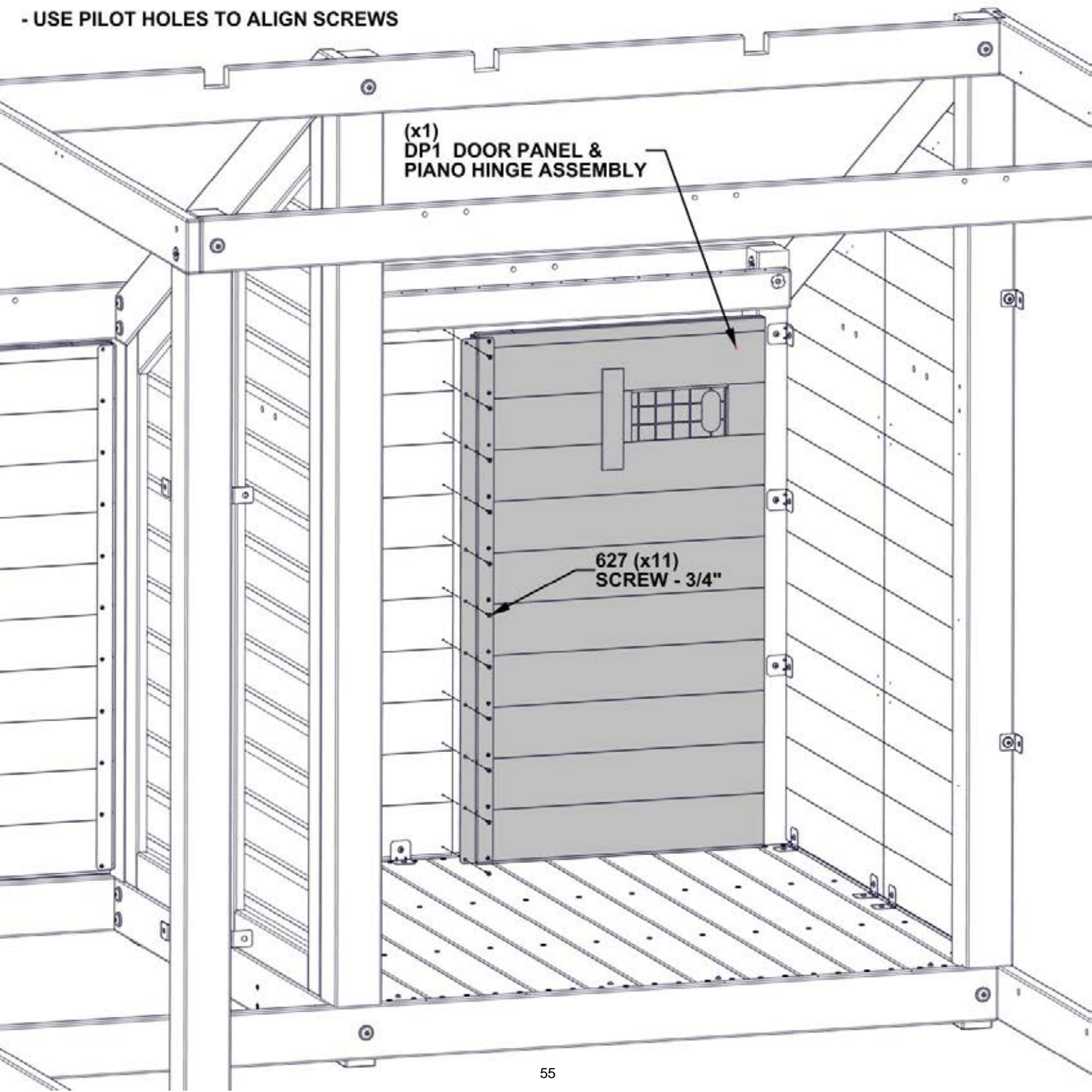

STEP 23 A - WP2 ASSEMBLY

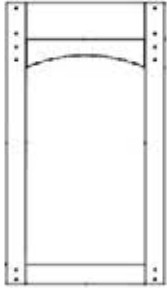

WP2 DOOR FRAME - W2A04045
 (x1) 1 7/16"X18 13/16"X29 1/16" (36x478x850)

Qty	PART NUMBER	DESCRIPTION
9	H100392	SCREW PWH 8x3/4 BLK

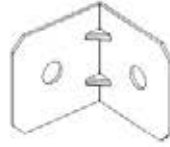

A4M01785 ANGLE BRACKET
 (x5)

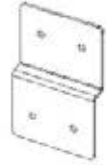

A4M01846 Z TIE BRACKET
 (x2)

- USE PILOT HOLES TO ALIGN SCREWS

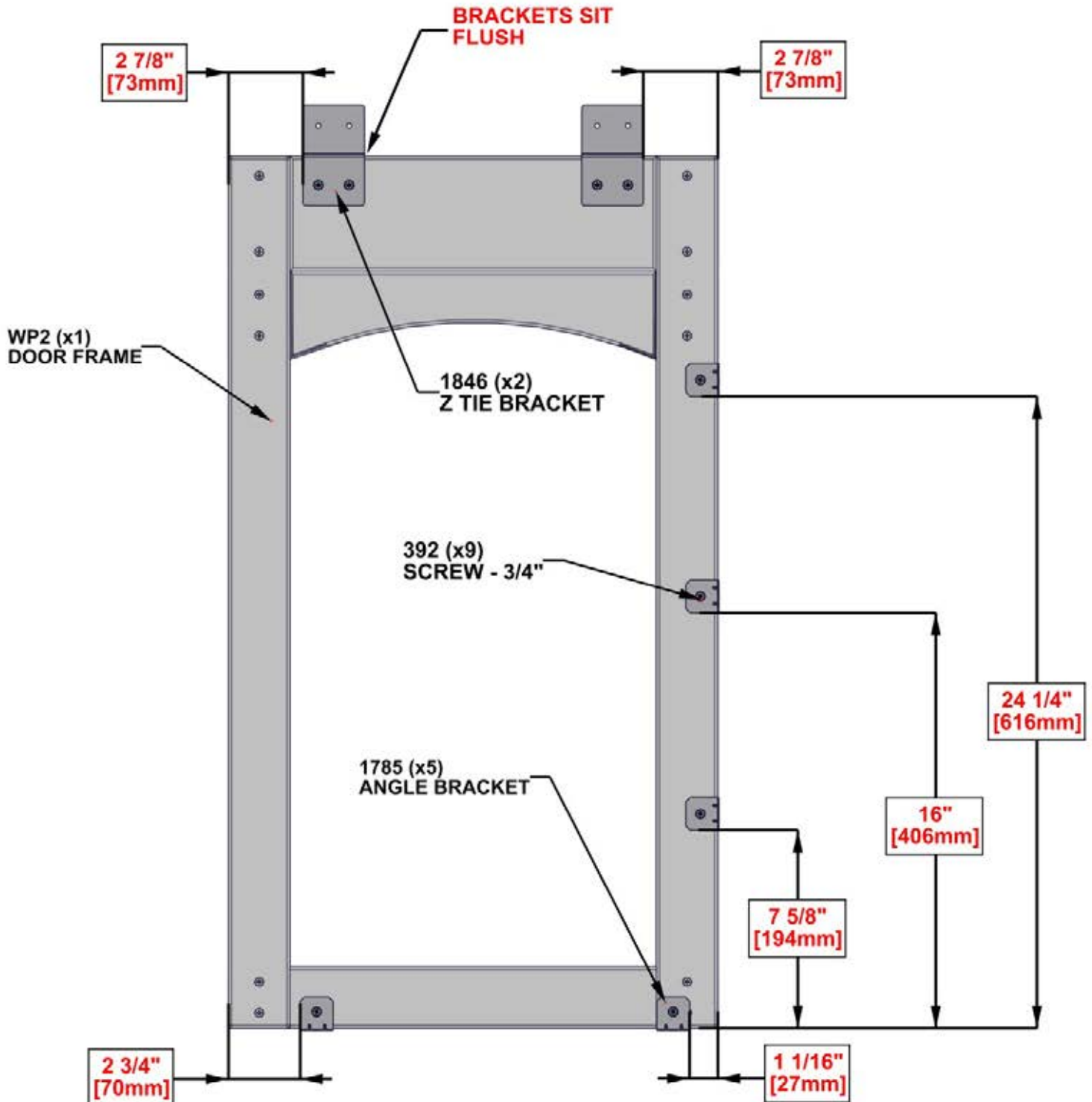

STEP 23 B - DOG KENNEL ASSEMBLY

Qty	PART NUMBER	DESCRIPTION
5	H100392	SCREW PWH 8x3/4 BLK

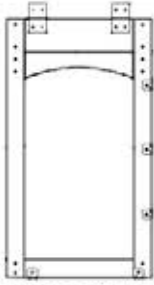

WP2 DOOR ASSEMBLY
(x1) (FROM STEP 23 A)

- PREDRILL 1/8" [3mm] PILOT HOLES FOR THE ATTACHMENT OF HARDWARE ON FLOORING BOARDS
- USE PILOT HOLES TO ALIGN SCREWS

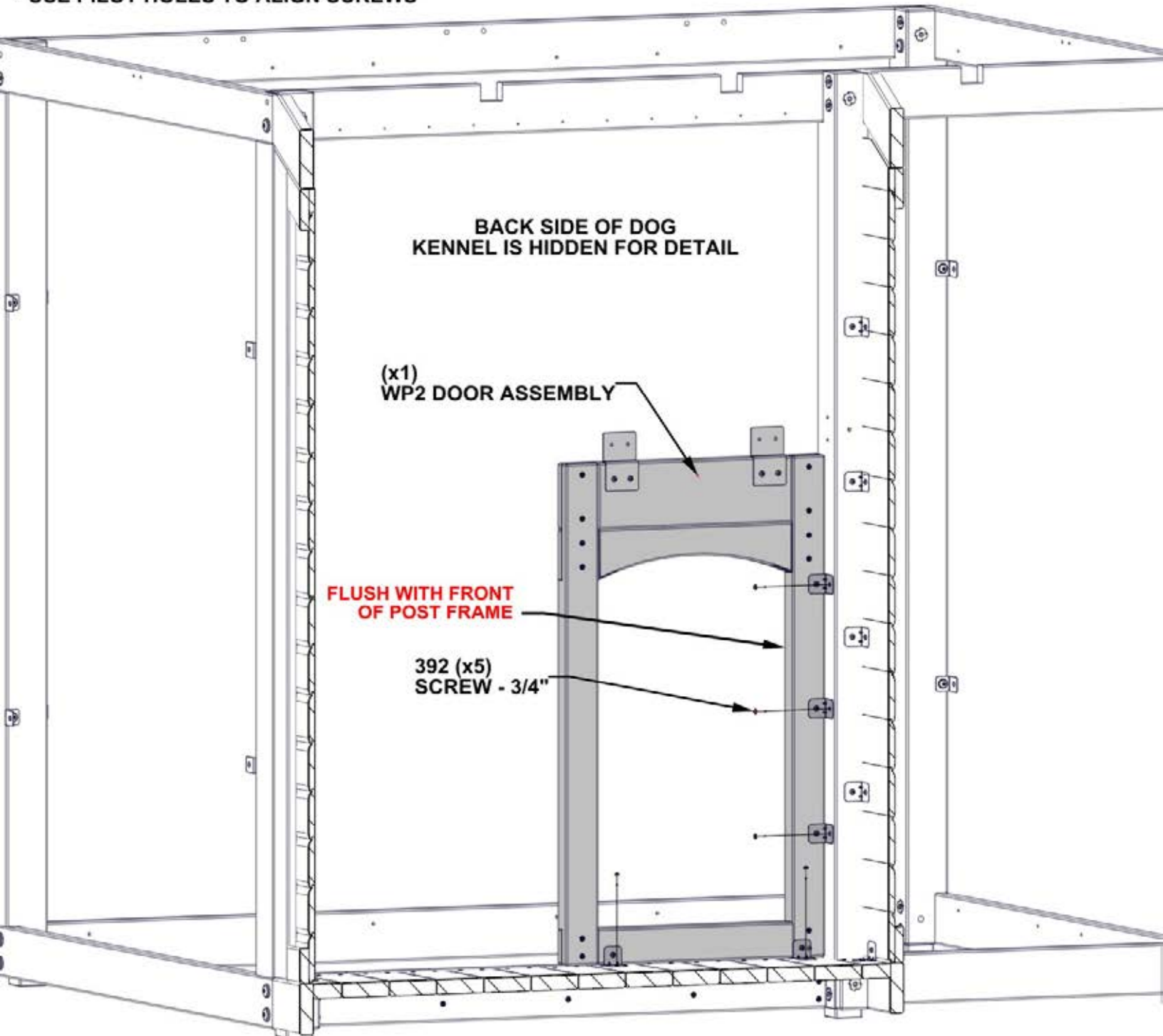

STEP 24 A - WP1 ASSEMBLY

Qty	PART NUMBER	DESCRIPTION
7	H100392	SCREW PWH 8x3/4 BLK



WP1 WALL PANEL - W2A04044
(x1) 1 1/16"X18 3/4"X33 1/2" (27x477x850)

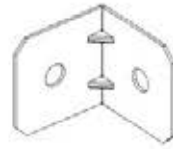

A4M01785 ANGLE BRACKET
(x5)



A4M00997 METAL CLEAT
(x1)

- USE PILOT HOLES TO ALIGN SCREWS

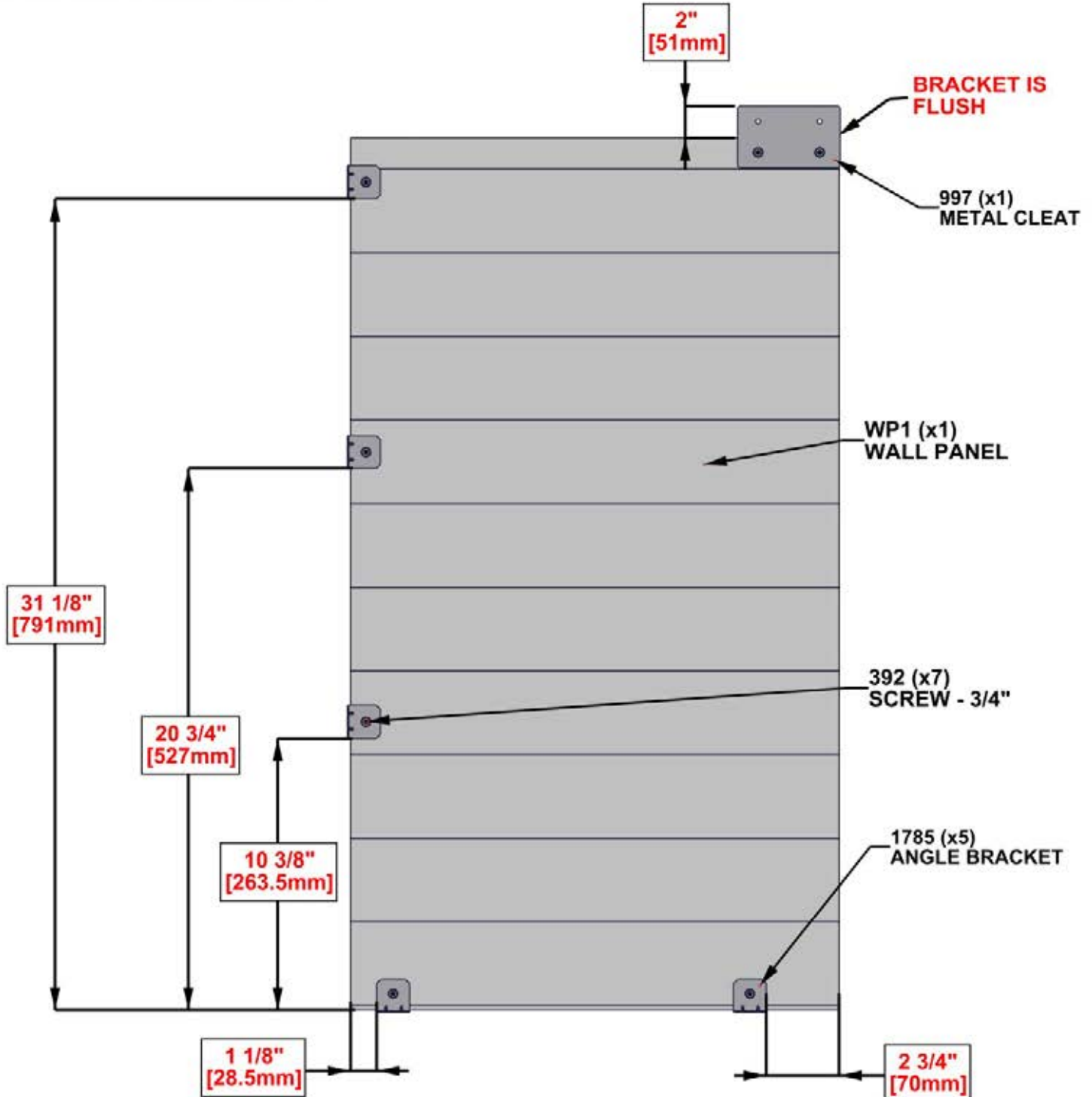

STEP 24 B - DOG KENNEL ASSEMBLY

Qty	PART NUMBER	DESCRIPTION
5	H100392	SCREW PWH 8x3/4 BLK

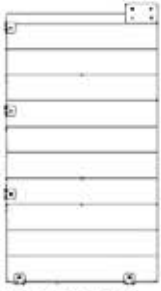

WP1 ASSEMBLY
(x1) (FROM STEP 24 A)

- PREDRILL 1/8" [3mm] PILOT HOLES FOR THE ATTACHMENT OF HARDWARE ON FLOORING BOARDS
- USE PILOT HOLES TO ALIGN SCREWS

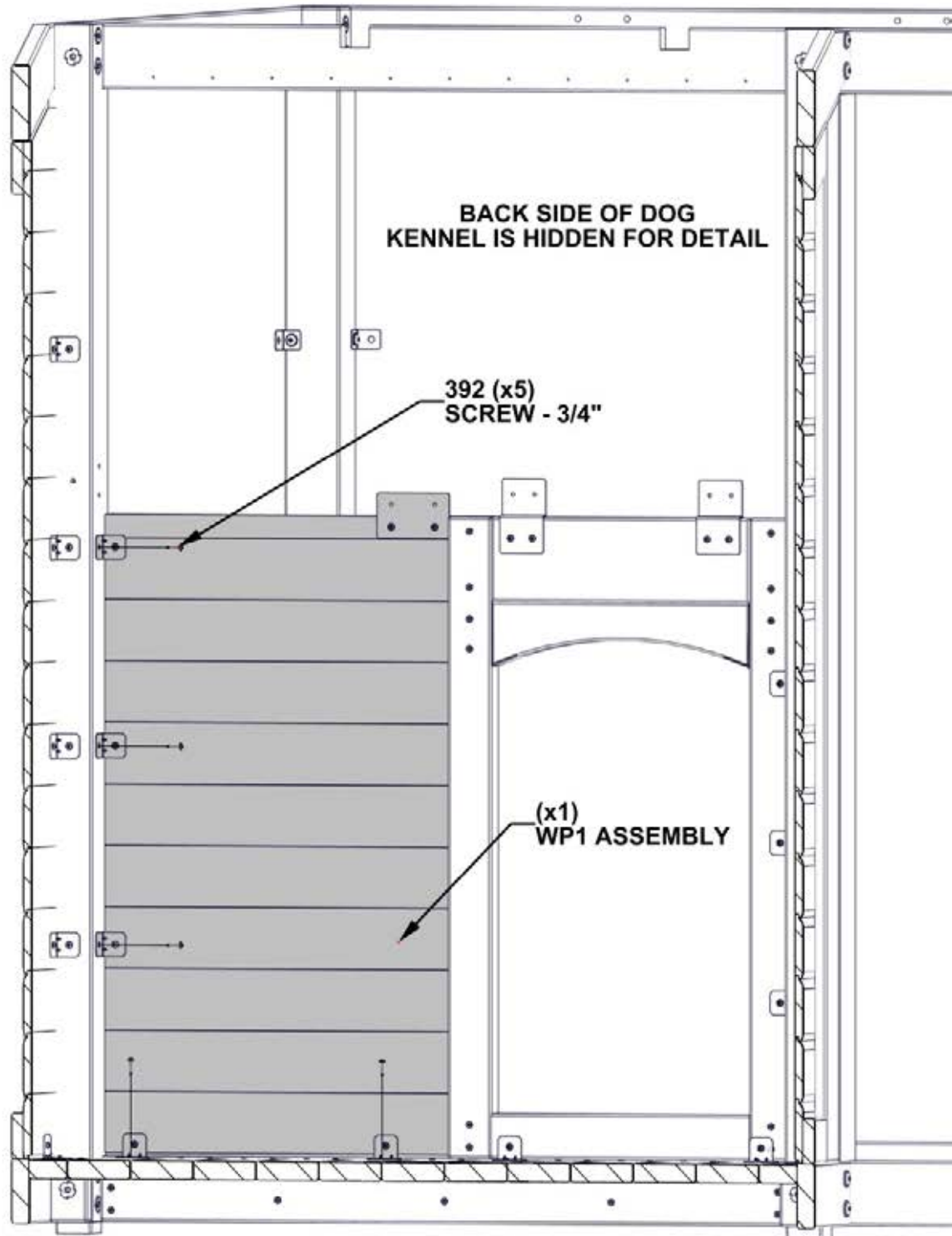

STEP 25 A - DOG KENNEL ASSEMBLY



A4M00855 L BRACKET
(x2)

Qty	PART NUMBER	DESCRIPTION
4	H100469	NUT BARREL WH 5/16X5/8 BLK
4	H100663	BOLT WH 5/16x3/4 BLK
4	H100198	WASHER LOCK EXT 8x19



H15 WALL BOARD - W4L19180
(x1) 15/16"X3 3/8"X37 3/4" (24x86x959)

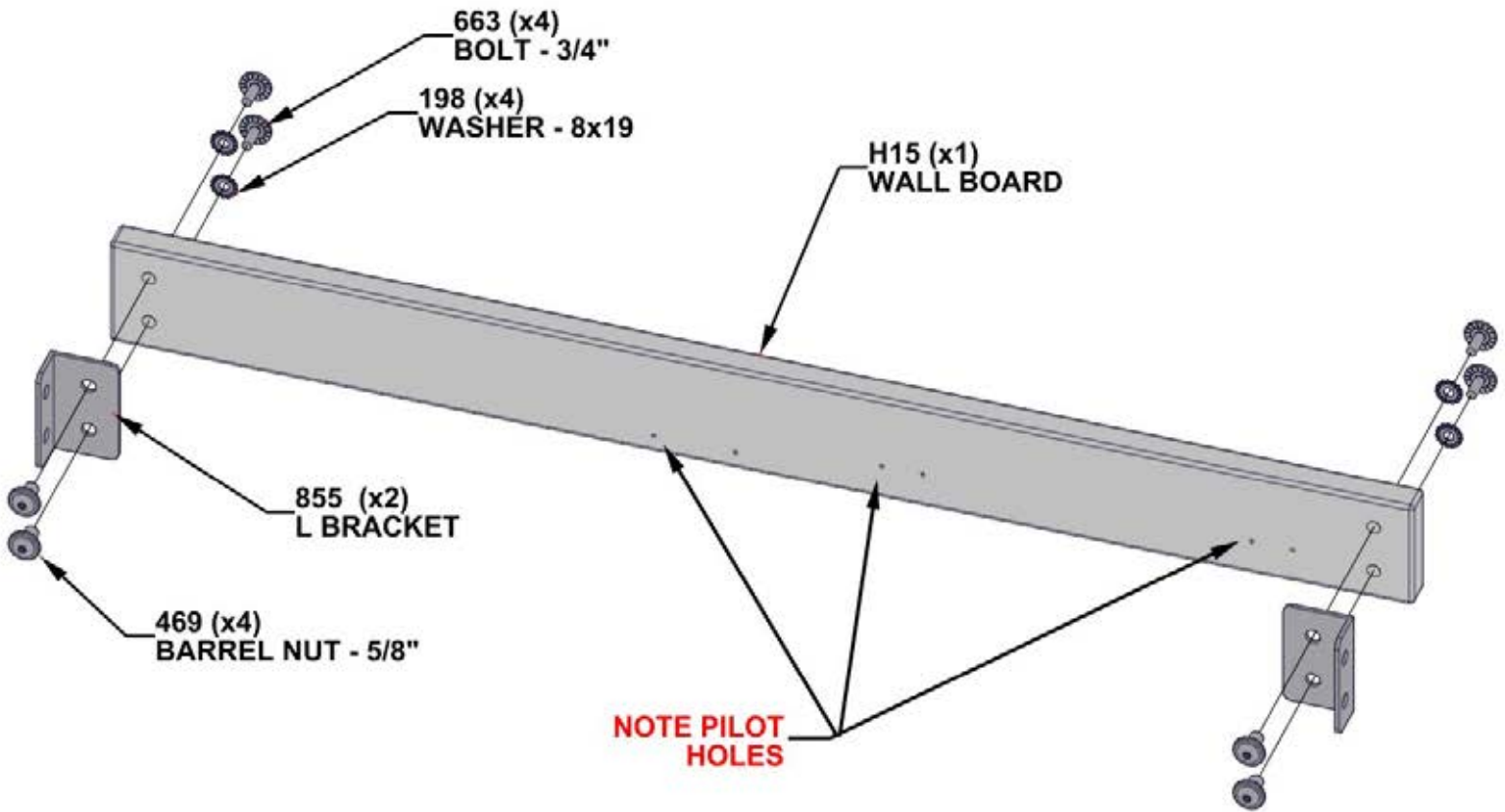

STEP 25 B - DOG KENNEL ASSEMBLY

Qty	PART NUMBER	DESCRIPTION
4	H100854	LAG SCREW WH 5/16x1 BLK
6	H100392	SCREW PWH 8x3/4 BLK

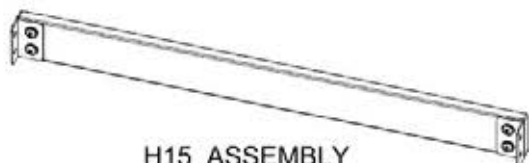

H15 ASSEMBLY
(x1)

- USE PILOT HOLES TO ALIGN SCREWS

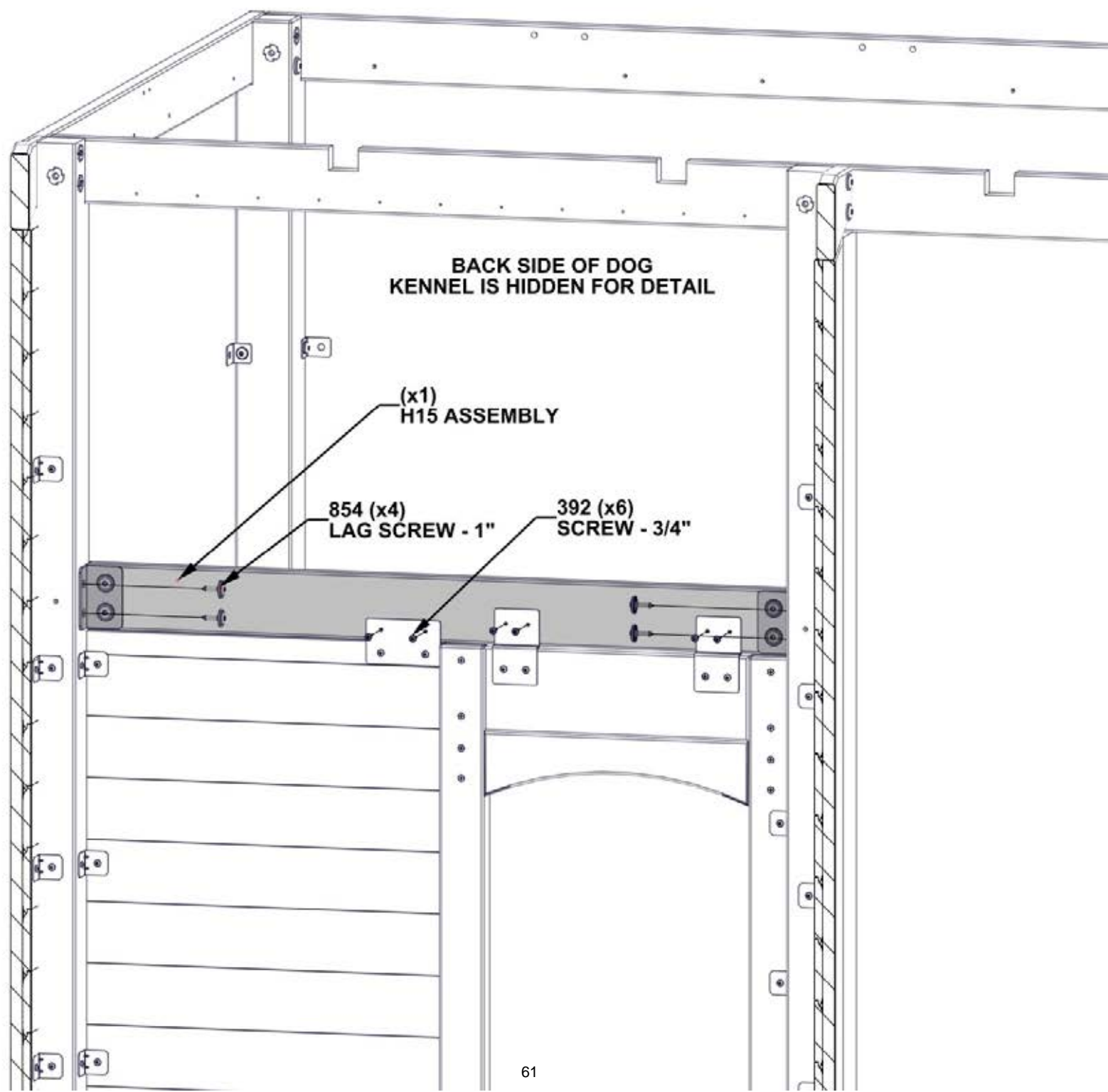

STEP 26 A - DOG KENNEL ASSEMBLY

Qty	PART NUMBER	DESCRIPTION
4	H100479	NUT LOCK 5/16 BLK
4	H100468	BOLT WH 5/16x1 BLK
4	H100198	WASHER LOCK EXT 8x19
4	H100630	WASHER FLAT 8x19 BLK

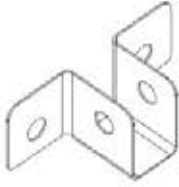

A4M02606 JOIST HANGER 90°
(x2)

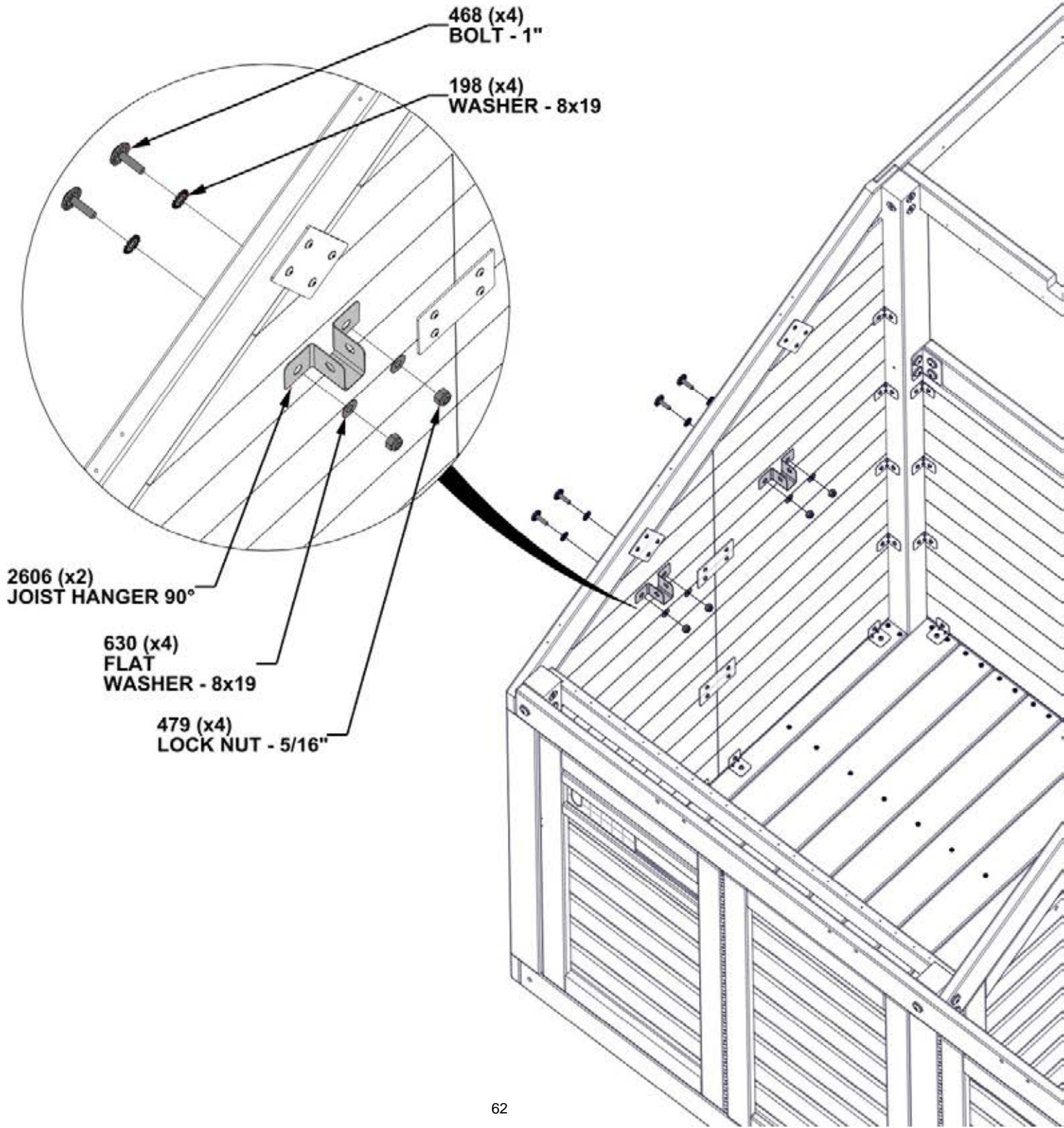

STEP 26 B - DOG KENNEL ASSEMBLY

Qty	PART NUMBER	DESCRIPTION
4	H100479	NUT LOCK 5/16 BLK
4	H100468	BOLT WH 5/16x1 BLK
4	H100630	WASHER FLAT 8x19 BLK
4	H100198	WASHER LOCK EXT 8x19

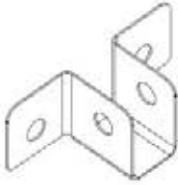

A4M02606 JOIST HANGER 90°
(x2)

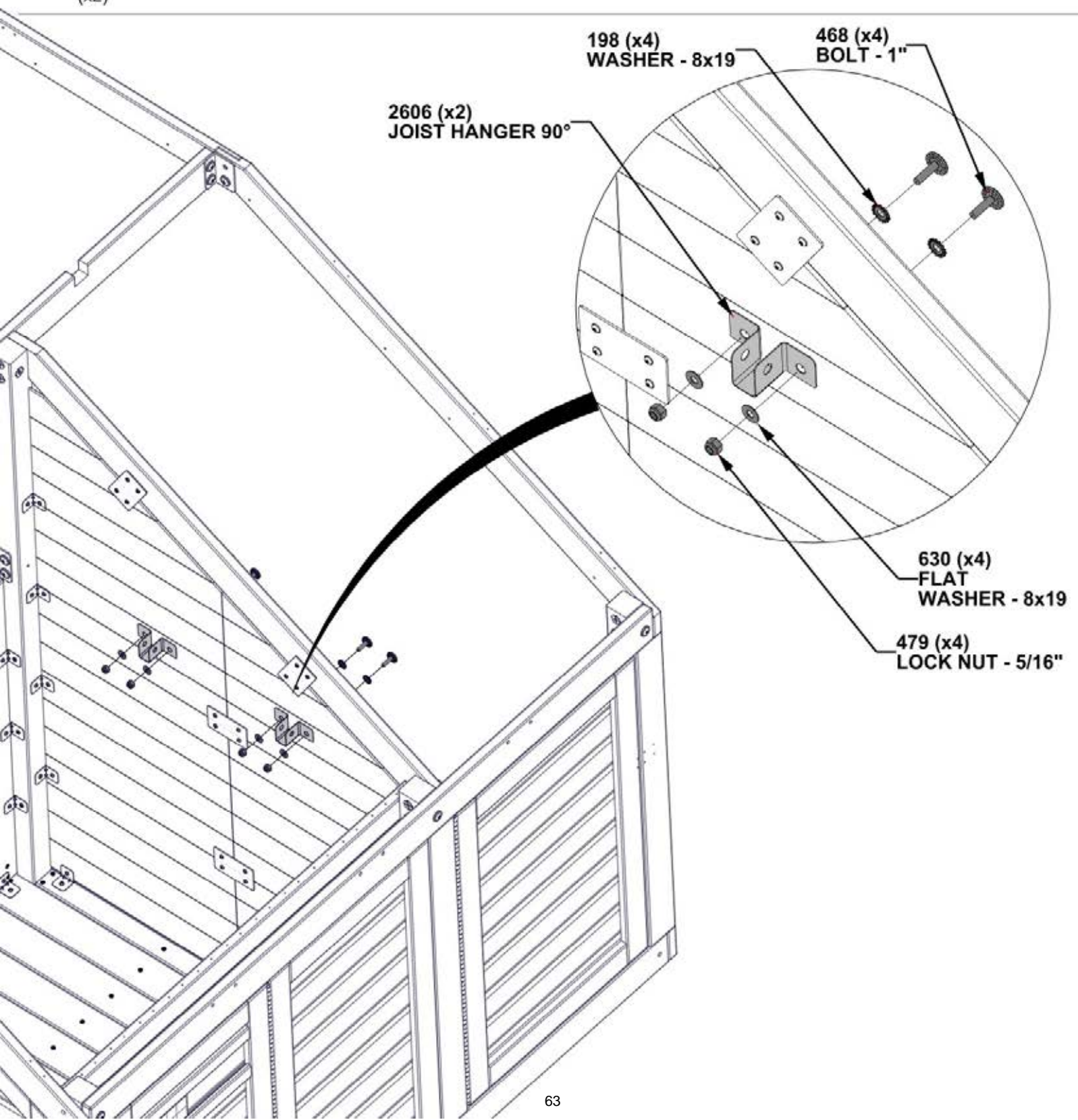

STEP 27 - DOG KENNEL ASSEMBLY

Qty	PART NUMBER	DESCRIPTION
2	H100458	LAG SCREW WH 5/16x2 BLK
2	H100198	WASHER LOCK EXT 8x19
4	H100469	NUT BARREL WH 5/16X5/8 BLK
4	H100663	BOLT WH 5/16x3/4 BLK



J5 FLOOR JOIST - W4L19454
(x1) 15/16"X2 3/8"X41 9/16" (24x60x1055)

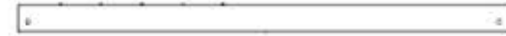

J6 FLOOR JOIST - W4L19455
(x2) 15/16"X2 3/8"X41 9/16" (24x60x1055)

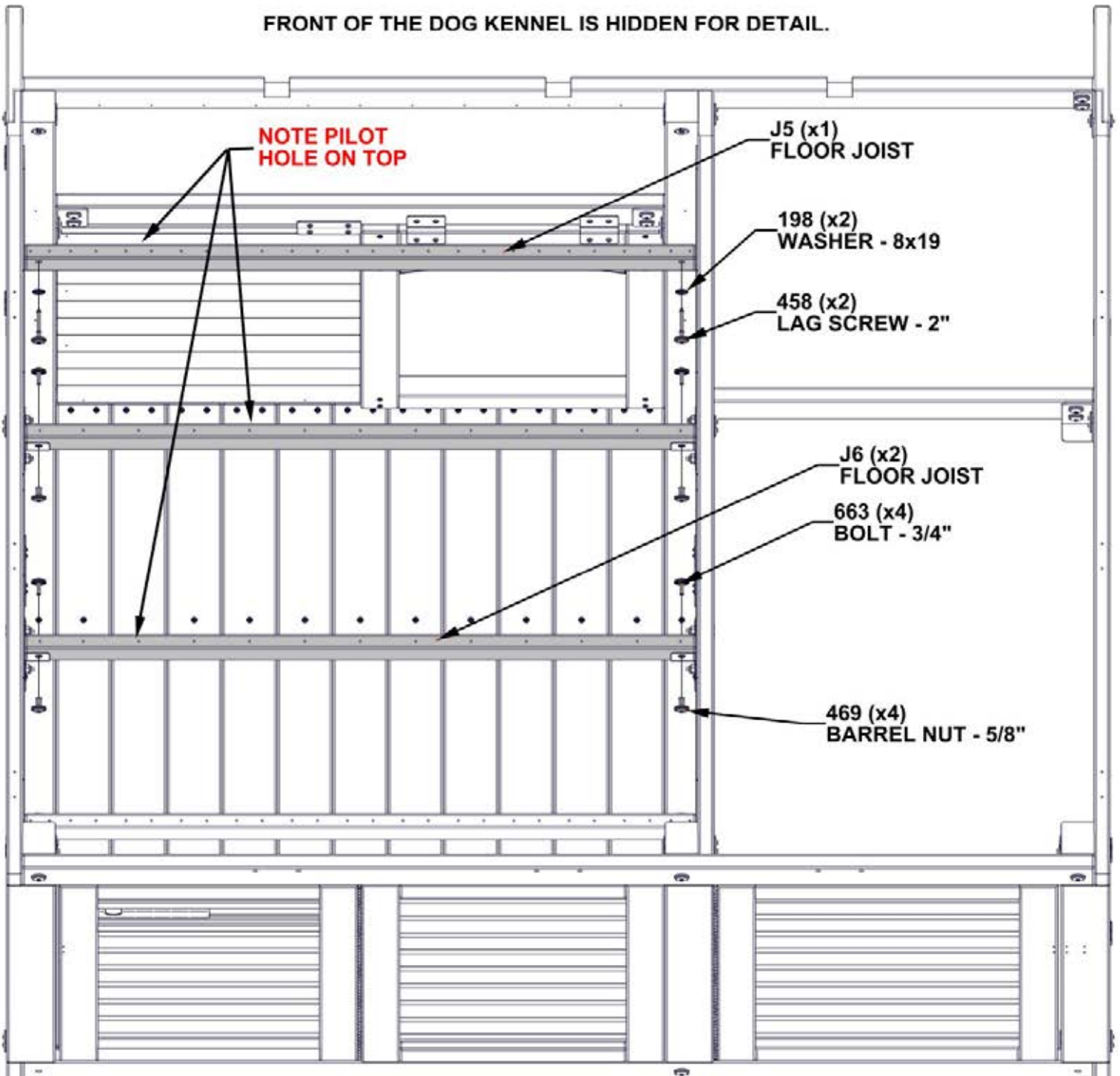

STEP 28 - DOG KENNEL ASSEMBLY

Qty	PART NUMBER	DESCRIPTION
74	H100387	SCREW PFH 8x1 1/4 BLK

M4 FLOOR BOARD - W4L19456
(x5) 5/8"x3 3/8"x42 3/16" (16x86x1072)

M2 FLOOR BOARD - W4L19469
(x1) 5/8"x3 3/8"x40 3/16" (16x86x1021)

M1 FLOORBOARD - W4L19457
(x2) 5/8"x3 3/8"x42 3/16" (16x86x1072)

M3 FLOOR BOARD - W4L19470
(x3) 5/8"x3 3/8"x40 3/16" (16x86x1021)

N2 FLOOR BOARD - W4L19458
(x2) 5/8"x1 7/8"x38 1/8" (16x48x968)

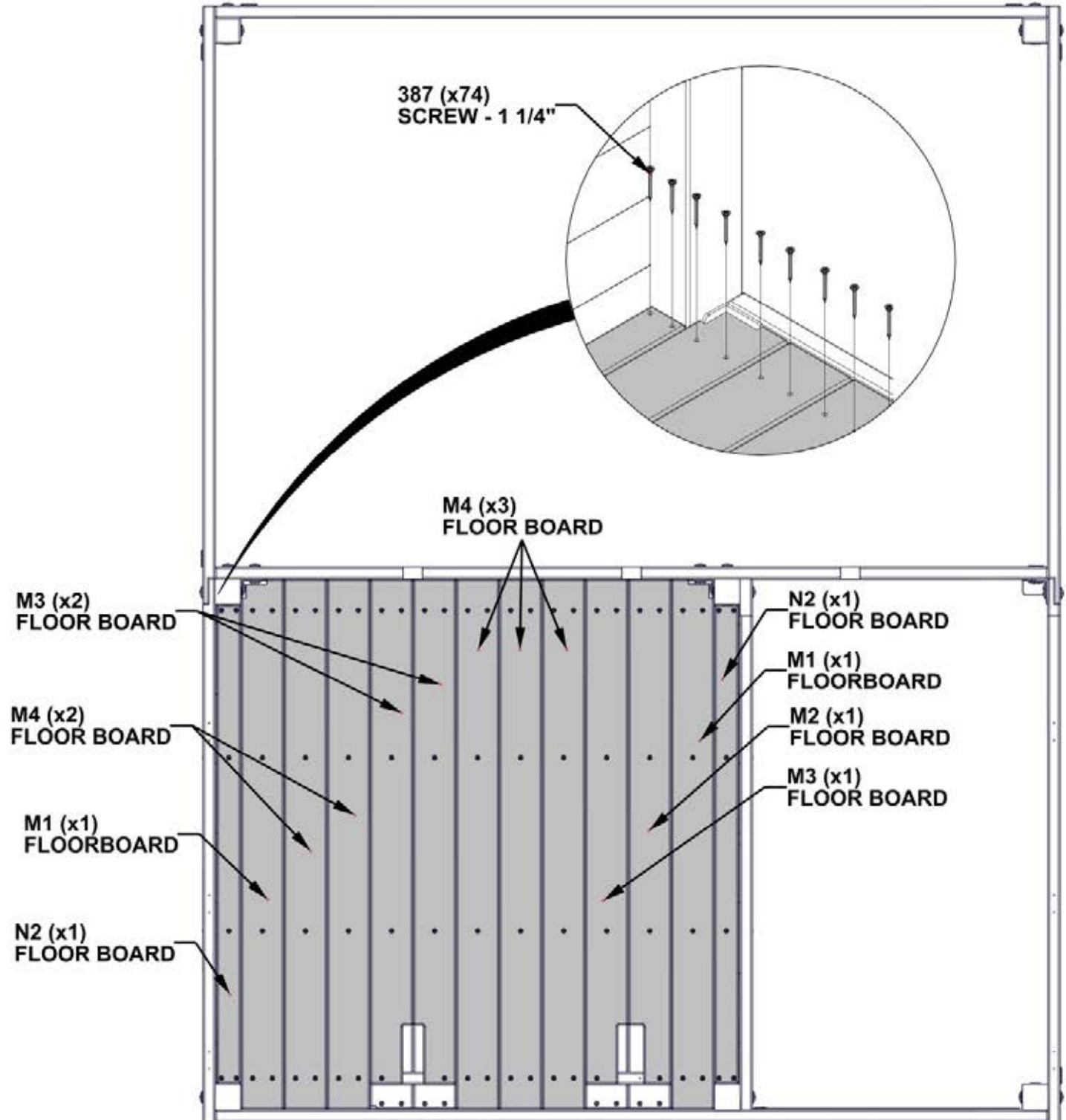

STEP 29 A - DOG KENNEL ASSEMBLY

Qty	PART NUMBER	DESCRIPTION
11	H100627	SCREW PFH 6x3/4 BLK

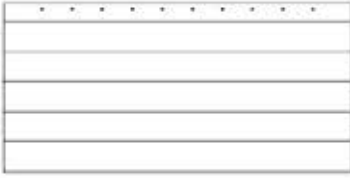

DP3 STORAGE DOOR - W2A04053
(x1) 1 1/16"X18 1/4"X37 5/16" (27x464x947)



A4M02726 HINGE 832mm
(x1)

- USE PILOT HOLES TO ALIGN HINGE

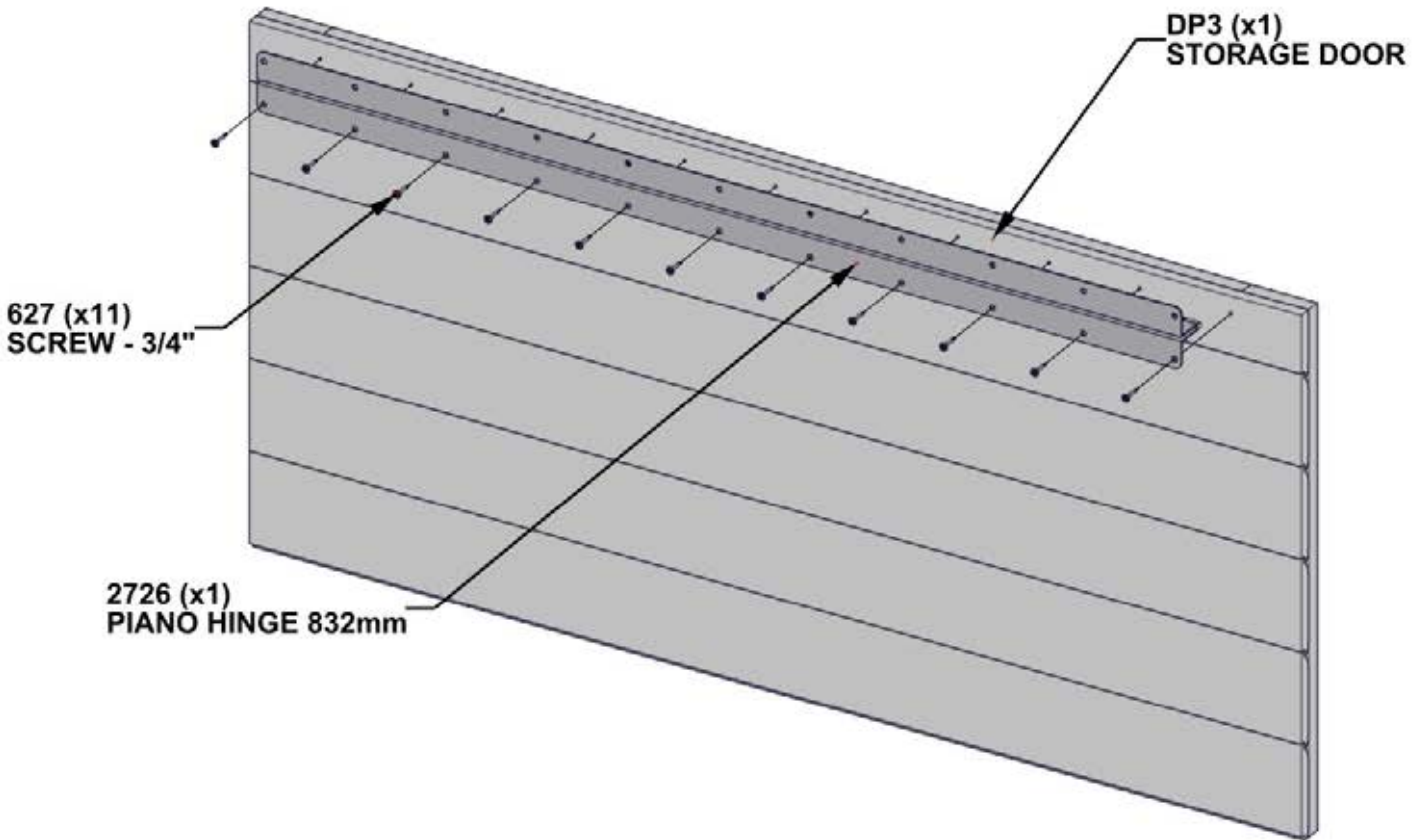

STEP 29 B - DOG KENNEL ASSEMBLY

Qty	PART NUMBER	DESCRIPTION
11	H100627	SCREW PFH 6x3/4 BLK

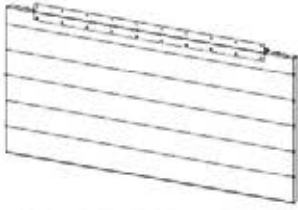

STORAGE DOOR & PIANO HINGE ASSEMBLY
(x1) (FROM STEP 29 A)

- USE PILOT HOLES TO ALIGN SCREWS

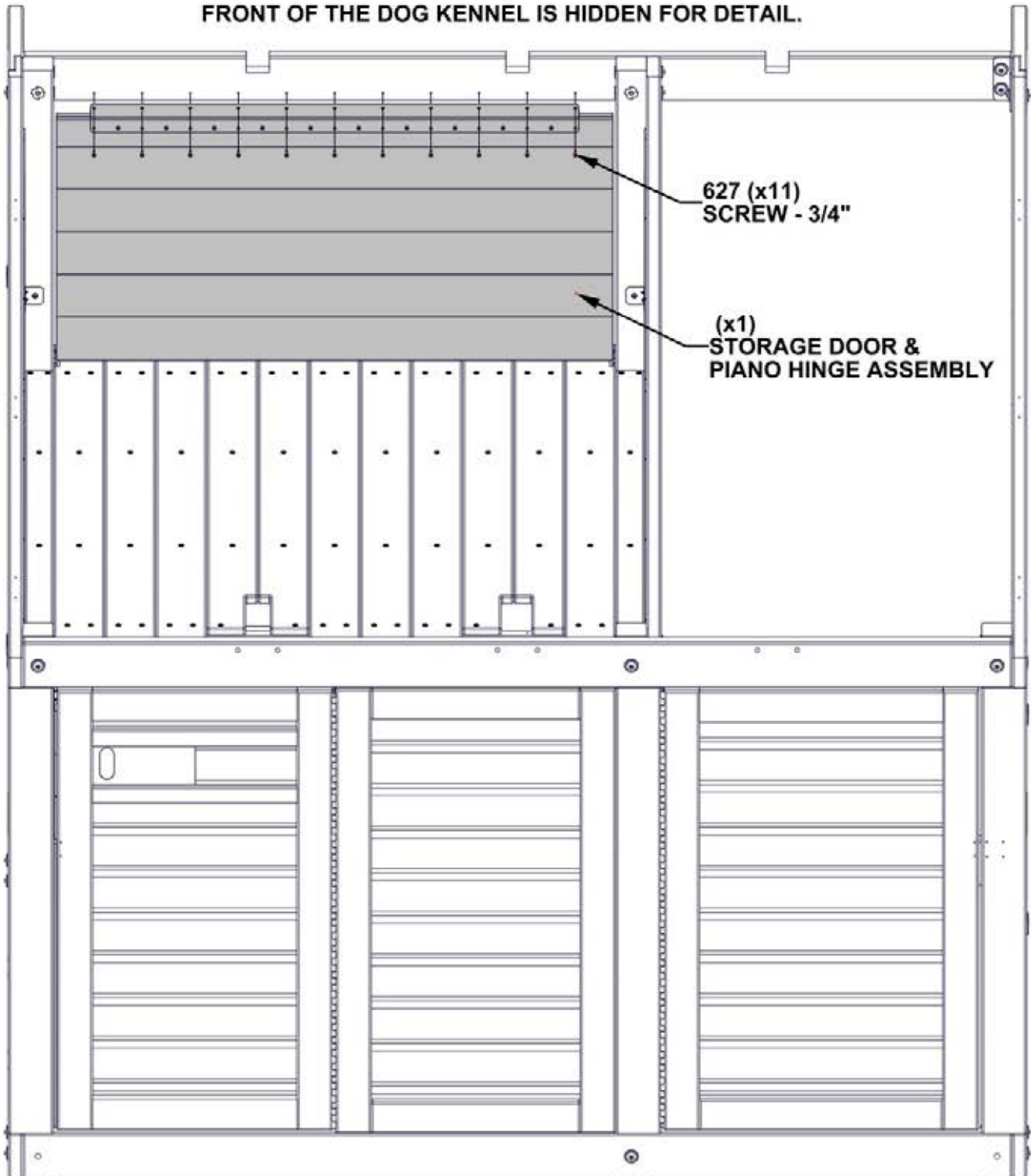

STEP 30 - DOG KENNEL ASSEMBLY

Qty	PART NUMBER	DESCRIPTION
4	H100200	SCREW PFH 8x1 1/2 BLK



J10 CLEAT - W4L19527
 (x1) 15/16"x2 3/8"x6 7/8" (24x60x175)

- PREDRILL 1/8" [3mm] PILOT HOLES FOR THE ATTACHMENT OF HARDWARE ON TOP FLOORING BOARDS.

BOARD SITS FLUSH AGAINST STORAGE DOOR DP3

200 (x4) SCREW - 1 1/2"

J10 (x1) CLEAT



STEP 31 - DOG KENNEL ASSEMBLY

Qty	PART NUMBER	DESCRIPTION
5	H100202	SCREW PWH 8x5/8 BLK



A4M02627 SCREW ON HASP LOCK
(x1)

TIP INSTALL BOTTOM PART OF HASP LOCK FIRST

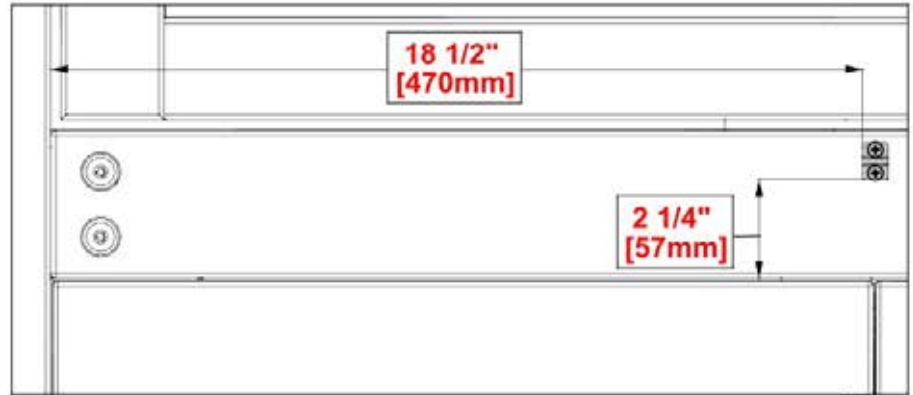

USE BOTTOM PART OF HASP LOCK TO ALIGN TOP PART OF HASP LOCK

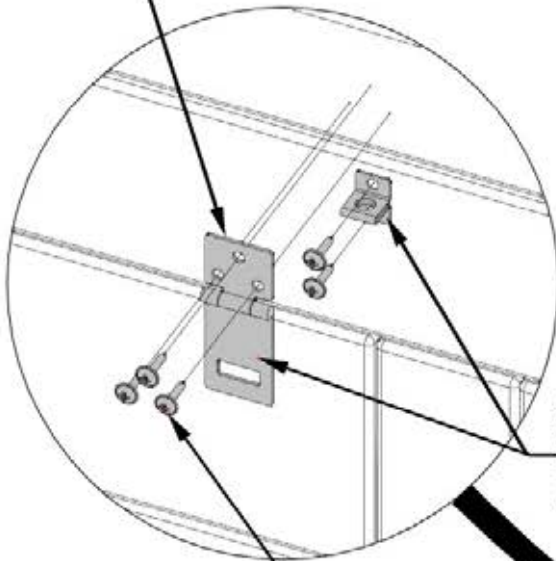

2627 (x1)
SCREW ON
HASP LOCK
ASSEMBLY

202 (x5)
SCREW - 5/8"

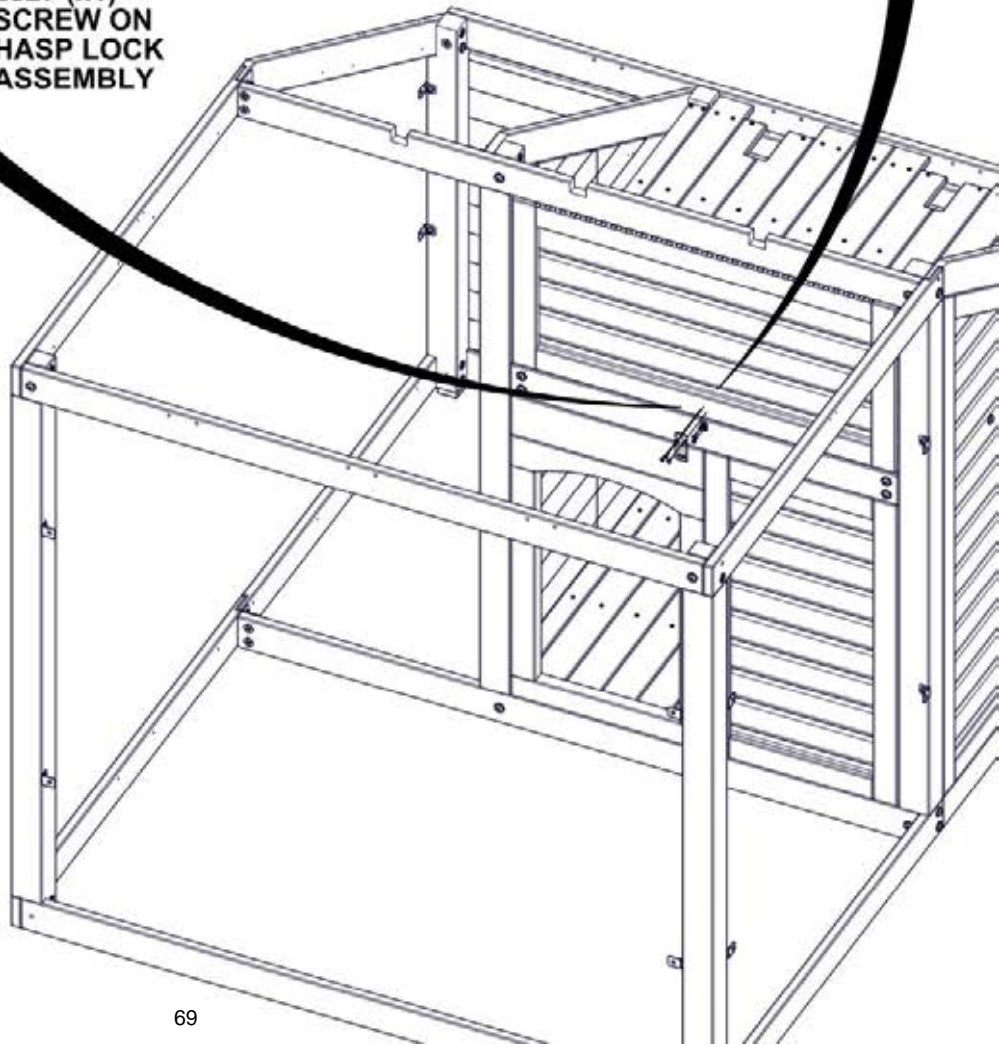

STEP 32 - DOG KENNEL ASSEMBLY

Qty	PART NUMBER	DESCRIPTION
4	H100203	SCREW PFH 8x1/2 BLK



A4M00559 PULL HANDLE
(x1)

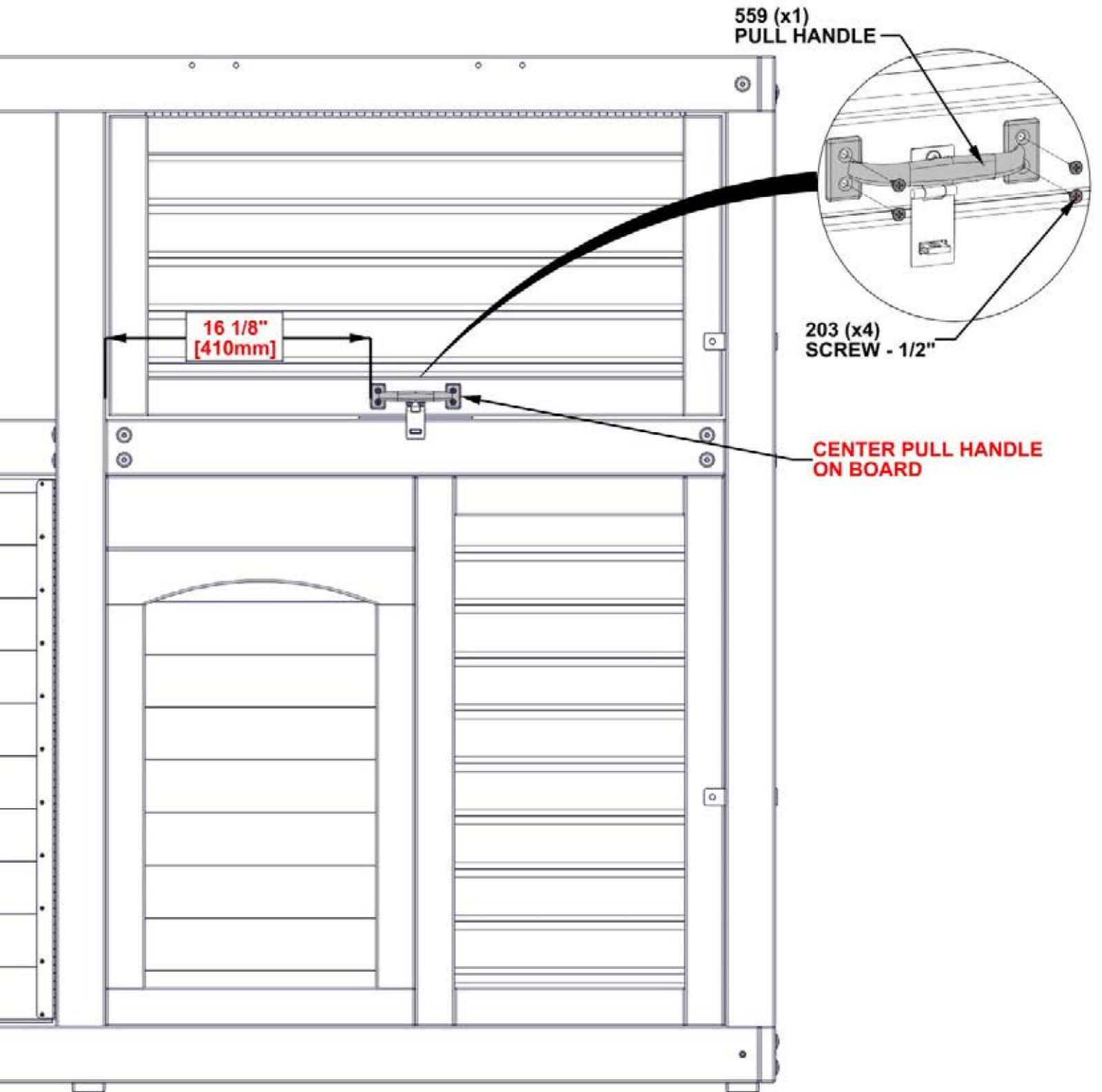

CHOOSING A DOOR LOCATION

- BEFORE PROCEEDING INSTALLING THE WIRE PANELS, PLEASE DETERMINE THE PLACEMENT OF THE GATE.
- IF YOU CHOOSE A GATE POSITION OTHER THAN POSITION 1, YOU WILL SIMPLY SWAP THE GATE WITH THE PANEL IN THAT POSITION.
- DO NOT OVERTIGHTEN HARDWARE ON TO AVOID DAMAGING THE PANELS.

DOOR POSITION 1

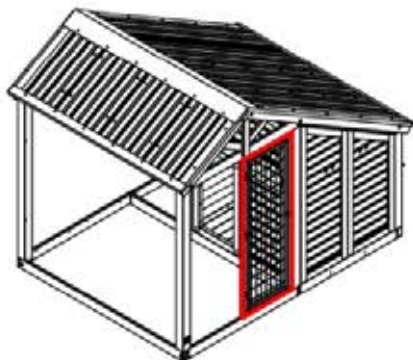

DOOR POSITION 2



DOOR POSITION 3



DOOR POSITION 4



DOOR POSITION 5

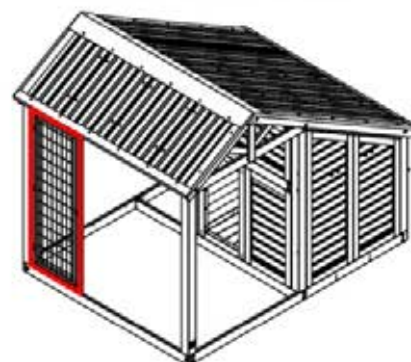

DOOR POSITION 6



DOOR POSITION 7



STEP 33 A - RIGHT SIDE CAGE

Qty	PART NUMBER	DESCRIPTION
2	H100404	NUT BARREL WH 1/4X5/8 BLK
2	H100486	BOLT WH 1/4x5/8 BLK
4	H100460	LAG SCREW WH 1/4x1 BLK

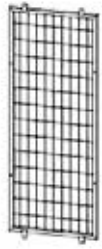

MP01 METAL PANEL - A4M02614
 (x1) 1 1/16"X20 1/2"X58 9/16" (27.4x520x1488)

- USE PILOT HOLES TO ALIGN CAGE HOLES

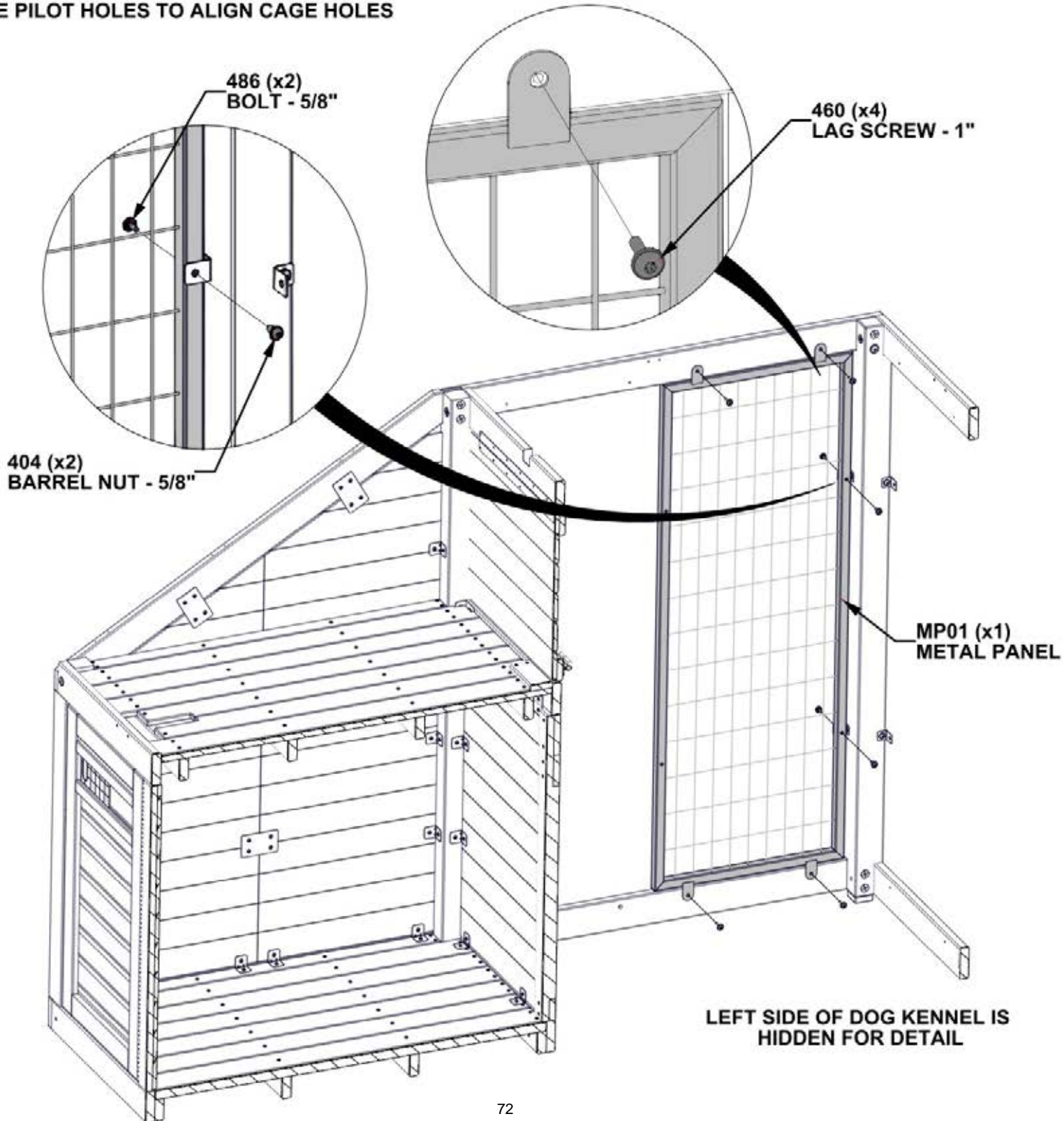

STEP 33 B - RIGHT SIDE CAGE

Qty	PART NUMBER	DESCRIPTION
2	H100404	NUT BARREL WH 1/4X5/8 BLK
2	H100486	BOLT WH 1/4x5/8 BLK
4	H100460	LAG SCREW WH 1/4x1 BLK

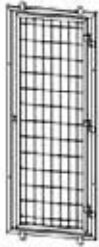

MP04 METAL DOOR PANEL ASSEMBLY - A4M02619
 (x1) 1 1/16"X20 1/2"X58 9/16" (27x520x1488)

- USE PILOT HOLES TO ALIGN CAGE HOLES

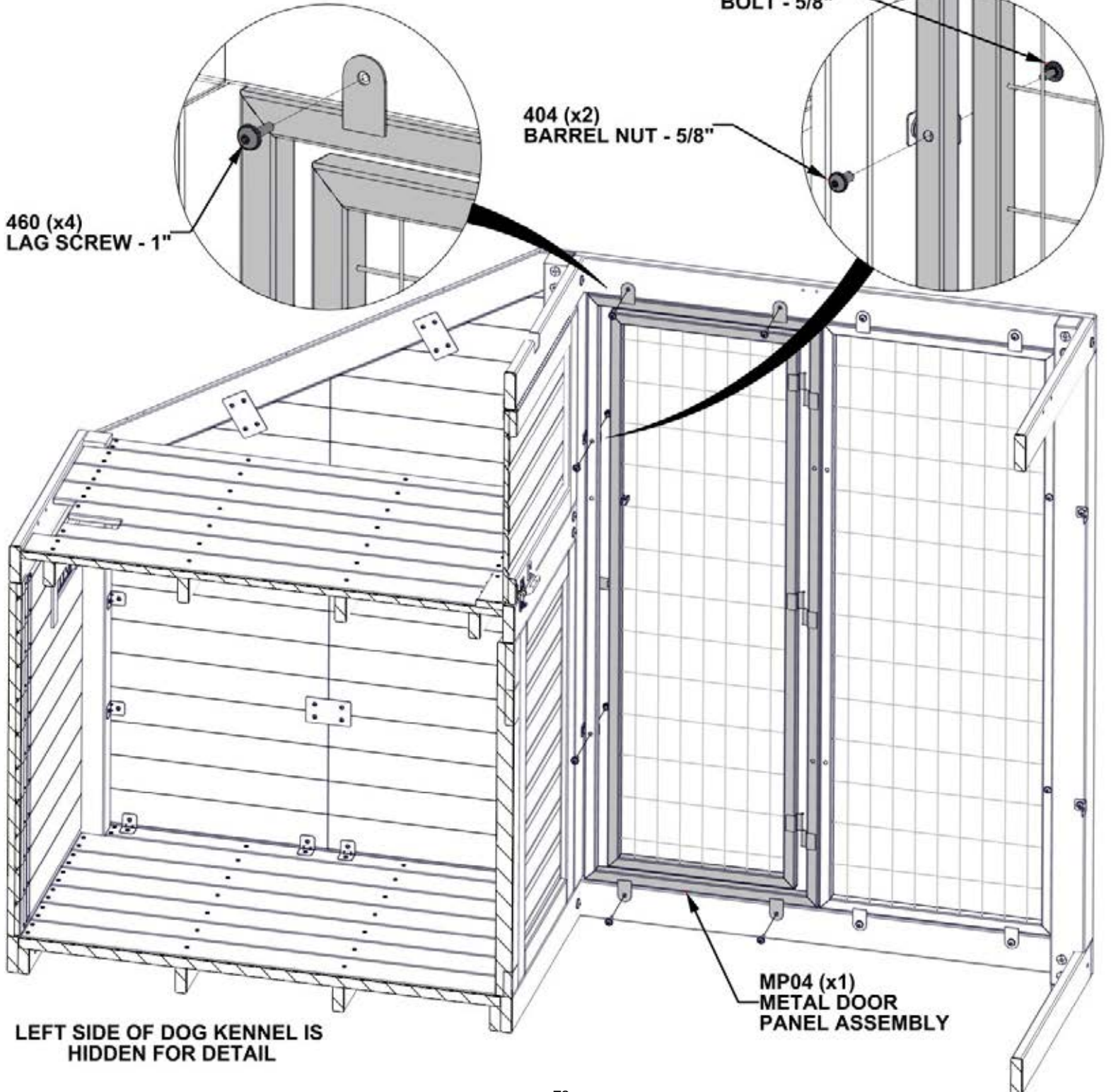

STEP 33 C - RIGHT SIDE CAGE

Qty	PART NUMBER	DESCRIPTION
1	H100404	NUT BARREL WH 1/4X5/8 BLK
1	H100488	BOLT WH 1/4X2 BLK

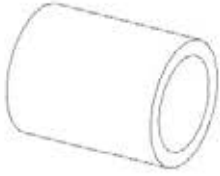

A6P00964 SPACER
(x2)

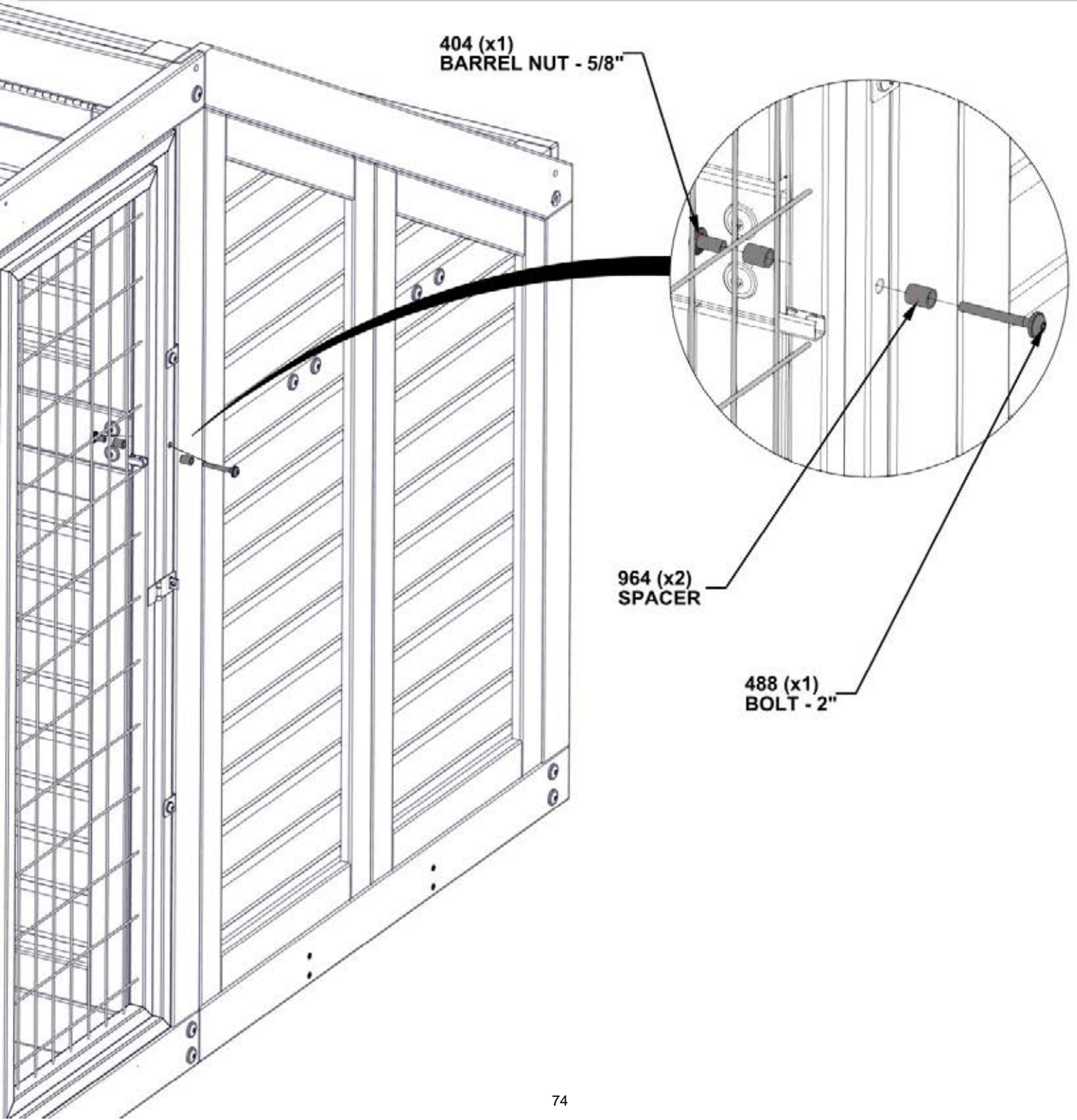

STEP 33 D - RIGHT SIDE CAGE



A4M03140 U-BAR
(x1)

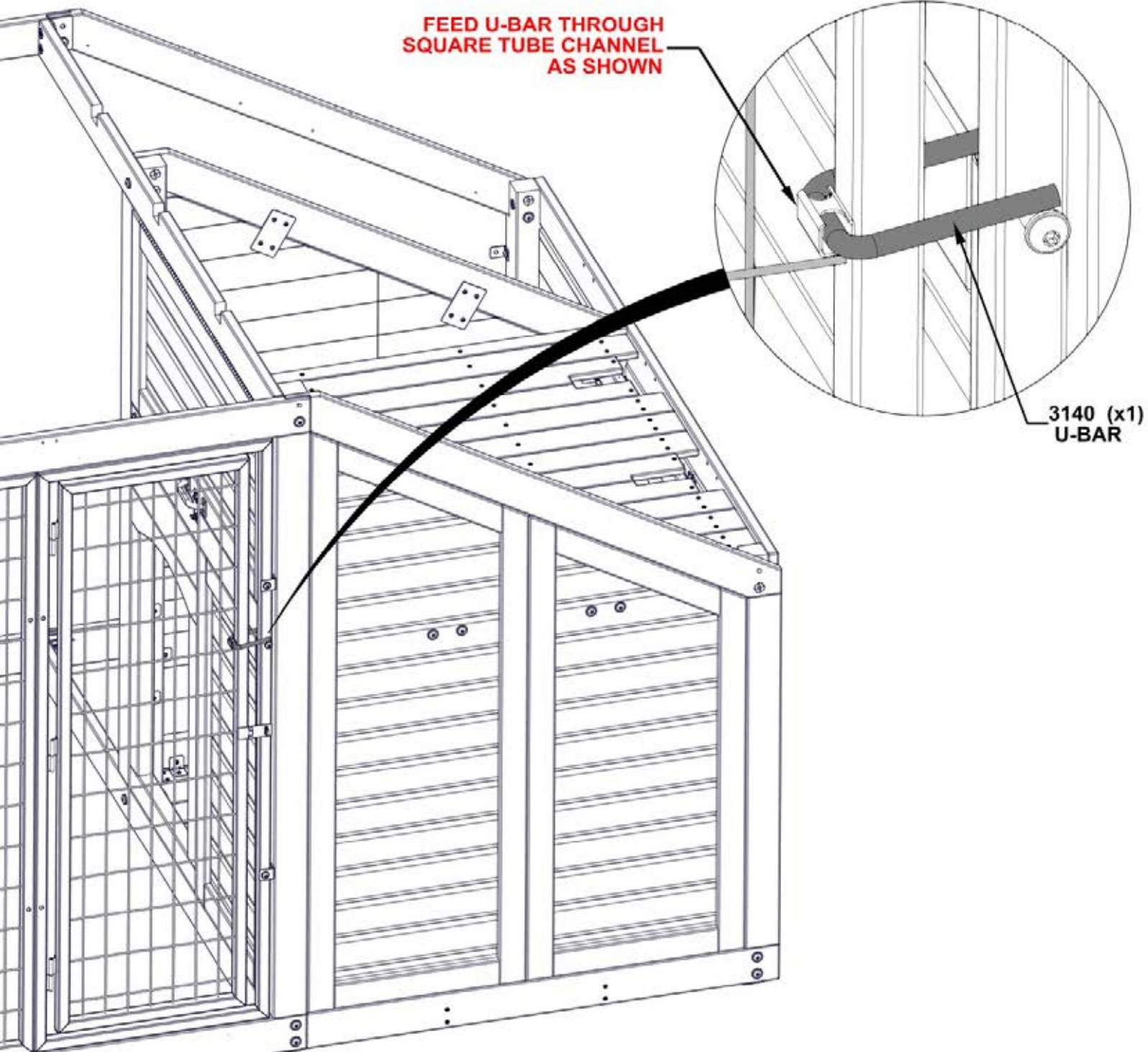

STEP 33 E - RIGHT SIDE CAGE

Qty	PART NUMBER	DESCRIPTION
4	H100404	NUT BARREL WH 1/4X5/8 BLK
4	H100486	BOLT WH 1/4x5/8 BLK



A4M02616 METAL PANEL FLAT BRACKET
(x2)

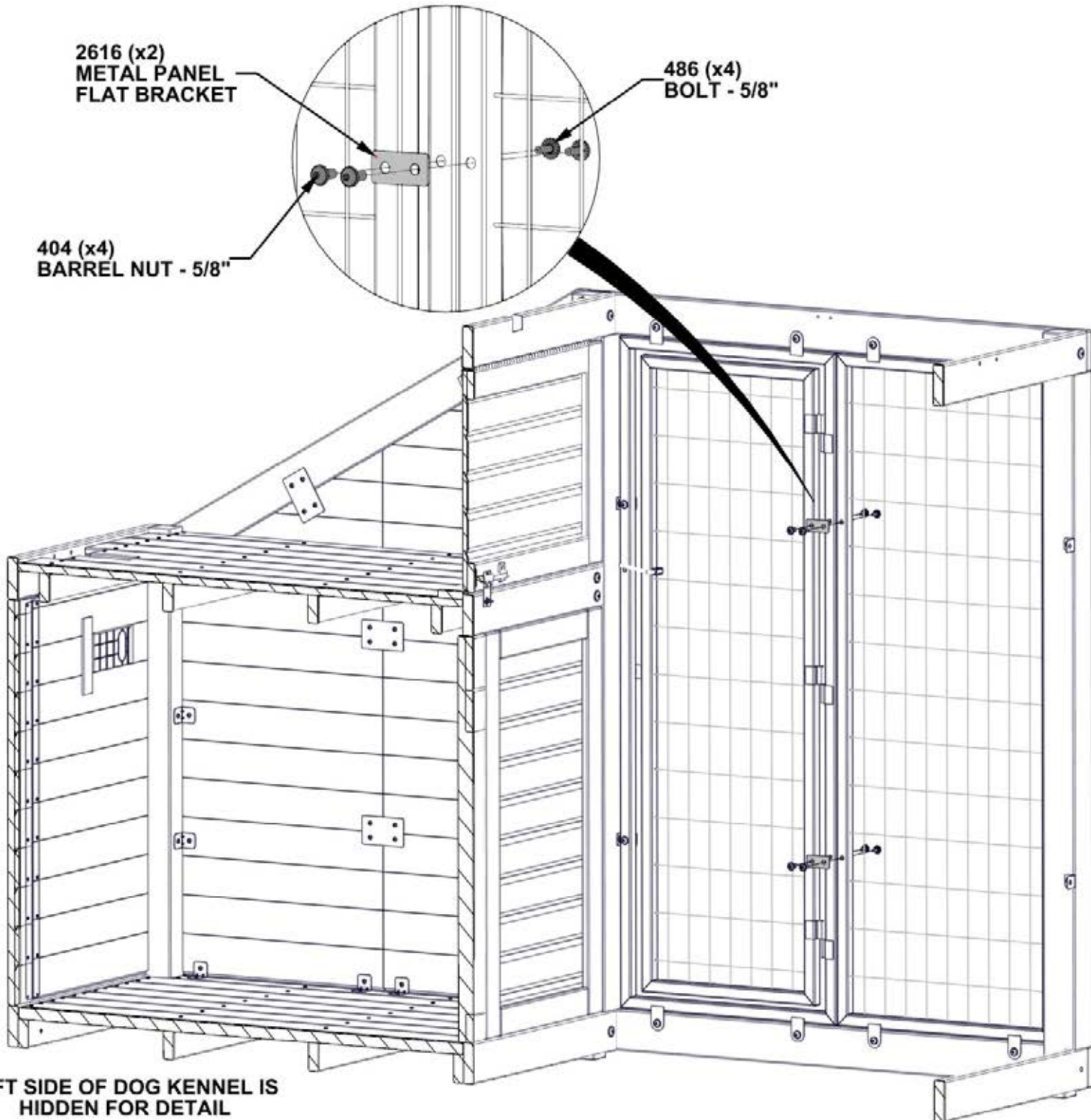

2616 (x2)
METAL PANEL
FLAT BRACKET

486 (x4)
BOLT - 5/8"

404 (x4)
BARREL NUT - 5/8"

LEFT SIDE OF DOG KENNEL IS
HIDDEN FOR DETAIL

STEP 34 A - FRONT SIDE CAGE

Qty	PART NUMBER	DESCRIPTION
2	H100404	NUT BARREL WH 1/4X5/8 BLK
2	H100486	BOLT WH 1/4X5/8 BLK
4	H100460	LAG SCREW WH 1/4x1 BLK

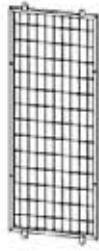

MP01 METAL PANEL - A4M02614
 (x1) 1 1/16"X20 1/2"X58 9/16" (27.4x520x1488)

- USE PILOT HOLES TO ALIGN CAGE HOLES

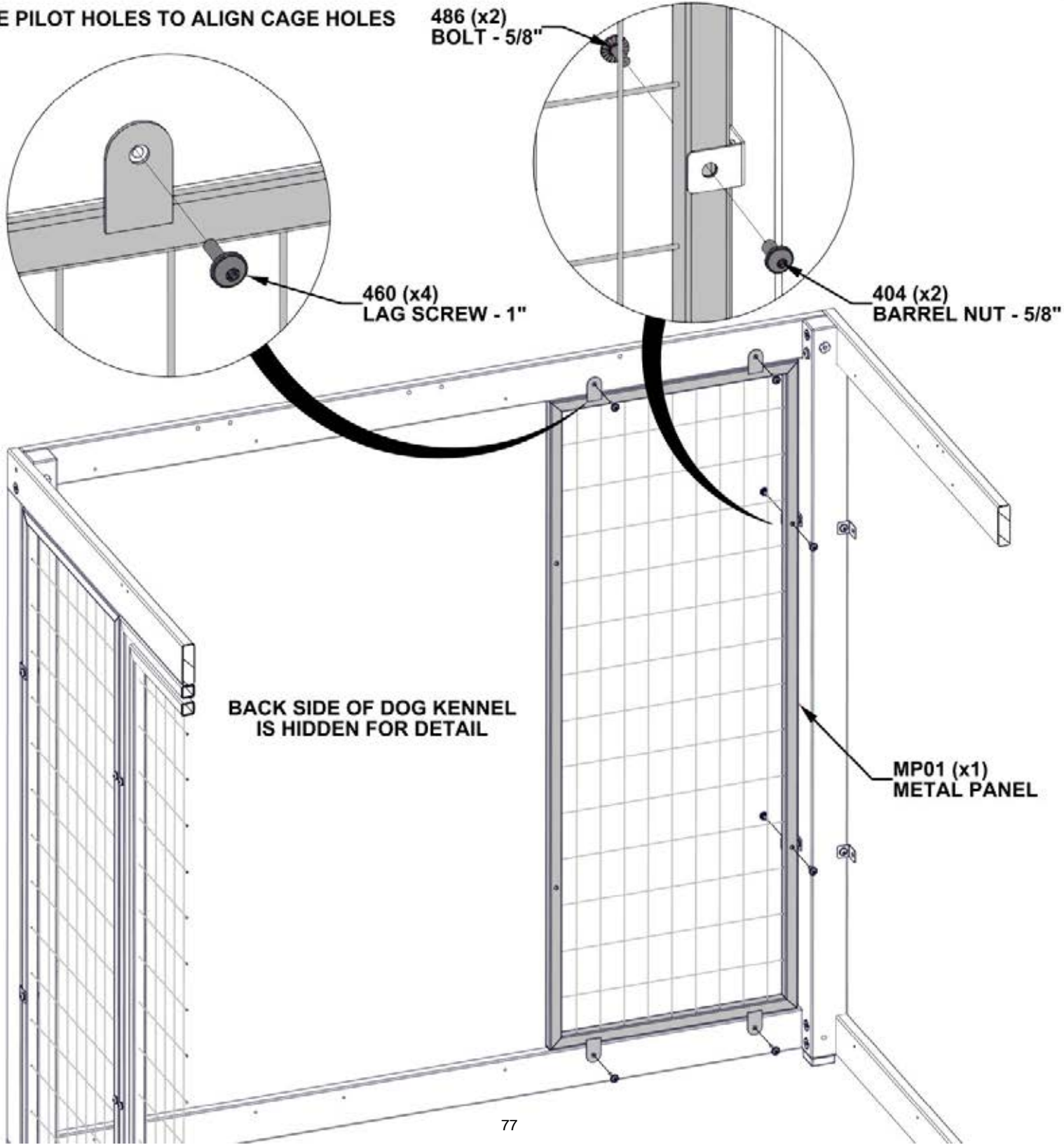

STEP 34 B - FRONT SIDE CAGE

Qty	PART NUMBER	DESCRIPTION
2	H100404	NUT BARREL WH 1/4X5/8 BLK
2	H100486	BOLT WH 1/4X5/8 BLK
4	H100460	LAG SCREW WH 1/4X1 BLK

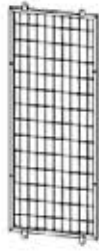

MP01 METAL PANEL - A4M02614
 (x1) 1 1/16"X20 1/2"X58 9/16" (27.4x520x1488)

- USE PILOT HOLES TO ALIGN CAGE HOLES

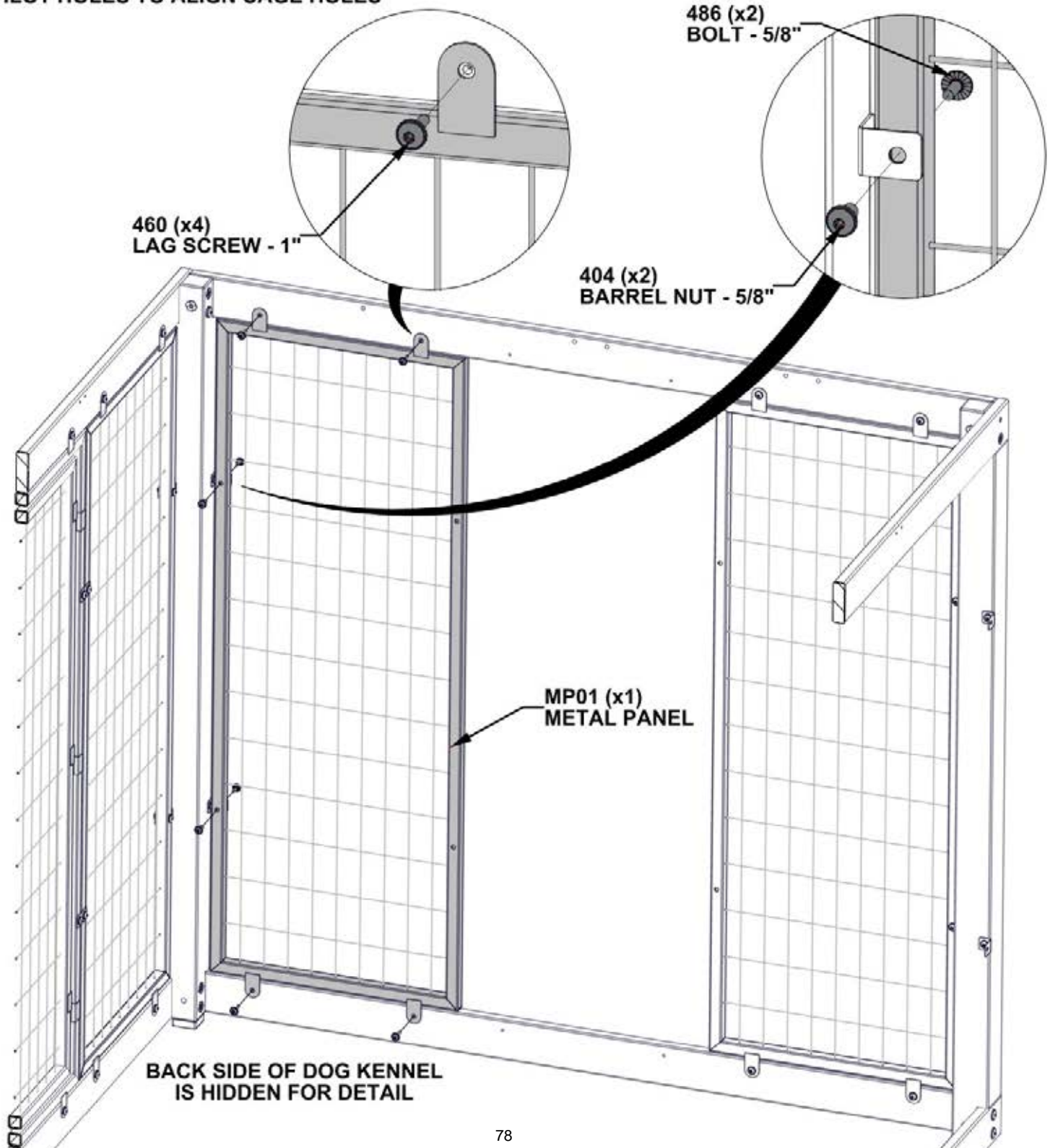

460 (x4)
LAG SCREW - 1"

486 (x2)
BOLT - 5/8"

404 (x2)
BARREL NUT - 5/8"

MP01 (x1)
METAL PANEL

BACK SIDE OF DOG KENNEL
IS HIDDEN FOR DETAIL

STEP 34 C - FRONT SIDE CAGE

Qty	PART NUMBER	DESCRIPTION
4	H100460	LAG SCREW WH 1/4x1 BLK



MP01 METAL PANEL - A4M02614
(x1) 1 1/16"X20 1/2"X58 9/16" (27.4x520x1488)

- USE PILOT HOLES TO ALIGN CAGE HOLES

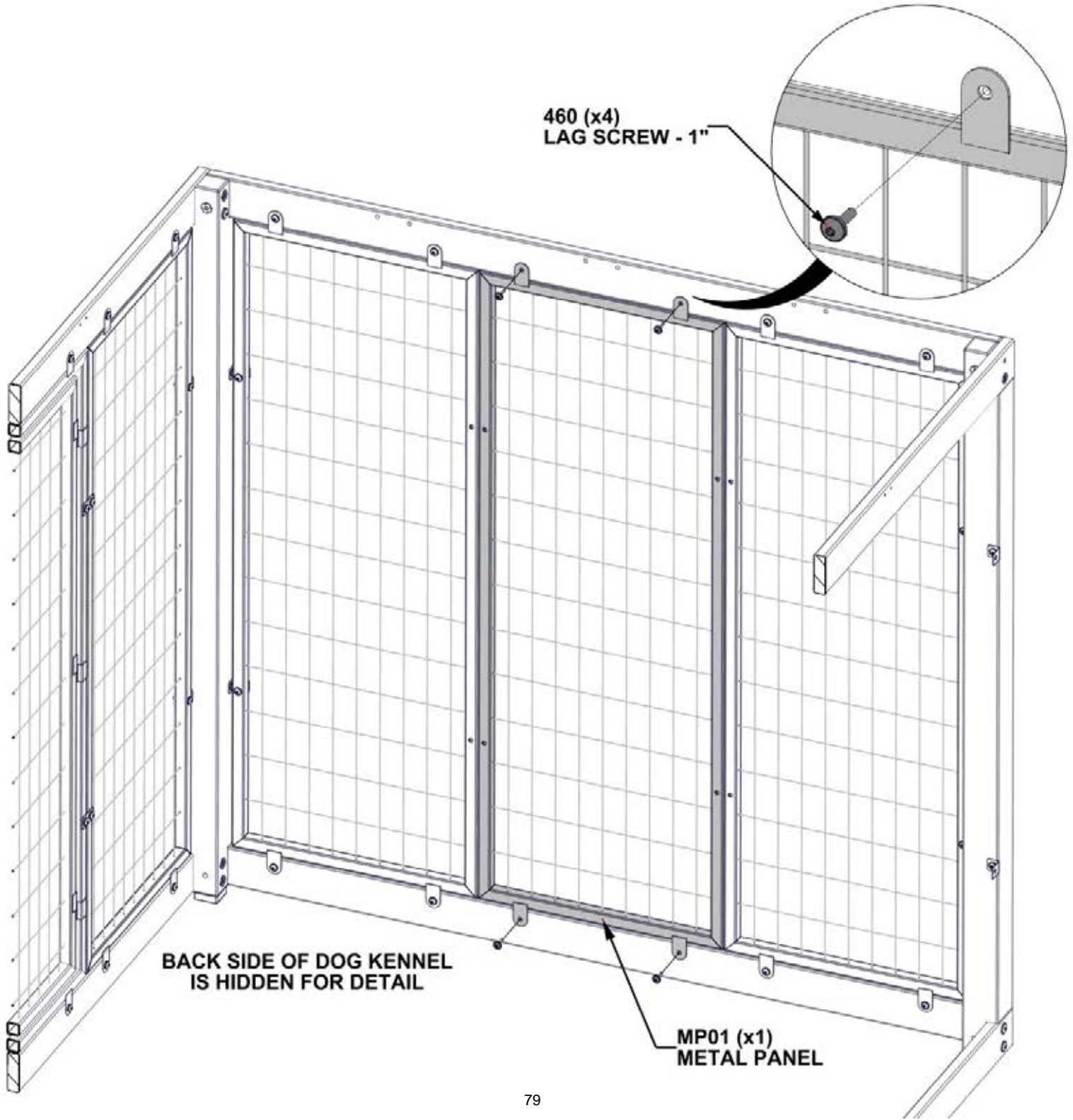

STEP 34 D - FRONT SIDE CAGE

Qty	PART NUMBER	DESCRIPTION
8	H100404	NUT BARREL WH 1/4X5/8 BLK
8	H100486	BOLT WH 1/4X5/8 BLK



A4M02616 METAL PANEL FLAT BRACKET
(x4)

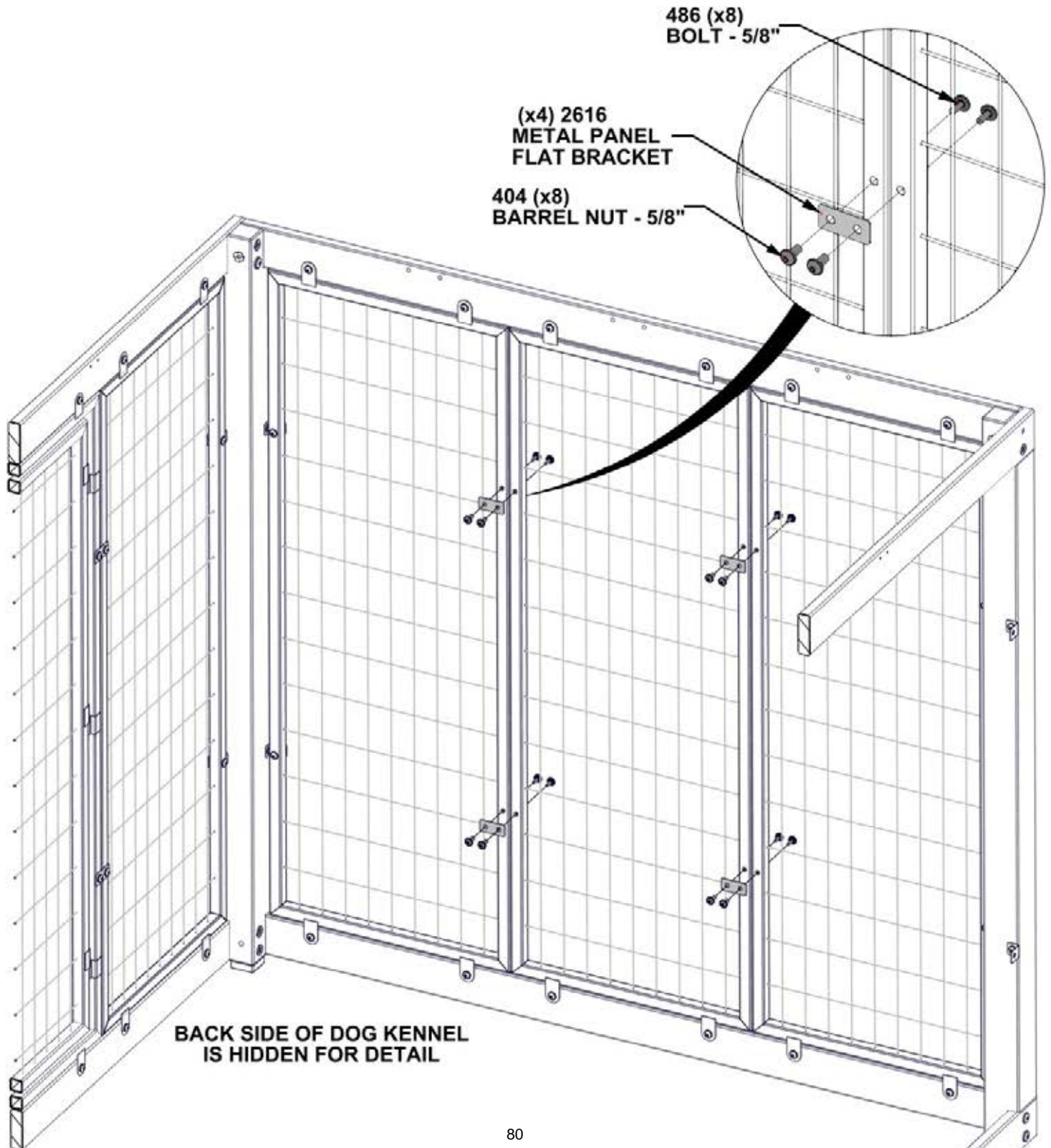

STEP 35 A - LEFT SIDE CAGE

Qty	PART NUMBER	DESCRIPTION
2	H100404	NUT BARREL WH 1/4X5/8 BLK
2	H100486	BOLT WH 1/4x5/8 BLK
4	H100460	LAG SCREW WH 1/4x1 BLK

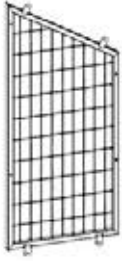

MP02 METAL PANEL - A4M02618
 (x1) 1 1/16"X20 1/2"X46 15/16" (27x520x1192)

- USE PILOT HOLES TO ALIGN CAGE HOLES

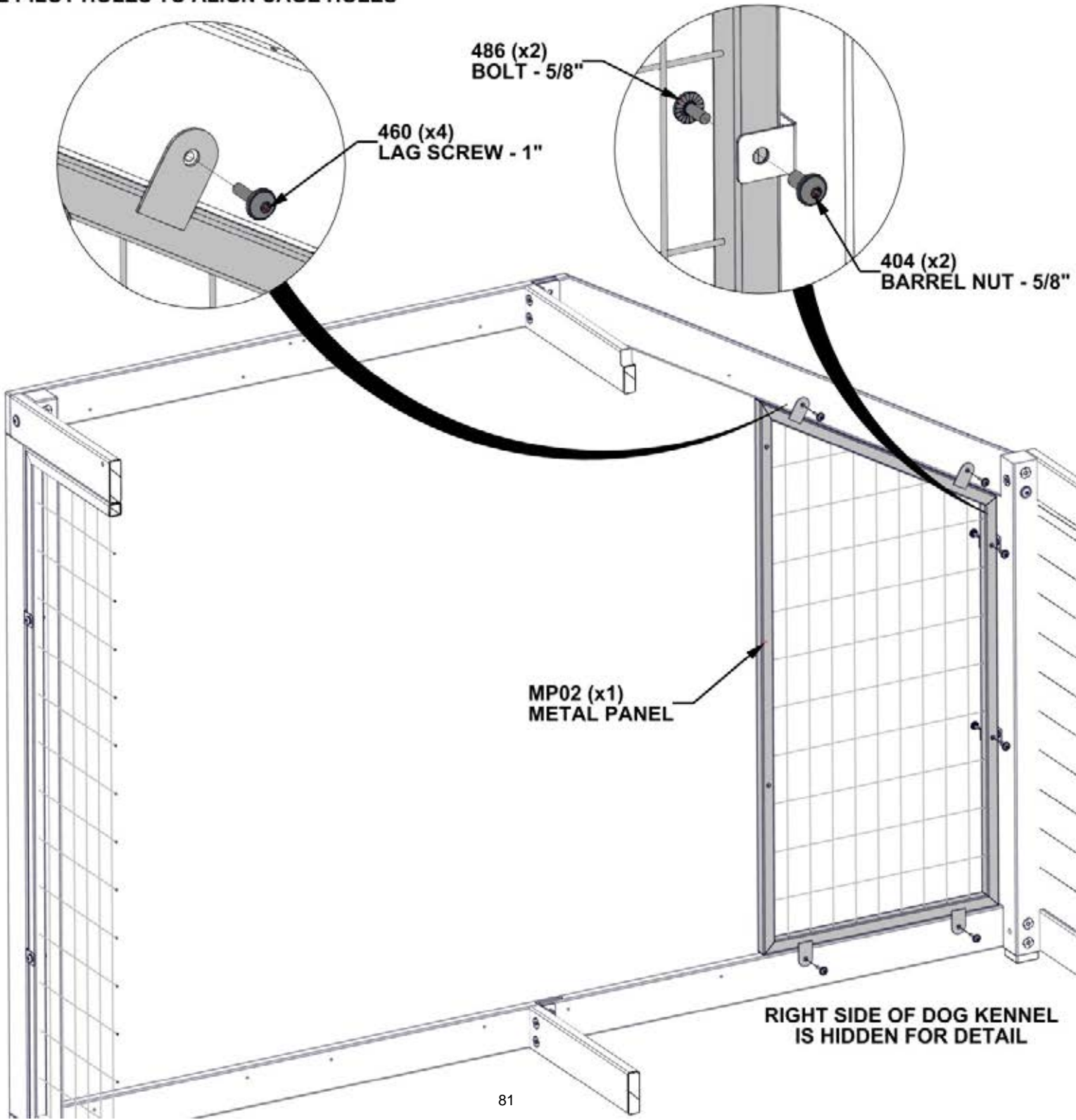

STEP 35 B - LEFT SIDE CAGE

Qty	PART NUMBER	DESCRIPTION
2	H100404	NUT BARREL WH 1/4X5/8 BLK
2	H100486	BOLT WH 1/4x5/8 BLK
4	H100460	LAG SCREW WH 1/4x1 BLK

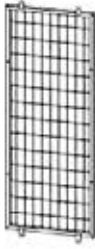

MP01 METAL PANEL - A4M02614
 (x1) 1 1/16"X20 1/2"X58 9/16" (27.4x520x1488)

- USE PILOT HOLES TO ALIGN CAGE HOLES

460 (x4)
LAG SCREW - 1"

486 (x2)
BOLT - 5/8"

404 (x2)
BARREL NUT - 5/8"

MP01 (x1)
METAL PANEL

RIGHT SIDE OF DOG KENNEL
IS HIDDEN FOR DETAIL

STEP 35 C - LEFT SIDE CAGE

Qty	PART NUMBER	DESCRIPTION
4	H100460	LAG SCREW WH 1/4x1 BLK

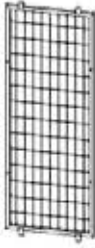

MP01 METAL PANEL - A4M02614
(x1) 1 1/16"X20 1/2"X58 9/16" (27.4x520x1488)

- USE PILOT HOLES TO ALIGN CAGE HOLES

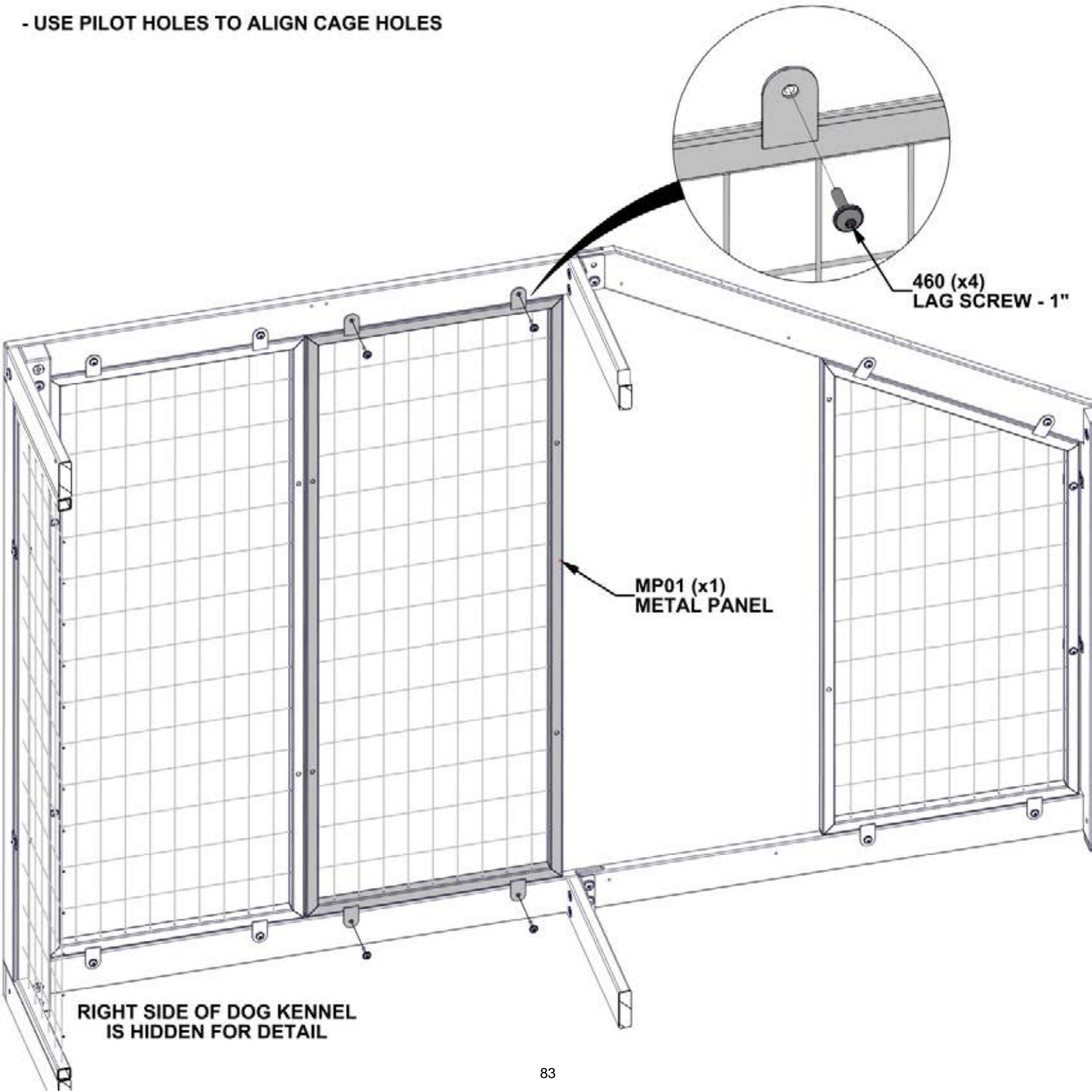

STEP 35 D - LEFT SIDE CAGE

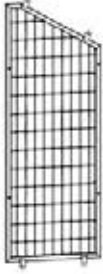

Qty	PART NUMBER	DESCRIPTION
4	H100460	LAG SCREW WH 1/4x1 BLK

MP03 METAL PANEL - A4M02617
(x1) 1 1/16"X20 1/2"X57 15/16" (27.4x520x1472)

- USE PILOT HOLES TO ALIGN CAGE HOLES

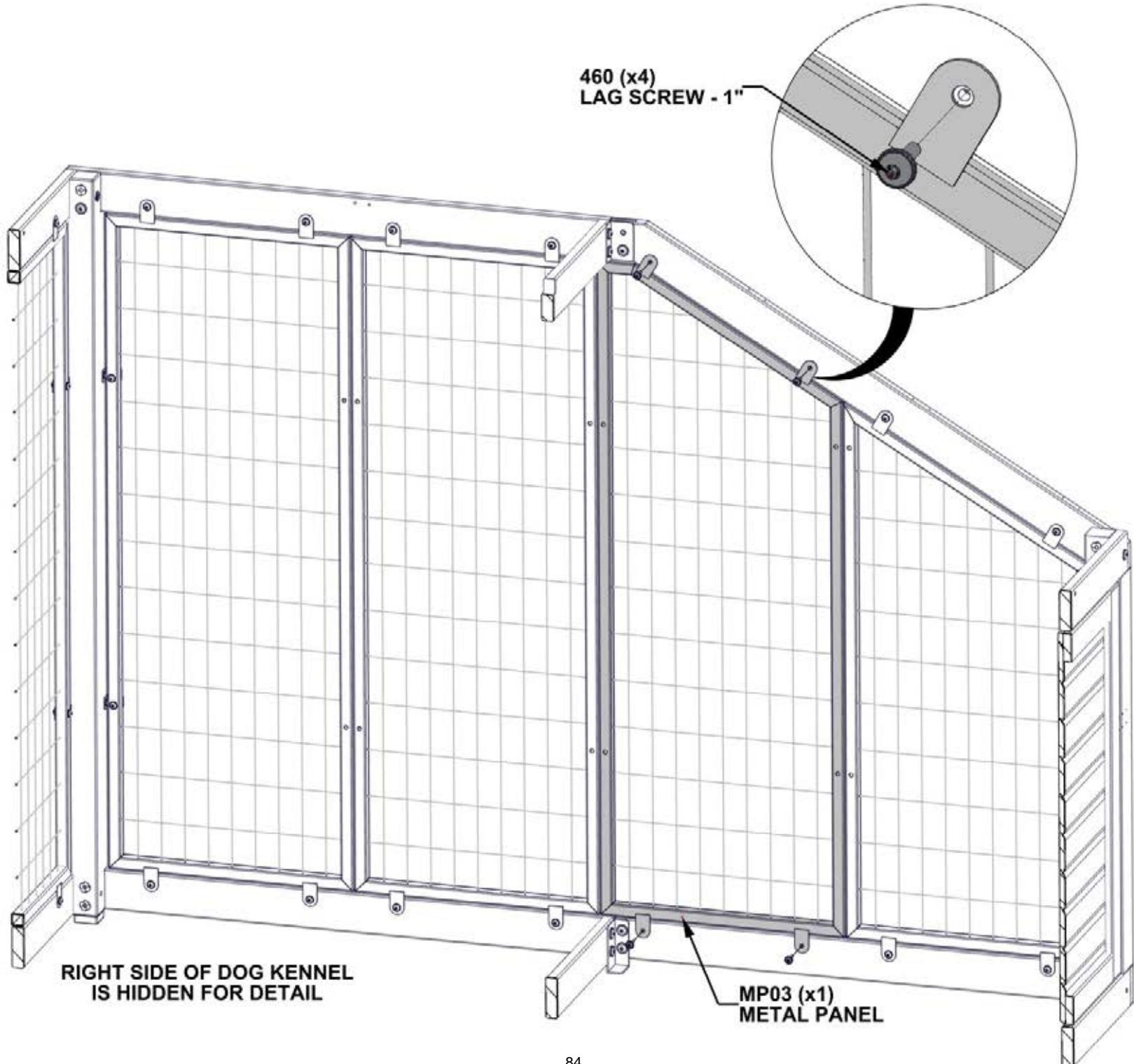

STEP 35 E - LEFT SIDE CAGE

Qty	PART NUMBER	DESCRIPTION
12	H100404	NUT BARREL WH 1/4X5/8 BLK
12	H100486	BOLT WH 1/4x5/8 BLK



A4M02616 METAL PANEL FLAT BRACKET
(x6)

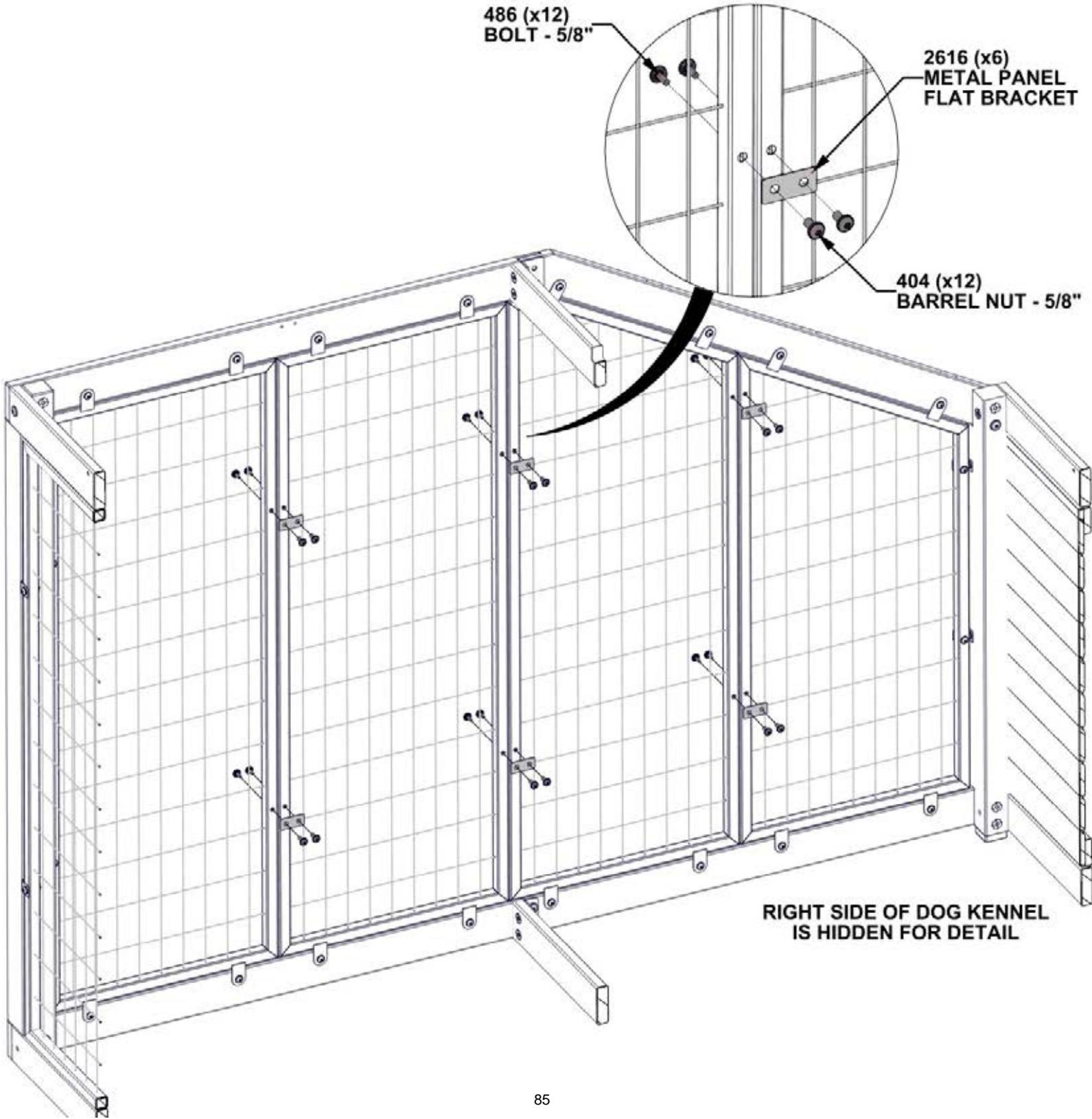

486 (x12)
BOLT - 5/8"

2616 (x6)
METAL PANEL
FLAT BRACKET

404 (x12)
BARREL NUT - 5/8"

RIGHT SIDE OF DOG KENNEL
IS HIDDEN FOR DETAIL

STEP 36 A - DOG KENNEL ASSEMBLY

Qty	PART NUMBER	DESCRIPTION
4	H100200	SCREW PFH 8x1 1/2 BLK



H28 DOG BOWL CLEAT - W4L19525
(x1) 15/16"x3 3/8"x10 9/16" (24x86x268)

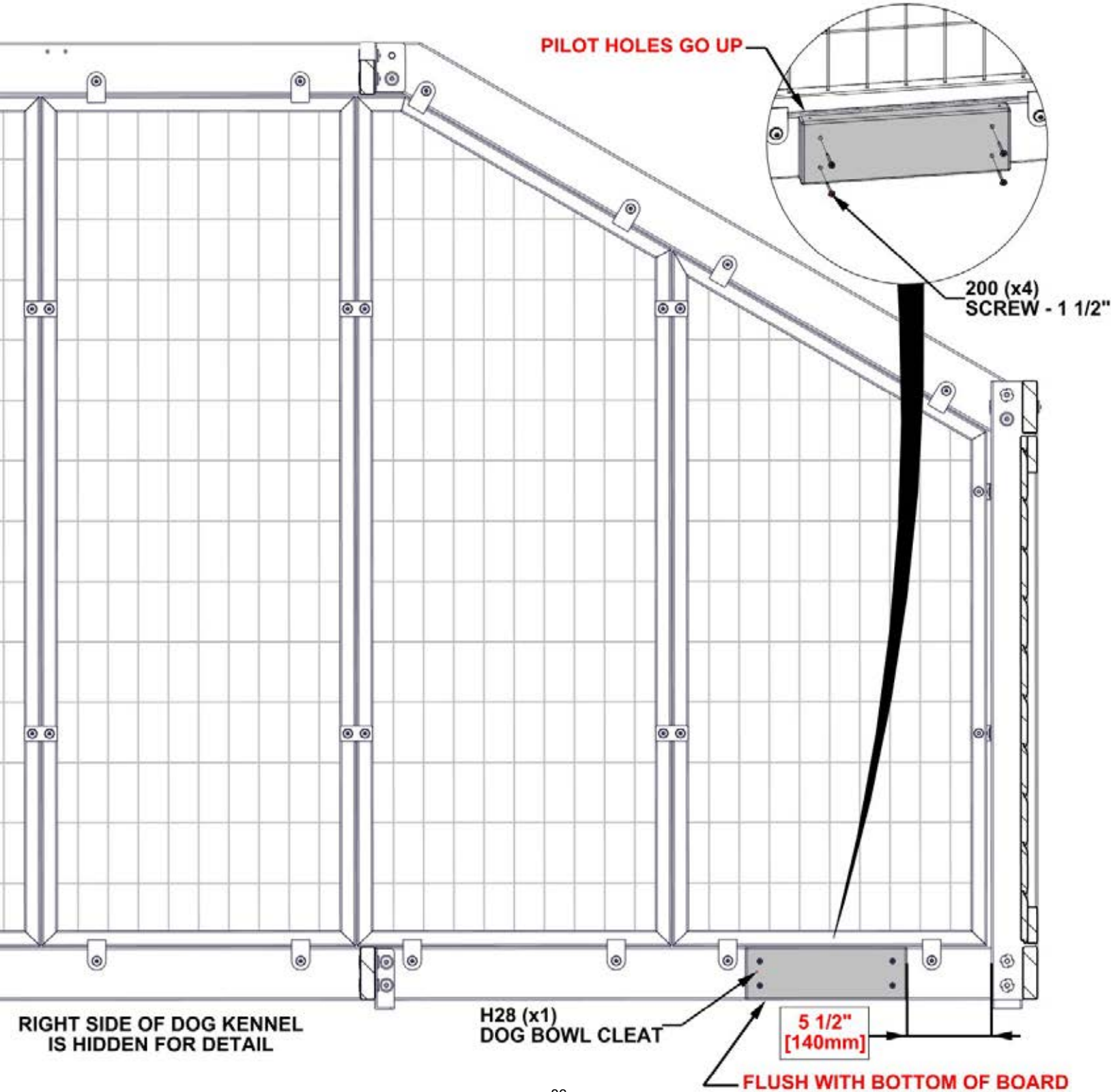

STEP 36 B - DOG KENNEL ASSEMBLY

Qty	PART NUMBER	DESCRIPTION
4	H100200	SCREW PFH 8x1 1/2 BLK



H28 DOG BOWL CLEAT - W4L19525
 (x1) 15/16"x3 3/8"x10 9/16" (24x86x268)

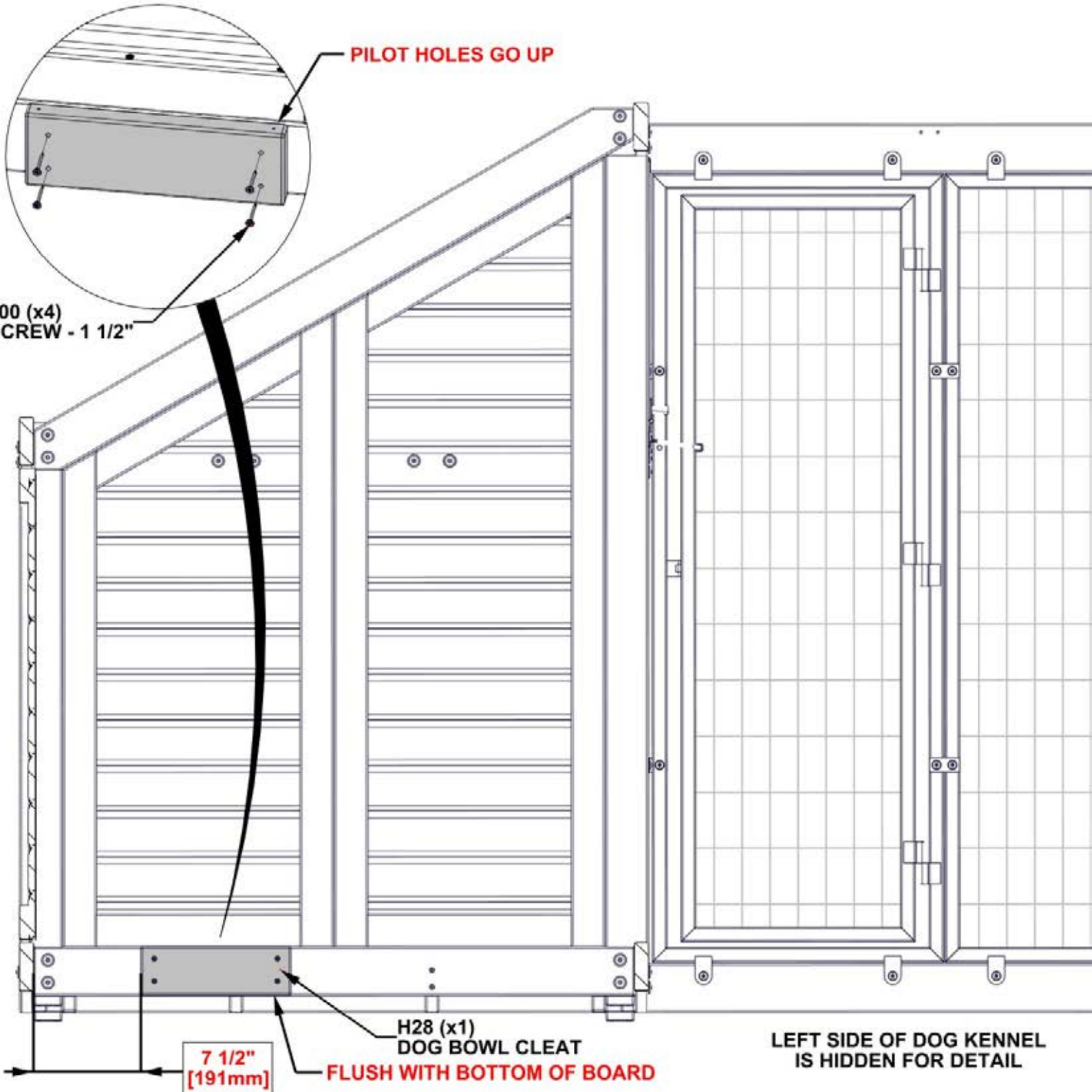

STEP 36 C - DOG BOWL FRAME ASSEMBLY

Qty	PART NUMBER	DESCRIPTION
2	H100823	SCREW PWH 8x1 1/2 BLK

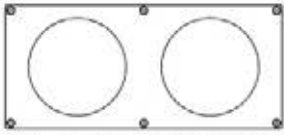

A6P00678 DOG BOWL FRAME
(x1)



AD01 DOG BOWL CLEAT - W4L19526
(x1) 15/16"x4"x10 9/16" (24x102x268)

- USE PILOT HOLES TO ALIGN SCREWS

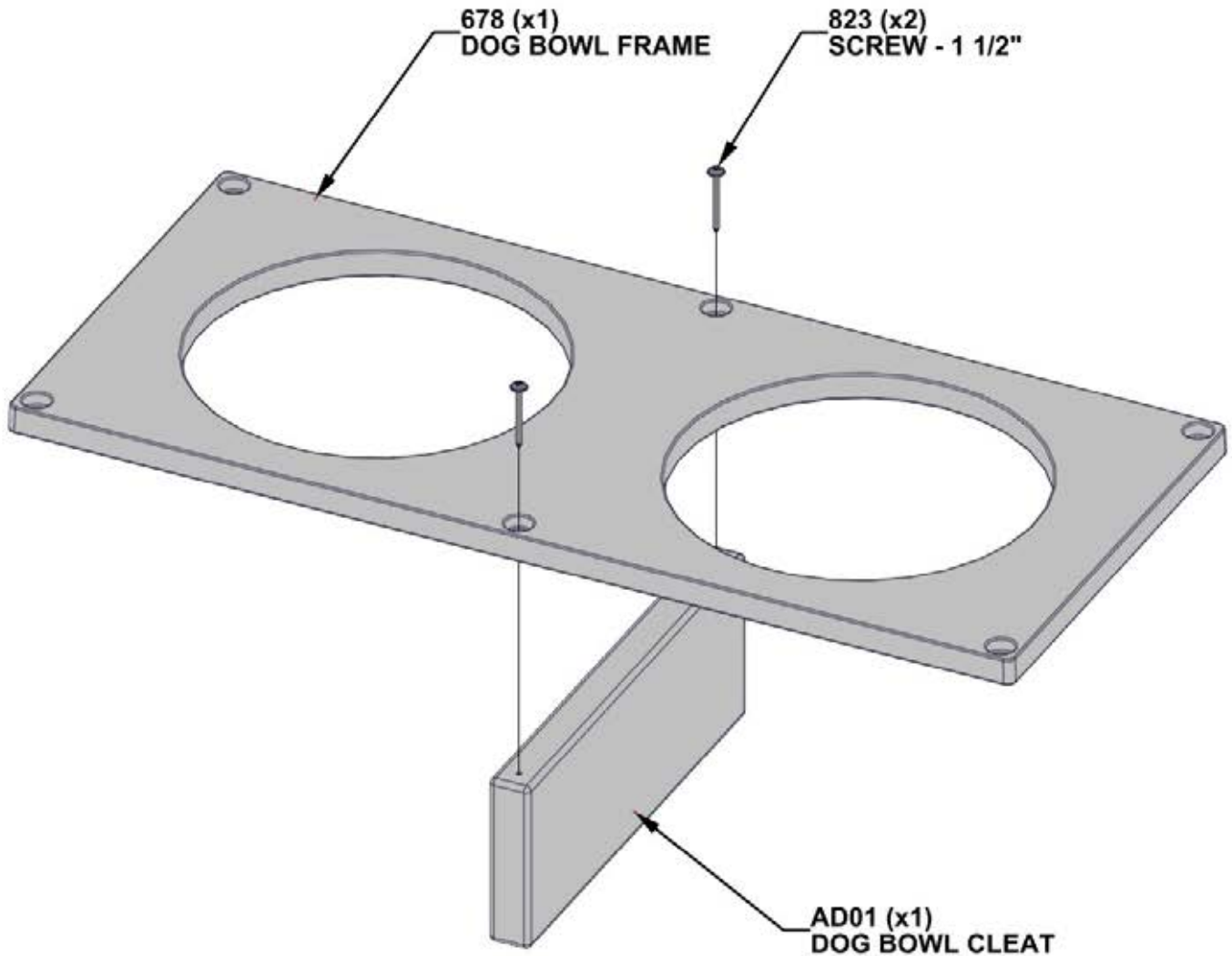

STEP 36 D - DOG KENNEL ASSEMBLY

Qty	PART NUMBER	DESCRIPTION
4	H100823	SCREW PWH 8x1 1/2 BLK

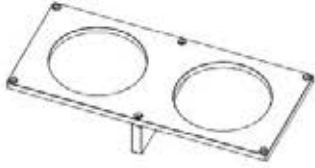

DOG BOWL FRAME ASSEMBLY
(x1) (FROM STEP 36 C)

- USE PILOT HOLES TO ALIGN SCREWS

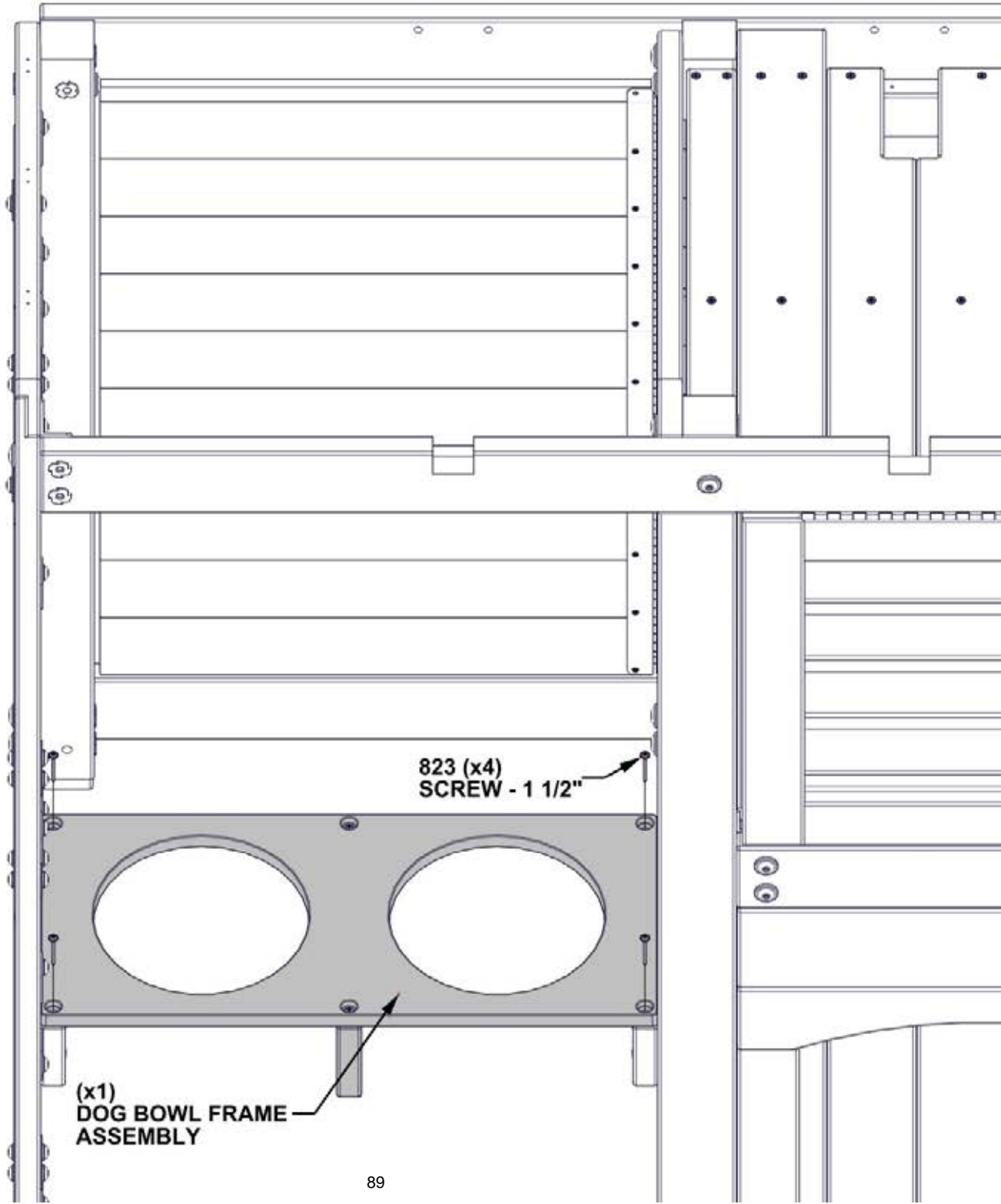

STEP 37 A - DOG KENNEL ASSEMBLY

Qty	PART NUMBER	DESCRIPTION
3	H100415	BOLT WH 5/16x3 3/4 BLK
3	H100198	WASHER LOCK EXT 8x19



H25 FASCIA BOARD - W4L19522
(x1) 15/16"x3 3/8"x31 5/16" (24x86x795)



H26 FASCIA BOARD - W4L19523
(x1) 15/16"x3 3/8"x77 3/8" (24x86x1966)

- PILOT HOLES GO TO THE INSIDE

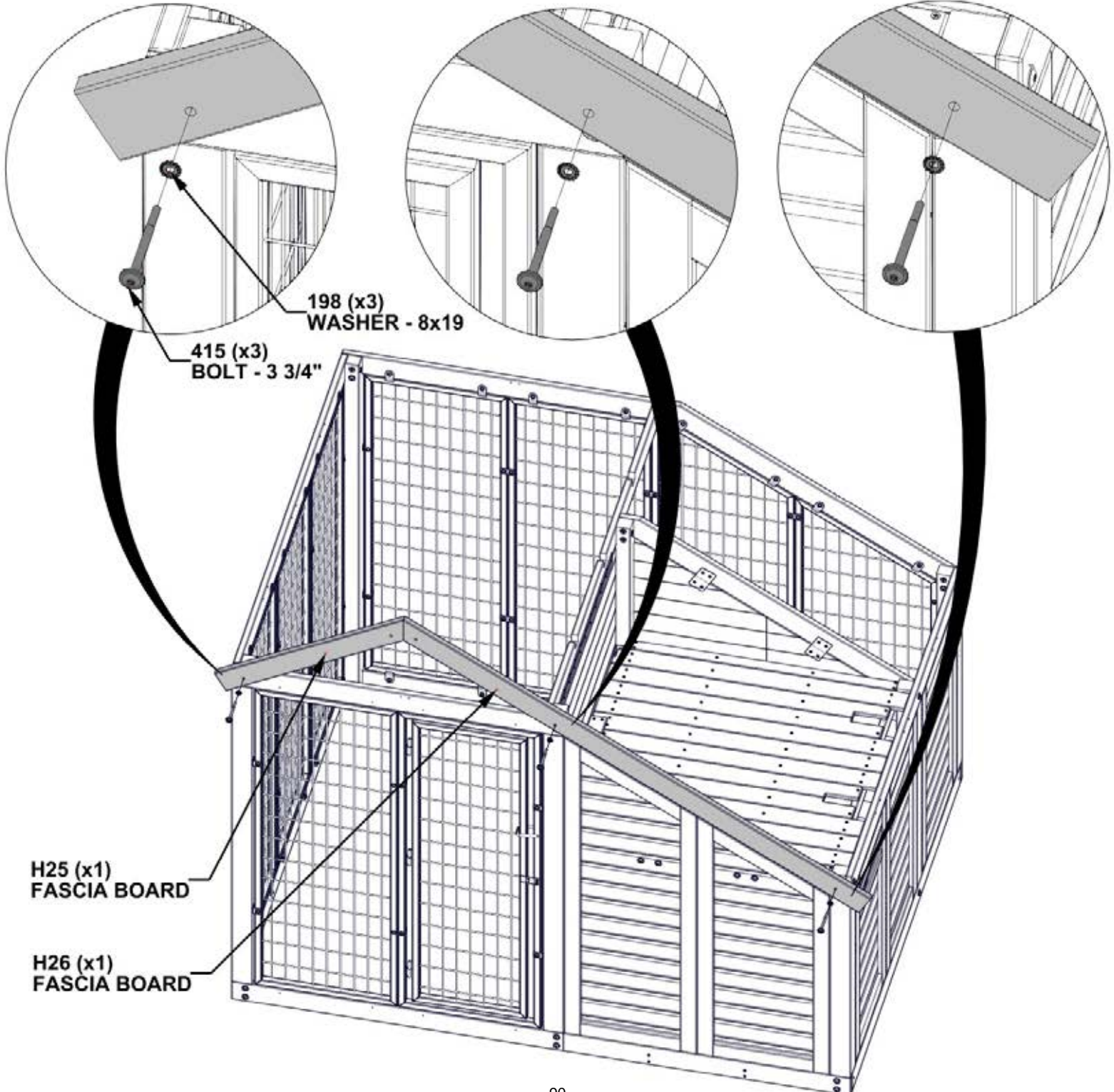

STEP 37 B - DOG KENNEL ASSEMBLY

Qty	PART NUMBER	DESCRIPTION
3	H100797	SCREW PWH 8x1 BLK
10	H100200	SCREW PFH 8x1 1/2 BLK



J8 GABLE BOARD - W4L19462
(x1) 15/16"X2 3/8"X13 7/16" (24x60x341)



J9 GABLE BOARD - W4L19465
(x2) 15/16"X2 3/8"X12 5/8" (24x60x320)



METAL STRAP 118mm - A4M02632
(x1)

- USE PILOT HOLES TO ALIGN SCREWS

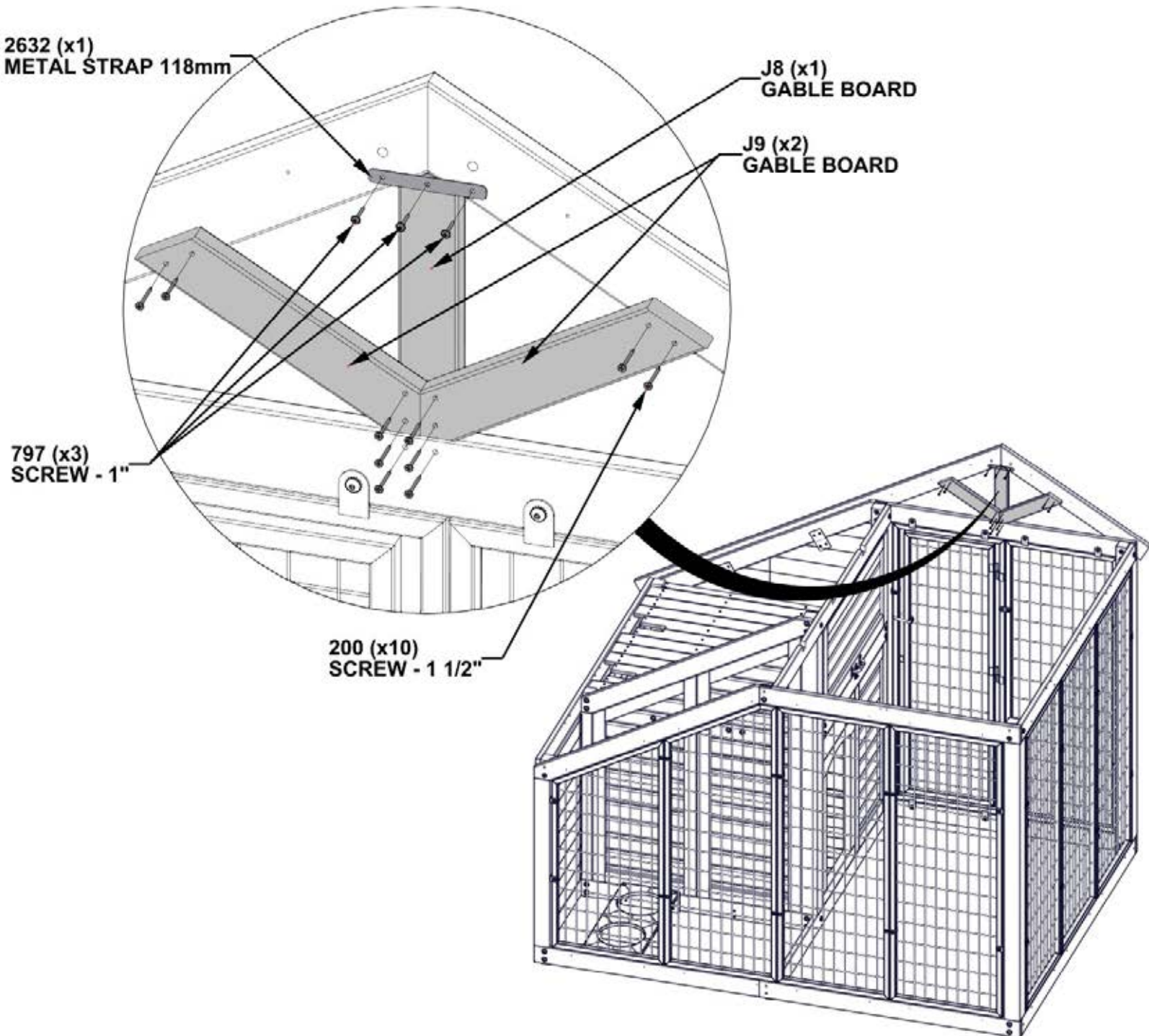

STEP 37 C - DOG KENNEL ASSEMBLY

Qty	PART NUMBER	DESCRIPTION
6	H100200	SCREW PFH 8x1 1/2 BLK



S1 CLEAT - W4L19521
(x2) 15/16"x15/16"x17 11/16" (24x24x450)

- USE PILOT HOLES TO ALIGN SCREWS

PILOT HOLES GO UP

200 (x6)
SCREW - 1 1/2"

S1 (x2)
CLEAT

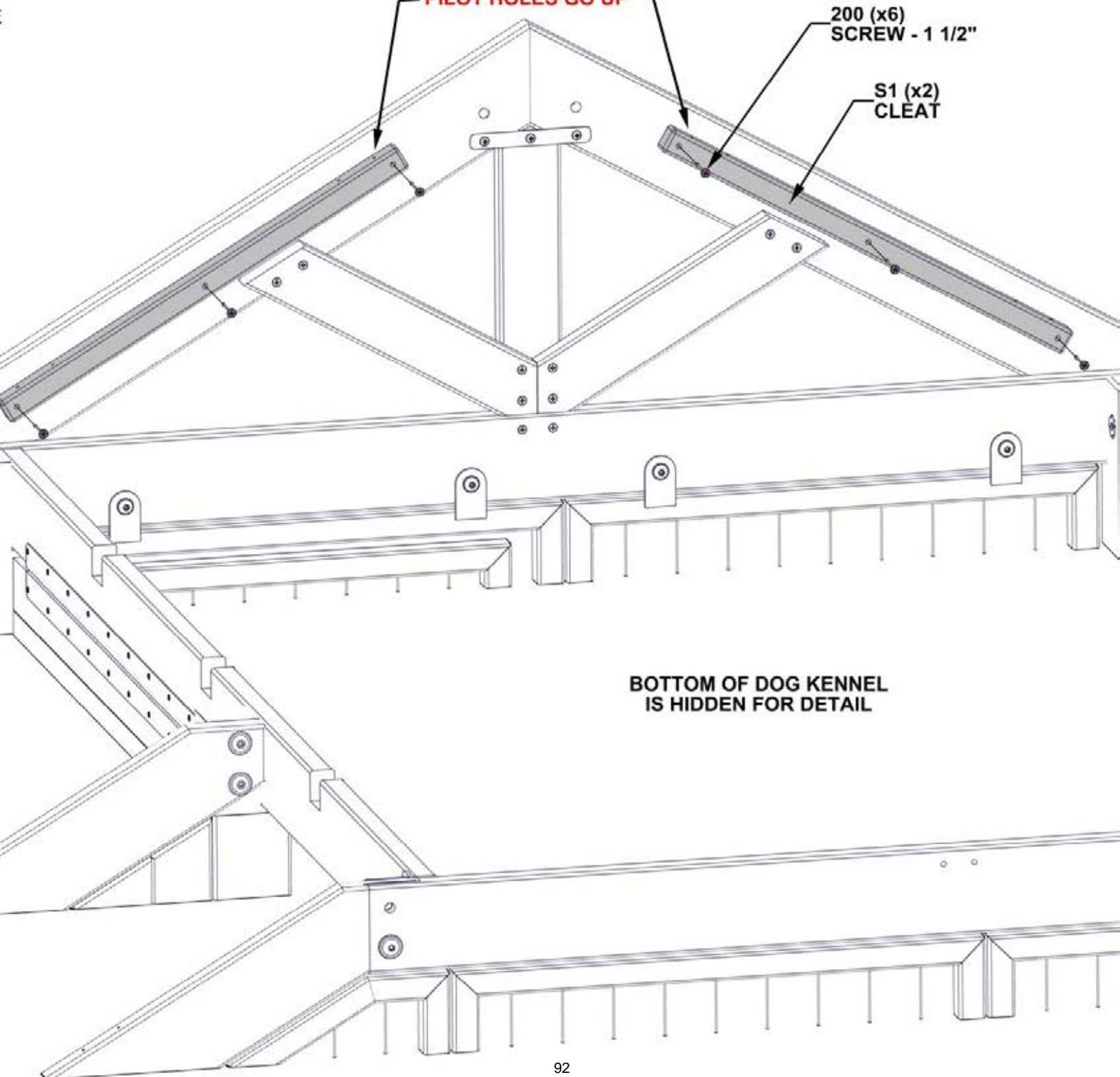

**BOTTOM OF DOG KENNEL
IS HIDDEN FOR DETAIL**

STEP 38 A - DOG KENNEL ASSEMBLY

Qty	PART NUMBER	DESCRIPTION
1	H100469	NUT BARREL WH 5/16X5/8 BLK
1	H100378	BOLT WH 5/16x1 3/4 BLK
1	H100199	WASHER LOCK EXT 12x19
2	H100415	BOLT WH 5/16x3 3/4 BLK
2	H100198	WASHER LOCK EXT 8x19

H20 FASCIA BOARD - W4L19463
(x1) 15/16"x3 3/8"x31 5/16" (24x86x795)

H21 FASCIA BOARD - W4L19464
(x1) 15/16"x3 3/8"x77 3/8" (24x86x1966)

- PILOT HOLES GO TO THE INSIDE

BACKSIDE OF H21
DETAIL VIEW

199 (x1)
WASHER - 12x19

469 (x1)
BARREL NUT - 5/8"

415 (x2)
BOLT - 3 3/4"

198 (x2)
WASHER - 8x19

378 (x1)
BOLT - 1 3/4"

H21 (x1)
FASCIA BOARD

H20 (x1)
FASCIA BOARD

STEP 38 B - DOG KENNEL ASSEMBLY



J8 GABLE BOARD - W4L19462
(x1) 15/16"X2 3/8"X13 7/16" (24x60x341)



J9 GABLE BOARD - W4L19465
(x2) 15/16"X2 3/8"X12 5/8" (24x60x320)

Qty	PART NUMBER	DESCRIPTION
3	H100797	SCREW PWH 8x1 BLK
10	H100200	SCREW PFH 8x1 1/2 BLK



A4M02632 METAL STRAP 118mm
(x1)

- USE PILOT HOLES TO ALIGN SCREWS

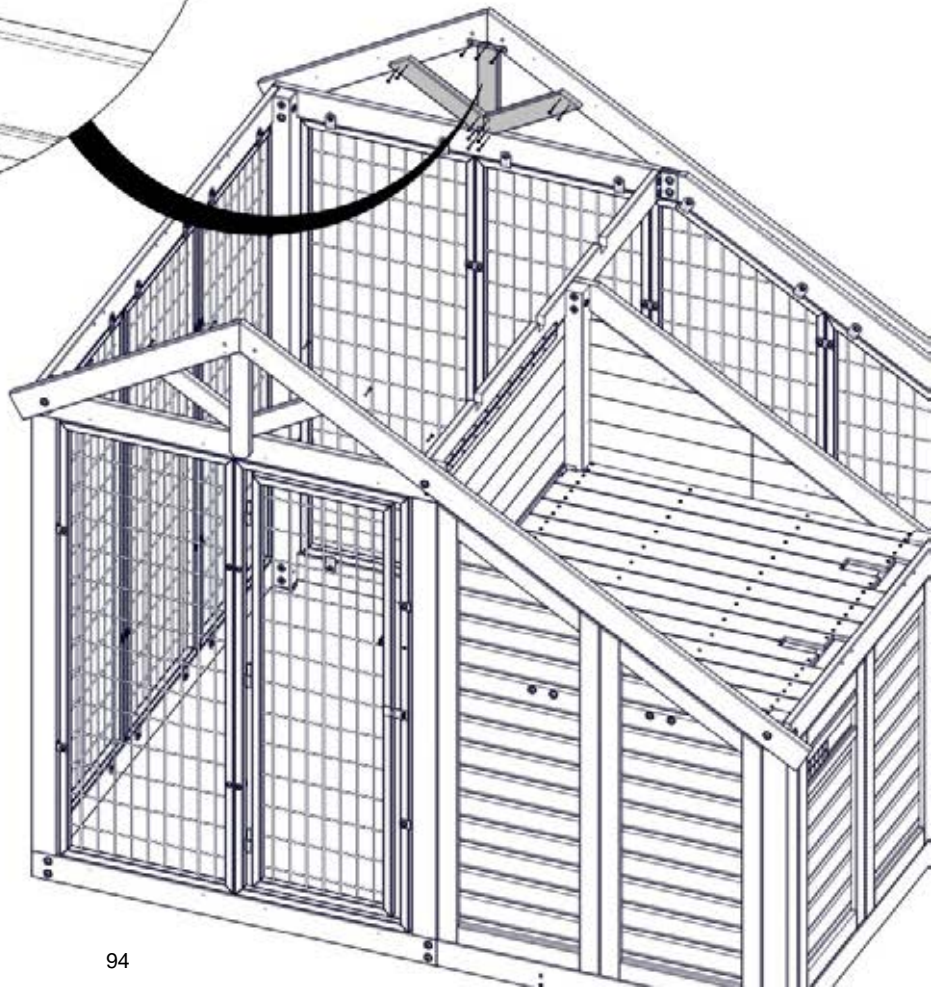
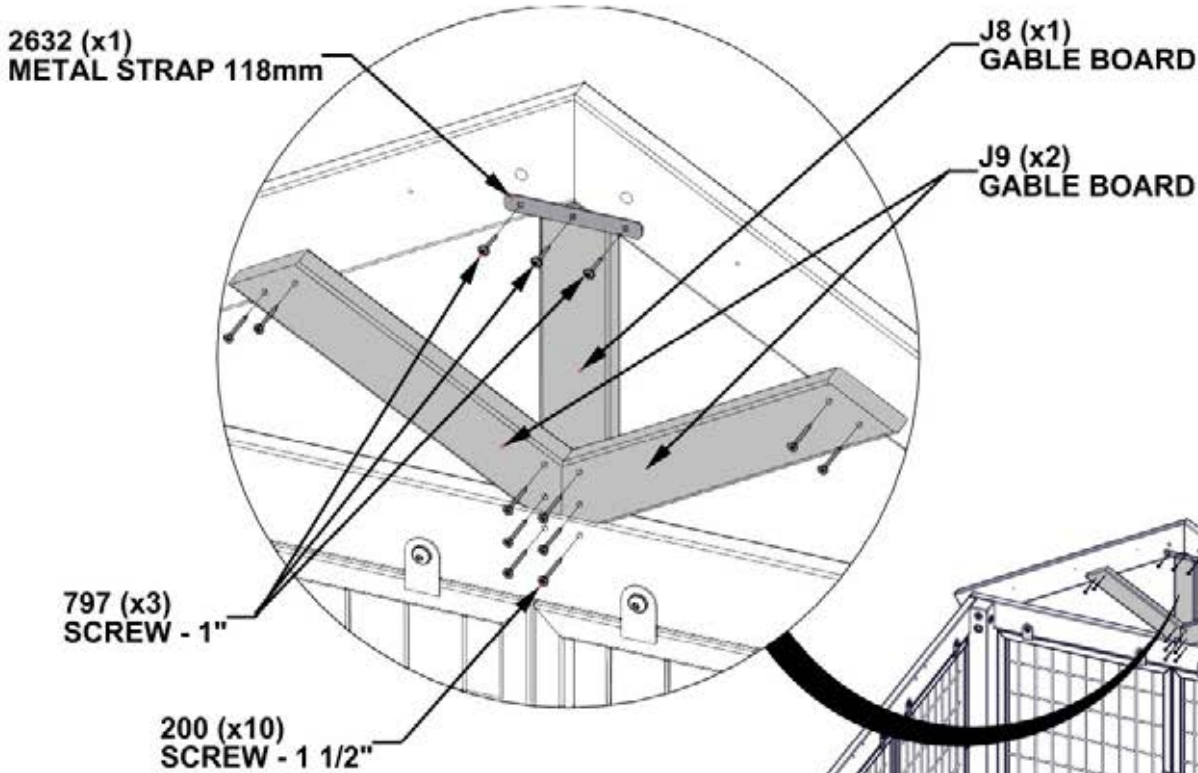

STEP 38 C - DOG KENNEL ASSEMBLY

Qty	PART NUMBER	DESCRIPTION
6	H100200	SCREW PFH 8x1 1/2 BLK



S1 CLEAT - W4L19521
(x2) 15/16"x15/16"x17 11/16" (24x24x450)

- USE PILOT HOLES TO ALIGN SCREWS

PILOT HOLES GO UP

S1 (x2)
CLEAT

200 (x6)
SCREW - 1 1/2"

BOTTOM OF DOG KENNEL
IS HIDDEN FOR DETAIL

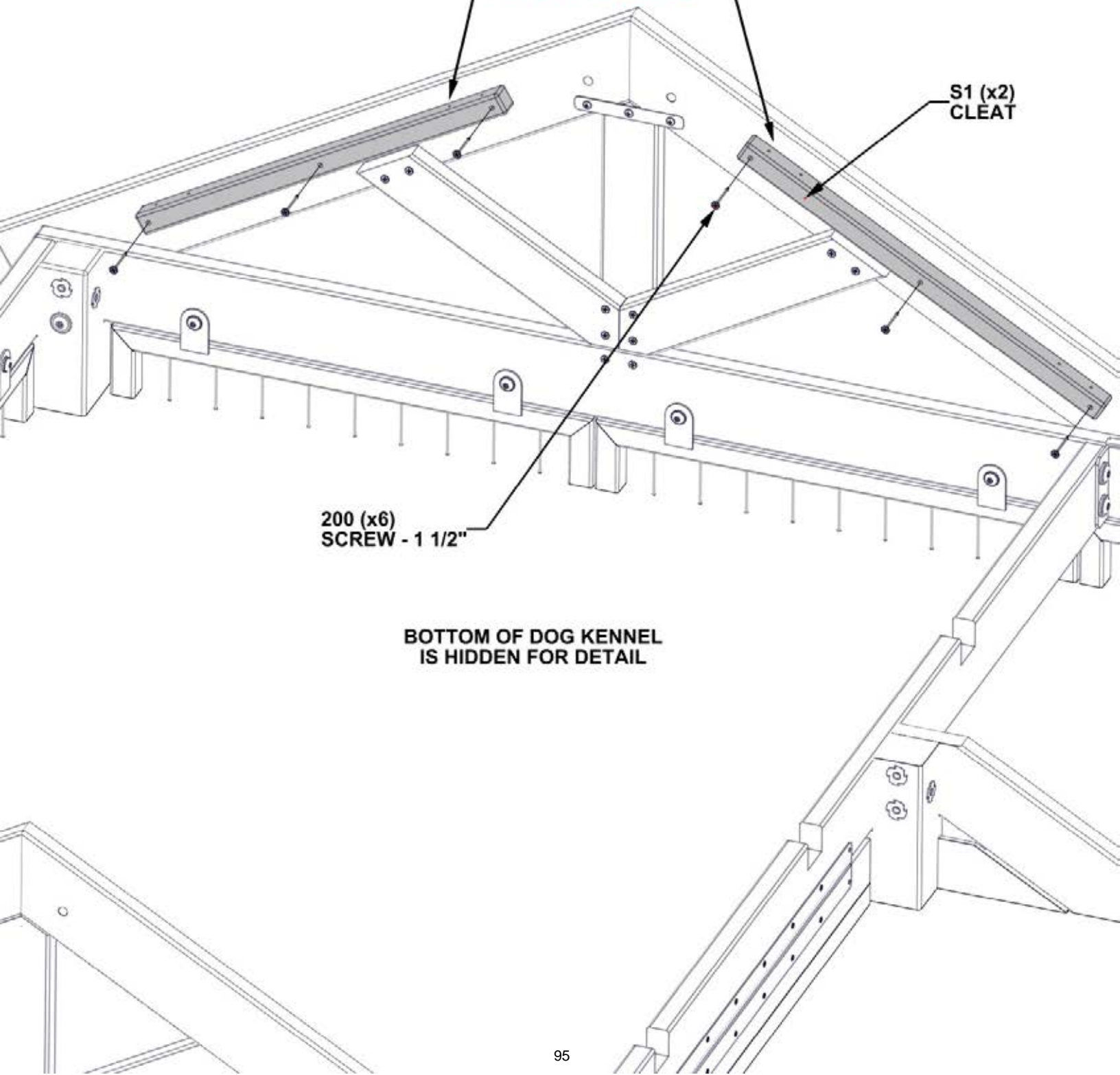

STEP 39 - DOG KENNEL ASSEMBLY

Qty	PART NUMBER	DESCRIPTION
6	H100404	NUT BARREL WH 1/4X5/8 BLK
6	H100486	BOLT WH 1/4x5/8 BLK
6	H100405	WASHER LOCK EXT 6x15

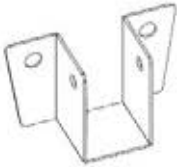

A4M01787 RAFTER BRACKET
(x3)

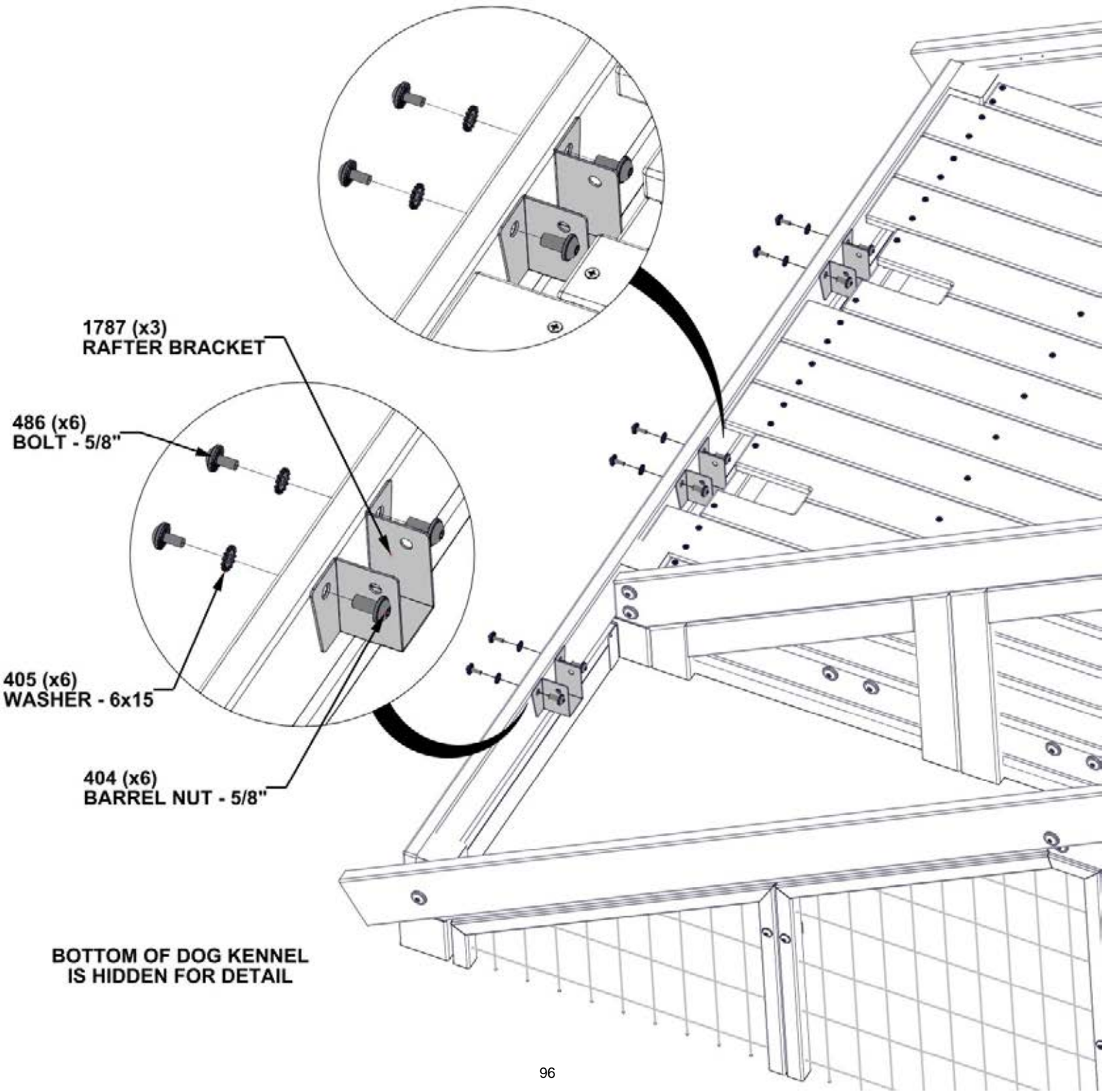

1787 (x3)
RAFTER BRACKET

486 (x6)
BOLT - 5/8"

405 (x6)
WASHER - 6x15

404 (x6)
BARREL NUT - 5/8"

BOTTOM OF DOG KENNEL
IS HIDDEN FOR DETAIL

STEP 40 - DOG KENNEL ASSEMBLY

Qty	PART NUMBER	DESCRIPTION
6	H100404	NUT BARREL WH 1/4X5/8 BLK
6	H100486	BOLT WH 1/4x5/8 BLK
6	H100405	WASHER LOCK EXT 6x15

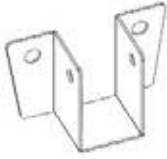

A4M01787 RAFTER BRACKET
(x3)

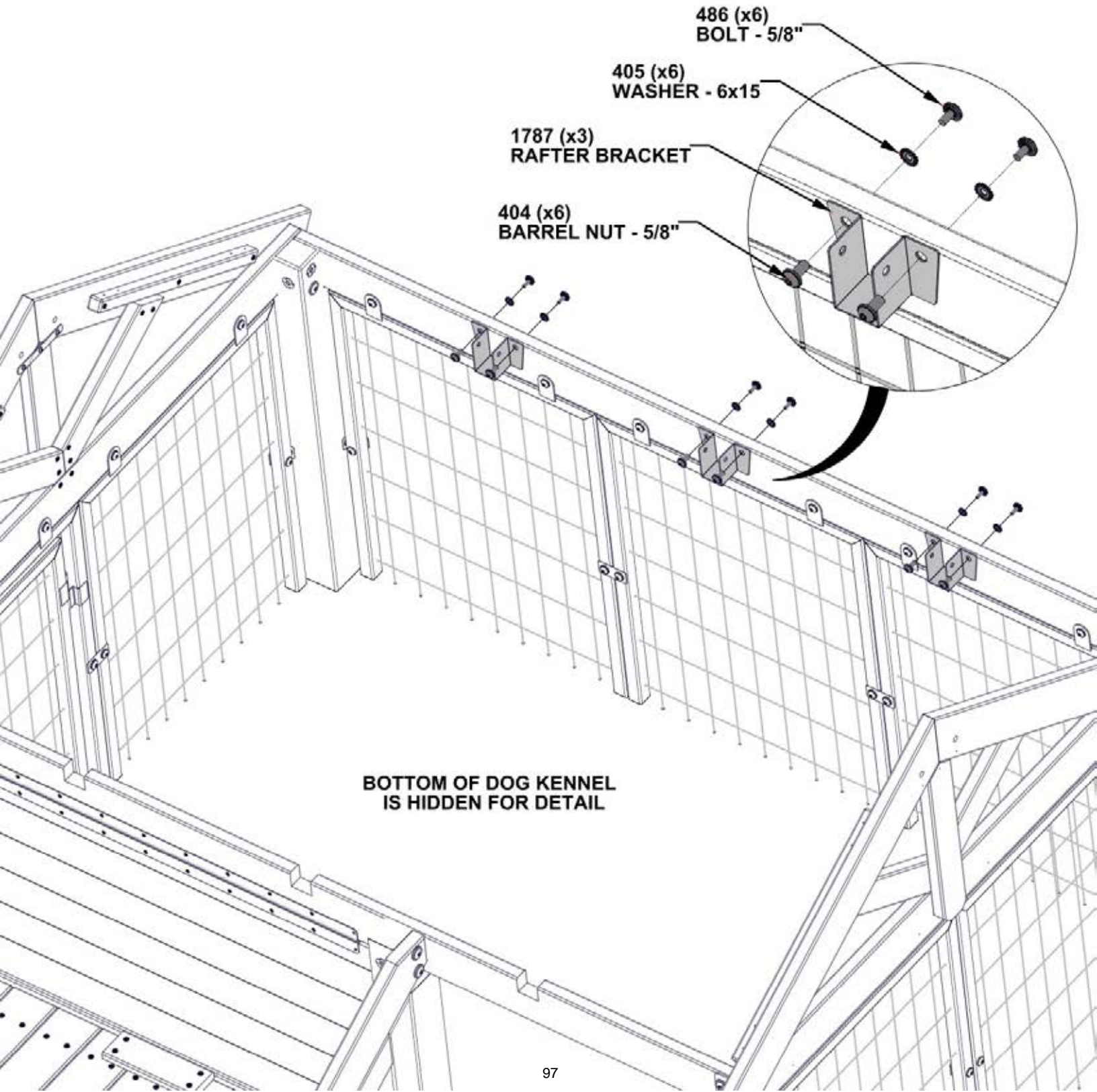

**BOTTOM OF DOG KENNEL
IS HIDDEN FOR DETAIL**

STEP 41 - DOG KENNEL ASSEMBLY

Qty	PART NUMBER	DESCRIPTION
4	H100469	NUT BARREL WH 5/16X5/8 BLK
4	H100663	BOLT WH 5/16x3/4 BLK
4	H100198	WASHER LOCK EXT 8x19

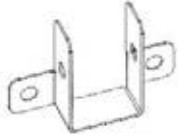

A4M01148 TRUSS BRACKET
(x2)

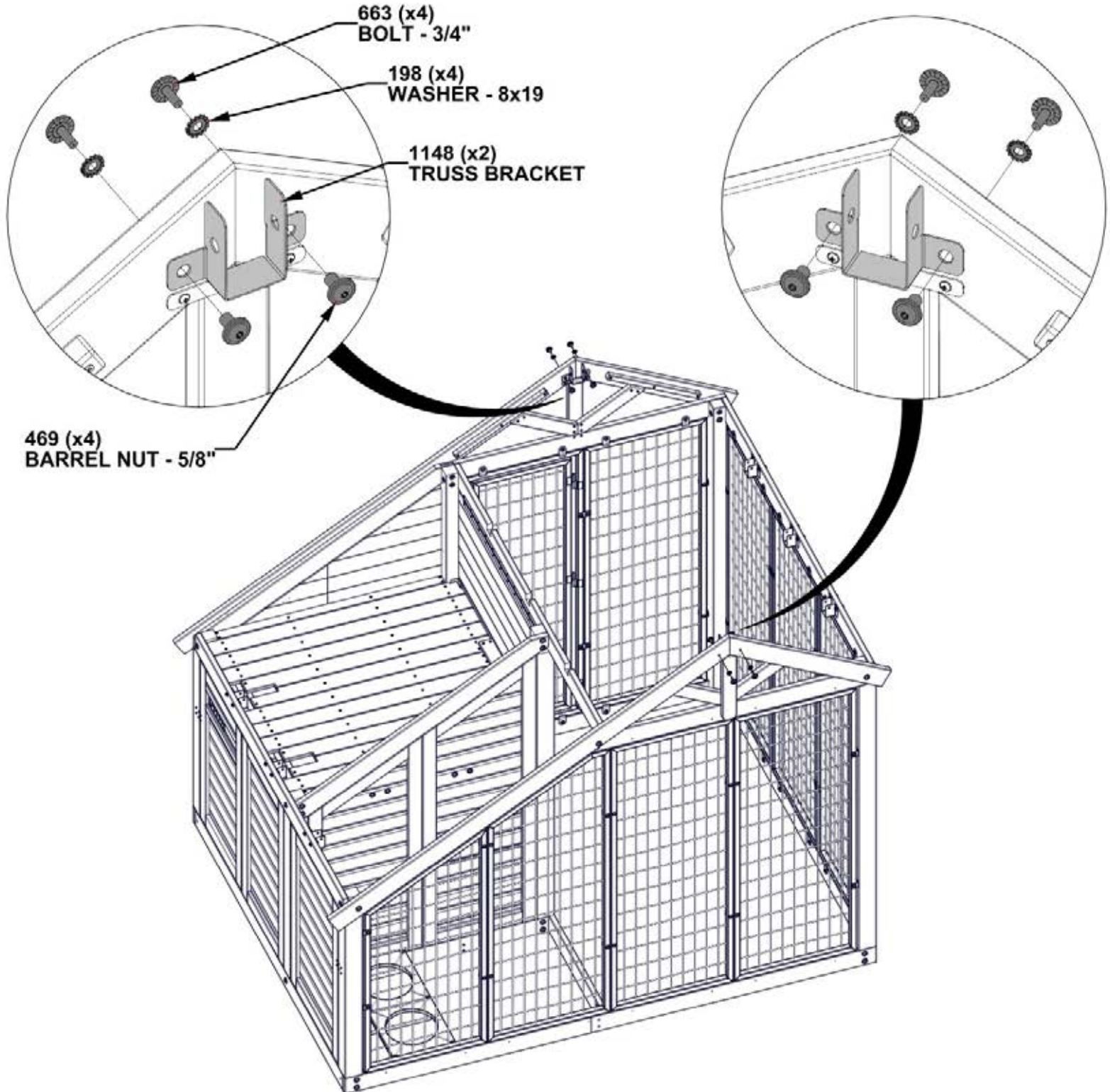

STEP 42 A - ROOF PANEL A ASSEMBLY

ROOF PANEL A

- USE THIS STEP TO FAMILIARIZE YOURSELF WITH THE ROOF PANEL AND ASSIST YOU IN STEPS 42 - 44.
- REMOVE PROTECTIVE BLUE FILM.
- START AT END INDICATED AND ASSEMBLE IN THE DIRECTIONS OF THE ARROW.
- **GLOVES SHOULD BE WORN WHEN HANDLING ROOF PANELS. EDGES ARE SHARP.**



ROOF PANEL STEPS 42 - 44

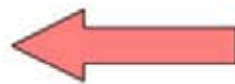

STEP 42 B - ROOF PANEL A ASSEMBLY

Qty	PART NUMBER	DESCRIPTION
6	H100391	SCREW PFH 8x2 BLK
15	H100382	SCREW PFH 8x1 3/4 BLK

E3 RAFTER - W4L19529
(x1) 1 7/16"x3 3/8"x73 1/8" (36x86x1857)

E2 RAFTER - W4L19468
(x2) 1 7/16"x3 3/8"x73 1/8" (36x86x1857)

H22 RIDGE BEAM - W4L19466
(x1) 15/16"x3 3/8"x68 1/4" (24x86x1734)

H27 SHEATHING BOARD - W4L19524
(x5) 15/16"x3 3/8"x68 1/4" (24x86x1734)

- USE PILOT HOLES TO ALIGN SCREWS

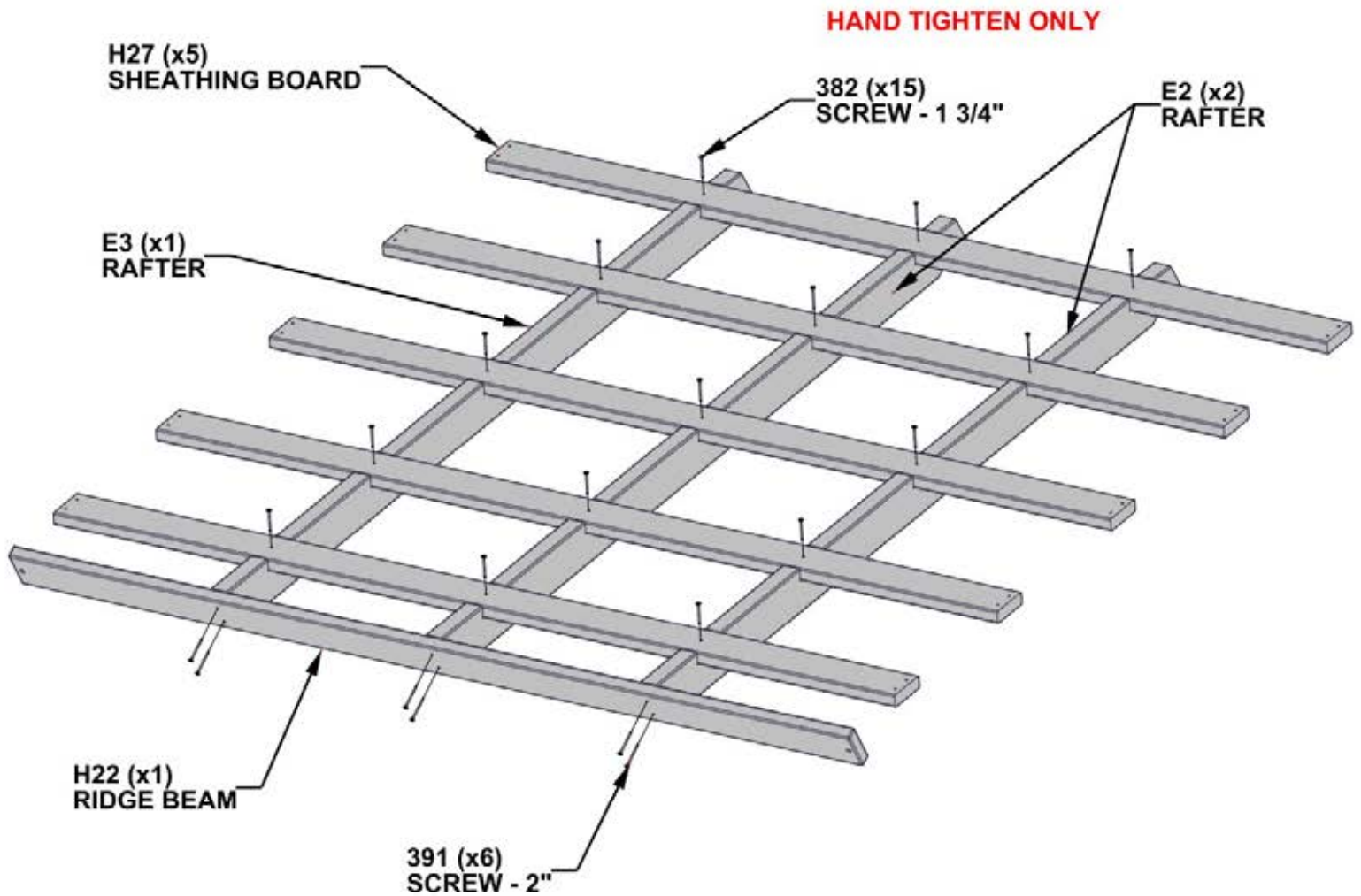

STEP 42 C - ROOF PANEL A ASSEMBLY

CRITICAL:

- SQUARE UNIT BEFORE PROCEEDING TO NEXT STEP.
- THE BELOW DIMENSIONS ARE CRITICAL TO THE FINAL ROOF ASSEMBLY.
- MEASUREMENTS SHOULD BE HELD WITHIN $\pm 1/4"$ (6mm).
- MEASUREMENTS OUTSIDE OF THE TOLERANCE WILL LEAD TO THE INABILITY TO ASSEMBLE THE ROOF.

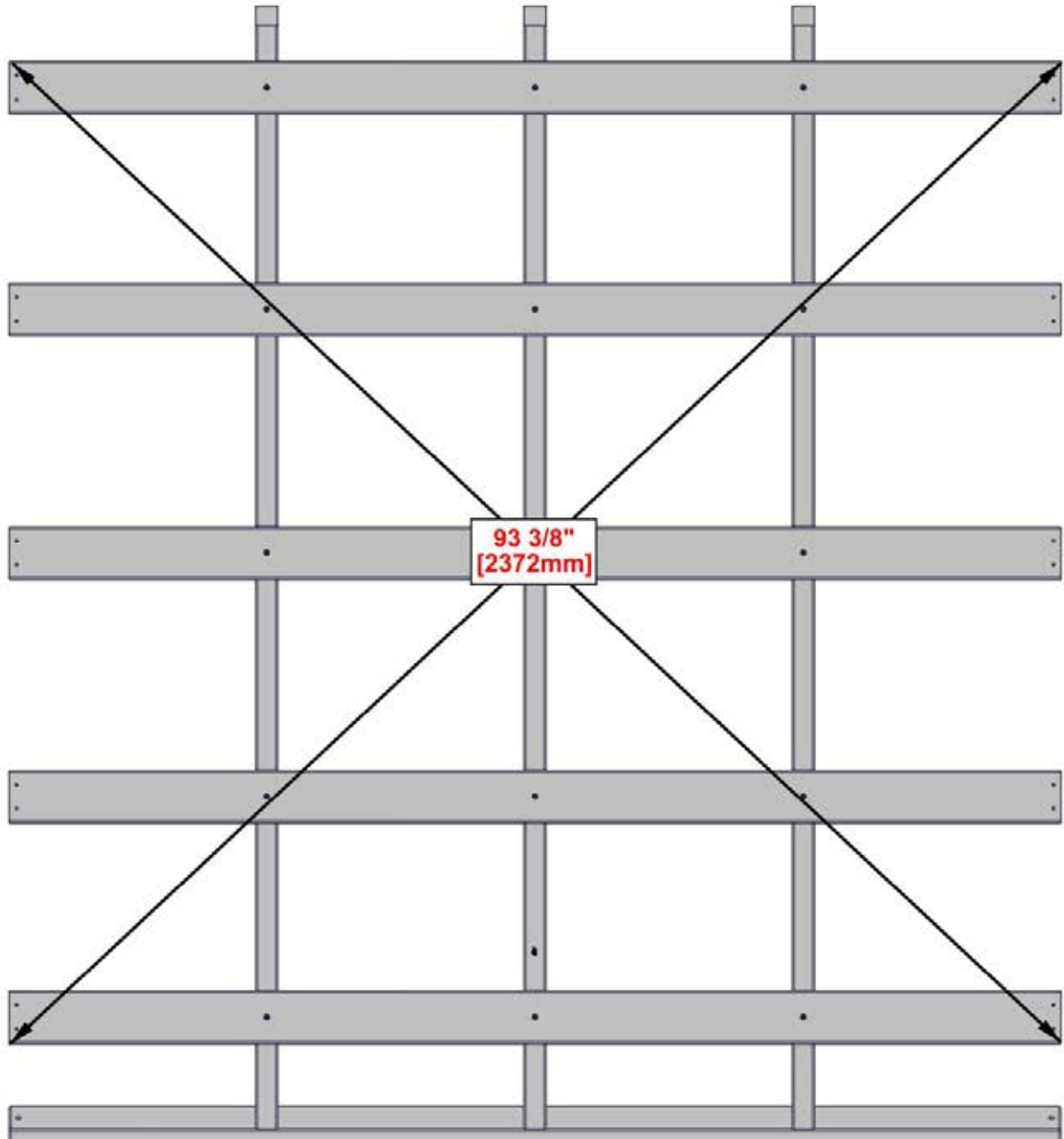

ONCE PANEL IS SQUARED, FULLY TIGHTEN SCREWS

STEP 43 - ROOF PANEL A ASSEMBLY

Qty	PART NUMBER	DESCRIPTION
3	H100653	NUT LOCK 1/4 BLK
3	H100488	BOLT WH 1/4x2 BLK
3	H101133	WASHER FLAT 7x14 BLK
20	H100382	SCREW PFH 8x1 3/4 BLK



ROOF PANEL ASSEMBLY (LONG SIDE)
(x1) (FROM STEP 42)

- USE PILOT HOLES TO ALIGN SCREWS

10 LOCATIONS

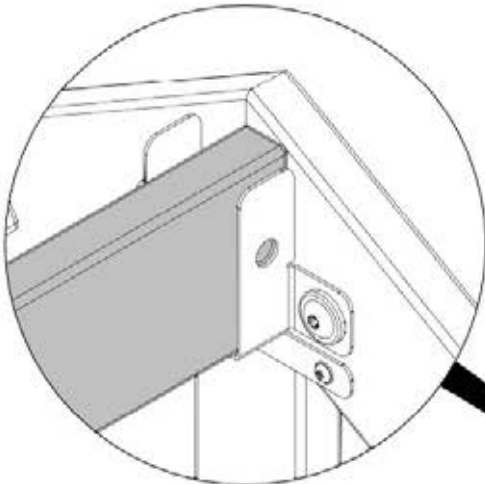

ALIGN TRUSS IN BRACKET
AS SHOWN BOTH ENDS
OF TRUSS

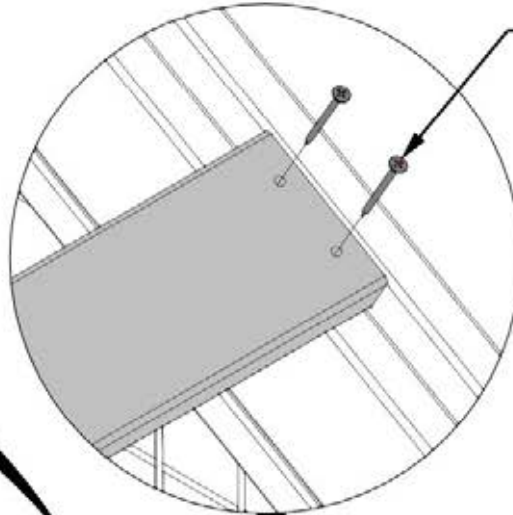

382 (x20)
SCREW - 1 3/4"

488 (x3)
BOLT - 2"

3 LOCATIONS

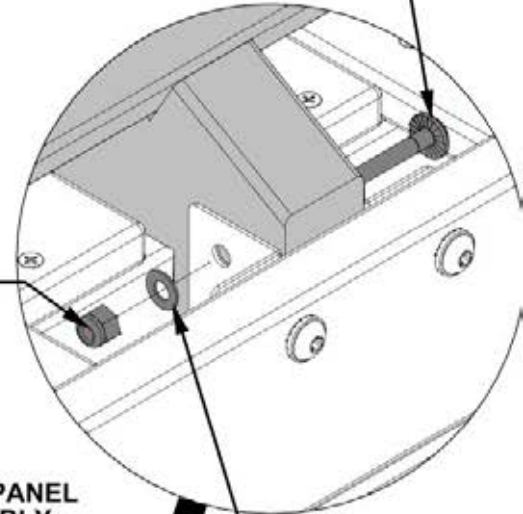

653 (x3)
LOCK NUT - 1/4"

(x1)
ROOF PANEL
ASSEMBLY
(LONG SIDE)

1133 (x3)
WASHER - 7x14

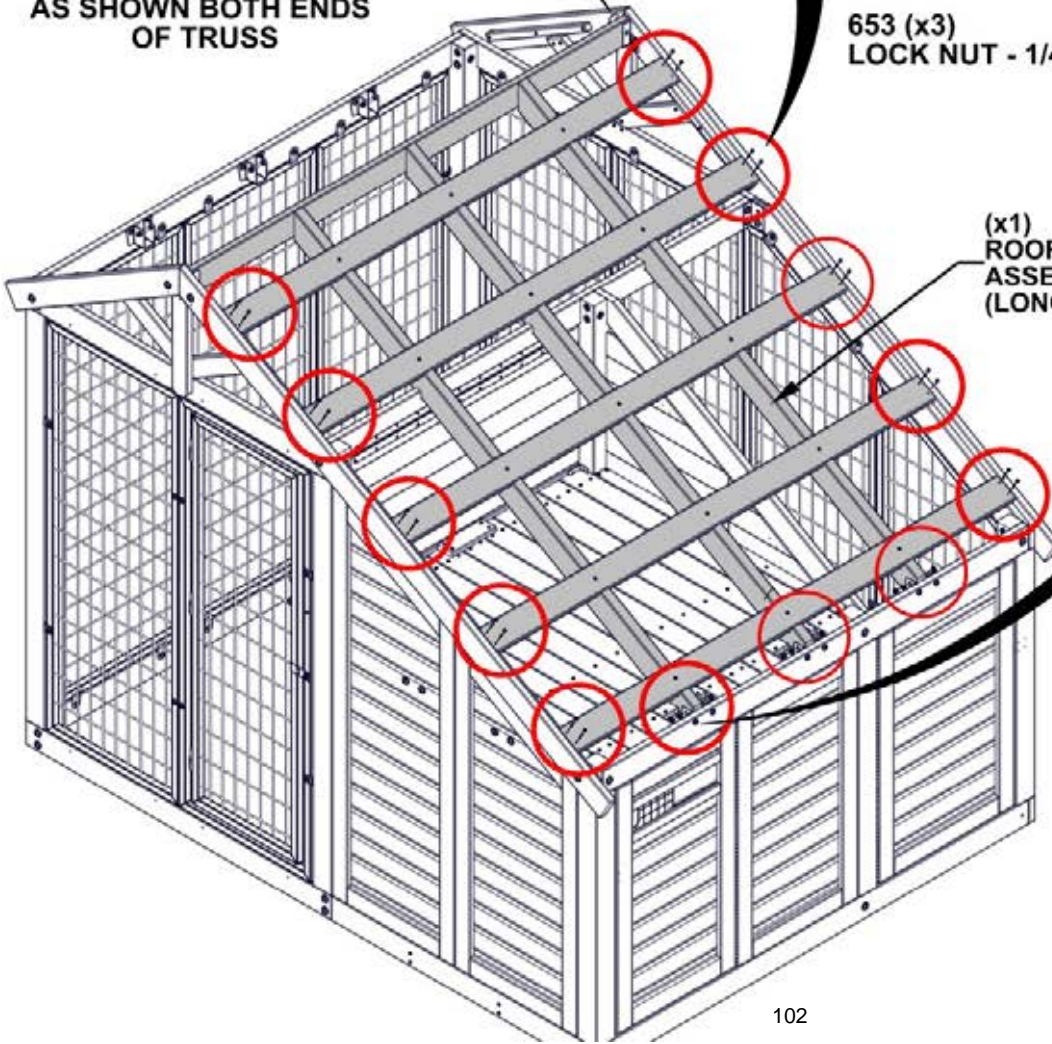

STEP 44 A - DOG KENNEL ASSEMBLY

Qty	PART NUMBER	DESCRIPTION
10	H101117	SCREW WOODGRIP 10-16x3/4"

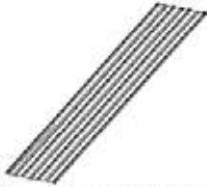

A4M02621 29 GA SHEETING (x1)



A4M02620 29 GA SHEETING (x1)

- MAKE SURE YOUR ROOF PANEL IS SQUARE BEFORE MOVING ON
- DO NOT PUT SCREWS IN FIRST ROW OF HOLES

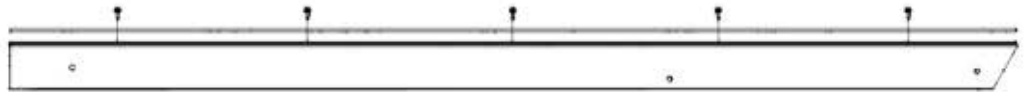

NOTE RIB OVERLAP

FLUSH

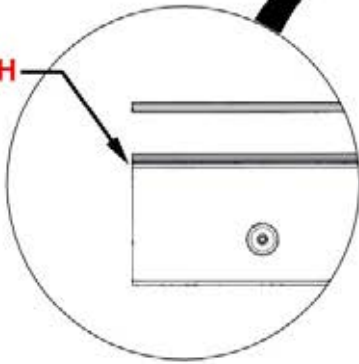

1117 (x10)
SCREW WOODGRIP

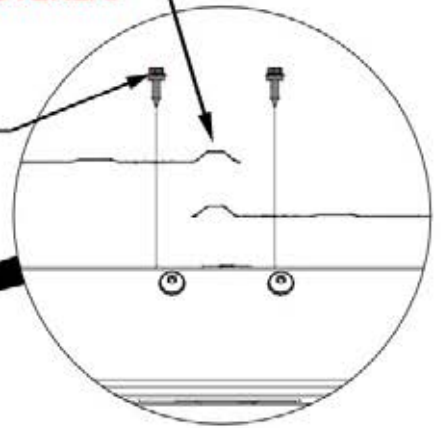

BOTTOM OF DOG KENNEL IS HIDDEN FOR DETAIL

2621 (x1)
29 GA SHEETING

2620 (x1)
29 GA SHEETING



PLACE SHEETING ON ROOF PANEL, ALIGNING EDGE OF RIB 1/4" [5mm] FROM END OF H BOARD

H18 FASCIA

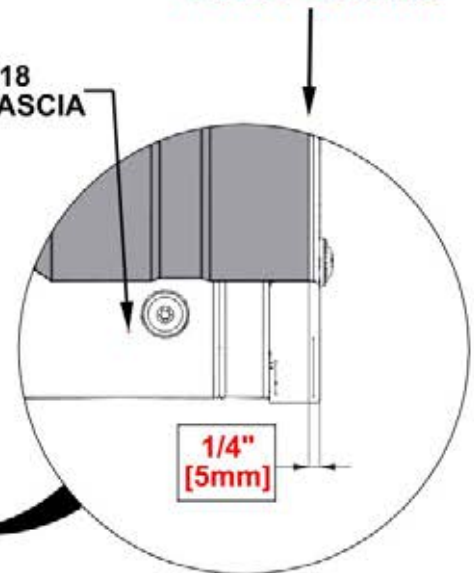

1/4" [5mm]

STEP 44 B - DOG KENNEL ASSEMBLY

Qty	PART NUMBER	DESCRIPTION
20	H101117	SCREW WOODGRIP 10-16x3/4"

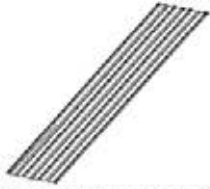

A4M02621 29 GA SHEETING (x1)



A4M02620 29 GA SHEETING (x1)

- DO NOT PUT SCREWS IN LAST ROW OF HOLES

NOTE RIB OVERLAP

1117 (x20)
SCREW WOODGRIP

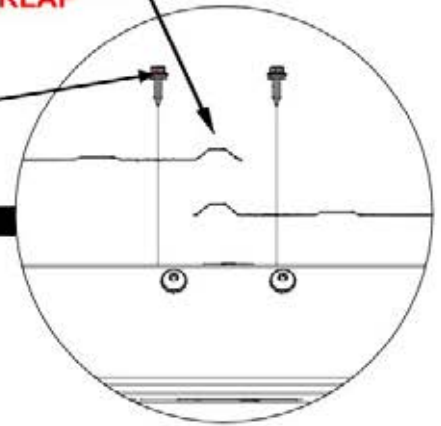

ENSURE CORRECT PLACEMENT OF 2620 STEEL SHEETING.

2620 (x1)
29 GA SHEETING

2621 (x1)
29 GA SHEETING



ENDS OF ALL SHEETS SHOULD BE FLUSH

BOTTOM OF DOG KENNEL IS HIDDEN FOR DETAIL

STEP 45 A - ROOF PANEL B ASSEMBLY

ROOF PANEL B

- USE THIS STEP TO FAMILIARIZE YOURSELF WITH THE ROOF PANEL AND ASSIST YOU IN STEPS 45 - 47.
- REMOVE PROTECTIVE BLUE FILM.
- START AT END INDICATED AND ASSEMBLE IN THE DIRECTIONS OF THE ARROW.
- **GLOVES SHOULD BE WORN WHEN HANDLING ROOF PANELS. EDGES ARE SHARP.**



ROOF PANEL STEPS 45 - 47

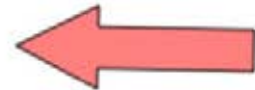

STEP 45 B - ROOF PANEL B ASSEMBLY

Qty	PART NUMBER	DESCRIPTION
6	H100382	SCREW PFH 8x1 3/4 BLK
6	H100391	SCREW PFH 8x2 BLK



E1 RAFTER - W4L19467
(x3) 1 7/16"x3 3/8"x28 1/4" (36x86x716)

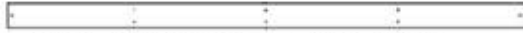

H22 RIDGE BEAM - W4L19466
(x1) 15/16"x3 3/8"x68 1/4" (24x86x1734)



H27 SHEATHING BOARD - W4L19524
(x2) 15/16"x3 3/8"x68 1/4" (24x86x1734)

- USE PILOT HOLES TO ALIGN SCREWS

HAND TIGHTEN ONLY

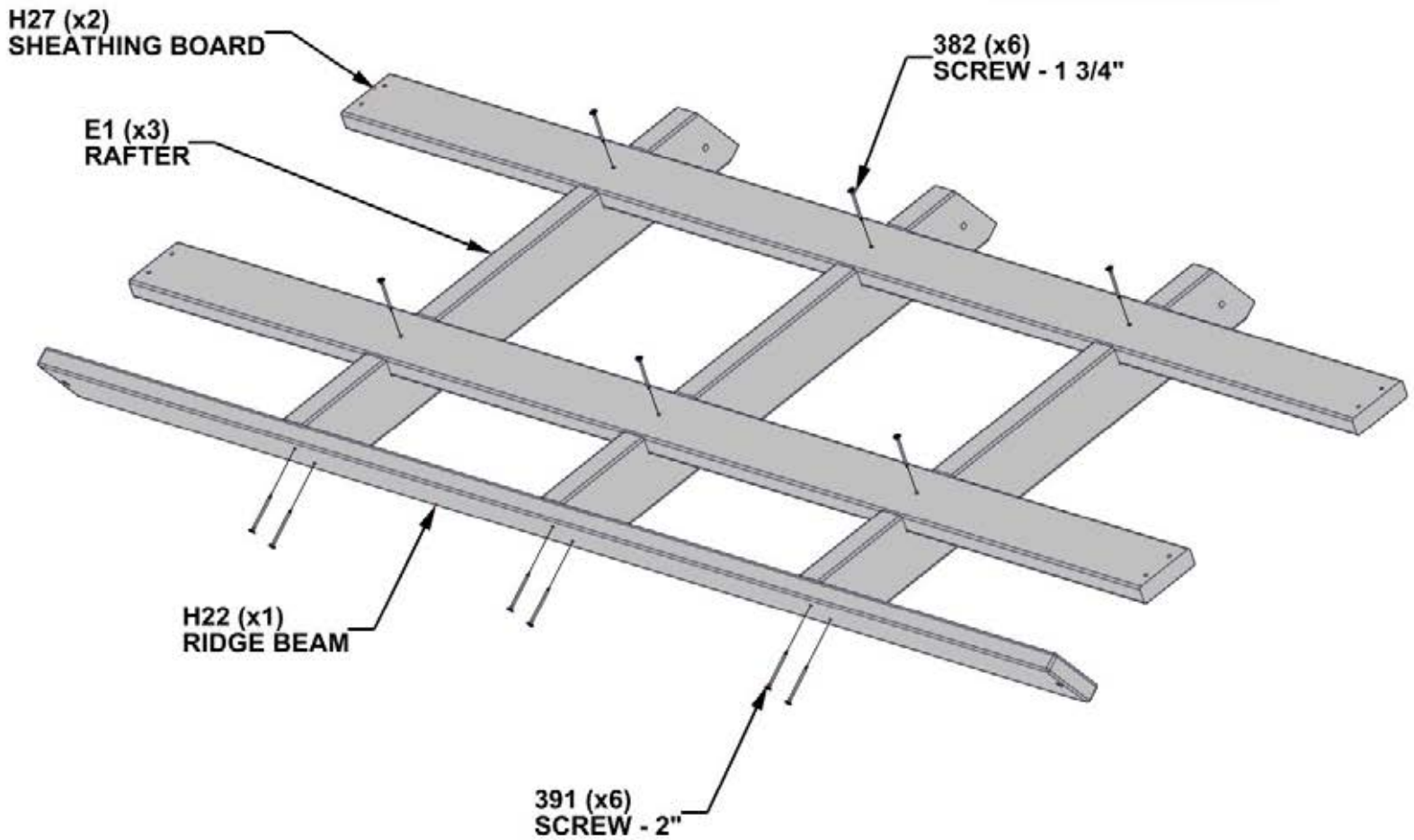

STEP 45 C - ROOF PANEL B ASSEMBLY

CRITICAL:

- SQUARE UNIT BEFORE PROCEEDING TO NEXT STEP.
- THE BELOW DIMENSIONS ARE CRITICAL TO THE FINAL ROOF ASSEMBLY.
- MEASUREMENTS SHOULD BE HELD WITHIN $\pm 1/4"$ (6mm).
- MEASUREMENTS OUTSIDE OF THE TOLERANCE WILL LEAD TO THE INABILITY TO ASSEMBLE THE ROOF.

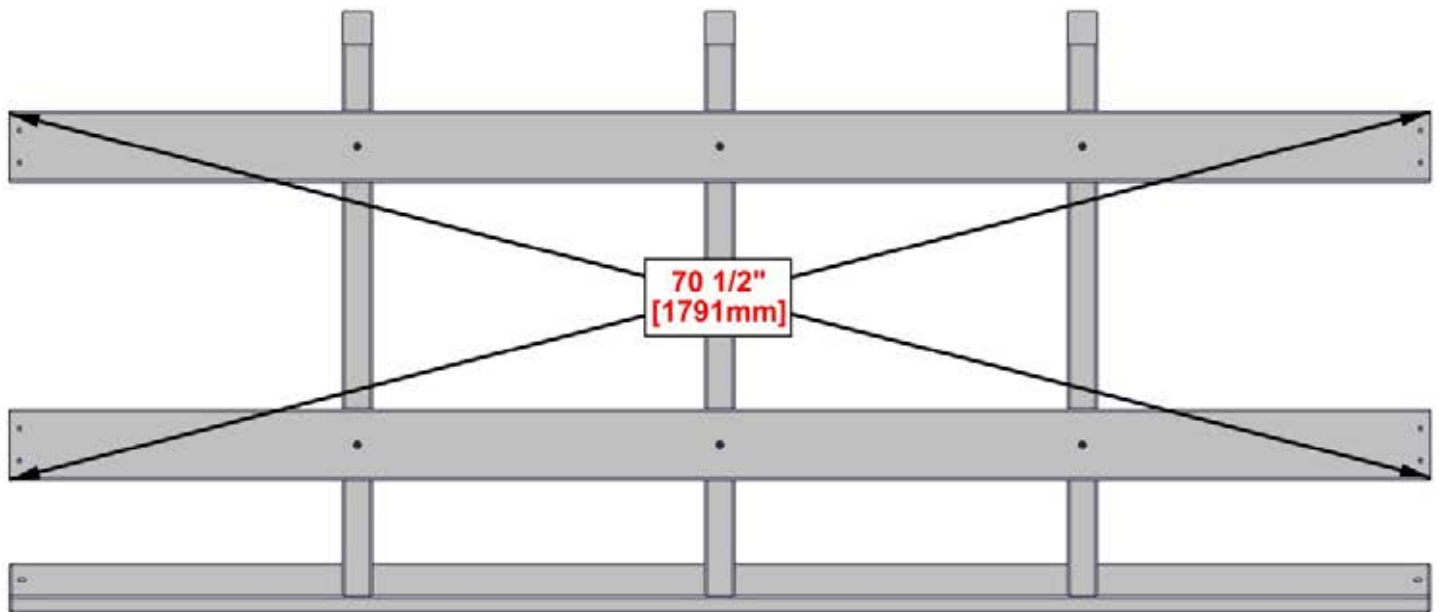

ONCE PANEL IS SQUARED, FULLY TIGHTEN SCREWS

STEP 46 - ROOF PANEL B ASSEMBLY

Qty	PART NUMBER	DESCRIPTION
2	H100469	NUT BARREL WH 5/16X5/8 BLK
2	H100378	BOLT WH 5/16x1 3/4 BLK
3	H100653	NUT LOCK 1/4 BLK
3	H100488	BOLT WH 1/4x2 BLK
3	H101133	WASHER FLAT 7x14 BLK
8	H100382	SCREW PFH 8x1 3/4 BLK

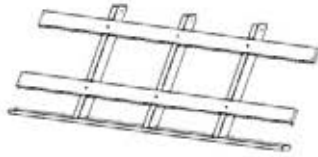

ROOF PANEL ASSEMBLY (SHORT SIDE)
(x1) (FROM STEP 45)

- USE PILOT HOLES TO ALIGN SCREWS

382 (x8)
SCREW - 1 3/4"

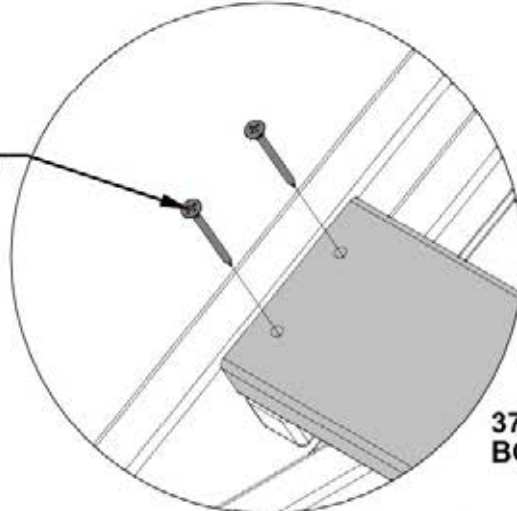

469 (x2)
BARREL NUT - 5/8"

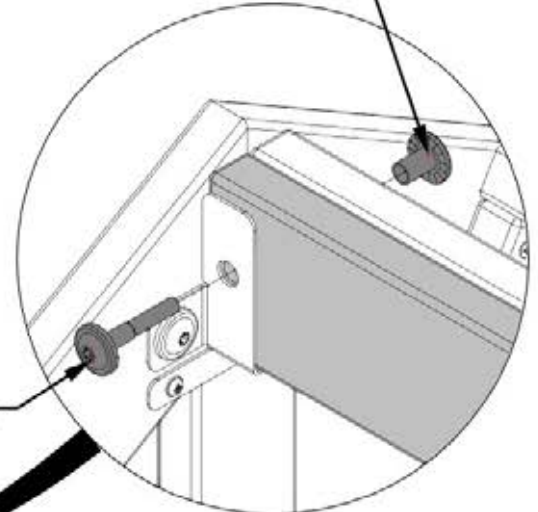

378 (x2)
BOLT - 1 3/4"

4 LOCATIONS

BOTH ENDS
OF TRUSS

488 (x3)
BOLT - 2"

(x1)
ROOF PANEL
ASSEMBLY
(SHORT SIDE)

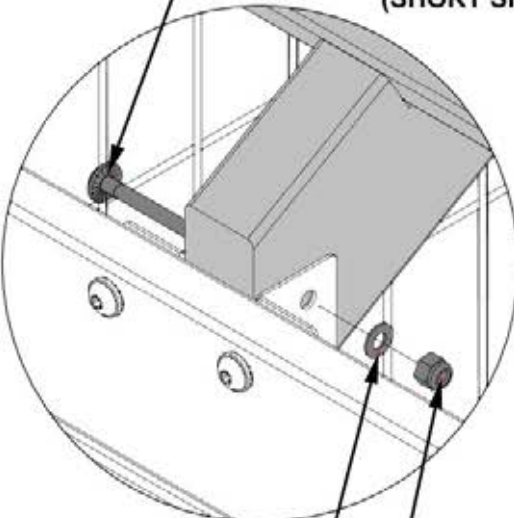

3 LOCATIONS

1133 (x3)
WASHER - 7x14

653 (x3)
LOCK NUT - 1/4"

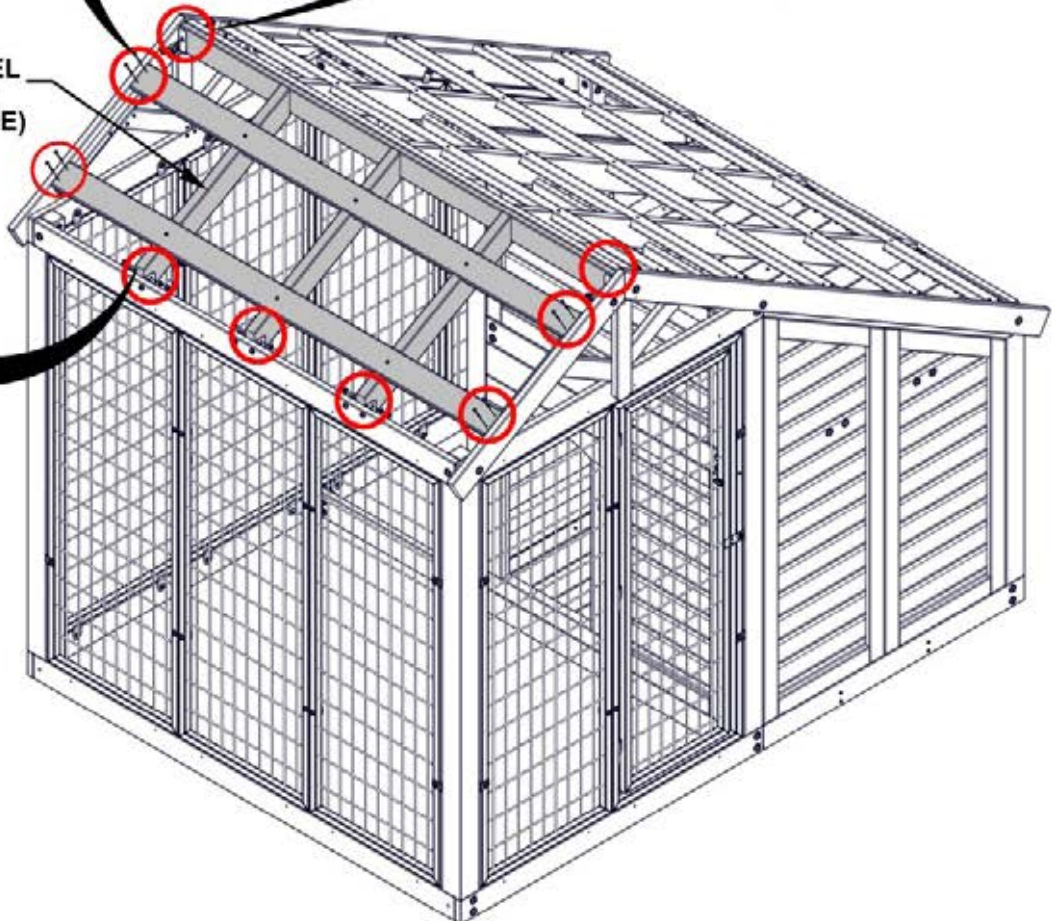

STEP 47 A - ROOF PANEL B ASSEMBLY

Qty	PART NUMBER	DESCRIPTION
4	H101117	SCREW WOODGRIP 10-16x3/4"



A4M02622 29 GA SHEETING (x1)

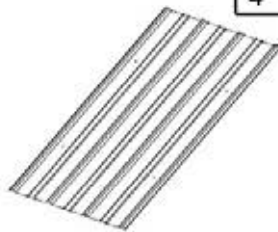

A4M02623 29 GA SHEETING (x1)

- MAKE SURE YOUR ROOF PANEL IS SQUARE BEFORE MOING ON
- DO NOT PUT SCREWS IN FIRST ROW OF HOLES



NOTE RIB OVERLAP

FLUSH

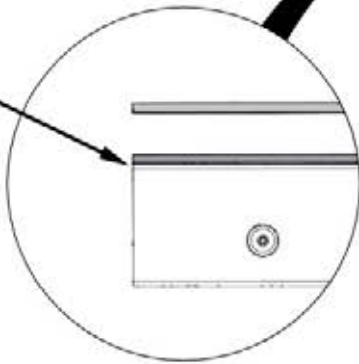

1117 (x4)
SCREW WOODGRIP

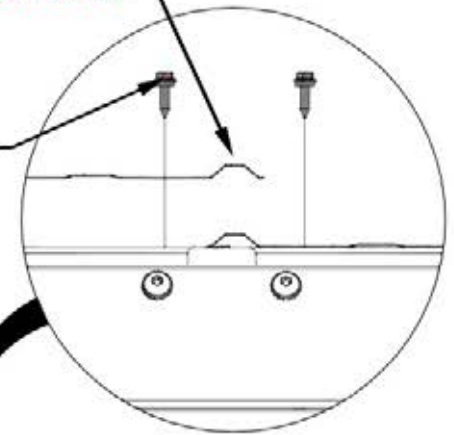

BOTTOM OF DOG KENNEL IS HIDDEN FOR DETAIL.

2623 (x1)
29 GA SHEETING

2622 (x1)
29 GA SHEETING

PLACE SHEETING ON ROOF PANEL, ALIGNING EDGE OF RIB 1/4" [5mm] FROM END OF H BOARD

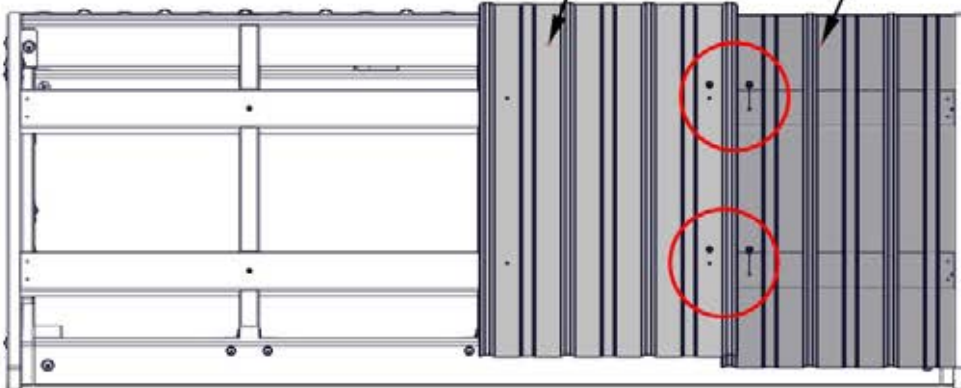

H1 FASCIA

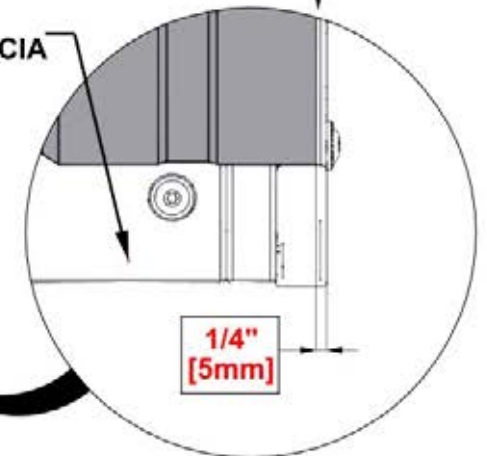

1/4" [5mm]

STEP 47 B - ROOF PANEL B ASSEMBLY

Qty	PART NUMBER	DESCRIPTION
8	H101117	SCREW WOODGRIP 10-16x3/4"



A4M02622 29 GA SHEETING (x1)

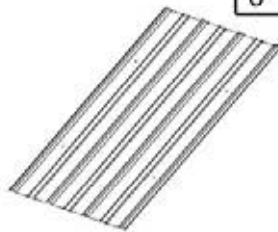

A4M02623 29 GA SHEETING (x1)

- DO NOT PUT SCREWS IN LAST ROW OF HOLES

NOTE RIB OVERLAP

1117 (x8)
SCREW WOODGRIP

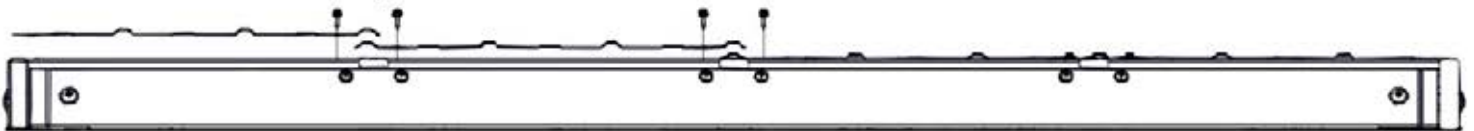
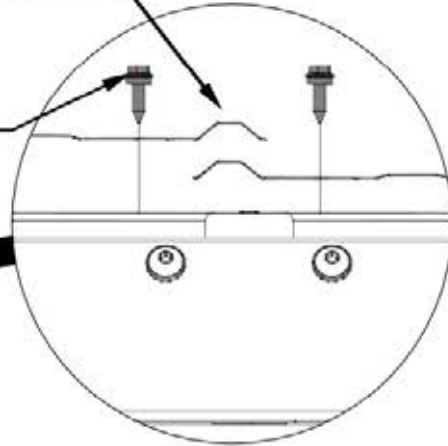

2622 (x1)
29 GA SHEETING

2623 (x1)
29 GA SHEETING

ENSURE CORRECT PLACEMENT OF 2622 STEEL SHEETING.

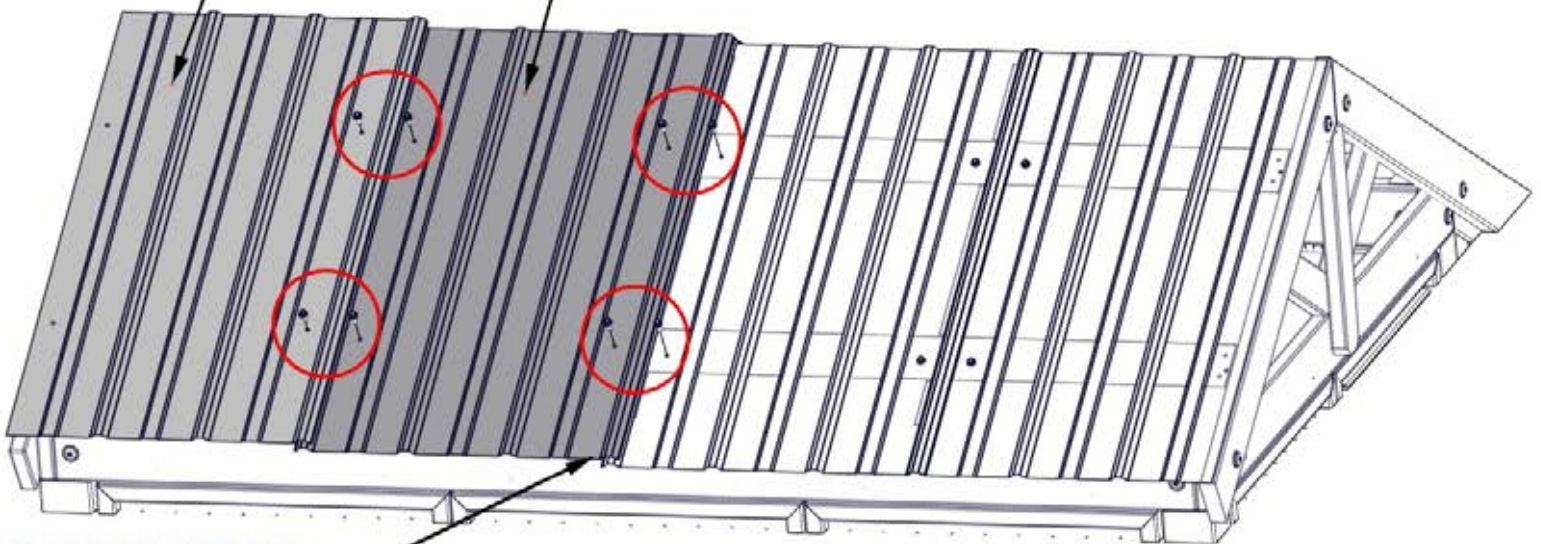

ENDS OF ALL SHEETS SHOULD BE FLUSH

BOTTOM OF DOG KENNEL IS HIDDEN FOR DETAIL

STEP 48 A - DOG KENNEL ASSEMBLY

Qty	PART NUMBER	DESCRIPTION
4	H101117	SCREW WOODGRIP 10-16x3/4"



A4M02630 ROOF EDGE TRIM
(x1)



A4M02631 ROOF EDGE TRIM
(x1)

- DUE TO MULTIPLE LAYERS OF METAL ON THE EDGE TRIM, IT IS RECOMMENDED THAT A 1/8" [3mm] DRILL BIT IS USED TO CREATE STARTER HOLES.
- REMOVE PROTECTIVE BLUE FILM.
- **GLOVES SHOULD BE WORN WHEN HANDLING ROOF METAL. EDGES ARE SHARP.**

1117 (x4)
SCREW WOODGRIP

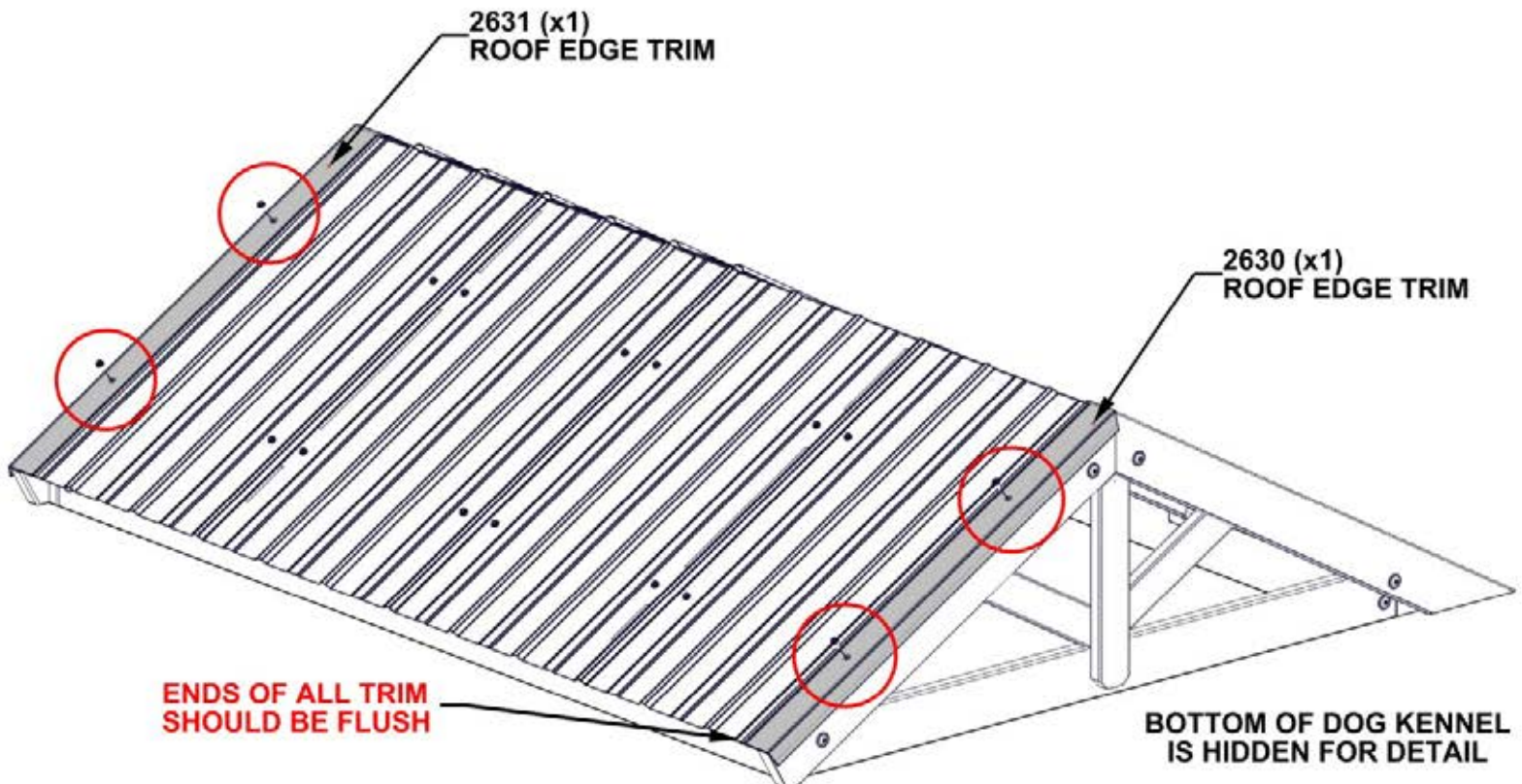
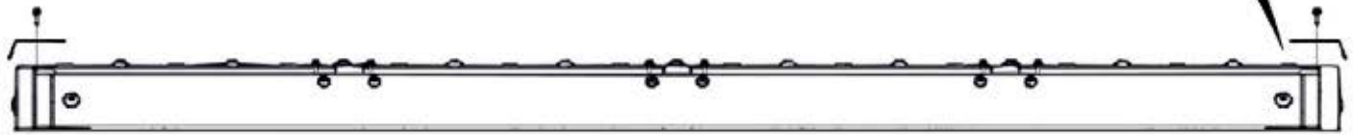
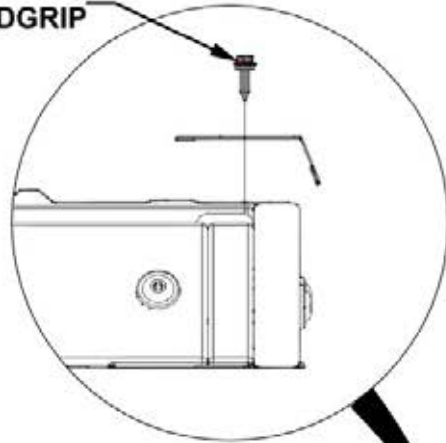

STEP 48 B - DOG KENNEL ASSEMBLY

Qty	PART NUMBER	DESCRIPTION
6	H101117	SCREW WOODGRIP 10-16x3/4"

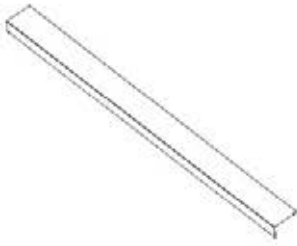

A4M02625 ROOF EDGE TRIM
(x1)

- DUE TO MULTIPLE LAYERS OF METAL ON THE EDGE TRIM, IT IS RECOMMENDED THAT A 1/8" [3mm] DRILL BIT IS USED TO CREATE STARTER HOLES.
- REMOVE PROTECTIVE BLUE FILM.
- GLOVES SHOULD BE WORN WHEN HANDLING ROOF METAL. EDGES ARE SHARP.

SCREWS GO THROUGH EDGE TRIM INTO THE TOP OF THE RIBS IN THE APPROXIMATE LOCATIONS SHOWN

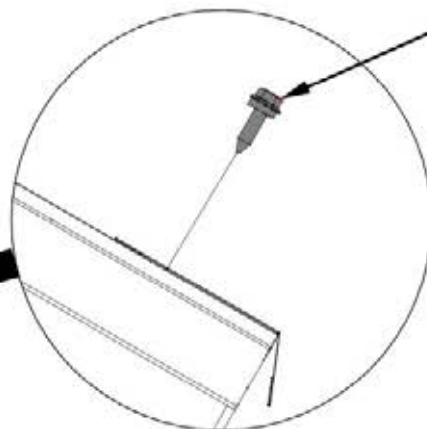

1117 (x6)
SCREW WOODGRIP

SIDE VIEW

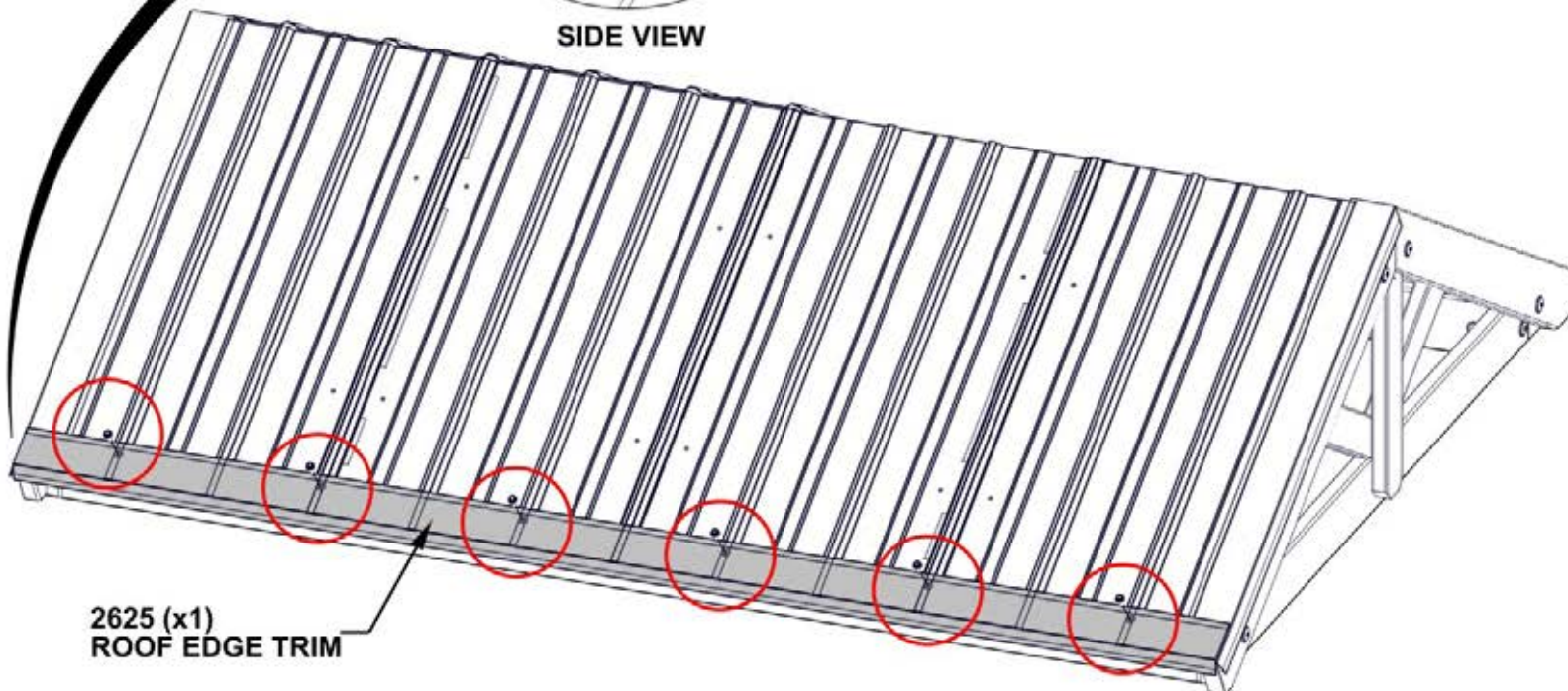

2625 (x1)
ROOF EDGE TRIM

ENSURE THAT BOTH ENDS ARE FLUSH WITH THE EDGES OF ROOF PANELS.

BOTTOM OF DOG KENNEL IS HIDDEN FOR DETAIL

STEP 48 C - DOG KENNEL ASSEMBLY

Qty	PART NUMBER	DESCRIPTION
4	H101117	SCREW WOODGRIP 10-16x3/4"

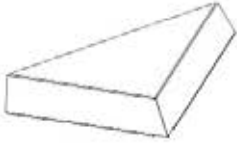

A4M02696 CORNER CAP
(x2)

- DUE TO MULTIPLE LAYERS OF METAL ON THE EDGE TRIM, IT IS RECOMMENDED THAT A 1/8" [3mm] DRILL BIT IS USED TO CREATE STARTER HOLES.
- REMOVE PROTECTIVE BLUE FILM.
- **GLOVES SHOULD BE WORN WHEN HANDLING ROOF METAL. EDGES ARE SHARP.**

1117 (x4)
SCREW WOODGRIP

2696 (x2)
CORNER CAP

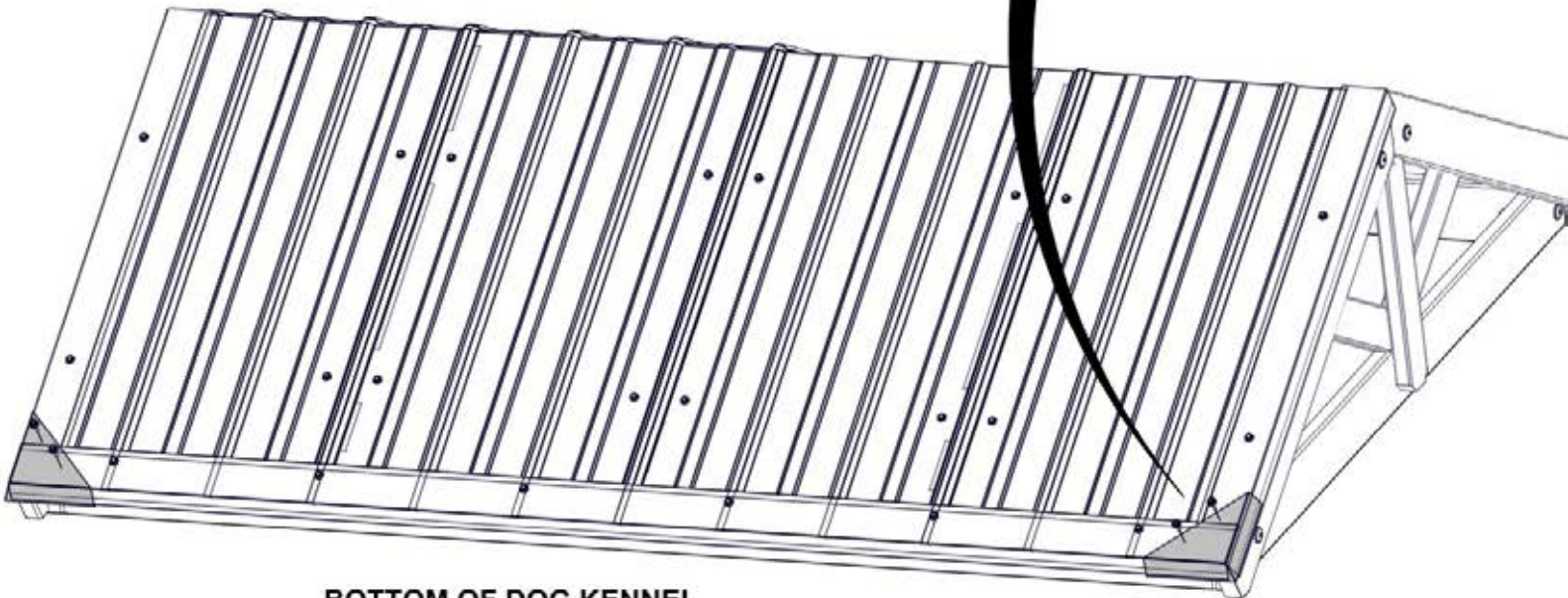
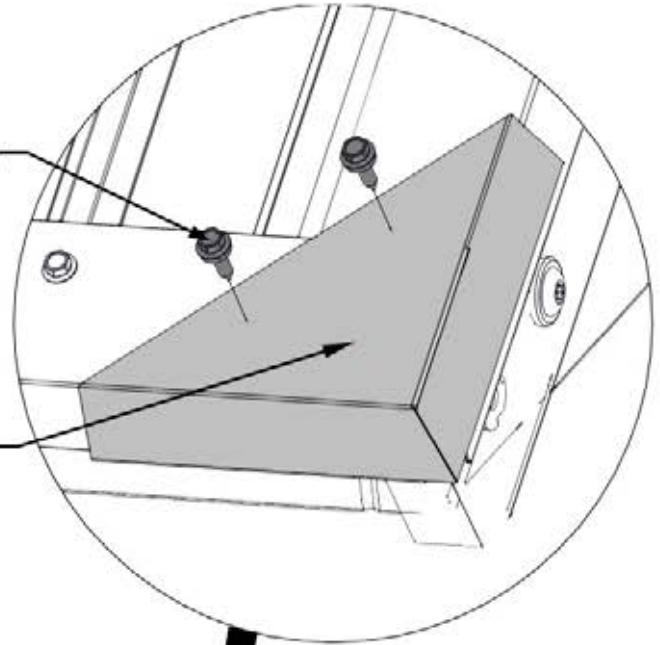

BOTTOM OF DOG KENNEL
IS HIDDEN FOR DETAIL

STEP 49 A - DOG KENNEL ASSEMBLY

Qty	PART NUMBER	DESCRIPTION
10	H101117	SCREW WOODGRIP 10-16x3/4"



A4M02628 ROOF EDGE TRIM (x1)



A4M02629 ROOF EDGE TRIM (x1)

- DUE TO MULTIPLE LAYERS OF METAL ON THE EDGE TRIM, IT IS RECOMMENDED THAT A 1/8" [3mm] DRILL BIT IS USED TO CREATE STARTER HOLES.
- REMOVE PROTECTIVE BLUE FILM.
- **GLOVES SHOULD BE WORN WHEN HANDLING ROOF METAL. EDGES ARE SHARP.**

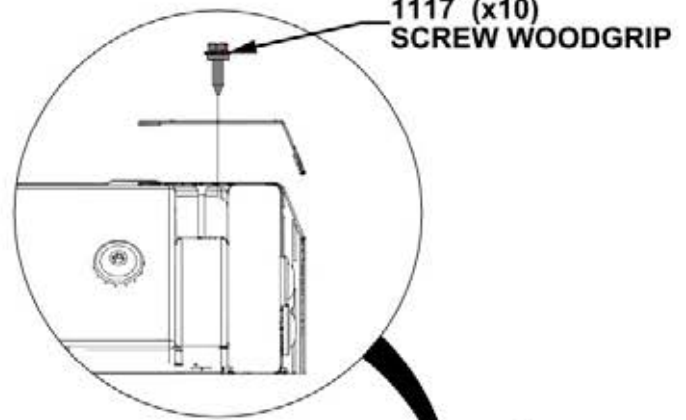

2628 (x1) ROOF EDGE TRIM

2629 (x1) ROOF EDGE TRIM

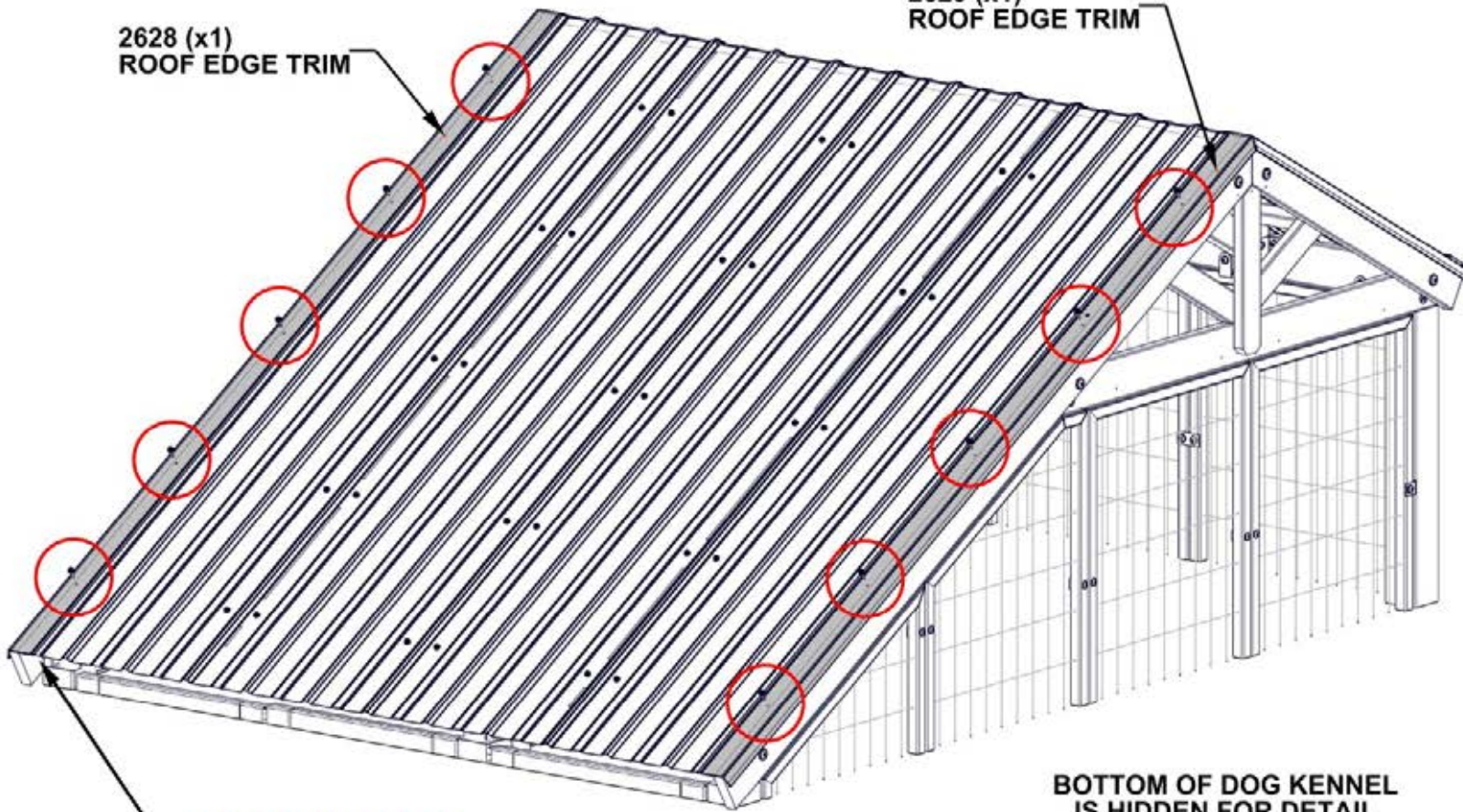

ENDS OF ALL TRIM SHOULD BE FLUSH

BOTTOM OF DOG KENNEL IS HIDDEN FOR DETAIL

STEP 49 B - DOG KENNEL ASSEMBLY

Qty	PART NUMBER	DESCRIPTION
6	H101117	SCREW WOODGRIP 10-16x3/4"

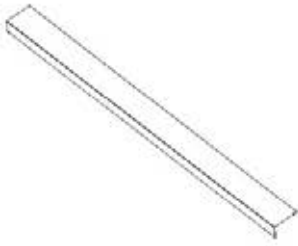

A4M02625 ROOF EDGE TRIM
(x1)

- DUE TO MULTIPLE LAYERS OF METAL ON THE EDGE TRIM, IT IS RECOMMENDED THAT A 1/8" [3mm] DRILL BIT IS USED TO CREATE STARTER HOLES.
- REMOVE PROTECTIVE BLUE FILM.
- **GLOVES SHOULD BE WORN WHEN HANDLING ROOF METAL. EDGES ARE SHARP.**

SCREWS GO THROUGH EDGE TRIM INTO THE TOP OF THE RIBS IN THE APPROXIMATE LOCATIONS SHOWN

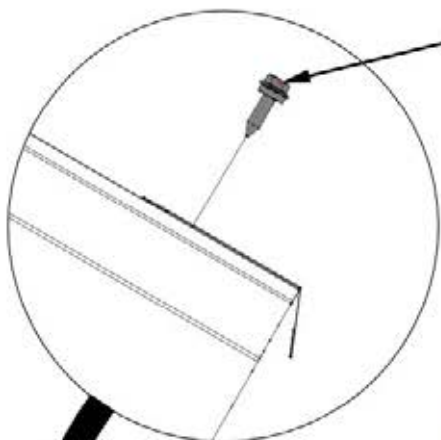

SIDE VIEW

1117 (x6)
SCREW WOODGRIP

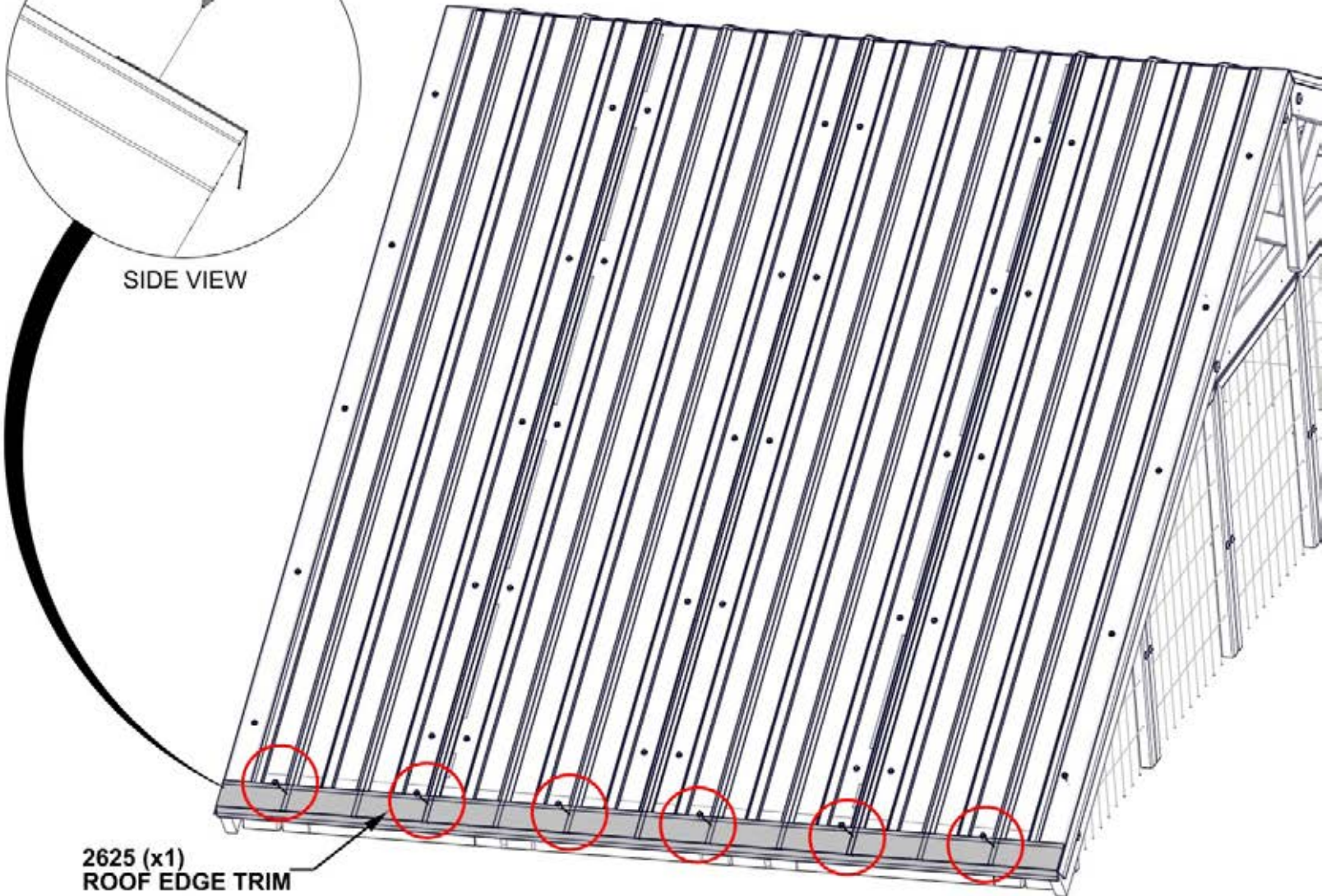

2625 (x1)
ROOF EDGE TRIM

ENSURE THAT BOTH ENDS ARE FLUSH WITH THE EDGES OF ROOF PANELS.

BOTTOM OF DOG KENNEL IS HIDDEN FOR DETAIL

STEP 49 C - DOG KENNEL ASSEMBLY

Qty	PART NUMBER	DESCRIPTION
4	H101117	SCREW WOODGRIP 10-16x3/4"

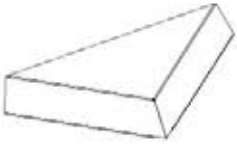

A4M02696 CORNER CAP
(x2)

- DUE TO MULTIPLE LAYERS OF METAL ON THE EDGE TRIM, IT IS RECOMMENDED THAT A 1/8" [3mm] DRILL BIT IS USED TO CREATE STARTER HOLES.
- REMOVE PROTECTIVE BLUE FILM.
- **GLOVES SHOULD BE WORN WHEN HANDLING ROOF METAL. EDGES ARE SHARP.**

1117 (x4)
SCREW WOODGRIP

2696 (x2)
CORNER CAP

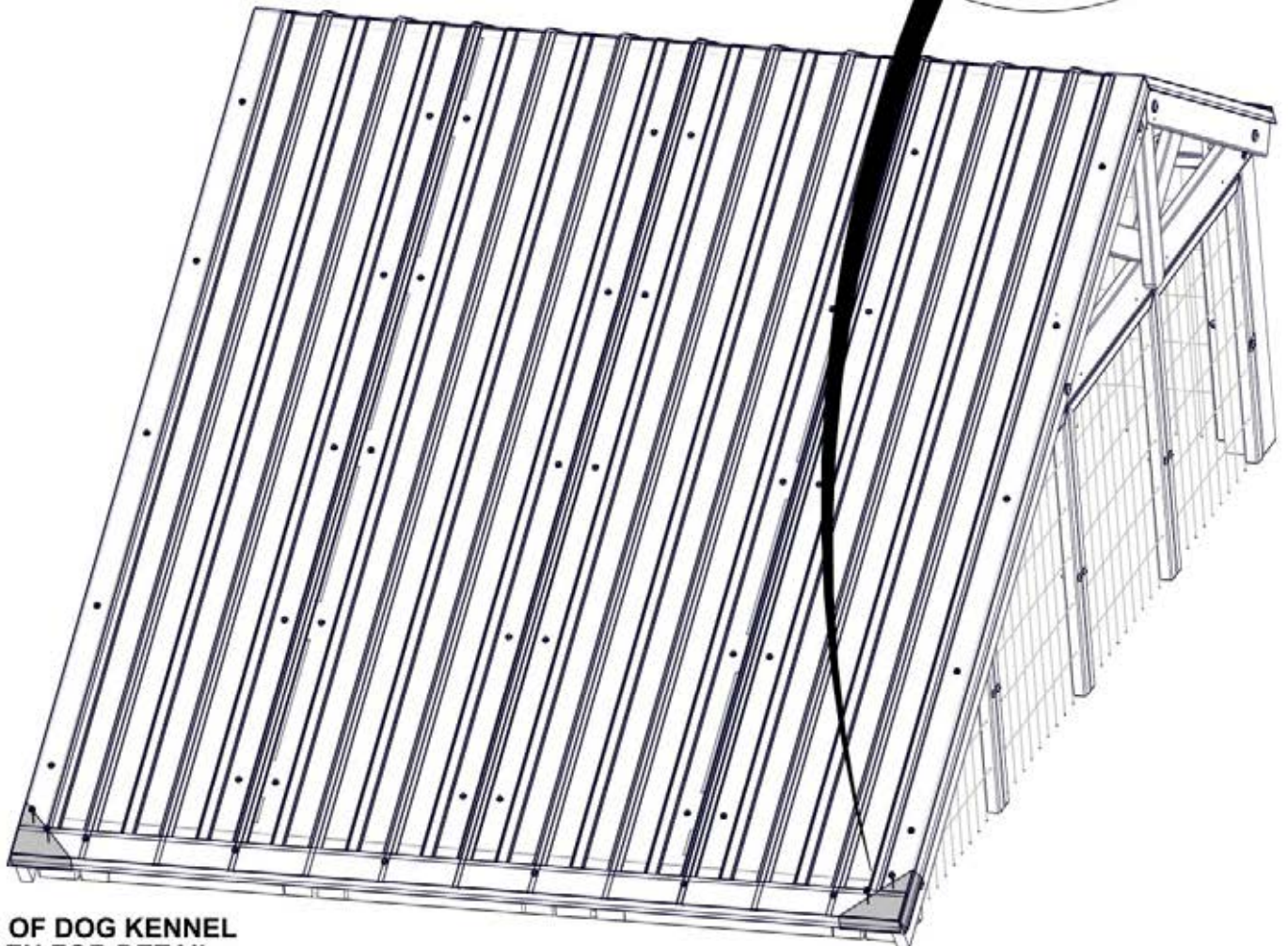
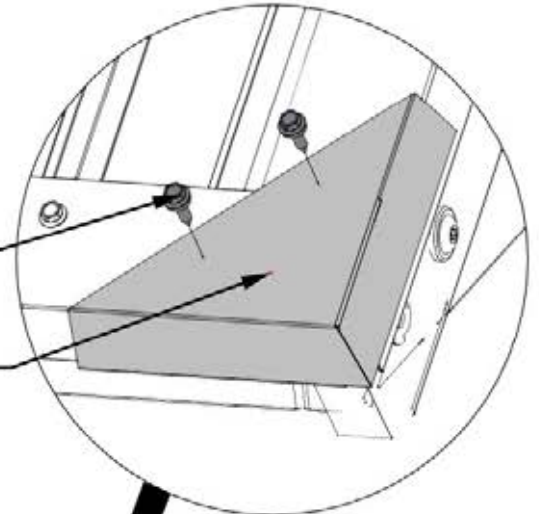

**BOTTOM OF DOG KENNEL
IS HIDDEN FOR DETAIL**

STEP 50 - DOG KENNEL ASSEMBLY

Qty	PART NUMBER	DESCRIPTION
12	H101117	SCREW WOODGRIP 10-16x3/4"



A4M02624 RIDGE CAP
(x1)

- DUE TO MULTIPLE LAYERS OF METAL ON THE EDGE TRIM, IT IS RECOMMENDED THAT A 1/8" [3mm] DRILL BIT IS USED TO CREATE STARTER HOLES.
- REMOVE PROTECTIVE BLUE FILM.
- **GLOVES SHOULD BE WORN WHEN HANDLING ROOF METAL. EDGES ARE SHARP.**

SCREWS GO THROUGH EDGE TRIM INTO THE TOP OF THE RIBS IN THE APPROXIMATE LOCATIONS SHOWN



1117 (x12)
SCREW WOODGRIP

2624 (x1)
RIDGE CAP

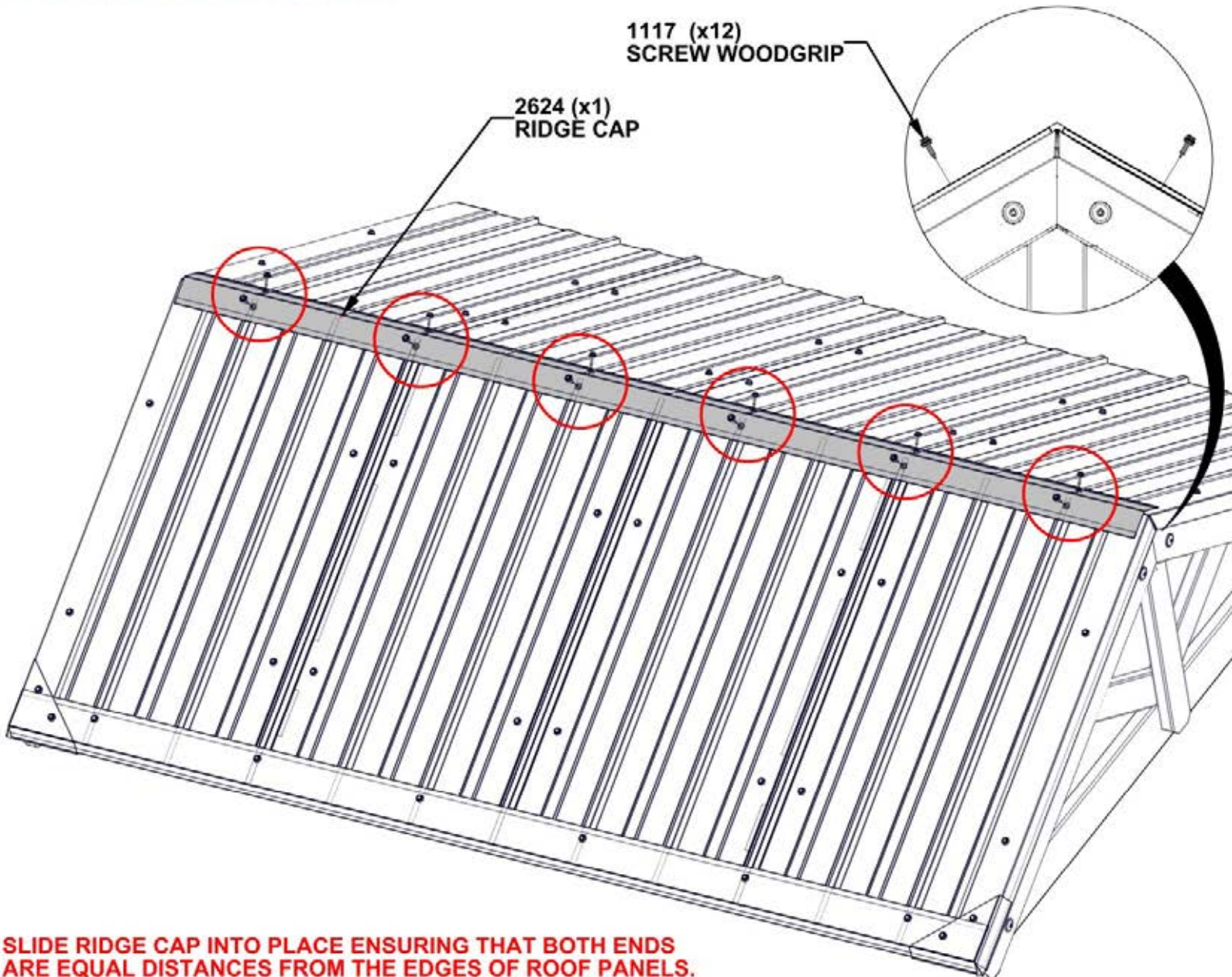

SLIDE RIDGE CAP INTO PLACE ENSURING THAT BOTH ENDS ARE EQUAL DISTANCES FROM THE EDGES OF ROOF PANELS.

BOTTOM OF DOG KENNEL IS HIDDEN FOR DETAIL

STEP 51 - DOG KENNEL ASSEMBLY

Qty	PART NUMBER	DESCRIPTION
12	H100385	SCREW PFH 8x1 BLK

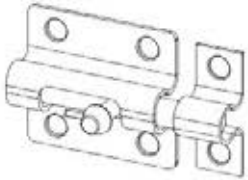

A100266 DEAD BOLT
(x2)

- USE PILOT HOLES TO ALIGN SCREWS

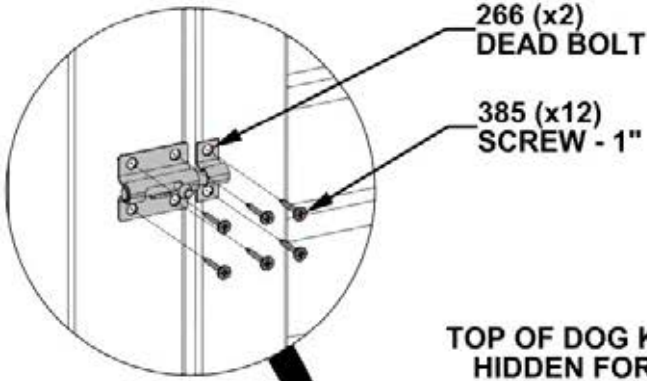

1 1/4"
[32mm]

1 1/4"
[32mm]

24"
[610mm]

24"
[610mm]

STEP 52 - DOG KENNEL ASSEMBLY

Qty	PART NUMBER	DESCRIPTION
8	H100203	SCREW PFH 8x1/2 BLK



A4M00559 PULL HANDLE
(x2)

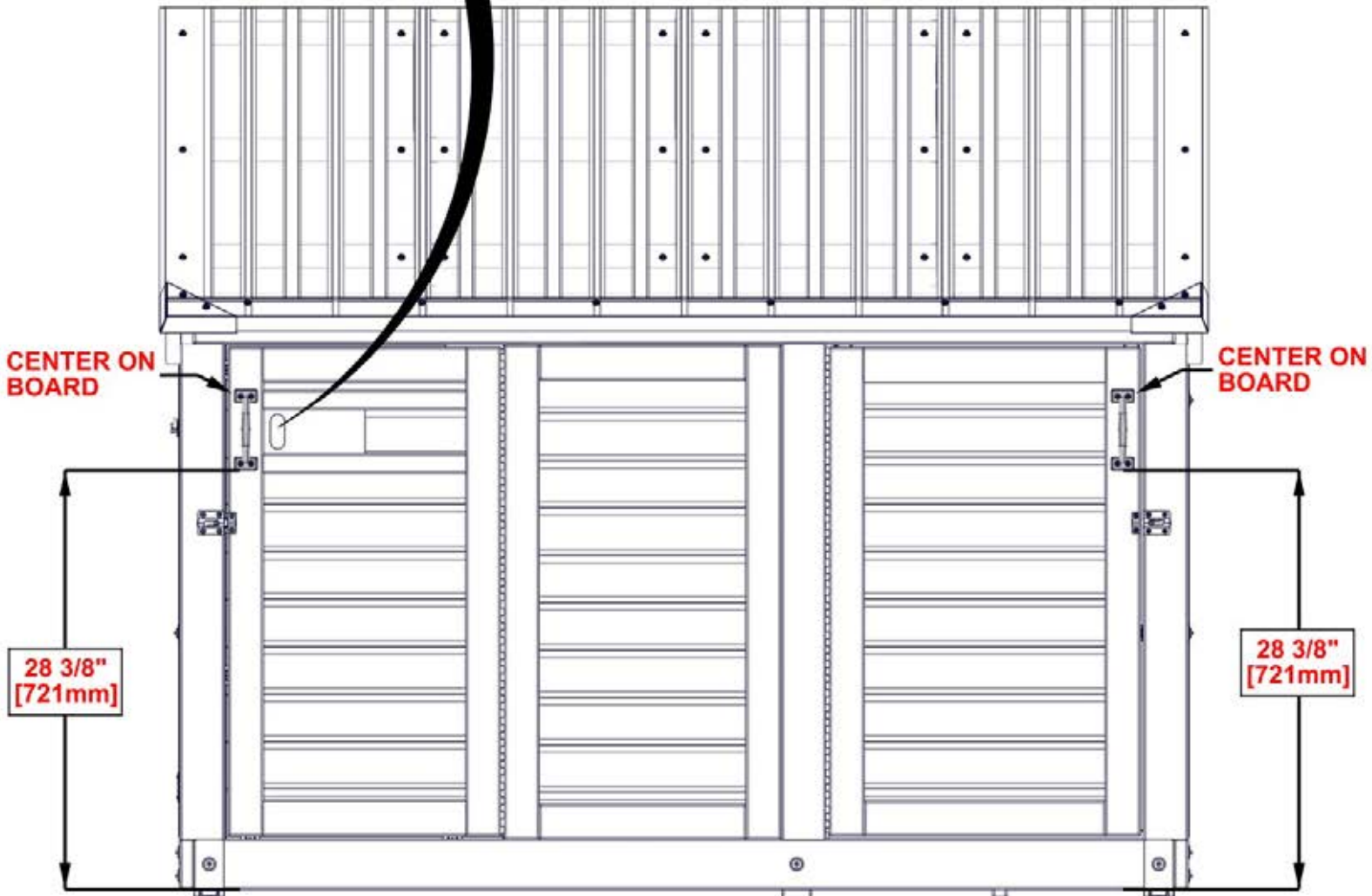
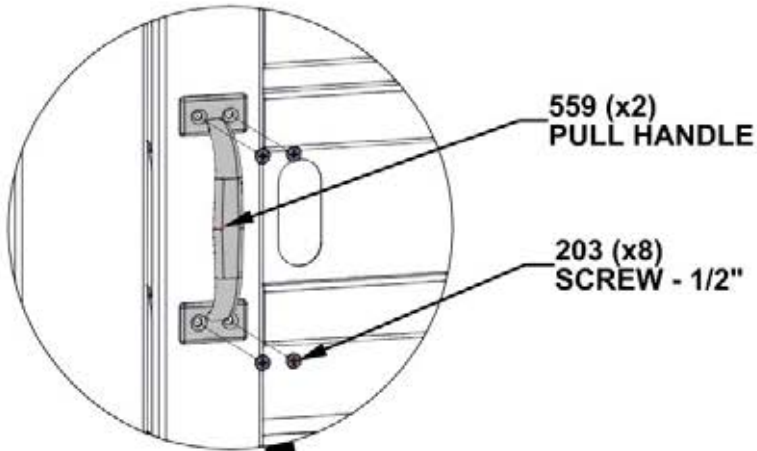

STEP 53 - DOG KENNEL ASSEMBLY

Qty	PART NUMBER	DESCRIPTION
4	H100392	SCREW PWH 8x3/4 BLK



A4M02158 BYD ID TAG PATIO
(x1)

- USE PILOT HOLES TO ALIGN SCREWS

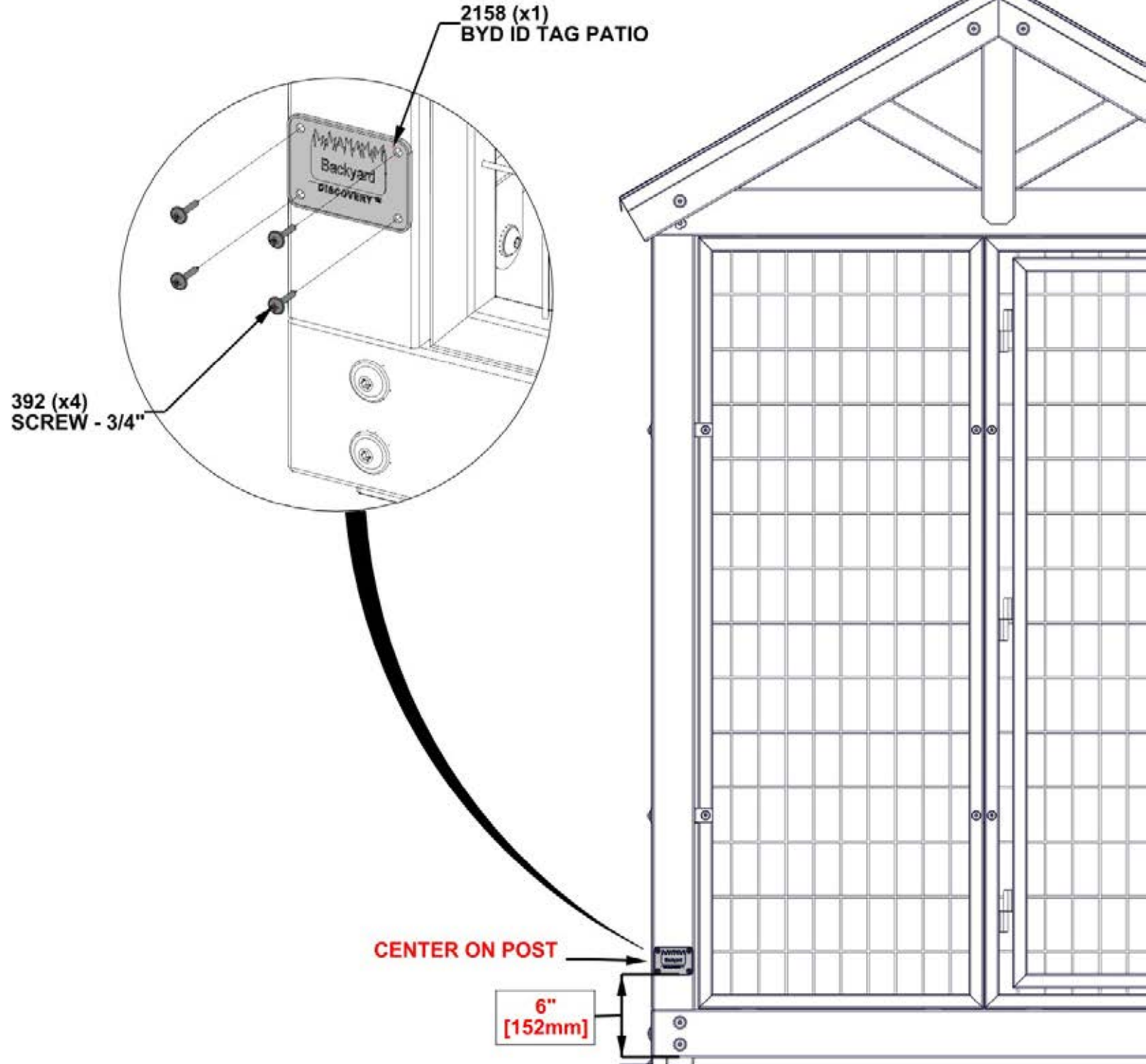

STEP 54 - DOG KENNEL ASSEMBLY



A4M02971 CARABINER
(x2)

- CARABINERS HAVE BEEN PROVIDED
FOR OPTIONAL USE OF SECURING
DOOR LATCHES

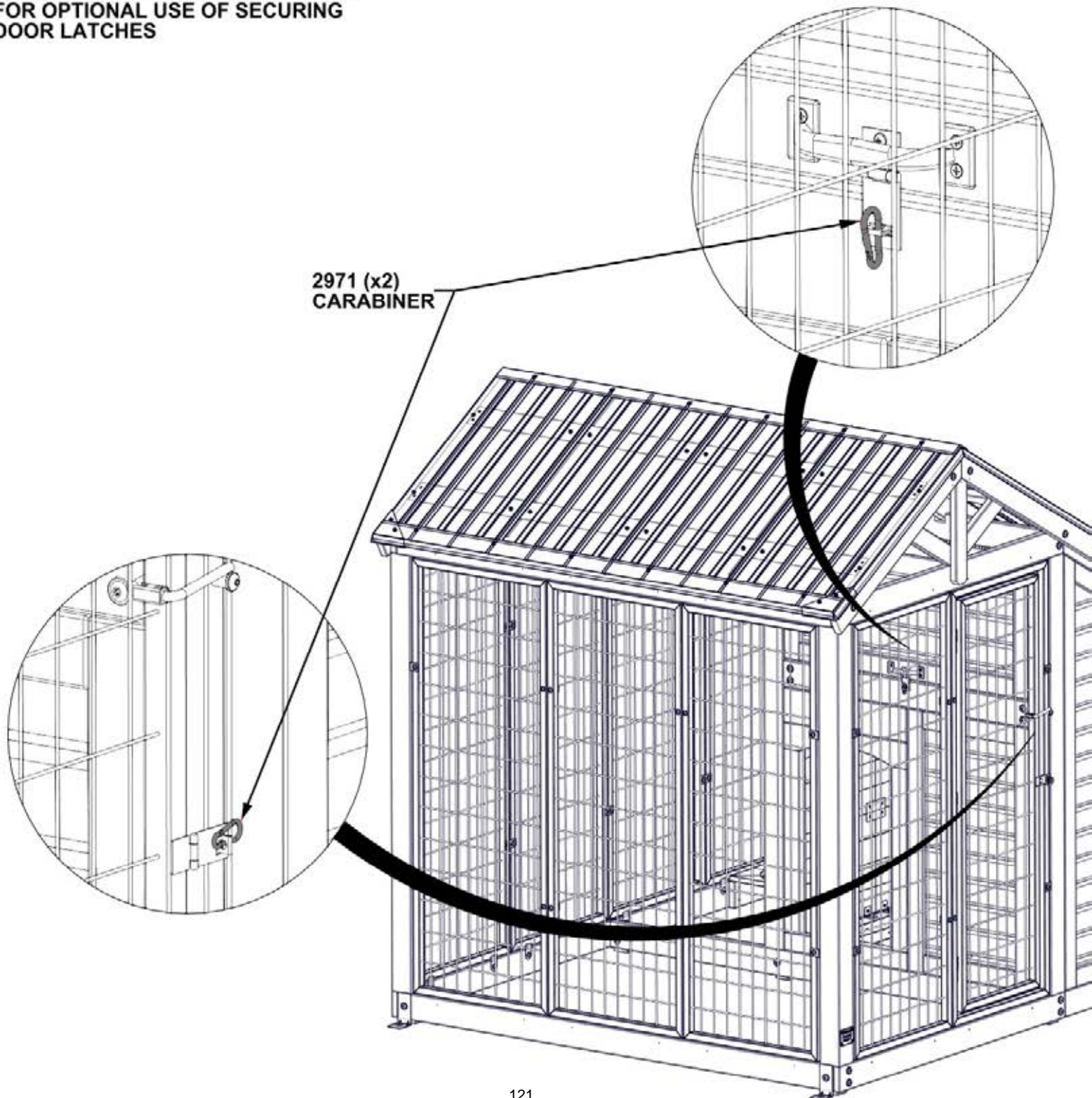

2971 (x2)
CARABINER

STEP 55 A - DOG KENNEL ASSEMBLY

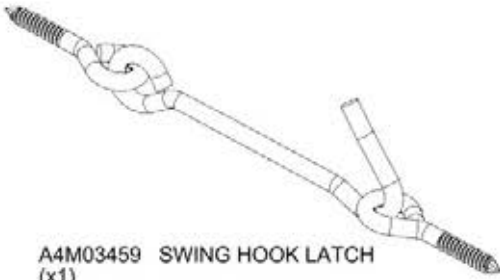

A4M03459 SWING HOOK LATCH
(x1)

- PREDRILL 1/8" [3mm] PILOT HOLES FOR THE ATTACHMENT OF SWING HOOK LATCH
- ATTACH EYELET SCREW & SAVE HOOK FOR NEXT STEP

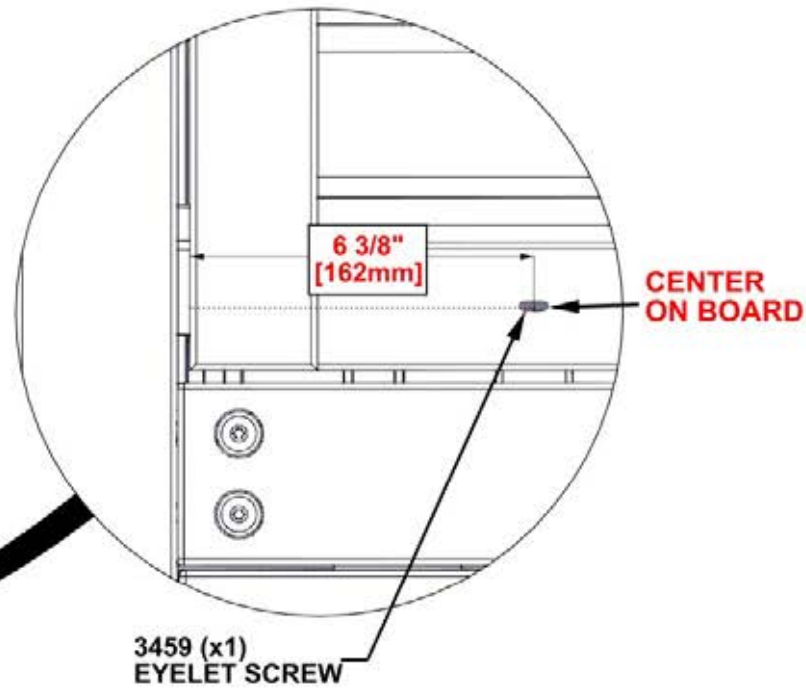
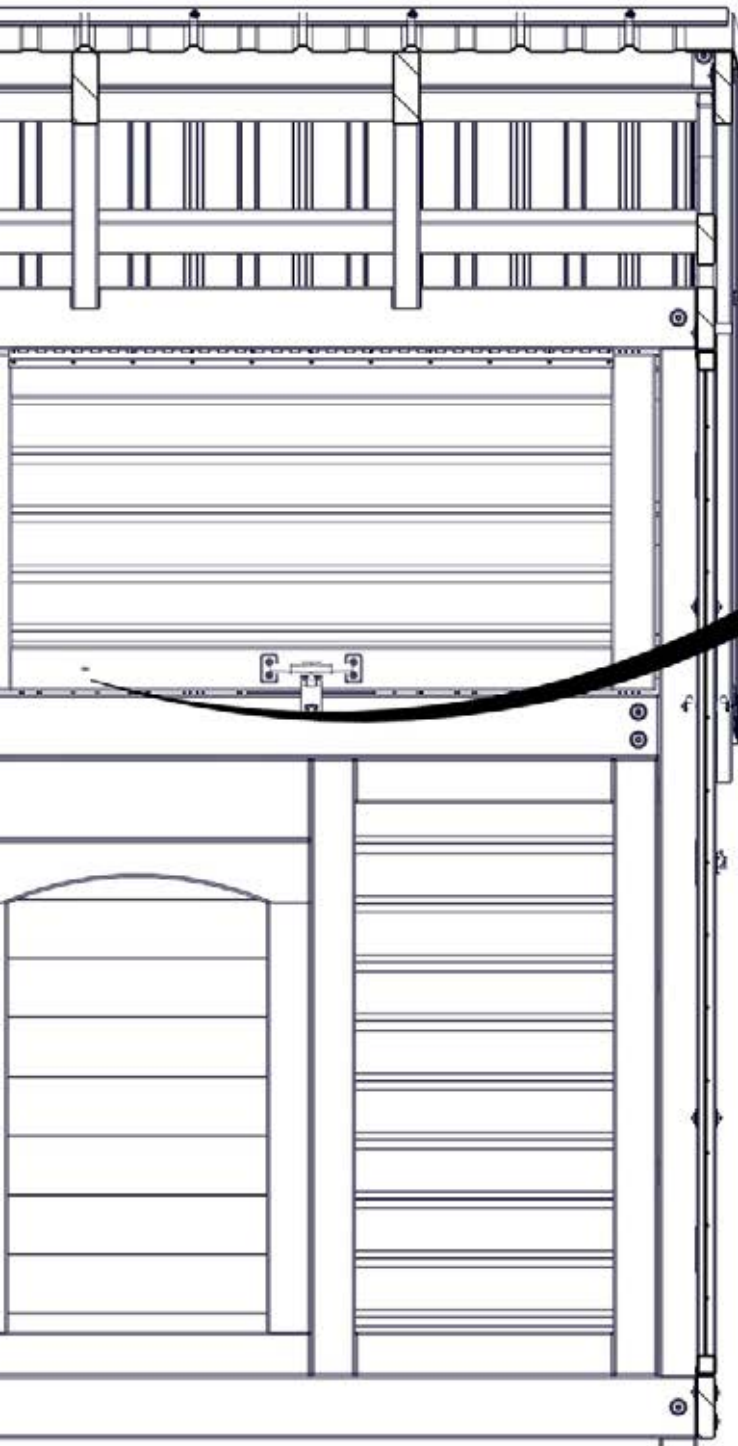

STEP 55 B - DOG KENNEL ASSEMBLY

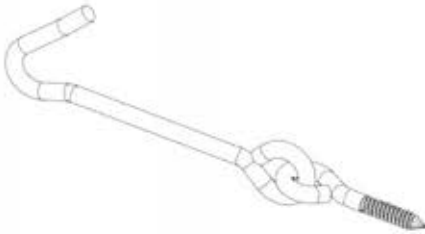

A4M03459 SWING HOOK LATCH
(x1)

- USE HOOK FROM FROM PREVIOUS STEP

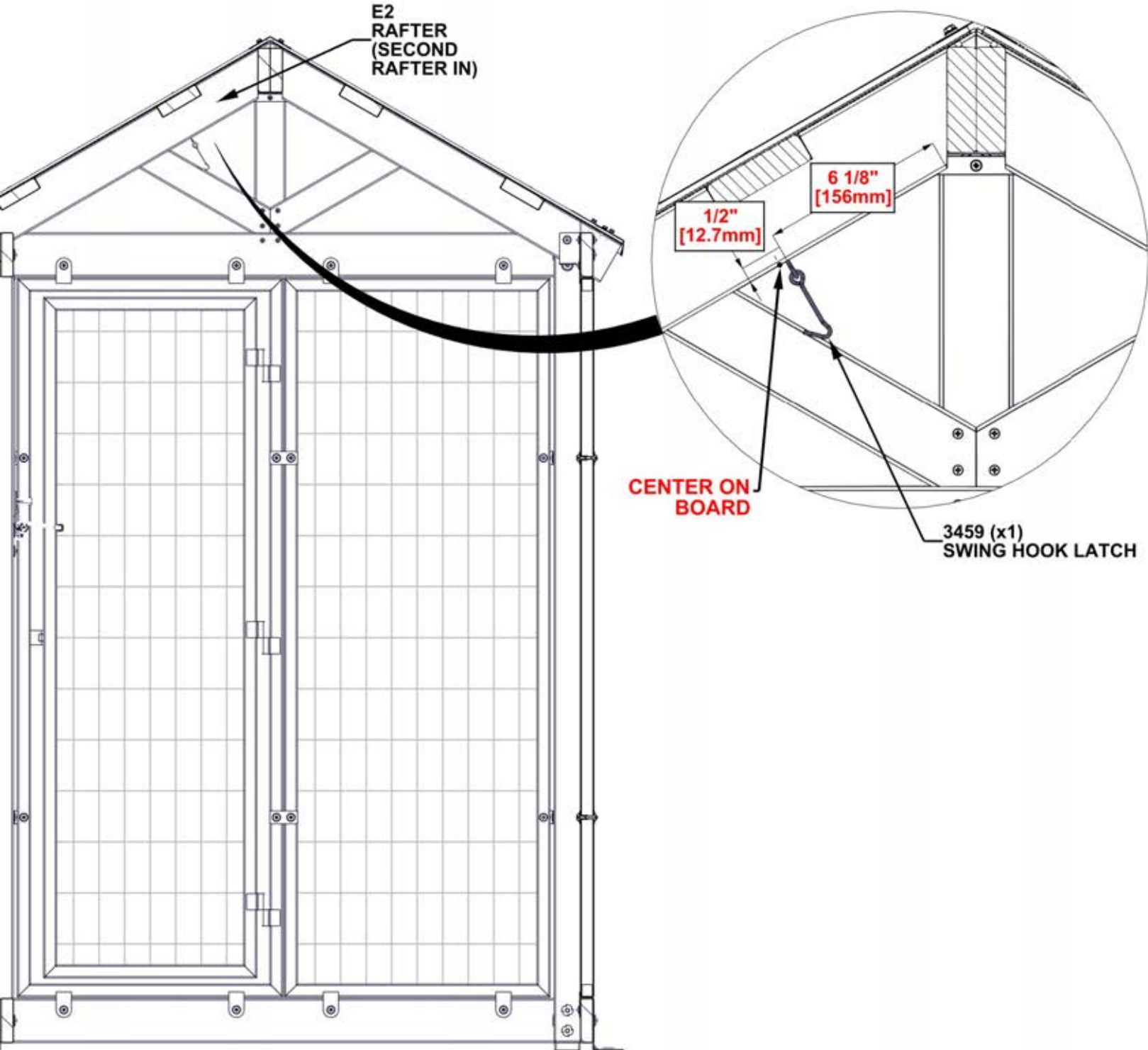

STEP 55 C - DOG KENNEL ASSEMBLY

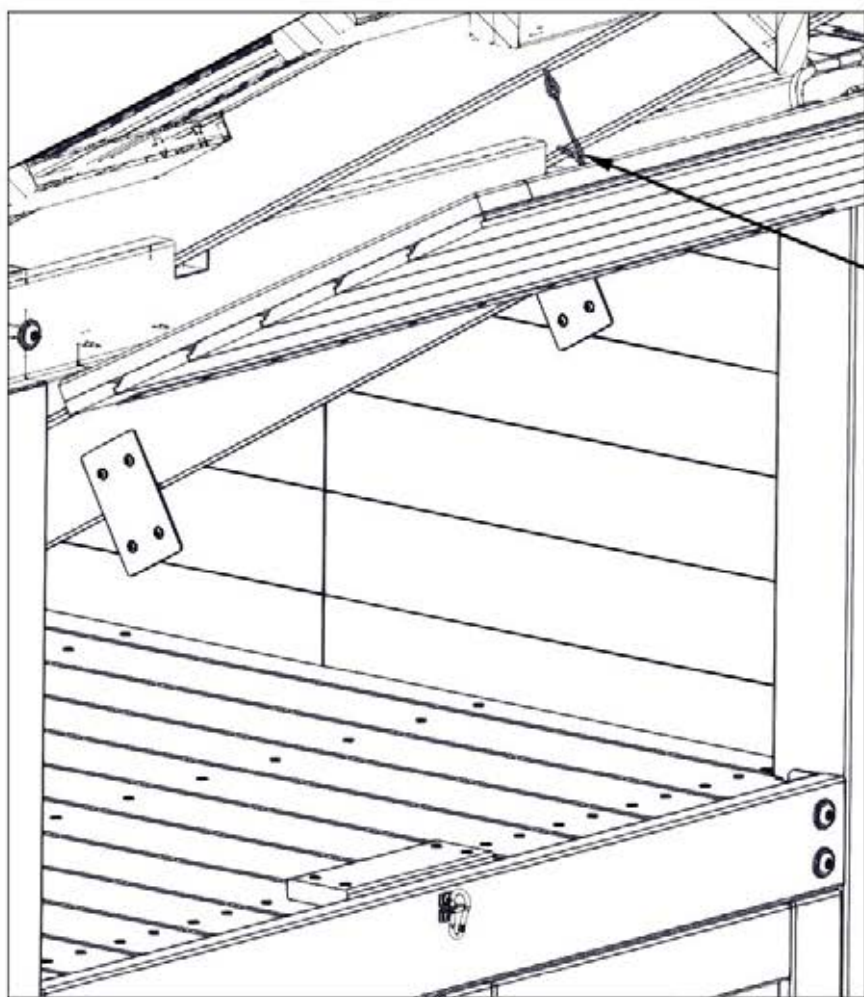

AFTER INSTALLING THE SWING HOOK LATCH, YOU CAN SECURE THE STORAGE DOOR IN THE OPEN POSITION AS SHOWN. PLEASE NOTE THAT THE MANUFACTURER RECOMMENDS KEEPING THE STORAGE DOOR CLOSED WHEN NOT IN USE.

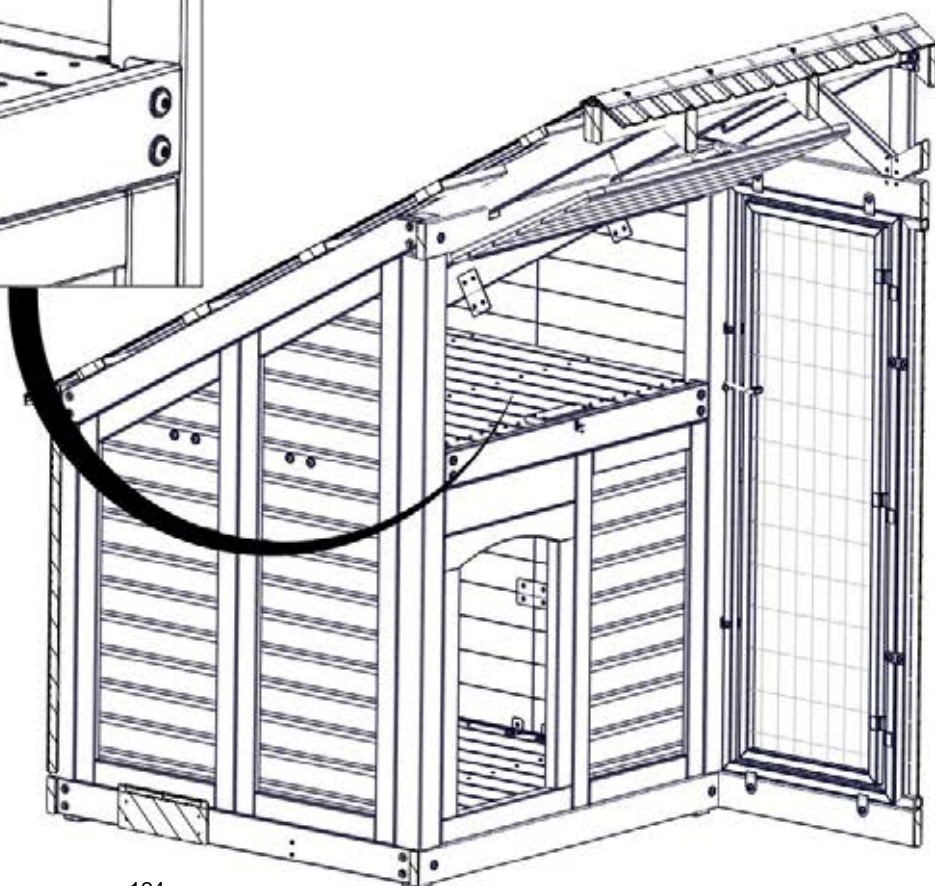

FRONT & LEFT OF DOG KENNEL IS HIDDEN FOR DETAIL

STEP 56 A - ANCHORING IN GROUND



A4M02091 GROUND STAKE
(x4)

IF DOG KENNEL IS ON A CONCRETE SURFACE, SEE STEP 55 B FOR ANCHORING STRUCTURE.

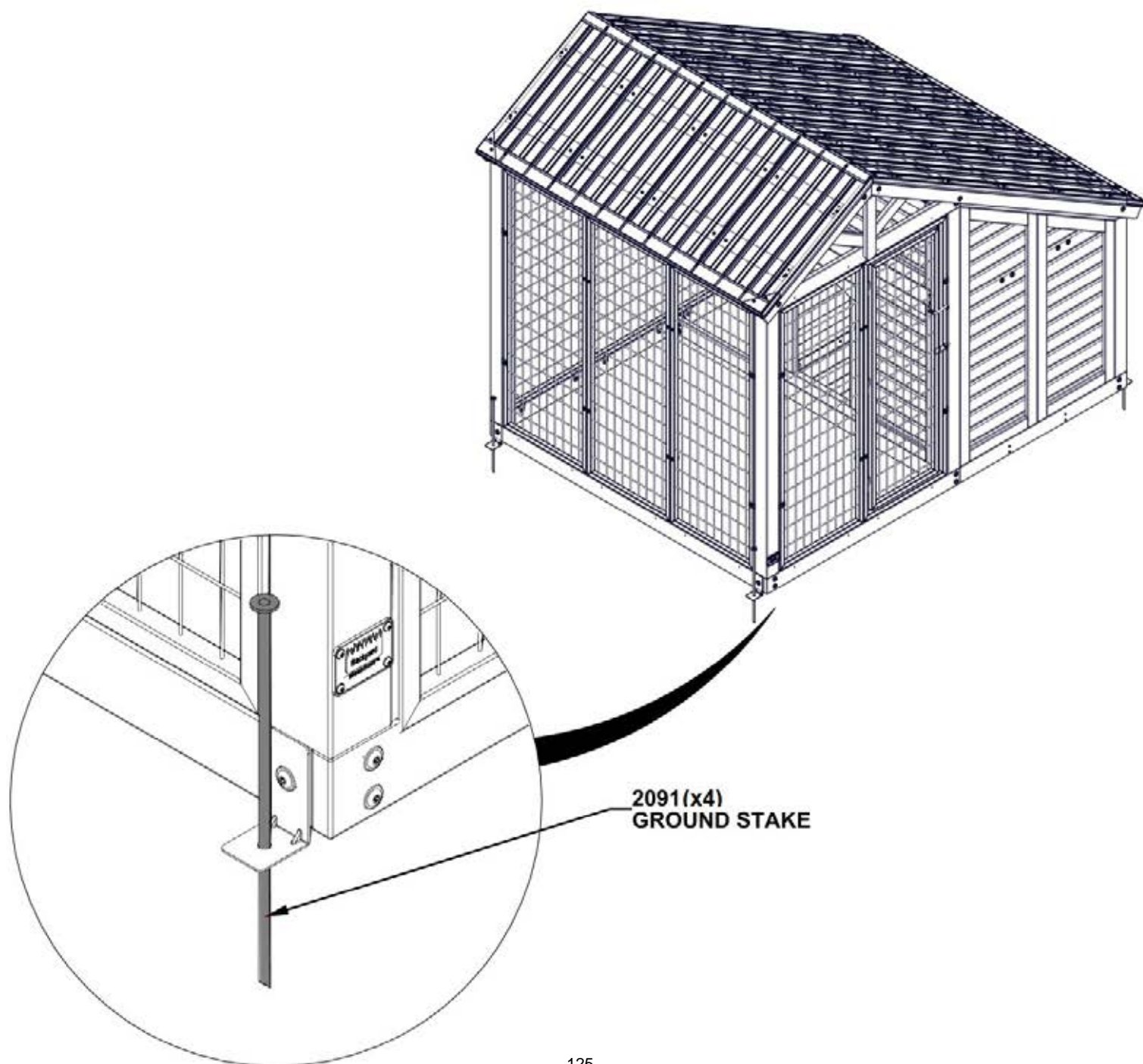

STEP 56 B - ANCHORING TO CONCRETE

Qty	PART NUMBER	DESCRIPTION
4	H101165	CONCRETE ANCHOR 3/8"x3" BLK

IF DOG KENNEL IS NOT ON A CONCRETE SURFACE, SEE STEP 55 A FOR ANCHORING STRUCTURE.

IT IS RECOMMENDED TO ANCHOR YOUR DOG KENNEL ONTO CONCRETE PAD OR POSTS.

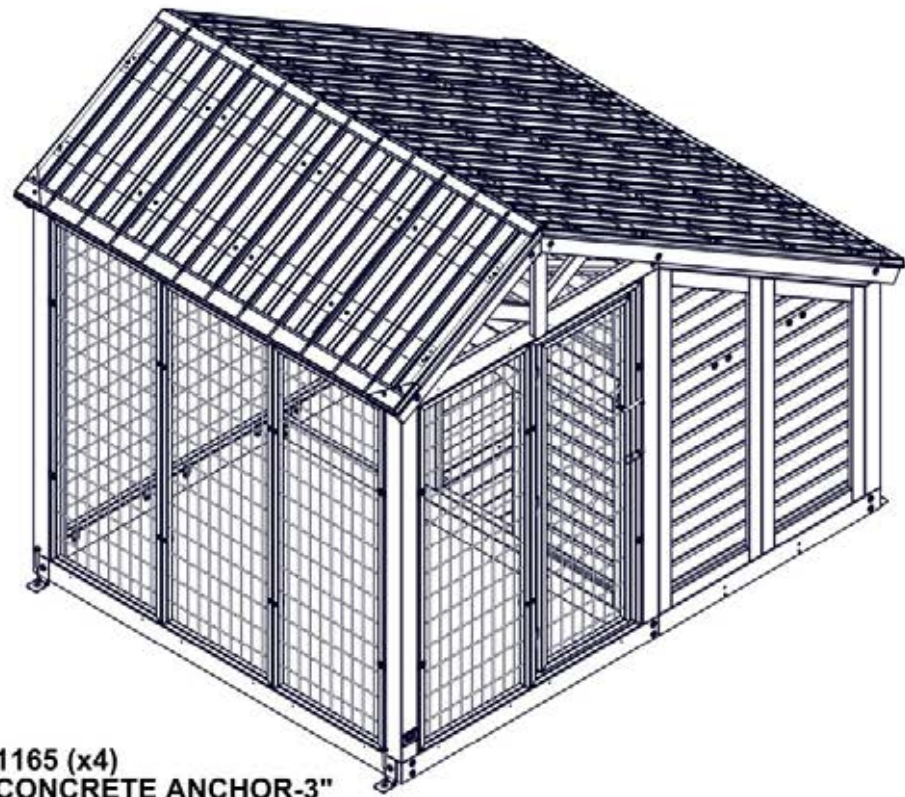

1165 (x4)
CONCRETE ANCHOR-3"

PRE-DRILL FOR CONCRETE ANCHORS USING A 5/16" [8mm] CONCRETE DRILL BIT