



MANUFACTURED BY:
Backyard Discovery
3305 Airport Drive, Pittsburg, KS 66762
800-856-4445

Basepoint Business Centre: Rivermead Drive, Westlea, Swindon SN5 7EX Phone: 0800-118-2476
J.P. Coenstraat 7, The Bridge, The Hague, 2595 WP, Netherlands

SKYFORT II

Swing Set

Model # 2200111, 2400030



WARNING
Adult Assembly Required.
Not suitable for children under 36 months due to small parts.
FOR DOMESTIC USE ONLY. INTENDED FOR OUTDOOR USE.



Please visit www.backyarddiscovery.com

For the most up to date assembly manual, to register your set, or to order replacement parts
Para obtener instrucciones en español, visite www.backyarddiscovery.com



EASY STEP-BY-STEP
3D INTERACTIVE INSTRUCTIONS
DOWNLOAD THE FREE APP



Made in China
INS-2200111, 2400030-A-SKYFORT II-ENG 9-10-24

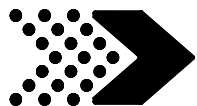

Place the set on level ground, not less than 6'-7" [2 m] from any structure or obstruction such as a fence, garage, house, overhanging branches, laundry lines, or electrical wires.

- While assembling unit, take time before and after each phase to make sure fort is level. If fort is not level, assembly will be difficult and improper assembly may result. Extra care must be taken to insure the fort is square.
- The safe play area refers to a zone extending 6'-7" (2 m) beyond the play product on all sides, including the space above the play product.

SAFE PLAY AREA DIAGRAM

Ground Dimension

22'-0" [6706 mm] x 16'-11 1/2" [5170mm]

Safe Play Area

35'-2" [10718mm] x 30'-1 1/2" [9182mm]

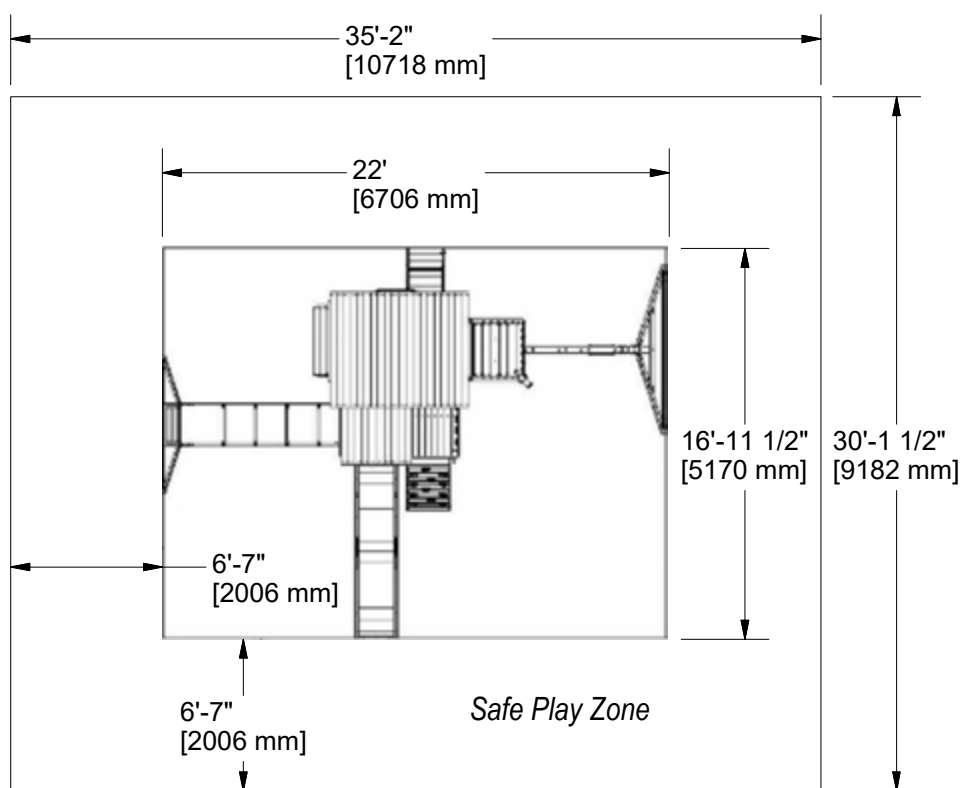

SAFE PLAY HEIGHT: 18'-11 1/4" [5770mm]
MAXIMUM FALL HEIGHT: 7'-5 3/4" [2279 m]

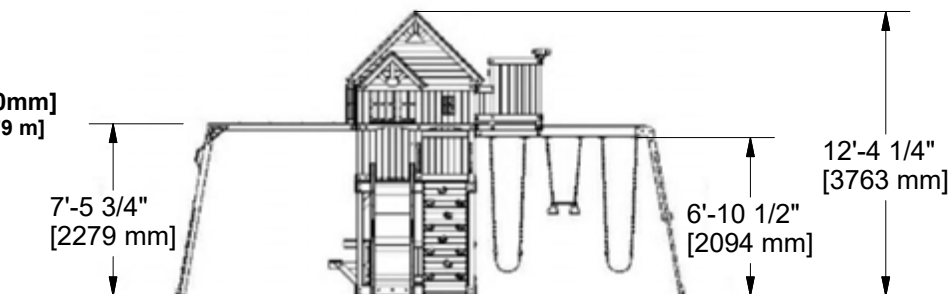

General Information:

Your set has been designed and engineered for children only and for residential use only.
 A maximum of 150 lbs. per child is recommended for play activities designed for individual use.
 A maximum of 120 lbs. per child is recommended for play activities designed for multiple child use.
 A maximum of 9 children is recommended for this swing set.

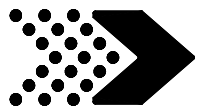

Wood Components (Not to Scale)



A1 | SWING BEAM - W4L15890
(1) | 3 3/8"x5 1/4"x89 1/2" (86x134x2274)

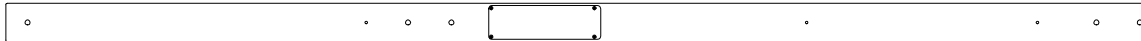

B1 | TOWER LEG - W2A03355
(1) | 3"x3"x89 1/2" (76x76x2274)



B2 | TOWER LEG - W4L04561
(1) | 3"x3"x89 1/2" (76x76x2274)

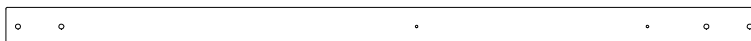

B3 | TOWER LEG - W4L04564
(1) | 3"x3"x59" (76x76x1500)



B4 | TOWER LEG - W4L04568
(1) | 3"x3"x59" (76x76x1500)

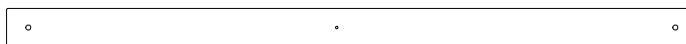

B5 | BACK LEFT CLUB HOUSE CORNER - W4L04612
(1) | 3"x3"x53 7/8" (76x76x1370)

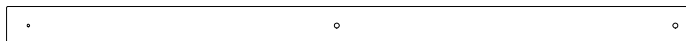

B6 | FRONT LEFT CLUB HOUSE CORNER - W4L04615
(1) | 3"x3"x53 7/8" (76x76x1370)

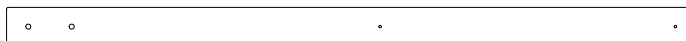

B7 | FRONT RIGHT FORT CORNER - W4L15897
(1) | 3"x3"x53 7/8" (76x76x1370)

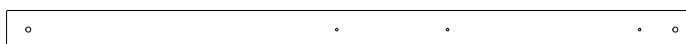

B8 | BACK RIGHT FORT CORNER - W4L15898
(1) | 3"x3"x53 7/8" (76x76x1370)

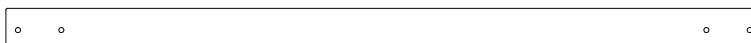

E1 | TOWER LEG - W4L04563
(1) | 1 3/8"x3 3/8"x59" (36x86x1500)



E2 | TOWER LEG - W4L04567
(1) | 1 3/8"x3 3/8"x59" (36x86x1500)

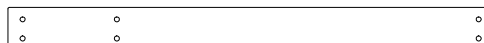

E03 | CROWS NEST FLOOR RAIL - W4L15901
(2) | 1 3/8"x3 3/8"x38" (36x86x964)

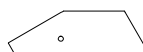

E8 | CROWS NEST DECK BRACE - W4L15902
(2) | 1 7/16"x3 3/8"x10 7/8" (36x86x276)



E6 | DECK BRACE - W4L15942
(8) | 1 7/16"x3 3/8"x20" (36x86x508)

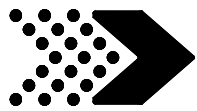

Wood Components (Not to Scale)

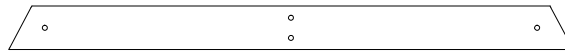

E50 | END SUPPORT - W4L15893
(1) | 1 3/8"x3 3/8"x44 1/8" (36x86x1120)



E7 | ANGLE BRACE - W4L15892
(2) | 1 3/8"x3 3/8"x87 1/8" (36x86x2212)



E4 | MONKEY BAR RAIL - W4L15936
(2) | 1 3/8"x3 3/8"x77 1/8" (36x86x1959)

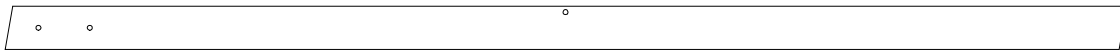

E5 | MONKEY BAR UPRIGHT - W4L15937
(2) | 1 3/8"x3 3/8"x87 5/8" (36x86x2226)



E72 | ROCKWALL RAIL - W4L15923
(2) | 1 3/8"x3 3/8"x64 5/8" (36x86x1640)



E77 | LEFT UPRIGHT - W4L15932
(1) | 1 3/8"x3 3/8"x64 3/8" (36x86x1634)



E78 | RIGHT UPRIGHT - W4L15933
(1) | 1 3/8"x3 3/8"x64 3/8" (36x86x1634)



F02 | CROWS NEST WALL SUPPORT - W4L15908
(2) | 1 3/8"x2 3/8"x37 1/2" (36x60x952)



F03 | CROWS NEST WALL SUPPORT - W4L15909
(2) | 1 3/8"x2 3/8"x37 1/2" (36x60x952)

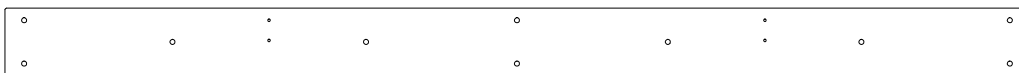

G1 | TOP FLOOR RAIL - W4L04566
(1) | 1"x5 1/4"x80" (24x134x2032)

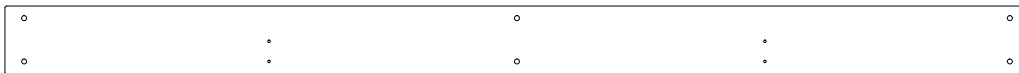

G2 | TOP FLOOR RAIL - W4L04569
(1) | 1"x5 1/4"x80" (24x134x2032)

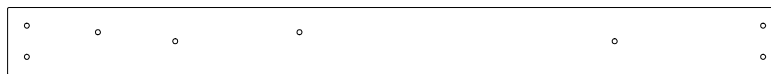

G3 | FLOOR RAIL - W4L04571
(1) | 1"x5 1/4"x60 1/2" (24x134x1537)



G4 | FLOOR RAIL - W4L04675
(1) | 1"x5 1/4"x60 1/2" (24x134x1537)

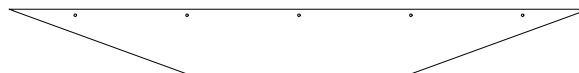

G5 | BAY WINDOW HEADER - W4L04659
(4) | 1"x5 1/4"x45 1/4" (24x134x1150)



Wood Components (Not to Scale)



G6 | FLOOR RAIL - W4L11777
(1) | 1"x5 1/4"x60 1/2" (24x134x1537)

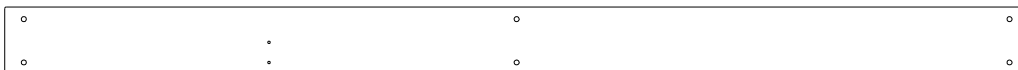

G7 | BOTTOM FLOOR RAIL - W4L11775
(2) | 1"x5 1/4"x80" (24x134x2032)



G08 | GROUND BOARD - W4L15894
(1) | 1"x5 1/4"x86 3/4" (24x134x2202)



H1 | WALL RAIL - W4L04620
(1) | 1"x3 3/8"x80" (24x86x2032)



H2 | WALL RAIL - W4L15900
(1) | 1"x3 3/8"x80" (24x86x2032)



H3 | PICNIC TABLE RAIL - W4L04578
(1) | 1"x3 3/8"x67 1/4" (24x86x1708)



H4 | ROOF SUPPORT RAIL - W4L04623
(2) | 1"x3 3/8"x67 1/4" (24x86x1709)

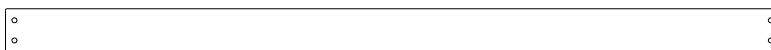

H5 | FLOOR RAIL - W4L04608
(1) | 1"x3 3/8"x60 1/2" (24x86x1537)

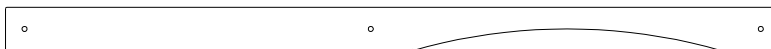

H6 | BACK CLUB HOUSE RAIL - W4L04621
(1) | 1"x3 3/8"x60 1/2" (24x86x1537)

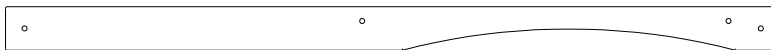

H7 | FRONT CLUB HOUSE WALL RAIL - W4L04625
(1) | 1"x3 3/8"x60 1/2" (24x86x1537)

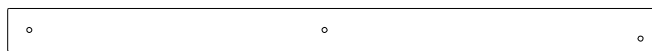

H8 | FORT UPRIGHT - W4L15899
(1) | 1"x3 3/8"x50 1/2" (24x86x1284)

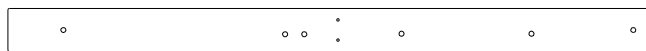

H9 | FORT WALL BOARD - W4L15916
(2) | 1"x3 3/8"x50 1/2" (24x86x1284)



H10 | PORCH LEG - W4L04683
(1) | 1"x3 3/8"x50 1/2" (24x86x1282)



H11 | PORCH LEG - W4L04610
(1) | 1"x3 3/8"x50 1/2" (24x86x1282)



Wood Components (Not to Scale)



H12 | ROOF RAFTER - W4L04640
(4) | 1"x3 3/8"x50 3/8" (24x86x1278)



H13 | CLUB HOUSE WALL RAIL - W4L04624
(1) | 1"x3 3/8"x50 1/4" (24x86x1277)

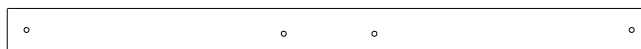

H14 | SWING BEAM MOUNT - W4L15895
(1) | 1"x3 3/8"x50 1/4" (24x86x1277)



H15 | PICNIC TABLE SEAT - W4L04600
(4) | 1"x3 3/8"x35 3/8" (24x86x897)

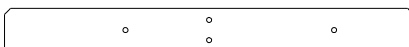

H16 | PICNIC TABLE SEAT RAIL - W4L04597
(1) | 1"x3 3/8"x32" (24x86x812)

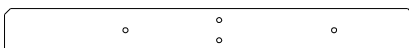

H17 | PICNIC TABLE SEAT RAIL - W4L04599
(1) | 1"x3 3/8"x32" (24x86x812)

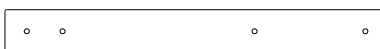

H18 | CLUB HOUSE WALL RAIL - W4L04616
(1) | 1"x3 3/8"x29 7/8" (24x86x758)



H19 | CROWS NEST FLOOR RAIL - W4L15903
(1) | 1"x3 3/8"x27" (24x86x686)



H20 | PORCH ROOF RAFTER - W4L04655
(4) | 1"x3 3/8"x24 1/2" (24x86x622)



H21 | CROWS NEST FLOOR SUPPORT - W4L15904
(1) | 1"x3 3/8"x24 1/8" (24x86x614)



H22 | MONKEY BAR BRACE - W4L15934
(2) | 1"x3 3/8"x53 1/4" (24x86x1352)

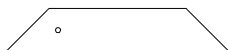

H23 | PICNIC TABLE BRACE - W4L04598
(2) | 1"x3 3/8"x17 1/2" (24x86x444)

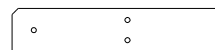

H24 | PICNIC TABLE TOP SUPPORT - W4L04601
(1) | 1"x3 3/8"x16 1/2" (24x86x418)



H25 | TOP FLOOR SUPPORT - W4L04606
(2) | 1"x3 3/8"x3" (24x86x76)



H26 | FLOOR JOIST - W4L04573
(3) | 1"x3 3/8"x60 1/2" (24x86x1537)

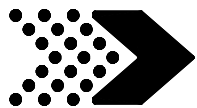

Wood Components (Not to Scale)



H27 | PICNIC TABLE SUPPORT - W4L04574
(1) | 1"x3 3/8"x28 5/8" (24x86x728)



H28 | FRONT WALL RAIL - W4L11774
(1) | 1"x3 3/8"x60 1/2" (24x86x1537)



H29 | CROWS NEST WALL RAIL - W4L15910
(2) | 1"x3 3/8"x30 5/8" (24x86x778)



H30 | CROWS NEST WALL RAIL - W4L11782
(2) | 1"x3 3/8"x29 7/8" (24x86x758)



H31 | CROWS NEST WALL RAIL - W4L15907
(2) | 1"x3 3/8"x38 7/8" (24x86x988)



H32 | MONKEY BAR GROUND BOARD - W4L15935
(1) | 1"x3 3/8"x70 3/8" (24x86x1786)



H76 | LADDER RUNG - W4L15931
(5) | 1"x3 3/8"x18 1/8" (24x86x460)



H77 | ATTACHMENT BOARD - W4L15929
(1) | 1"x3 3/8"x20 1/8" (24x86x512)



K2 | FLOOR RAIL - W4L04570
(1) | 5/8"x5 1/4"x60 1/2" (16x134x1537)



K3 | FLOOR RAIL - W4L04572
(1) | 5/8"x5 1/4"x60 1/2" (16x134x1537)

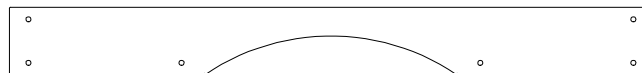

K5 | CLUB HOUSE WALL RAIL - W4L04626
(1) | 5/8"x5 1/4"x50 1/4" (16x134x1277)

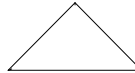

K6 | TRIANGLE SUNBURST - W4L04827
(2) | 5/8"x5 1/4"x10 3/8" (16x134x265)



L01 | CROWS NEST FLOOR BOARD - W4L15905
(7) | 5/8"x4 3/8"x27" (16x112x686)



L03 | CROWS NEST FLOOR BOARD - W4L15906
(2) | 5/8"x4 3/8"x27" (16x112x686)



L2 | SAND BOX SEAT - W4L11776
(2) | 5/8"x4 3/8"x24" (16x112x610)



Wood Components (Not to Scale)

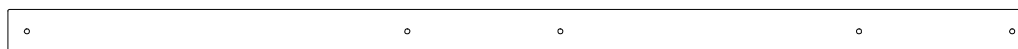

M1 | TOP WALL RAIL - W4L04619
(1) | 5/8"x3 3/8"x80" (16x86x2032)

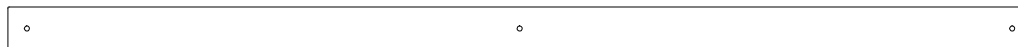

M2 | BOTTOM WALL RAIL - W4L04596
(2) | 5/8"x3 3/8"x80" (16x86x2032)



M3 | BOTTOM WALL RAIL - W4L04579
(1) | 5/8"x3 3/8"x60 1/2" (16x86x1537)



M4 | CROWS NEST WALL RAIL - W4L11773
(2) | 5/8"x3 3/8"x29 7/8" (16x86x758)



M5 | GABLE BOARD - W4L04641
(2) | 5/8"x3 3/8"x59 1/2" (16x86x1510)

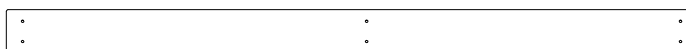

M6 | CLUB HOUSE WALL BOARD - W4L04635
(1) | 5/8"x3 3/8"x53 7/8" (16x86x1370)

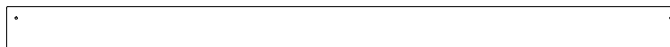

M7 | GABLE BOARD - W4L04642
(2) | 5/8"x3 3/8"x52 5/8" (16x86x1338)



M8 | FORT WALL BOARD - W4L15914
(7) | 5/8"x3 3/8"x50 1/2" (16x86x1284)

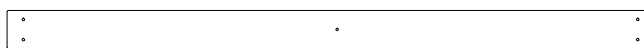

M9 | FORT WALL BOARD - W4L15915
(2) | 5/8"x3"x50 1/2" (16x76x1284)



M10 | CLUB HOUSE WALL RAIL - W4L04614
(1) | 5/8"x3 3/8"x50 1/4" (16x86x1277)

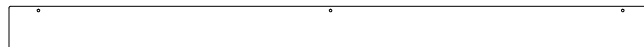

M11 | SOFFIT CAP - W4L04653
(1) | 5/8"x3 3/8"x50 1/4" (16x86x1277)



M12 | GABLE BOARD - W4L04650
(1) | 5/8"x3 3/8"x45 7/8" (16x86x1166)



M13 | PICNIC TABLE TOP - W4L04602
(4) | 5/8"x3 3/8"x41 1/4" (16x86x1049)

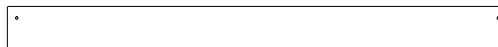

M14 | GABLE BOARD - W4L04651
(1) | 5/8"x3 3/8"x39 1/8" (16x86x994)



M15 | WALL BOARD - W4L15943
(4) | 5/8"x3 3/8"x29 7/8" (16x86x758)



M16 | CENTER PICNIC TABLE TOP - W4L04603
(1) | 5/8"x3"x38 1/4" (16x76x973)



Wood Components (Not to Scale)



M17 | FRONT WINDOW WALL BOARD - W4L15920
(2) | 5/8"x3 3/8"x35" (16x86x889)



M18 | GABLE BOARD - W4L04652
(1) | 5/8"x3 3/8"x32 3/8" (16x86x822)



M19 | FRONT PORCH ROOF SUPPORT - W4L04658
(1) | 5/8"x3 3/8"x30 5/8" (16x86x779)



M21 | CLUB HOUSE WALL RAIL - W4L04613
(3) | 5/8"x3 3/8"x30 1/4" (16x86x768)



M22 | FORT WALL BOARD - W4L15917
(4) | 5/8"x3 3/8"x29 7/8" (16x86x758)



M23 | FORT WALL BOARD - W4L15918
(2) | 5/8"x3 1/8"x29 7/8" (16x80x758)



M24 | WALL BOARD - W4L04632
(19) | 5/8"x3 3/8"x29 7/8" (16x86x758)



M26 | WALL BOARD - W4L04636
(2) | 5/8"x3 3/8"x26 1/8" (16x86x664)



M27 | BOTTOM WALL BOARD - W4L15944
(18) | 5/8"x3 3/8"x21 3/8" (16x86x544)



M28 | GABLE WINDOW BOARD - W4L04647
(2) | 5/8"x3 3/8"x19 1/2" (16x86x496)



M29 | GABLE WINDOW BOARD - W4L04643
(2) | 5/8"x3 3/8"x16 1/8" (16x86x410)

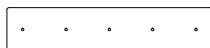

M30 | PICNIC TABLE TOP CLEAT - W4L04604
(1) | 5/8"x3 3/8"x16" (16x86x406)



M31 | GABLE WINDOW BOARD - W4L04644
(2) | 5/8"x3 3/8"x12 3/4" (16x86x324)



Wood Components (Not to Scale)



M32 | CROWS NEST WALL RAIL - W4L04671
(2) | 5/8"x3 3/8"x10" (16x86x254)



M33 | FRONT WINDOW WALL BOARD - W4L15921
(2) | 5/8"x3 3/8"x6 3/8" (16x86x162)



M34 | WALL RAIL - W4L04611
(1) | 5/8"x3 3/8"x6 3/8" (16x86x162)



M61 | ATTACHMENT BOARD - W4L15924
(1) | 5/8"x3 3/8"x22 7/8" (16x86x580)

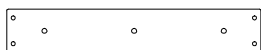

M70 | SLIDE BED SUPPORT - W100935
(1) | 5/8"x3 3/8"x19 7/8" (16x86x505)



M73 | REAR SUPPORT - W4L15930
(1) | 5/8"x3 3/8"x20 1/8" (16x86x512)



M74 | ROCK WALL BOARD - W4L15927
(10) | 5/8"x3 3/8"x22 7/8" (16x86x580)

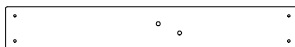

M75 | ROCK WALL BOARD - W4L15926
(4) | 5/8"x3 3/8"x22 7/8" (16x86x580)



M76 | ROCK WALL BOARD - W4L15922
(4) | 5/8"x3 3/8"x22 7/8" (16x86x580)

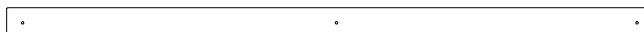

N1 | FORT WALL BOARD - W4L15913
(2) | 5/8"x2 3/8"x50 1/2" (16x60x1284)

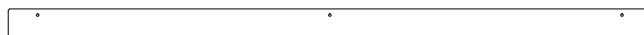

N2 | SOFFIT CAP - W4L04654
(1) | 5/8"x2 3/8"x50 1/4" (16x60x1277)

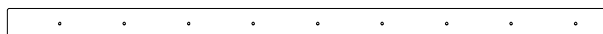

N3 | ROOF SUPPORT - W103535
(2) | 5/8"x2 3/8"x47" (16x60x1193)



N04 | CROWS NEST WALL BOARD - W4L15912
(2) | 5/8"x2 3/8"x18 1/8" (16x60x461)



N5 | FRONT PORCH GABLE TRIM - W4L04656
(1) | 5/8"x2 3/8"x15" (16x60x381)

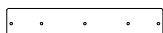

N6 | WINDOW TRIM - W4L04646
(2) | 5/8"x2 3/8"x12 1/4" (16x60x310)



Wood Components (Not to Scale)



N7 | GABLE TRIM - W4L04648
(2) | 5/8"x2 3/8"x11 1/2" (16x60x292)



N8 | FRONT PORCH GABLE TRIM - W4L04657
(2) | 5/8"x2 3/8"x9 1/2" (16x60x241)



N9 | GABLE TRIM - W4L04649
(4) | 5/8"x2 3/8"x6 1/2" (16x60x165)



N10 | GABLE BOARD - W4L04645
(2) | 5/8"x2 3/8"x27 5/8" (16x60x702)

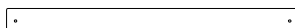

N11 | ROCK WALL BOARD - W4L15928
(1) | 5/8"x2"x22 7/8" (16x50x580)



O1 | CROWS NEST WALL BOARD - W4L15911
(18) | 5/8"x1 3/8"x32 1/4" (16x34x819)

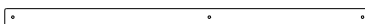

O2 | SAFETY BOARD - W4L04605
(1) | 5/8"x1 3/8"x28 5/8" (16x34x726)



SP1 | SWING BEAM SUPPORT - W4L15891
(1) | 3 3/8"x3 3/8"x48 3/8" (86x86x1229)

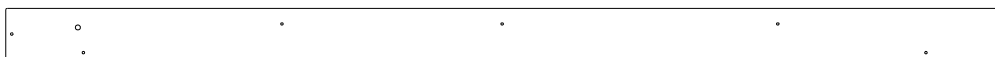

Y1 | TOP FLOOR BOARD - W4L15964
(2) | 5/8"x4"x78" (16x102x1980)

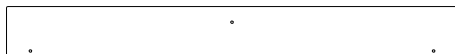

Y2 | BOTTOM FLOOR BOARD - W4L04577
(2) | 5/8"x4"x35 1/4" (16x102x895)



Y3 | ROCK WALL END BOARD - W4L15925
(1) | 5/8"x3 5/8"x22 7/8" (16x92x580)



FP1 | BOTTOM FLOOR PANEL - W2A01485
(4) | 1 5/8"x13 1/2"x35 3/8" (40x344x897)



FP2 | FLOOR PANEL - W2A03345
(4) | 1 1/4"x13 1/2"x81 7/8" (32x344x2080)



Wood Components (Not to Scale)

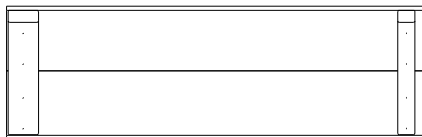

RP1 | LEFT PORCH PEAK ROOF PANEL - W2A02630
(1) | 1 5/8"x10 1/2"x32 7/8" (42x268x834)

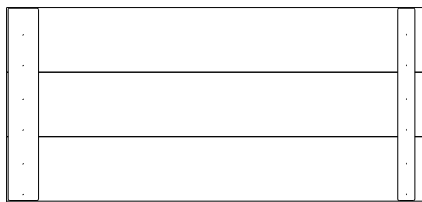

RP2 | LEFT PORCH ROOF PANEL - W2A02628
(1) | 1 5/8"x15 5/8"x32 7/8" (42x396x834)

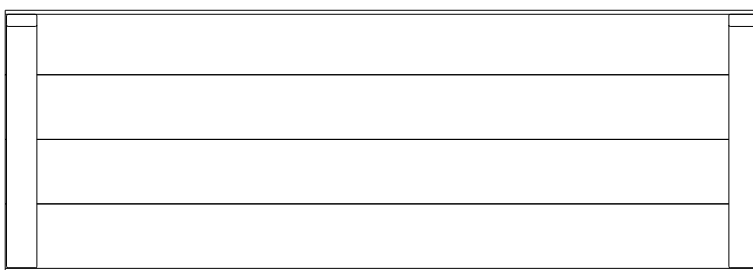

RP3 | PEAK ROOF PANEL - W2A02626
(2) | 1 5/8"x20 5/8"x59" (42x524x1499)

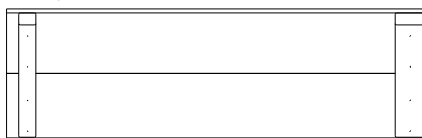

RP4 | RIGHT PORCH PEAK ROOF PANEL - W2A02631
(1) | 1 5/8"x10 1/2"x32 7/8" (42x268x834)

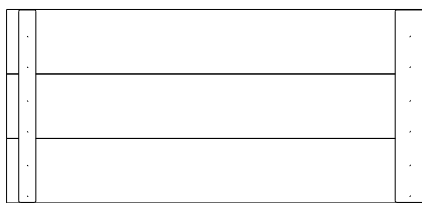

RP5 | RIGHT PORCH ROOF PANEL - W2A02629
(1) | 1 5/8"x15 5/8"x32 7/8" (42x396x834)

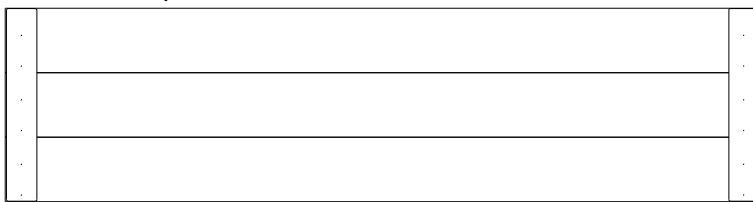

RP6 | ROOF PANEL - W2A02627
(4) | 1 5/8"x15 5/8"x59" (42x396x1499)

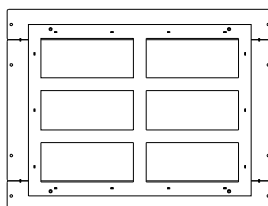

WP1 | BAY WINDOW PANEL - W2A01496
(6) | 7/8"x15 3/4"x20 3/4" (21x400x526)



Hardware Components

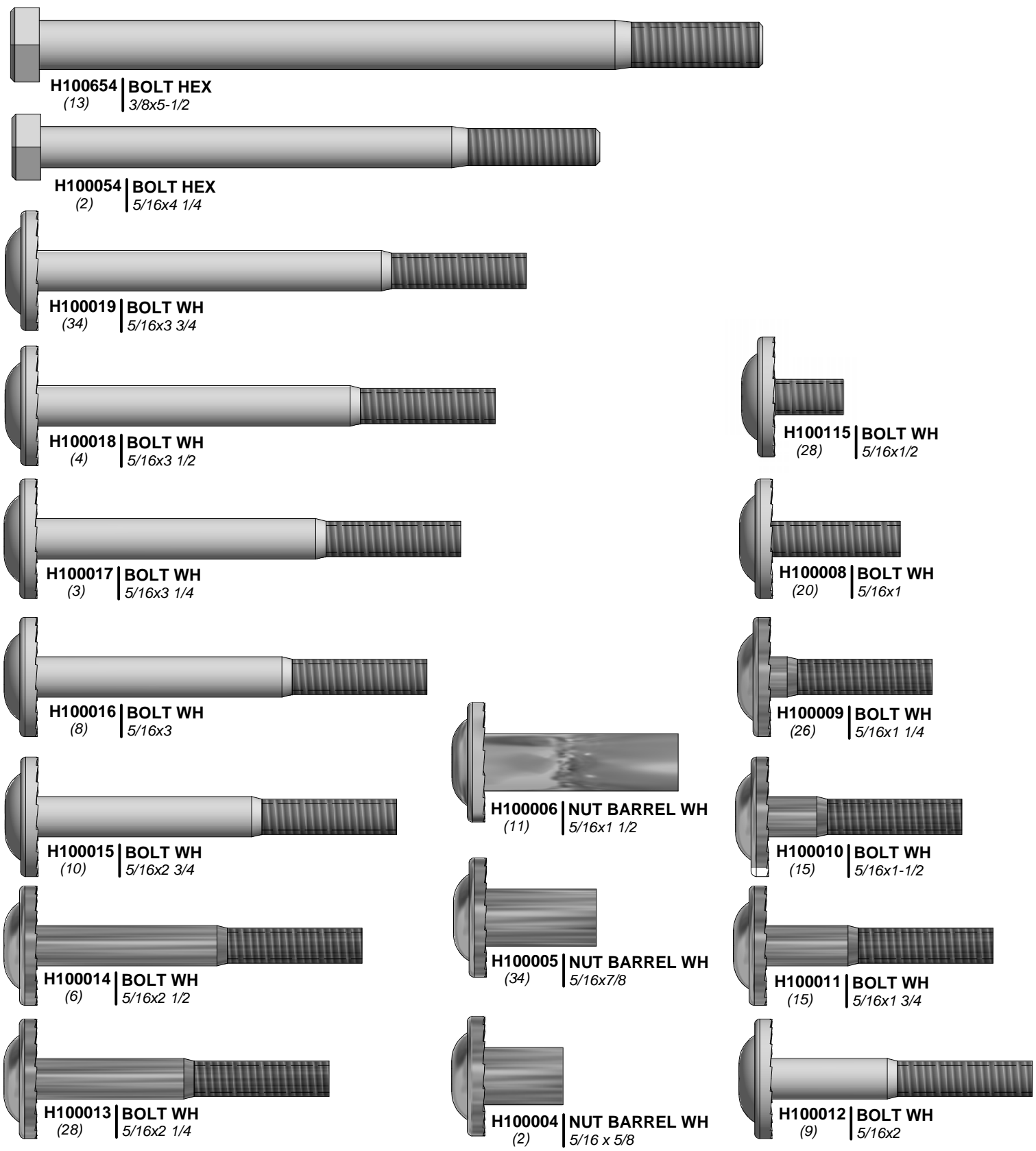



Hardware Components

9220119 | TOOL KIT
(1)

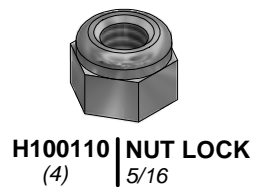
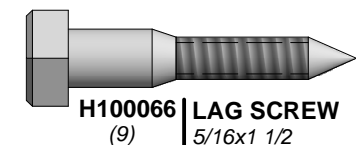
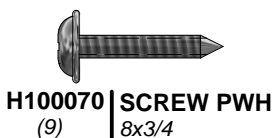
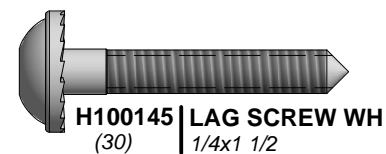
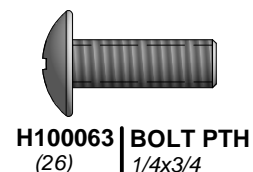
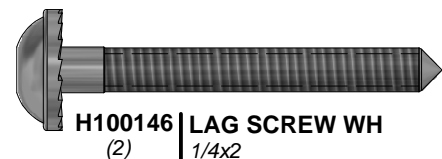
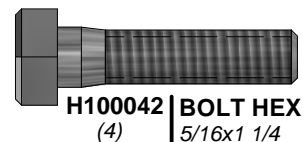
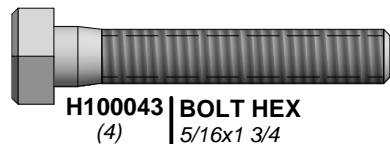
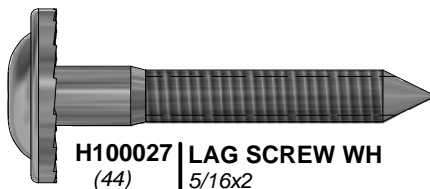
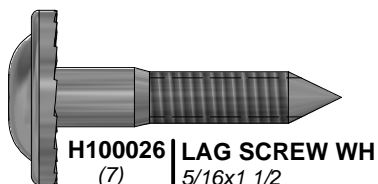
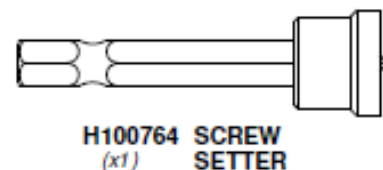
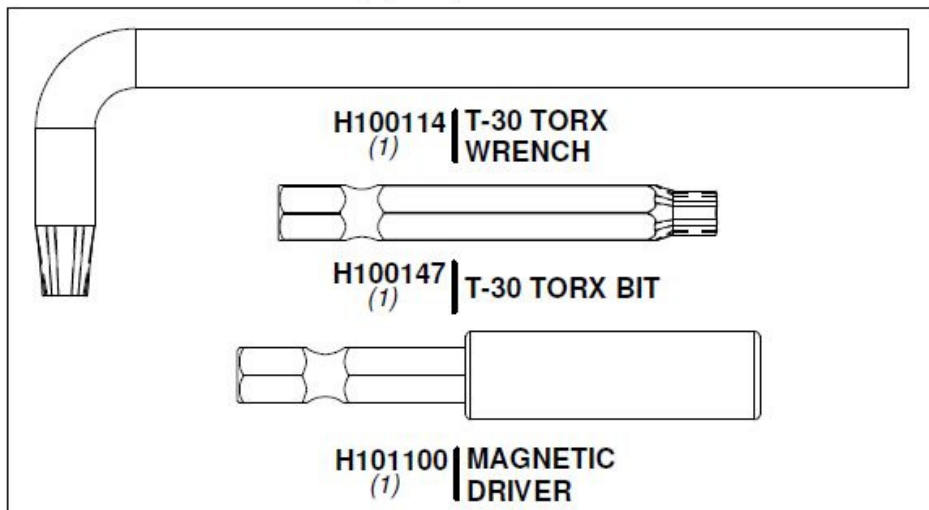

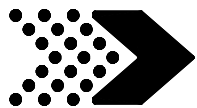

Hardware Components



H100090 | SCREW PFH
(51) | 8x2 1/2"



H100091 | SCREW PFH
(35) | 8x2 1/4



H100111 | SCREW PFH
(88) | 8x2



H100089 | SCREW PFH
(4) | 8x1 3/4



H100086 | SCREW PFH
(360) | 8x1 1/2



H100087 | SCREW PFH
(4) | 8x1 1/4



H100088 | SCREW PFH
(401) | 8x1 1/8



H100085 | SCREW PFH
(9) | 8x1

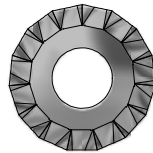

H100030 | WASHER LOCK EXT
(187) | 8x19

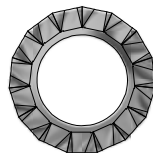

H100031 | WASHER LOCK EXT
(34) | 12x19

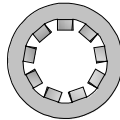

H100108 | WASHER LOCK INT
(28) | 8x15

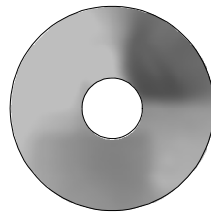

H100105 | WASHER FLAT
(28) | 8x27

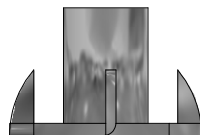

H100073 | T-NUT
(13) | 3/8

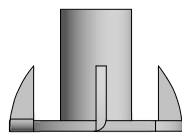

H100074 | T-NUT
(152) | 5/16

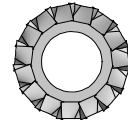

H100138 | WASHER LOCK EXT
(13) | 6x15

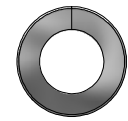

H100095 | WASHER SPLIT
(22) | 5/16

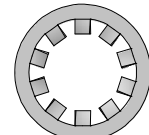

H100107 | WASHER LOCK INT
(13) | 10x18

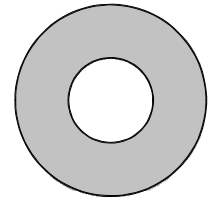

H100102 | WASHER FLAT
(13) | 11x25

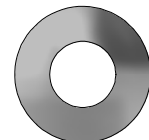

H100106 | WASHER FLAT
(11) | 9x18

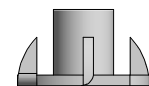

H100072 | T-NUT
(26) | 1/4



Accessory Components (Not to Scale)

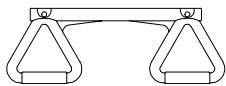

A6P00034 (1) | TRAPEZE YELLOW

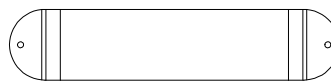

A100027 (2) | SWING SEAT GREEN 26"

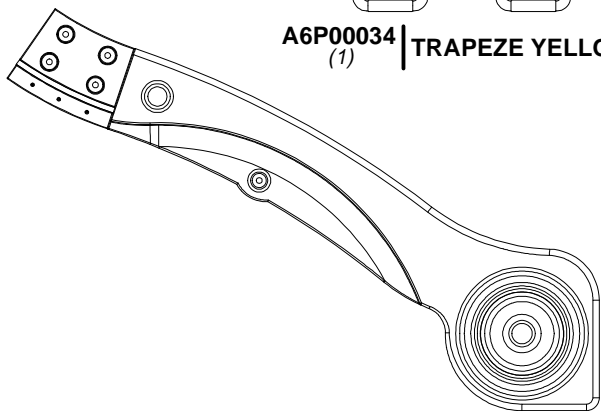

A6P00483 (1) | SLIDE RAIL 10' BOTTOM LEFT GREEN

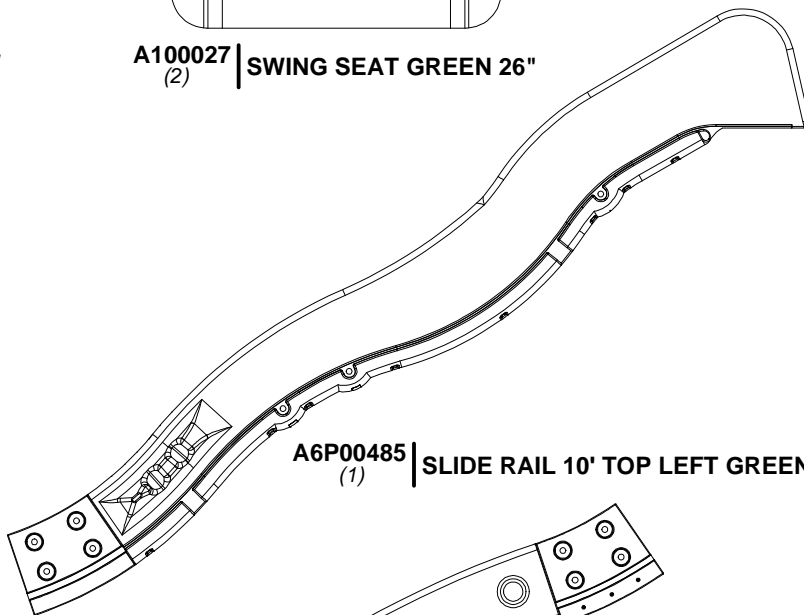

A6P00485 (1) | SLIDE RAIL 10' TOP LEFT GREEN

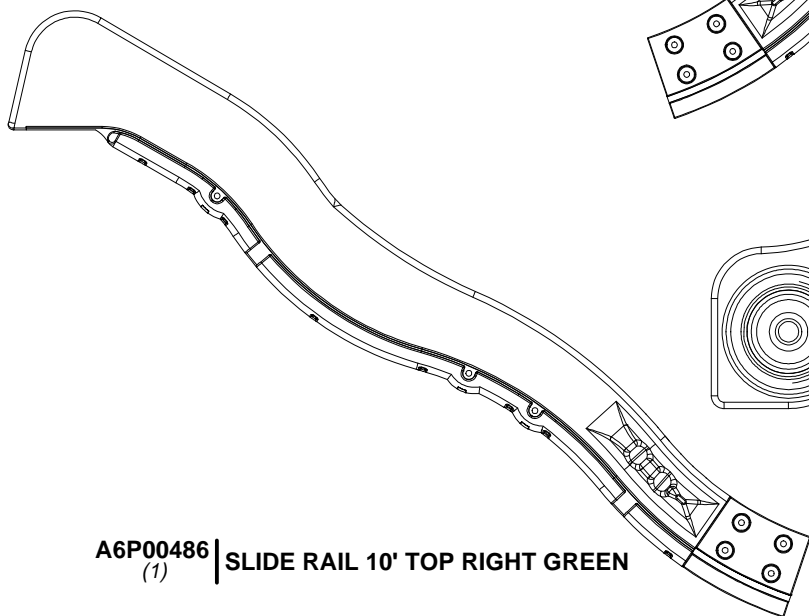

A6P00486 (1) | SLIDE RAIL 10' TOP RIGHT GREEN

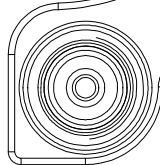

A6P00484 (1) | SLIDE RAIL 10' BOTTOM RIGHT GREEN



A6P00036 (6) | GREEN HC ROCK #1



A6P00037 (6) | GREEN HC ROCK #2

A100035 (1) | SLIDE BED 10' LIGHT GREEN



A6P00487-DNU (4) | SLIDE SUPPORT TUBE



A100164 (1) | BYD ID TAG (LARGE) AGES 3-10

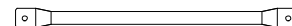

A100045 (8) | METAL RUNG 559 GREEN



Accessory Components (Not to Scale)



A100183 | ROPE-CHAIN GREEN 57"
(4)



A100083 | ROPE-CHAIN GREEN 33"
(2)

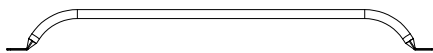

A100134 | HAND GRIP GREEN 816 C/C
(2)

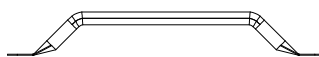

A100324 | LADDER RUNG 578 GREEN
(2)



A100140 | L BRACKET 66x66x127
(2)

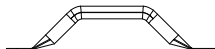

A100118 | HAND GRIP METAL GREEN 381 c/c
(6)



A100069 | QUICK LINK
(6)

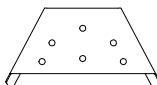

A4M01169 | A-FRAME BRACKET
(1)

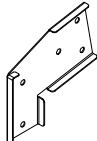

A100325 | SWING BEAM
EXTENSION
BRACKET-LEFT
(1)



A100314 | "A" REVISION TAG
(1)

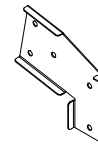

A100326 | SWING BEAM
EXTENSION
BRACKET-RIGHT
(1)

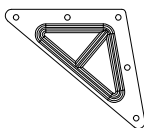

A100294 | TRIANGLE
PLATE 100° 5
HOLE
(2)

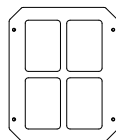

A100146 | WINDOW 216x267 GREEN
(2)

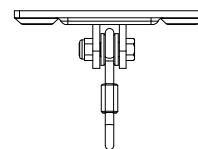

A4M00505 | SWING HANGER
(6)



A100396 | L BRACKET
51x32x82x3.175
(4)



A100178 | AUGER GROUND STAKE
(8)



A4M01046 | L BRACKET
2.5x38x55x55
(15)

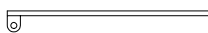

A4M00527 | GROUND STAKE REBAR
(2)

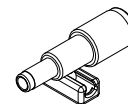

A6P00096 | TELESCOPE
(1)

PRE-ASSEMBLY STEP 1 - SORTING PARTS

It is critical for ease of assembly that you take the time to sort and organize the wood and hardware.

WOOD PARTS:

- Organize wood parts by the three-digit, alpha-numeric number stamped on each board (ex. P01).
- If there are multiple boards with the same stamped number, stack those pieces together.
- Stamps can be found on the flat surface of the boards or on the end of the boards.
- Allow yourself plenty of room - the wood pieces can take up a significant amount of space.

NOTE: CARTONS ARE NOT ORGANIZED BY BOARD NUMBER.

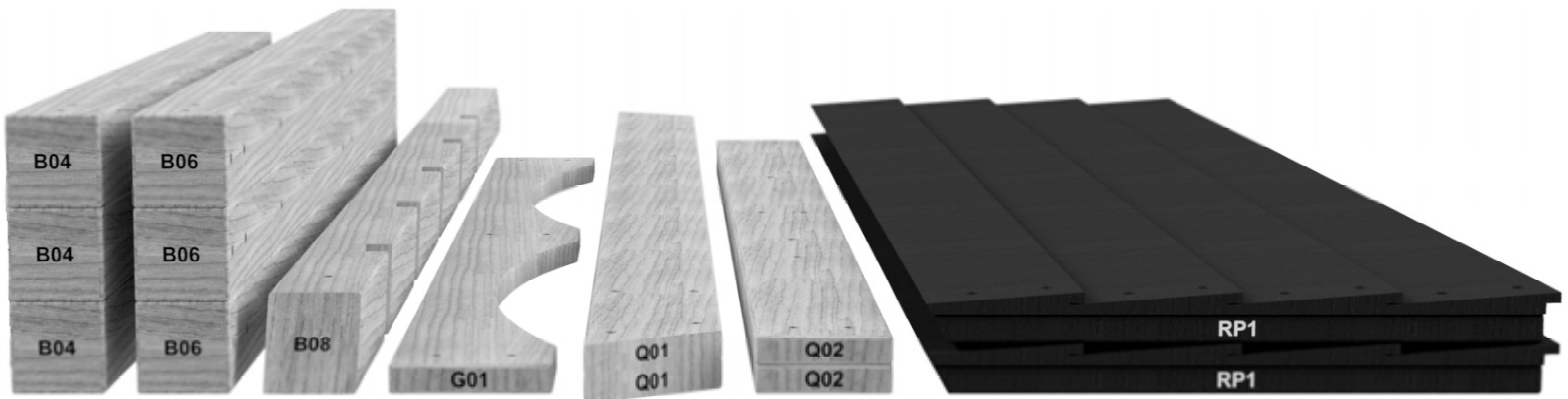

HARDWARE PARTS:

- We recommend that you have a separate table to organize the hardware.
- Hardware bags are printed with a seven-digit, alpha-numeric part number.
- You can organize your hardware by part number or group by hardware type (i.e. bolts, nuts, etc.).
- During assembly you only need to reference the last four digits of the number.

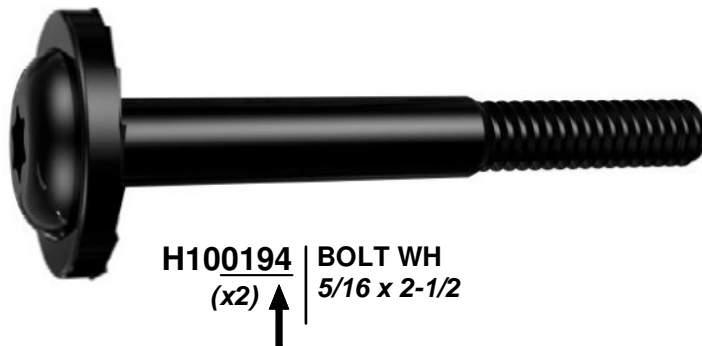

PRE-ASSEMBLY STEP 2 - TOOLS REQUIRED



**Cordless Drill or
Electric Drill**



**Drill Attachments:
Phillips Head**



**1/8", 3/16", 3/8" & 7/16"
Drill Bits**



Phillips Screw Driver



Open End Wrenches 1/2" & 9/16"



**3/8" Drive Ratchet, 1/2" &
9/16" STD Sockets 1/2" & 9/16" Deep
Sockets**



Claw Hammer



Rubber Mallet - Optional



Tape Measure

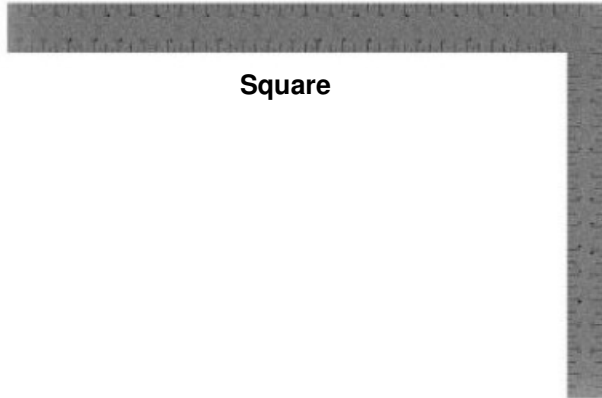

Square



Level 24"

PRE-ASSEMBLY STEP 3 - CHOOSE YOUR ASSEMBLY METHOD

There are several types of assembly instructions available to you.

1. Printed Assembly Manual included with your set
2. BILT APP - 3D interactive instructions
3. Combination of the Printed Manual and BILT APP (Note: Step numbers can differ between the two methods)

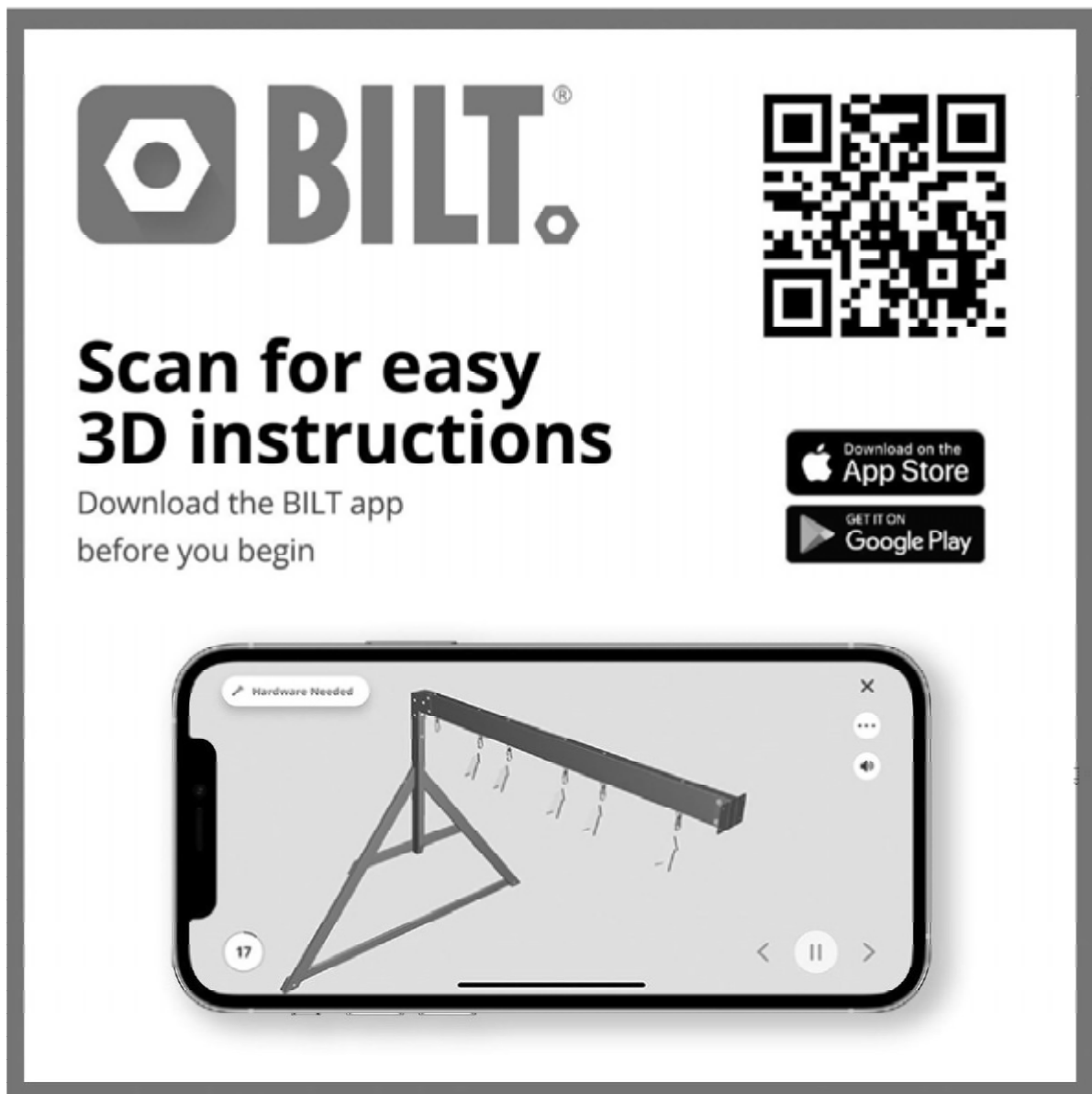

The advertisement features the BILT logo on the left, a QR code on the right, and a smartphone displaying a 3D assembly instruction. The text 'Scan for easy 3D instructions' is prominently displayed, along with download instructions for the App Store and Google Play.

BILT.[®]

**Scan for easy
3D instructions**

Download the BILT app
before you begin

Download on the
App Store

GET IT ON
Google Play

Hardware Needed

17

X

...

▶

< || >

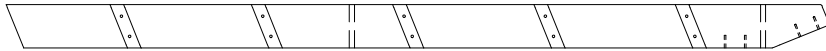

E77 | LEFT UPRIGHT - W4L15932
(1) | 1 3/8"x3 3/8"x64 3/8" (36x86x1634)



H76 | LADDER RUNG - W4L15931
(5) | 1"x3 3/8"x18 1/8" (24x86x460)



H100111 | SCREW PFH
(10) | 8x2

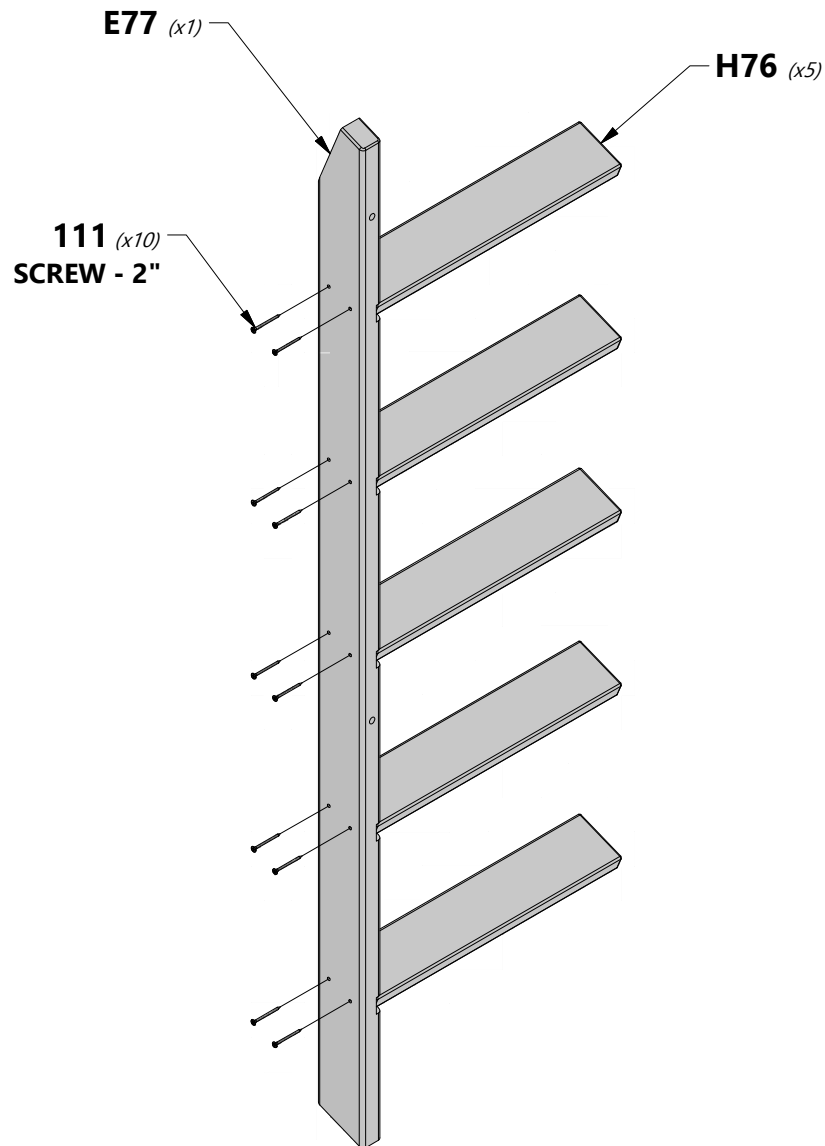



E78 | RIGHT UPRIGHT - W4L15933
(1) | 1 3/8"x3 3/8"x64 3/8" (36x86x1634)



H100111 | SCREW PFH
(10) | 8x2

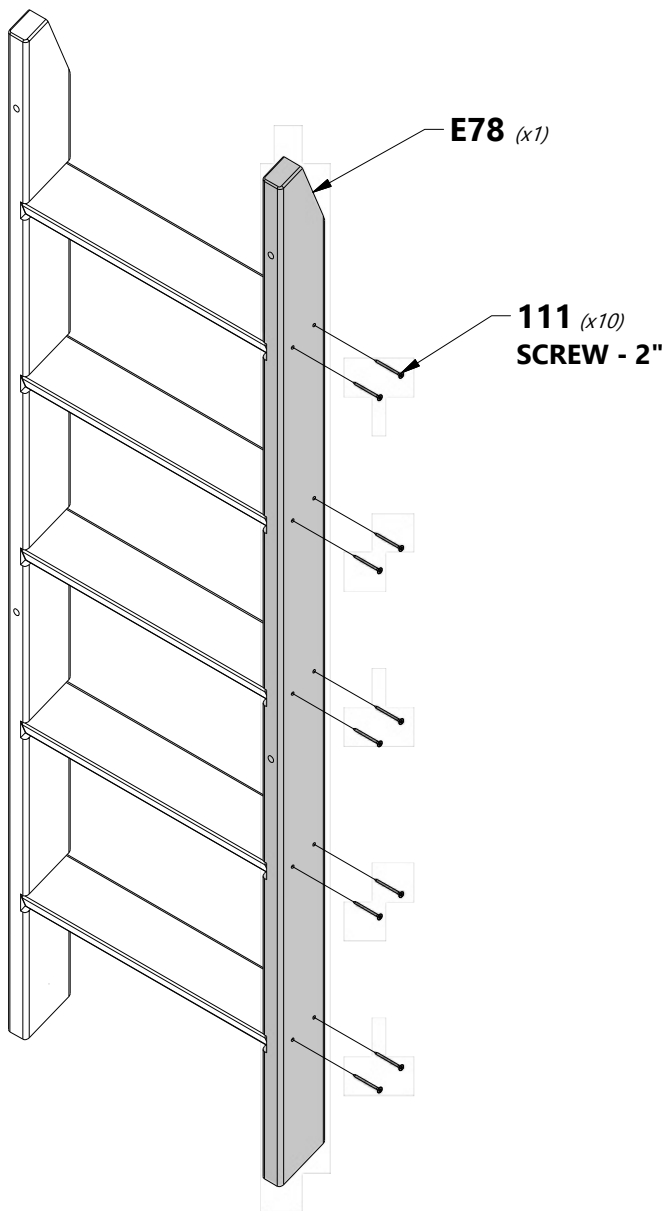



H77 | ATTACHMENT BOARD - W4L15929
(1) | 1"x3 3/8"x20 1/8" (24x86x512)

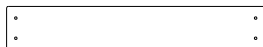

M73 | REAR SUPPORT - W4L15930
(1) | 5/8"x3 3/8"x20 1/8" (16x86x512)



H100111 | SCREW PFH
(8) | 8x2

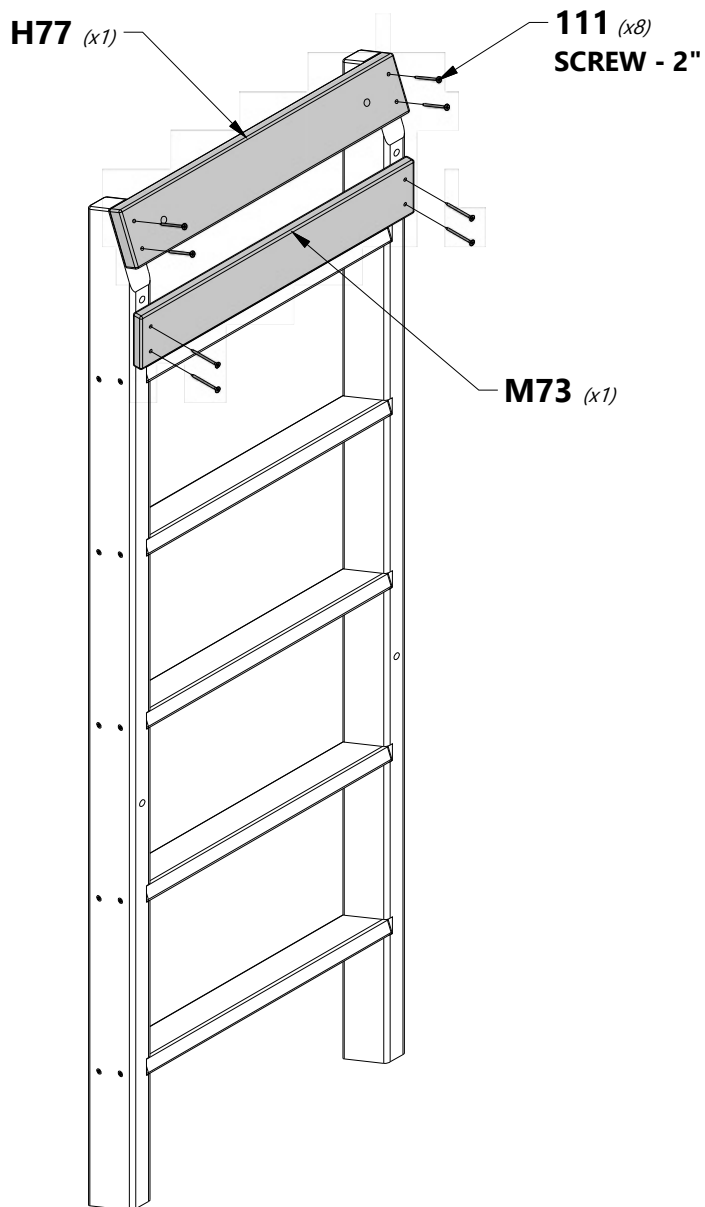

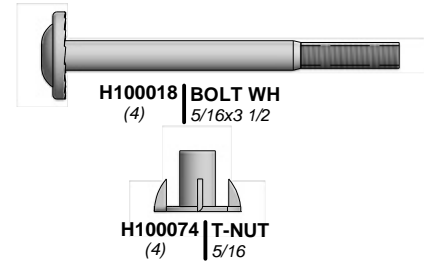

TIP:
INSTALL T-NUTS INTO BOARDS
BEFORE ASSEMBLY

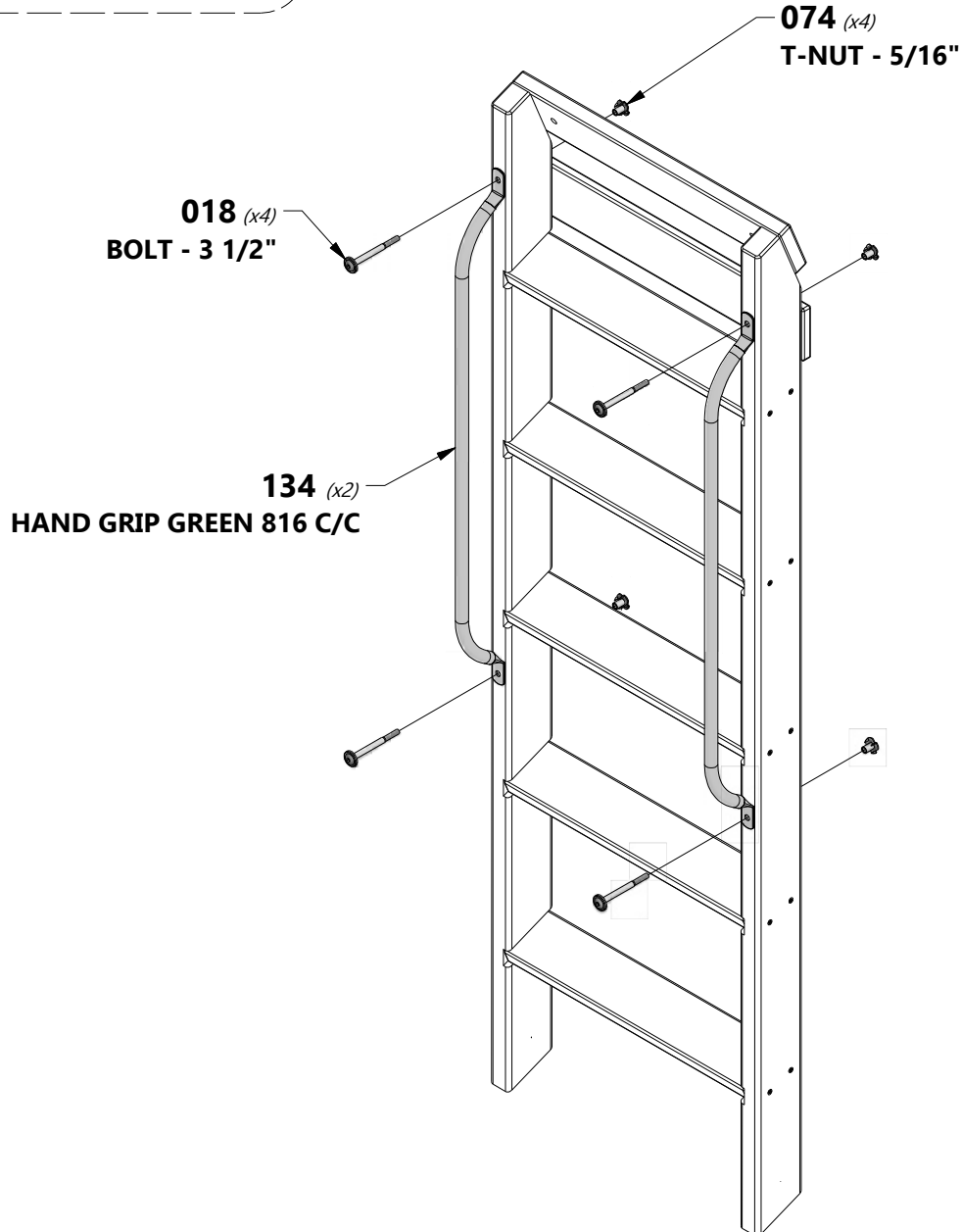



ROCKWALL ASSEMBLY

STEP 1



M76 | ROCK WALL BOARD - W4L15922
(4) 5/8"x3 3/8"x22 7/8" (16x86x580)



M75 | ROCK WALL BOARD - W4L15926
(4) 5/8"x3 3/8"x22 7/8" (16x86x580)

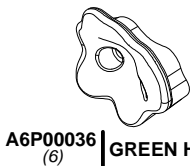

A6P00036 | GREEN HC ROCK #1
(6)



A6P00037 | GREEN HC ROCK #2
(6)



H100108 | WASHER LOCK
(24) INT
8x15



H100063 | BOLT PTH
(24) 1/4x3/4



H100072 | T-NUT
(24) 1/4

TIP:
INSTALL T-NUTS INTO BOARDS
BEFORE ASSEMBLY

INSTALL WITH FINGER GRIPS UPWARD.
****PLACE ROCKS AS DESIRED****

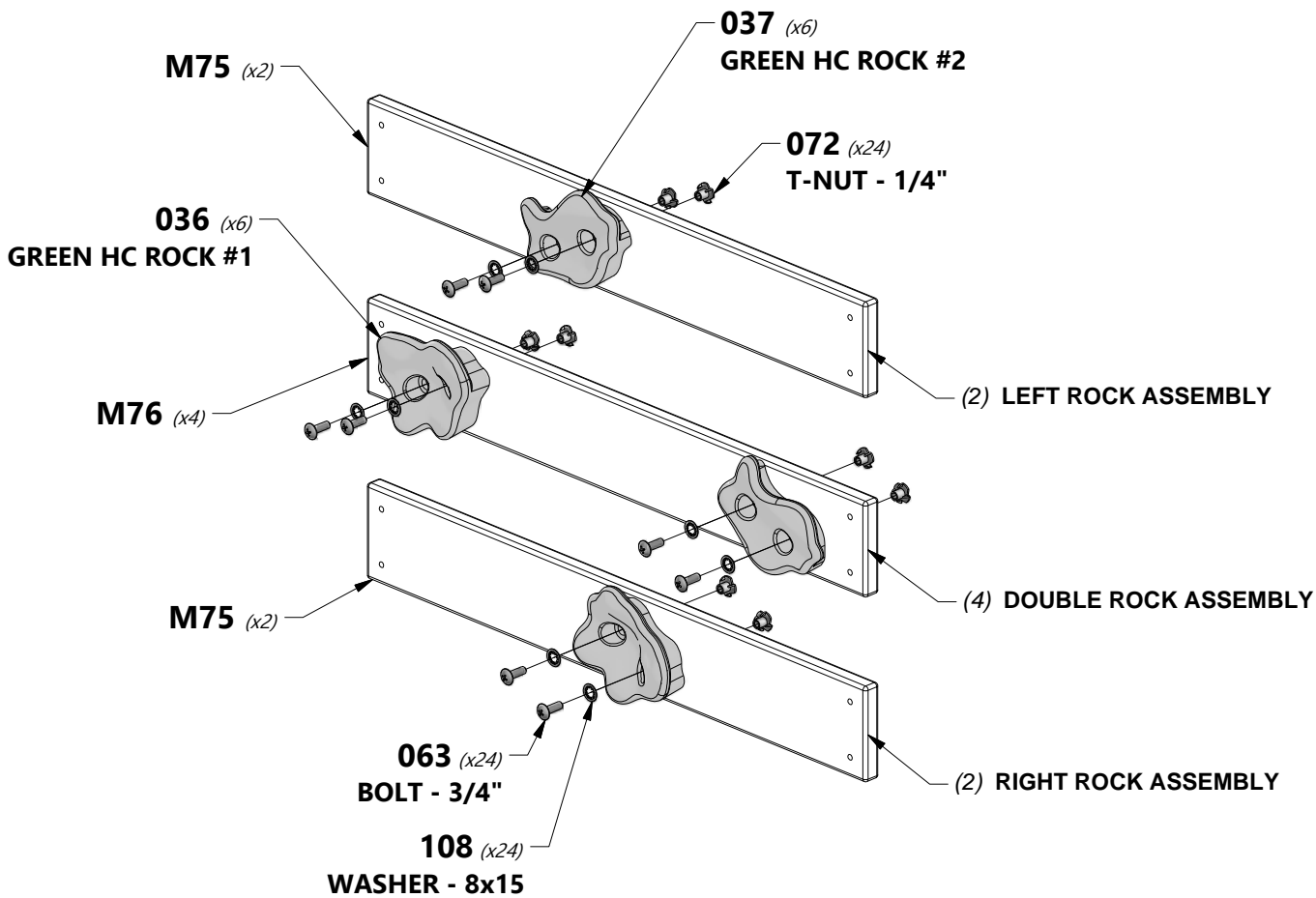
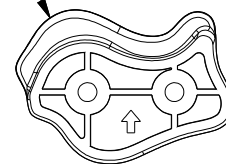
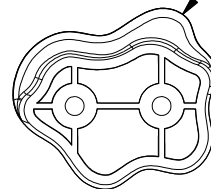



ROCKWALL ASSEMBLY

STEP 2

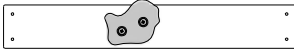

(2) LEFT ROCK ASSEMBLY

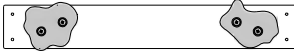

(4) DOUBLE ROCK ASSEMBLY



(2) RIGHT ROCK ASSEMBLY

N11 ROCK WALL BOARD - W4L15928
(1) 5/8"x2"x22 7/8" (16x50x580)

M74 ROCK WALL BOARD - W4L15927
(10) 5/8"x3 3/8"x22 7/8" (16x86x580)

E72 ROCKWALL RAIL - W4L15923
(2) 1 3/8"x3 3/8"x64 5/8" (36x86x1640)

H100086 SCREW PFH
(74) 8x1 1/2

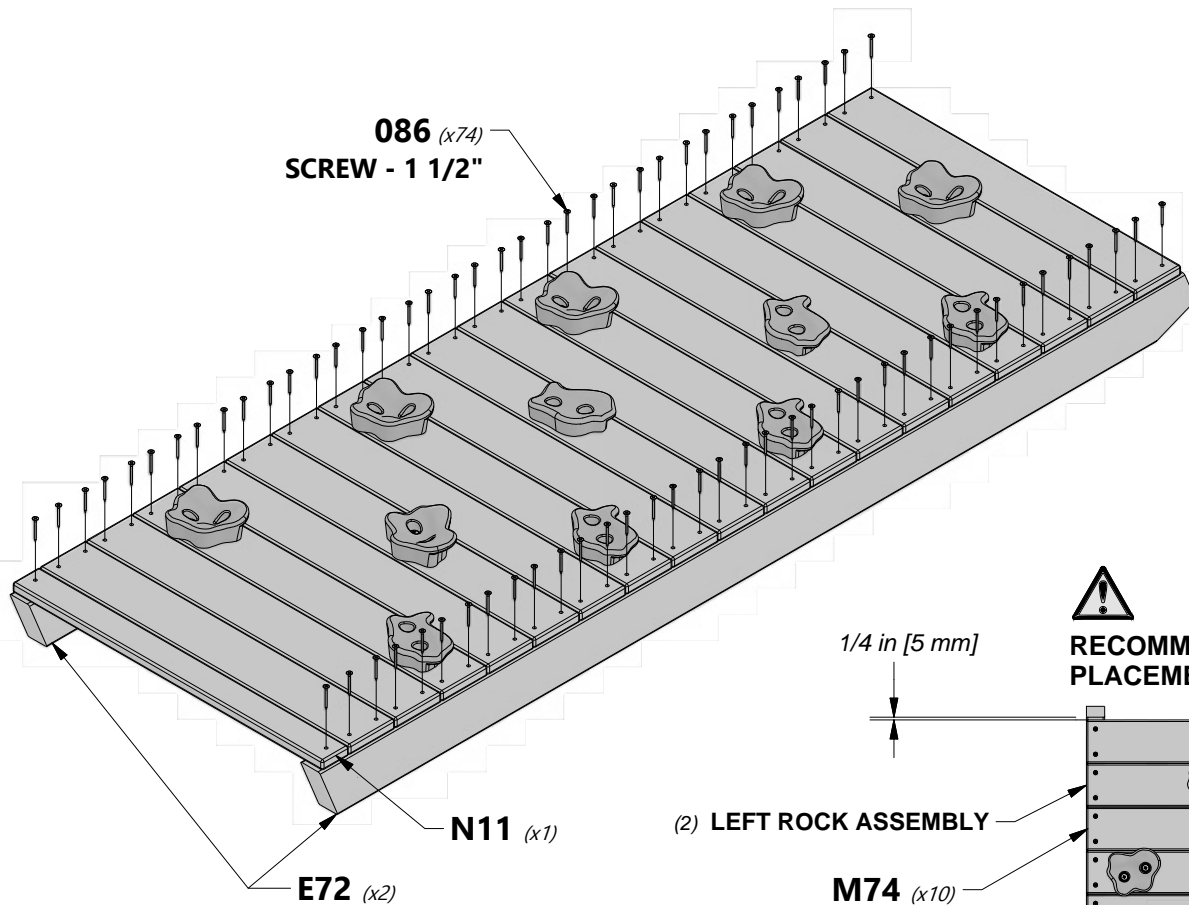

086 (x74)
SCREW - 1 1/2"

N11 (x1)

E72 (x2)

(2) LEFT ROCK ASSEMBLY

M74 (x10)

(2) RIGHT ROCK ASSEMBLY

(4) DOUBLE ROCK ASSEMBLY



TOP

RECOMMENDED BOARD
PLACEMENT PATTERN

1/4 in [5 mm]

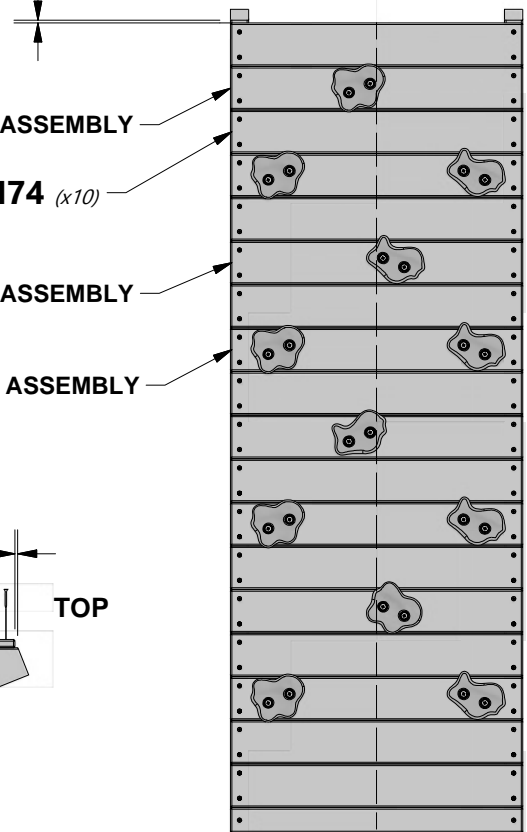

1/4 in [5 mm]

TOP

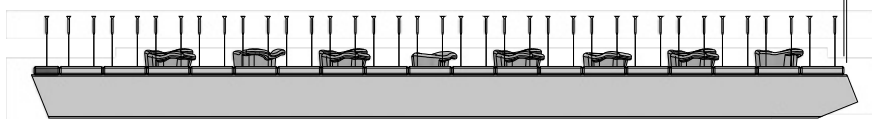

SIDE VIEW



ROCKWALL ASSEMBLY

STEP 3



Y3 | ROCK WALL END BOARD - W4L15925
(1) | 5/8"x3 5/8"x22 7/8" (16x92x580)



H100086 | SCREW PFH
(4) | 8x1 1/2

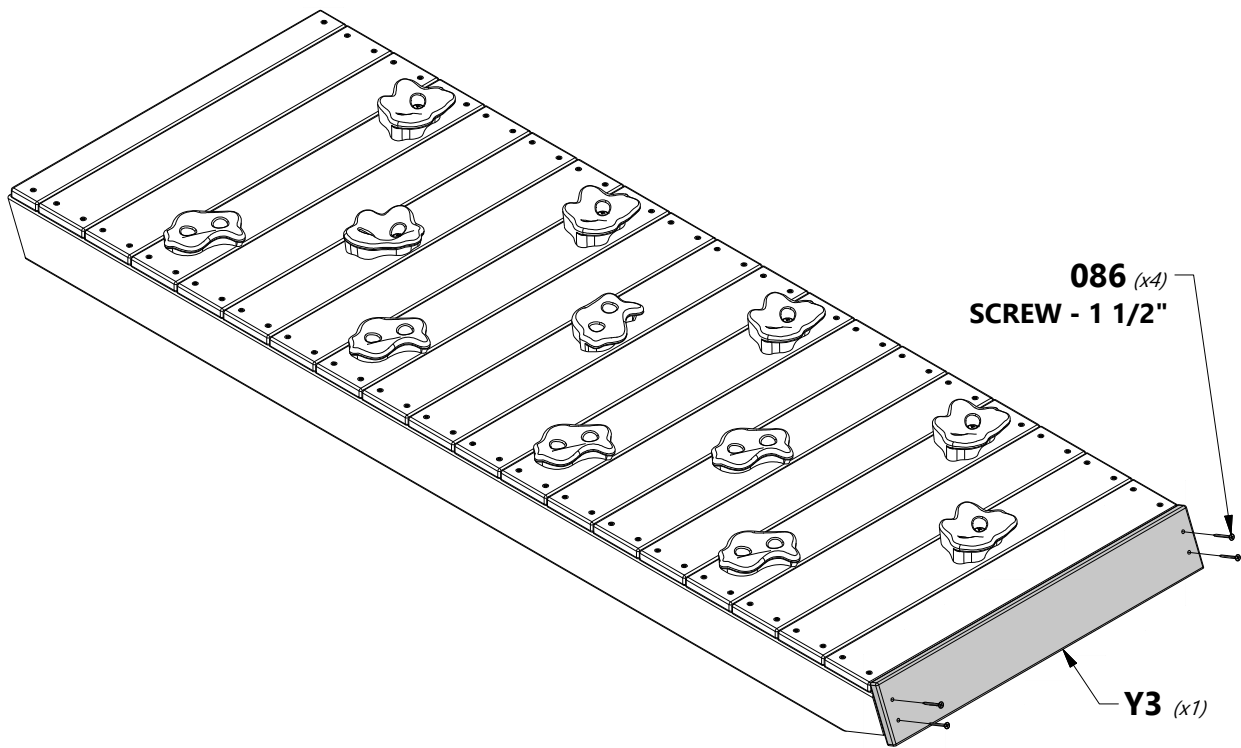

SIDE VIEW

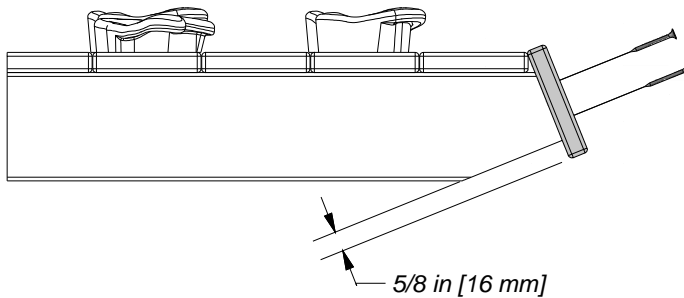



ROCKWALL ASSEMBLY

STEP 4



M61 | ATTACHMENT BOARD - W4L15924
(1) | 5/8"x3 3/8"x22 7/8" (16x86x580)



H100086 | SCREW PFH
(4) | 8x1 1/2



H100074 | T-NUT
(2) | 5/16



TIP:
INSTALL T-NUTS INTO BOARDS
BEFORE ASSEMBLY

M61 (x1)

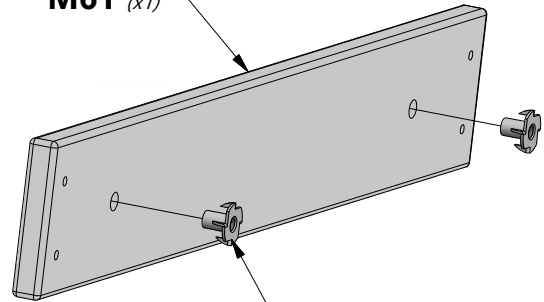

074 (x2)
T-NUT - 5/16"

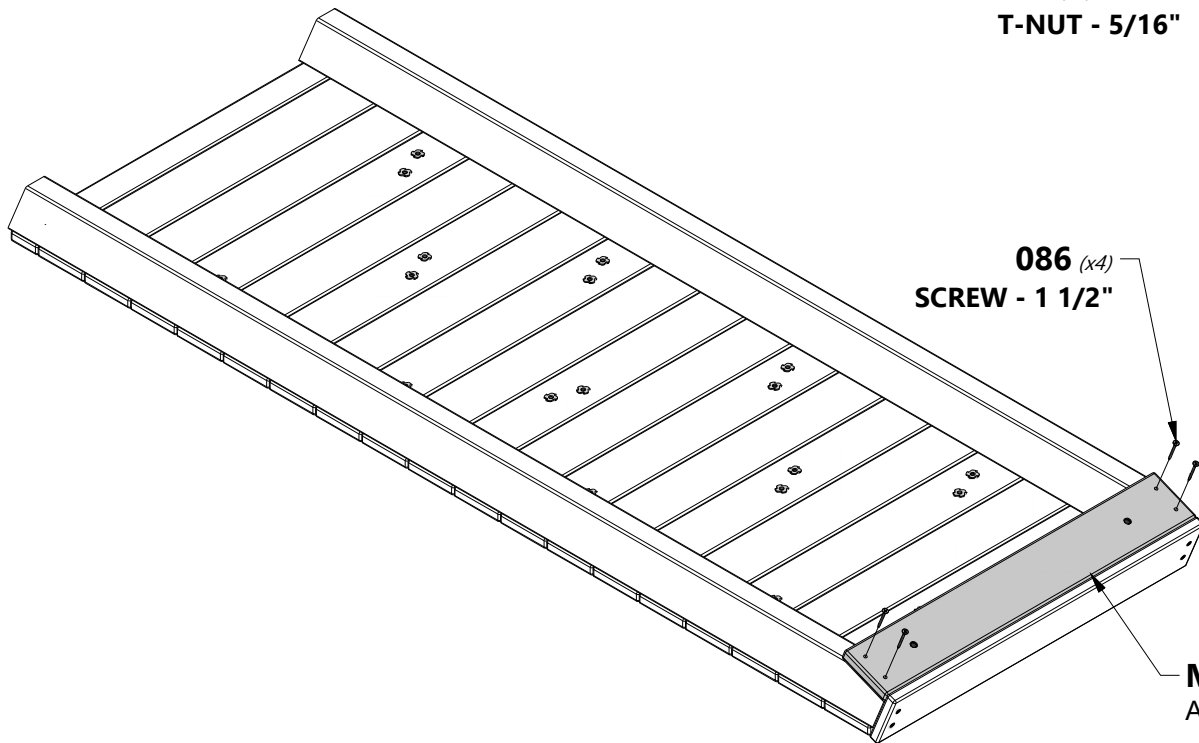

086 (x4)
SCREW - 1 1/2"

M61
ASSEMBLY

SIDE VIEW

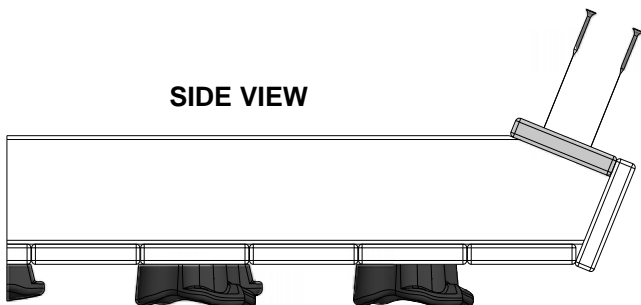

**T-NUTS TO THE INSIDE
WHEN INSTALLING BOARD**

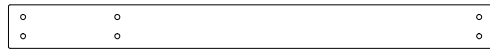

E03 | CROWS NEST FLOOR RAIL - W4L15901
(2) | 1 3/8"x3 3/8"x38" (36x86x964)

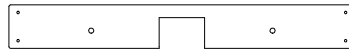

H19 | CROWS NEST FLOOR RAIL - W4L15903
(1) | 1"x3 3/8"x27" (24x86x686)

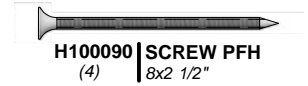

H100090 | SCREW PFH
(4) | 8x2 1/2"

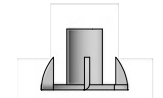

H100074 | T-NUT
(4) | 5/16"

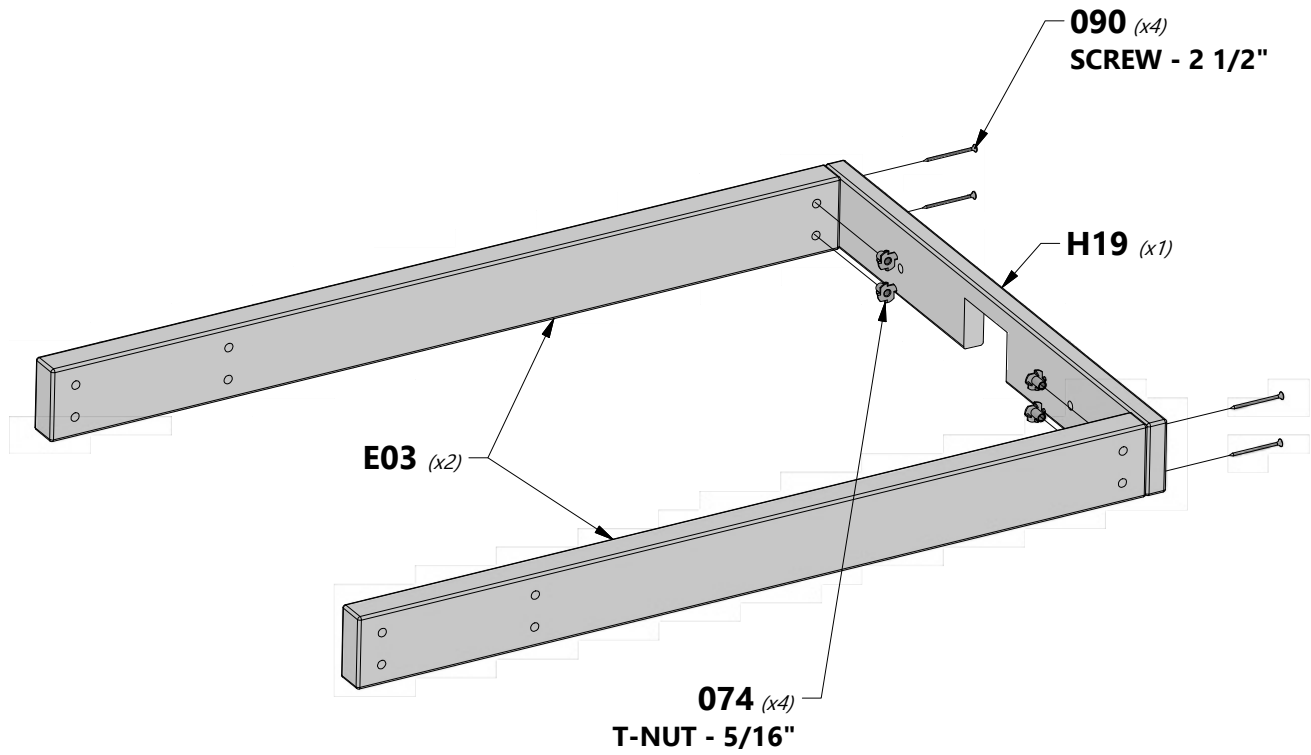



CROWS NEST

STEP 2

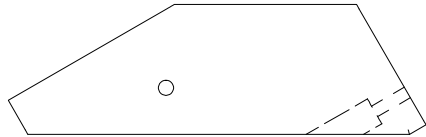

E8 | CROWS NEST DECK BRACE - W4L15902
(2) | 1 7/16"x3 3/8"x10 7/8" (36x86x276)

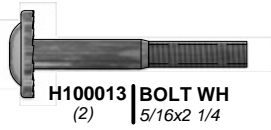

H100013 | BOLT WH
(2) | 5/16x2 1/4



H100074 | T-NUT
(2) | 5/16



H100030 | WASHER LOCK EXT
(2) | 8x19



TIP:
INSTALL T-NUTS INTO
BOARDS BEFORE ASSEMBLY.

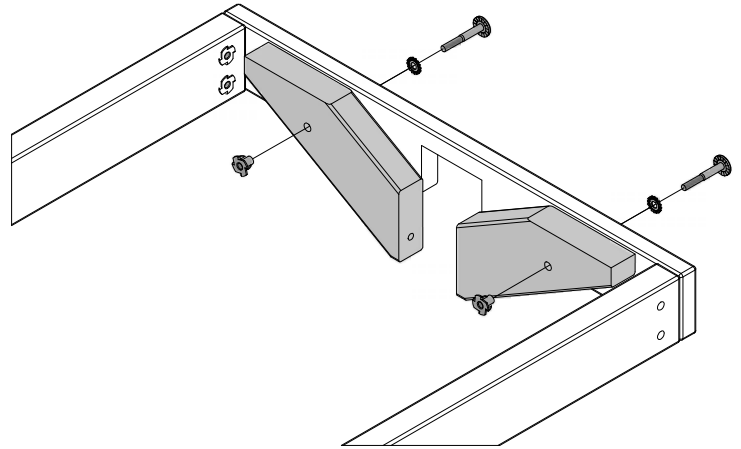

INSIDE VIEW

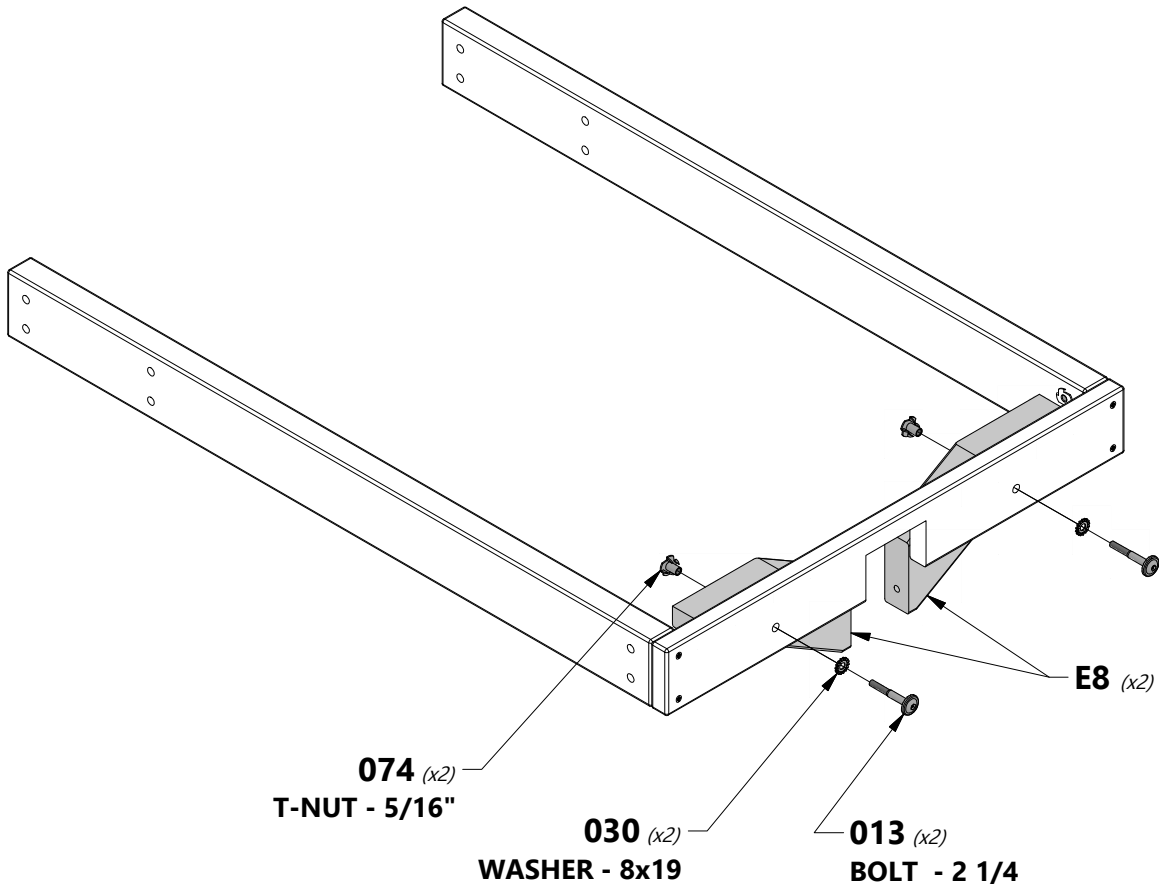

074 (x2)
T-NUT - 5/16"

030 (x2)
WASHER - 8x19

013 (x2)
BOLT - 2 1/4

E8 (x2)



L01 | CROWS NEST FLOOR BOARD - W4L15905
(7) | 5/8"x4 3/8"x27" (16x112x686)



L03 | CROWS NEST FLOOR BOARD - W4L15906
(2) | 5/8"x4 3/8"x27" (16x112x686)



H100086 | SCREW PFH
(34) | 8x1 1/2

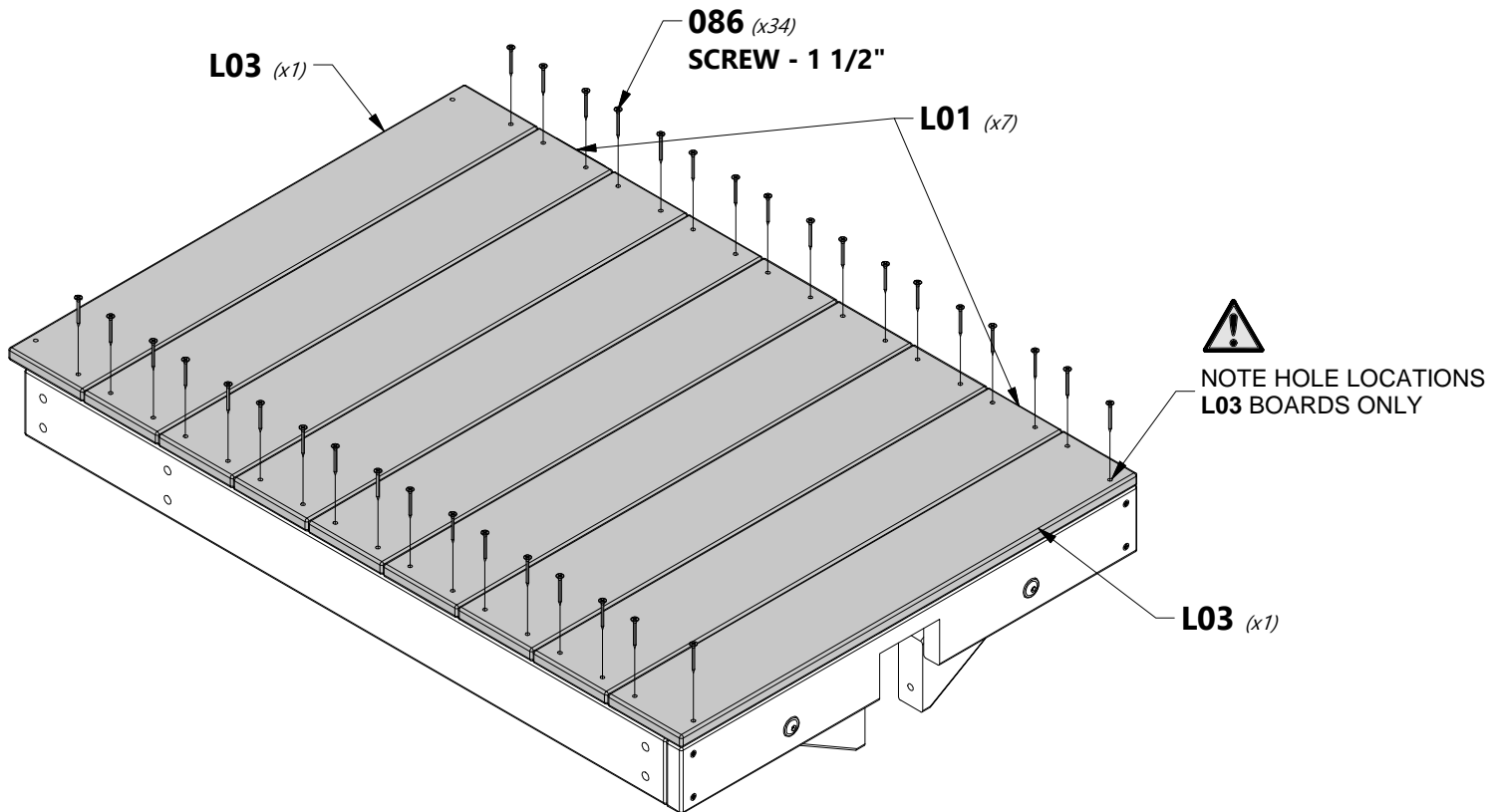
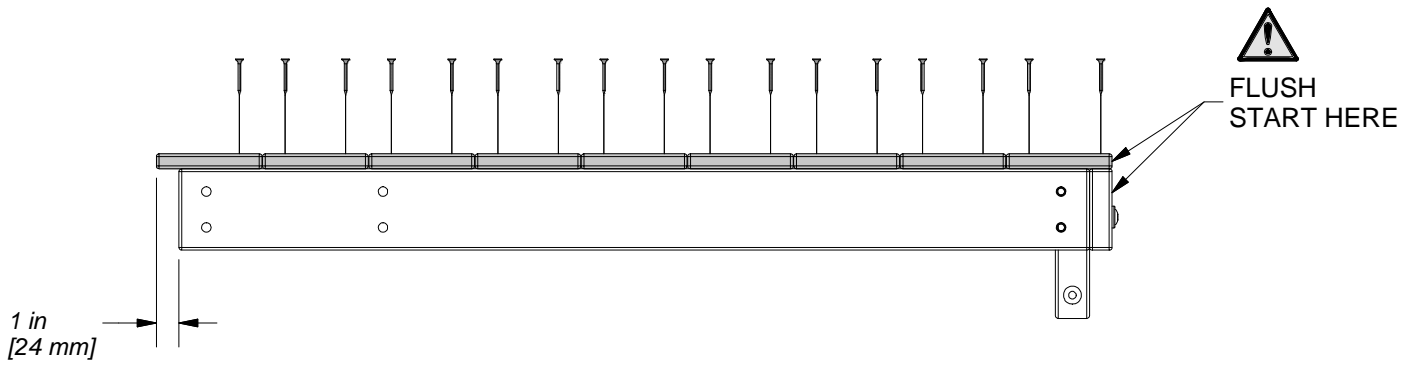





H21 | CROWS NEST FLOOR SUPPORT - W4L15904
(1) | 1"x3 3/8"x24 1/8" (24x86x614)

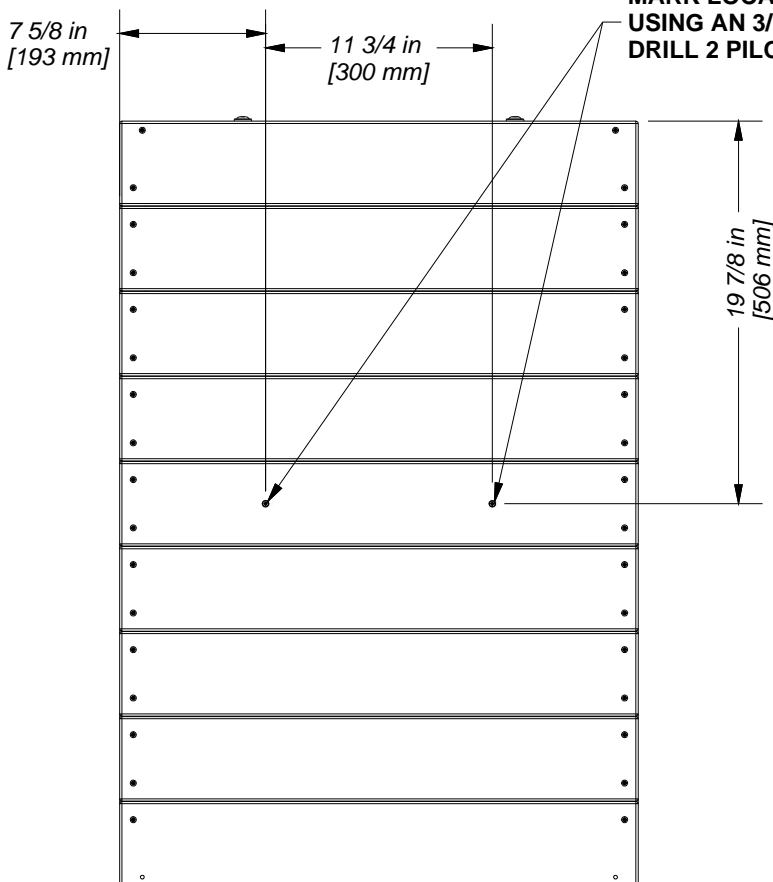
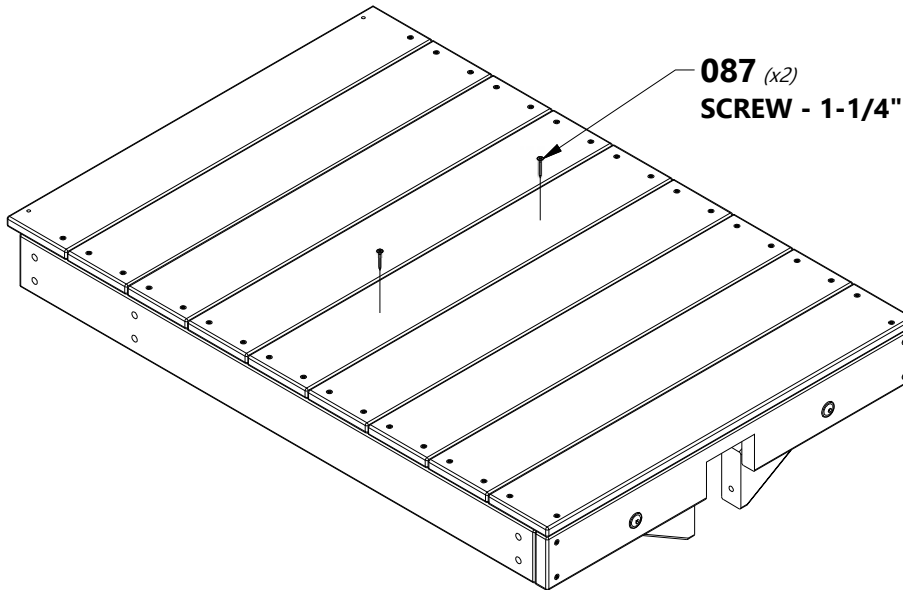

H100087 | SCREW PFH
(2) | 8x1 1/4



MARK LOCATIONS SHOWN.  USING AN 3/16\" DRILL BIT DRILL 2 PILOT HOLES.

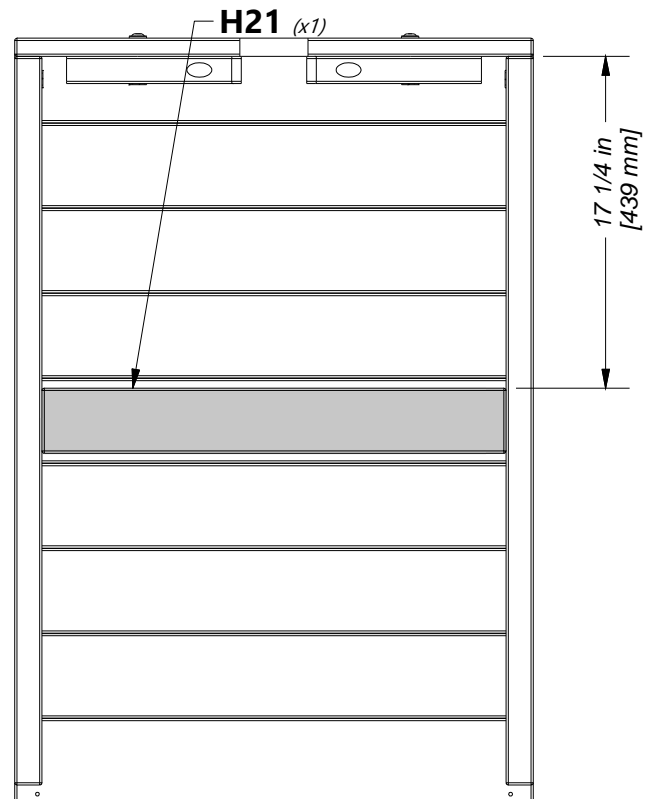

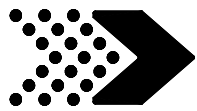

MONKEY BAR ASSEMBLY

STEP 1

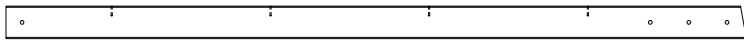

E4 | MONKEY BAR RAIL - W4L15936
(x2) | 1 3/8"x3 3/8"x77 1/8" (36x86x1959)



A100045 | METAL RUNG 559 GREEN
(x4)



A100294 | TRIANGLE
(x2) | PLATE 100° 5
HOLE



A4M01046 | L BRACKET
(x4) | 2.5x38x55x55



H100012 | BOLT WH
(x2) | 5/16x2



H100009 | BOLT WH
(x6) | 5/16x1 1/4



H100145 | LAG SCREW WH
(x8) | 1/4x1 1/2

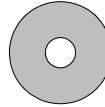

H100105 | WASHER FLAT
(x2) | 8x27

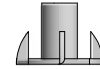

H100074 | T-NUT
(x6) | 5/16



H100110 | NUT LOCK
(x2) | 5/16



TIP:
SCREW TAPPING 14x1-1/2
USE A #3 PHILLIPS BIT.



TIP:
INSTALL T-NUTS INTO
BOARDS BEFORE ASSEMBLY.

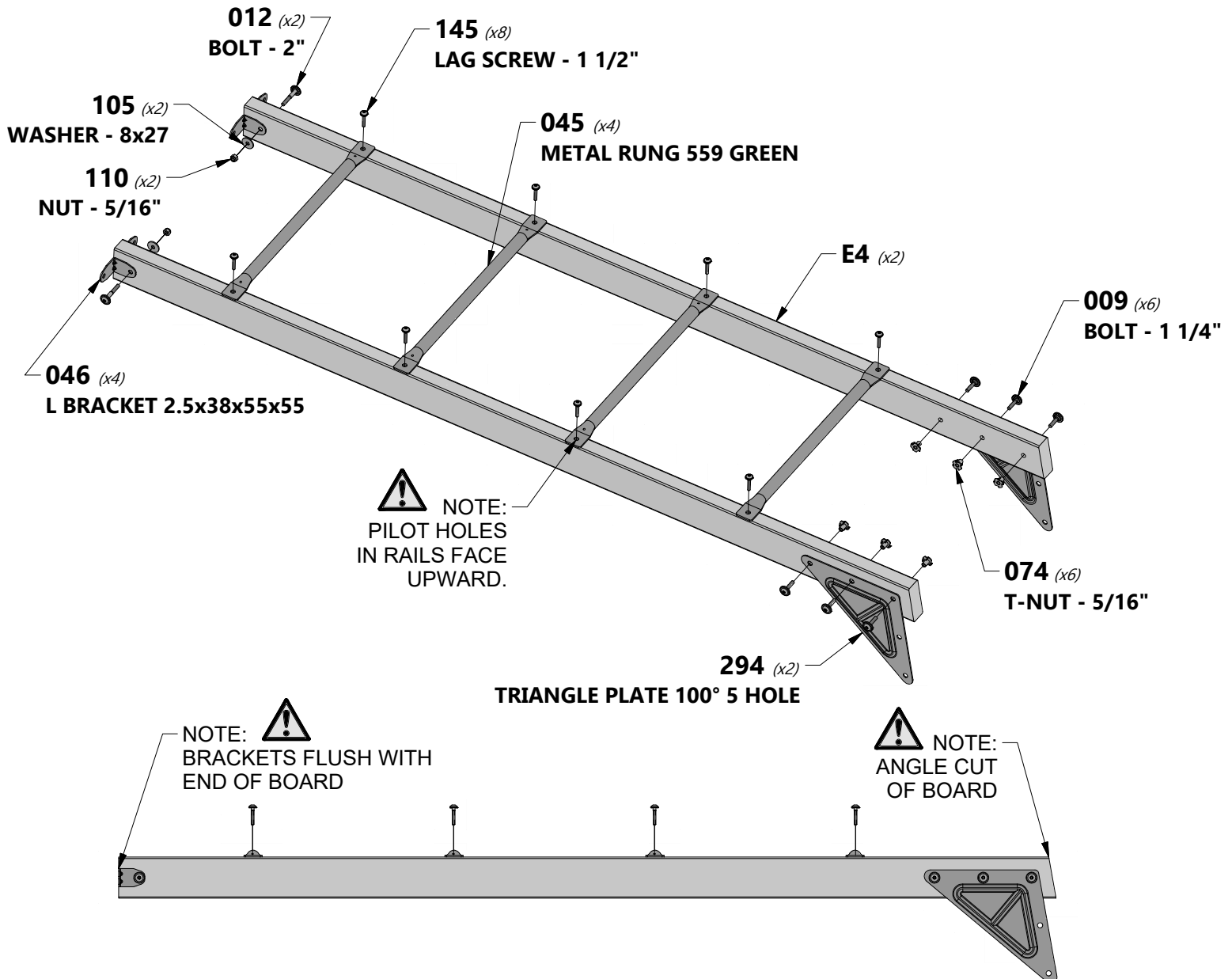

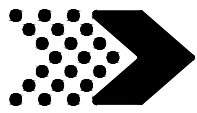

MONKEY BAR ASSEMBLY

STEP 2

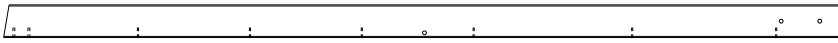

E5 | MONKEY BAR UPRIGHT - W4L15937
(x2) | 1 3/8"x3 3/8"x87 5/8" (36x86x2226)



A100045 | METAL RUNG 559 GREEN
(x4)



A100118 | HAND GRIP METAL GREEN 381 c/c
(x2)



H100145 | LAG SCREW WH
(x12) | 1/4x1 1/2

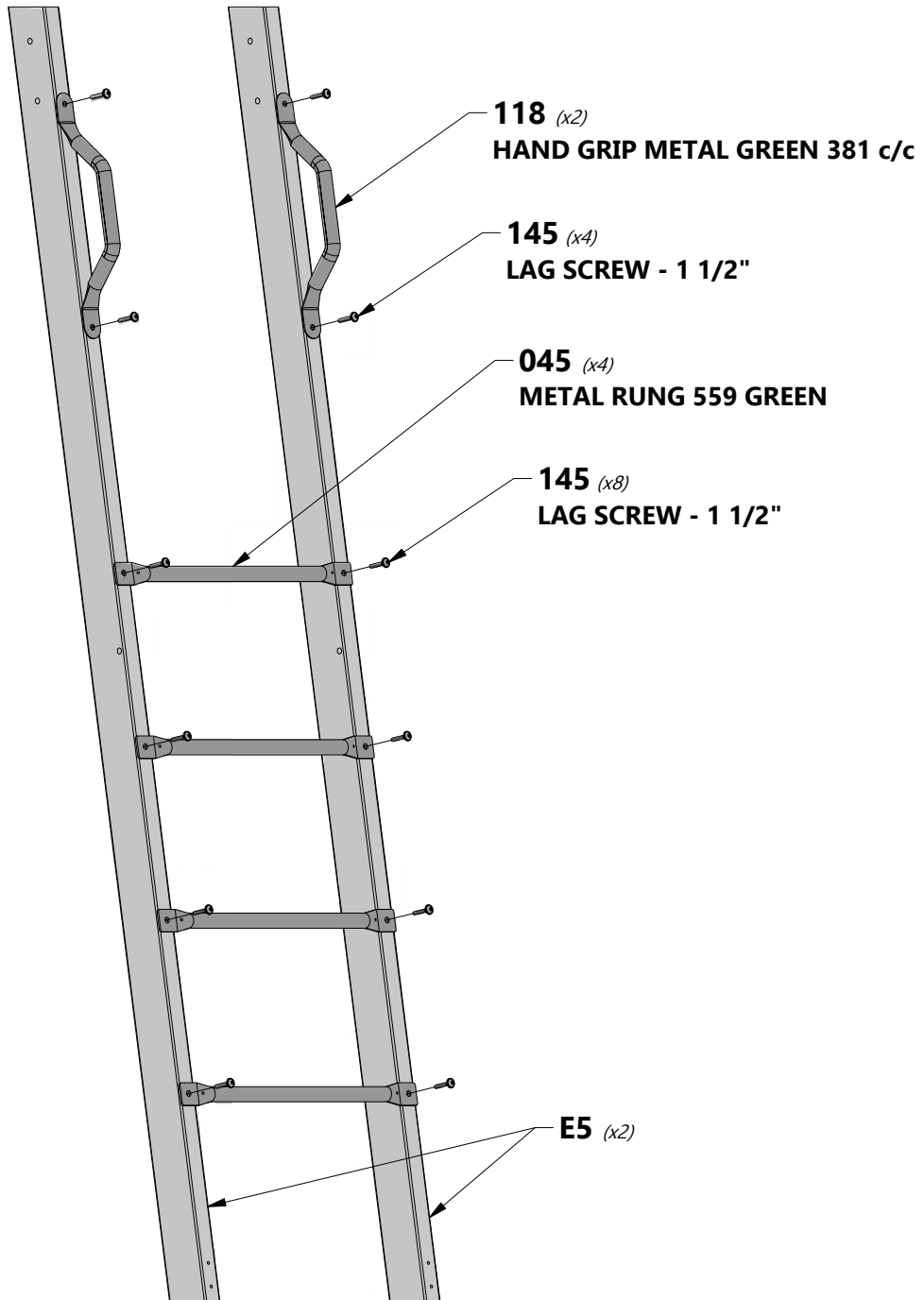

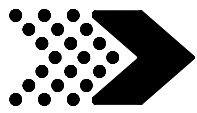

MONKEY BAR ASSEMBLY

STEP 3

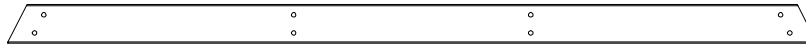

H32 | MONKEY BAR GROUND BOARD - W4L15935
(x1) | 1"x3 3/8"x70 3/8" (24x86x1786)



H22 | MONKEY BAR BRACE - W4L15934
(x2) | 1"x3 3/8"x51 1/2" (24x86x1308)



H100047 | BOLT HEX
(x2) | 5/16x2 3/4



H100028 | LAG SCREW WH
(x4) | 5/16x2 1/2

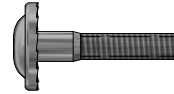

H100010 | BOLT WH
(x4) | 5/16x1-1/2

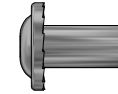

H100005 | NUT BARREL WH
(x4) | 5/16x7/8



H100074 | T-NUT
(x2) | 5/16



H100031 | WASHER LOCK EXT
(x4) | 12x19



H100030 | WASHER LOCK EXT
(x8) | 8x19



H100106 | WASHER FLAT
(x2) | 9x18



H100108 | WASHER LOCK INT
(x2) | 8x15



TIP:
INSTALL T-NUTS INTO
BOARDS BEFORE ASSEMBLY.

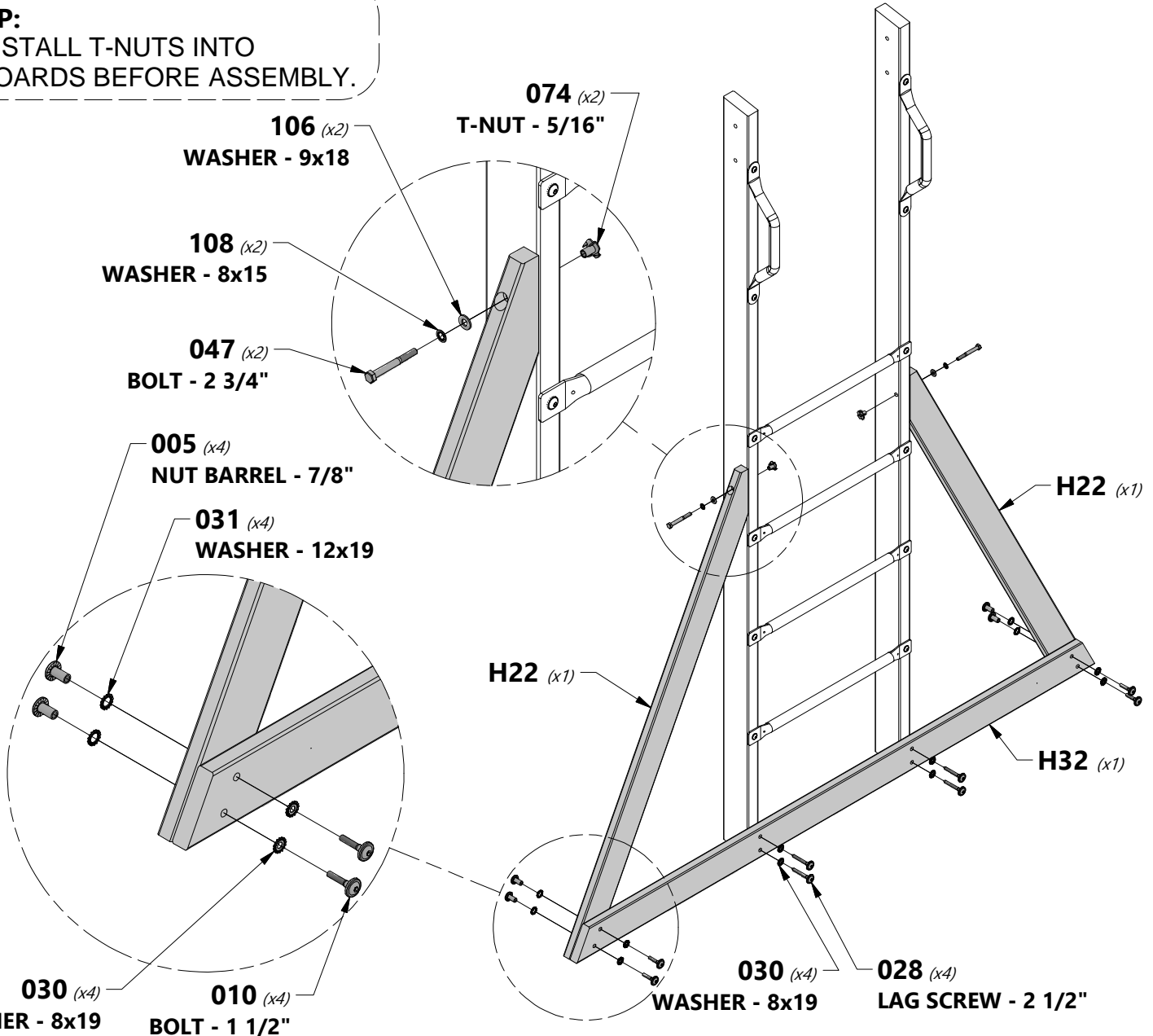

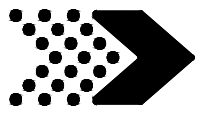

MONKEY BAR ASSEMBLY

STEP 4

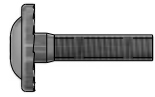

H100009 | BOLT WH
(x4) | 5/16x1 1/4



H100074 | T-NUT
(x4) | 5/16

 **TIP:**
INSTALL T-NUTS INTO BOARDS
BEFORE ASSEMBLY

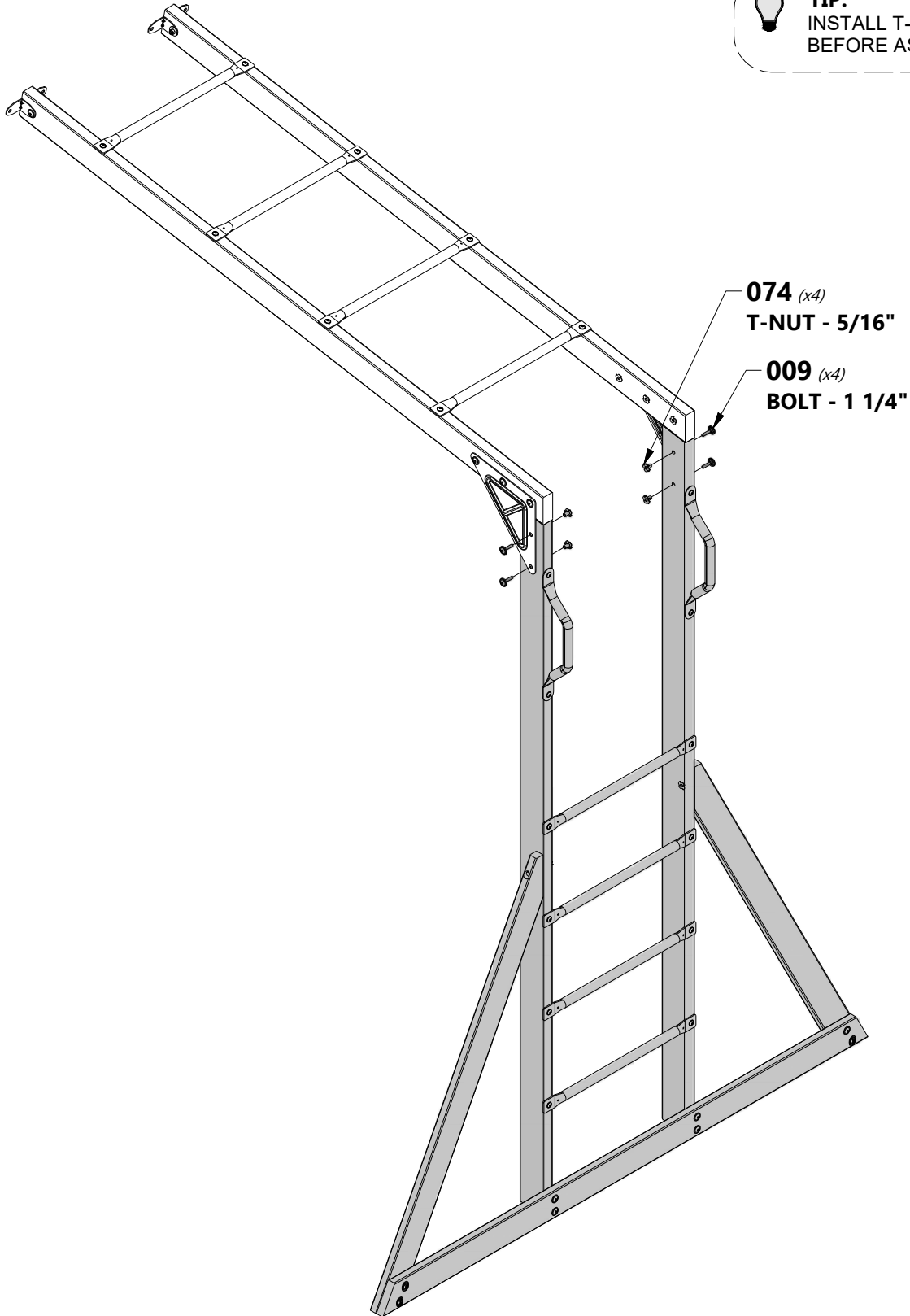



SLIDE ASSEMBLY

STEP 1



A100035 | SLIDE BED 10' LIGHT GREEN
(x1)

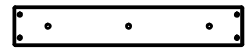

M70 | SLIDE SUPPORT BOARD - W100935
(x1) | 5/8"x3 3/8"x19 7/8" (16x86x505)



H100074 | T-NUT
(x3) | 5/16"



H100115 | BOLT WH
(x3) | 5/16x1/2"



NOTE:

TAKE NOTE OF SLIDE BED SURFACE FINISH, THE DULL SIDE WILL BE TOWARDS THE GROUND. PLACE SLIDE BRACE CENTERED ON THE BOTTOM (DULL SIDE) AND 1/2" FROM THE EDGE. USE **M70** BOARD AS A TEMPLATE FOR DRILLING BOTTOM HOLE PATTERN IN SLIDE BED. USE A 5/16" DRILL BIT.



TIP:

PRE-BENDING THE ENDS WILL EASE ASSEMBLY. PLACING THE SLIDE BED OUT IN THE SUN MAKES IT EASIER TO BEND.

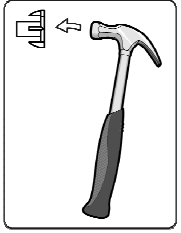

TOP

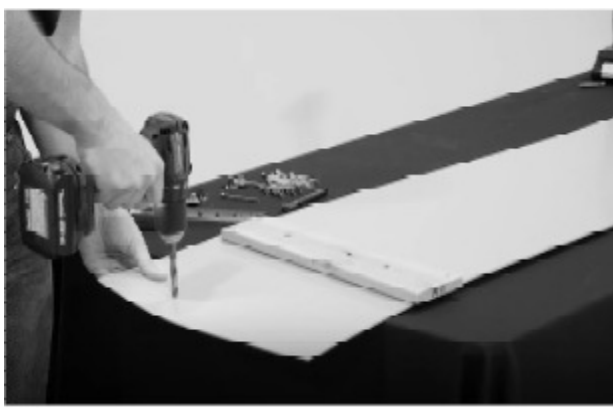
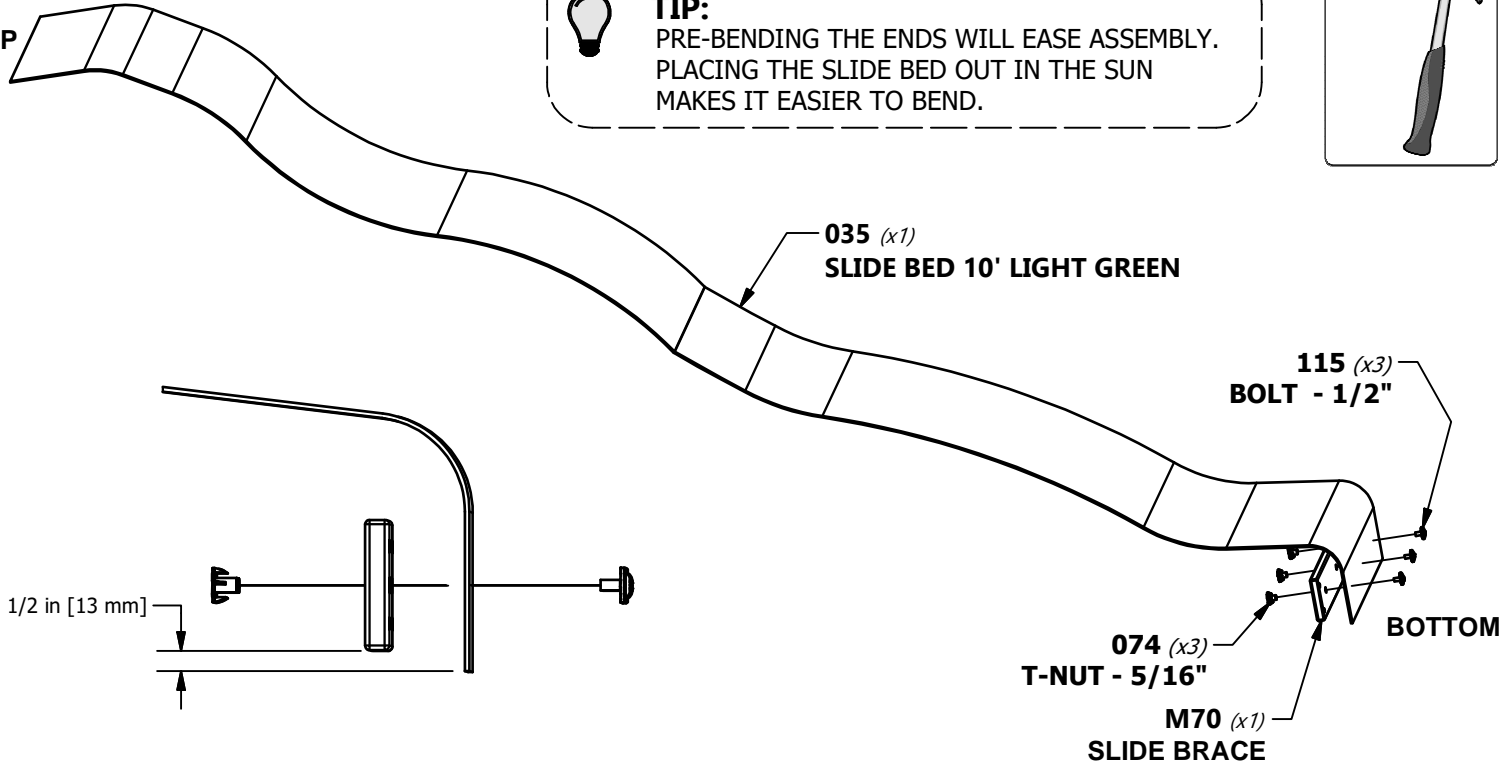



SLIDE ASSEMBLY

STEP 2



A6P00484 | SLIDE RAIL 10' BOTTOM RIGHT GREEN
(x1)



A6P00486 | SLIDE RAIL 10' TOP RIGHT GREEN
(x1)



A6P00483 | SLIDE RAIL 10' BOTTOM LEFT GREEN
(x1)



A6P00485 | SLIDE RAIL 10' TOP LEFT GREEN
(x1)



H100115 | BOLT WH
(x8) | 5/16x1/2

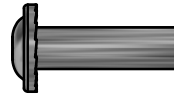

H100006 | NUT BARREL WH
(x8) | 5/16x1 1/2



NOTE:
REPEAT ON OTHER SIDE, MAKING
A LEFT AND RIGHT ASSEMBLY.

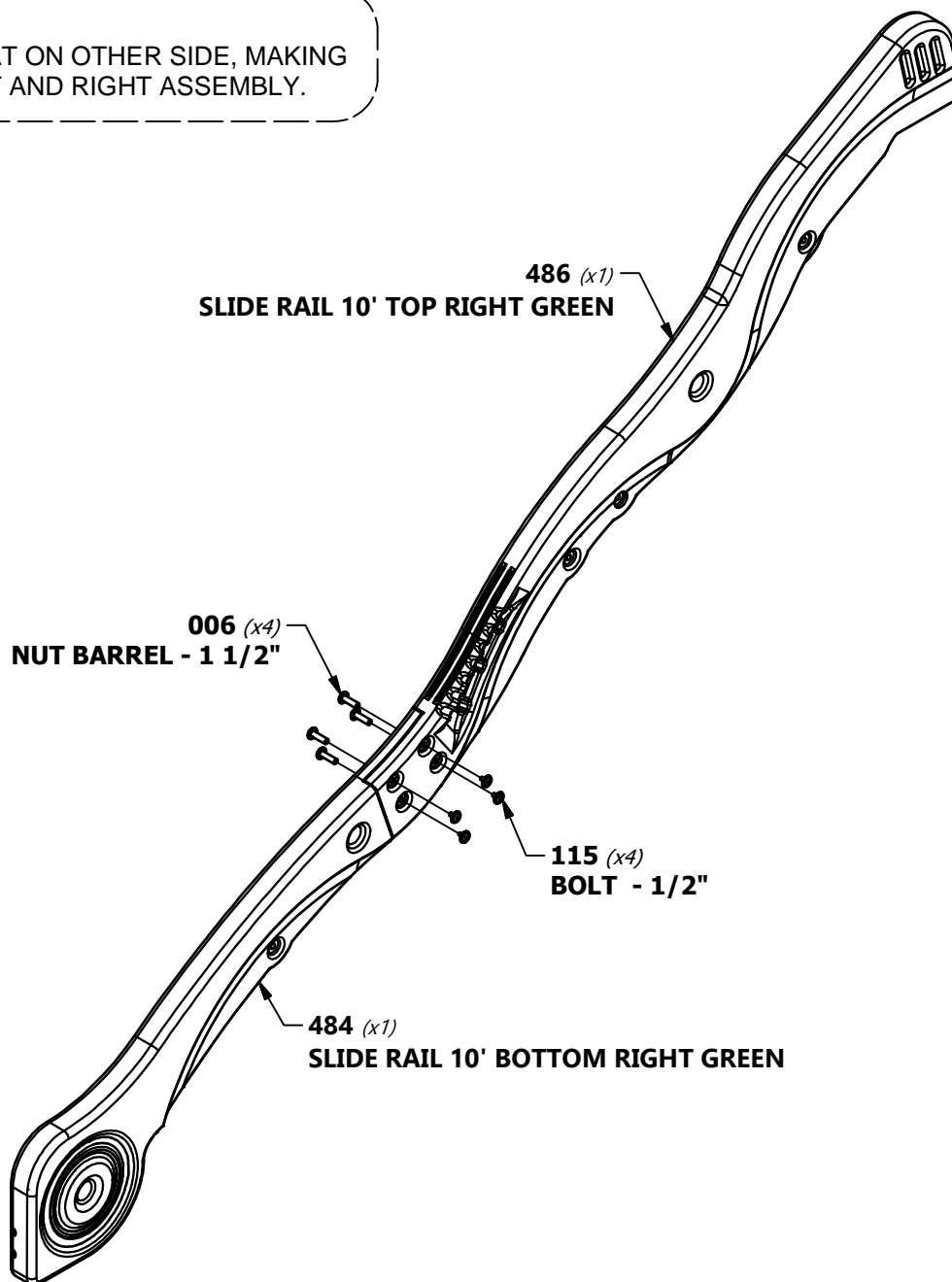

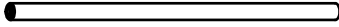

A6P00487 | SLIDE TUBE SUPPORT
 (x4)

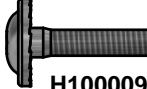
H100009 | BOLT WH
 (x4) | 5/16x1 1/4

**NOTE:**

INSERT THE (4) SLIDE SUPPORT TUBES INTO THEIR RESPECTIVE PILOT LOCATIONS (FIGURE 1).

PLACE (1) SLIDE RAIL ASSEMBLY ON A FLAT SURFACE AND BEGIN INSERTING SLIDE BED AT THE BOTTOM OF THE SLIDE RAIL (FIGURE 2). HAVE A HELPER BEND THE SLIDE BED TOWARDS THE TOP OF THE SLIDE AND INSERT THE BED INTO THE SLIDE CAVITY. MAKE SURE SLIDE BED IS INSERTED WITHIN 1/8" (3mm) OF GROOVE BOTTOM.

**TIP:**

A HELPER IS RECOMMENDED FOR THESE FOLLOWING STEPS.

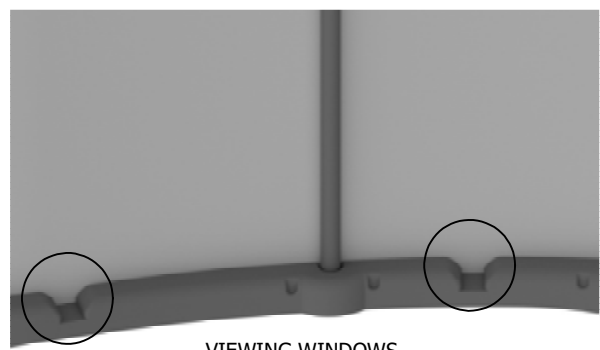
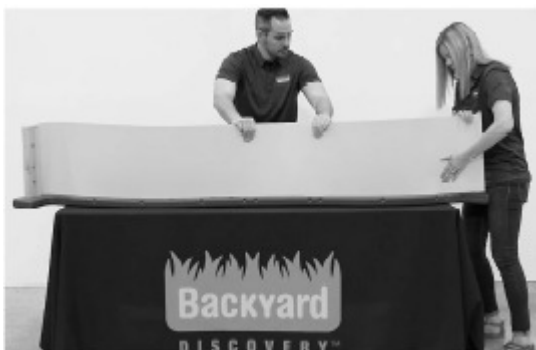
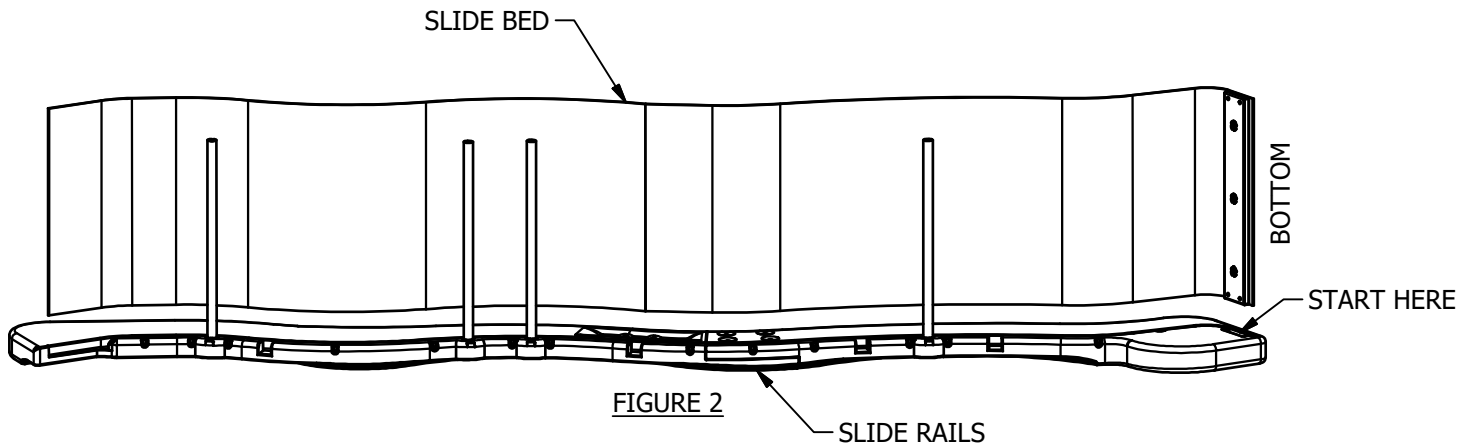
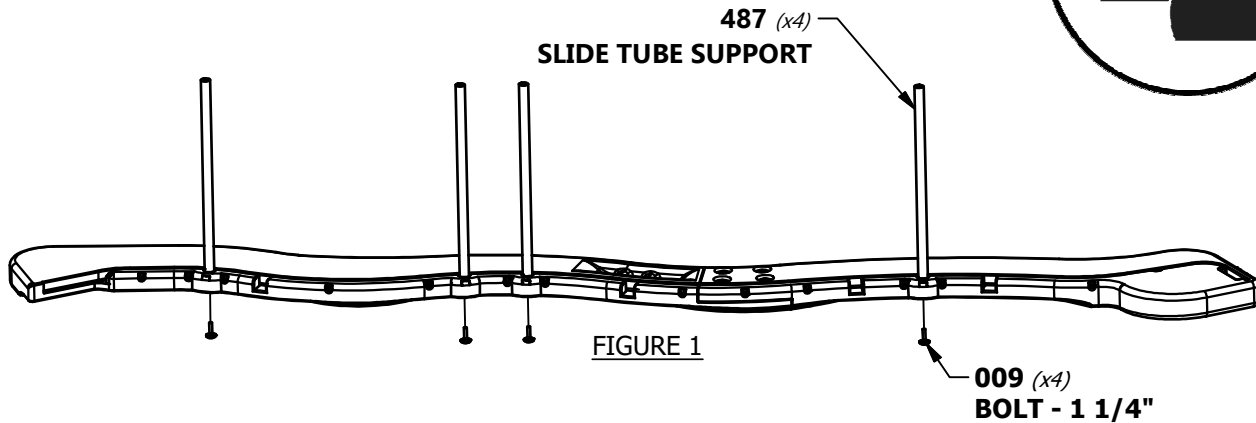

VIEWING WINDOWS



NOTE:

PLACE SECOND SLIDE RAIL ASSEMBLY OVER THE TOP OF THE SLIDE BED AND SLIDE SUPPORT TUBES. INSERT THE SLIDE BED AND SLIDE SUPPORT TUBES INTO THE SLIDE CAVITY. MAKE SURE SLIDE BED IS INSERTED WITHIN 1/8" (3mm) OF GROOVE BOTTOM.



FAILURE TO INSERT SLIDE BED PROPERLY MAY RESULT IN INJURY OR AMPUTATION. EXPOSED SLIDE EDGES CAN BE SHARP AND BECOME A LACERATION HAZARD IF THE SLIDE IS NOT PROPERLY ASSEMBLED.

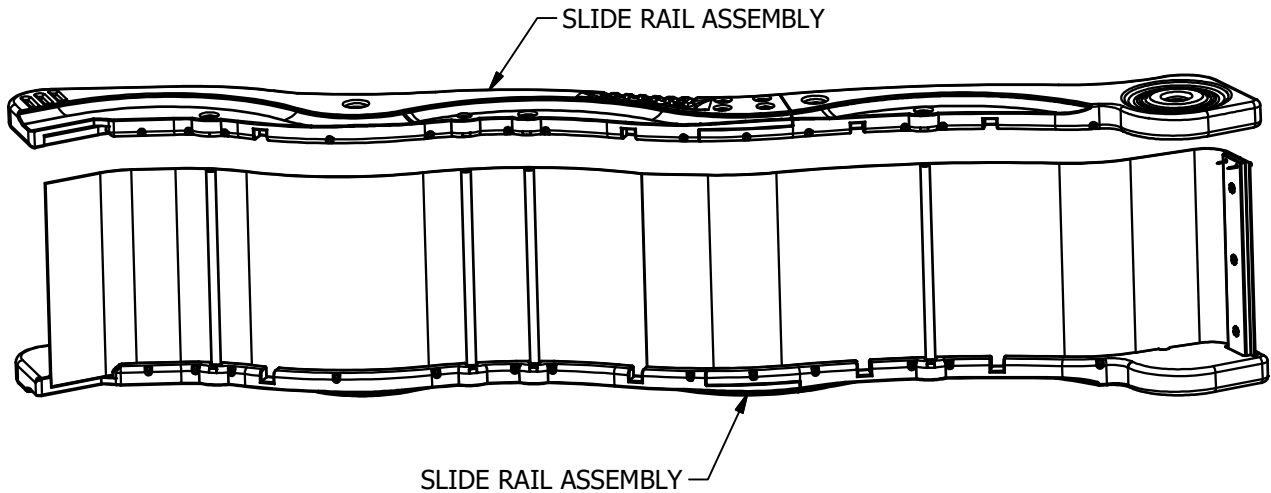
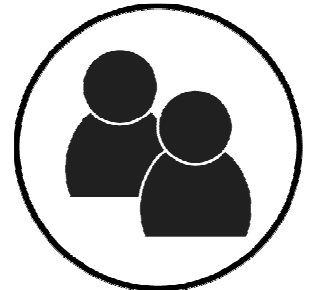

TIP:

USE A RUBBER Mallet TO FULLY SEAT THE SLIDE BED INTO THE SLIDE CAVITY.

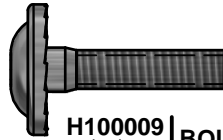

H100009 | BOLT WH 5/16x1 1/4
(x4)



NOTE:
USE 1 1/4" BOLTS TO FASTEN EACH
SIDE OF THE SLIDE SUPPORT TUBES.



TIP:
HAVING A HELPER HOLD THE SLIDE
ASSEMBLY TOGETHER WHILE YOU FASTEN
WILL MAKE IT EASIER TO ASSEMBLE.

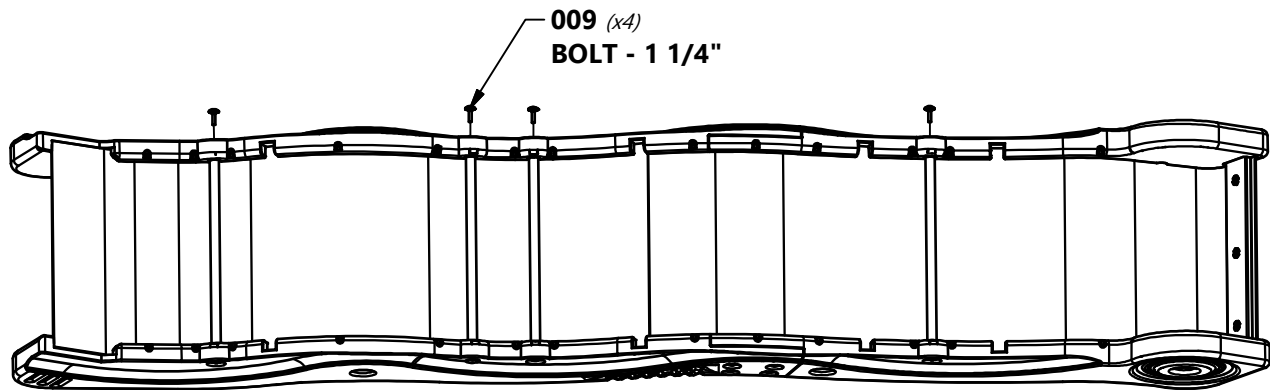



H100090 | SCREW PFH
(x30) | 8x2 1/2"



NOTE:

USING AN 1/8" DRILL BIT, DRILL PILOT HOLES IN EACH INDENTATION ALONG EACH SIDE RAIL. THERE SHOULD BE 15 INDENTATIONS ON EACH RAIL. BE SURE TO DRILL THROUGH THE SLIDE RAIL AND THE SLIDE BED. THEN SECURE WITH THE PROVIDED HARDWARE.

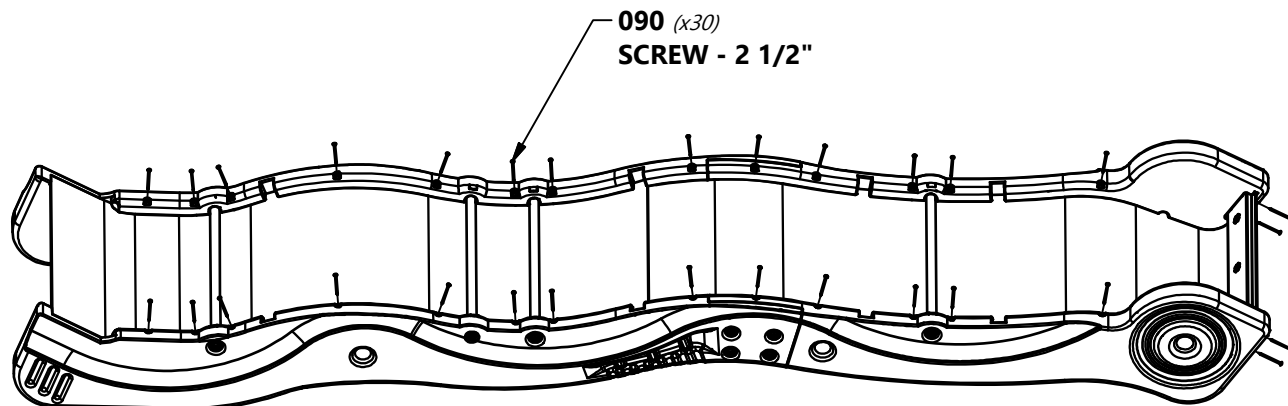

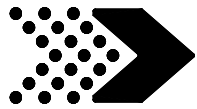

BAY WINDOW ASSEMBLY

STEP 1



H100086 | SCREW PFH
(40) | 8x1 1/2



H100085 | SCREW PFH
(8) | 8x1

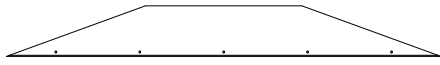

G5 | BAY WINDOW HEADER - W4L04659
(4) | 1"x5 1/4"x45 1/4" (24x134x1150)

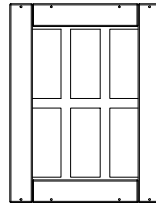

WP1 | BAY WINDOW PANEL - W2A01496
(6) | 7/8"x15 3/4"x20 3/4" (21x400x526)

MAKE 2 WINDOW ASSEMBLIES.

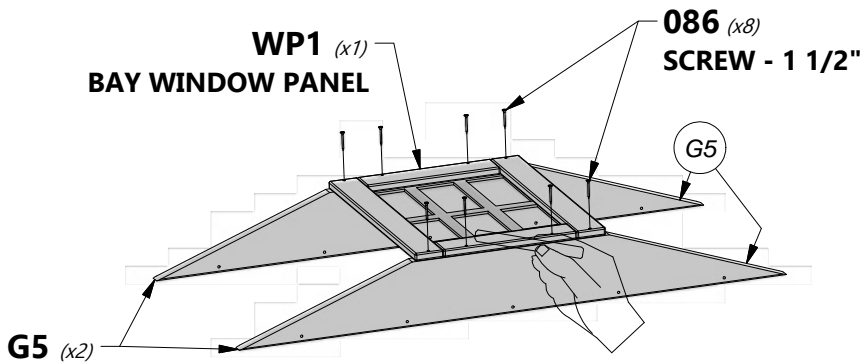

NOTE:
MARK CENTERS ON EACH PART
THEN ALIGN PARTS ON MARKS.

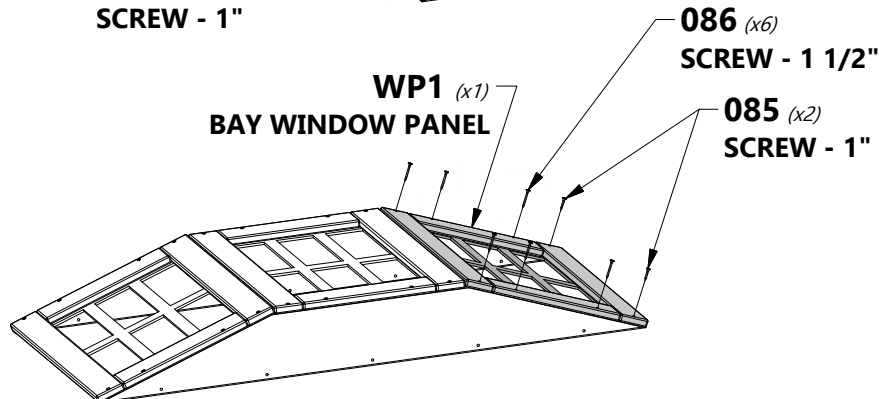
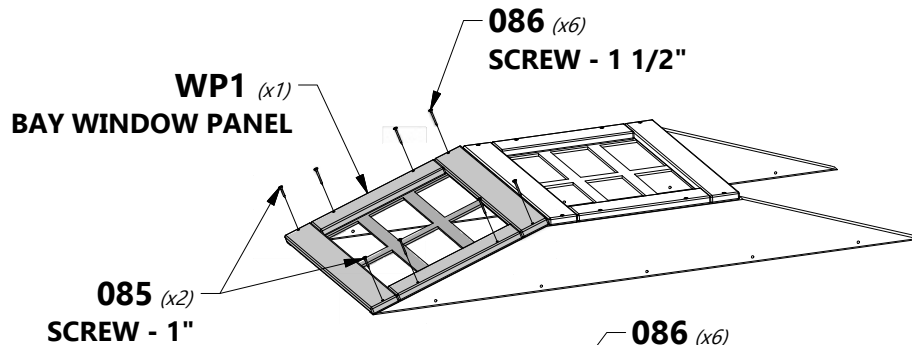



SWING BEAM

STEP 1

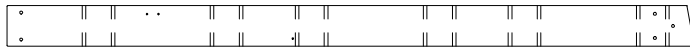

A1 | SWING BEAM - W4L15890
(1) | 3 3/8"x5 1/4"x89 1/2" (86x134x2274)

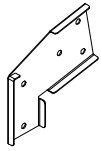

A100325 | SWING BEAM
EXTENSION
BRACKET-LEFT
(1)



A100140 | L BRACKET
(2) | 66x66x127

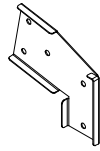

A100326 | SWING BEAM
EXTENSION
BRACKET-RIGHT
(1)



H100054 | BOLT HEX
(2) | 5/16x4 1/4



H100110 | NUT LOCK
(2) | 5/16



H100105 | WASHER FLAT
(4) | 8x27

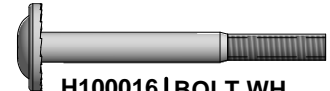

H100016 | BOLT WH
(3) | 5/16x3

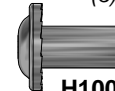

H100005 | NUT BARREL WH
(3) | 5/16x7/8



NOTE THIS
EDGE UPWARD

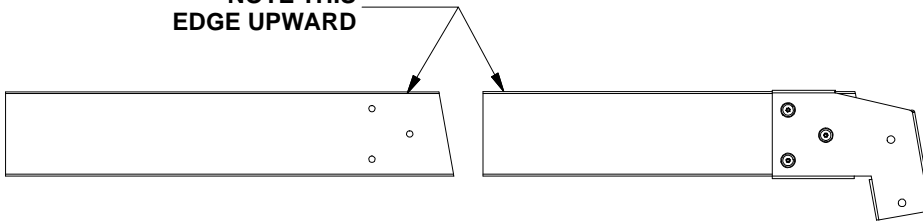

140 (x2)
L BRACKET 66x66x127

110 (x2)
NUT - 5/16"

105 (x2)
WASHER - 8x27

105 (x2)
WASHER - 8x27

054 (x2)
BOLT - 4 1/4"

A1 (x1)

005 (x3)
NUT BARREL - 7/8"

016 (x3)
BOLT - 3"



DO NOT TIGHTEN BRACKET
HARDWARE AT THIS TIME

325 (x1)

SWING BEAM EXTENSION BRACKET-LEFT

326 (x1)

SWING BEAM EXTENSION BRACKET-RIGHT

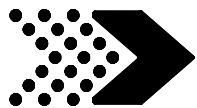

SWING BEAM

STEP 2



H100654 | BOLT HEX
(12) | 3/8x5-1/2



H100107 | WASHER LOCK
(12) | INT
10x18

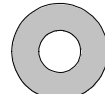

H100102 | WASHER FLAT
(12) | 11x25

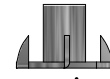

H100073 | T-NUT
(12) | 3/8

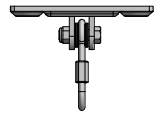

A4M00505 | SWING HANGER
(6)



TIP:
INSTALL T-NUTS INTO
BOARDS BEFORE ASSEMBLY.

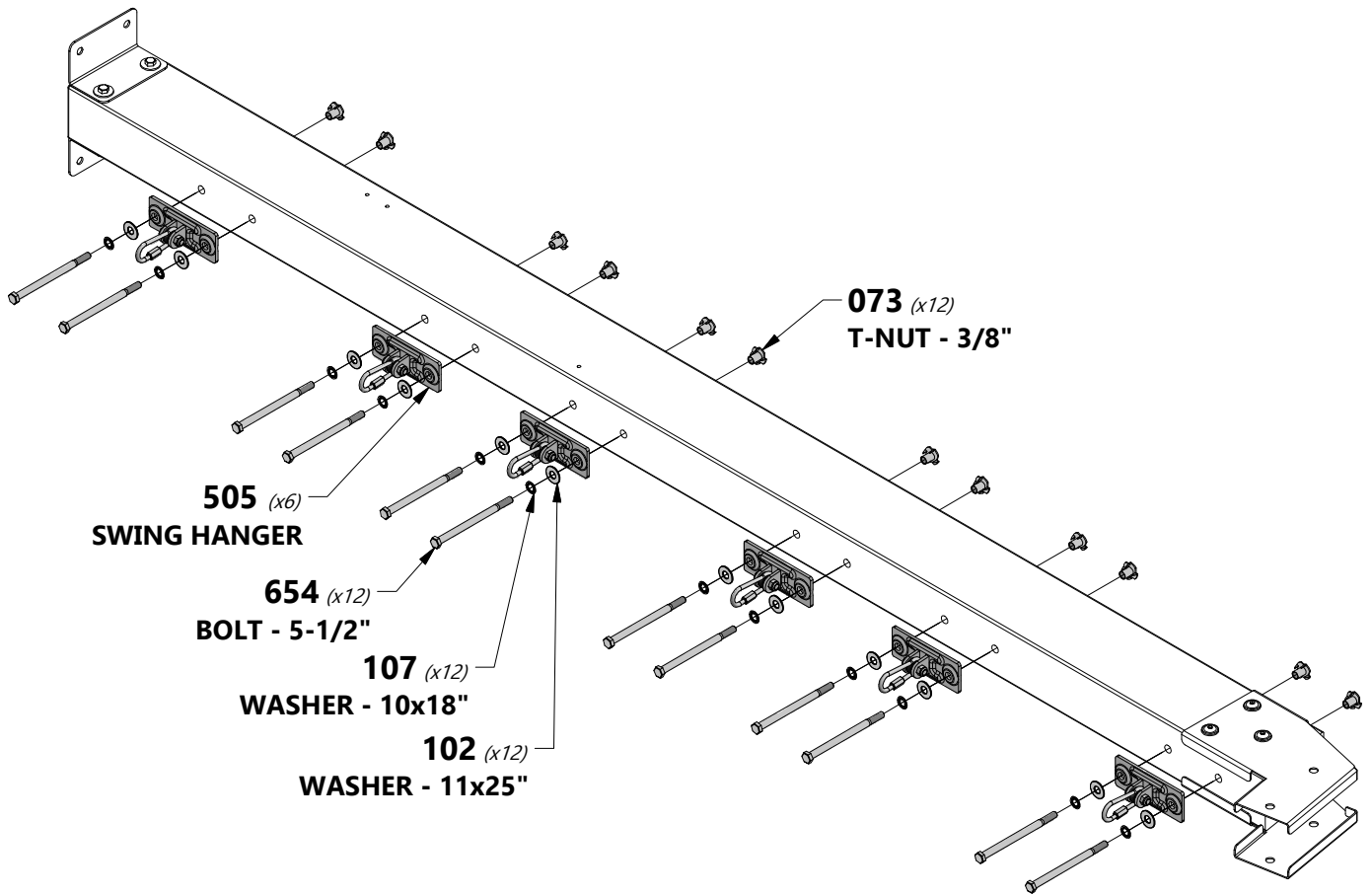

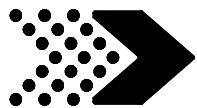

SWING BEAM

STEP 3

SP1 | SWING BEAM SUPPORT - W4L15891
 (1) | 3 3/8"x3 3/8"x48 3/8" (86x86x1229)

E50 | END SUPPORT - W4L15893
 (1) | 1 3/8"x3 3/8"x44 1/8" (36x86x1120)

A4M01169 | A-FRAME
 (1) | BRACKET

H100019 | BOLT WH
 (2) | 5/16x3 3/4

H100005 | NUT BARREL WH
 (2) | 5/16x7/8

H100016 | BOLT WH
 (2) | 5/16x3

H100006 | NUT BARREL WH
 (2) | 5/16x1 1/2

H100031 | WASHER LOCK
 (4) | EXT
 12x19

H100030 | WASHER LOCK
 (2) | EXT
 8x19

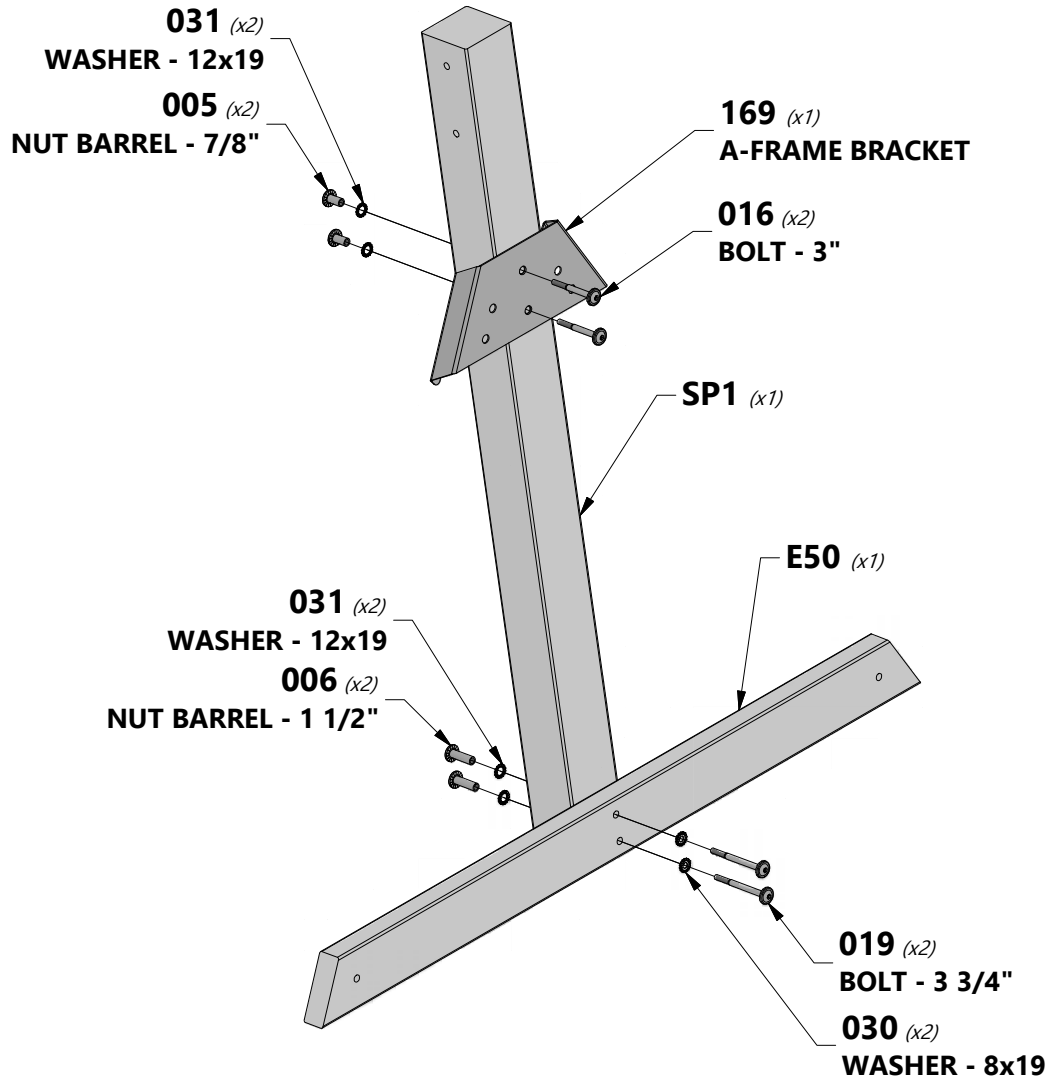

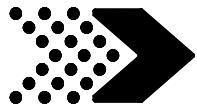

SWING BEAM

STEP 4

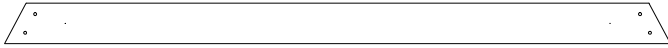

G08 | GROUND BOARD - W4L15894
(1) | 1"x5 1/4"x86 3/4" (24x134x2202)

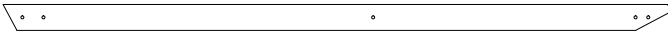

E7 | ANGLE BRACE - W4L15892
(2) | 1 3/8"x3 3/8"x87 1/8" (36x86x2212)



H100014 | BOLT WH
(2) | 5/16x2 1/2



H100005 | NUT BARREL WH
(10) | 5/16x7/8



H100012 | BOLT WH
(4) | 5/16x2

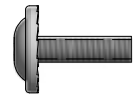

H100008 | BOLT WH
(4) | 5/16x1



H100031 | WASHER LOCK
(10) | EXT
12x19



H100030 | WASHER LOCK
(6) | EXT
8x19

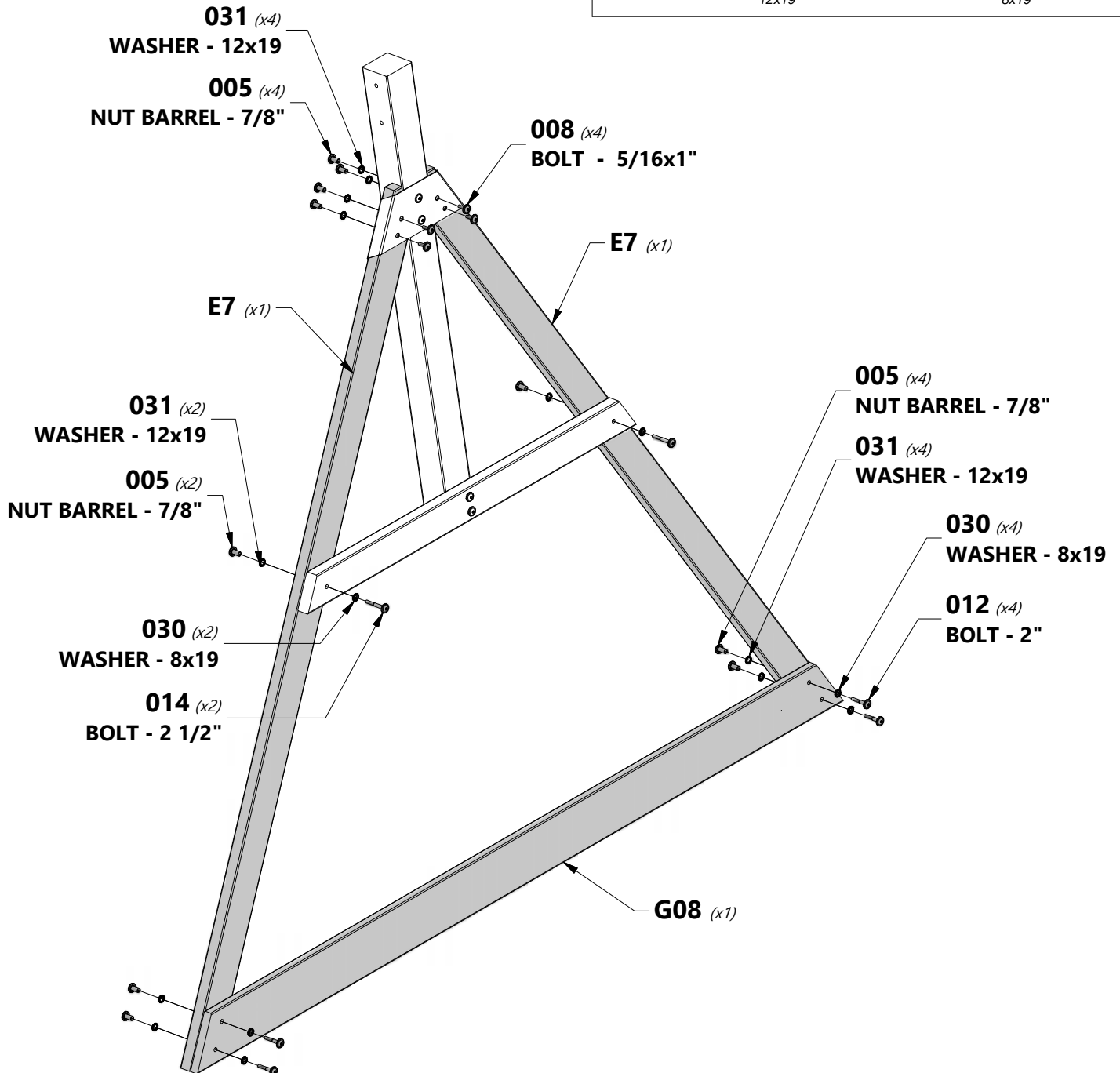

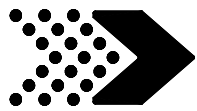

SWING BEAM

STEP 5

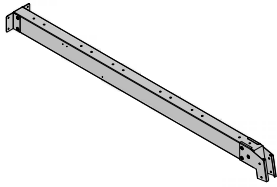

(1) BEAM ASSEMBLY

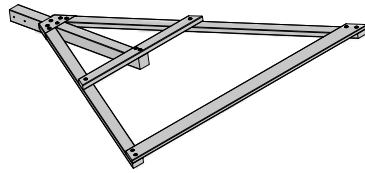

(1) END ASSEMBLY

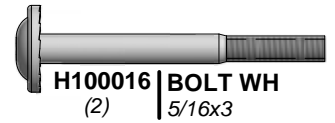

H100016 | BOLT WH
(2) | 5/16x3



H100005 | NUT BARREL WH
(2) | 5/16x7/8

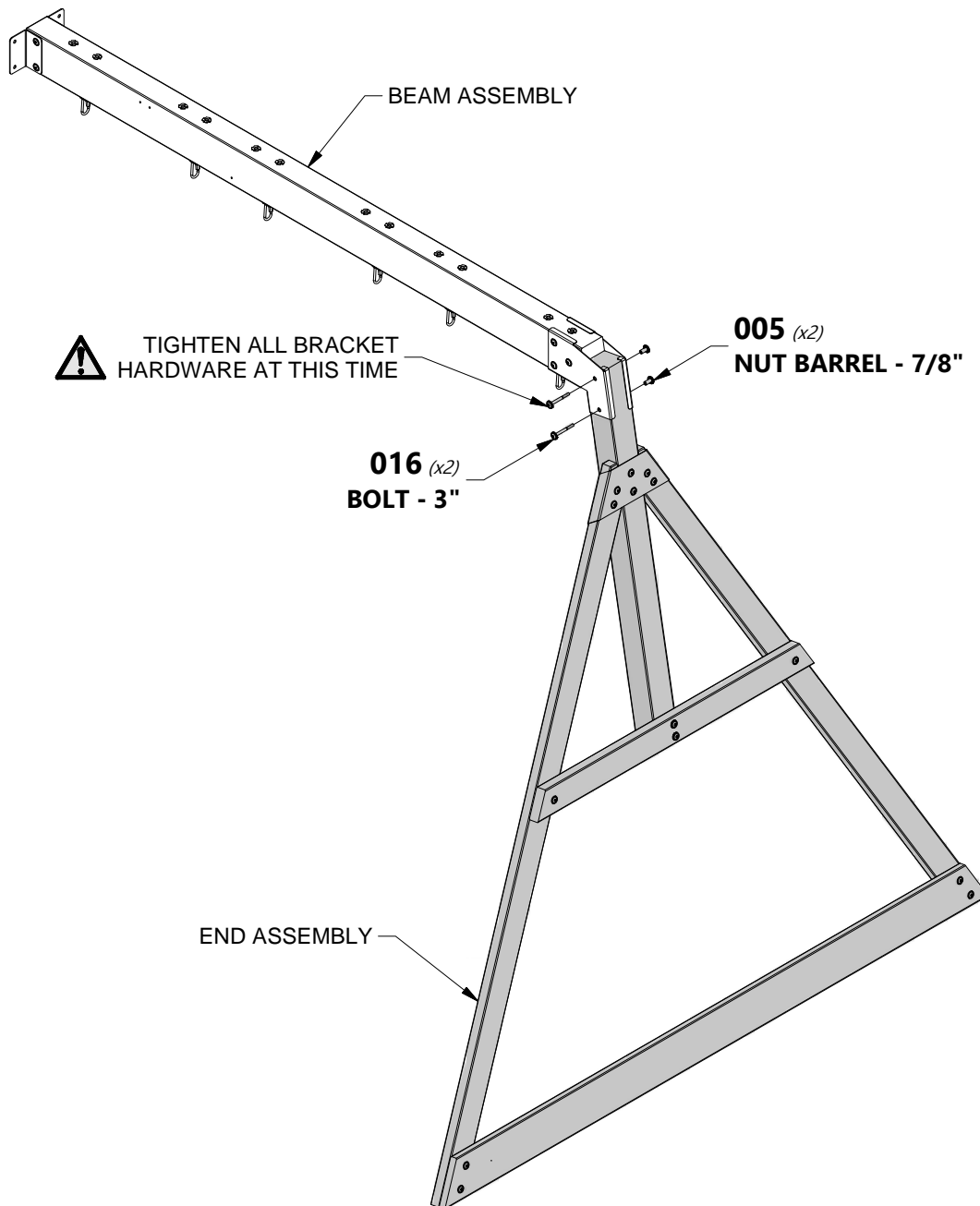

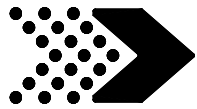

PORCH ROOF

STEP 1



(4) **H20 - PORCH ROOF RAFTER - W4L04655**
1"x3 3/8"x24 1/2" (24x86x622)



H100091 | SCREW PFH
(2) | 8X2 1/4



NOTE:
USING A 3/16" DRILL BIT, MARK AND DRILL A PILOT HOLE INTO 'H20' RAFTER TO PREVENT SPLITTING.
ONLY DRILL THROUGH ONE RAFTER NOT BOTH.

1 1/4 in [32 mm] 1/2 in [12 mm]

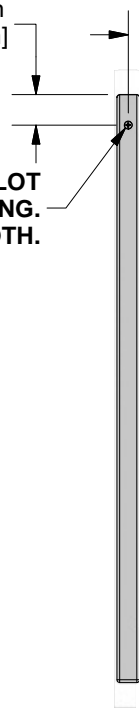

091 (x2)
SCREW - 2 1/4"

H20 (x4)

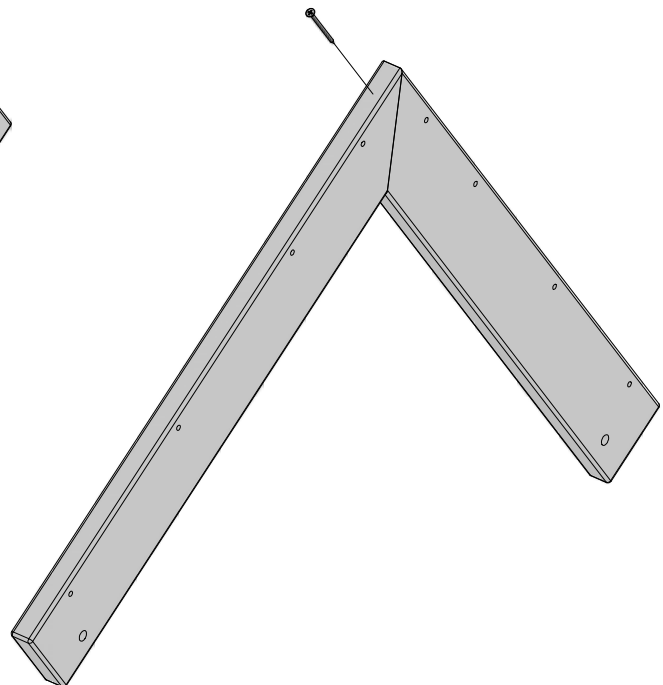
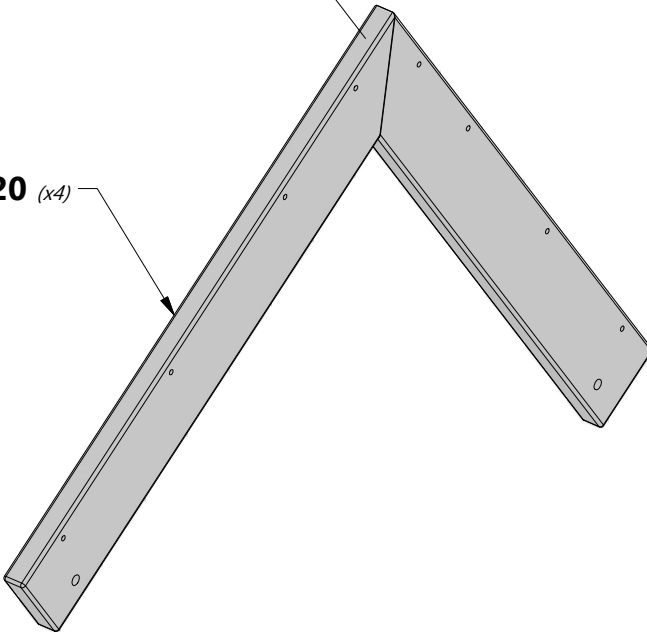

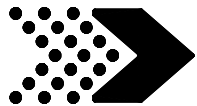

PORCH ROOF

STEP 2

M19 FRONT PORCH ROOF SUPPORT -
W4L04658
(1) 5/8"x3 3/8"x30 5/8" (16x86x779)



A100164 BYD ID TAG (LARGE) AGES 3-10
(1)

N8 FRONT PORCH GABLE TRIM -
W4L04657
(2) 5/8"x2 3/8"x9 1/2" (16x60x241)

N5 FRONT PORCH GABLE TRIM -
W4L04656
(1) 5/8"x2 3/8"x15" (16x60x381)

H100088 SCREW PFH
(6) 8x1 1/8

H100128 SCREW PWH
(4) 8x5/8

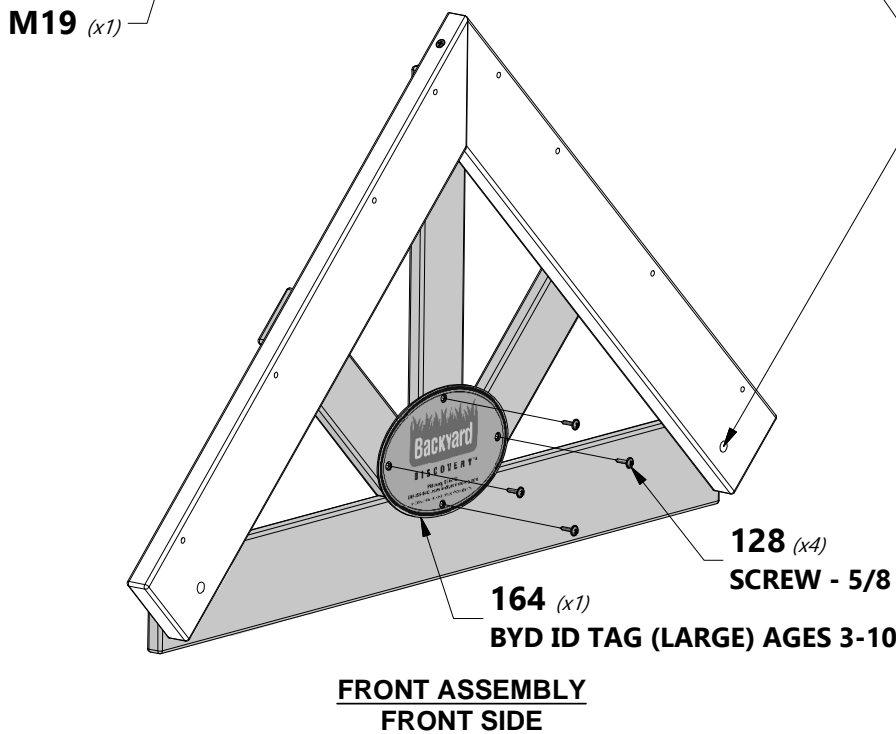
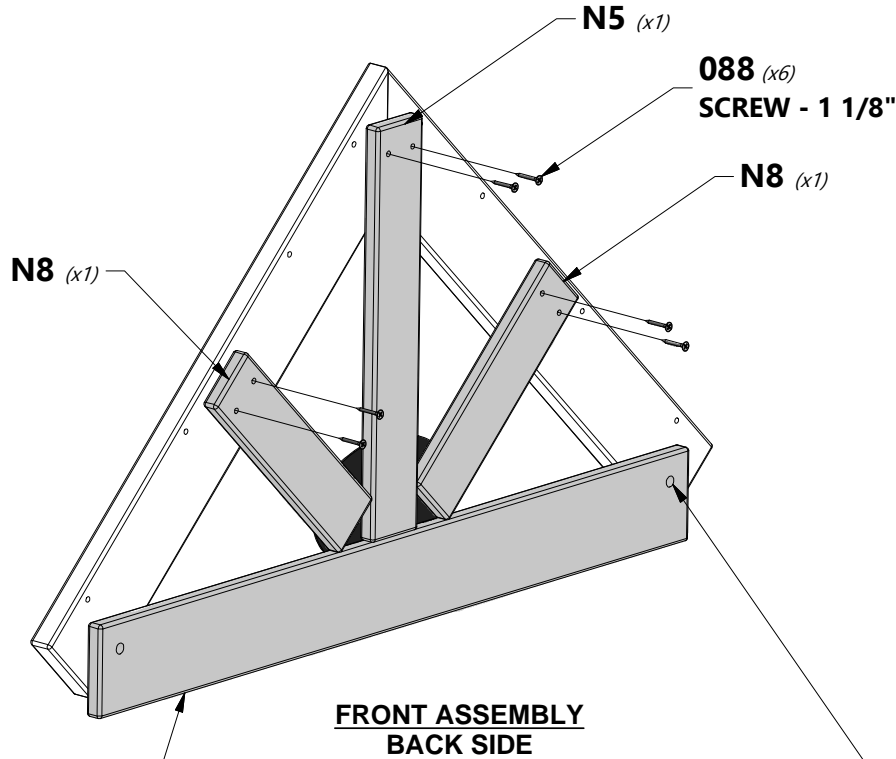

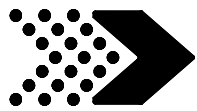

PORCH ROOF

STEP 3

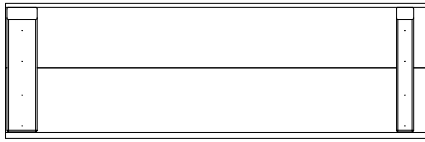

RP1 | LEFT PORCH PEAK ROOF PANEL - W2A02630
(1) | 1 5/8"x10 1/2"x32 7/8" (42x268x834)

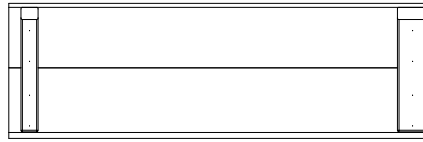

RP4 | RIGHT PORCH PEAK ROOF PANEL - W2A02631
(1) | 1 5/8"x10 1/2"x32 7/8" (42x268x834)



H100111 | SCREW PFH
(8) | 8x2

**FRONT ASSEMBLY
BACK SIDE**

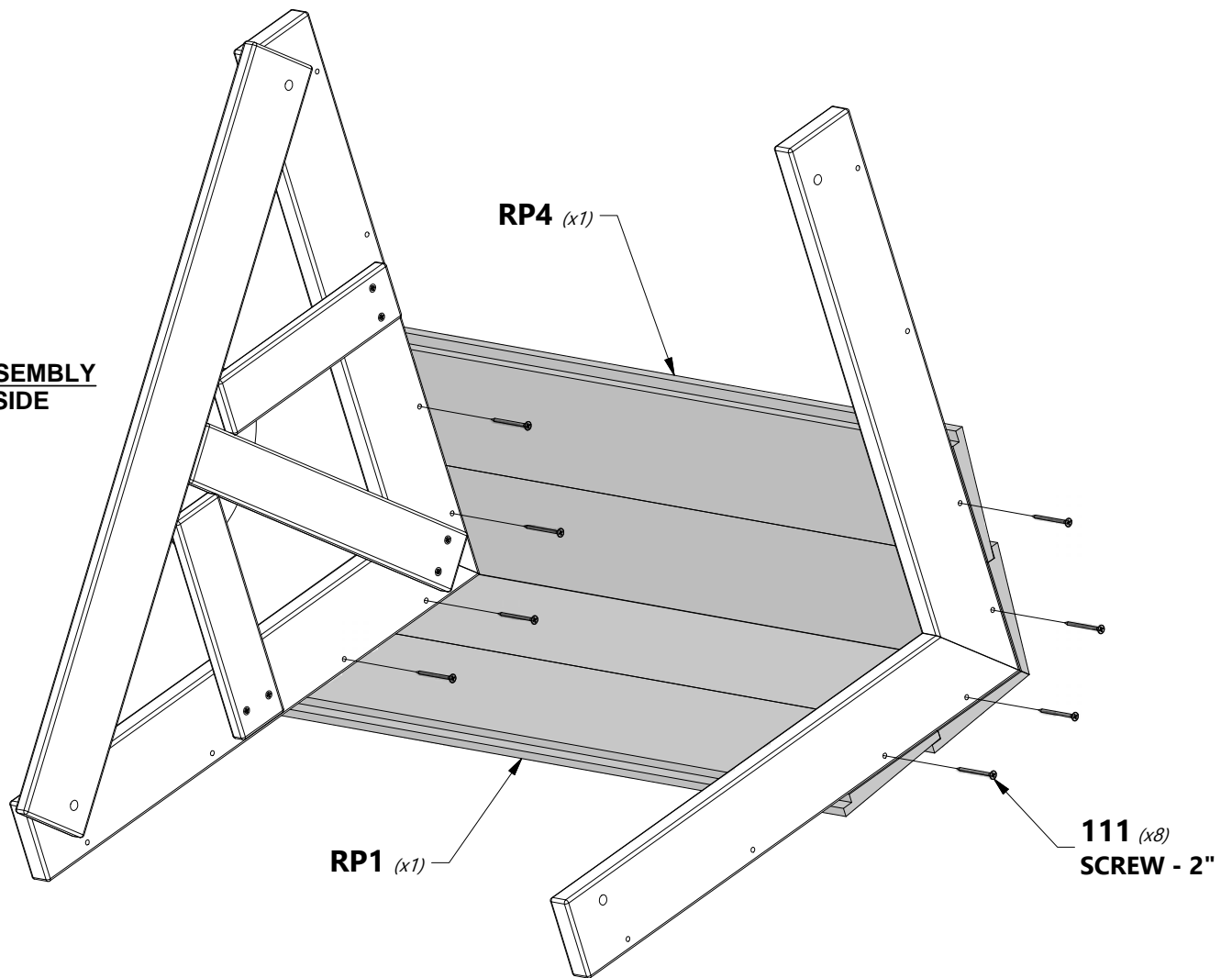

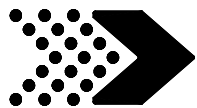

PORCH ROOF

STEP 4



H100111 | SCREW PFH
(8) | 8x2

RP2 | LEFT PORCH ROOF PANEL - W2A02628
(1) | 1 5/8"x15 5/8"x32 7/8" (42x396x834)

RP5 | RIGHT PORCH ROOF PANEL - W2A02629
(1) | 1 5/8"x15 5/8"x32 7/8" (42x396x834)

FRONT ASSEMBLY
BACK SIDE

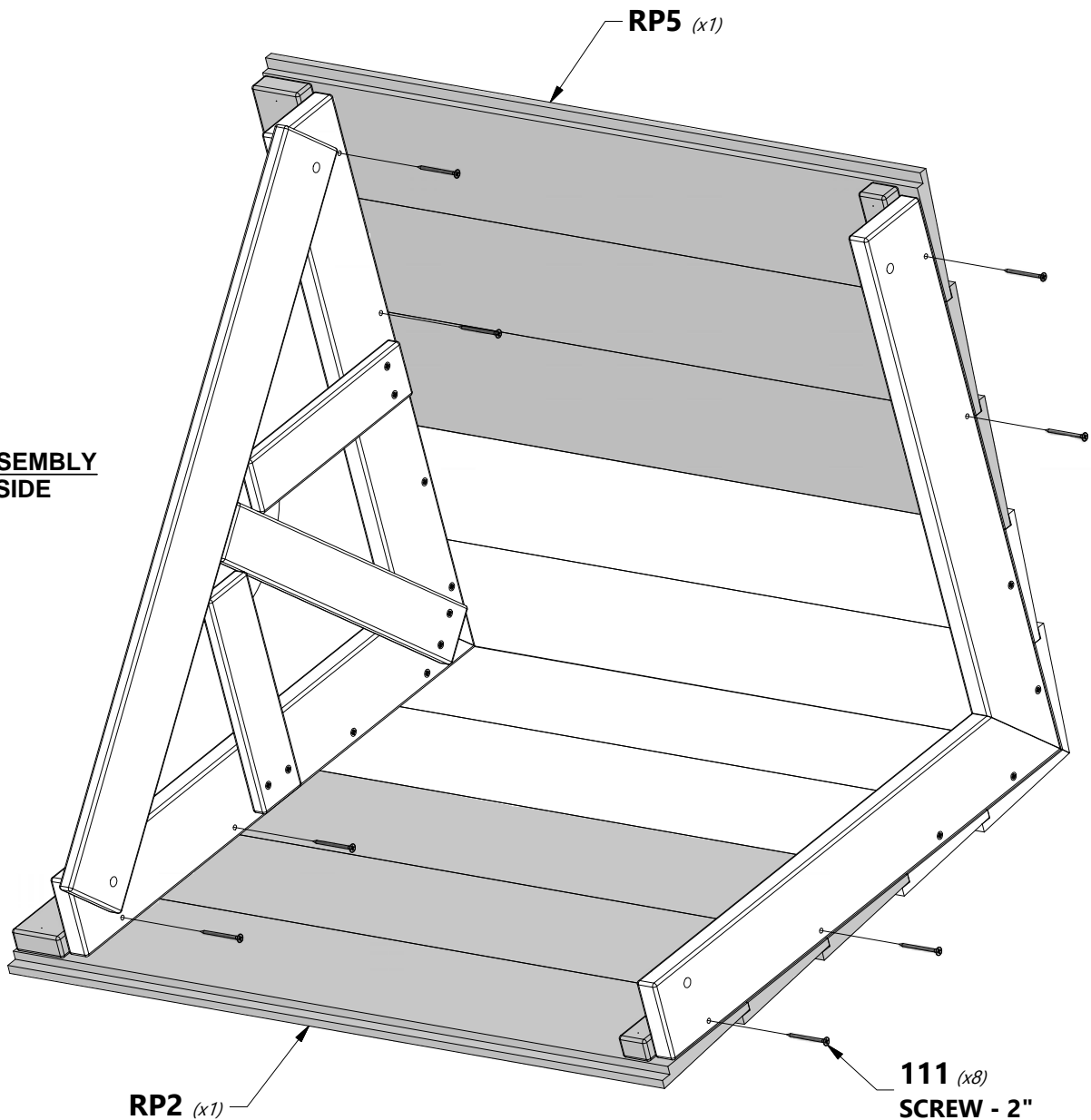

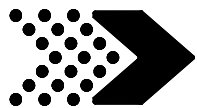

B1 | TOWER LEG - W2A03355
(1) | 3"x3"x89 1/2" (76x76x2274)

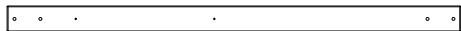

E1 | TOWER LEG - W4L04563
(1) | 1 3/8"x3 3/8"x59" (36x86x1500)

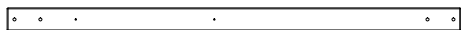

B3 | TOWER LEG - W4L04564
(1) | 3"x3"x59" (76x76x1500)

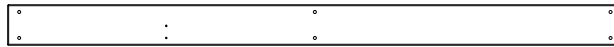

G7 | BOTTOM FLOOR RAIL - W4L11775
(1) | 1"x5 1/4"x80" (24x134x2032)

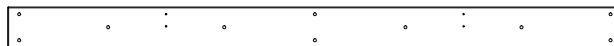

G1 | TOP FLOOR RAIL - W4L04566
(1) | 1"x5 1/4"x80" (24x134x2032)



H100019 | BOLT WH
(8) | 5/16x3 3/4



H100013 | BOLT WH
(4) | 5/16x2 1/4

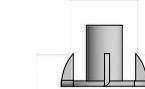

H100074 | T-NUT
(12) | 5/16



H100030 | WASHER LOCK
EXT
(12) | 8x19

TIP:
INSTALL T-NUTS INTO BOARDS
BEFORE ASSEMBLY

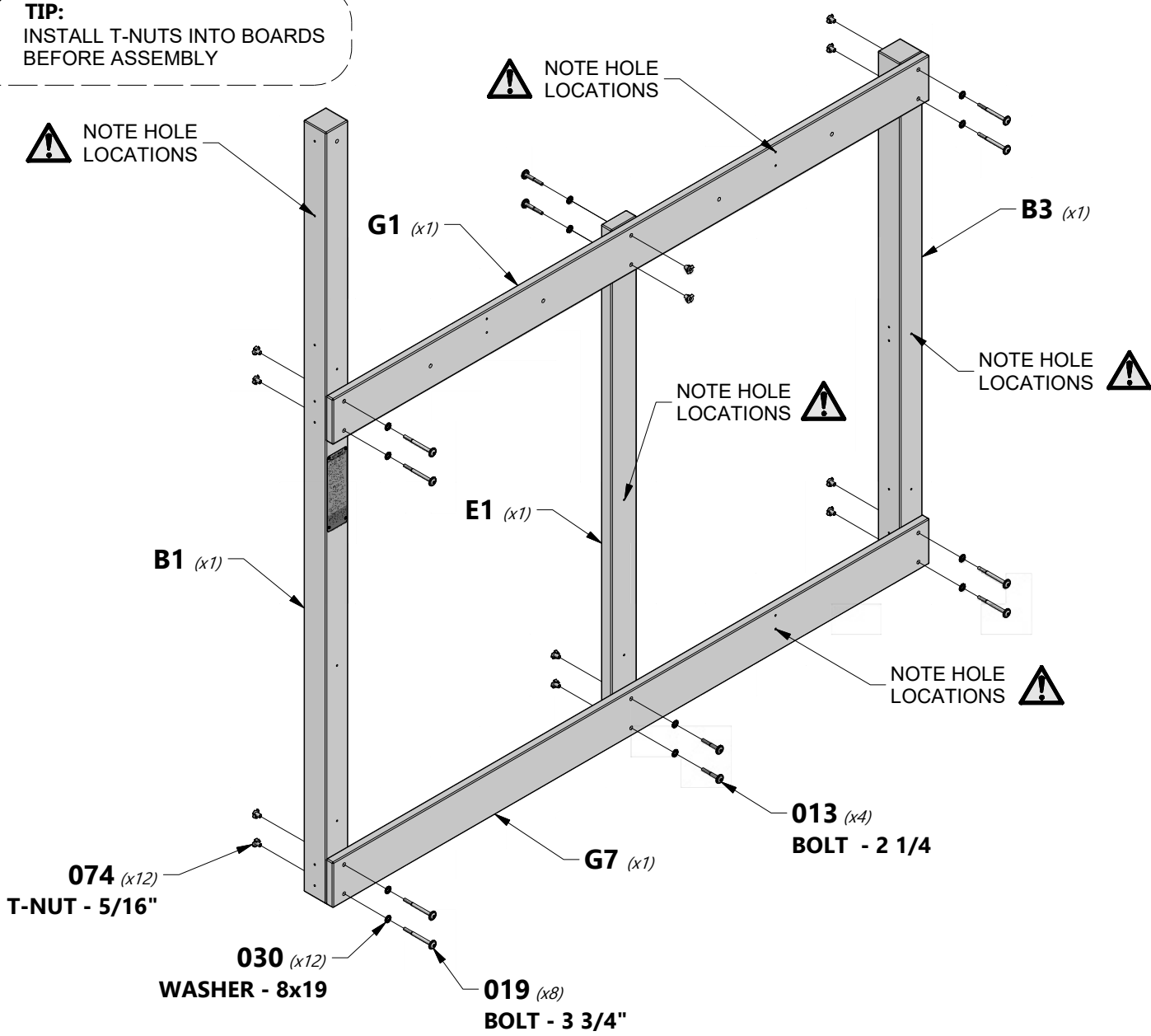

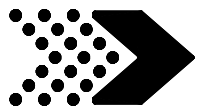

- B2** | TOWER LEG - W4L04561
(1) | 3"x3"x89 1/2" (76x76x2274)
- E2** | TOWER LEG - W4L04567
(1) | 1 3/8"x3 3/8"x59" (36x86x1500)
- B4** | TOWER LEG - W4L04568
(1) | 3"x3"x59" (76x76x1500)

- G7** | BOTTOM FLOOR RAIL - W4L11775
(1) | 1"x5 1/4"x80" (24x134x2032)
- G2** | TOP FLOOR RAIL - W4L04569
(1) | 1"x5 1/4"x80" (24x134x2032)

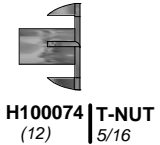
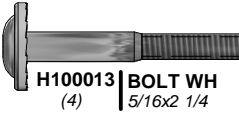
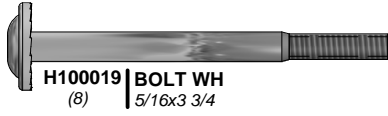

TIP:
INSTALL T-NUTS INTO
BOARDS BEFORE ASSEMBLY.

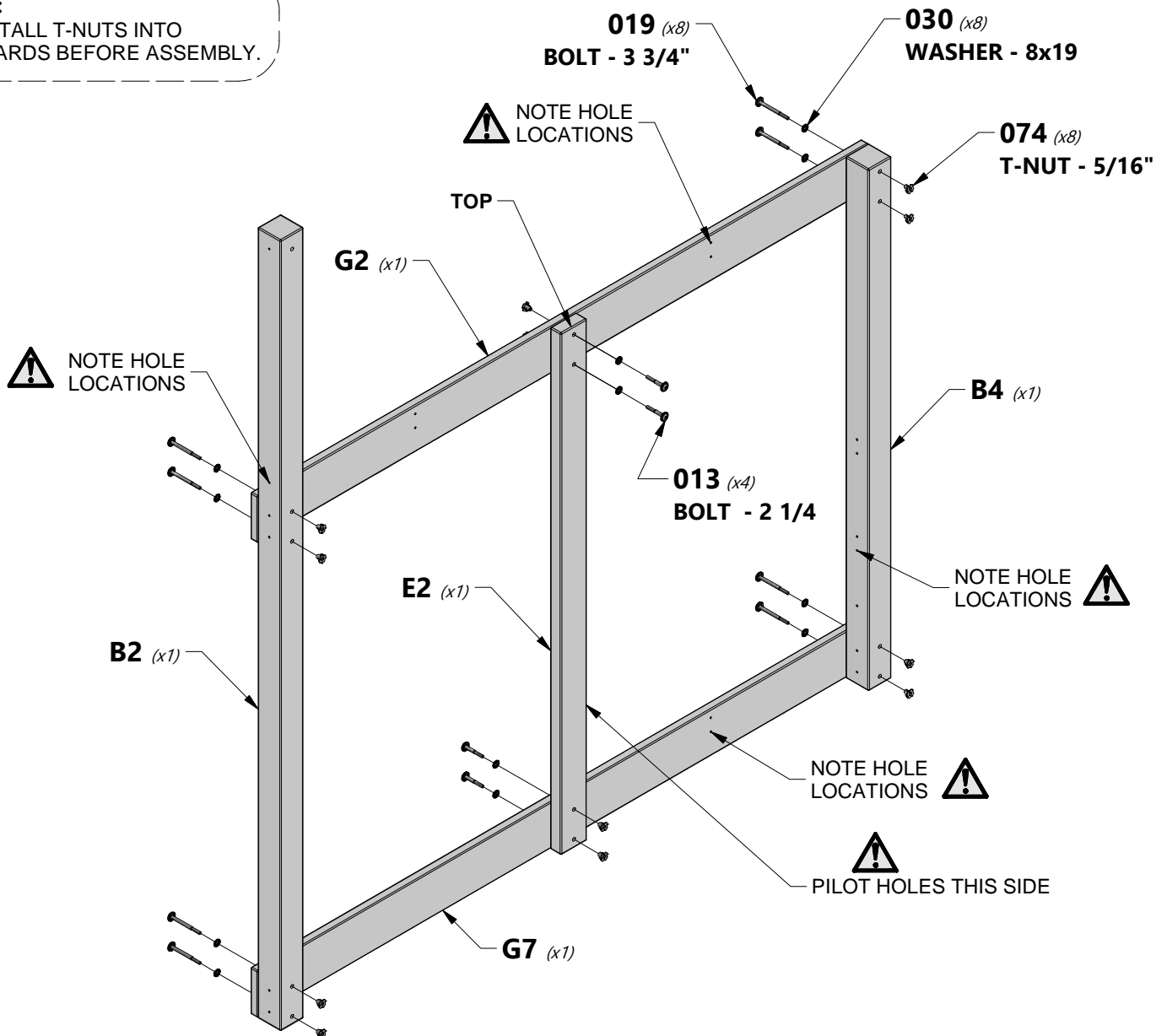

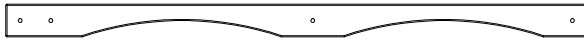
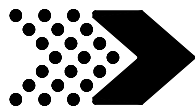

H28 | FRONT WALL RAIL - W4L11774
(1) | 1"x3 3/8"x60 1/2" (24x86x1537)



G3 | FLOOR RAIL - W4L04571
(1) | 1"x5 1/4"x60 1/2" (24x134x1537)



G6 | FLOOR RAIL - W4L11777
(1) | 1"x5 1/4"x60 1/2" (24x134x1537)



H100028 | LAG SCREW WH
(8) | 5/16x2 1/2



H100027 | LAG SCREW WH
(2) | 5/16x2



H100030 | WASHER LOCK
(10) | EXT
8x19

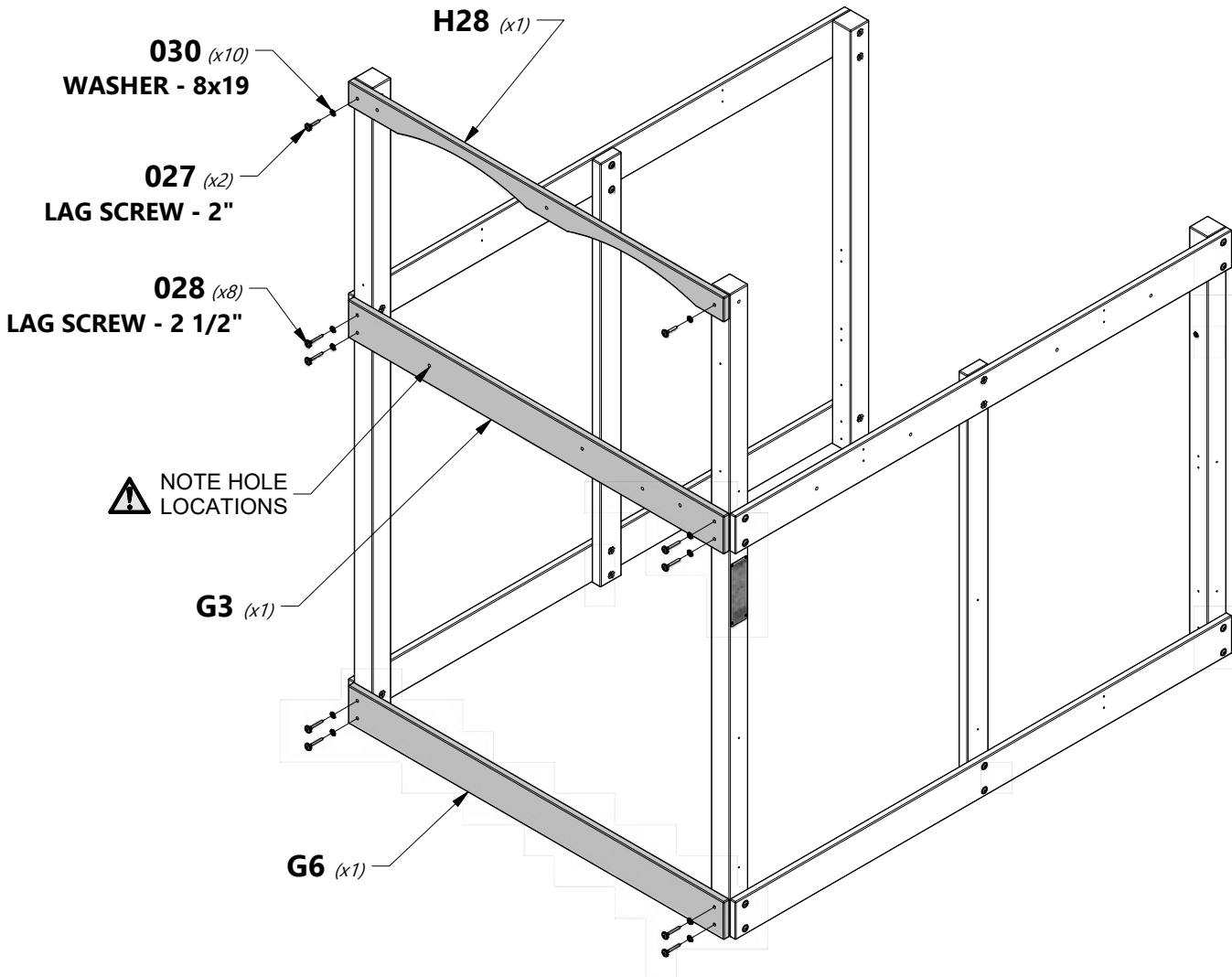

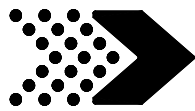

G4 | FLOOR RAIL - W4L04675
(1) | 1"x5 1/4"x60 1/2" (24x134x1537)



K2 | FLOOR RAIL - W4L04570
(1) | 5/8"x5 1/4"x60 1/2" (16x134x1537)

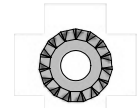

H100030 | WASHER LOCK
(8) | EXT
8x19



H100027 | LAG SCREW WH
(4) | 5/16x2



H100028 | LAG SCREW WH
(4) | 5/16x2 1/2

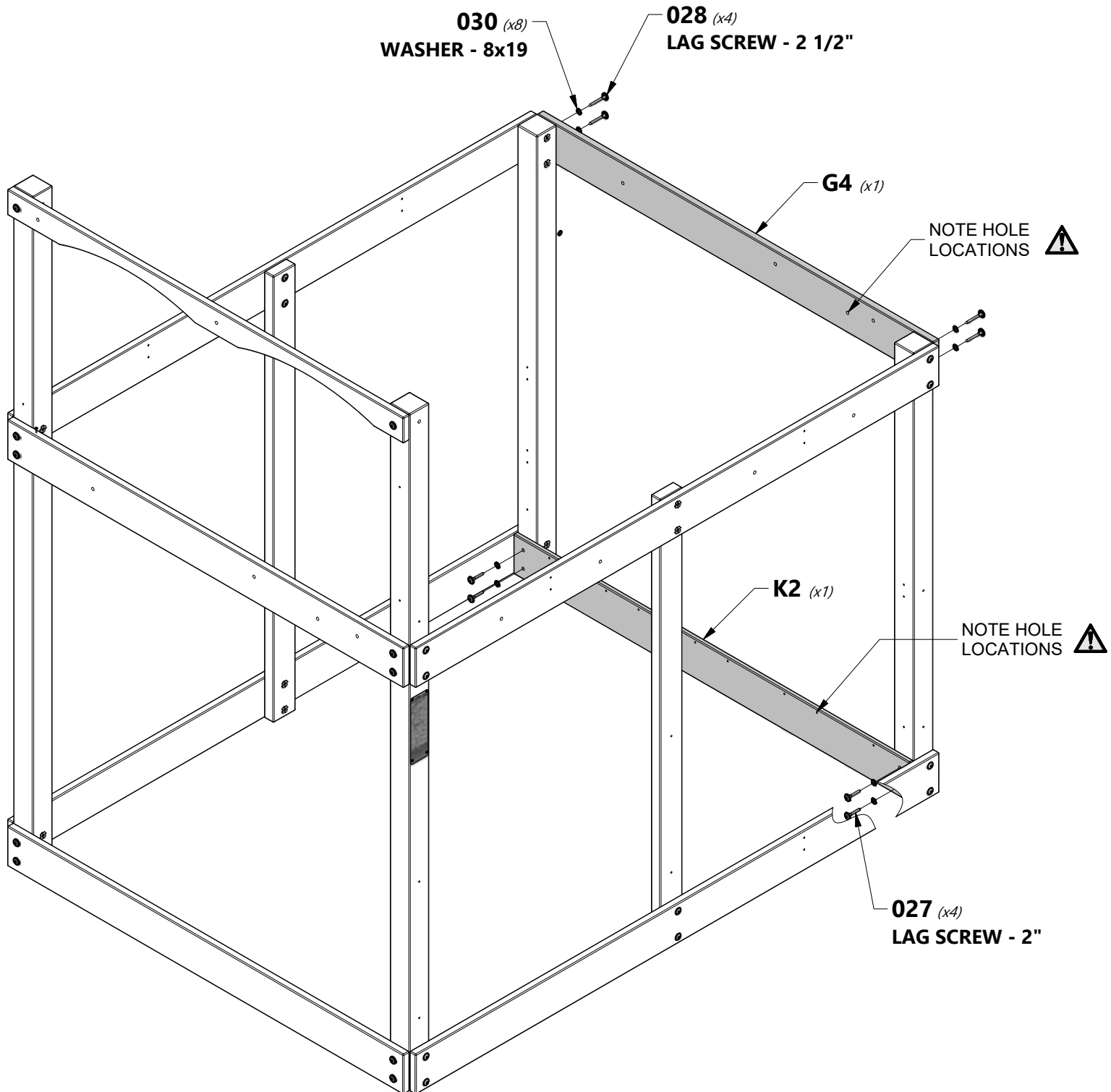

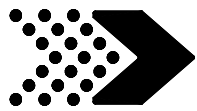

FORT ASSEMBLY

STEP 5



K3 | FLOOR RAIL - W4L04572
(1) | 5/8"x5 1/4"x60 1/2" (16x134x1537)



H26 | FLOOR JOIST - W4L04573
(1) | 1"x3 3/8"x60 1/2" (24x86x1537)



H100027 | LAG SCREW WH
(4) | 5/16x2



H100030 | WASHER LOCK
(4) | EXT
8x19



H100090 | SCREW PFH
(4) | 8x2 1/2"

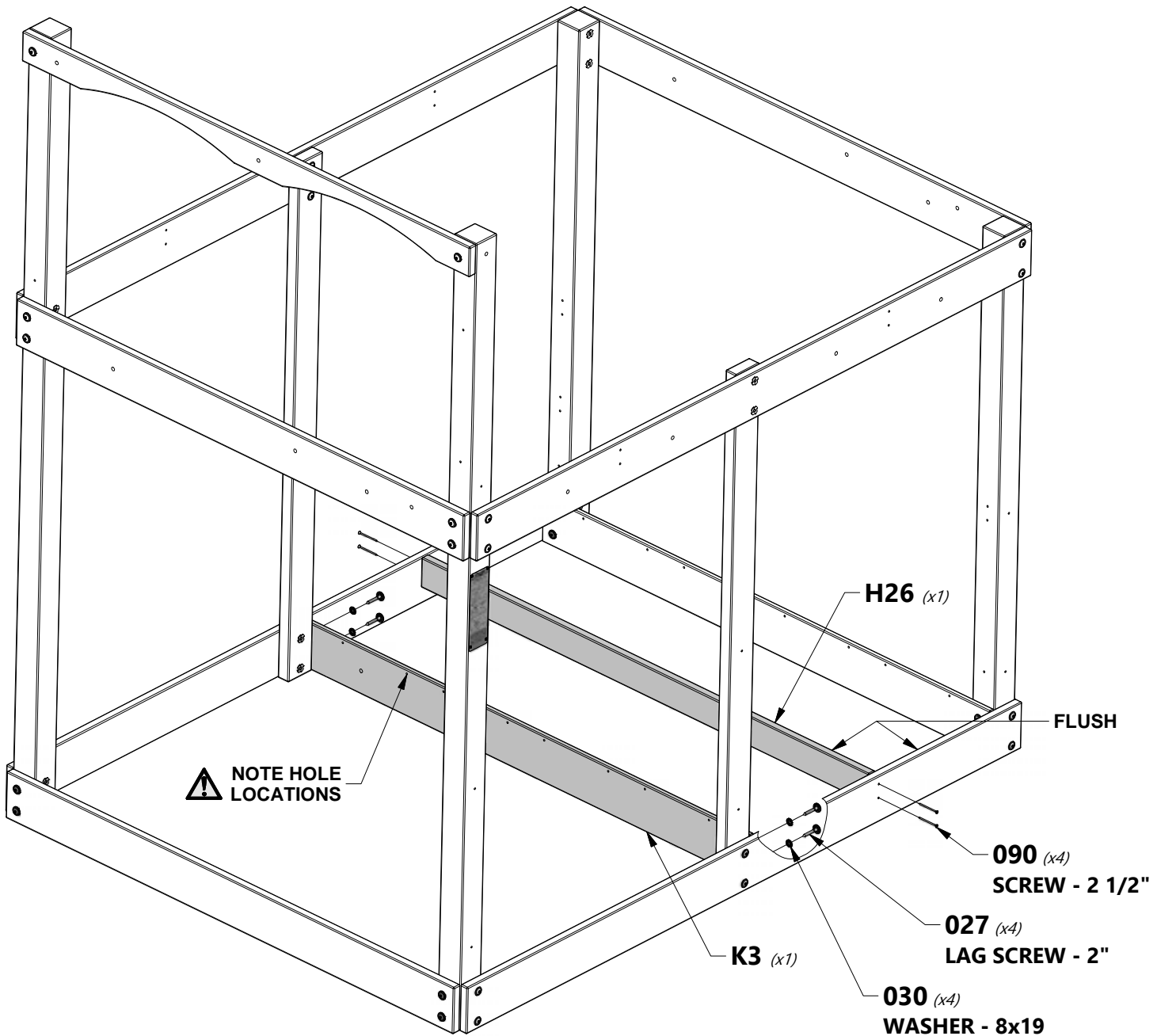



FORT ASSEMBLY

STEP 6



L2 | SAND BOX SEAT - W4L11776
(2) | 5/8"x4 3/8"x24" (16x112x610)

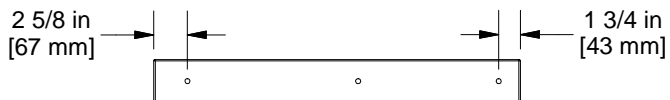

H27 | PICNIC TABLE SUPPORT - W4L04574
(1) | 1"x3 3/8"x28 5/8" (24x86x728)



H100086 | SCREW PFH
(8) | 8x1 1/2



H100010 | BOLT WH
(1) | 5/16x1-1/2



H100030 | WASHER LOCK
(1) | EXT
8x19



H100074 | T-NUT
(1) | 5/16



TIP:
INSTALL T-NUTS INTO
BOARDS BEFORE ASSEMBLY.

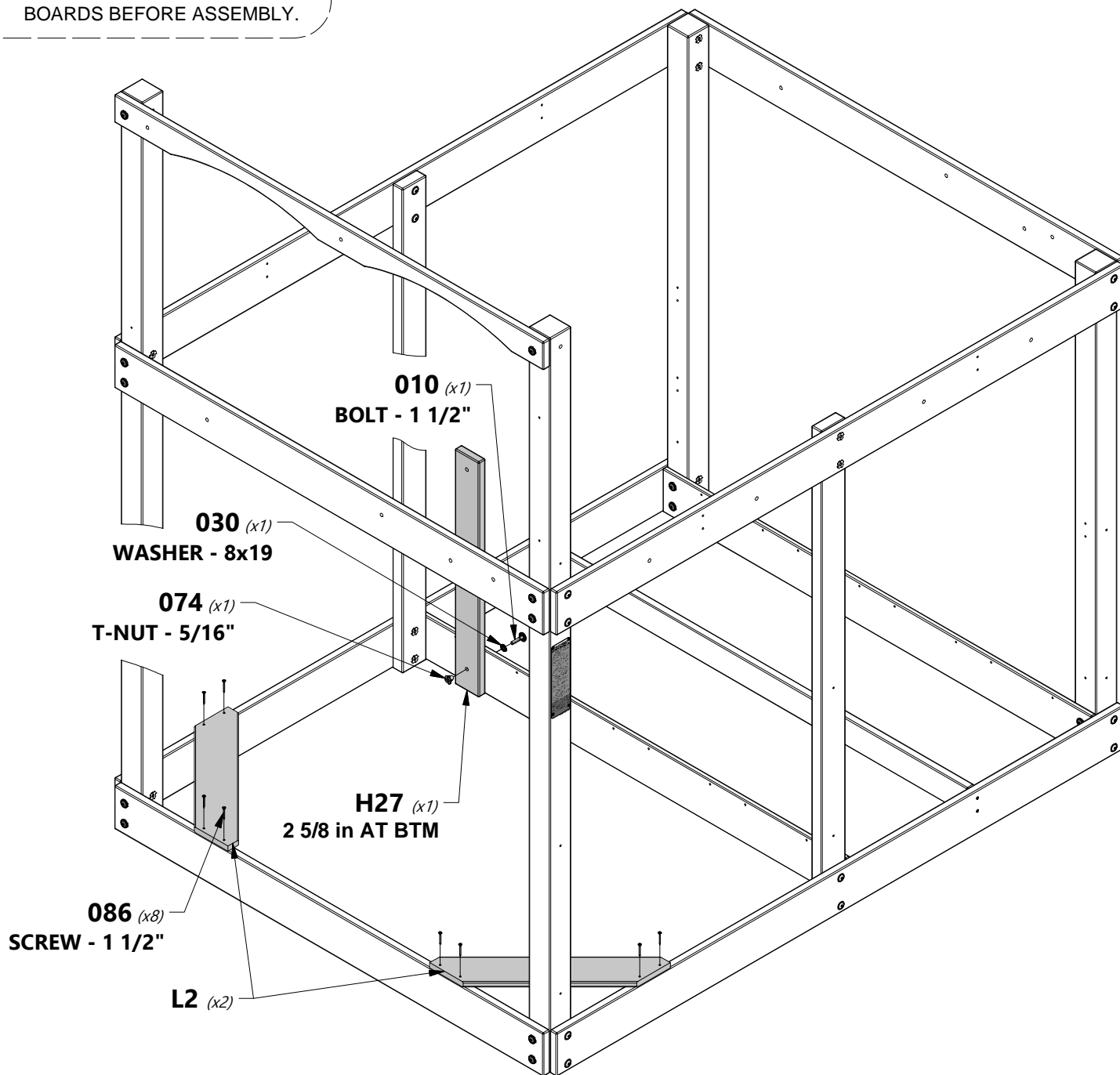

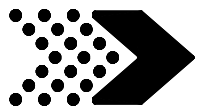

FP1 | **BOTTOM FLOOR PANEL - W2A01485**
(4) | 1 5/8"x13 1/2"x35 3/8" (40x344x897)

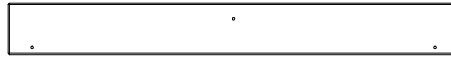

Y2 | **BOTTOM FLOOR BOARD - W4L04577**
(2) | 5/8"x4"x35 1/4" (16x102x895)



H100086 | **SCREW PFH**
(38) | 8x1 1/2

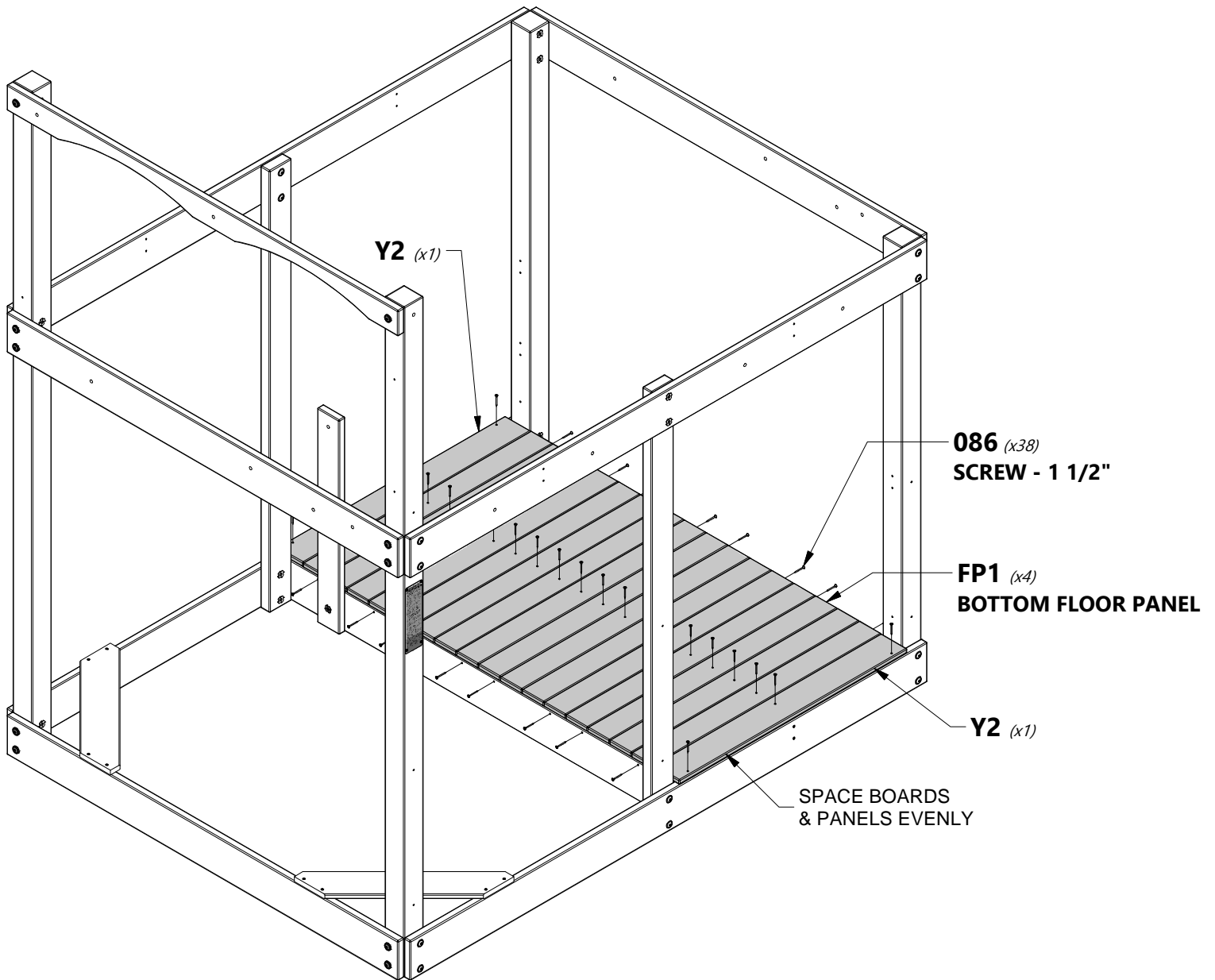



H3 | PICNIC TABLE RAIL - W4L04578
(1) | 1"x3 3/8"x67 1/4" (24x86x1708)



M3 | BOTTOM WALL RAIL - W4L04579
(1) | 5/8"x3 3/8"x60 1/2" (16x86x1537)



H100028 | LAG SCREW WH
(4) | 5/16x2 1/2



H100030 | WASHER LOCK
(6) | EXT
8x19



H100027 | LAG SCREW WH
(2) | 5/16x2

NOTE ANGLE CUT
FACES DOWNWARD

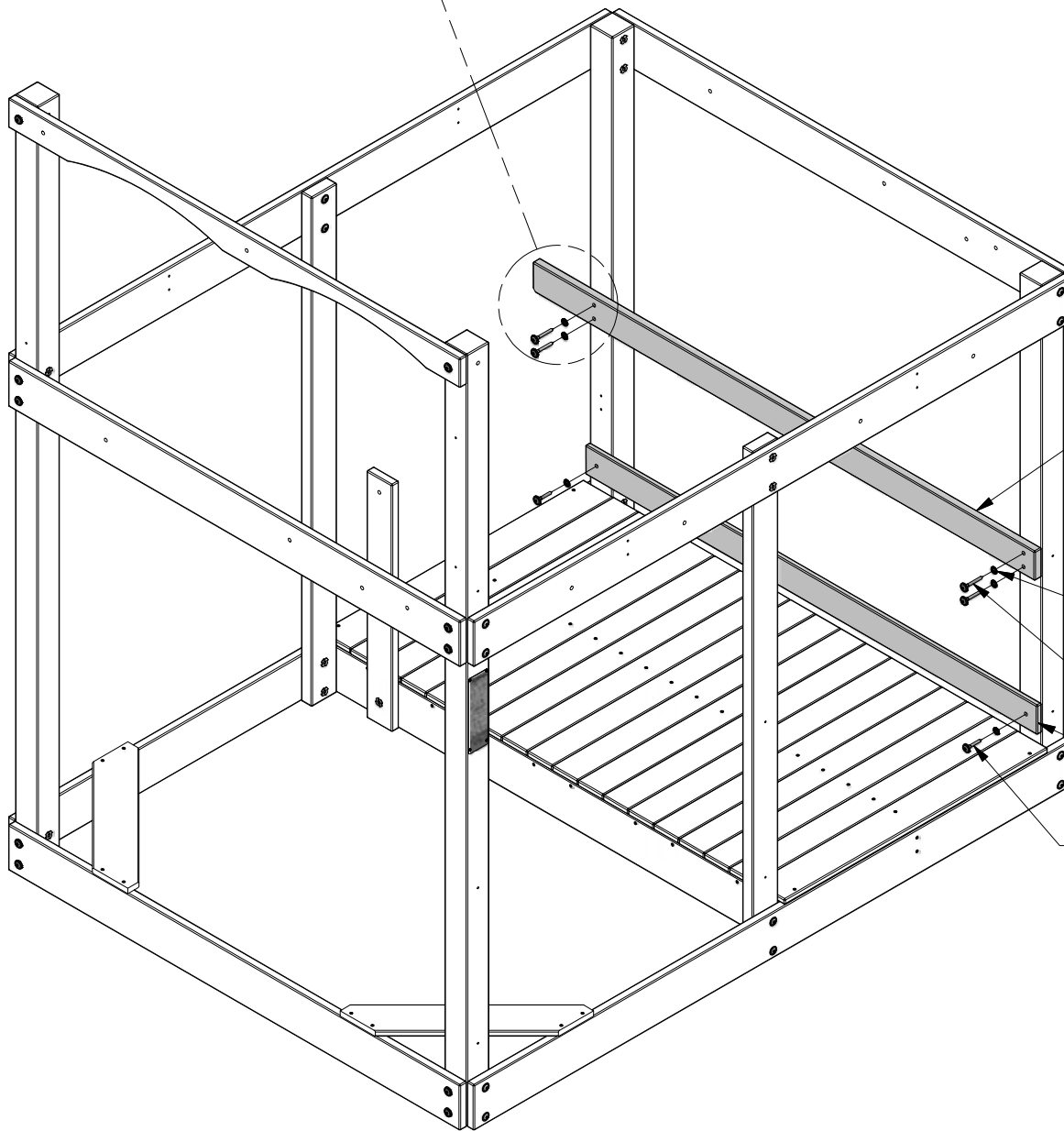
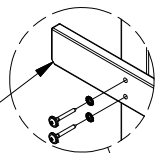

H3 (x1)

030 (x6)
WASHER - 8x19

028 (x4)
LAG SCREW - 2 1/2"

M3 (x1)

027 (x2)
LAG SCREW - 2"

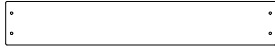
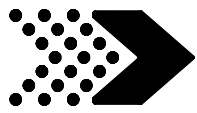

M27 | **BOTTOM WALL BOARD - W4L15944**
(8) | 5/8"x3 3/8"x21 3/8" (16x86x544)



H100088 | **SCREW PFH**
(32) | 8x1 1/8

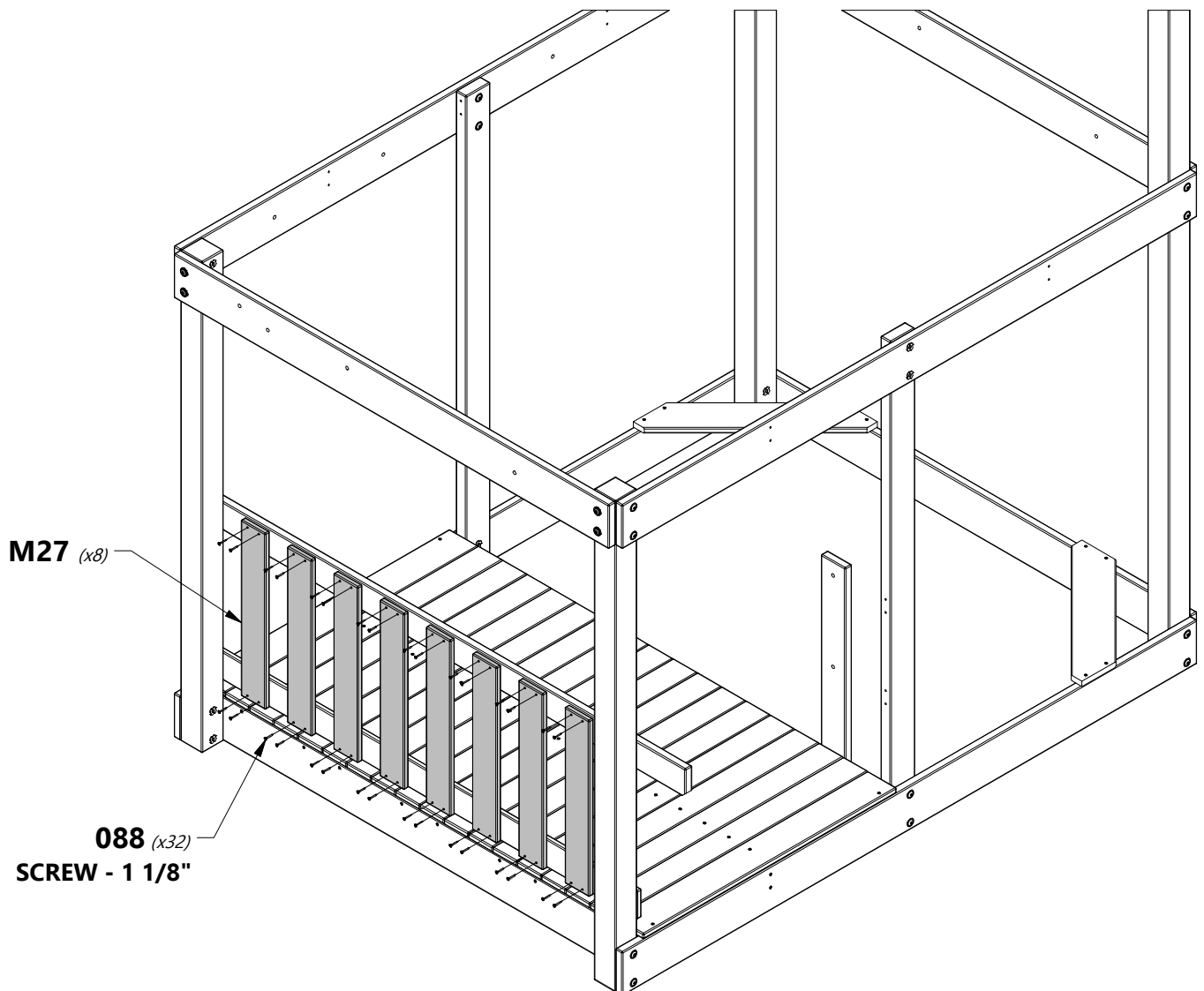
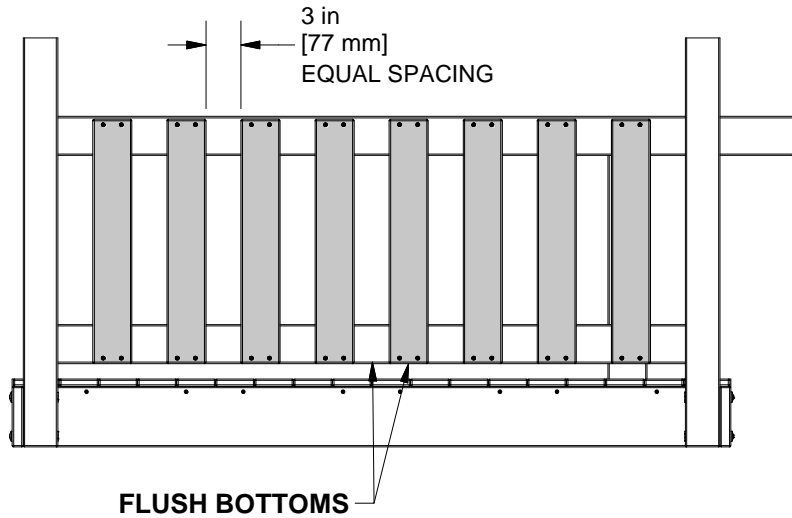

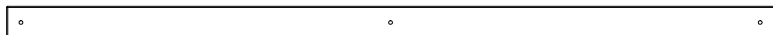
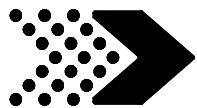

M2 | **BOTTOM WALL RAIL - W4L04596**
(2) | 5/8"x3 3/8"x80" (16x86x2032)



H100027 | **LAG SCREW WH**
(4) | 5/16x2



H100030 | **WASHER LOCK**
(6) | **EXT**
8x19



H100026 | **LAG SCREW WH**
(2) | 5/16x1 1/2

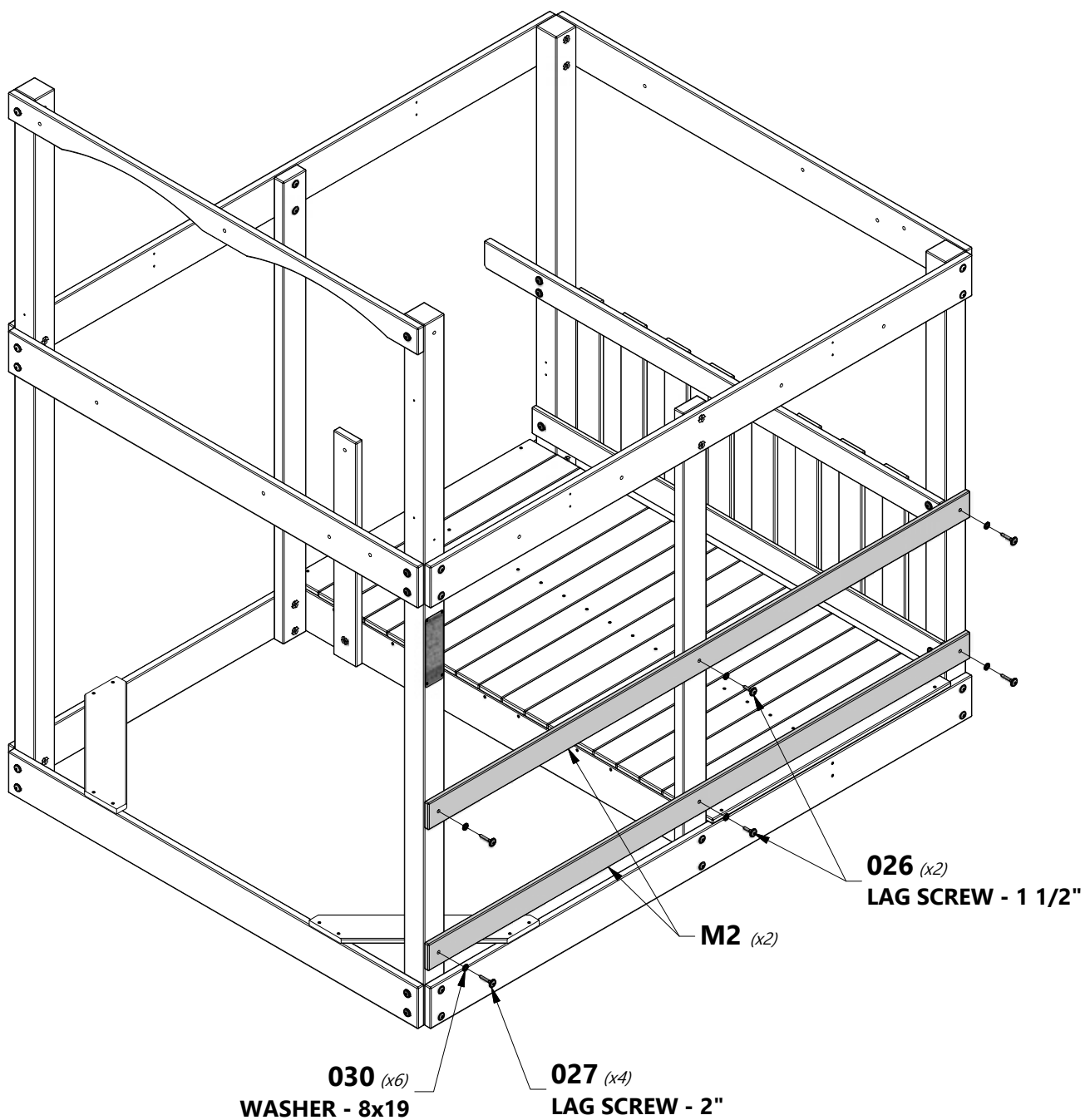

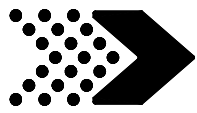

M27 | **BOTTOM WALL BOARD - W4L15944**
(10) | 5/8"x3 3/8"x21 3/8" (16x86x544)



H100088 | **SCREW PFH**
(40) | 8x1 1/8

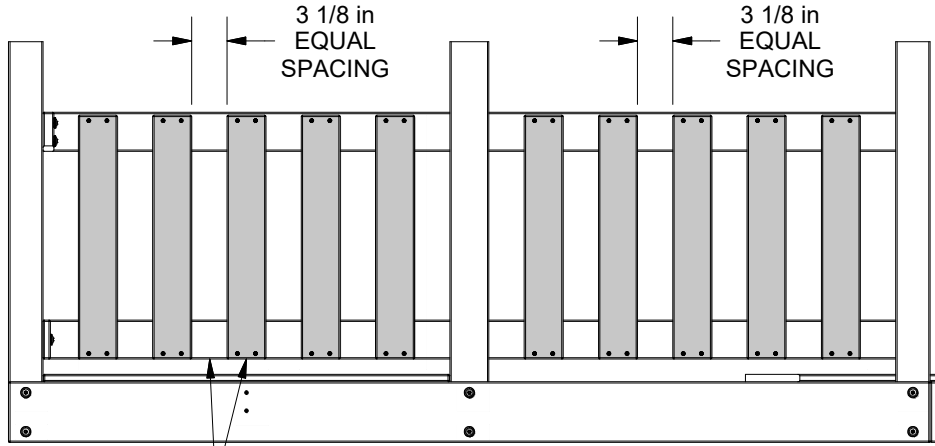

FLUSH BOTTOMS

M27 (x10)

088 (x40)
SCREW - 1 1/8"

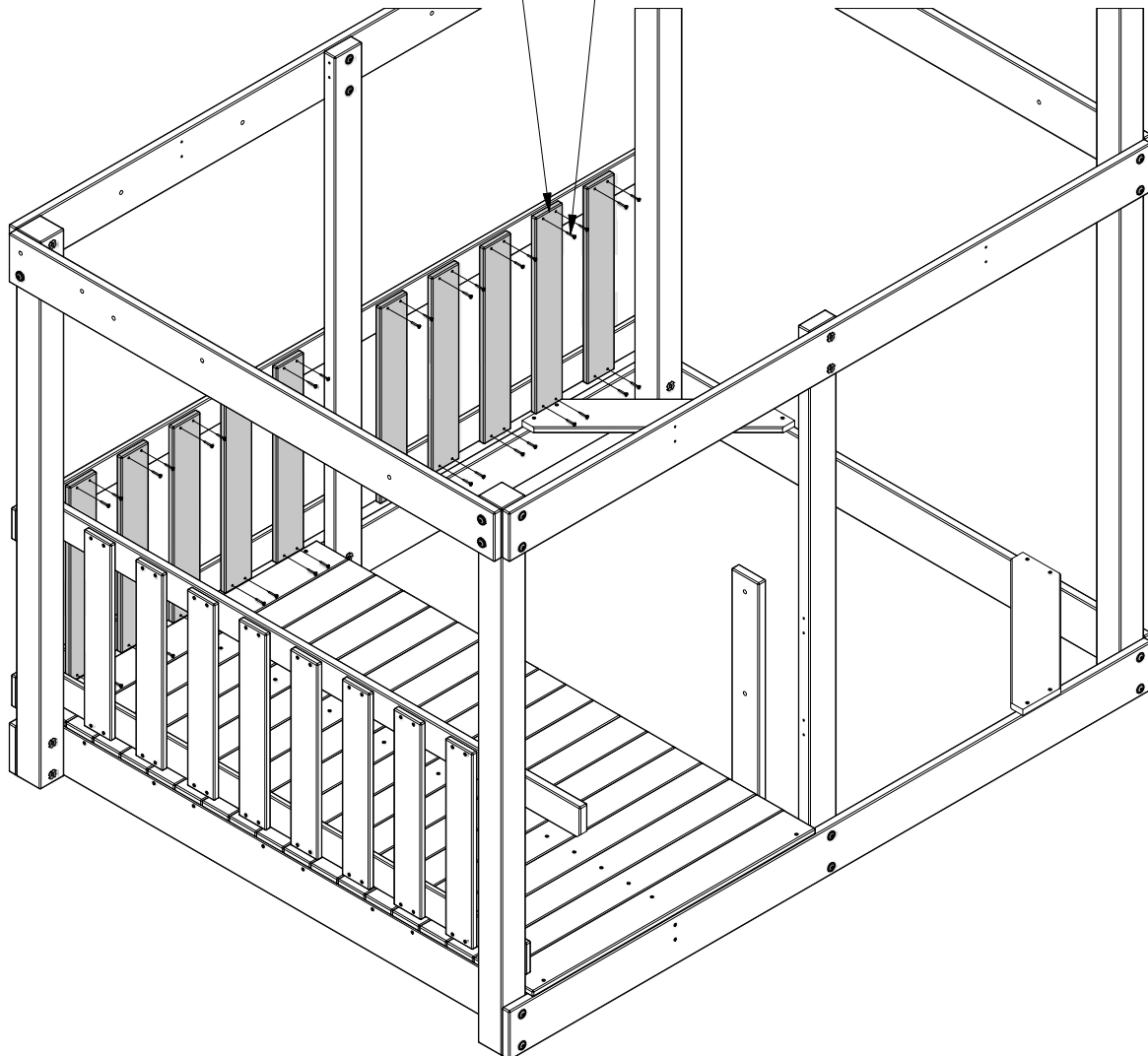

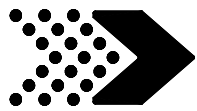

FORT ASSEMBLY

STEP 12

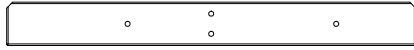

H16 | PICNIC TABLE SEAT RAIL - W4L04597
(1) | 1"x3 3/8"x32" (24x86x812)



H23 | PICNIC TABLE BRACE - W4L04598
(1) | 1"x3 3/8"x17 1/2" (24x86x444)



H100028 | LAG SCREW WH
(2) | 5/16x2 1/2



H100010 | BOLT WH
(1) | 5/16x1-1/2



H100138 | WASHER LOCK
EXT
(1) | 6x15



H100146 | LAG SCREW WH
(1) | 1/4x2



H100011 | BOLT WH
(1) | 5/16x1 3/4



H100030 | WASHER LOCK
EXT
(4) | 8x19

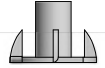

H100074 | T-NUT
(2) | 5/16



TIP:
INSTALL T-NUTS INTO BOARDS
BEFORE ASSEMBLY

H23 (x1)

M27

074 (x2)

T-NUT - 5/16"

H16 (x1)

030 (x4)

WASHER - 8x19

146 (x1)

LAG SCREW - 2"

138 (x1)

WASHER - 6x15

011 (x1)

BOLT - 1 3/4"

USING 'H16' AS A GUIDE, DRILL
3/8" DIAMETER HOLE IN 'M27'

010 (x1)

BOLT - 1 1/2"

028 (x2)

LAG SCREW - 2 1/2"

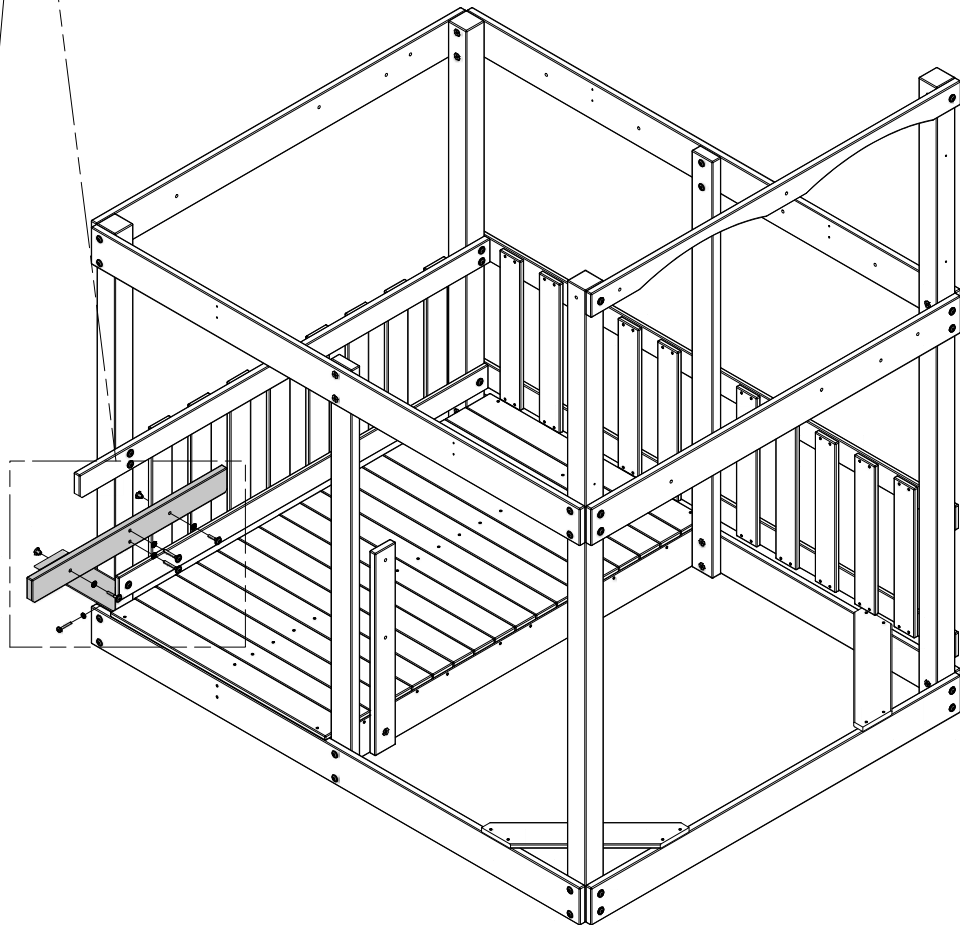

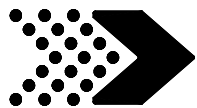

FORT ASSEMBLY

STEP 13



H17 | PICNIC TABLE SEAT RAIL - W4L04599
(1) | 1"x3 3/8"x32" (24x86x812)



H23 | PICNIC TABLE BRACE - W4L04598
(1) | 1"x3 3/8"x17 1/2" (24x86x444)



H100028 | LAG SCREW WH
(2) | 5/16x2 1/2



H100011 | BOLT WH
(2) | 5/16x1 3/4

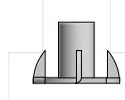

H100074 | T-NUT
(2) | 5/16



H100146 | LAG SCREW WH
(1) | 1/4x2



H100030 | WASHER LOCK
(4) | EXT
8x19



H100138 | WASHER LOCK
(1) | EXT
6x15

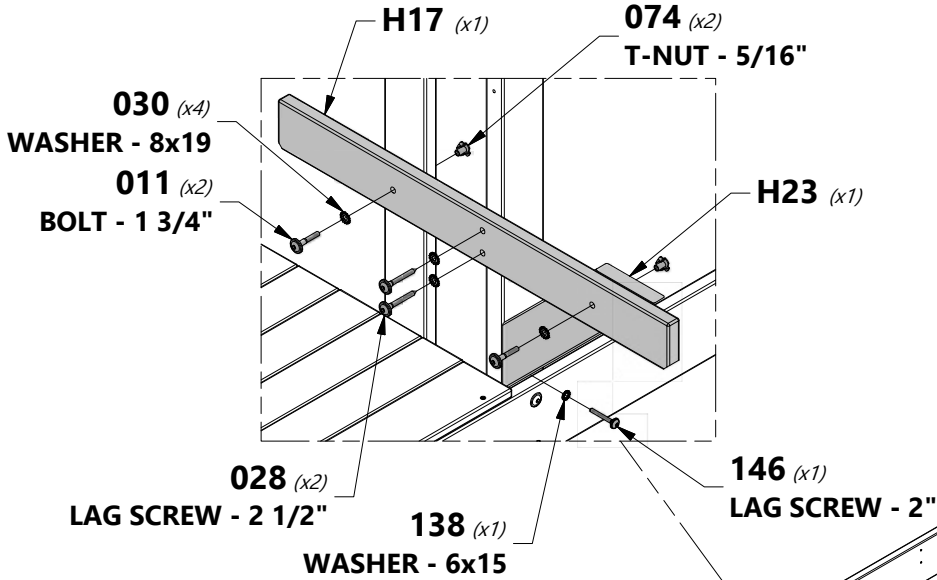

 **TIP:**
INSTALL T-NUTS INTO
BOARDS BEFORE ASSEMBLY.

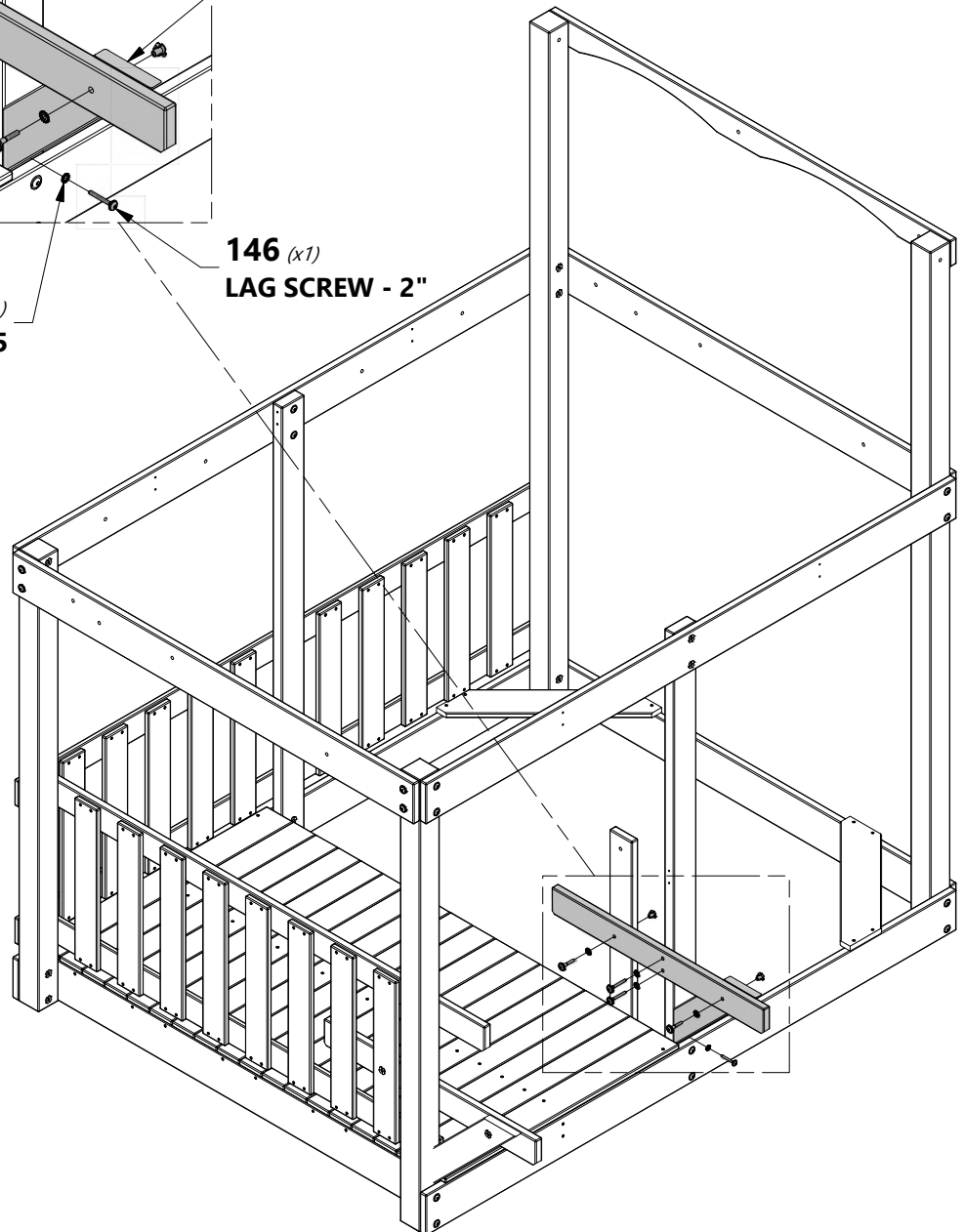

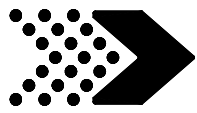

H15 | PICNIC TABLE SEAT - W4L04600
(4) | 1"x3 3/8"x35 3/8" (24x86x897)



H100111 | SCREW PFH
(16) | 8x2

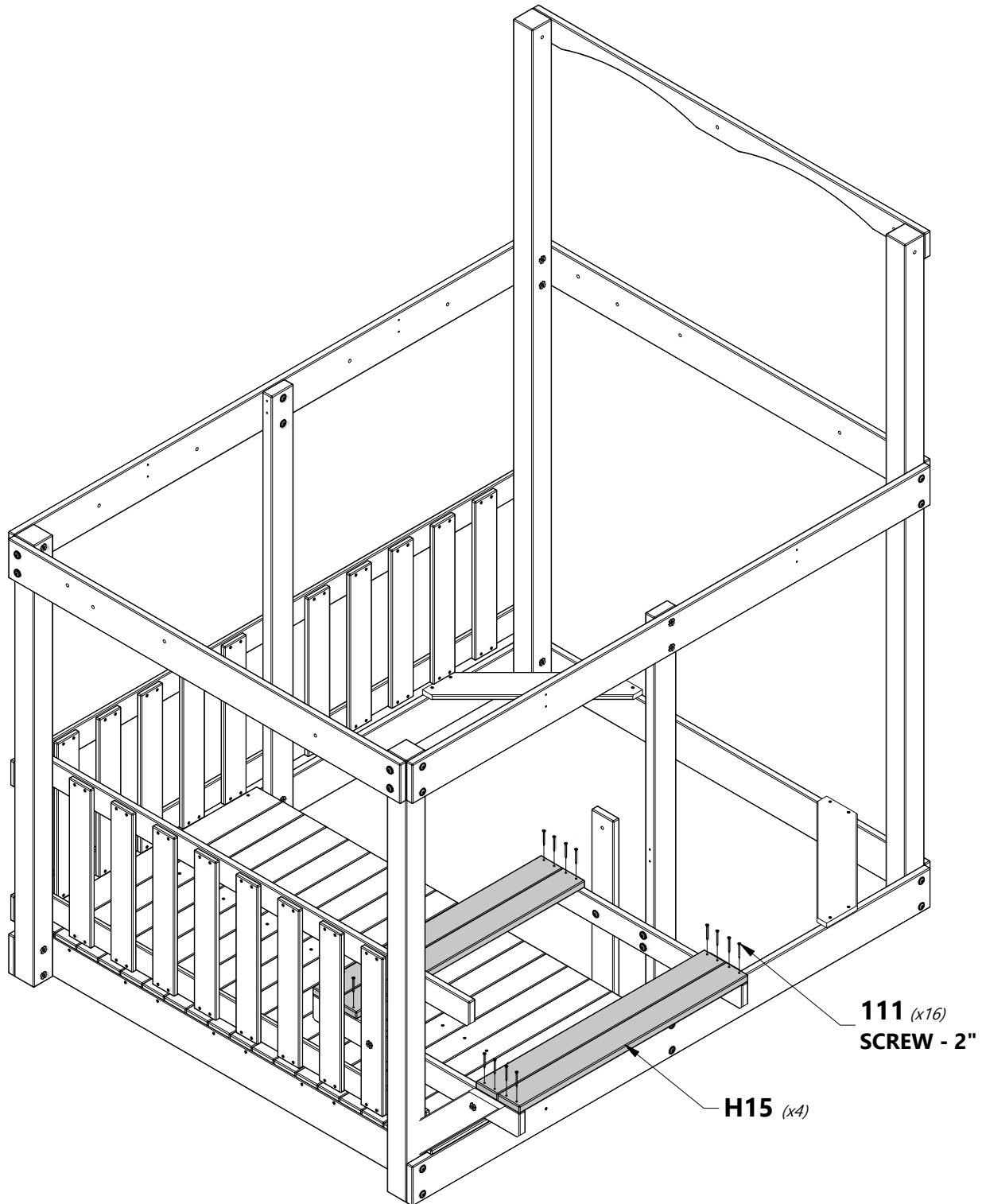

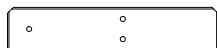
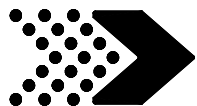

H24 | PICNIC TABLE TOP SUPPORT - W4L04601
(1) | 1"x3 3/8"x16 1/2" (24x86x418)



H100011 | BOLT WH
(1) | 5/16x1 3/4



H100028 | LAG SCREW WH
(2) | 5/16x2 1/2

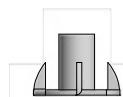

H100074 | T-NUT
(1) | 5/16

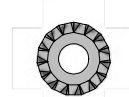

H100030 | WASHER LOCK
(3) | EXT
8x19



TIP:
INSTALL T-NUTS INTO
BOARDS BEFORE ASSEMBLY.

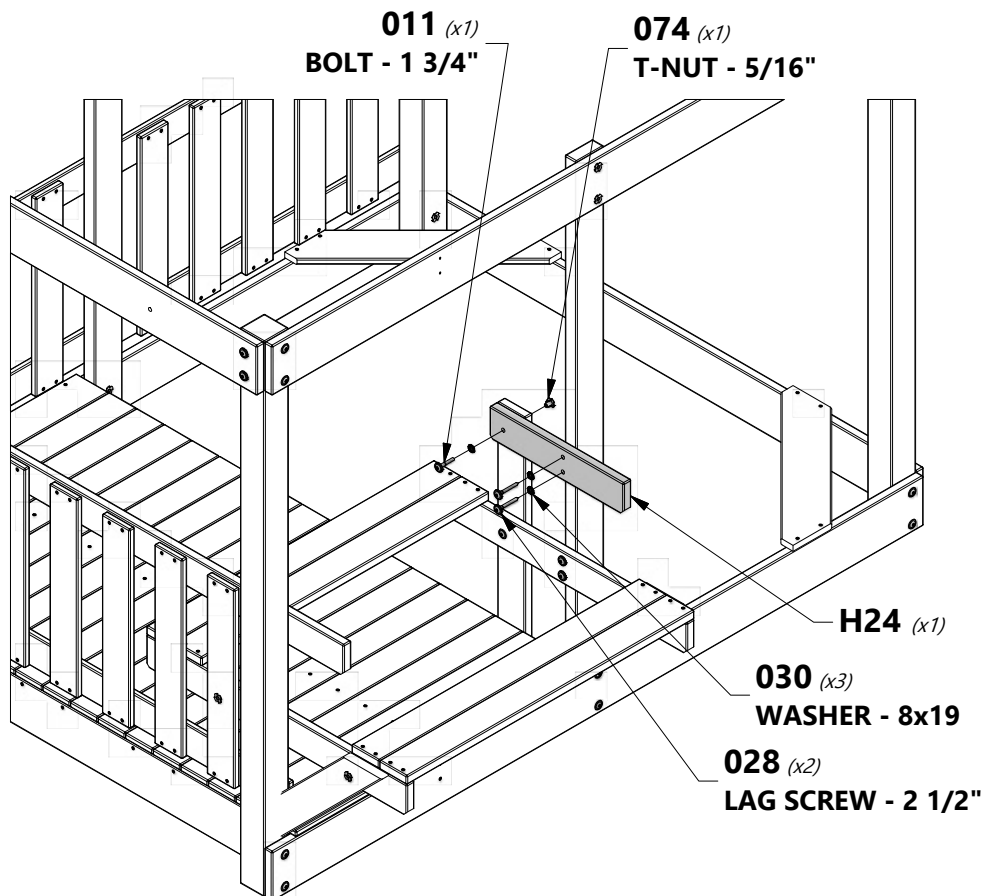



M16 | CENTER PICNIC TABLE TOP - W4L04603
(1) | 5/8"x3"x38 1/4" (16x76x973)



M13 | PICNIC TABLE TOP - W4L04602
(4) | 5/8"x3 3/8"x41 1/4" (16x86x1049)

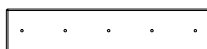

M30 | PICNIC TABLE TOP CLEAT - W4L04604
(1) | 5/8"x3 3/8"x16" (16x86x406)



H100086 | SCREW PFH
(20) | 8x1 1/2



H100088 | SCREW PFH
(5) | 8x1 1/8

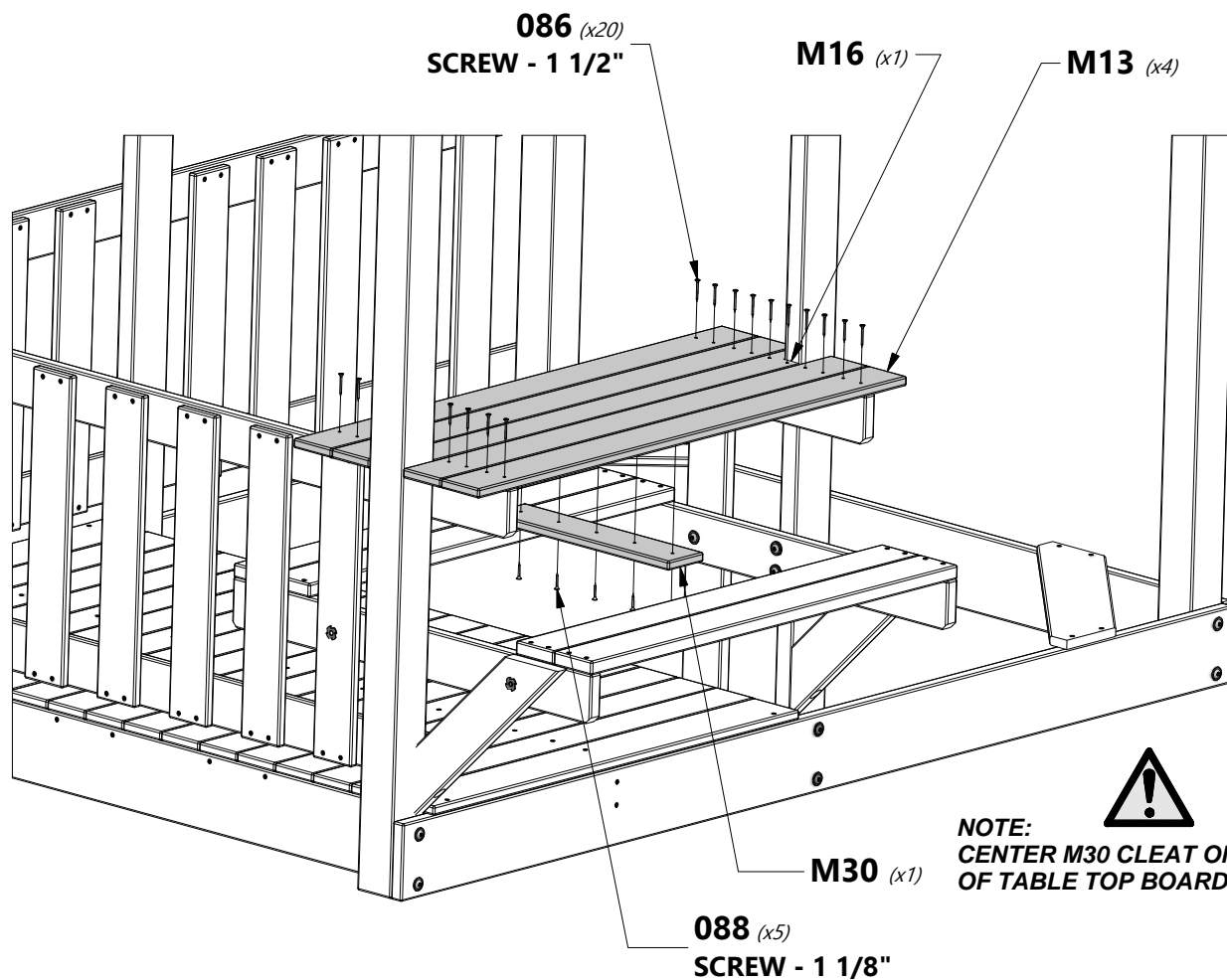

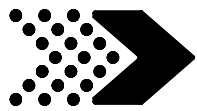

H25 | TOP FLOOR SUPPORT - W4L04606
(2) | 1"x3 3/8"x3" (24x86x76)



H100111 | SCREW PFH
(4) | 8x2

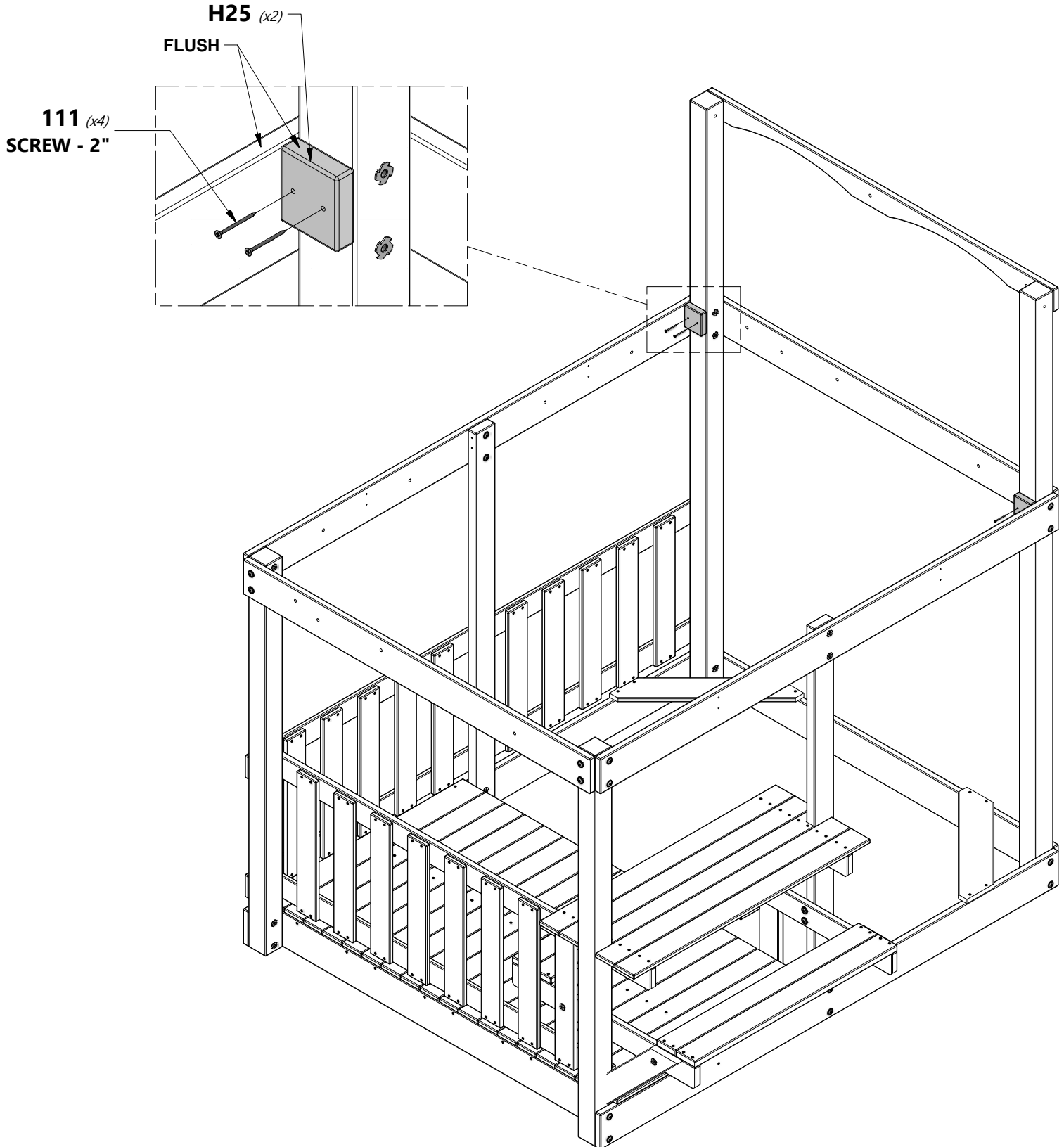

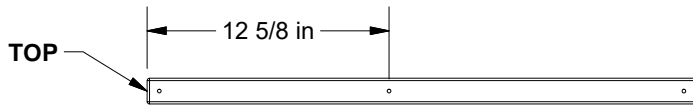
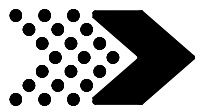

O2 SAFETY BOARD - W4L04605
(1) 5/8"x1 3/8"x28 5/8" (16x34x726)



H100088 SCREW PFH
(3) 8x1 1/8

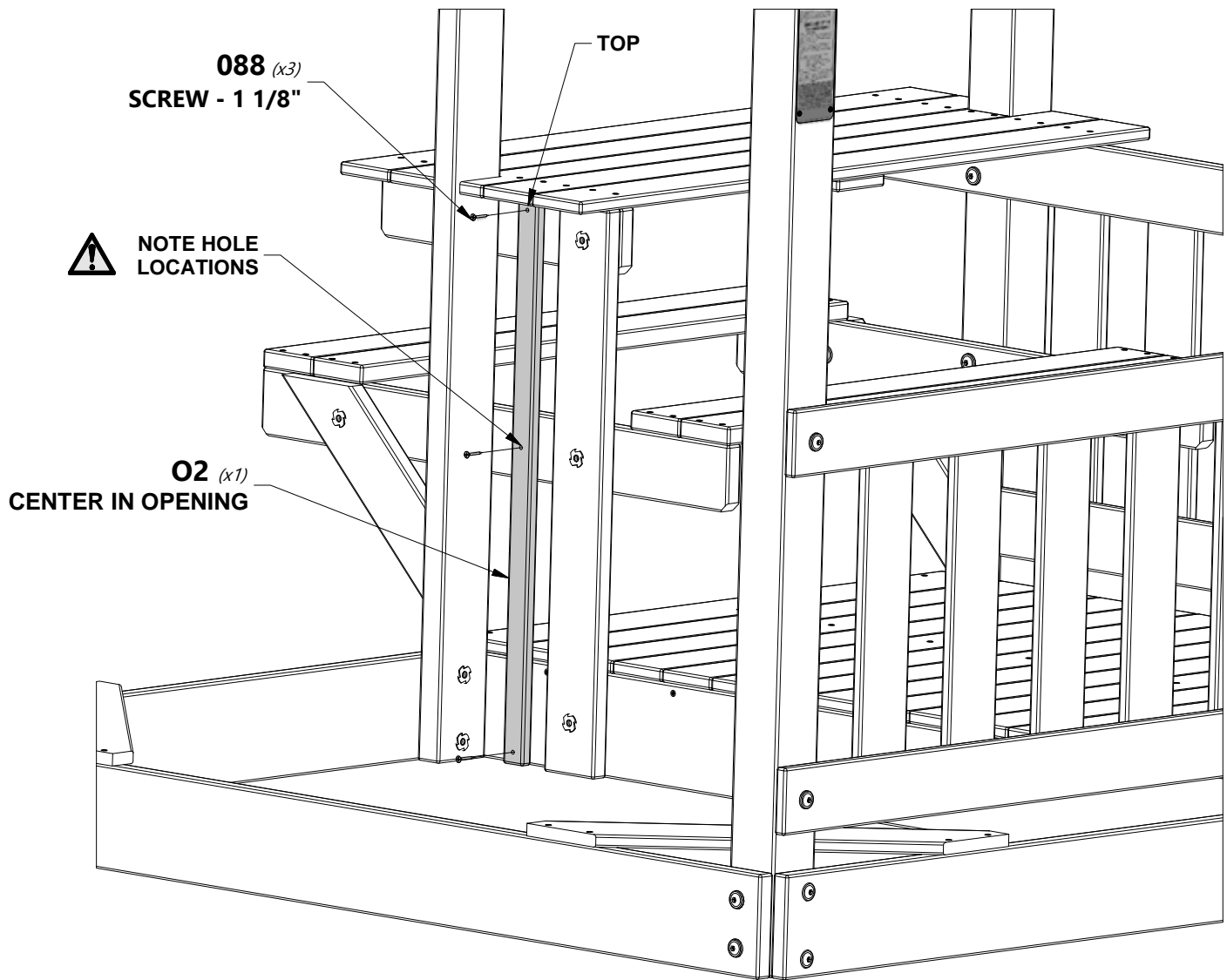

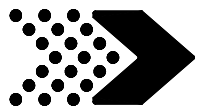

FORT ASSEMBLY

STEP 19

E6 | DECK BRACE - W4L15942
 (8) | 1 7/16"x3 3/8"x20" (36x86x508)

H100013 | BOLT WH
 (8) | 5/16x2 1/4

H100074 | T-NUT
 (8) | 5/16



H100138 | WASHER LOCK
 (8) | EXT
 6x15

H100649 | LAG SCREW WH
 (8) | 1/4x2 1/2

H100030 | WASHER LOCK
 (8) | EXT
 8x19

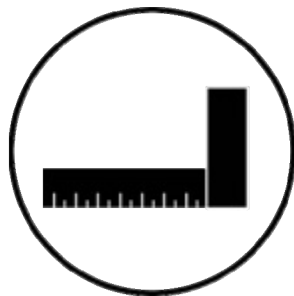

TIP:
 INSTALL T-NUTS INTO
 BOARDS BEFORE ASSEMBLY.

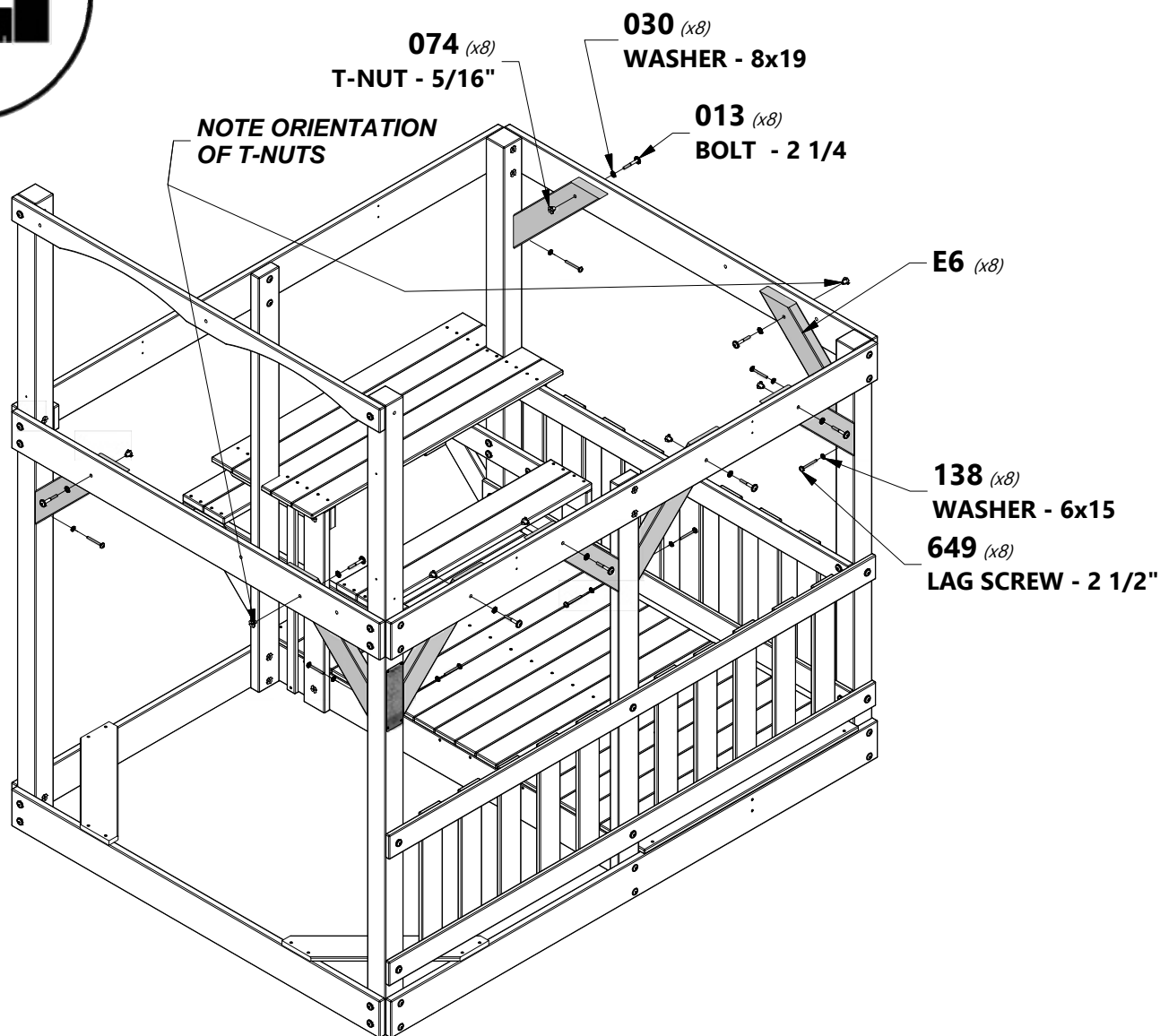

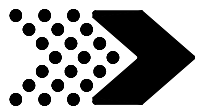

H5 | FLOOR RAIL - W4L04608
(1) | 1"x3 3/8"x60 1/2" (24x86x1537)



H26 | FLOOR JOIST - W4L04573
(2) | 1"x3 3/8"x60 1/2" (24x86x1537)



H100027 | LAG SCREW WH
(4) | 5/16x2



H100030 | WASHER LOCK
(4) | EXT
8x19



H100090 | SCREW PFH
(8) | 8x2 1/2"

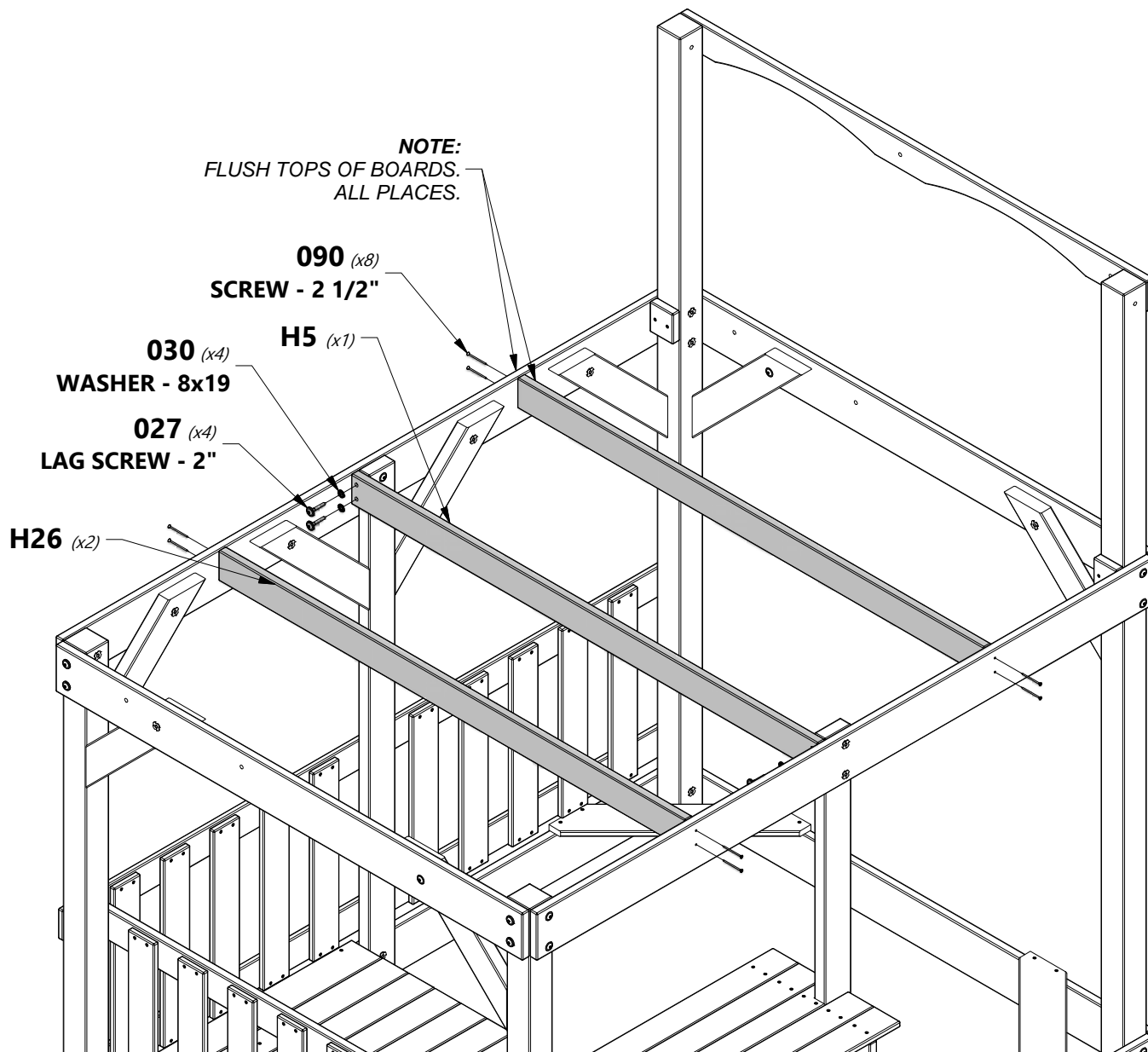

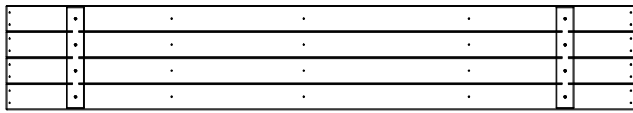

FP2 | FLOOR PANEL - W2A03345
(4) | 1 1/4"x13 1/2"x81 7/8" (32x344x2080)

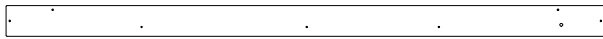

Y1 | TOP FLOOR BOARD - W4L15964
(2) | 5/8"x4"x78" (16x102x1980)



H100086 | SCREW PFH
(126) | 8x1 1/2



H100074 | T-NUT
(2) | 5/16

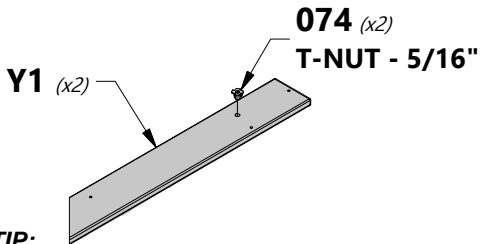

TIP:
INSTALL T-NUTS ON BOTTOM SIDE
OF BOTH Y1 FLOOR BOARDS
BEFORE ATTACHING TO FORT.

 **NOTE:**
ENSURE PILOT HOLES ARE
CENTERED ON FLOOR JOISTS.

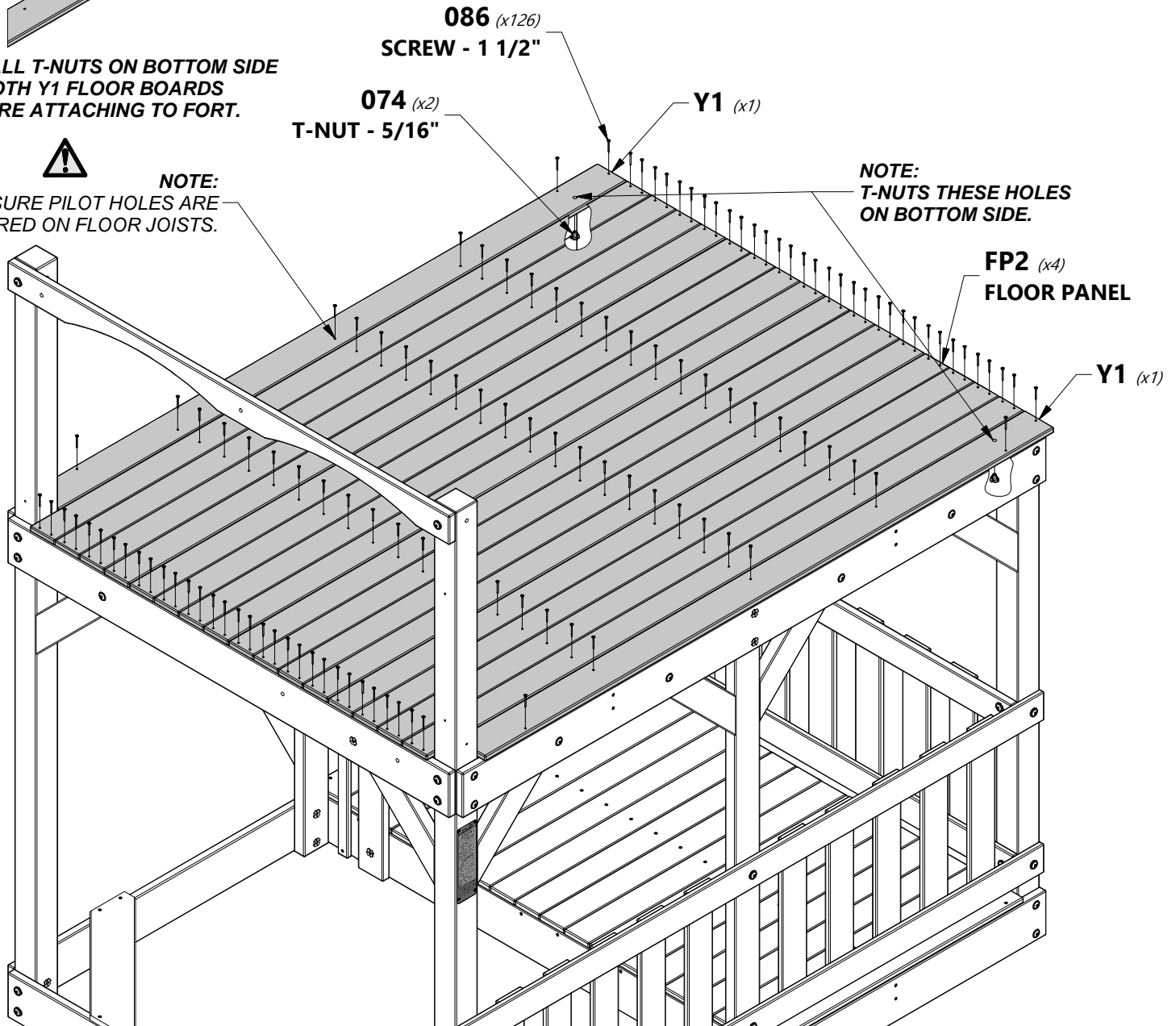

NOTE:
T-NUTS THESE HOLES
ON BOTTOM SIDE.



1 3/4 in
[43 mm]

1 1/2 in
[38 mm]

B8 | BACK RIGHT CLUB HOUSE CORNER - W4L04618
(1) | 3"x3"x53 7/8" (76x76x1370)

M21 | CLUB HOUSE WALL RAIL - W4L04613
(1) | 5/8"x3 3/8"x30 1/4" (16x86x768)

H4 | ROOF SUPPORT RAIL - W4L04623
(1) | 1"x3 3/8"x67 1/4" (24x86x1709)



A4M01046 | L BRACKET
(2) | 2.5x38x55x55

B5 | BACK LEFT CLUB HOUSE CORNER - W4L04612
(1) | 3"x3"x53 7/8" (76x76x1370)

H6 | BACK CLUB HOUSE RAIL - W4L04621
(1) | 1"x3 3/8"x60 1/2" (24x86x1537)



H100014 | BOLT WH
(1) | 5/16x2 1/2



H100115 | BOLT WH
(2) | 5/16x1/2



H100019 | BOLT WH
(2) | 5/16x3 3/4



H100030 | WASHER LOCK
(4) | EXT
8x19



H100017 | BOLT WH
(1) | 5/16x3 1/4

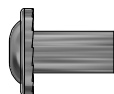

H100005 | NUT BARREL WH
(2) | 5/16x7/8



H100027 | LAG SCREW WH
(2) | 5/16x2



H100031 | WASHER LOCK
(2) | EXT
12x19



H100074 | T-NUT
(2) | 5/16



TIP:
INSTALL T-NUTS INTO
BOARDS BEFORE ASSEMBLY.

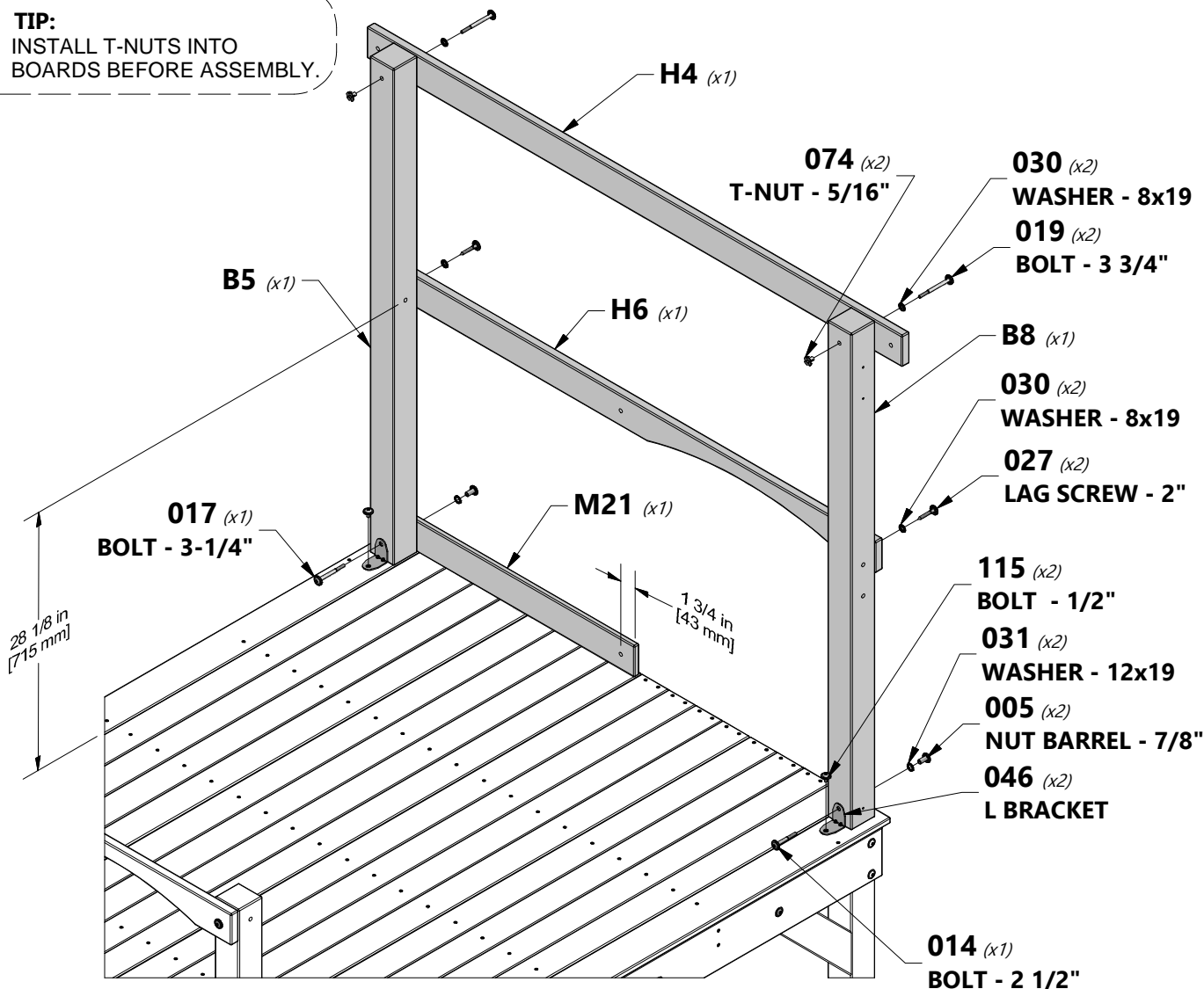

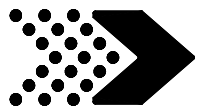

M10 | CLUB HOUSE WALL RAIL - W4L04614
(1) | 5/8"x3 3/8"x50 1/4" (16x86x1277)

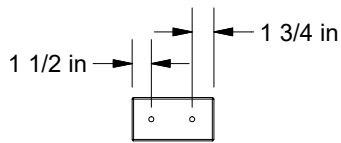

M34 | WALL RAIL - W4L04611
(1) | 5/8"x3 3/8"x6 3/8" (16x86x162)



H100027 | LAG SCREW WH
(4) | 5/16x2



H100030 | WASHER LOCK EXT
(4) | 8x19



M1 | TOP WALL RAIL - W4L04619
(1) | 5/8"x3 3/8"x80" (16x86x2032)

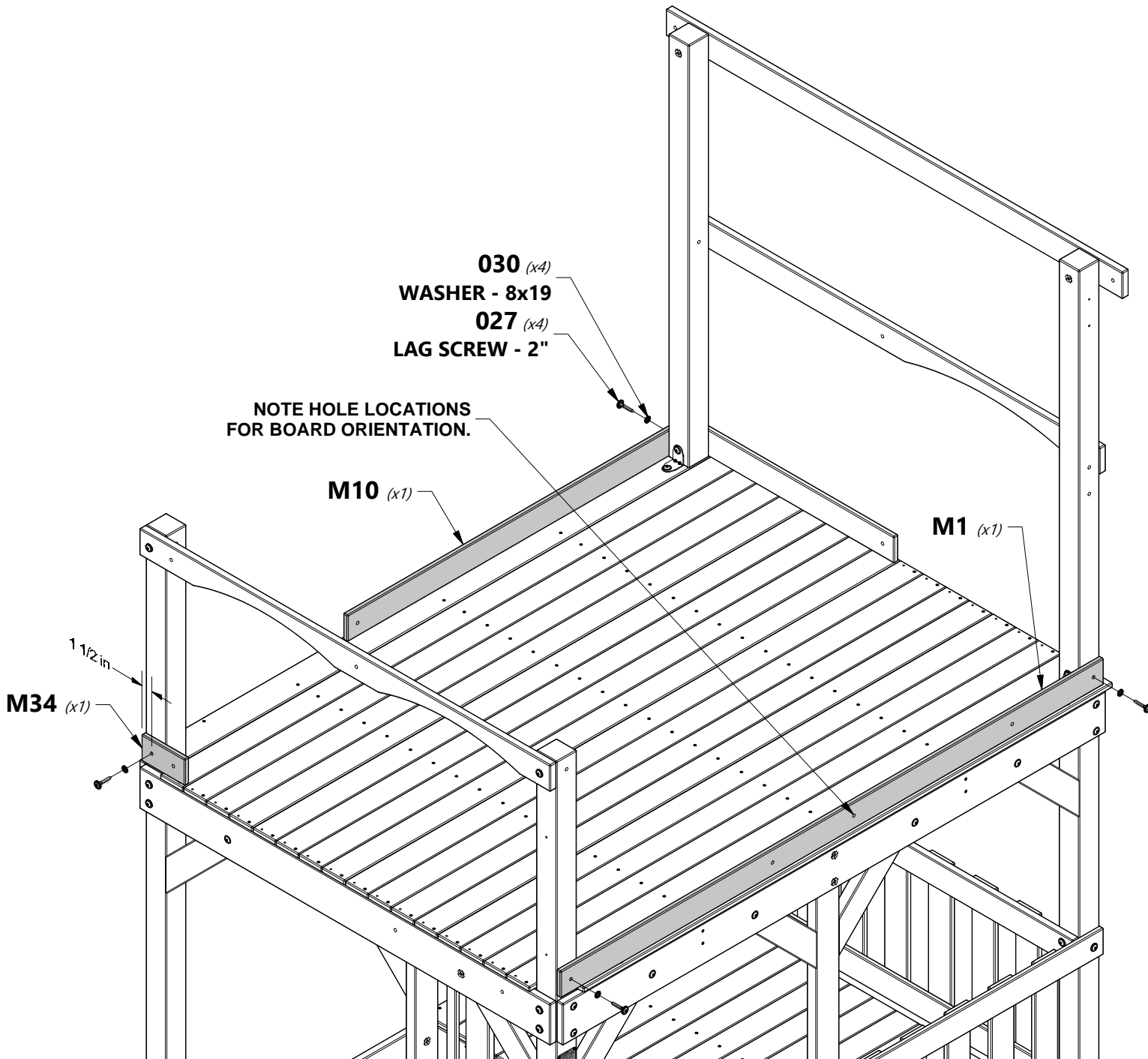

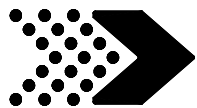

H18 | CLUB HOUSE WALL RAIL - W4L04616
(1) | 1"x3 3/8"x29 7/8" (24x86x758)



A4M01046 | L BRACKET 2.5x38x55x55
(1)



H100011 | BOLT WH
(1) | 5/16x1 3/4

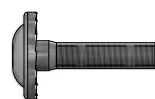

H100009 | BOLT WH
(1) | 5/16x1 1/4



H100115 | BOLT WH
(1) | 5/16x1/2



H100074 | T-NUT
(2) | 5/16



H100005 | NUT BARREL WH
(1) | 5/16x7/8



H100031 | WASHER LOCK
(1) | EXT
12x19



H100030 | WASHER LOCK
(1) | EXT
8x19



TIP:
INSTALL T-NUTS INTO
BOARDS BEFORE ASSEMBLY.

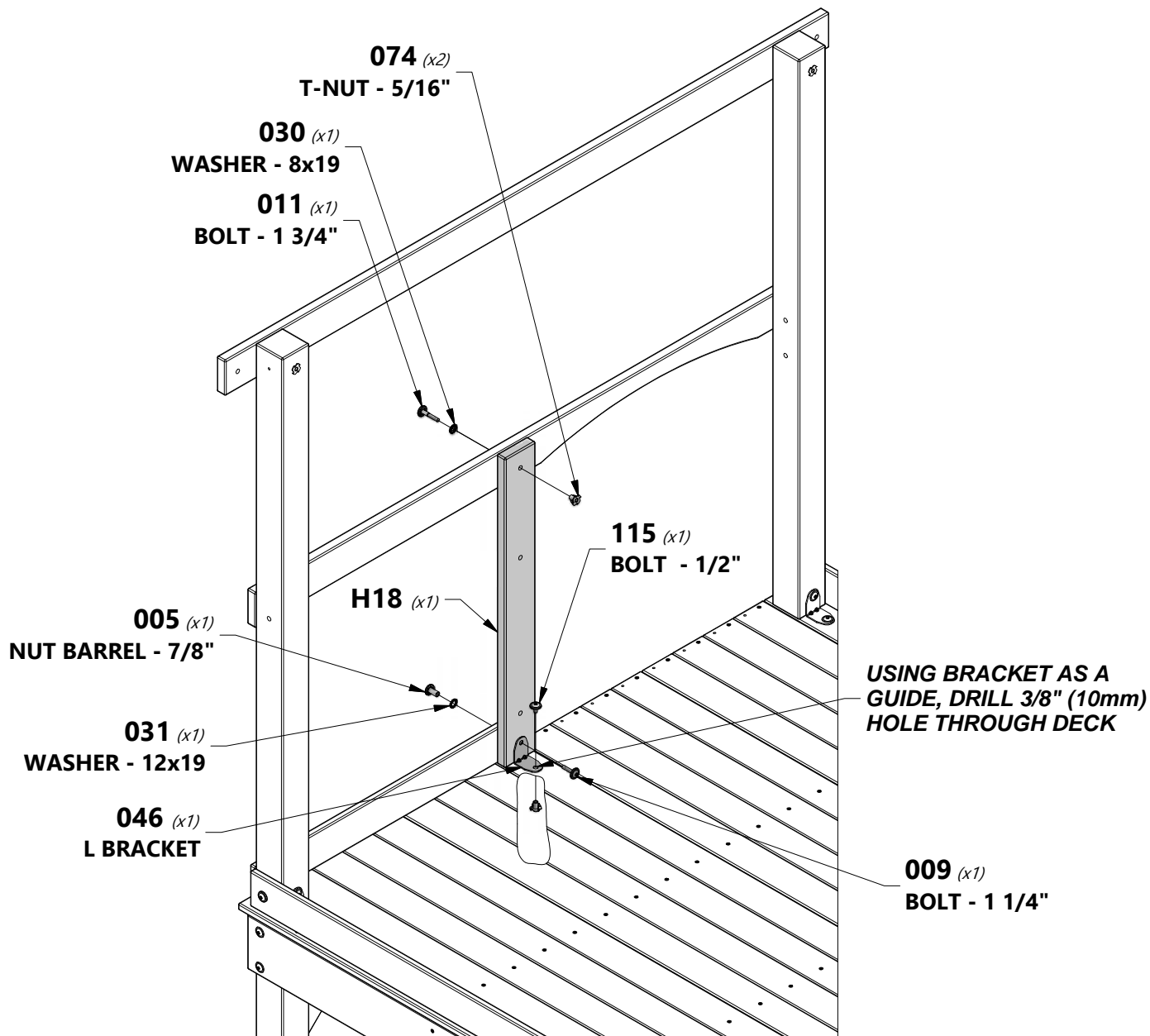

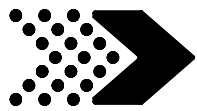

A4M01046 | L BRACKET
(1) | 2.5x38x55x55



H1 | WALL RAIL - W4L04620
(1) | 1"x3 3/8"x80" (24x86x2032)

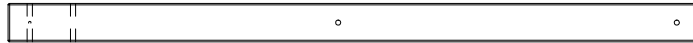

B6 | FRONT LEFT CLUB HOUSE CORNER - W4L04615
(1) | 3"x3"x53 7/8" (76x76x1370)



H100019 | BOLT WH
(3) | 5/16x3 3/4

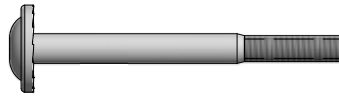

H100017 | BOLT WH
(1) | 5/16x3 1/4



H100005 | NUT BARREL WH
(1) | 5/16x7/8



H100115 | BOLT WH
(1) | 5/16x1/2

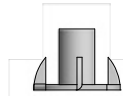

H100074 | T-NUT
(4) | 5/16



H100031 | WASHER LOCK
(1) | EXT
12x19



H100030 | WASHER LOCK
(3) | EXT
8x19



TIP:
INSTALL T-NUTS INTO
BOARDS BEFORE ASSEMBLY.

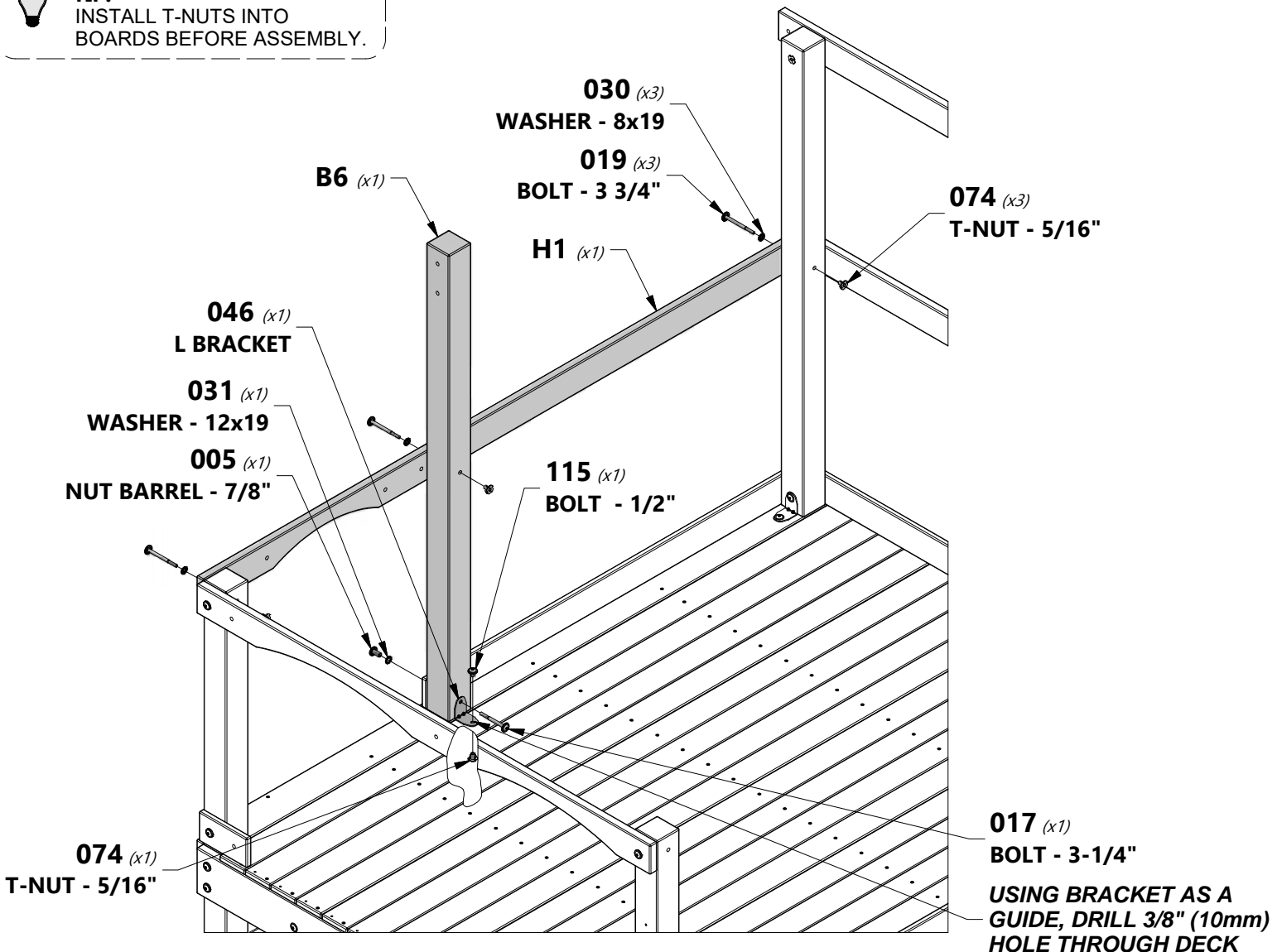

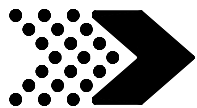

A4M01046 | L BRACKET
(1) | 2.5x38x55x55



H2 | WALL RAIL - W4L15900
(1) | 1"x3 3/8"x80" (24x86x2032)

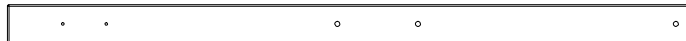

B7 | FRONT RIGHT CLUB HOUSE CORNER - W4L04617
(1) | 3"x3"x53 7/8" (76x76x1370)



H100019 | BOLT WH
(3) | 5/16x3 3/4

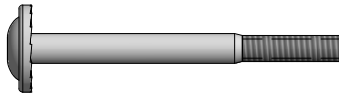

H100017 | BOLT WH
(1) | 5/16x3 1/4

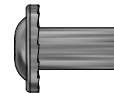

H100005 | NUT BARREL WH
(1) | 5/16x7/8



H100115 | BOLT WH
(1) | 5/16x1/2



H100030 | WASHER LOCK
(3) | EXT
8x19



H100031 | WASHER LOCK
(1) | EXT
12x19



H100074 | T-NUT
(4) | 5/16

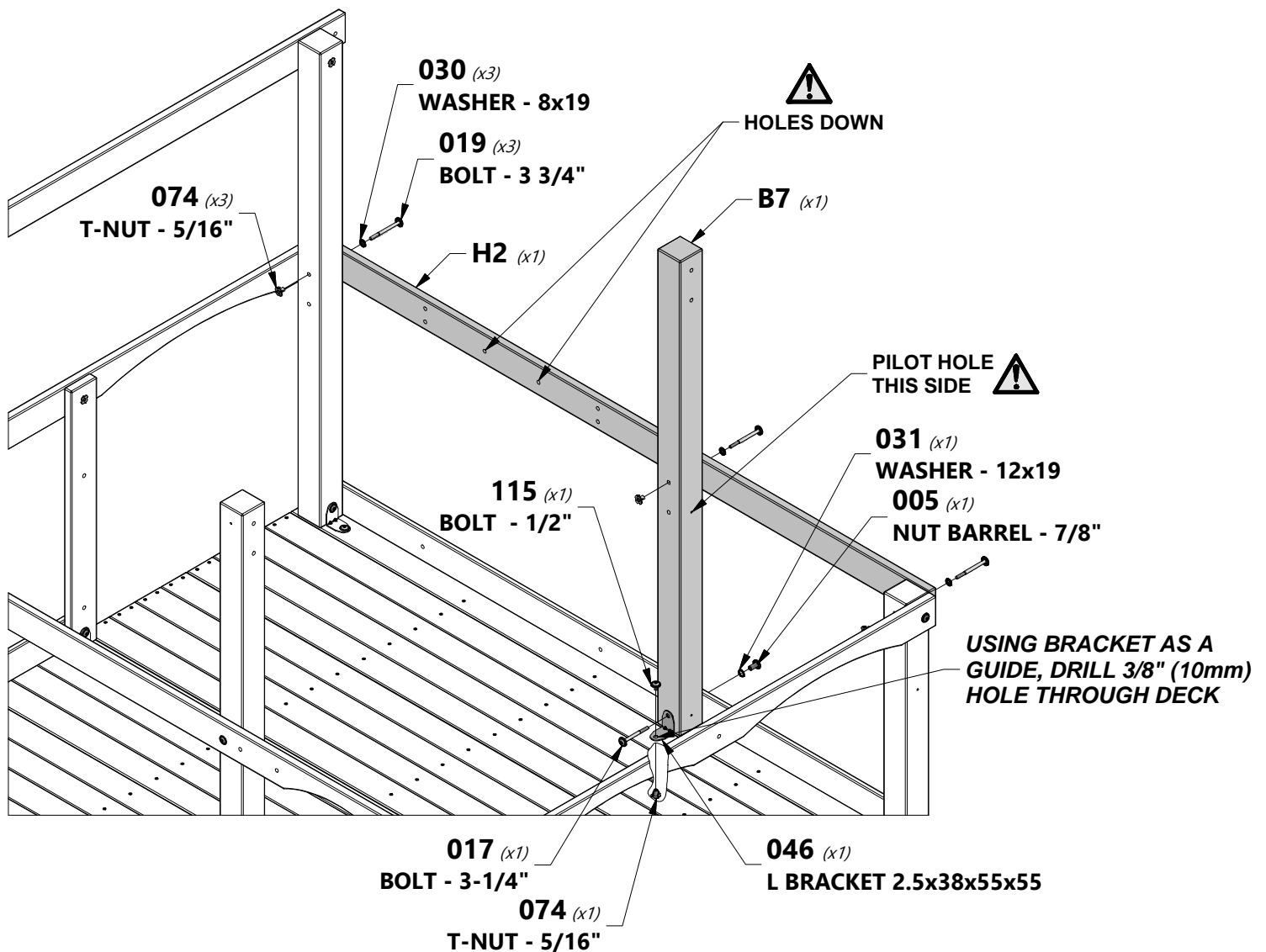

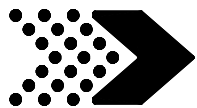

A100396 | L BRACKET
(2) | 51x32x82x3.175



H9 | FORT WALL BOARD - W4L15916
(2) | 1"x3 3/8"x50 1/2" (24x86x1284)

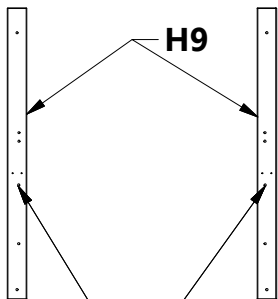

NOTE:
HOLES ARE CLOSER TO THE INSIDE
WHEN INSTALLED.



H100044 | BOLT HEX
(4) | 5/16x2



**H100030 | WASHER LOCK
EXT**
(2) | 8x19

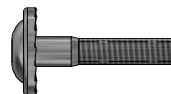

H100010 | BOLT WH
(2) | 5/16x1-1/2



H100074 | T-NUT
(6) | 5/16



H100095 | WASHER SPLIT
(4) | 5/16



H100105 | WASHER FLAT
(4) | 8x27



TIP:
INSTALL T-NUTS INTO
BOARDS BEFORE ASSEMBLY.

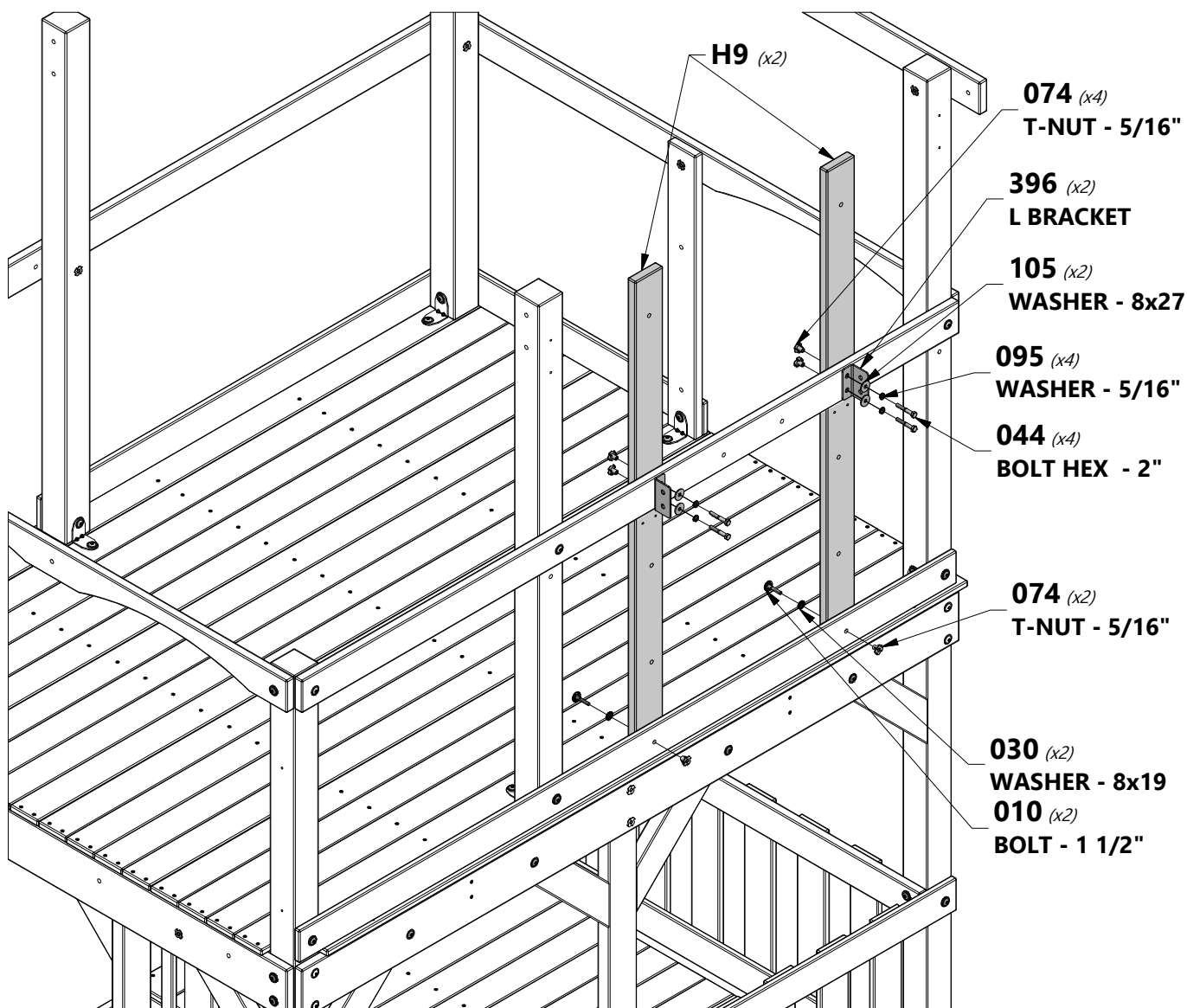





K5 | CLUB HOUSE WALL RAIL - W4L04626
(1) | 5/8"x5 1/4"x50 1/4" (16x134x1277)

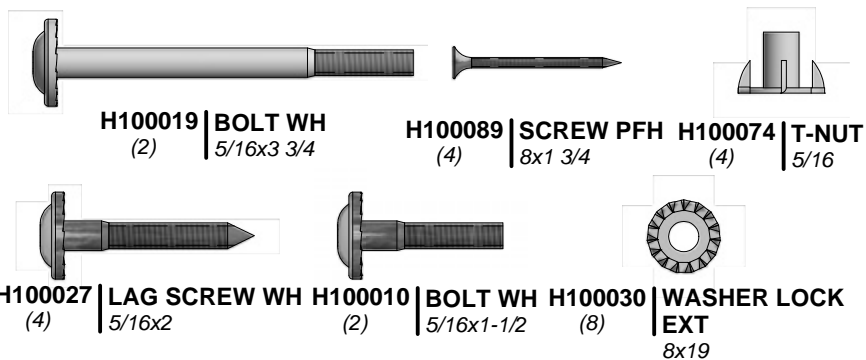

H14 | SWING BEAM MOUNT - W4L04628
(1) | 1"x3 3/8"x50 1/4" (24x86x1277)



 **TIP:**
INSTALL T-NUTS INTO
BOARDS BEFORE ASSEMBLY.

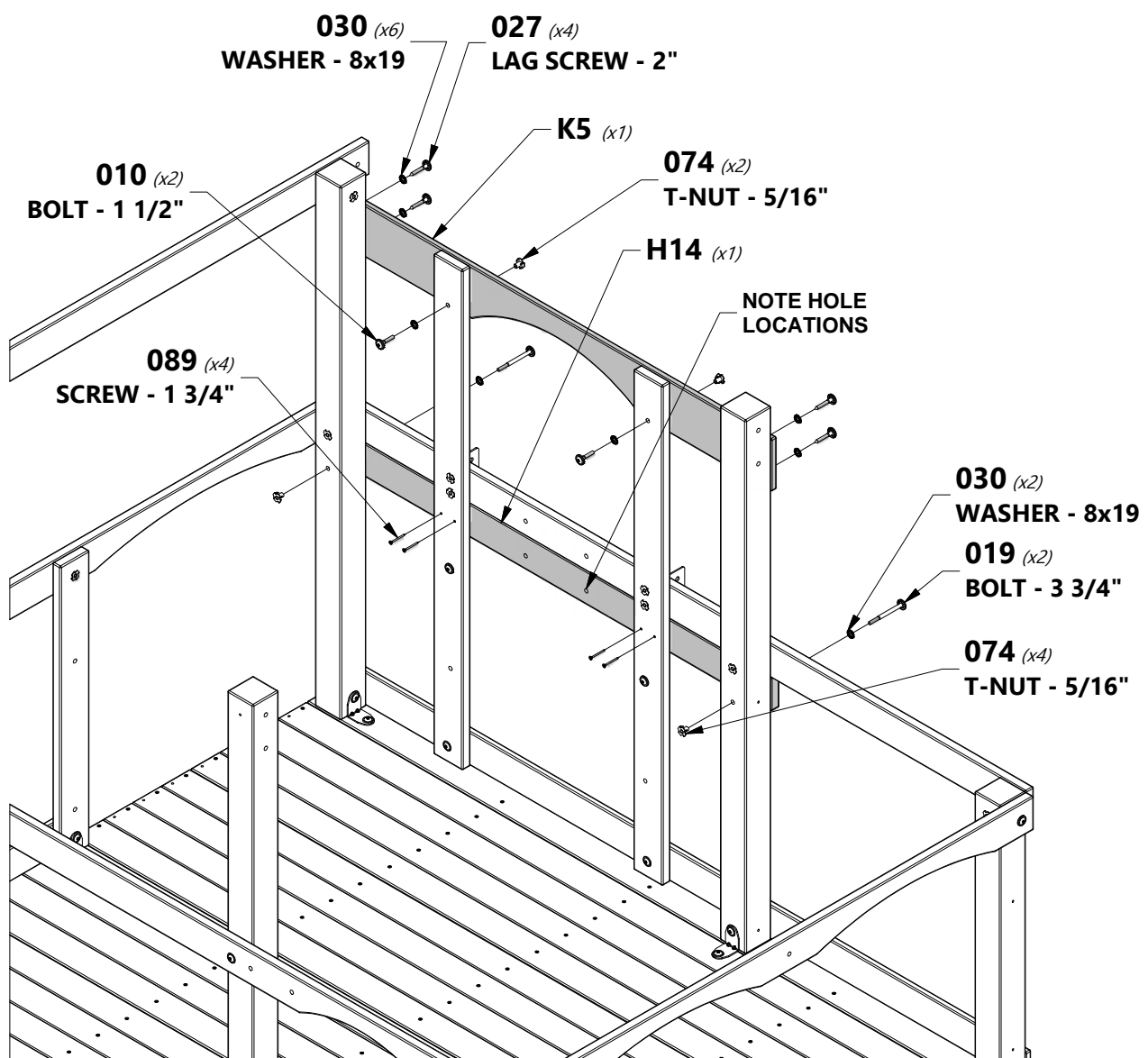

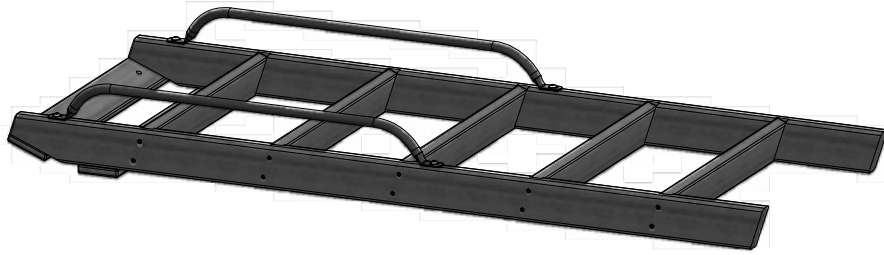
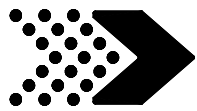

(1) LADDER ASSEMBLY



H100011 | BOLT WH
(2) | 5/16x1 3/4



H100030 | WASHER LOCK
(2) | EXT
8x19

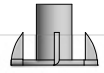

H100074 | T-NUT
(2) | 5/16

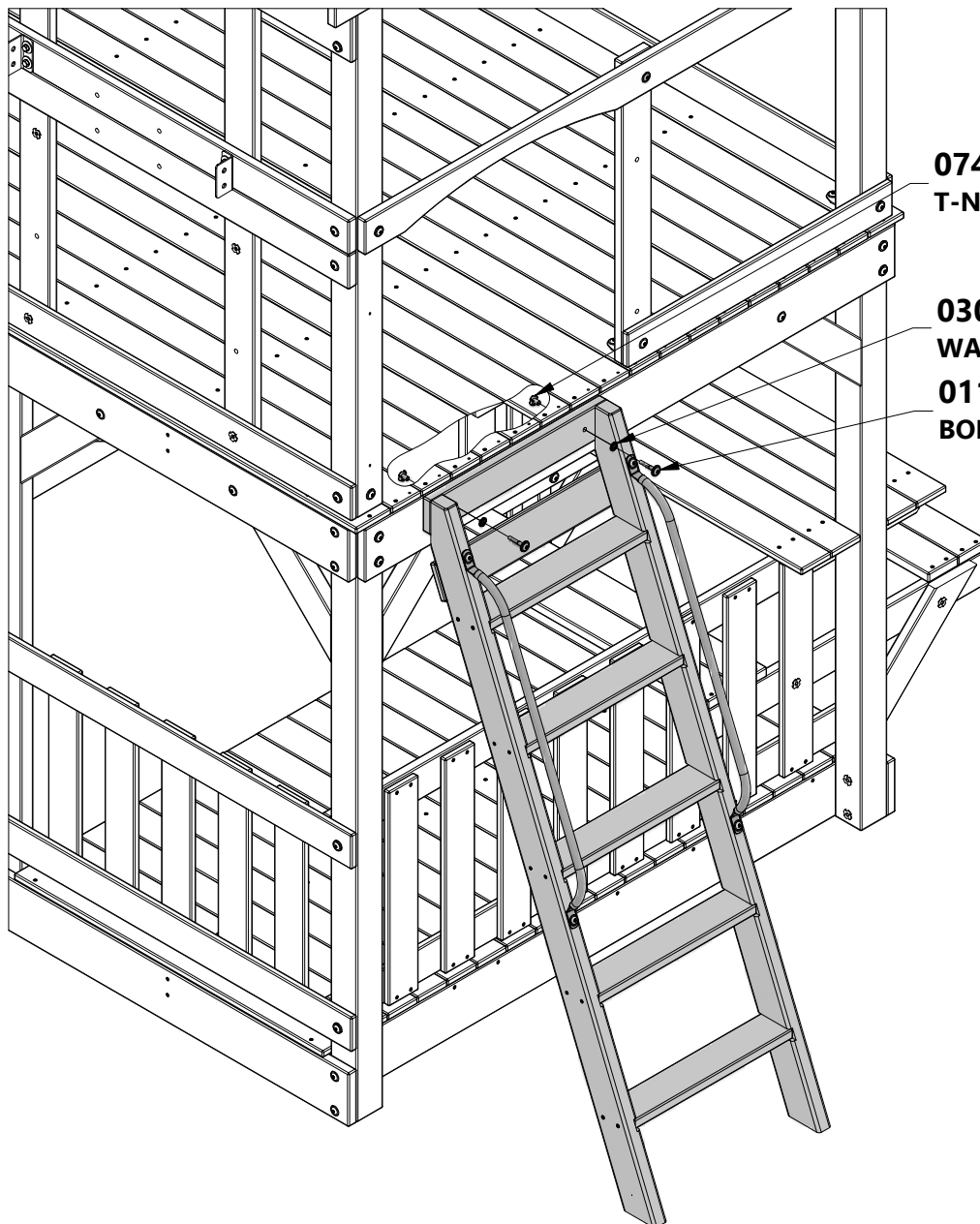

074 (x2)
T-NUT - 5/16"

030 (x2)
WASHER - 8x19

011 (x2)
BOLT - 1 3/4"

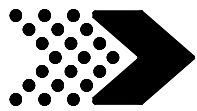

H4 | ROOF SUPPORT RAIL - W4L04623
(1) | 1"x3 3/8"x67 1/4" (24x86x1709)



H100019 | BOLT WH
(4) | 5/16x3 3/4



H7 | FRONT CLUB HOUSE WALL RAIL - W4L04625
(1) | 1"x3 3/8"x60 1/2" (24x86x1537)



H100074 | T-NUT
(4) | 5/16



H100030 | WASHER LOCK
(4) | EXT
8x19



TIP:
INSTALL T-NUTS INTO
BOARDS BEFORE ASSEMBLY.

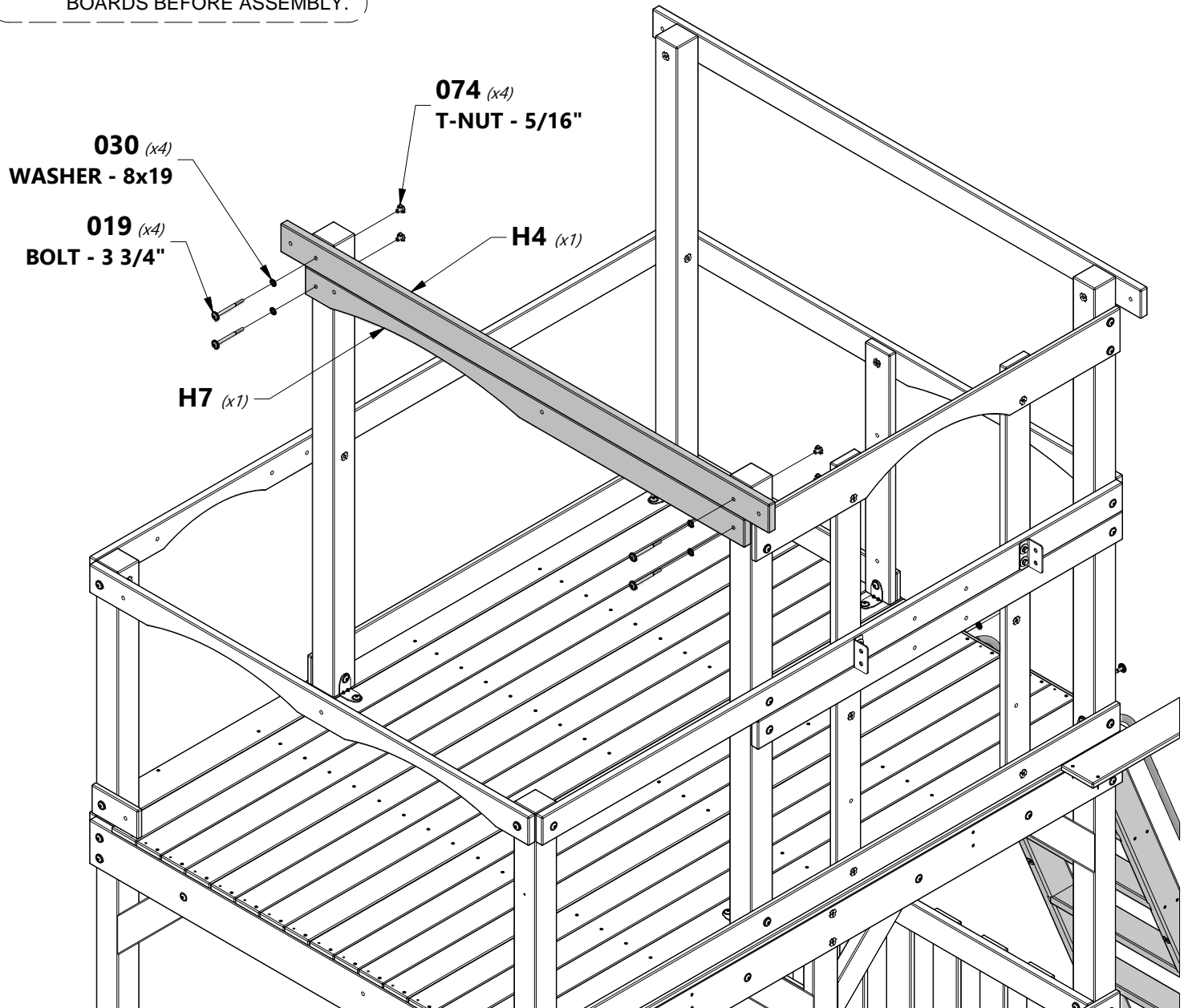



FORT ASSEMBLY

STEP 31



A4M01046 | L BRACKET
(1) | 2.5x38x55x55



H8 | CLUB HOUSE LEG - W4L04637
(1) | 1"x3 3/8"x50 1/2" (24x86x1284)

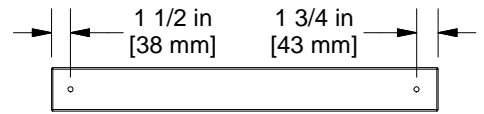

M21 | CLUB HOUSE WALL RAIL - W4L04613
(2) | 5/8"x3 3/8"x30 1/4" (16x86x768)



H100027 | LAG SCREW WH
(2) | 5/16x2



H100010 | BOLT WH
(1) | 5/16x1-1/2

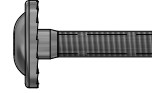

H100009 | BOLT WH
(1) | 5/16x1 1/4



H100115 | BOLT WH
(1) | 5/16x1/2

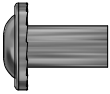

H100005 | NUT BARREL WH
(1) | 5/16x7/8



H100031 | WASHER LOCK
(1) | EXT
12x19



H100030 | WASHER LOCK
(3) | EXT
8x19

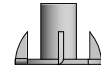

H100074 | T-NUT
(2) | 5/16

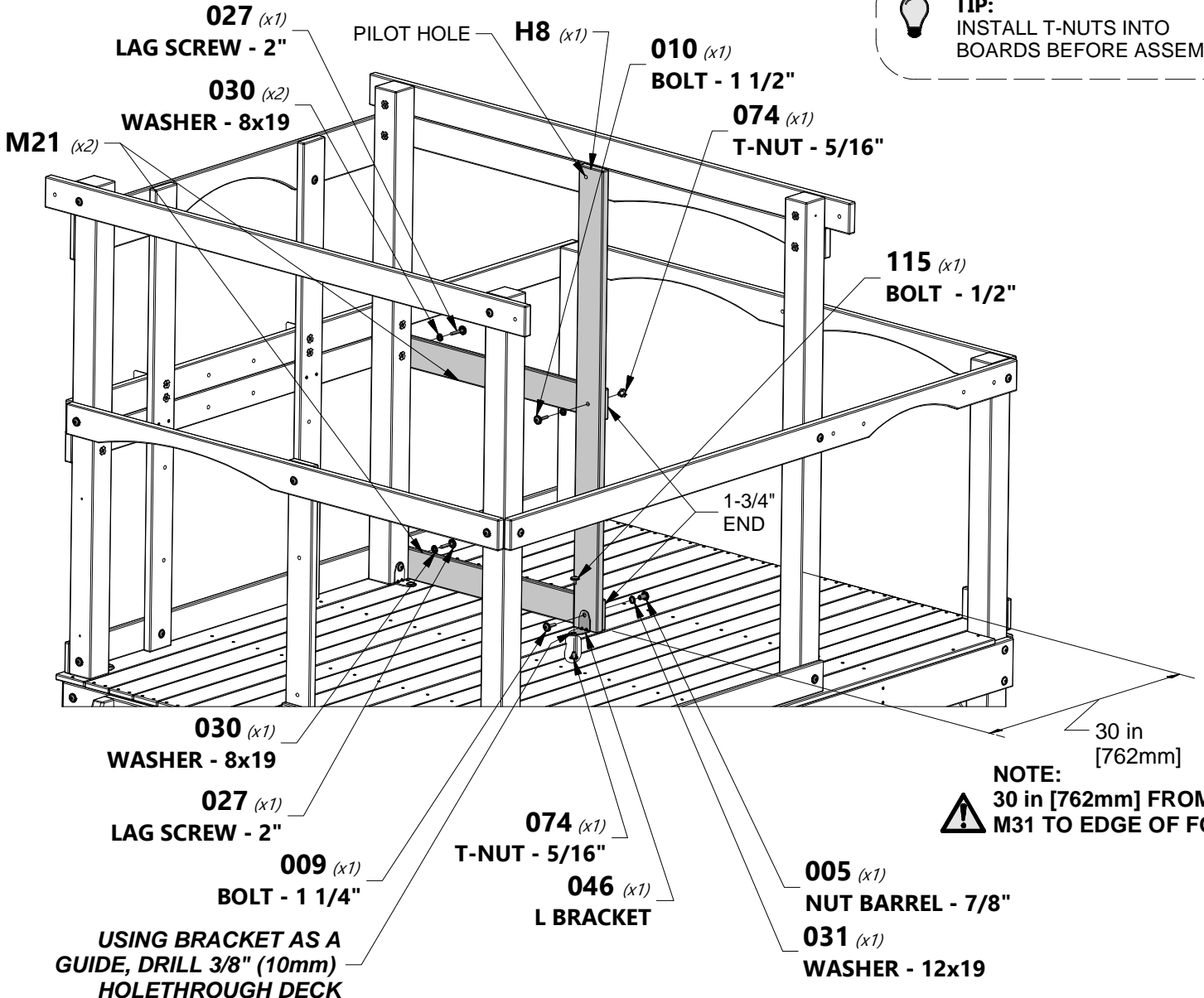

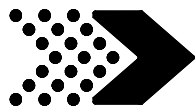

H13 | CLUB HOUSE WALL RAIL - W4L04624
(1) | 1"x3 3/8"x50 1/4" (24x86x1277)



H100027 | LAG SCREW WH
(2) | 5/16x2



H100030 | WASHER LOCK
(2) | EXT
8x19

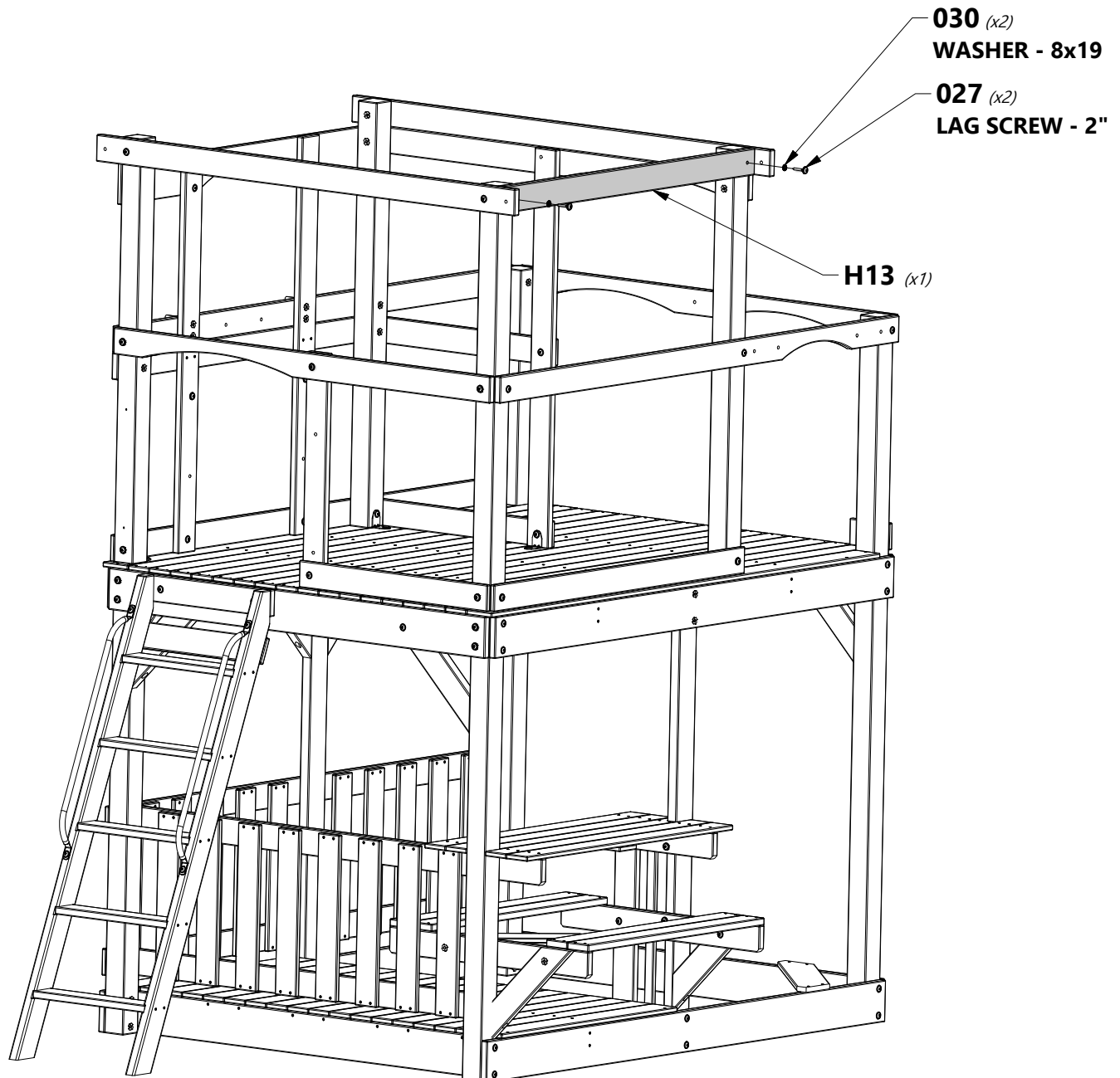



FORT ASSEMBLY

STEP 33



A4M01046 | L BRACKET
(1) | 2.5x38x55x55

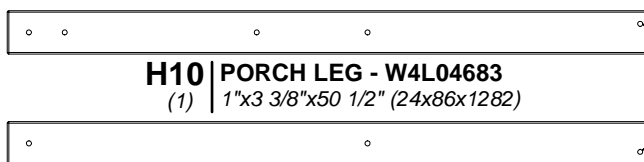

H10 | PORCH LEG - W4L04683
(1) | 1"x3 3/8"x50 1/2" (24x86x1282)



H11 | PORCH LEG - W4L04610
(1) | 1"x3 3/8"x50 1/2" (24x86x1282)

NOTE:
HOLES GO OUTWARD
WHEN INSTALLED.



H100011 | BOLT WH
(2) | 5/16x1 3/4



H100010 | BOLT WH
(1) | 5/16x1-1/2



H100115 | BOLT WH
(2) | 5/16x1/2



H100005 | NUT BARREL WH
(1) | 5/16x7/8



H100030 | WASHER LOCK
(3) | EXT
8x19



H100031 | WASHER LOCK
(1) | EXT
12x19



H100074 | T-NUT
(4) | 5/16



TIP:
INSTALL T-NUTS INTO
BOARDS BEFORE ASSEMBLY.

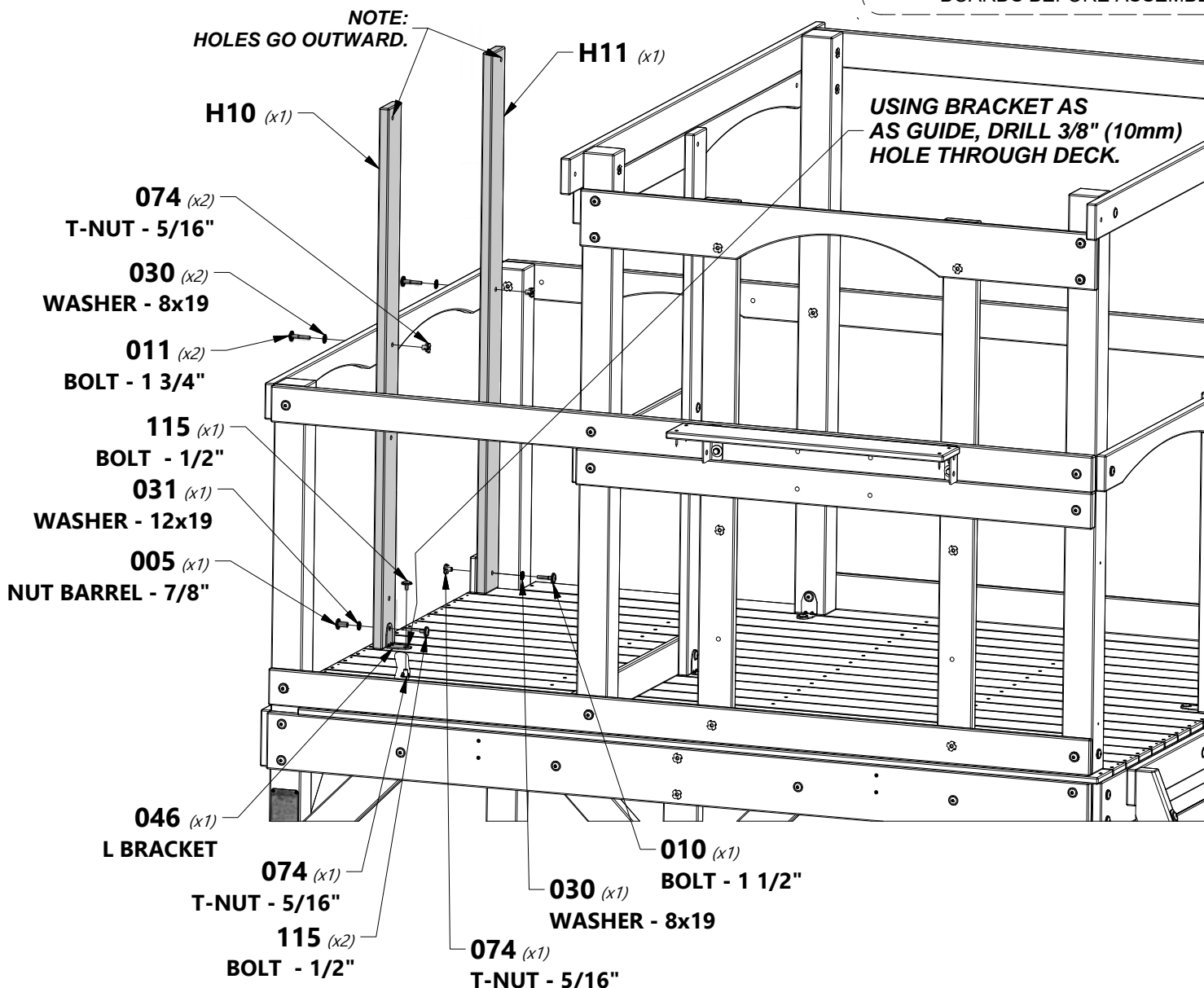

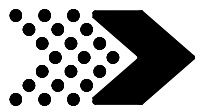

M8 CLUB HOUSE WALL BOARD - W4L04630
 (2) 5/8"x3 3/8"x50 1/2" (16x86x1284)

N1 CLUB HOUSE WALL BOARD - W4L04629
 (2) 5/8"x2 3/8"x50 1/2" (16x60x1284)

H100088 SCREW PFH
 (56) 8x1 1/8"

M9 CLUB HOUSE WALL BOARD - W4L04631
 (2) 5/8"x3"x50 1/2" (16x76x1284)

M23 CLUB HOUSE WALL BOARD - W4L04634
 (2) 5/8"x3 1/8"x29 7/8" (16x80x758)

M22 CLUB HOUSE WALL BOARD - W4L04633
 (4) 5/8"x3 3/8"x29 7/8" (16x86x758)

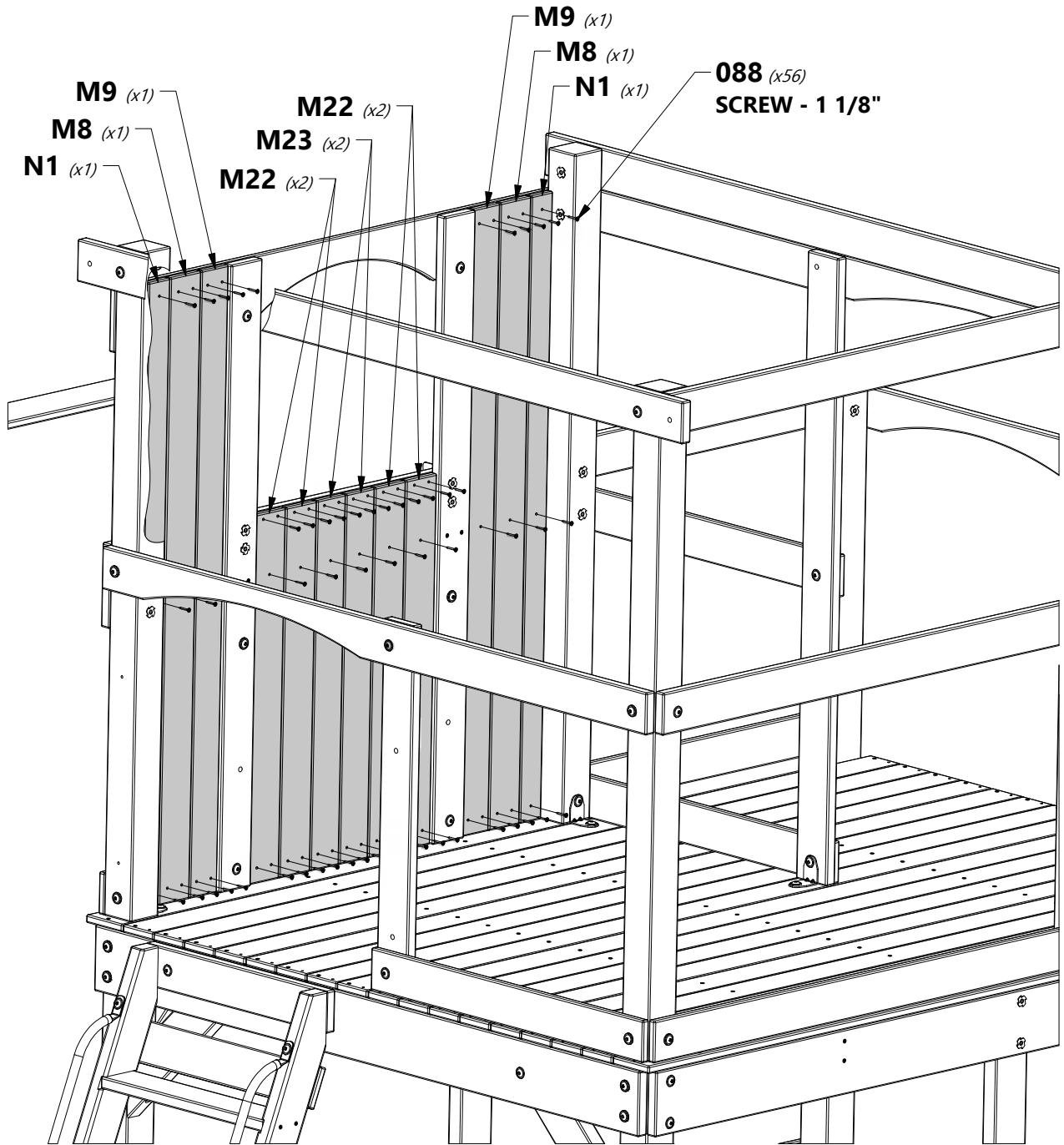



M26 | WALL BOARD - W4L04636
(2) | 5/8"x3 3/8"x26 1/8" (16x86x664)



M24 | WALL BOARD - W4L04632
(6) | 5/8"x3 3/8"x29 7/8" (16x86x758)



M6 | CLUB HOUSE WALL BOARD - W4L04635
(1) | 5/8"x3 3/8"x53 7/8" (16x86x1370)



H100088 | SCREW PFH
(38) | 8x1 1/8

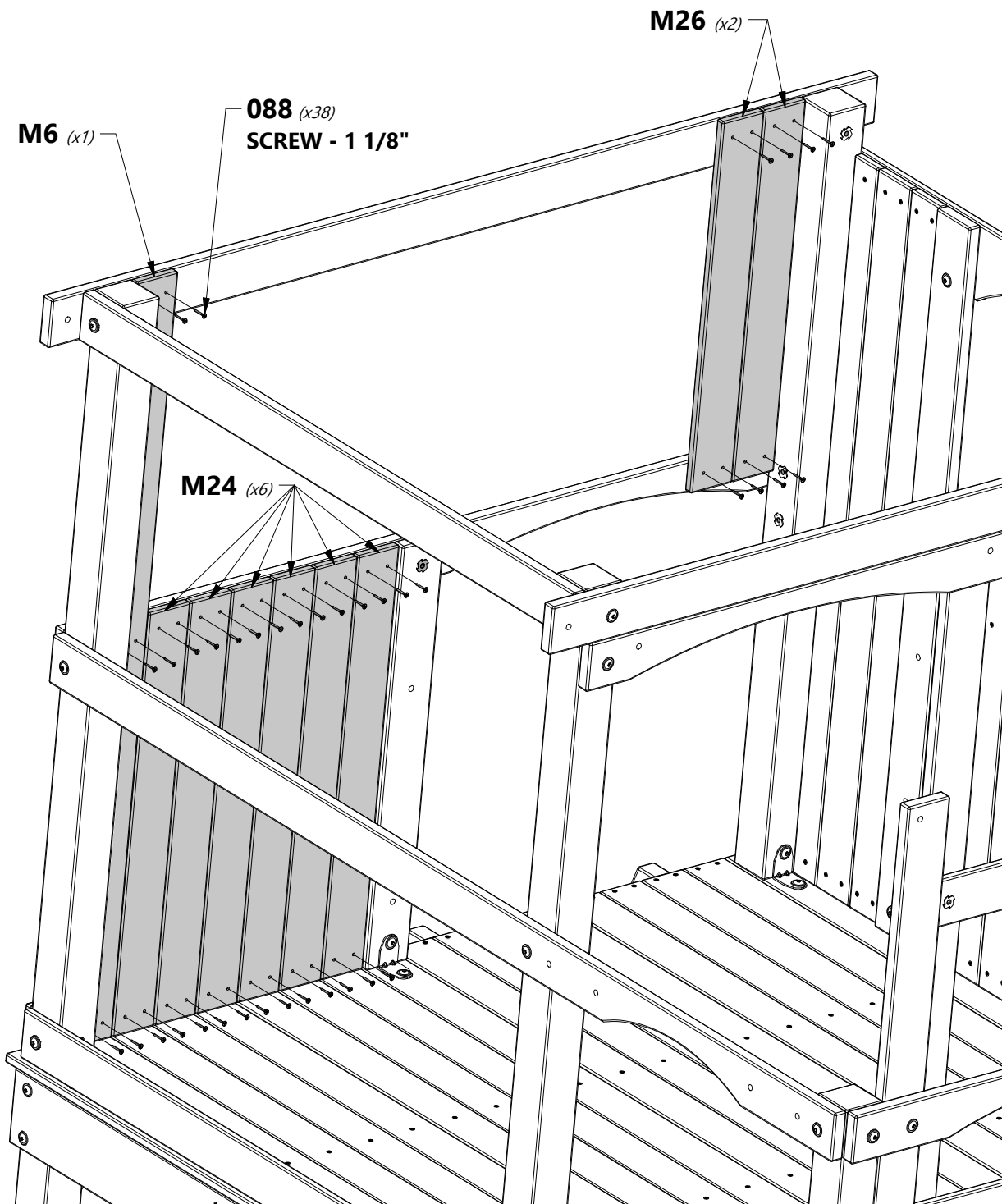

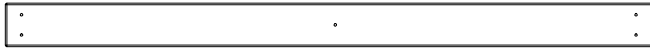
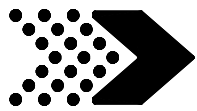

M8 | FORT WALL BOARD - W4L15914
(5) | 5/8"x3 3/8"x50 1/2" (16x86x1284)



M33 | FRONT WINDOW WALL BOARD - W4L04638
(2) | 5/8"x3 3/8"x6 3/8" (16x86x162)



M17 | FRONT WINDOW WALL BOARD - W4L04639
(2) | 5/8"x3 3/8"x35" (16x86x889)



H100088 | SCREW PFH
(35) | 8x1 1/8

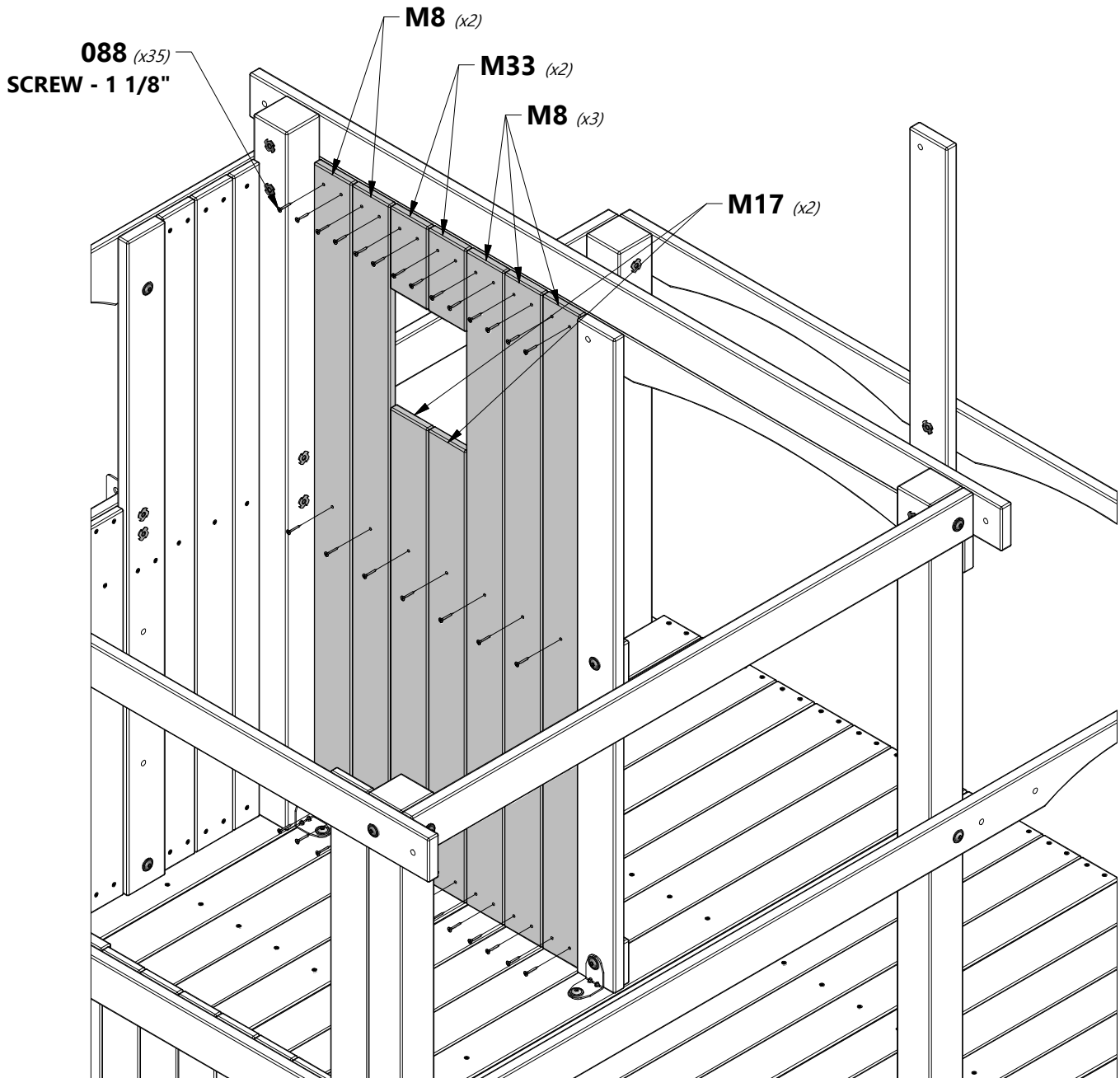

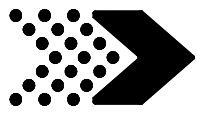

M24 | WALL BOARD - W4L04632
(13) | 5/8"x3 3/8"x29 7/8" (16x86x758)



H100088 | SCREW PFH
(52) | 8x1 1/8"

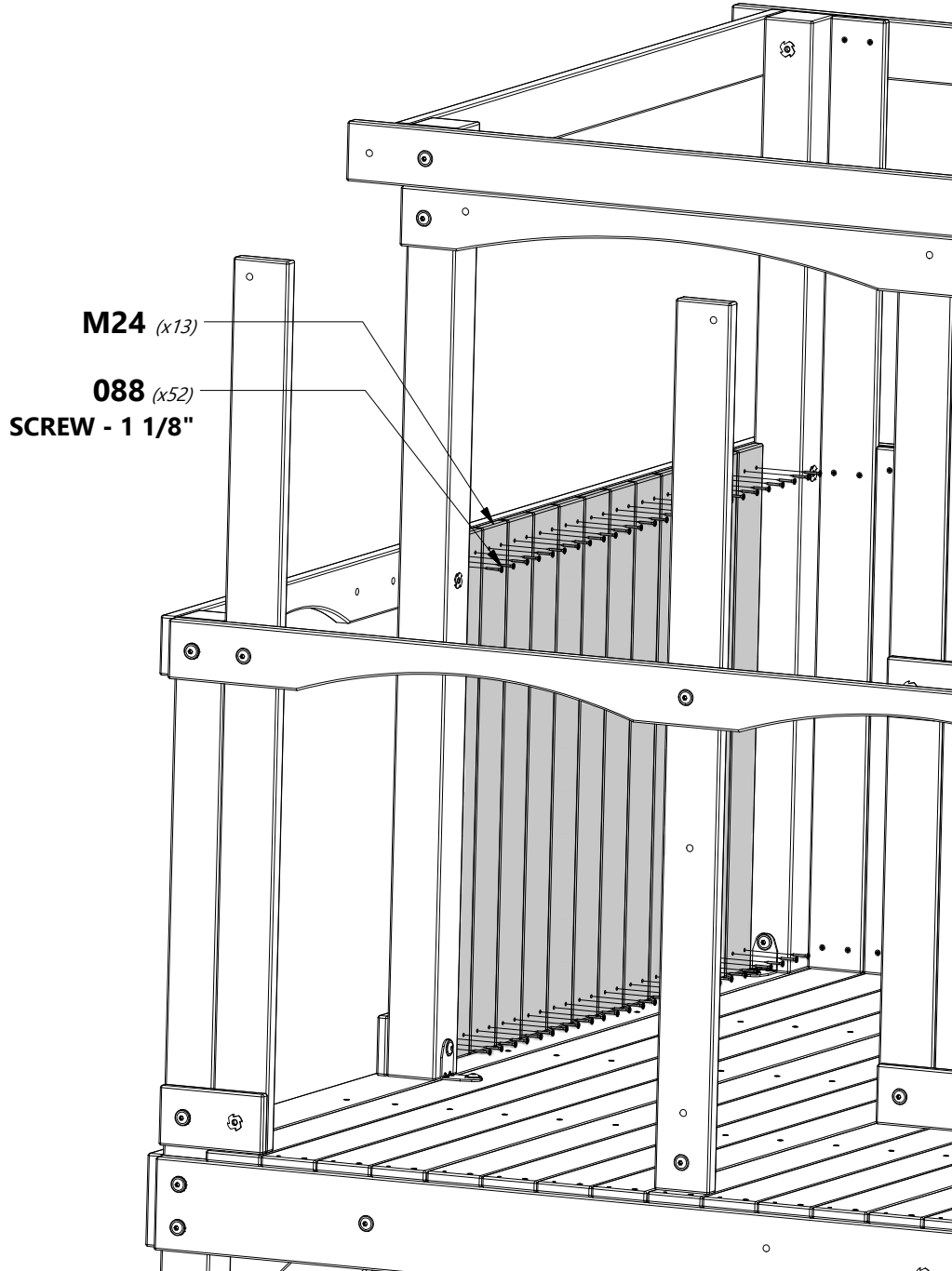

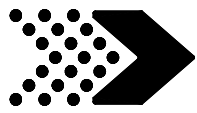

M15 | WALL BOARD - W4L15943
(4) | 5/8"x3 3/8"x29 7/8" (16x86x758)



H100088 | SCREW PFH
(16) | 8x1 1/8



2 5/8 in
EQUAL SPACING

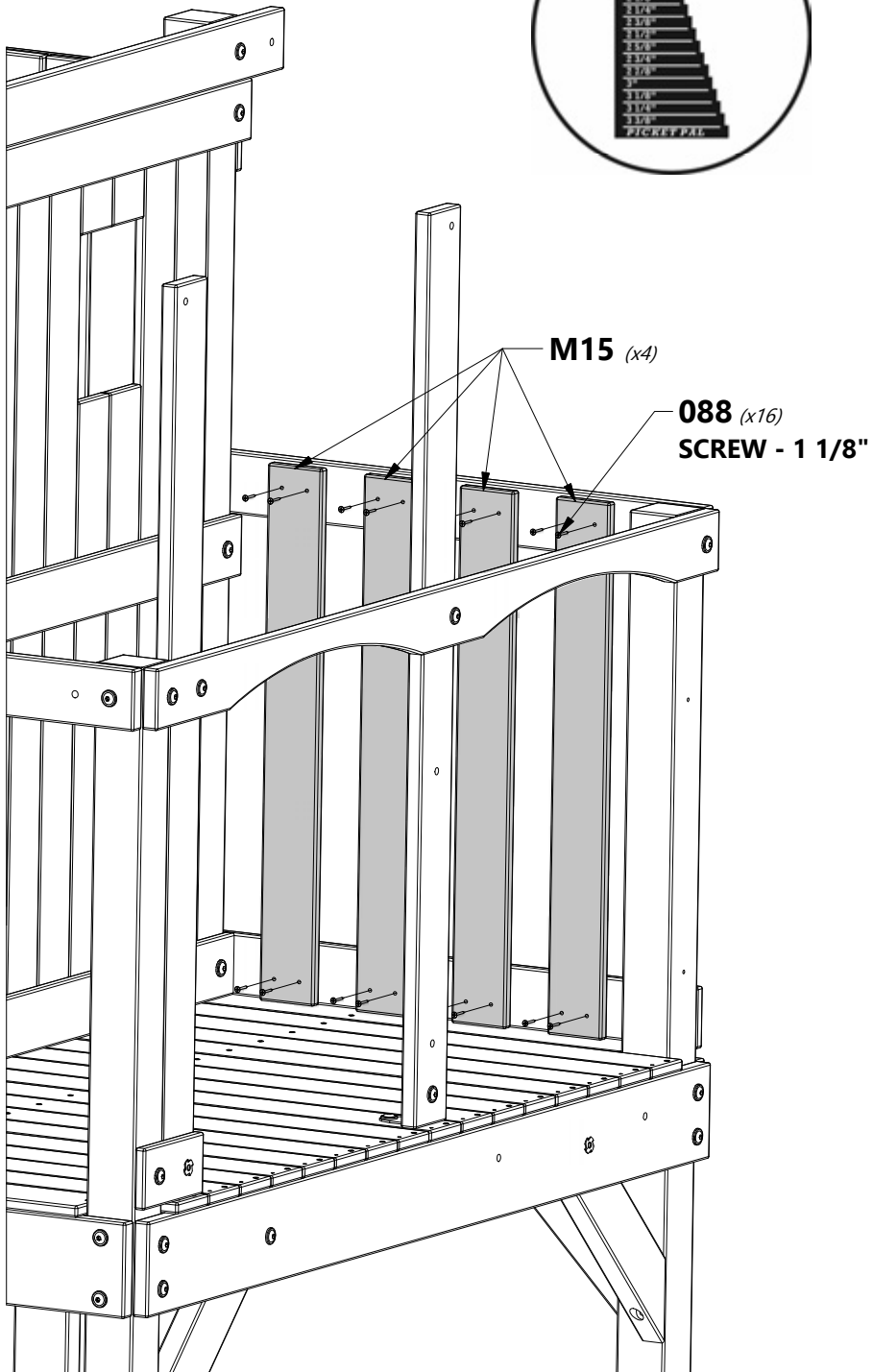
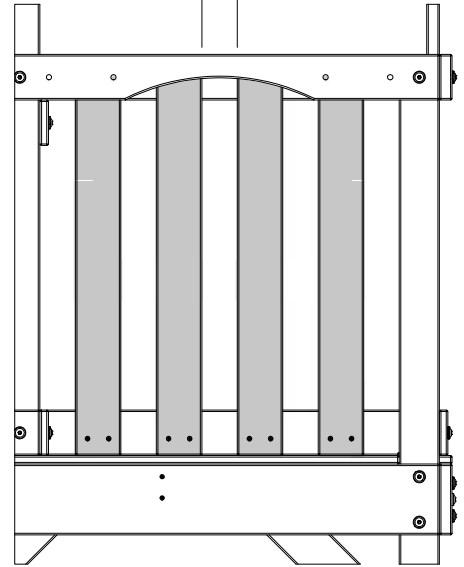

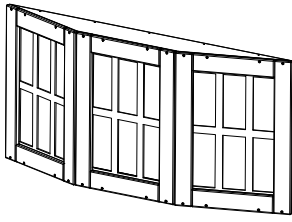
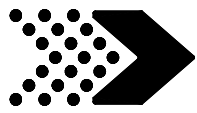

(2) BAY WINDOW ASSEMBLY



H100111 | SCREW PFH
(20) | 8x2



H100128 | SCREW PWH
(24) | 8x5/8

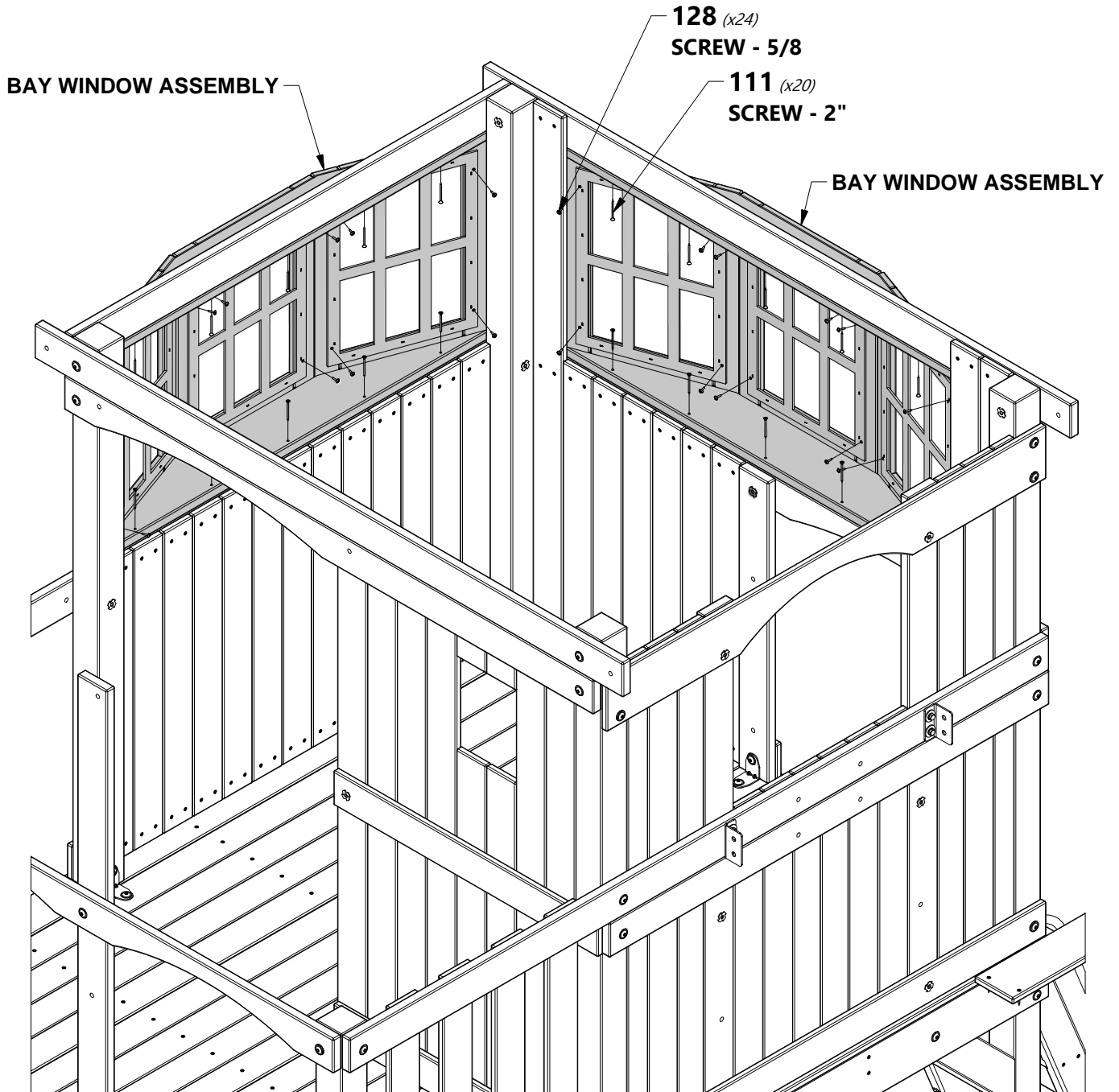

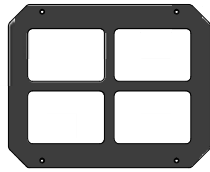
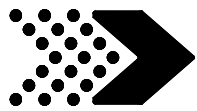

A100146 | WINDOW
(1) | 216x267 GREEN



H100070 | SCREW PWH
(4) | 8x3/4

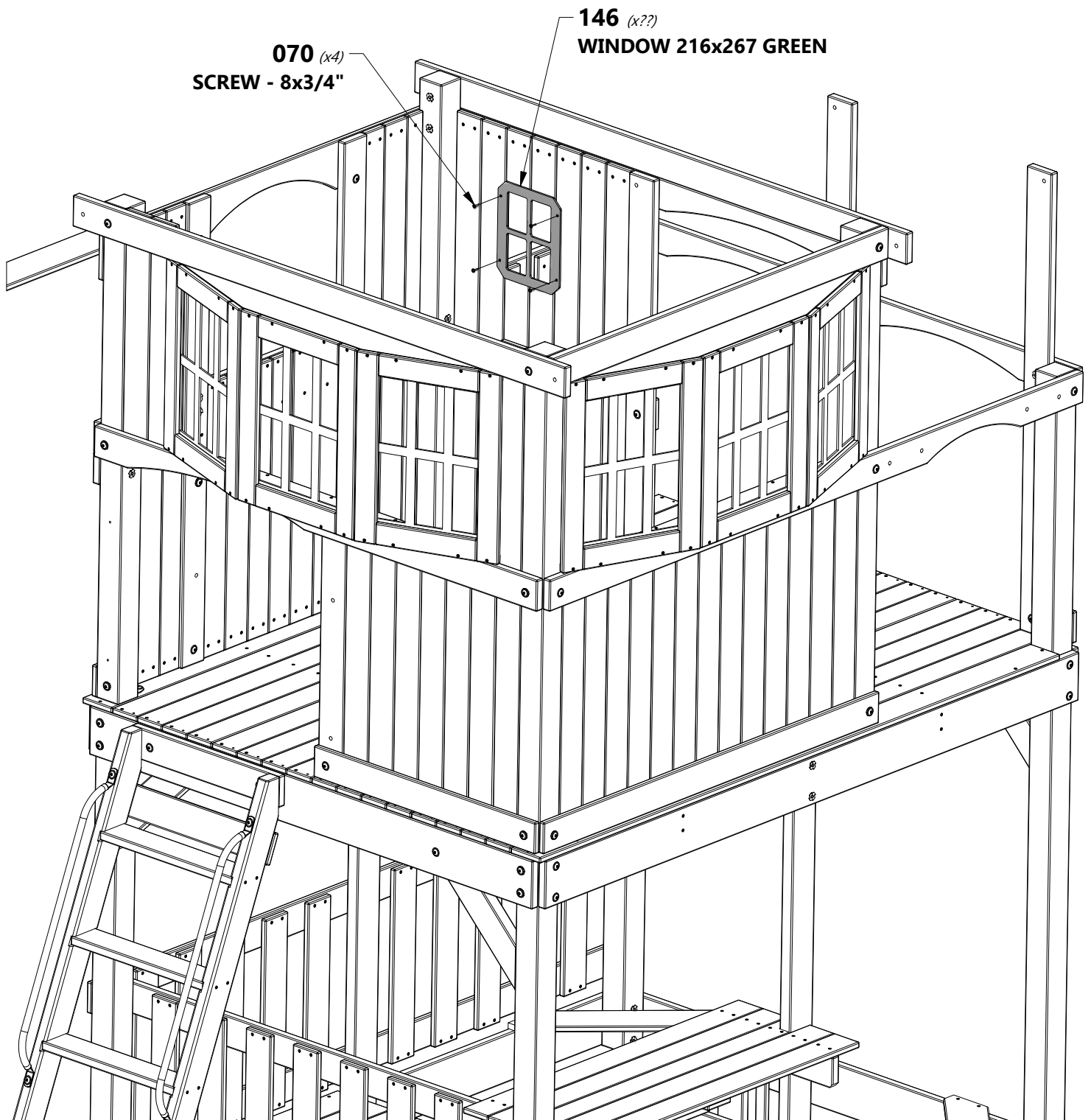

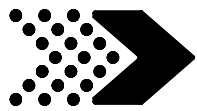

A100324 | LADDER RUNG
(2) | 578 GREEN

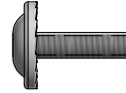

H100008 | BOLT WH
(4) | 5/16x1

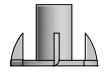

H100074 | T-NUT
(4) | 5/16



TIP:
INSTALL T-NUTS INTO
BOARDS BEFORE ASSEMBLY.

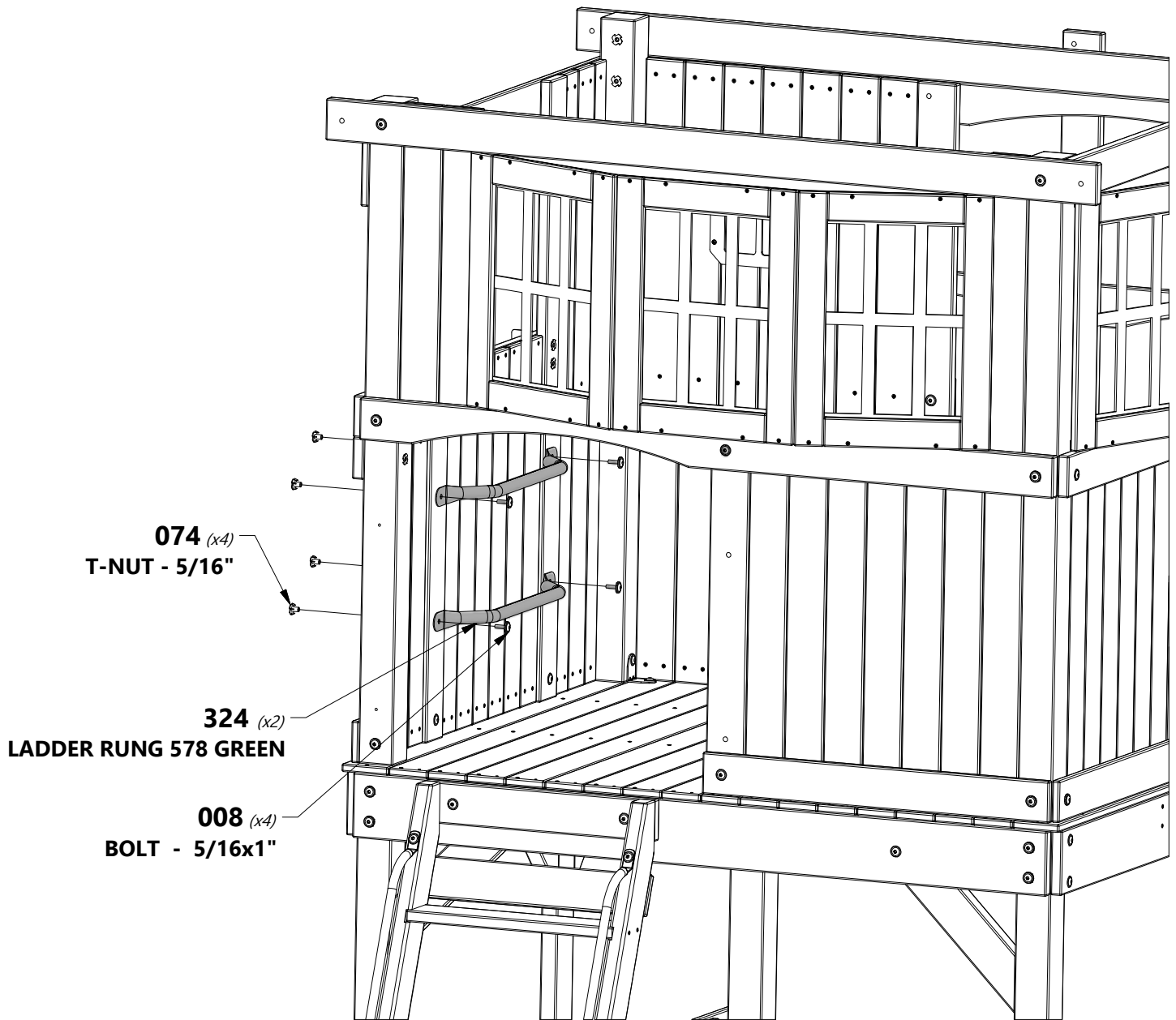

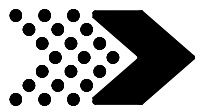

H12 | ROOF RAFTER - W4L04640
(4) | 1"x3 3/8"x50 3/8" (24x86x1278)



H100011 | BOLT WH
(4) | 5/16x1 3/4

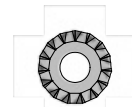

H100030 | WASHER LOCK
(4) | EXT
8x19



H100091 | SCREW PFH
(2) | 8X2 1/4

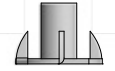

H100074 | T-NUT
(4) | 5/16



TIP:
INSTALL T-NUTS INTO
BOARDS BEFORE ASSEMBLY.

USING A 3/16" DRILL BIT, MARK AND DRILL A PILOT
HOLE INTO 'H12' RAFTER TO PREVENT SPLITTING.
ONLY DRILL THROUGH ONE RAFTER NOT BOTH.

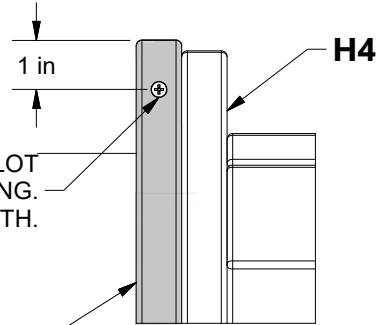

H12 (x4)

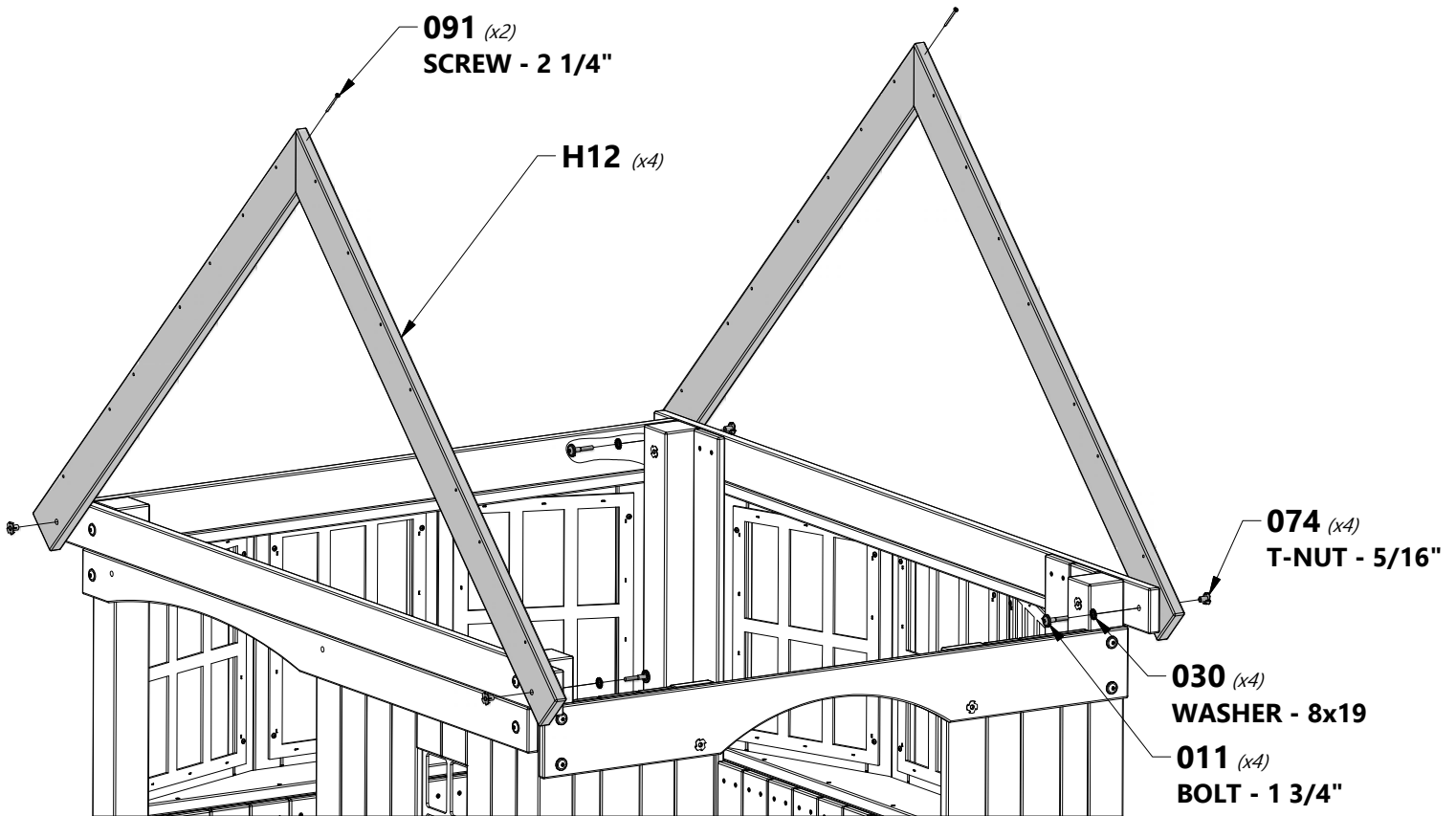

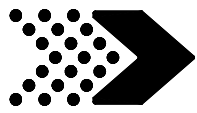

M5 | GABLE BOARD - W4L04641
(2) | 5/8"x3 3/8"x59 1/2" (16x86x1510)



M7 | GABLE BOARD - W4L04642
(2) | 5/8"x3 3/8"x52 5/8" (16x86x1338)



H100088 | SCREW PFH
(8) | 8x1 1/8

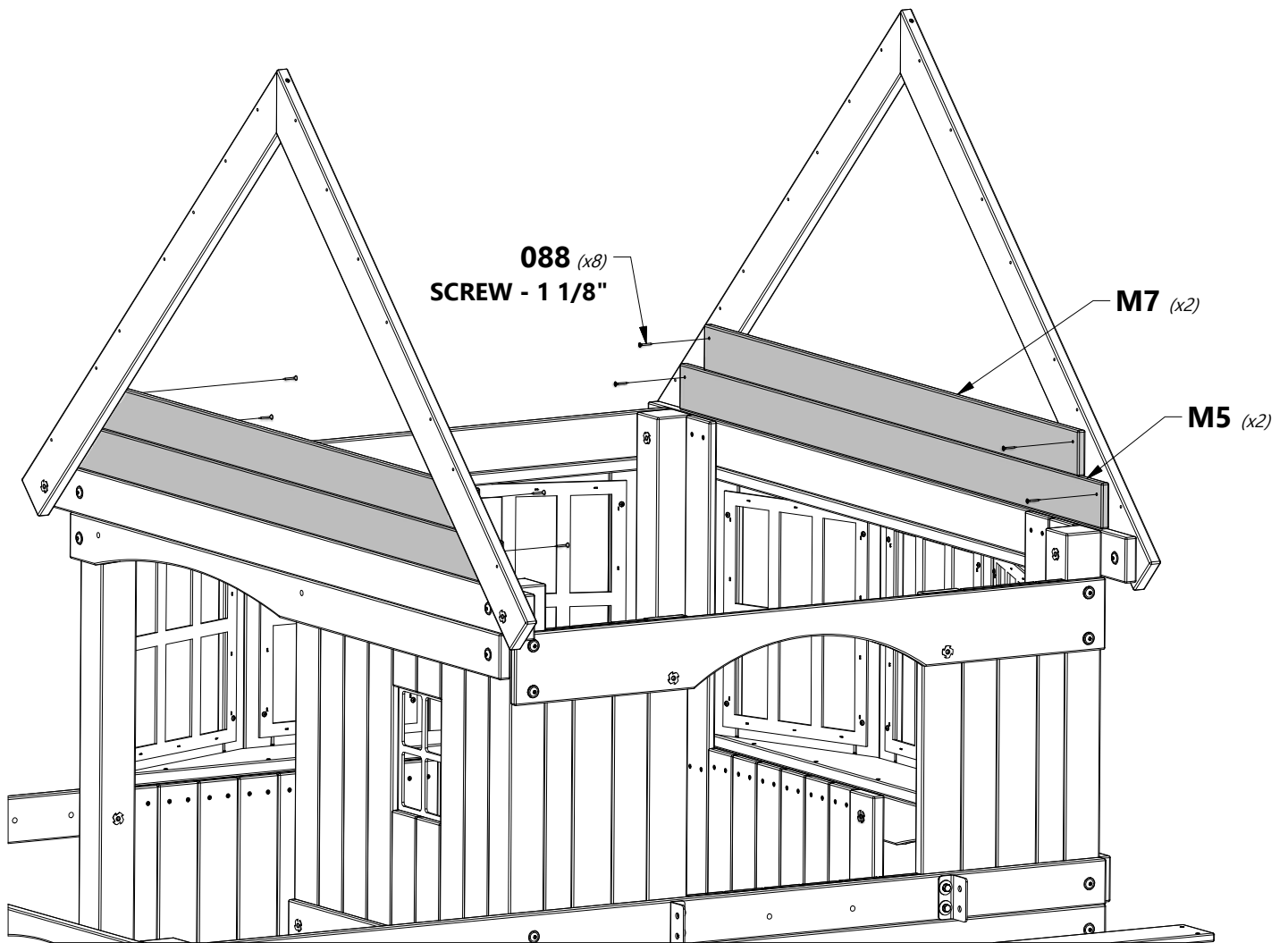

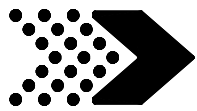

N6 | WINDOW TRIM - W4L04646
 (2) | 5/8"x2 3/8"x12 1/4" (16x60x310)

M29 | GABLE WINDOW BOARD - W4L04643
 (2) | 5/8"x3 3/8"x16 1/8" (16x86x410)

M31 | GABLE WINDOW BOARD - W4L04644
 (2) | 5/8"x3 3/8"x12 3/4" (16x86x324)

H100088 | SCREW PFH
 (18) | 8x1 1/8

N10 | GABLE BOARD - W4L04645
 (1) | 5/8"x2 3/8"x27 5/8" (16x60x702)

M28 | GABLE WINDOW BOARD - W4L04647
 (2) | 5/8"x3 3/8"x19 1/2" (16x86x496)

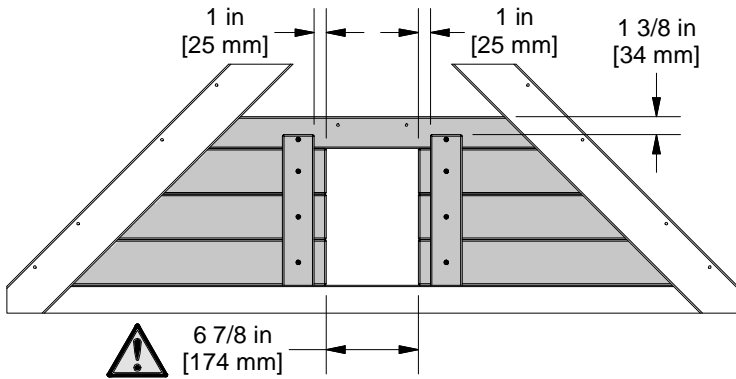

088 (x18)
 SCREW - 1 1/8"

N10 (x1)

N6 (x2)

M31 (x2)

M29 (x2)

M28 (x2)

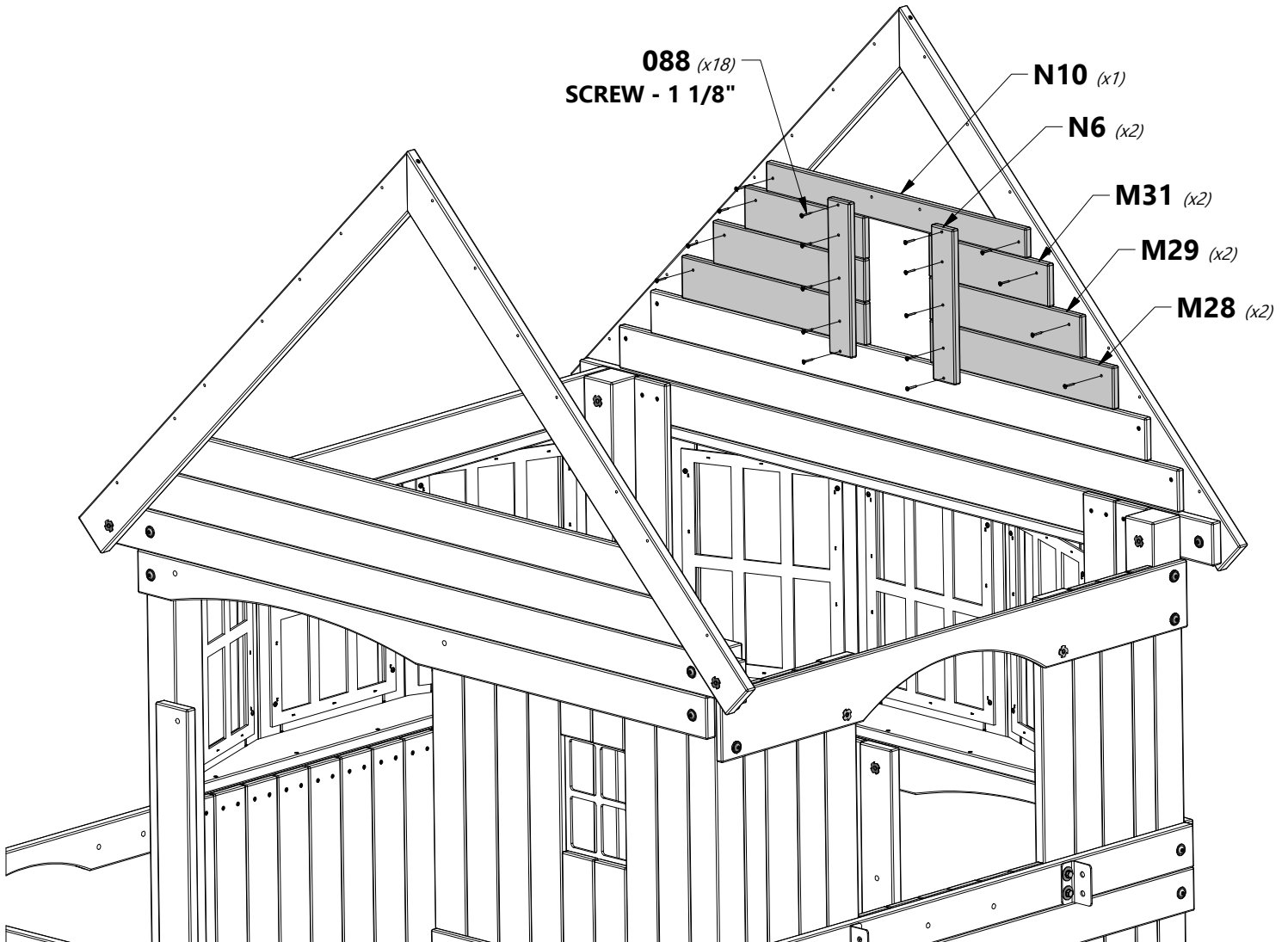



N10 | GABLE BOARD - W4L04645
 (1) | 5/8"x2 3/8"x27 5/8" (16x60x702)

M14 | GABLE BOARD - W4L04651
 (1) | 5/8"x3 3/8"x39 1/8" (16x86x994)

M18 | GABLE BOARD - W4L04652
 (1) | 5/8"x3 3/8"x32 3/8" (16x86x822)

M12 | GABLE BOARD - W4L04650
 (1) | 5/8"x3 3/8"x45 7/8" (16x86x1166)

 **H100088** | SCREW PFH
 (8) | 8x1 1/8

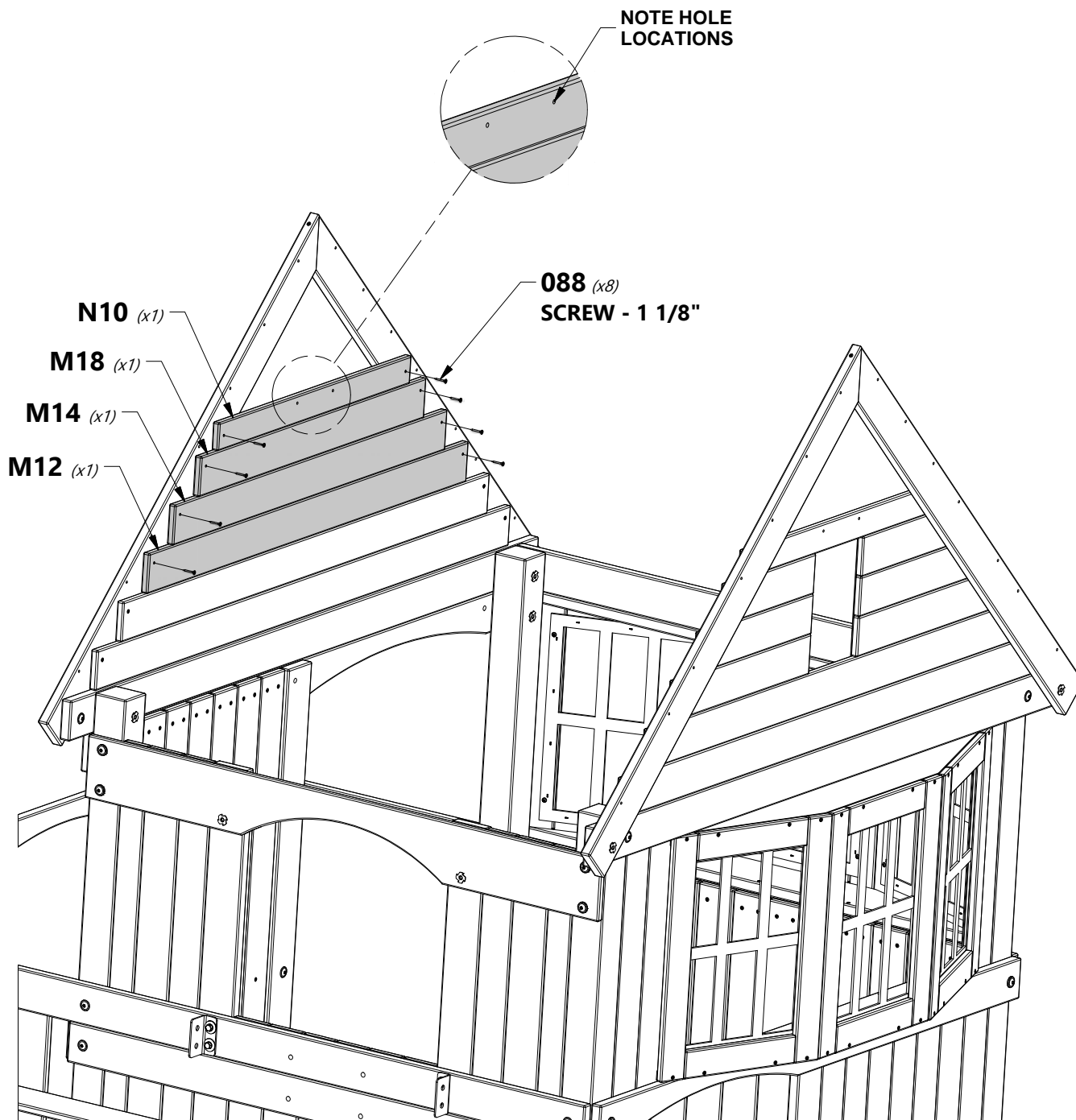

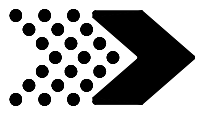

N7 | GABLE TRIM - W4L04648
(2) | 5/8"x2 3/8"x11 1/2" (16x60x292)



N9 | GABLE TRIM - W4L04649
(4) | 5/8"x2 3/8"x6 1/2" (16x60x165)

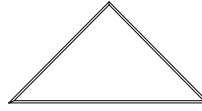

K6 | TRIANGLE SUNBURST - W4L04827
(2) | 5/8"x5 1/4"x10 3/8" (16x134x265)



H100088 | SCREW PFH
(22) | 8x1 1/8

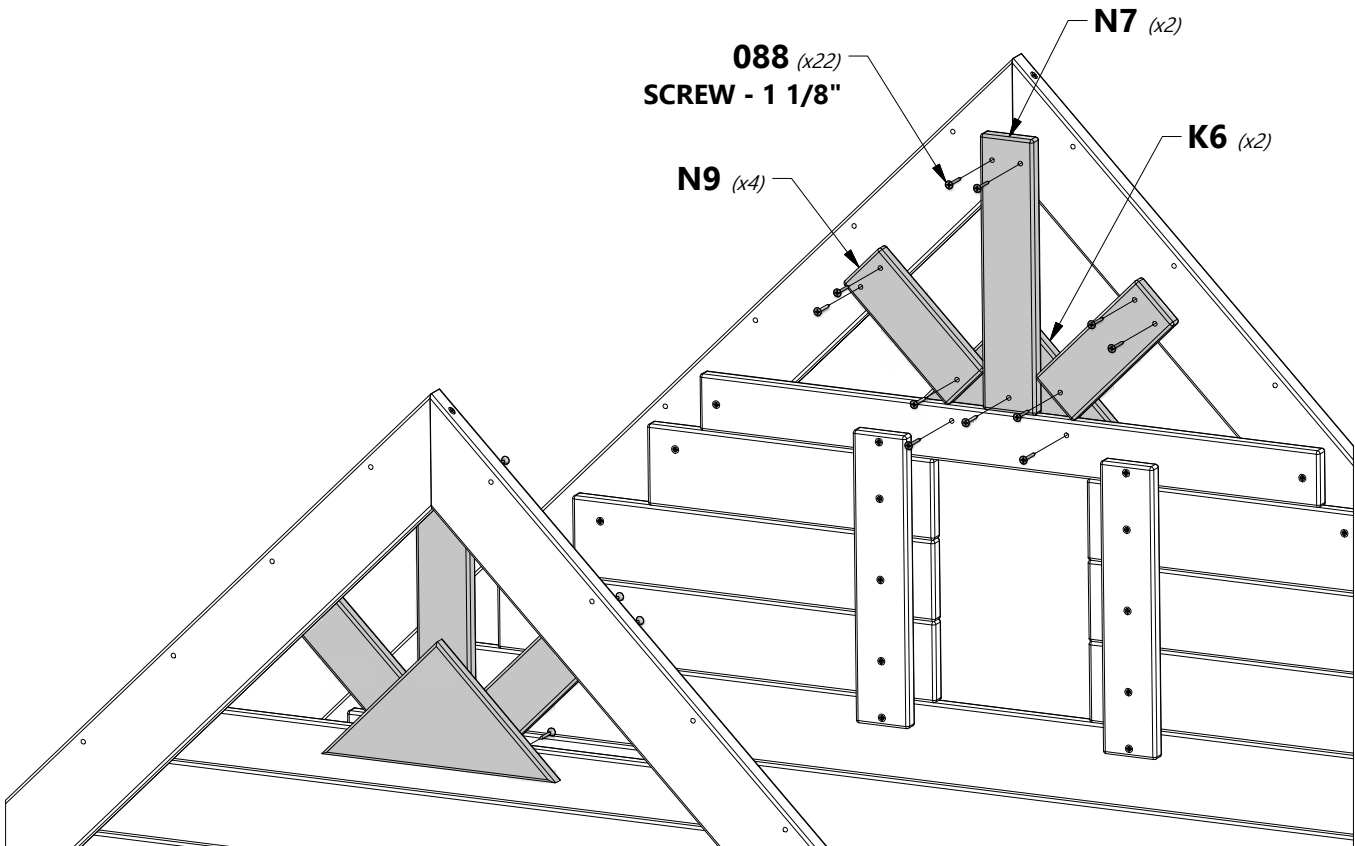
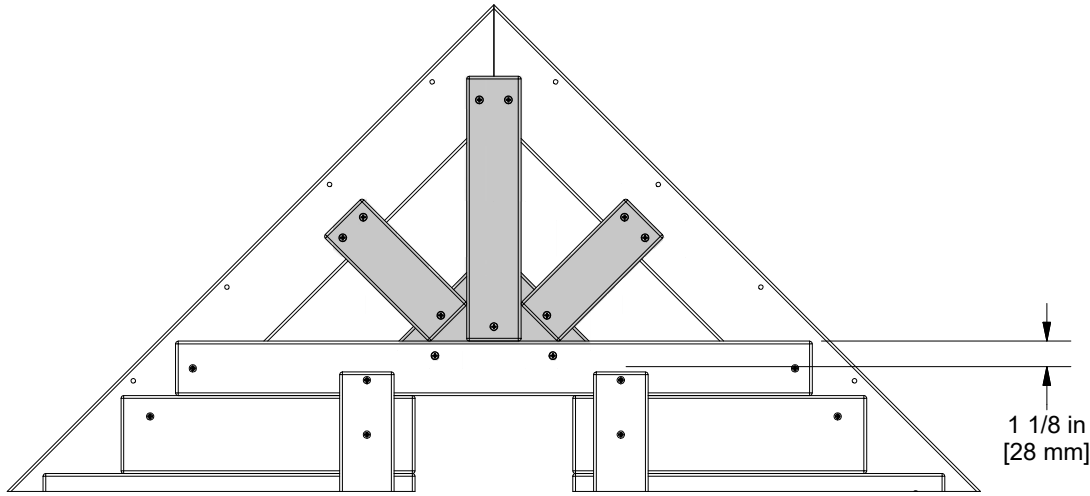

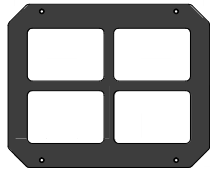
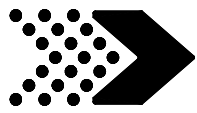

A100146 | WINDOW
(1) | 216x267 GREEN



H100070 | SCREW PWH
(4) | 8x3/4

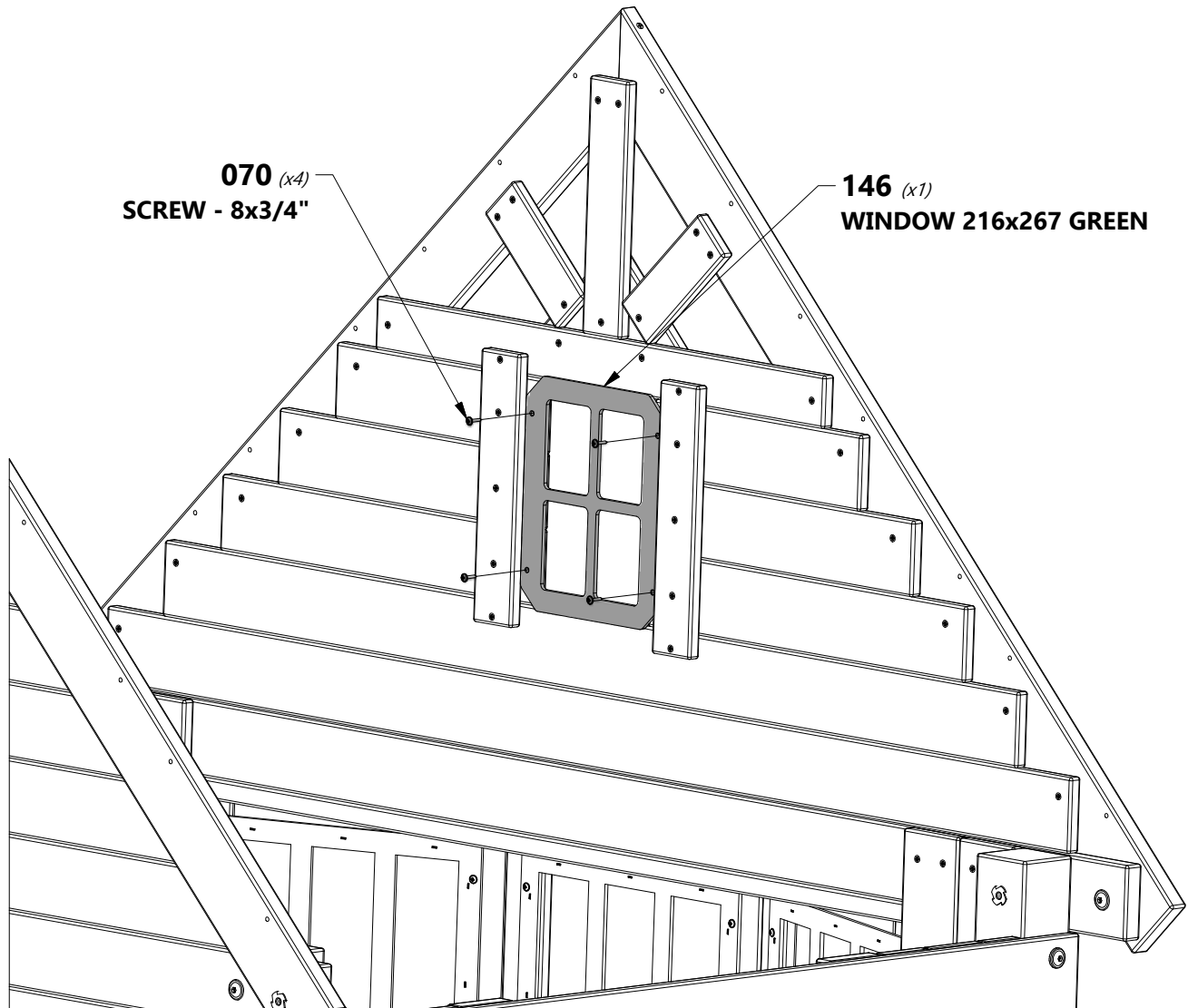

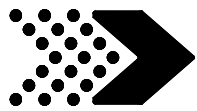

M11 | SOFFIT CAP - W4L04653
(1) 5/8"x3 3/8"x50 1/4" (16x86x1277)

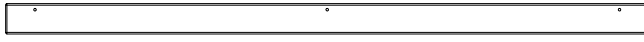

N2 | SOFFIT CAP - W4L04654
(1) 5/8"x2 3/8"x50 1/4" (16x60x1277)



H100086 | SCREW PFH
(6) 8x1 1/2

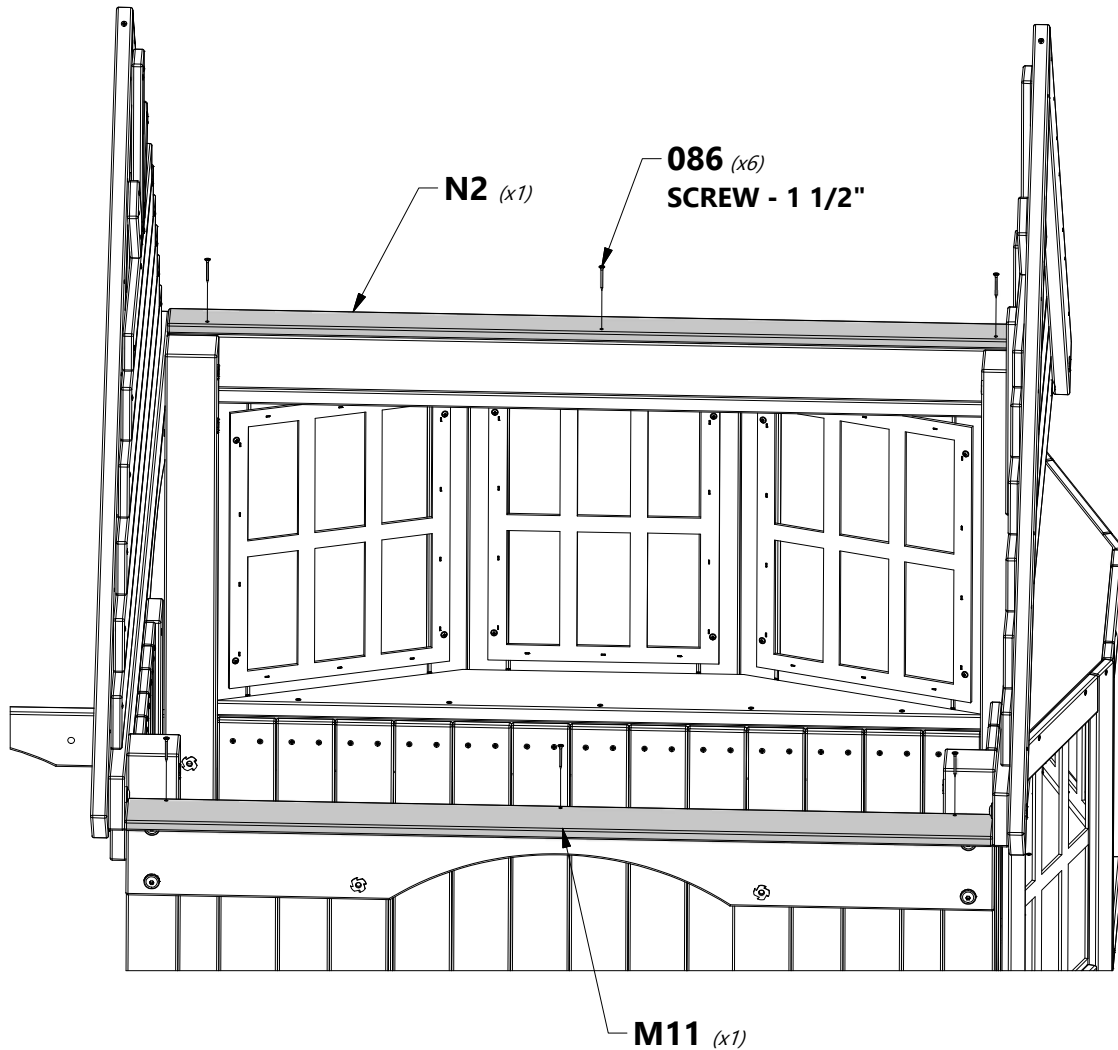
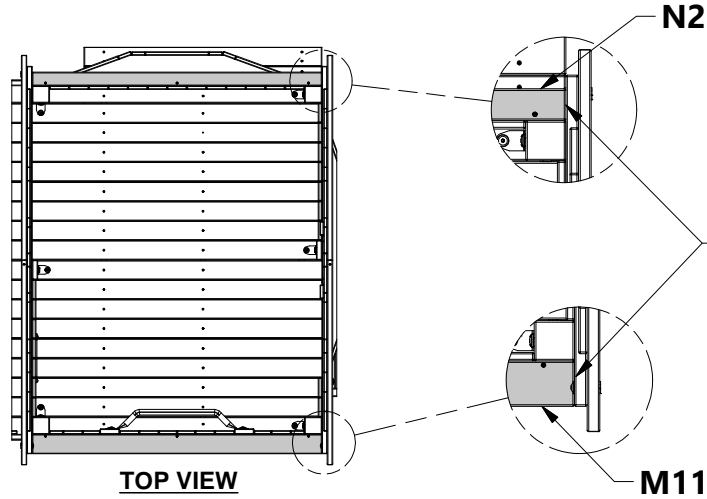

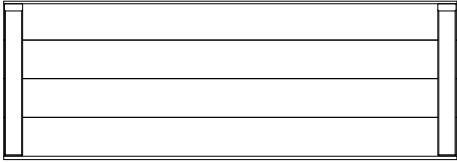
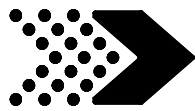

RP3 | PEAK ROOF PANEL - W2A02626
(1) | 1 5/8"x20 5/8"x59" (42x524x1499)

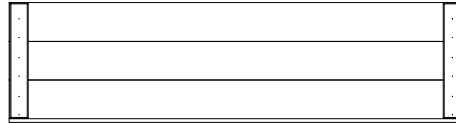

RP6 | ROOF PANEL - W2A02627
(2) | 1 5/8"x15 5/8"x59" (42x396x1499)



H100091 | SCREW PFH
(14) | 8X2 1/4

NOTE:
START WITH TOP PANEL FIRST.
FLUSH EDGES.

091 (x14)
SCREW - 2 1/4"

RP3 (x1)
PEAK ROOF PANEL

RP6 (x2)
ROOF PANEL

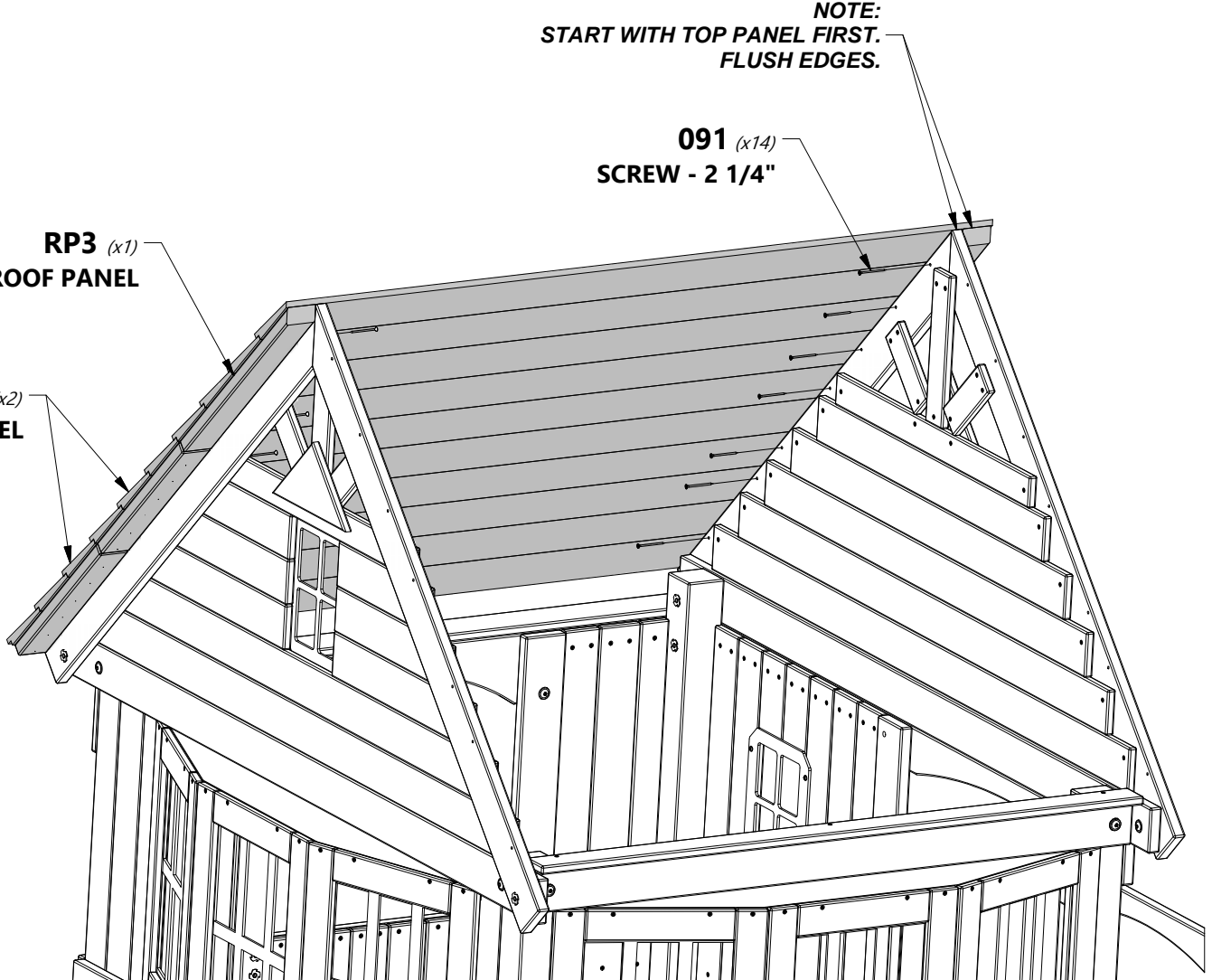

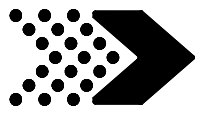

N3 | ROOF SUPPORT - W103535
(1) | 5/8"x2 3/8"x47" (16x60x1193)



H100088 | SCREW PFH
(9) | 8x1 1/8

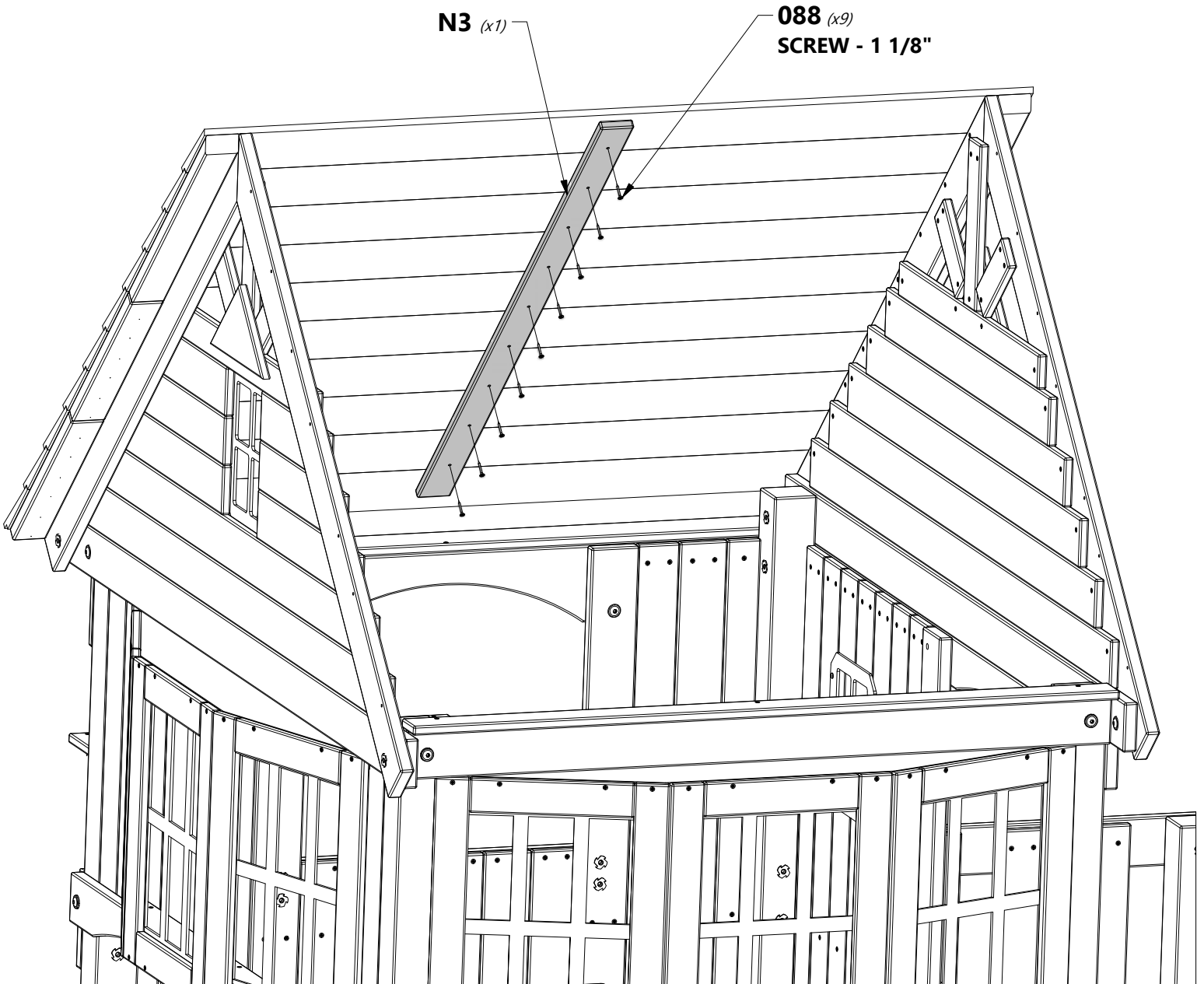
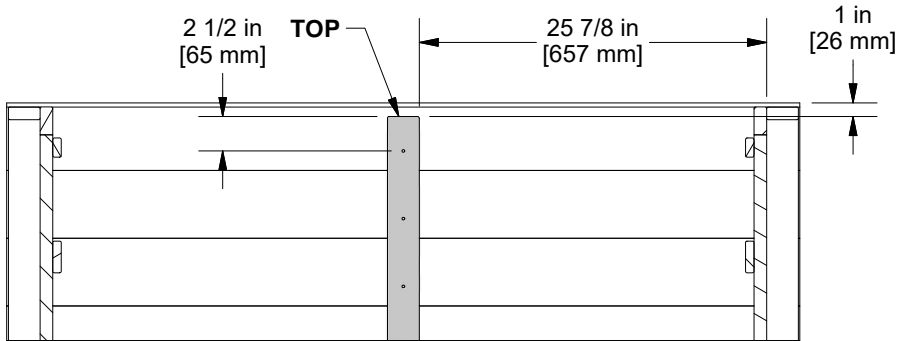

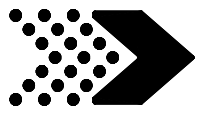

**REPEAT STEPS 49 & 50 TO ATTACH LEFT
SIDE ROOF PANELS.**

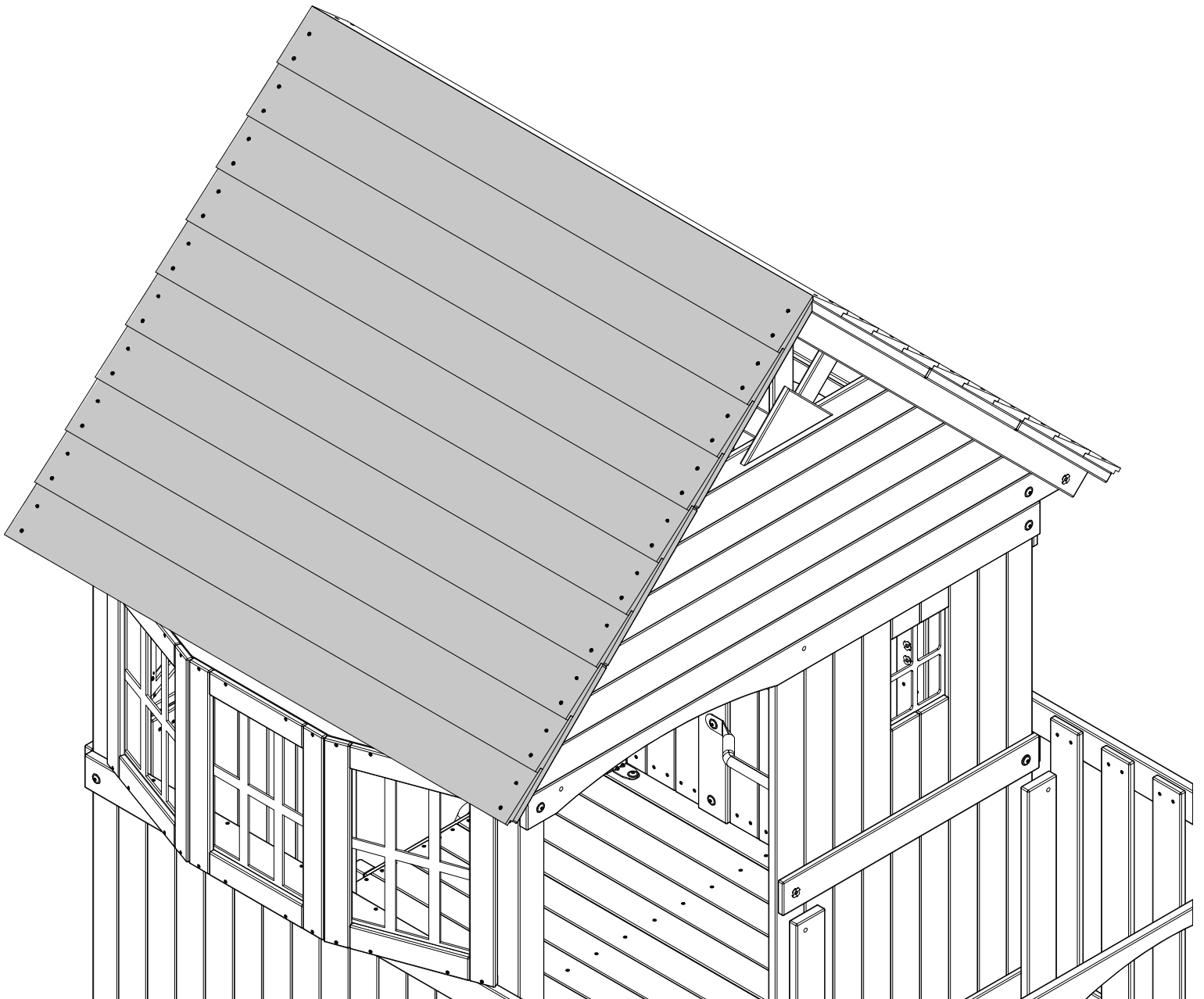

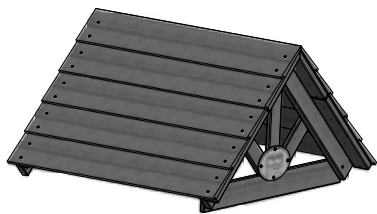
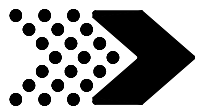

(1) PORCH ROOF ASSEMBLY



H100015 | BOLT WH
(1) | 5/16x2 3/4



H100014 | BOLT WH
(2) | 5/16x2 1/2



H100030 | WASHER LOCK
(4) | EXT
8x19



H100011 | BOLT WH
(1) | 5/16x1 3/4

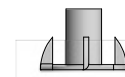

H100074 | T-NUT
(4) | 5/16

 **TIP:**
INSTALL T-NUTS INTO
BOARDS BEFORE ASSEMBLY.

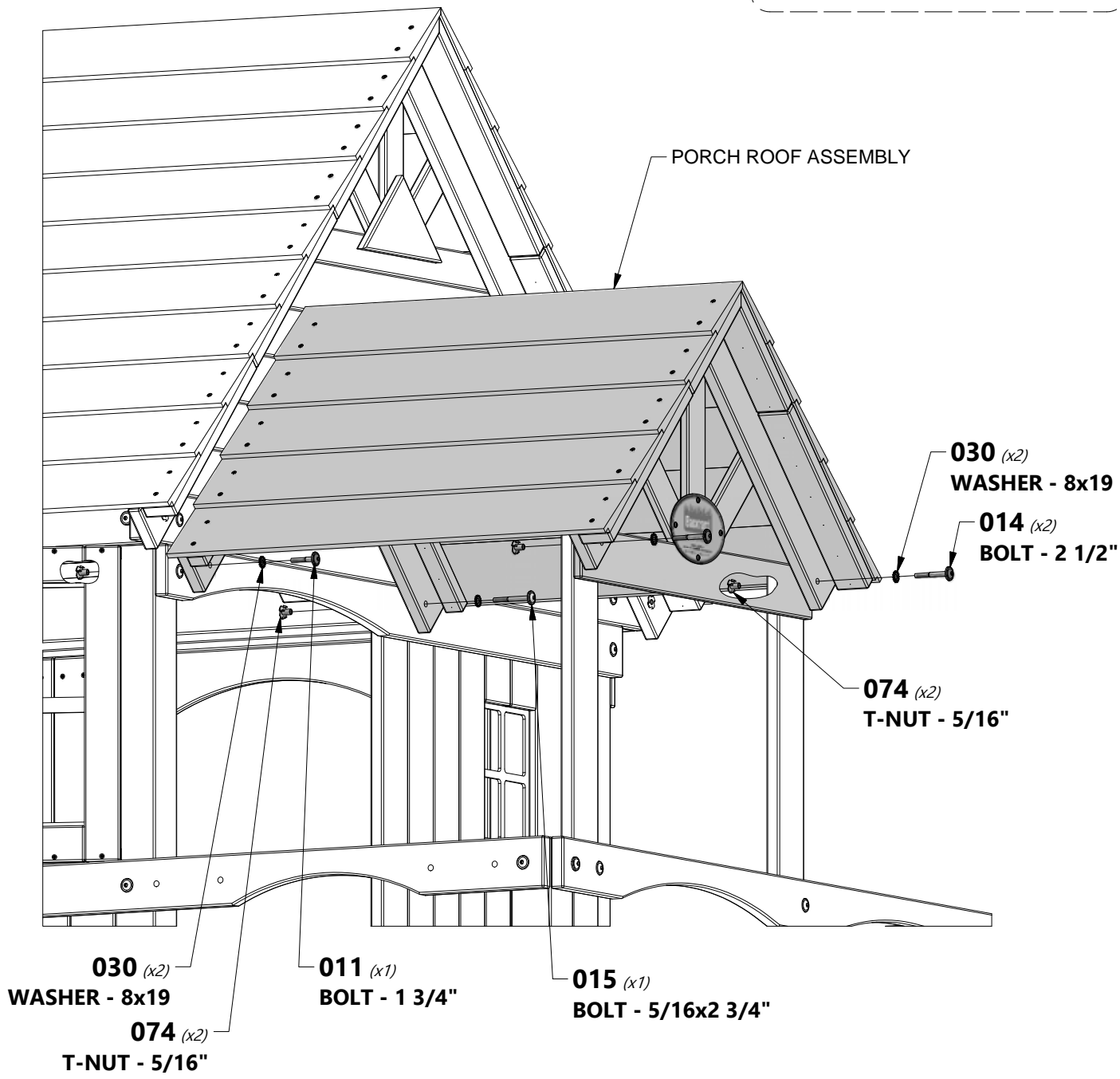

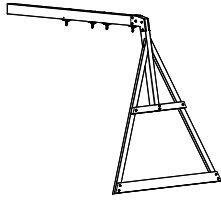
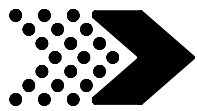

(1) SWING BEAM ASSEMBLY



H100043 | BOLT HEX
(4) | 5/16x1 3/4



H100095 | WASHER SPLIT
(4) | 5/16



H100074 | T-NUT
(4) | 5/16



H100105 | WASHER FLAT
(4) | 8x27

- 095 (x4) WASHER - 5/16"
- 105 (x4) WASHER - 8x27
- 043 (x4) BOLT - 1 3/4"

 **TIP:**
INSTALL T-NUTS INTO
BOARDS BEFORE ASSEMBLY.

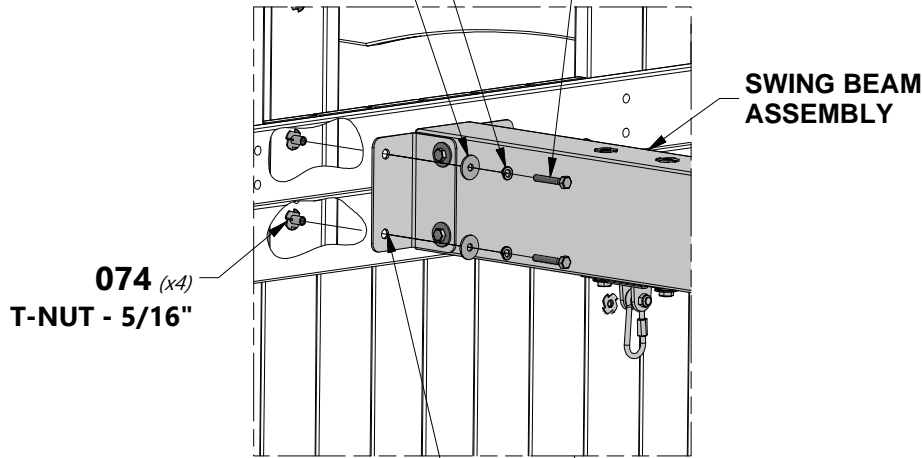

USING BRACKETS AS GUIDE,
DRILL 3/8" HOLES

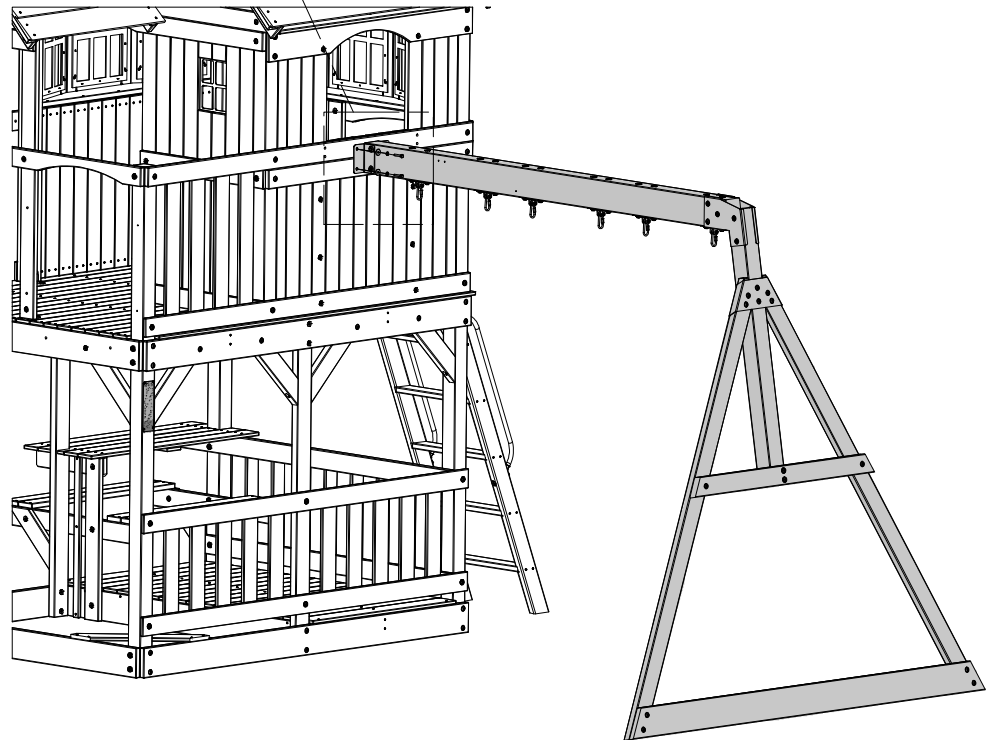

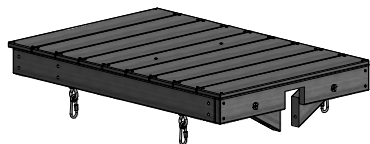

(1) CROW'S NEST DECK ASSEMBLY



H100649 | LAG SCREW WH
(2) | 1/4x2 1/2

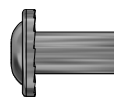

H100005 | NUT BARREL WH
(4) | 5/16x7/8



H100042 | BOLT HEX
(4) | 5/16x1 1/4



H100086 | SCREW PFH
(2) | 8x1 1/2



H100105 | WASHER FLAT
(4) | 8x27



H100095 | WASHER SPLIT
(4) | 5/16



H100138 | WASHER LOCK
(2) | EXT
6x15



H100031 | WASHER LOCK
(4) | EXT
12x19



649 (x2)
LAG SCREW - 2 1/2"

138 (x2)
WASHER - 6x15

086 (x2)
SCREW - 1 1/2"
(TOP SIDE)

031 (x4)
WASHER - 12x19

005 (x4)
NUT BARREL - 7/8"

105 (x4)
WASHER - 8x27

095 (x4)
WASHER - 5/16"

042 (x4)
BOLT HEX - 1 1/4"

CROWS NEST ASSEMBLY



A100396 | L BRACKET
(2) | 51x32x82x3.175



H100066 | LAG SCREW
(8) | 5/16x1 1/2



H100095 | WASHER SPLIT
(8) | 5/16



H100105 | WASHER FLAT
(8) | 8x27

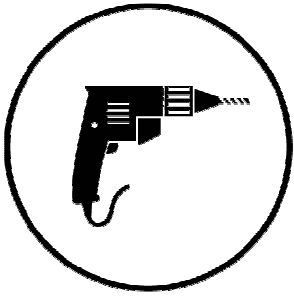

066 (x8)
LAG SCREW - 1 1/2"

095 (x8)
WASHER - 5/16"

105 (x8)
WASHER - 8x27

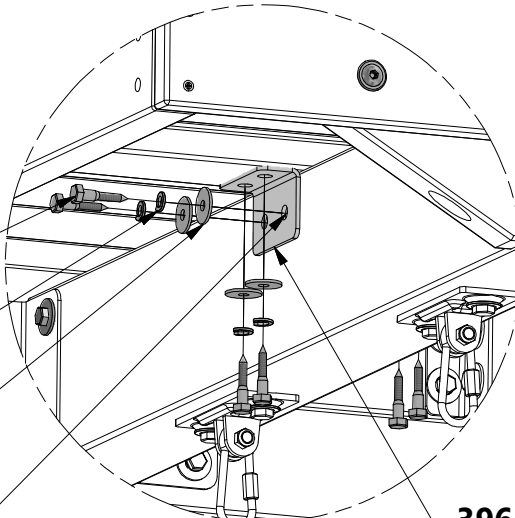

396 (x2)
L BRACKET

⚠ USING BRACKET AS GUIDE, DRILL 3/16 in [5 mm] HOLES.

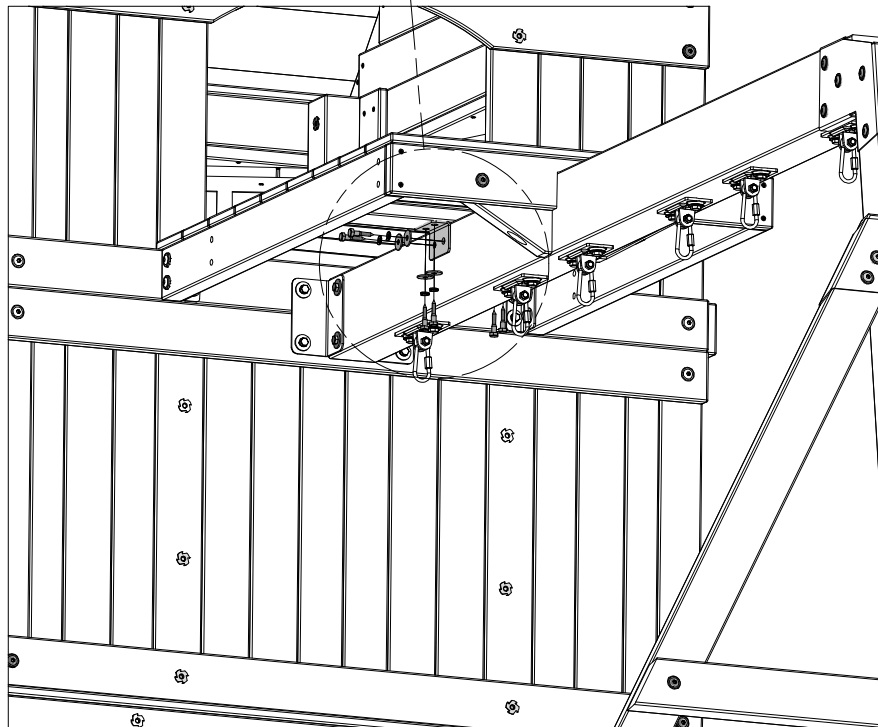

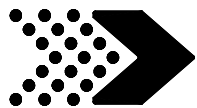

F03 | CROWS NEST WALL SUPPORT - W4L15909
(2) | 1 3/8"x2 3/8"x37 1/2" (36x60x952)



F02 | CROWS NEST WALL SUPPORT - W4L15908
(2) | 1 3/8"x2 3/8"x37 1/2" (36x60x952)

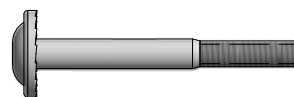

H100015 | BOLT WH
(8) | 5/16x2 3/4



H100030 | WASHER LOCK
(8) | EXT
8x19



H100074 | T-NUT
(4) | 5/16



TIP:
INSTALL T-NUTS INTO
BOARDS BEFORE ASSEMBLY.

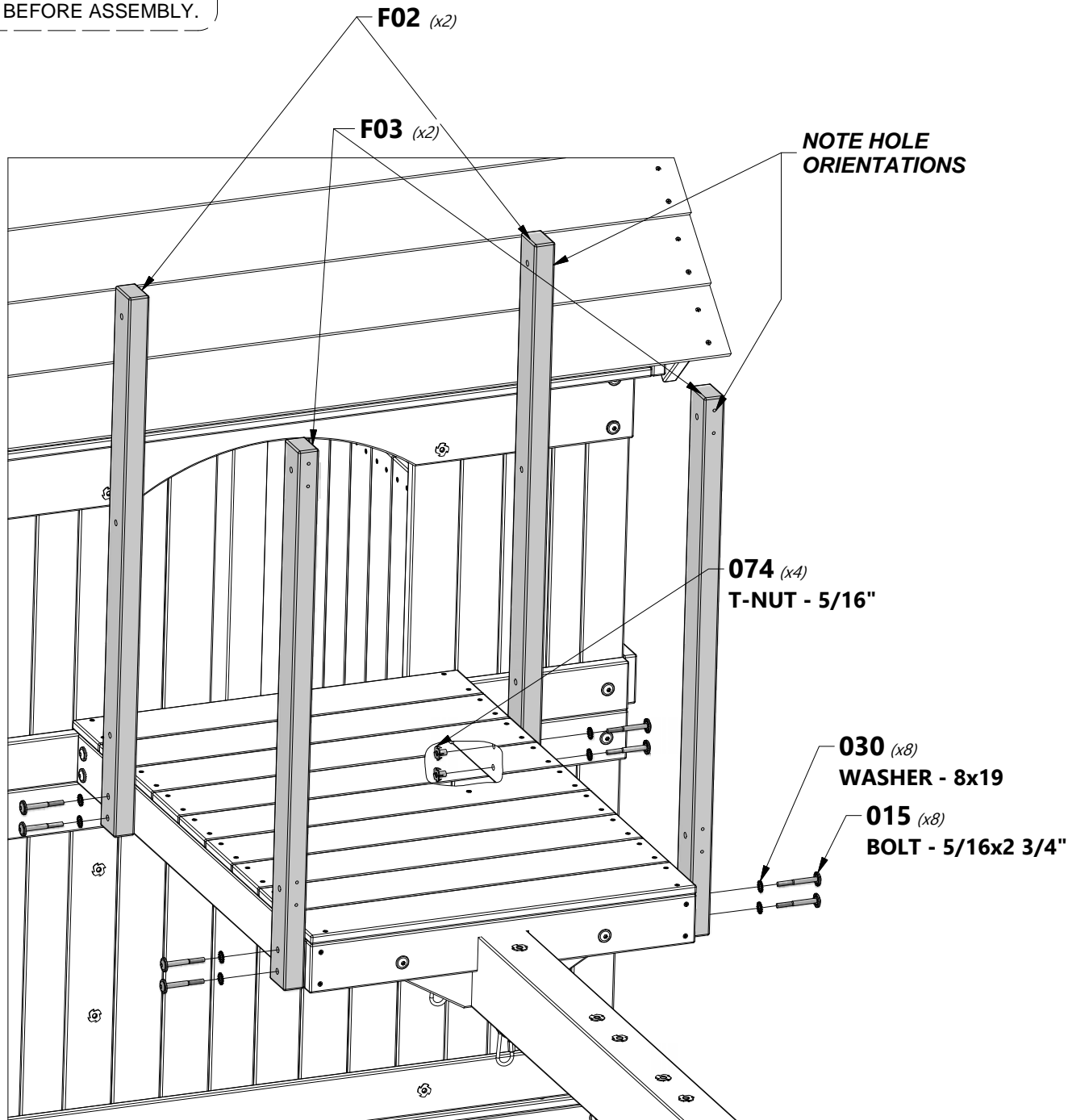

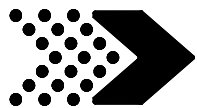

H31 | CROWS NEST WALL RAIL - W4L15907
(2) | 1"x3 3/8"x38 7/8" (24x86x988)



H30 | CROWS NEST WALL RAIL - W4L11782
(1) | 1"x3 3/8"x29 7/8" (24x86x758)



H100028 | LAG SCREW WH
(4) | 5/16x2 1/2

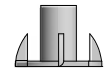

H100074 | T-NUT
(4) | 5/16



H100013 | BOLT WH
(4) | 5/16x2 1/4



H100030 | WASHER LOCK
(8) | EXT
8x19



TIP:
INSTALL T-NUTS INTO
BOARDS BEFORE ASSEMBLY.

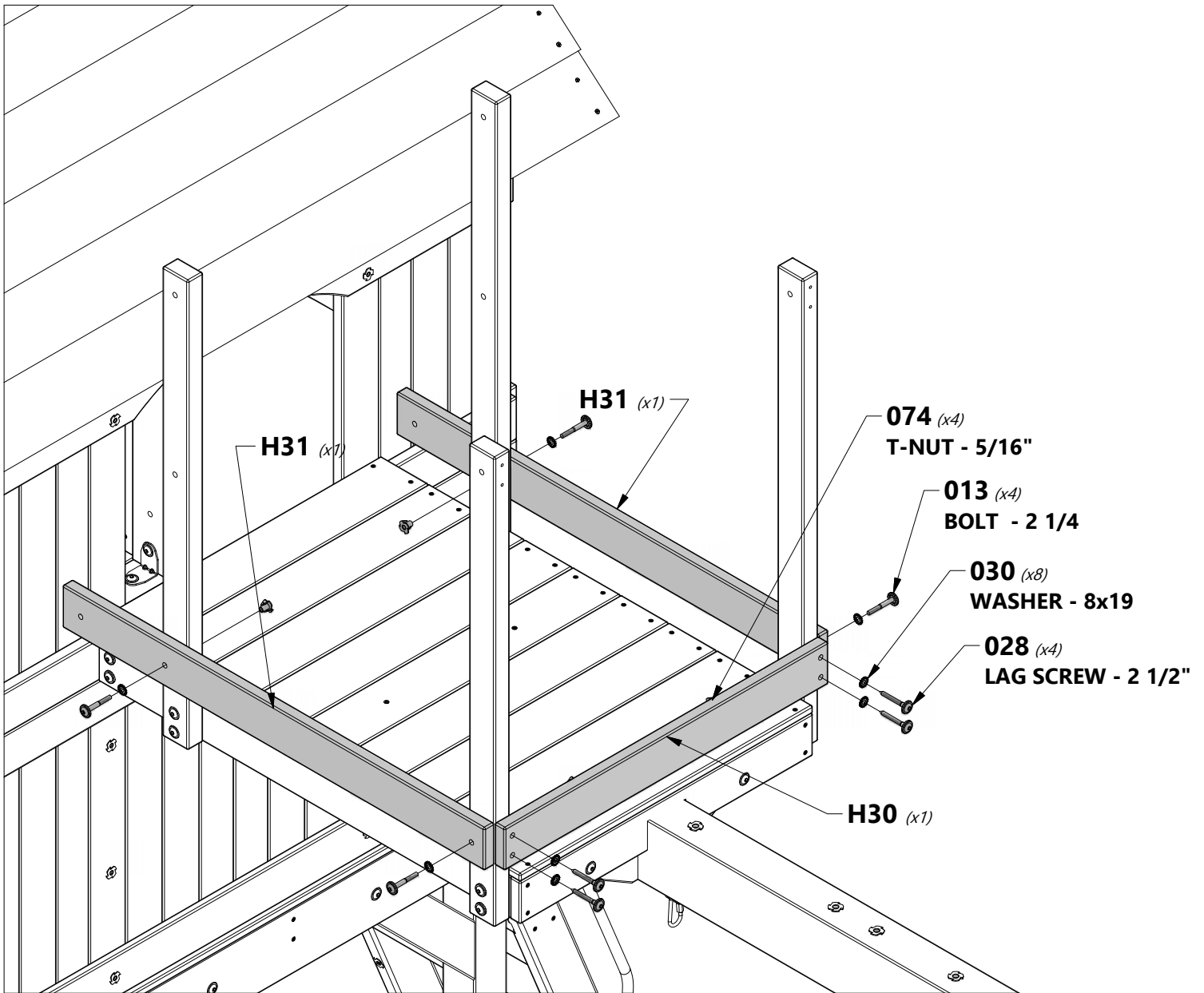



A4M01046 | L BRACKET
(2) | 2.5x38x55x55

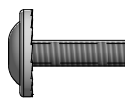

H100008 | BOLT WH
(2) | 5/16x1



H100115 | BOLT WH
(2) | 5/16x1/2



H100074 | T-NUT
(4) | 5/16



TIP:
INSTALL T-NUTS INTO
BOARDS BEFORE ASSEMBLY.

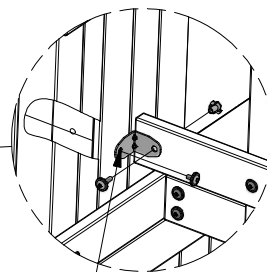
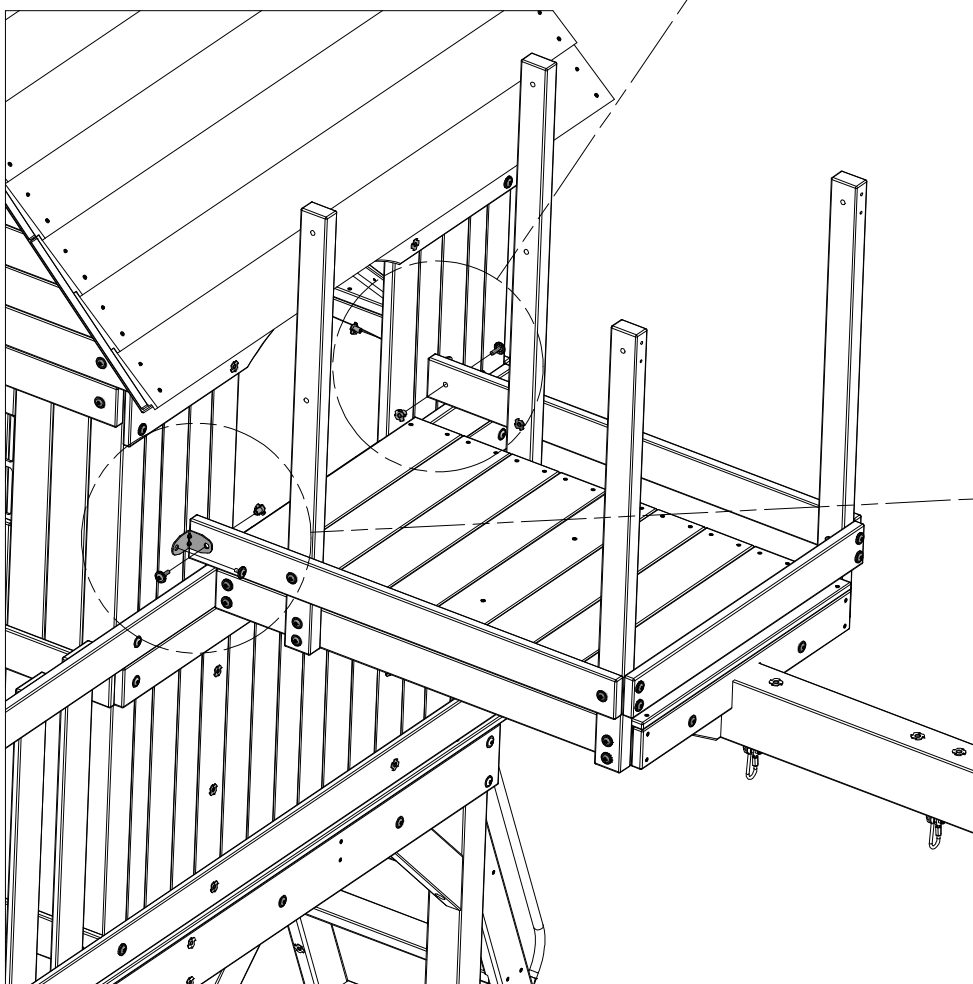
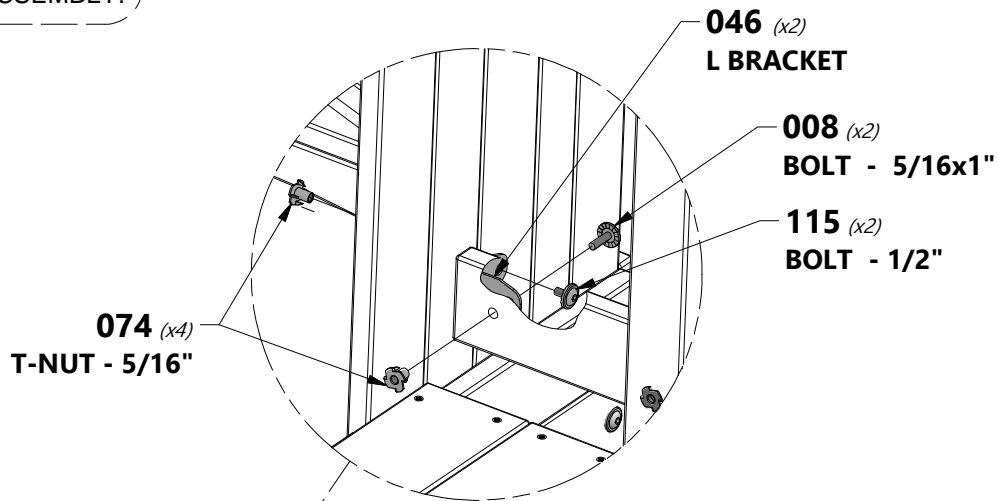

**USING BRACKETS AS A GUIDE,
DRILL 3/8 in [10 mm] HOLES
THROUGH WALL BOARD.**

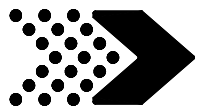

M4 | CROWS NEST WALL RAIL - W4L11773
(2) | 5/8"x3 3/8"x29 7/8" (16x86x758)

H30 | CROWS NEST WALL RAIL - W4L11782
(1) | 1"x3 3/8"x29 7/8" (24x86x758)

H29 | CROWS NEST WALL RAIL - W4L15910
(2) | 1"x3 3/8"x30 5/8" (24x86x778)



H100013 | BOLT WH
(4) | 5/16x2 1/4



H100028 | LAG SCREW WH
(4) | 5/16x2 1/2



H100027 | LAG SCREW WH
(8) | 5/16x2



H100030 | WASHER LOCK
(16) | EXT
8x19

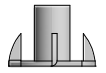

H100074 | T-NUT
(4) | 5/16



TIP:
INSTALL T-NUTS INTO
BOARDS BEFORE ASSEMBLY.

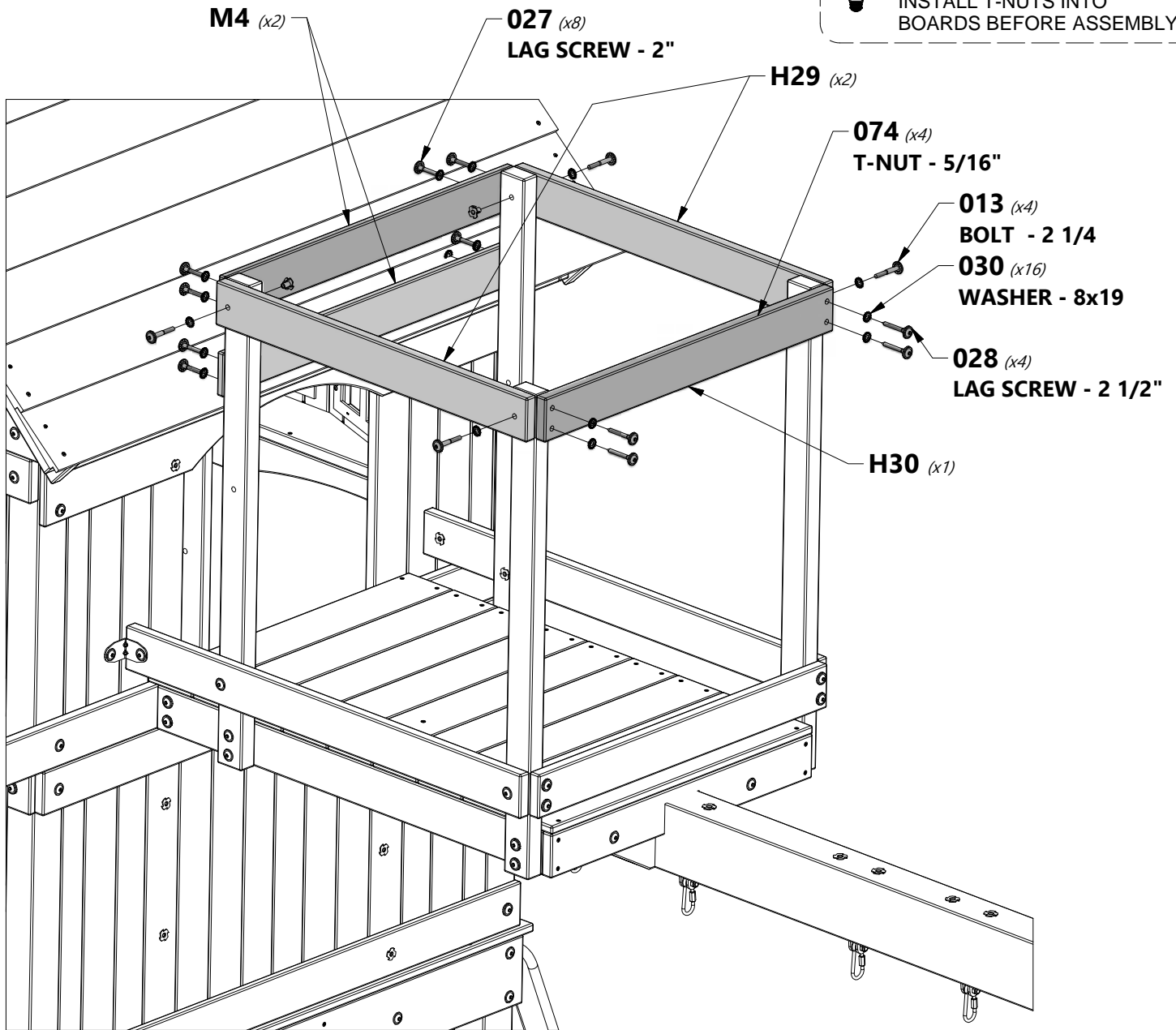

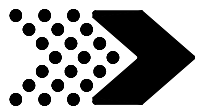

FORT ASSEMBLY

STEP 60

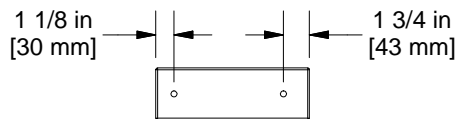

M32 | CROWS NEST WALL RAIL - W4L04671
 (2) | 5/8"x3 3/8"x10" (16x86x254)



A4M01046 | L BRACKET
 (2) | 2.5x38x55x55



H100012 | BOLT WH
 (2) | 5/16x2

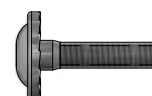

H100009 | BOLT WH
 (2) | 5/16x1 1/4



H100115 | BOLT WH
 (2) | 5/16x1/2



H100074 | T-NUT
 (6) | 5/16



H100030 | WASHER LOCK
 (2) | EXT
 8x19



TIP:
 INSTALL T-NUTS INTO
 BOARDS BEFORE ASSEMBLY.

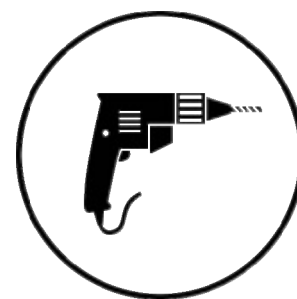

**USING BRACKETS
 AS A GUIDE, DRILL
 3/8in [10mm] HOLES
 THROUGH WALL.**

046 (x2)
 L BRACKET

009 (x2)
 BOLT - 1 1/4"

M32 (x2)

074 (x6)
 T-NUT - 5/16"

030 (x2)
 WASHER - 8x19

012 (x2)
 BOLT - 2"

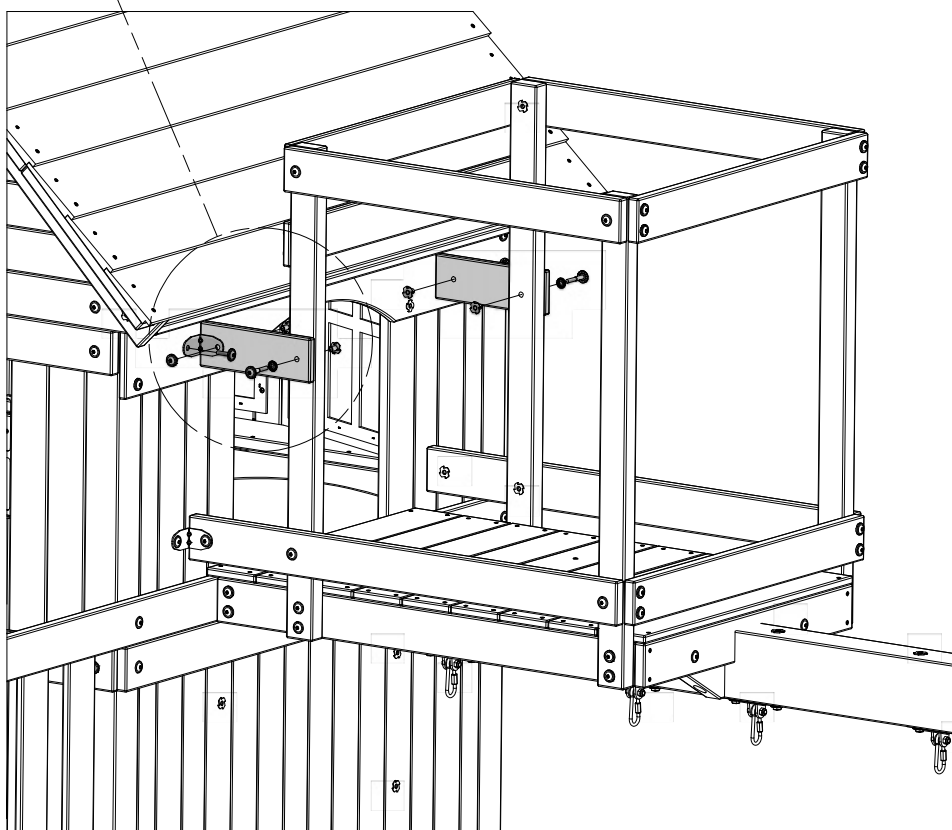

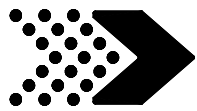



N04 | CROWS NEST WALL BOARD - W4L15912
 (2) | 5/8"x2 3/8"x18 1/8" (16x60x461)

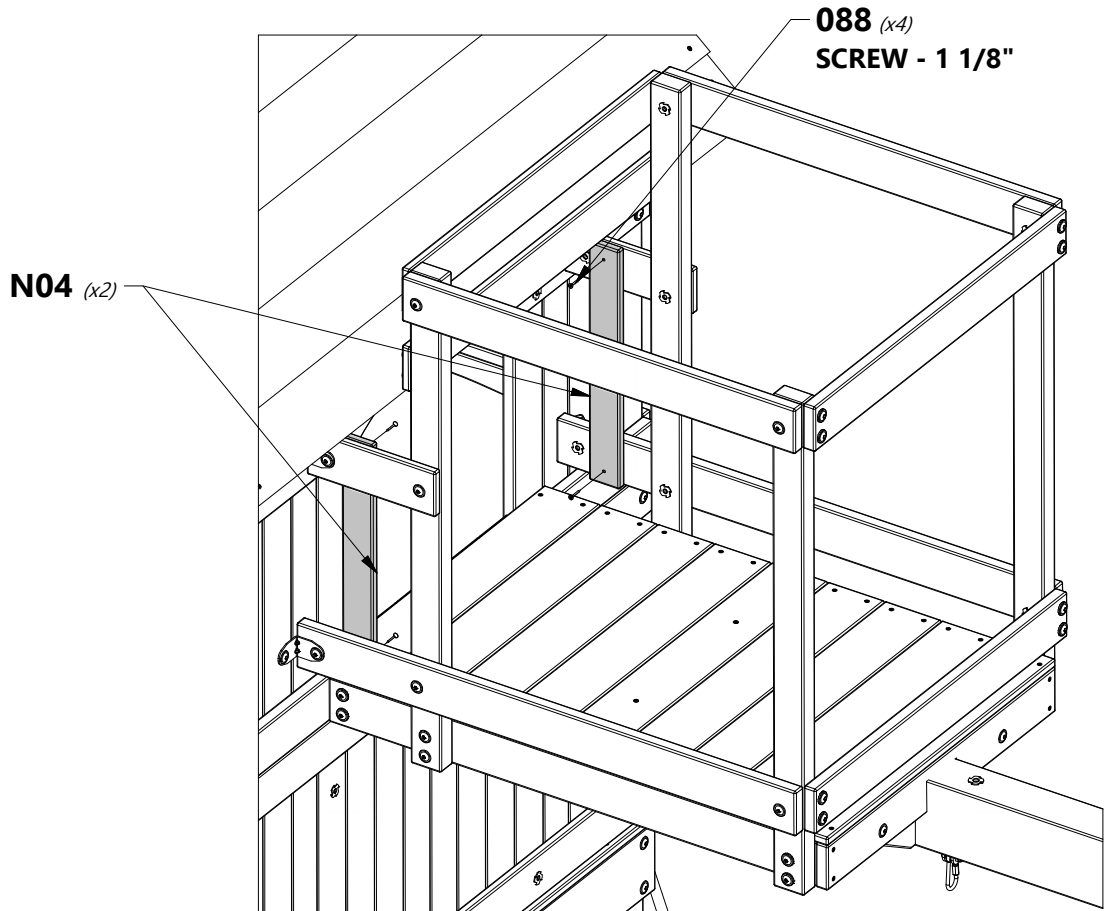
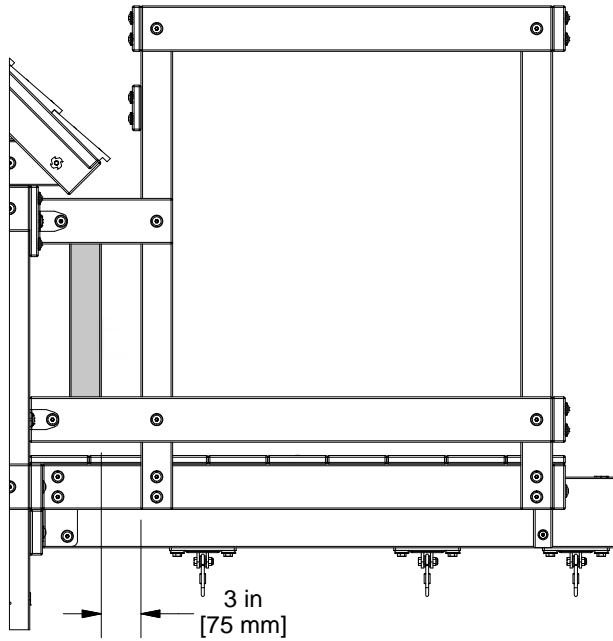

H100088 | SCREW PFH
 (4) | 8x1 1/8"

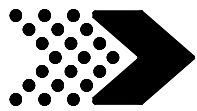





O1 | CROWS NEST WALL BOARD - W4L15911
(6) | 5/8"x1 3/8"x32 1/4" (16x34x819)

H100088 | SCREW PFH
(12) | 8x1 1/8"

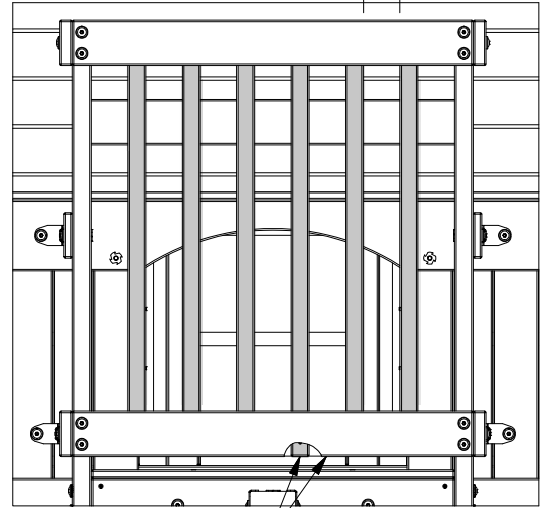
2 3/4 in
[69 mm]
EQUAL SPACING



FLUSH BOTTOMS

088 (x12)
SCREW - 1 1/8"

O1 (x6)

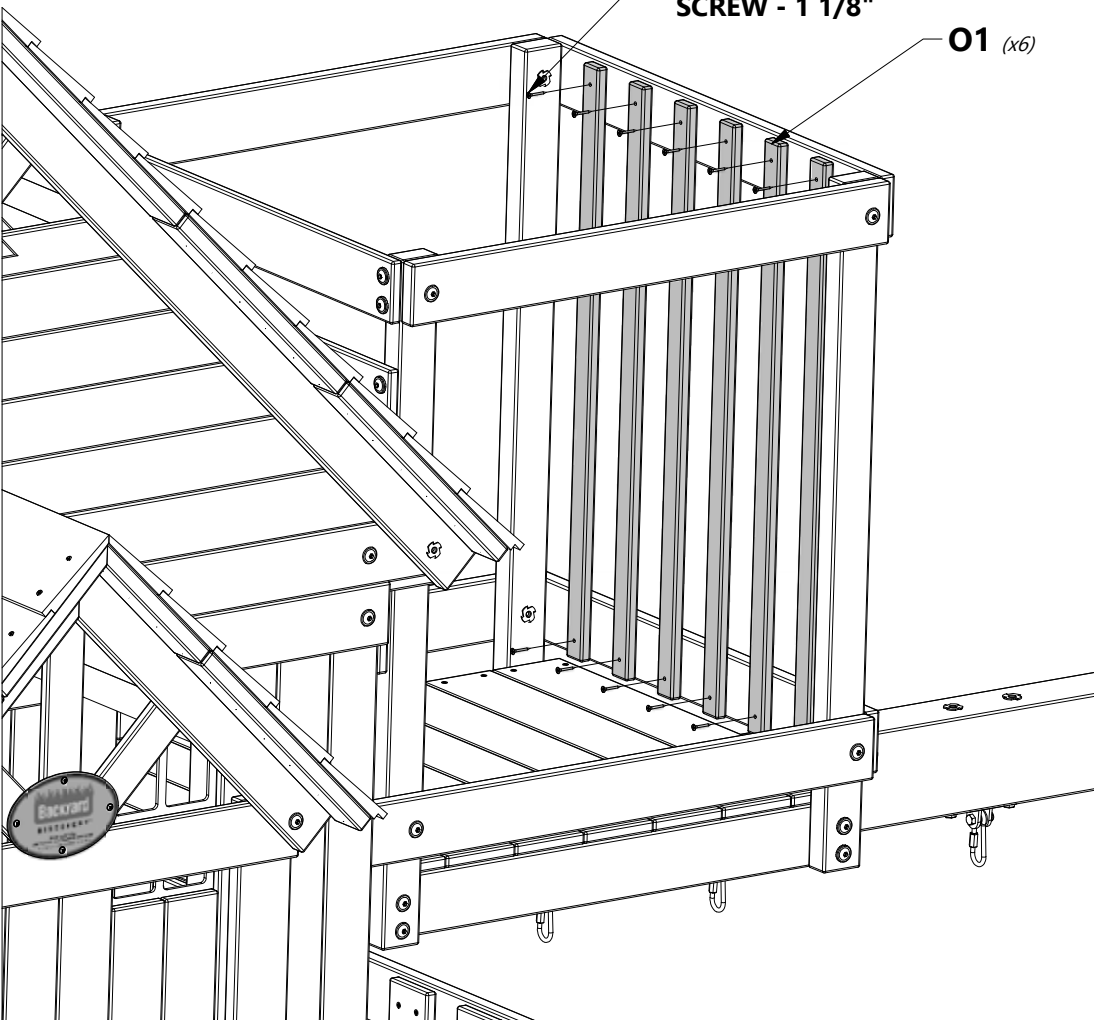

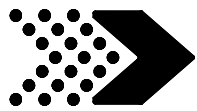

O1 | CROWS NEST WALL BOARD - W4L15911
(12) | 5/8"x1 3/8"x32 1/4" (16x34x819)



H100088 | SCREW PFH
(24) | 8x1 1/8

2 1/2 in
[65 mm]
EQUAL
SPACING

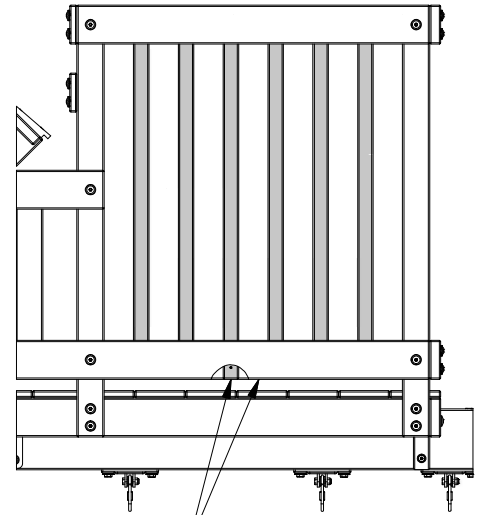

FLUSH BOTTOMS

088 (x24)
SCREW - 1 1/8"

O1 (x12)

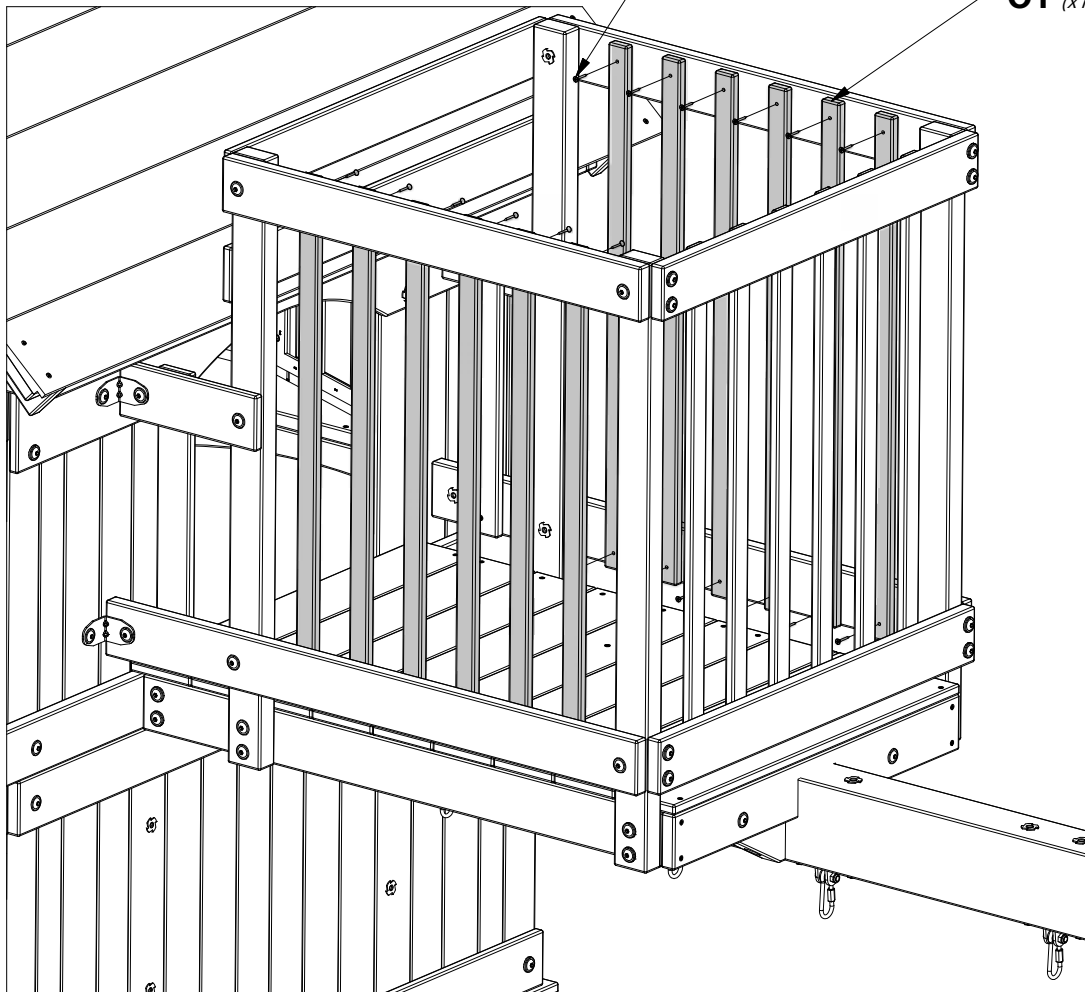

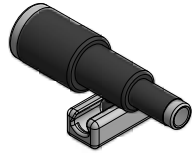
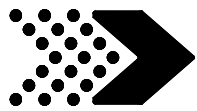

A6P00096 | TELESCOPE
(1)



H100087 | SCREW PFH
(2) | 8x1-1/4"

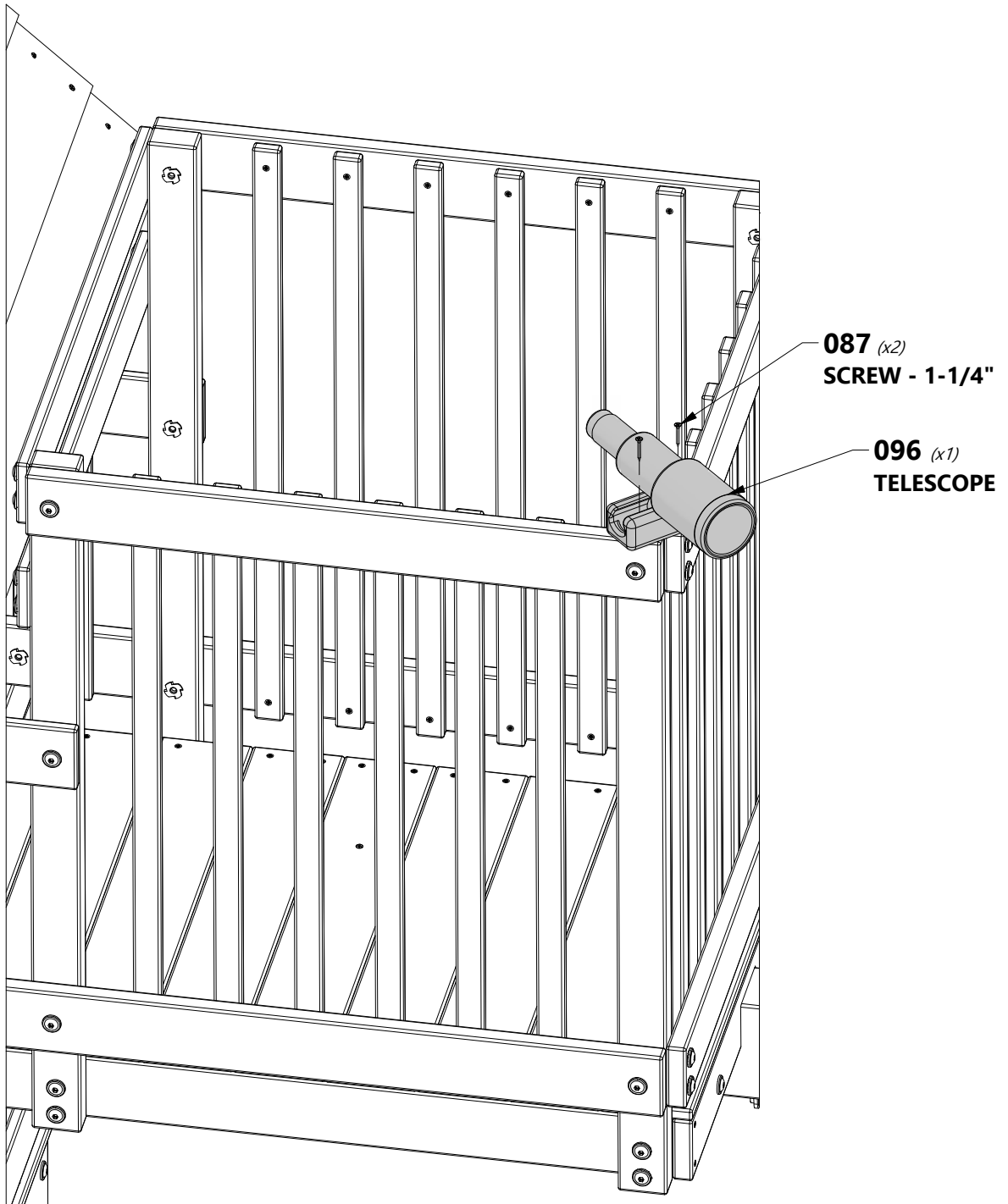



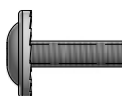

A100118 | **HAND GRIP**
 (4) | **METAL GREEN**
 381 c/c

H100026 | **LAG SCREW WH**
 (4) | 5/16x1 1/2

H100008 | **BOLT WH**
 (4) | 5/16x1

H100074 | **T-NUT**
 (4) | 5/16

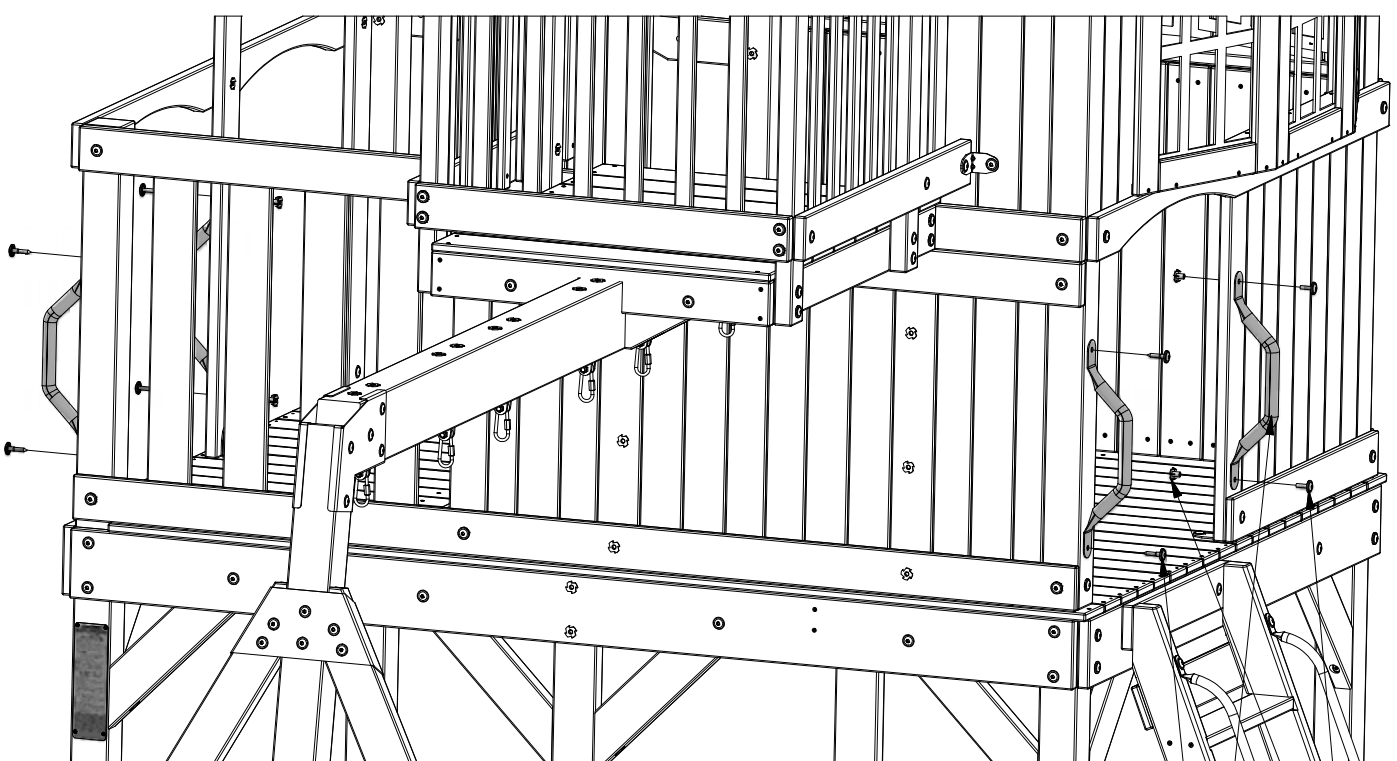
 **TIP:**
 INSTALL T-NUTS INTO
 BOARDS BEFORE ASSEMBLY.



026 (x4)
LAG SCREW - 1 1/2"

008 (x4)
BOLT - 5/16x1"

118 (x4)
HAND GRIP METAL GREEN 381 c/c

074 (x4)
T-NUT - 5/16"

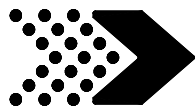

FINAL ASSEMBLY

STEP 1

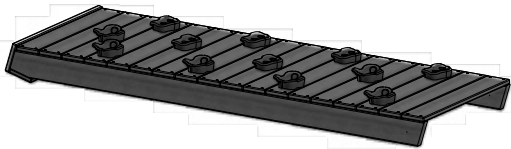

(1) ROCK WALL ASSEMBLY



H100010 | BOLT WH
(2) | 5/16x1-1/2



H100030 | WASHER LOCK
(2) | EXT
8x19

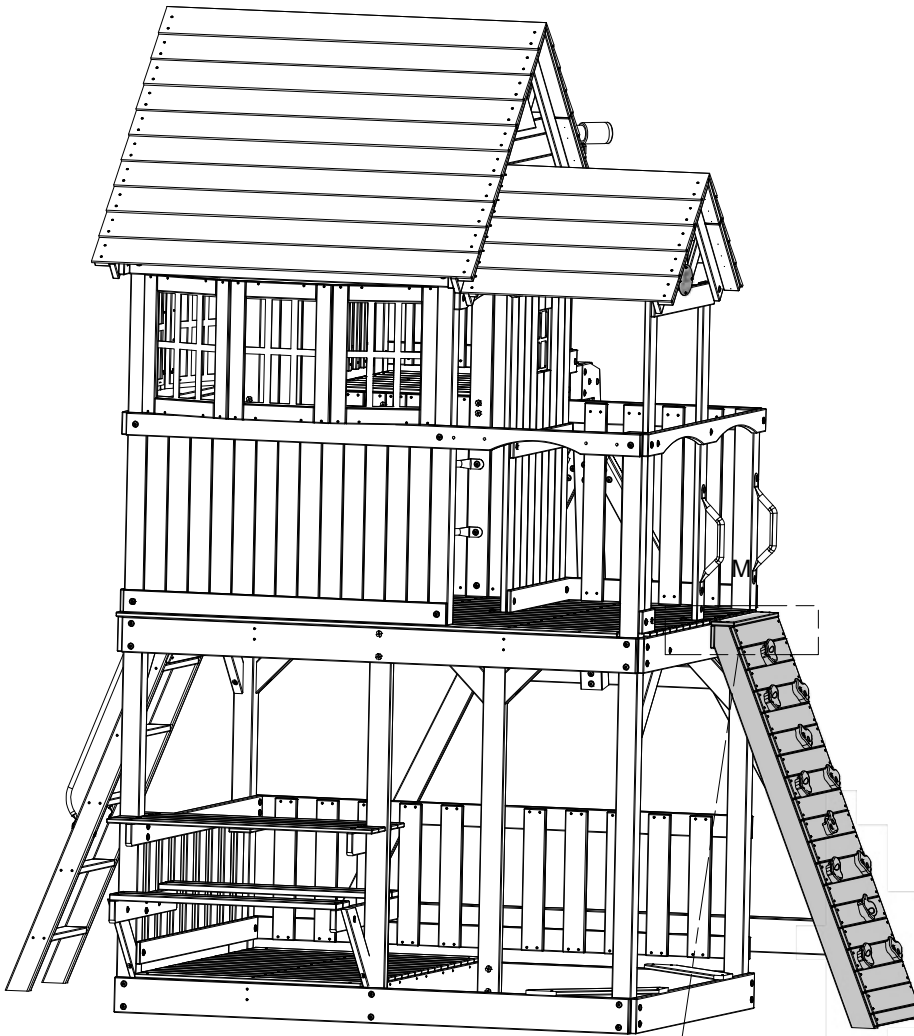

010 (x2)
BOLT - 1 1/2"

030 (x2)
WASHER - 8x19

ROCK WALL ASSEMBLY

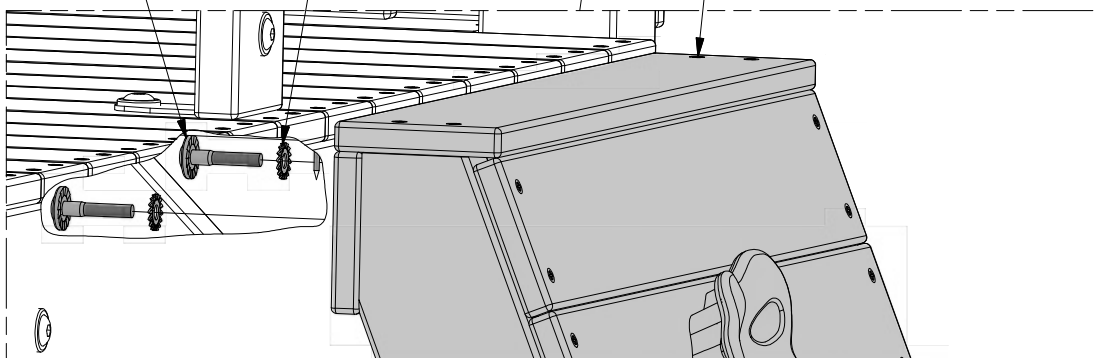

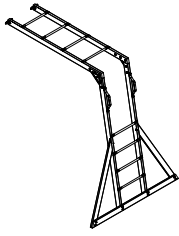
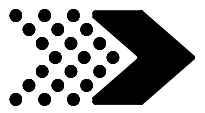

(1) MONKEY BAR ASSEMBLY

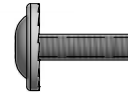

H100008 | BOLT WH
(4) | 5/16x1

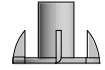

H100074 | T-NUT
(4) | 5/16



TIP:
INSTALL T-NUTS INTO
BOARDS BEFORE ASSEMBLY.

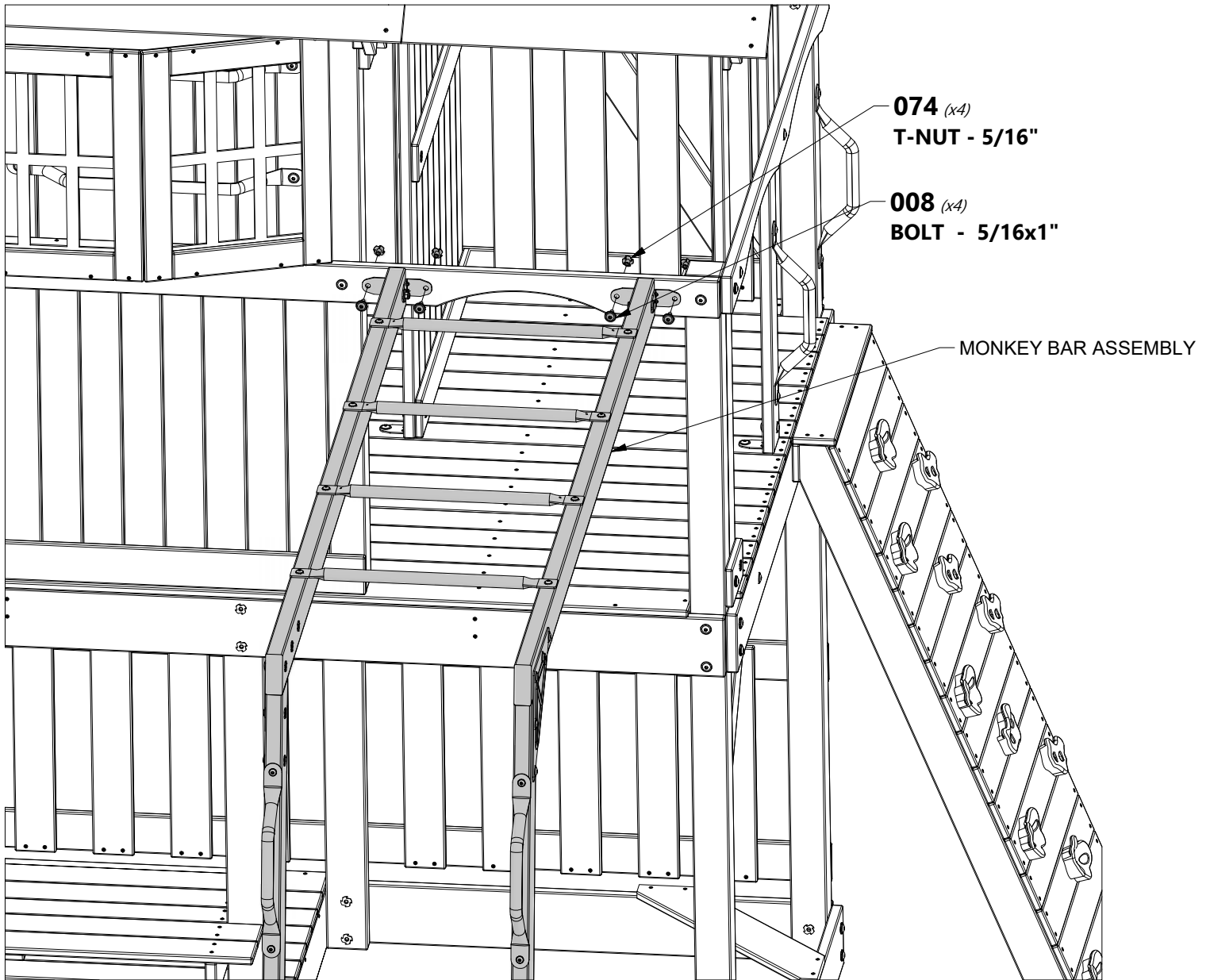



FINAL ASSEMBLY

STEP 3



(1) SLIDE ASSEMBLY



H100115 | BOLT WH
(3) | 5/16x1/2



H100074 | T-NUT
(3) | 5/16

NOTE:
CENTER SLIDE IN OPENING. USING DIMENSIONS BELOW AS A TEMPLATE, DRILL (3) 3/8" HOLES THROUGH DECK FOR HARDWARE.



TIP:
INSTALL T-NUTS INTO BOARDS BEFORE ASSEMBLY.

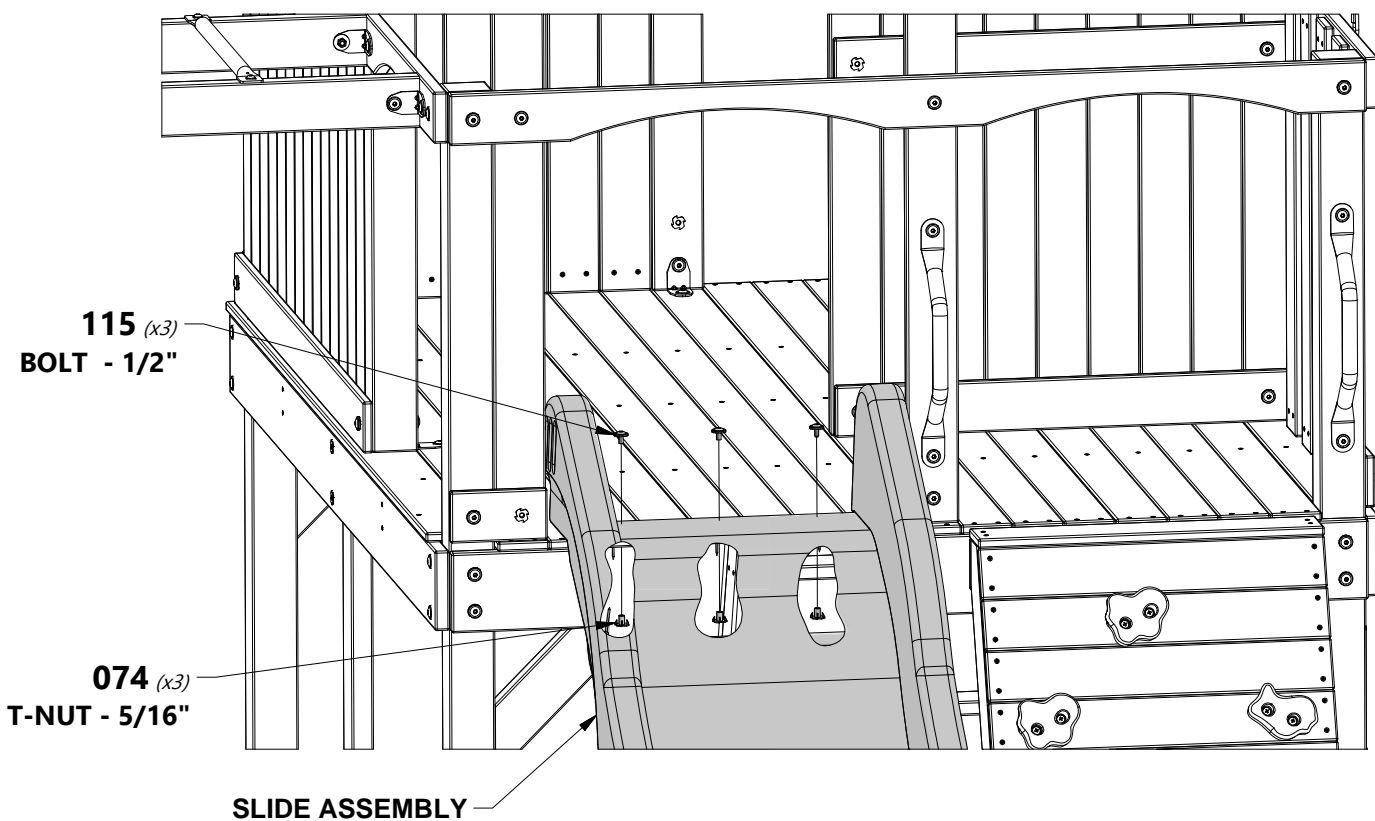
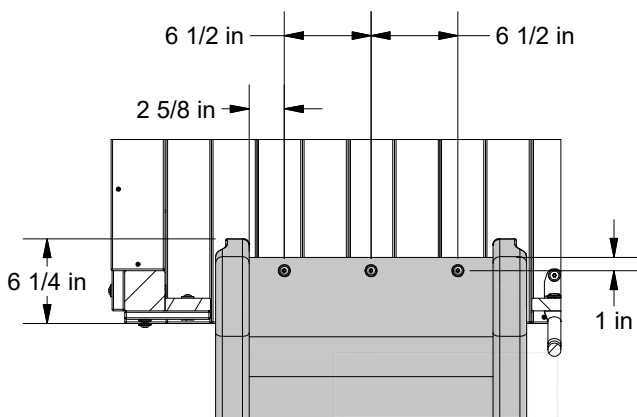

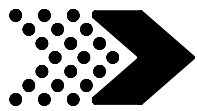

A100314 | "A" REVISION TAG
(1)



H100128 | SCREW PWH
(2) | 8x5/8

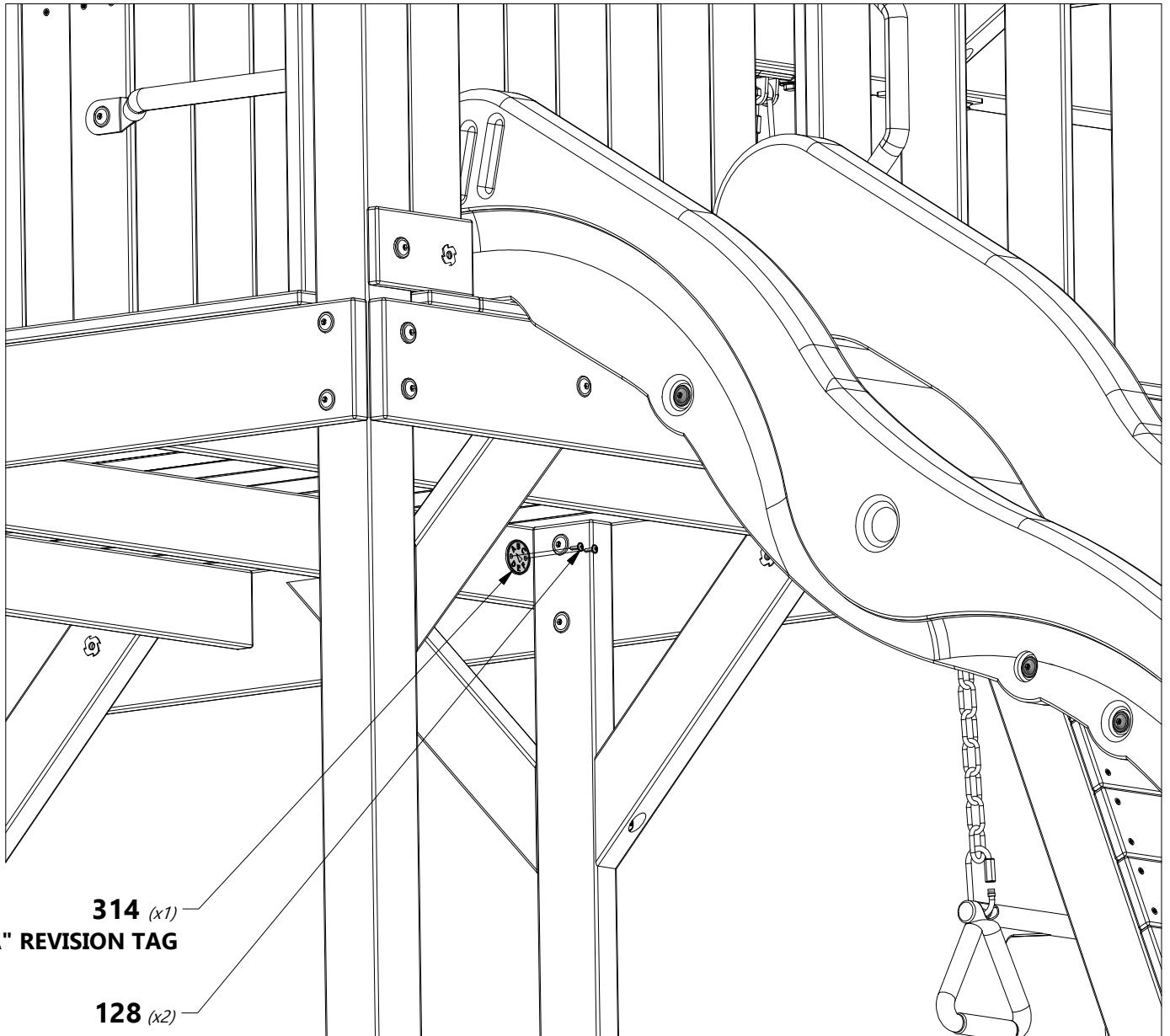

314 (x1)
"A" REVISION TAG

128 (x2)
SCREW - 5/8

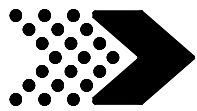

A100083 | ROPE-CHAIN
(2) | GREEN 33"

A100069 | QUICK LINK
(6)

A100027 | SWING SEAT
(2) | GREEN 26"

A6P00034 | TRAPEZE
(1) | YELLOW

A100183 | ROPE-CHAIN
(4) | GREEN 57"

WHEN HANING YOUR SWINGS, IT IS REQUIRED TO ONLY TRIM AROUND THE SPECIFIC CHAIN LOOP THAT ALLOWS THE BOTTOM OF THE SWING SEAT, (WHEN SITTING ON IT) TO BE NO LOWER THAN (35CM) 13 7/8 INCHES FROM THE GROUND.

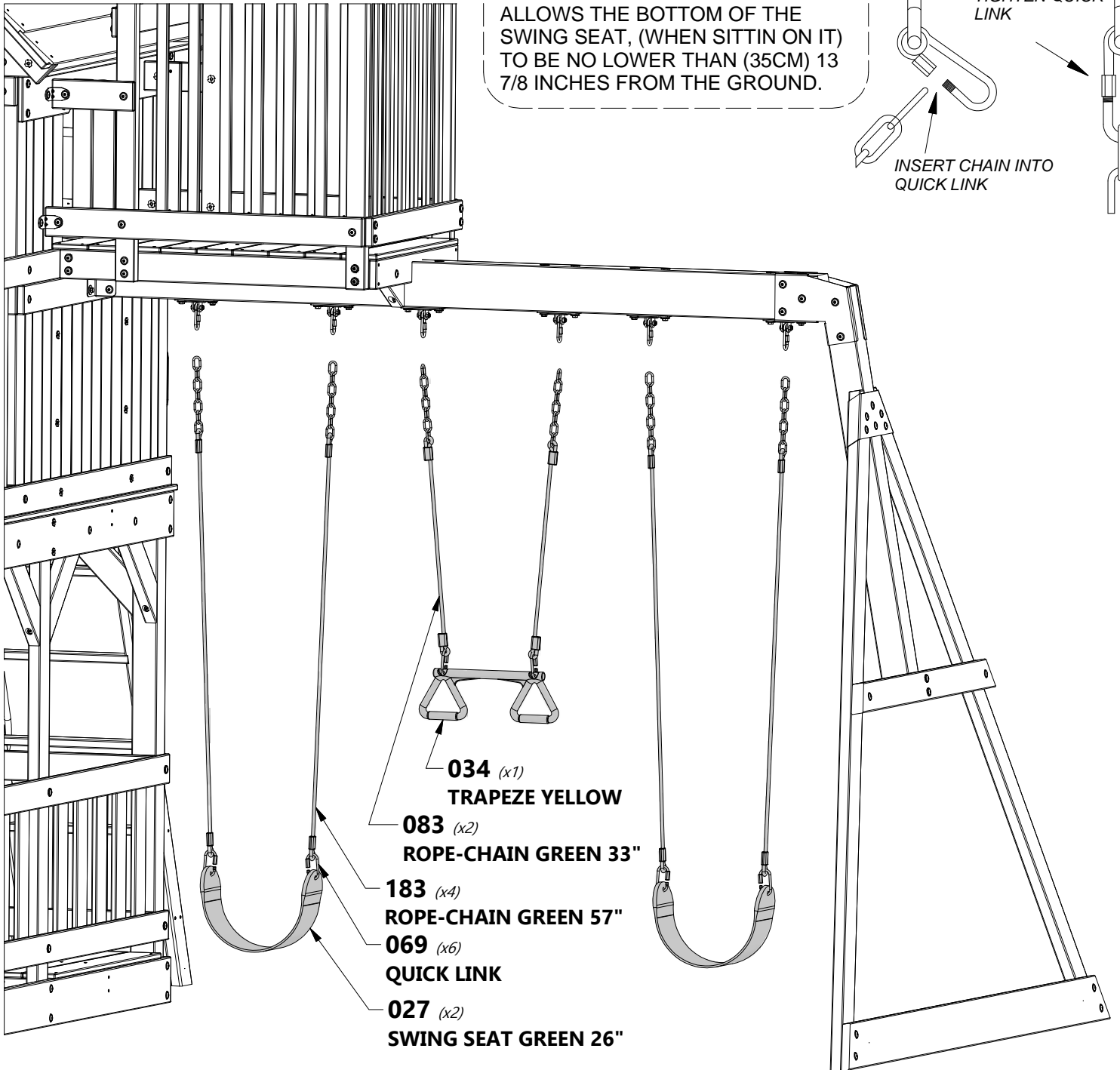
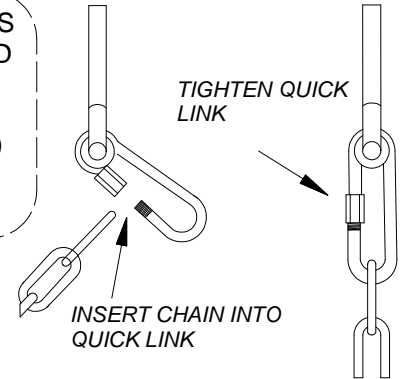



FINAL ASSEMBLY

STEP 6



A100178 | AUGER GROUND STAKE
(8)



A4M00527 | GROUND STAKE REBAR
(2)



H100145 | LAG SCREW WH
(8) | 1/4x1 1/2



H100106 | WASHER FLAT
(8) | 9x18



H100031 | WASHER LOCK
(2) | EXT
12x19

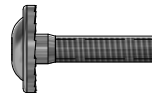

H100009 | BOLT WH
(2) | 5/16x1 1/4



H100004 | NUT BARREL WH
(2) | 5/16 x 5/8

FINAL STEP
DOUBLE CHECK EVERY BOLT, SCREW AND NUT FOR TIGHTNESS. MAKE SURE EVERY BOARD IS SECURE AND MAKE SURE THE PLAY SET IS LEVEL.

NOTE:
FAILURE TO ATTACH GROUND STAKES COULD CAUSE INJURY AND WILL VOID WARRANTY!

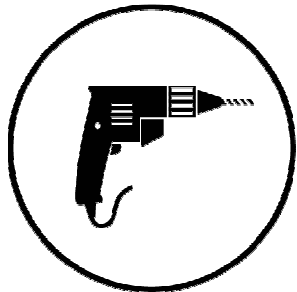

DETAIL 'A'
TWIST STAKES INTO GROUND AGAINST GROUND BOARDS AND CORNER POSTS IN LOCATIONS SHOWN. USING STAKE AS A TEMPLATE, DRILL A 3/16" [5 mm] HOLE FOR LAGS.

DETAIL 'B'
TWIST STAKES INTO GROUND AGAINST GROUND BOARDS AND CORNER POSTS IN LOCATIONS SHOWN. USING STAKE AS A TEMPLATE, DRILL A 3/16" [5 mm] HOLE FOR LAGS.

DETAIL 'C' & 'D'
DRIVE STAKE INTO GROUND AT LOCATIONS SHOWN. USING STAKE AS A TEMPLATE, DRILL A 7/16" [10 mm] HOLE FOR HARDWARE.

