



MANUFACTURED BY:
Backyard Discovery
3305 Airport Drive, Pittsburg, KS 66762
800-856-4445

Backyard Discovery Australia Pty Ltd 2/7 Hood Street, Hampton VIC 3188, Phone: 1800-087-941

AURORA

Swing Set

Model # 2400283

The assembly manual must be retained since it contains important information



WARNING

Adult Assembly Required.

Not suitable for children under 36 months due to small parts.

FOR DOMESTIC USE ONLY. INTENDED FOR OUTDOOR USE.



Please visit www.backyarddiscovery.com

For the most up to date assembly manual, to register your set, or to order replacement parts

Para obtener instrucciones en español, visite www.backyarddiscovery.com



EASY STEP-BY-STEP
3D INTERACTIVE INSTRUCTIONS
DOWNLOAD THE FREE APP

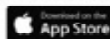

INSTALLATION SERVICES AVAILABLE!
See inside for details



Place the set on level ground, not less than 6'-7" [2 m] from any structure or obstruction such as a fence, garage, house, overhanging branches, laundry lines, or electrical wires.

- While assembling unit, take time before and after each phase to make sure fort is level. If fort is not level, assembly will be difficult and improper assembly may result. Extra care must be taken to insure the fort is square.
- The safe play area refers to a zone extending 6'-7" (2m) beyond the play product on all sides, including the space above the play product.

SAFE PLAY AREA DIAGRAM

Swingset Ground Dimension

8'-11 3/8" [2.7m] x 10'-2 7/8" [3.1m]

Safe Play Zone

22'-1 1/4" [6.7m] x 23'-4 7/8" [7.1m]

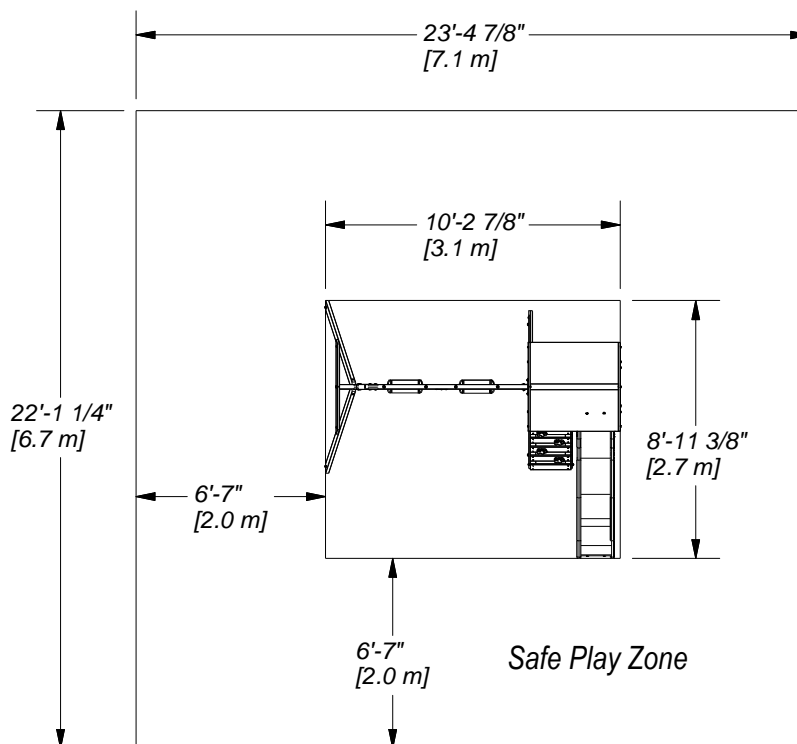

SAFE PLAY HEIGHT: 14'-3" [4.3 m]
MAXIMUM FALL HEIGHT: 5'-8 1/2" [1.7 m]

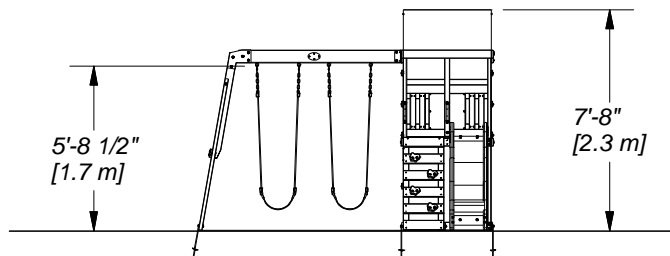

General Information:

Your set has been designed and engineered for children only and for residential use only.
 A maximum of 150 lbs. per child is recommended for play activities designed for individual use.
 A maximum of 120 lbs. per child is recommended for play activities designed for multiple child use.
 A maximum of 9 children is recommended for this swing set.



Wood Components (Not to Scale)

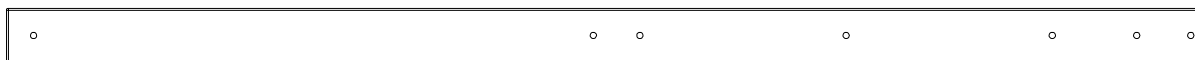

E1 | RIGHT FRONT UPRIGHT - W4L15660
(1) | 1 3/8"x3 3/8"x75" (36x86x1905)

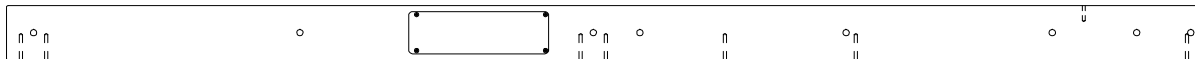

E2 | POST ASSEMBLY - W2A02839
(1) | 1 7/16"x3 3/8"x75" (36x86x1905)

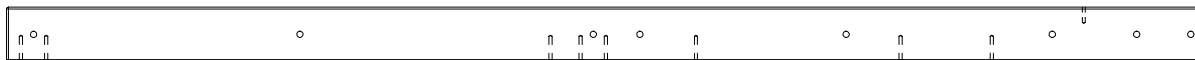

E3 | LEFT BACK UPRIGHT - W4L13210
(1) | 1 3/8"x3 3/8"x75" (36x86x1905)

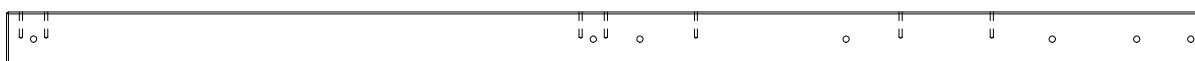

E4 | RIGHT BACK UPRIGHT - W4L13211
(1) | 1 3/8"x3 3/8"x75" (36x86x1905)



E77 | ANGLE BRACE - W4L13293
(2) | 1 3/8"x3 3/8"x72 7/8" (36x86x1850)



F1 | UPRIGHT - W4L13283
(1) | 1 7/16"x2 3/8"x43 3/4" (36x60x1111)



F2 | UPRIGHT - W4L13284
(1) | 1 7/16"x2 3/8"x43 3/4" (36x60x1111)

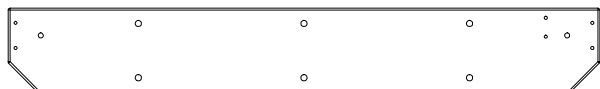

G1 | TOP RAIL - W4L13219
(1) | 1"x5 1/4"x37" (24x134x940)

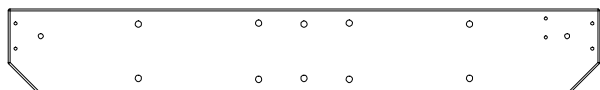

G2 | TOP RAIL - W4L13228
(1) | 1"x5 1/4"x37" (24x134x940)



H1 | FLOOR RAIL - W4L13212
(1) | 1"x3 3/8"x36 5/8" (24x86x930)



H2 | FLOOR RAIL - W4L13213
(2) | 1"x3 3/8"x26" (24x86x660)



H3 | FLOOR RAIL - W4L13221
(1) | 1"x3 3/8"x24 1/8" (24x86x612)



H4 | FLOOR SUPPORT - W4L13222
(4) | 1"x3 3/8"x3 3/8" (24x86x86)

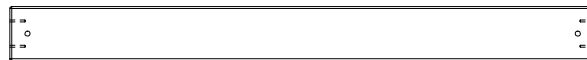

H5 | TOP RAIL - W4L13227
(2) | 1"x3 3/8"x36 5/8" (24x86x930)

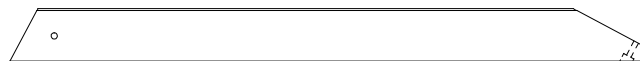

H6 | ANGLE BRACE - W4L13288
(1) | 15/16"x3 3/8"x40 1/16" (24x86x1018)



H7 | ANGLE BRACE - W4L13290
(2) | 15/16"x3 3/8"x11 13/16" (24x86x300)



H8 | FLOOR RAIL - W4L13295
(1) | 1"x3 3/8"x36 5/8" (24x86x930)

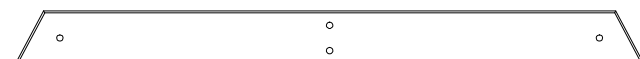

H79 | END SUPPORT - W4L13294
(1) | 1"x3 1/2"x39 1/2" (24x86x1000)



J1 | UPRIGHT - W4L13226
(1) | 1"x2"x36" (24x52x914)



J2 | PICKET - W4L13282
(2) | 1"x2 3/8"x15 1/8" (24x60x385)



Wood Components (Not to Scale)



J3 | SAFETY RAIL - W4L13299
(1) | 1"x2 3/8"x36 5/8" (24x60x930)

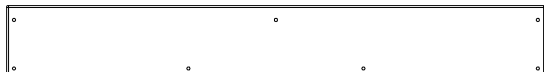

L1 | FLOOR BOARD - W4L13223
(1) | 5/8"x4 3/8"x33 3/4" (16x112x856)



L2 | FLOOR BOARD - W4L13225
(1) | 5/8"x4 3/8"x33 3/4" (16x112x856)



L3 | LADDER RUNG - W4L13285
(1) | 5/8"x4 3/8"x16 7/8" (16x112x430)

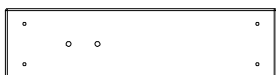

L4 | LADDER RUNG - W4L13286
(4) | 5/8"x4 3/8"x16 7/8" (16x112x430)



L5 | TOP LADDER RUNG - W4L13287
(1) | 5/8"x4 3/8"x16 7/8" (16x112x430)



M1 | GROUND RAIL - W4L13215
(1) | 5/8"x3 3/8"x36 5/8" (16x86x930)



M2 | GROUND RAIL - W4L13216
(1) | 5/8"x3 3/8"x25 3/8" (16x86x644)

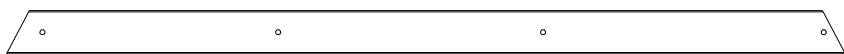

M3 | ANGLE GROUND RAIL - W4L13217
(1) | 5/8"x3 3/8"x65 5/8" (16x86x1666)



M4 | FLOOR BOARD - W4L13224
(5) | 5/8"x3 3/8"x36 5/8" (16x86x930)



SB74 | SWING BEAM 2 POSITION - W4L13291
(1) | 2"x5 1/4"x68 3/4" (50x134x1745)



M5 | GROUND RAIL - W4L13209
(1) | 5/8"x3 3/8"x36 5/8" (16x86x930)



M6 | GROUND RAIL - W4L13296
(1) | 5/8"x3 3/8"x21 3/8" (16x86x542)



M77 | SLIDE BRACE - W4L13297
(1) | 5/8"x3 3/8"x14 1/4" (16x86x362)



M78 | SLIDE BRACE - W4L13298
(1) | 5/8"x3 3/8"x14 1/4" (16x86x362)



N1 | SIDE RAIL - W4L13214
(7) | 5/8"x2 3/8"x24 1/8" (16x60x612)



N2 | SIDE RAIL - W4L13218
(3) | 5/8"x2 3/8"x36 5/8" (16x60x930)

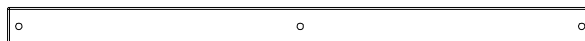

N3 | TOP RAIL - W4L13220
(1) | 5/8"x2 3/8"x36 5/8" (16x60x930)



N4 | TOP RAIL - W4L13229
(2) | 5/8"x2 3/8"x21 1/8" (16x60x538)



N5 | TOP RAIL - W4L13280
(1) | 5/8"x2 3/8"x36 5/8" (16x60x930)



N6 | PICKET - W4L13281
(4) | 5/8"x2 3/8"x15 1/8" (16x60x385)



T1 | FLOOR SUPPORT - W4L13289
(2) | 15/16"x1 5/16"x17 1/4" (24x34x438)



W71 | SWING BEAM SUPPORT - W4L13292
(1) | 2"x3 3/8"x44 1/4" (50x86x1123)



Hardware Components

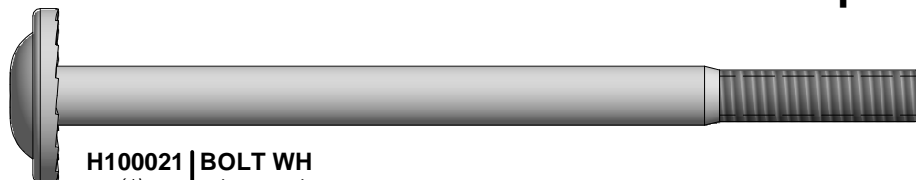

H100021 | BOLT WH
(1) | 5/16x4 1/2

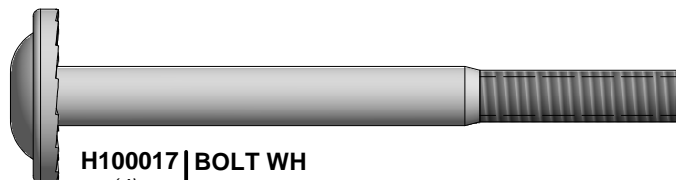

H100017 | BOLT WH
(4) | 5/16x3 1/4



H100029 | LAG SCREW WH
(1) | 5/16x3

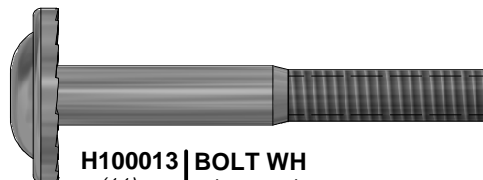

H100013 | BOLT WH
(11) | 5/16x2 1/4



H100028 | LAG SCREW WH
(8) | 5/16x2 1/2

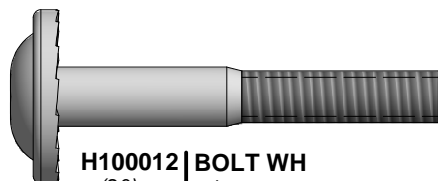

H100012 | BOLT WH
(20) | 5/16x2



H100027 | LAG SCREW WH
(22) | 5/16x2

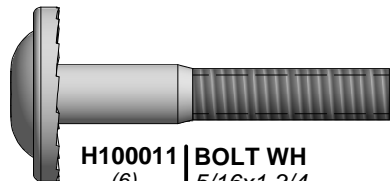

H100011 | BOLT WH
(6) | 5/16x1 3/4

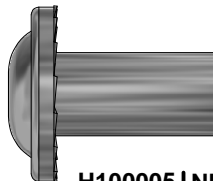

H100005 | NUT BARREL WH
(10) | 5/16x7/8

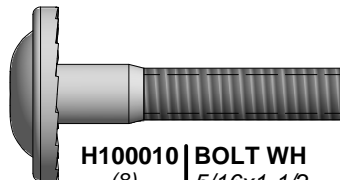

H100010 | BOLT WH
(8) | 5/16x1-1/2

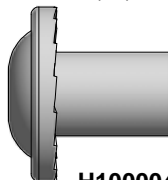

H100004 | NUT BARREL WH
(7) | 5/16 x 5/8

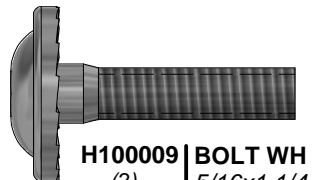

H100009 | BOLT WH
(2) | 5/16x1 1/4

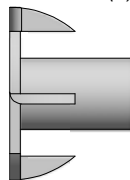

H100074 | T-NUT
(49) | 5/16

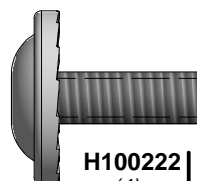

H100222 | BOLT WH
(4) | 5/16x3/4

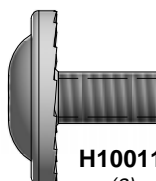

H100115 | BOLT WH
(8) | 5/16x1/2

H100099 | SWING HANGER
(4) | 5/16x9 1/2

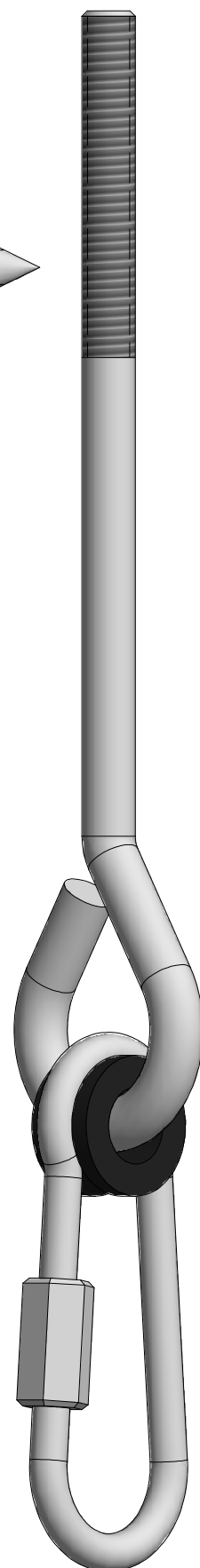



Hardware Components



H100047 | BOLT HEX
(2) | 5/16x2 3/4

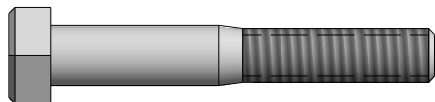

H100044 | BOLT HEX
(2) | 5/16x2



H100042 | BOLT HEX
(2) | 5/16x1 1/4

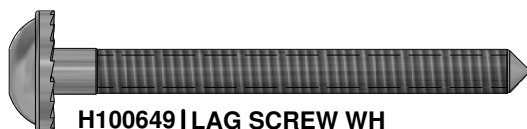

H100649 | LAG SCREW WH
(3) | 1/4x2 1/2



H100145 | LAG SCREW WH
(3) | 1/4x1 1/2



H100142 | BOLT WH
(2) | 1/4x1-1/4



H100137 | BOLT WH
(4) | 1/4x1

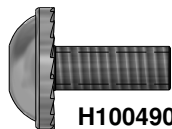

H100490 | BOLT WH
(7) | 1/4x5/8

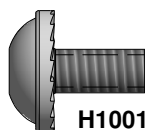

H100141 | BOLT WH
(2) | 1/4 x 1/2"

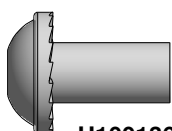

H100136 | NUT BARREL WH
(7) | 1/4x5/8



H100090 | SCREW PFH
(22) | 8x2 1/2"



H100111 | SCREW PFH
(13) | 8x2



H100089 | SCREW PFH
(11) | 8x1 3/4



H100086 | SCREW PFH
(71) | 8x1 1/2



H100088 | SCREW PFH
(17) | 8x1 1/8



H100121 | SCREW PFH
(9) | 8x3/4



H100070 | SCREW PWH
(11) | 8x3/4



H100128 | SCREW PWH
(11) | 8x5/8



H100392 | SCREW PWH BLK
(7) | 8x3/4

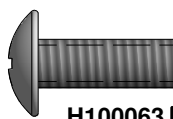

H100063 | BOLT PTH
(9) | 1/4x3/4

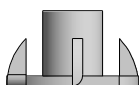

H100072 | T-NUT
(18) | 1/4



H100110 | NUT LOCK
(7) | 5/16

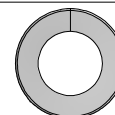

H100095 | WASHER SPLIT
(4) | 5/16

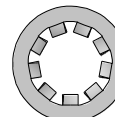

H100108 | WASHER LOCK INT
(9) | 8x15

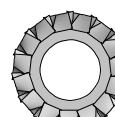

H100138 | WASHER LOCK EXT
(8) | 6x15

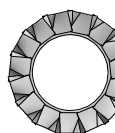

H100139 | WASHER LOCK EXT
(7) | 8x15

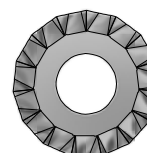

H100030 | WASHER LOCK EXT
(72) | 8x19

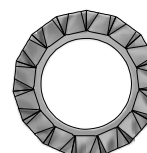

H100031 | WASHER LOCK EXT
(11) | 12x19

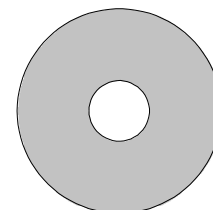

H100105 | WASHER FLAT
(13) | 8x27

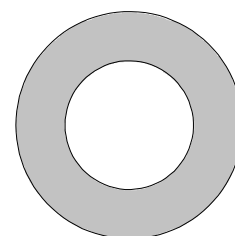

H100103 | WASHER SAFETY
(4) | 17x30



Accessory Components (Not to Scale)

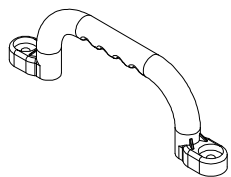

A6P00314 | HAND GRIP
(2) | BLUE PLASTIC

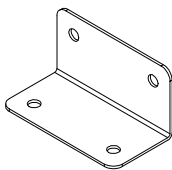

A100153 | L BRACKET
(2) | 66x66x127 BLUE

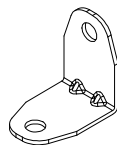

A4M01048 | L BRACKET
(2) | 2.5x38x55x55

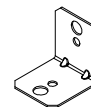

A4M01110 | 90° L-BRACKET -
(6) | BLK



A100175 | BYD ID TAG
(1) | (MEDIUM) AGES
3-10

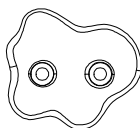

A6P00040 | BLUE HC ROCK
(4) | #1

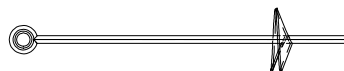

A100178 | AUGER GROUND
(6) | STAKE



A100314 | "A" REVISION
(1) | TAG

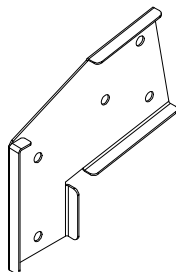

A4M00511 | SWING BEAM
(1) | EXT. BRACKET
BLUE - LEFT

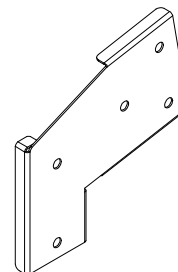

A4M00512 | SWING BEAM
(1) | EXT BRACKET
BLUE - RIGHT

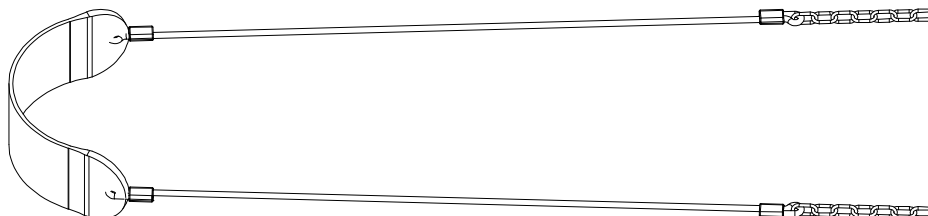

A6P00405 | ROPE-CHAIN B /
(2) | SEAT B

9220119 | TOOL KIT
(1)

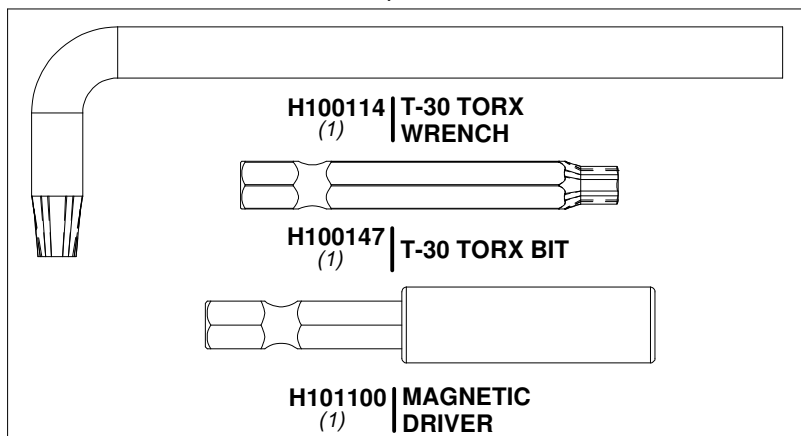

H100114 | T-30 TORX
(1) | WRENCH

H100147 | T-30 TORX BIT
(1)

H101100 | MAGNETIC
(1) | DRIVER

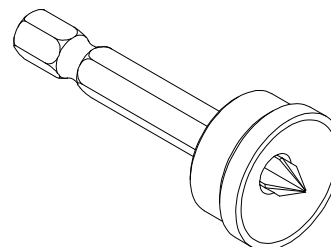

H100764 | SCREW SETTER
(1)



Accessory Components (Not to Scale)

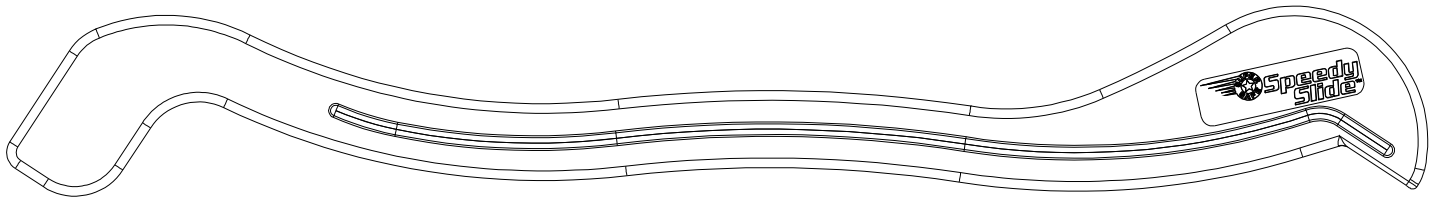

A6P00402 | 6 FT SLIDE RAIL
(1) | LEFT

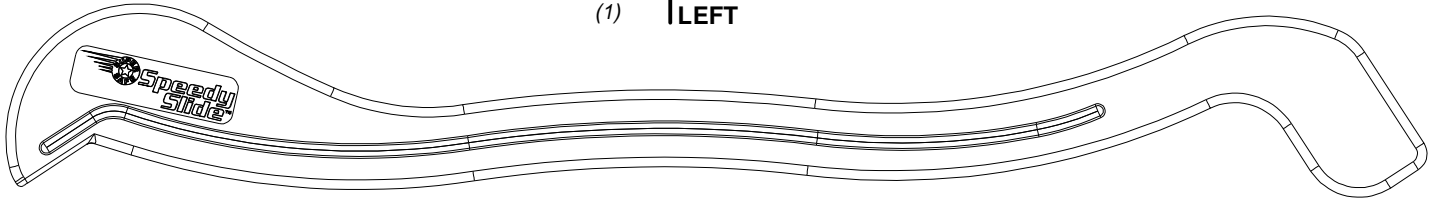

A6P00403 | 6 FT SLIDE RAIL
(1) | RIGHT

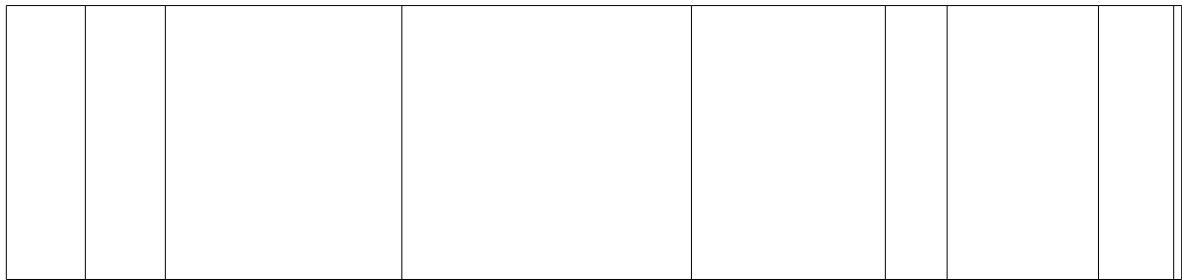

A6P00404 | 6 FT SLIDE BED
(1)

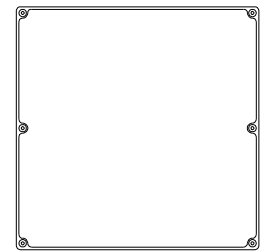

A6P00323 | CHALK BOARD
(1)

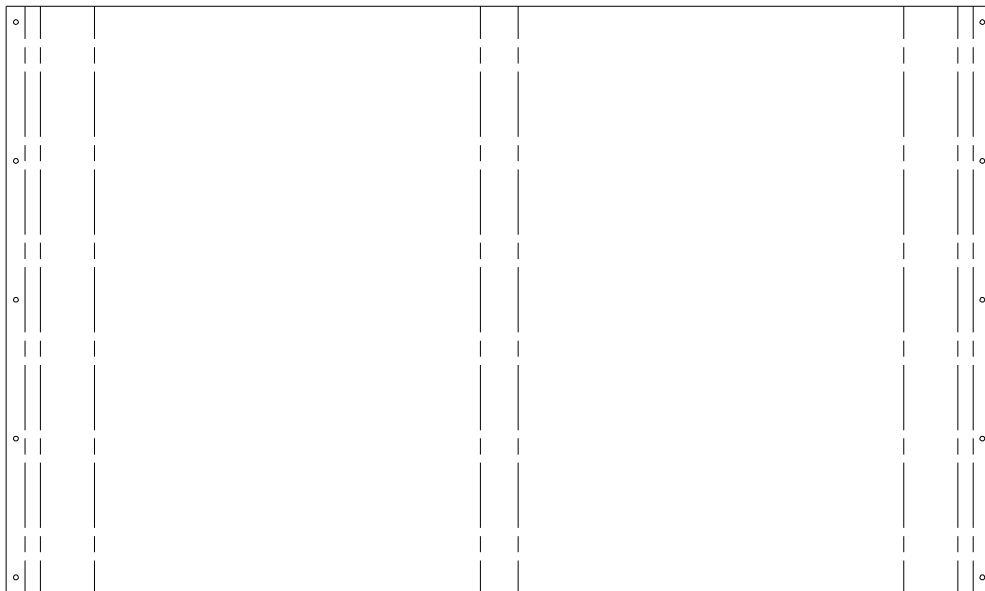

A6P00400 | ROOF TARP
(1)

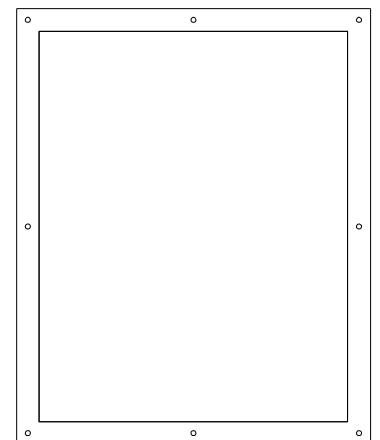

A6P00401 | MESH PANEL
(2)

PRE-ASSEMBLY STEP 1 - SORTING PARTS

It is critical for ease of assembly that you take the time to sort and organize the wood and hardware.

WOOD PARTS:

- Organize wood parts by the three-digit, alpha-numeric number stamped on each board (ex. P01).
- If there are multiple boards with the same stamped number, stack those pieces together.
- Stamps can be found on the flat surface of the boards or on the end of the boards.
- Allow yourself plenty of room - the wood pieces can take up a significant amount of space.

NOTE: CARTONS ARE NOT ORGANIZED BY BOARD NUMBER.

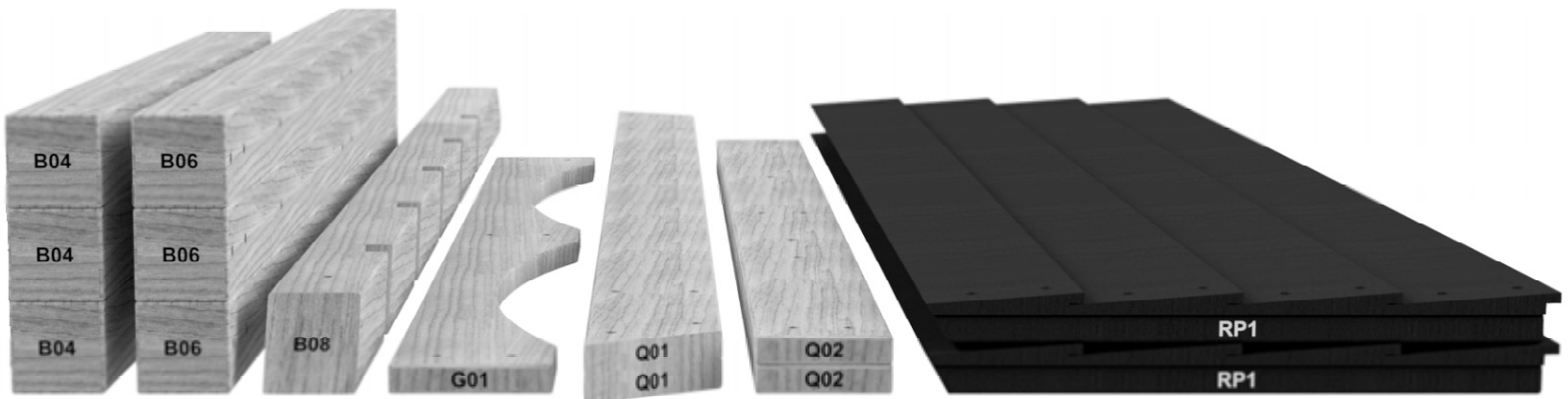

HARDWARE PARTS:

- We recommend that you have a separate table to organize the hardware.
- Hardware bags are printed with a seven-digit, alpha-numeric part number.
- You can organize your hardware by part number or group by hardware type (i.e. bolts, nuts, etc.).
- During assembly you only need to reference the last four digits of the number.

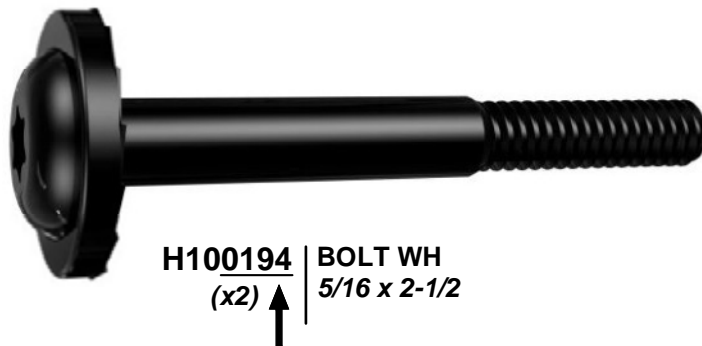

PRE-ASSEMBLY STEP 2 - TOOLS REQUIRED



Cordless Drill or
Electric Drill



Drill Attachments:
Phillips Head



1/8", 3/16", 3/8" & 7/16"
Drill Bits



Phillips Screw Driver



Open End Wrenches 1/2" & 9/16"



3/8" Drive Ratchet, 1/2" &
9/16" STD Sockets 1/2" & 9/16" Deep
Sockets



Claw Hammer



Rubber Mallet - Optional



Tape Measure

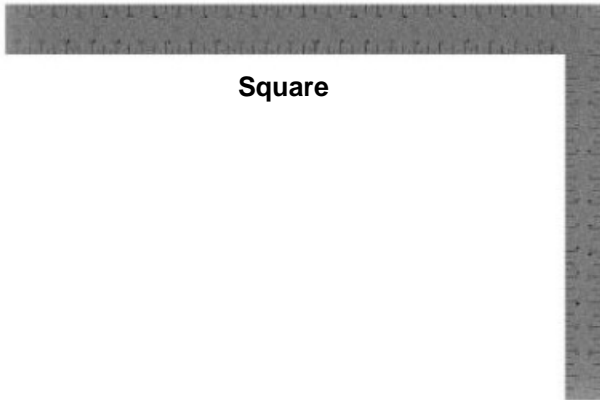

Square



Level 24"

PRE-ASSEMBLY STEP 3 - CHOOSE YOUR ASSEMBLY METHOD

There are several types of assembly instructions available to you.

1. Printed Assembly Manual included with your set
2. BILT APP - 3D interactive instructions
3. Combination of the Printed Manual and BILT APP (Note: Step numbers can differ between the two methods)

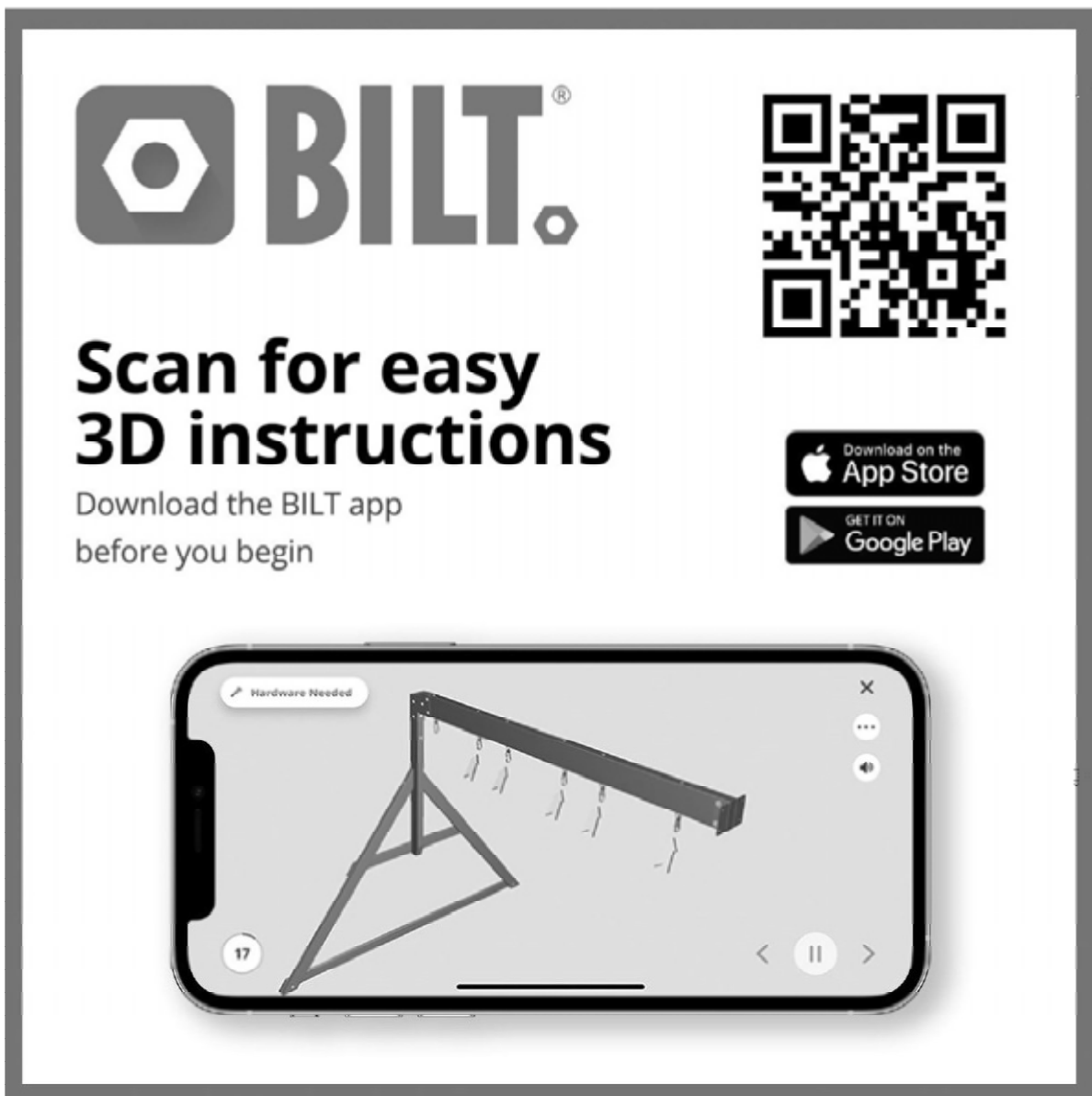

The advertisement features the BILT logo (a hexagon with a dot) and the text "BILT.®" in a large, bold font. To the right is a QR code. Below the logo, the text reads "Scan for easy 3D instructions" and "Download the BILT app before you begin". There are two buttons: "Download on the App Store" and "GET IT ON Google Play". At the bottom, a smartphone displays a 3D assembly instruction for step 17, showing a metal frame with a horizontal bar and several hanging components. The phone screen also shows a "Hardware Needed" list, a close button (X), and navigation icons (back, pause, forward).



LADDER ASSEMBLY

STEP 1



L4 | LADDER RUNG - W4L13286
(x4) | 5/8"x4 3/8"x16 7/8" (16x112x430)



A6P00040 | BLUE HC ROCK #1
(x4)



H100063 | BOLT PTH
(x8) | 1/4x3/4



H100108 | WASHER
(8) | LOCK INT
8x15



H100072 | T-NUT
(x8) | 1/4

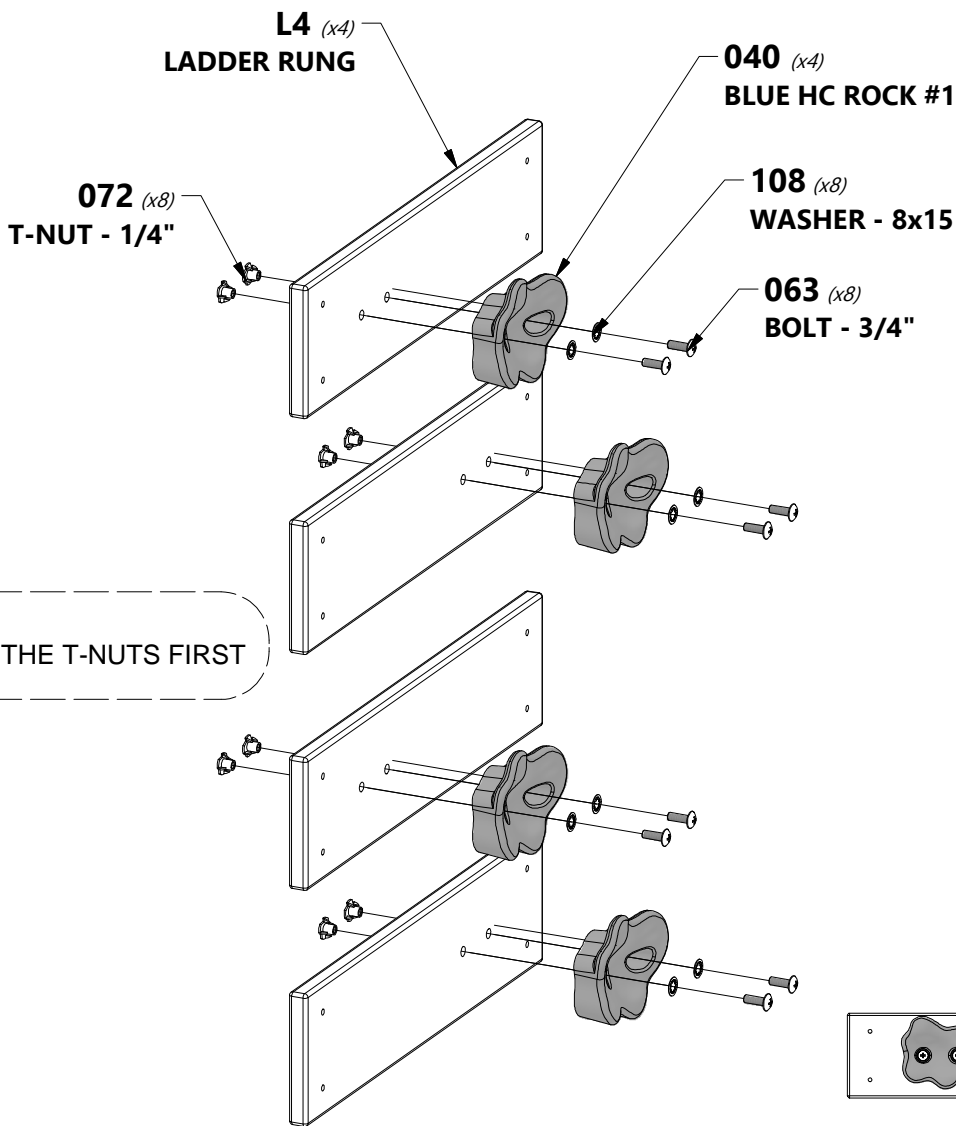

LEFT RUNG ASSEMBLY (x2)



RIGHT RUNG ASSEMBLY (x2)

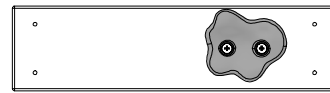



LADDER ASSEMBLY

STEP 2



L3 | LADDER RUNG - W4L13285
(x1) | 5/8"x4 3/8"x16 7/8" (16x112x430)

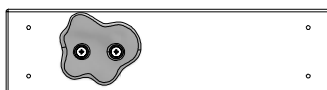

LEFT RUNG ASSEMBLY (x2)



RIGHT RUNG ASSEMBLY (x2)



H100086 | SCREW PFH
(x20) | 8x1 1/2



F1 | UPRIGHT - W4L13283
(x1) | 1 7/16"x2 3/8"x43 3/4" (36x60x1111)



F2 | UPRIGHT - W4L13284
(x1) | 1 7/16"x2 3/8"x43 3/4" (36x60x1111)

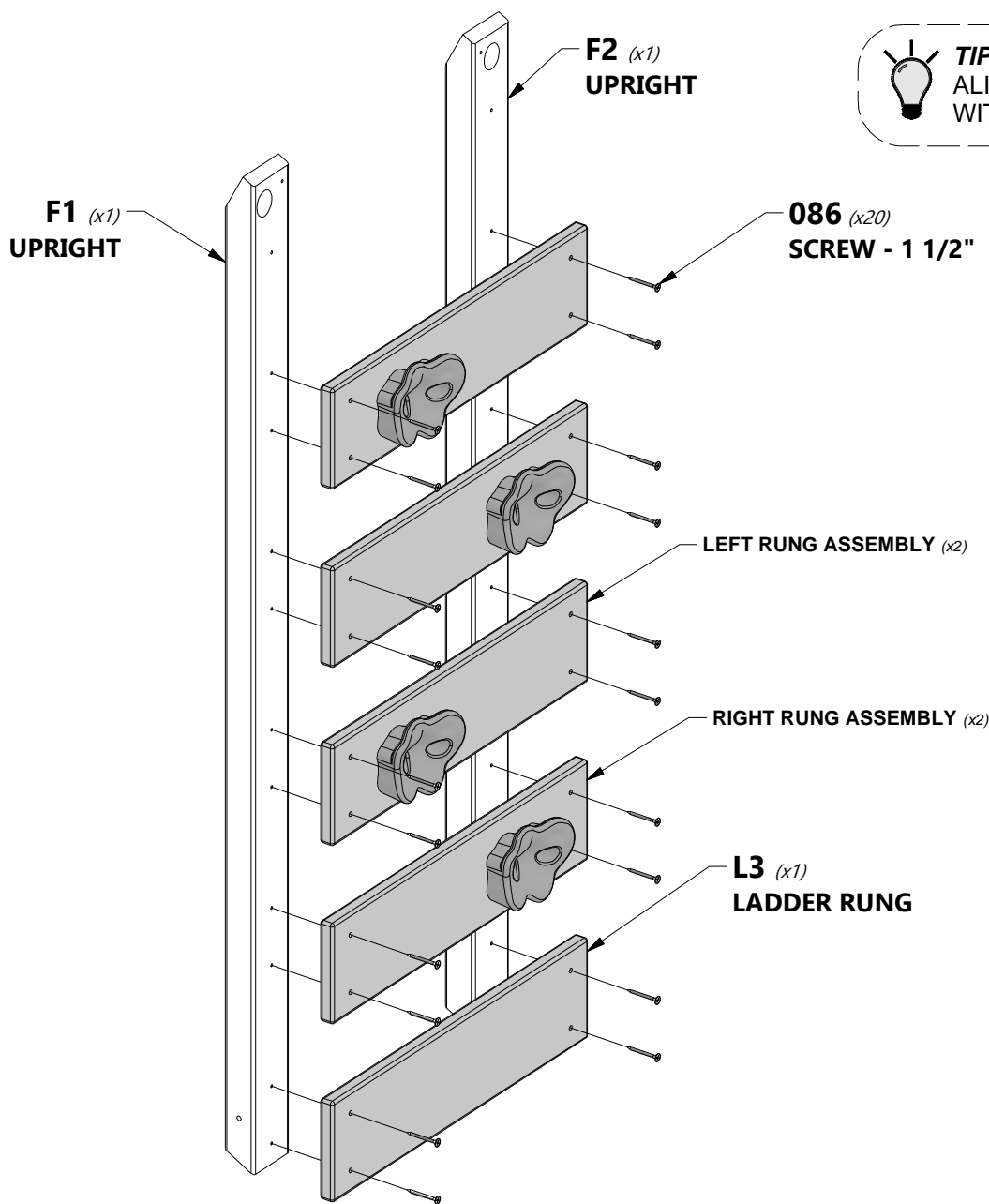

TIP:
ALIGN HOLES IN RUNGS WITH HOLES IN UPRIGHTS.

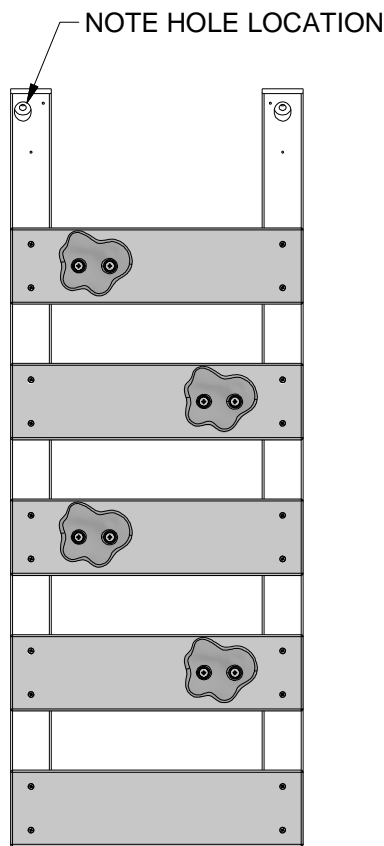



SLIDE ASSEMBLY

STEP 1



A6P00404 | 6 FT SLIDE BED
(1)



M77 | SLIDE BRACE - W4L13297
(1) | 5/8"x3 3/8"x14 1/4" (16x86x362)



H100115 | BOLT WH
(2) | 5/16x1/2



H100074 | T-NUT
(2) | 5/16



NOTE:

TAKE NOTE OF SLIDE BED SURFACE FINISH, THE DULL SIDE WILL BE TOWARDS THE GROUND. PLACE SLIDE BRACE CENTERED ON THE BOTTOM (DULL SIDE) AND 1/2" FROM THE EDGE. USE **M77** BOARD AS A TEMPLATE FOR DRILLING BOTTOM HOLE PATTERN IN SLIDE BED. USE A 5/16" DRILL BIT.



TIP:

PRE-BENDING THE ENDS WILL EASE ASSEMBLY. PLACING THE SLIDE BED OUT IN THE SUN MAKES IT EASIER TO BEND.

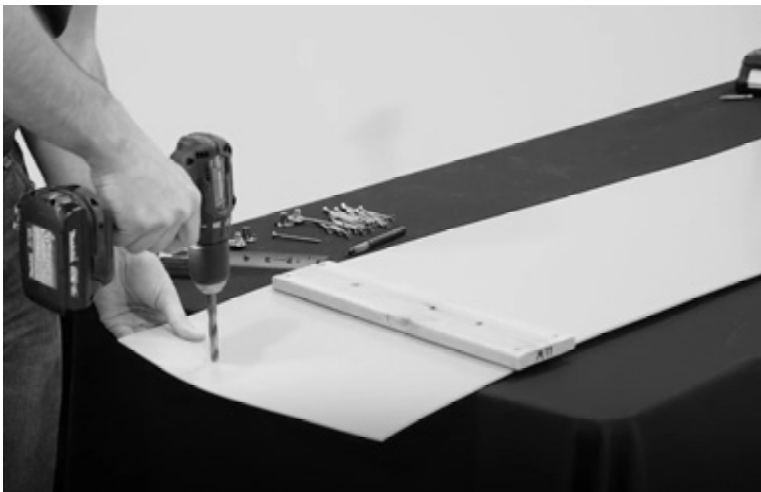
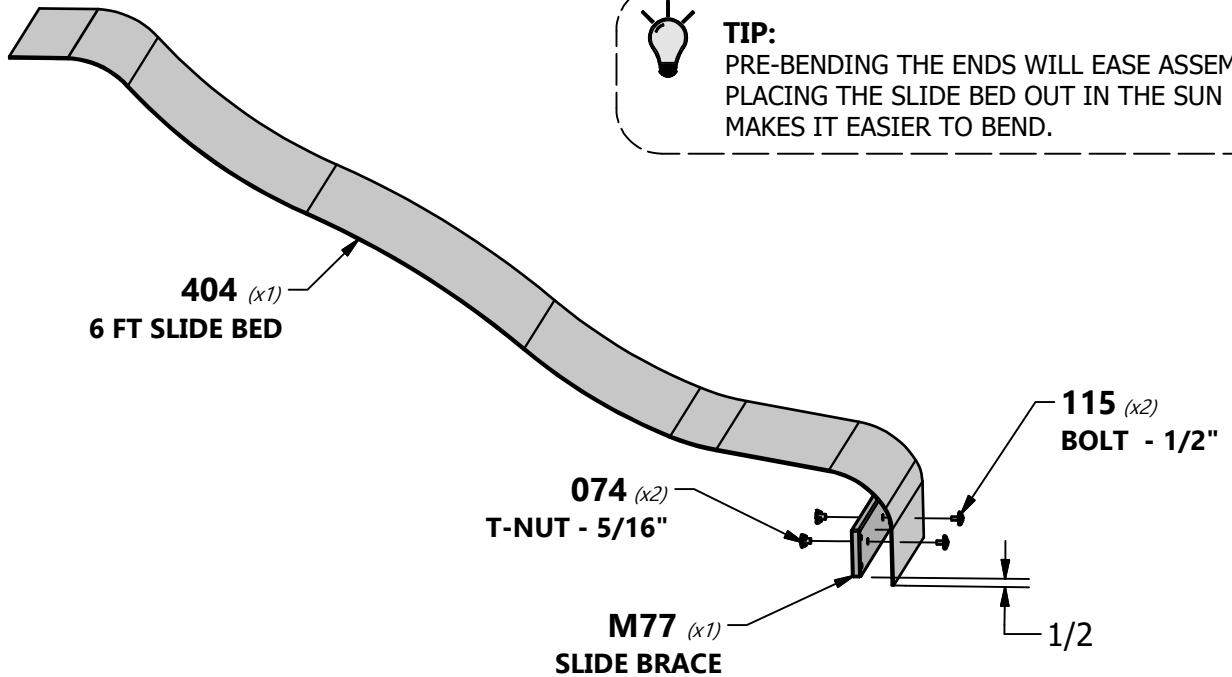



M78 | SLIDE BRACE - W4L13298
(1) | 5/8"x3 3/8"x14 1/4" (16x86x362)



A6P00403 | 6 FT SLIDE RAIL RIGHT
(1)



A6P00402 | 6 FT SLIDE RAIL LEFT
(1)



H100090 | SCREW PFH
(16) | 8x2 1/2"



NOTE:

PLACE SECOND SLIDE RAIL ASSEMBLY OVER THE TOP OF THE SLIDE BED AND M78 CENTER SLIDE BRACES. INSERT THE SLIDE BED AND CENTER SLIDE BRACES INTO THE SLIDE CAVITY. MAKE SURE SLIDE BED IS COMPLETELY IN THE SLIDE CAVITY. USE A RUBBER Mallet TO FULLY SEAT THE SLIDE BED INTO THE SLIDE CAVITY.

USING AN 1/8" DRILL BIT, DRILL PILOT HOLES IN EACH INDENTATION ALONG EACH SIDE RAIL. THERE SHOULD BE 12 INDENTATIONS ON EACH RAIL. BE SURE TO DRILL THROUGH THE SLIDE RAIL AND THE SLIDE BED. THEN SECURE WITH THE PROVIDED HARDWARE.



FAILURE TO INSERT SLIDE BED COMPLETELY AND SECURED MAY RESULT IN INJURY OR AMPUTATION. EXPOSED SLIDE EDGES CAN BE SHARP AND BECOME A LACERATION HAZARD IF THE SLIDE IS NOT PROPERLY ASSEMBLED.



TIP:

A HELPER IS REQUIRED FOR THIS STEP.

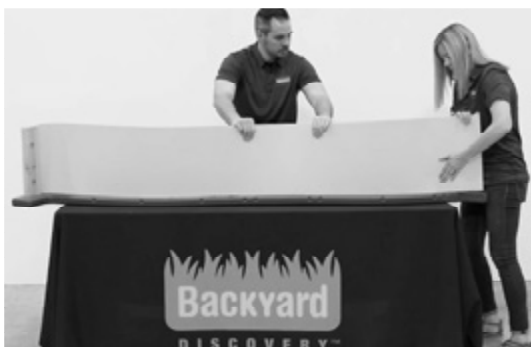
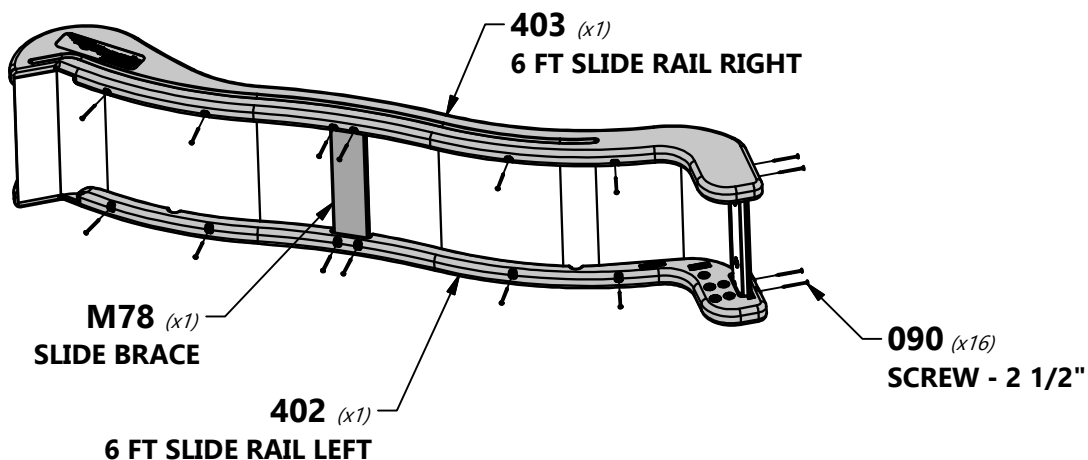



SWING BEAM

STEP 1

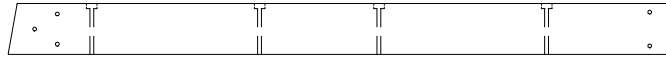

SB74 | SWING BEAM 2 POSITION - W4L13291
(1) | 2"x5 1/4"x68 3/4" (50x134x1745)

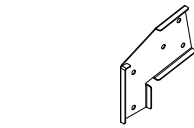

A4M00511 | SWING BEAM
EXT. BRACKET
BLUE - LEFT
(1)

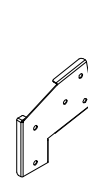

A4M00512 | SWING BEAM
EXT BRACKET
BLUE - RIGHT
(1)



A100153 | L BRACKET
(2) | 66x66x127 BLUE



A100175 | BYD ID TAG
(1) | (MEDIUM) AGES
3-10



H100047 | BOLT HEX
(2) | 5/16x2 3/4

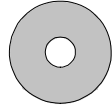

H100105 | WASHER FLAT
(4) | 8x27



H100110 | NUT LOCK
(2) | 5/16



H100011 | BOLT WH
(3) | 5/16x1 3/4

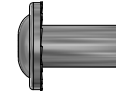

H100005 | NUT BARREL WH
(3) | 5/16x7/8



H100128 | SCREW PWH
(4) | 8x5/8

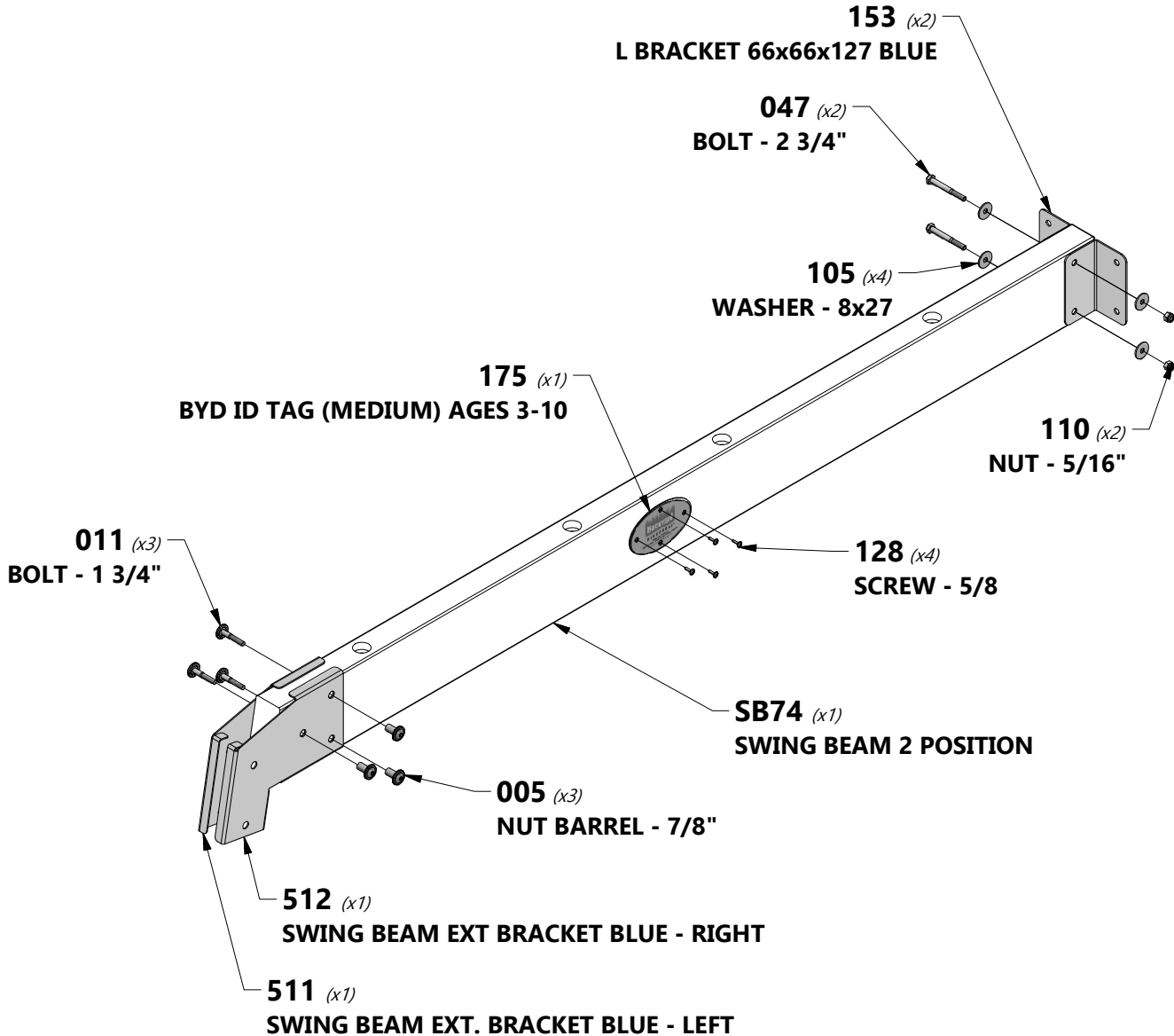



SWING BEAM

STEP 2

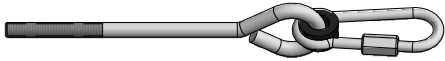

H100099 | SWING HANGER
(4) | 5/16x9 1/2

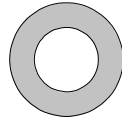

H100103 | WASHER SAFETY
(4) | 17x30

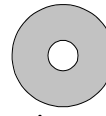

H100105 | WASHER FLAT
(4) | 8x27



H100110 | NUT LOCK
(4) | 5/16

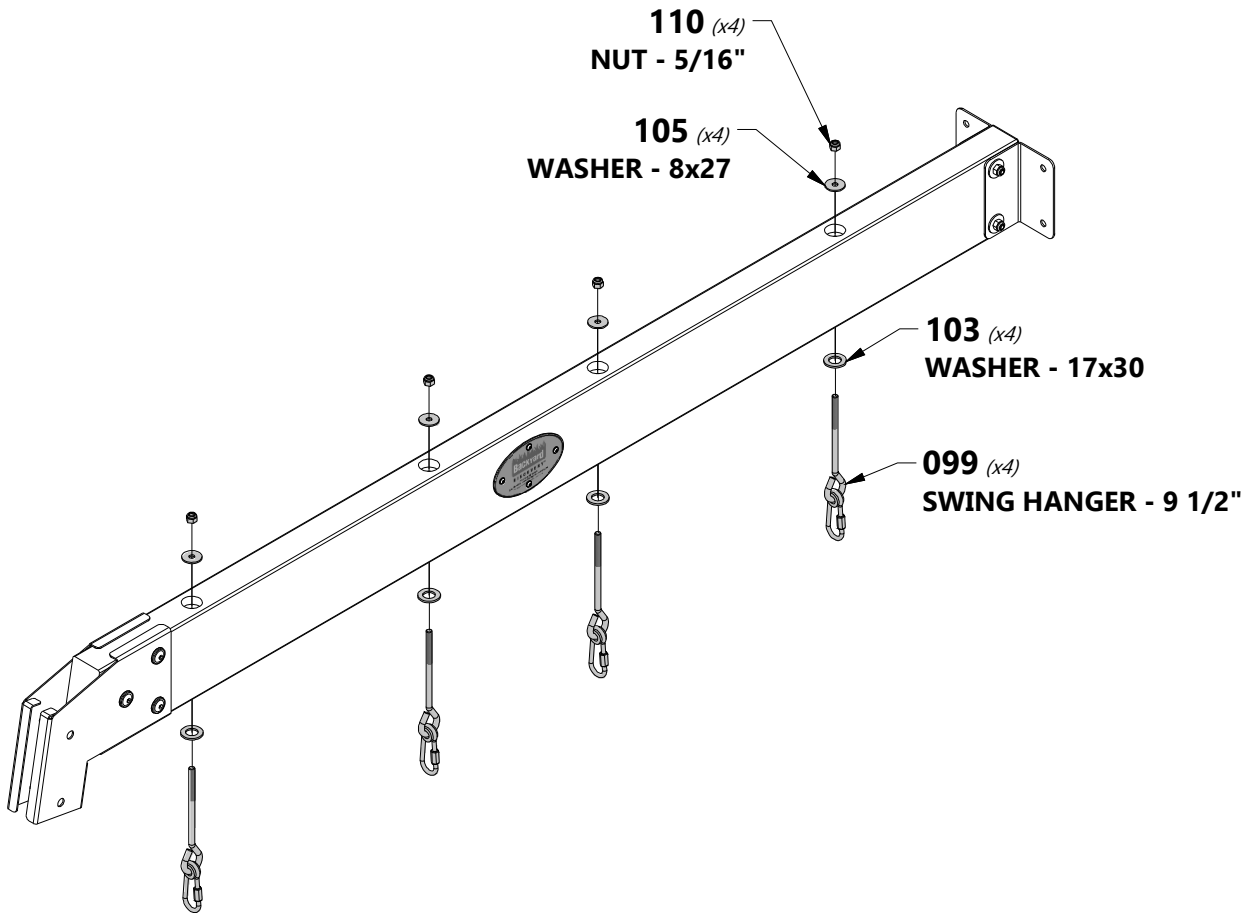



SWING BEAM

STEP 3



W71 | SWING BEAM SUPPORT - W4L13292
(1) | 2"x3 3/8"x44 1/4" (50x86x1123)

E77 | ANGLE BRACE - W4L13293
(2) | 1 3/8"x3 3/8"x72 7/8" (36x86x1850)

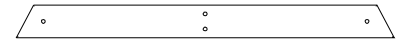

H79 | END SUPPORT - W4L13294
(1) | 1"x3 1/2"x39 1/2" (24x86x1000)

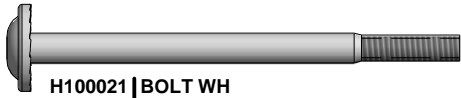

H100021 | BOLT WH
(1) | 5/16x4 1/2

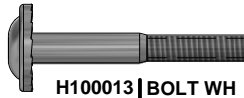

H100013 | BOLT WH
(2) | 5/16x2 1/4



H100027 | LAG SCREW WH
(2) | 5/16x2

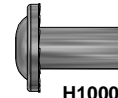

H100005 | NUT BARREL WH
(1) | 5/16x7/8



H100031 | WASHER LOCK EXT
(1) | 12x19



H100030 | WASHER LOCK EXT
(5) | 8x19



H100074 | T-NUT
(2) | 5/16

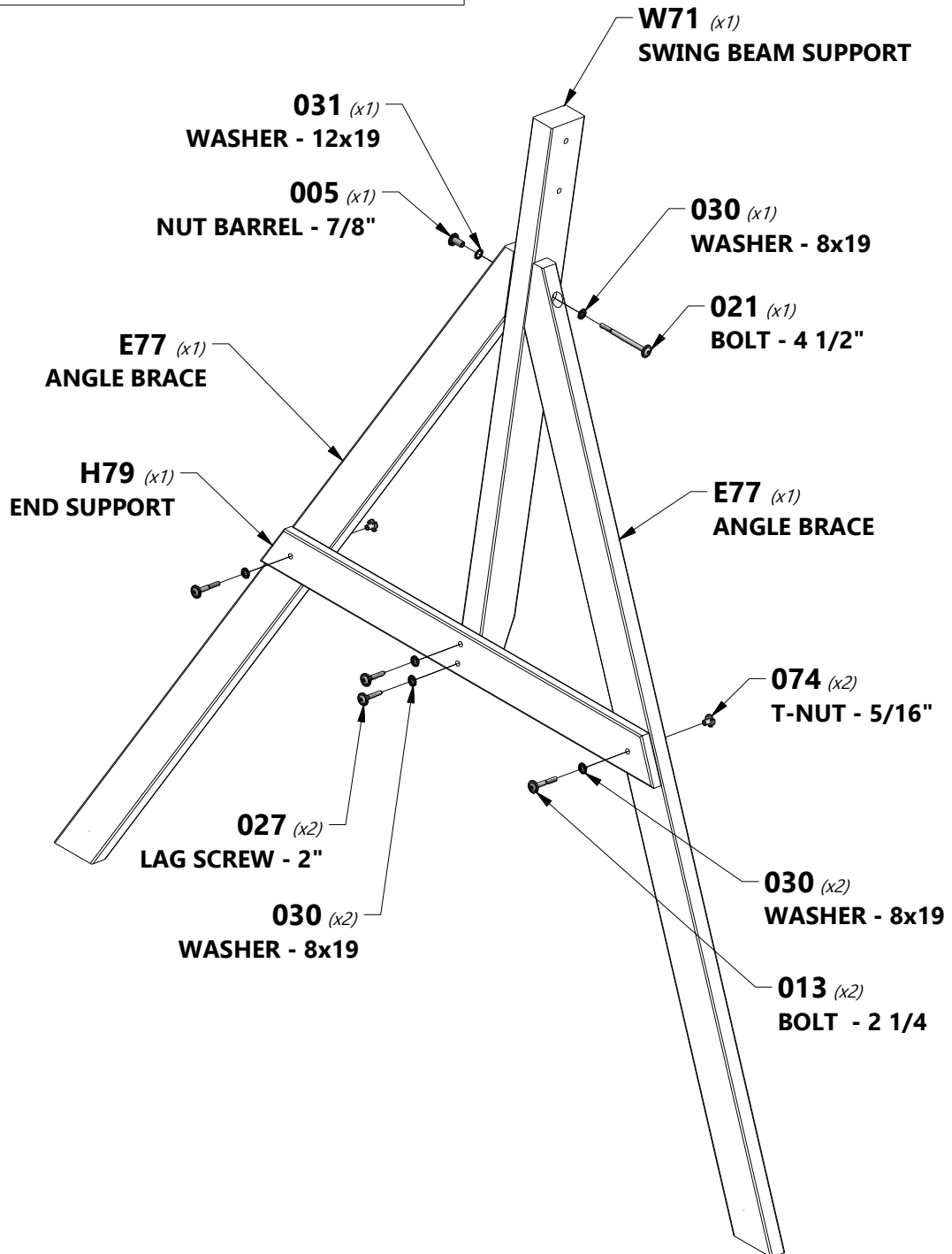



SWING BEAM

STEP 4

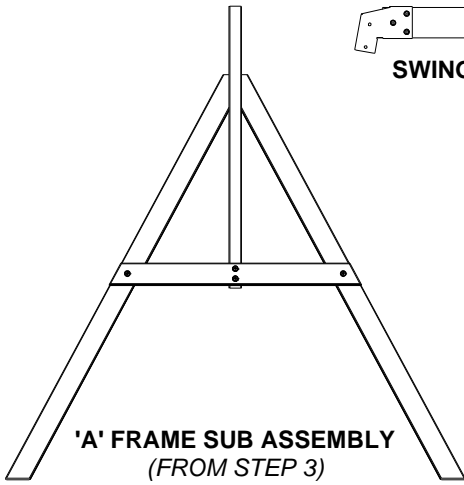

'A' FRAME SUB ASSEMBLY
(FROM STEP 3)

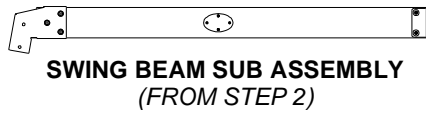

SWING BEAM SUB ASSEMBLY
(FROM STEP 2)



H100011 | BOLT WH
(2) | 5/16x1 3/4

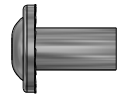

H100005 | NUT BARREL WH
(2) | 5/16x7/8

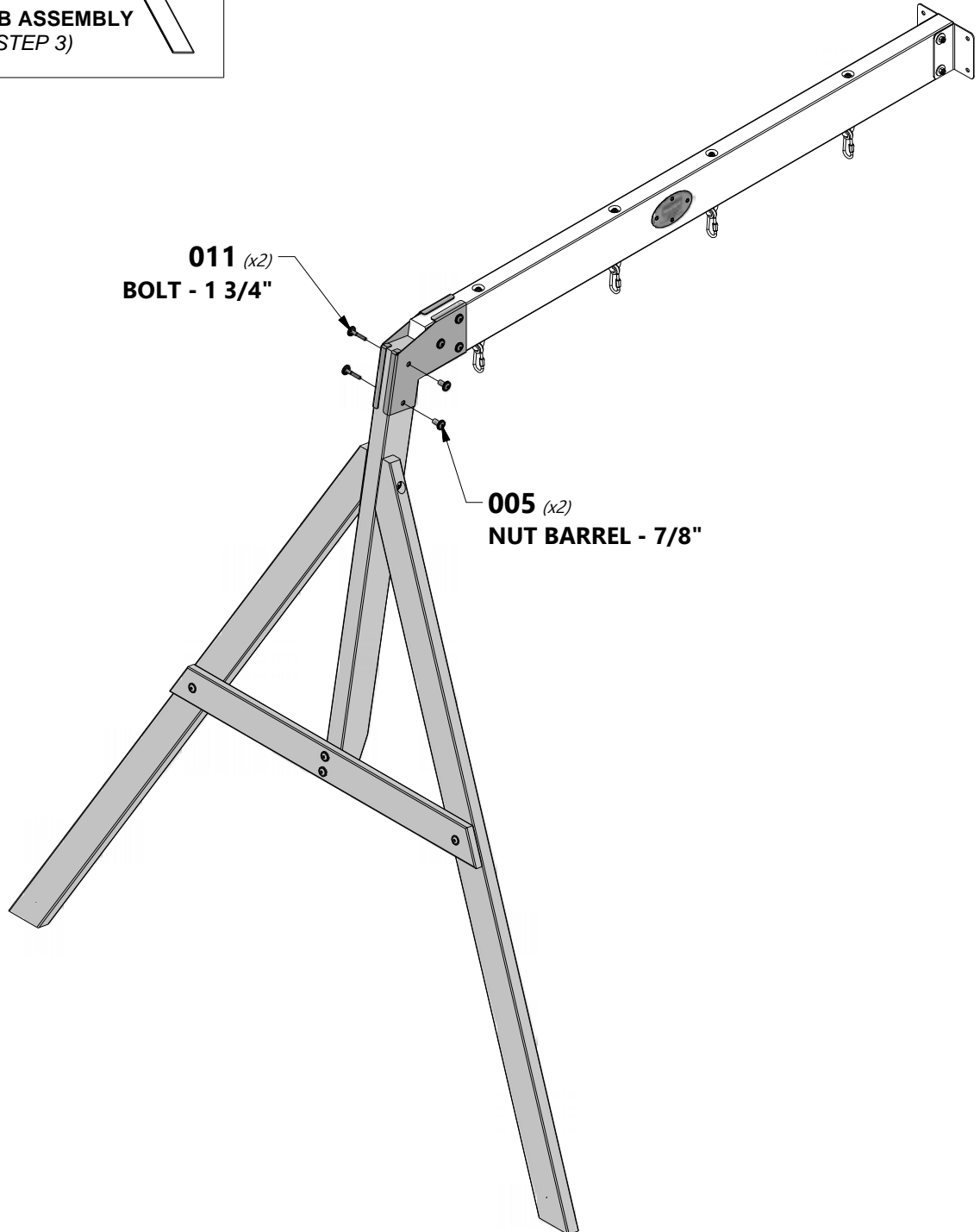

011 (x2)
BOLT - 1 3/4"

005 (x2)
NUT BARREL - 7/8"



FORT ASSEMBLY

STEP 1

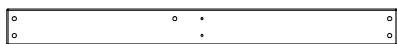

H8 | FLOOR RAIL - W4L13295
(1) | 1"x3 3/8"x36 5/8" (24x86x930)



M5 | GROUND RAIL - W4L13209
(1) | 5/8"x3 3/8"x36 5/8" (16x86x930)

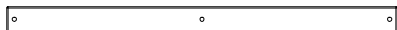

N3 | TOP RAIL - W4L13220
(1) | 5/8"x2 3/8"x36 5/8" (16x60x930)

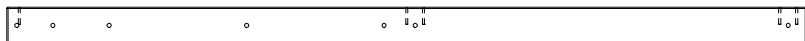

E1 | RIGHT FRONT UPRIGHT - W4L15660
(1) | 1 3/8"x3 3/8"x75" (36x86x1905)

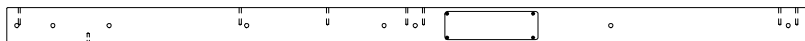

E2 | POST ASSEMBLY - W2A02839
(1) | 1 7/16"x3 3/8"x75" (36x86x1905)

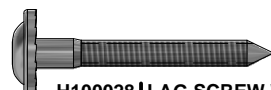

H100028 | LAG SCREW WH
(3) | 5/16x2 1/2



H100027 | LAG SCREW WH
(6) | 5/16x2



H100030 | WASHER LOCK
(9) | EXT
8x19

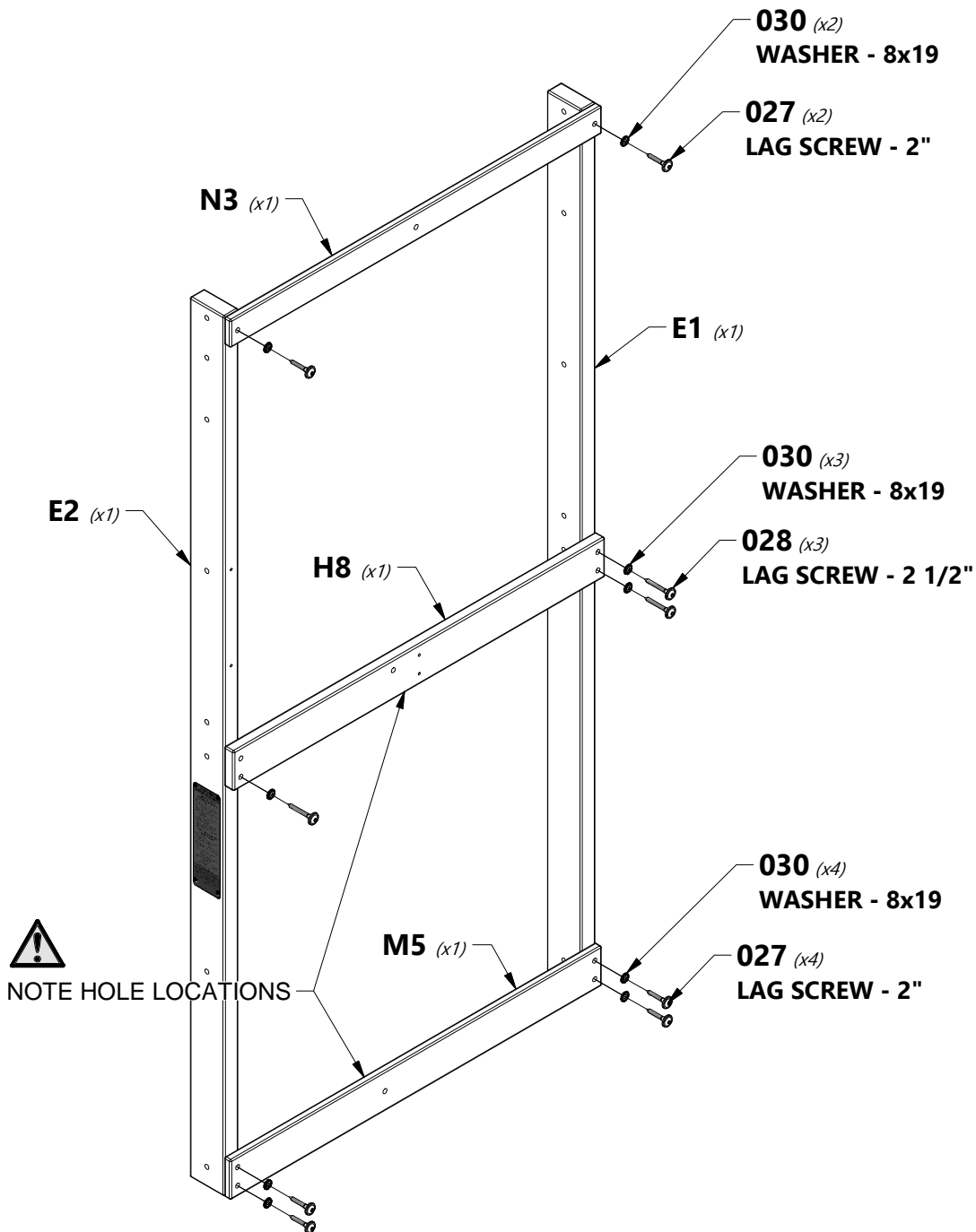



FORT ASSEMBLY

STEP 2

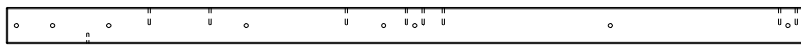

E3 | LEFT BACK UPRIGHT - W4L13210
(1) | 1 3/8"x3 3/8"x75" (36x86x1905)

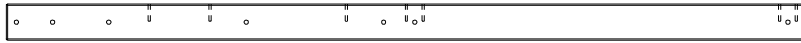

E4 | RIGHT BACK UPRIGHT - W4L13211
(1) | 1 3/8"x3 3/8"x75" (36x86x1905)



M1 | GROUND RAIL - W4L13215
(1) | 5/8"x3 3/8"x36 5/8" (16x86x930)

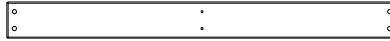

H1 | FLOOR RAIL - W4L13212
(1) | 1"x3 3/8"x36 5/8" (24x86x930)



N2 | SIDE RAIL - W4L13218
(2) | 5/8"x2 3/8"x36 5/8" (16x60x930)



H100028 | LAG SCREW WH
(4) | 5/16x2 1/2



H100027 | LAG SCREW WH
(8) | 5/16x2



H100030 | WASHER LOCK
(12) | EXT
8x19

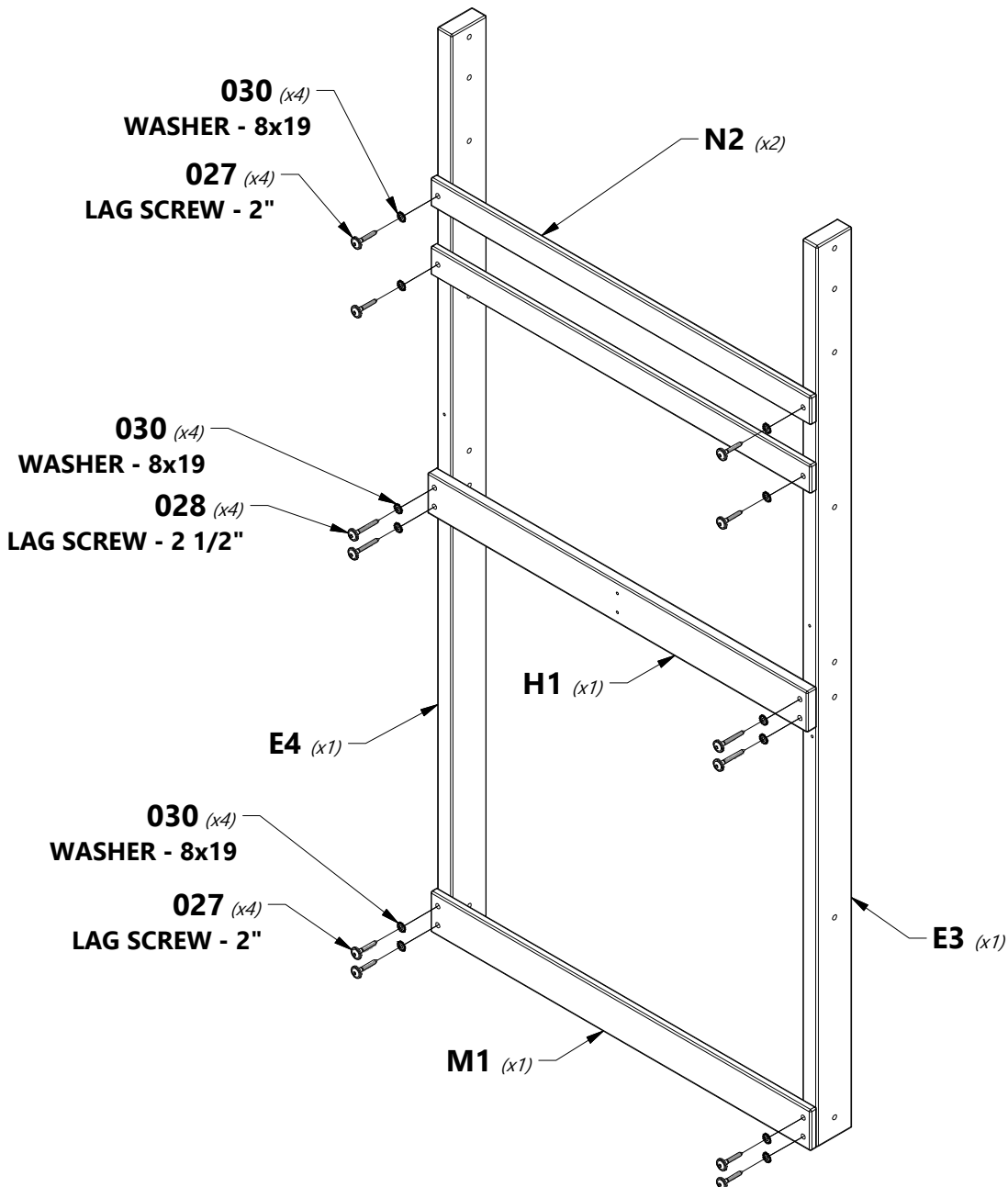



FORT ASSEMBLY

STEP 3



M3 | ANGLE GROUND RAIL - W4L13217
(1) | 5/8"x3 3/8"x65 5/8" (16x86x1666)



N1 | SIDE RAIL - W4L13214
(1) | 5/8"x2 3/8"x24 1/8" (16x60x612)

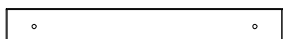

H2 | FLOOR RAIL - W4L13213
(1) | 1"x3 3/8"x26" (24x86x660)



H4 | FLOOR SUPPORT - W4L13222
(2) | 1"x3 3/8"x3 3/8" (24x86x86)



H100017 | BOLT WH
(2) | 5/16x3 1/4

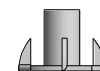

H100074 | T-NUT
(6) | 5/16



H100012 | BOLT WH
(4) | 5/16x2



H100030 | WASHER LOCK
(6) | EXT
8x19

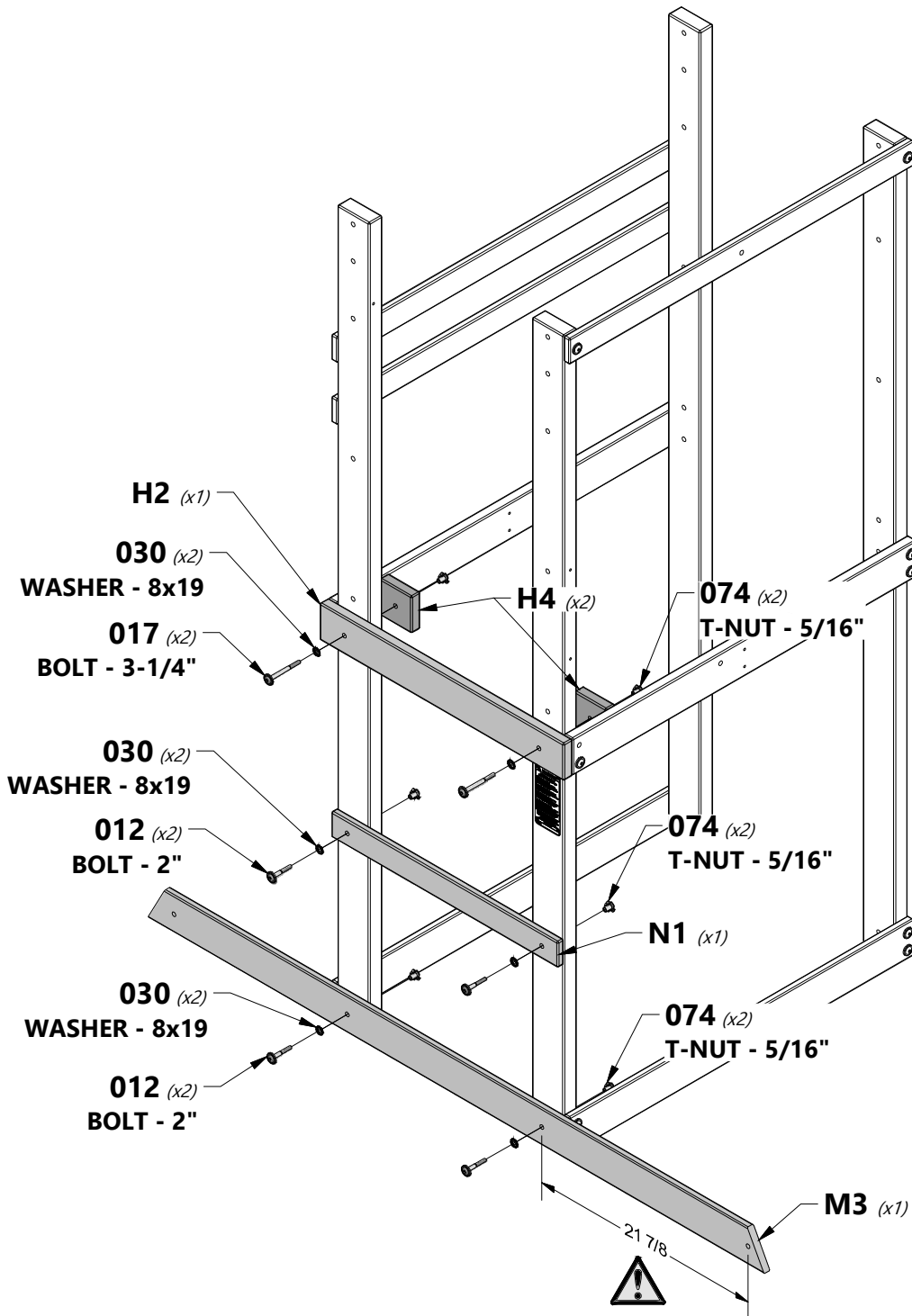

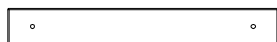

M2 | GROUND RAIL - W4L13216
(1) | 5/8"x3 3/8"x25 3/8" (16x86x644)

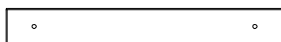

H2 | FLOOR RAIL - W4L13213
(1) | 1"x3 3/8"x26" (24x86x660)



H4 | FLOOR SUPPORT - W4L13222
(2) | 1"x3 3/8"x3 3/8" (24x86x86)



H100017 | BOLT WH
(2) | 5/16x3 1/4



H100074 | T-NUT
(4) | 5/16



H100012 | BOLT WH
(2) | 5/16x2



H100030 | WASHER LOCK
(4) | EXT
8x19

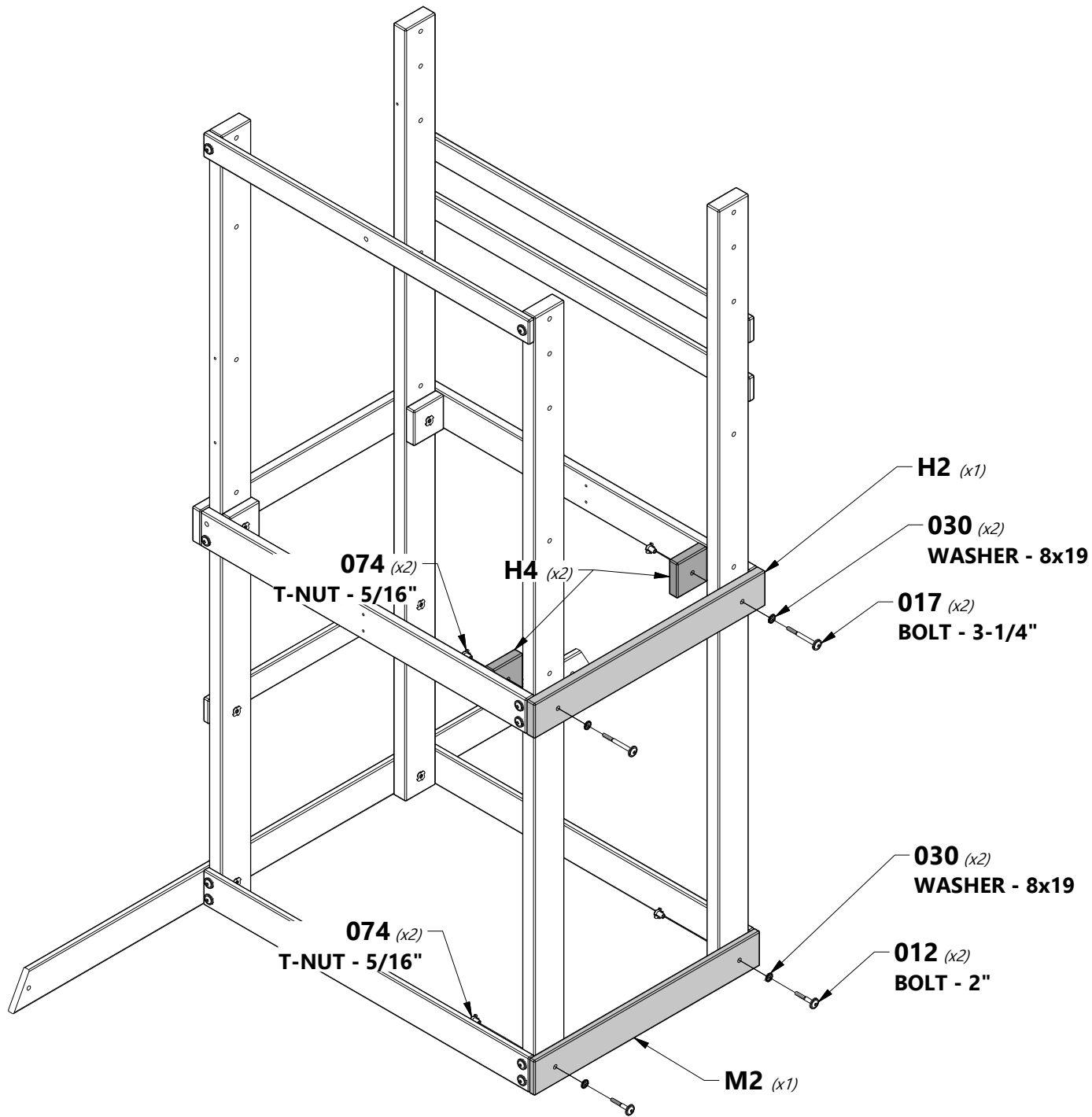



H3 | FLOOR RAIL - W4L13221
(1) | 1"x3 3/8"x24 1/8" (24x86x612)



T1 | FLOOR SUPPORT - W4L13289
(2) | 15/16"x1 5/16"x17 1/4" (24x34x438)



A100314 | "A" REVISION TAG
(1)



H100090 | SCREW PFH
(4) | 8x2 1/2"



H100089 | SCREW PFH
(10) | 8x1 3/4"



H100128 | SCREW PWH
(2) | 8x5/8"

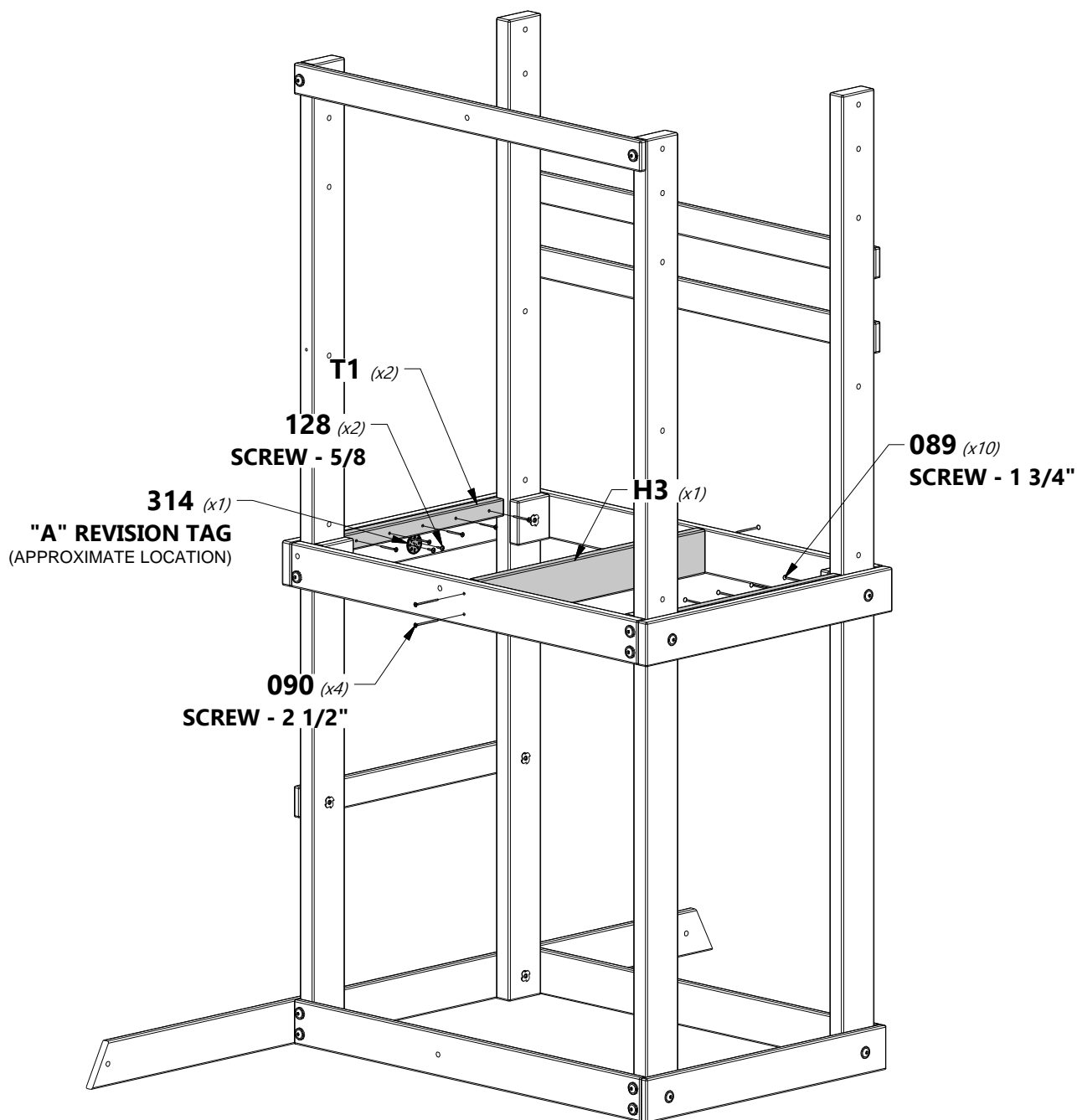

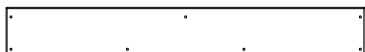

L1 | FLOOR BOARD - W4L13223
(1) | 5/8"x4 3/8"x33 3/4" (16x112x856)

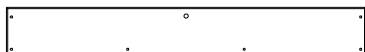

L2 | FLOOR BOARD - W4L13225
(1) | 5/8"x4 3/8"x33 3/4" (16x112x856)



M4 | FLOOR BOARD - W4L13224
(5) | 5/8"x3 3/8"x36 5/8" (16x86x930)

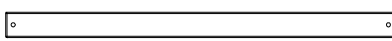

N2 | SIDE RAIL - W4L13218
(1) | 5/8"x2 3/8"x36 5/8" (16x60x930)



H100027 | LAG SCREW WH
(2) | 5/16x2



**H100030 | WASHER LOCK
EXT**
8x19



H100086 | SCREW PFH
(43) | 8x1 1/2



NOTE:
INSTALL FLOOR BEFORE N2 BOARD.

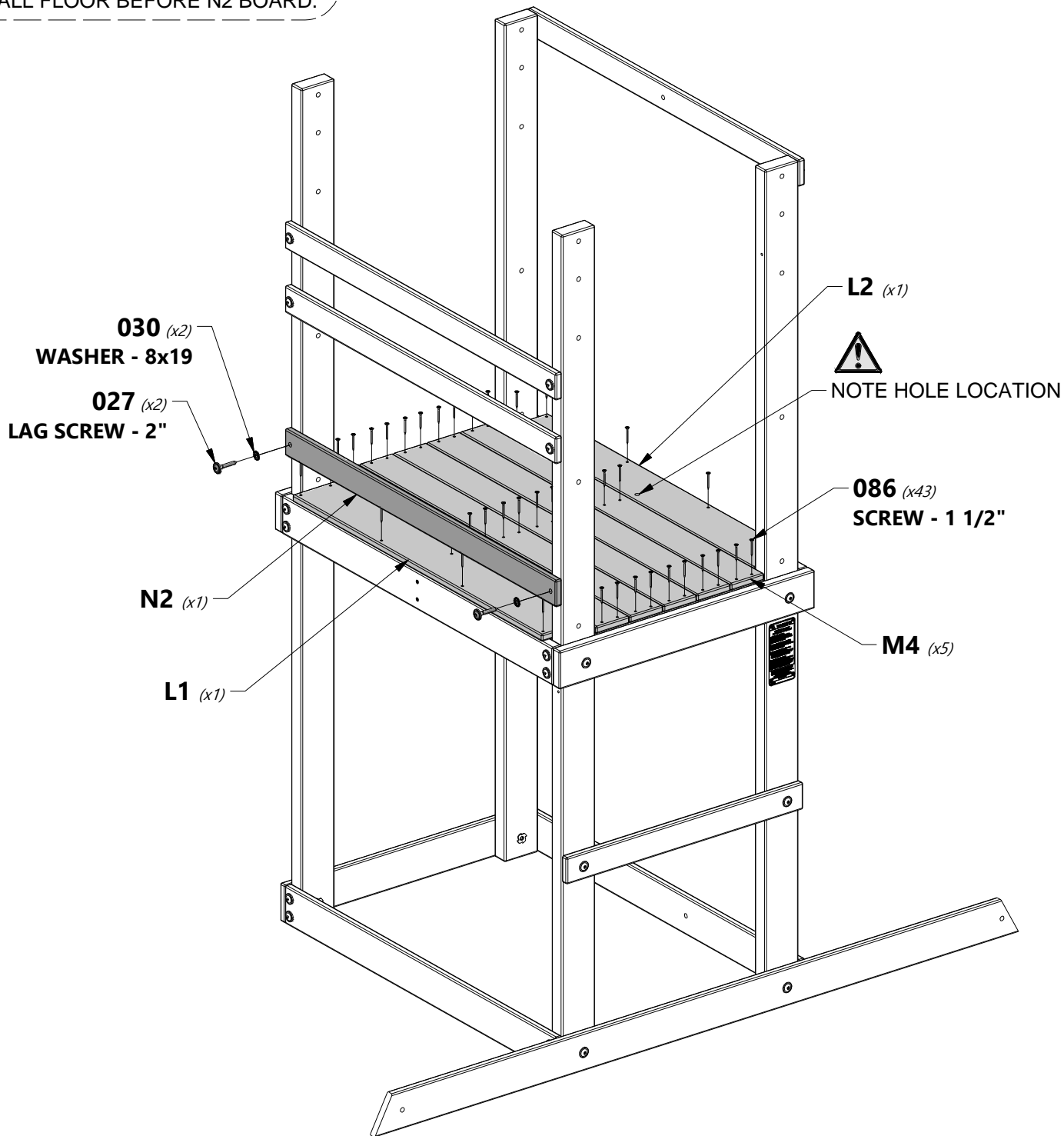



FORT ASSEMBLY

STEP 7

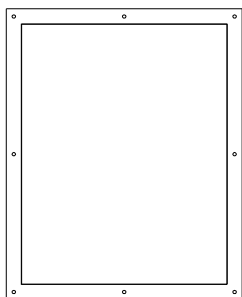

A6P00401 | MESH PANEL
(1)

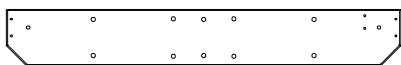

G2 | TOP RAIL - W4L13228
(1) | 1"x5 1/4"x37" (24x134x940)



N1 | SIDE RAIL - W4L13214
(3) | 5/8"x2 3/8"x24 1/8" (16x60x612)



H100013 | BOLT WH
(4) | 5/16x2 1/4

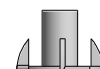

H100074 | T-NUT
(10) | 5/16



H100128 | SCREW PWH
(2) | 8x5/8



H100012 | BOLT WH
(6) | 5/16x2



H100030 | WASHER LOCK
(10) | EXT
8x19

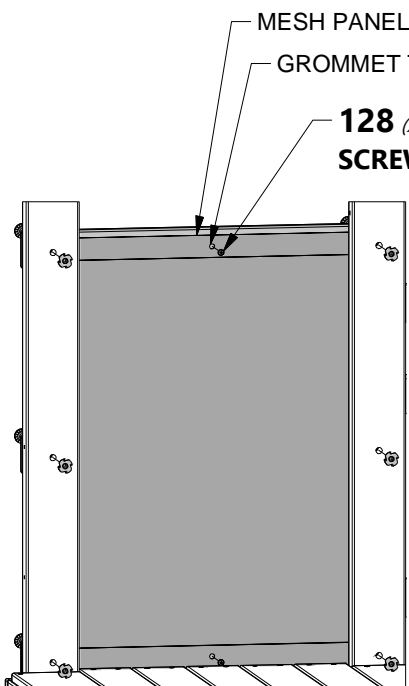
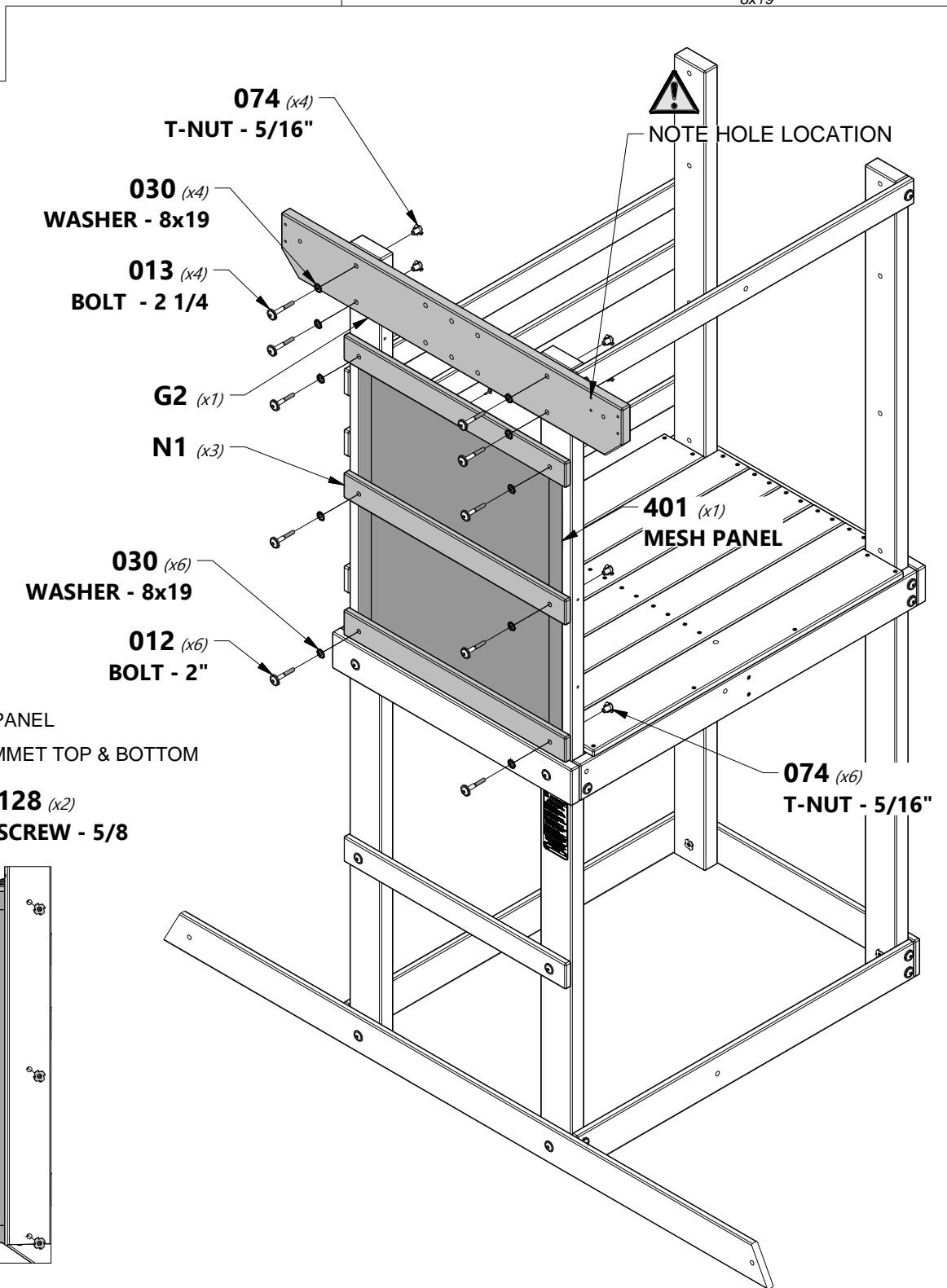

INSIDE VIEW

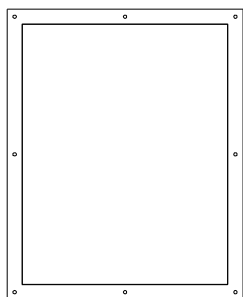

A6P00401
(1) MESH PANEL

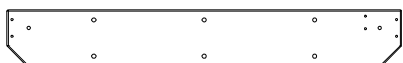

G1 | TOP RAIL - W4L13219
(1) | 1"x5 1/4"x37" (24x134x940)



N1 | SIDE RAIL - W4L13214
(3) | 5/8"x2 3/8"x24 1/8" (16x60x612)



H100013 | BOLT WH
(4) | 5/16x2 1/4



H100074 | T-NUT
(10) | 5/16



H100128 | SCREW PWH
(2) | 8x5/8



H100012 | BOLT WH
(6) | 5/16x2



H100030 | WASHER LOCK
(10) | EXT
8x19



NOTE HOLE LOCATION

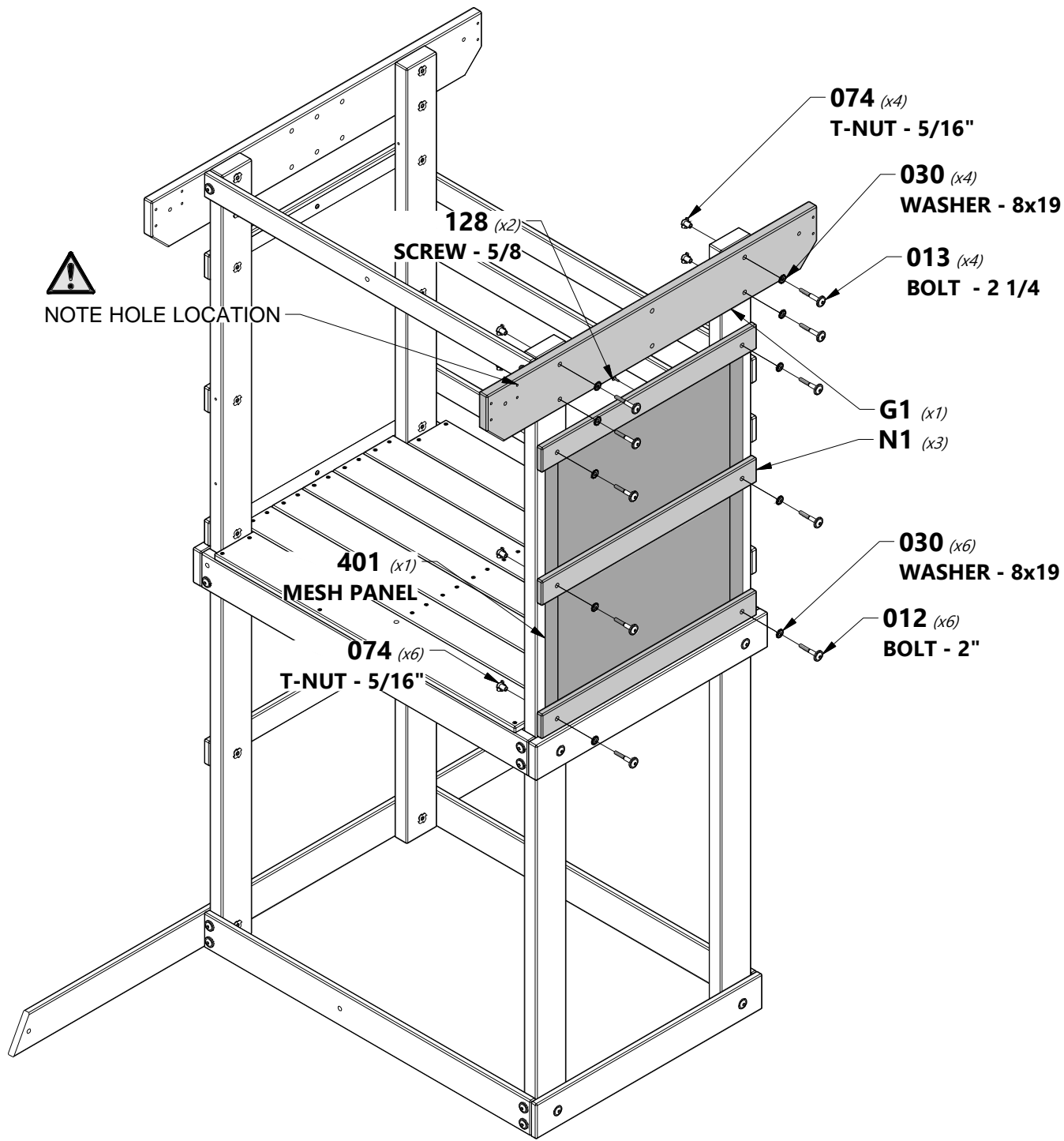

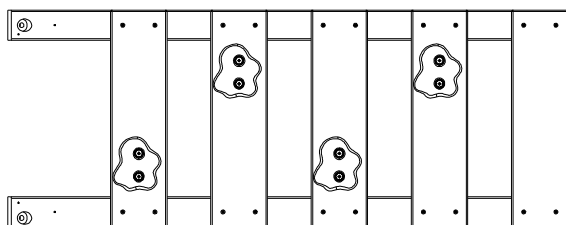

(1) LADDER ASSEMBLY



H100029 | LAG SCREW WH
(1) | 5/16x3



H100027 | LAG SCREW WH
(1) | 5/16x2

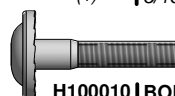

H100010 | BOLT WH
(1) | 5/16x1-1/2



H100030 | WASHER LOCK
(3) | EXT
8x19



H100074 | T-NUT
(1) | 5/16

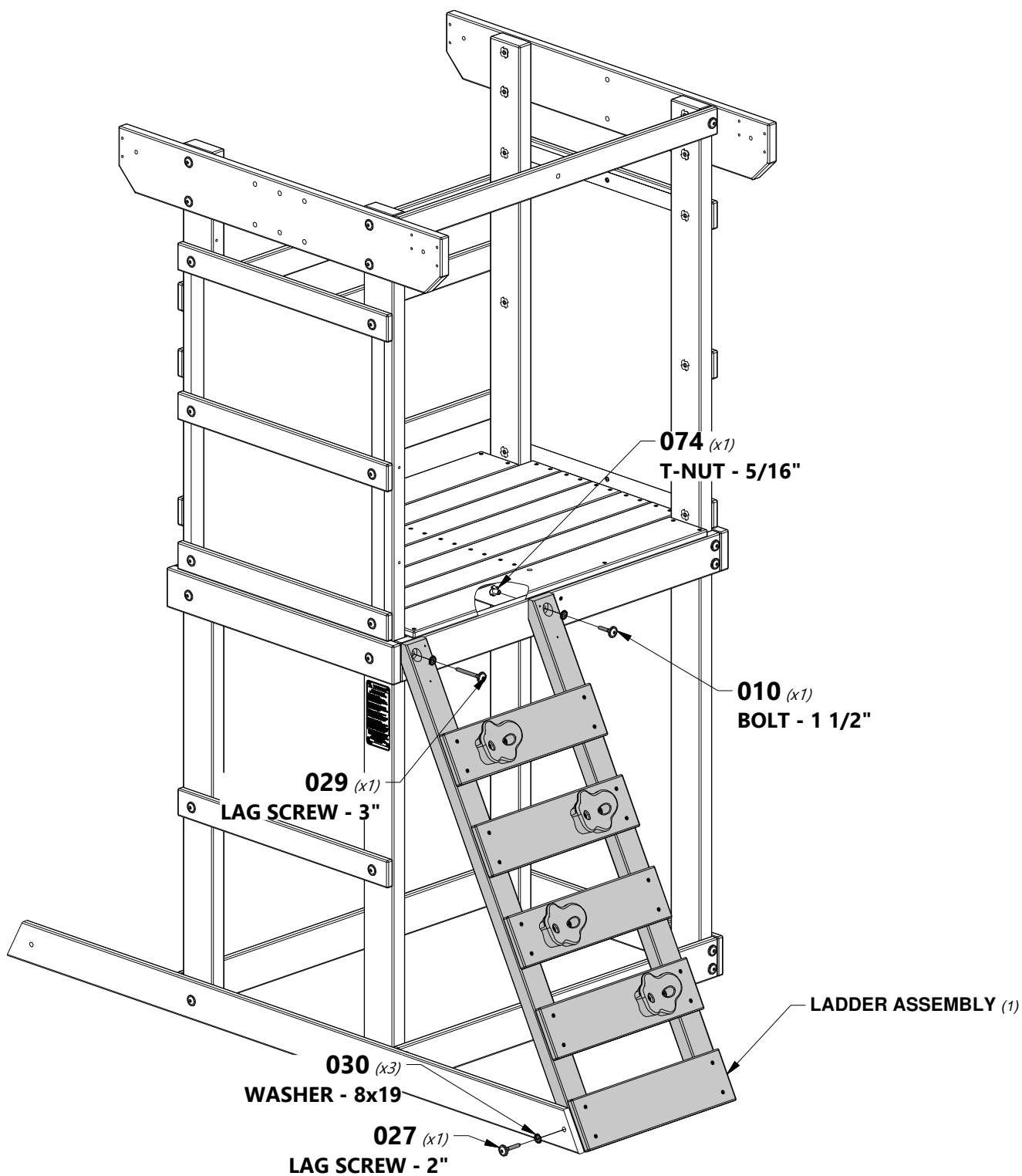



FORT ASSEMBLY

STEP 10

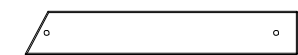

M6 | GROUND RAIL - W4L13296
(1) | 5/8"x3 3/8"x21 3/8" (16x86x542)



L5 | TOP LADDER RUNG - W4L13287
(1) | 5/8"x4 3/8"x16 7/8" (16x112x430)



A4M01048 | L BRACKET
(1) | 2.5x38x55x55



H100027 | LAG SCREW WH
(1) | 5/16x2



H100115 | BOLT WH
(2) | 5/16x1/2



H100004 | NUT BARREL WH
(2) | 5/16 x 5/8



H100030 | WASHER LOCK
(1) | EXT
8x19



H100031 | WASHER LOCK
(2) | EXT
12x19



H100086 | SCREW PFH
(4) | 8x1 1/2

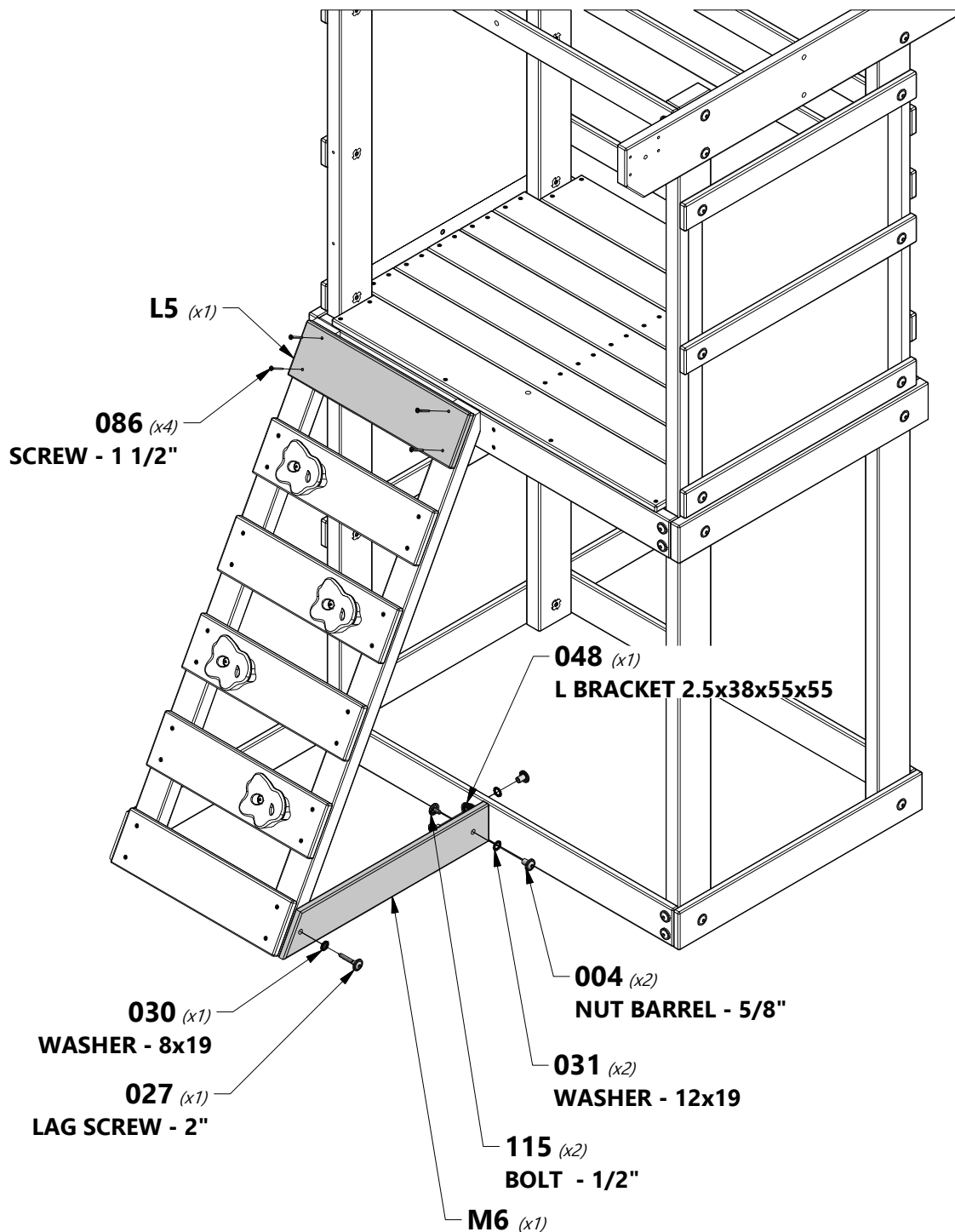



N6 | PICKET - W4L13281
(4) | 5/8"x2 3/8"x15 1/8" (16x60x385)

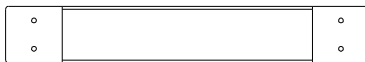

J2 | PICKET - W4L13282
(2) | 1"x2 3/8"x15 1/8" (24x60x385)



H100088 | SCREW PFH
(16) | 8x1 1/8"



H100121 | SCREW PFH
(8) | 8x3/4"

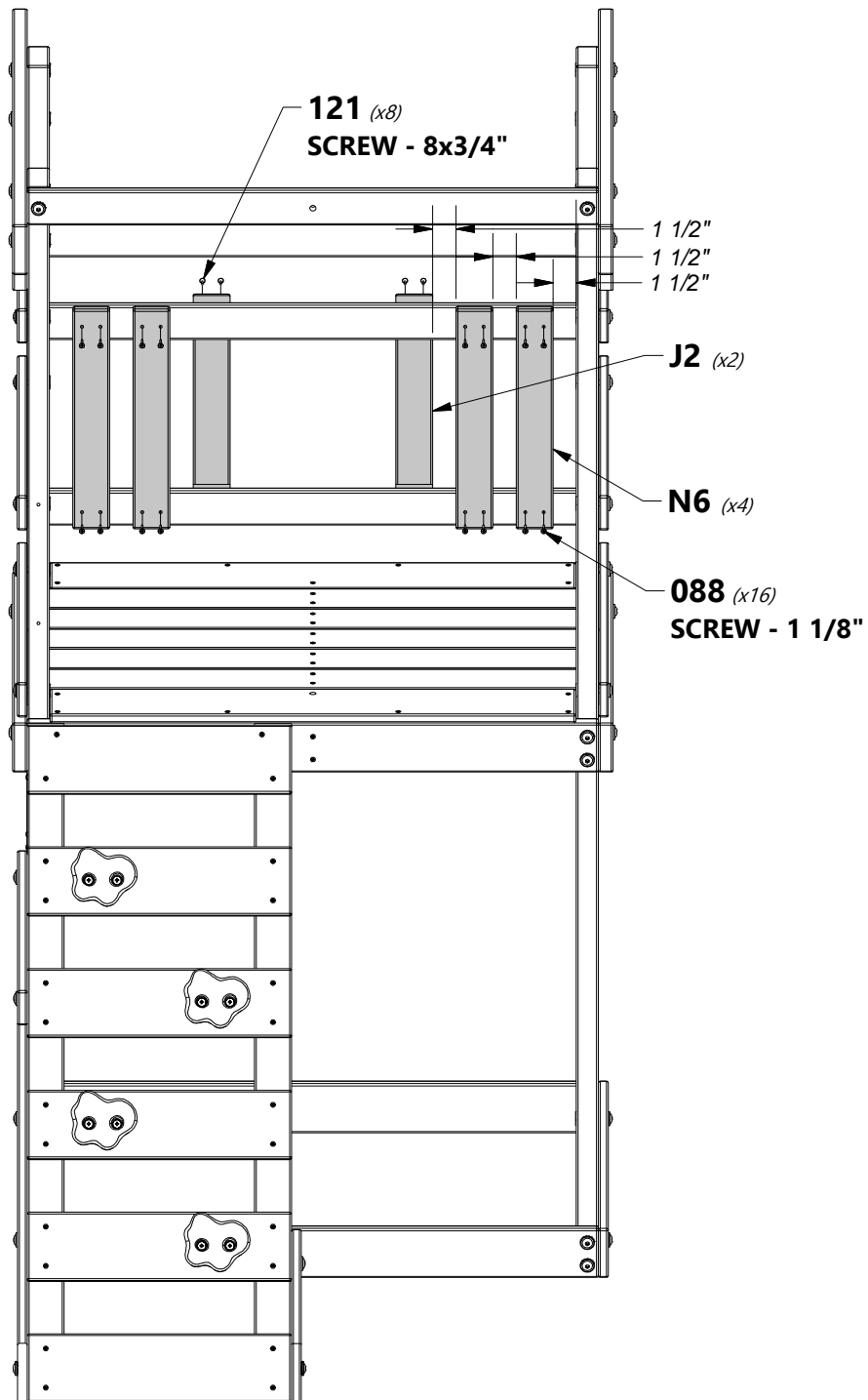

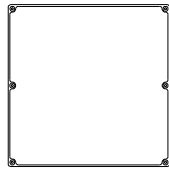

A6P00323 | CHALK BOARD
(1)



H100392 | SCREW PWH BLK
(6) | 8x3/4

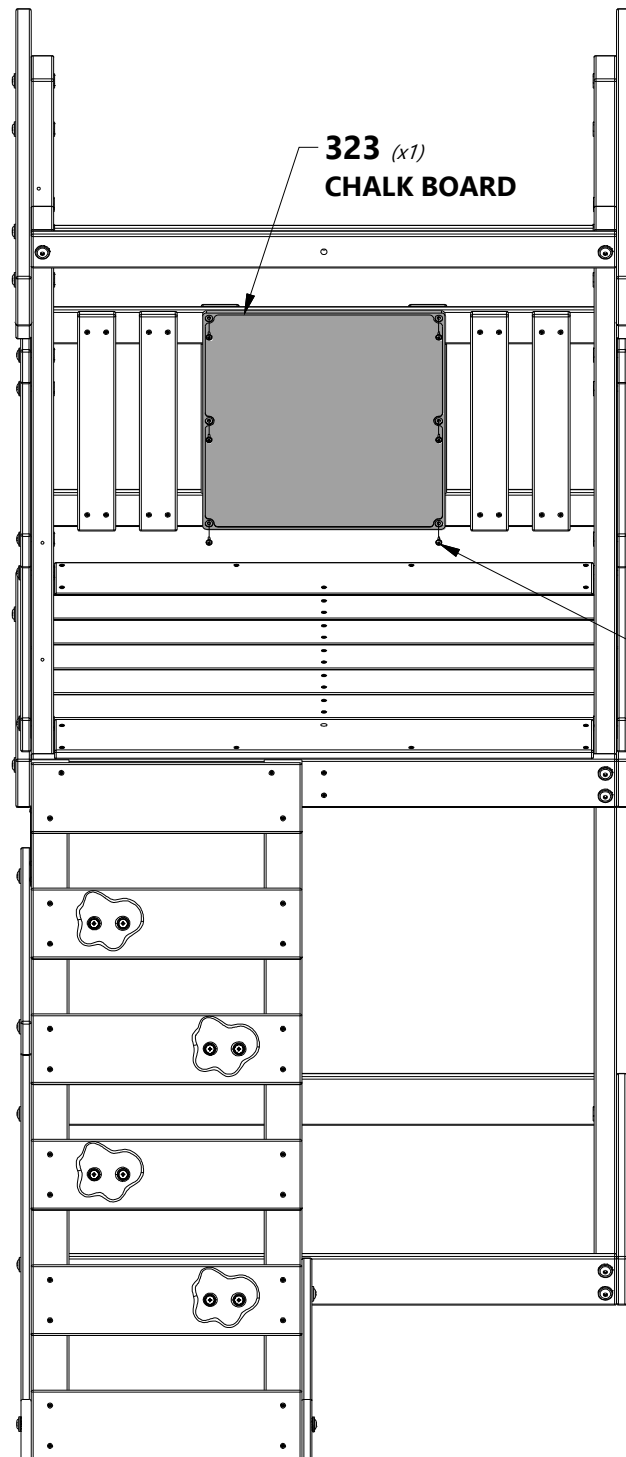



J1 | UPRIGHT - W4L13226
(1) | 1"x2"x36" (24x52x914)



A4M01048 | L BRACKET
(1) | 2.5x38x55x55



H100145 | LAG SCREW WH
(1) | 1/4x1 1/2

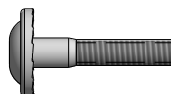

H100010 | BOLT WH
(1) | 5/16x1-1/2



H100115 | BOLT WH
(1) | 5/16x1/2

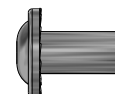

H100005 | NUT BARREL WH
(1) | 5/16x7/8



H100030 | WASHER LOCK
(1) | EXT
8x19



H100031 | WASHER LOCK
(1) | EXT
12x19



H100074 | T-NUT
(1) | 5/16

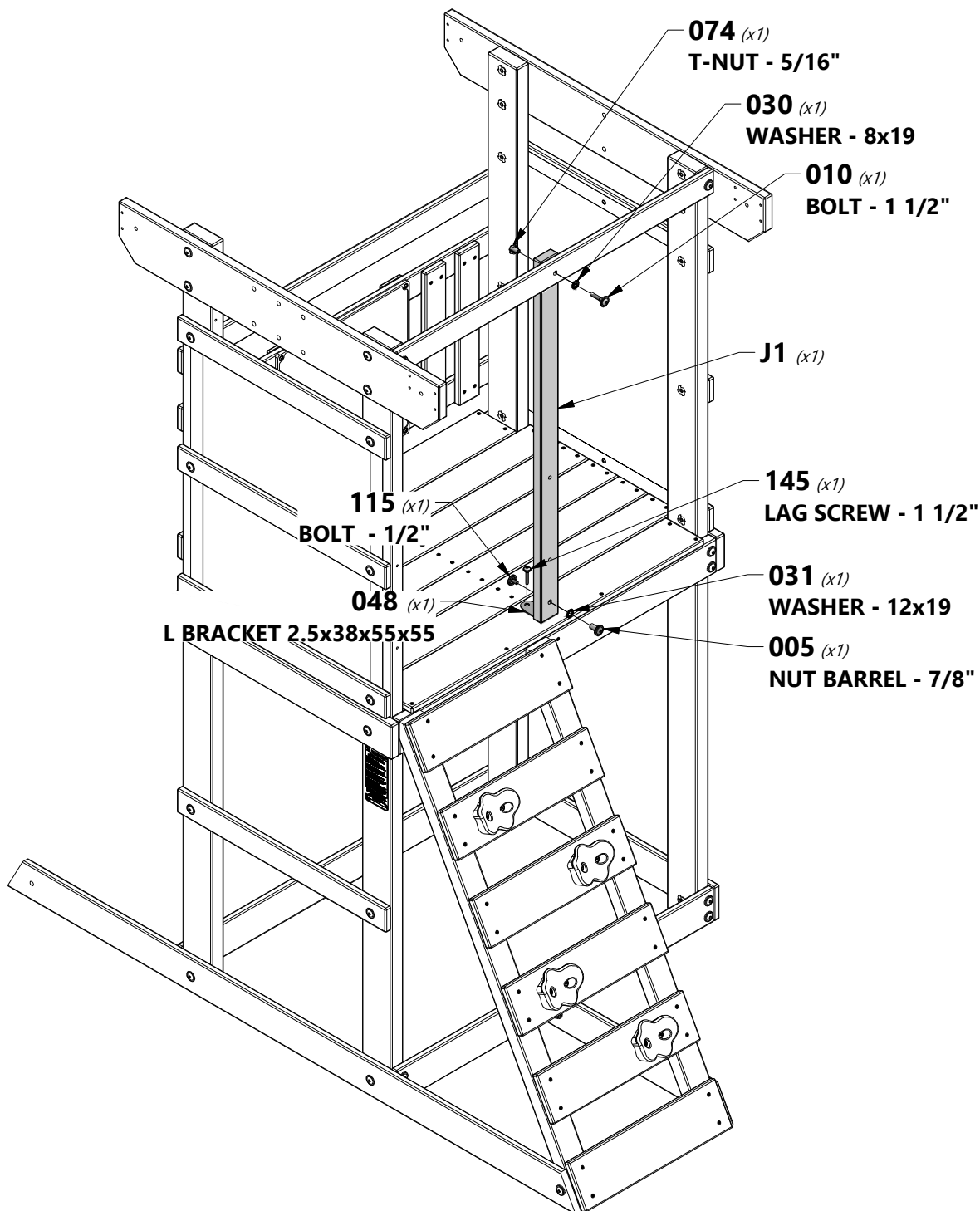



H6 | ANGLE BRACE - W4L13288
(1) | 15/16"x3 3/8"x40 1/16" (24x86x1018)



H100010 | BOLT WH
(1) | 5/16x1-1/2



H100649 | LAG SCREW WH
(1) | 1/4x2 1/2



H100030 | WASHER LOCK
(1) | EXT
8x19



H100074 | T-NUT
(1) | 5/16



H100138 | WASHER LOCK
(1) | EXT
6x15

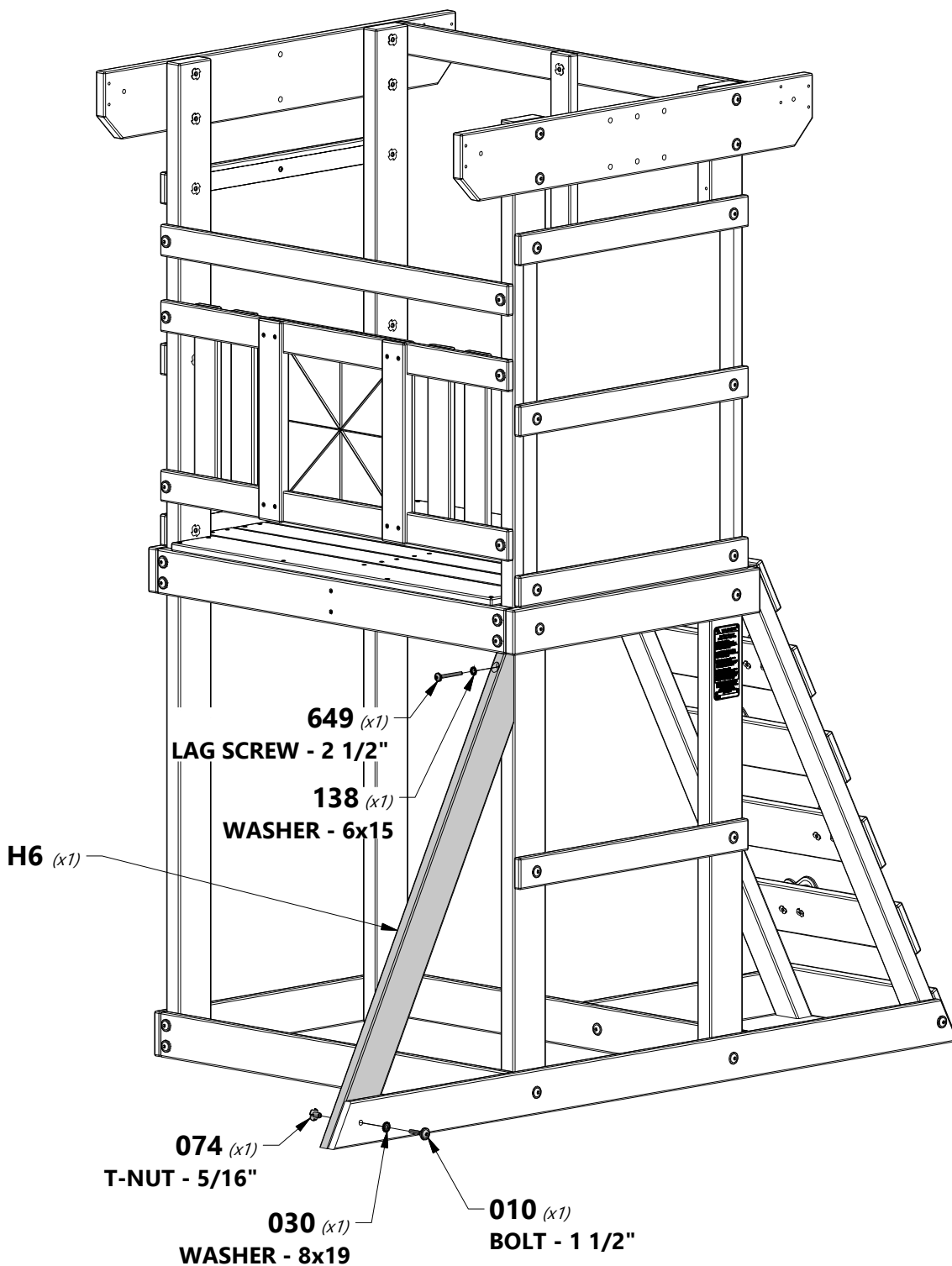



H5 | TOP RAIL - W4L13227
(2) 1"x3 3/8"x36 5/8" (24x86x930)

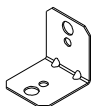

A4M01110 | 90° L-BRACKET - BLK
(4)

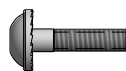

H100137 | BOLT WH 1/4x1
(4)



H100490 | BOLT WH 1/4x5/8
(4)



H100136 | NUT BARREL WH 1/4x5/8
(4)



H100111 | SCREW PFH 8x2
(8)



H100139 | WASHER LOCK EXT 8x15
(4)



H100072 | T-NUT 1/4
(4)

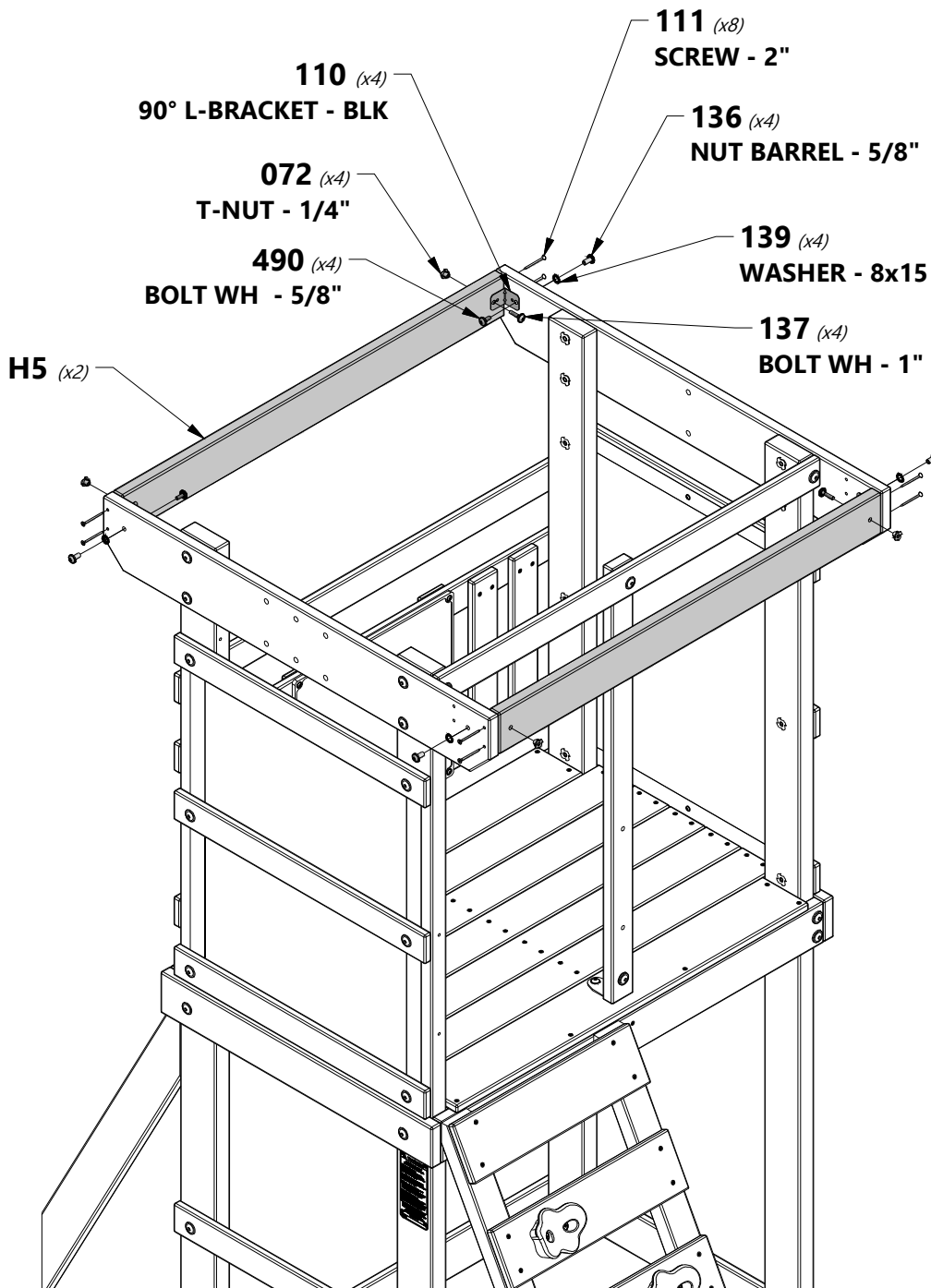

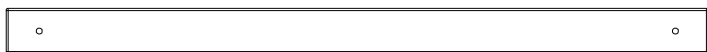

N5 | TOP RAIL - W4L13280
(1) | 5/8"x2 3/8"x36 5/8" (16x60x930)



N4 | TOP RAIL - W4L13229
(2) | 5/8"x2 3/8"x21 1/8" (16x60x538)

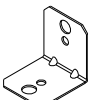

A4M01110 | 90° L-BRACKET - BLK
(2)



H100010 | BOLT WH
(4) | 5/16x1-1/2



H100030 | WASHER LOCK EXT
(4) | 8x19



H100074 | T-NUT
(4) | 5/16



H100490 | BOLT WH
(2) | 1/4x5/8



H100141 | BOLT WH
(2) | 1/4 x 1/2"



H100136 | NUT BARREL WH
(2) | 1/4x5/8



H100139 | WASHER LOCK EXT
(2) | 8x15



H100072 | T-NUT
(2) | 1/4

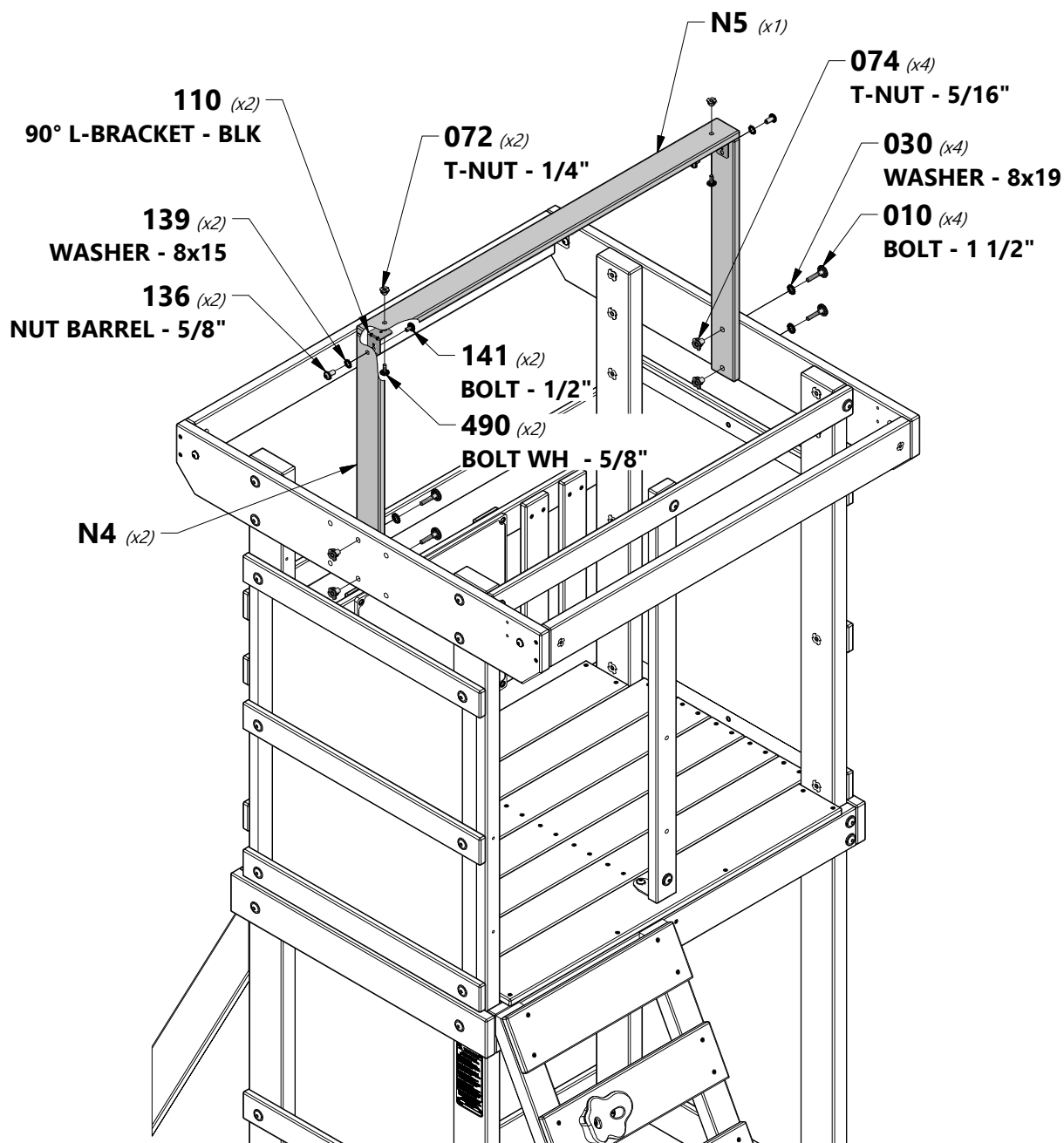



H7 | ANGLE BRACE - W4L13290
(2) | 15/16"x3 3/8"x11 13/16" (24x86x300)



H100649 | LAG SCREW WH
(2) | 1/4x2 1/2



H100138 | WASHER LOCK
(2) | EXT
6x15

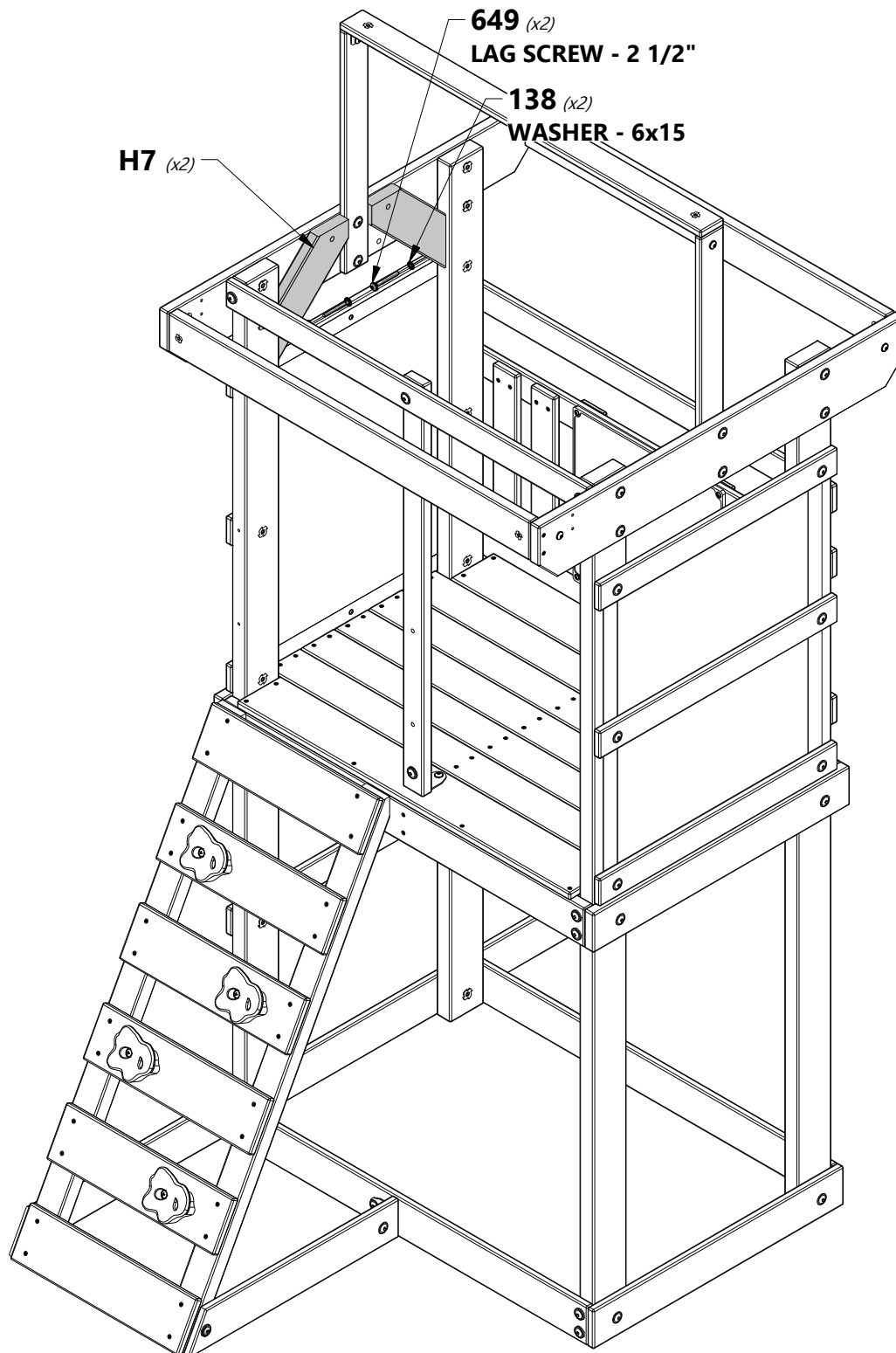

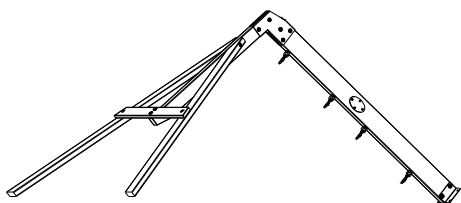

(1) SWING BEAM ASSEMBLY



H100044 | BOLT HEX
(2) | 5/16x2



H100042 | BOLT HEX
(2) | 5/16x1 1/4

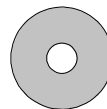

H100105 | WASHER FLAT
(4) | 8x27



H100095 | WASHER SPLIT
(4) | 5/16



H100074 | T-NUT
(4) | 5/16

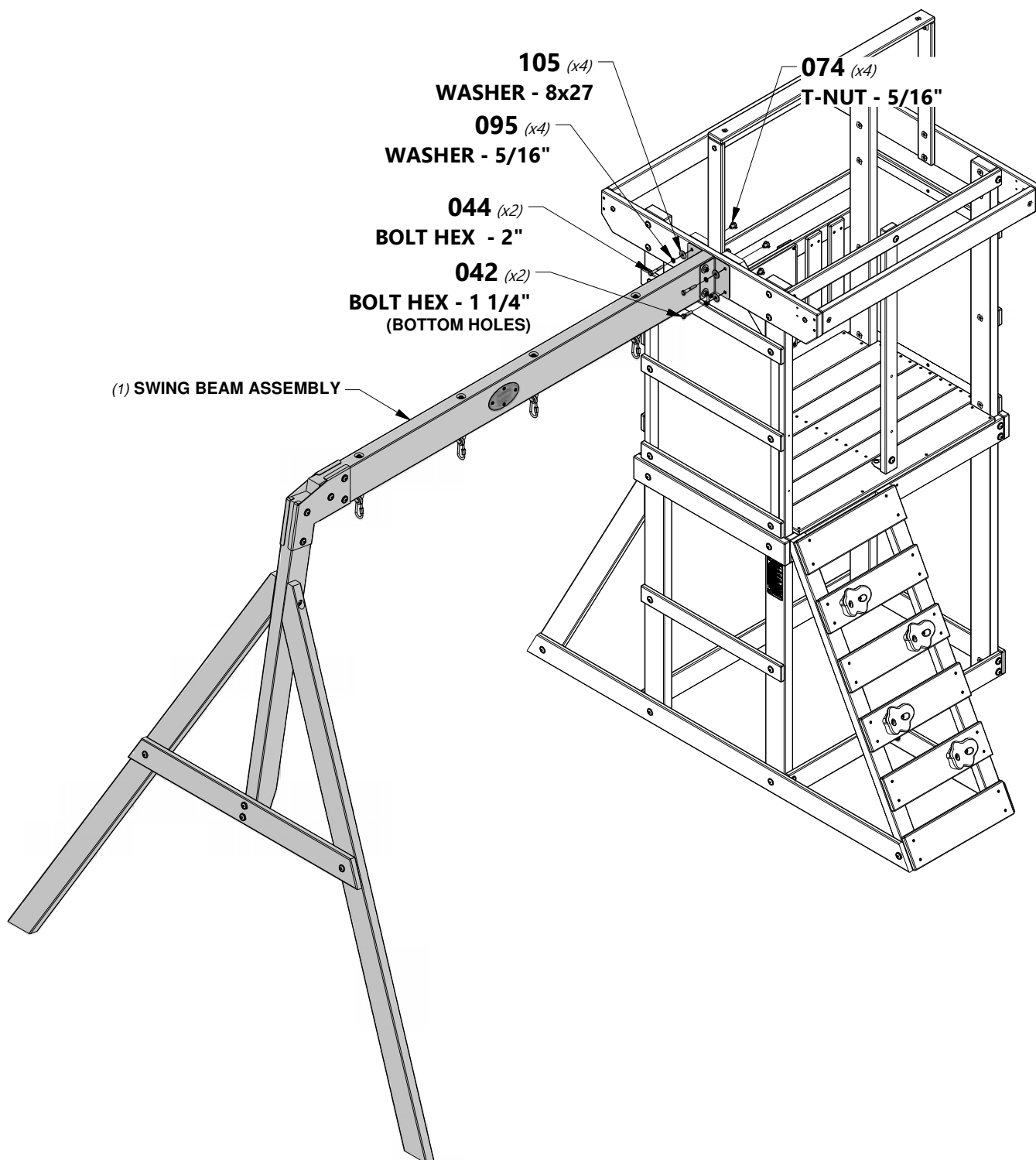

(1) SWING BEAM ASSEMBLY

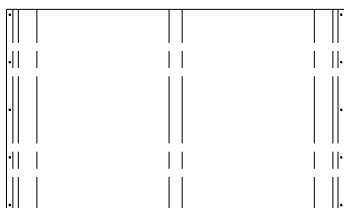

A6P00400 | ROOF TARP
(1)



H100070 | SCREW PWH
(10) | 8x3/4

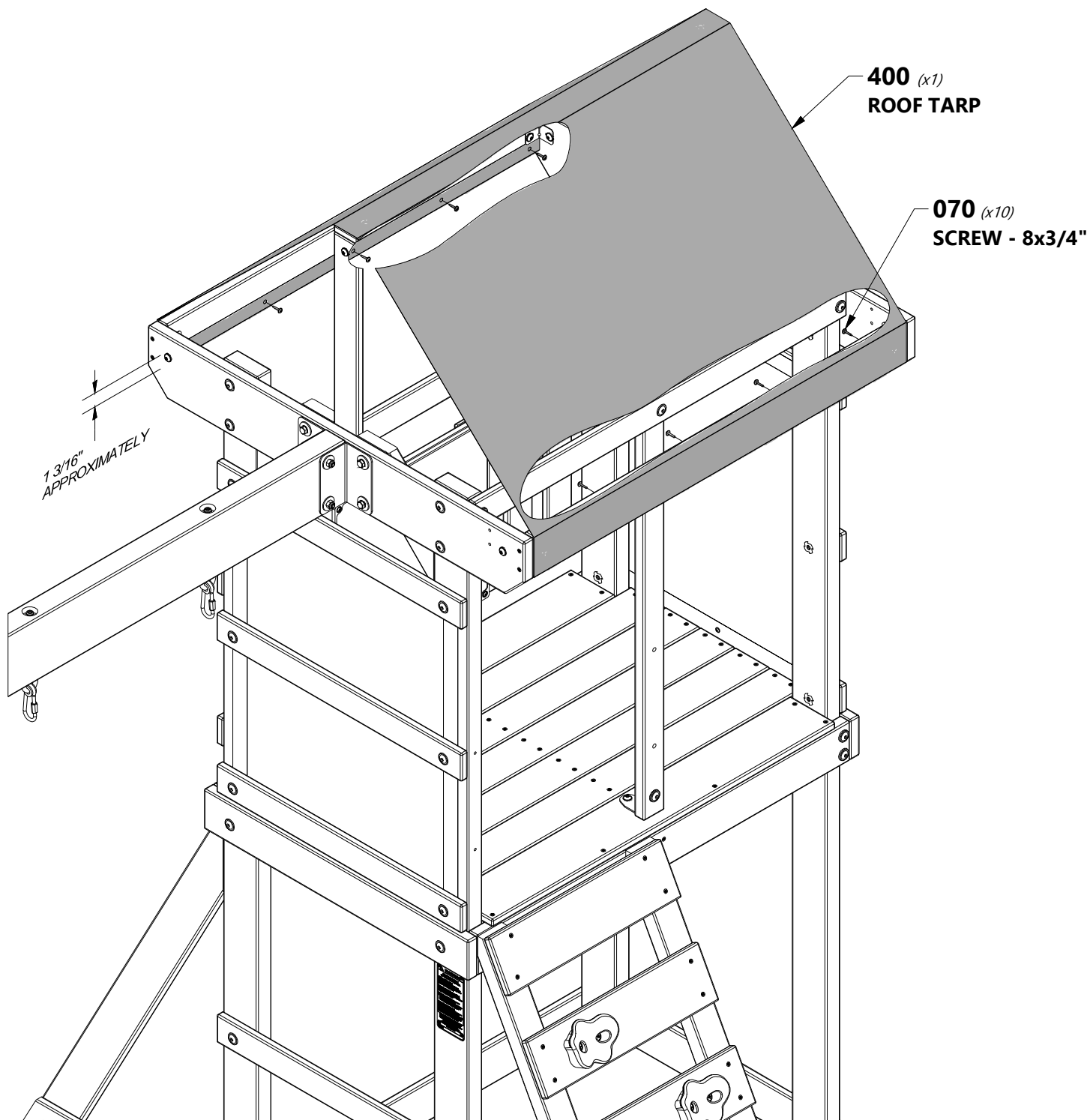

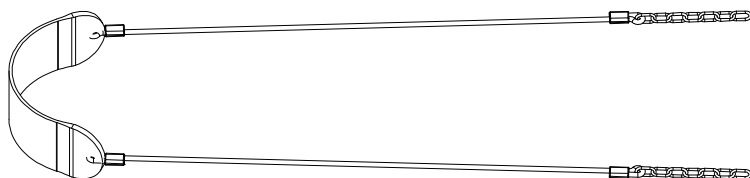

A6P00405 | ROPE-CHAIN B /
(2) | SEAT B

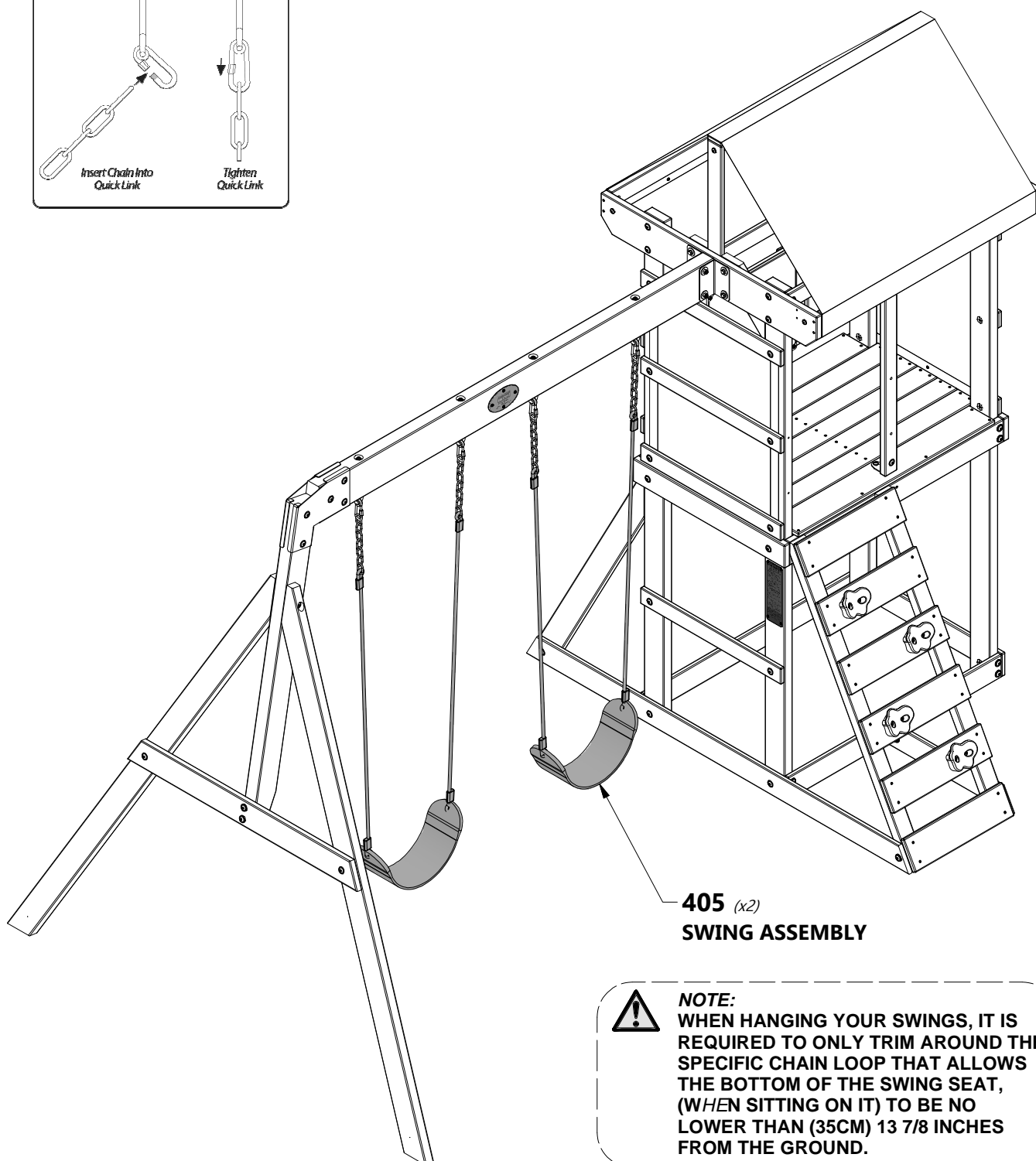
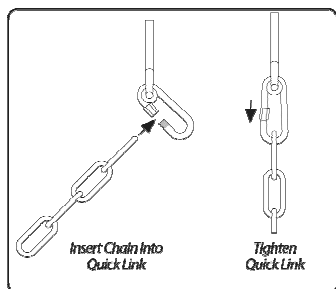

405 (x2)
SWING ASSEMBLY



NOTE: WHEN HANGING YOUR SWINGS, IT IS REQUIRED TO ONLY TRIM AROUND THE SPECIFIC CHAIN LOOP THAT ALLOWS THE BOTTOM OF THE SWING SEAT, (WHEN SITTING ON IT) TO BE NO LOWER THAN (35CM) 13 7/8 INCHES FROM THE GROUND.

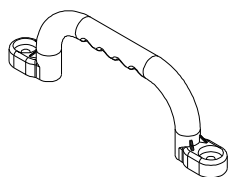

A6P00314 | **HAND GRIP**
(2) | **BLUE PLASTIC**



H100145 | **LAG SCREW WH**
(2) | **1/4x1 1/2**



H100138 | **WASHER LOCK**
(4) | **EXT**
6x15



H100142 | **BOLT WH**
(2) | **1/4x1-1/4**



H100072 | **T-NUT**
(2) | **1/4**

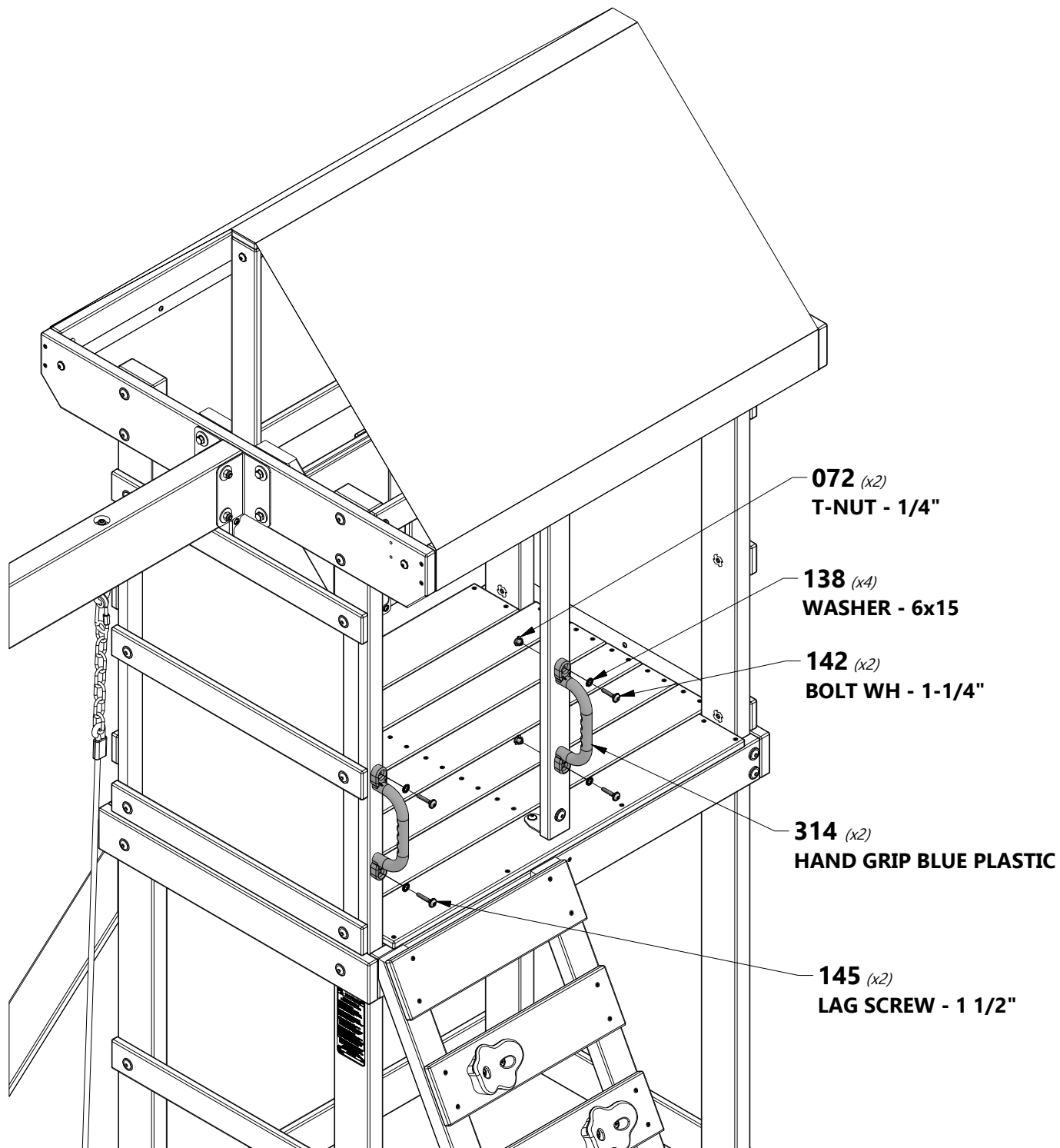

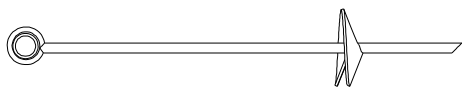

A100178 | AUGER GROUND STAKE
(6)

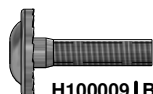

H100009 | BOLT WH
(2) | 5/16x1 1/4



H100222 | BOLT WH
(4) | 5/16x3/4



H100031 | WASHER LOCK EXT
(6) | 12x19

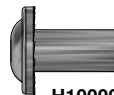

H100005 | NUT BARREL WH
(2) | 5/16x7/8



H100004 | NUT BARREL WH
(4) | 5/16 x 5/8



NOTE:
TWIST GROUND STAKES INTO GROUND IN LOCATIONS SHOWN.
USING GROUND STAKE AS A GUIDE, DRILL 7/16" HOLE FOR HARDWARE.

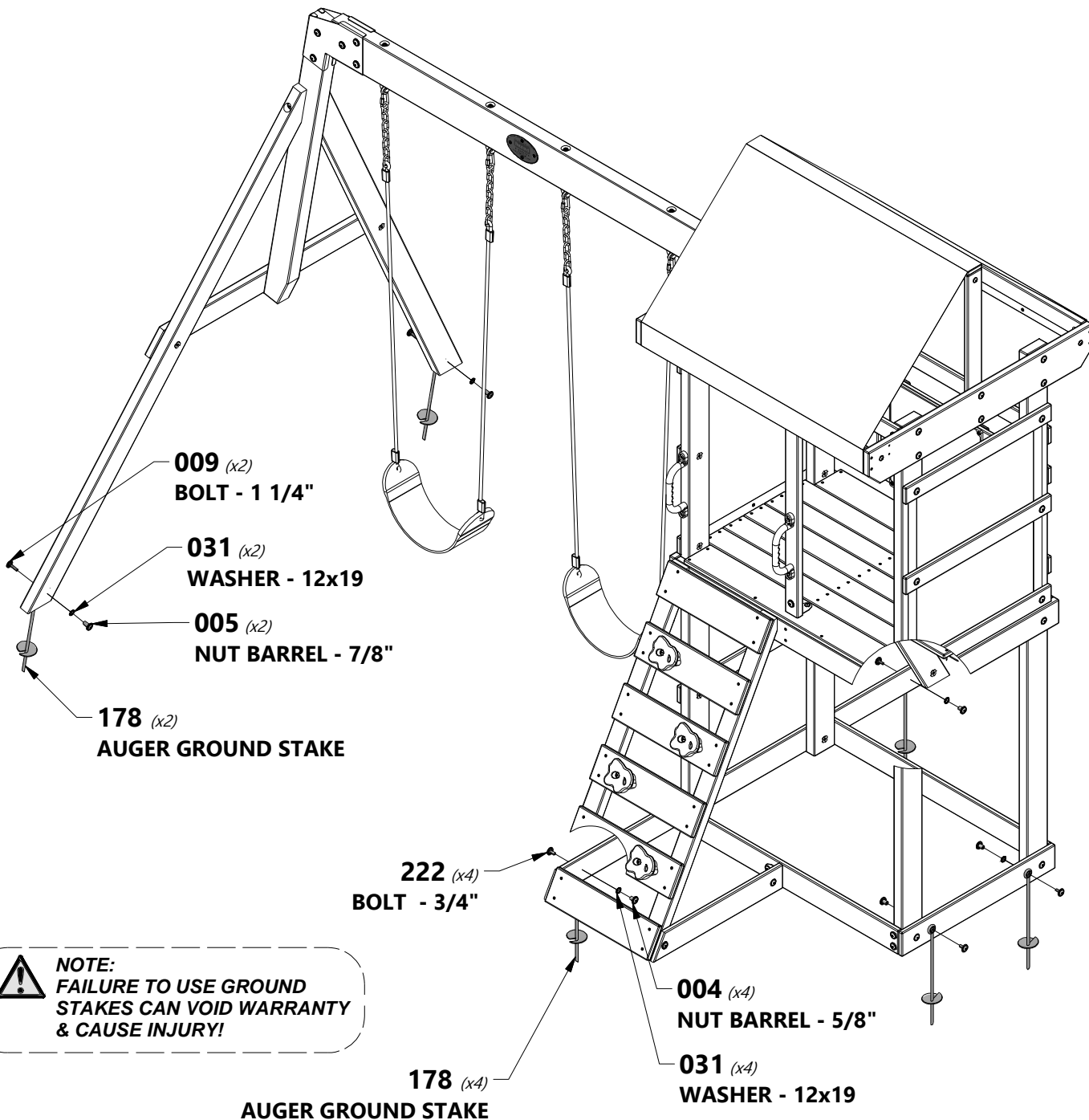

NOTE:
FAILURE TO USE GROUND STAKES CAN VOID WARRANTY & CAUSE INJURY!

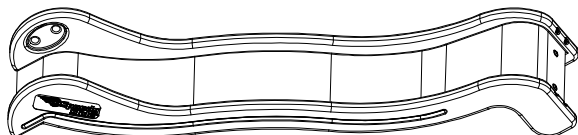

9208018 | SLIDE
(1) ASSEMBLY



H100115 | BOLT WH
(2) 5/16x1/2



H100074 | T-NUT
(2) 5/16

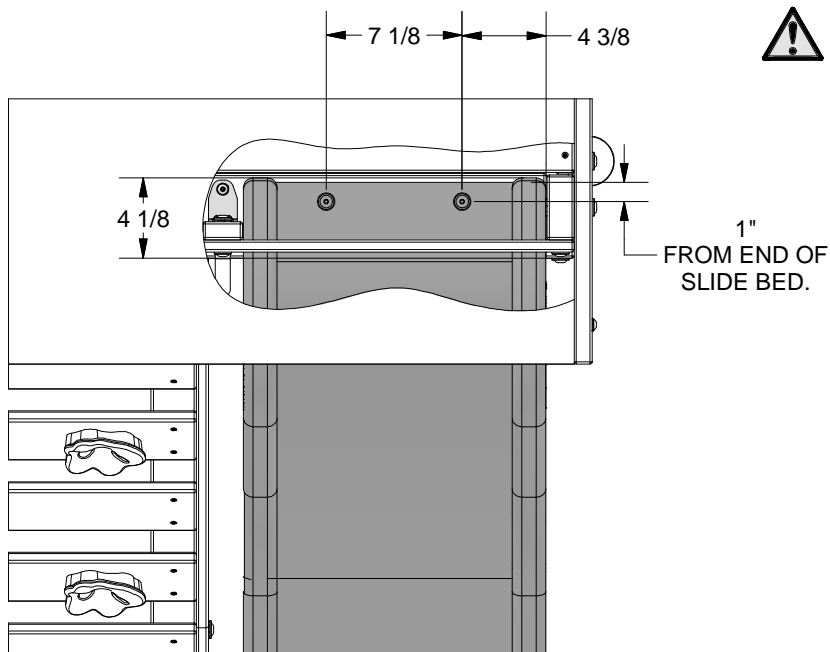

NOTE:
 CENTER SLIDE IN OPENING.
 USING DIMENSIONS SHOWN AS
 A TEMPLATE, DRILL (2) 3/8" HOLES
 THROUGH SLIDE & DECK FOR
 HARDWARE.

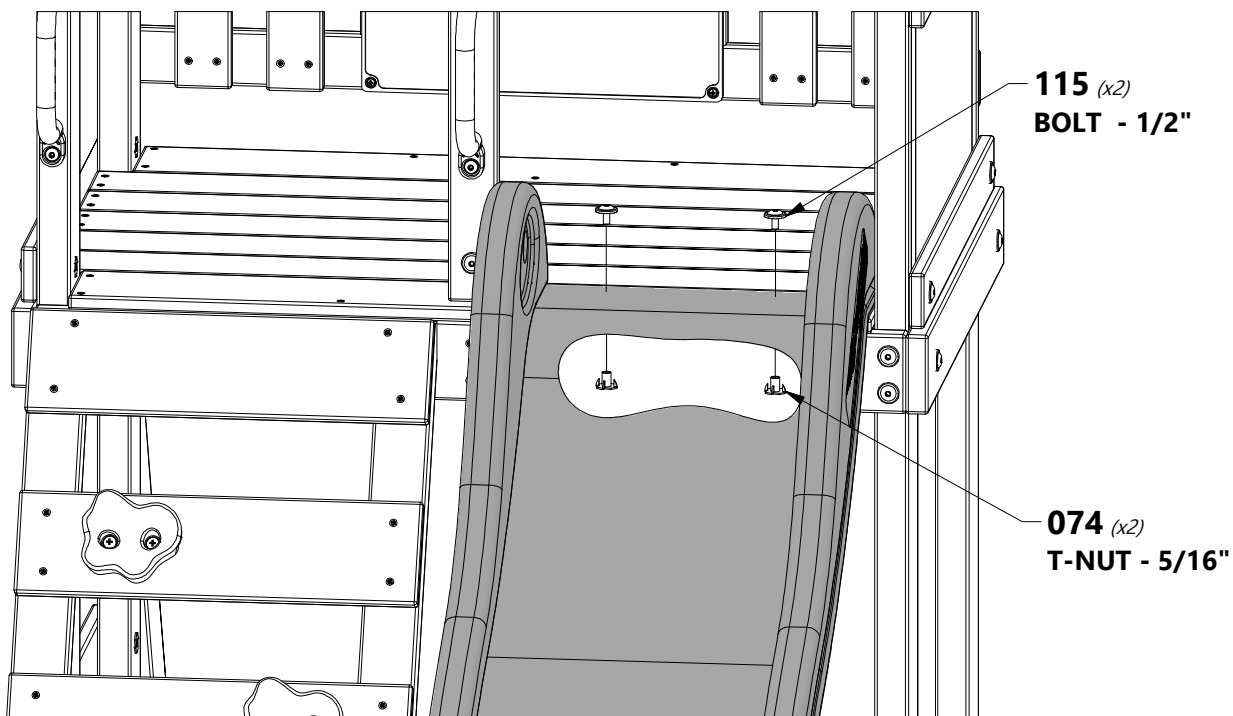

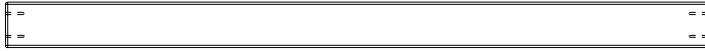

J3 SAFETY RAIL - W4L13299
(1) 1"x2 3/8"x36 5/8" (24x60x930)



H100111 SCREW PFH
(4) 8x2

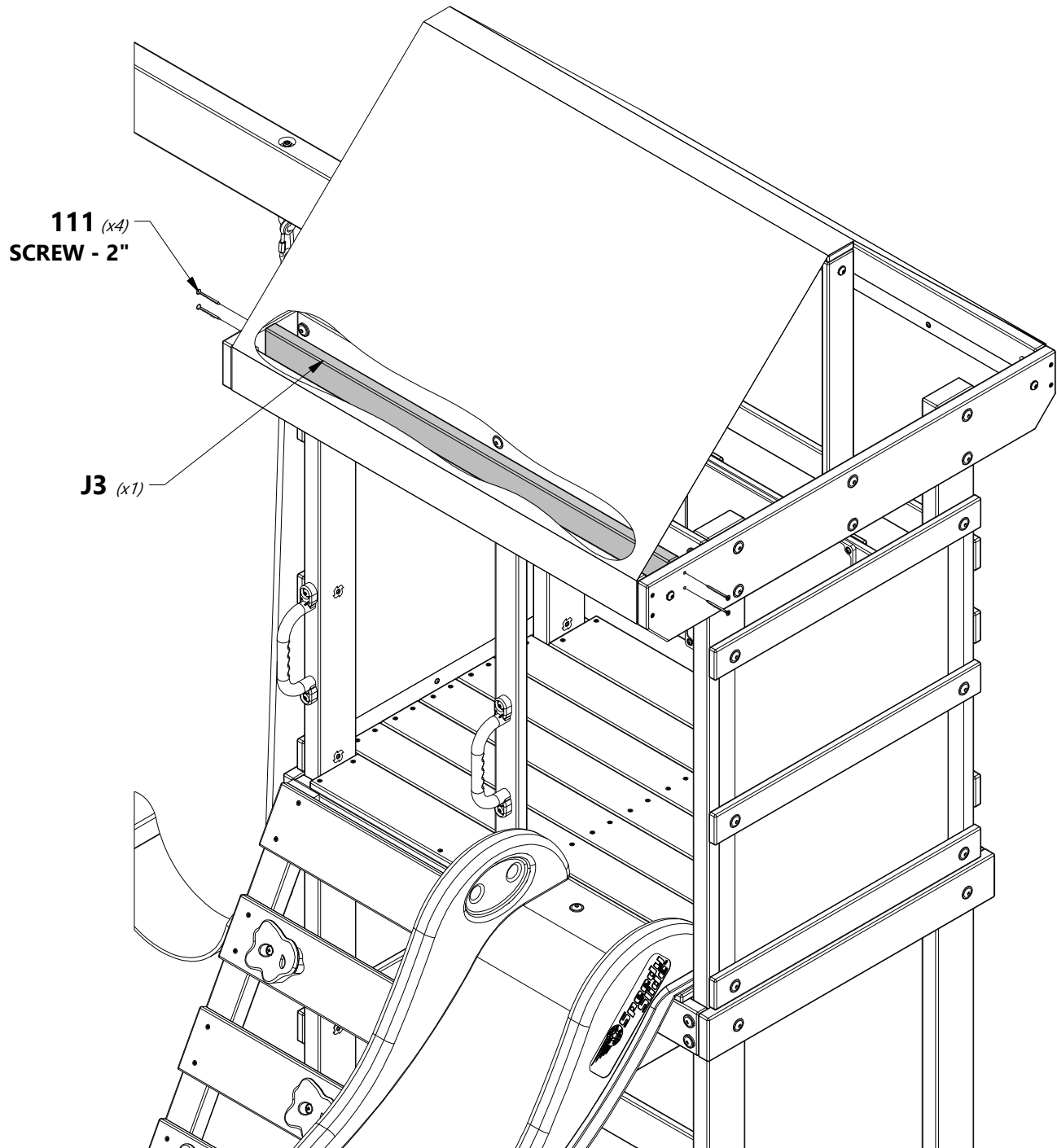

111 (x4)
SCREW - 2"

J3 (x1)