



Manufactured by:
Backyard Discovery
3305 Airport Drive, Pittsburg, KS 66762
800-856-4445

Backyard Discovery Australia Pty Ltd 2/7 Hood Street, Hampton VIC 3188, Phone: 1800-087-941

BELMONT

SWING SET

MODEL: # 2400290



WARNING

Adult Assembly Required.

The assembly manual must be retained since it contains important information
Not suitable for children under 36 months due to small parts.

FOR DOMESTIC USE ONLY. INTENDED FOR OUTDOOR USE.



Please visit www.backyarddiscovery.com

For the most up to date assembly manual, to register your product, or to order replacement parts

Para obtener instrucciones en español, visite www.backyarddiscovery.com



EASY STEP-BY-STEP
3D INTERACTIVE INSTRUCTIONS
DOWNLOAD THE FREE APP





Place the set on level ground, not less than 6'-7" [2 m] from any structure or obstruction such as a fence, garage, house, overhanging branches, laundry lines, or electrical wires.

- While assembling unit, take time before and after each phase to make sure fort is level. If fort is not level, assembly will be difficult and improper assembly may result. Extra care must be taken to insure the fort is square.
- The safe play area refers to a zone extending 6'-7" (2m) beyond the play product on all sides, including the space above the play product.

SAFE PLAY AREA DIAGRAM

Ground Dimension

17' - 7 3/8" (5.4m) x 7' - 3 3/4" (2.2m) x 9' - 5" (2.9m)

Safe Play Area

30' - 9 3/8" (9.4m) x 20' - 5 3/4" (6.2m)

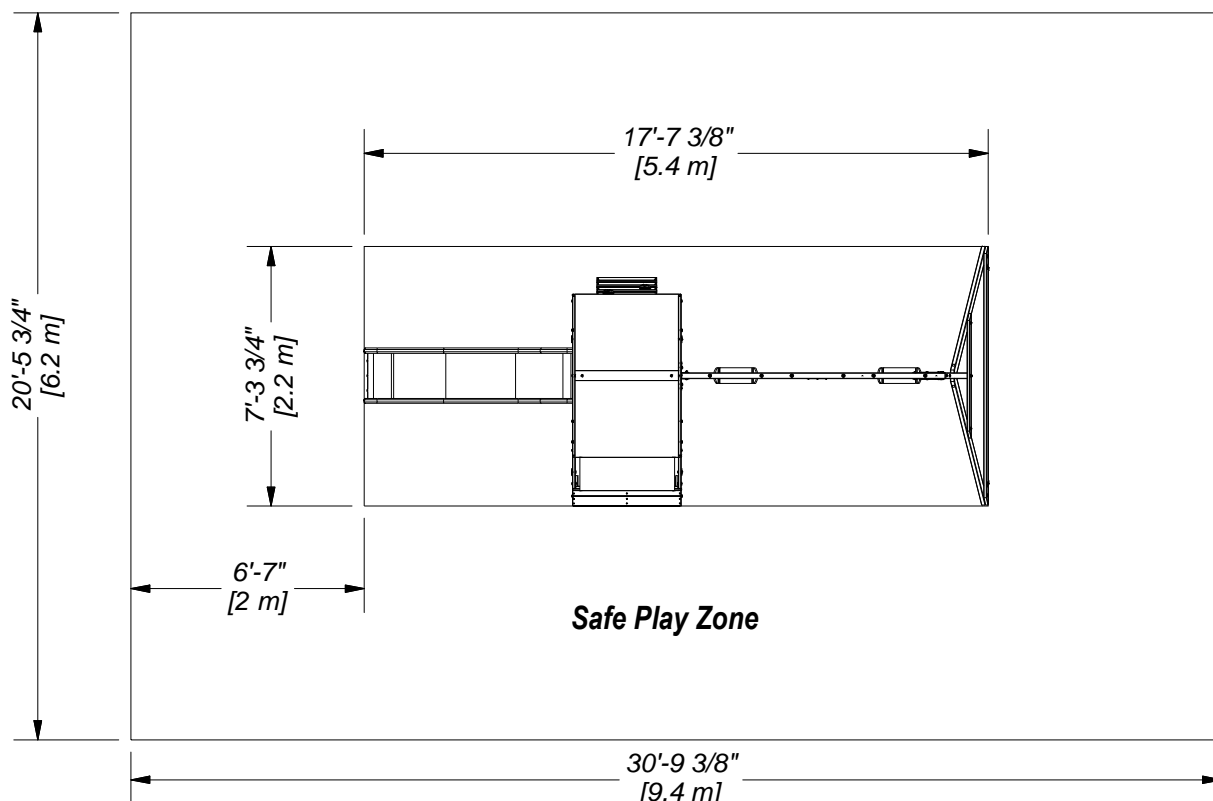

SAFE PLAY HEIGHT: 16'-0" [4.9 m]
MAXIMUM FALL HEIGHT: 6'-1 1/8" [1.9 m]

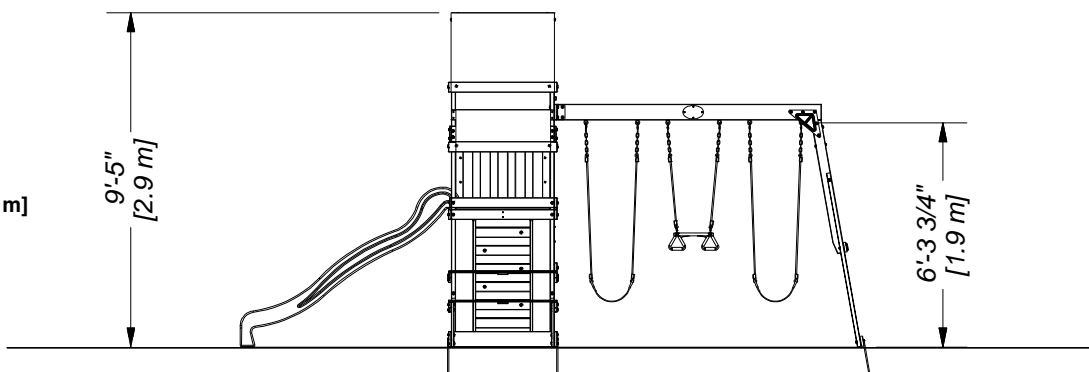

General Information:

Your set has been designed and engineered for children only and for residential use only.
 A maximum of 150 lbs. per child is recommended for play activities designed for individual use.
 A maximum of 120 lbs. per child is recommended for play activities designed for multiple child use.
 A maximum of 9 children is recommended for this swing set.



Wood Components (Not to Scale)



E1 | FORT UPRIGHT - W4L13102
(1) 1 3/8"x3 3/8"x89 1/2" (36x86x2273)



E2 | FORT UPRIGHT - W4L13103
(1) 1 3/8"x3 3/8"x89 1/2" (36x86x2273)



E3 | FORT UPRIGHT - W2A03069
(1) 1 7/16"x3 3/8"x89 1/2" (36x86x2273)

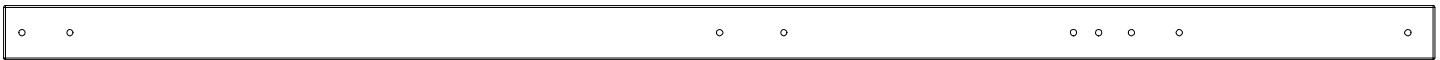

E4 | FORT UPRIGHT - W4L13553
(1) 1 3/8"x3 3/8"x89 1/2" (36x86x2273)



E77 | ANGLE BRACE - W4L13104
(2) 1 3/8"x3 3/8"x73 1/4" (36x86x1862)



F1 | ANGLE BRACE - W4L13105
(2) 1 3/8"x2 3/8"x18 1/8" (36x60x460)



F2 | ANGLE BRACE - W4L13106
(2) 1 3/8"x2 3/8"x12 1/4" (36x60x310)



G1 | GROUND BOARD - W4L13107
(2) 1"x5 1/4"x59 1/2" (24x134x1511)

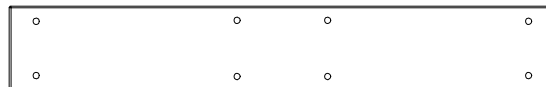

G2 | SWING BEAM SUPPORT - W4L13108
(1) 1"x5 1/4"x34 1/8" (24x134x868)

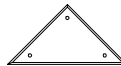

G3 | PICNIC SUPPORT - W4L13109
(2) 1"x5 1/4"x5 1/4" (24x134x134)

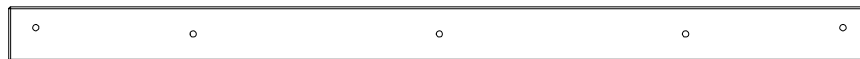

H1 | ROOF CROSS BRACE - W4L13110
(2) 1"x3 3/8"x53 7/8" (24x86x1368)



H2 | FLOOR JOIST - W4L13111
(3) 1"x3 3/8"x34 1/8" (24x86x868)



Wood Components (Not to Scale)



H4 | FLOOR BRACE - W4L13112
(1) 1"x3 3/8"x34 1/8" (24x86x868)



H5 | PICNIC TARP SUPPORT - W4L13554
(2) 1"x3 3/8"x24 1/2" (24x86x622)



H6 | WALL SLAT - W4L13114
(2) 1"x3 3/8"x25 1/2" (24x86x648)



H7 | PICNIC SUPPORT - W4L13115
(2) 1"x3 3/8"x15 1/4" (24x86x387)

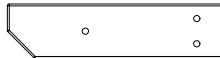

H8 | PICNIC SUPPORT - W4L13116
(2) 1"x3 3/8"x13 1/2" (24x86x344)

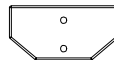

H9 | PICNIC SUPPORT - W4L13117
(2) 1"x3 3/8"x6 3/4" (24x86x172)



H10 | FLOOR BRACE - W4L13118
(4) 1"x3 3/8"x3 3/8" (24x86x86)



H11 | FLOOR JOIST - W4L13527
(1) 1"x3 3/8"x34 1/8" (24x86x868)



H73 | ROCK WALL RAIL - W4L13119
(2) 1"x3 3/8"x48 3/4" (24x86x1238)

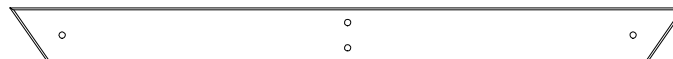

H79 | END SUPPORT - W4L13120
(1) 1"x3 1/2"x42" (24x86x1072)

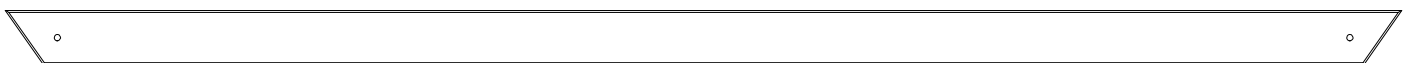

H80 | GROUND BOARD - W4L13121
(1) 1"x3 3/8"x87 3/8" (24x86x2218)



J1 | WALL SLAT - W4L13122
(2) 1"x2 3/8"x25 1/2" (24x60x648)



Wood Components (Not to Scale)



K1 | WALL RAIL - W4L13123
(3) 5/8"x5 1/4"x34 7/8" (16x134x887)



K2 | ARCHED WALL RAIL - W4L13124
(1) 5/8"x5 1/4"x34 7/8" (16x134x887)

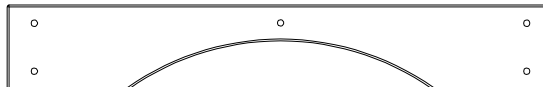

K3 | ARCHED WALL RAIL - W4L13125
(1) 5/8"x5 1/4"x34 1/8" (16x134x868)

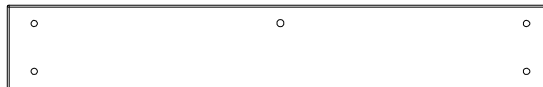

K4 | WALL RAIL - W4L13126
(1) 5/8"x5 1/4"x34 1/8" (16x134x868)



M1 | TARP SUPPORT - W4L13127
(2) 5/8"x3 3/8"x40" (16x86x1016)



M2 | FLOOR BOARD - W4L13128
(13) 5/8"x3 3/8"x36 3/4" (16x86x935)



M3 | TARP SUPPORT - W4L13129
(3) 5/8"x3 3/8"x36 3/4" (16x86x935)



M4 | FLOOR/TARP SUPPORT - W4L13130
(1) 5/8"x3 3/8"x34 7/8" (16x86x887)



M5 | WALL RAIL - W4L13131
(1) 5/8"x3 3/8"x34 7/8" (16x86x887)



M6 | WALL RAIL - W4L13132
(1) 5/8"x3 3/8"x34 7/8" (16x86x887)



M7 | FLOOR BOARD - W4L13133
(2) 5/8"x3 3/8"x32 1/8" (16x86x815)



Wood Components (Not to Scale)



M8 | PICNIC CLEAT - W4L13134
(1) | 5/8"x3 3/8"x10 1/8" (16x86x258)



M9 | PICNIC CLEAT - W4L13135
(1) | 5/8"x3 3/8"x6 3/4" (16x86x172)



M10 | WALL RAIL - W4L13136
(2) | 5/8"x3 3/8"x6 1/4" (16x86x160)



M11 | WALL RAIL - W4L13137
(2) | 5/8"x3 3/8"x4 3/4" (16x86x122)



M12 | WALL SLAT - W4L13138
(9) | 5/8"x3 3/8"x25 1/4" (16x86x640)



M13 | WALL RAIL - W4L13139
(1) | 5/8"x3 3/8"x34 7/8" (16x86x887)



M14 | FLOOR/TARP SUPPORT - W4L13528
(1) | 5/8"x3 3/8"x34 7/8" (16x86x887)



M71 | ROCK BOARD - W4L13140
(6) | 5/8"x3 3/8"x20 1/4" (16x86x514)



M72 | ROCK WALL SLAT - W4L13421
(2) | 5/8"x3 3/8"x20 1/4" (16x86x514)

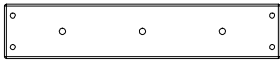

M77 | SLIDE BRACE - W4L08748
(1) | 5/8"x3 3/8"x17 1/4" (16x86x438)



M78 | CENTER SLIDE BRACE - W4L08749
(2) | 5/8"x3 3/8"x17 1/4" (16x86x438)



N1 | WALL RAIL - W4L13422
(1) | 5/8"x1 1/8"x34 1/8" (16x30x868)



SB74 | SWING BEAM - W4L13423
(1) | 2"x5 1/4"x89 1/2" (50x134x2274)



W71 | SWING BEAM SUPPORT - W4L13424
(1) | 2"x3 3/8"x46 1/8" (50x86x1170)



Hardware Components

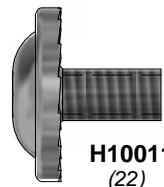

H100115 | BOLT WH
(22) | 5/16x1/2

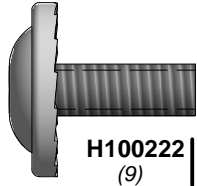

H100222 | BOLT WH
(9) | 5/16x3/4

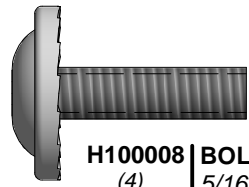

H100008 | BOLT WH
(4) | 5/16x1

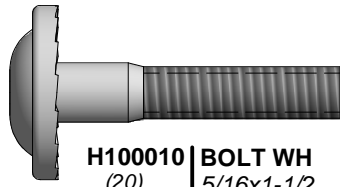

H100010 | BOLT WH
(20) | 5/16x1-1/2

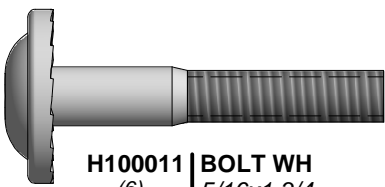

H100011 | BOLT WH
(6) | 5/16x1 3/4

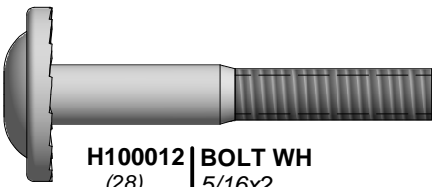

H100012 | BOLT WH
(28) | 5/16x2

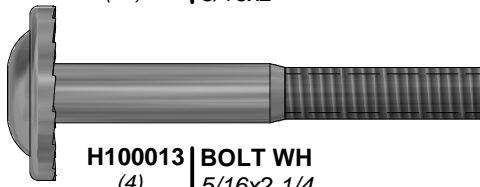

H100013 | BOLT WH
(4) | 5/16x2 1/4

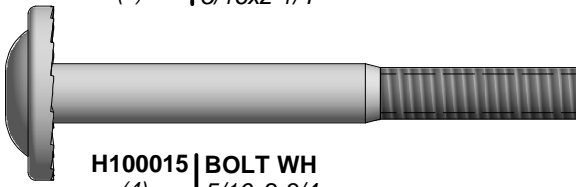

H100015 | BOLT WH
(4) | 5/16x2 3/4

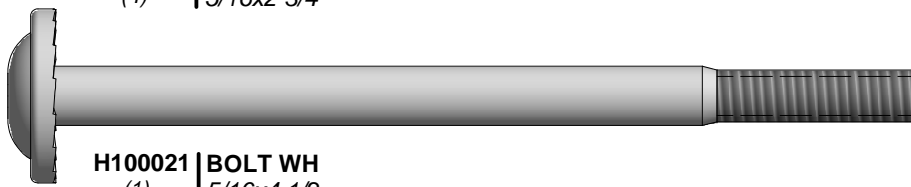

H100021 | BOLT WH
(1) | 5/16x4 1/2



H100027 | LAG SCREW WH
(38) | 5/16x2

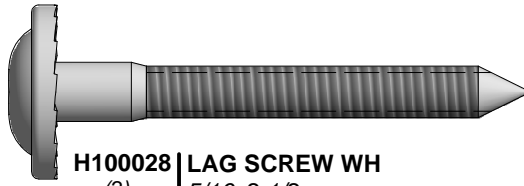

H100028 | LAG SCREW WH
(2) | 5/16x2 1/2

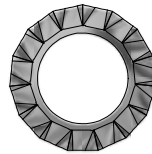

H100031 | WASHER LOCK EXT
(73) | 12x19

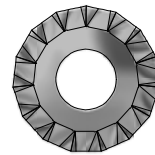

H100030 | WASHER LOCK EXT
(101) | 8x19

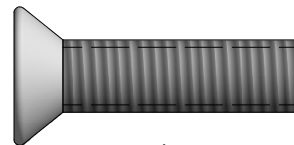

H100001 | BOLT FA
(7) | 3/8x1 1/2

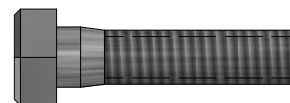

H100042 | BOLT HEX
(4) | 5/16x1 1/4

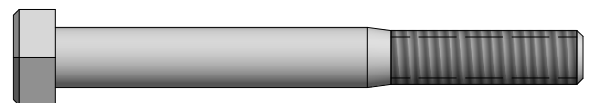

H100047 | BOLT HEX
(2) | 5/16x2 3/4

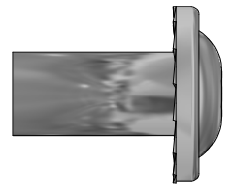

H100005 | NUT BARREL WH
(70) | 5/16x7/8

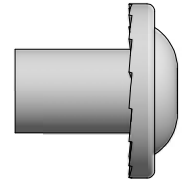

H100004 | NUT BARREL WH
(4) | 5/16 x 5/8

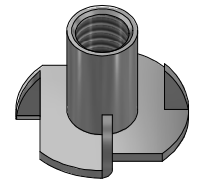

H100074 | T-NUT
(24) | 5/16

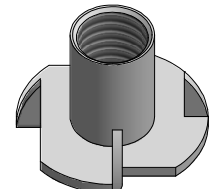

H100073 | T-NUT
(7) | 3/8



H100128 | SCREW PWH
(19) | 8x5/8



Hardware Components



H100088 | SCREW PFH
(48) | 8x1 1/8



H100087 | SCREW PFH
(9) | 8x1 1/4



H100086 | SCREW PFH
(136) | 8x1 1/2



H100089 | SCREW PFH
(9) | 8x1 3/4



H100090 | SCREW PFH
(30) | 8x2 1/2"



H100006 | NUT BARREL WH
(2) | 5/16x1 1/2

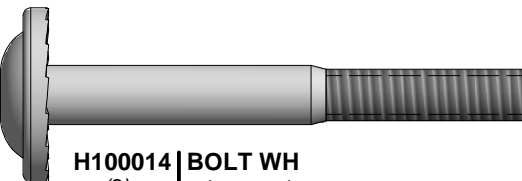

H100014 | BOLT WH
(2) | 5/16x2 1/2



H100062 | BOLT PTH
(4) | 1/4x1 1/4



H100083 | SCREW TAPPING
(9) | 14x3/4



H100072 | T-NUT
(4) | 1/4

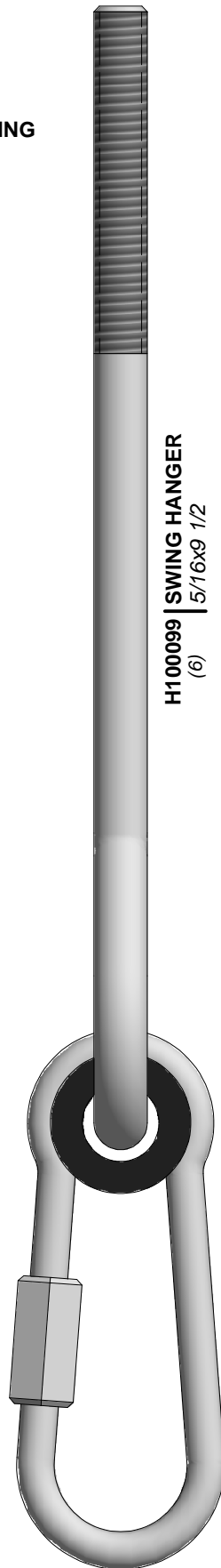

H100099 | SWING HANGER
(6) | 5/16x9 1/2

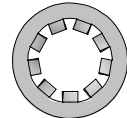

H100108 | WASHER LOCK INT
(4) | 8x15

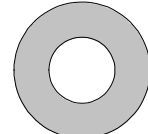

H100106 | WASHER FLAT
(4) | 9x18

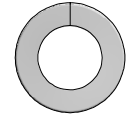

H100095 | WASHER SPLIT
(4) | 5/16

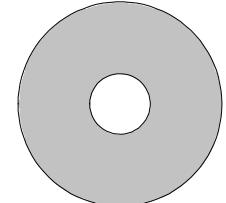

H100105 | WASHER FLAT
(15) | 8x27

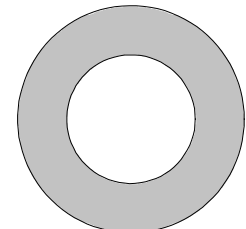

H100103 | WASHER SAFETY
(7) | 17x30

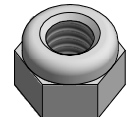

H100110 | NUT LOCK
(9) | 5/16



Accessory Components (Not to Scale)



A100054 | SLIDE RAIL 8' GREEN RIGHT
(1)



A100055 | SLIDE RAIL 8' GREEN LEFT
(1)



A6P00386 | SLIDE BED 8' DARK GREEN
(1)

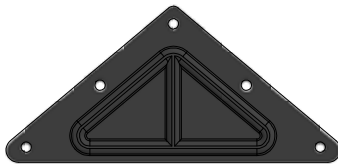

A100294 | TRIANGLE PLATE 100° 5 HOLE
(2)

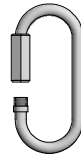

A100069 | QUICK LINK
(6)



A100028 | HAND GRIP GREEN PLASTIC
(2)



A100164 | BYD ID TAG (LARGE) AGES 3-10
(1)

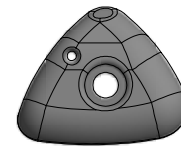

A100060 | CLIMBING ROCK GREEN SMALL
(6)



A100314 | "A" REVISION TAG
(1)

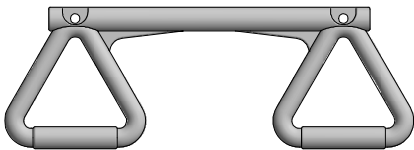

A6P00034 | TRAPEZE YELLOW
(1)

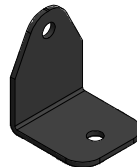

A100053 | L BRACKET 54x67 - GRN
(4)



A4M01046 | L BRACKET 2.5x38x55x55
(8)



A6P00054 | SWING SEAT GREEN 22IN
(2)

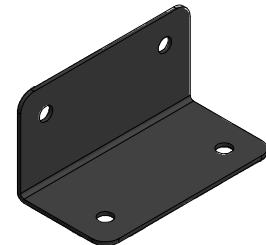

A100140 | L BRACKET 66x66x127
(2)



A100083 | ROPE-CHAIN GREEN 33"
(2)



A100087 | ROPE-CHAIN GREEN 51.25"
(4)



Accessory Components (Not to Scale)

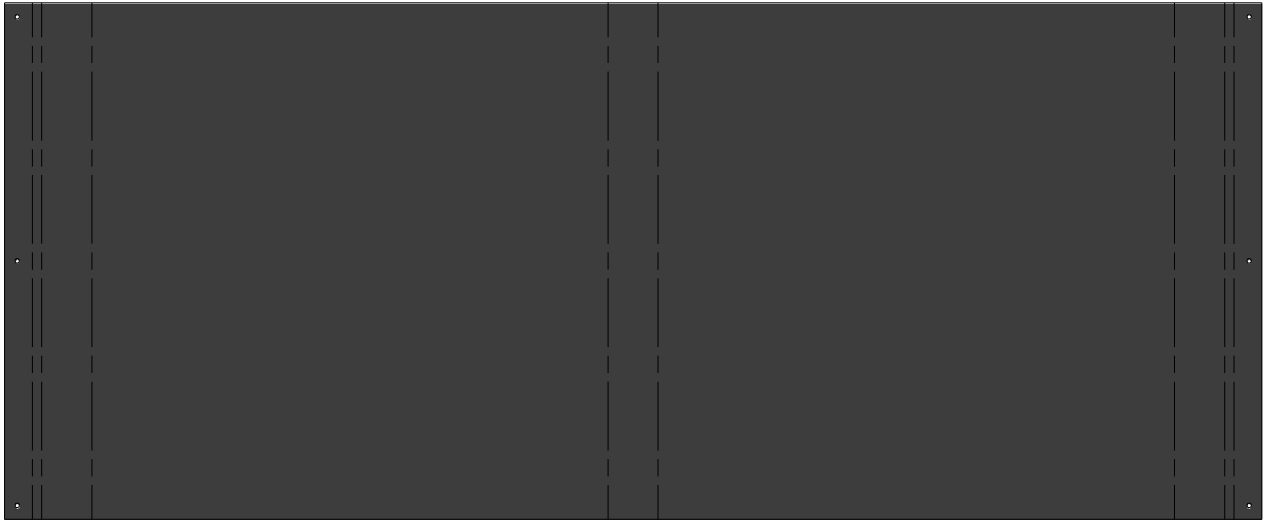

A6P00382 | ROOF TARP
(1)



A6P00383 | PICNIC TABLE TARP
(1)



A4M00527 | GROUND STAKE REBAR
(6)

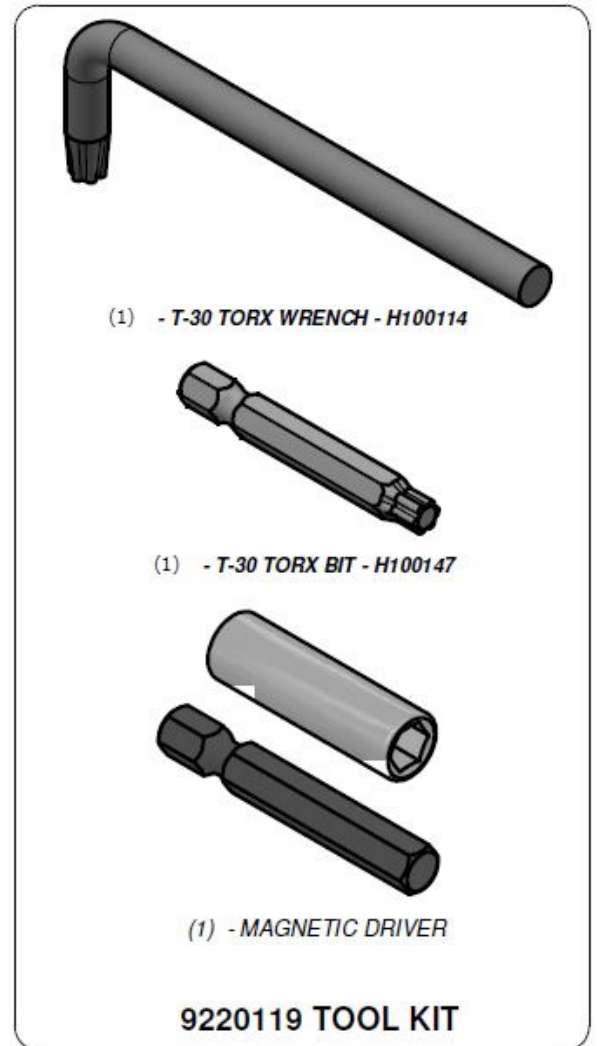

(1) - T-30 TORX WRENCH - H100114

(1) - T-30 TORX BIT - H100147

(1) - MAGNETIC DRIVER

9220119 TOOL KIT

PRE-ASSEMBLY STEP 1 - SORTING PARTS

It is critical for ease of assembly that you take the time to sort and organize the wood and hardware.

WOOD PARTS:

- Organize wood parts by the three-digit, alpha-numeric number stamped on each board (ex. P01).
- If there are multiple boards with the same stamped number, stack those pieces together.
- Stamps can be found on the flat surface of the boards or on the end of the boards.
- Allow yourself plenty of room - the wood pieces can take up a significant amount of space.

NOTE: CARTONS ARE NOT ORGANIZED BY BOARD NUMBER.

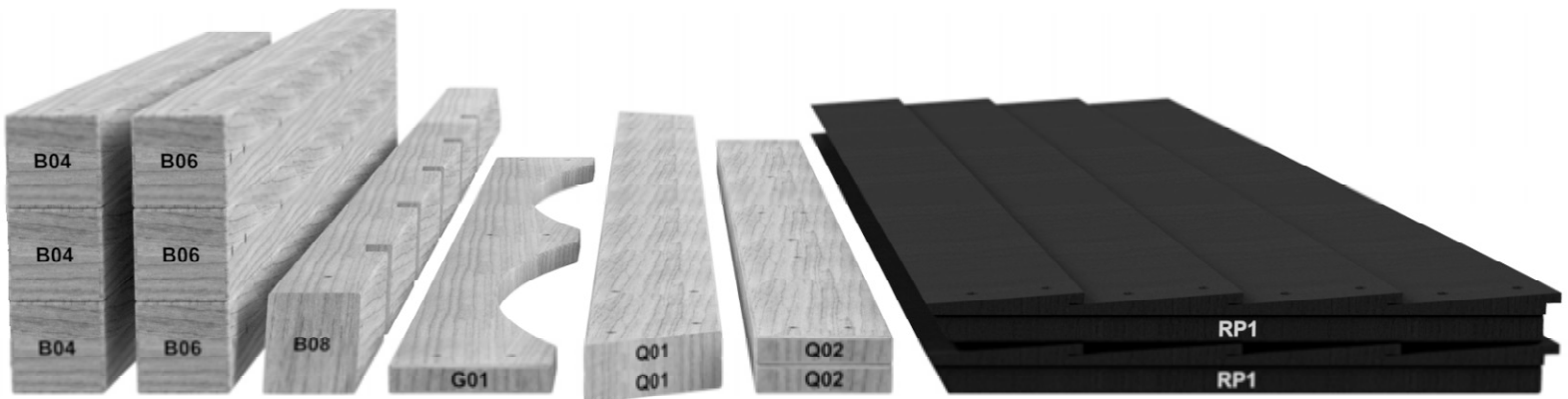

HARDWARE PARTS:

- We recommend that you have a separate table to organize the hardware.
- Hardware bags are printed with a seven-digit, alpha-numeric part number.
- You can organize your hardware by part number or group by hardware type (i.e. bolts, nuts, etc.).
- During assembly you only need to reference the last four digits of the number.

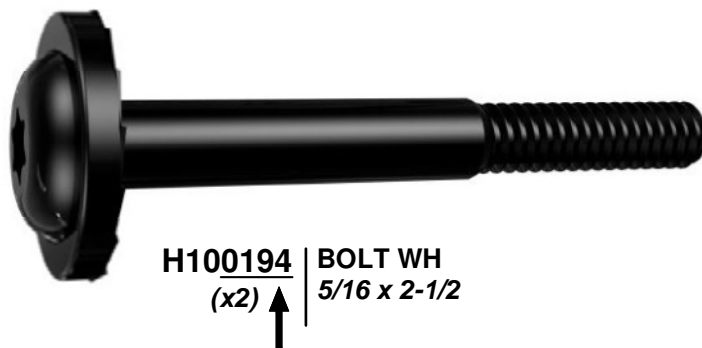

PRE-ASSEMBLY STEP 2 - TOOLS REQUIRED



**Cordless Drill or
Electric Drill**



**Drill Attachments:
Phillips Head**



**1/8", 3/16", 3/8" & 7/16"
Drill Bits**



Phillips Screw Driver



Open End Wrenches 1/2" & 9/16"



**3/8" Drive Ratchet, 1/2" &
9/16" STD Sockets 1/2" & 9/16" Deep
Sockets**



Claw Hammer



Rubber Mallet - Optional



Tape Measure

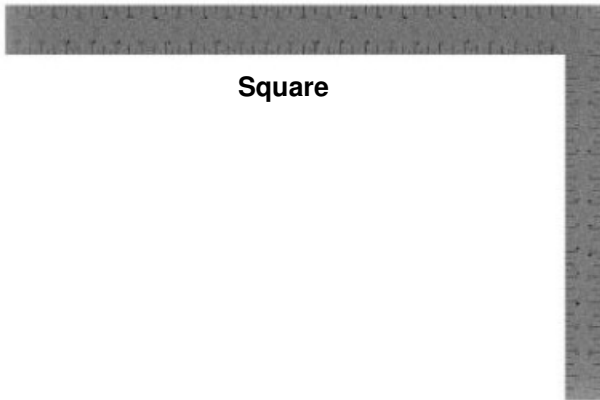

Square



Level 24"

PRE-ASSEMBLY STEP 3 - CHOOSE YOUR ASSEMBLY METHOD

There are several types of assembly instructions available to you.

1. Printed Assembly Manual included with your set
2. BILT APP - 3D interactive instructions
3. Combination of the Printed Manual and BILT APP (Note: Step numbers can differ between the two methods)

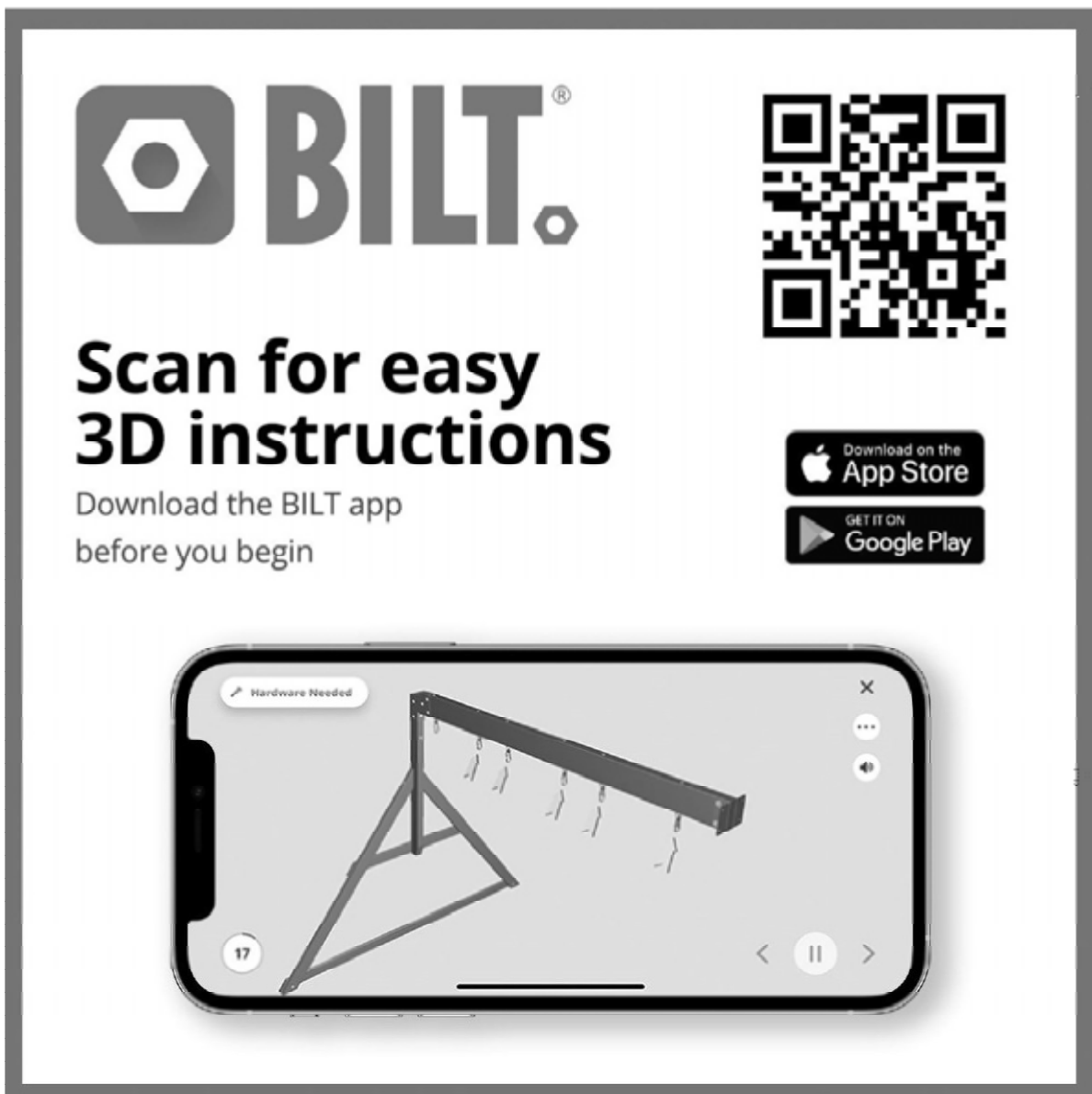

The advertisement features the BILT logo on the left, a QR code on the right, and a smartphone displaying a 3D assembly instruction. The text 'Scan for easy 3D instructions' is prominently displayed, along with download instructions for the App Store and Google Play.

BILT.[®]

**Scan for easy
3D instructions**

Download the BILT app
before you begin

Download on the
App Store

GET IT ON
Google Play

Hardware Needed

17

X

⋮

⏸

< >



SLIDE ASSEMBLY

STEP 1



A6P00386 | SLIDE BED 8' DARK GREEN
(x1)



M77 | SLIDE BRACE - W4L08748
(x1) | 5/8"x3 3/8"x17 1/4" (16x86x438)



H100115 | BOLT WH
(x3) | 5/16x1/2



H100074 | T-NUT
(x3) | 5/16



NOTE:

TAKE NOTE OF SLIDE BED SURFACE FINISH, THE DULL SIDE WILL BE TOWARDS THE GROUND. PLACE SLIDE BRACE CENTERED ON THE BOTTOM (DULL SIDE) AND 1/2" FROM THE EDGE. USE **M77** BOARD AS A TEMPLATE FOR DRILLING BOTTOM HOLE PATTERN IN SLIDE BED. USE A 5/16" DRILL BIT.



TIP:

PRE-BENDING THE ENDS WILL EASE ASSEMBLY. PLACING THE SLIDE BED OUT IN THE SUN MAKES IT EASIER TO BEND.

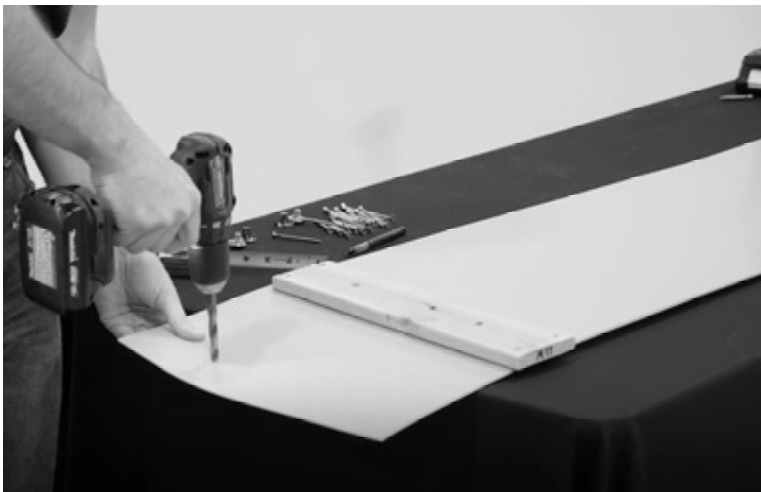
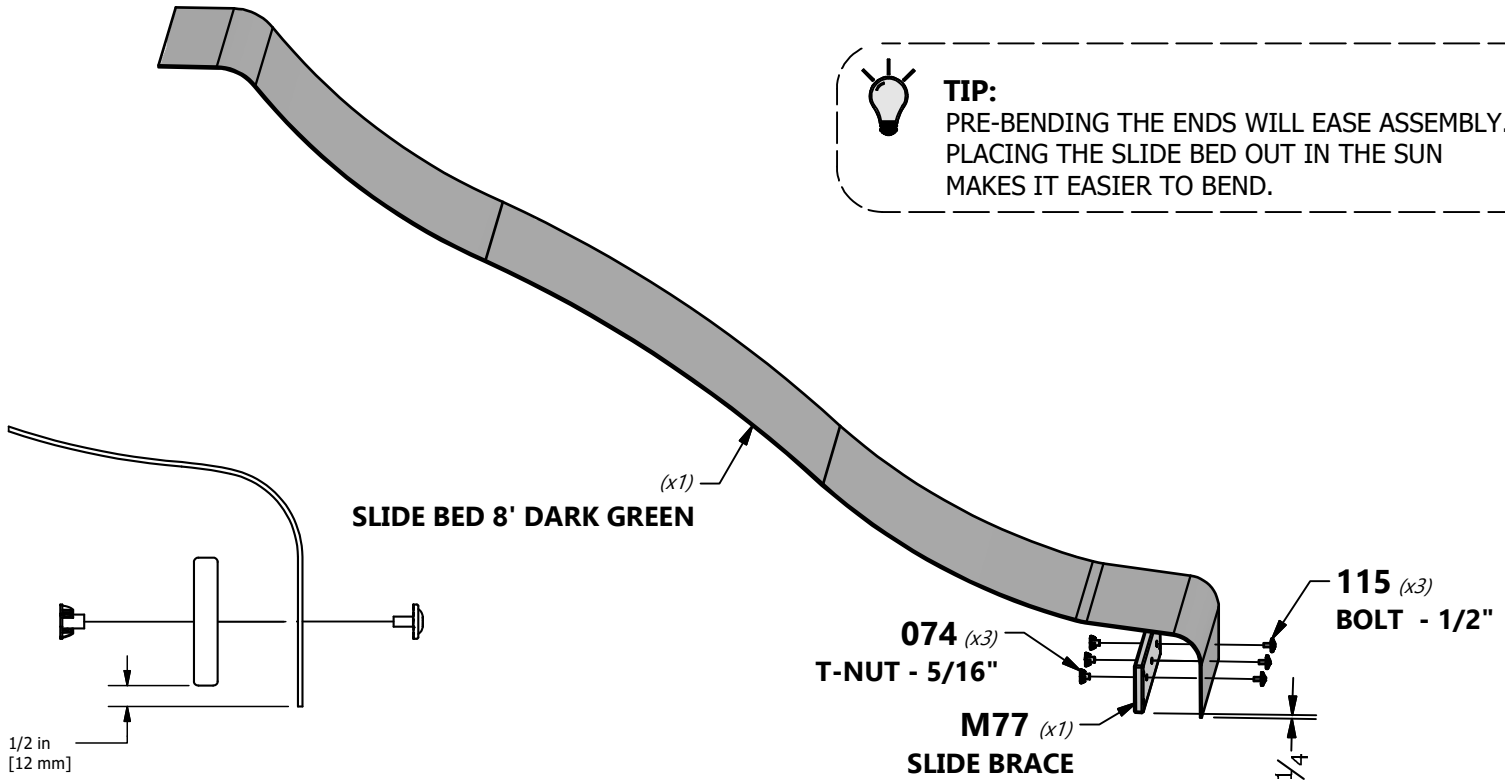



SLIDE ASSEMBLY

STEP 2



M78 | CENTER SLIDE BRACE - W4L08749
(x2) | 5/8"x3 3/8"x17 1/4" (16x86x438)



A100054 | SLIDE RAIL 8' GREEN RIGHT
(x1)



A100055 | SLIDE RAIL 8' GREEN LEFT
(x1)



H100090 | SCREW PFH
(x24) | 8x2 1/2"



NOTE:

USING A 1/8" DRILL BIT, DRILL PILOT HOLES IN EACH INDENTATION ALONG EACH SIDE RAIL. THERE SHOULD BE 12 INDENTIONS ON EACH RAIL.

PLACE THE SLIDE RAIL ON FLAT SURFACE. STARTING AT THE BOTTOM, INSERT THE SLIDE BED INTO THE CHANNEL ON THE INSIDE OF THE RAIL. HOLD THE SLIDE BED IN PLACE WHILE A HELPER BENDS THE SLIDE BED INTO THE CHANNEL. MAKE SURE THE SLIDE BED IS COMPLETELY INSERTED INTO THE CHANNEL.

INSERT THE TWO CENTER SLIDE BRACES INTO THEIR RESPECTIVE LOCATIONS. SECURE THE SLIDE BED AND CENTER USING THE PROVIDED HARDWARE.

PLACE SECOND SLIDE RAIL ASSEMBLY OVER THE TOP OF THE SLIDE BED AND M78 CENTER SLIDE BRACES. INSERT THE SLIDE BED AND CENTER SLIDE BRACES INTO THE SLIDE CAVITY. MAKE SURE SLIDE BED IS COMPLETELY IN THE SLIDE CAVITY.



TIP:

A HELPER IS REQUIRED FOR THIS PHASE.



FAILURE TO INSERT SLIDE BED COMPLETELY AND SECURED MAY RESULT IN INJURY OR AMPUTATION. EXPOSED SLIDE EDGES CAN BE SHARP AND BECOME A LACERATION HAZARD IF THE SLIDE IS NOT PROPERLY ASSEMBLED.

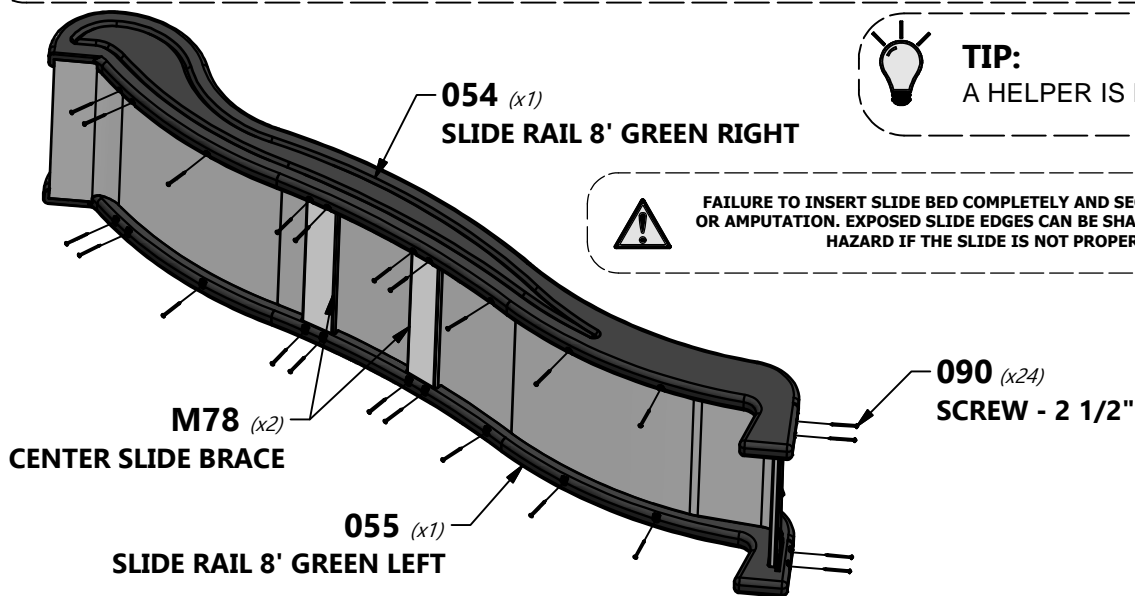



SWING BEAM ASSEMBLY

STEP 1



SB74 | SWING BEAM - W4L13423
(1) | 2"x5 1/4"x89 1/2" (50x134x2274)



A100294 | TRIANGLE
PLATE 100° 5
HOLE
(2)



A100140 | L BRACKET
66x66x127
(2)



H100047 | BOLT HEX
(2) | 5/16x2 3/4

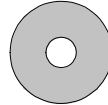

H100105 | WASHER FLAT
(4) | 8x27



H100110 | NUT LOCK
(2) | 5/16



H100011 | BOLT WH
(3) | 5/16x1 3/4

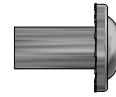

H100005 | NUT BARREL WH
(3) | 5/16x7/8

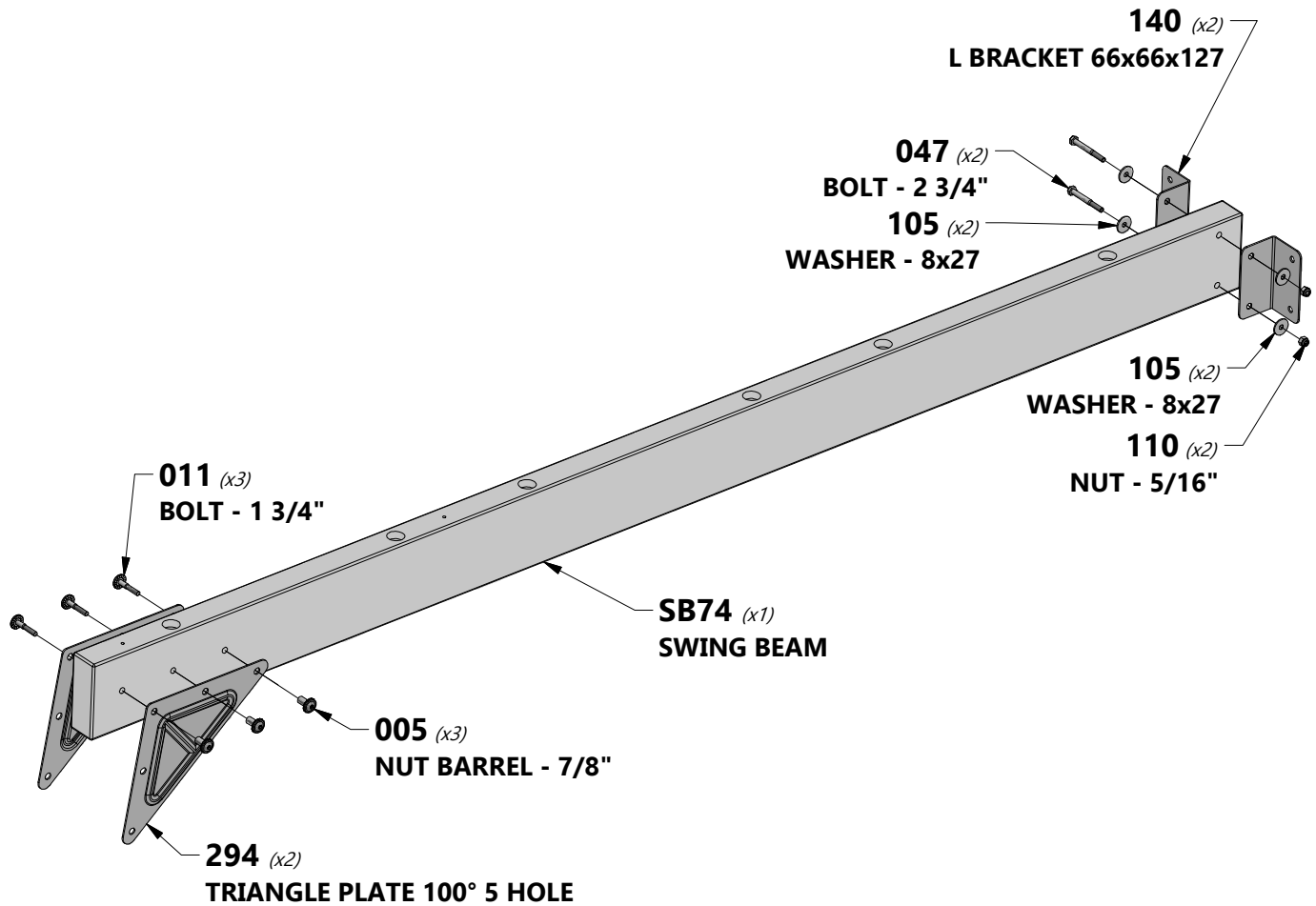



SWING BEAM ASSEMBLY

STEP 2

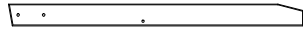

W71 | SWING BEAM SUPPORT - W4L13424
(1) | 2"x3 3/8"x46 1/8" (50x86x1170)

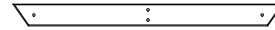

H79 | END SUPPORT - W4L13120
(1) | 1"x3 1/2"x42" (24x86x1072)

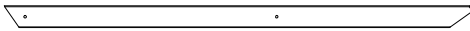

E77 | ANGLE BRACE - W4L13104
(2) | 1 3/8"x3 3/8"x73 1/4" (36x86x1862)

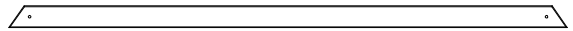

H80 | GROUND BOARD - W4L13121
(1) | 1"x3 3/8"x87 3/8" (24x86x2218)



H100021 | BOLT WH
(1) | 5/16x4 1/2

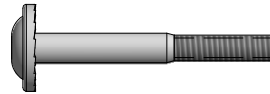

H100014 | BOLT WH
(2) | 5/16x2 1/2



H100012 | BOLT WH
(4) | 5/16x2



H100031 | WASHER LOCK EXT
(7) | 12x19



H100027 | LAG SCREW WH
(2) | 5/16x2

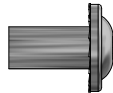

H100005 | NUT BARREL WH
(5) | 5/16x7/8



H100006 | NUT BARREL WH
(2) | 5/16x1 1/2



H100030 | WASHER LOCK EXT
(9) | 8x19

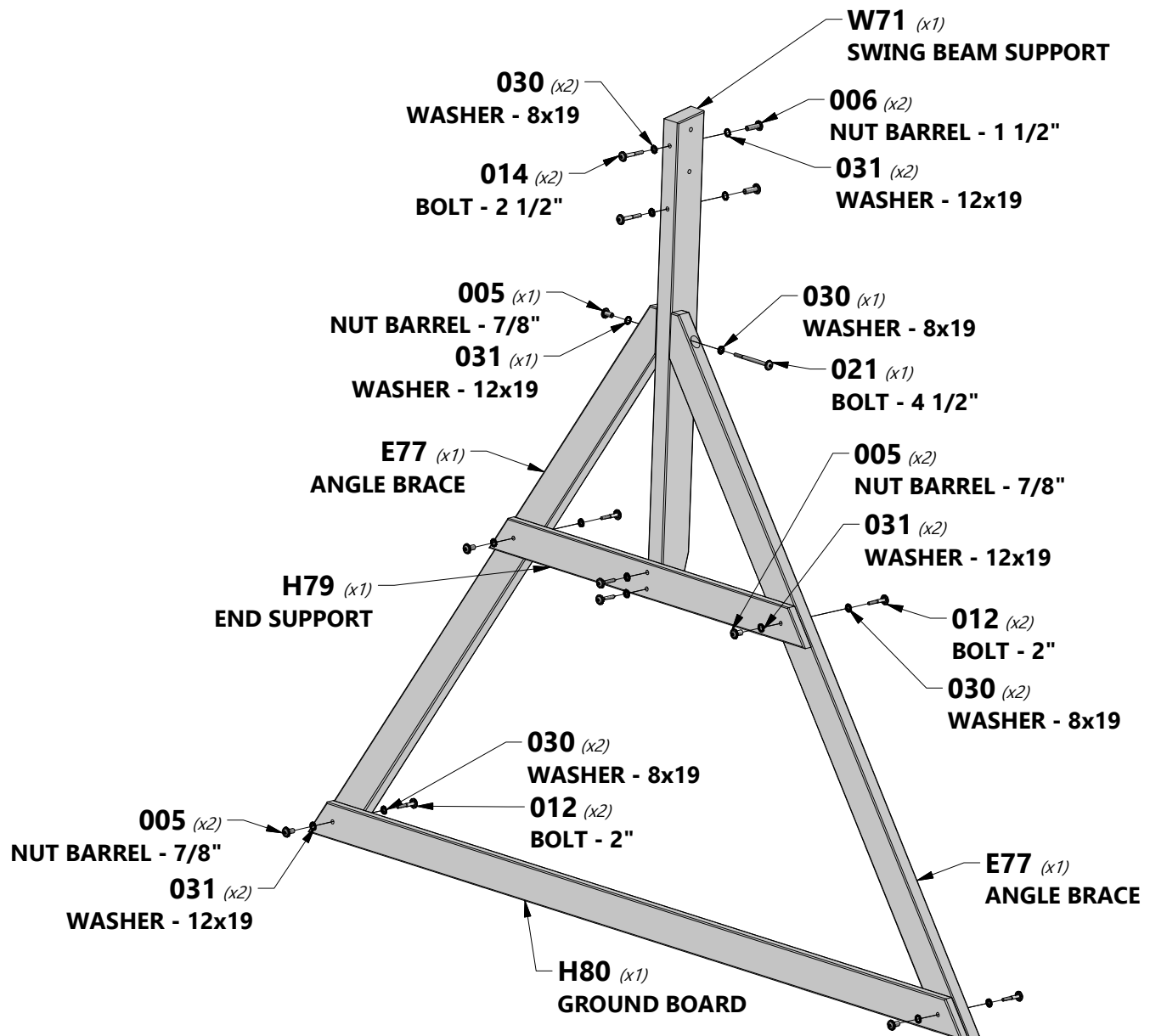



SWING BEAM ASSEMBLY

STEP 3

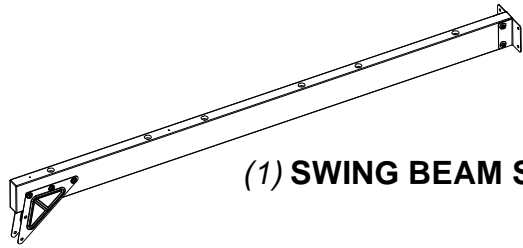

(1) SWING BEAM SUBASSEMBLY

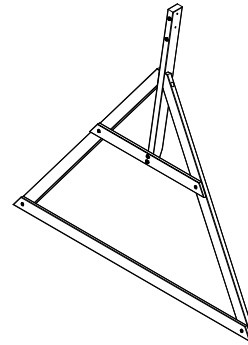

(1) SWING BEAM END SUBASSEMBLY



H100011 | BOLT WH
(2) | 5/16x1 3/4

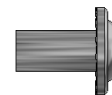

H100005 | NUT BARREL WH
(2) | 5/16x7/8

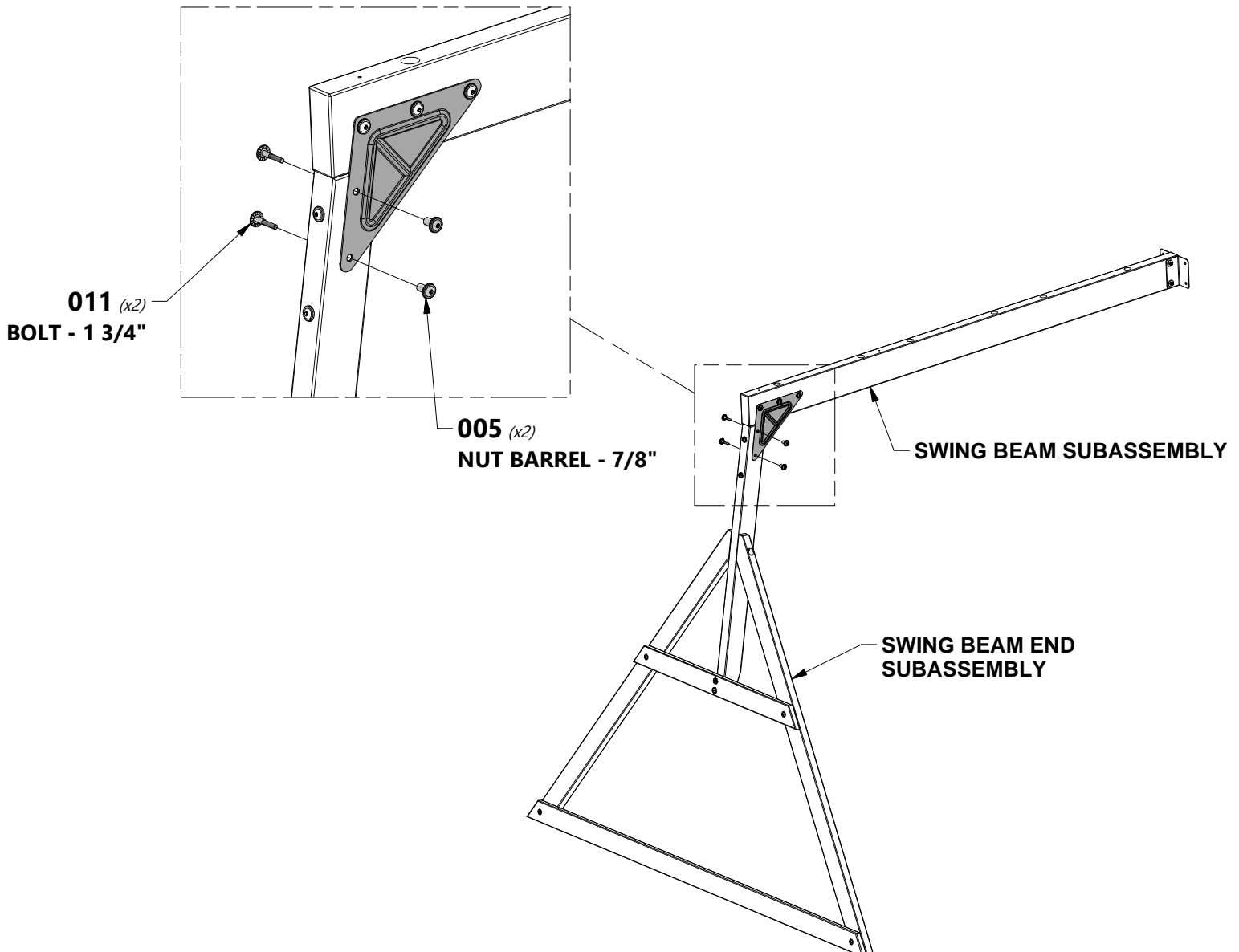



SWING BEAM ASSEMBLY

STEP 4



H100099 | SWING HANGER
(6) | 5/16x9 1/2

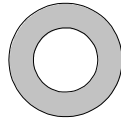

H100103 | WASHER SAFETY
(6) | 17x30

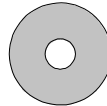

H100105 | WASHER FLAT
(6) | 8x27



H100110 | NUT LOCK
(6) | 5/16

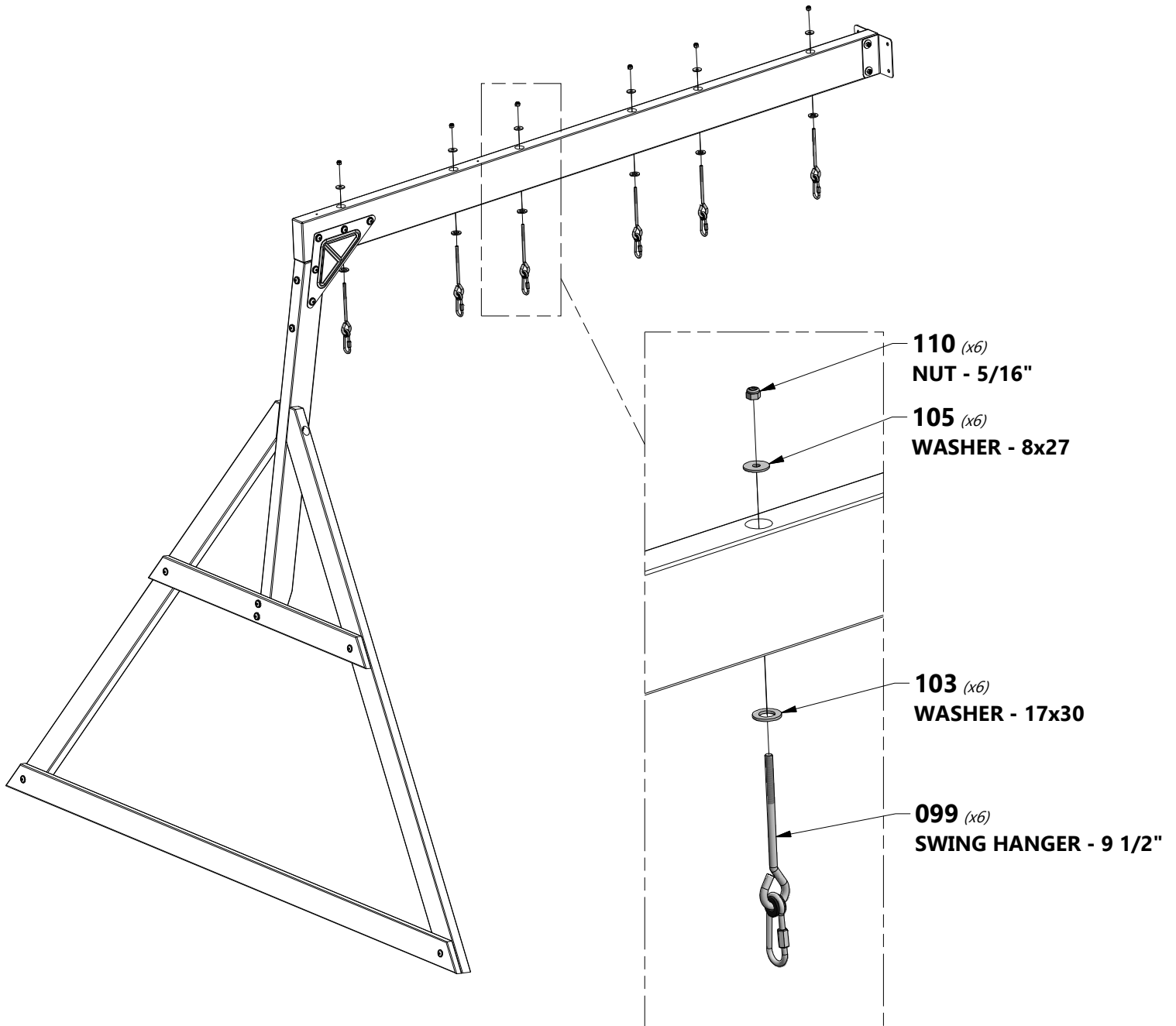



ROCK LADDER ASSEMBLY

STEP 1

M71 | ROCK BOARD - W4L13140
(6) 5/8"x3 3/8"x20 1/4" (16x86x514)

M72 | ROCK WALL SLAT - W4L13421
(2) 5/8"x3 3/8"x20 1/4" (16x86x514)

H73 | ROCK WALL RAIL - W4L13119
(2) 1"x3 3/8"x48 3/4" (24x86x1238)

H100086 | SCREW PFH
(32) 8x1 1/2



NOTE:

1. Assemble slats to rails as shown.
2. Note orientation of slats, be sure to arrange as shown.
3. See drawing below for slat spacing on rails.
4. Using slats as a guide, pre-drill top edges of rails with a 1/8" drill bit. Failure to pre-drill may result in board splitting.

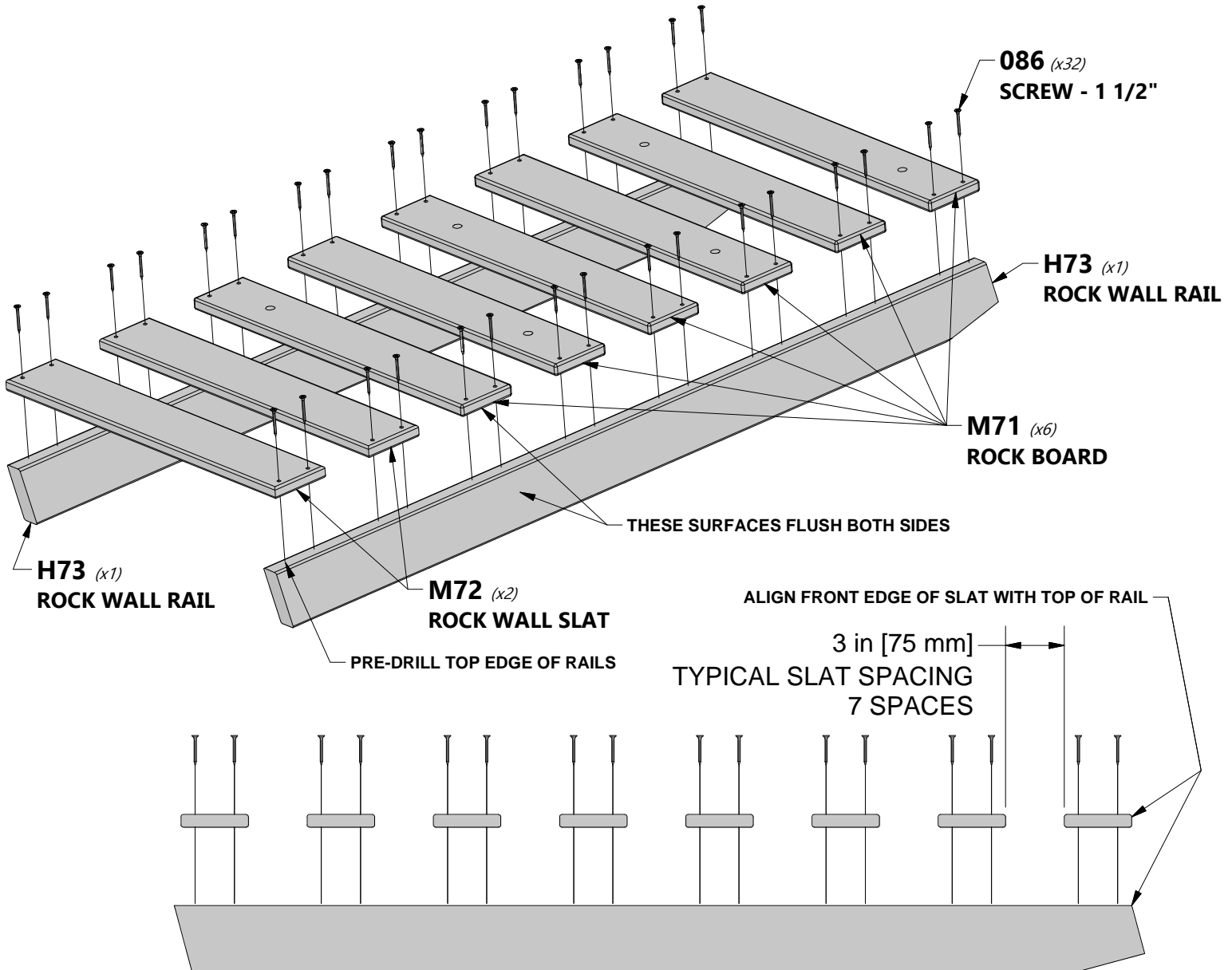
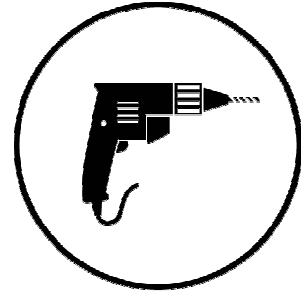



ROCK LADDER ASSEMBLY

STEP 2

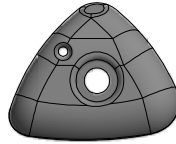

A100060 | CLIMBING ROCK GREEN SMALL
(6)



H100088 | SCREW PFH
(6) | 8x1 1/8



H100001 | BOLT FA
(6) | 3/8x1 1/2

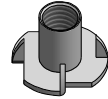

H100073 | T-NUT
(6) | 3/8



NOTE:

1. Install T-nuts before attaching rocks.
2. Orient top edge of rocks with top edge of slats.
3. Fasten rocks as shown.

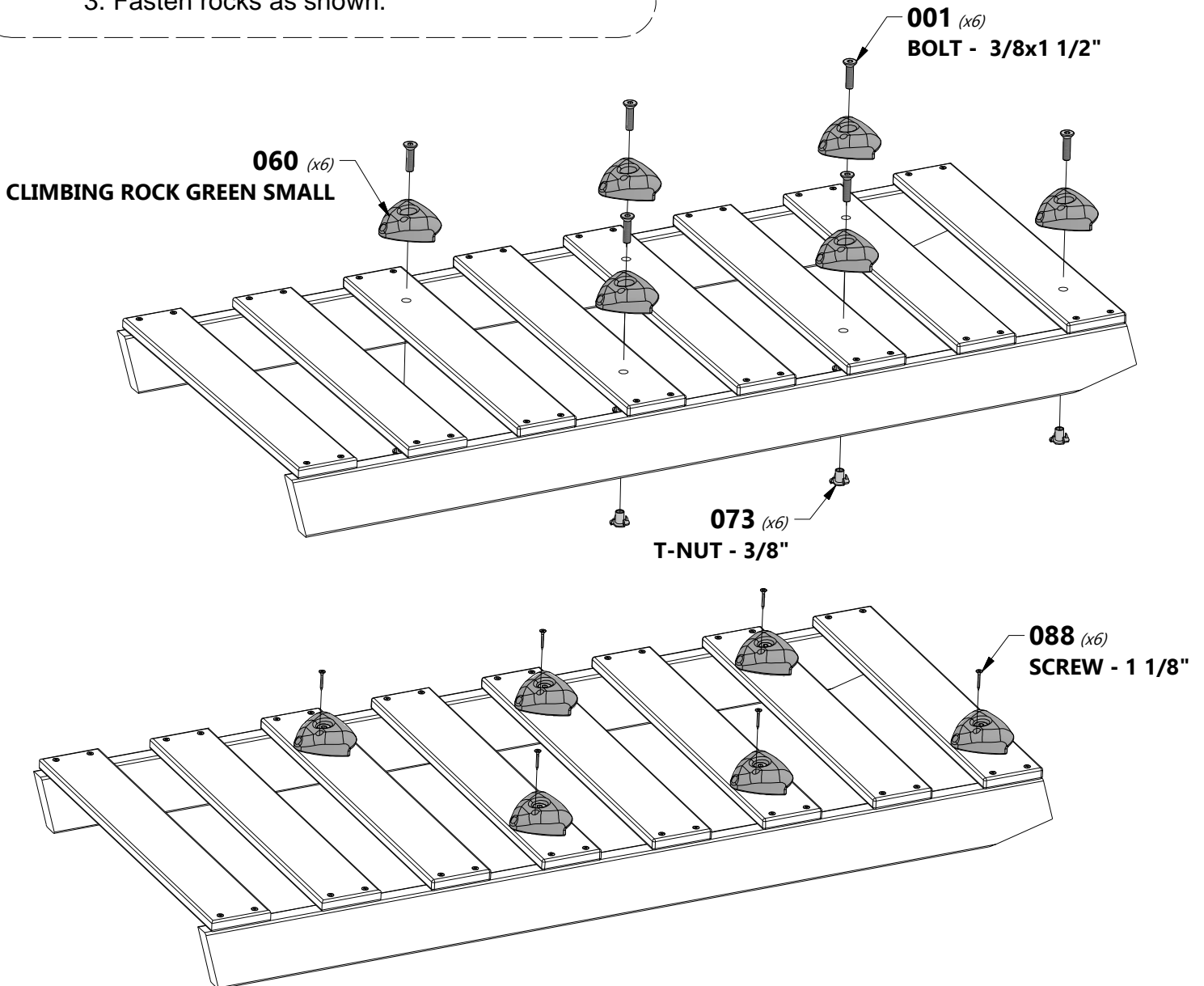

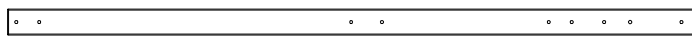

E2 | FORT UPRIGHT - W4L13103
(1) | 1 3/8"x3 3/8"x89 1/2" (36x86x2273)

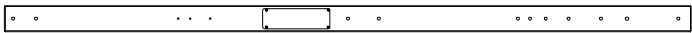

E3 | FORT UPRIGHT - W2A03069
(1) | 1 7/16"x3 3/8"x89 1/2" (36x86x2273)



G1 | GROUND BOARD - W4L13107
(1) | 1"x5 1/4"x59 1/2" (24x134x1511)



H2 | FLOOR JOIST - W4L13111
(1) | 1"x3 3/8"x34 1/8" (24x86x868)

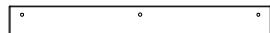

K4 | WALL RAIL - W4L13126
(1) | 5/8"x5 1/4"x34 1/8" (16x134x868)

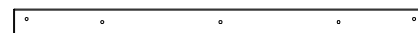

H1 | ROOF CROSS BRACE - W4L13110
(1) | 1"x3 3/8"x53 7/8" (24x86x1368)



N1 | WALL RAIL - W4L13422
(1) | 5/8"x1 1/8"x34 1/8" (16x30x868)

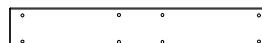

G2 | SWING BEAM SUPPORT - W4L13108
(1) | 1"x5 1/4"x34 1/8" (24x134x868)



H100012 | BOLT WH
(10) | 5/16x2



H100027 | LAG SCREW WH
(2) | 5/16x2



H100030 | WASHER LOCK EXT
(16) | 8x19



H100005 | NUT BARREL WH
(14) | 5/16x7/8



H100010 | BOLT WH
(4) | 5/16x1-1/2



H100089 | SCREW PFH
(2) | 8x1 3/4



H100031 | WASHER LOCK EXT
(14) | 12x19



TIP:

FOR EASE OF ASSEMBLY WE RECOMMEND USING SAW HORSES TO ASSEMBLE FORT.

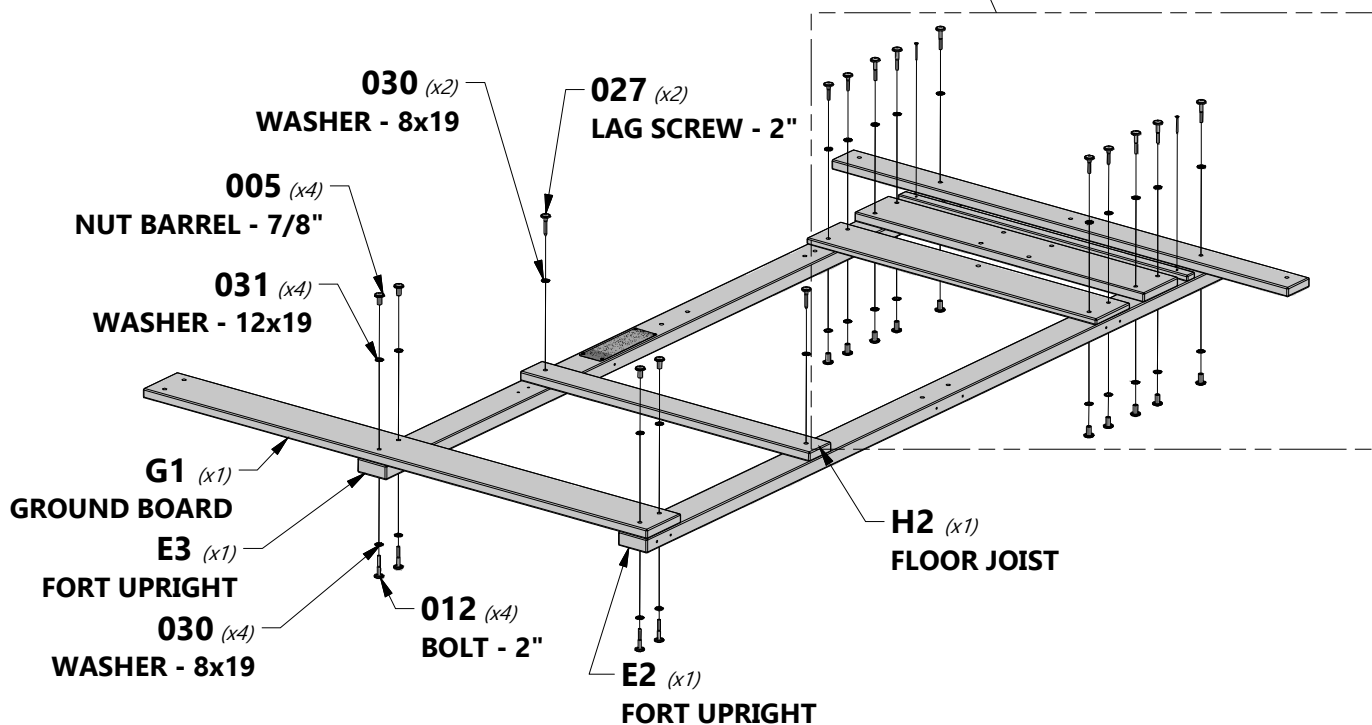
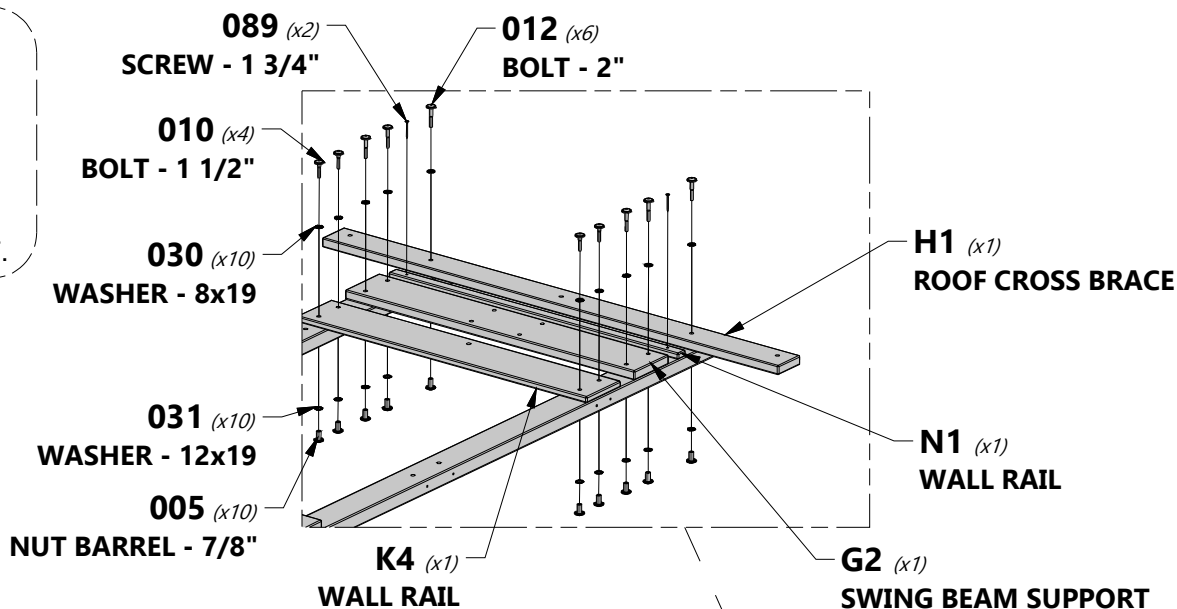

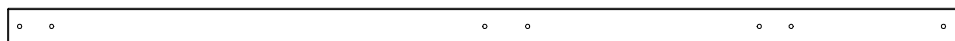

E1 | FORT UPRIGHT - W4L13102
(1) | 1 3/8"x3 3/8"x89 1/2" (36x86x2273)

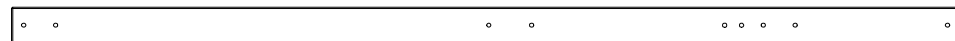

E4 | FORT UPRIGHT - W4L13553
(1) | 1 3/8"x3 3/8"x89 1/2" (36x86x2273)



G1 | GROUND BOARD - W4L13107
(1) | 1"x5 1/4"x59 1/2" (24x134x1511)



K3 | ARCHED WALL RAIL - W4L13125
(1) | 5/8"x5 1/4"x34 1/8" (16x134x868)



H1 | ROOF CROSS BRACE - W4L13110
(1) | 1"x3 3/8"x53 7/8" (24x86x1368)

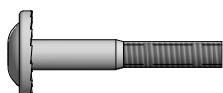

H100012 | BOLT WH
(6) | 5/16x2



H100030 | WASHER LOCK EXT
(10) | 8x19

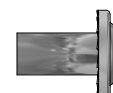

H100005 | NUT BARREL WH
(10) | 5/16x7/8

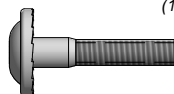

H100010 | BOLT WH
(4) | 5/16x1-1/2



H100031 | WASHER LOCK EXT
(10) | 12x19

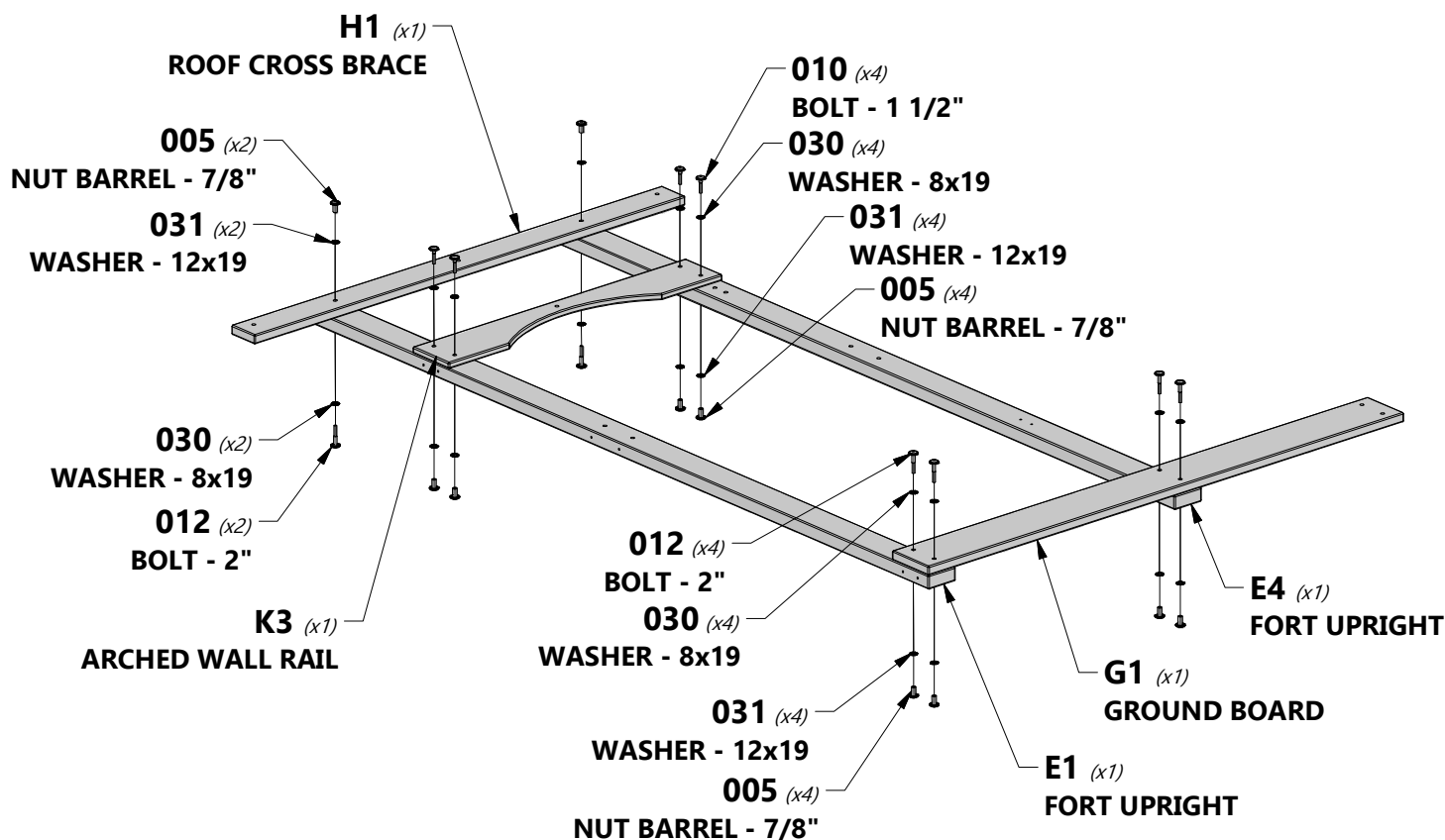



M3 | TARP SUPPORT - W4L13129
(2) | 5/8"x3 3/8"x36 3/4" (16x86x935)



M13 | WALL RAIL - W4L13139
(1) | 5/8"x3 3/8"x34 7/8" (16x86x887)



K1 | WALL RAIL - W4L13123
(3) | 5/8"x5 1/4"x34 7/8" (16x134x887)

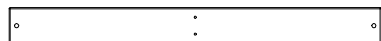

M5 | WALL RAIL - W4L13131
(1) | 5/8"x3 3/8"x34 7/8" (16x86x887)



M14 | FLOOR/TARP SUPPORT - W4L13528
(1) | 5/8"x3 3/8"x34 7/8" (16x86x887)

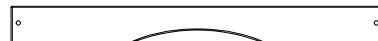

K2 | ARCHED WALL RAIL - W4L13124
(1) | 5/8"x5 1/4"x34 7/8" (16x134x887)



H100027 | LAG SCREW WH
(20) | 5/16x2



H100115 | BOLT WH
(4) | 5/16x1/2

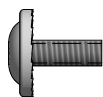

H100222 | BOLT WH
(4) | 5/16x3/4

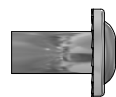

H100005 | NUT BARREL WH
(4) | 5/16x7/8



H100086 | SCREW PFH
(4) | 8x1 1/2



H100030 | WASHER LOCK EXT
(20) | 8x19



H100031 | WASHER LOCK EXT
(4) | 12x19



H100074 | T-NUT
(4) | 5/16



A4M01046 | L BRACKET 2.5x38x55x55
(4)

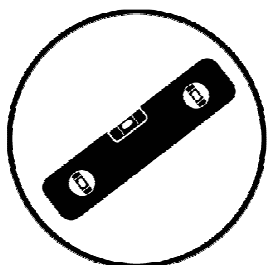
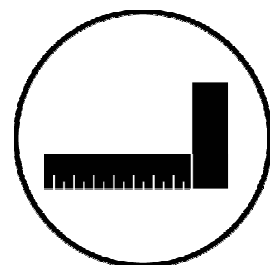
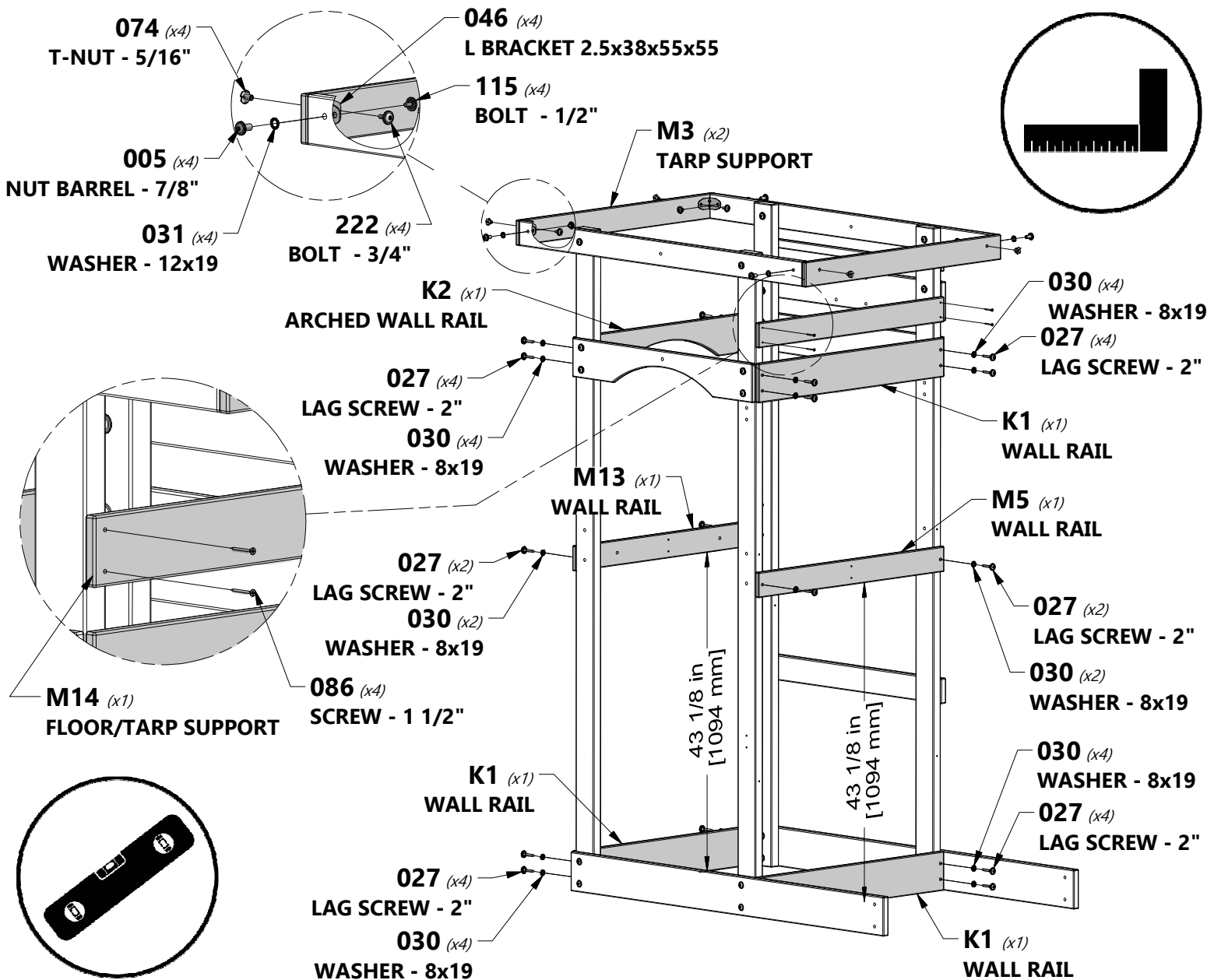



H2 | FLOOR JOIST - W4L13111
(1) | 1"x3 3/8"x34 1/8" (24x86x868)



H4 | FLOOR BRACE - W4L13112
(1) | 1"x3 3/8"x34 1/8" (24x86x868)



H10 | FLOOR BRACE - W4L13118
(4) | 1"x3 3/8"x3 3/8" (24x86x86)



H11 | FLOOR JOIST - W4L13527
(1) | 1"x3 3/8"x34 1/8" (24x86x868)

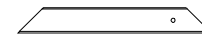

F1 | ANGLE BRACE - W4L13105
(2) | 1 3/8"x2 3/8"x18 1/8" (36x60x460)

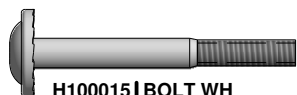

H100015 | BOLT WH
(4) | 5/16x2 3/4



H100013 | BOLT WH
(2) | 5/16x2 1/4



H100031 | WASHER LOCK EXT
(4) | 12x19



H100027 | LAG SCREW WH
(2) | 5/16x2



H100030 | WASHER LOCK EXT
(8) | 8x19



H100005 | NUT BARREL WH
(4) | 5/16x7/8

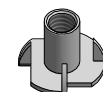

H100074 | T-NUT
(2) | 5/16

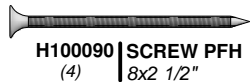

H100090 | SCREW PFH
(4) | 8x2 1/2"

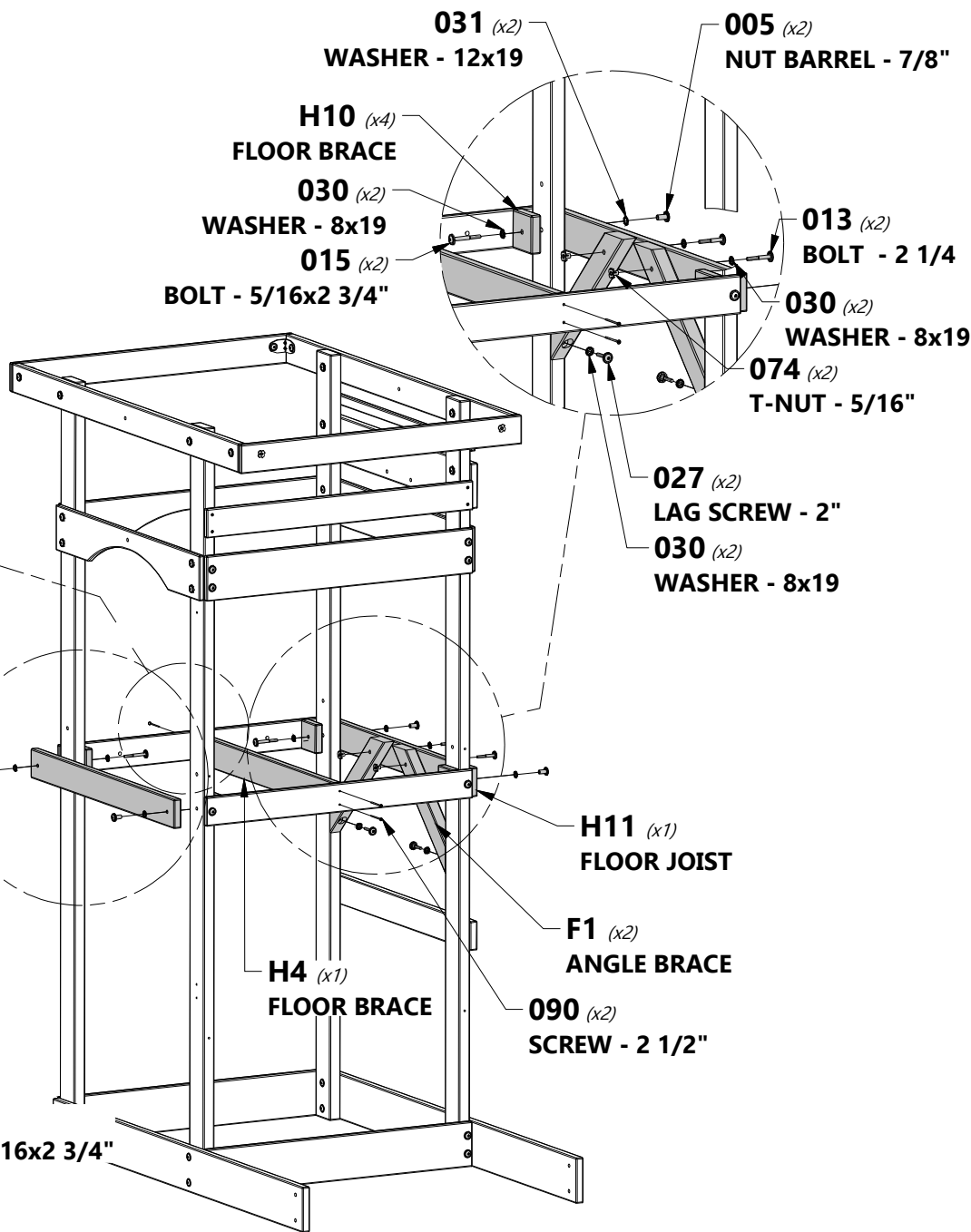
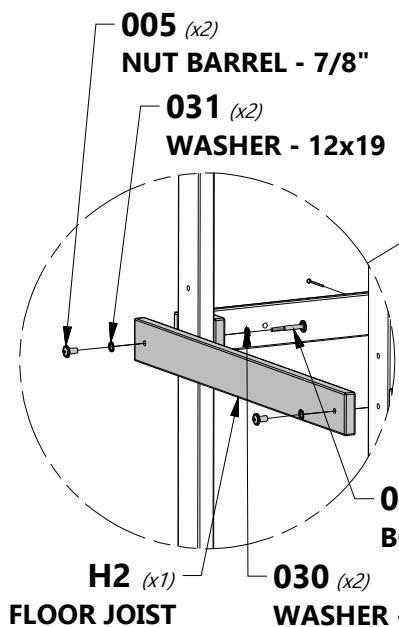
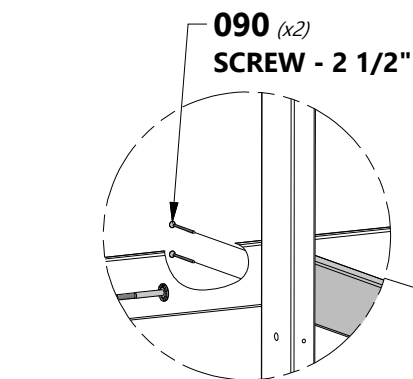
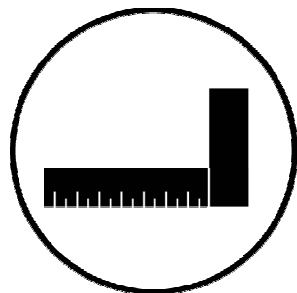



M2 | FLOOR BOARD - W4L13128
(8) | 5/8"x3 3/8"x36 3/4" (16x86x935)

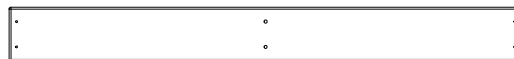

M7 | FLOOR BOARD - W4L13133
(2) | 5/8"x3 3/8"x32 1/8" (16x86x815)



H100086 | SCREW PFH
(60) | 8x1 1/2

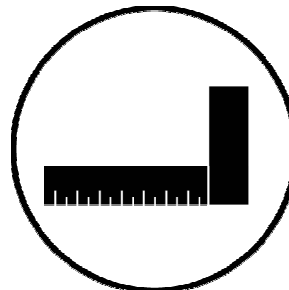
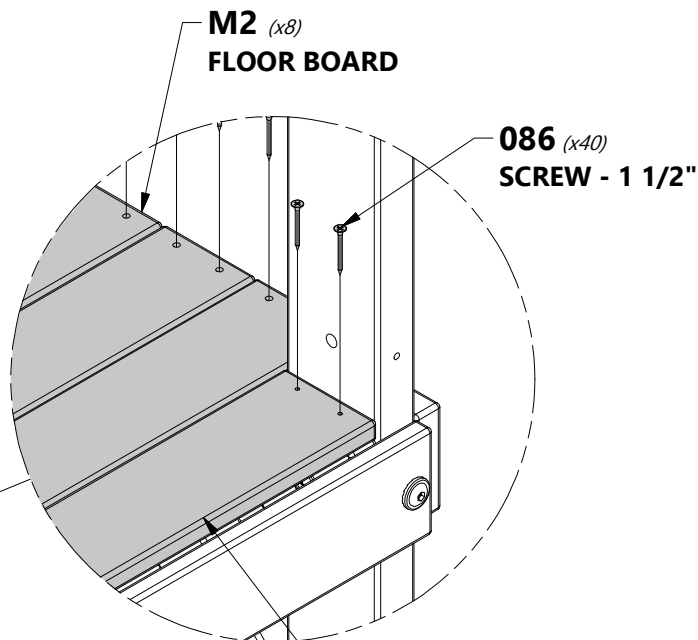
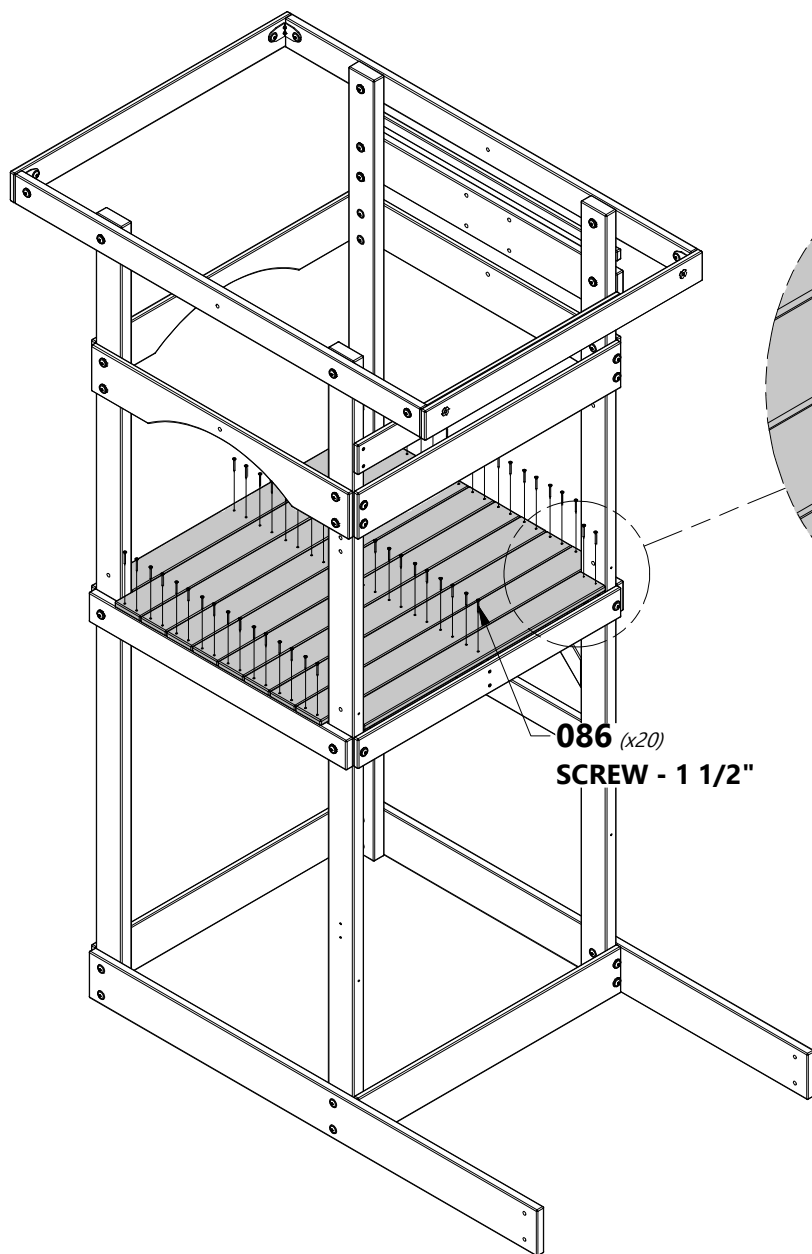



H2 | FLOOR JOIST - W4L13111
(1) 1"x3 3/8"x34 1/8" (24x86x868)



M6 | WALL RAIL - W4L13132
(1) 5/8"x3 3/8"x34 7/8" (16x86x887)



M10 | WALL RAIL - W4L13136
(2) 5/8"x3 3/8"x6 1/4" (16x86x160)



M11 | WALL RAIL - W4L13137
(2) 5/8"x3 3/8"x4 3/4" (16x86x122)



H100012 | BOLT WH
(2) 5/16x2

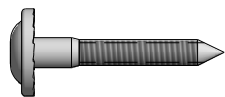

H100027 | LAG SCREW WH
(4) 5/16x2



H100030 | WASHER LOCK EXT
(8) 8x19

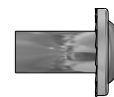

H100005 | NUT BARREL WH
(4) 5/16x7/8



H100010 | BOLT WH
(2) 5/16x1-1/2



H100031 | WASHER LOCK EXT
(4) 12x19

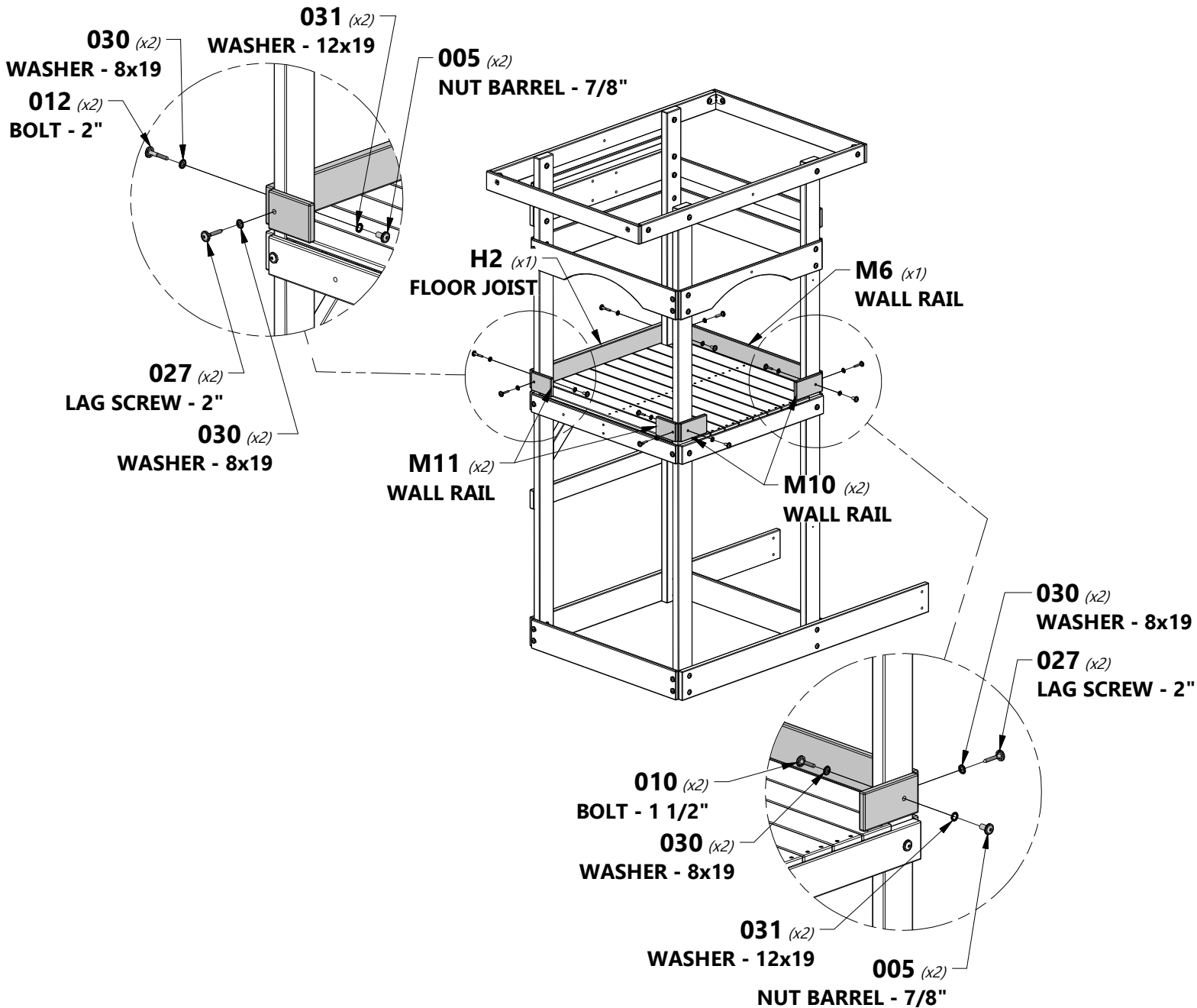



H6 | WALL SLAT - W4L13114
(2) | 1"x3 3/8"x25 1/2" (24x86x648)

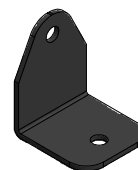

A100053 | L BRACKET 54x67 - GRN
(2)



H100086 | SCREW PFH
(8) | 8x1 1/2



H100083 | SCREW TAPPING
(4) | 14x3/4

REPEAT FOR OTHER SIDE

H6 (x2)
WALL SLAT

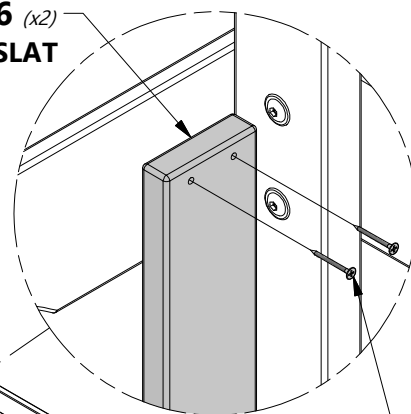

086 (x4)
SCREW - 1 1/2"

053 (x2)
L BRACKET 54x67 - GRN

083 (x4)
SCREW - 14x3/4"

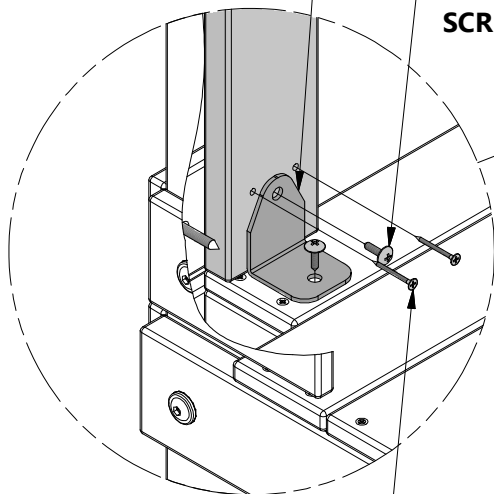

086 (x4)
SCREW - 1 1/2"

REPEAT FOR OTHER SIDE

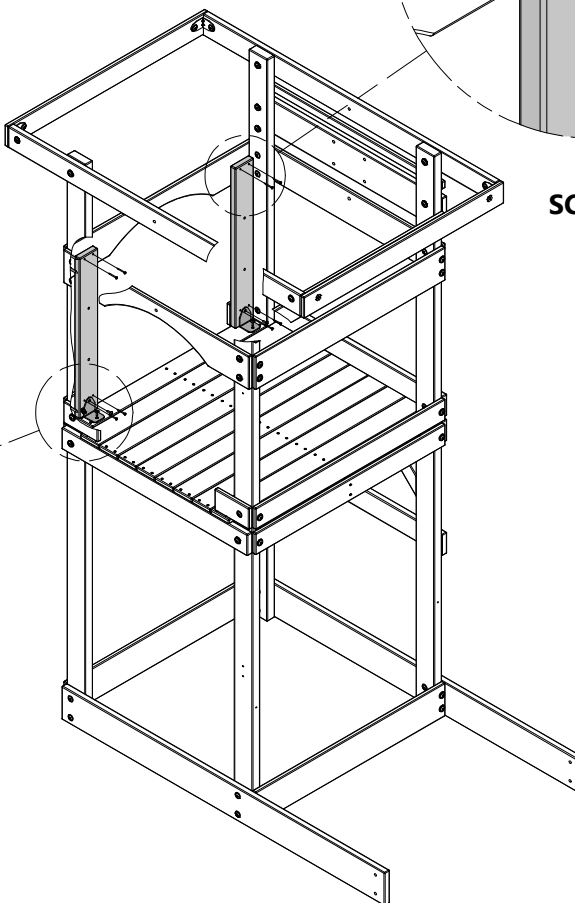



M12 | WALL SLAT - W4L13138
(4) | 5/8"x3 3/8"x25 1/4" (16x86x640)



H100088 | SCREW PFH
(8) | 8x1 1/8"



H100087 | SCREW PFH
(8) | 8x1 1/4"

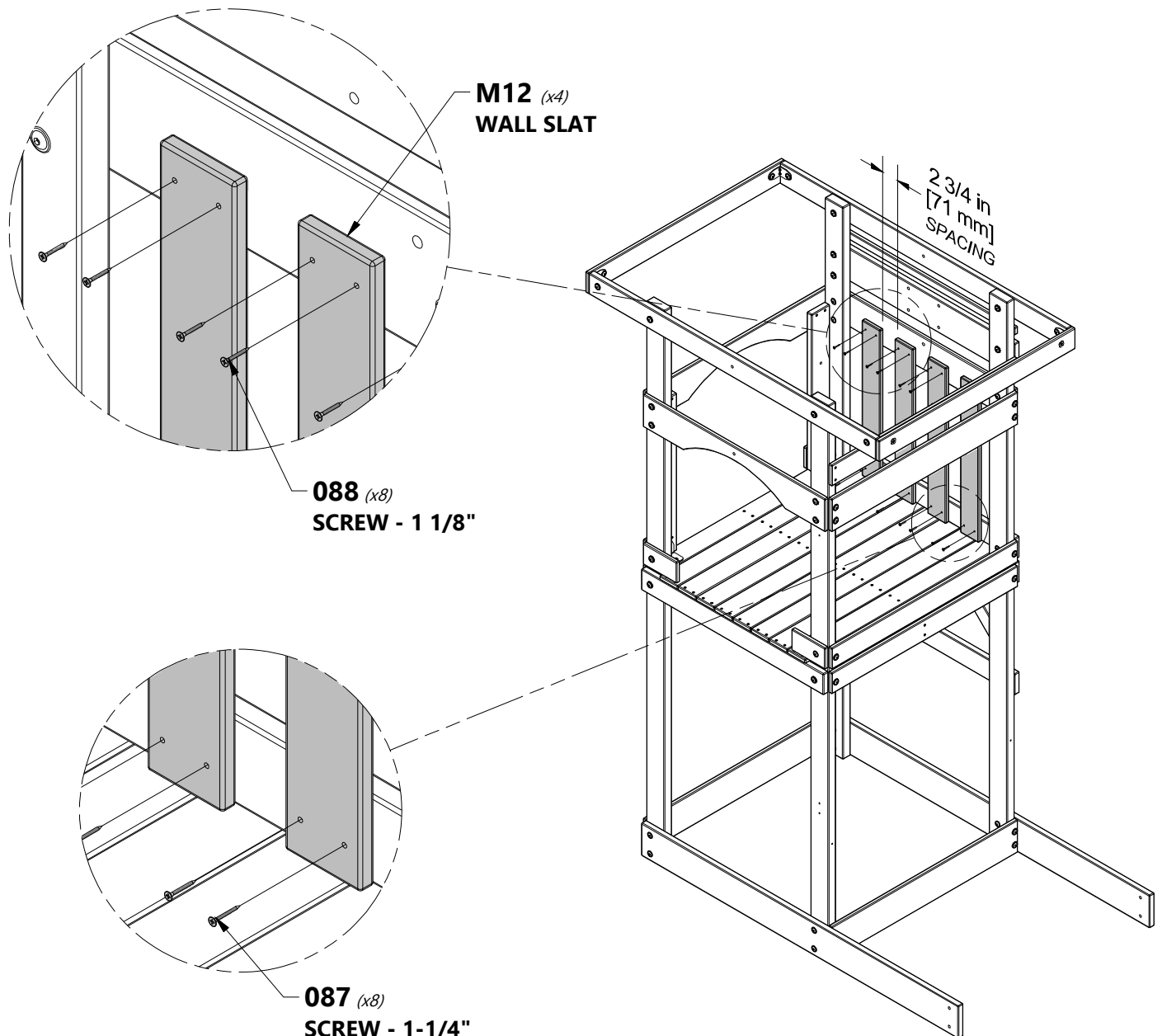



M12 | WALL SLAT - W4L13138
(5) | 5/8"x3 3/8"x25 1/4" (16x86x640)

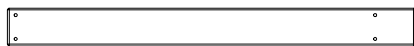

J1 | WALL SLAT - W4L13122
(2) | 1"x2 3/8"x25 1/2" (24x60x648)



A100053 | L BRACKET 54x67 - GRN
(2)



H100088 | SCREW PFH
(20) | 8x1 1/8"



H100086 | SCREW PFH
(8) | 8x1 1/2"



H100083 | SCREW TAPPING
(4) | 14x3/4"

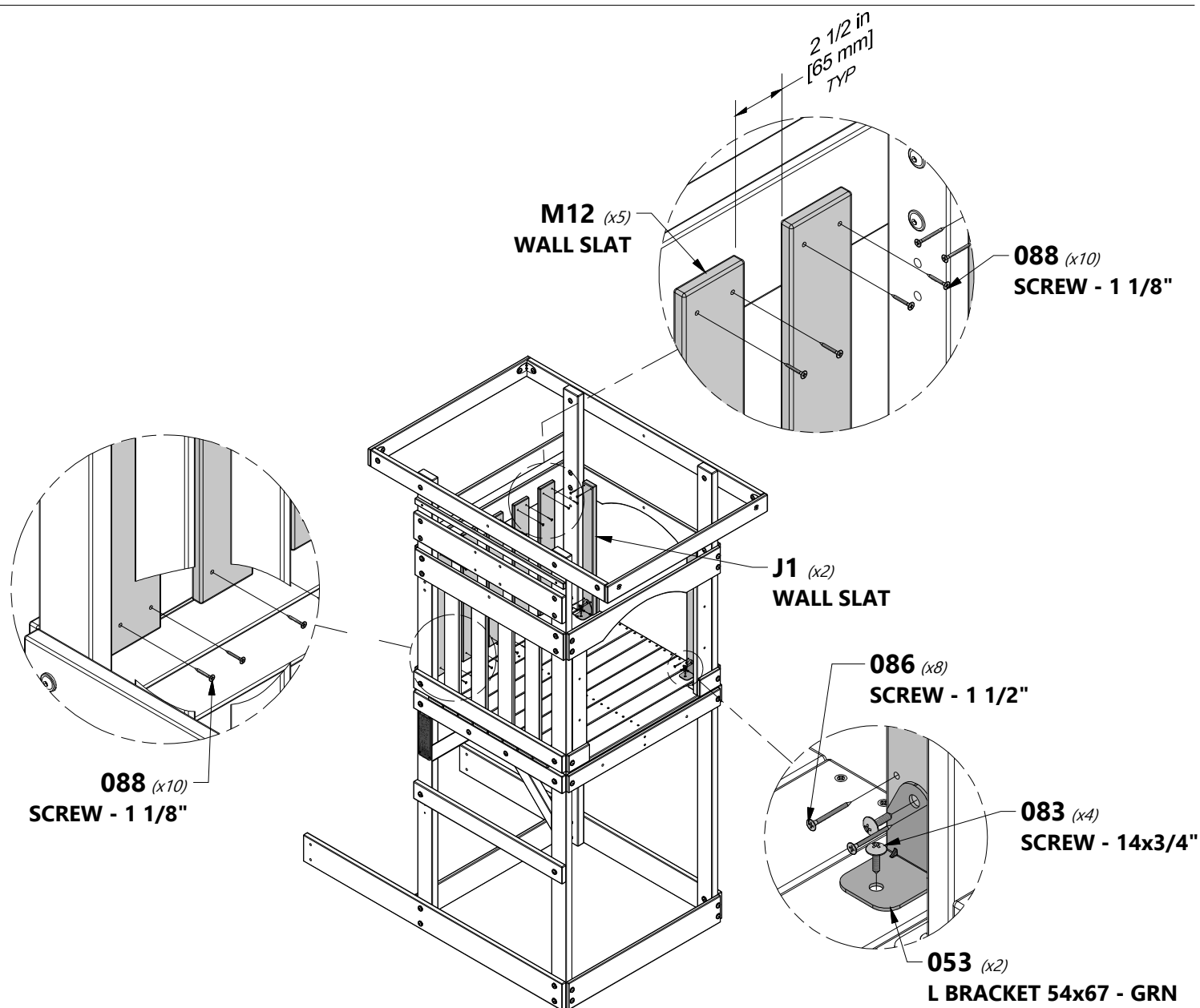



1 1/4 in
[33 mm]

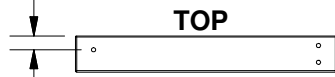

H5 | PICNIC TARP SUPPORT - W4L13554
(2) | 1"x3 3/8"x24 1/2" (24x86x622)



M3 | TARP SUPPORT - W4L13129
(1) | 5/8"x3 3/8"x36 3/4" (16x86x935)



A4M01046 | L BRACKET 2.5x38x55x55
(2)



H100012 | BOLT WH
(4) | 5/16x2



H100031 | WASHER LOCK EXT
(6) | 12x19

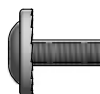

H100222 | BOLT WH
(2) | 5/16x3/4



H100115 | BOLT WH
(2) | 5/16x1/2



H100030 | WASHER LOCK EXT
(4) | 8x19



H100005 | NUT BARREL WH
(6) | 5/16x7/8



H100074 | T-NUT
(2) | 5/16

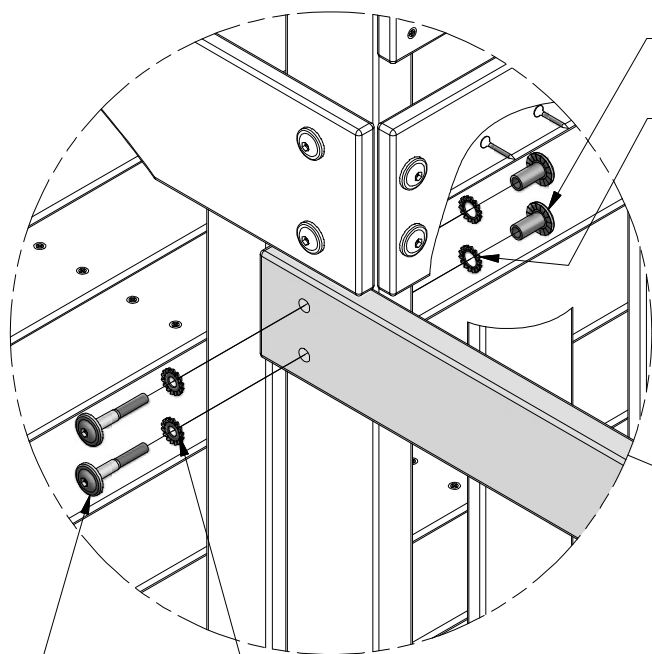

012 (x4)
BOLT - 2"

030 (x4)
WASHER - 8x19

005 (x4)
NUT BARREL - 7/8"

031 (x4)
WASHER - 12x19

H5 (x2)
PICNIC TARP SUPPORT

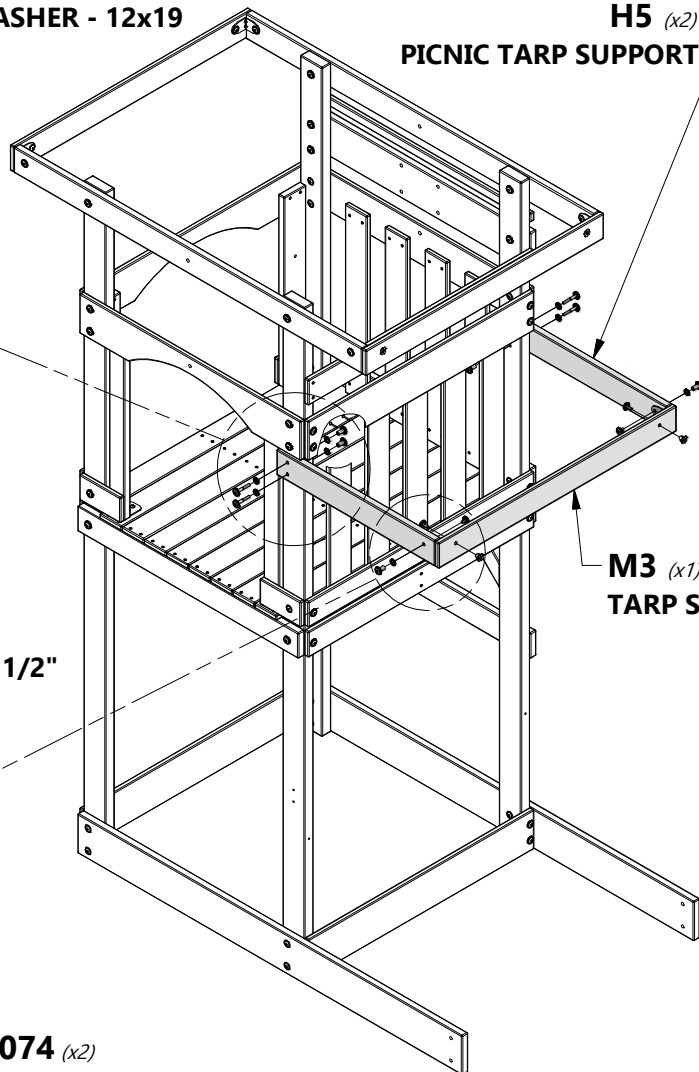

M3 (x1)
TARP SUPPORT

222 (x2)
BOLT - 3/4"

115 (x2)
BOLT - 1/2"

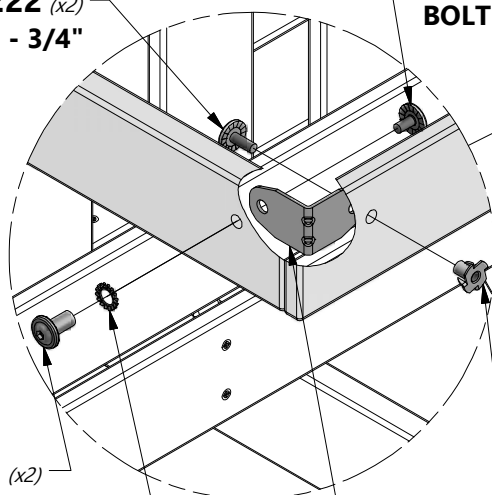

074 (x2)
T-NUT - 5/16"

005 (x2)
NUT BARREL - 7/8"

046 (x2)
L BRACKET 2.5x38x55x55

031 (x2)
WASHER - 12x19



F2 | ANGLE BRACE - W4L13106
(2) | 1 3/8"x2 3/8"x12 1/4" (36x60x310)

H8 | PICNIC SUPPORT - W4L13116
(2) | 1"x3 3/8"x13 1/2" (24x86x344)

M8 | PICNIC CLEAT - W4L13134
(1) | 5/8"x3 3/8"x10 1/8" (16x86x258)



M2 | FLOOR BOARD - W4L13128
(3) | 5/8"x3 3/8"x36 3/4" (16x86x935)



H100013 | BOLT WH
(2) | 5/16x2 1/4



H100027 | LAG SCREW WH
(6) | 5/16x2



H100030 | WASHER LOCK EXT
(8) | 8x19



H100088 | SCREW PFH
(6) | 8x1 1/8



H100086 | SCREW PFH
(12) | 8x1 1/2



H100074 | T-NUT
(2) | 5/16

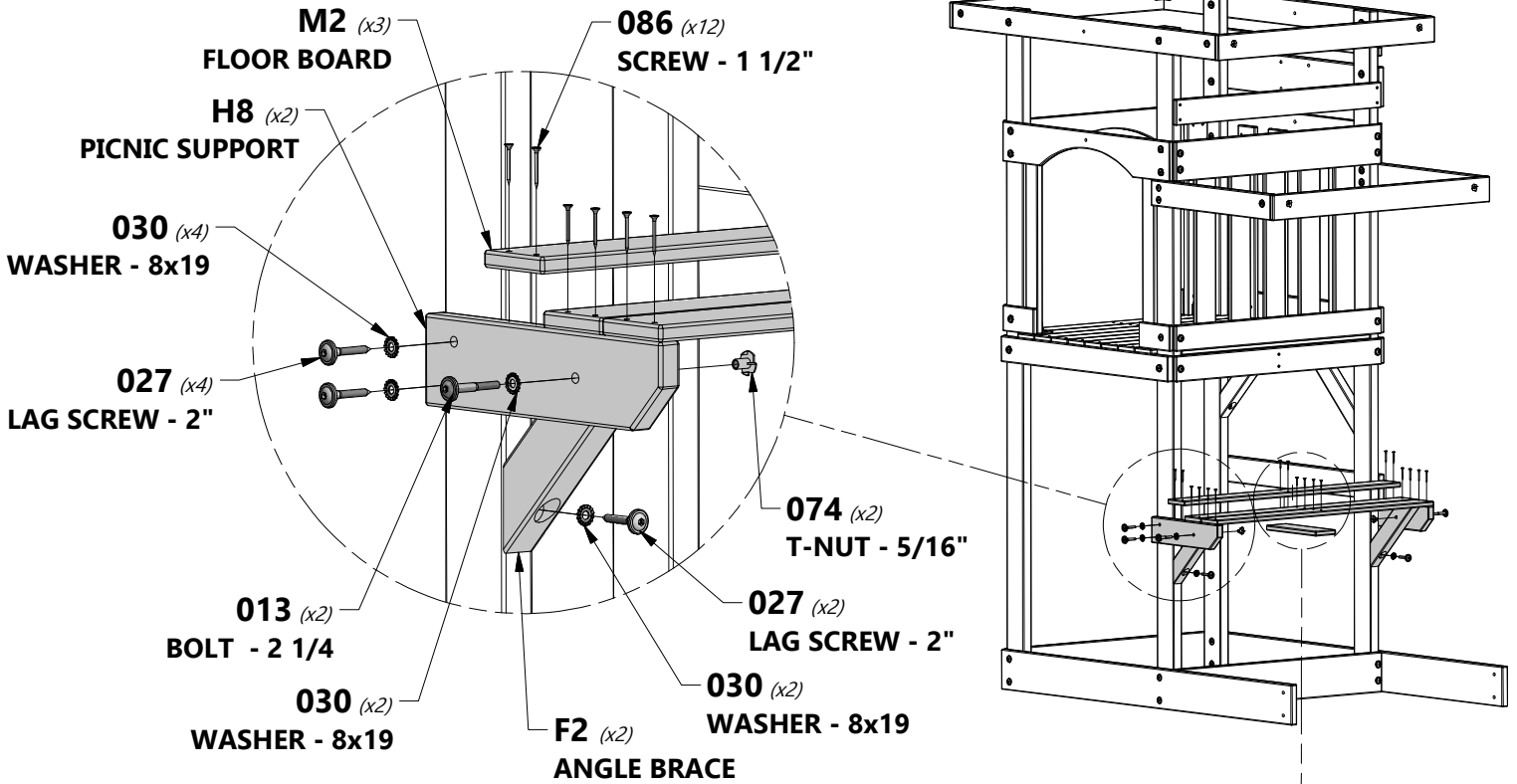

TIP:

WE RECOMMEND INSTALLING T-NUTS INTO BOARDS BEFORE ASSEMBLY.

088 (x6)
SCREW - 1 1/8"

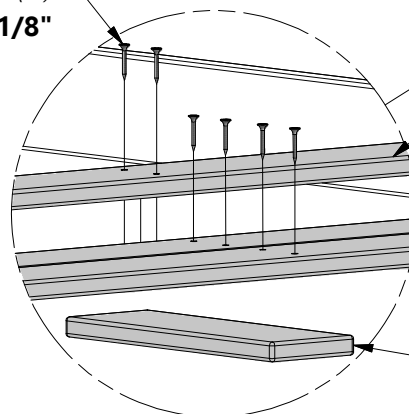

M2
FLOOR BOARD

M8 (x1)
PICNIC CLEAT



G3 | PICNIC SUPPORT - W4L13109
(2) | 1"x5 1/4"x5 1/4" (24x134x134)

H9 | PICNIC SUPPORT - W4L13117
(2) | 1"x3 3/8"x6 3/4" (24x86x172)

H7 | PICNIC SUPPORT - W4L13115
(2) | 1"x3 3/8"x15 1/4" (24x86x387)

M2 | FLOOR BOARD - W4L13128
(2) | 5/8"x3 3/8"x36 3/4" (16x86x935)

M9 | PICNIC CLEAT - W4L13135
(1) | 5/8"x3 3/8"x6 3/4" (16x86x172)

H100088 | SCREW PFH
(4) | 8x1 1/8

H100086 | SCREW PFH
(8) | 8x1 1/2

H100030 | WASHER LOCK EXT
(8) | 8x19

H100005 | NUT BARREL WH
(8) | 5/16x7/8

H100010 | BOLT WH
(8) | 5/16x1-1/2

H100089 | SCREW PFH
(6) | 8x1 3/4

H100031 | WASHER LOCK EXT
(8) | 12x19

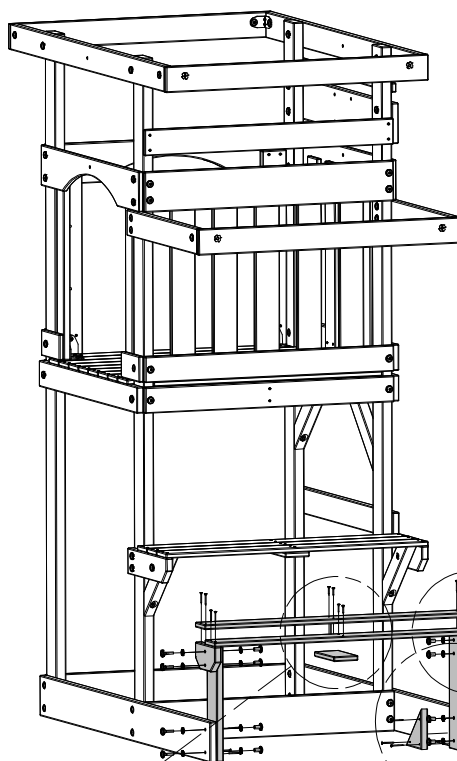

086 (x8)
SCREW - 1 1/2"

M2 (x2)
FLOOR BOARD

H9 (x2)
PICNIC SUPPORT

010 (x4)
BOLT - 1 1/2"

030 (x4)
WASHER - 8x19

031 (x4)
WASHER - 12x19

005 (x4)
NUT BARREL - 7/8"

088 (x4)
SCREW - 1 1/8"

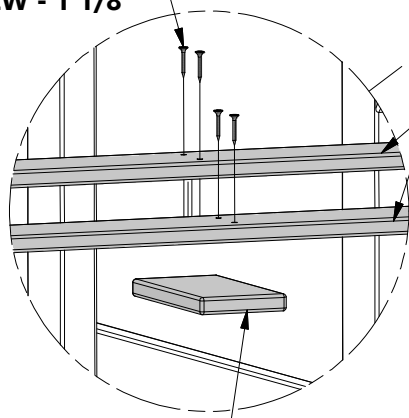

M2
FLOOR BOARD

089 (x6)
SCREW - 1 3/4"

G3 (x2)
PICNIC SUPPORT

005 (x4)
NUT BARREL - 7/8"

M9 (x1)
PICNIC CLEAT

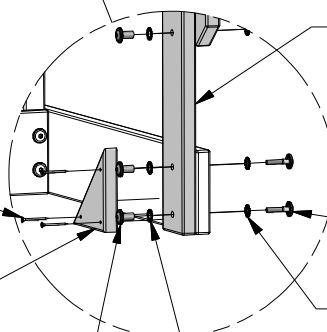

H7 (x2)
PICNIC SUPPORT

010 (x4)
BOLT - 1 1/2"

030 (x4)
WASHER - 8x19

031 (x4)
WASHER - 12x19

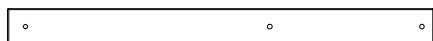

M1 | TARP SUPPORT - W4L13127
(2) | 5/8"x3 3/8"x40" (16x86x1016)

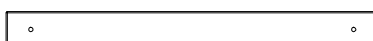

M4 | FLOOR/TARP SUPPORT - W4L13130
(1) | 5/8"x3 3/8"x34 7/8" (16x86x887)



A4M01046 | L BRACKET 2.5x38x55x55
(2)



H100008 | BOLT WH
(4) | 5/16x1



H100030 | WASHER LOCK EXT
(4) | 8x19

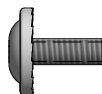

H100222 | BOLT WH
(2) | 5/16x3/4



H100005 | NUT BARREL WH
(2) | 5/16x7/8



H100074 | T-NUT
(2) | 5/16



H100115 | BOLT WH
(2) | 5/16x1/2



H100031 | WASHER LOCK EXT
(6) | 12x19



H100004 | NUT BARREL WH
(4) | 5/16 x 5/8

030 (x2)
WASHER - 8x19

008 (x2)
BOLT - 5/16x1"

074 (x2)
T-NUT - 5/16"

M4 (x1)
FLOOR/TARP SUPPORT

M1 (x2)
TARP SUPPORT

004 (x2)
NUT BARREL - 5/8"

031 (x2)
WASHER - 12x19
005 (x2)
NUT BARREL - 7/8"

031 (x2)
WASHER - 12x19

222 (x2)
BOLT - 3/4"

115 (x2)
BOLT - 1/2"

008 (x2)
BOLT - 5/16x1"
030 (x2)
WASHER - 8x19

031 (x2)
WASHER - 12x19
004 (x2)
NUT BARREL - 5/8"

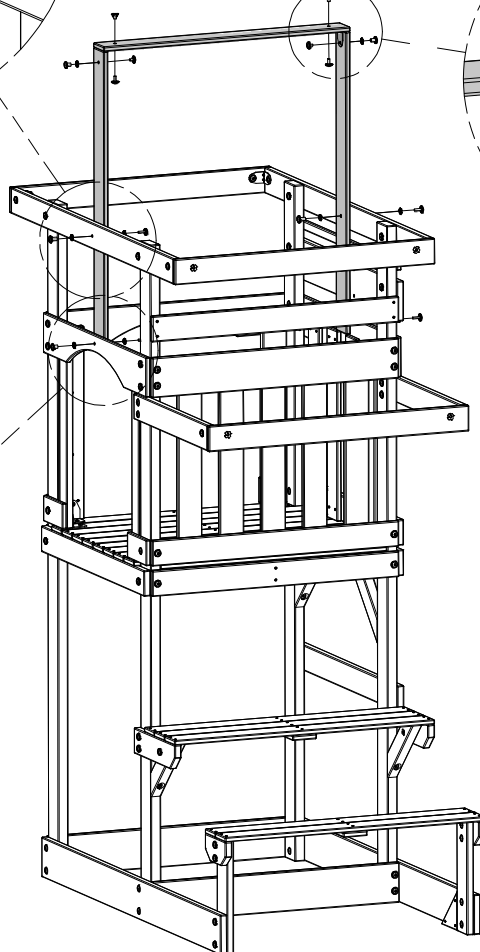



A6P00382 | ROOF TARP
(1)

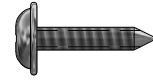

H100128 | SCREW PWH
(6) | 8x5/8

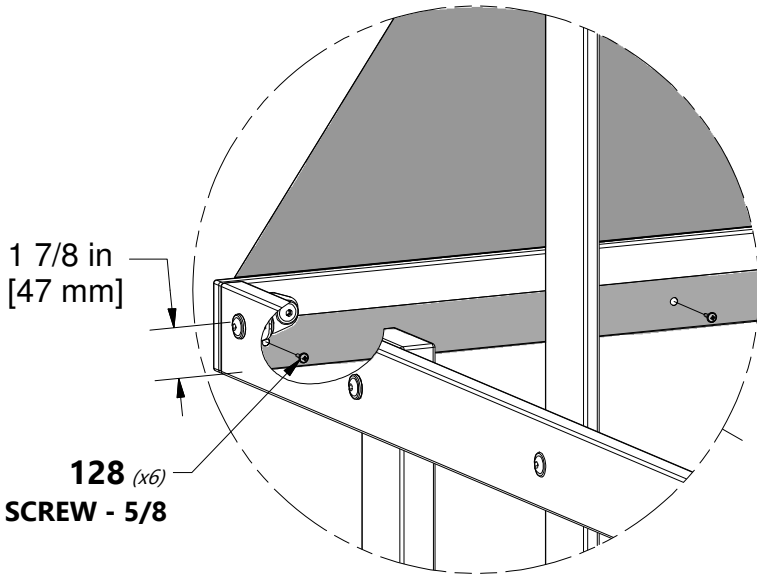

REPEAT FOR OTHER SIDE

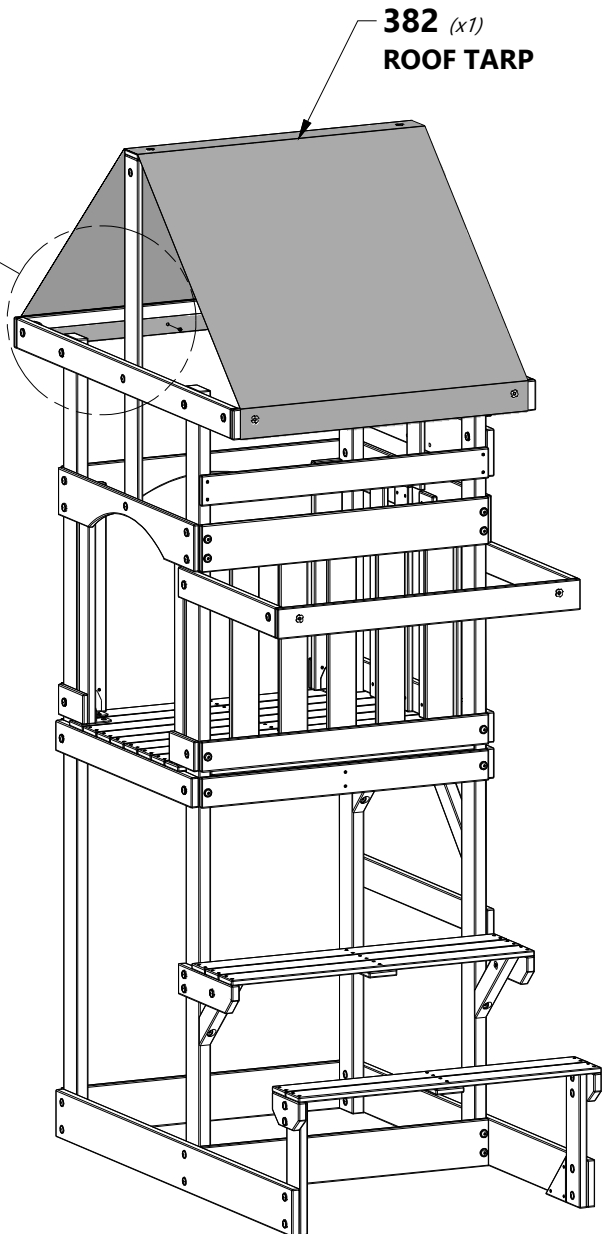



A6P00383 | PICNIC TABLE TARP
(1)



H100128 | SCREW PWH
(6) | 8x5/8

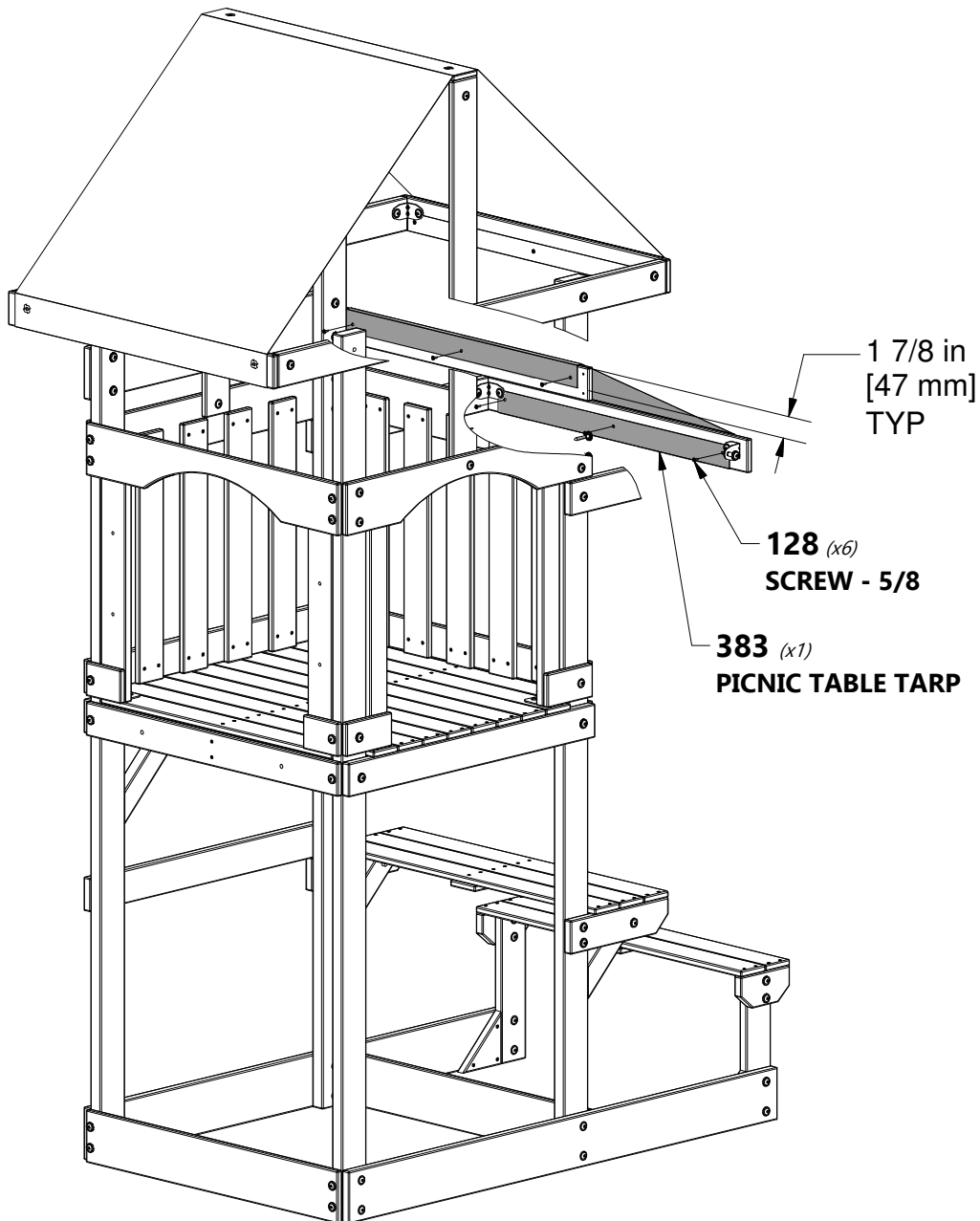



A100028 | **HAND GRIP GREEN PLASTIC**
(2)



H100062 | **BOLT PTH**
(4) | 1/4x1 1/4"



H100108 | **WASHER LOCK INT**
(4) | 8x15



H100106 | **WASHER FLAT**
(4) | 9x18



H100072 | **T-NUT**
(4) | 1/4"

028 (x2)
HAND GRIP GREEN PLASTIC

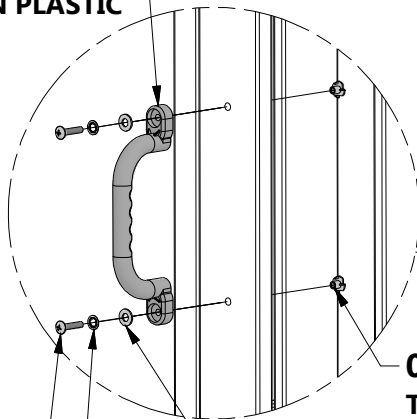

072 (x4)
T-NUT - 1/4"

062 (x4)
BOLT - 1/4x1 1/4"

106 (x4)
WASHER - 9x18

108 (x4)
WASHER - 8x15

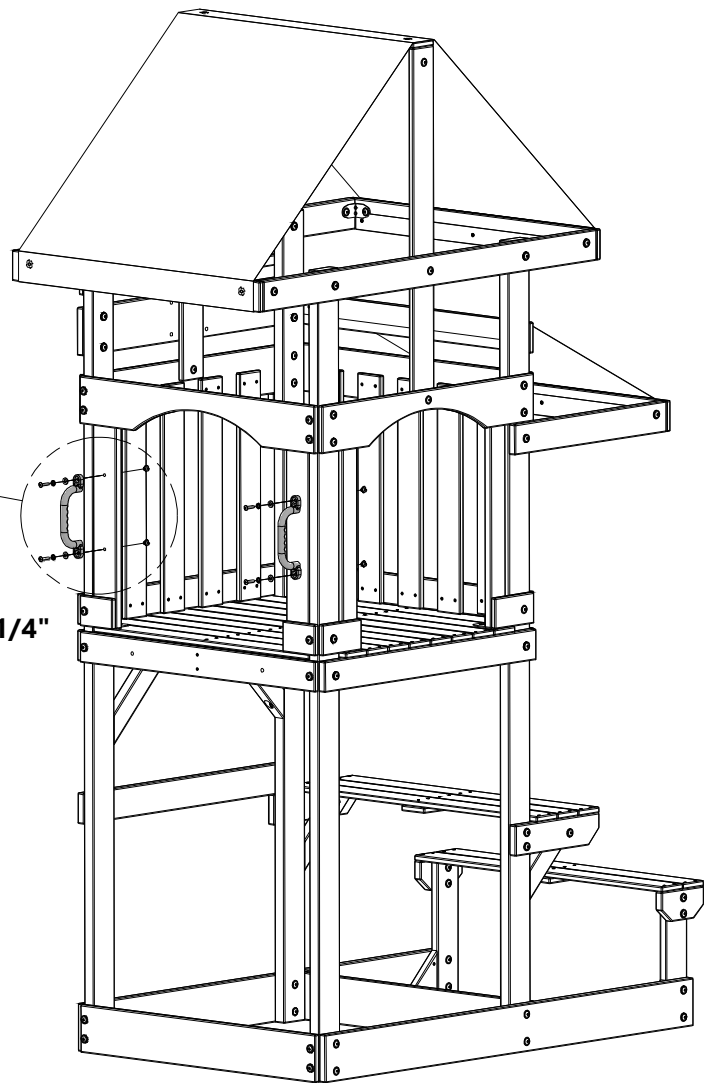

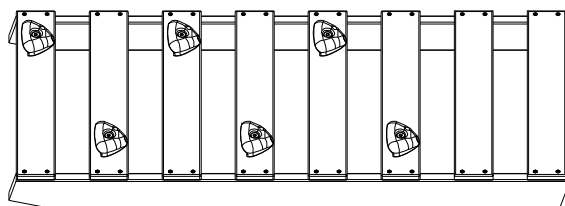

(1) 4 FT ROCK LADDER



H100028 | LAG SCREW WH
(2) 5/16x2 1/2



H100030 | WASHER LOCK EXT
(2) 8x19

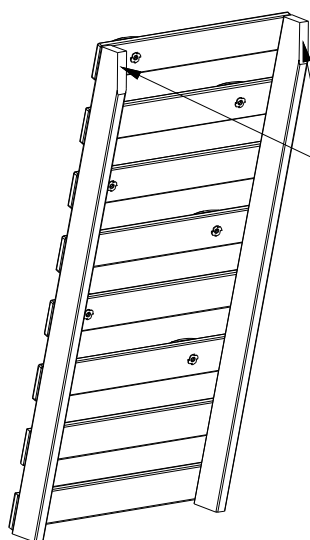

Using 'M13' ladder attachment holes as a guide, predrill these edges.

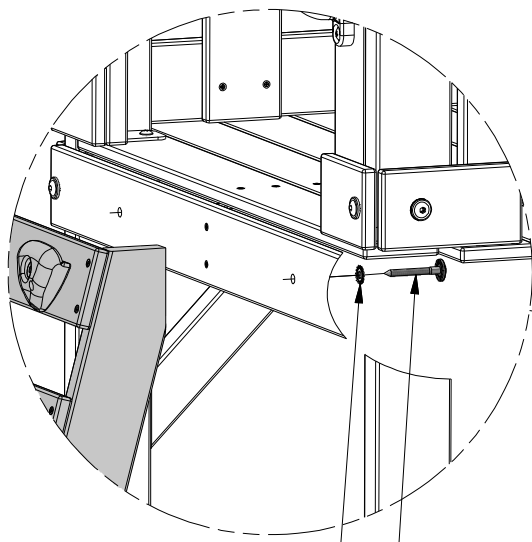

030 (x2)
WASHER - 8x19

028 (x2)
LAG SCREW - 2 1/2"



'M13' ladder attachment holes.

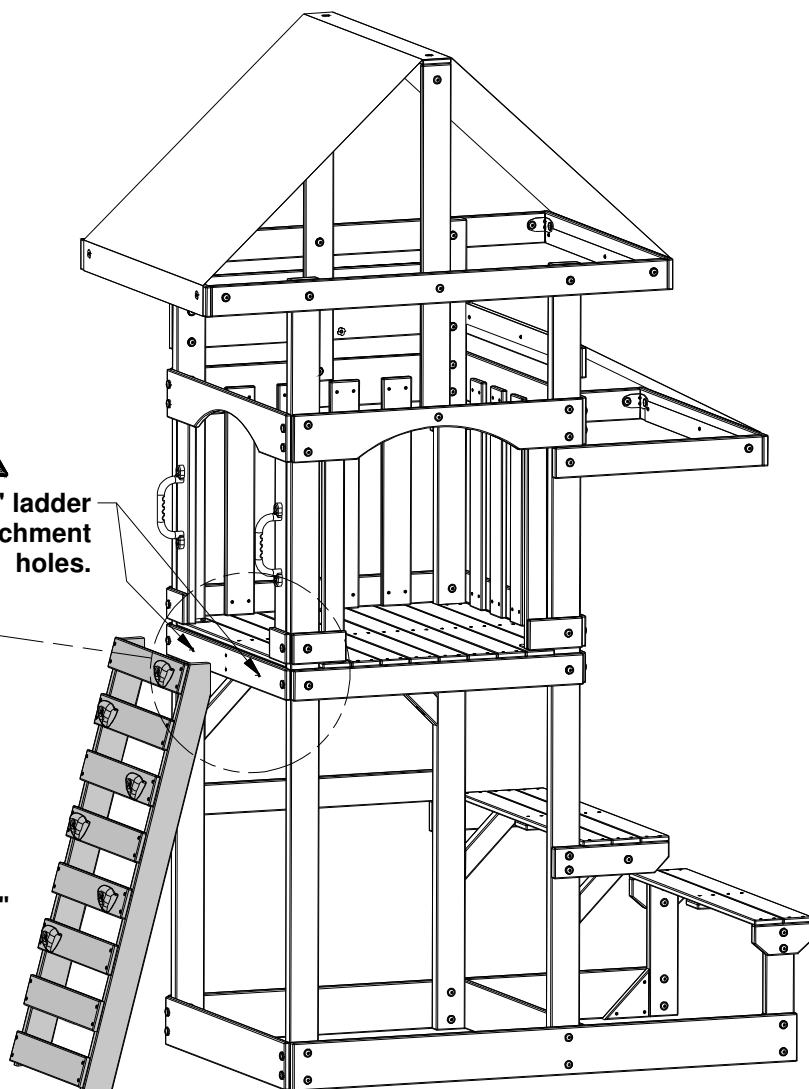

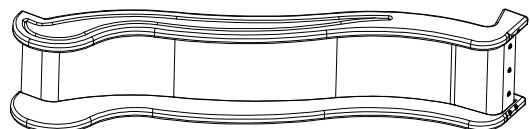

9208100 | 8 FT - FLAT PACK SLIDE
(1)



H100115 | BOLT WH
(3) | 5/16x1/2



H100074 | T-NUT
(3) | 5/16

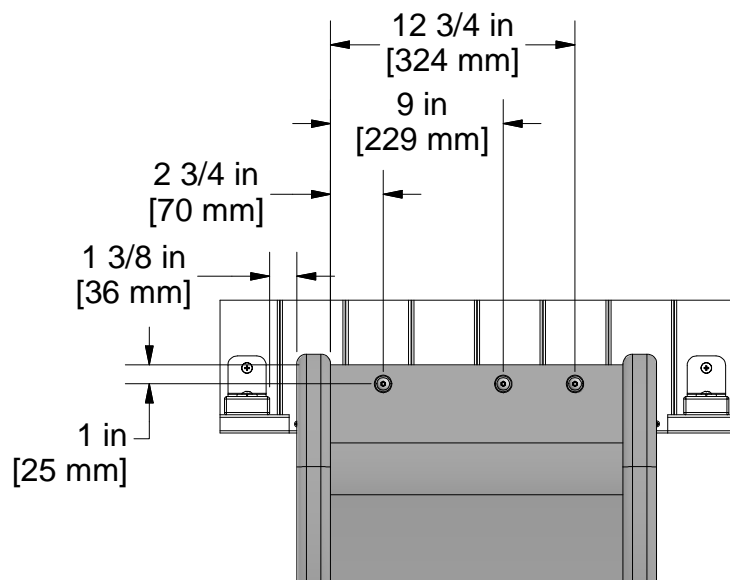
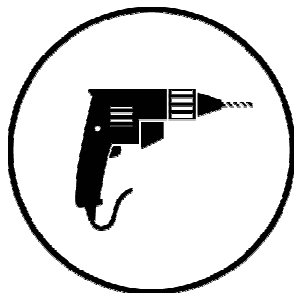

**SLIDE BED
DRILLING PATTERN**

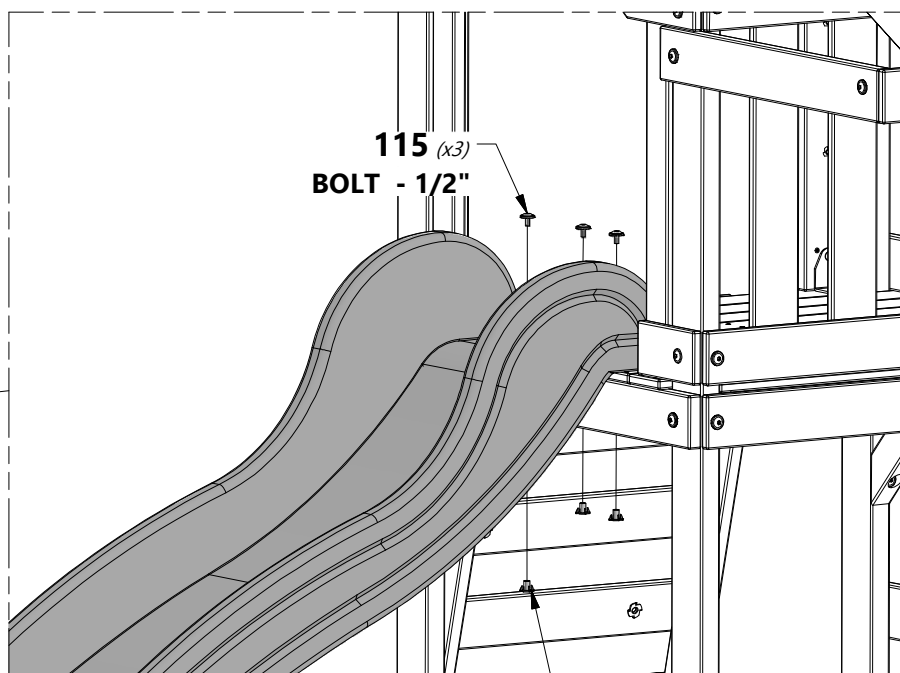
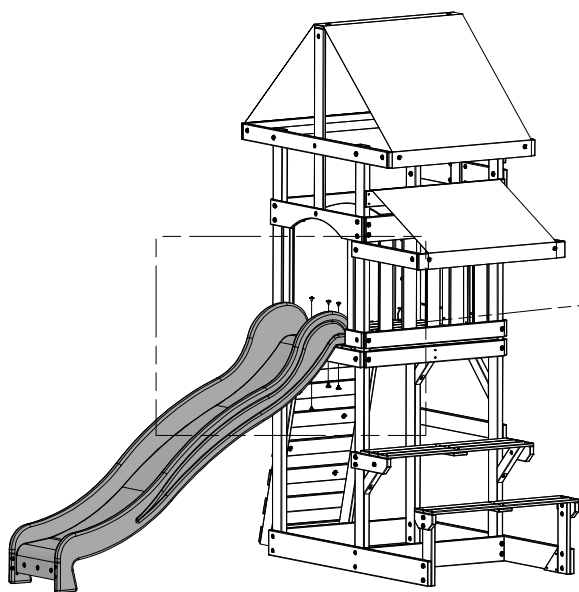

**115 (x3)
BOLT - 1/2"**

**074 (x3)
T-NUT - 5/16"**

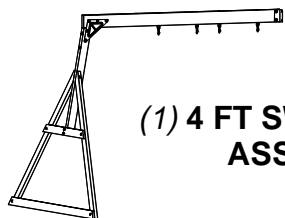

(1) 4 FT SWING BEAM ASSEMBLY



A100164 (1) | BYD ID TAG (LARGE) AGES 3-10



A100314 (1) | "A" REVISION TAG



H100042 (4) | BOLT HEX 5/16x1 1/4



H100095 (4) | WASHER SPLIT 5/16

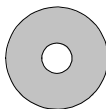

H100105 (4) | WASHER FLAT 8x27



H100074 (4) | T-NUT 5/16



H100128 (6) | SCREW PWH 8x5/8



NOTE:
INSERT T-NUTS BEFORE ATTACHMENT OF SWING BEAM.

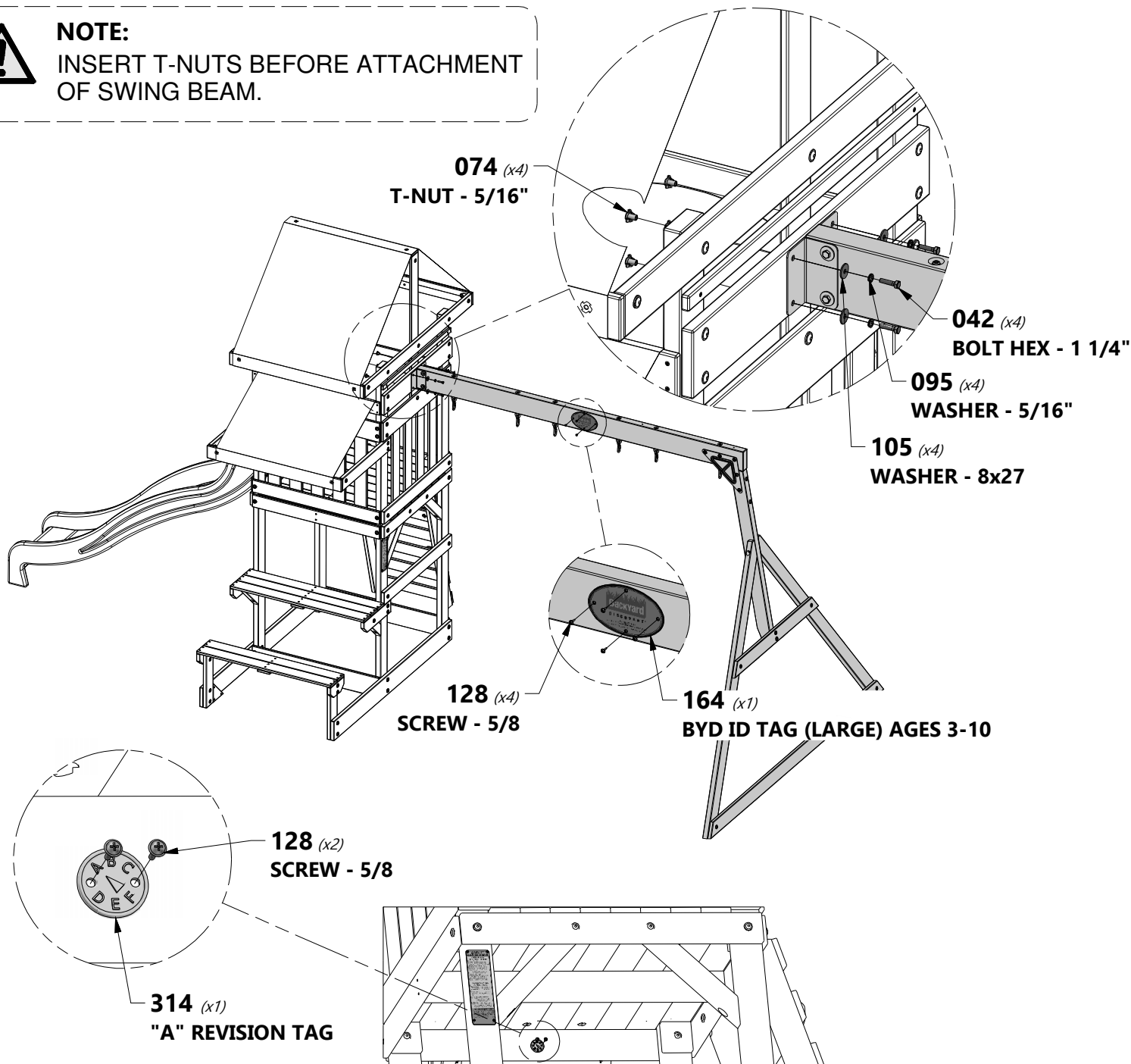

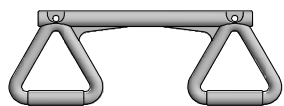

A6P00034
(1) | **TRAPEZE YELLOW**

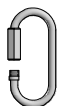

A100069
(6) | **QUICK LINK**



A6P00054
(2) | **SWING SEAT GREEN 22IN**



A100083
(2) | **ROPE-CHAIN GREEN 33"**



A100087
(4) | **ROPE-CHAIN GREEN 51.25"**



NOTE:

WHEN HANGING YOUR SWINGS IT IS RECOMMENDED THAT THE BOTTOM OF THE SWING SEAT, WHEN SITTING ON IT, IS LOCATED NO LOWER THAN (35 cm) 13 7/8 INCHES FROM THE GROUND.

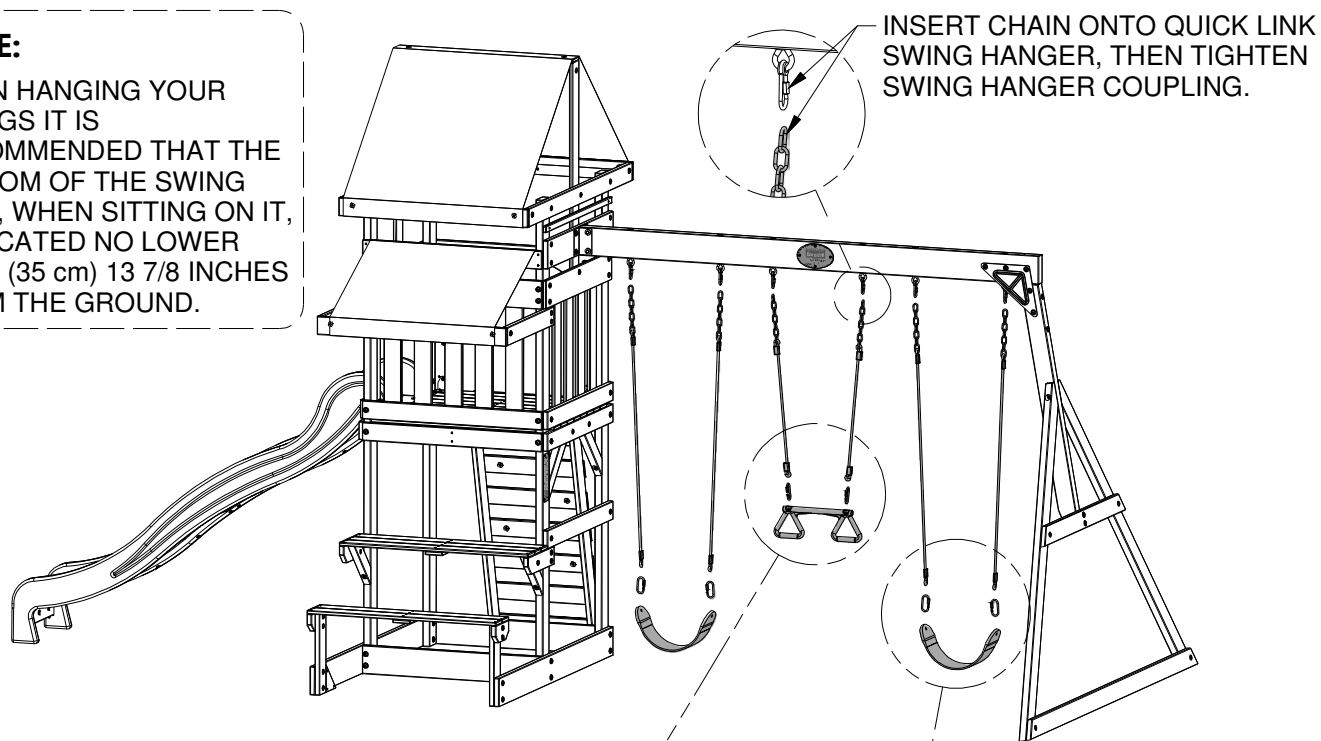

INSERT CHAIN ONTO QUICK LINK SWING HANGER, THEN TIGHTEN SWING HANGER COUPLING.

083 (x2)
ROPE-CHAIN GREEN 33"

069 (x2)
QUICK LINK

034 (x2)
TRAPEZE YELLOW

087 (x4)
ROPE-CHAIN GREEN 51.25"

069 (x4)
QUICK LINK

397 (x2)
SWING SEAT GREEN 22"

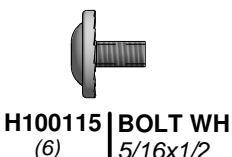

NOTE:
FAILURE TO USE GROUND STAKES CAN VOID WARRANTY AND CAUSE INJURY!

1. DRIVE REBAR GROUND STAKE INTO THE GROUND AT A 45 ° ANGLE NEXT TO THE GROUND BOARD, IN THE LOCATIONS SHOWN.

2. USE HARDWARE PROVIDED TO SECURE THE REBAR GROUND STAKE TO THE GROUND BOARD.

3. MAKE SURE ALL BOLTS, SCREWS, AND NUTS ARE TIGHTENED. MAKE SURE EVERY BOARD IS SECURED. MAKE SURE YOUR SWING SET IS LEVEL. ENJOY THE USE OF YOUR NEW SWING SET!

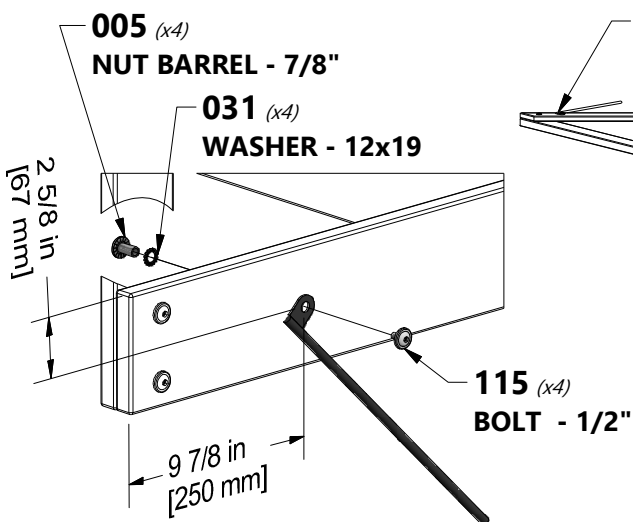

FORT STAKES

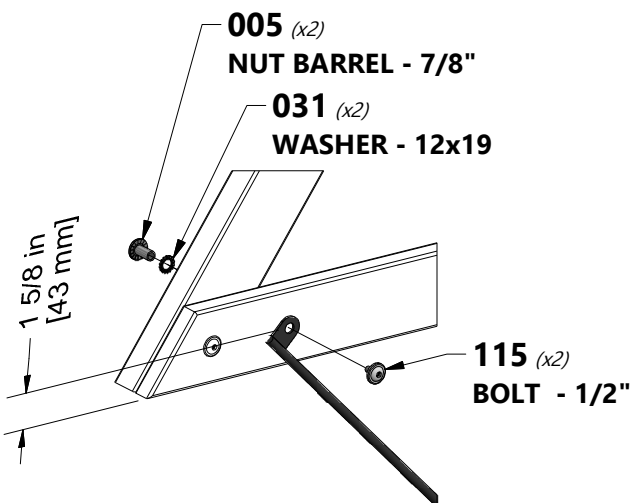
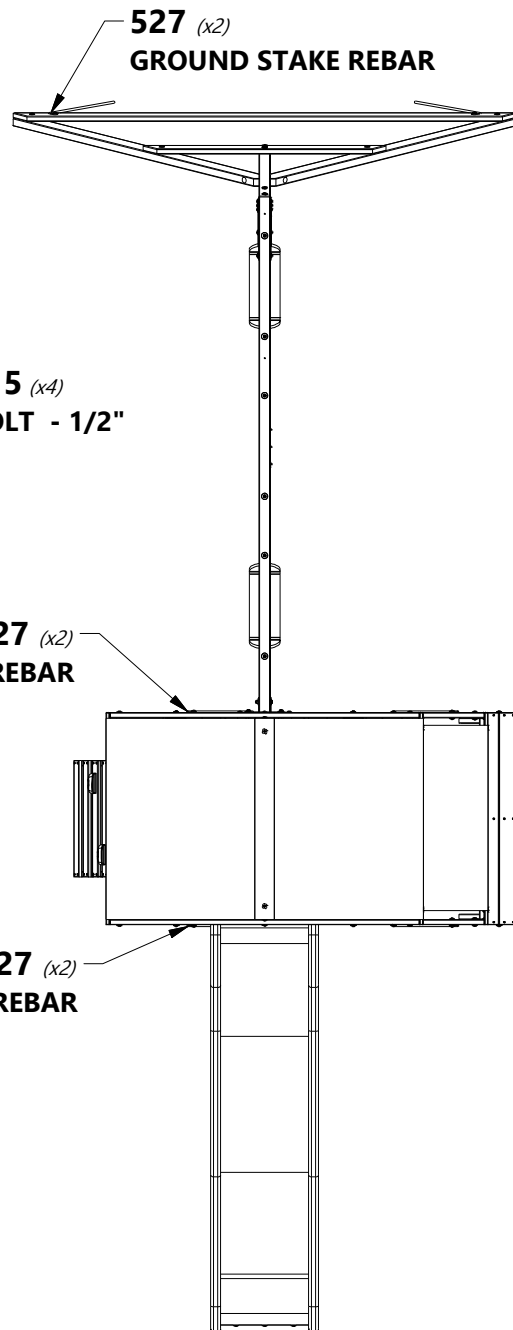

SWING BEAM STAKES