



Manufactured by:
Backyard Discovery
3305 Airport Drive, Pittsburg, KS 66762
800-856-4445

Backyard Discovery Australia Pty Ltd 2/7 Hood Street, Hampton VIC 3188, Phone: 1800-087-941

NORTHBROOK

SWING SET

MODEL: # 2400306



WARNING

Adult Assembly Required.

The assembly manual must be retained since it contains important information
Not suitable for children under 36 months due to small parts.
FOR DOMESTIC USE ONLY. INTENDED FOR OUTDOOR USE.

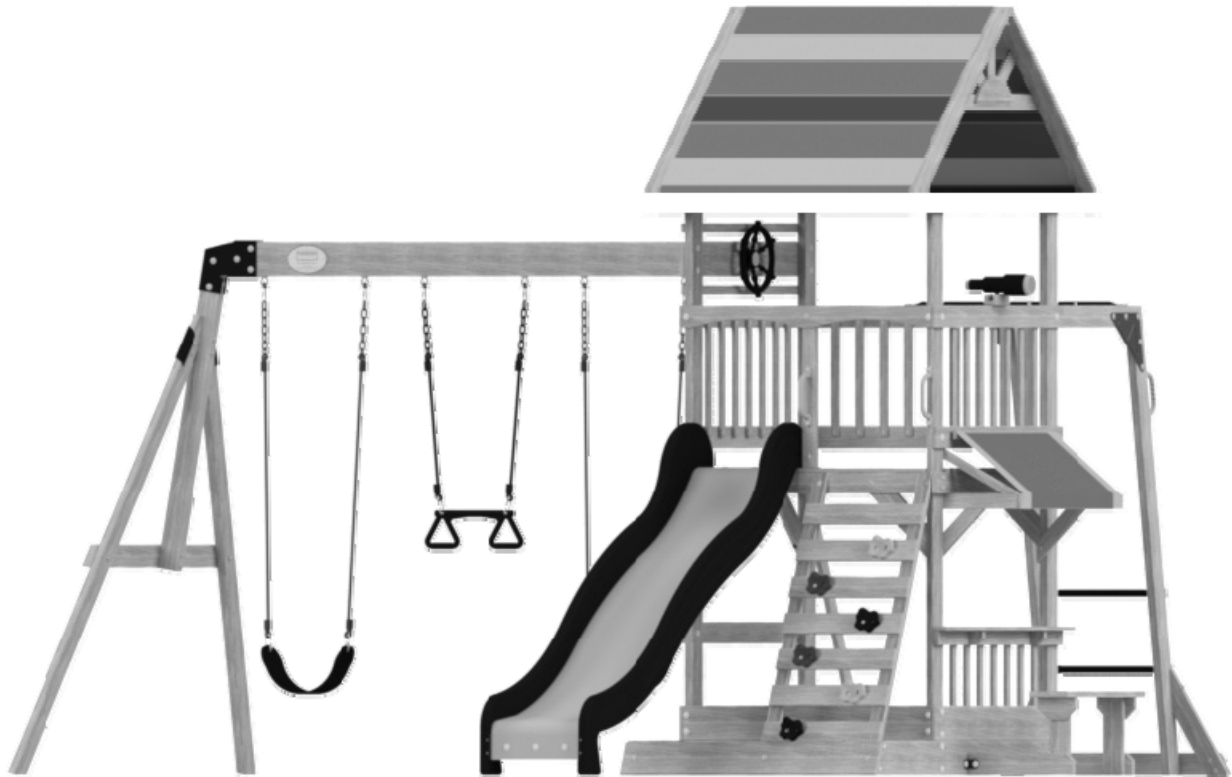

Please visit www.backyarddiscovery.com

For the most up to date assembly manual, to register your product, or to order replacement parts

Para obtener instrucciones en español, visite www.backyarddiscovery.com



EASY STEP-BY-STEP
3D INTERACTIVE INSTRUCTIONS
DOWNLOAD THE FREE APP



Made in China

INS-2400306-A-NORTHBROOK-AUS 08-20-24

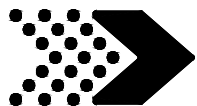

Place the set on level ground, not less than 6'-7" [2 m] from any structure or obstruction such as a fence, garage, house, overhanging branches, laundry lines, or electrical wires.

- While assembling unit, take time before and after each phase to make sure fort is level. If fort is not level, assembly will be difficult and improper assembly may result. Extra care must be taken to insure the fort is square.
- The safe play area refers to a zone extending 6'-7" (2m) beyond the play product on all sides, including the space above the play product.

SAFE PLAY AREA DIAGRAM

Ground Dimension

EXAMPLE: 14' - 5" (4.4m) x 14' - 2" (4.3m) x 9' - 10 1/2" (3.0m)

Safe Play Area

EXAMPLE: 27' - 7 1/2" (8.4m) x 27' - 4" (8.3m)

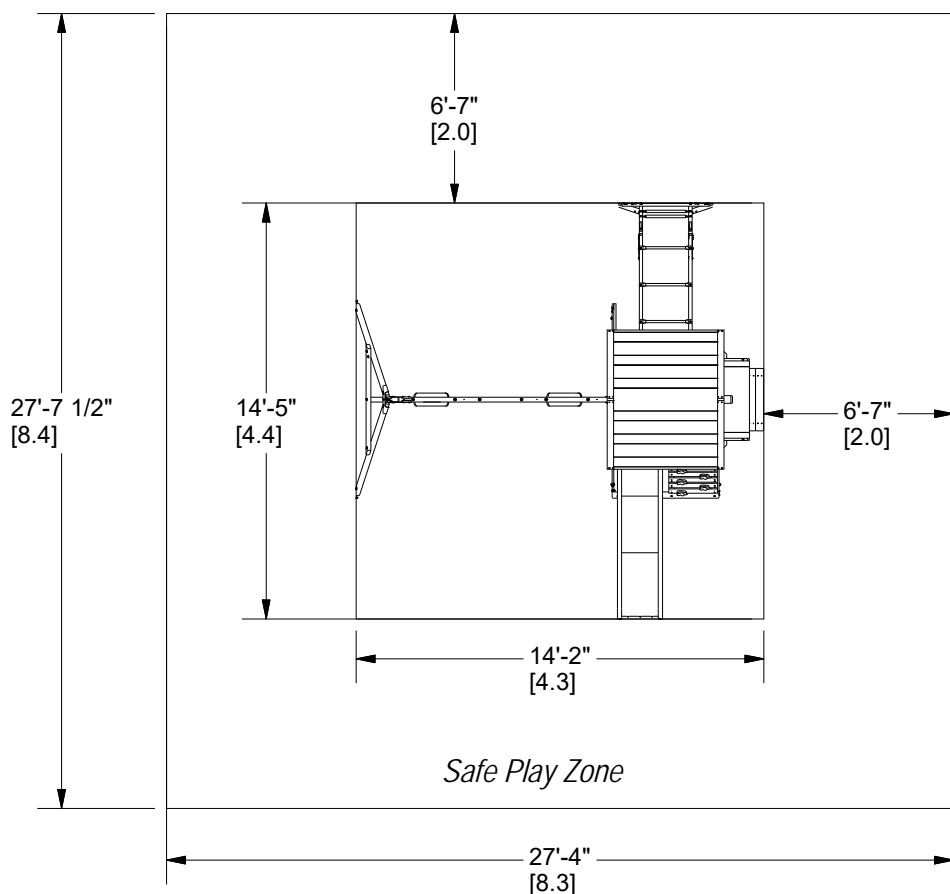

SAFE PLAY HEIGHT: 15'-10 1/2" [5.0 m]

MAXIMUM FALL HEIGHT: 6'-10" [2.1 m]

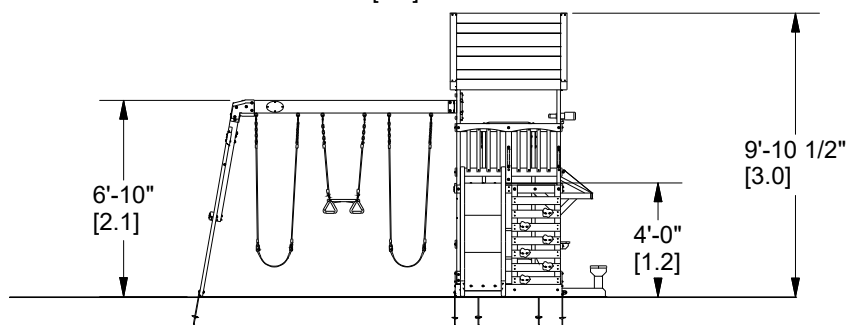

General Information:

Your set has been designed and engineered for children only and for residential use only.
 A maximum of 150 lbs. per child is recommended for play activities designed for individual use.
 A maximum of 120 lbs. per child is recommended for play activities designed for multiple child use.
 A maximum of 9 children is recommended for this swing set.



Wood Components (Not to Scale)

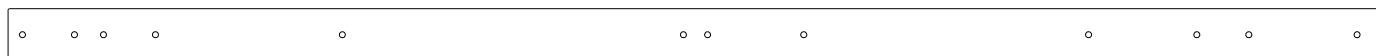

E1 | UPRIGHT - W4L06890
(1) 1 3/8"x3 3/8"x89 1/2" (36x86x2274)

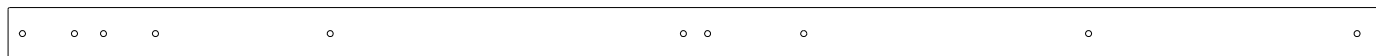

E2 | UPRIGHT - W4L06891
(1) 1 3/8"x3 3/8"x89 1/2" (36x86x2274)

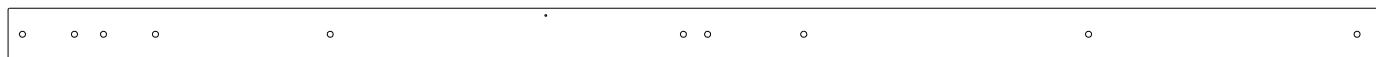

E3 | UPRIGHT - W4L06892
(1) 1 3/8"x3 3/8"x89 1/2" (36x86x2274)

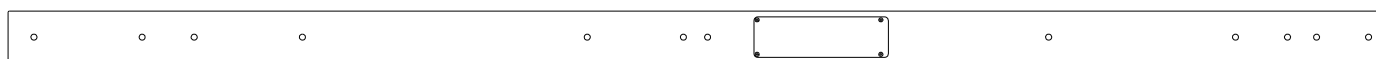

E4 | UPRIGHT - W2A01970
(1) 1 3/8"x3 3/8"x89 1/2" (36x86x2274)



E5 | MONKEY BAR UPRIGHT - W4L13840
(2) 1 3/8"x3 3/8"x70 3/8" (36x86x1786)



E7 | MONKEY BAR RAIL - W4L13841
(2) 1 3/8"x3 3/8"x48" (36x86x1219)

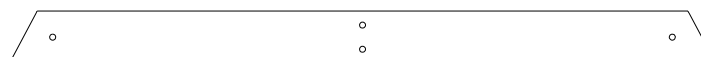

E50 | END SUPPORT - W4L13843
(1) 1 3/8"x3 3/8"x46" (36x86x1168)



E77 | ANGLE BRACE - W4L13842
(2) 1 3/8"x3 3/8"x81 3/8" (36x86x2068)

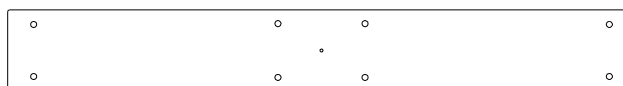

G1 | SWING BEAM MOUNT - W4L06945
(1) 1"x5 1/4"x40 7/8" (24x134x1038)



G2 | SANDBOX SEAT - W4L06433
(2) 1"x5 1/4"x14 5/8" (24x134x370)



H1 | FLOOR RAIL - W4L06898
(1) 1"x3 3/8"x42 1/8" (24x86x1070)

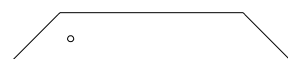

H2 | DECK BRACE - W4L06909
(4) 1"x3 3/8"x18 3/4" (24x86x475)



Wood Components (Not to Scale)



H3 | FLOOR SUPPORT - W4L06915
(1) | 1"x3 3/8"x40 7/8" (24x86x1038)



H4 | HORIZONTAL TARP SUPPORT - W4L13838
(2) | 1"x3 3/8"x56 1/8" (24x86x1425)

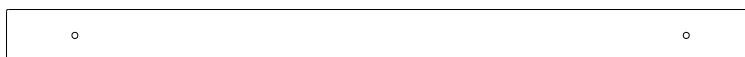

H5 | HORIZONTAL TARP SUPPORT - W4L13839
(2) | 1"x3 3/8"x48 3/4" (24x86x1237)



H6 | ROOF BOARD - W4L06950
(4) | 1"x3 3/8"x40 3/8" (24x86x1025)



H7 | BENCH GROUND BOARD - W4L06967
(2) | 1"x3 3/8"x18 1/8" (24x86x460)



H8 | BENCH UPRIGHT - W4L06968
(2) | 1"x3 3/8"x11 3/4" (24x86x300)



H9 | BENCH SEAT SUPPORT - W4L06969
(2) | 1"x3 3/8"x6 1/2" (24x86x166)



H10 | FLOOR RAIL - W4L07317
(1) | 1"x3 3/8"x42 1/8" (24x86x1070)



H12 | BENCH SEAT - W4L13837
(2) | 1"x3 3/8"x26" (24x86x660)



H81 | MONKEY BAR BRACE - W4L13849
(2) | 1"x3 3/8"x18 5/8" (24x86x474)



J1 | WALL RAIL - W4L06900
(1) | 1"x2 3/8"x40 7/8" (24x60x1038)



J2 | SHELF SUPPORT - W4L06903
(2) | 1"x2 3/8"x2 3/8" (24x60x60)



J3 | ANGLE BRACE - W4L06905
(1) | 1"x2 3/8"x47 1/4" (24x60x1200)



J4 | AWNING BOARD - W4L06906
(2) | 1"x2 3/8"x14 1/8" (24x60x358)

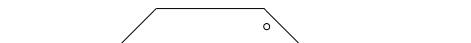

J5 | AWNING SUPPORT - W4L06908
(2) | 1"x2 3/8"x11 3/4" (24x60x298)

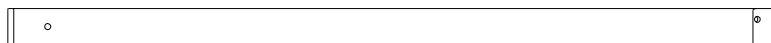

J6 | LADDER RAIL - W4L13845
(1) | 1"x2 3/8"x50 3/8" (24x60x1279)



J7 | LADDER RAIL - W4L13846
(1) | 1"x2 3/8"x50 3/8" (24x60x1279)



J8 | WALL BOARD - W4L06947
(1) | 1"x2 3/8"x25" (24x60x634)



J9 | SUPPORT BOARD - W4L06064
(4) | 1"x2 3/8"x3" (24x60x76)



J10 | ROOF BOARD - W4L06952
(2) | 1"x2 3/8"x4" (24x60x102)



Wood Components (Not to Scale)



K1 | GROUND BOARD - W4L13848
(1) 5/8"x5 1/4"x80 3/8" (16x134x2043)



K2 | GROUND BOARD - W4L06894
(4) 5/8"x5 1/4"x43 1/4" (16x134x1097)



K3 | GROUND BOARD - W4L06896
(2) 5/8"x5 1/4"x42 1/8" (16x134x1070)

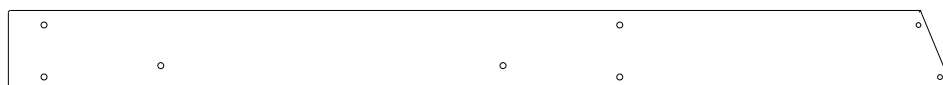

K4 | GROUND BOARD - W4L13847
(1) 5/8"x5 1/4"x61 1/2" (16x134x1564)



K5 | SERVING SHELF - W4L06902
(1) 5/8"x5 1/4"x40 7/8" (16x134x1038)



K6 | GROUND BOARD - W4L13852
(1) 5/8"x5 1/4"x44 1/2" (16x134x1129)



M1 | SAFETY BOARD - W4L06895
(1) 5/8"x3 3/8"x40 7/8" (16x86x1038)



M2 | FLOOR RAIL - W4L06897
(1) 5/8"x3 3/8"x43 1/4" (16x86x1097)



M3 | LADDER RUNG - W4L06912
(1) 5/8"x3 3/8"x20 1/4" (16x86x515)



M4 | LADDER RUNG - W4L06913
(6) 5/8"x3 3/8"x20 1/4" (16x86x515)

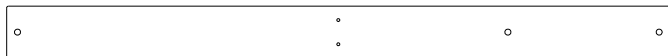

M5 | FLOOR RAIL - W4L06914
(1) 5/8"x3 3/8"x43 1/4" (16x86x1097)

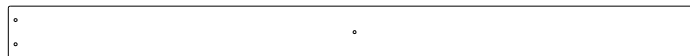

M6 | FLOOR BOARD - W4L06918
(10) 5/8"x3 3/8"x45 1/8" (16x86x1145)



M7 | WALL RAIL - W4L06919
(2) 5/8"x3 3/8"x41 1/2" (16x86x1054)



M8 | WALL RAIL - W4L06920
(2) 5/8"x3 3/8"x42 1/8" (16x86x1070)



M9 | WALL RAIL - W4L06941
(1) 5/8"x3 3/8"x43 1/4" (16x86x1097)



M10 | WALL RAIL - W4L06942
(1) 5/8"x3 3/8"x43 1/4" (16x86x1097)

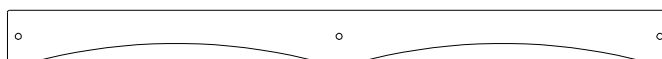

M11 | ARCHED WALL RAIL - W4L06943
(1) 5/8"x3 3/8"x43 1/4" (16x86x1097)



Wood Components (Not to Scale)

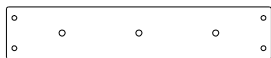

M77 | SLIDE BRACE - W100544
(1) 5/8"x3 3/8"x17 1/4" (16x86x438)



M78 | CENTER SLIDE BRACE - W100545
(2) 5/8"x3 3/8"x17 1/4" (16x86x438)

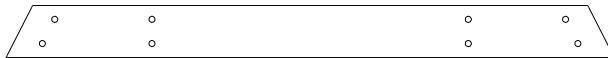

M82 | MONKEY BAR GROUND BOARD - W4L13850
(1) 5/8"x3 3/8"x39 5/8" (16x86x1006)



N1 | AWNING BOARD - W4L06907
(1) 5/8"x2 3/8"x34 1/8" (16x60x866)



N2 | ROOF BOARD - W4L06953
(2) 5/8"x2 3/8"x33 1/8" (16x60x840)



N3 | SUNBURST BOARD - W4L06955
(2) 5/8"x2 3/8"x11 3/4" (16x60x299)



N4 | SUNBURST BOARD - W4L06956
(4) 5/8"x2 3/8"x8 1/8" (16x60x205)



O1 | PICKET - W4L06901
(7) 5/8"x1 3/8"x13 1/4" (16x34x336)



O2 | PICKET - W4L06944
(23) 5/8"x1 3/8"x18 1/4" (16x34x465)



O3 | SAFETY BOARD - W4L06948
(2) 5/8"x1 3/8"x40 7/8" (16x34x1038)



O4 | AWNING BOARD - W4L06957
(1) 5/8"x1 3/8"x32 1/4" (16x34x818)

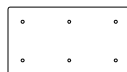

Q2 | SANDBOX SEAT SUPPORT - W4L06434
(4) 1"x4 3/8"x8" (24x112x202)



SB74 | SWING BEAM EXTENDED - W4L06961
(1) 2"x5 1/4"x89 1/2" (50x134x2274)



T1 | ROOF BOARD - W4L06951
(1) 1"x1 3/8"x48 3/4" (24x34x1237)



T2 | SAFETY BOARD - W4L13853
(2) 1"x1 3/8"x15 3/4" (24x34x400)



W71 | SWING BEAM SUPPORT - W4L13844
(1) 2"x3 3/8"x49 5/8" (50x86x1260)

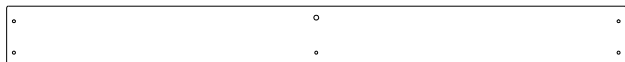

Y1 | FLOOR BOARD - W4L13851
(1) 5/8"x4"x40 3/8" (16x102x1024)

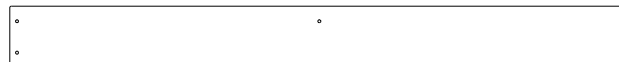

Y2 | FLOOR BOARD - W4L06917
(1) 5/8"x4"x40 3/8" (16x102x1024)



Y3 | SUNBURST HALF MOON - W4L06954
(2) 5/8"x4"x12" (16x102x306)

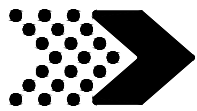

Hardware Components

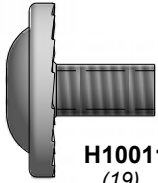

H100115 | BOLT WH
(19) | 5/16x1/2

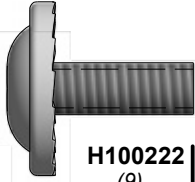

H100222 | BOLT WH
(9) | 5/16x3/4

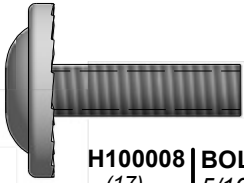

H100008 | BOLT WH
(17) | 5/16x1

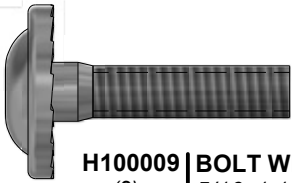

H100009 | BOLT WH
(2) | 5/16x1 1/4

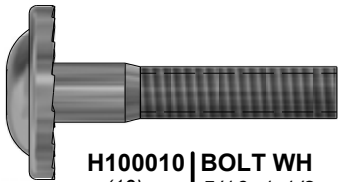

H100010 | BOLT WH
(19) | 5/16x1-1/2

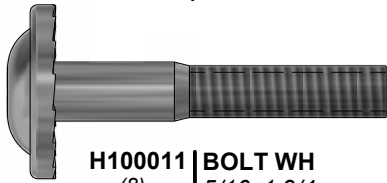

H100011 | BOLT WH
(8) | 5/16x1 3/4



H100012 | BOLT WH
(28) | 5/16x2

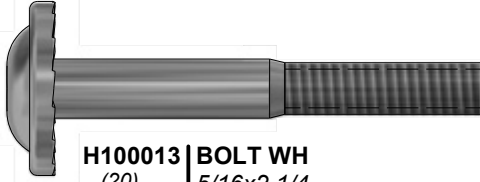

H100013 | BOLT WH
(20) | 5/16x2 1/4

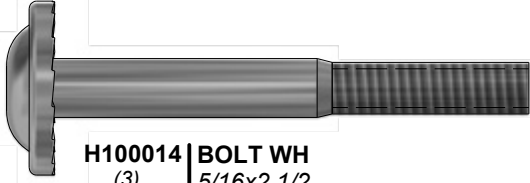

H100014 | BOLT WH
(3) | 5/16x2 1/2

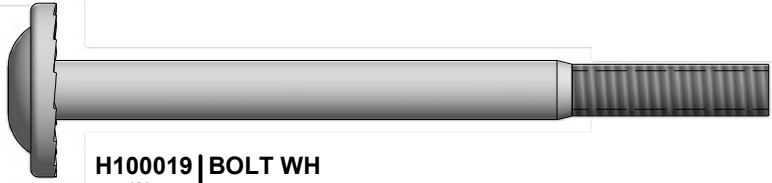

H100019 | BOLT WH
(2) | 5/16x3 3/4

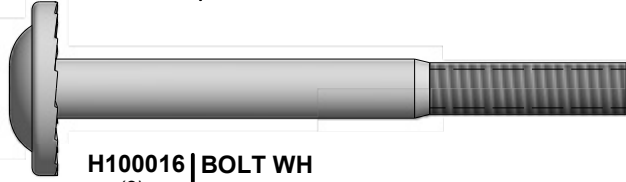

H100016 | BOLT WH
(2) | 5/16x3

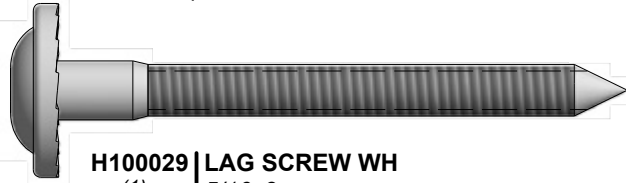

H100029 | LAG SCREW WH
(1) | 5/16x3

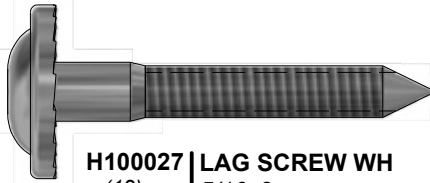

H100027 | LAG SCREW WH
(12) | 5/16x2



H100026 | LAG SCREW WH
(27) | 5/16x1 1/2

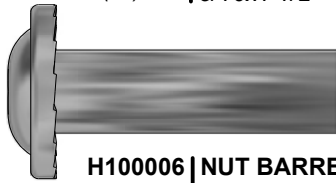

H100006 | NUT BARREL WH
(3) | 5/16x1 1/2

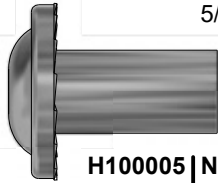

H100005 | NUT BARREL WH
(30) | 5/16x7/8

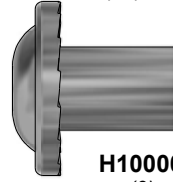

H100004 | NUT BARREL WH
(9) | 5/16 x 5/8

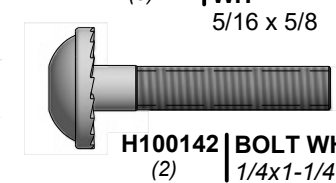

H100142 | BOLT WH
(2) | 1/4x1-1/4

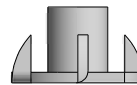

H100072 | T-NUT
(15) | 1/4

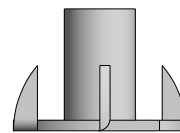

H100074 | T-NUT
(86) | 5/16

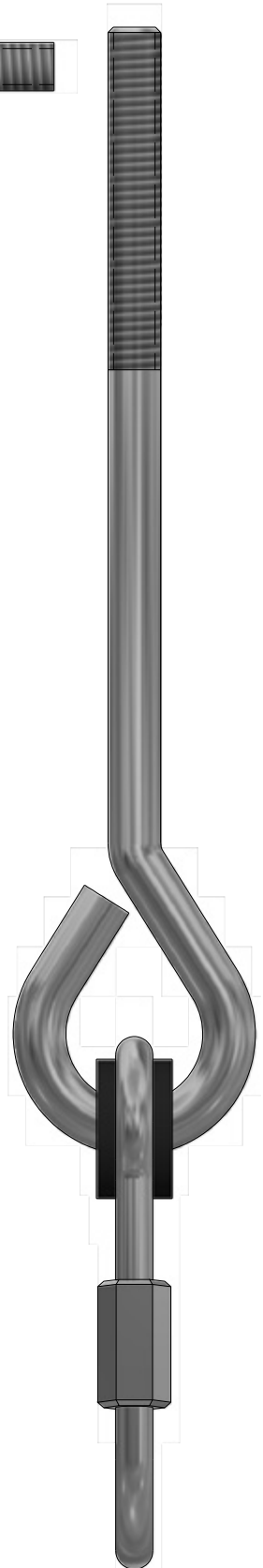

H100099 | SWING HANGER
(6) | 5/16x9 1/2

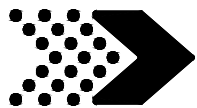

Hardware Components



H100084 | SCREW PFH
(4) | 6x3/4



H100085 | SCREW PFH
(13) | 8x1



H100088 | SCREW PFH
(92) | 8x1 1/8



H100087 | SCREW PFH
(39) | 8x1 1/4



H100086 | SCREW PFH
(96) | 8x1 1/2



H100089 | SCREW PFH
(60) | 8x1 3/4



H100111 | SCREW PFH
(4) | 8x2



H100090 | SCREW PFH
(26) | 8x2 1/2"



H100042 | BOLT HEX
(4) | 5/16x1 1/4



H100047 | BOLT HEX
(4) | 5/16x2 3/4



H100063 | BOLT PTH
(13) | 1/4x3/4



H100128 | SCREW PWH
(17) | 8x5/8



H100145 | LAG SCREW WH
(30) | 1/4x1 1/2

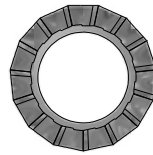

H100031 | WASHER
(35) | LOCK EXT
12x19

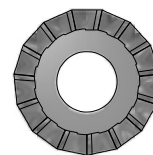

H100030 | WASHER
(105) | LOCK EXT
8x19

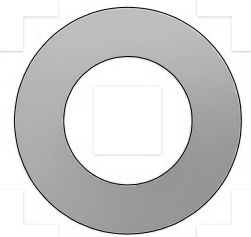

H100103 | WASHER
(7) | SAFETY
17x30

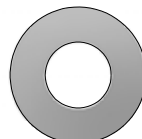

H100106 | WASHER
(2) | FLAT
9x18

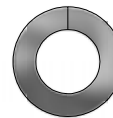

H100095 | WASHER
(4) | SPLIT
5/16

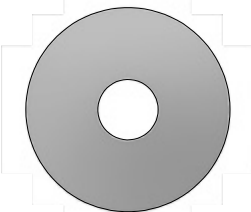

H100105 | WASHER
(16) | FLAT
8x27

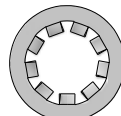

H100108 | WASHER
(17) | LOCK INT
8x15

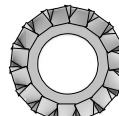

H100138 | WASHER
(18) | LOCK EXT
6x15



H100110 | NUT LOCK
(9) | 5/16

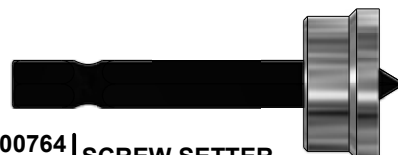

H100764 | SCREW SETTER
(1)



A100042 | T-40 TORX BIT
(2)



H100147 | T-30 TORX BIT
(2)



H100114 | T-30 TORX WRENCH
(2)

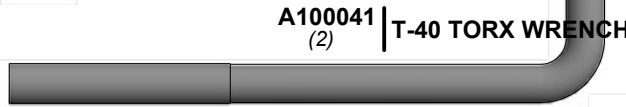

A100041 | T-40 TORX WRENCH
(2)

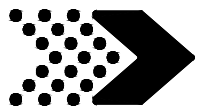

Accessory Components (Not to Scale)



A100069 | QUICK LINK
(6)



A4M00646 | L BRACKET
(2) | BLUE 32x51



A4M01048 | L BRACKET
(8) | 2.5x38x55x55

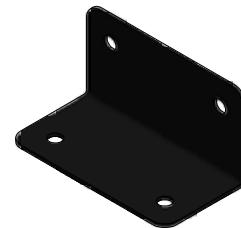

A100153 | L BRACKET
(2) | 66x66x127 BLUE

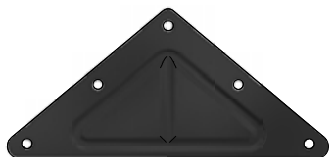

A100309 | TRIANGLE
(2) | PLATE BLUE 100
5 HOLE

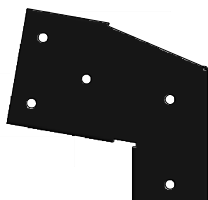

A4M00511 | SWING BEAM
(1) | EXT. BRACKET
BLUE - LEFT

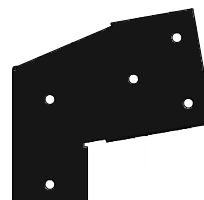

A4M00512 | SWING BEAM
(1) | EXT BRACKET
BLUE - RIGHT

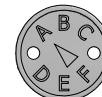

A100314 | "A" REVISION
(1) | TAG



A6P00292 | ROPE-CHAIN BLUE 51.25"
(4)



A6P00293 | ROPE-CHAIN BLUE 31"
(2)



A4M00585 | METAL RUNG 559 BLUE
(5)



A100178 | AUGER GROUND STAKE
(8)



A6P00125 | SHIPS WHEEL
(1) | BLUE/LIME

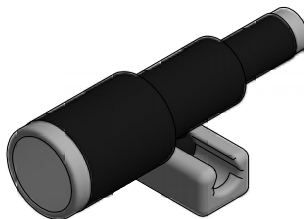

A6P00126 | TELESCOPE
(1) | BLUE/LIME



A4M01174 | A-FRAME
(1) | BRACKET

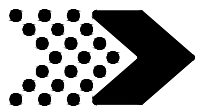

Accessory Components (Not to Scale)

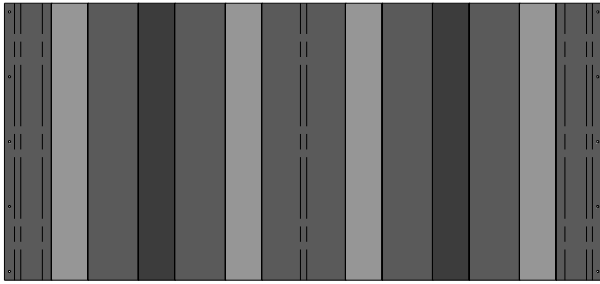

A6P00123 | TARP
(1)



A6P00124 | AWNING
(1)



A6P00131 | SLIDE BED 8' LIME
(1)



A100161 | SLIDE RAIL 8' BLUE RIGHT
(1)



A100162 | SLIDE RAIL 8' BLUE LEFT
(1)



A6P00133 | SWING SEAT BLUE 22"
(2)



A100164 | BYD ID TAG (LARGE) AGES 3-10
(1)



A6P00128 | LIME HC ROCK #1
(2)



A6P00040 | BLUE HC ROCK #2
(2)



A6P00129 | CRANBERRY HC ROCK #1
(2)



A6P00127 | HAND GRIP LIME
(4) PLASTIC



A6P00134 | BLUE TRAPEZE
(1)

PRE-ASSEMBLY STEP 1 - SORTING PARTS

It is critical for ease of assembly that you take the time to sort and organize the wood and hardware.

WOOD PARTS:

- Organize wood parts by the three-digit, alpha-numeric number stamped on each board (ex. P01).
- If there are multiple boards with the same stamped number, stack those pieces together.
- Stamps can be found on the flat surface of the boards or on the end of the boards.
- Allow yourself plenty of room - the wood pieces can take up a significant amount of space.

NOTE: CARTONS ARE NOT ORGANIZED BY BOARD NUMBER.

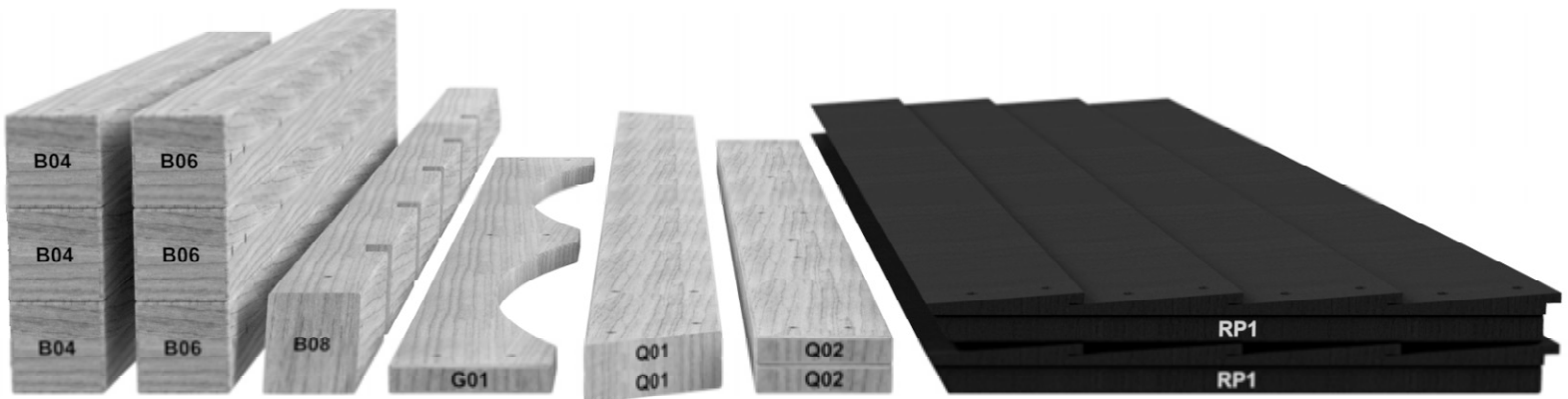

HARDWARE PARTS:

- We recommend that you have a separate table to organize the hardware.
- Hardware bags are printed with a seven-digit, alpha-numeric part number.
- You can organize your hardware by part number or group by hardware type (i.e. bolts, nuts, etc.).
- During assembly you only need to reference the last four digits of the number.

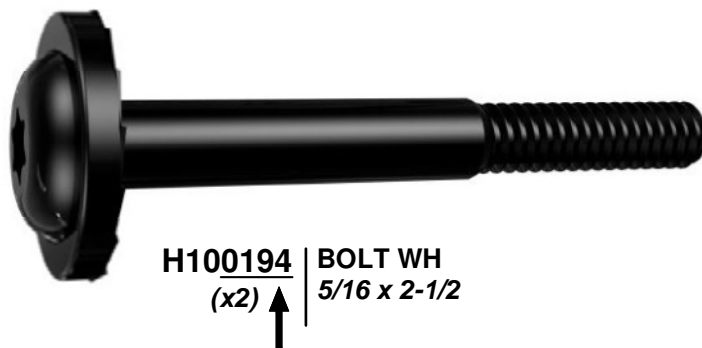

PRE-ASSEMBLY STEP 2 - TOOLS REQUIRED



**Cordless Drill or
Electric Drill**



**Drill Attachments:
Phillips Head**



**1/8", 3/16", 3/8" & 7/16"
Drill Bits**



Phillips Screw Driver



Open End Wrenches 1/2" & 9/16"



**3/8" Drive Ratchet, 1/2" &
9/16" STD Sockets 1/2" & 9/16" Deep
Sockets**



Claw Hammer



Rubber Mallet - Optional



Tape Measure

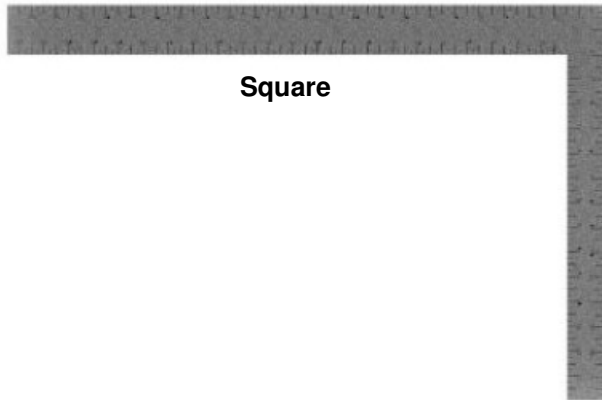

Square



Level 24"

PRE-ASSEMBLY STEP 3 - CHOOSE YOUR ASSEMBLY METHOD

There are several types of assembly instructions available to you.

1. Printed Assembly Manual included with your set
2. BILT APP - 3D interactive instructions
3. Combination of the Printed Manual and BILT APP (Note: Step numbers can differ between the two methods)

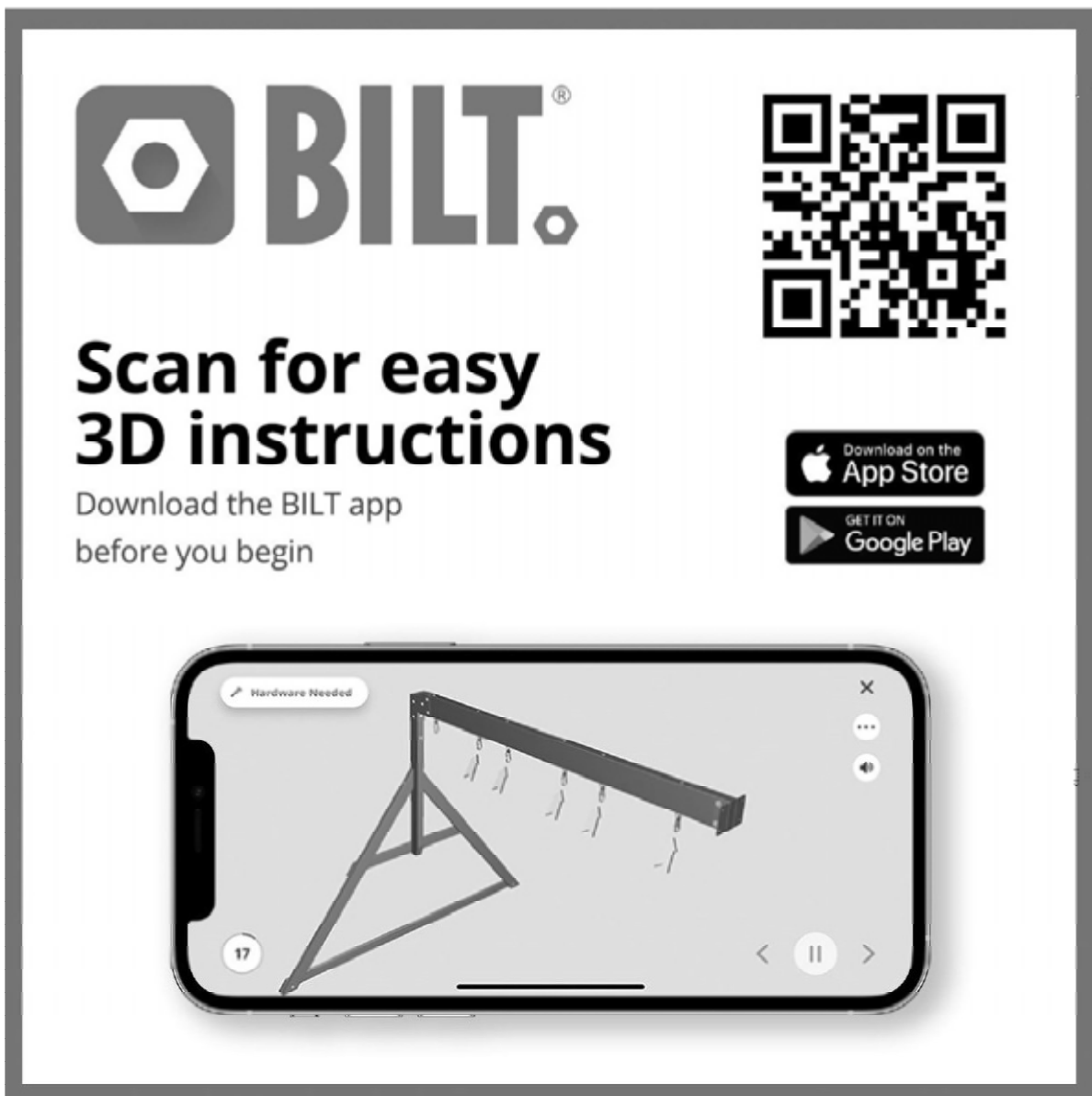

The advertisement features the BILT logo (a hexagon with a dot) and the text "BILT.®" in a large, bold font. To the right is a QR code. Below the logo, the text reads "Scan for easy 3D instructions" and "Download the BILT app before you begin". There are two buttons: "Download on the App Store" and "GET IT ON Google Play". At the bottom, a smartphone displays a 3D assembly instruction for a step labeled "17", showing a metal frame with a horizontal bar and several hanging components. The phone screen also shows a "Hardware Needed" list, a close button (X), and navigation arrows.

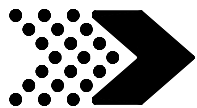

SWING BEAM

STEP 1

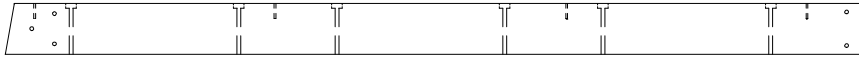

SB74 | SWING BEAM EXTENDED - W4L06961
(1) | 2"x5 1/4"x89 1/2" (50x134x2274)



H100011 | BOLT WH
(3) | 5/16x1 3/4

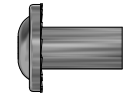

H100005 | NUT BARREL WH
(3) | 5/16x7/8



H100047 | BOLT HEX
(2) | 5/16x2 3/4



H100110 | NUT LOCK
(2) | 5/16

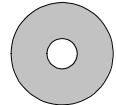

H100105 | WASHER FLAT
(4) | 8x27

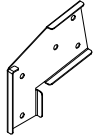

A4M00511 | SWING BEAM
EXT. BRACKET
BLUE - LEFT
(1)

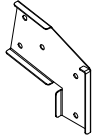

A4M00512 | SWING BEAM
EXT BRACKET
BLUE - RIGHT
(1)



A100153 | L BRACKET
(2) | 66x66x127 BLUE

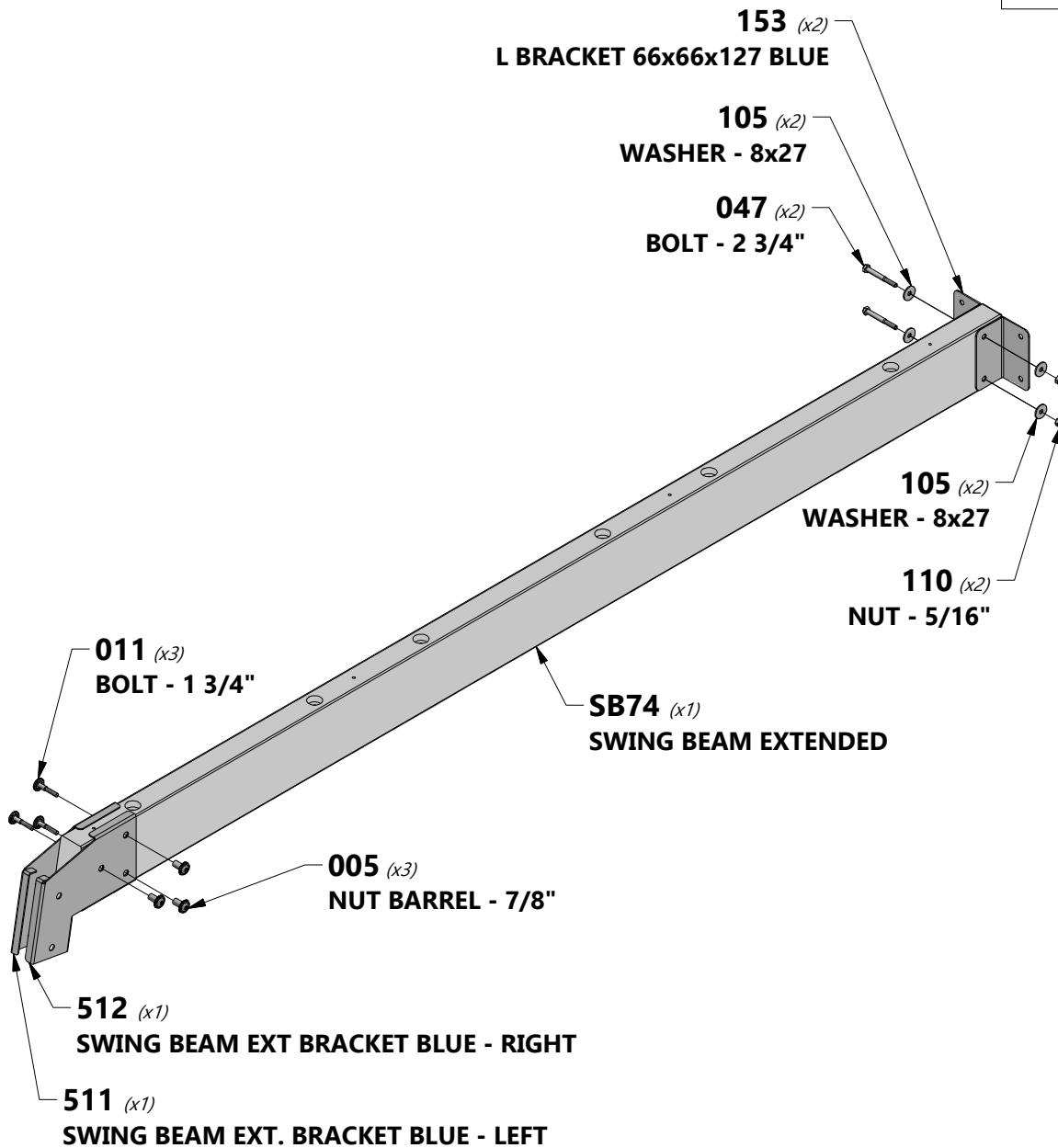

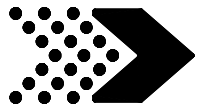

SWING BEAM

STEP 2

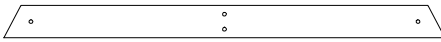

E50 | END SUPPORT - W4L13843
(1) | 1 3/8"x3 3/8"x46" (36x86x1168)

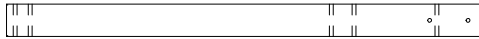

W71 | SWING BEAM SUPPORT - W4L13844
(1) | 2"x3 3/8"x49 5/8" (50x86x1260)

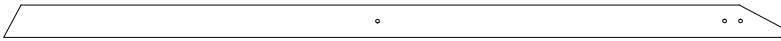

E77 | ANGLE BRACE - W4L13842
(2) | 1 3/8"x3 3/8"x81 3/8" (36x86x2068)

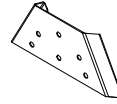

A4M01174 | A-FRAME
(1) | BRACKET



H100019 | BOLT WH
(2) | 5/16x3 3/4



H100016 | BOLT WH
(2) | 5/16x3

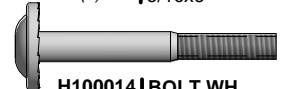

H100014 | BOLT WH
(2) | 5/16x2 1/2



H100006 | NUT BARREL
(2) | WH
5/16x1 1/2



H100008 | BOLT WH
(4) | 5/16x1

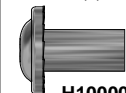

H100005 | NUT BARREL
(8) | WH
5/16x7/8



H100031 | WASHER
(10) | LOCK EXT
12x19



H100030 | WASHER
(4) | LOCK EXT
8x19

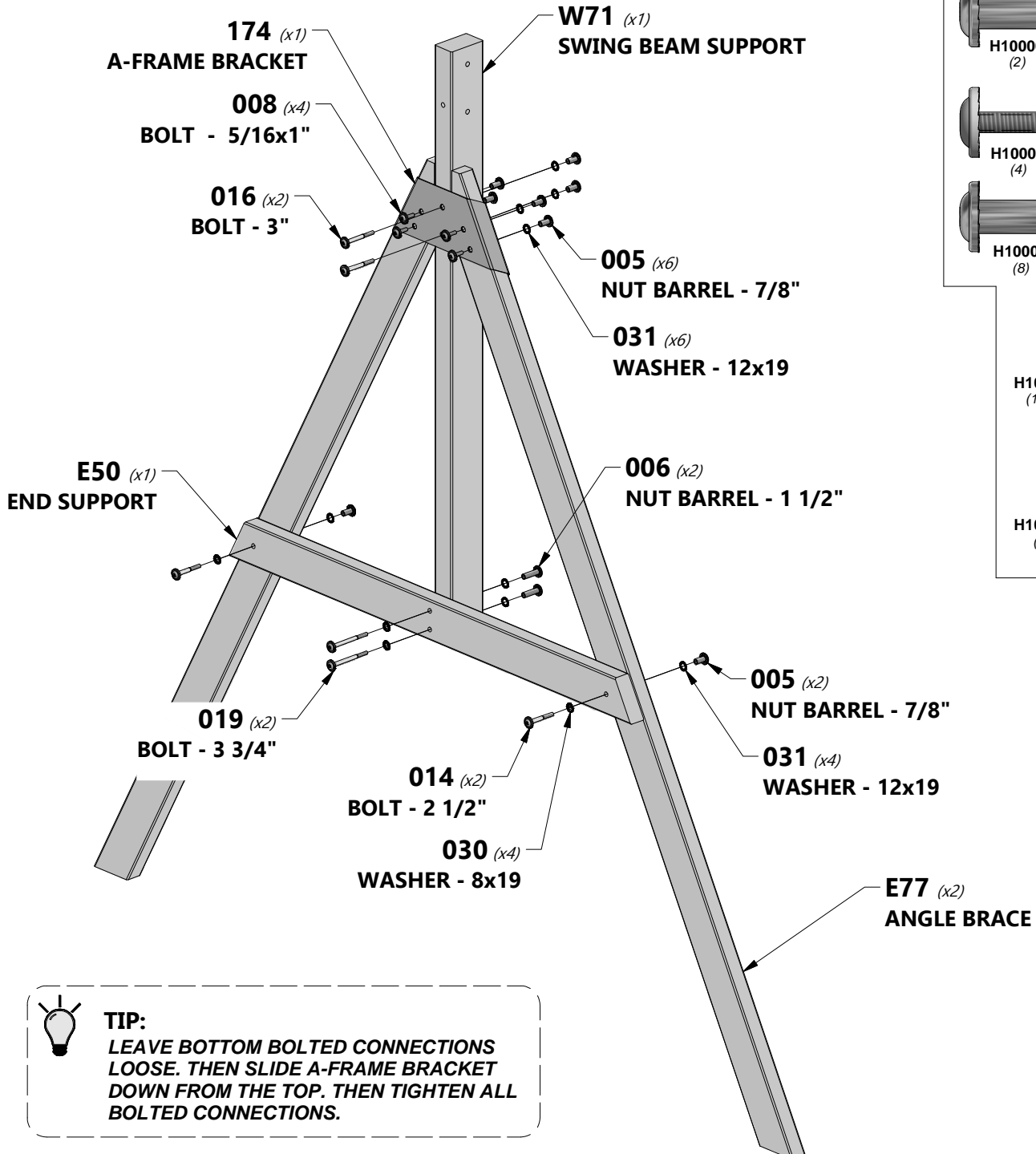

TIP:
LEAVE BOTTOM BOLTED CONNECTIONS LOOSE. THEN SLIDE A-FRAME BRACKET DOWN FROM THE TOP. THEN TIGHTEN ALL BOLTED CONNECTIONS.

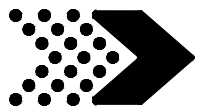

SWING BEAM

STEP 3

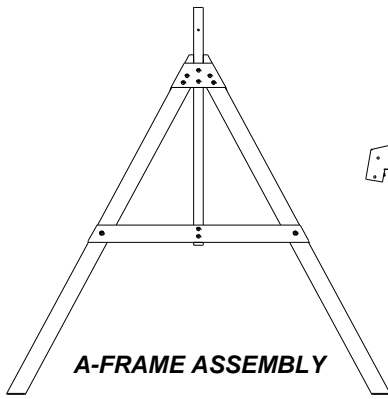

A-FRAME ASSEMBLY

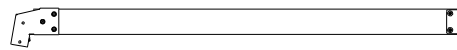

BEAM ASSEMBLY

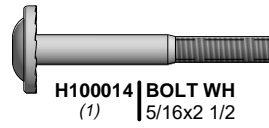

H100014 | BOLT WH
(1) | 5/16x2 1/2

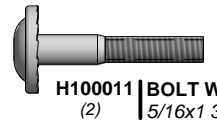

H100011 | BOLT WH
(2) | 5/16x1 3/4

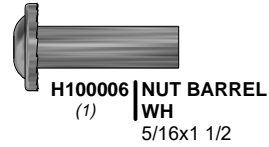

H100006 | NUT BARREL
(1) | WH
5/16x1 1/2

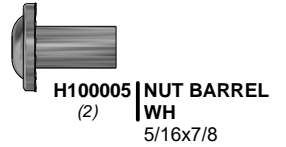

H100005 | NUT BARREL
(2) | WH
5/16x7/8



H100031 | WASHER
(1) | LOCK EXT
12x19



H100030 | WASHER
(1) | LOCK EXT
8x19

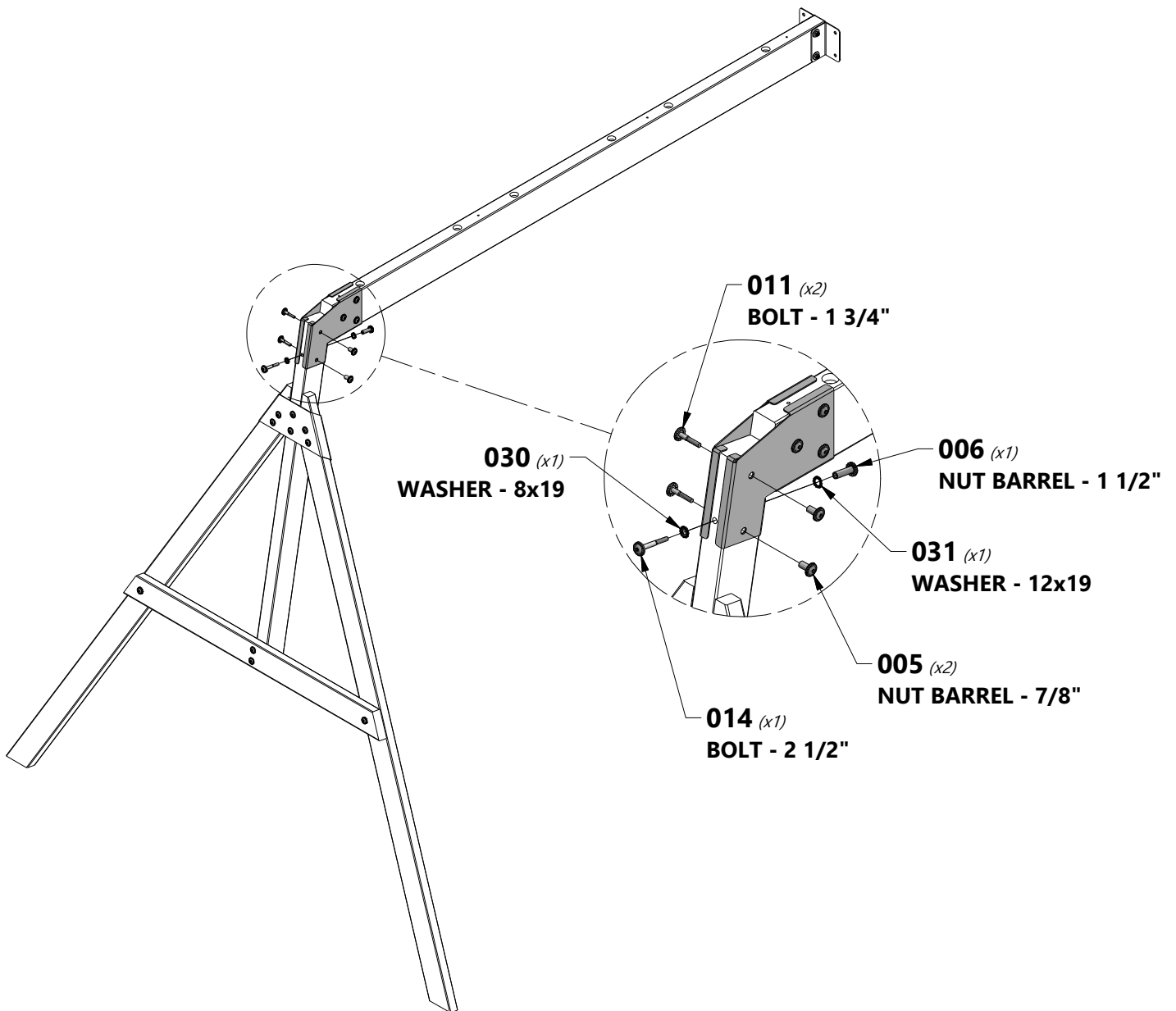

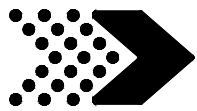

SWING BEAM

STEP 4

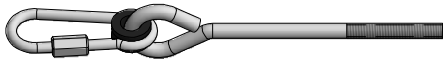

H100099 | 9 1/2" SWING
(6) | HANGER QUICK
LINK

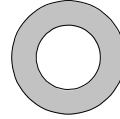

H100103 | WASHER
(6) | SAFETY
17x30

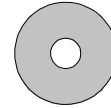

H100105 | WASHER
(6) | FLAT
8x27



H100110 | NUT LOCK
(6) | 5/16

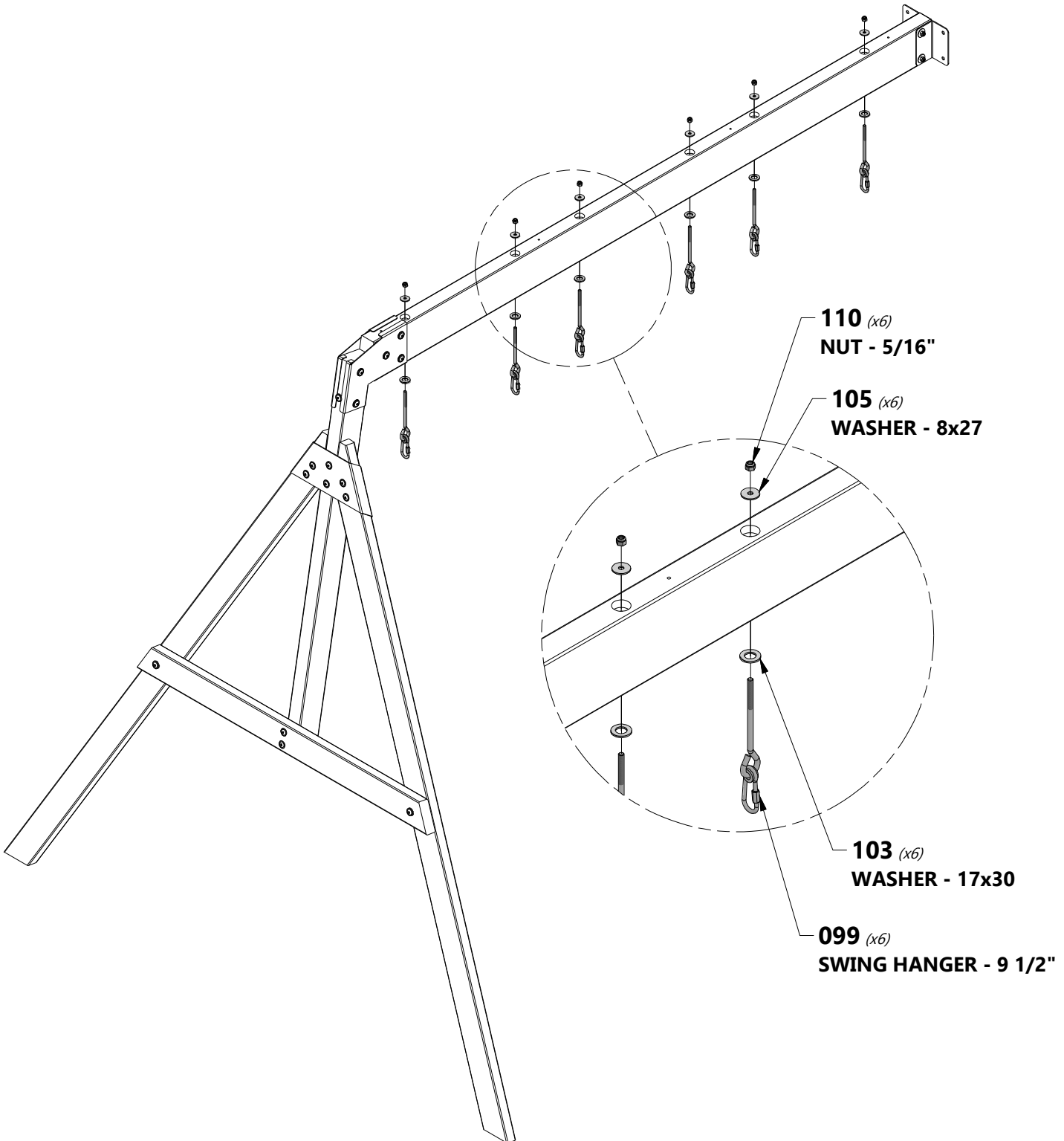

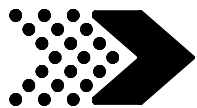

MONKEY BAR

STEP 1

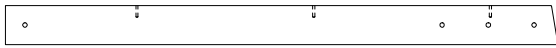

E7 | MONKEY BAR RAIL - W4L13841
(1) | 1 3/8"x3 3/8"x48" (36x86x1219)

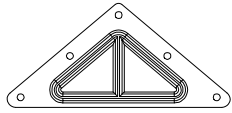

A100309 | TRIANGLE
(1) | PLATE BLUE 100
5 HOLE



A4M01048 | L BRACKET
(1) | 2.5x38x55x55



H100010 | BOLT WH
(3) | 5/16x1-1/2

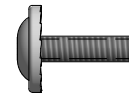

H100008 | BOLT WH
(1) | 5/16x1

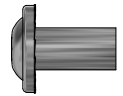

H100005 | NUT BARREL
(1) | WH
5/16x7/8



H100074 | T-NUT
(3) | 5/16



H100030 | WASHER
(1) | LOCK EXT
8x19

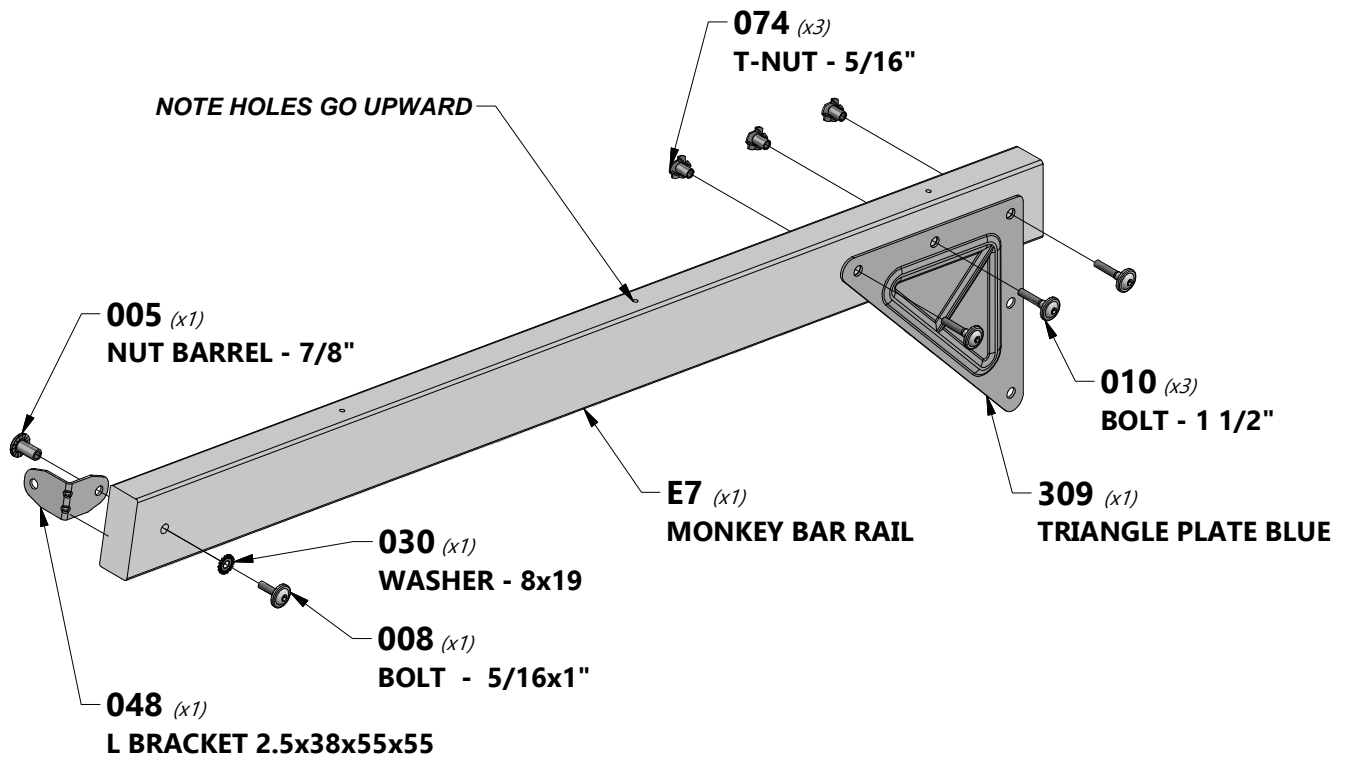

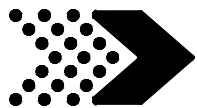

MONKEY BAR

STEP 2



E7 | MONKEY BAR RAIL - W4L13841
(1) | 1 3/8"x3 3/8"x48" (36x86x1219)

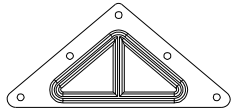

A100309 | TRIANGLE
(1) | PLATE BLUE 100
5 HOLE



A4M01048 | L BRACKET
(1) | 2.5x38x55x55



H100010 | BOLT WH
(3) | 5/16x1-1/2

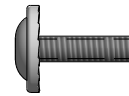

H100008 | BOLT WH
(1) | 5/16x1

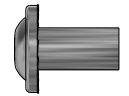

H100005 | NUT BARREL
(1) | WH
5/16x7/8



H100074 | T-NUT
(3) | 5/16



H100030 | WASHER
(1) | LOCK EXT
8x19

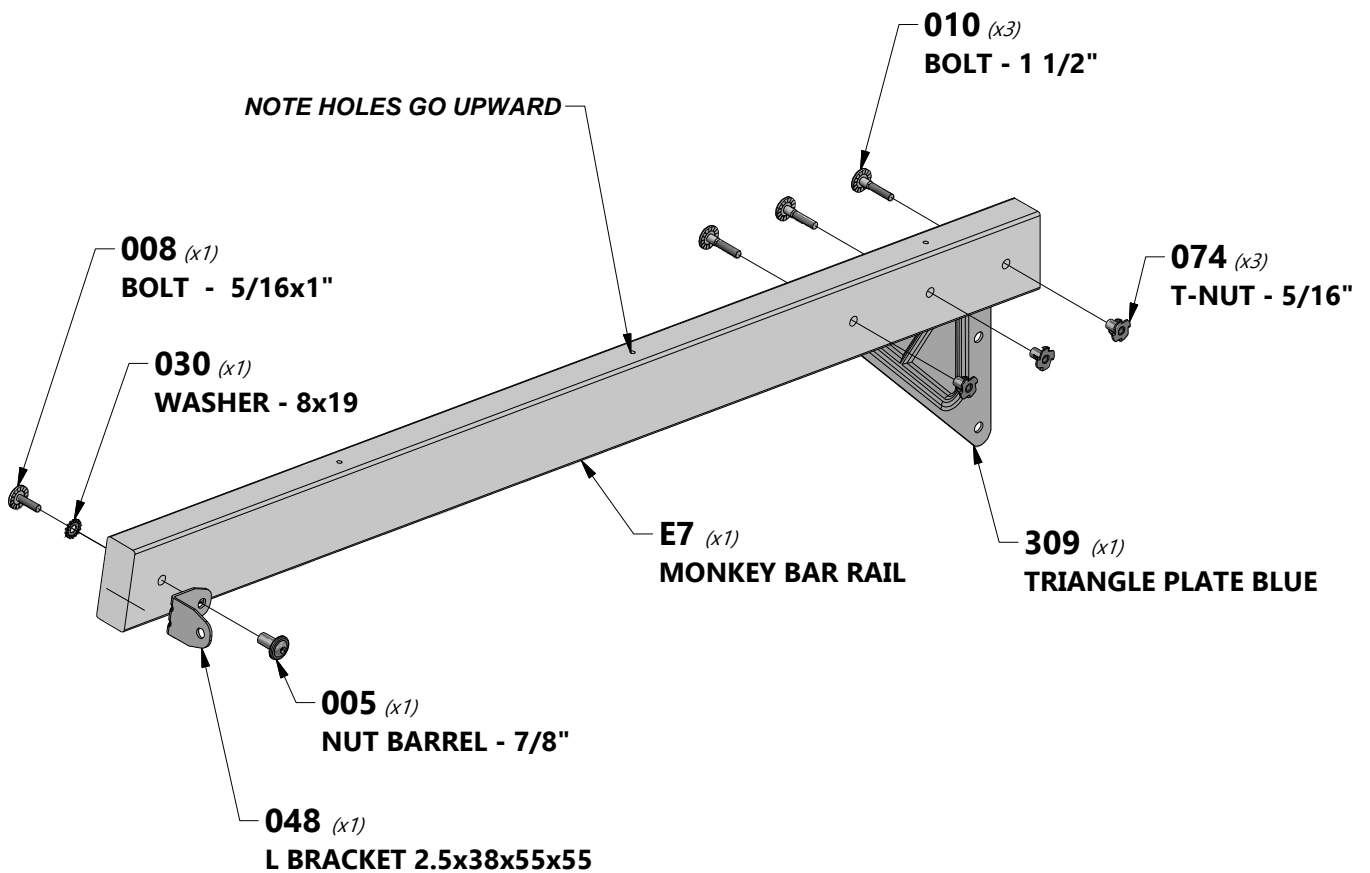

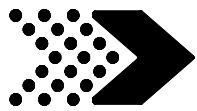

MONKEY BAR

STEP 3



E5 | MONKEY BAR UPRIGHT - W4L13840
(1) | 1 3/8"x3 3/8"x70 3/8" (36x86x1786)

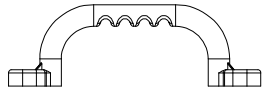

A6P00127 | HAND GRIP LIME
(1) | PLASTIC



H100010 | BOLT WH
(2) | 5/16x1-1/2



H100145 | LAG SCREW
(2) | WH
1/4x1 1/2



H100138 | WASHER
(2) | LOCK EXT
6x15



H100074 | T-NUT
(2) | 5/16

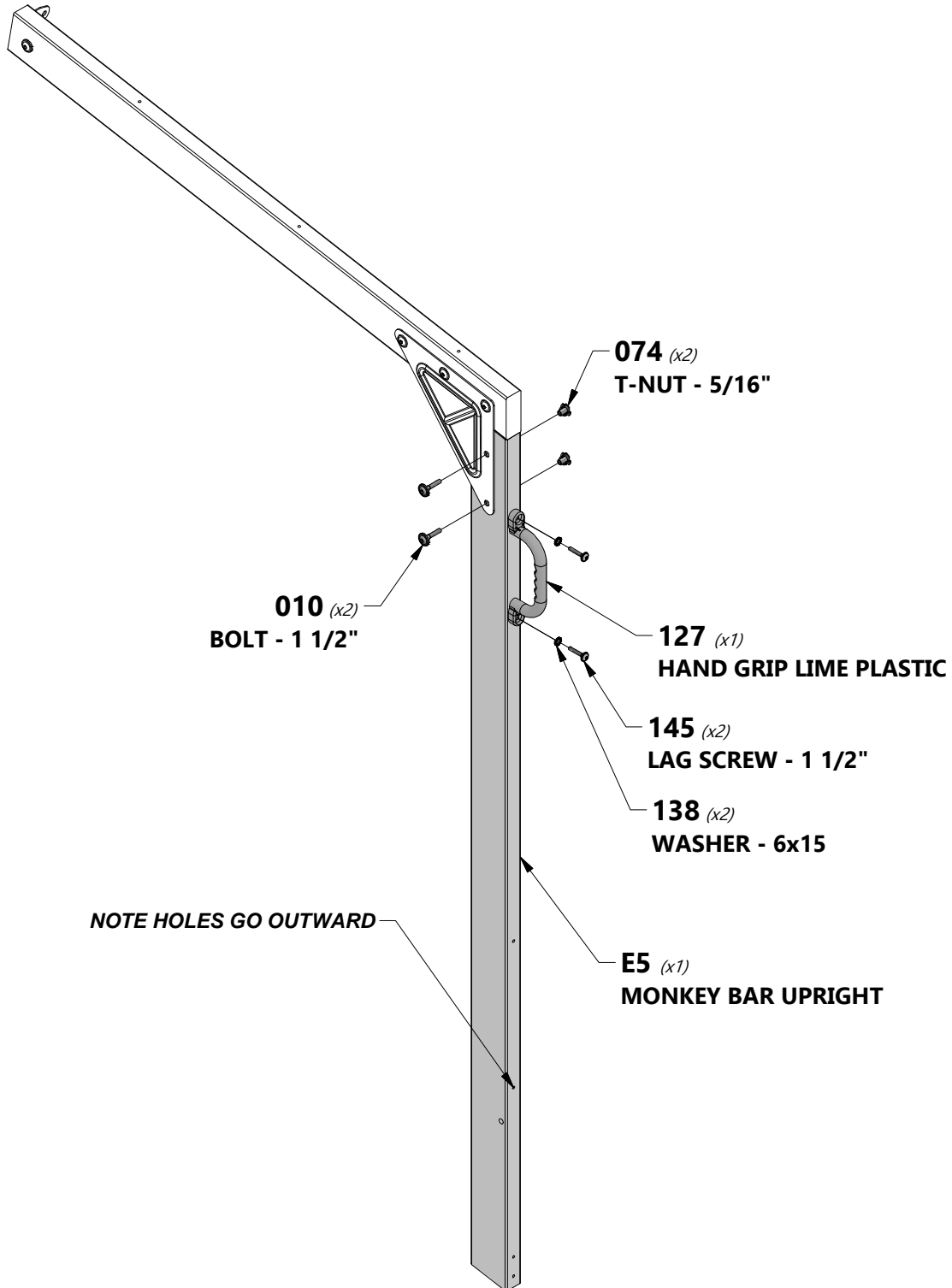

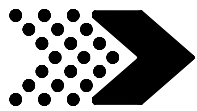

MONKEY BAR

STEP 4



E5 | MONKEY BAR UPRIGHT - W4L13840
(1) | 1 3/8"x3 3/8"x70 3/8" (36x86x1786)

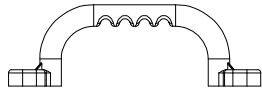

A6P00127 | HAND GRIP LIME PLASTIC
(1)



H100010 | BOLT WH
(2) | 5/16x1-1/2



H100145 | LAG SCREW WH
(2) | 1/4x1 1/2

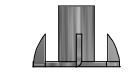

H100074 | T-NUT
(2) | 5/16



H100138 | WASHER LOCK EXT
(2) | 6x15

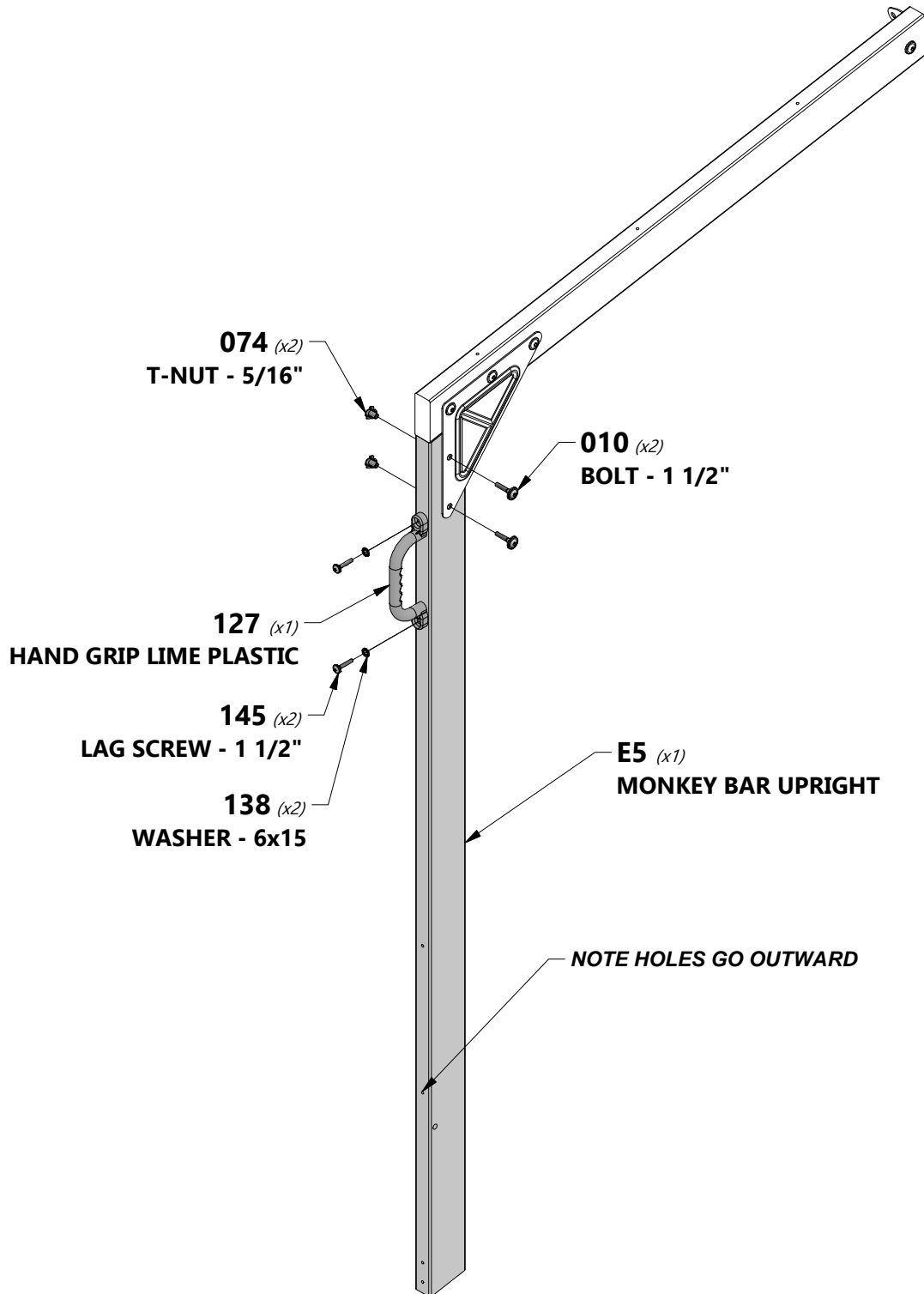

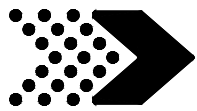

MONKEY BAR

STEP 5

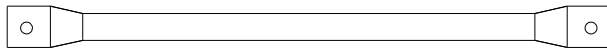

A4M00585 | METAL RUNG 559 BLUE
(5)



H100145 | LAG SCREW WH
(10) | 1/4x1 1/2

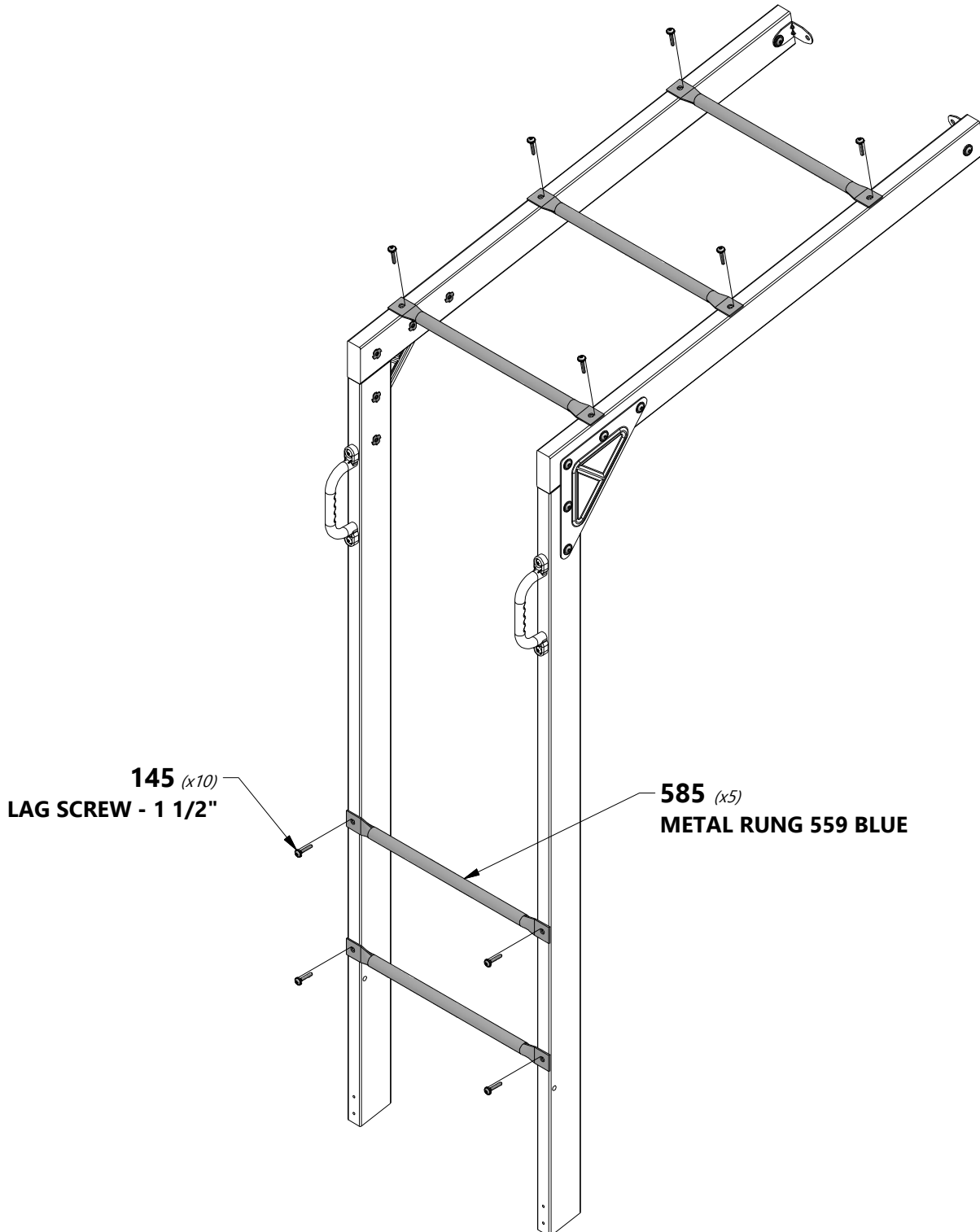

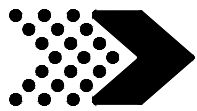

MONKEY BAR

STEP 6

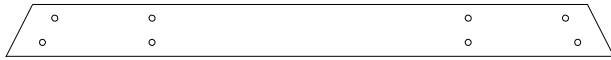

M82 | MONKEY BAR GROUND BOARD - W4L13850
(1) | 5/8"x3 3/8"x39 5/8" (16x86x1006)



H81 | MONKEY BAR BRACE - W4L13849
(2) | 1"x3 3/8"x18 5/8" (24x86x474)



H100047 | BOLT HEX
(2) | 5/16x2 3/4

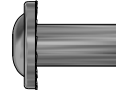

H100005 | NUT BARREL
(4) | WH
5/16x7/8



H100027 | LAG SCREW
(4) | WH
5/16x2



H100008 | BOLT WH
(4) | 5/16x1



H100108 | WASHER
(2) | LOCK INT
8x15

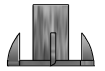

H100074 | T-NUT
(2) | 5/16



H100106 | WASHER
(2) | FLAT
9x18



H100031 | WASHER
(4) | LOCK EXT
12x19



H100030 | WASHER
(8) | LOCK EXT
8x19

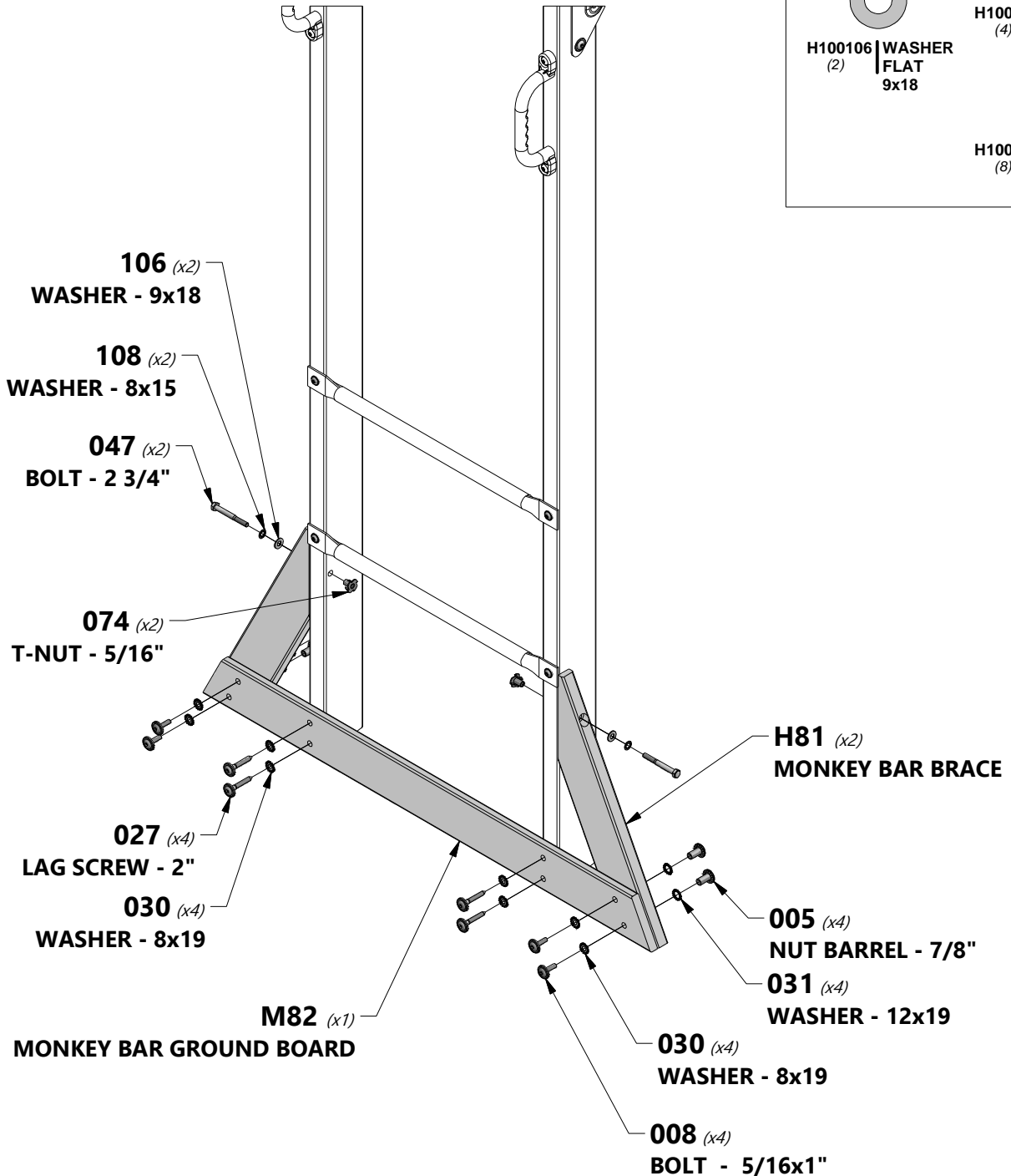

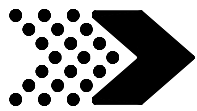

BENCH ASSEMBLY

STEP 1



H7 | BENCH GROUND BOARD - W4L06967
(2) 1"x3 3/8"x18 1/8" (24x86x460)



A4M00646 | L BRACKET
(2) BLUE 32x51

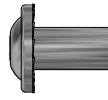

H100005 | NUT BARREL WH
(2) 5/16x7/8

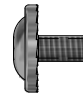

H100115 | BOLT WH
(2) 5/16x1/2



H100031 | WASHER
(2) LOCK EXT
12x19

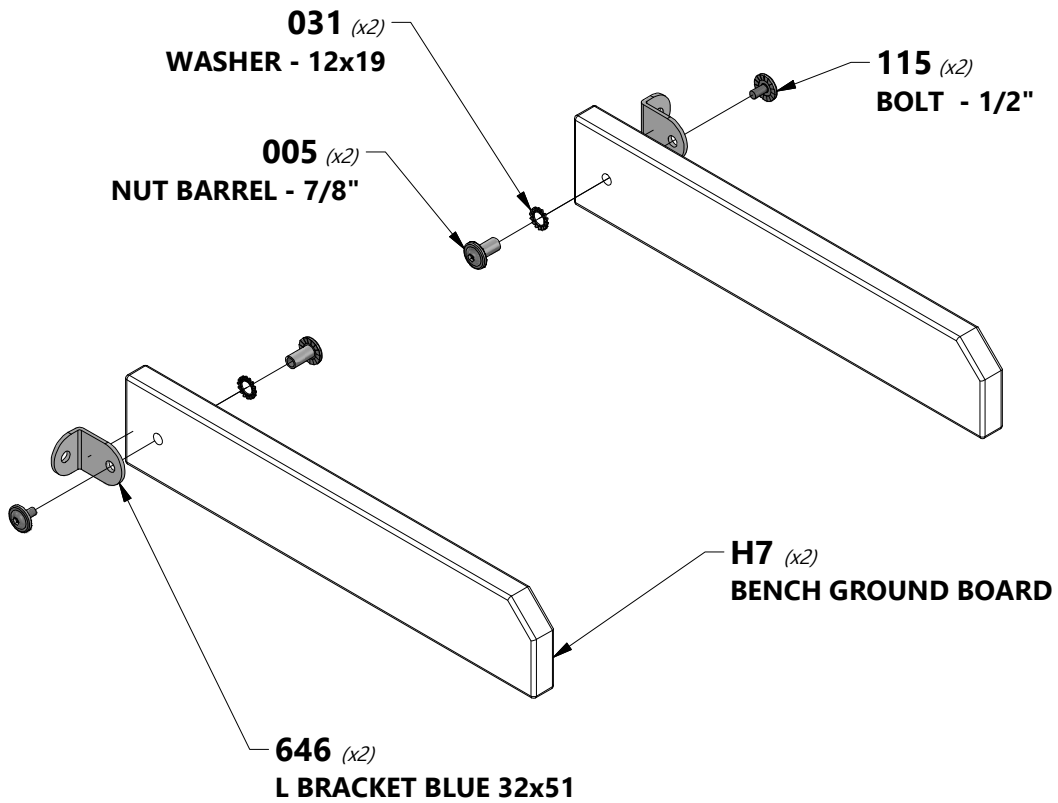

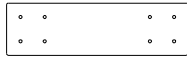
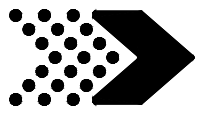

H8 | BENCH UPRIGHT - W4L06968
(2) | 1"x3 3/8"x11 3/4" (24x86x300)



H100089 | SCREW PFH
(8) | 8x1 3/4

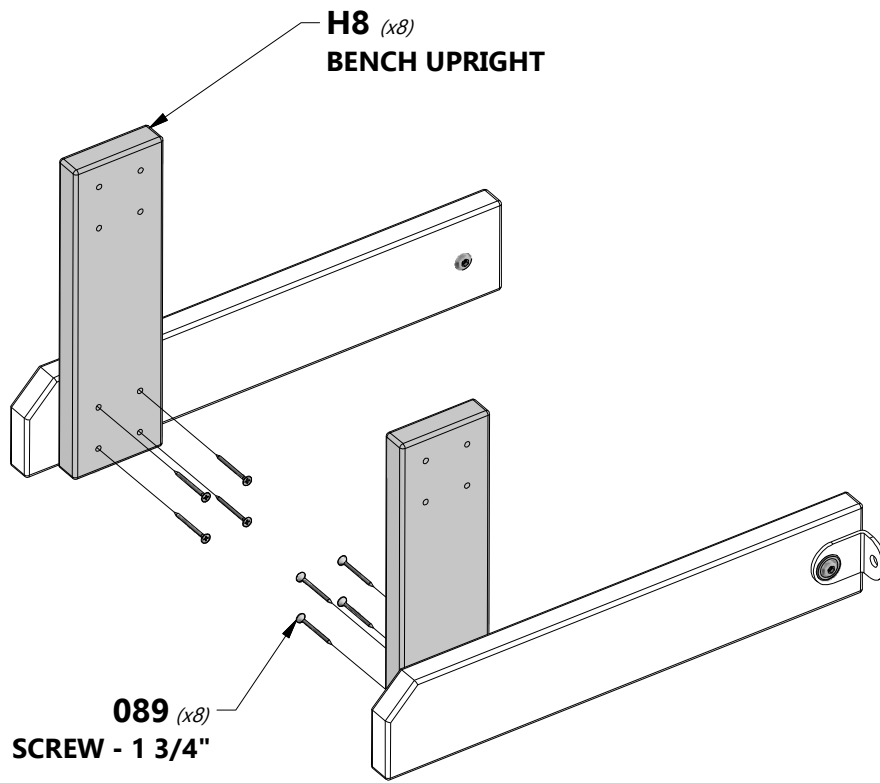

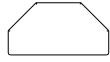
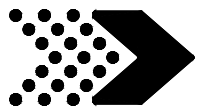

H9 | BENCH SEAT SUPPORT - W4L06969
(2) | 1"x3 3/8"x6 1/2" (24x86x166)



H100089 | SCREW PFH
(8) | 8x1 3/4

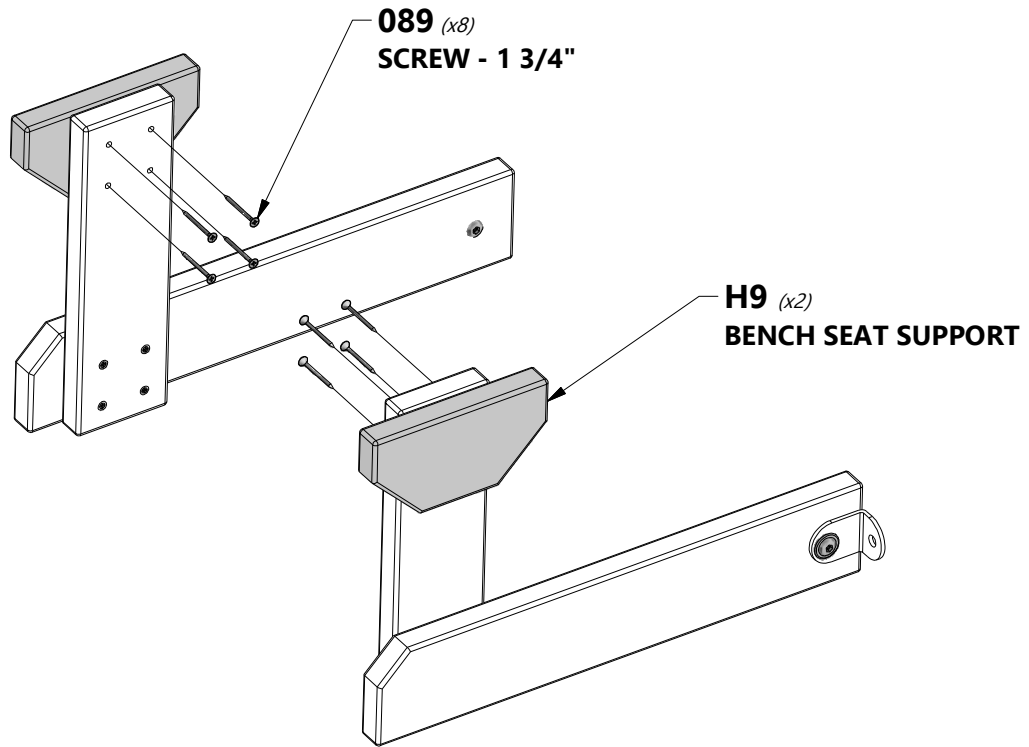

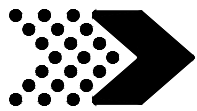

H12 | BENCH SEAT - W4L13837
(2) | 1"x3 3/8"x26" (24x86x660)



H100089 | SCREW PFH
(8) | 8x1 3/4

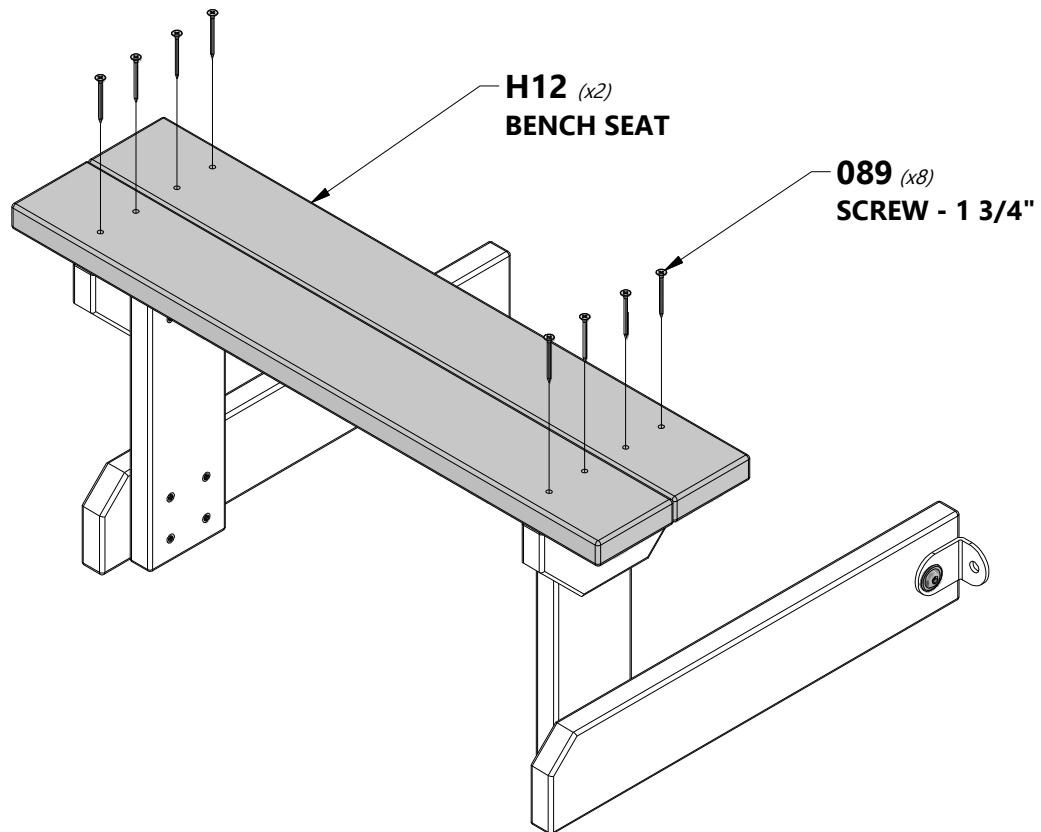



SLIDE ASSEMBLY

STEP 1



A6P00131 | SLIDE BED 8' LIME
(x1)



M77 | SLIDE BRACE - W100544
(x1) | 5/8"x3 3/8"x17 1/4" (16x86x438)



H100115 | BOLT WH
(x3) | 5/16x1/2



H100074 | T-NUT
(x3) | 5/16

 **NOTE:** TAKE NOTE OF SLIDE BED SURFACE FINISH, THE DULL SIDE WILL BE TOWARDS THE GROUND. PLACE SLIDE BRACE CENTERED ON THE BOTTOM (DULL SIDE) AND 1/2" FROM THE EDGE. USE M77 BOARD AS A TEMPLATE FOR DRILLING BOTTOM HOLE PATTERN IN SLIDE BED. USE A 5/16" DRILL BIT.



TIP: PRE-BENDING THE ENDS WILL EASE ASSEMBLY. PLACING THE SLIDE BED OUT IN THE SUN MAKES IT EASIER TO BEND.

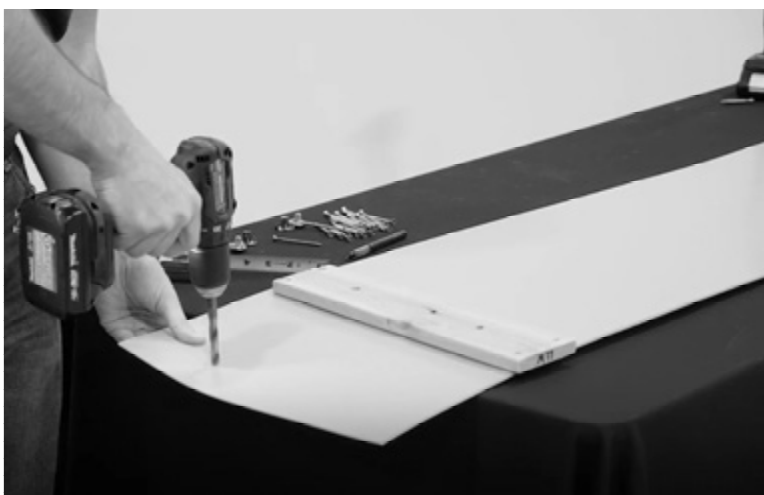
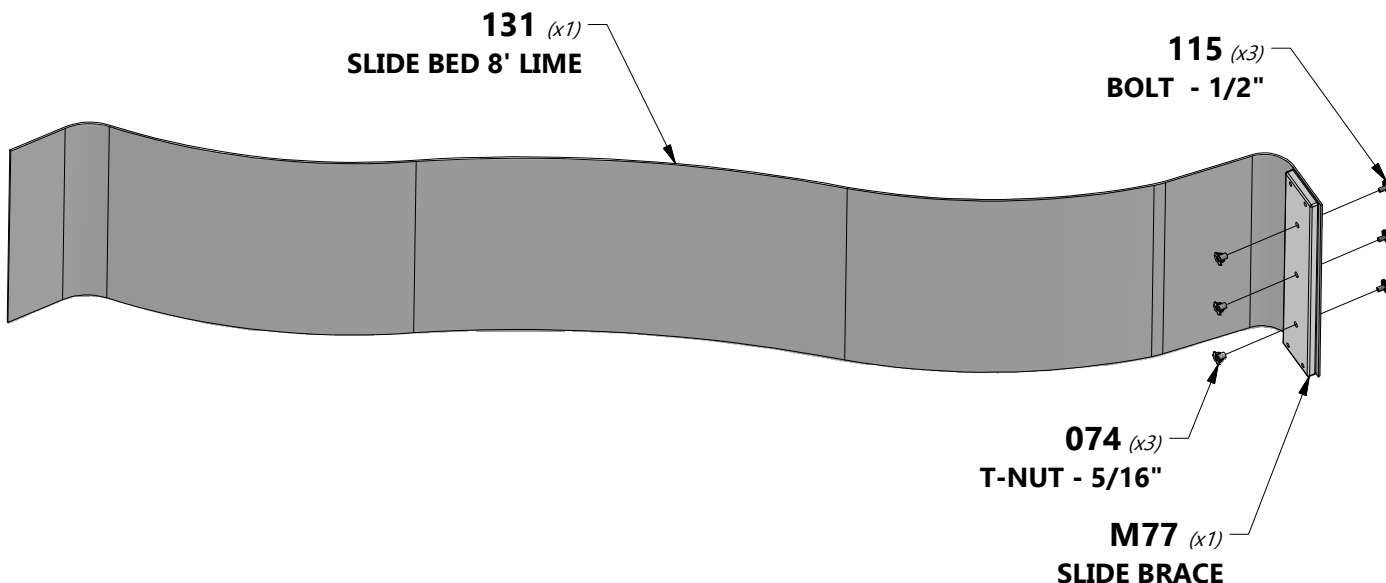



SLIDE ASSEMBLY

STEP 2



M78 | CENTER SLIDE BRACE - W100545
(x2) 5/8"x3 3/8"x17 1/4" (16x86x438)



A100162 | SLIDE RAIL 8' BLUE LEFT
(x1)



A100161 | SLIDE RAIL 8' BLUE RIGHT
(x1)



H100090 | SCREW PFH
(x24) 8x2 1/2"



NOTE:
PLACE SECOND SLIDE RAIL ASSEMBLY OVER THE TOP OF THE SLIDE BED AND **M78** CENTER SLIDE BRACES. INSERT THE SLIDE BED AND CENTER SLIDE BRACES INTO THE SLIDE CAVITY. MAKE SURE SLIDE BED IS COMPLETELY IN THE SLIDE CAVITY.



FAILURE TO INSERT SLIDE BED COMPLETELY AND SECURED MAY RESULT IN INJURY OR AMPUTATION. EXPOSED SLIDE EDGES CAN BE SHARP AND BECOME A LACERATION HAZARD IF THE SLIDE IS NOT PROPERLY ASSEMBLED.



NOTE:
USING AN 1/8" DRILL BIT, DRILL PILOT HOLES IN EACH INDENTATION ALONG EACH SIDE RAIL. THERE SHOULD BE 12 INDENTATIONS ON EACH RAIL. BE SURE TO DRILL THROUGH THE SLIDE RAIL AND THE SLIDE BED. THEN SECURE WITH THE PROVIDED HARDWARE.

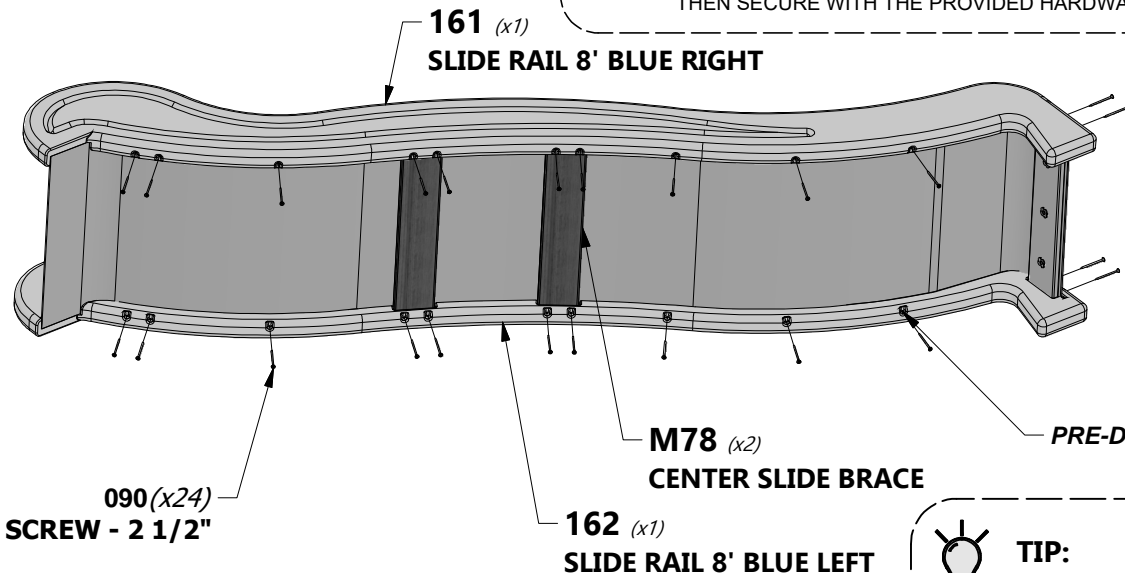

TIP:
USE A RUBBER Mallet TO FULLY SEAT THE SLIDE BED INTO THE SLIDE CAVITY.





E2 | UPRIGHT - W4L06891
(1) | 1 3/8"x3 3/8"x89 1/2" (36x86x2274)

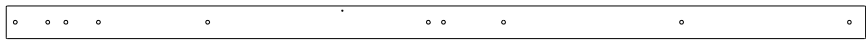

E3 | UPRIGHT - W4L06892
(1) | 1 3/8"x3 3/8"x89 1/2" (36x86x2274)



K3 | GROUND BOARD - W4L06896
(1) | 5/8"x5 1/4"x42 1/8" (16x134x1070)

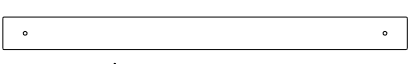

M8 | WALL RAIL - W4L06920
(1) | 5/8"x3 3/8"x42 1/8" (16x86x1070)

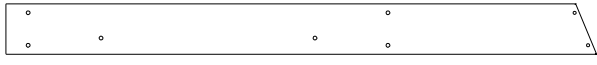

K4 | GROUND BOARD - W4L13847
(1) | 5/8"x5 1/4"x61 1/2" (16x134x1564)

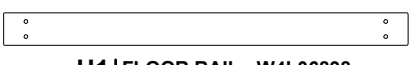

H1 | FLOOR RAIL - W4L06898
(1) | 1"x3 3/8"x42 1/8" (24x86x1070)

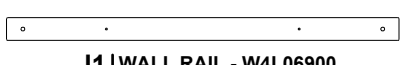

J1 | WALL RAIL - W4L06900
(1) | 1"x2 3/8"x40 7/8" (24x60x1038)

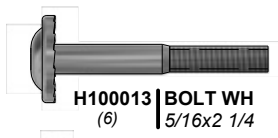

H100013 | BOLT WH
(6) | 5/16x2 1/4

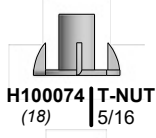

H100074 | T-NUT
(18) | 5/16

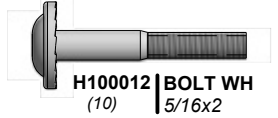

H100012 | BOLT WH
(10) | 5/16x2



**H100030 | WASHER
LOCK EXT**
(16) | 8x19

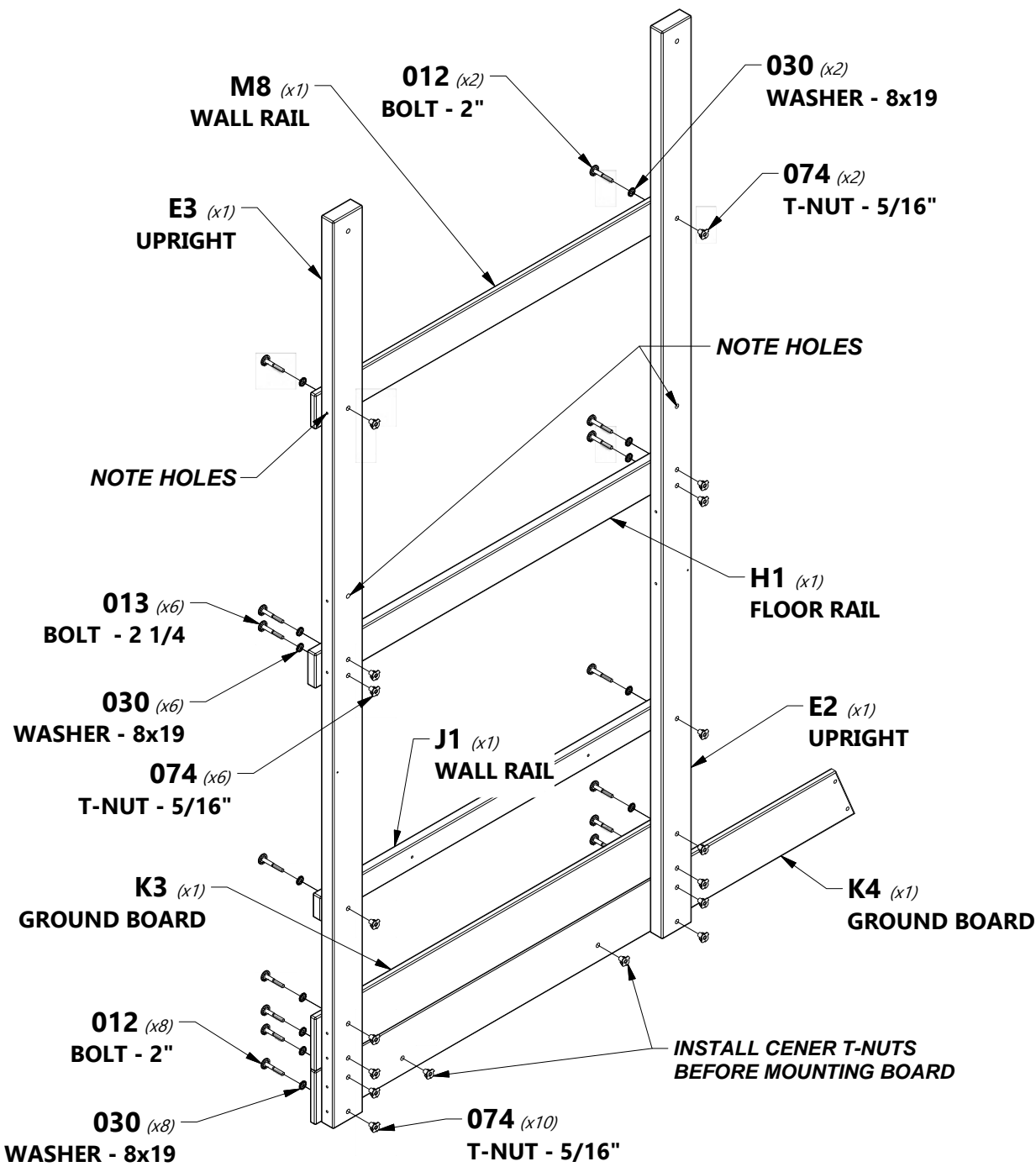

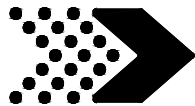

E4 | UPRIGHT - W2A01970
(1) 1 3/8"x3 3/8"x57 3/8" (36x86x2274)

E1 | UPRIGHT - W4L06890
(1) 1 3/8"x3 3/8"x89 1/2" (36x86x2274)

K1 | GROUND BOARD - W4L13848
(1) 5/8"x5 1/4"x80 3/8" (16x134x2043)

G1 | SWING BEAM MOUNT - W4L06945
(1) 1"x5 1/4"x40 7/8" (24x134x1038)

H10 | FLOOR RAIL - W4L07317
(1) 1"x3 3/8"x42 1/8" (24x86x1070)

O3 | SAFETY BOARD - W4L06948
(2) 5/8"x1 3/8"x40 7/8" (16x34x1038)

K3 | GROUND BOARD - W4L06896
(1) 5/8"x5 1/4"x42 1/8" (16x134x1070)

M8 | WALL RAIL - W4L06920
(1) 5/8"x3 3/8"x42 1/8" (16x86x1070)

M1 | SAFETY BOARD - W4L06895
(1) 5/8"x3 3/8"x40 7/8" (16x86x1038)

H100128 | SCREW PWH
(2) 8x5/8

A100314 | "A" REVISION TAG
(1)

H100013 | BOLT WH
(8) 5/16x2 1/4

H100012 | BOLT WH
(12) 5/16x2

H100030 | WASHER LOCK EXT
(20) 8x19

H100074 | T-NUT
(24) 5/16

H100089 | SCREW PFH
(4) 8x1 3/4

H100128 | SCREW PWH
(2) 8x5/8

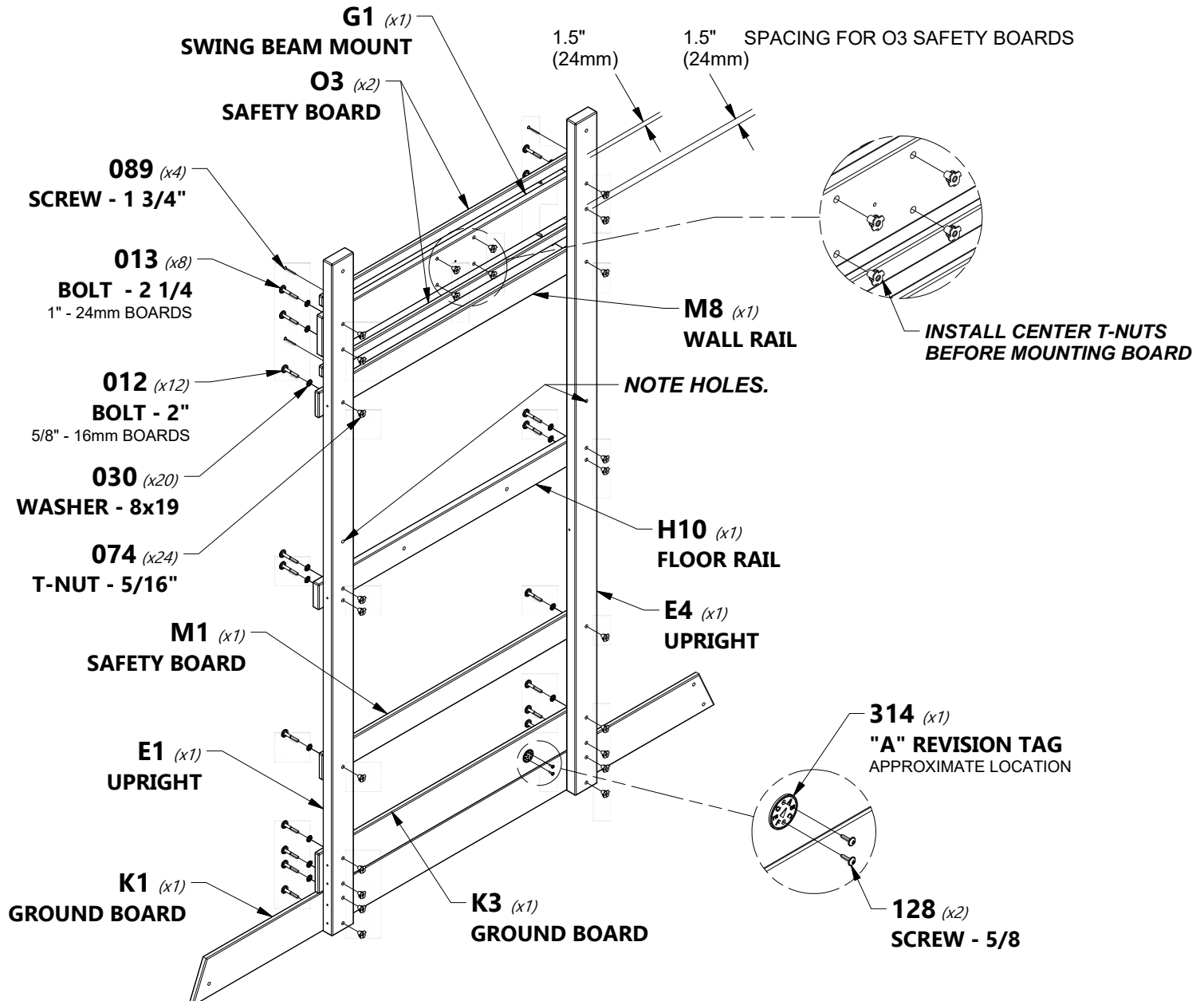

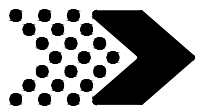

K2 | GROUND BOARD - W4L06894
(4) | 5/8"x5 1/4"x43 1/4" (16x134x1097)



H100026 | LAG SCREW WH
(16) | 5/16x1 1/2



H100030 | WASHER
(16) | LOCK EXT
8x19

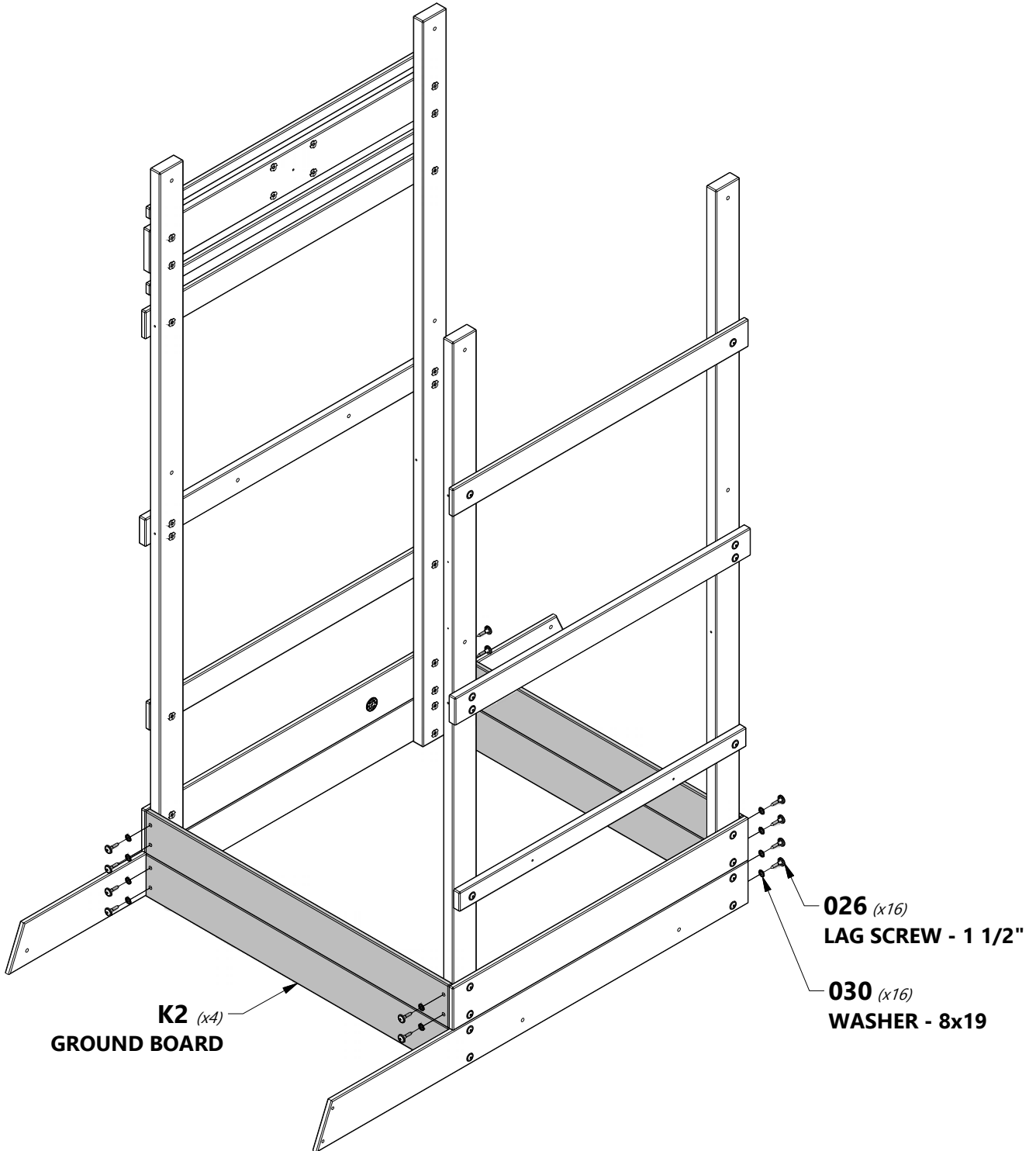

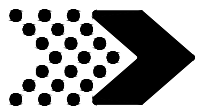

G2 | SANDBOX SEAT - W4L06433
(2) 1"x5 1/4"x14 5/8" (24x134x370)

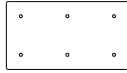

Q2 | SANDBOX SEAT SUPPORT - W4L06434
(4) 1"x4 3/8"x8" (24x112x202)



H100089 | SCREW PFH
(8) 8x1 3/4"



H100086 | SCREW PFH
(24) 8x1 1/2"

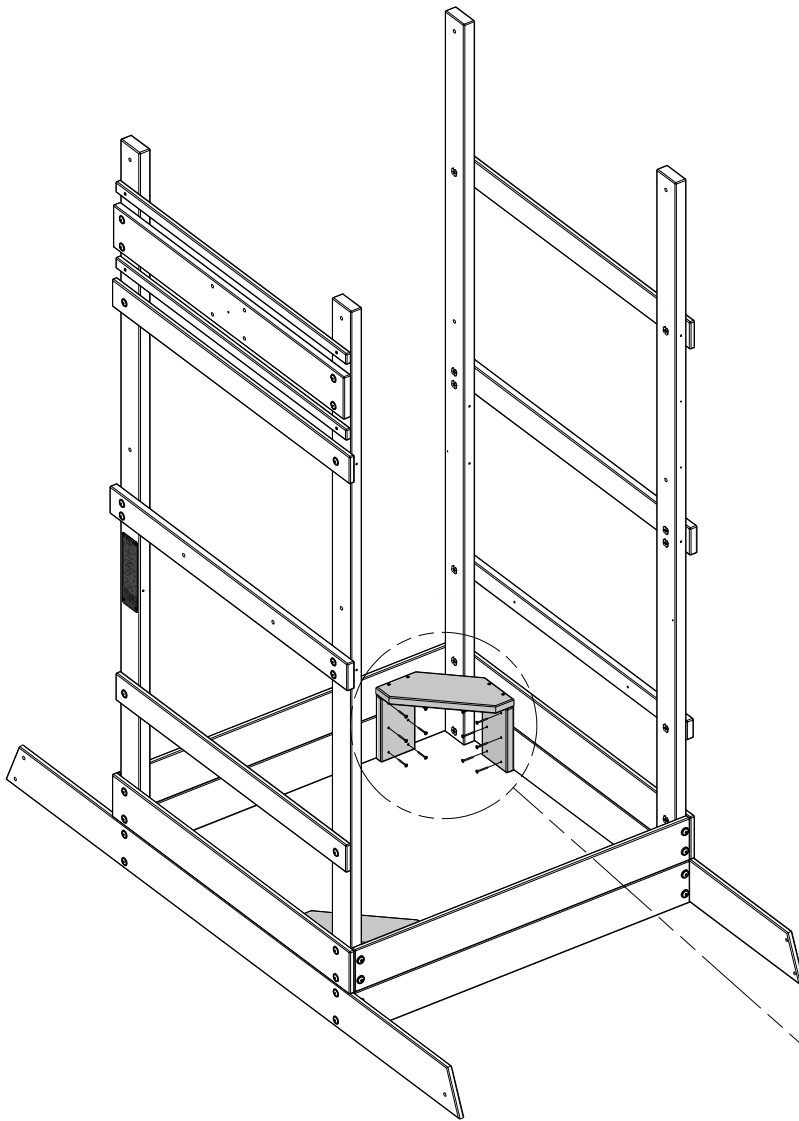

BENCH SUB ASSEMBLY

089 (x8)
SCREW - 1 3/4"

G2 (x2)
SANDBOX SEAT

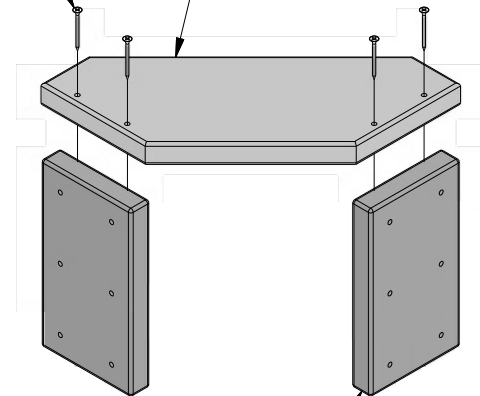

Q2 (x4)
SANDBOX SEAT SUPPORT

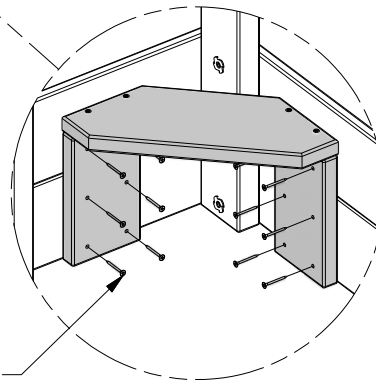

086 (x24)
SCREW - 1 1/2"

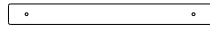
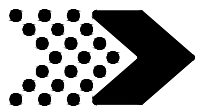

O1 PICKET - W4L06901
(7) 5/8"x1 3/8"x13 1/4" (16x34x336)



H100088 SCREW PFH
(14) 8x1 1/8

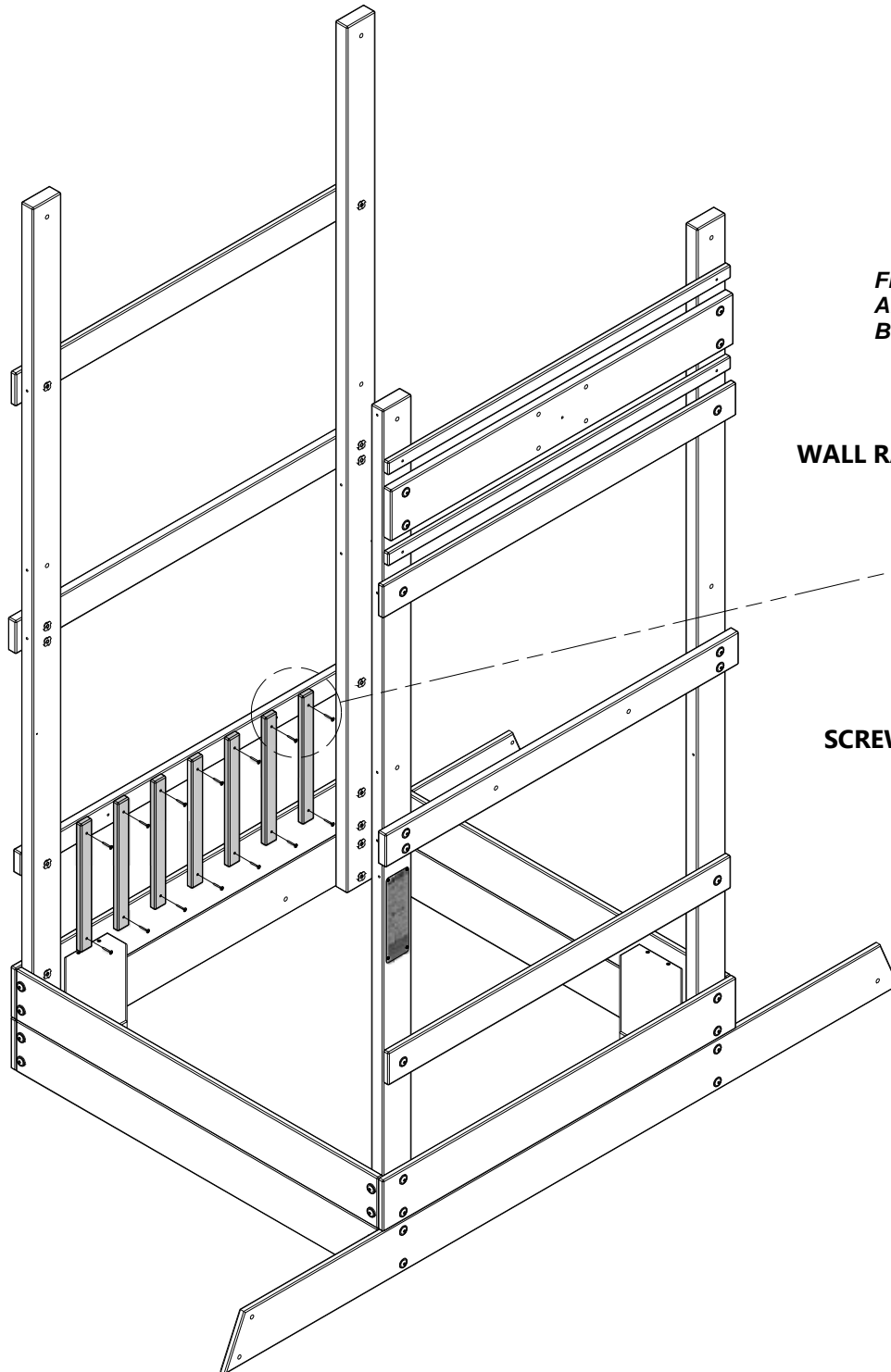

**FLUSH O1 BOARDS TO TOP OF J1 BOARD.
APPROXIMATELY 3 1/8" - 79mm SPACING
BETWEEN PICKETS.**

J1
WALL RAIL

O1 (x7)
PICKET

O88 (x14)
SCREW - 1 1/8"



K5 | SERVING SHELF - W4L06902
(1) 5/8"x5 1/4"x40 7/8" (16x134x1038)



J2 | SHELF SUPPORT - W4L06903
(2) 1"x2 3/8"x2 3/8" (24x60x60)



H100089 | SCREW PFH
(8) 8x1 3/4

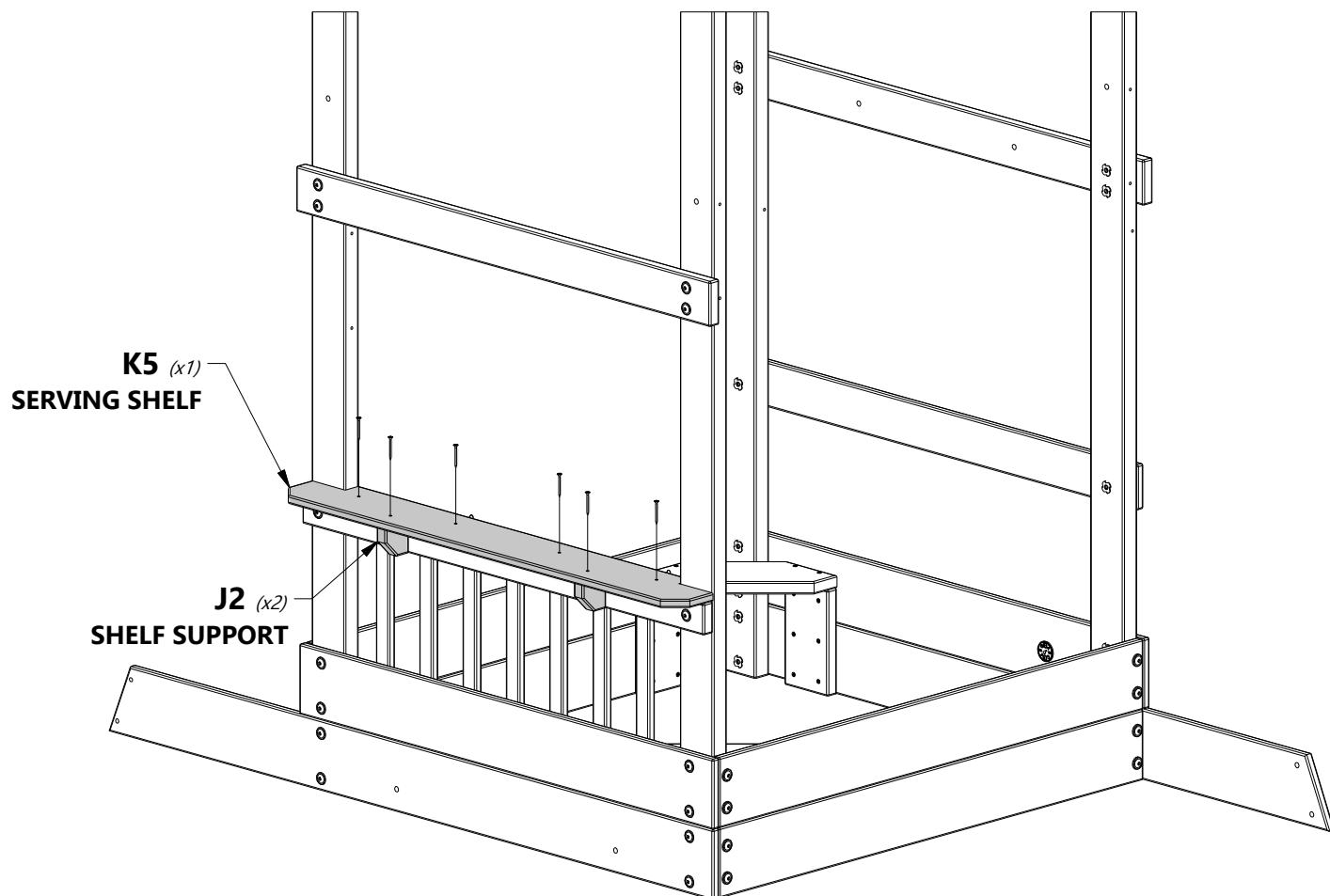

089 (x8)
SCREW - 1 3/4"

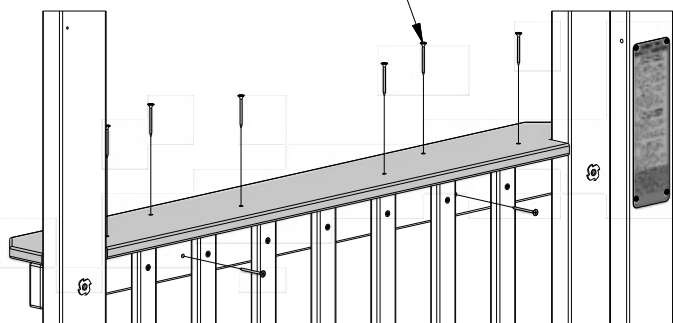

BACK VIEW



J6 | LADDER RAIL - W4L13845
(1) | 1"x2 3/8"x50 3/8" (24x60x1279)

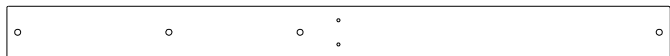

M2 | FLOOR RAIL - W4L06897
(1) | 5/8"x3 3/8"x43 1/4" (16x86x1097)



M5 | FLOOR RAIL - W4L06914
(1) | 5/8"x3 3/8"x43 1/4" (16x86x1097)



H100027 | LAG SCREW WH
(1) | 5/16x2



H100026 | LAG SCREW WH
(3) | 5/16x1 1/2



H100145 | LAG SCREW WH
(2) | 1/4x1 1/2



H100030 | WASHER
LOCK EXT
(4) | 8x19



H100138 | WASHER
LOCK EXT
(2) | 6x15

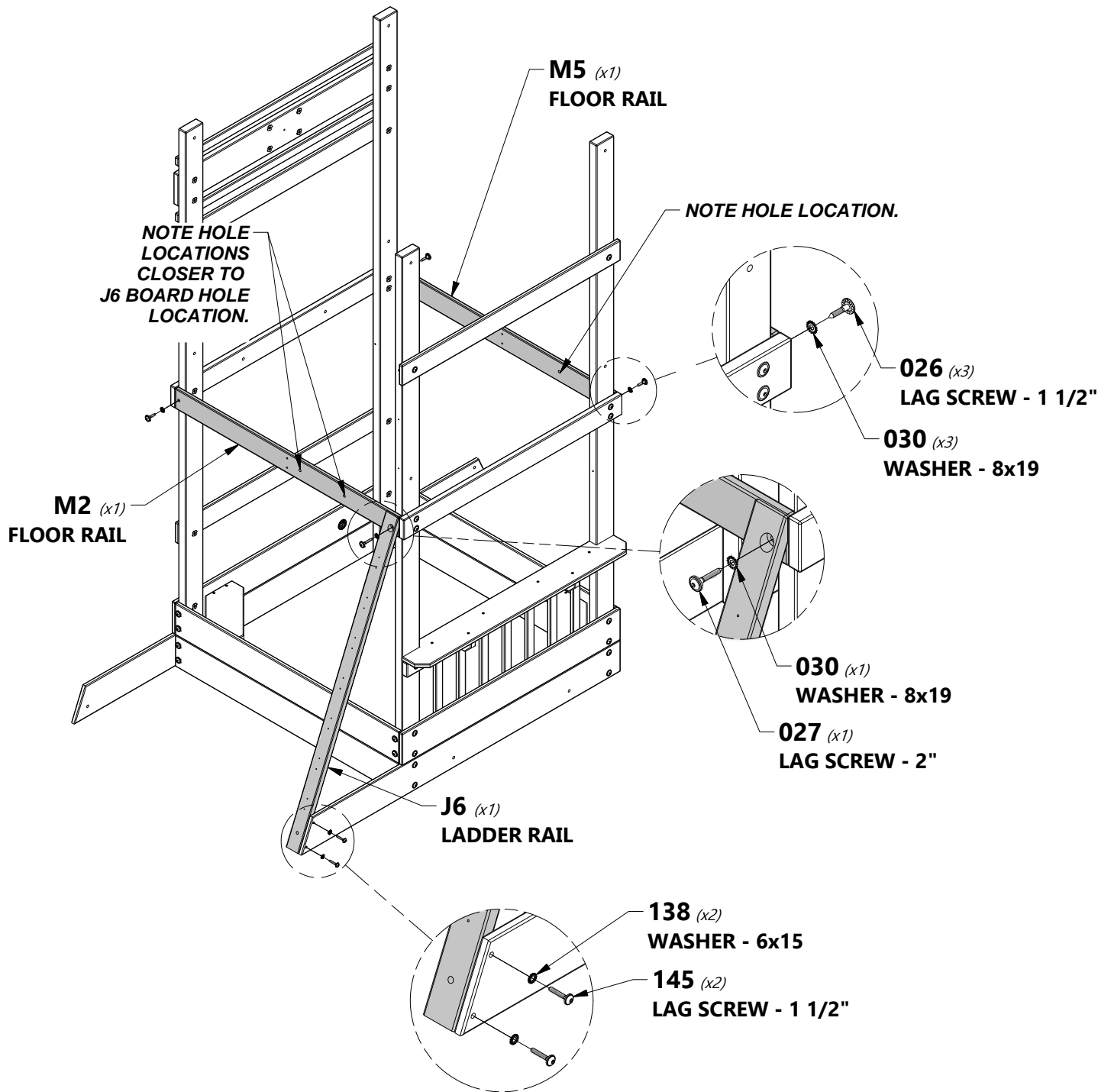

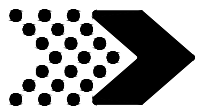

H2 | DECK BRACE - W4L06909
(4) | 1"x3 3/8"x18 3/4" (24x86x475)

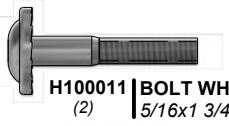

H100011 | BOLT WH
(2) | 5/16x1 3/4

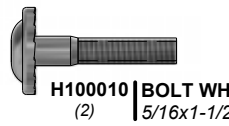

H100010 | BOLT WH
(2) | 5/16x1-1/2



H100145 | LAG SCREW WH
(4) | 1/4x1 1/2



H100138 | WASHER
(4) | LOCK EXT
6x15



H100030 | WASHER
(4) | LOCK EXT
8x19



H100074 | T-NUT
(5) | 5/16



**SQUARE WHEN
PUTTING ON H2
BOARDS.**

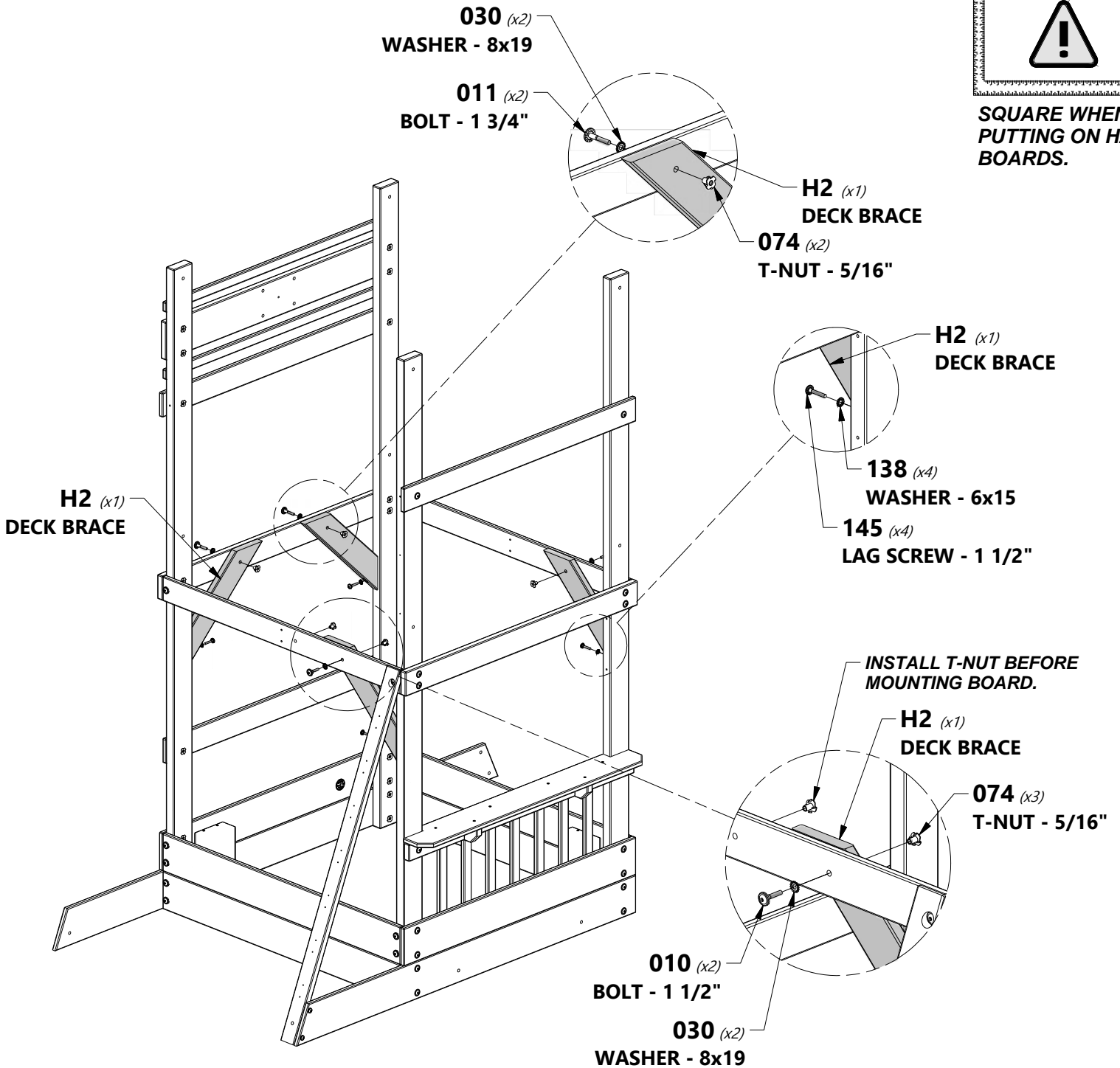

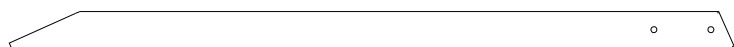

J3 ANGLE BRACE - W4L06905
(1) 1"x2 3/8"x47 1/4" (24x60x1200)



H100010 BOLT WH
(2) 5/16x1-1/2



H100145 LAG SCREW WH
(1) 1/4x1 1/2



H100138 WASHER LOCK EXT
(1) 6x15



H100030 WASHER LOCK EXT
(2) 8x19



H100074 T-NUT
(2) 5/16

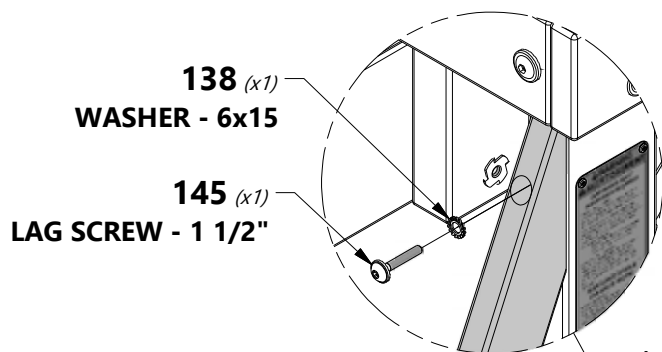

138 (x1)
WASHER - 6x15

145 (x1)
LAG SCREW - 1 1/2"

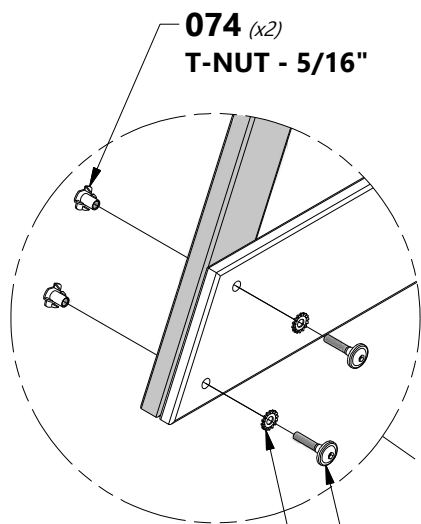

074 (x2)
T-NUT - 5/16"

010 (x2)
BOLT - 1 1/2"

030 (x2)
WASHER - 8x19

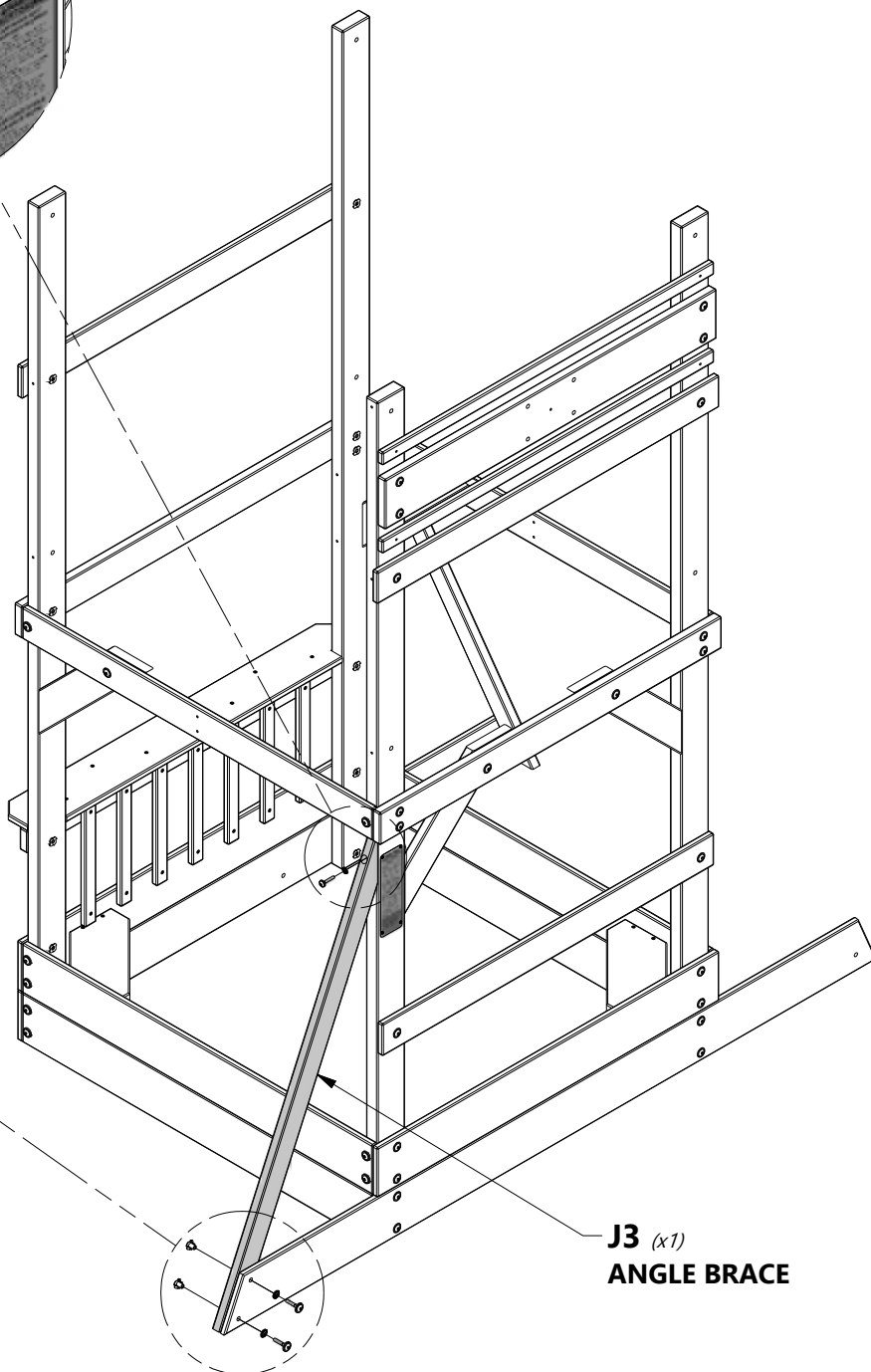

J3 (x1)
ANGLE BRACE

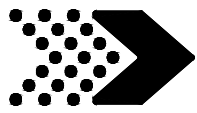

J9 | SUPPORT BOARD - W4L06064
(4) | 1"x2 3/8"x3" (24x60x76)



H100089 | SCREW PFH
(8) | 8x1 3/4

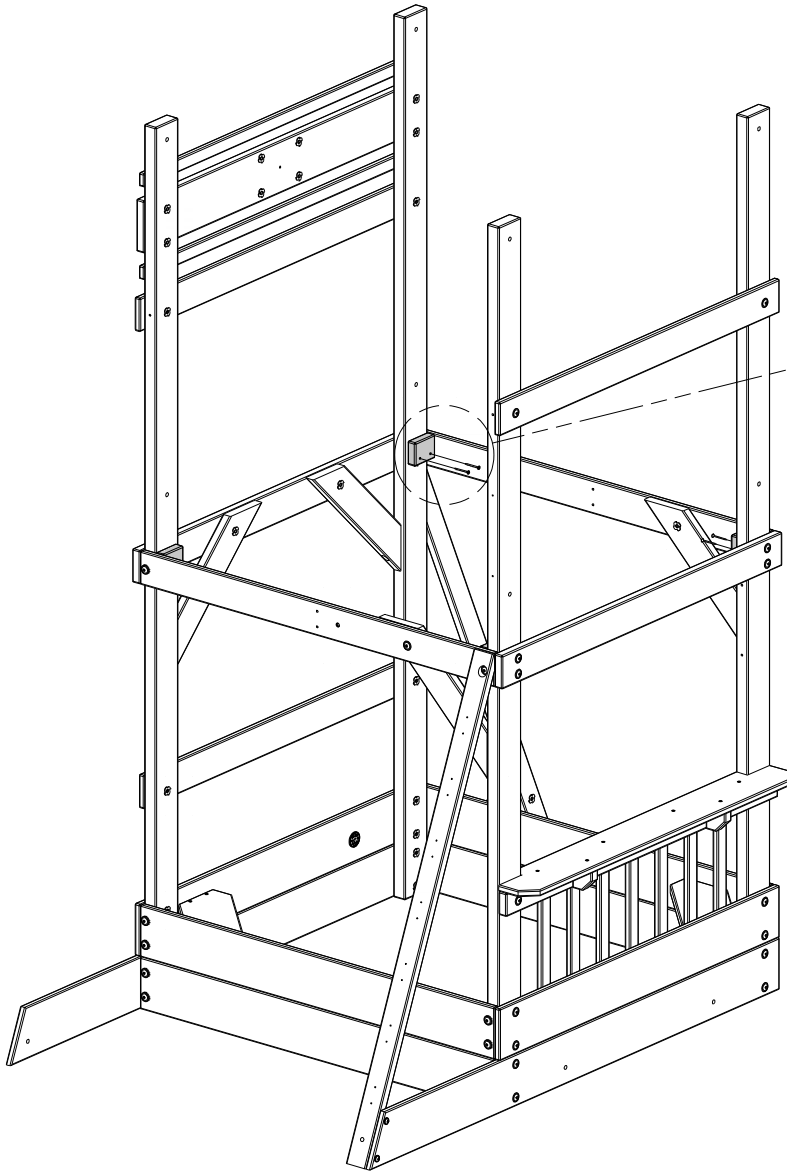

FLUSH TOPS
J9 (x4)
SUPPORT BOARD

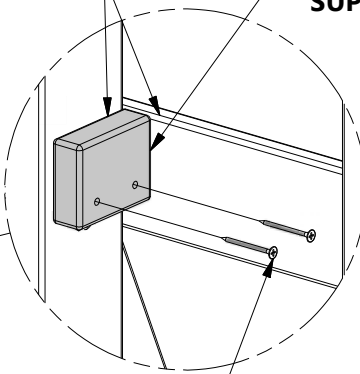

089 (x8)
SCREW - 1 3/4"

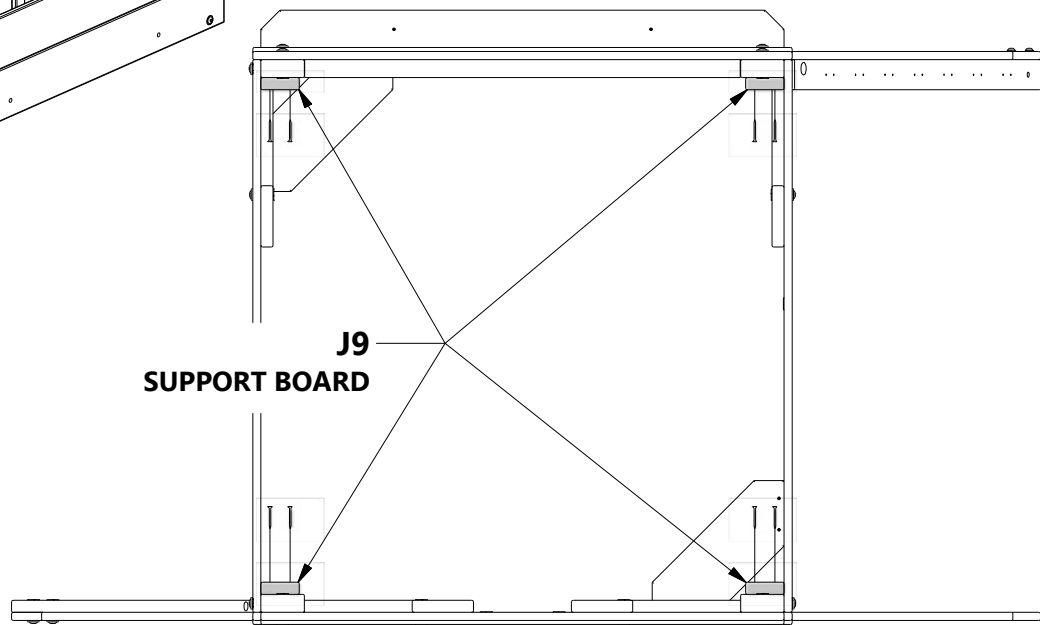

J9
SUPPORT BOARD

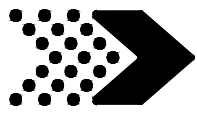

H3 | FLOOR SUPPORT - W4L06915
(1) | 1"x3 3/8"x40 7/8" (24x86x1038)



H100111 | SCREW PFH
(4) | 8x2

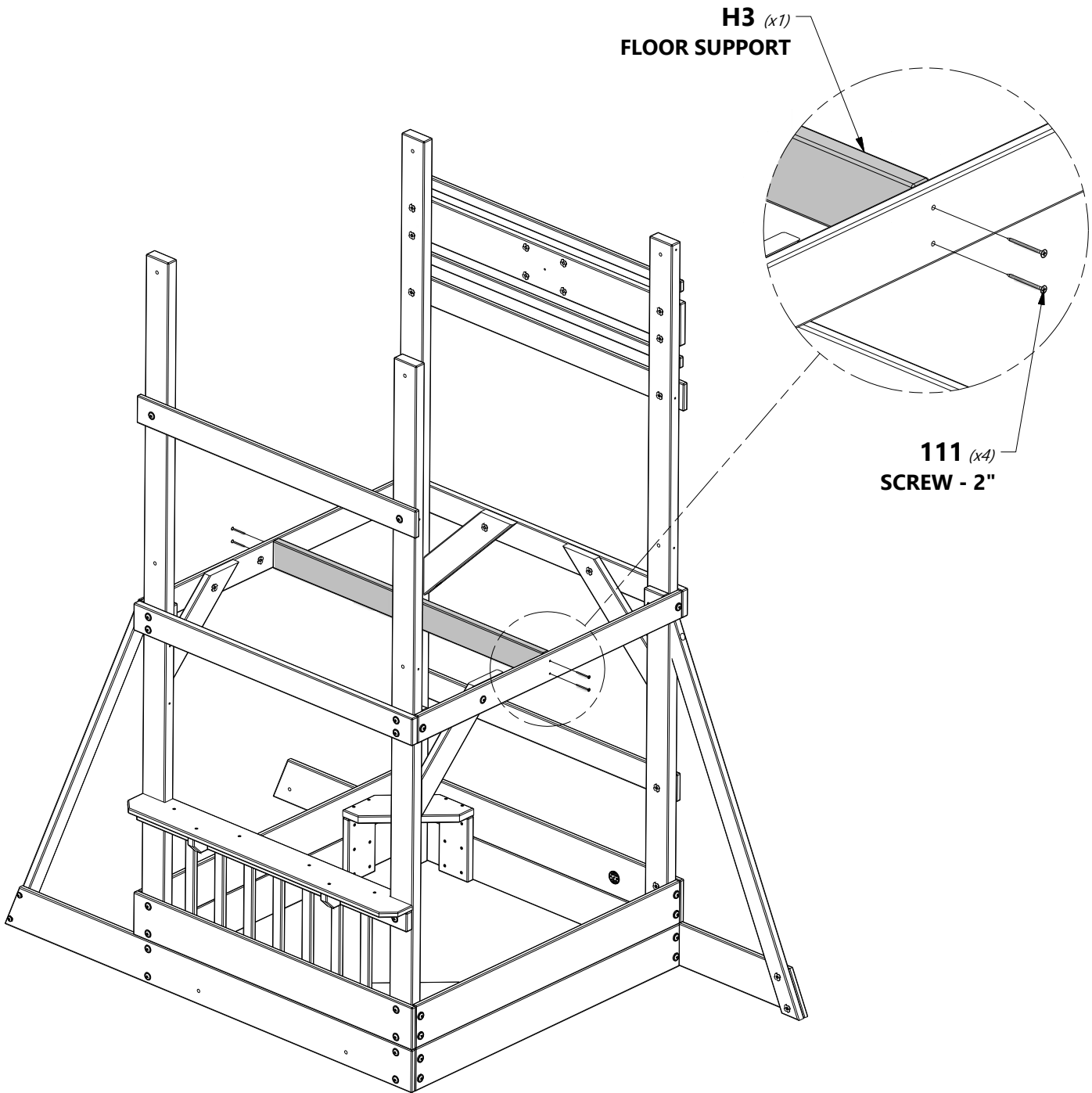



J5 | AWNING SUPPORT - W4L06908
(2) 1"x2 3/8"x11 3/4" (24x60x298)



H100027 | LAG SCREW WH
(2) 5/16x2

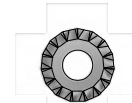

H100030 | WASHER LOCK EXT
(2) 8x19

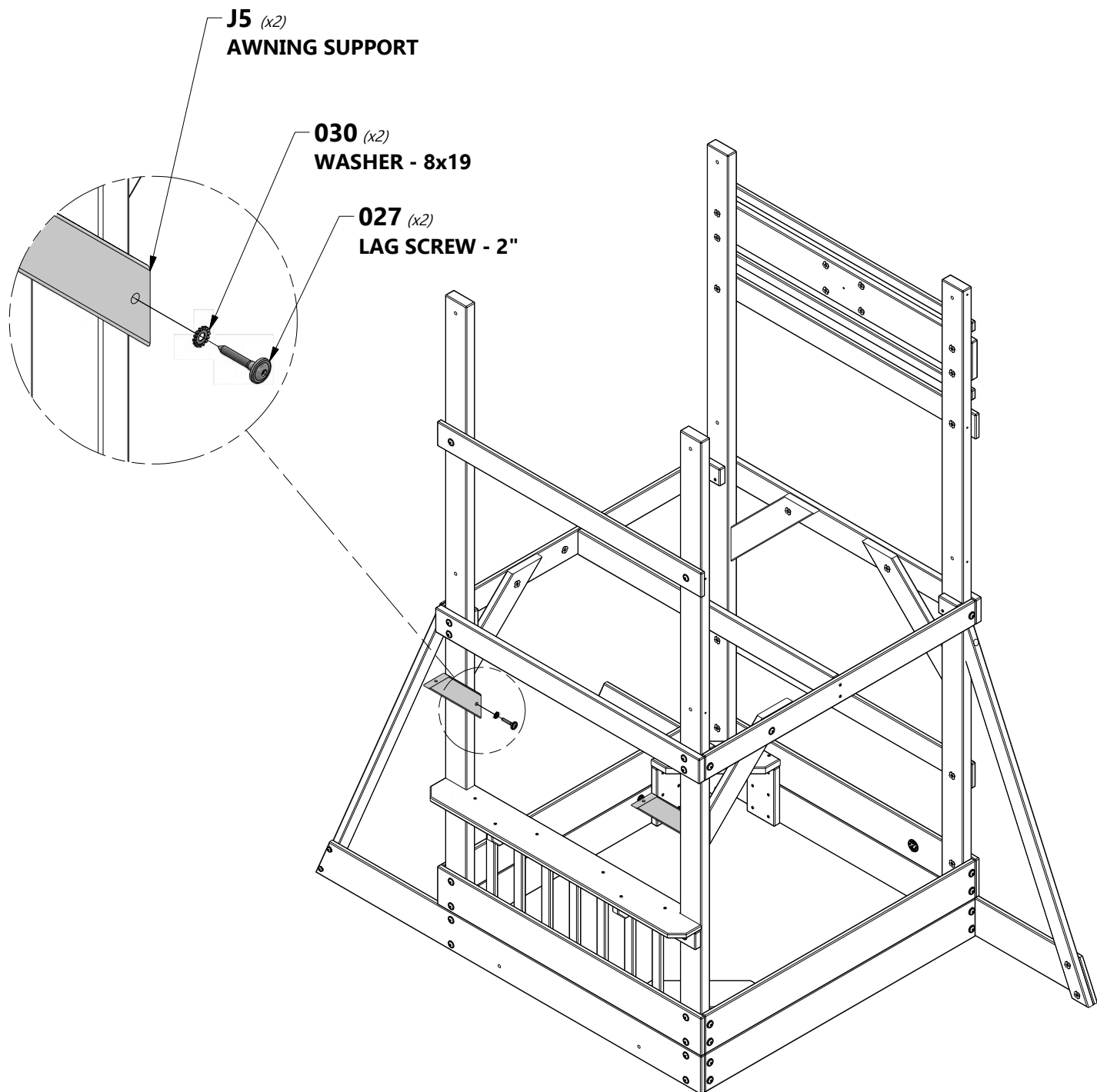

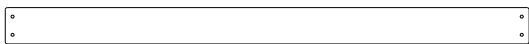

N1 | AWNING BOARD - W4L06907
(1) 5/8"x2 3/8"x34 1/8" (16x60x866)



J4 | AWNING BOARD - W4L06906
(2) 1"x2 3/8"x14 1/8" (24x60x358)



T2 | SAFETY BOARD - W4L13853
(2) 1"x1 3/8"x15 3/4" (24x34x400)



H100027 | LAG SCREW
(4) WH 5/16x2



H100145 | LAG SCREW
(4) WH 1/4x1 1/2



H100089 | SCREW PFH
(4) 8x1 3/4



H100138 | WASHER
(4) LOCK EXT 6x15



H100030 | WASHER
(4) LOCK EXT 8x19

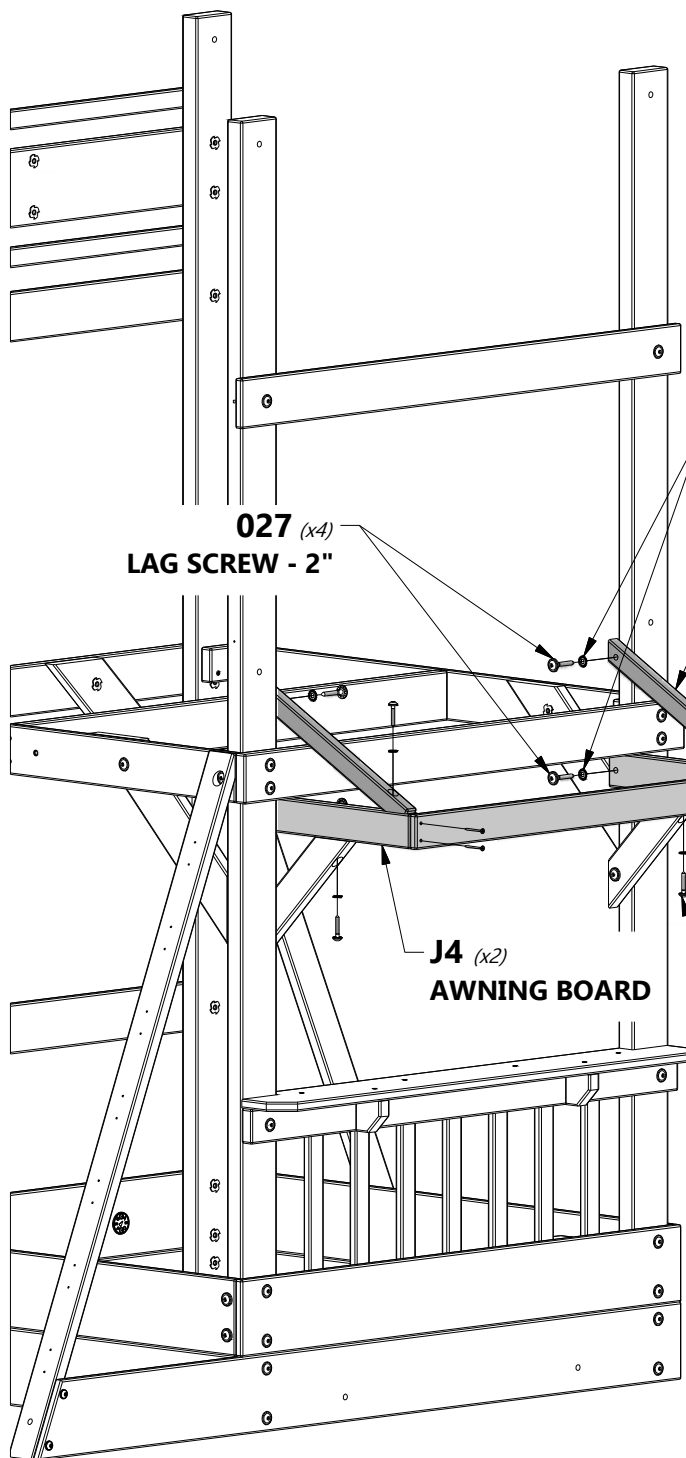
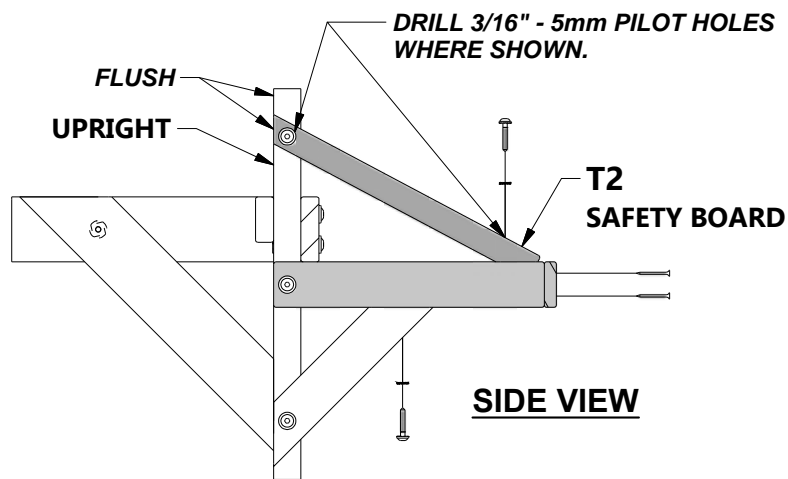

030 (x4)
WASHER - 8x19

027 (x4)
LAG SCREW - 2"

T2 (x2)
SAFETY BOARD

145 (x2)
LAG SCREW - 1 1/2"

138 (x2)
WASHER - 6x15

089 (x4)
SCREW - 1 3/4"

J4 (x2)
AWNING BOARD

N1 (x1)
AWNING BOARD

138 (x2)
WASHER - 6x15

145 (x2)
LAG SCREW - 1 1/2"

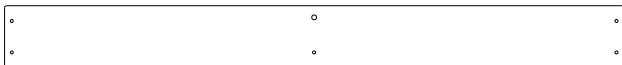

Y1 | FLOOR BOARD - W4L13851
(1) 5/8"x4"x40 3/8" (16x102x1024)



M6 | FLOOR BOARD - W4L06918
(10) 5/8"x3 3/8"x45 1/8" (16x86x1145)

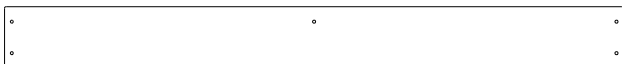

Y2 | FLOOR BOARD - W4L06917
(1) 5/8"x4"x40 3/8" (16x102x1024)



H100086 | SCREW PFH
(60) 8x1 1/2

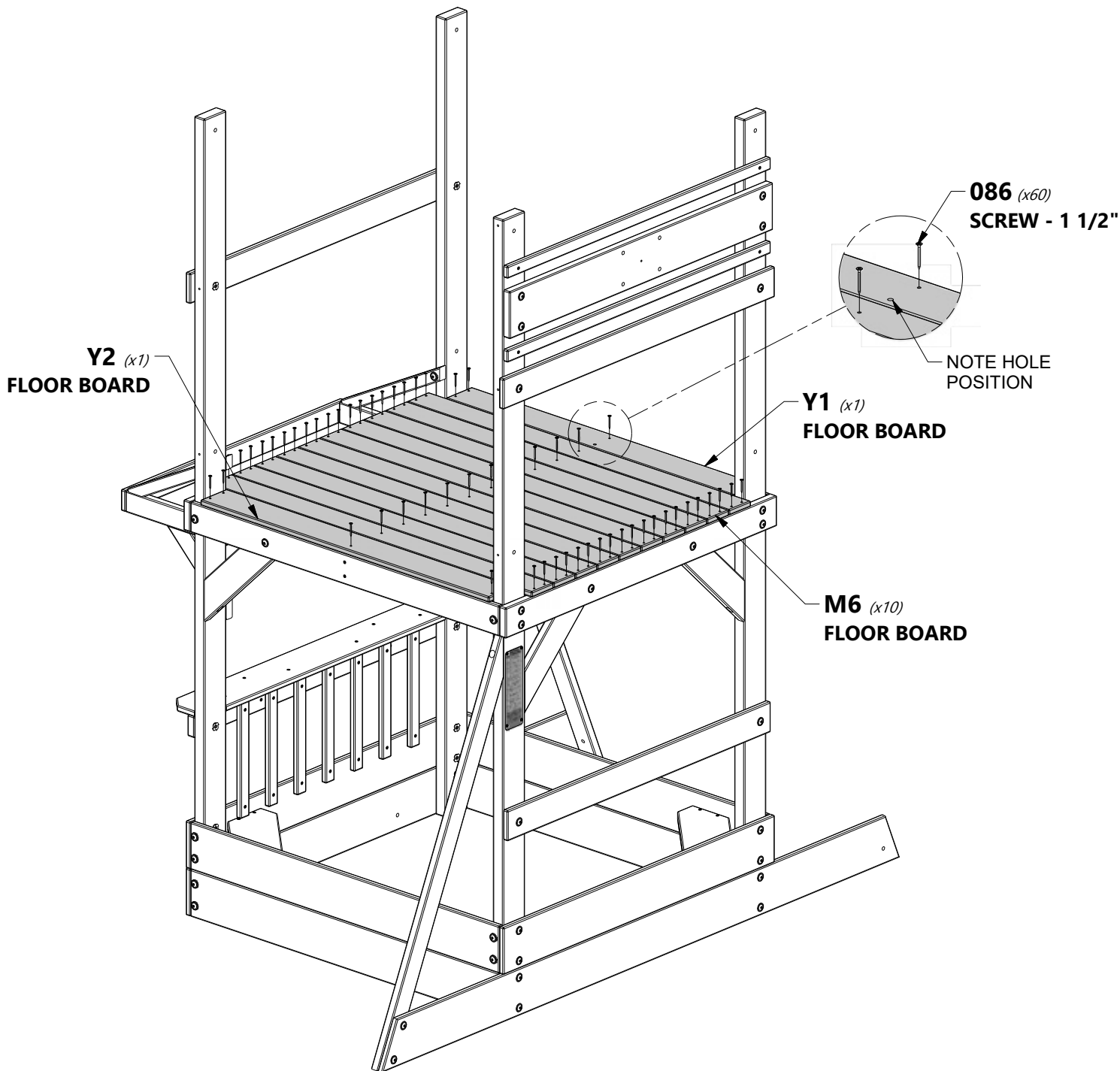

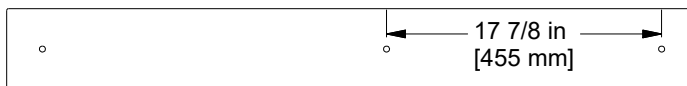

K6 | GROUND BOARD - W4L13852
(1) | 5/8"x5 1/4"x44 1/2" (16x134x1129)

J7 | LADDER RAIL - W4L13846
(1) | 1"x2 3/8"x50 3/8" (24x60x1279)



A4M01048 | L BRACKET
(1) | 2.5x38x55x55

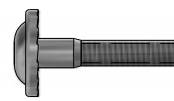

H100010 | BOLT WH
(2) | 5/16x1-1/2

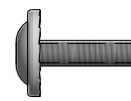

H100008 | BOLT WH
(1) | 5/16x1



H100004 | NUT BARREL
(2) | WH
5/16 x 5/8

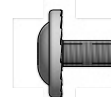

H100115 | BOLT WH
(2) | 5/16x1/2



H100030 | WASHER
(3) | LOCK EXT
8x19



H100031 | WASHER
(2) | LOCK EXT
12x19



H100074 | T-NUT
(2) | 5/16

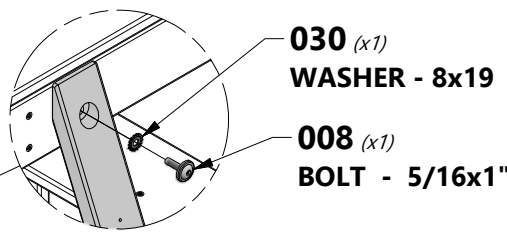
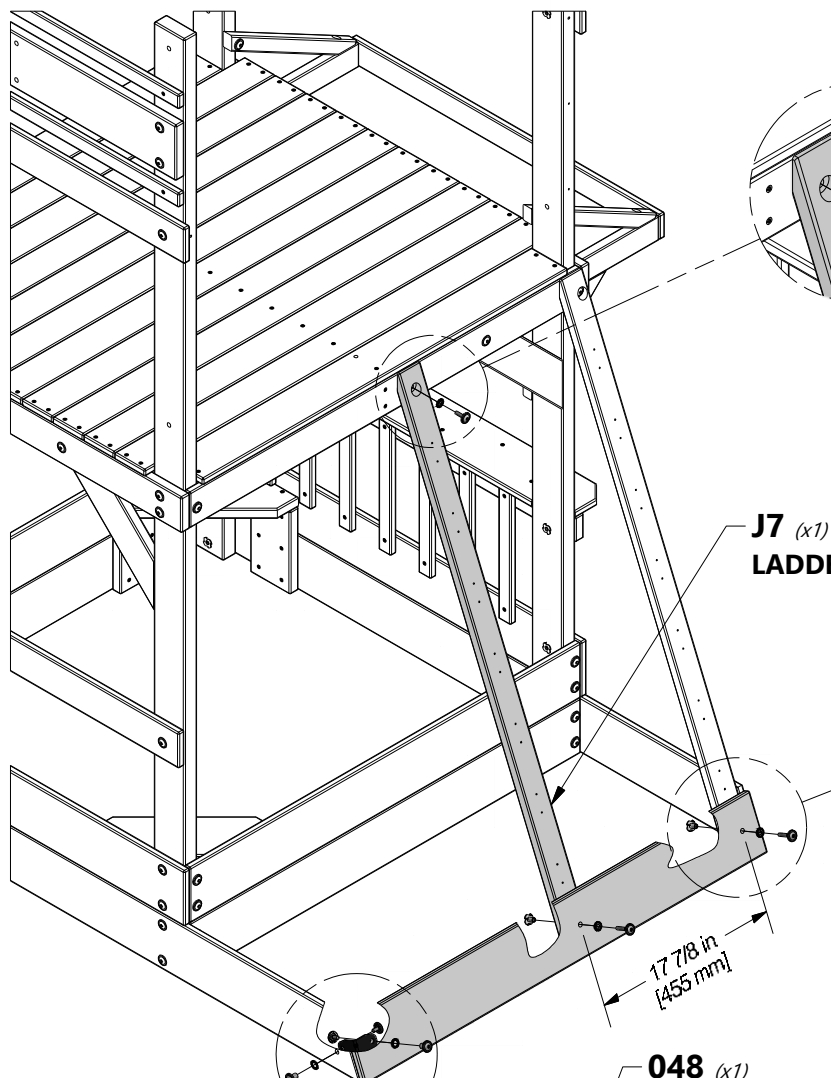

030 (x1)
WASHER - 8x19

008 (x1)
BOLT - 5/16x1"

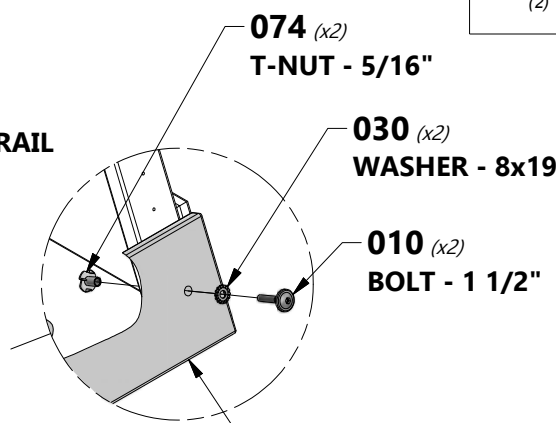

074 (x2)
T-NUT - 5/16"

030 (x2)
WASHER - 8x19

010 (x2)
BOLT - 1 1/2"

K6 (x1)
GROUND BOARD

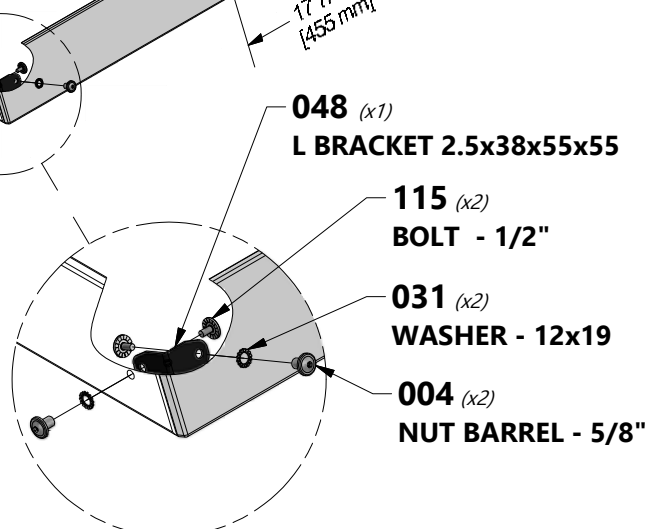

048 (x1)
L BRACKET 2.5x38x55x55

115 (x2)
BOLT - 1/2"

031 (x2)
WASHER - 12x19

004 (x2)
NUT BARREL - 5/8"

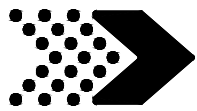

M7 | WALL RAIL - W4L0691
(2) | 5/8"x3 3/8"x41 1/2" (16x86x1054)



M9 | WALL RAIL - W4L06941
(1) | 5/8"x3 3/8"x43 1/4" (16x86x1097)

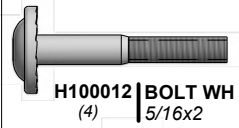

H100012 | BOLT WH
(4) | 5/16x2

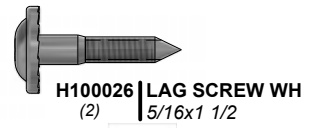

H100026 | LAG SCREW WH
(2) | 5/16x1 1/2



H100030 | WASHER LOCK EXT
(6) | 8x19

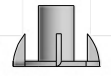

H100074 | T-NUT
(4) | 5/16

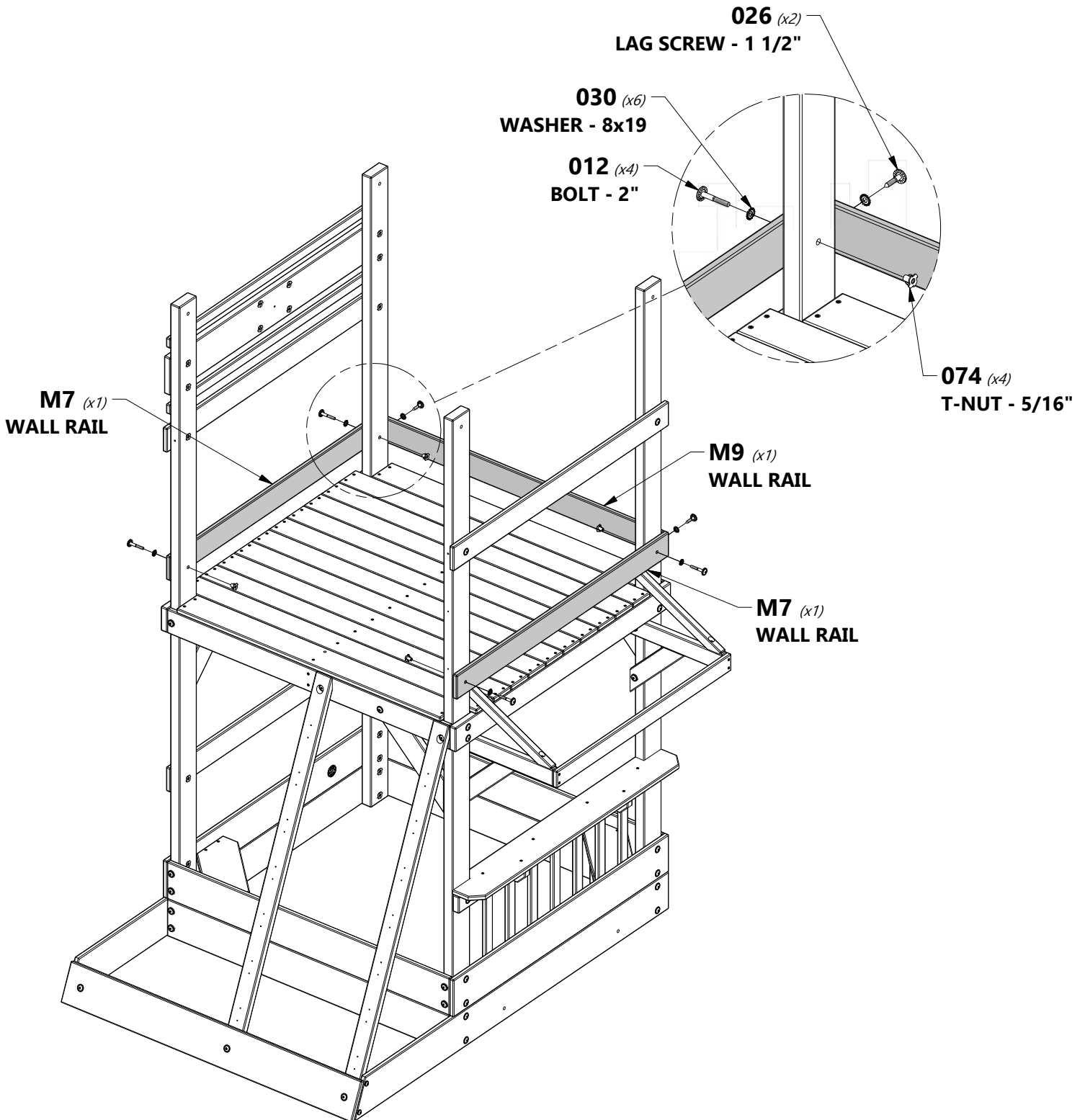

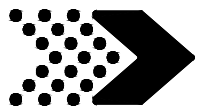

O4 | AWNING BOARD - W4L06957
(1) 5/8"x1 3/8"x32 1/4" (16x34x818)

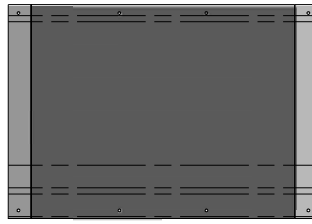

A6P00124 | AWNING
(1)



H100088 | SCREW PFH
(4) 8x1 1/8



H100128 | SCREW PWH
(4) 8x5/8

HOLD O4 BOARD DOWN 1" - 25mm FROM TOP & CENTERED IN OPENING.

O4 (x1)
AWNING BOARD
1" (25mm)

088 (x4)
SCREW - 1 1/8"

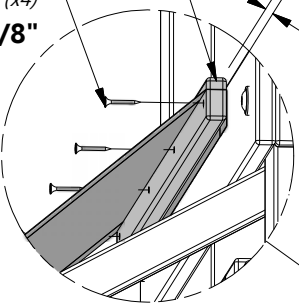

124 (x1)
AWNING

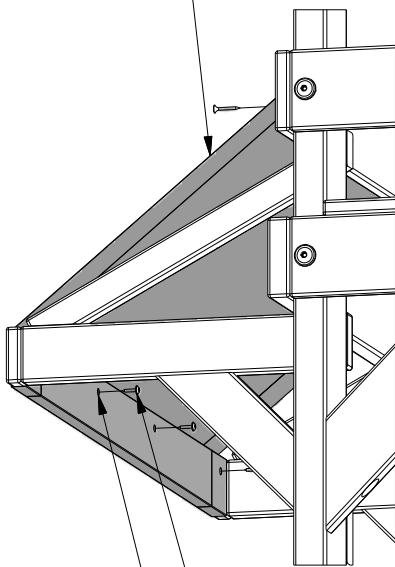

128 (x4)
SCREW - 5/8

GROMMETS THIS END

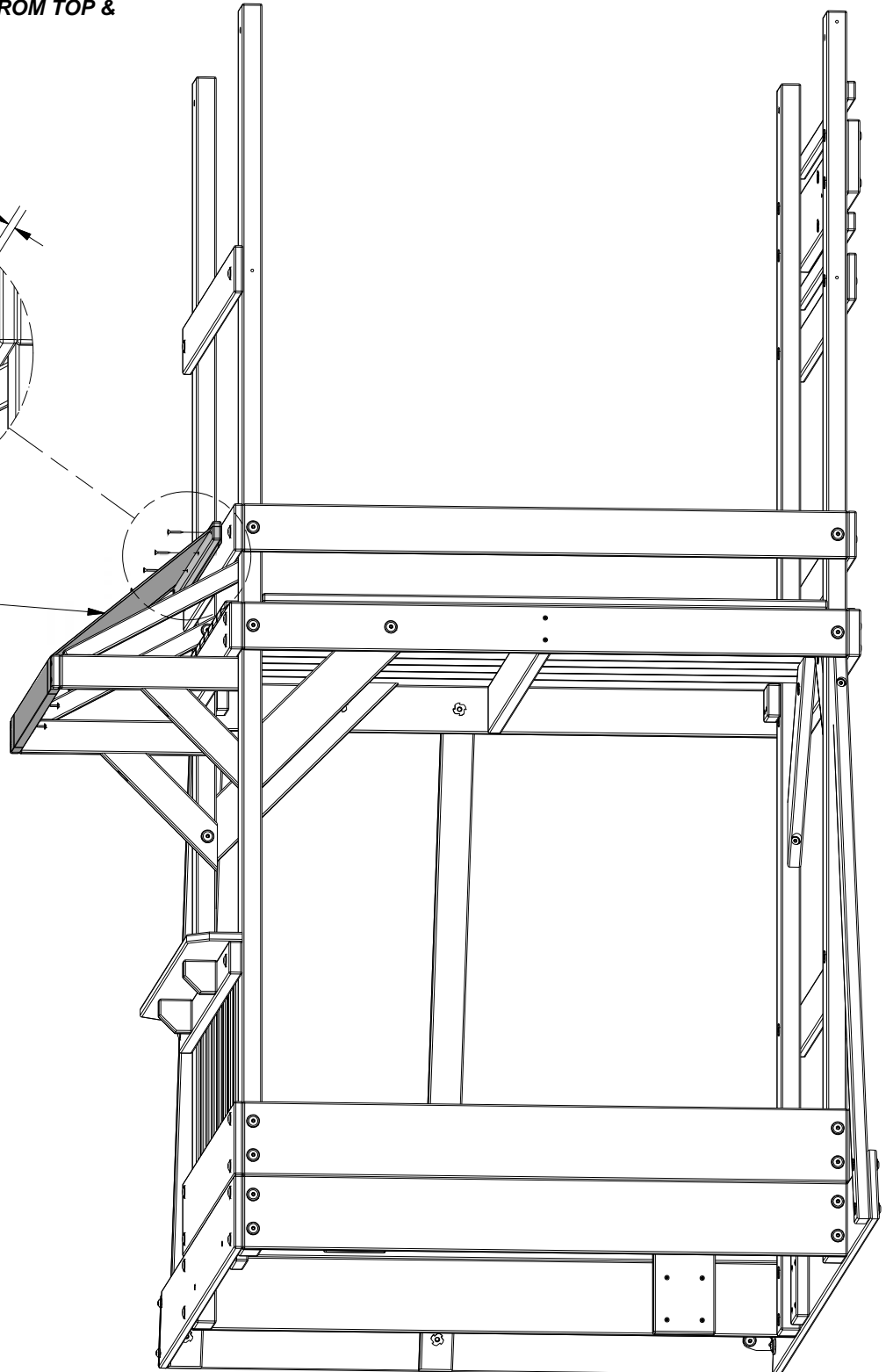



M10 | WALL RAIL - W4L06942
(1) 5/8"x3 3/8"x43 1/4" (16x86x1097)

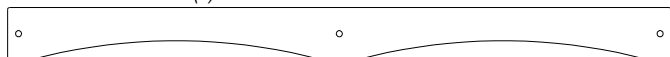

M11 | ARCHED WALL RAIL - W4L06943
(1) 5/8"x3 3/8"x43 1/4" (16x86x1097)



H100026 | LAG SCREW WH
(4) 5/16"x1 1/2"



**H100030 | WASHER
LOCK EXT**
(4) 8x19



H100074 | T-NUT
(2) 5/16"

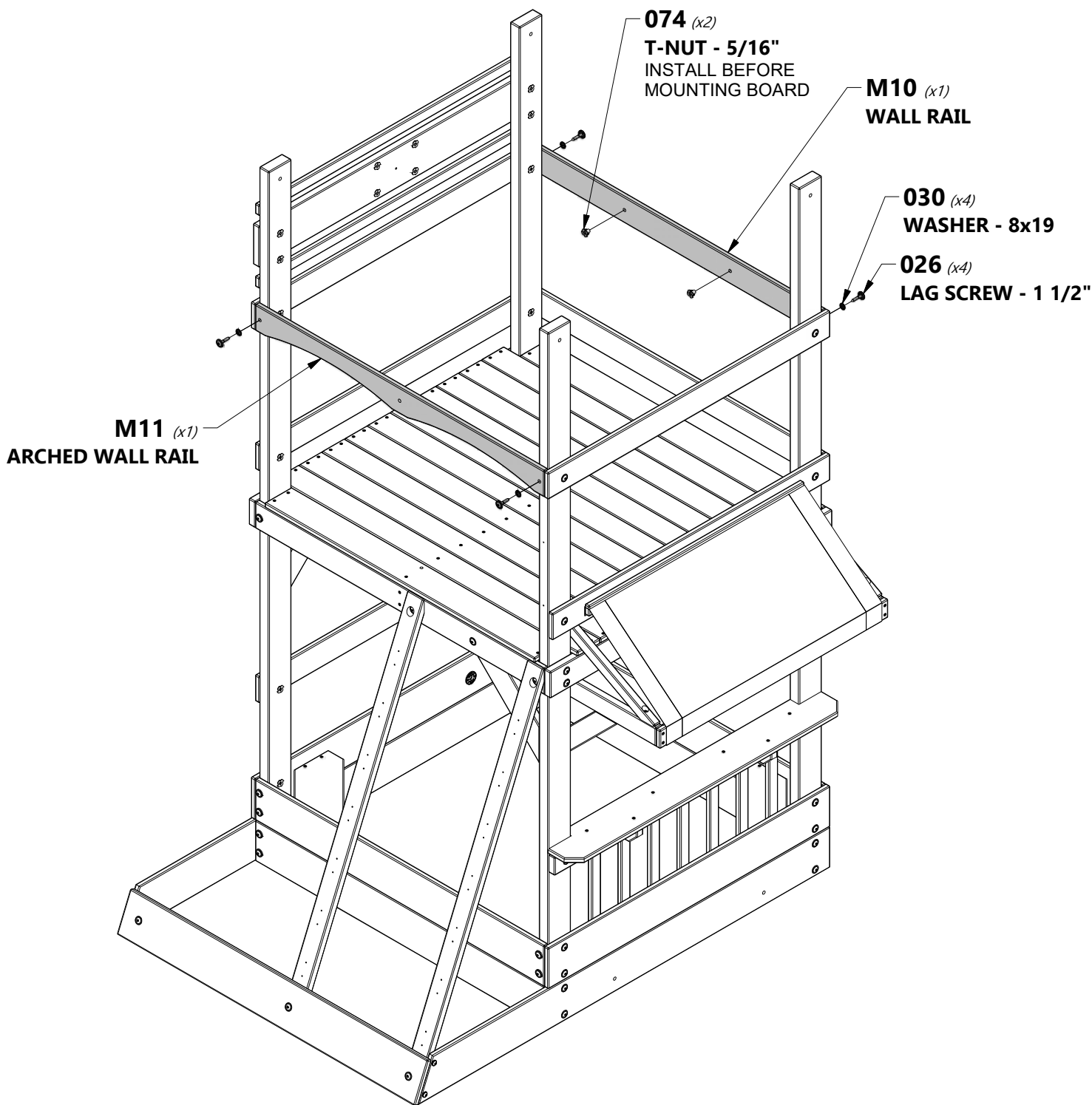

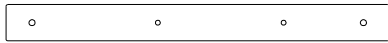
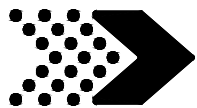

J8 WALL BOARD - W4L06947
(1) 1"x2 3/8"x25" (24x60x634)



A4M01048 L BRACKET
(1) 2.5x38x55x55



H100010 BOLT WH
(1) 5/16x1-1/2



H100115 BOLT WH
(1) 5/16x1/2



H100145 LAG SCREW WH
(1) 1/4x1 1/2

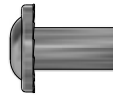

H100005 NUT BARREL WH
(1) 5/16x7/8



H100030 WASHER LOCK EXT
(1) 8x19



H100031 WASHER LOCK EXT
(1) 12x19



H100074 T-NUT
(1) 5/16

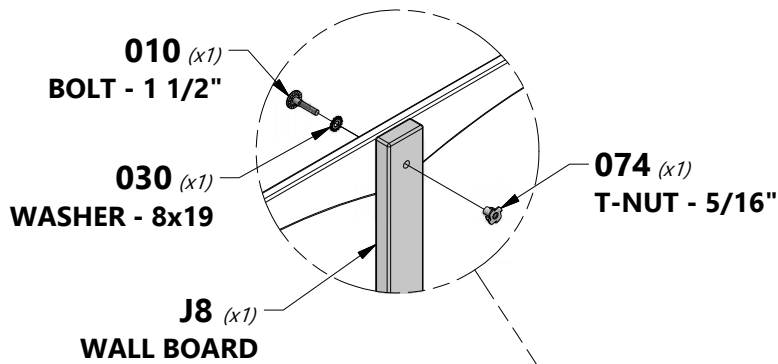

NOTE CENTER HOLES ON J8 BOARD LOCATED CLOSER TO THE DECK.

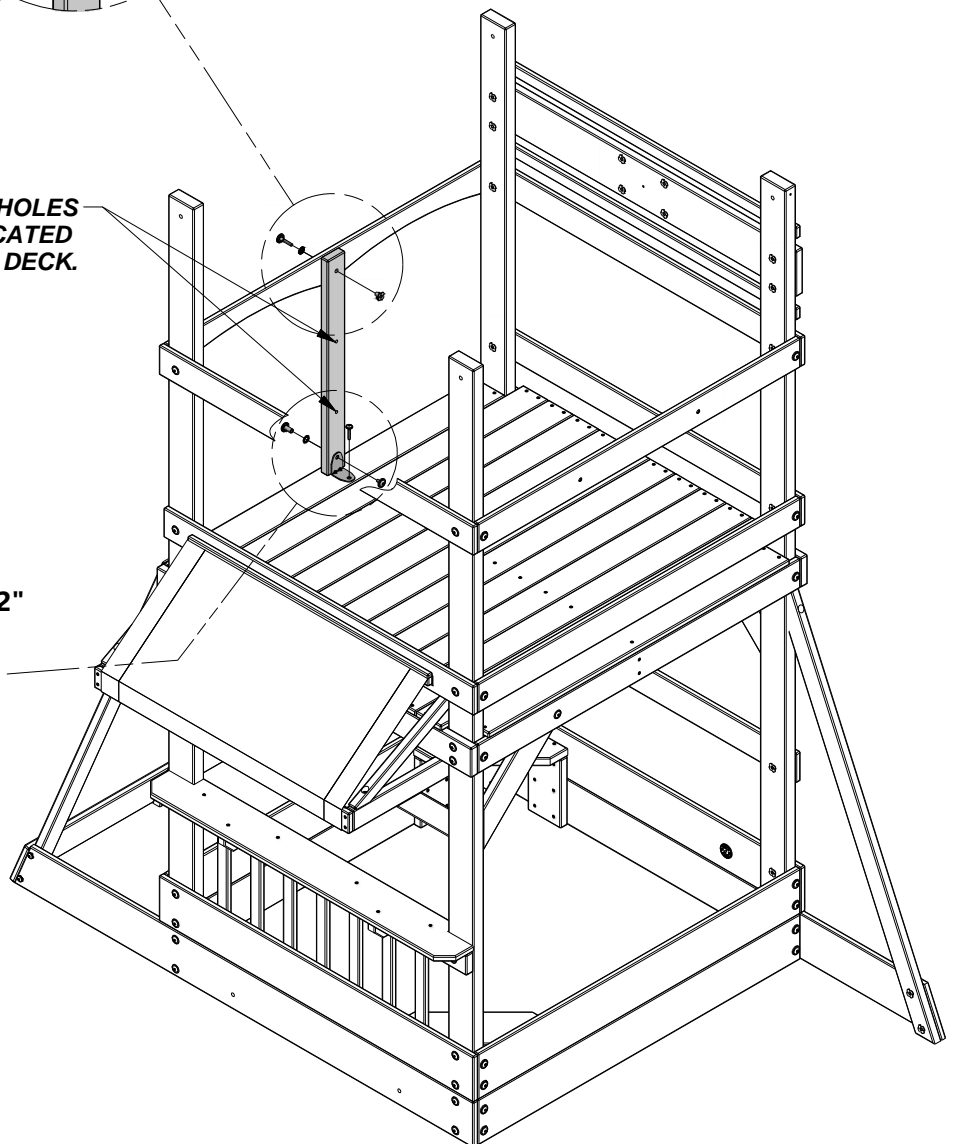
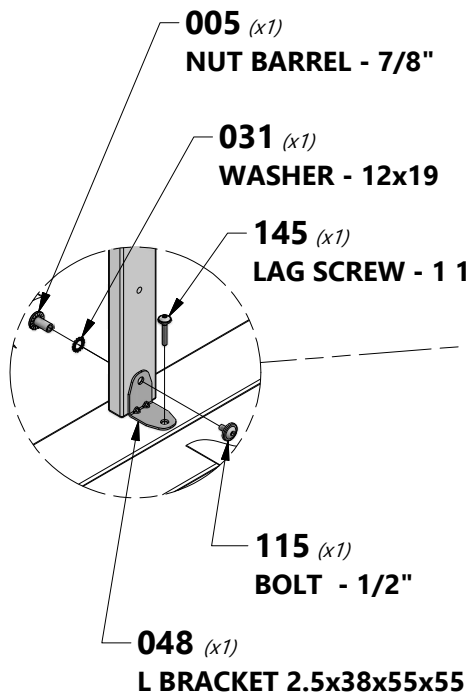

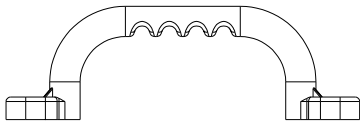

A6P00127 | HAND GRIP LIME PLASTIC
(2)



H100142 | BOLT WH
(2) 1/4x1-1/4



H100145 | LAG SCREW WH
(2) 1/4x1 1/2



H100138 | WASHER LOCK EXT
(2) 6x15



H100108 | WASHER LOCK INT
(2) 8x15



H100072 | T-NUT
(2) 1/4

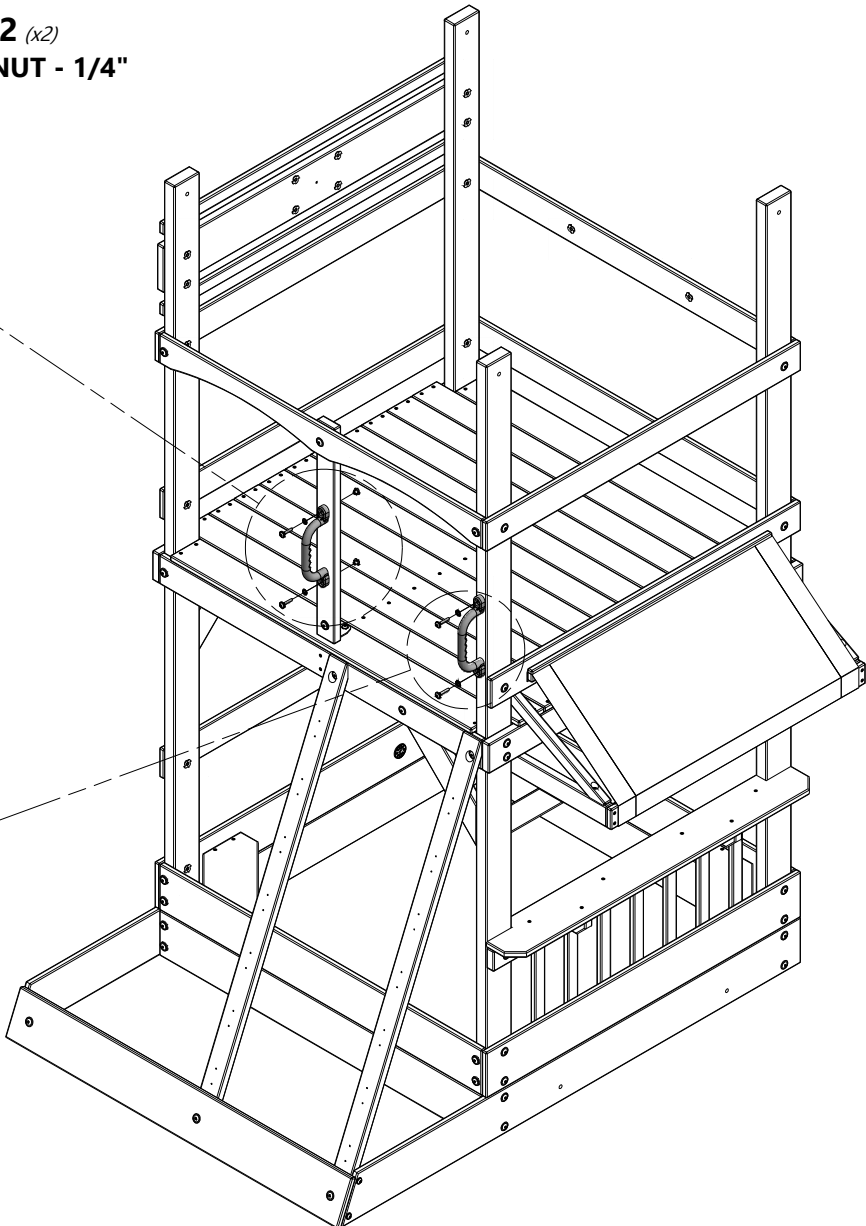
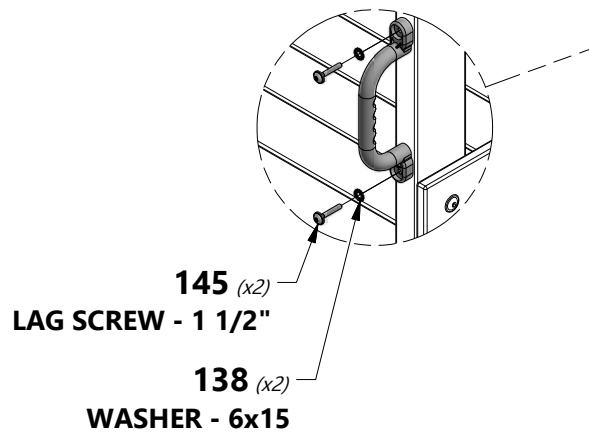
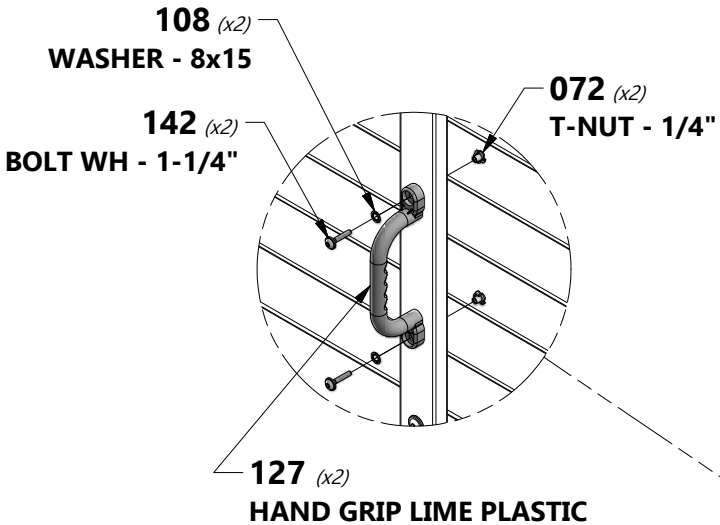

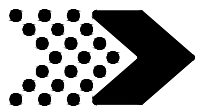

O2 PICKET - W4L06944
(7) 5/8"x1 3/8"x18 1/4" (16x34x465)



H100088 SCREW PFH
(14) 8x1 1/8

CENTER O2 BOARDS IN OPENING, APPROXIMATELY 1 7/8" - 46mm DOWN FROM M8 BOARD. APPROXIMATELY 3 1/8" - 79mm SPACING BETWEEN PICKETS.

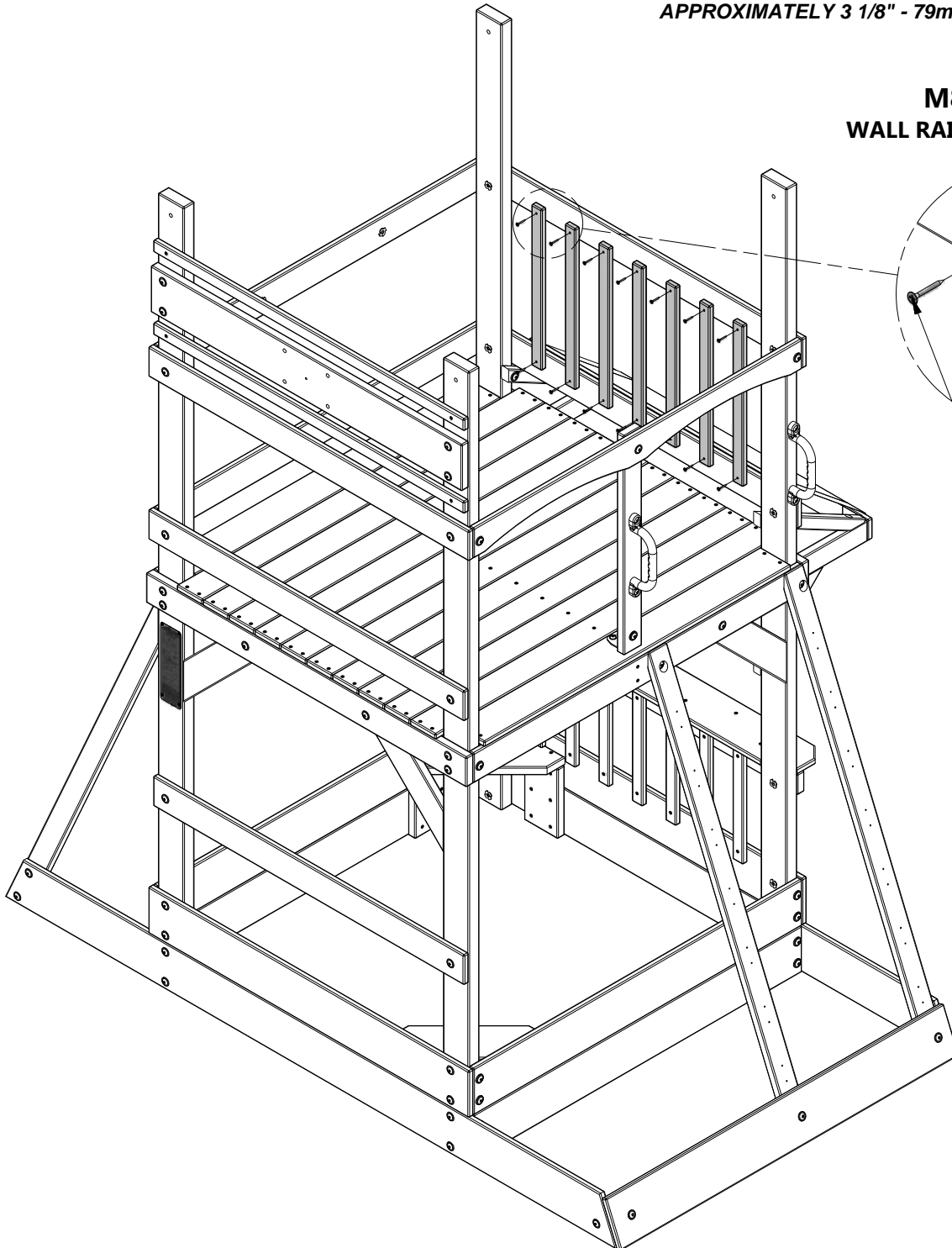

M8 WALL RAIL

O2 (x7) PICKET

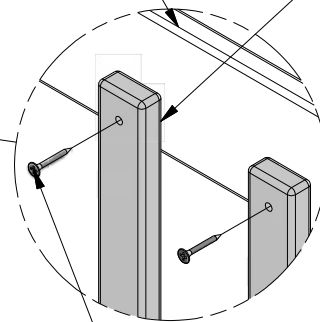

088 (x14) SCREW - 1 1/8"



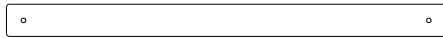
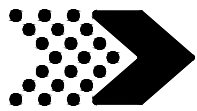

O2 PICKET - W4L06944
(9) 5/8"x1 3/8"x18 1/4" (16x34x465)



H100088 SCREW PFH
(18) 8x1 1/8"

**CENTER O2 BOARDS IN OPENING, APPROXIMATELY
1 7/8" - 46mm DOWN FROM M10 BOARD.
2 7/8" - 72mm SPACING BETWEEN PICKETS.**

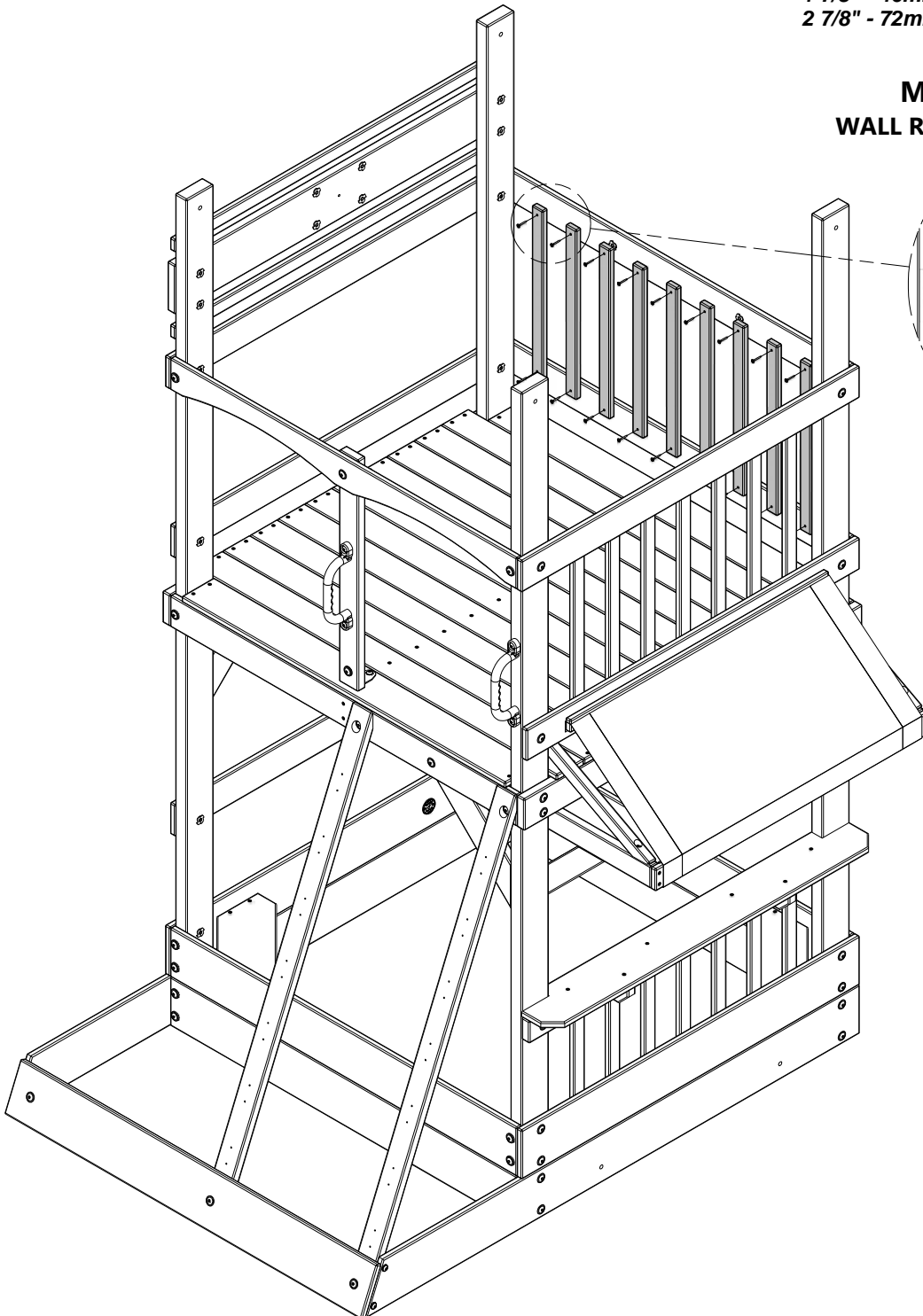

**M10
WALL RAIL**

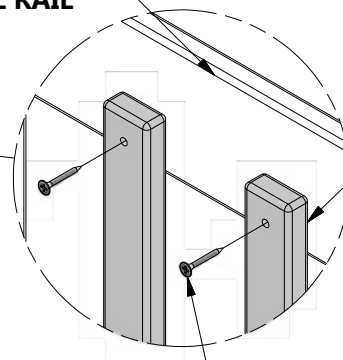

**O2 (x9)
PICKET**

**088 (x18)
SCREW - 1 1/8"**



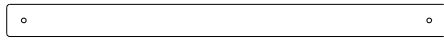
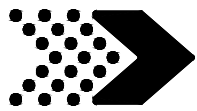

O2 PICKET - W4L06944
 (7) | 5/8"x1 3/8"x18 1/4" (16x34x465)



H100088 | SCREW PFH
 (14) | 8x1 1/8"

CENTER O2 BOARDS IN OPENING, APPROXIMATELY 1 7/8" - 46mm DOWN FROM M8 BOARD. APPROXIMATELY 3 1/8" - 79mm SPACING BETWEEN PICKETS.

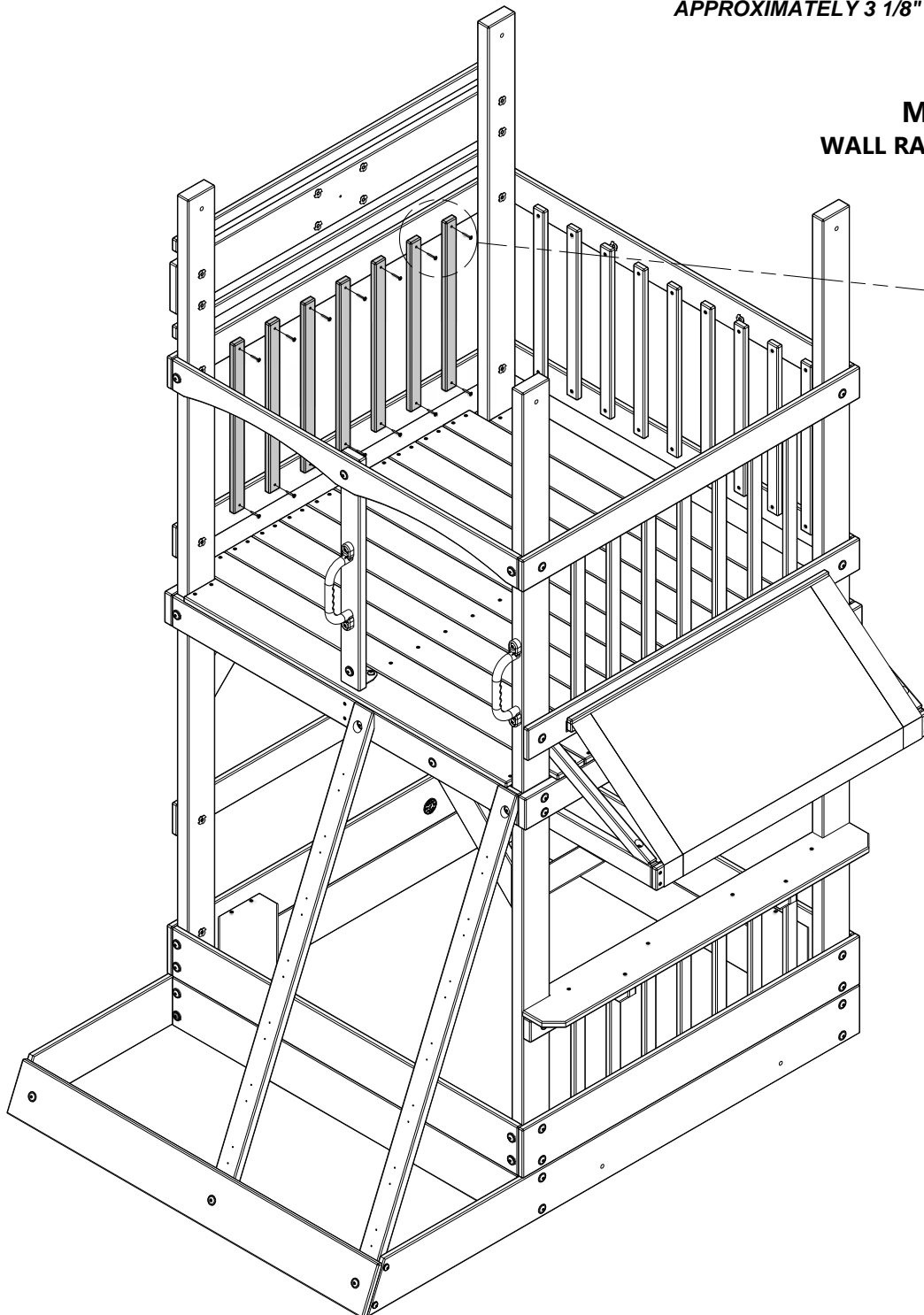

M8
WALL RAIL

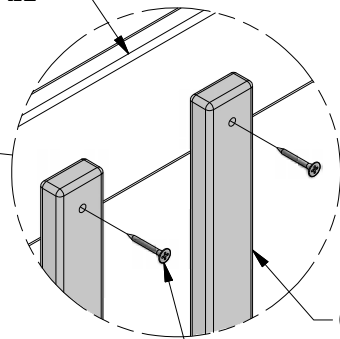

O2 (x7)
PICKET

088 (x14)
SCREW - 1 1/8"





H4 | HORIZONTAL TARP SUPPORT - W4L13838
(2) | 1"x3 3/8"x56 1/8" (24x86x1425)



H5 | HORIZONTAL TARP SUPPORT - W4L13839
(2) | 1"x3 3/8"x48 3/4" (24x86x1237)

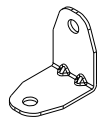

A4M01048 | L BRACKET
(4) | 2.5x38x55x55



H100013 | BOLT WH
(4) | 5/16x2 1/4

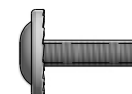

H100008 | BOLT WH
(4) | 5/16x1

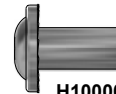

H100005 | NUT BARREL
(4) | WH
5/16x7/8



H100115 | BOLT WH
(4) | 5/16x1/2



H100030 | WASHER
(4) | LOCK EXT
8x19



H100031 | WASHER
(4) | LOCK EXT
12x19



H100074 | T-NUT
(8) | 5/16

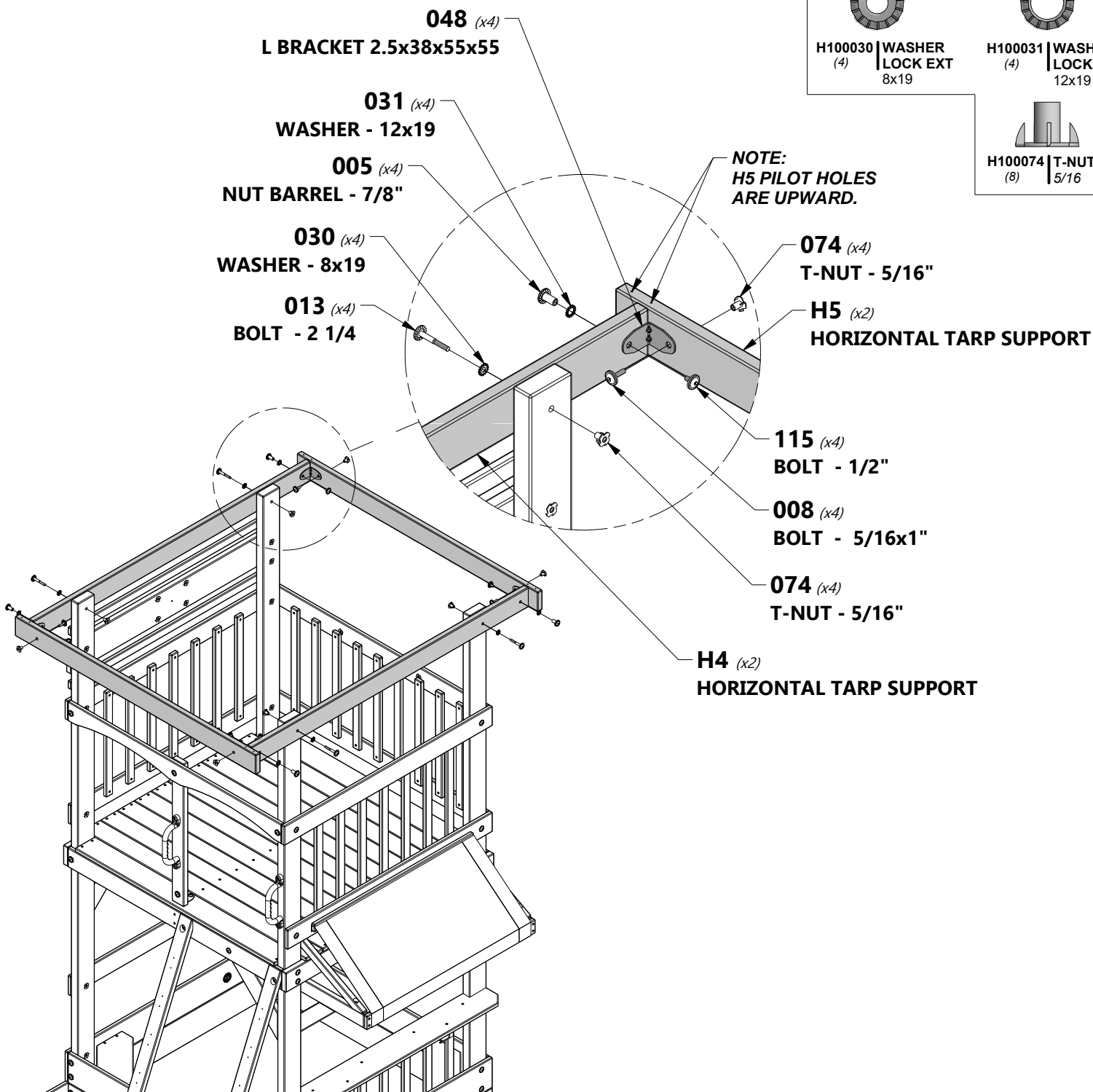

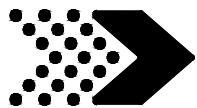

FORT ASSEMBLY

STEP 25



H6 | ROOF BOARD - W4L06950
(4) | 1"x3 3/8"x40 3/8" (24x86x1025)

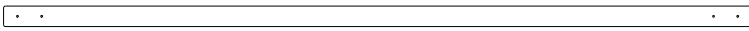

T1 | ROOF BOARD - W4L06951
(1) | 1"x1 3/8"x48 3/4" (24x34x1237)



085 (x8)
SCREW - 1"

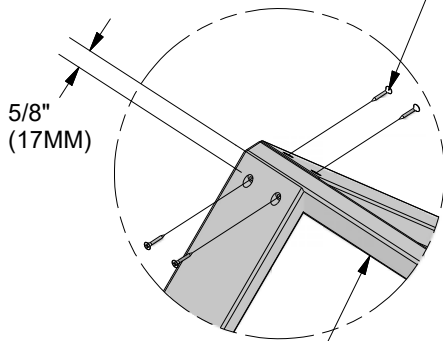

T1 (x1)
ROOF BOARD

H6 (x4)
ROOF BOARD

086 (x8)
SCREW - 1 1/2"

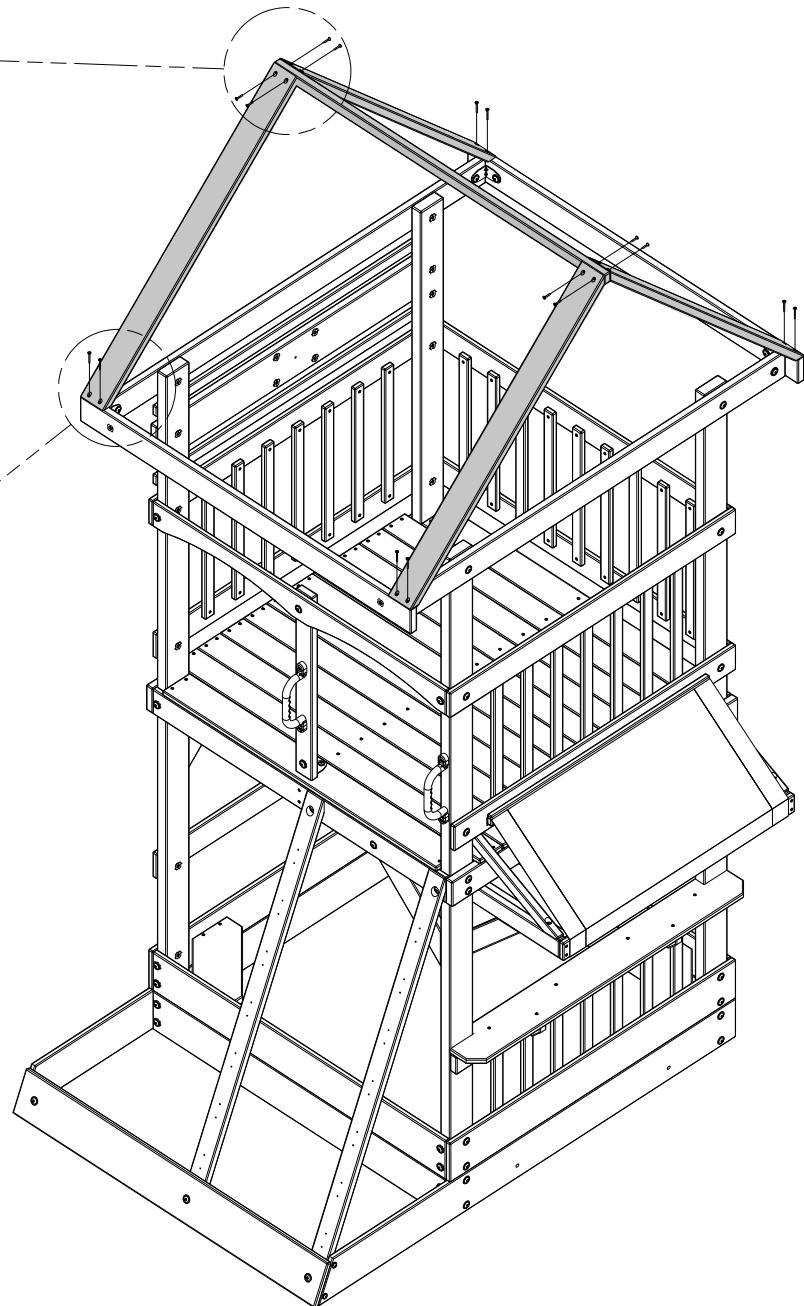
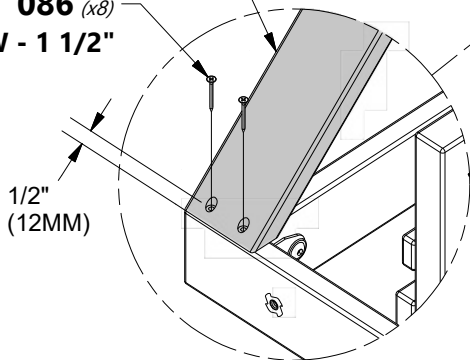

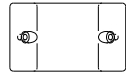
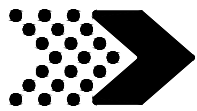

J10 ROOF BOARD - W4L06952
(2) 1"x2 3/8"x4" (24x60x102)



H100085 SCREW PFH
(4) 8x1

FLUSH J10 BOARD TO THE INSIDE OF H6 BOARDS.

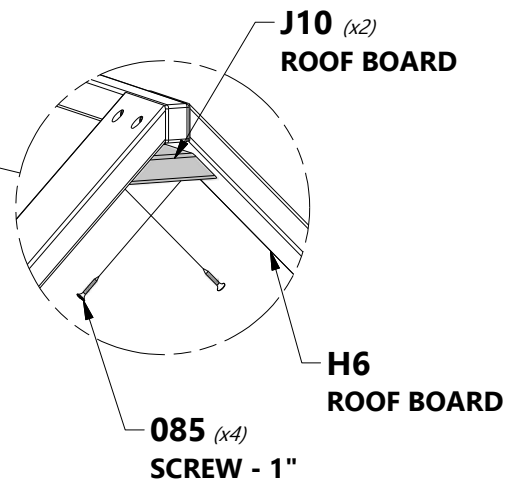
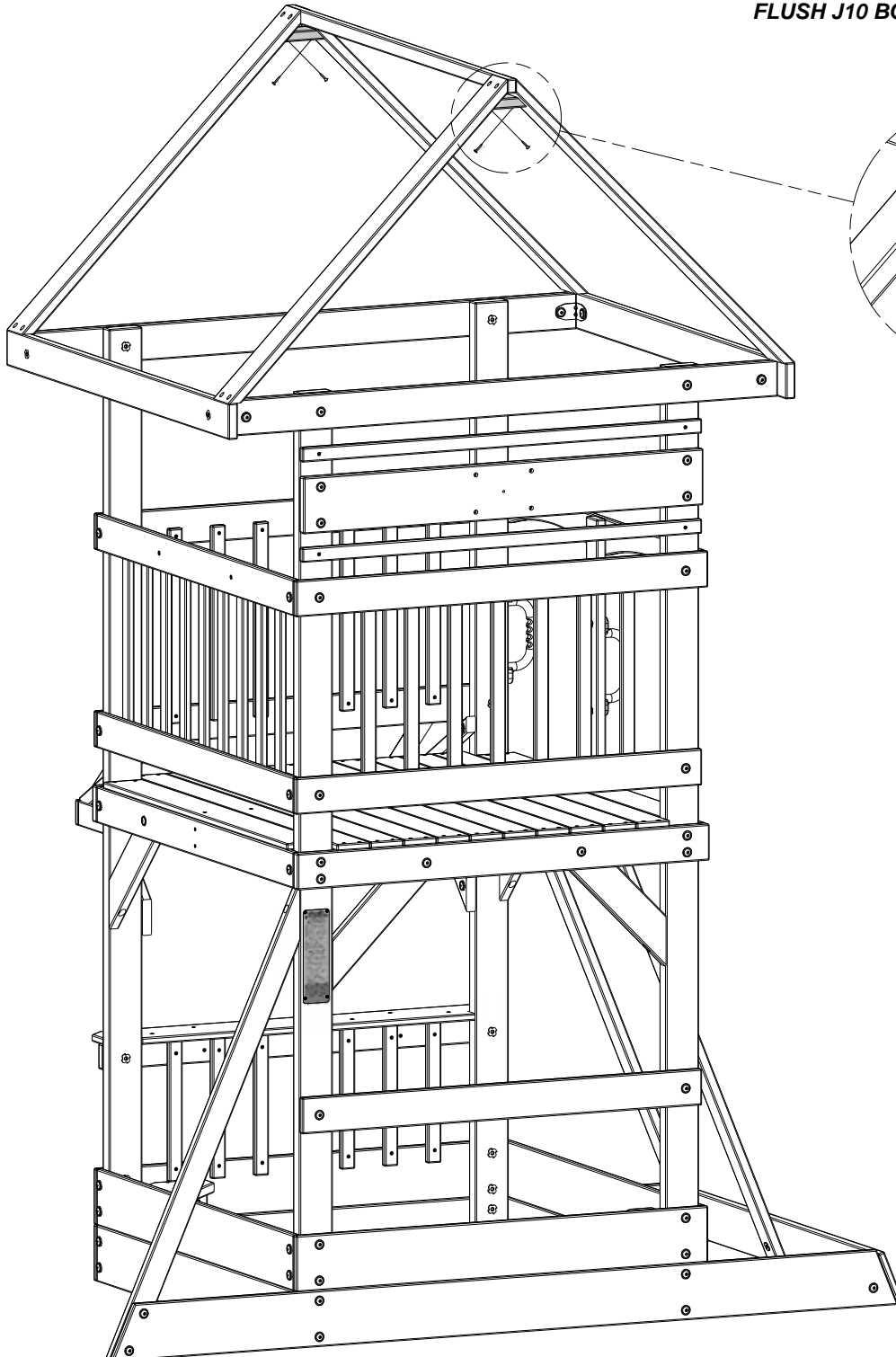

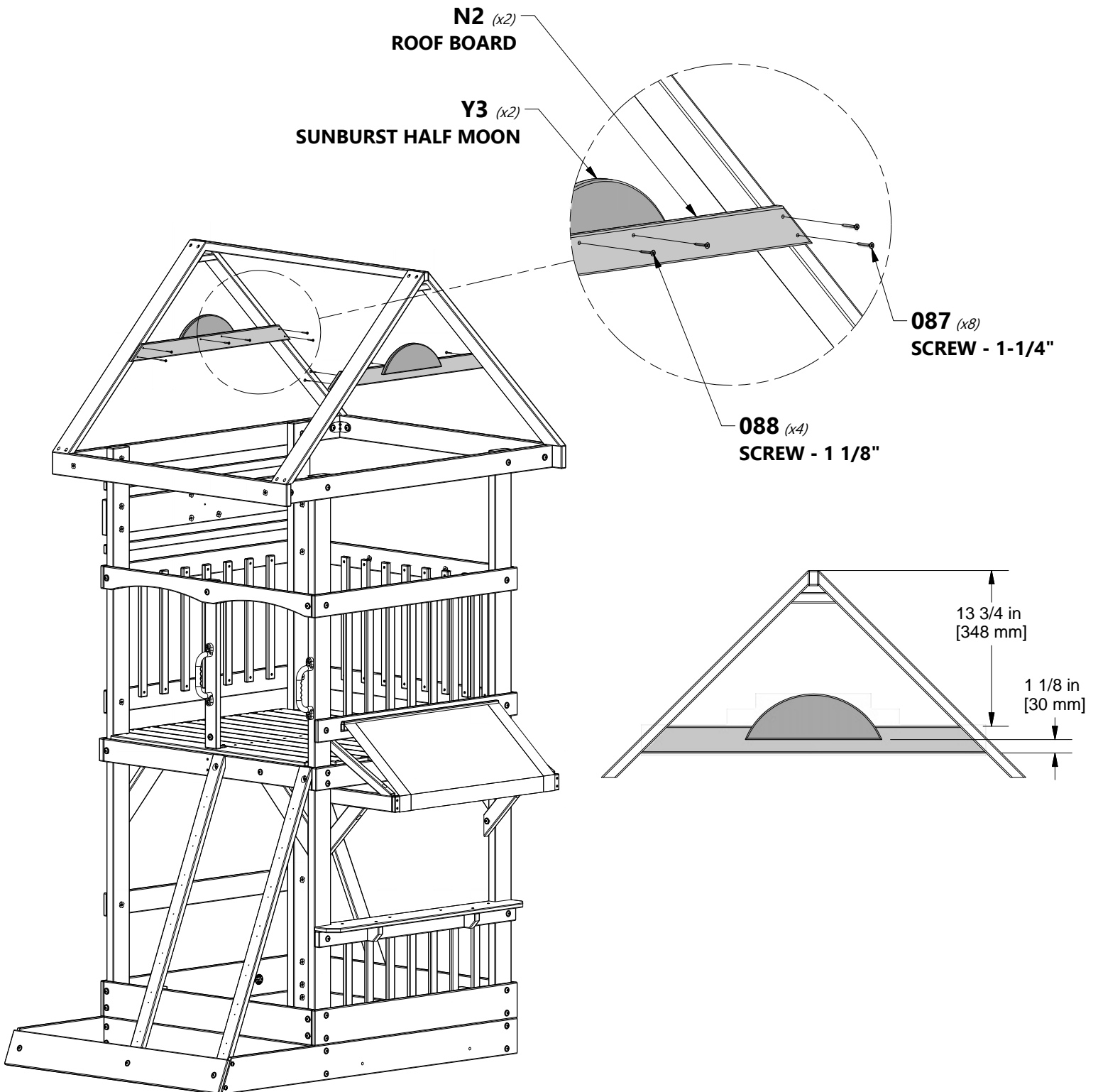
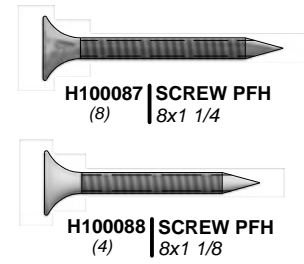
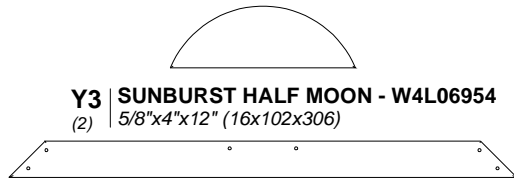
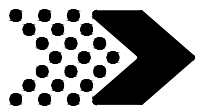



N4 | SUNBURST BOARD - W4L06956
 (4) 5/8"x2 3/8"x8 1/8" (16x60x205)



N3 | SUNBURST BOARD - W4L06955
 (2) 5/8"x2 3/8"x11 3/4" (16x60x299)



H100088 | SCREW PFH
 (18) 8x1 1/8"

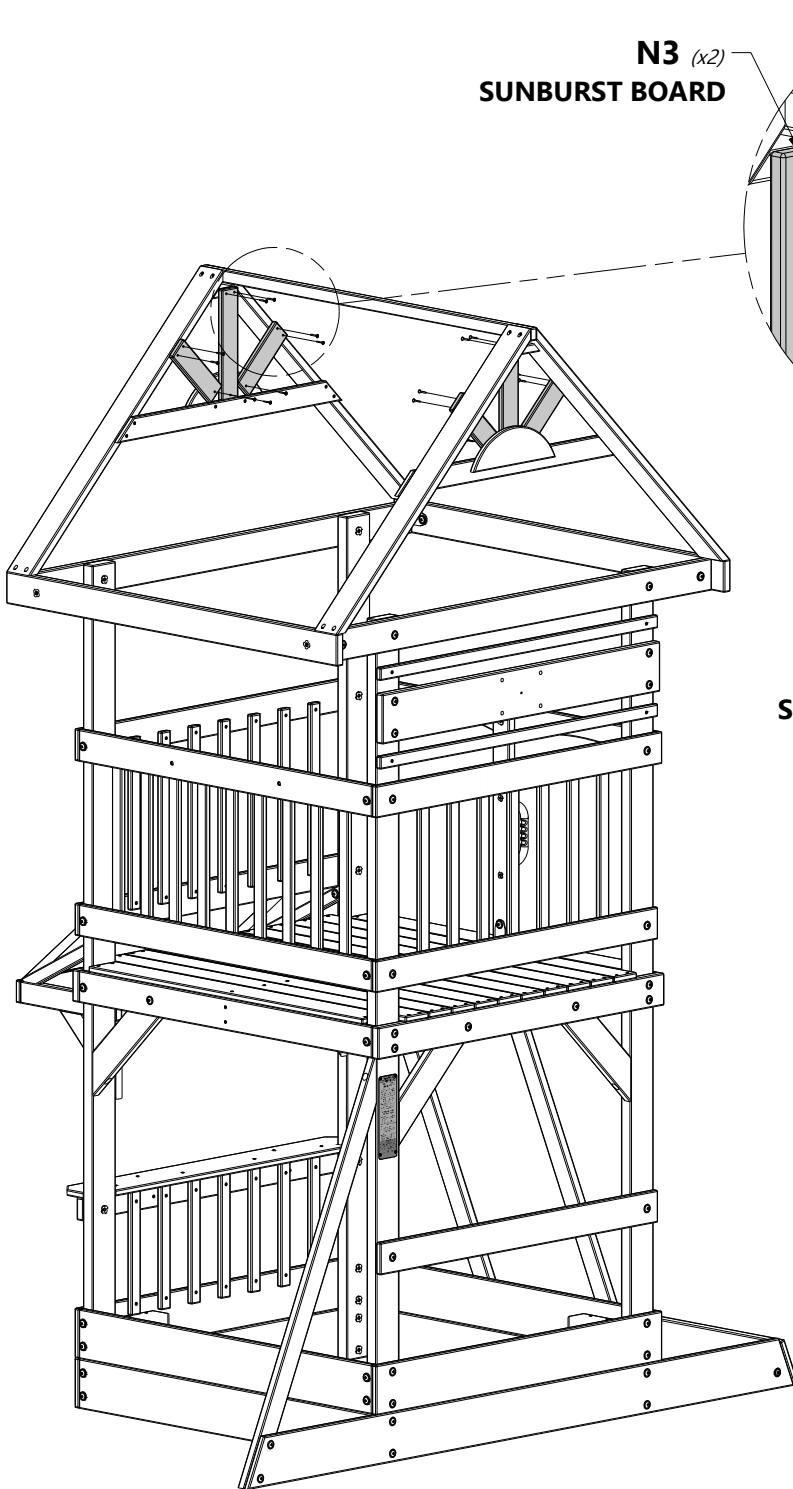

N3 (x2)
SUNBURST BOARD

N4 (x4)
SUNBURST BOARD

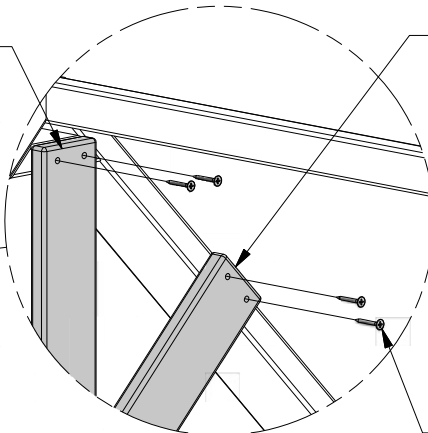

088 (x18)
SCREW - 1 1/8"

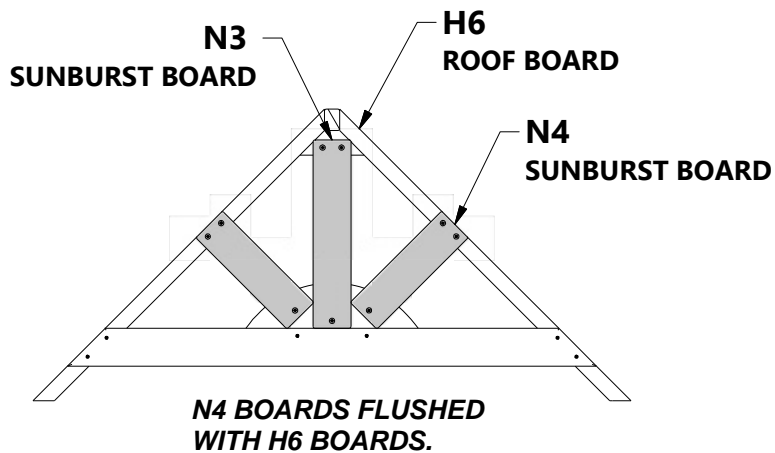

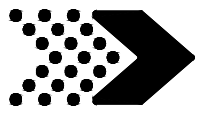

FORT ASSEMBLY

STEP 29

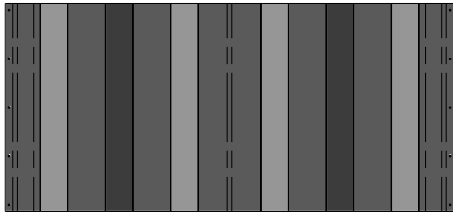

A6P00123 | TARP
(1)



H100128 | SCREW PWH
(10) | 8x5/8

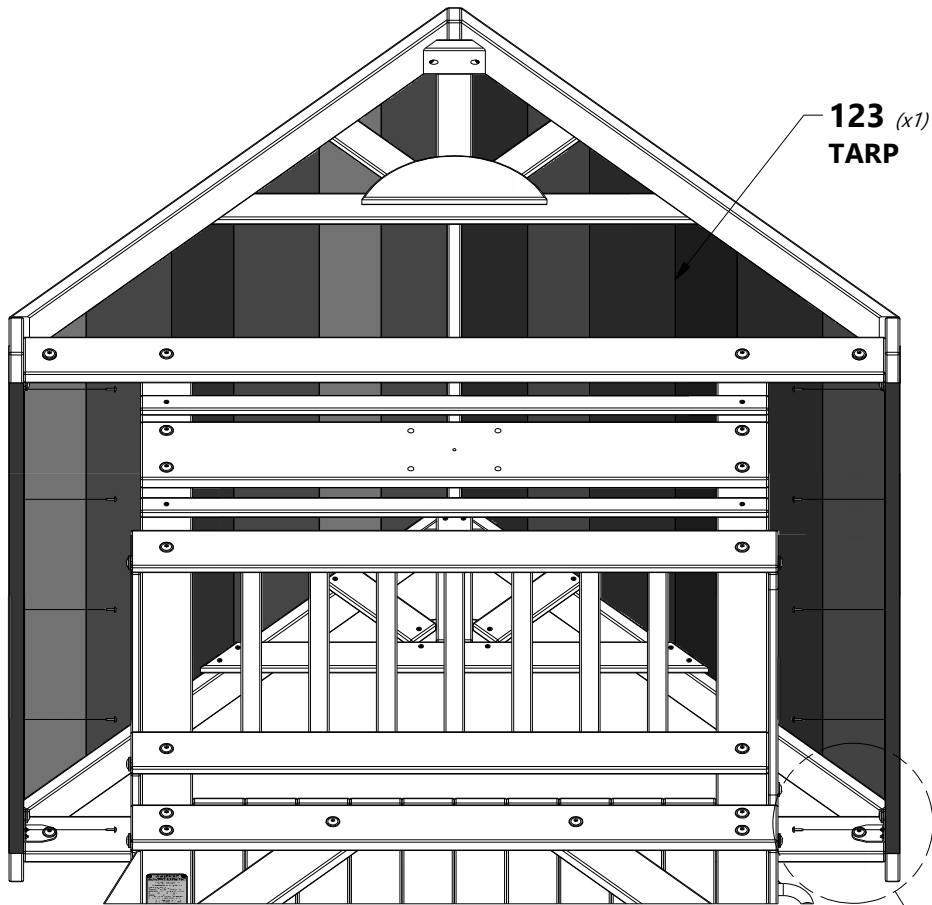

128 (x10)
SCREW - 5/8

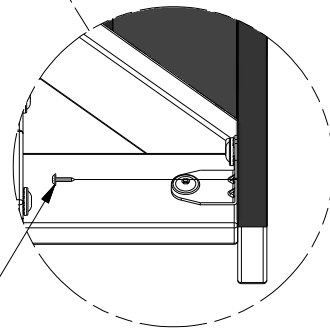

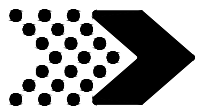

FORT ASSEMBLY

STEP 30



M4 LADDER RUNG - W4L06913
(6) 5/8"x3 3/8"x20 1/4" (16x86x515)



M3 LADDER RUNG - W4L06912
(1) 5/8"x3 3/8"x20 1/4" (16x86x515)



A6P00040 BLUE HC ROCK #2
(2)



A6P00128 LIME HC ROCK #1
(2)



A6P00129 CRANBERRY HC ROCK #1
(2)



H100063 BOLT PTH
(12) 1/4x3/4



H100087 SCREW PFH
(28) 8x1 1/4



H100108 WASHER
(12) LOCK INT
8x15



H100072 T-NUT
(12) 1/4

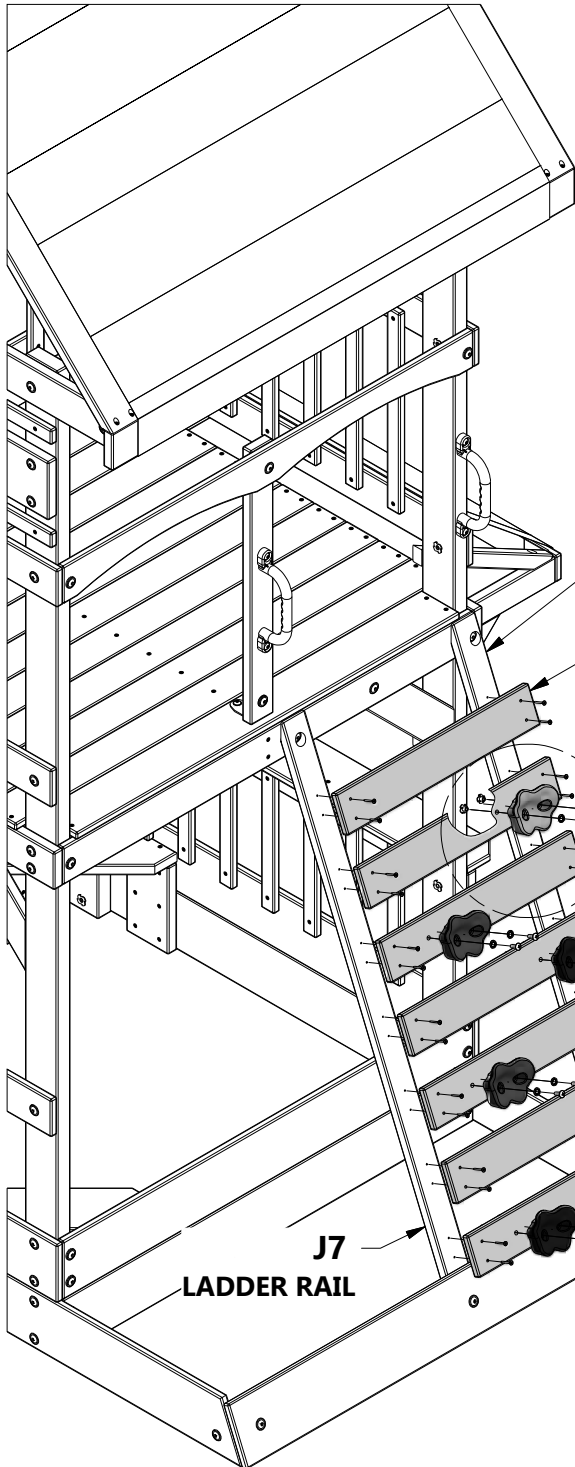

NOTE:
PLACE THE ROCKS AND HARDWARE ONTO THE M4 BOARDS
BEFORE PLACING ON J6 AND J7 BOARDS.
ARRANGE COLORS AS DESIRED.

J6
LADDER RAIL

M3 (x1)
LADDER RUNG

072 (x12)
T-NUT - 1/4"

108 (x12)
WASHER - 8x15

063 (x12)
BOLT - 3/4"

087 (x28)
SCREW - 1-1/4"

M4 (x6)
LADDER RUNG

J7
LADDER RAIL

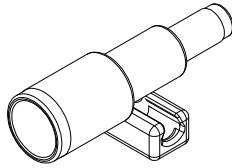
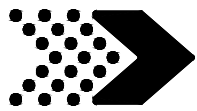

A6P00126 | TELESCOPE BLUE/LIME
(1)



H100088 | SCREW PFH
(2) | 8x1 1/8

088 (x2)
SCREW - 1 1/8"

PLACE TELESCOPE
APPROXIMATELY
CENTER OF M8 BOARD.

M8
WALL RAIL

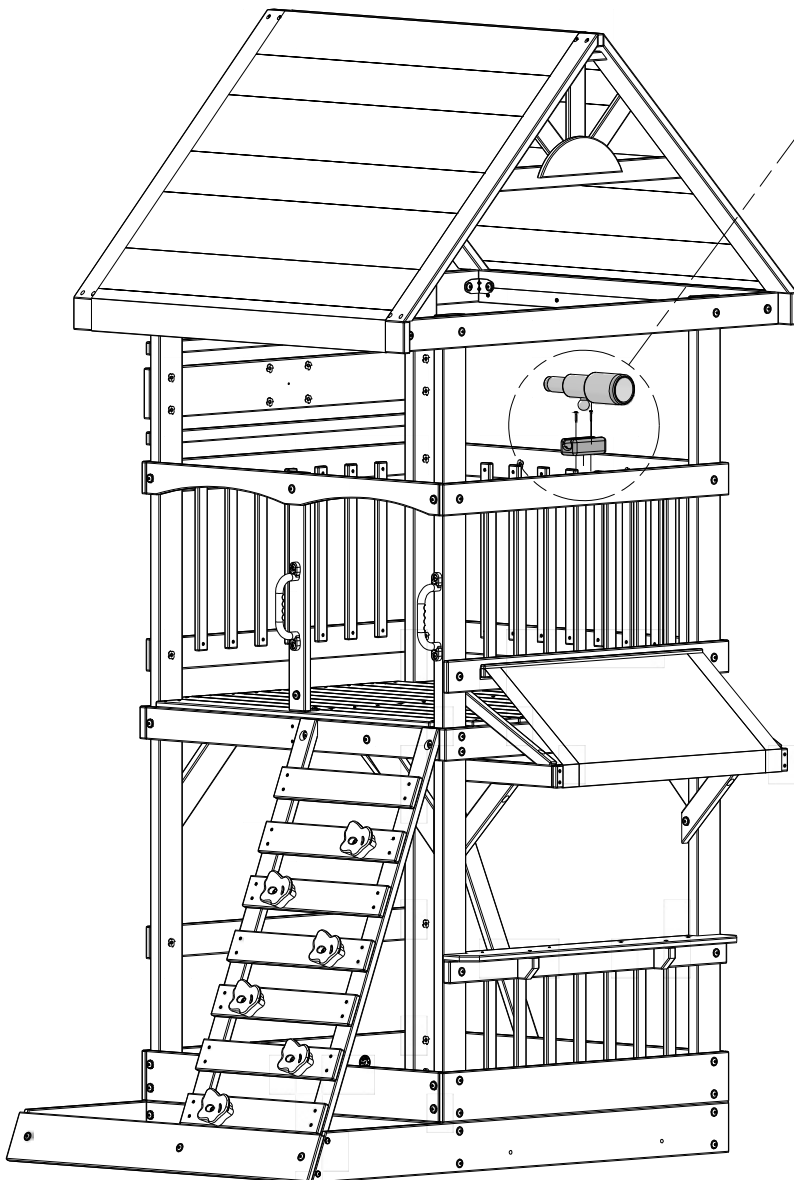

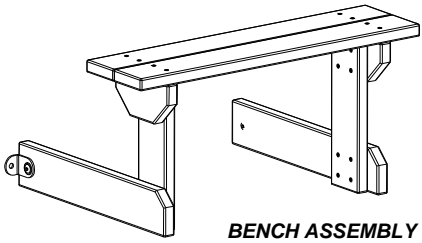
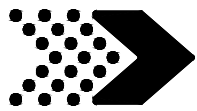

BENCH ASSEMBLY



H100115 | **BOLT WH**
(2) | **5/16x1/2**

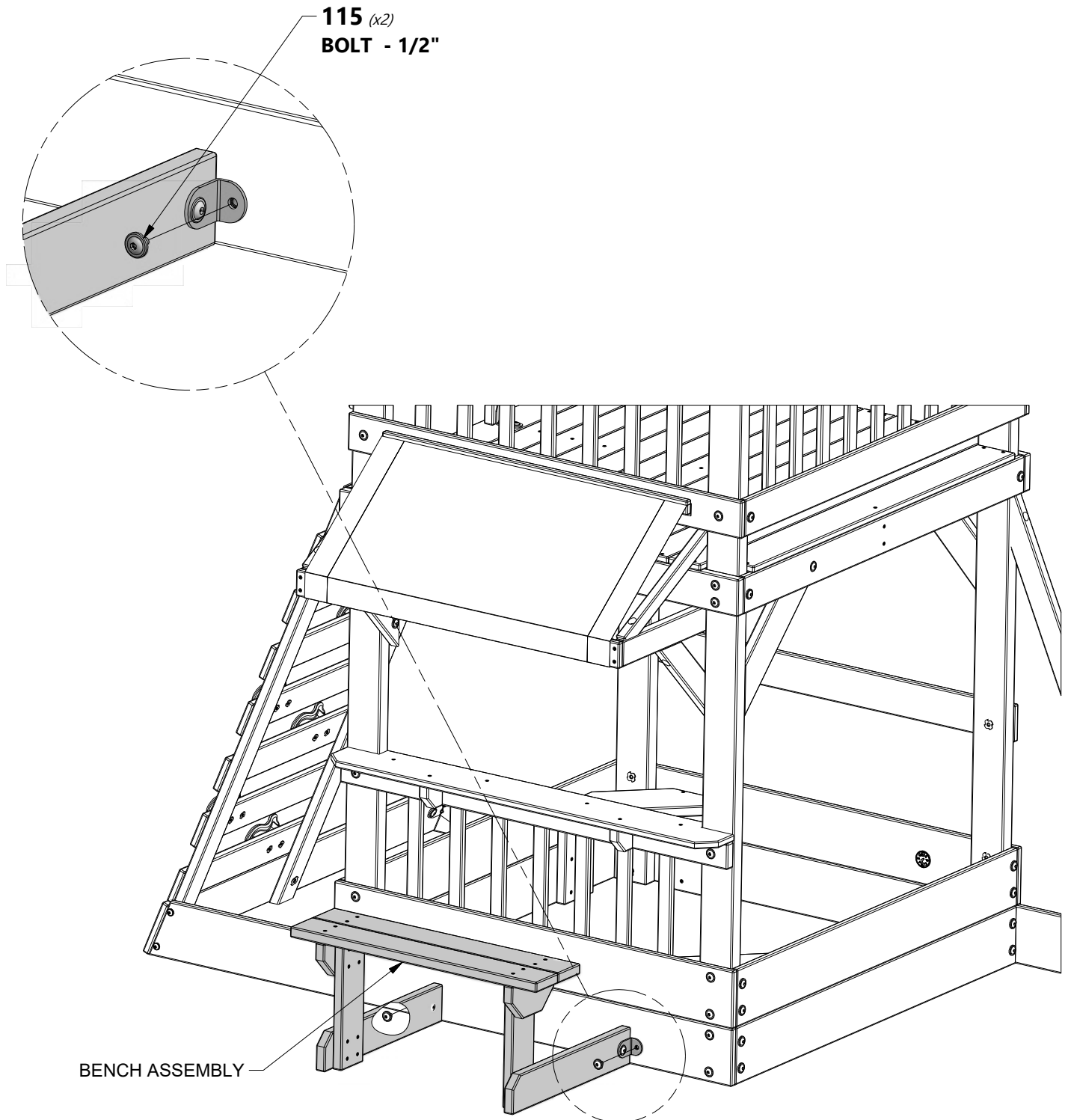

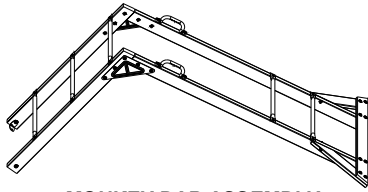
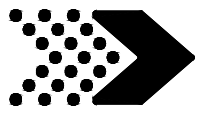

MONKEY BAR ASSEMBLY

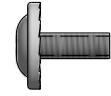

H100222 | **BOLT WH**
(2) | 5/16x3/4

222 (x2)
BOLT - 3/4"

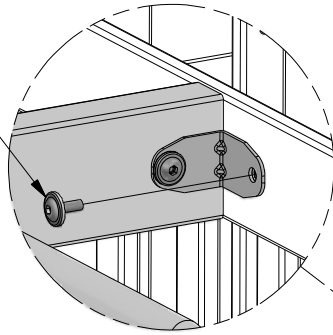

MONKEY BAR ASSEMBLY

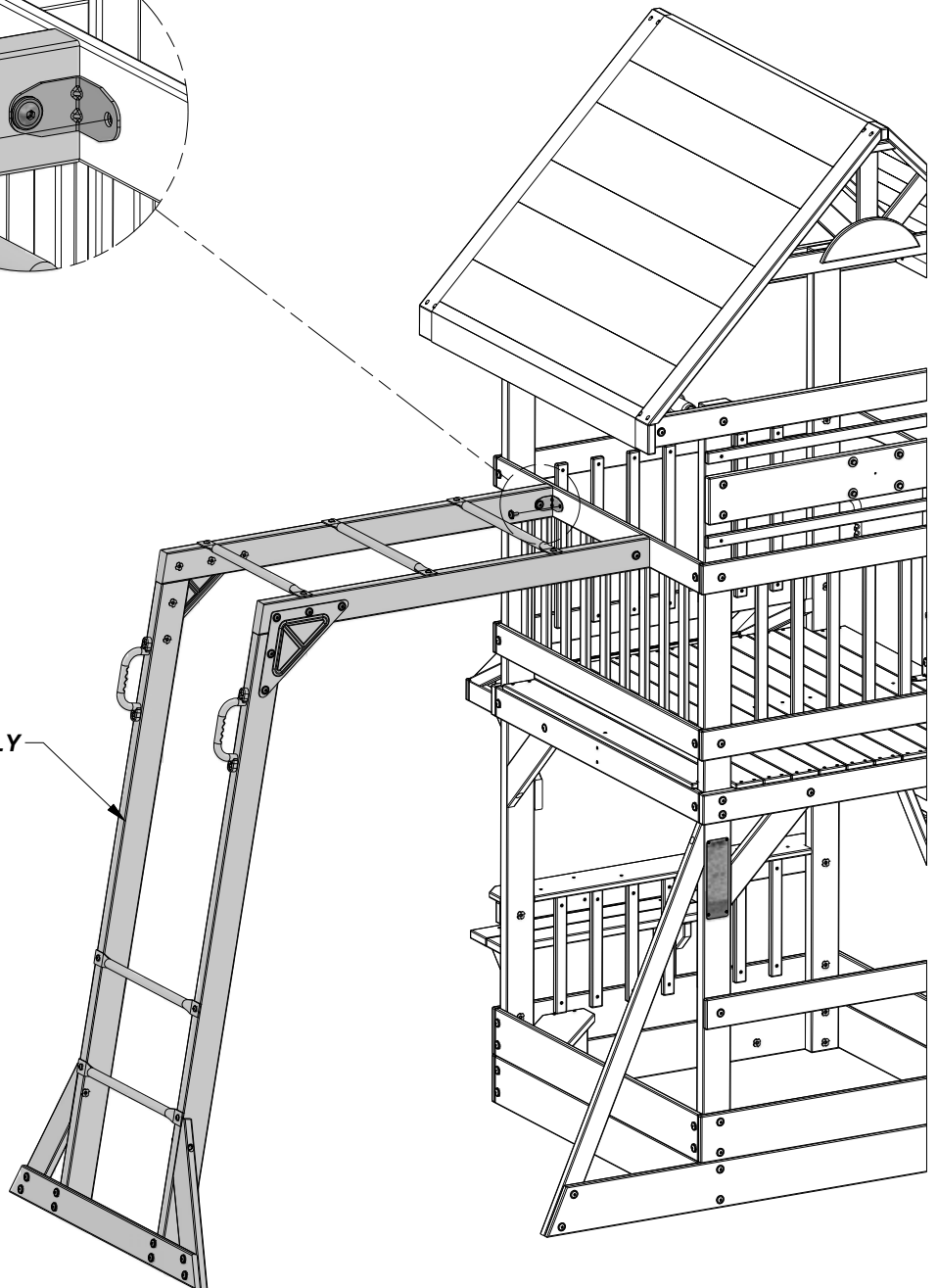



FORT ASSEMBLY

STEP 34

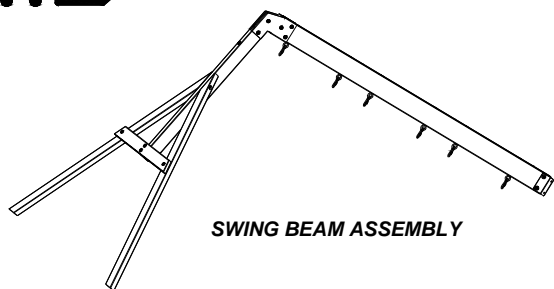

SWING BEAM ASSEMBLY



A100164 (1) BYD ID TAG (LARGE) AGES 3-10



H100042 (4) BOLT HEX 5/16x1 1/4



H100084 (4) SCREW PFH 6x3/4



H100095 (4) WASHER SPLIT 5/16



H100105 (4) WASHER FLAT 8x27

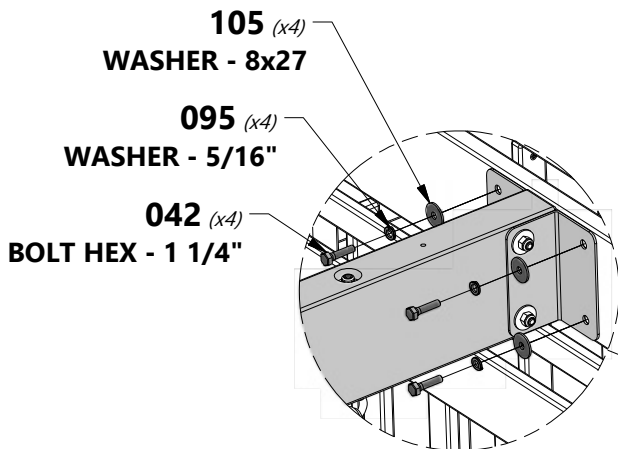

105 (x4) WASHER - 8x27

095 (x4) WASHER - 5/16"

042 (x4) BOLT HEX - 1 1/4"

164 (x1) BYD ID TAG (LARGE) AGES 3-10

SWING BEAM ASSEMBLY

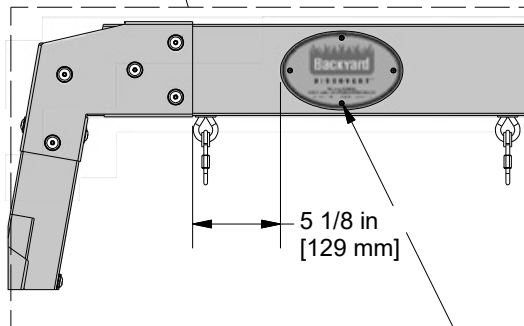
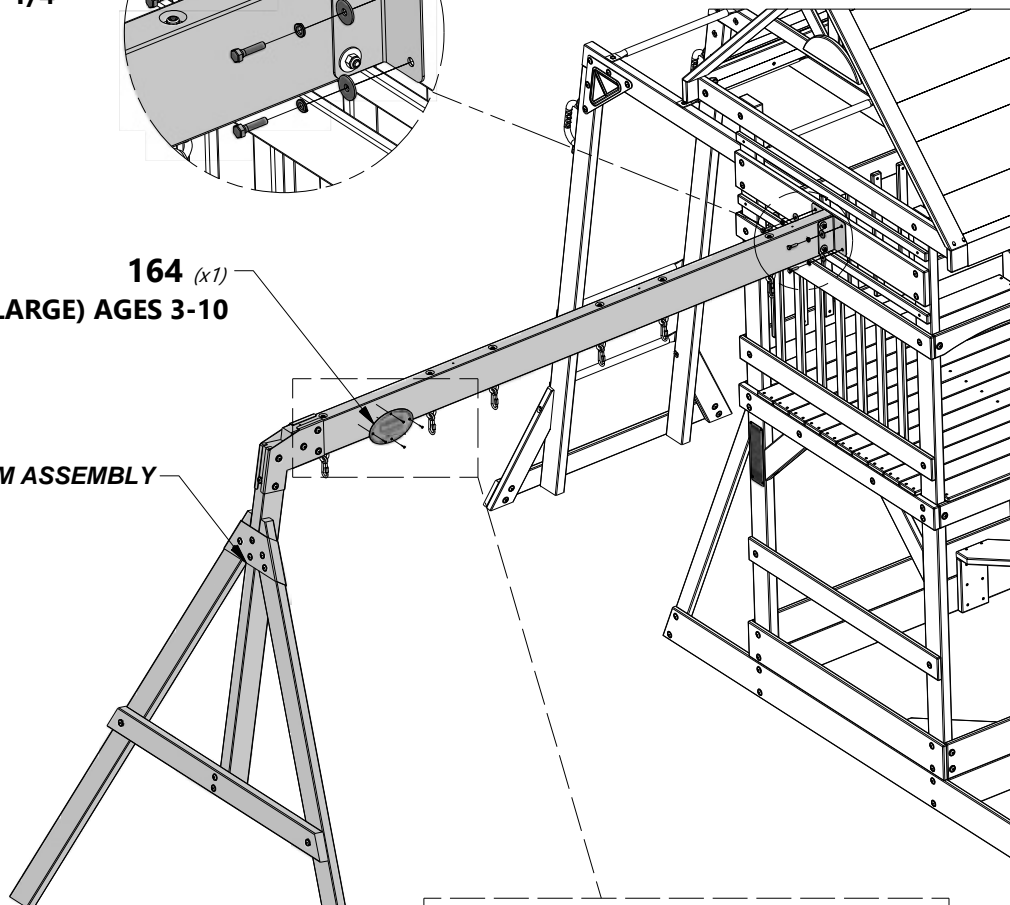

084 (x4) SCREW - 6x3/4

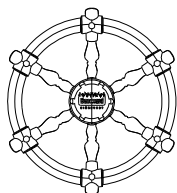

SHIPS WHEEL
(1) | SHIPS WHEEL BLUE/LIME

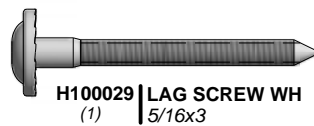

H100029 | LAG SCREW WH
(1) | 5/16x3



H100105 | WASHER FLAT
(1) | 8x27

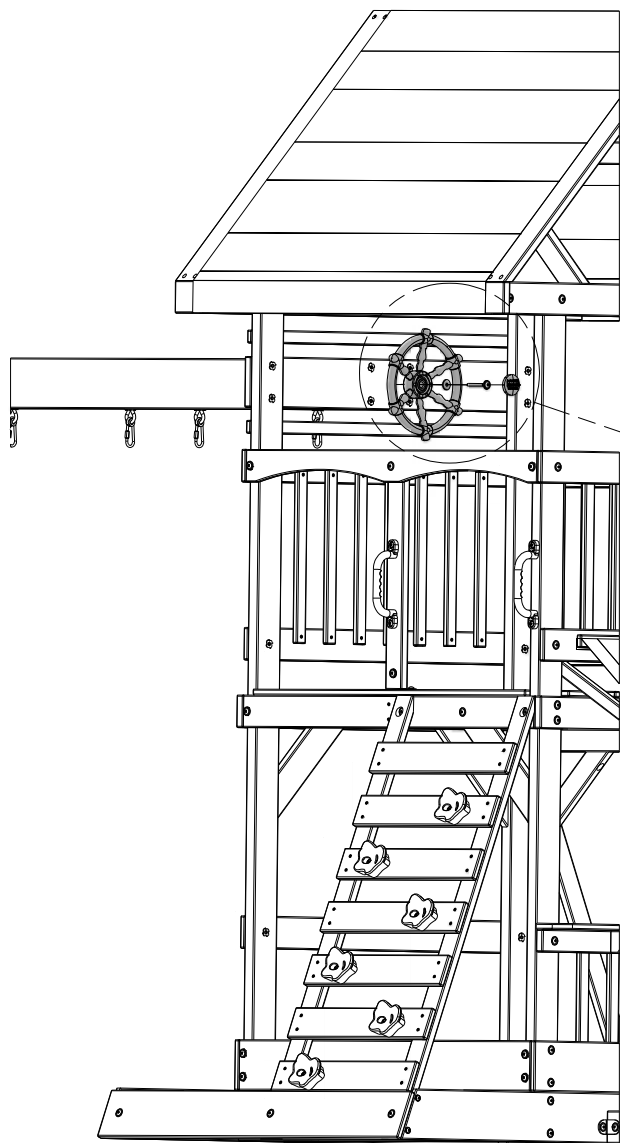

SHIPS WHEEL BLUE/LIME (x1)

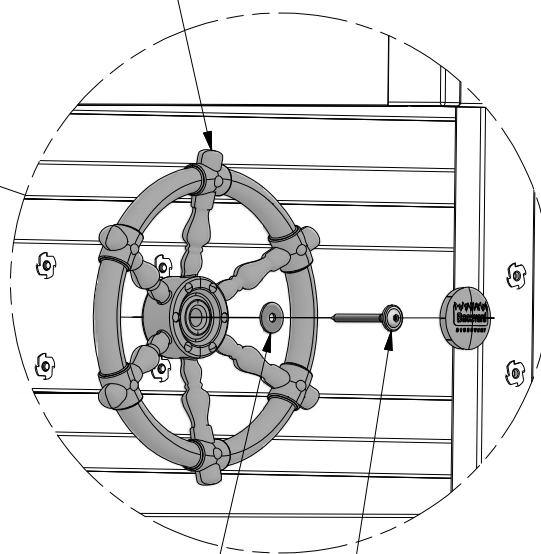

105 (x1)
WASHER - 8x27

029 (x1)
LAG SCREW - 3"

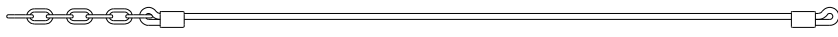
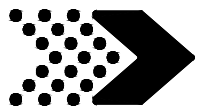

A6P00292 | ROPE-CHAIN BLUE 51.25"
(4)



A6P00293 | ROPE-CHAIN BLUE 31"
(2)



A100069 | QUICK LINK
(6)

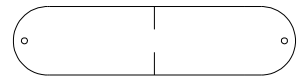

A6P00133 | SWING SEAT BLUE 22"
(2)

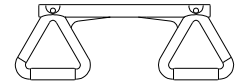

A6P00134 | BLUE TRAPEZE
(1)

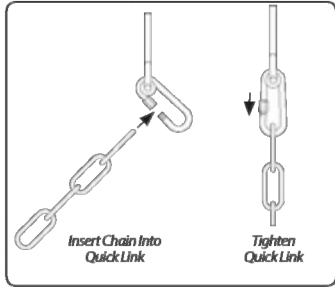

Insert Chain Into Quick Link

Tighten Quick Link

NOTE:
WHEN HANGING YOUR SWINGS, IT IS REQUIRED TO ONLY TRIM AROUND THE SPECIFIC CHAIN LOOP THAT ALLOWS THE BOTTOM OF THE SWING SEAT, (WHEN SITTING ON IT) TO BE NO LOWER THAN (35CM) 13 7/8 INCHES FROM THE GROUND.

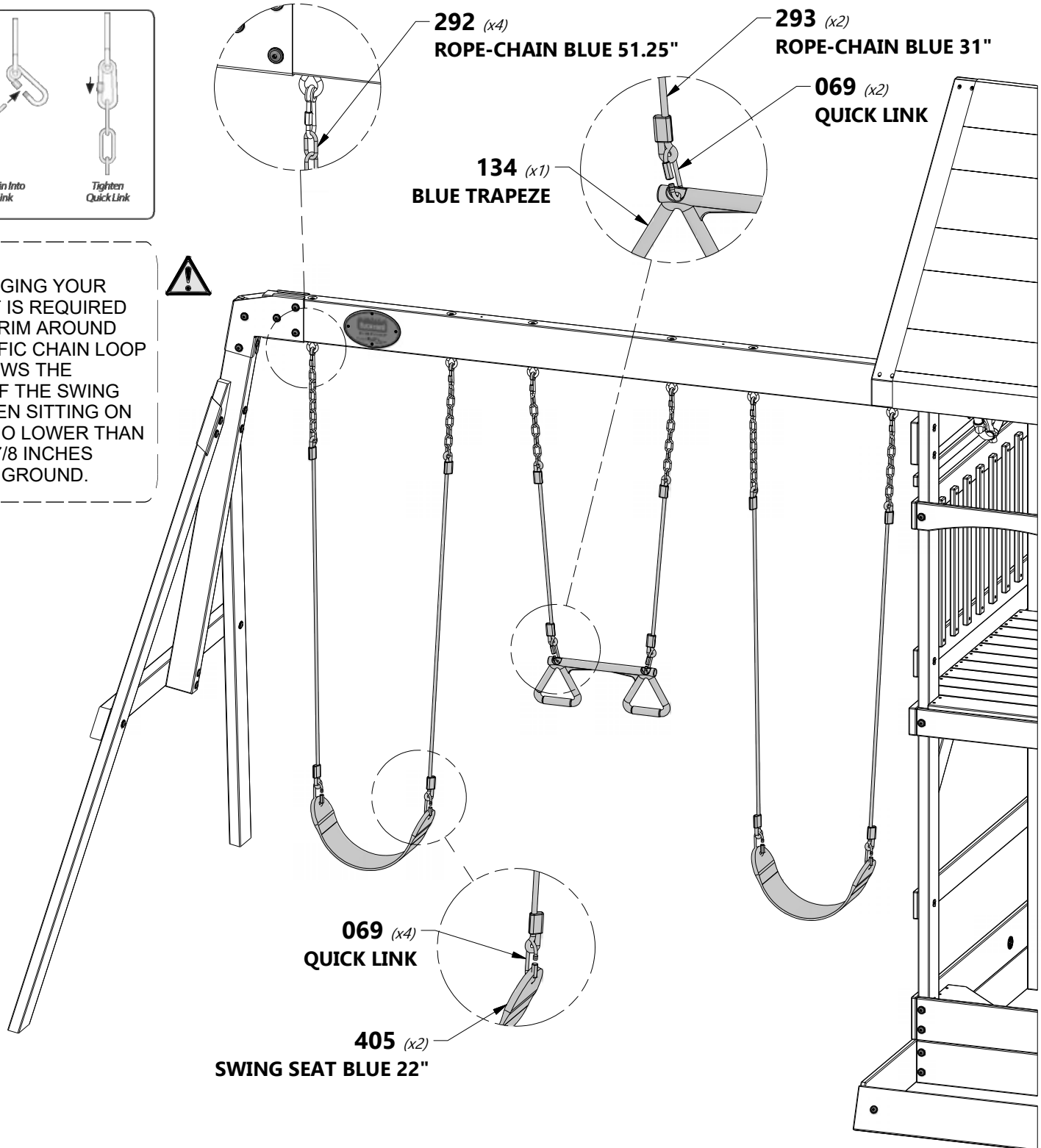

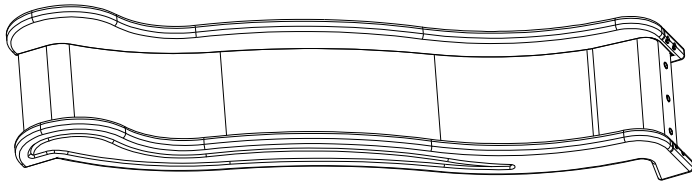
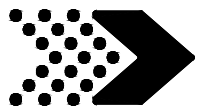

SLIDE ASSEMBLY



H100115 BOLT WH
(3) 5/16x1/2



H100074 T-NUT
(3) 5/16

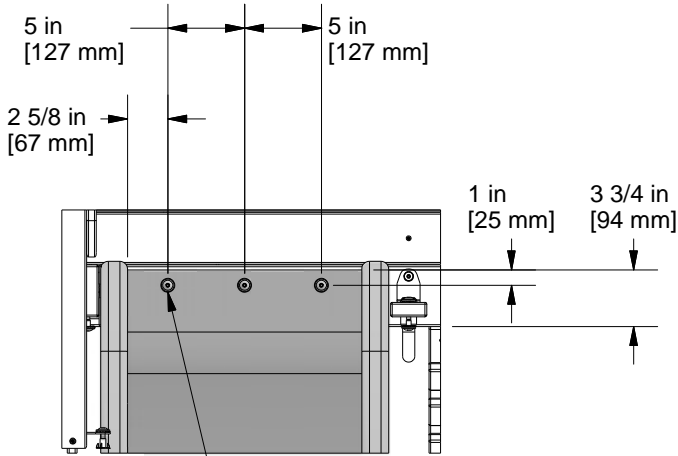

DRILL (3) 3/8" - (10mm) HOLES THROUGH SLIDE BED AND FLOOR BOARDS.

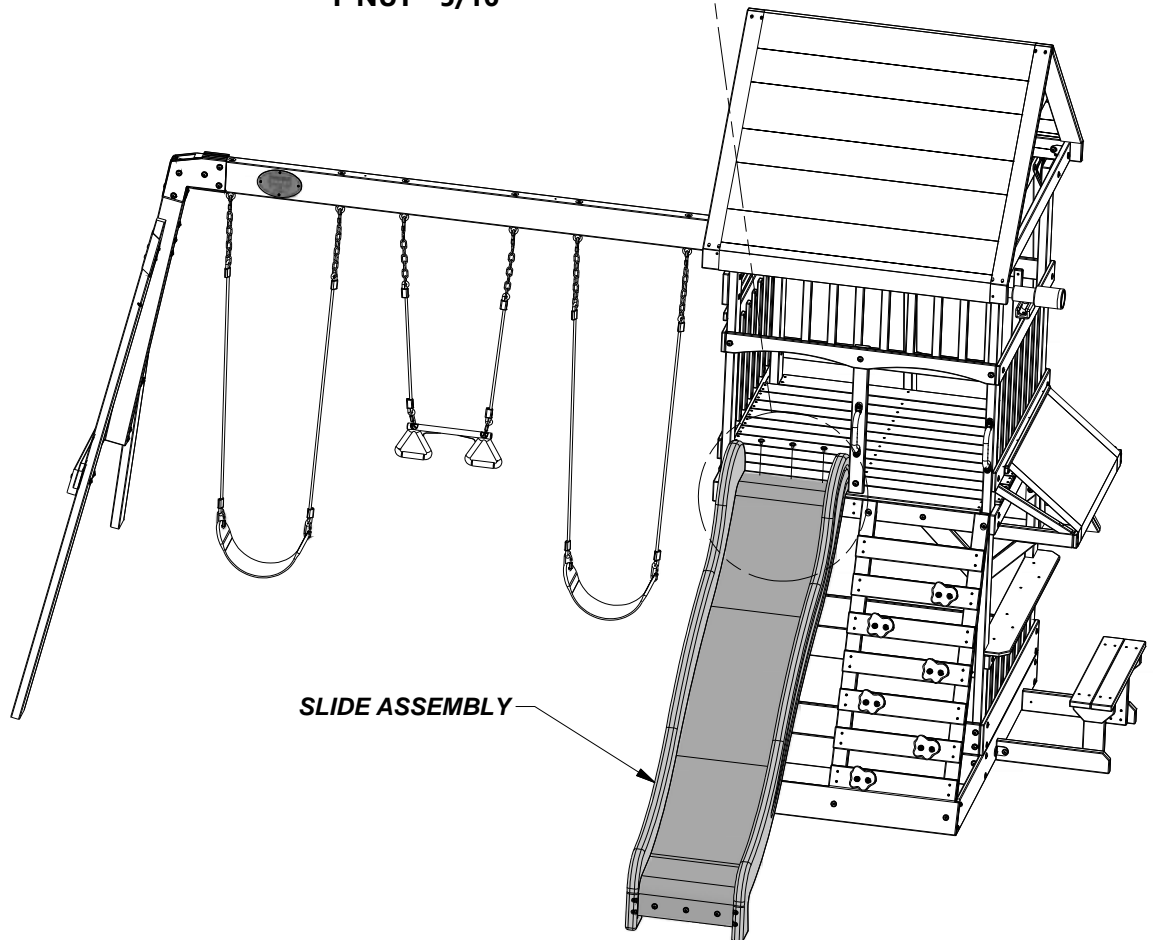
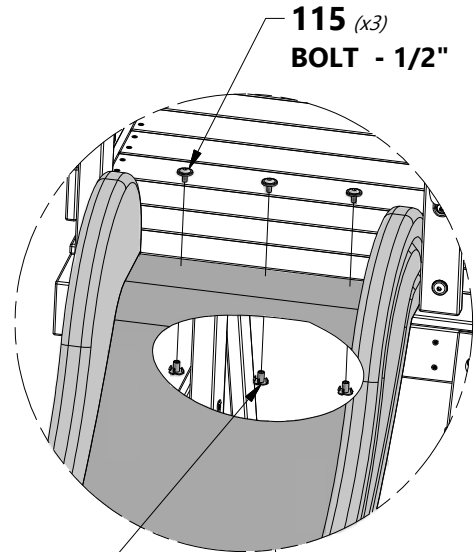

SLIDE ASSEMBLY

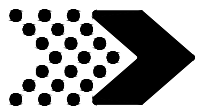

ANCHORING

STEP 38

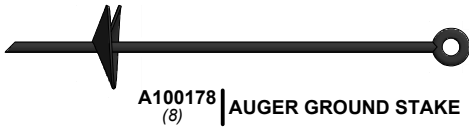

A100178 | AUGER GROUND STAKE
(8)

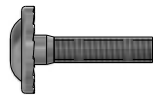

H100009 | BOLT WH
(2) | 5/16x1 1/4

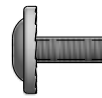

H100222 | BOLT WH
(6) | 5/16x3/4

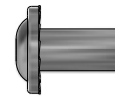

H100005 | NUT BARREL
(2) WH
5/16x7/8

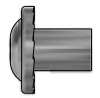

H100004 | NUT BARREL
(6) WH
5/16 x 5/8



H100031 | WASHER
(8) LOCK EXT
12x19

NOTE:
FAILURE TO USE GROUND STAKES CAN VOID WARRANTY & CAUSE INJURY!

SCREW AUGER INTO GROUND AT LOCATIONS SHOWN. USING AUGER AS A TEMPLATE DRILL 3/8" - (10mm) HOLES THRU BOARD, & ATTACH USING SUPPLIED HARDWARE.

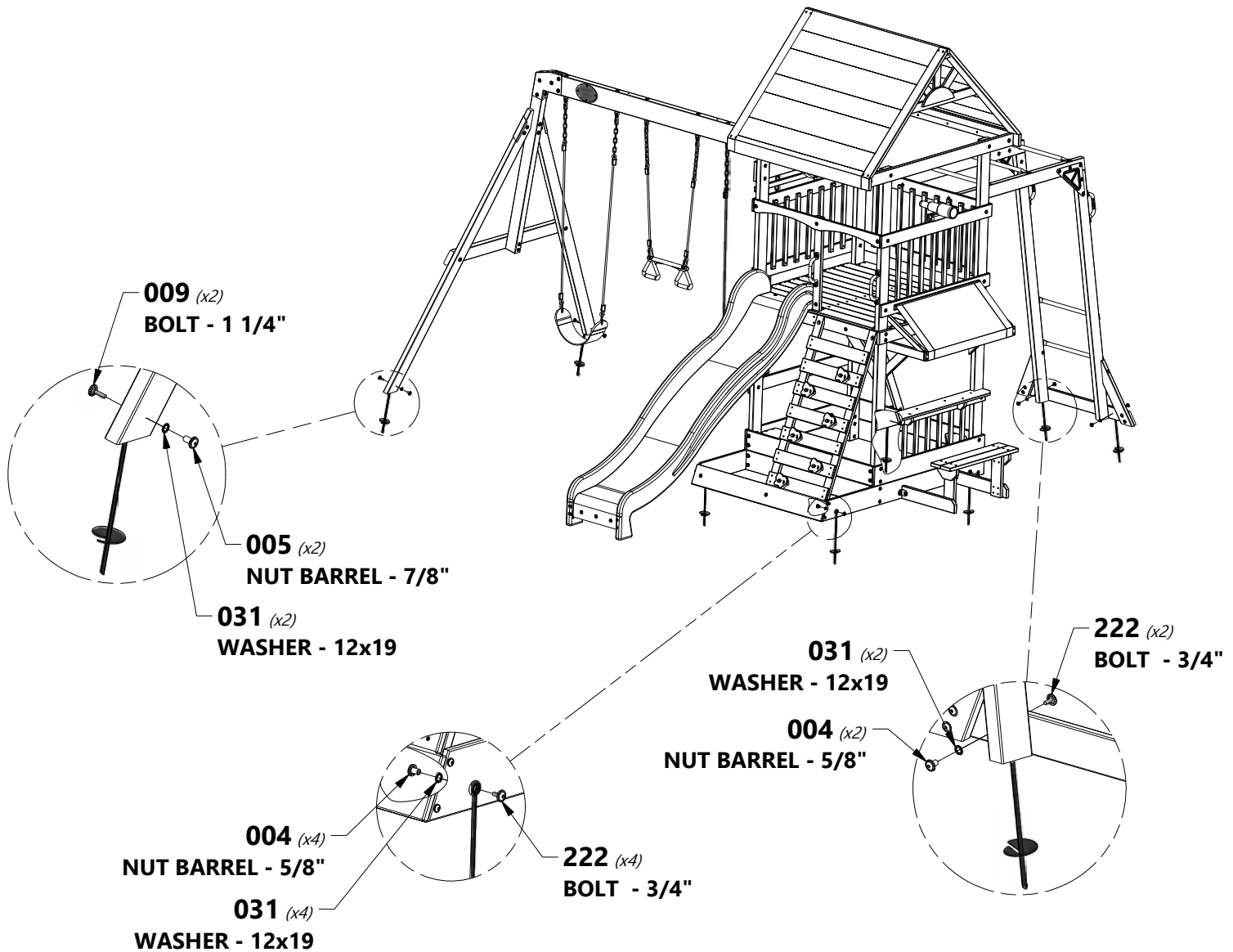

FINAL STEP

DOUBLE CHECK EVERY BOLT, SCREW AND NUT FOR TIGHTNESS. MAKE SURE EVERY BOARD IS SECURE AND MAKE SURE THE PLAY SET IS LEVEL.

ENJOY YOUR NEW PLAY SET!