



MANUFACTURED BY:  
Backyard Discovery  
3305 Airport Drive, Pittsburg, KS 66762  
800-856-4445

Backyard Discovery Australia Pty Ltd 2/7 Hood Street, Hampton VIC 3188, Phone: 1800-087-941

# ASPEN

## Playhouse

### Model # 2403031

The assembly manual must be retained since it contains important information



#### WARNING

**Adult Assembly Required.**

Not suitable for children under two years due to sharp points and small parts.

**FOR DOMESTIC USE ONLY. INTENDED FOR OUTDOOR USE.**



**Please visit [www.backyarddiscovery.com](http://www.backyarddiscovery.com)**

For the most up to date assembly manual, to register your set, or to order replacement parts



EASY STEP-BY-STEP  
3D INTERACTIVE INSTRUCTIONS  
DOWNLOAD THE FREE APP



INS-2403031-A-ASPEN-ENG 9-4-2024

# Owner's Manual - Basic Setup Dimensions & Assembly Notes

Place the set on level ground, not less than 6'-7" [2 m] from any structure or obstruction such as a fence, garage, house, overhanging branches, laundry lines, or electrical wires.

- While assembling unit, take time before and after each phase to make sure fort is level. If fort is not level, assembly will be difficult and improper assembly may result. Extra care must be taken to insure the fort is square.
- The safe play area refers to a zone extending 6'-7" (2 m) beyond the play product on all sides, including the space above the play product.

## SAFE PLAY AREA DIAGRAM

### Ground Dimensions

6'-6 13/16" [2002mm] x 4'- 11/16" [1237mm]

### Safe Play Area

19'-8 13/16" [6015mm] x 17'-2 11/16" [5250mm] x 12'-3/16" [3707mm]

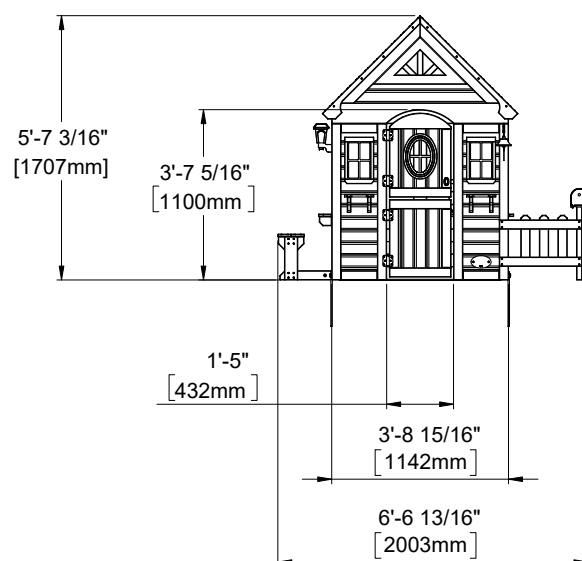
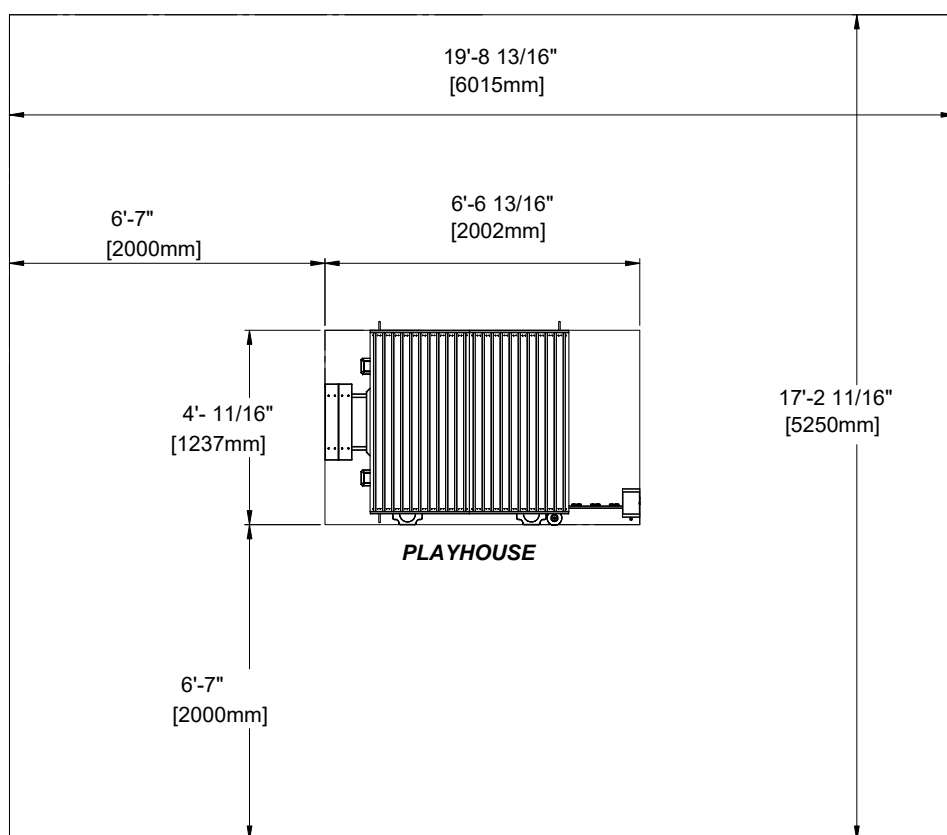

### General Information:

Your set has been designed and engineered for children only and for residential use only.  
A maximum of 150 lbs. per child is recommended for play activities designed for individual use.  
A maximum of 120 lbs. per child is recommended for play activities designed for multiple child use.  
A maximum of 9 children is recommended for this swing set.

# OWNER'S MANUAL - PARTS IDENTIFICATION

## WOOD PARTS (NOT TO SCALE)



N1 WINDOW SHELF - W4L17326  
(x1) 5/8"x2 3/8"x15 3/16" (16x60x386)



N2 WALL TRIM - W4L17327  
(x1) 5/8"x2 3/8"x39 3/4" (16x60x1010)



L1 WINDOW - W4L17328  
(x1) 5/8"x4 7/16"x17 5/8" (16x112x448)

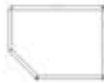

J1 SHELF SUPPPORT - W4L17329  
(x2) 15/16"x2 3/8"x3 1/8" (24x60x80)



G1 FRONT HEADER - W4L17330  
(x1) 15/16"x5 1/4"x44 15/16" (24x134x1142)



G2 REAR HEADER - W4L17331  
(x1) 15/16"x5 1/4"x44 15/16" (24x134x1142)



H1 ANGLED HEADER - W4L17332  
(x2) 15/16"x3"x40 13/16" (24x76x1036)



J5 SUPPORT BOARD - W4L17333  
(x1) 15/16"x2 3/8"x6 11/16" (24x60x170)



M1 FASCIA BOARD - W4L17334  
(x4) 5/8"x3 3/8"x35 3/16" (16x86x894)



M2 BENCH SEAT - W4L17335  
(x2) 5/8"x3 3/8"x19 1/8" (16x86x485)



H3 BENCH UPRIGHT - W4L17336  
(x2) 15/16"x3 3/8"x11" (24x86x280)



H4 BENCH SEAT SUPPORT - W4L17337  
(x2) 15/16"x3 3/8"x6 9/16" (24x86x166)

# OWNER'S MANUAL - PARTS IDENTIFICATION

## WOOD PARTS (NOT TO SCALE)



P01 FENCE POST - W4L17339  
(x1) 1 7/16" x 1 7/16" x 19" (36x36x483)



L2 CABINET TOP - W4L17340  
(x1) 5/8" x 4 7/16" x 42 13/16" (16x112x1087)



M3 FRONT CABINET BOARD - W4L17341  
(x1) 5/8" x 3 3/8" x 42 13/16" (16x86x1087)



J2 BENCH GROUND BOARD - W4L17338  
(x1) 15/16" x 2 3/8" x 13 3/16" (24x60x335)



J3 BENCH GROUND BOARD - W4L17343  
(x1) 15/16" x 2 3/8" x 13 3/16" (24x60x335)



G3 SHELF SUPPORT - W4L17342  
(x1) 15/16" x 5 1/4" x 5 7/8" (24x134x150)



J4 SUPPORT BOARD - W4L17346  
(x1) 15/16" x 2 3/8" x 6 11/16" (24x60x170)



N5 DOOR STOP - W4L17348  
(x1) 5/8" x 2 3/8" x 3 3/8" (16x60x86)



N6 WALL TRIM - W4L17349  
(x1) 5/8" x 2 3/8" x 39 3/4" (16x60x1010)



M4 BACK UPRIGHT - W4L17350  
(x1) 5/8" x 3 3/8" x 26" (16x86x660)



K901 GABLE BOARD - W4L17351  
(x2) 7/16" x 3 3/8" x 43 1/8" (11x86x1095)



K902 GABLE BOARD - W4L17352  
(x2) 7/16" x 3 3/8" x 36 3/4" (11x86x933)



K903 GABLE BOARD - W4L17353  
(x2) 7/16" x 3 3/8" x 17 11/16" (11x86x450)



M5 GABLE TRIM - W4L17354  
(x2) 5/8" x 3 3/8" x 30 1/2" (16x86x774)



M6 GABLE TRIM - W4L17355  
(x2) 5/8" x 3 3/8" x 30 1/2" (16x86x774)

# OWNER'S MANUAL - PARTS IDENTIFICATION

## WOOD PANELS (NOT TO SCALE)

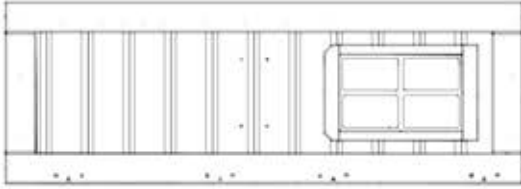

WP1 WALL PANEL - W2A03573  
(x1) 3 3/8"x14"x39 3/4" (27x355x1010)

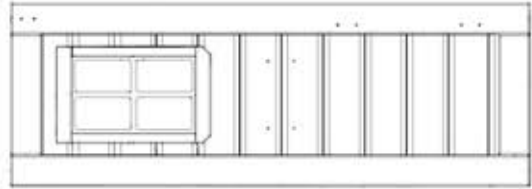

WP2 WALL PANEL - W2A03574  
(x1) 3 3/8"x14"x39 3/4" (27x355x1010)

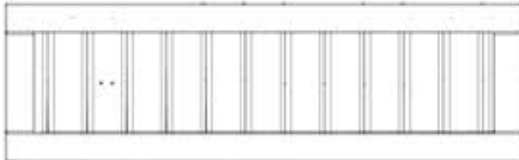

WP3 WALL PANEL - W2A03575  
(x1) 1 1/16"x12 3/4"x41 5/8" (27x324x1058)

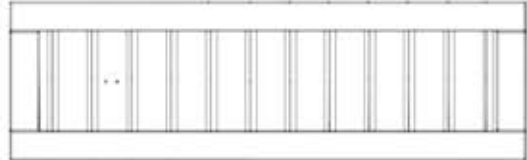

WP4 WALL PANEL - W2A03576  
(x1) 1 1/16"x12 3/4"x41 5/8" (27x324x1058)



WP5 WALL PANEL - W2A03577  
(x1) 1 1/4"x15 3/16"x16 1/8" (32x386x410)



WP6 WALL PANEL - W2A03578  
(x1) 1 1/4"x15 3/16"x16 1/8" (32x386x410)

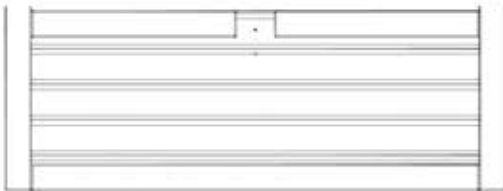

WP7 WALL PANEL - W2A03579  
(x1) 1 1/4"x16 1/8"x42 7/8" (32x410x1088)

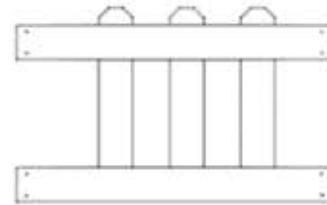

WP8 FENCE PANEL - W2A03584  
(x1) 1 1/8"x13"x21 1/16" (28x330x535)

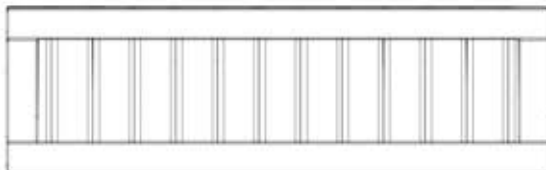

WP9 WALL PANEL - W2A03585  
(x1) 1 1/16"x12 3/4"x41 5/8" (27x324x1058)

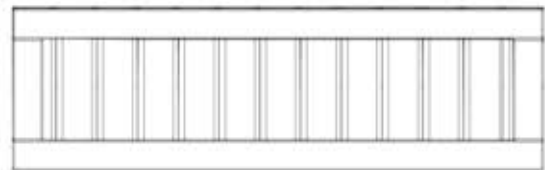

WP10 WALL PANEL - W2A03586  
(x1) 1 1/16"x12 3/4"x41 5/8" (27x324x1058)

# OWNER'S MANUAL - PARTS IDENTIFICATION

## WOOD PANELS (NOT TO SCALE)

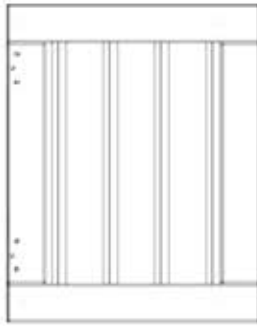

DP1 BOTTOM DOOR PANEL - W2A03580  
(x1) 1 1/16"X15 11/16"X19 11/16" (27x398x500)

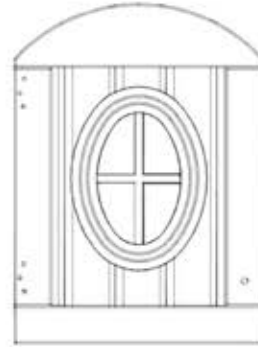

DP2 TOP DOOR PANEL - W2A03581  
(x1) 1 1/16"x15 11/16"x21 3/8" (27x398x542)



RP1 ROOF PANEL - W2A03583  
(x2) 11x17 1/2"x44 3/4" (35x445x1136)



RP2 ROOF PANEL - W2A03587  
(x2) 1 3/8"x17 7/8"x44 3/4" (35x454x1136)

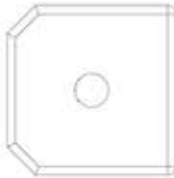

J6 INNER CURTAIN ROD HOLDER - W4L17102  
(x1) 15/16"x2 3/8"x 2 3/8" (24x60x60)

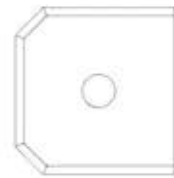

J7 OUTER CURTAIN ROD HOLDER - W4L17101  
(x2) 15/16"x2 3/8"x 2 3/8" (24x60x60)

# OWNER'S MANUAL - PARTS IDENTIFICATION

## ACCESSORY COMPONENTS (NOT TO SCALE)



A100257 METAL TIE STRAP  
(x1)



A100327 HINGE (DOOR, SPRING LOADED)  
(x2)



A4M00528 BYD ID TAG (MEDIUM) AGES 2 TO 10  
(x1)

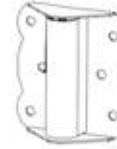

A4M00558 HINGE (DOOR, NON-SPRING LOADED)  
(x2)



A4M00997 METAL CLEAT  
(x18)



A4M01045 BELL ASSEMBLY  
(x1)



A4M01047 L BRACKET 2.5x38x55x55  
(x2)



A4M01785 ANGLE BRACKET  
(x12)



A4M01846 Z TIE BRACKET  
(x1)



A6P00017 MAILBOX ASSEMBLY  
(x1)



A6P00020 LATCHING KNOB KIT  
(x1)



A6P00023 FLOWER POT HOLDER  
(x2)



A6P00024 FAUCET KIT  
(x1)



A6P00025 STOVE KIT  
(x1)

# OWNER'S MANUAL - PARTS IDENTIFICATION

## ACCESSORY COMPONENTS (NOT TO SCALE)



A6P00032 SURFACE MOUNT BASIN  
(x1)



A6P00068 OUTDOOR LIGHT FIXTURE  
(x2)

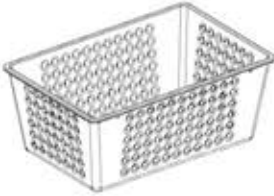

A6P00069 FRUIT BASKET KIT  
(x1)



A4M00527 GROUND STAKE REBAR  
(x4)

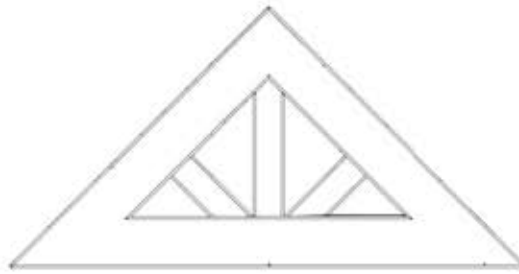

A100322 PLASTIC SUNBURST  
(x2)



A6P00057 PLASTIC CURTAIN ROD  
(x1)



A6P00553 CURTAIN  
(x2)



# OWNER'S MANUAL - PARTS IDENTIFICATION

## HARDWARE COMPONENTS (NOT TO SCALE)



**H100397 | BOLT WH BLK**  
(x2) | 1/4x1 1/4

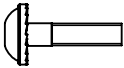

**H100171 | BOLT WH BLK**  
(x2) | 1/4x1



**H100201 | SCREW PFH BLK**  
(x8) | 8 x 2 1/2



**H100382 | SCREW PFH BLK**  
(x36) | 8 x 1 3/4



**H100200 | SCREW PFH BLK**  
(x39) | 8 x 1 1/2



**H100387 | SCREW PFH BLK**  
(x37) | 8 x 1 1/4



**H100380 | SCREW PFH BLK**  
(x8) | 8 x 1 1/8

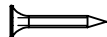

**H100385 | SCREW PFH BLK**  
(x16) | 8 x 1



**H100395 | SCREW PFH BLK**  
(x10) | 8 x 3/4



**H100203 | SCREW PFH BLK**  
(x6) | 8 x 1/2



**H100797 | SCREW PWH BLK**  
(x20) | 8 x 1



**H100392 | SCREW PWH BLK**  
(x82) | 8 x 3/4



**H100202 | SCREW PWH BLK**  
(x10) | 8 x 5/8



**H100408 | SCREW PWH BLK**  
(x2) | 8 x 1/2



**H100459 | BOLT WH BLK**  
(x4) | 5/16 x 1 1/4

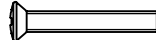

**H100806 | SCREW POH-MS BLK**  
(x24) | 8/32 x 1 1/8"



**H100379 | T-NUT BLK**  
(x4) | 5/16



**H100804 | T-NUT**  
(x24) | 8/32



**H100398 | T-NUT BLK**  
(x4) | 1/4

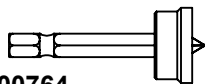

**H100764 | SCREW SETTER**  
(x1)

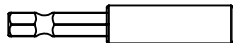

**H101100 | MAGNETIC DRIVER**  
(x1)

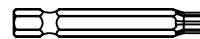

**H100147 | T-30 TORX BIT**  
(x1)



**H100114 | TORX WRENCH**  
(x1) | T-30

# PRE-ASSEMBLY STEP 1 - SORTING PARTS

It is critical for ease of assembly that you take the time to sort and organize the wood and hardware.

---

## WOOD PARTS:

- Organize wood parts by the three-digit, alpha-numeric number stamped on each board (ex. P01).
- If there are multiple boards with the same stamped number, stack those pieces together.
- Stamps can be found on the flat surface of the boards or on the end of the boards.
- Allow yourself plenty of room - the wood pieces can take up a significant amount of space.

**NOTE: CARTONS ARE NOT ORGANIZED BY BOARD NUMBER.**

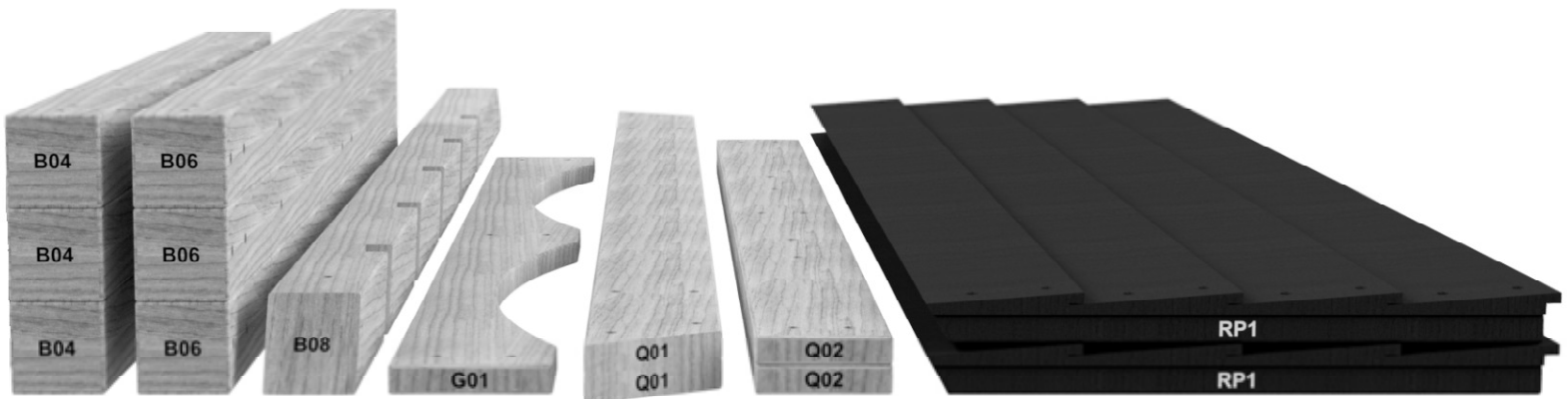

---

## HARDWARE PARTS:

- We recommend that you have a separate table to organize the hardware.
- Hardware bags are printed with a seven-digit, alpha-numeric part number.
- You can organize your hardware by part number or group by hardware type (i.e. bolts, nuts, etc.).
- During assembly you only need to reference the last four digits of the number.

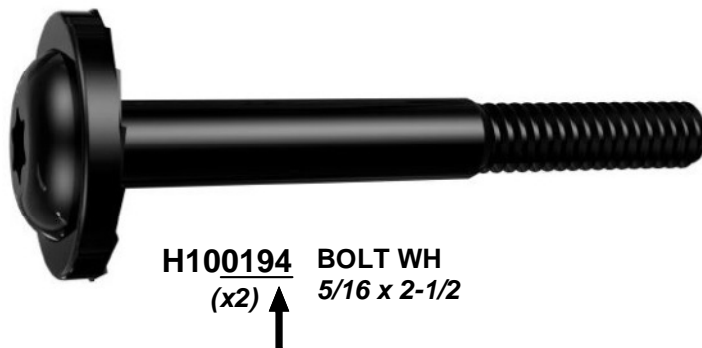

# PRE-ASSEMBLY STEP 2 - TOOLS REQUIRED



Cordless Drill or  
Electric Drill



Drill Attachments:  
Phillips Head



1/8", 3/16", 3/8" & 7/16"  
Drill Bits



Phillips Screw Driver



Open End Wrenches 1/2" & 9/16"



3/8" Drive Ratchet, 1/2" &  
9/16" STD Sockets 1/2" & 9/16" Deep  
Sockets



Claw Hammer



Rubber Mallet - Optional



Tape Measure

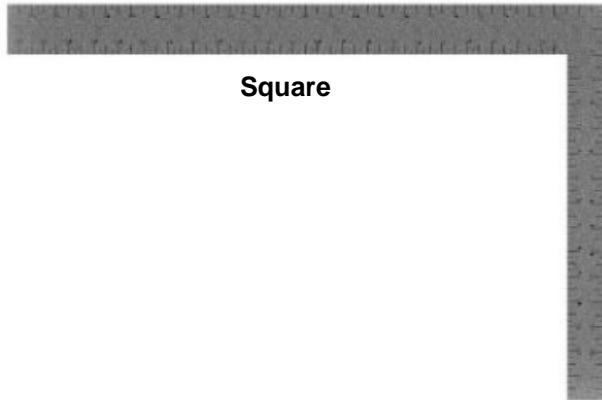

Square



Level 24"

# PRE-ASSEMBLY STEP 3 - CHOOSE YOUR ASSEMBLY METHOD

There are several types of assembly instructions available to you.

1. Printed Assembly Manual included with your set
2. BILT APP - 3D interactive instructions
3. Combination of the Printed Manual and BILT APP (Note: Step numbers can differ between the two methods)

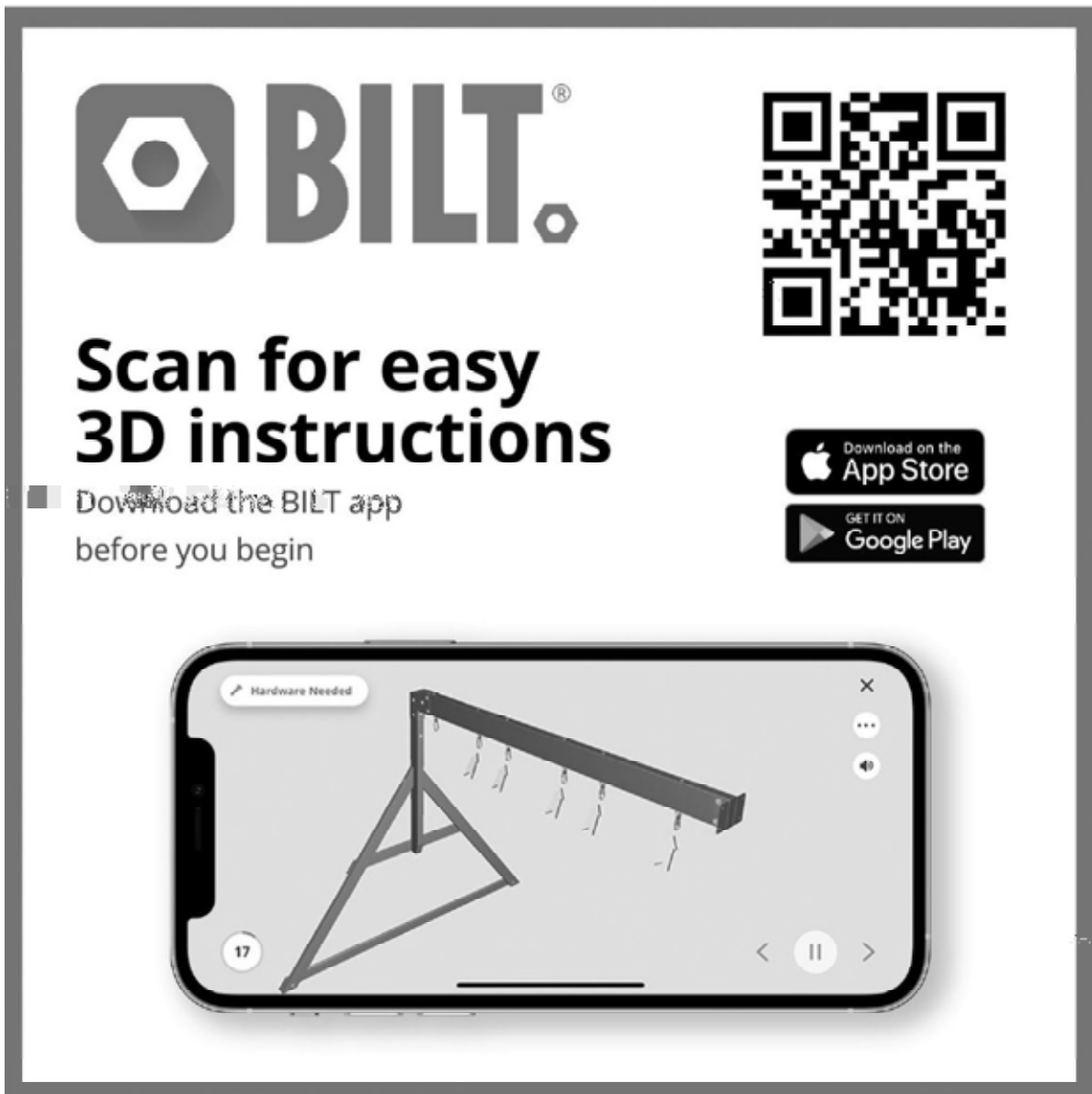

The advertisement features the BILT logo (a hexagon with a dot) and the text "BILT.®" in a large, bold font. To the right is a QR code. Below the logo, the text "Scan for easy 3D instructions" is displayed in a large, bold font. Underneath this, it says "Download the BILT app before you begin". To the right of the text are two buttons: "Download on the App Store" and "GET IT ON Google Play". At the bottom, a smartphone screen displays a 3D assembly instruction for a step labeled "17". The screen shows a 3D model of a structure with a horizontal beam and a triangular base. A "Hardware Needed" button is visible in the top left corner of the app interface. Navigation icons (back, pause, forward) are at the bottom of the screen.

# STEP 1 - PLAYHOUSE ASSEMBLY

QTY	PART NUMBER	DESCRIPTION
16	H100392	SCREW PWH 8x3/4 BLK



WP3 WALL PANEL - W2A03575  
(x1) 1 1/16"x12 3/4"x41 5/8" (27x324x1058)



WP4 WALL PANEL - W2A03576  
(x1) 1 1/16"x12 3/4"x41 5/8" (27x324x1058)



WP6 WALL PANEL - W2A03578  
(x1) 1 1/4"x15 3/16"x16 1/8" (32x386x410)



A4M00997 METAL CLEAT  
(x4)

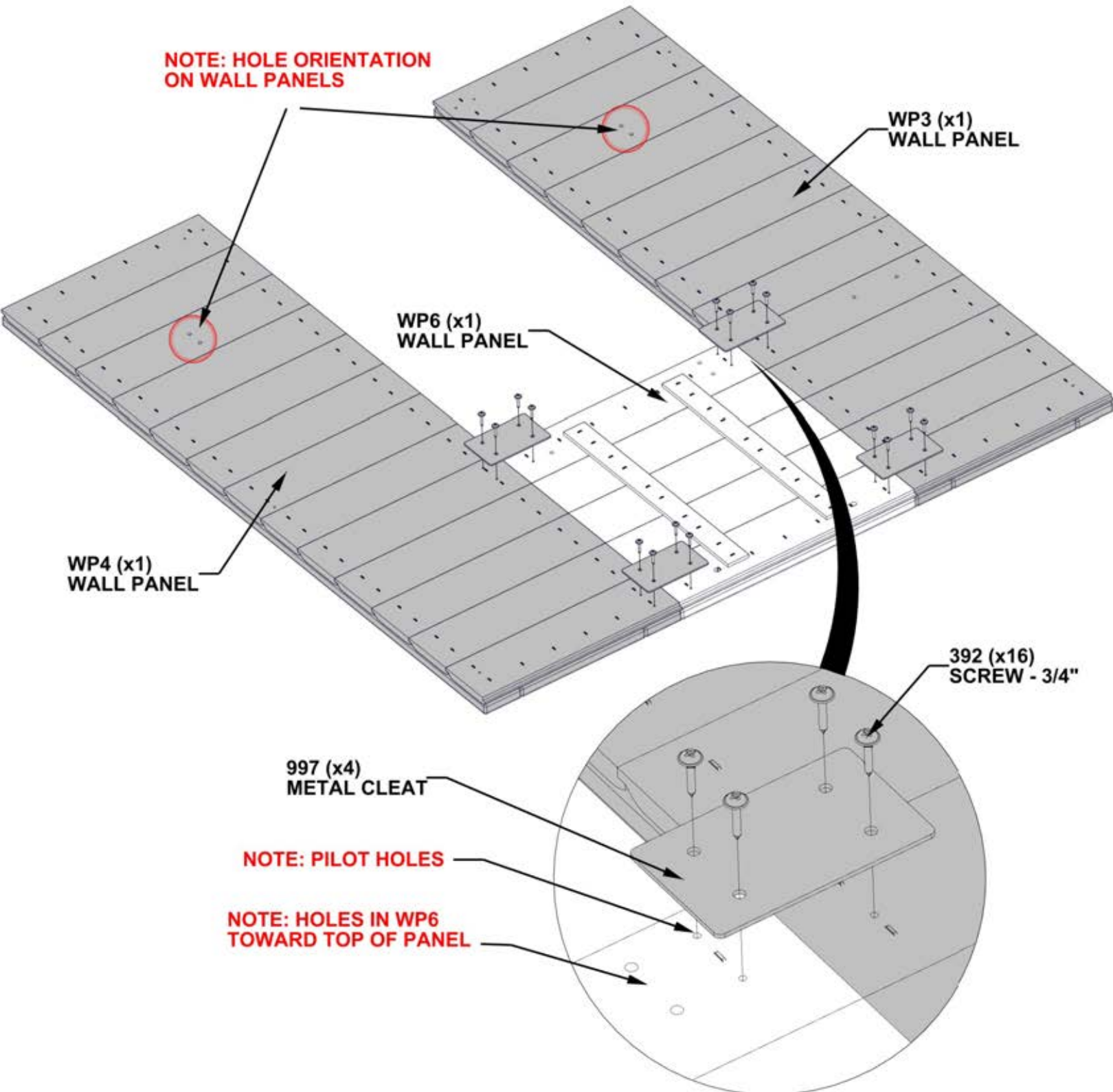

# STEP 2 - PLAYHOUSE ASSEMBLY

QTY	PART NUMBER	DESCRIPTION
4	H100385	SCREW PFH 8x1 BLK



WP7 WALL PANEL - W2A03579  
(x1) 1 1/4"x16 1/8"x42 7/8" (32x410x1088)



N6 WALL TRIM - W4L17349  
(x1) 5/8"x2 3/8"x39 3/4" (16x60x1010)



N2 WALL TRIM - W4L17327  
(x1) 5/8"x2 3/8"x39 3/4" (16x60x1010)

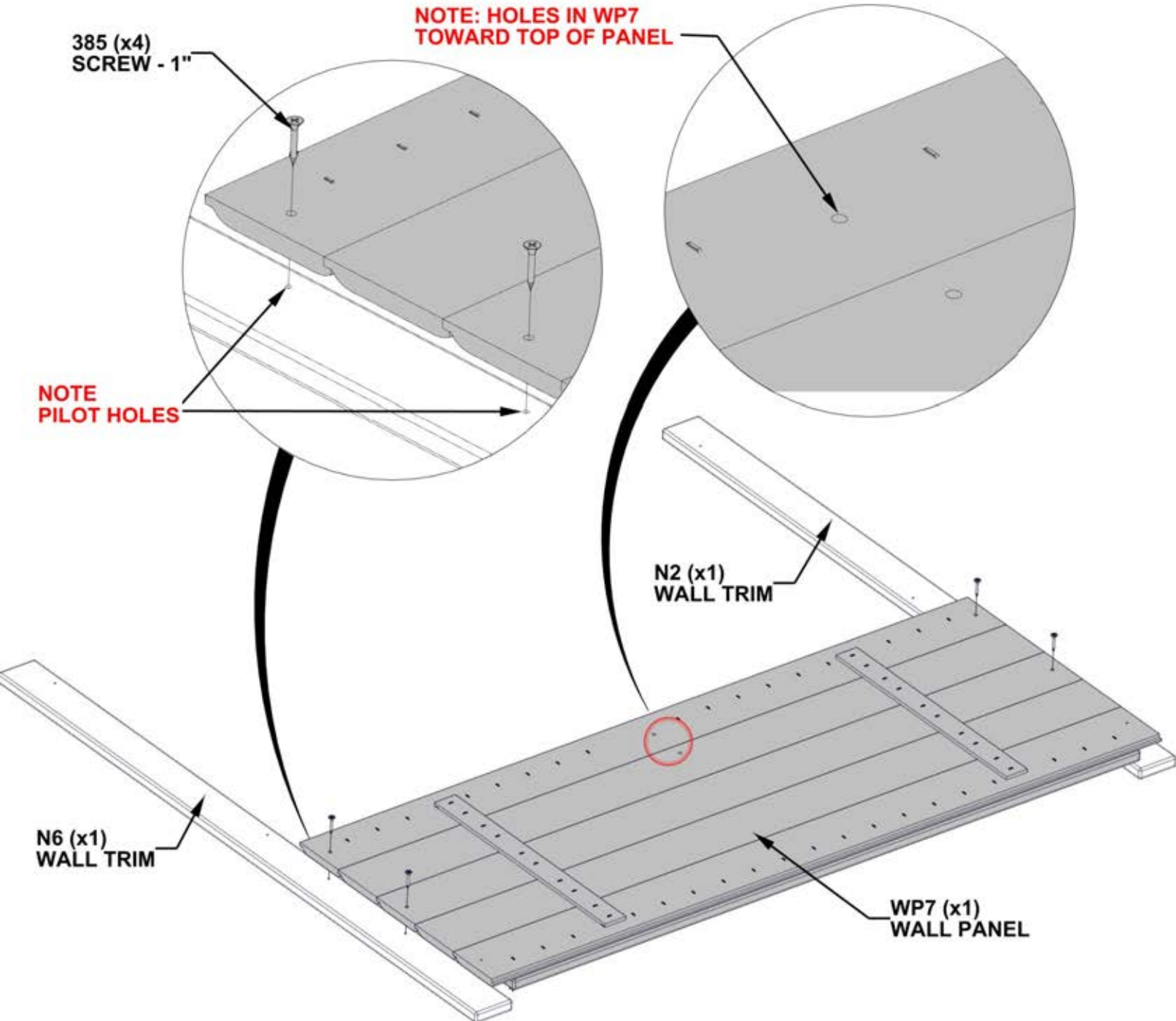

# STEP 3 - PLAYHOUSE ASSEMBLY

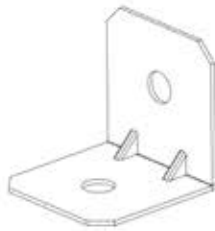

A4M01785 ANGLE BRACKET  
(x3)

QTY	PART NUMBER	DESCRIPTION
2	H100202	SCREW PWH 8x5/8 BLK
4	H100797	SCREW PWH 8x1 BLK

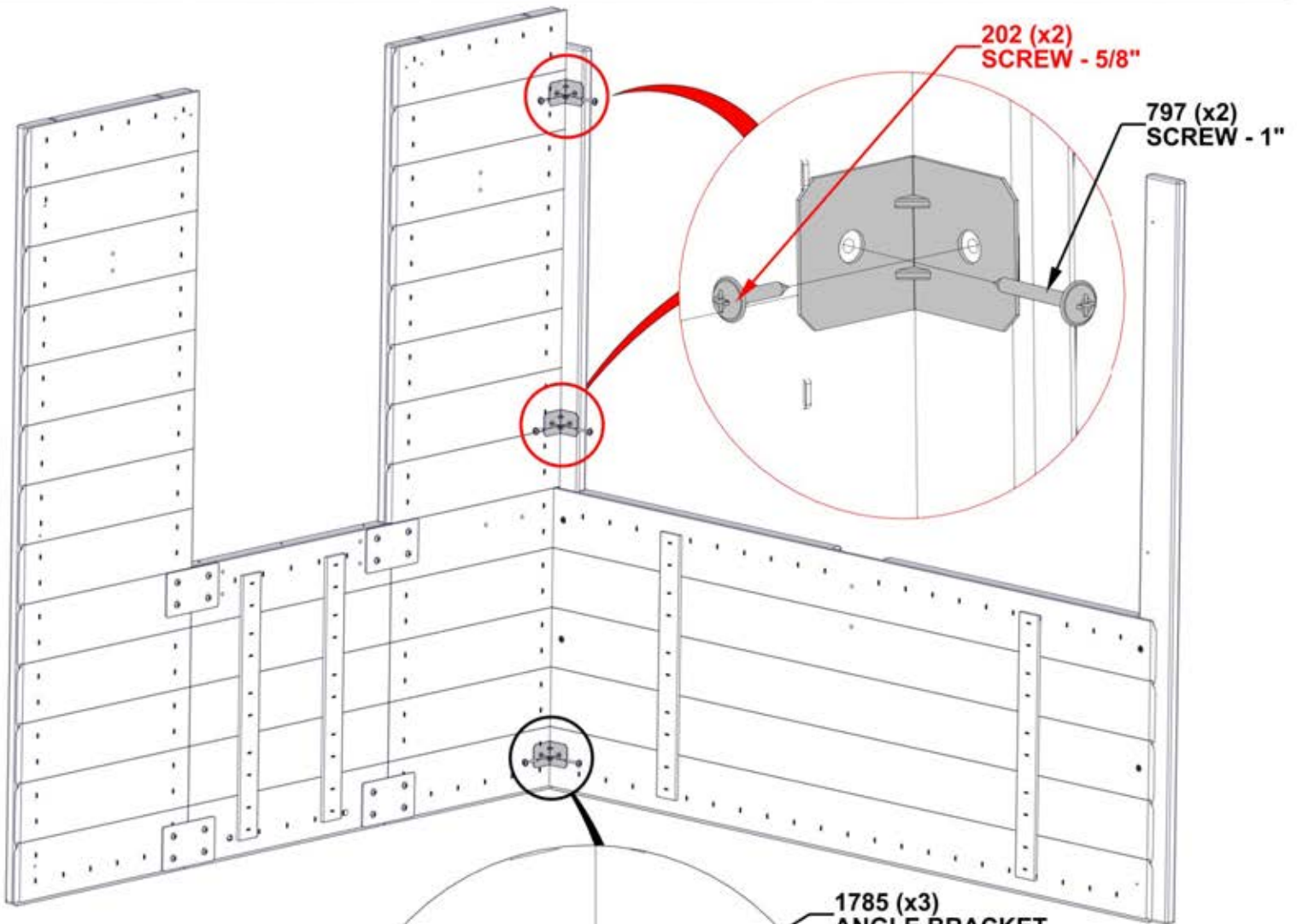

**NOTE: ALIGN ANGLE BRACKETS WITH PILOT HOLES**

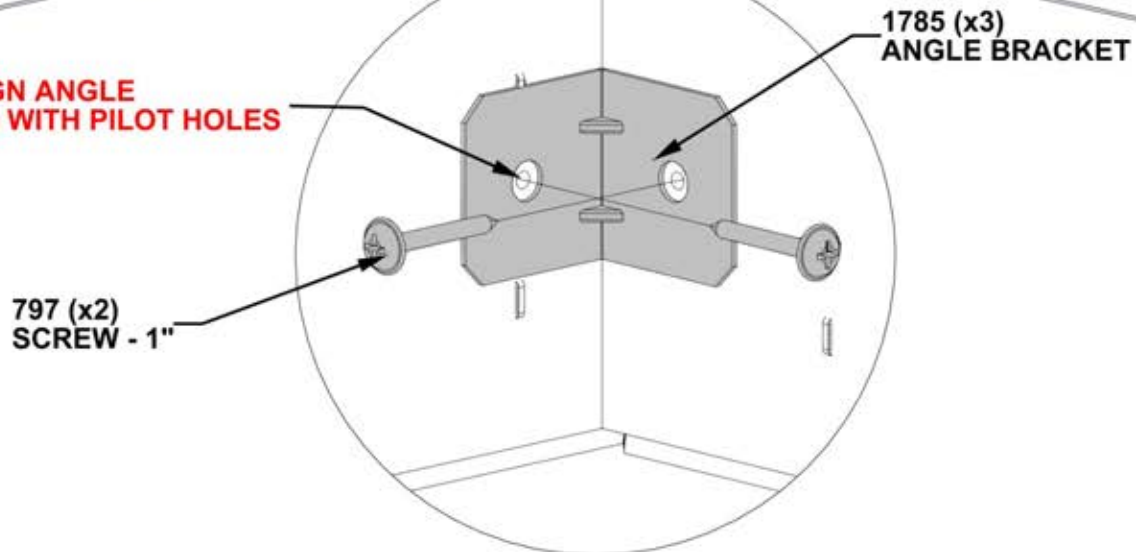

# STEP 4 - PLAYHOUSE ASSEMBLY

QTY	PART NUMBER	DESCRIPTION
16	H100392	SCREW PWH 8x3/4 BLK

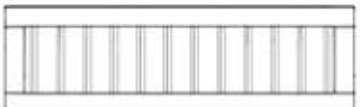

WP9 WALL PANEL - W2A03585  
(x1) 1 1/16"x12 3/4"x41 5/8" (27x324x1058)



WP10 WALL PANEL - W2A03586  
(x1) 1 1/16"x12 3/4"x41 5/8" (27x324x1058)



WP5 WALL PANEL - W2A03577  
(x1) 1 1/4"x15 3/16"x16 1/8" (32x386x410)



A4M00997 METAL CLEAT  
(x4)

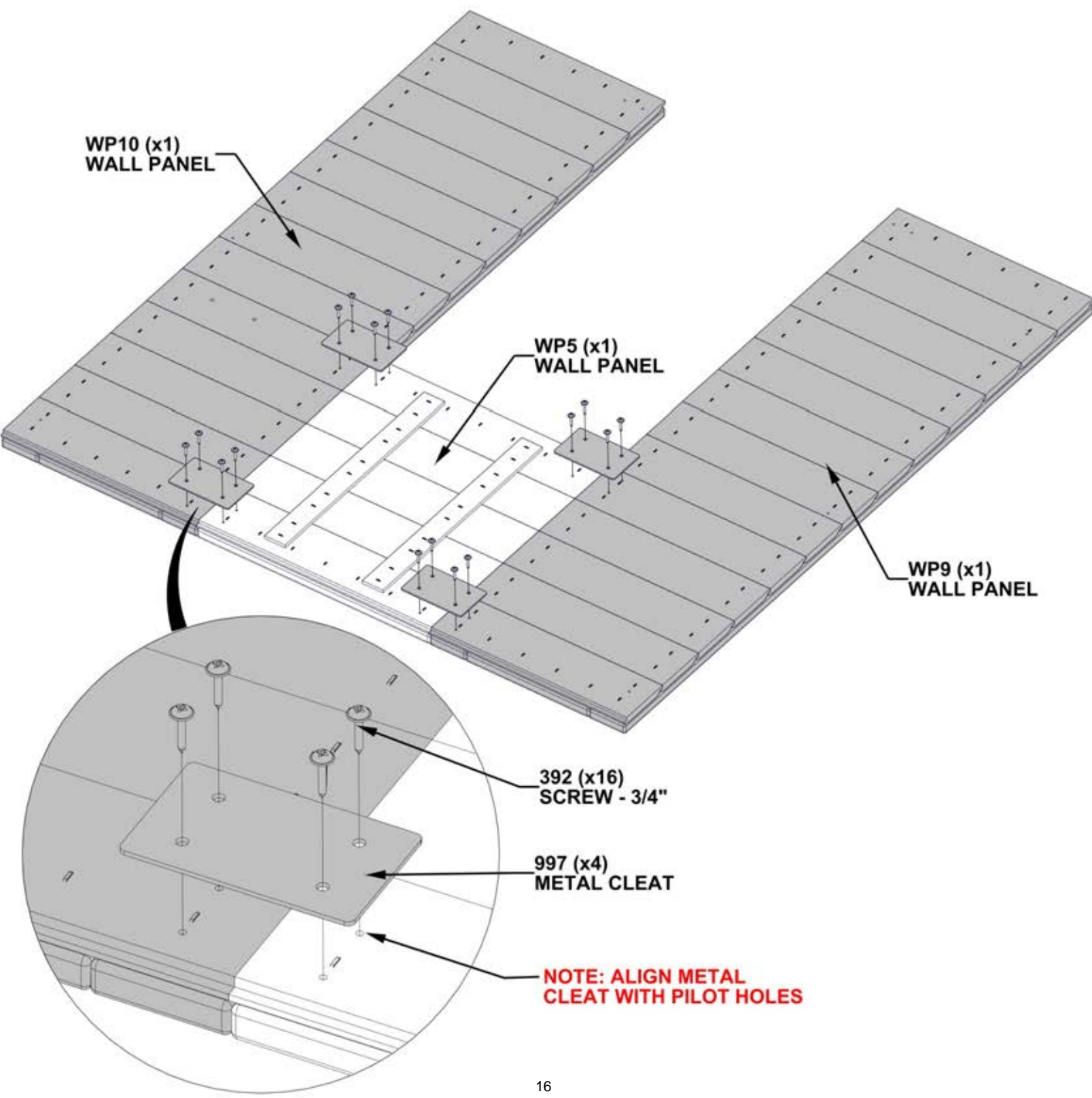



# STEP 5 - PLAYHOUSE ASSEMBLY

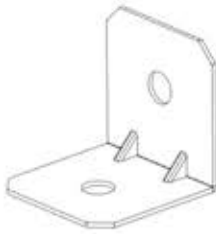

A4M01785 ANGLE BRACKET  
(x3)

QTY	PART NUMBER	DESCRIPTION
2	H100202	SCREW PWH 8x5/8 BLK
4	H100797	SCREW PWH 8x1 BLK

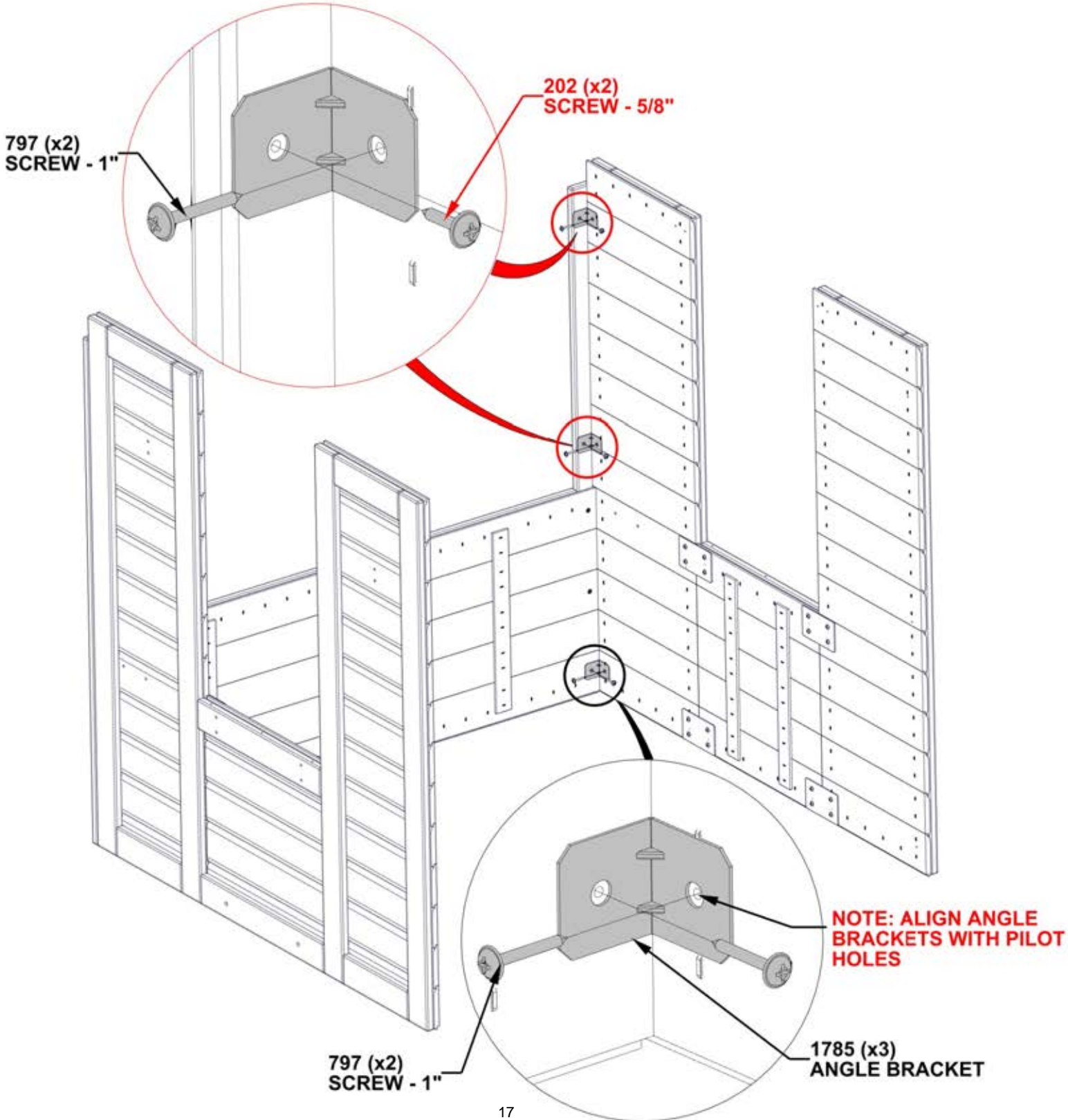

# STEP 6 - PLAYHOUSE ASSEMBLY

QTY	PART NUMBER	DESCRIPTION
6	H100797	SCREW PWH 8x1 BLK

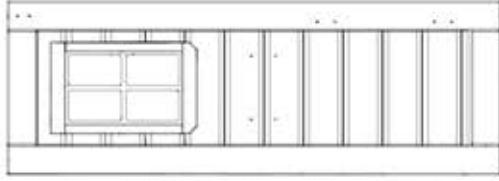

WP2 WALL PANEL - W2A03574  
(x1) 3 3/8"x14"x39 3/4" (27x355x1010)

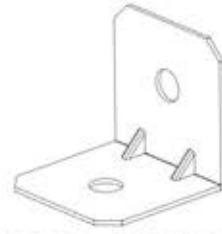

A4M01785 ANGLE BRACKET  
(x3)

**NOTE: ALIGN ANGLE BRACKET WITH PILOT HOLES IN PANEL**

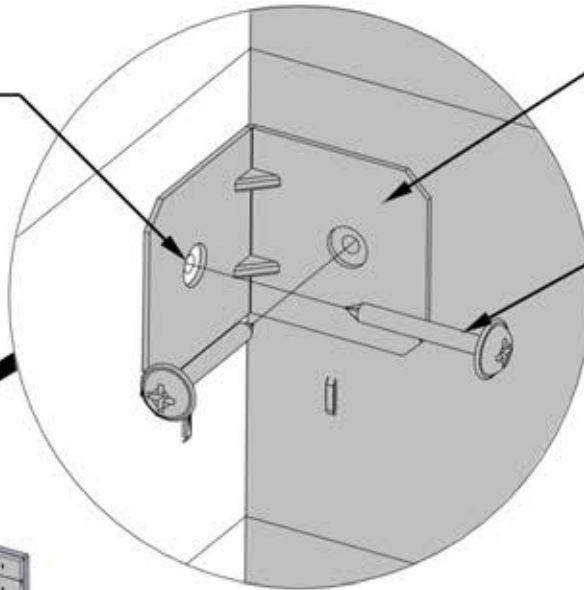

1785 (x3)  
ANGLE BRACKET

797 (x6)  
SCREW - 1"

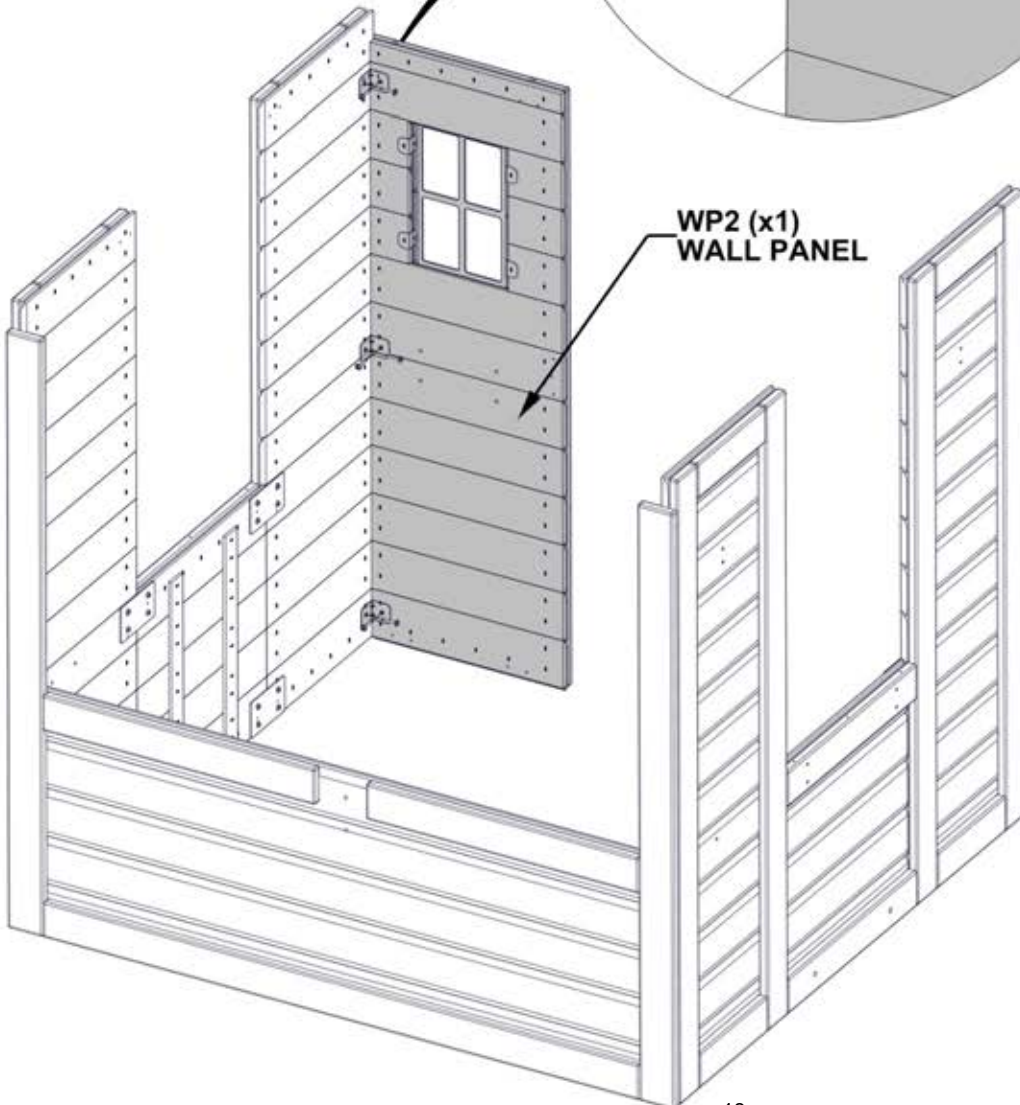

WP2 (x1)  
WALL PANEL

# STEP 7 - PLAYHOUSE ASSEMBLY

QTY	PART NUMBER	DESCRIPTION
6	H100797	SCREW PWH 8x1 BLK

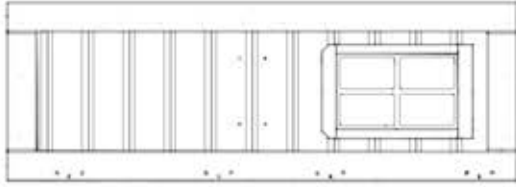

WP1 WALL PANEL - W2A03573  
(x1) 3 3/8"x14"x39 3/4" (27x355x1010)

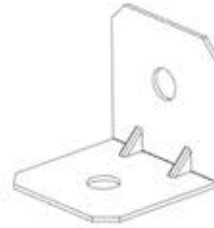

A4M01785 ANGLE BRACKET  
(x3)

1785 (x3)  
ANGLE BRACKET

797 (x6)  
SCREW - 1"

**NOTE: ALIGN ANGLE BRACKET  
WITH PILOT HOLES IN PANEL**

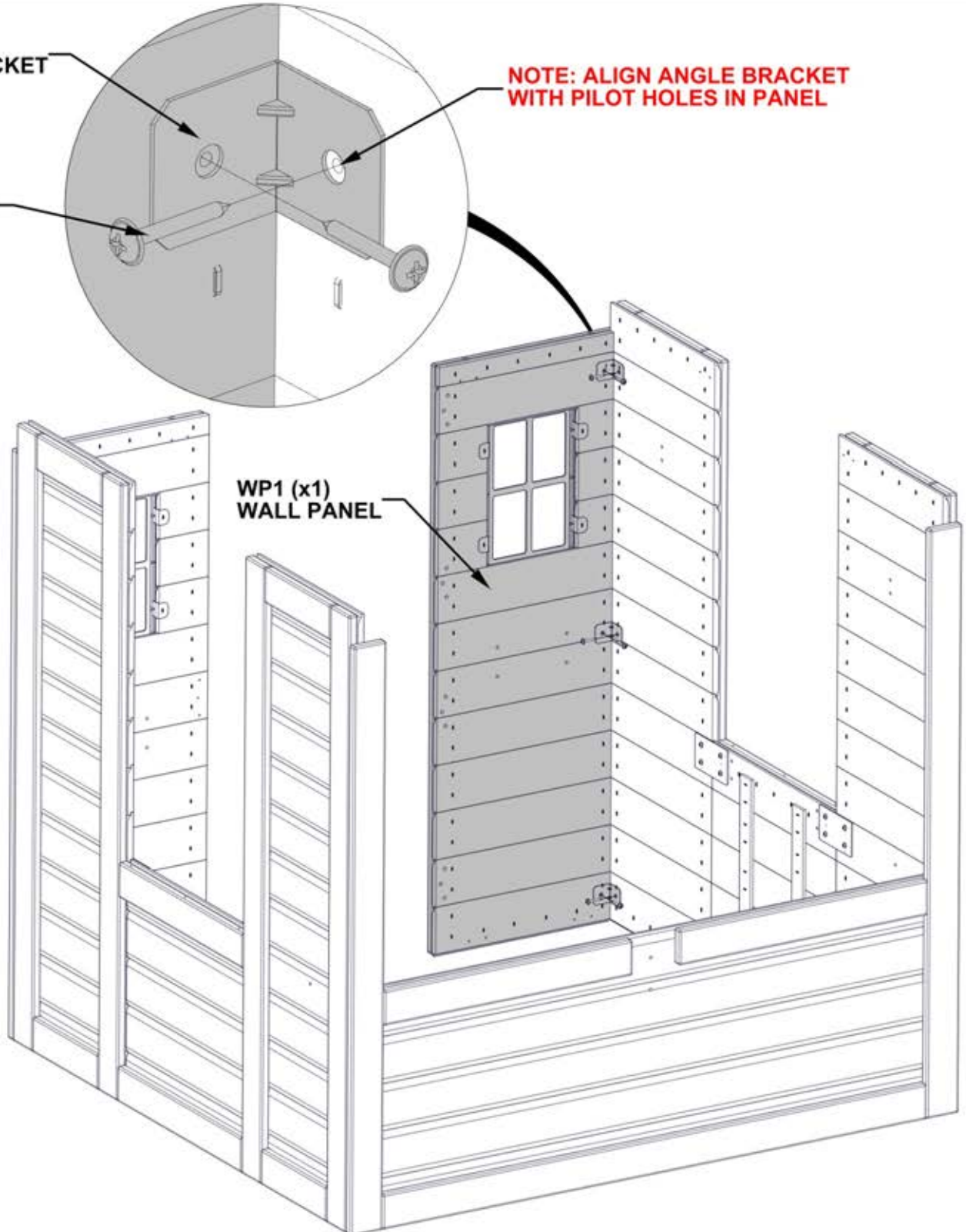

WP1 (x1)  
WALL PANEL

# STEP 8 - PLAYHOUSE ASSEMBLY

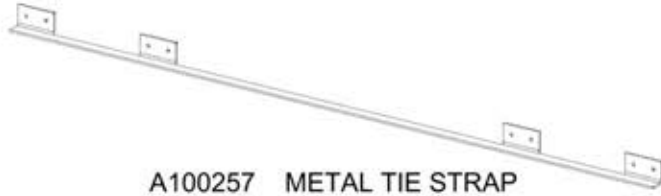

A100257 METAL TIE STRAP  
(x1)

QTY	PART NUMBER	DESCRIPTION
8	H100392	SCREW PWH 8x3/4 BLK

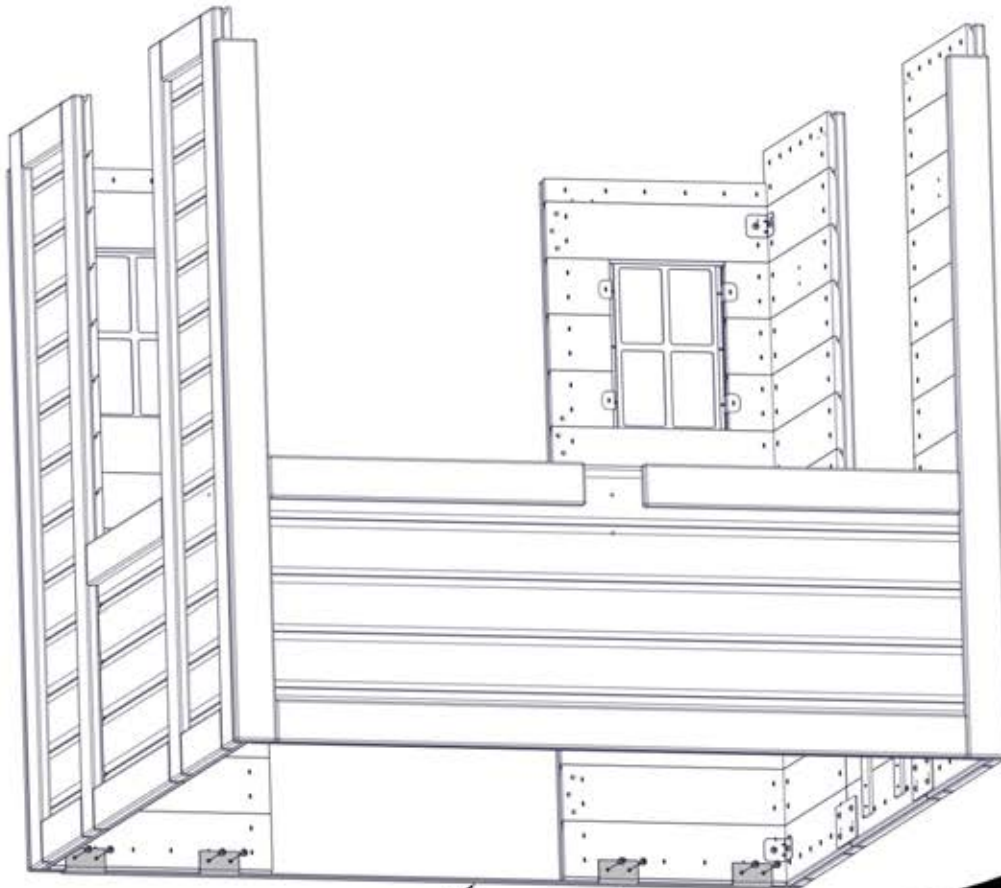

**NOTE: ALIGN METAL TIE STRAP WITH PILOT HOLES IN BOTTOM OF PANELS**

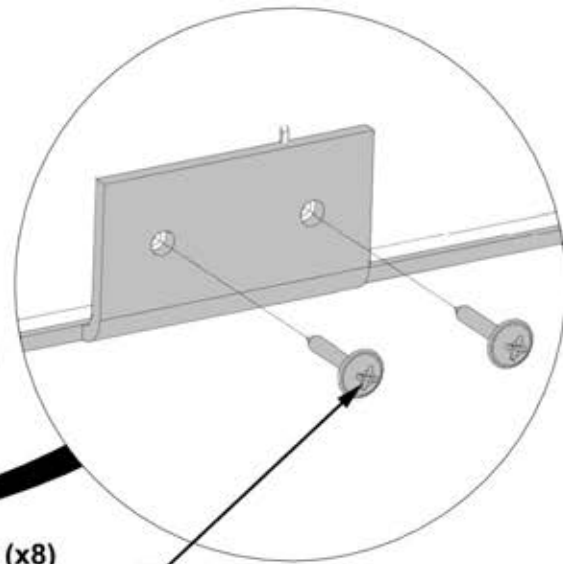

257 (x1)  
METAL TIE STRAP

392 (x8)  
SCREW - 3/4"

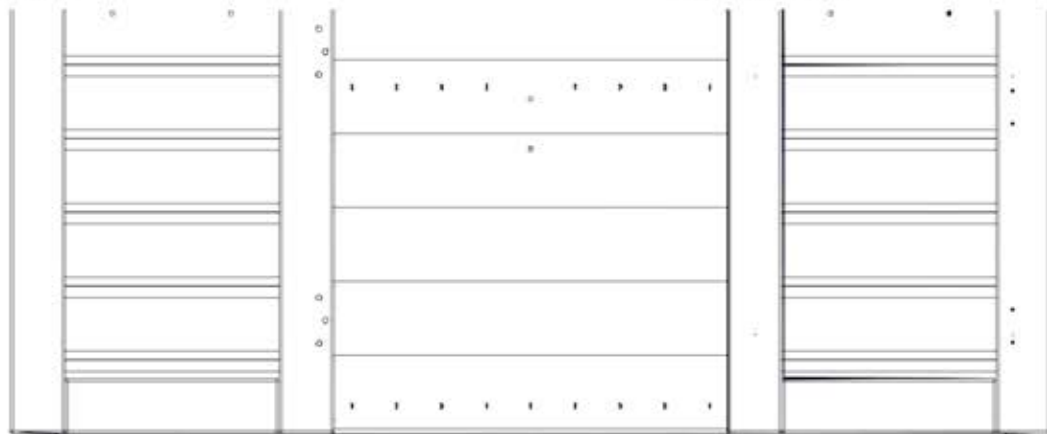

17 inches  
[432 mm]

**NOTE: MAKE SURE DOOR OPENING IS HELD AT DIMENSION ABOVE**

# STEP 9 - PLAYHOUSE ASSEMBLY

QTY	PART NUMBER	DESCRIPTION
16	H100392	SCREW PWH 8x3/4 BLK



H1 ANGLED HEADER - W4L17332  
(x2) 15/16"x3"x40 13/16" (24x76x1036)



A4M00997 METAL CLEAT  
(x4)

**NOTE: ALIGN METAL CLEAT WITH PILOT HOLES**

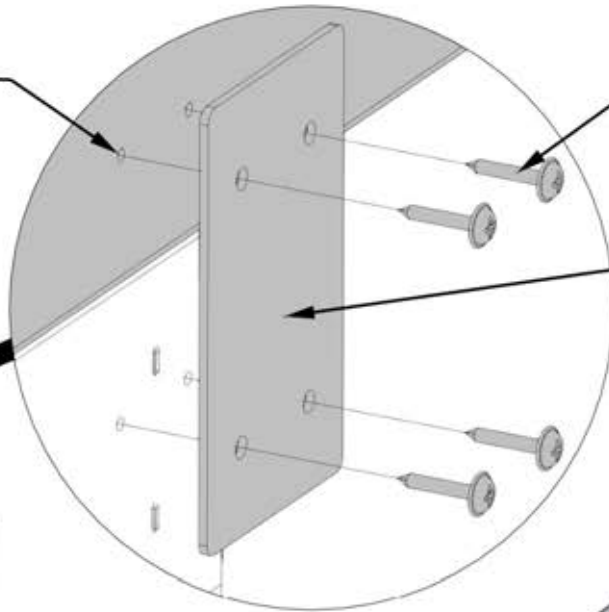

392 (x16)  
SCREW - 3/4"

997 (x4)  
METAL CLEAT

H1 (x1)  
ANGLED HEADER

H1 (x1)  
ANGLED HEADER

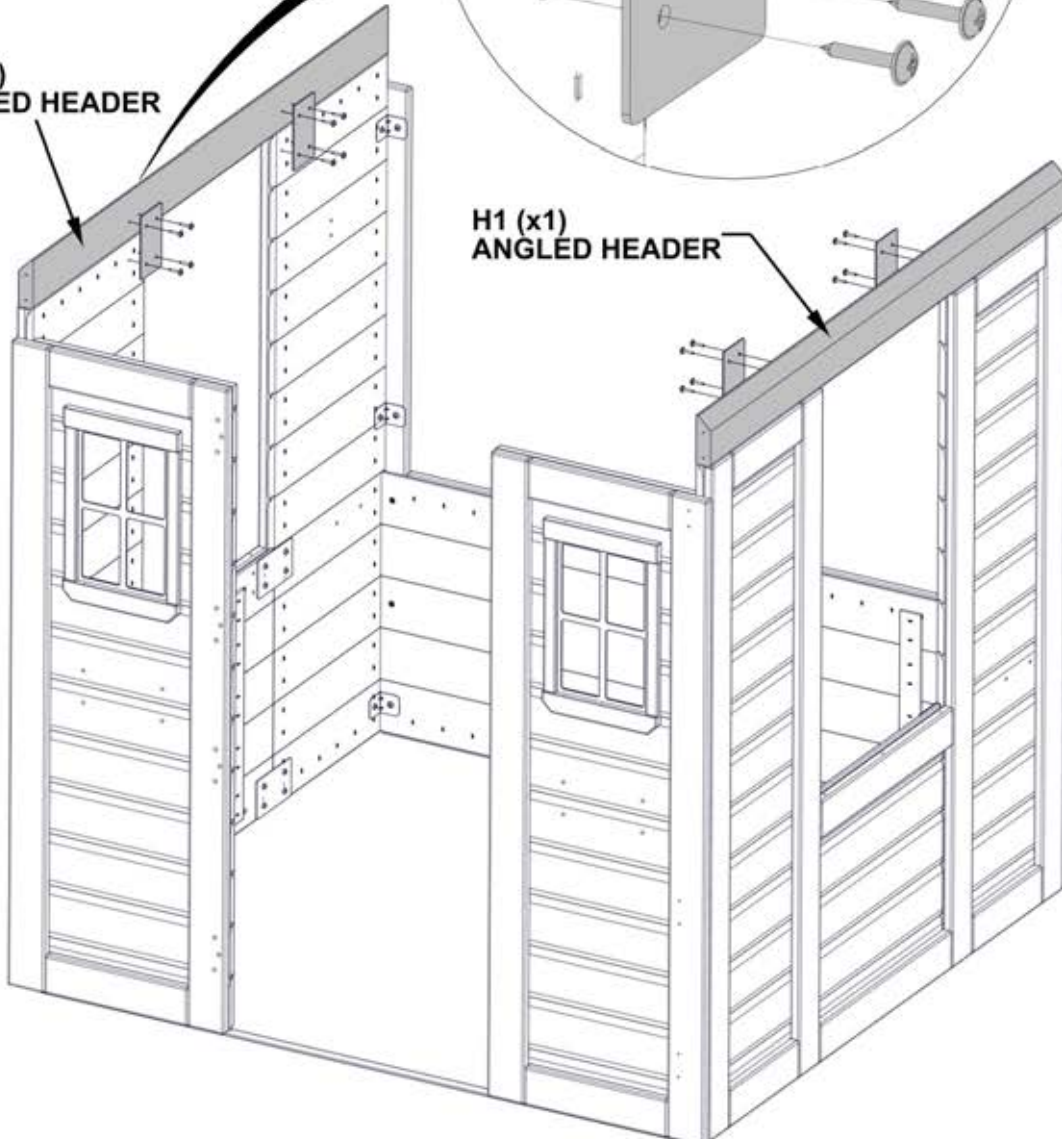

# STEP 10A - PLAYHOUSE ASSEMBLY



G1 FRONT HEADER - W4L17330  
 (x1) 15/16"x5 1/4"x44 15/16" (24x134x1142)

QTY	PART NUMBER	DESCRIPTION
4	H100201	SCREW PFH 8x2 1/2 BLK

**NOTE: ALIGN FRONT  
 HEADER WITH PILOT HOLES**

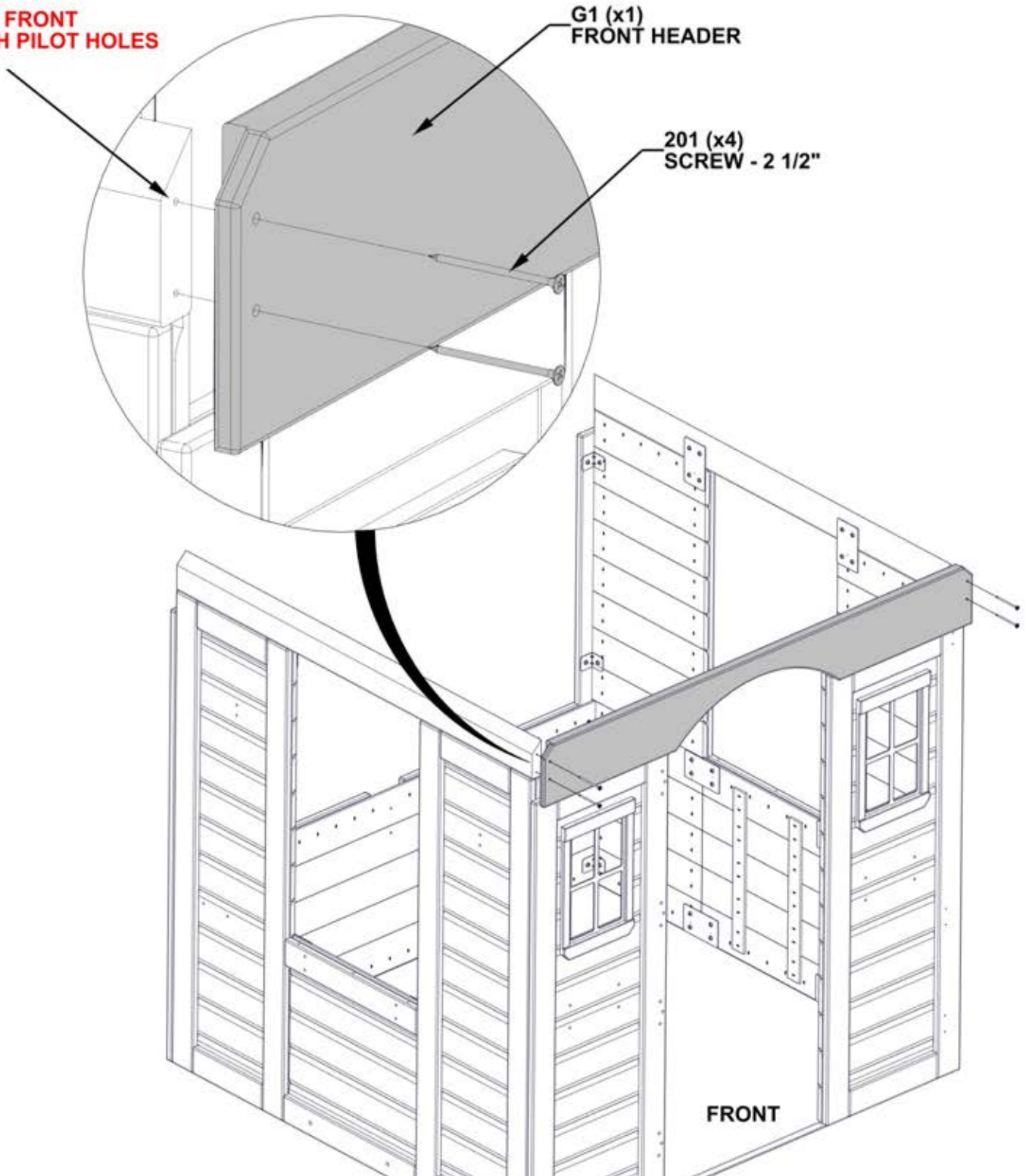

# STEP 10B - PLAYHOUSE ASSEMBLY



A4M00997 METAL CLEAT  
(x2)

QTY	PART NUMBER	DESCRIPTION
8	H100392	SCREW PWH 8x3/4 BLK

997 (x2)  
METAL CLEAT

**NOTE: ALIGN METAL  
CLEAT WITH PILOT HOLES**

392 (x8)  
SCREW - 3/4"

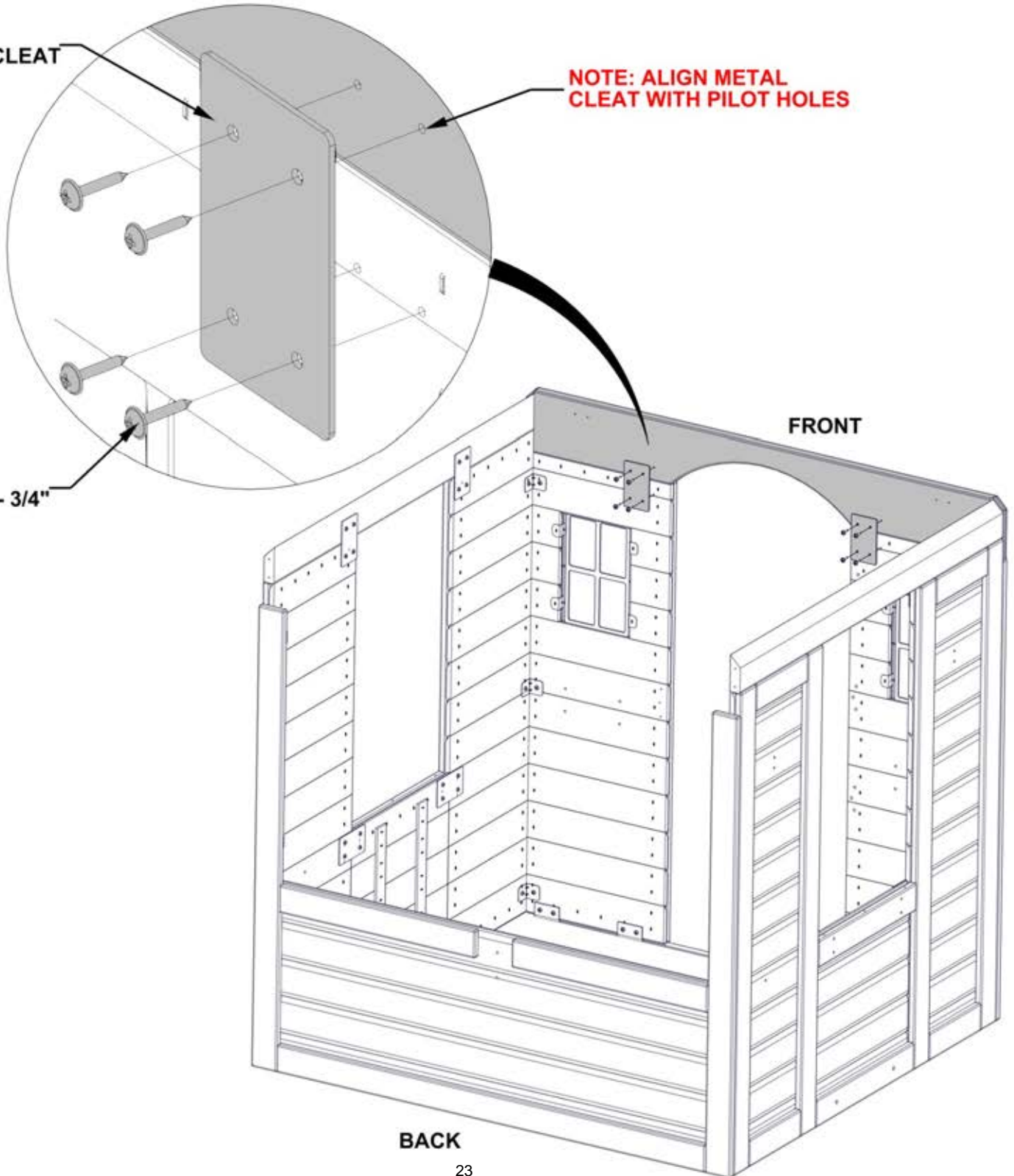

BACK

# STEP 11 - PLAYHOUSE ASSEMBLY



G2 REAR HEADER - W4L17331  
(x1) 15/16"x5 1/4"x44 15/16" (24x134x1142)

QTY	PART NUMBER	DESCRIPTION
4	H100201	SCREW PFH 8x2 1/2 BLK

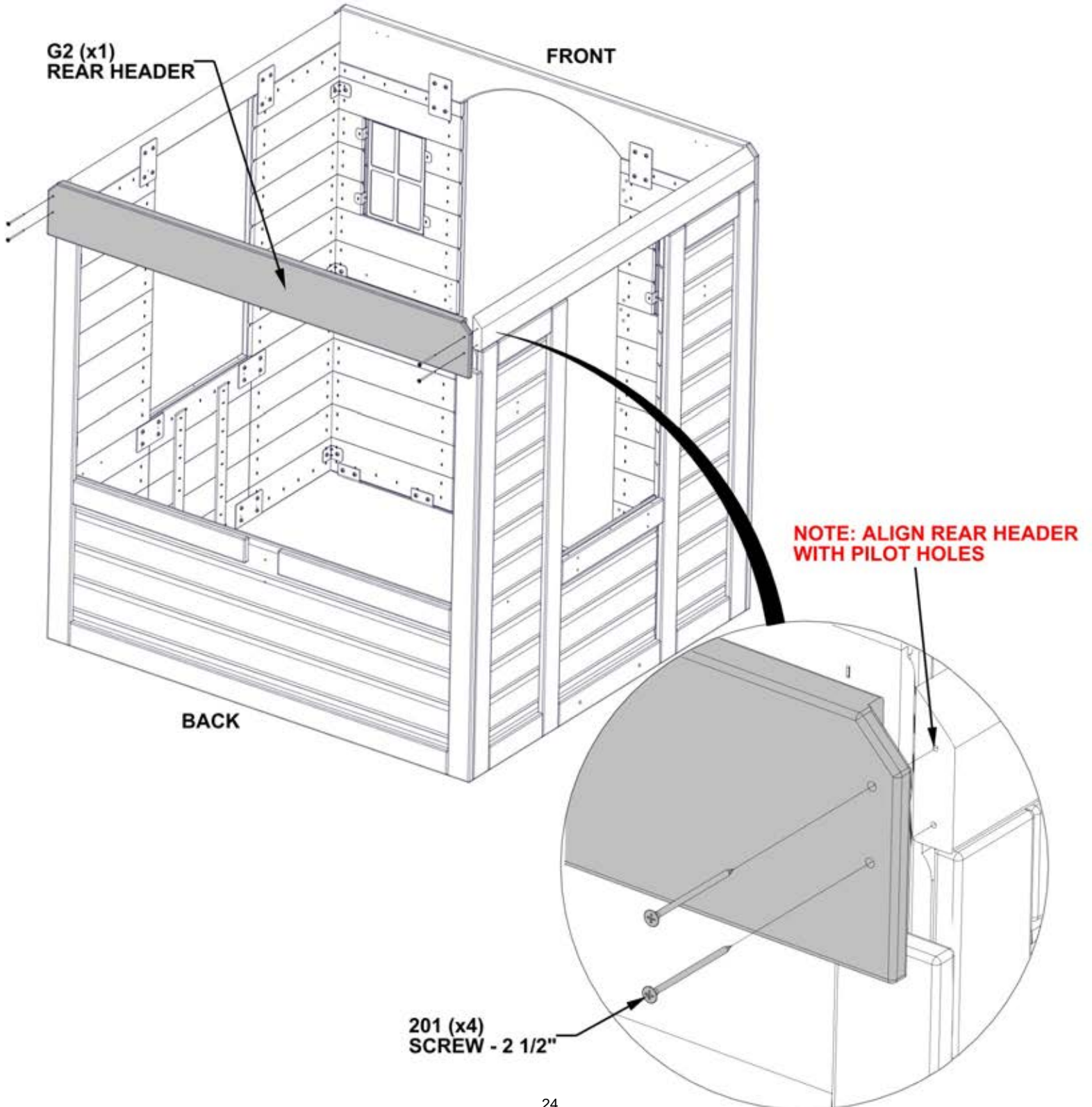



# STEP 12A - PLAYHOUSE ASSEMBLY

QTY	PART NUMBER	DESCRIPTION
2	H100382	SCREW PFH 8x1 3/4 BLK



M4 BACK UPRIGHT - W4L17350  
(x1) 5/8"x3 3/8"x26" (16x86x660)



G3 SHELF SUPPORT - W4L17342  
(x1) 15/16"x5 1/4"x5 7/8" (24x134x150)

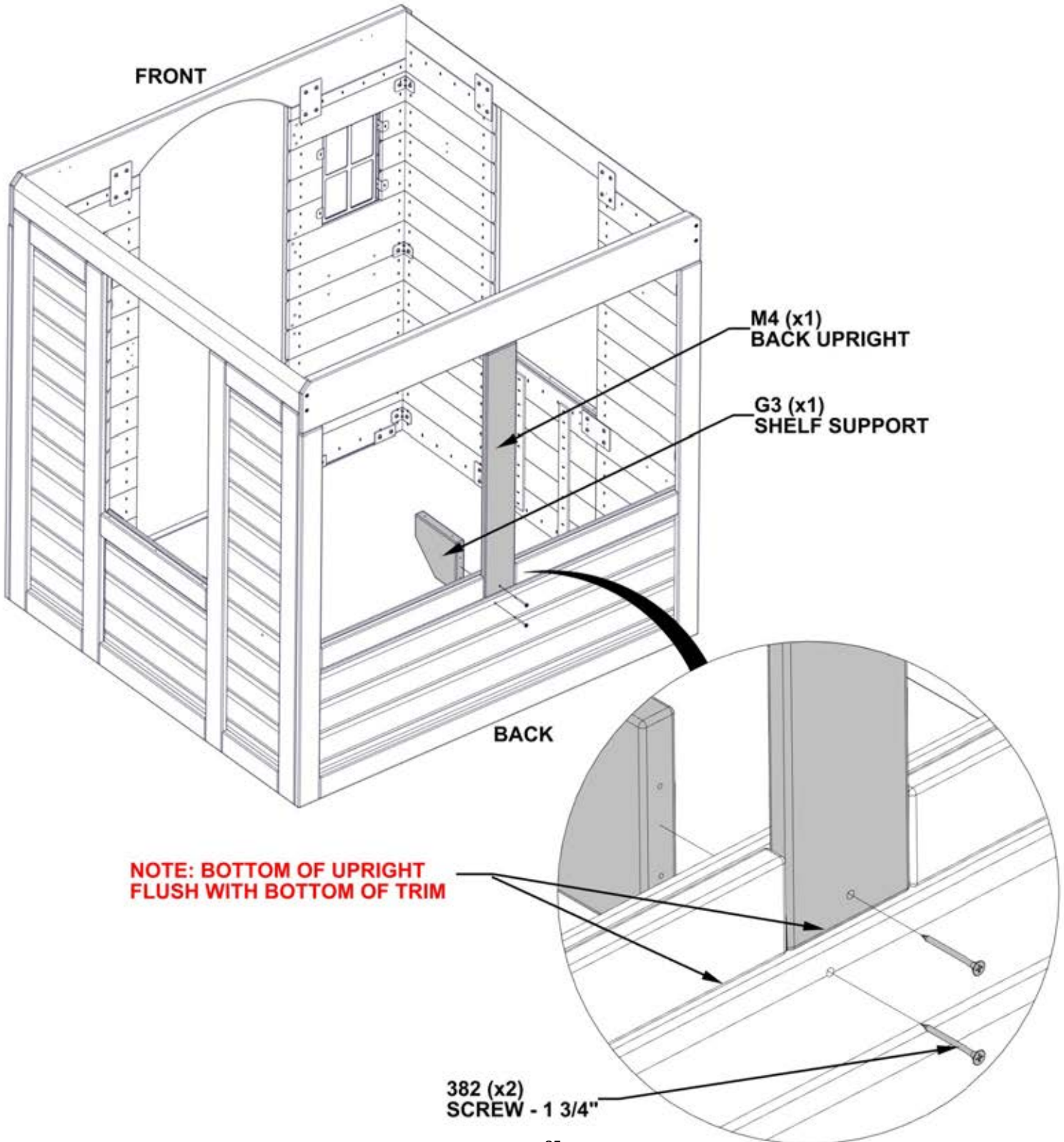

# STEP 12B - PLAYHOUSE ASSEMBLY



A4M01846 Z TIE BRACKET  
(x1)

QTY	PART NUMBER	DESCRIPTION
2	H100202	SCREW PWH 8x5/8 BLK
2	H100392	SCREW PWH 8x3/4 BLK

**NOTE: ALIGN Z TIE BRACKET WITH PILOT HOLES IN REAR HEADER**

1846 (x1)  
Z TIE BRACKET

392 (x2)  
SCREW - 3/4"

202 (x2)  
SCREW - 5/8"

BACK

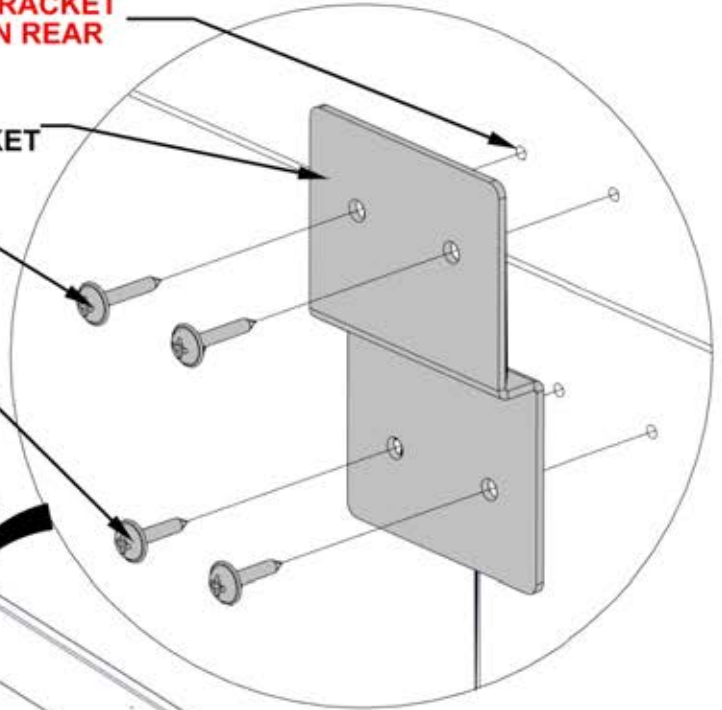

FRONT

# STEP 13 - PLAYHOUSE ASSEMBLY

QTY	PART NUMBER	DESCRIPTION
4	H100380	SCREW PFH 8x1 1/8 BLK



J4 SUPPORT BOARD - W4L17346  
(x1) 15/16"x2 3/8"x6 11/16" (24x60x170)



J5 SUPPORT BOARD - W4L17333  
(x1) 15/16"x2 3/8"x6 11/16" (24x60x170)

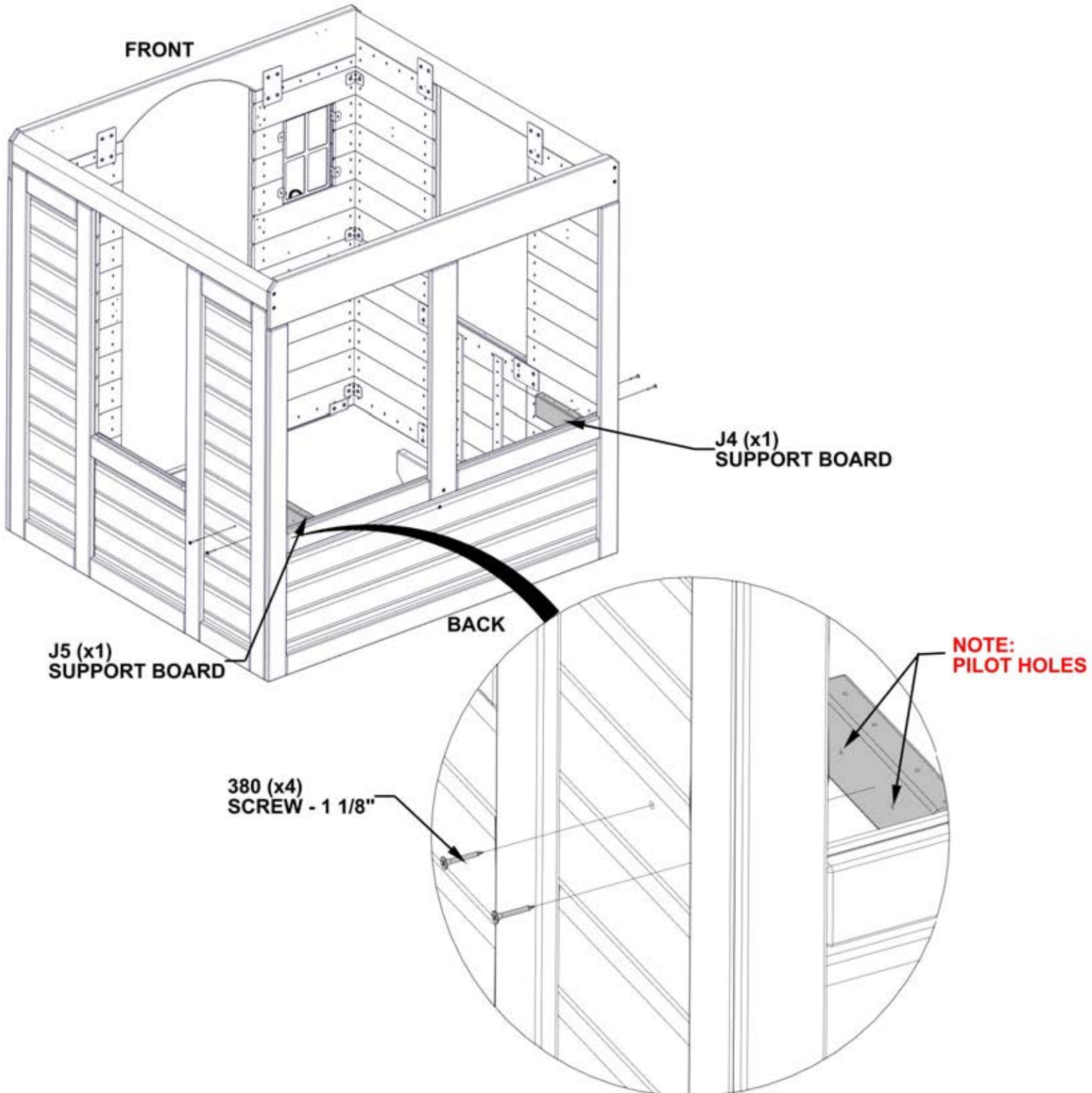

# STEP 14 - PLAYHOUSE ASSEMBLY

QTY	PART NUMBER	DESCRIPTION
10	H100387	SCREW PFH 8x1 1/4 BLK



M3 FRONT CABINET BOARD - W4L17341  
(x1) 5/8"x3 3/8"x42 13/16" (16x86x1087)



L2 CABINET TOP - W4L17340  
(x1) 5/8"x4 7/16"x42 13/16" (16x112x1087)

NOTE: ALIGN CABINET BOARD WITH PILOT HOLES IN SUPPORT. INSERT SCREWS AS SHOWN BELOW.

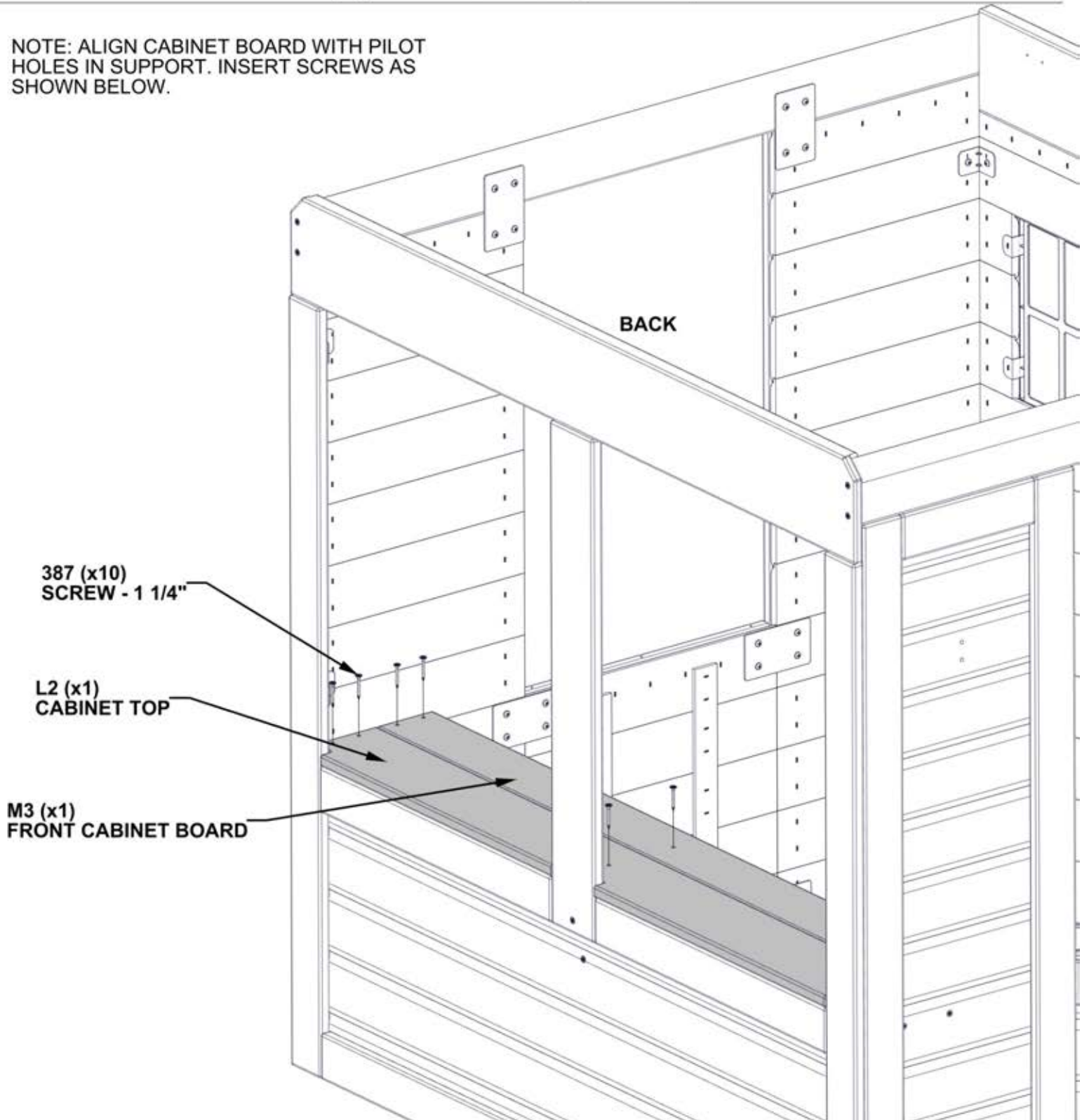

# STEP 15 - PLAYHOUSE ASSEMBLY



N1 WINDOW SHELF - W4L17326  
(x1) 5/8"x2 3/8"x15 3/16" (16x60x386)

QTY	PART NUMBER	DESCRIPTION
3	H100387	SCREW PFH 8x1 1/4 BLK

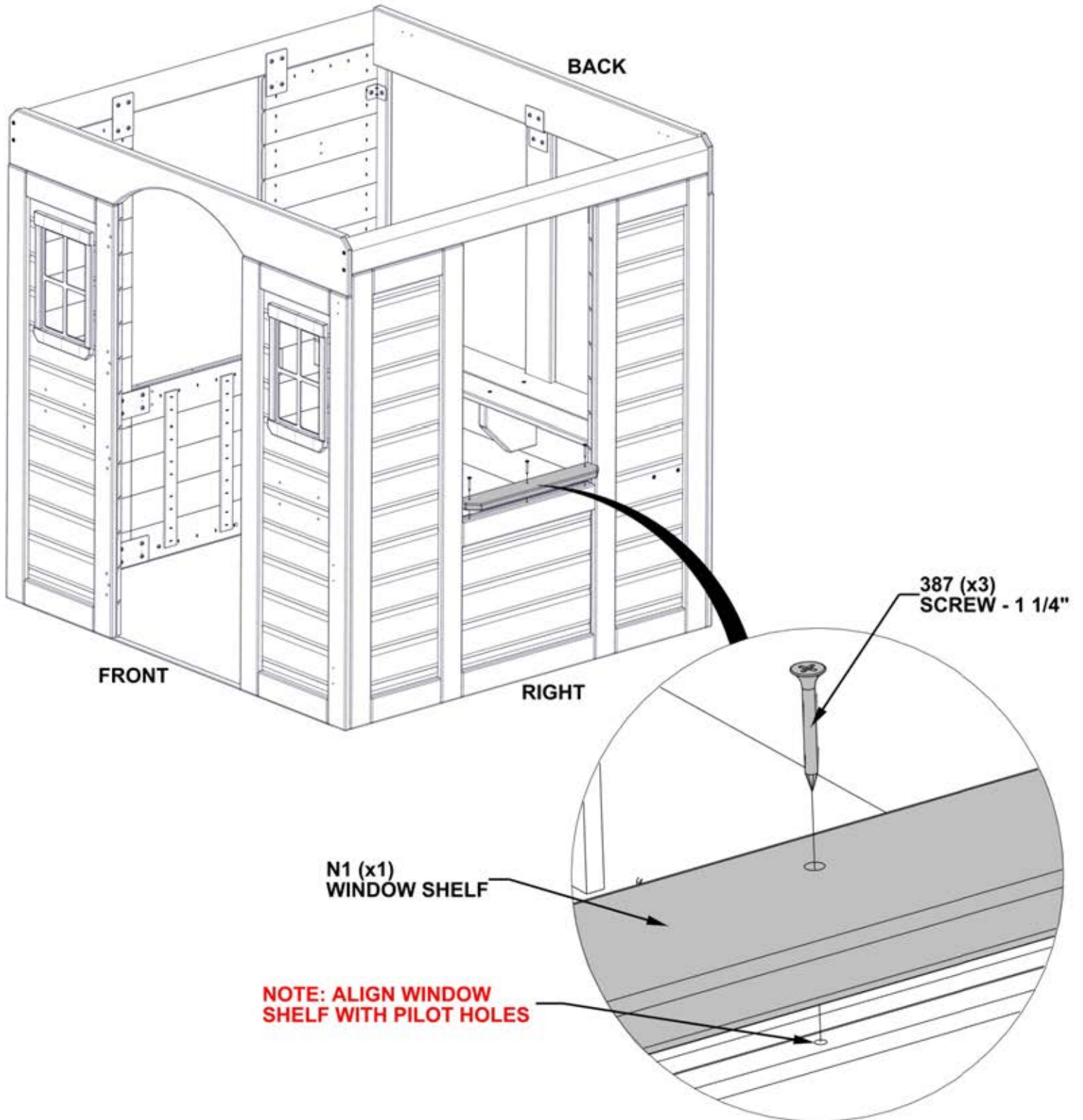

**NOTE: ALIGN WINDOW SHELF WITH PILOT HOLES**

# STEP 16 - PLAYHOUSE ASSEMBLY

QTY	PART NUMBER	DESCRIPTION
4	H100382	SCREW PFH 8x1 3/4 BLK
5	H100387	SCREW PFH 8x1 1/4 BLK



L1 WINDOW - W4L17328  
(x1) 5/8"x4 7/16"x17 5/8" (16x112x448)



J1 SHELF SUPPORT - W4L17329  
(x2) 15/16"x2 3/8"x3 1/8" (24x60x80)

**NOTE: ALIGN SCREWS WITH ALL PILOT HOLES**

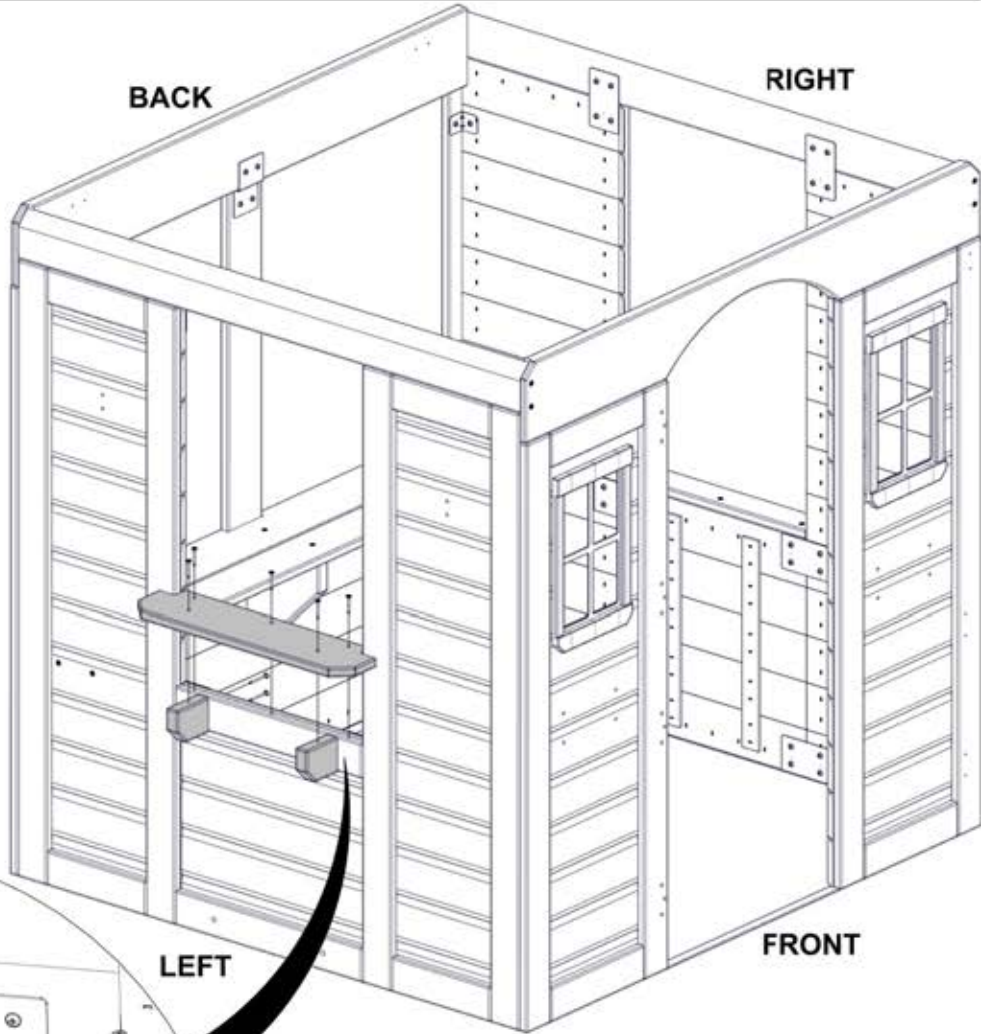

387 (x5)  
SCREW - 1 1/4"

LEFT

L1 (x1)  
WINDOW

382 (x4)  
SCREW - 1 3/4"

J1 (x2)  
SHELF SUPPORT

# STEP 17 - PLAYHOUSE ASSEMBLY



A6P00023 FLOWER POT HOLDER  
(x2)

QTY	PART NUMBER	DESCRIPTION
8	H100387	SCREW PFH 8x1 1/4 BLK

NOTE: ALIGN FLOWER POT HOLDER WITH HOLES IN FRONT PANELS. INSERT SCREWS AS SHOWN BELOW.

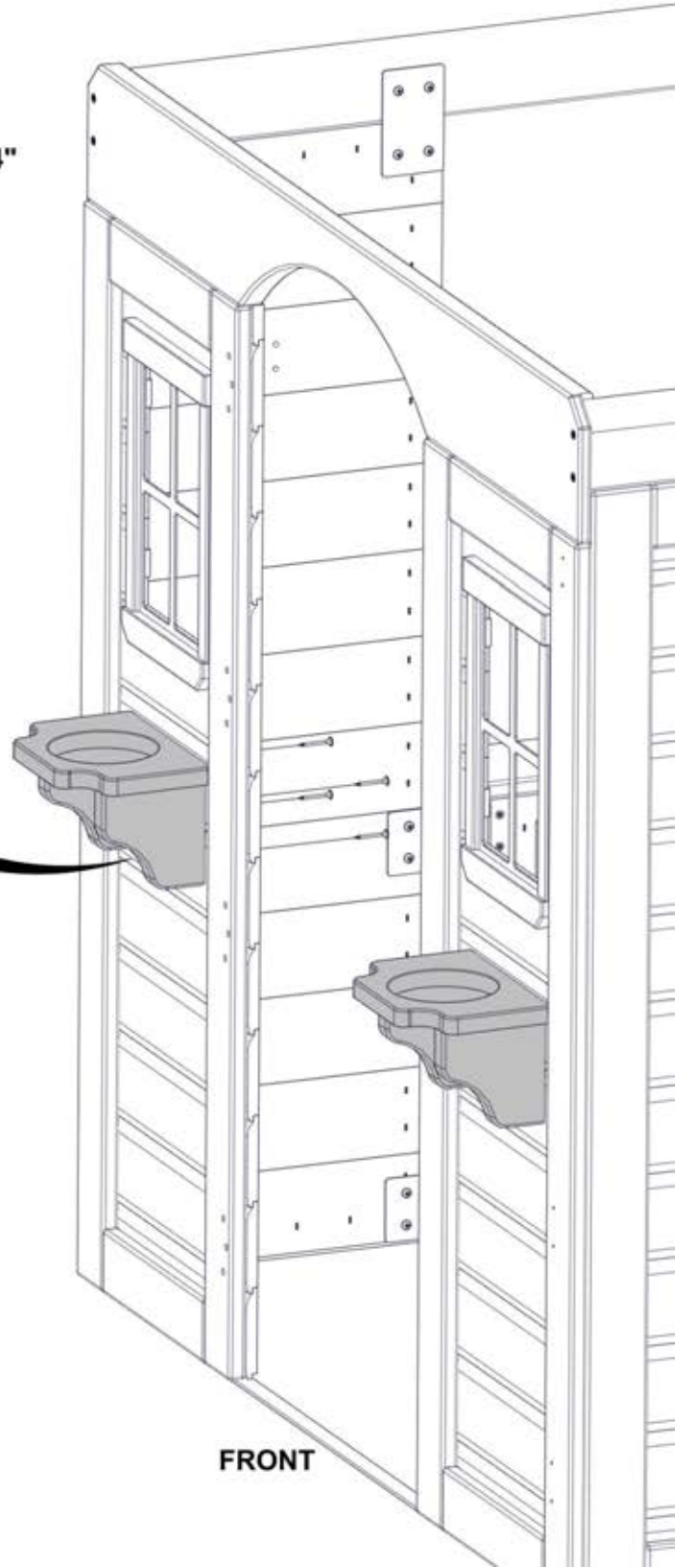
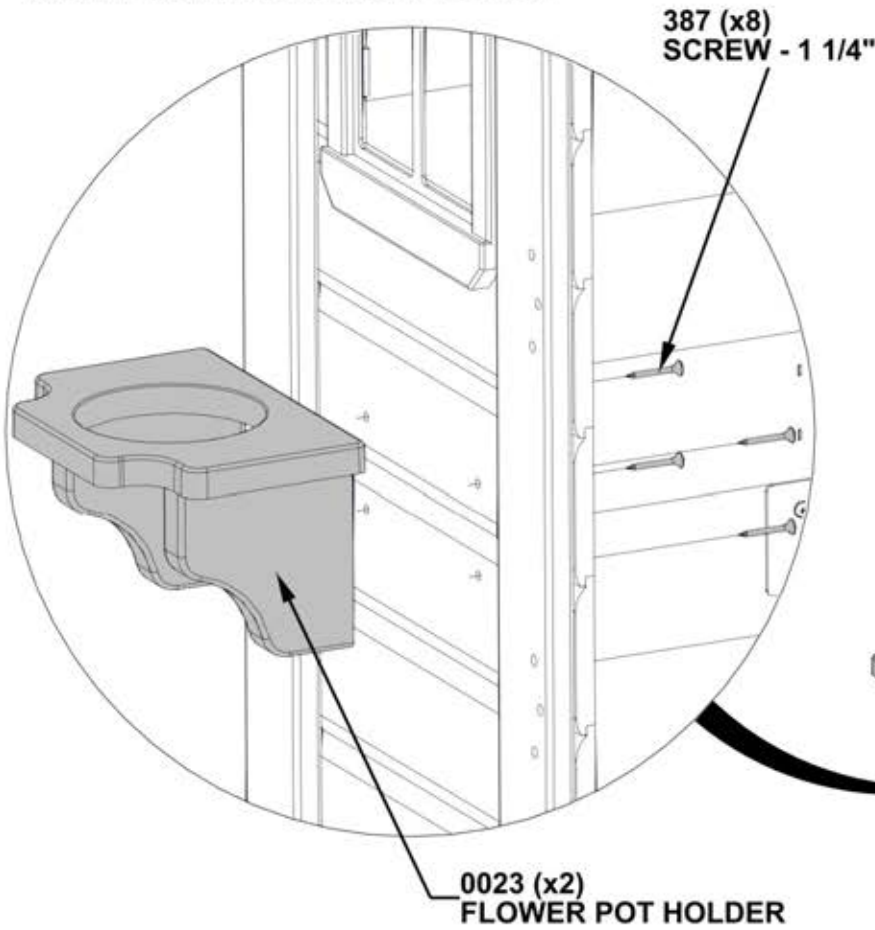

# STEP 18 - PLAYHOUSE ASSEMBLY



A4M01045 BELL ASSEMBLY  
(x1)

QTY	PART NUMBER	DESCRIPTION
2	H100202	SCREW PWH 8x5/8 BLK

**NOTE: ALIGN BELL ASSEMBLY WITH PILOT HOLES IN PANEL**

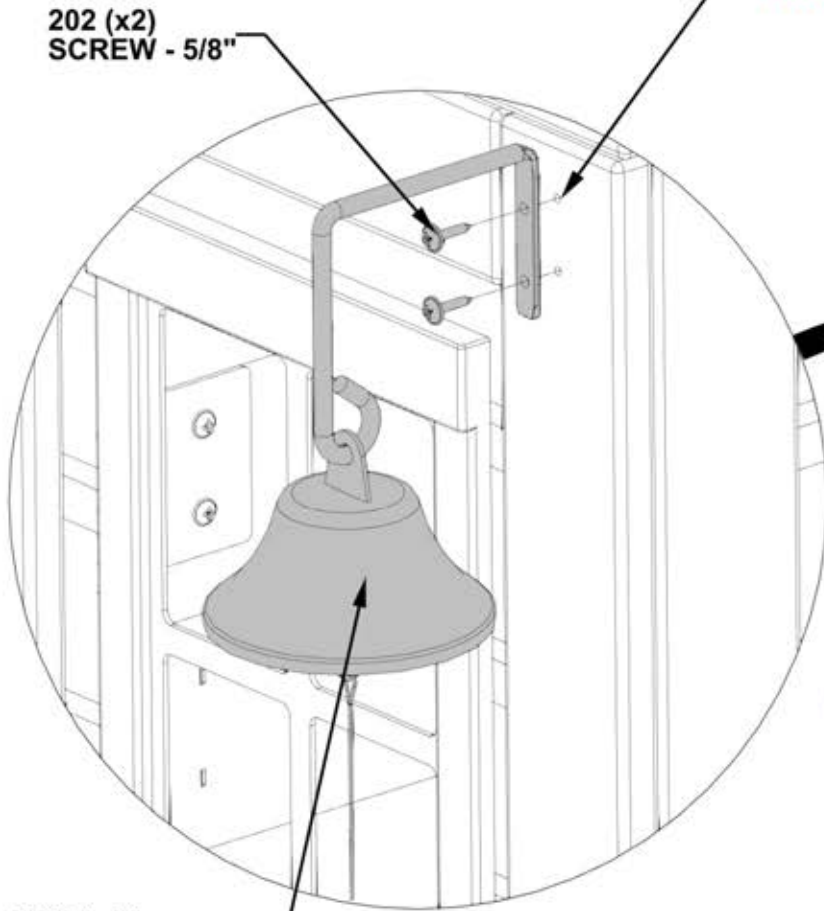

202 (x2)  
SCREW - 5/8"

1045 (x1)  
BELL ASSEMBLY

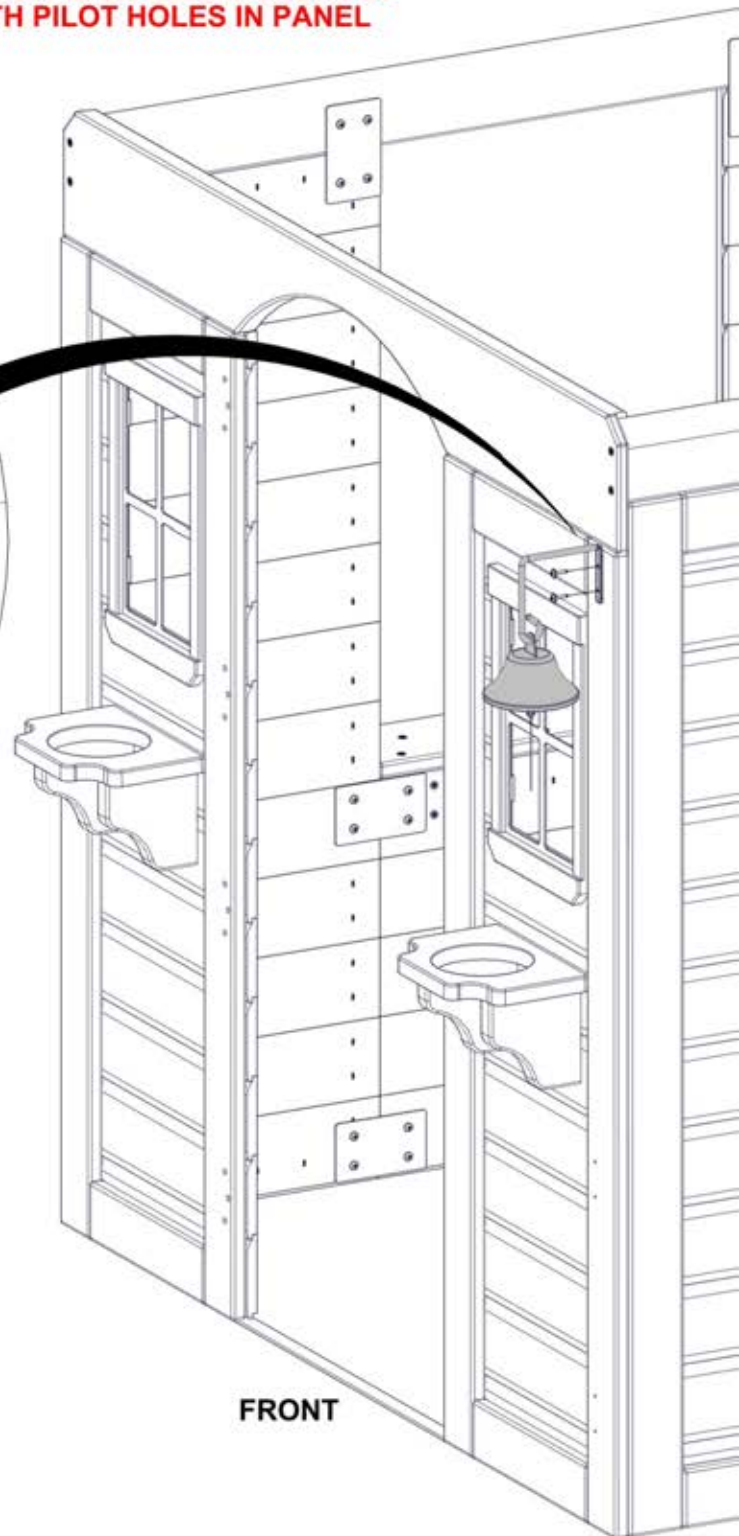

FRONT



# STEP 19 - PLAYHOUSE ASSEMBLY



A6P00068 OUTDOOR LIGHT FIXTURE  
(x2)

QTY	PART NUMBER	DESCRIPTION
4	H100387	SCREW PFH 8x1 1/4 BLK

NOTE: ALIGN LIGHT FIXTURE WITH HOLES IN LEFT PANELS. INSERT SCREWS AS SHOWN BELOW.

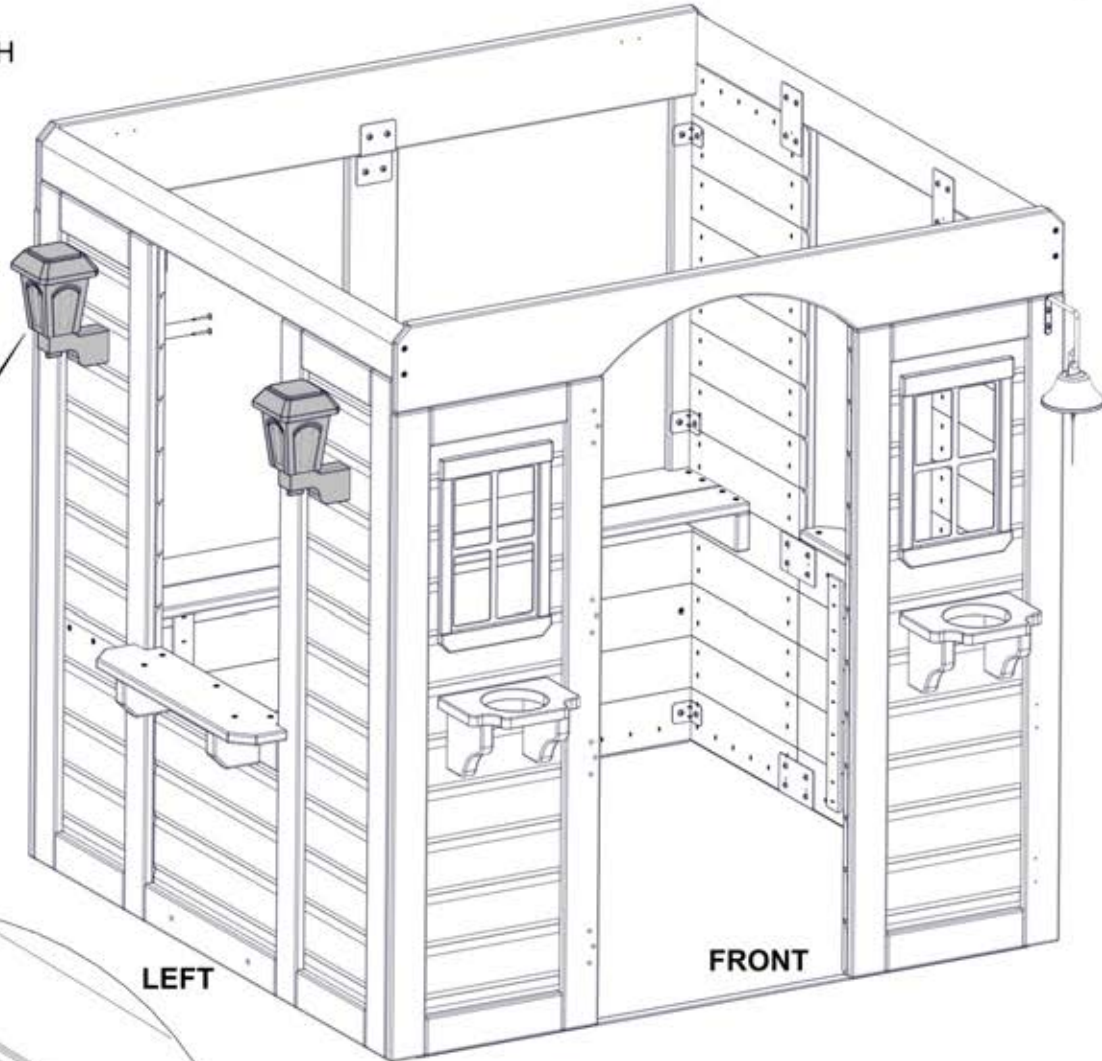

0068 (x2)  
OUTDOOR LIGHT  
FIXTURE

LEFT

FRONT

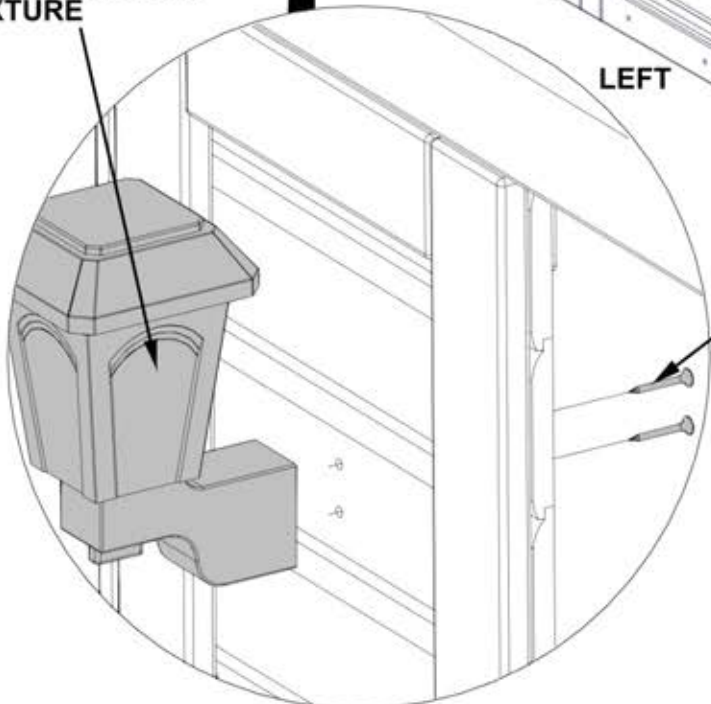

387 (x4)  
SCREW - 1 1/4"

# STEP 20 - PLAYHOUSE ASSEMBLY



A6P00024 FAUCET KIT  
(x1)

QTY	PART NUMBER	DESCRIPTION
2	H100200	SCREW PFH 8x1 1/2 BLK

BACK

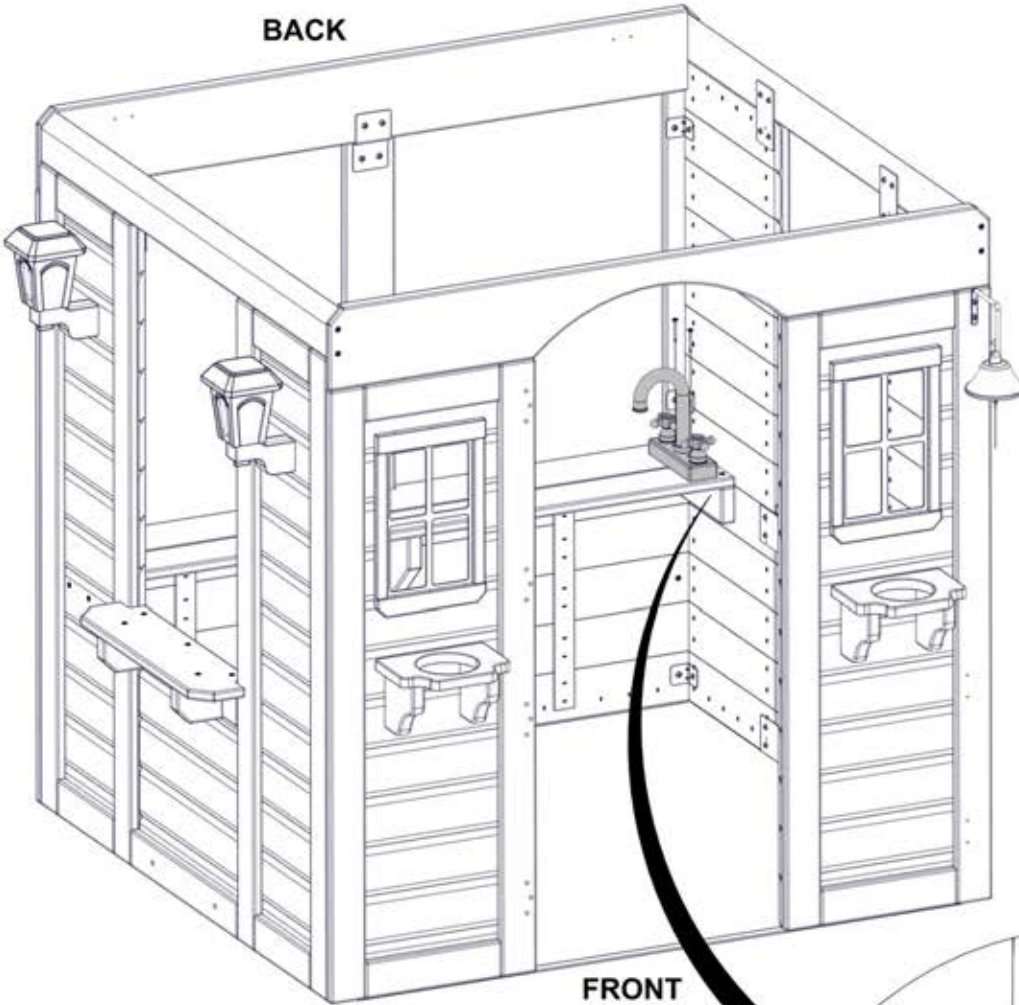

FRONT

1"  
[25.4 mm]

RIGHT

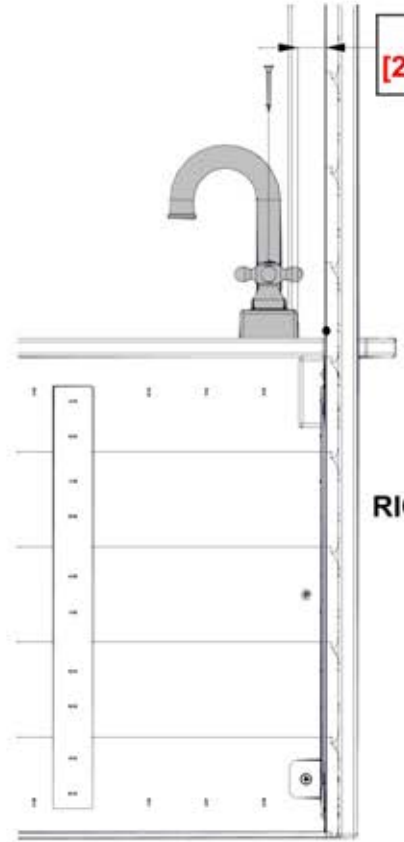

FRONT

200 (x2)  
SCREW - 1 1/2"

0024 (x1)  
FAUCET KIT

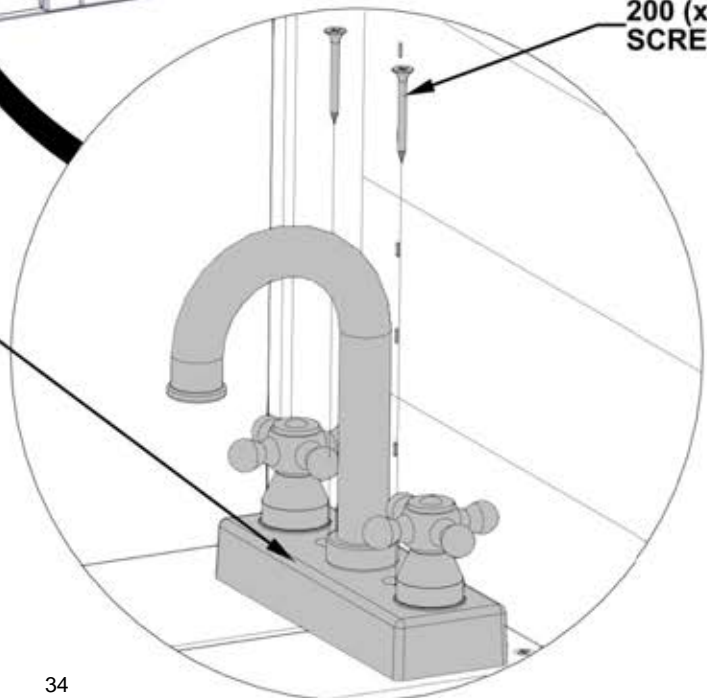

# STEP 21 - PLAYHOUSE ASSEMBLY



QTY	PART NUMBER	DESCRIPTION
2	H100202	SCREW PWH 8x5/8 BLK

A6P00032 SURFACE MOUNT BASIN  
(x1)

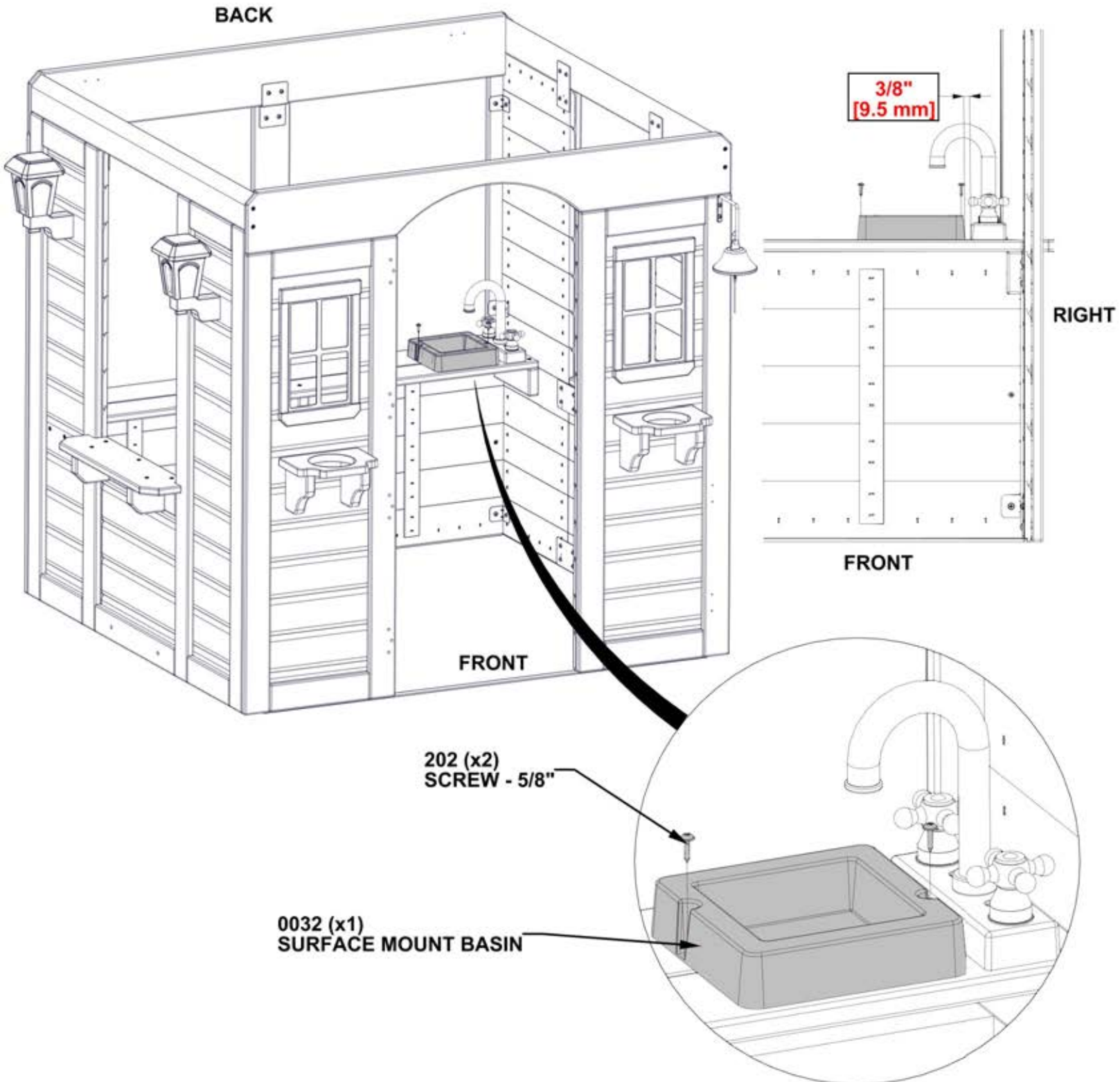

# STEP 22 - PLAYHOUSE ASSEMBLY

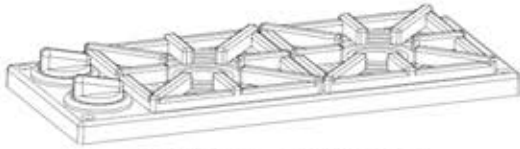

A6P00025 STOVE KIT  
(x1)

QTY	PART NUMBER	DESCRIPTION
4	H100380	SCREW PFH 8x1 1/8 BLK

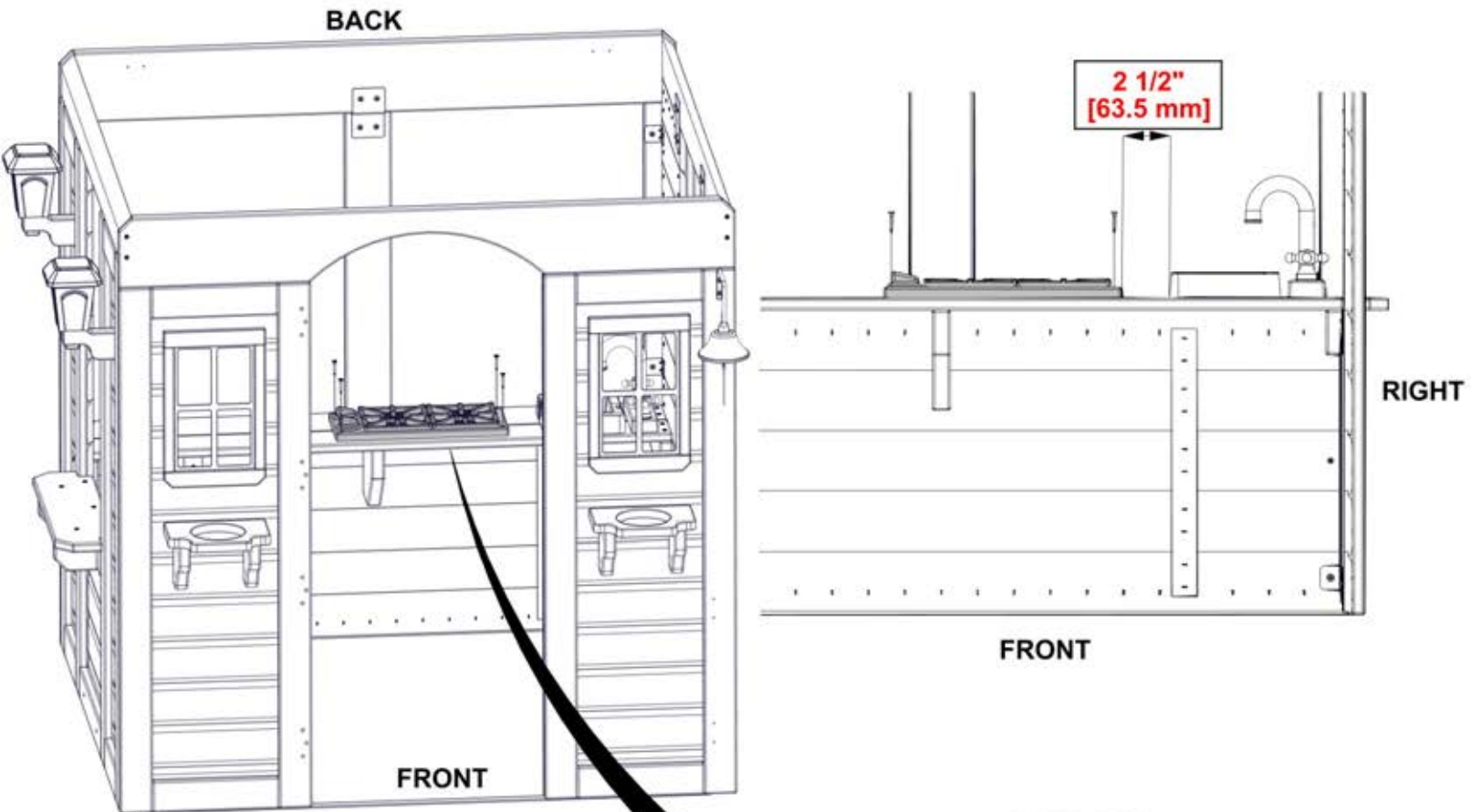

380 (x4)  
SCREW - 1 1/8"

0025 (x1)  
STOVE KIT

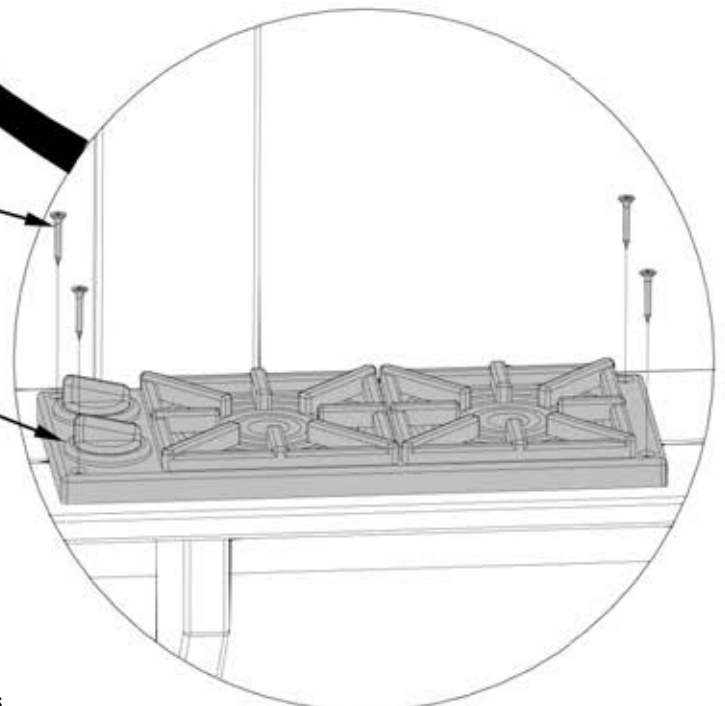

# STEP 23 - PLAYHOUSE ASSEMBLY

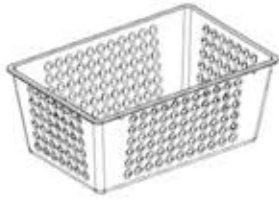

A6P00069 FRUIT BASKET KIT  
(x1)

QTY	PART NUMBER	DESCRIPTION
6	H100203	SCREW PFH 8x1/2 BLK

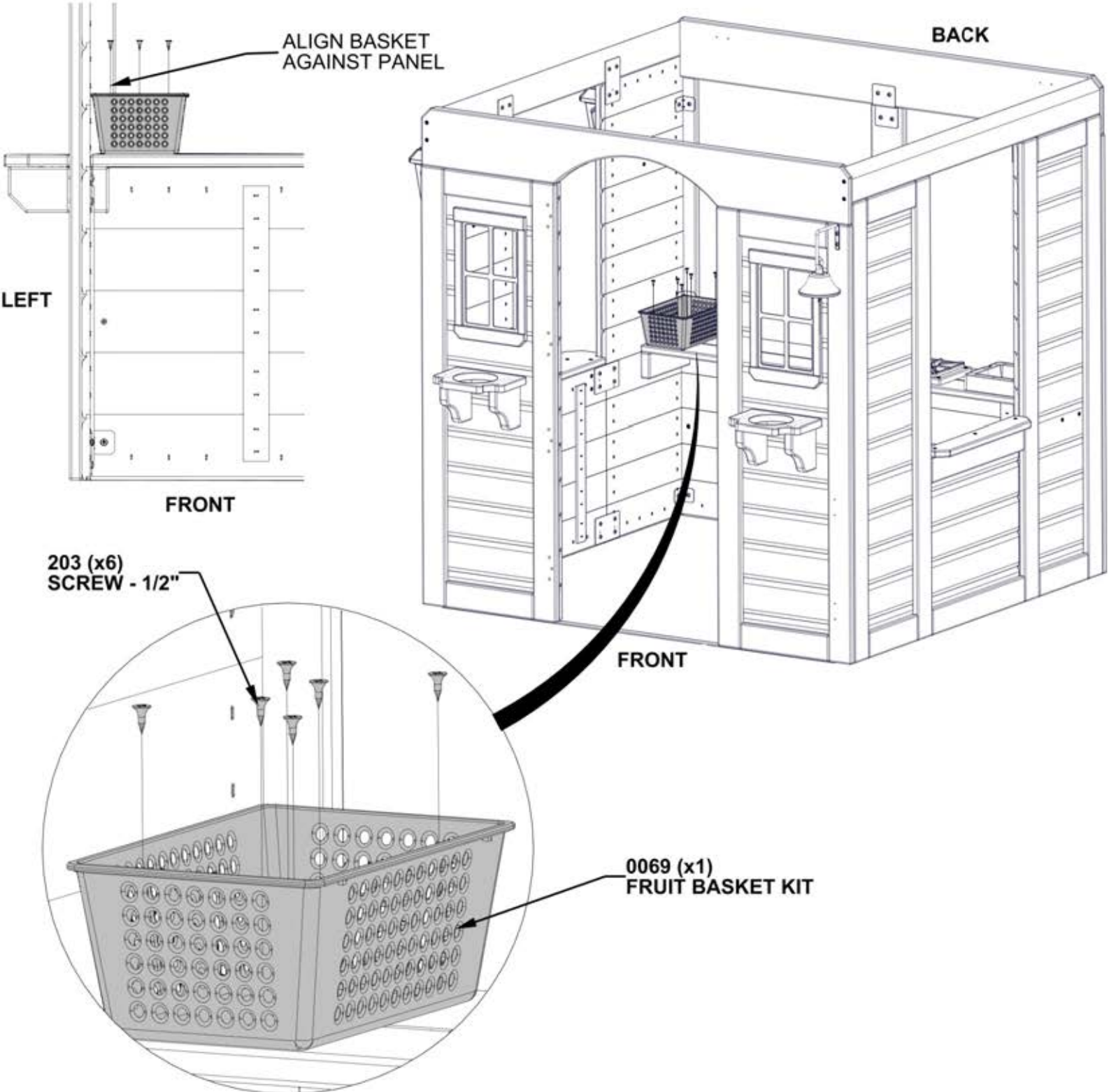

# STEP 24 - PLAYHOUSE ASSEMBLY



QTY	PART NUMBER	DESCRIPTION
3	H100387	SCREW PFH 8x1 1/4 BLK

N5 DOOR STOP - W4L17348  
 (x1) 5/8"x2 3/8"x3 3/8" (16x60x86)

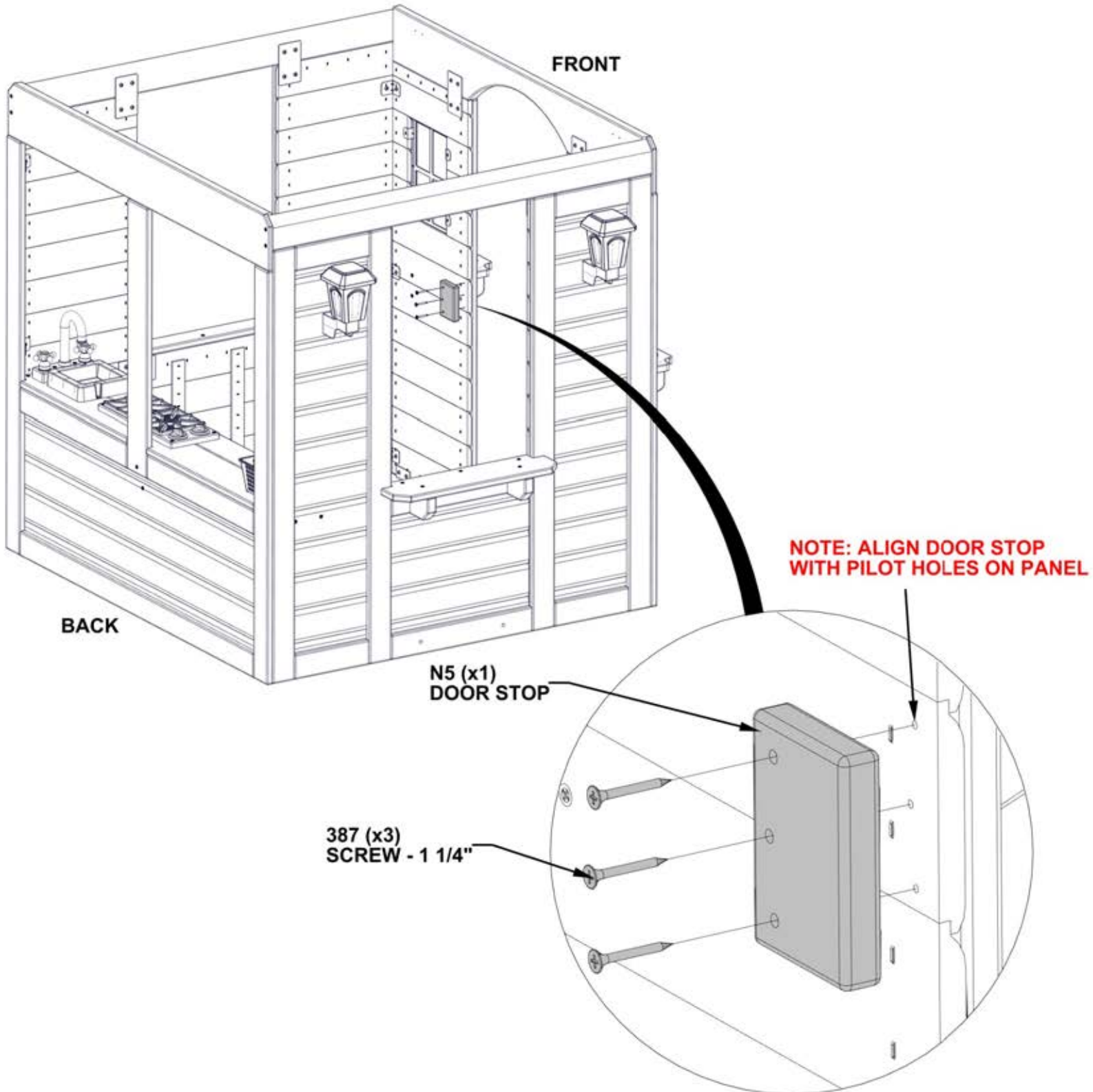

# STEP 25A - PLAYHOUSE ASSEMBLY

QTY	PART NUMBER	DESCRIPTION
12	H100804	T-NUT 8/32
12	H100806	SCREW POH-MS 8/32x1 1/8" BLK



DP1 BOTTOM DOOR PANEL - W2A03580  
(x1) 1 1/16"X15 11/16"X19 11/16" (27x398x500)



A100327 HINGE (DOOR, SPRING LOADED)  
(x2)

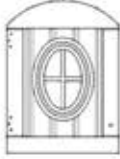

DP2 TOP DOOR PANEL - W2A03581  
(x1) 1 1/16"x15 11/16"x21 3/8" (27x398x542)



A4M00558 HINGE (DOOR, NON-SPRING LOADED)  
(x2)

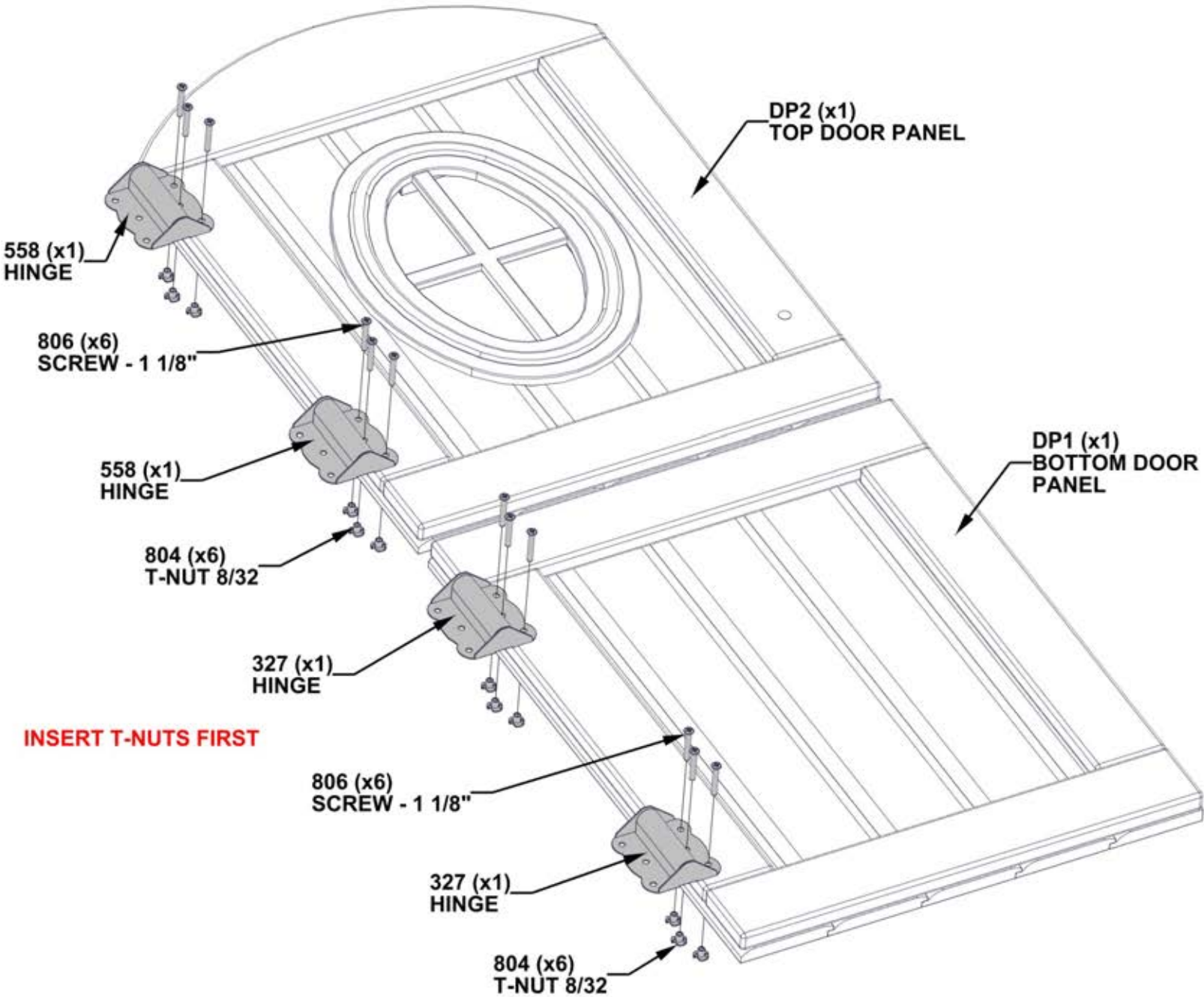

# STEP 25B - PLAYHOUSE ASSEMBLY

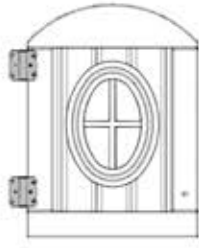

TOP DOOR ASSEMBLY

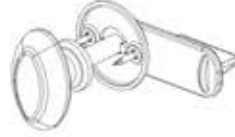

A6P00020 LATCHING KNOB KIT  
(x1)

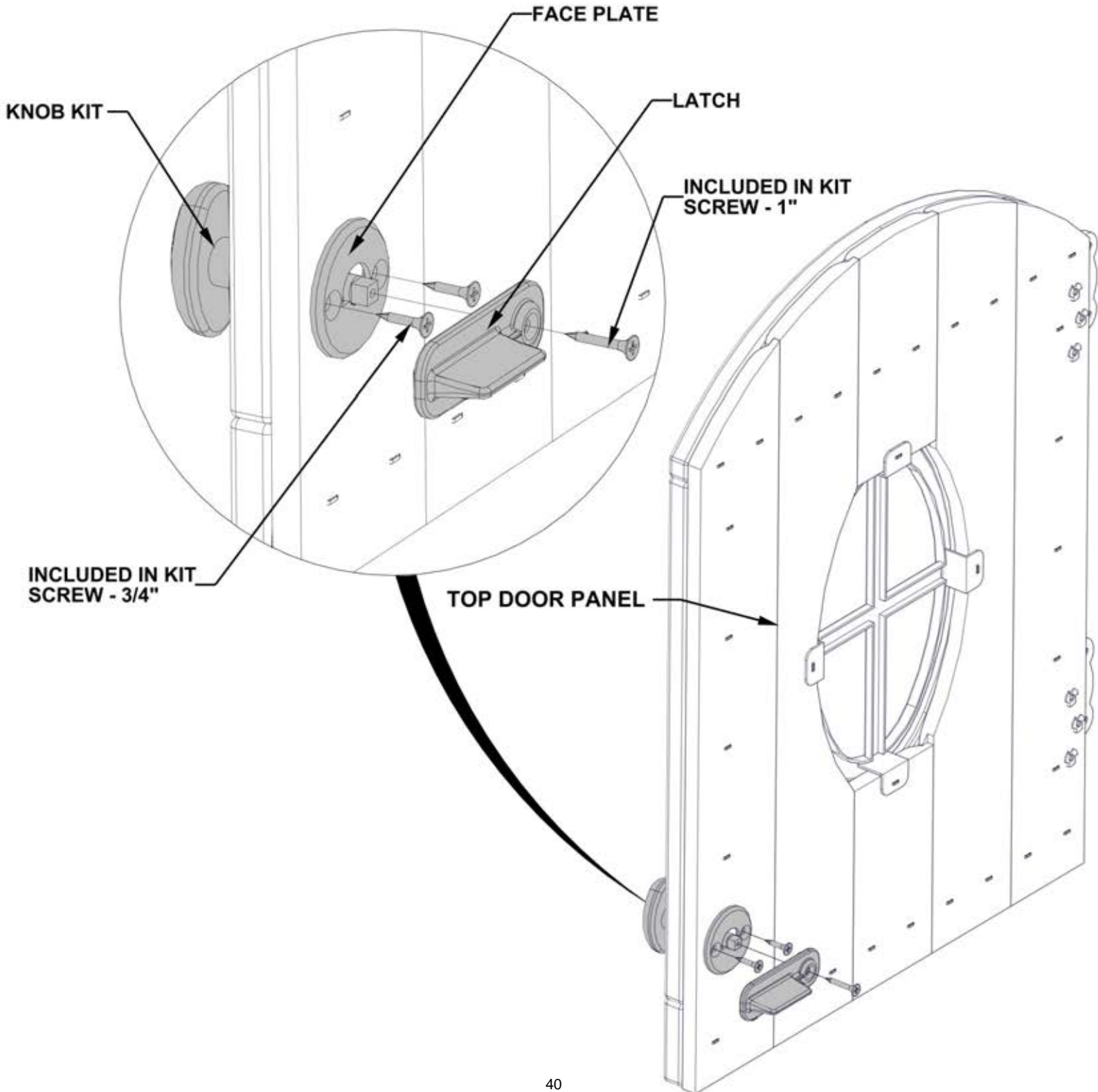



# STEP 26 - PLAYHOUSE ASSEMBLY

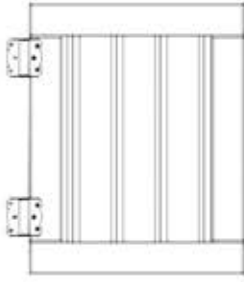

BOTTOM DOOR ASSEMBLY

QTY	PART NUMBER	DESCRIPTION
6	H100804	T-NUT 8/32
6	H100806	SCREW POH-MS 8/32x1 1/8" BLK

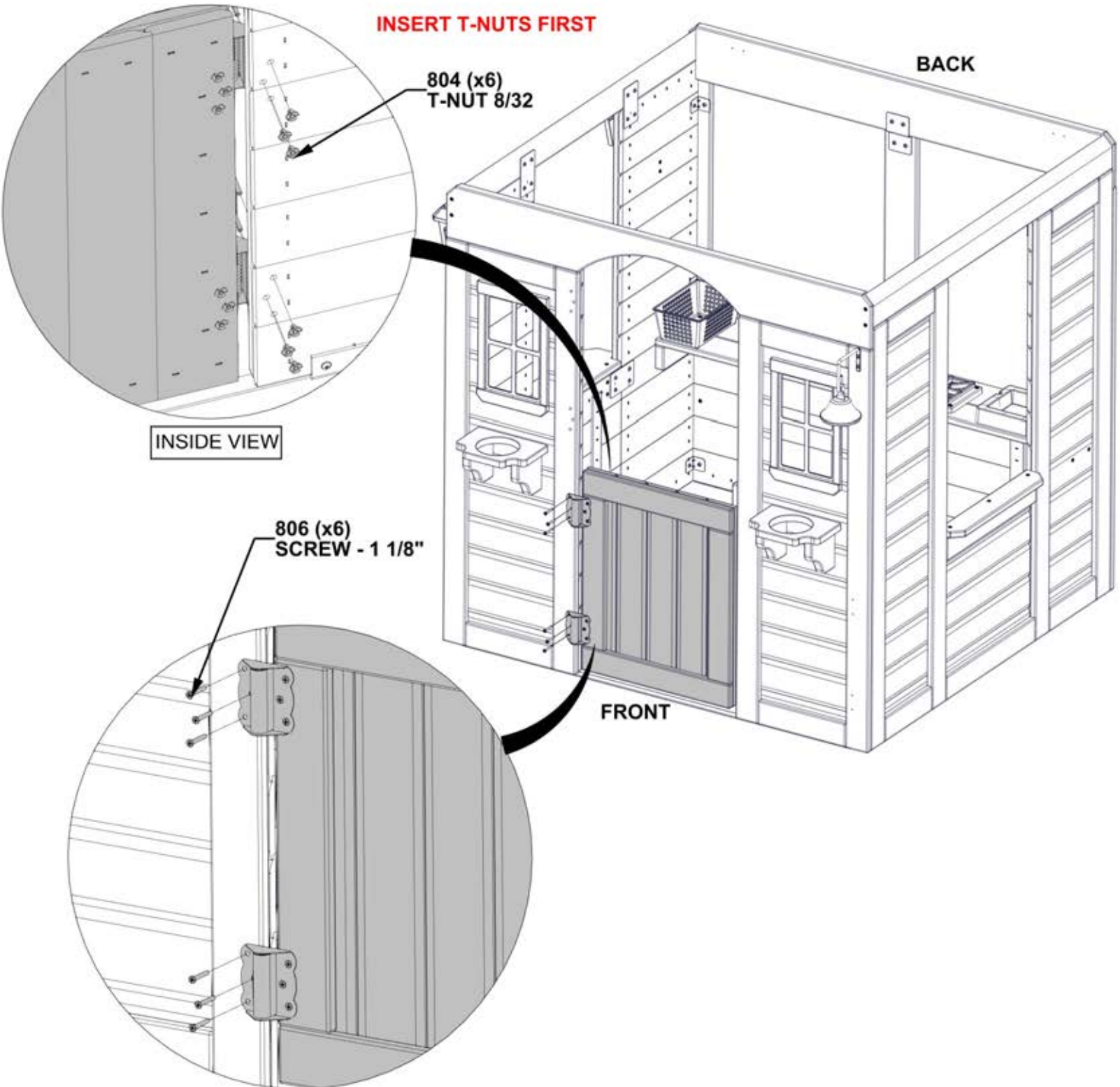

**INSERT T-NUTS FIRST**

804 (x6)  
T-NUT 8/32

INSIDE VIEW

806 (x6)  
SCREW - 1 1/8"

FRONT

BACK

# STEP 27 - PLAYHOUSE ASSEMBLY

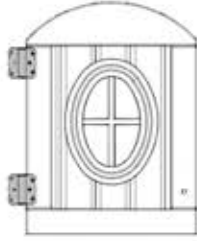

TOP DOOR ASSEMBLY

QTY	PART NUMBER	DESCRIPTION
6	H100804	T-NUT 8/32
6	H100806	SCREW POH-MS 8/32x1 1/8" BLK

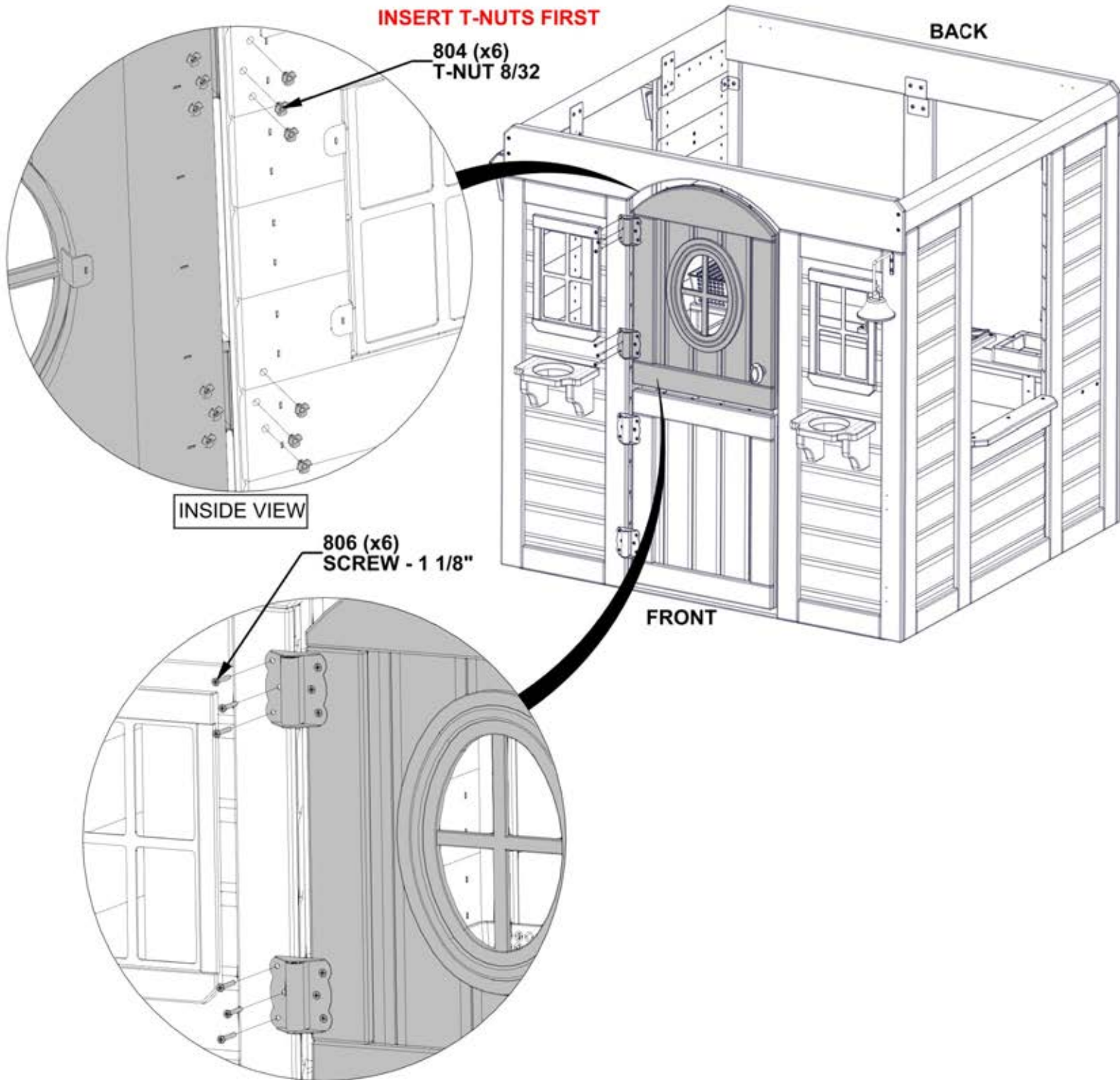

# STEP 28 - PLAYHOUSE ASSEMBLY



A4M00997 METAL CLEAT  
(x2)

QTY	PART NUMBER	DESCRIPTION
4	H100392	SCREW PWH 8x3/4 BLK

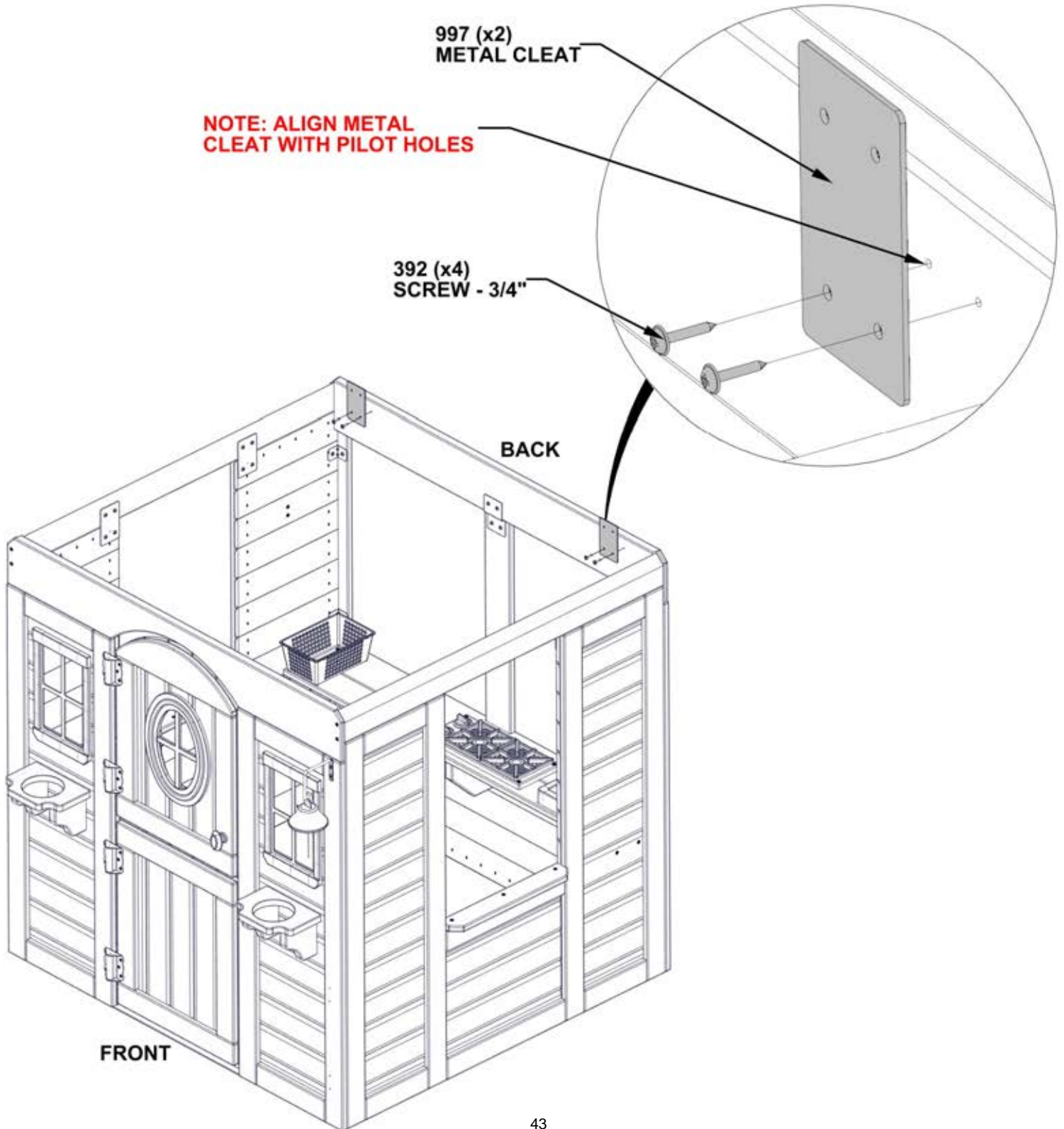

# STEP 29 - PLAYHOUSE ASSEMBLY



A4M00997 METAL CLEAT  
(x2)

QTY	PART NUMBER	DESCRIPTION
4	H100392	SCREW PWH 8x3/4 BLK

997 (x2)  
METAL CLEAT

**NOTE: ALIGN METAL  
CLEAT WITH PILOT HOLES**

392 (x4)  
SCREW - 3/4"

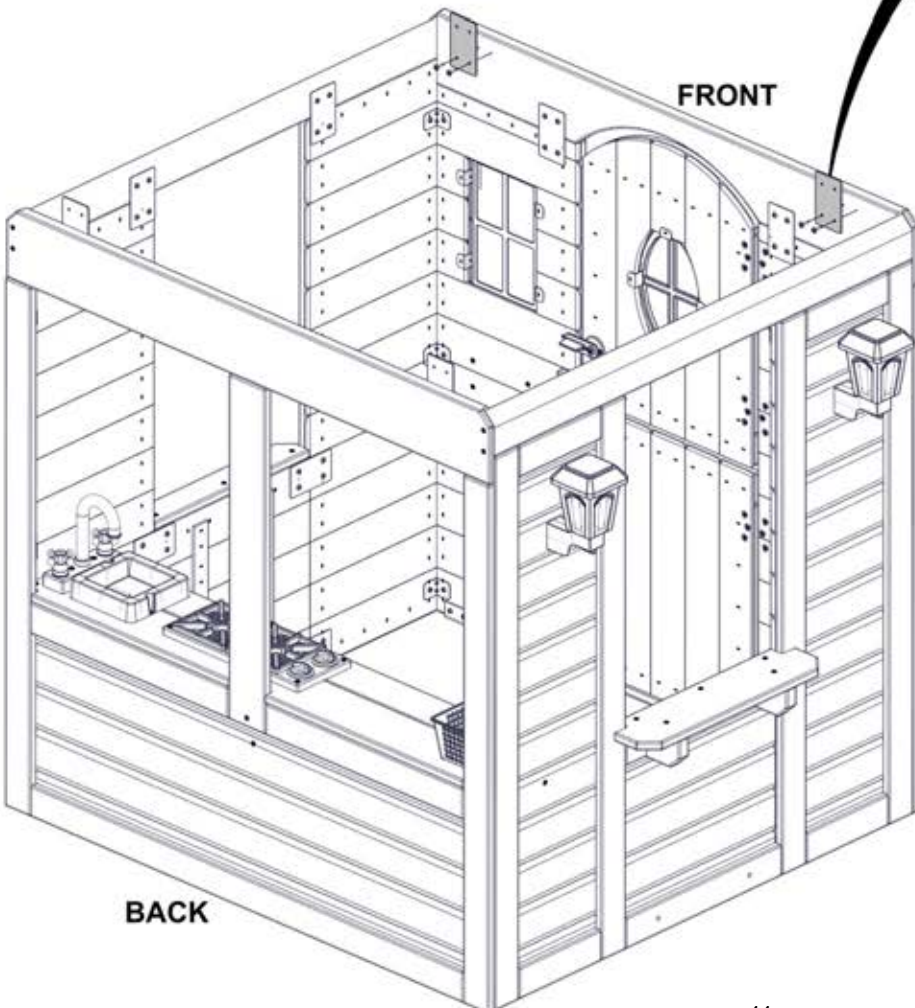
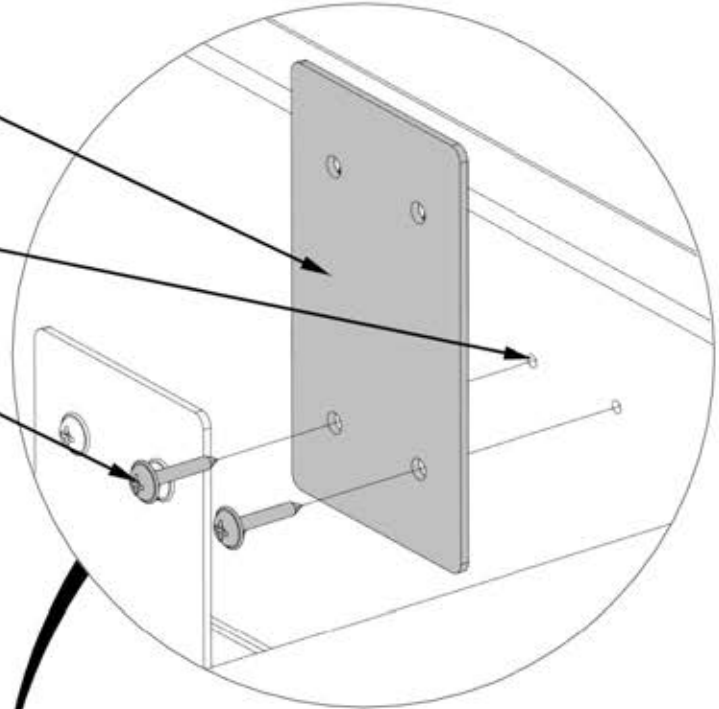

BACK

# STEP 30A - PLAYHOUSE ASSEMBLY

QTY	PART NUMBER	DESCRIPTION
8	H100385	SCREW PFH 8x1 BLK

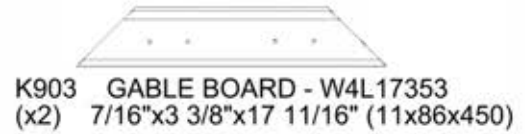
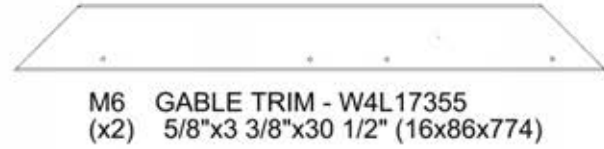
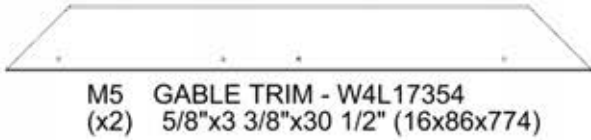

**COMPLETE THIS STEP TWICE**

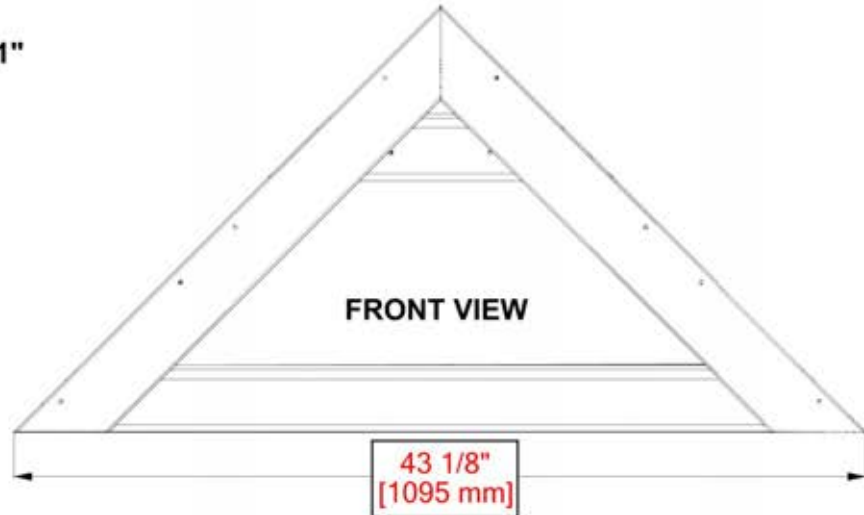
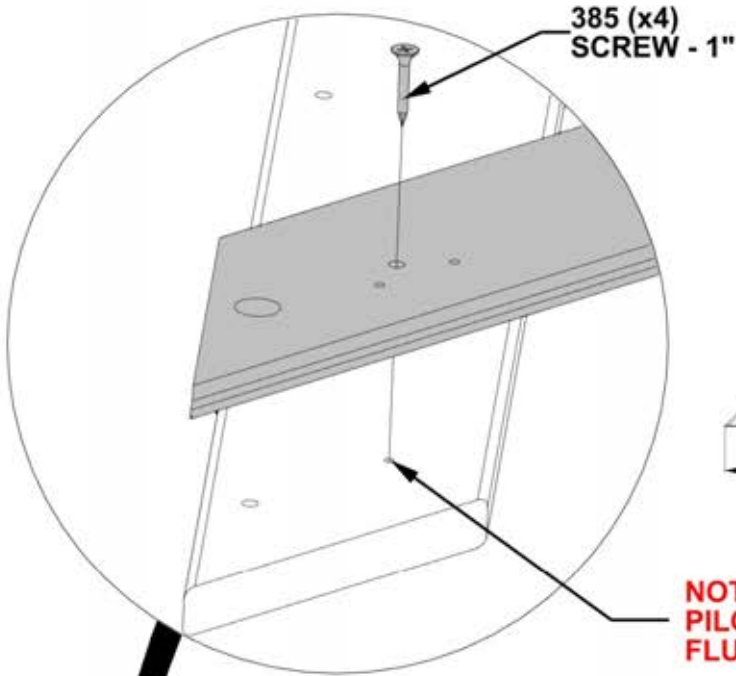

**NOTE: ALIGN K9 BOARDS WITH PILOT HOLES IN GABLE TRIM. FLUSH EDGES**

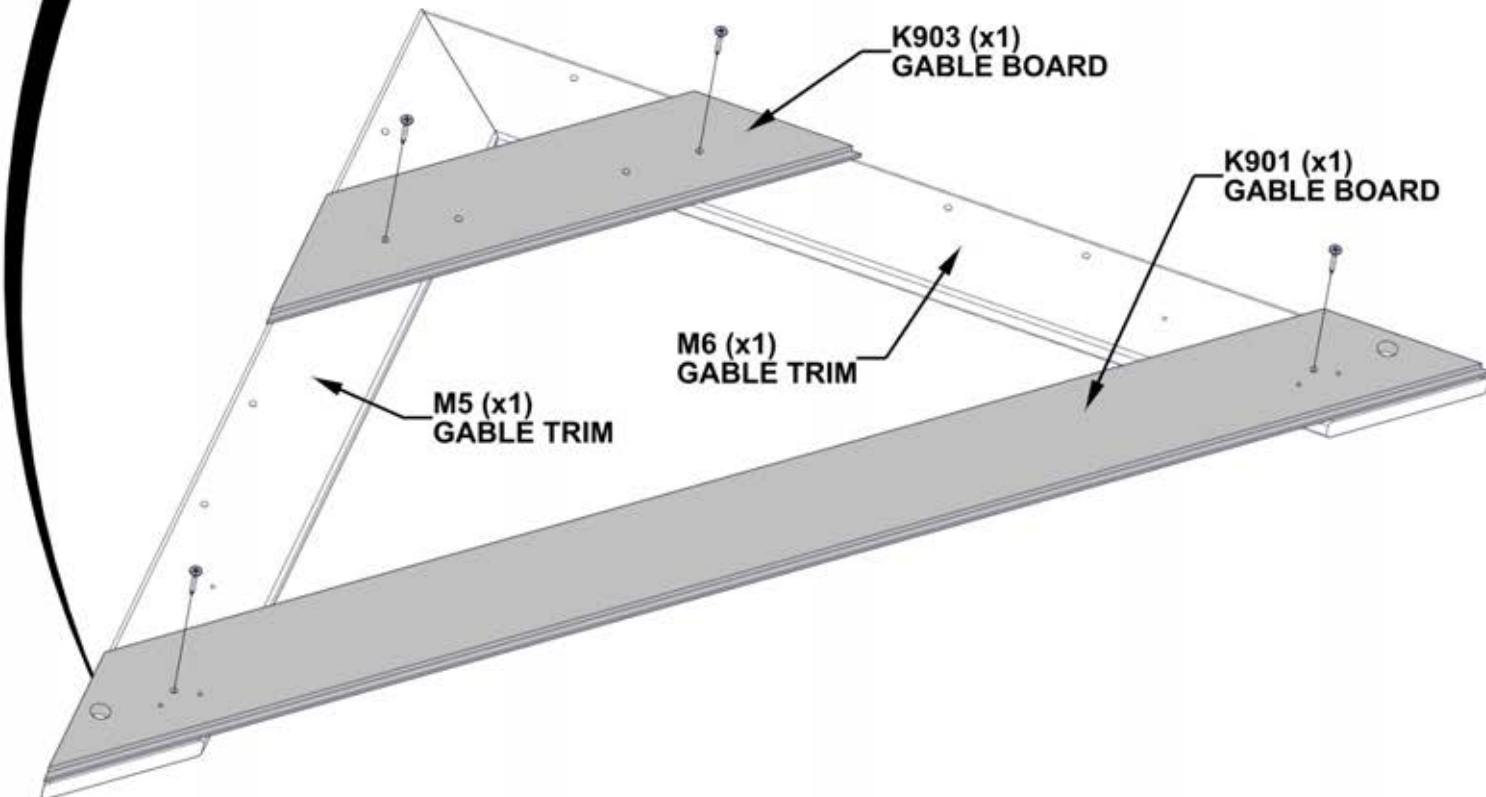

# STEP 30B - PLAYHOUSE ASSEMBLY

QTY	PART NUMBER	DESCRIPTION
4	H100385	SCREW PFH 8x1 BLK
10	H100395	SCREW PFH 8x3/4 BLK



K902 GABLE BOARD - W4L17352  
(x2) 7/16"x3 3/8"x36 3/4" (11x86x933)

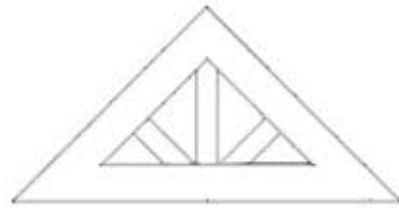

A100322 PLASTIC SUNBURST  
(x2)

**COMPLETE THIS STEP TWICE**

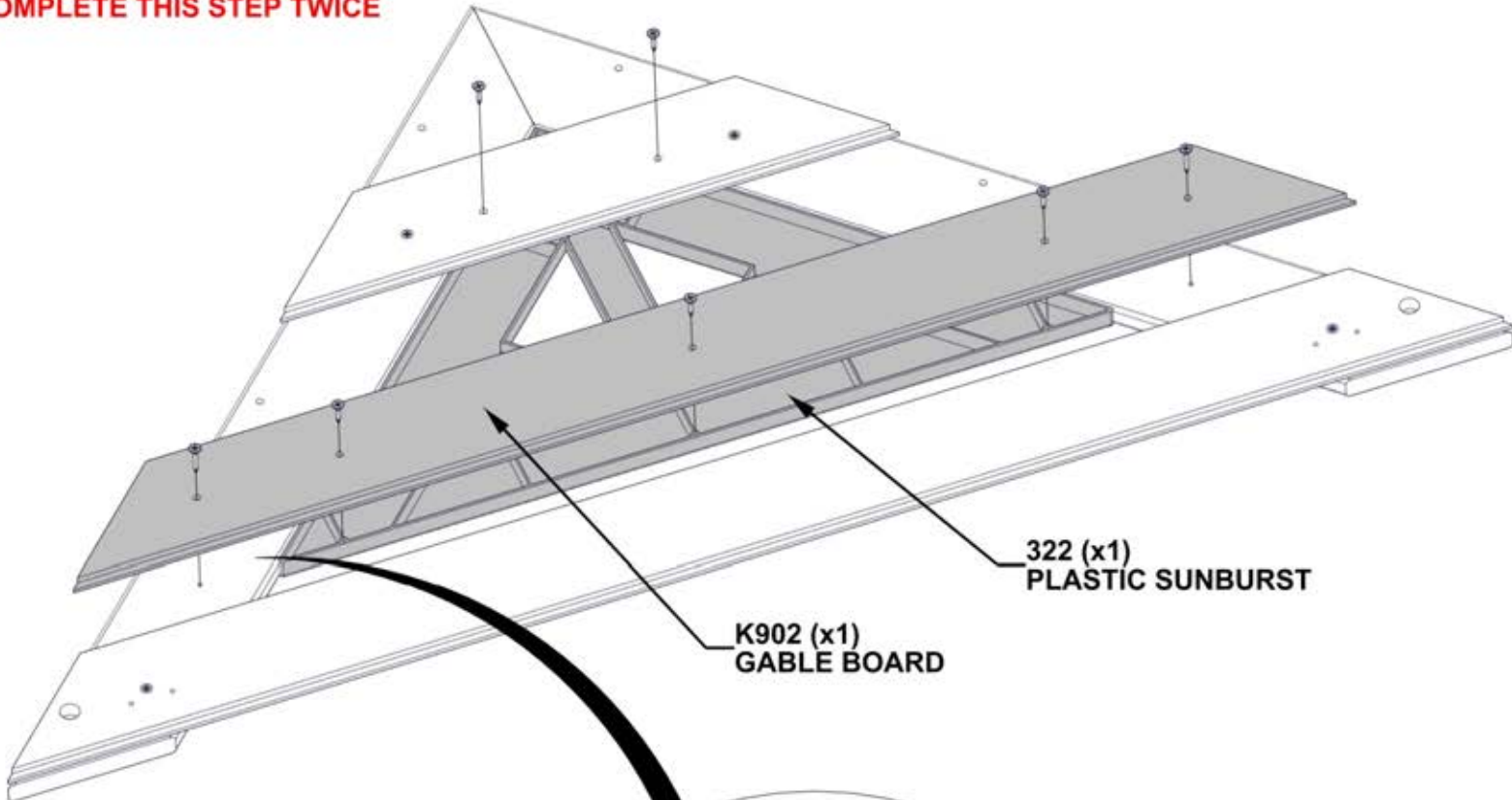

322 (x1)  
PLASTIC SUNBURST

K902 (x1)  
GABLE BOARD

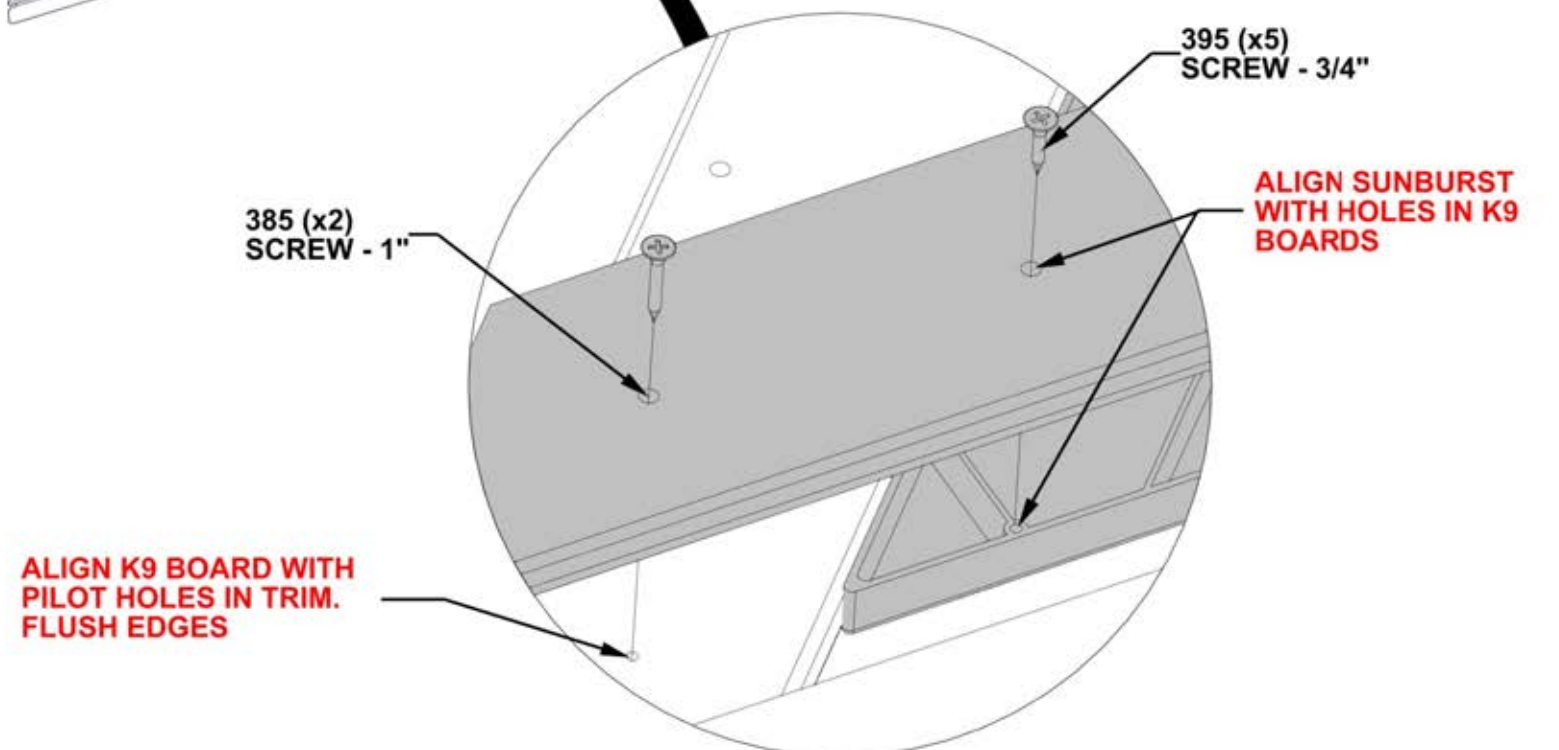

395 (x5)  
SCREW - 3/4"

**ALIGN SUNBURST  
WITH HOLES IN K9  
BOARDS**

385 (x2)  
SCREW - 1"

**ALIGN K9 BOARD WITH  
PILOT HOLES IN TRIM.  
FLUSH EDGES**

# STEP 31A - PLAYHOUSE ASSEMBLY

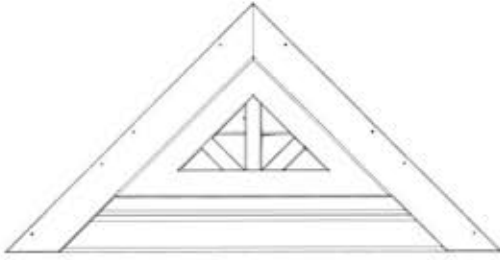

(x2) GABLE PANEL ASSY FROM PREVIOUS STEP

QTY	PART NUMBER	DESCRIPTION
8	H100392	SCREW PWH 8x3/4 BLK

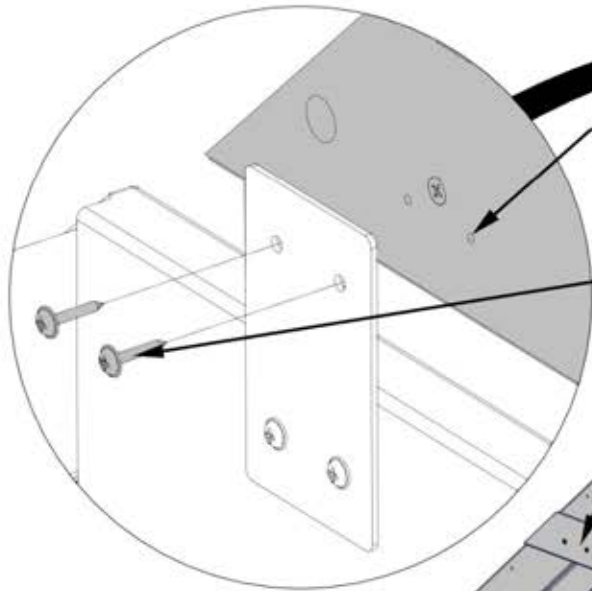

**NOTE: ALIGN CLEAT WITH PILOT HOLES IN GABLE PANELS.**

392 (x4) SCREW - 3/4"

GABLE PANEL ASSEMBLY

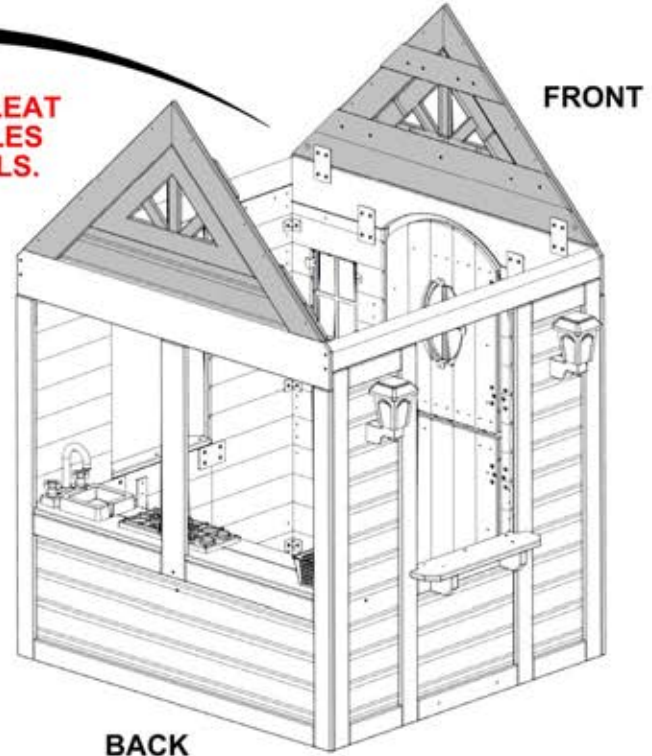

BACK

392 (x4) SCREW - 3/4"

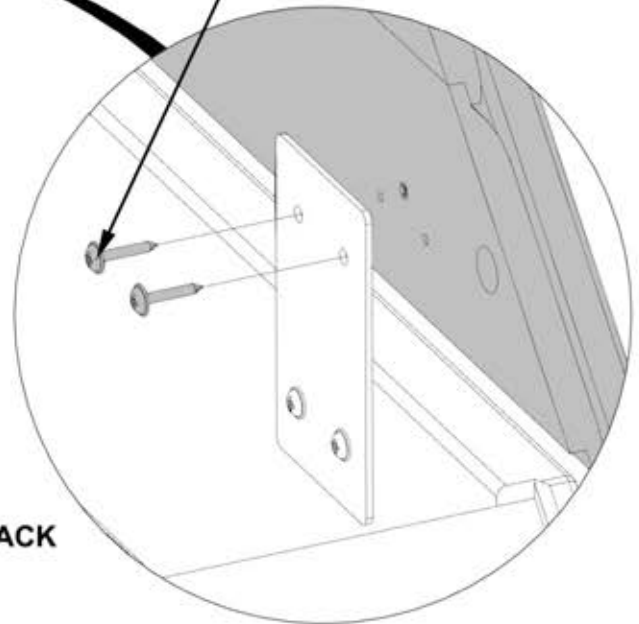

BACK

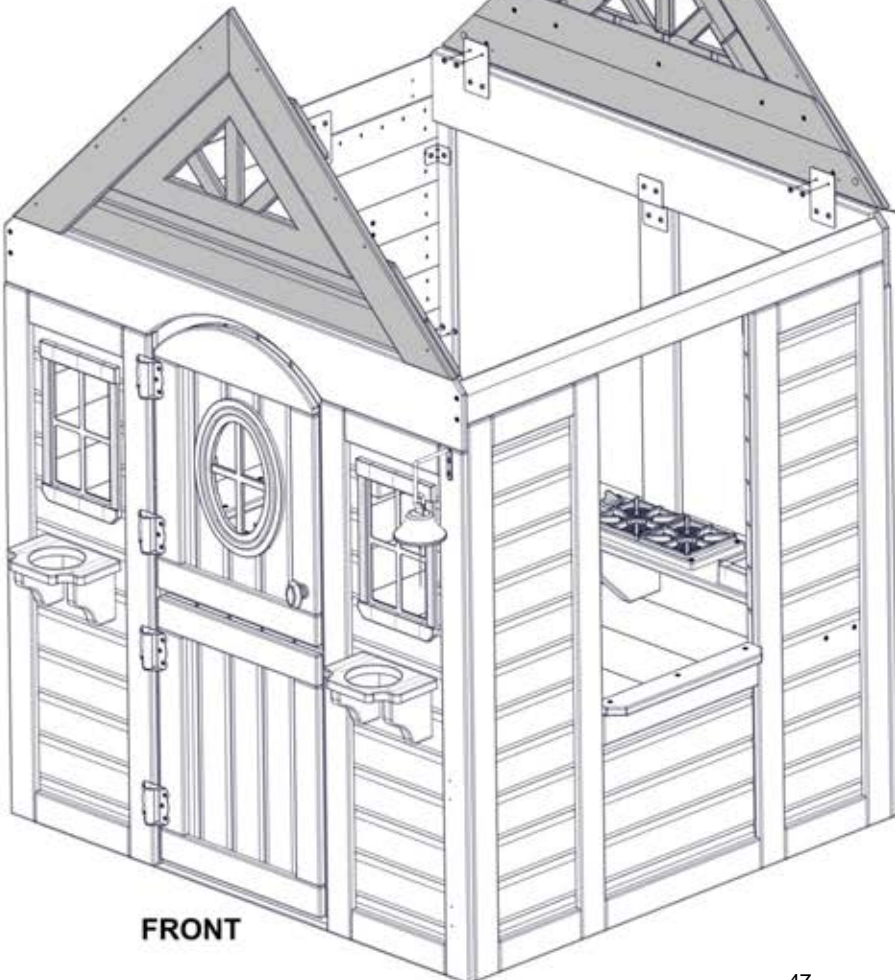

FRONT

# STEP 31B - PLAYHOUSE ASSEMBLY

QTY	PART NUMBER	DESCRIPTION
6	H100382	SCREW PFH 8x1 3/4 BLK



J6 INNER CURTAIN ROD HOLDER - W4L17102  
(x1) 15/16"x2 3/8"x 2 3/8" (24x60x60)



J7 OUTER CURTAIN ROD HOLDER - W4L17101  
(x2) 15/16"x2 3/8"x 2 3/8" (24x60x60)



A6P00553 CURTAIN  
(x2)



A6P00057 CURTAIN ROD  
(x1)

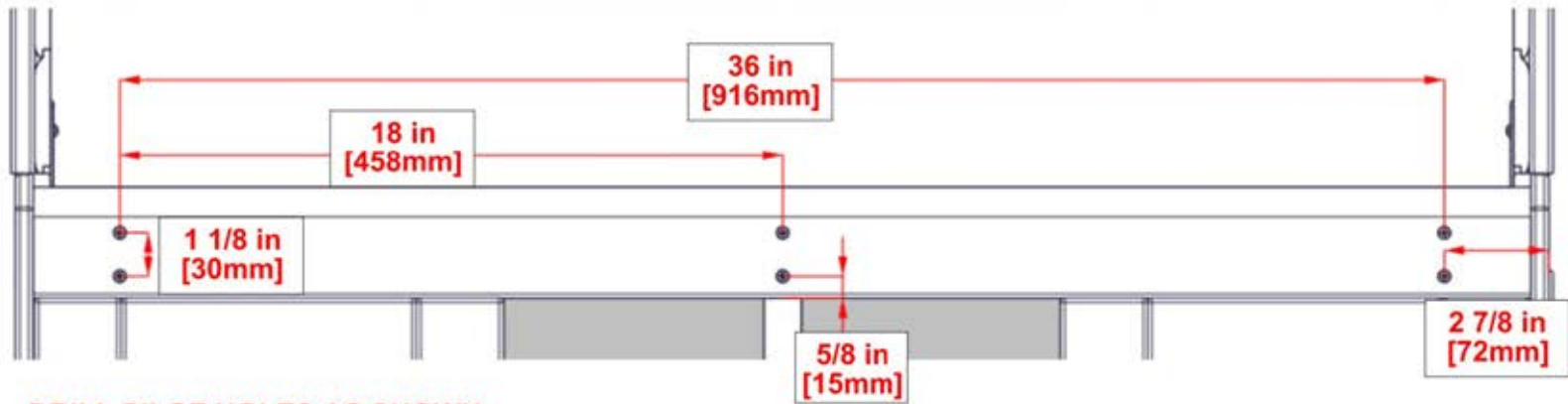

**DRILL PILOT HOLES AS SHOWN.  
USING A 3/16" [5mm] DRILL BIT.**

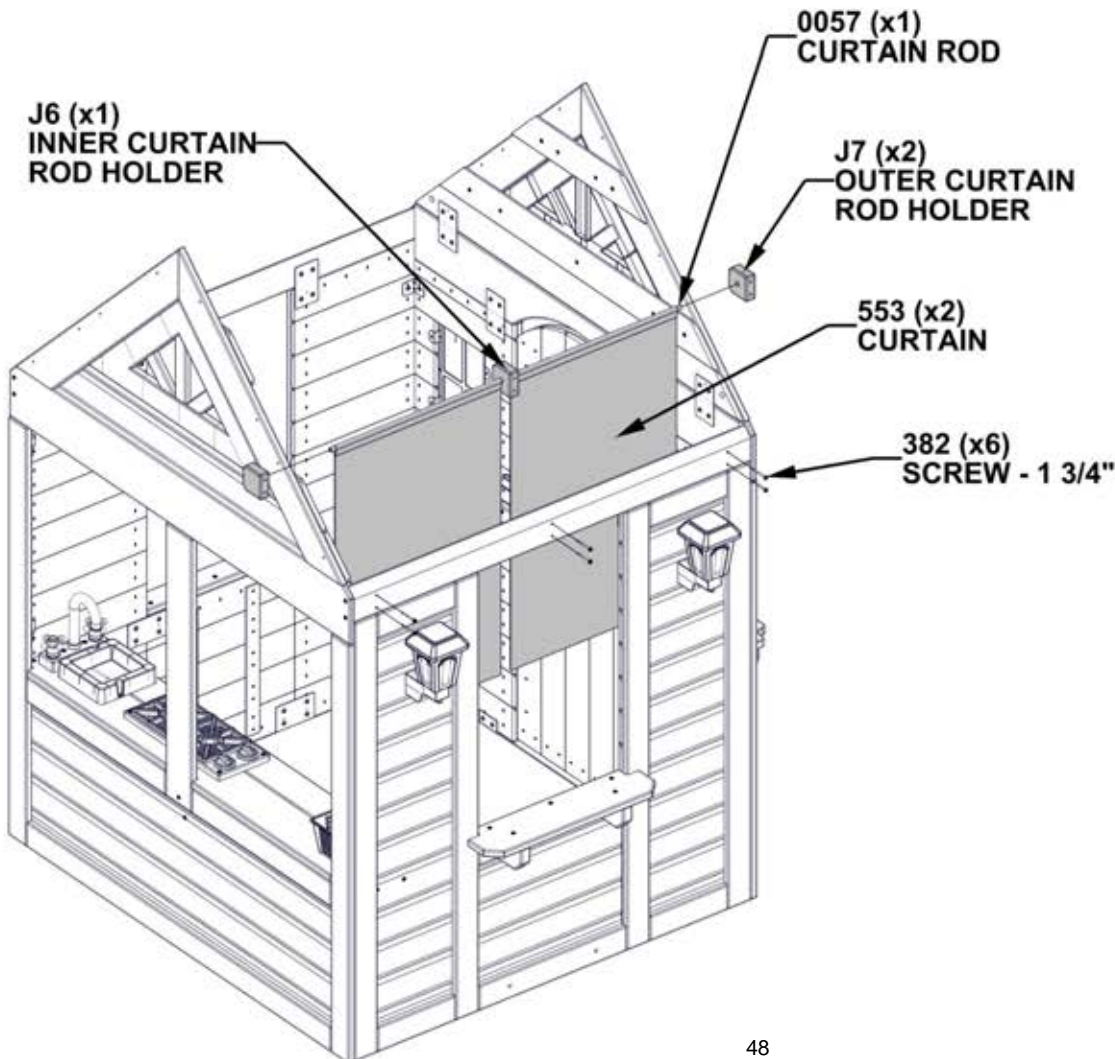



# STEP 32 - PLAYHOUSE ASSEMBLY



QTY	PART NUMBER	DESCRIPTION
8	H100200	SCREW PFH 8x1 1/2 BLK

RP1 ROOF PANEL - W2A03583  
(x2) 11x17 1/2"x44 3/4" (35x445x1136)

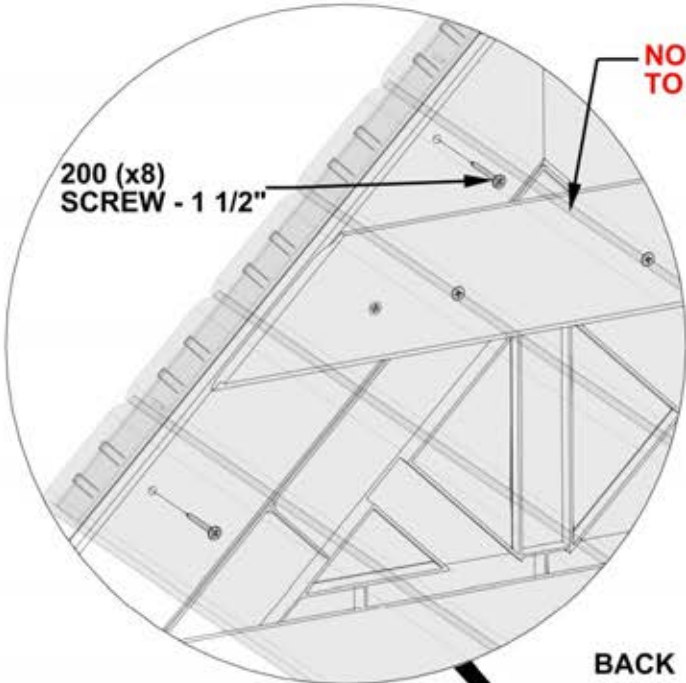

200 (x8)  
SCREW - 1 1/2"

**NOTE: FASTEN ROOF PANEL TO GABLE FROM INSIDE.**

**NOTE: ALIGN ROOF PANEL FLUSH AT PEAK OF ROOF**

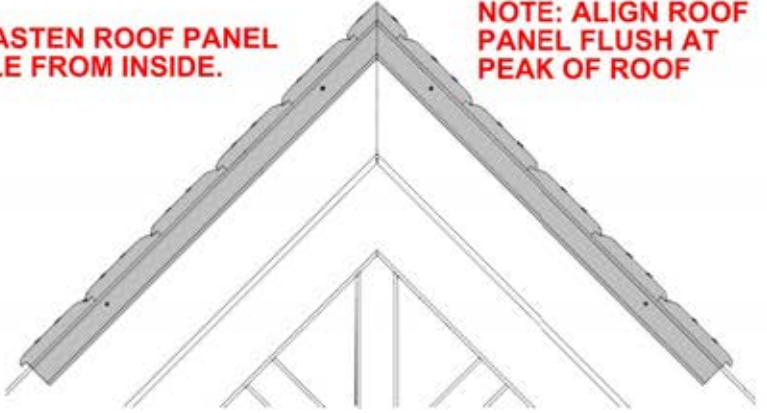

INSIDE VIEW

BACK

RP1 (x2)  
ROOF PANEL

LEFT

RIGHT

FRONT

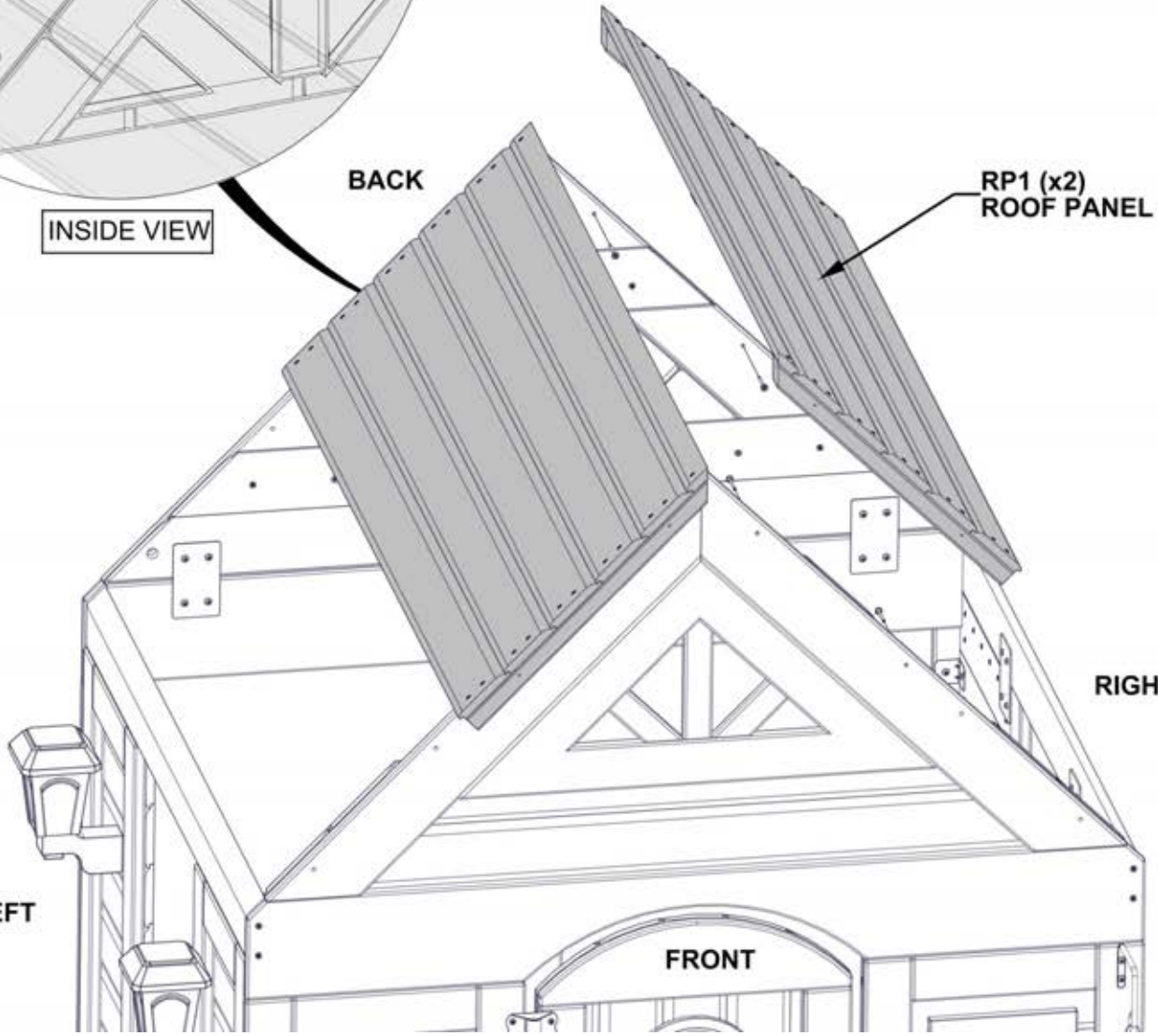

# STEP 33 - PLAYHOUSE ASSEMBLY



RP2 ROOF PANEL - W2A03587  
 (x2) 1 3/8"x17 7/8"x44 3/4" (35x454x1136)

QTY	PART NUMBER	DESCRIPTION
8	H100200	SCREW PFH 8x1 1/2 BLK

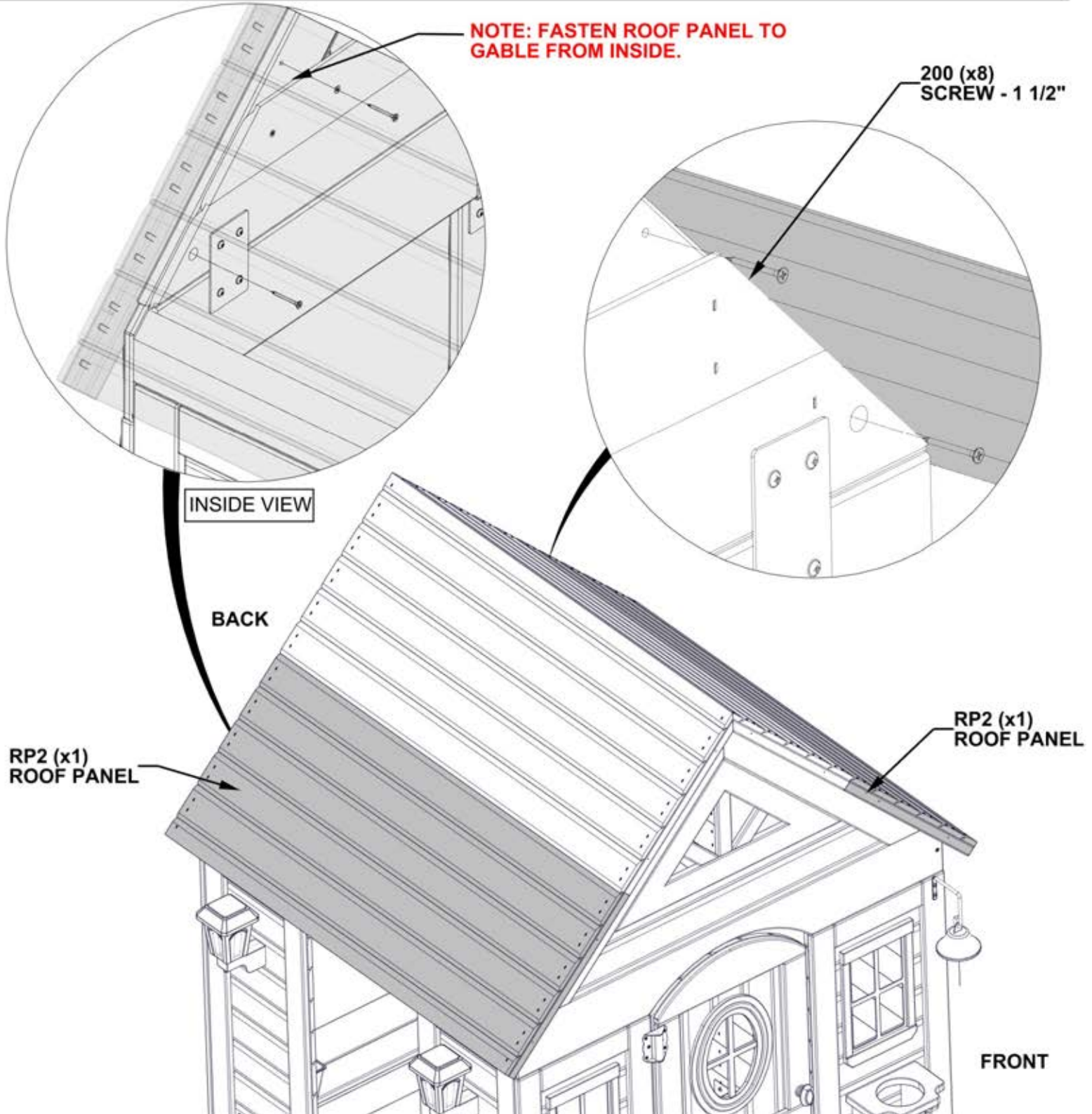

# STEP 34 - PLAYHOUSE ASSEMBLY

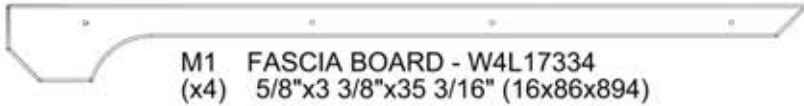

M1 FASCIA BOARD - W4L17334  
 (x4) 5/8"x3 3/8"x35 3/16" (16x86x894)

QTY	PART NUMBER	DESCRIPTION
16	H100200	SCREW PFH 8x1 1/2 BLK

M1 (x4)  
 FASCIA BOARD

TOP EDGE  
 FLUSH

NOTE: ALIGN FASCIA BOARD WITH  
 PILOT HOLES IN ROOF PANELS

200 (x16)  
 SCREW - 1 1/2"

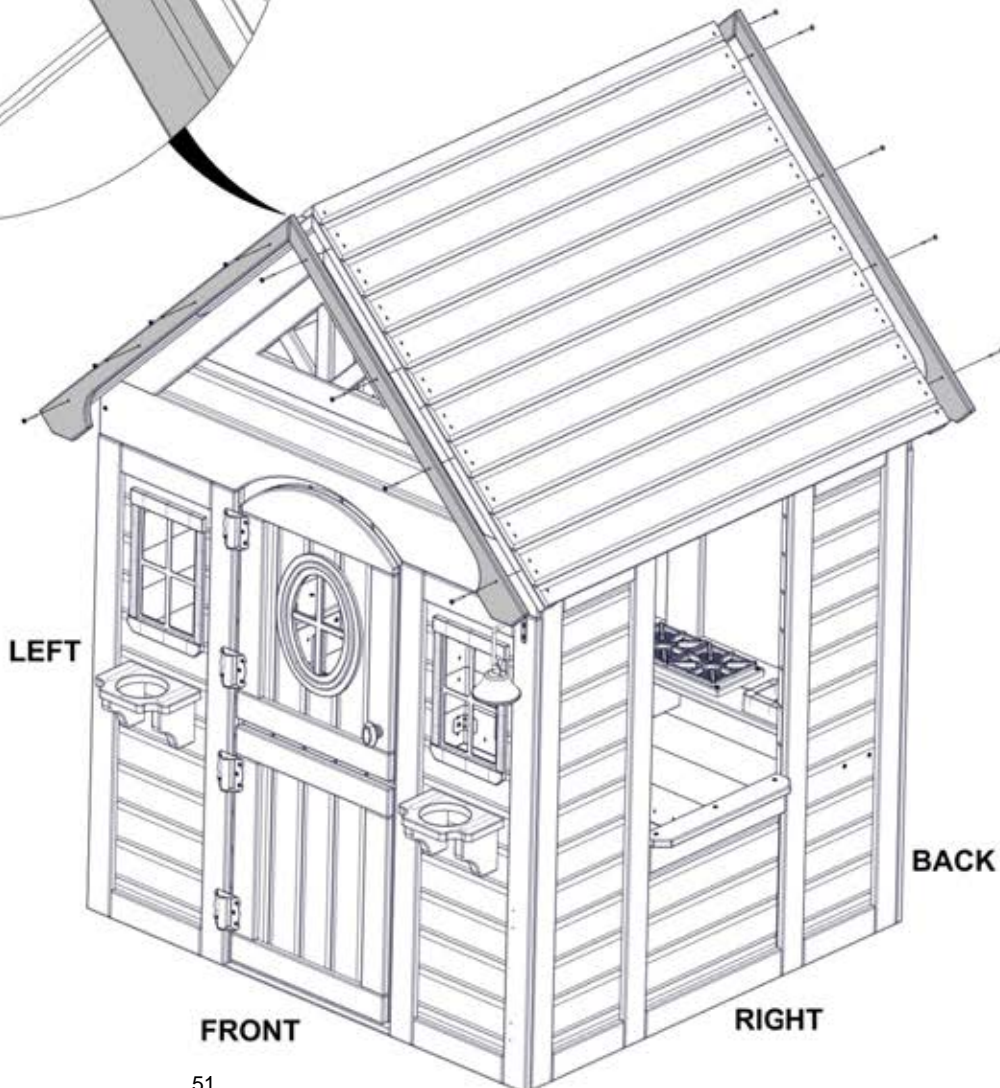

# STEP 35 - PLAYHOUSE ASSEMBLY

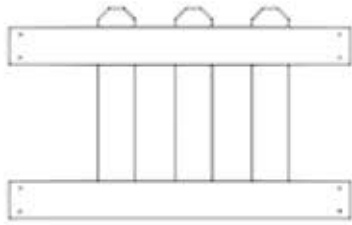

WP8 FENCE PANEL - W2A03584  
(x1) 1 1/8"x13"x21 1/16" (28x330x535)

QTY	PART NUMBER	DESCRIPTION
4	H100200	SCREW PFH 8x1 1/2 BLK
4	H100387	SCREW PFH 8x1 1/4 BLK



P01 FENCE POST - W4L17339  
(x1) 1 7/16"x1 7/16"x19" (36x36x483)

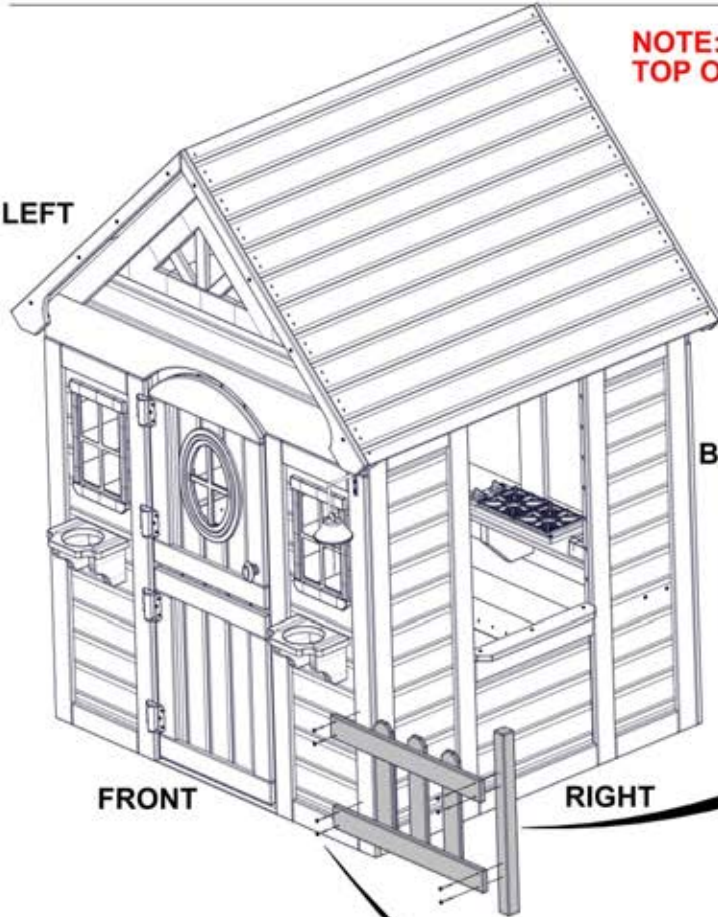

**NOTE: PILOT HOLE IN TOP OF FENCE POST**

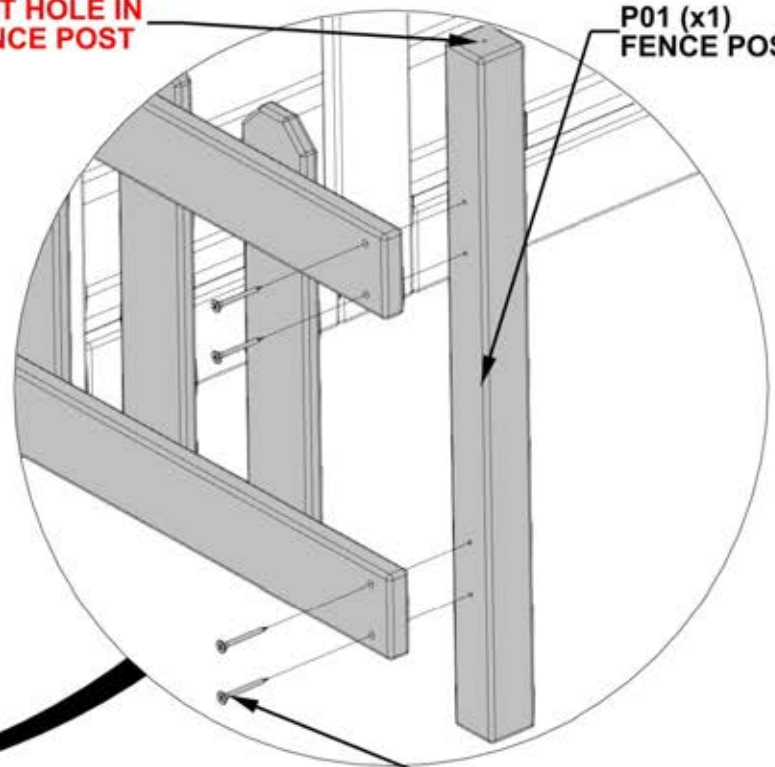

P01 (x1)  
FENCE POST

200 (x4)  
SCREW - 1 1/2"

WP8 (x1)  
FENCE PANEL

**NOTE: ALIGN FENCE PANEL WITH PILOT HOLES**

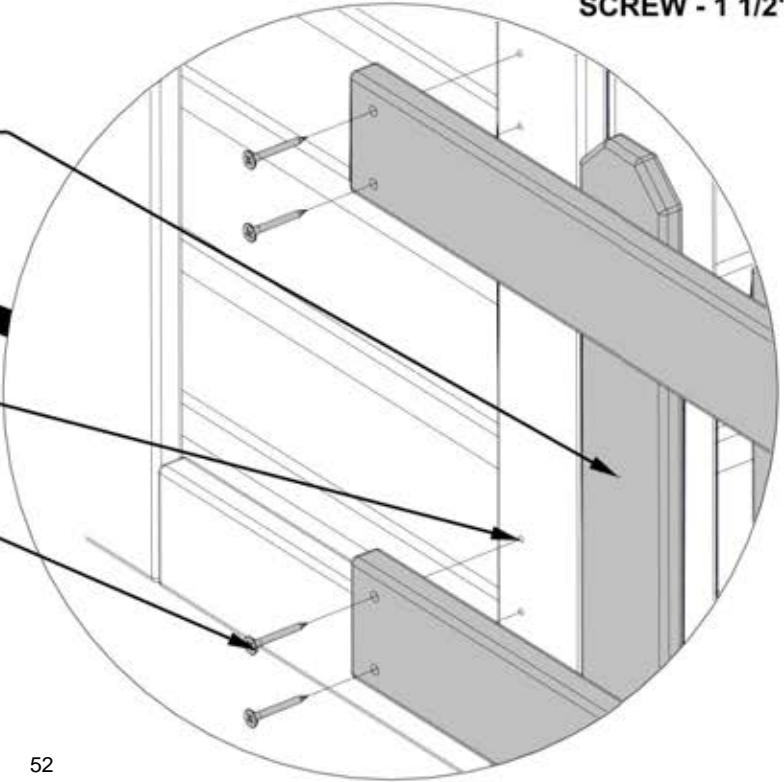

387 (x4)  
SCREW - 1 1/4"

# STEP 36 - PLAYHOUSE ASSEMBLY



A6P00017 MAILBOX ASSEMBLY  
(x1)

QTY	PART NUMBER	DESCRIPTION
1	H100200	SCREW PFH 8x1 1/2 BLK

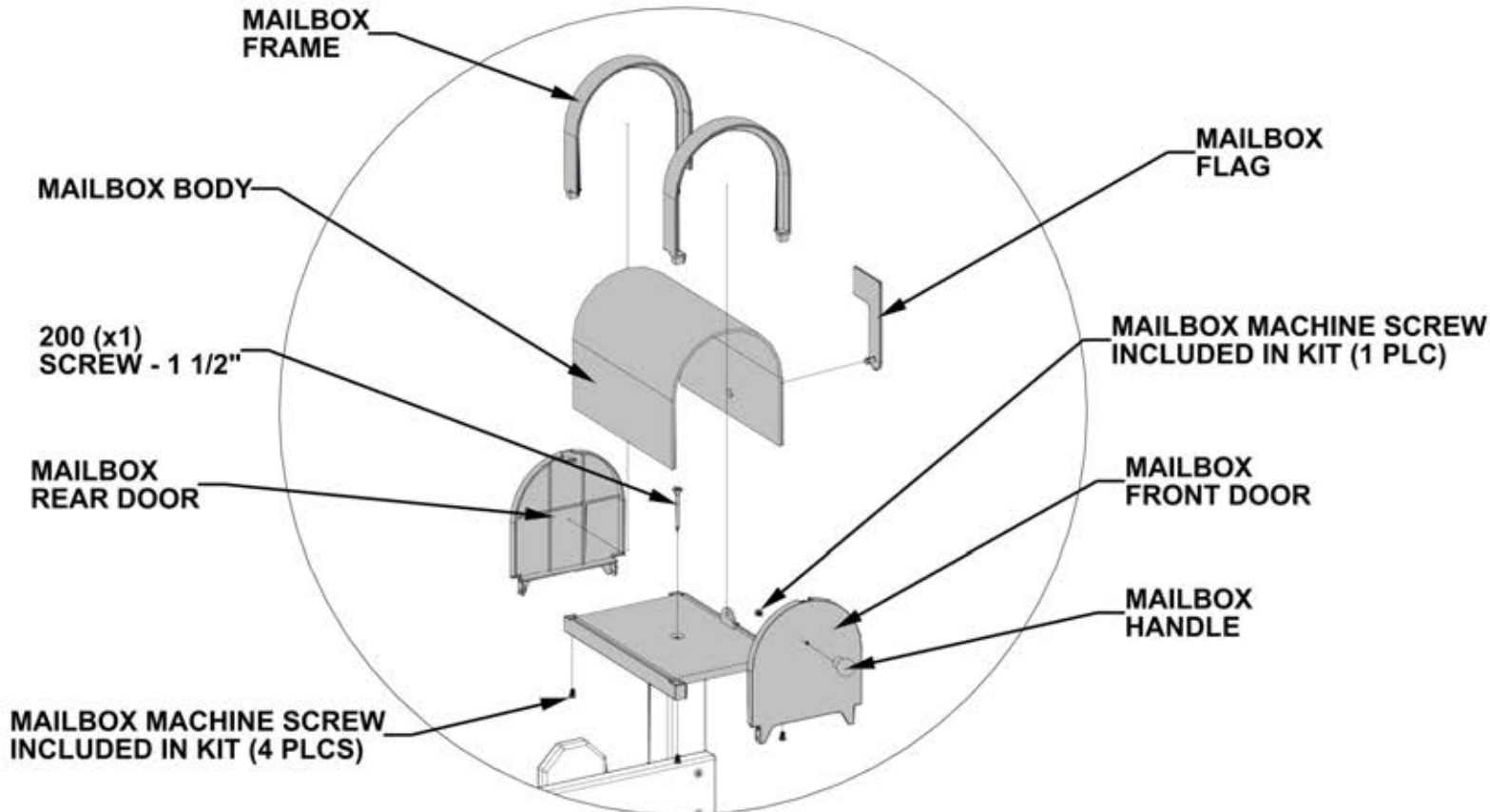

ASSEMBLE MAILBOX BASE TO PICKET FENCE POST USING (1) 8 x 1 1/2" PFH SCREW.

PRESS MAILBOX BODY INTO INSIDE OF MAILBOX FRAMES AND ATTACH TO BASE USING (4) MAILBOX MACHINE SCREWS.

LOCATE MAILBOX REAR DOOR AND SNAP INTO PLACE INSIDE MAILBOX FRAME. LOCATE MAILBOX FRONT DOOR AND MAILBOX HANDLE.

ASSEMBLE HANDLE TO MAILBOX FRONT DOOR USING (1) MAILBOX MACHINE SCREW.

SNAP MAILBOX FRONT DOOR INTO MAILBOX FRAME.

FINALLY, PRESS THE MAILBOX FLAG INTO PLACE ON THE SIDE OF THE MAILBOX BODY.



# STEP 37 - BENCH ASSEMBLY

QTY	PART NUMBER	DESCRIPTION
2	H100171	BOLT WH 1/4x1 BLK
2	H100398	TNUT-1/4" BLK

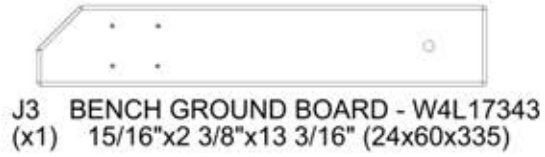

A4M01047 L BRACKET 2.5x38x55x55  
(x2)

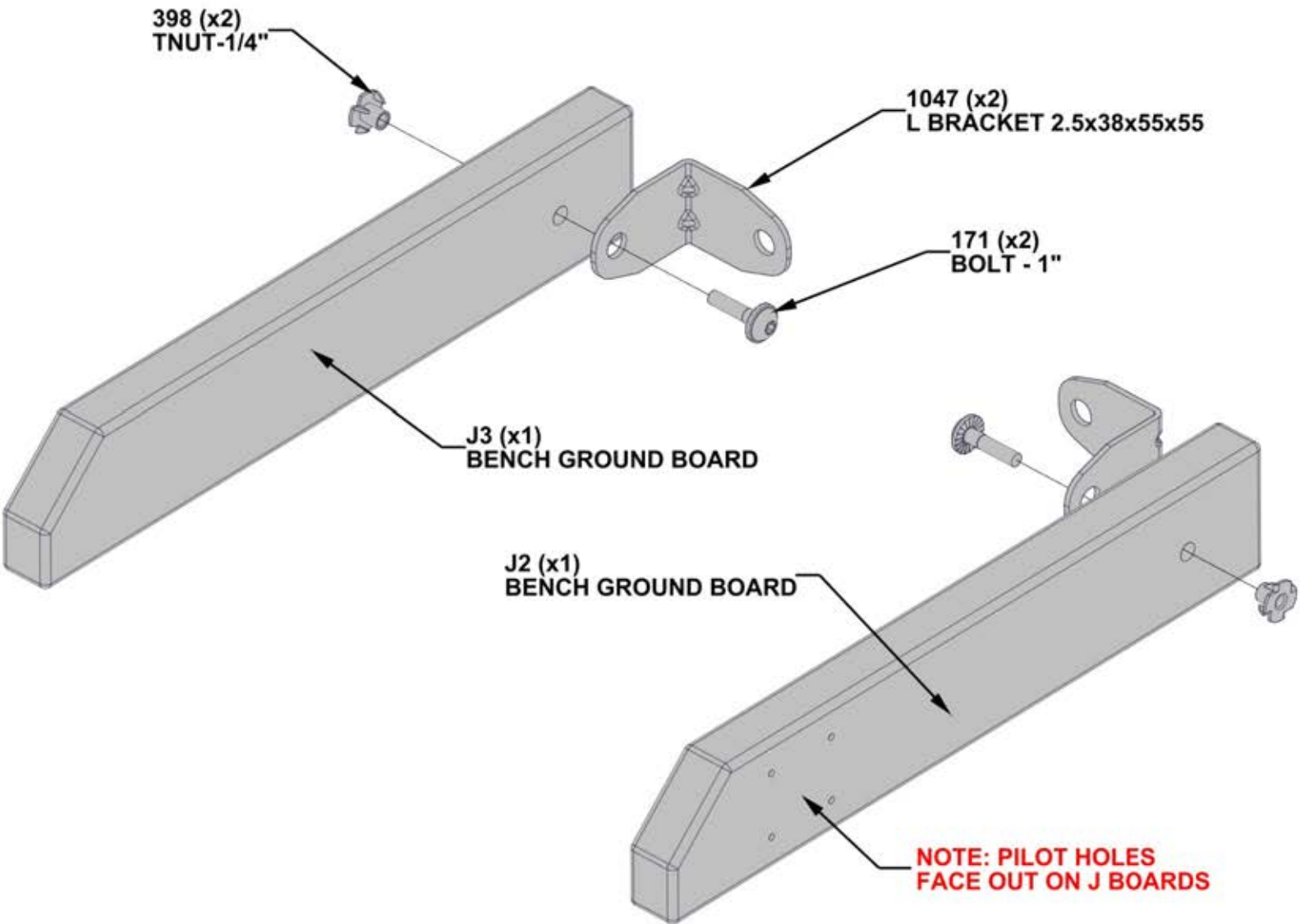

# STEP 38 - BENCH ASSEMBLY



H3 BENCH UPRIGHT - W4L17336  
(x2) 15/16"x3 3/8"x11" (24x86x280)

QTY	PART NUMBER	DESCRIPTION
8	H100382	SCREW PFH 8x1 3/4 BLK

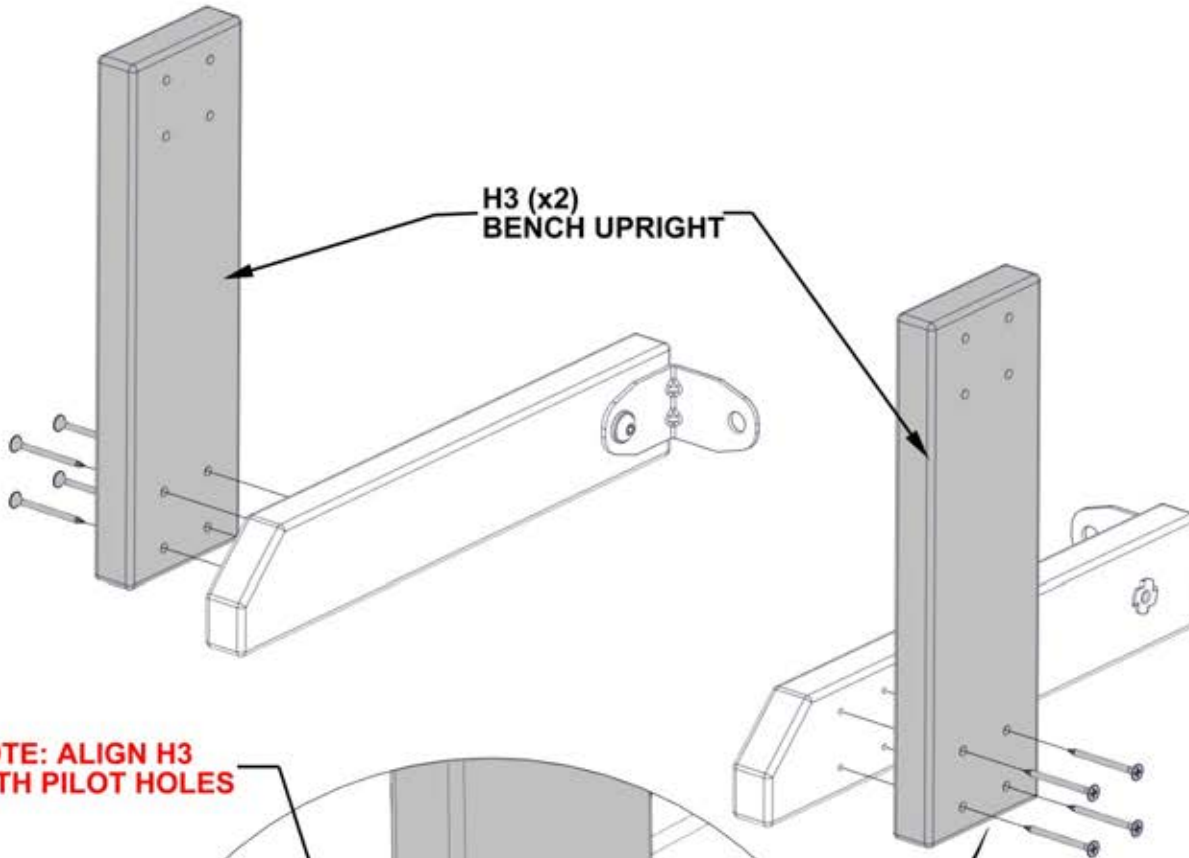

**NOTE: ALIGN H3 WITH PILOT HOLES**

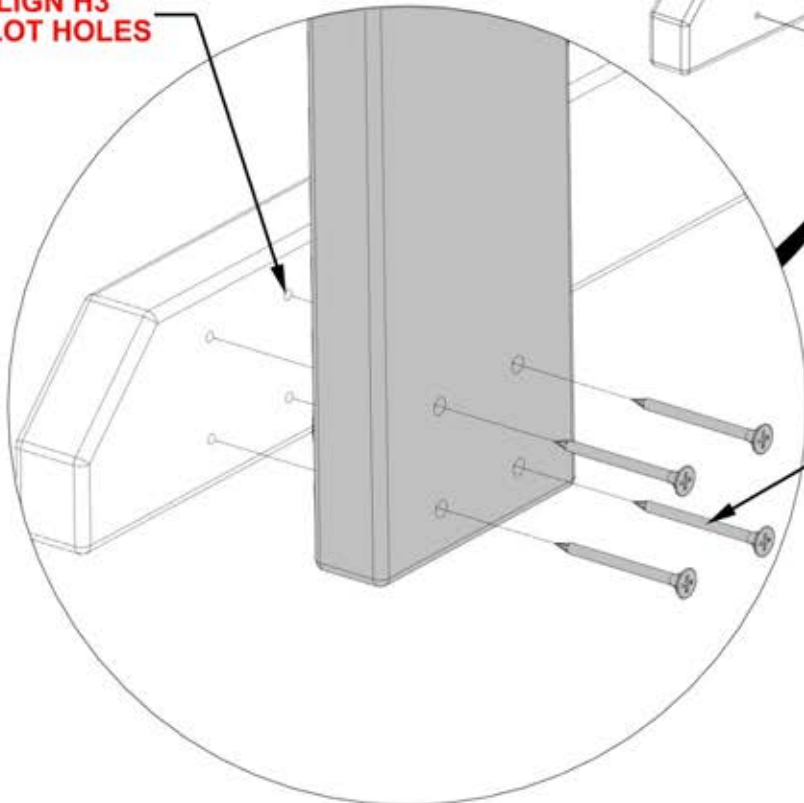

**382 (x8)  
SCREW - 1 3/4"**

# STEP 39 - BENCH ASSEMBLY

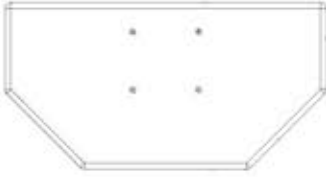

QTY	PART NUMBER	DESCRIPTION
8	H100382	SCREW PFH 8x1 3/4 BLK

H4 BENCH SEAT SUPPORT - W4L17337  
 (x2) 15/16"x3 3/8"x6 9/16" (24x86x166)

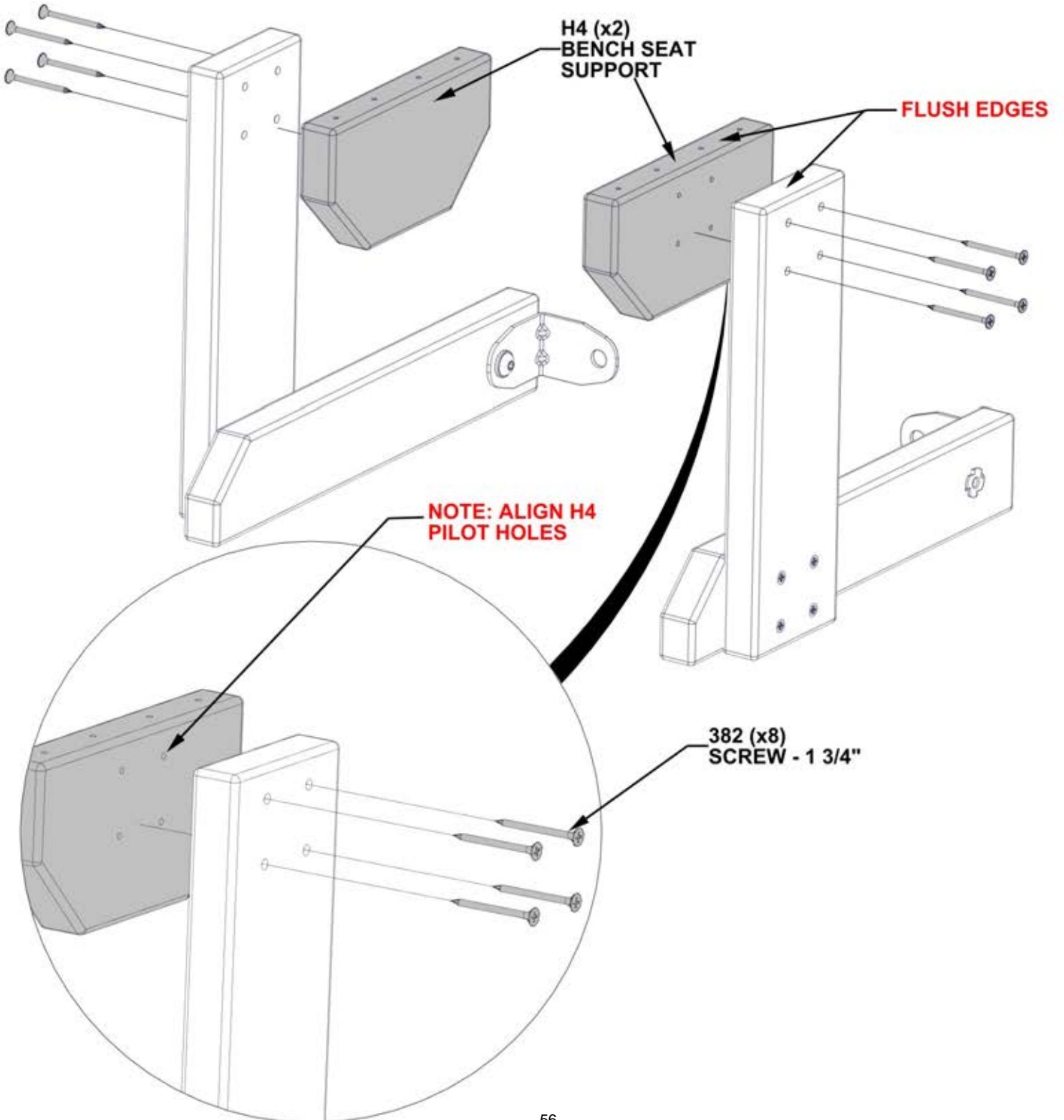



# STEP 40 - BENCH ASSEMBLY



M2 BENCH SEAT - W4L17335  
(x2) 5/8"x3 3/8"x19 1/8" (16x86x485)

QTY	PART NUMBER	DESCRIPTION
8	H100382	SCREW PFH 8x1 3/4 BLK

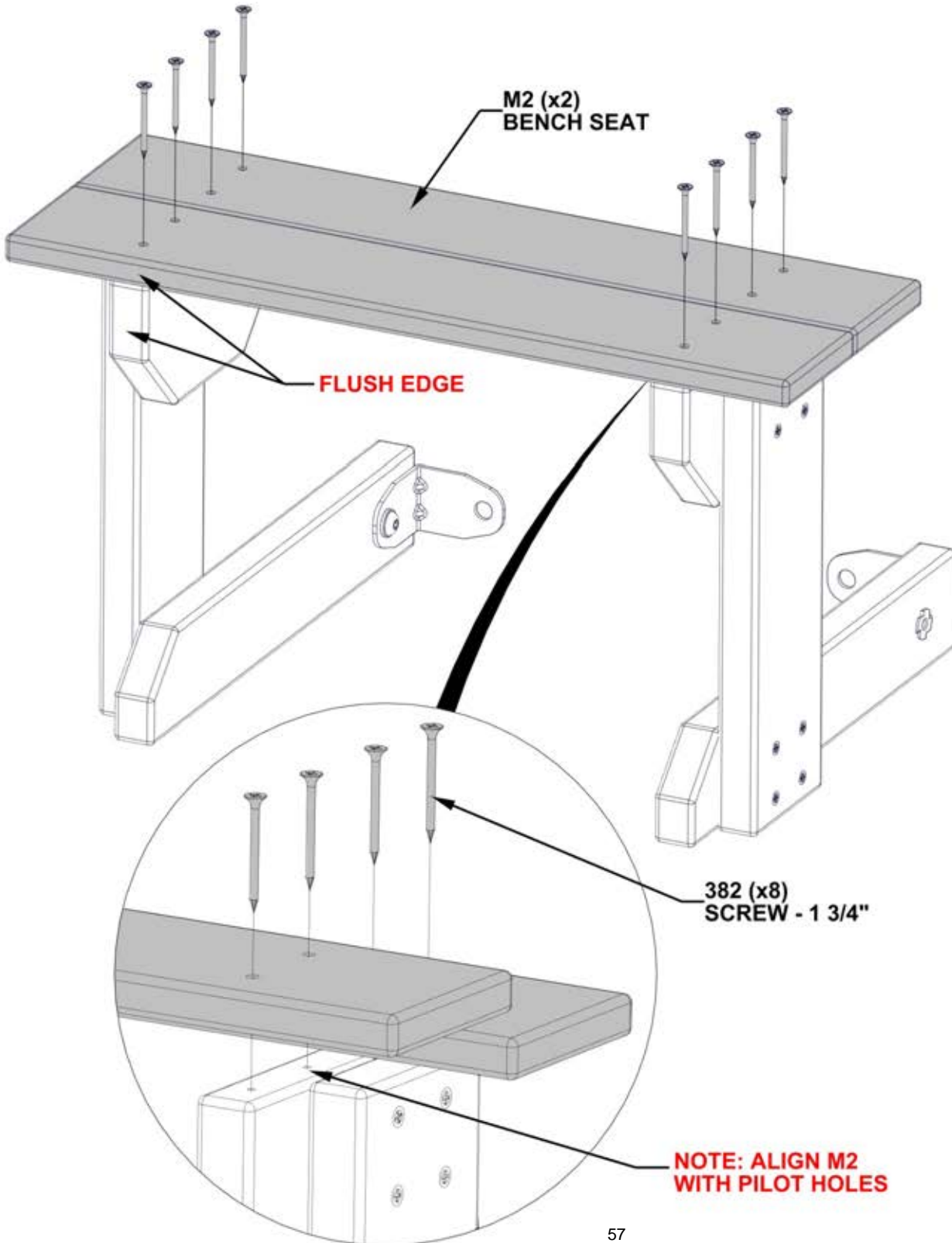

# STEP 41 - PLAYHOUSE ASSEMBLY



BENCH ASSEMBLY

QTY	PART NUMBER	DESCRIPTION
2	H100397	BOLT WH 1/4x1 1/4 BLK
2	H100398	TNUT-1/4" BLK

**NOTE: INSERT T-NUTS FIRST**

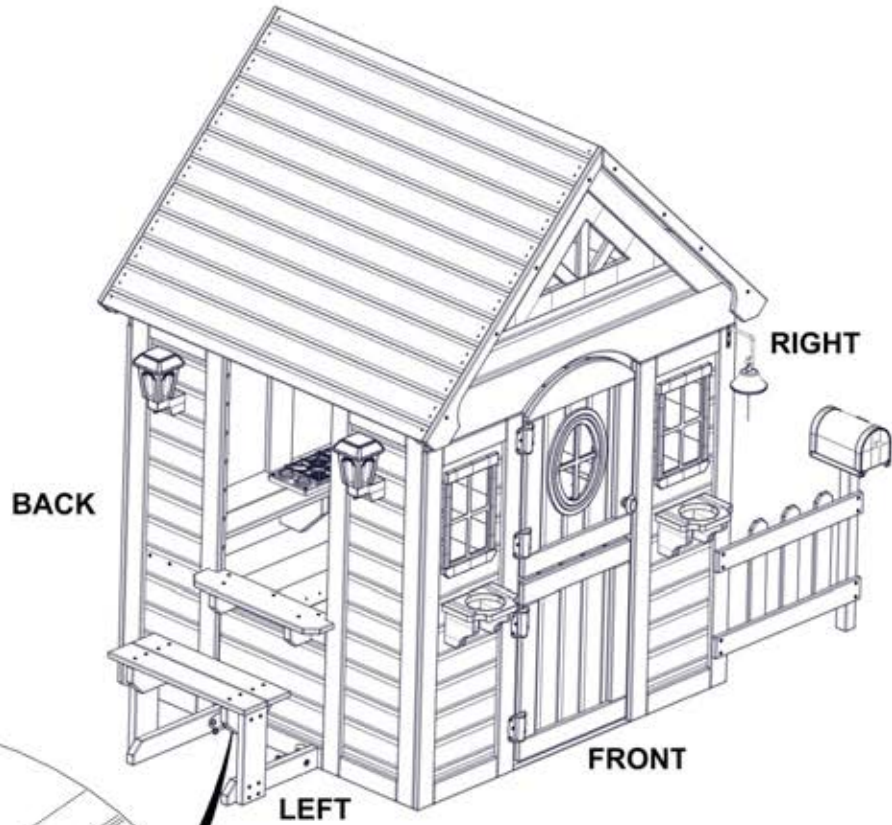

397 (x)  
BOLT - 1 1/4"

398 (x)  
TNUT-1/4"

# STEP 42 - PLAYHOUSE ASSEMBLY



QTY	PART NUMBER	DESCRIPTION
2	H100408	SCREW PWH 8x1/2 BLK

A4M00528 BYD ID TAG (MEDIUM) AGES 2 TO 10  
(x1)

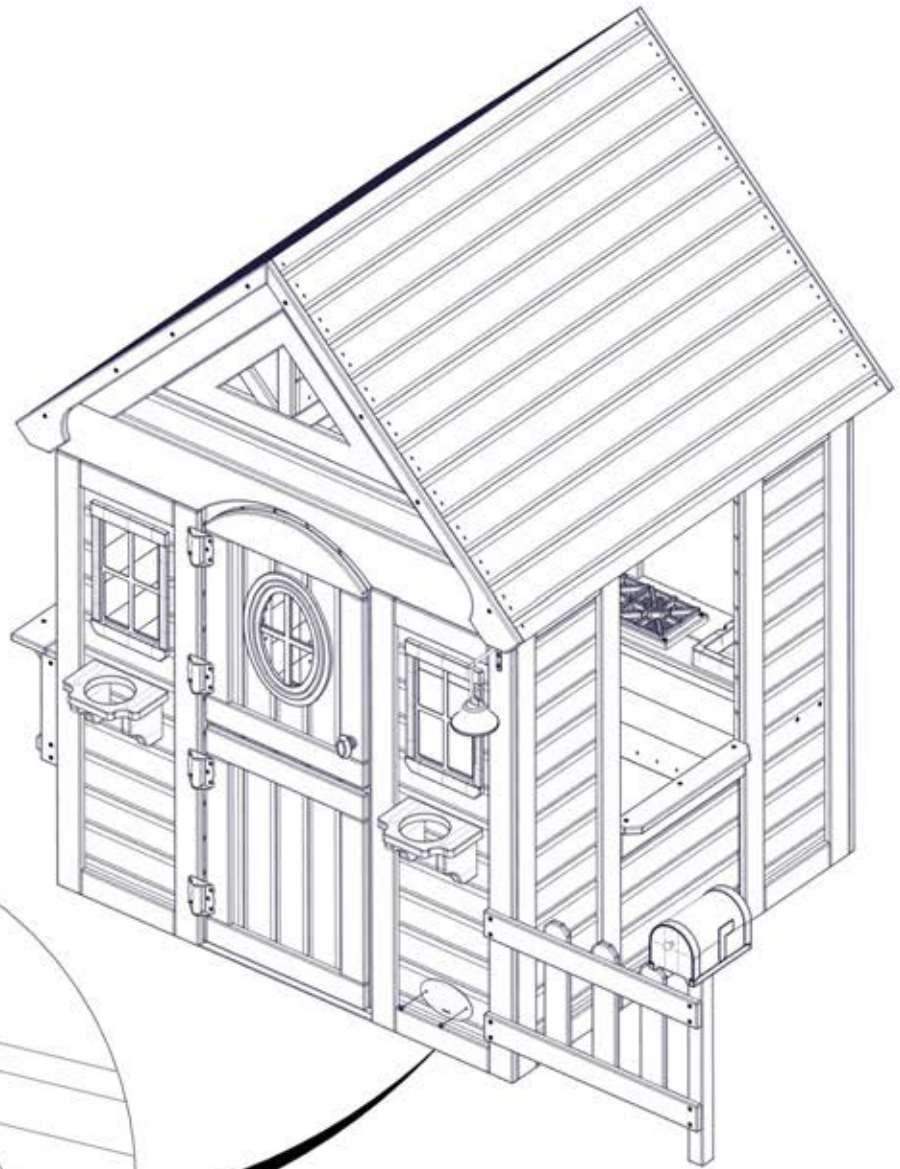

528 (x1)  
BYD ID TAG (MEDIUM) AGES 2 TO 10

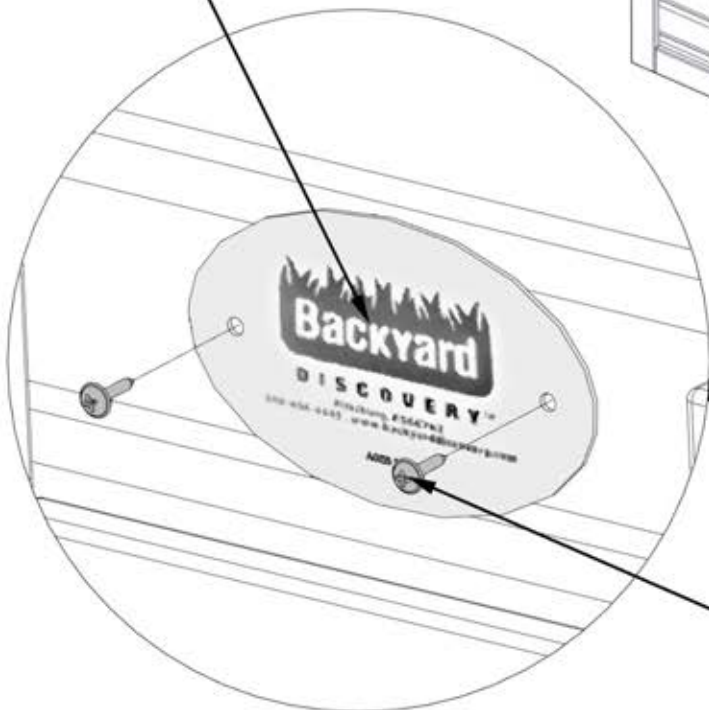

408 (x2)  
SCREW - 1/2"

# STEP 43 - PLAYHOUSE ASSEMBLY



QTY	PART NUMBER	DESCRIPTION
4	H100379	T-NUT 5/16 BLK
4	H100459	BOLT WH 5/16x1 1/4 BLK

LOCATE STAKES AS SHOWN. TAP IN GROUND AT APPROXIMATE 30 DEGREES AS SHOWN. USING GROUND STAKE AS GUIDE, DRILL (4) 7/16" [10 mm] DIA. HOLES THROUGH PANELS, INSERT T-NUTS AND HARDWARE AS SHOWN IN THE APPROXIMATE LOCATION SHOWN BELOW.

