



Manufactured by:
Backyard Discovery
3305 Airport Drive, Pittsburg, KS 66762
800-856-4445

Basepoint Business Centre: Rivermead Drive, Westlea, Swindon SN5 7EX Phone: 0800-118-2476
J.P. Coenstraat 7, The Bridge, The Hague, 2595 WP, Netherlands Phone: 08005678990

8x6 PRIVACY PANEL ADD ON KIT

MODEL # : 2404038



Please visit www.backyarddiscovery.com

For the most up to date assembly manual, to register your product, or to order replacement parts *Para obtener instrucciones en español, visite* www.backyarddiscovery.com

OWNER'S MANUAL - BASIC SETUP DIMENSIONS & ASSEMBLY NOTES

It is critically important that you start with a square and level concrete pad to attach your structure

- Pay close attention to the items needed for each step. Make sure you are using the correct hardware for each step. Using incorrect hardware may result in improper assembly
- Remember to double check for underground utilities and overhead electrical lines

Post mounts are provided with your structure which allows you to permanently install your product to a concrete surface. See Anchor Instructions for further details and recommendations.

- The hardware to attach the post mounts to the structure is included.
- The hardware to mount the structure permanently to a concrete surface is included.

- Layout below is shown as if you chose to use a single, straight wall addition.
- For the bent wall addition, use the measurements shown to estimate size of the additional wall kit.

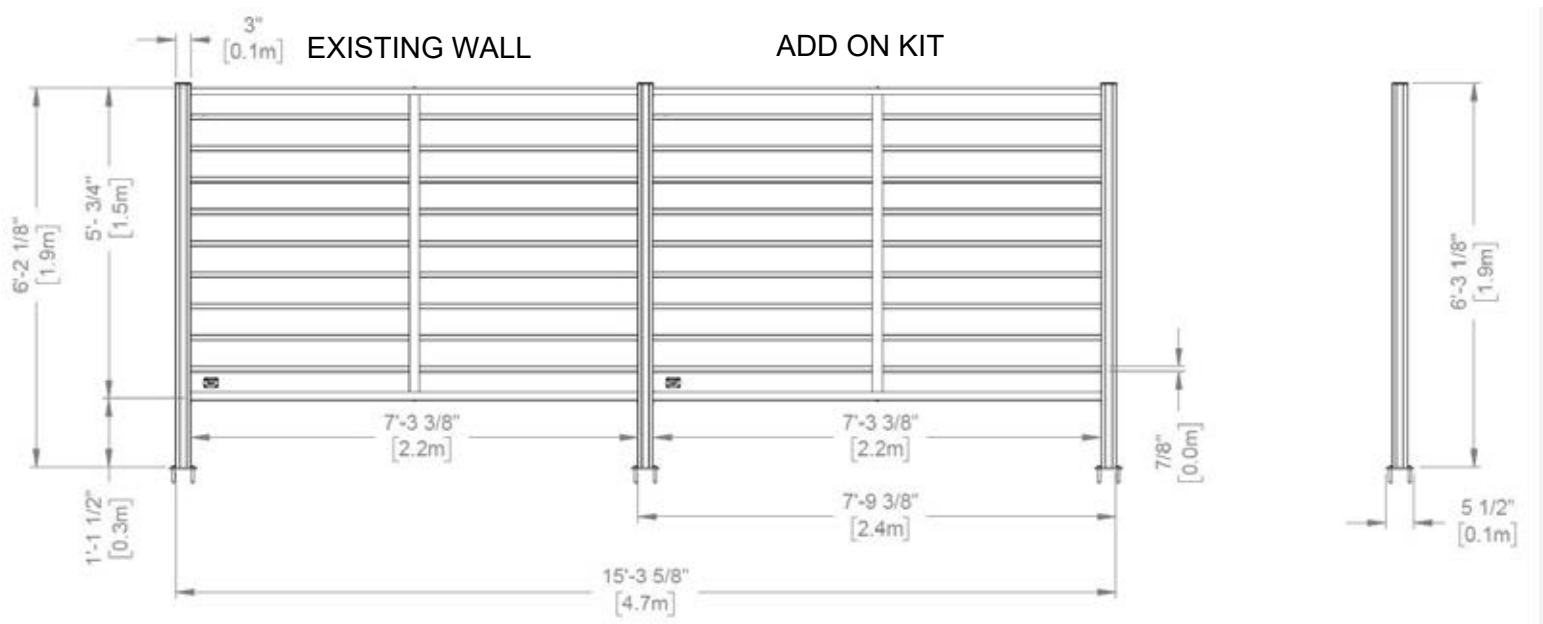

OWNER'S MANUAL - ANCHORING LAYOUT BETWEEN 2 POSTS

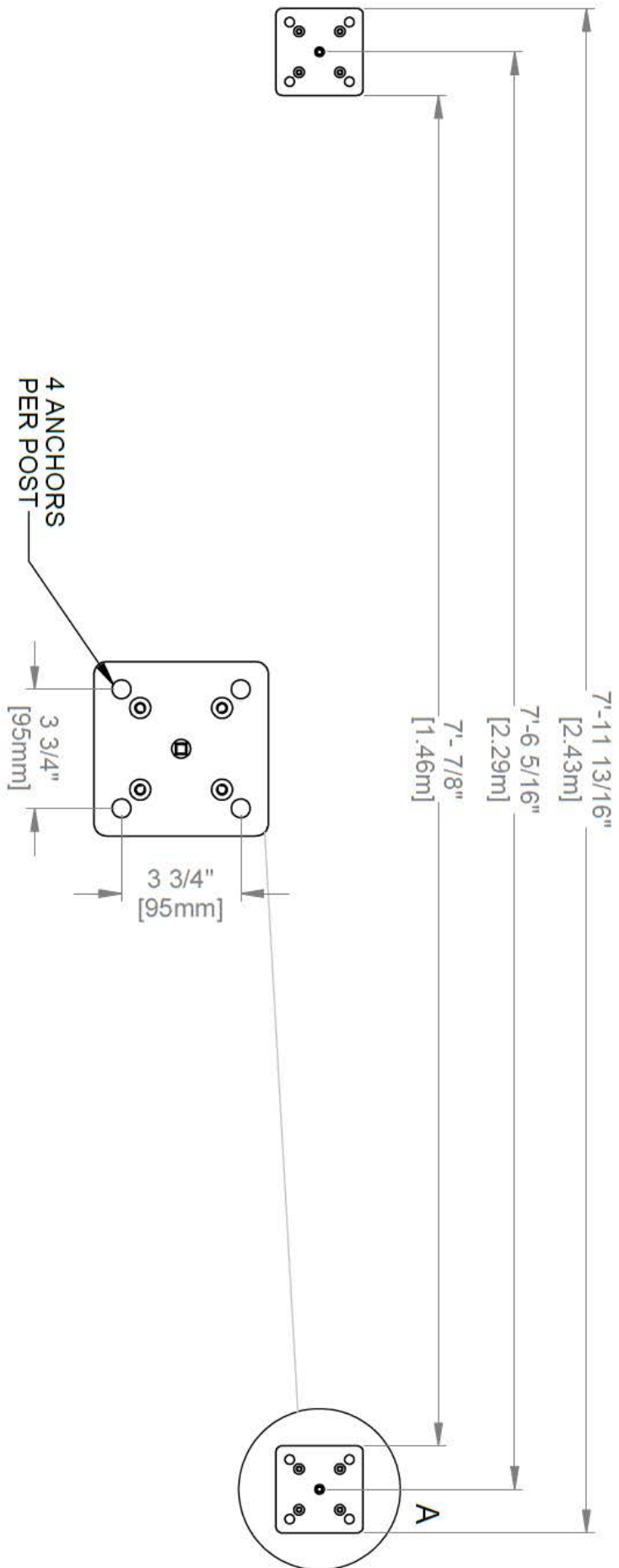

NOTE: DIMENSIONS ARE TO ANCHOR PLATES ON BOTTOM OF POST EXCEPT WHERE NOTED.

OWNER'S MANUAL - PARTS IDENTIFICATION

METAL COMPONENTS (NOT TO SCALE)

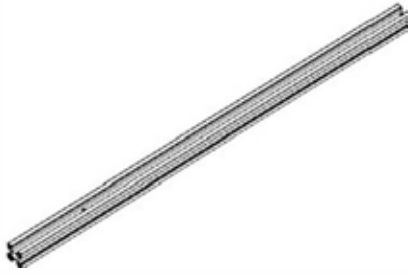

P01 POST ASSEMBLY - A4M02244
(x1) 3"x3"x74 13/16" (76x76x1900)

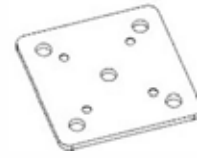

P02 POST FOOT - A4M02182
(x1) 1/4"x5 1/2"x5 1/2" (6x139x139)



A1 HORIZONTAL BRACE ASSEMBLY - A4M01806
(x2) 1 7/16"x2 5/16"x88" (36x58x2235)



A2 VERTICAL SUPPORT - A4M02039
(x1) 1 15/16"x1 3/16"x57 7/8" (30x50x1470)

ACCESSORY COMPONENTS (NOT TO SCALE)



A6P00545 INSERT
(x2)



A4M02158 BYD ID TAG PATIO
(x1)

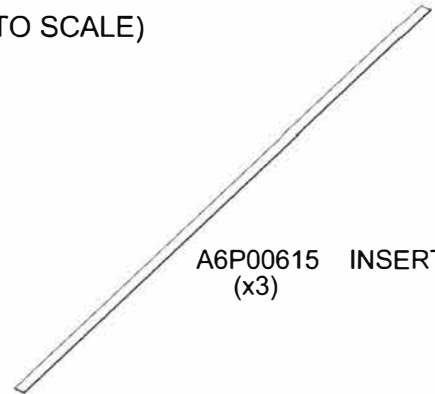

A6P00615 INSERT
(x3)



A6P00544 POST CAP
(x1)

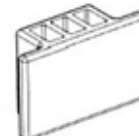

A6P00560 SPACER
(x36)



B01 WOOD SLAT - W4L18023
(x3) 15/16"x5 1/4"x44 1/8" (24x134x1120)



B02 WOOD SLAT - W4L18024
(x16) 15/16"x5 1/4"x44 1/8" (24x134x1120)



B03 WOOD SLAT WITH TAG - W2A04020
(x1) 15/16"x5 1/4"x44 1/8" (24x134x1120)

OWNER'S MANUAL - PARTS IDENTIFICATION

HARDWARE COMPONENTS (NOT TO SCALE)



H100392 SCREW PWH
(x4) 8x3/4 BLK



H101271 TORX PAN HEAD
(x4) 1/4-20x 1 1/4" BLK

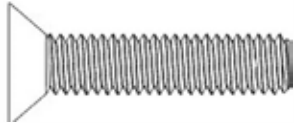

H101164 TORX FLAT HEAD
(x4) 5/16-18x1 1/2" BLK



H101126 TORX PAN HEAD
(x4) 1/4-20x 2 1/8" BLK



H101165 CONCRETE ANCHOR
(x4) 3/8"x3" BLK

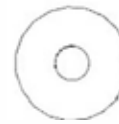

H101053 STEEL WASHER
(x4) 6x20

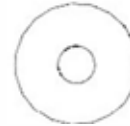

H101054 SEALANT WASHER
(x4)

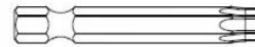

H100147 TORX BIT
(x1) T-30



H100114 TORX WRENCH
(x1) T-30



H101100 MAGNETIC DRIVER
(x1)

PRE-ASSEMBLY STEP 1 - SORTING PARTS

It is critical for ease of assembly that you take the time to sort and organize the parts and hardware.

METAL PARTS:

- Organize metal parts by the three-digit, alpha-numeric number stamped on each part (ex. P01).
- If there are multiple parts with the same stamped number, stack those pieces together.
- Stamps can be found on the flat surface of the parts or on the end of the parts.
- Allow yourself plenty of room - the parts can take up a significant amount of space.

NOTE: CARTONS ARE NOT ORGANIZED BY PART NUMBER.

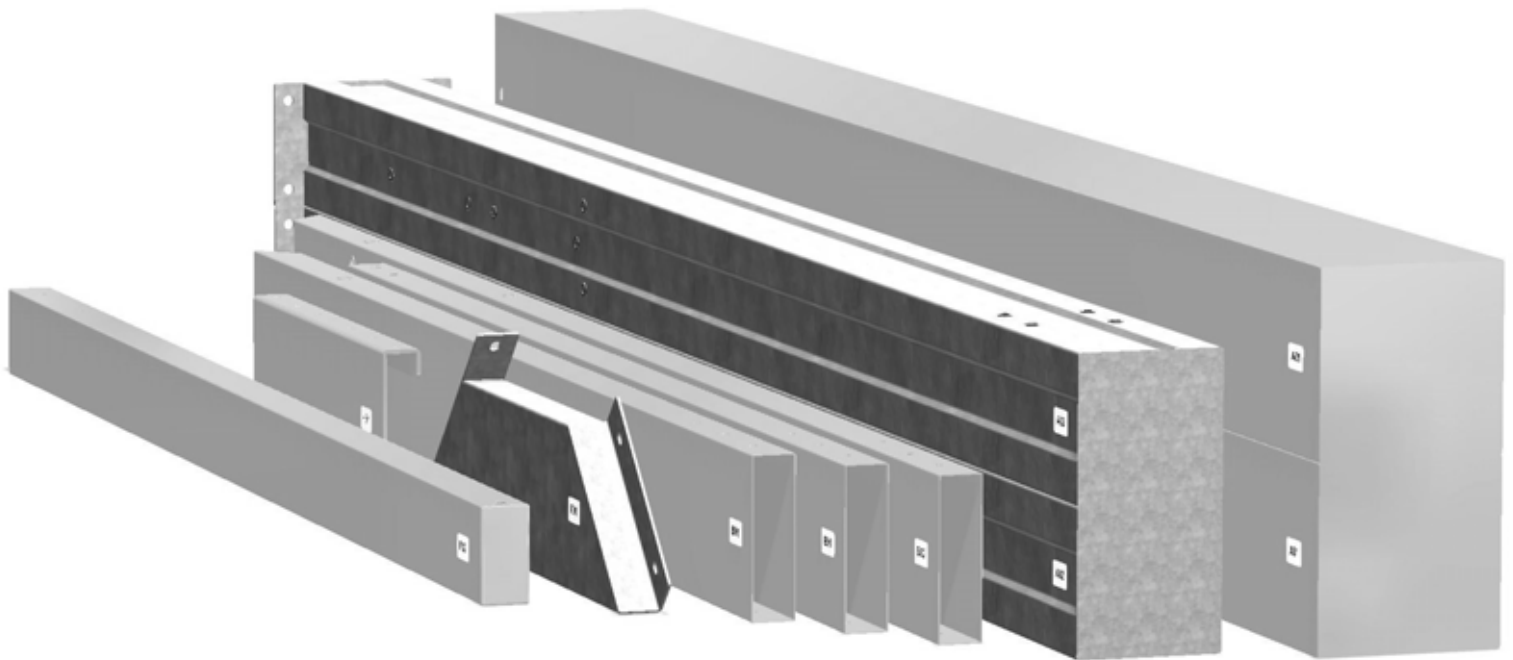

HARDWARE PARTS:

- We recommend that you have a separate table to organize the hardware.
- Hardware bags are printed with a seven-digit, alpha-numeric part number.
- You can organize your hardware by part number or group by hardware type (i.e. bolts, nuts, etc.).
- During assembly you only need to reference the last four digits of the number.

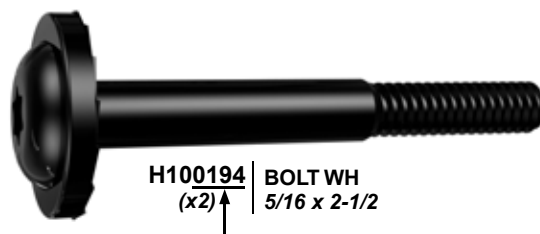

PRE-ASSEMBLY STEP 2 - TOOLS REQUIRED



Cordless Drill or Electric Drill



Drill Attachments:
Phillips Head



1/8", 3/16", 3/8" & 7/16" Drill Bits



Phillips Screw Driver



Open End Wrench
7/16"



3/8" Drive Ratchet, 1/2" & 7/16" STD Sockets 1/2" & 7/16" Deep Sockets



Claw Hammer



Rubber Mallet -
Optional



Tape Measure

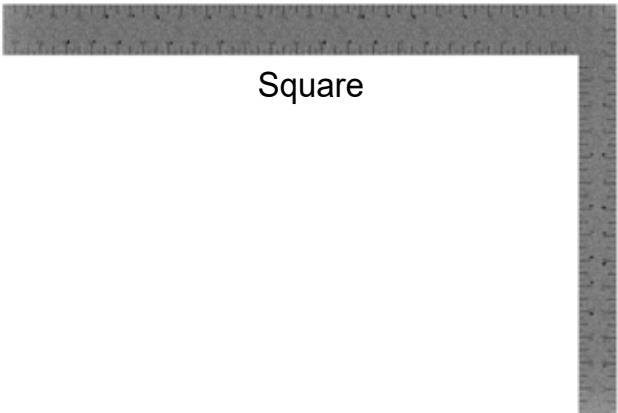

Square



Level 24"

STEP 1 - ADD ON KIT PREP

NOTE:

- THE ADD ON KIT CAN BE ADDED TO ANY SIDE OF ANY POST TO CREATE ANY ORIENTATION YOU WOULD LIKE.

-THE FOLLOWING STEPS ARE SHOWN AS IF THE STRAIGHT WALL ADD ON WAS CHOSEN.

- FROM THE EXISTING PRIVACY WALL, DETERMINE WHICH SIDE OF THE POST TO ATTACH THE ADD ON KIT TO.

- REMOVE THE EXISTING POST CAP AND INSERT FROM DESIGNATED SIDE OF POST.

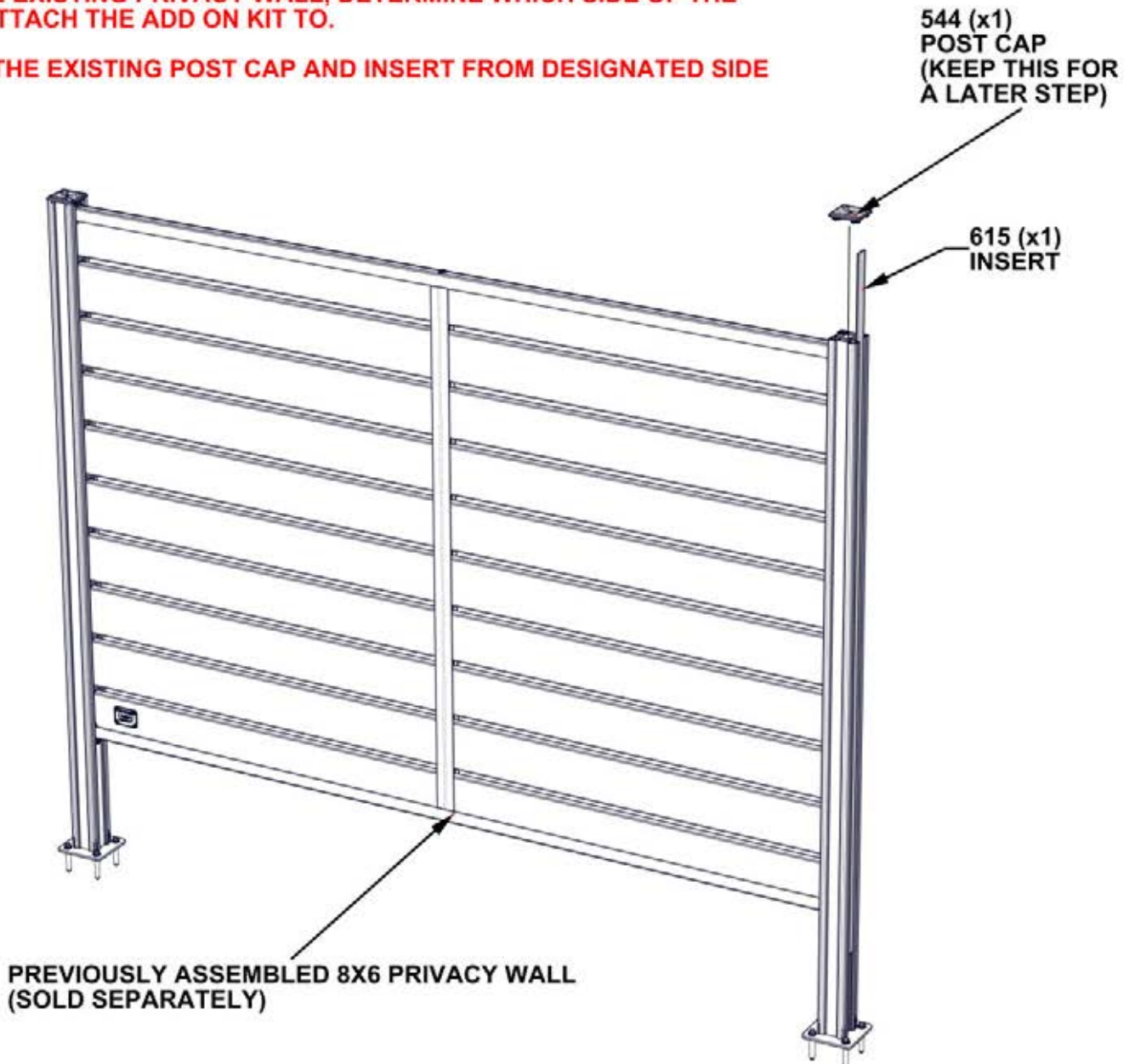

STEP 2 - INSERT INSTALLATION



A6P00545 INSERT
(x1)

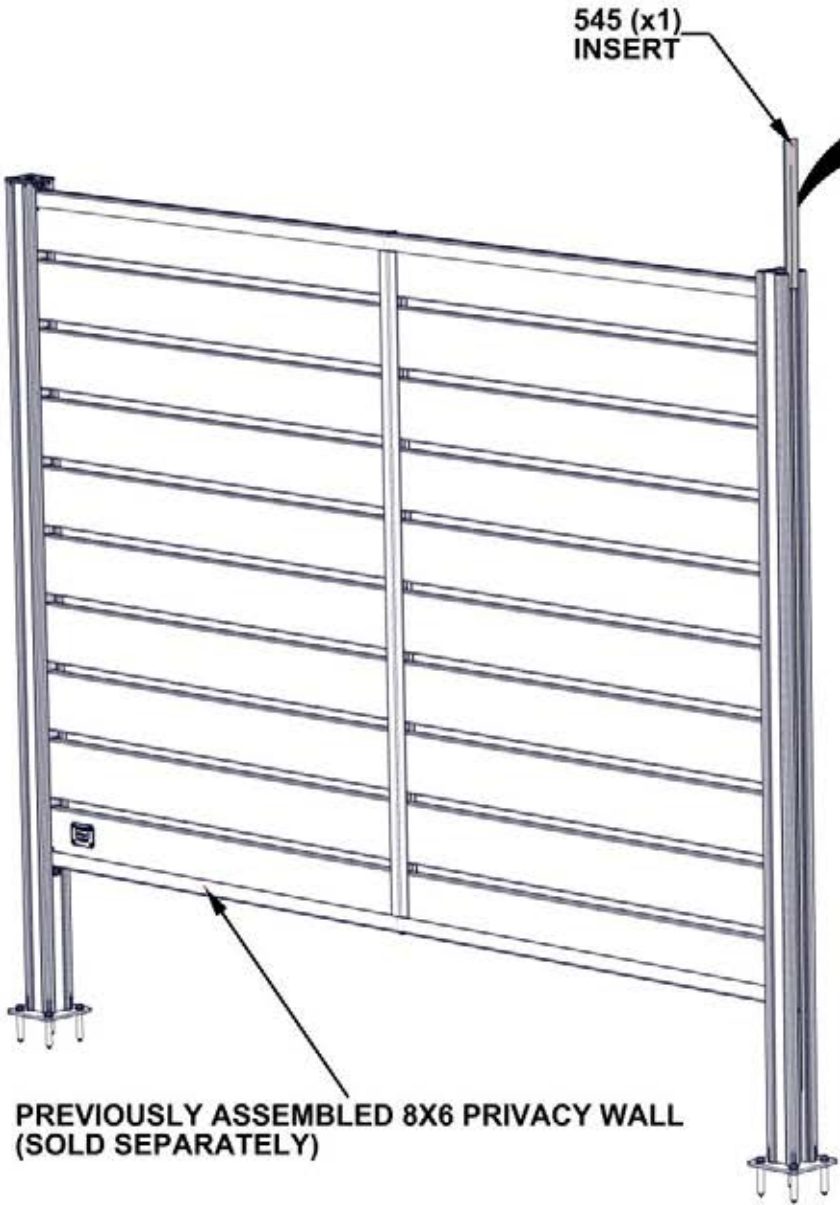

**SLIDE INSERT INTO POST GROOVE.
INSERT WILL SLIDE TO THE BOTTOM
OF THE POST.**

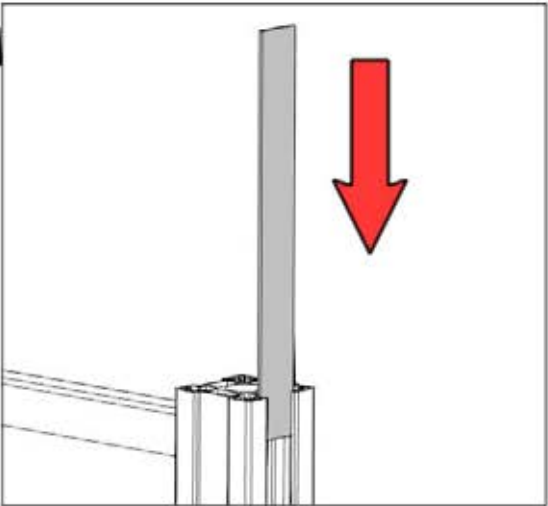

STEP 3 - POST ASSEMBLY

Qty	Part Number	Description
4	H101164	TORX FLAT HEAD SCREW 5/16-18 UNC

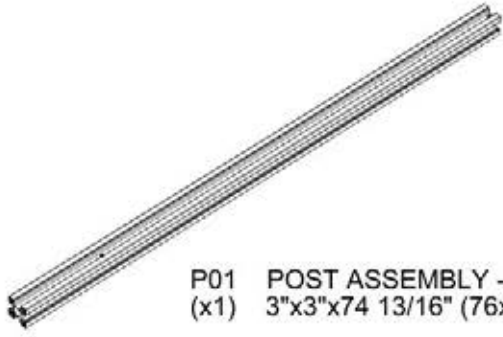

P01 POST ASSEMBLY - A4M02244
(x1) 3"x3"x74 13/16" (76x76x1900)



P02 POST FOOT - A4M02182
(x1) 1/4"x5 1/2"x5 1/2" (6x139x139)

NOTE: POST MUST BE ORIENTED AS SHOWN BELOW.

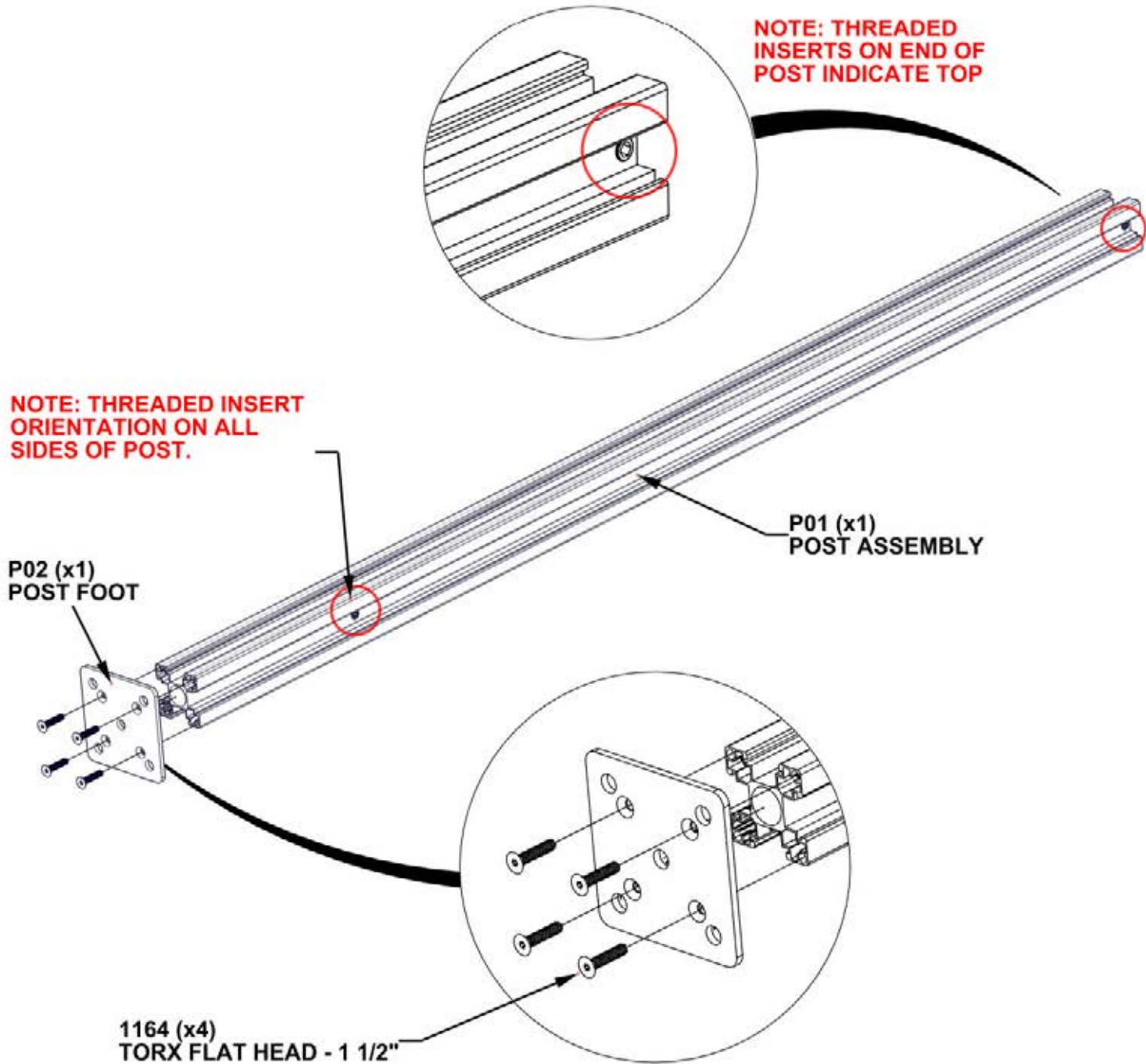

STEP 4 - INSERT INSTALLATION



A6P00545 INSERT
(x1)

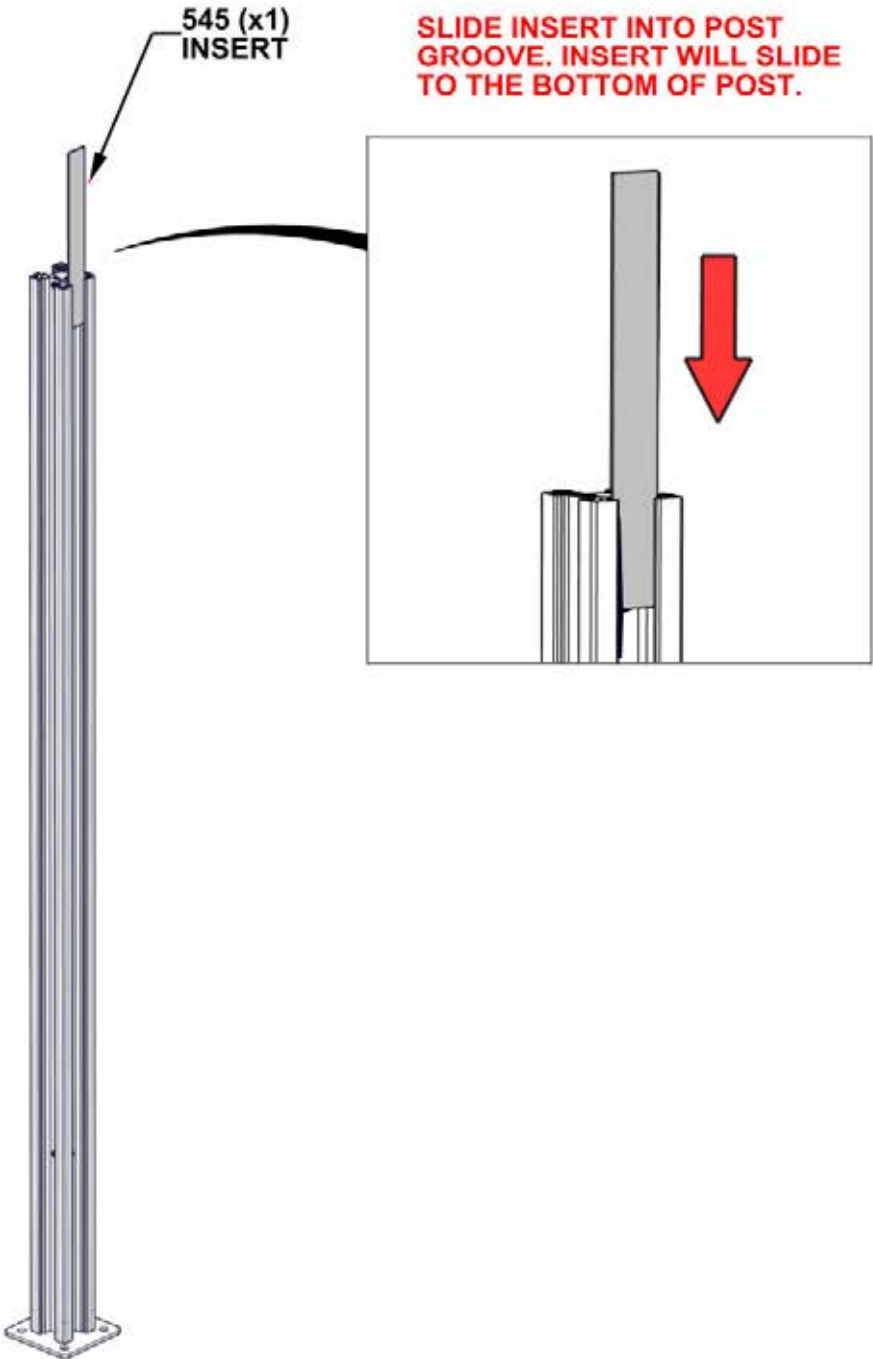

STEP 5A - BRACE INSTALLATION

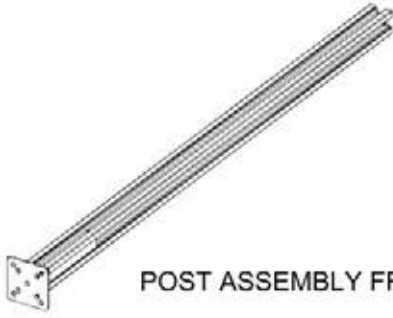

POST ASSEMBLY FROM STEPS 3-4

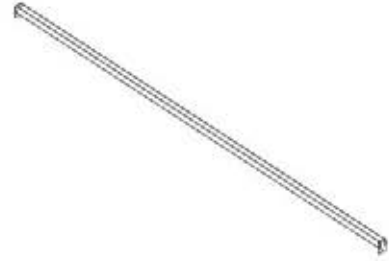

A1 HORIZONTAL BRACE ASSEMBLY - A4M01806
(x1) 1 7/16"X2 5/16"X88" (36x58x2235)

NOTE: TWO PEOPLE ARE RECOMMENDED FOR THIS STEP.

ORIENT EACH POST TO WHERE INSERTS FROM PREVIOUS STEP ARE FACING EACH OTHER.

ATTACH HORIZONTAL BRACE ASSEMBLY TO EACH POST ASSEMBLY BY INSERTING THE BRACE BRACKET INTO POST GROOVE.

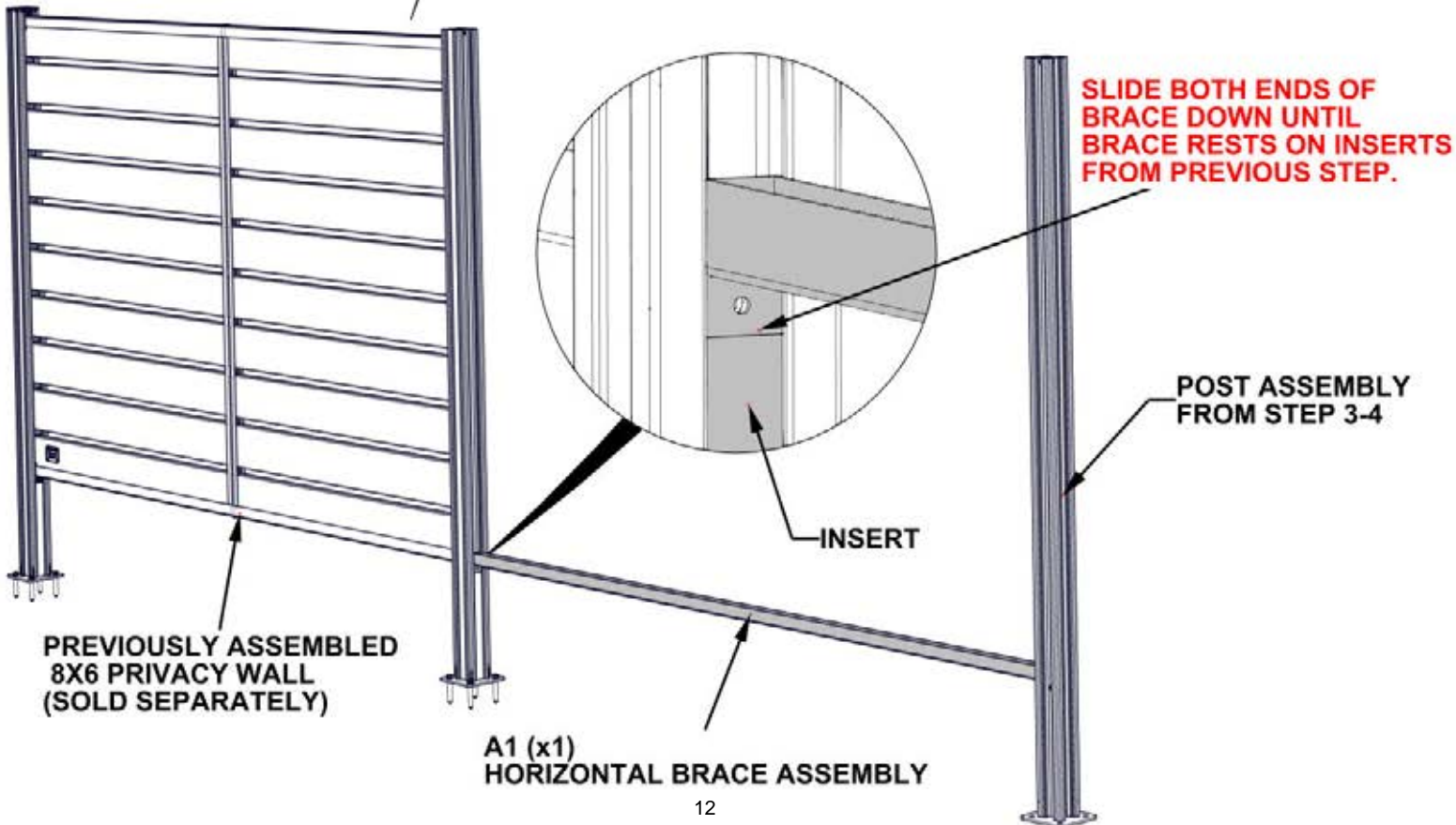
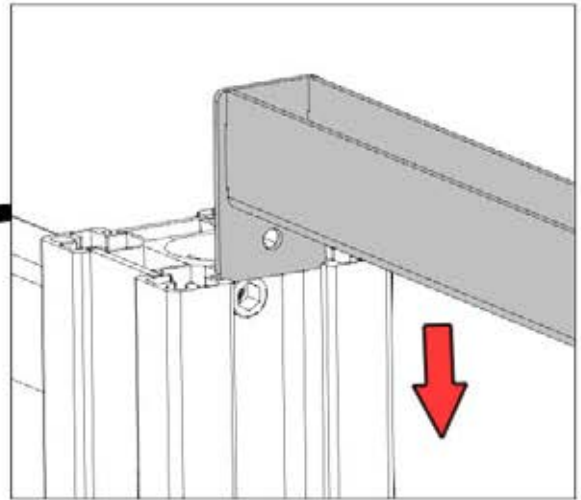

STEP 5B - BRACE INSTALLATION

Qty	Part Number	Description
2	H101053	STEEL WASHER 6x20
2	H101054	SEALANT WASHER
2	H101271	TORX PAN HEAD 1/4-20x1 1/4"

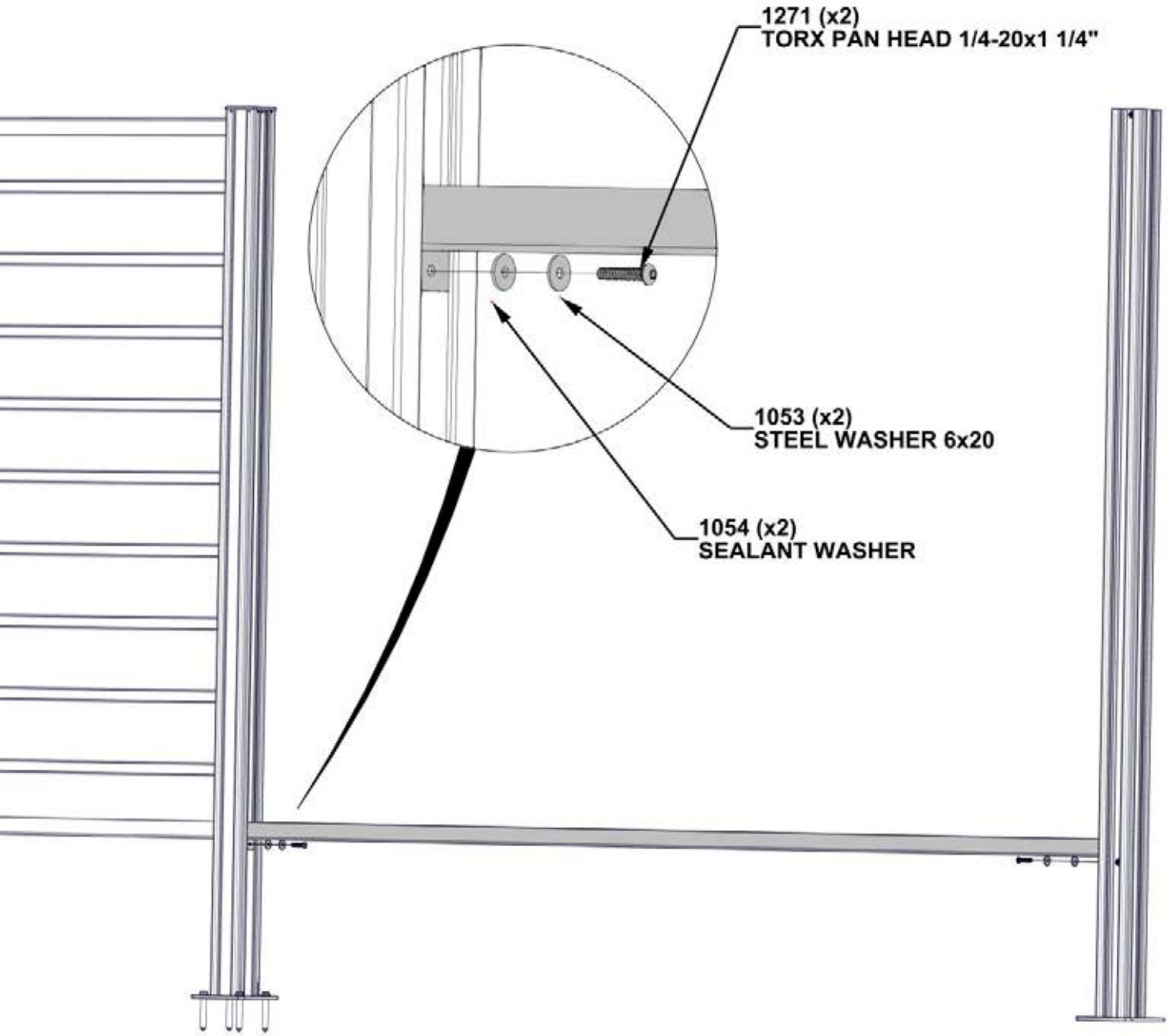

STEP 6 - ANCHOR INSTALLATION

Qty	Part Number	Description
4	H101165	CONCRETE ANCHOR 3/8"x3" BLK

MANUFACTURER RECOMMENDS USING INSTALLATION ON CONCRETE SURFACE AS SHOWN BELOW.

SQUARE POST AS NEEDED BEFORE INSTALLING CONCRETE ANCHORS.

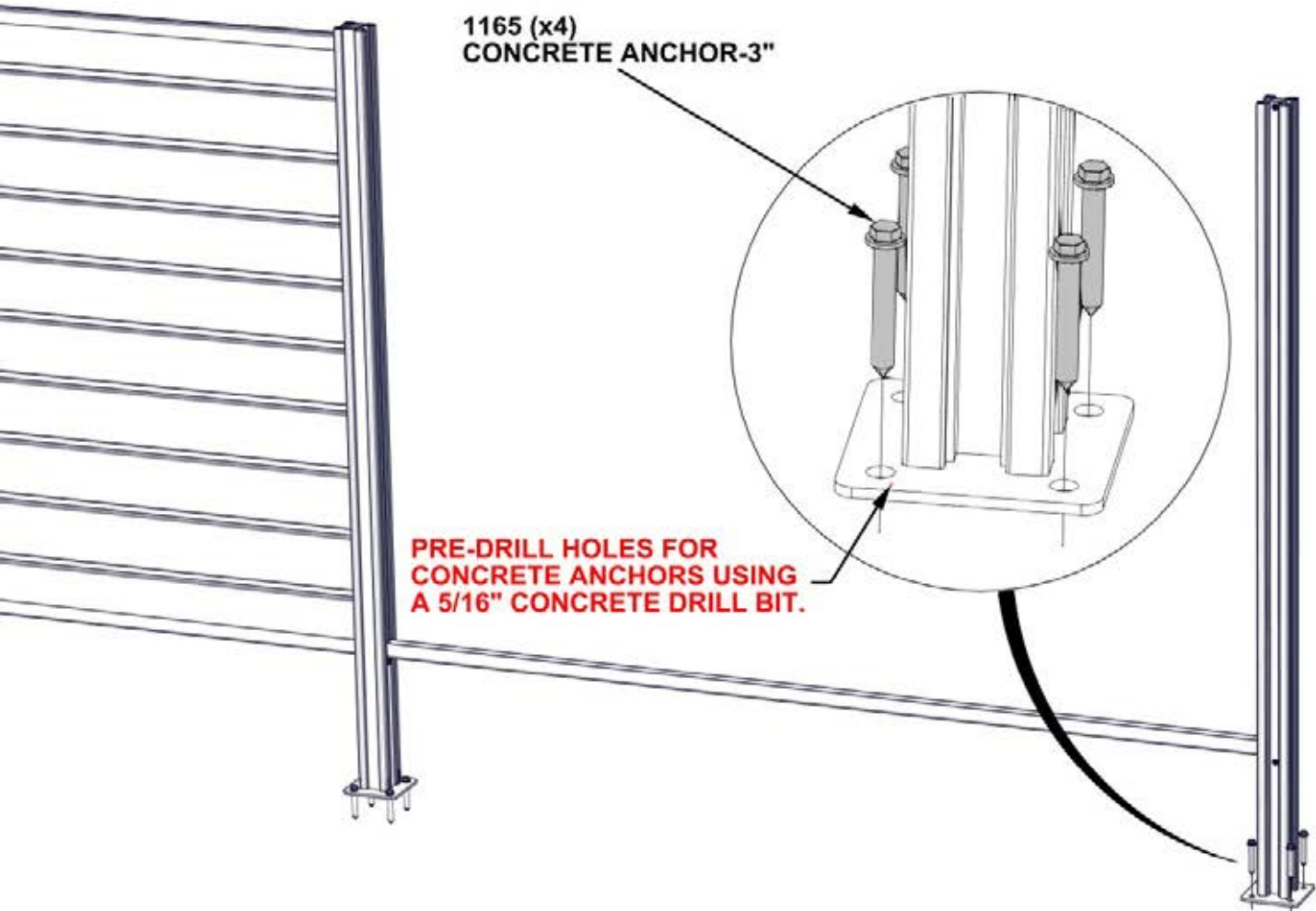

STEP 7 - VERTICAL SUPPORT INSTALLATION

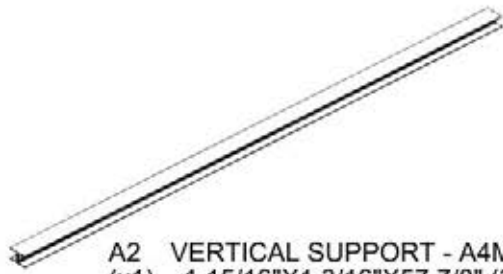

A2 VERTICAL SUPPORT - A4M02039
(x1) 1 15/16"X1 3/16"X57 7/8" (30x50x1470)

Qty	Part Number	Description
2	H101126	TORX PAN HEAD

**FLUSH BOTH SIDES
OF VERTICAL SUPPORT
WITH HORIZONTAL BRACE**

1126 (x2)
TORX PAN HEAD 1/4-20x2 1/8"

A2 (x1)
VERTICAL SUPPORT

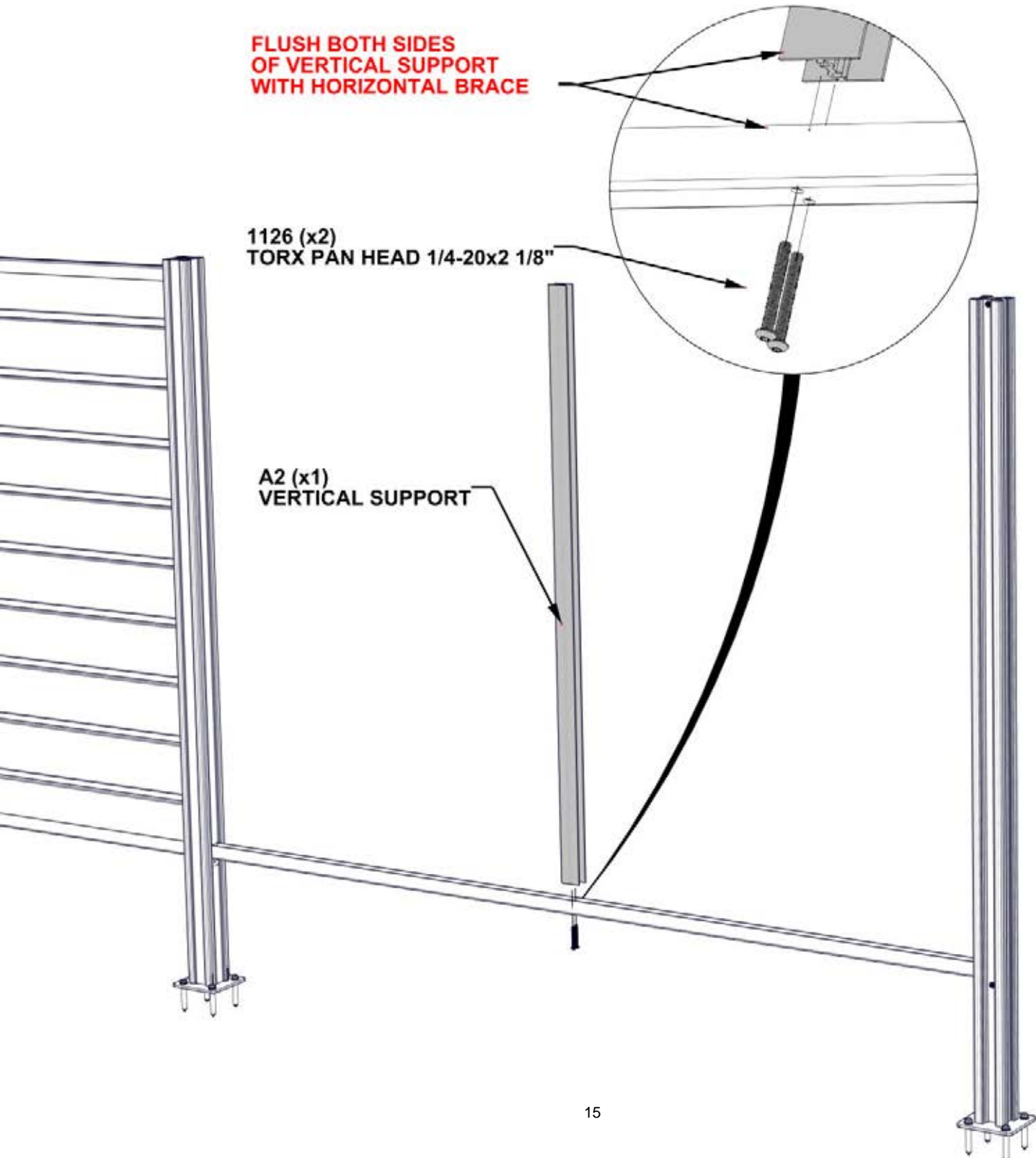

STEP 8 -NOTCHED SLAT INSTALLATION



B01 WOOD SLAT - W4L18023
(x2) 15/16"x5 1/4"x44 1/8" (24x134x1120)

NOTE: INSTALL WOOD SLATS BY ALIGNING ENDS OF BOARDS WITH GROOVES IN POST AND VERTICAL SUPPORT.

NOTE: NOTCH IN THE END OF BOARD IS ON POST SIDE AND TOWARDS BOTTOM.

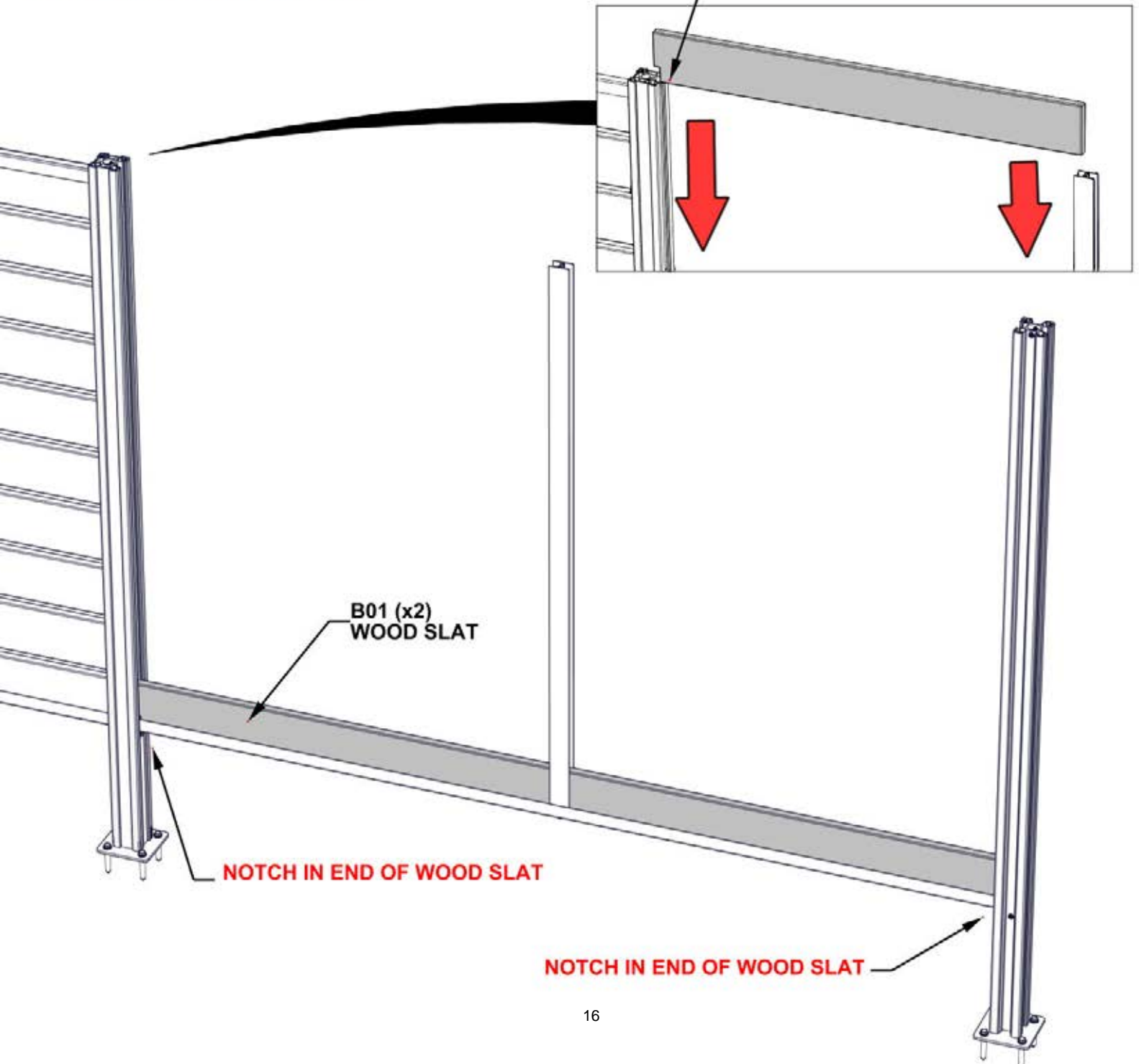

STEP 9 - SPACER INSTALLATION

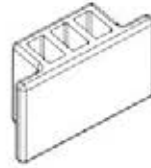

A6P00560 SPACER
(x4)

NOTE: THE DIFFERENT ORIENTATION OF THE SPACERS IS CRITICAL TO ASSEMBLY.

NOTE: ORIENTATION OF EACH SPACER IN EACH POST GROOVE.

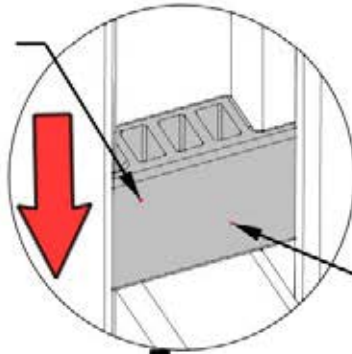

560 (x2)
SPACER

NOTE: ORIENTATION OF EACH SPACER IN VERTICAL SUPPORT.

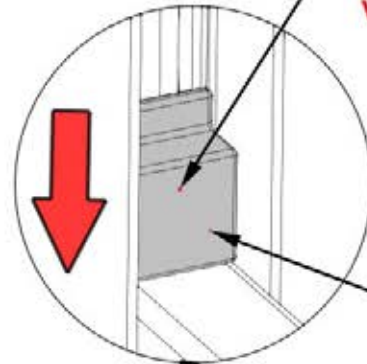

560 (x2)
SPACER

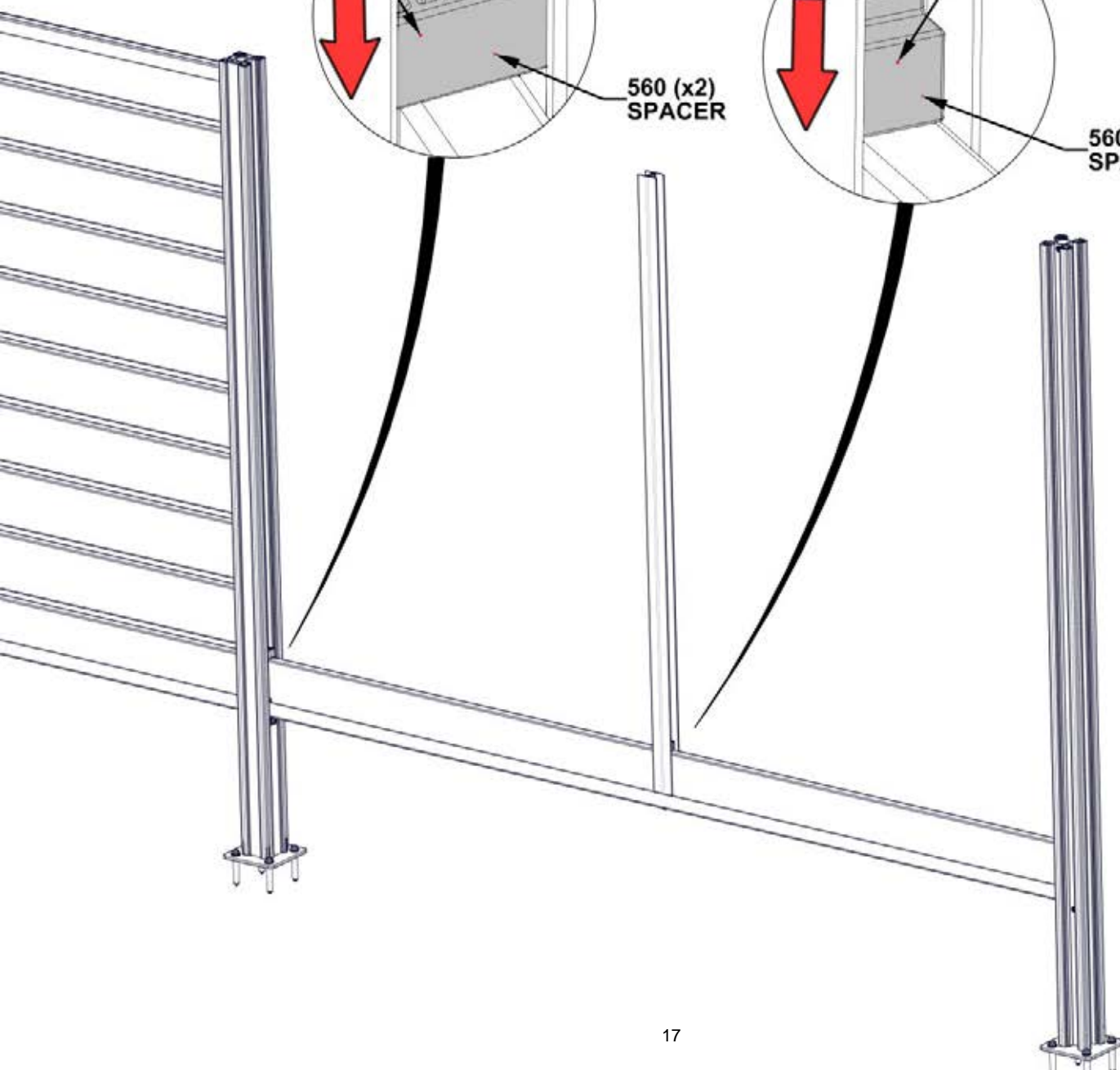

STEP 10 - SLAT INSTALLATION



B02 WOOD SLAT - W4L18024
(x2) 15/16"x5 1/4"x44 1/8" (24x134x1120)

**INSTALL WOOD SLATS BY ALIGNING
ENDS OF BOARDS WITH GROOVES
IN POST AND VERTICAL SUPPORT**

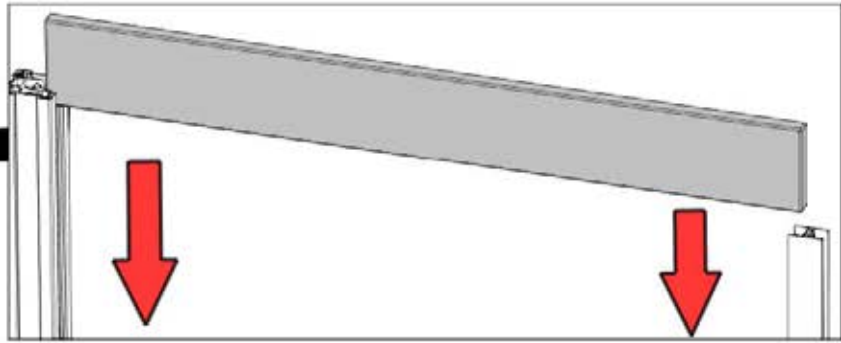

**MAKE SURE POST
REMAINS SQUARE
WHEN INSTALLING
WOOD SLATS.**

**MAKE SURE POST
REMAINS SQUARE
WHEN INSTALLING
WOOD SLATS.**

B02 (x1)
WOOD SLAT

B02 (x1)
WOOD SLAT

STEP 11 - SLAT INSTALLATION



B02 WOOD SLAT - W4L18024
(x14) 15/16"x5 1/4"x44 1/8" (24x134x1120)



A6P00560 SPACER
(x28)

**REPEAT STEPS 9 -10 TO INSTALL
REMAINING B02 WOOD SLATS**

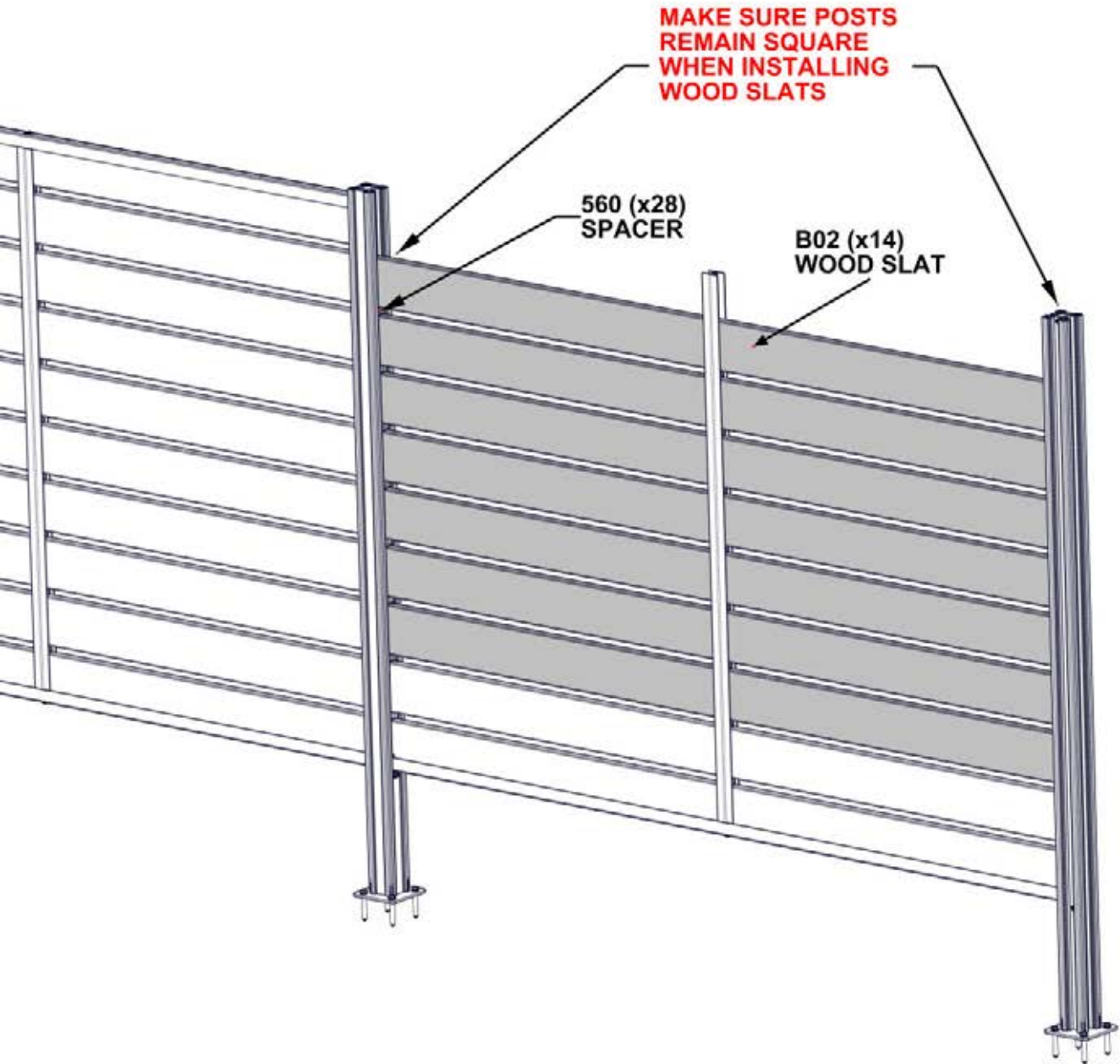

STEP 12 - SLAT INSTALLATION



B03 WOOD SLAT WITH TAG - W2A04020
(x1) 15/16"x5 1/4"x44 1/8" (24x134x1120)



B01 WOOD SLAT - W4L18023
(x1) 15/16"x5 1/4"x44 1/8" (24x134x1120)

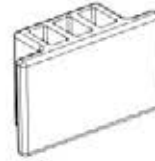

A6P00560 SPACER
(x4)

**NOTE: NOTCH IN END OF
BOARDS GO TOWARD POST
SIDES AND FACE UP.**

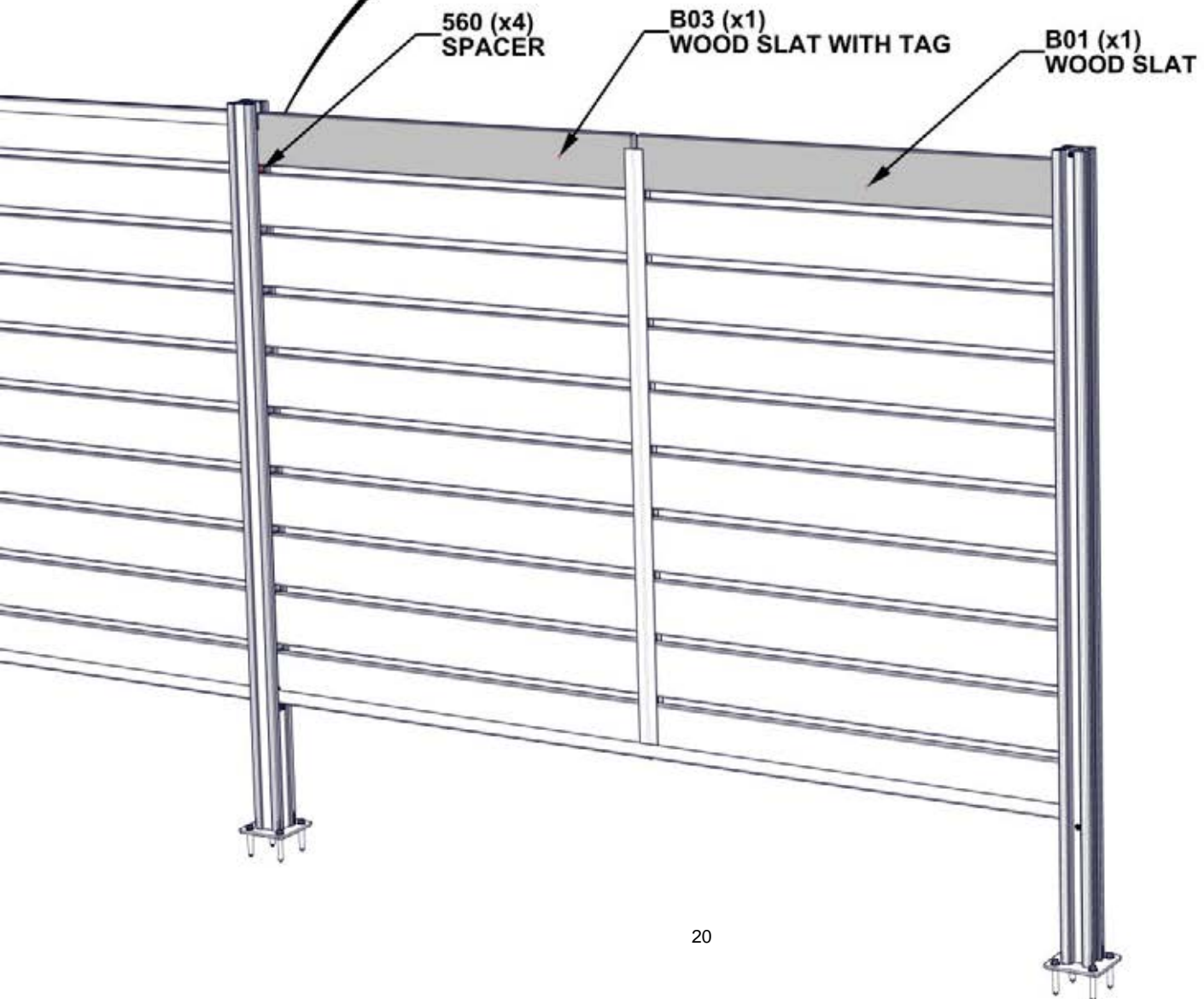
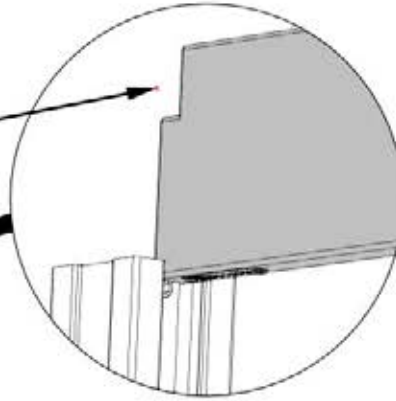

STEP 13A - BRACE INSTALLATION

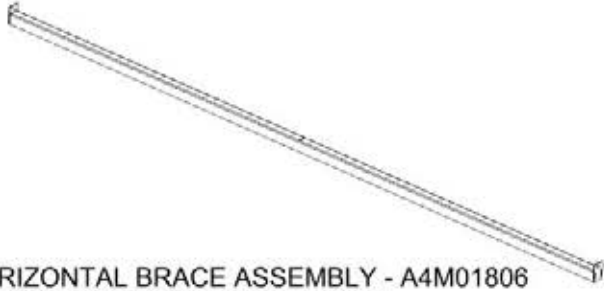

Qty	Part Number	Description
2	H101126	TORX PAN HEAD

A1 HORIZONTAL BRACE ASSEMBLY - A4M01806
(x1) 1 7/16"X2 5/16"X88" (36x58x2235)

DO NOT FULLY TIGHTEN HARDWARE AT THIS STEP

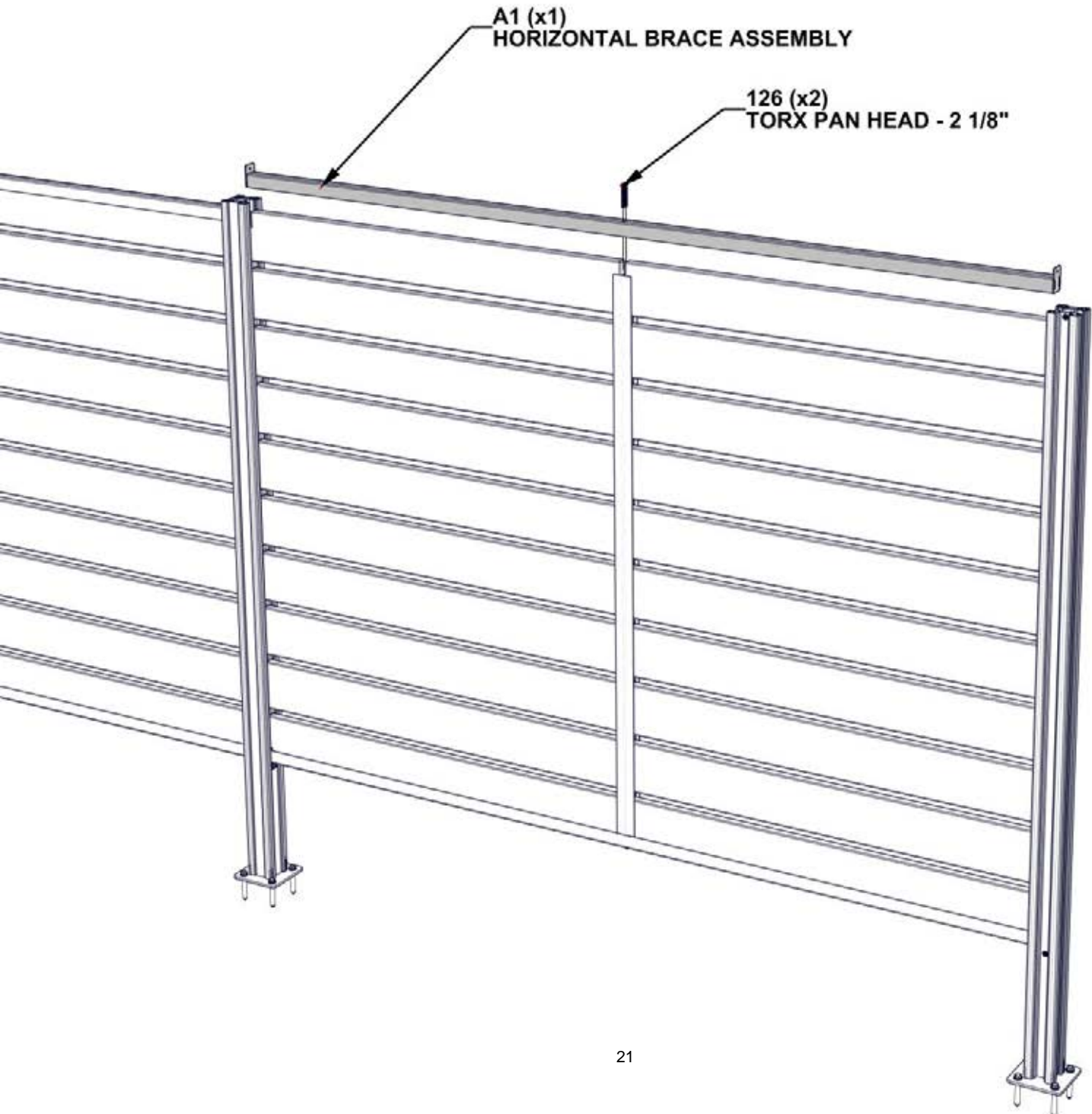

STEP 13B - BRACE ATTACHMENT

Qty	Part Number	Description
2	H101053	STEEL WASHER 6x20
2	H101054	SEALANT WASHER
2	H101271	TORX PAN HEAD 1/4-20x1 1/4"

**INSTALL HARDWARE TO HOLD BRACE TO POST.
TIGHTEN HARDWARE FROM PREVIOUS STEP.**

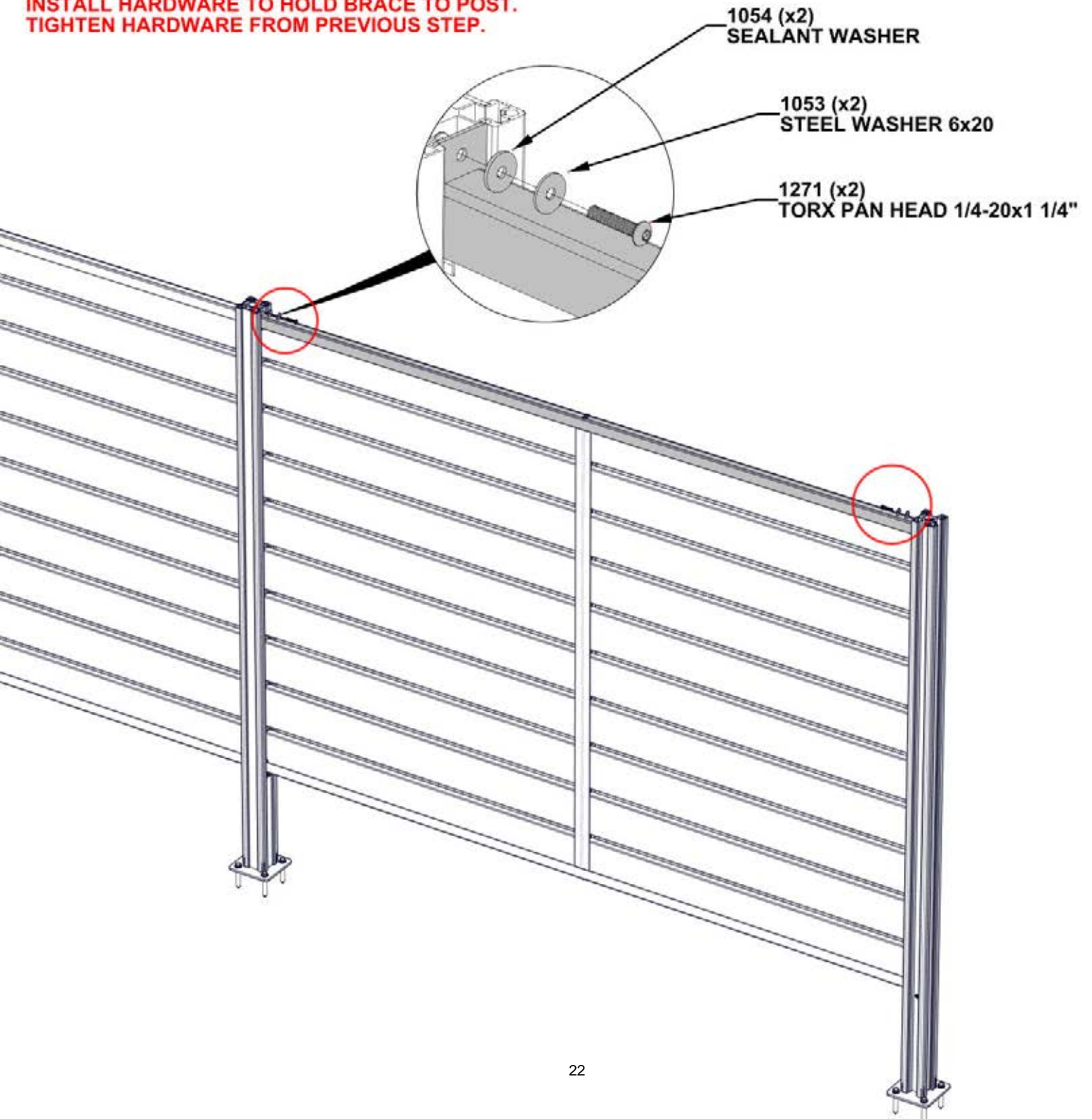

STEP 14 - INSERT INSTALLATION

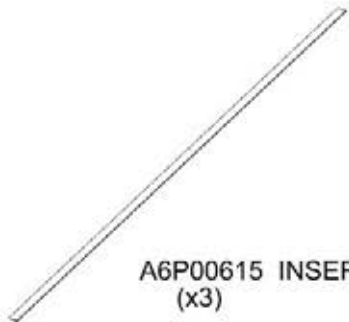

**INSTALL INSERTS TO EACH EMPTY
SLOT OF POST TO HIDE HARDWARE**

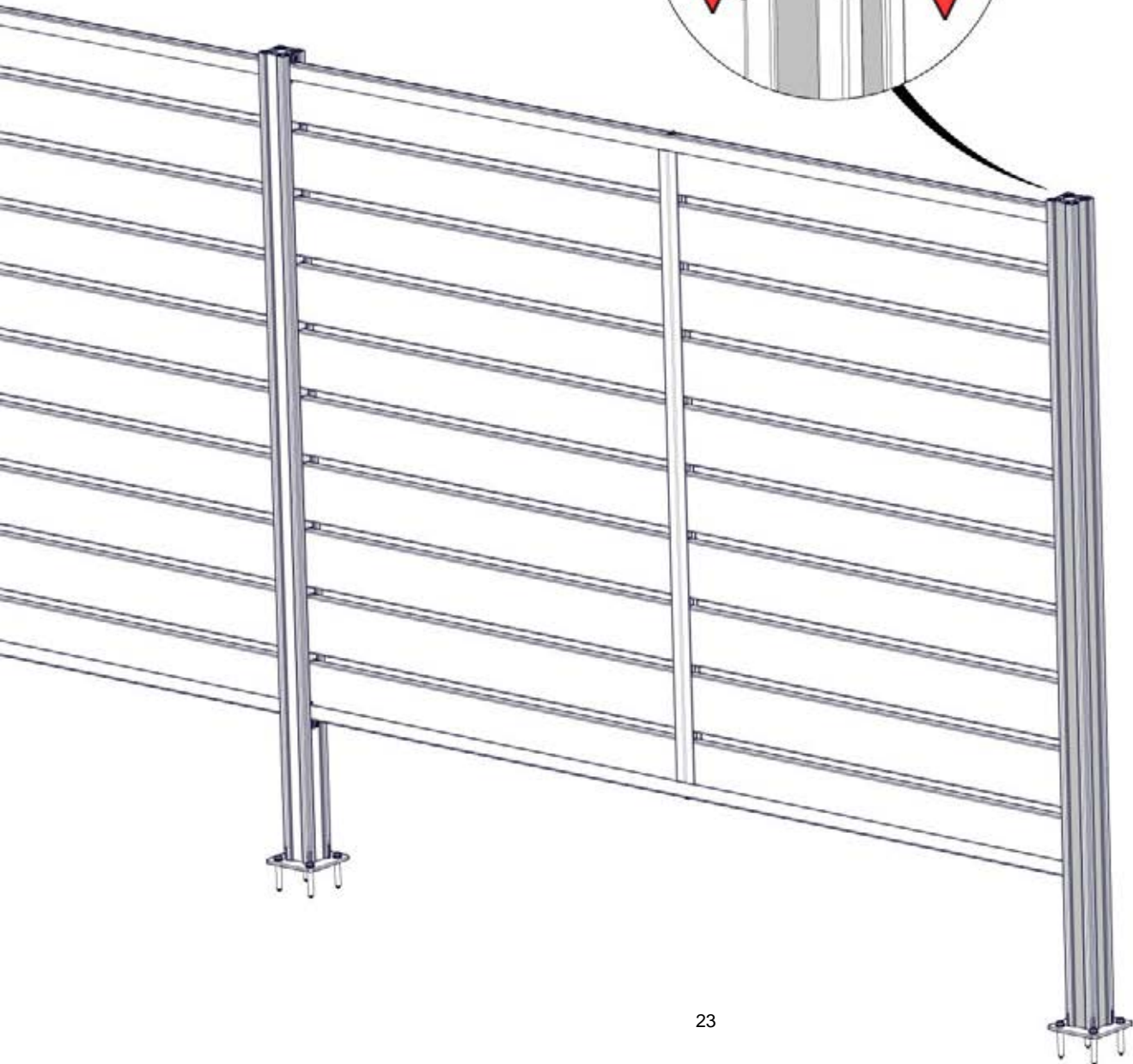
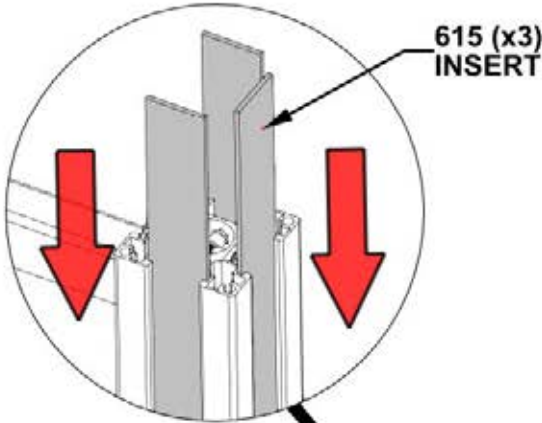

STEP 15 - POST CAP INSTALLATION



A6P00544 POST CAP
(x2)

**USE A RUBBER Mallet TO
TAP THE NEW POST CAP AND
EXISTING POST CAP INTO PLACE**

544 (x2)
POST CAP

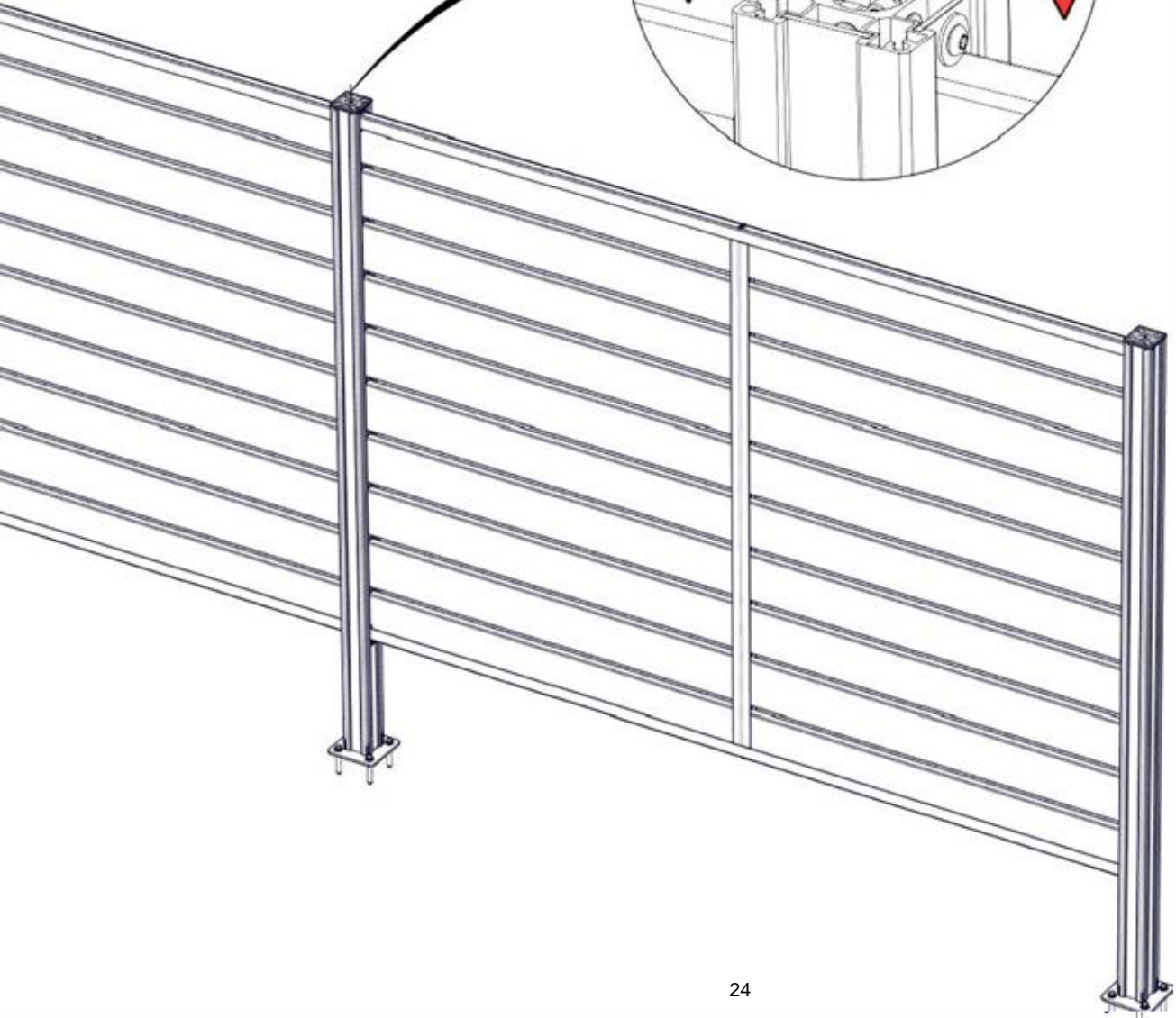
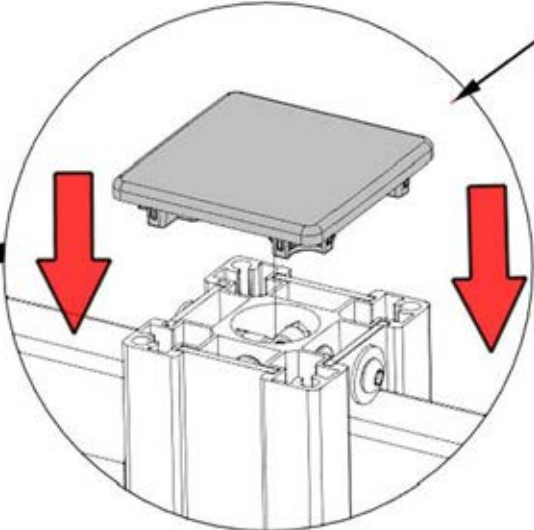

STEP 16 - PANEL ACCESSORIES



A4M02158 BYD ID TAG PATIO
(x1)

Qty	Part Number	Description
4	H100392	SCREW PWH BLK

