



Manufactured by: Backyard
Discovery
3305 Airport Drive,
Pittsburg, KS 66762
800-856-4445

Basepoint Business Centre: Rivermead Drive, Westlea, Swindon SN5 7EX Phone:
0800-118-2476 J.P. Coenstraat 7, The Bridge, The Hague, 2595 WP, Netherlands Phone: 08005678990

ARGENTINE SANTA MARIA XL GRILL

MODEL # : 2404045



Please visit www.backyarddiscovery.com
For the most up to date assembly manual, to register your product, or to order
replacement parts *Para obtener instrucciones en español, visite*
www.backyarddiscovery.com



EASY STEP-BY-STEP
3D INTERACTIVE INSTRUCTIONS
DOWNLOAD THE FREE APP



OWNER'S MANUAL - BASIC SETUP DIMENSIONS & ASSEMBLY NOTES

- Pay close attention to the items needed for each step. Make sure you are using the correct hardware for each step. Using incorrect hardware may result in improper assembly

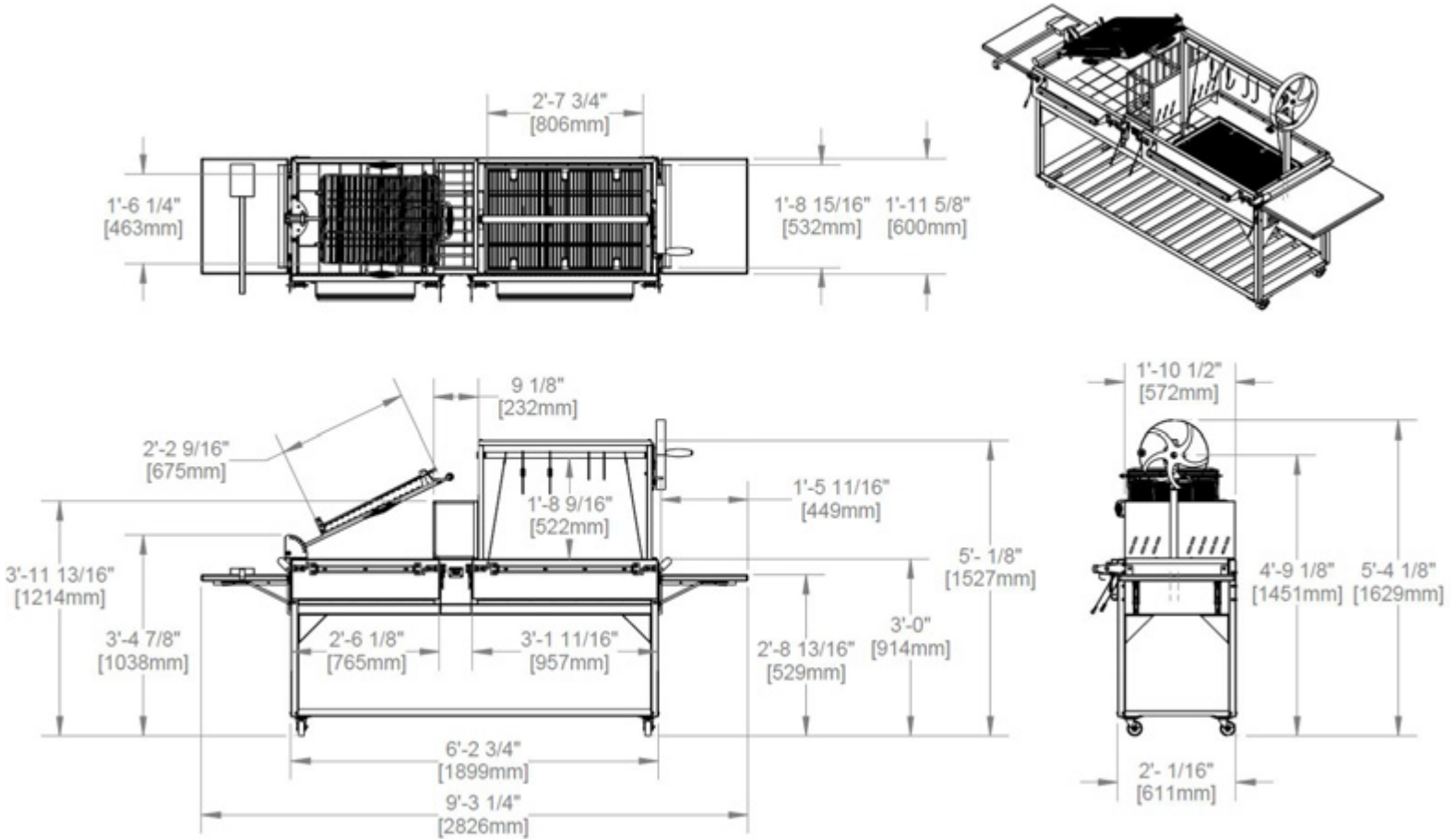

OWNER'S MANUAL - PARTS IDENTIFICATION

METAL COMPONENTS (NOT TO SCALE)

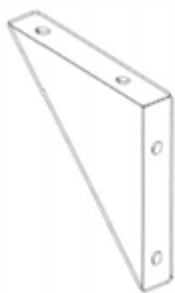

B01 LEG BRACE - A4M02910
(x8) 1"x5 3/4"x5 3/4" (26x146x146)



B02 BOTTOM RACK ASSEMBLY - A4M02767
(x1) 1 5/8"x24 1/16"x74 3/4" (40.5x611.5x1898)

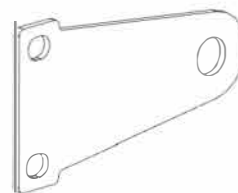

B03 LATCH BRACKET - A4M02413
(x2) 1/8"x2 3/16"x4 1/8" (2.5x56x104)



B05 UPRIGHT CABLE BRACKET - A4M02270
(x2) 1 3/16"x2 15/16"x5 11/16" (30x74.5x143.8)

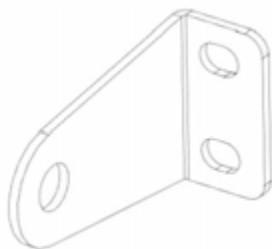

B06 LATCH BRACKET - A4M02765
(x2) 1"x1 3/4"x2 13/16" (25x44x71.0)

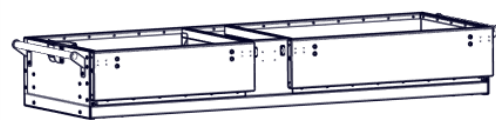

C01 COAL PAN ASSEMBLY - A4M02768
(x1) 11 1/2"x25 9/16"x74 1/2" (292x650x1893)



DC01 DOOR CABLE - A4M02504
(x2) 1/8"x9 7/16" (2.5x240)



F01 FIRE BOX - A4M02772
(x1) 11 11/16"x9 1/8"x22 1/2" (298x232x572)

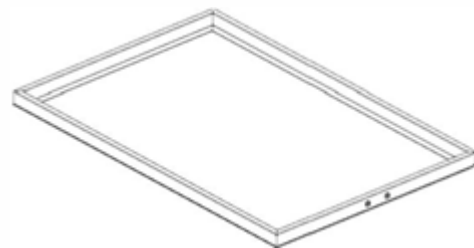

G01 GRATE TRAY ASSEMBLY - A4M02144
(x1) 1 1/4"x21 13/16"x33 1/16" (31.80x554x839)



DC02 DOOR CABLE - A4M04135
(x2) 1/8"x8 11/16" (2.5x220)

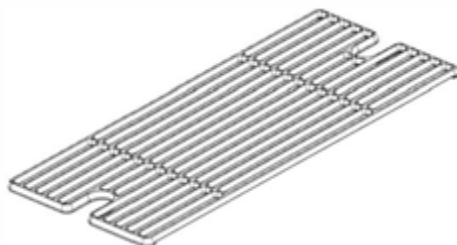

G02 GRATE - A4M02145
(x3) 7/16"x10 1/2"x20 1/2" (12x266x520)



H02 SPROCKET HANDLE ASSEMBLY - A4M02760
(x1) 3 5/8"x4 1/2"x9 5/16" (92x115x236)



H01 DOOR HANDLE ASSEMBLY - A4M02761
(x1) 2 3/8"x3 3/4"x30 1/4" (60x95x769)

OWNER'S MANUAL - PARTS IDENTIFICATION

METAL COMPONENTS (NOT TO SCALE)

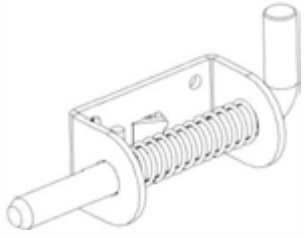

DL01 DOOR LATCH - A4M02496
(x4) 1 5/16"x1 7/8"x4 3/8" (33x47x111)

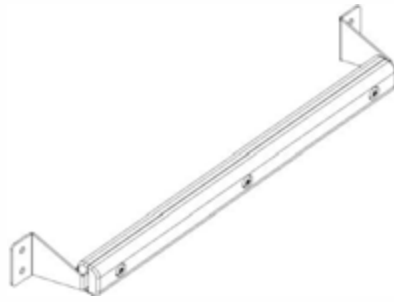

H04 DOOR HANDLE ASSEMBLY - A4M02777
(x1) 2 3/8"x3 3/4"x22 11/16" (60x95x576)



H05 WIRE HANDLE ASSEMBLY - A4M03500
(x3) 1 1/2"x2 11/16"x7 9/16" (38x69x192)



L01 LEG - A4M02912
(x1) 1 1/2"x1 1/2"x31 13/16" (38x38x808)



L02 LEG - A4M02913
(x1) 1 1/2"x1 1/2"x31 13/16" (38x38x808)



L03 LEG - A4M02914
(x1) 1 1/2"x1 1/2"x31 13/16" (38x38x808)



L04 LEG - A4M02915
(x1) 1 1/2"x1 1/2"x31 13/16" (38x38x808)



MH01 MEAT HOOK - A4M02402
(x2) 3/16"x3 7/8"x5 11/16" (5x98x145)



MH02 MEAT HOOK - A4M02407
(x2) 3/16"x3"x8 13/16" (5x77x224)

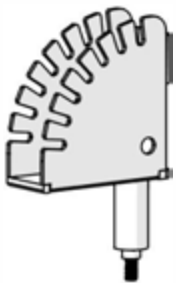

P01 ASADO PIVOT BRACKET - A4M04134
(x1) 1 11/16"x4 7/16"x7 9/16" (43x113x192)



R01 TOP ASADO RACK - A4M02785
(x1) 5/16"x18 3/8"x30 5/16" (8x466x770)



SH01 SHOVEL - A4M02513
(x1) 2 1/4"x4 7/8"x31 5/16" (57x124x798)

OWNER'S MANUAL - PARTS IDENTIFICATION

METAL COMPONENTS (NOT TO SCALE)



R02 BOTTOM ASADO RACK - A4M02786
(x1) 5 7/16"x18 1/2"x34" (138x470x864)



R03 HOLDING ROD - A4M02787
(x1) 1/4"x1 7/16"x21 13/16" (6x36x554)



R04 PIVOT ROD - A4M02784
(x1) 1/2"x1 7/16"x12 1/4" (12x36x312)



S01 SPINDLE ASSEMBLY - A4M02150
(x1) 1 3/16"x37 5/8" (x30x955)



S02 SPROCKET - A4M02147
(x1) 3/16"x4 11/16"x4 11/16" (4x119x119)



S03 SPRING - A4M02506
(x1) 1/16"x7/16"x1 13/16" (1.5x11x46)



U01 UPRIGHT ASSEMBLY - A4M02923
(x1) 2 5/8"x7 7/8"x31 5/8" (67x200x803.2)

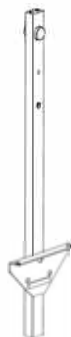

U02 UPRIGHT ASSEMBLY - A4M02759
(x1) 2 5/16"x7 7/8"x31" (58.8x200x788)



U03 TOP RAIL - A4M02149
(x1) 1"x1 1/2"x35 1/4" (25x38x896)



2094 FOLDING TABLE BRACKET - A4M02094
(x4) 1 3/8"x6 13/16"x15 15/16" (34x173x405)



W01 WHEEL ASSEMBLY - A4M02146
(x1) 2 3/8"x7" (x59.7x178)



A4M04136 CASTER
(x4)

OWNER'S MANUAL - PARTS IDENTIFICATION

ACCESSORY COMPONENTS (NOT TO SCALE)



2499 BUSHING - A4M02499
(x6) 1/4"x3/8"x1/4" (6.5x9.7x6.35)



A4M02158 BYD ID TAG PATIO
(x1)

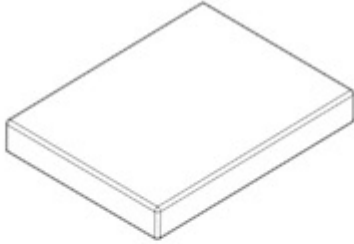

A6P00729 FIRE BRICK
(x66)

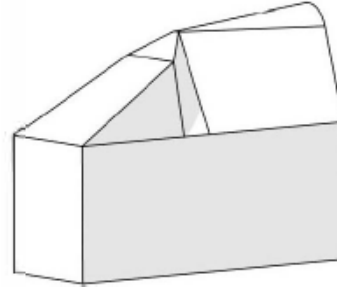

A6P00912 GRILL COVER
(x1)



A4M04045 FLAT WASHER
(x1) 24x35 COPPER

WOOD COMPONENTS (NOT TO SCALE)



T01 TABLE TOP - W4L18241
(x2) 1 1/4"x17 11/16"x23 5/8" (32x450x600)



H04 WHEEL HANDLE - W4L19101
(x1) 1 9/16"x5 1/8" (x40x130)

OWNER'S MANUAL - PARTS IDENTIFICATION

HARDWARE COMPONENTS

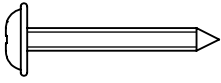

H100797 SCREW PWH
(x12) 8 x 1 BLK



H101264 TORX PAN HEAD
(x86) 1/4-20 x 3/4" BLK (LOCTITE)



H101265 TORX PAN HEAD
(x15) 1/4-20 x 3/4" SS (LOCTITE)

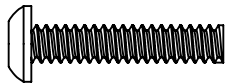

H101279 TORX PAN HEAD
(x6) 1/4-20 x 1" BLK (LOCTITE)



H101282 TORX PAN HEAD
(x6) 1/4-20x1 1/4" SS (LOCTITE)



H101200 TORX PAN HEAD
(x4) 1/4-20 x 2" SS (LOCTITE)

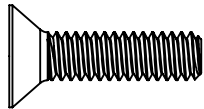

H101266 SCREW TFH
(x6) 1/4-20 x 1 BLK (LOCTITE)

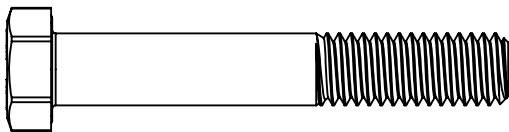

H101302 BOLT WH
(x1) 3/8x2 3/8 SS

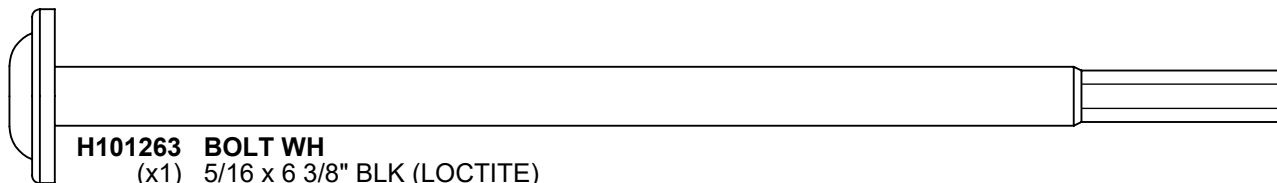

H101263 BOLT WH
(x1) 5/16 x 6 3/8" BLK (LOCTITE)

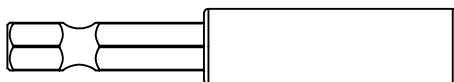

H101100 MAGNETIC DRIVER
(x1)

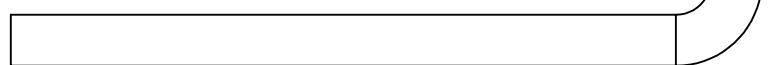

H100114 TORX WRENCH
(x1) T-30

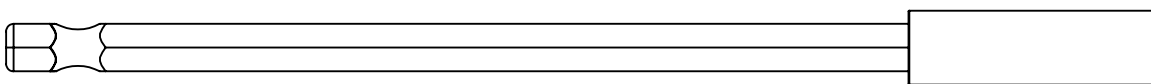

H101278 6" MAGNETIC DRIVER EXTENSION
(x1)

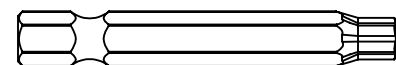

H100147 TORX BIT
(x1) T-30



H101159 PHILLIPS ROUNDED HEAD
(x16) 8-18 x 1/2" BLK



H101262 PHILLIPS ROUNDED HEAD
(x4) 8-18x.5 SS



H101273 HEX JAM NUT
(x1) 1/4-20 SS (LOCTITE)

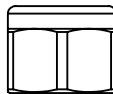

H101274 NUT LOCK
(x3) 3/8-16 SS

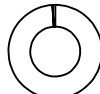

H101182 WASHER SPLIT
(x5) 1/4 SS

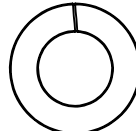

H101301 WASHER SPLIT
(x1) 3/8 SS



H101303 COTTER PIN SS
(x1)



H101183 WASHER FLAT
(x26) 8x16 SS

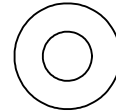

H101280 WASHER FLAT
(x92) 7x14 SS

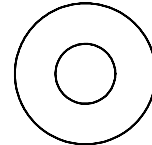

H100630 WASHER FLAT
(x2) 8x19 BLK

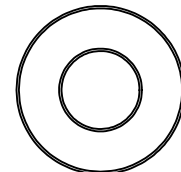

H101299 WASHER FLAT
(x3) 10x22 SS

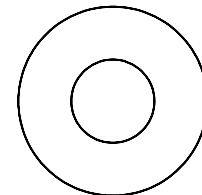

H101167 WASHER FLAT
(x1) 11x25 BLK

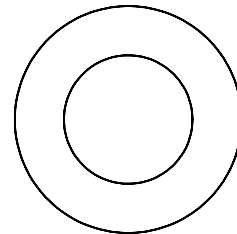

H100497 WASHER FLAT
(x1) 17x30 BLK

PRE-ASSEMBLY STEP 1 - SORTING PARTS

It is critical for ease of assembly that you take the time to sort and organize the metal and hardware.

METAL PARTS:

- Organize metal parts by the three-digit, alpha-numeric part label on each bag (ex. A01).
- If there are multiple parts with the same part label, stack those pieces together.
- Part labels can be found on the bags of the parts.
- Keep parts in bags until required step.
- Allow yourself plenty of room - the metal pieces can take up a significant amount of space.

NOTE: CARTONS ARE NOT ORGANIZED BY PART OR STEP NUMBER.

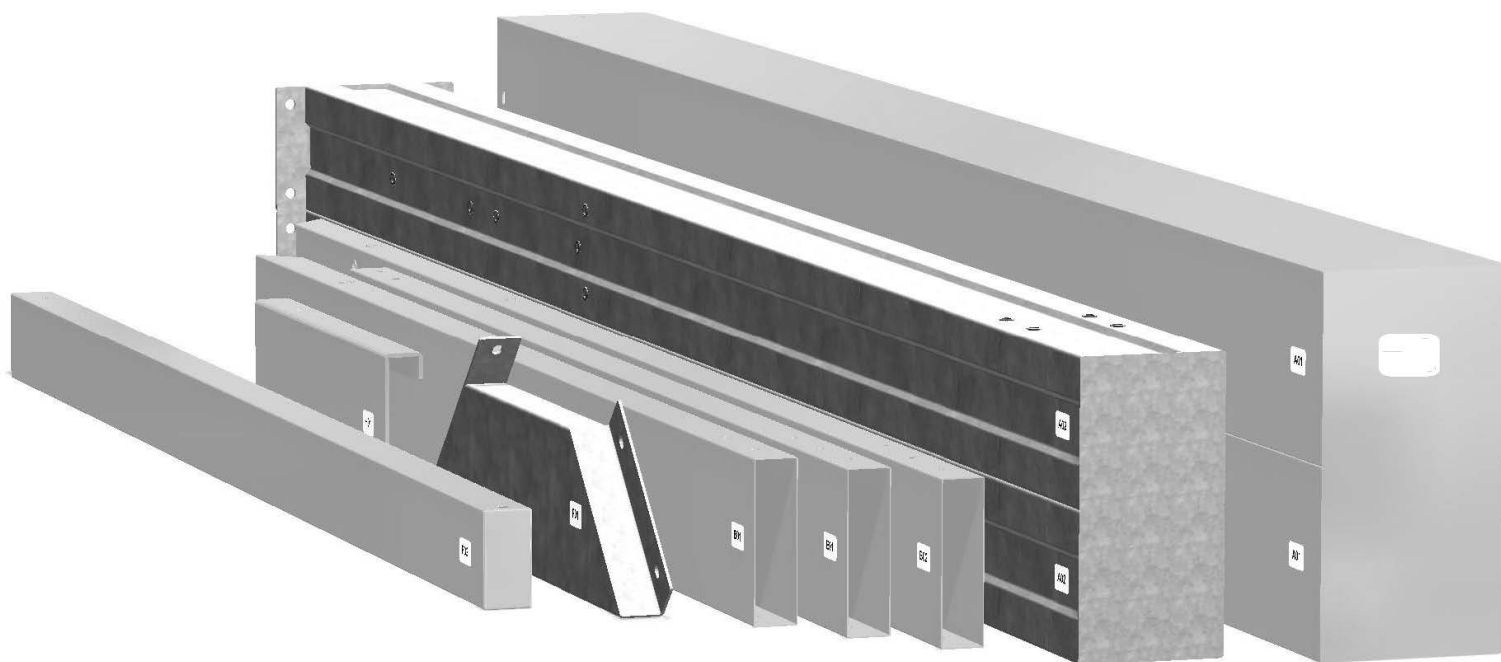

HARDWARE PARTS:

- We recommend that you have a separate table to organize the hardware.
- Hardware bags are printed with a seven-digit, alpha-numeric part number.
- You can organize your hardware by part number or group by hardware type (e.g. bolts, nuts, etc.).
- During assembly you only need to reference the last four digits of the number.

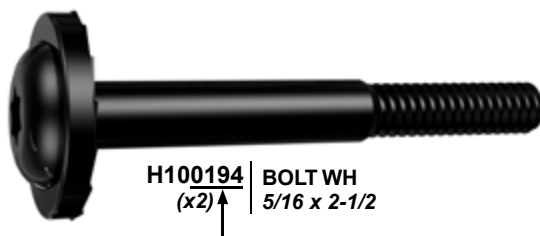

PRE-ASSEMBLY STEP 2 - TOOLS REQUIRED



Cordless Drill
or Electric Drill



Drill
Attachments:
Phillips Head

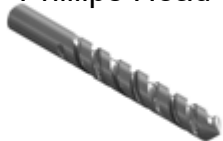

1/8", 3/16", 3/8" &
7/16" Drill Bits



Phillips Screw Driver



Open End
Wrenches
1/2" & 9/16"



3/8" Drive Ratchet, 1/2" &
7/16" STD Sockets 1/2" & 7/16"
Deep Sockets



Claw Hammer



Rubber Mallet
- Optional



Tape Measure

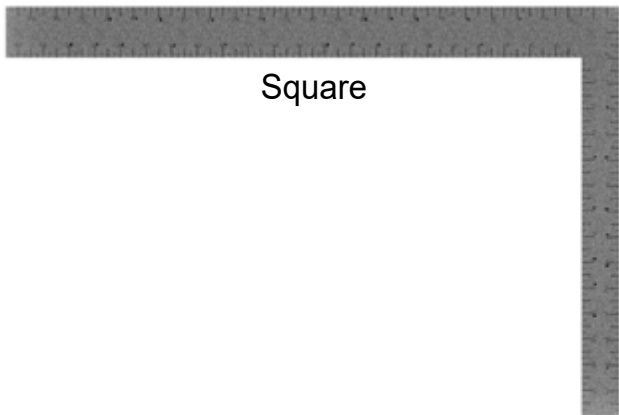

Square



Level 24"

PRE-ASSEMBLY STEP 3 - CHOOSE YOUR ASSEMBLY METHOD

There are several types of assembly instructions available to you.

1. Printed Assembly Manual included with your set
2. BILT APP - 3D interactive instructions
3. Combination of the Printed Manual and BILT APP (Note: Step numbers can differ between the two methods)

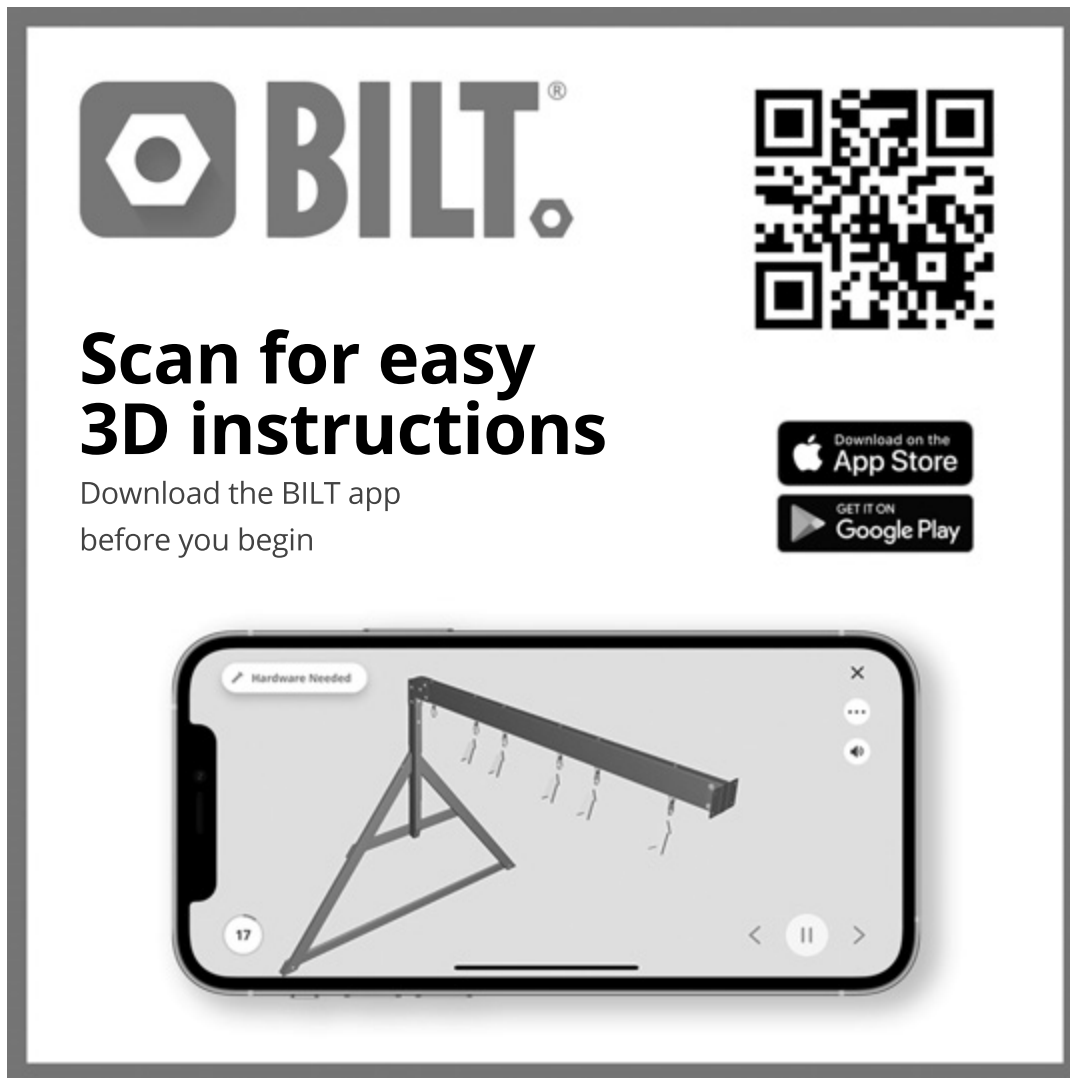

The graphic features the BILT logo (a hexagon with a bolt head inside) and the text "BILT.®" in a bold, sans-serif font. To the right is a large QR code. Below the logo, the text "Scan for easy 3D instructions" is written in a large, bold font. Underneath this, it says "Download the BILT app before you begin". To the right of this text are two buttons: "Download on the App Store" and "GET IT ON Google Play". At the bottom, a smartphone screen displays a 3D assembly instruction for step 17, showing a metal frame with a horizontal bar being attached. The screen includes a "Hardware Needed" list, a close button (X), a menu button (three dots), a back button (left arrow), a play/pause button (II), and a forward button (right arrow).

STEP 1A - CART ASSEMBLY

QTY	PART NUMBER	DESCRIPTION
1	H101266	SCREW TFH 1/4-20 X 1 BLK (LOCTITE)

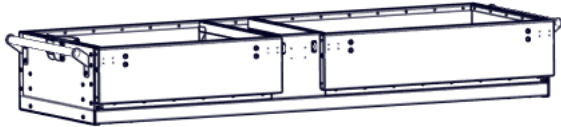

C01 COAL PAN ASSEMBLY - A4M02768
(x1) 11 1/2"x25 9/16"x74 1/2" (292x650x1893)



L03 LEG - A4M02914
(x1) 1 1/2"x1 1/2"x31 13/16" (38x38x808)

- PLACE COAL PAN ASSEMBLY UPSIDE DOWN AND ATTACH LEG AS SHOWN BELOW.
- FOR EASE OF ASSEMBLY, WE RECOMMEND USING SAW HORSES FOR STEPS 1-6.
- IF ASSEMBLING ON THE GROUND, LAY A PIECE OF CARDBOARD, BLANKET, OR RUG DOWN BEFORE SETTING COAL PAN ASSEMBLY UPSIDE DOWN.

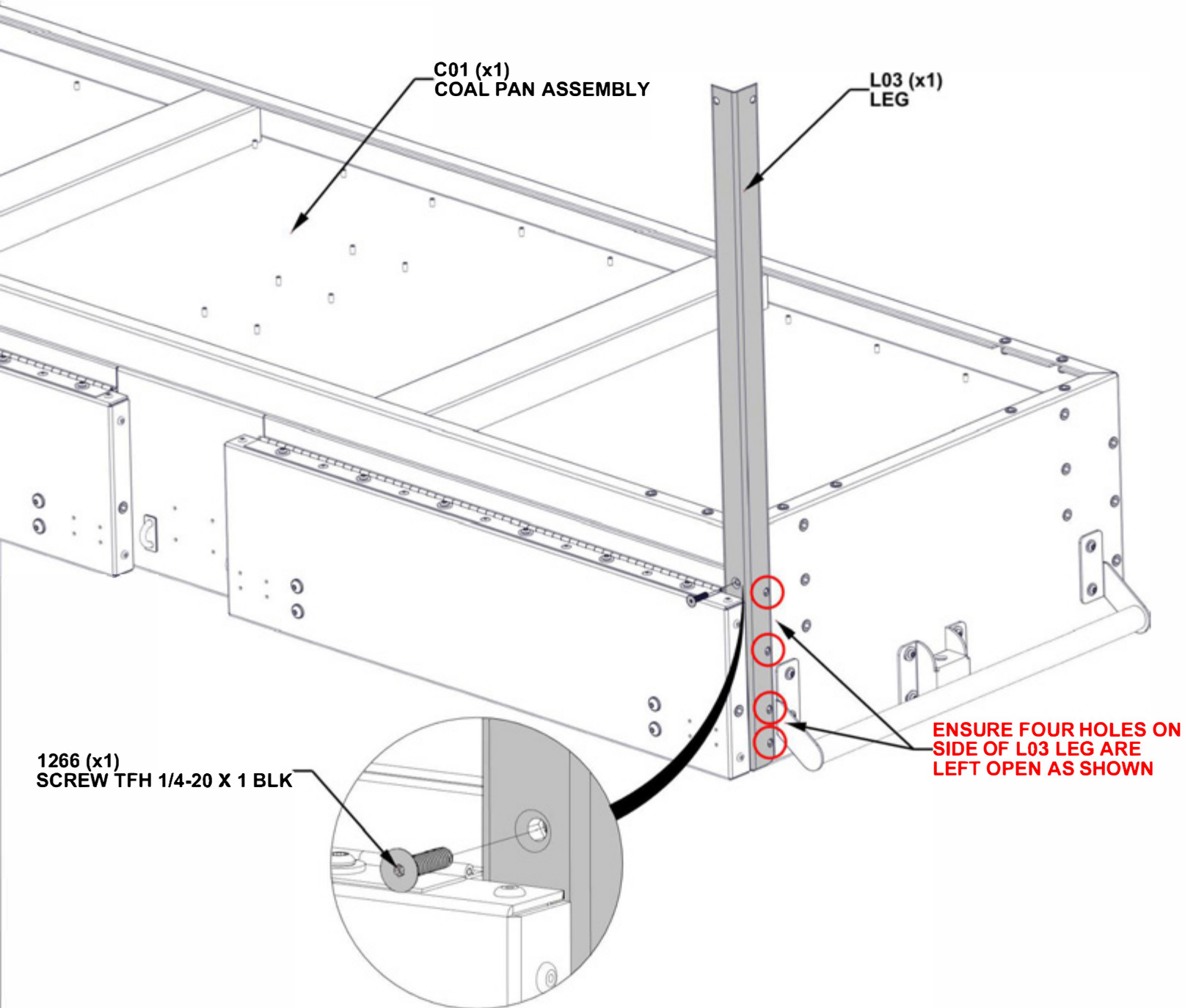

STEP 1B - CART ASSEMBLY

QTY	PART NUMBER	DESCRIPTION
2	H101264	TORX PAN HEAD 1/4-20x3/4" BLK (LOCTITE)
2	H101266	SCREW TFH 1/4-20 X 1 BLK (LOCTITE)
2	H101280	WASHER FLAT 7x14 SS

- OPEN COAL PAN ASSEMBLY DOOR AND ATTACH LEG HARDWARE AS SHOWN BELOW.

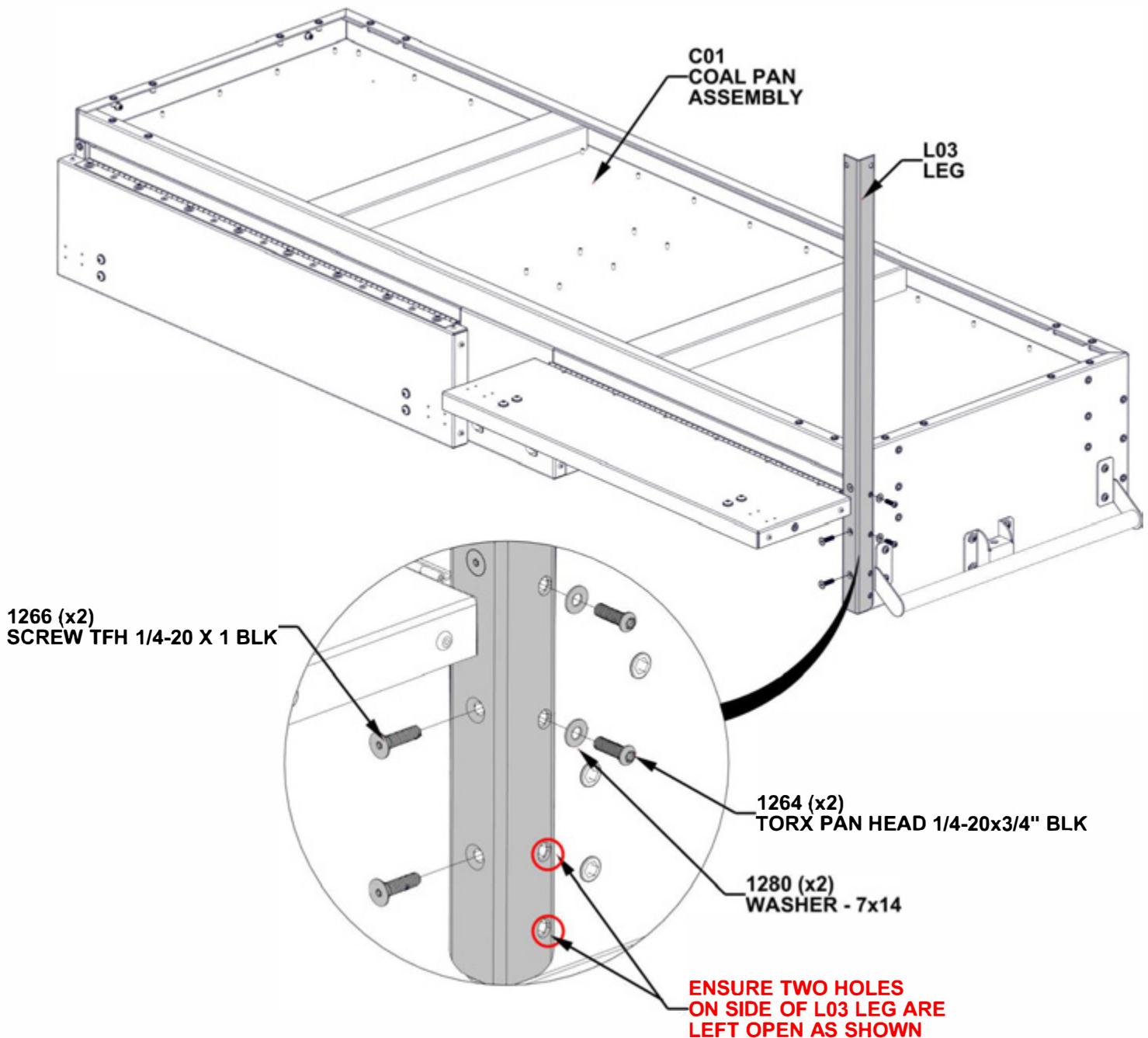

STEP 2A - CART ASSEMBLY



QTY	PART NUMBER	DESCRIPTION
2	H101264	TORX PAN HEAD 1/4-20x3/4" BLK (LOCTITE)
1	H101266	SCREW TFH 1/4-20 X 1 BLK (LOCTITE)
2	H101280	WASHER FLAT 7x14 SS

L04 LEG - A4M02915
 (x1) 1 1/2"x1 1/2"x31 13/16" (38x38x808)

- POSITION LEG AS SHOWN BELOW. ENSURE BOLTS ARE INSERTED IN THE CORRECT HOLES SHOWN BELOW.

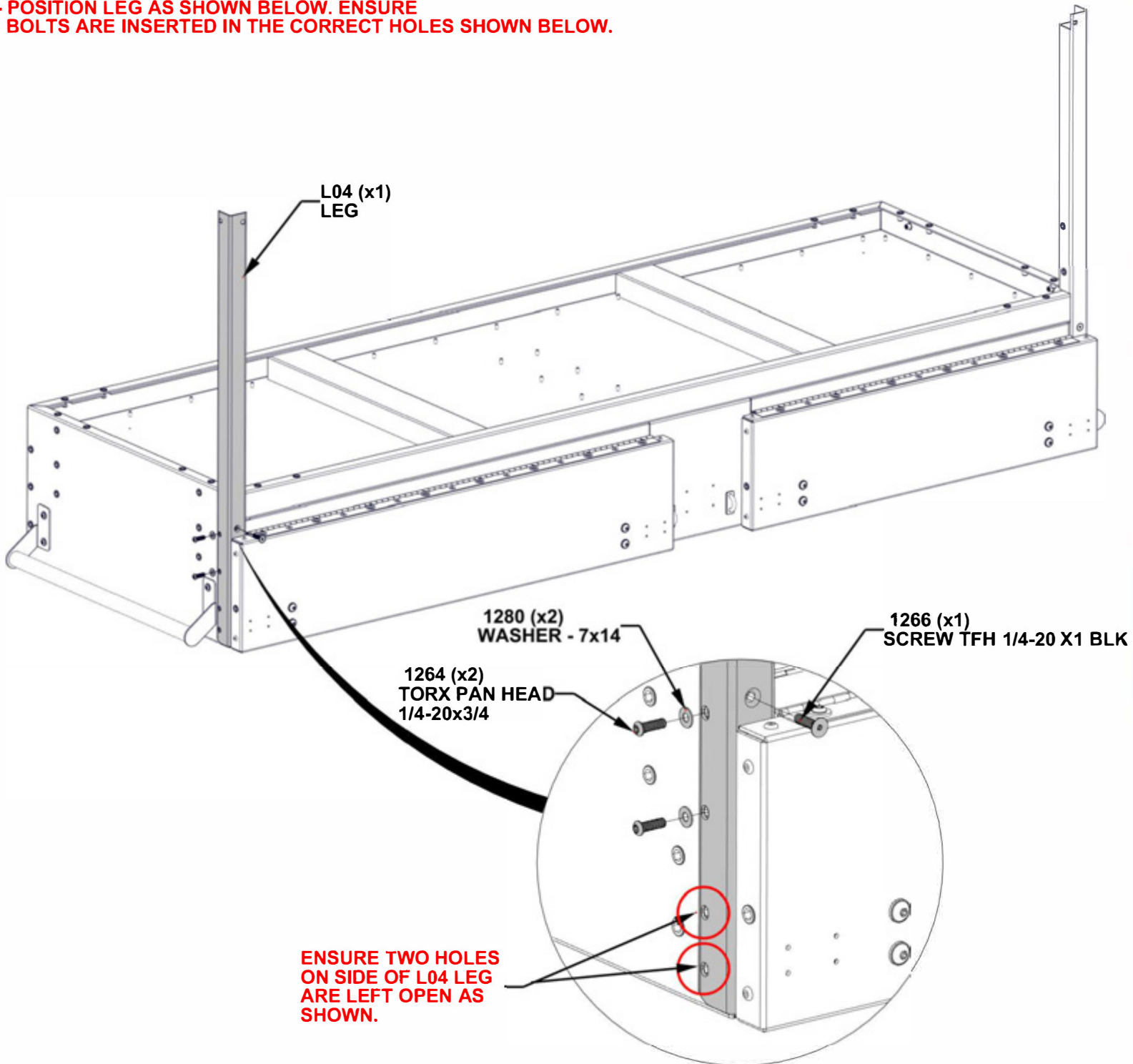

STEP 2B - CART ASSEMBLY

QTY	PART NUMBER	DESCRIPTION
2	H101266	SCREW TFH 1/4-20 X 1 BLK (LOCTITE)

- OPEN COAL PAN ASSEMBLY DOOR AND ATTACH LEG HARDWARE AS SHOWN BELOW.

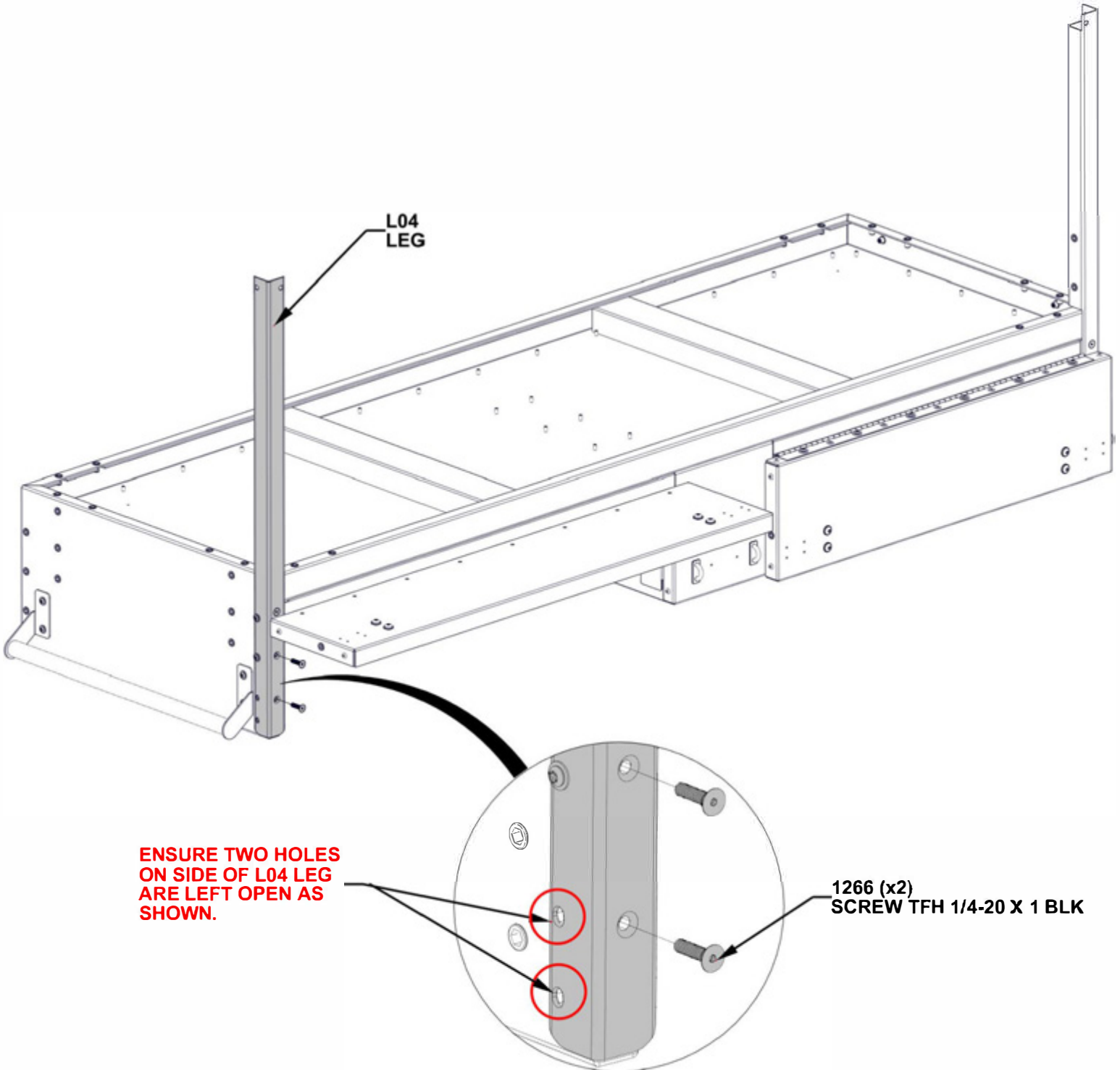

STEP 3 - CART ASSEMBLY

QTY	PART NUMBER	DESCRIPTION
12	H101264	TORX PAN HEAD 1/4-20x3/4" BLK (LOCTITE)
12	H101280	WASHER FLAT 7x14 SS



L02 LEG - A4M02913
(x1) 1 1/2"x1 1/2"x31 13/16" (38x38x808)



L01 LEG - A4M02912
(x1) 1 1/2"x1 1/2"x31 13/16" (38x38x808)

- INSTALL BACK LEGS AS SHOWN BELOW.

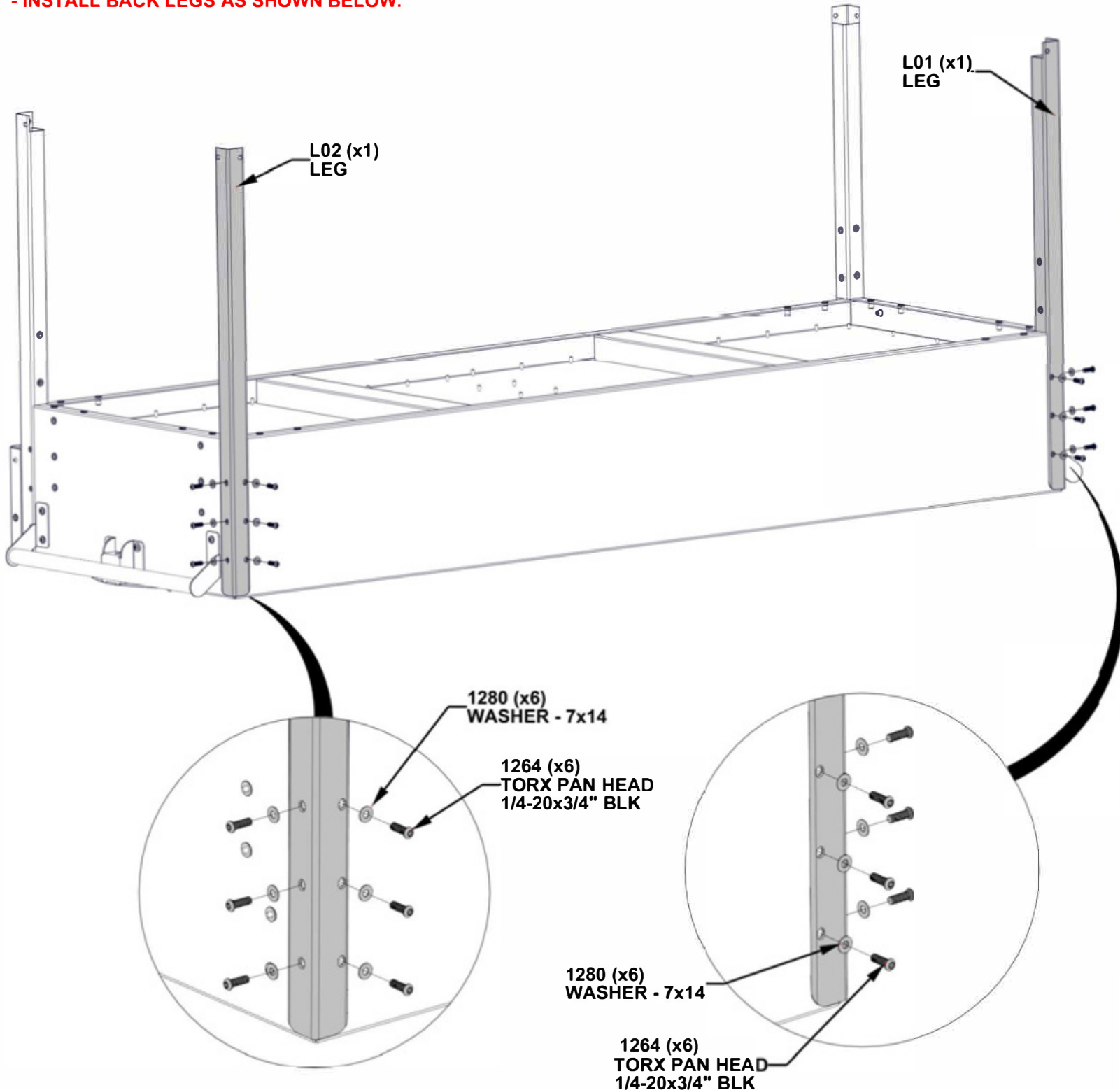

STEP 4 - CART ASSEMBLY



QTY	PART NUMBER	DESCRIPTION
8	H101264	TORX PAN HEAD 1/4-20x3/4" BLK (LOCTITE)
8	H101280	WASHER FLAT 7x14 SS

B02 BOTTOM RACK ASSEMBLY - A4M02767
(x1) 1 5/8"x24 1/16"x74 3/4" (40.5x611.5x1898)

- INSTALL BOTTOM RACK ASSEMBLY AS SHOWN BELOW.

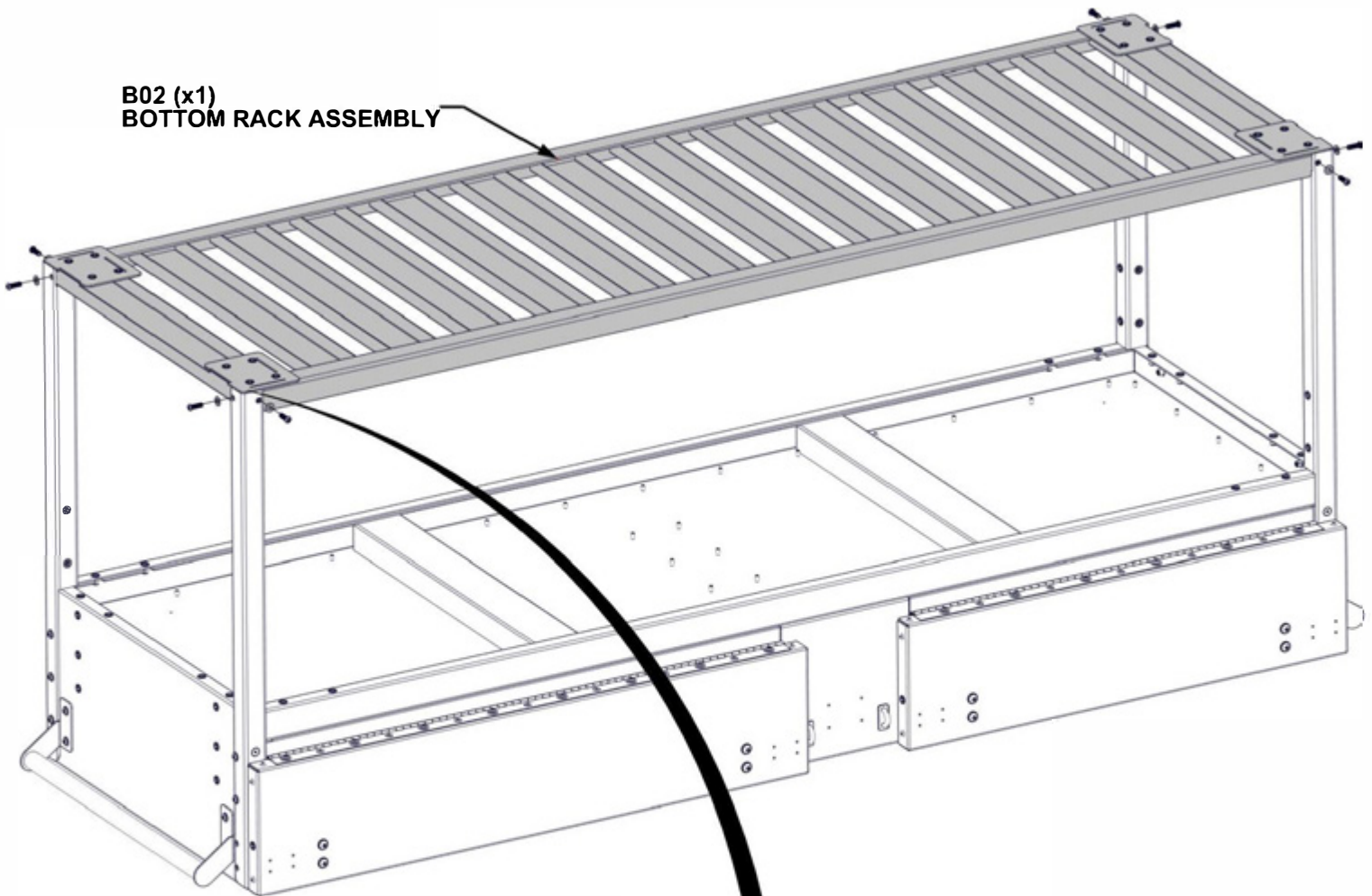

**B02 (x1)
BOTTOM RACK ASSEMBLY**

**CART LEGS
WILL REST ON
SURFACE OF RACK**

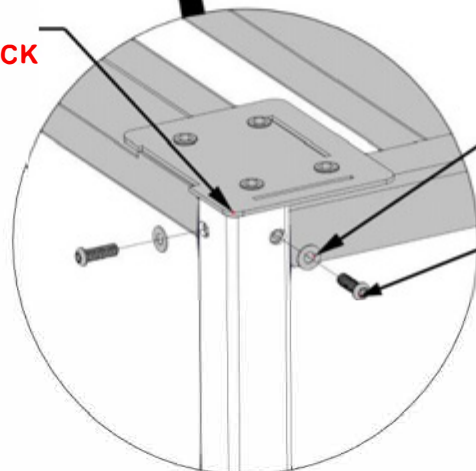

**1280 (x8)
WASHER - 7x14**

**1264 (x8)
TORX PAN HEAD
1/4-20x3/4" BLK**

STEP 5 - CART ASSEMBLY

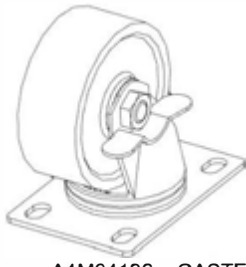

A4M04136 CASTER
(x4)

QTY	PART NUMBER	DESCRIPTION
16	H101264	TORX PAN HEAD 1/4-20x3/4" BLK (LOCTITE)
16	H101280	WASHER FLAT 7x14 SS

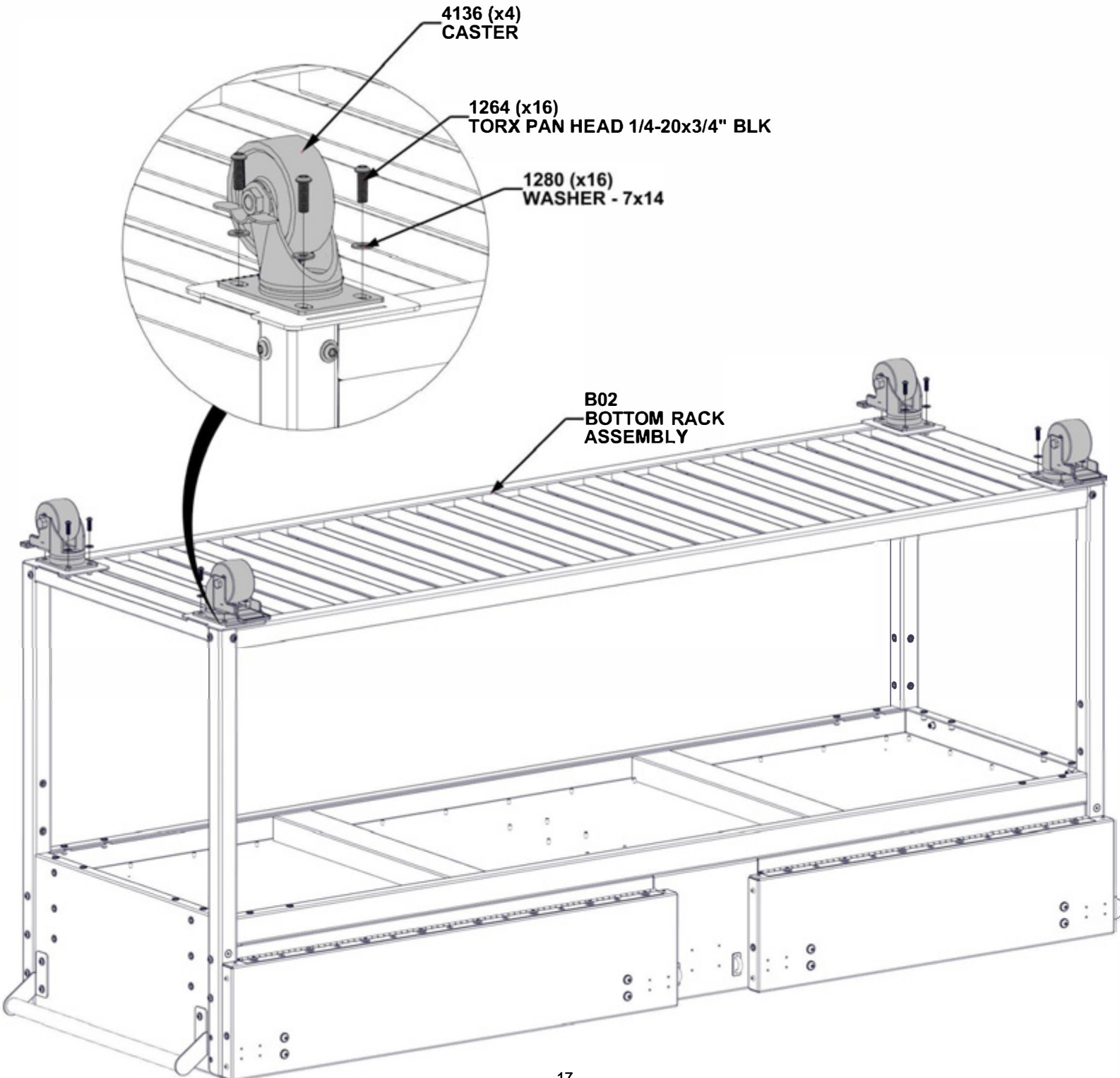

STEP 6 - CART ASSEMBLY

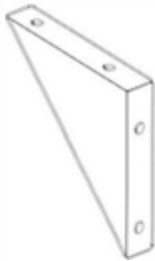

B01 LEG BRACE - A4M02910
(x8) 1"x5 3/4"x5 3/4" (26x146x146)

QTY	PART NUMBER	DESCRIPTION
32	H101264	TORX PAN HEAD 1/4-20x3/4" BLK (LOCTITE)
32	H101280	WASHER FLAT 7x14 SS

- ONCE ALL LEG BRACES ARE ATTACHED, TIGHTEN HARDWARE.

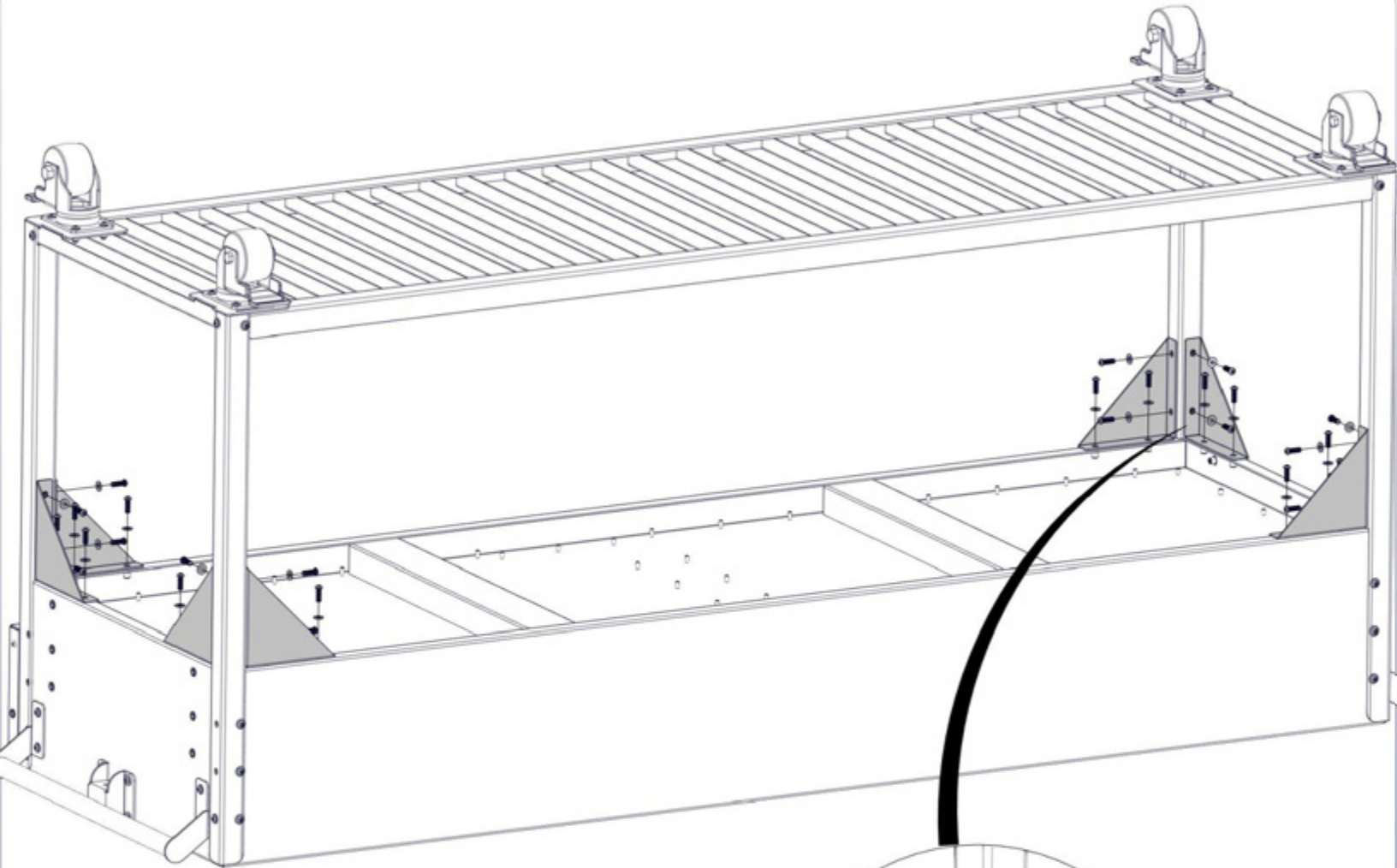

1264 (x32)
TORX PAN HEAD 1/4-20x3/4" BLK

1280 (x32)
WASHER - 7x14

B01 (x8)
LEG BRACE

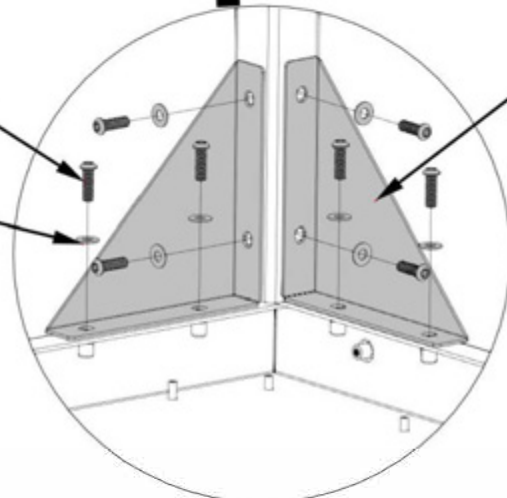

STEP 7 - CART ASSEMBLY

QTY	PART NUMBER	DESCRIPTION
16	H101159	PHILLIPS ROUND HEAD 8-18x.5

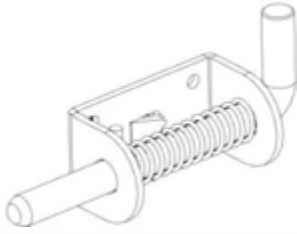

DL01 DOOR LATCH - A4M02496
(x4) 1 5/16"x1 7/8"x4 3/8" (33x47x111)

- WITH AT LEAST TWO PEOPLE, SET CART ASSEMBLY ON ALL FOUR CASTERS.
- ATTACH DOOR LATCHES AS SHOWN.
- REPEAT THIS STEP TWO TIMES ON EACH DOOR.
- ALIGN DOOR LATCH WITH PILOT HOLES IN DOOR.

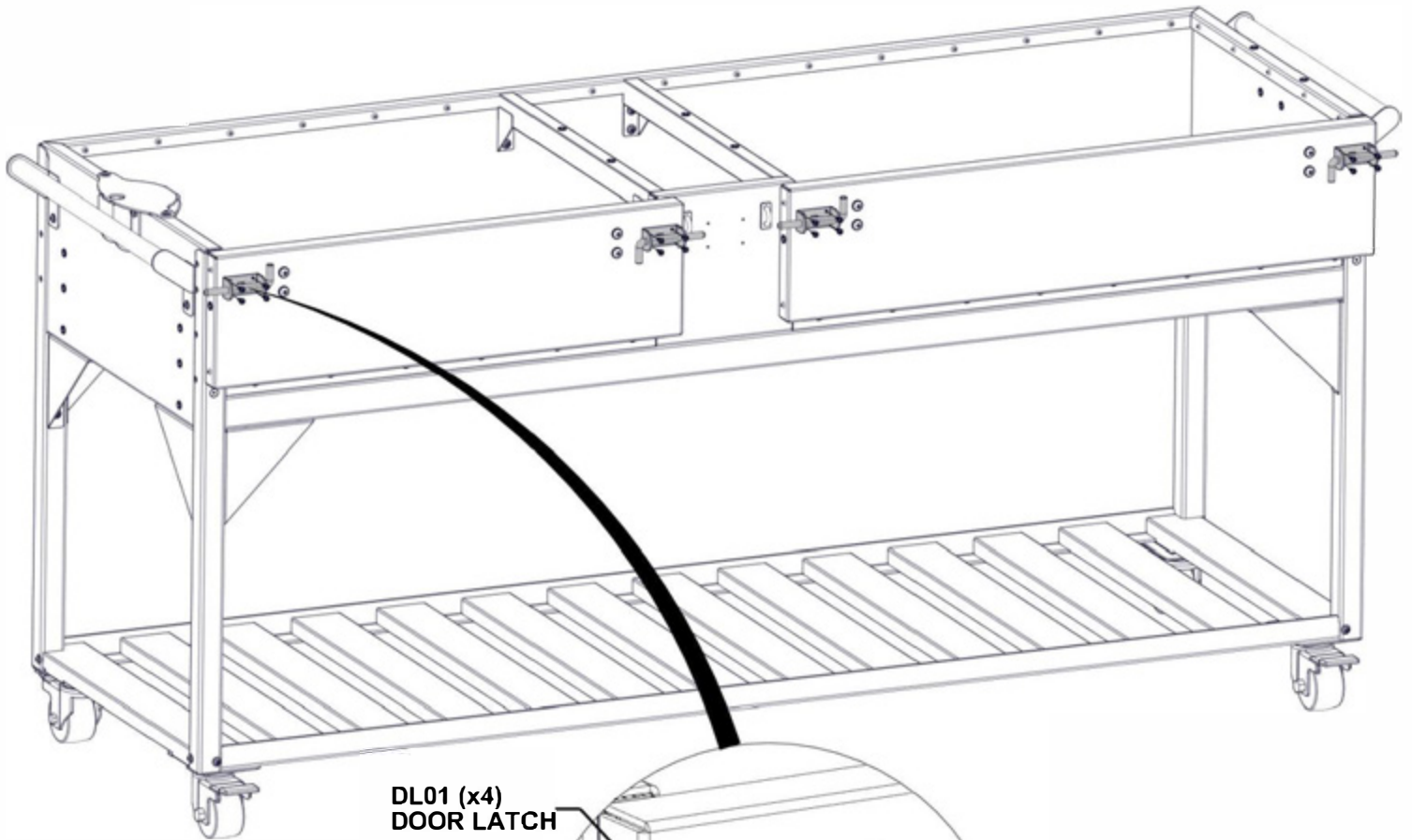

DL01 (x4)
DOOR LATCH

1159 (x16)
PHILLIPS ROUND HEAD 8-18x.5

STEP 8 - CART ASSEMBLY

QTY	PART NUMBER	DESCRIPTION
2	H101264	TORX PAN HEAD 1/4-20x3/4" BLK (LOCTITE)
4	H101279	TORX PAN HEAD 1/4-20x1" (LOCTITE)
6	H101280	WASHER FLAT 7x14 SS



DC01 DOOR CABLE - A4M02504
(x2) 1/8"x9 7/16" (2.5x240)



A4M02499 BUSHING
(x4)

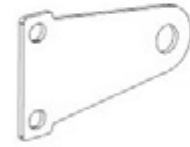

B03 LATCH BRACKET - A4M02413
(x2) 1/8"x2 3/16"x4 1/8" (2.5x56x104)

**- ATTACH LATCH BRACKETS AS SHOWN.
- REPEAT THIS STEP FOR BOTH SIDES OF THE COAL BOX.**

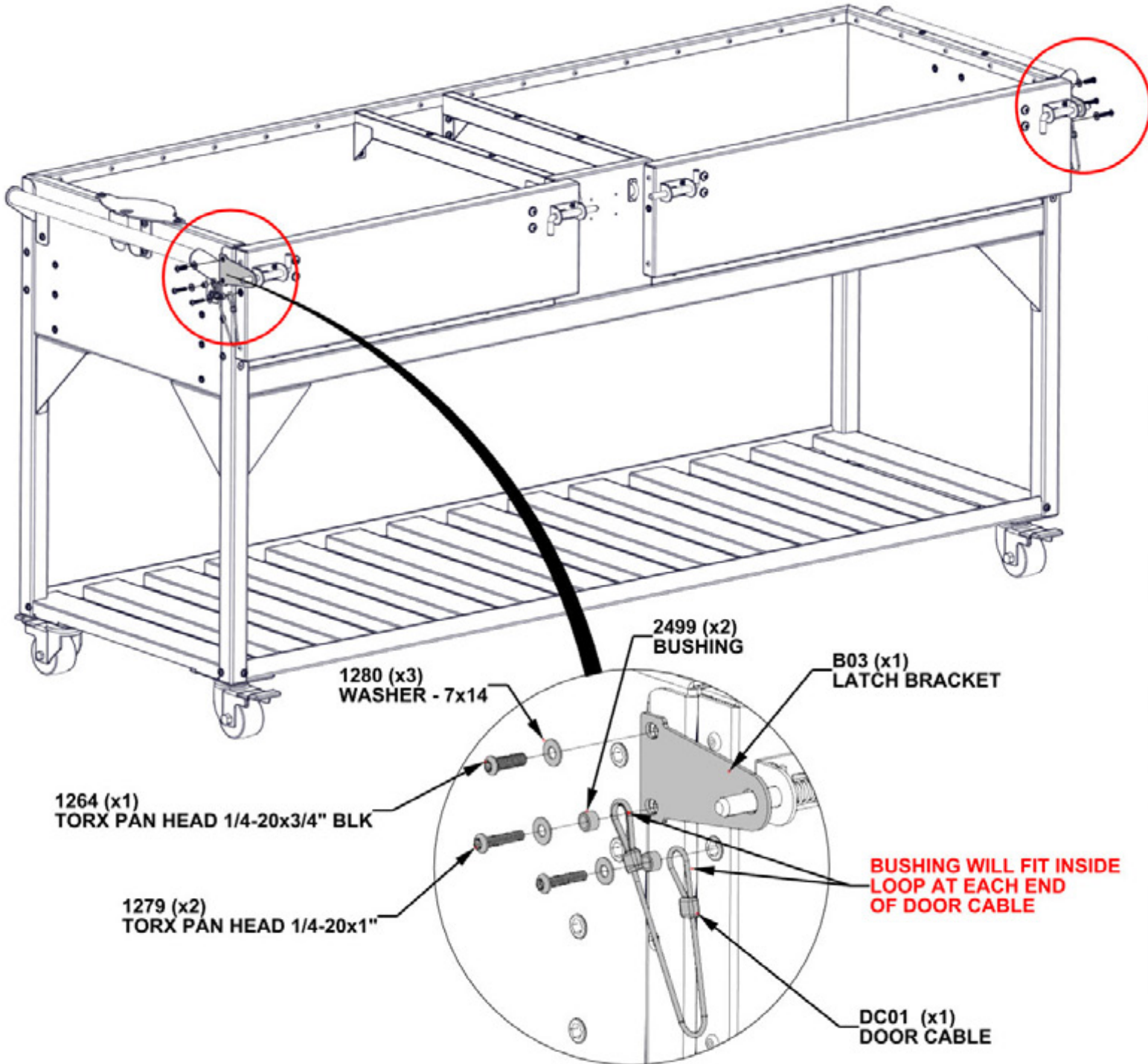

STEP 9A - CART ASSEMBLY

- REMOVE NUT 1273, WASHER 1182, U-BOLT 1283, AND SHIMS FROM THE COAL BOX ASSEMBLY.
- HARDWARE WILL BE USED IN THE FOLLOWING STEPS.

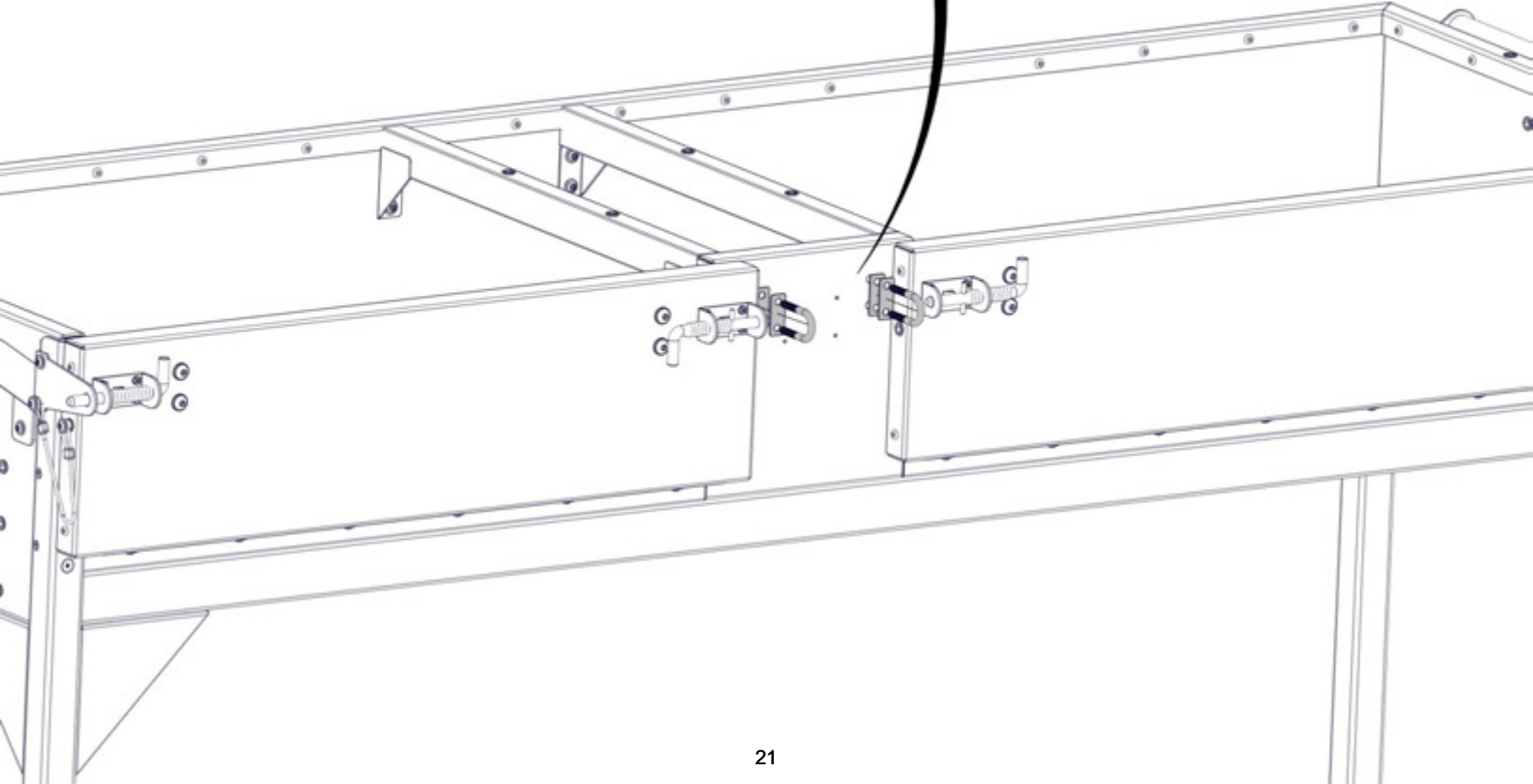
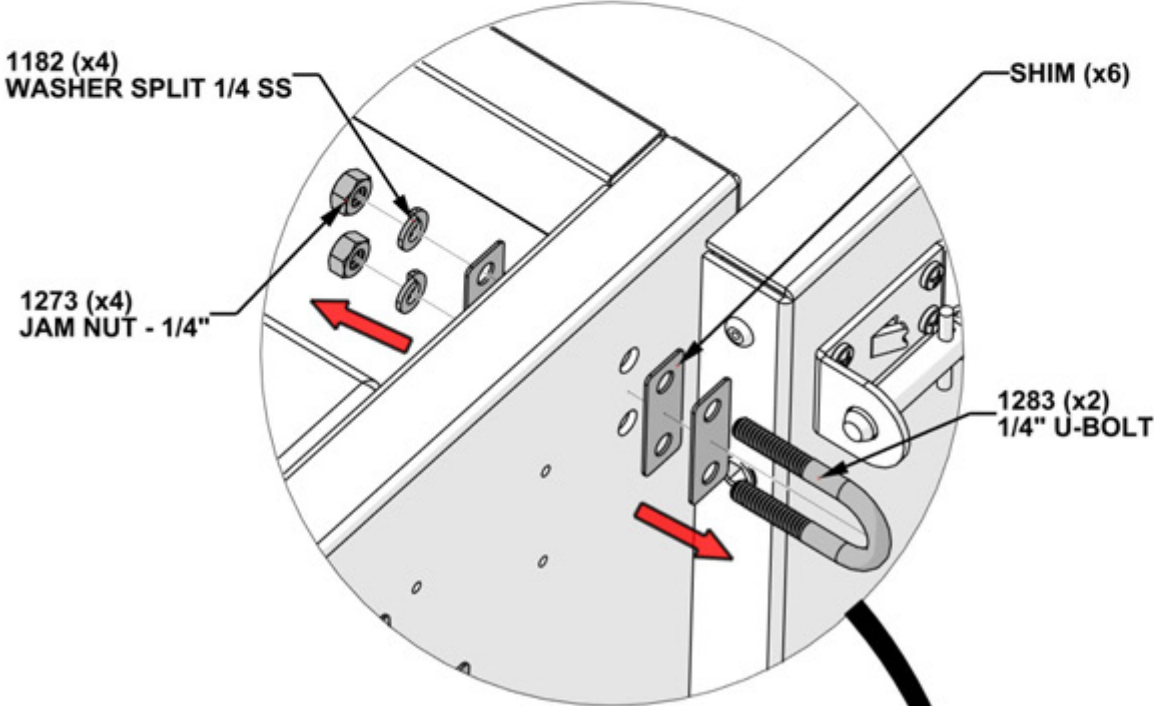

STEP 9B - CART ASSEMBLY

QTY	PART NUMBER	DESCRIPTION
4	H101182	WASHER SPLIT 1/4 SS
4	H101273	HEX JAM NUT 1/4"-20 SS (LOCTITE)
2	H101283	1/4" U-BOLT

NOTE: USE HARDWARE FROM STEP 9A



DC02 DOOR CABLE - A4M03415
(x2) 1/8"x8 11/16" (2.5x220)

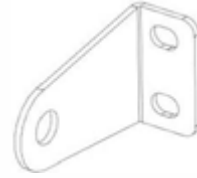

B06 LATCH BRACKET - A4M02765
(x2) 1"x1 3/4"x2 13/16" (25x44x71.0)

- ATTACH ONE END OF DOOR CABLE TO U-BOLT, BEFORE ATTACHING TO LATCH BRACKET.
- RE-ATTACH HARDWARE FROM PREVIOUS STEP.

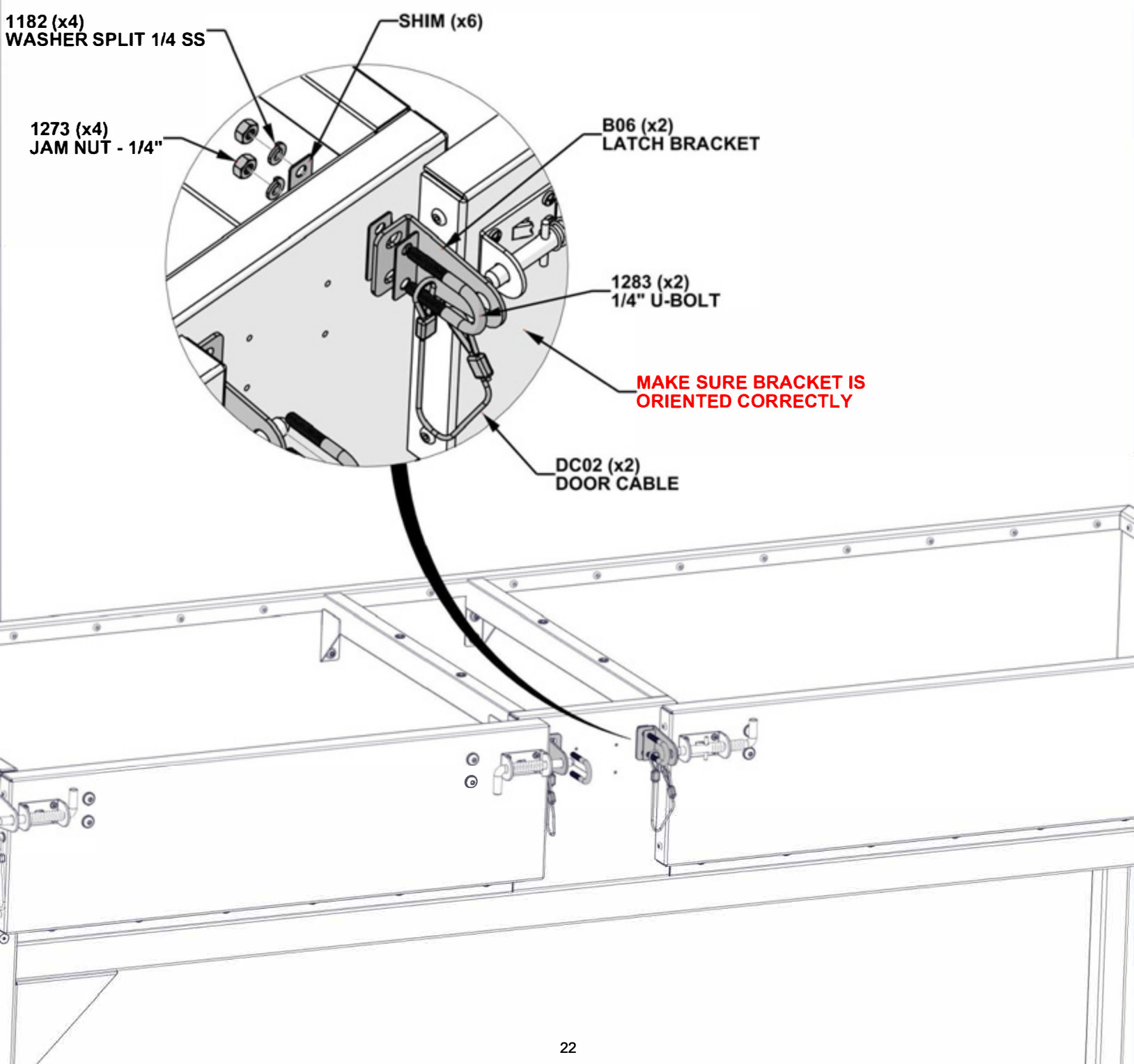

STEP 9C - CART ASSEMBLY



A4M02499 BUSHING
(x2)

QTY	PART NUMBER	DESCRIPTION
2	H101279	TORX PAN HEAD 1/4-20x1" (LOCTITE)
2	H101280	WASHER FLAT 7x14 SS

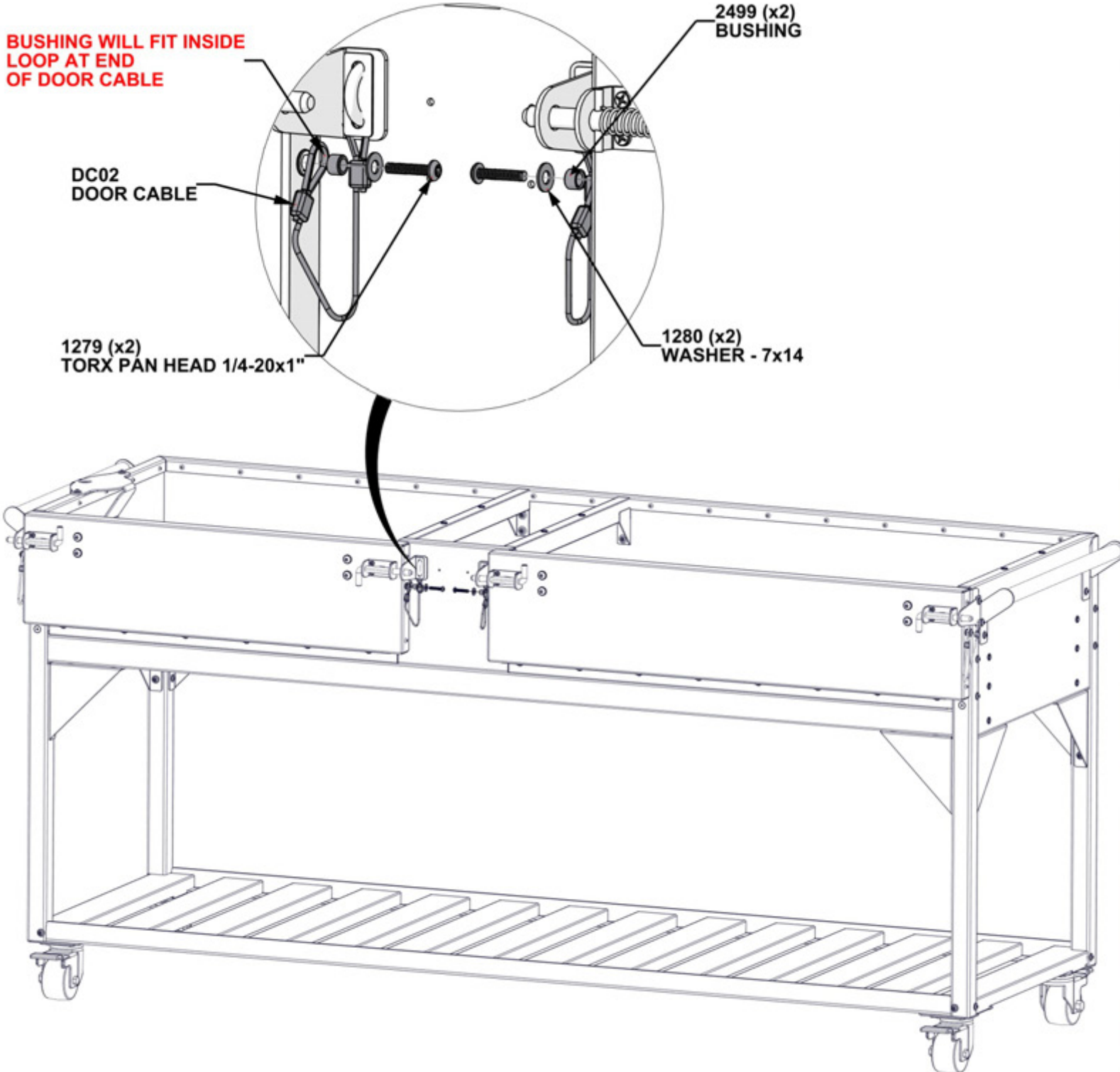

STEP 10A - CART ASSEMBLY

REMOVE THE 8 FACTORY ASSEMBLED BOLTS FROM THE FRONT OF THE COAL PAN DOOR. KEEP HARDWARE TO BE USED IN NEXT STEP TO ATTACH HANDLES.

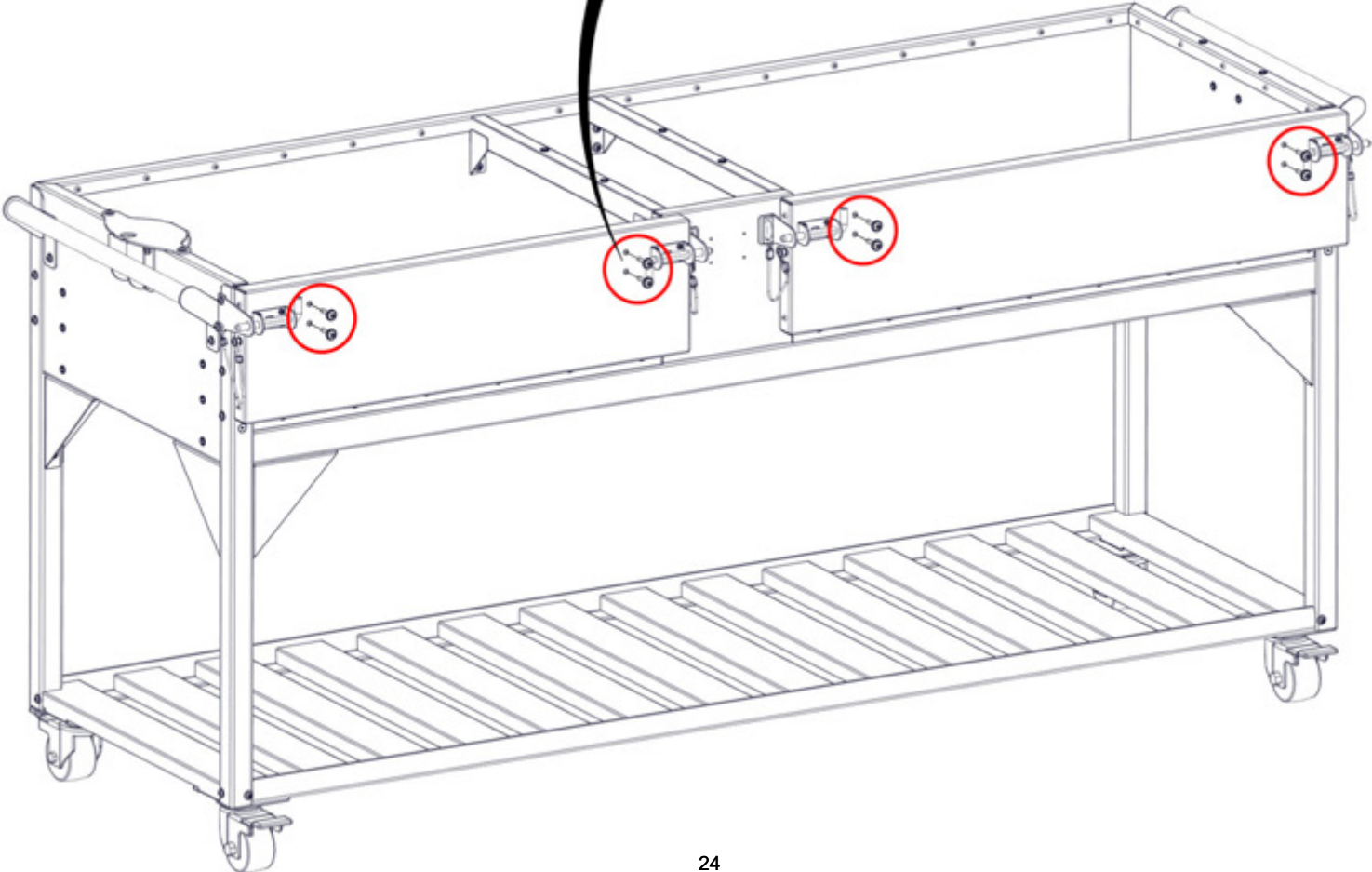
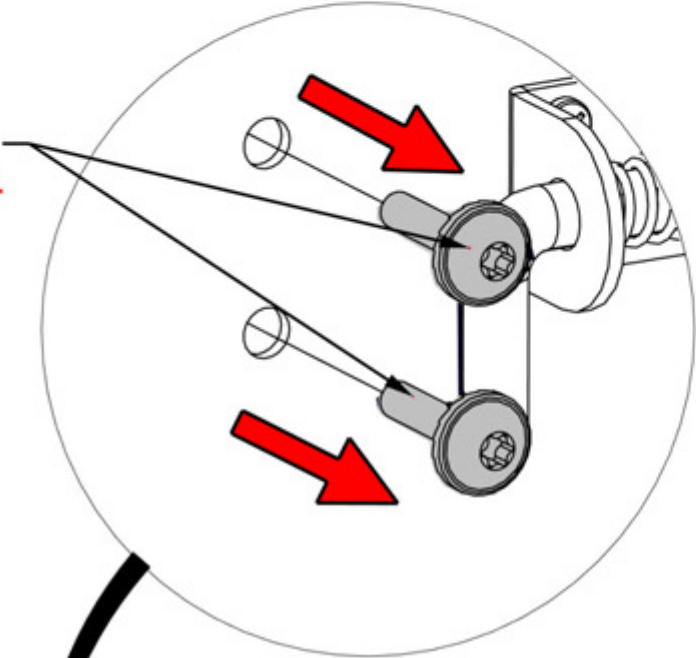

STEP 10B - CART ASSEMBLY

QTY	PART NUMBER	DESCRIPTION
8	H101277	BOLT WH 1/4x1 BLK (LOCTITE)

NOTE: USE HARDWARE FROM STEP 10A

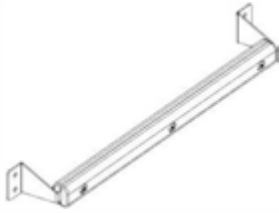

H04 DOOR HANDLE ASSEMBLY - A4M02777
(x1) 2 3/8"x3 3/4"x22 11/16" (60x95x576)



H01 DOOR HANDLE ASSEMBLY - A4M02761
(x1) 2 3/8"x3 3/4"x30 1/4" (60x95x769)

- USING BOLTS FROM PREVIOUS STEPS, ATTACH DOOR HANDLES AS SHOWN BELOW.

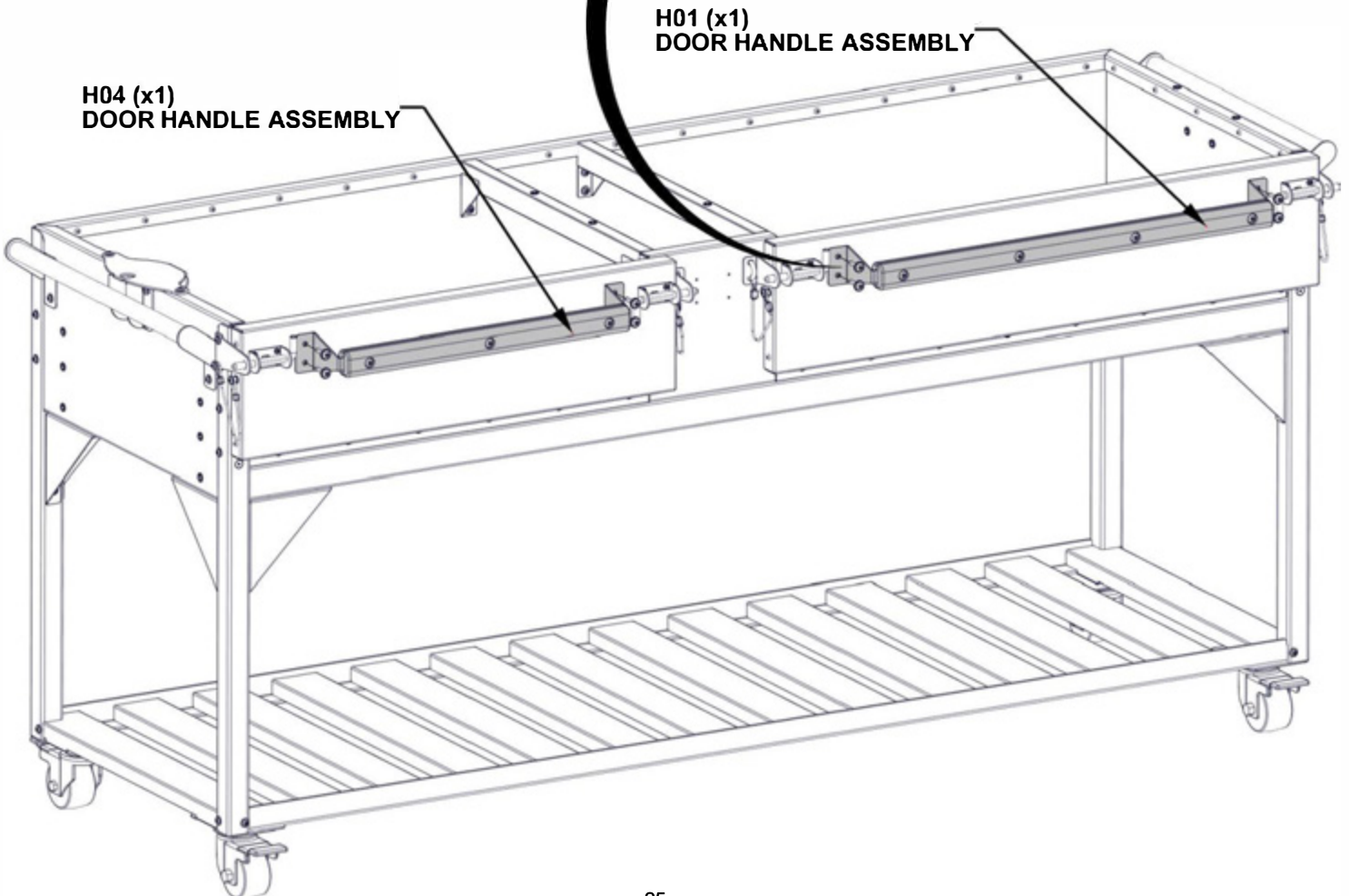
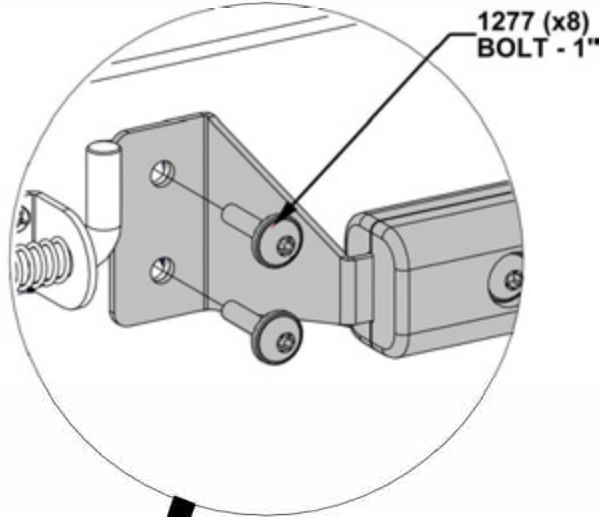

STEP 11 - CART ASSEMBLY

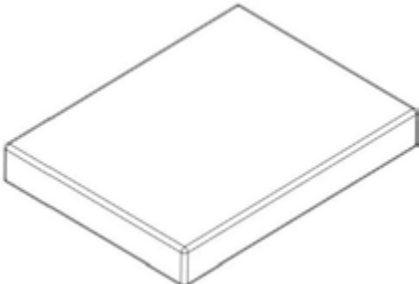

A6P00729 FIRE BRICK
(x66)

- PLACE ALL FIRE BRICKS IN THE GRILL CART.
- ENSURE BRICKS ARE ORIENTED AS SHOWN.
- EVENLY SPACE ALL BRICKS

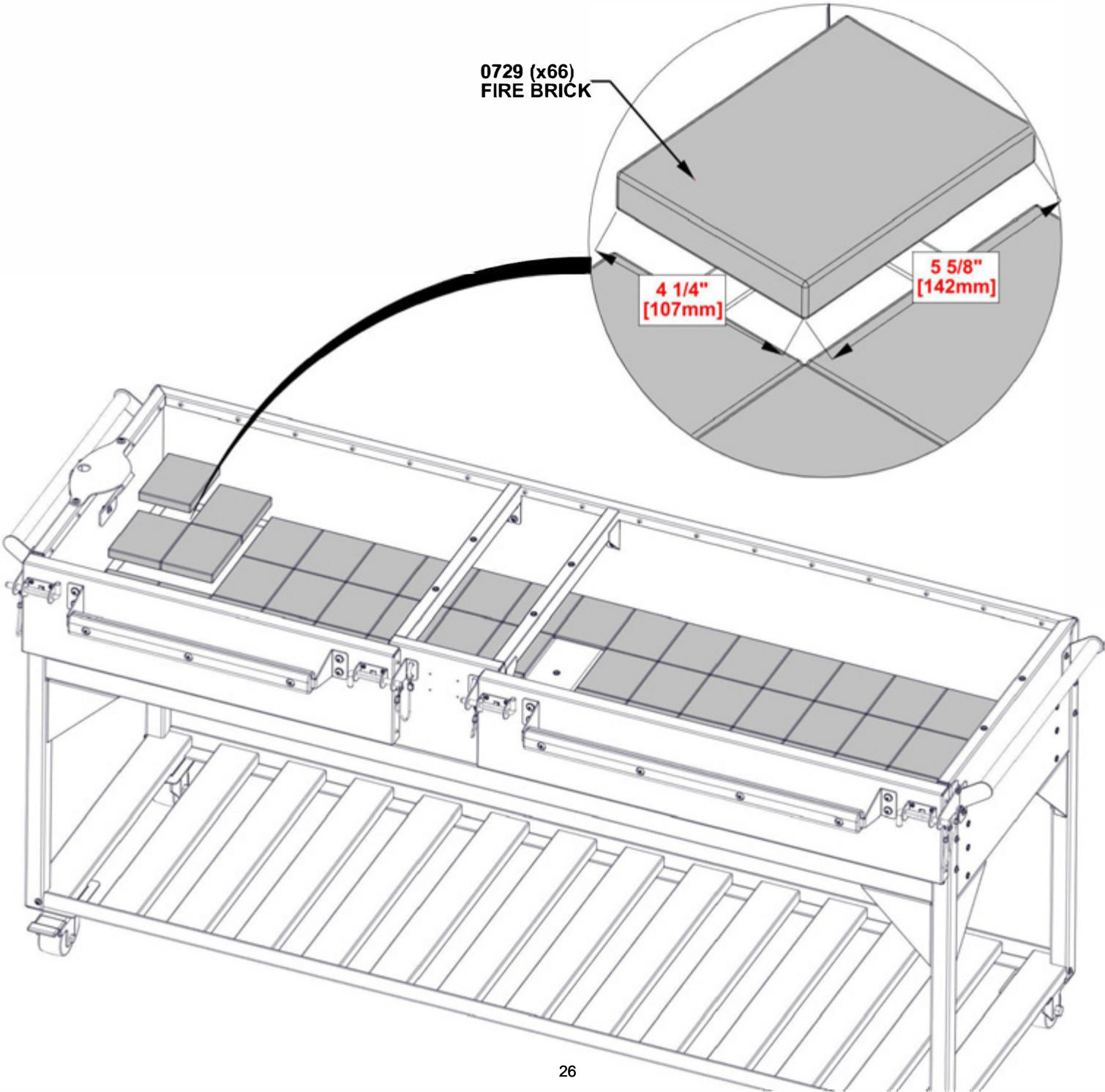

STEP 12 - CART ASSEMBLY



U02 UPRIGHT ASSEMBLY - A4M02759
 (x1) 2 5/16"x7 7/8"x31" (58.8x200x788)

QTY	PART NUMBER	DESCRIPTION
4	H101183	WASHER FLAT 8x16 SS
4	H101265	TORX PAN HEAD 1/4-20x3/4" SS (LOCTITE)

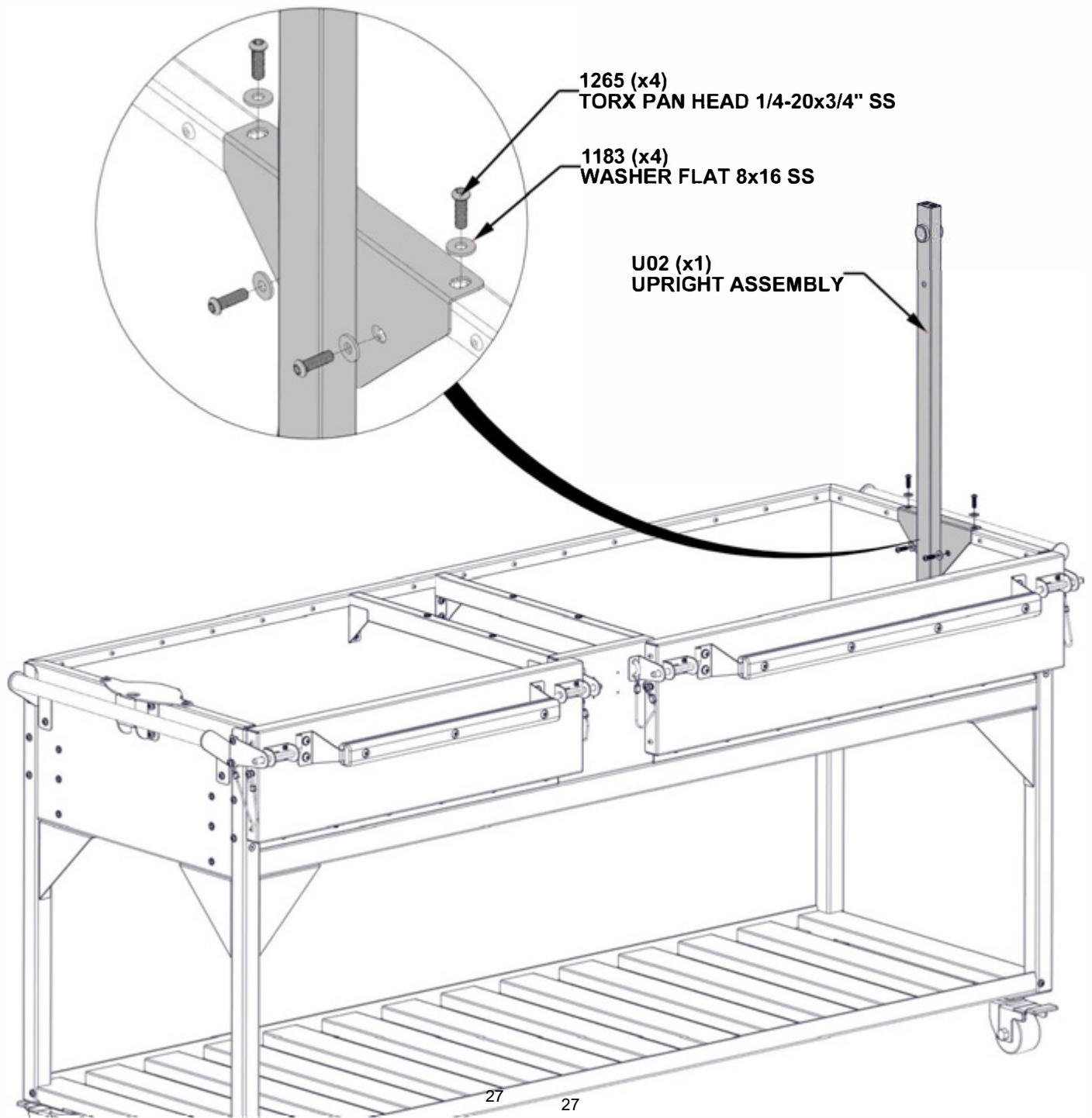

STEP 13 - CART ASSEMBLY



S01 SPINDLE ASSEMBLY - A4M02150
(x1) 1 3/16"x37 5/8" (30x955)



U01 UPRIGHT ASSEMBLY - A4M02923
(x1) 2 5/8"x7 7/8"x31 5/8" (67x200x803.2)

- ATTACH SPINDLE AND UPRIGHT ASSEMBLY BY SLIDING IN PLACE.
- SHAFT END OF SPINDLE WILL ATTACH TO U02 UPRIGHT ASSEMBLY.

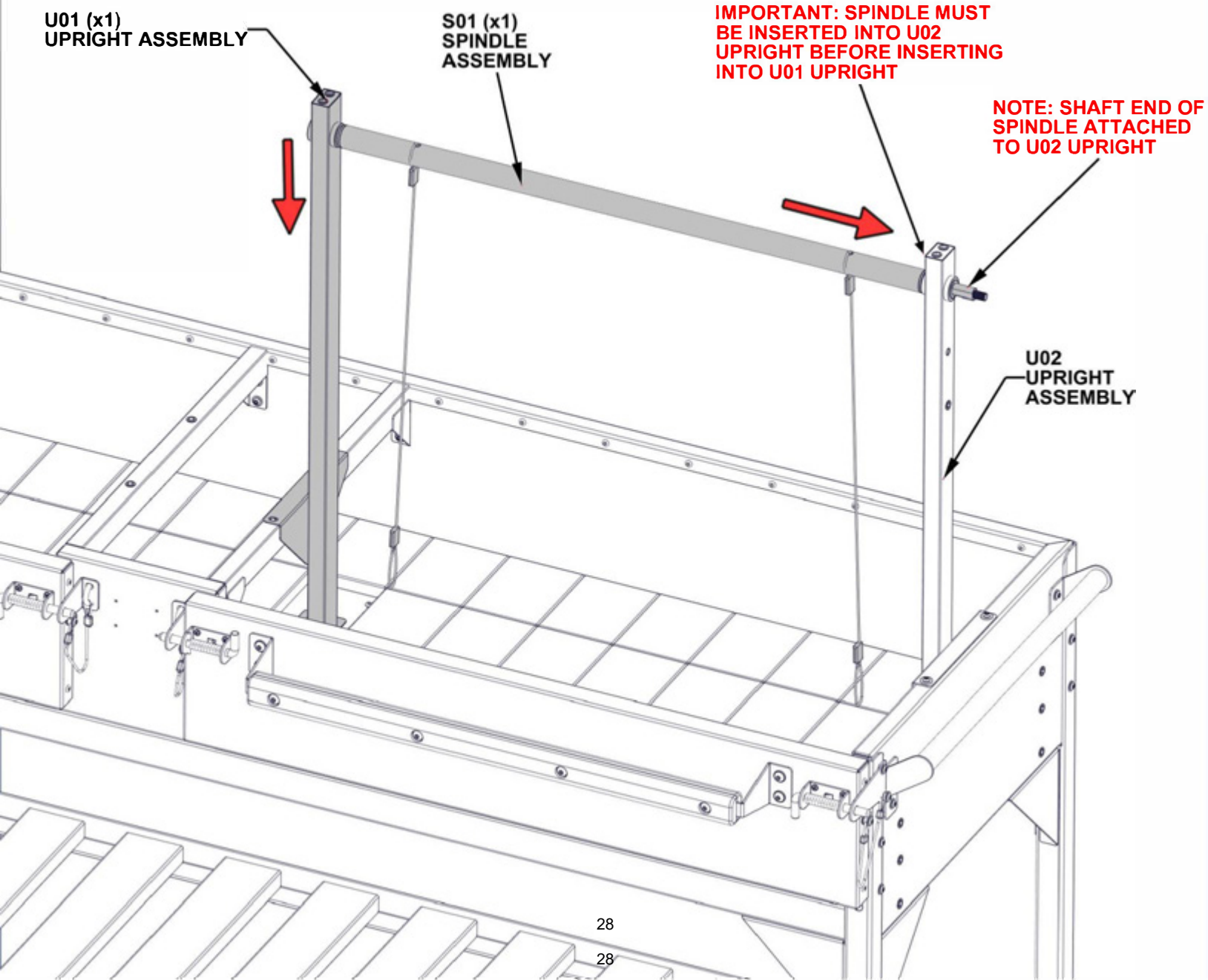

STEP 14 - CART ASSEMBLY



U03 TOP RAIL - A4M02149
(x1) 1"x1 1/2"x35 1/4" (25x38x896)

QTY	PART NUMBER	DESCRIPTION
4	H101183	WASHER FLAT 8x16 SS
4	H101200	TORX PAN HEAD 1/4-20x2 SS (LOCTITE)

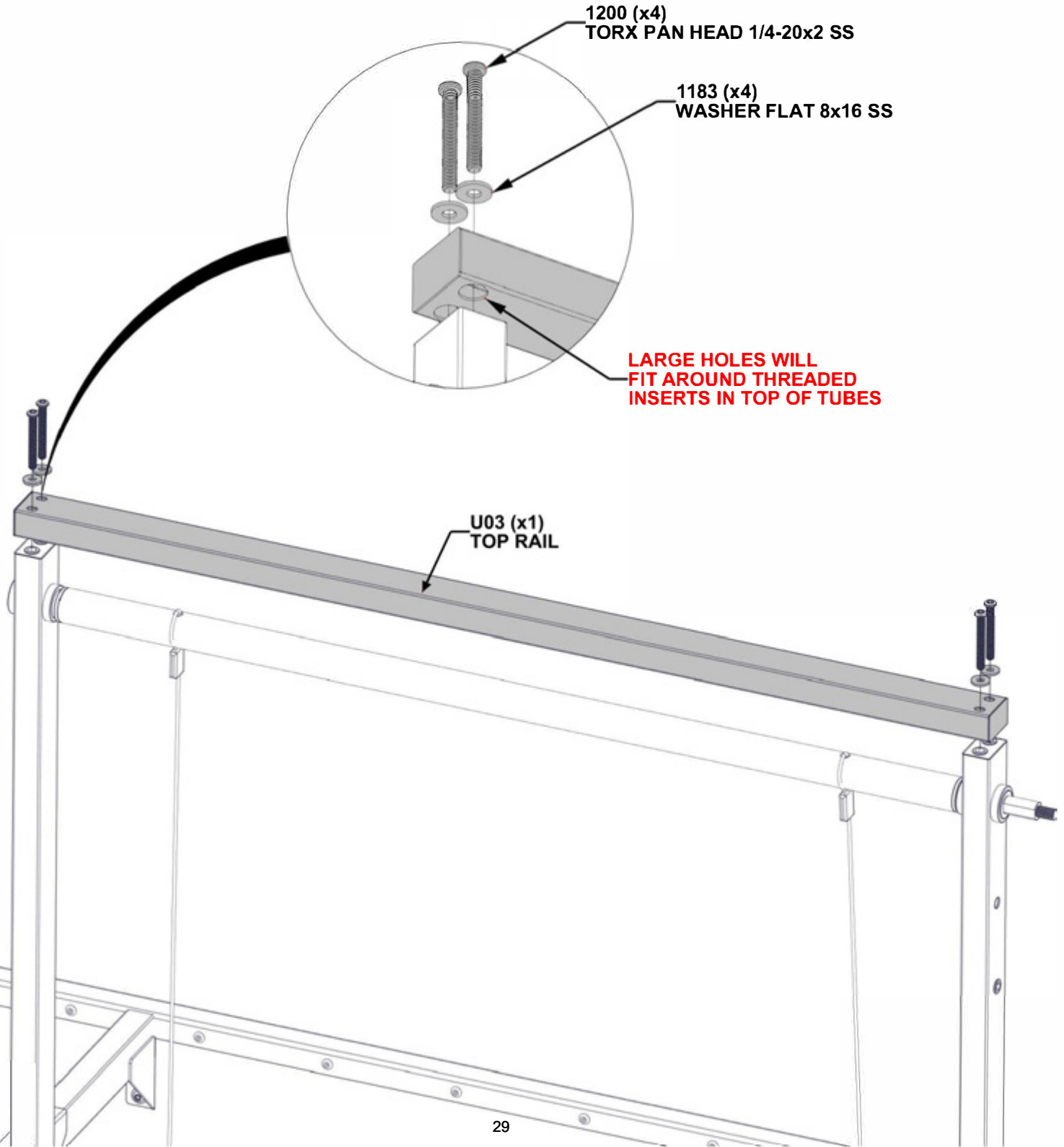

STEP 15 - CART ASSEMBLY

QTY	PART NUMBER	DESCRIPTION
4	H101182	WASHER SPLIT 1/4 SS
4	H101183	WASHER FLAT 8x16 SS
4	H101265	TORX PAN HEAD 1/4-20x3/4" SS (LOCTITE)

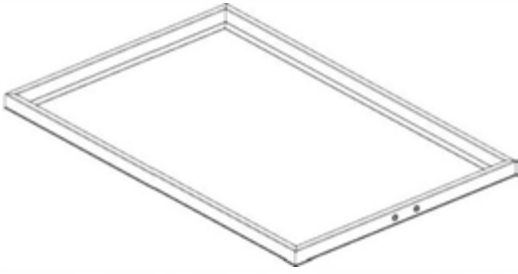

G01 GRATE TRAY ASSEMBLY - A4M02144
(x1) 1 1/4"x21 13/16"x33 1/16" (31.80x554x839)



B05 UPRIGHT CABLE BRACKET - A4M02270
(x2) 1 3/16"x2 15/16"x5 11/16" (30x74.5x143.8)

- ENSURE CORRECT ORIENTATION OF GRATE TRAY BRACKETS.
- SQUARE UPRIGHT BRACKETS TO GRATE TRAY BEFORE TIGHTENING HARDWARE.

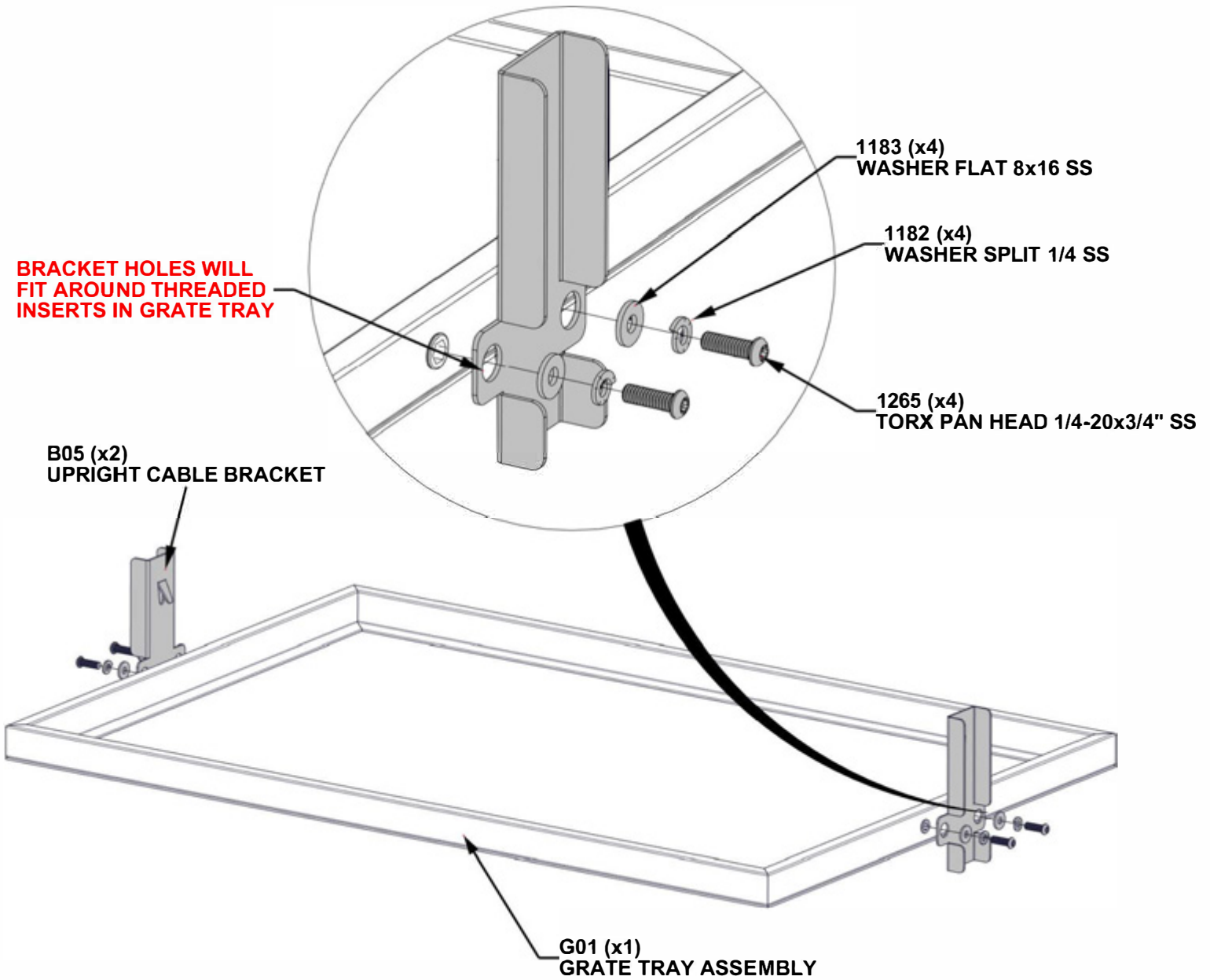

STEP 16 - CART ASSEMBLY

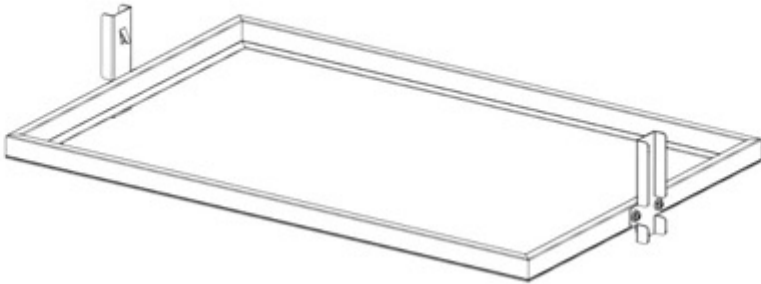

GRILL GRATE FRAME - FROM STEP 15

- CAREFULLY SET GRILL GRATE FRAME INTO COAL PAN ASSEMBLY BY HOLDING FRAME AT AN ANGLE AS SHOWN BELOW.

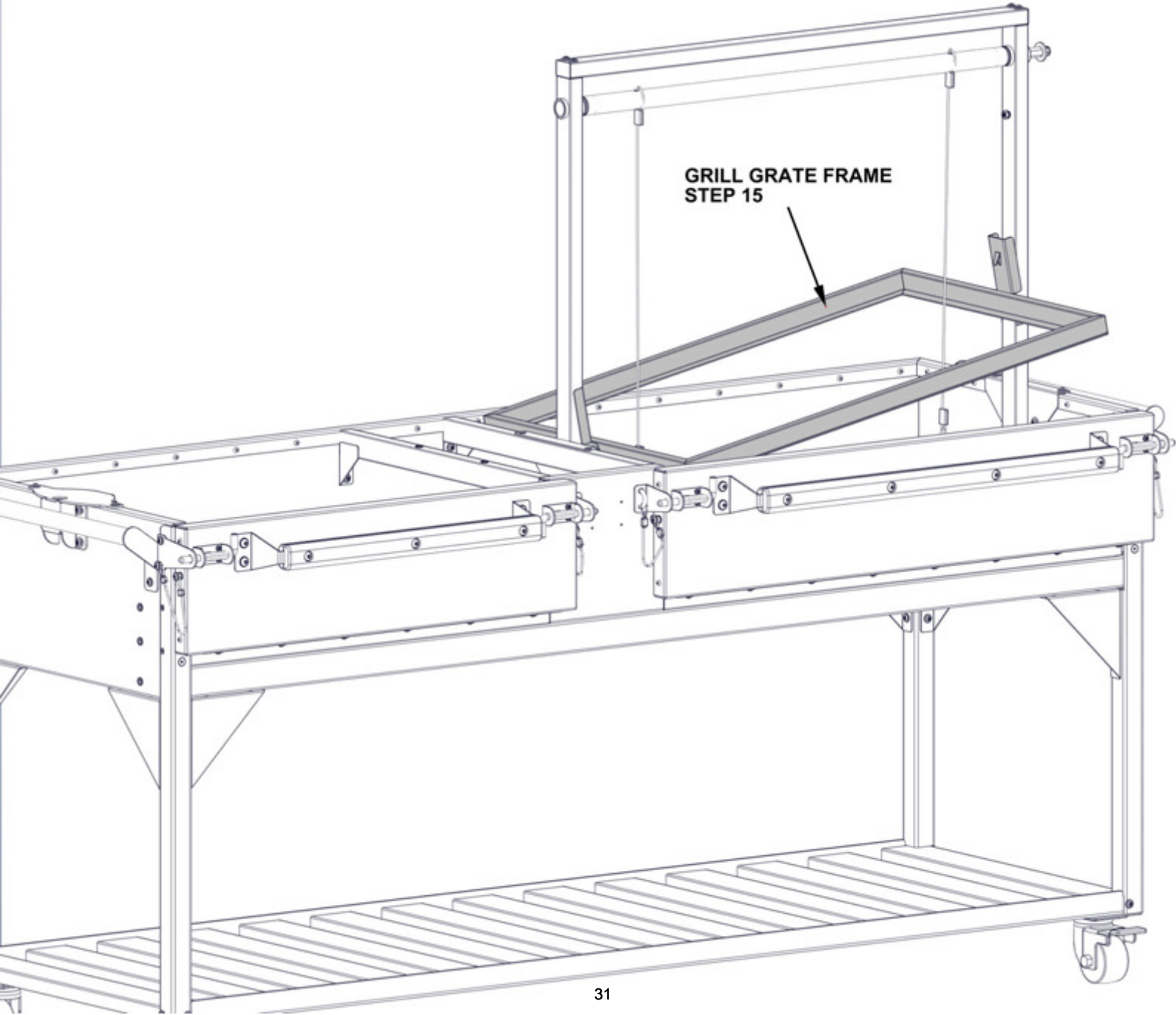

GRILL GRATE FRAME
STEP 15

STEP 17A - CART ASSEMBLY



QTY	PART NUMBER	DESCRIPTION
1	H101182	WASHER SPLIT 1/4 SS
1	H101183	WASHER FLAT 8x16 SS
1	H101273	HEX JAM NUT 1/4"-20 SS (LOCTITE)

H02 SPROCKET HANDLE ASSEMBLY - A4M02760
 (x1) 3 5/8"x4 1/2"x9 5/16" (92x115x236)

- DO NOT OVERTIGHTEN HARDWARE.

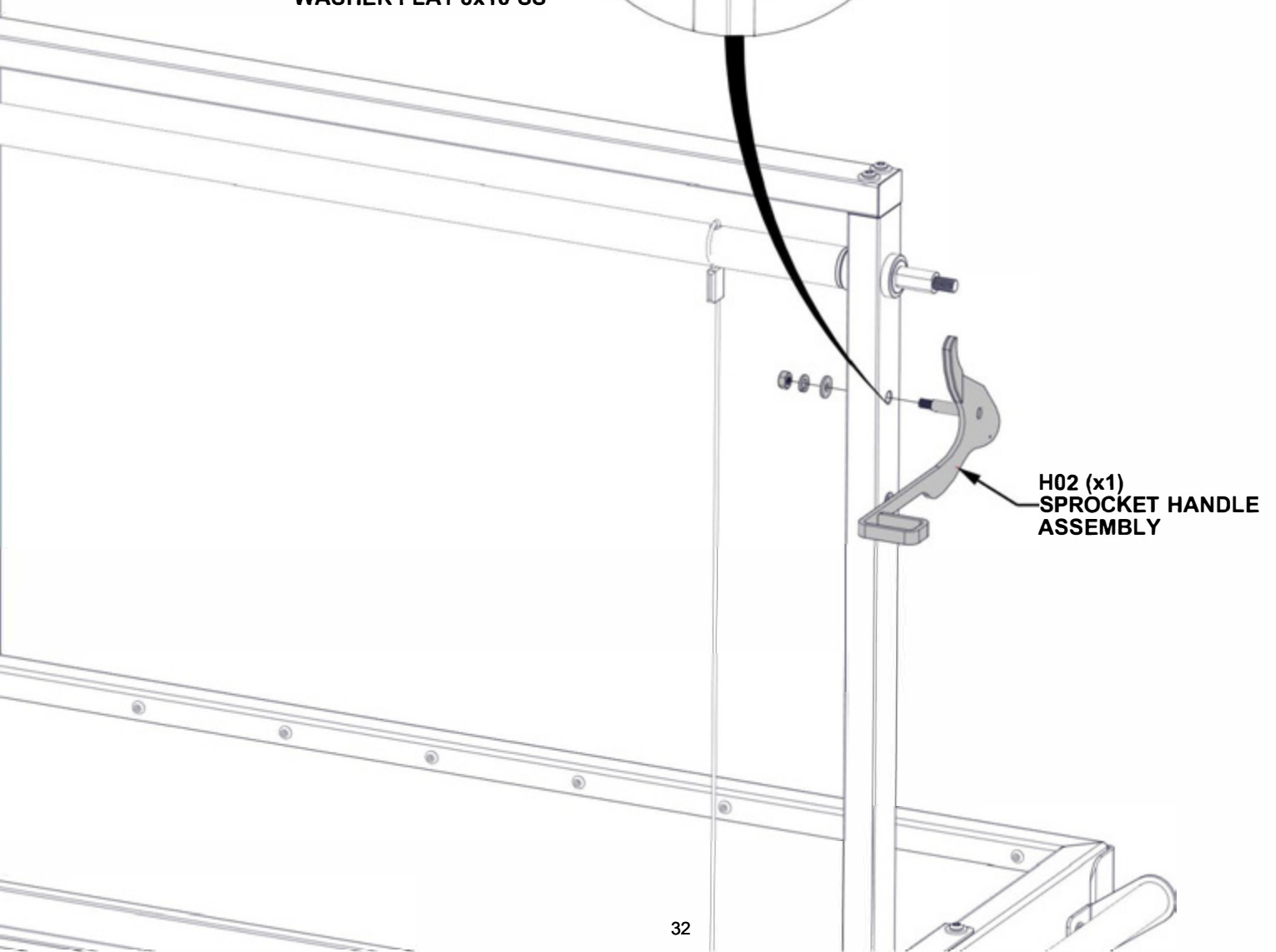
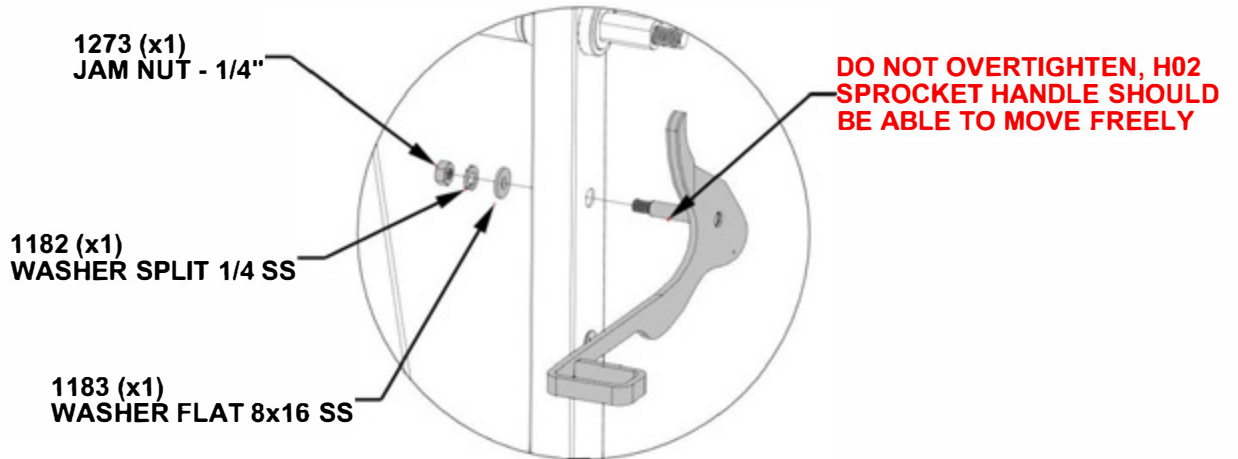

STEP 17B - CART ASSEMBLY



S03 SPRING - A4M02506
(x1) 1/16"x7/16"x1 13/16" (1.5x11x46)

QTY	PART NUMBER	DESCRIPTION
1	H101183	WASHER FLAT 8x16 SS
1	H101265	TORX PAN HEAD 1/4-20x3/4" SS (LOCTITE)

- DO NOT OVERTIGHTEN HARDWARE.
- SPRING TENSION IS INTENDED TO BE TIGHT.
- YOU WILL NEED PLIERS TO ATTACH SPRING TO HANDLE.

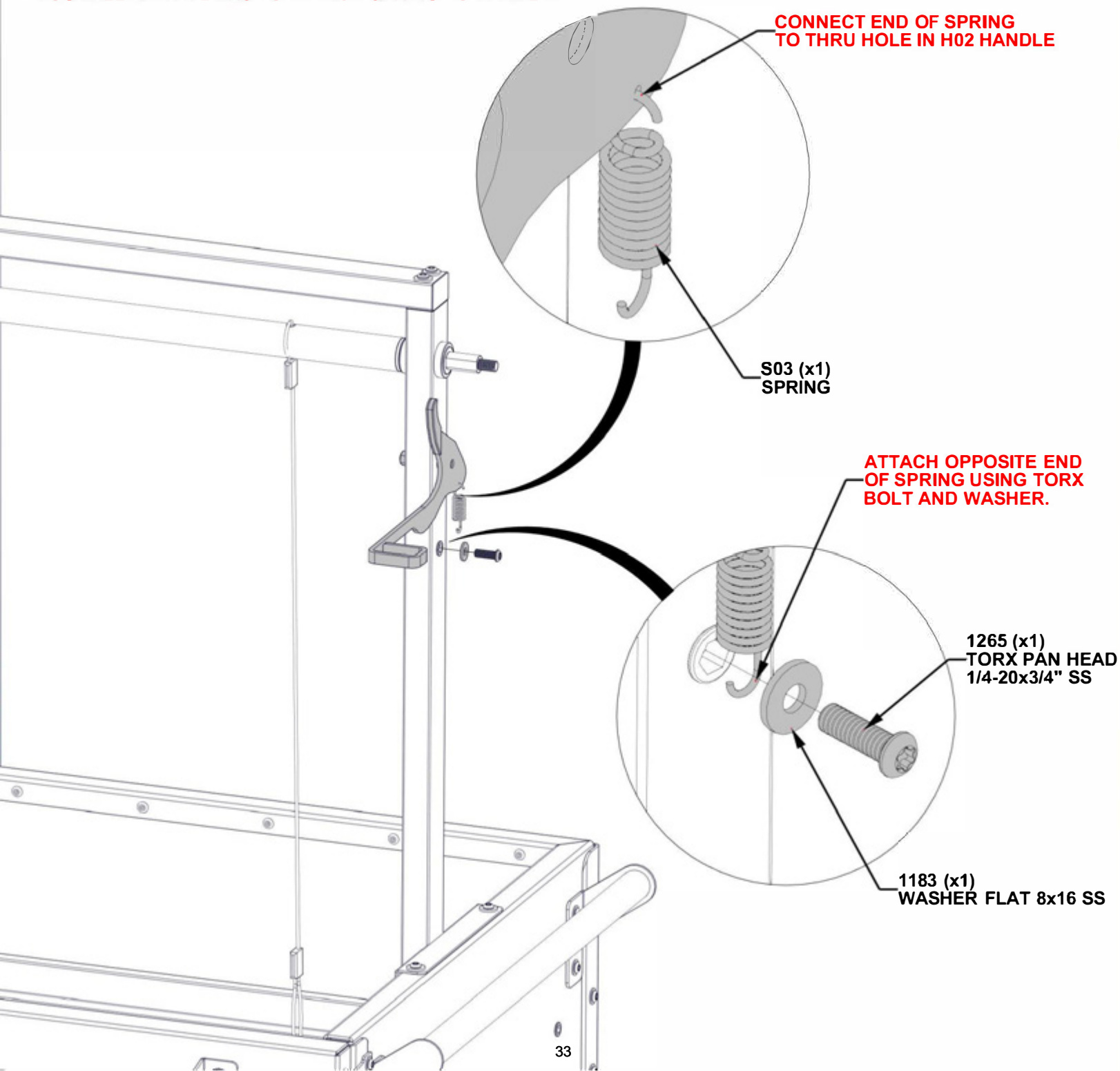

STEP 18 - CART ASSEMBLY

QTY	PART NUMBER	DESCRIPTION
1	H100497	WASHER FLAT 17x30 BLK
1	H101167	WASHER FLAT 11x25 BLK
1	H101274	NUT LOCK 3/8"-16 SS



W01 WHEEL ASSEMBLY - A4M02146
(x1) 2 3/8"x7" (59.7x178)



S02 SPROCKET - A4M02147
(x1) 3/16"x4 11/16"x4 11/16" (4x119x119)

- DO NOT OVERTIGHTEN HARDWARE.
- ORIENTATION OF SPROCKET AND WHEEL ASSEMBLY ARE CRITICAL AND SHOULD BE ORIENTED AS SHOWN BELOW.

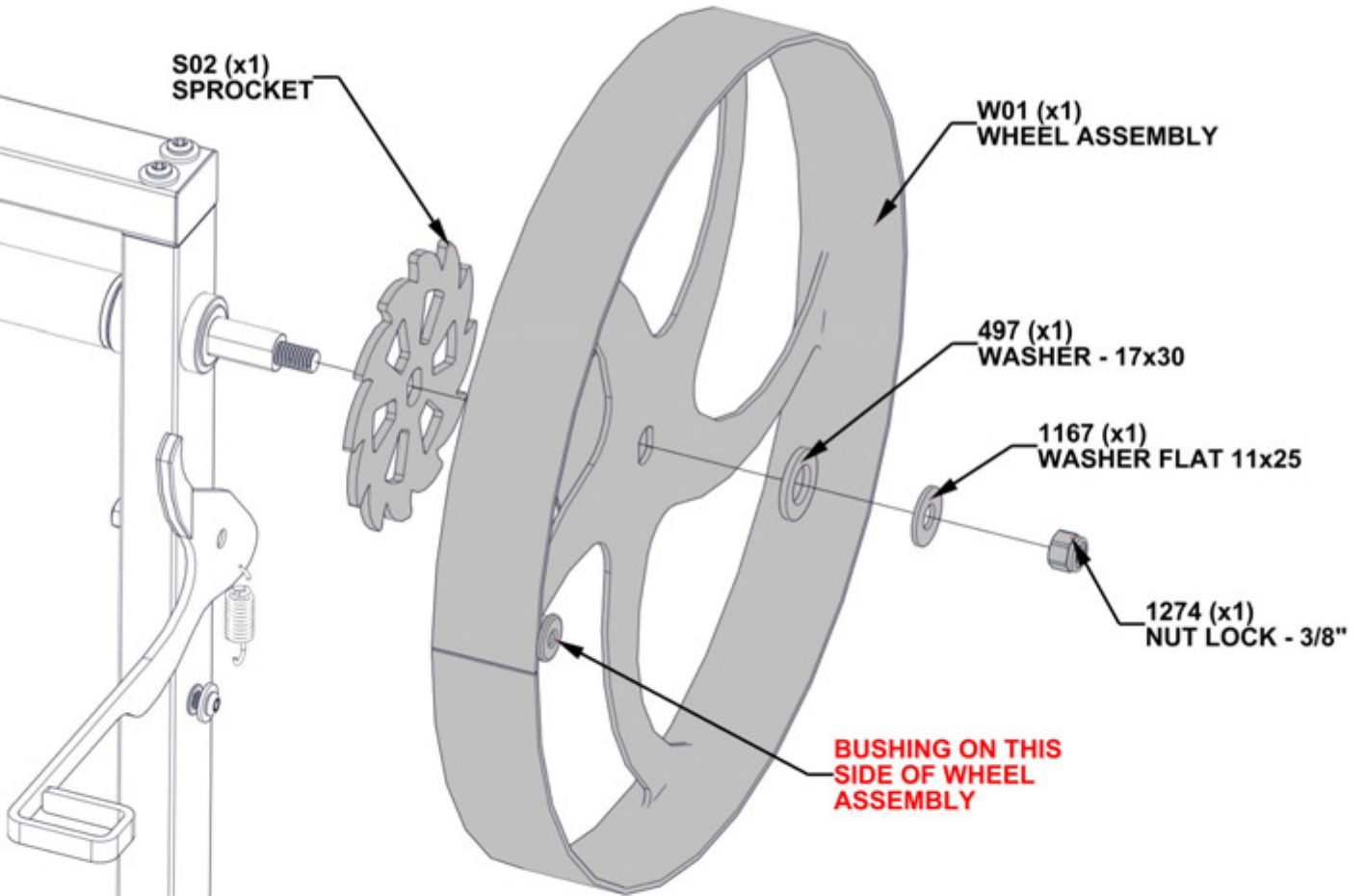

**PUSH SPROCKET HANDLE DOWN
 OUT OF THE WAY WHEN SLIDING
 SPROCKET ONTO SPINDLE**

STEP 19 - CART ASSEMBLY

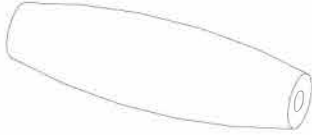

H04 WHEEL HANDLE - W4L19101
(x1) 1 9/16"x5 1/8" (40x130)

QTY	PART NUMBER	DESCRIPTION
2	H100630	WASHER FLAT 8x19 BLK
1	H101263	BOLT WH 5/16x6 3/8 BLK (LOCTITE)

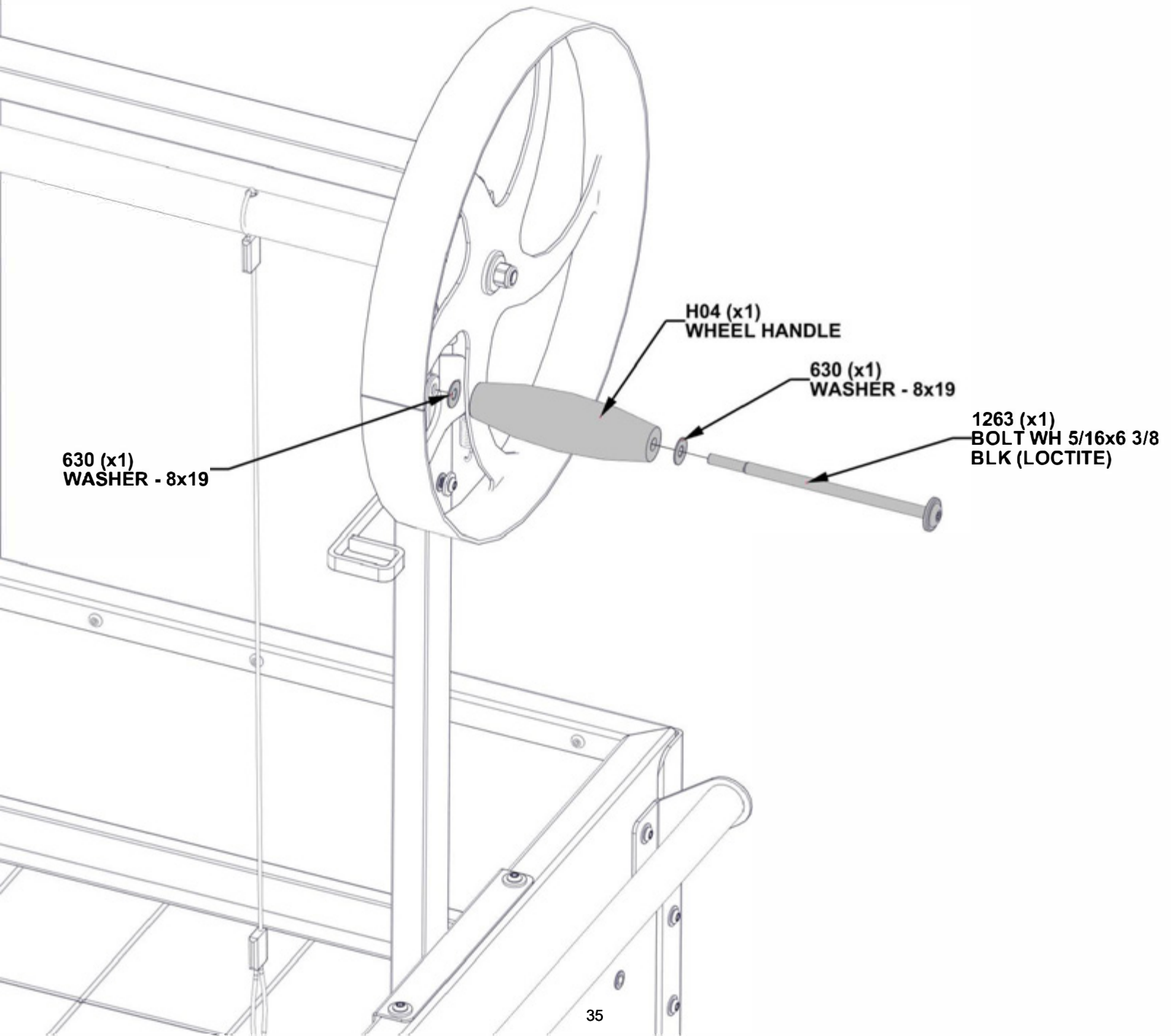

STEP 20 - CART ASSEMBLY

ATTACH LOOPED ENDS OF THE CABLES ONTO THE BRACKET TABS AS SHOWN.

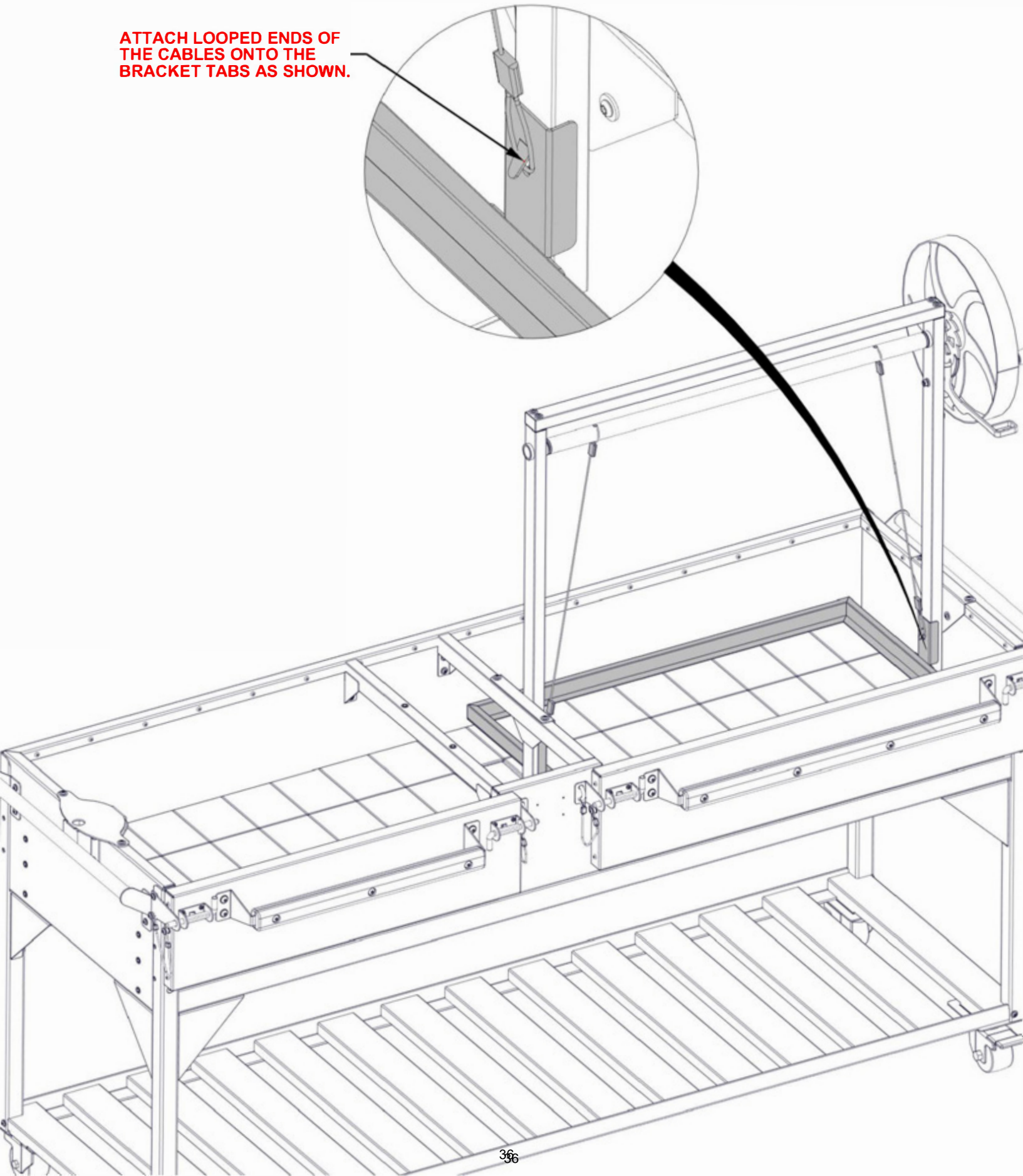

STEP 21 - CART ASSEMBLY

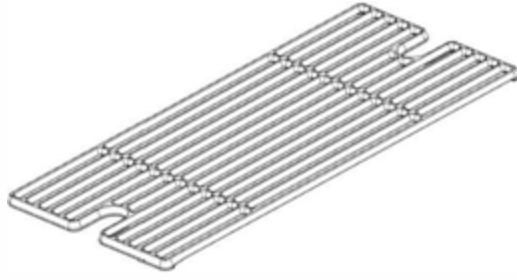

G02 GRATE - A4M02145
(x3) 7/16"x10 1/2"x20 1/2" (12x266x520)

- PLACE GRATES INTO GRATE TRAY.

- IT IS RECOMMENDED TO SEASON YOUR GRILL GRATES TO PREVENT RUSTING OVER TIME.

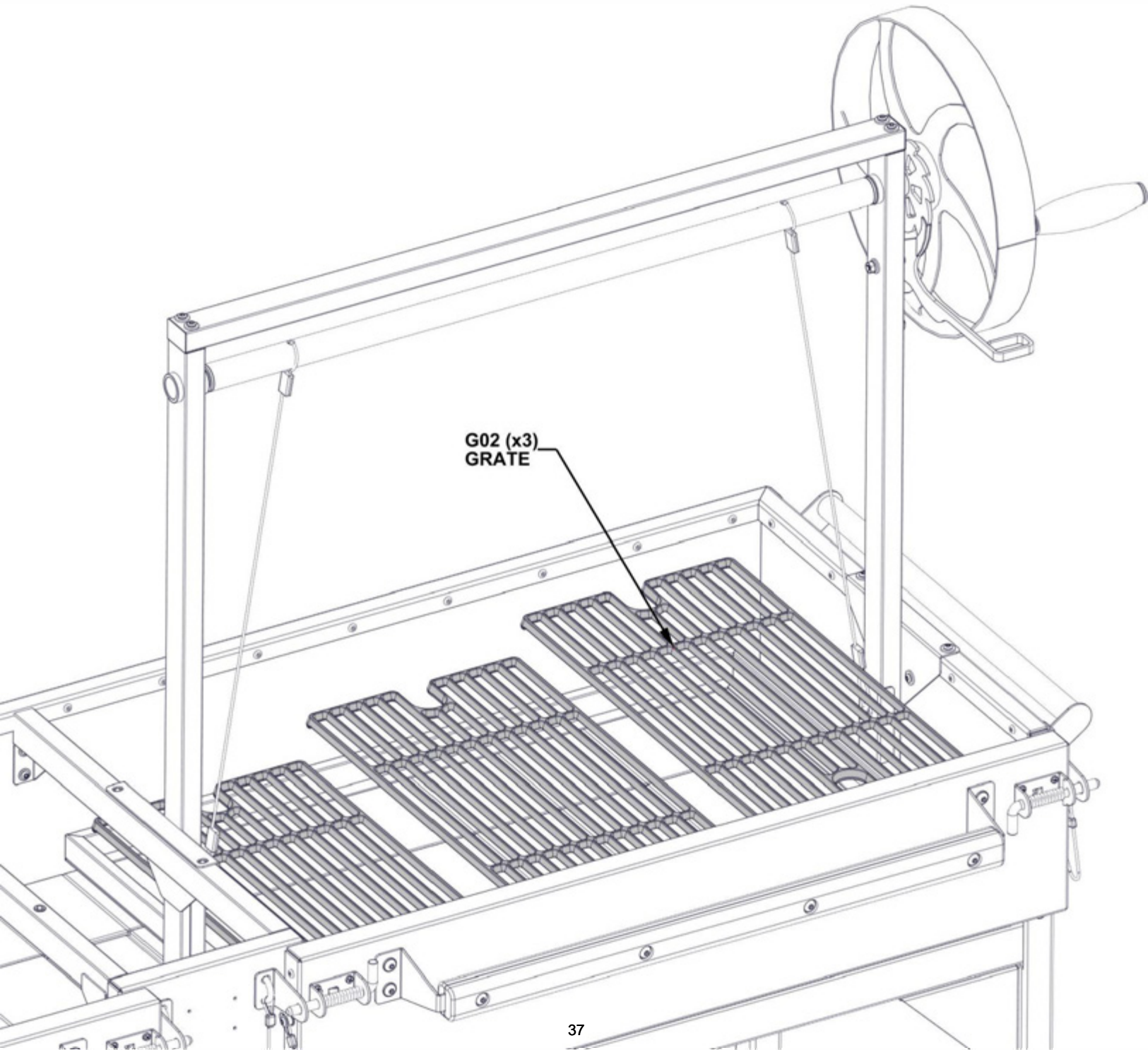

STEP 22A - CART ASSEMBLY

QTY	PART NUMBER	DESCRIPTION
2	H101183	WASHER FLAT 8x16 SS
2	H101265	TORX PAN HEAD 1/4-20x3/4" SS (LOCTITE)

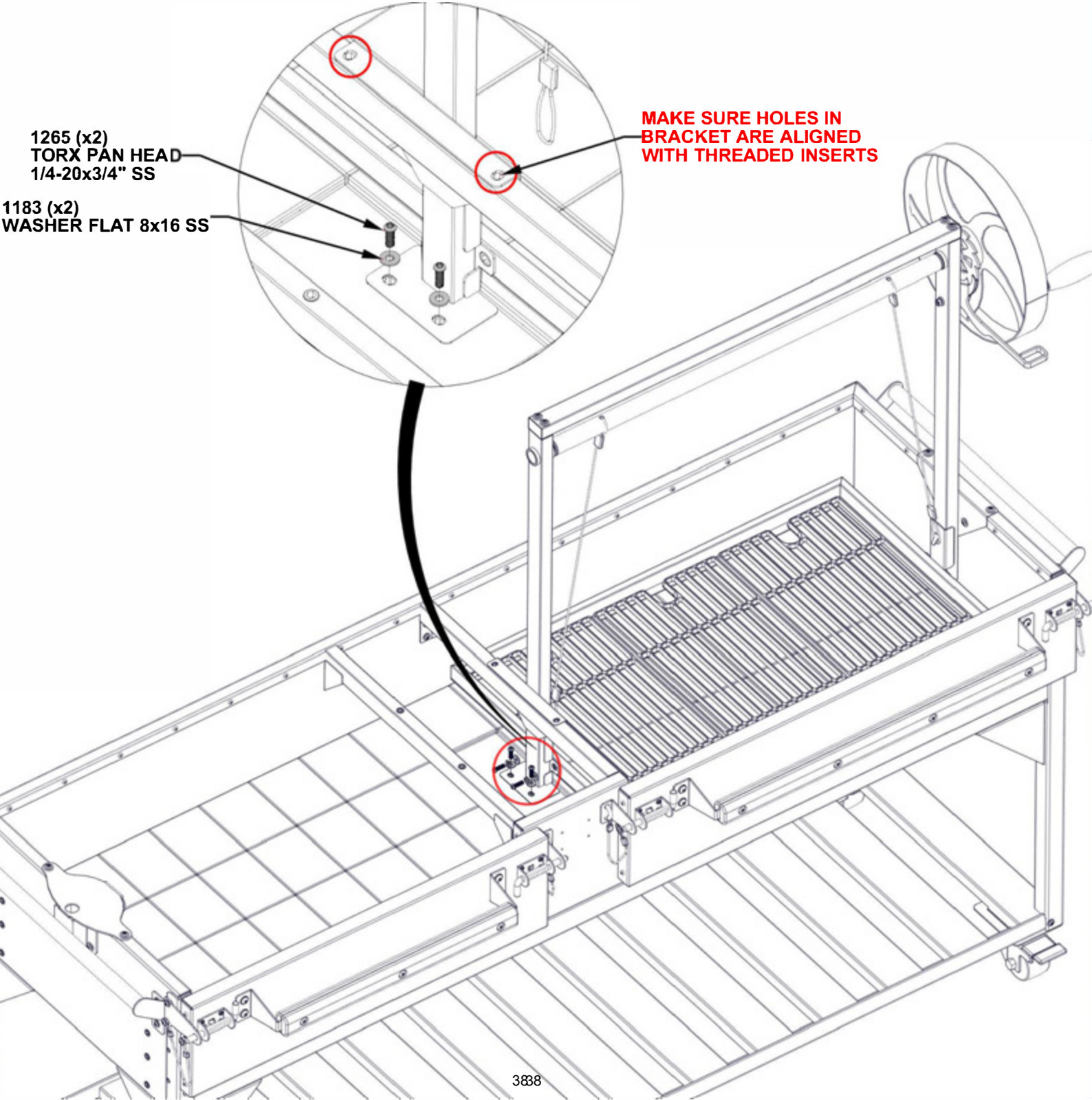

STEP 22B - CART ASSEMBLY



QTY	PART NUMBER	DESCRIPTION
4	H101183	WASHER FLAT 8x16 SS
4	H101265	TORX PAN HEAD 1/4-20x3/4" SS (LOCTITE)

F01 FIRE BOX - A4M02772
 (x1) 11 11/16"x9 1/8"x22 1/2" (298x232x572)

- DO NOT TIGHTEN HARDWARE AT THIS STEP.

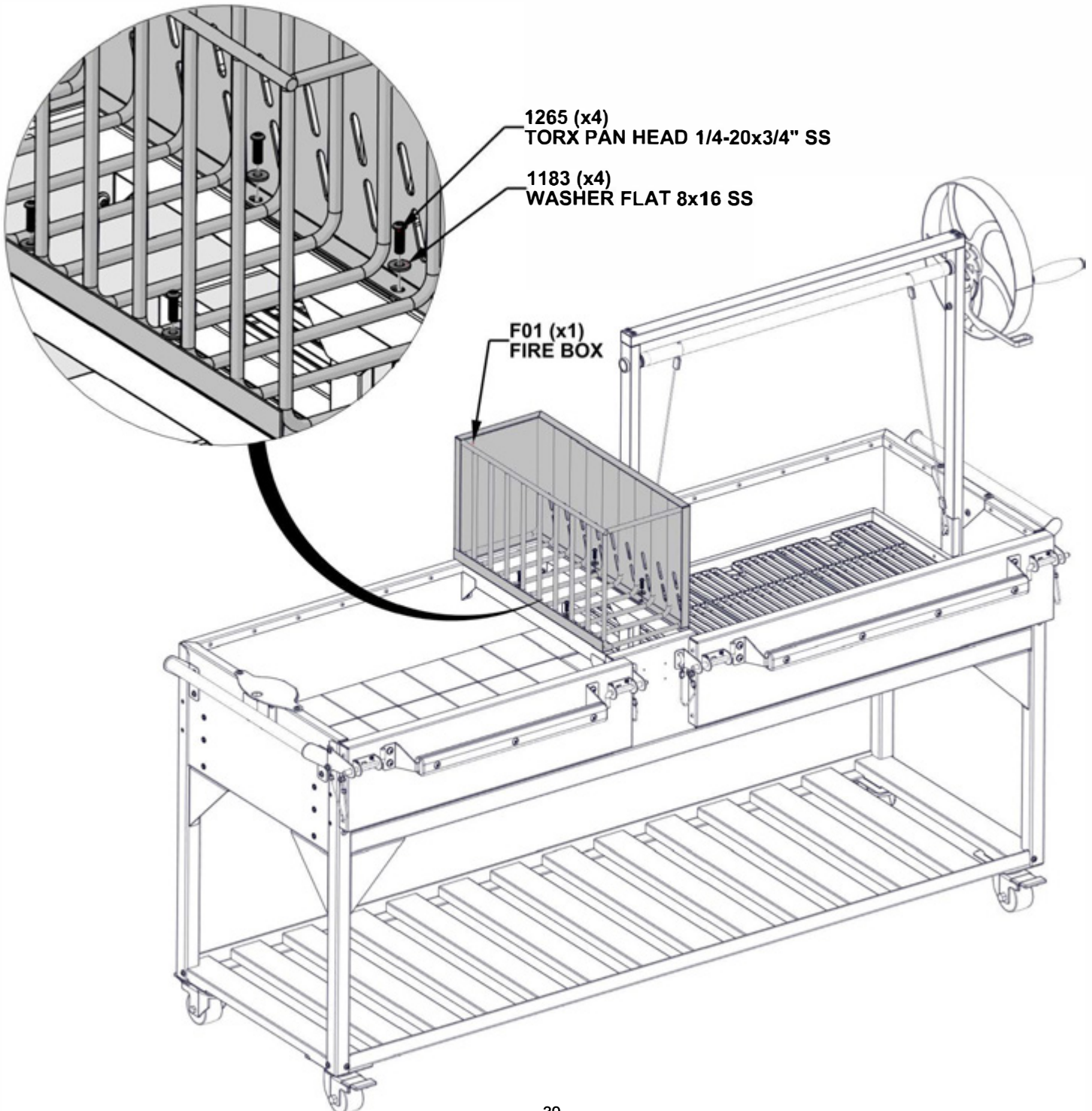

STEP 23 - CART ASSEMBLY

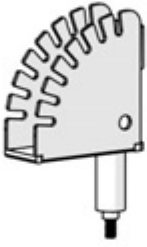

P01 ASADO PIVOT BRACKET - A4M04134
(x1) 1 11/16"x4 7/16"x7 9/16" (43x113x192)

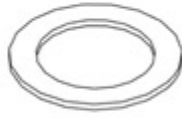

A4M04045 FLAT WASHER
(x1) 24x35 COPPER

QTY	PART NUMBER	DESCRIPTION
1	H101274	NUT LOCK 3/8"-16 SS
1	H101299	WASHER FLAT 10x22 SS

- ENSURE CORRECT ORIENTATION OF PIVOT BRACKET WHEN INSTALLING.

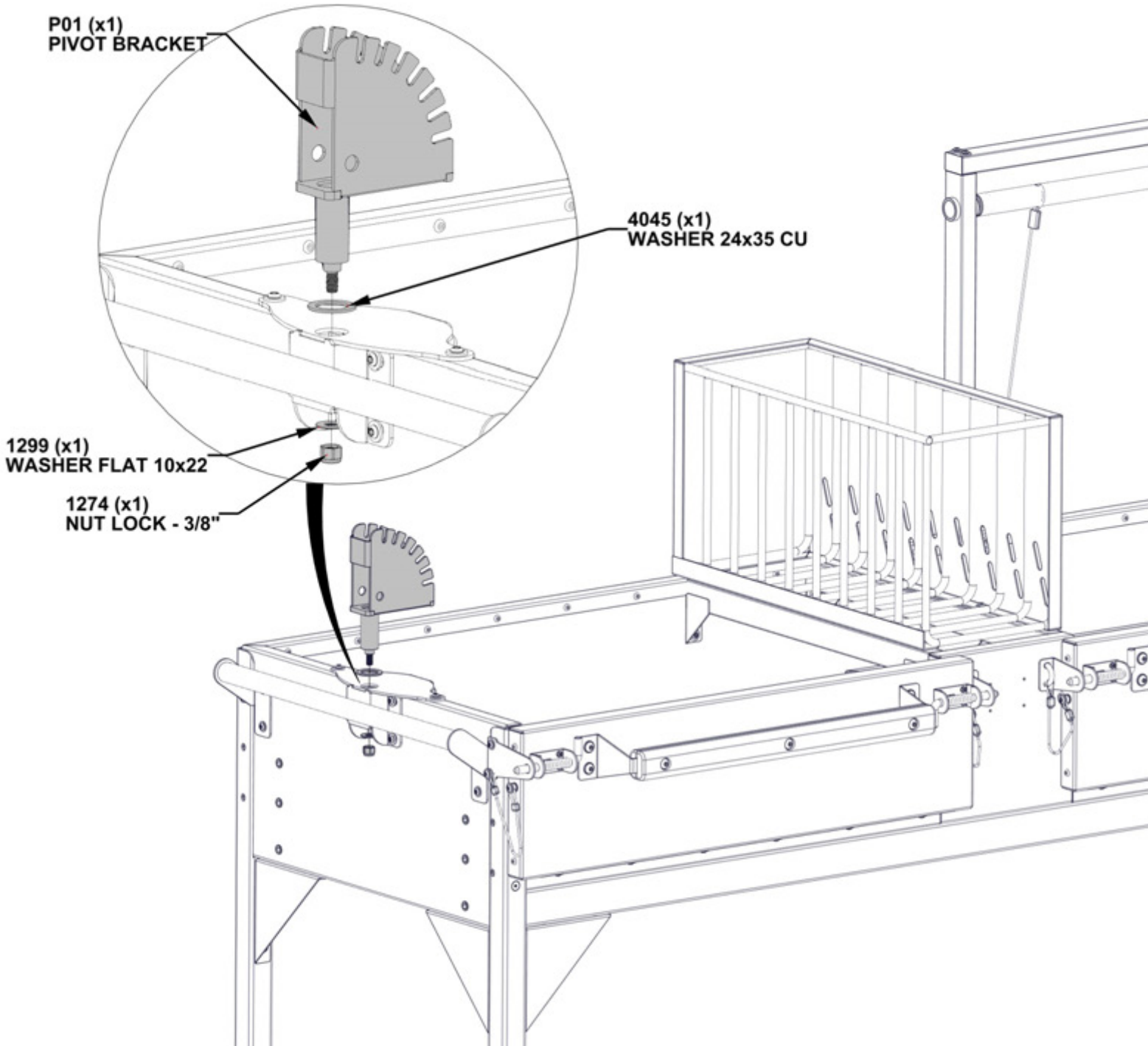

STEP 24 - CART ASSEMBLY



R04 PIVOT ROD - A4M02784
(x1) 1/2"x1 7/16"x12 1/4" (12.0x36x312)

QTY	PART NUMBER	DESCRIPTION
1	H101274	NUT LOCK 3/8"-16 SS
2	H101299	WASHER FLAT 10x22 SS
1	H101301	WASHER SPLIT 3/8 SS
1	H101302	BOLT WH 3/8x2 3/8" S.S.

- INSERT PIVOT ROD INTO ASADO PIVOT BRACKET.
- LINE UP HOLE IN PIVOT ROD WITH HOLE IN BRACKET AND INSTALL HARDWARE AS SHOWN.

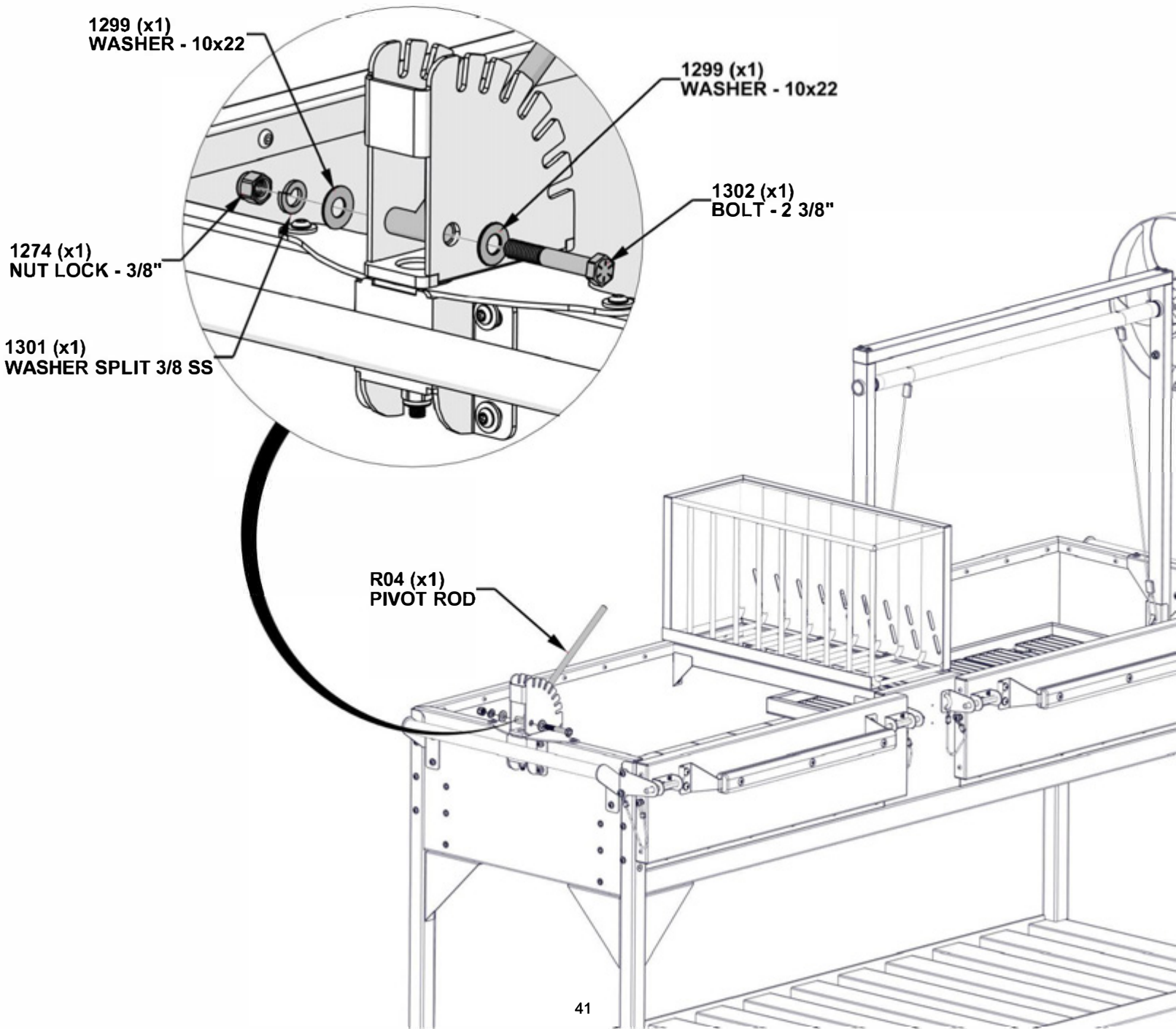

STEP 25A - ASADO ASSEMBLY

QTY	PART NUMBER	DESCRIPTION
6	H101183	WASHER FLAT 8x16 SS
6	H101282	TORX PAN HEAD 1/4-20x1 1/4" SS (LOCTITE)



R02 BOTTOM ASADO RACK - A4M02786
(x1) 4 1/4"x18 1/2"x34" (108x470x864)



H05 WIRE HANDLE ASSEMBLY - A4M03500
(x3) 1 1/2"x2 11/16"x7 9/16" (38x69x192)

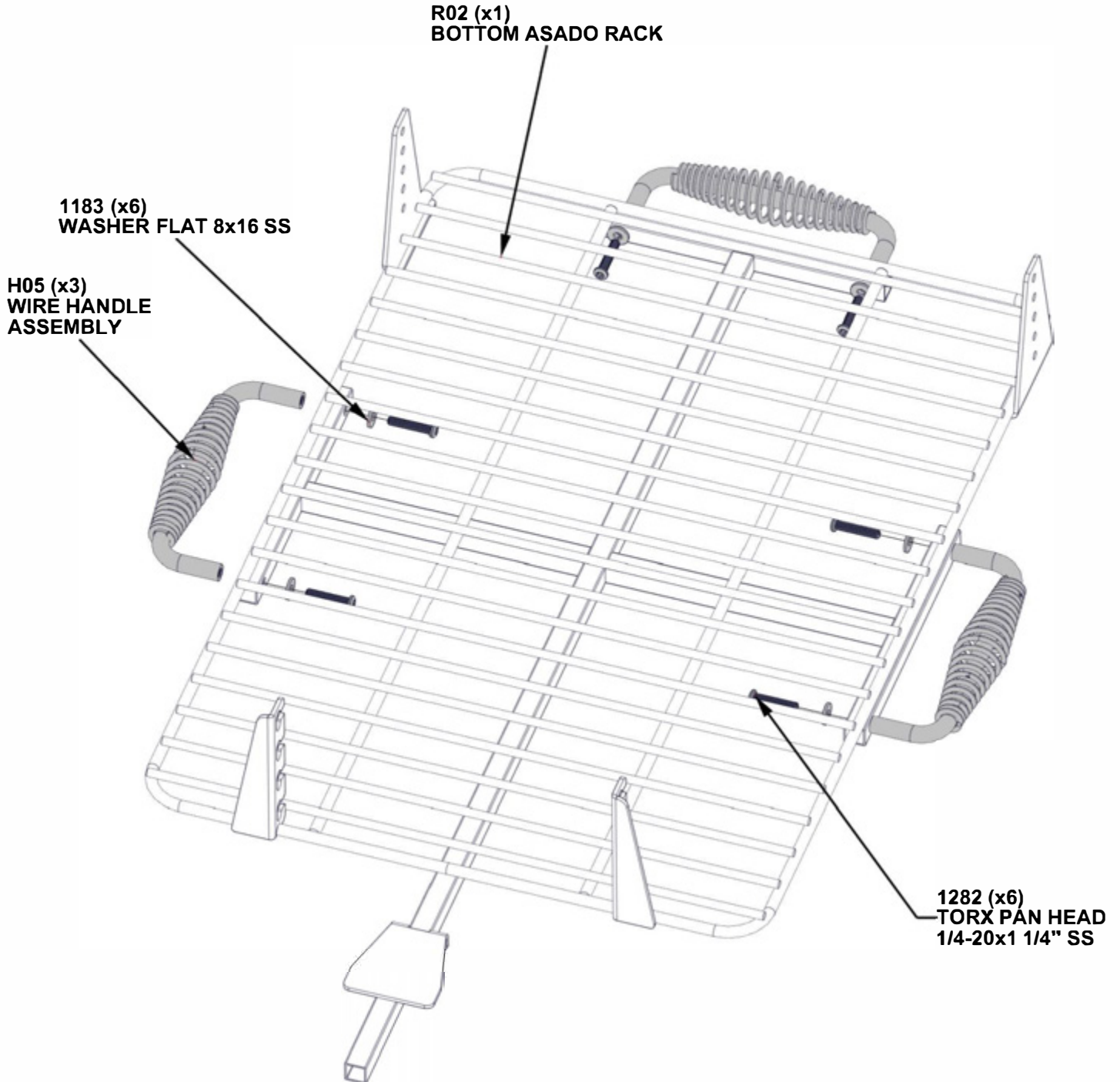

STEP 25B - ASADO ASSEMBLY



R01 TOP ASADO RACK - A4M02785
(x1) 5/16"x18 3/8"x30 5/16" (8x466x770)

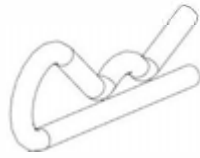

H101303 COTTER PIN SS
(x1)



R03 HOLDING ROD - A4M02787
(x1) 1/4"x1 3/16"x21 7/16" (6x30x544)

- THE SLOT SELECTED IS SOLELY DEPENDENT ON THE THICKNESS OF MEAT BEING COOKED.
- WHEN NOT IN USE IT IS RECOMMENDED TO LEAVE THE TOP RACK IN THE BOTTOM SLOT AND RESPECTIVE R03 HOLE.

INSERT TOP ASADO RACK INTO A SLOT

SLIDE THE HOLDING ROD INTO THE HOLES ON THE SIDE TABS OF THE BOTTOM ASADO RACK

AFTER HOLDING ROD HAS BEEN INSERTED FULLY INSTALL COTTER PIN

1303 (x1) COTTER PIN SS

R01 (x1) TOP ASADO RACK

R03 (x1) HOLDING ROD

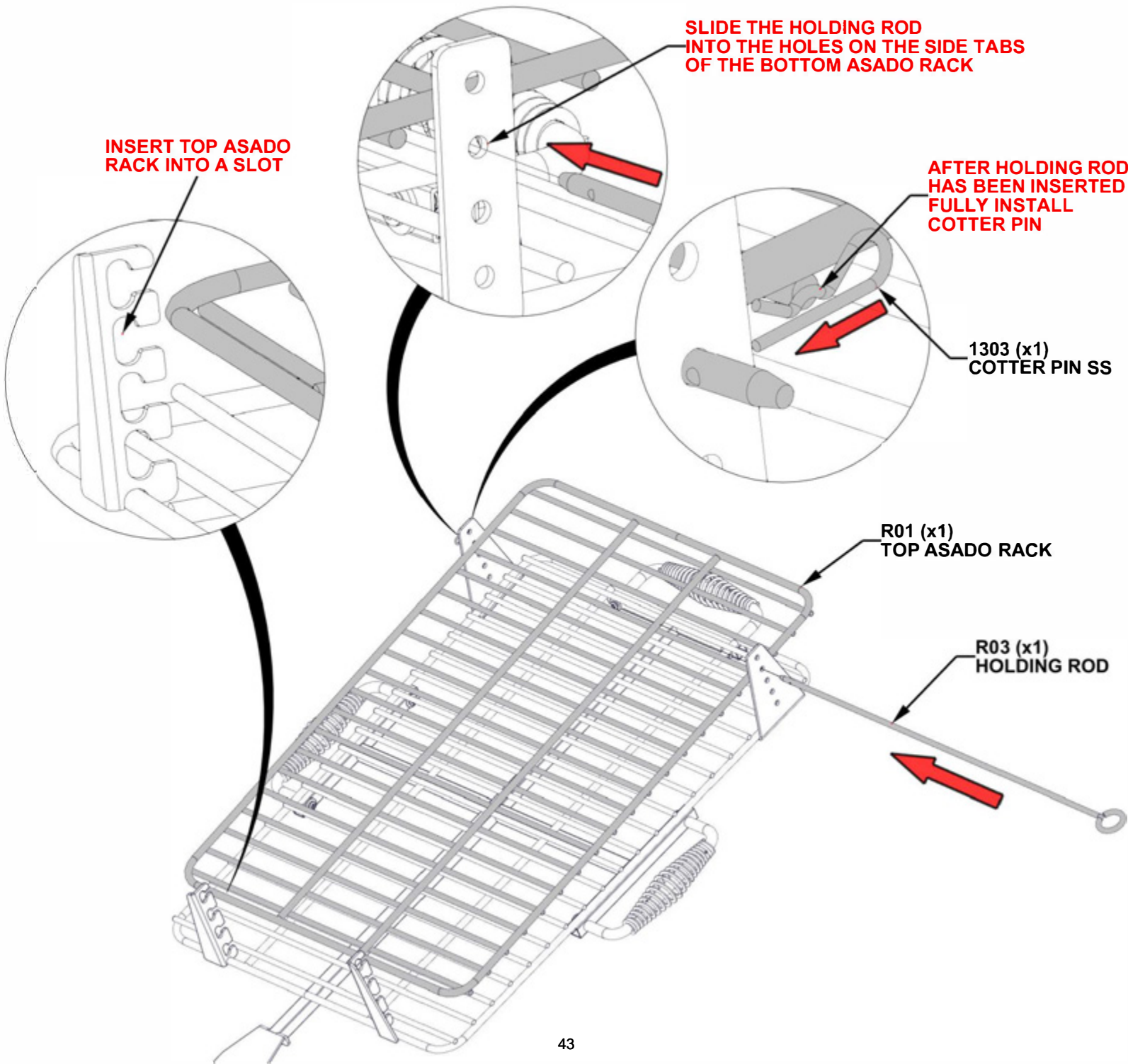

STEP 26 - ASADO ASSEMBLY



ASADO RACK ASSEMBLY FROM STEPS 25

- ENSURE CORRECT ORIENTATION OF THE ASADO RACK ASSEMBLY.
- SLIDE ASADO RACK ASSEMBLY FROM STEP 25 ON TO THE ASADO PIVOT FROM STEP 24.

SLIDE TAB ON ASADO RACK INTO THE ASADO PIVOT BRACKET NOTCHES.

INSERT PIVOT ROD INTO THE ASADO RACK AS SHOWN

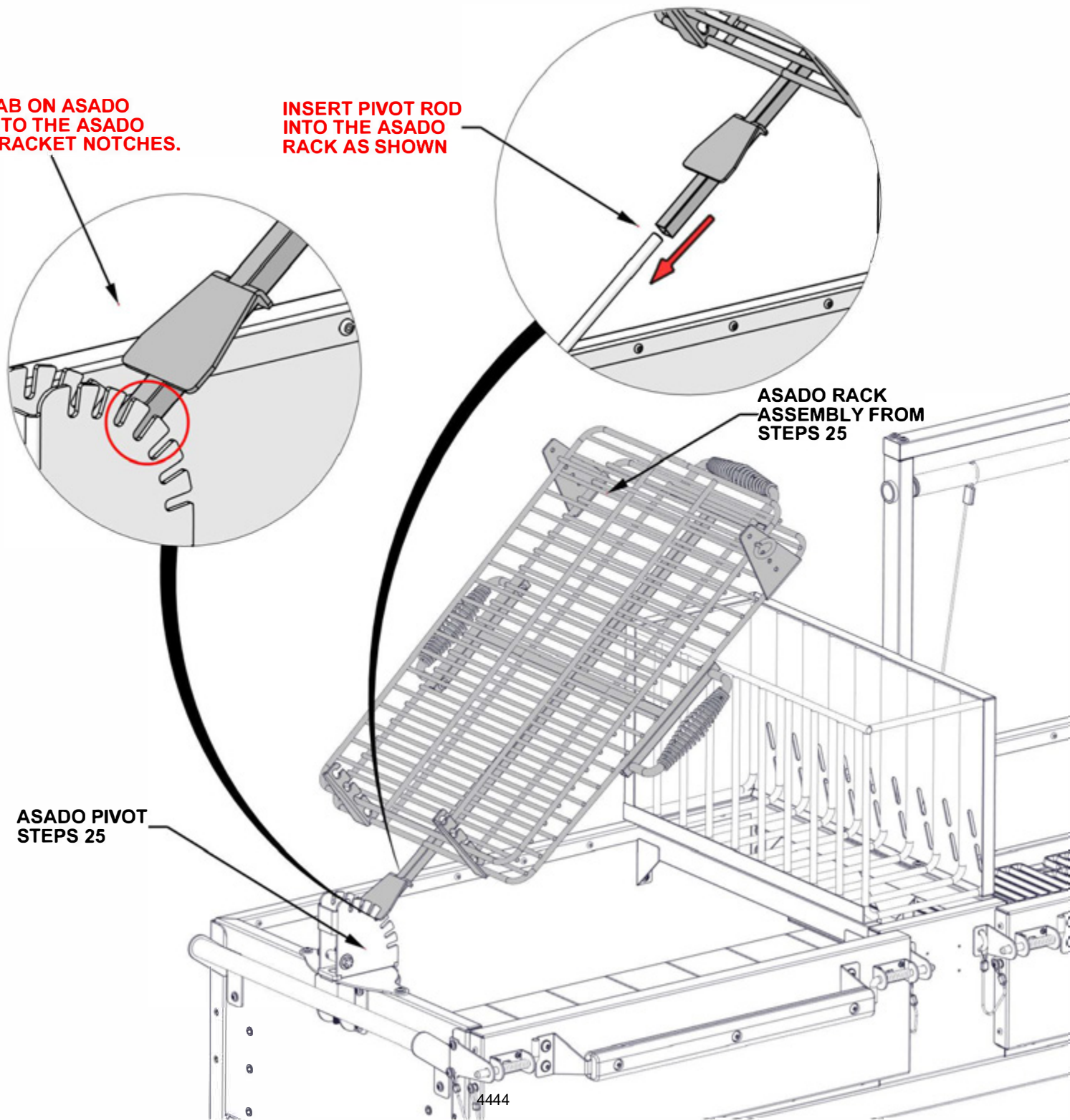

ASADO PIVOT STEPS 25

ASADO RACK ASSEMBLY FROM STEPS 25

STEP 27 - GRILL TABLE ASSEMBLY

QTY	PART NUMBER	DESCRIPTION
12	H100797	SCREW PWH 8x1 BLK



T01 TABLE TOP - W4L18241
(x2) 1 1/4"x17 11/16"x23 5/8" (32x450x600)



2094 TABLE BRACKET - A4M02094
(x4) 1 3/8"x6 13/16"x15 15/16" (34x173x405)

- DO NOT OVERTIGHTEN SCREWS.
- COMPLETE THIS STEP TWICE.
- IT IS RECOMMENDED TO USE THE 6" MAGNETIC DRIVER EXTENSION PROVIDED IN YOUR HARDWARE KIT FOR THIS STEP.

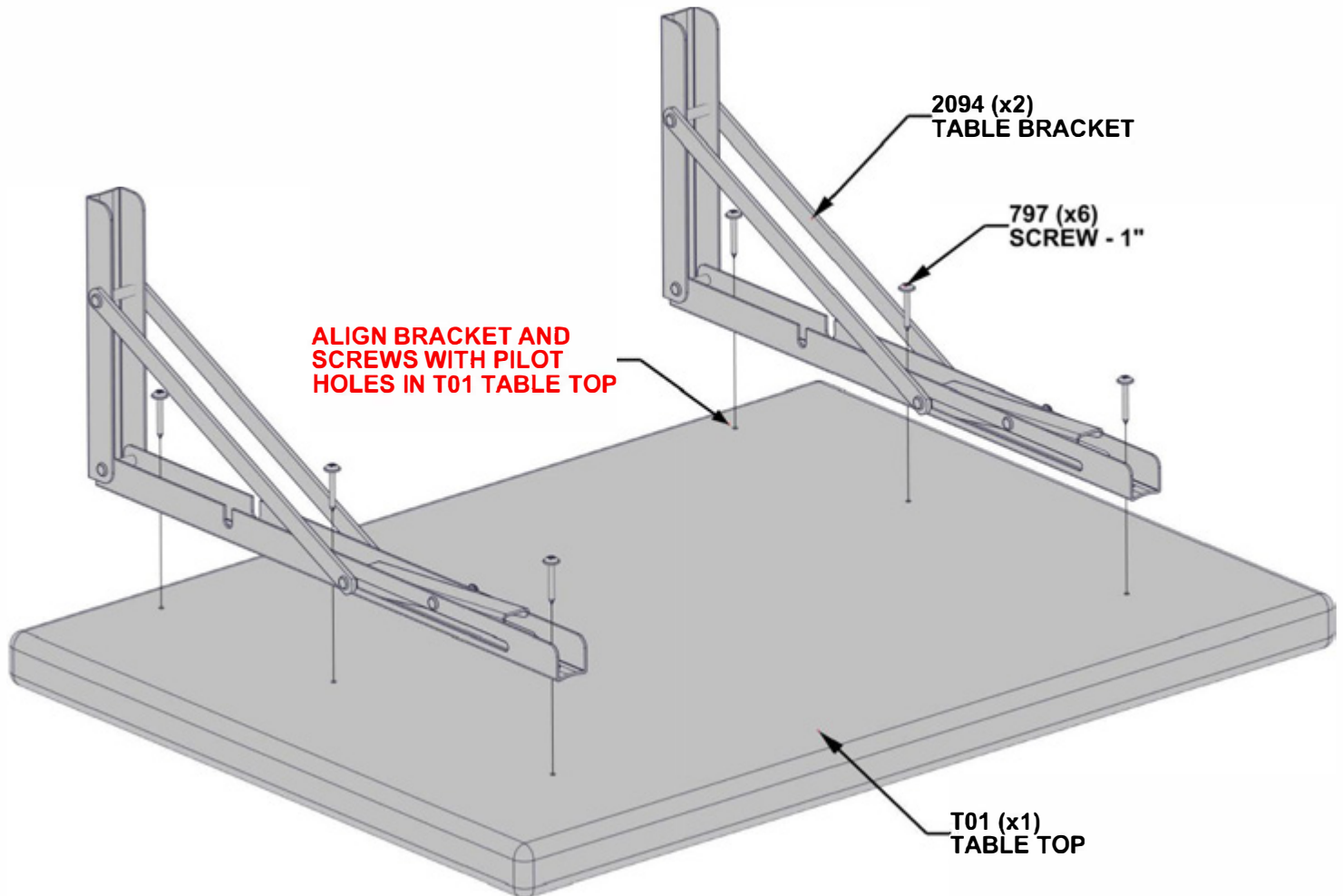

STEP 28 - GRILL TABLE ASSEMBLY



TABLE ASSEMBLY FROM STEP 27

QTY	PART NUMBER	DESCRIPTION
12	H101264	TORX PAN HEAD 1/4-20x3/4" BLK (LOCTITE)
12	H101280	WASHER FLAT 7x14 SS

-REPEAT THIS STEP FOR BOTH SIDES OF THE COAL BOX ASSEMBLY.

- IT IS RECOMMENDED TO USE THE 6" MAGNETIC DRIVER EXTENSION PROVIDED IN YOUR HARDWARE KIT FOR THIS STEP.

1264 (x6)
TORX PAN HEAD
1/4-20x3/4 ASSY

1280 (x6)
WASHER - 7x14

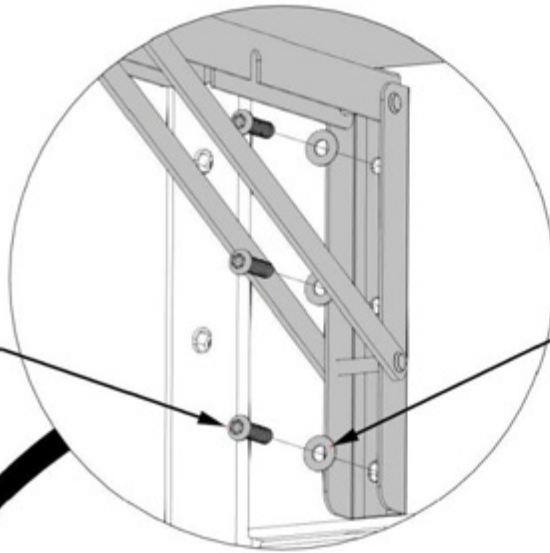
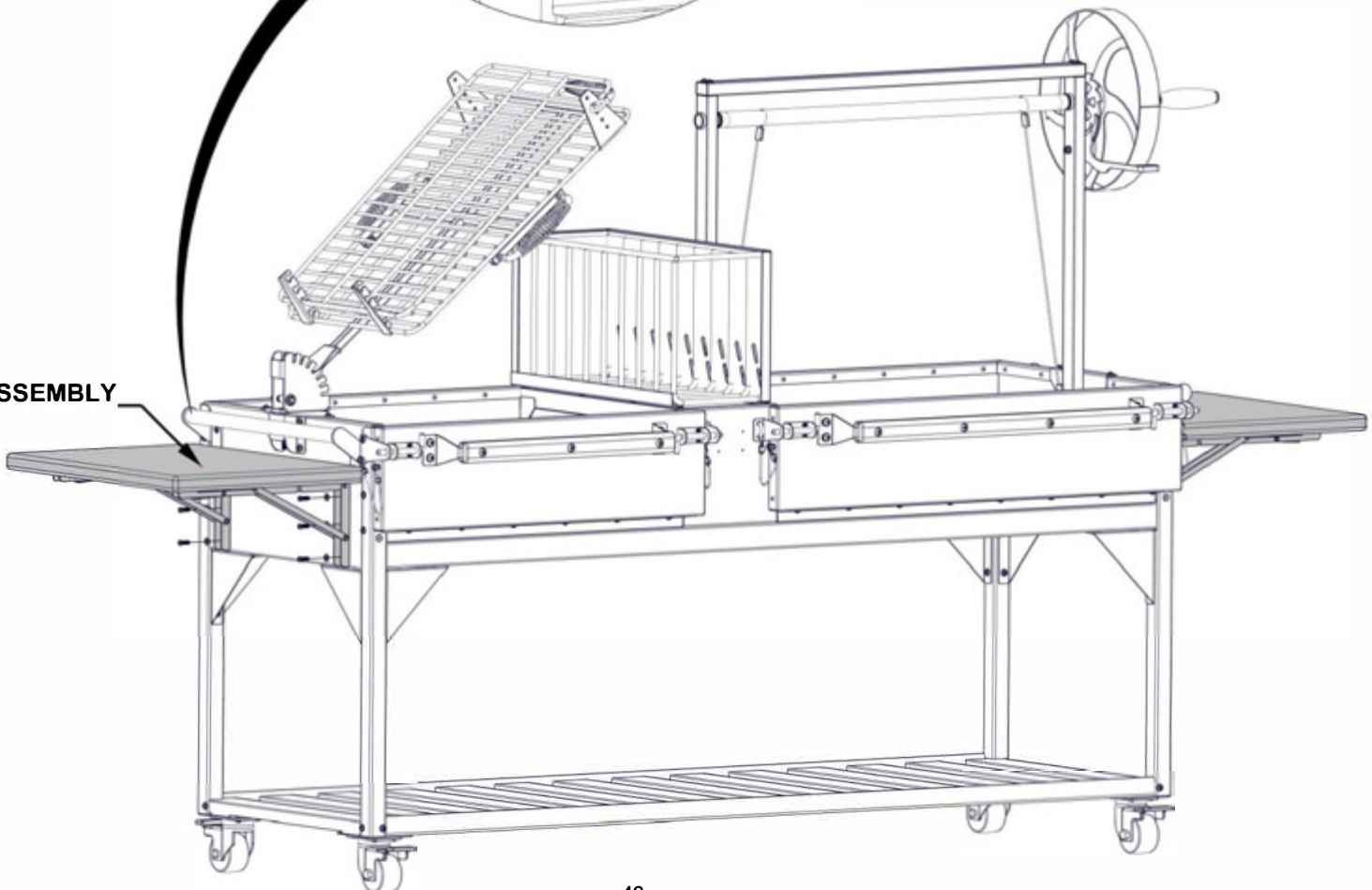

TABLE ASSEMBLY
STEP 27



STEP 29 - CART ASSEMBLY



A4M02158 BYD ID TAG PATIO
(x1)

QTY	PART NUMBER	DESCRIPTION
4	H101262	PHILLIPS ROUNDED HEAD 8-18x.5

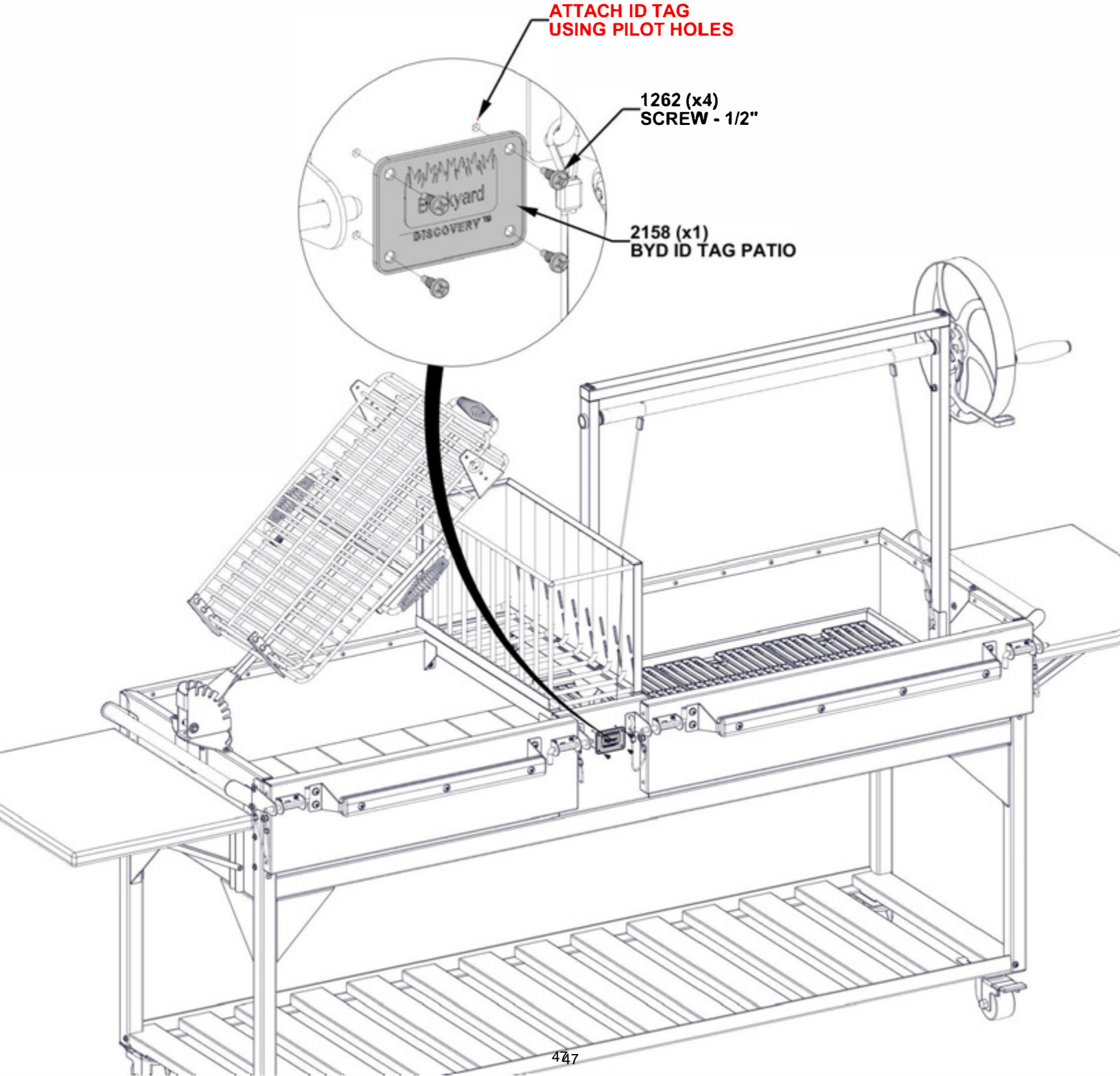

**ATTACH ID TAG
USING PILOT HOLES**

**1262 (x4)
SCREW - 1/2"**

**2158 (x1)
BYD ID TAG PATIO**

STEP 30 - CART ASSEMBLY



MH01 MEAT HOOK - A4M02402
(x2) 3/16"x3 7/8"x5 11/16" (5x98x145)



MH02 MEAT HOOK - A4M02407
(x2) 3/16"x3"x8 13/16" (5x77x224)



SH01 SHOVEL - A4M02513
(x1) 2 1/4"x4 7/8"x31 7/16" (57x124x798)

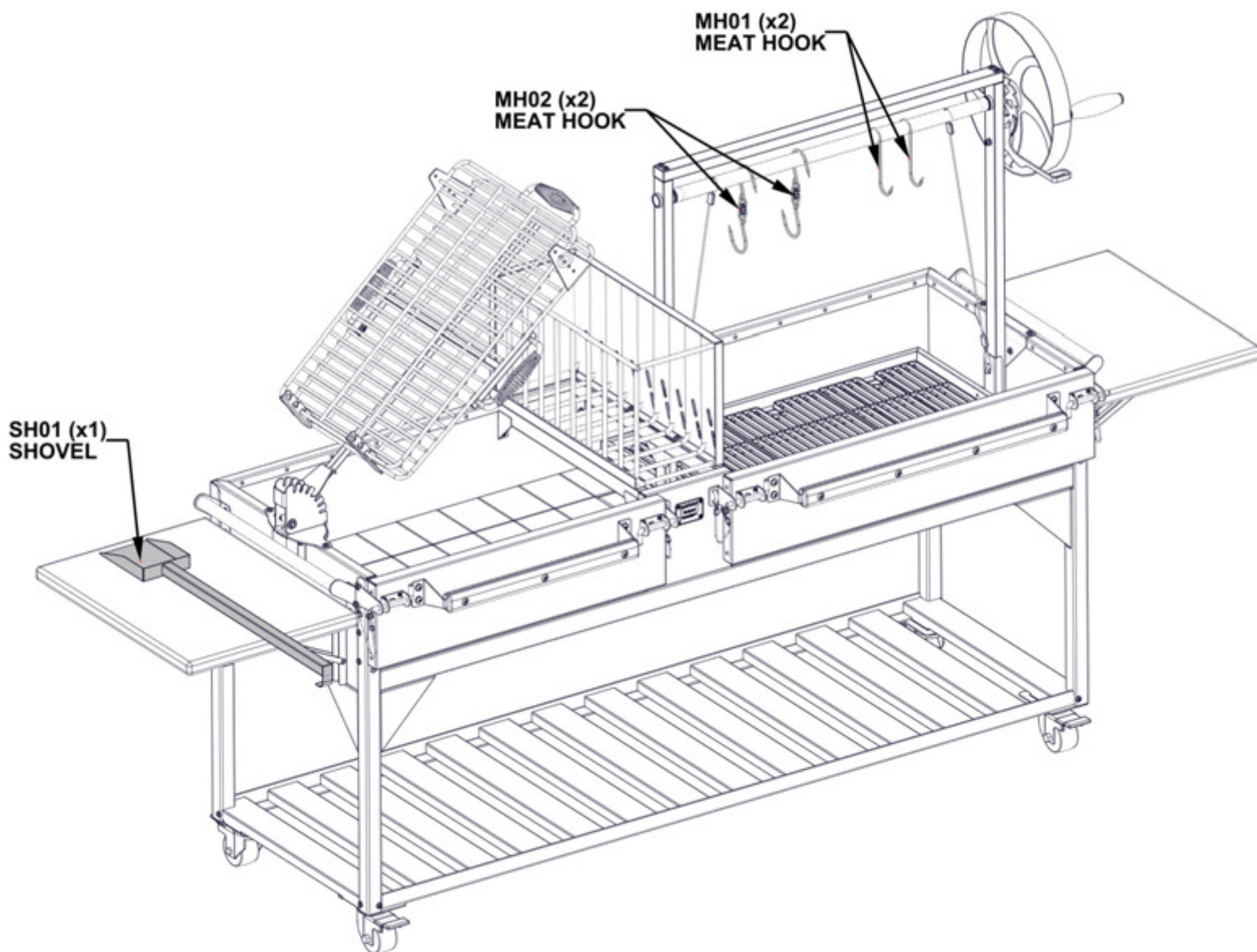

STEP 31 - CART ASSEMBLY

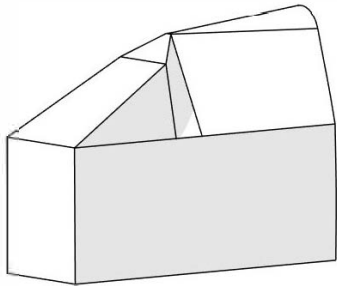

A6P00912 GRILL COVER
(x1)

- INSTALL COVER TO PROPERLY CARE FOR YOUR GRILL WHEN NOT IN USE.
- MAKE SURE GRILL HAS COOLED TO AN AMBIENT TEMPERATURE BEFORE COVERING WITH COVER.

