



Manufactured by:
Backyard Discovery
3305 Airport Drive, Pittsburg, KS 66762
800-856-4445

Basepoint Business Centre: Rivermead Drive, Westlea, Swindon SN5 7EX Phone: 0800-118-2476
J.P. Coenstraat 7, The Bridge, The Hague, 2595 WP, Netherlands Phone: 08005678990

LANCASTER LINEAR OUTDOOR KITCHEN

MODEL #: 2404151



WARNING

Cancer and Reproductive Harm
www.P65Warnings.ca.gov



Please visit www.backyarddiscovery.com
For the most up to date assembly manual, to register your product, or to order
replacement parts Para obtener instrucciones en español, visite
www.backyarddiscovery.com



EASY STEP-BY-STEP
3D INTERACTIVE INSTRUCTIONS
DOWNLOAD THE FREE APP



OWNER'S MANUAL - BASIC SETUP DIMENSIONS & ASSEMBLY NOTES

It is critically important that you start with square and level footings or concrete pad to attach your structure.

- Pay close attention to the items needed for each step. Make sure you are using the correct hardware for each step. Using incorrect hardware may result in improper assembly
- Remember to double check for underground utilities and overhead electrical lines

Post mounts are provided with your structure which allows you to permanently install your structure to a pre-existing or new wood or concrete surface. See Anchor Instructions for further details and recommendations.

- The hardware to attach the post mounts to the structure is included.
- The hardware to mount the structure permanently to a concrete surface is included.
- The hardware to mount the structure permanently to a wood deck is NOT included and will need to be purchased separately. You must ensure there is ample structural support under the deck before permanently attaching.

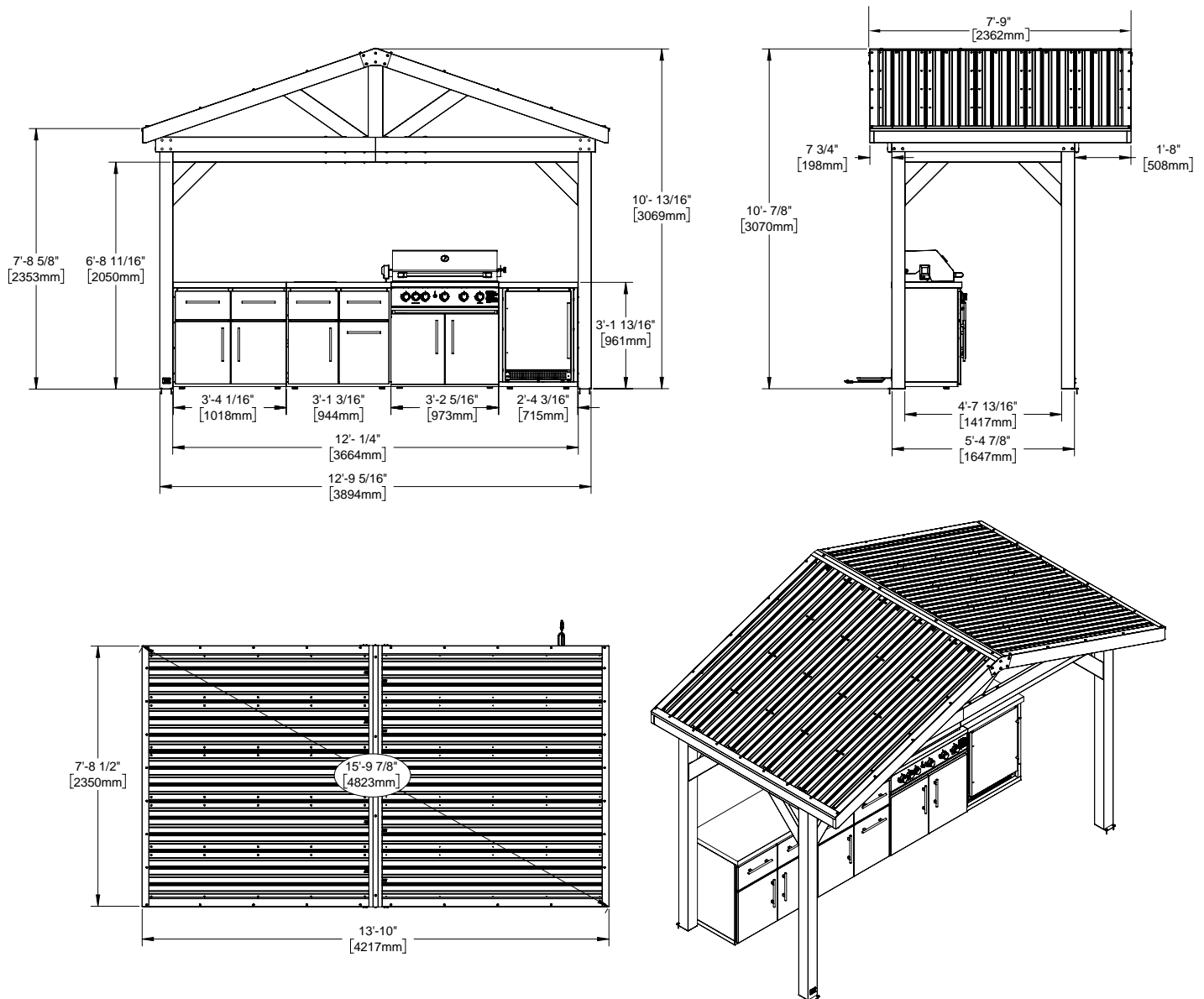

OWNER'S MANUAL - ANCHORING LAYOUT

NOTE: DIMENSIONS ARE TO ANCHOR PLATES MOUNTED TO POSTS EXCEPT WHERE NOTED.

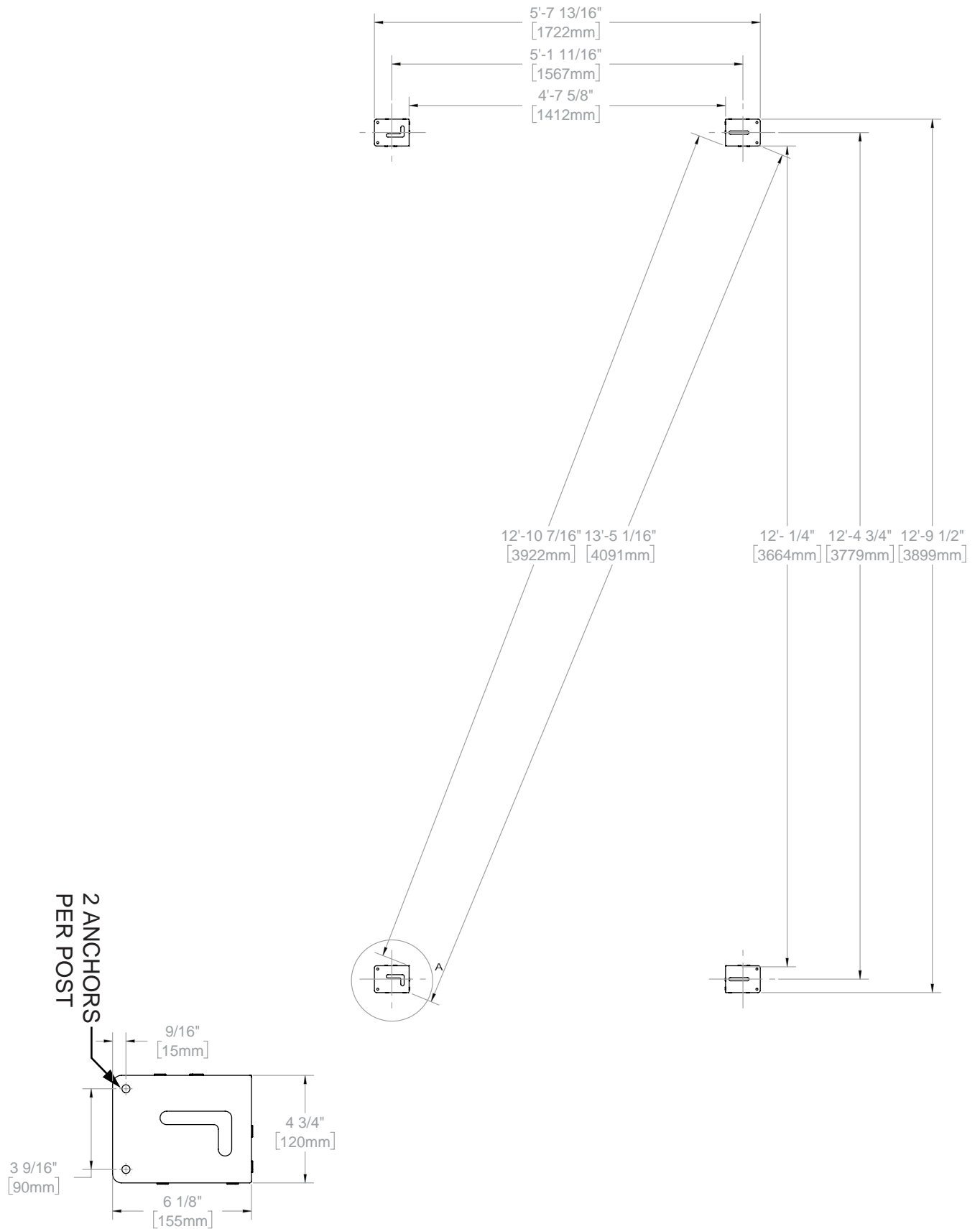

OWNER'S MANUAL - PARTS IDENTIFICATION

METAL COMPONENTS FOR PERGOLA (NOT TO SCALE)

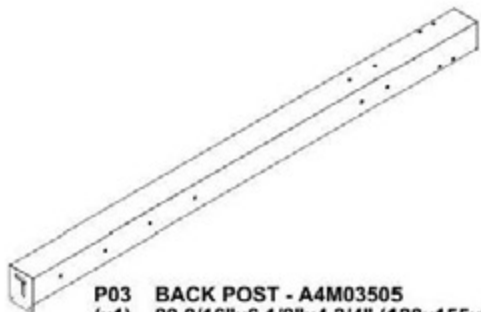

P03 BACK POST - A4M03505
(x1) 89 9/16"x6 1/8"x4 3/4" (120x155x2275)

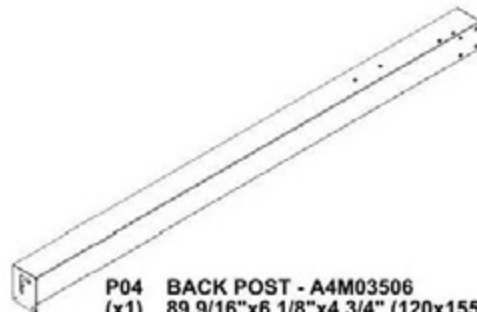

P04 BACK POST - A4M03506
(x1) 89 9/16"x6 1/8"x4 3/4" (120x155x2275)

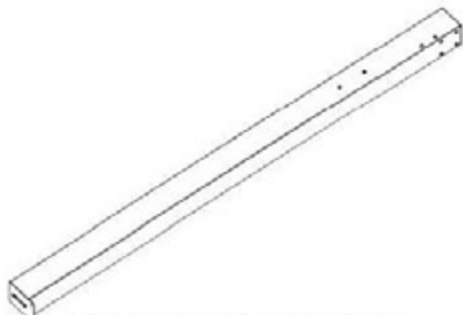

P05 FRONT POST - A4M03646
(x1) 89 9/16"x6 1/8"x4 3/4" (120x155x2275)

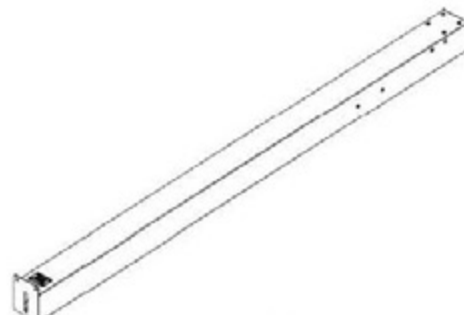

P06 FRONT POST - A4M03654
(x1) 89 9/16"x6 1/8"x4 3/4" (120x155x2275)



B03 FRONT BEAM ASSEMBLY - A4M03509
(x2) 78 3/16"x5 1/4"x1 7/16" (36x134x1986)



B04 FRONT BEAM ASSEMBLY - A4M03510
(x2) 78 3/16"x5 1/4"x1 7/16" (36x134x1986)



B05 FRONT BEAM ASSEMBLY - A4M03511
(x2) 72"x5 1/4"x1 7/16" (36x134x1829)



B06 FRONT BEAM ASSEMBLY - A4M03512
(x2) 72"x5 1/4"x1 7/16" (36x134x1829)



B17 SIDE BEAM ASSEMBLY - A4M03648
(x2) 64 15/16"x5 5/16"x1 7/16" (36x135.50x1649)

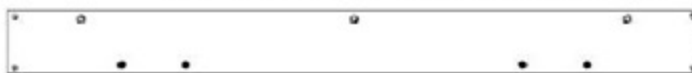

B18 SIDE BEAM ASSEMBLY - A4M03649
(x2) 55 9/16"x5 1/4"x1 1/2" (37.50x134x1411)



B07 GABLE ARM ASSEMBLY - A4M03513
(x2) 29 3/16"x5 1/4"x1 7/16" (36x134x741)

OWNER'S MANUAL - PARTS IDENTIFICATION

METAL COMPONENTS FOR PERGOLA (NOT TO SCALE)



B16 RIDGE BEAM ASSEMBLY - A4M03647
(x1) 92 15/16"x5 5/16"x1 9/16" (39x135.50x2361)

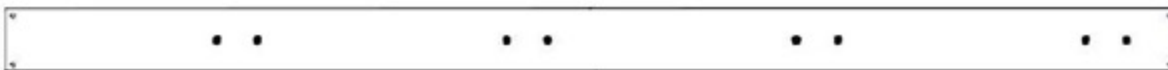

B19 DRIP BEAM ASSEMBLY - A4M03650
(x2) 89 15/16"x4 13/16"x1 7/16" (36x122x2285)

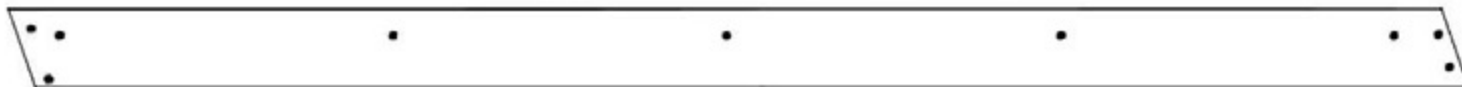

B12 GABLE BEAM ASSEMBLY - A4M03518
(x2) 88 13/16"x5 1/4"x1 7/16" (36x134x2255)



B13 GABLE BEAM ASSEMBLY - A4M03519
(x2) 88 13/16"x5 1/4"x1 7/16" (36x134x2255)



R01 RAFTER ASSEMBLY - A4M03522
(x2) 86 3/8"x4 5/16"x3 1/8" (80x110x2194.6)



R02 RAFTER ASSEMBLY - A4M03523
(x2) 86 3/8"x4 5/16"x3 1/8" (80x110x2194.6)



R03 RAFTER ASSEMBLY - A4M03524
(x4) 86 3/8"x4 5/16"x3 1/8" (80x110x2194.6)



C01 CORBEL ASSEMBLY - A4M03525
(x4) 21 13/16"x5 1/4"x2 3/4" (70x134x553.5)



C02 CORBEL ASSEMBLY - A4M03526
(x4) 21 13/16"x5 1/4"x2 3/4" (70x134x553.5)

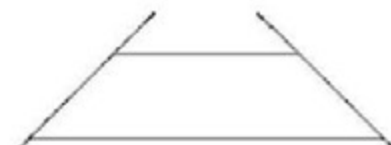

C03 CORBEL ASSEMBLY - A4M03527
(x2) 23 3/8"x12"x1 7/16" (36x304x593)



E03 PURLIN ASSEMBLY - A4M03651
(x10) 89 15/16"x1 15/16"x1 9/16" (40x50x2284)



B08 GABLE ARM ASSEMBLY - A4M03514
(x2) 40 1/16"x5 1/4"x1 7/16" (36x134x1017)



B09 GABLE ARM ASSEMBLY - A4M03515
(x2) 40 1/16"x5 1/4"x1 7/16" (36x134x1017)



J1 SPLICE BRACKET - A4M02230
(x4) 1 5/16"x5 3/16"x39 3/8" (33.2x131.2x1000)

OWNER'S MANUAL - PARTS IDENTIFICATION

METAL COMPONENTS FOR PERGOLA (NOT TO SCALE)



J3 GABLE BRACKET - A4M03805
(x2) 11 1/8"x6 7/16"x1/16" (2x163x282)



J4 BEAM BRACKET - A4M02990
(x8) 1"x1 5/16"x5 1/16" (25x33.2x128)



J5 RAFTER BRACKET - A4M03803
(x4) 3 5/8"x2 11/16"x2 1/16" (52x68x91.5)



J7 RAFTER BRACKET - A4M03802
(x4) 3 5/8"x2 3/16"x2" (50x55x92)



J8 GABLE BRACKET - A4M03804
(x4) 4 13/16"x1 9/16"x1 9/16" (40x40x123)



J9 BEAM BRACKET - A4M03807
(x4) 1"x1 5/16"x4 9/16" (25x33.20x116)



J10 SUPPORT RING - A4M03808
(x4) 13/16"x7/16" (11x20)



A4M01352 HOLE COVER
(x70)



A4M03528 STEEL SHEETING
(x10)



A4M03653 DRIP TRIM
(x2)



A4M03532 EDGE TRIM
(x4)



A4M03652 RIDGE CAP
(x1)

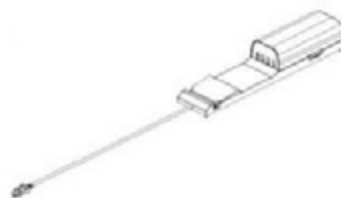

9205413 ELECTRICAL ENCLOSURE
(x1)

OWNER'S MANUAL - PARTS IDENTIFICATION

METAL COMPONENTS FOR CABINETS (NOT TO SCALE)

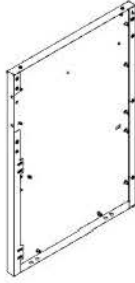

S3 SINK CABINET SIDE PANEL ASSEMBLY L - A4M03562
(x1) 33 3/8"x23 3/8"x1 3/8" (35.00x594.00x848.20)

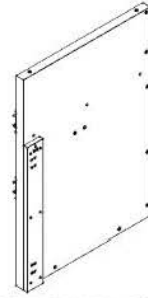

S4 SINK CABINET SIDE PANEL ASSEMBLY R - A4M03563
(x1) 33 3/8"x23 3/8"x2 5/8" (67.00x594.00x848.20)

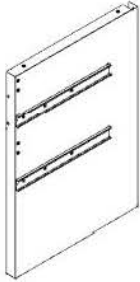

S5 SINK CABINET SIDE PANEL ASSEMBLY M - A4M03567
(x1) 33 3/8"x23 3/8"x2 3/16" (56.20x593.00x847.00)



S6 GRILL CABINET SIDE PANEL ASSEMBLY M - A4M03586
(x1) 23 3/8"x22 7/8"x1 3/8" (35.00x581.00x593.00)

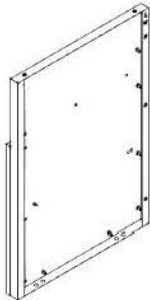

S7 FRIDGE CABINET SIDE PANEL ASSEMBLY L - A4M03597
(x1) 33 7/16"x23 3/8"x2 1/16" (53.00x594.00x849.70)

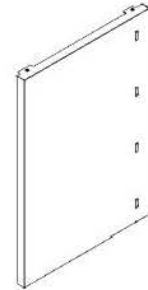

S8 FRIDGE CABINET SIDE PANEL ASSEMBLY R - A4M03598
(x1) 33 3/8"x23 3/8"x1 15/16" (50.00x594.00x848.20)

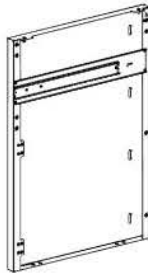

S16 STORAGE CABINET SIDE PANEL ASSEMBLY L - A4M03689
(x1) 33 3/8"x23 3/8"x1 15/16" (50.00x594.00x848.20)

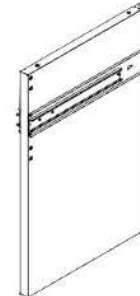

S17 STORAGE CABINET SIDE PANEL ASSEMBLY M - A4M03690
(x1) 33 3/8"x23 3/8"x1 3/8" (35.00x593.20x847.20)

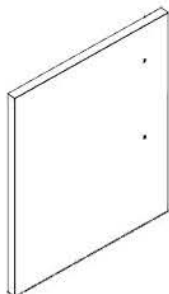

D6 SINK CABINET DOOR ASSEMBLY L - A4M03577
(x1) 22 1/4"x17 13/16"x15/16" (24.00x452.00x565.00)

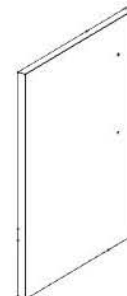

D7 GRILL CABINET DOOR ASSEMBLY L - A4M03587
(x1) 24 13/16"x19 1/16"x15/16" (24.00x484.15x630.00)

OWNER'S MANUAL - PARTS IDENTIFICATION

METAL COMPONENTS FOR CABINETS (NOT TO SCALE)

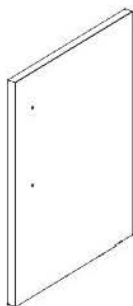

D8 GRILL CABINET DOOR ASSEMBLY R - A4M03590
(x1) 24 13/16"x19 1/16"x15/16" (24.00x484.15x630.00)

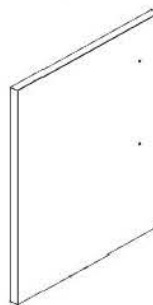

D20 DOOR PANEL ASSEMBLY L - A4M03701
(x1) 22 1/4"x19 5/8"x15/16" (24x498.28x565.50)

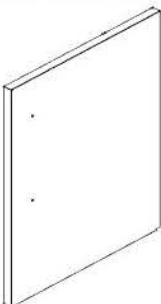

D21 DOOR PANEL ASSEMBLY R - A4M03703
(x1) 22 1/4"x19 5/8"x15/16" (24x498.26x565.50)

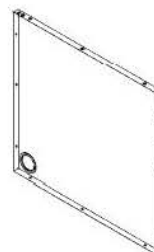

G3 SINK CABINET BACK PANEL ASSEMBLY - A4M03564
(x1) 34 5/16"x33 3/8"x1 3/16" (30.00x847.20x872.00)

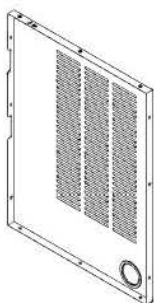

G4 FRIDGE CABINET BACK PANEL ASSEMBLY - A4M03599
(x1) 25 5/16"x33 3/8"x1 3/16" (30.00x847.20x643.00)

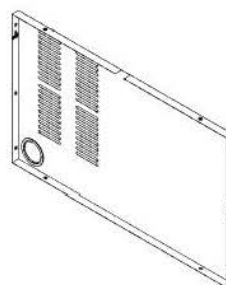

G10 GRILL CABINET BACK PANEL ASSEMBLY - A4M03055
(x1) 1 3/16"x22 7/8"x38 3/16" (30x581x970)

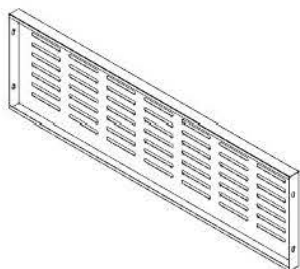

G11 GRILL VENTILATION PANEL - A4M03056
(x1) 1 5/16"x11 3/16"x38 3/16" (33x284x970)

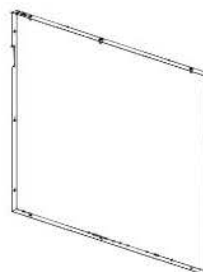

G12 STORAGE CABINET BACK PANEL ASSEMBLY - A4M03691
(x1) 38 3/4"x33 3/8"x1 3/16" (30.00x847.20847.20x984.00)

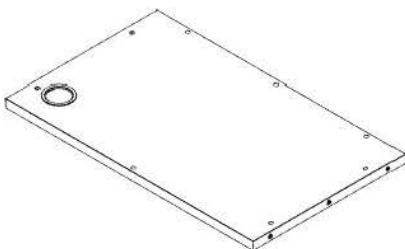

T2 GRILL TABLETOP ASSEMBLY - A4M03057
(x1) 1 1/4"x23 3/8"x38 3/16" (32x594x970)

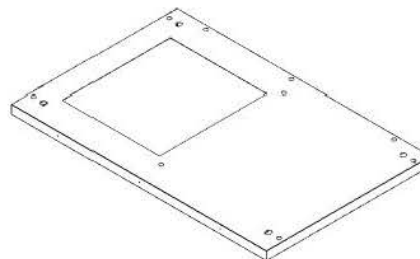

T4 SINK CABINET TABLETOP FRAME - A4M03566
(x1) 37 3/16"x24 1/8"x1 1/4" (32x612x944)

OWNER'S MANUAL - PARTS IDENTIFICATION

METAL COMPONENTS FOR CABINETS (NOT TO SCALE)



T7 FRIDGE CABINET TABLETOP - A4M03641
(x1) 27 3/8"x24 1/8"x1 1/4" (32x612x696)

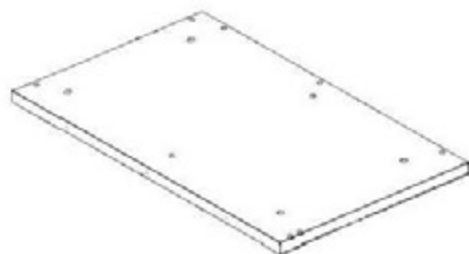

T12 STORAGE CABINET TABLETOP ASSEMBLY - A4M03693
(x1) 39 7/16"x24 1/8"x1 1/4" (32.00x612.00x1001.00)

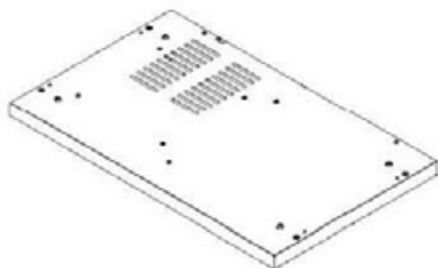

F2 GRILL CABINET FLOOR PANEL ASSEMBLY - A4M03048
(x1) 25 5/8"x23 3/8"x38 1/4" (66x594x972)

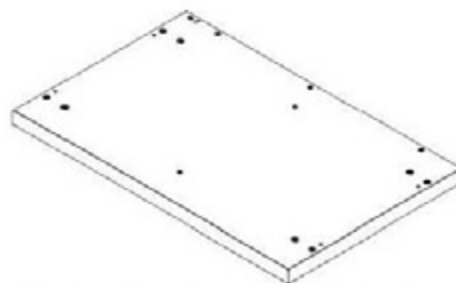

F3 SINK CABINET FLOOR PANEL ASSEMBLY - A4M03560
(x1) 37 3/16"x23 3/8"x2 5/8" (66x594x944)

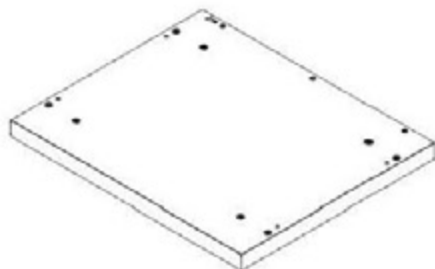

F4 FRIDGE CABINET FLOOR PANEL ASSEMBLY - A4M03595
(x1) 28 1/8"x23 3/8"x2 5/8" (66x594x715)



F7 STORAGE CABINET FLOOR ASSEMBLY - A4M03687
(x1) 40 3/16"x23 3/8"x2 5/8" (66x594x1020)

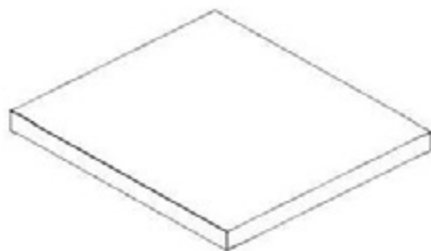

M3 FRIDGE CABINET MARBLE - A4M03602
(x1) 28 1/8"x24 15/16"x1 15/16" (50x634x715)

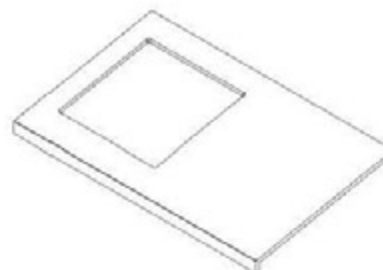

M7 SINK CABINET MARBLE - A4M03655
(x1) 37 3/16"x24 15/16"x1 15/16" (50x634x944)

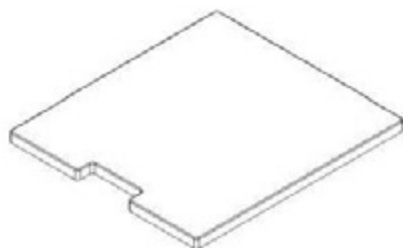

M5 SINK COVER MARBLE - A4M03147
(x1) 11 1/16"x14 3/4"x16 5/16" (18x375x415)

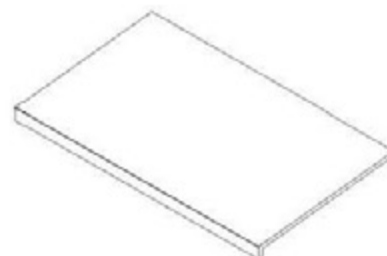

M10 STORAGE CABINET MARBLE - A4M03694
(x1) 40 3/16"x24 15/16"x1 15/16" (50x634x1020)

OWNER'S MANUAL - PARTS IDENTIFICATION

METAL COMPONENTS FOR CABINETS (NOT TO SCALE)

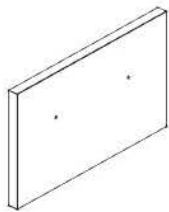

D3 SINK CABINET DRAWER PANEL ASSEMBLY - A4M03569
(x1) 17 3/4"x10 1/4"x15/16" (24.00x260.00x451.00)

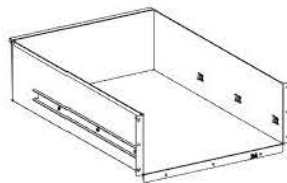

D4 SINK CABINET DRAWER BODY FRAME - A4M03571
(x1) 22 1/4"x16 1/16"x6 7/16" (164.20x408.40x565.40)

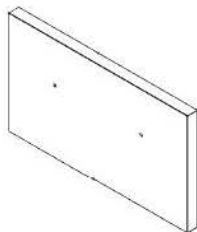

D5 SINK CABINET TRIM PANEL ASSEMBLY - A4M03576
(x1) 17 13/16"x10 1/4"x1" (26.00x260.00x452.00)

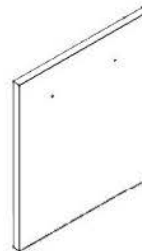

D9 TRASH CAN PANEL ASSEMBLY - A4M03608
(x1) 22 1/4"x17 3/4"x15/16" (24.00x451.00x565.00)

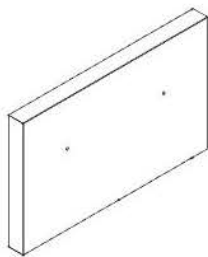

D18 DRAWER PANEL ASSEMBLY - A4M03696
(x1) 19 9/16"x10 1/4"x15/16" (24.00x260.00x498.25)

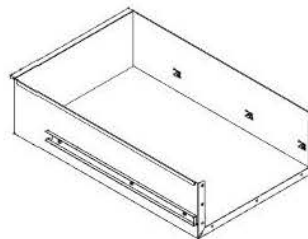

D19 DRAWER BODY - A4M03698
(x2) 22 1/4"x17 3/4"x5 3/4" (145x436.60x552)

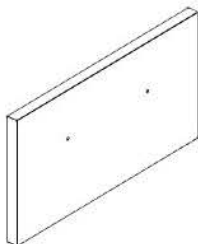

D22 DRAWER PANEL ASSEMBLY R - A4M03706
(x1) 19 9/16"x10 1/4"x15/16" (24.00x260.00x498.25)

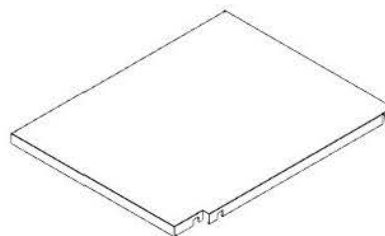

L2 GRILL CABINET SHELF ASSEMBLY - A4M03589
(x1) 23 1/4"x18 3/8"x1" (25.00x467.00x591.00)

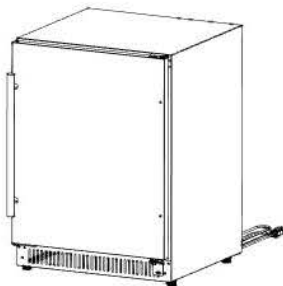

9240162 OUTDOOR KITCHEN FRIDGE - RIGHT OPEN
(x1)

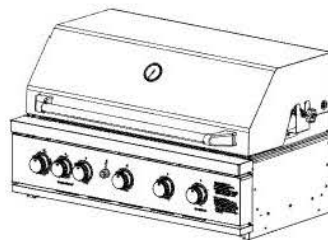

9240025 OUTDOOR KITCHEN GRILL KIT
(x1)

OWNER'S MANUAL - PARTS IDENTIFICATION

METAL COMPONENTS FOR CABINETS (NOT TO SCALE)

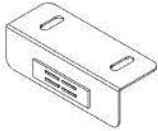

A2 MAGNET BRACKET - A4M03026
(x5) 1"x1 1/4"x3 1/8" (25x31x80)

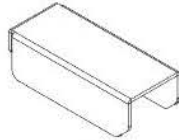

A5 SHELF BRACKET - A4M03141
(x2) 5/8"x7/8"x2 1/16" (16x22x53)

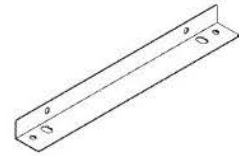

A6 ANGLED BRACKET - A4M03053
(x3) 1 3/8"x1 15/16"x17 1/8" (35x50x435)

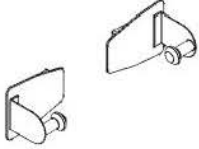

A4M02290 MAGNETIC PAPER TOWEL HOLDER
(x2)



A4M03151 GARDEN HOSE ADAPTER
(x1)

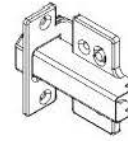

A4M03025 FULL OVERLAY HINGE
(x10)

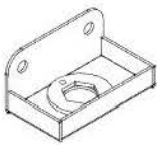

A9 HOSE BRACKET ASSEMBLY - A4M03060
(x1) 1 1/4"x1 7/16"x2 9/16" (31.5x36.5x65)

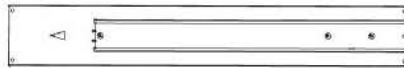

A10 SLIDE BRACKET ASSEMBLY - A4M03083
(x1) 15/16"x3 3/8"x22 5/8" (23x85x575)

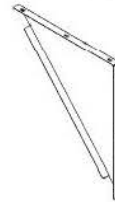

A11 TRIANGLE PANEL - A4M03086
(x2) 13/16"x13 3/4"x13 3/4" (20x350x350)

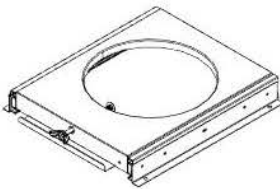

A13 GAS TANK HOLDER ASSEMBLY - A4M03047
(x1) 1 15/16"x12 7/8"x14 3/4" (49x327x374)

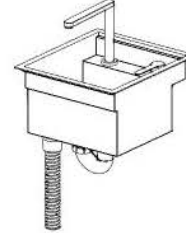

A16 SINK ASSEMBLY - A4M03143
(x1) 15 1/8"x15 5/16"x16 7/8" (384x389x429)

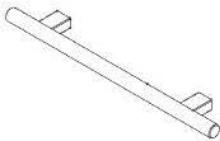

H2 STAINLESS STEEL HANDLE - A4M03024
(x10) 5/8"x1 9/16"x11 13/16" (16x40x300)

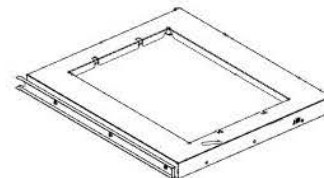

H3 TRASH CAN BRACKET ASSEMBLY - A4M03610
(x1) 1 3/8"x18 1/16"x15 13/16" (35.00x401.60x458.00)

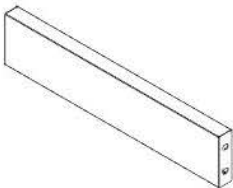

H4 HORIZONTAL BEAM ASSEMBLY L - A4M03575
(x4) 16 1/4"x3 3/8"x1" (25.00x85.00x413.00)



H11 DRAWER FIXING PIECE - A4M03692
(x1) 5 3/8"x1 1/16"x11/16" (17.20x27.00x137.00)

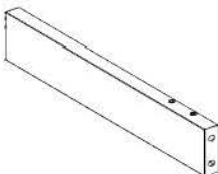

H12 HORIZONTAL BEAM ASSEMBLY - A4M03695
(x4) 18 1/4"x2 15/16"x1" (25.00x75.00x464.00)

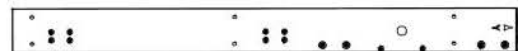

H13 HINGE CHANNEL - A4M03700
(x1) 33 3/8"x2 15/16"x11/16" (18.00x74.80x847.00)

OWNER'S MANUAL - PARTS IDENTIFICATION

HARDWARE COMPONENTS

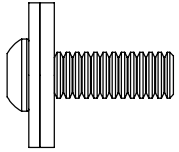

H101202 | TORX PAN HEAD
(x363) | 1/4-20x3/4 ASSY

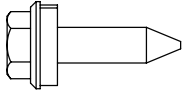

H101117 | SCREW WOODGRIP
(x100) | 10-16 x 3/4 BLK

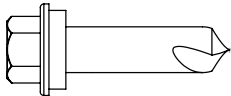

H101116 | SCREW SELF TAPPING
(x34) | 1/4x1 BLK

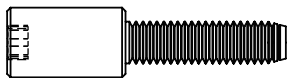

H101132 | TORX SOCKET SCREW SHORT
(x40) | 1/4-20 BLK



H101103 | TORX SOCKET SCREW
(x99) | 1/4-20 BLK

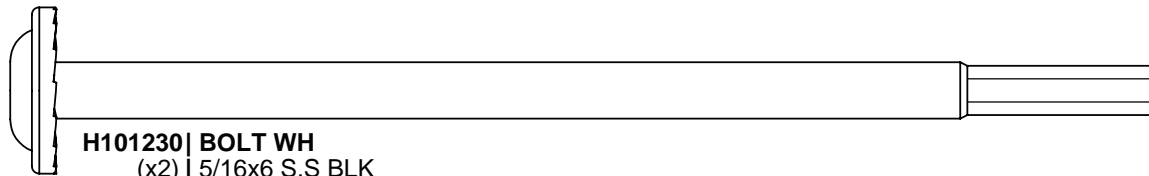

H101230 | BOLT WH
(x2) | 5/16x6 S.S BLK

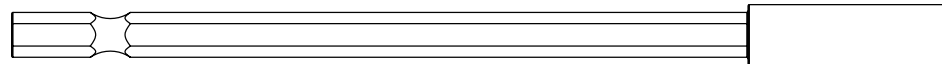

H101278 | MAGNETIC DRIVER EXTENSION
(x1) |



H100147 | TORX BIT
(x1) | T-30

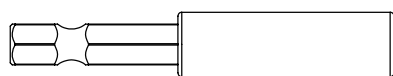

H101100 | MAGNETIC DRIVER
(x1) |



H100114 | TORX BIT
(x1) | T-30



H101185 | PHILLIPS FLAT HEAD
(x60) | 8-32x.5 BLK

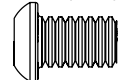

H101292 | TORX PAN HEAD
(x16) | 1/4-20x13/32" BLK



H101289 | PAN HEAD SCREW
(x63) | 8-32x1/2" SS BLK



H101287 | PAN HEAD SCREW
(x6) | 8-32x1" SS BLK

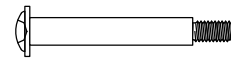

H101307 | SHOULDER BOLT
(x18) | 8-32x30mm SS BLK



H101293 | TORX PAN HEAD
(x4) | 1/4-20x1 3/8" BLK

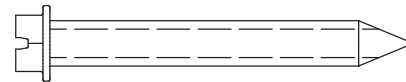

H100120 | CONCRETE ANCHOR
(x8) | 1/4"x2" BLK

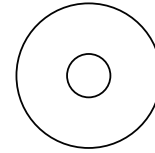

H101053 | STEEL WASHER
(x16) | 6x20 BLK

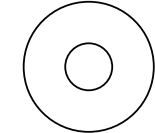

H101054 | SEALANT WASHER
(x16) | 6.5x18 BLK

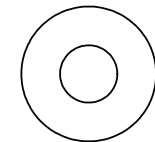

H100630 | WASHER FLAT
(x8) | 8x19 BLK

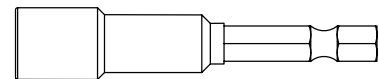

H101106 | SOCKET DRIVER
(x1) |

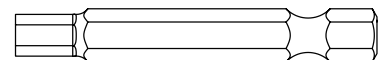

H101294 | HEX DRIVER
(x1) |

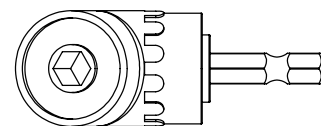

H101114 | RIGHT ANGLE DRILL ADAPTER
(x1) |

PRE-ASSEMBLY STEP 1 - SORTING PARTS

It is critical for ease of assembly that you take the time to sort and organize the parts and hardware.

METAL PARTS:

- Organize metal parts by the three-digit, alpha-numeric number stamped on each part (ex. P01).
- If there are multiple parts with the same stamped number, stack those pieces together.
- Stamps can be found on the flat surface of the parts or on the end of the parts.
- Allow yourself plenty of room - the parts can take up a significant amount of space.

NOTE: CARTONS ARE NOT ORGANIZED BY PART OR STEP NUMBER.

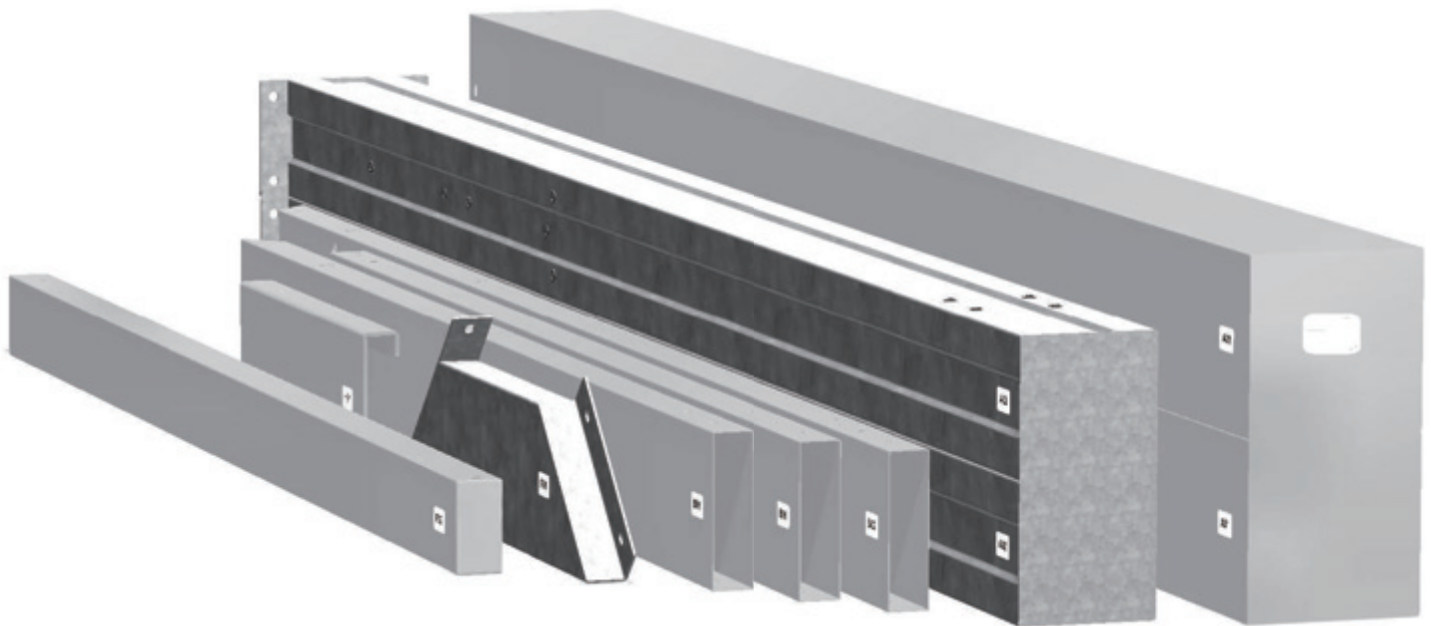

HARDWARE PARTS:

- We recommend that you have a separate table to organize the hardware.
- Hardware bags are printed with a seven-digit, alpha-numeric part number.
- You can organize your hardware by part number or group by hardware type (e.g. bolts, nuts, etc.).
- During assembly you only need to reference the last four digits of the number.



PRE-ASSEMBLY STEP 2 - TOOLS REQUIRED



Cordless Drill or
Electric Drill



Drill Attachments:
Phillips Head



1/8", 3/16", 3/8" &
7/16" Drill Bits



Phillips Screw Driver

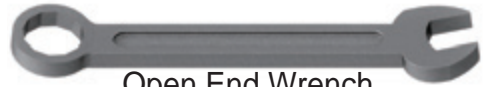

Open End Wrench
7/16"



3/8" Drive Ratchet, 1/2" &
7/16" STD Sockets 1/2" & 7/16"
Deep Sockets



Claw Hammer



Rubber Mallet -
Optional



Tape Measure

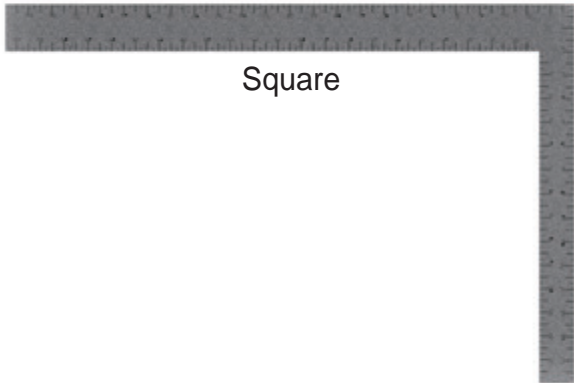

Square



Level 24"

PRE-ASSEMBLY STEP 3 - CHOOSE YOUR ASSEMBLY METHOD

There are several types of assembly instructions available to you.

1. Printed Assembly Manual included with your set
2. BILT APP - 3D interactive instructions
3. Combination of the Printed Manual and BILT APP (Note: Step numbers can differ between the two methods)



BILT[®]

Scan for easy
3D instructions

Download the BILT app
before you begin

Download on the
App Store

GET IT ON
Google Play

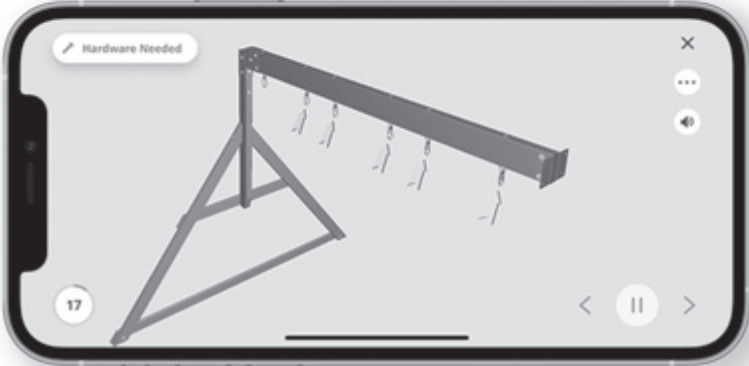

Hardware Needed

17

< || >

The image is a promotional graphic for the BILT app. It features the BILT logo at the top left, a QR code at the top right, and a smartphone at the bottom showing a 3D assembly instruction. The text 'Scan for easy 3D instructions' is prominently displayed in the center. Below the QR code are buttons for downloading the app from the App Store and Google Play. The smartphone screen shows a 3D model of a structure with a horizontal beam and a triangular support, with a 'Hardware Needed' label and a step number '17'.

STEP 1 - BEAM ASSEMBLY

QTY	PartNo	Description
6	H101202	TORX PAN HEAD 1/4-20x3/4 ASSY



B04 FRONT BEAM ASSEMBLY - A4M03510
 (x1) 78 3/16"x5 1/4"x1 7/16" (36x134x1986)



J1 SPLICE BRACKET - A4M02230
 (x1) 1 5/16"x5 3/16"x39 3/8" (33.2x131.2x1000)

- FOR EASE OF ASSEMBLY, WE RECOMMEND USING SAW HORSES FOR STEPS 1 - 12.

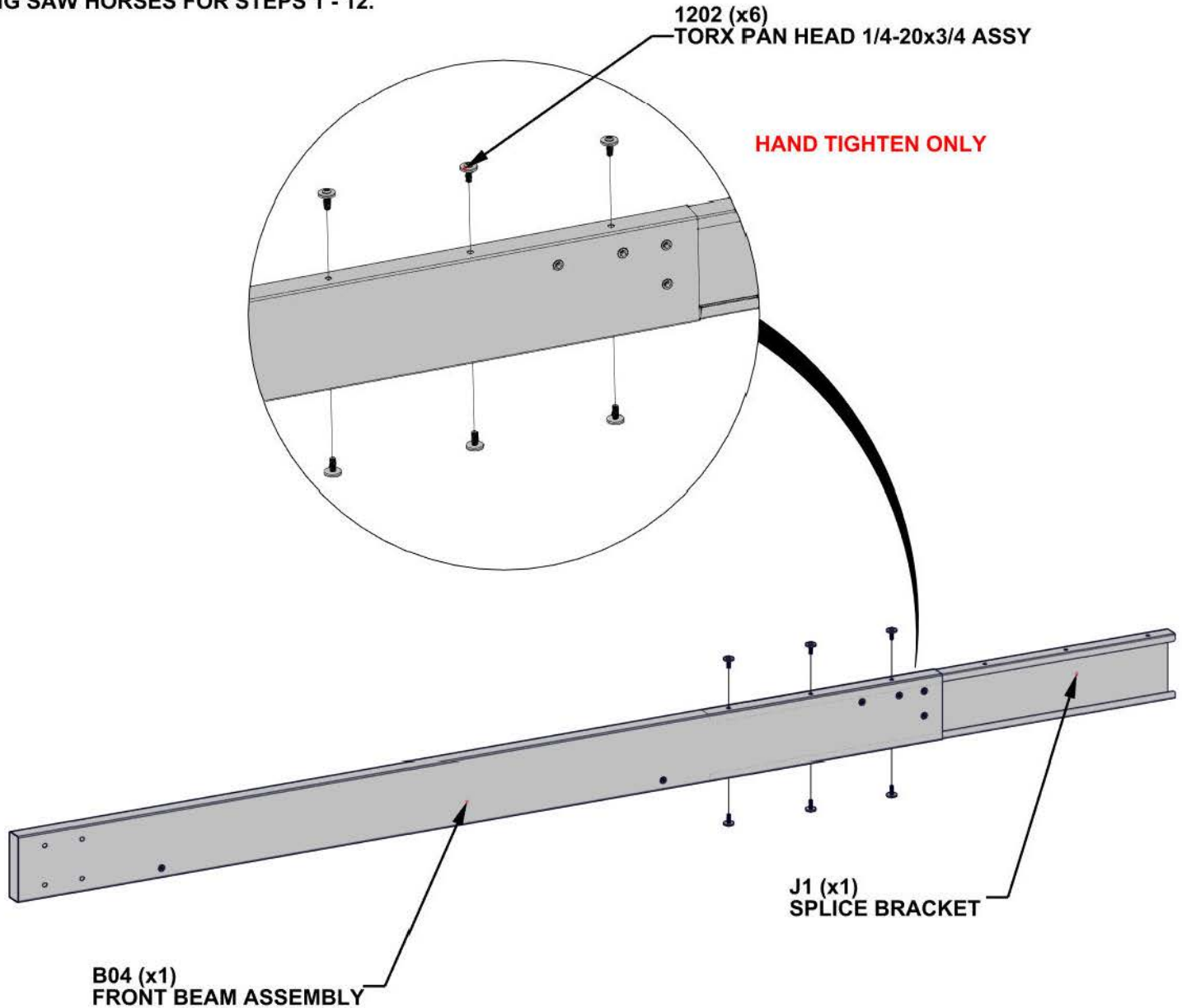

BEAM AND SPLICE MUST BE ORIENTED AS SHOWN ABOVE. SLIDE J1 INTO B04 AND LINE UP THREE HOLES TOP AND BOTTOM

STEP 2 - BEAM ASSEMBLY

QTY	PartNo	Description
6	H101202	TORX PAN HEAD 1/4-20x3/4 ASSY



B03 FRONT BEAM ASSEMBLY - A4M03509
(x1) 78 3/16"x5 1/4"x1 7/16" (36x134x1986)

- SLIDE B03 INTO SPLICE BRACKET.
GENTLY TAP ENDS OF ASSEMBLY WITH
RUBBER Mallet UNTIL GAP CLOSES.

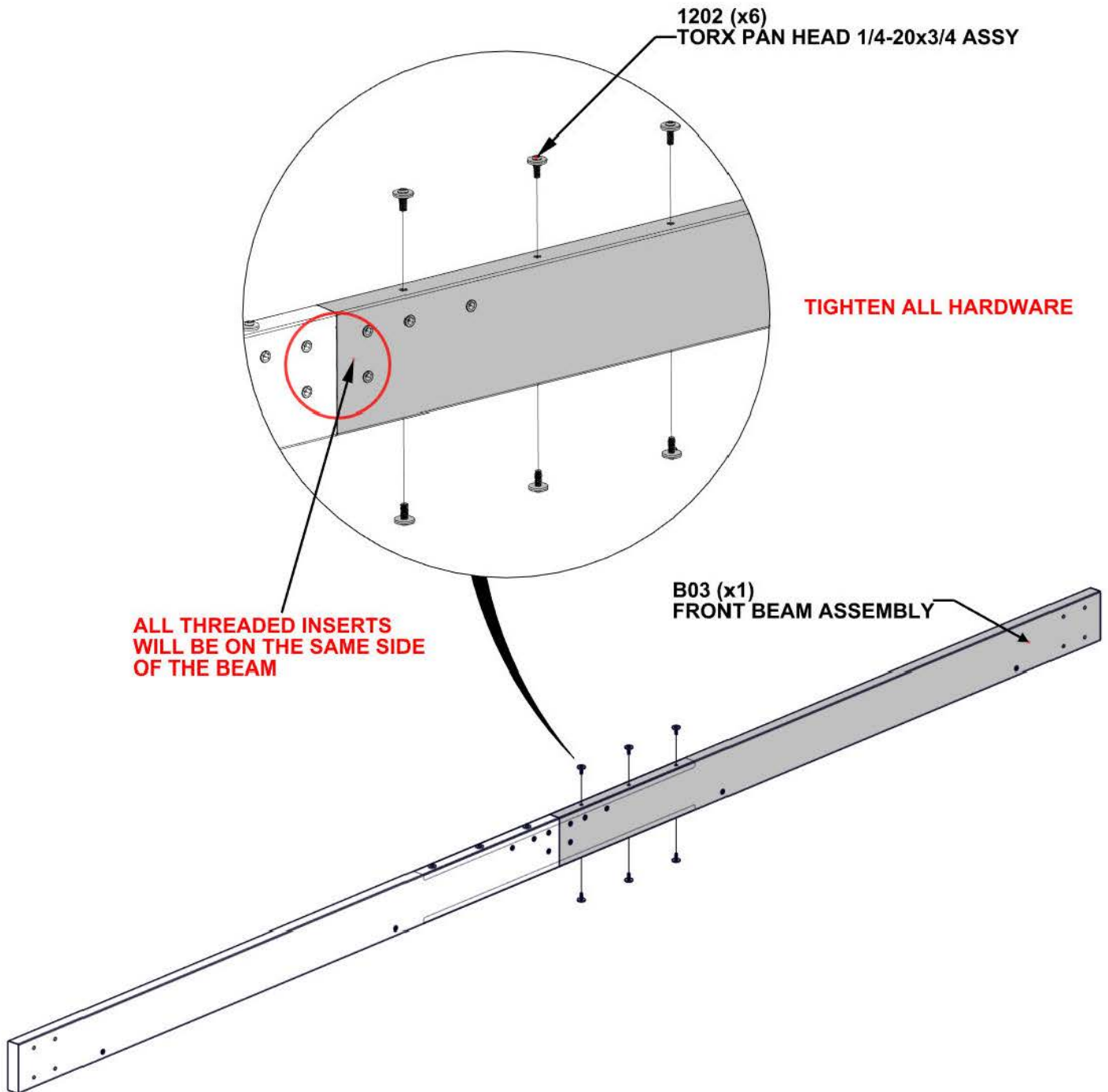

STEP 3 - BEAM ASSEMBLY

QTY	PartNo	Description
6	H101202	TORX PAN HEAD 1/4-20x3/4 ASSY



B06 FRONT BEAM ASSEMBLY - A4M03512
 (x1) 72"x5 1/4"x1 7/16" (36x134x1829)



J1 SPLICE BRACKET - A4M02230
 (x1) 1 5/16"x5 3/16"x39 3/8" (33.2x131.2x1000)

1202 (x6)
 TORX PAN HEAD 1/4-20x3/4 ASSY

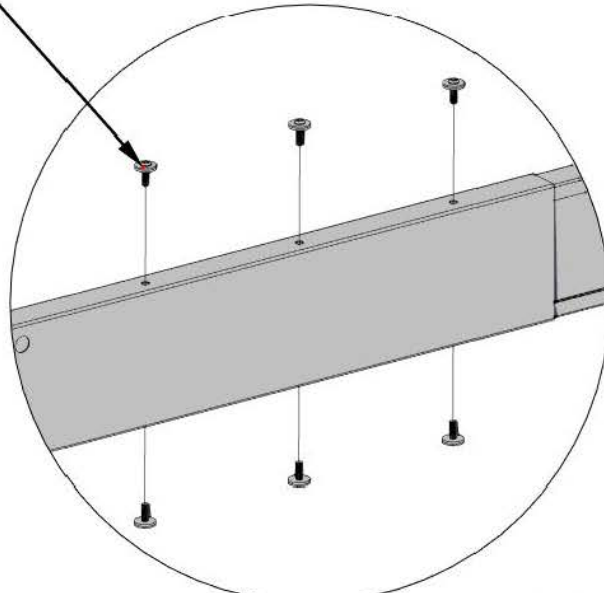

HAND TIGHTEN ONLY

J1 (x1)
 SPLICE BRACKET

B06 (x1)
 FRONT BEAM ASSEMBLY

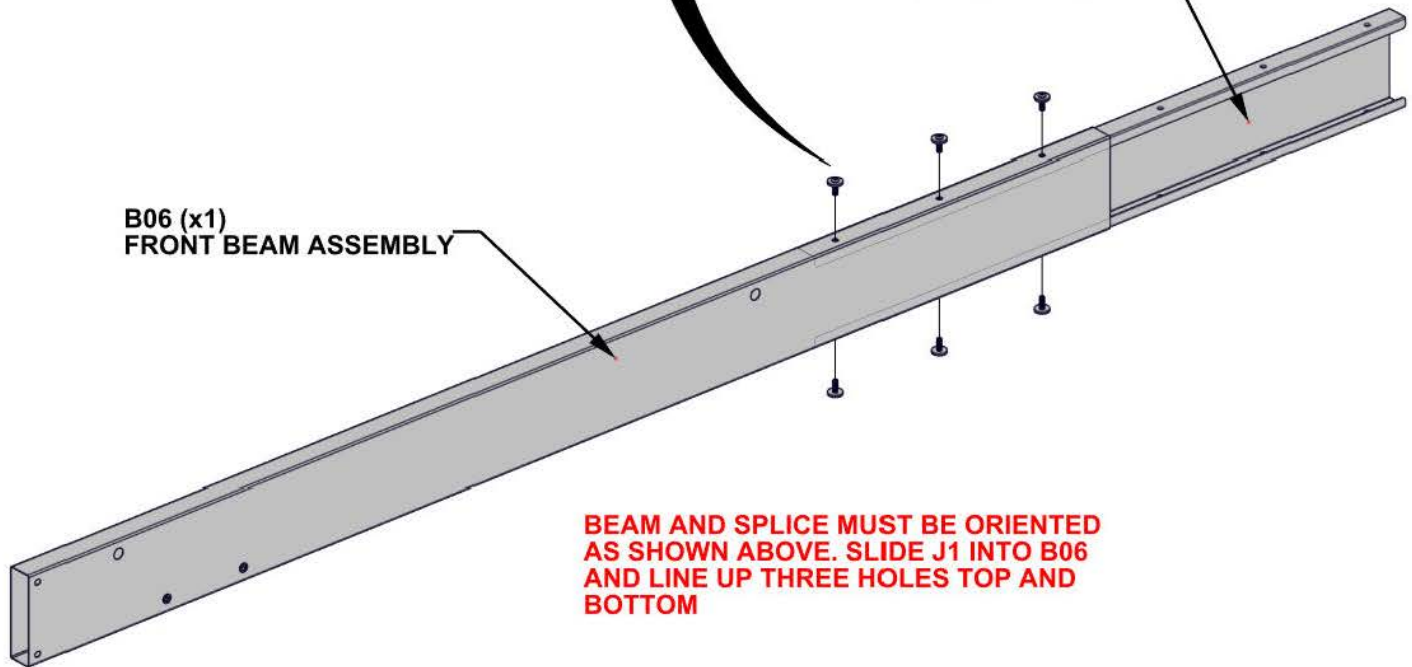

BEAM AND SPLICE MUST BE ORIENTED AS SHOWN ABOVE. SLIDE J1 INTO B06 AND LINE UP THREE HOLES TOP AND BOTTOM

STEP 4 - BEAM ASSEMBLY

QTY	PartNo	Description
6	H101202	TORX PAN HEAD 1/4-20x3/4 ASSY



B05 FRONT BEAM ASSEMBLY - A4M03511
(x1) 72"x5 1/4"x1 7/16" (36x134x1829)

- SLIDE B05 INTO SPLICE BRACKET.
GENTLY TAP ENDS OF ASSEMBLY WITH
RUBBER Mallet UNTIL GAP CLOSES.

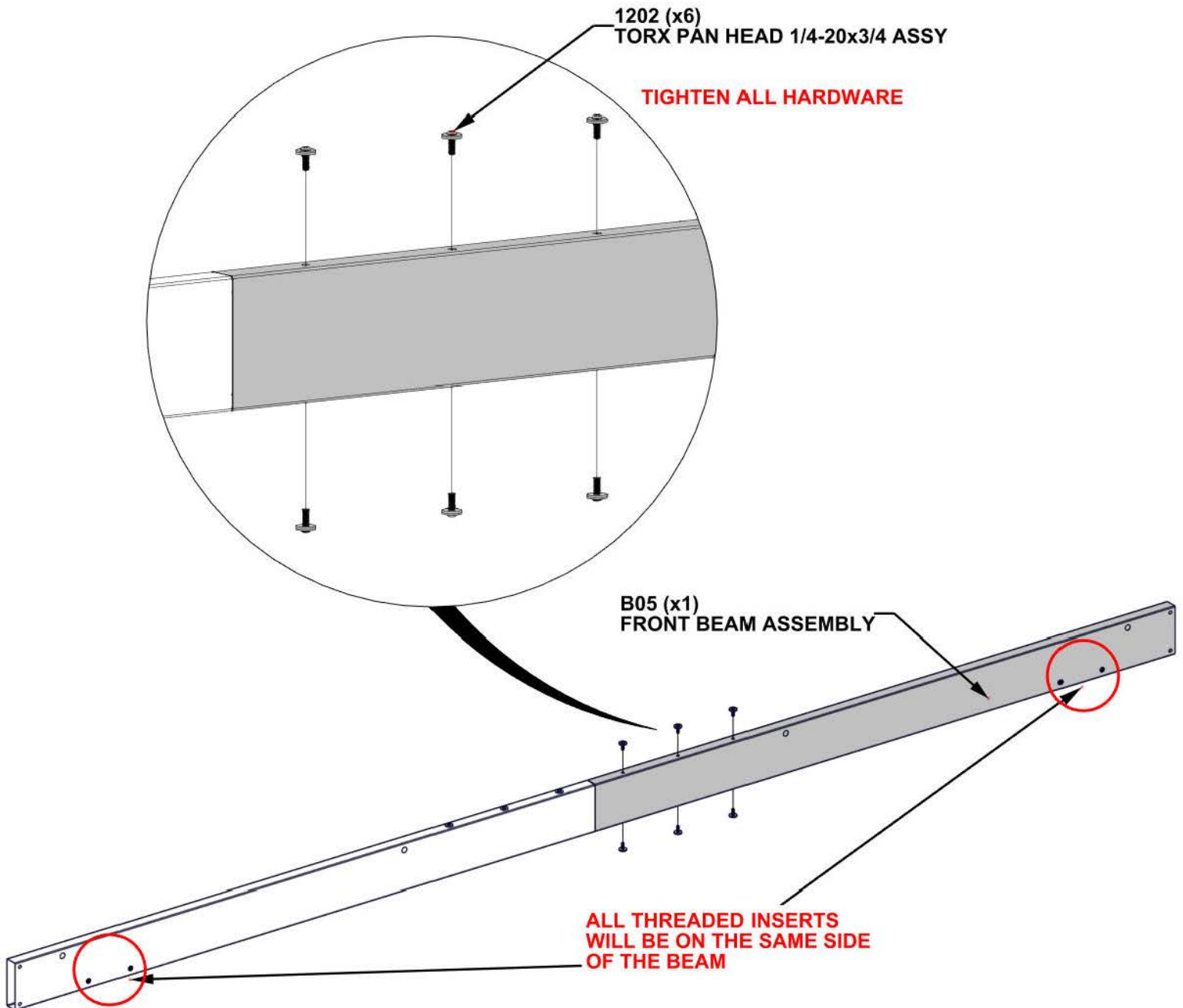

STEP 5 - BEAM ASSEMBLY

QTY	PartNo	Description
4	H101103	TORX SOCKET SCREW 1/4-20

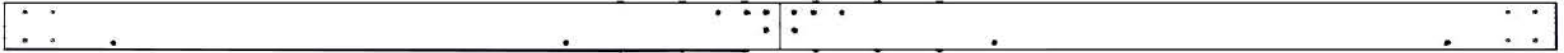

UPPER BEAM ASSEMBLY STEPS 1 - 2

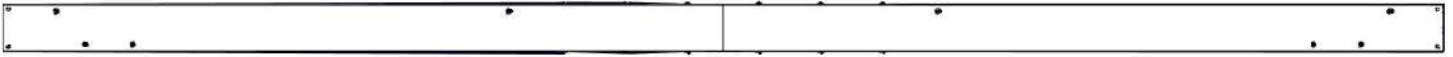

LOWER BEAM ASSEMBLY STEPS 3 - 4

- ALIGN THRU HOLES IN LOWER BEAM ASSEMBLY WITH THREADED INSERTS IN UPPER BEAM ASSEMBLY

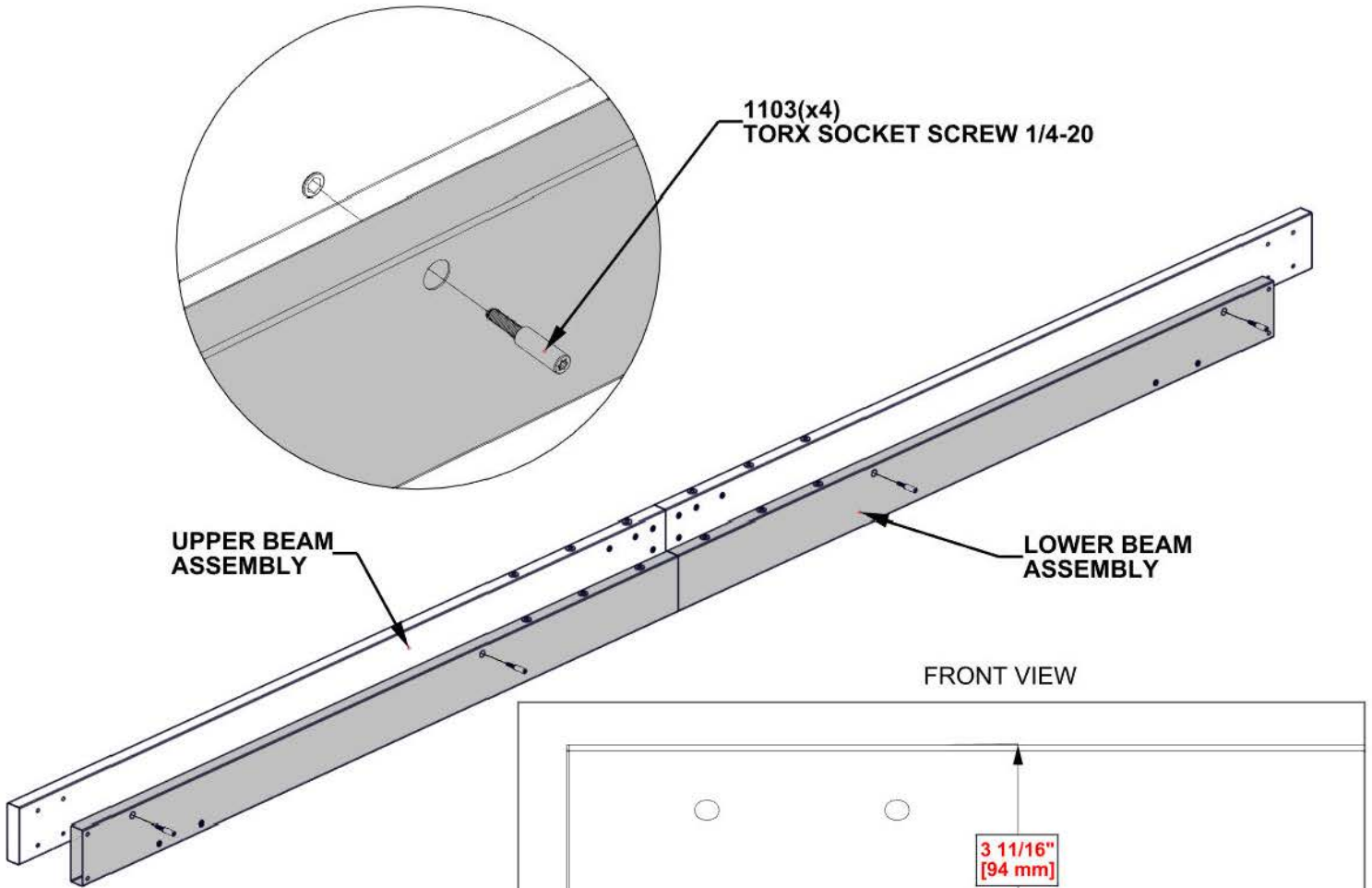

FRONT VIEW

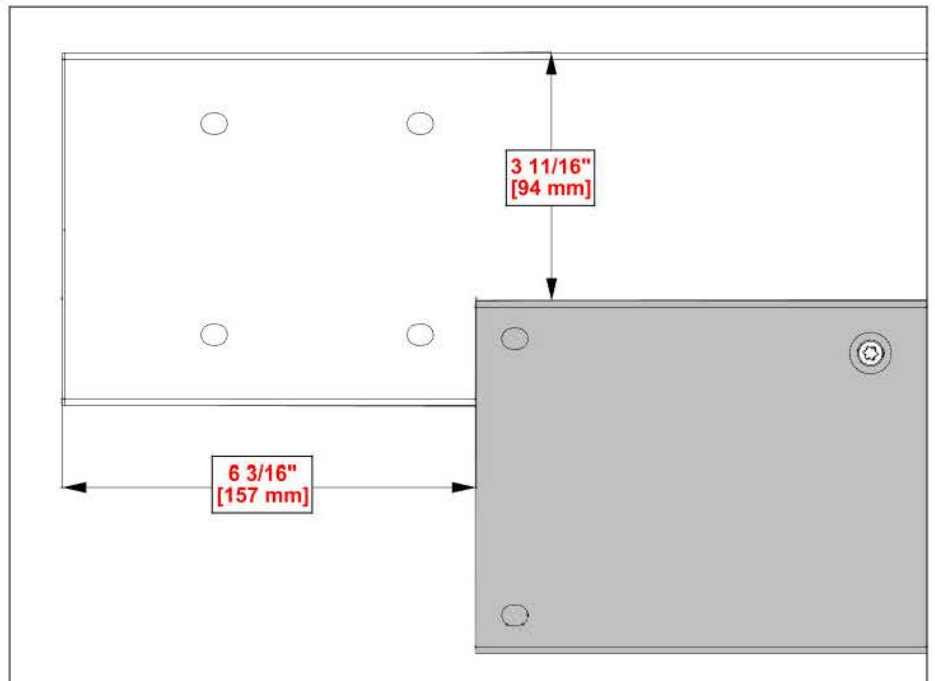

DIMENSIONS ARE THE SAME AT BOTH ENDS AND CRITICAL TO THE BEAM ASSEMBLY

**REPEAT BEAM ASSEMBLY
STEPS 1 THROUGH 5**

STEP 6 - POST ASSEMBLY

QTY	PartNo	Description
4	H101202	TORX PAN HEAD 1/4-20x3/4 ASSY

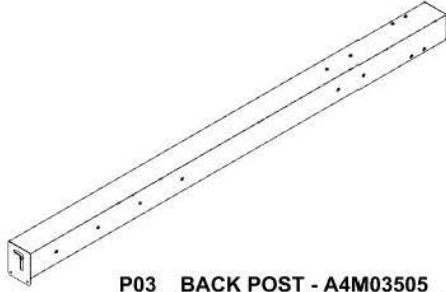

P03 BACK POST - A4M03505
(x1) 89 9/16"x6 1/8"x4 3/4" (120x155x2275)



J4 BEAM BRACKET - A4M02990
(x2) 1"x1 5/16"x5 1/16" (25x33.2x128)

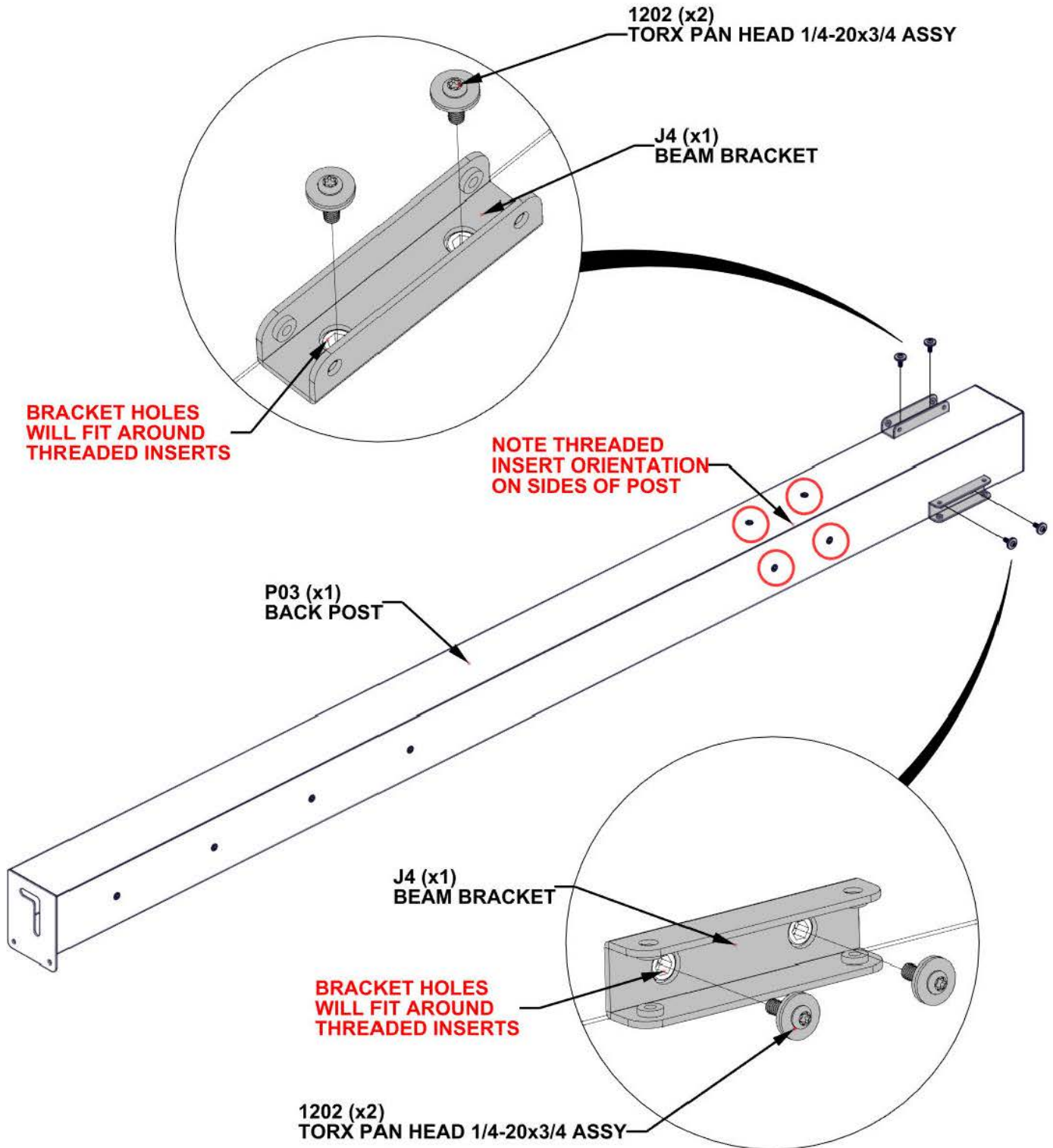

STEP 7 - POST ASSEMBLY

QTY	PartNo	Description
4	H101202	TORX PAN HEAD 1/4-20x3/4 ASSY

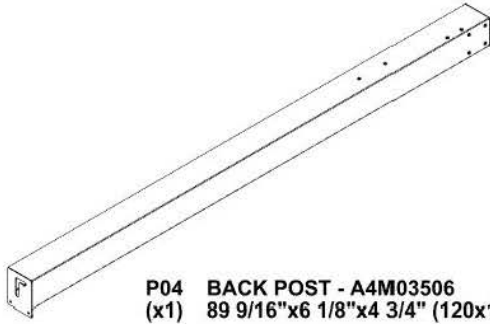

P04 BACK POST - A4M03506
(x1) 89 9/16"x6 1/8"x4 3/4" (120x155x2275)



J4 BEAM BRACKET - A4M02990
(x2) 1"x1 5/16"x5 1/16" (25x33.2x128)

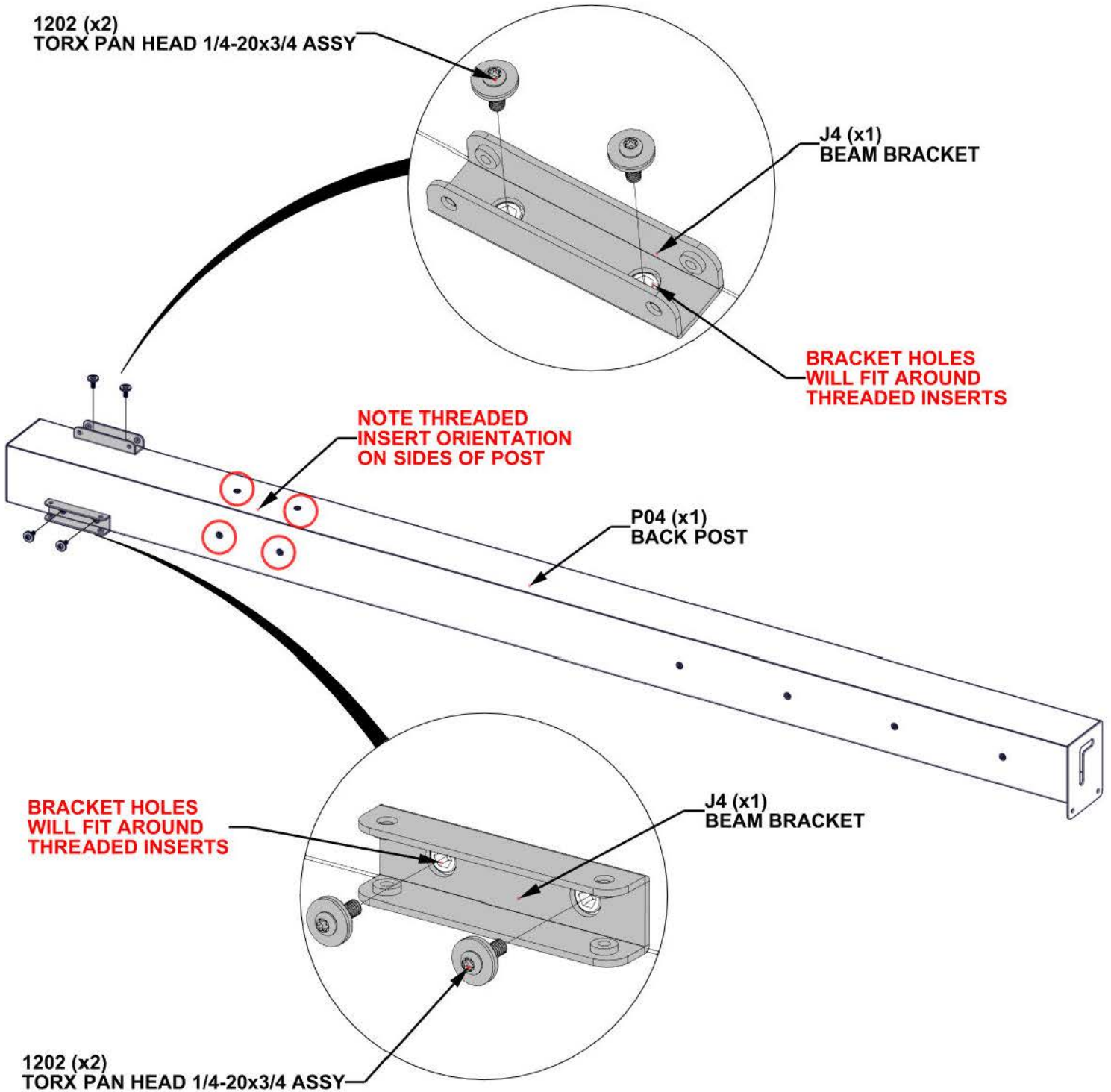

STEP 8A - FRAME ASSEMBLY

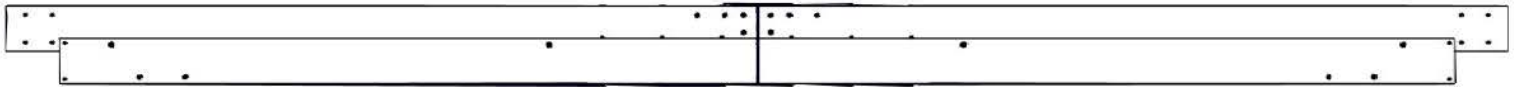

BEAM ASSEMBLY FROM STEPS 1 - 5

- SLIDE EACH POST ASSEMBLY INTO THE BEAM ASSEMBLY FROM STEPS 1 - 5.

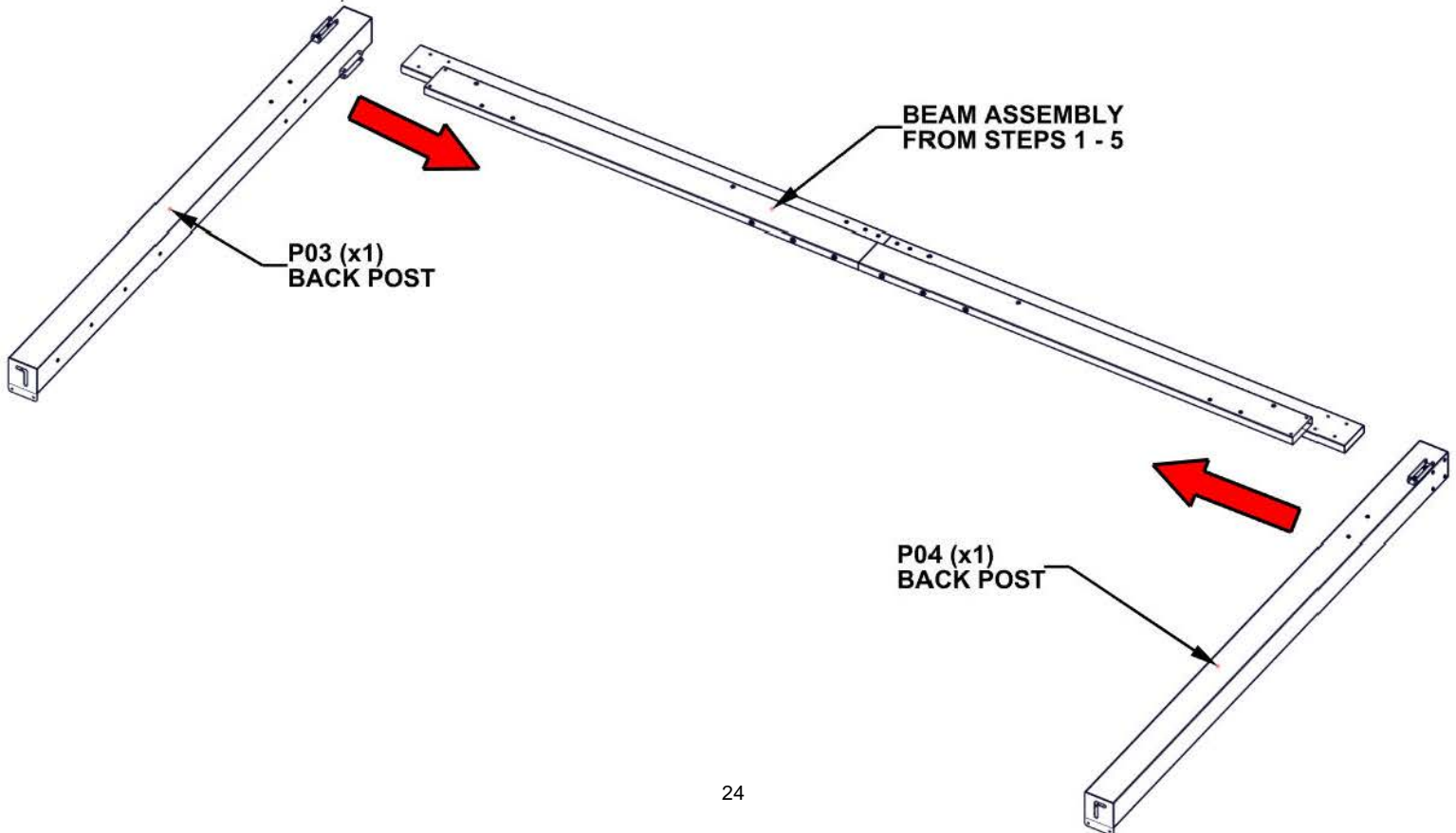
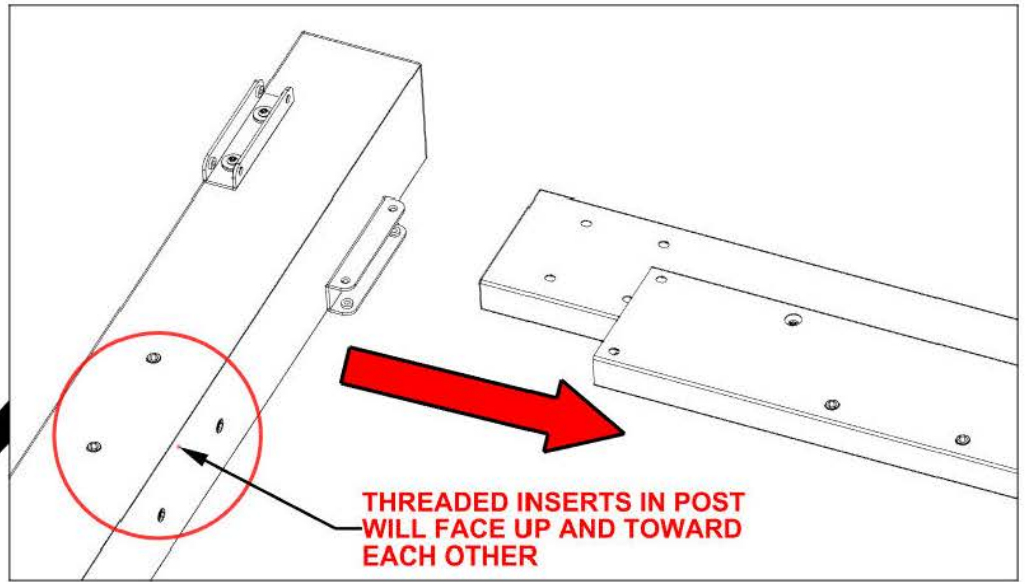

STEP 8B - FRAME ASSEMBLY

QTY	PartNo	Description
4	H101202	TORX PAN HEAD 1/4-20x3/4 ASSY

1202 (x4)
TORX PAN HEAD 1/4-20x3/4 ASSY

HAND TIGHTEN ONLY

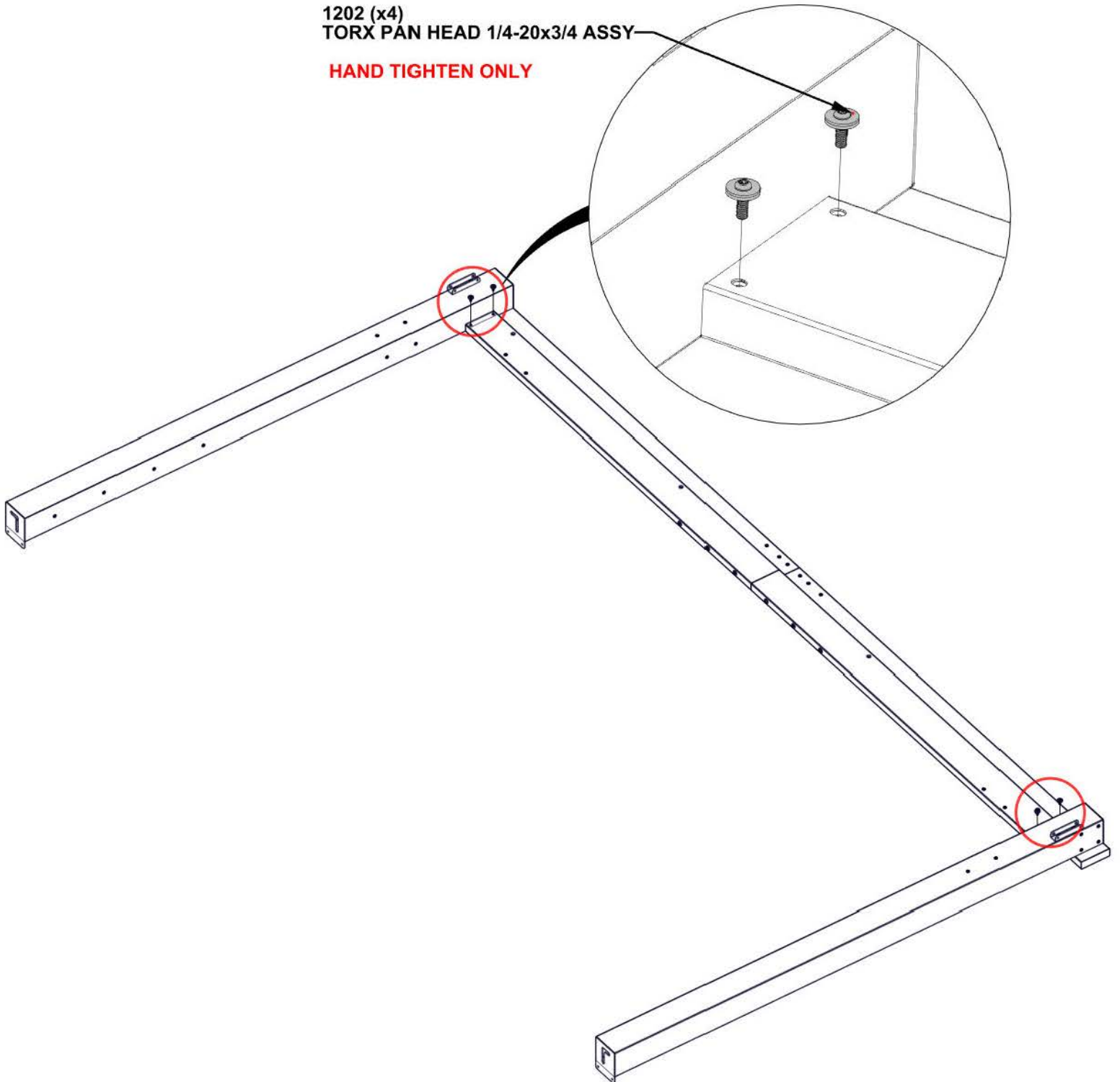

STEP 8C - FRAME ASSEMBLY

QTY	PartNo	Description
8	H101202	TORX PAN HEAD 1/4-20x3/4 ASSY



C01 CORBEL ASSEMBLY - A4M03525
 (x1) 21 13/16"x5 1/4"x2 3/4" (70x134x553.5)



C02 CORBEL ASSEMBLY - A4M03526
 (x1) 21 13/16"x5 1/4"x2 3/4" (70x134x553.5)

- ATTACH CORBELS TO BEAM AND POST.
- SQUARE AS NEEDED BEFORE TIGHTENING ALL HARDWARE FROM PREVIOUS STEPS.

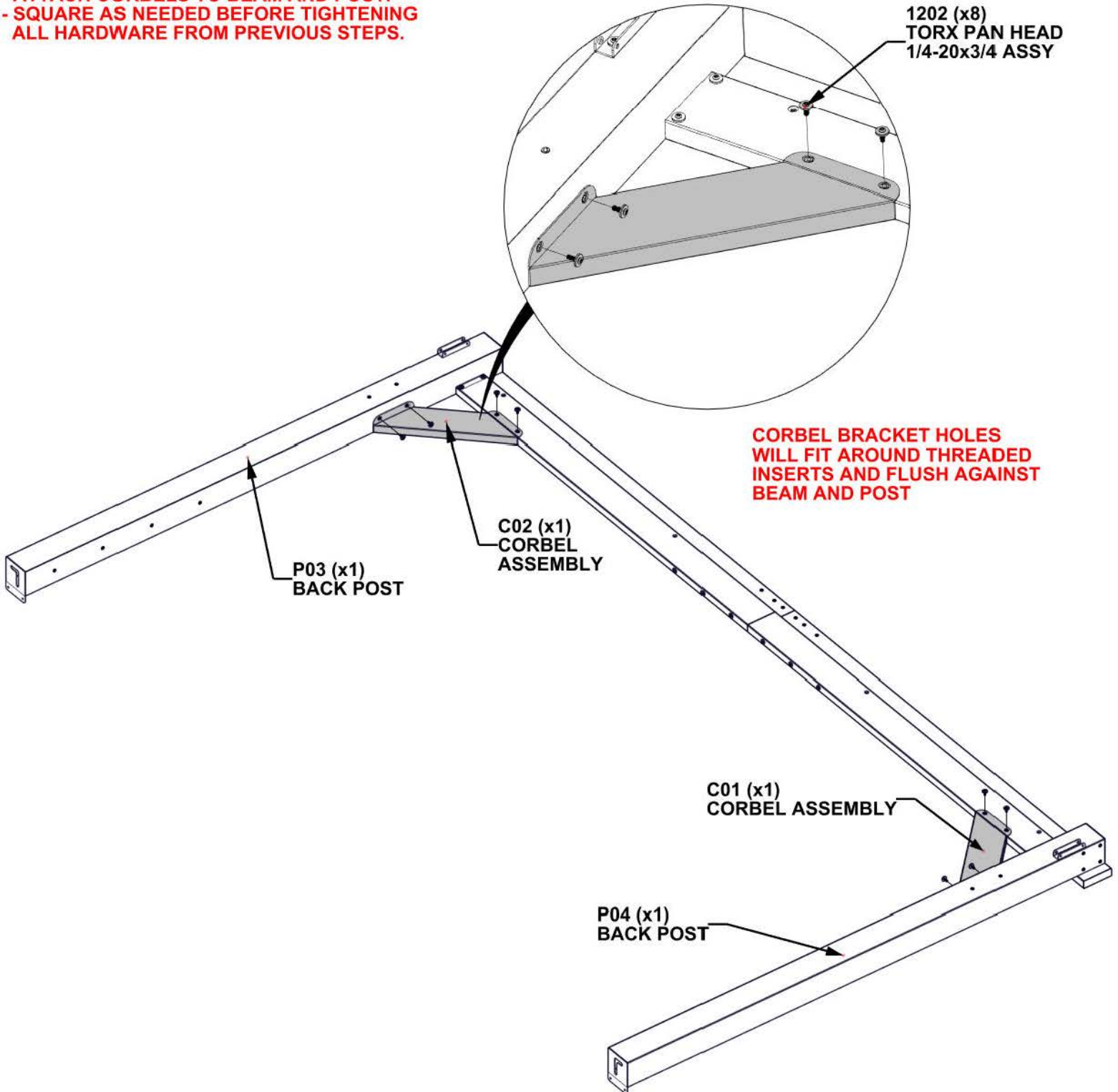

STEP 8D - FRAME ASSEMBLY

QTY	PartNo	Description
8	H101103	TORX SOCKET SCREW 1/4-20

- WITH AN ADDITIONAL PERSON, FLIP POST AND BEAM ASSEMBLY

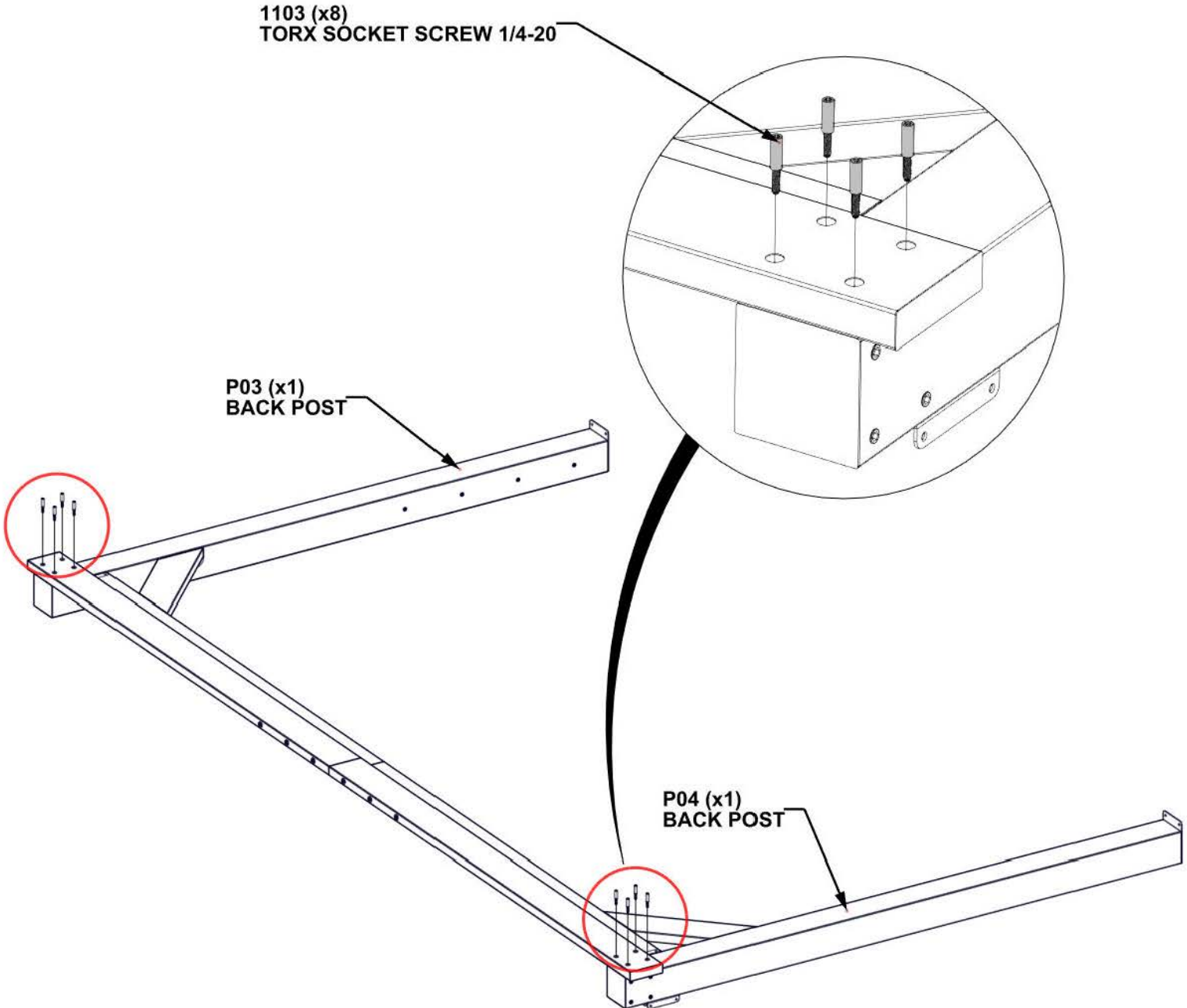

STEP 9 - BEAM ASSEMBLY

QTY	PartNo	Description
3	H101103	TORX SOCKET SCREW 1/4-20



B17 SIDE BEAM ASSEMBLY - A4M03648
 (x1) 64 15/16"x5 5/16"x1 7/16" (36x135.50x1649)



B18 SIDE BEAM ASSEMBLY - A4M03649
 (x1) 55 9/16"x5 1/4"x1 1/2" (37.50x134x1411)

- ALIGN THRU HOLES IN B18 BEAM WITH THREADED INSERTS IN B17 BEAM.

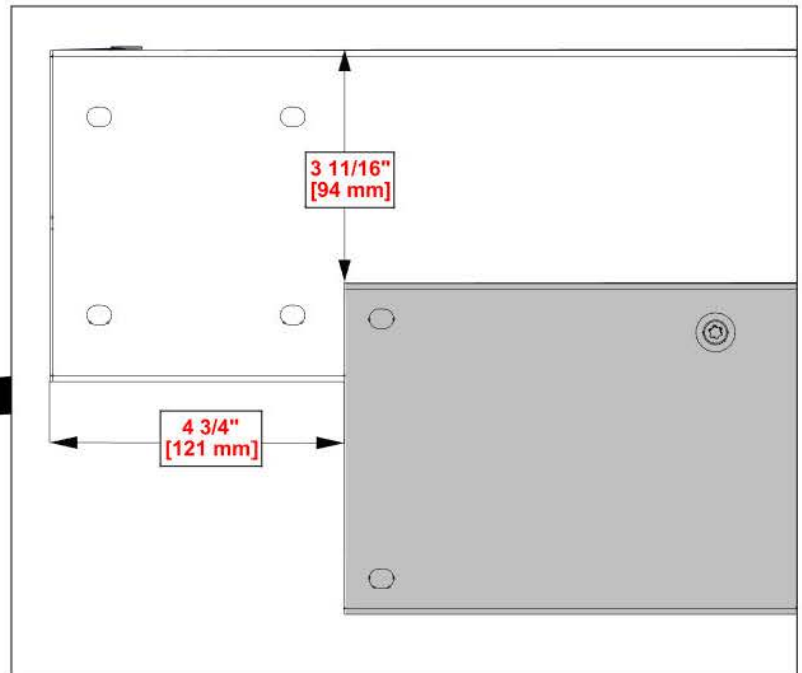
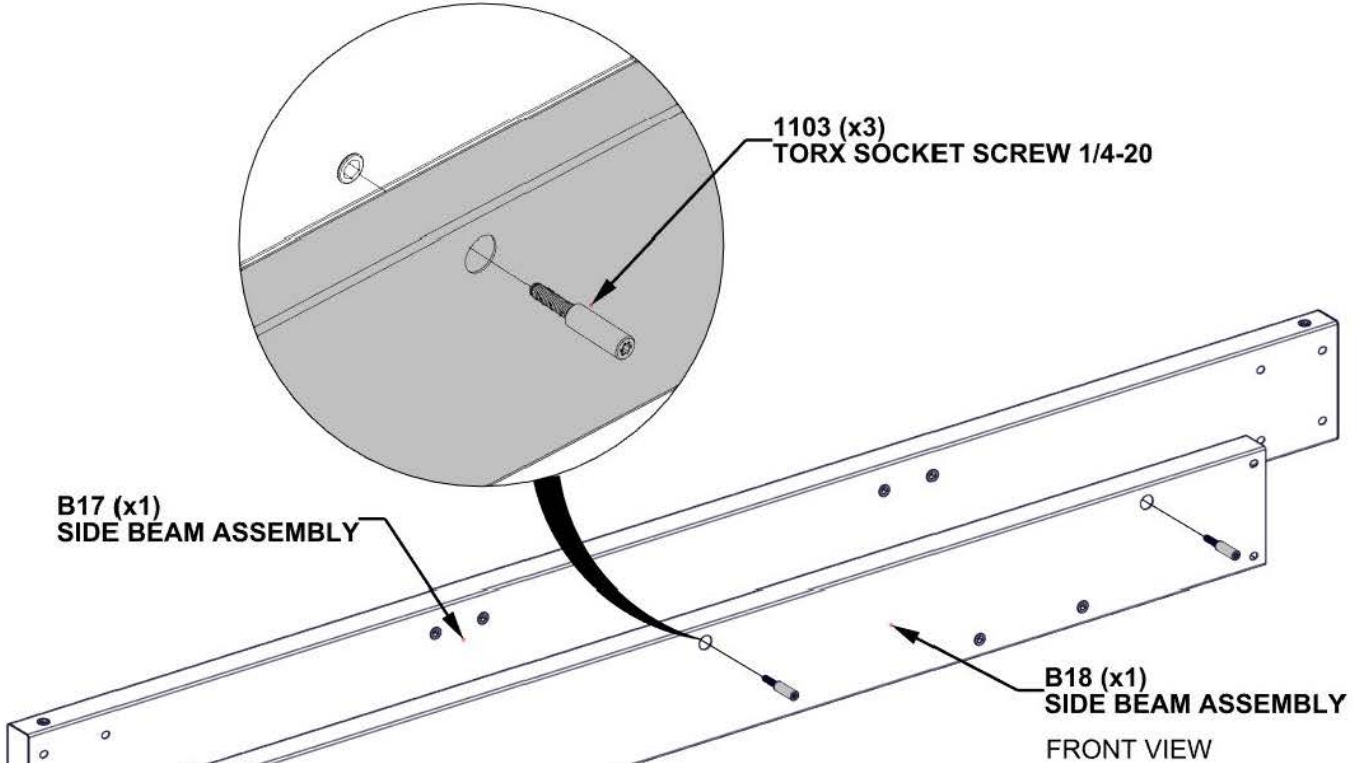

DIMENSIONS ARE THE SAME AT BOTH ENDS AND CRITICAL TO THE BEAM ASSEMBLY

STEP 10 - BEAM ASSEMBLY

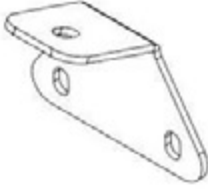

QTY	PartNo	Description
4	H101202	TORX PAN HEAD 1/4-20x3/4 ASSY

J5 RAFTER BRACKET - A4M03803
(x2) 3 5/8"x2 11/16"x2 1/16" (52x68x91.5)

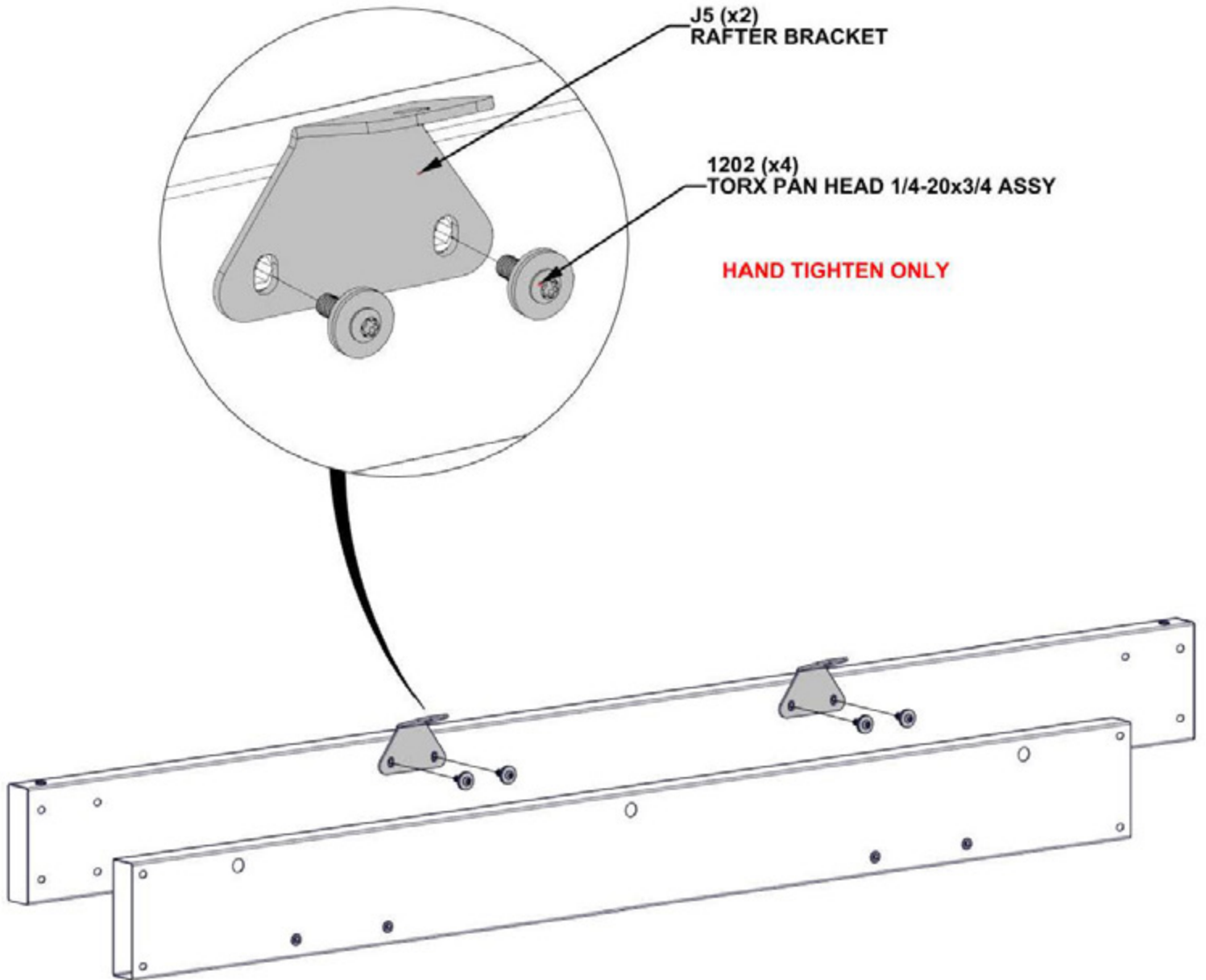

**REPEAT BEAM ASSEMBLY
STEPS 9 THROUGH 10**

STEP 11 - POST ASSEMBLY

QTY	PartNo	Description
4	H101202	TORX PAN HEAD 1/4-20x3/4 ASSY

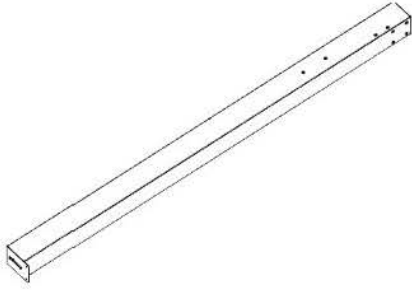

P05 FRONT POST - A4M03646
(x1) 89 9/16"x6 1/8"x4 3/4" (120x155x2275)

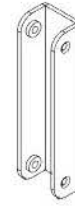

J4 BEAM BRACKET - A4M02990
(x2) 1"x1 5/16"x5 1/16" (25x33.2x128)

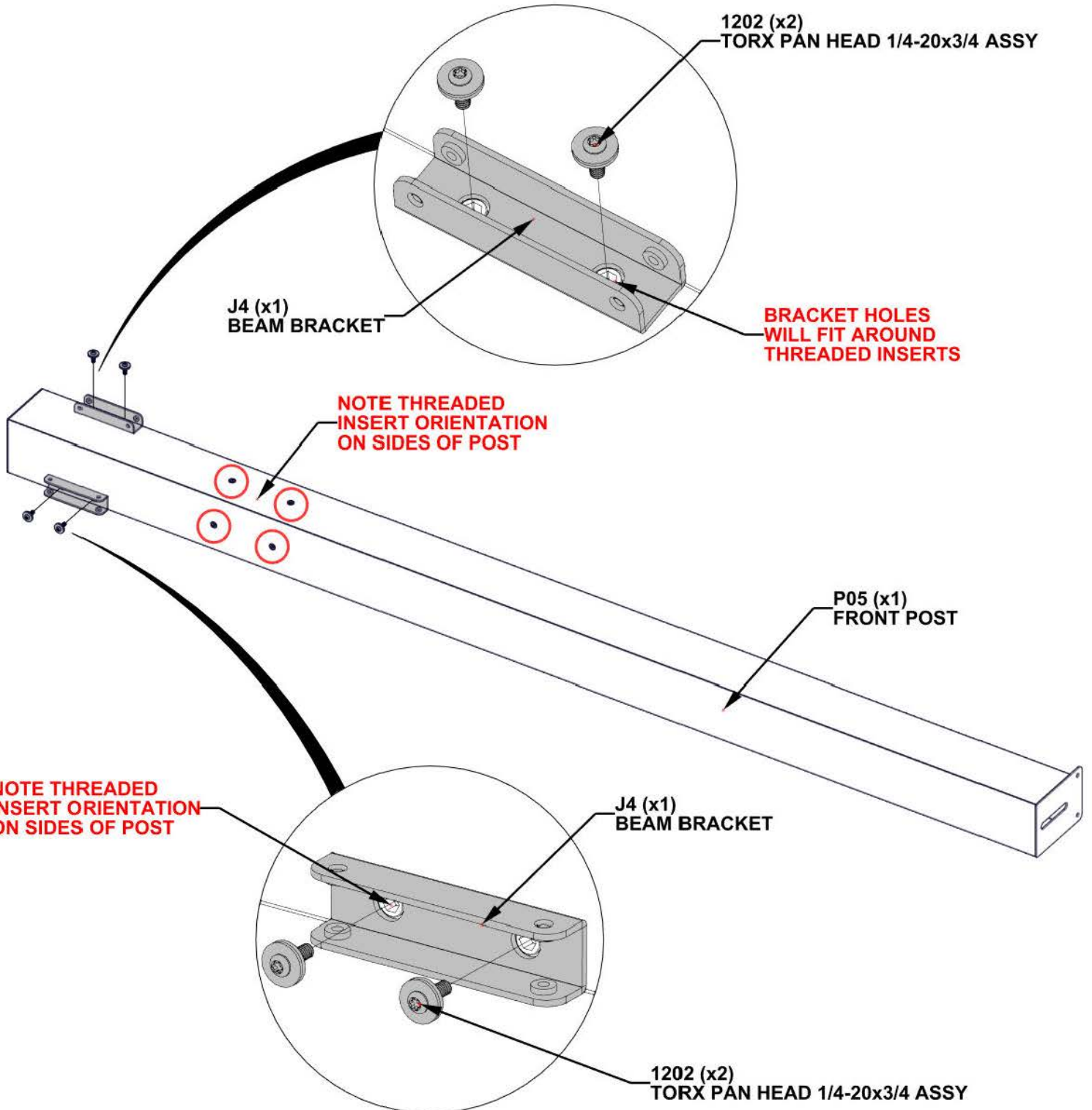

STEP 12A - FRAME ASSEMBLY

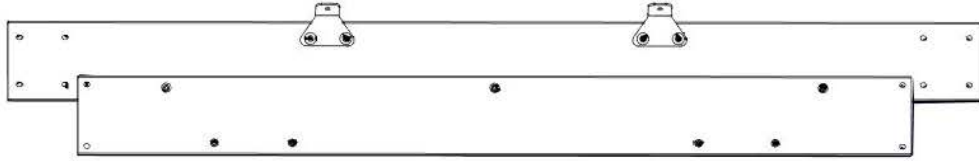

BEAM ASSEMBLY FROM STEPS 9 - 10

- SLIDE POST ASSEMBLY FROM STEP 11 INTO THE BEAM ASSEMBLY FROM STEPS 9 - 10.

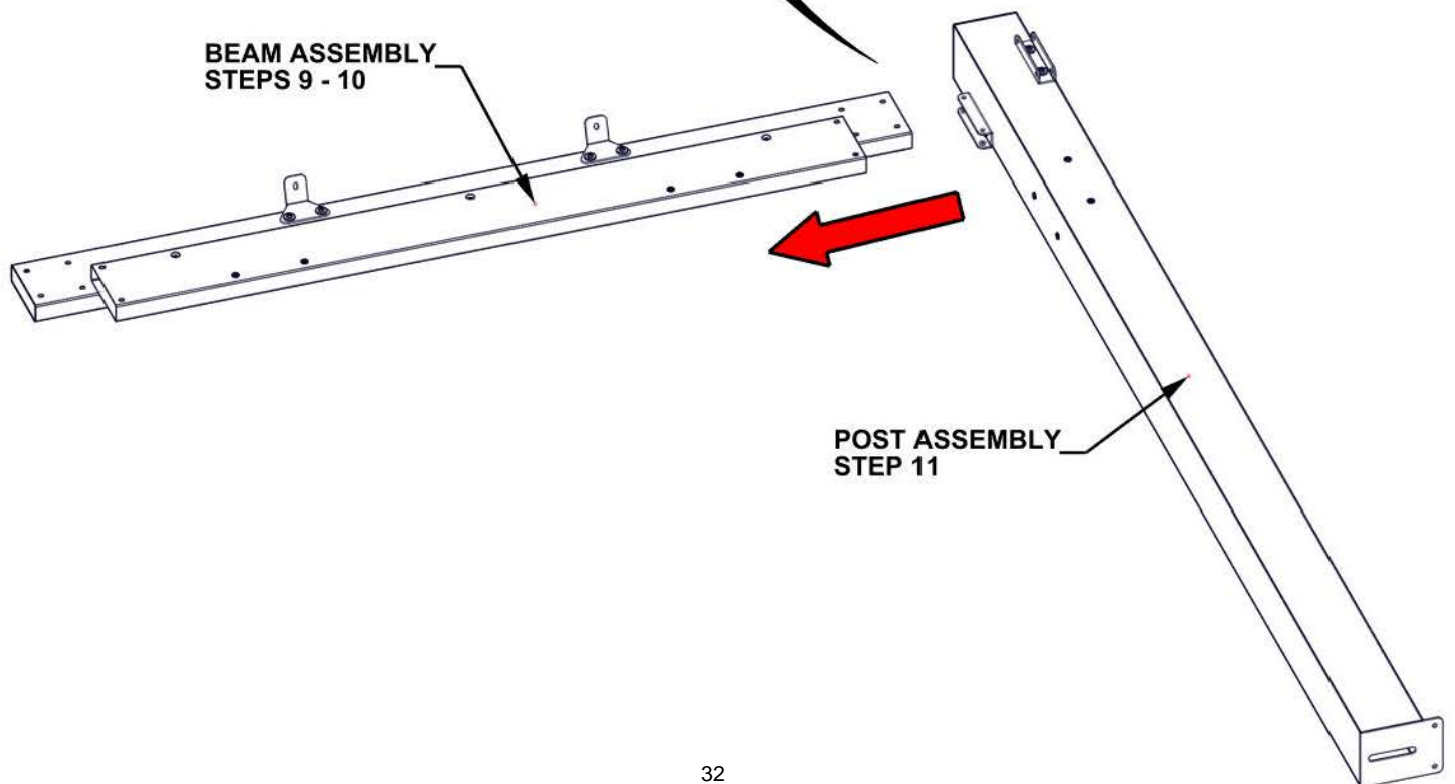
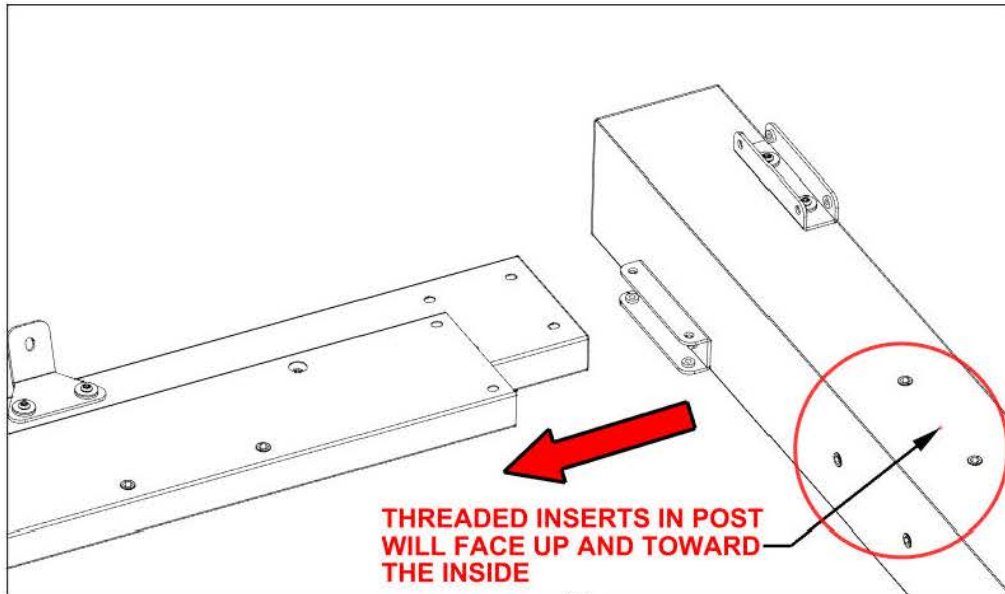

STEP 12B - FRAME ASSEMBLY

QTY	PartNo	Description
2	H101202	TORX PAN HEAD 1/4-20x3/4 ASSY

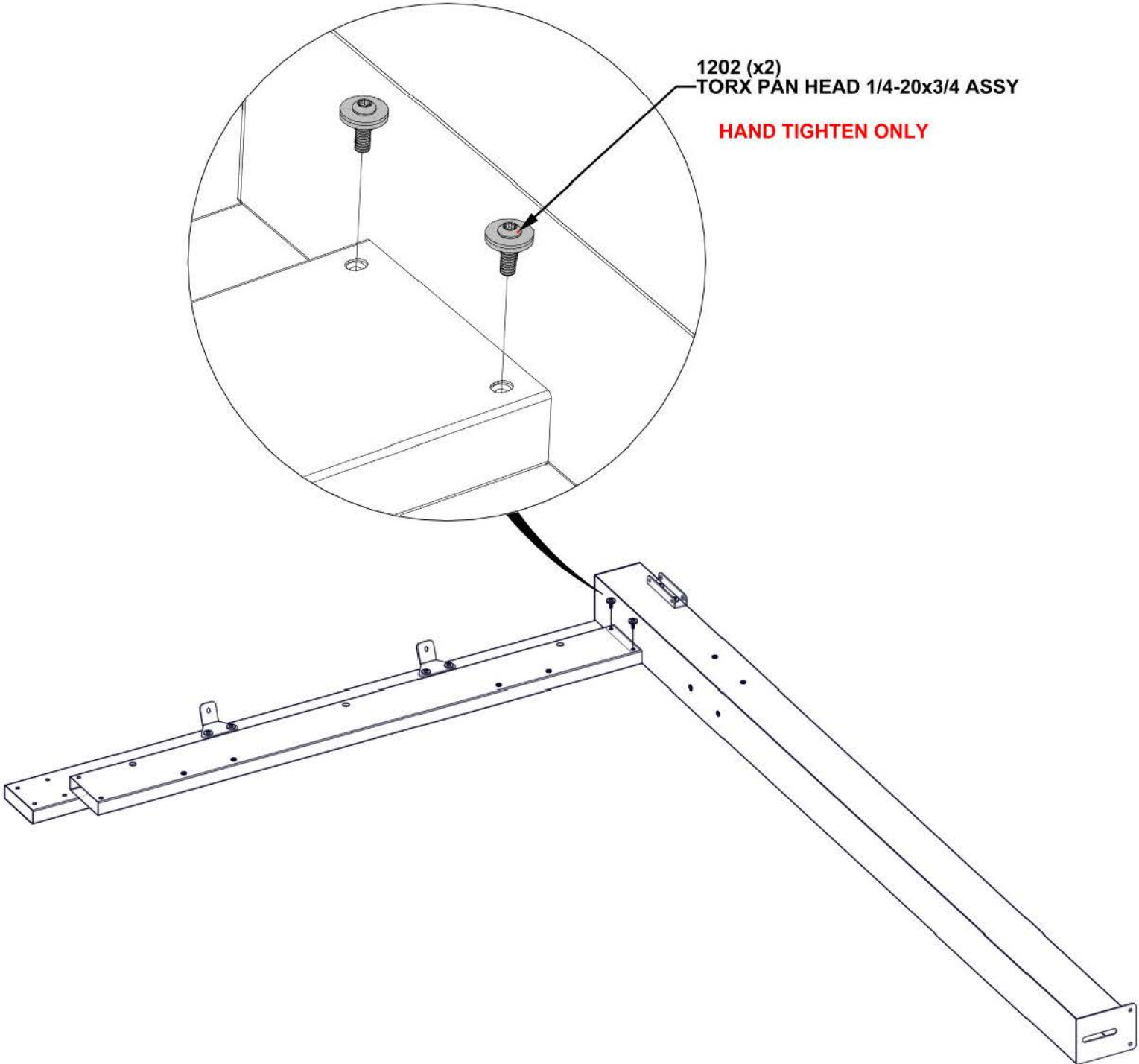

STEP 12C - FRAME ASSEMBLY



QTY	PartNo	Description
4	H101202	TORX PAN HEAD 1/4-20x3/4 ASSY

C01 CORBEL ASSEMBLY - A4M03525
 (x1) 21 13/16"x5 1/4"x2 3/4" (70x134x553.5)

- ATTACH CORBEL TO BEAM AND POST.
- SQUARE AS NEEDED BEFORE TIGHTENING ALL HARDWARE FROM PREVIOUS STEPS.

1202 (x4)
 TORX PAN HEAD 1/4-20x3/4 ASSY

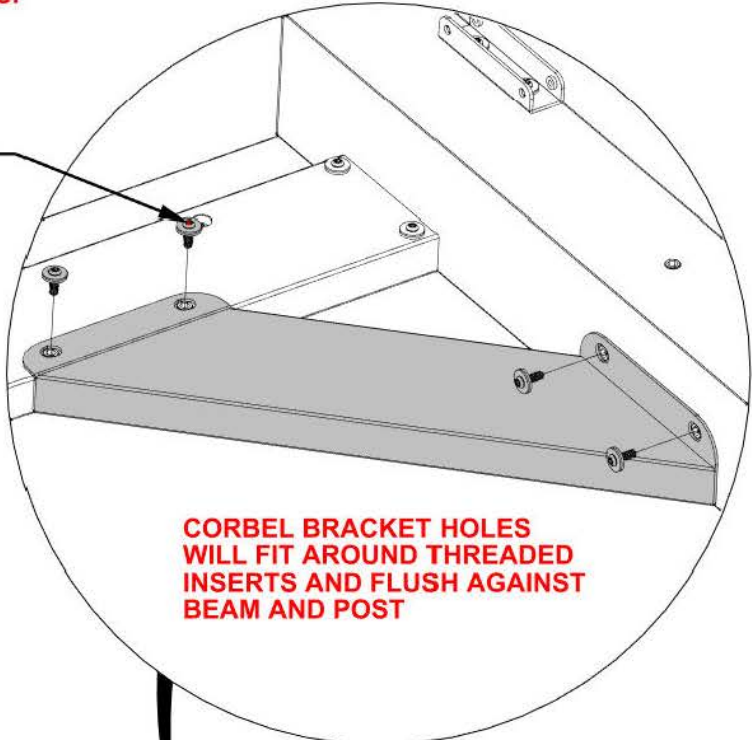

**CORBEL BRACKET HOLES
 WILL FIT AROUND THREADED
 INSERTS AND FLUSH AGAINST
 BEAM AND POST**

C01 (x1)
 CORBEL ASSEMBLY

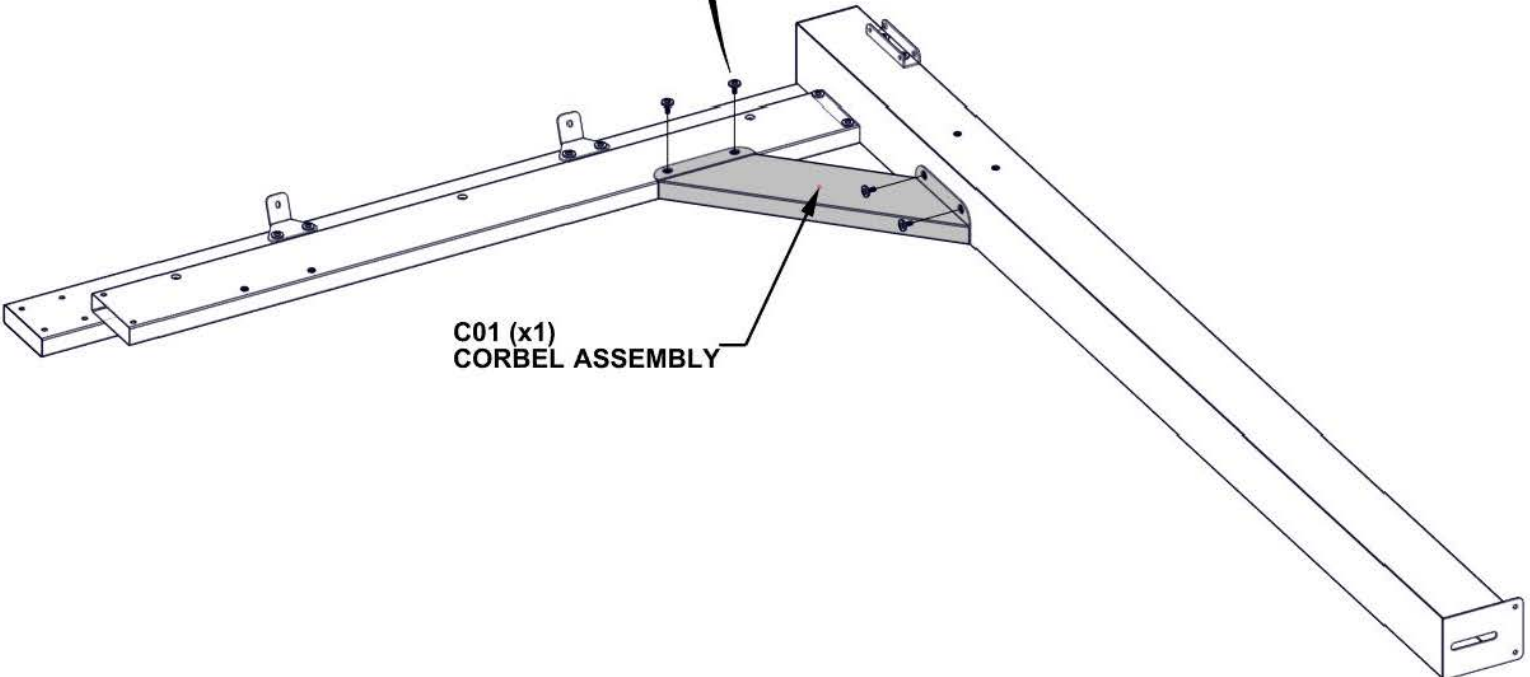

STEP 12D - FRAME ASSEMBLY

QTY	PartNo	Description
4	H101103	TORX SOCKET SCREW 1/4-20

- WITH AN ADDITIONAL PERSON, FLIP POST AND BEAM ASSEMBLY

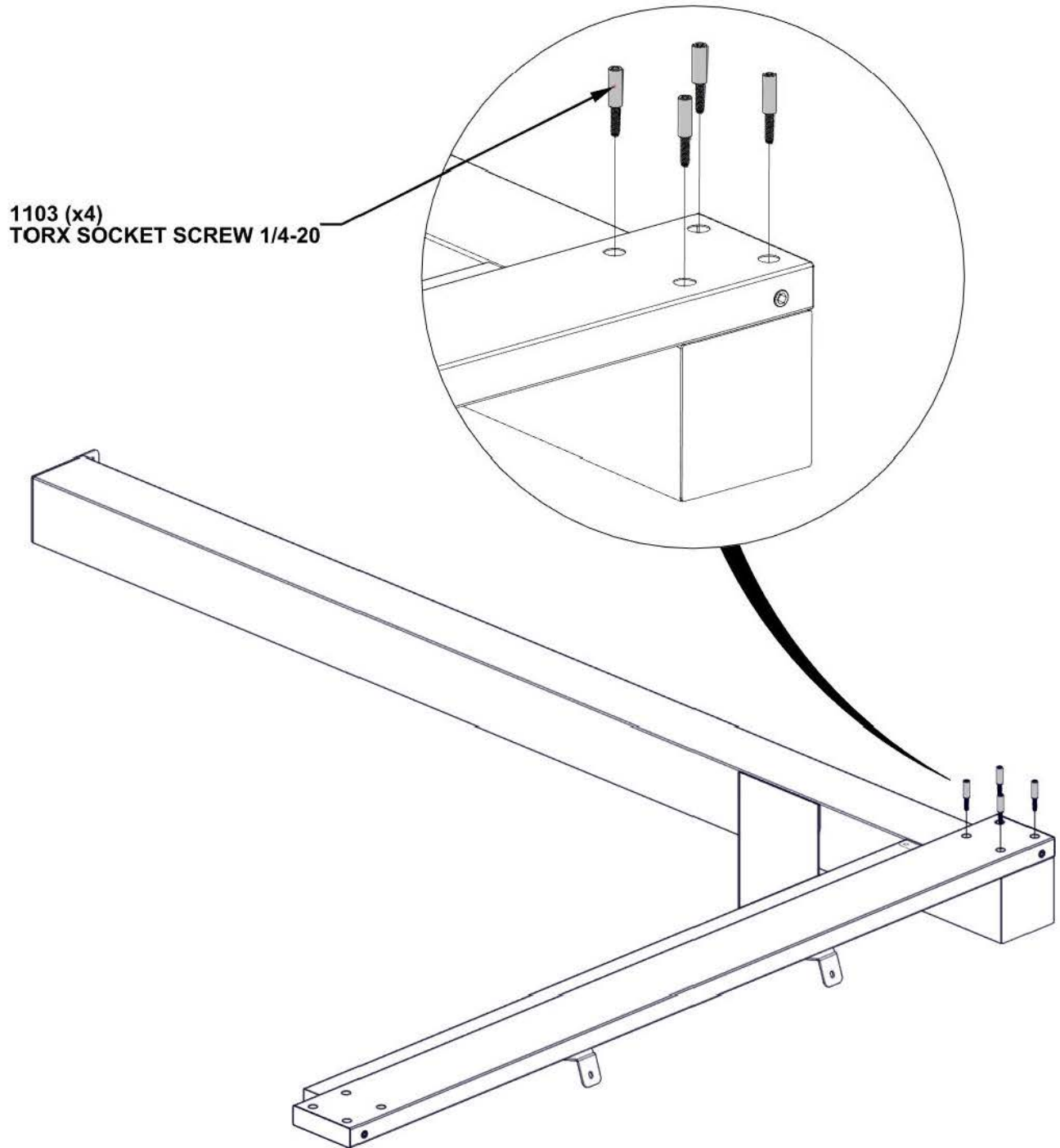

STEP 13A - FRAME ASSEMBLY

- WITH AT LEAST THREE OTHER PEOPLE, ATTACH BEAM AND POST ASSEMBLIES BY SLIDING IN PLACE.

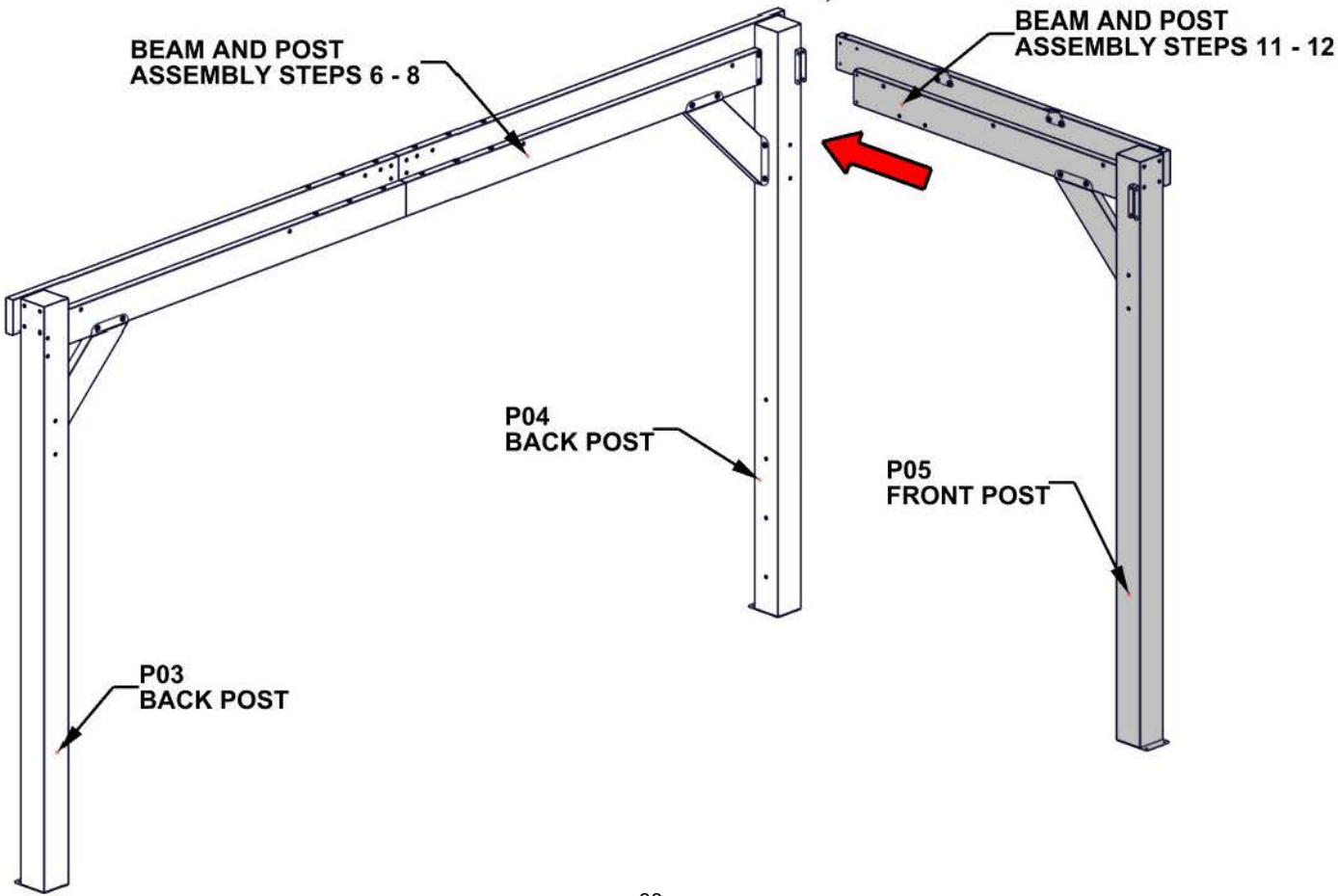
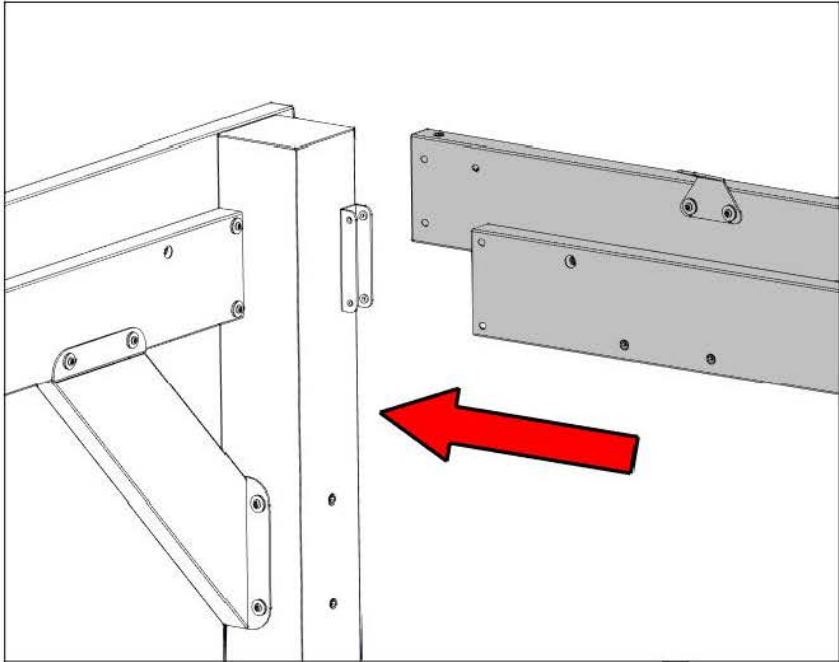

STEP 13B - FRAME ASSEMBLY

QTY	PartNo	Description
4	H101103	TORX SOCKET SCREW 1/4-20

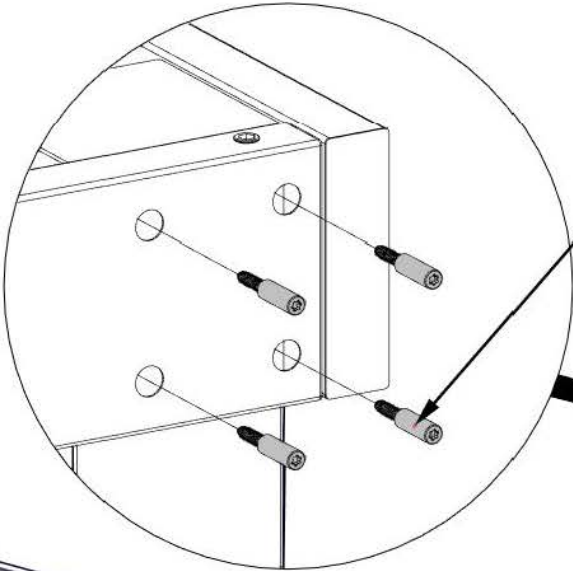

1103 (x4)
TORX SOCKET SCREW 1/4-20
HAND TIGHTEN ONLY

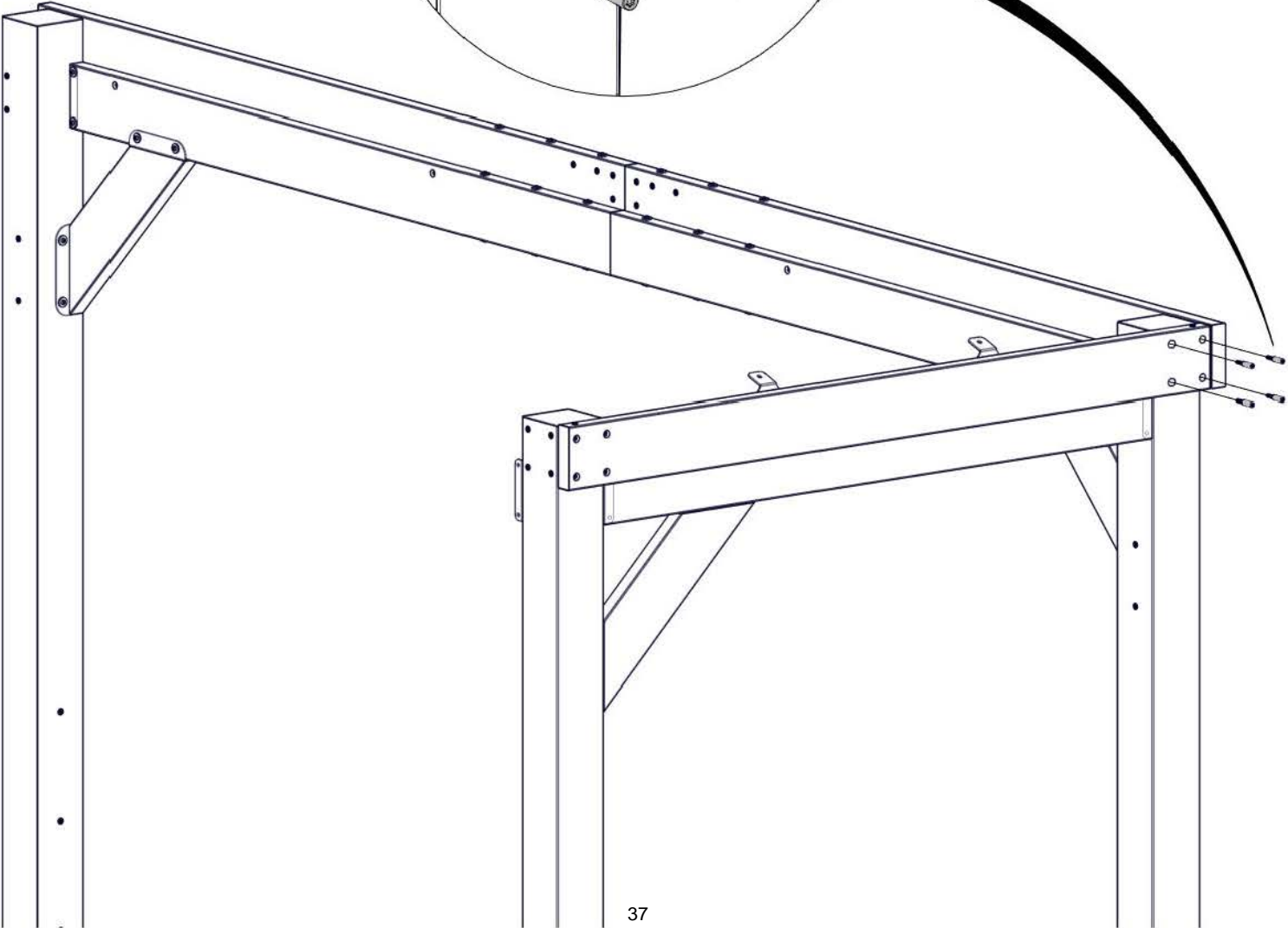

STEP 13C - FRAME ASSEMBLY

QTY	PartNo	Description
2	H101202	TORX PAN HEAD 1/4-20x3/4 ASSY

- SQUARE BEAM ASSEMBLY TO POST

1202 (x2)
TORX PAN HEAD 1/4-20x3/4 ASSY

TIGHTEN ALL HARDWARE

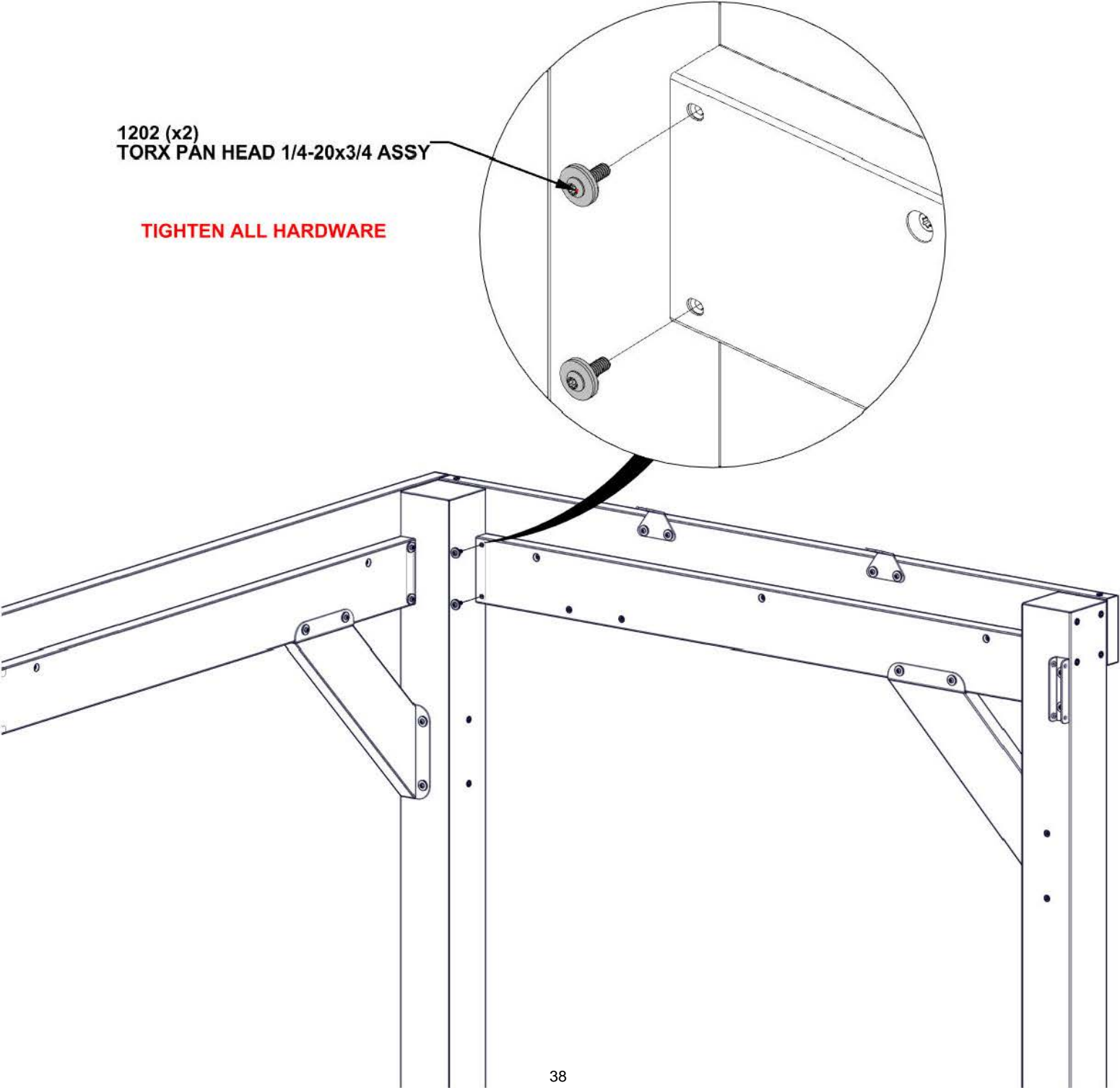

STEP 14 - FRAME ASSEMBLY

QTY	PartNo	Description
4	H101202	TORX PAN HEAD 1/4-20x3/4 ASSY



C02 CORBEL ASSEMBLY - A4M03526
(x1) 21 13/16"x5 1/4"x2 3/4" (70x134x553.5)

- ATTACH CORBEL TO BEAM AND POST.
- SQUARE AS NEEDED BEFORE TIGHTENING ALL HARDWARE.

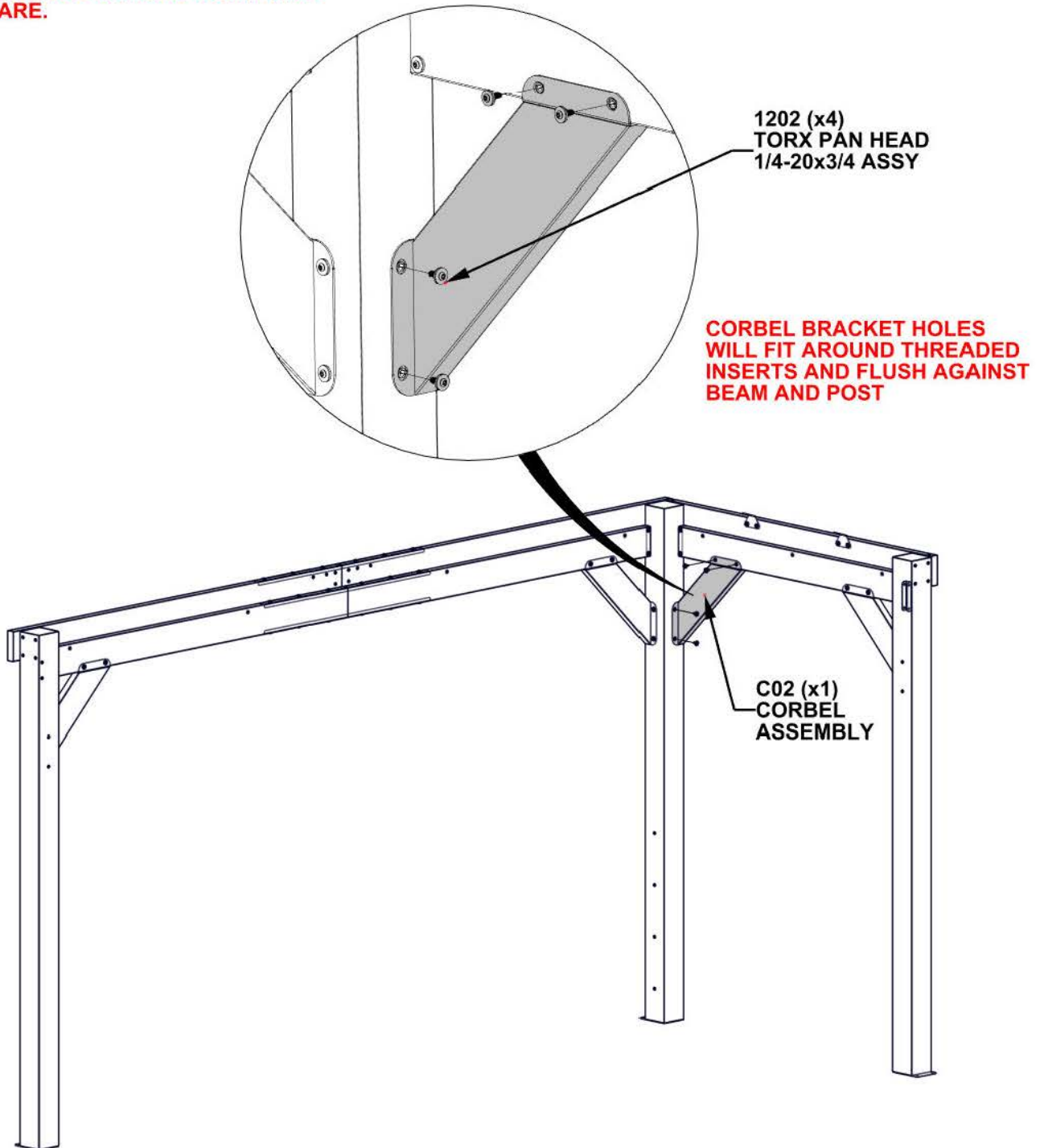

STEP 15 - POST ASSEMBLY

QTY	PartNo	Description
4	H101202	TORX PAN HEAD 1/4-20x3/4 ASSY

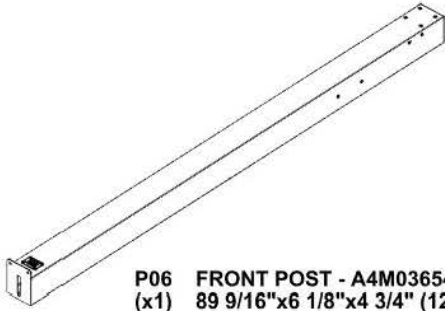

P06 FRONT POST - A4M03654
(x1) 89 9/16"x6 1/8"x4 3/4" (120x155x2275)



J4 BEAM BRACKET - A4M02990
(x2) 1"x1 5/16"x5 1/16" (25x33.2x128)

- FOR EASE OF ASSEMBLY, WE RECOMMEND USING SAW HORSES FOR STEPS 15 - 16.

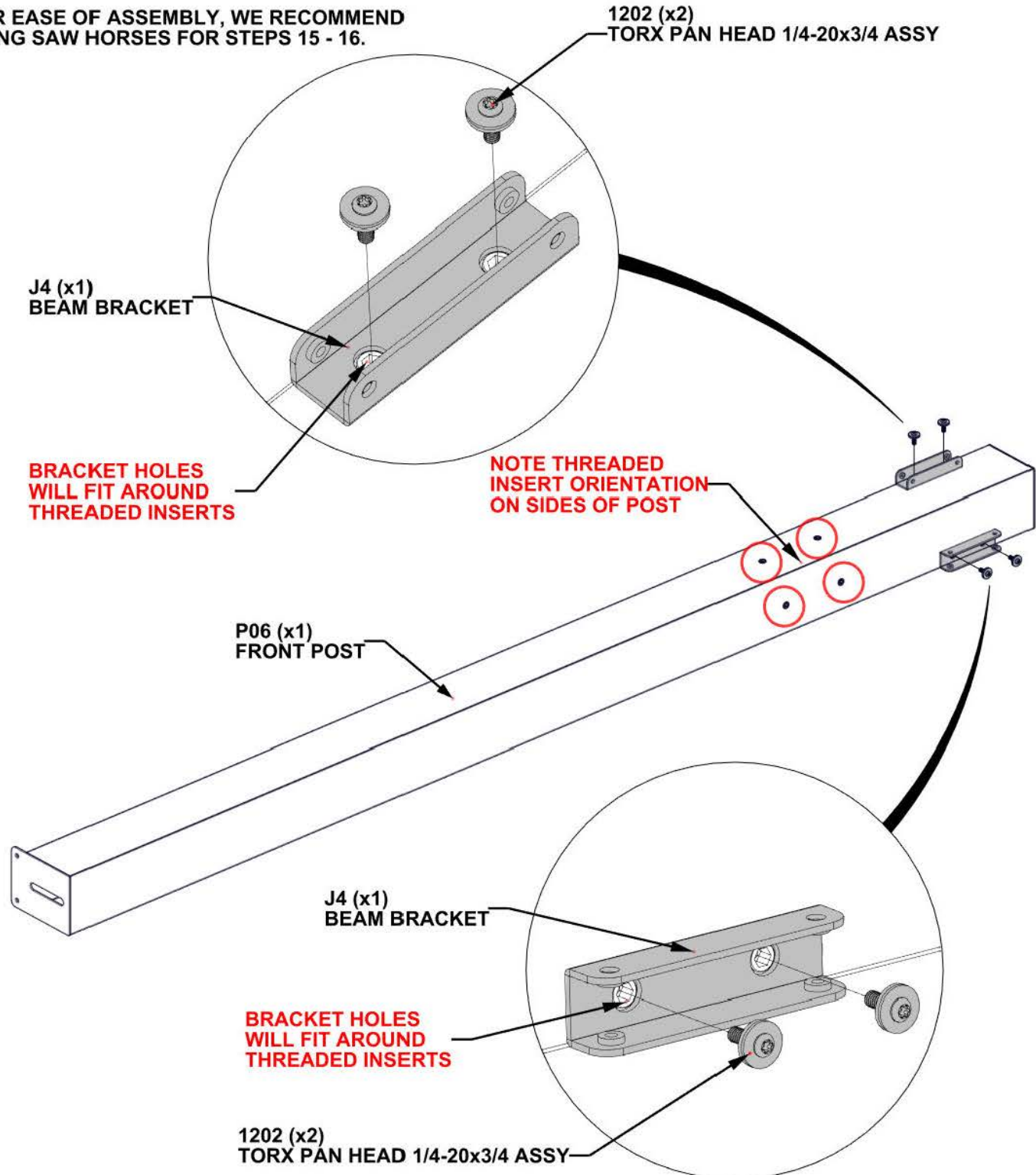

STEP 16A - FRAME ASSEMBLY

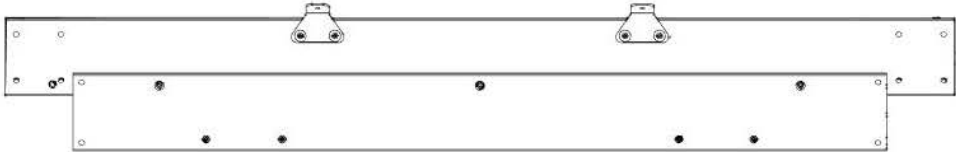

BEAM ASSEMBLY FROM STEPS 9 - 10

- SLIDE POST ASSEMBLY FROM STEP 15 INTO THE BEAM ASSEMBLY FROM STEPS 9 - 10.

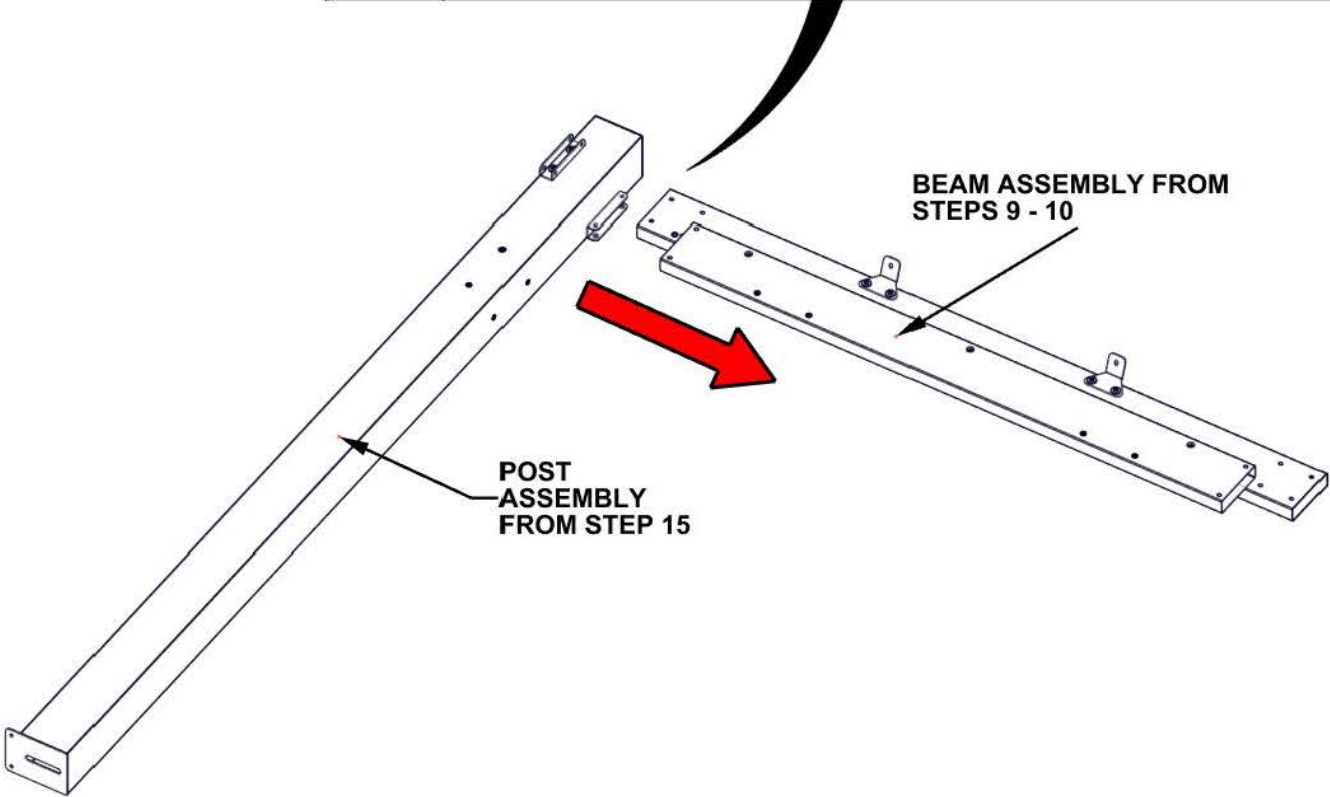
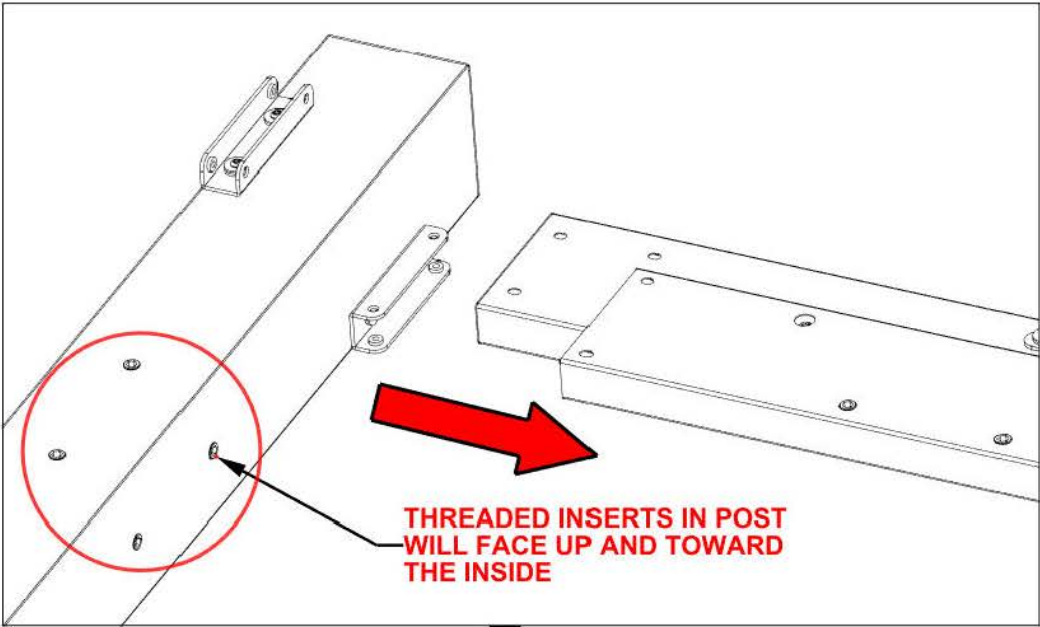

STEP 16B - FRAME ASSEMBLY

QTY	PartNo	Description
2	H101202	TORX PAN HEAD 1/4-20x3/4 ASSY

1202 (x2)
TORX PAN HEAD 1/4-20x3/4 ASSY
HAND TIGHTEN ONLY

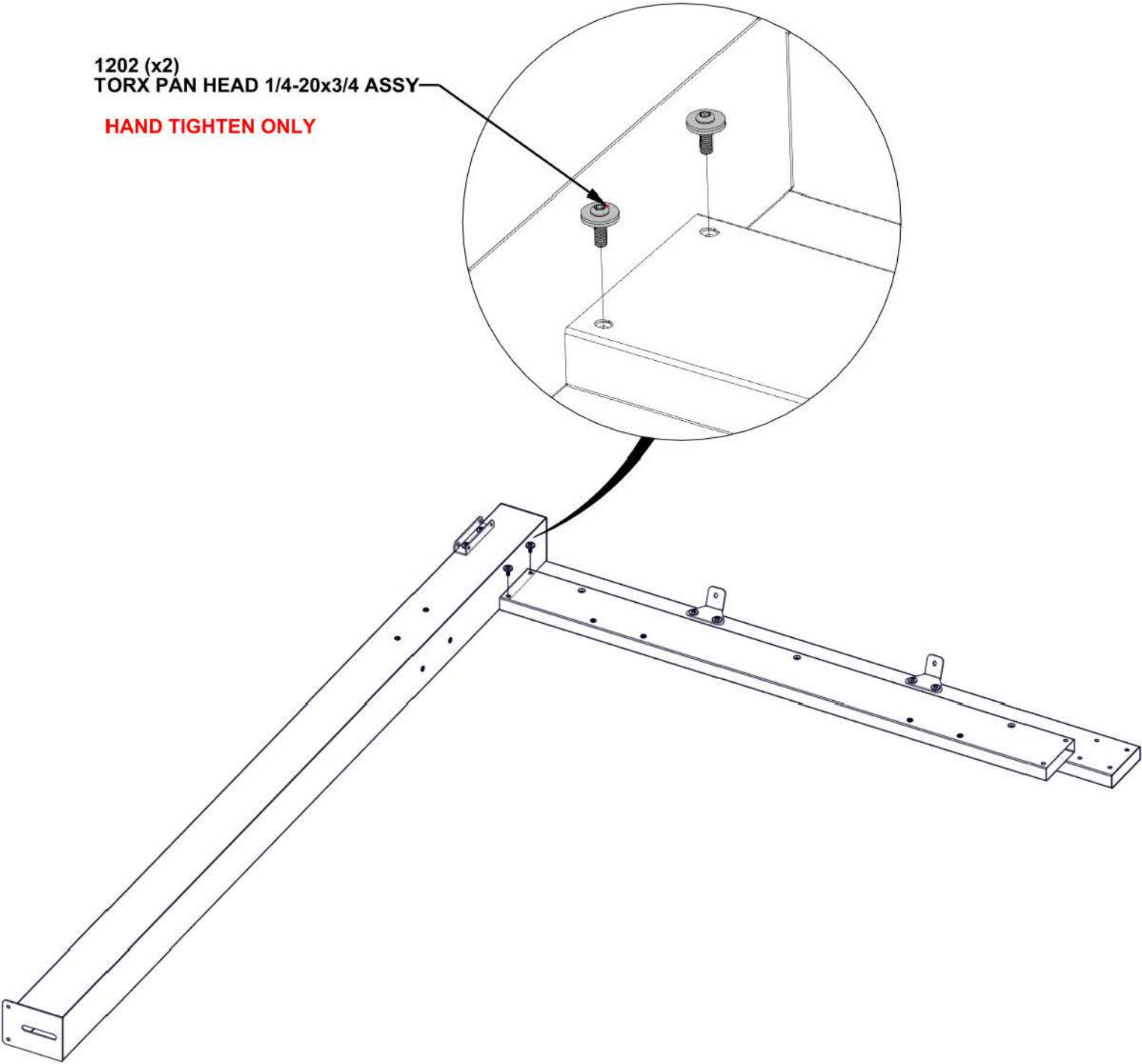

STEP 16C - FRAME ASSEMBLY



C02 CORBEL ASSEMBLY - A4M03526
(x1) 21 13/16"x5 1/4"x2 3/4" (70x134x553.5)

QTY	PartNo	Description
4	H101202	TORX PAN HEAD 1/4-20x3/4 ASSY

- ATTACH CORBEL TO BEAM AND POST.
- SQUARE AS NEEDED BEFORE TIGHTENING ALL HARDWARE FROM PREVIOUS STEPS.

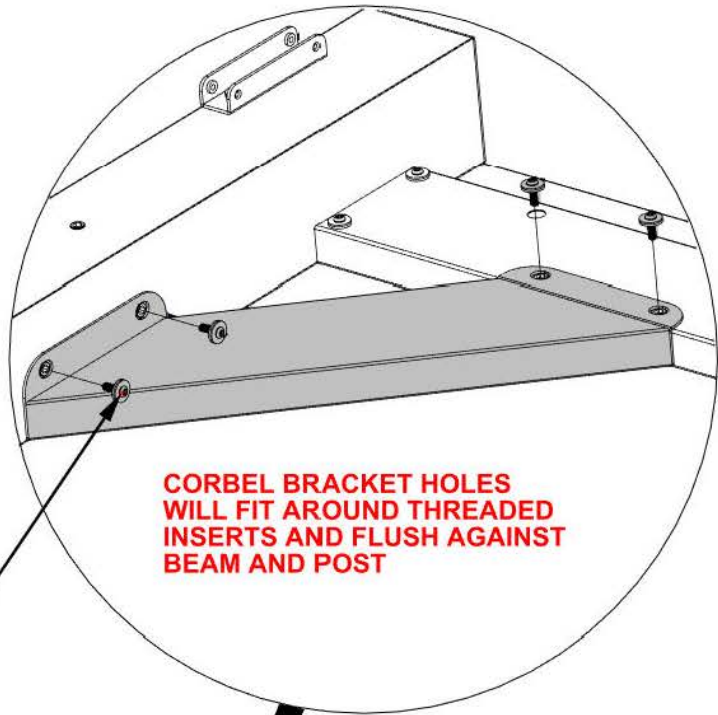

CORBEL BRACKET HOLES WILL FIT AROUND THREADED INSERTS AND FLUSH AGAINST BEAM AND POST

1202 (x4)
TORX PAN HEAD 1/4-20x3/4 ASSY

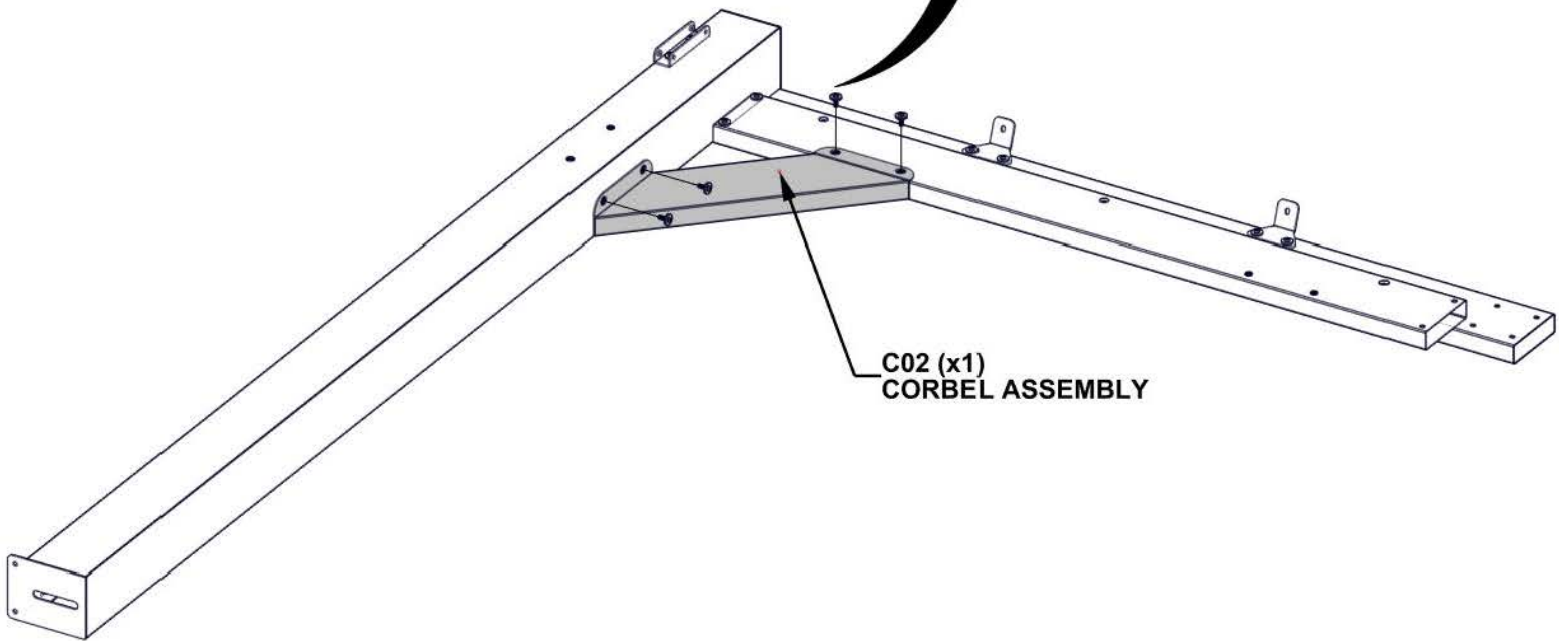

C02 (x1)
CORBEL ASSEMBLY

STEP 16D - FRAME ASSEMBLY

QTY	PartNo	Description
4	H101103	TORX SOCKET SCREW 1/4-20

- WITH AN ADDITIONAL PERSON, FLIP POST AND BEAM ASSEMBLY

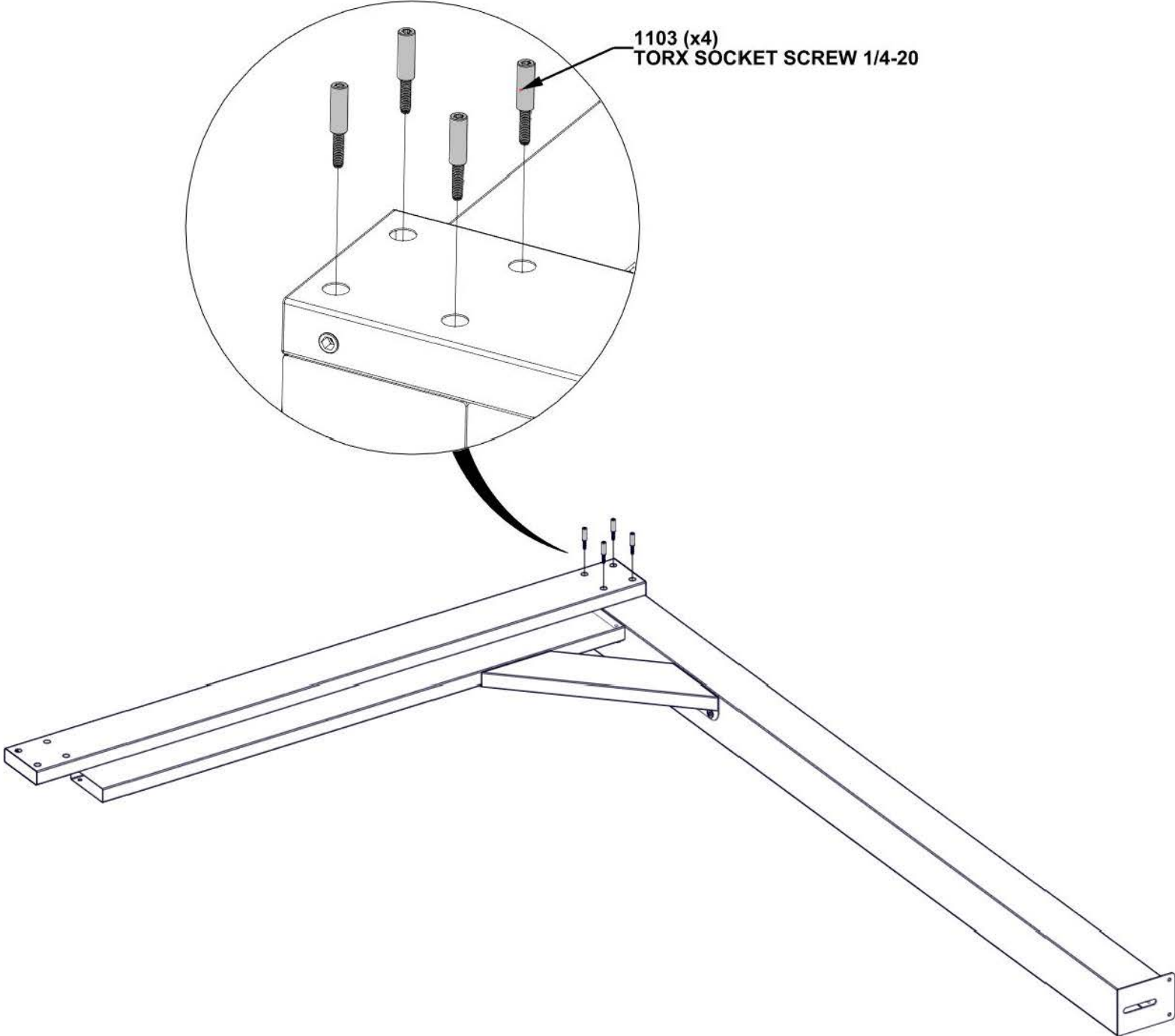

STEP 17A - FRAME ASSEMBLY

- WITH AT LEAST TWO OTHER PEOPLE, ATTACH BEAM AND POST ASSEMBLIES BY SLIDING IN PLACE.

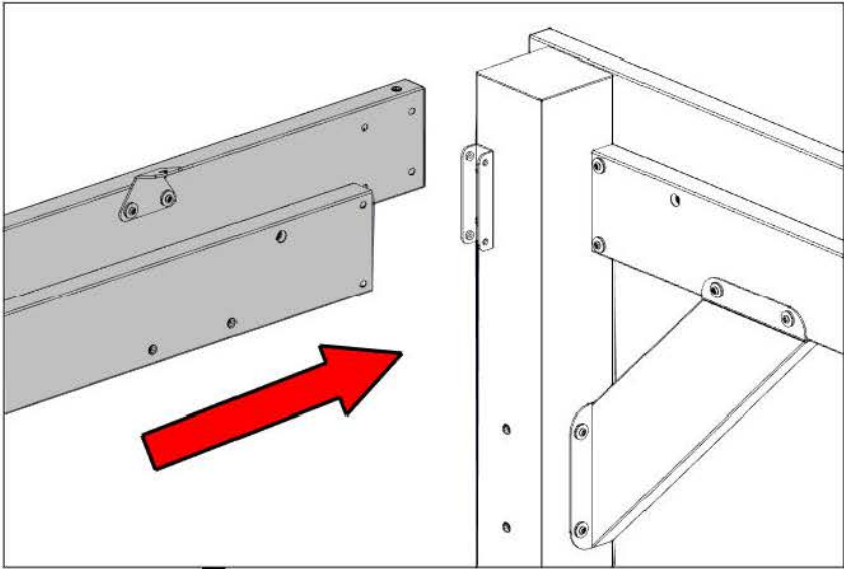

BEAM AND POST ASSEMBLY STEPS 15 - 16

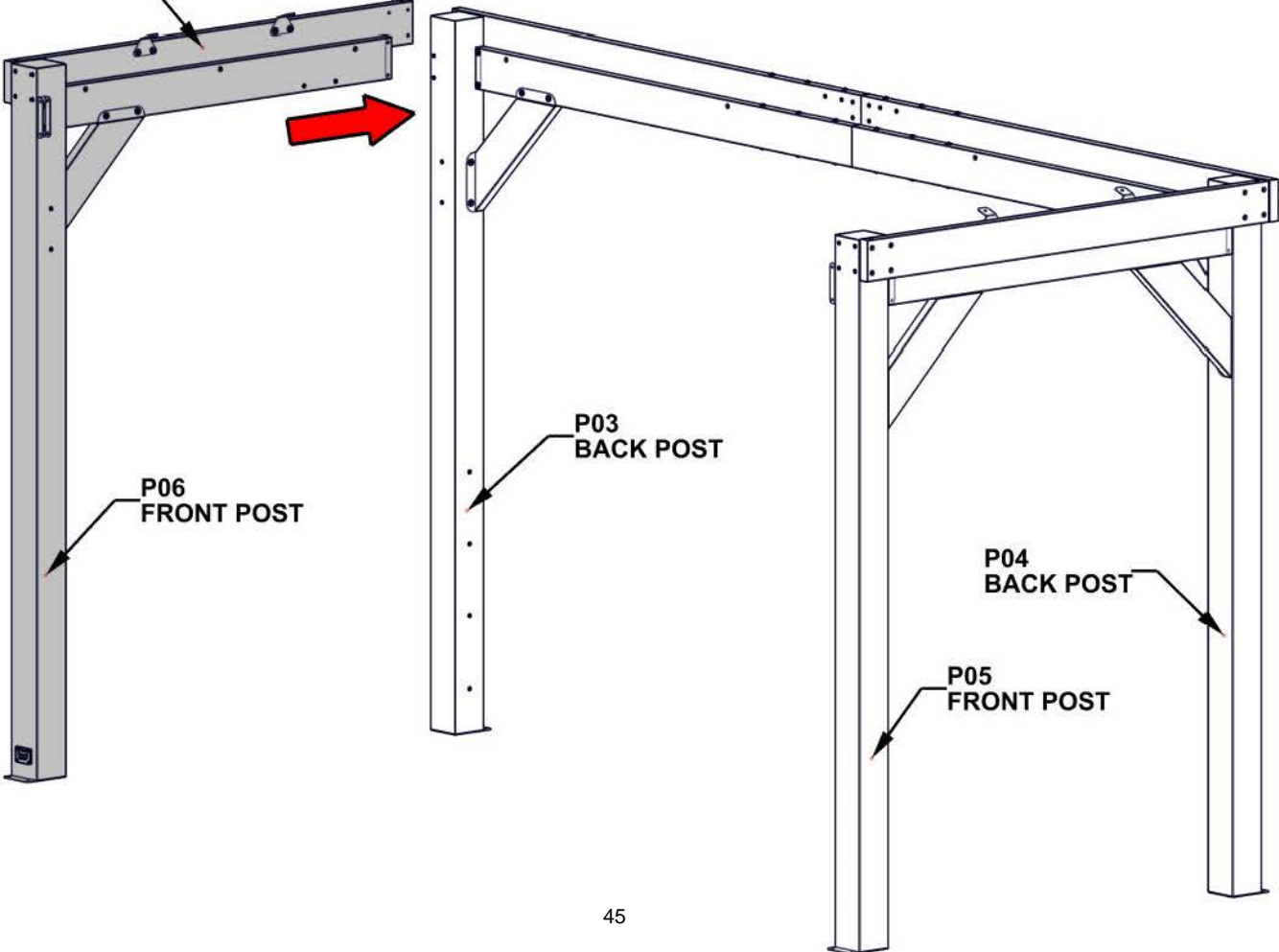

STEP 17B - FRAME ASSEMBLY

QTY	PartNo	Description
4	H101103	TORX SOCKET SCREW 1/4-20

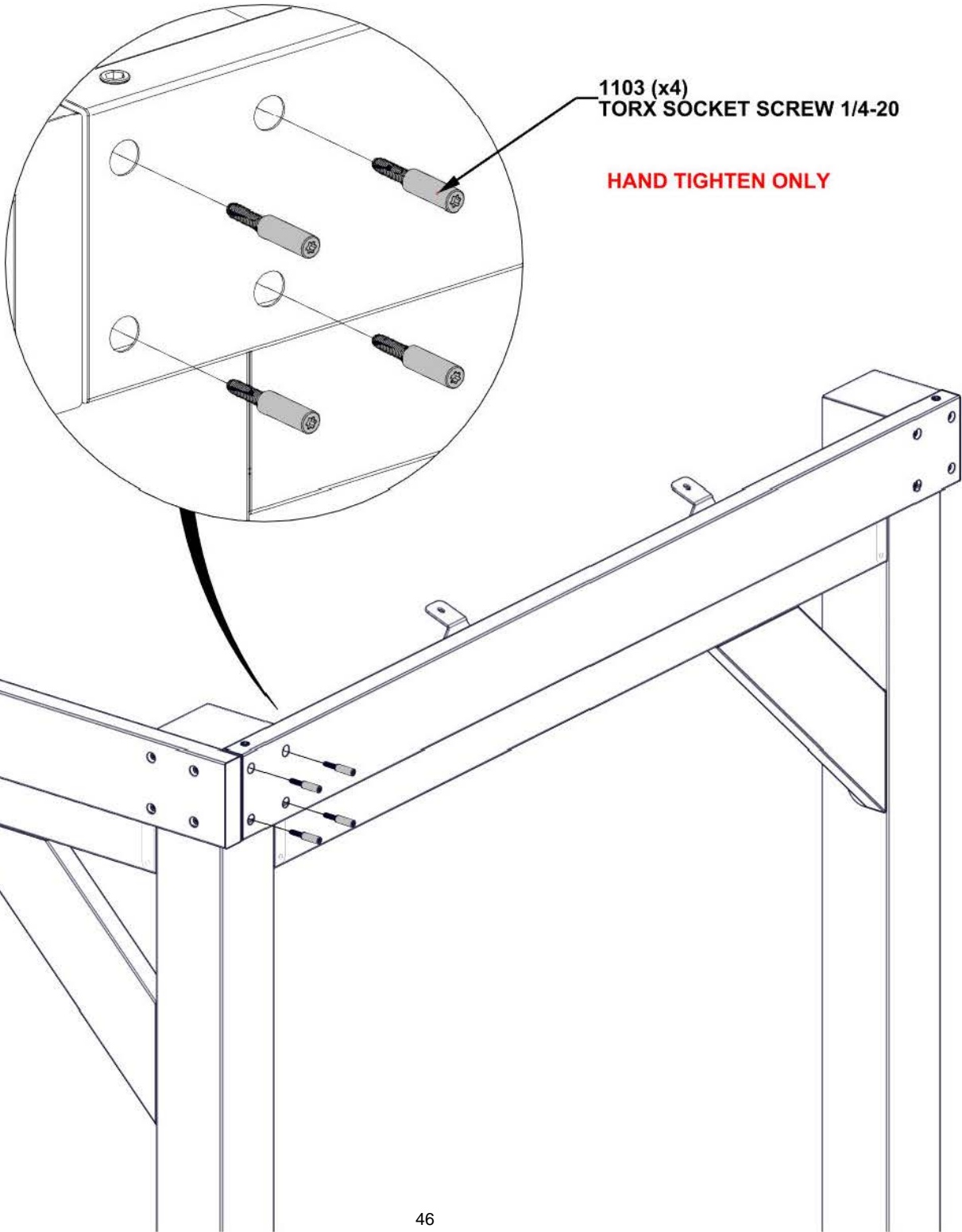

STEP 17C - FRAME ASSEMBLY

QTY	PartNo	Description
2	H101202	TORX PAN HEAD 1/4-20x3/4 ASSY

- SQUARE BEAM ASSEMBLY TO POST

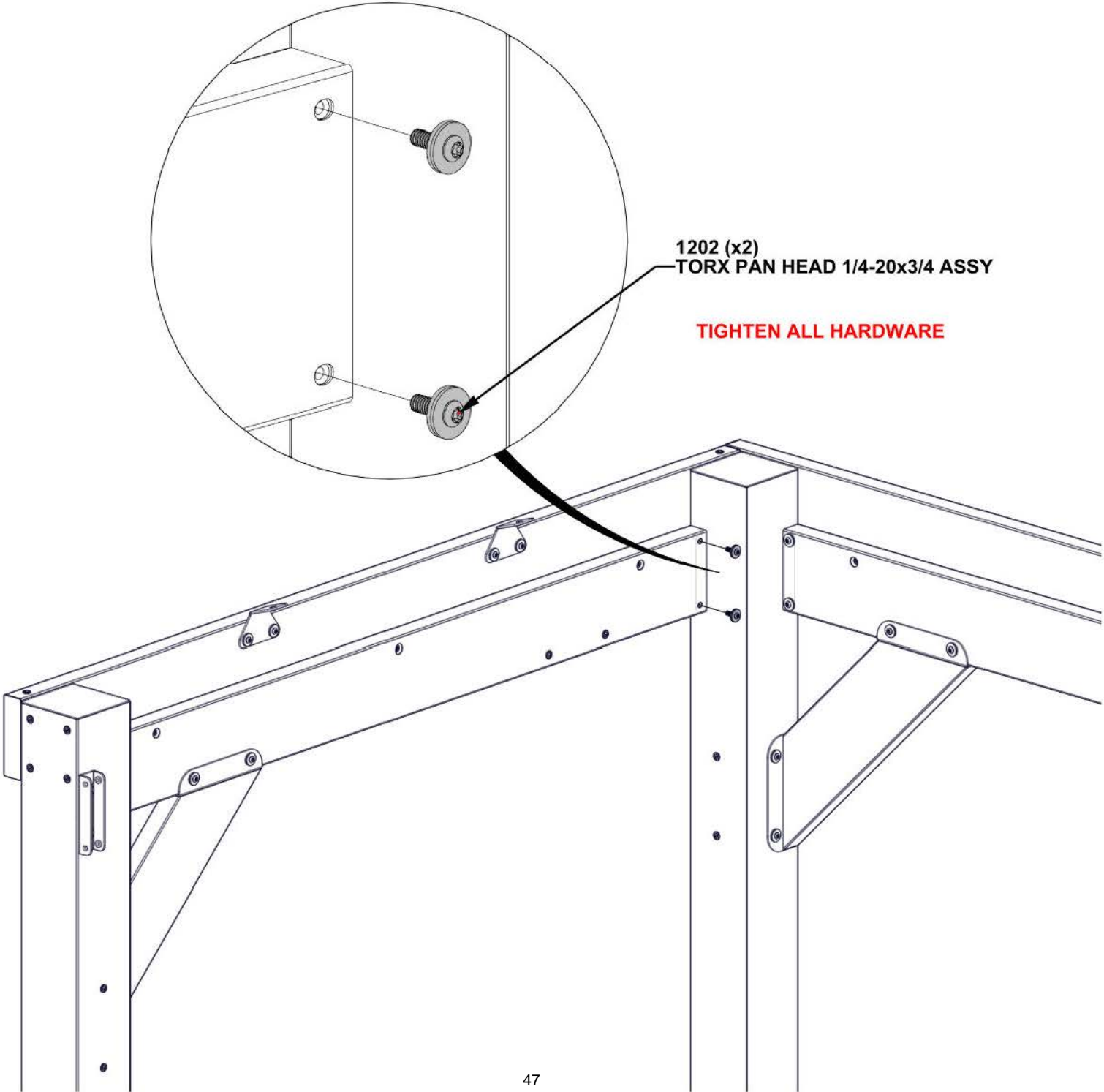

STEP 18 - FRAME ASSEMBLY

QTY	PartNo	Description
4	H101202	TORX PAN HEAD 1/4-20x3/4 ASSY



C01 CORBEL ASSEMBLY - A4M03525
(x1) 21 13/16"x5 1/4"x2 3/4" (70x134x553.5)

- ATTACH CORBEL TO BEAM AND POST.
- SQUARE AS NEEDED BEFORE TIGHTENING ALL HARDWARE.

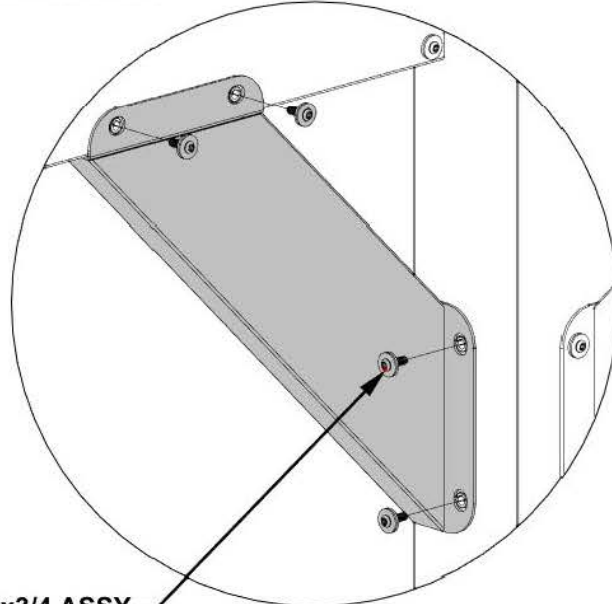

**CORBEL BRACKET HOLES
WILL FIT AROUND THREADED
INSERTS AND FLUSH AGAINST
BEAM AND POST**

1202 (x4)
TORX PAN HEAD 1/4-20x3/4 ASSY

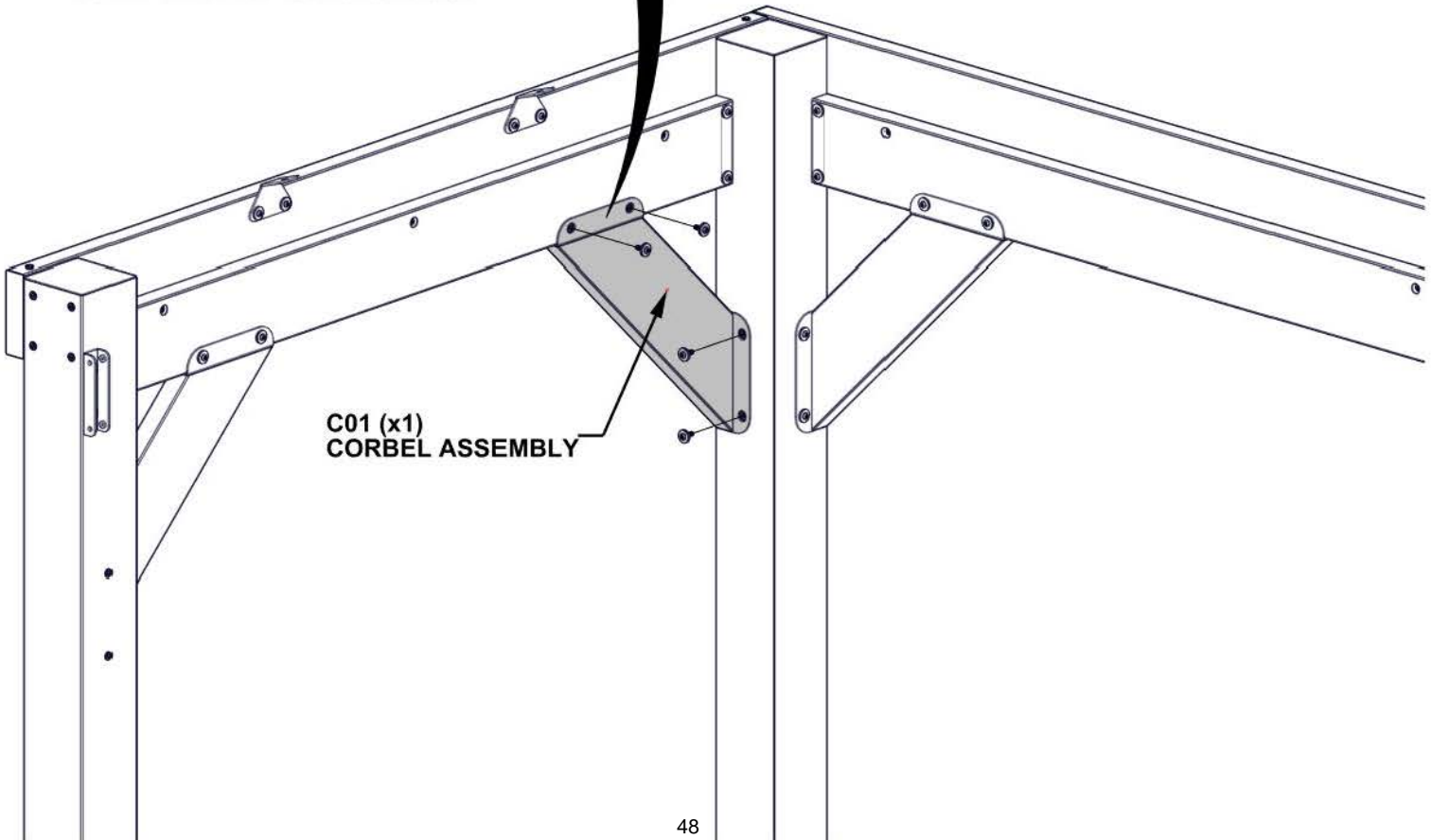

C01 (x1)
CORBEL ASSEMBLY

STEP 19A - FRAME ASSEMBLY

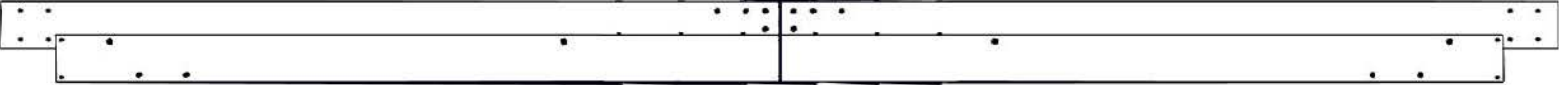

BEAM ASSEMBLY FROM STEPS 1 - 5

- WITH AT LEAST TWO OTHER PEOPLE, SPREAD FRONT POST APART ENOUGH TO ATTACH BEAM ASSEMBLY INTO BEAM BRACKETS.

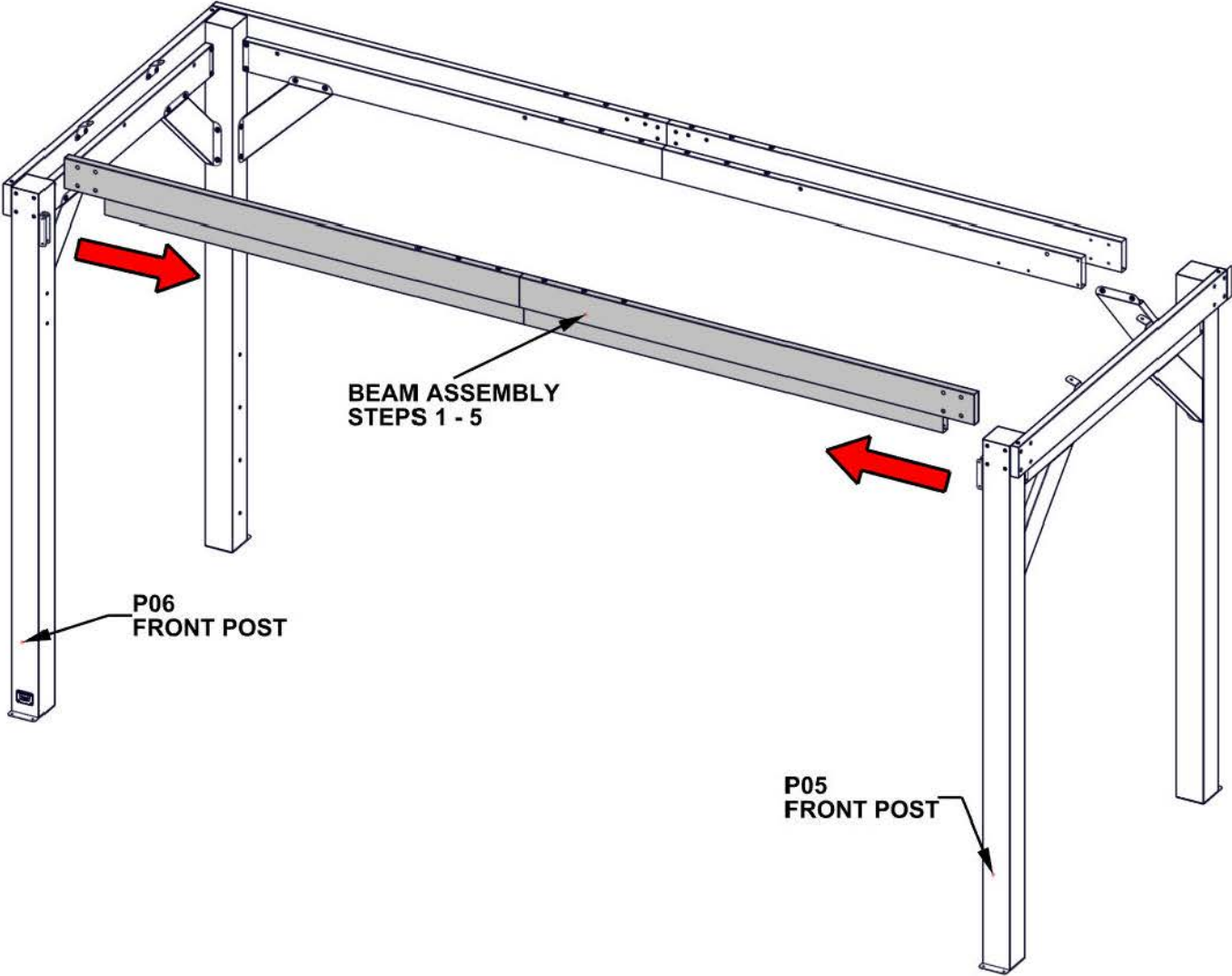

STEP 19B - FRAME ASSEMBLY

QTY	PartNo	Description
8	H101103	TORX SOCKET SCREW 1/4-20

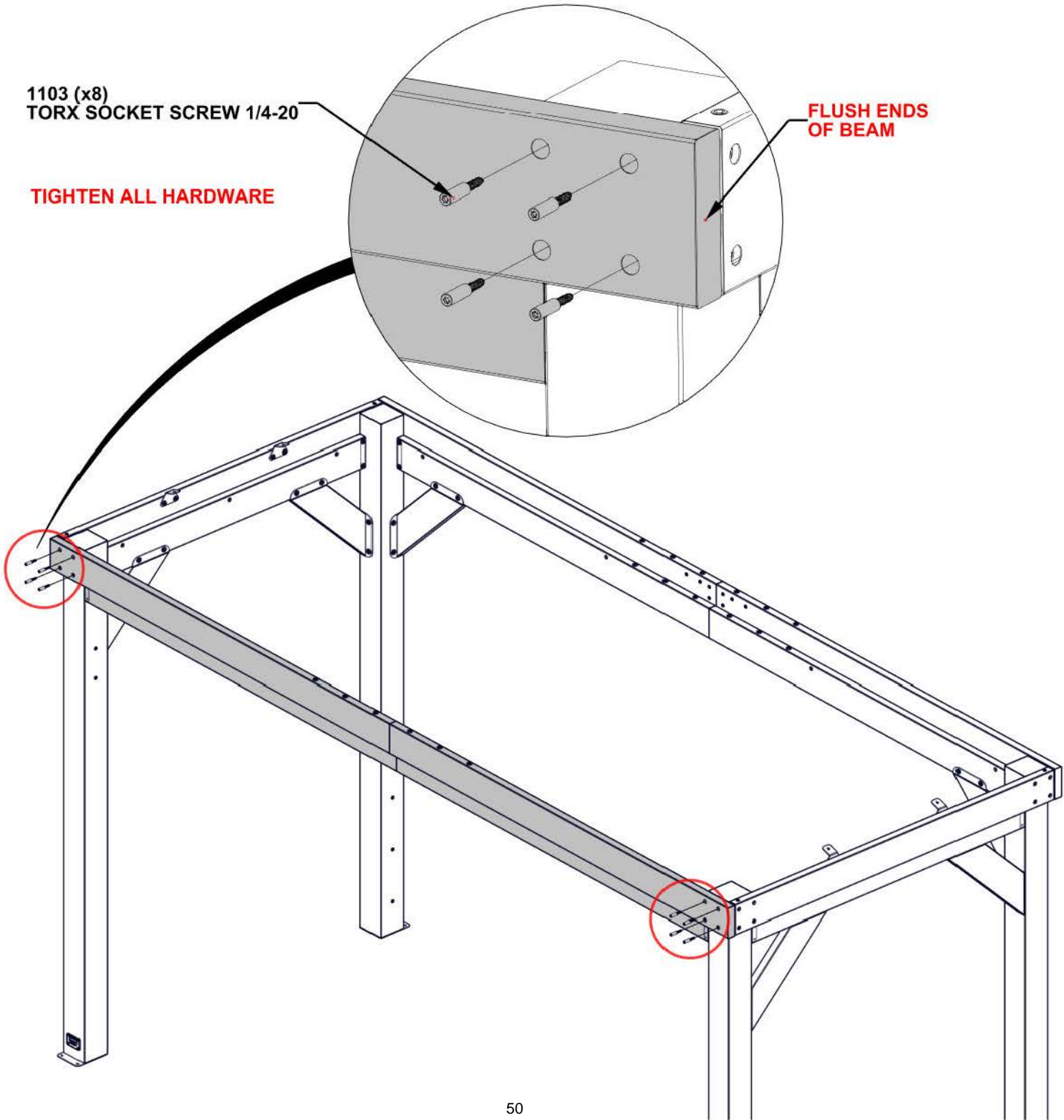

STEP 19C - FRAME ASSEMBLY

QTY	PartNo	Description
4	H101202	TORX PAN HEAD 1/4-20x3/4 ASSY

- SQUARE BEAM ASSEMBLY TO POST

1202 (x4)
TORX PAN HEAD 1/4-20x3/4 ASSY

TIGHTEN ALL HARDWARE

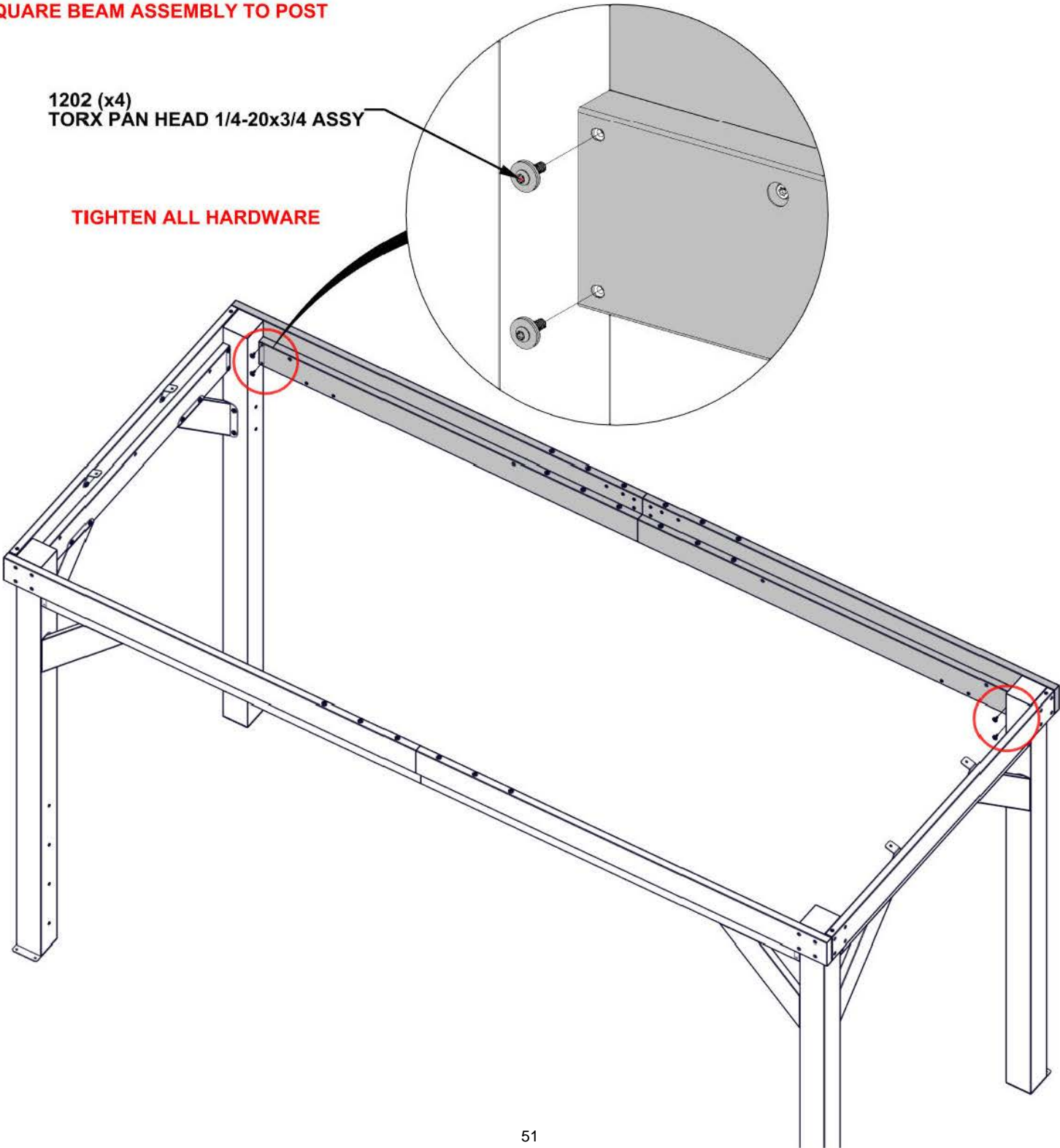

STEP 20 - FRAME ASSEMBLY

QTY	PartNo	Description
8	H101202	TORX PAN HEAD 1/4-20x3/4 ASSY



C01 CORBEL ASSEMBLY - A4M03525
(x1) 21 13/16"x5 1/4"x2 3/4" (70x134x553.5)



C02 CORBEL ASSEMBLY - A4M03526
(x1) 21 13/16"x5 1/4"x2 3/4" (70x134x553.5)

- ATTACH CORBELS TO BEAM AND POST.
- SQUARE AS NEEDED BEFORE TIGHTENING ALL HARDWARE FROM PREVIOUS STEPS.

1202 (x8)
TORX PAN HEAD 1/4-20x3/4 ASSY

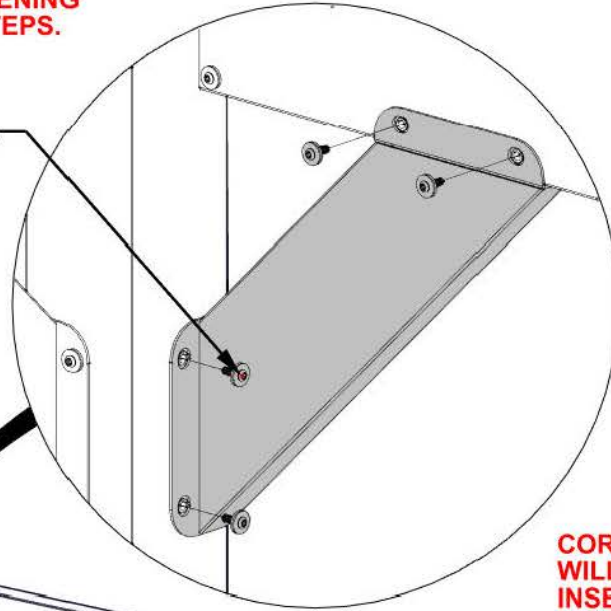

CORBEL BRACKET HOLES
WILL FIT AROUND THREADED
INSERTS AND FLUSH AGAINST
BEAM AND POST

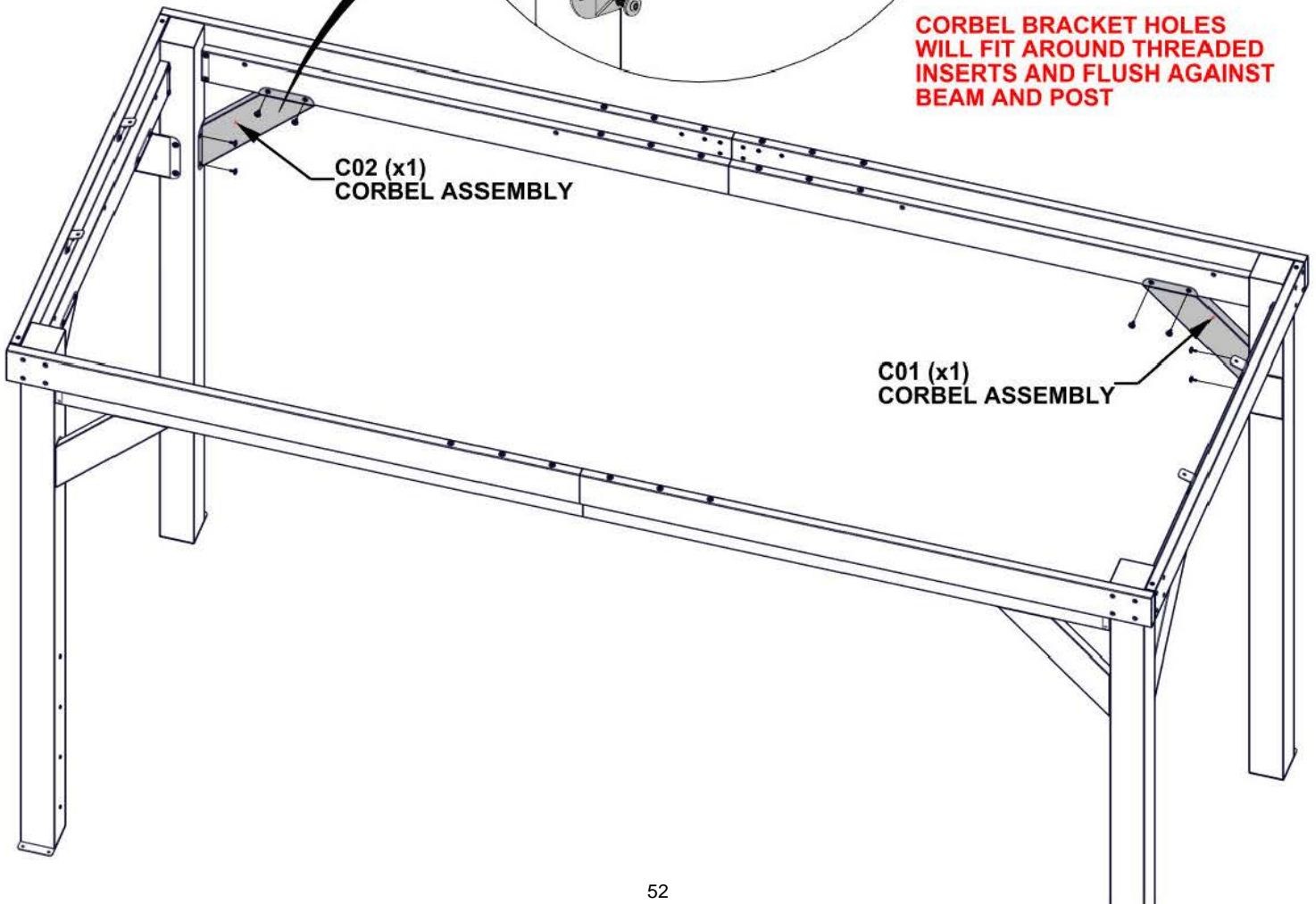

C02 (x1)
CORBEL ASSEMBLY

C01 (x1)
CORBEL ASSEMBLY

STEP 21 - SQUARE STRUCTURE

- CRITICAL:**
- SQUARE UNIT BEFORE PROCEEDING TO NEXT STEPS.
 - THE BELOW DIMENSIONS ARE CRITICAL TO THE FINAL ASSEMBLY.
 - MEASUREMENTS SHOULD BE WITHIN +/- 1/4" (6mm).
 - MEASUREMENTS OUTSIDE OF TOLERANCE WILL LEAD TO ISSUES ON FUTURE ASSEMBLY STEPS.
 - TIGHTEN ALL HARDWARE FROM PREVIOUS STEPS.

MEASUREMENTS TAKEN FROM INSIDE CORNER TO INSIDE CORNER OF POST

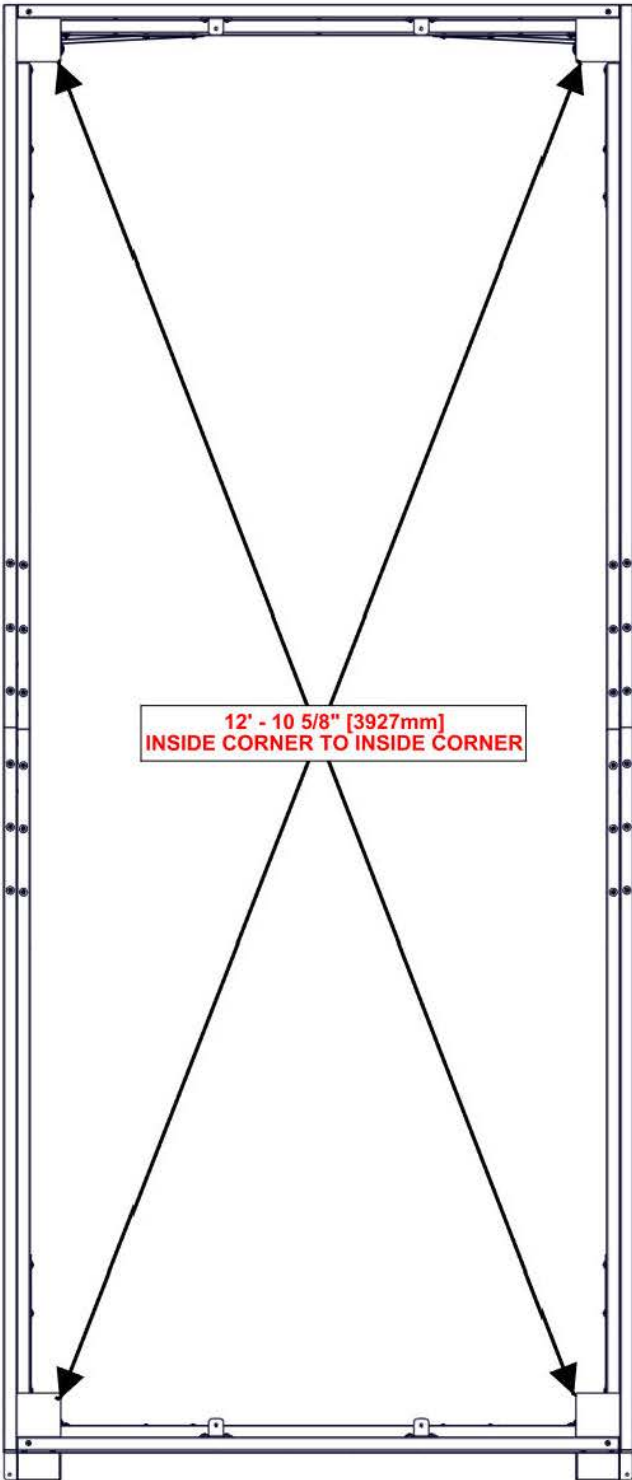

STEP 22 - GABLE ASSEMBLY

QTY	PartNo	Description
8	H101103	TORX SOCKET SCREW 1/4-20



B07 GABLE ARM ASSEMBLY - A4M03513
(x2) 29 3/16"x5 1/4"x1 7/16" (36x134x741)

1103 (x8)
TORX SOCKET SCREW 1/4-20

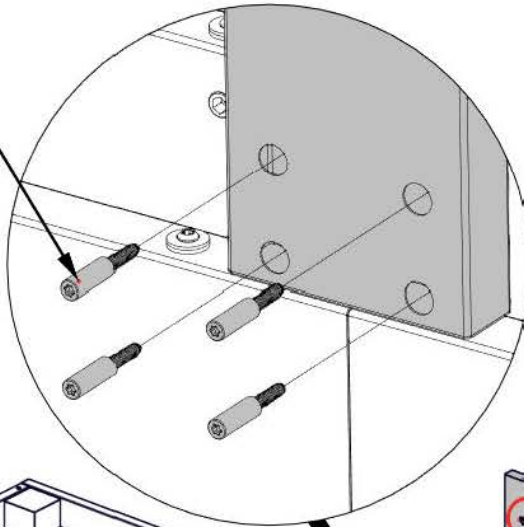

**THREADED INSERTS WILL
FACE TOWARD EACH OTHER
ON GABLE ARMS**

B07 (x2)
GABLE ARM ASSEMBLY

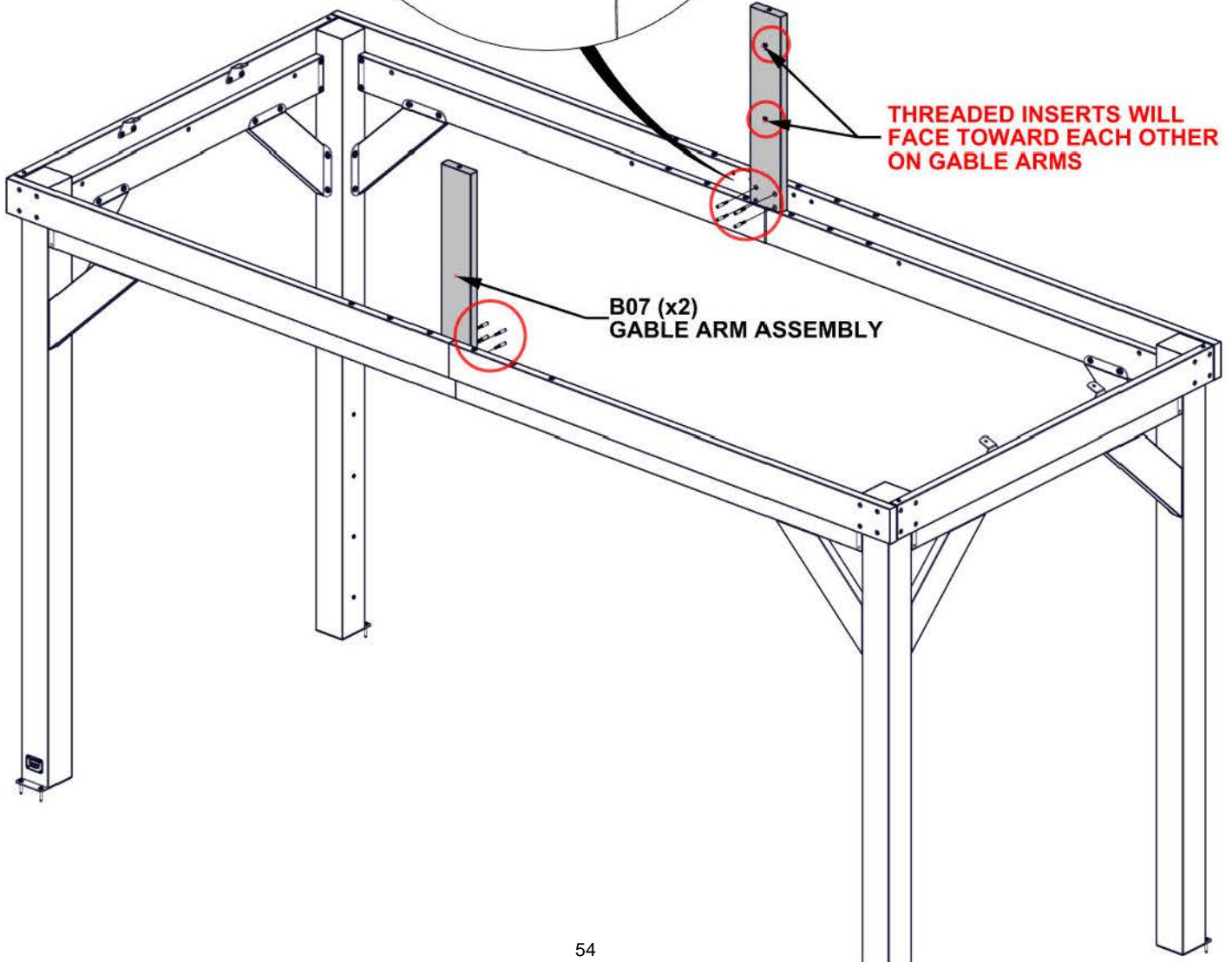

STEP 23 - RIDGE BEAM ASSEMBLY

QTY	PartNo	Description
4	H101202	TORX PAN HEAD 1/4-20x3/4 ASSY

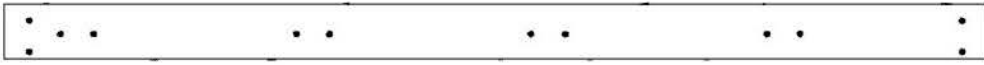

B16 RIDGE BEAM ASSEMBLY - A4M03647
 (x1) 92 15/16"x5 5/16"x1 9/16" (39x135.50x2361)

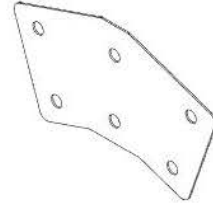

J3 GABLE BRACKET - A4M03805
 (x2) 11 1/8"x6 7/16"x1/16" (2x163x282)

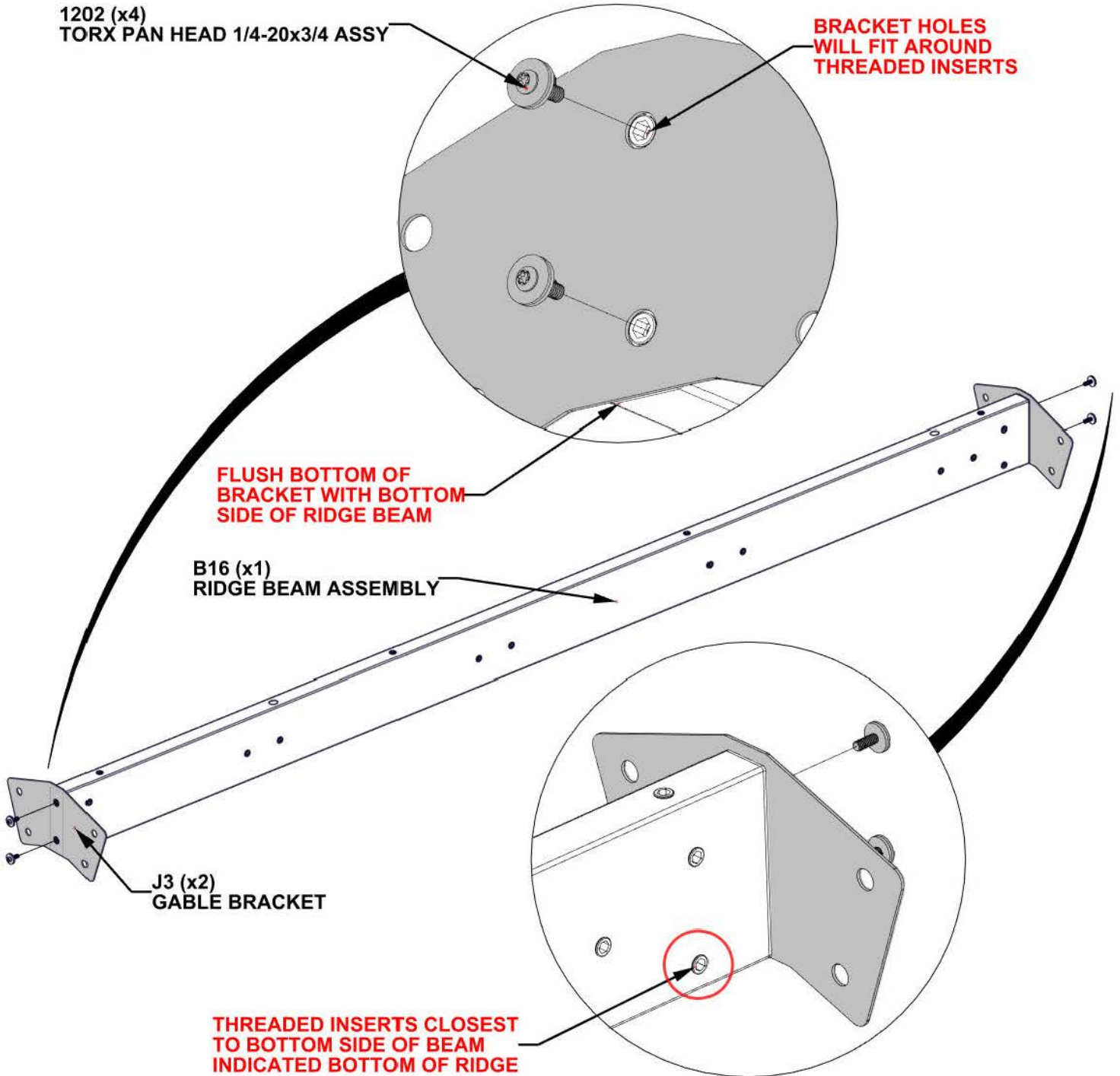

STEP 24 - RIDGE ASSEMBLY

QTY	PartNo	Description
2	H101230	BOLT WH 5/16x6 S.S.

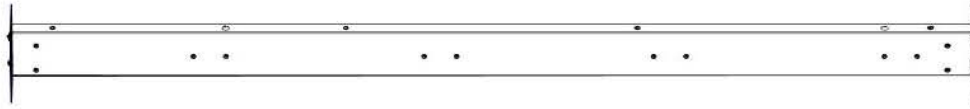

RIDGE BEAM ASSEMBLY STEP - 23

- WITH AT LEAST TWO PEOPLE, ATTACH RIDGE BEAM ASSEMBLY TO GABLE UPRIGHTS.
- RIDGE BEAM ASSEMBLY MUST BE ORIENTED AS SHOWN BELOW WITH LONG OVERHANG TOWARD THE FRONT

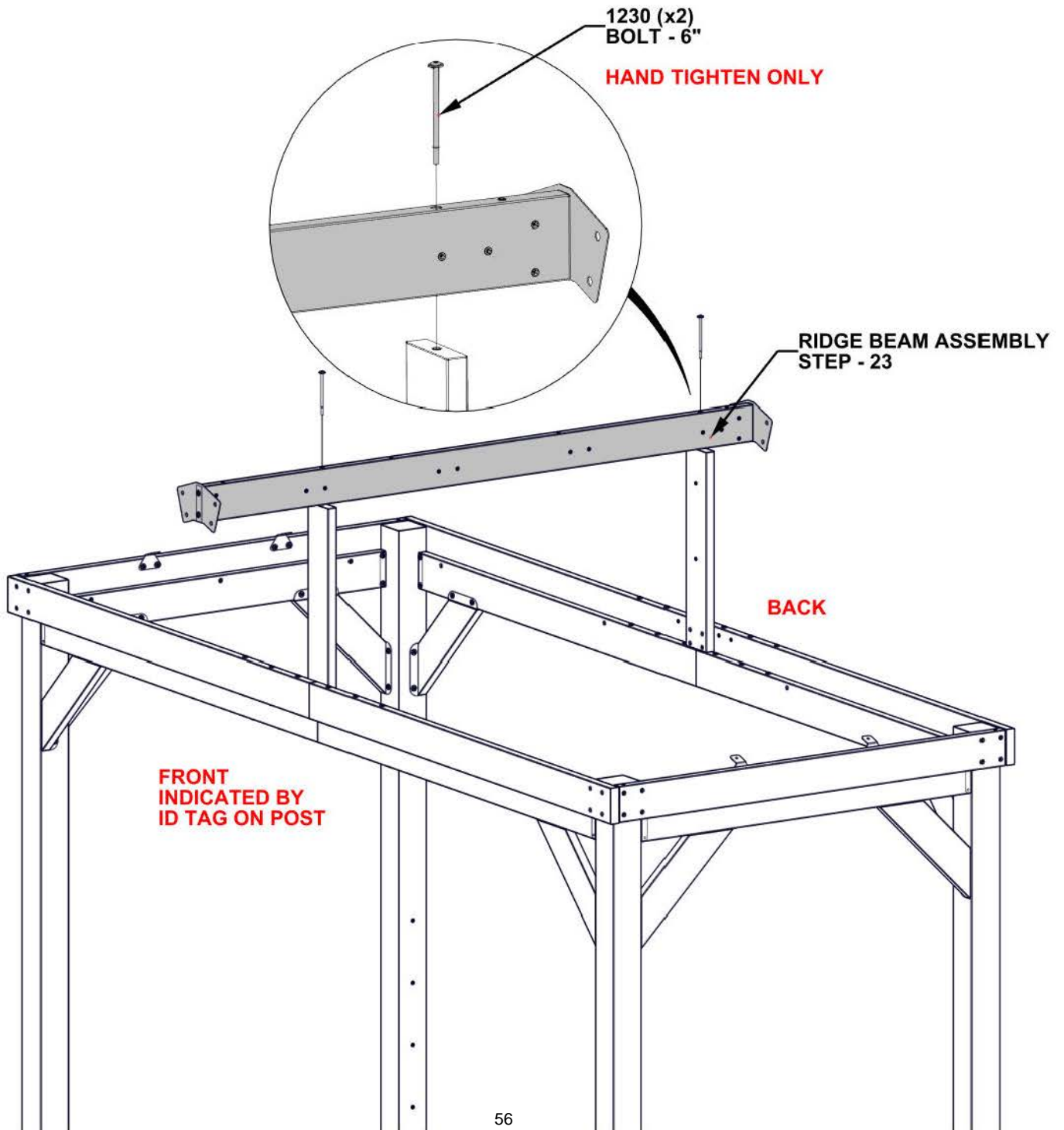

STEP 25 - RIDGE ASSEMBLY

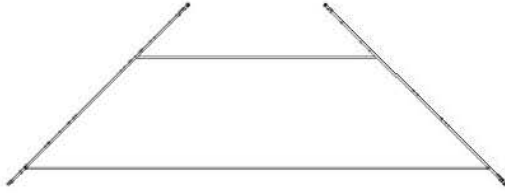

C03 CORBEL ASSEMBLY - A4M03527
(x2) 23 3/8"x12"x1 7/16" (36x304x593)

QTY	PartNo	Description
8	H101202	TORX PAN HEAD 1/4-20x3/4 ASSY

- IT IS RECOMMENDED TO USE PROVIDED ANGLE DRIVER TO INSTALL
- ATTACH CORBELS TO RIDGE BEAM AND GABLE ARMS.
- SQUARE AS NEEDED BEFORE TIGHTENING ALL HARDWARE FROM PREVIOUS STEPS.

1202 (x8)
TORX PAN HEAD 1/4-20x3/4 ASSY

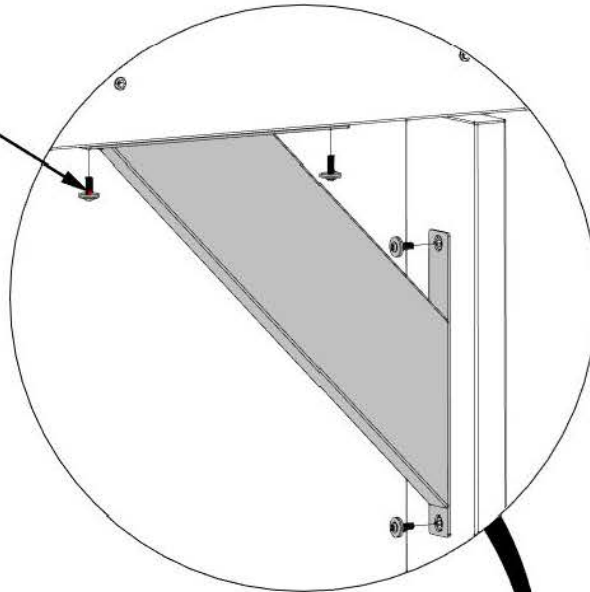

TIGHTEN ALL HARDWARE

CORBEL BRACKET HOLES
WILL FIT AROUND THREADED
INSERTS AND FLUSH AGAINST
RIDGE BEAM AND GABLE

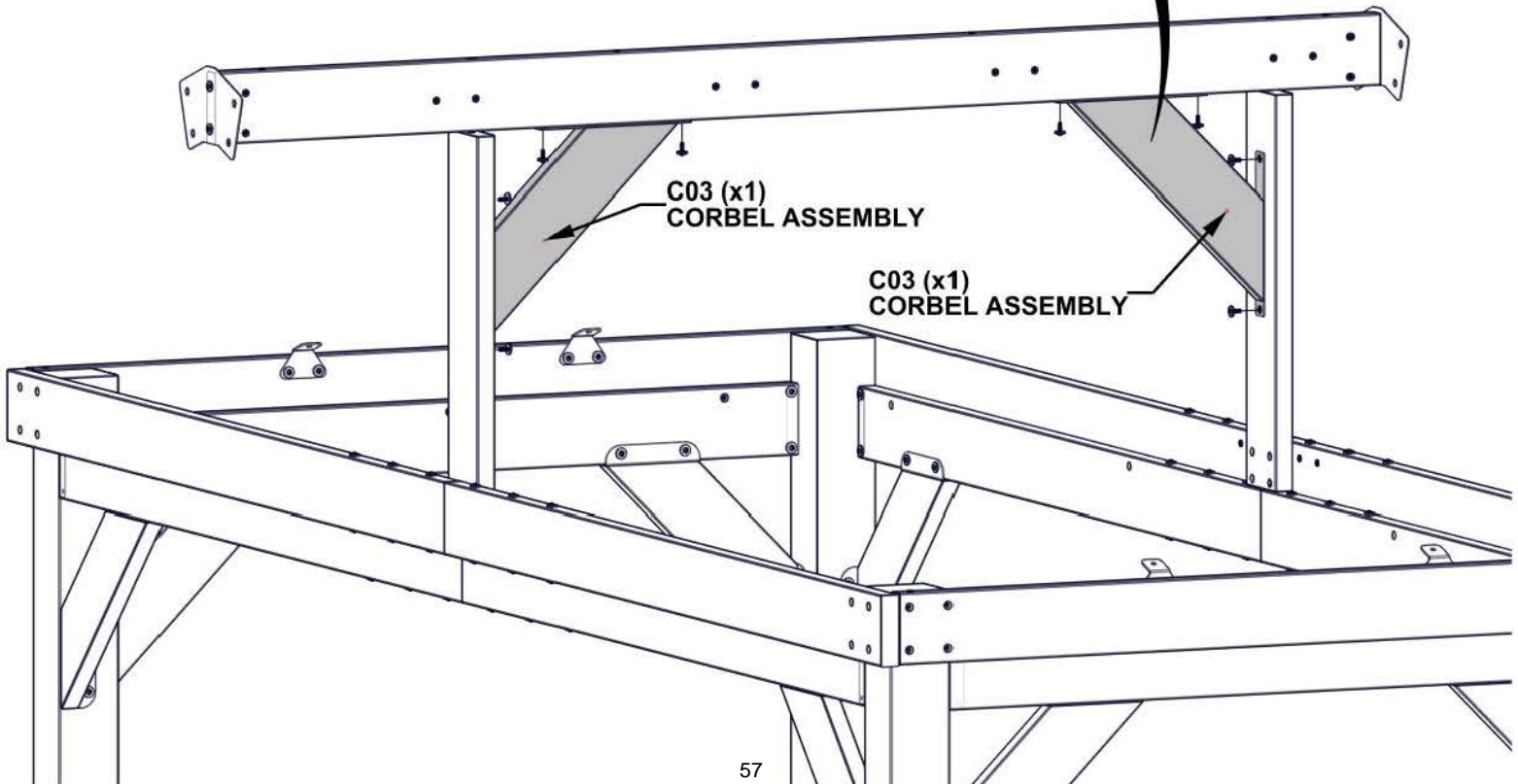

C03 (x1)
CORBEL ASSEMBLY

C03 (x1)
CORBEL ASSEMBLY

STEP 26 - RIDGE ASSEMBLY

QTY	PartNo	Description
4	H101293	TORX PAN HEAD 1/4-20x1 3/8"
4	H101054	SEALANT WASHER
4	H101053	STEEL WASHER 6x20

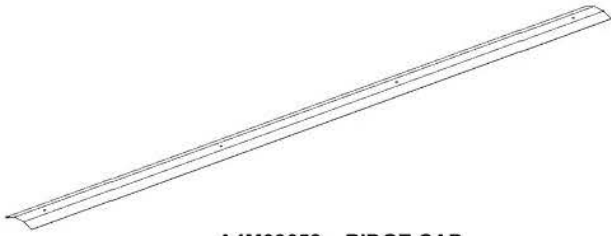

A4M03652 RIDGE CAP
(x1)



J10 SUPPORT RING - A4M03808
(x4) 13/16"x7/16" (11x20)

- REMOVE PROTECTIVE FILM.
- ORIENT RIDGE CAP AS SHOWN BELOW.
- **WARNING: GLOVES ARE RECOMMENDED WHEN HANDLING STEEL ROOF PIECE.**

FLUSH END OF RIDGE CAP WITH RIDGE PLATE

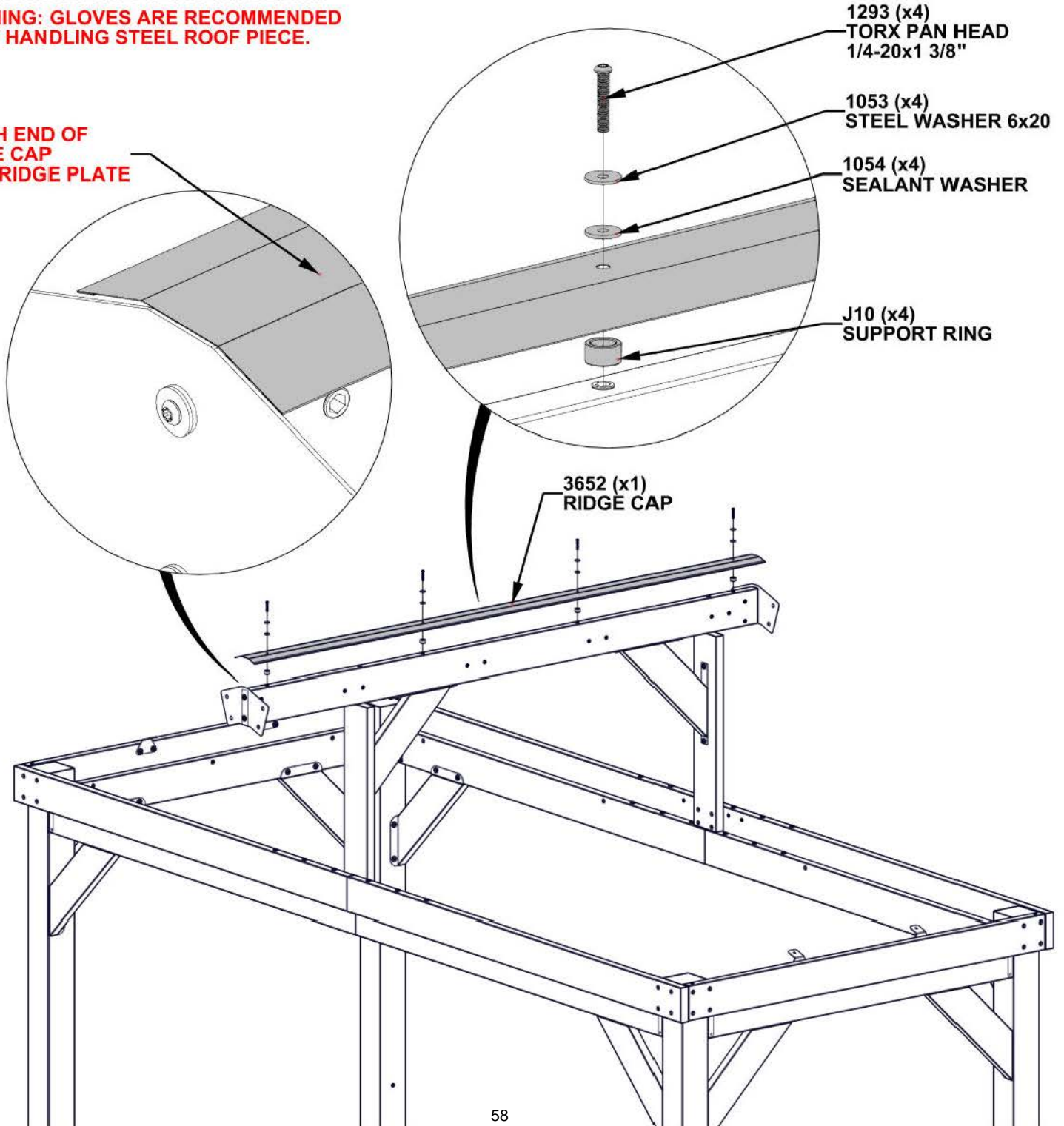

STEP 27 - ROOF ASSEMBLY

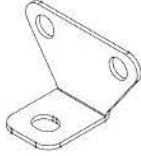

QTY	PartNo	Description
4	H101202	TORX PAN HEAD 1/4-20x3/4 ASSY

J7 RAFTER BRACKET - A4M03802
(x4) 3 5/8"x2 3/16"x2" (50x55x92)

1202 (x4)
TORX PAN HEAD
1/4-20x3/4 ASSY

HAND TIGHTEN ONLY.

**BRACKET HOLES
WILL FIT AROUND
THREADED INSERTS**

J7 (x4)
RAFTER BRACKET

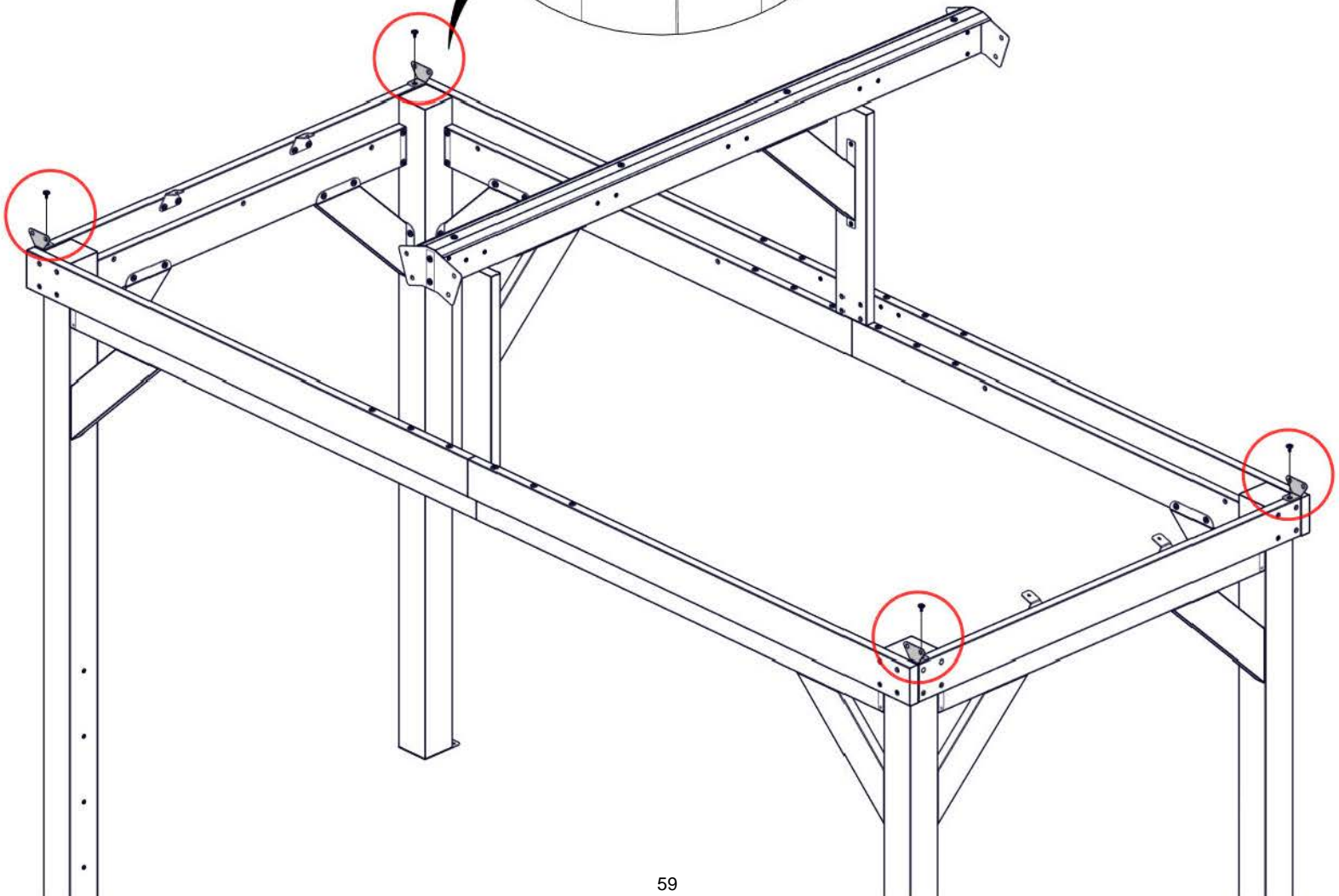
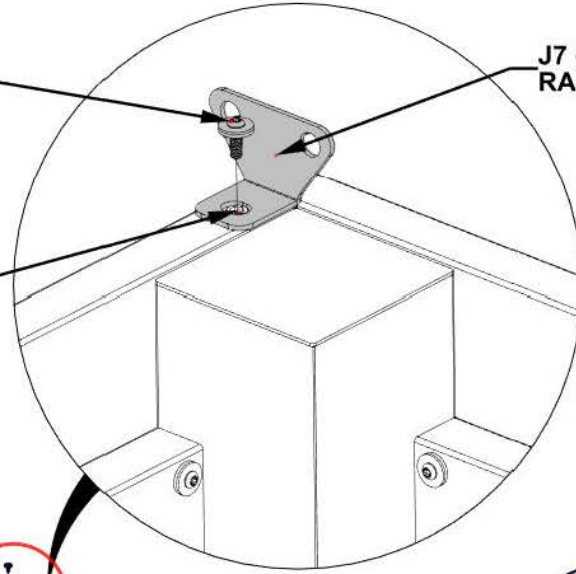

STEP 28 - ROOF ASSEMBLY

QTY	PartNo	Description
16	H101202	TORX PAN HEAD 1/4-20x3/4 ASSY



R01 RAFTER ASSEMBLY - A4M03522
(x2) 86 3/8"x4 5/16"x3 1/8" (80x110x2194.6)



R02 RAFTER ASSEMBLY - A4M03523
(x2) 86 3/8"x4 5/16"x3 1/8" (80x110x2194.6)

- INSERTS ON THE SIDE OF EACH RAFTER MUST FACE TOWARD THE INSIDE OF THE STRUCTURE.
- ATTACH EACH RAFTER AT THE RIDGE AS SHOWN BELOW.
- ONCE SUPPORTED, ATTACH END OF RAFTER TO RAFTER BRACKETS AT TOP OF EACH POST.

BRACKET HOLES WILL FIT AROUND THREADED INSERTS

BRACKET HOLES WILL FIT AROUND THREADED INSERTS

1202 (x8)
TORX PAN HEAD
1/4-20x3/4 ASSY

HAND TIGHTEN ONLY.

1202 (x8)
TORX PAN HEAD
1/4-20x3/4 ASSY

HAND TIGHTEN ONLY.

R02 (x1)
RAFTER
ASSEMBLY

THREADED INSERTS
NEED TO FACE
TOWARD THE INSIDE

FRONT

R01 (x1)
RAFTER
ASSEMBLY

R01 (x1)
RAFTER
ASSEMBLY

R02 (x1)
RAFTER
ASSEMBLY

BACK

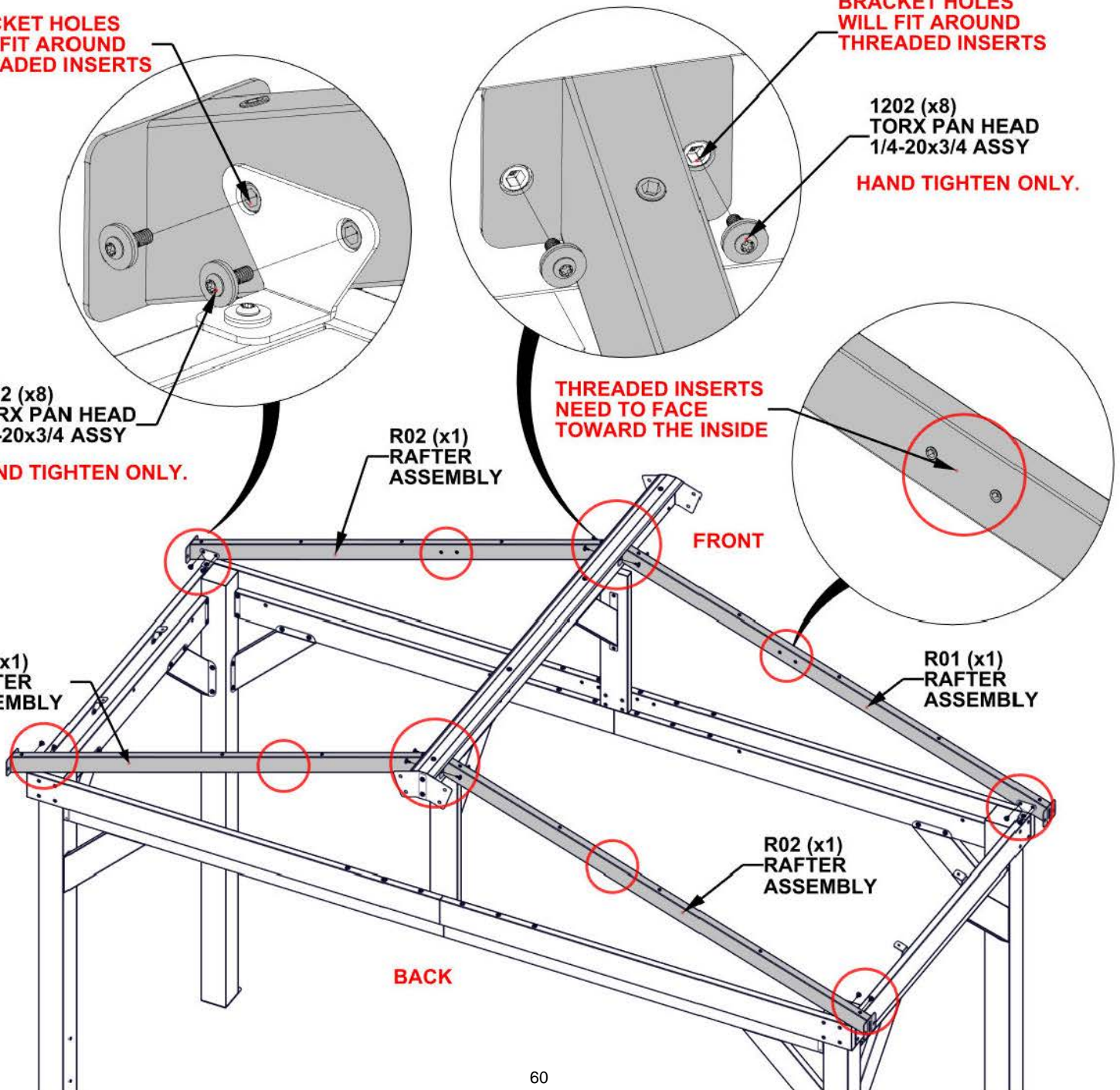

STEP 29 - ROOF ASSEMBLY

QTY	PartNo	Description
16	H101103	TORX SOCKET SCREW 1/4-20



B08 GABLE ARM ASSEMBLY - A4M03514
(x2) 40 1/16"x5 1/4"x1 7/16" (36x134x1017)



B09 GABLE ARM ASSEMBLY - A4M03515
(x2) 40 1/16"x5 1/4"x1 7/16" (36x134x1017)

**FLUSH TOP SURFACE
OF GABLE AND RAFTER**

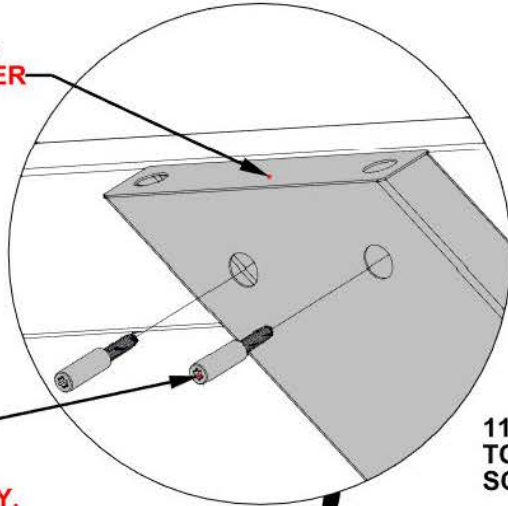

**1103 (x8)
TORX SOCKET
SCREW 1/4-20**

HAND TIGHTEN ONLY.

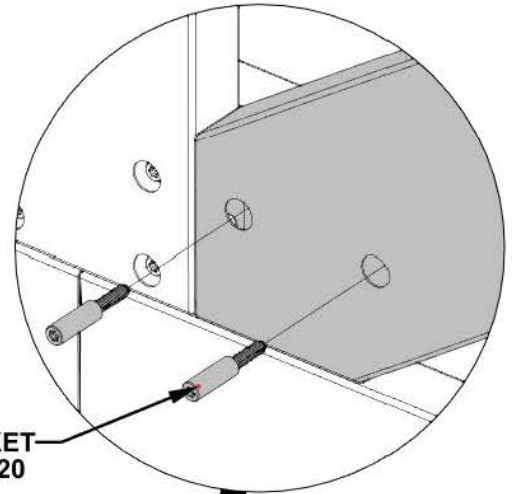

**1103 (x8)
TORX SOCKET
SCREW 1/4-20**

BACK

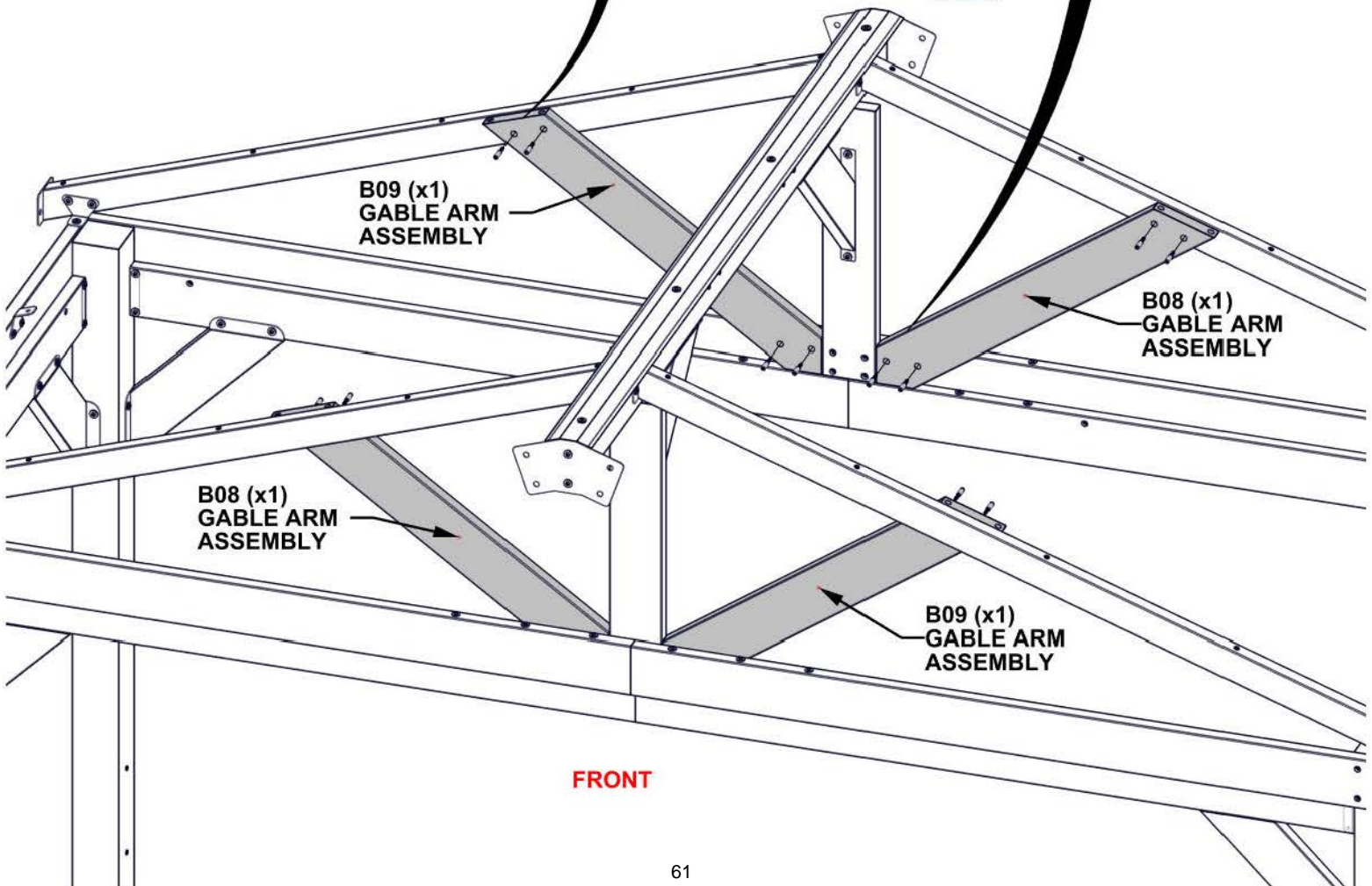

FRONT

STEP 30A - ROOF ASSEMBLY

QTY	PartNo	Description
8	H101202	TORX PAN HEAD 1/4-20x3/4 ASSY



R03 RAFTER ASSEMBLY - A4M03524
(x4) 86 3/8"x4 5/16"x3 1/8" (80x110x2194.6)

- ATTACH EACH RAFTER AT THE RIDGE AS SHOWN BELOW.

**BRACKET HOLES
WILL FIT AROUND
THREADED INSERTS**

1202 (x8)
TORX PAN HEAD
1/4-20x3/4 ASSY

HAND TIGHTEN ONLY

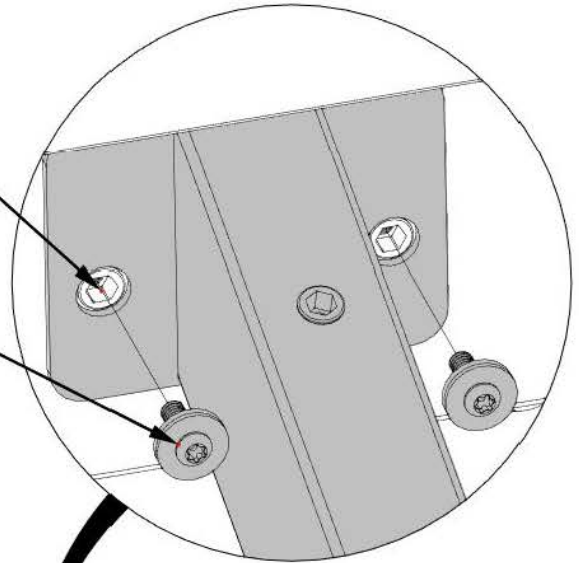

R03 (x4)
RAFTER ASSEMBLY

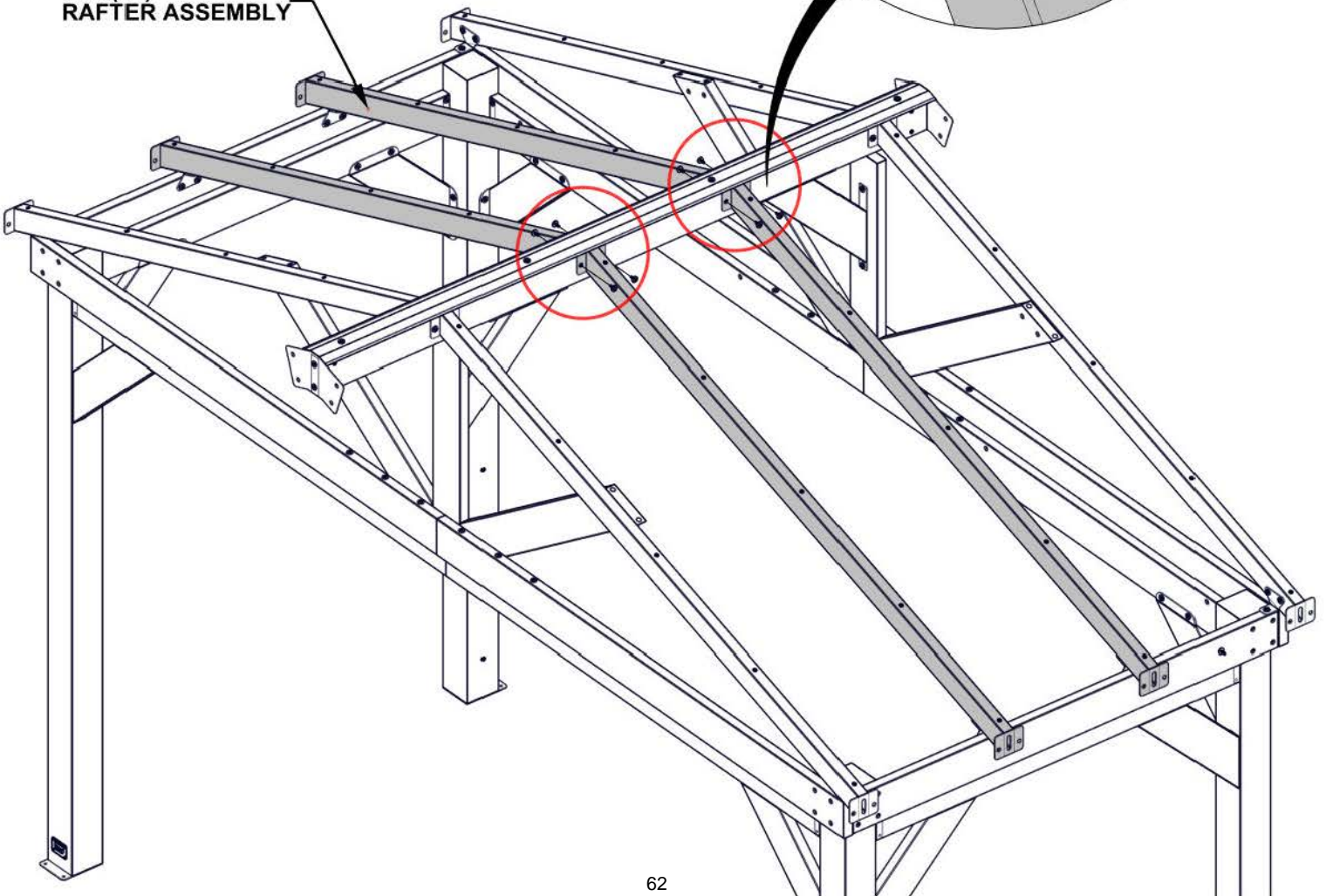

STEP 30B - ROOF ASSEMBLY

QTY	PartNo	Description
4	H101202	TORX PAN HEAD 1/4-20x3/4 ASSY

- ATTACH END OF EACH RAFTER TO BRACKETS ALONG SIDE BEAMS.

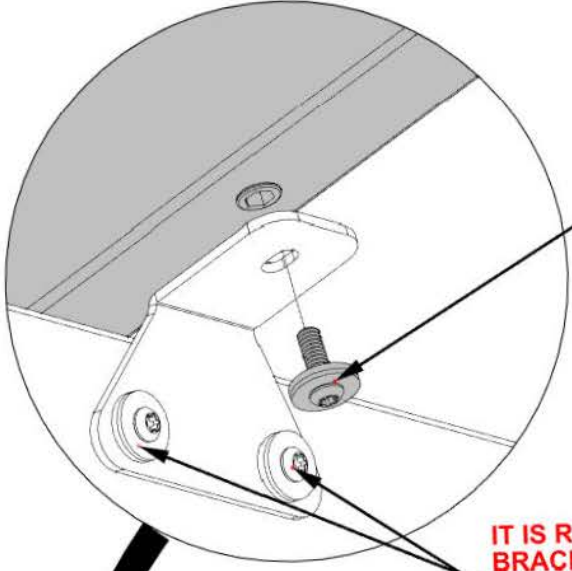

1202 (x4)
TORX PAN HEAD
1/4-20x3/4 ASSY

HAND TIGHTEN ONLY

**IT IS RECOMMENDED TO LEAVE
BRACKET HARDWARE LOOSE
TO HELP IN LATER STEPS**

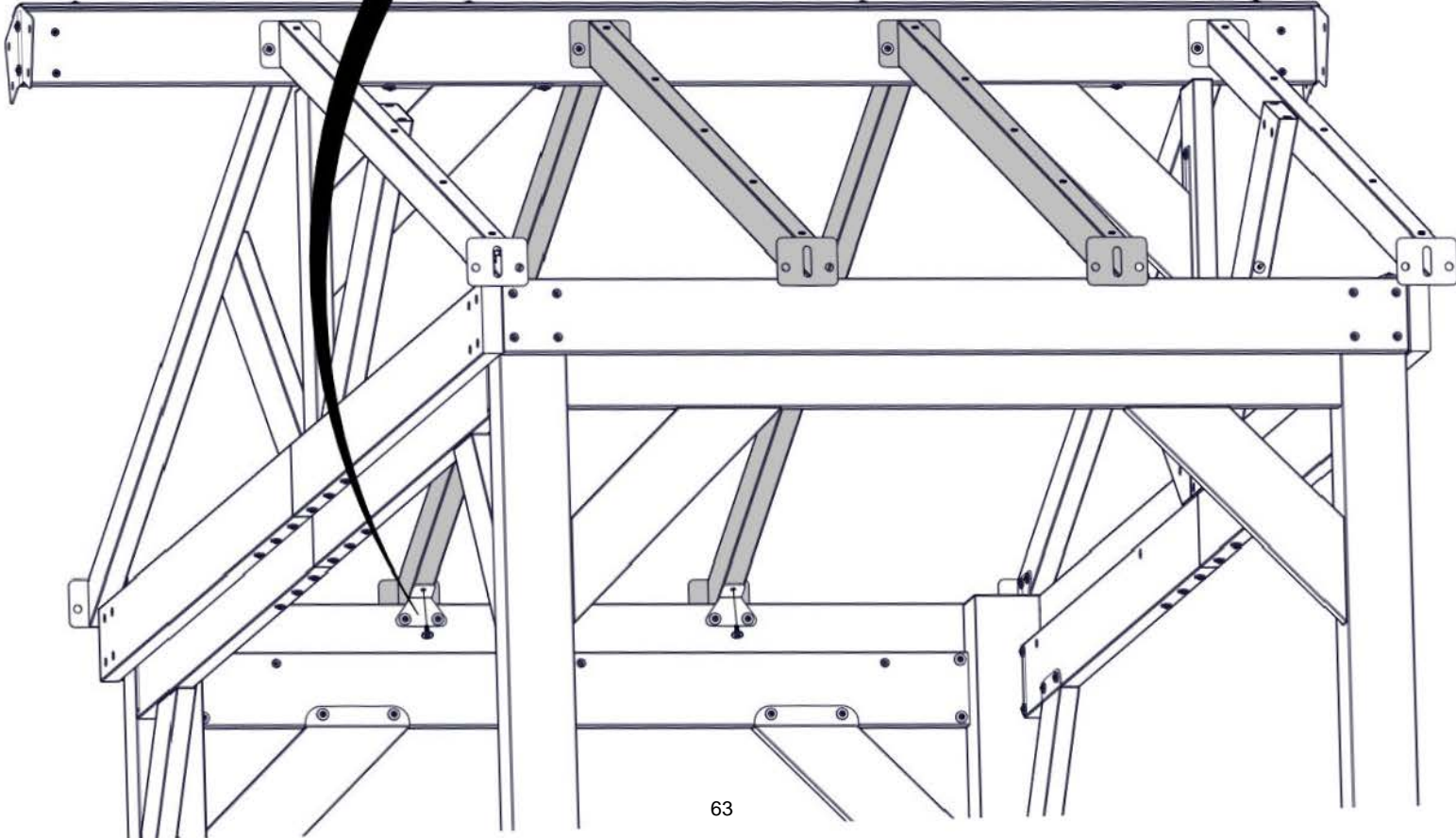

STEP 31 - ROOF ASSEMBLY

QTY	PartNo	Description
16	H101202	TORX PAN HEAD 1/4-20x3/4 ASSY

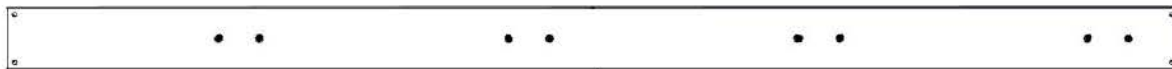

B19 DRIP BEAM ASSEMBLY - A4M03650
(x2) 89 15/16"x4 13/16"x1 7/16" (36x122x2285)

- WITH AT LEAST TWO ADDITIONAL PEOPLE, ATTACH BEAM ASSEMBLY TO RAFTER ENDS.
- BEAM ASSEMBLY MUST BE ORIENTED AS SHOWN BELOW WITH LONG OVERHANG TOWARD THE FRONT

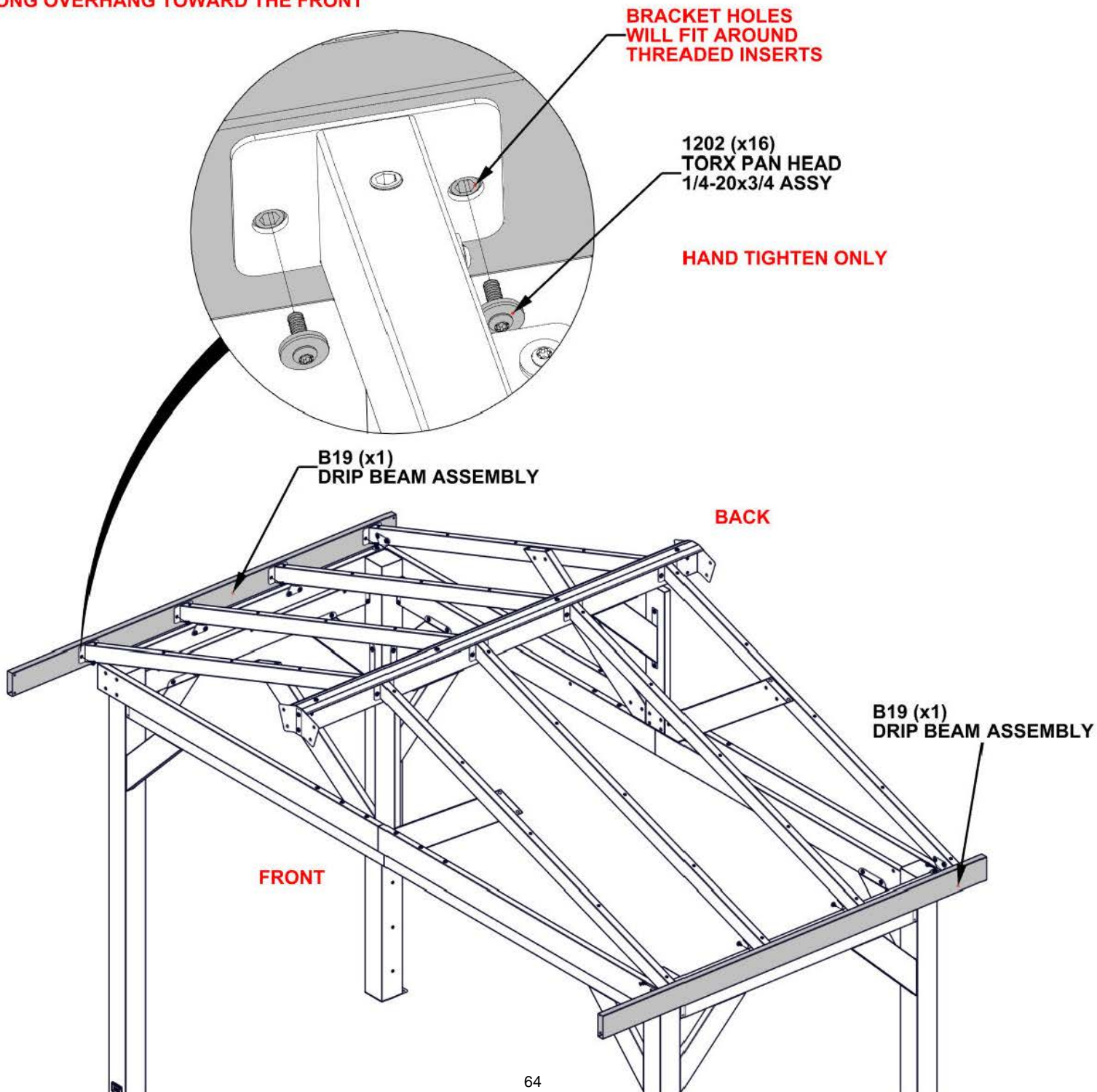

STEP 32 - ROOF ASSEMBLY

QTY	PartNo	Description
4	H101202	TORX PAN HEAD 1/4-20x3/4 ASSY

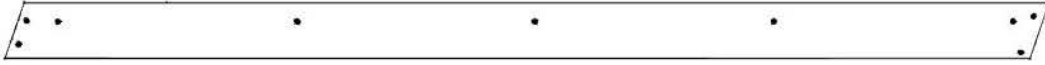

B13 GABLE BEAM ASSEMBLY - A4M03519
(x2) 88 13/16"x5 1/4"x1 7/16" (36x134x2255)

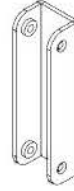

J9 BEAM BRACKET - A4M03807
(x2) 1"x1 5/16"x4 9/16" (25x33.20x116)

- REPEAT THIS STEP TWICE

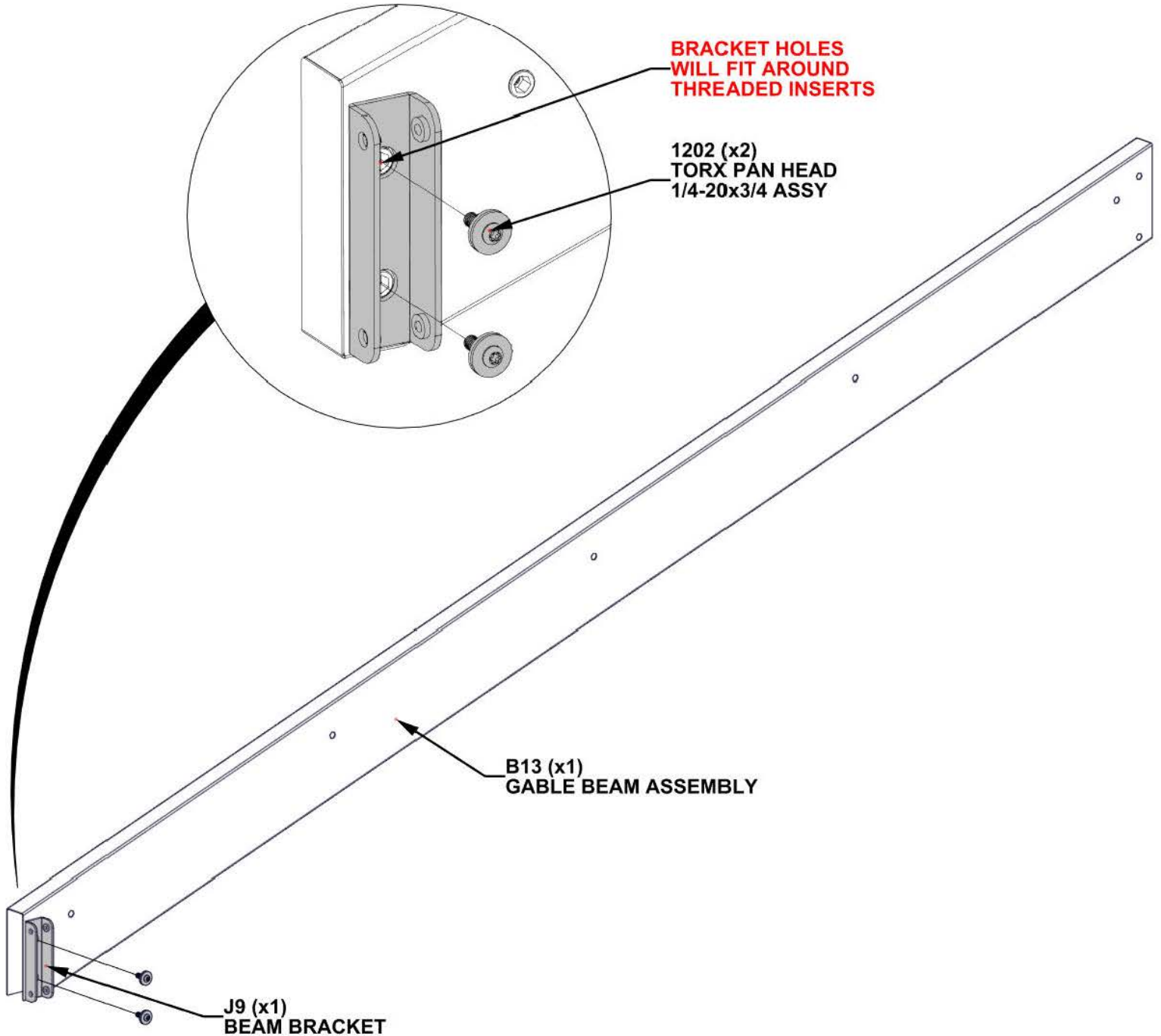

STEP 33 - ROOF ASSEMBLY

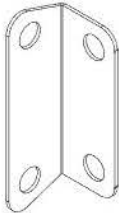

QTY	PartNo	Description
4	H101202	TORX PAN HEAD 1/4-20x3/4 ASSY

J8 GABLE BRACKET - A4M03804
 (x2) 4 13/16"x1 9/16"x1 9/16" (40x40x123)

- REPEAT THIS STEP TWICE

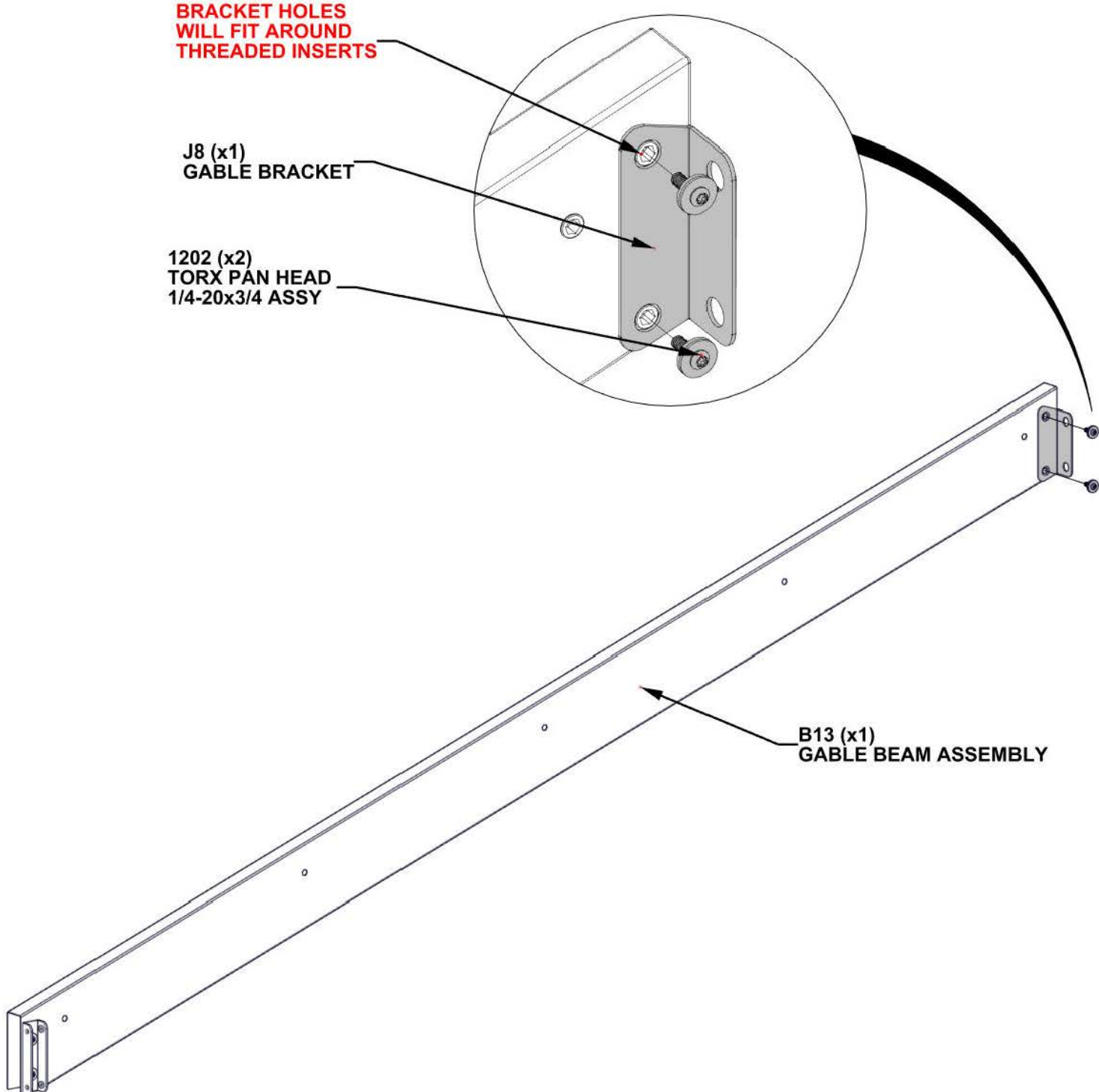

STEP 34A - ROOF ASSEMBLY

QTY	PartNo	Description
4	H101202	TORX PAN HEAD 1/4-20x3/4 ASSY

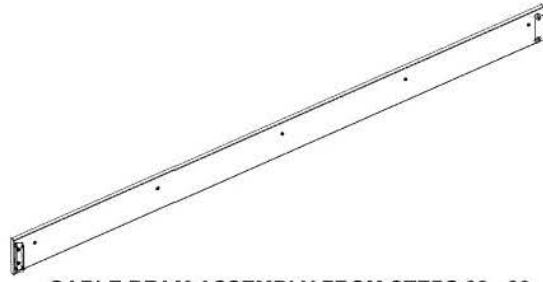

GABLE BEAM ASSEMBLY FROM STEPS 32 - 33

- WITH AT LEAST TWO ADDITIONAL PEOPLE, ATTACH GABLE BEAM ASSEMBLY.
- REPEAT THIS STEP TWICE FOR BOTH SIDES OF STRUCTURE

BRACKET HOLES
WILL FIT AROUND
THREADED INSERTS

1202 (x4)
TORX PAN HEAD
1/4-20x3/4 ASSY

HAND TIGHTEN ONLY

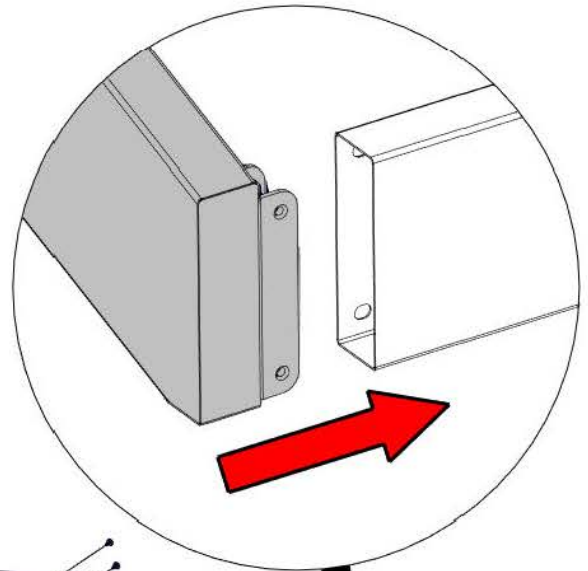

BACK

FRONT

GABLE BEAM
ASSEMBLY FROM
STEPS 32 - 33

STEP 34B - ROOF ASSEMBLY

QTY	PartNo	Description
8	H101202	TORX PAN HEAD 1/4-20x3/4 ASSY

- REPEAT THIS STEP TWICE FOR BOTH SIDES OF STRUCTURE

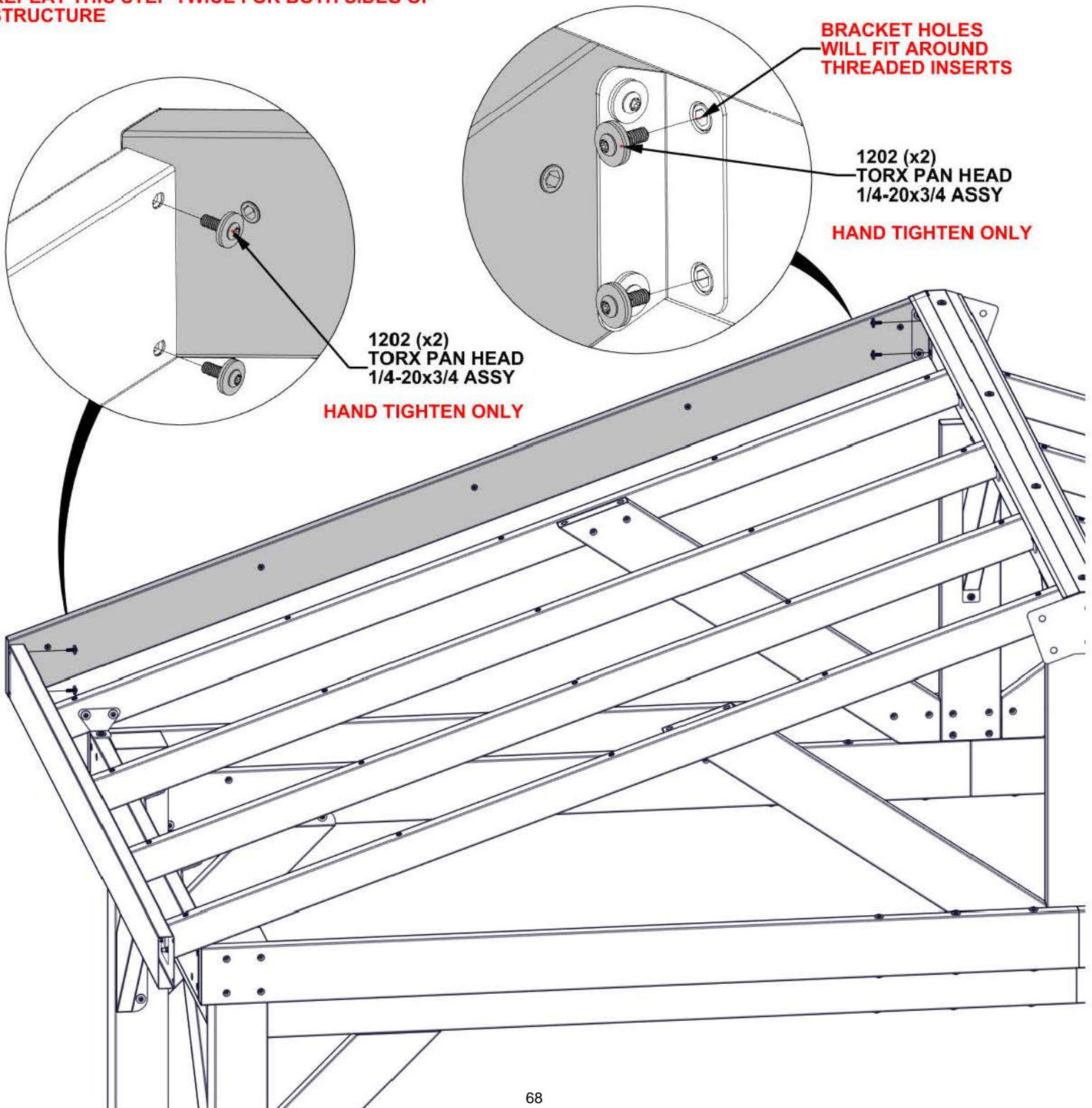

STEP 35 - ROOF ASSEMBLY

QTY	PartNo	Description
4	H101202	TORX PAN HEAD 1/4-20x3/4 ASSY

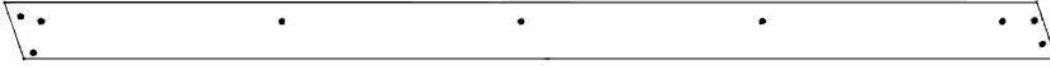

B12 GABLE BEAM ASSEMBLY - A4M03518
(x2) 88 13/16"x5 1/4"x1 7/16" (36x134x2255)

J9 BEAM BRACKET - A4M03807
(x2) 1"x1 5/16"x4 9/16" (25x33.20x116)

- REPEAT THIS STEP TWICE

**BRACKET HOLES
WILL FIT AROUND
THREADED INSERTS**

**1202 (x2)
TORX PAN HEAD
1/4-20x3/4 ASSY**

**B12 (x1)
GABLE BEAM ASSEMBLY**

**J9 (x1)
BEAM BRACKET**

STEP 36 - ROOF ASSEMBLY

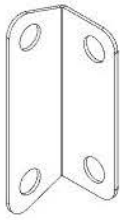

QTY	PartNo	Description
4	H101202	TORX PAN HEAD 1/4-20x3/4 ASSY

J8 GABLE BRACKET - A4M03804
(x2) 4 13/16"x1 9/16"x1 9/16" (40x40x123)

- REPEAT THIS STEP TWICE

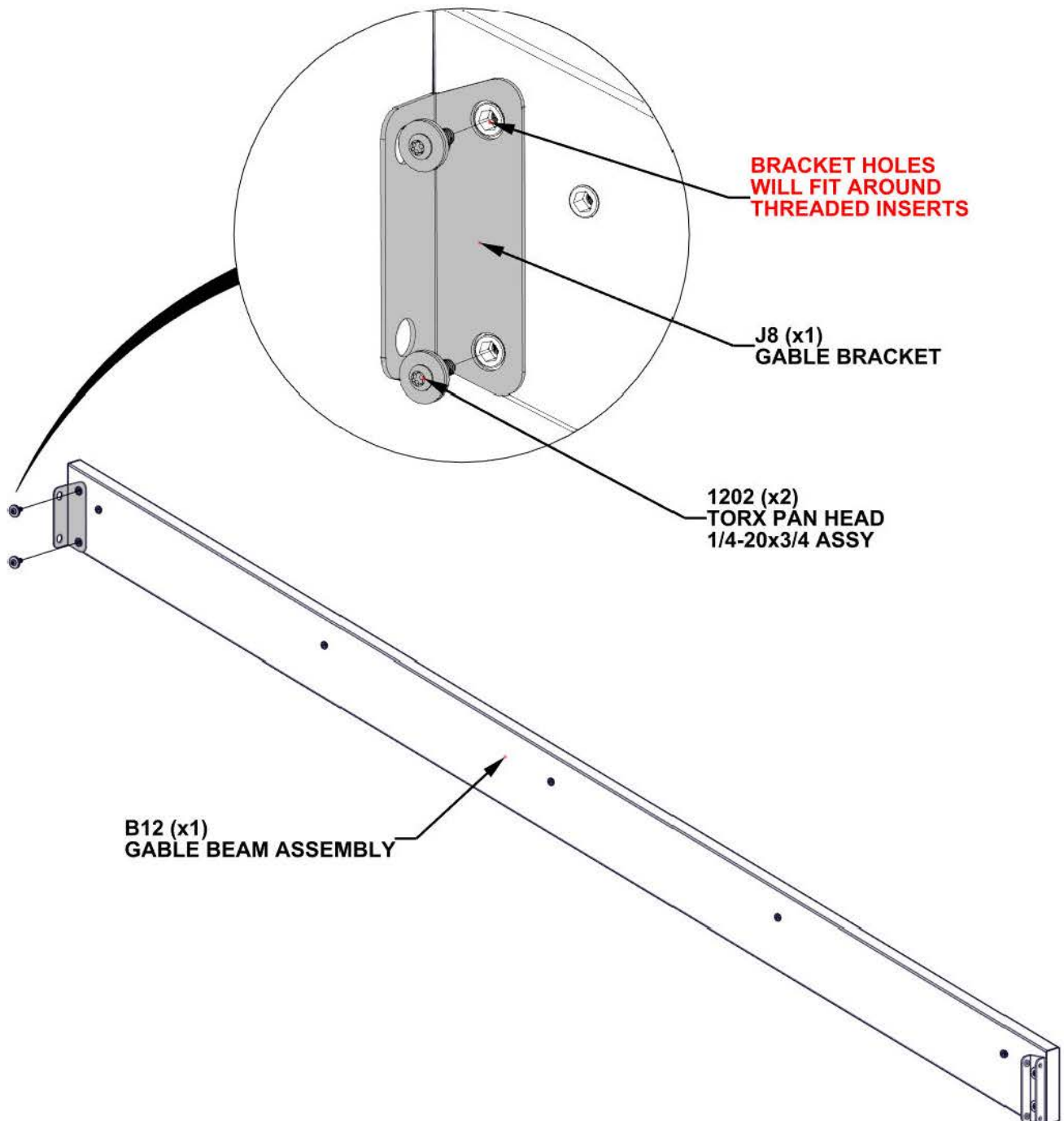

STEP 37A - ROOF ASSEMBLY

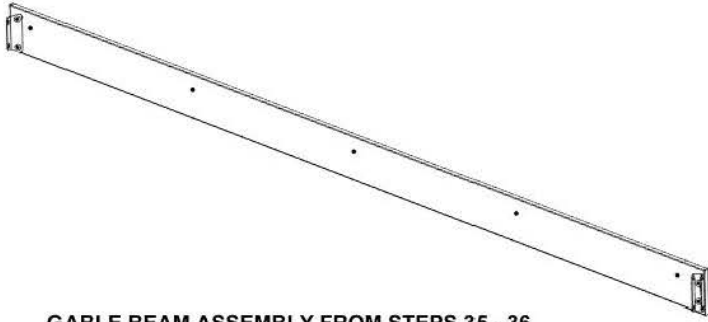

GABLE BEAM ASSEMBLY FROM STEPS 35 - 36

QTY	PartNo	Description
4	H101202	TORX PAN HEAD 1/4-20x3/4 ASSY

- WITH AT LEAST TWO ADDITIONAL PEOPLE, ATTACH GABLE BEAM ASSEMBLY.
- REPEAT THIS STEP TWICE FOR BOTH SIDES OF STRUCTURE

BRACKET HOLES
WILL FIT AROUND
THREADED INSERTS

1202 (x4)
TORX PAN HEAD
1/4-20x3/4 ASSY

HAND TIGHTEN ONLY

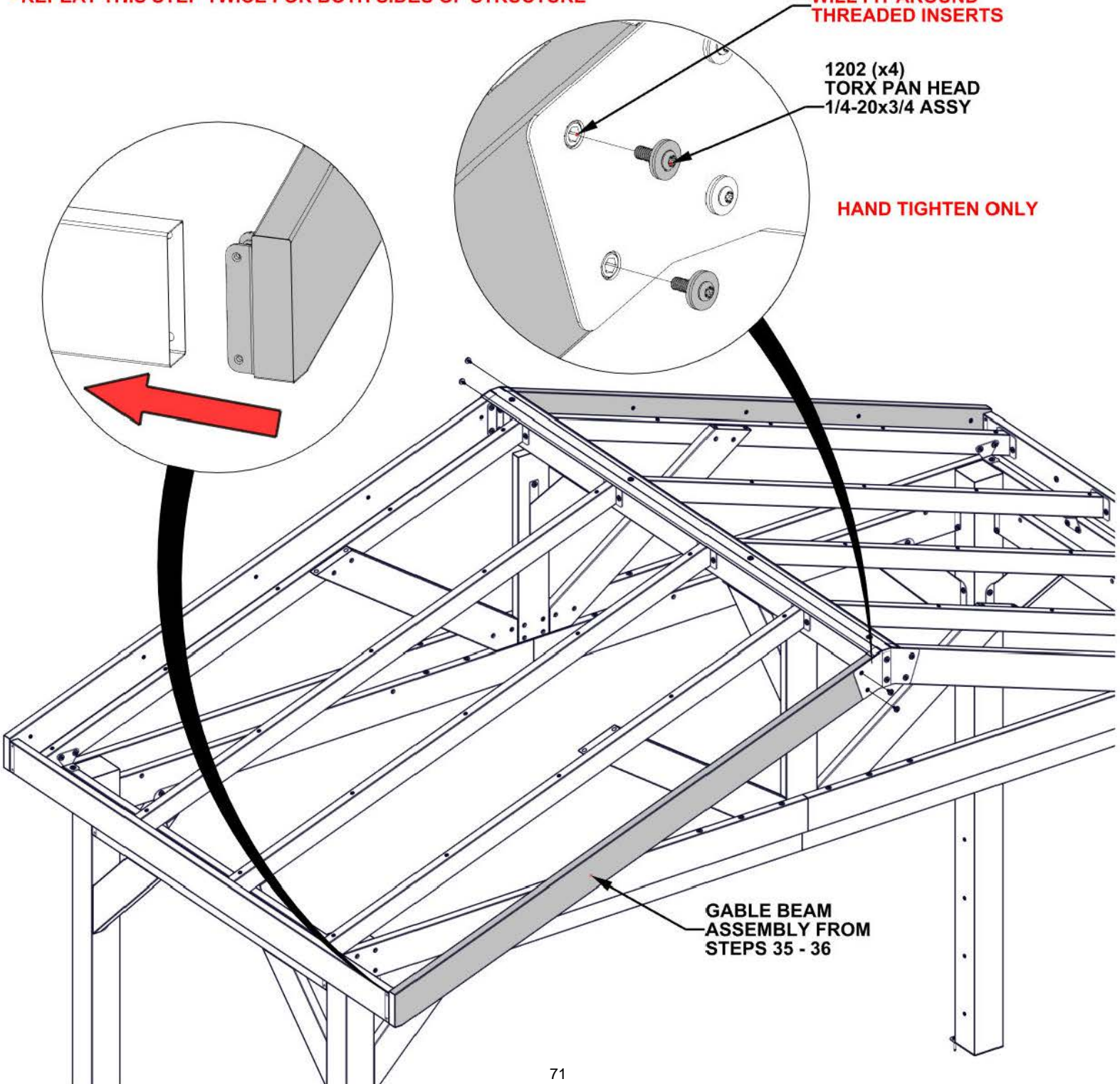

GABLE BEAM
ASSEMBLY FROM
STEPS 35 - 36

STEP 37B - ROOF ASSEMBLY

QTY	PartNo	Description
8	H101202	TORX PAN HEAD 1/4-20x3/4 ASSY

- REPEAT THIS STEP TWICE FOR BOTH SIDES OF STRUCTURE.

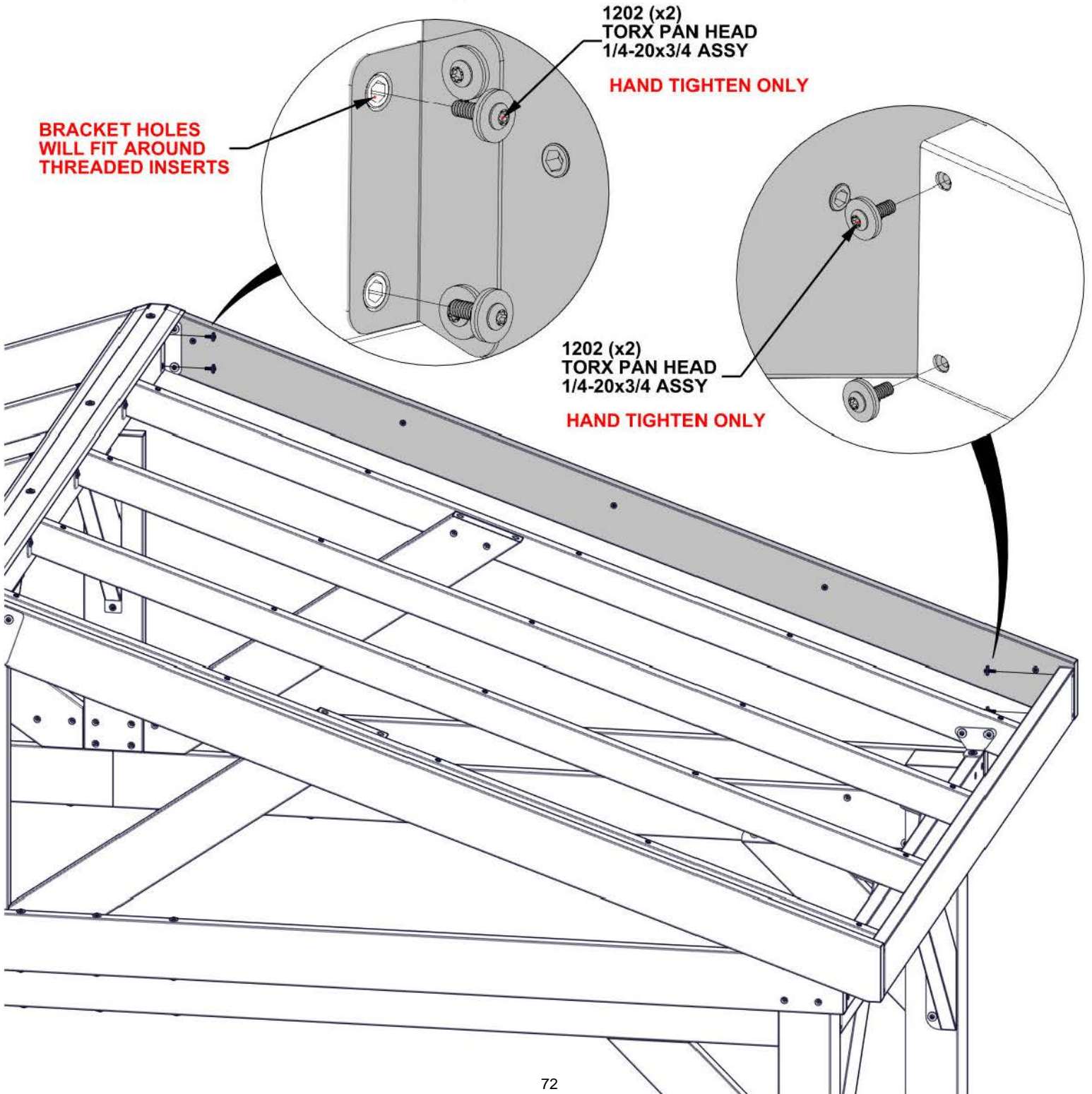

STEP 38A - ROOF ASSEMBLY

QTY	PartNo	Description
40	H101132	TORX SOCKET SCREW SHORT 1/4-20

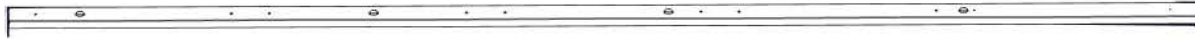

E03 PURLIN ASSEMBLY - A4M03651
(x10) 89 15/16"x1 15/16"x1 9/16" (40x50x2284)

- ATTACH PURLINS.
- STARTING AT THE RIDGE AND WORKING DOWN WILL MAKE IT EASIER TO INSTALL PURLIN ASSEMBLIES.

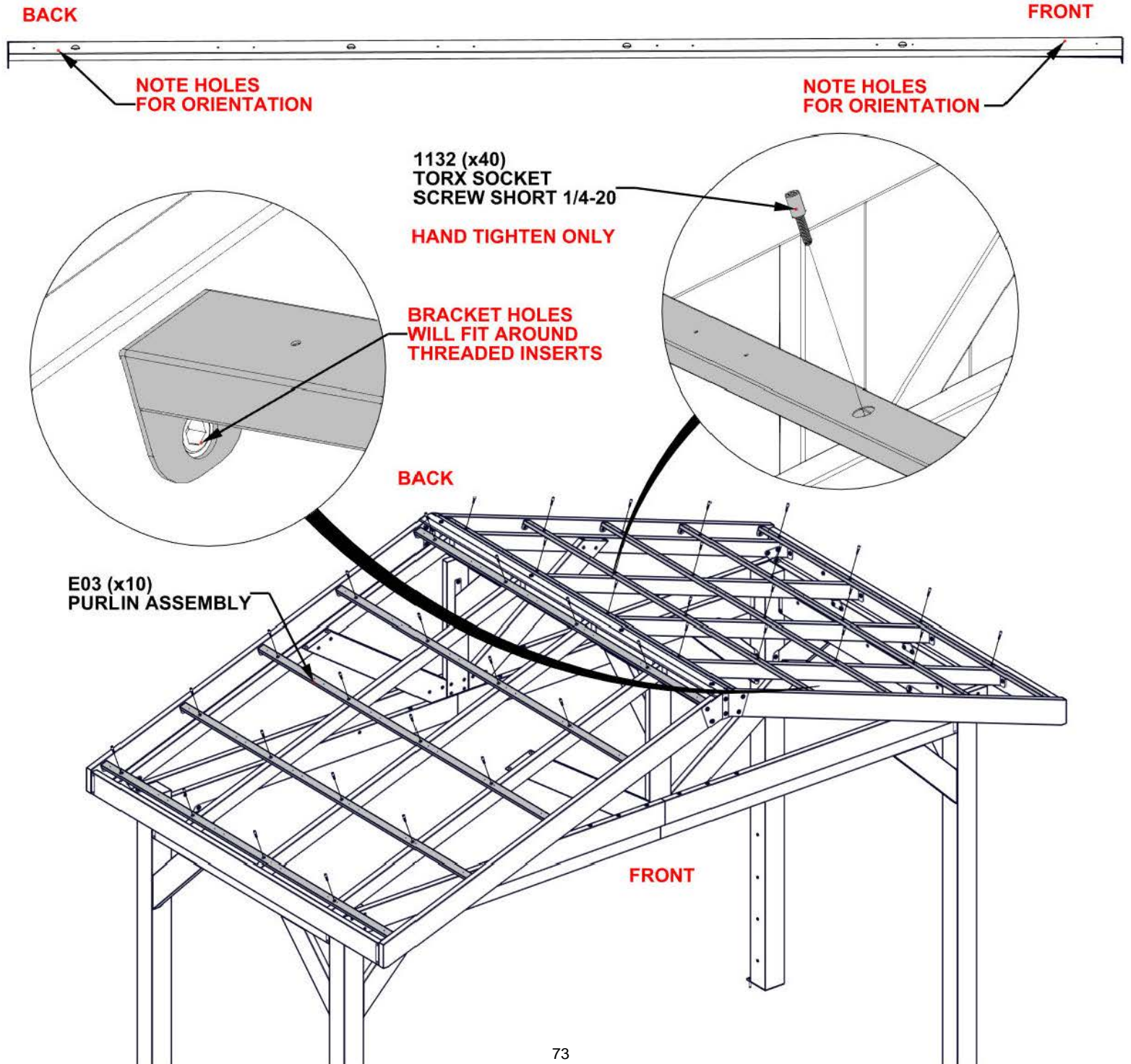

STEP 38B - ROOF ASSEMBLY

QTY	PartNo	Description
20	H101202	TORX PAN HEAD 1/4-20x3/4 ASSY

- ONCE PURLINS HAVE BEEN INSTALLED, TIGHTEN ALL HARDWARE FROM PREVIOUS STEPS.

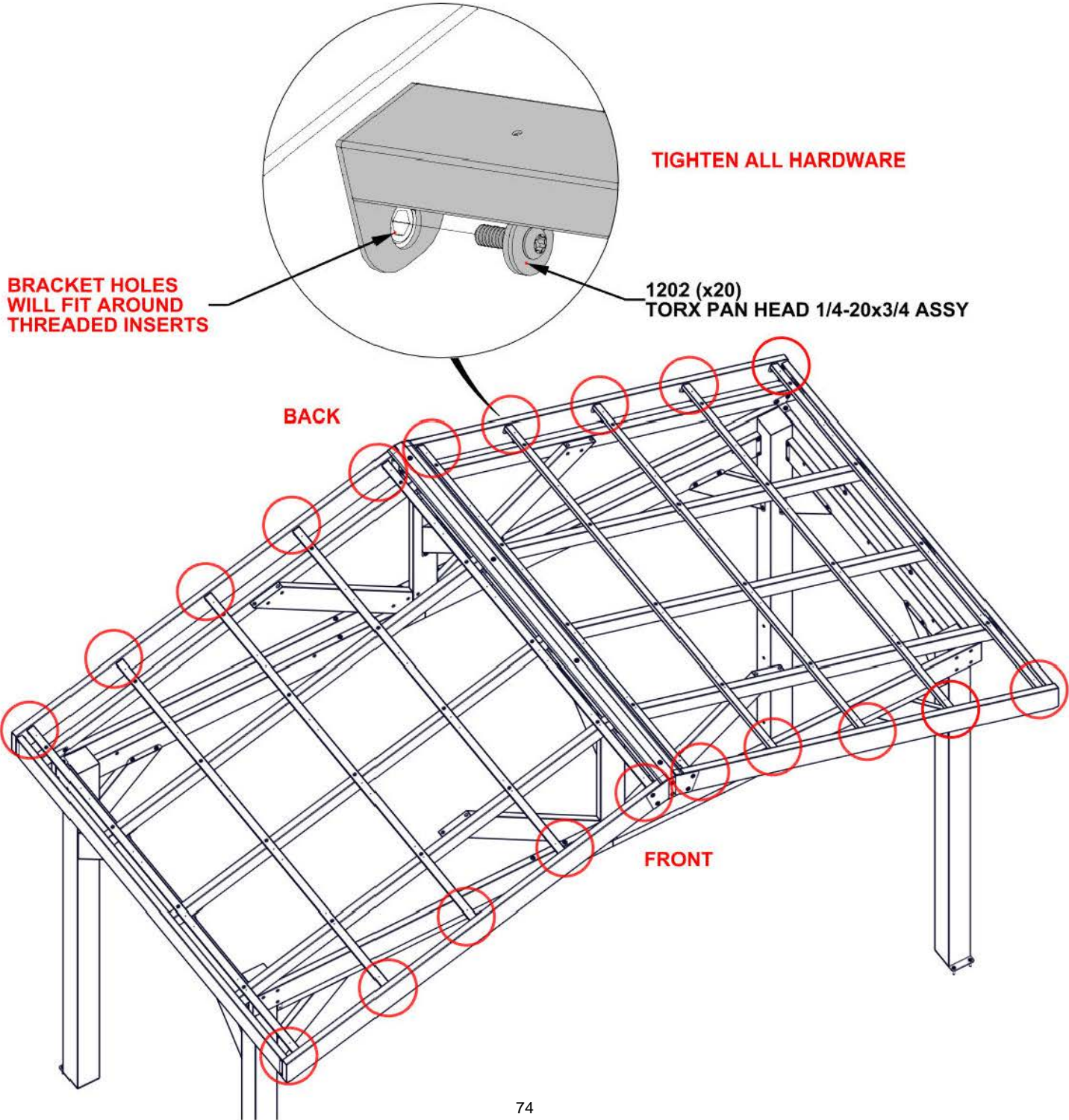

STEP 39 - ROOF ASSEMBLY

QTY	PartNo	Description
10	H101117	SCREW WOODGRIP 10-16x3/4" BLK

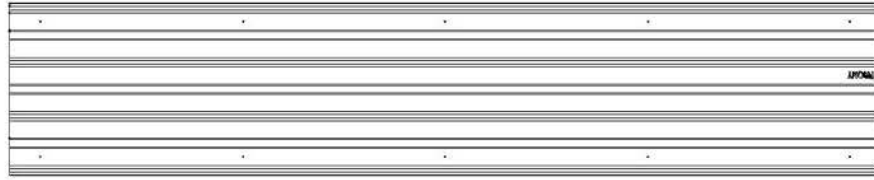

A4M03528 STEEL SHEETING
(x1)

- REMOVE PROTECTIVE FILM.
- SLIDE ROOF SHEET UP, MAKING SURE IT SLIDES UNDERNEATH THE RIDGE CAP.
- STARTING AT THE LEFT SIDE AND WORKING TO THE RIGHT, LINE UP THE HOLES IN THE ROOF SHEET WITH THE PILOT HOLES IN THE PURLINS.

- WARNING: GLOVES ARE RECOMMENDED WHEN HANDLING STEEL ROOF PIECES.

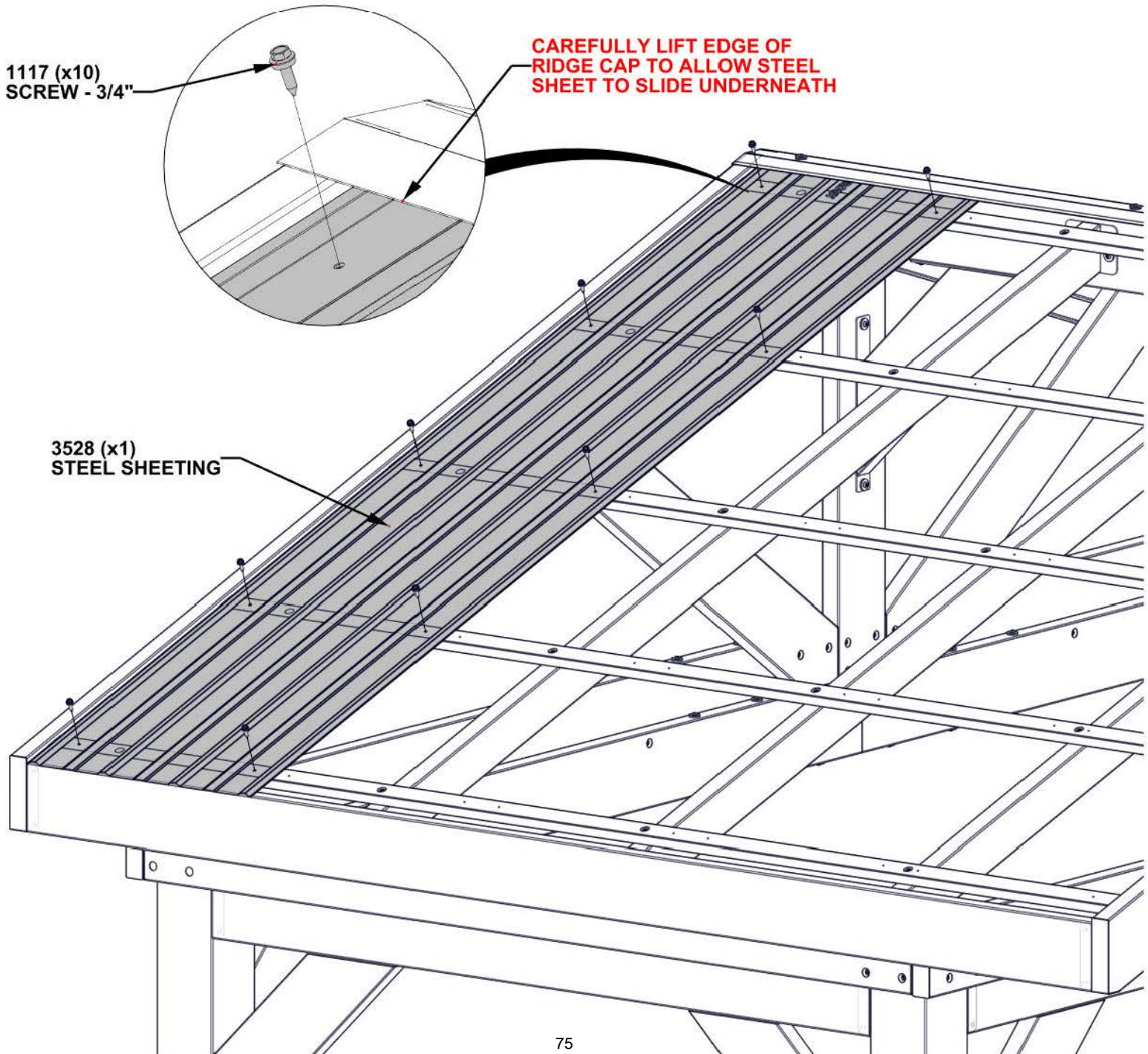

STEP 40 - ROOF ASSEMBLY

QTY	PartNo	Description
10	H101117	SCREW WOODGRIP 10-16x3/4" BLK



A4M03528 STEEL SHEETING
(x1)

- REMOVE PROTECTIVE FILM.
- SLIDE ROOF SHEET UP, MAKING SURE IT SLIDES UNDERNEATH THE RIDGE CAP.
- STARTING AT THE LEFT SIDE AND WORKING TO THE RIGHT, LINE UP THE HOLES IN THE ROOF SHEET WITH THE PILOT HOLES IN THE PURLINS.

- WARNING: GLOVES ARE RECOMMENDED WHEN HANDLING STEEL ROOF PIECES.

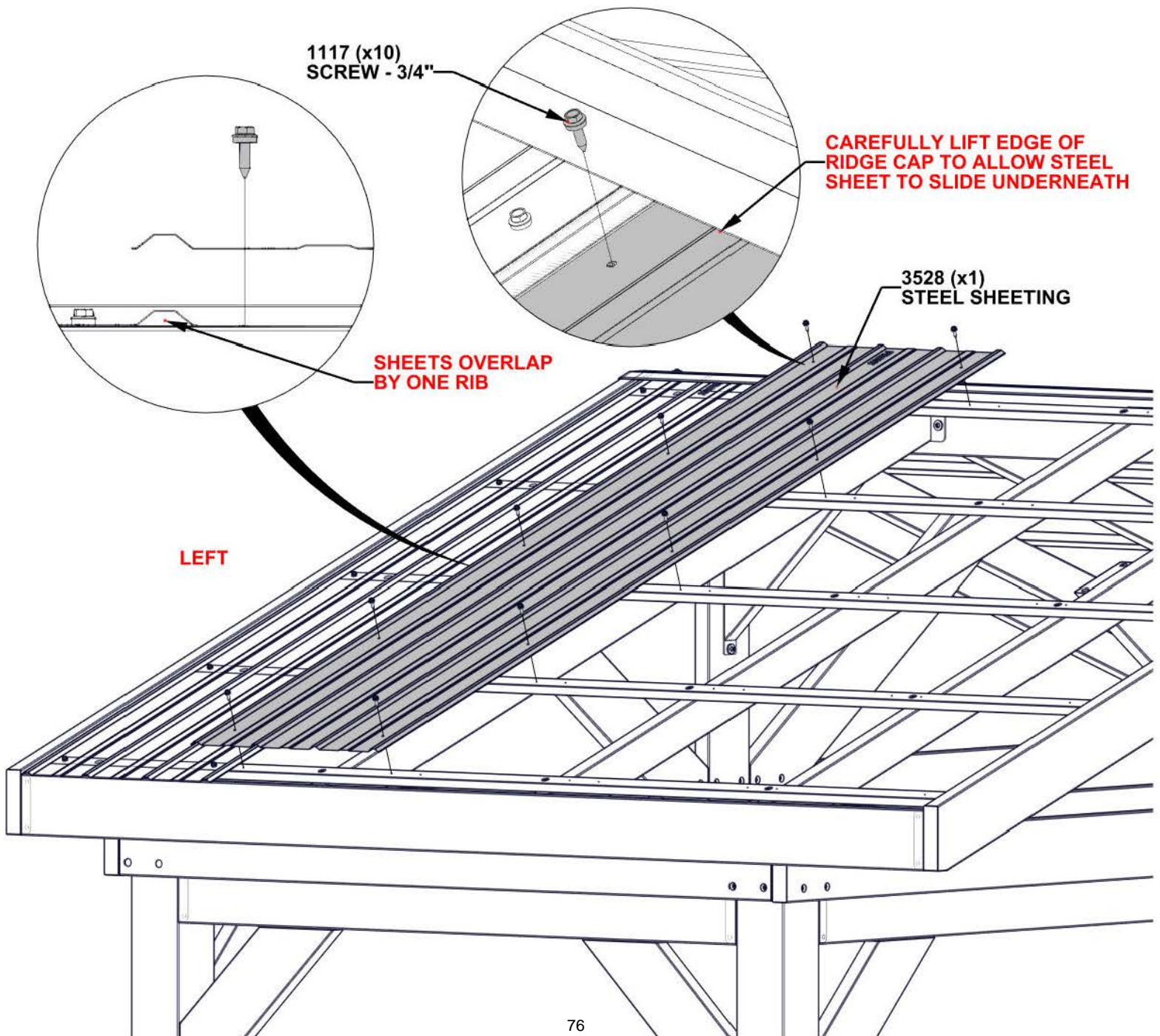

STEP 41 - ROOF ASSEMBLY

QTY	PartNo	Description
30	H101117	SCREW WOODGRIP 10-16x3/4" BLK

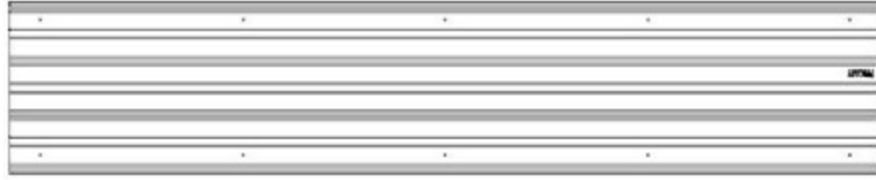

A4M03528 STEEL SHEETING
(x3)

- REMOVE PROTECTIVE FILM.
- INSTALL THREE SHEETS IN THE SAME WAY AS THE FIRST TWO.
- ATTACH AND FULLY TIGHTEN ALL SCREWS ON EACH ROOF SHEET BEFORE ATTACHING THE NEXT ONE. THIS MAKES IT POSSIBLE TO REACH ALL THE SCREWS WITHOUT GETTING ON THE ROOF.
- **WARNING: GLOVES ARE RECOMMENDED WHEN HANDLING STEEL ROOF PIECES.**

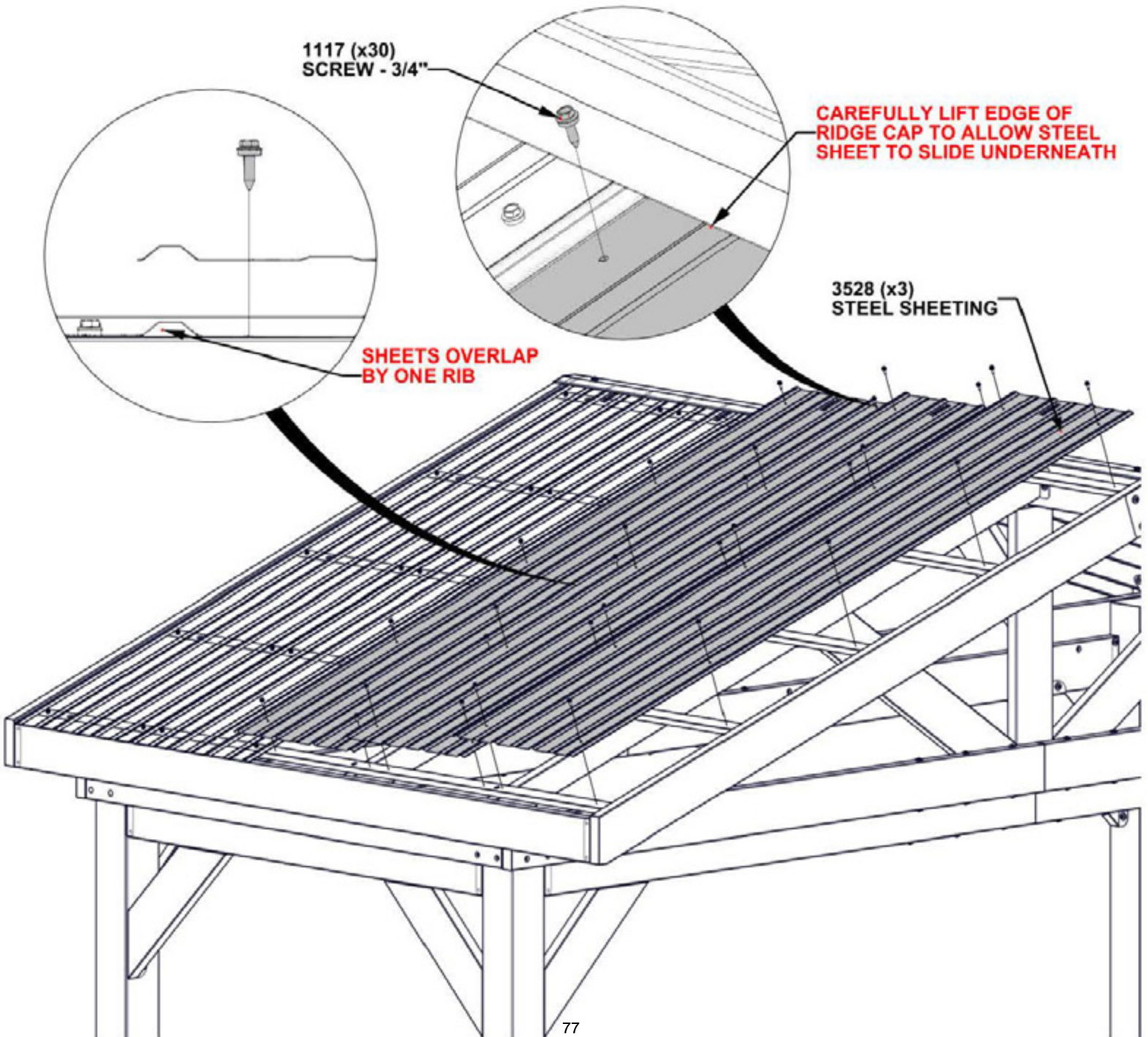

STEP 42 - ROOF ASSEMBLY

QTY	PartNo	Description
8	H101116	SCREW SELF TAPPING 1/4x1 BLK



A4M03532 EDGE TRIM
(x2)

- REMOVE PROTECTIVE FILM.
- SLIDE EDGE TRIM UNTIL ONE END IS POSITIONED UNDERNEATH RIDGE CAP AND OTHER END IS FLUSH WITH END.
- STARTING AT THE TOP, ALIGN SCREWS WITH SHEET SCREWS.
- **DUE TO MULTIPLE LAYERS OF METAL ON THE DRIP EDGE, IT IS RECOMMENDED THAT A 1/8" (3mm) DRILL BIT BE USED TO CREATE STARTER HOLES.**
- **WARNING: GLOVES ARE RECOMMENDED WHEN HANDLING STEEL ROOF PIECES.**

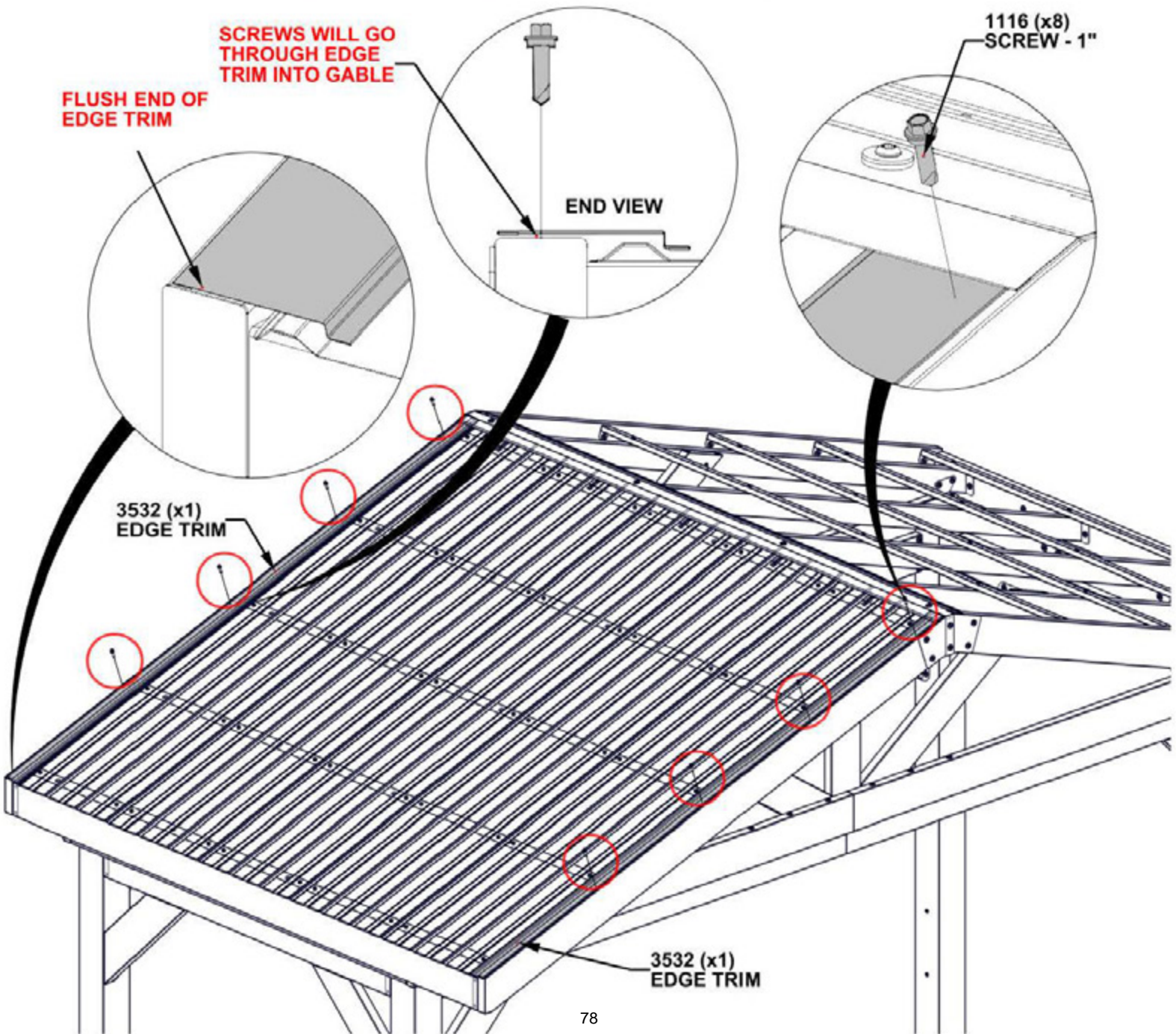

STEP 43 - ROOF ASSEMBLY

QTY	PartNo	Description
9	H101116	SCREW SELF TAPPING 1/4x1 BLK



A4M03653 DRIP TRIM
(x1)

- REMOVE PROTECTIVE FILM.
- ORIENT DRIP TRIM AS SHOWN BELOW.
- STARTING IN THE FRONT CORNER, ATTACH SCREWS SPACING EVERY OTHER RIB.
- **DUE TO MULTIPLE LAYERS OF METAL ON THE DRIP EDGE, IT IS RECOMMENDED THAT A 1/8" (3mm) DRILL BIT BE USED TO CREATE STARTER HOLES.**
- **WARNING: GLOVES ARE RECOMMENDED WHEN HANDLING STEEL ROOF PIECES.**

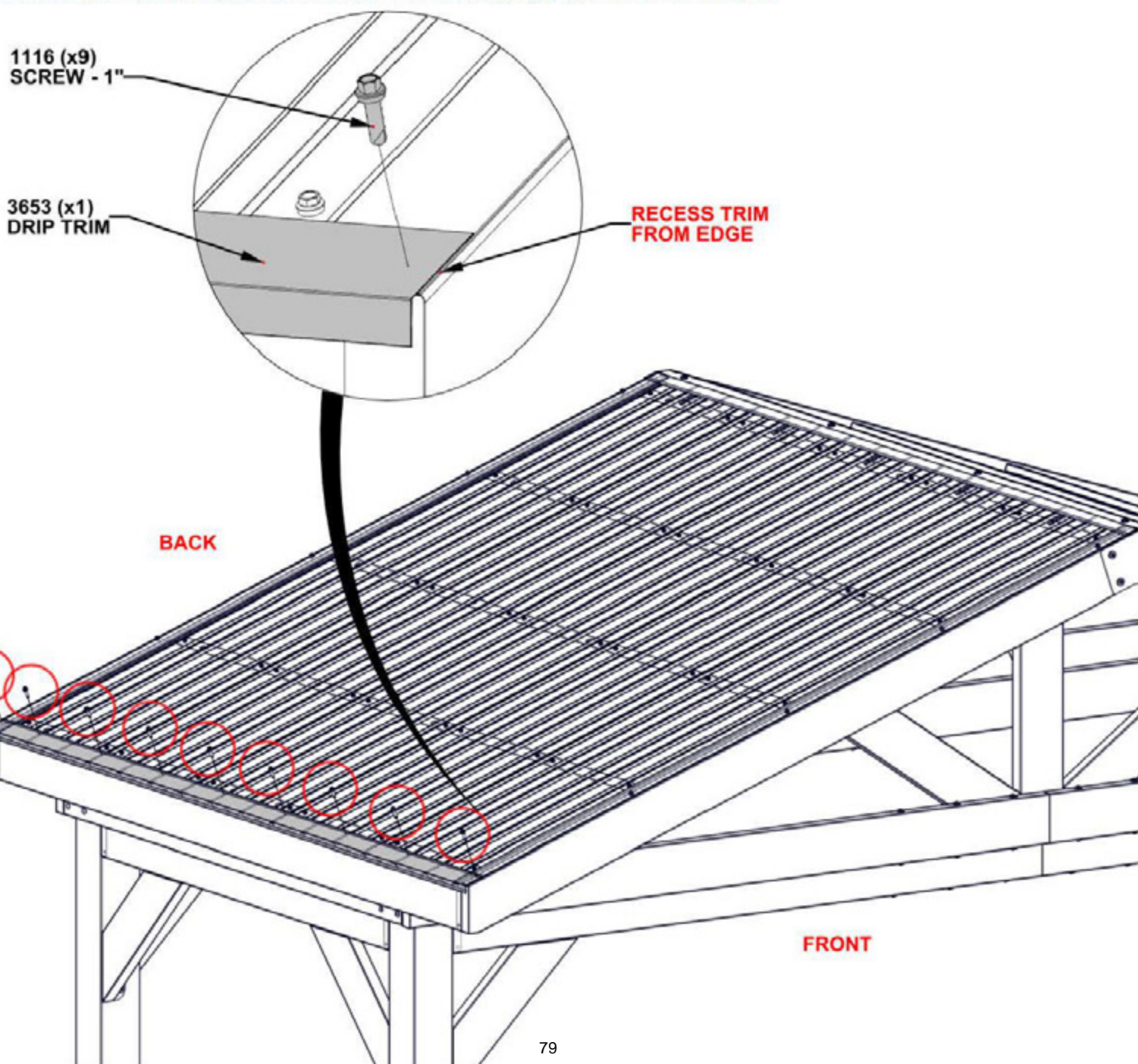

**REPEAT ROOF ASSEMBLY STEPS 39 - 43
TO INSTALL SHEETMETAL ON OPPOSITE SIDE OF ROOF**

STEP 44 - STRUCTURE ASSEMBLY



A4M01352 HOLE COVER
(x70)

- USE A SMALL PIECE OF WOOD AND RUBBER Mallet TO TAP HOLE COVERS IN.
- DO NOT TAP DIRECTLY WITH A HAMMER AS YOU MAY DAMAGE THE POWDER COAT FINISH ON PRODUCT.

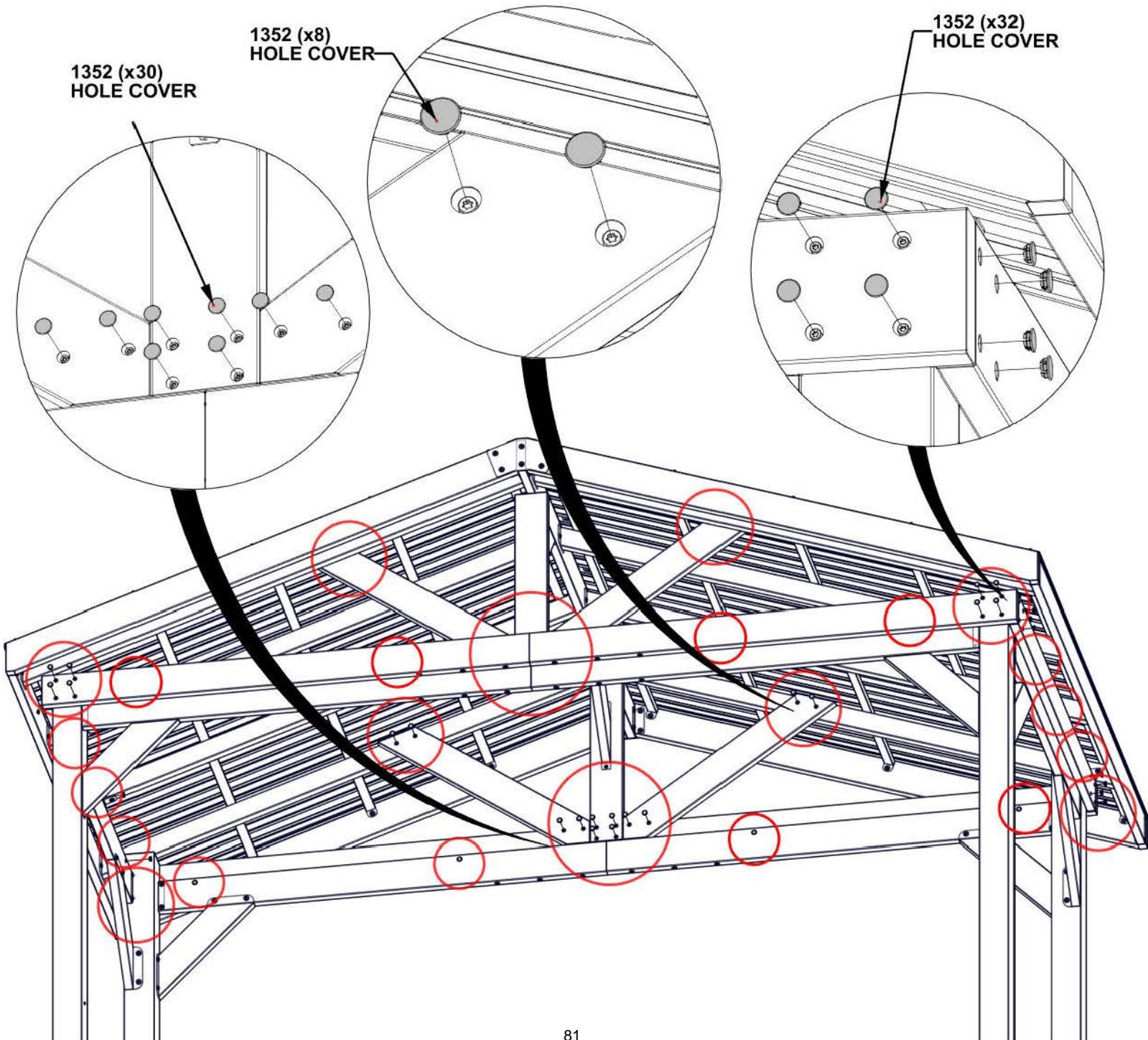

STEP 45 - FRIDGE CABINET INSTALLATION

QTY	PartNo	Description
2	H101202	TORX PAN HEAD 1/4-20x3/4 ASSY

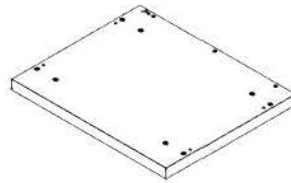
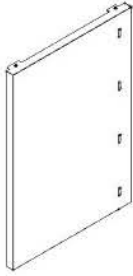

S8 FRIDGE CABINET SIDE PANEL ASSEMBLY R - A4M03598
(x1) 33 3/8"x23 3/8"x1 15/16" (50.00x594.00x848.20)

F4 FRIDGE CABINET FLOOR PANEL ASSEMBLY - A4M03595
(x1) 28 1/8"x23 3/8"x2 5/8" (66x594x715)

- POSITION FLOOR PANEL IN THE PROXIMITY OF WHERE YOUR KITCHEN WILL BE.
- EACH FLOOR PANEL HAS FACTORY INSTALLED ADJUSTABLE FEET. USE PROVIDED HEX DRIVER TO ADJUST EACH FOOT UNTIL PANEL IS LEVEL.

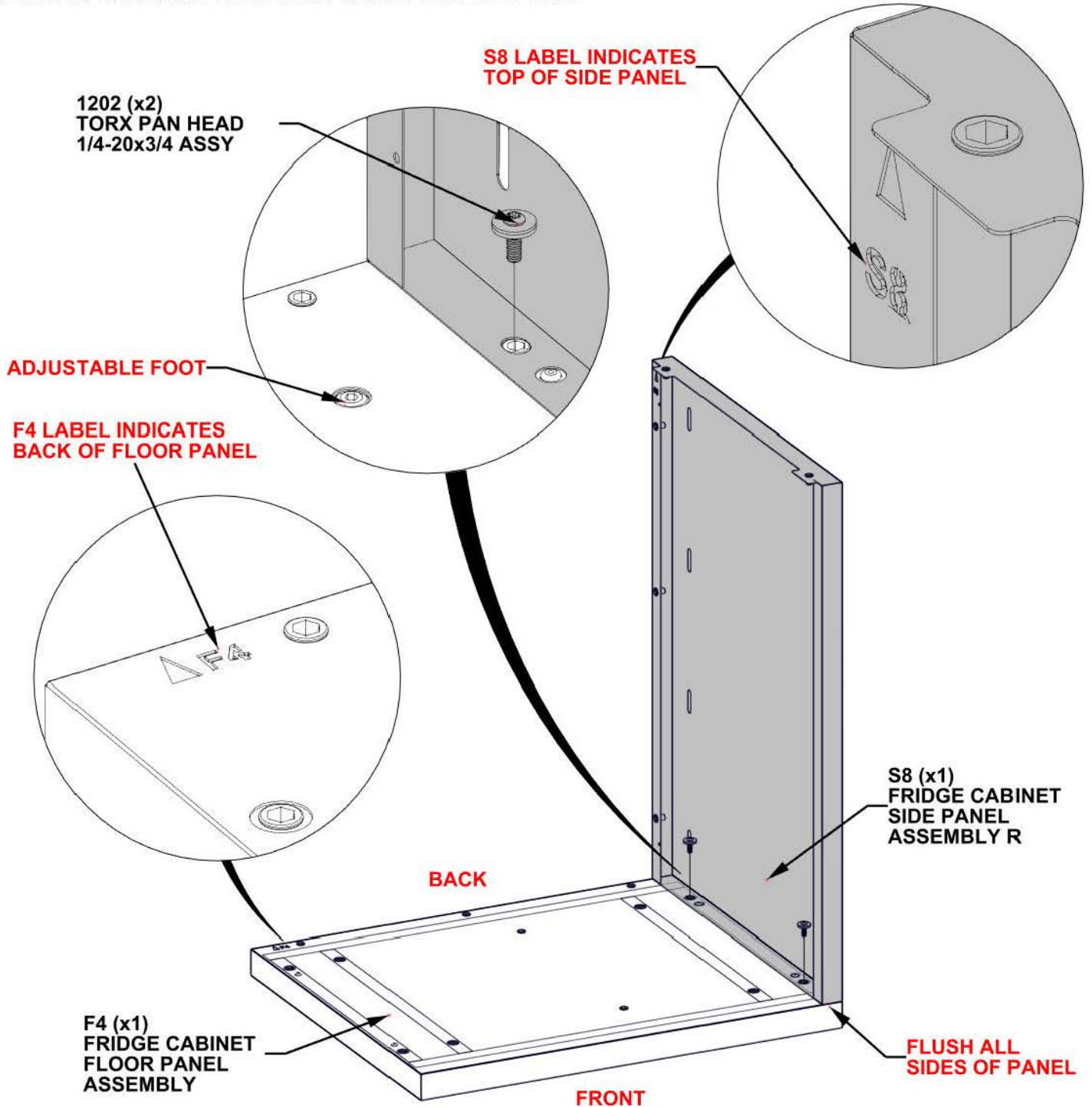

STEP 46 - FRIDGE CABINET INSTALLATION

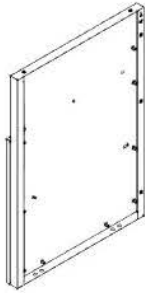

QTY	PartNo	Description
2	H101202	TORX PAN HEAD 1/4-20x3/4 ASSY

S7 FRIDGE CABINET SIDE PANEL ASSEMBLY L - A4M03597
 (x1) 33 7/16"x23 3/8"x2 1/16" (53.00x594.00x849.70)

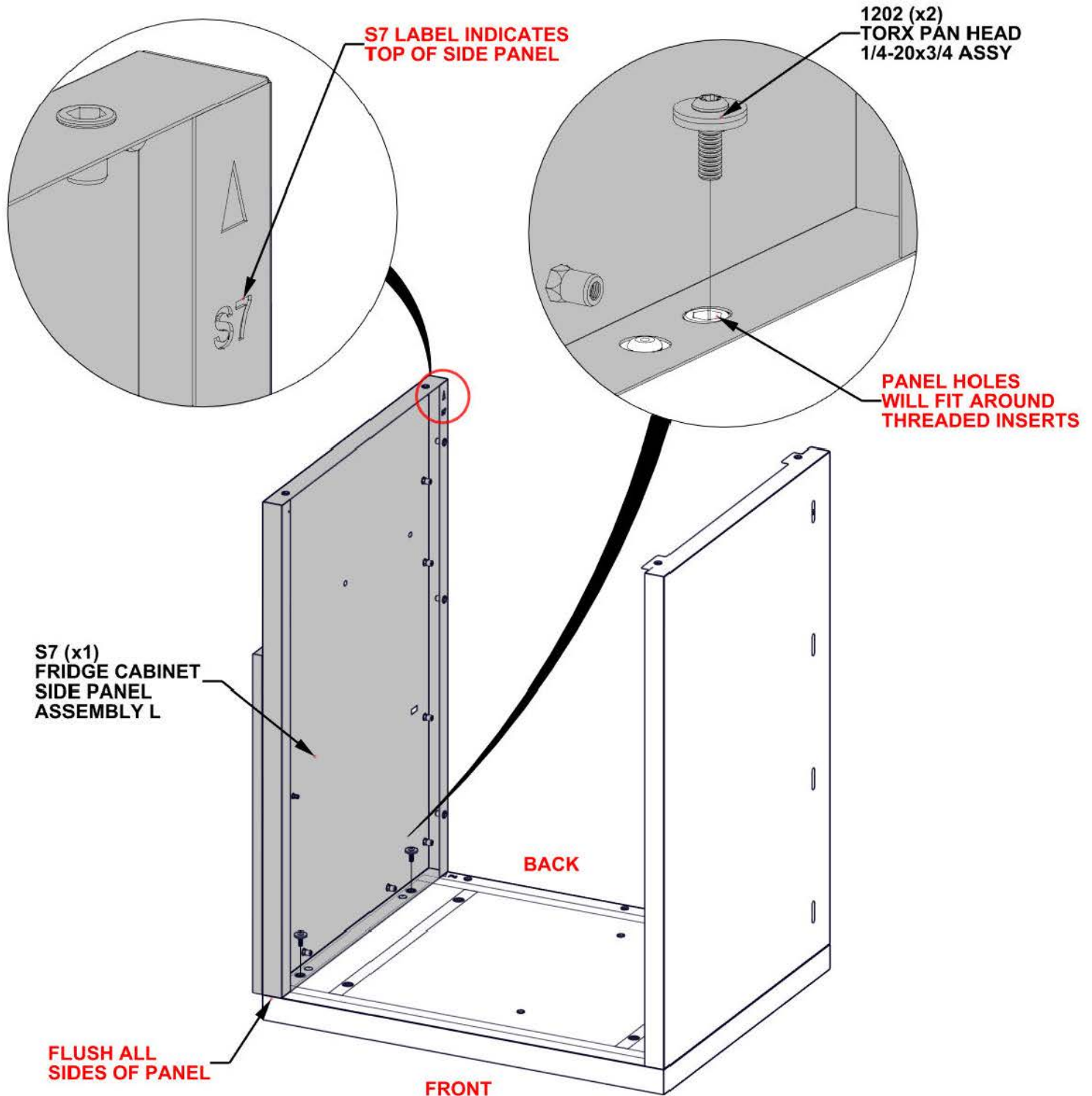

STEP 47 - FRIDGE CABINET INSTALLATION

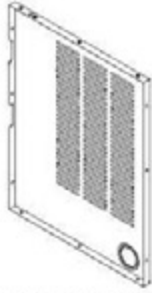

QTY	PartNo	Description
9	H101202	TORX PAN HEAD 1/4-20x3/4 ASSY

G4 FRIDGE CABINET BACK PANEL ASSEMBLY - A4M03599
(x1) 25 5/16"x33 3/8"x1 3/16" (30.00x847.20x643.00)

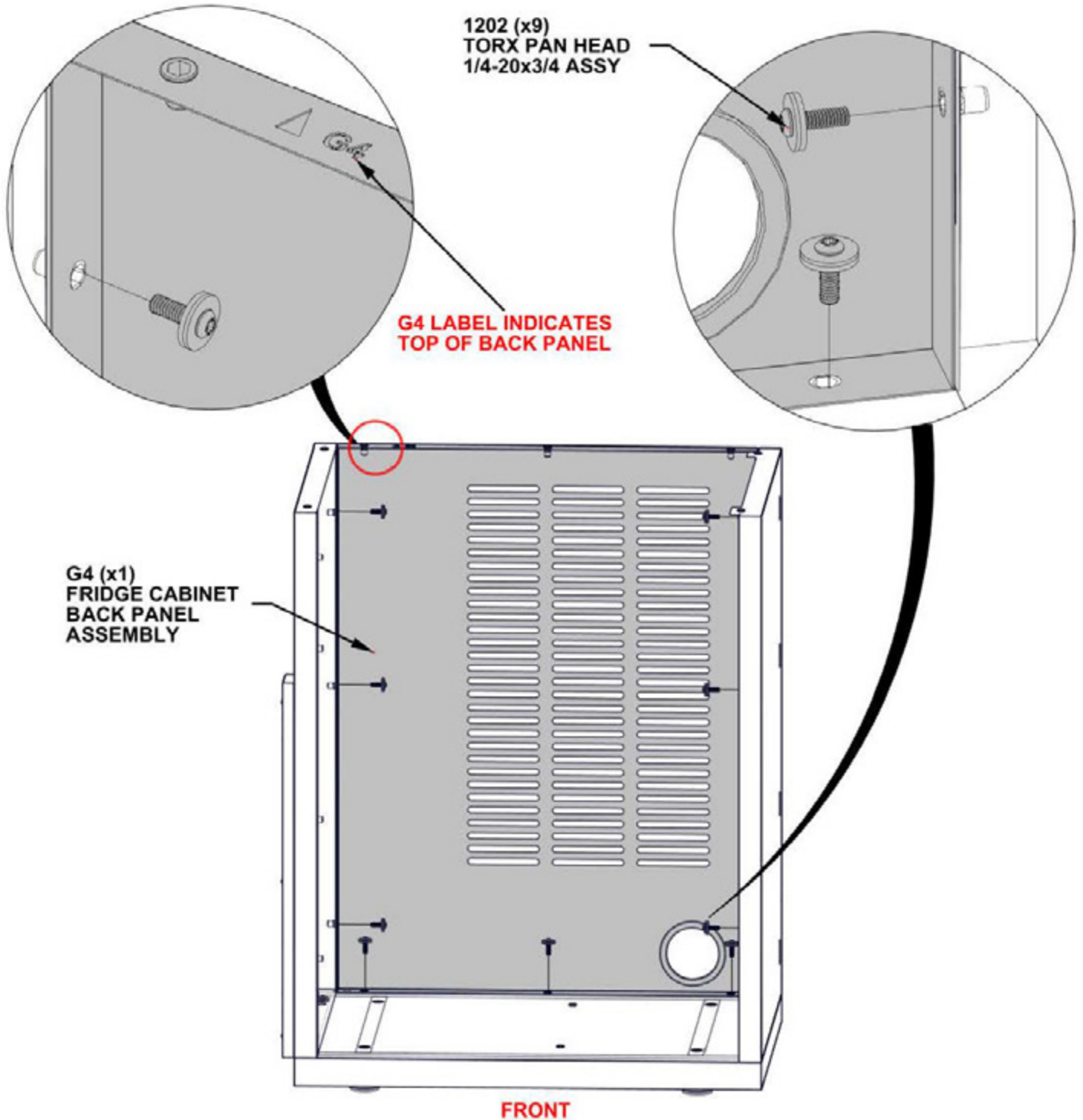

STEP 48 - FRIDGE CABINET INSTALLATION

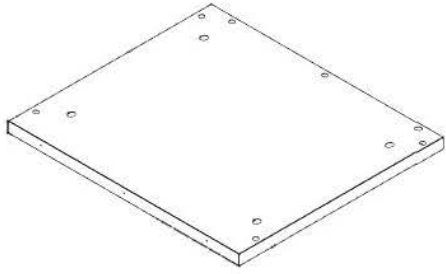

QTY	PartNo	Description
7	H101103	TORX SOCKET SCREW 1/4-20

T7 FRIDGE CABINET TABLETOP - A4M03641
(x1) 27 3/8"x24 1/8"x1 1/4" (32x612x696)

- FLUSH BACK AND SIDES OF PANEL ASSEMBLY.
- SQUARE ALL SIDES OF CABINET BEFORE TIGHTENING HARDWARE.

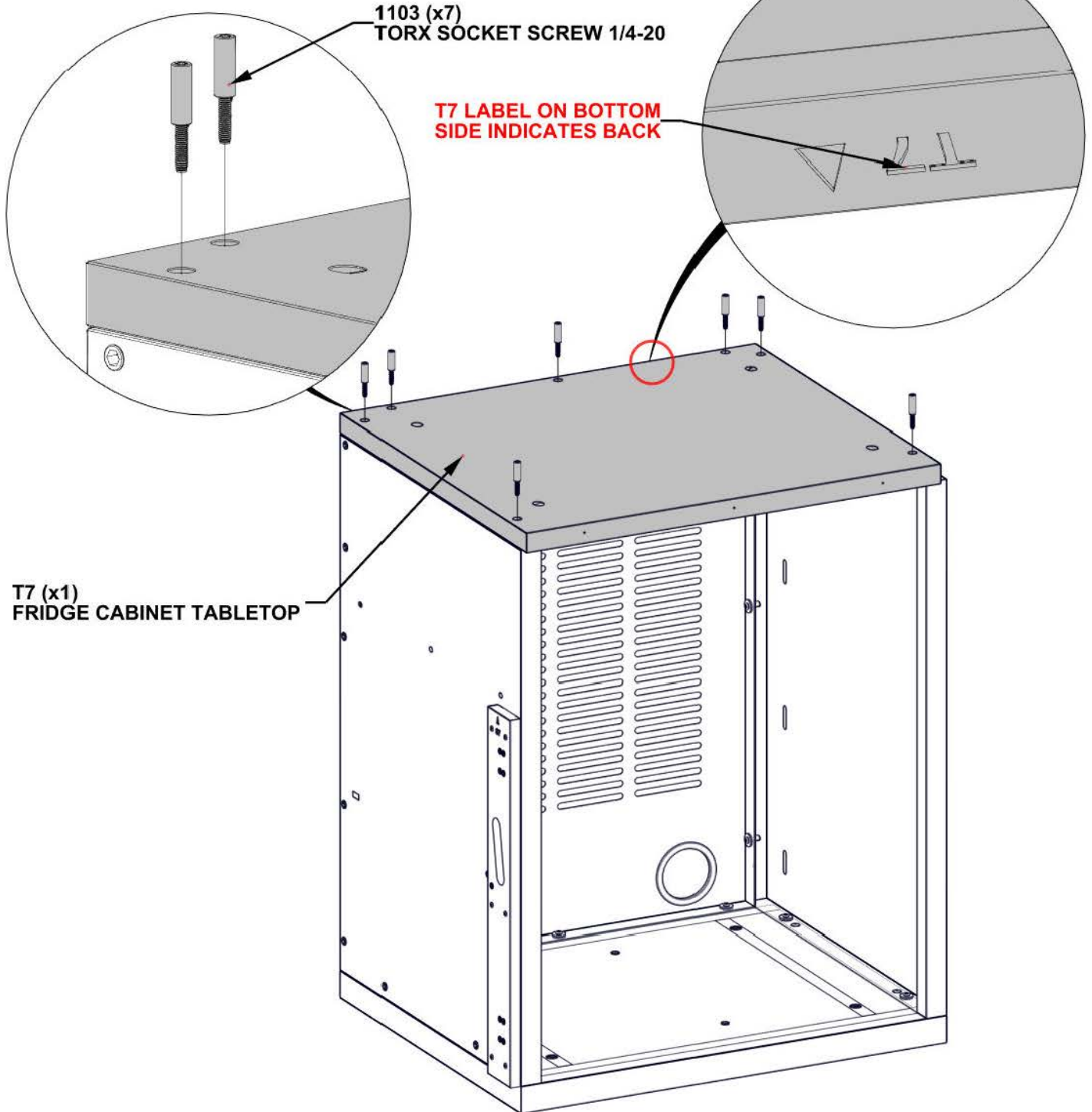

STEP 49 - FRIDGE CABINET INSTALLATION

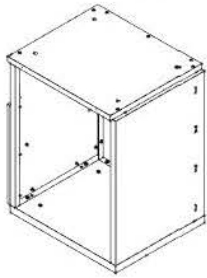

FRIDGE CABINET FROM
STEPS 45 - 48

QTY	PartNo	Description
4	H101202	TORX PAN HEAD 1/4-20x3/4 ASSY

- POSITION FRIDGE CABINET ASSEMBLY UNDERNEATH LANCASTER LINEAR STRUCTURE.
- SIDE OF FRIDGE CABINET WILL SIT AGAINST THE INSIDE OF THE BACK RIGHT POST.
- BACKSIDE OF FRIDGE CABINET WILL SIT FLUSH WITH BACKSIDE OF POST.
- **BEFORE TIGHTENING HARDWARE, ADJUST CABINET FEET AS NEEDED UNTIL FRIDGE CABINET IS LEVEL.**

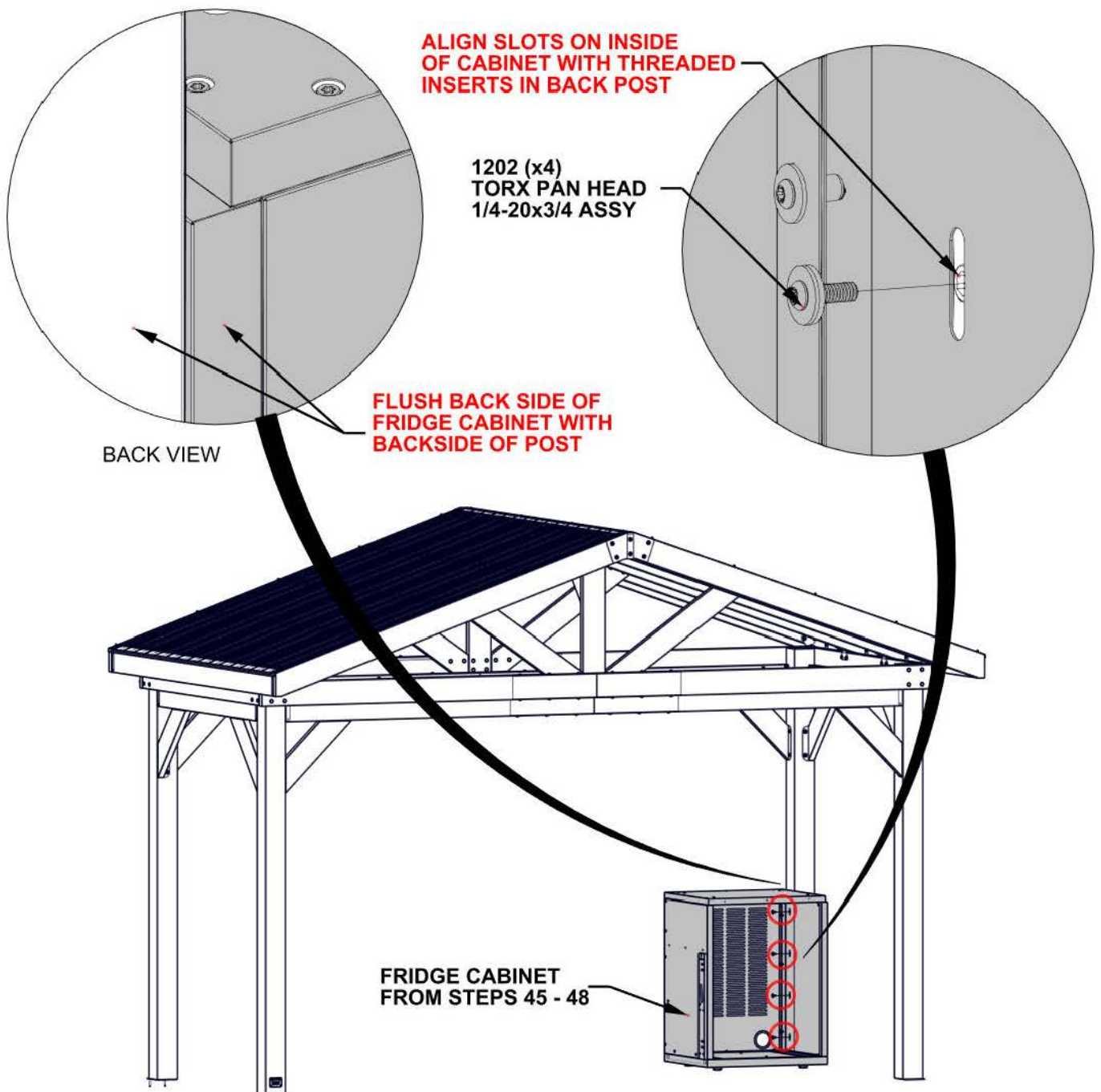

STEP 50 - SINK CABINET ASSEMBLY

QTY	PartNo	Description
2	H101202	TORX PAN HEAD 1/4-20x3/4 ASSY

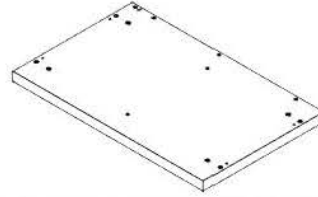

S3 SINK CABINET SIDE PANEL ASSEMBLY L - A4M03562
 (x1) 33 3/8"x23 3/8"x1 3/8" (35.00x594.00x848.20)

F3 SINK CABINET FLOOR PANEL ASSEMBLY - A4M03560
 (x1) 37 3/16"x23 3/8"x2 5/8" (66x594x944)

- POSITION FLOOR PANEL IN THE PROXIMITY OF WHERE YOUR KITCHEN WILL BE.
- EACH FLOOR PANEL HAS FACTORY INSTALLED ADJUSTABLE FEET. USE PROVIDED HEX DRIVER TO ADJUST EACH FOOT UNTIL PANEL IS LEVEL.

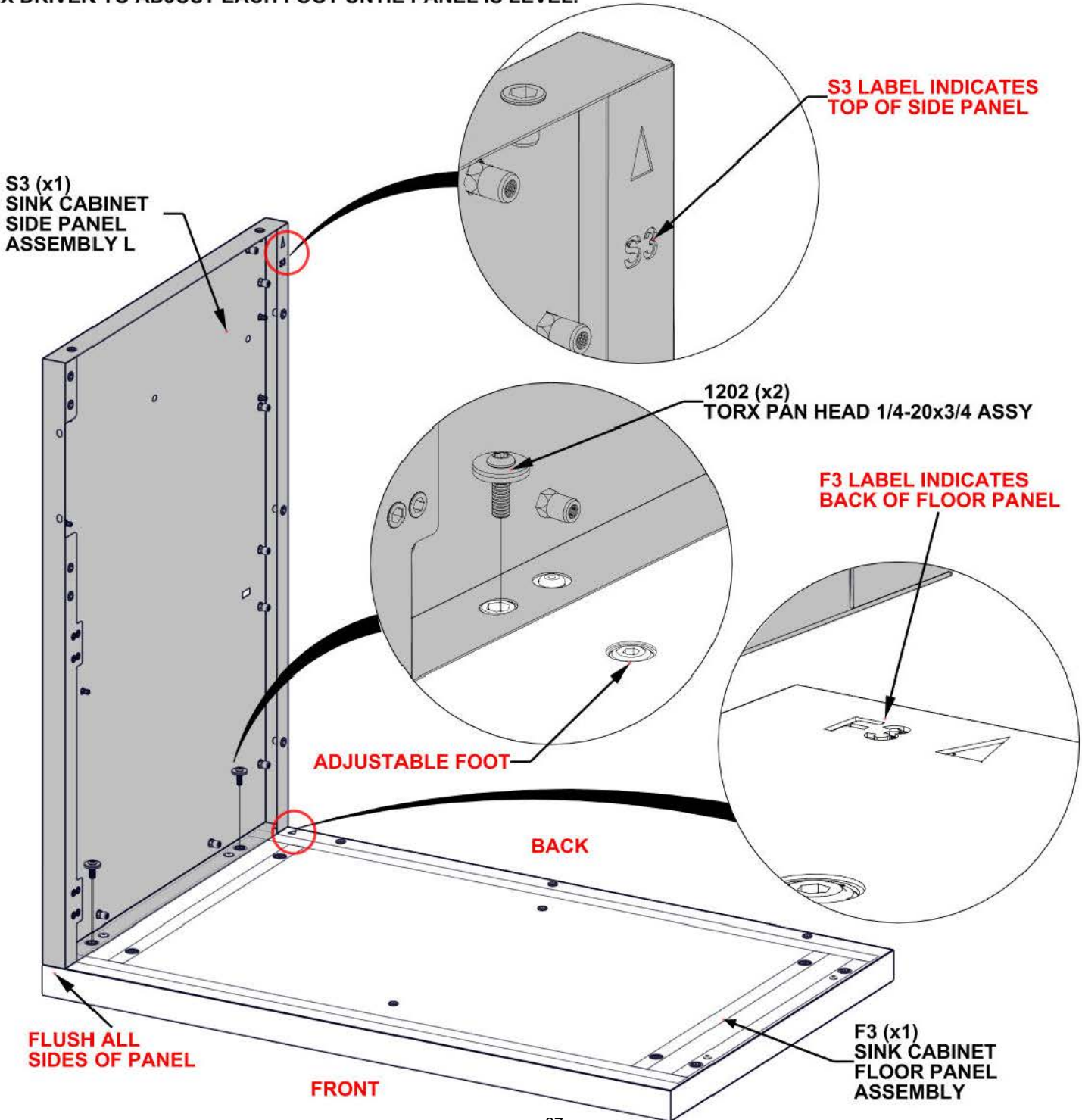

STEP 51 - SINK CABINET ASSEMBLY

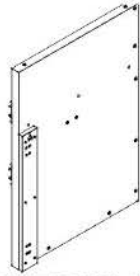

QTY	PartNo	Description
2	H101202	TORX PAN HEAD 1/4-20x3/4 ASSY

S4 SINK CABINET SIDE PANEL ASSEMBLY R - A4M03563
 (x1) 33 3/8"x23 3/8"x2 5/8" (67.00x594.00x848.20)

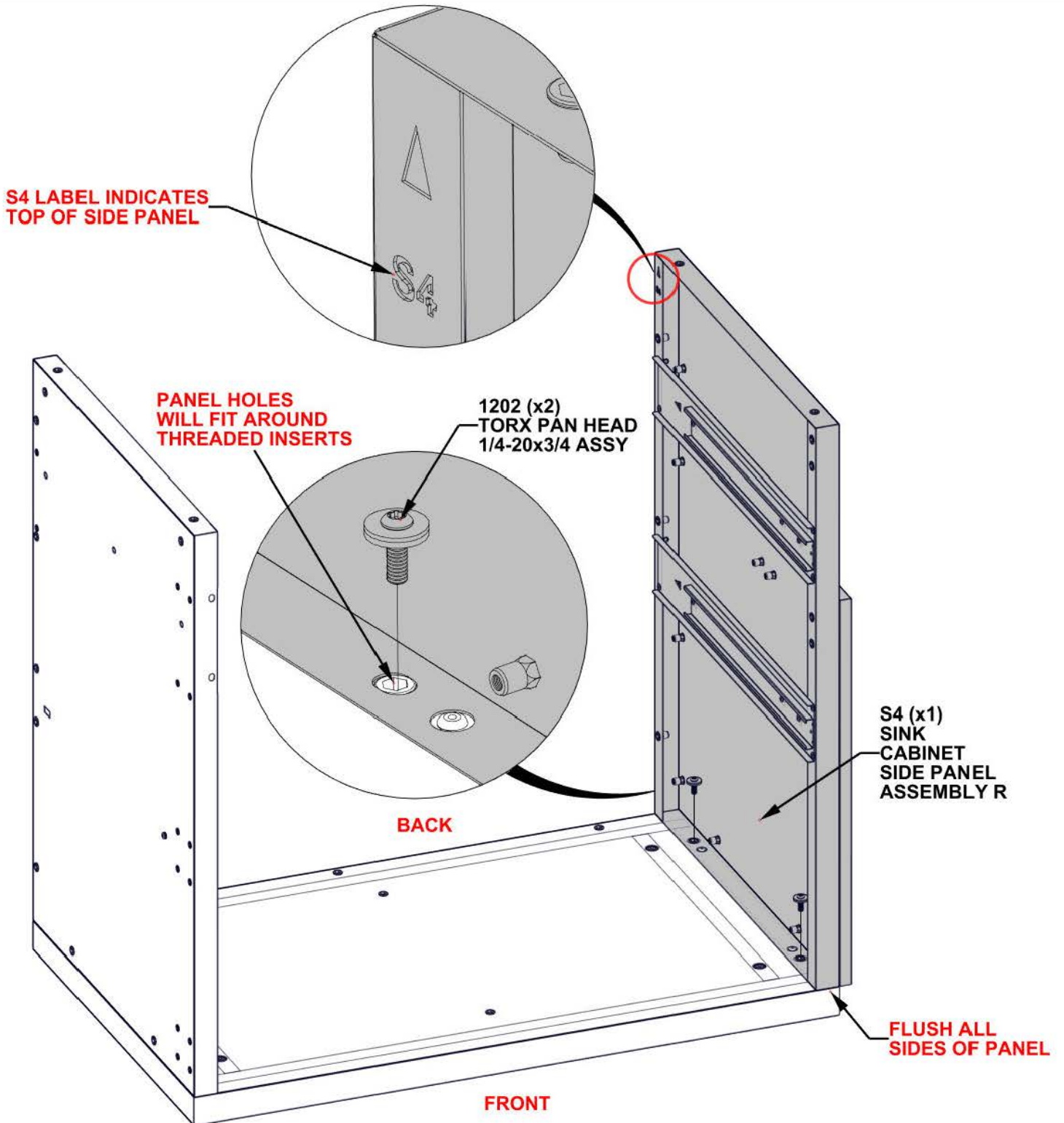

STEP 52 - SINK CABINET ASSEMBLY

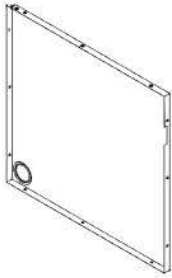

QTY	PartNo	Description
9	H101202	TORX PAN HEAD 1/4-20x3/4 ASSY

G3 SINK CABINET BACK PANEL ASSEMBLY - A4M03564
 (x1) 34 5/16"x33 3/8"x1 3/16" (30.00x847.20x872.00)

**G3 LABEL INDICATES
TOP OF BACK PANEL**

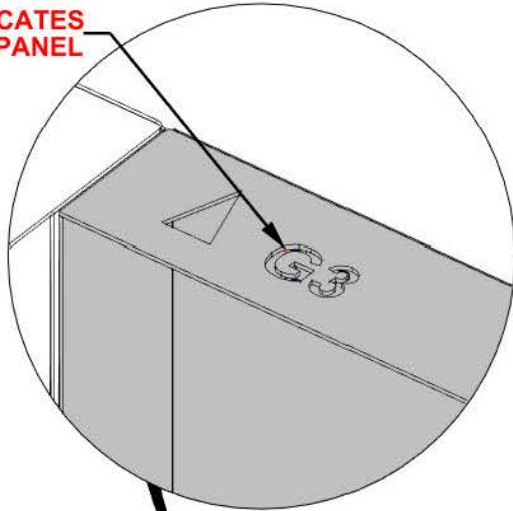

**1202 (x9)
TORX PAN HEAD
1/4-20x3/4 ASSY**

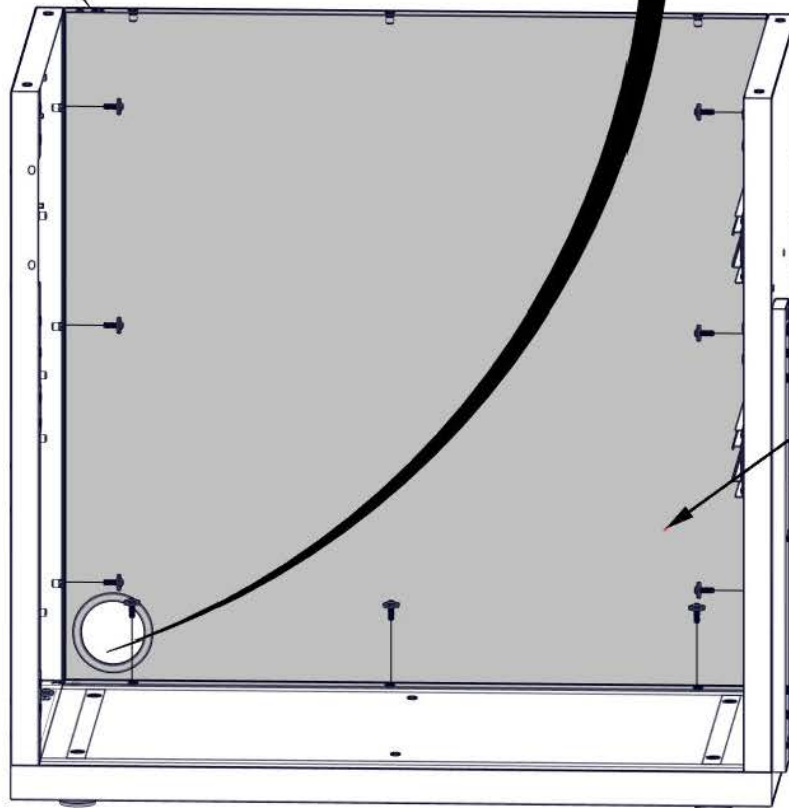
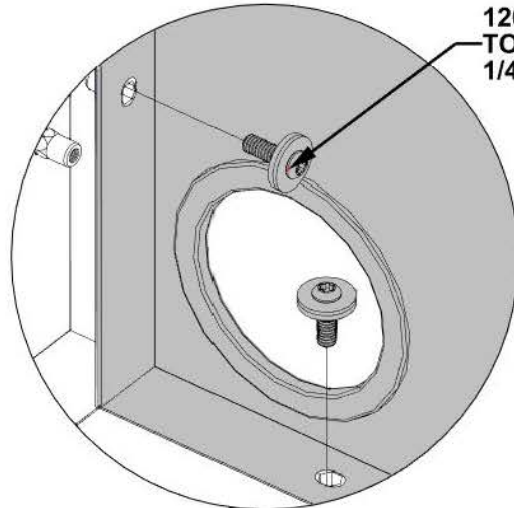

**G3 (x1)
SINK CABINET
BACK PANEL
ASSEMBLY**

FRONT

STEP 53 - SINK CABINET ASSEMBLY

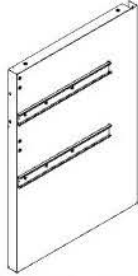

QTY	PartNo	Description
2	H101202	TORX PAN HEAD 1/4-20x3/4 ASSY

S5 SINK CABINET SIDE PANEL ASSEMBLY M - A4M03567
 (x1) 33 3/8"x23 3/8"x2 3/16" (56.20x593.00x847.00)

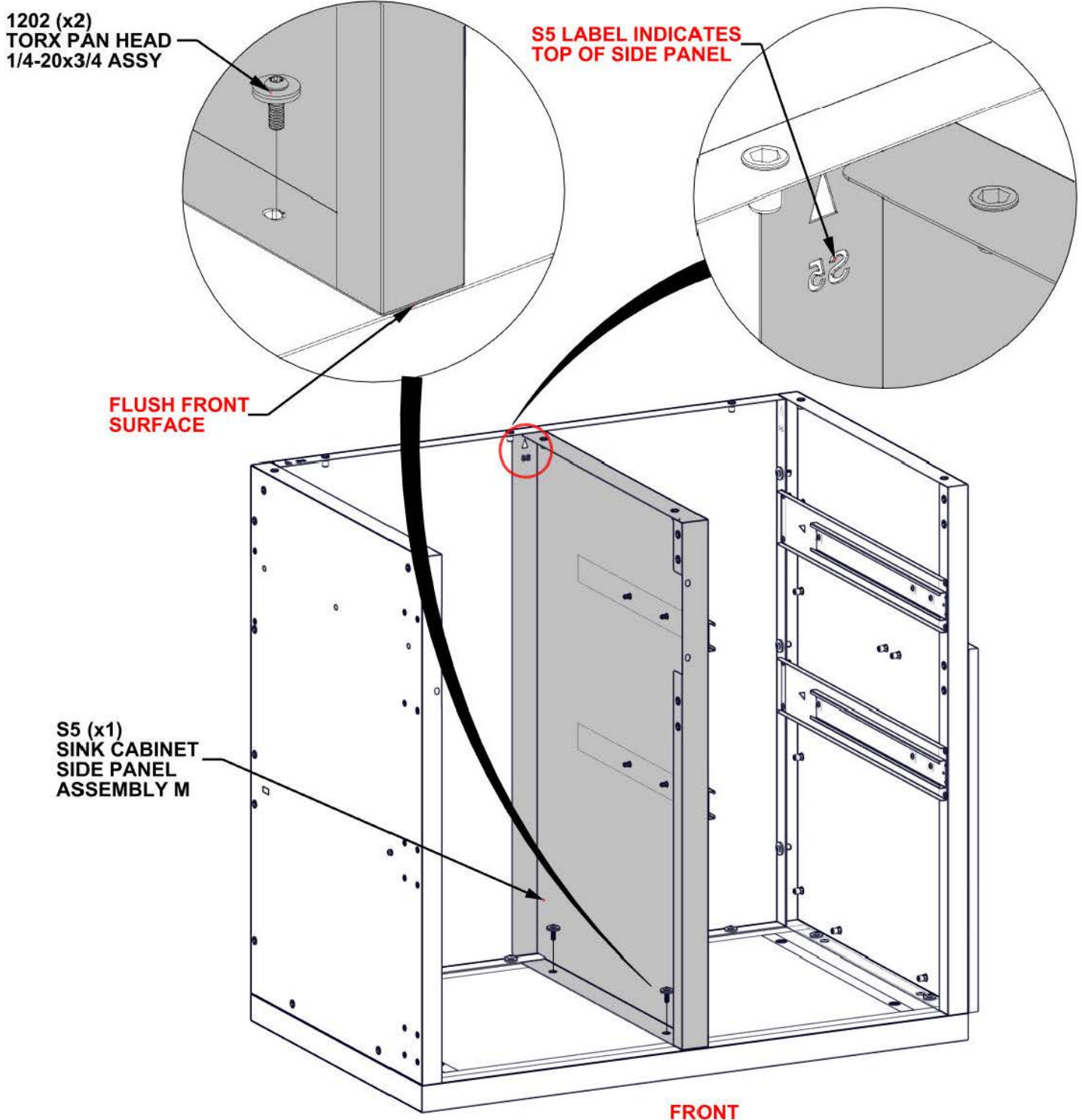

STEP 54 - SINK CABINET ASSEMBLY

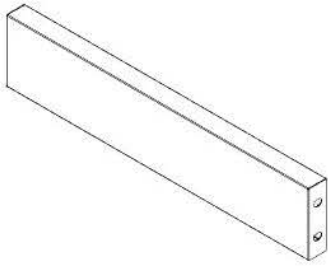

QTY	PartNo	Description
16	H101202	TORX PAN HEAD 1/4-20x3/4 ASSY

H4 HORIZONTAL BEAM ASSEMBLY L - A4M03575
(x4) 16 1/4"x3 3/8"x1" (25.00x85.00x413.00)

- HARDWARE ATTACHES ON INSIDE OF CABINET

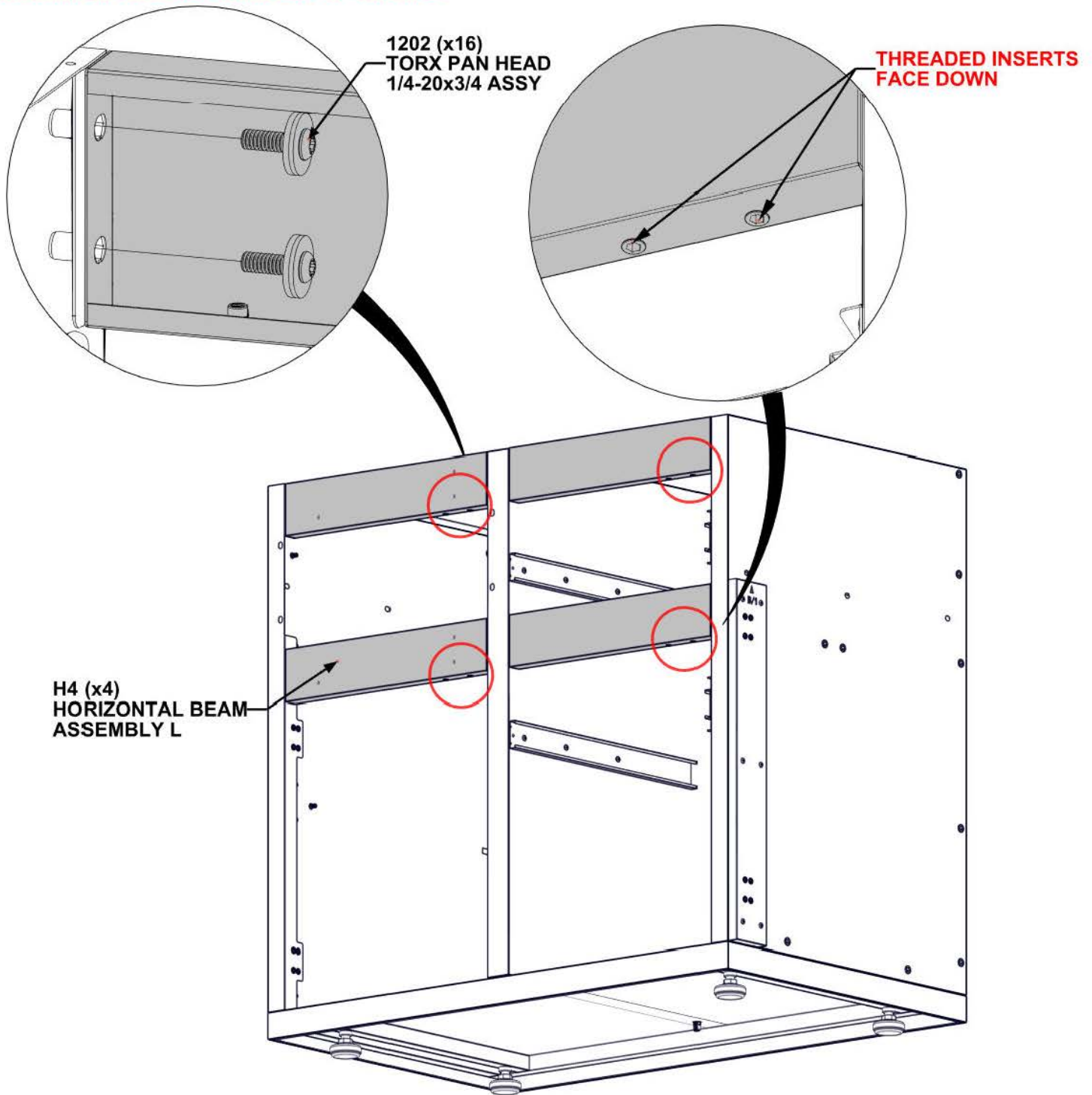

STEP 55 - SINK CABINET ASSEMBLY



QTY	PartNo	Description
2	H101289	PAN HEAD SCREW 8-32x1/2" SS

A2 MAGNET BRACKET - A4M03026
(x1) 1"x1 1/4"x3 1/8" (25x31x80)

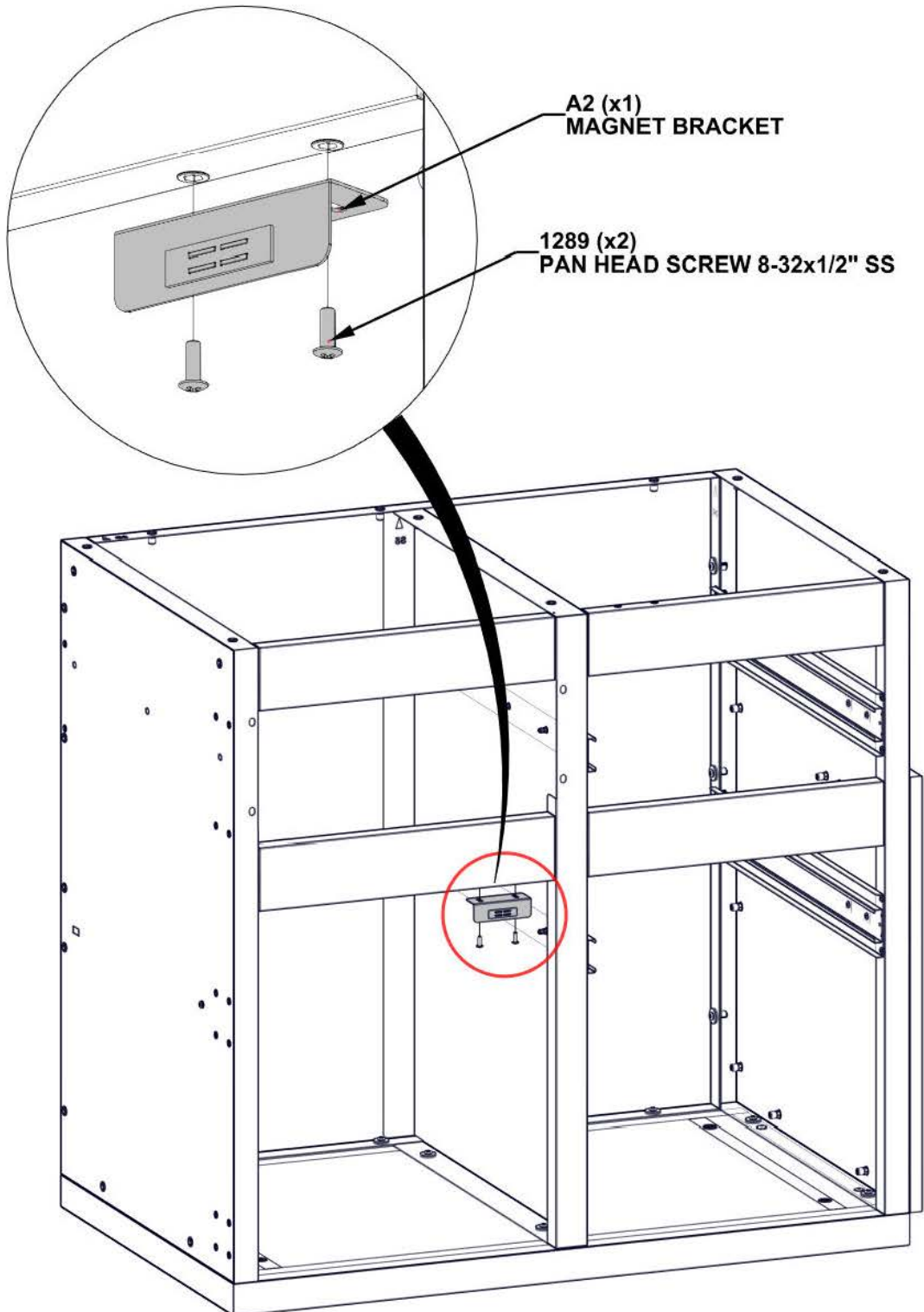

STEP 56 - SINK CABINET ASSEMBLY

QTY	PartNo	Description
6	H101287	PAN HEAD SCREW 8-32x1" SS

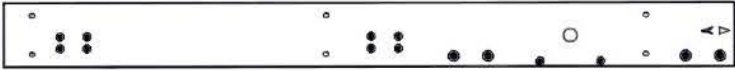

H13 HINGE CHANNEL - A4M03700
 (x1) 33 3/8"x2 15/16"x11/16" (18.00x74.80x847.00)

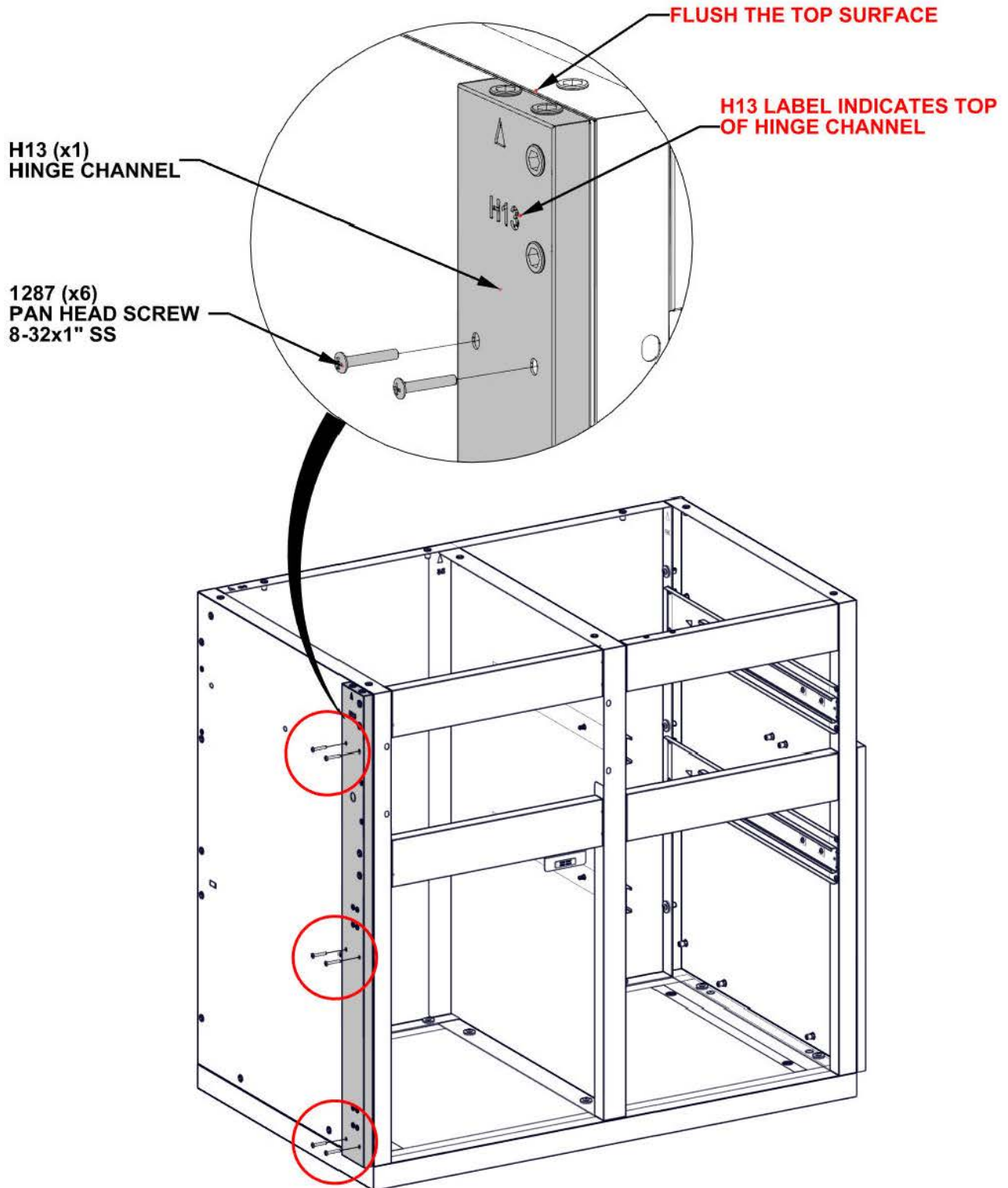

STEP 57 - SINK CABINET ASSEMBLY

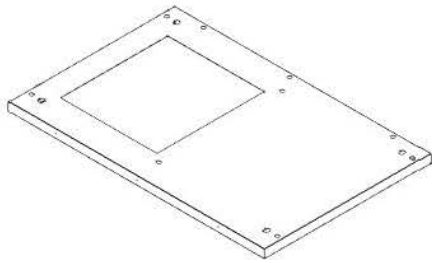

QTY	PartNo	Description
9	H101103	TORX SOCKET SCREW 1/4-20

T4 SINK CABINET TABLETOP FRAME - A4M03566
 (x1) 37 3/16"x24 1/8"x1 1/4" (32x612x944)

- FLUSH BACK AND SIDE OF PANEL ASSEMBLY.
- SQUARE ALL SIDES OF CABINET BEFORE TIGHTENING HARDWARE.

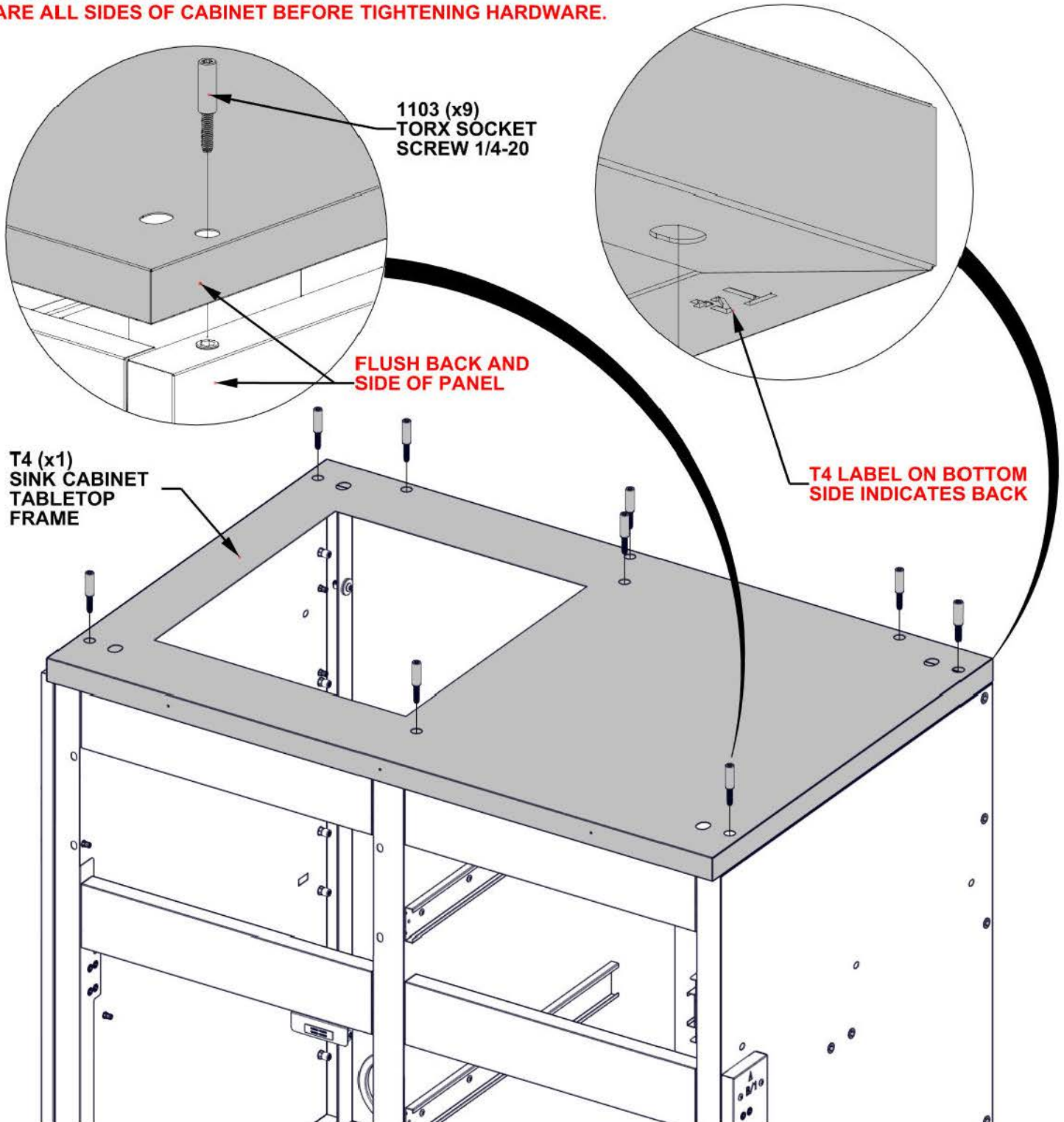

STEP 58 - SINK CABINET ASSEMBLY

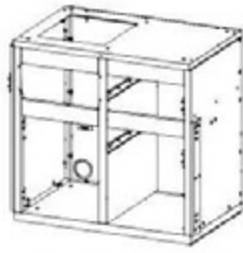

SINK CABINET FROM
STEPS 50 - 57

- POSITION SINK CABINET ASSEMBLY UNDERNEATH LANCASTER LINEAR STRUCTURE.
- DISTANCE BETWEEN FRIDGE CABINET WILL BE DETERMINED IN NEXT STEP.

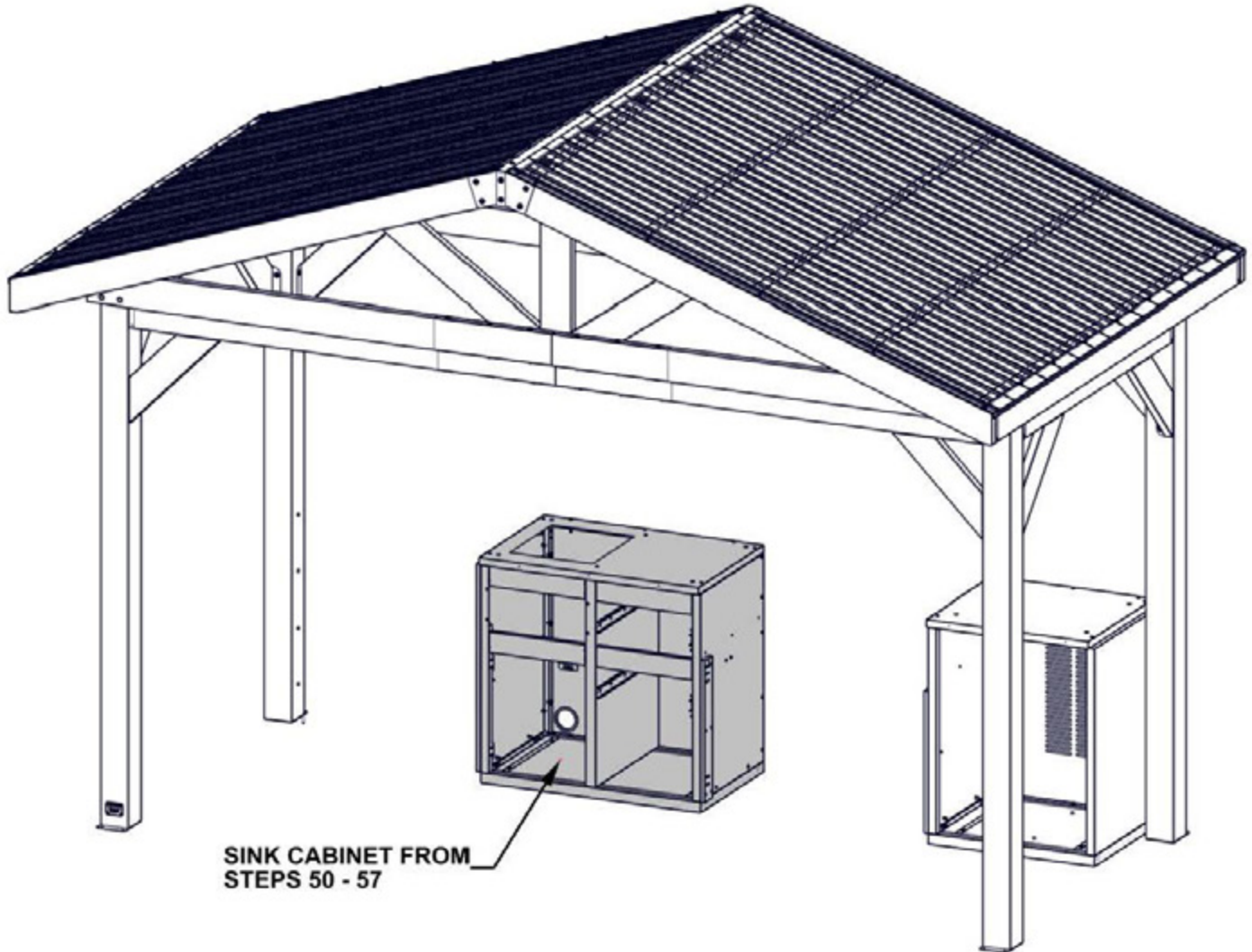

SINK CABINET FROM
STEPS 50 - 57

STEP 59 - GRILL CABINET ASSEMBLY

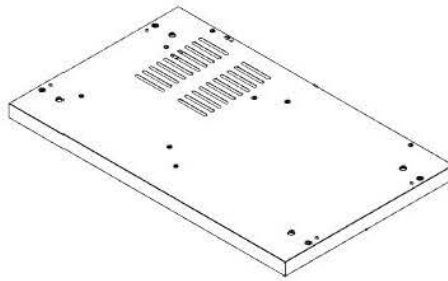

F2 GRILL CABINET FLOOR PANEL ASSEMBLY - A4M03048
(x1) 2 5/8"x23 3/8"x38 1/4" (66x594x972)

- ONLY KITCHEN CABINETS ARE SHOWN FOR DETAIL.
- **LOOKING AT THE FRONT SIDE OF THE CABINETS, SLIDE FLOOR PANEL IN BETWEEN SINK AND FRIDGE CABINETS.**

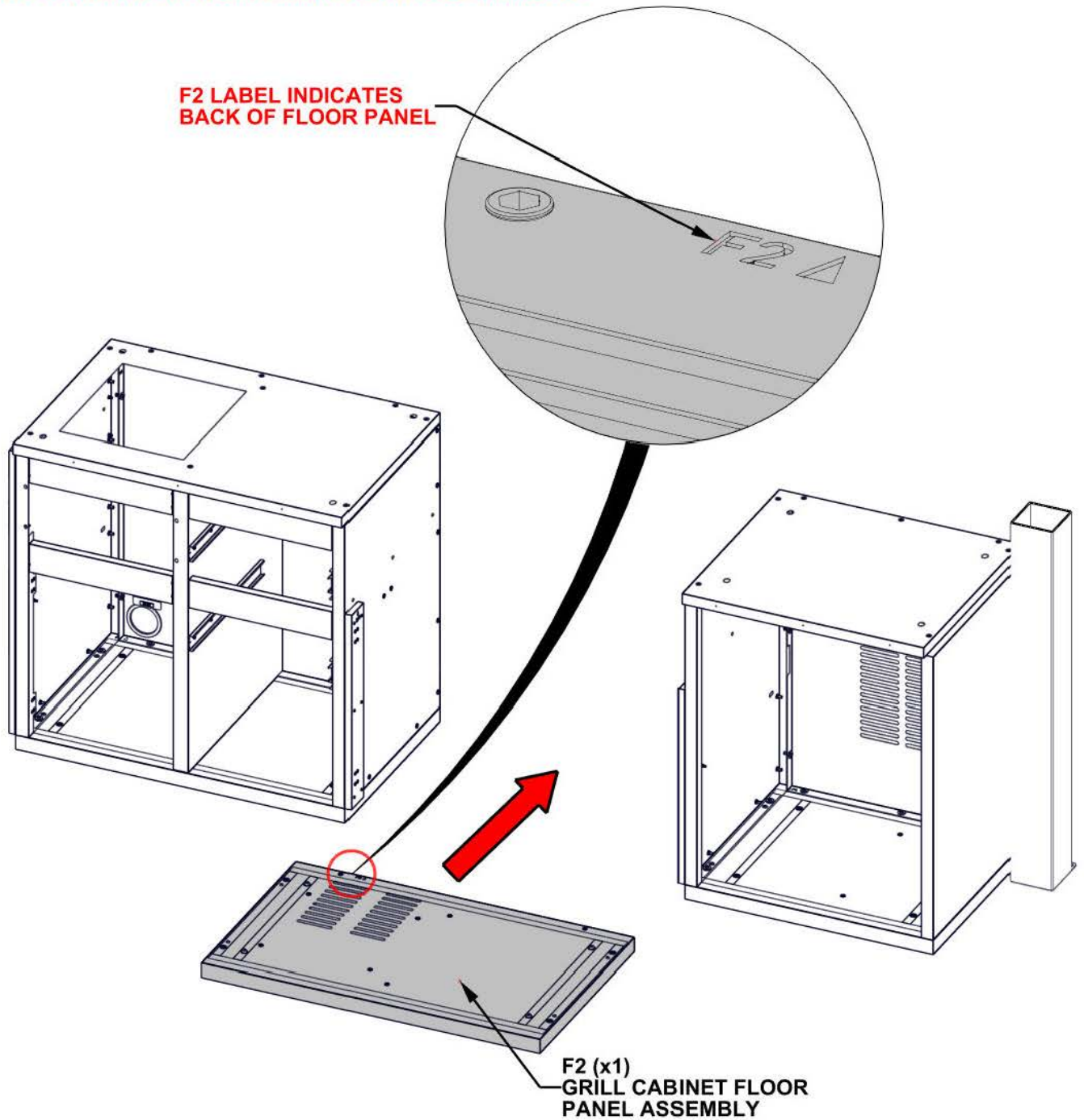

STEP 60 - GRILL CABINET ASSEMBLY

- ONLY KITCHEN CABINETS ARE SHOWN FOR DETAIL.
- POSITION FLOOR PANEL AS SHOWN BELOW.
- EACH FLOOR PANEL HAS FACTORY INSTALLED ADJUSTABLE FEET. USE PROVIDED HEX DRIVER TO ADJUST EACH FOOT UNTIL PANEL IS LEVEL.
- ADJUST SINK AND FRIDGE CABINET TO ELIMINATE ANY GAPS BETWEEN FLOOR PANEL AND CABINETS.

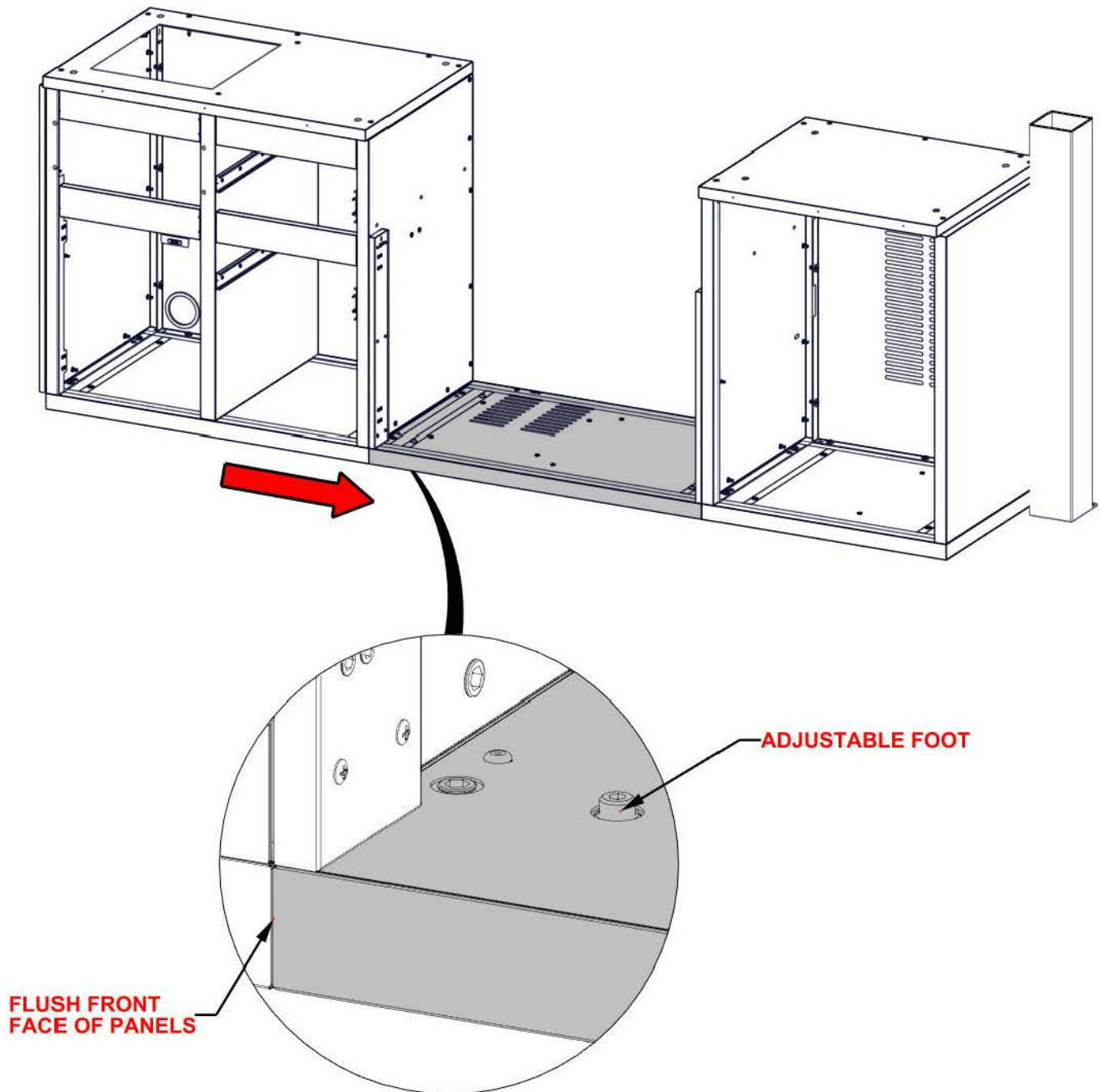

STEP 61 - GRILL CABINET ASSEMBLY

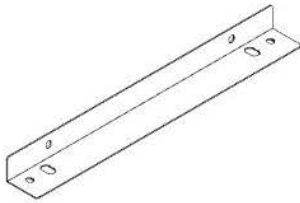

QTY	PartNo	Description
4	H101202	TORX PAN HEAD 1/4-20x3/4 ASSY

A6 ANGLED BRACKET - A4M03053
 (x1) 1 3/8"x1 15/16"x17 1/8" (35x50x435)

- ONLY KITCHEN CABINETS ARE SHOWN FOR DETAIL.

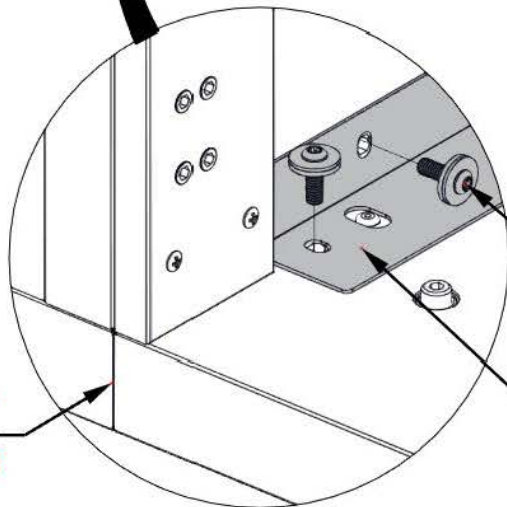
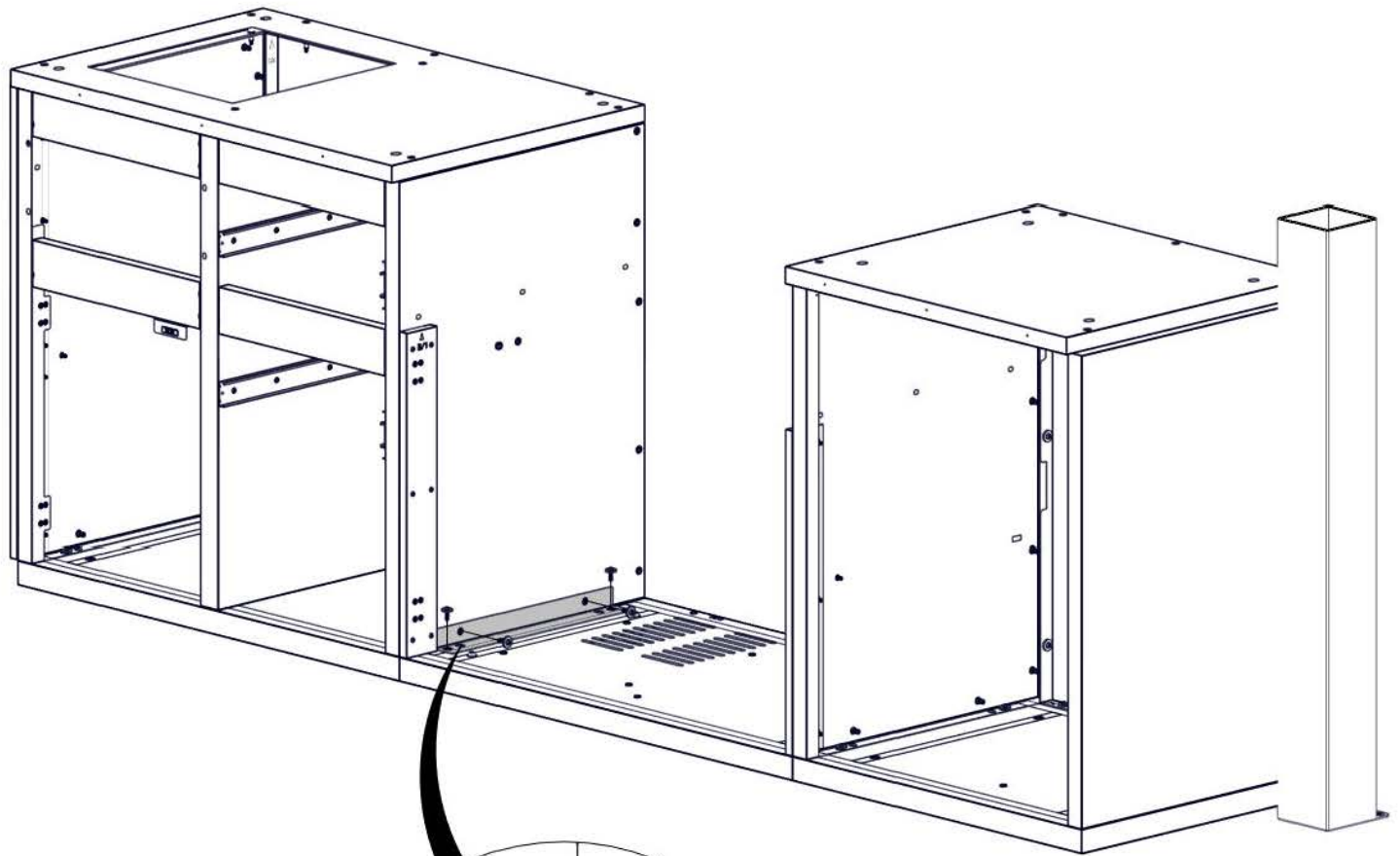

**MAKE SURE FRONT
 FACE OF FLOOR
 PANELS ARE FLUSH**

1202 (x4)
 TORX PAN HEAD 1/4-20x3/4 ASSY

A6 (x1)
 ANGLED BRACKET

STEP 62 - GRILL CABINET ASSEMBLY

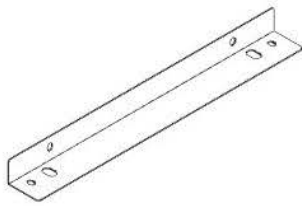

QTY	PartNo	Description
4	H101202	TORX PAN HEAD 1/4-20x3/4 ASSY

A6 ANGLED BRACKET - A4M03053
 (x1) 1 3/8"x1 15/16"x17 1/8" (35x50x435)

- ONLY KITCHEN CABINETS ARE SHOWN FOR DETAIL.

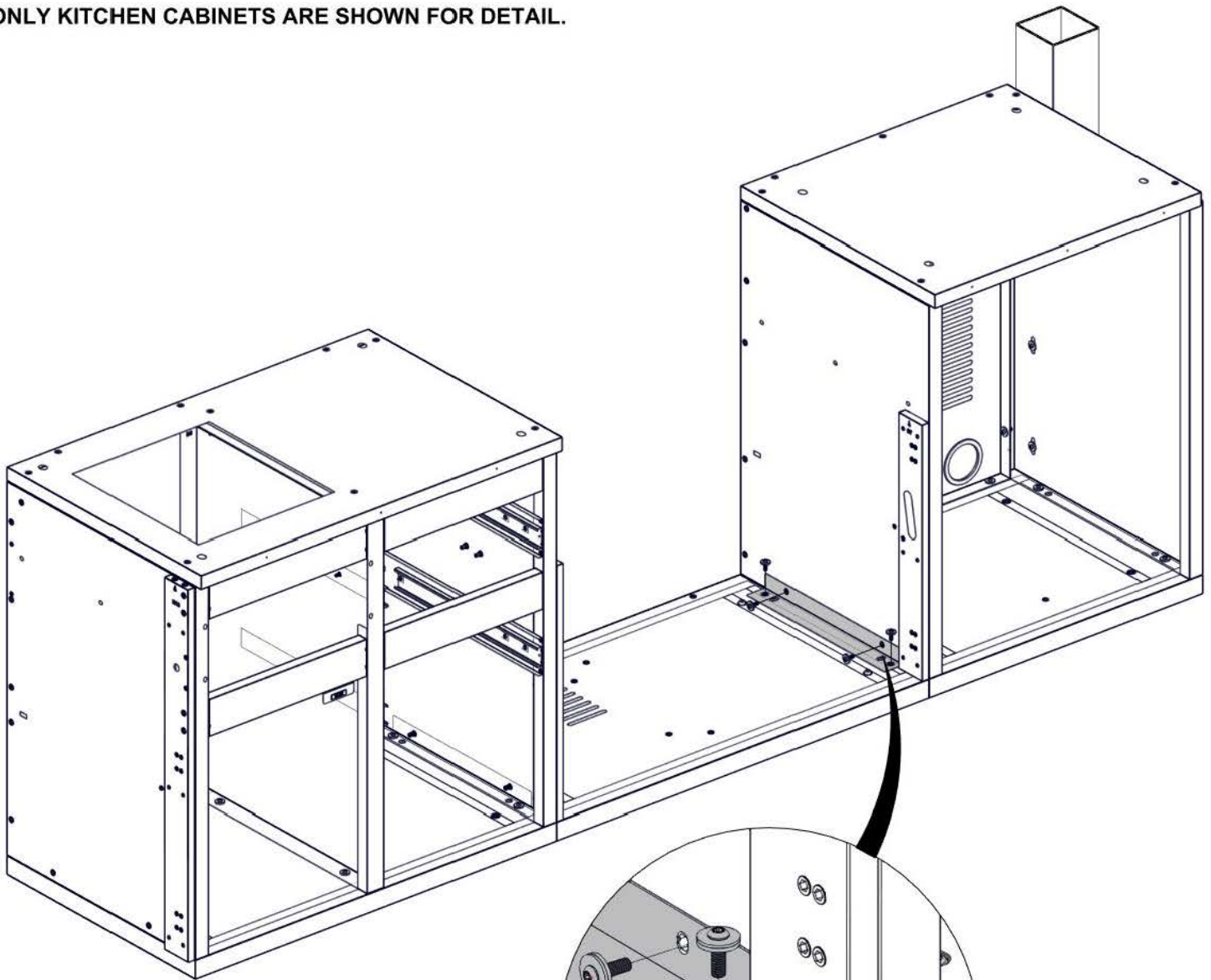

1202 (x4)
 TORX PAN HEAD 1/4-20x3/4 ASSY

A6 (x1)
 ANGLED BRACKET

**MAKE SURE FRONT
 FACE OF FLOOR
 PANELS ARE FLUSH**

STEP 63 - GRILL CABINET ASSEMBLY

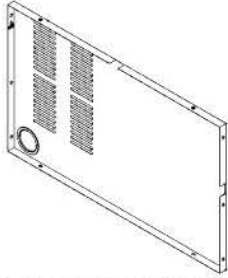

QTY	PartNo	Description
8	H101202	TORX PAN HEAD 1/4-20x3/4 ASSY

G10 GRILL CABINET BACK PANEL ASSEMBLY - A4M03055
 (x1) 1 3/16"x22 7/8"x38 3/16" (30x581x970)

- ONLY KITCHEN CABINETS ARE SHOWN FOR DETAIL.

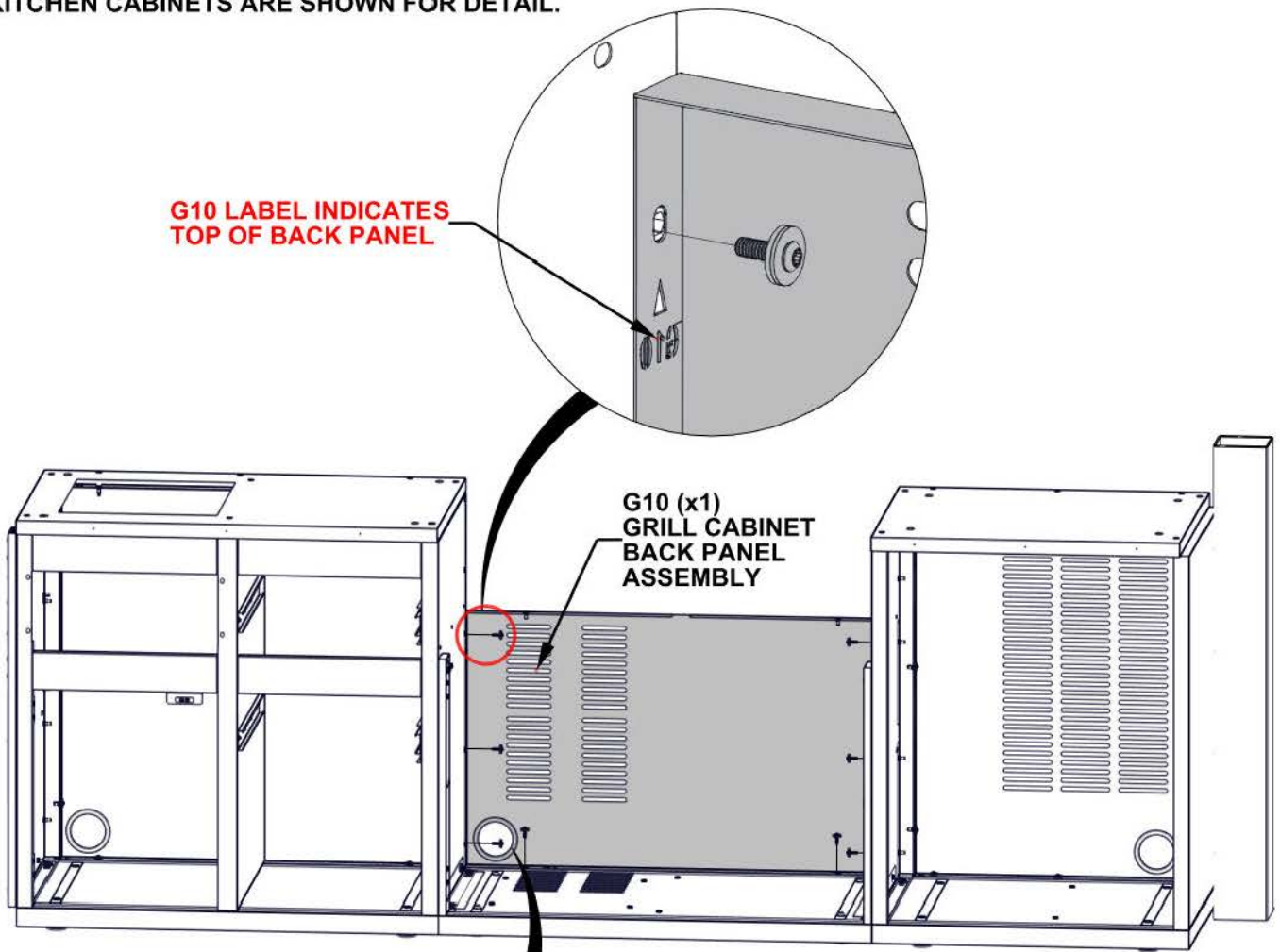

G10 LABEL INDICATES
TOP OF BACK PANEL

G10 (x1)
GRILL CABINET
BACK PANEL
ASSEMBLY

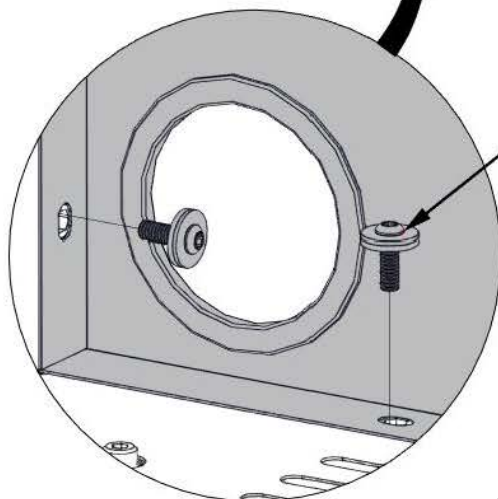

1202 (x8)
TORX PAN HEAD 1/4-20x3/4 ASSY

TIGHTEN ALL HARDWARE

STEP 64 - GRILL CABINET ASSEMBLY

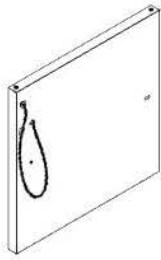

QTY	PartNo	Description
2	H101202	TORX PAN HEAD 1/4-20x3/4 ASSY

S6 GRILL CABINET SIDE PANEL ASSEMBLY M - A4M03586
 (x1) 23 3/8"x22 7/8"x1 3/8" (35.00x581.00x593.00)

- ONLY KITCHEN CABINETS ARE SHOWN FOR DETAIL.

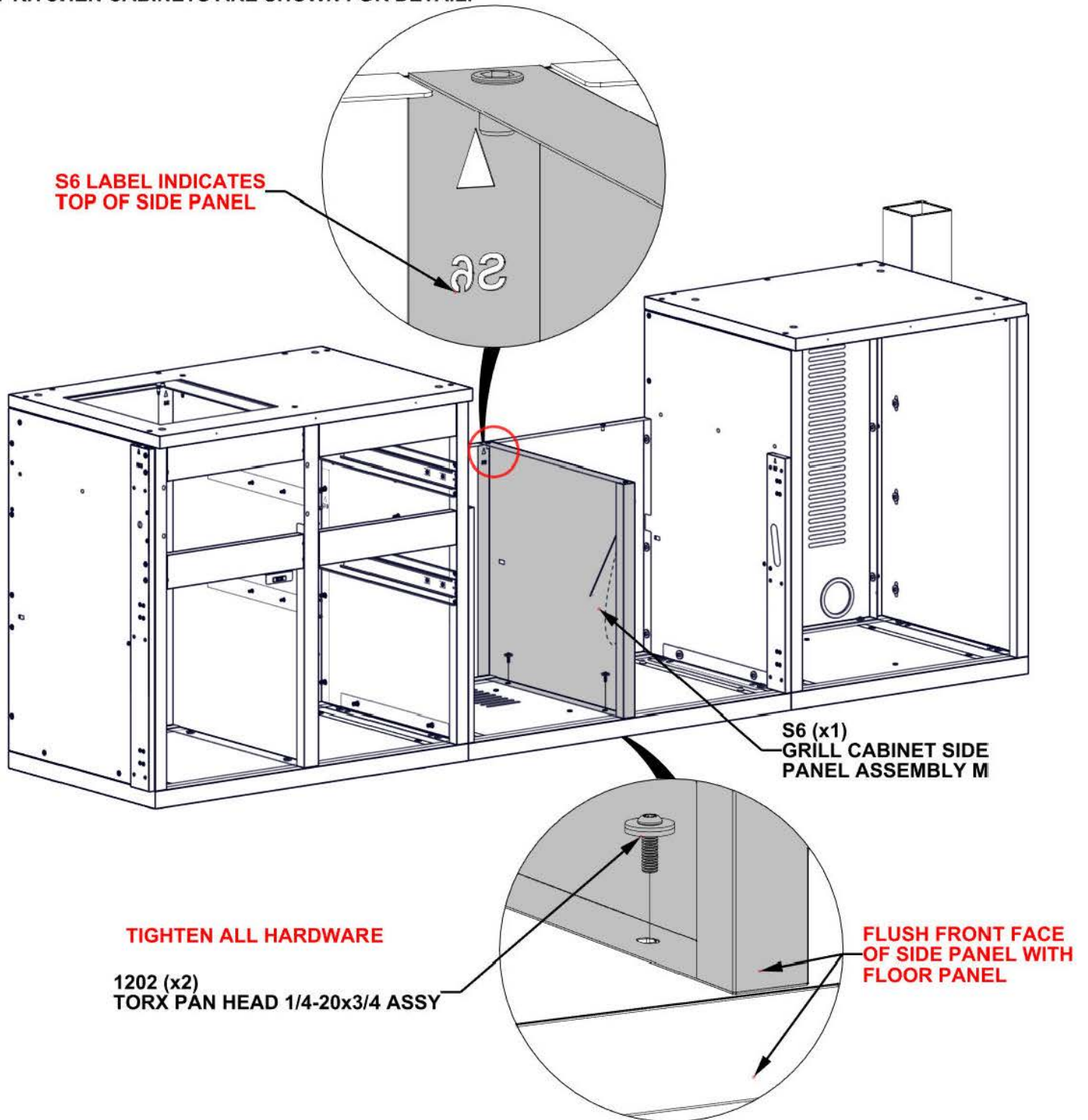

STEP 65A - GRILL CABINET ASSEMBLY

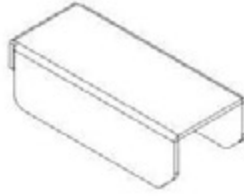

A5 SHELF BRACKET - A4M03141
(x2) 5/8"x7/8"x2 1/16" (16x22x53)

- ONLY KITCHEN CABINETS ARE SHOWN FOR DETAIL.
- ATTACH SHELF BRACKETS ON BOTH SIDES OF CENTER GRILL CABINET.

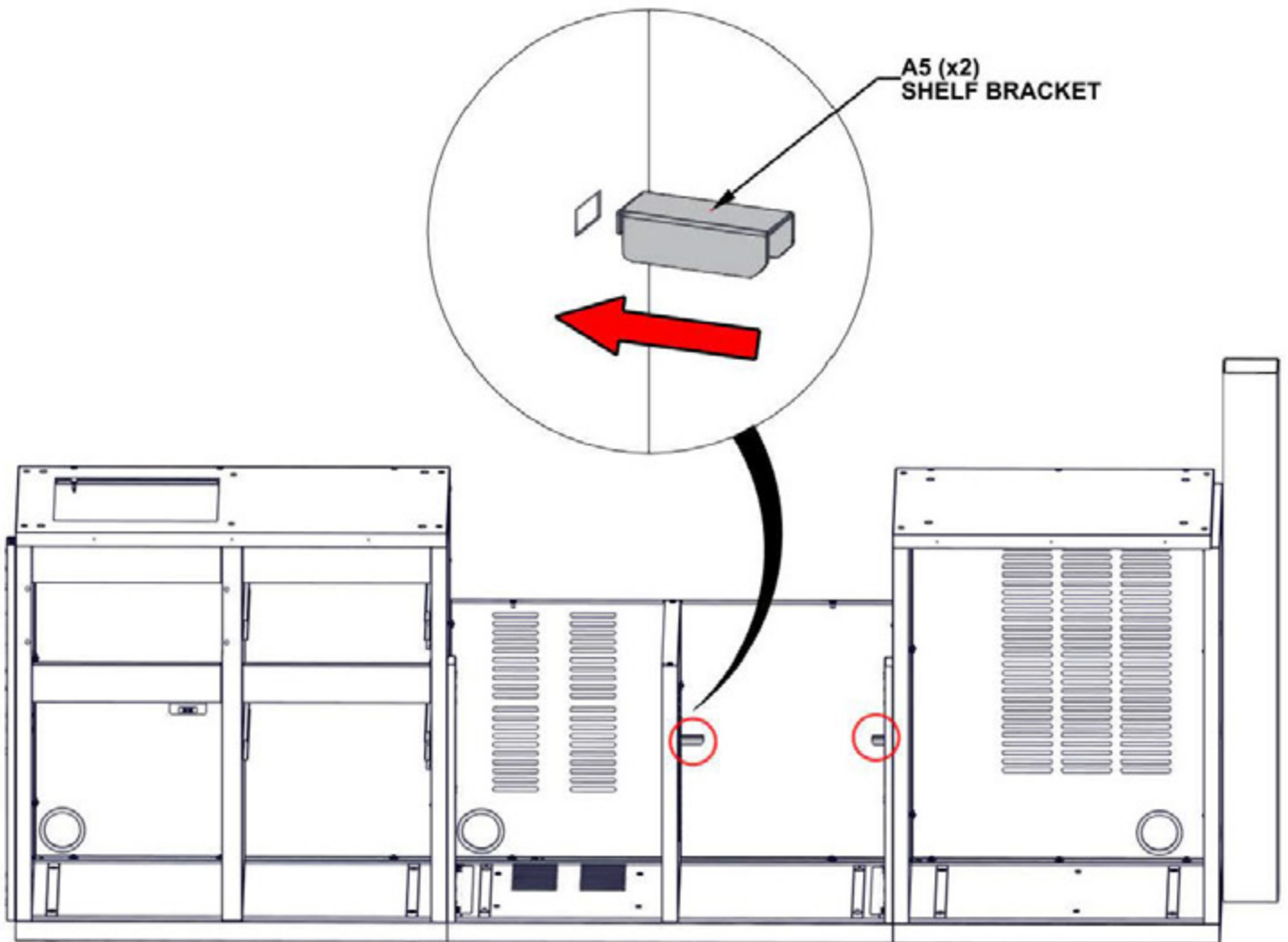

STEP 65B - GRILL CABINET ASSEMBLY

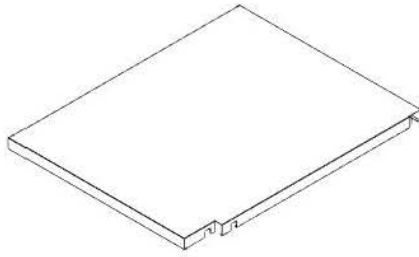

QTY	PartNo	Description
3	H101289	PAN HEAD SCREW 8-32x1/2" SS

L2 GRILL CABINET SHELF ASSEMBLY - A4M03589
 (x1) 23 1/4"x18 3/8"x1" (25.00x467.00x591.00)

- ONLY KITCHEN CABINETS ARE SHOWN FOR DETAIL.
- PARTIALLY THREAD SCREWS INTO THREADED INSERTS.
- SET SHELF ONTO SCREWS AND THEN TIGHTEN HARDWARE TO FASTEN IN PLACE.

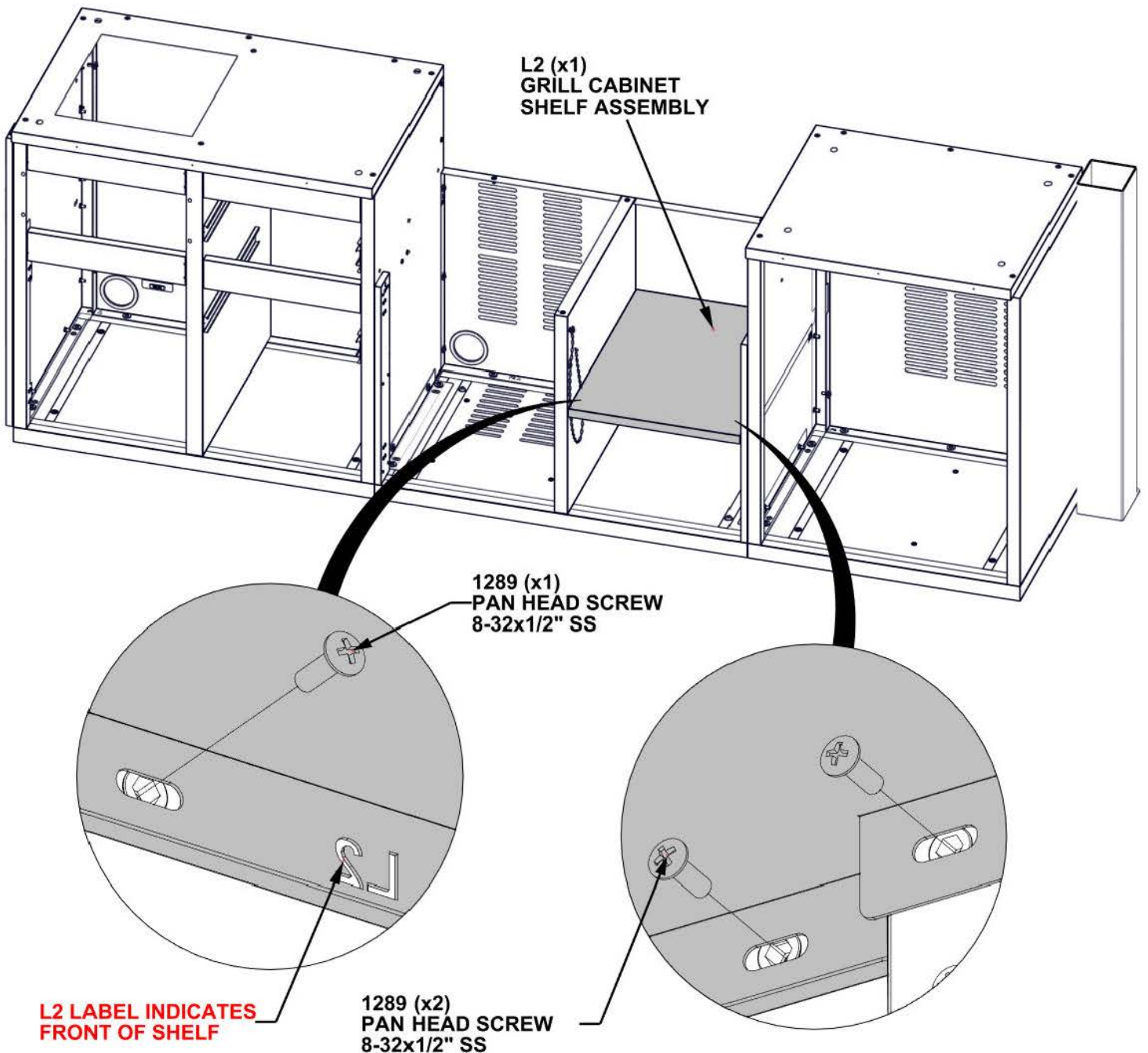

STEP 66 - GRILL CABINET ASSEMBLY



QTY	PartNo	Description
2	H101202	TORX PAN HEAD 1/4-20x3/4 ASSY

A9 HOSE BRACKET ASSEMBLY - A4M03060
(x1) 1 1/4"x1 7/16"x2 9/16" (31.5x36.5x65)

- ONLY KITCHEN CABINETS ARE SHOWN FOR DETAIL.

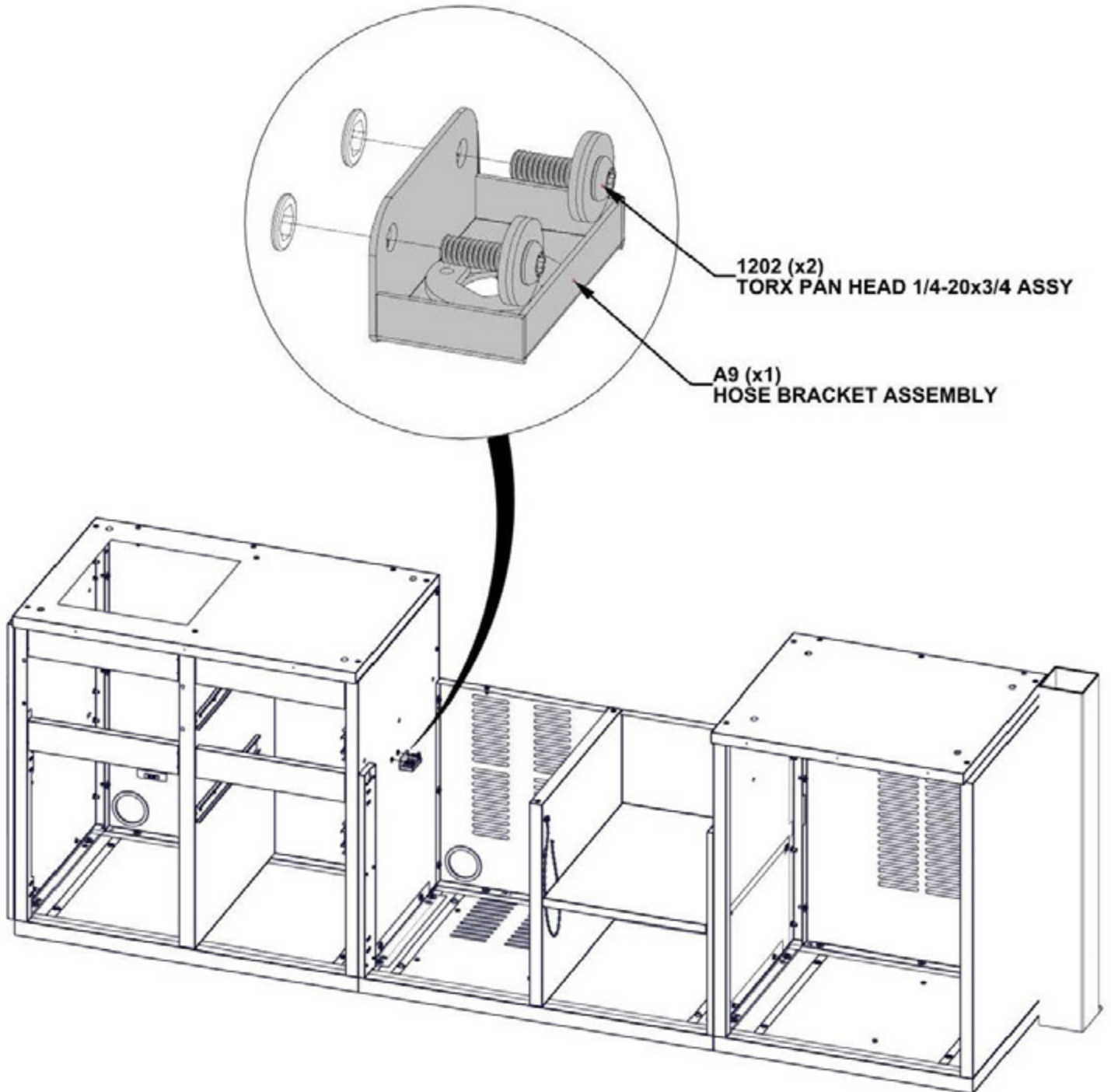

STEP 67 - GRILL CABINET ASSEMBLY

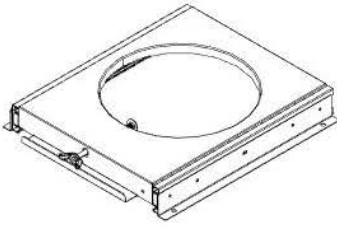

QTY	PartNo	Description
4	H101292	TORX PAN HEAD 1/4-20x13/32"

A13 GAS TANK HOLDER ASSEMBLY - A4M03047
 (x1) 1 15/16"x12 7/8"x14 3/4" (49x327x374)

- ONLY KITCHEN CABINETS ARE SHOWN FOR DETAIL.

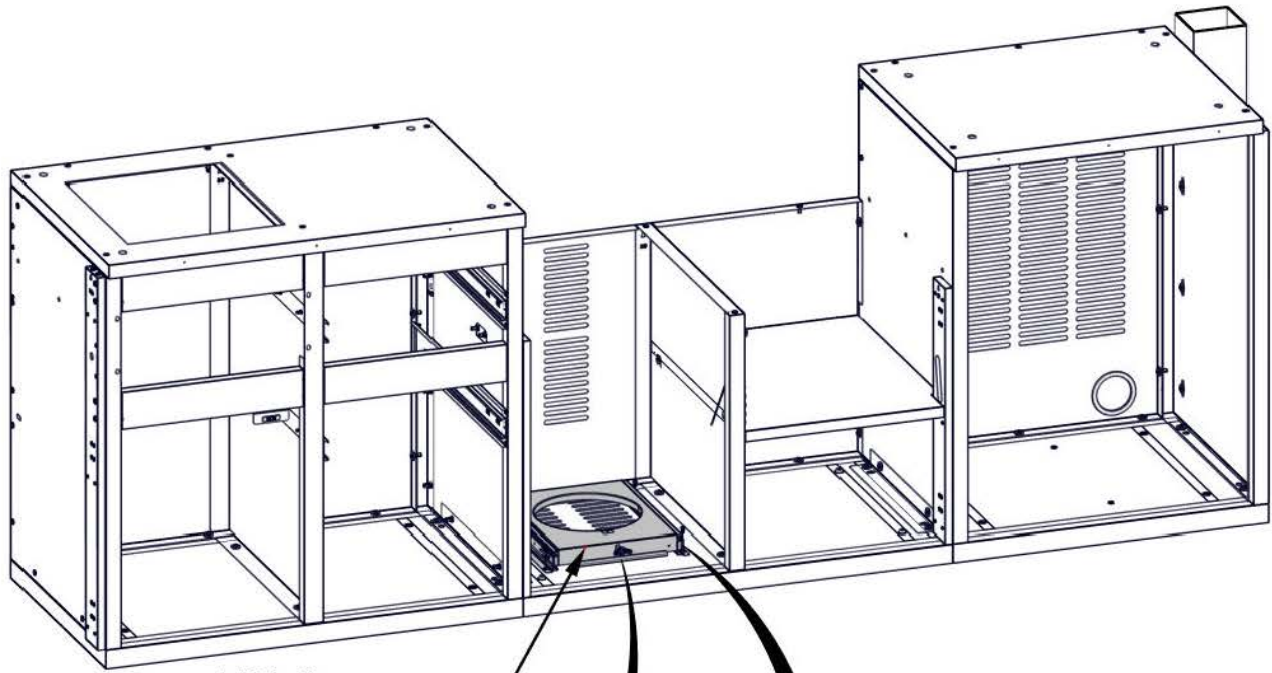

A13 (x1)
GAS TANK HOLDER
ASSEMBLY

1292 (x4)
TORX PAN HEAD 1/4-20x13/32"

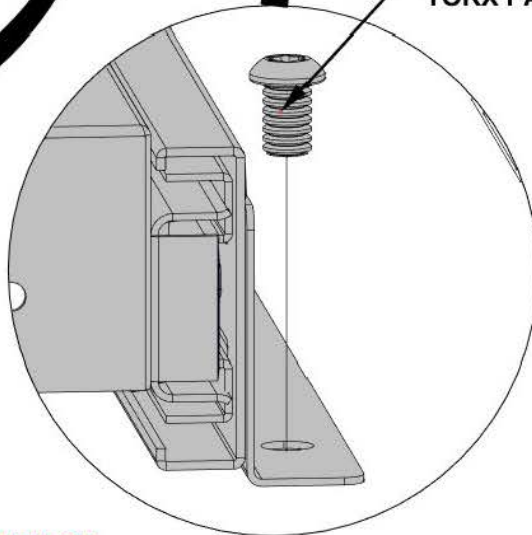
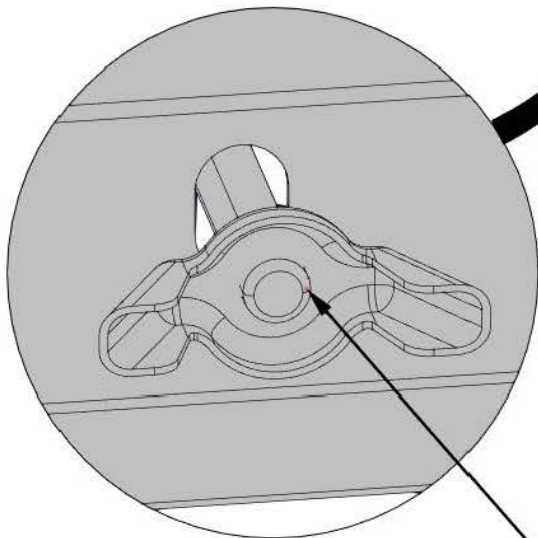

NOTE ORIENTATION OF
WING NUT TOWARDS FRONT

STEP 68 - GRILL CABINET ASSEMBLY

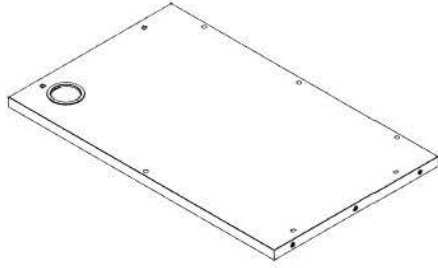

T2 GRILL TABLETOP ASSEMBLY - A4M03057
 (x1) 1 1/4"x23 3/8"x38 3/16" (32x594x970)

QTY	PartNo	Description
4	H101289	PAN HEAD SCREW 8-32x1/2" SS



A2 MAGNET BRACKET - A4M03026
 (x2) 1"x1 1/4"x3 1/8" (25x31x80)

- ONLY KITCHEN CABINETS ARE SHOWN FOR DETAIL.

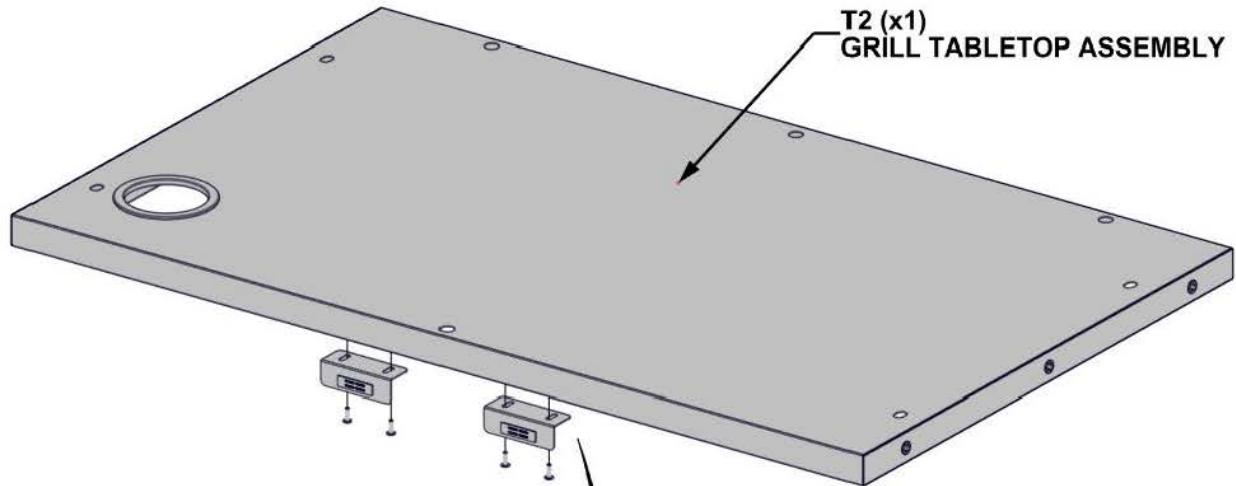

T2 (x1)
GRILL TABLETOP ASSEMBLY

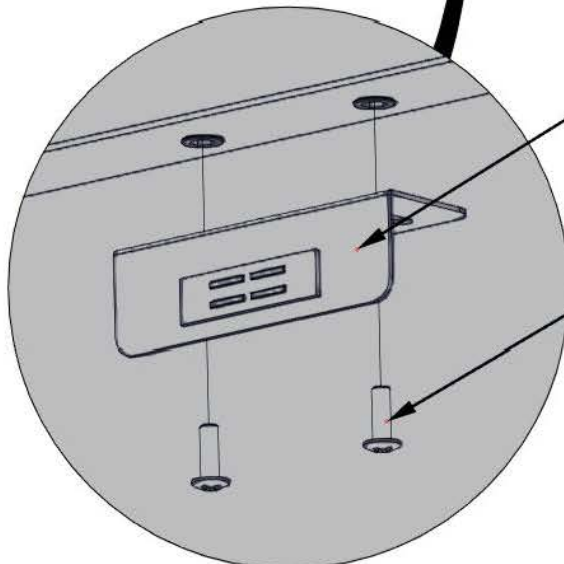

A2 (x2)
MAGNET BRACKET

1289 (x4)
PAN HEAD SCREW 8-32x1/2" SS

STEP 69A - GRILL CABINET ASSEMBLY

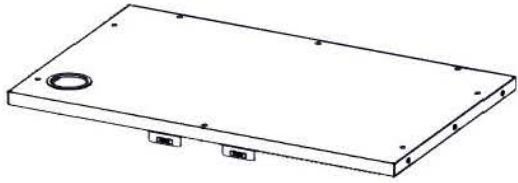

QTY	PartNo	Description
6	H101202	TORX PAN HEAD 1/4-20x3/4 ASSY

GRILL TABLETOP
ASSEMBLY FROM STEP 68

- ONLY KITCHEN CABINETS ARE SHOWN FOR DETAIL.
- **HARDWARE ATTACHES ON INSIDE OF CABINET**

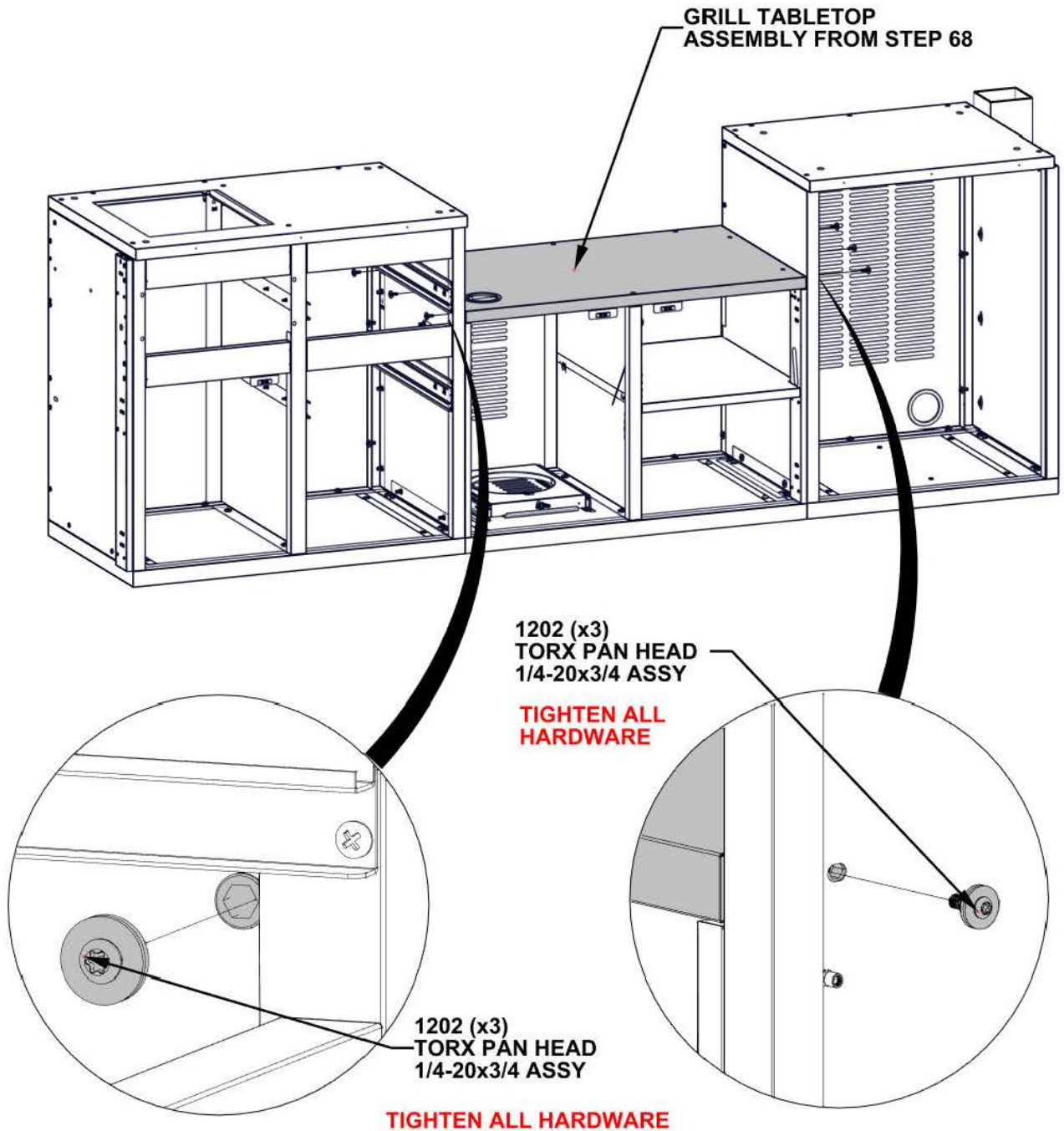

STEP 69B - GRILL CABINET ASSEMBLY

QTY	PartNo	Description
4	H101103	TORX SOCKET SCREW 1/4-20

- ONLY KITCHEN CABINETS ARE SHOWN FOR DETAIL.

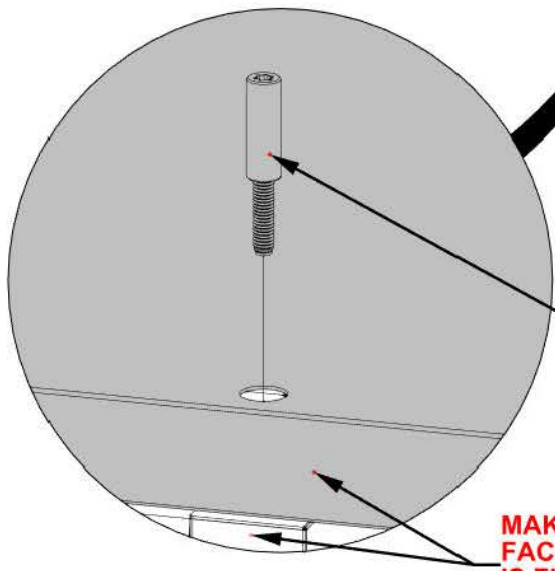
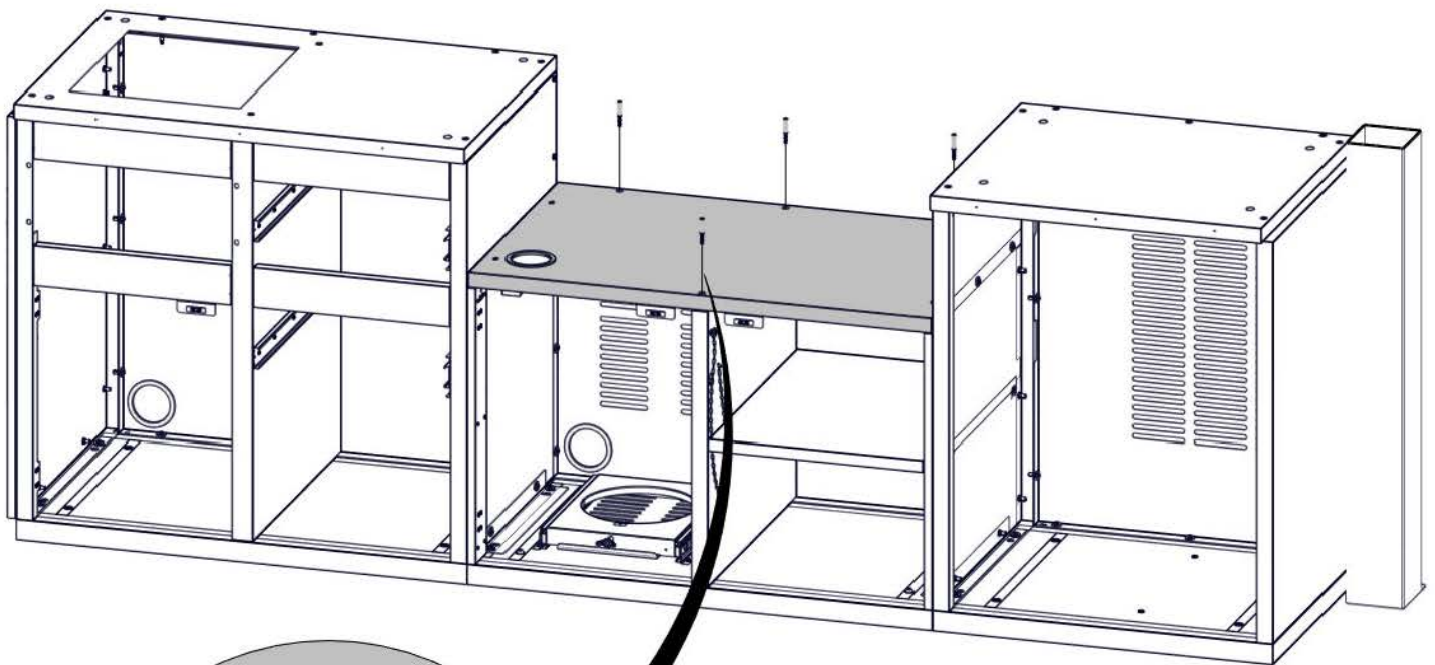

TIGHTEN ALL HARDWARE

1103 (x4)
TORX SOCKET SCREW 1/4-20

**MAKE SURE FRONT
FACE OF TABLETOP
IS FLUSH WITH
UPRIGHT PANEL**

STEP 70 - GRILL CABINET ASSEMBLY

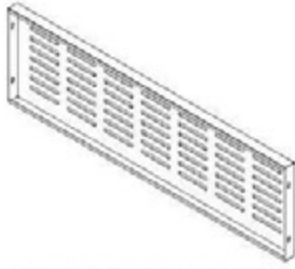

QTY	PartNo	Description
4	H101202	TORX PAN HEAD 1/4-20x3/4 ASSY

G11 GRILL VENTILATION PANEL - A4M03056
(x1) 1 5/16"x11 3/16"x38 3/16" (33x284x970)

- ONLY KITCHEN CABINETS ARE SHOWN FOR DETAIL.

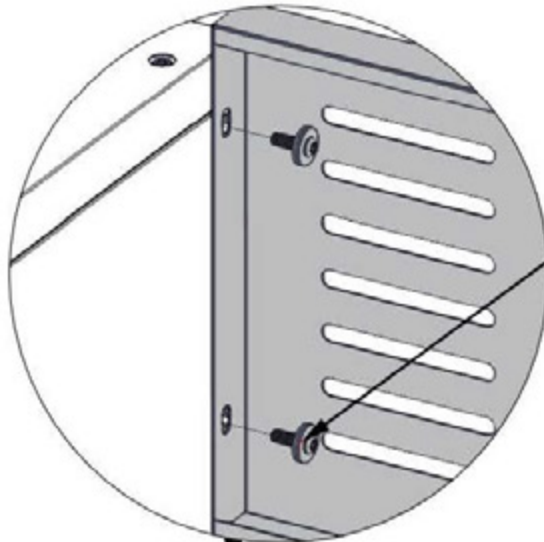

1202 (x4)
TORX PAN HEAD 1/4-20x3/4 ASSY

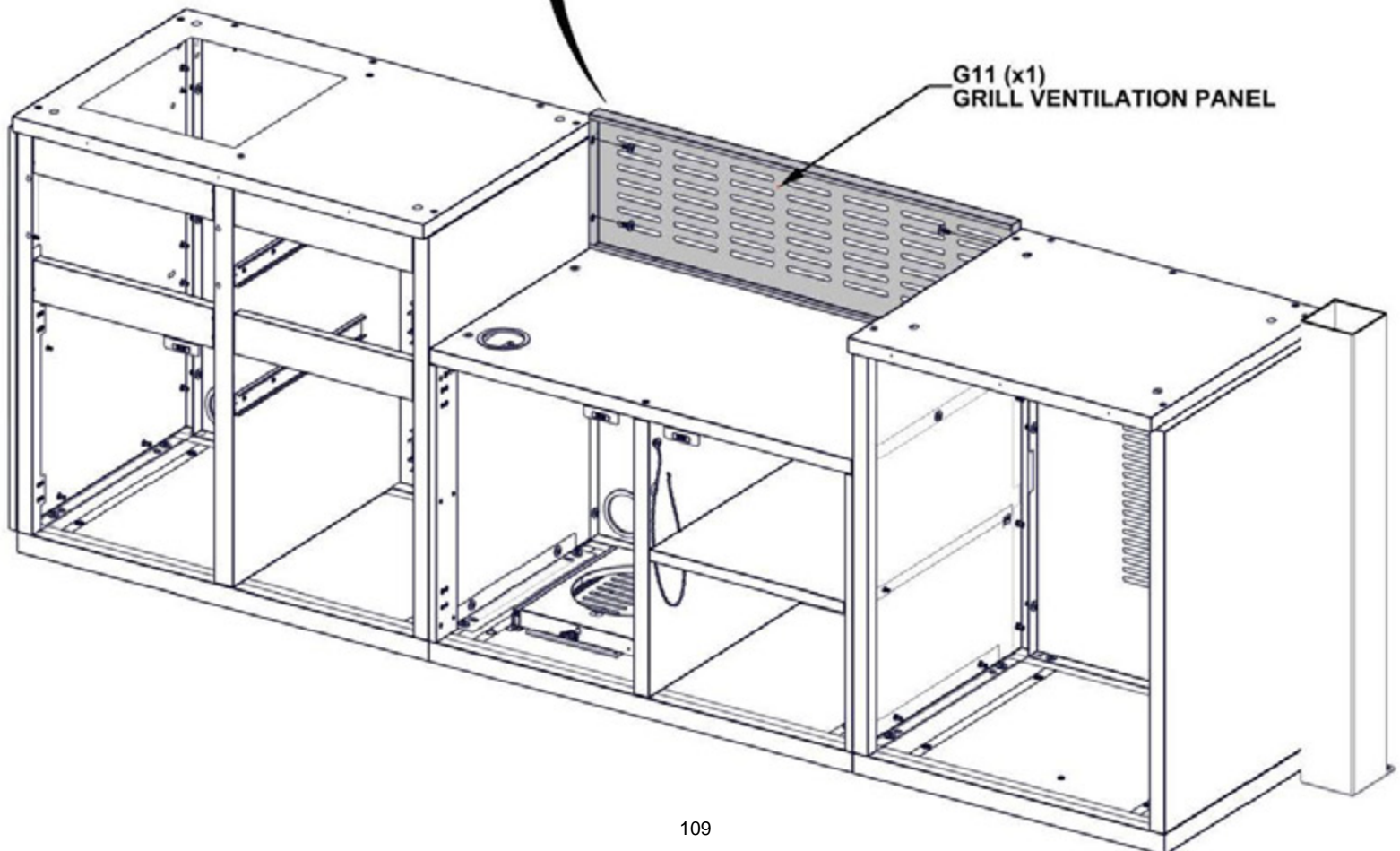

G11 (x1)
GRILL VENTILATION PANEL

STEP 71A - STORAGE CABINET ASSEMBLY

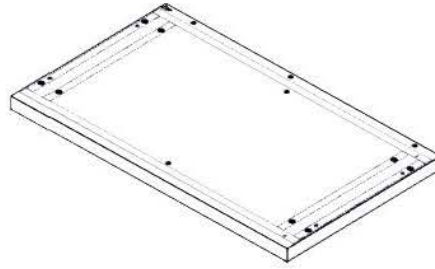

F7 STORAGE CABINET FLOOR ASSEMBLY - A4M03687
(x1) 40 3/16"x23 3/8"x2 5/8" (66x594x1020)

- ONLY KITCHEN CABINETS ARE SHOWN FOR DETAIL.
- **LOOKING AT THE FRONT SIDE OF THE CABINETS, SLIDE FLOOR PANEL IN BETWEEN P03 POST AND SINK CABINET.**

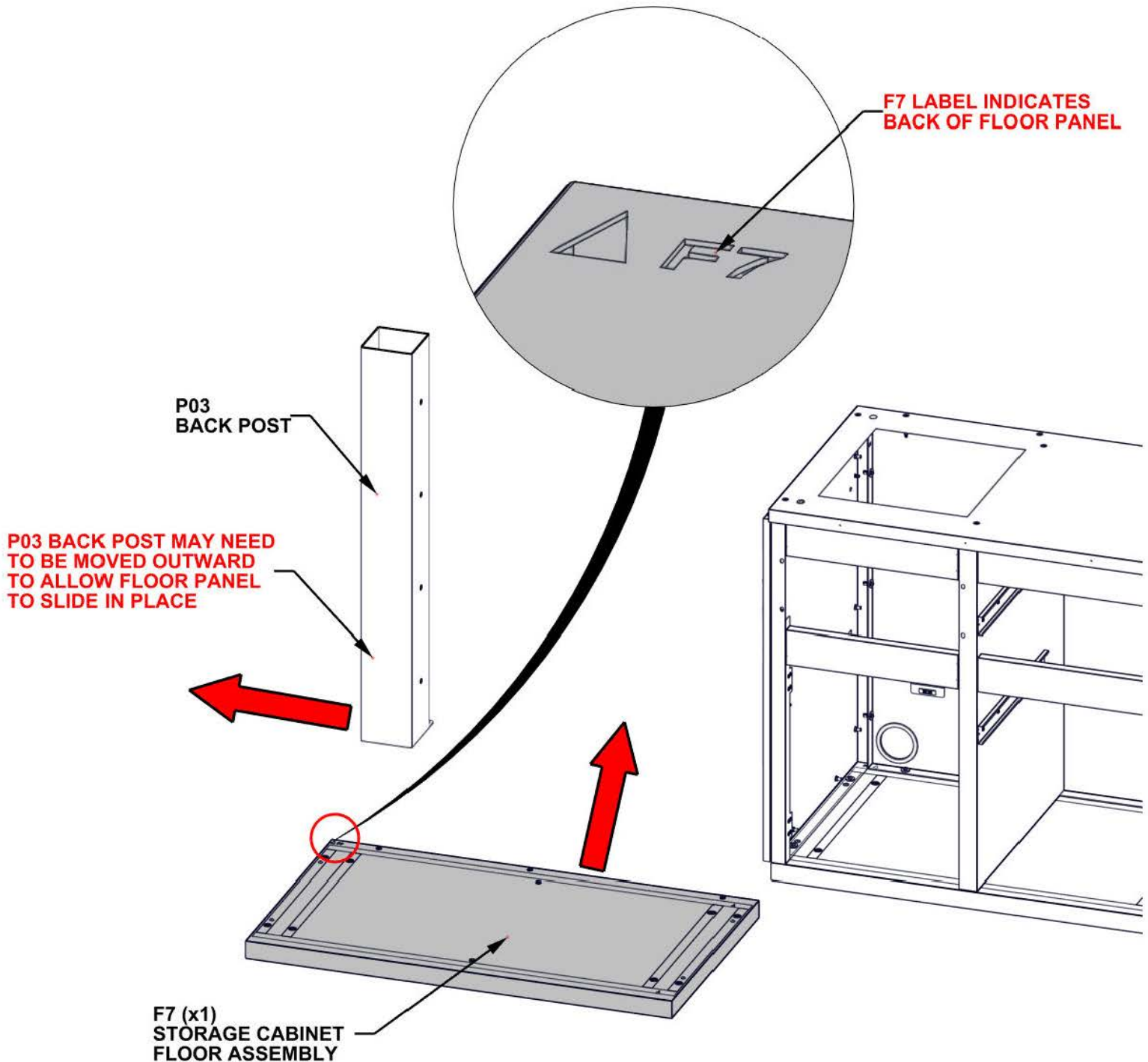

STEP 71B - STORAGE CABINET ASSEMBLY

- ONLY KITCHEN CABINETS ARE SHOWN FOR DETAIL.
- POSITION FLOOR PANEL AS SHOWN BELOW.
- EACH FLOOR PANEL HAS FACTORY INSTALLED ADJUSTABLE FEET. USE PROVIDED HEX DRIVER TO ADJUST EACH FOOT UNTIL PANEL IS LEVEL.
- ADJUST LEFT POST AND RIGHT CORNER CABINET TO ELIMINATE ANY GAPS BETWEEN FLOOR PANEL AND POST AND CABINETS.

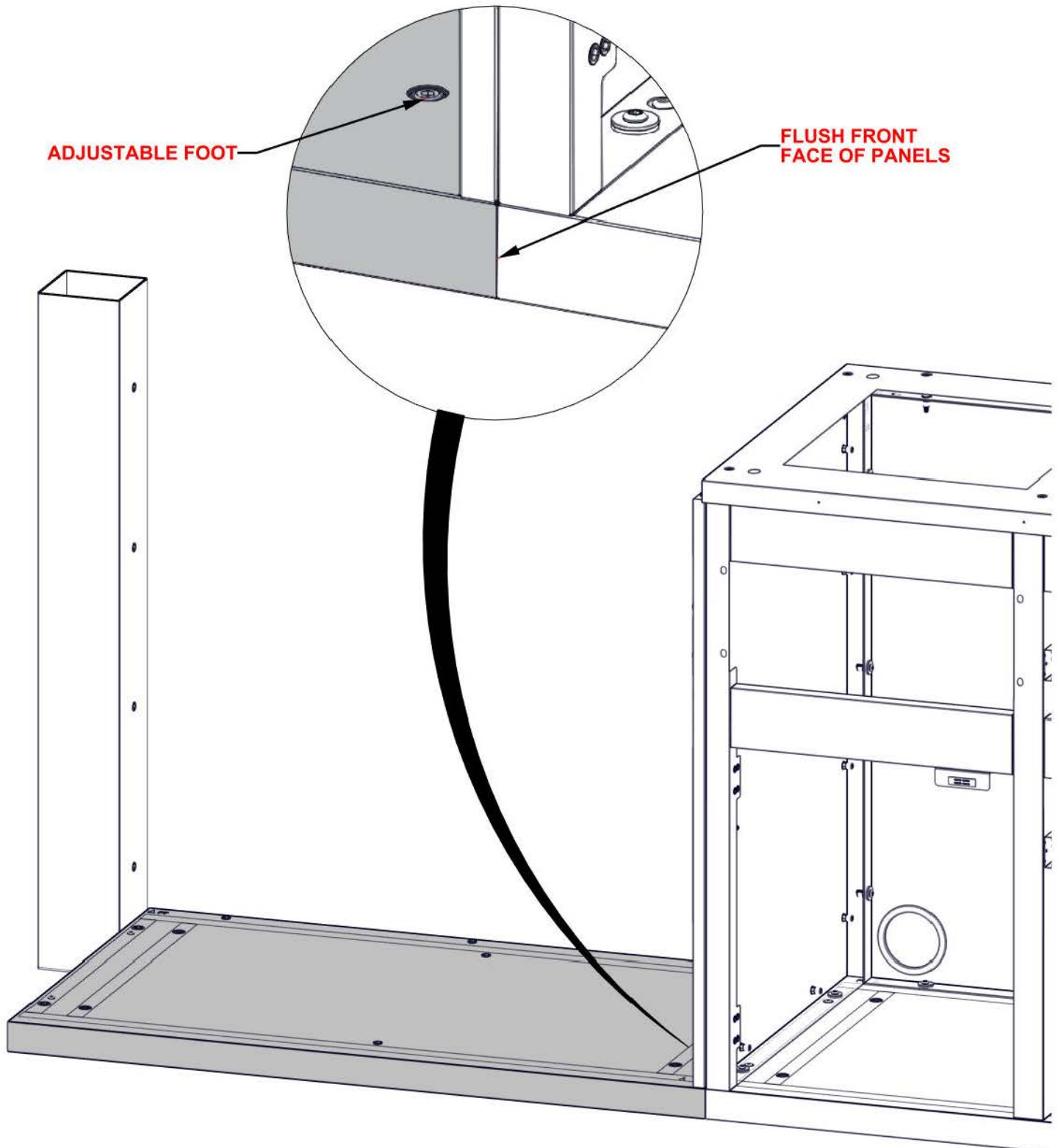

STEP 72 - STORAGE CABINET ASSEMBLY

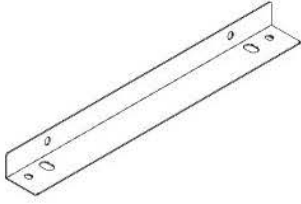

QTY	PartNo	Description
4	H101202	TORX PAN HEAD 1/4-20x3/4 ASSY

A6 ANGLED BRACKET - A4M03053
(x1) 1 3/8"x1 15/16"x17 1/8" (35x50x435)

- ONLY KITCHEN CABINETS ARE SHOWN FOR DETAIL.

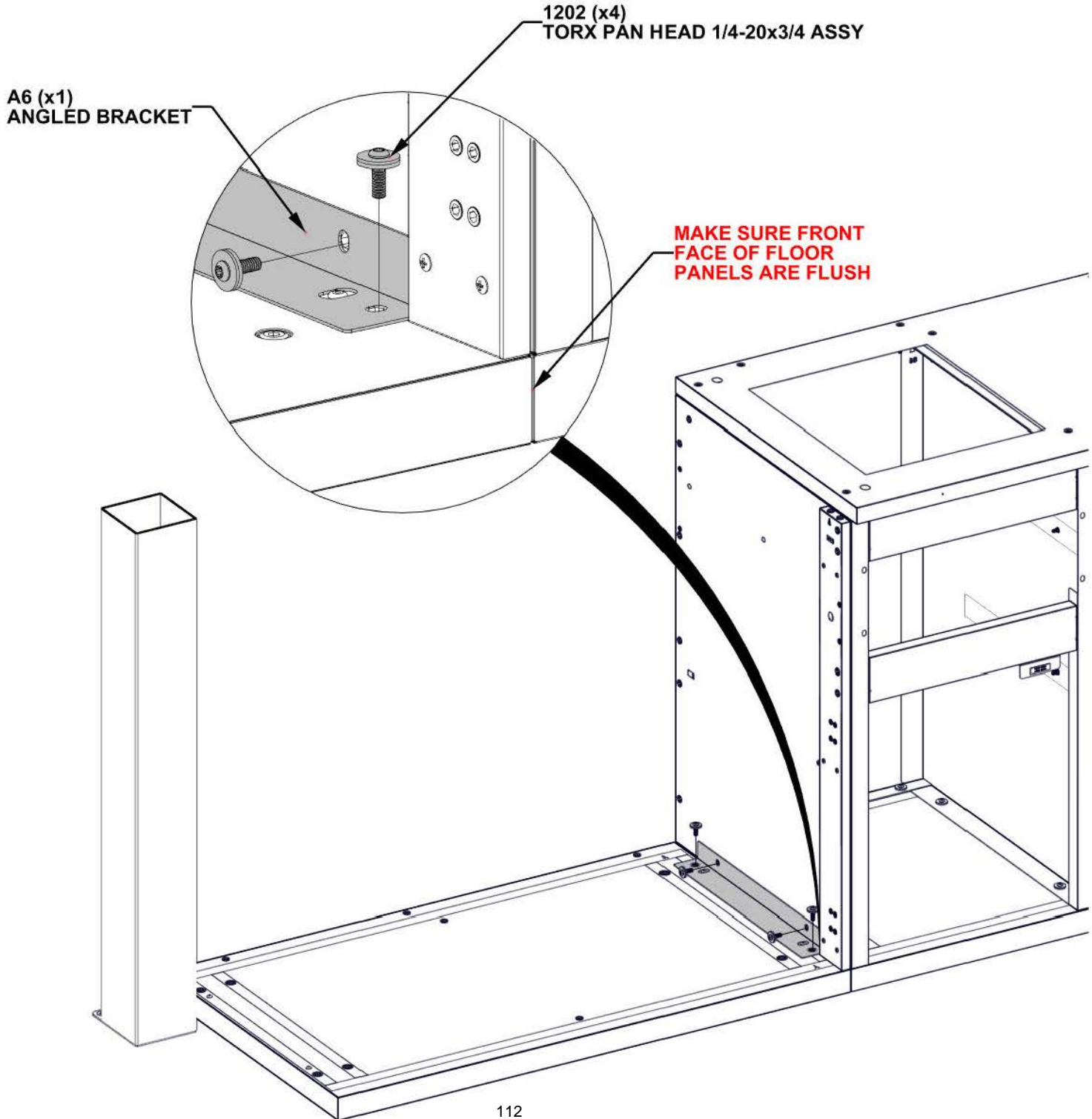

STEP 73 - STORAGE CABINET ASSEMBLY

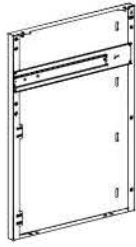

QTY	PartNo	Description
6	H101202	TORX PAN HEAD 1/4-20x3/4 ASSY

S16 STORAGE CABINET SIDE PANEL ASSEMBLY L - A4M03689
 (x1) 33 3/8"x23 3/8"x1 15/16" (50.00x594.00x848.20)

- ONLY KITCHEN CABINETS ARE SHOWN FOR DETAIL.

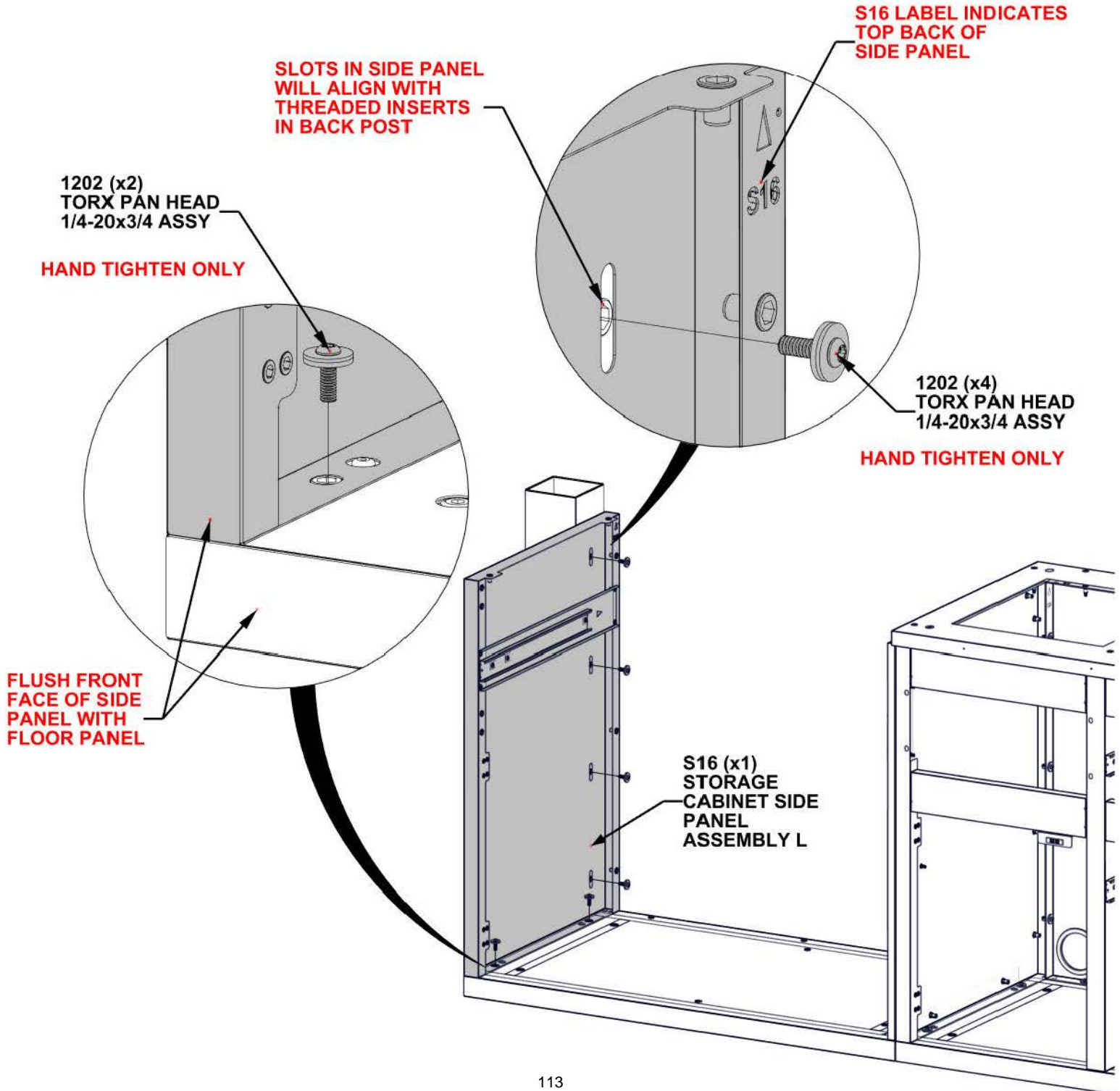

STEP 74 - STORAGE CABINET ASSEMBLY

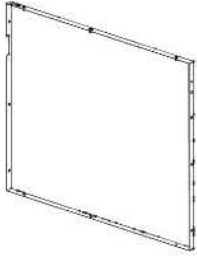

QTY	PartNo	Description
9	H101202	TORX PAN HEAD 1/4-20x3/4 ASSY

G12 STORAGE CABINET BACK PANEL ASSEMBLY - A4M03691
(x1) 38 3/4"x33 3/8"x1 3/16" (30.00x847.20847.20x984.00)

- ONLY KITCHEN CABINETS ARE SHOWN FOR DETAIL.

**G12 LABEL INDICATES
TOP OF BACK PANEL**

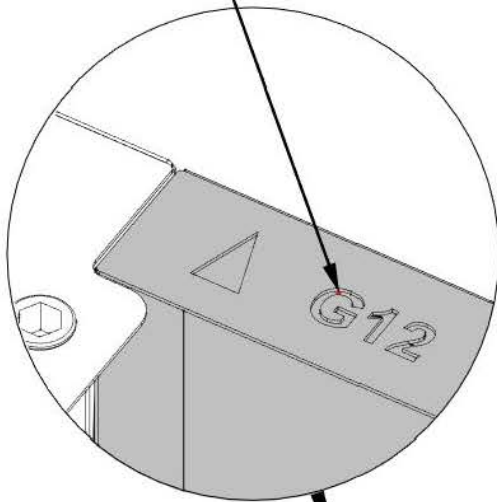

1202 (x9)
TORX PAN HEAD
1/4-20x3/4 ASSY

HAND TIGHTEN ONLY

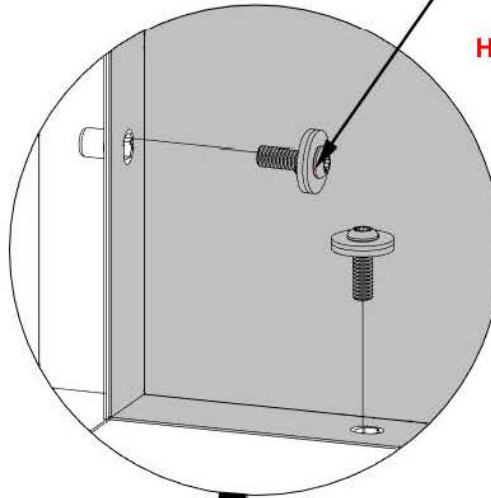

G12 (x1)
STORAGE CABINET
BACK PANEL ASSEMBLY

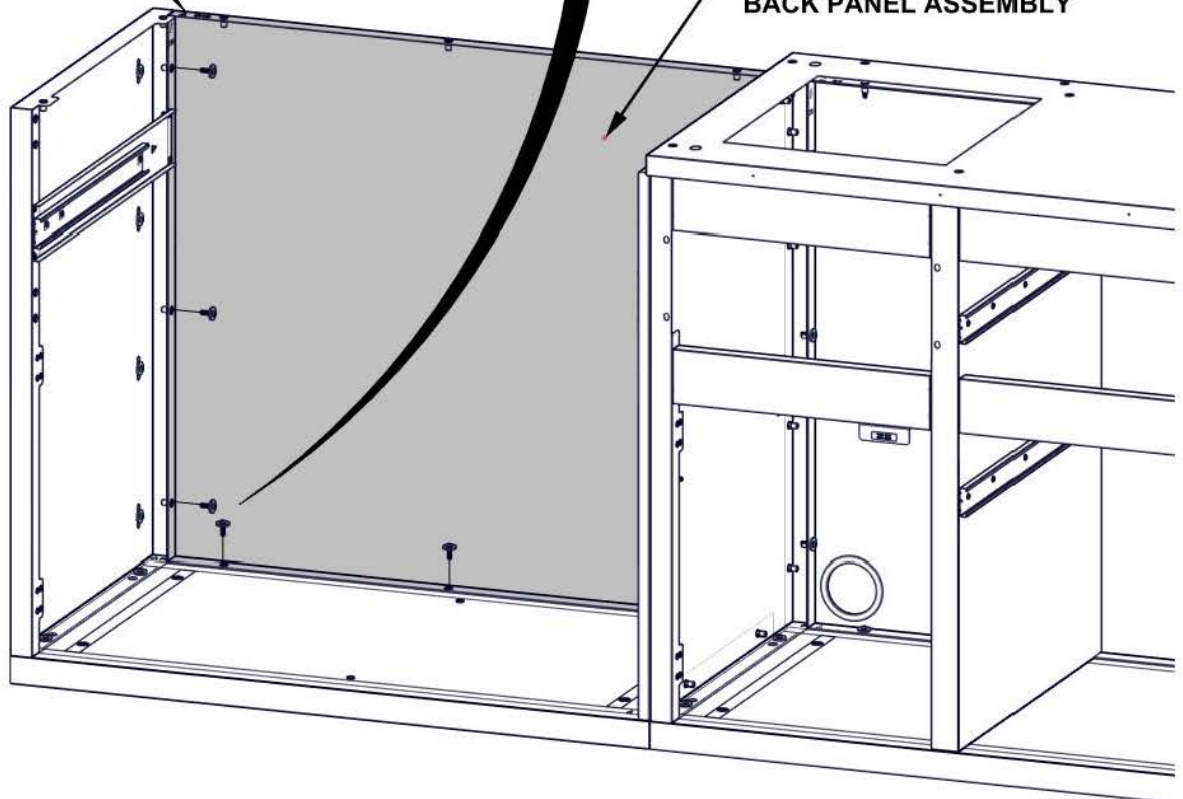

STEP 75 - STORAGE CABINET ASSEMBLY



QTY	PartNo	Description
2	H101289	PAN HEAD SCREW 8-32x1/2" SS

H11 DRAWER FIXING PIECE - A4M03692
(x1) 5 3/8"x1 1/16"x11/16" (17.20x27.00x137.00)

- ONLY KITCHEN CABINETS ARE SHOWN FOR DETAIL.

- **TIGHTEN ALL HARDWARES FROM PREVIOUS STEP.**

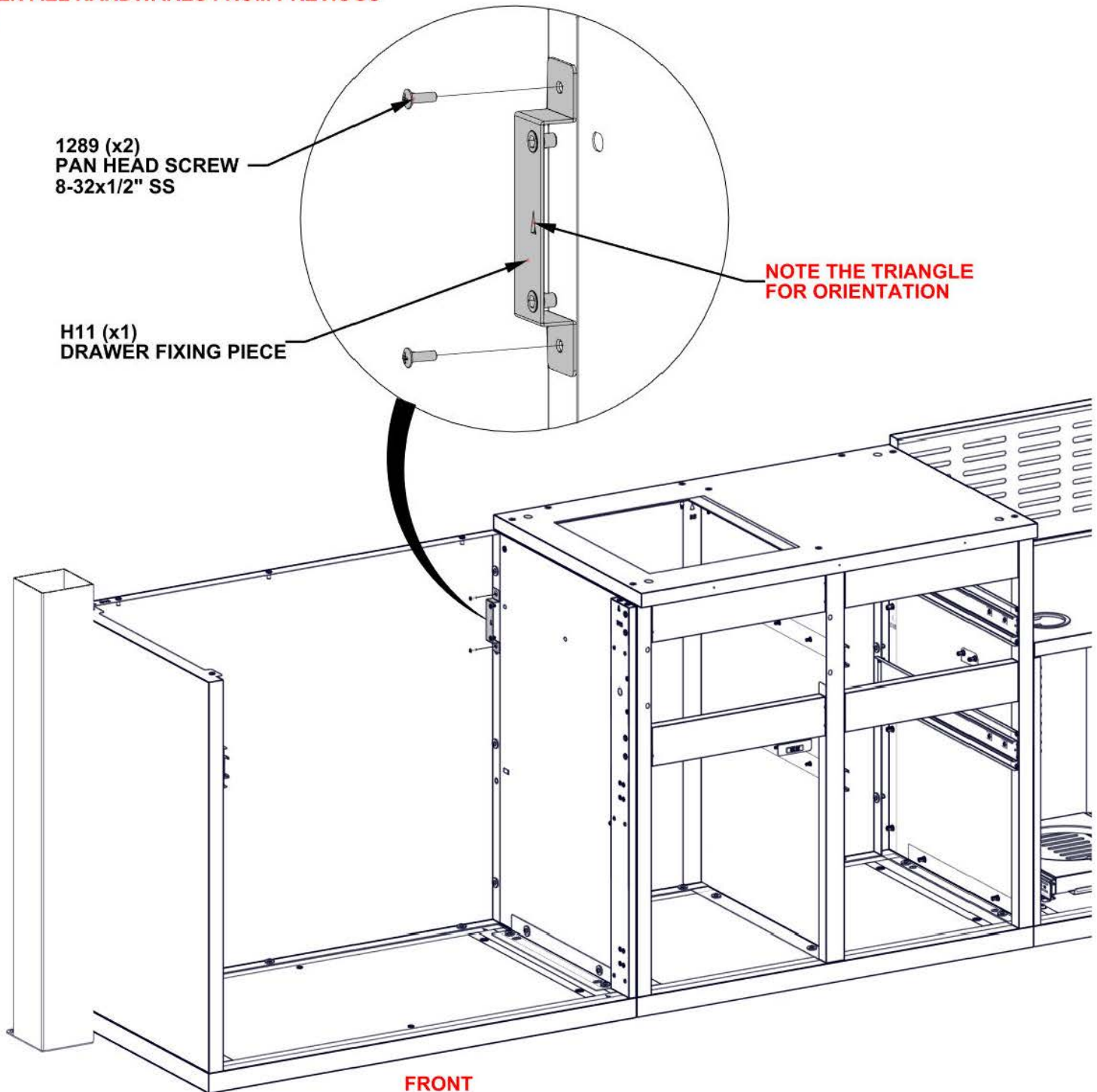

1289 (x2)
PAN HEAD SCREW
8-32x1/2" SS

H11 (x1)
DRAWER FIXING PIECE

**NOTE THE TRIANGLE
FOR ORIENTATION**

FRONT

STEP 76 - STORAGE CABINET ASSEMBLY

QTY	PartNo	Description
4	H101289	PAN HEAD SCREW 8-32x1/2" SS

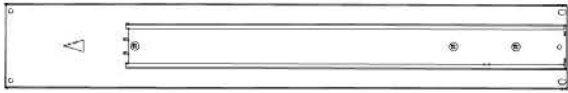

A10 SLIDE BRACKET ASSEMBLY - A4M03083
 (x1) 15/16"x3 3/8"x22 5/8" (23x85x575)

- ONLY KITCHEN CABINETS ARE SHOWN FOR DETAIL.

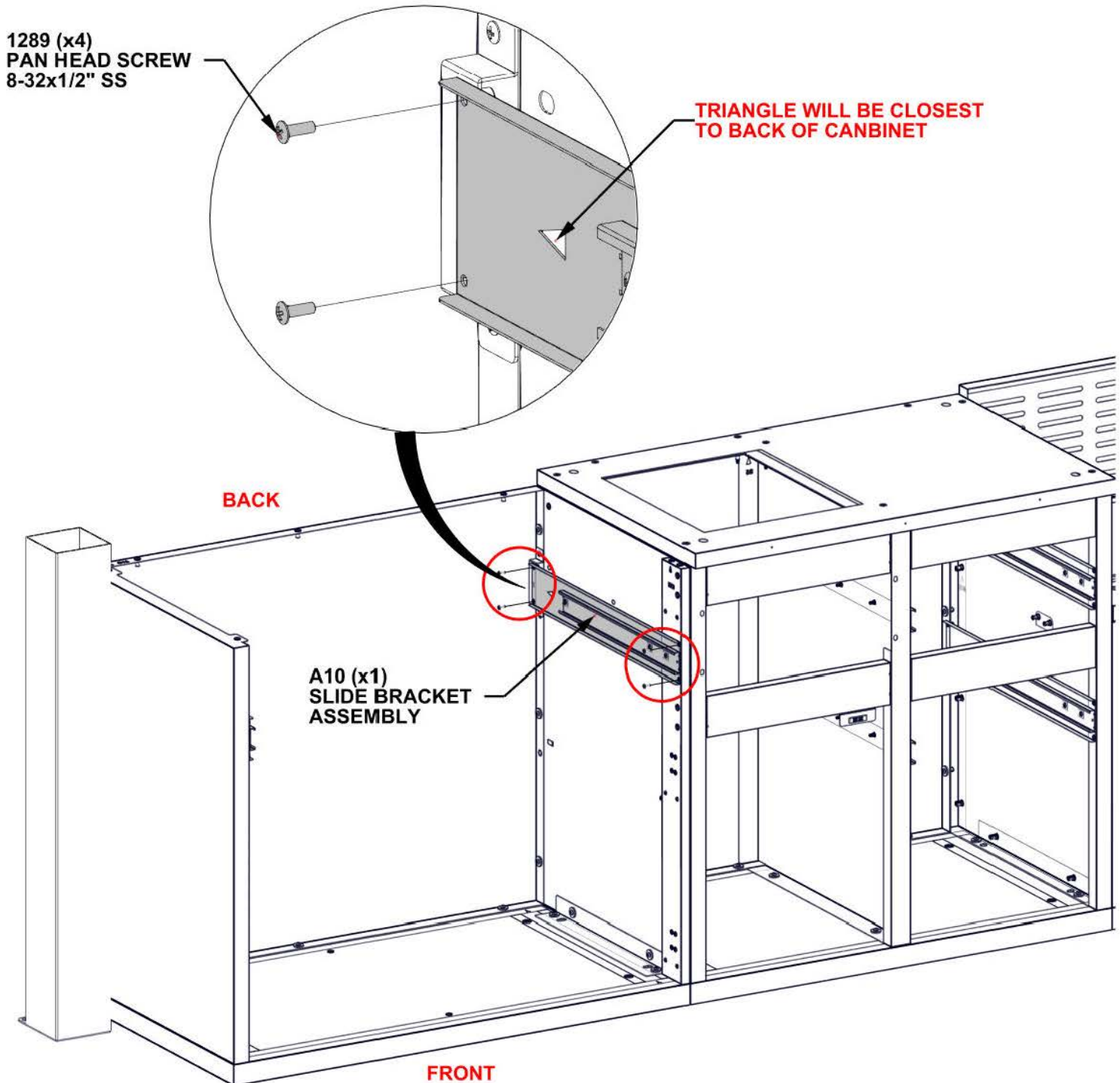

STEP 77 - STORAGE CABINET ASSEMBLY



QTY	PartNo	Description
2	H101202	TORX PAN HEAD 1/4-20x3/4 ASSY

S17 STORAGE CABINET SIDE PANEL ASSEMBLY M - A4M03690
 (x1) 33 3/8"x23 3/8"x1 3/8" (35.00x593.20x847.20)

- ONLY KITCHEN CABINETS ARE SHOWN FOR DETAIL.

1202 (x2)
 TORX PAN HEAD
 1/4-20x3/4 ASSY

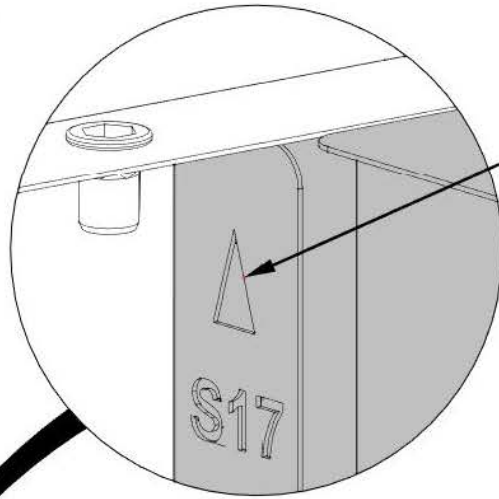
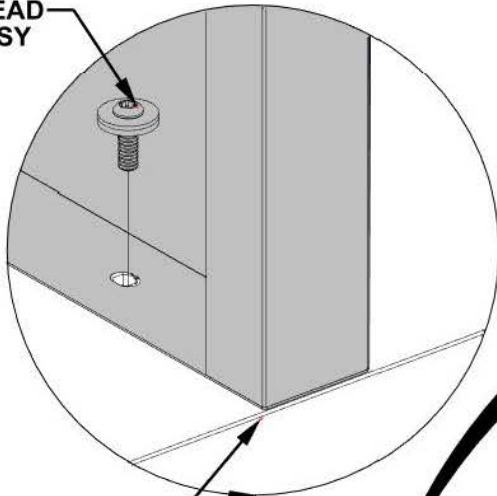

S17 LABEL INDICATES
 TOP OF SIDE PANEL

FLUSH FRONT
 SURFACE

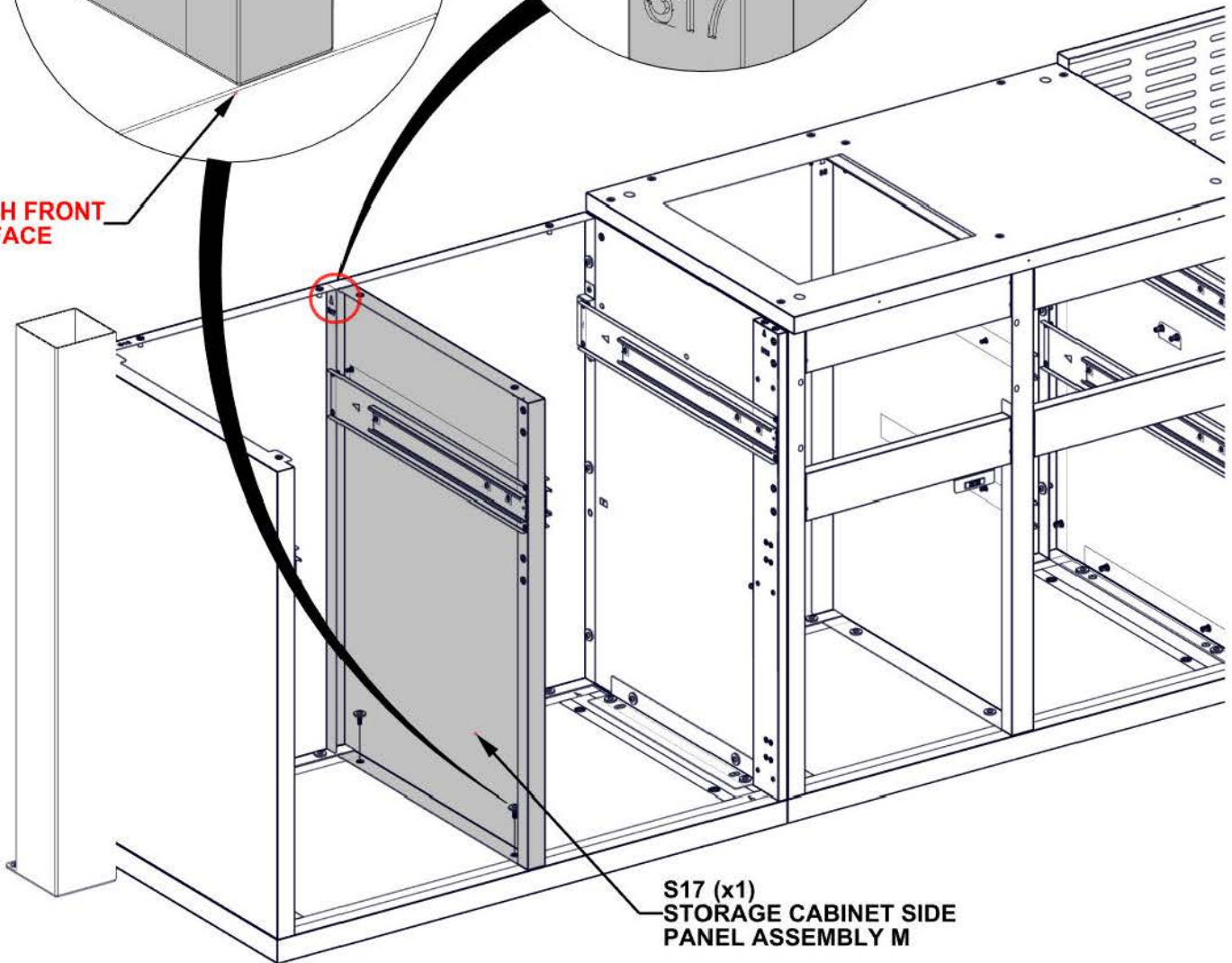

S17 (x1)
 STORAGE CABINET SIDE
 PANEL ASSEMBLY M

STEP 78 - STORAGE CABINET ASSEMBLY

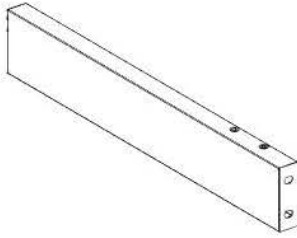

QTY	PartNo	Description
16	H101202	TORX PAN HEAD 1/4-20x3/4 ASSY

H12 HORIZONTAL BEAM ASSEMBLY - A4M03695
(x4) 18 1/4"x2 15/16"x1" (25.00x75.00x464.00)

- ONLY KITCHEN CABINETS ARE SHOWN FOR DETAIL.
- **HARDWARE ATTACHES ON INSIDE OF CABINET**

1202 (x16)
TORX PAN HEAD
1/4-20x3/4 ASSY

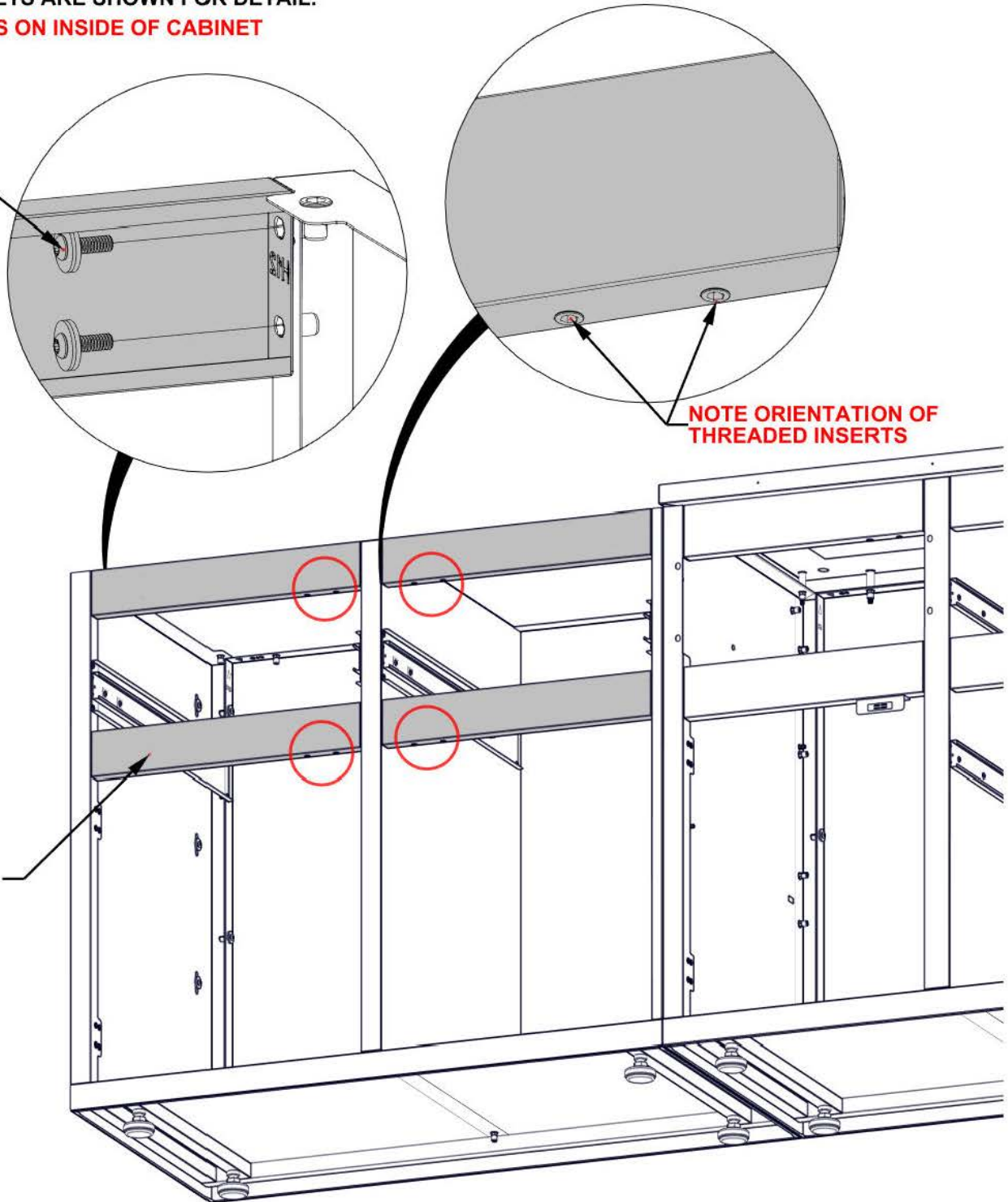

**NOTE ORIENTATION OF
THREADED INSERTS**

H12 (x4)
HORIZONTAL BEAM
ASSEMBLY

STEP 79 - STORAGE CABINET ASSEMBLY

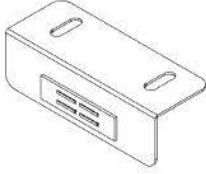

QTY	PartNo	Description
4	H101289	PAN HEAD SCREW 8-32x1/2" SS

A2 MAGNET BRACKET - A4M03026
(x2) 1"x1 1/4"x3 1/8" (25x31x80)

- ONLY KITCHEN CABINETS ARE SHOWN FOR DETAIL.

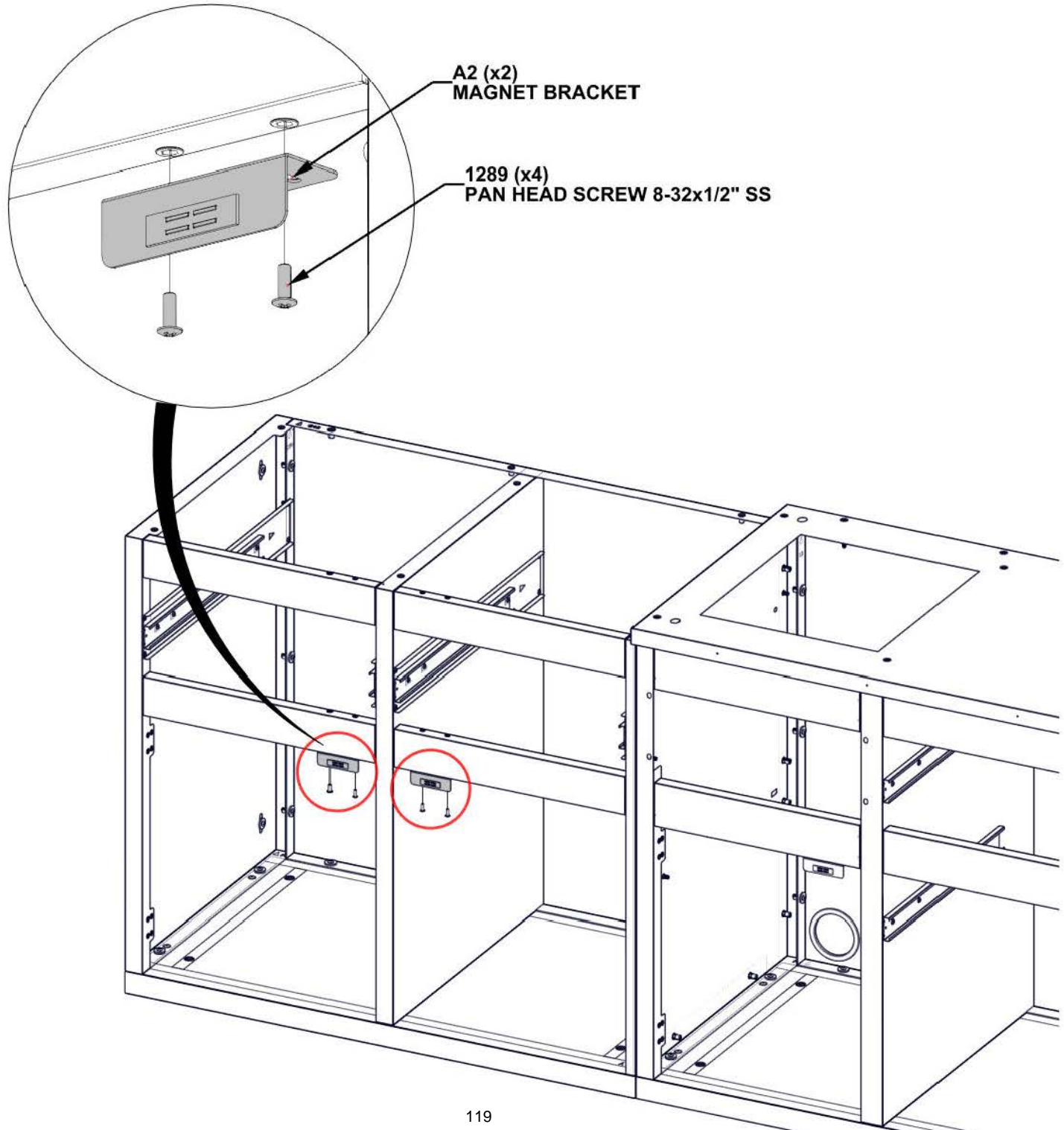

STEP 80 - STORAGE CABINET ASSEMBLY

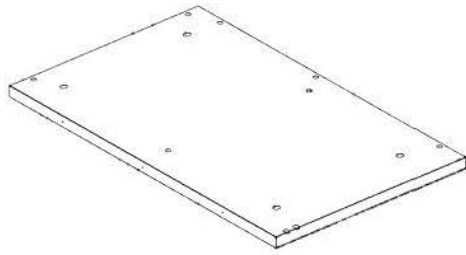

QTY	PartNo	Description
9	H101103	TORX SOCKET SCREW 1/4-20

T12 STORAGE CABINET TABLETOP ASSEMBLY - A4M03693
 (x1) 39 7/16"x24 1/8"x1 1/4" (32.00x612.00x1001.00)

- ONLY KITCHEN CABINETS ARE SHOWN FOR DETAIL.
- SQUARE ALL SIDES OF CABINET BEFORE TIGHTENING HARDWARE.

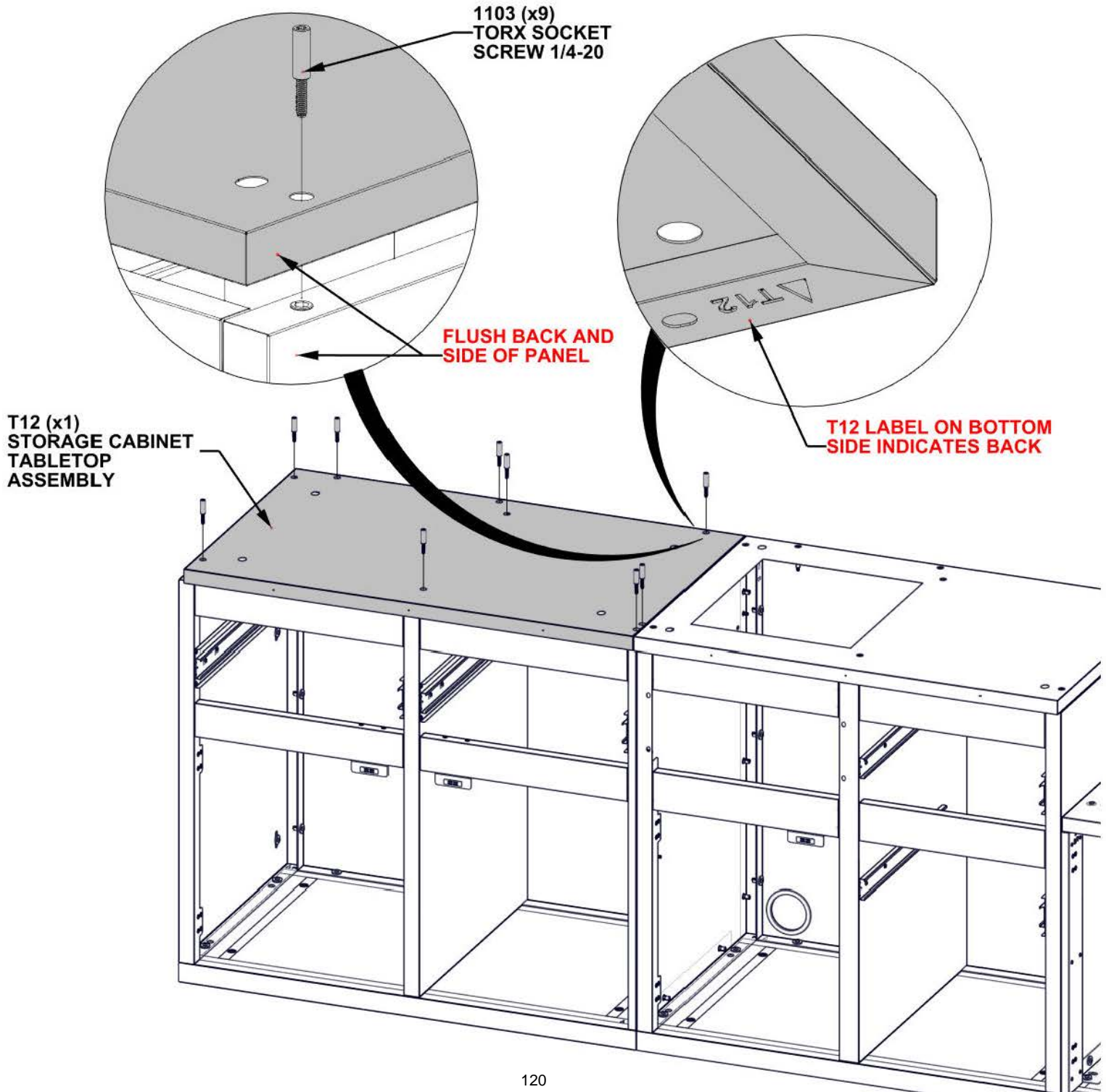

STEP 81 - SINK CABINET FALSE PANEL ASSEMBLY

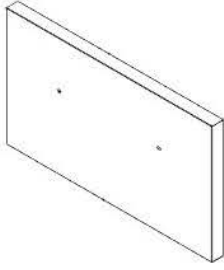

D5 SINK CABINET TRIM PANEL ASSEMBLY - A4M03576
 (x1) 17 13/16"x10 1/4"x1" (26.00x260.00x452.00)

QTY	PartNo	Description
2	H101289	PAN HEAD SCREW 8-32x1/2" SS

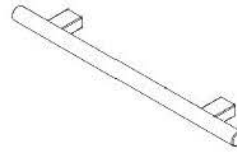

H2 STAINLESS STEEL HANDLE - A4M03024
 (x1) 5/8"x1 9/16"x11 13/16" (16x40x300)

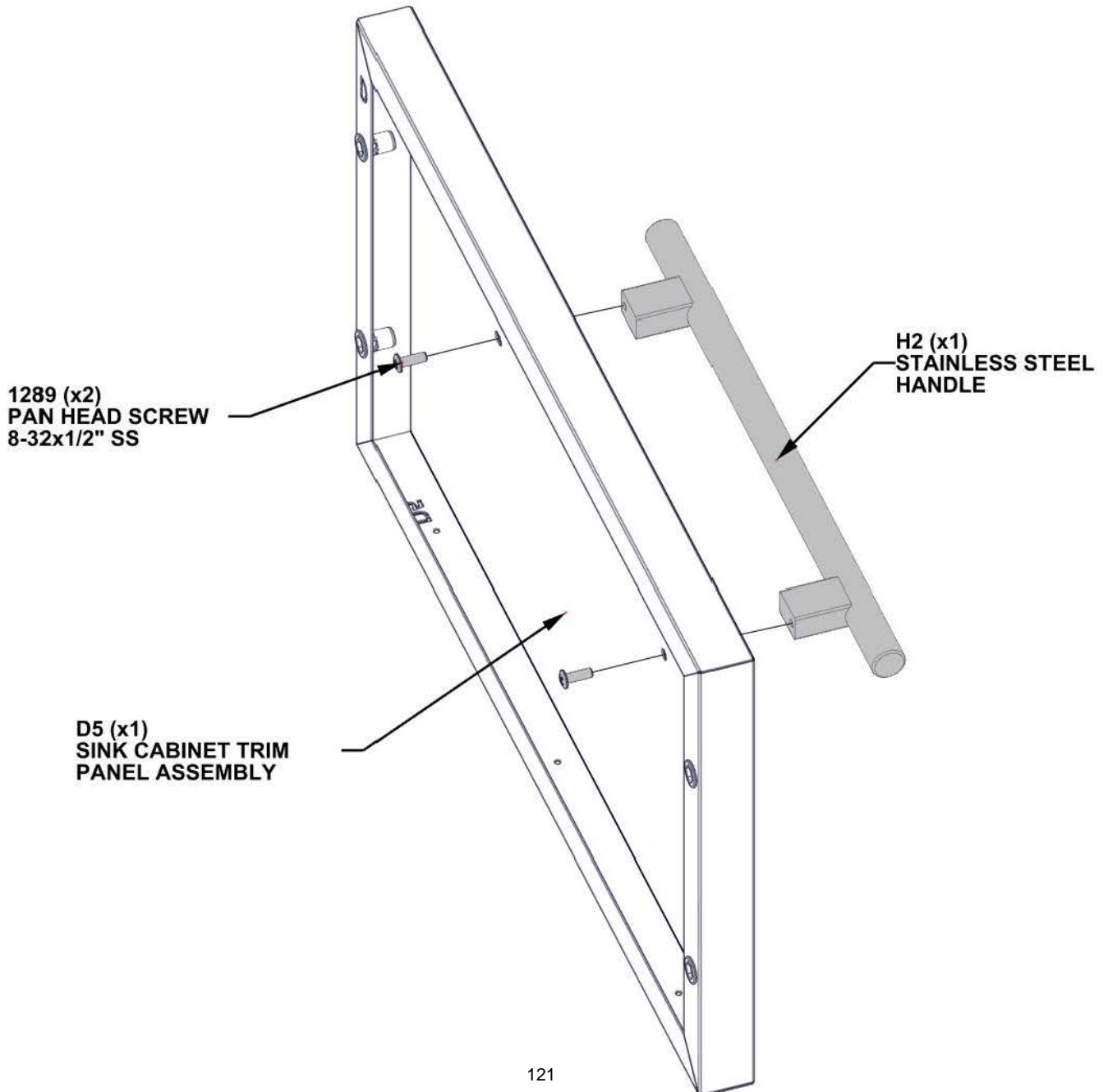

STEP 82 - SINK CABINET FALSE PANEL ATTACHMENT

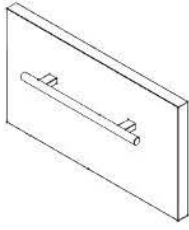

FALSE PANEL ASSEMBLY
FROM STEP 81

QTY	PartNo	Description
4	H101202	TORX PAN HEAD 1/4-20x3/4 ASSY

- ONLY KITCHEN CABINETS ARE SHOWN FOR DETAIL.
- **HARDWARE ATTACHES ON INSIDE OF CABINET.**

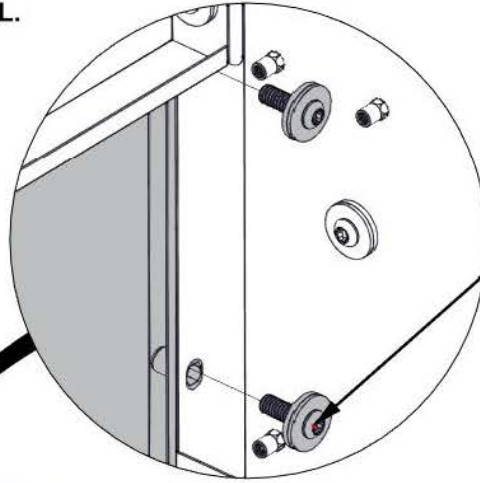

1202 (x4)
TORX PAN HEAD
1/4-20x3/4 ASSY

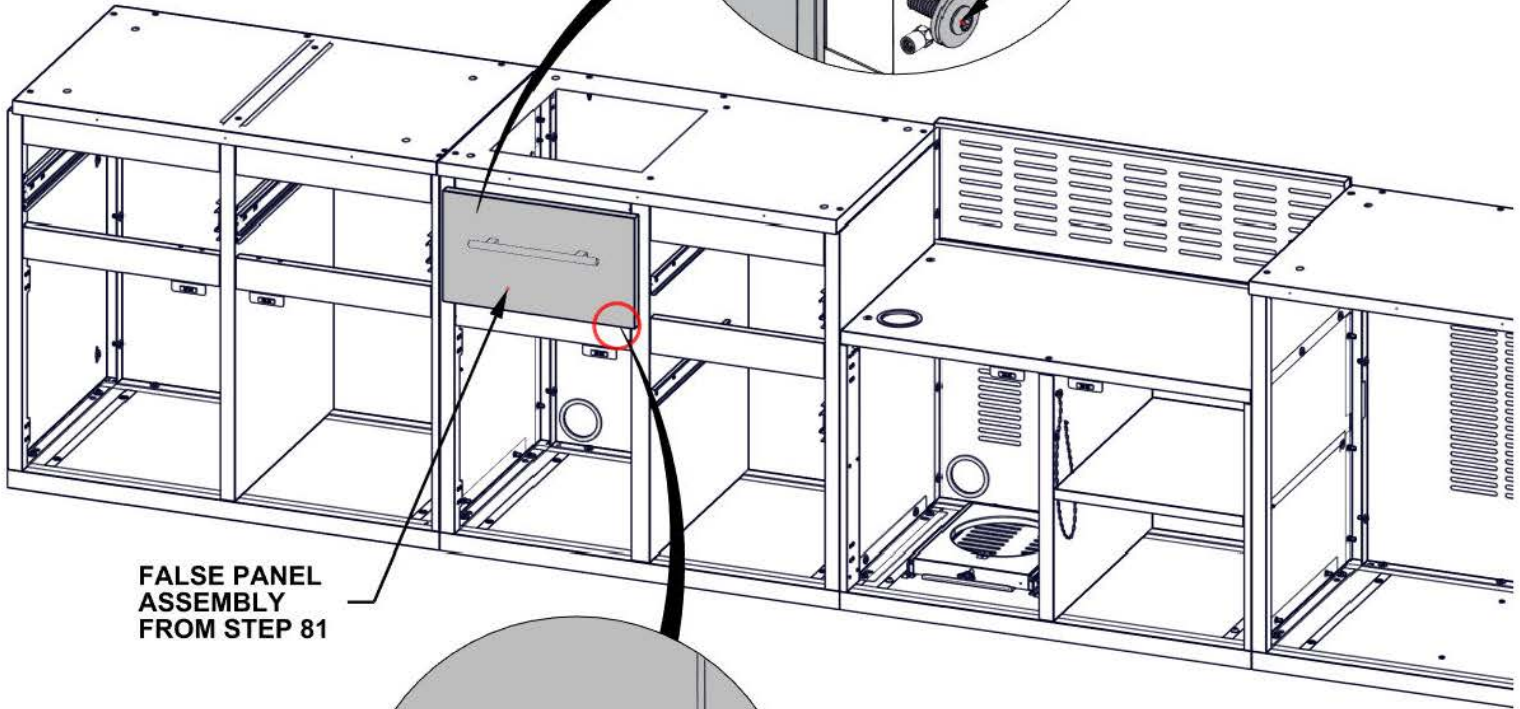

FALSE PANEL
ASSEMBLY
FROM STEP 81

**D5 LABEL INDICATES
BOTTOM OF PANEL**

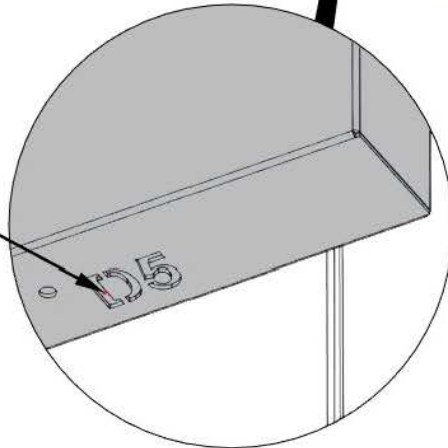

STEP 83A - SINK INSTALLATION

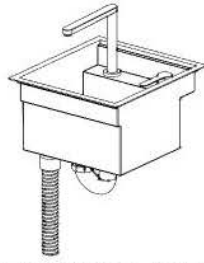

A16 SINK ASSEMBLY - A4M03143
(x1) 15 1/8"x15 5/16"x16 7/8" (384x389x429)

1. INSTALLING THE SINK DRAIN

- SET DRAIN INSIDE OF SINK BODY, PLACING FOAM GASKET BETWEEN SURFACES.
- FASTEN IN PLACE USING RUBBER GASKET AND DRAIN NUT FROM BOTTOM SIDE.

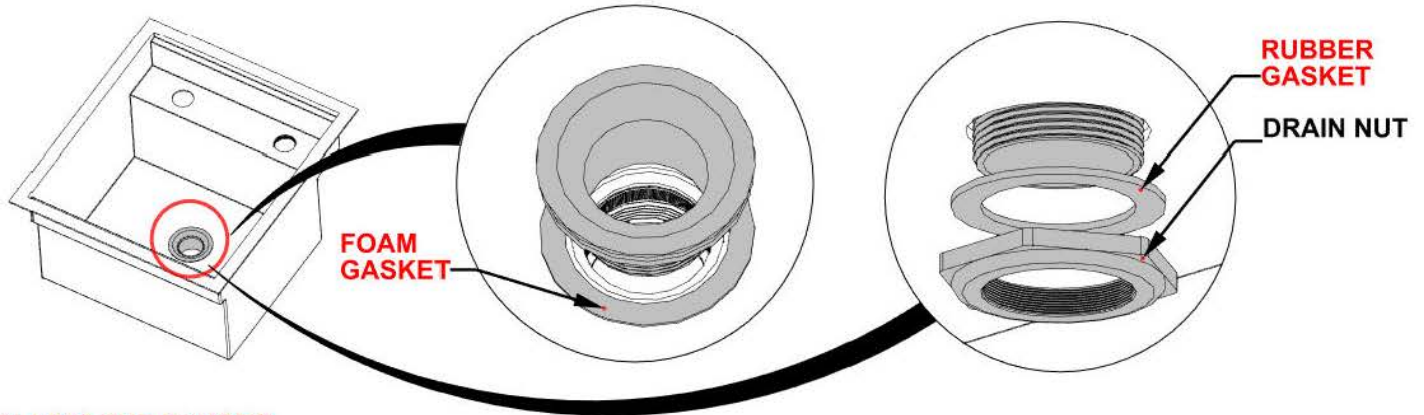

2. INSTALLING THE FAUCET

- INSTALL FAUCET BY PLACING HANDLE AND SPOUT INTO SINK OPENINGS AND SECURING IN PLACE VIA NUT.
- INSERT SCREWS TO LOCK.
- CONNECT WATER FAUCET LINES TOGETHER.

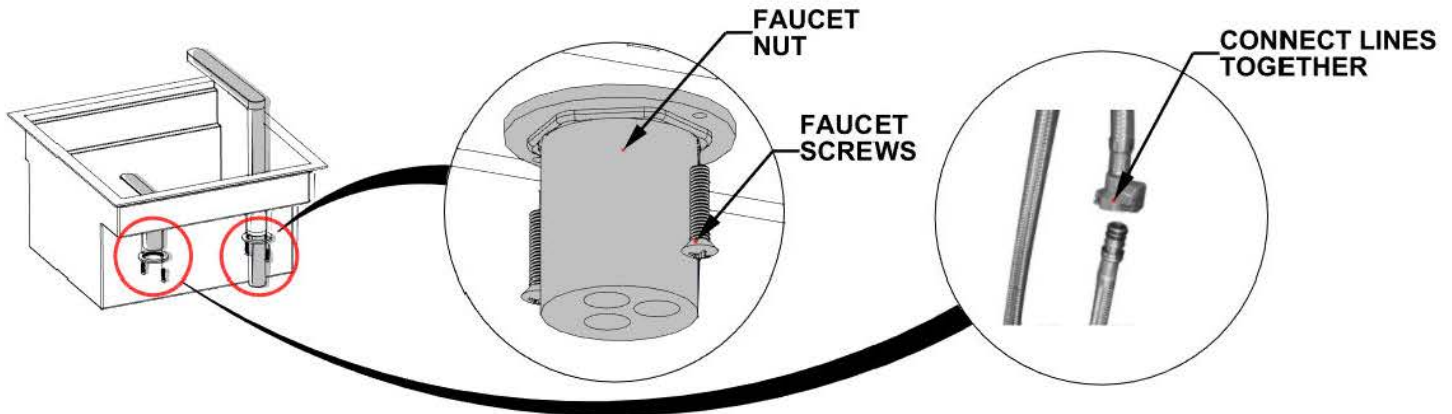

3. INSTALLING THE DRAIN FITTING

- ATTACH DRAIN FITTING TO SINK DRAIN.

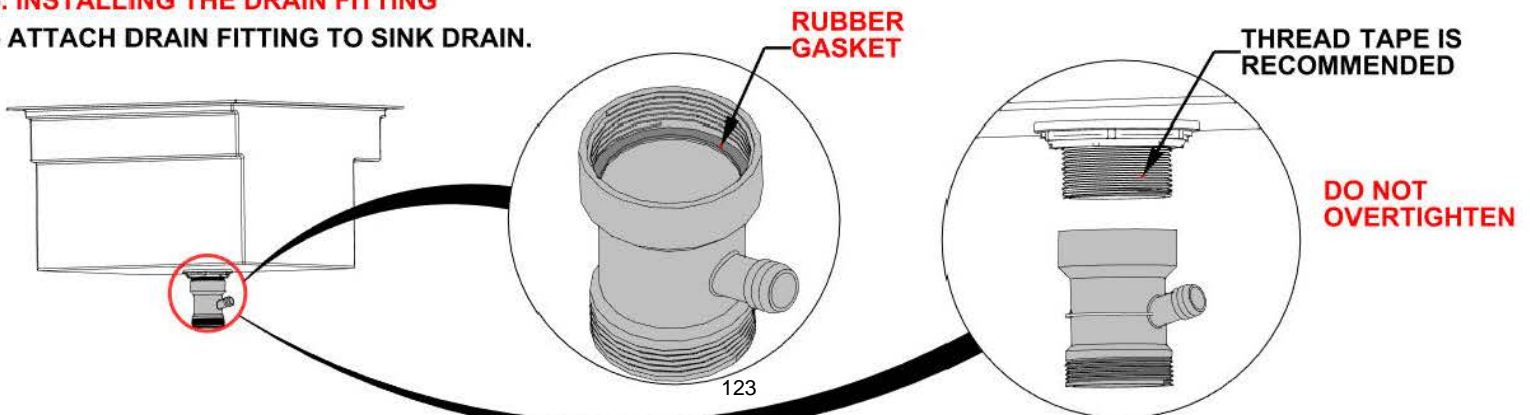

STEP 83B - SINK INSTALLATION

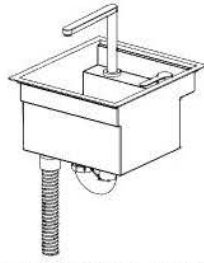

A16 SINK ASSEMBLY - A4M03143
(x1) 15 1/8"x15 5/16"x16 7/8" (384x389x429)

4. INSTALLING THE OVERFLOW DRAIN

- MAKE SURE RUBBER GASKET IS INSTALLED IN OVERFLOW DRAIN.
- INSERT DRAIN SCREW TO HOLD IN PLACE.

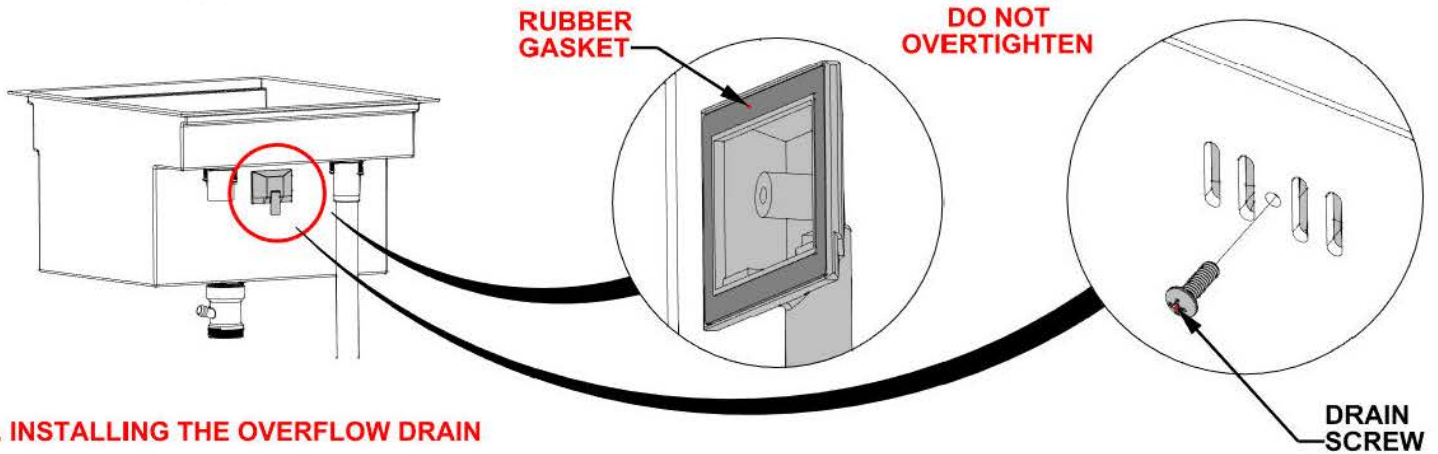

5. INSTALLING THE OVERFLOW DRAIN

- ATTACH OVERFLOW DRAIN BY CONNECTING EACH END AS SHOWN.

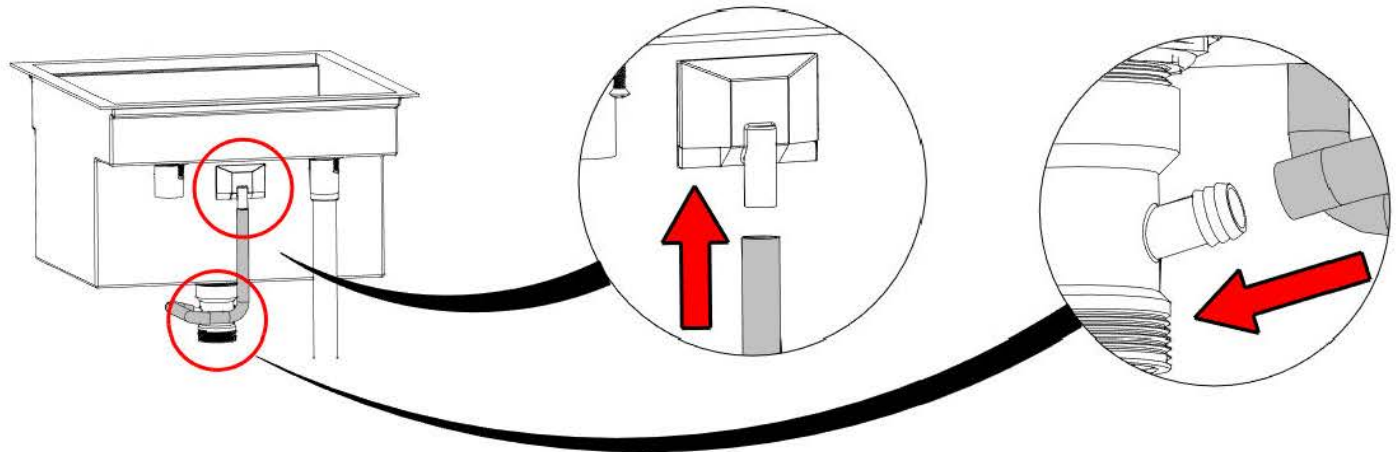

6. INSTALLING THE MAIN DRAIN AND TRAP

- ATTACH TRAP AND CORRUGATED DRAIN HOSE TO DRAIN FITTING.

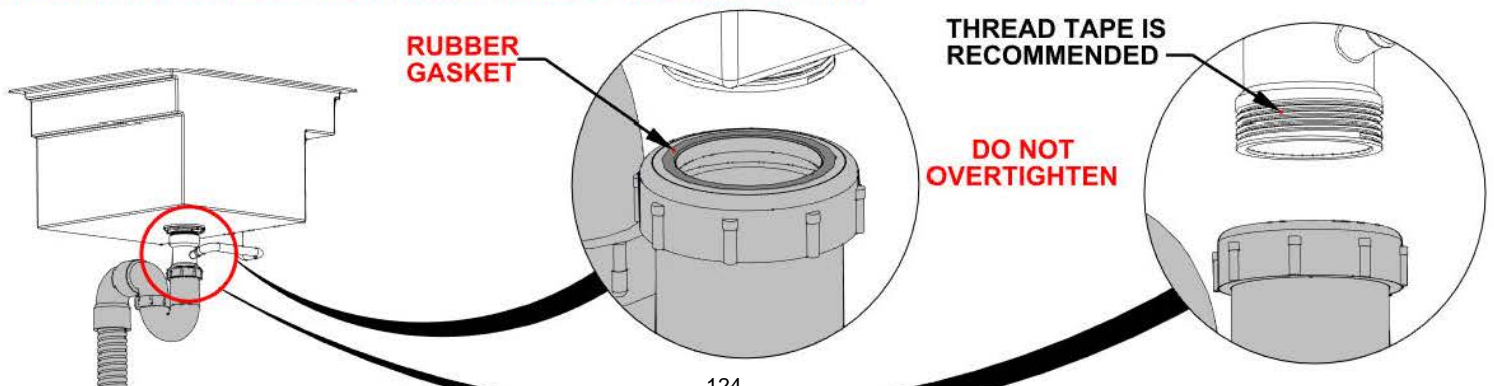

STEP 83C - SINK INSTALLATION

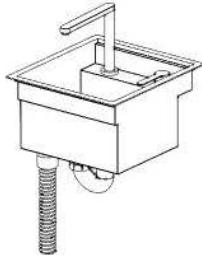

A16 SINK ASSEMBLY - A4M03143
(x1) 15 1/8"x15 5/16"x16 7/8" (384x389x429)



A4M03151 GARDEN HOSE ADAPTER
(x1)

- DRAIN STRAINER MUST BE USED WHEN DISCARDING FOOD INSIDE OF SINK.
- DO NOT LET SOLID MATERIAL ENTER SINK BASIN.

OPTIONS FOR WATER INLET SUPPLY HOOKUP:

- GARDEN HOSE ATTACHMENT USING PROVIDED ADAPTER
- WATER INLET SUPPLY LINE

OPTIONS FOR DRAIN DISCHARGE:

- BUCKET OR GREY WATER CONTAINER
- FRENCH DRAIN OR DRY BASIN
- INTEGRATED SEWER SYSTEM
- CHECK YOUR LOCAL REQUIREMENTS.

IT IS RECOMMENDED TO APPLY A FINE BEAD OF SILICONE, TO UNDERNEATH SIDE OF ALL SINK FLANGES BEFORE INSTALLING

ATTACH ADAPTER TO INLET LINE AND TIGHTEN WITH WRENCH

3151 (x1)
GARDEN HOSE
ADAPTER

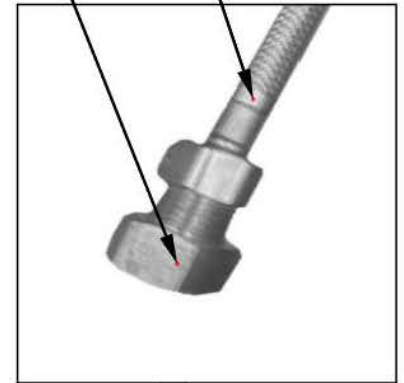

A16 (x1)
SINK ASSEMBLY

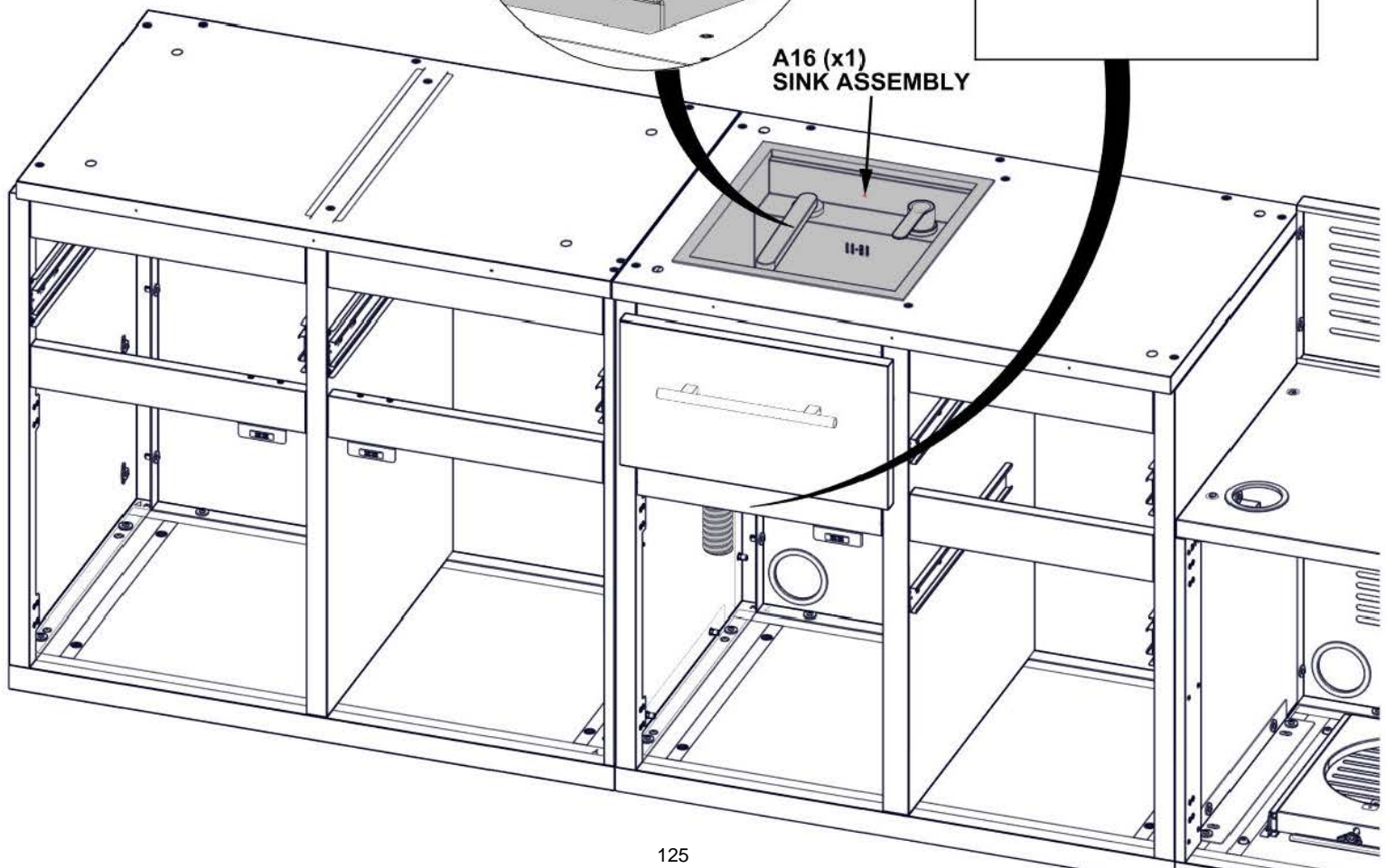

STEP 84A - FRIDGE CABINET MARBLE INSTALLATION

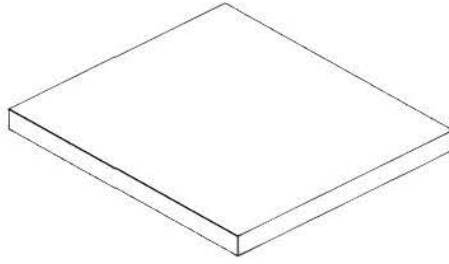

M3 FRIDGE CABINET MARBLE - A4M03602
(x1) 28 1/8"x24 15/16"x1 15/16" (50x634x715)

- ONLY KITCHEN CABINETS ARE SHOWN FOR DETAIL.
- IT IS RECOMMENDED TO HAVE AT LEAST TWO PEOPLE SET MARBLE COUNTERTOP IN PLACE.
- SLIDE IN PLACE UNTIL MARBLE IS TIGHT AGAINST POST AND SIDES ARE FLUSH WITH PANEL.
- **WHEN SETTING MARBLE IN PLACE, MAKE SURE YOUR FINGERS ARE CLEAR AND NOT UNDERNEATH MARBLE.**

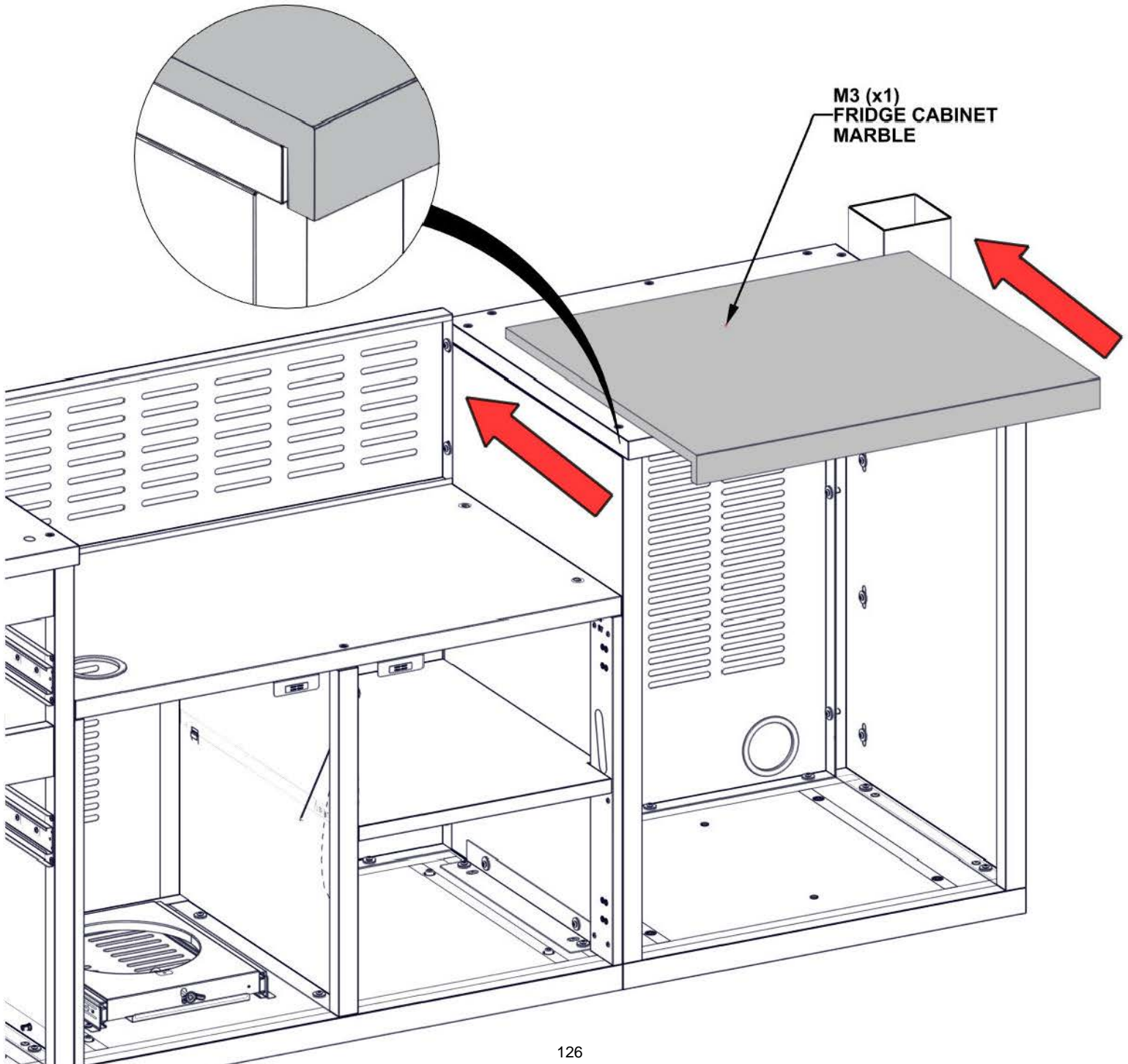

STEP 84B - FRIDGE CABINET MARBLE INSTALLATION

QTY	PartNo	Description
4	H101292	TORX PAN HEAD 1/4-20x13/32"
4	H101054	SEALANT WASHER
4	H101053	STEEL WASHER 6x20

- ONLY KITCHEN CABINETS ARE SHOWN FOR DETAIL.
- MAKE SURE YOU ARE USING THE CORRECT HARDWARE FOR THIS STEP.
- ONCE MARBLE IS IN PLACE, IT IS RECOMMENDED TO COVER WITH A PIECE OF CARDBOARD OR FOAM UNTIL ASSEMBLY IS FINISHED TO PREVENT DAMAGE.
- DO NOT USE MARBLE SURFACE AS A WORK BENCH.

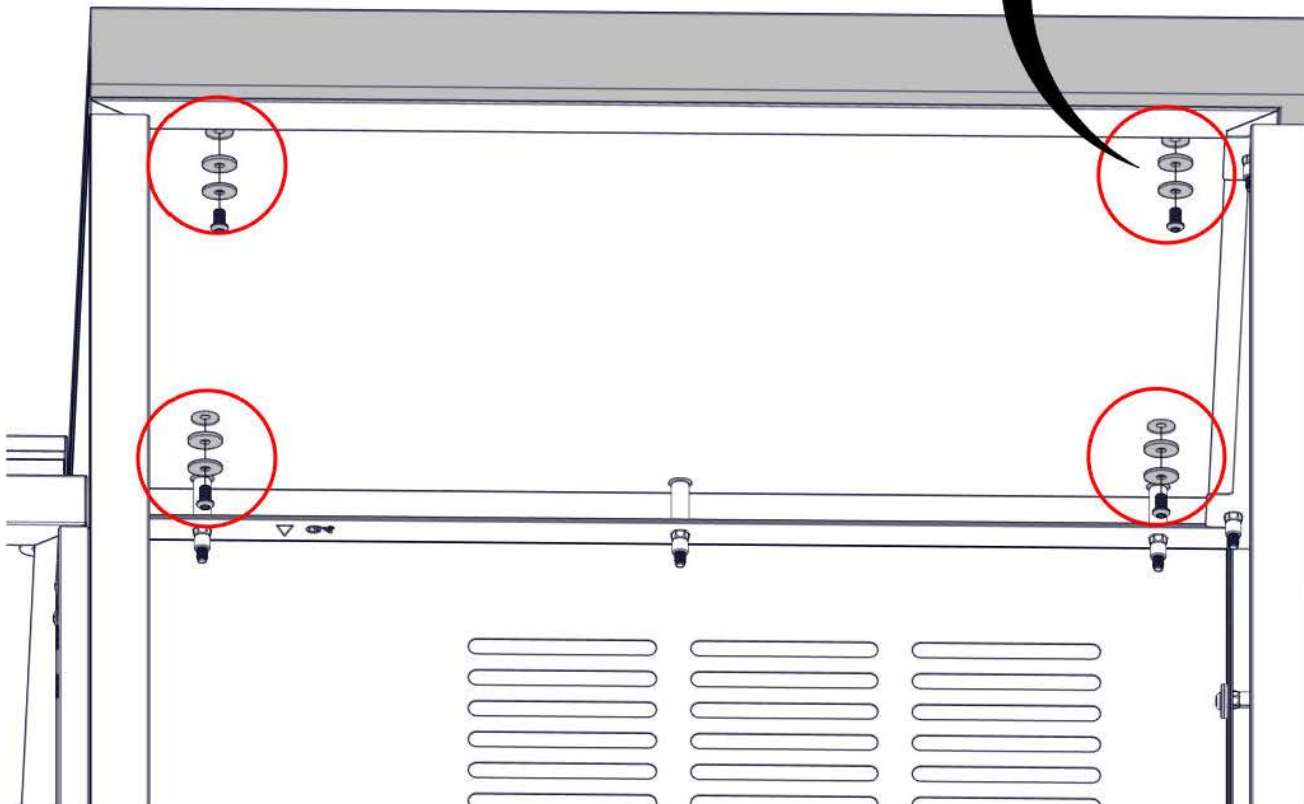
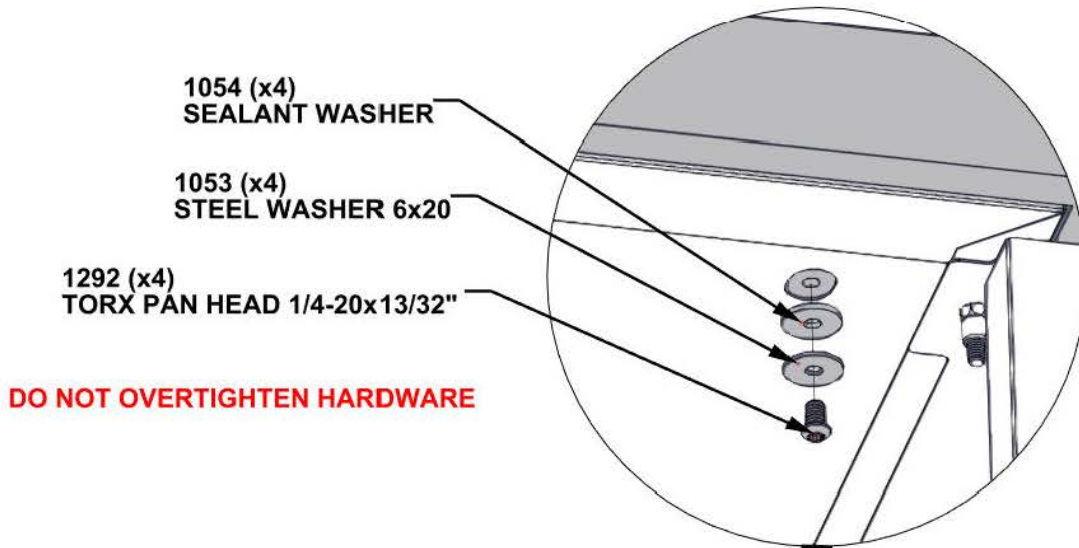

STEP 85A - SINK CABINET MARBLE INSTALLATION

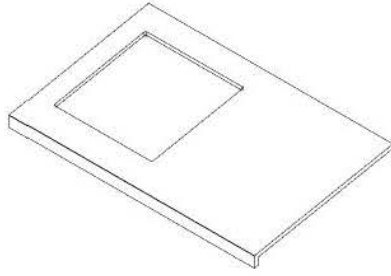

M7 SINK CABINET MARBLE - A4M03655
(x1) 37 3/16"x24 15/16"x1 15/16" (50x634x944)

- ONLY KITCHEN CABINETS ARE SHOWN FOR DETAIL.
- IT IS RECOMMENDED TO HAVE AT LEAST TWO PEOPLE SET MARBLE COUNTERTOP IN PLACE.
- SLIDE IN PLACE UNTIL MARBLE IS TIGHT AGAINST PANEL AND SIDES ARE FLUSH WITH PANEL.
- **WHEN SETTING MARBLE IN PLACE, MAKE SURE YOUR FINGERS ARE CLEAR AND NOT UNDERNEATH MARBLE.**

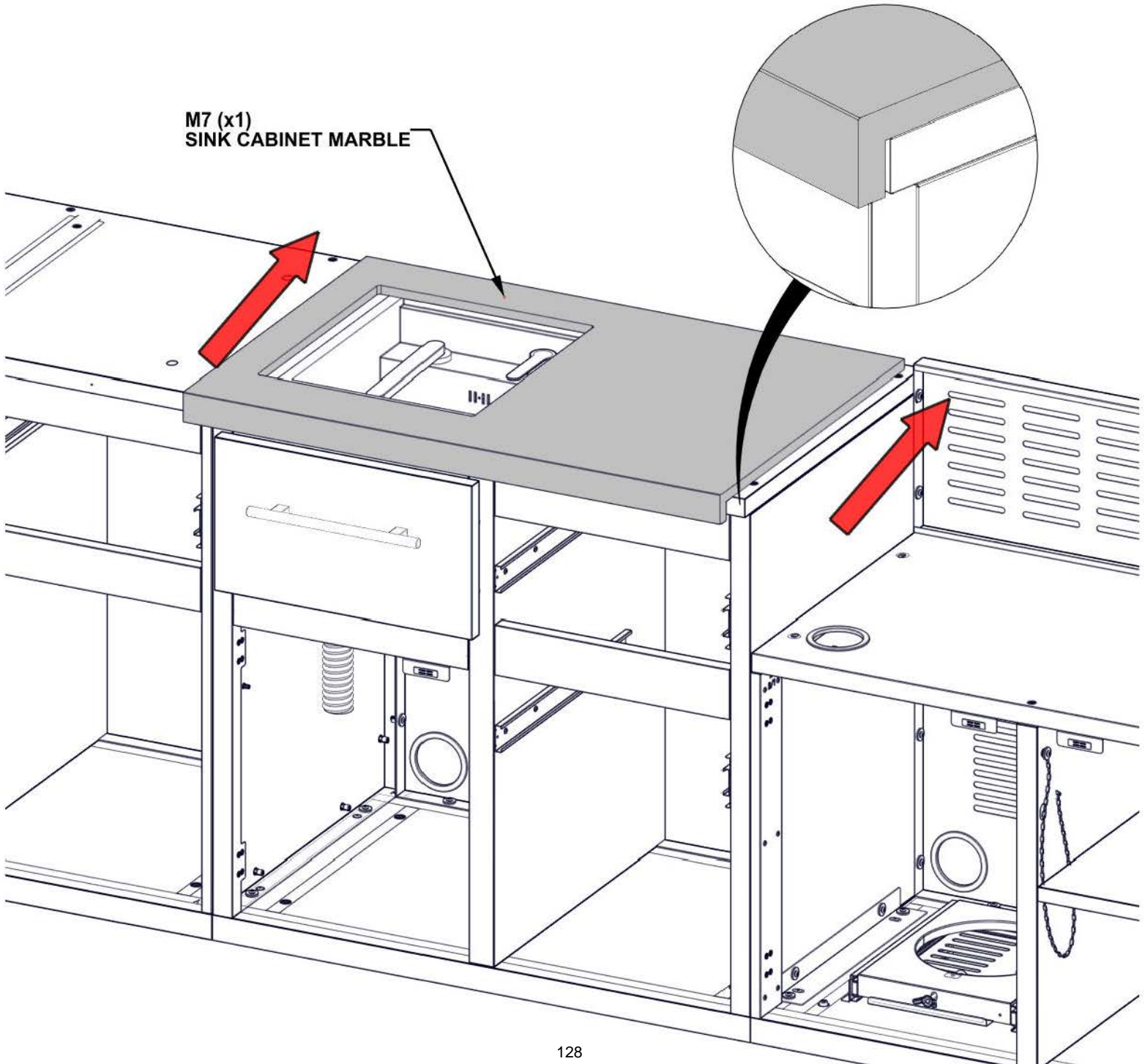

STEP 85B - SINK CABINET MARBLE INSTALLATION

QTY	PartNo	Description
4	H101292	TORX PAN HEAD 1/4-20x13/32"
4	H101054	SEALANT WASHER
4	H101053	STEEL WASHER 6x20

- ONLY KITCHEN CABINETS ARE SHOWN FOR DETAIL.
- IT IS RECOMMENDED TO USE THE 6" MAGNETIC DRIVER EXTENSION PROVIDED IN YOUR HARDWARE KIT FOR THIS STEP.
- MAKE SURE YOU ARE USING THE CORRECT HARDWARE FOR THIS STEP.
- ONCE MARBLE IS IN PLACE, IT IS RECOMMENDED TO COVER WITH A PIECE OF CARDBOARD OR FOAM UNTIL ASSEMBLY IS FINISHED TO PREVENT DAMAGE.
- DO NOT USE MARBLE SURFACE AS A WORK BENCH.

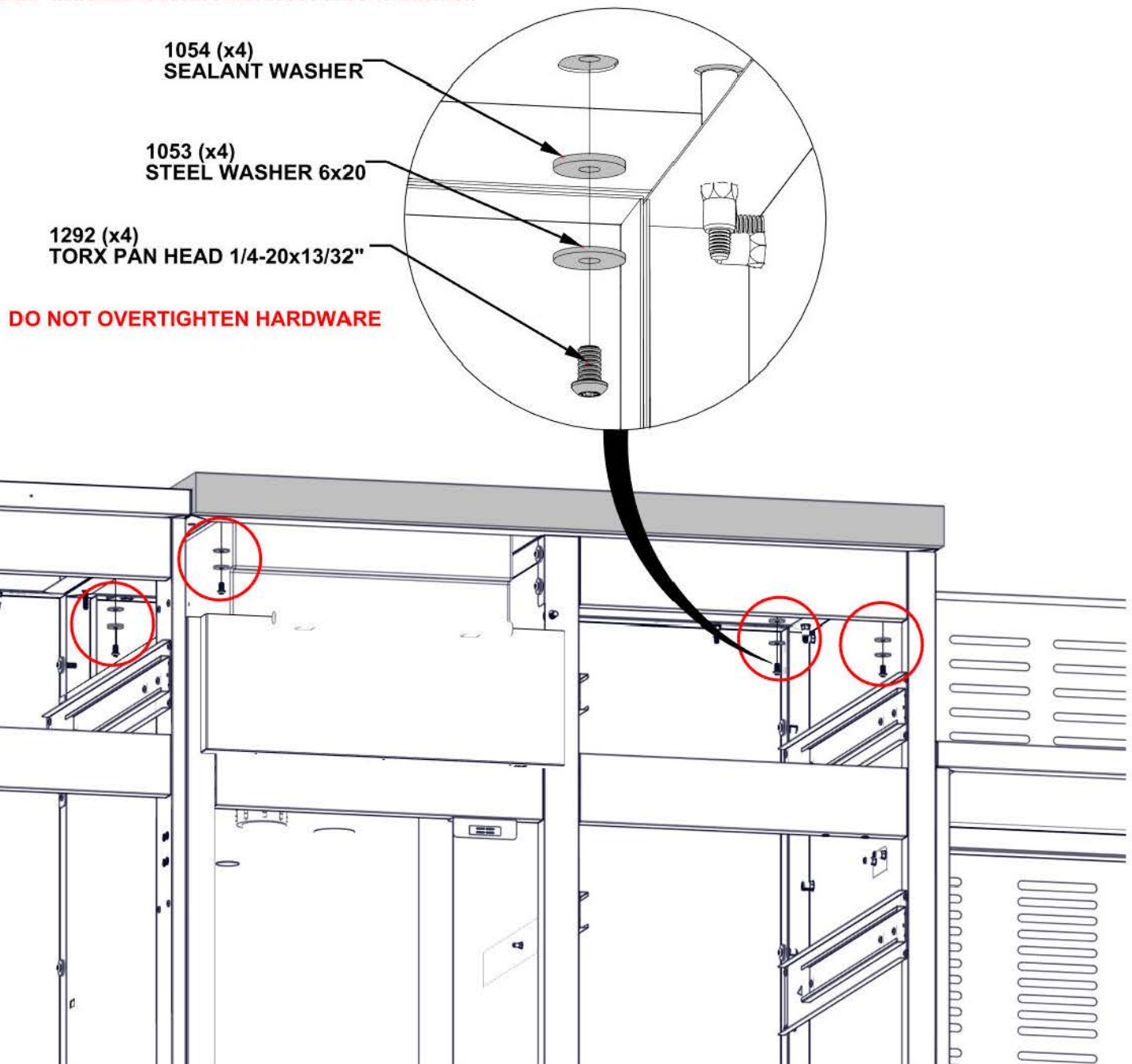

STEP 86 - SINK CABINET MARBLE INSTALLATION

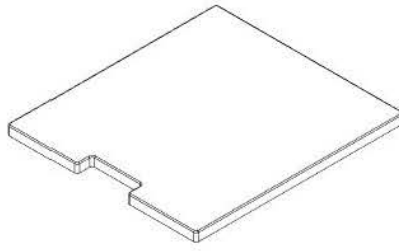

M5 SINK COVER MARBLE - A4M03147
(x1) 11/16"x14 3/4"x16 5/16" (18x375x415)

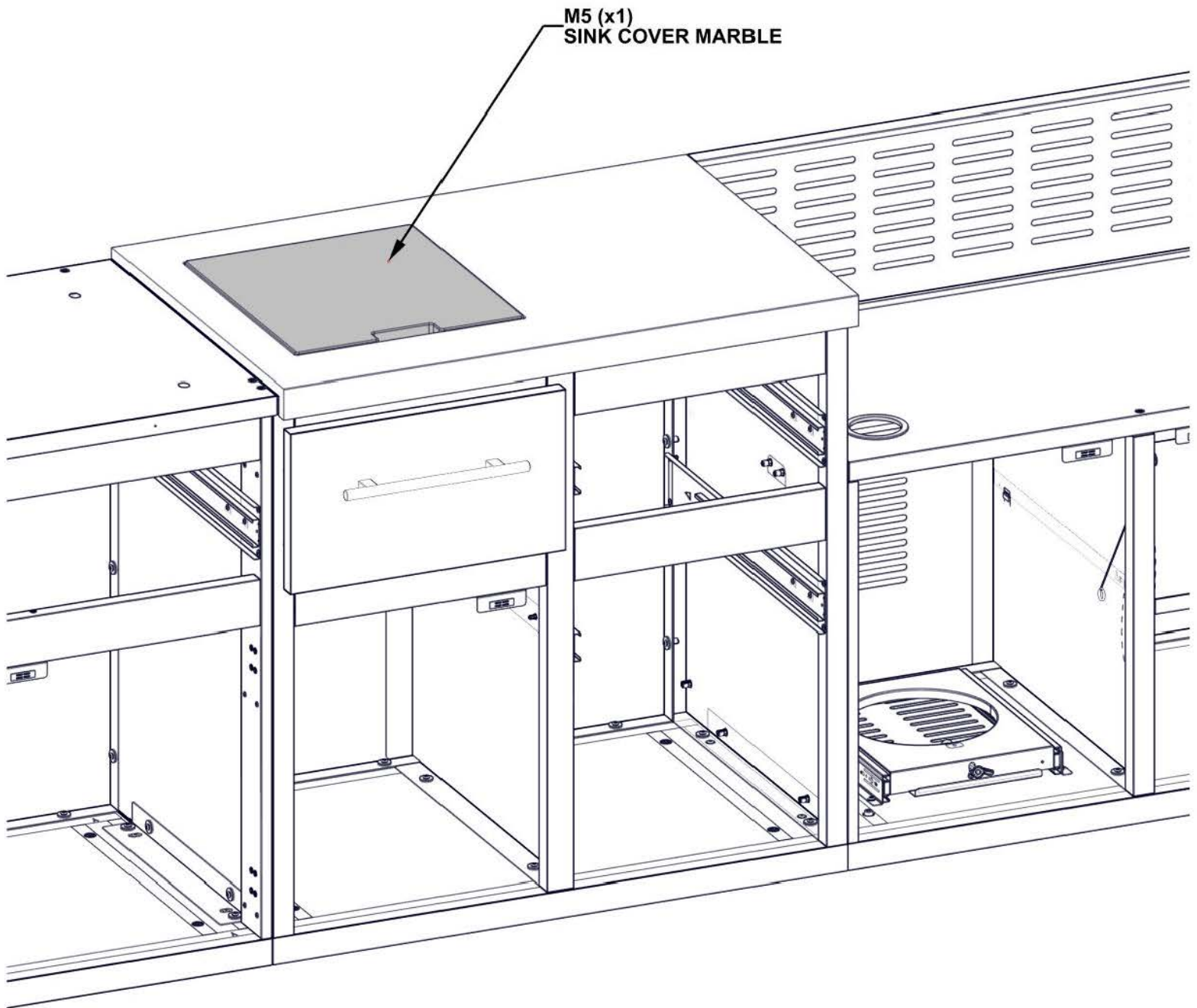

M5 (x1)
SINK COVER MARBLE

STEP 87A - STORAGE CABINET MARBLE INSTALLATION

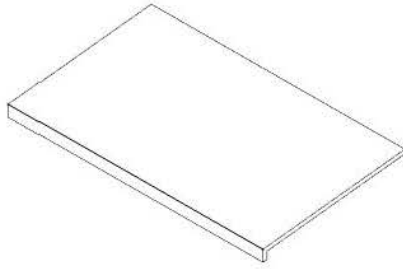

M10 STORAGE CABINET MARBLE - A4M03694
(x1) 40 3/16"x24 15/16"x1 15/16" (50x634x1020)

- ONLY KITCHEN CABINETS ARE SHOWN FOR DETAIL.
- IT IS RECOMMENDED TO HAVE AT LEAST TWO PEOPLE SET MARBLE COUNTERTOP IN PLACE.
- SLIDE IN PLACE UNTIL MARBLE IS TIGHT AGAINST POST AND SIDES ARE FLUSH WITH PANEL.
- **WHEN SETTING MARBLE IN PLACE, MAKE SURE YOUR FINGERS ARE CLEAR AND NOT UNDERNEATH MARBLE.**

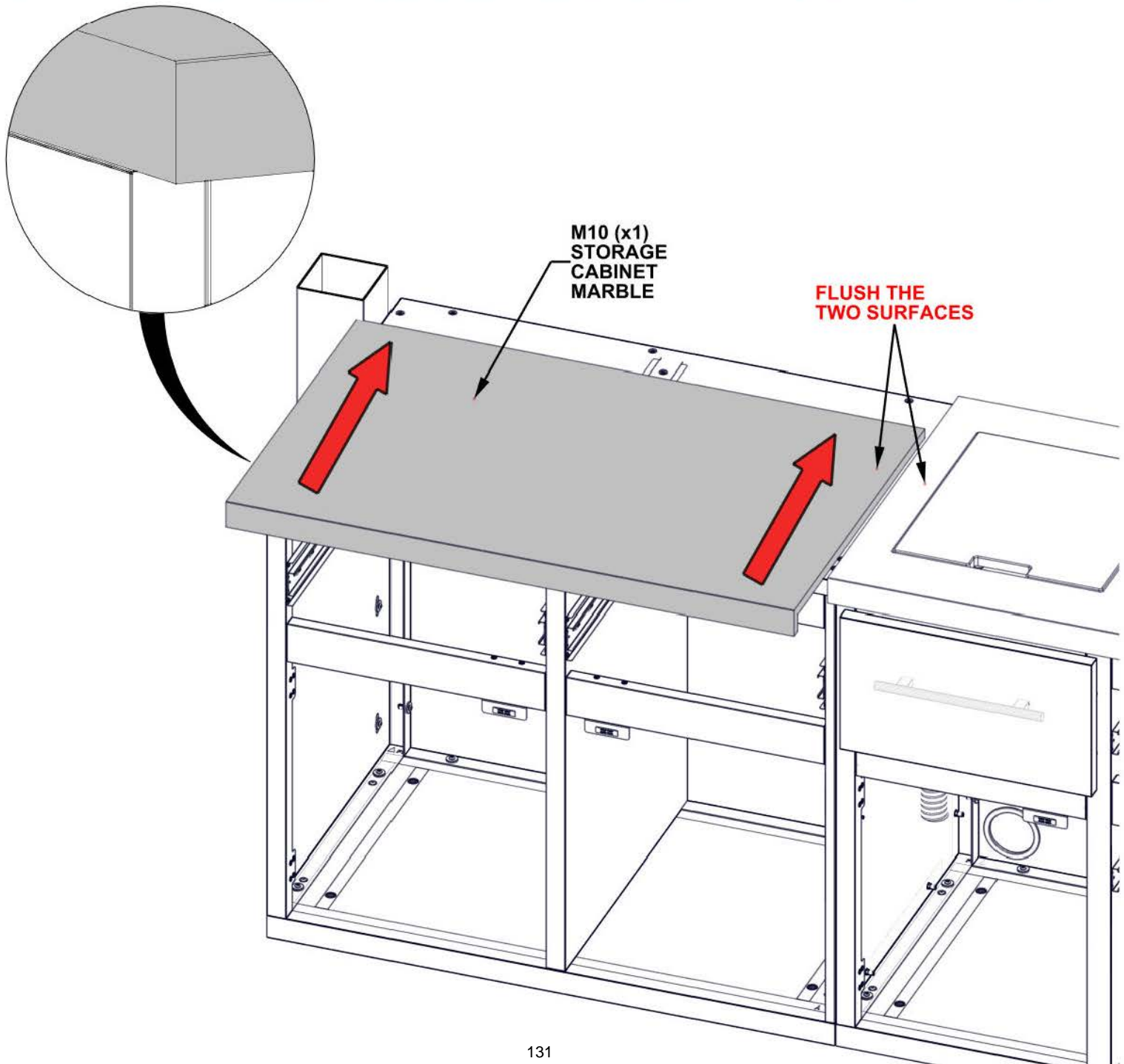

STEP 87B - STORAGE CABINET MARBLE INSTALLATION

QTY	PartNo	Description
4	H101292	TORX PAN HEAD 1/4-20x13/32"
4	H101054	SEALANT WASHER
4	H101053	STEEL WASHER 6x20

- ONLY KITCHEN CABINETS ARE SHOWN FOR DETAIL.

- MAKE SURE YOU ARE USING THE CORRECT HARDWARE FOR THIS STEP.

- ONCE MARBLE IS IN PLACE, IT IS RECOMMENDED TO COVER WITH A PIECE OF CARDBOARD OR FOAM UNTIL ASSEMBLY IS FINISHED TO PREVENT DAMAGE.

- DO NOT USE MARBLE SURFACE AS A WORK BENCH.

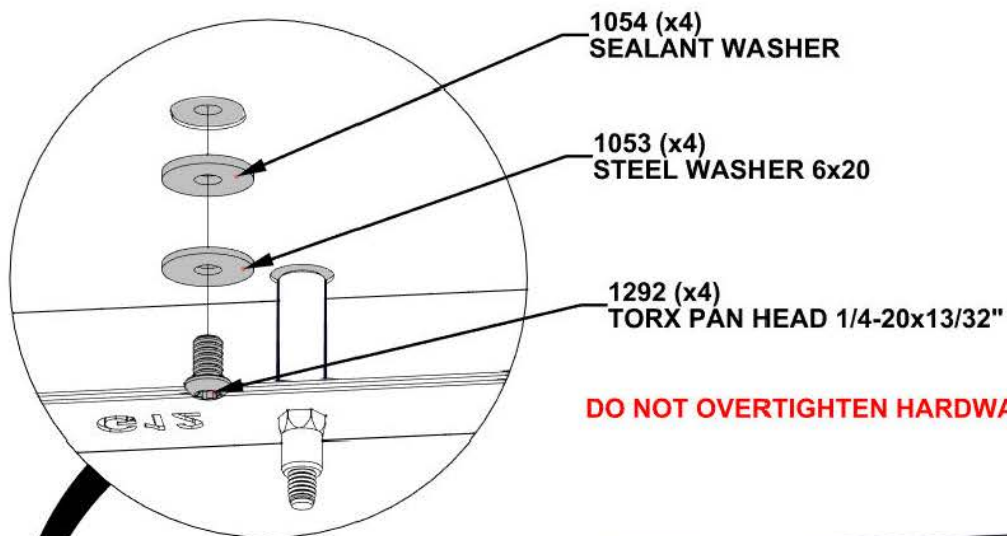

DO NOT OVERTIGHTEN HARDWARE

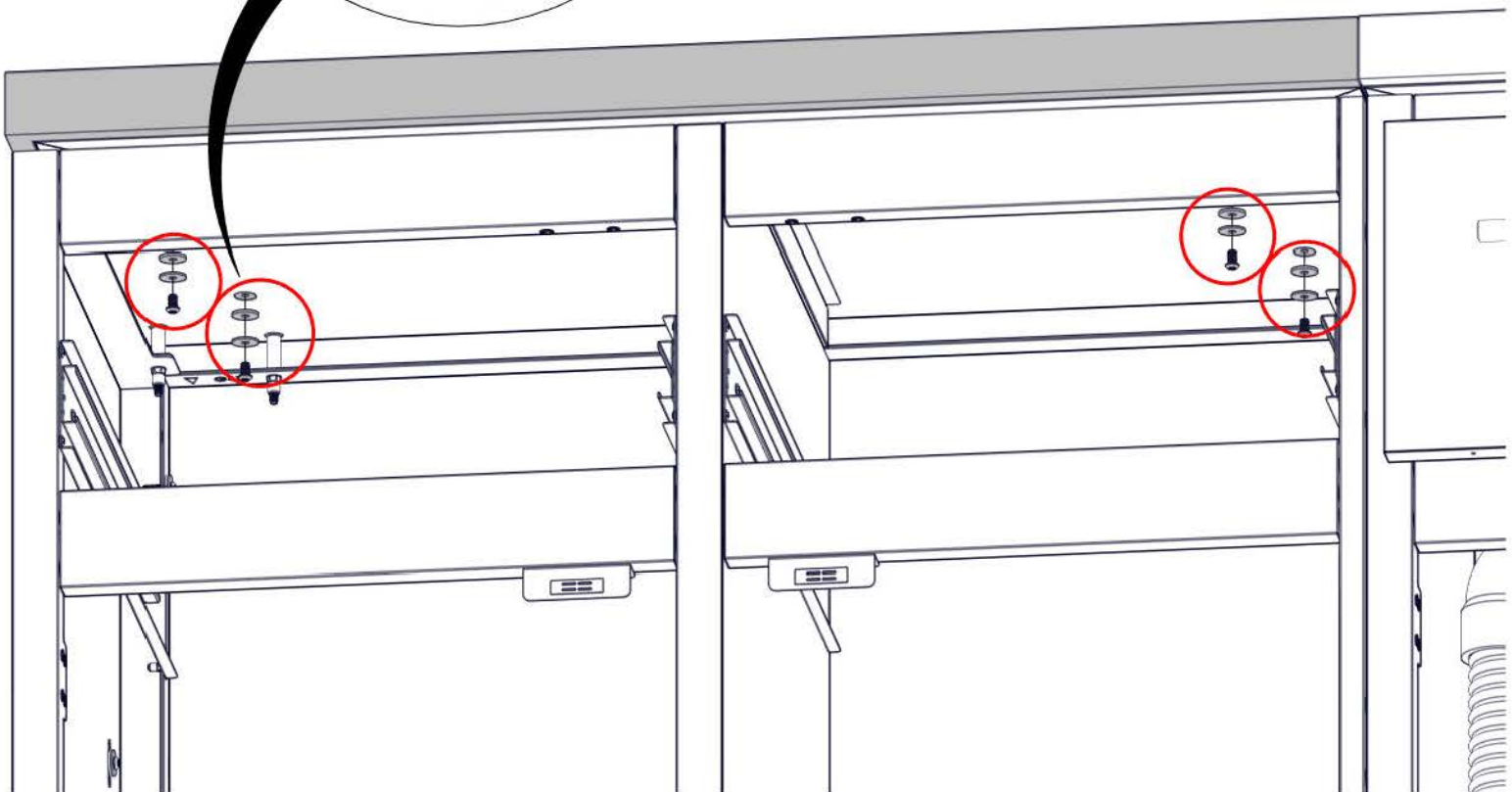

STEP 88A - KITCHEN TRASH CAN ASSEMBLY

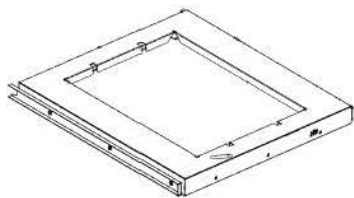

QTY	PartNo	Description
6	H101289	PAN HEAD SCREW 8-32x1/2" SS

H3 TRASH CAN BRACKET ASSEMBLY - A4M03610
(x1) 1 3/8"x18 1/16"x15 13/16" (35.00x401.60x458.00)

A11 TRIANGLE PANEL - A4M03086
(x2) 13/16"x13 3/4"x13 3/4" (20x350x350)

- IT IS RECOMMENDED TO USE THE 6" MAGNETIC DRIVER EXTENSION PROVIDED IN YOUR HARDWARE KIT FOR THIS STEP.

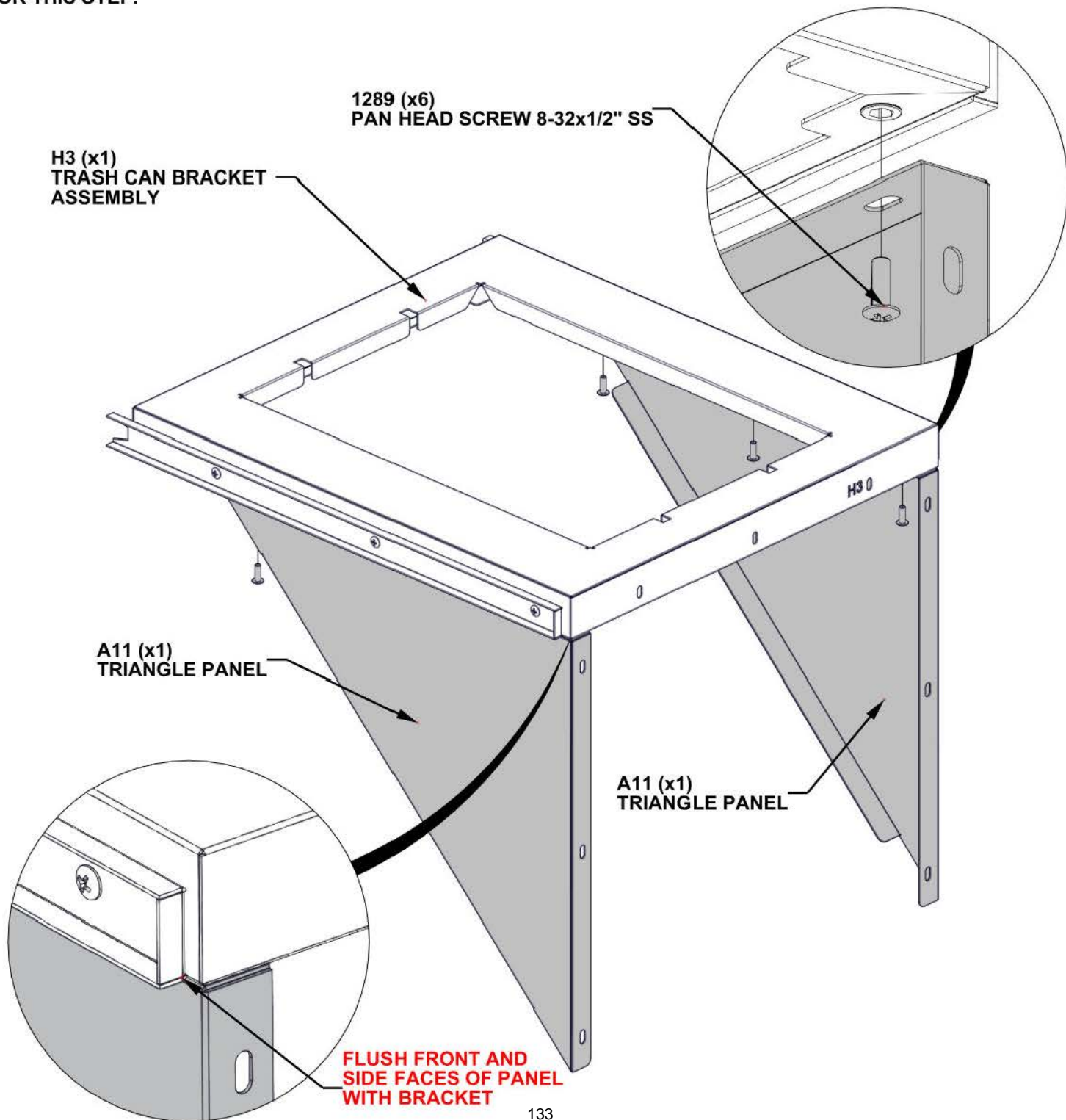

STEP 88B - KITCHEN TRASH CAN ASSEMBLY

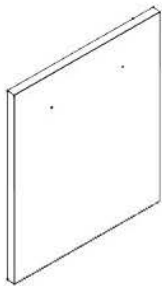

QTY	PartNo	Description
9	H101289	PAN HEAD SCREW 8-32x1/2" SS

D9 TRASH CAN PANEL ASSEMBLY - A4M03608
 (x1) 22 1/4"x17 3/4"x15/16" (24.00x451.00x565.00)

- IT IS RECOMMENDED TO USE THE 6" MAGNETIC DRIVER EXTENSION PROVIDED IN YOUR HARDWARE KIT FOR THIS STEP.

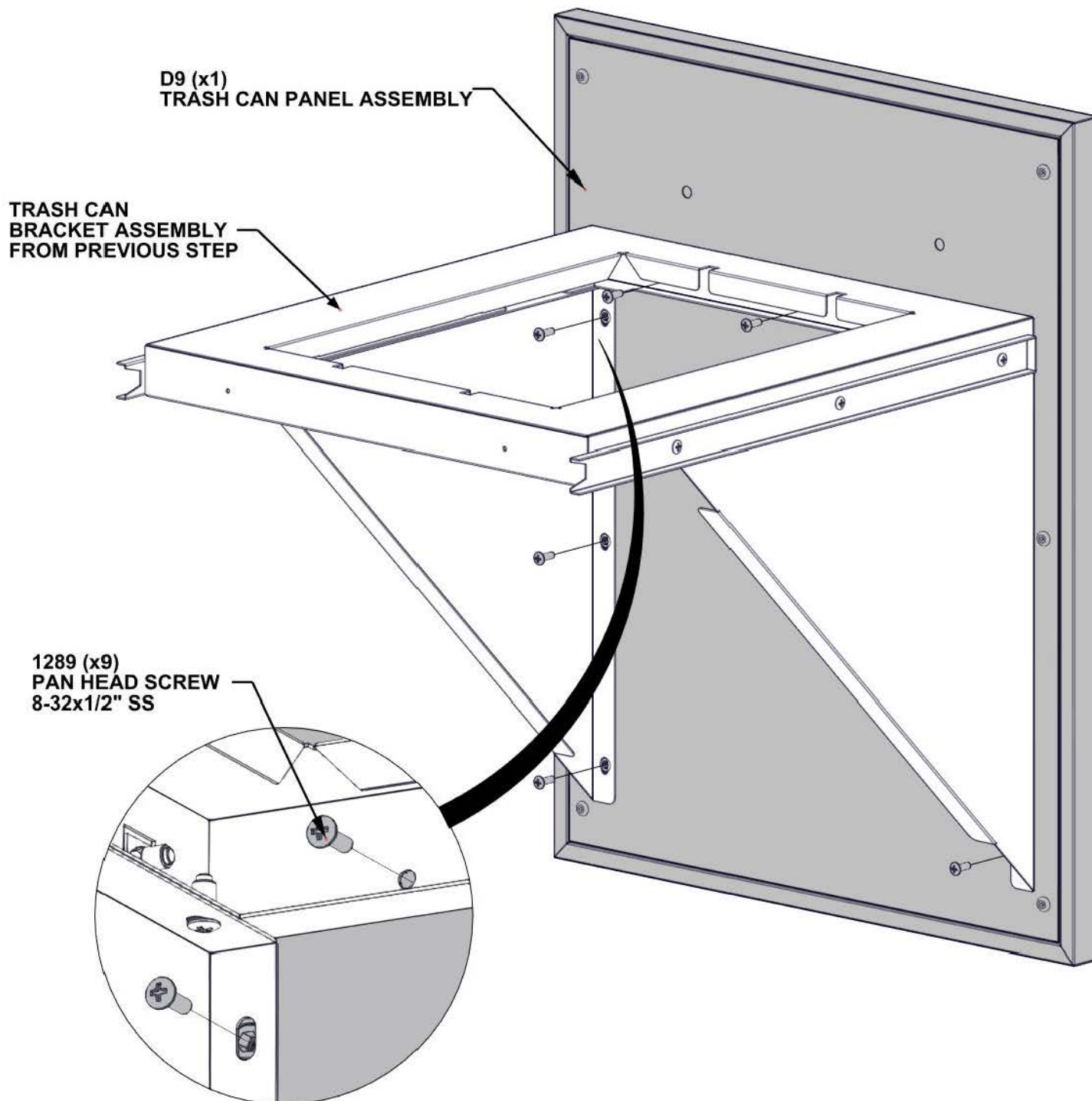

STEP 88C - KITCHEN TRASH CAN ASSEMBLY

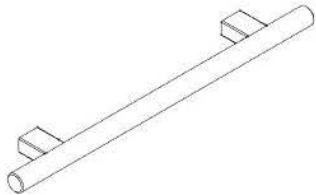

H2 STAINLESS STEEL HANDLE - A4M03024
(x1) 5/8"x1 9/16"x11 13/16" (16x40x300)

QTY	PartNo	Description
2	H101307	SHOULDER BOLT 8-32x30mm SS

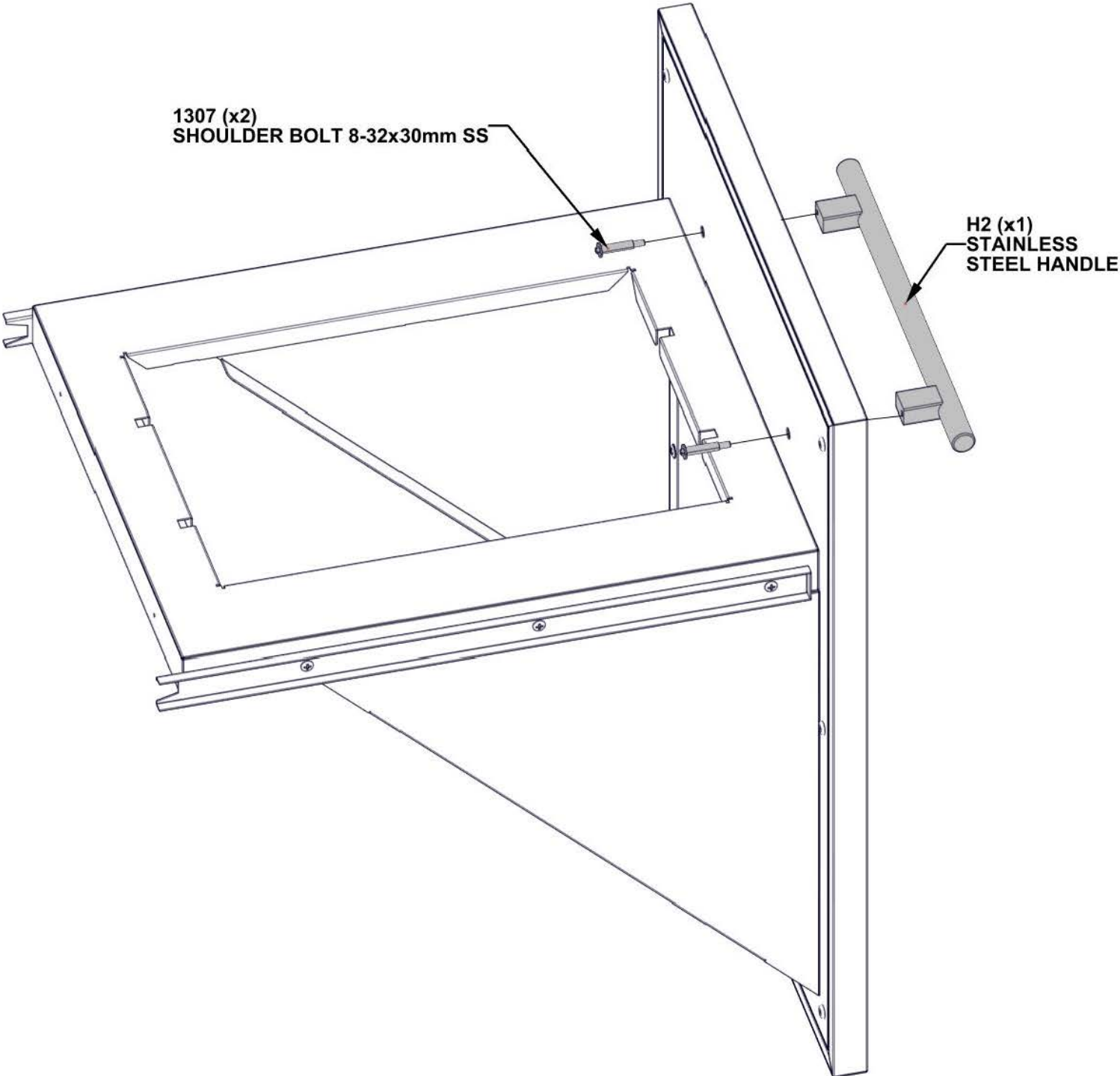

STEP 89 - KITCHEN TRASH CAN INSTALLATION



**TRASH CAN ASSEMBLY
STEPS 88A - 88C**

- ONLY KITCHEN CABINETS ARE SHOWN FOR DETAIL.
- ATTACH TRASH CAN ASSEMBLY BY ALIGNING BOTH ENDS OF FACTORY ASSEMBLED DRAWER SLIDES WITH ONE ANOTHER.
- PRESS TOGETHER UNTIL DRAWER SLIDES CONNECT.

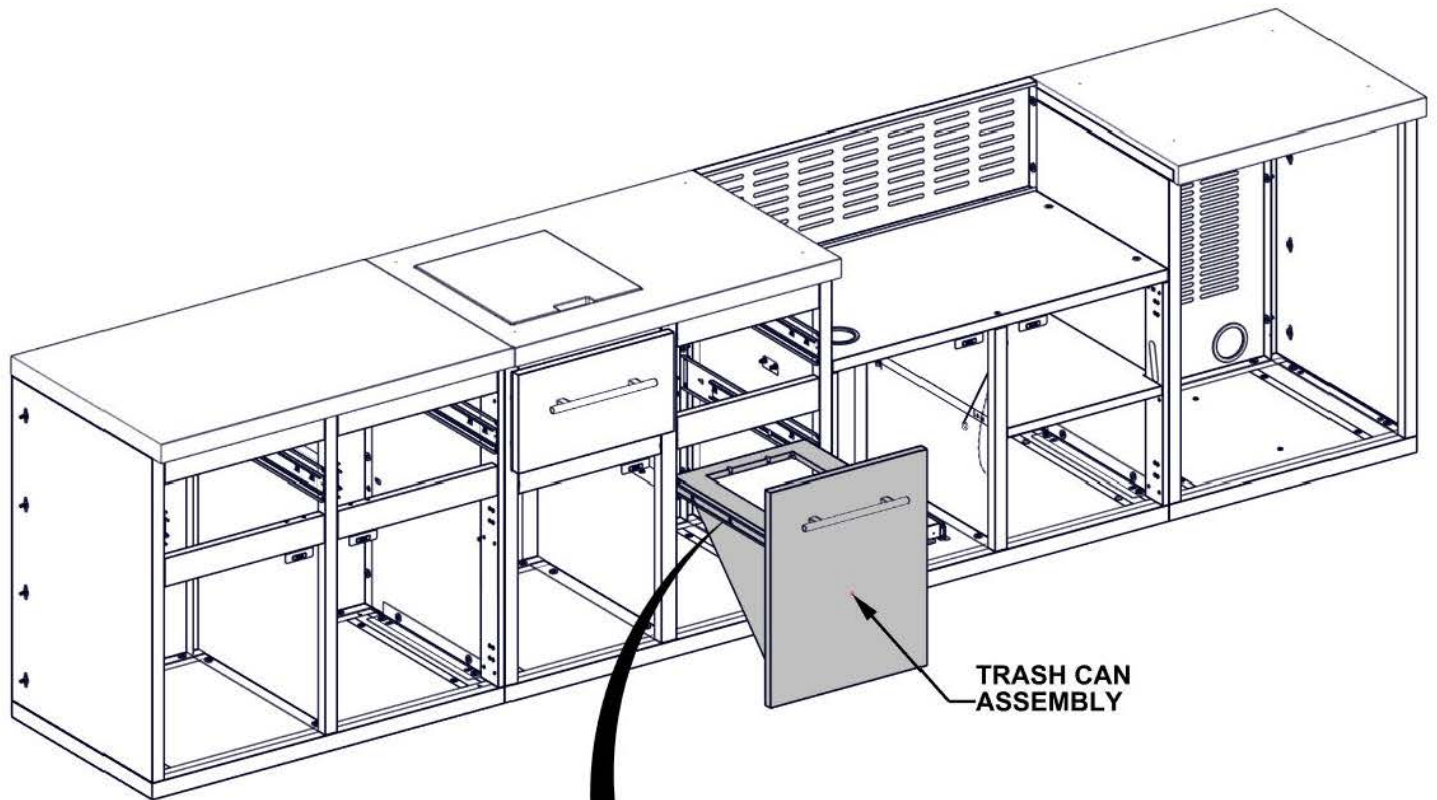

**SLIDE INNER RACE
OF DRAWER SLIDE OUT
BEFORE ATTACHING SLIDES**

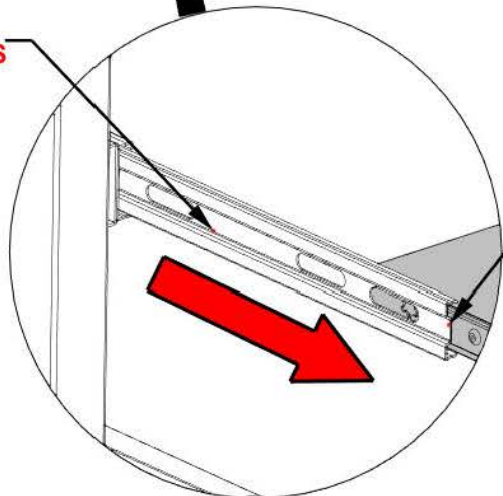

**ALIGN DRAWER SLIDES
ON BOTH SIDES OF TRASH
CAN HOLDER**

STEP 90A - KITCHEN DRAWER ASSEMBLY

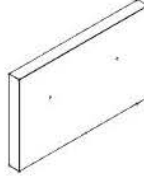
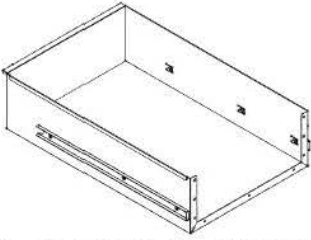

QTY	PartNo	Description
9	H101289	PAN HEAD SCREW 8-32x1/2" SS

D19 DRAWER BODY - A4M03698
 (x1) 22 1/4"x17 3/4"x5 3/4" (145x436.60x552)

D18 DRAWER PANEL ASSEMBLY - A4M03696
 (x1) 19 9/16"x10 1/4"x15/16" (24.00x260.00x498.25)

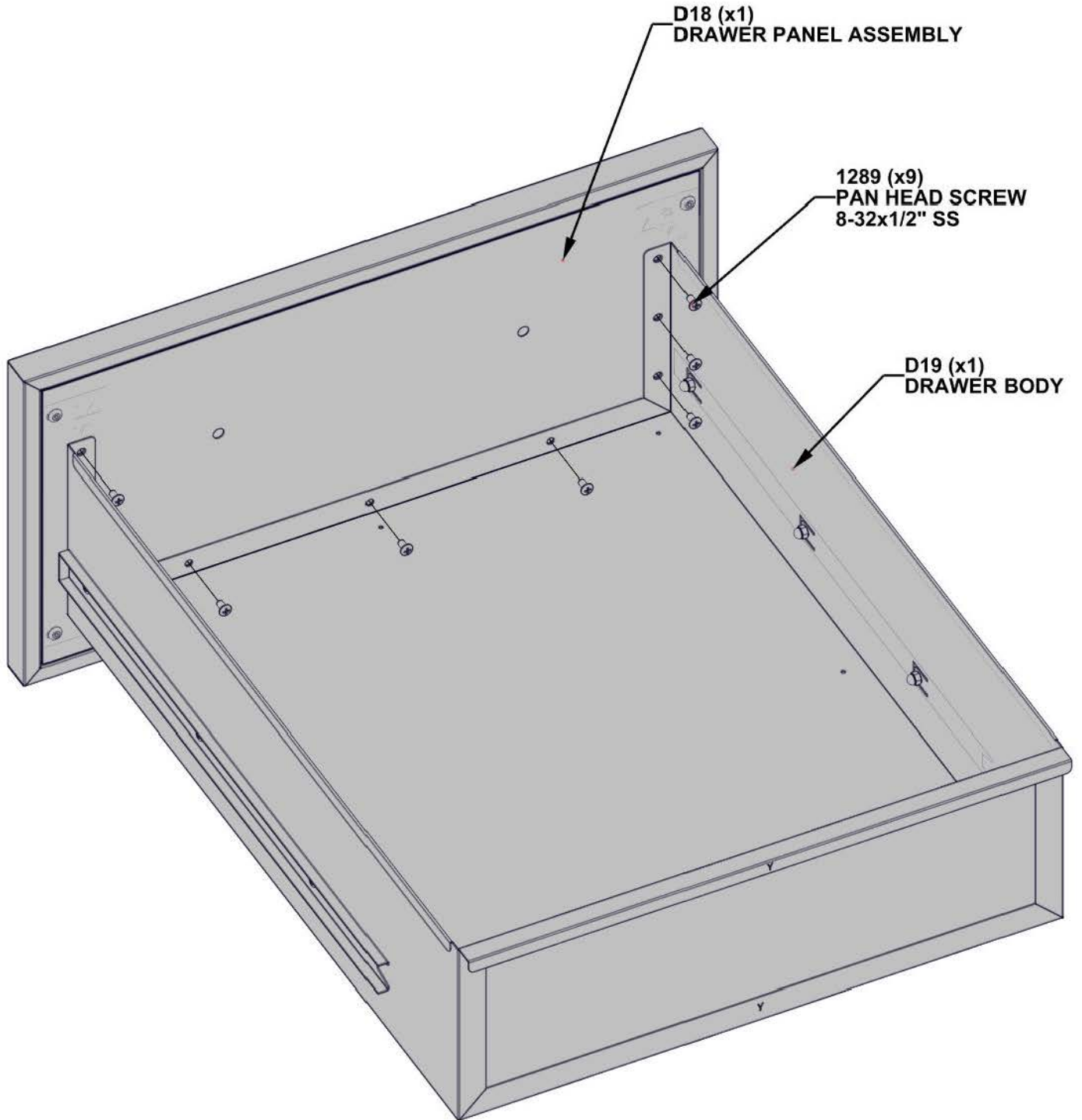

STEP 90B - KITCHEN DRAWER ASSEMBLY

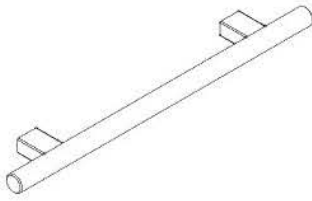

QTY	PartNo	Description
2	H101307	SHOULDER BOLT 8-32x30mm SS

H2 STAINLESS STEEL HANDLE - A4M03024
(x1) 5/8"x1 9/16"x11 13/16" (16x40x300)

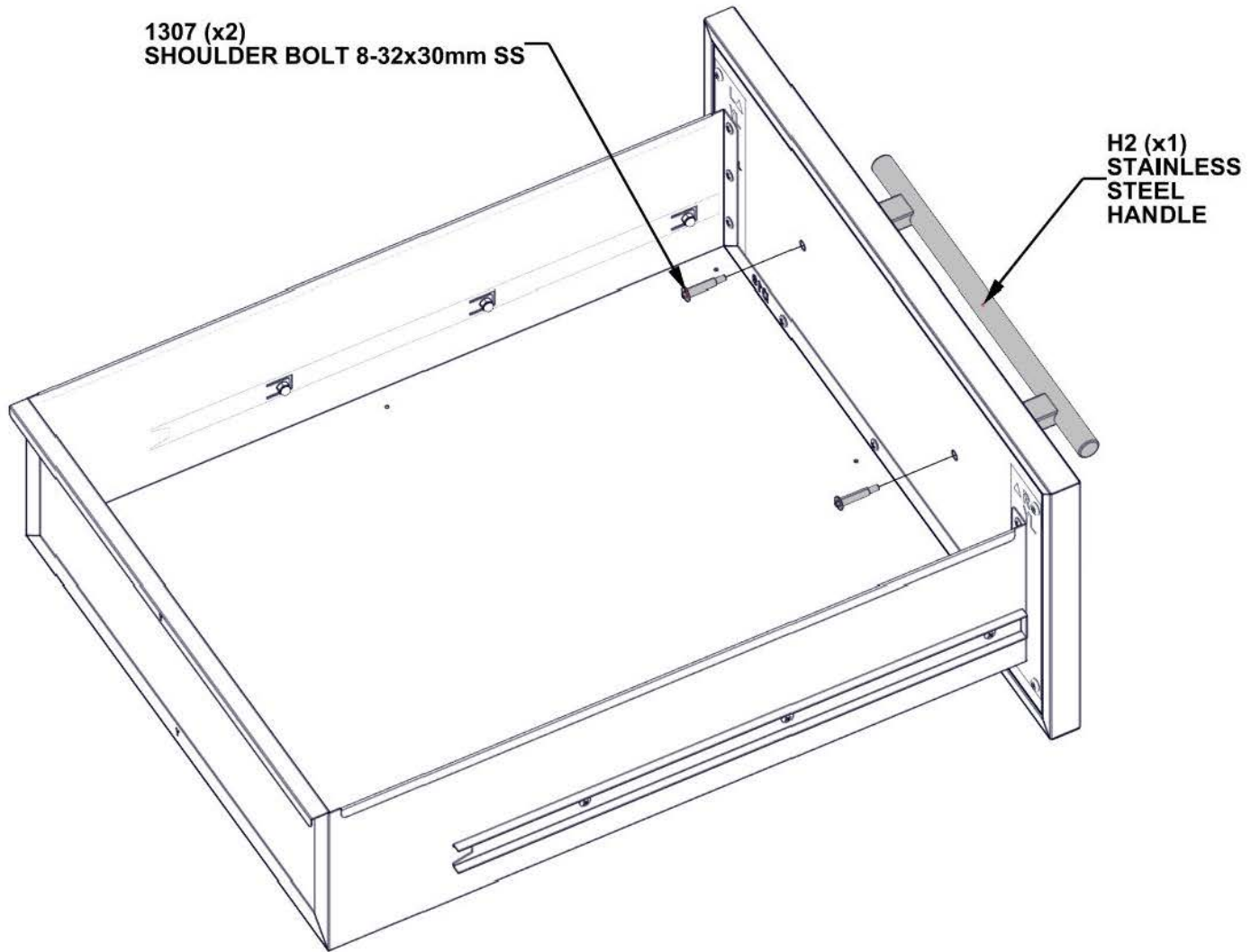

STEP 90C - KITCHEN DRAWER ASSEMBLY

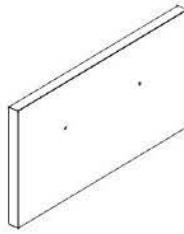
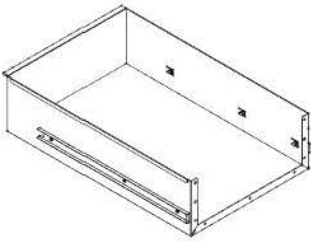

QTY	PartNo	Description
9	H101289	PAN HEAD SCREW 8-32x8mm SS

D19 DRAWER BODY - A4M03698
 (x1) 22 1/4"x17 3/4"x5 3/4" (145x436.60x552)

D22 DRAWER PANEL ASSEMBLY R - A4M03706
 (x1) 19 9/16"x10 1/4"x15/16" (24.00x260.00x498.25)

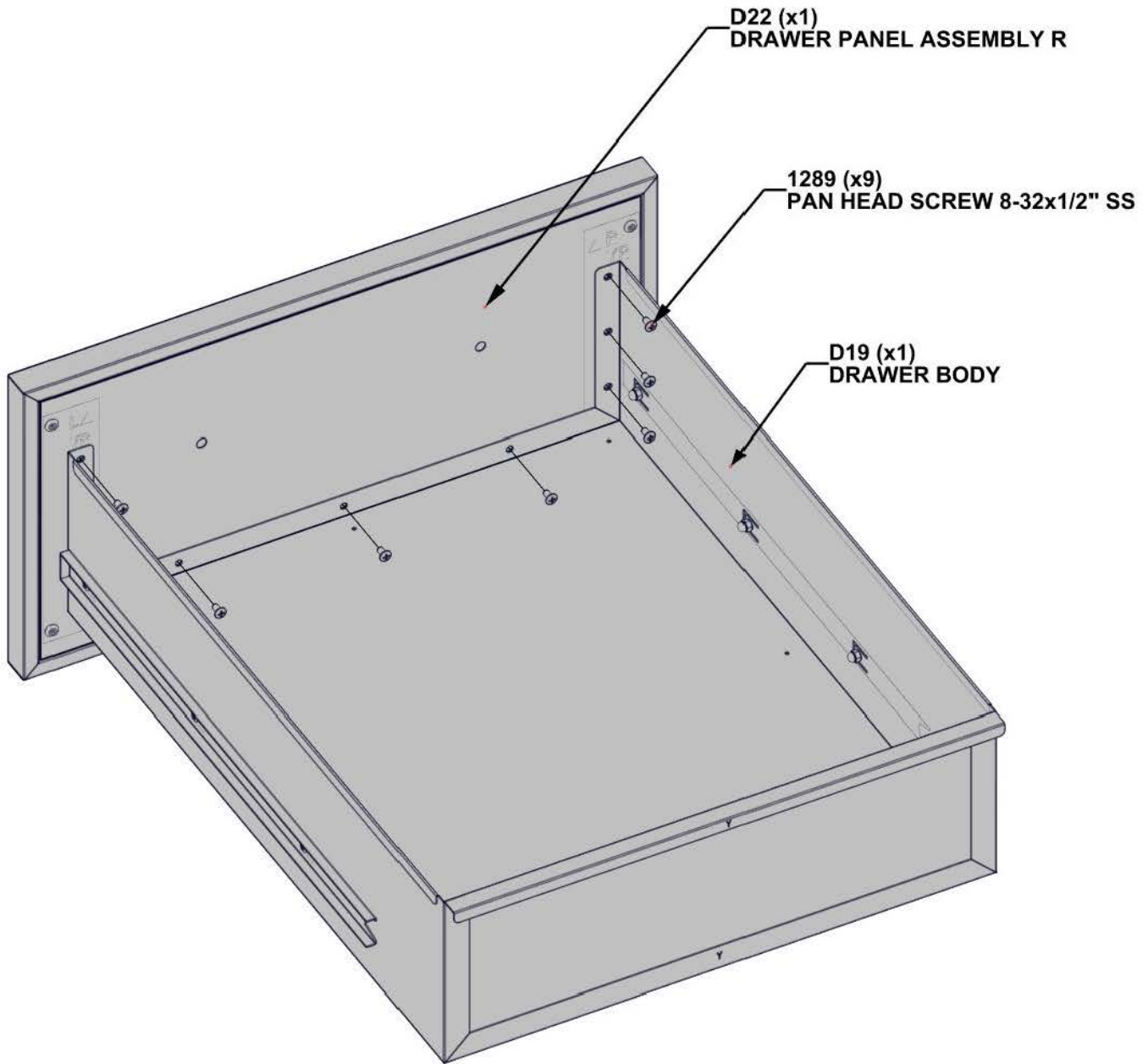

STEP 90D - KITCHEN DRAWER ASSEMBLY

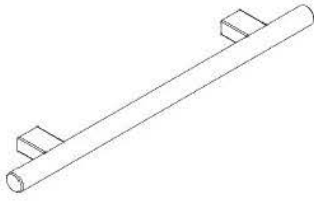

QTY	PartNo	Description
2	H101307	SHOULDER BOLT 8-32x30mm SS

H2 STAINLESS STEEL HANDLE - A4M03024
(x1) 5/8"x1 9/16"x11 13/16" (16x40x300)

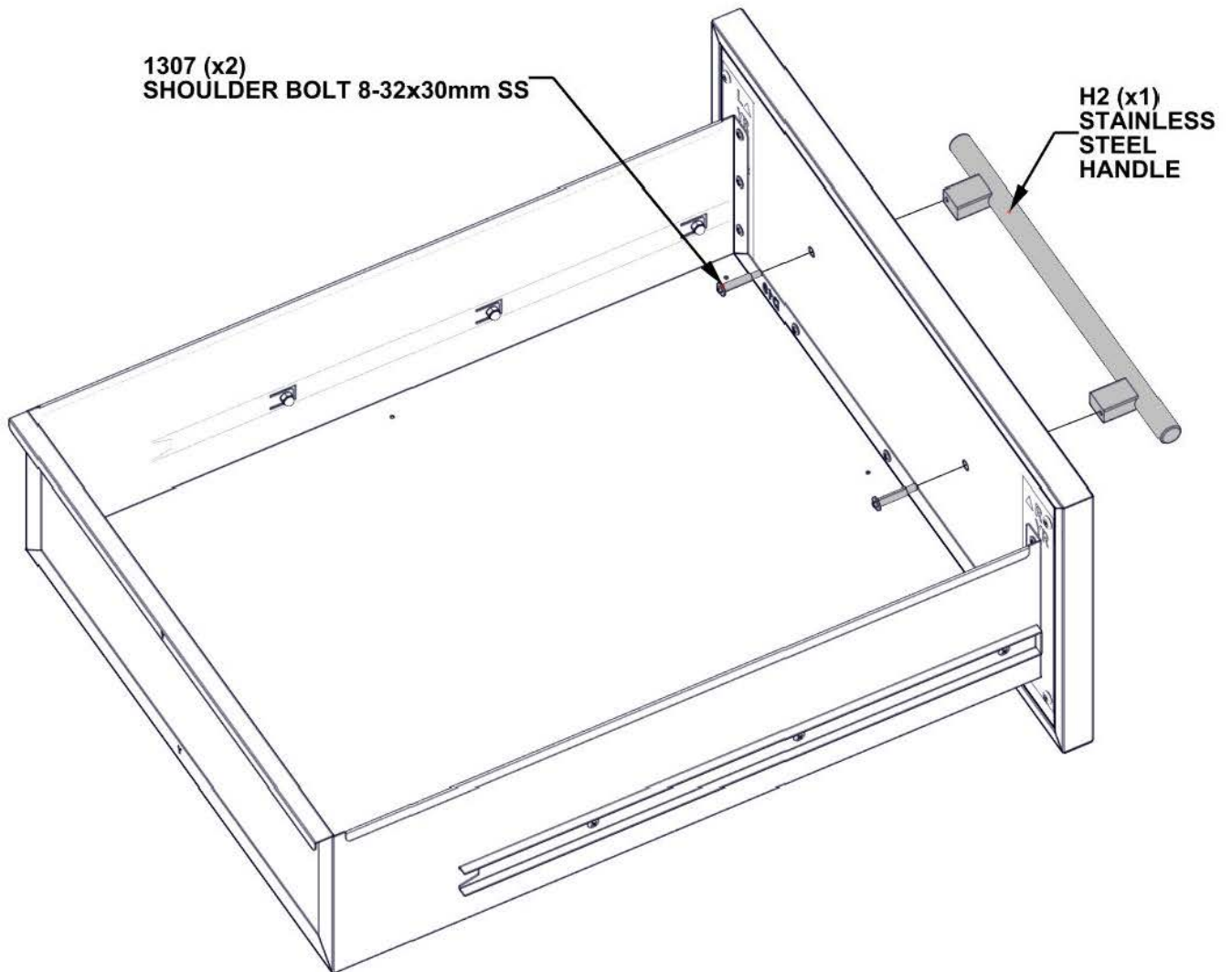

STEP 91A - KITCHEN DRAWER ASSEMBLY

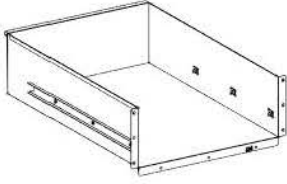

D4 SINK CABINET DRAWER BODY FRAME - A4M03571
 (x1) 22 1/4"x16 1/16"x6 7/16" (164.20x408.40x565.40)

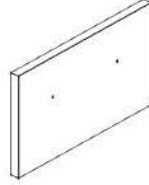

D3 SINK CABINET DRAWER PANEL ASSEMBLY - A4M03569
 (x1) 17 3/4"x10 1/4"x15/16" (24.00x260.00x451.00)

QTY	PartNo	Description
9	H101289	PAN HEAD SCREW 8-32x1/2" SS

- ALIGN SCREWS WITH PILOT HOLES.

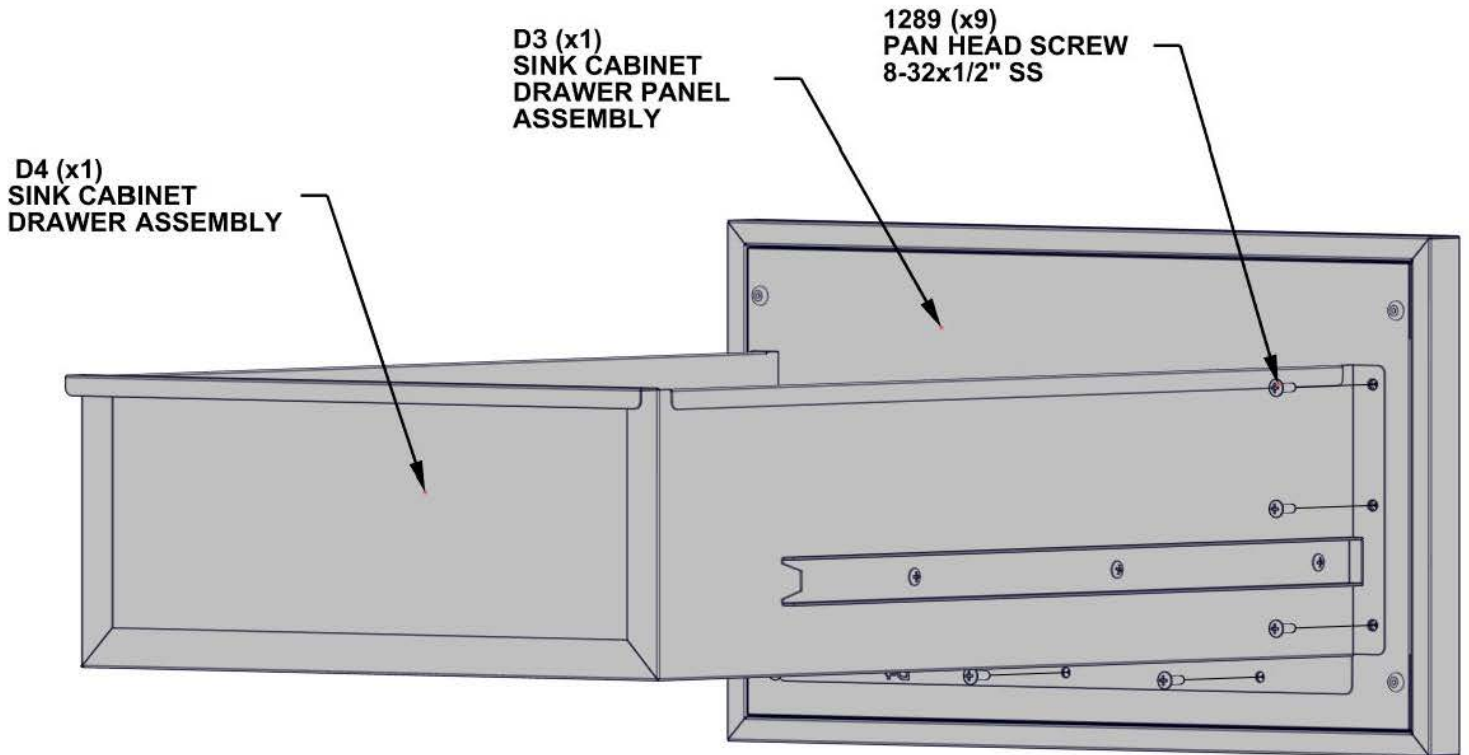

STEP 91B - KITCHEN DRAWER ASSEMBLY

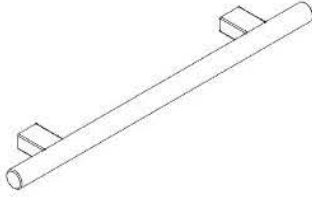

H2 STAINLESS STEEL HANDLE - A4M03024
(x1) 5/8"x1 9/16"x11 13/16" (16x40x300)

QTY	PartNo	Description
2	H101307	SHOULDER BOLT 8-32x30mm SS

- INSTALL DRAWER HANDLE TO DRAWER.

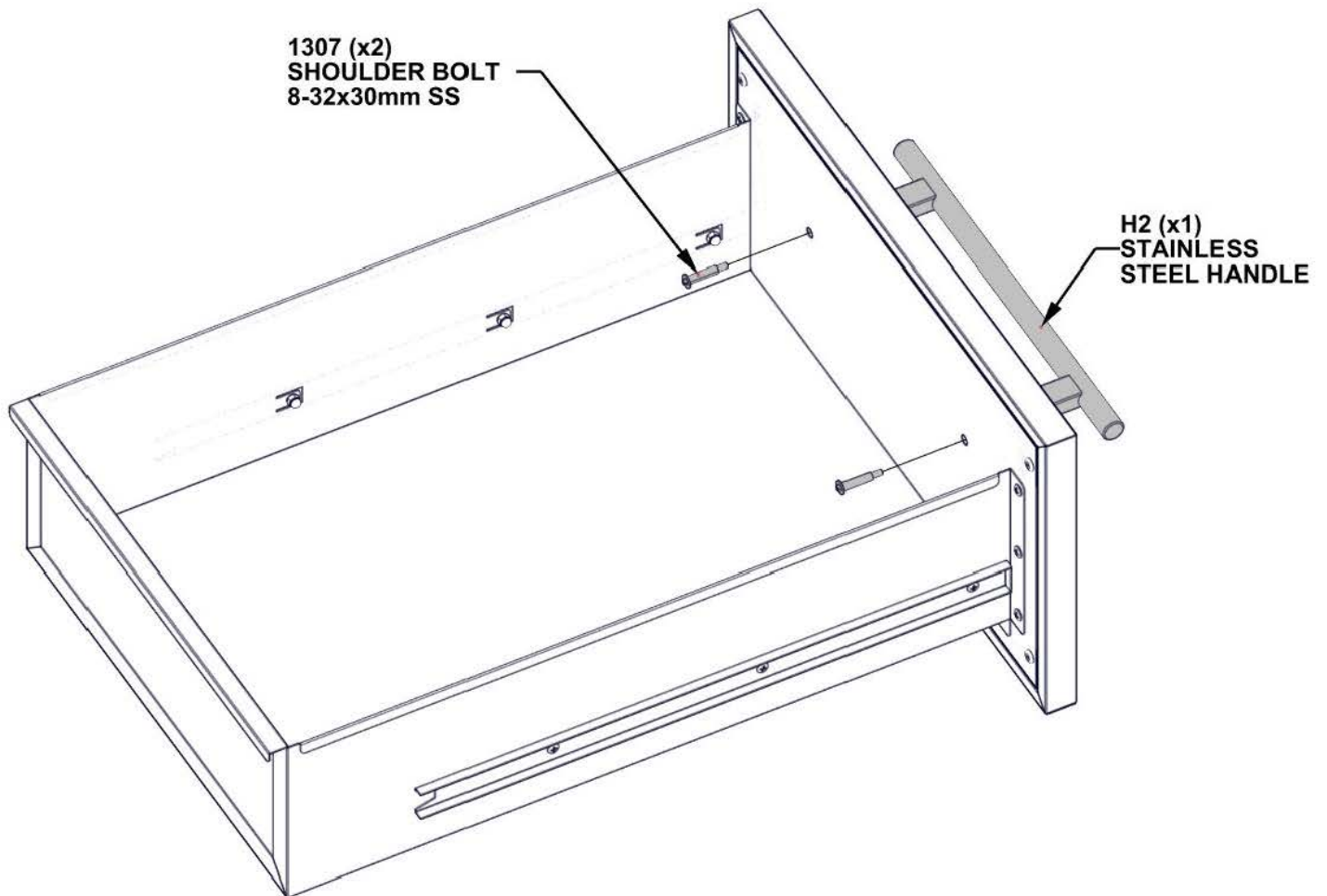

STEP 92A - KITCHEN DRAWER ASSEMBLY

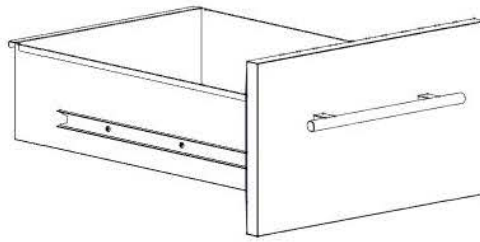

**DRAWER ASSEMBLY
STEPS 91A - 91B**

- ONLY KITCHEN CABINETS ARE SHOWN FOR DETAIL.
- ATTACH DRAWER ASSEMBLY BY ALIGNING BOTH ENDS OF FACTORY ASSEMBLED DRAWER SLIDES WITH ONE ANOTHER.
- PRESS TOGETHER UNTIL DRAWER SLIDES CONNECT.

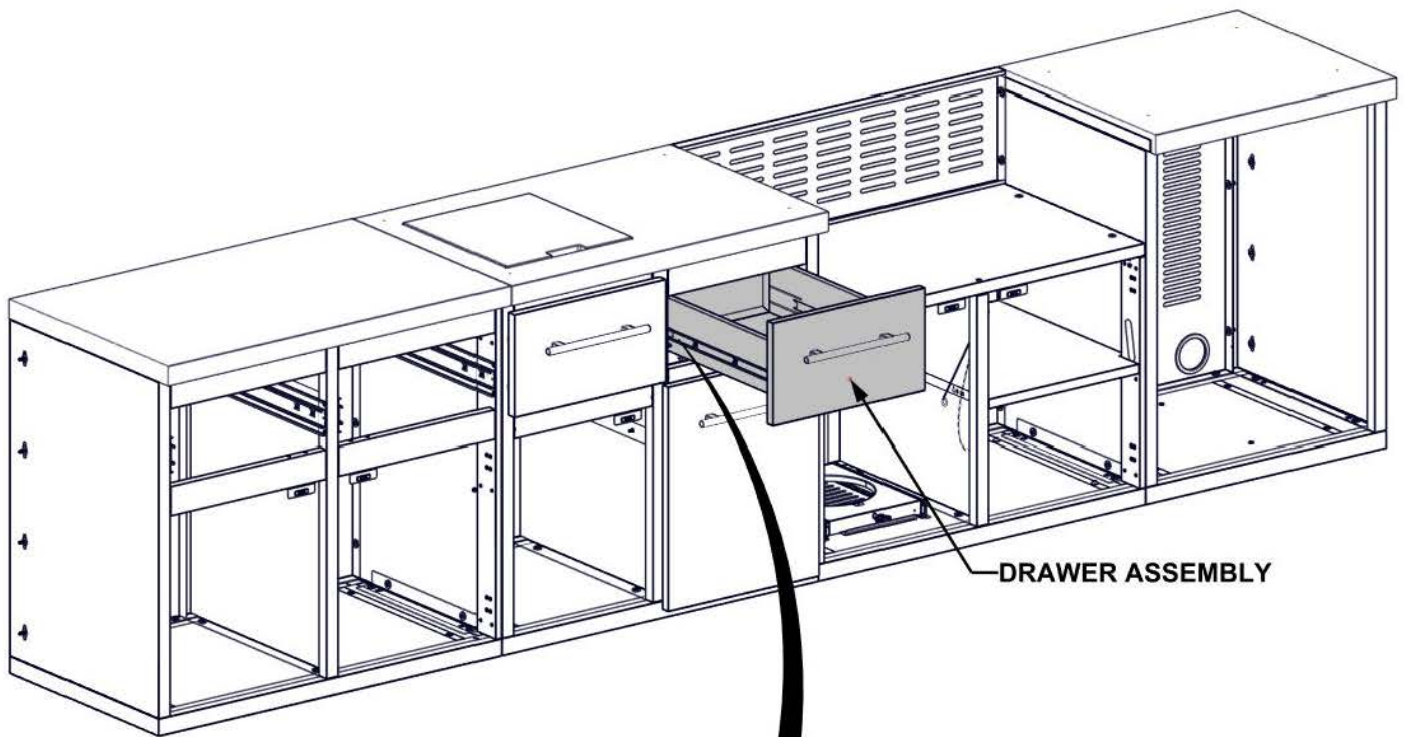

**SLIDE INNER RACE
OF DRAWER SLIDE OUT
BEFORE ATTACHING SLIDES**

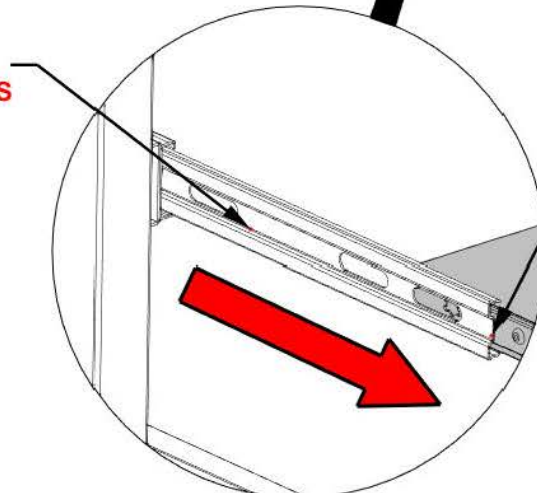

**ALIGN DRAWER SLIDES
ON BOTH SIDES OF
DRAWER HOLDER**

STEP 92B - KITCHEN DRAWER ASSEMBLY

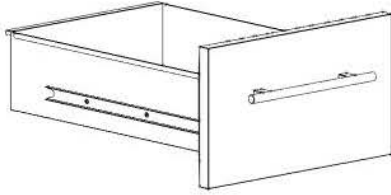

**DRAWER ASSEMBLY
STEPS 90A - 90B**

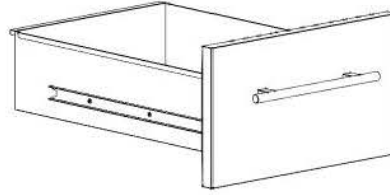

**DRAWER ASSEMBLY
STEPS 90C - 90D**

- ONLY KITCHEN CABINETS ARE SHOWN FOR DETAIL.

- REPEAT STEP 92A TO INSTALL REMAINING TWO DRAWERS.

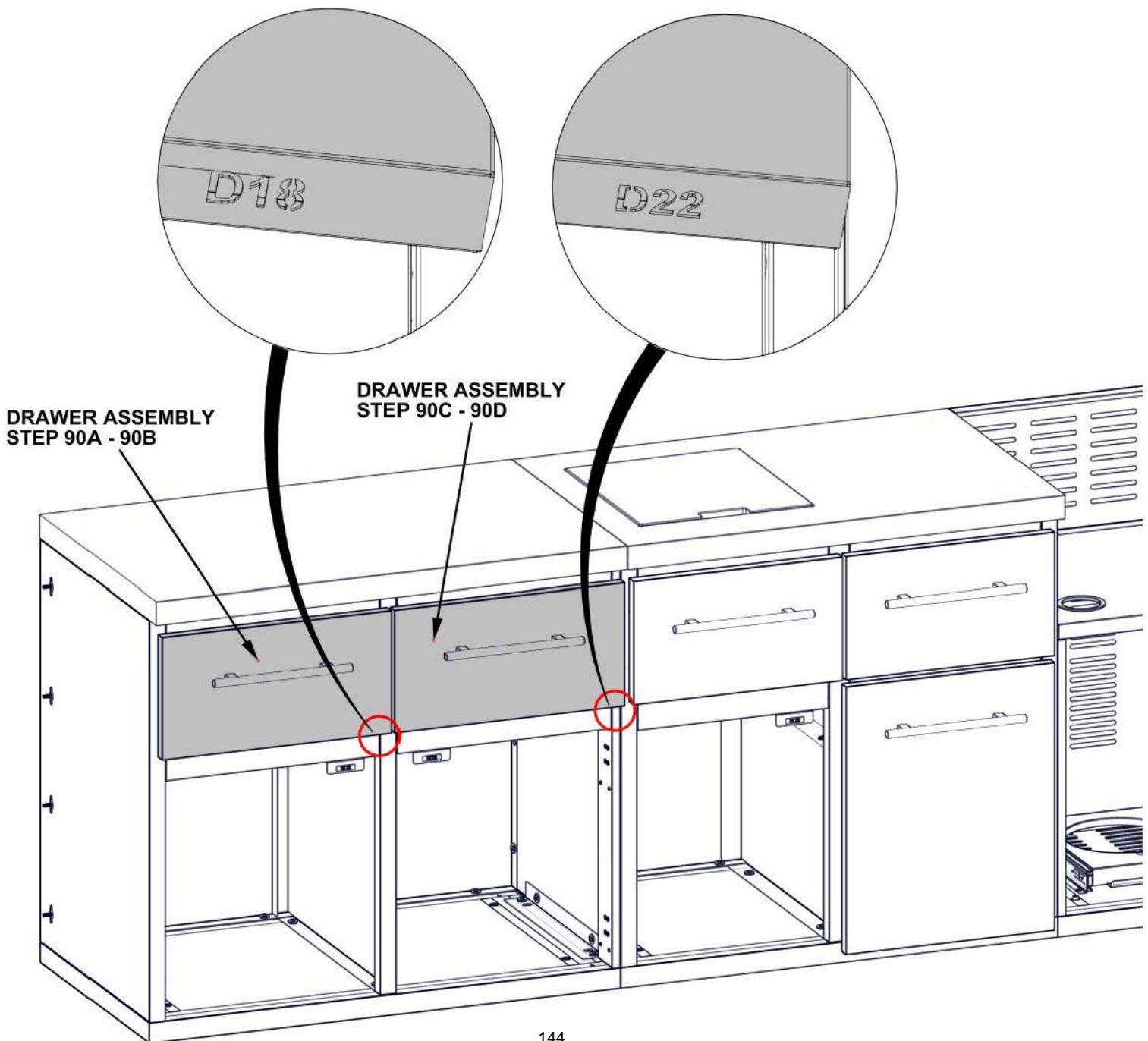

STEP 93A - DOOR ASSEMBLY

QTY	PartNo	Description
20	H101185	PHILLIPS FLAT HEAD 8-32x.5 SCREW

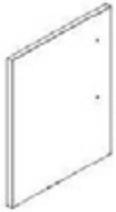

D20 DOOR PANEL ASSEMBLY L - A4M03701
(x1) 22 1/4"x19 5/8"x15/16" (24x498.28x565.50)

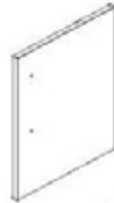

D21 DOOR PANEL ASSEMBLY R - A4M03703
(x1) 22 1/4"x19 5/8"x15/16" (24x498.26x565.50)

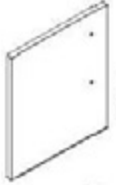

D6 SINK CABINET DOOR ASSEMBLY L - A4M03577
(x1) 22 1/4"x17 13/16"x15/16" (24.00x452.00x565.00)



D7 GRILL CABINET DOOR ASSEMBLY L - A4M03587
(x1) 24 13/16"x19 1/16"x15/16" (24.00x484.15x630.00)

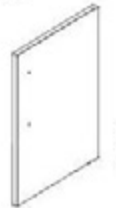

D8 GRILL CABINET DOOR ASSEMBLY R - A4M03590
(x1) 24 13/16"x19 1/16"x15/16" (24.00x484.15x630.00)



A4M03025 FULL OVERLAY HINGE
(x10)

- INSTALL CABINET HINGES TO ALL DOORS.

DO NOT OVERTIGHTEN HARDWARE.

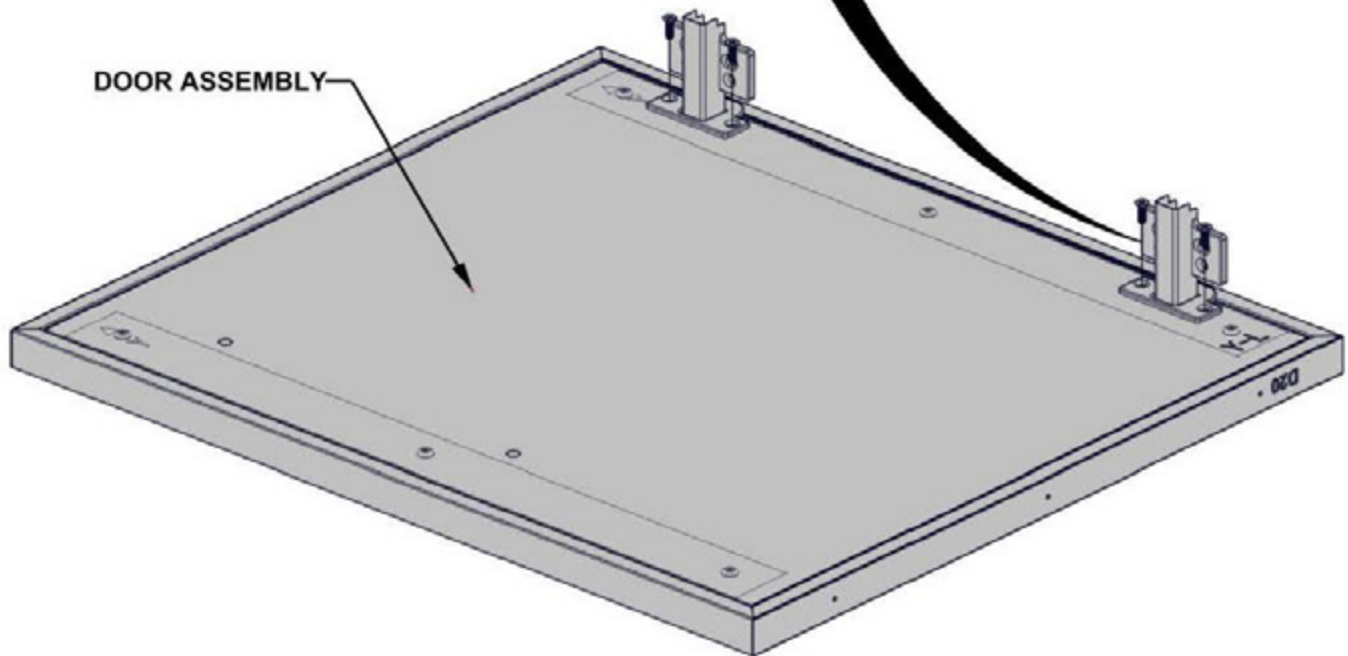
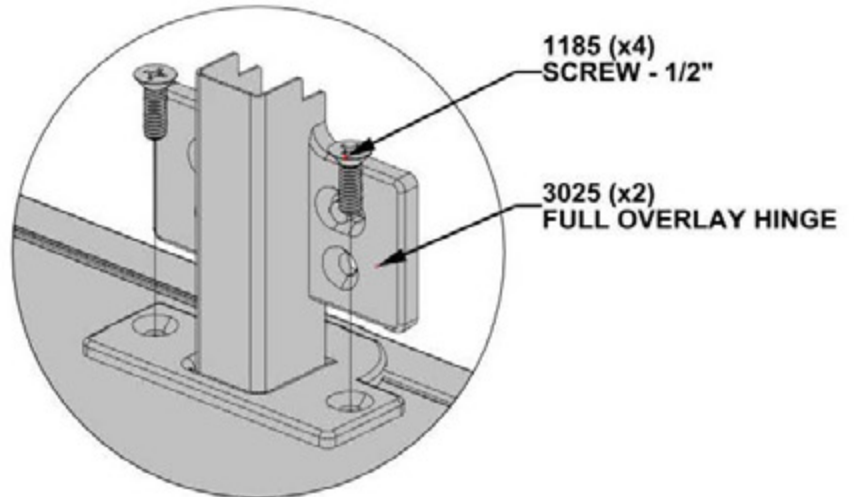

STEP 93B - DOOR ASSEMBLY

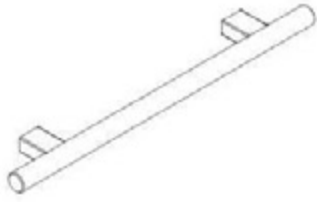

H2 STAINLESS STEEL HANDLE - A4M03024
(x5) 5/8"x1 9/16"x11 13/16" (16x40x300)

QTY	PartNo	Description
10	H101307	SHOULDER BOLT 8-32x30mm SS

- INSTALL CABINET HANDLES TO ALL DOORS.
- REPEAT THIS STEP 5 TIMES.

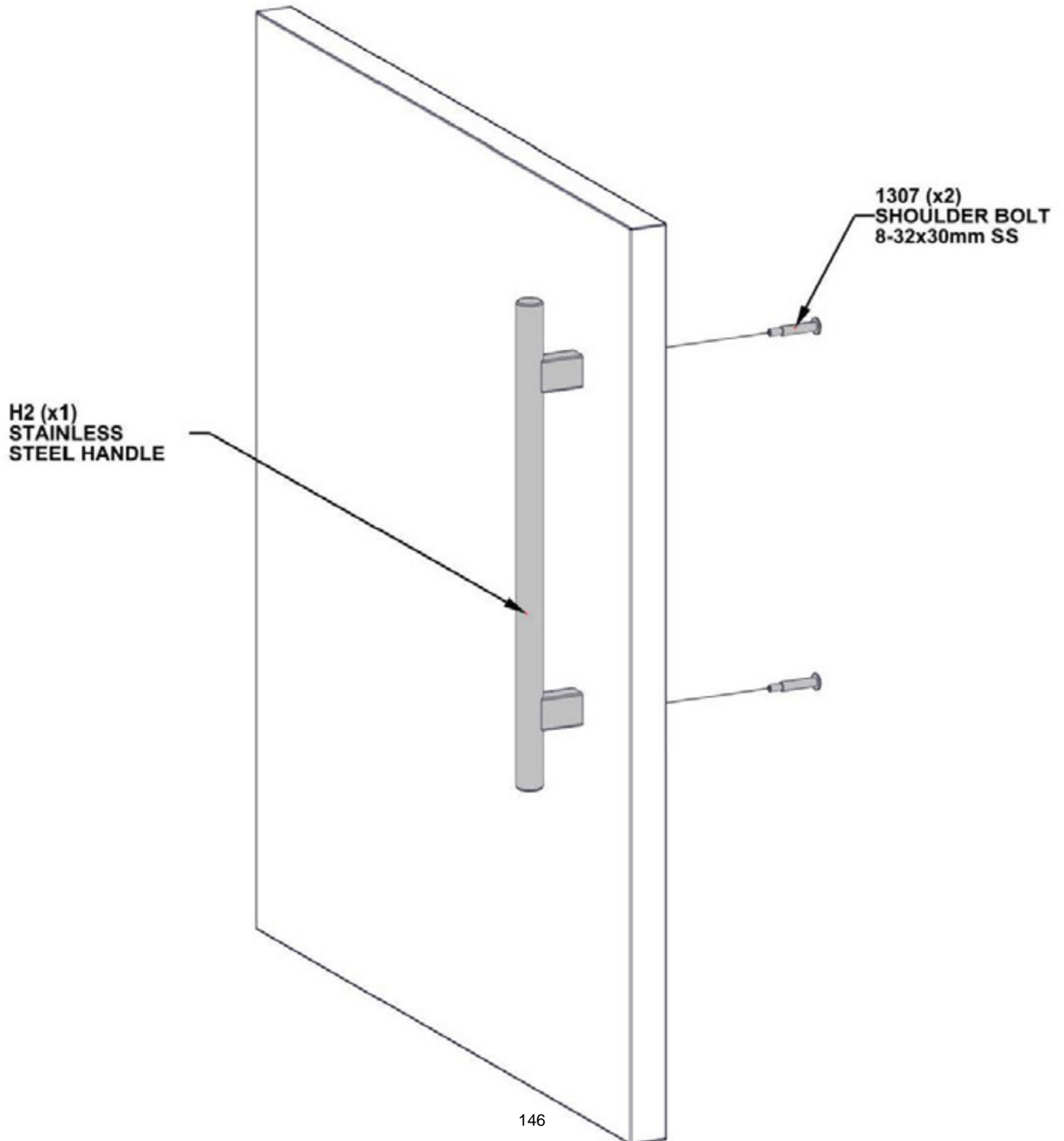

STEP 94 - CABINET DOOR ATTACHMENT



QTY	PartNo	Description
8	H101185	PHILLIPS FLAT HEAD 8-32x.5 SCREW

D20 DOOR PANEL ASSEMBLY L - A4M03701
(x1) 22 1/4"x19 5/8"x15/16" (24x498.28x565.50)

- ONLY KITCHEN CABINETS ARE SHOWN
- FOR THIS STEP IT IS HELPFUL TO HAVE AN ADDITIONAL PERSON HELP HOLD DOOR IN PLACE.
- WITH CABINET HINGES ATTACHED TO DOOR, ALIGN HOLES IN HINGE BRACKET WITH THREADED INSERTS IN SIDE OF CABINET PANEL.

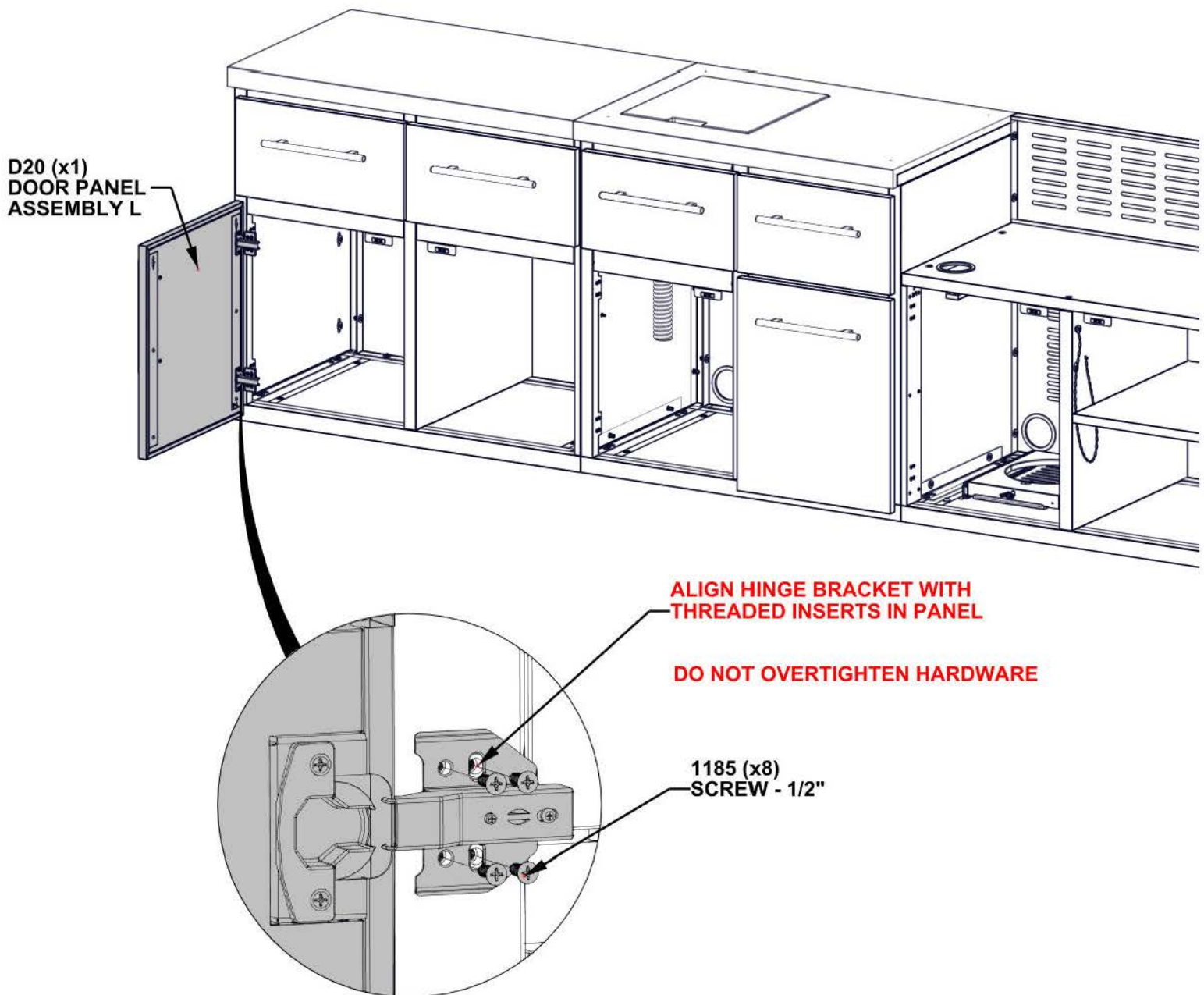

STEP 95 - CABINET DOOR ATTACHMENT

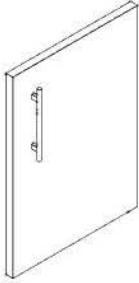

QTY	PartNo	Description
8	H101185	PHILLIPS FLAT HEAD 8-32x.5 SCREW

D21 DOOR PANEL ASSEMBLY R - A4M03703
(x1) 22 1/4"x19 5/8"x15/16" (24x498.26x565.50)

- ONLY KITCHEN CABINETS ARE SHOWN
- FOR THIS STEP IT IS HELPFUL TO HAVE AN ADDITIONAL PERSON HELP HOLD DOOR IN PLACE.
- WITH CABINET HINGES ATTACHED TO DOOR, ALIGN HOLES IN HINGE BRACKET WITH THREADED INSERTS IN SIDE OF CABINET PANEL.

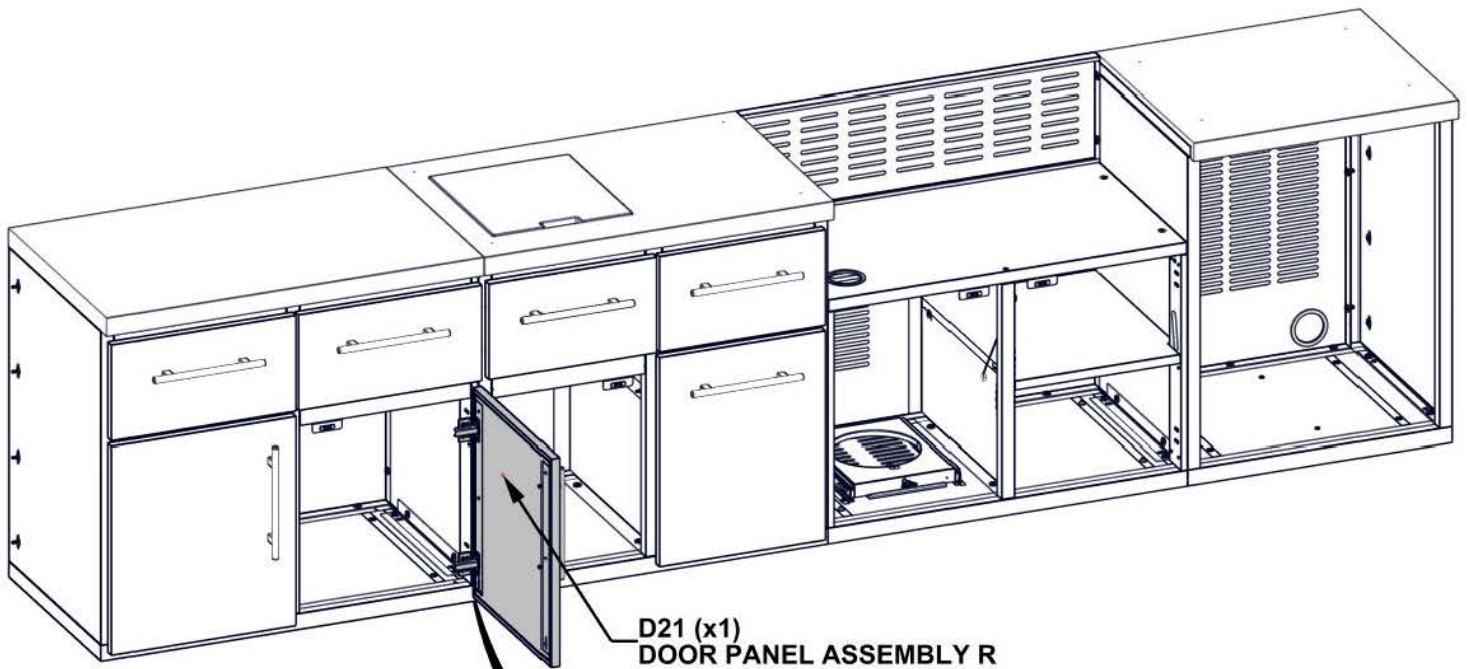

**ALIGN HINGE BRACKET WITH
THREADED INSERTS IN PANEL**

DO NOT OVERTIGHTEN HARDWARE

1185 (x8)
SCREW - 1/2"

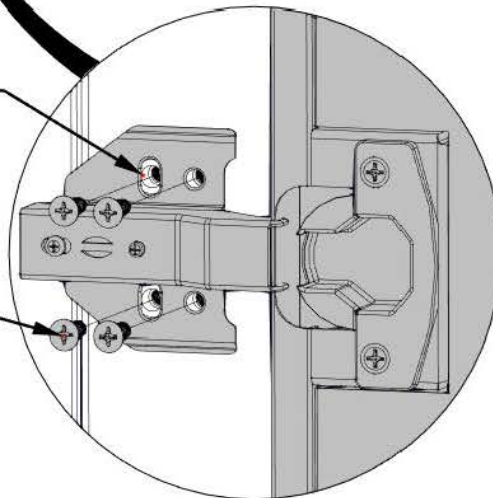

STEP 96 - CABINET DOOR ATTACHMENT



QTY	PartNo	Description
8	H101185	PHILLIPS FLAT HEAD 8-32x.5 SCREW

D6 SINK CABINET DOOR ASSEMBLY L - A4M03577
(x1) 22 1/4"x17 13/16"x15/16" (24.00x452.00x565.00)

- ONLY KITCHEN CABINETS ARE SHOWN
- FOR THIS STEP IT IS HELPFUL TO HAVE AN ADDITIONAL PERSON HELP HOLD DOOR IN PLACE.
- WITH CABINET HINGES ATTACHED TO DOOR, ALIGN HOLES IN HINGE BRACKET WITH THREADED INSERTS IN SIDE OF CABINET PANEL.

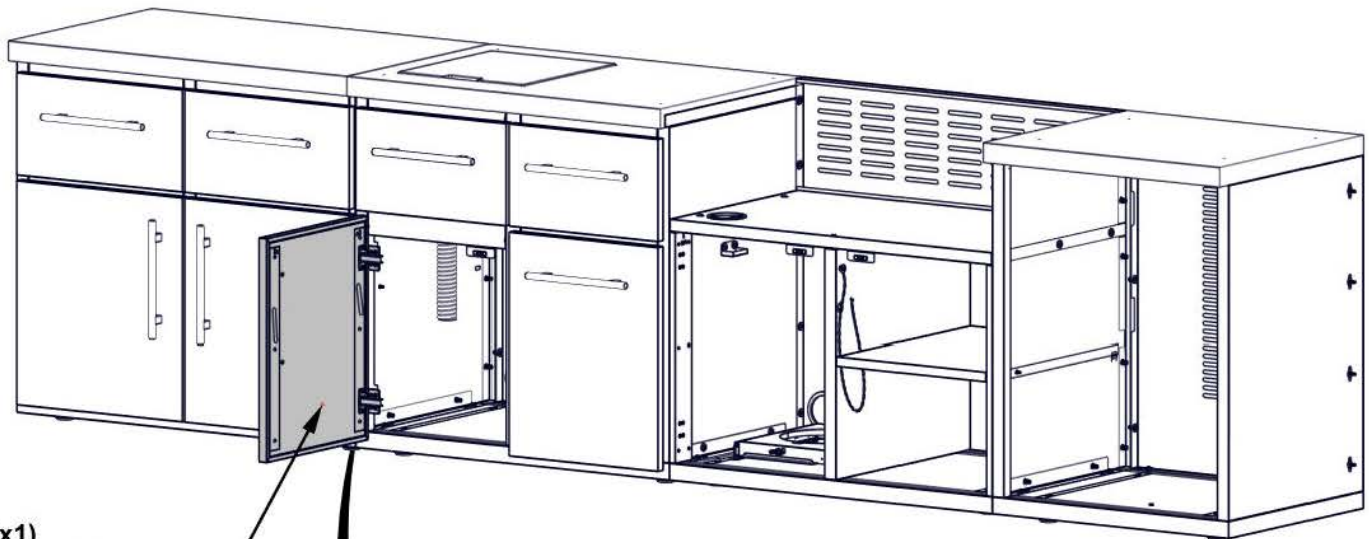

D6 (x1)
SINK CABINET
DOOR ASSEMBLY L

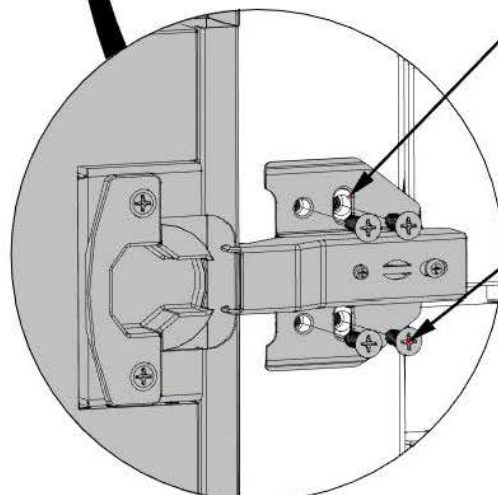

**ALIGN HINGE BRACKET WITH
THREADED INSERTS IN PANEL**

DO NOT OVERTIGHTEN HARDWARE

**1185 (x8)
SCREW - 1/2"**

STEP 97 - CABINET DOOR ATTACHMENT



QTY	PartNo	Description
8	H101185	PHILLIPS FLAT HEAD 8-32x.5 SCREW

D7 GRILL CABINET DOOR ASSEMBLY L - A4M03587
(x1) 24 13/16"x19 1/16"x15/16" (24.00x484.15x630.00)

- ONLY KITCHEN CABINETS ARE SHOWN
- FOR THIS STEP IT IS HELPFUL TO HAVE AN ADDITIONAL PERSON HELP HOLD DOOR IN PLACE.
- WITH CABINET HINGES ATTACHED TO DOOR, ALIGN HOLES IN HINGE BRACKET WITH THREADED INSERTS IN SIDE OF CABINET PANEL.

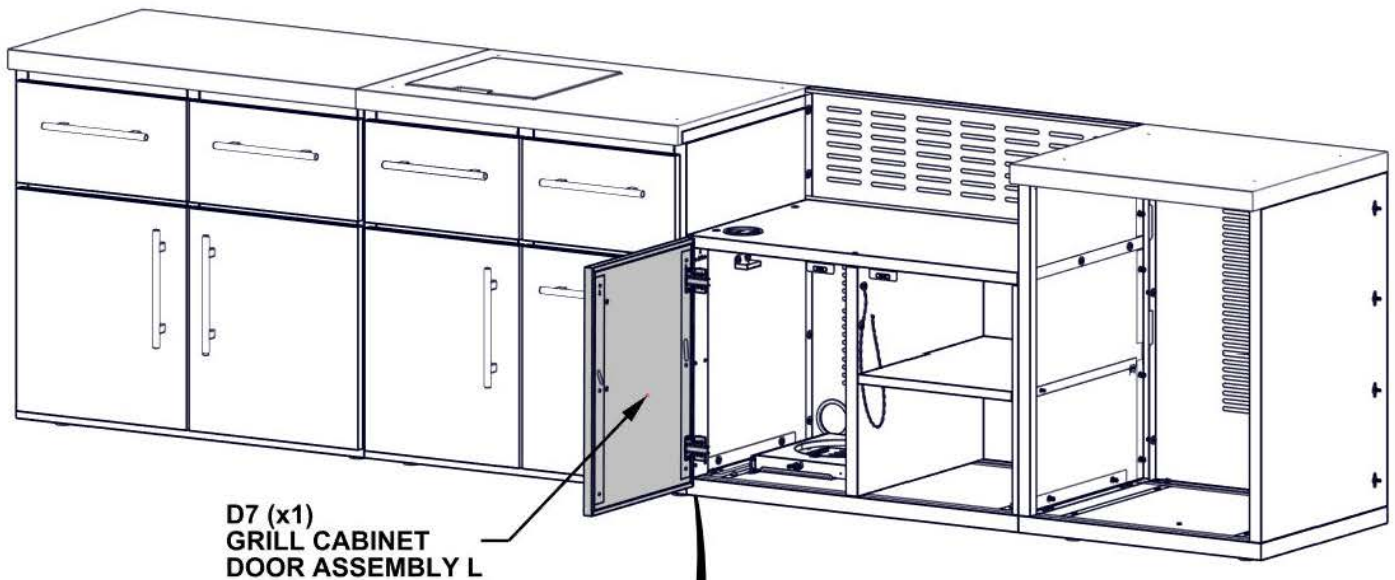

D7 (x1)
GRILL CABINET
DOOR ASSEMBLY L

**ALIGN HINGE BRACKET WITH
THREADED INSERTS IN PANEL**

DO NOT OVERTIGHTEN HARDWARE

1185 (x8)
SCREW - 1/2"

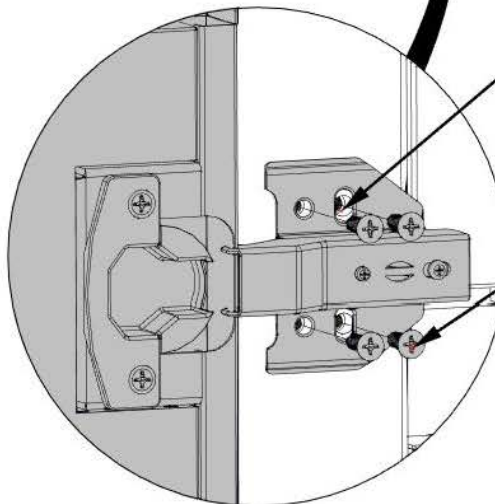

STEP 98 - CABINET DOOR ATTACHMENT



QTY	PartNo	Description
8	H101185	PHILLIPS FLAT HEAD 8-32x.5 SCREW

D8 GRILL CABINET DOOR ASSEMBLY R - A4M03590
(x1) 24 13/16"x19 1/16"x15/16" (24.00x484.15x630.00)

- ONLY KITCHEN CABINETS ARE SHOWN
- FOR THIS STEP IT IS HELPFUL TO HAVE AN ADDITIONAL PERSON HELP HOLD DOOR IN PLACE.
- WITH CABINET HINGES ATTACHED TO DOOR, ALIGN HOLES IN HINGE BRACKET WITH THREADED INSERTS IN SIDE OF CABINET PANEL.

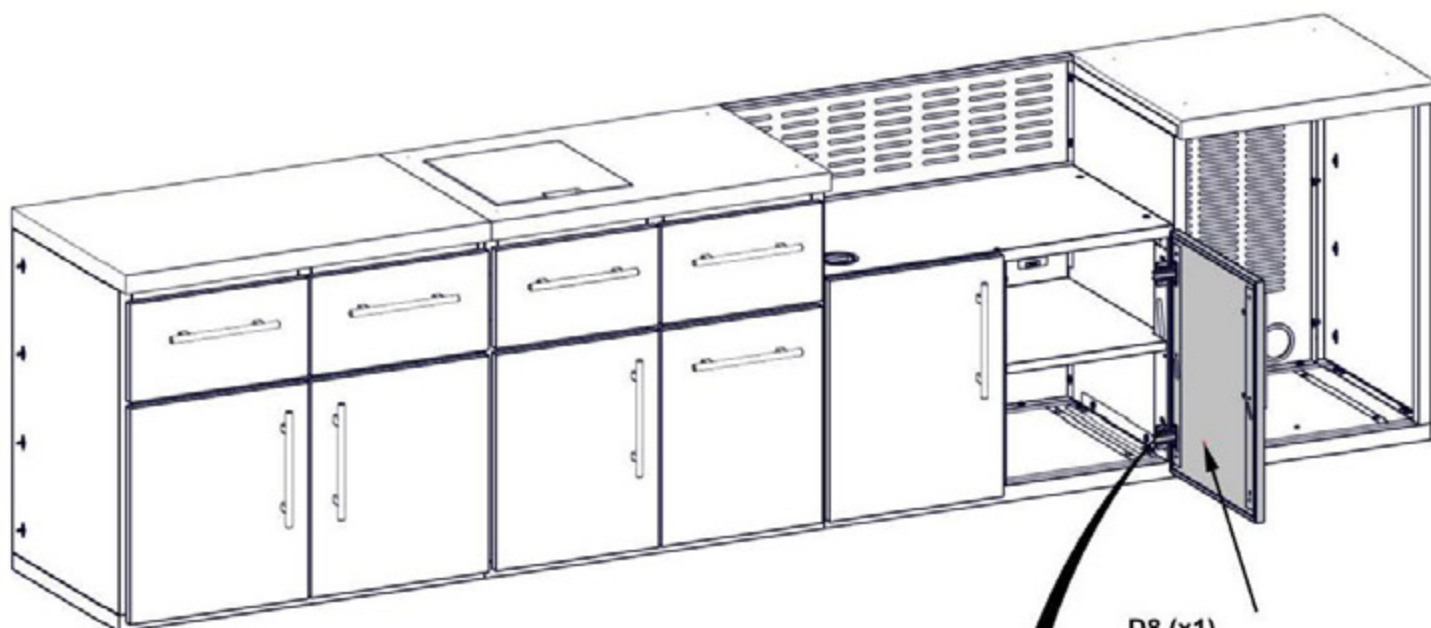

D8 (x1)
GRILL CABINET
DOOR ASSEMBLY R

**ALIGN HINGE BRACKET WITH
THREADED INSERTS IN PANEL**

**DO NOT OVERTIGHTEN
HARDWARE**

1185 (x8)
SCREW - 1/2"

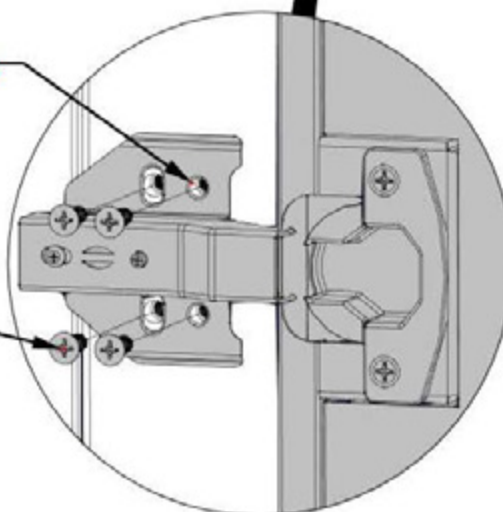

STEP 99 - CABINET DOOR ADJUSTMENT (AS NEEDED)

- ONLY KITCHEN CABINETS ARE SHOWN FOR DETAIL.
- ADJUST HINGES (AS NEEDED) SO THAT THE GAP AROUND ALL DOORS IS THE SAME AND THERE IS NO INTERFERENCE BETWEEN DOORS AND CABINETS.
- ADJUST MAGNET CATCH BRACKETS AS NEEDED.

**LOOSEN SCREWS TO ADJUST
MAGNET BRACKET, UNTIL IT
COMES IN CONTACT WITH
DOOR IN THE SHUT POSITION**

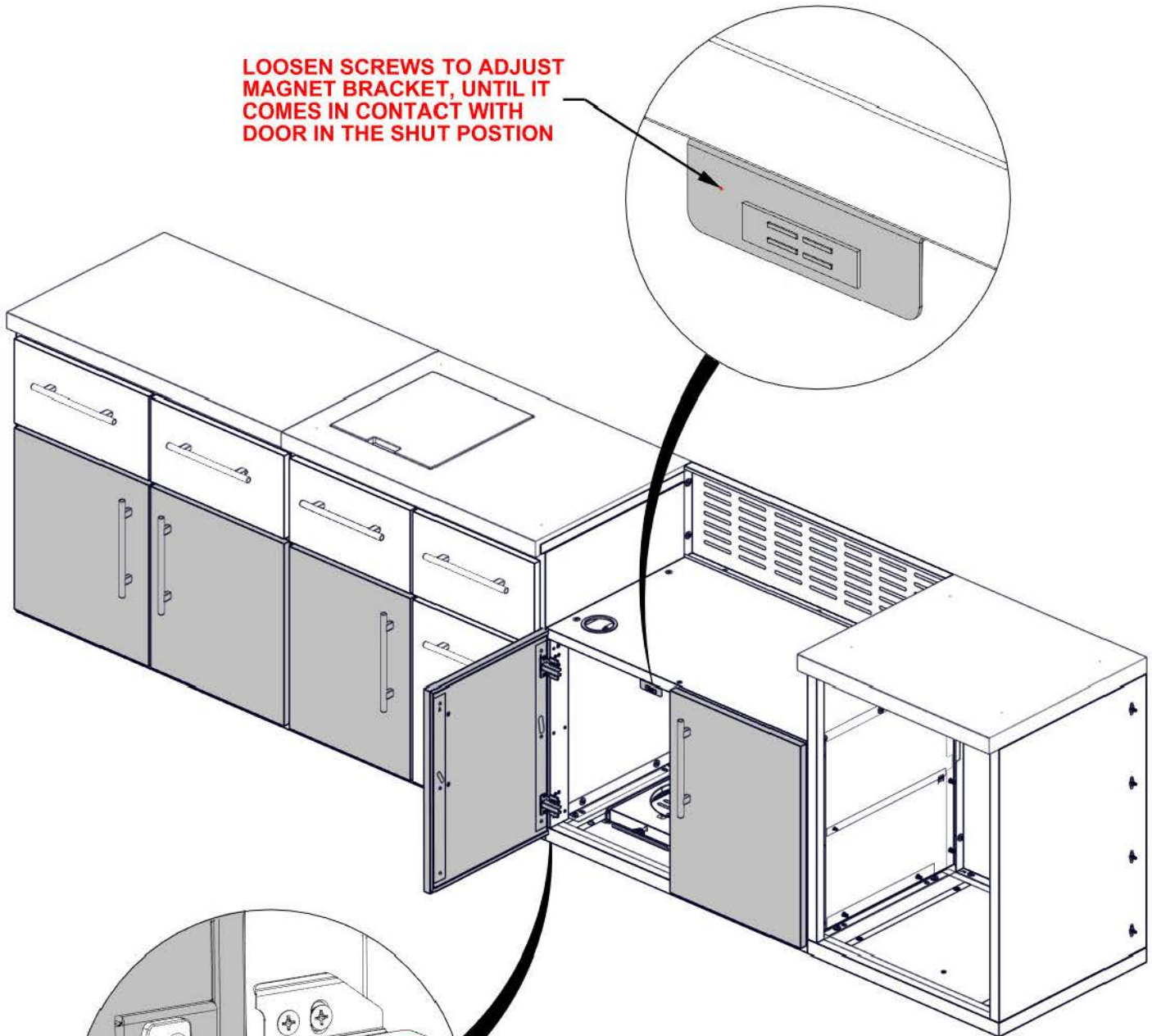

**SCREW #2:
LOOSEN THESE SCREWS TO
SLIDE DOOR TOWARD CABINET
OR AWAY FROM CABINET**

**SCREW #1:
SCREW CLOCKWISE TO BRING
EDGE OF DOOR AWAY FROM
CABINET. SCREW COUNTER
CLOCKWISE TO BRING EDGE OF
DOOR CLOSER TO CABINET**

STEP 100 - KITCHEN ACCESSORY

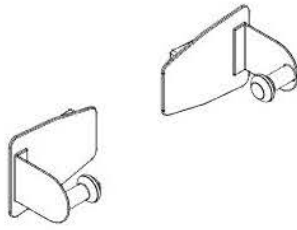

A4M02290 MAGNETIC PAPER TOWEL HOLDER
(x2)

- ONLY KITCHEN CABINETS ARE SHOWN FOR DETAIL.
- MAGNETIC PAPER TOWEL HOLDER CAN BE ATTACHED TO ANY METAL SURFACE ON KITCHEN.
- WE RECOMMEND ATTACHING TO THE INSIDE OF GRILL CABINET DOOR.
- **MAKE SURE TO KEEP PAPER TOWEL HOLDER AT A SAFE DISTANCE FROM GRILLING SURFACE.**

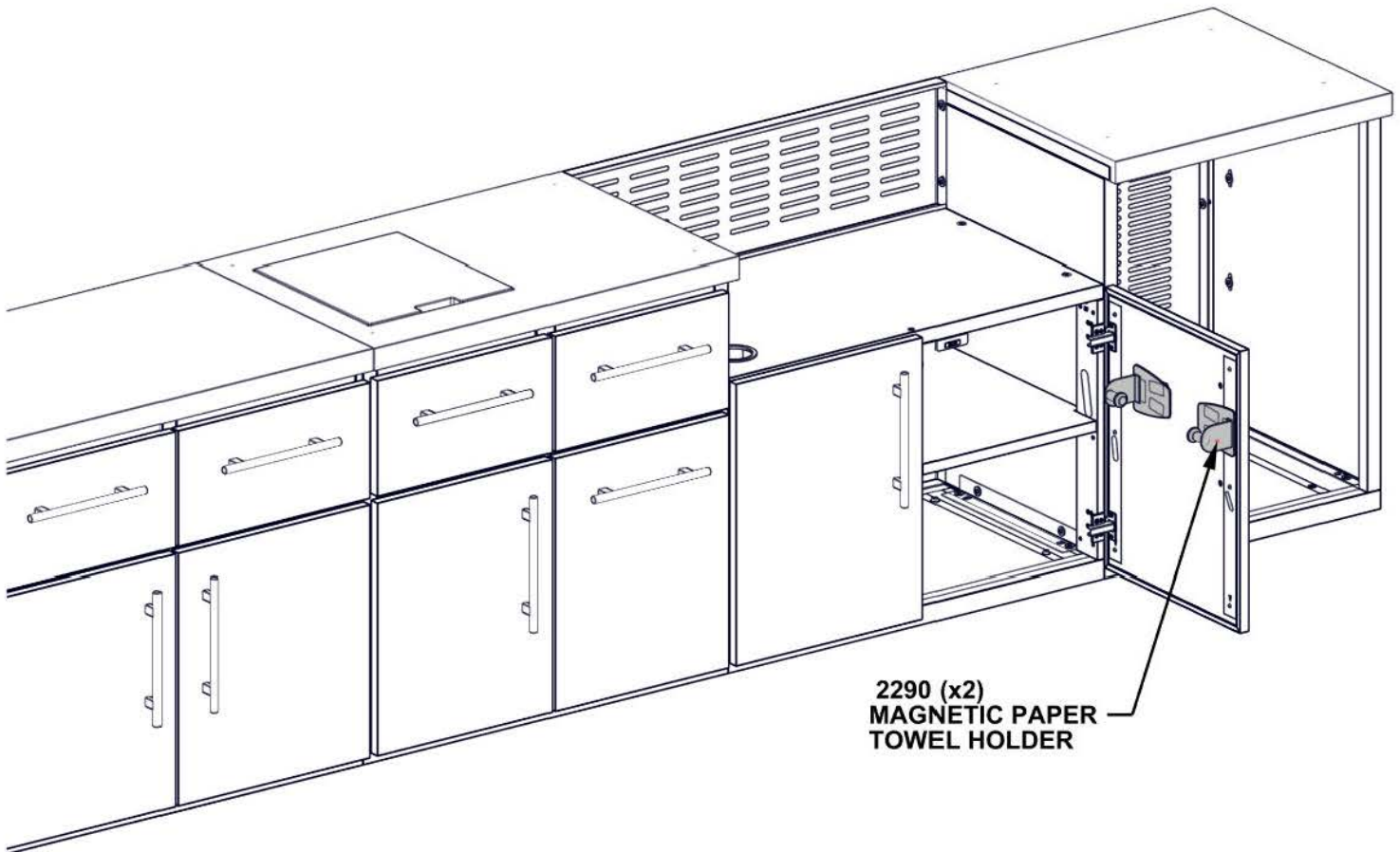

2290 (x2)
MAGNETIC PAPER
TOWEL HOLDER

STEP 101 - KITCHEN ANCHORING

QTY	PartNo	Description
8	H100630	WASHER FLAT 8x19 BLK
8	H100120	CONCRETE ANCHOR 1/4"x2"

- MANUFACTURER RECOMMENDS INSTALLATION ON CONCRETE SURFACE OR CONCRETE POST PADS AS SHOWN BELOW.
- FOR INSTALLATION ON WOOD DECK, YOU MUST ENSURE THERE IS AMPLE STRUCTURAL SUPPORT UNDER THE DECK. HARDWARE NOT INCLUDED FOR DECK ATTACHMENT.

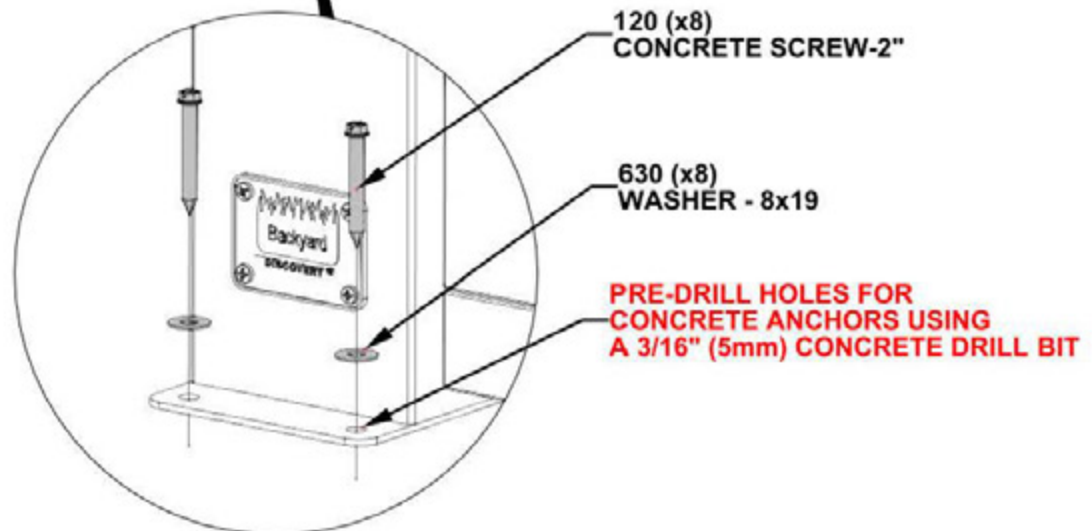
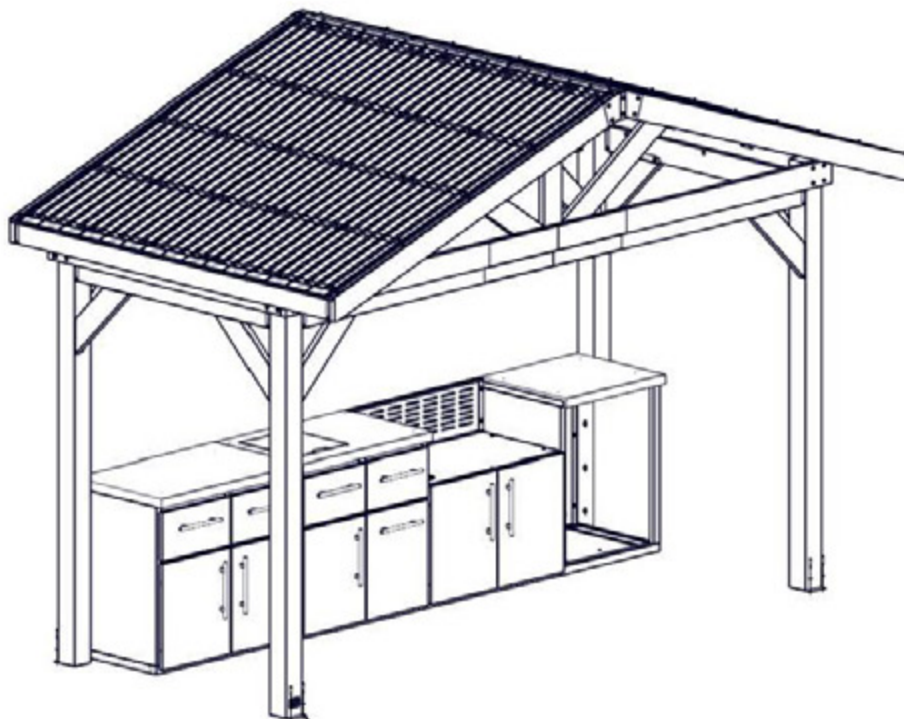

OUTDOOR KITCHEN GRILL KIT

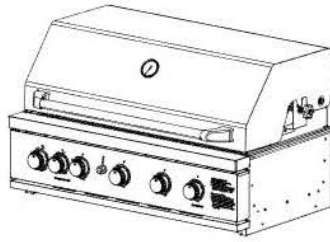

9240025 OUTDOOR KITCHEN GRILL KIT
(x1)

- FOR INSTALLATION AND DETAILED INFORMATION OF OUTDOOR KITCHEN GRILL KIT, REFER TO ASSEMBLY INSTRUCTIONS THAT COME PACKAGED WITH THE OUTDOOR KITCHEN GRILL KIT.
- FOLLOW DIRECTIONS FOR PROPER CARE AND USE.

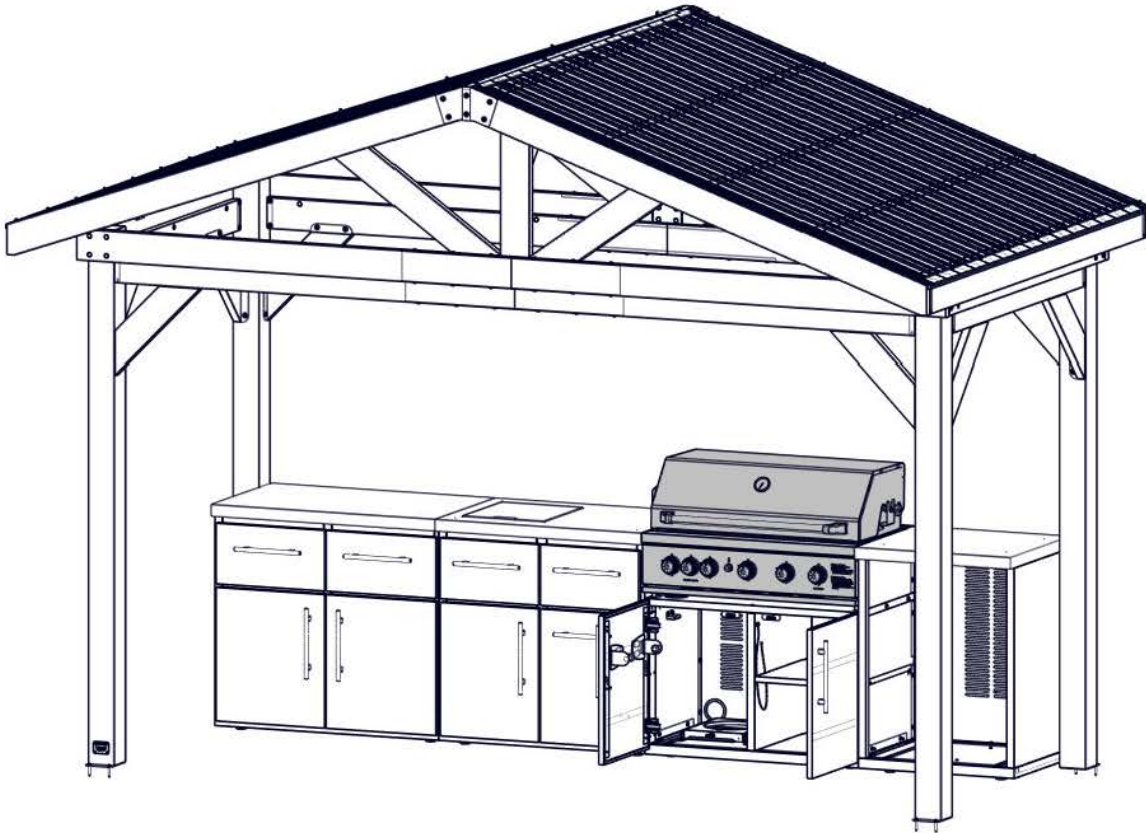

**NATURAL GAS CONVERSION KIT AVAILABLE BY CONTACTING BACKYARD DISCOVERY AT
www.backyarddiscovery.com 1-800-856-4445**

OUTDOOR KITCHEN FRIDGE



9240162 OUTDOOR KITCHEN FRIDGE - RIGHT OPEN
(x1)

- FOR INSTALLATION OF OUTDOOR KITCHEN FRIDGE, REFER TO PAGES IN THIS INSTRUCTION MANUAL.
- FOR DETAILED INFORMATION OF OUTDOOR KITCHEN FRIDGE, REFER TO ASSEMBLY INSTRUCTIONS THAT COME PACKAGED WITH THE OUTDOOR KITCHEN FRIDGE.
- FOLLOW DIRECTIONS FOR PROPER CARE AND USE.

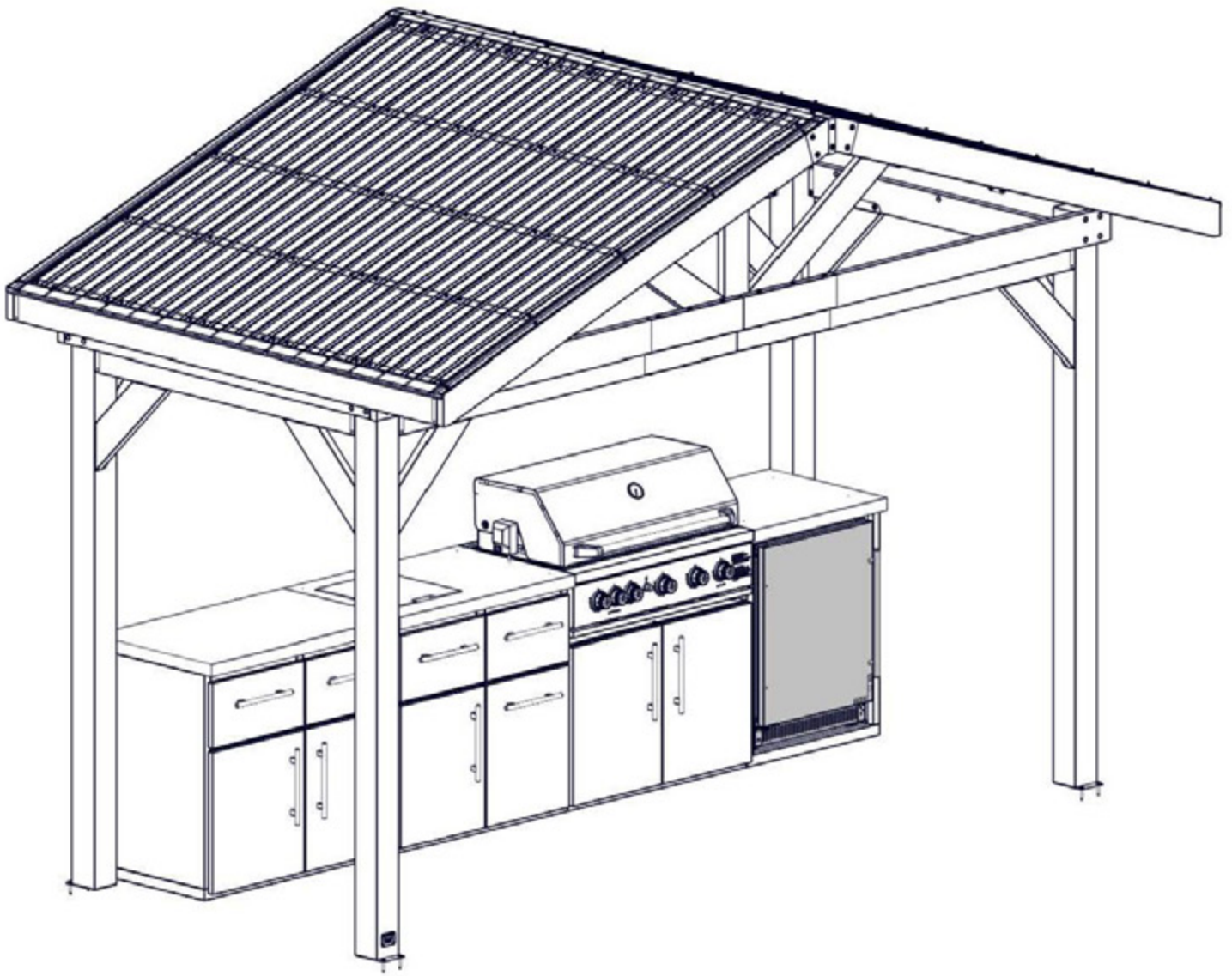

OUTDOOR KITCHEN FRIDGE

- CAREFULLY SLIDE FRIDGE INTO CABINET OPENING MAKING SURE THAT THE ELECTRICAL CORD IS ROUTED THROUGH THE HOLES IN THE SIDE PANELS OF THE CABINET.
- IF FRIDGE IS NOT IN UPRIGHT POSITION, PLEASE LET SIT FOR 24 HRS BEFORE PLUGGING INTO RECEPTACLE.
- FRIDGE CANNOT BE CONNECTED TO ELECTRICAL ENCLOSURE ATTACHED TO OUTDOOR STRUCTURE.

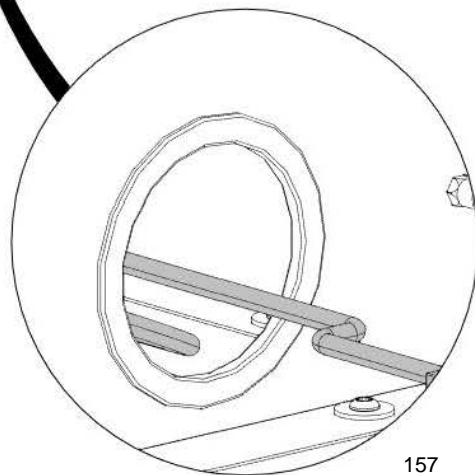
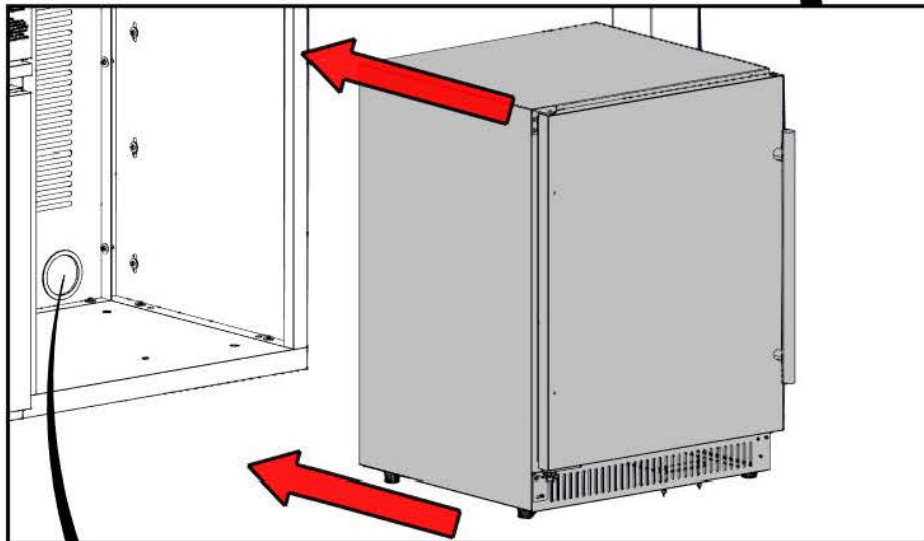
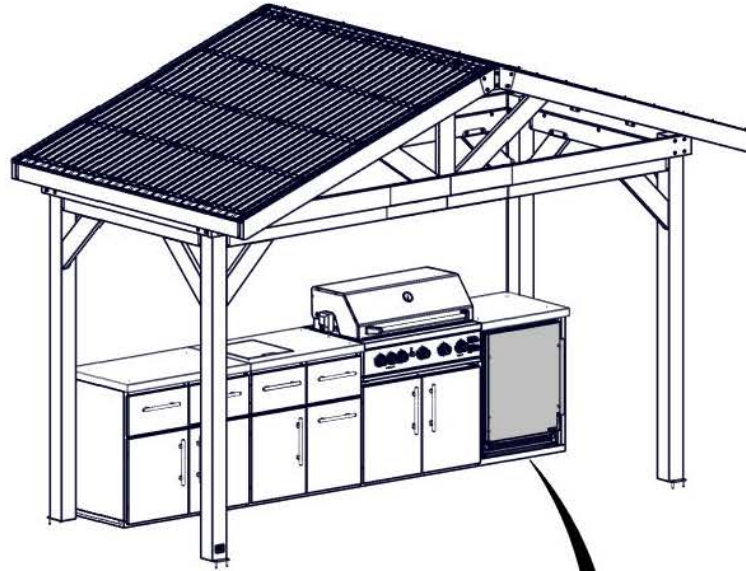

OUTDOOR KITCHEN FRIDGE

- ALIGN FEET ON FRIDGE UNIT SO THAT IT IS LEVEL AND DOES NOT TILT.
- TURN FEET CLOCKWISE TO EXTEND THEM AND COUNTERCLOCKWISE TO SHORTEN. REPEAT THIS FOR ALL FOUR FRIDGE FEET AS NEEDED TO LEVEL.

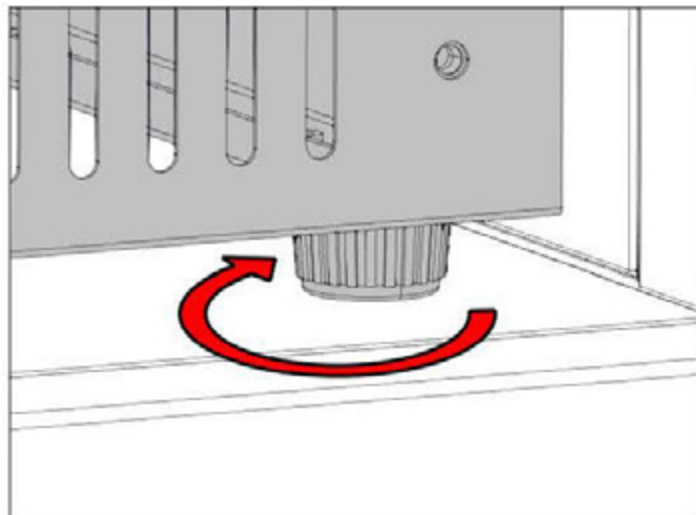
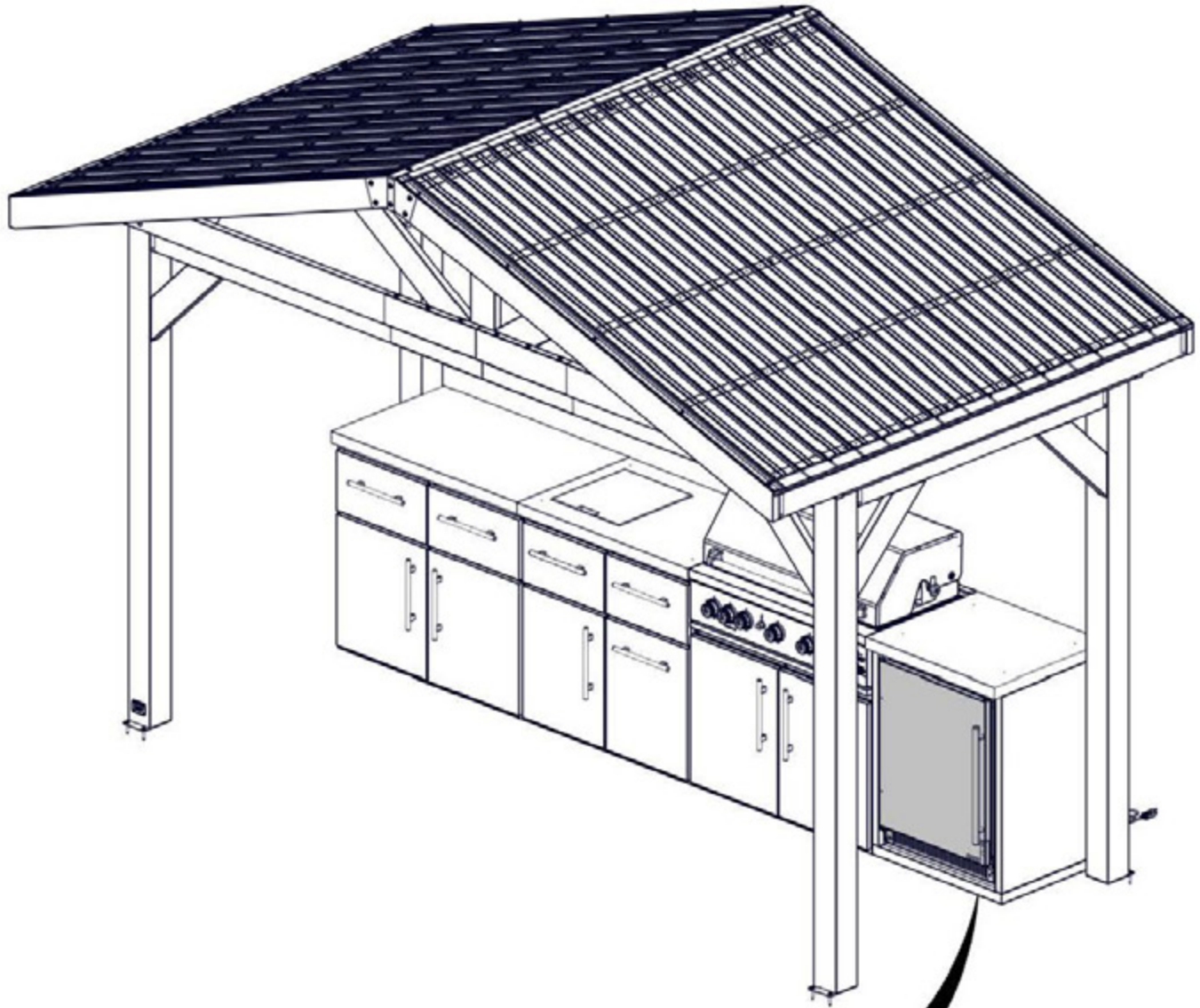

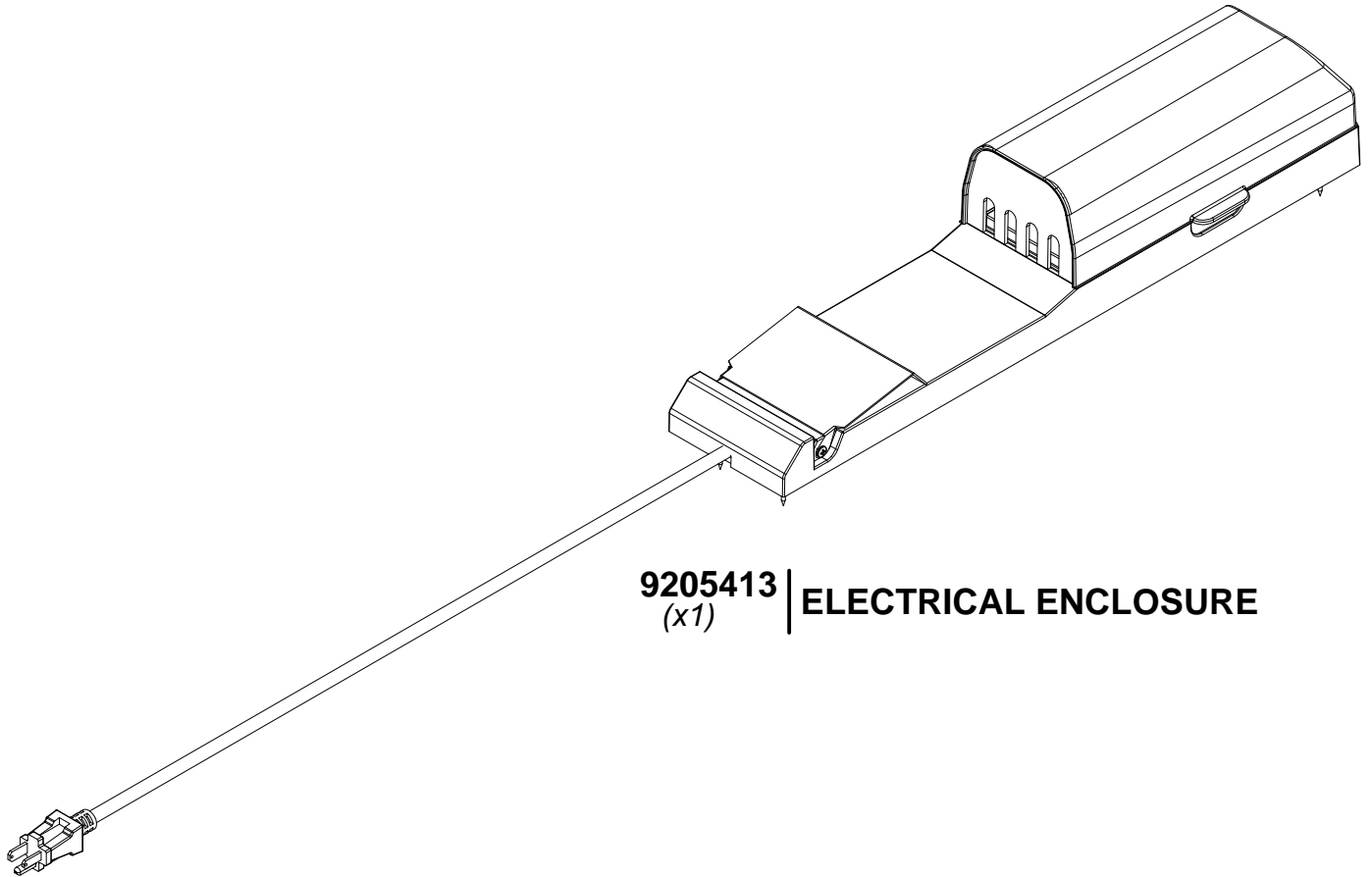

9205413 | **ELECTRICAL ENCLOSURE**
(x1)

FOR POWERPORT INSTALLATION REFER TO ASSEMBLY INSTRUCTIONS THAT COME PACKAGED WITH THE POWERPORT KIT. INSTALL ON ANY EXTERIOR POST THAT IS DESIRED. FOLLOW DIRECTIONS FOR PROPER INSTALLATION.