



Manufactured by:  
Backyard Discovery  
3305 Airport Drive, Pittsburg, KS 66762  
800-856-4445

Basepoint Business Centre: Rivermead Drive, Westlea, Swindon SN5 7EX Phone: 0800-118-2476  
J.P. Coenstraat 7, The Bridge, The Hague, 2595 WP, Netherlands Phone: 08005678990

# BEAUMONT 12X12 PERGOLA

MODEL: # 2405028



Please visit [www.backyarddiscovery.com](http://www.backyarddiscovery.com)  
For the most up to date assembly manual, to register your product, or to order replacement parts  
*Para obtener instrucciones en español, visite [www.backyarddiscovery.com](http://www.backyarddiscovery.com)*



EASY STEP-BY-STEP  
3D INTERACTIVE INSTRUCTIONS  
DOWNLOAD THE FREE APP



# OWNER'S MANUAL - BASIC SETUP DIMENSIONS & ASSEMBLY NOTES

It is critically important that you start with square and level footings or concrete pad to attach your structure

- Pay close attention to the items needed for each step. Make sure you are using the correct hardware for each step. Using incorrect hardware may result in improper assembly
- Remember to double check for underground utilities and overhead electrical lines

Post mounts are provided with your structure which allows you to permanently install your structure to a pre-existing or new wood or concrete surface. See Anchor Instructions for further details and recommendations.

- The hardware to attach the post mounts to the structure is included.
- The hardware to mount the structure permanently to a concrete surface is included.
- The hardware to mount the structure permanently to a wood deck is NOT included and will need to be purchased separately. You must ensure there is ample structural support under the deck before permanently attaching.

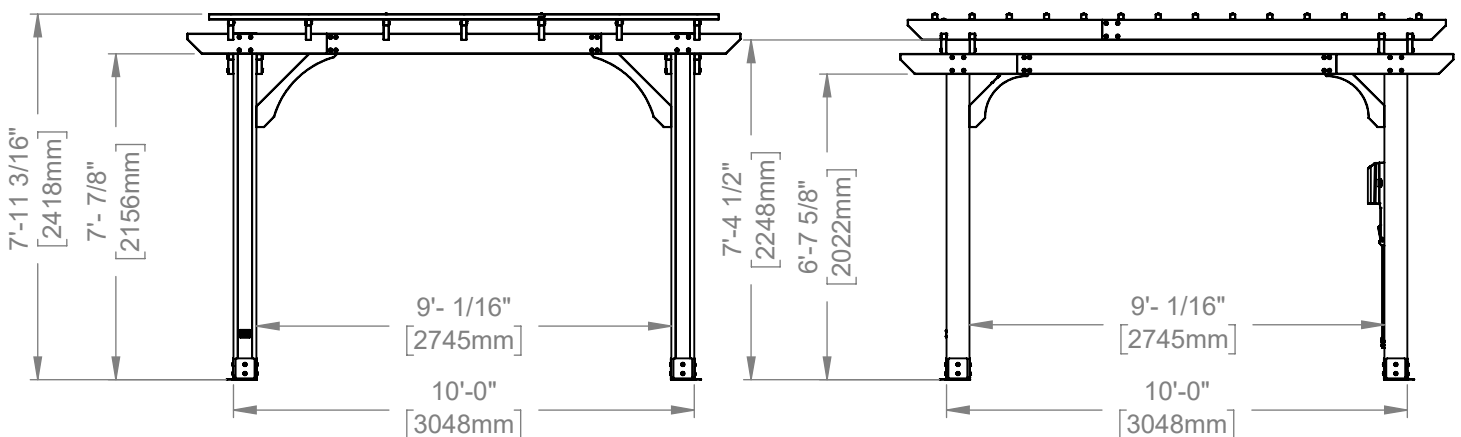
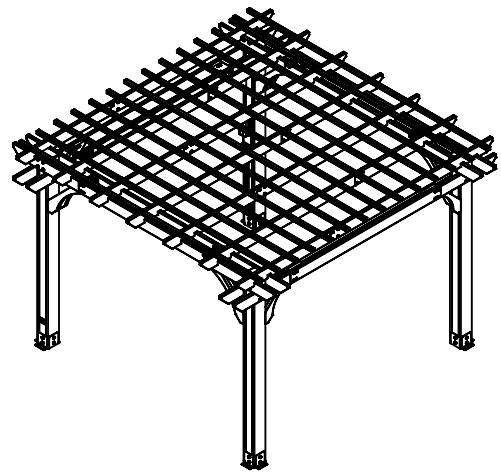
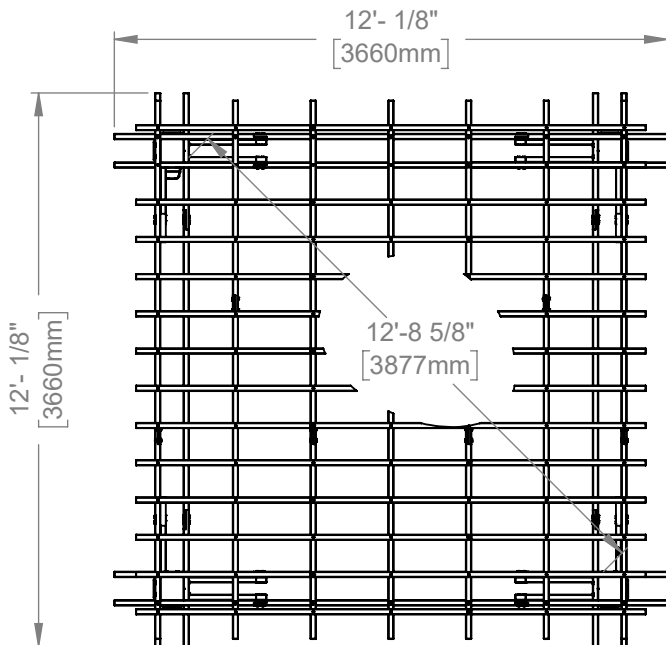

# OWNER'S MANUAL - ANCHORING LAYOUT

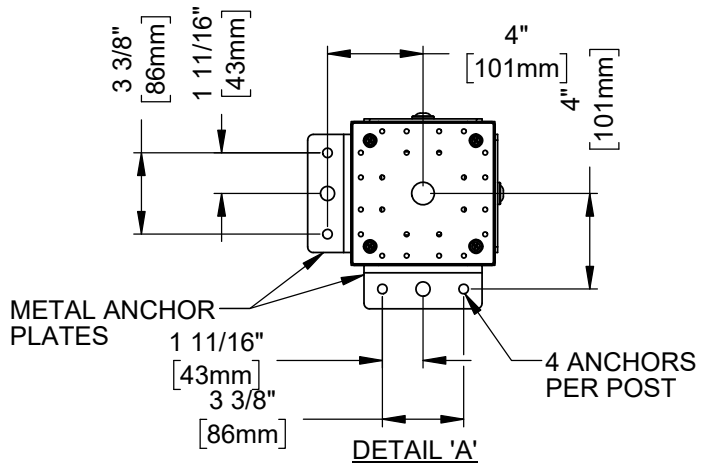
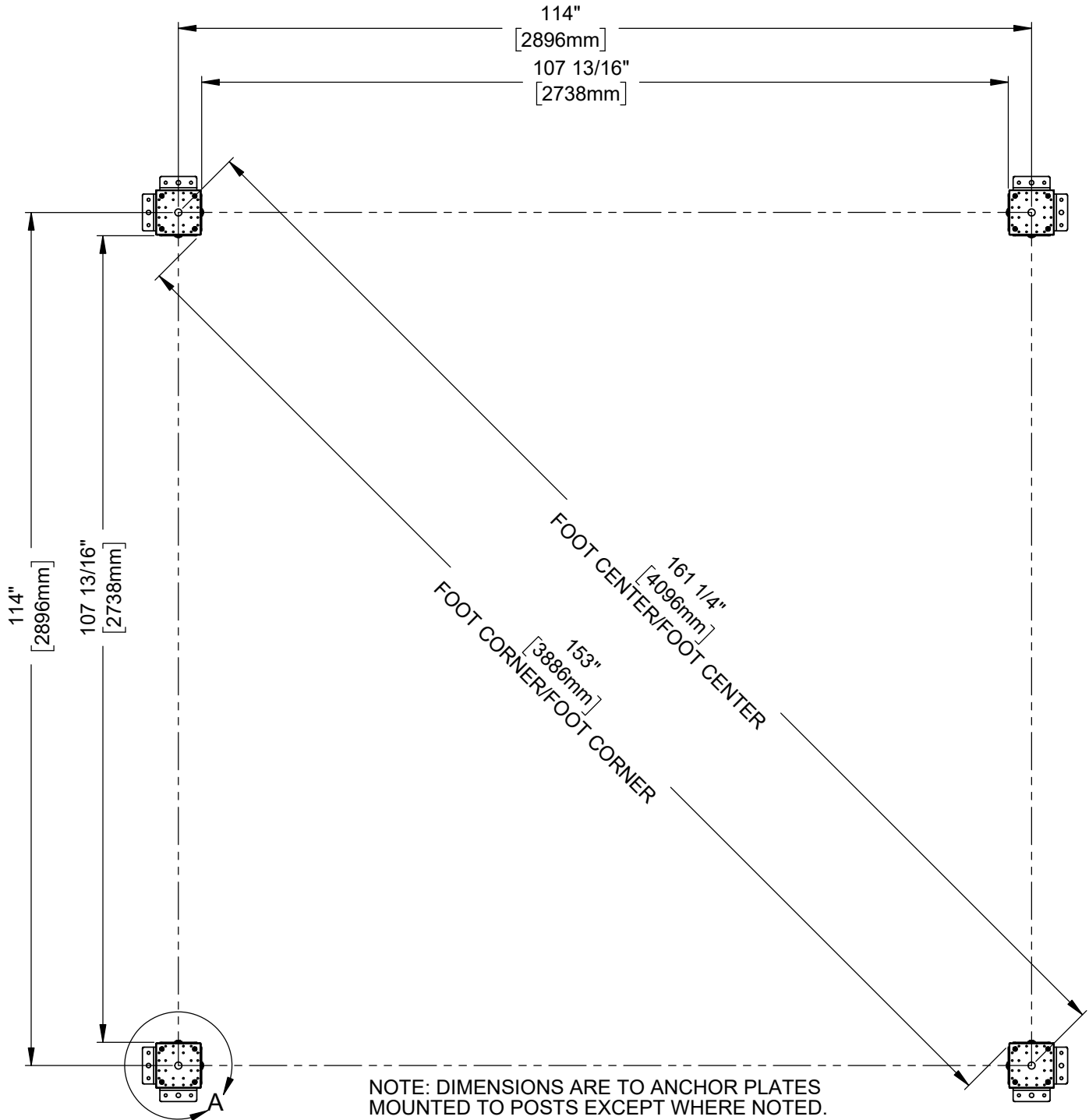

# OWNER'S MANUAL - PARTS IDENTIFICATION

WOOD COMPONENTS (NOT TO SCALE)



D01 JOIST END - W4L15500  
(x4) 1 3/8"X5 1/4"X35 1/2" (36x134x902)



D02 JOIST END - W4L15501  
(x4) 1 3/8"X5 1/4"X35 1/2" (36x134x902)



D03 JOIST END - W4L20657  
(x2) 1 3/8"X5 1/4"X39 3/4" (36x134x1009)



D04 JOIST END - W4L20658  
(x2) 1 3/8"X5 1/4"X39 3/4" (36x134x1009)



D05 JOIST - W4L20660  
(x2) 1 3/8"X5 1/4"X71 1/2" (36x134x1815)



D06 JOIST END - W4L20661  
(x2) 1 3/8"X5 1/4"X39 3/4" (36x134x1009)



D07 JOIST - W4L15506  
(x4) 1 3/8"X5 1/4"X83 1/8" (36x134x2112)



D08 JOIST - W4L20659  
(x2) 1 3/8"X5 1/4"X71 1/2" (36x134x1815)



D09 JOIST END - W4L20662  
(x2) 1 3/8"X5 1/4"X39 3/4" (36x134x1009)



D11 CORBEL - W4L15510  
(x8) 1 3/8"X5 1/4"X32 1/2" (36x134x826)



D12 CORBEL - W4L15513  
(x3) 1 3/8"X5 1/4"X28 1/4" (36x134x719)



D14 SLOTTED JOIST - W4L15515  
(x7) 1 3/8"X5 1/4"X55 3/4" (36x134x1416)



D15 SLOTTED JOIST - W4L15517  
(x7) 1 3/8"X5 1/4"X89 1/2" (36x134x2274)



P10 PURLIN - W4L20663  
(x14) 1 3/8"X1 3/8"X46 7/8" (36x36x1191)



P11 PURLIN - W4L20664  
(x14) 1 3/8"X1 3/8"X87 3/8" (36x36x2219)

# OWNER'S MANUAL - PARTS IDENTIFICATION

WOOD COMPONENTS (NOT TO SCALE)



D13 CORBEL - W2A03243  
(x1) 1 3/8"X5 1/4"X28 1/4" (36x134x719)



P01 POST - W2A04448  
(x2) 6"X6"X89 1/2" (152x152x2274)

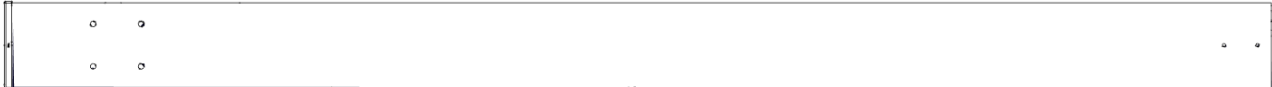

P02 POST - W2A04449  
(x2) 6"X6"X89 1/2" (152x152x2274)

# OWNER'S MANUAL - PARTS IDENTIFICATION

## Hardware Components

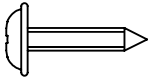

**H100202 | SCREW PWH BLK**  
(x4) | 8x5/8

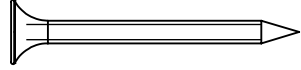

**H100200 | SCREW PFH BLK**  
(x16) | 8x1-1/2

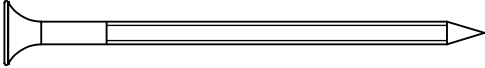

**H100201 | SCREW PFH BLK**  
(x84) | 8x2-1/2

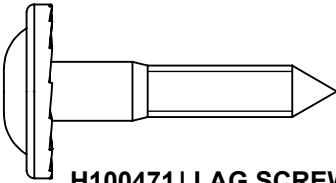

**H100471 | LAG SCREW WH BLK**  
(x32) | 5/16x1-1/2



**H100204 | LAG SCREW WH BLK**  
(x14) | 5/16x5-1/2

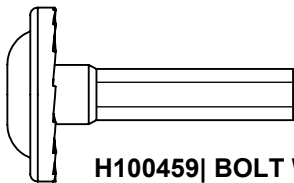

**H100459 | BOLT WH BLK**  
(x44) | 5/16x1-1/4

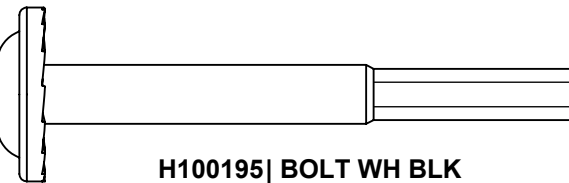

**H100195 | BOLT WH BLK**  
(x48) | 5/16x2-3/4

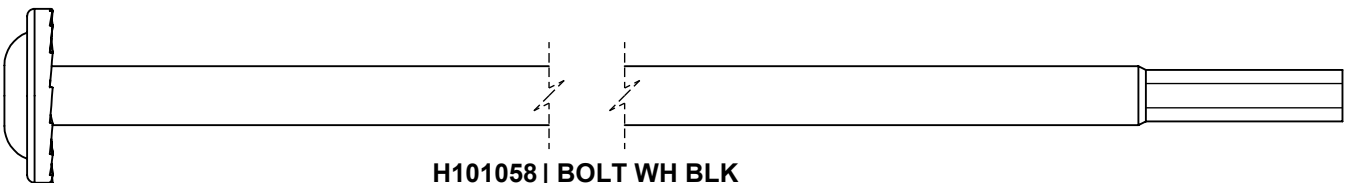

**H101058 | BOLT WH BLK**  
(x32) | 5/16x8-3/4

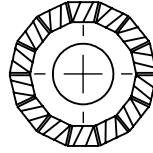

**H100198 | WASHER LOCK EXT BLK**  
(x138) | 8x19

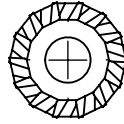

**H100405 | WASHER LOCK EXT BLK**  
(x26) | 6x15

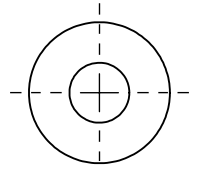

**H100630 | WASHER FLAT BLK**  
(x16) | 8x19

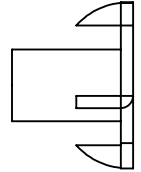

**H100379 | T-NUT BLK**  
(x124) | 5/16

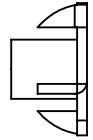

**H100398 | T-NUT BLK**  
(x14) | 1/4

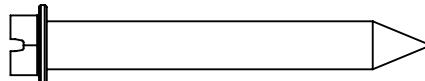

**H100120 | CONCRETE ANCHOR**  
(x16) | 1/4x2

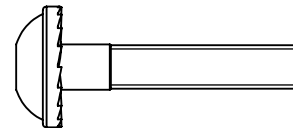

**H100397 | BOLT WH BLK**  
(x14) | 1/4x1-1/4

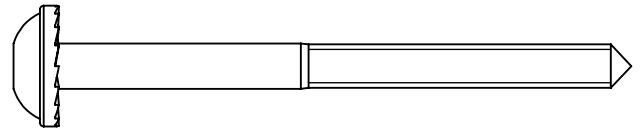

**H100792 | LAG SCREW WH BLK**  
(x12) | 1/4x3

# OWNER'S MANUAL - PARTS IDENTIFICATION

## Hardware Components

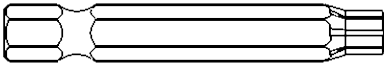

**H100147 | TORX BIT**  
(x1) | T-30

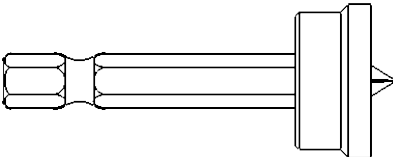

**H100764 | SCREW SETTER**  
(x1) |

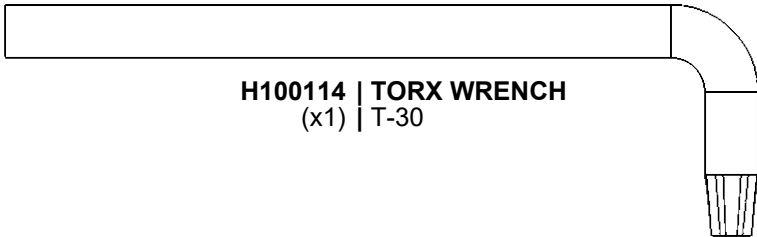

**H100114 | TORX WRENCH**  
(x1) | T-30

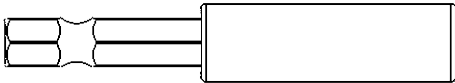

**H101100 | MAGNETIC DRIVER**  
(x1) |

# OWNER'S MANUAL - PARTS IDENTIFICATION

ACCESSORY COMPONENTS (NOT TO SCALE)

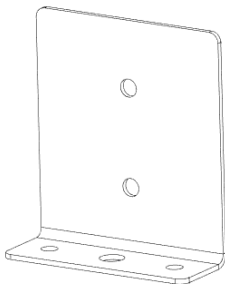

A4M00977 POST ANCHORING PLATE  
(x8)

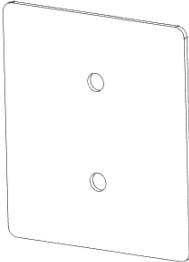

A4M00978 POST PLATE  
(x8)



A4M02158 BYD ID TAG PATIO  
(x1)

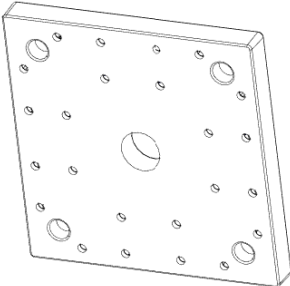

A6P00308 6x6 POST FOOT  
(x4)

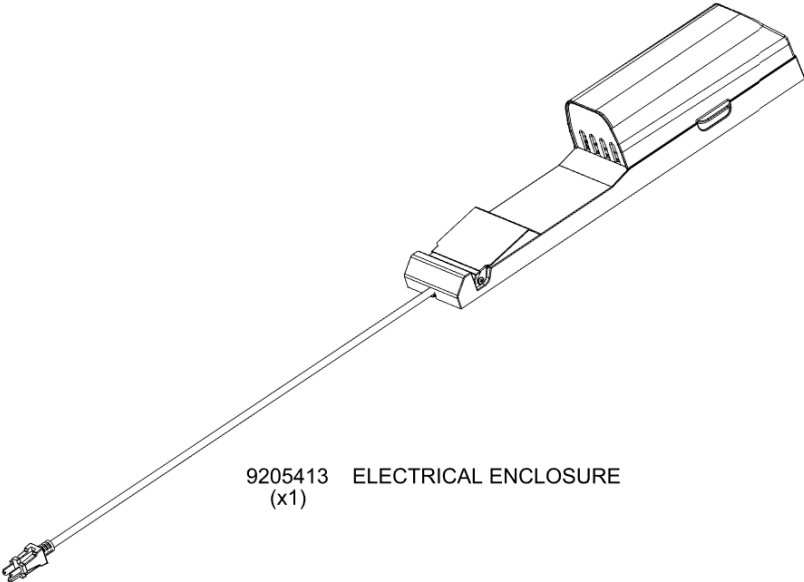

9205413 ELECTRICAL ENCLOSURE  
(x1)



# PRE-ASSEMBLY STEP 1 - SORTING PARTS

It is critical for ease of assembly that you take the time to sort and organize the wood and hardware.

---

## WOOD PARTS:

- Organize wood parts by the three-digit, alpha-numeric number stamped on each board (ex. P01).
- If there are multiple boards with the same stamped number, stack those pieces together.
- Stamps can be found on the flat surface of the boards or on the end of the boards.
- Allow yourself plenty of room - the wood pieces can take up a significant amount of space.

**NOTE: CARTONS ARE NOT ORGANIZED BY BOARD OR STEP NUMBER.**



## HARDWARE PARTS:

- We recommend that you have a separate table to organize the hardware.
- Hardware bags are printed with a seven-digit, alpha-numeric part number.
- You can organize your hardware by part number or group by hardware type (e.g. bolts, nuts, etc.).
- During assembly you only need to reference the last four digits of the number.

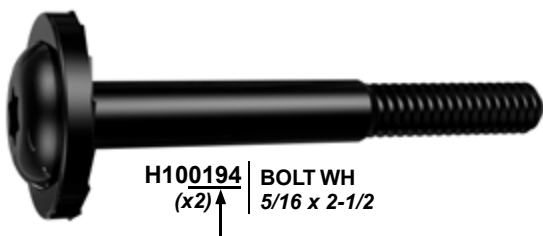

# PRE-ASSEMBLY STEP 2 - TOOLS REQUIRED



Cordless Drill  
or Electric Drill



Drill  
Attachments:  
Phillips Head



1/8", 3/16", 3/8" &  
7/16" Drill Bits



Phillips Screw Driver



Open End  
Wrenches 1/2"  
& 9/16"



3/8" Drive Ratchet, 1/2" &  
7/16" STD Sockets 1/2" & 7/16"  
Deep Sockets



Claw Hammer



Rubber Mallet  
- Optional



Tape Measure

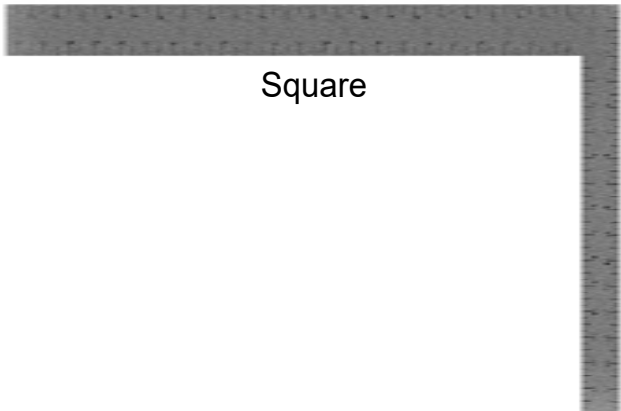

Square



Level 24"

# PRE-ASSEMBLY STEP 3 - CHOOSE YOUR ASSEMBLY METHOD

There are several types of assembly instructions available to you.

1. Printed Assembly Manual included with your set
2. BILT APP - 3D interactive instructions
3. Combination of the Printed Manual and BILT APP (Note: Step numbers can differ between the two methods)

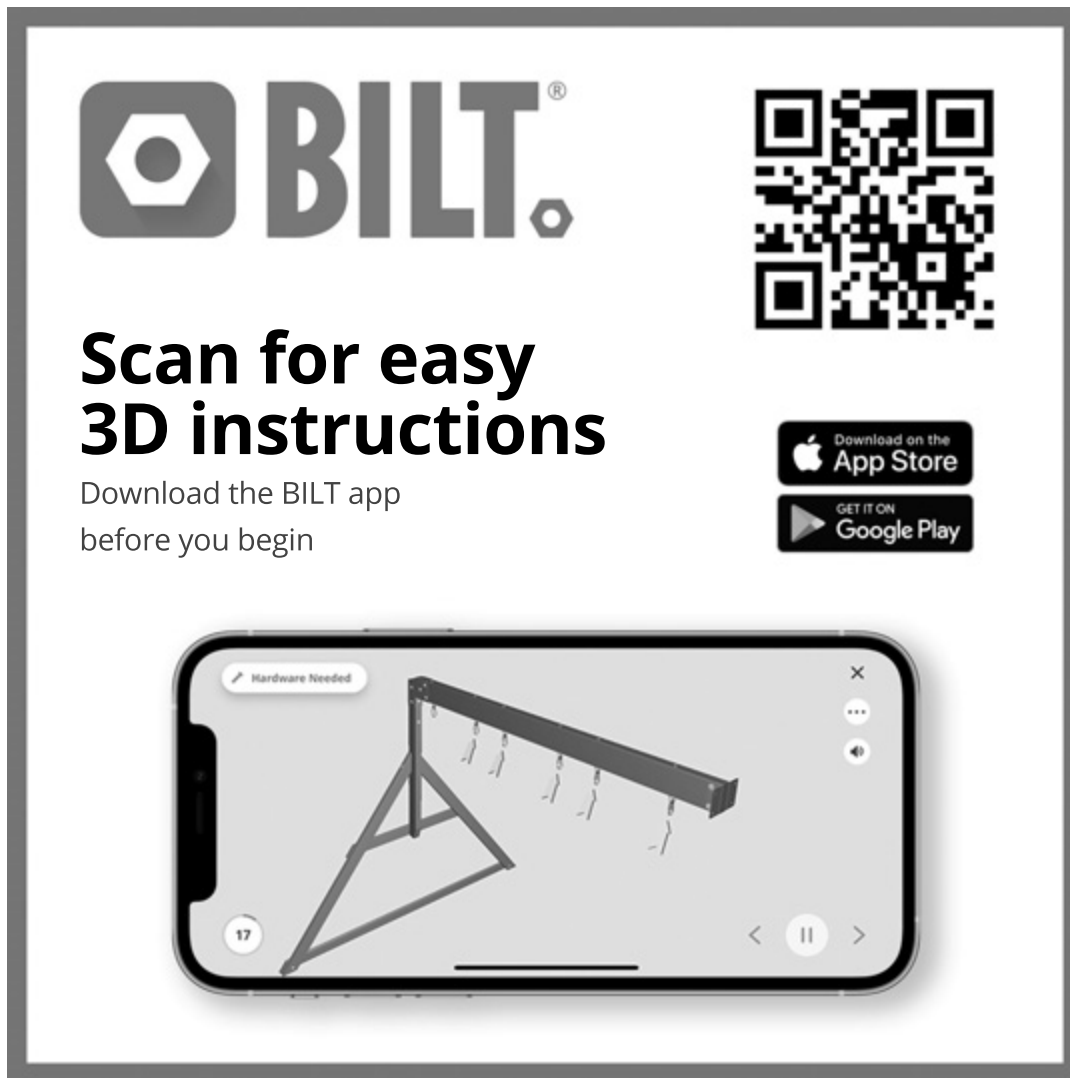

The graphic features the BILT logo (a hexagon with a white dot inside) and the word "BILT." in a bold, sans-serif font. To the right is a large QR code. Below the logo, the text "Scan for easy 3D instructions" is written in a large, bold font. Underneath this, it says "Download the BILT app before you begin". To the right of the text are two buttons: "Download on the App Store" and "GET IT ON Google Play". At the bottom, a smartphone screen displays a 3D assembly instruction for step 17, showing a metal frame structure with a horizontal bar and several hanging components. The screen includes a "Hardware Needed" button, a close button (X), a menu button (three dots), a volume icon, and navigation arrows.

# STEP 1 - PERGOLA ASSEMBLY

QTY	PART NUMBER	DESCRIPTION
16	H100200	SCREW PFH 8x1 1/2 BLK



P01 POST - W2A04448  
(x2) 6"X6"X89 1/2" (152x152x2274)



P02 POST - W2A04449  
(x2) 6"X6"X89 1/2" (152x152x2274)

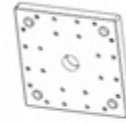

A6P00308 6x6 POST FOOT  
(x4)

- FOR EASE OF ASSEMBLY, WE RECOMMEND USING SAWHORSES FOR STEPS 1-7.
- COMPLETE THIS STEP TWICE.

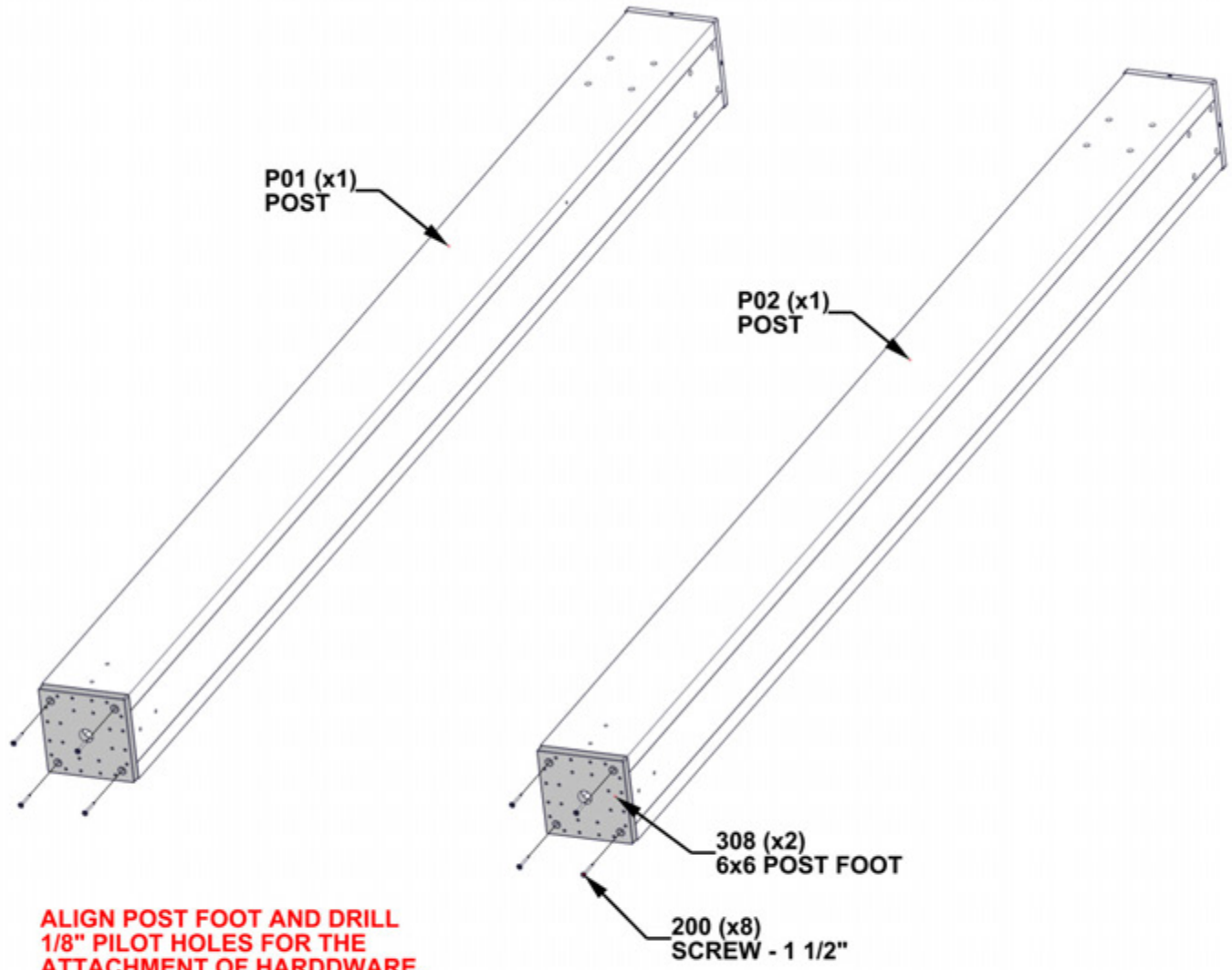

**ALIGN POST FOOT AND DRILL  
1/8" PILOT HOLES FOR THE  
ATTACHMENT OF HARDWARE.**

# STEP 2 - PERGOLA ASSEMBLY

QTY	PART NUMBER	DESCRIPTION
8	H100195	BOLT WH 5/16x2 3/4 BLK
8	H100198	WASHER LOCK EXT 8x19
8	H100379	TNUT-5/16" BLK



D01 JOIST END - W4L15500  
(x1) 1 3/8"X5 1/4"X35 1/2" (36x134x902)



D02 JOIST END - W4L15501  
(x1) 1 3/8"X5 1/4"X35 1/2" (36x134x902)



D07 JOIST - W4L15506  
(x1) 1 3/8"X5 1/4"X83 1/8" (36x134x2112)

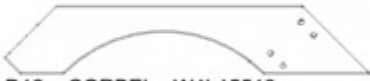

D12 CORBEL - W4L15513  
(x1) 1 3/8"X5 1/4"X28 1/4" (36x134x719)

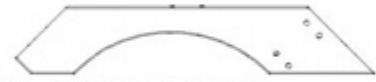

D13 CORBEL - W2A03243  
(x1) 1 3/8"X5 1/4"X28 1/4" (36x134x719)

**- INSERT T-NUTS FIRST.  
- HAND TIGHTEN ONLY.**

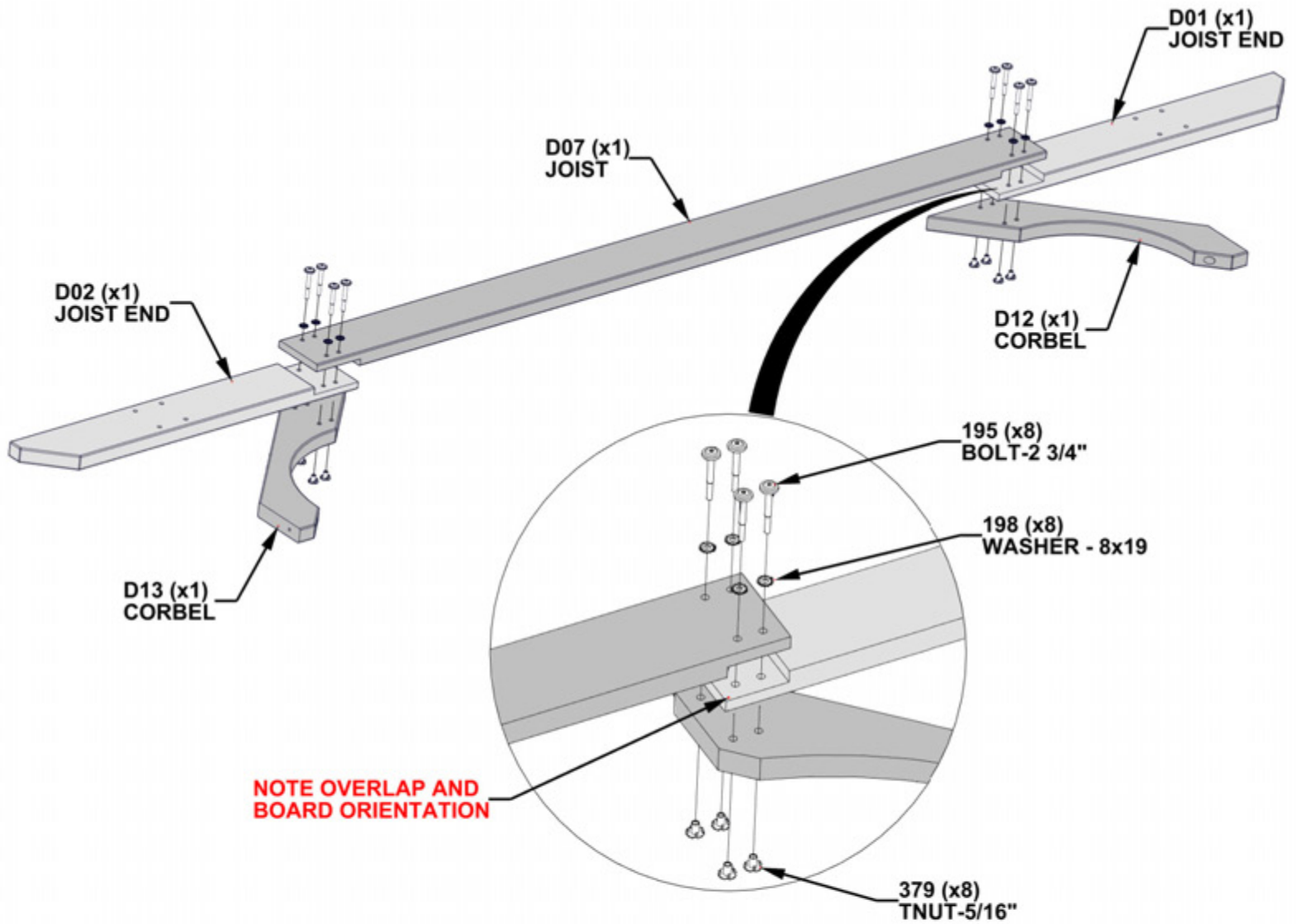

# STEP 3 - PERGOLA ASSEMBLY

QTY	PART NUMBER	DESCRIPTION
8	H100195	BOLT WH 5/16x2 3/4 BLK
8	H100198	WASHER LOCK EXT 8x19
8	H100379	TNUT-5/16" BLK

D01 JOIST END - W4L15500  
(x1) 1 3/8"X5 1/4"X35 1/2" (36x134x902)

D02 JOIST END - W4L15501  
(x1) 1 3/8"X5 1/4"X35 1/2" (36x134x902)



D07 JOIST - W4L15506  
(x1) 1 3/8"X5 1/4"X83 1/8" (36x134x2112)



D12 CORBEL - W4L15513  
(x2) 1 3/8"X5 1/4"X28 1/4" (36x134x719)

**- INSERT T-NUTS FIRST.  
- HAND TIGHTEN ONLY.**

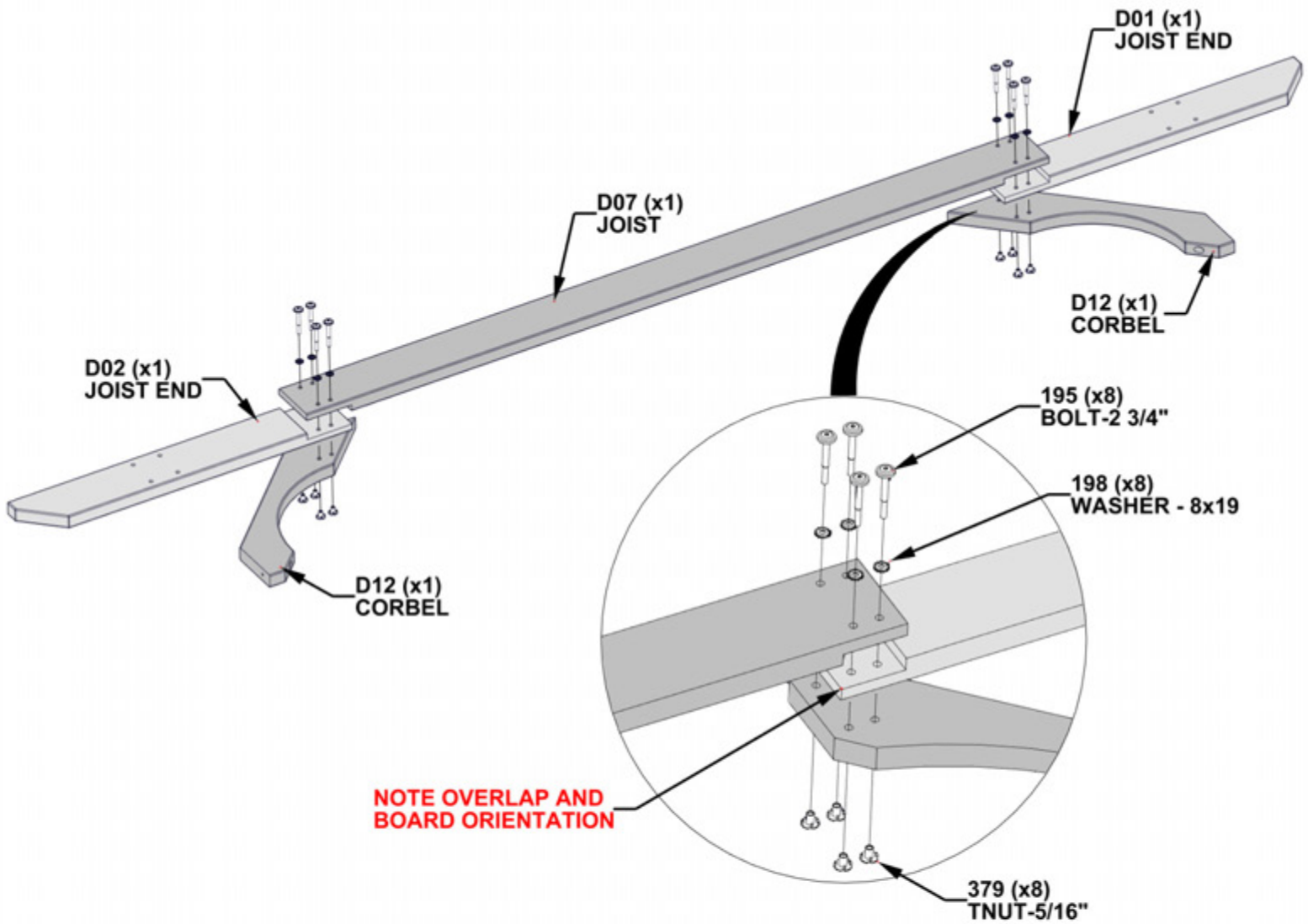

# STEP 4 - PERGOLA ASSEMBLY

QTY	PART NUMBER	DESCRIPTION
16	H100198	WASHER LOCK EXT 8x19
16	H100379	T-NUT 5/16 BLK
16	H100459	BOLT WH 5/16x1 1/4 BLK



D01 JOIST END - W4L15500  
(x2) 1 3/8"X5 1/4"X35 1/2" (36x134x902)



D02 JOIST END - W4L15501  
(x2) 1 3/8"X5 1/4"X35 1/2" (36x134x902)



D07 JOIST - W4L15506  
(x2) 1 3/8"X5 1/4"X83 1/8" (36x134x2112)

- INSERT T-NUTS FIRST.
- HAND TIGHTEN ONLY.
- COMPLETE THIS STEP TWICE.

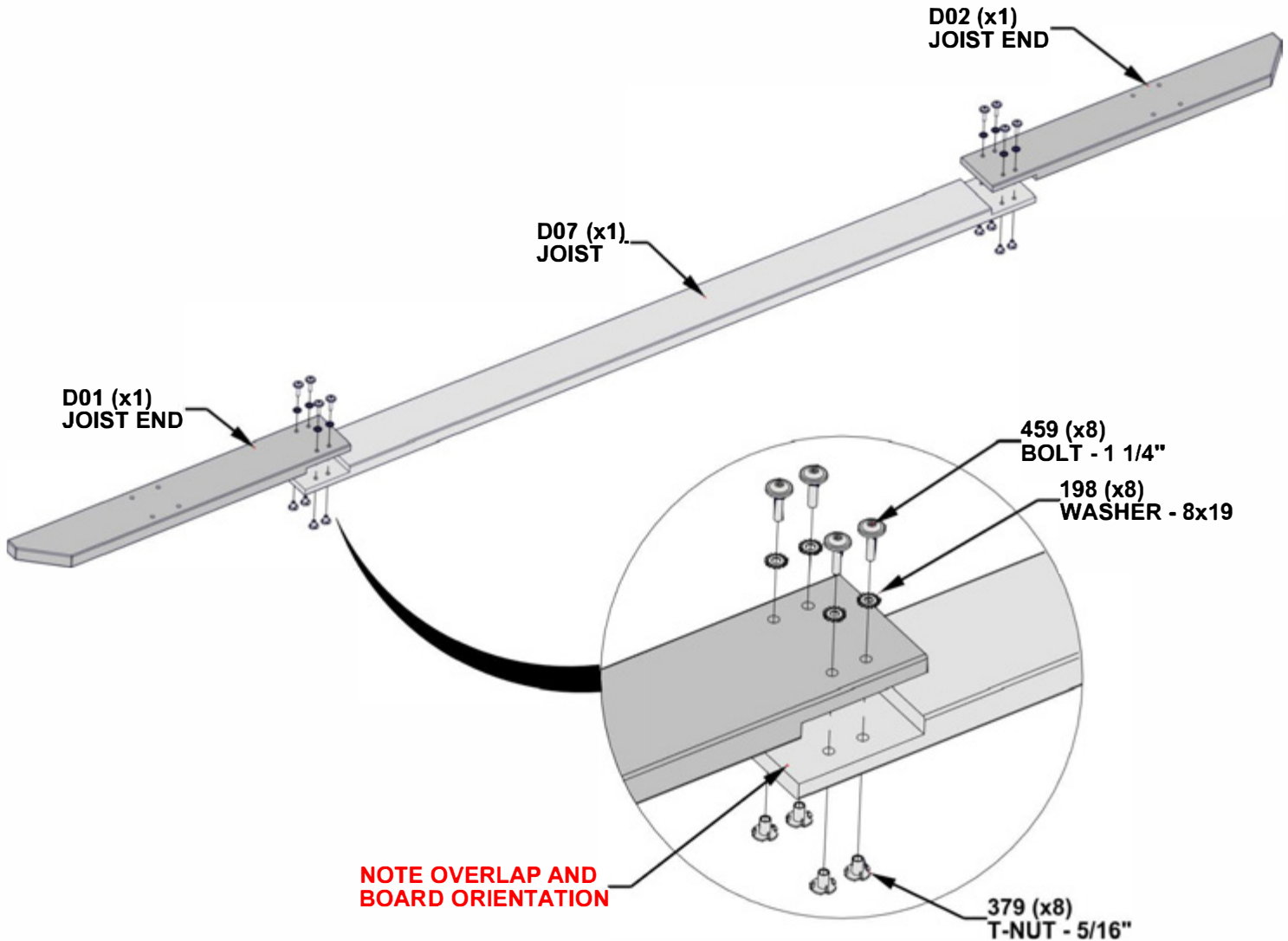

# STEP 5 - PERGOLA ASSEMBLY

QTY	PART NUMBER	DESCRIPTION
16	H100198	WASHER LOCK EXT 8x19
16	H100379	TNUT-5/16" BLK
4	H100405	WASHER LOCK EXT 6x15
4	H100792	LAG SCREW WH 1/4x3 BLK
16	H101058	BOLT WH 5/16x8 3/4 BLK



P01 POST - W2A04448  
(x2) 6"X6"X89 1/2" (152x152x2274)



P02 POST - W2A04449  
(x2) 6"X6"X89 1/2" (152x152x2274)

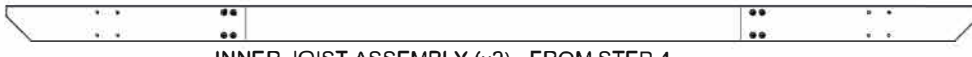

INNER JOIST ASSEMBLY (x2) - FROM STEP 4

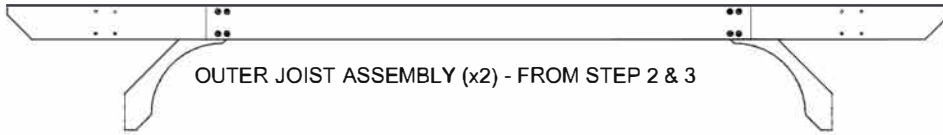

OUTER JOIST ASSEMBLY (x2) - FROM STEP 2 & 3

- INSERT T-NUTS FIRST.
- FULLY TIGHTEN HARDWARE FROM STEPS 2 - 4.
- COMPLETE THIS STEP TWICE.
- IF BOLT DOES NOT ENGAGE, CHECK FOR SAWDUST BUILD UP IN HOLES.

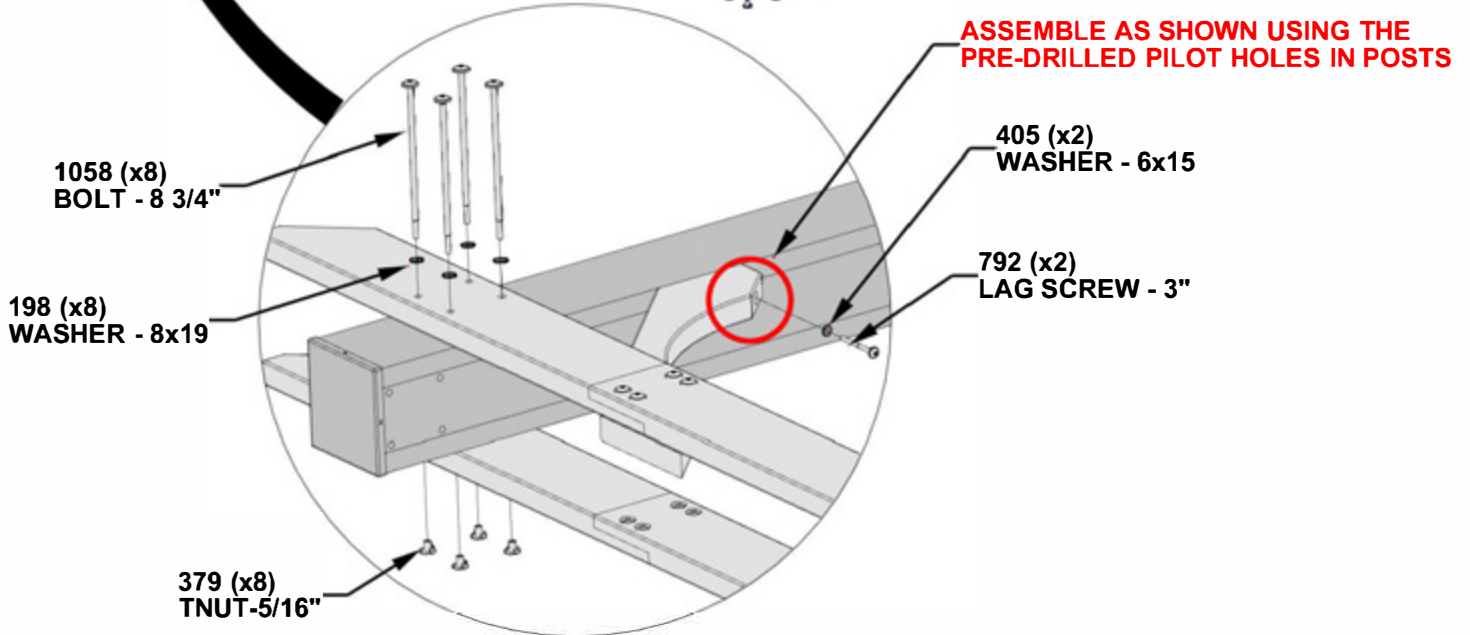
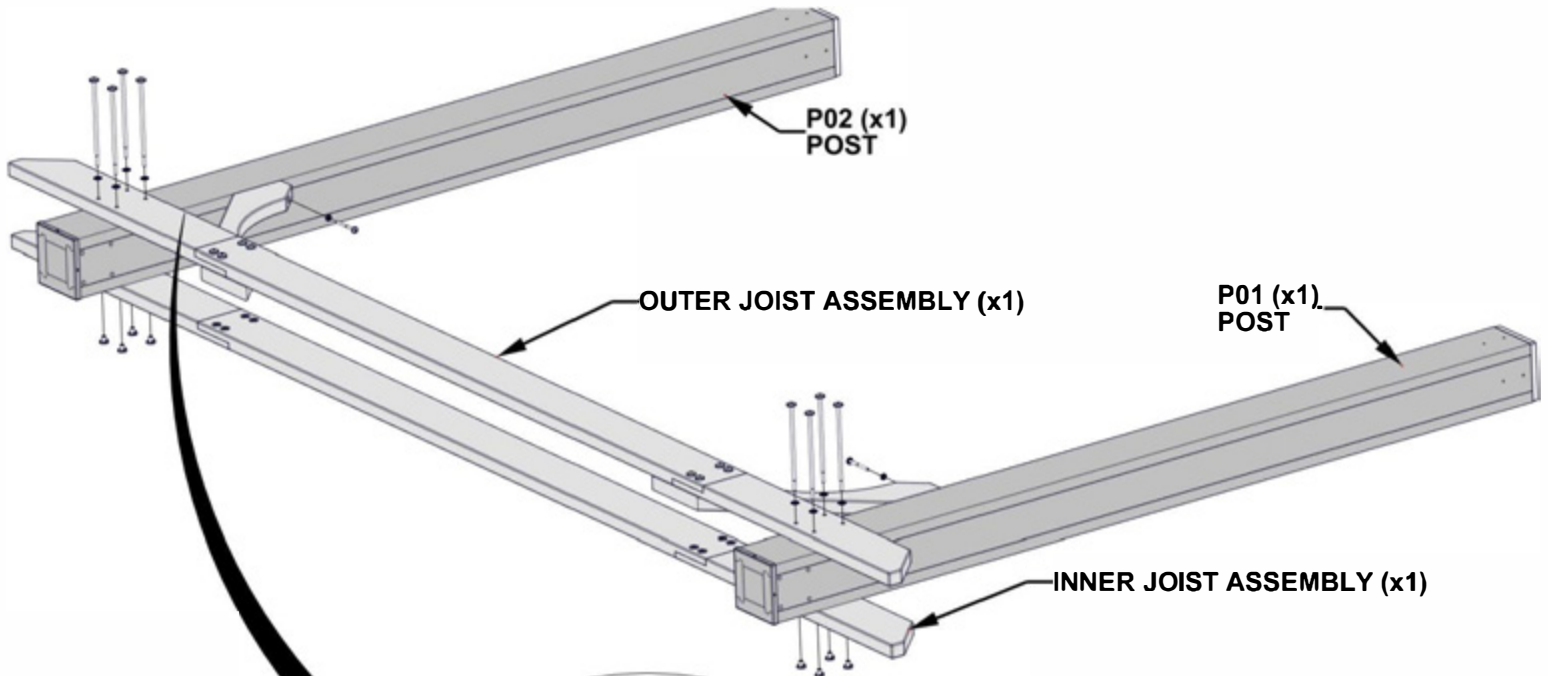

1058 (x8)  
BOLT - 8 3/4"

198 (x8)  
WASHER - 8x19

379 (x8)  
TNUT-5/16"

**ASSEMBLE AS SHOWN USING THE PRE-DRILLED PILOT HOLES IN POSTS**

405 (x2)  
WASHER - 6x15

792 (x2)  
LAG SCREW - 3"



# STEP 6 - PERGOLA ASSEMBLY

QTY	PART NUMBER	DESCRIPTION
16	H100195	BOLT WH 5/16x2 3/4 BLK
16	H100198	WASHER LOCK EXT 8x19
16	H100379	TNUT-5/16" BLK

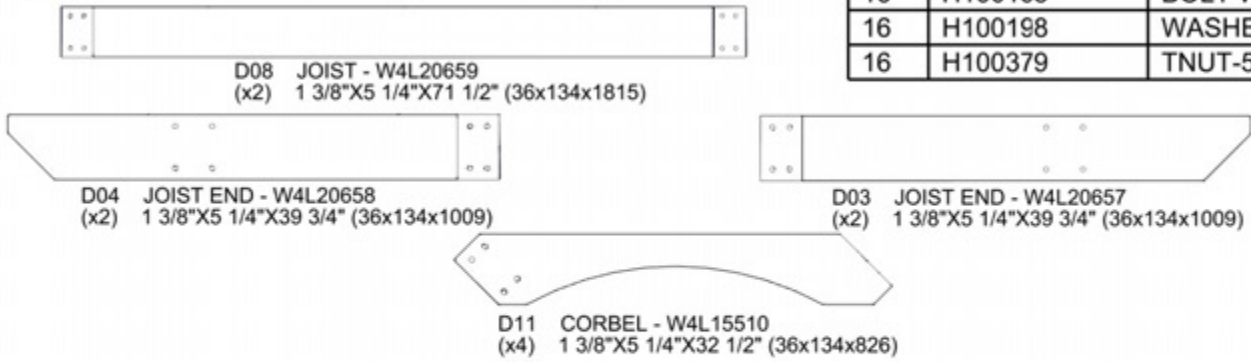

- INSERT T-NUTS FIRST.
- COMPLETE THIS STEP TWICE.

## OUTER JOIST ASSEMBLY

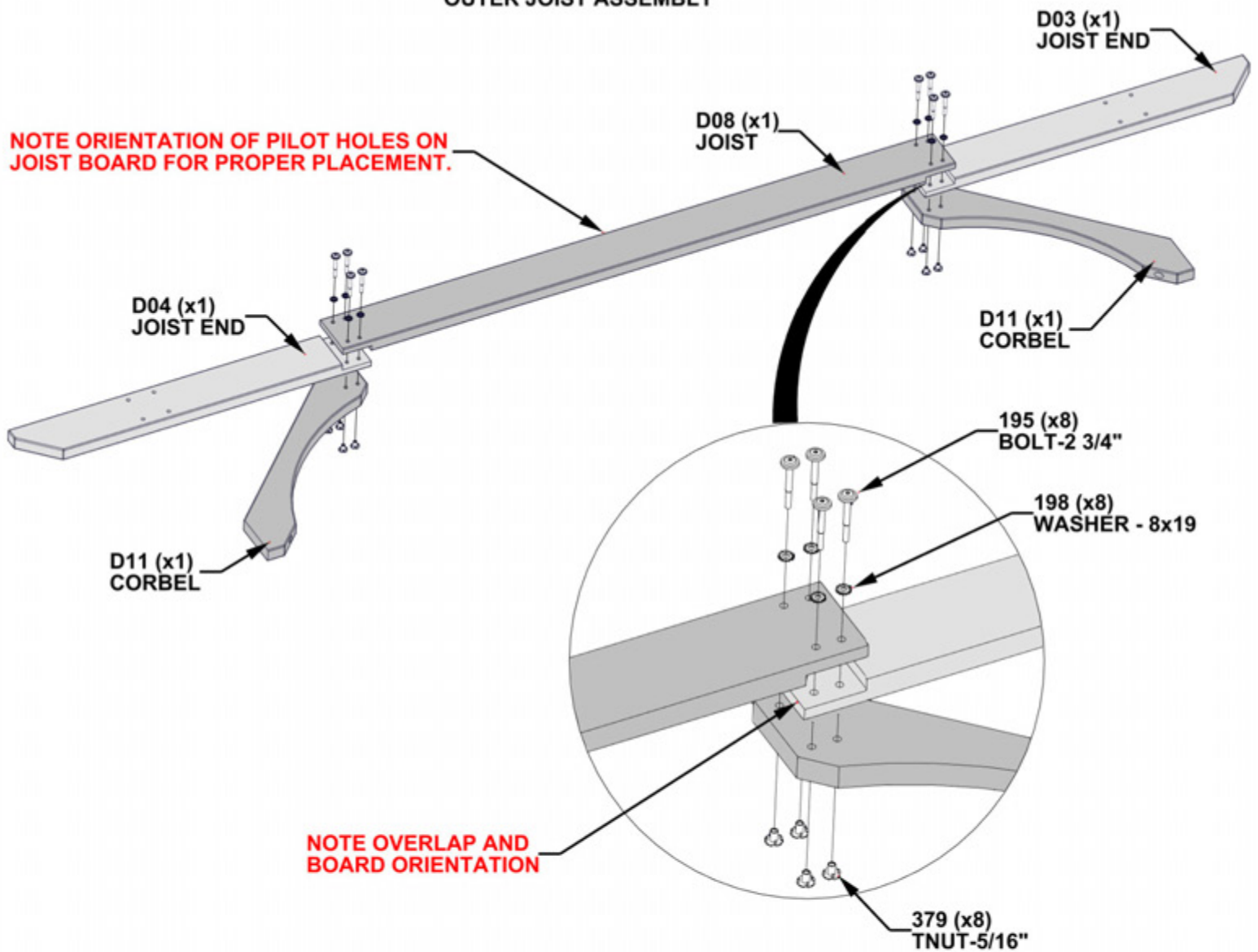

# STEP 7 - PERGOLA ASSEMBLY

QTY	PART NUMBER	DESCRIPTION
16	H100195	BOLT WH 5/16x2 3/4 BLK
16	H100198	WASHER LOCK EXT 8x19
16	H100379	TNUT-5/16" BLK



D05 JOIST - W4L20660  
(x2) 1 3/8"X5 1/4"X71 1/2" (36x134x1815)



D06 JOIST END - W4L20661  
(x2) 1 3/8"X5 1/4"X39 3/4" (36x134x1009)



D11 CORBEL - W4L15510  
(x4) 1 3/8"X5 1/4"X32 1/2" (36x134x826)



D09 JOIST END - W4L20662  
(x2) 1 3/8"X5 1/4"X39 3/4" (36x134x1009)

- INSERT T-NUTS FIRST.
- COMPLETE THIS STEP TWICE.

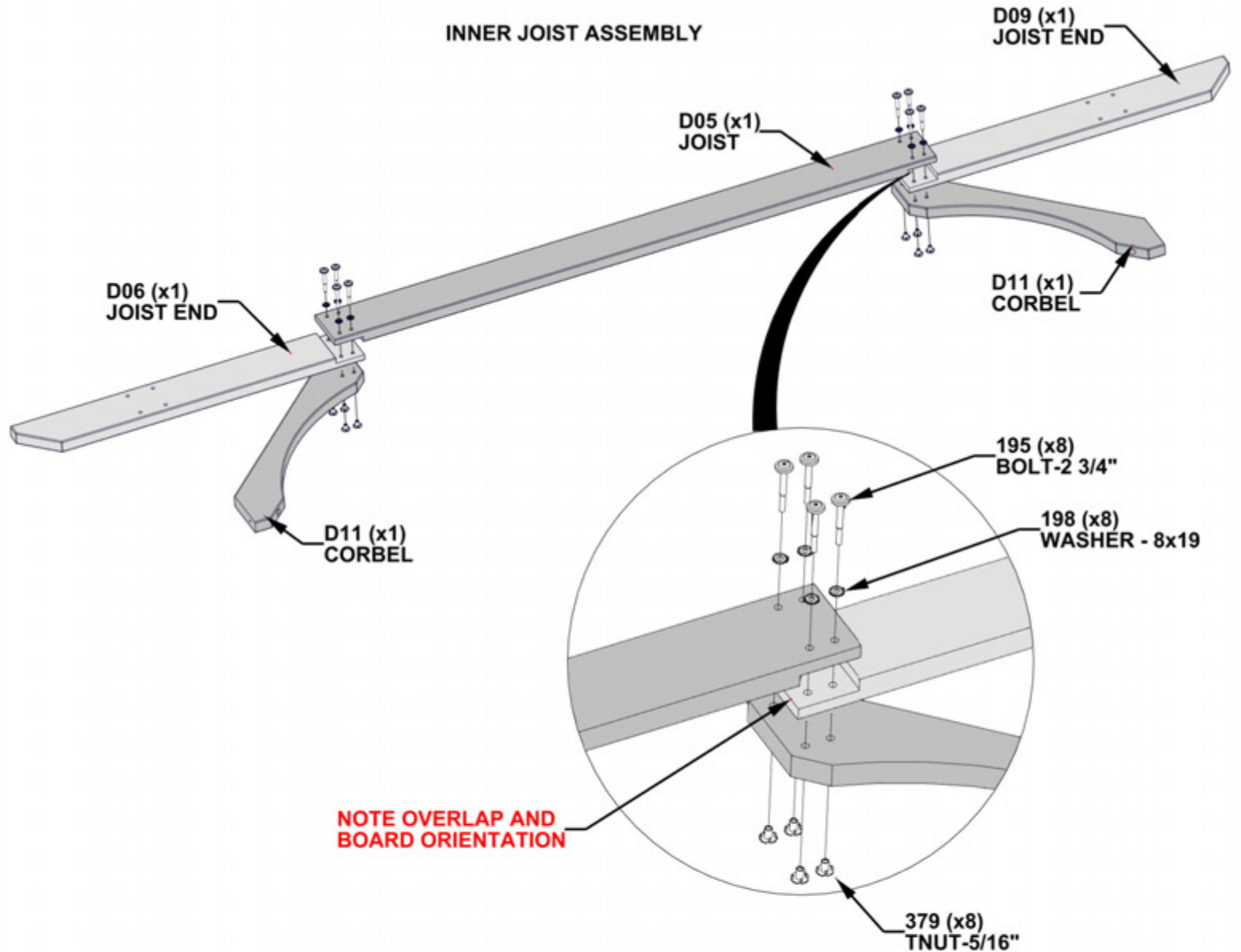

# STEP 8 - PERGOLA ASSEMBLY

QTY	PART NUMBER	DESCRIPTION
16	H100198	WASHER LOCK EXT 8x19
16	H100379	TNUT-5/16" BLK
8	H100405	WASHER LOCK EXT 6x15
8	H100792	LAG SCREW WH 1/4x3 BLK
16	H101058	BOLT WH 5/16x8 3/4 BLK

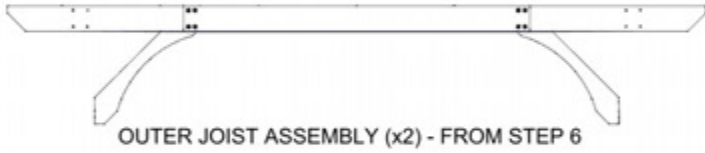
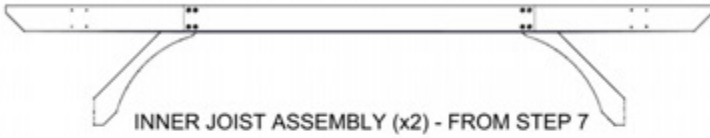

**- INSERT T-NUTS FIRST.**

- A THIRD PERSON IS HELPFUL FOR THIS STEP.
- WITH BOTH UPRIGHT ASSEMBLIES STANDING, BOLT INNER AND OUTER JOIST ASSEMBLIES TO ONE SIDE. THEN BOLT ON JOIST ASSEMBLIES TO OTHER SIDE.
- SQUARE UP POSTS TO JOIST AND FULLY TIGHTEN ALL BOLTS AND SCREWS.

198 (x16)  
WASHER - 8x19"

379 (x16)  
TNUT-5/16"

1058 (x16)  
BOLT - 8 3/4"

**ASSEMBLE AS SHOWN USING THE PRE-DRILLED PILOT HOLES IN POSTS**

405 (x8)  
WASHER - 6x15

792 (x8)  
LAG SCREW - 3"

OUTER JOIST ASSEMBLY (x2)

INNER JOIST ASSEMBLY (x2)

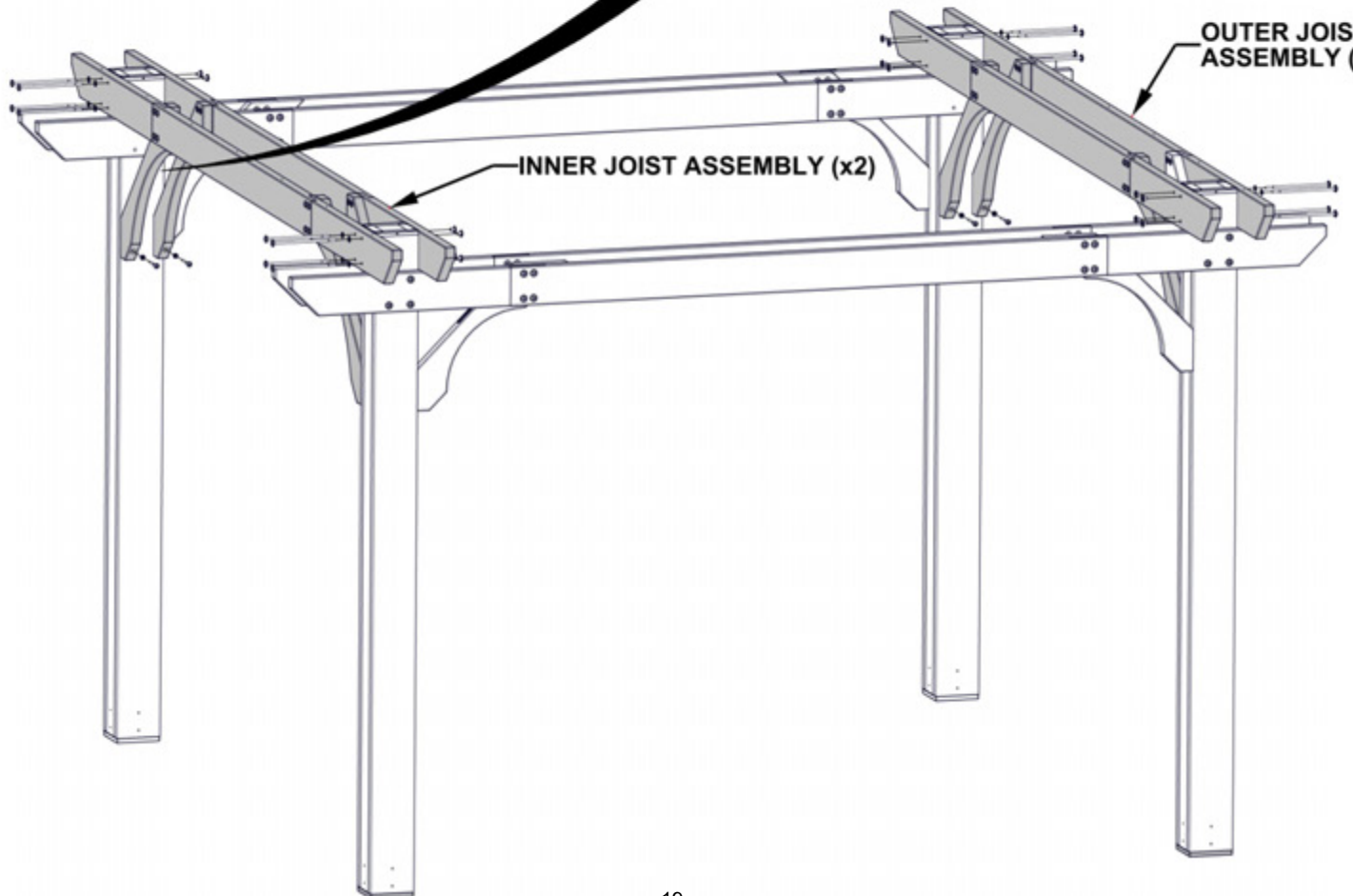

# STEP 9 - PERGOLA ASSEMBLY

QTY	PART NUMBER	DESCRIPTION
28	H100198	WASHER LOCK EXT 8x19
28	H100379	T-NUT 5/16 BLK
28	H100459	BOLT WH 5/16x1 1/4 BLK



D14 SLOTTED JOIST - W4L15515  
(x7) 1 3/8"X5 1/4"X55 3/4" (36x134x1416)



D15 SLOTTED JOIST - W4L15517  
(x7) 1 3/8"X5 1/4"X89 1/2" (36x134x2274)

- INSERT T-NUTS FIRST.
- COMPLETE THIS STEP 7 TIMES.

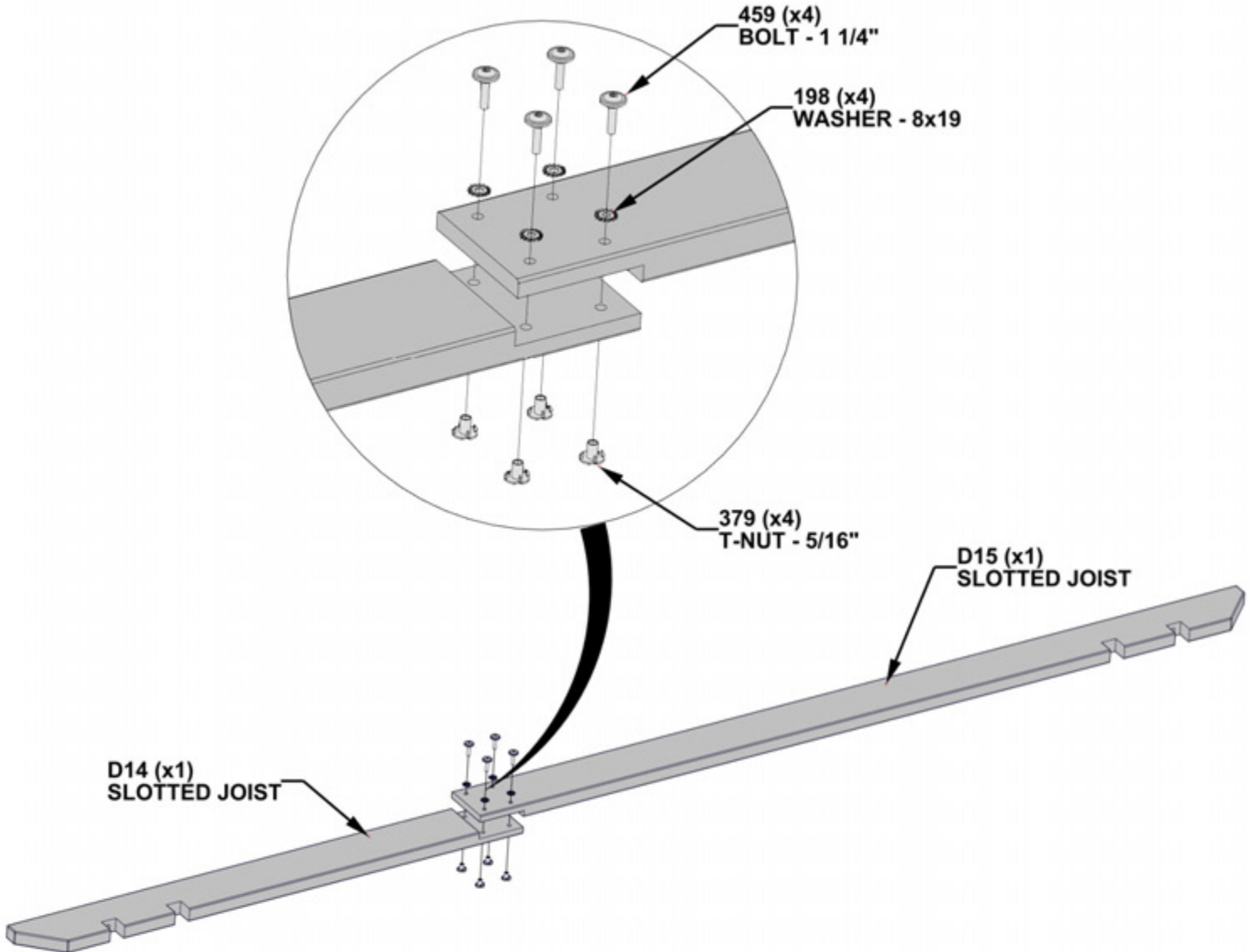

# STEP 10 - PERGOLA ASSEMBLY

QTY	PART NUMBER	DESCRIPTION
14	H100198	WASHER LOCK EXT 8x19
14	H100204	LAG SCREW WH 5/16x5 1/2 BLK



SLOTTED JOIST ASSEMBLY (x7) - FROM STEP 9

**- ATTACH SLOTTED JOIST ASSEMBLIES USING PILOT HOLES IN OUTER JOIST ASSEMBLIES.**

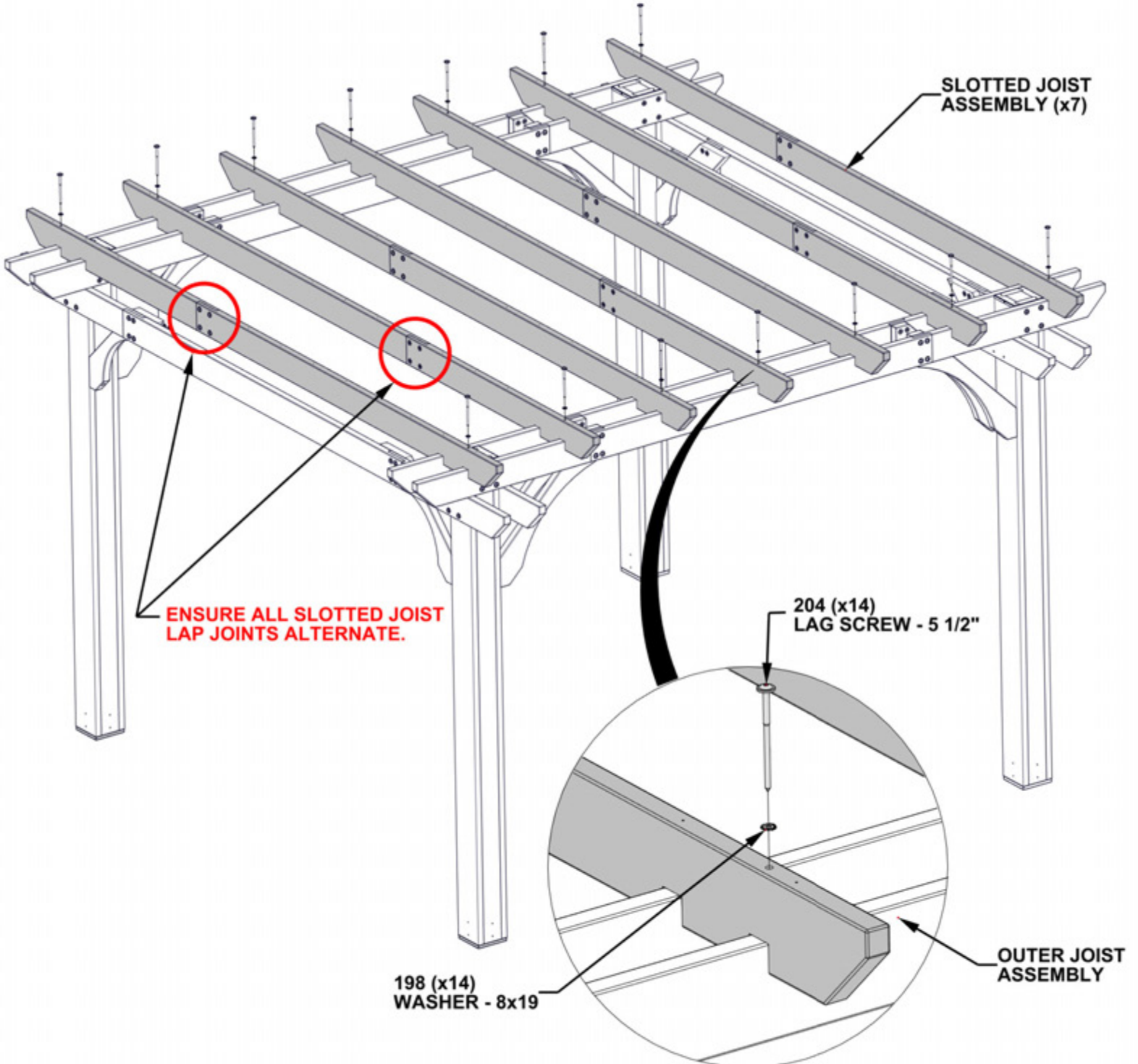

# STEP 11 - PERGOLA ASSEMBLY

QTY	PART NUMBER	DESCRIPTION
14	H100397	BOLT WH 1/4x1 1/4 BLK
14	H100398	T-NUT 1/4 BLK
14	H100405	WASHER LOCK EXT 6x15



P10 PURLIN - W4L20663  
(x14) 1 3/8"X1 3/8"X46 7/8" (36x36x1191)



P11 PURLIN - W4L20664  
(x14) 1 3/8"X1 3/8"X87 3/8" (36x36x2219)

- INSERT T-NUTS FIRST.
- COMPLETE THIS STEP FOURTEEN TIMES.

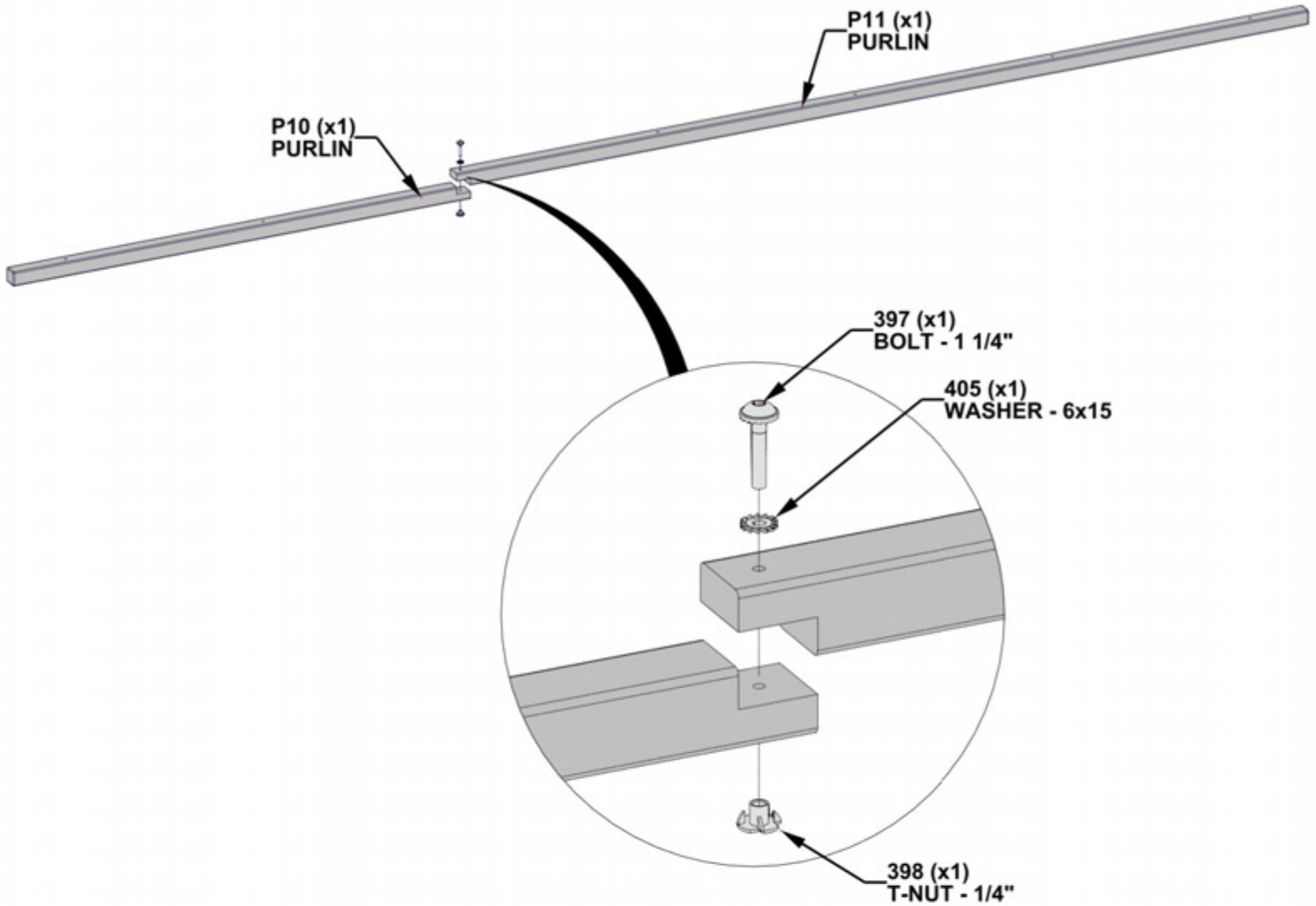

# STEP 12 - PERGOLA ASSEMBLY

QTY	PART NUMBER	DESCRIPTION
84	H100201	SCREW PFH 8x2 1/2 BLK



PURLIN ASSEMBLY (x14) - FROM STEP 11

- ALIGN PILOT HOLES.
- WHEN LIFTING UP EACH PURLIN ASSEMBLY, ENSURE THAT JOINTS ARE SUPPORTED AND PURLIN IS KEPT LEVEL.
- TO AVOID WOOD SPLITTING OUT, IT IS RECOMMENDED THAT A 1/8" [3mm] DEEP PILOT HOLE IS MADE USING A 1/8" [3mm] DRILL BIT AT THE LAP JOINTS WHERE PURLINS FASTEN TO AS SHOWN BELOW.

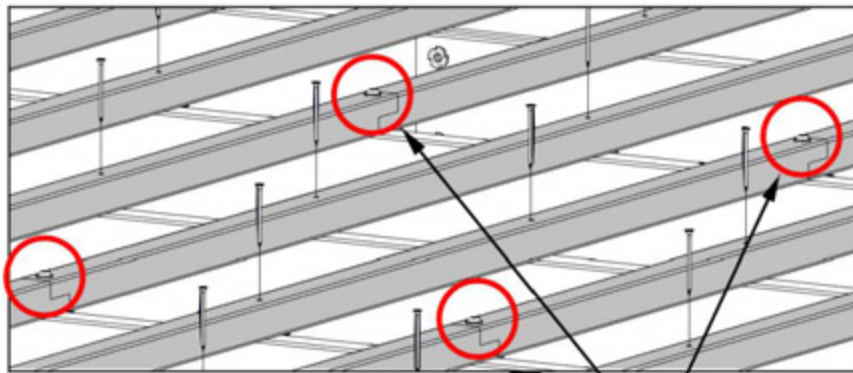

ALTERNATE PURLIN JOIST AS SHOWN.

201 (x84)  
SCREW - 2 1/2"

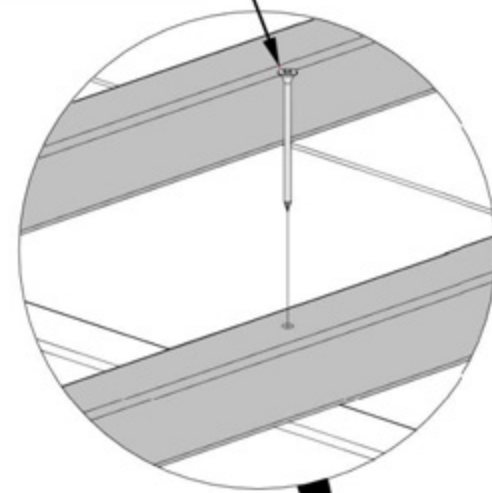

PURLIN ASSEMBLY (x14)

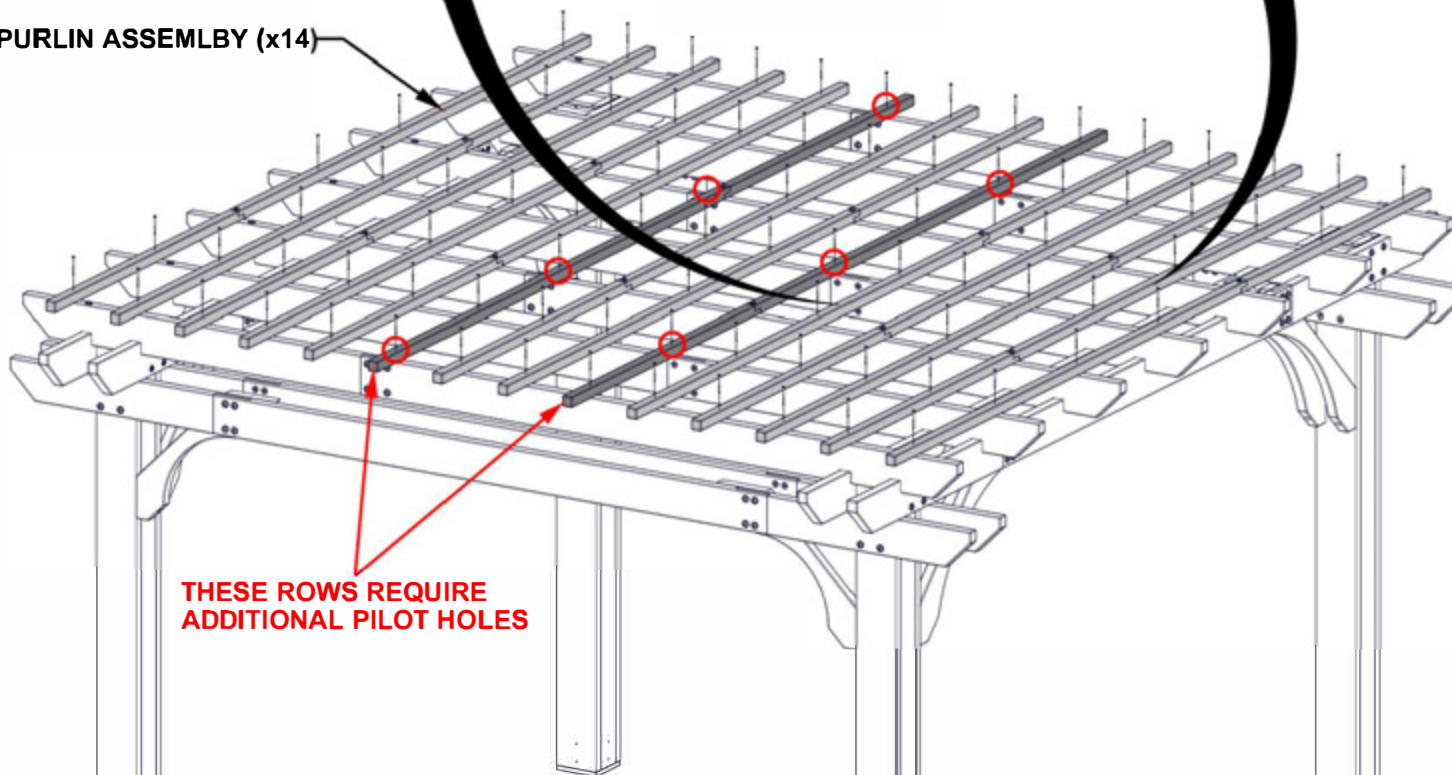

THESE ROWS REQUIRE  
ADDITIONAL PILOT HOLES

# STEP 13 - PERGOLA ASSEMBLY

QTY	PART NUMBER	DESCRIPTION
32	H100471	LAG SCREW WH 5/16x1 1/2 BLK



A4M00977 POST ANCHORING PLATE  
(x8)



A4M00978 POST PLATE  
(x8)

- ALL 977 STEEL POST ANCHORING PLATES MOUNTS ON THE OUTSIDE OF POSTS AS SHOWN.
- ALL 978 STEEL POST PLATES MOUNTS ON THE INSIDES OF THE POST AS SHOWN.

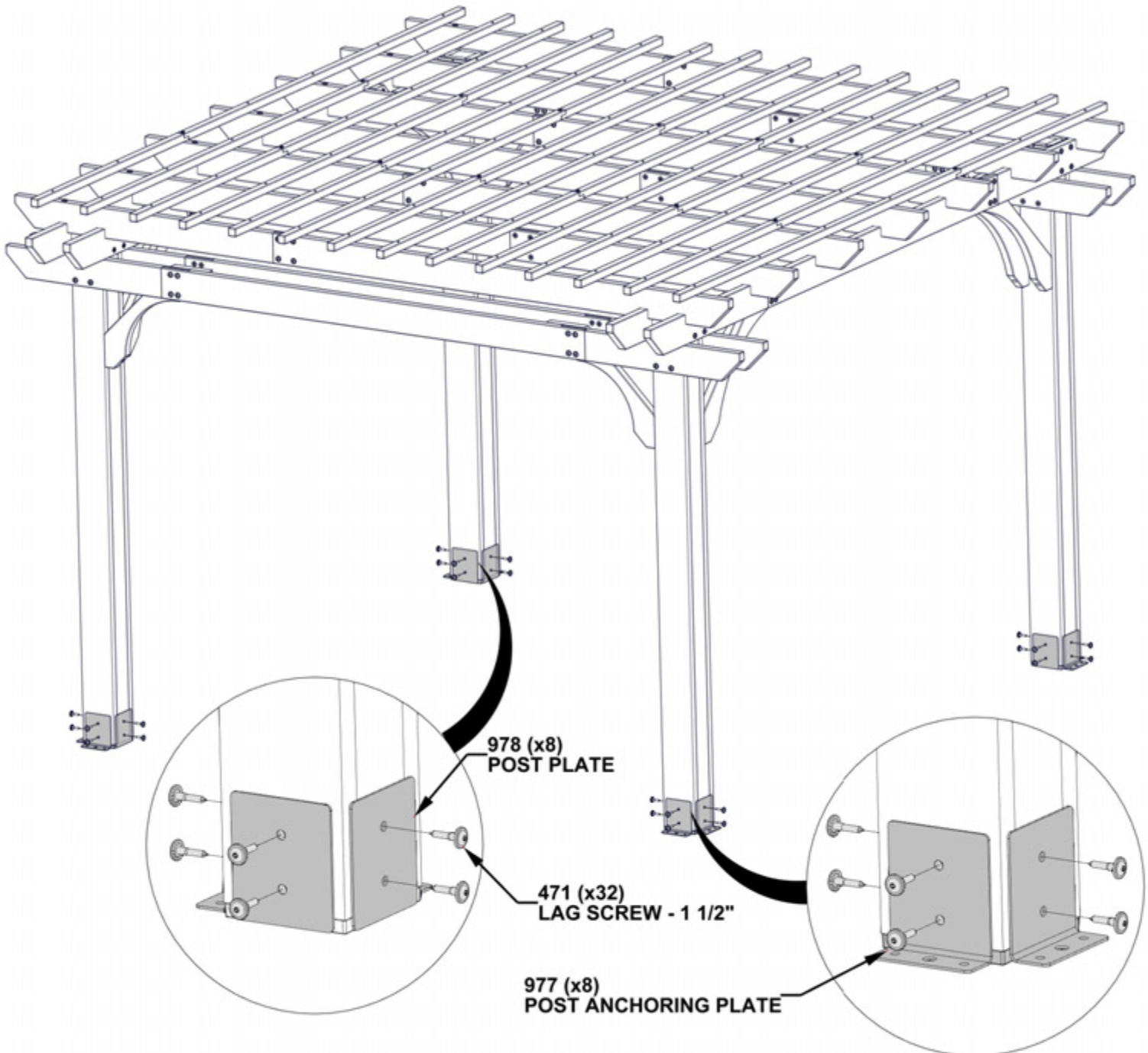



# STEP 14 - PERGOLA ASSEMBLY

QTY	PART NUMBER	DESCRIPTION
4	H100202	SCREW PWH 8x5/8 BLK



A4M02158 BYD ID TAG PATIO  
(x1)

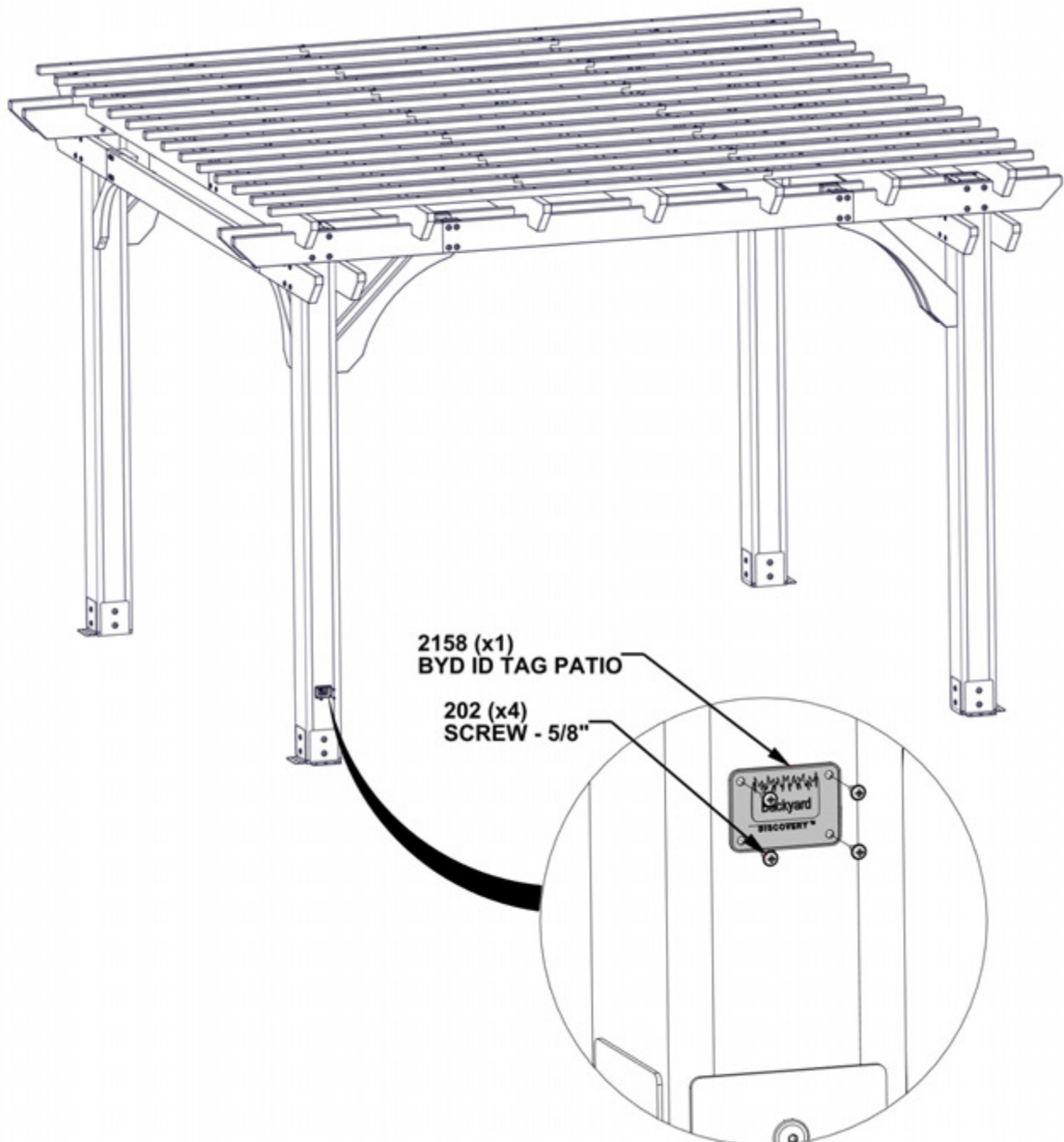

# STEP 15 - PERGOLA ASSEMBLY

QTY	PART NUMBER	DESCRIPTION
16	H100120	CONCRETE ANCHOR 1/4"x2"
16	H100630	WASHER FLAT 8x19 BLK

- MANUFACTURER RECOMMENDS INSTALLATION ON CONCRETE SURFACE OR CONCRETE POST PAD AS SHOWN BELOW.
- FOR INSTALLATION ON WOOD DECKS, YOU MUST ENSURE THERE IS AMPLE STRUCTURAL SUPPORT UNDER THE DECK. HARDWARE NOT INCLUDED FOR DECK ATTACHMENT.

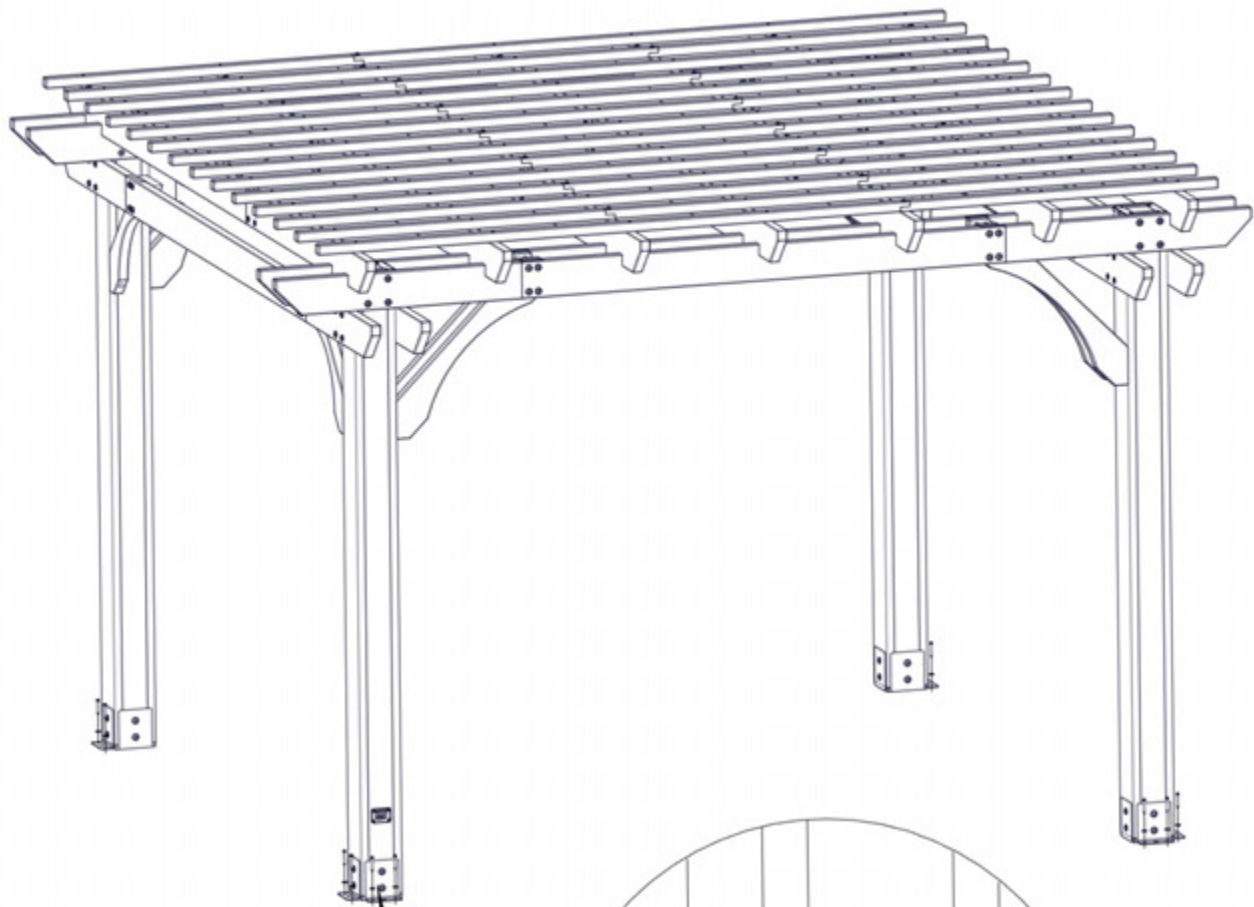

120 (x16)  
CONCRETE ANCHOR

630 (x16)  
WASHER - 8x19

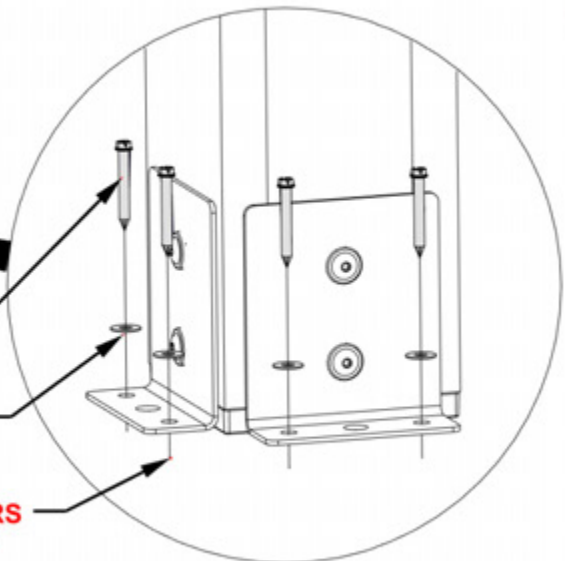

PRE-DRILL HOLES FOR CONCRETE ANCHORS  
USING A 3/16" [5mm] CONCRETE DRILL BIT.

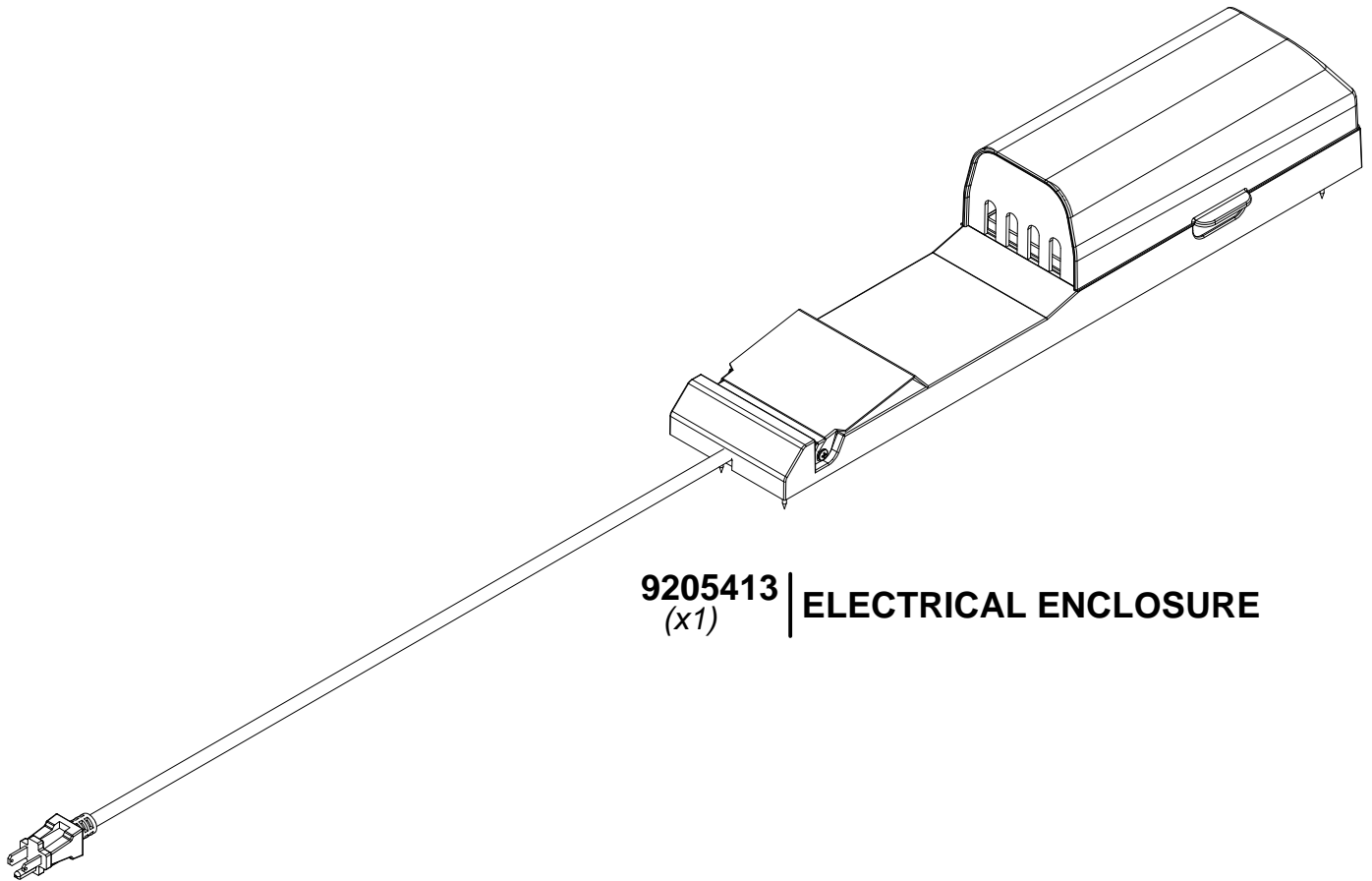

**9205413** | **ELECTRICAL ENCLOSURE**  
*(x1)*

FOR POWERPORT INSTALLATION REFER TO ASSEMBLY INSTRUCTIONS THAT COME PACKAGED WITH THE POWERPORT KIT. INSTALL ON ANY POST THAT IS DESIRED. FOLLOW DIRECTIONS FOR PROPER INSTALLATION.