



Manufactured by:
Backyard Discovery
3305 Airport Drive, Pittsburg, KS 66762
800-856-4445

Basepoint Business Centre: Rivermead Drive, Westlea, Swindon SN5 7EX Phone: 0800-118-2476
J.P. Coenstraat 7, The Bridge, The Hague, 2595 WP, Netherlands Phone: 08005678990

BEAUMONT 24X12 PERGOLA

MODEL: # 2405035



Please visit www.backyarddiscovery.com

For the most up to date assembly manual, to register your product, or to order replacement parts
Para obtener instrucciones en español, visite www.backyarddiscovery.com



EASY STEP-BY-STEP
3D INTERACTIVE INSTRUCTIONS

DOWNLOAD THE FREE APP



OWNER'S MANUAL - BASIC SETUP DIMENSIONS & ASSEMBLY NOTES

It is critically important that you start with square and level footings or concrete pad to attach your structure

- Pay close attention to the items needed for each step. Make sure you are using the correct hardware for each step. Using incorrect hardware may result in improper assembly
- Remember to double check for underground utilities and overhead electrical lines

Post mounts are provided with your structure which allows you to permanently install your structure to a pre-existing or new wood or concrete surface. See Anchor Instructions for further details and recommendations.

- The hardware to attach the post mounts to the structure is included.
- The hardware to mount the structure permanently to a concrete surface is included.
- The hardware to mount the structure permanently to a wood deck is NOT included and will need to be purchased separately. You must ensure there is ample structural support under the deck before permanently attaching.

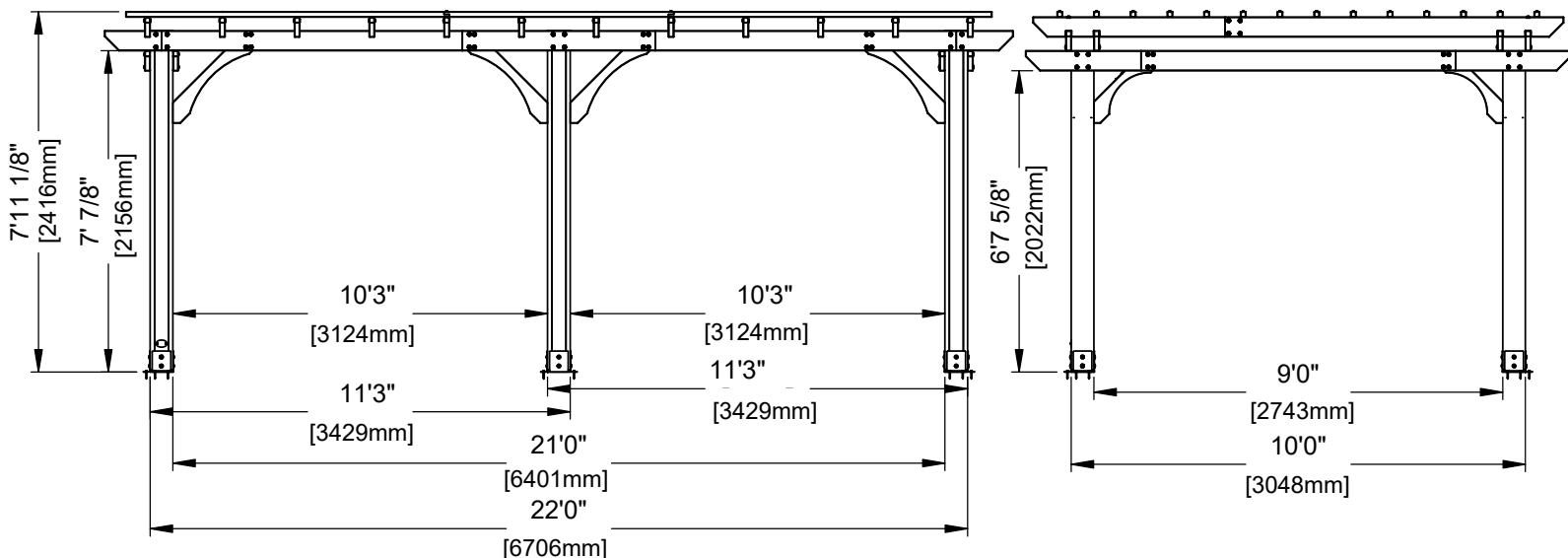
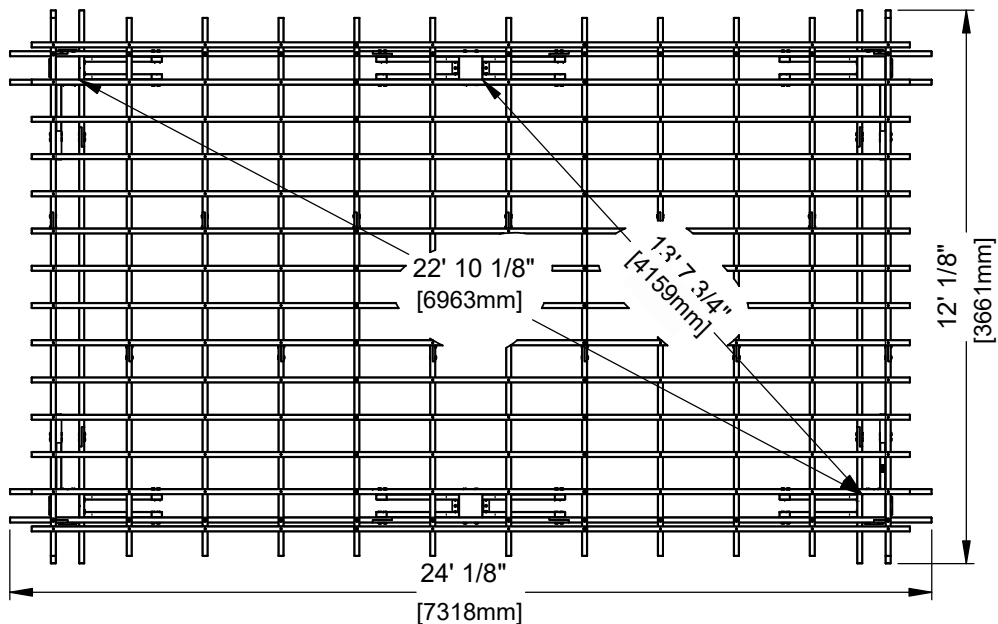

OWNER'S MANUAL - ANCHORING LAYOUT

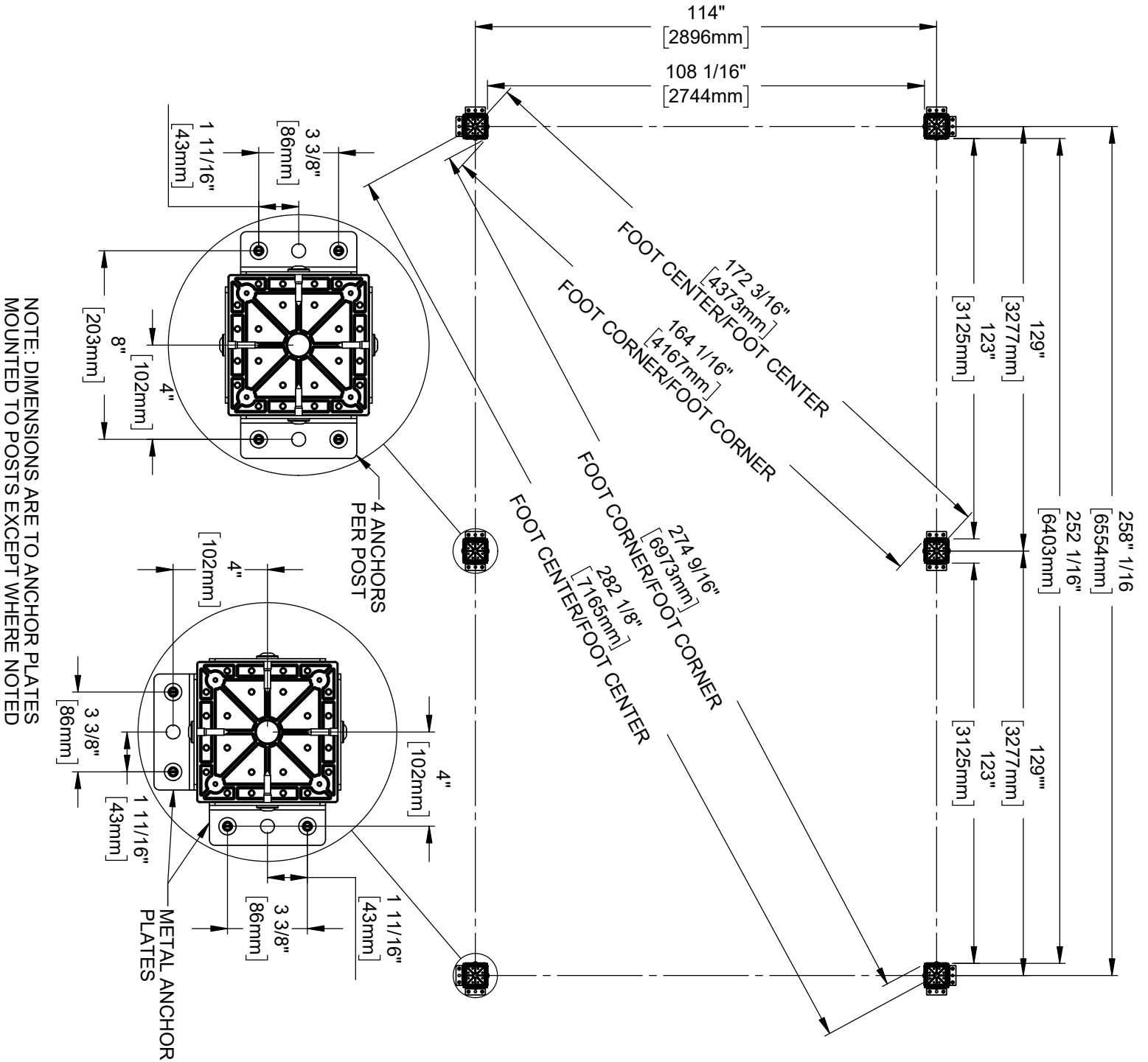

NOTE: DIMENSIONS ARE TO ANCHOR PLATES MOUNTED TO POSTS EXCEPT WHERE NOTED

OWNER'S MANUAL - PARTS IDENTIFICATION

Wood Components (NOT TO SCALE)



D01 JOIST END - W4L15500
(x4) 1 3/8"X5 1/4"X35 1/2" (36x134x902)



D02 JOIST END - W4L15501
(x4) 1 3/8"X5 1/4"X35 1/2" (36x134x902)



D03 JOIST END - W4L20744
(x4) 1 3/8"X5 1/4"X40 1/2" (36x134x1030)



D04 JOIST END - W4L20745
(x4) 1 3/8"X5 1/4"X1030 (36x134x40 1/2")



D07 JOIST - W4L15506
(x4) 1 3/8"X5 1/4"X83 1/8" (36x134x2112)



D08 JOIST - W4L20751
(x4) 1 3/8"X5 1/4"X88 1/8" (36x134x2237)



D09 JOIST - W4L20746
(x4) 1 3/8"X5 1/4"X88 1/8" (36x134x2237)



D11 CORBEL - W4L15510
(x16) 1 3/8"X5 1/4"X32 1/2" (36x134x826)



D12 CORBEL - W4L15513
(x3) 1 3/8"X5 1/4"X28 1/4" (36x134x719)



D13 CORBEL - W2A03243
(x1) 1 3/8"X5 1/4"X28 1/4" (36x134x719)



D14 SLOTTED JOIST - W4L15515
(x14) 1 3/8"X5 1/4"X55 3/4" (36x134x1416)

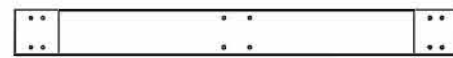

D17 JOIST - W4L20750
(x4) 1 3/8"X5 1/4"X51" (36x134x1296)

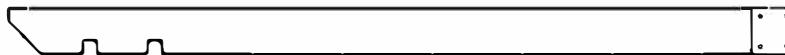

D15 SLOTTED JOIST - W4L15517
(x14) 1 3/8"X5 1/4"X89 1/2" (36x134x2274)



P10 PURLIN END - W4L20747
(x28) 1 3/8"X1 3/8"X88 1/8" (36x36x2239)



P11 PURLIN - W4L20748
(x14) 1 3/8"X1 3/8" (36x36x1074)



P12 PURLIN - W4L20749
(x14) 1 3/8"X1 3/8" (36x36x1593)

OWNER'S MANUAL - PARTS IDENTIFICATION

Wood Components (NOT TO SCALE)



P01 POST - W2A03241
(x2) 6"X6"X89 1/2" (152x152x2274)



P02 POST - W2A03242
(x2) 6"X6"X89 1/2" (152x152x2274)

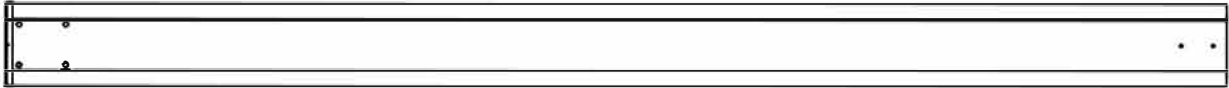

P03 POST - W2A03244
(x2) 6"X6"X89 1/2" (152x152x2274)

OWNER'S MANUAL - PARTS IDENTIFICATION

Hardware Components

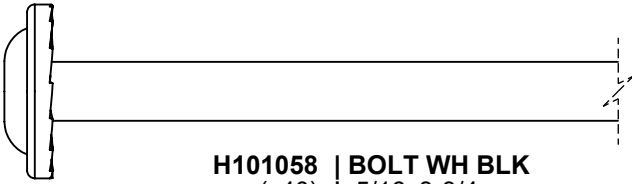

H101058 | BOLT WH BLK
(x40) | 5/16x8-3/4

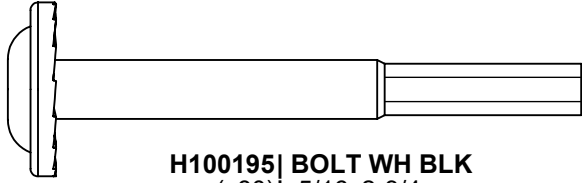
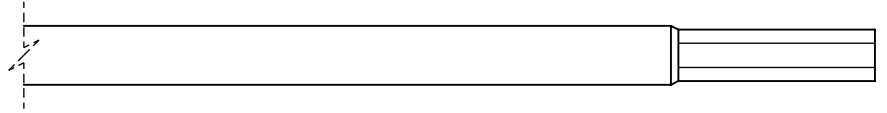

H100195 | BOLT WH BLK
(x80) | 5/16x2-3/4

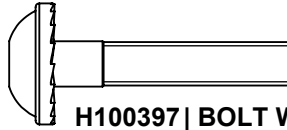

H100397 | BOLT WH BLK
(x42) | 1/4x1-1/4

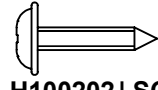

H100202 | SCREW PWH BLK
(x4) | 8x5/8

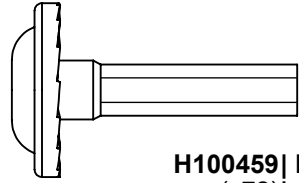

H100459 | BOLT WH BLK
(x72) | 5/16x1-1/4

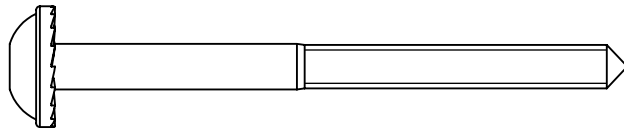

H100792 | LAG SCREW WH BLK
(x20) | 1/4x3

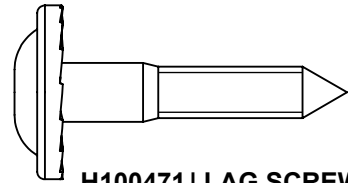

H100471 | LAG SCREW WH BLK
(x48) | 5/16x1-1/2

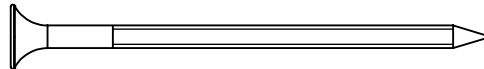

H100201 | SCREW PFH BLK
(x154) | 8x2-1/2

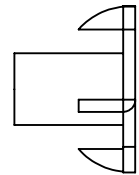

H100379 | T-NUT BLK
(x192) | 5/16

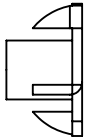

H100398 | T-NUT BLK
(x42) | 1/4



H100200 | SCREW PFH BLK
(x24) | 8x1-1/2

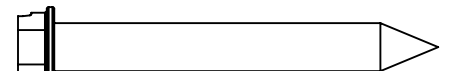

H100120 | CONCRETE ANCHOR
(x24) | 1/4x2

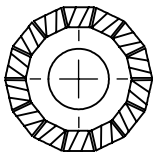

H100198 | WASHER LOCK EXT BLK
(x220) | 8x19

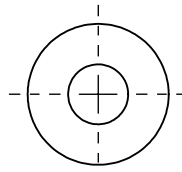

H100630 | WASHER FLAT BLK
(x24) | 8x19

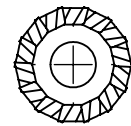

H100405 | WASHER LOCK EXT BLK
(x62) | 6x15

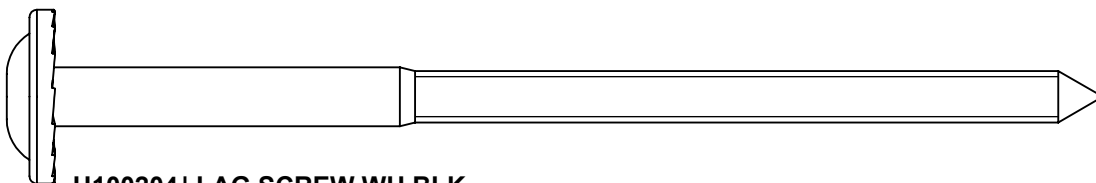

H100204 | LAG SCREW WH BLK
(x28) | 5/16x5-1/2

OWNER'S MANUAL - PARTS IDENTIFICATION

Hardware Components

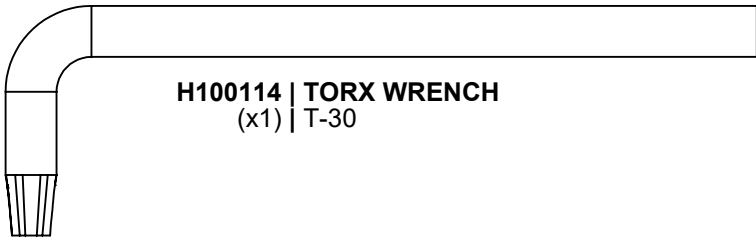

H100114 | TORX WRENCH
(x1) | T-30

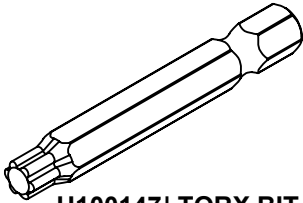

H100147 | TORX BIT
(x1) | T-30

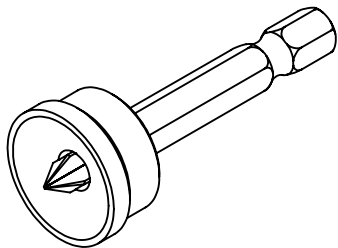

H100764 | SCREW SETTER
(x1) |

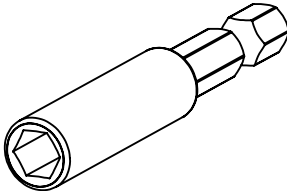

H101100 | MAGNETIC DRIVER
(x1) |

OWNERS MANUAL - PARTS IDENTIFICATION

Accessory Components (NOT TO SCALE)



A4M02158
BYD ID TAG PATIO
(x1)

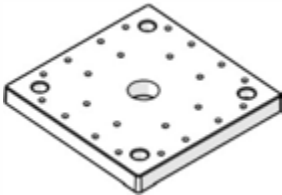

A6P00308 6x6 POST FOOT
(x6)



A4M00978 POST PLATE
(x12)

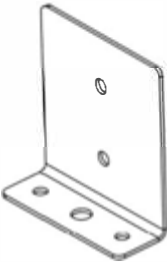

A4M00977 POST ANCHORING PLATE WITH FLANGE
(x12)

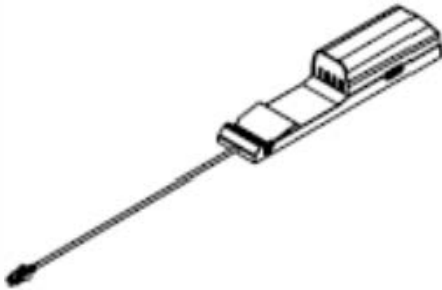

9205413 ELECTRICAL ENCLOSURE
(x1)

PRE-ASSEMBLY STEP 1 - SORTING WOOD PARTS

It is critical for ease of assembly that you take the time to sort and organize the wood and hardware.

WOOD PARTS:

- Organize wood parts by the three-digit, alpha-numeric number stamped on each board (ex. P01).
- If there are multiple boards with the same stamped number, stack those pieces together.
- Stamps can be found on the flat surface of the boards or on the end of the boards.
- Allow yourself plenty of room - the wood pieces can take up a significant amount of space.

NOTE: CARTONS ARE NOT ORGANIZED BY BOARD NUMBER.



HARDWARE PARTS:

- We recommend that you have a separate table to organize the hardware.
- Hardware bags are printed with a seven-digit, alpha-numeric part number.
- You can organize your hardware by part number or group by hardware type (i.e. bolts, nuts, etc.).
- During assembly you only need to reference the last four digits of the number.

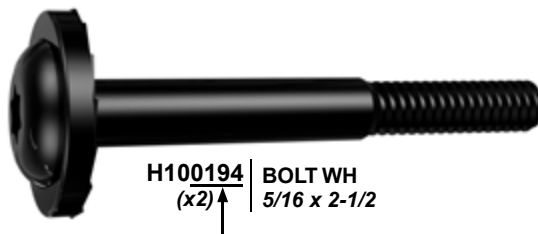

PRE-ASSEMBLY STEP 2 - TOOLS REQUIRED



Cordless Drill
or Electric Drill



Drill
Attachments:
Phillips Head

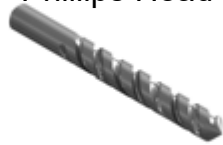

1/8", 3/16", 3/8" &
7/16" Drill Bits



Phillips Screw Driver



Open End
Wrenches 1/2" &
9/16"



3/8" Drive Ratchet, 1/2" &
7/16" STD Sockets 1/2" & 7/16"
Deep Sockets



Claw Hammer



Rubber Mallet
- Optional

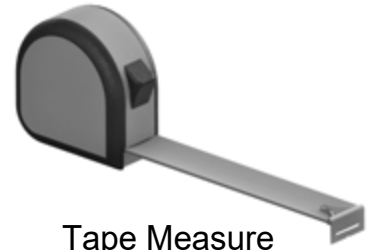

Tape Measure

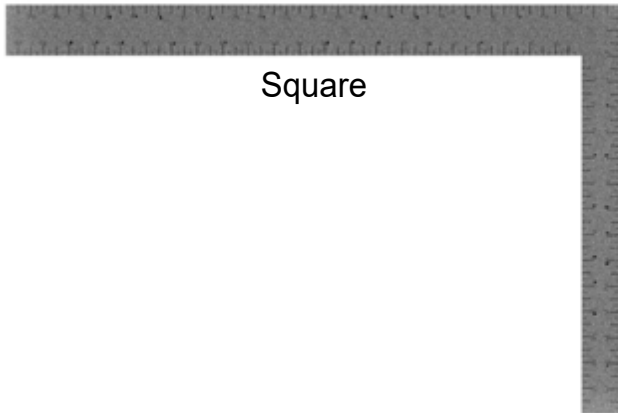

Square



Level 24"

PRE-ASSEMBLY STEP 3 - CHOOSE YOUR ASSEMBLY METHOD

There are several types of assembly instructions available to you.

1. Printed Assembly Manual included with your set
2. BILT APP - 3D interactive instructions
3. Combination of the Printed Manual and BILT APP (Note: Step numbers can differ between the two methods)

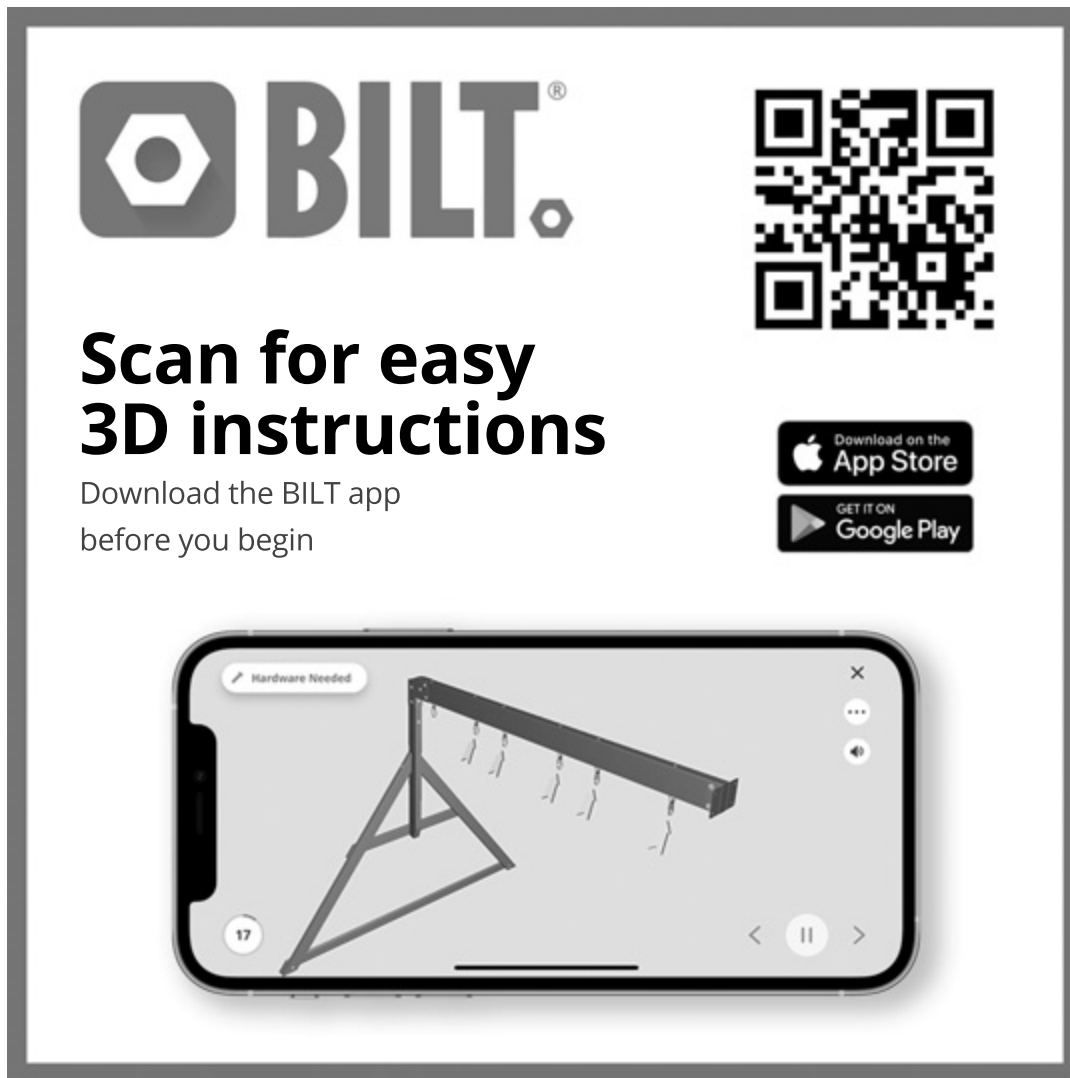

The graphic features the BILT logo (a hexagon with a white dot inside) and the word "BILT." in a bold, sans-serif font. To the right is a large QR code. Below the logo, the text "Scan for easy 3D instructions" is written in a large, bold font. Underneath this, it says "Download the BILT app before you begin". To the right of the text are two buttons: "Download on the App Store" and "GET IT ON Google Play". At the bottom, a smartphone screen displays a 3D assembly instruction for step 17, showing a metal frame with a horizontal bar and several screws being attached. The screen has a "Hardware Needed" label at the top left, a close button (X) at the top right, and navigation arrows at the bottom.

STEP 1 - PERGOLA ASSEMBLY



P01 POST - W2A03241
(x2) 6"X6"X89 1/2" (152x152x2274)



P02 POST - W2A03242
(x2) 6"X6"X89 1/2" (152x152x2274)

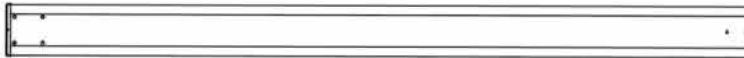

P03 POST - W2A03244
(x2) 6"X6"X89 1/2" (152x152x2274)

QTY	PART NUMBER	DESCRIPTION
24	H100200	SCREW PFH 8x1 1/2 BLK

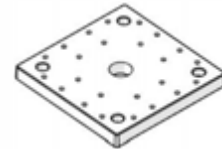

A6P00308 6x6 POST FOOT
(x6)

- FOR EASE OF ASSEMBLY, WE RECOMMEND USING SAWHORSES FOR STEPS 1-11.
- COMPLETE THIS STEP TWICE.

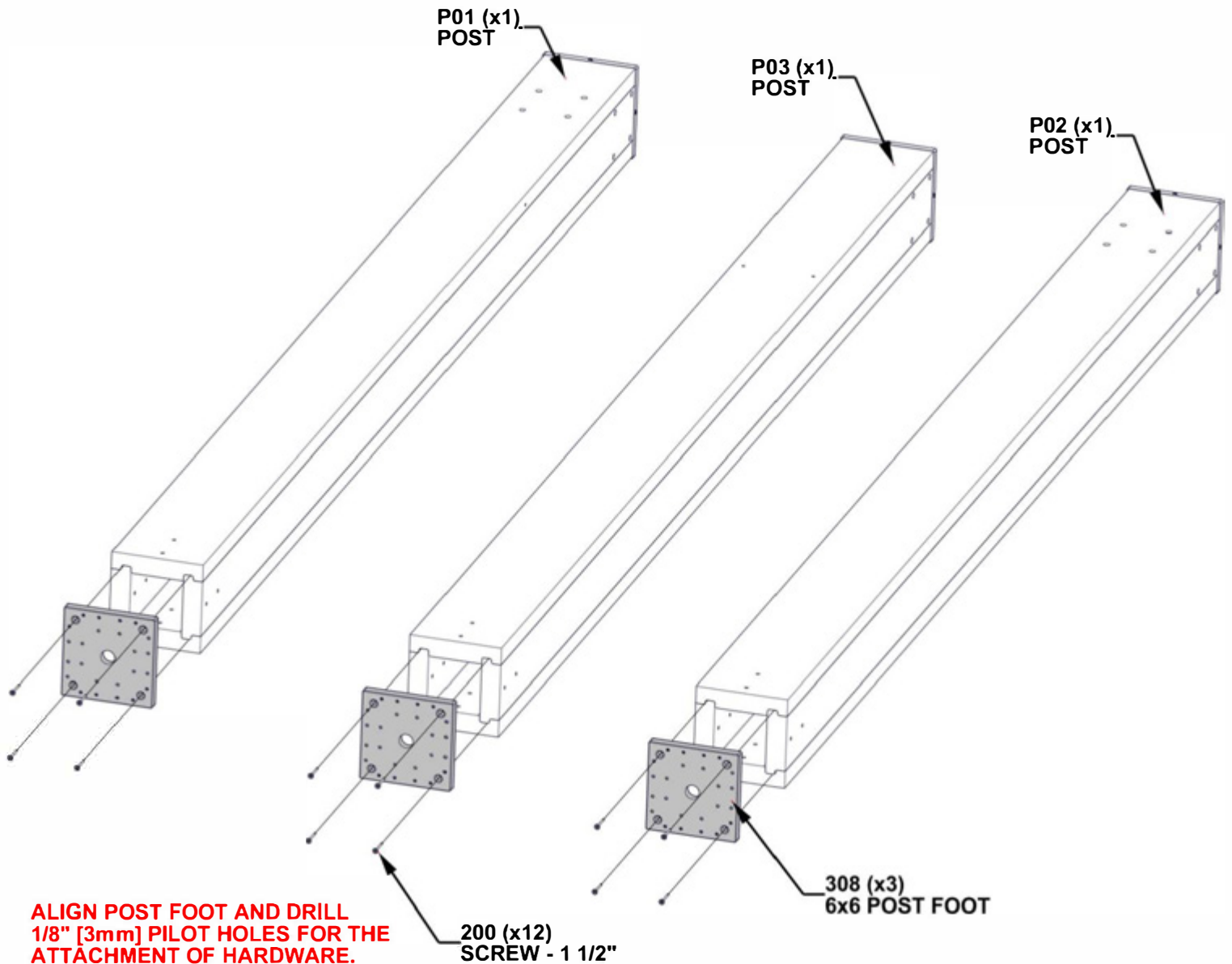

STEP 2 - PERGOLA ASSEMBLY

QTY	PART NUMBER	DESCRIPTION
8	H100195	BOLT WH 5/16x2 3/4 BLK
8	H100198	WASHER LOCK EXT 8x19
8	H100379	T-NUT 5/16 BLK

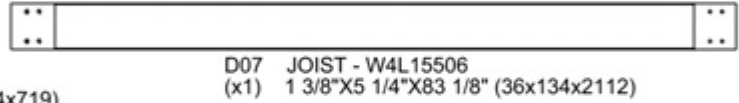
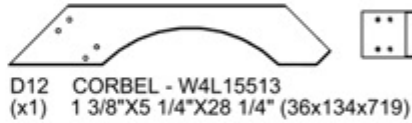
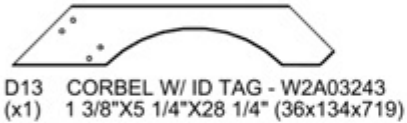
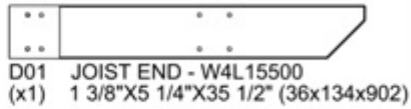
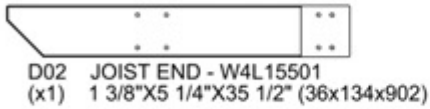

- INSERT T-NUTS FIRST.
- HAND TIGHTEN ONLY.

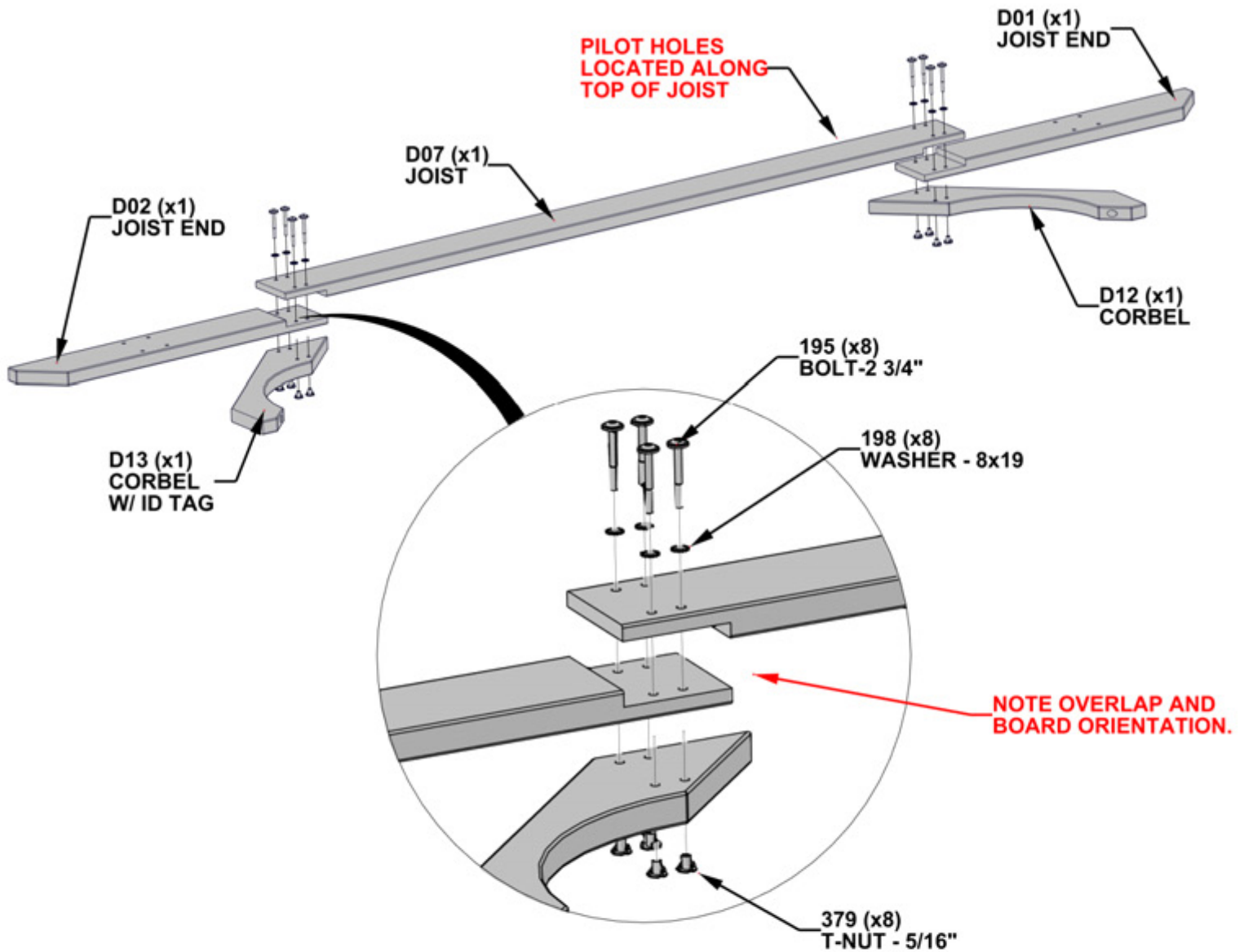

STEP 3 - PERGOLA ASSEMBLY

QTY	PART NUMBER	DESCRIPTION
8	H100195	BOLT WH 5/16x2 3/4 BLK
8	H100198	WASHER LOCK EXT 8x19
8	H100379	T-NUT 5/16 BLK

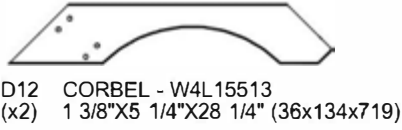
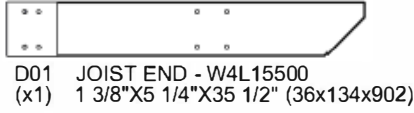
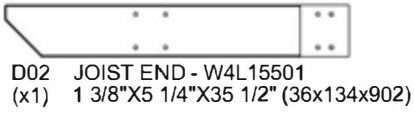

- INSERT T-NUTS FIRST.
- HAND TIGHTEN ONLY.

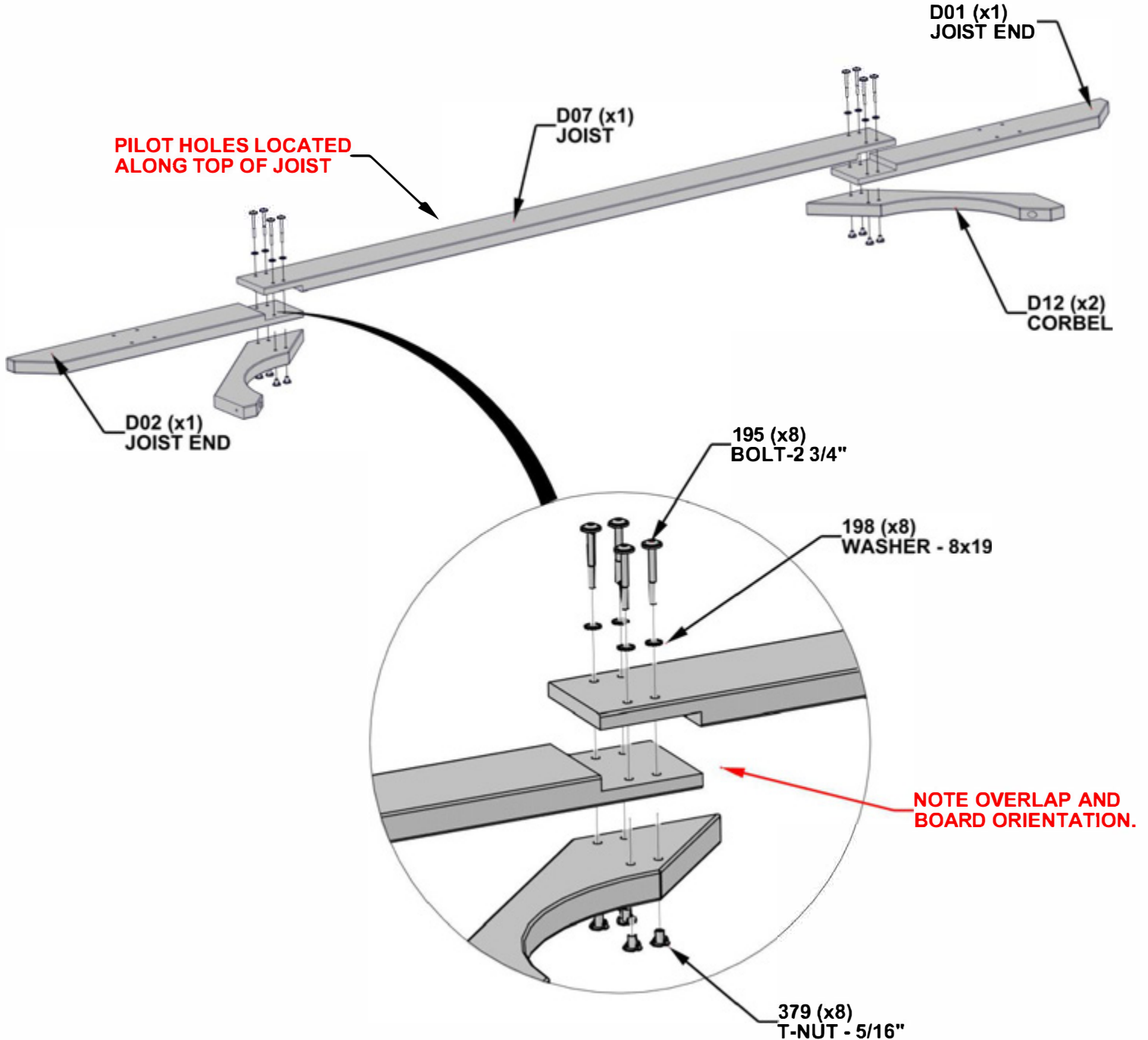

STEP 4 - PERGOLA ASSEMBLY

QTY	PART NUMBER	DESCRIPTION
16	H100198	WASHER LOCK EXT 8x19
16	H100379	T-NUT 5/16 BLK
16	H100459	BOLT WH 5/16x1 1/4 BLK



D02 JOIST END - W4L15501
(x2) 1 3/8"X5 1/4"X35 1/2" (36x134x902)



D01 JOIST END - W4L15500
(x2) 1 3/8"X5 1/4"X35 1/2" (36x134x902)

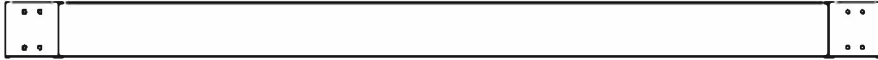

D07 JOIST - W4L15506
(x2) 1 3/8"X5 1/4"X83 1/8" (36x134x2112)

- **INSERT T-NUTS FIRST.**
- COMPLETE THIS STEP TWICE.
- HAND TIGHTEN ONLY.

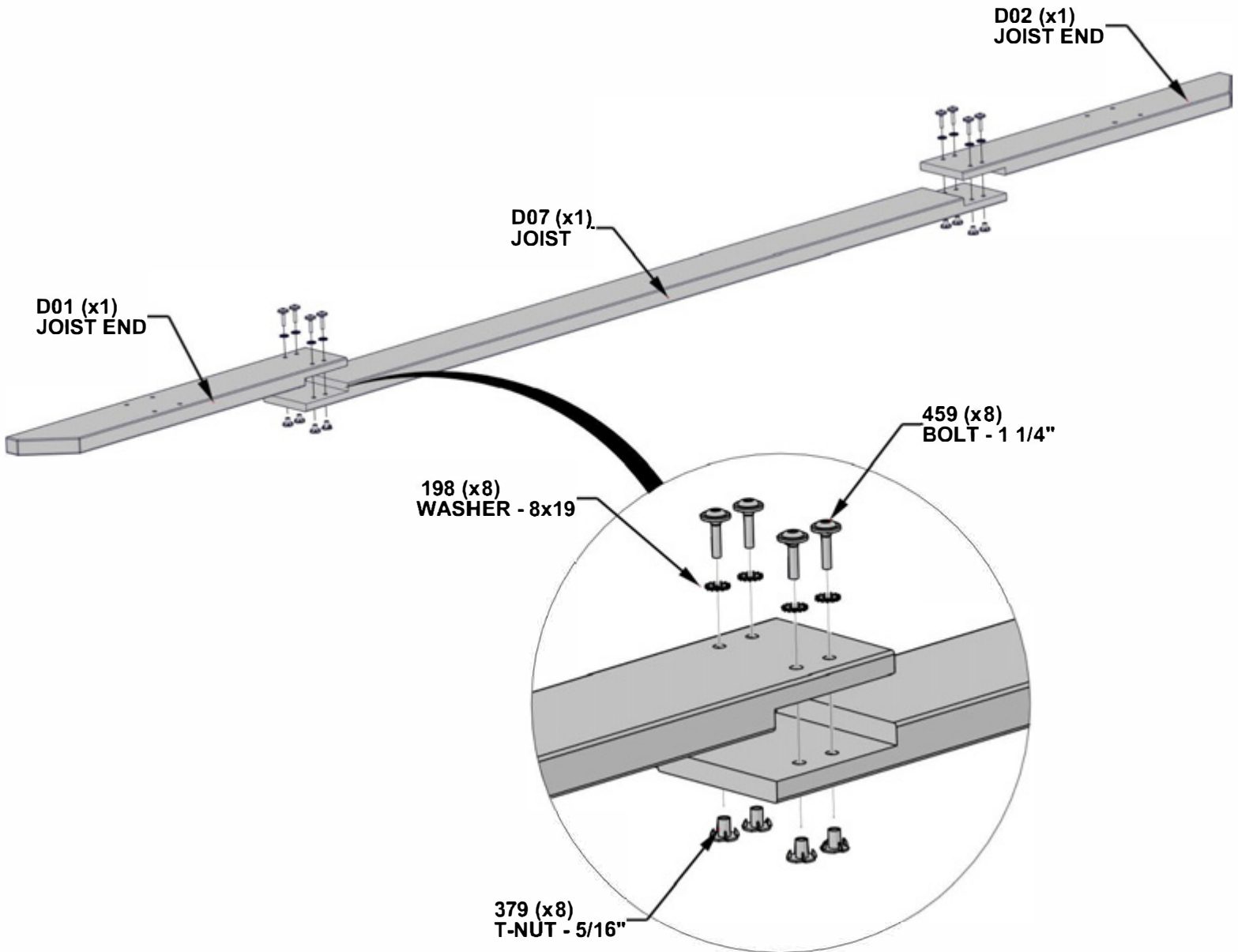

STEP 5 - PERGOLA ASSEMBLY

QTY	PART NUMBER	DESCRIPTION
16	H100198	WASHER LOCK EXT 8x19
16	H100379	T-NUT 5/16 BLK
4	H100405	WASHER LOCK EXT 6x15
4	H100792	LAG SCREW WH 1/4x3 BLK
16	H101058	BOLT WH 5/16x8 3/4 BLK

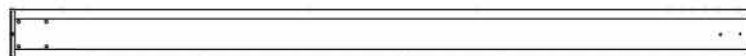

P01 POST - W2A03241
(x2) 6"X6"X89 1/2" (152x152x2274)



P02 POST - W2A03242
(x2) 6"X6"X89 1/2" (152x152x2274)

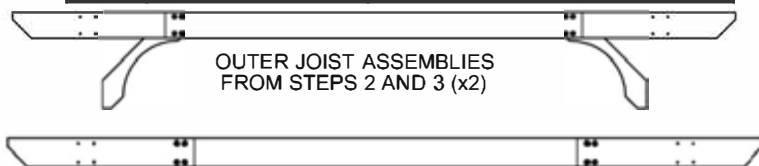

OUTER JOIST ASSEMBLIES
FROM STEPS 2 AND 3 (x2)



INNER JOIST ASSEMBLY
FROM STEP 4 (x2)

- **INSERT T-NUTS FIRST.**
- COMPLETE THIS STEP TWICE.
- IF BOLT DOES NOT ENGAGE, CHECK FOR SAWDUST BUILD UP IN HOLES.
- COMPLETELY TIGHTEN ALL HARDWARE FROM STEPS 1-5.

ASSEMBLE AS SHOWN USING THE PRE-DRILLED PILOT HOLES IN POSTS

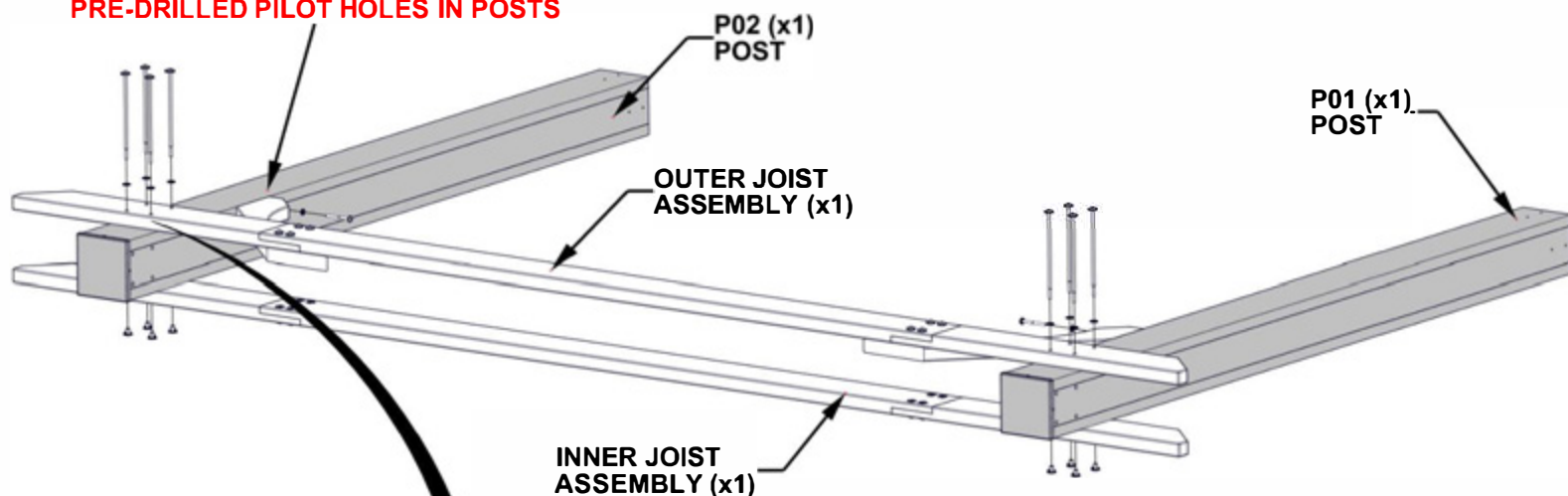

1058 (x8)
BOLT - 8 3/4"

198 (x8)
WASHER - 8x19

405 (x2)
WASHER - 6x15

792 (x2)
LAG SCREW - 3"

379 (x8)
T-NUT - 5/16"

STEP 6 - PERGOLA ASSEMBLY

QTY	PART NUMBER	DESCRIPTION
8	H100195	BOLT WH 5/16x2 3/4 BLK
8	H100198	WASHER LOCK EXT 8x19
8	H100379	T-NUT 5/16 BLK

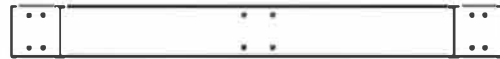
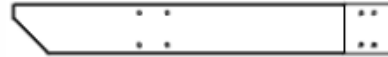

- INSERT T-NUTS FIRST.
- HAND TIGHTEN HARDWARE.

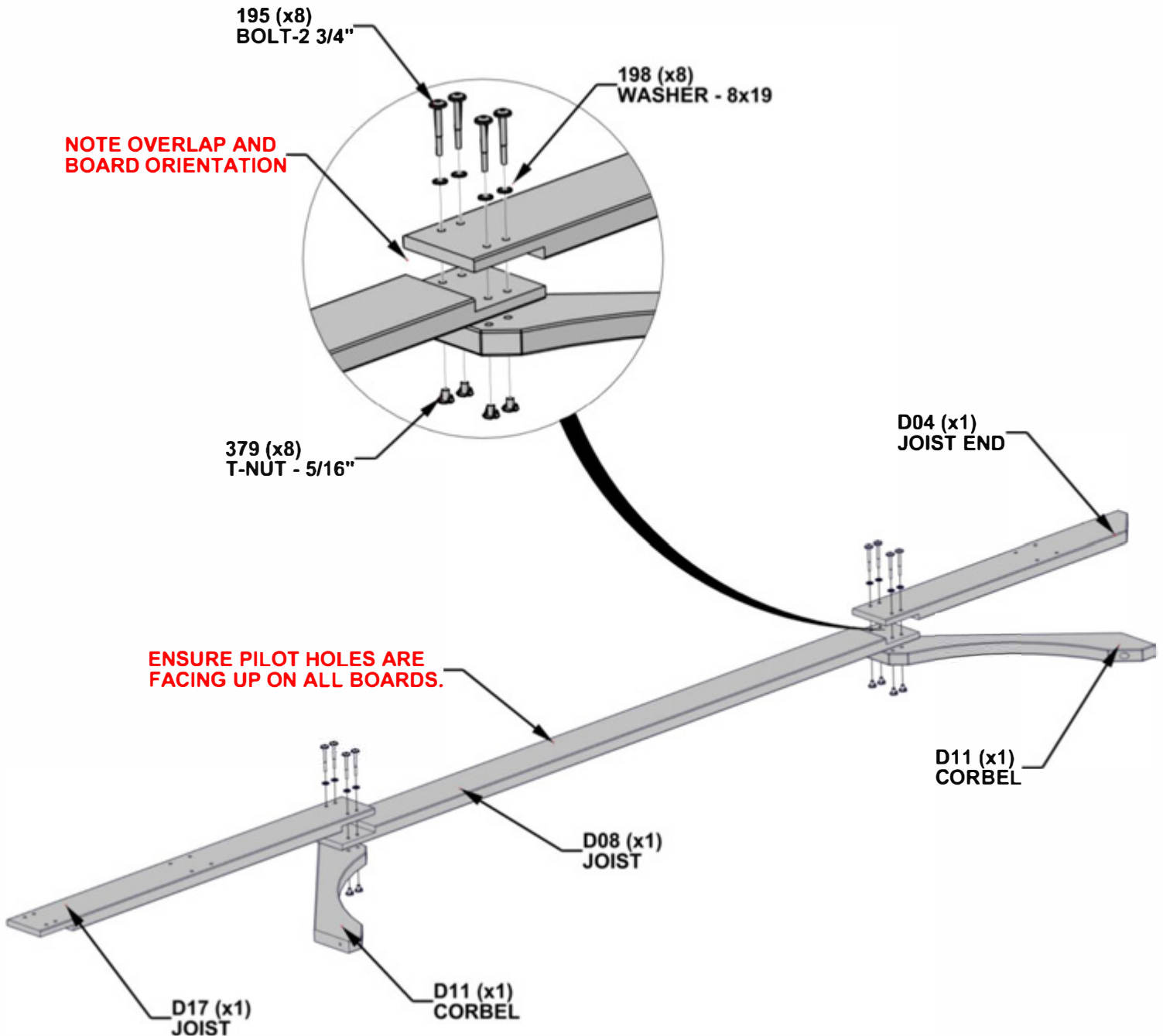

STEP 7 - PERGOLA ASSEMBLY

QTY	PART NUMBER	DESCRIPTION
8	H100195	BOLT WH 5/16x2 3/4 BLK
8	H100198	WASHER LOCK EXT 8x19
8	H100379	T-NUT 5/16 BLK

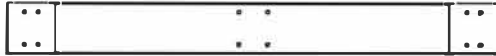

D17 JOIST - W4L20750
(x1) 1 3/8"X5 1/4"X51" (36x134x1296)

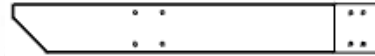

D03 JOIST END - W4L20744
(x1) 1 3/8"X5 1/4"X40 1/2" (36x134x1030)

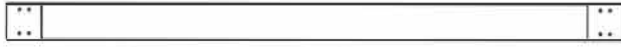

D09 JOIST - W4L20746
(x1) 1 3/8"X5 1/4"X88 1/8" (36x134x2237)



D11 CORBEL - W4L 15510
(x2) 1 3/8"X5 1/4"X32 1/2" (36x134x826)

- INSERT T-NUTS FIRST.
- HAND TIGHTEN HARDWARE.

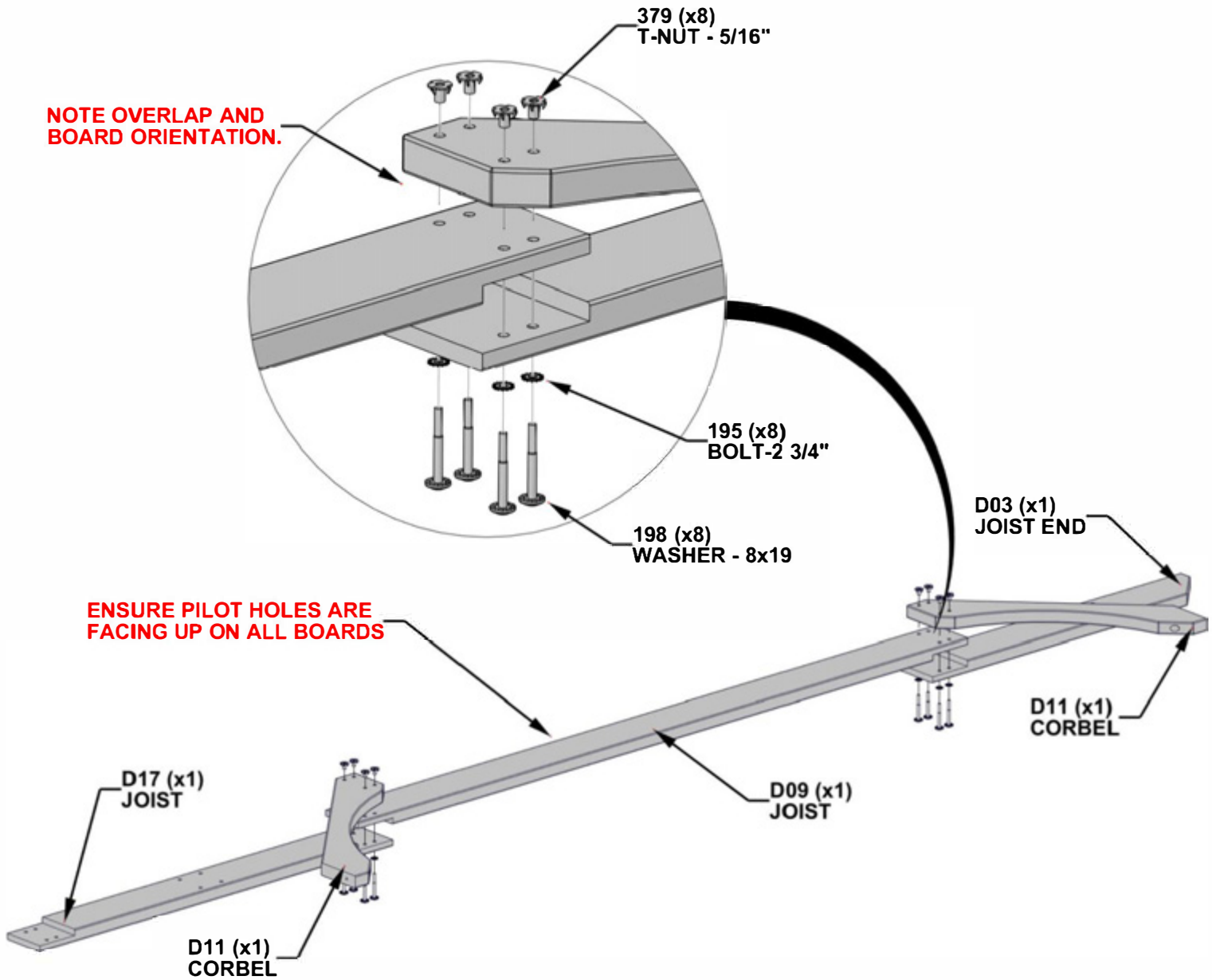

STEP 8 - PERGOLA ASSEMBLY

QTY	PART NUMBER	DESCRIPTION
4	H100198	WASHER LOCK EXT 8x19
4	H100379	T-NUT 5/16 BLK
2	H100405	WASHER LOCK EXT 6x15
2	H100792	LAG SCREW WH 1/4x3 BLK
4	H101058	BOLT WH 5/16x8 3/4 BLK

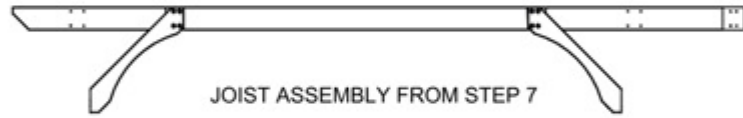
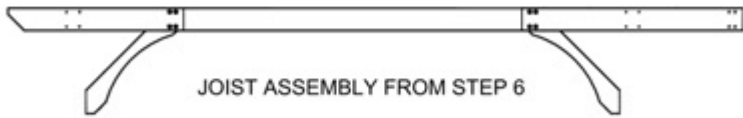

P03 POST - W2A03244
(x1) 6"X6"X89 1/2" (152x152x2274)

- INSERT T-NUTS FIRST.

- TIGHTEN ALL HARDWARE FROM STEPS 6-8.

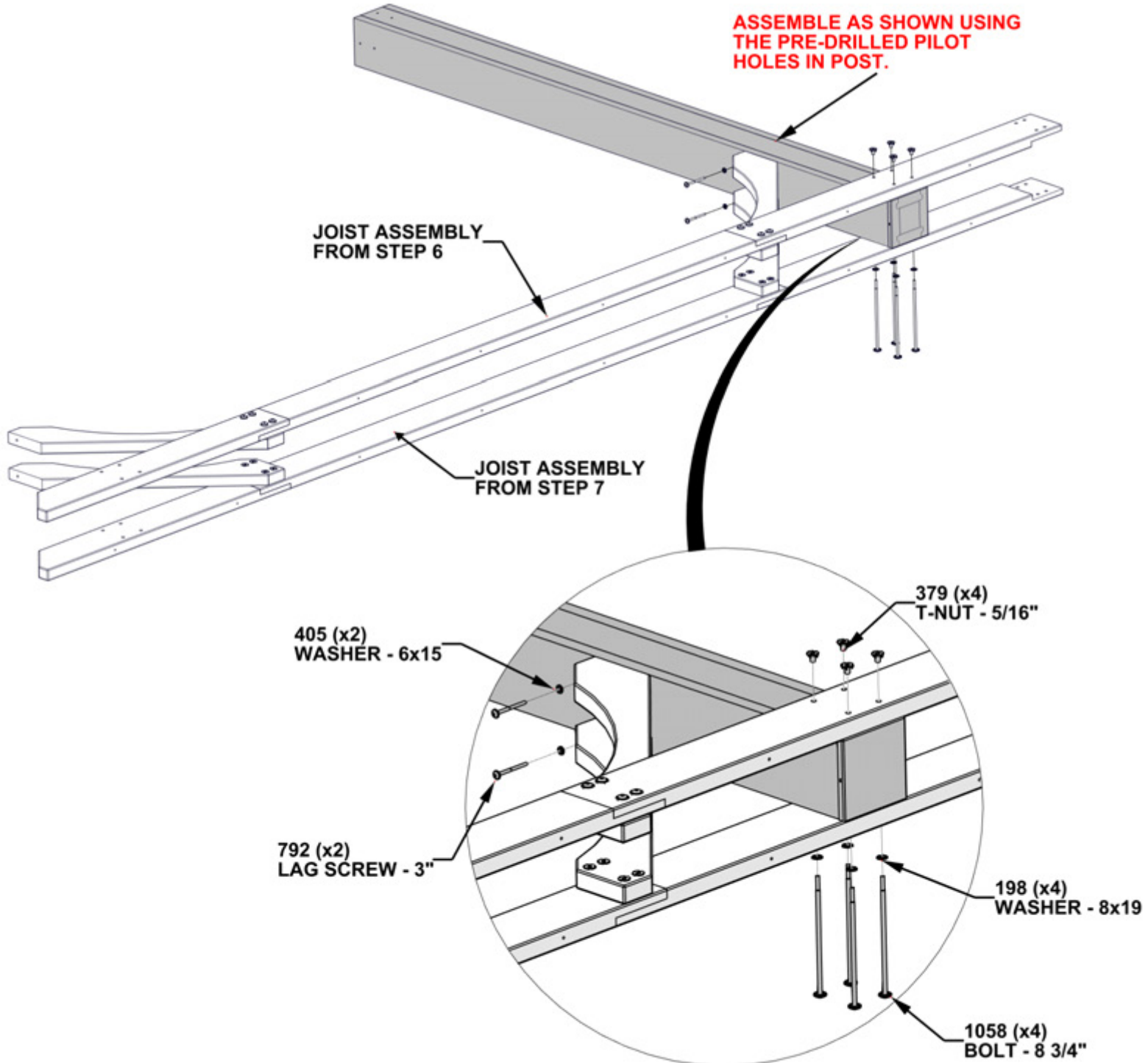

STEP 9 - PERGOLA ASSEMBLY

QTY	PART NUMBER	DESCRIPTION
8	H100195	BOLT WH 5/16x2 3/4 BLK
8	H100198	WASHER LOCK EXT 8x19
8	H100379	T-NUT 5/16 BLK

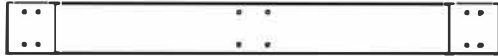

D17 JOIST - W4L20750
(x1) 1 3/8"X5 1/4"X51" (36x134x1296)

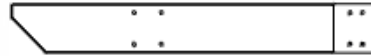

D03 JOIST END - W4L20744
(x1) 1 3/8"X5 1/4"X40 1/2" (36x134x1030)

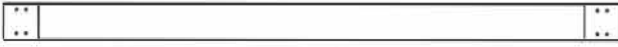

D09 JOIST - W4L20746
(x1) 1 3/8"X5 1/4"X88 1/8" (36x134x2237)



D11 CORBEL - W4L15510
(x2) 1 3/8"X5 1/4"X32 1/2" (36x134x826)

- INSERT T-NUTS FIRST.
- HAND TIGHTEN HARDWARE.

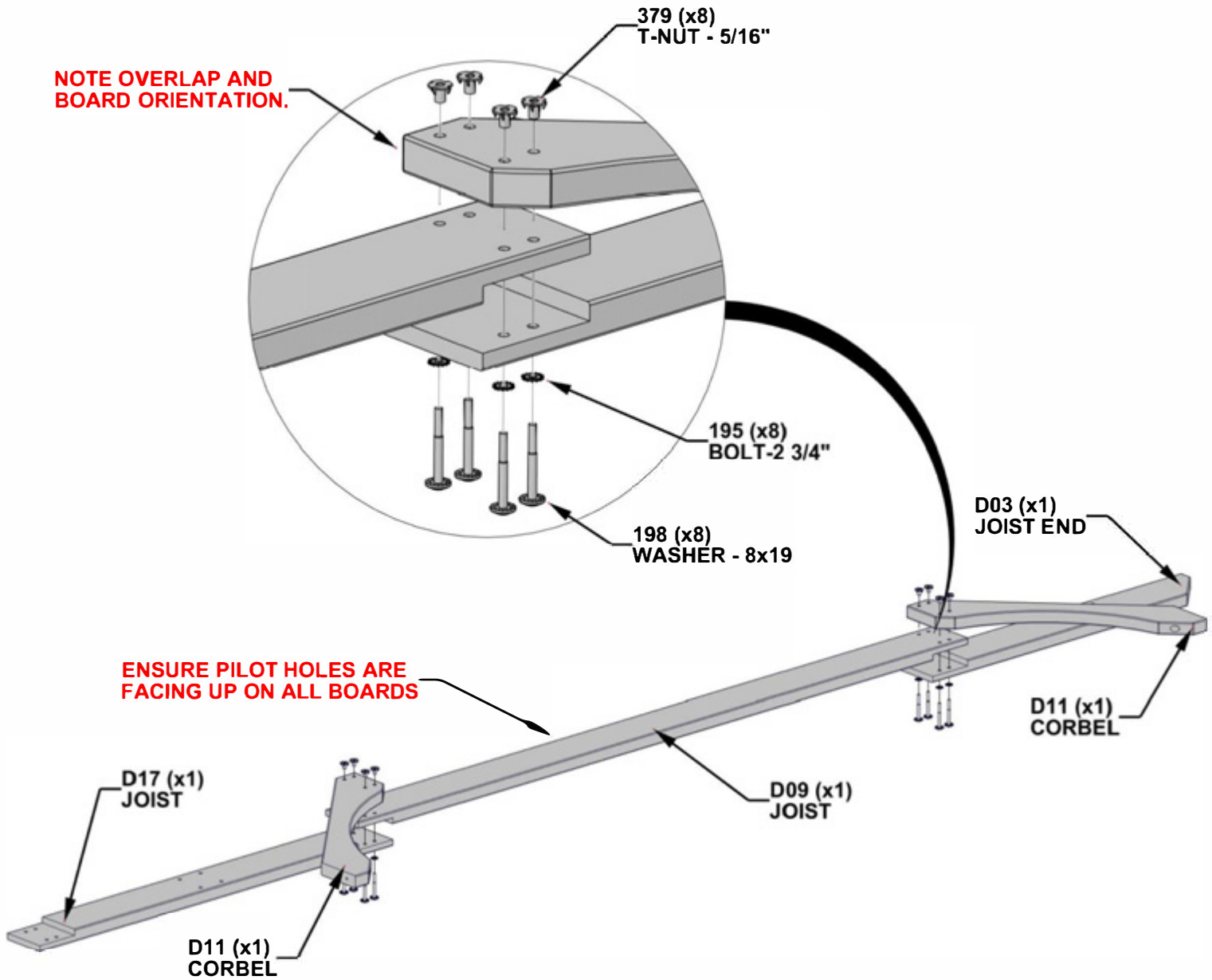

STEP 10 - PERGOLA ASSEMBLY

QTY	PART NUMBER	DESCRIPTION
8	H100195	BOLT WH 5/16x2 3/4 BLK
8	H100198	WASHER LOCK EXT 8x19
8	H100379	T-NUT 5/16 BLK

D11 CORBEL - W4L15510
(x2) 1 3/8"X5 1/4"X32 1/2" (36x134x826)

D08 JOIST - W4L20751
(x1) 1 3/8"X5 1/4"X88 1/8" (36x134x2237)

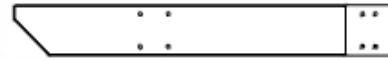

D04 JOIST END - W4L20745
(x1) 1 3/8"X5 1/4"X1030 (36x134x40 1/2")

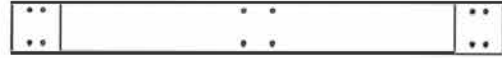

D17 JOIST - W4L20750
(x1) 1 3/8"X5 1/4"X51" (36x134x1296)

- INSERT T-NUTS FIRST.
- HAND TIGHTEN HARDWARE.

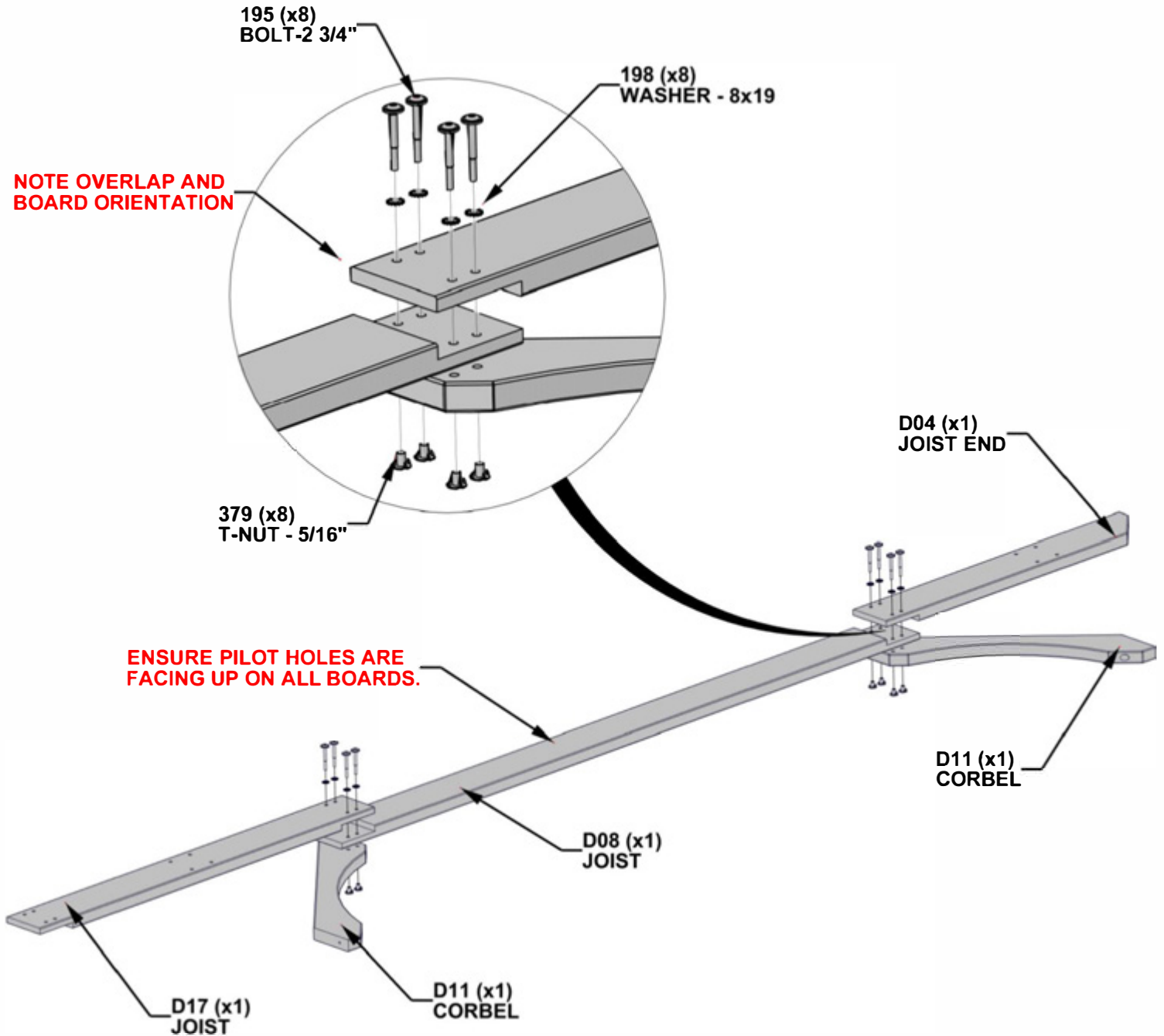

STEP 11 - PERGOLA ASSEMBLY

QTY	PART NUMBER	DESCRIPTION
4	H100198	WASHER LOCK EXT 8x19
4	H100379	T-NUT 5/16 BLK
2	H100405	WASHER LOCK EXT 6x15
2	H100792	LAG SCREW WH 1/4x3 BLK
4	H101058	BOLT WH 5/16x8 3/4 BLK

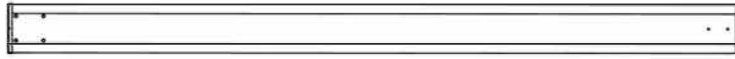

P03 POST - W2A03244
(x1) 6"X6"X89 1/2" (152x152x2274)

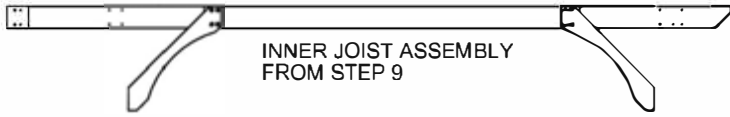

INNER JOIST ASSEMBLY
FROM STEP 9

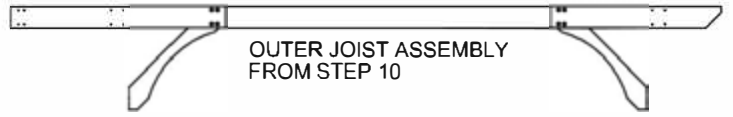

OUTER JOIST ASSEMBLY
FROM STEP 10

- INSERT T-NUTS FIRST.

- TIGHTEN ALL HARDWARE FROM STEPS 9-11.

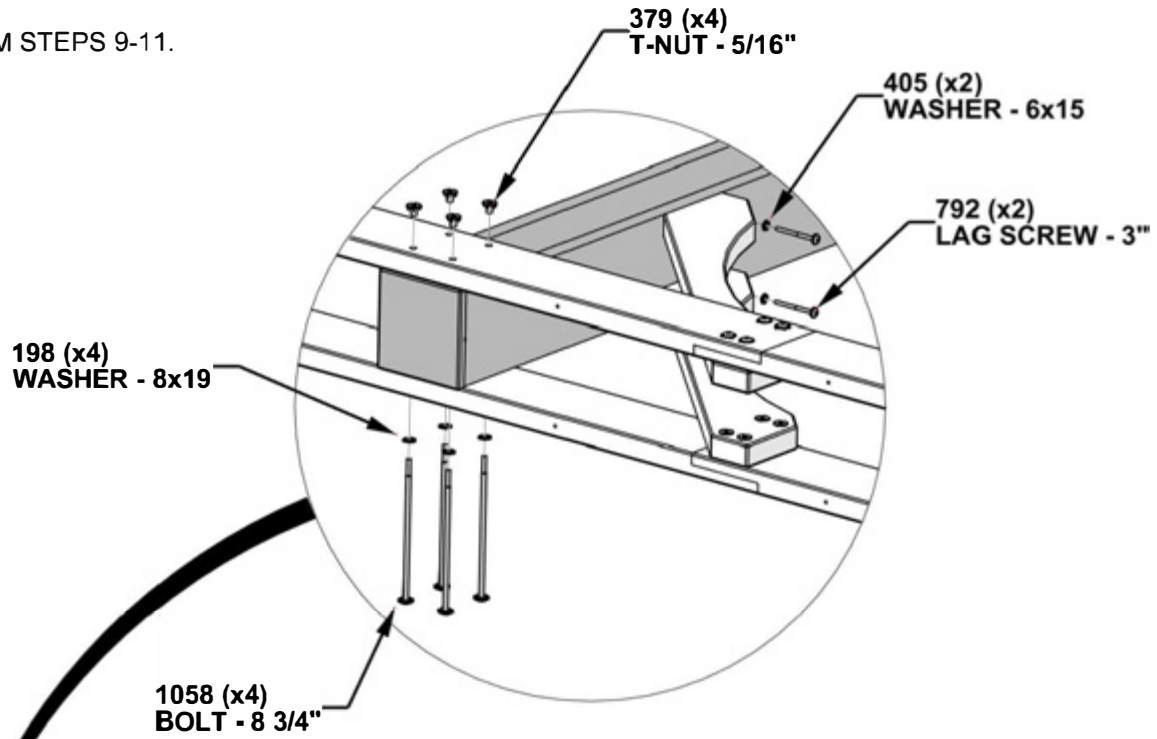

**ASSEMBLE AS SHOWN
USING THE PRE-DRILLED
PILOT HOLES IN POST.**

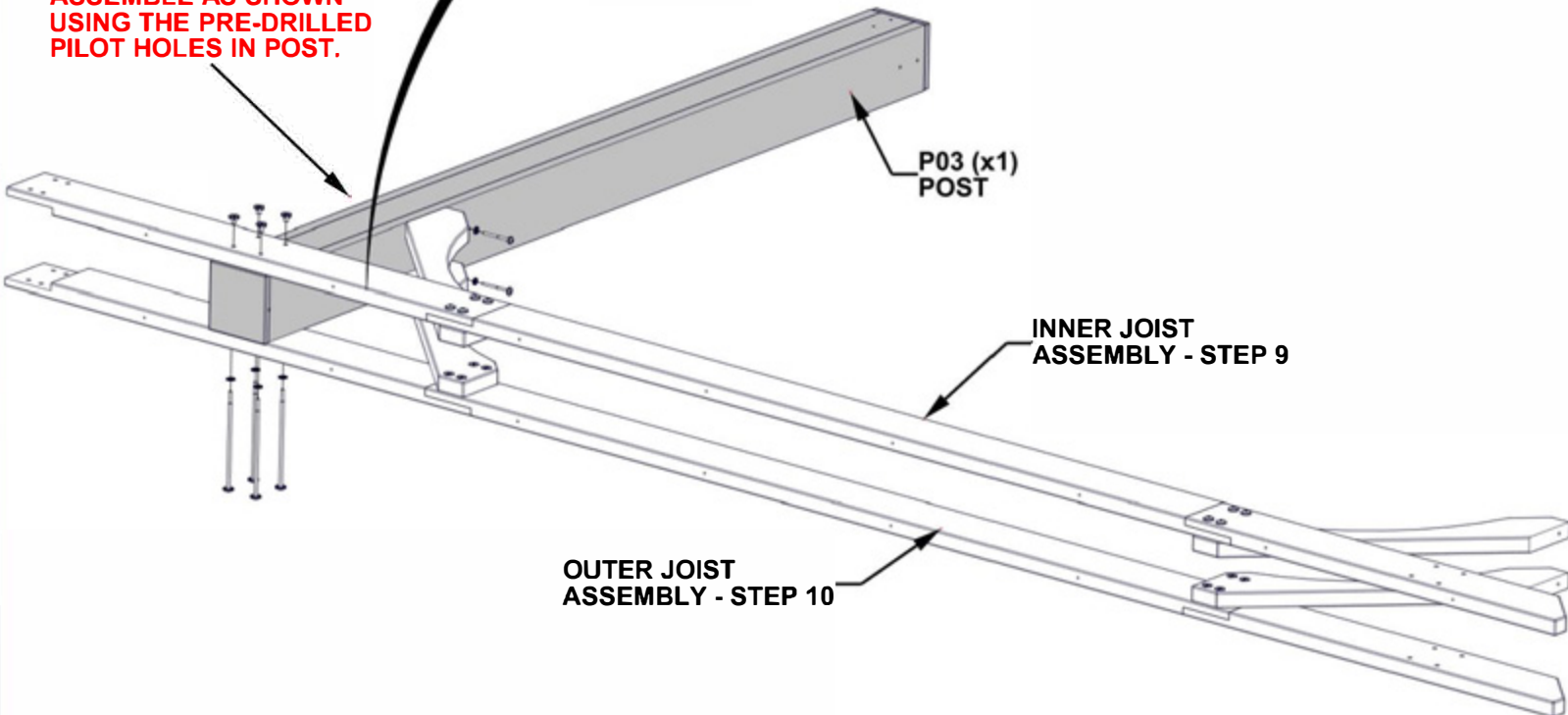

STEP 12 - PERGOLA ASSEMBLY

QTY	PART NUMBER	DESCRIPTION
8	H100198	WASHER LOCK EXT 8x19
8	H100379	T-NUT 5/16 BLK
4	H100405	WASHER LOCK EXT 6x15
4	H100792	LAG SCREW WH 1/4x3 BLK
8	H101058	BOLT WH 5/16x8 3/4 BLK

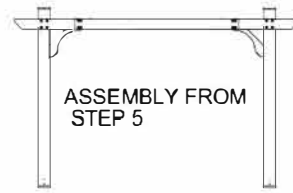
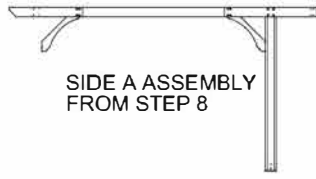
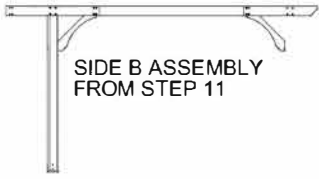

- STAND THE UPRIGHT ASSEMBLY AND ATTACH ONE SIDE ASSEMBLY AT A TIME. ENSURE THAT THE SIDE ASSEMBLIES ARE ORIENTED CORRECTLY.

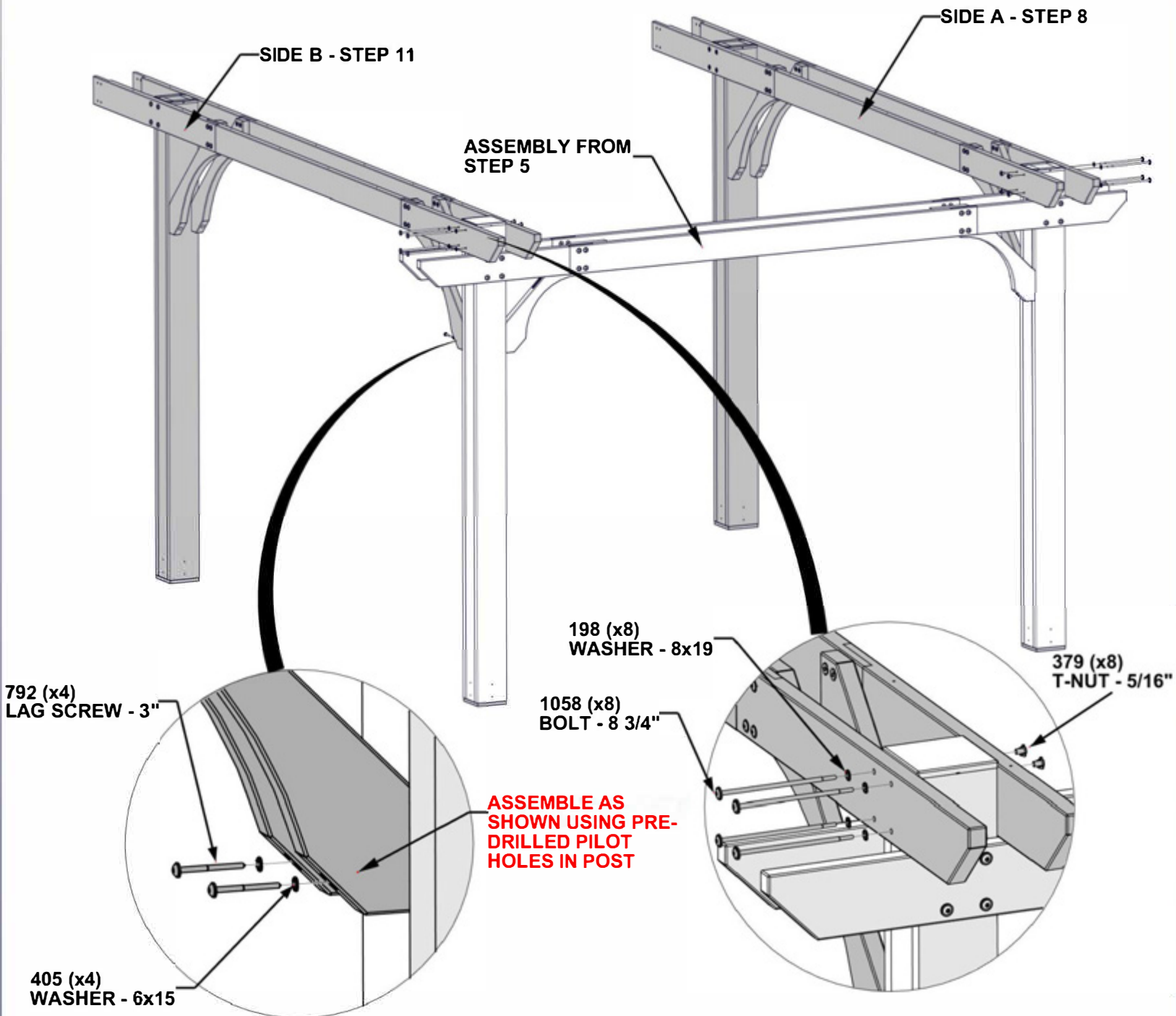

STEP 13 - PERGOLA ASSEMBLY

QTY	PART NUMBER	DESCRIPTION
8	H100195	BOLT WH 5/16x2 3/4 BLK
8	H100198	WASHER LOCK EXT 8x19
8	H100379	T-NUT 5/16 BLK

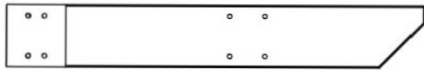

D03 JOIST END - W4L20744
(x2) 1 3/8"X5 1/4"X40 1/2" (36x134x1030)



D09 JOIST - W4L20746
(x2) 1 3/8"X5 1/4"X88 1/8" (36x134x2237)



D11 CORBEL - W4L15510
(x2) 1 3/8"X5 1/4"X32 1/2" (36x134x826)

- INSERT T-NUTS FIRST.

- COMPLETE THIS STEP TWICE.
- HAND TIGHTEN HARDWARE.

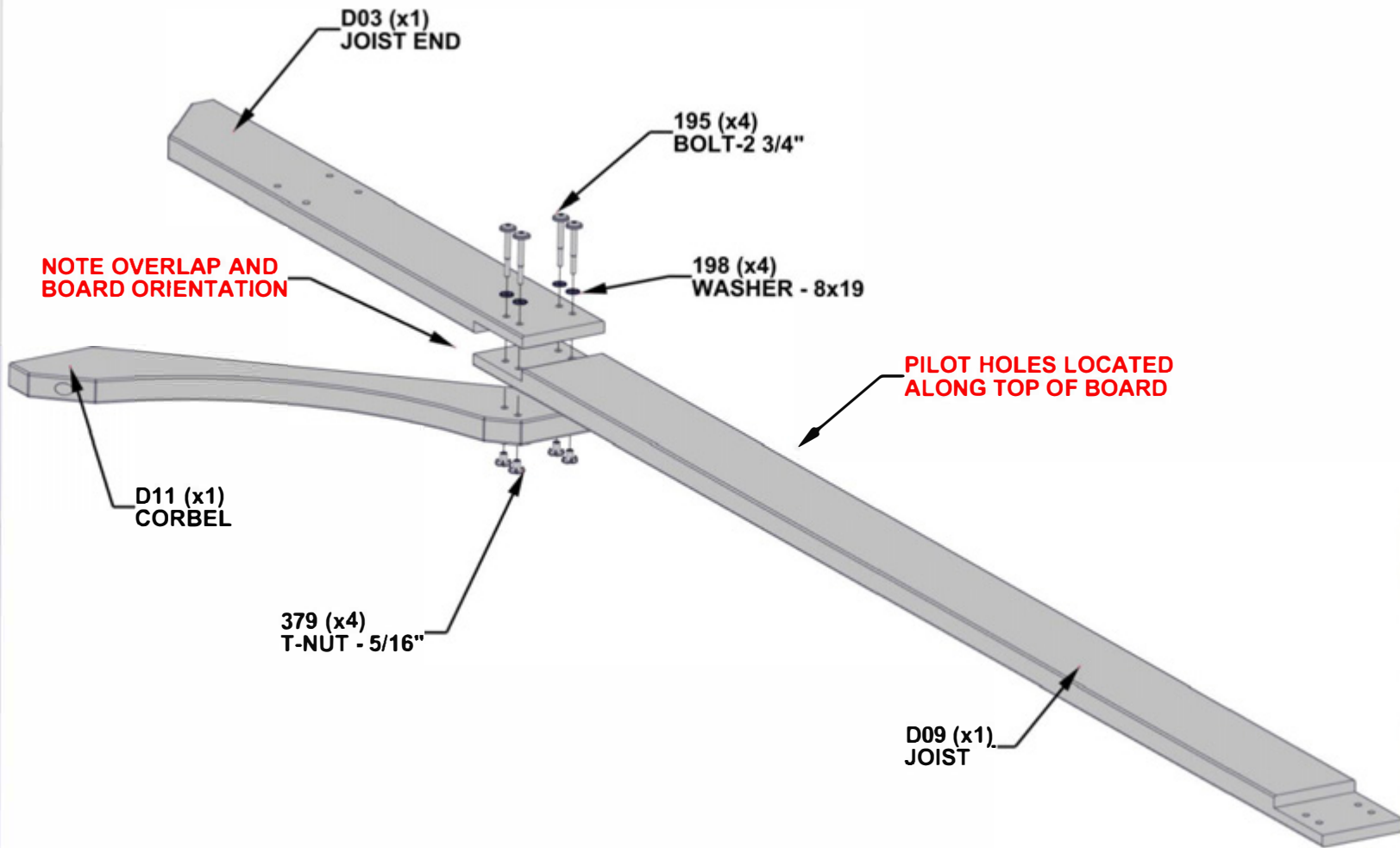

STEP 14 - PERGOLA ASSEMBLY

QTY	PART NUMBER	DESCRIPTION
8	H100195	BOLT WH 5/16x2 3/4 BLK
8	H100198	WASHER LOCK EXT 8x19
8	H100379	T-NUT 5/16 BLK

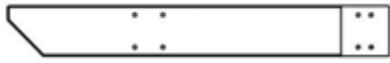

D04 JOIST END - W4L20745
(x2) 1 3/8"X5 1/4"X1030 (36x134x40 1/2")

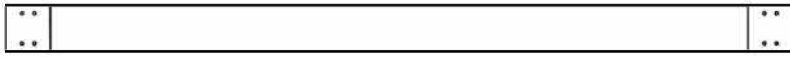

D08 JOIST - W4L20751
(x2) 1 3/8"X5 1/4"X88 1/8" (36x134x2237)



D11 CORBEL - W4L15510
(x2) 1 3/8"X5 1/4"X32 1/2" (36x134x826)

- INSERT T-NUTS FIRST.

- COMPLETE THIS STEP TWICE.
- HAND TIGHTEN HARDWARE.

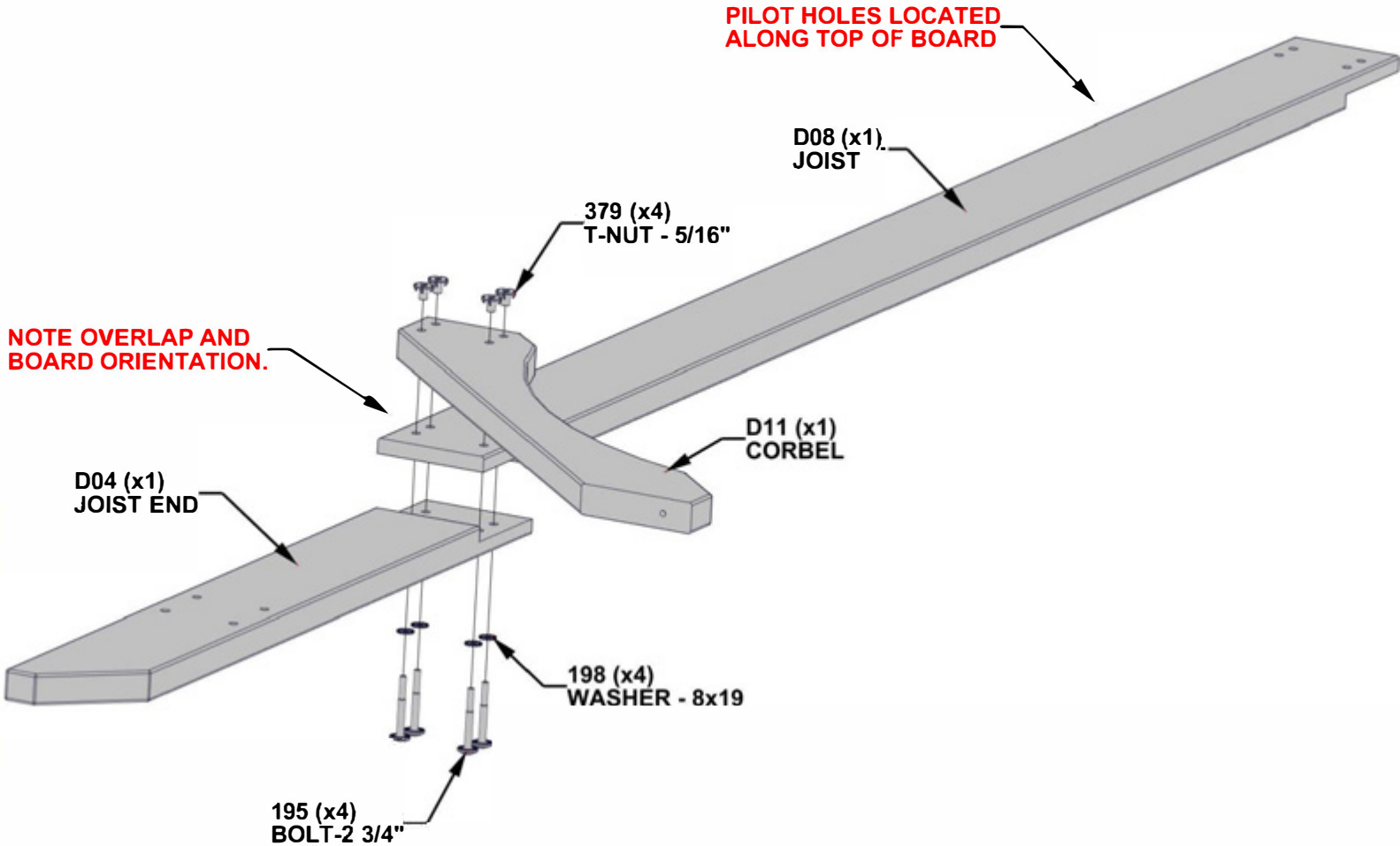

STEP 15 - PERGOLA ASSEMBLY

QTY	PART NUMBER	DESCRIPTION
8	H100198	WASHER LOCK EXT 8x19
8	H100379	T-NUT 5/16 BLK
4	H100405	WASHER LOCK EXT 6x15
4	H100792	LAG SCREW WH 1/4x3 BLK
8	H101058	BOLT WH 5/16x8 3/4 BLK

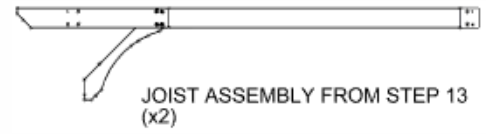
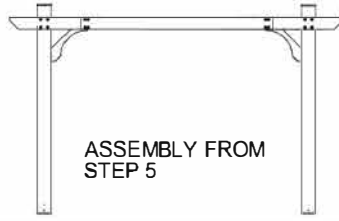
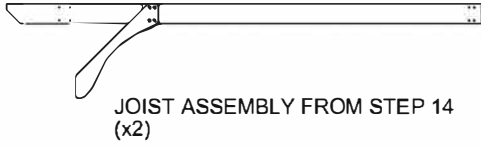

- FOR EASE OF ASSEMBLY, IT IS RECOMMEND TO USE SAWHORSES FOR THIS STEP.
- FULLY TIGHTEN ALL HARDWARE FROM STEPS 13-15.

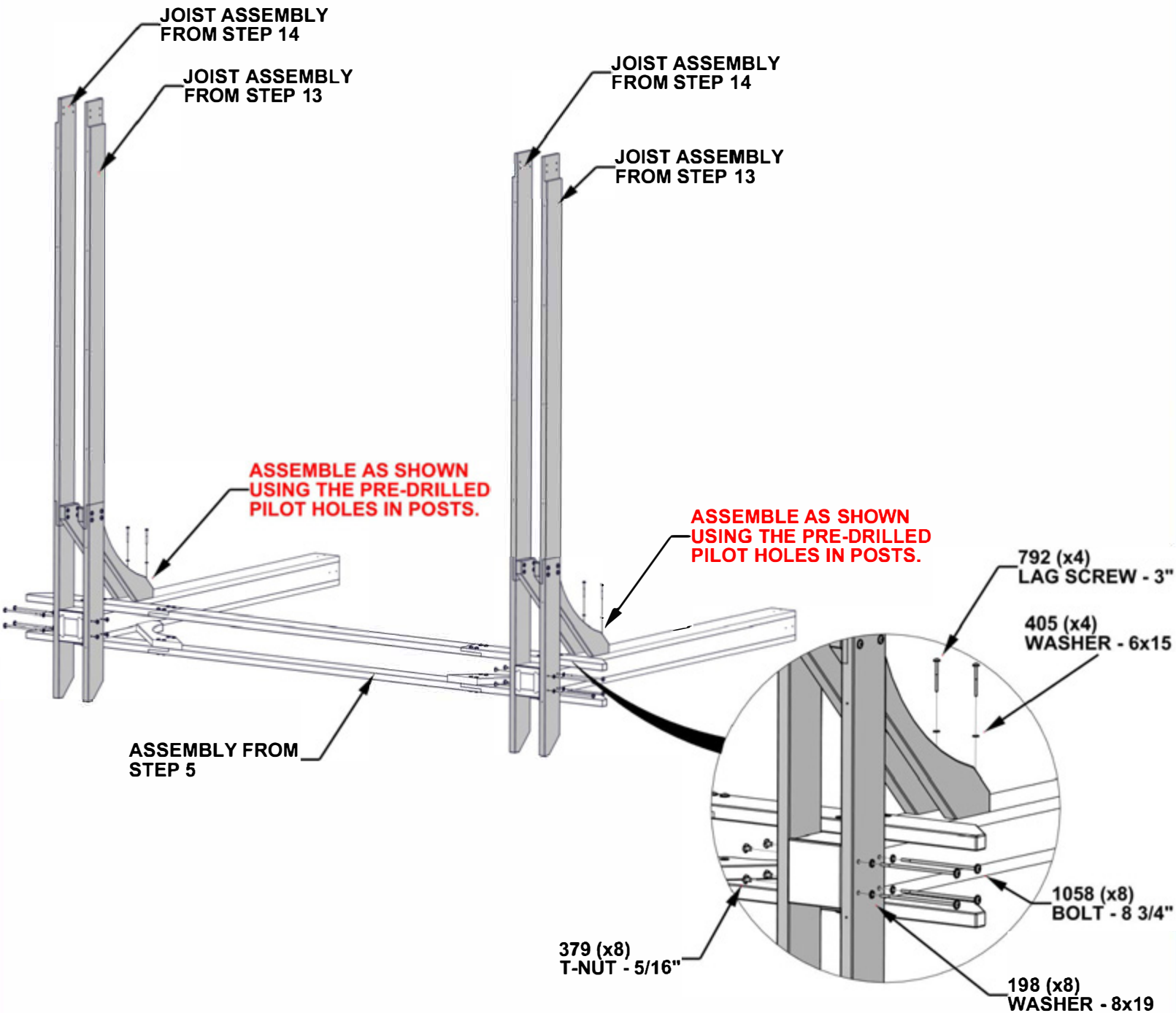

STEP 16 - PERGOLA ASSEMBLY

QTY	PART NUMBER	DESCRIPTION
16	H100195	BOLT WH 5/16x2 3/4 BLK
16	H100198	WASHER LOCK EXT 8x19
16	H100379	T-NUT 5/16 BLK
4	H100405	WASHER LOCK EXT 6x15
4	H100792	LAG SCREW WH 1/4x3 BLK



D11 CORBEL - W4L15510
(x4) 1 3/8"X5 1/4"X32 1/2" (36x134x826)

- ATTACH CORBELS BEFORE ATTACHING JOIST ASSEMBLY FROM STEP 15.
- INSERT T-NUTS FIRST.

- ADDITIONAL PEOPLE ARE HELPFUL FOR THIS STEP.
- FASTEN CORBELS TO POST FIRST, THEN STAND UP ASSEMBLY FROM STEP 15 AND FASTEN TOGETHER.
- HAND TIGHTEN HARDWARE UNTIL ALL BOLTS ARE IN, THEN FULLY TIGHTEN.
- ATTACH IN NUMERICAL ORDER AS SHOWN BELOW.

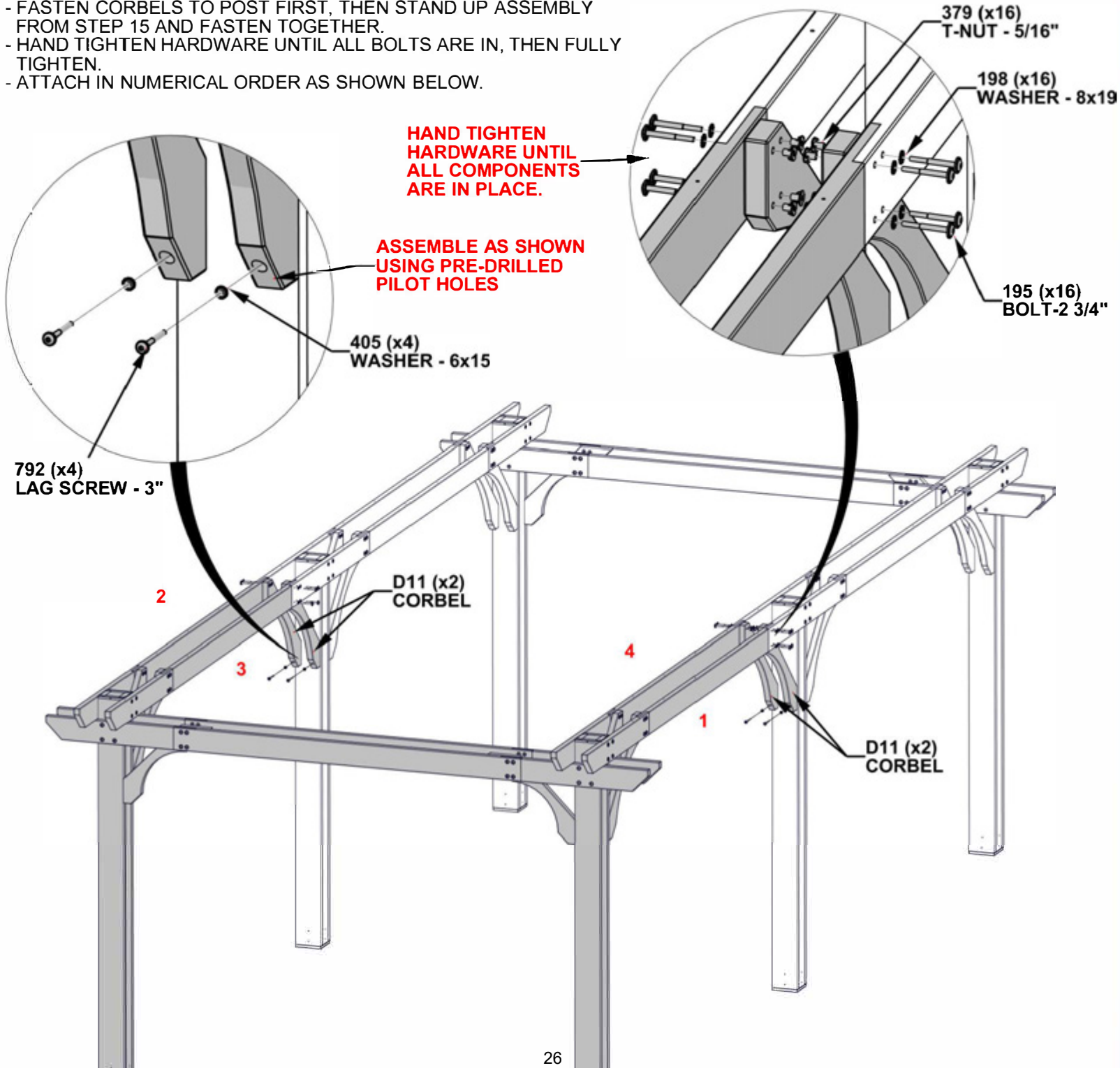

STEP 17 - PERGOLA ASSEMBLY

QTY	PART NUMBER	DESCRIPTION
56	H100198	WASHER LOCK EXT 8x19
56	H100379	T-NUT 5/16 BLK
56	H100459	BOLT WH 5/16x1 1/4 BLK

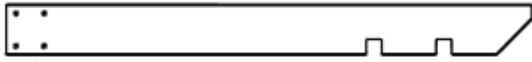

D14 SLOTTED JOIST - W4L15515
(x14) 1 3/8"X5 1/4"X55 3/4" (36x134x1416)



D15 SLOTTED JOIST - W4L15517
(x14) 1 3/8"X5 1/4"X89 1/2" (36x134x2274)

- INSERT T-NUTS FIRST.
- COMPLETE THIS STEP 14 TIMES.

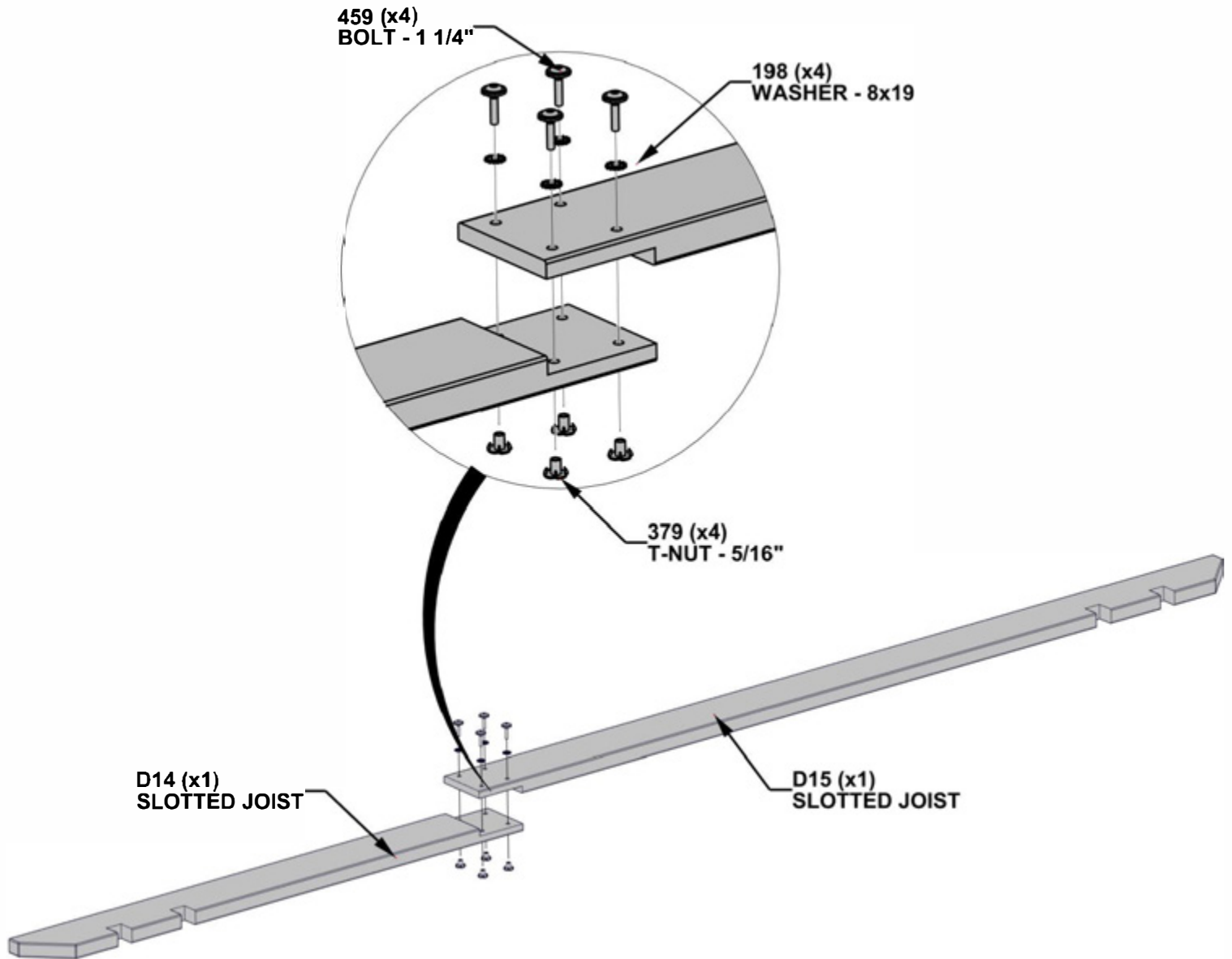

STEP 18 - PERGOLA ASSEMBLY

QTY	PART NUMBER	DESCRIPTION
28	H100198	WASHER LOCK EXT 8x19
28	H100204	LAG SCREW WH 5/16x5 1/2 BLK

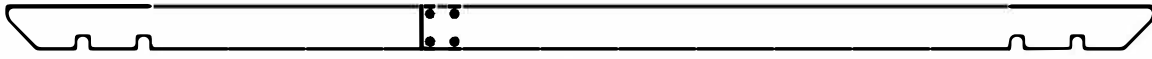

ROOF JOIST ASSEMBLY FROM STEP 17
(x14)

ATTACH ROOF JOIST ASSEMBLIES USING PILOT HOLES IN OUTER JOIST ASSEMBLY.

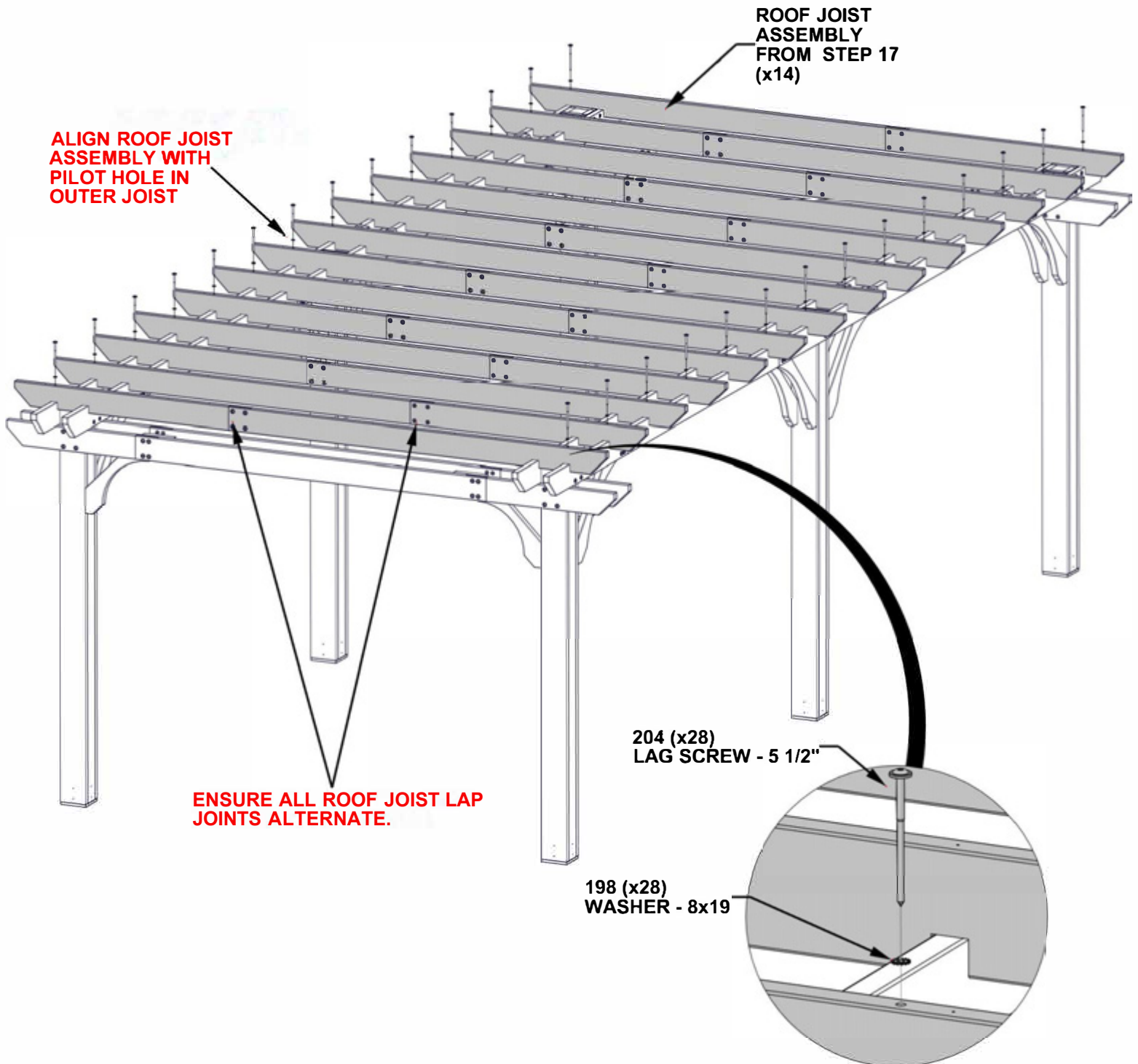

STEP 19 - PERGOLA ASSEMBLY

QTY	PART NUMBER	DESCRIPTION
42	H100397	BOLT WH 1/4x1 1/4 BLK
42	H100398	T-NUT 1/4 BLK
42	H100405	WASHER LOCK EXT 6x15

P11 PURLIN - W4L20748
(x14) 1 3/8"X1 3/8" (36x36x1074)

P12 PURLIN - W4L20749
(x14) 1 3/8"X1 3/8" (36x36x1593)

P10 PURLIN END - W4L20747
(x28) 1 3/8"X1 3/8"X88 1/8" (36x36x2239)

- INSERT T-NUTS FIRST.
- REPEAT THIS STEP 14 TIMES.

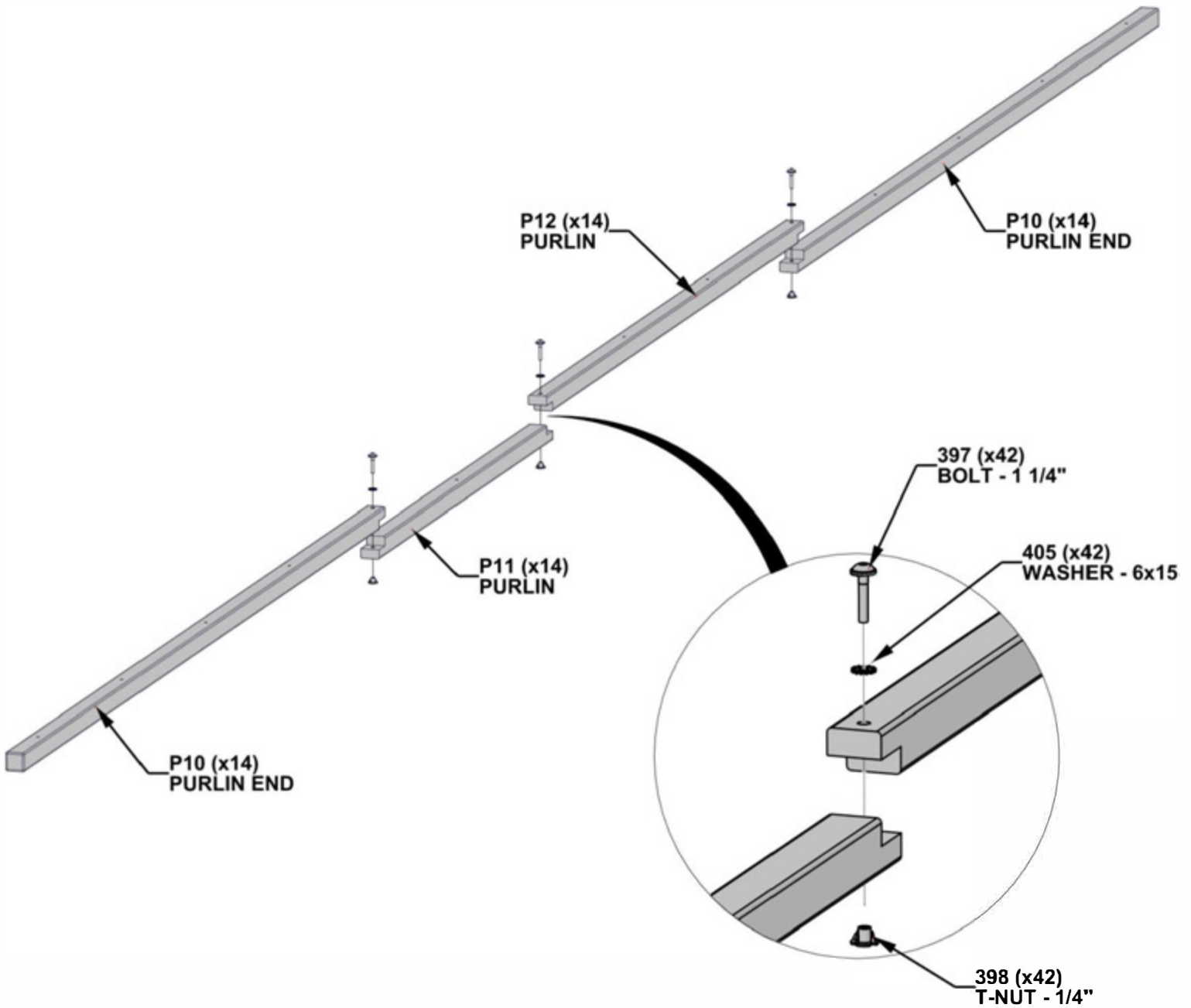

STEP 20 - PERGOLA ASSEMBLY

QTY	PART NUMBER	DESCRIPTION
154	H100201	SCREW PFH 8x2 1/2 BLK



PURLIN ASSEMBLY FROM STEP 19
(x14)

- WHEN LIFTING UP EACH PURLIN ASSMBLY, ENSURE THAT JOINTS ARE SUPPORTED AND PURLIN IS KEPT LEVEL.
- TO AVOID WOOD SPLITTING OUT, IT IS RECOMMENDED THAT A 1/8" [3mm] DEEP PILOT HOLE IS MADE USING A 1/8" [3mm] DRILL BIT AT THE LAP JOINTS WHERE THE PURLINS FASTEN.

**ATTACH PURLIN ASSEMBLIES
USING PILOT HOLES IN
SLOTTED JOIST ASSEMBLIES.**

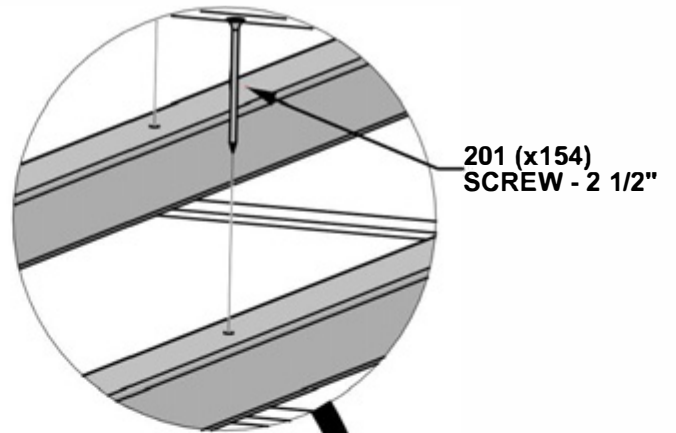

PURLIN ASSEMBLY
FROM STEP 19 (x14)

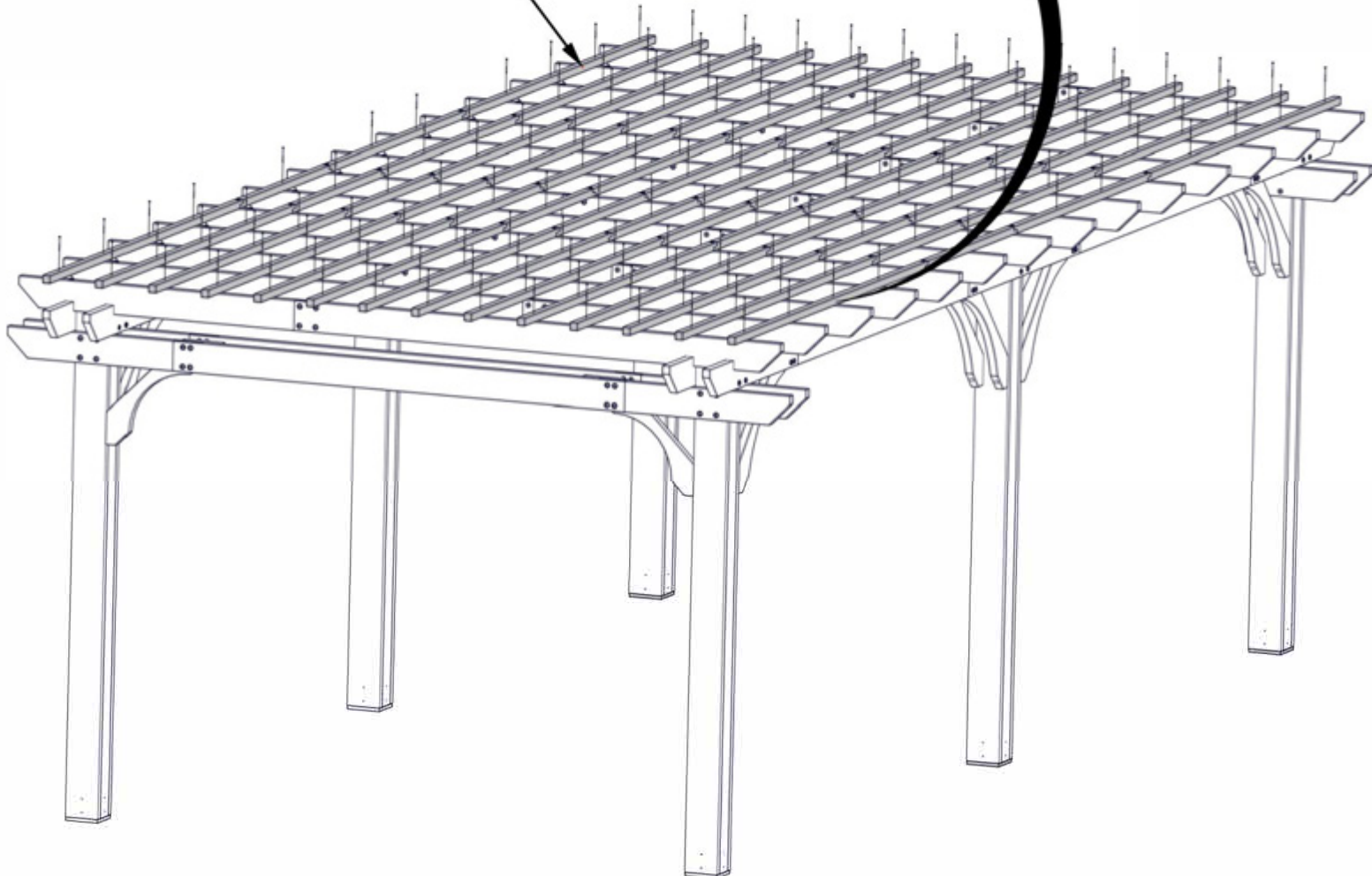

STEP 21 - PERGOLA ASSEMBLY

QTY	PART NUMBER	DESCRIPTION
48	H100471	LAG SCREW WH 5/16x1 1/2 BLK



A4M00977 POST ANCHORING PLATE WITH FLANGE
(x12)



A4M00978 POST PLATE
(x12)

- ALIGN POST PLATES WITH PILOT HOLES IN POSTS.

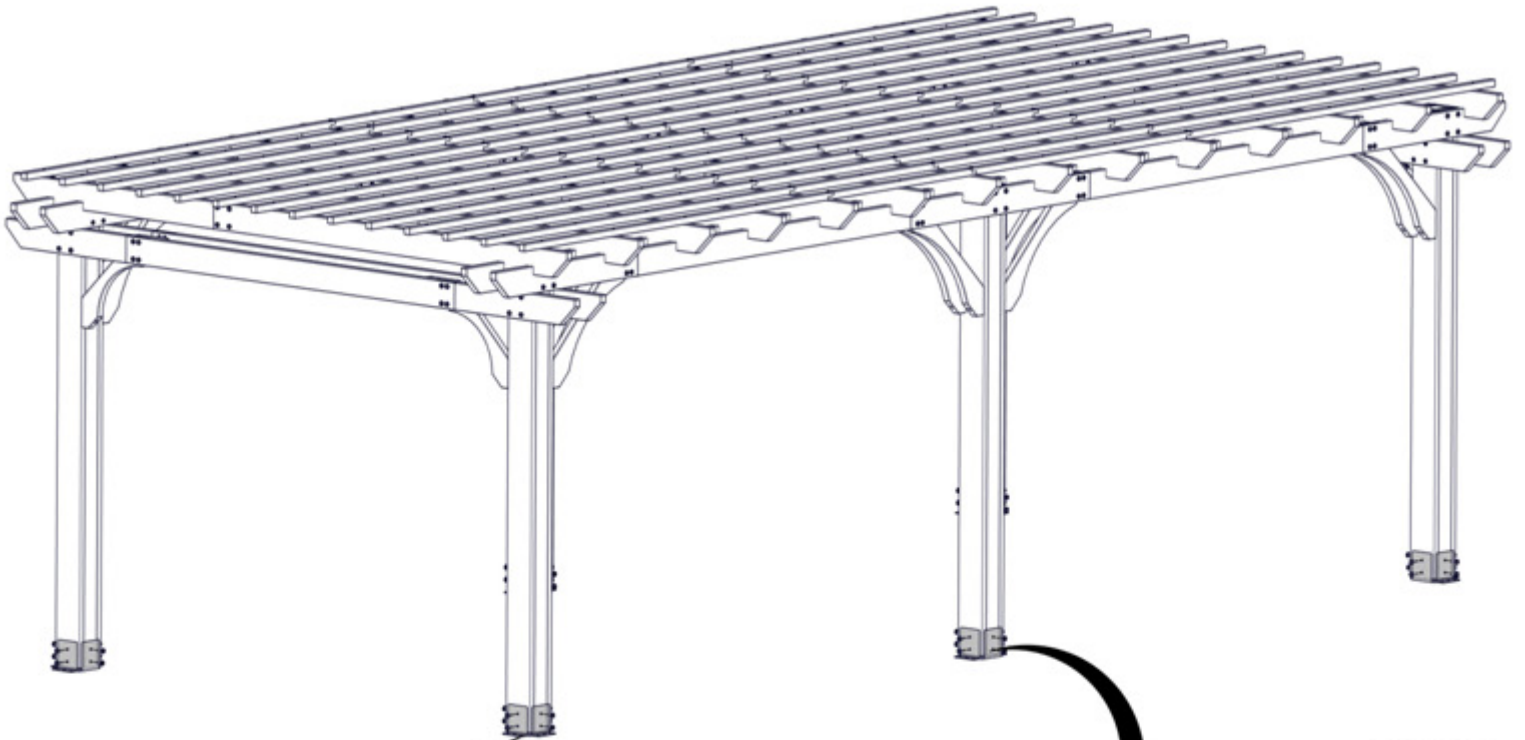

977 (x12)
POST ANCHORING PLATE
WITH FLANGE

471 (x48)
LAG SCREW - 1 1/2"

978 (x12)
POST PLATE

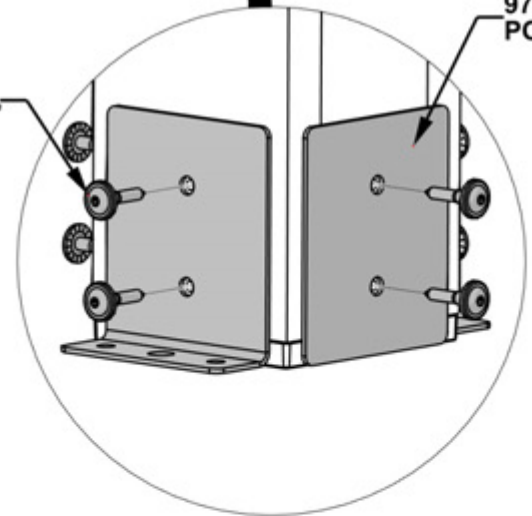
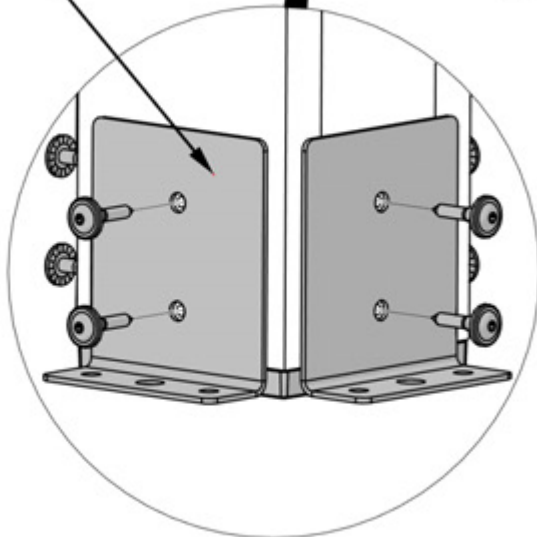

STEP 22 - PERGOLA ASSEMBLY

QTY	PART NUMBER	DESCRIPTION
4	H100202	SCREW PWH 8x5/8 BLK

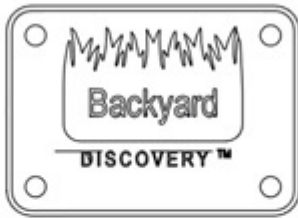

A4M02158
BYD ID TAG PATIO
(x1)

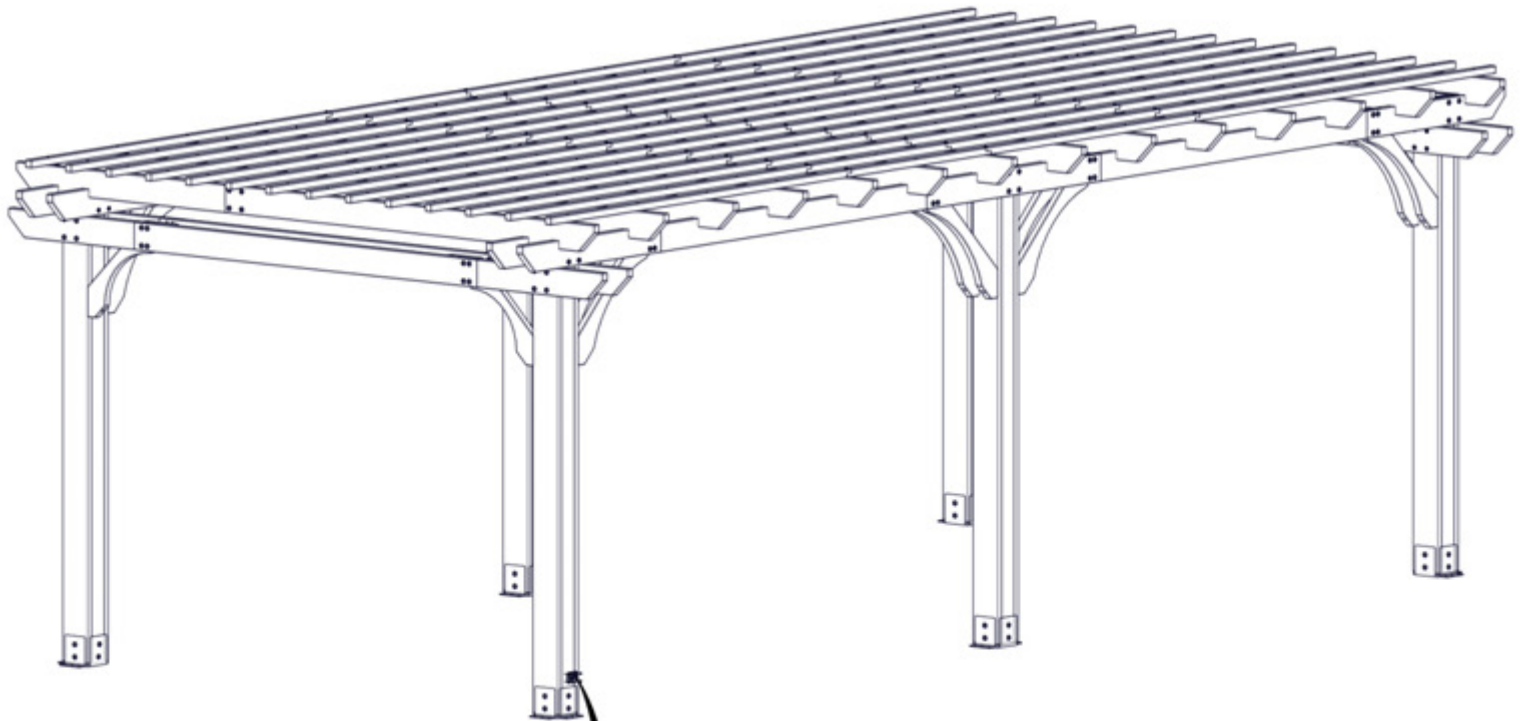

2158 (x1)
BYD ID TAG PATIO

202 (x4)
SCREW - 5/8"

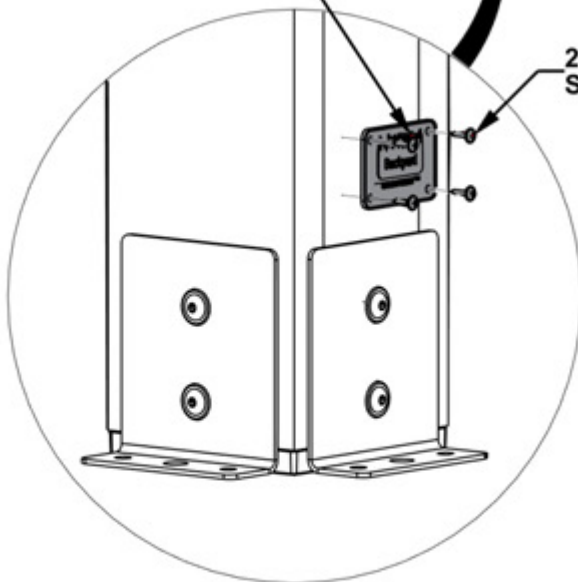

STEP 23 - PERGOLA ASSEMBLY

QTY	PART NUMBER	DESCRIPTION
24	H100120	CONCRETE ANCHOR 1/4"x2"
24	H100630	WASHER FLAT 8x19 BLK

- MANUFACTURER RECOMMENDS INSTALLATION ON CONCRETE SURFACE OR CONCRETE POST PAD AS SHOWN BELOW.
- FOR INSTALLATION ON WOOD DECKS, YOU MUST ENSURE THERE IS AMPLE STRUCTURAL SUPPORT UNDER THE DECK.
- HARDWARE NOT INCLUDED FOR DECK ATTACHMENT.

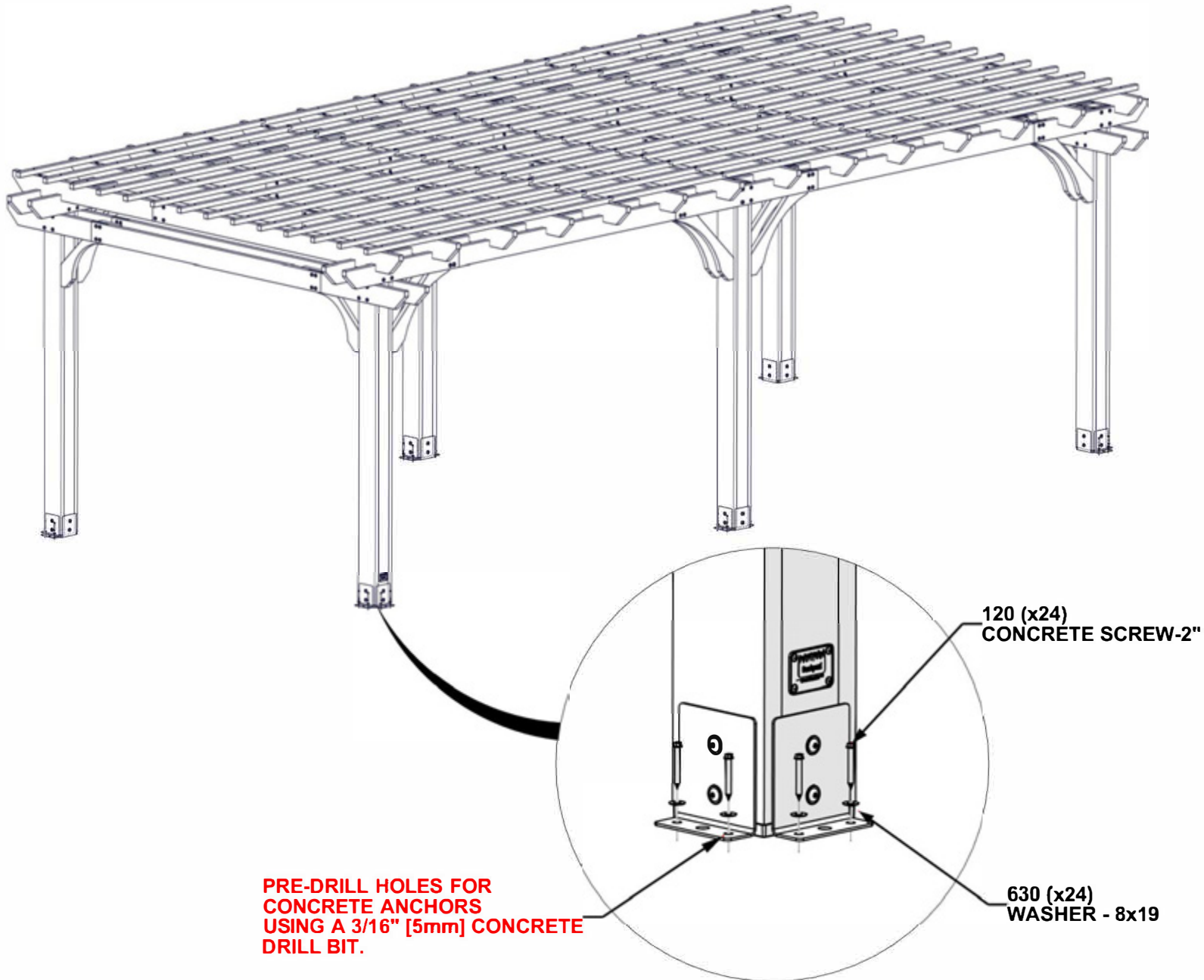

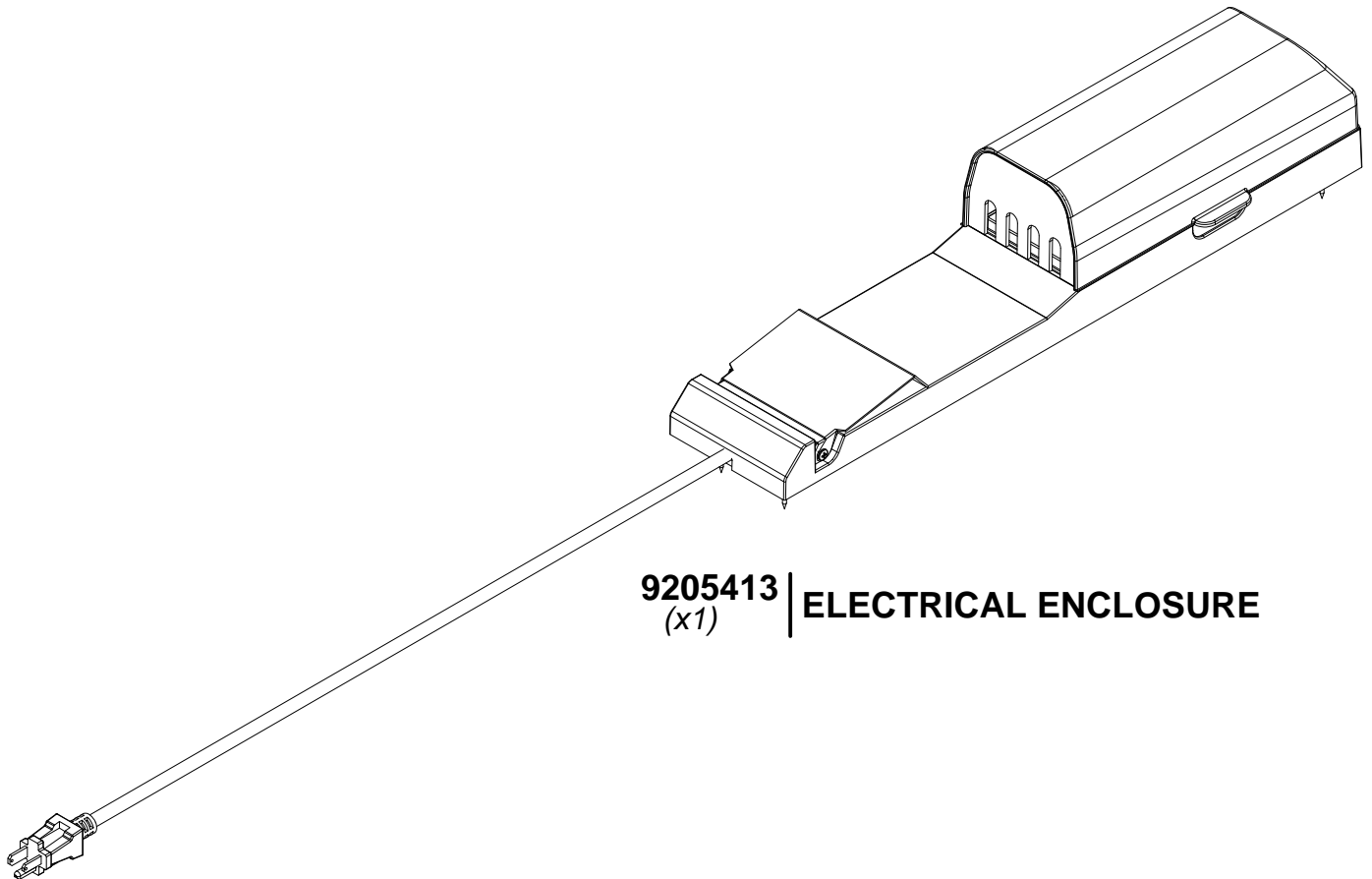

9205413 | **ELECTRICAL ENCLOSURE**
(x1)

FOR POWERPORT INSTALLATION REFER TO ASSEMBLY INSTRUCTIONS THAT COME PACKAGED WITH THE POWERPORT KIT. INSTALL ON ANY POST THAT IS DESIRED. FOLLOW DIRECTIONS FOR PROPER INSTALLATION.