



Manufactured by:  
Backyard Discovery  
3305 Airport Drive, Pittsburg, KS  
66762 800-856-4445

Basepoint Business Centre: Rivermead Drive, Westlea, Swindon SN5 7EX Phone: 0800-118-2476  
J.P. Coenstraat 7, The Bridge, The Hague, 2595 WP, Netherlands Phone: 08005678990

# 14x10 NORWOOD GAZEBO

## MODEL # : 2406018

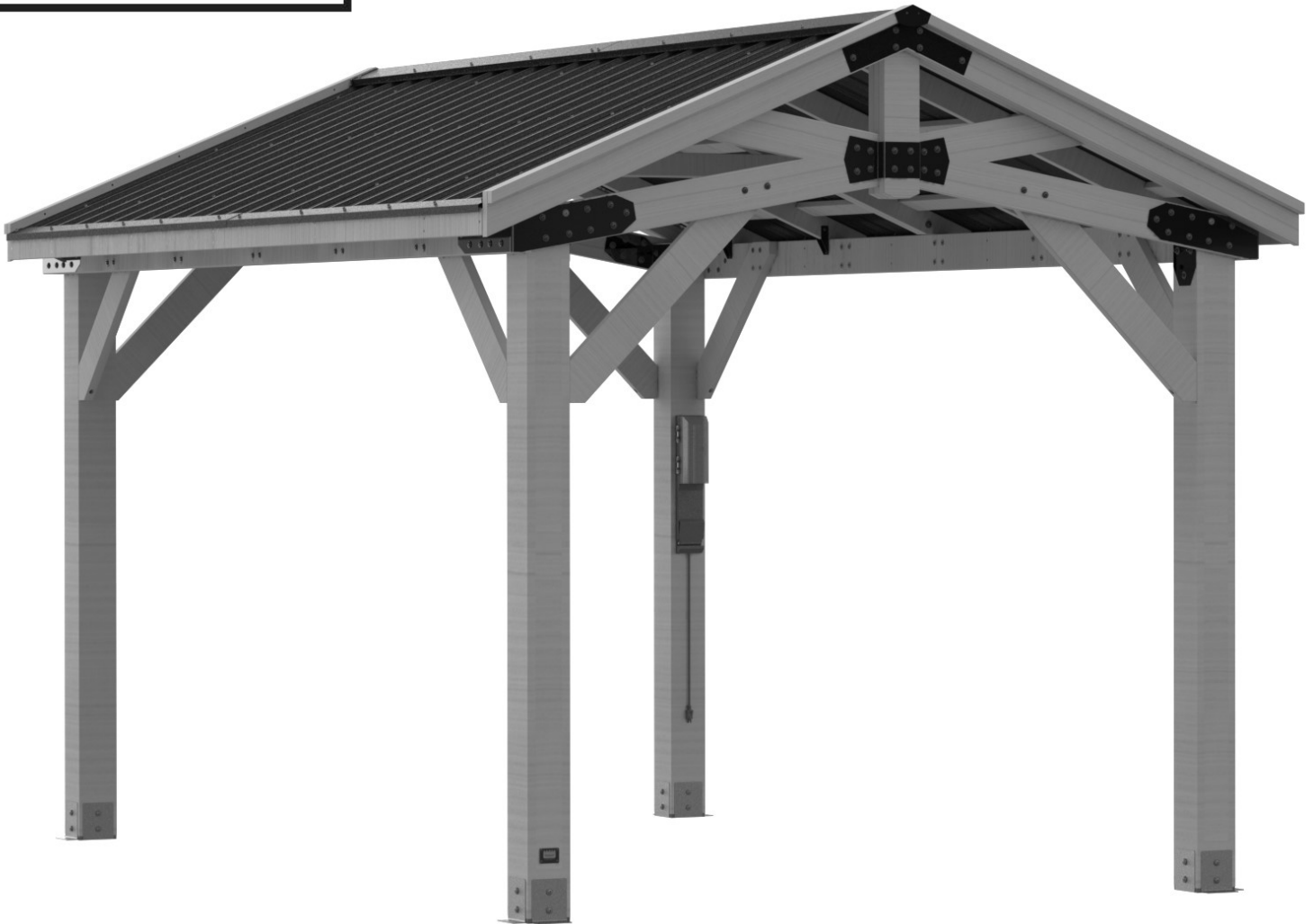

Please visit [www.backyarddiscovery.com](http://www.backyarddiscovery.com)  
For the most up to date assembly manual, to register your product, or to order replacement parts *Para obtener instrucciones en español, visite* [www.backyarddiscovery.com](http://www.backyarddiscovery.com)



EASY STEP-BY-STEP  
3D INTERACTIVE INSTRUCTIONS  
DOWNLOAD THE FREE APP



# OWNER'S MANUAL - BASIC SETUP DIMENSIONS & ASSEMBLY NOTES

It is critically important that you start with square and level footings, concrete pad or deck to attach your structure

- Pay close attention to the items needed for each step. Make sure you are using the correct hardware for each step. Using incorrect hardware may result in improper assembly
- Remember to double check for underground utilities and overhead electrical lines

**Post mounts are provided with your structure which allows you to permanently install your structure to a pre-existing or new wood or concrete surface. See Anchor Instructions for further details and recommendations.**

- The hardware to attach the post mounts to the structure is included.
- The hardware to mount the structure permanently to a concrete surface is included.
- The hardware to mount the structure permanently to a wood deck is NOT included and will need to be purchased separately. You must ensure there is ample structural support under the deck before permanently attaching.

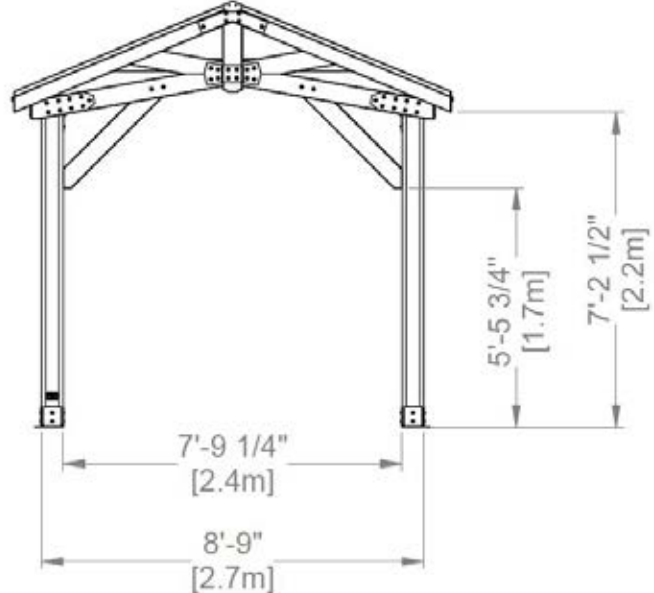
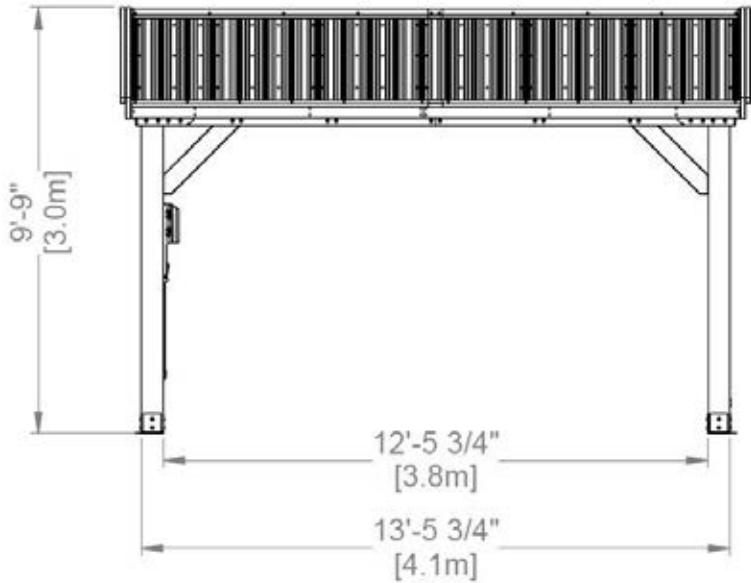
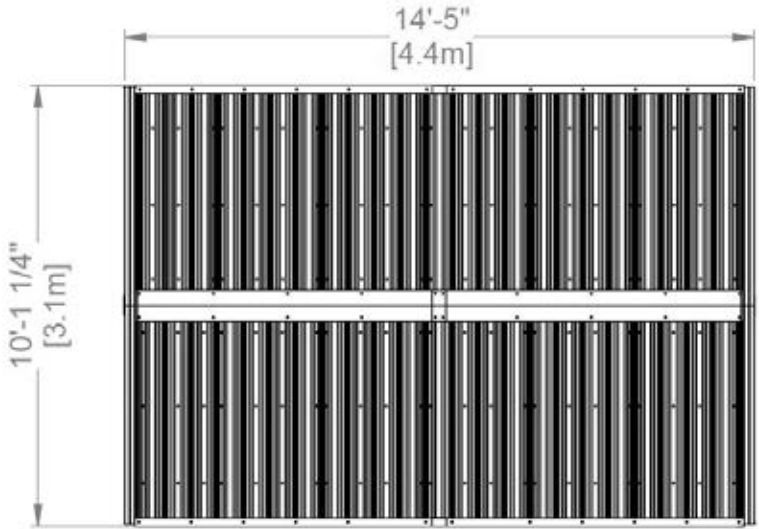

# OWNER'S MANUAL - ANCHORING LAYOUT

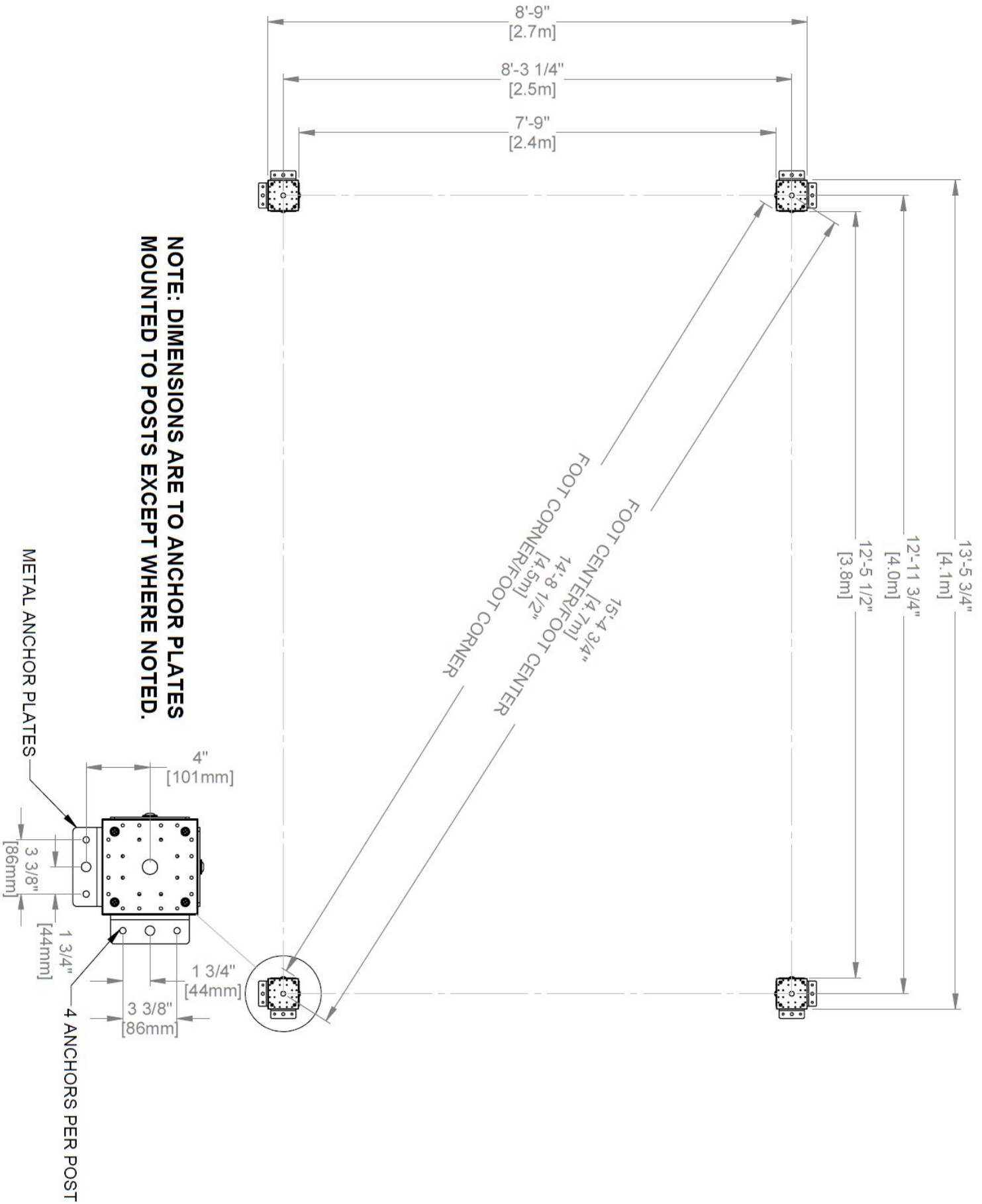

# OWNER'S MANUAL - PARTS IDENTIFICATION

## WOOD COMPONENTS (NOT TO SCALE)



D01 GABLE BOARD - W4L19991  
(x4) 1 3/8"X5 1/4"X21 3/4" (36x134x553)



D02 TOP RAIL - W4L16886  
(x4) 1 3/8"X5 1/4"X53 3/4" (36x134x1366)



D03 TOP RAIL - W4L16887  
(x2) 1 3/8"X5 1/4"X57" (36x134x1448)



D04 CORBEL - W4L16853  
(x4) 1 3/8"X5 1/4"X34 7/16" (36x134x875)



D05 GABLE BOARD - W4L16854  
(x2) 1 3/8"X1 1/2"X5 1/4" (36x38x134)



D06 CORBEL - W4L16855  
(x3) 1 3/8"X5 1/4"X44 1/16" (36x134x1119)



D07 TOP RAIL - W4L16888  
(x4) 1 3/8"X5 1/4"X82 1/4" (36x134x2091)



E01 RAFTER - W4L19631  
(x4) 1 7/16"X3 3/8"X63 3/8" (36x86x1610)



E02 RAFTER - W4L19632  
(x8) 1 7/16"X3 3/8"X63 3/8" (36x86x1610)



E09 ACCESSORY TRUSS - W4L16756  
(x2) 1 3/8"X3 3/8"X73 7/8" (36x86x1875)



F01 TRUSS - W4L17203  
(x4) 1 7/16"X2 3/8"X62 1/16" (36x60x1576)

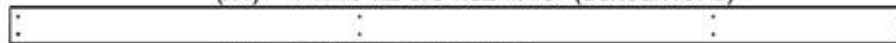

H02 FASCIA - W4L16891  
(x2) 1"X3 3/8"X80 3/8" (24x86x2040)



H03 FASCIA - W4L16892  
(x2) 1"X3 3/8"X87" (24x86x2209)



H04 RAFTER - W4L16893  
(x2) 1"X3 3/8"X89 1/4" (24x86x2267)



H05 RAFTER - W4L16894  
(x2) 1"X3 3/8"X69 1/2" (24x86x1766)

# OWNER'S MANUAL - PARTS IDENTIFICATION

## WOOD COMPONENTS (NOT TO SCALE)

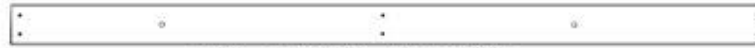

H06 FASCIA - W4L16895  
(x2) 1"X3 3/8"X63 1/2" (24x86x1614)



H07 FASCIA - W4L16896  
(x2) 1"X3 3/8"X70 1/8" (24x86x1783)



H08 NOTCHED SUPPORT BOARD - W4L16915  
(x2) 1"X3 3/8"X89 1/2" (24x86x2274)



H09 SHEATHING BOARD - W4L19629  
(x6) 1"X3 3/8"X80 3/8" (24x86x2040)



H10 SHEATHING BOARD - W4L19630  
(x6) 1"X3 3/8"X87" (24x86x2209)



J09 RIDGE CAP STIFFENER - W4L16897  
(x2) 1"X2 3/8"X77 5/8" (24x60x1973)



J10 RIDGE CAP STIFFENER - W4L16898  
(x2) 1"X2 3/8"X89 1/2" (24x60x2273)



CA01 CORBEL - W2A03504  
(x1) 1 3/8"x1 3/8"x44" (36x134x1119)

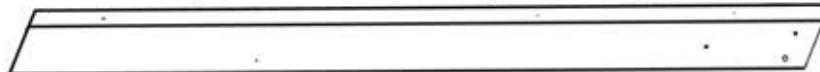

GP1 GABLE PANEL - W2A03515  
(x2) 2 13/16"x5 1/4"x67 3/16" (72x134x1706)

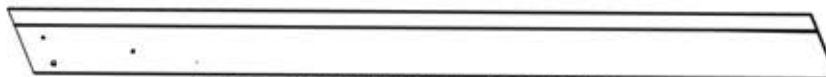

GP2 GABLE PANEL - W2A03516  
(x2) 2 13/16"x5 1/4"x67 3/16" (72x134x1706)

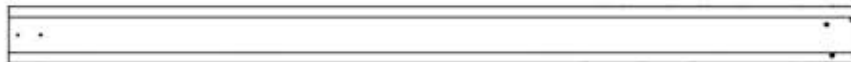

P01 POST - W2A03501  
(x2) 6"X6"X89 1/2" (152x152x2274)

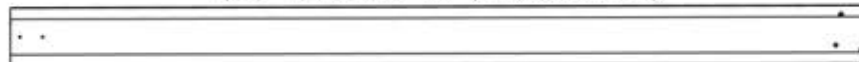

P02 POST - W2A03502  
(x2) 6"X6"X89 1/2" (152x152x2274)

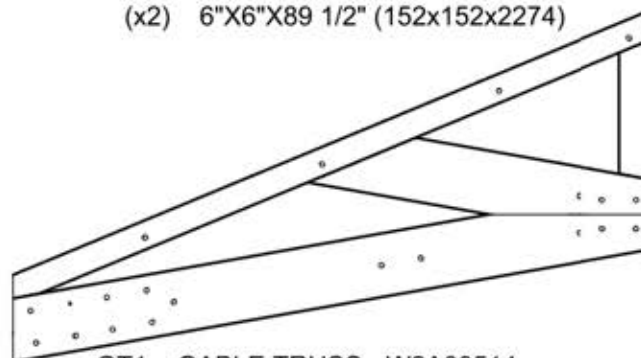

GT1 GABLE TRUSS - W2A03514  
(x4) 1 7/16"x29 1/16"x52 9/16" (36x738x1335)

# OWNER'S MANUAL - PARTS IDENTIFICATION

## ACCESSORY COMPONENTS (NOT TO SCALE)



A4M00977 POST ANCHORING PLATE WITH FLANGE (x8)



A4M00978 POST PLATE (x8)

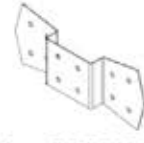

A4M01129 GABLE BRACKET (x4)

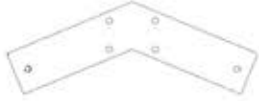

A4M01130 GABLE BRACKET (x2)



A4M01147 PEAK SEAM BRACKET (x2)



A4M01148 TRUSS BRACKET (x2)



A4M01228 RAFTER CLIP (x8)



A4M01232 LEFT ANGLE BRACKET (x2)

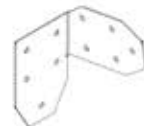

A4M01233 RIGHT ANGLE BRACKET (x2)

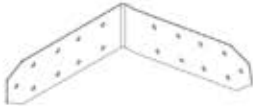

A4M01301 RIGHT OUTSIDE BRACKET (x2)

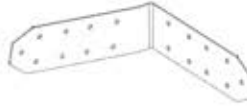

A4M01302 LEFT OUTSIDE BRACKET (x2)



A4M02158 BYD ID TAG PATIO (x1)



A4M02501 FAN MOUNT BRACKET (x1)

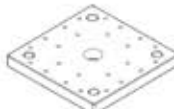

A6P00308 6x6 POST FOOT (x4)

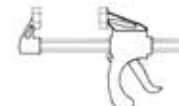

A6P00460 6" QUICK RELEASE BAR CLAMP (x2)



A6P00398 RIDGE CAP PROTECTOR (x2)

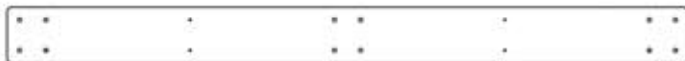

A4M02376 GAZEBO BRACE (x2)



A4M02520 RIDGE BRACE (x1)

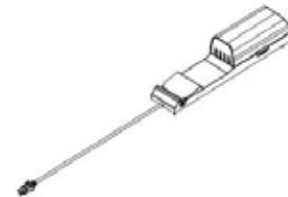

9205413 ELECTRICAL ENCLOSURE (x1)

# OWNER'S MANUAL - PARTS IDENTIFICATION

## ACCESSORY COMPONENTS (NOT TO SCALE)

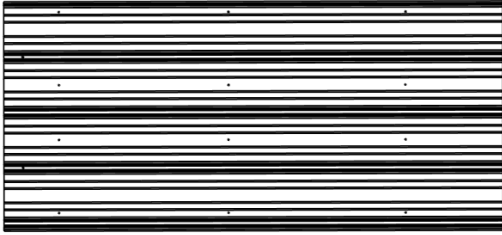

A4M02799 29GA STEEL SHEETING  
(x1)



A4M02800 29GA STEEL SHEETING  
(x2)

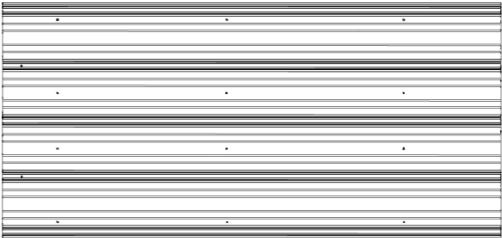

A4M02801 29GA STEEL SHEETING  
(x6)

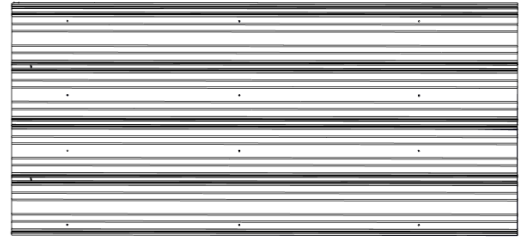

A4M02806 29GA STEEL SHEETING  
(x1)

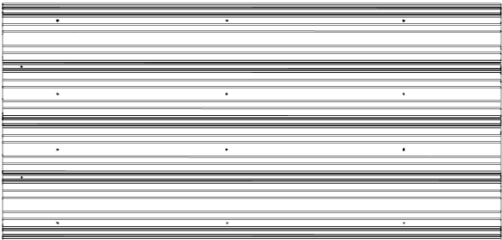

A4M03111 29GA STEEL SHEETING  
(x1)

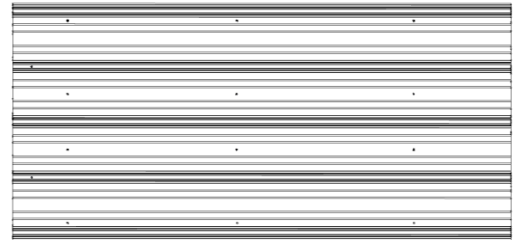

A4M03112 29GA STEEL SHEETING  
(x1)

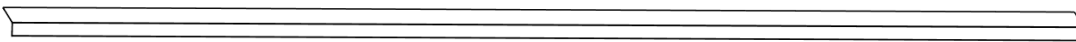

A4M02714 ROOF EDGE TRIM  
(x4)



A4M02638 ROOF EDGE TRIM SPLICE  
(x2)

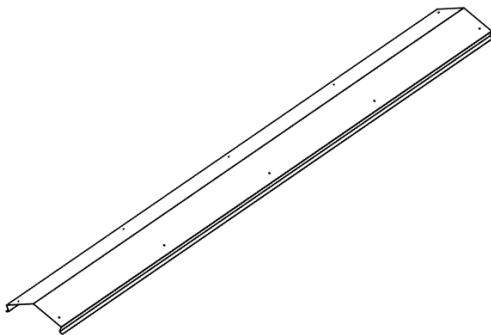

A4M02713 14 FOOT RIDGE CAP 29GA  
(x2)

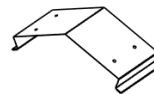

A4M02640 RIDGE CAP SPLICE  
(x1)

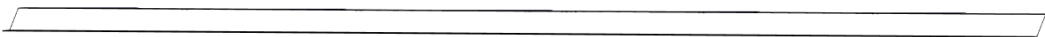

A4M02938 ROOF END TRIM  
(x2)

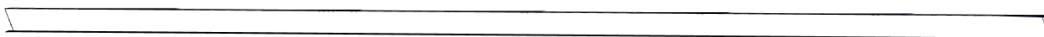

A4M02939 ROOF END TRIM  
(x2)

# OWNER'S MANUAL - PARTS IDENTIFICATION

HARDWARE COMPONENTS (NOT TO SCALE)

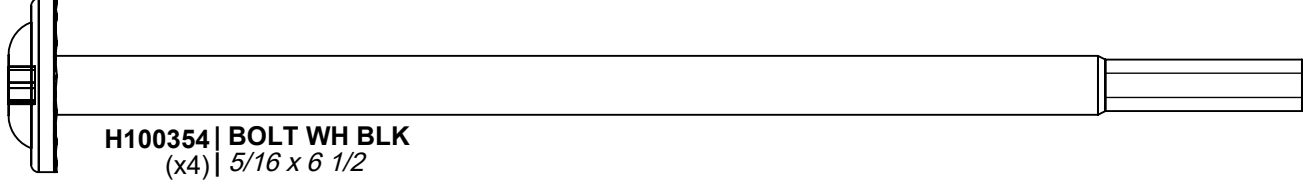
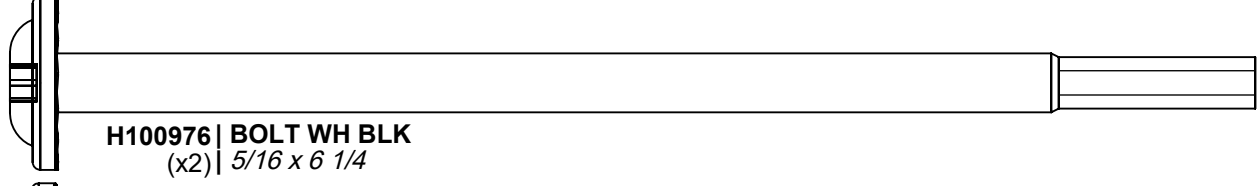
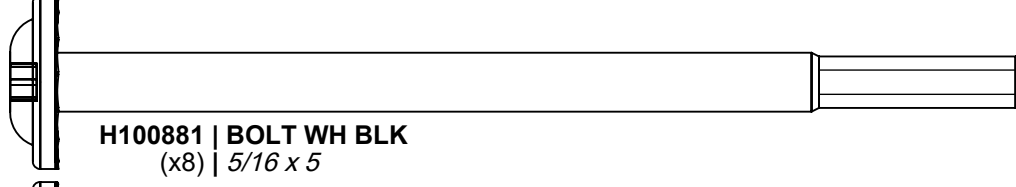
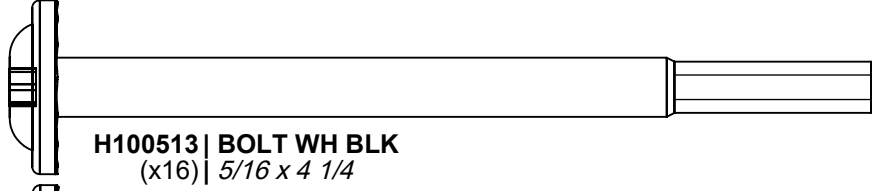
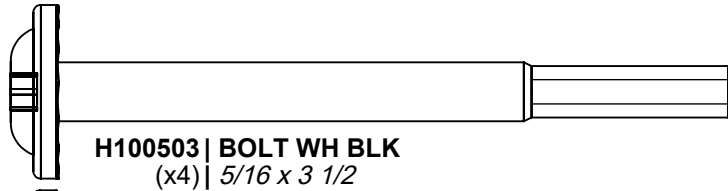
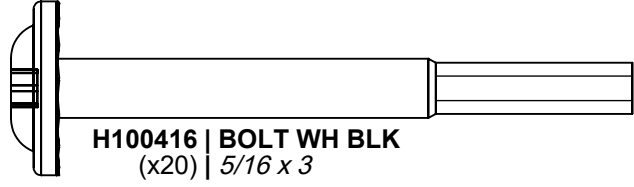
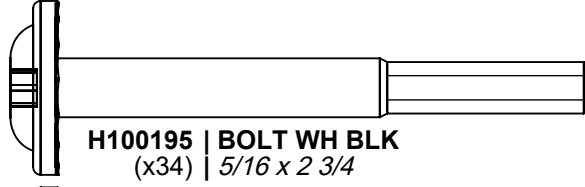
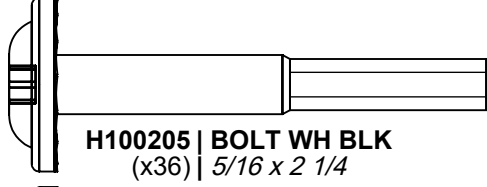
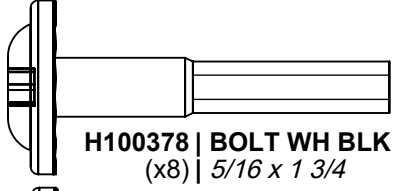
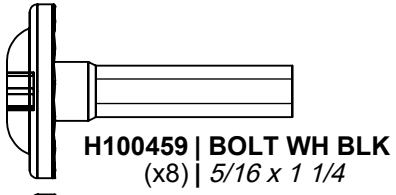



# OWNER'S MANUAL - PARTS IDENTIFICATION

## HARDWARE COMPONENTS (NOT TO SCALE)

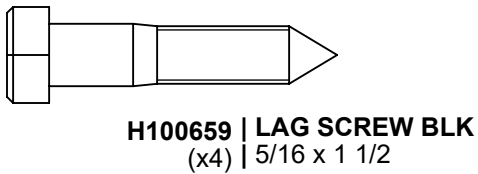
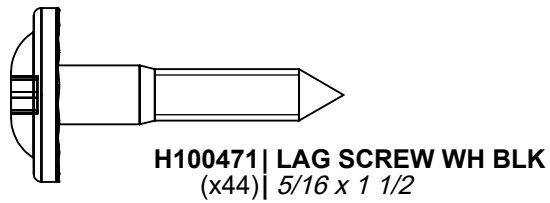
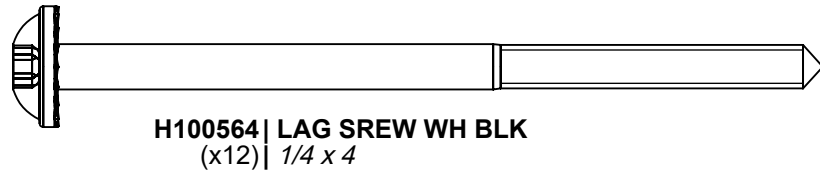
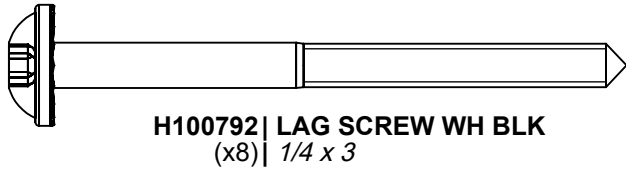
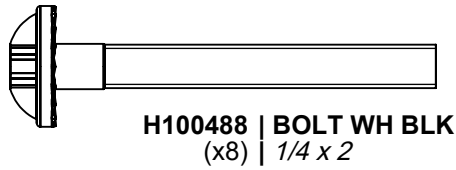
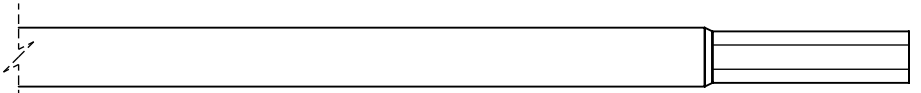
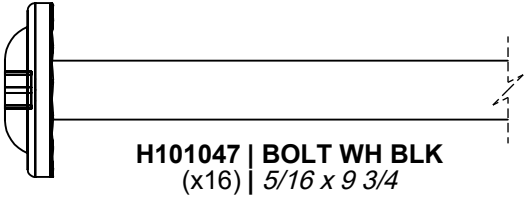
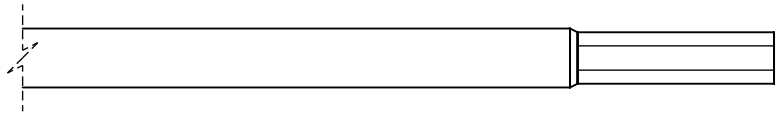
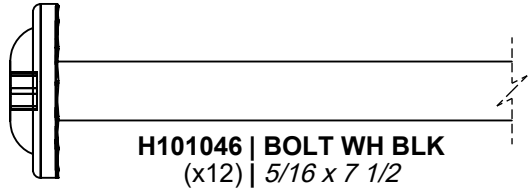

# OWNER'S MANUAL - PARTS IDENTIFICATION

## HARDWARE COMPONENTS (NOT TO SCALE)

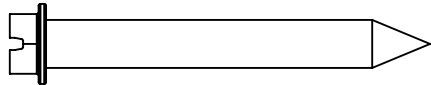

**H100120 | CONCRETE ANCHOR**  
(x16) | 1/4 x 2

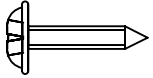

**H100202 | SCREW PWH BLK**  
(x4) | 8 x 5/8

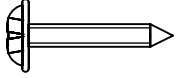

**H100392 | SCREW PWH BLK**  
(x23) | 8 x 3/4

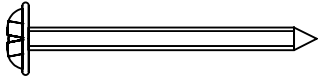

**H100823 | SCREW PWH BLK**  
(x16) | 8 x 1 1/2

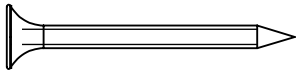

**H100200 | SCREW PFH BLK**  
(x20) | 8 x 1 1/2

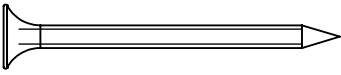

**H100382 | SCREW PFH BLK**  
(x14) | 8 x 1 3/4

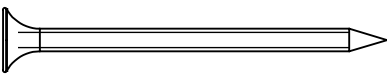

**H100391 | SCREW PFH BLK**  
(x124) | 8 x 2

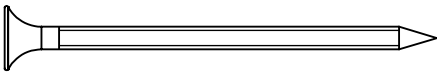

**H100483 | SCREW PFH BLK**  
(x4) | 8 x 2 1/4

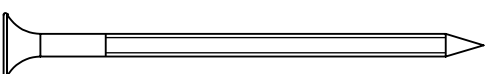

**H100201 | SCREW PFH BLK**  
(x36) | 8 x 2 1/2

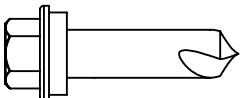

**H100759 | SCREW TAPPING**  
(x24) | 1/4 x 1

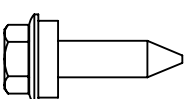

**H100833 | SCREW WOODGRIP**  
(x170) | 10 x 3/4



**H100653 | NUT LOCK BLK**  
(x8) | 1/4

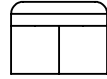

**H100479 | NUT LOCK BLK**  
(x72) | 5/16

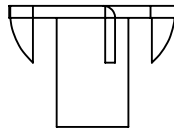

**H100379 | T-NUT BLK**  
(x96) | 5/16

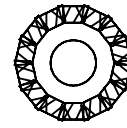

**H100405 | WASHER LOCK EXT BLK**  
(x20) | 6 x 15

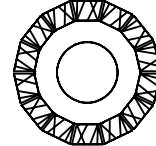

**H100198 | WASHER LOCK EXT BLK**  
(x70) | 8 x 19

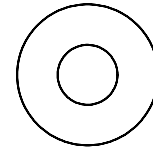

**H100630 | WASHER FLAT BLK**  
(x24) | 8 x 19

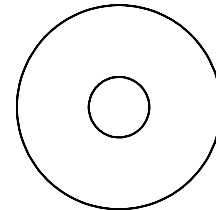

**H100478 | WASHER FLAT BLK**  
(x76) | 8 x 27

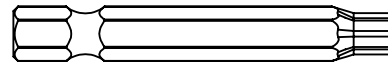

**H100147 | TORX BIT**  
(x1) | T-30

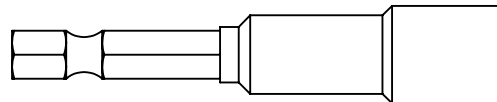

**H101106 | SOCKET DRIVER**  
(x1)

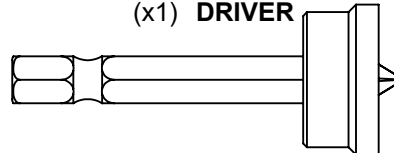

**H100764 | SCREW SETTER**  
(x1)

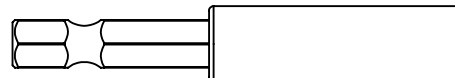

**H101100 | MAGNETIC DRIVER**  
(x1)

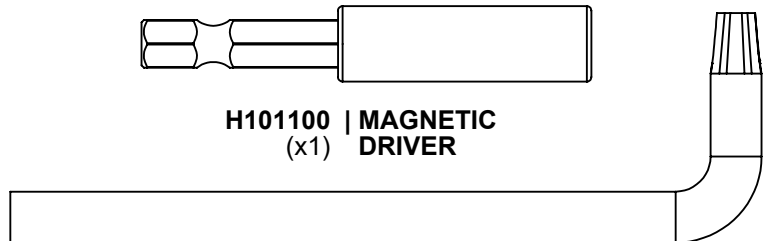

**H100114 | TORX WRENCH**  
(x1) | T-30

# PRE-ASSEMBLY STEP 1 - SORTING PARTS

It is critical for ease of assembly that you take the time to sort and organize the wood and hardware.

---

## WOOD PARTS:

- Organize wood parts by the three-digit, alpha-numeric number stamped on each board (ex. P01).
- If there are multiple boards with the same stamped number, stack those pieces together.
- Stamps can be found on the flat surface of the boards or on the end of the boards.
- Allow yourself plenty of room - the wood pieces can take up a significant amount of space.

**NOTE: CARTONS ARE NOT ORGANIZED BY BOARD NUMBER.**



---

## HARDWARE PARTS:

- We recommend that you have a separate table to organize the hardware.
- Hardware bags are printed with a seven-digit, alpha-numeric part number.
- You can organize your hardware by part number or group by hardware type (i.e. bolts, nuts, etc.).
- During assembly you only need to reference the last four digits of the number.

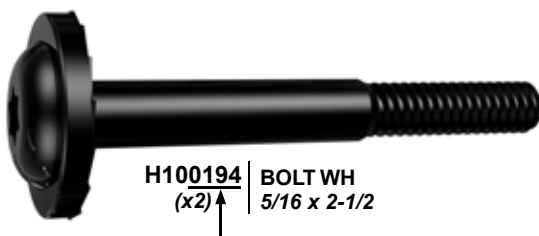

# PRE-ASSEMBLY STEP 2 - TOOLS REQUIRED



Cordless Drill  
or Electric Drill

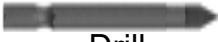

Drill  
Attachments:  
Phillips Head



1/8", 3/16", 3/8" &  
7/16" Drill Bits



Open End  
Wrenches 1/2" &  
9/16"



3/8" Drive Ratchet, 1/2" &  
7/16" STD Sockets 1/2" & 7/16"  
Deep Sockets



Phillips Screw Driver



Claw Hammer



Rubber Mallet  
- Optional

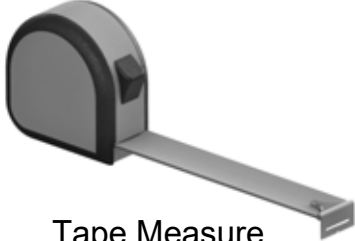

Tape Measure

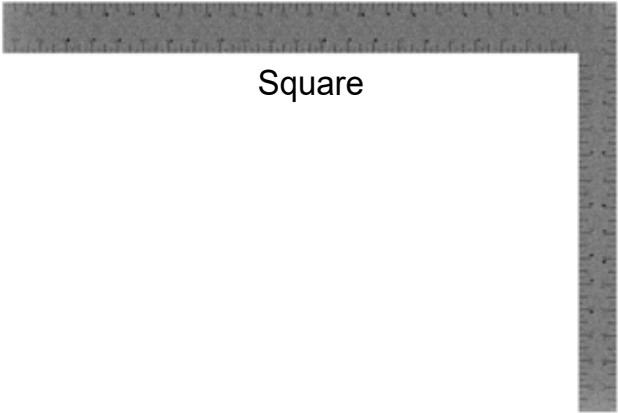

Square



Level 24"

# PRE-ASSEMBLY STEP 3 - CHOOSE YOUR ASSEMBLY METHOD

There are several types of assembly instructions available to you.

1. Printed Assembly Manual included with your set
2. BILT APP - 3D interactive instructions
3. Combination of the Printed Manual and BILT APP (Note: Step numbers can differ between the two methods)

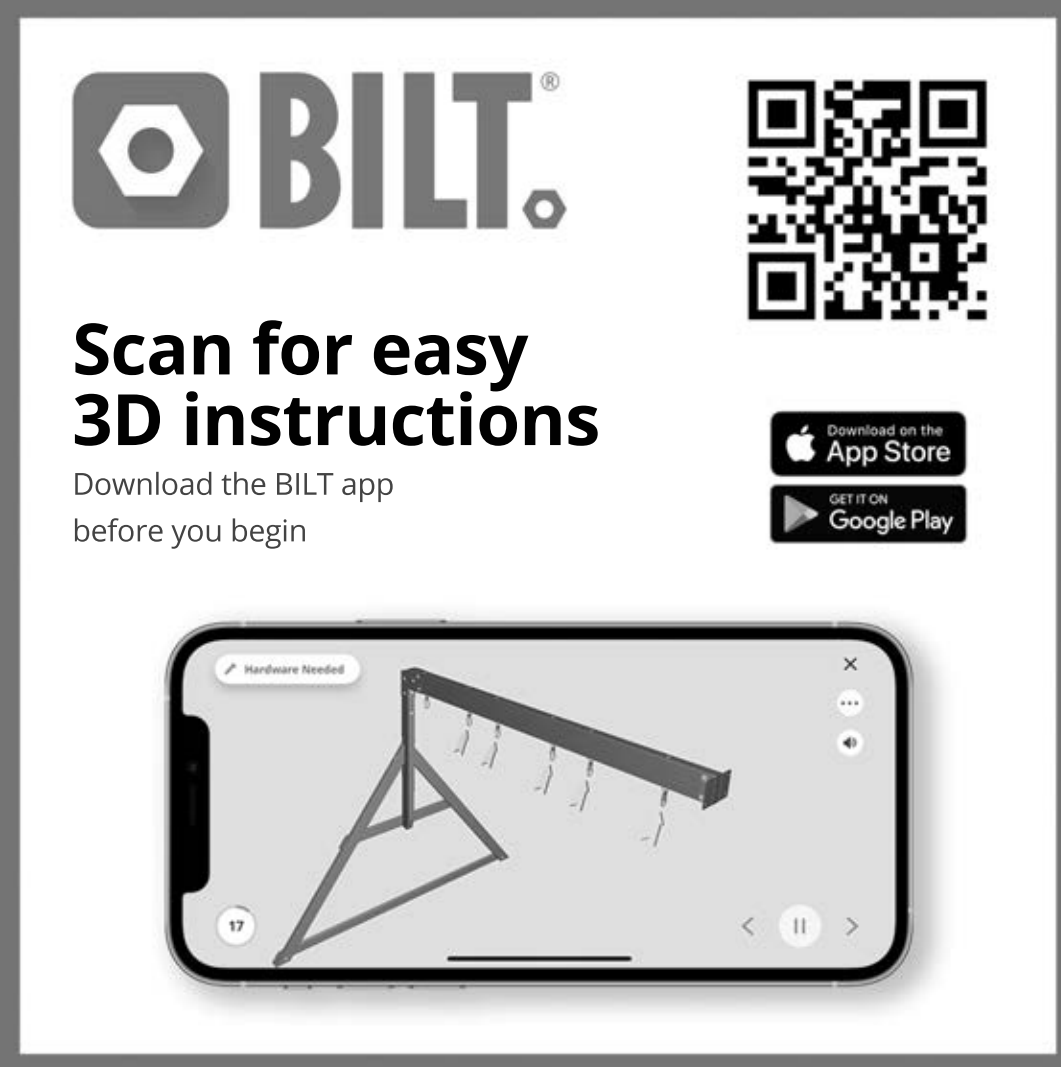

The graphic features the BILT logo (a hexagon with a bolt head inside) and the word "BILT." in a bold, sans-serif font. To the right is a large QR code. Below the logo, the text "Scan for easy 3D instructions" is written in a large, bold font. Underneath that, it says "Download the BILT app before you begin". To the right of this text are two buttons: "Download on the App Store" and "GET IT ON Google Play". At the bottom, a smartphone screen displays a 3D assembly instruction for step 17, showing a metal frame with a horizontal bar being attached. The screen includes a "Hardware Needed" label, a close button (X), a menu button (three dots), a volume icon, and navigation arrows.

# STEP 1 - POST ASSEMBLY

QTY	PART NUMBER	DESCRIPTION
16	H100200	SCREW PFH 8 X 1 1/2 BLK



P01 POST - W2A03501  
(x2) 6"X6"X89 1/2" (152x152x2274)



P02 POST - W2A03502  
(x2) 6"X6"X89 1/2" (152x152x2274)

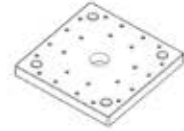

A6P00308 6x6 POST FOOT  
(x4)

- FOR EASE OF ASSEMBLY, WE RECOMMEND USING SAWHORSES FOR STEPS 1 - 8

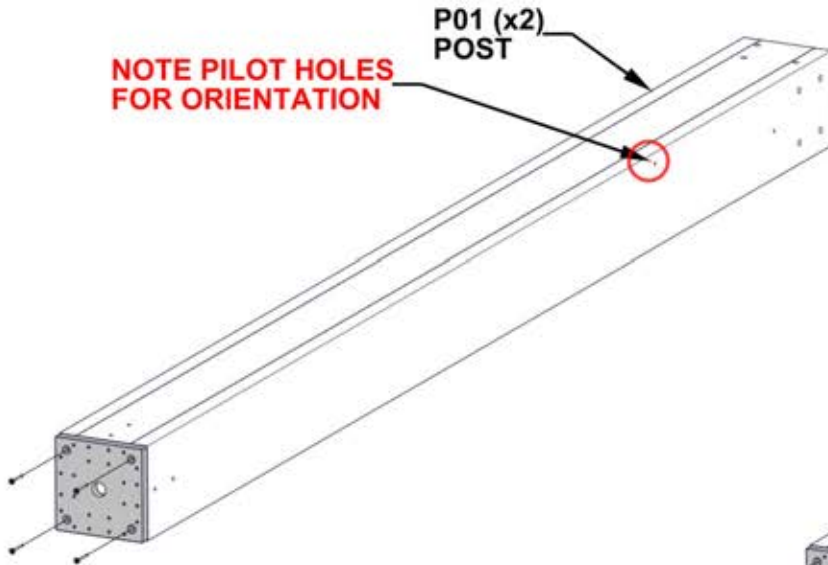

**NOTE PILOT HOLES FOR ORIENTATION**

P01 (x2)  
POST

**ALIGN POST FOOT AND DRILL 1/8" (3mm) PILOT HOLES FOR THE ATTACHMENT OF HARDWARE**

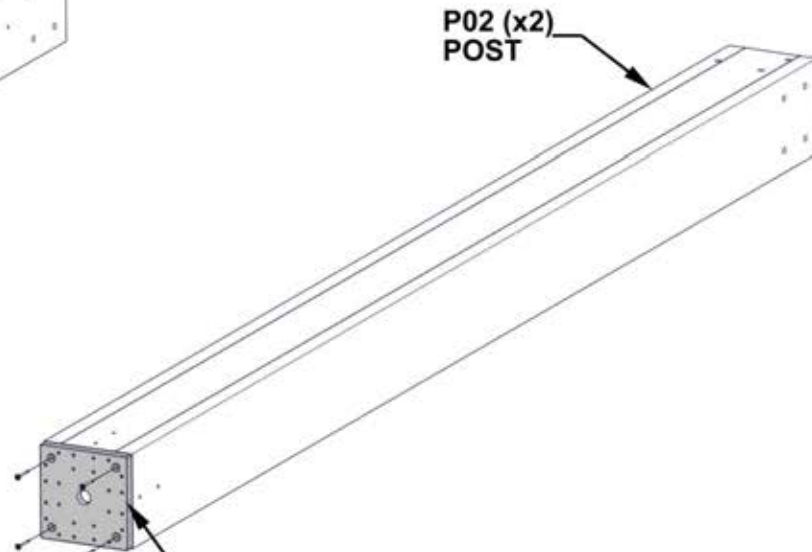

P02 (x2)  
POST

308 (x4)  
6x6 POST FOOT

200 (x16)  
SCREW - 1 1/2"

## STEP 2 - GABLE ASSEMBLY

QTY	PART NUMBER	DESCRIPTION
2	H100483	SCREW PFH 8 X 2 1/4 BLK



D01 GABLE BOARD - W4L19991  
(x1) 1 3/8"X5 1/4"X21 3/4" (36x134x553)



D05 GABLE BOARD - W4L16854  
(x1) 1 3/8"X1 1/2"X5 1/4" (36x38x134)

- ALIGN D05 WITH D01 ENSURING THAT BOTTOM FACES ARE FLUSH.
- DRILL 1/8" (3mm) PILOT HOLES IN D01 USING D05 AS TEMPLATE.

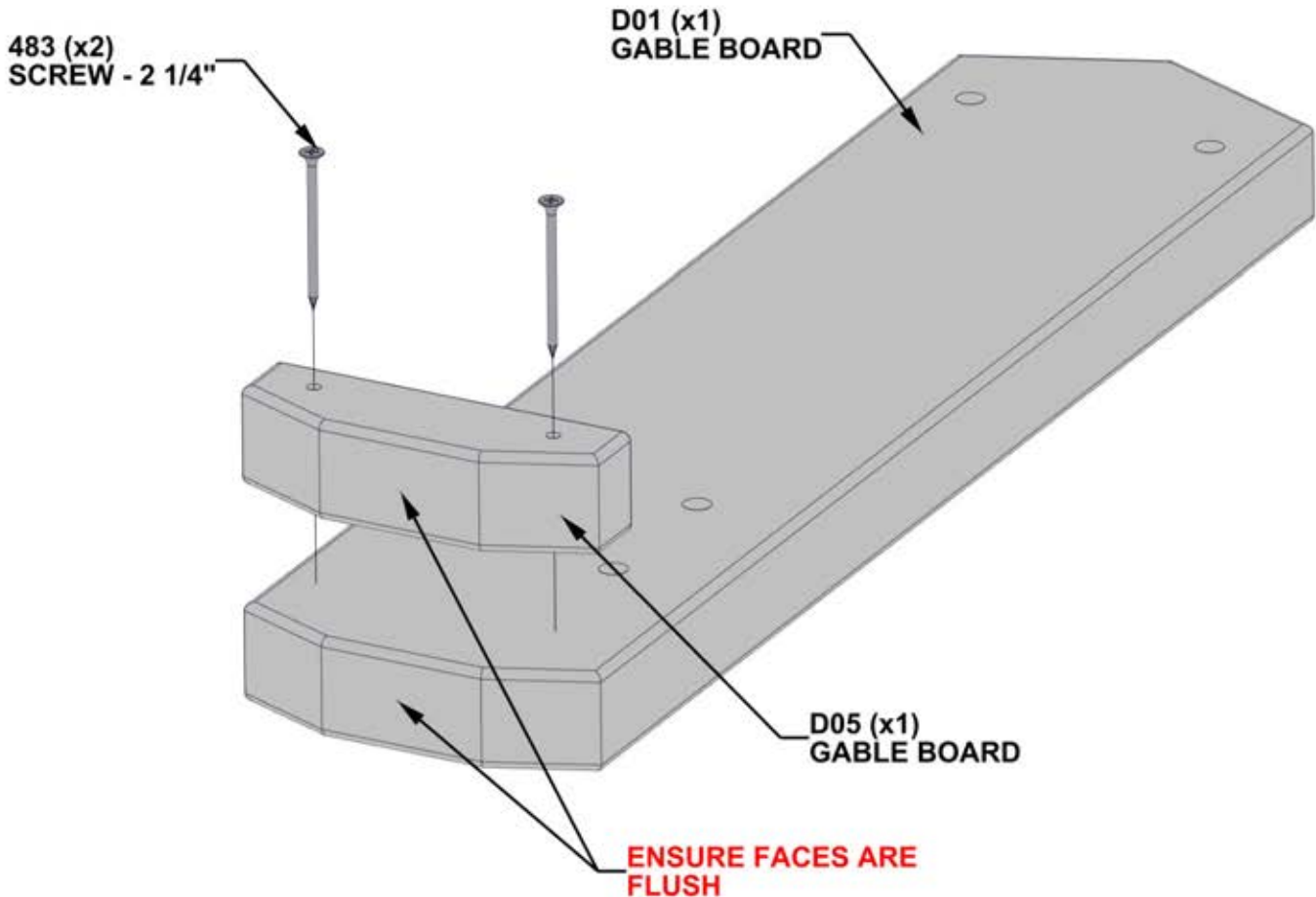

# STEP 3 - GABLE ASSEMBLY

QTY	PART NUMBER	DESCRIPTION
4	H100478	WASHER FLAT 8X27 BLK
4	H100479	NUT LOCK 5/16 BLK
4	H100881	BOLT WH 5/16 X 5 BLK

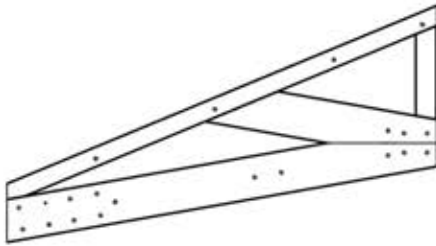

GT1 GABLE TRUSS - W2A03514  
(x2) 1 7/16"x29 1/16"x52 9/16" (36x738x1335)



D01 GABLE BOARD - W4L19991  
(x1) 1 3/8"x5 1/4"x21 3/4" (36x134x553)

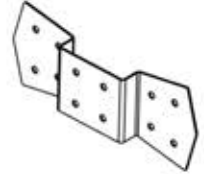

A4M01129 GABLE BRACKET  
(x2)

- IF HOLES DO NOT ALIGN, USE THE METAL BRACKET AS A GUIDE AND A 7/16" (10mm) DRILL BIT TO DRILL THROUGH THE BOARDS.

**TEMPORARILY ADD LONG BOLTS TO HELP ALIGN WOOD PARTS**

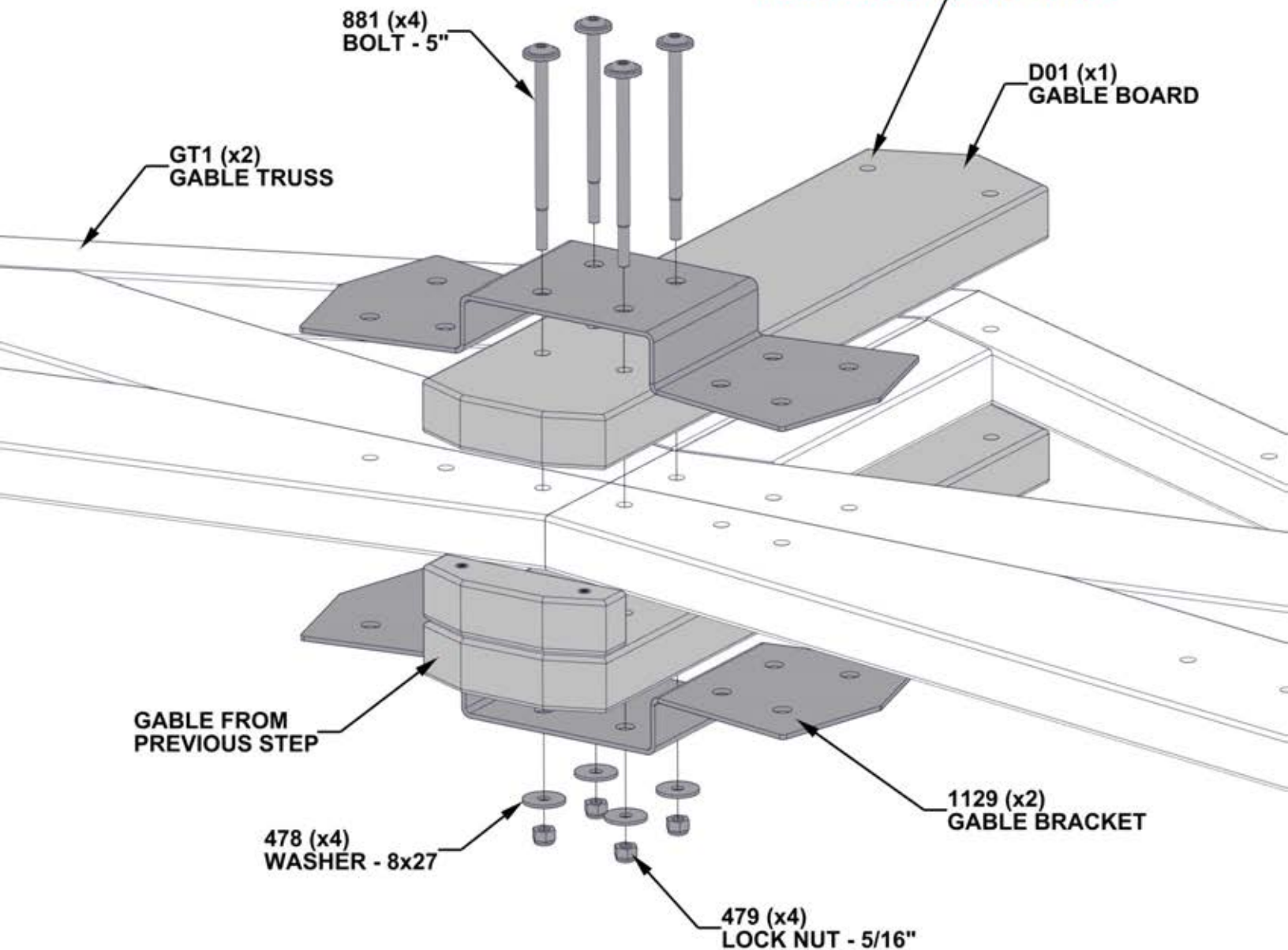



# STEP 4 - GABLE ASSEMBLY

QTY	PART NUMBER	DESCRIPTION
8	H100205	BOLT WH 5/16 X 2 1/4 BLK
8	H100478	WASHER FLAT 8X27 BLK
8	H100479	NUT LOCK 5/16 BLK

- IF HOLES DO NOT ALIGN, USE THE METAL BRACKET AS A GUIDE AND A 7/16" (10mm) DRILL BIT TO DRILL THROUGH THE BOARDS.

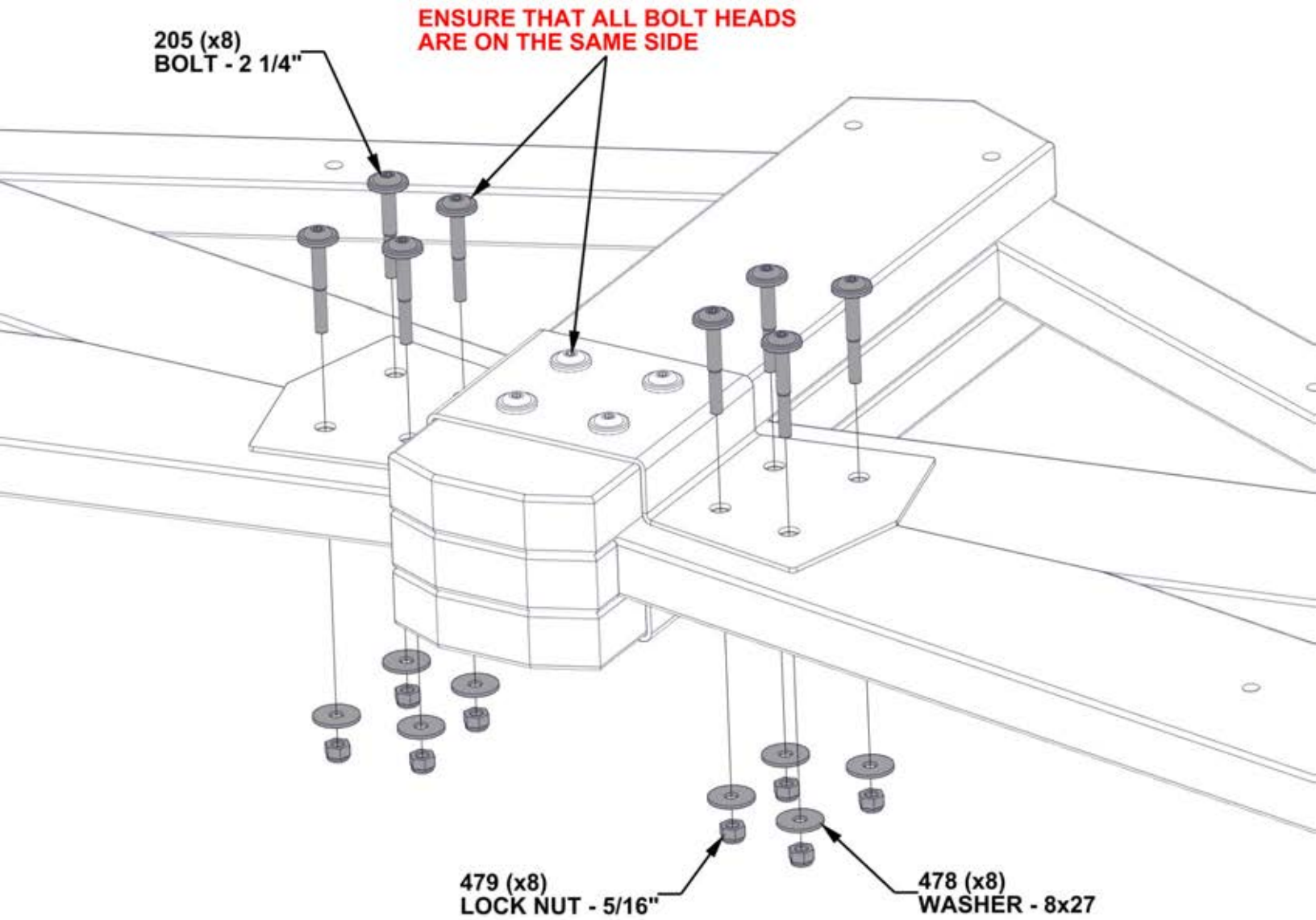

# STEP 5A - GABLE ASSEMBLY

QTY	PART NUMBER	DESCRIPTION
5	H100205	BOLT WH 5/16 X 2 1/4 BLK
8	H100379	T-NUT 5/16 BLK
5	H100416	BOLT WH 5/16 X 3 BLK
1	H100471	LAG SCREW WH 5/16 X 1 1/2 BLK
10	H100478	WASHER FLAT 8X27 BLK
9	H100479	NUT LOCK 5/16 BLK
1	H100659	LAG SCREW HEX 5/16x1 1/2 BLK
3	H101046	BOLT WH 5/16 X 7 1/2 BLK
4	H101047	BOLT WH 5/16 X 9 3/4 BLK

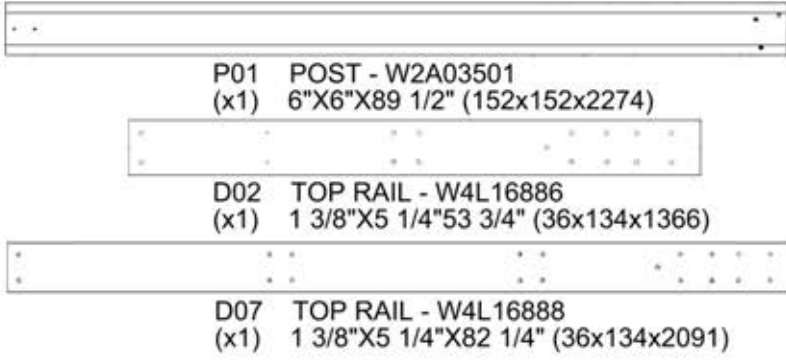

**- INSERT T-NUTS FIRST**

**NOTE PILOT HOLES FOR ORIENTATION**

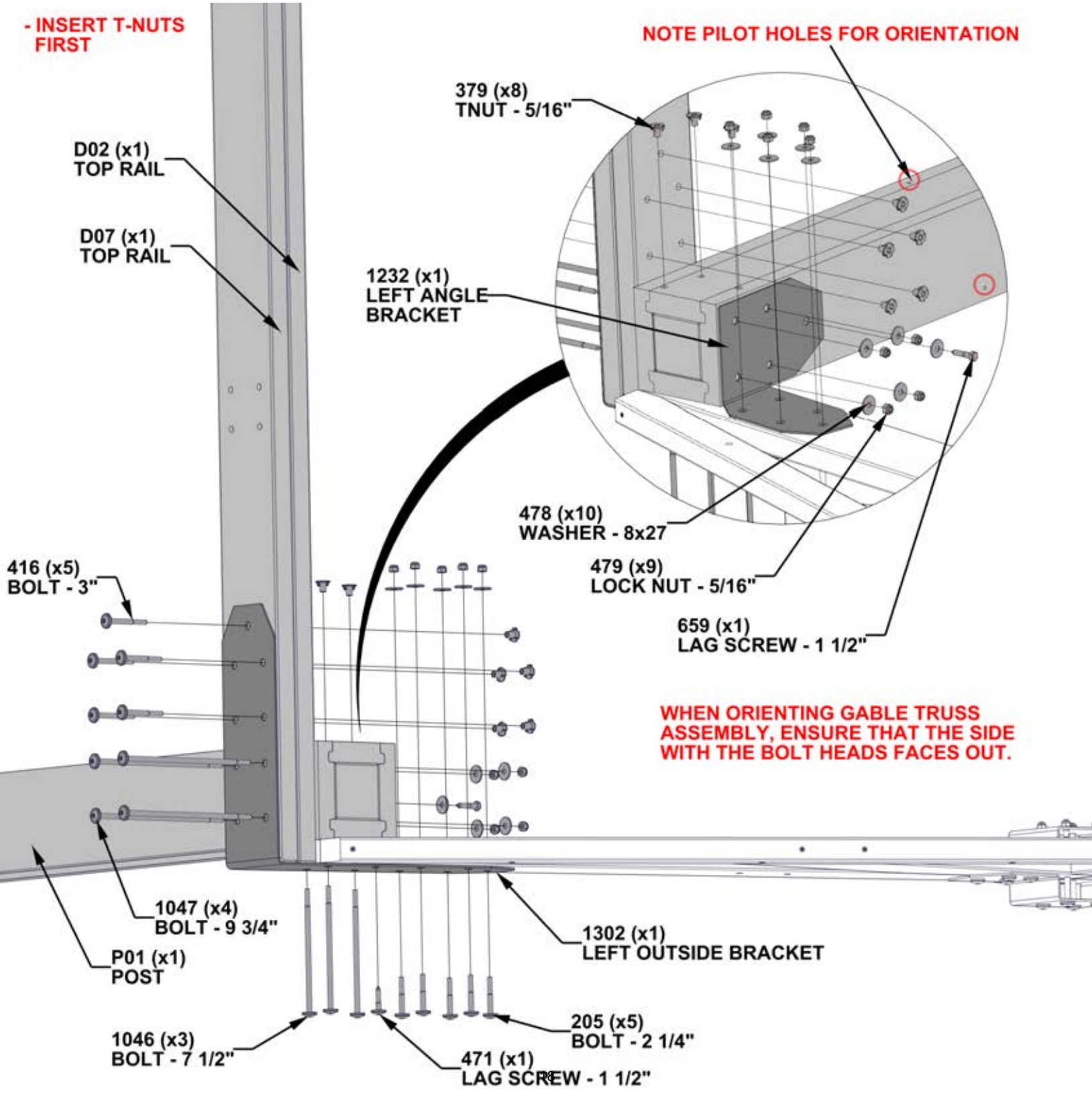

# STEP 5B - GABLE ASSEMBLY

QTY	PART NUMBER	DESCRIPTION
5	H100205	BOLT WH 5/16 X 2 1/4 BLK
8	H100379	T-NUT 5/16 BLK
5	H100416	BOLT WH 5/16 X 3 BLK
1	H100471	LAG SCREW WH 5/16 X 1 1/2 BLK
10	H100478	WASHER FLAT 8X27 BLK
9	H100479	NUT LOCK 5/16 BLK
1	H100659	LAG SCREW HEX 5/16x1 1/2 BLK
3	H101046	BOLT WH 5/16 X 7 1/2 BLK
4	H101047	BOLT WH 5/16 X 9 3/4 BLK

P02 POST - W2A03502  
(x1) 6"X6"X89 1/2" (152x152x2274)

D07 TOP RAIL - W4L16888  
(x1) 1 3/8"X5 1/4"X82 1/4" (36x134x2091)

D02 TOP RAIL - W4L16886  
(x1) 1 3/8"X5 1/4"X53 3/4" (36x134x1366)

A4M01301 RIGHT OUTSIDE BRACKET  
(x1)

A4M01233 RIGHT ANGLE BRACKET  
(x1)

**- INSERT T-NUTS FIRST**

**NOTE PILOT HOLES FOR ORIENTATION**

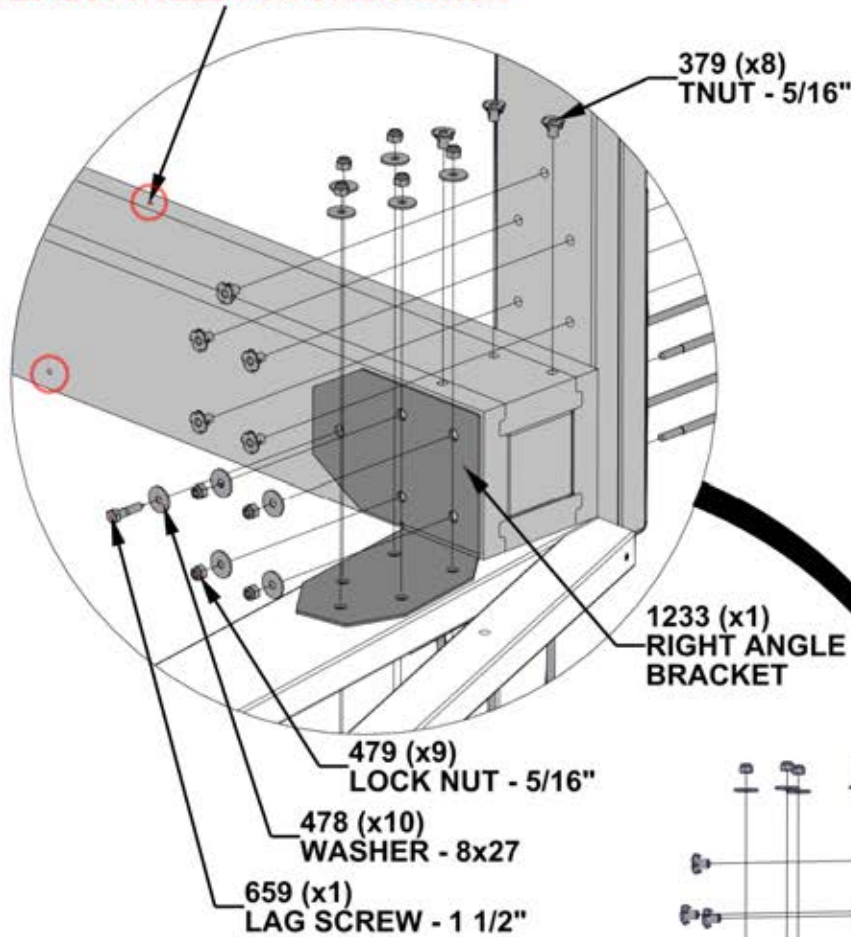

**WHEN ORIENTING GABLE TRUSS ASSEMBLY, ENSURE THAT THE SIDE WITH THE BOLT HEADS FACES OUT.**

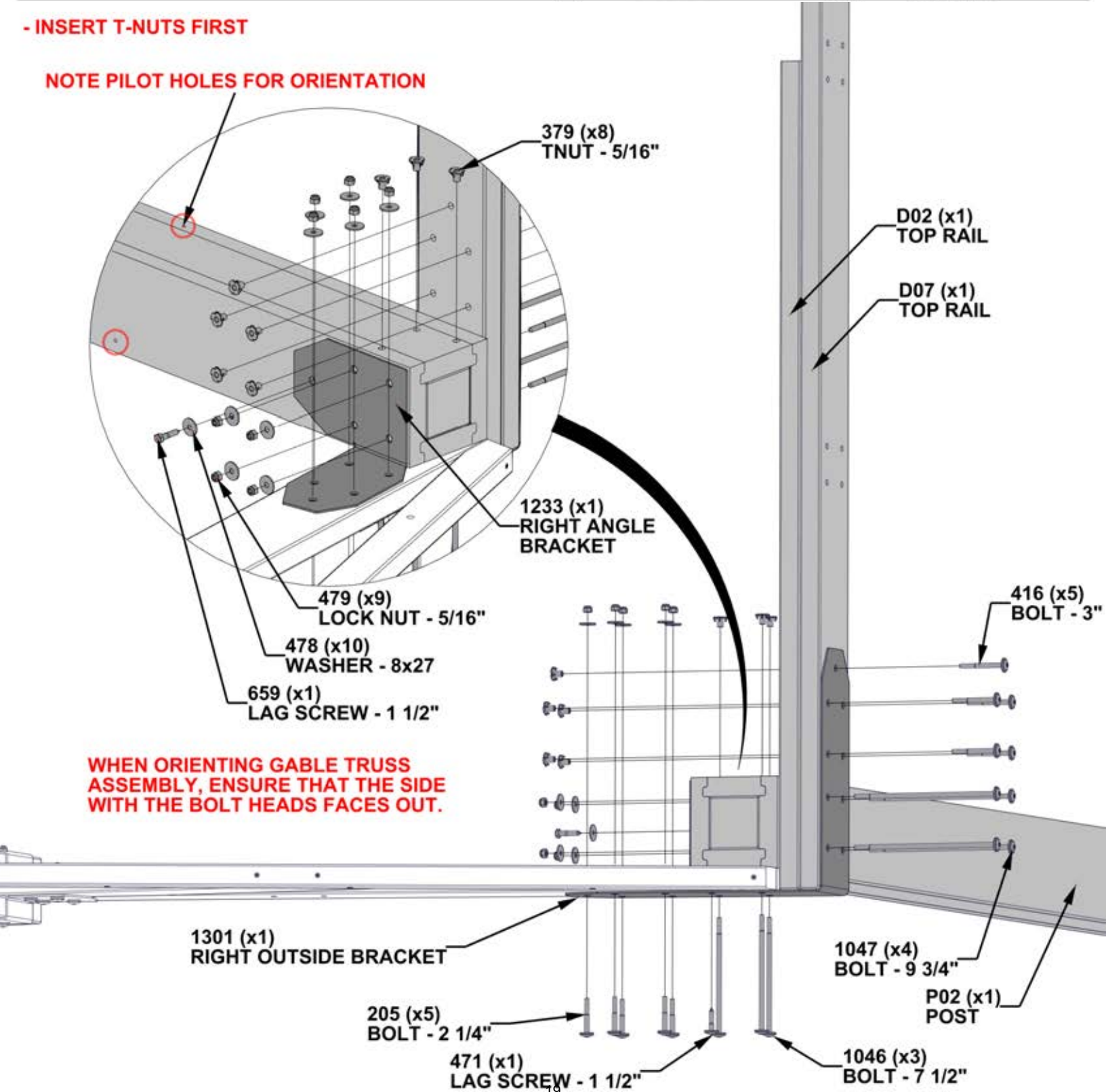

# STEP 6 - GABLE ASSEMBLY

QTY	PART NUMBER	DESCRIPTION
4	H100195	BOLT WH 5/16 X 2 3/4 BLK
4	H100198	WASHER LOCK EXT 8X19 BLK
4	H100379	T-NUT 5/16 BLK
2	H100405	WASHER LOCK EXT 6X15 BLK
2	H100792	LAG SCREW WH 1/4 X 3 BLK



CA01 CORBEL - W2A03504  
(x1) 1 3/8"x1 3/8"x44" (36x134x1119)



D06 CORBEL - W4L16855  
(x1) 1 3/8"x5 1/4"x44 1/16" (36x134x1119)

- WHEN BUILDING THE SECOND GABLE, TWO D06 CORBELS WILL BE USED.
- INSERT T-NUTS FIRST

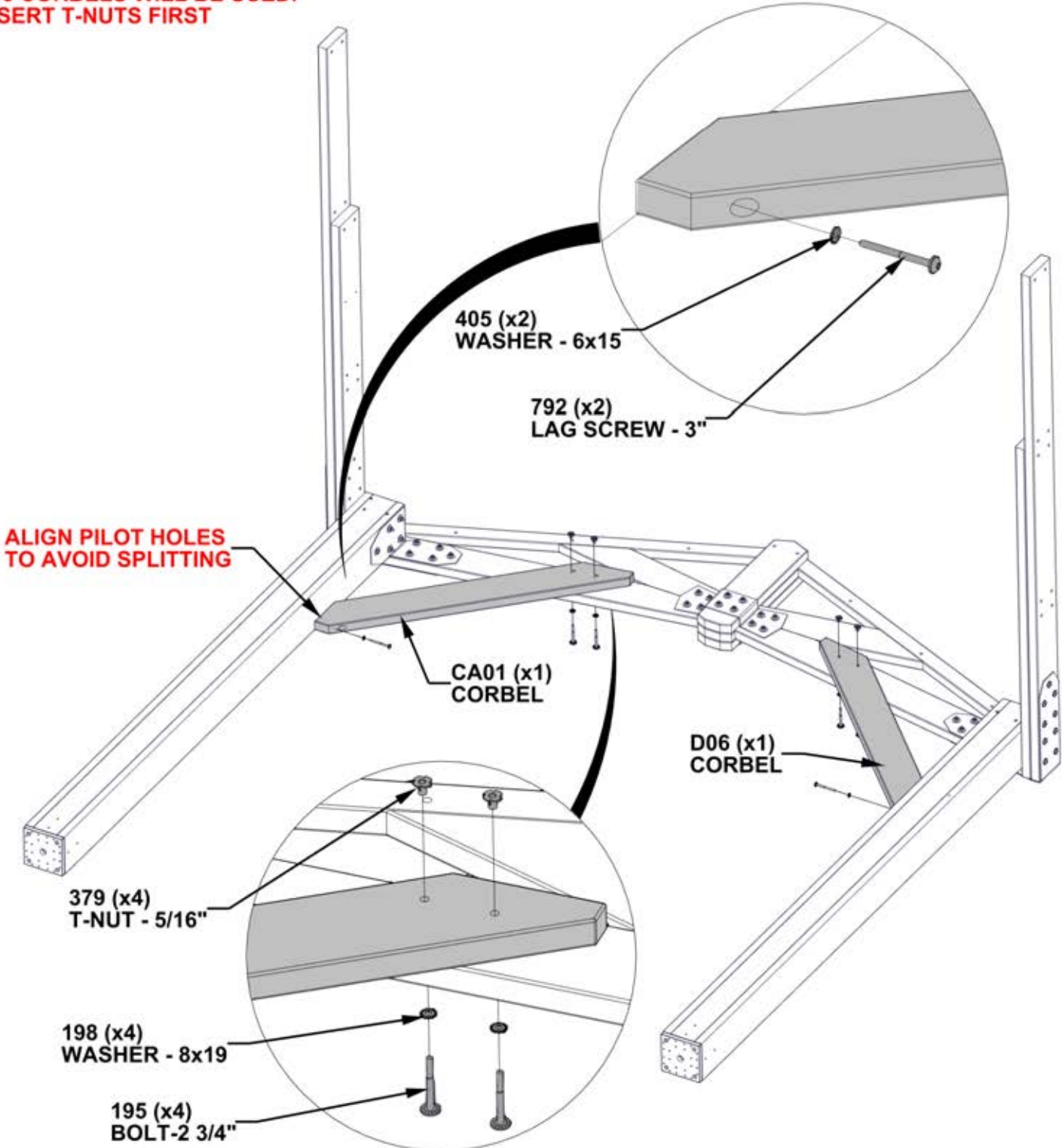

# STEP 7 - GAZEBO ASSEMBLY

QTY	PART NUMBER	DESCRIPTION
8	H100198	WASHER LOCK EXT 8X19 BLK
8	H100379	T-NUT 5/16 BLK
2	H100405	WASHER LOCK EXT 6X15 BLK
8	H100513	BOLT WH 5/16 X 4 1/4 BLK
2	H100792	LAG SCREW WH 1/4 X 3 BLK



D04 CORBEL - W4L16853  
 (x2) 1 3/8"X5 1/4"X34 7/16" (36x134x875)

**- INSERT T-NUTS FIRST**

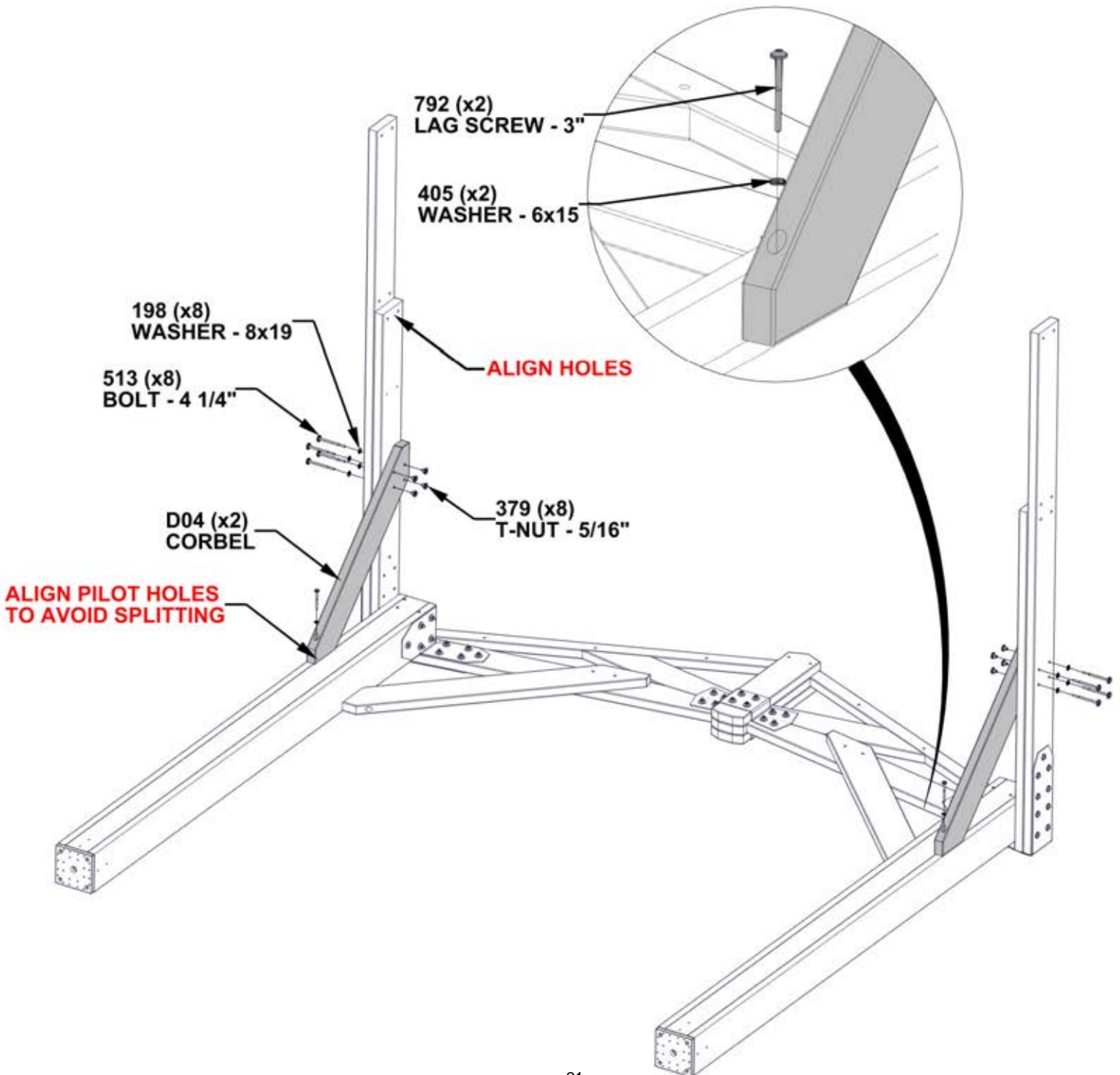

**REPEAT GABLE ASSEMBLY  
STEPS 2 THROUGH 7**

# STEP 8A - GAZEBO ASSEMBLY

QTY	PART NUMBER	DESCRIPTION
4	H100195	BOLT WH 5/16 X 2 3/4 BLK
4	H100198	WASHER LOCK EXT 8X19 BLK
4	H100201	SCREW PFH 8 X 2 1/2 BLK
4	H100379	T-NUT 5/16 BLK



A4M02376 GAZEBO BRACE  
(x2)

- ATTACH 2376 BRACE BY SLIDING IN BETWEEN BOARDS TO THE FIRST SET OF BOLT HOLES.

- INSERT T-NUTS FIRST

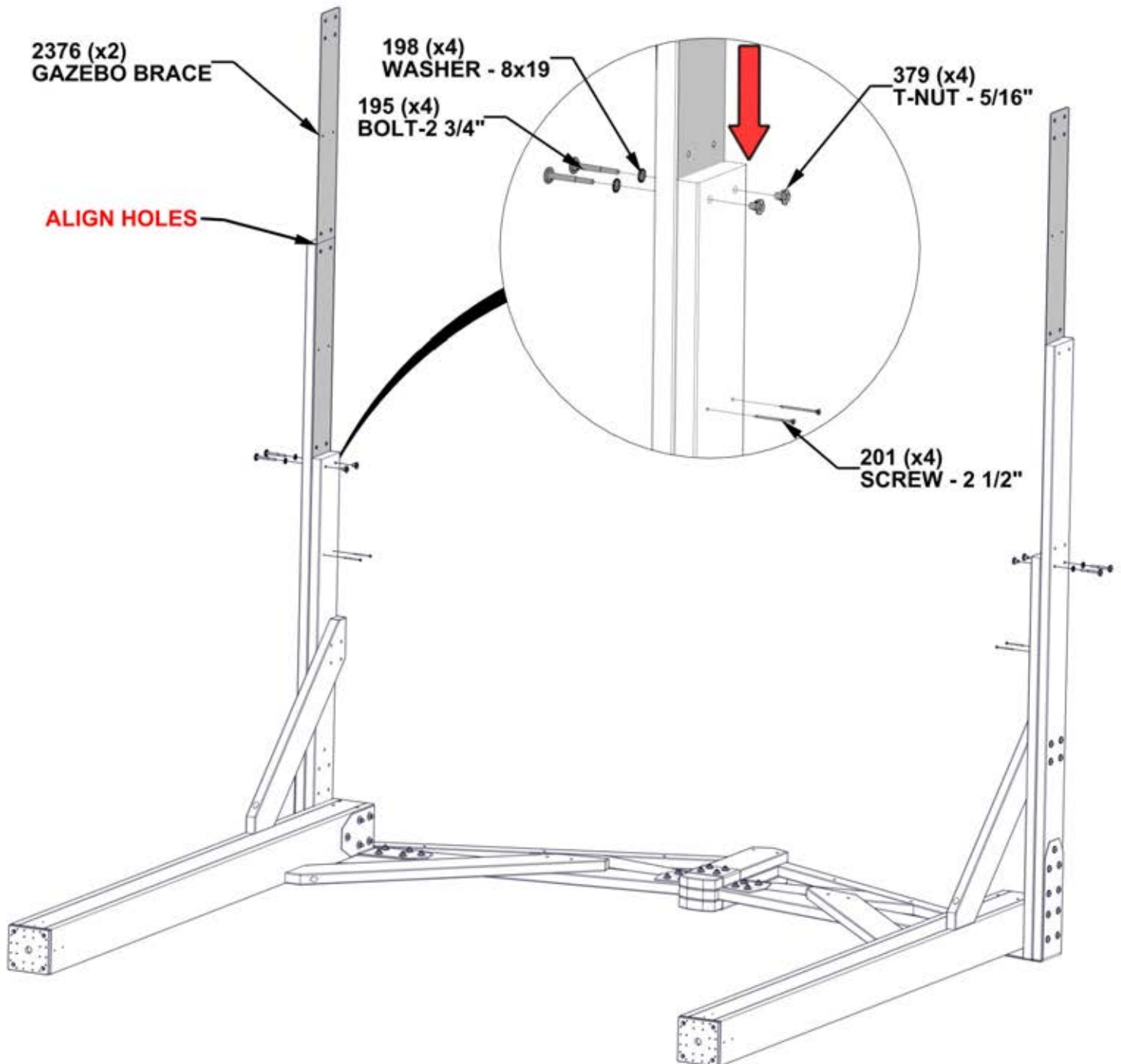

# STEP 8B - GAZEBO ASSEMBLY

QTY	PART NUMBER	DESCRIPTION
8	H100195	BOLT WH 5/16 X 2 3/4 BLK
8	H100198	WASHER LOCK EXT 8X19 BLK
4	H100201	SCREW PFH 8 X 2 1/2 BLK
8	H100379	T-NUT 5/16 BLK



D03 TOP RAIL - W4L16887  
 (x2) 1 3/8"X5 1/4"X57" (36x134x1448)

**- INSERT T-NUTS FIRST**

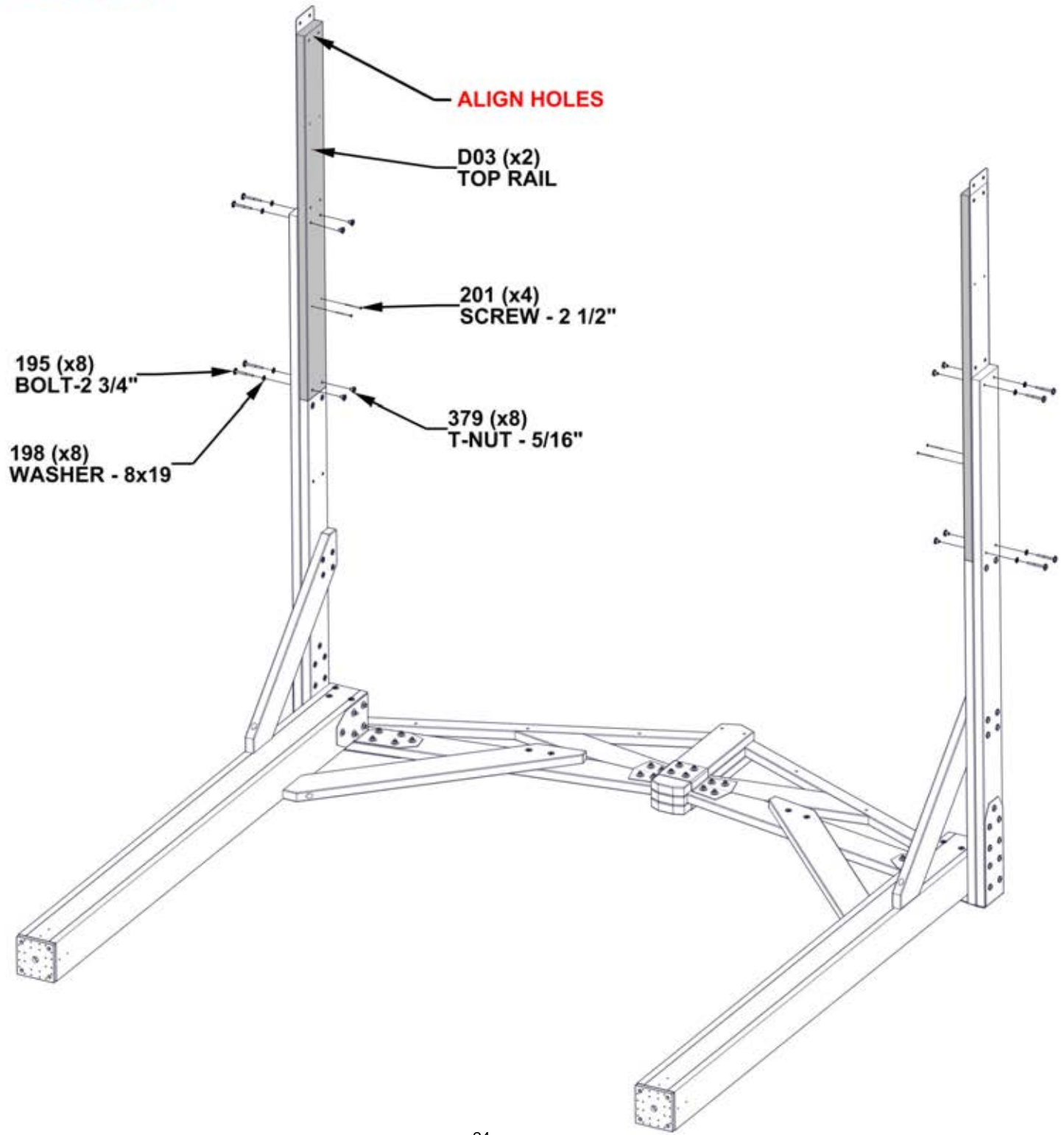



# STEP 9 - GAZEBO ASSEMBLY



H08 NOTCHED SUPPORT BOARD - W4L16915  
(x2) 1"X3 3/8"X89 1/2" (24x86x2274)

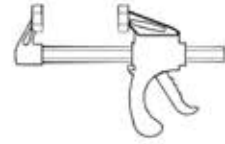

A6P00460 6" QUICK RELEASE  
(x2) BAR CLAMP

- ADDITIONAL PEOPLE ARE HELPFUL FOR THIS STEP.
- USING THE INCLUDED CLAMP AND H08 BOARDS, SECURE CLAMPS AS SHOWN TO SUPPORT GABLE ASSEMBLY.

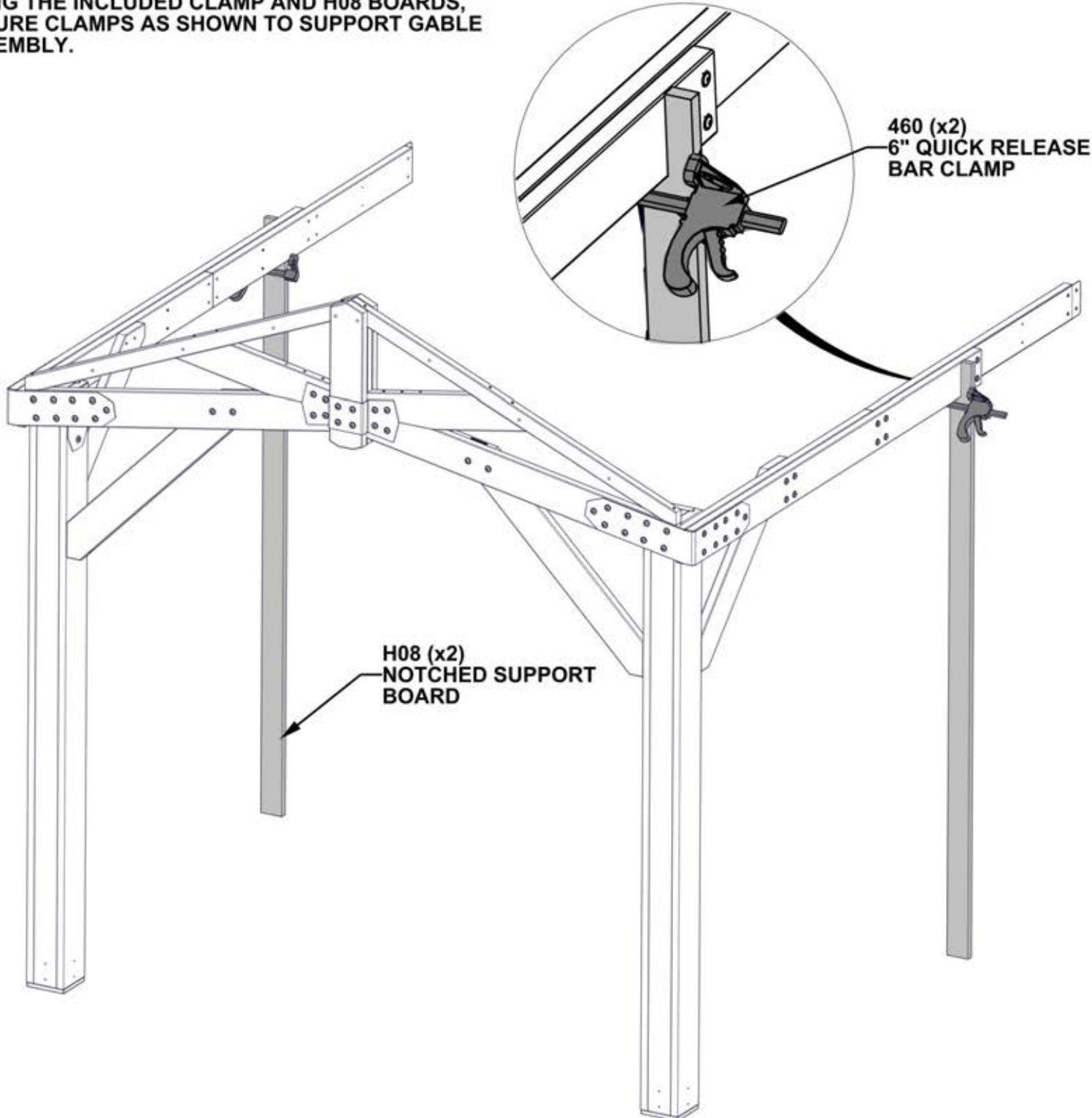

# STEP 10 - GAZEBO ASSEMBLY

QTY	PART NUMBER	DESCRIPTION
12	H100195	BOLT WH 5/16 X 2 3/4 BLK
12	H100198	WASHER LOCK EXT 8X19 BLK
8	H100201	SCREW PFH 8 X 2 1/2 BLK
12	H100379	T-NUT 5/16 BLK

**- INSERT T-NUTS FIRST**

- ADDITIONAL PEOPLE ARE HELPFUL FOR THIS STEP.
- STAND UP OTHER GABLE END AND ATTACH HARDWARE AS SHOWN.
- ONCE ALL HARDWARE IS SECURELY ATTACHED, REMOVE CLAMPS AND H08 BOARDS.

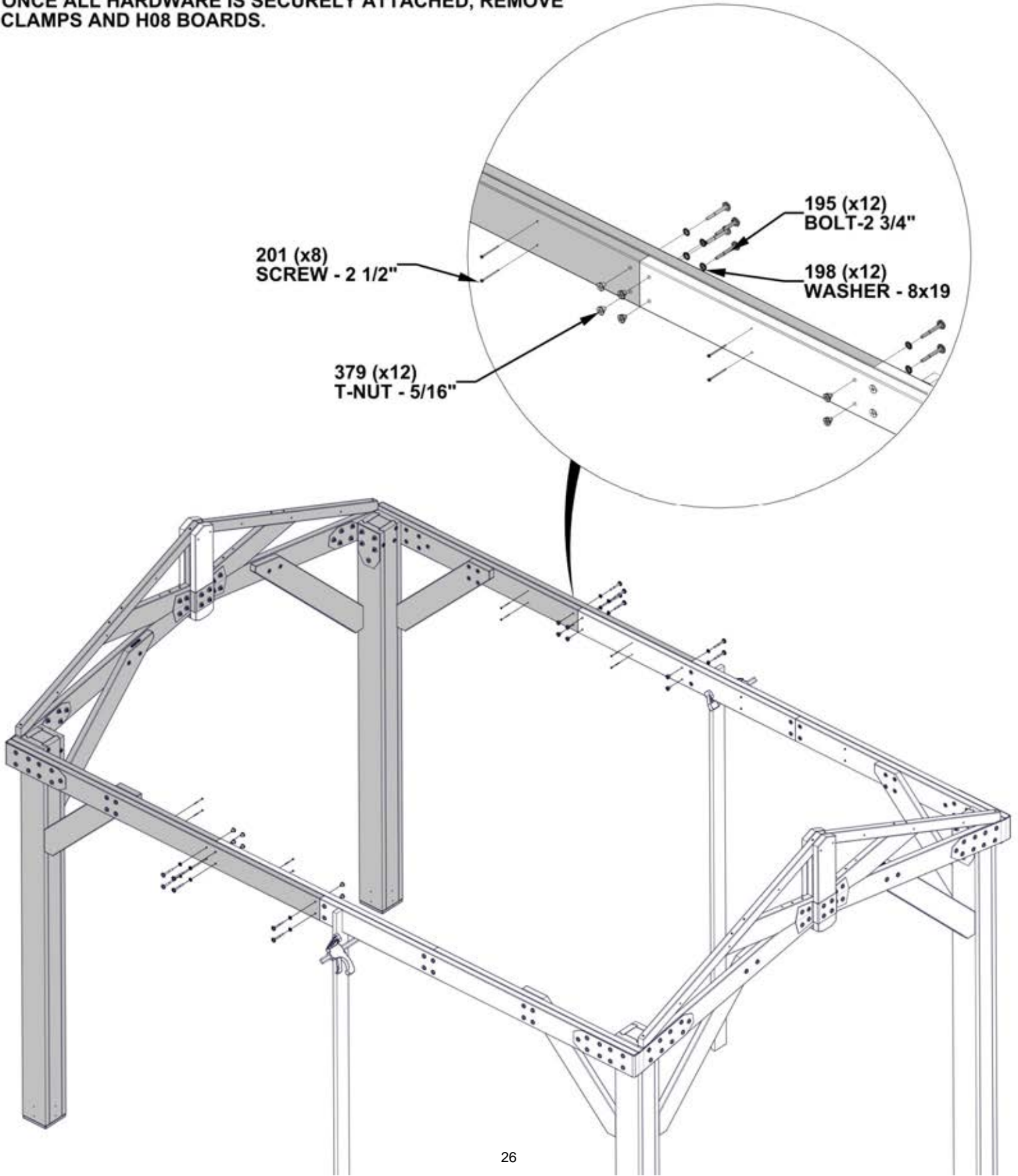

# STEP 11 - GAZEBO ASSEMBLY

QTY	PART NUMBER	DESCRIPTION
16	H100201	SCREW PFH 8 X 2 1/2 BLK



F01 TRUSS - W4L17203  
(x4) 1 7/16"x2 3/8"x62 1/16" (36x60x1576)

COMPLETE THIS STEP TWICE FOR OPPOSITE SIDE

ALIGN HOLES FOR  
CORRECT ORIENTATION

FLUSH TOPS

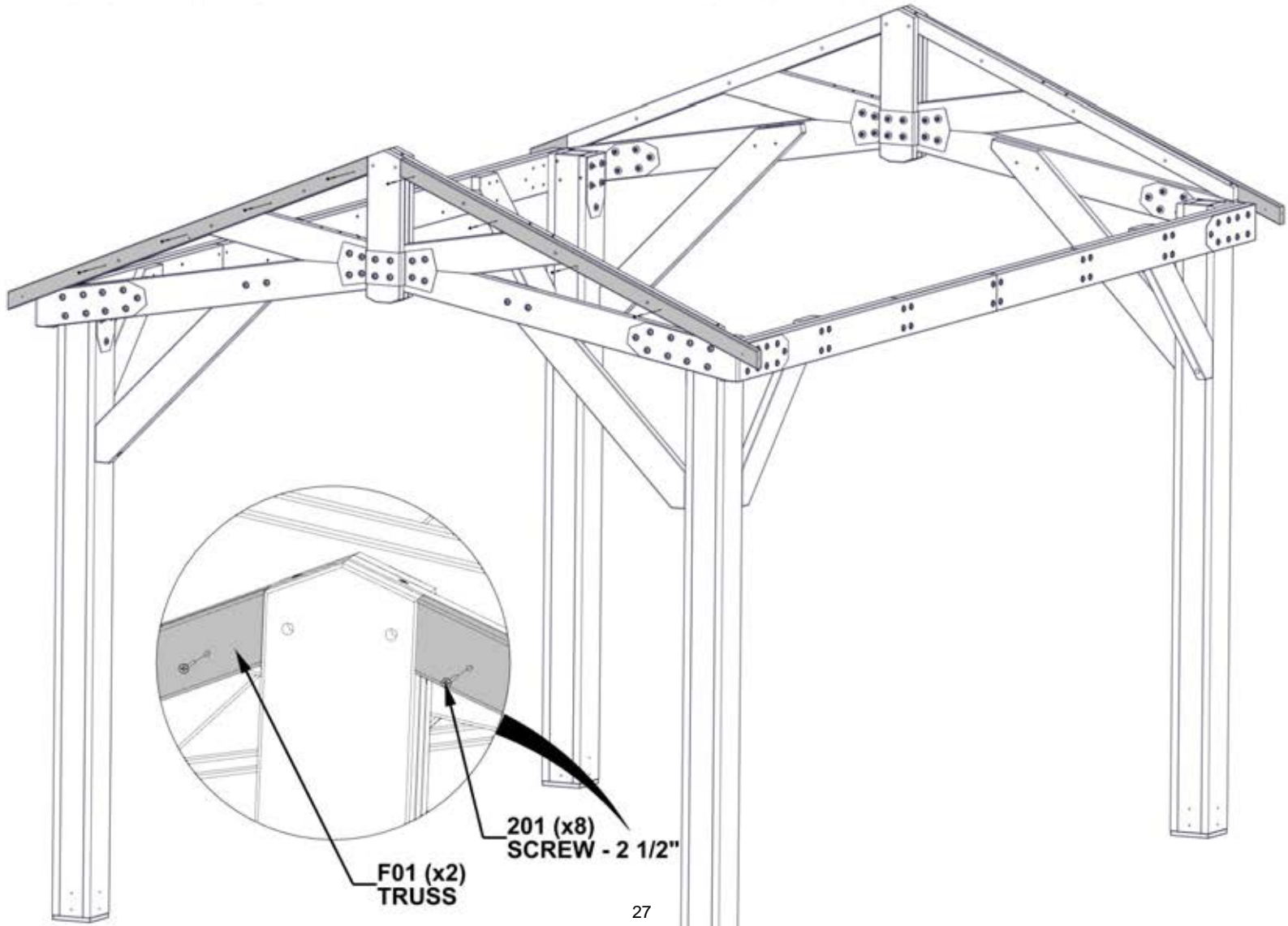
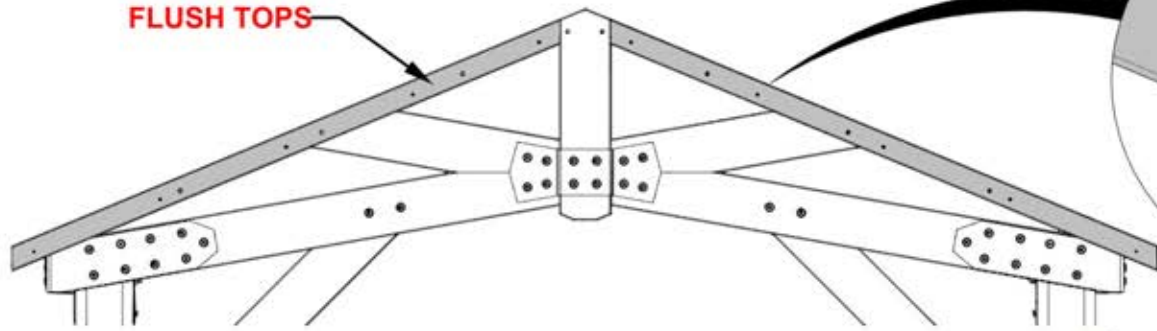

201 (x8)  
SCREW - 2 1/2"

F01 (x2)  
TRUSS

# STEP 12 - GAZEBO ASSEMBLY

QTY	PART NUMBER	DESCRIPTION
4	H100201	SCREW PFH 8 X 2 1/2 BLK
12	H100405	WASHER LOCK EXT 6X15 BLK
12	H100564	LAG SCREW WH 1/4 X 4 BLK



GP1 GABLE PANEL - W2A03515  
(x2) 2 13/16"x5 1/4"x67 3/16" (72x134x1706)

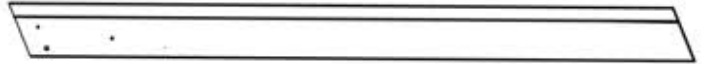

GP2 GABLE PANEL - W2A03516  
(x2) 2 13/16"x5 1/4"x67 3/16" (72x134x1706)

## - ALIGN PILOT HOLES

**TEMPORARILY INSERT 354 BOLTS TO ALIGN GABLE PANEL WITH GABLE**

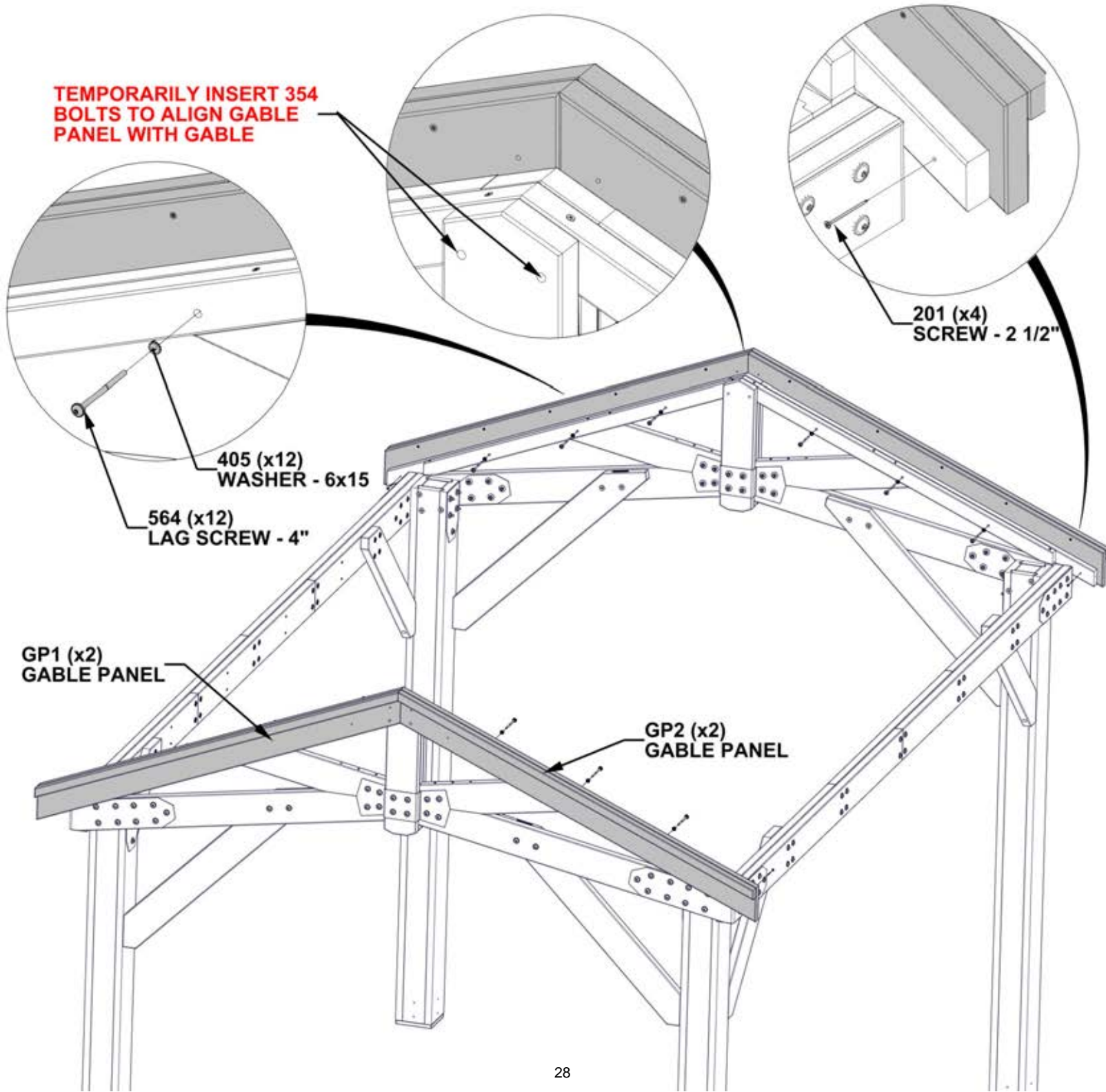

# STEP 13 - GAZEBO ASSEMBLY

QTY	PART NUMBER	DESCRIPTION
4	H100200	SCREW PFH 8 X 1 1/2 BLK
4	H100354	BOLT WH 5/16 X 6 1/2 BLK
8	H100471	LAG SCREW WH 5/16 X 1 1/2 BLK
4	H100478	WASHER FLAT 8X27 BLK
4	H100479	NUT LOCK 5/16 BLK

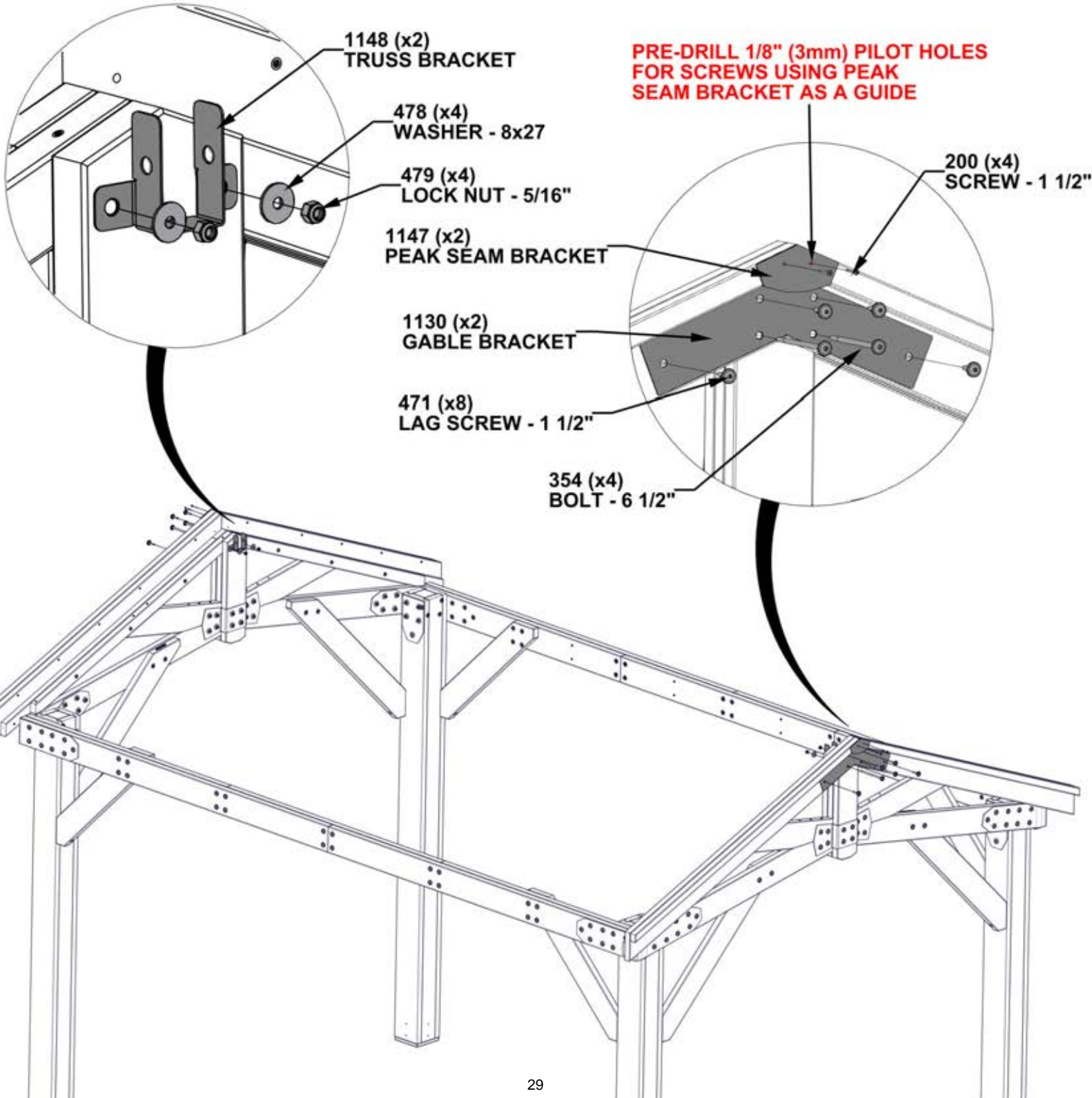
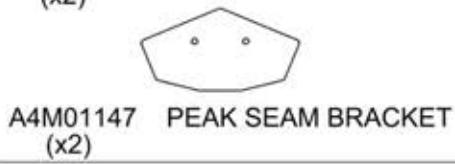

# STEP 14 - SQUARE ASSEMBLY

**CRITICAL: SQUARE ASSEMBLY BEFORE PROCEEDING TO NEXT STEPS.  
ONCE SQUARE, ENSURE ALL HARDWARE IS FULLY TIGHTENED.**

**MEASUREMENTS TAKEN FROM INSIDE OF POST TO INSIDE OF POST**

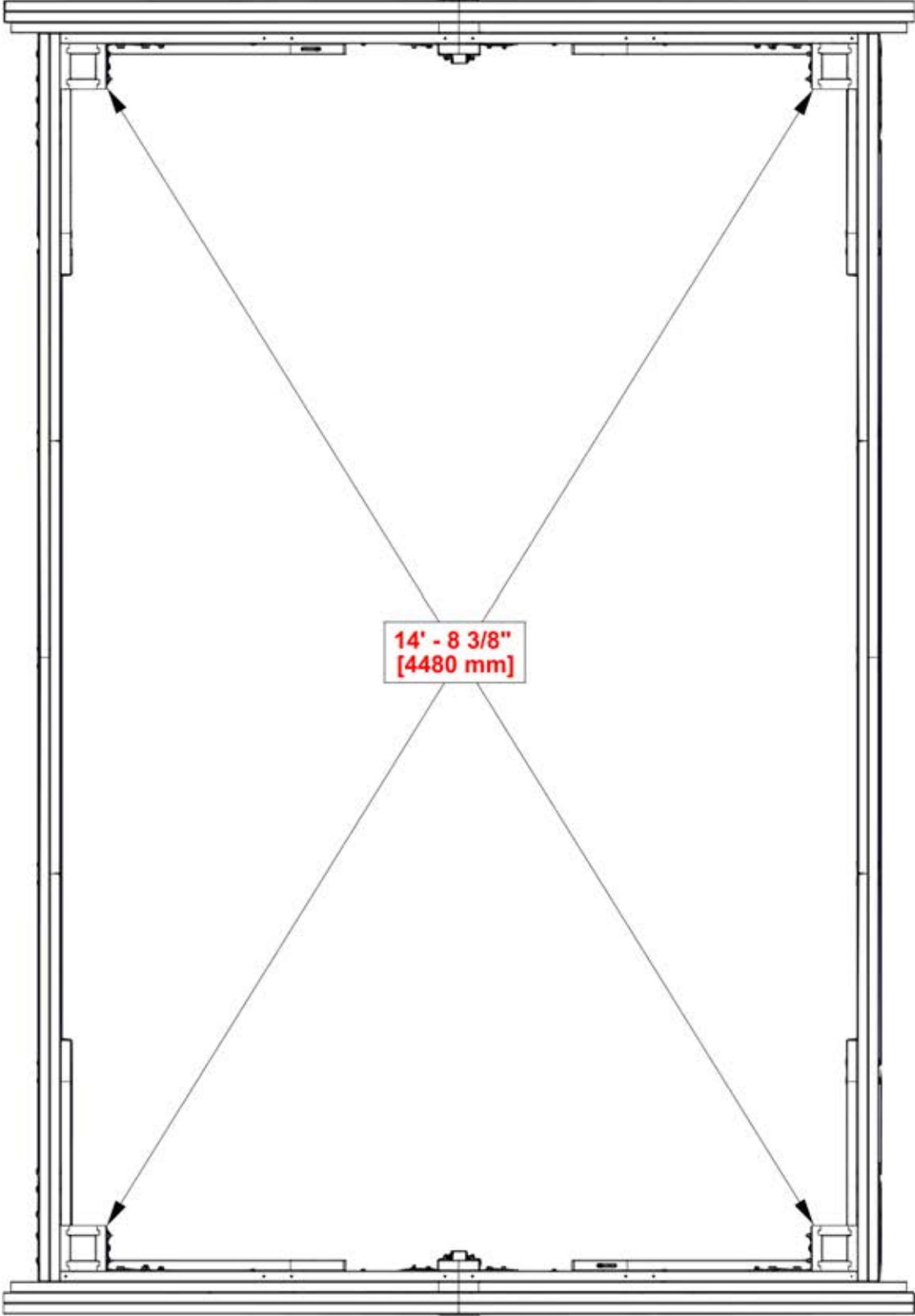

# STEP 15 - RIDGE ASSEMBLY

QTY	PART NUMBER	DESCRIPTION
8	H100198	WASHER LOCK EXT 8X19 BLK
16	H100379	T-NUT 5/16 BLK
10	H100382	SCREW PFH 8 X 1 3/4 BLK
8	H100459	BOLT WH 5/16 X 1 1/4 BLK



H05 RAFTER - W4L16894  
(x2) 1"X3 3/8"X69 1/2" (24x86x1766)



H04 RAFTER - W4L16893  
(x2) 1"X3 3/8"X89 1/4" (24x86x2267)



A4M02520 RIDGE BRACE  
(x1)

**- INSERT INTERIOR T-NUTS FIRST BEFORE ANY OTHER HARDWARE IS ATTACHED.**

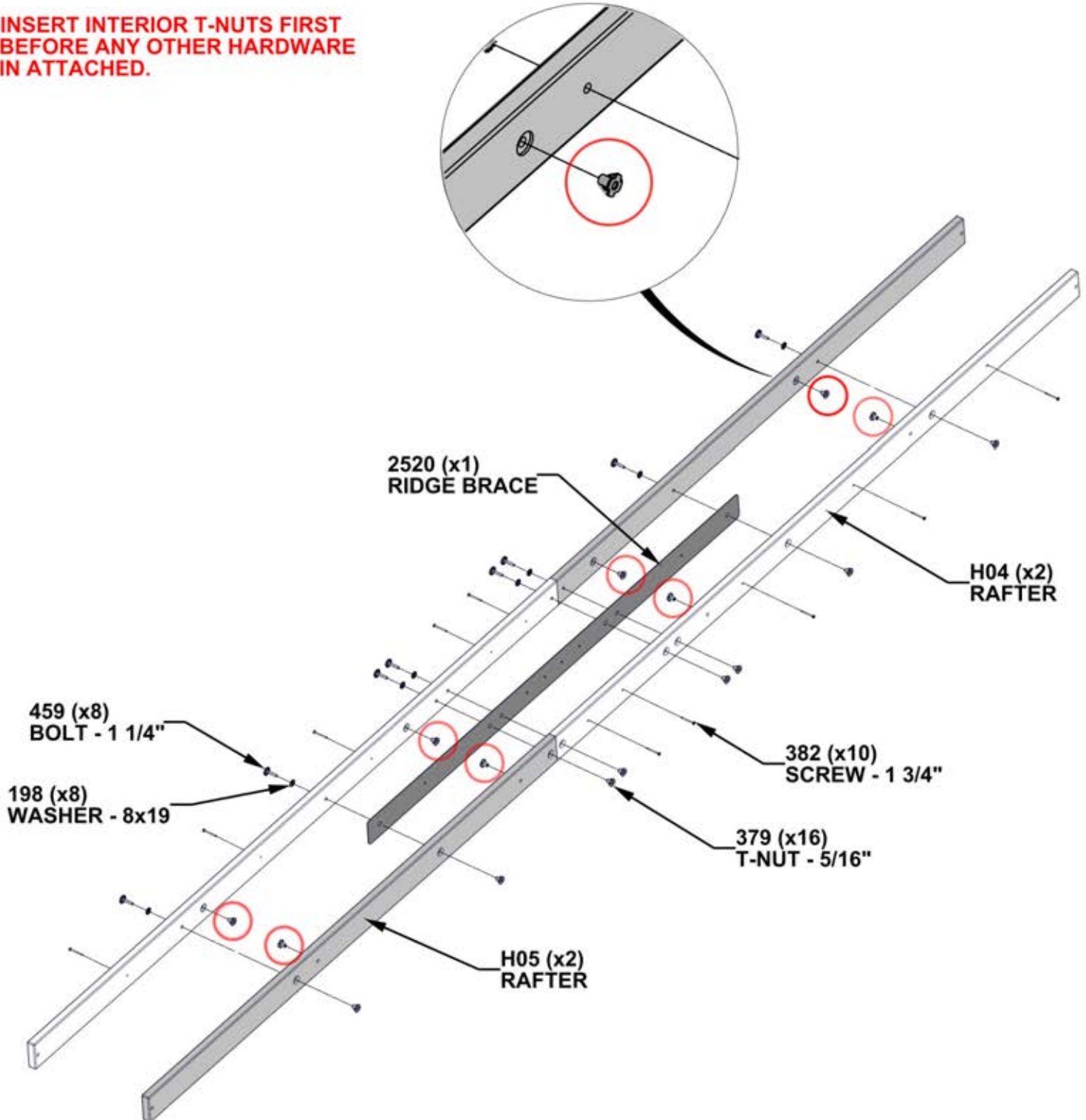
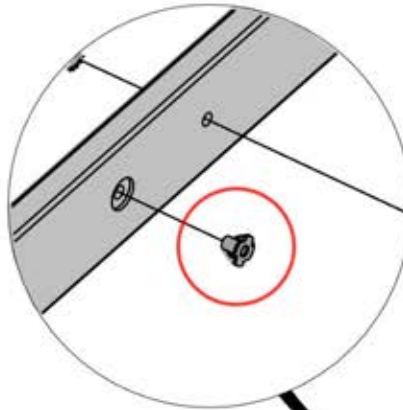

# STEP 16 - RIDGE ASSEMBLY

QTY	PART NUMBER	DESCRIPTION
2	H100195	BOLT WH 5/16 X 2 3/4 BLK
2	H100478	WASHER FLAT 8X27 BLK
2	H100479	NUT LOCK 5/16 BLK



RIDGE ASSEMBLY  
STEP 15

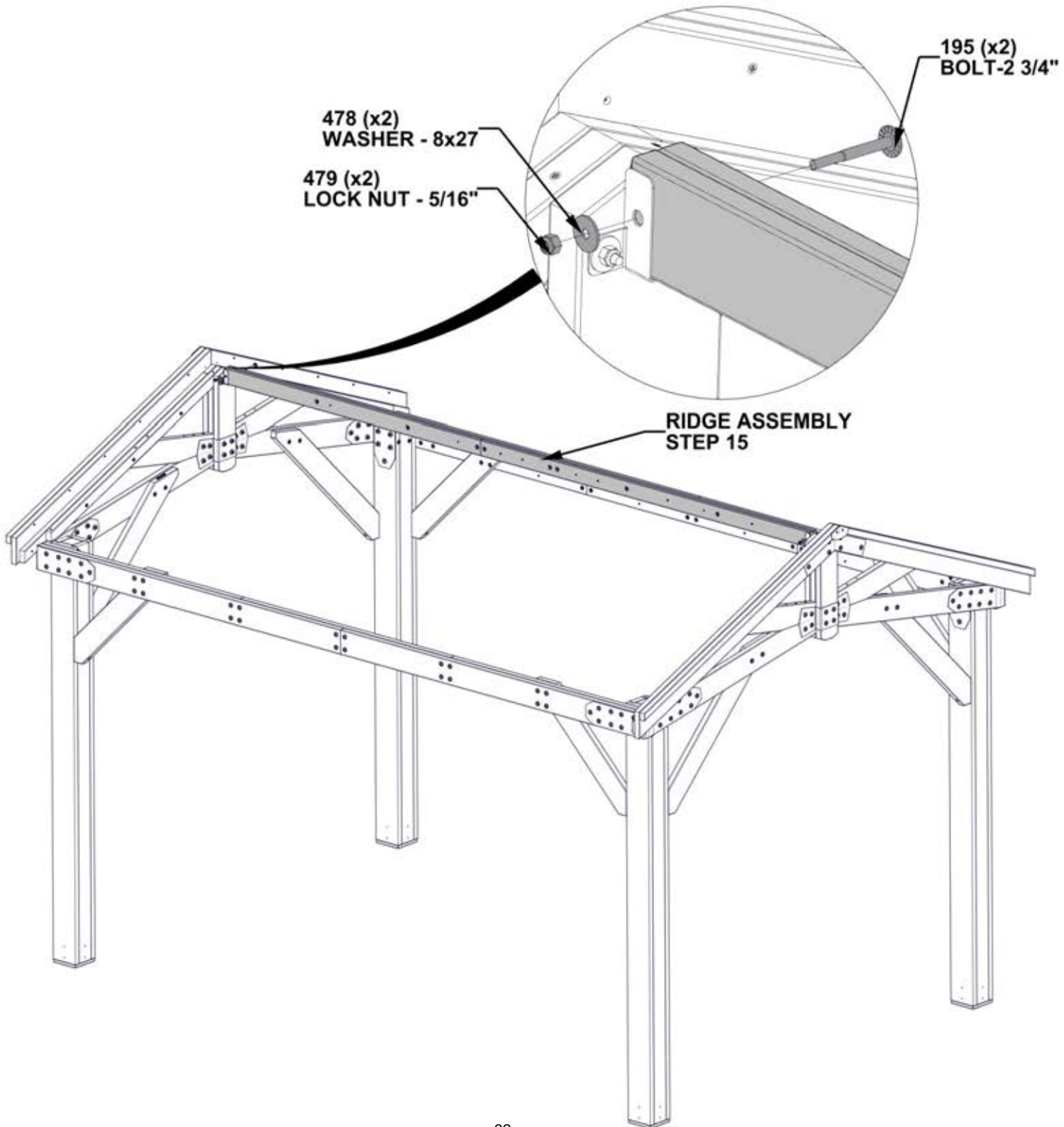



# STEP 17 - ROOF PANEL A ASSEMBLY

QTY	PART NUMBER	DESCRIPTION
2	H100198	WASHER LOCK EXT 8X19 BLK
24	H100391	SCREW PFH 8 X 2 BLK
2	H100478	WASHER FLAT 8X27 BLK
2	H100479	NUT LOCK 5/16 BLK
2	H100503	BOLT WH 5/16 X 3 1/2 BLK

E01 RAFTER - W4L19631  
(x2) 1 7/16"x3 3/8"x63 3/8" (36x86x1610)

E02 RAFTER - W4L19632  
(x4) 1 7/16"x3 3/8"x63 3/8" (36x86x1610)

H02 FASCIA - W4L16891  
(x1) 1"x3 3/8"x80 3/8" (24x86x2040)

H03 FASCIA - W4L16892  
(x1) 1"x3 3/8"x87" (24x86x2209)

H06 FASCIA - W4L16895  
(x1) 1"x3 3/8"x63 1/2" (24x86x1614)

H07 FASCIA - W4L16896  
(x1) 1"x3 3/8"x70 1/8" (24x86x1783)

## ROOF PANEL A

**DO NOT REPEAT THIS STEP FOR SECOND 14FT PANEL. IT IS ASSEMBLED DIFFERENTLY STARTING IN STEP 24**

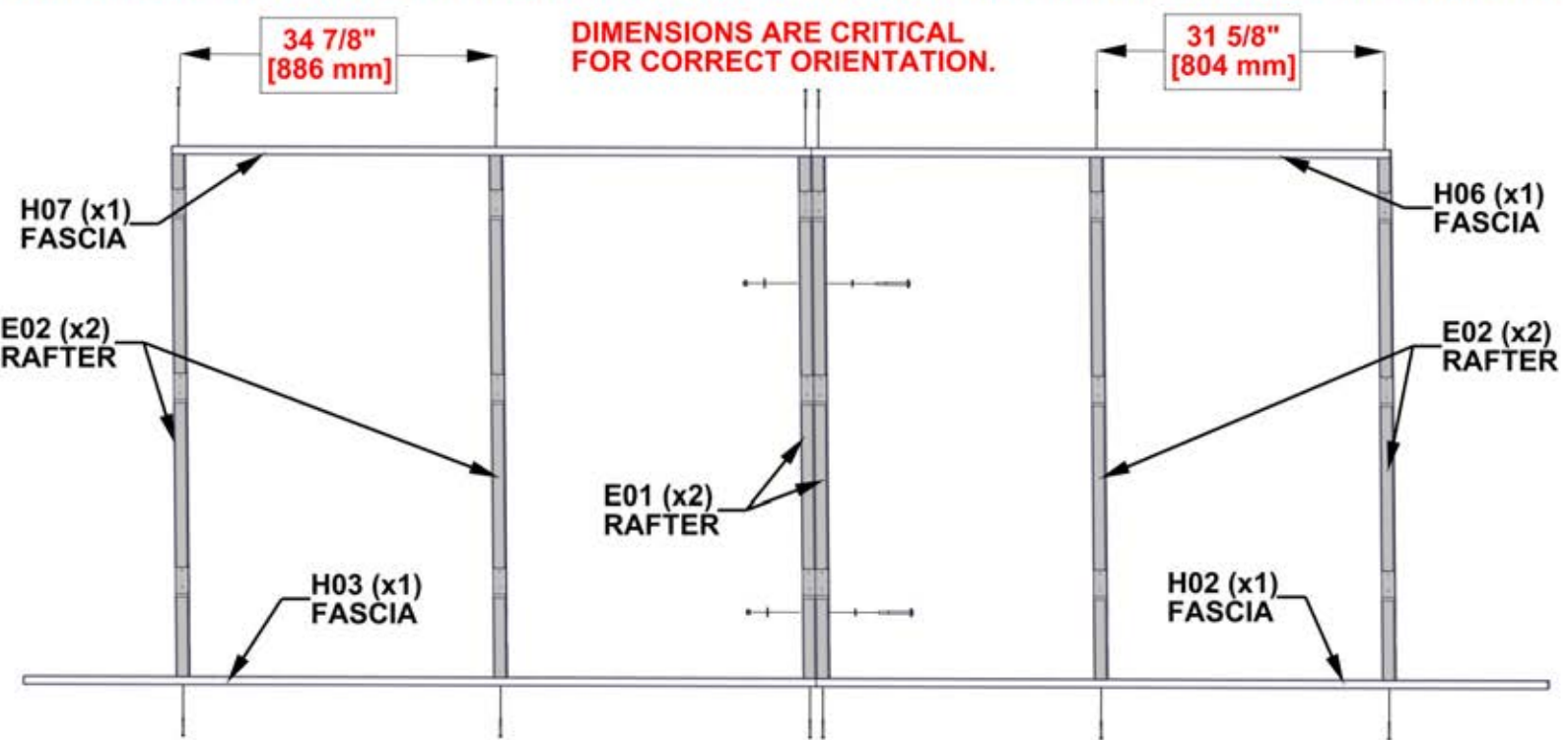

**CORRECT ORIENTATION AND PLACEMENT OF H BOARDS IS CRITICAL FOR LATER STEPS**

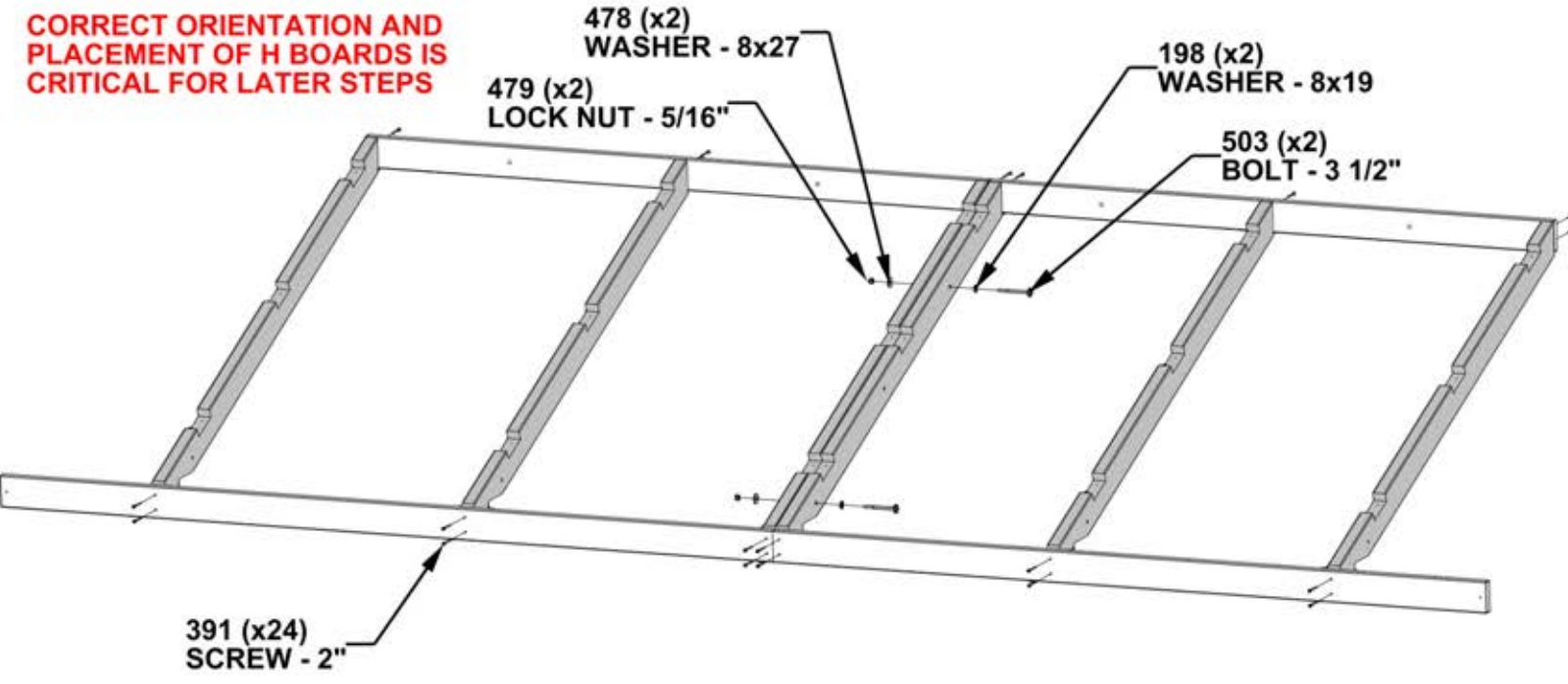

# STEP 18A - ROOF PANEL A ASSEMBLY

QTY	PART NUMBER	DESCRIPTION
36	H100391	SCREW PFH 8 X 2 BLK



H09 SHEATHING BOARD - W4L19629  
(x3) 1"X3 3/8"X80 3/8" (24x86x2040)



H10 SHEATHING BOARD - W4L19630  
(x3) 1"X3 3/8"X87" (24x86x2209)

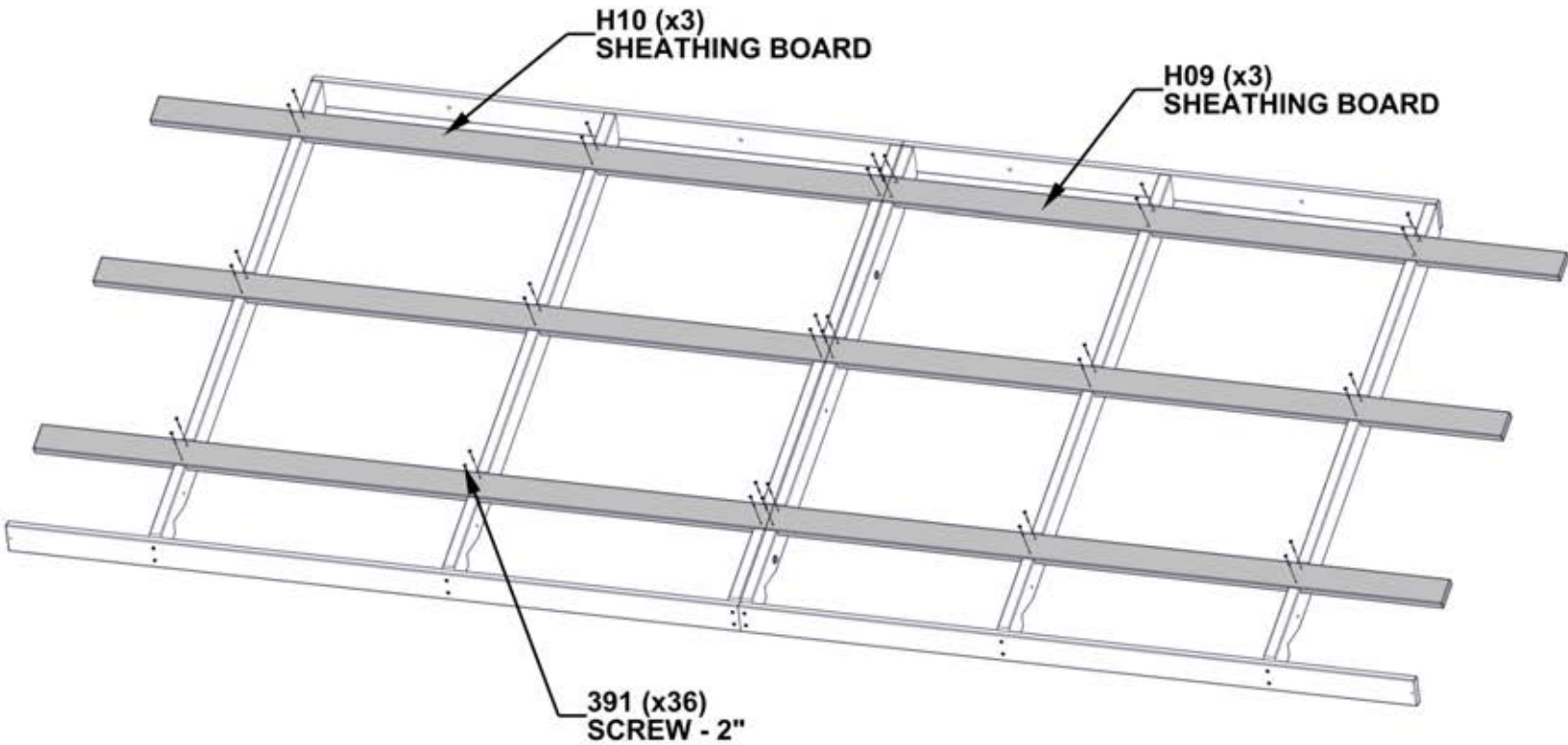

**DO NOT FULLY TIGHTEN SCREWS.**

## STEP 18B - ROOF PANEL A ASSEMBLY

### CRITICAL:

- SQUARE UNIT BEFORE PROCEEDING TO NEXT STEPS.
- THE BELOW DIMENSIONS ARE CRITICAL TO THE FINAL ROOF ASSEMBLY.
- MEASUREMENTS SHOULD BE HELD WITHIN  $\pm 1/4"$  (6mm).
- MEASUREMENTS OUTSIDE OF THE TOLERANCE WILL LEAD TO THE INABILITY TO ASSEMBLE THE ROOF.

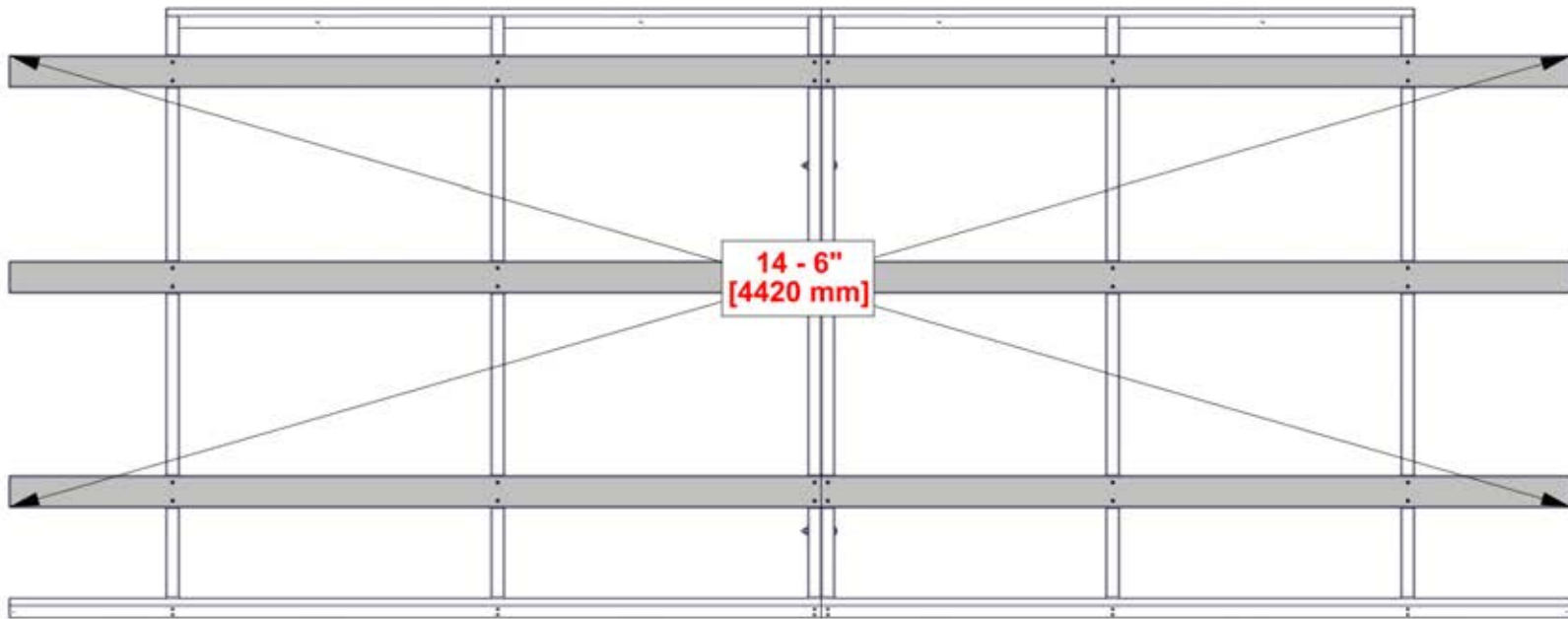

**ONCE PANEL IS SQUARED, FULLY TIGHTEN SCREWS**

# STEP 19 - ROOF PANEL A ASSEMBLY

## ROOF PANEL A

- USE THIS STEP TO FAMILIARIZE YOURSELF WITH THE ROOF PANEL AND ASSIST YOU IN STEPS 20-23.
- REMOVE PROTECTIVE BLUE FILM.
- START AT THE END INDICATED AND ASSEMBLE IN THE DIRECTION OF THE ARROW.
- **GLOVES SHOULD BE WORN WHEN HANDLING ROOF PANELS. EDGES ARE SHARP.**

**THE PRE-DRILLED HOLES ON EACH PANEL SHOULD ALWAYS BE POSITIONED ON THE RIDGE SIDE**

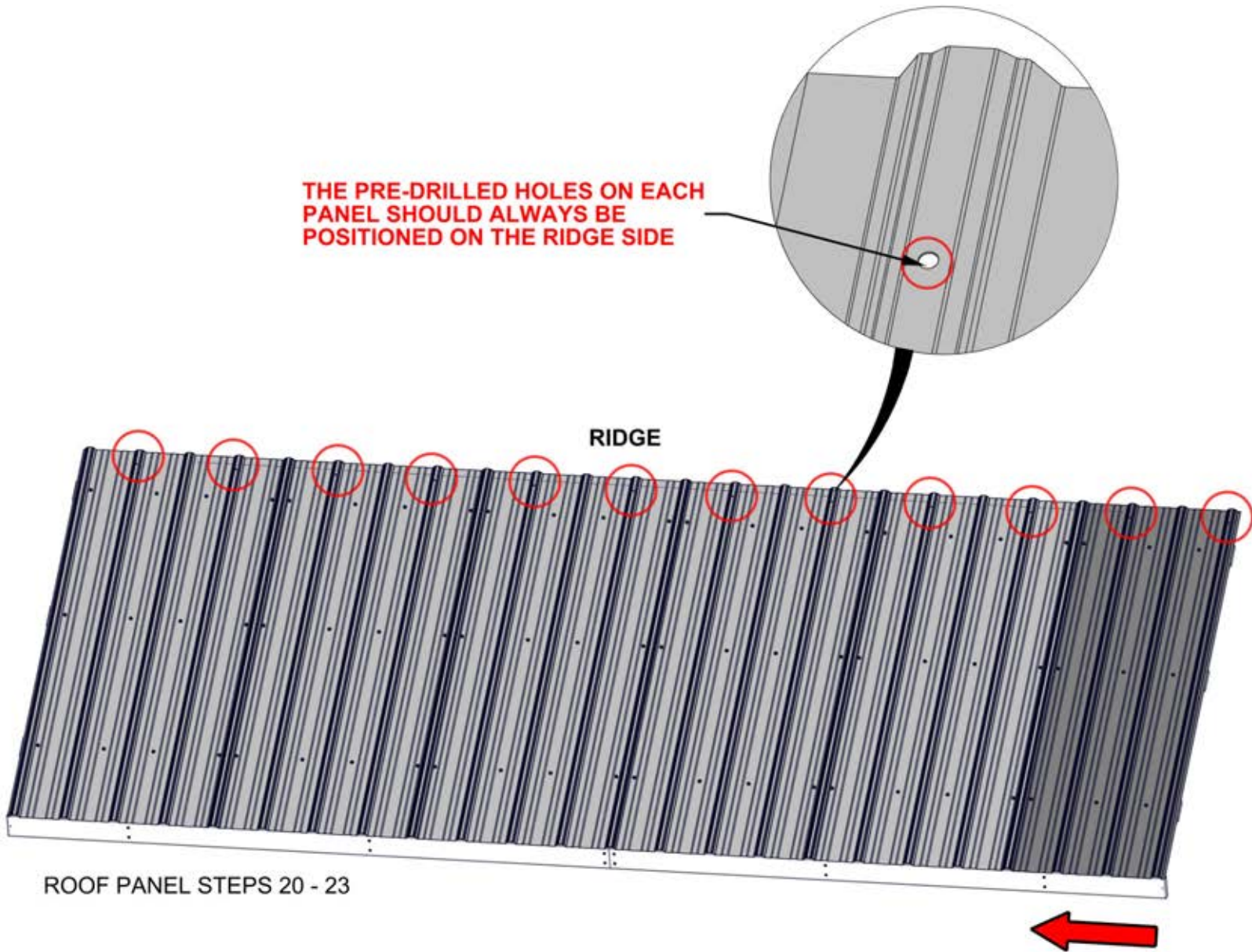

# STEP 20 - ROOF PANEL A ASSEMBLY

QTY	PART NUMBER	DESCRIPTION
21	H100833	SCREW WOODGRIP 10-16x3/4"

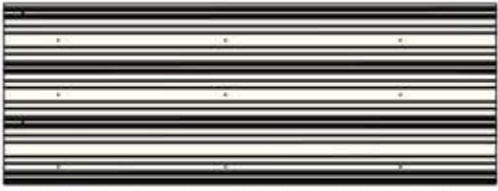

A4M02800 29GA STEEL SHEETING (x1)

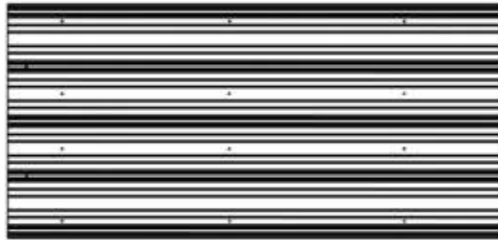

A4M02801 29GA STEEL SHEETING (x1)

**- MAKE SURE YOUR ROOF PANEL IS SQUARE BEFORE MOVING ON.**

**NOTE RIB OVERLAP**

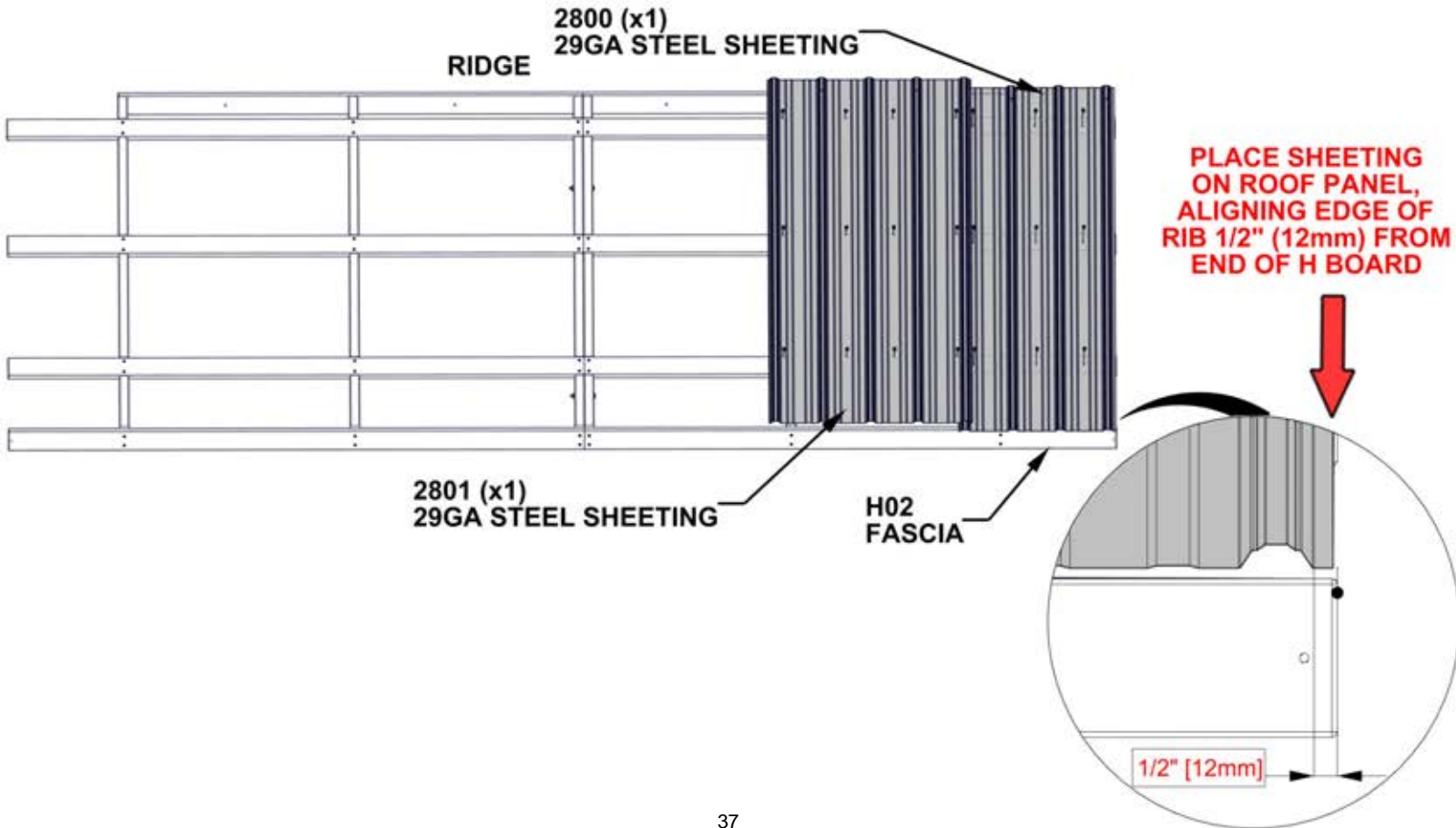
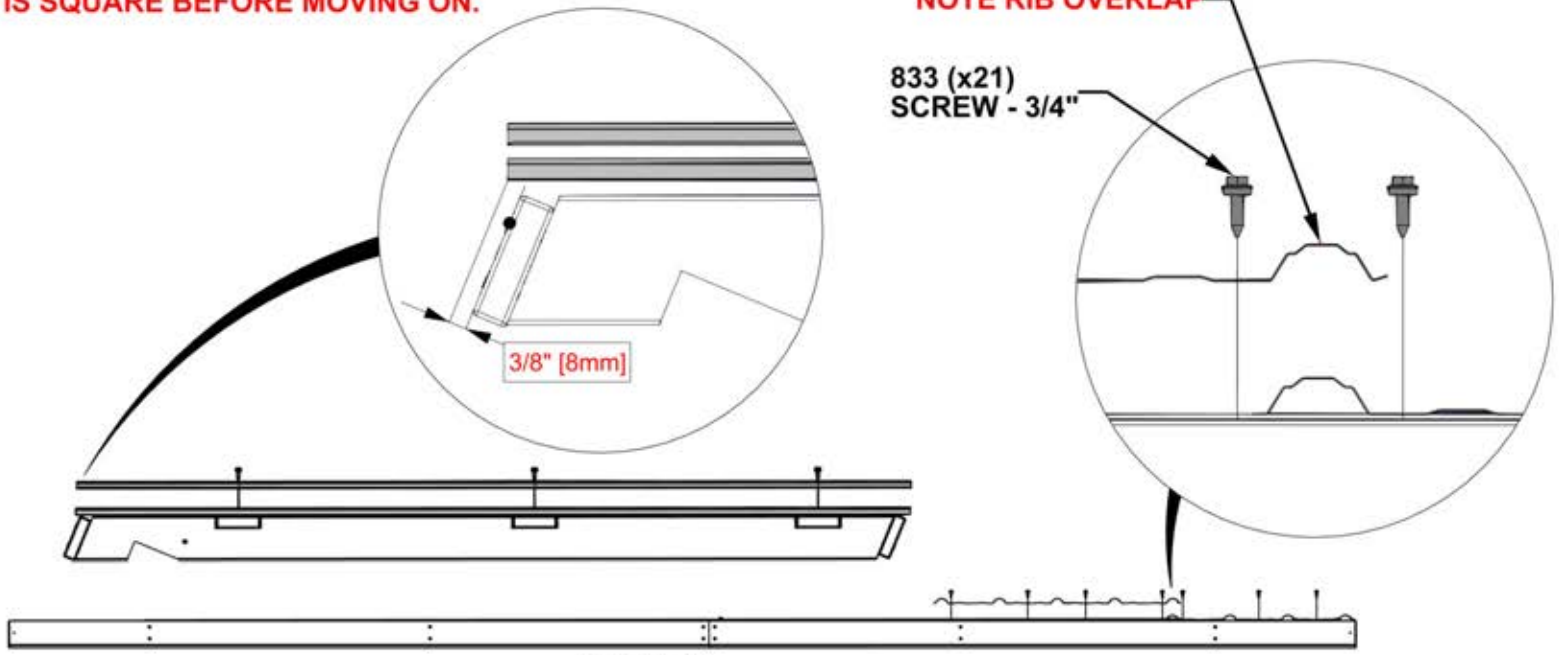

# STEP 21 - ROOF PANEL A ASSEMBLY

QTY	PART NUMBER	DESCRIPTION
24	H100833	SCREW WOODGRIP 10-16x3/4"



A4M02806 29GA STEEL SHEETING (x1)

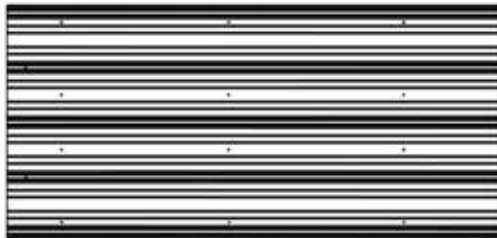

A4M03111 29GA STEEL SHEETING (x1)

**NOTE RIB OVERLAP**

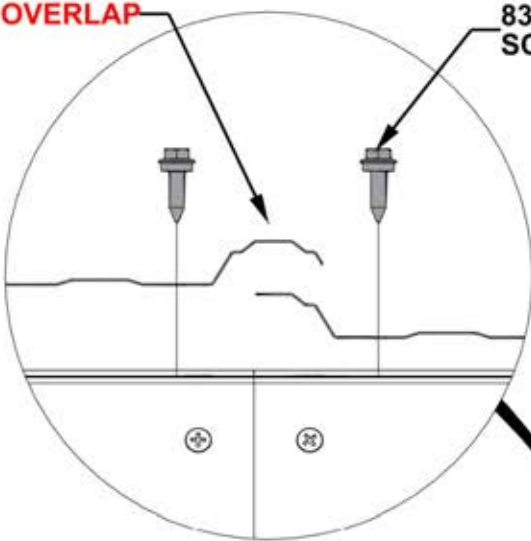

833 (x24)  
SCREW - 3/4"

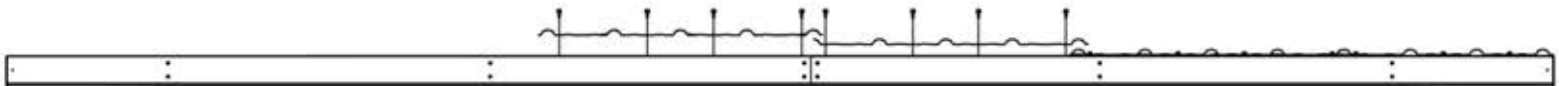

**ENSURE CORRECT  
PLACEMENT OF 2806 AND  
3111 STEEL SHEETING.**

3111 (x1)  
29GA STEEL SHEETING

2806 (x1)  
29GA STEEL SHEETING

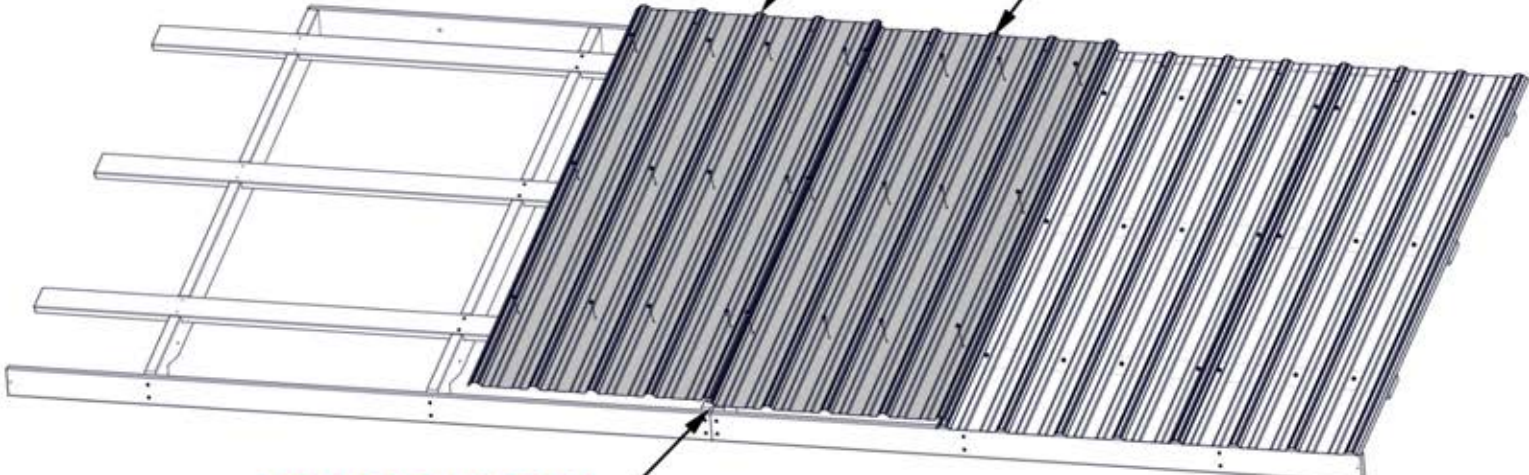

**ENDS OF ALL SHEETS  
SHOULD BE FLUSH**

# STEP 22 - ROOF PANEL A ASSEMBLY

QTY	PART NUMBER	DESCRIPTION
24	H100833	SCREW WOODGRIP 10-16x3/4"

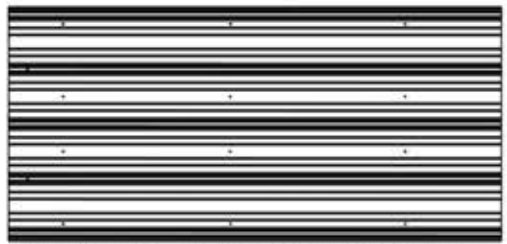

A4M02801 29GA STEEL SHEETING  
(x2)

**NOTE RIB OVERLAP**

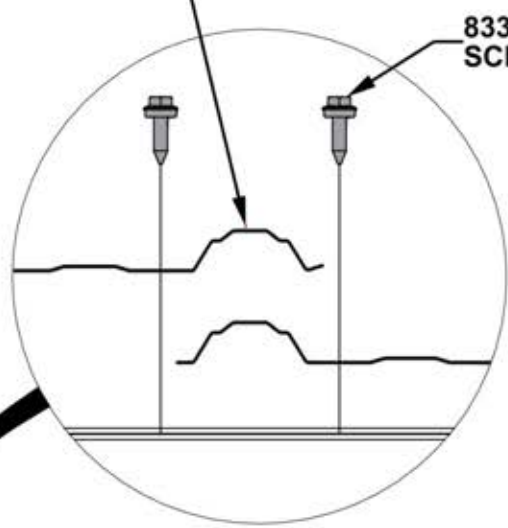

2801 (x2)  
29GA STEEL SHEETING

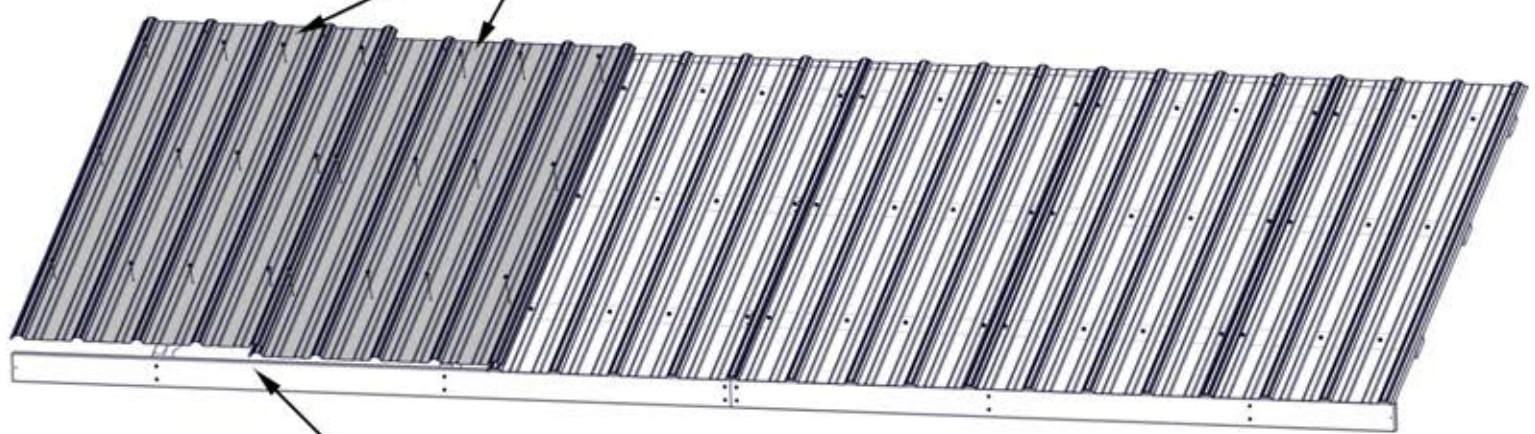

**FLUSH ENDS OF ALL SHEETS**

# STEP 23 - ROOF PANEL A ASSEMBLY

SEPARATE ROOF PANEL AT THIS TIME FOR EASE OF ASSEMBLING.

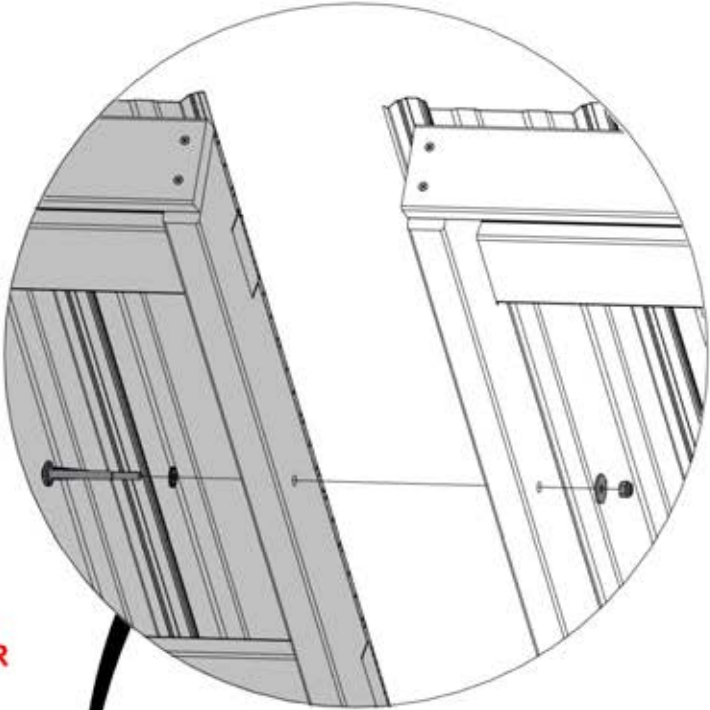

REMOVE HARDWARE AND SET TO THE SIDE AS IT WILL BE USED AGAIN AFTER BOTH ROOF PANELS ARE INSTALLED.

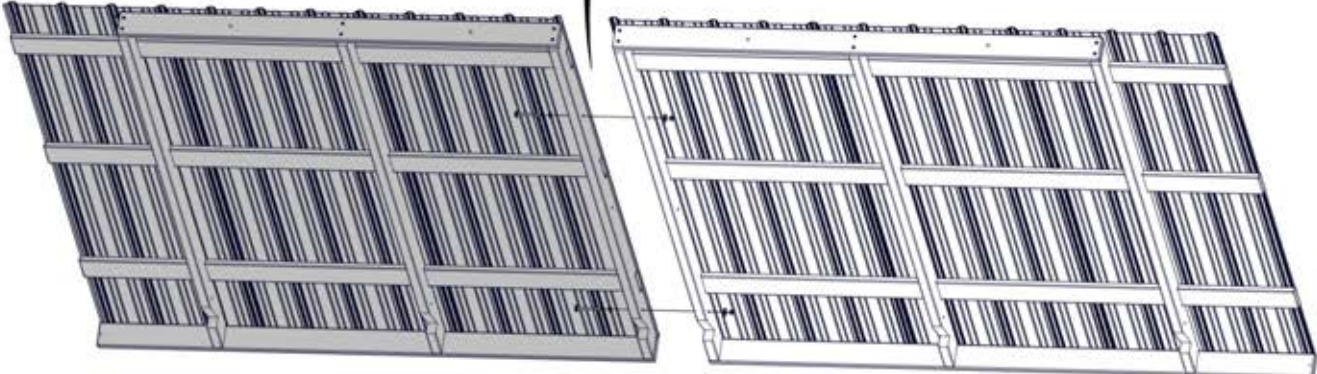

SECTION 1

SECTION 2



# STEP 24 - ROOF PANEL B ASSEMBLY

QTY	PART NUMBER	DESCRIPTION
2	H100198	WASHER LOCK EXT 8X19 BLK
24	H100391	SCREW PFH 8 X 2 BLK
2	H100478	WASHER FLAT 8X27 BLK
2	H100479	NUT LOCK 5/16 BLK
2	H100503	BOLT WH 5/16 X 3 1/2 BLK

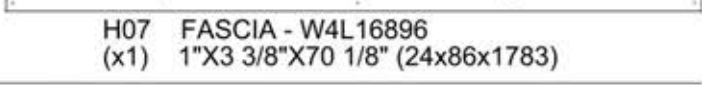
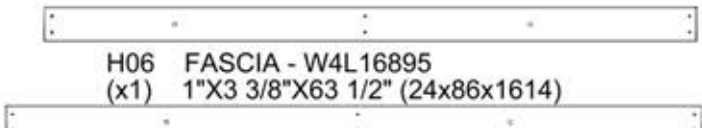
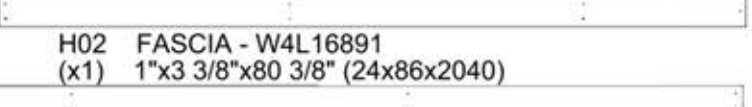
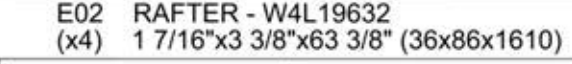
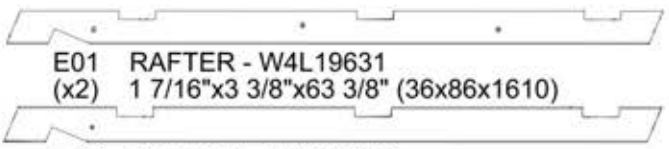

## ROOF PANEL B

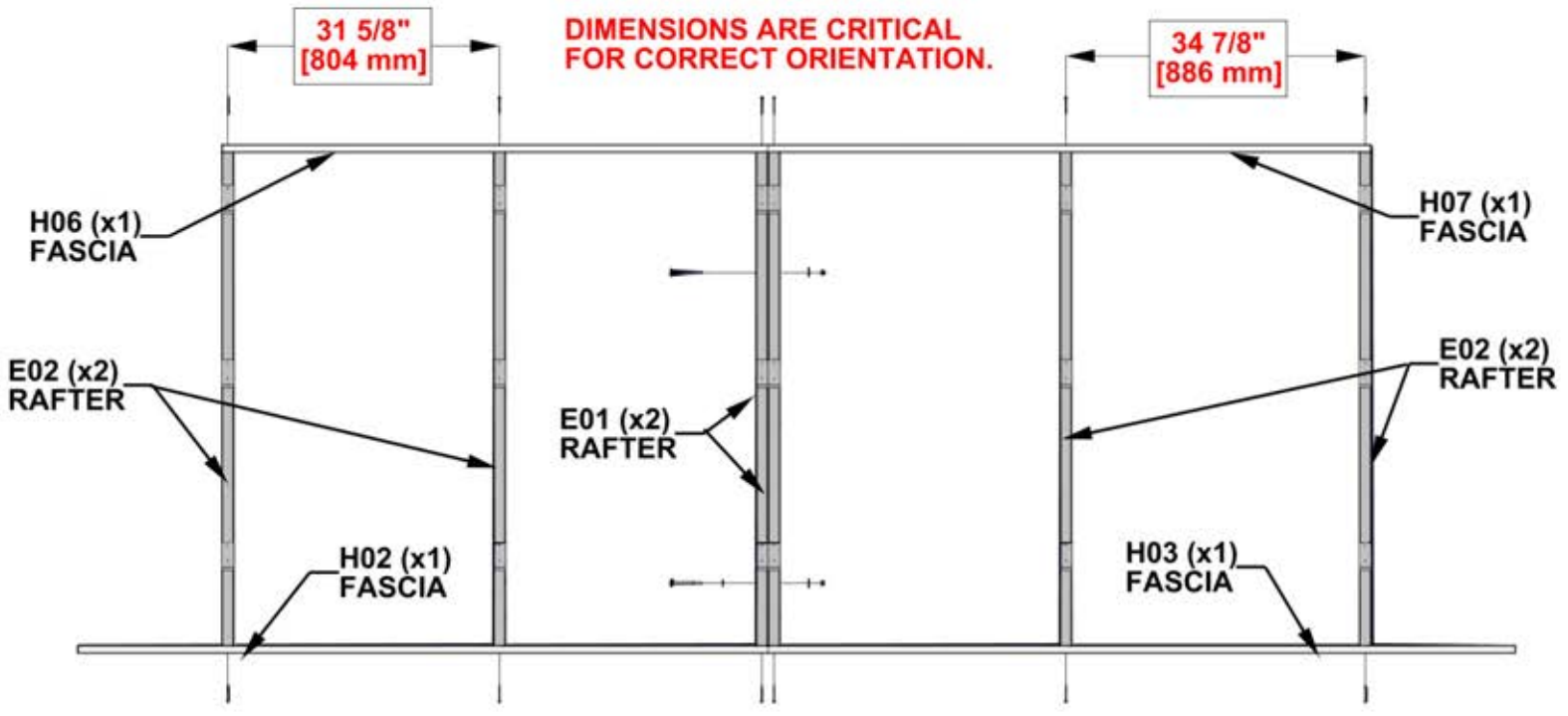

**CORRECT ORIENTATION AND PLACEMENT OF H BOARDS IS CRITICAL FOR LATER STEPS**

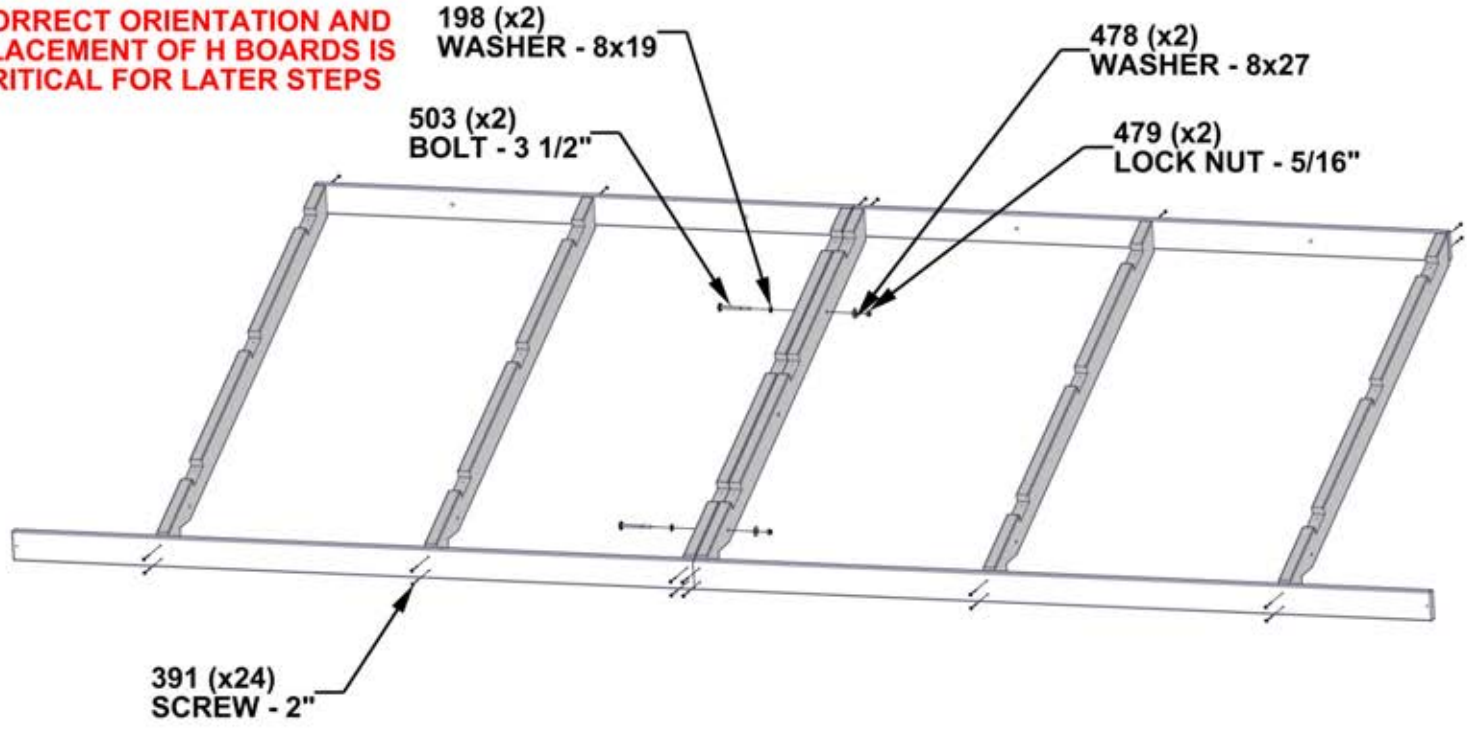

# STEP 25A - ROOF PANEL B ASSEMBLY

QTY	PART NUMBER	DESCRIPTION
36	H100391	SCREW PFH 8 X 2 BLK



H09 SHEATHING BOARD - W4L19629  
(x3) 1"X3 3/8"X80 3/8" (24x86x2040)

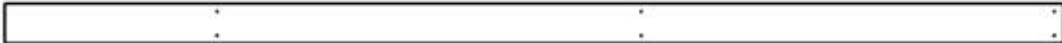

H10 SHEATHING BOARD - W4L19630  
(x3) 1"X3 3/8"X87" (24x86x2209)

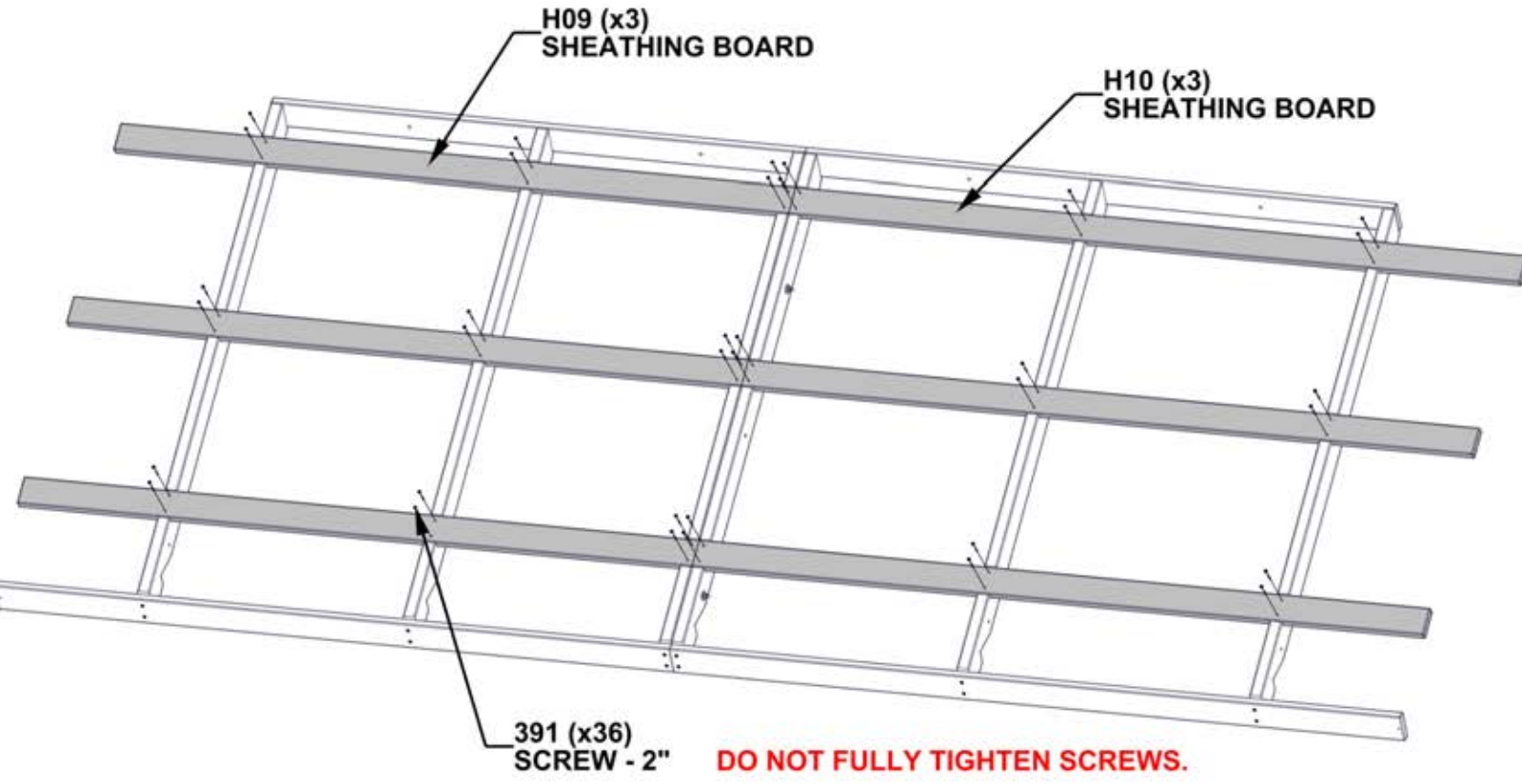

## STEP 25B - ROOF PANEL B ASSEMBLY

**CRITICAL:**

- SQUARE UNIT BEFORE PROCEEDING TO NEXT STEPS.
- THE BELOW DIMENSIONS ARE CRITICAL TO THE FINAL ROOF ASSEMBLY.
- MEASUREMENTS SHOULD BE HELD WITHIN  $\pm 1/4"$  (6mm).
- MEASUREMENTS OUTSIDE OF THE TOLERANCE WILL LEAD TO THE INABILITY TO ASSEMBLE THE ROOF.

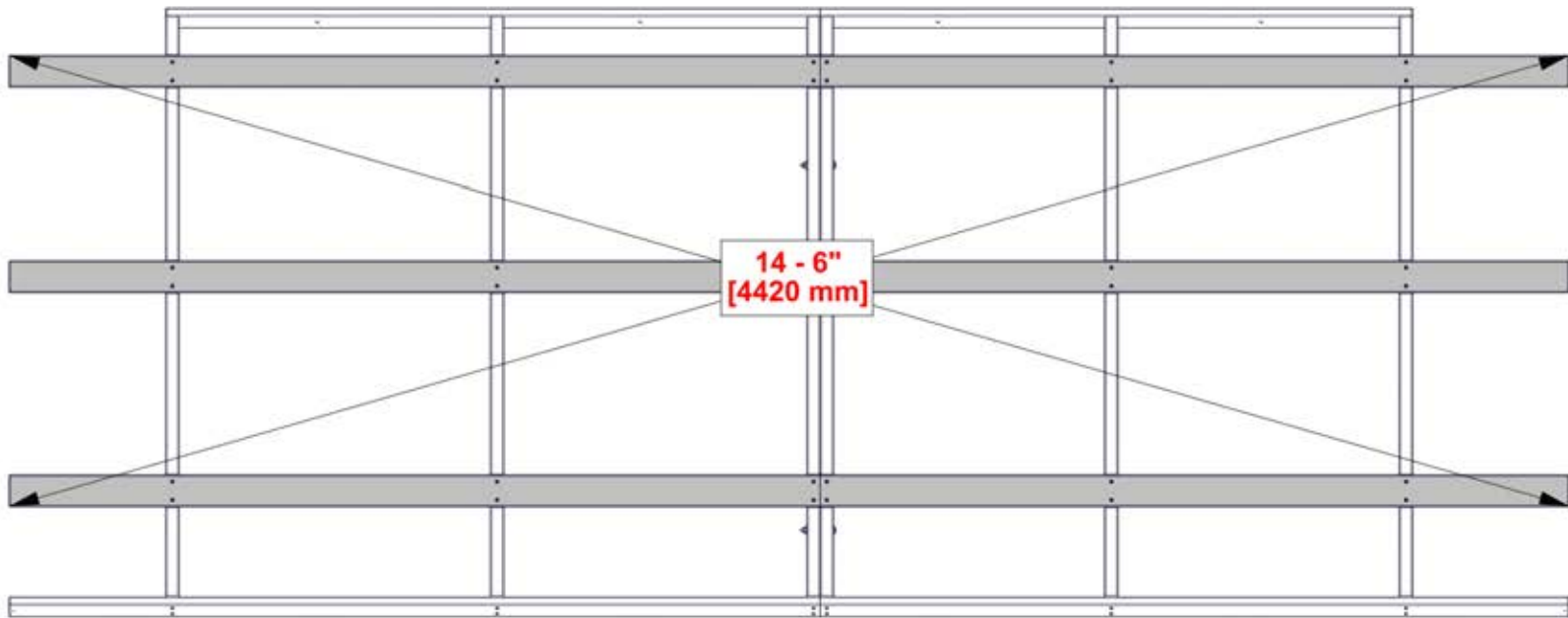

**ONCE PANEL IS SQUARED, FULLY TIGHTEN SCREWS**

# STEP 26 - ROOF PANEL B ASSEMBLY

## ROOF PANEL B

- USE THIS STEP TO FAMILIARIZE YOURSELF WITH THE ROOF PANEL AND ASSIST YOU IN STEPS 27-30.
- REMOVE PROTECTIVE BLUE FILM.
- START AT THE END INDICATED AND ASSEMBLE IN THE DIRECTION OF THE ARROW.
- **GLOVES SHOULD BE WORN WHEN HANDLING ROOF PANELS. EDGES ARE SHARP.**

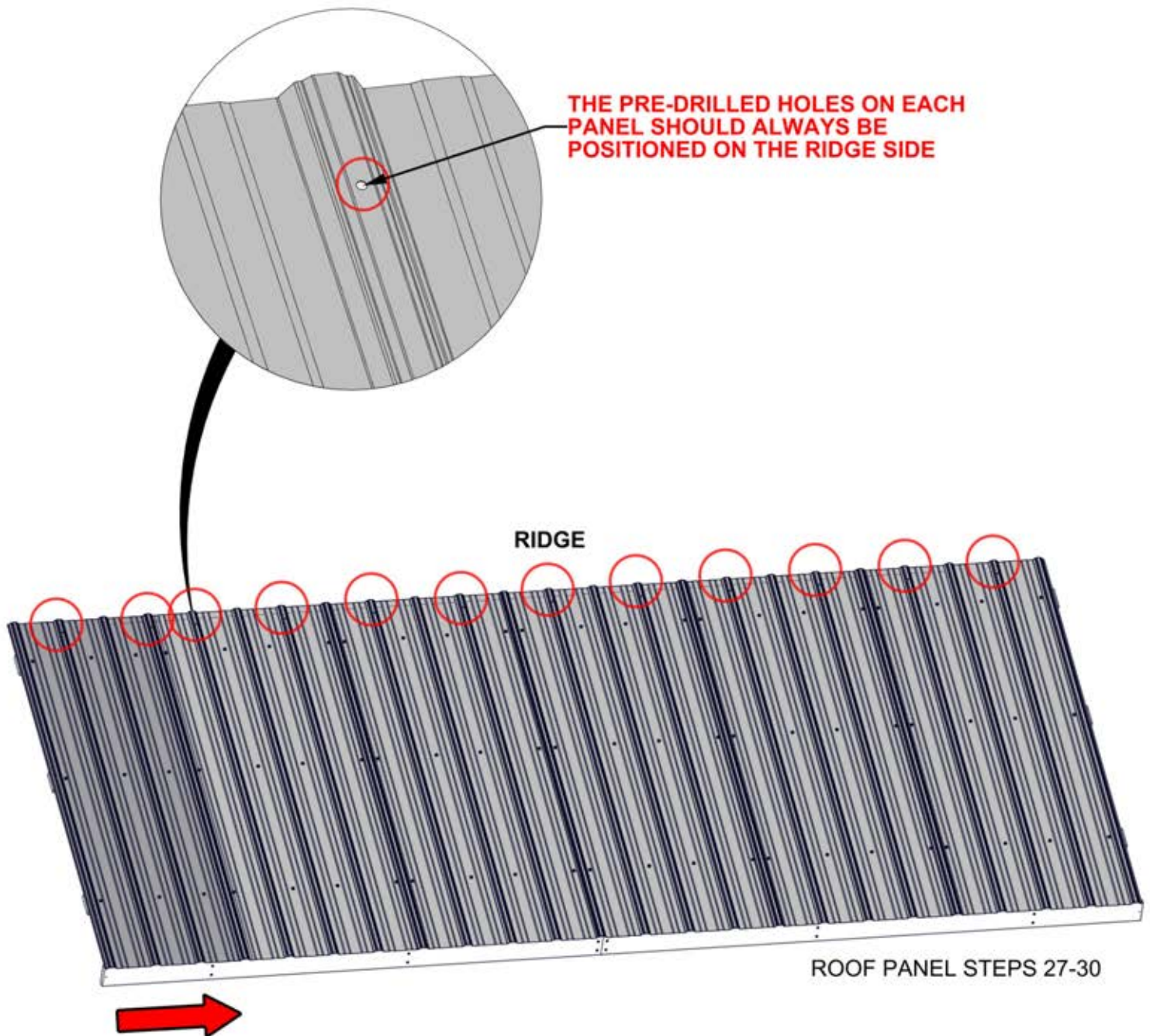

# STEP 27 - ROOF PANEL B ASSEMBLY

QTY	PART NUMBER	DESCRIPTION
21	H100833	SCREW WOODGRIP 10-16x3/4"

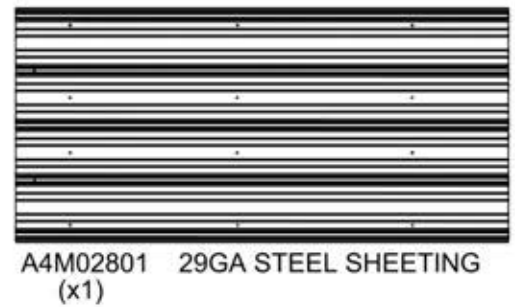
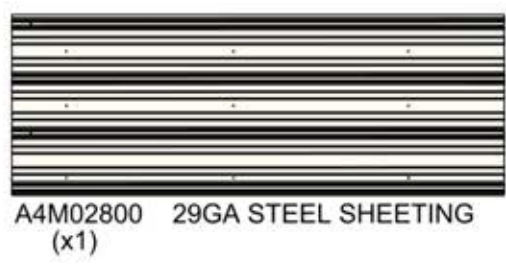

**- MAKE SURE YOUR ROOF PANEL IS SQUARE BEFORE MOVING ON.**

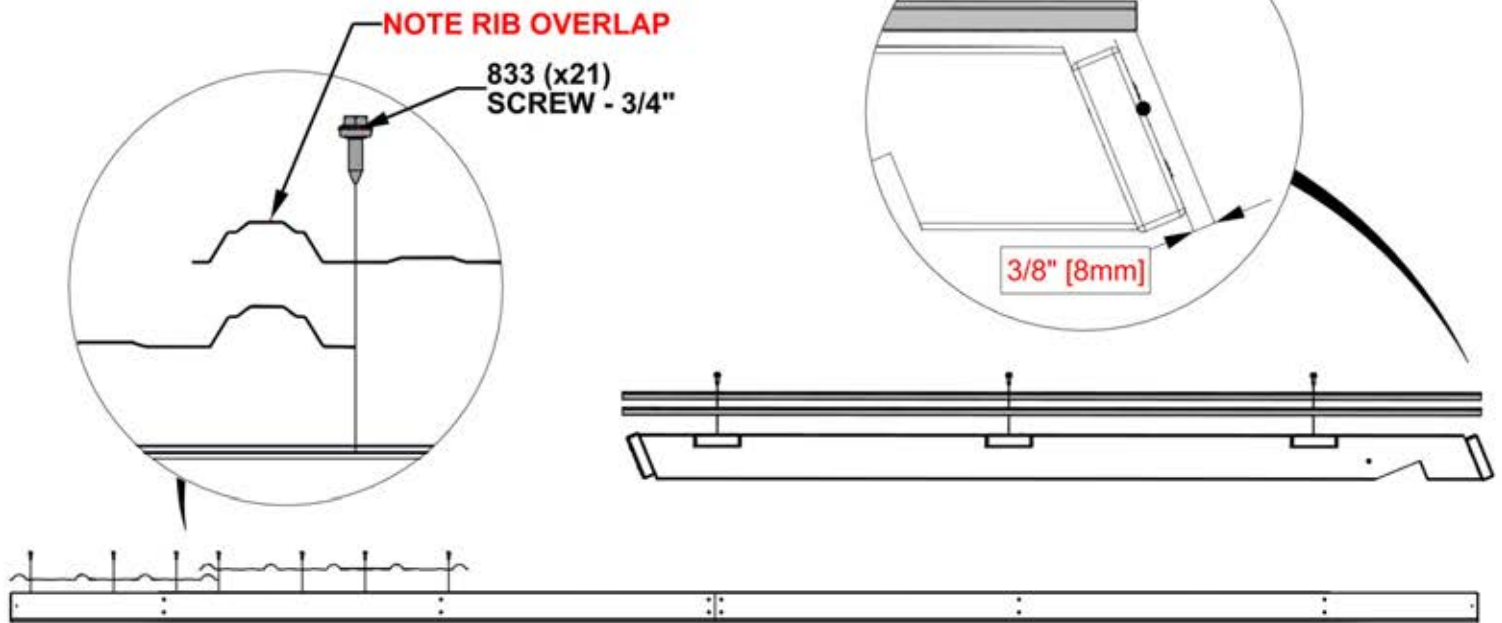

**AT RIB OVERLAP, PRE-DRILL 2801 THROUGH HOLE IN 2800 WITH A 5/16" [5mm] DRILL BIT.**

**PLACE SHEETING ON ROOF PANEL, ALIGNING EDGE OF RIB 3/8" (8mm) FROM END OF H BOARD**

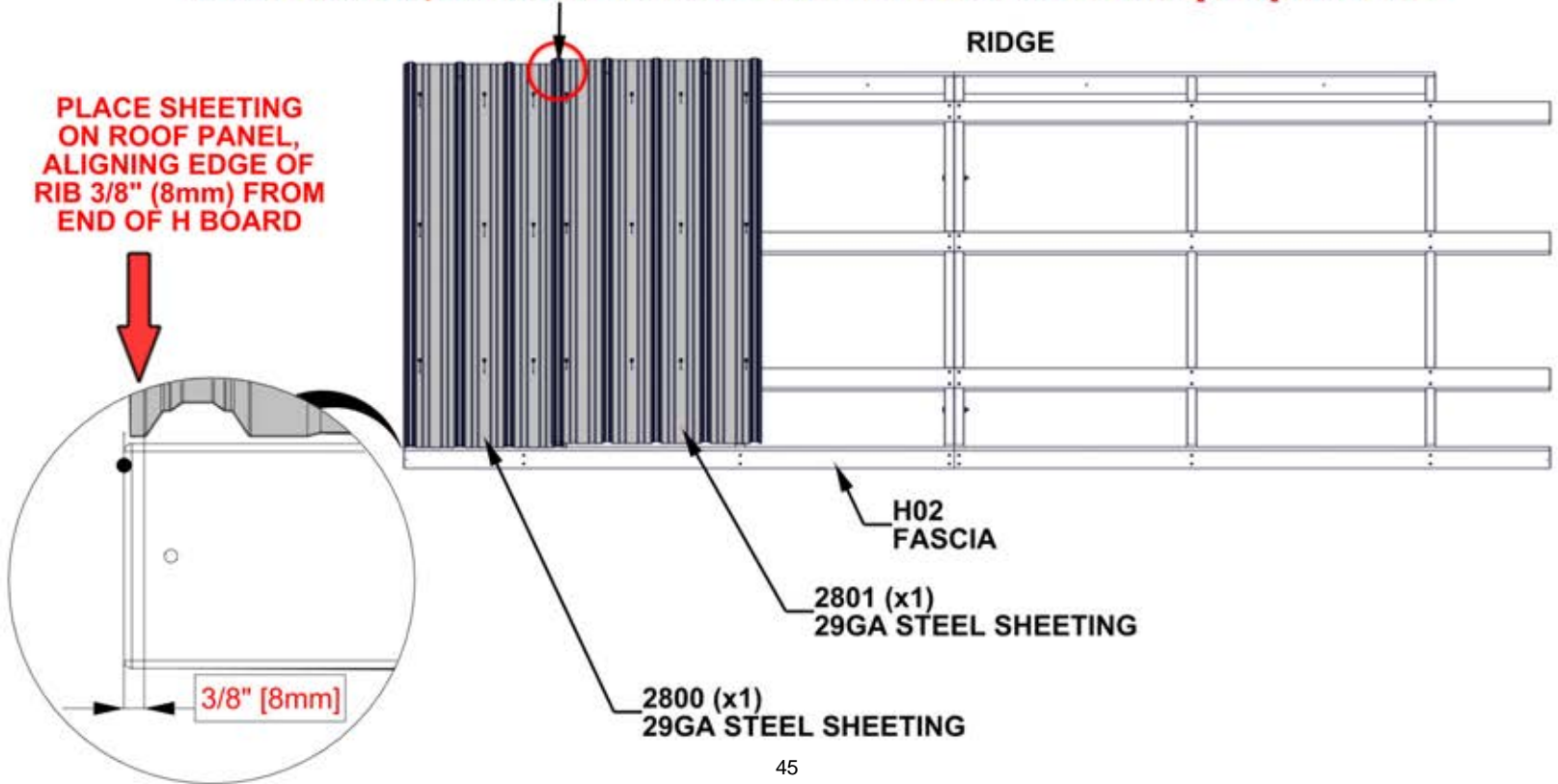

# STEP 28 - ROOF PANEL B ASSEMBLY

QTY	PART NUMBER	DESCRIPTION
24	H100833	SCREW WOODGRIP 10-16x3/4"

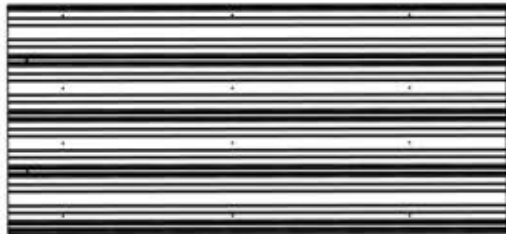

A4M02799 29GA STEEL SHEETING (x1)

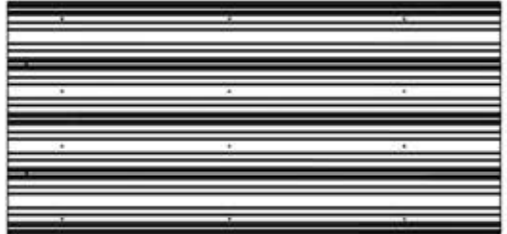

A4M03112 29GA STEEL SHEETING (x1)

**NOTE RIB OVERLAP**

833 (x24)  
SCREW - 3/4"

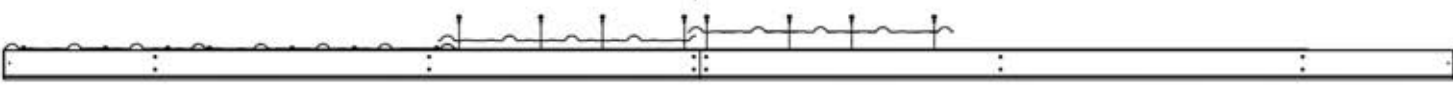
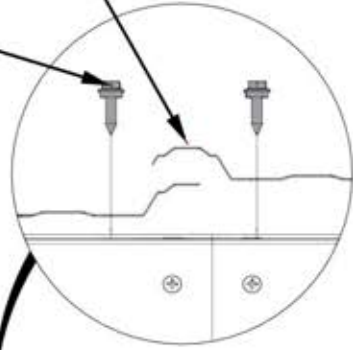

**ENSURE CORRECT  
PLACEMENT OF 2799 AND  
3112 STEEL SHEETING.**

2799 (x1)  
29GA STEEL SHEETING

3112 (x1)  
29GA STEEL SHEETING

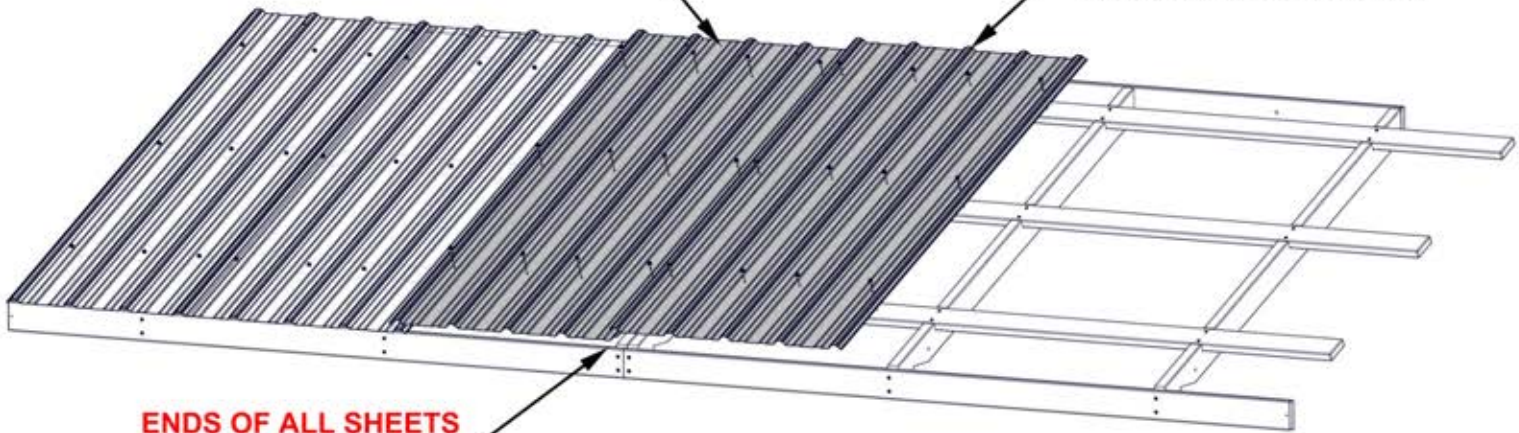

**ENDS OF ALL SHEETS  
SHOULD BE FLUSH**

# STEP 29 - ROOF PANEL B ASSEMBLY

QTY	PART NUMBER	DESCRIPTION
24	H100833	SCREW WOODGRIP 10-16x3/4"

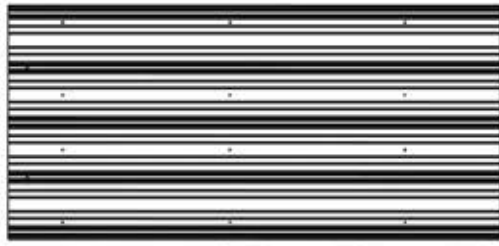

A4M02801 29GA STEEL SHEETING  
(x2)

**NOTE RIB OVERLAP**

833 (x24)  
SCREW - 3/4"

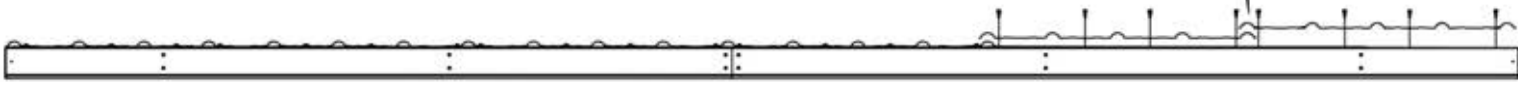
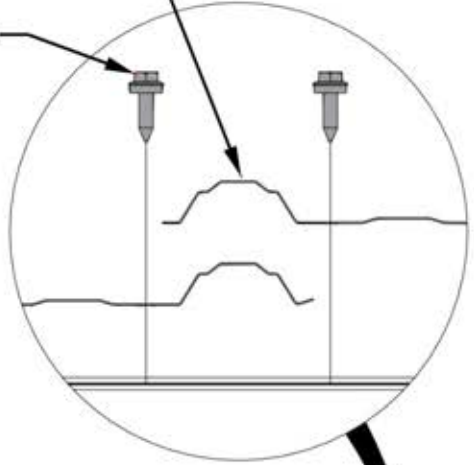

2801 (x2)  
29GA STEEL SHEETING



**ENDS OF ALL SHEETS  
SHOULD BE FLUSH**

# STEP 30 - ROOF PANEL B ASSEMBLY

SEPARATE ROOF PANEL AT THIS TIME FOR EASE OF ASSEMBLING.

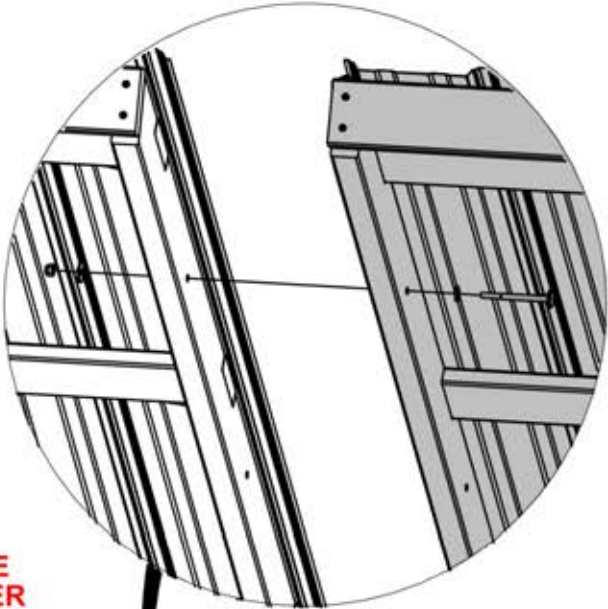

REMOVE HARDWARE AND SET TO THE SIDE AS IT WILL BE USED AGAIN AFTER BOTH ROOF PANELS ARE INSTALLED.

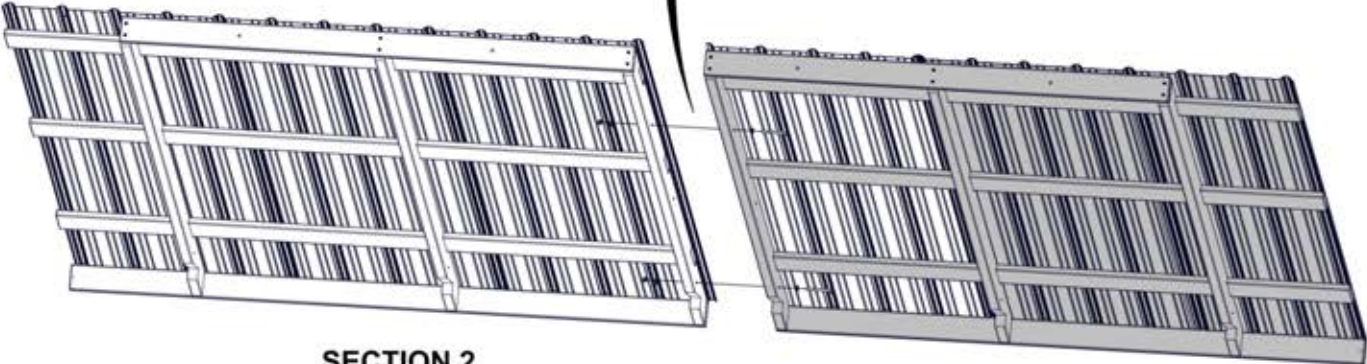

SECTION 2

SECTION 1



# STEP 31 - ROOF ASSEMBLY

QTY	PART NUMBER	DESCRIPTION
2	H100198	WASHER LOCK EXT 8X19 BLK
2	H100378	BOLT WH 5/16 X 1 3/4 BLK
1	H100391	SCREW PFH 8 X 2 BLK

## INSTALL ROOF PANEL A, SECTION 1

- ADDITIONAL PEOPLE ARE HELPFUL FOR THIS STEP.
- SLIDE ROOF PANEL ALONG TRACKS ON RAFTER. ONCE IN PLACE, INSTALL ATTACHMENT HARDWARE AS SHOWN.
- INSTALL BOLTS AND WASHERS BEFORE SCREWS.

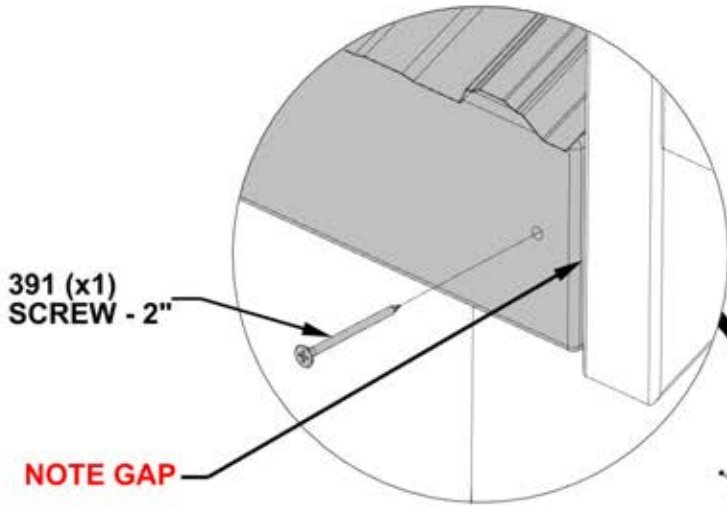
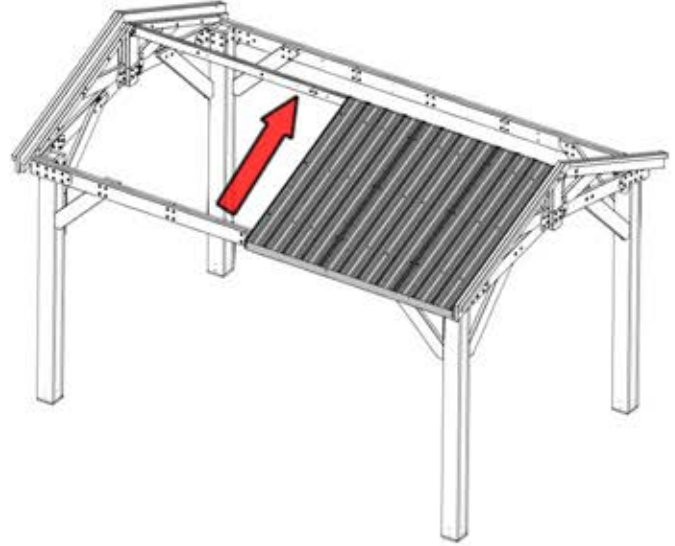

ROOF PANEL A  
SECTION 1

378 (x2)  
BOLT - 1 3/4"

198 (x2)  
WASHER - 8x19

# STEP 32 - ROOF ASSEMBLY

QTY	PART NUMBER	DESCRIPTION
2	H100198	WASHER LOCK EXT 8X19 BLK
2	H100378	BOLT WH 5/16 X 1 3/4 BLK
1	H100391	SCREW PFH 8 X 2 BLK

## INSTALL ROOF PANEL B, SECTION 1

- ADDITIONAL PEOPLE ARE HELPFUL FOR THIS STEP.
- SLIDE ROOF PANEL ALONG TRACKS ON RAFTER.
- ONCE IN PLACE, INSTALL ATTACHMENT HARDWARE AS SHOWN.
- INSTALL BOLTS AND WASHERS BEFORE SCREWS.

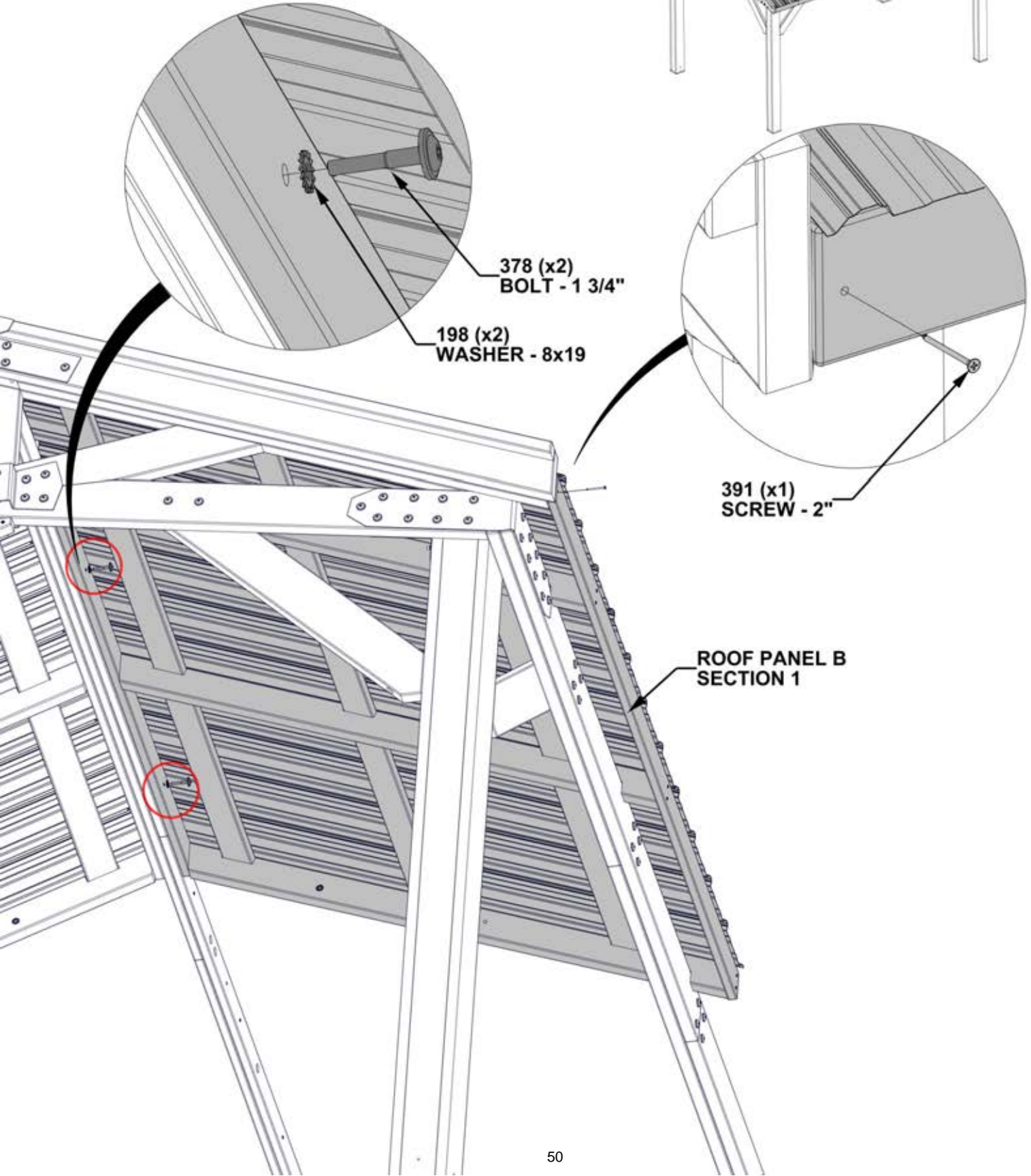
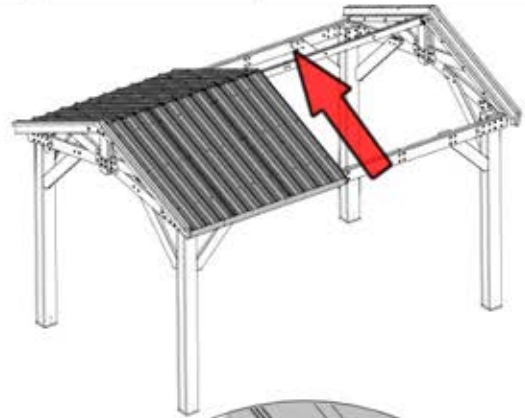

# STEP 33 - ROOF ASSEMBLY

## INSTALL ROOF PANEL B, SECTION 2

- ADDITIONAL PEOPLE ARE HELPFUL FOR THIS STEP.
- SLIDE ROOF PANEL ALONG TRACKS ON RAFTER. ONCE IN PLACE, INSTALL ATTACHMENT HARDWARE AS SHOWN.
- INSTALL BOLTS AND WASHERS BEFORE SCREWS.
- THE CORNER OF THE EXISTING ROOF PANEL MAY NEED TO BE LIFTED TO GET PANEL STARTED.

QTY	PART NUMBER	DESCRIPTION
4	H100198	WASHER LOCK EXT 8X19 BLK
2	H100378	BOLT WH 5/16 X 1 3/4 BLK
1	H100391	SCREW PFH 8 X 2 BLK
2	H100478	WASHER FLAT 8X27 BLK
2	H100479	NUT LOCK 5/16 BLK
2	H100503	BOLT WH 5/16 X 3 1/2 BLK

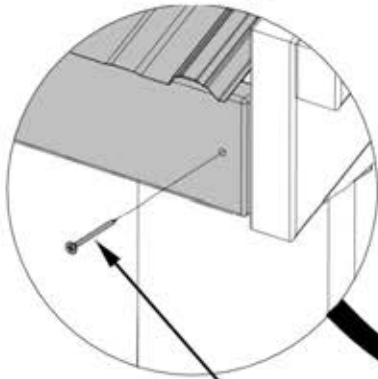
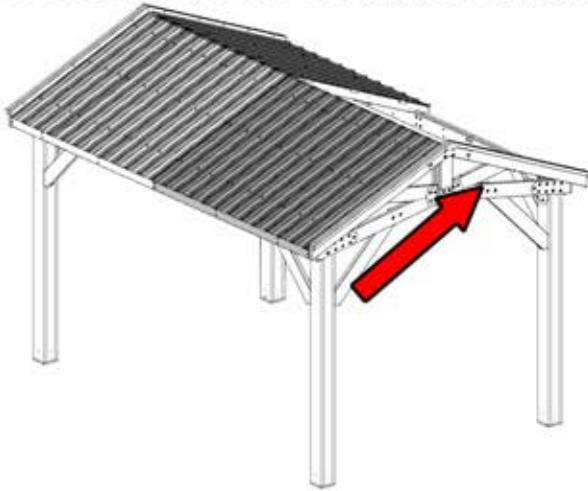

391 (x1)  
SCREW - 2"

479 (x2)  
LOCK NUT - 5/16"

478 (x2)  
WASHER - 8x27

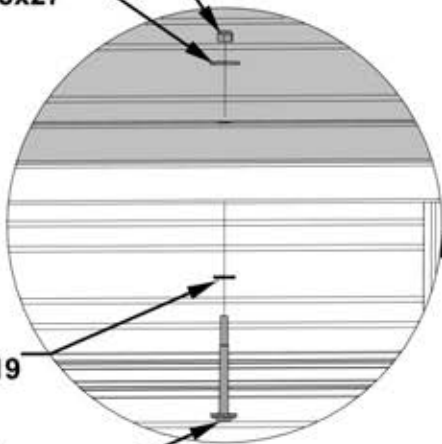

198 (x2)  
WASHER - 8x19

503 (x2)  
BOLT - 3 1/2"

**RE-INSERT HARDWARE  
REMOVED FROM STEP 30**

198 (x2)  
WASHER - 8x19

378 (x2)  
BOLT - 1 3/4"

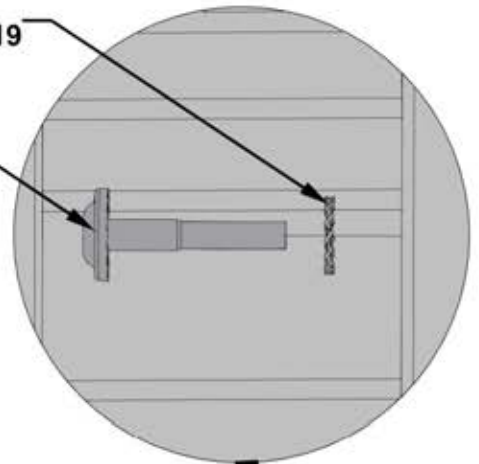

ROOF PANEL B  
SECTION 2

# STEP 34 - ROOF ASSEMBLY

## INSTALL ROOF PANEL A, SECTION 2

- ADDITIONAL PEOPLE ARE HELPFUL FOR THIS STEP.
- SLIDE ROOF PANEL ALONG TRACKS ON RAFTER.
- ONCE IN PLACE, INSTALL ATTACHMENT HARDWARE AS SHOWN.
- INSTALL BOLTS AND WASHERS BEFORE SCREWS.
- THE CORNER OF THE EXISTING ROOF PANEL MAY NEED TO BE LIFTED TO GET PANEL STARTED.

QTY	PART NUMBER	DESCRIPTION
4	H100198	WASHER LOCK EXT 8X19 BLK
2	H100378	BOLT WH 5/16 X 1 3/4 BLK
1	H100391	SCREW PFH 8 X 2 BLK
2	H100478	WASHER FLAT 8X27 BLK
2	H100479	NUT LOCK 5/16 BLK
2	H100503	BOLT WH 5/16 X 3 1/2 BLK

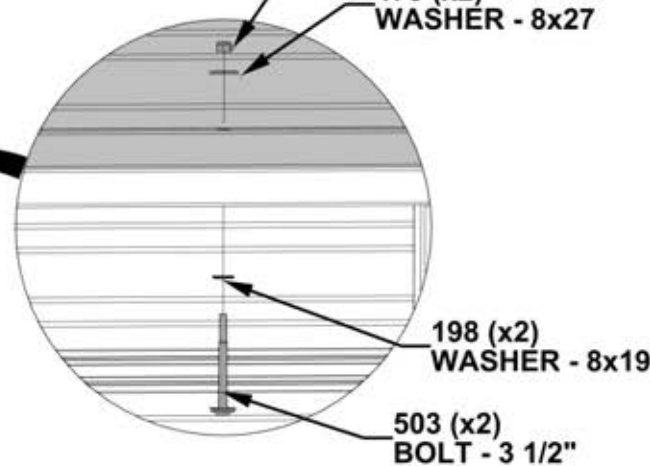
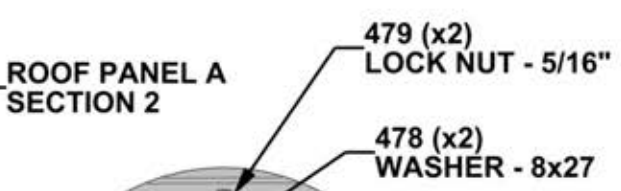
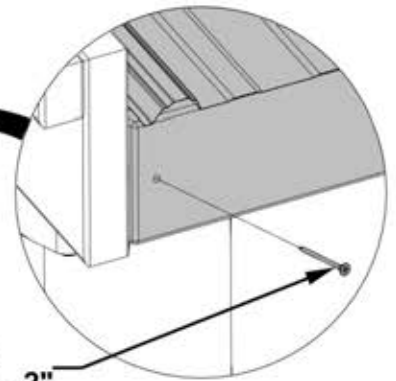
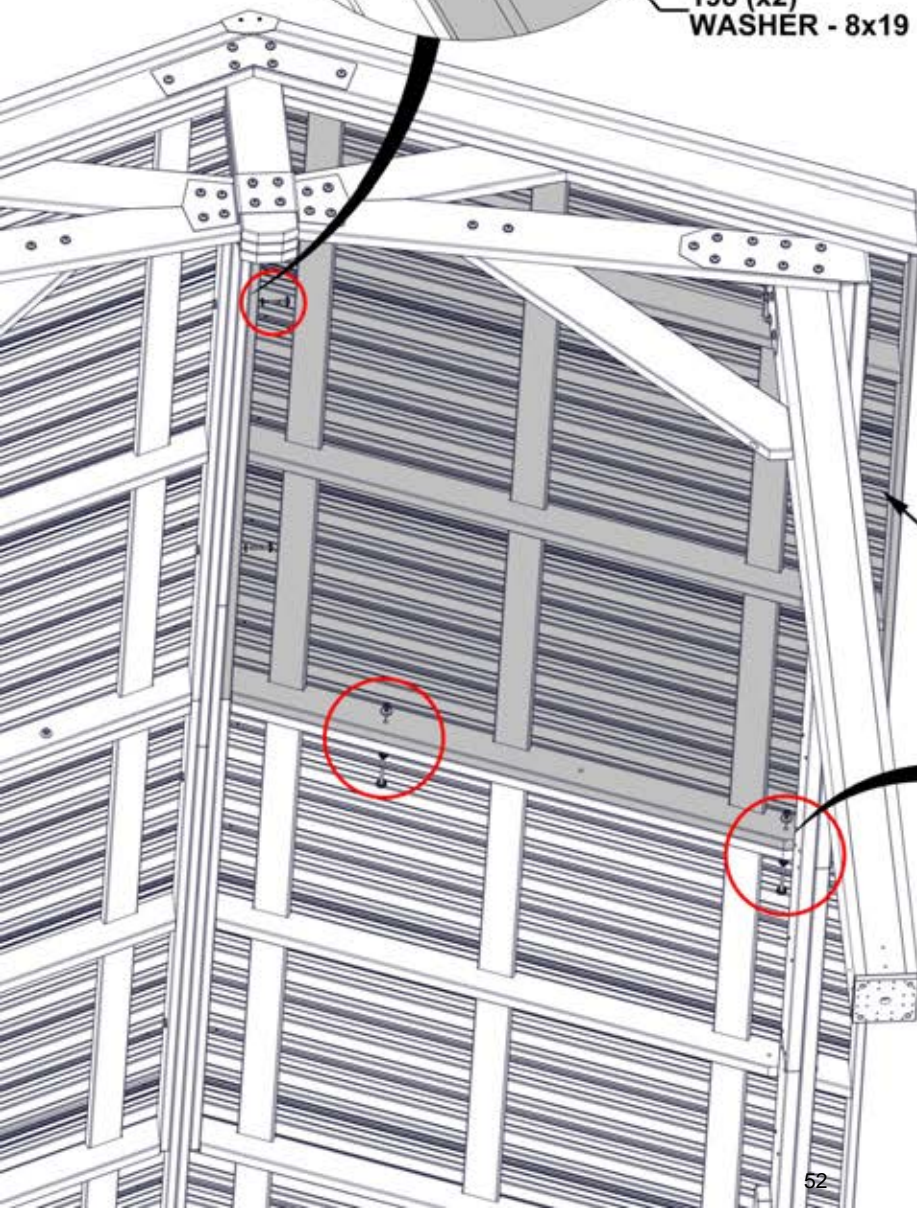
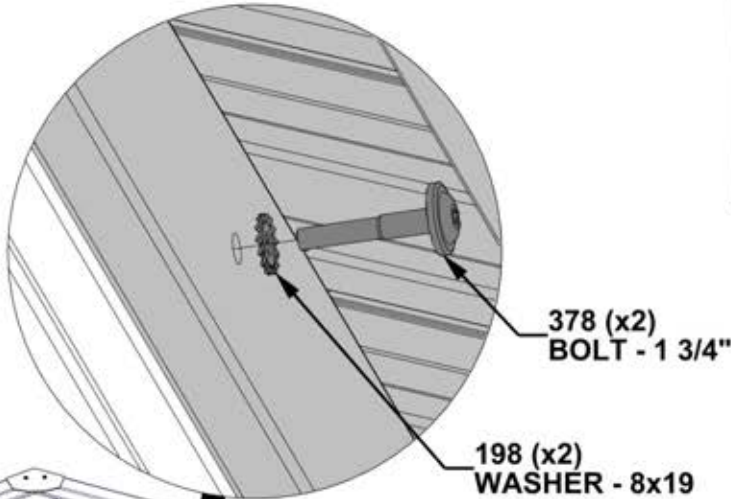
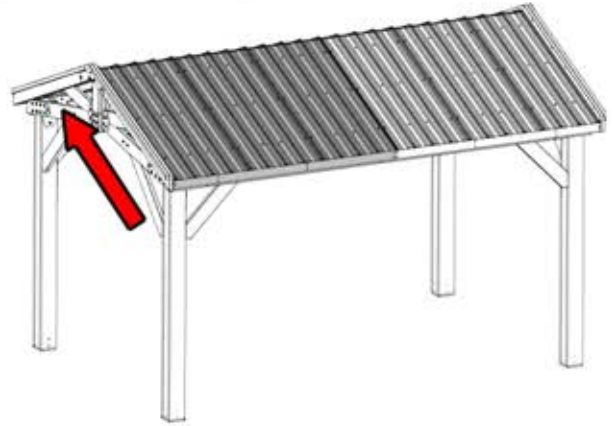

**RE-INSERT HARDWARE  
REMOVED FROM STEP 23**

# STEP 35 - ROOF ASSEMBLY

QTY	PART NUMBER	DESCRIPTION
2	H100198	WASHER LOCK EXT 8X19 BLK
2	H100478	WASHER FLAT 8X27 BLK
2	H100479	NUT LOCK 5/16 BLK
2	H100976	BOLT WH 5/16 X 6 1/4 BLK



E09 ACCESSORY TRUSS - W4L16756  
(x2) 1 3/8"x3 3/8"x73 7/8" (36x86x1875)

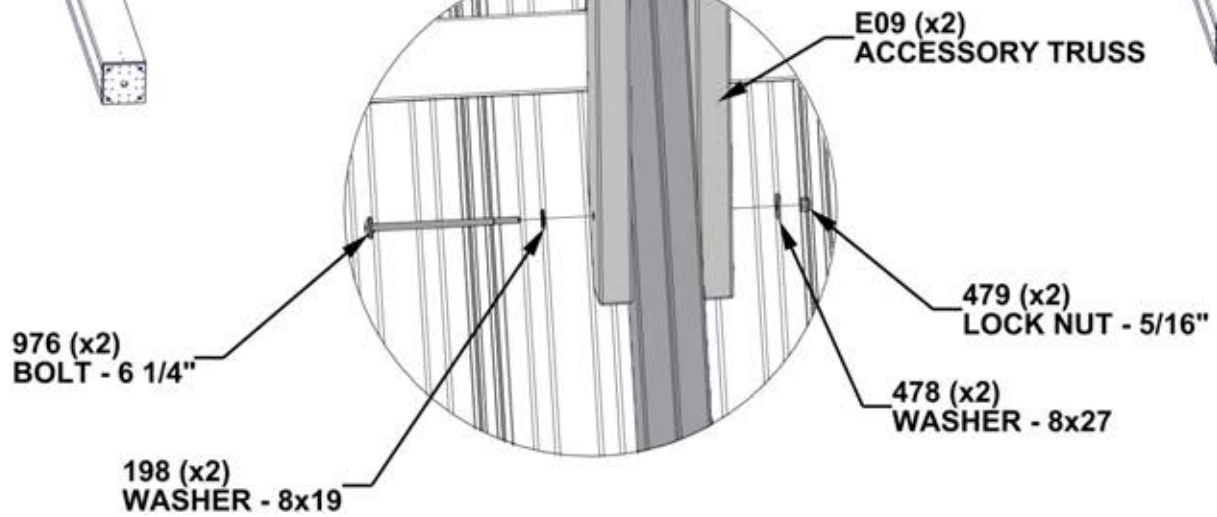
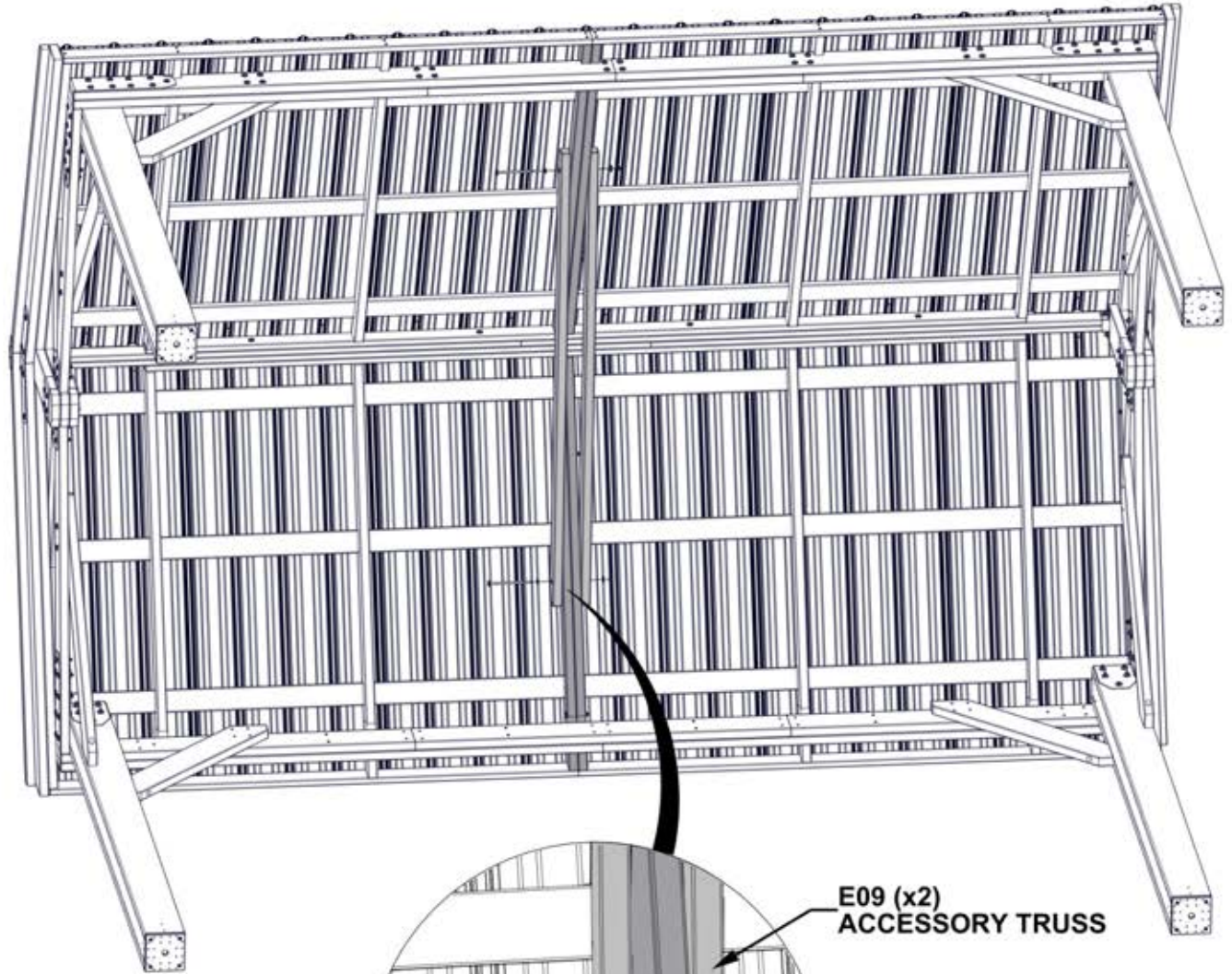

# STEP 36 - ROOF ASSEMBLY

QTY	PART NUMBER	DESCRIPTION
8	H100488	BOLT WH 1/4 X 2 BLK
8	H100630	WASHER FLAT 8x19 BLK
8	H100653	NUT LOCK 1/4 BLK
16	H100823	SCREW PWH 8 X 1 1/2 BLK



A4M01228 RAFTER CLIP  
(x8)

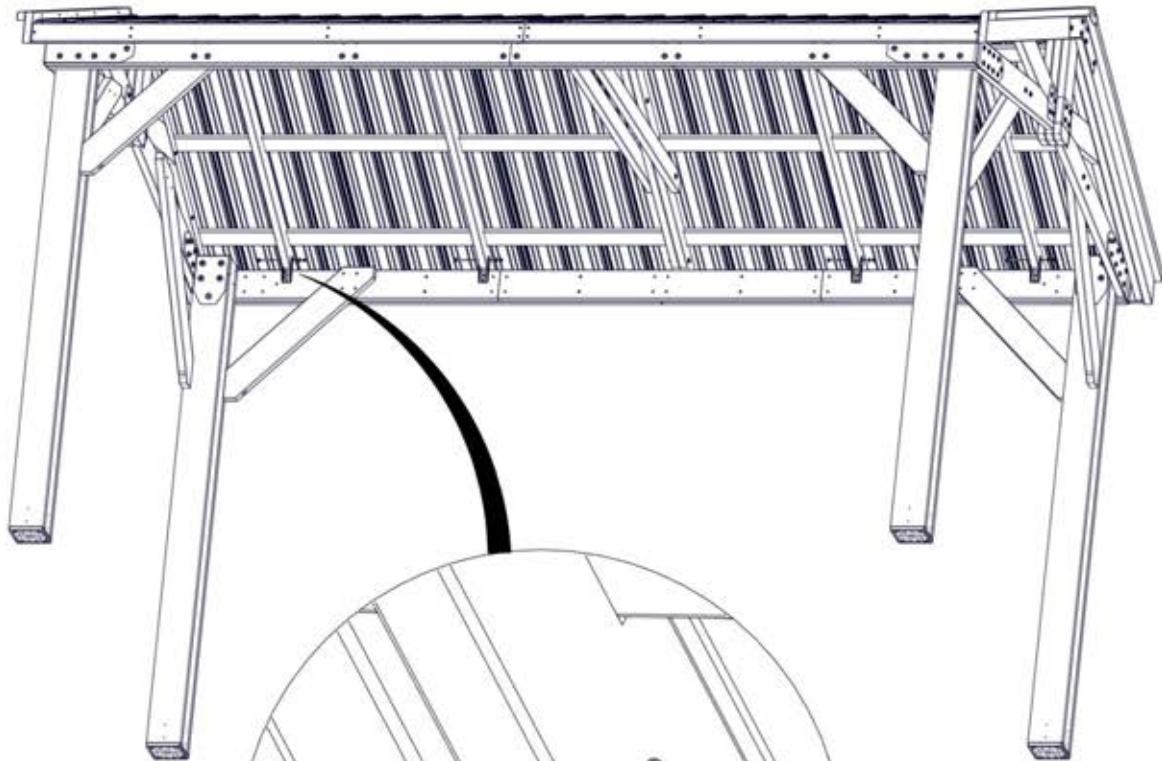

488 (x8)  
BOLT - 2"

653 (x8)  
LOCK NUT - 1/4"

630 (x8)  
WASHER - 8x19

823 (x16)  
SCREW - 1 1/2"

1228 (x8)  
RAFTER CLIP

# STEP 37A - ROOF ASSEMBLY

QTY	PART NUMBER	DESCRIPTION
12	H100833	SCREW WOODGRIP 10-16x3/4"

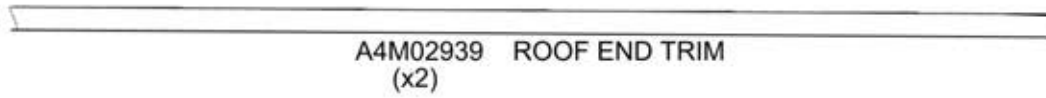
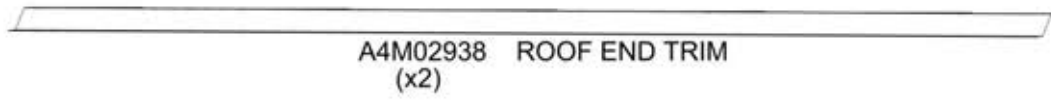

## COMPLETE THIS STEP TWICE

- REMOVE PROTECTIVE BLUE FILM.
- **GLOVES SHOULD BE WORN WHEN HANDLING ROOF METAL. EDGES ARE SHARP.**
- ATTACH SCREWS IN LINE WITH ROOF PANEL SCREWS.

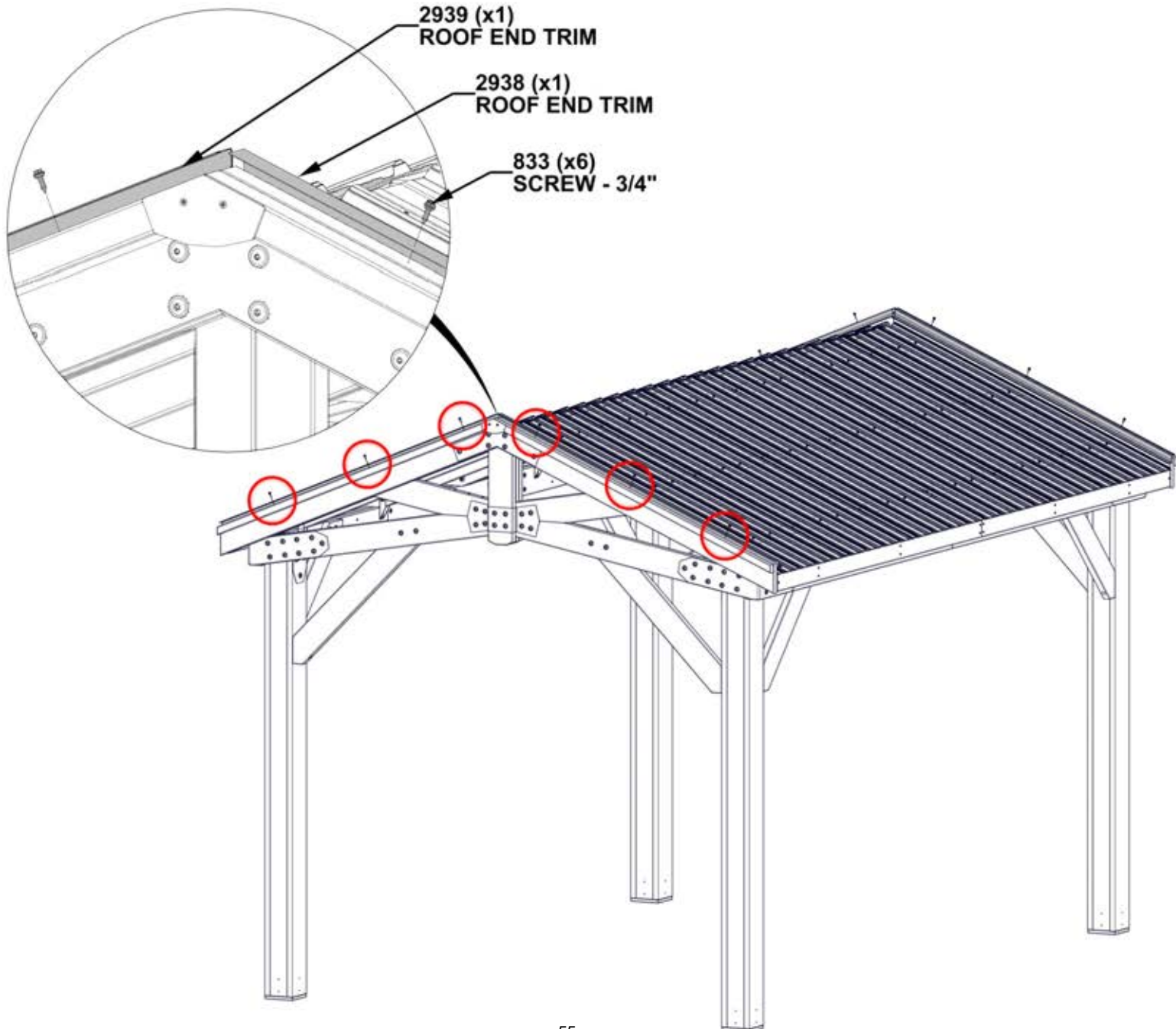

# STEP 37B - ROOF ASSEMBLY

QTY	PART NUMBER	DESCRIPTION
24	H100759	SCREW SELF TAPPING 1/4x1

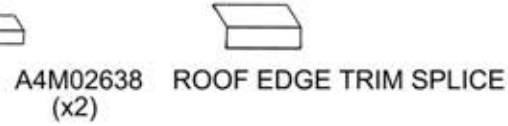

## COMPLETE THIS STEP TWICE

- DUE TO MULTIPLE LAYERS OF METAL ON THE EDGE TRIM, IT IS RECOMMENDED THAT A 1/8" (3mm) DRILL BIT IS USED TO CREATE STARTER HOLES.
- REMOVE PROTECTIVE BLUE FILM.
- **GLOVES SHOULD BE WORN WHEN HANDLING ROOF METAL. EDGES ARE SHARP.**

**SCREWS GO THROUGH EDGE TRIM INTO THE TOP OF THE RIBS IN THE APPROXIMATE LOCATIONS SHOWN**

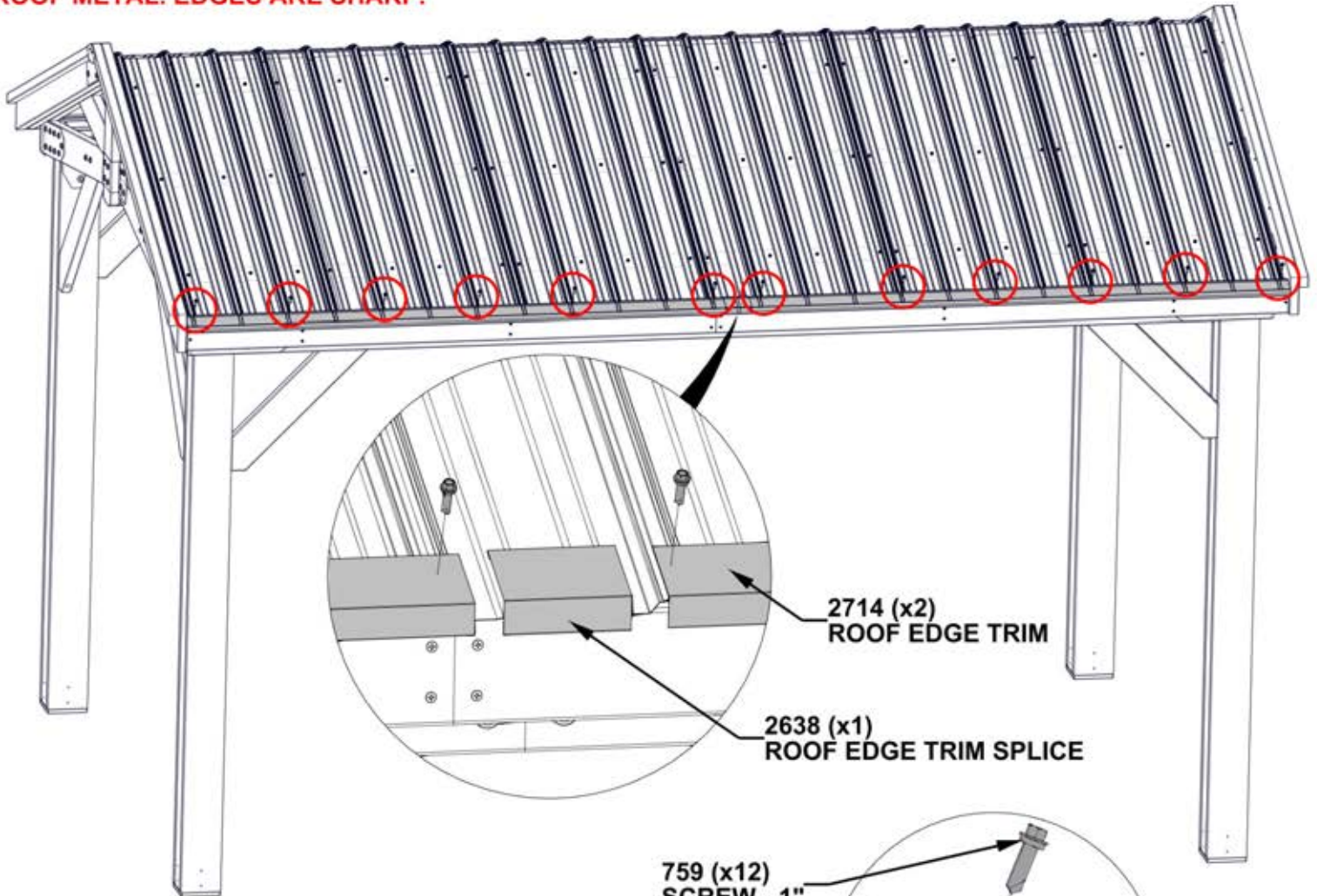

759 (x12) SCREW - 1"

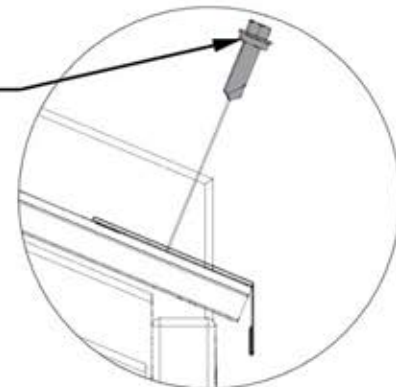

SIDE VIEW

**SLIDE TRIM INTO SPLICE ENSURING THAT BOTH ENDS ARE FLUSH WITH THE EDGES OF ROOF PANELS.**



# STEP 38 - RIDGE CAP ASSEMBLY

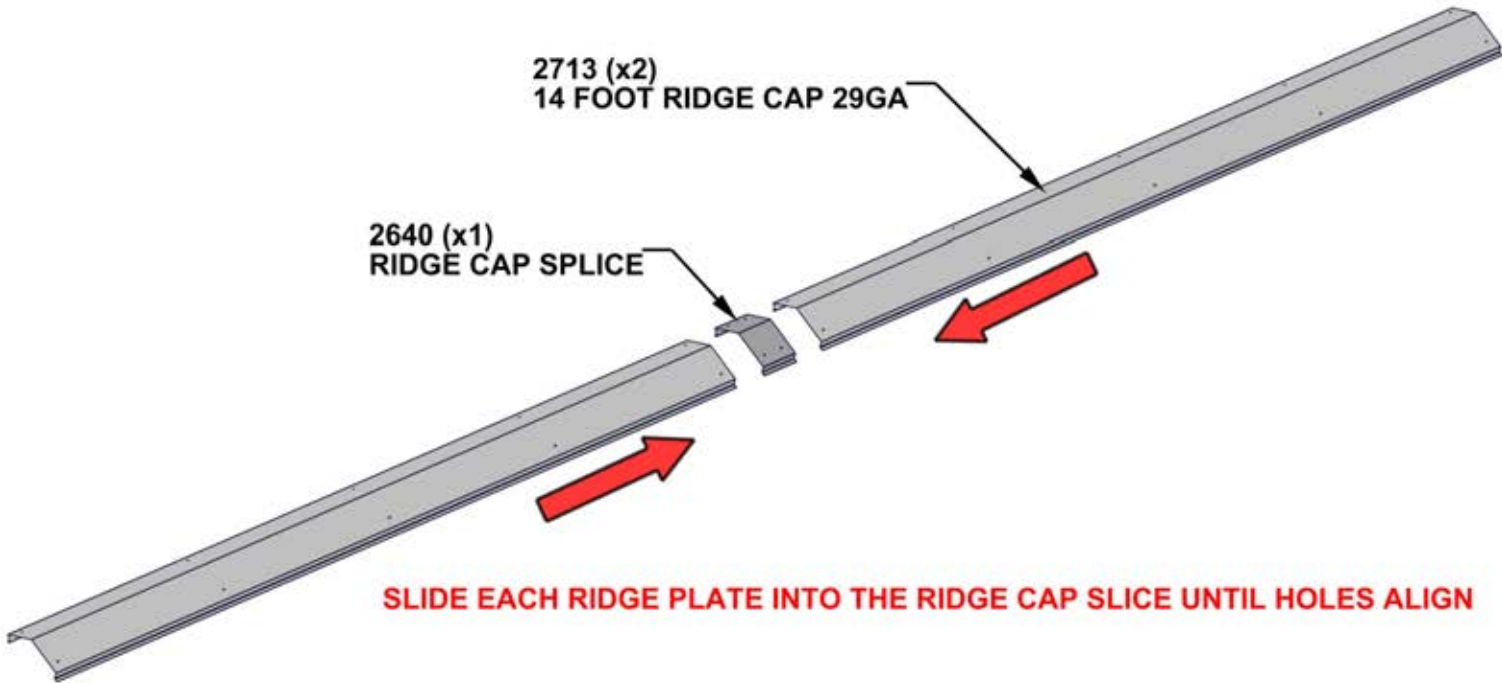
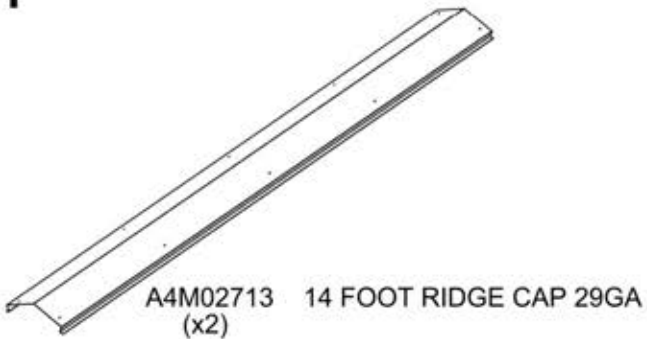
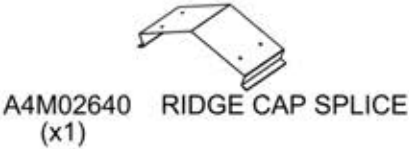

# STEP 39 - RIDGE CAP ASSEMBLY

QTY	PART NUMBER	DESCRIPTION
20	H100833	SCREW WOODGRIP 10-16x3/4"



A6P00398 RIDGE CAP PROTECTOR  
(x2)



J09 RIDGE CAP STIFFENER - W4L16897  
(x2) 1"X2 3/8"X77 5/8" (24x60x1973)

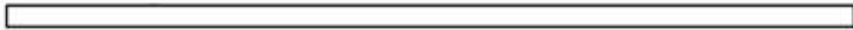

J10 RIDGE CAP STIFFENER - W4L16898  
(x2) 1"X2 3/8"X89 1/2" (24x60x2273)

- REMOVE SPACERS FROM RIDGE CAP PROTECTOR BEFORE INSTALLING.
- FINAL LENGTH: 13' - 11 3/8" [4250mm]

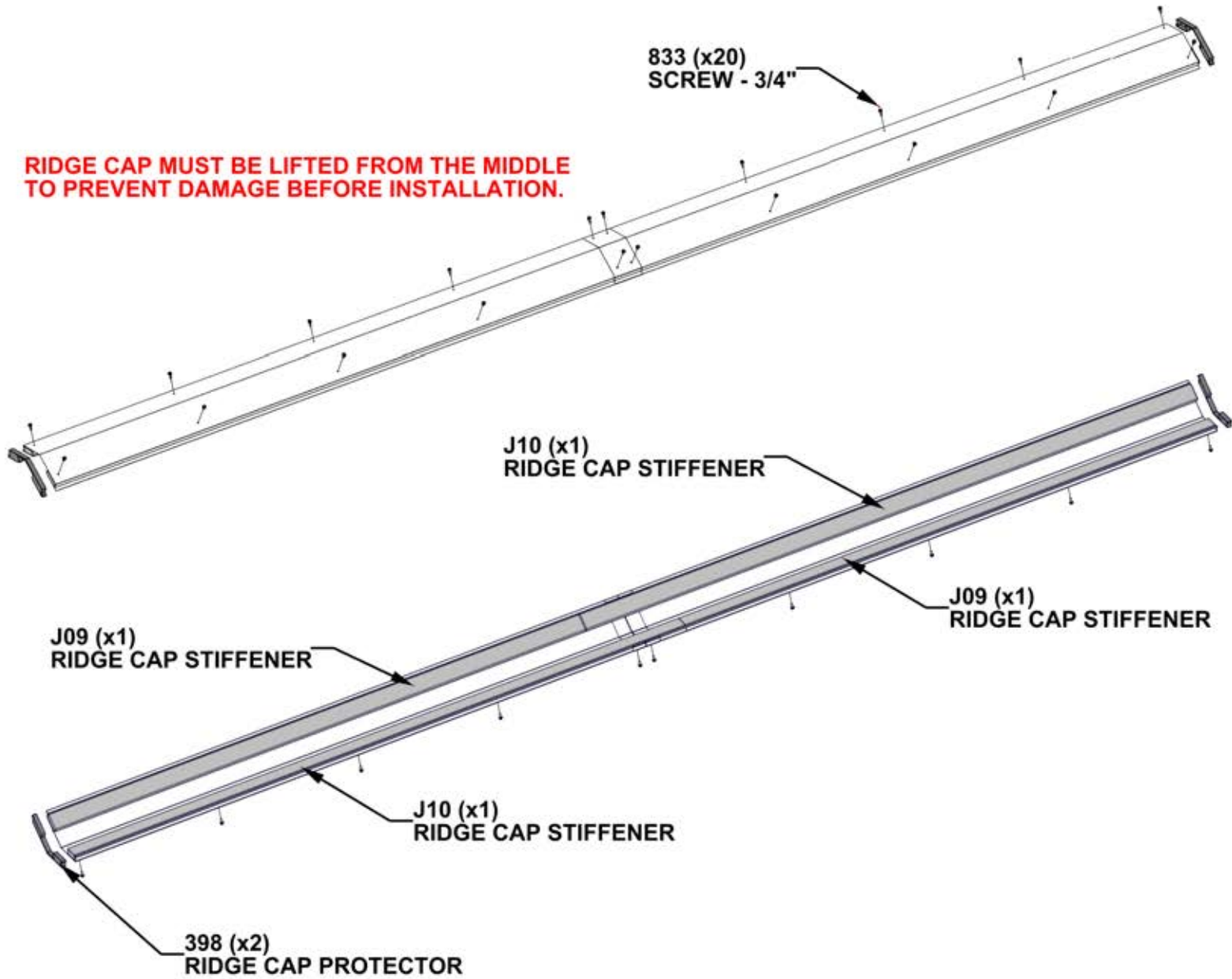

# STEP 40 - ROOF ASSEMBLY

QTY	PART NUMBER	DESCRIPTION
23	H100392	SCREW PWH 8 X 3/4 BLK

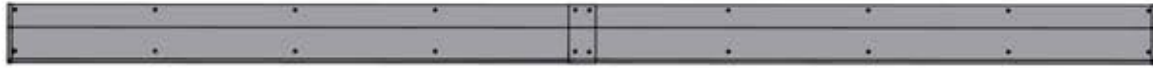

RIDGE CAP ASSEMBLY - FROM PREVIOUS STEPS

**DO NOT CLIMB ON ROOF TO INSTALL. ROOF CAP HAS BEEN DESIGNED TO INSTALL FROM A LADDER.**

- FOR PROPER INSTALLATION, USE AN ADULT HELPER TO KEEP DOWNWARD PRESSURE ON THE RIDGE CAP WHILE SCREWING IN SCREWS.

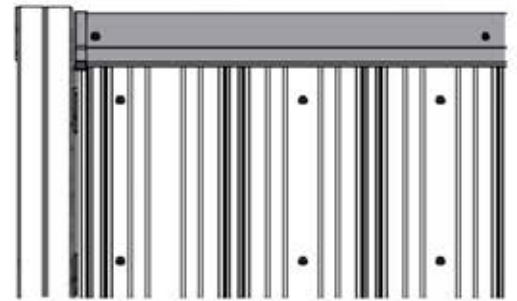
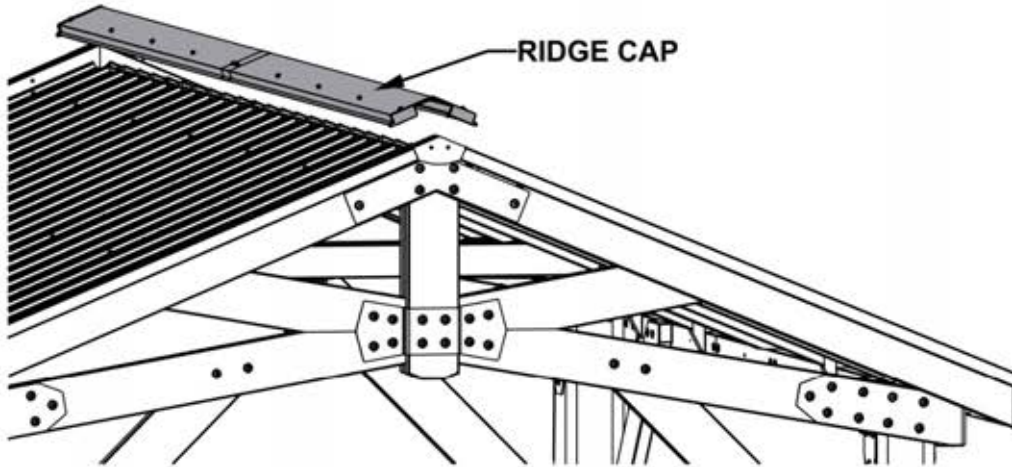

**INSTALL SCREWS THROUGH PILOT HOLES IN ROOF PANELS INTO RIDGE CAP STIFFENER BOARDS**

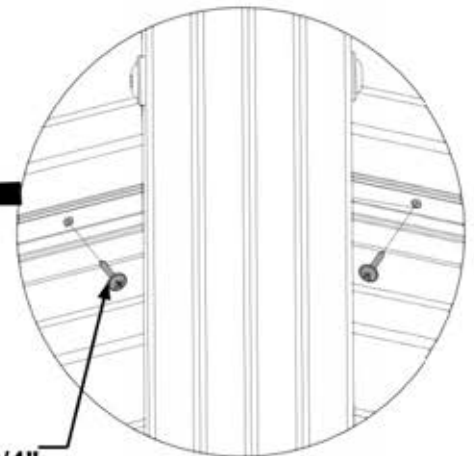
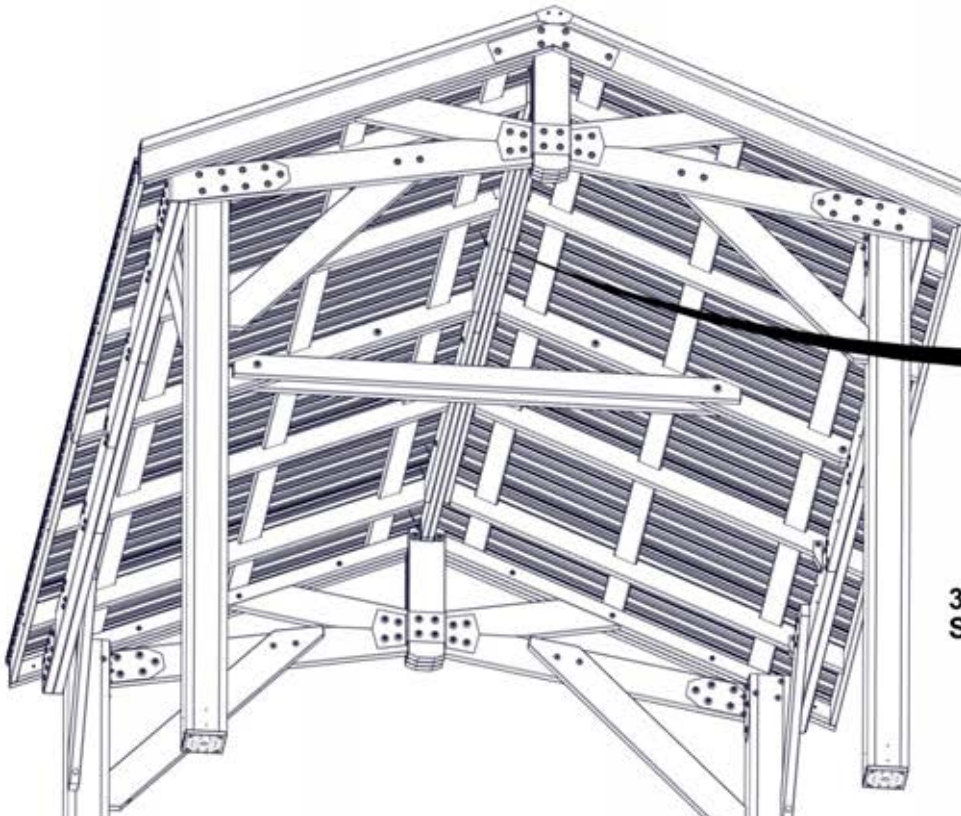

392 (x23)  
SCREW - 3/4"

# STEP 41 - GAZEBO ASSEMBLY (OPTIONAL)

QTY	PART NUMBER	DESCRIPTION
4	H100382	SCREW PFH 8 X 1 3/4 BLK

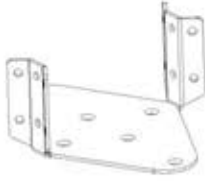

A4M02501 FAN MOUNT BRACKET  
(x1)

- ATTACH YOUR ELECTRICAL BOX (SOLD SEPARATELY) WITH THE PROVIDED HOLES IN FAN MOUNT BRACKET.
- PLACE FAN MOUNT BRACKET ON RIDGE BEAMS AND MOVE TO DESIRED FAN LOCATION.
- ROTATE BRACKET UNTIL MOUNTING FLANGES ALIGN BEST WITH RIDGE BEAMS.
- USE AN 1/8" (3mm) DRILL BIT AND DRILL PILOT HOLES AND ATTACH AS SHOWN.

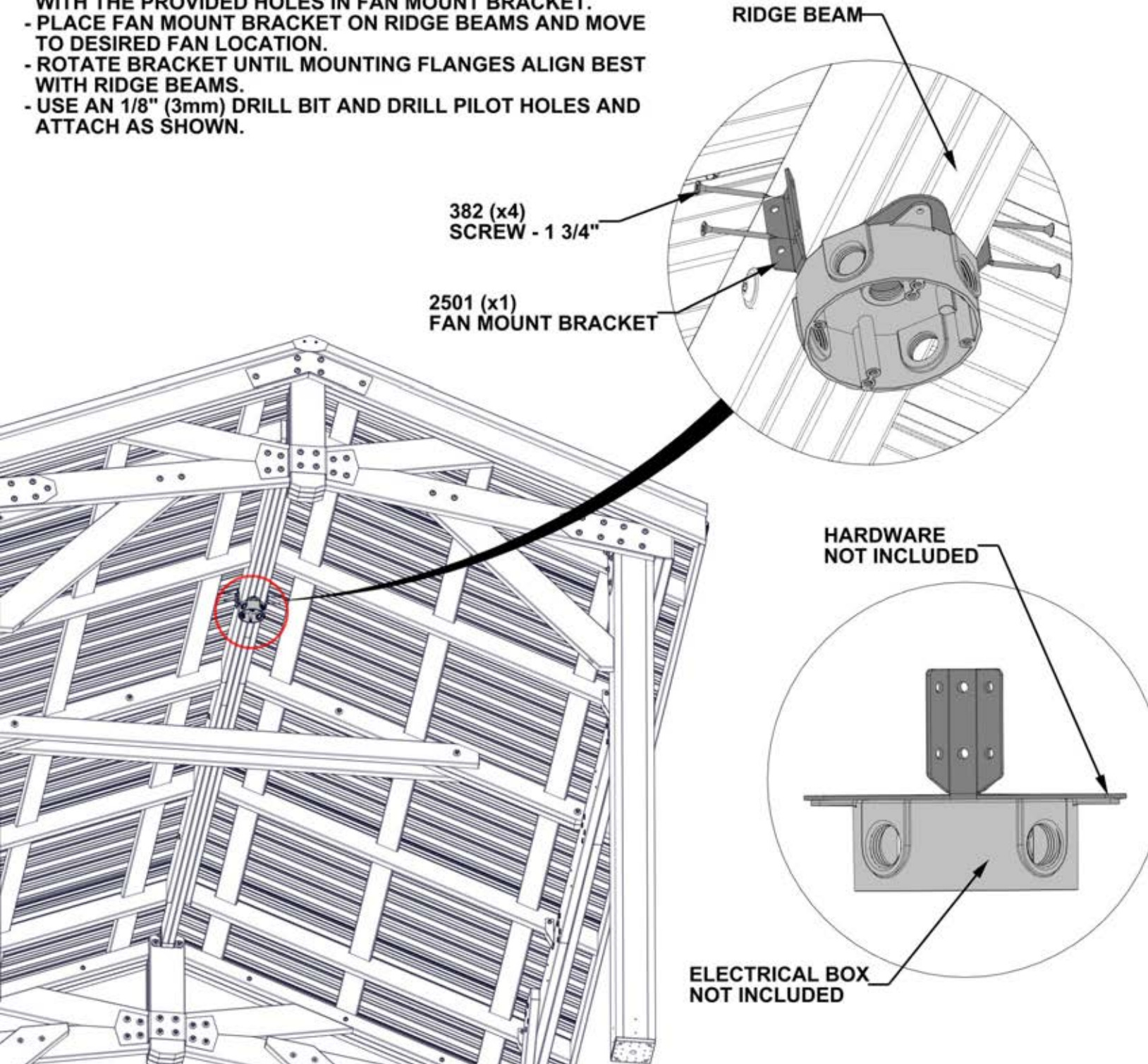

# STEP 42 - GAZEBO ASSEMBLY

QTY	PART NUMBER	DESCRIPTION
32	H100471	LAG SCREW WH 5/16 X 1 1/2 BLK

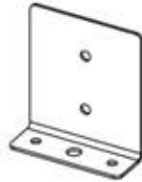

A4M00977 POST ANCHORING PLATE  
(x8)

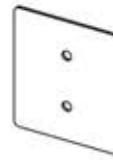

A4M00978 POST PLATE  
(x8)

- USE PILOT HOLES IN POST TO INSTALL LAG SCREWS

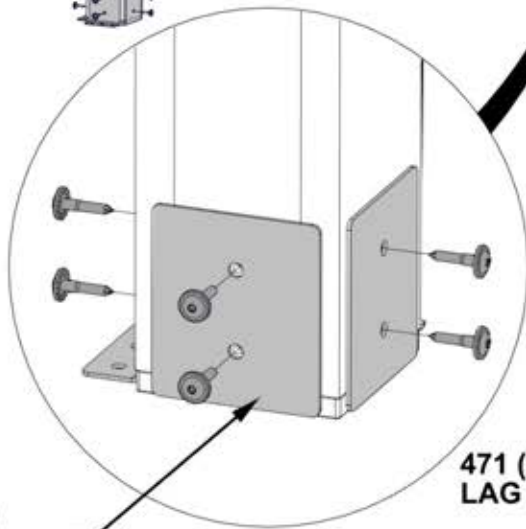
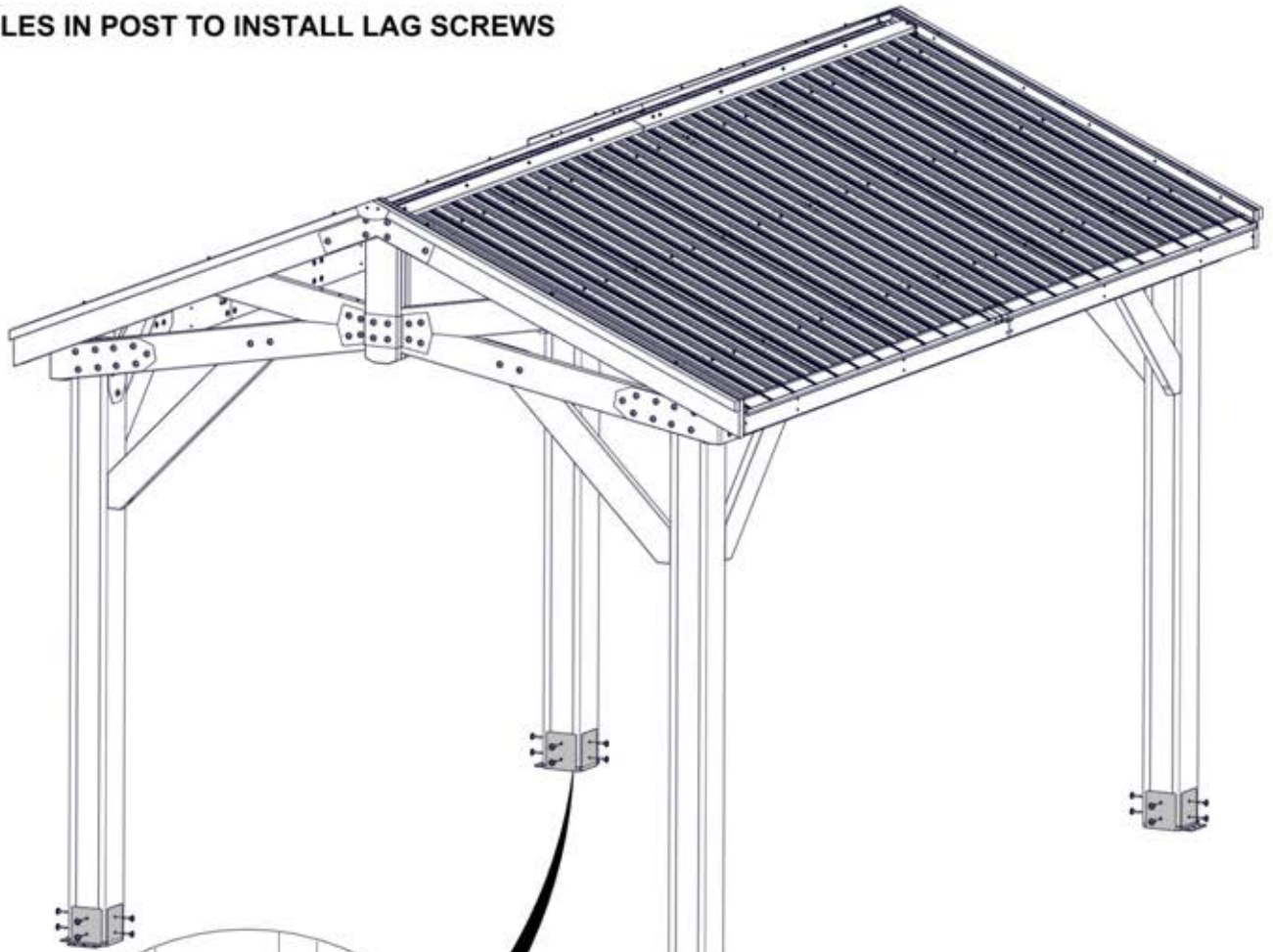

978 (x8)  
POST PLATE

471 (x32)  
LAG SCREW - 1 1/2"

977 (x8)  
POST ANCHORING PLATE

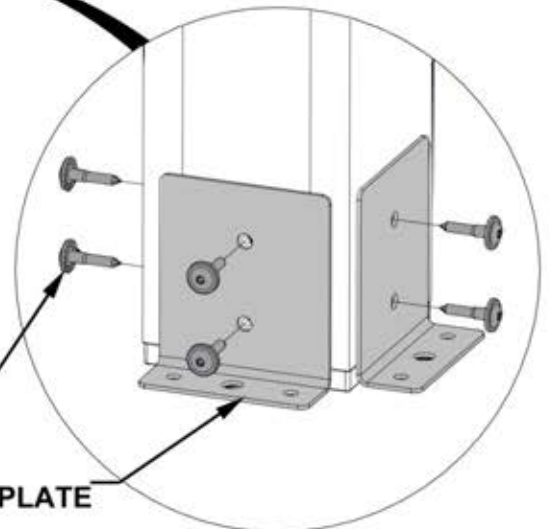

# STEP 43 - GAZEBO ASSEMBLY

QTY	PART NUMBER	DESCRIPTION
4	H100202	SCREW PWH 8 X 5/8 BLK



A4M02158 BYD ID TAG PATIO  
(x1)

- PLACE ID TAG IN APPROXIMATE LOCATION SHOWN.

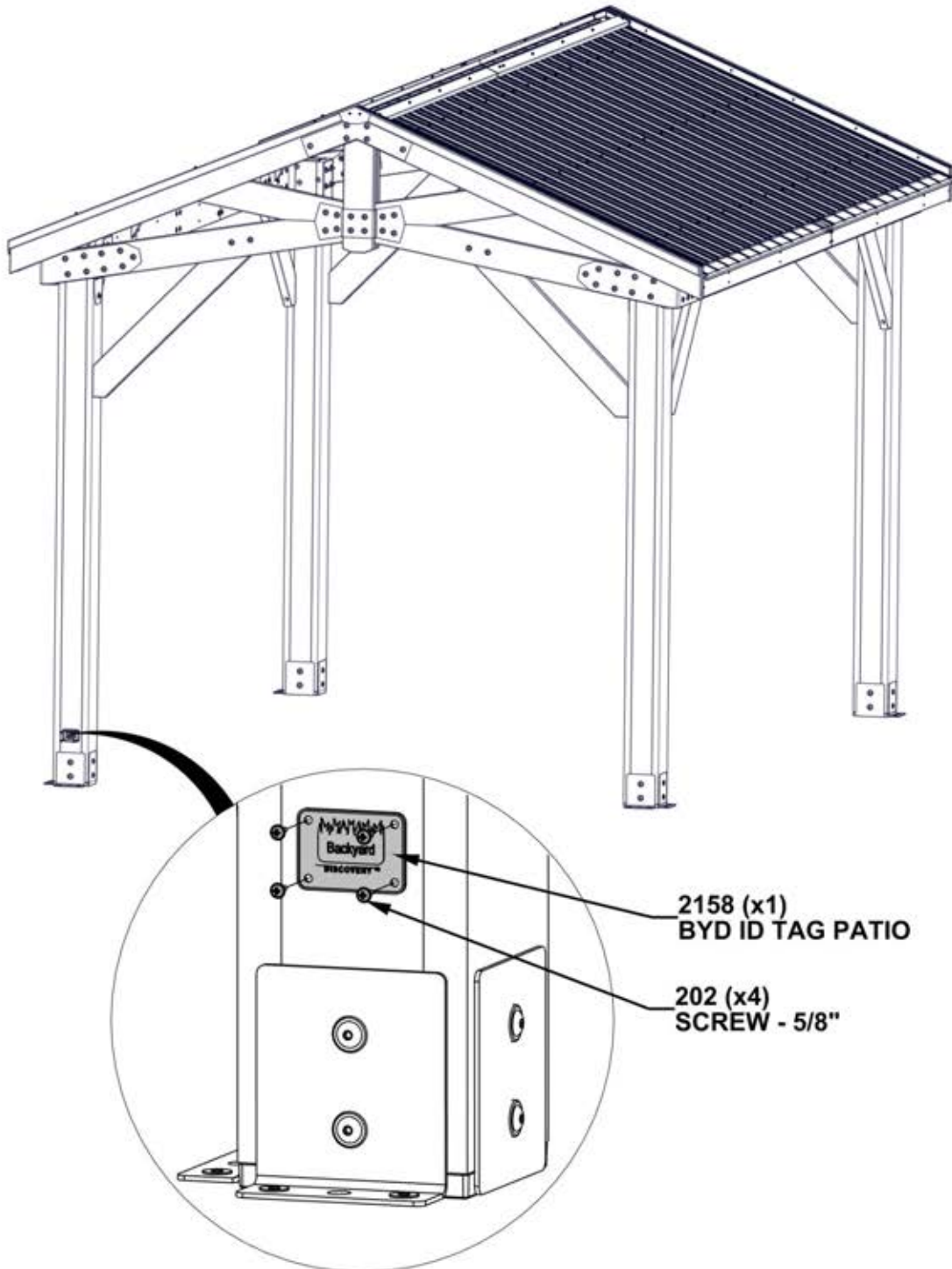

# STEP 44 - GAZEBO ASSEMBLY

QTY	PART NUMBER	DESCRIPTION
16	H100120	CONCRETE ANCHOR 1/4"x2"
16	H100630	WASHER FLAT 8x19 BLK

- MANUFACTURER RECOMMENDS INSTALLATION ON CONCRETE SURFACE OR CONCRETE POST PAD AS SHOWN BELOW.
- FOR INSTALLATION ON WOOD DECK, YOU MUST ENSURE THERE IS AMPLE STRUCTURAL SUPPORT UNDER THE DECK. HARDWARE NOT INCLUDED FOR DECK ATTACHMENT.

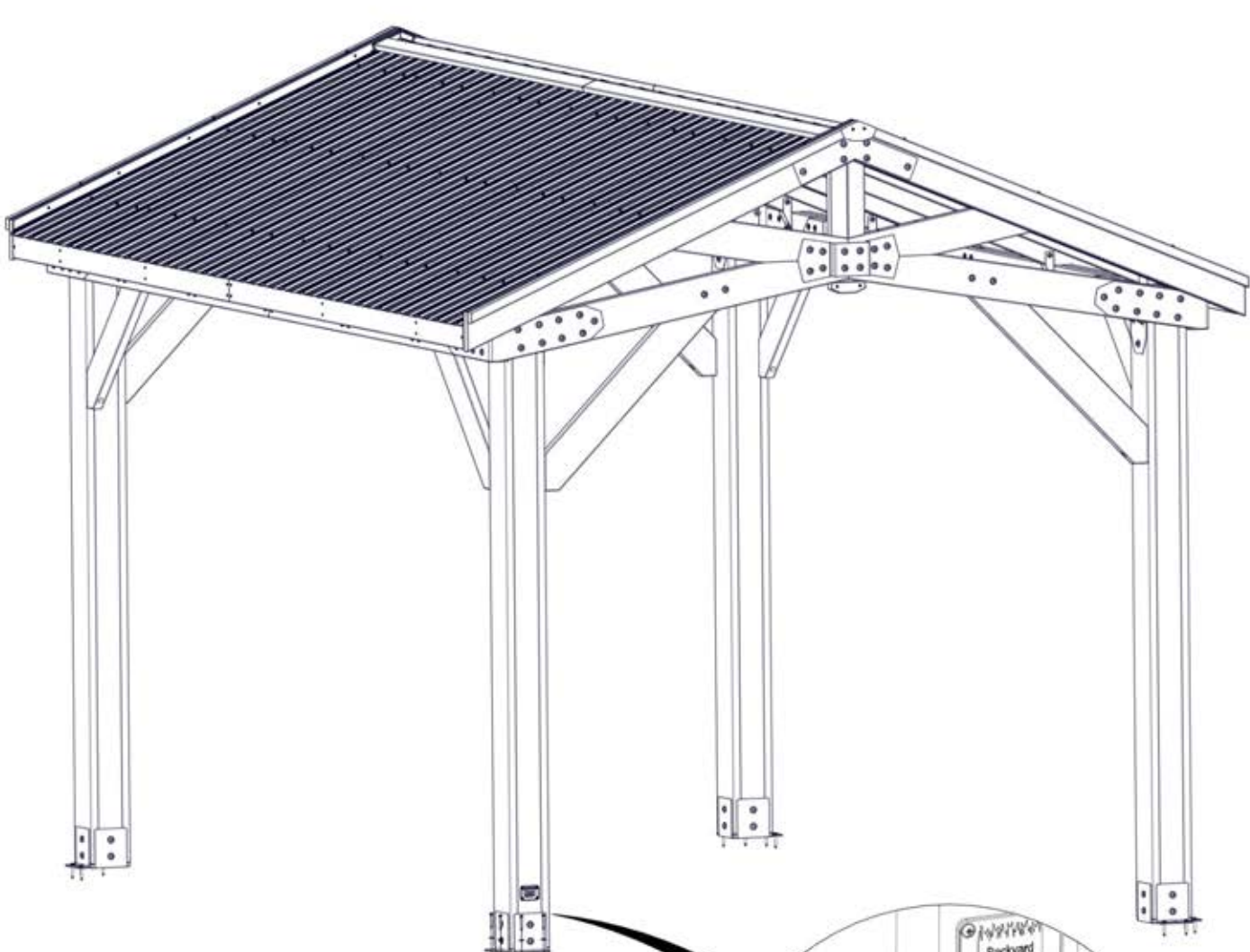

120 (x16)  
CONCRETE SCREW-2"

630 (x16)  
WASHER - 8x19

PRE-DRILL HOLES FOR CONCRETE ANCHORS USING A 3/16" CONCRETE DRILL BIT

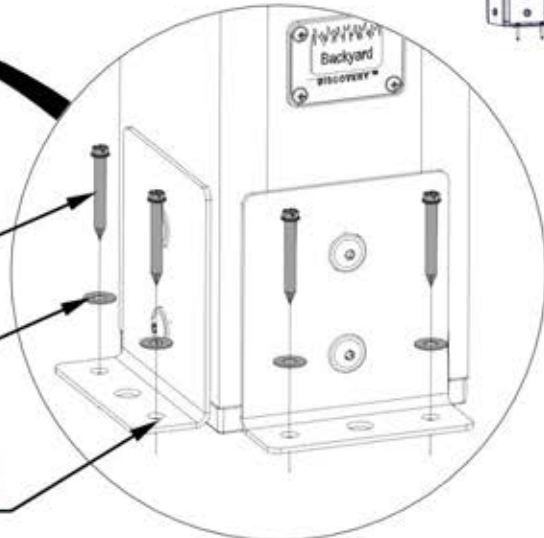

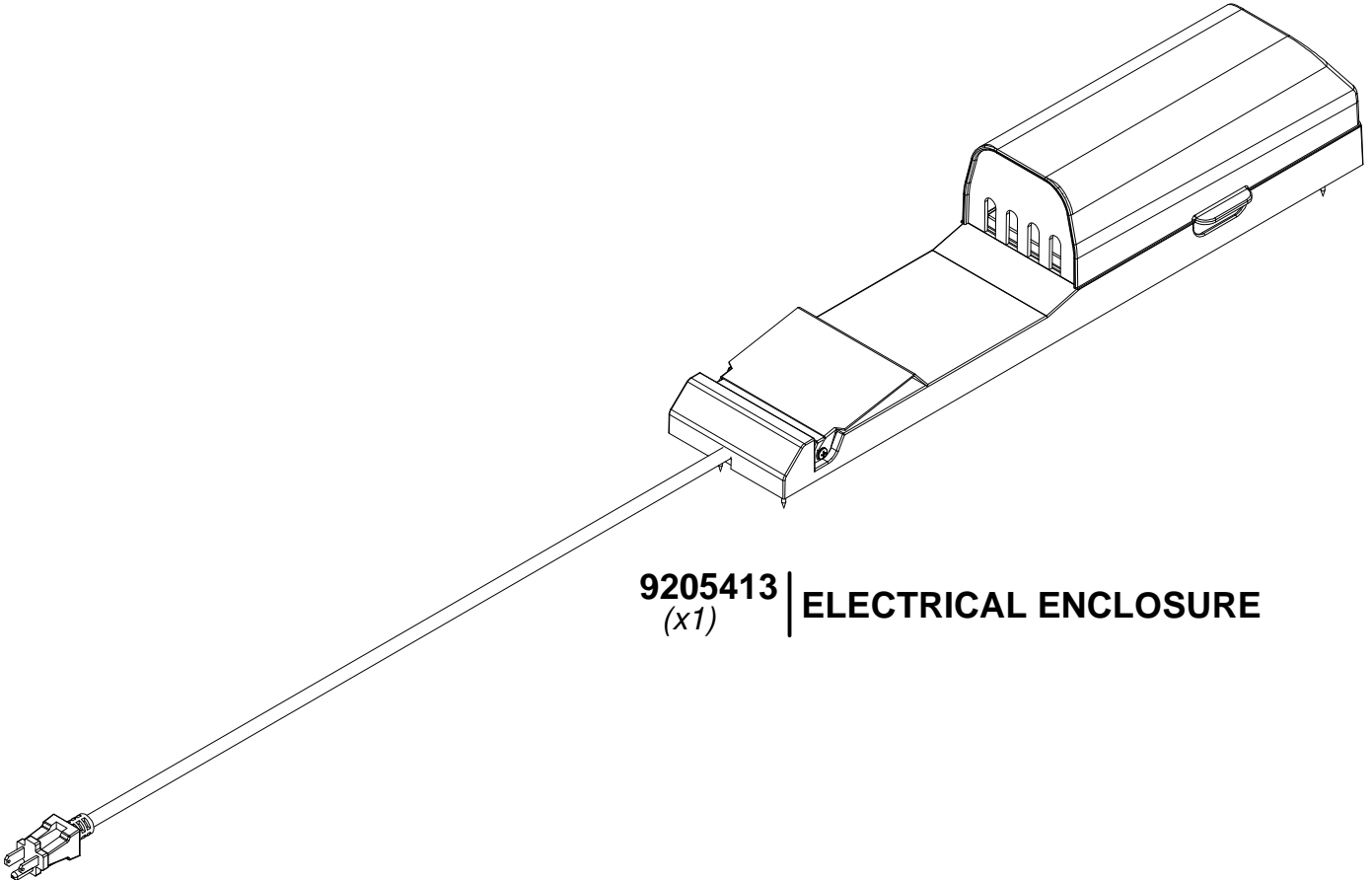

**9205413** | **ELECTRICAL ENCLOSURE**  
*(x1)*

**FOR POWERPORT INSTALLATION REFER TO ASSEMBLY INSTRUCTIONS THAT COME PACKAGED WITH THE POWERPORT KIT. INSTALL ON ANY POST THAT IS DESIRED. FOLLOW DIRECTIONS FOR PROPER INSTALLATION.**