



Manufactured by:
Backyard Discovery
3305 Airport Drive, Pittsburg, KS 66762
800-856-4445

Basepoint Business Centre: Rivermead Drive, Westlea, Swindon SN5 7EX Phone: 0800-118-2476 J.P. Coenstraat 7, The Bridge, The Hague, 2595 WP, Netherlands
Phone: 08005678990

24x12 Barrington Gazebo

MODEL # : 2406032



Please visit www.backyarddiscovery.com
For the most up to date assembly manual, to register your product, or to order replacement parts *Para obtener instrucciones en español, visite*
www.backyarddiscovery.com



EASY STEP-BY-STEP
3D INTERACTIVE INSTRUCTIONS
DOWNLOAD THE FREE APP



OWNER'S MANUAL - BASIC SETUP DIMENSIONS & ASSEMBLY NOTES

It is critically important that you start with square and level footings, concrete pad or deck to attach your structure

- Pay close attention to the items needed for each step. Make sure you are using the correct hardware for each step. Using incorrect hardware may result in improper assembly
- Remember to double check for underground utilities and overhead electrical lines

Post mounts are provided with your structure which allows you to permanently install your structure to a pre-existing or new wood or concrete surface. See Anchor Instructions for further details and recommendations.

- The hardware to attach the post mounts to the structure is included.
- The hardware to mount the structure permanently to a concrete surface is included.
- The hardware to mount the structure permanently to a wood deck is NOT included and will need to be purchased separately. You must ensure there is ample structural support under the deck before permanently attaching.

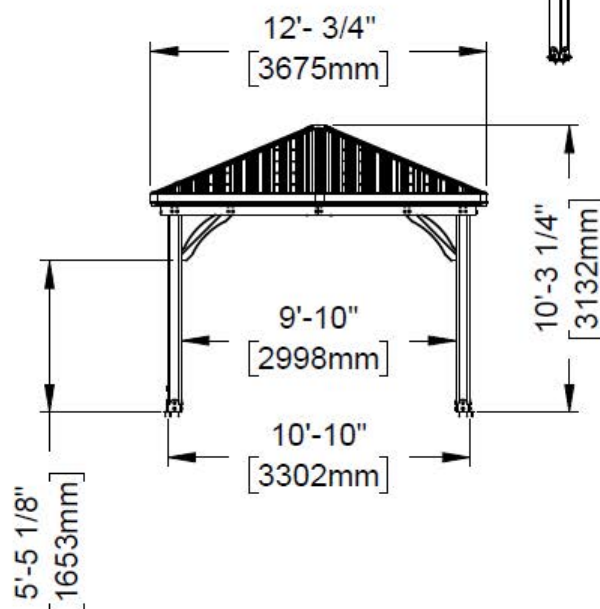
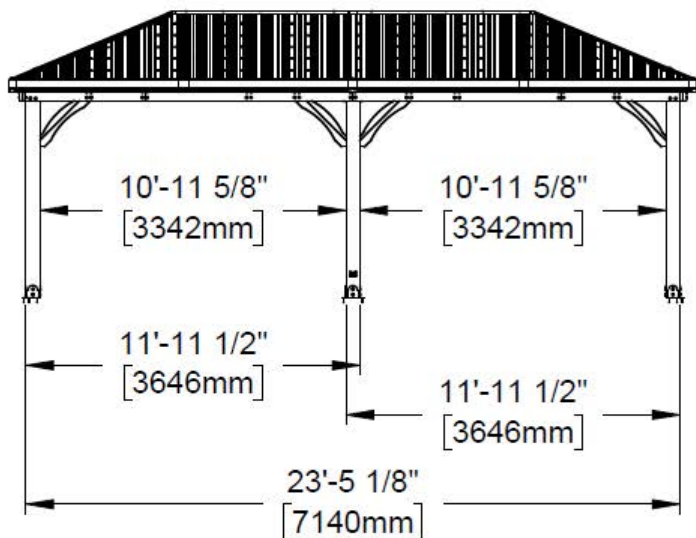
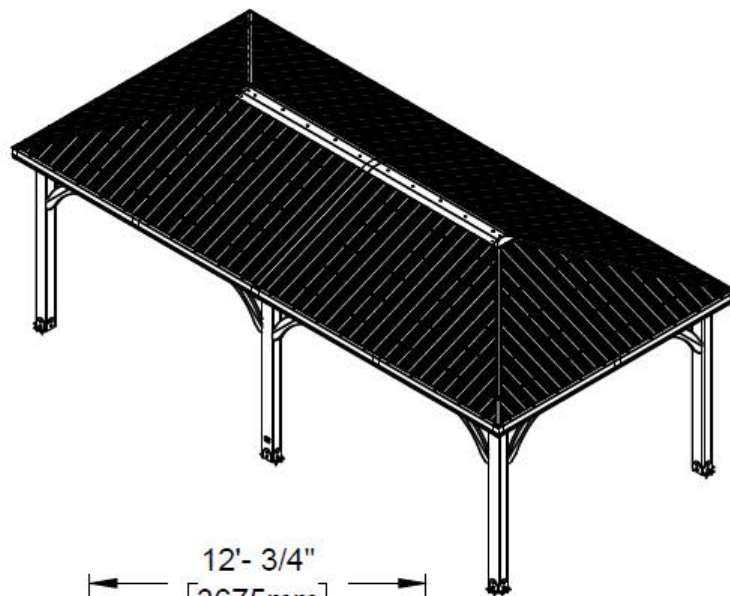
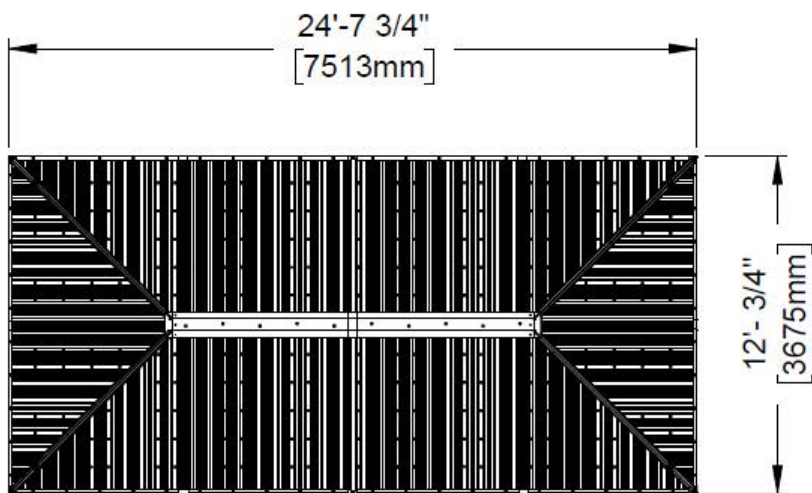

OWNER'S MANUAL - ANCHORING LAYOUT

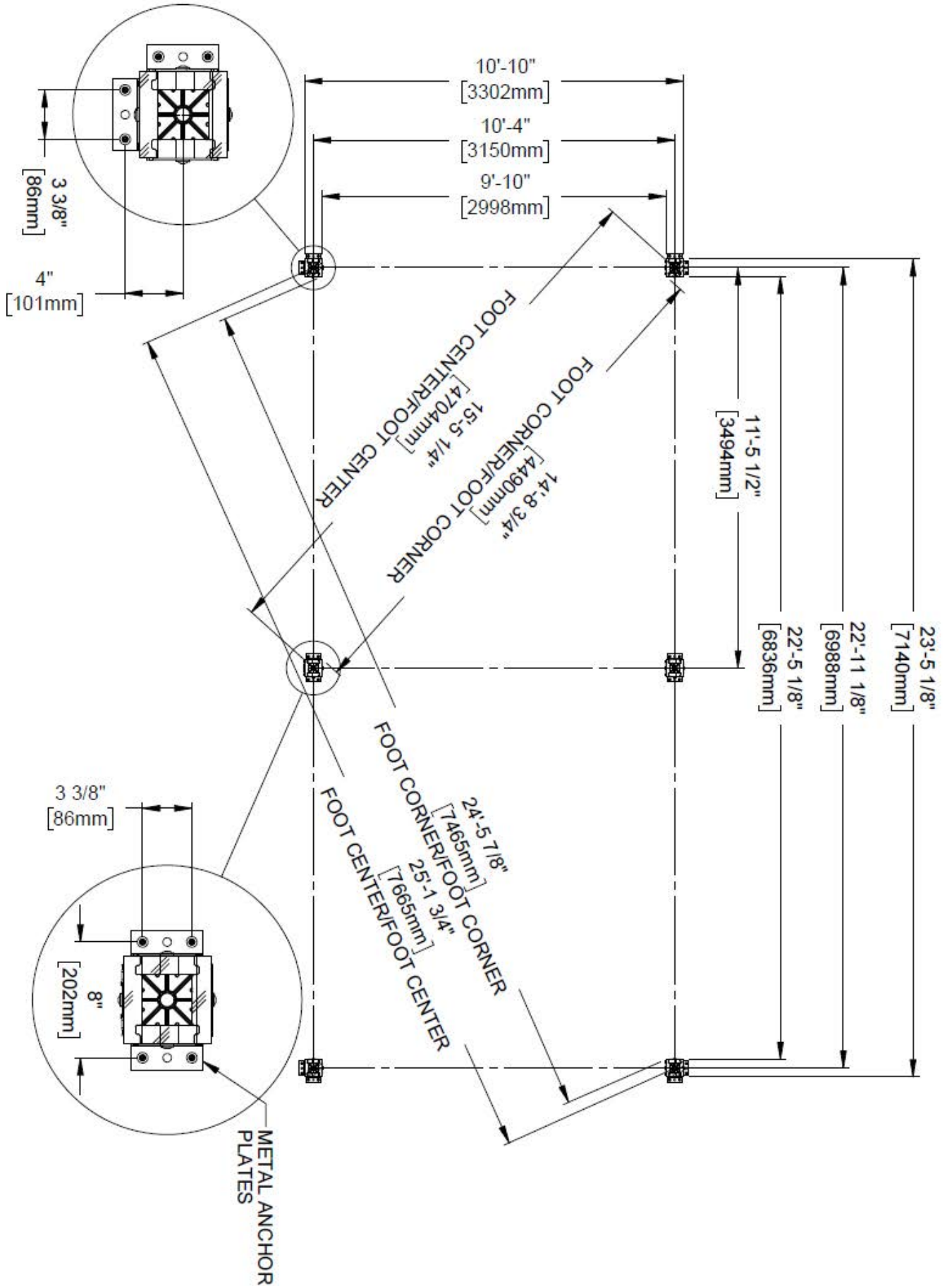

NOTE: DIMENSIONS ARE TO ANCHOR PLATES MOUNTED TO POSTS EXCEPT WHERE NOTED.

OWNER'S MANUAL - PARTS IDENTIFICATION

WOOD COMPONENTS (NOT TO SCALE)



AA01 MOUNTING BLOCK - W4L20731
(x2) 2 3/8"x3 3/4"x1 7/16" (60x96x36)



D01 BEAM - W4L20648
(x4) 1 7/16"x5 1/4"x29 15/16" (36x134x760)



D04 BEAM - W4L20650
(x4) 1 7/16"x5 1/4"x27 1/16" (36x134x688)



D02 BEAM - W4L20647
(x2) 1 7/16"x5 1/4"x75 13/16" (36x134x1926)



D03 BEAM - W4L20652
(x4) 1 7/16"x5 1/4"x67 13/16" (36x134x1723)



D05 BEAM - W4L20649
(x2) 1 7/16"x5 1/4"x89 7/16" (36x134x2272)



D06 BEAM - W4L20653
(x4) 1 7/16"x5 1/4"x89 1/2" (36x134x2274)



D07 BEAM - W4L19814
(x4) 1 7/16"x5 1/4"x51" (36x134x1296)



D08 BEAM - W4L20651
(x4) 1 7/16"x5 1/4"x68 3/4" (36x134x1746)



D09 TRUSS BRACE - W4L20714
(x2) 1 7/16"X5 1/4"X36 1/4" (36x134x920)



D10 TRUSS BRACE - W4L20715
(x2) 1 7/16"X5 1/4"X36 1/4" (36x134x920)



D11 BEAM - W4L20713
(x4) 1 7/16"X5 1/4"X65" (36x134x1651)



E01 RAFTER - W4L17533
(x2) 1 3/8"x3 3/8"x22" (36x86x557)



E02 RAFTER - W4L17534
(x2) 1 7/16"x3 3/8"x45 7/16" (36x86x1155)



E03 RAFTER - W4L17535
(x2) 1 7/16"x3 3/8"x69" (36x86x1752)



E04 RAFTER - W4L17536
(x2) 1 7/16"x3 3/8"x69" (36x86x1752)



E05 RAFTER - W4L17537
(x2) 1 7/16"x3 3/8"x45 7/16" (36x86x1155)



E06 RAFTER - W4L17538
(x2) 1 7/16"x3 3/8"x21 15/16" (36x86x557)

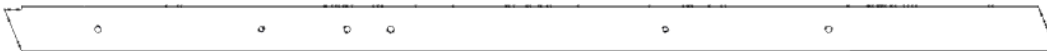

E07 RAFTER - W4L20654
(x2) 1 7/16"x3 3/8"x76 1/8" (36x86x1934)

OWNER'S MANUAL - PARTS IDENTIFICATION

WOOD COMPONENTS (NOT TO SCALE)



E08 RAFTER - W4L17552
(x4) 1 7/16"x3 3/8"x76 1/8" (36x86x1934)



E09 RAFTER - W4L17553
(x2) 1 7/16"x3 3/8"x67 1/8" (36x86x1705)



E10 RAFTER - W4L17554
(x2) 1 7/16"x3 3/8"x43 5/8" (36x86x1109)



E11 RAFTER - W4L17555
(x2) 1 7/16"x3 3/8"x20 3/16" (36x86x512)



E12 RAFTER - W4L17565
(x2) 3 3/8"x1 7/16"x20 3/16" (36x86x512)



E13 RAFTER - W4L17566
(x2) 1 7/16"x3 3/8"x43 5/8" (36x86x1109)



E14 RAFTER - W4L17567
(x2) 1 7/16"x3 3/8"x67 1/8" (36x86x1705)



E15 RAFTER - W4L20712
(x2) 1 7/16"x3 3/8"x76 1/8" (36x86x1934)



E16 RAFTER - W4L17572
(x4) 1 7/16"x76 1/8"x3 3/8" (36x86x1934)



E17 COLLAR TIE - W4L17573
(x4) 1 3/8"x3 3/8"x71 5/8" (36x86x1820)



E18 RAFTER - W4L19815
(x4) 1 7/16"x76 1/8"x3 3/8" (36x86x1934)



E19 COLLAR TIE - W4L19827
(x4) 1 3/8"x3 3/8"x71 5/8" (36x86x1820)



H01 RAFTER - W4L17521
(x4) 15/16"x3 3/8"x54 1/8" (24x86x1374)

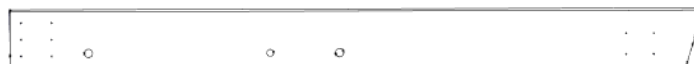

H02 RAFTER - W4L17522
(x4) 15/16"x3 3/8"x39 3/8" (24x86x1000)

OWNER'S MANUAL - PARTS IDENTIFICATION

WOOD COMPONENTS (NOT TO SCALE)



H03 RIDGE BOARD - W4L19452
(x2) 15/16"x3 3/8"x64 1/2" (24x86x1639)

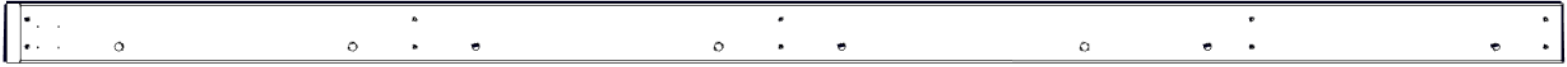

H04 RIDGE BOARD - W4L19453
(x2) 15/16"x3 3/8"x88 9/16" (24x86x2250)



H05 RAFTER - W4L20726
(x2) 15/16"x3 3/8"x68 9/16" (24x86x1742)



H06 RAFTER - W4L17528
(x2) 15/16"x3 3/8"x44 1/2" (24x86x1130)



H07 RAFTER - W4L17529
(x2) 15/16"x3 3/8"x53 3/16" (24x86x1351)



H08 RAFTER SUPPORT - W4L17530
(x2) 15/16"x3 3/8"x10 11/16" (24x86x272)



H09 RAFTER - W4L17531
(x2) 15/16"x3 3/8"x53 3/16" (24x86x1351)



H10 RAFTER - W4L17532
(x2) 15/16"x3 3/8"x44 1/2" (24x86x1130)



H11 PURLIN - W4L17539
(x2) 15/16"x3 3/8"x56" (24x86x1422)



H12 PURLIN - W4L17540
(x2) 15/16"x3 3/8"x70 1/2" (24x86x1791)



H13 PURLIN - W4L17541
(x2) 15/16"x3 3/8"x58 3/8" (24x86x1483)



H14 PURLIN - W4L17542
(x2) 15/16"x3 3/8"x43 7/8" (24x86x1114)

OWNER'S MANUAL - PARTS IDENTIFICATION

WOOD COMPONENTS (NOT TO SCALE)



H15 PURLIN - W4L17543
(x2) 15/16"x3 3/8"x75 11/16" (24x86x1922)



H16 PURLIN - W4L17544
(x2) 15/16"x3 3/8"x51 7/16" (24x86x1307)



H17 PURLIN - W4L17545
(x2) 15/16"x3 3/8"x27 1/4" (24x86x692)



H18 RAFTER - W4L17547
(x2) 15/16"x3 3/8"x44 1/2" (24x86x1130)



H19 RAFTER - W4L17548
(x2) 15/16"x3 3/8"x60 5/8" (24x86x1540)



H20 FASCIA - W4L19440
(x2) 15/16"x3 3/8"x74 7/8" (24x86x1902)



H21 PURLIN - W4L19443
(x4) 15/16"x3 3/8"x74 13/16" (24x86x1900)



H22 PURLIN - W4L19444
(x8) 15/16"x3 3/8"x64 13/16" (24x86x1646)



H23 PURLIN - W4L19445
(x4) 15/16"x3 3/8"x83 1/2" (24x86x2121)

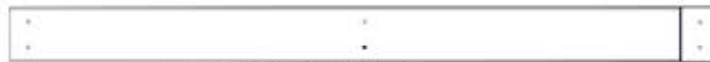

H24 PURLIN - W4L19446
(x8) 15/16"x3 3/8"x44" (24x86x1117)



H25 PURLIN - W4L19447
(x4) 15/16"x3 3/8"x50 9/16" (24x86x1284)



H26 PURLIN - W4L19448
(x4) 15/16"x3 3/8"x59 5/16" (24x86x1506)



H27 PURLIN - W4L19449
(x4) 15/16"x3 3/8"x88 3/4" (24x86x2255)

OWNER'S MANUAL - PARTS IDENTIFICATION

WOOD COMPONENTS (NOT TO SCALE)



H28 RAFTER - W4L17568
(x2) 15/16" x 3 3/8" x 44 1/2" (24x86x1130)



H29 RAFTER - W4L17569
(x2) 15/16" x 3 3/8" x 60 5/8" (24x86x1540)



H30 FASCIA - W4L19451
(x2) 15/16" x 3 3/8" x 74 7/8" (24x86x1902)



Q01 FASCIA - W4L17526
(x2) 15/16" x 4 7/16" x 65 15/16" (24x112x1675)



Q02 FASCIA - W4L17527
(x2) 24x4 7/16" x 80 1/2" (24x112x2044)



Q03 FASCIA - W4L19441
(x4) 15/16" x 4 7/16" x 63 3/16" (24x112x1605)



Q04 FASCIA - W4L19442
(x4) 15/16" x 4 7/16" x 85 13/16" (24x112x2179)



T01 PURLIN - W4L17546
(x2) 15/16" x 1 5/16" x 12 7/8" (24x34x327)



T02 PURLIN - W4L19450
(x4) 15/16" x 1 5/16" x 78 5/16" (24x34x1989)



C01 CORBEL - W2A03198
(x11) 1 7/16" x 6 7/16" x 35 1/8" (36x163x893)



C02 CORBEL W/TAG - W2A03199
(x1) 1 7/16" x 6 7/16" x 35 1/8" (36x163x893)

OWNER'S MANUAL - PARTS IDENTIFICATION

WOOD COMPONENTS (NOT TO SCALE)



P01 POST - W2A03202
(x2) 6"x6"x89 1/2" (152x152x2274)



P02 POST - W2A03203
(x2) 6"x6"x89 1/2" (152x152x2274)

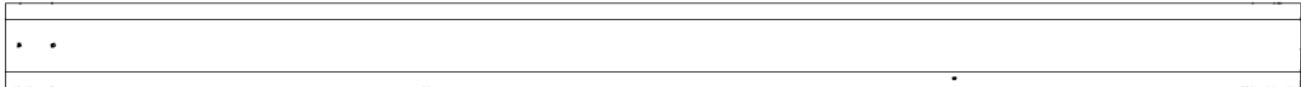

P03 MIDDLE POST - W2A04460
(x2) 6"x6"x89 1/2" (152x152x2274)



P04 CENTER POST - W2A04461
(x1) 6"x6"x32 5/16" (152x152x820)

OWNER'S MANUAL - PARTS IDENTIFICATION

HARDWARE COMPONENTS (NOT TO SCALE)

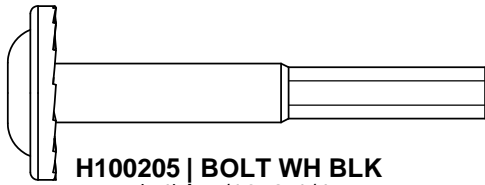

H100205 | BOLT WH BLK
(x4) | 5/16x2-1/4

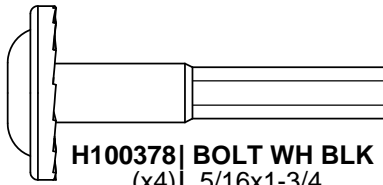

H100378 | BOLT WH BLK
(x4) | 5/16x1-3/4

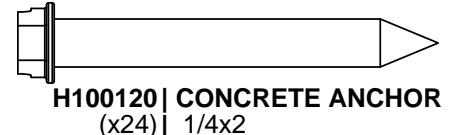

H100120 | CONCRETE ANCHOR
(x24) | 1/4x2

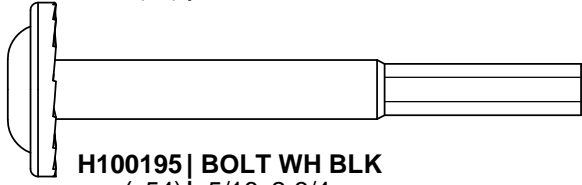

H100195 | BOLT WH BLK
(x54) | 5/16x2-3/4

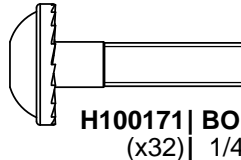

H100171 | BOLT WH BLK
(x32) | 1/4x1

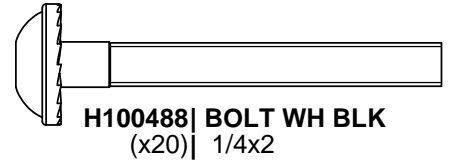

H100488 | BOLT WH BLK
(x20) | 1/4x2

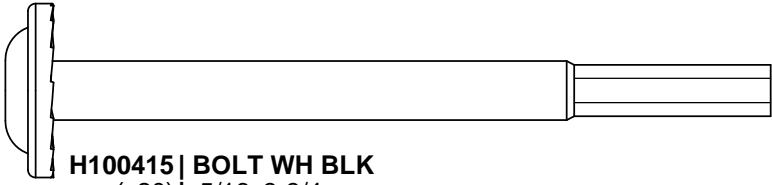

H100415 | BOLT WH BLK
(x20) | 5/16x3-3/4

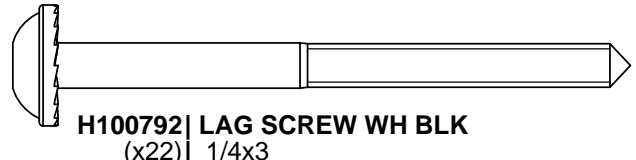

H100792 | LAG SCREW WH BLK
(x22) | 1/4x3

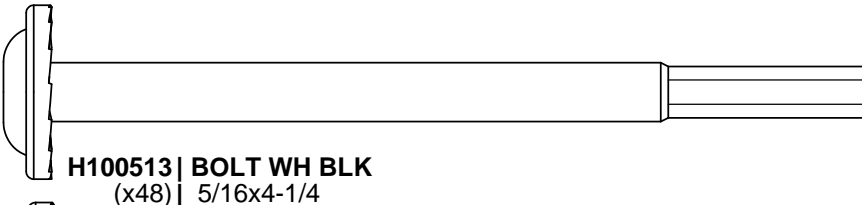

H100513 | BOLT WH BLK
(x48) | 5/16x4-1/4

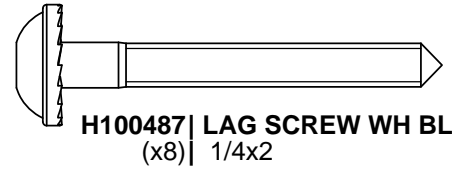

H100487 | LAG SCREW WH BLK
(x8) | 1/4x2

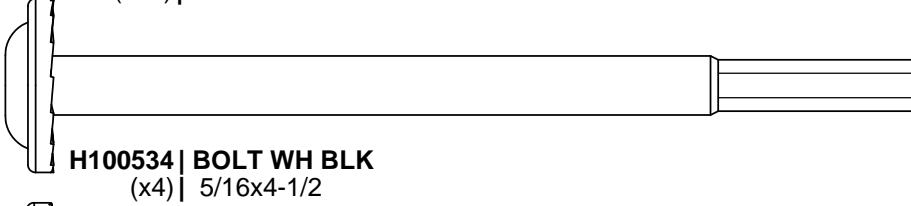

H100534 | BOLT WH BLK
(x4) | 5/16x4-1/2

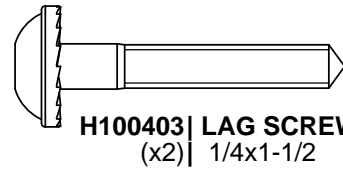

H100403 | LAG SCREW WH BLK
(x2) | 1/4x1-1/2

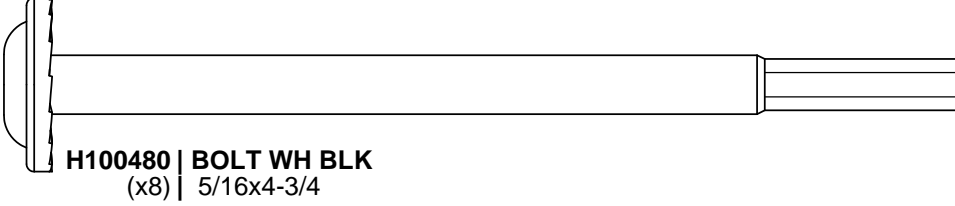

H100480 | BOLT WH BLK
(x8) | 5/16x4-3/4

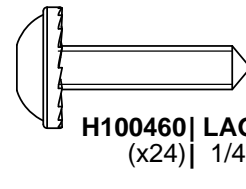

H100460 | LAG SCREW WH BLK
(x24) | 1/4x1

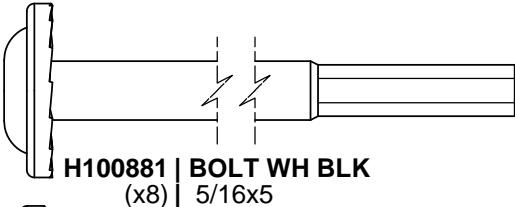

H100881 | BOLT WH BLK
(x8) | 5/16x5

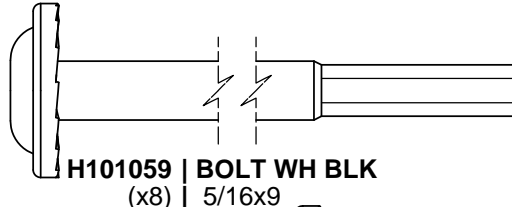

H101059 | BOLT WH BLK
(x8) | 5/16x9

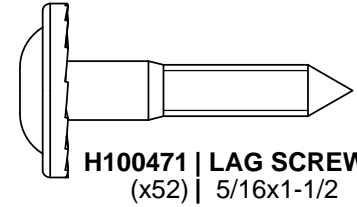

H100471 | LAG SCREW WH BLK
(x52) | 5/16x1-1/2

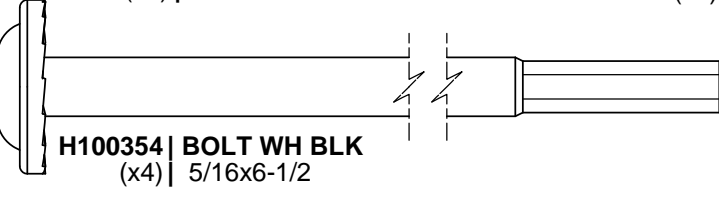

H100354 | BOLT WH BLK
(x4) | 5/16x6-1/2

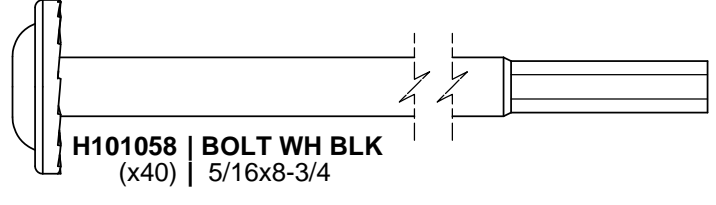

H101058 | BOLT WH BLK
(x40) | 5/16x8-3/4

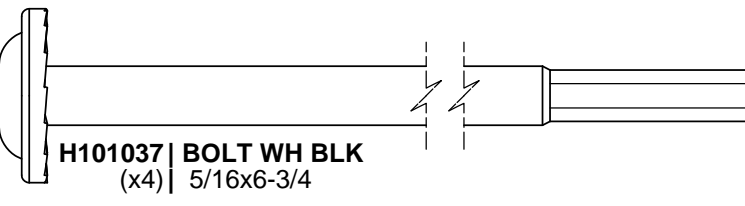

H101037 | BOLT WH BLK
(x4) | 5/16x6-3/4

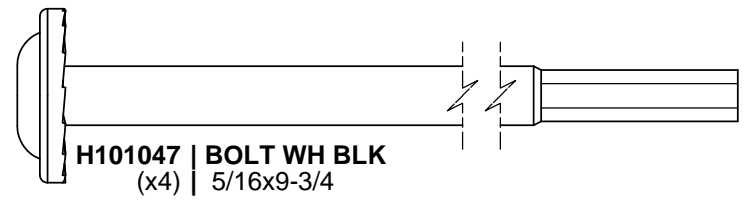

H101047 | BOLT WH BLK
(x4) | 5/16x9-3/4

OWNER'S MANUAL - PARTS IDENTIFICATION

HARDWARE COMPONENTS (NOT TO SCALE)

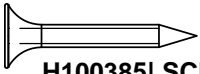

H100385 | SCREW PFH BLK
(x216) | 8x1



H100653 | NUT LOCK BLK
(x20) | 1/4

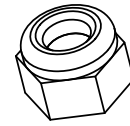

H100479 | NUT LOCK BLK
(x52) | 5/16

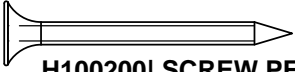

H100200 | SCREW PFH BLK
(x40) | 8x1-1/2

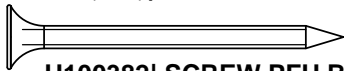

H100382 | SCREW PFH BLK
(x52) | 8x1-3/4

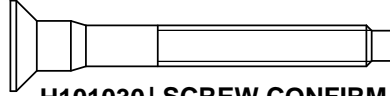

H101030 | SCREW CONFIRMAT BLK
(x160) | 7x2

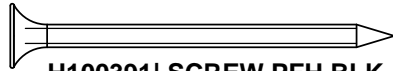

H100391 | SCREW PFH BLK
(x384) | 8x2



H100483 | SCREW PFH BLK
(x72) | 8x2-1/4

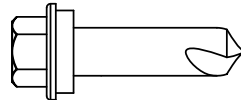

H100759 | SCREW TAPPING
(x74) | 1/4x1

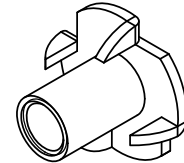

H100379 | T-NUT BLK
(x158) | 5/16

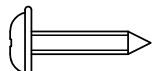

H100202 | SCREW PWH BLK
(x4) | 8x5/8

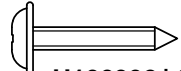

H100392 | SCREW PWH BLK
(x24) | 8x3/4

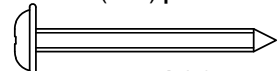

H100536 | SCREW PWH BLK
(x48) | 8x1-1/4

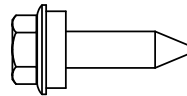

H100833 | SCREW WOODGRIP
(x530) | 10x3/4

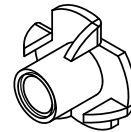

H100398 | T-NUT BLK
(x32) | 1/4

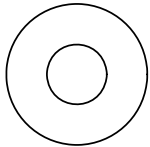

H100630 | WASHER FLAT BLK
(x44) | 8x19

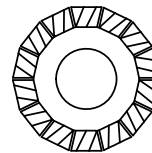

H100198 | WASHER LOCK EXT BLK
(x194) | 8x19

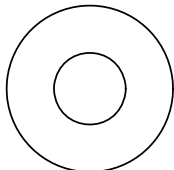

H100770 | WASHER FLAT BLK
(x44) | 5/16"

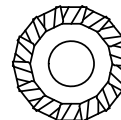

H100405 | WASHER LOCK EXT BLK
(x20) | 6x15

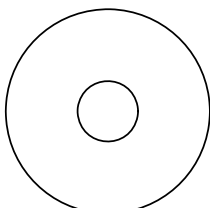

H100478 | WASHER FLAT BLK
(x16) | 8x27



H101034 | WEATHER PROOFING WASHER
(x10) | 1/8"x1/4" I.D. x 7/16" O.D.

OWNER'S MANUAL - PARTS IDENTIFICATION

HARDWARE COMPONENTS (NOT TO SCALE)

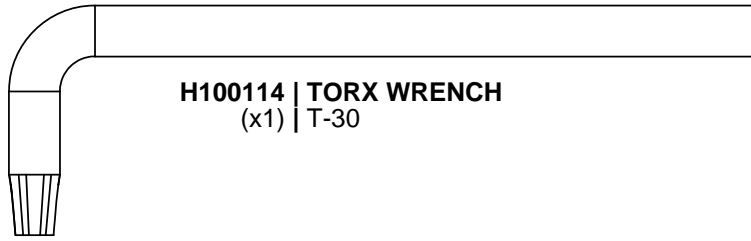

H100114 | TORX WRENCH
(x1) | T-30

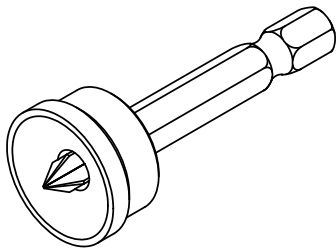

H100764 | SCREW SETTER
(x1) |

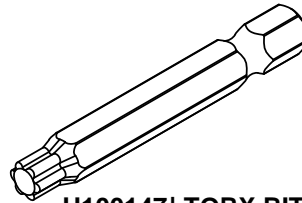

H100147 | TORX BIT
(x1) | T-30

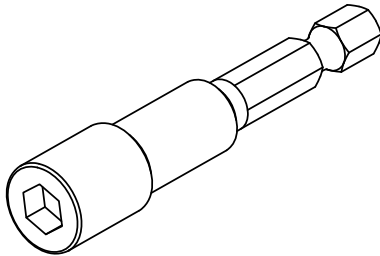

H101106 | SOCKET DRIVER
(x1) |

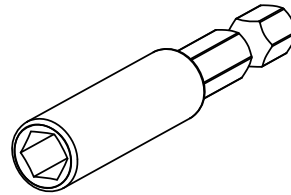

H101100 | MAGNETIC DRIVER
(x1) |

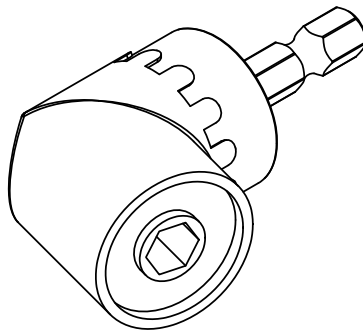

H101114 | RIGHT ANGLE DRILL ADAPTER
(x1) |

OWNER'S MANUAL - PARTS IDENTIFICATION

ACCESSORY COMPONENTS (NOT TO SCALE)

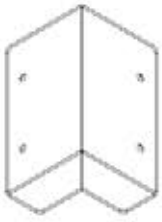

A4M01185 CORNER BRACKET
(x4)

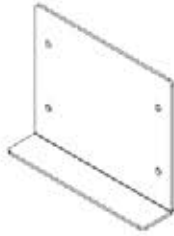

A4M01904 SPLICE PLATE
(x2)

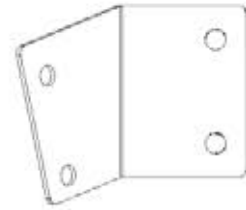

A4M01191 PANEL BRACKET
(x2)

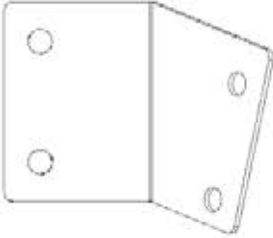

A4M01193 PANEL BRACKET
(x2)

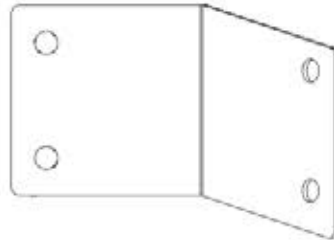

A4M01238 PANEL BRACKET
(x2)

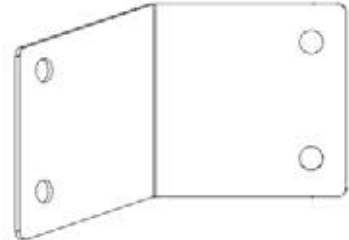

A4M01239 PANEL BRACKET
(x2)

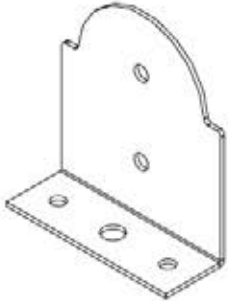

A4M01793 POST ANCHORING PLATE
(x12)



A4M01794 POST PLATE
(x12)

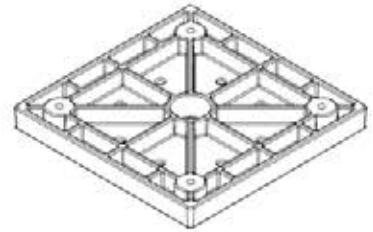

A6P00308 6x6 POST FOOT
(x6)

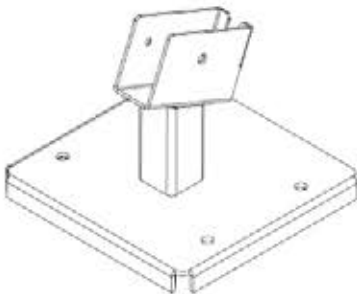

A4M01894 MIDDLE POST
CLIP ASSEMBLY
(x2)

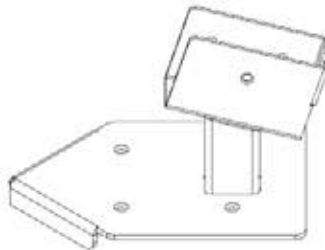

A4M01234 POST CLIP
ASSEMBLY
(x4)

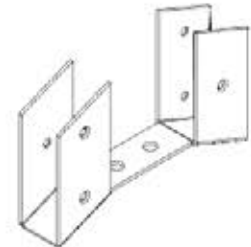

A4M01902 RAFTER HANGER
(x1)

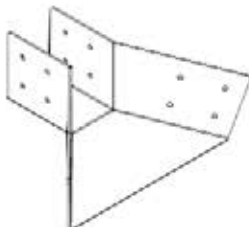

A4M01895 PANEL SUPPORT
BRACKET
(x2)

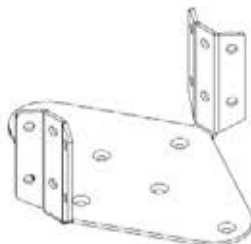

A4M02501 FAN MOUNT BRACKET
(x2)

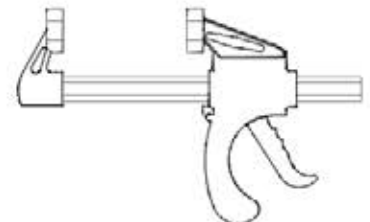

A6P00460 6" QUICK RELEASE BAR CLAMP
(x2)

OWNER'S MANUAL - PARTS IDENTIFICATION

ACCESSORY COMPONENTS (NOT TO SCALE)

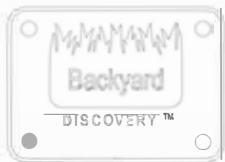

A4M02158 BYD ID TAG PATIO
(x1)



A4M02822 EDGE TRIM SPLICE
(x8)

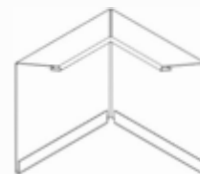

A4M02825 EDGE TRIM
CORNER SPLICE
(x4)



A4M01228 RAFTER CLIP
(x20)

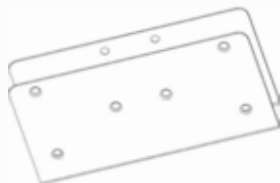

A4M01237 ROOF SUPPORT
SPLICE CLIP
(x12)



A4M01205 METAL SPACER
(x10)



A4M02850 RIDGE CAP CHANNEL
SHORT
(x8)



A4M02888 RIDGE CAP
(x1)

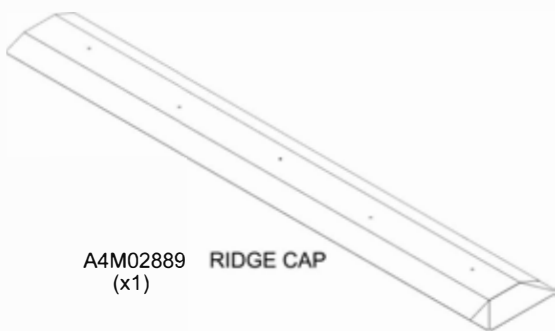

A4M02889 RIDGE CAP
(x1)



A4M02849 RIDGE CAP CHANNEL
(x4)



A4M02847 RIDGE CAP CHANNEL
LONG
(x8)



A4M02887 EDGE TRIM
(x8)



A4M02867 CORNER RIDGE CAP SHORT
(x4)



A4M02821 EDGE TRIM
(x4)



A4M02826 CORNER RIDGE CAP LONG
(x4)



A4M02848 EDGE TRIM
(x2)

OWNER'S MANUAL - PARTS IDENTIFICATION

ACCESSORY COMPONENTS (NOT TO SCALE)



A4M02818 29GA STEEL SHEETING
(x8)

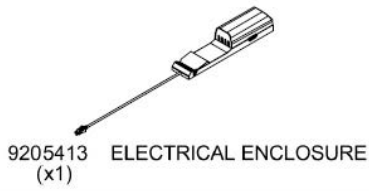

9205413 ELECTRICAL ENCLOSURE
(x1)



A4M02819 29GA STEEL SHEETING
(x4)



A4M02814-1 29GA STEEL SHEETING
(x2)



A4M02815-2 29GA STEEL SHEETING
(x2)



A4M02816-2 29GA STEEL SHEETING
(x2)



A4M02817-2 29GA STEEL SHEETING
(x2)



A4M02814-2 29GA STEEL SHEETING
(x2)



A4M02813-2 29GA STEEL SHEETING
(x2)

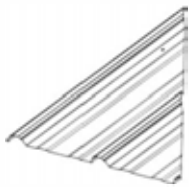

A4M02812-2 29GA STEEL SHEETING
(x2)



A4M02817-1 29GA STEEL SHEETING
(x2)

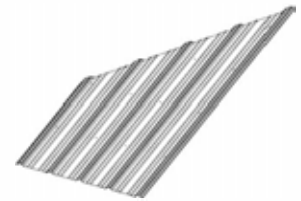

A4M02816-1 29GA STEEL SHEETING
(x2)



A4M02815-1 29GA STEEL SHEETING
(x2)



A4M02812-1 29GA STEEL SHEETING
(x2)



A4M02813-1 29GA STEEL SHEETING
(x2)

OWNER'S MANUAL - PARTS IDENTIFICATION

ACCESSORY COMPONENTS (NOT TO SCALE)



A4M02872 RIDGE BRACE
(x1)



A4M02873 RIDGE BRACE
(x4)

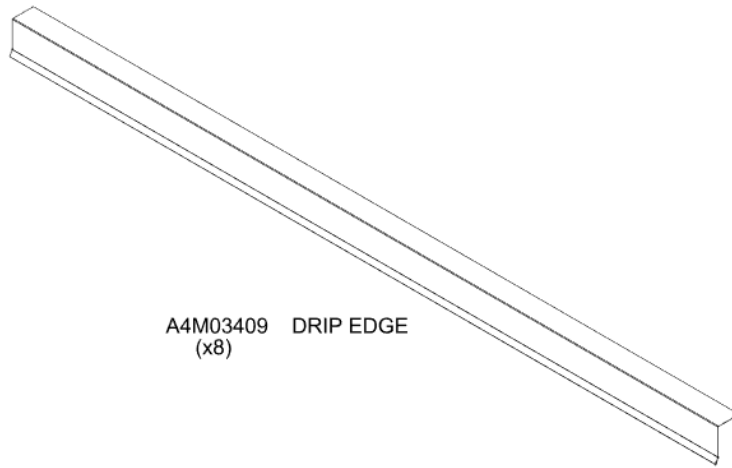

A4M03409 DRIP EDGE
(x8)

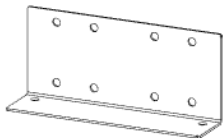

A4M00972 BRACKET
(x2)

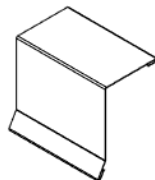

A4M03410 DRIP EDGE SPLICE
(x8)

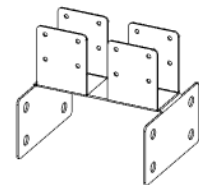

A4M04025 TRUSS BRACKET
(x1)

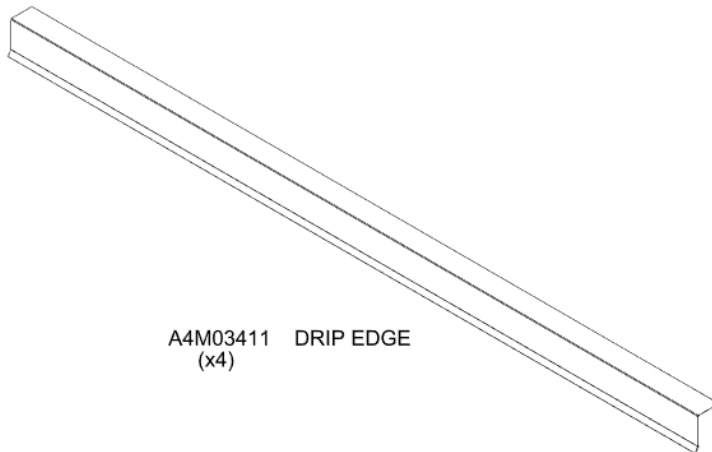

A4M03411 DRIP EDGE
(x4)

PRE-ASSEMBLY STEP 1 - SORTING PARTS

It is critical for ease of assembly that you take the time to sort and organize the wood and hardware.

WOOD PARTS:

- Organize wood parts by the three-digit, alpha-numeric number stamped on each board (ex. P01).
- If there are multiple boards with the same stamped number, stack those pieces together.
- Stamps can be found on the flat surface of the boards or on the end of the boards.
- Allow yourself plenty of room - the wood pieces can take up a significant amount of space.

NOTE: CARTONS ARE NOT ORGANIZED BY BOARD OR STEP NUMBER.



HARDWARE PARTS:

- We recommend that you have a separate table to organize the hardware.
- Hardware bags are printed with a seven-digit, alpha-numeric part number.
- You can organize your hardware by part number or group by hardware type (e.g. bolts, nuts, etc.).
- During assembly you only need to reference the last four digits of the number.

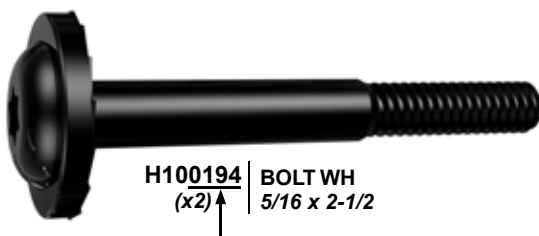

PRE-ASSEMBLY STEP 2 - TOOLS REQUIRED



Cordless Drill or Electric Drill



Drill Attachments:
Phillips Head



1/8" & 3/8" Drill Bits



Phillips Screw Driver



Open End Wrenches 1/2" & 7/16"



3/8" Drive Ratchet, 1/2" & 7/16" STD Sockets, 1/2" & 7/16" Deep Sockets



Tape Measure



Claw Hammer



Rubber Mallet - Optional

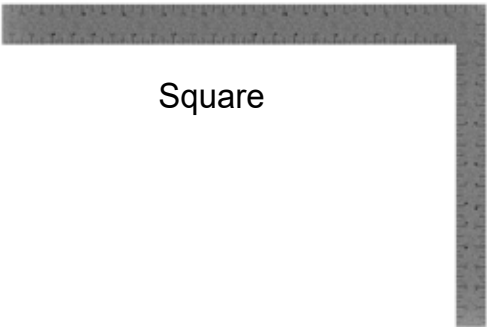

Square



Level 24"

PRE-ASSEMBLY STEP 3 - CHOOSE YOUR ASSEMBLY METHOD

There are several types of assembly instructions available to you.

1. Printed Assembly Manual included with your set
2. BILT APP - 3D interactive instructions
3. Combination of the Printed Manual and BILT APP (Note: Step numbers can differ between the two methods)



The graphic is a rectangular advertisement for the BILT app. At the top left is the BILT logo, which consists of a stylized hexagonal icon with a dot in the center, followed by the word "BILT." in a bold, sans-serif font. To the right of the logo is a large QR code. Below the logo and QR code, the text "Scan for easy 3D instructions" is written in a large, bold, black font. Underneath this, in a smaller font, it says "Download the BILT app before you begin". To the right of this text are two buttons: "Download on the App Store" with the Apple logo and "GET IT ON Google Play" with the Google Play logo. At the bottom of the graphic is a smartphone screen displaying a 3D interactive assembly instruction. The screen shows a 3D model of a structure with a horizontal beam and a triangular support. A red arrow points to a specific part of the structure. The screen also has a "Partners Needed" button in the top left, a close button (X) in the top right, and a play/pause button in the bottom right.

STEP 1 - POST ASSEMBLY

QTY	PART NUMBER	DESCRIPTION
12	H100200	SCREW PFH 8x1 1/2 BLK

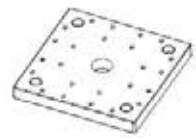
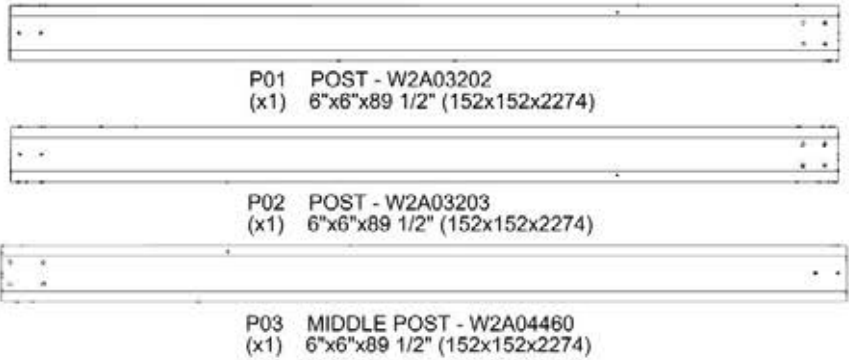

A6P00308 6x6 POST FOOT
(x3)

- FOR EASE OF ASSEMBLY, WE RECOMMEND USING SAW HORSES FOR THE FOLLOWING STEPS.

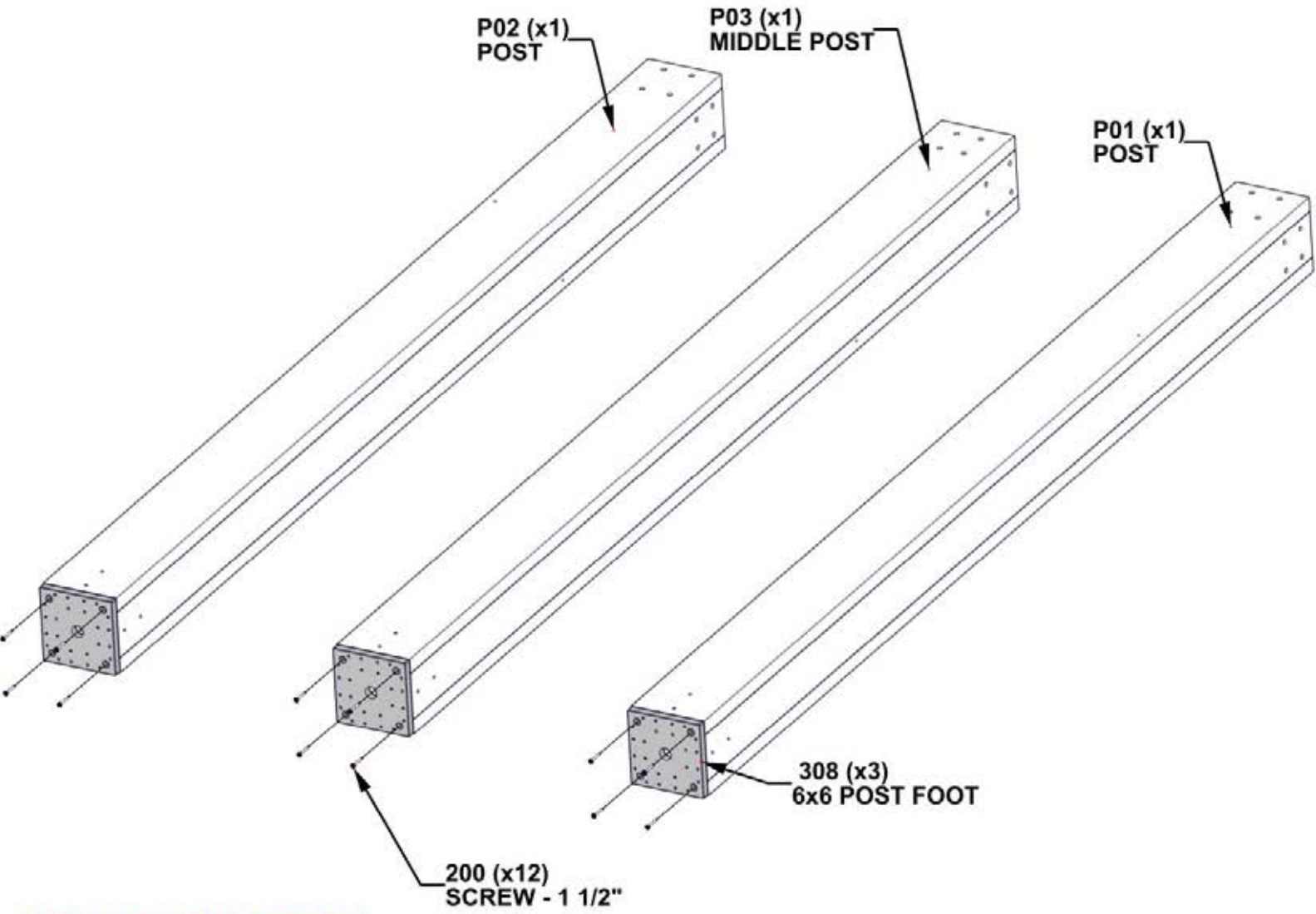

ALIGN POST FOOT AND DRILL 1/8" [3mm] PILOT HOLES FOR THE ATTACHMENT HARDWARE.

STEP 2 - 12FT BEAM ASSEMBLY

QTY	PART NUMBER	DESCRIPTION
4	H100195	BOLT WH 5/16x2 3/4 BLK
4	H100198	WASHER LOCK EXT 8x19
4	H100379	T-NUT 5/16 BLK



D03 BEAM - W4L20652
 (x2) 1 7/16"x5 1/4"x67 13/16" (36x134x1723)



D02 BEAM - W4L20647
 (x1) 1 7/16"x5 1/4"x75 13/16" (36x134x1926)

INSERT T-NUTS FIRST

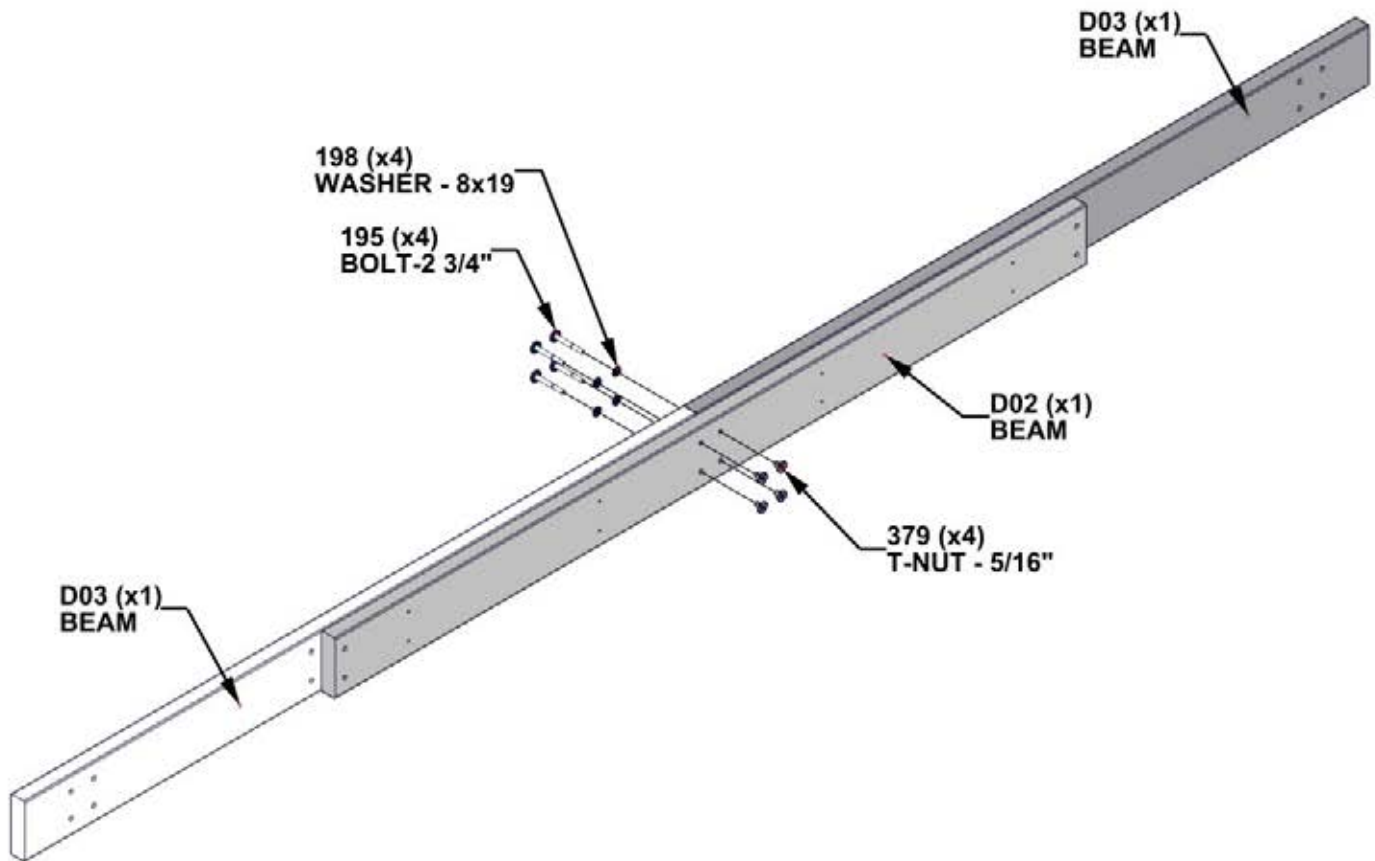

STEP 3 - 12FT BEAM ASSEMBLY

QTY	PART NUMBER	DESCRIPTION
8	H100198	WASHER LOCK EXT 8x19
8	H100379	T-NUT 5/16 BLK
8	H100513	BOLT WH 5/16x4 1/4 BLK



D01 BEAM - W4L20648
(x2) 1 7/16"x5 1/4"x29 15/16" (36x134x760)



C01 CORBEL - W2A03198
(x2) 1 7/16"x6 7/16"x35 1/8" (36x163x893)

INSERT T-NUTS FIRST

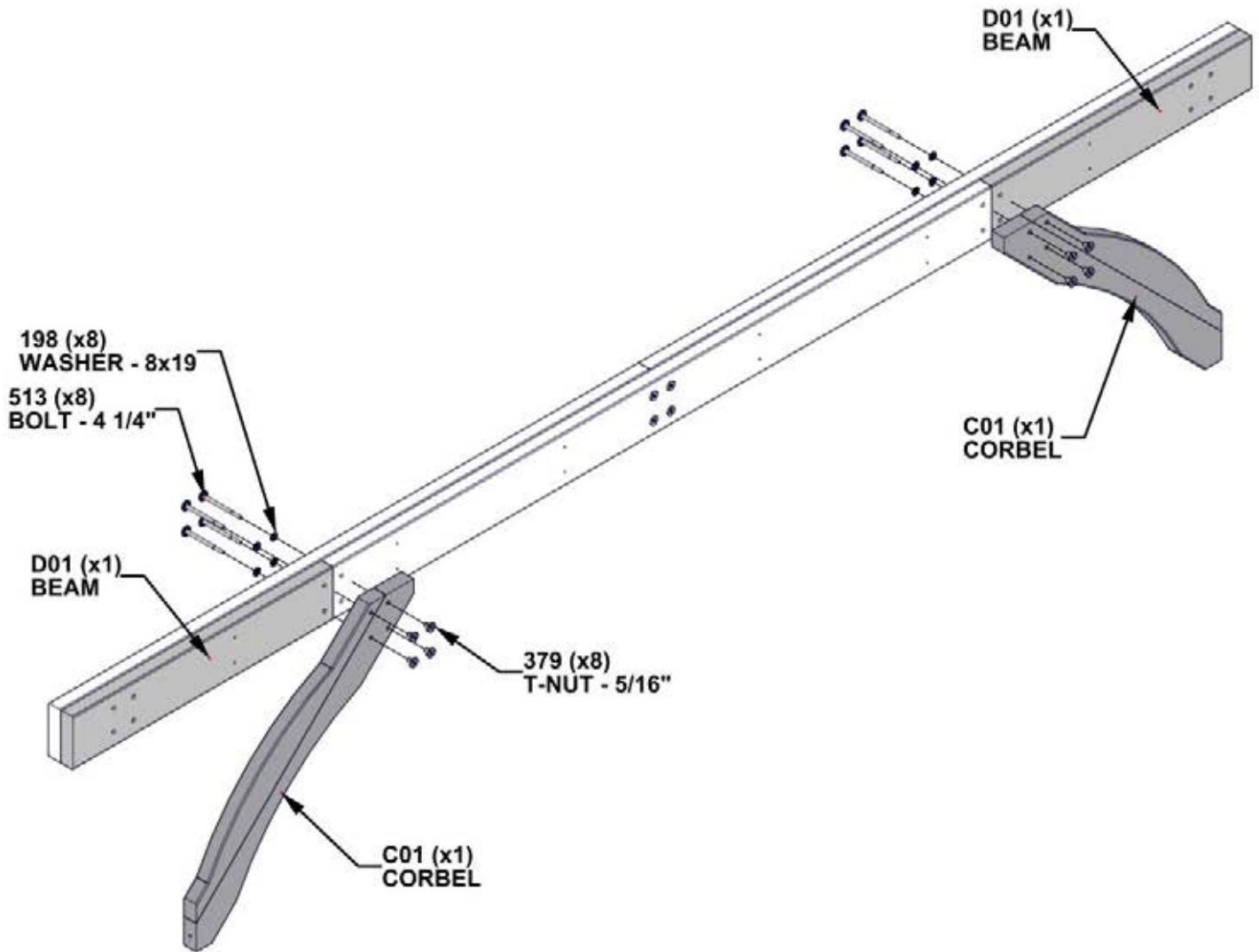

STEP 4 - 12FT BEAM ASSEMBLY

QTY	PART NUMBER	DESCRIPTION
12	H100483	SCREW PFH 8x2 1/4 BLK

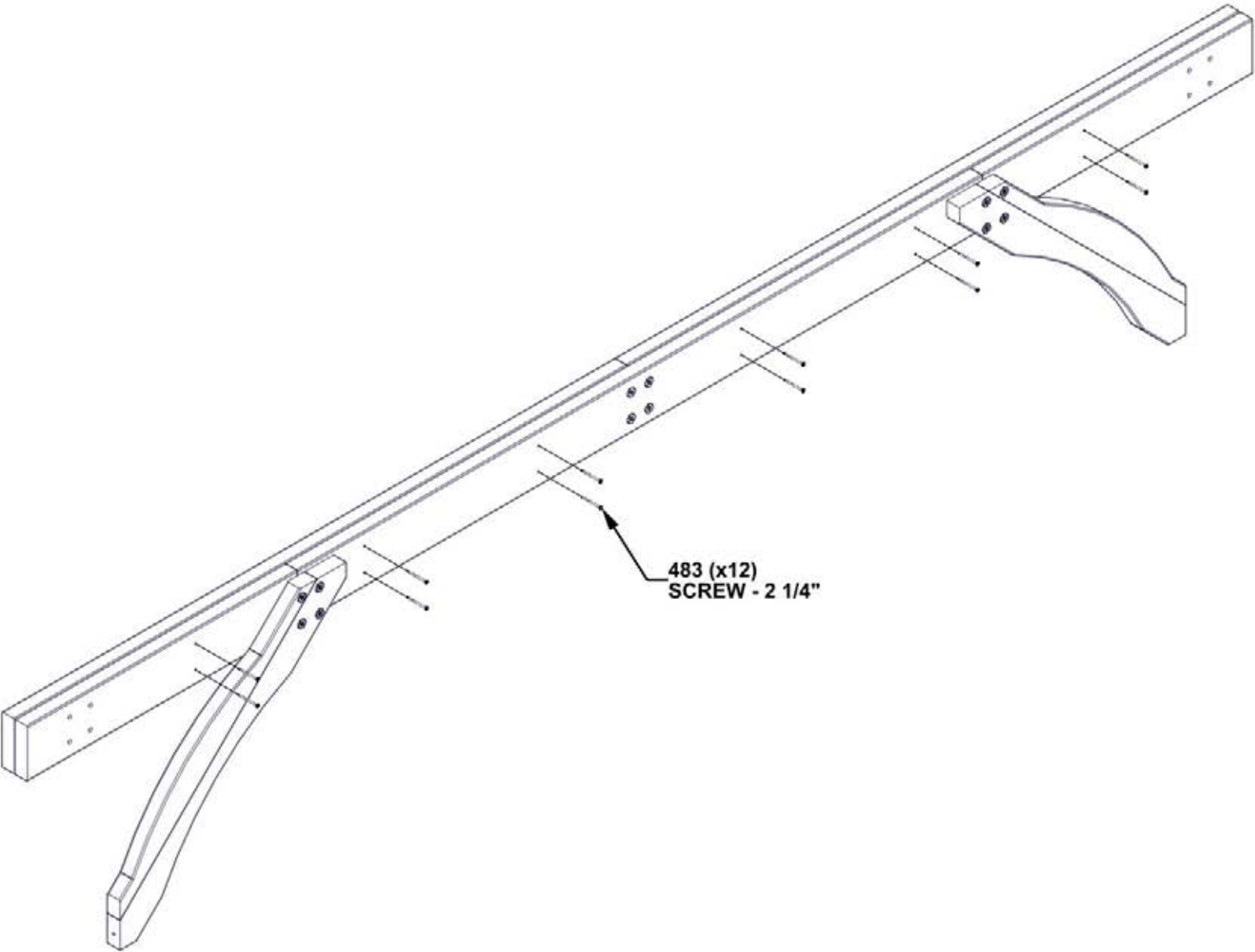
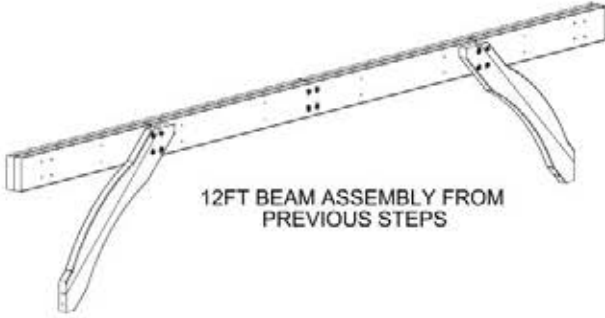

STEP 5 - 12FT END ASSEMBLY

QTY	PART NUMBER	DESCRIPTION
8	H100198	WASHER LOCK EXT 8x19
8	H100379	T-NUT 5/16 BLK
2	H100405	WASHER LOCK EXT 6x15
2	H100792	LAG SCREW WH 1/4x3 BLK
8	H101058	BOLT WH 5/16x8 3/4 BLK

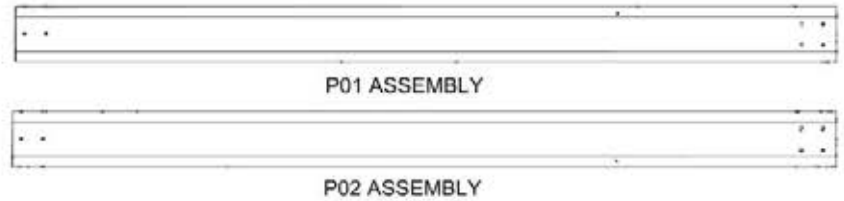
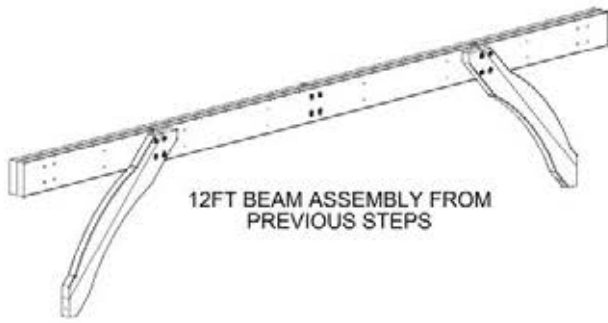

INSERT T-NUTS FIRST

SAW DUST CAN BE LEFT BEHIND IN BOLT HOLES. IF YOU HAVE TROUBLE WITH BOLTS ENGAGING, USE A LONG SCREW DRIVER TO REMOVE THE DEBRIS.

INSERT LAG SCREWS LAST.

TO AVOID WOOD SPLITTING, MAKE SURE LAG SCREWS GO INTO PILOT HOLES.

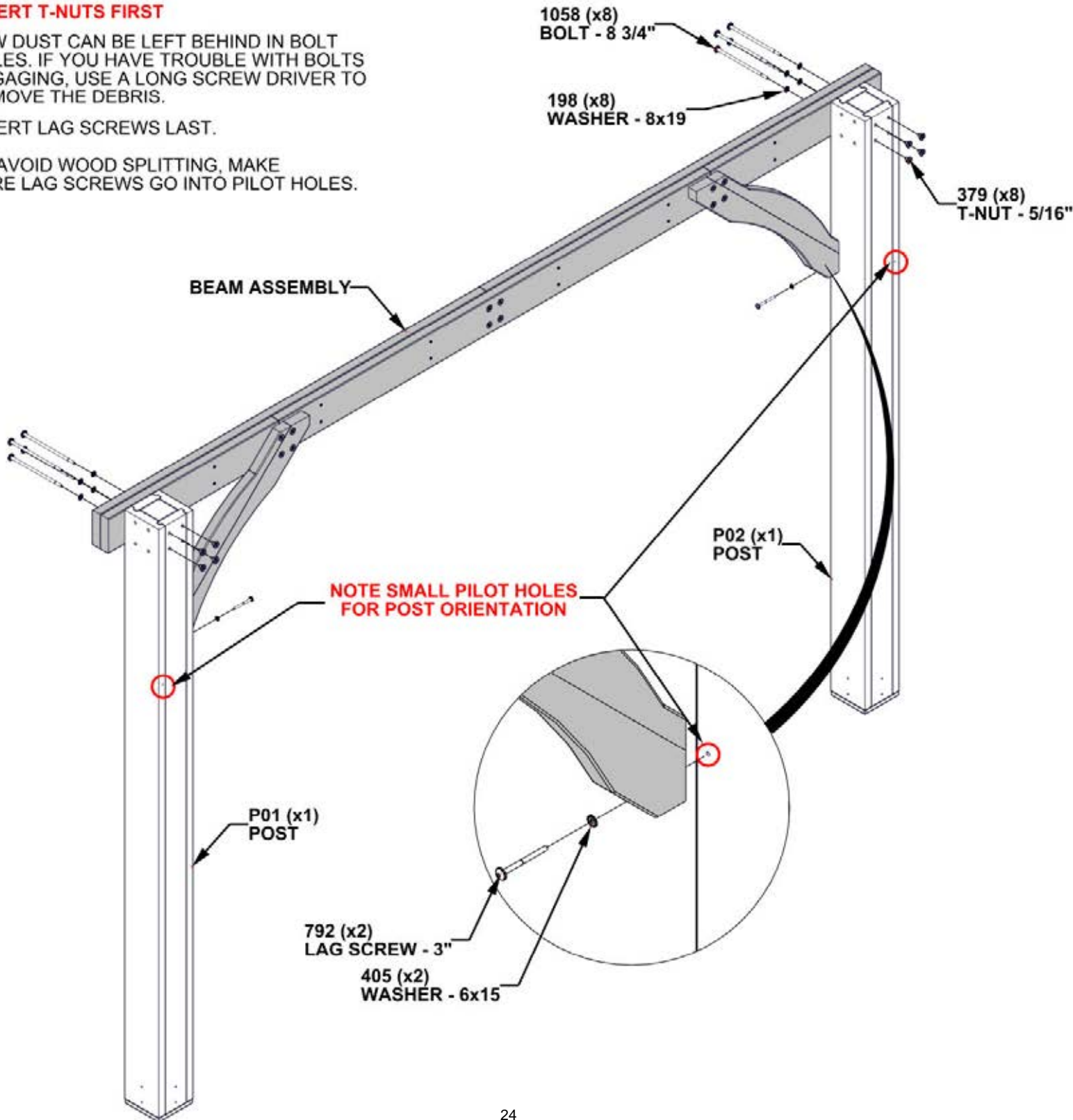

REPEAT STEPS 1 THROUGH 5

STEP 6A - BEAM ASSEMBLY

QTY	PART NUMBER	DESCRIPTION
2	H100483	SCREW PFH 8x2 1/4 BLK



D07 BEAM - W4L19814
(x1) 1 7/16"x5 1/4"x51" (36x134x1296)



D04 BEAM - W4L20650
(x1) 1 7/16"x5 1/4"x27 1/16" (36x134x688)

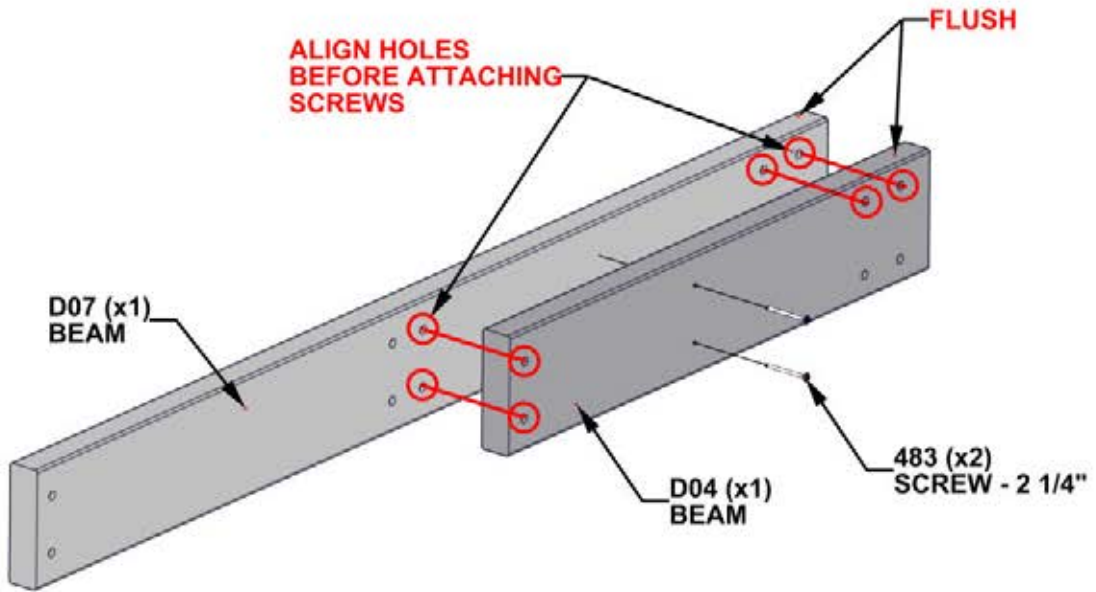

STEP 6B - BEAM ASSEMBLY

QTY	PART NUMBER	DESCRIPTION
6	H100195	BOLT WH 5/16x2 3/4 BLK
6	H100198	WASHER LOCK EXT 8x19
6	H100379	T-NUT 5/16 BLK
6	H100483	SCREW PFH 8x2 1/4 BLK

D08 BEAM - W4L20651
(x1) 1 7/16"x5 1/4"x68 3/4" (36x134x1746)

D06 BEAM - W4L20653
(x1) 1 7/16"x5 1/4"x89 1/2" (36x134x2274)

A4M02873 RIDGE BRACE
(x1)

INSERT T-NUTS FIRST

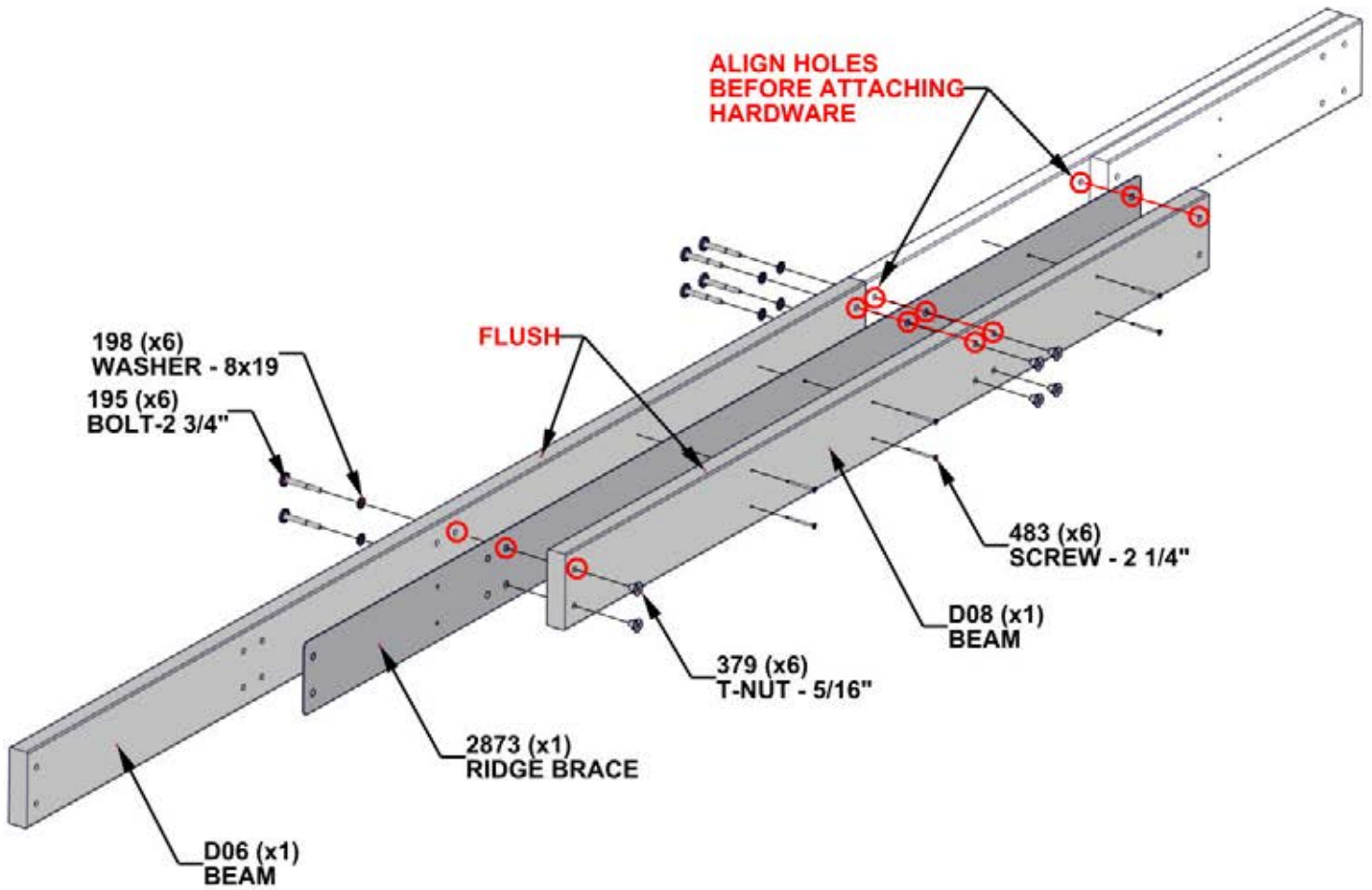

STEP 6C - BEAM ASSEMBLY

QTY	PART NUMBER	DESCRIPTION
2	H100195	BOLT WH 5/16x2 3/4 BLK
2	H100198	WASHER LOCK EXT 8x19
2	H100379	T-NUT 5/16 BLK
4	H100483	SCREW PFH 8x2 1/4 BLK

D05 BEAM - W4L20649
 (x1) 1 7/16"x5 1/4"x89 7/16" (36x134x2272)

INSERT T-NUTS FIRST

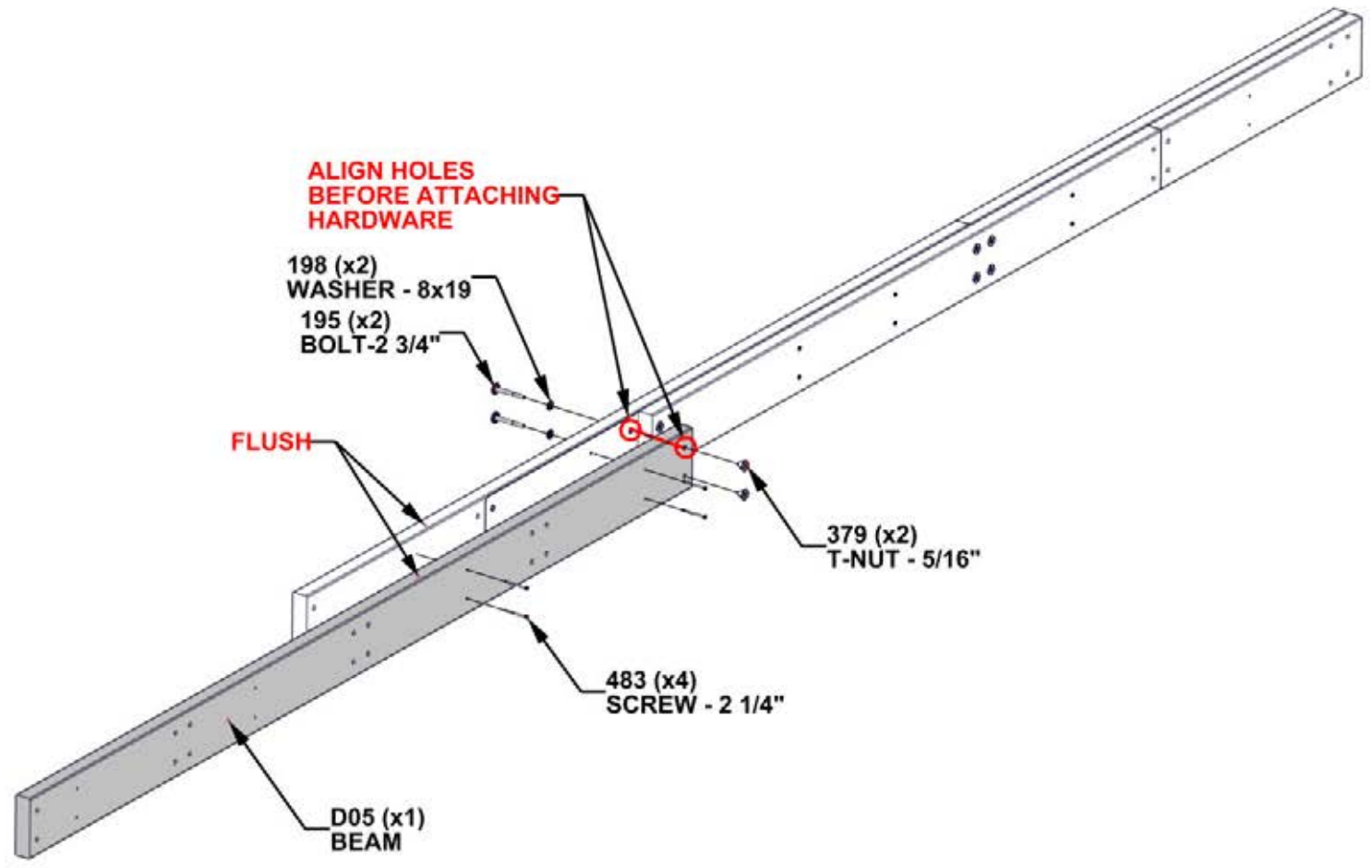

STEP 6D - BEAM ASSEMBLY

QTY	PART NUMBER	DESCRIPTION
8	H100198	WASHER LOCK EXT 8x19
8	H100379	T-NUT 5/16 BLK
8	H100513	BOLT WH 5/16x4 1/4 BLK



C01 CORBEL - W2A03198
(x1) 1 7/16"x6 7/16"x35 1/8" (36x163x893)



C02 CORBEL W/TAG - W2A03199
(x1) 1 7/16"x6 7/16"x35 1/8" (36x163x893)

INSERT T-NUTS FIRST

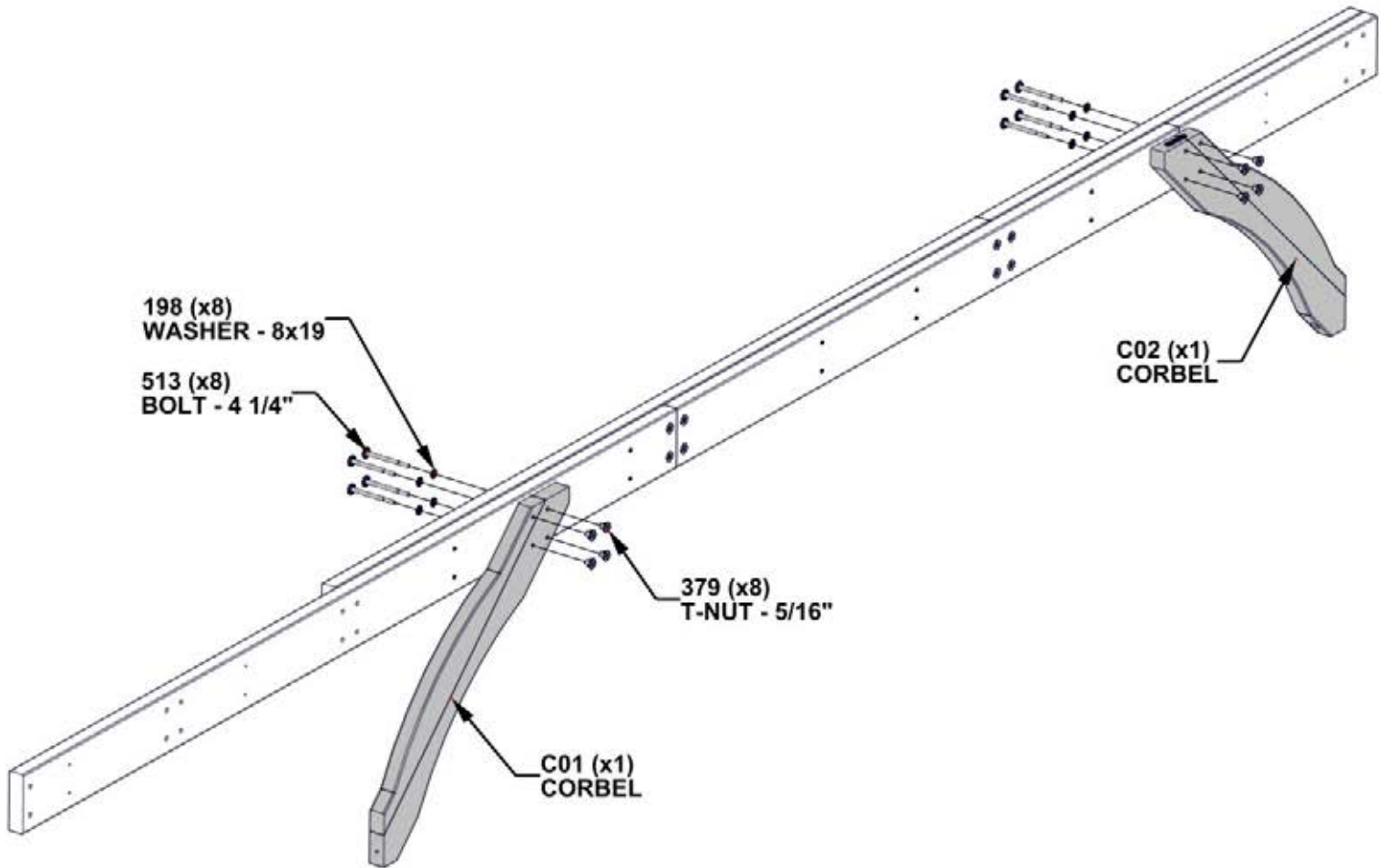

STEP 7 - GAZEBO ASSEMBLY

QTY	PART NUMBER	DESCRIPTION
6	H100198	WASHER LOCK EXT 8x19
6	H100379	T-NUT 5/16 BLK
2	H100405	WASHER LOCK EXT 6x15
2	H100792	LAG SCREW WH 1/4x3 BLK
6	H101058	BOLT WH 5/16x8 3/4 BLK

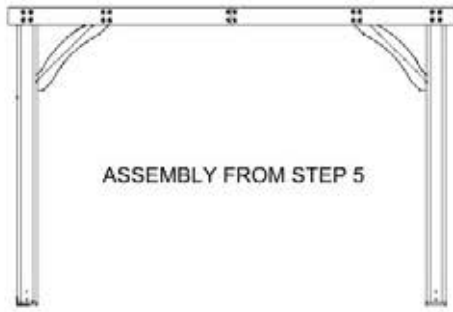

INSERT T-NUTS FIRST

FOR THIS STEP IT IS HELPFUL TO HAVE 3 ADDITIONAL PEOPLE TO HELP STAND UP THE ASSEMBLY AND ATTACH HARDWARE.

SAW DUST CAN BE LEFT BEHIND IN BOLT HOLES. IF YOU HAVE TROUBLE WITH BOLTS ENGAGING, USE A LONG SCREW DRIVER TO REMOVE THE DEBRIS.

INSERT LAG SCREWS LAST.

TO AVOID WOOD SPLITTING, MAKE SURE LAG SCREWS GO INTO PILOT HOLES.

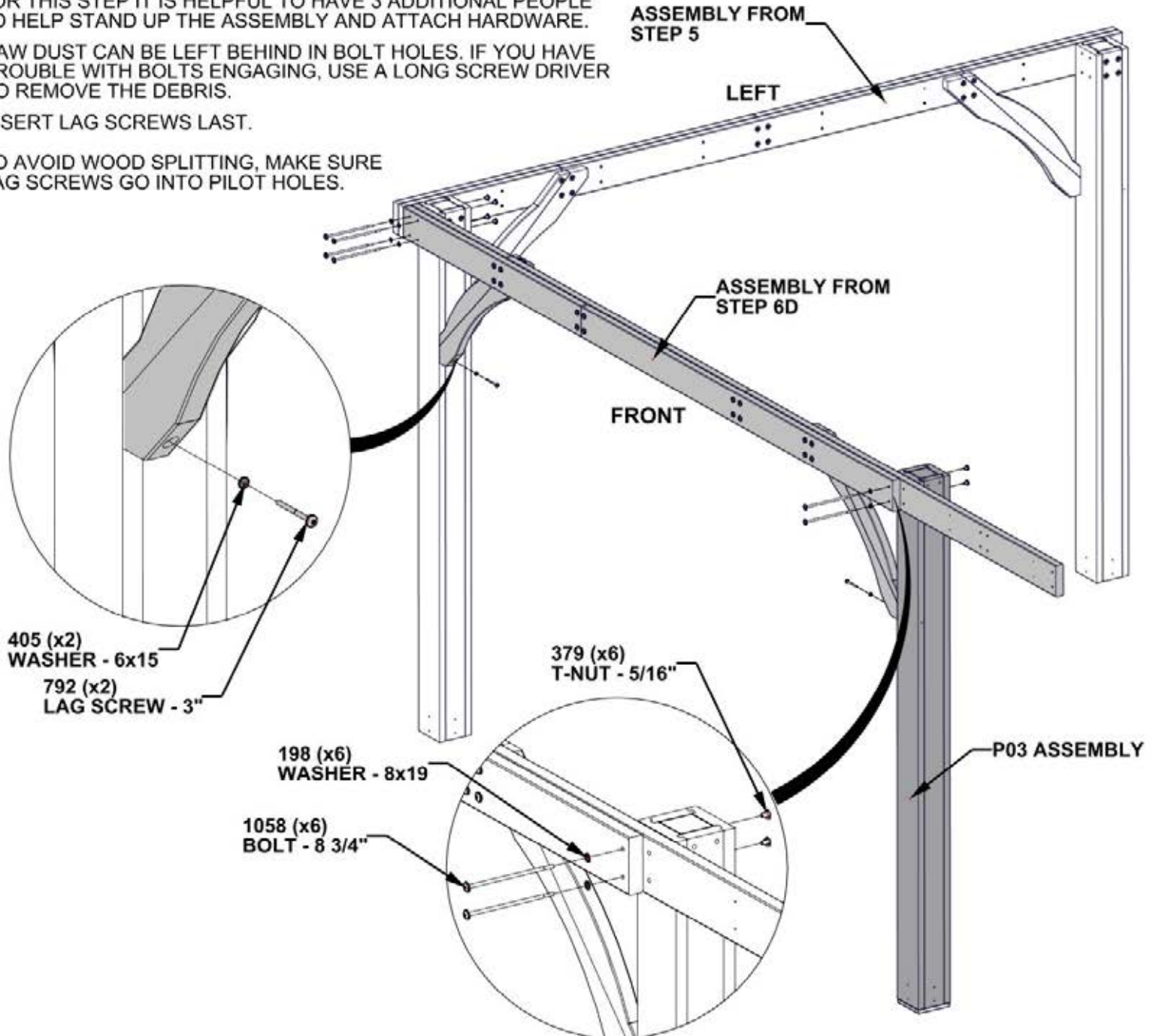

STEP 8A - BEAM ASSEMBLY

QTY	PART NUMBER	DESCRIPTION
2	H100483	SCREW PFH 8x2 1/4 BLK



D07 BEAM - W4L19814
(x1) 1 7/16"x5 1/4"x51" (36x134x1296)



D04 BEAM - W4L20650
(x1) 1 7/16"x5 1/4"x27 1/16" (36x134x688)

INSERT T-NUTS FIRST

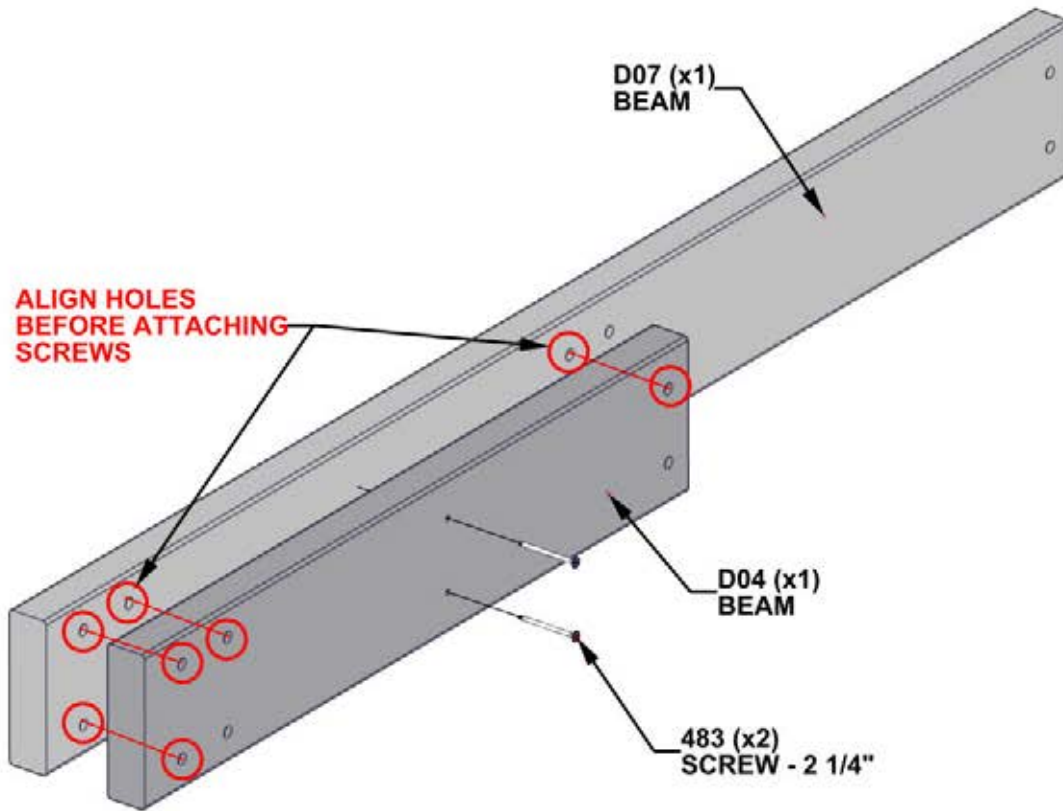

STEP 8B - BEAM ASSEMBLY

QTY	PART NUMBER	DESCRIPTION
6	H100195	BOLT WH 5/16x2 3/4 BLK
6	H100198	WASHER LOCK EXT 8x19
6	H100379	T-NUT 5/16 BLK
6	H100483	SCREW PFH 8x2 1/4 BLK



D08 BEAM - W4L20651
(x1) 1 7/16"x5 1/4"x68 3/4" (36x134x1746)



D06 BEAM - W4L20653
(x1) 1 7/16"x5 1/4"x89 1/2" (36x134x2274)



A4M02873 RIDGE BRACE
(x1)

INSERT T-NUTS FIRST

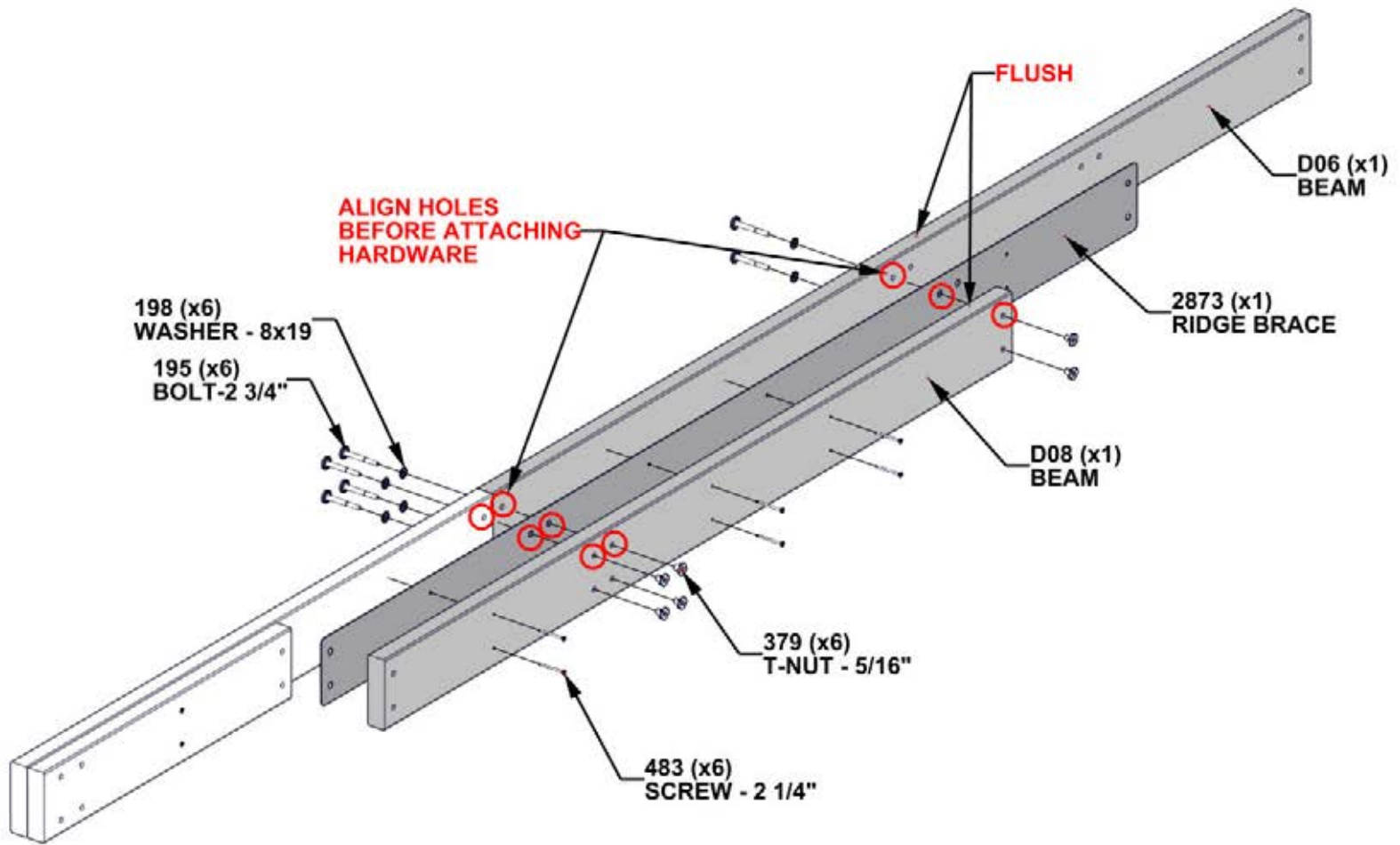

STEP 8C - BEAM ASSEMBLY

QTY	PART NUMBER	DESCRIPTION
2	H100195	BOLT WH 5/16x2 3/4 BLK
2	H100198	WASHER LOCK EXT 8x19
2	H100379	T-NUT 5/16 BLK
4	H100483	SCREW PFH 8x2 1/4 BLK

D05 BEAM - W4L20649
 (x1) 1 7/16"x5 1/4"x89 7/16" (36x134x2272)

INSERT T-NUTS FIRST

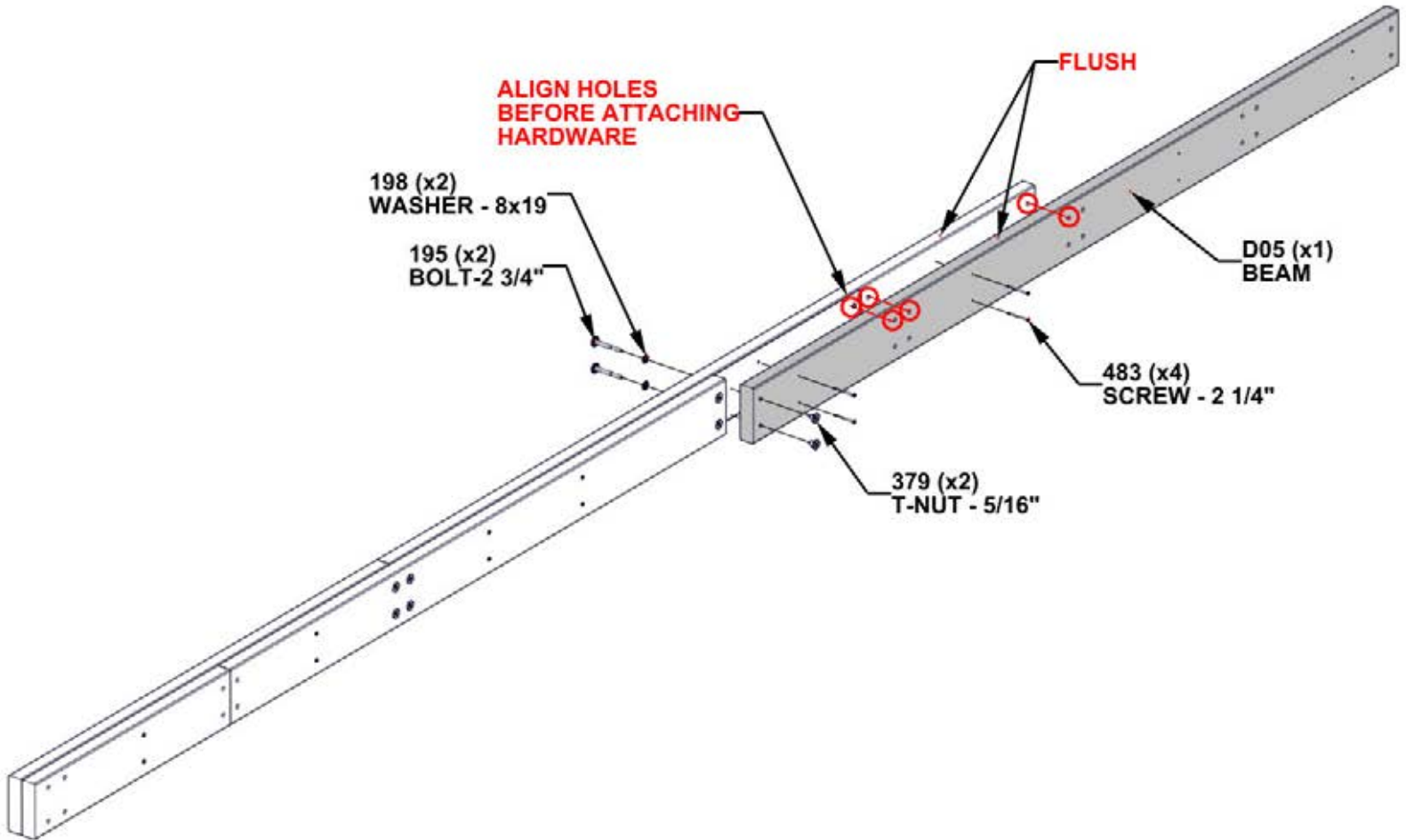

STEP 8D - BEAM ASSEMBLY

QTY	PART NUMBER	DESCRIPTION
8	H100198	WASHER LOCK EXT 8x19
8	H100379	T-NUT 5/16 BLK
8	H100513	BOLT WH 5/16x4 1/4 BLK

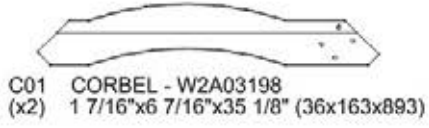

INSERT T-NUTS FIRST

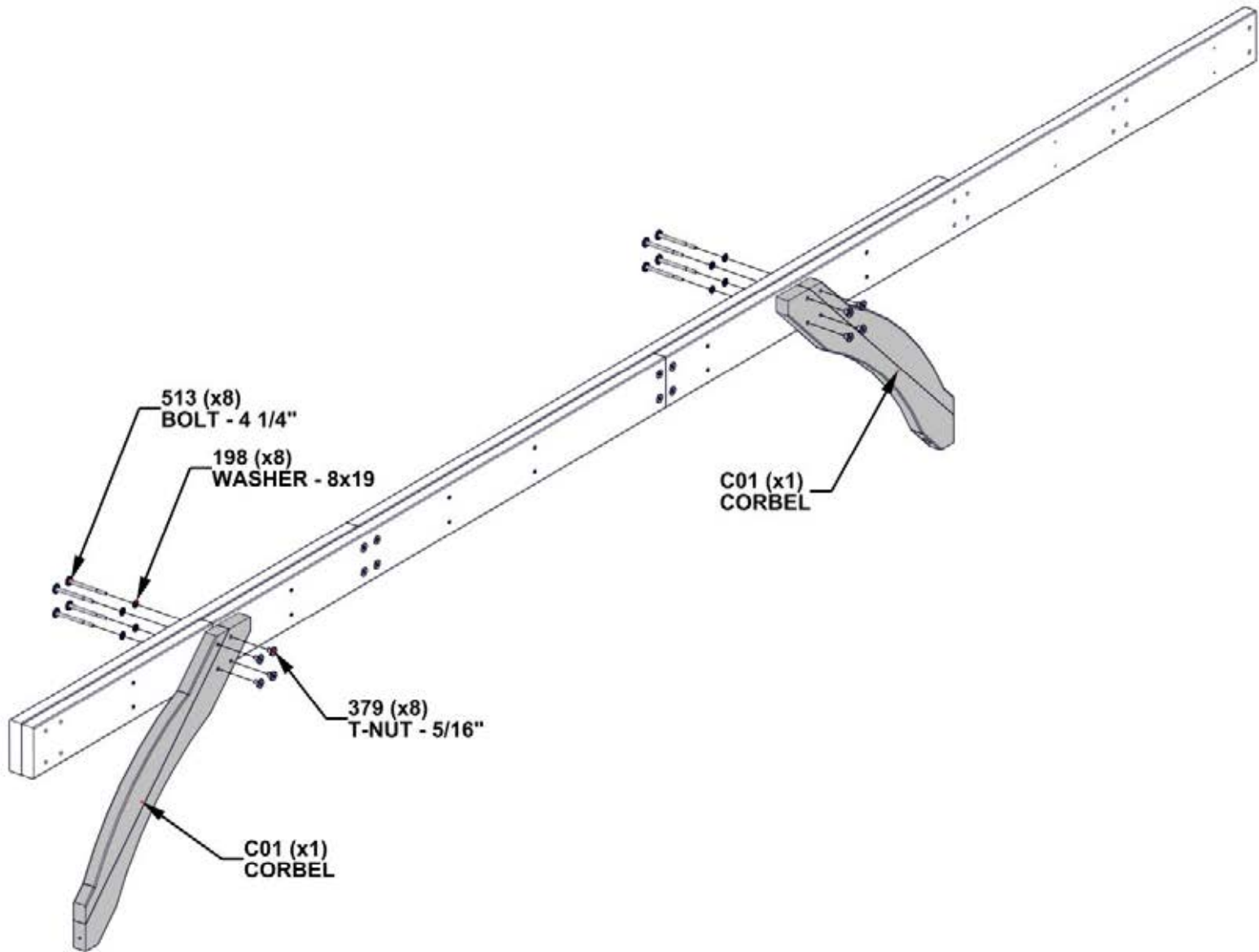

STEP 9 - GAZEBO ASSEMBLY

QTY	PART NUMBER	DESCRIPTION
6	H100198	WASHER LOCK EXT 8x19
6	H100379	T-NUT 5/16 BLK
2	H100405	WASHER LOCK EXT 6x15
2	H100792	LAG SCREW WH 1/4x3 BLK
6	H101058	BOLT WH 5/16x8 3/4 BLK

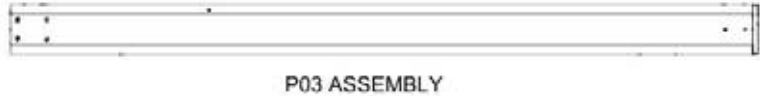
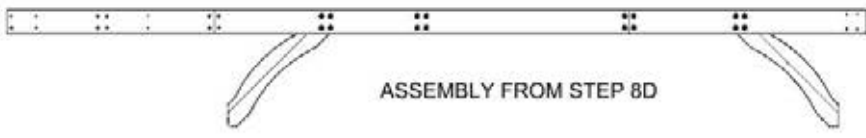

INSERT T-NUTS FIRST

FOR THIS STEP IT IS HELPFUL TO HAVE 3 ADDITIONAL PEOPLE TO HELP STAND UP THE ASSEMBLY AND ATTACH HARDWARE.

SAW DUST CAN BE LEFT BEHIND IN BOLT HOLES. IF YOU HAVE TROUBLE WITH BOLTS ENGAGING, USE A LONG SCREW DRIVER TO REMOVE THE DEBRIS.

INSERT LAG SCREWS LAST.

TO AVOID WOOD SPLITTING, MAKE SURE LAG SCREWS GO INTO PILOT HOLES.

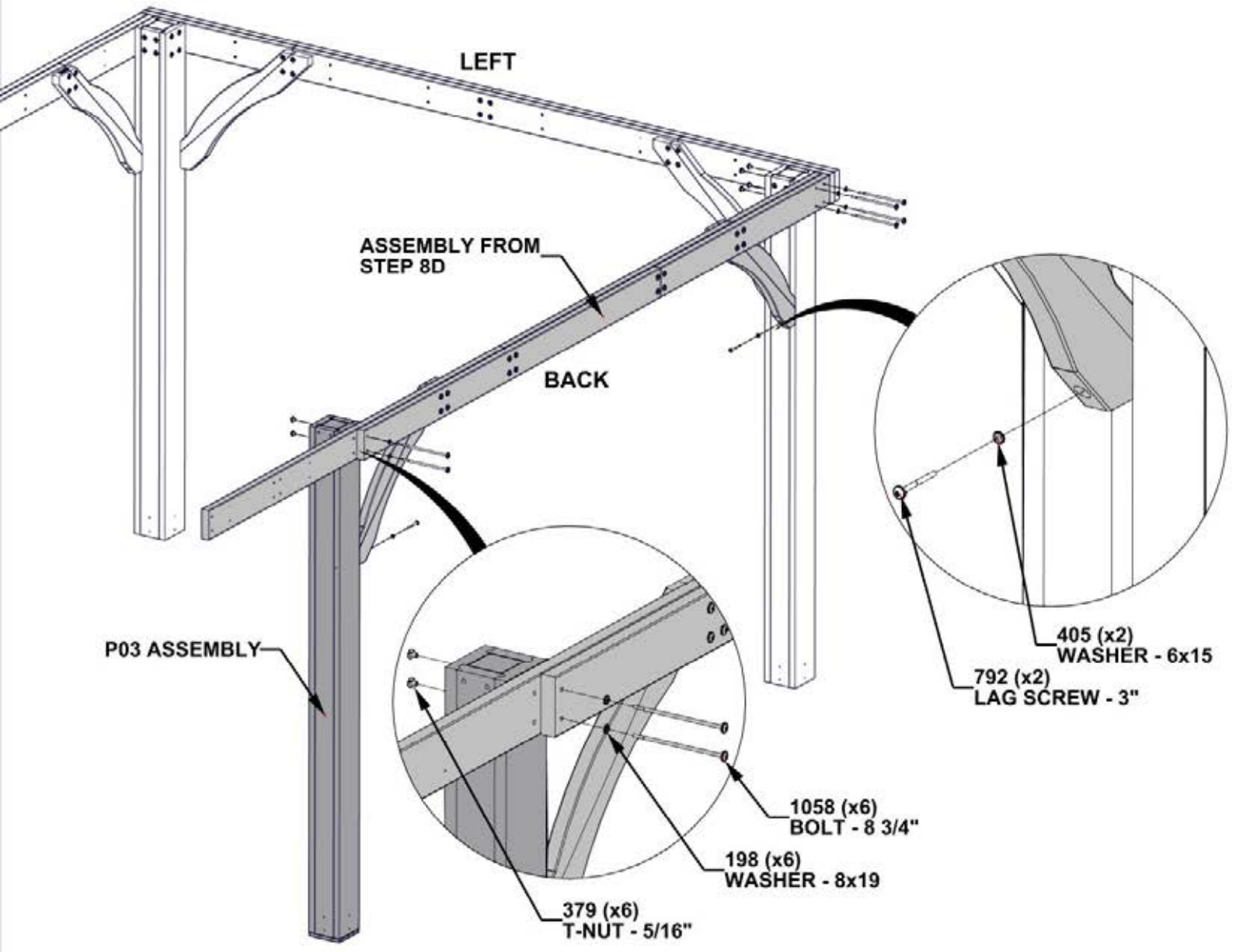

STEP 10A - BEAM ASSEMBLY

QTY	PART NUMBER	DESCRIPTION
2	H100483	SCREW PFH 8x2 1/4 BLK



D07 BEAM - W4L19814
(x1) 1 7/16"x5 1/4"x51" (36x134x1296)



D04 BEAM - W4L20650
(x1) 1 7/16"x5 1/4"x27 1/16" (36x134x688)

INSERT T-NUTS FIRST

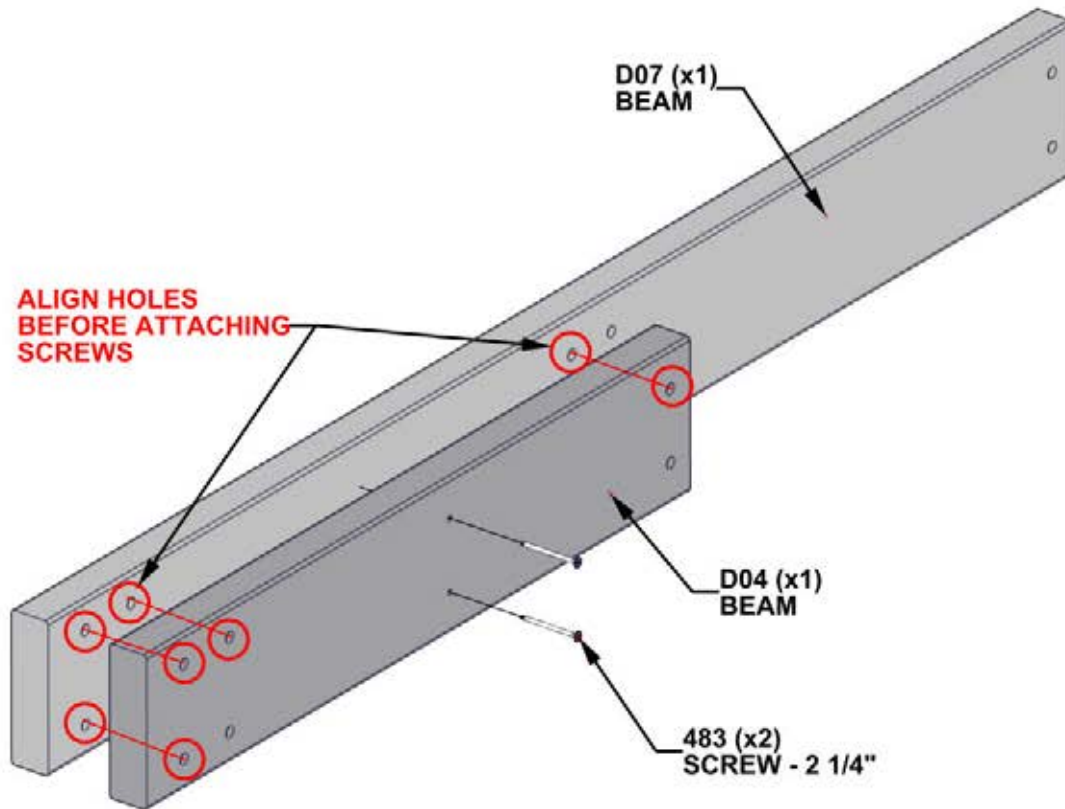

STEP 10B - BEAM ASSEMBLY

QTY	PART NUMBER	DESCRIPTION
6	H100195	BOLT WH 5/16x2 3/4 BLK
6	H100198	WASHER LOCK EXT 8x19
6	H100379	T-NUT 5/16 BLK
6	H100483	SCREW PFH 8x2 1/4 BLK

D08 BEAM - W4L20651
(x1) 1 7/16"x5 1/4"x68 3/4" (36x134x1746)

D06 BEAM - W4L20653
(x1) 1 7/16"x5 1/4"x89 1/2" (36x134x2274)

A4M02873 RIDGE BRACE
(x1)

INSERT T-NUTS FIRST

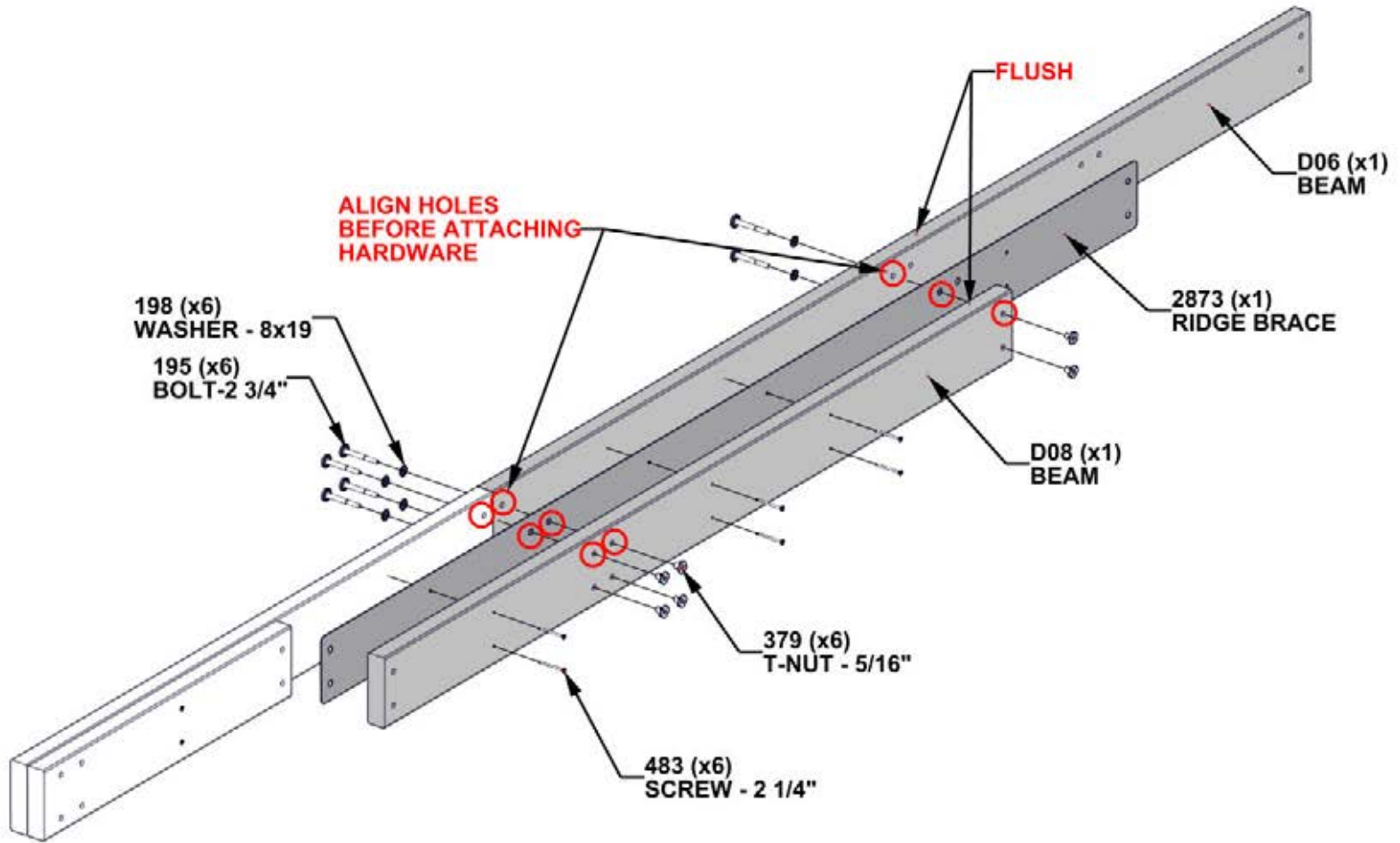

STEP 10C - BEAM ASSEMBLY

QTY	PART NUMBER	DESCRIPTION
4	H100198	WASHER LOCK EXT 8x19
4	H100379	T-NUT 5/16 BLK
4	H100513	BOLT WH 5/16x4 1/4 BLK

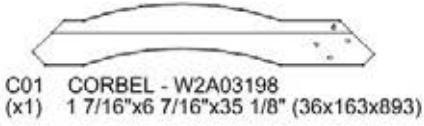

INSERT T-NUTS FIRST

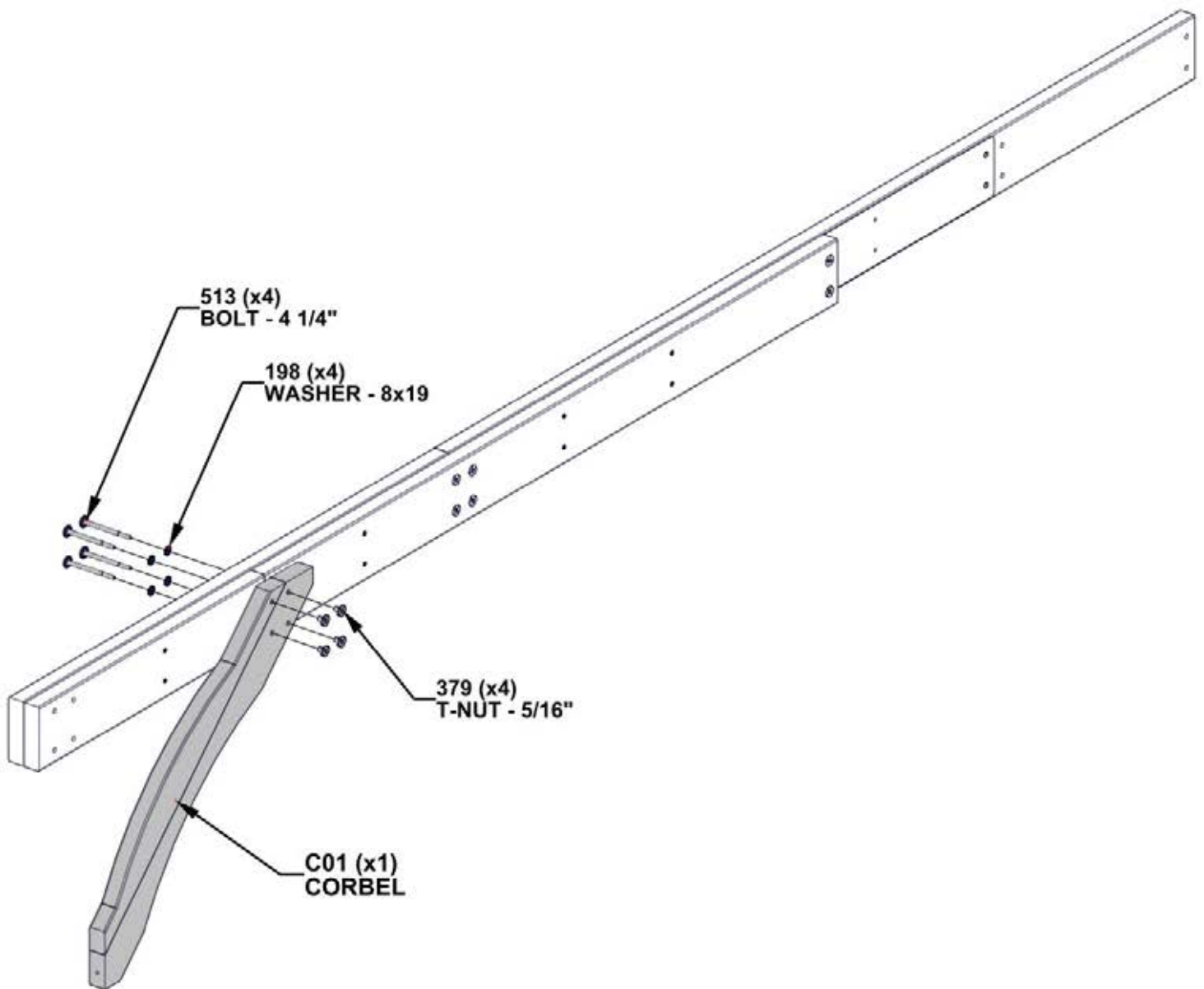

STEP 11A - GAZEBO ASSEMBLY

QTY	PART NUMBER	DESCRIPTION
2	H100195	BOLT WH 5/16x2 3/4 BLK
8	H100198	WASHER LOCK EXT 8x19
8	H100379	T-NUT 5/16 BLK
6	H101058	BOLT WH 5/16x8 3/4 BLK

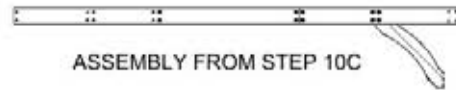
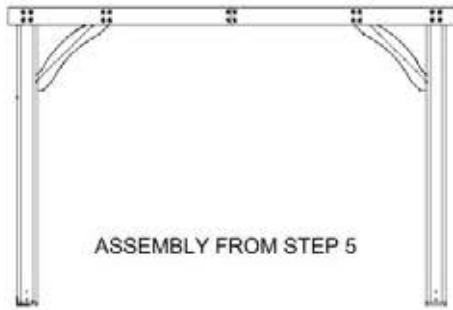

INSERT T-NUTS FIRST

FOR THIS STEP IT IS HELPFUL TO HAVE 3 ADDITIONAL PEOPLE TO HELP STAND UP THE ASSEMBLY AND ATTACH HARDWARE.

SAW DUST CAN BE LEFT BEHIND IN BOLT HOLES. IF YOU HAVE TROUBLE WITH BOLTS ENGAGING, USE A LONG SCREW DRIVER TO REMOVE THE DEBRIS.

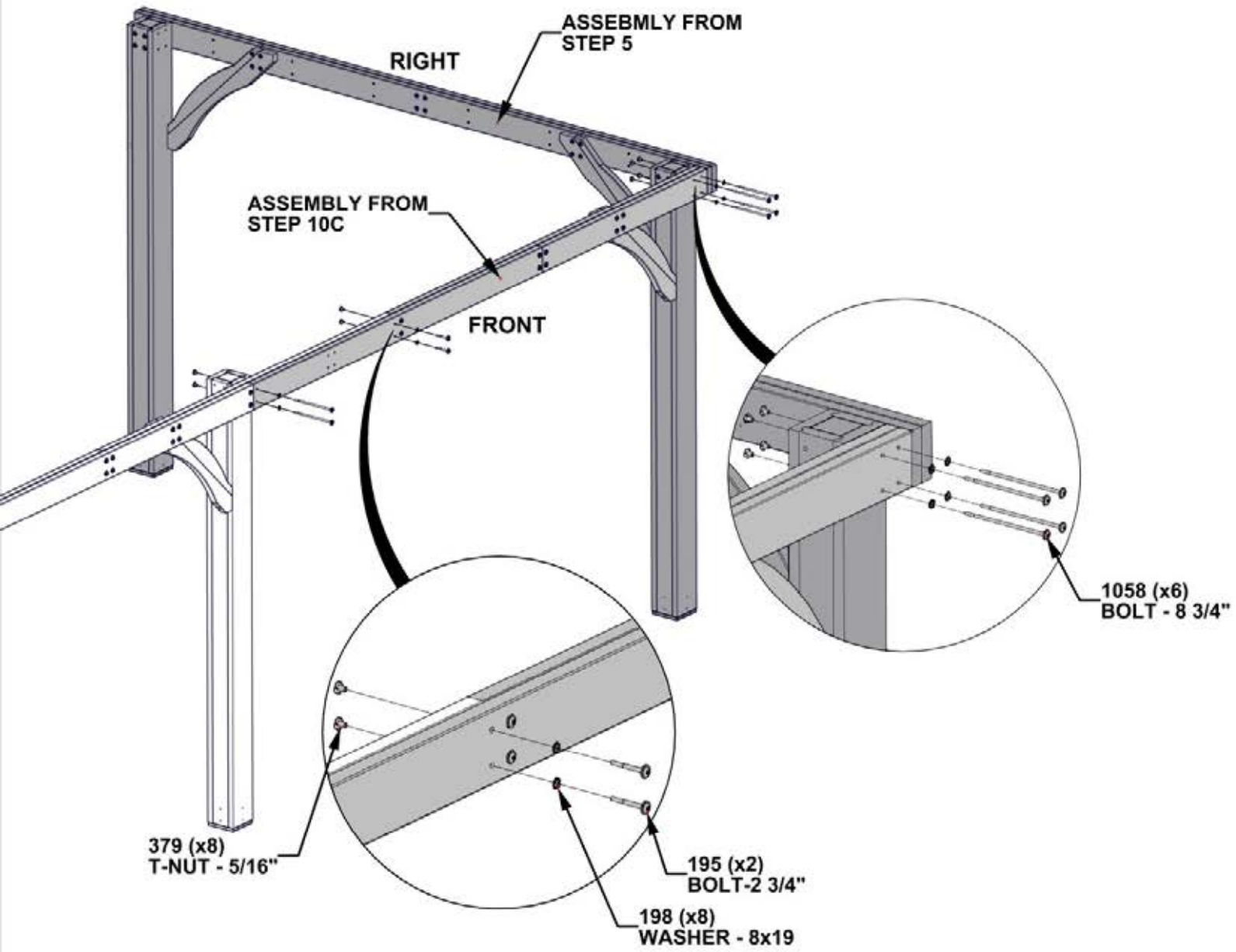

STEP 11B - GAZEBO ASSEMBLY

QTY	PART NUMBER	DESCRIPTION
4	H100198	WASHER LOCK EXT 8x19
4	H100379	T-NUT 5/16 BLK
2	H100405	WASHER LOCK EXT 6x15
4	H100513	BOLT WH 5/16x4 1/4 BLK
2	H100792	LAG SCREW WH 1/4x3 BLK



C01 CORBEL - W2A03198
(x1) 1 7/16"x6 7/16"x35 1/8" (36x163x893)

INSERT T-NUTS FIRST

INSERT LAG SCREWS LAST.

TO AVOID WOOD SPLITTING, MAKE SURE LAG SCREWS GO INTO PILOT HOLES.

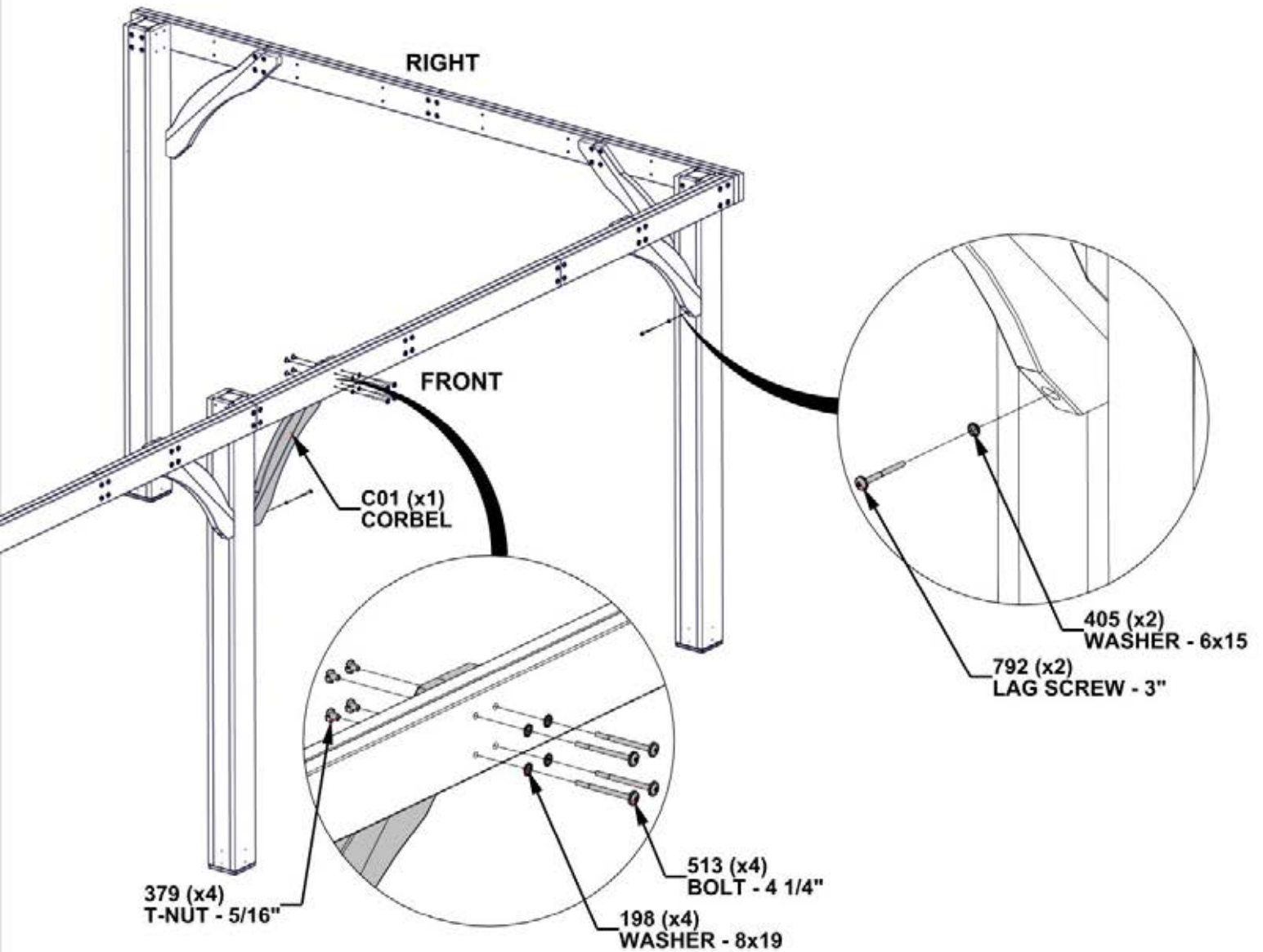

STEP 11C - GAZEBO ASSEMBLY

QTY	PART NUMBER	DESCRIPTION
4	H100483	SCREW PFH 8x2 1/4 BLK

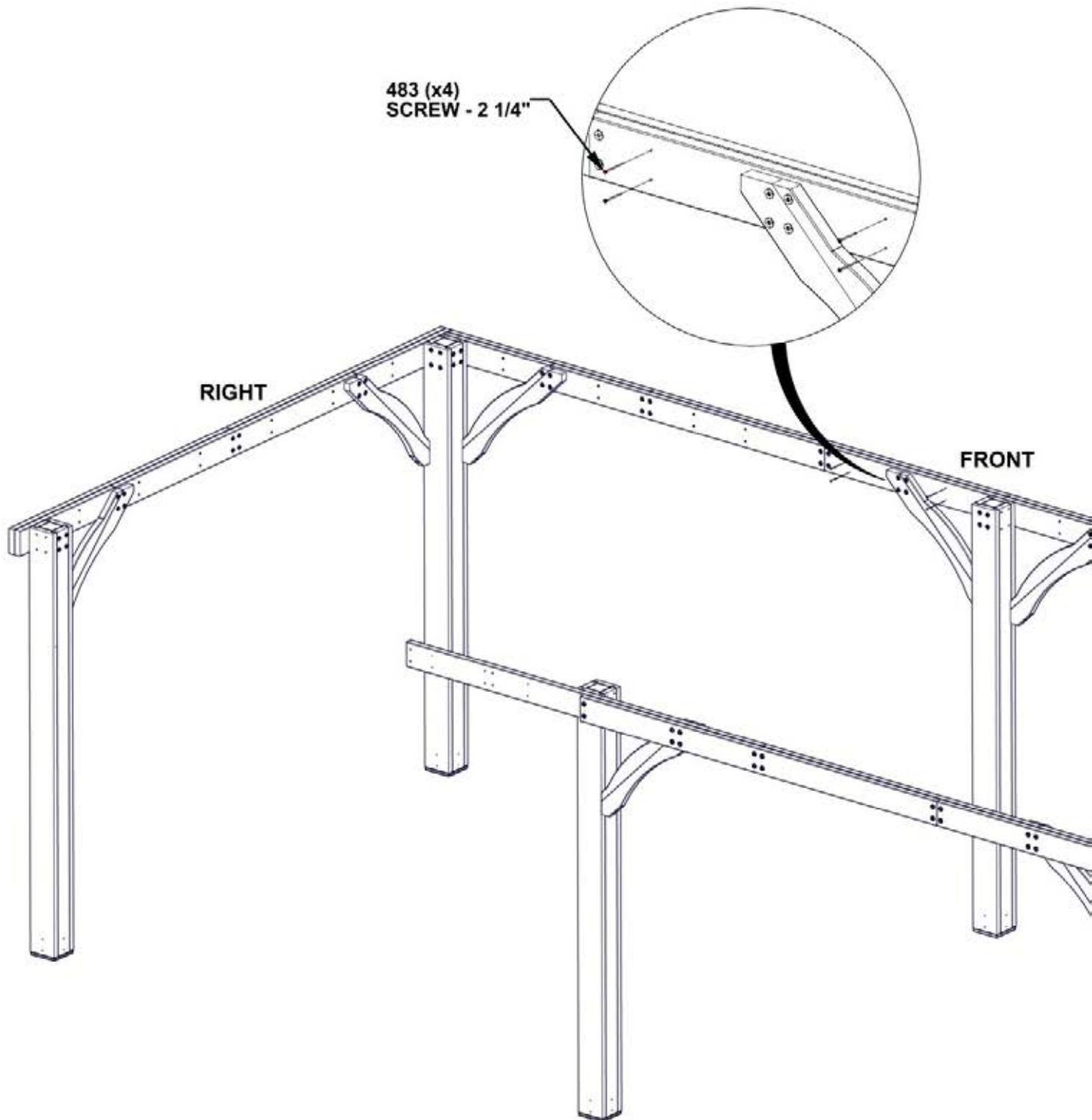

STEP 12A - BEAM ASSEMBLY

QTY	PART NUMBER	DESCRIPTION
2	H100483	SCREW PFH 8x2 1/4 BLK



D07 BEAM - W4L19814
(x1) 1 7/16"x5 1/4"x51" (36x134x1296)



D04 BEAM - W4L20650
(x1) 1 7/16"x5 1/4"x27 1/16" (36x134x688)

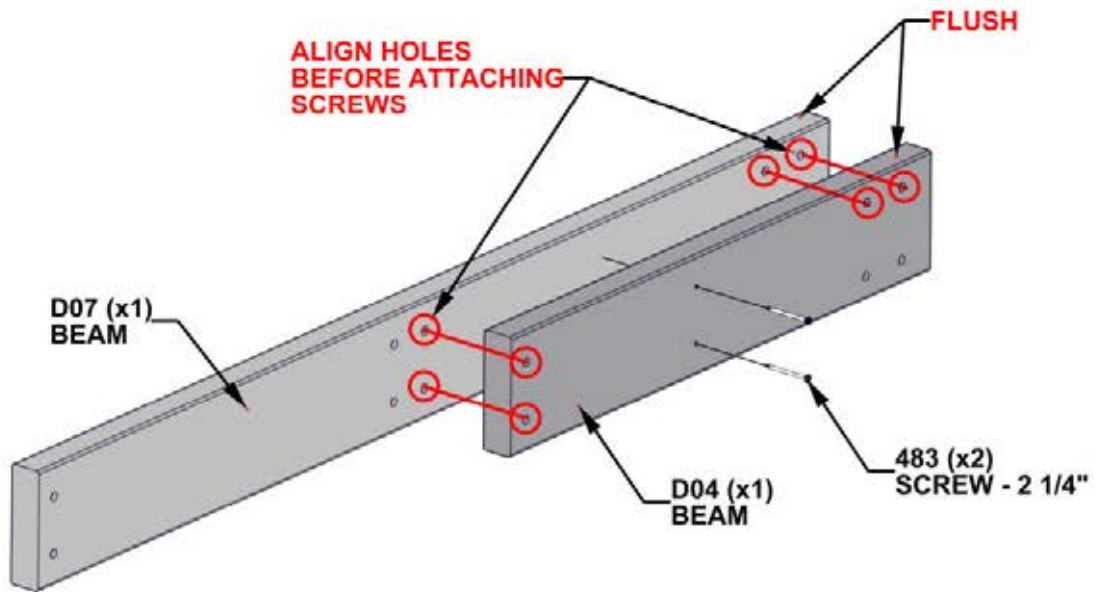

STEP 12B - BEAM ASSEMBLY

QTY	PART NUMBER	DESCRIPTION
6	H100195	BOLT WH 5/16x2 3/4 BLK
6	H100198	WASHER LOCK EXT 8x19
6	H100379	T-NUT 5/16 BLK
6	H100483	SCREW PFH 8x2 1/4 BLK

D08 BEAM - W4L20651
(x1) 1 7/16"x5 1/4"x68 3/4" (36x134x1746)

D06 BEAM - W4L20653
(x1) 1 7/16"x5 1/4"x89 1/2" (36x134x2274)

A4M02873 RIDGE BRACE
(x1)

INSERT T-NUTS FIRST

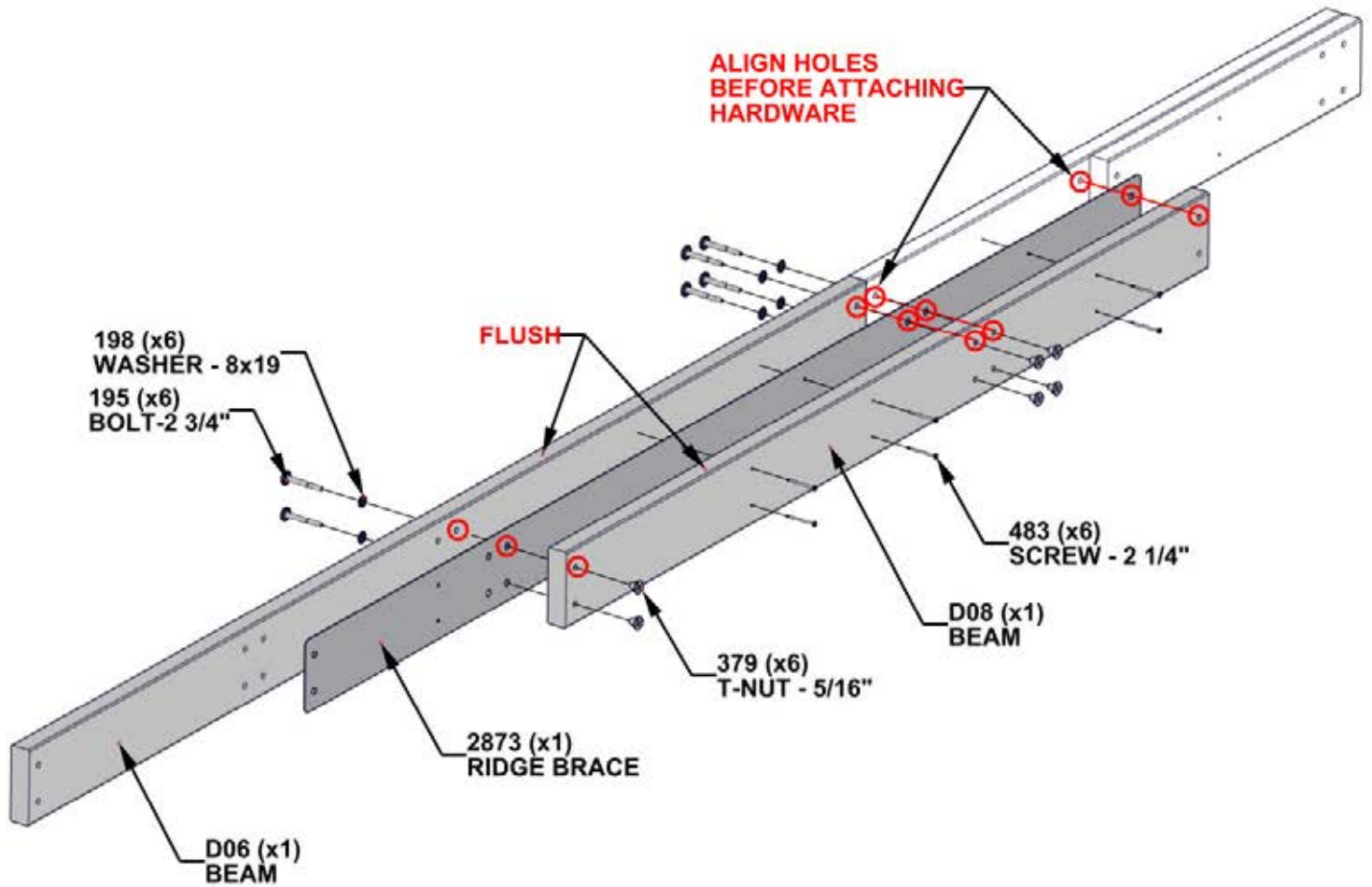

STEP 12C - BEAM ASSEMBLY

QTY	PART NUMBER	DESCRIPTION
4	H100198	WASHER LOCK EXT 8x19
4	H100379	T-NUT 5/16 BLK
4	H100513	BOLT WH 5/16x4 1/4 BLK



C01 CORBEL - W2A03198
(x1) 1 7/16"x6 7/16"x35 1/8" (36x163x893)

INSERT T-NUTS FIRST

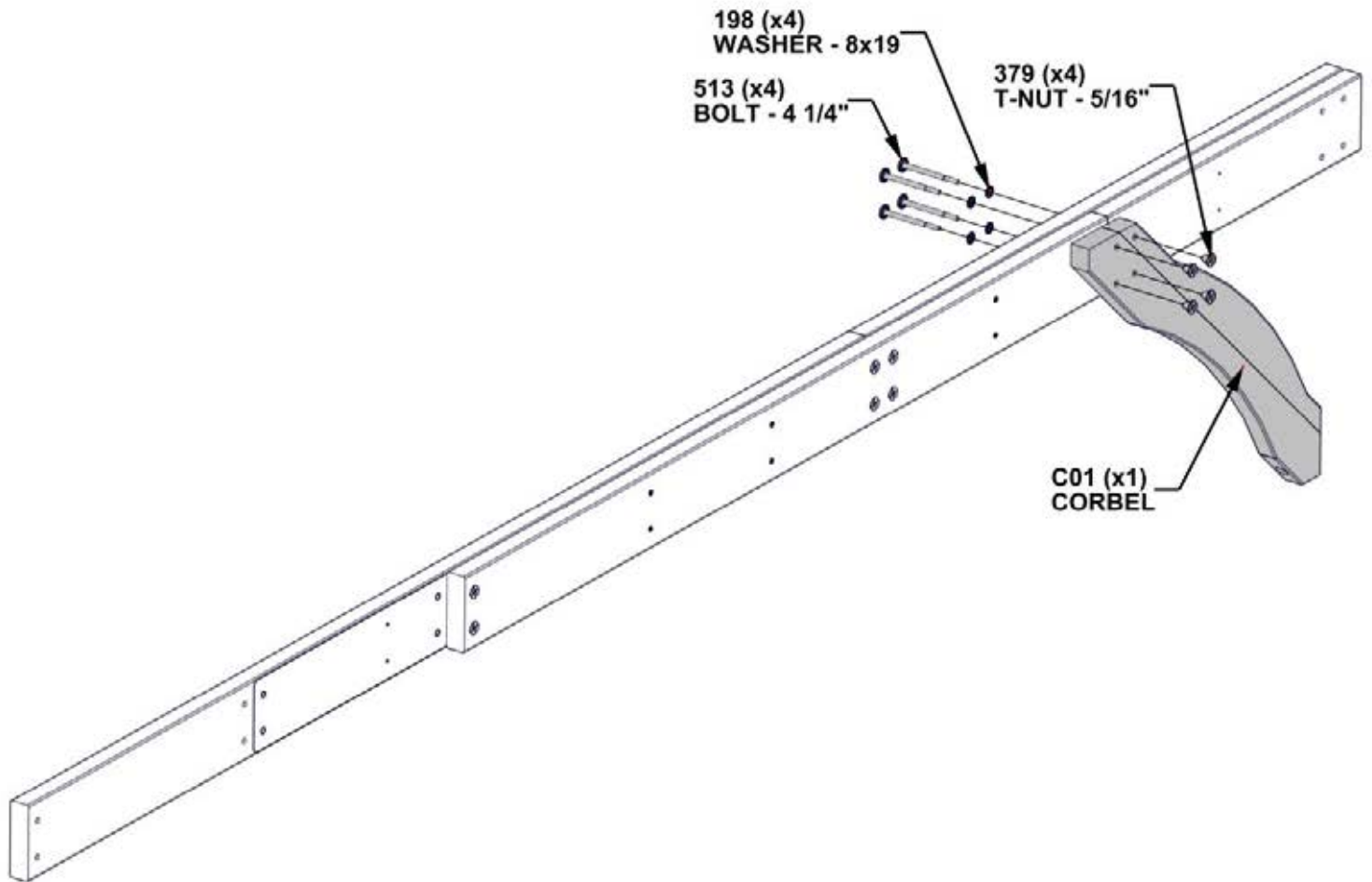

STEP 13A - GAZEBO ASSEMBLY

QTY	PART NUMBER	DESCRIPTION
2	H100195	BOLT WH 5/16x2 3/4 BLK
8	H100198	WASHER LOCK EXT 8x19
8	H100379	T-NUT 5/16 BLK
6	H101058	BOLT WH 5/16x8 3/4 BLK

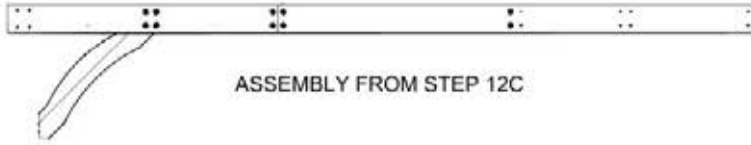

INSERT T-NUTS FIRST

FOR THIS STEP IT IS HELPFUL TO HAVE 3 ADDITIONAL PEOPLE TO HELP STAND UP THE ASSEMBLY AND ATTACH HARDWARE.

SAW DUST CAN BE LEFT BEHIND IN BOLT HOLES. IF YOU HAVE TROUBLE WITH BOLTS ENGAGING, USE A LONG SCREW DRIVER TO REMOVE THE DEBRIS.

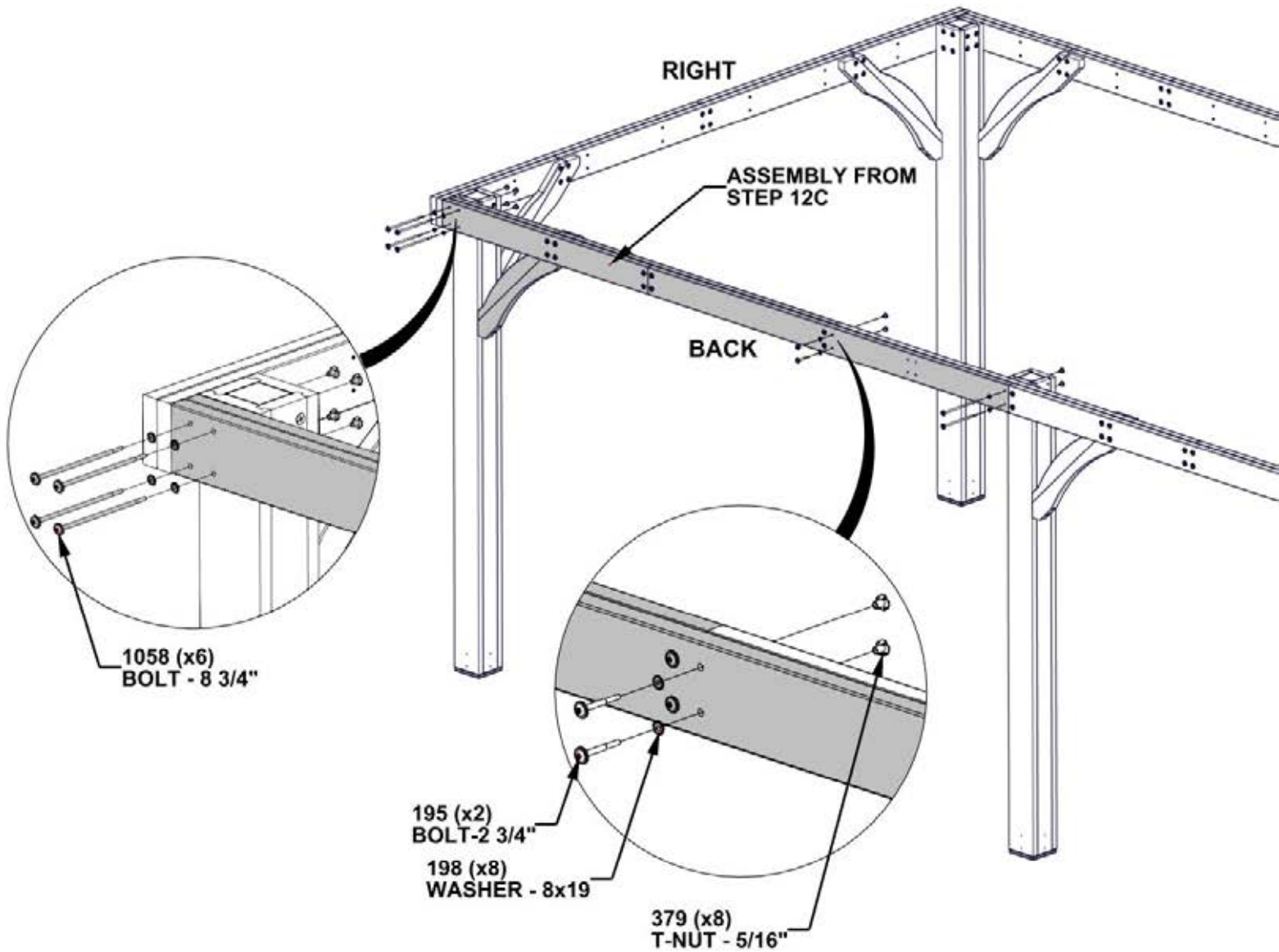

STEP 13B - GAZEBO ASSEMBLY

QTY	PART NUMBER	DESCRIPTION
4	H100198	WASHER LOCK EXT 8x19
4	H100379	T-NUT 5/16 BLK
2	H100405	WASHER LOCK EXT 6x15
4	H100513	BOLT WH 5/16x4 1/4 BLK
2	H100792	LAG SCREW WH 1/4x3 BLK



C01 CORBEL - W2A03198
(x1) 1 7/16"x6 7/16"x35 1/8" (36x163x893)

INSERT T-NUTS FIRST

INSERT LAG SCREWS LAST.

TO AVOID WOOD SPLITTING, MAKE SURE LAG SCREWS GO INTO PILOT HOLES.

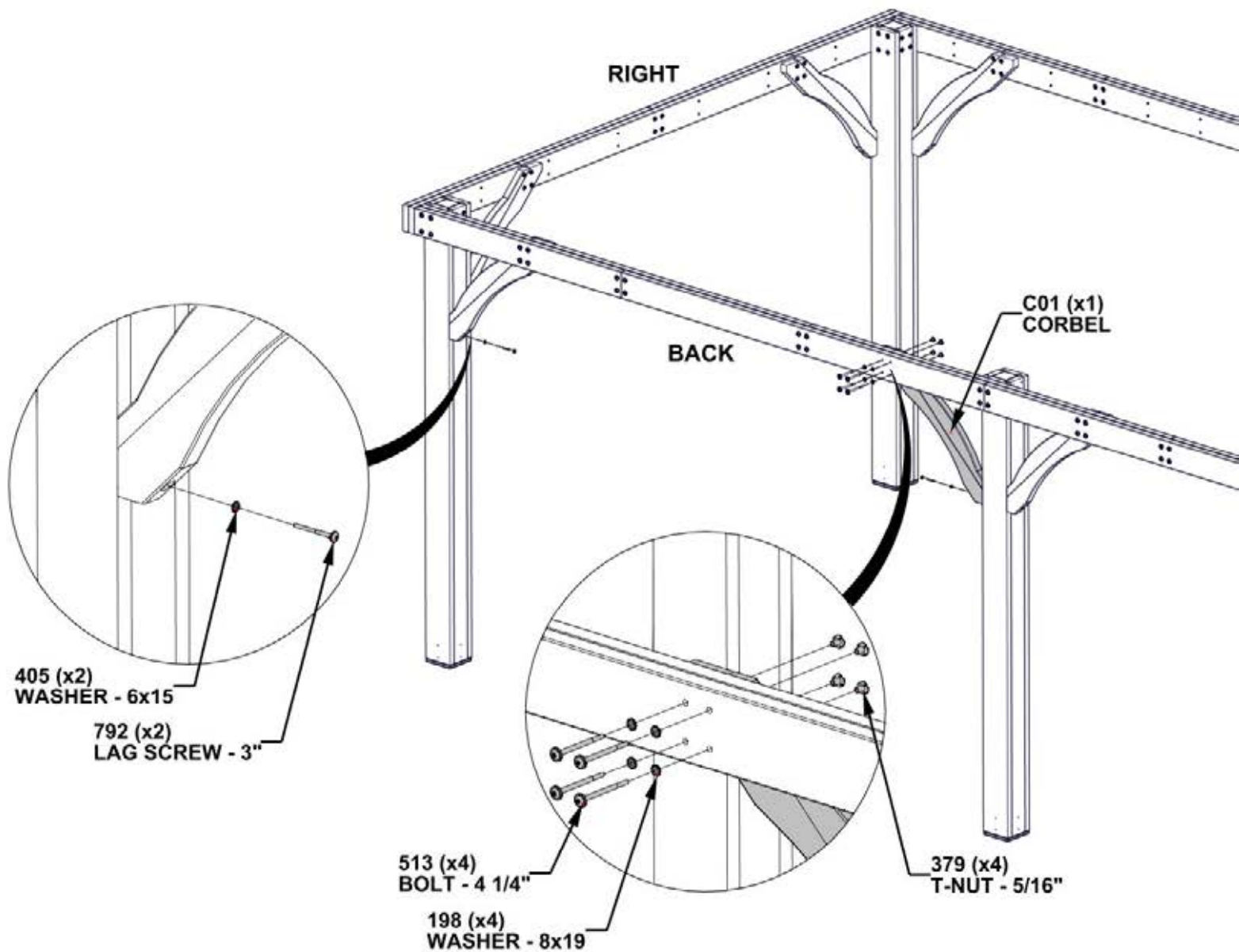

STEP 13C - GAZEBO ASSEMBLY

QTY	PART NUMBER	DESCRIPTION
4	H100483	SCREW PFH 8x2 1/4 BLK

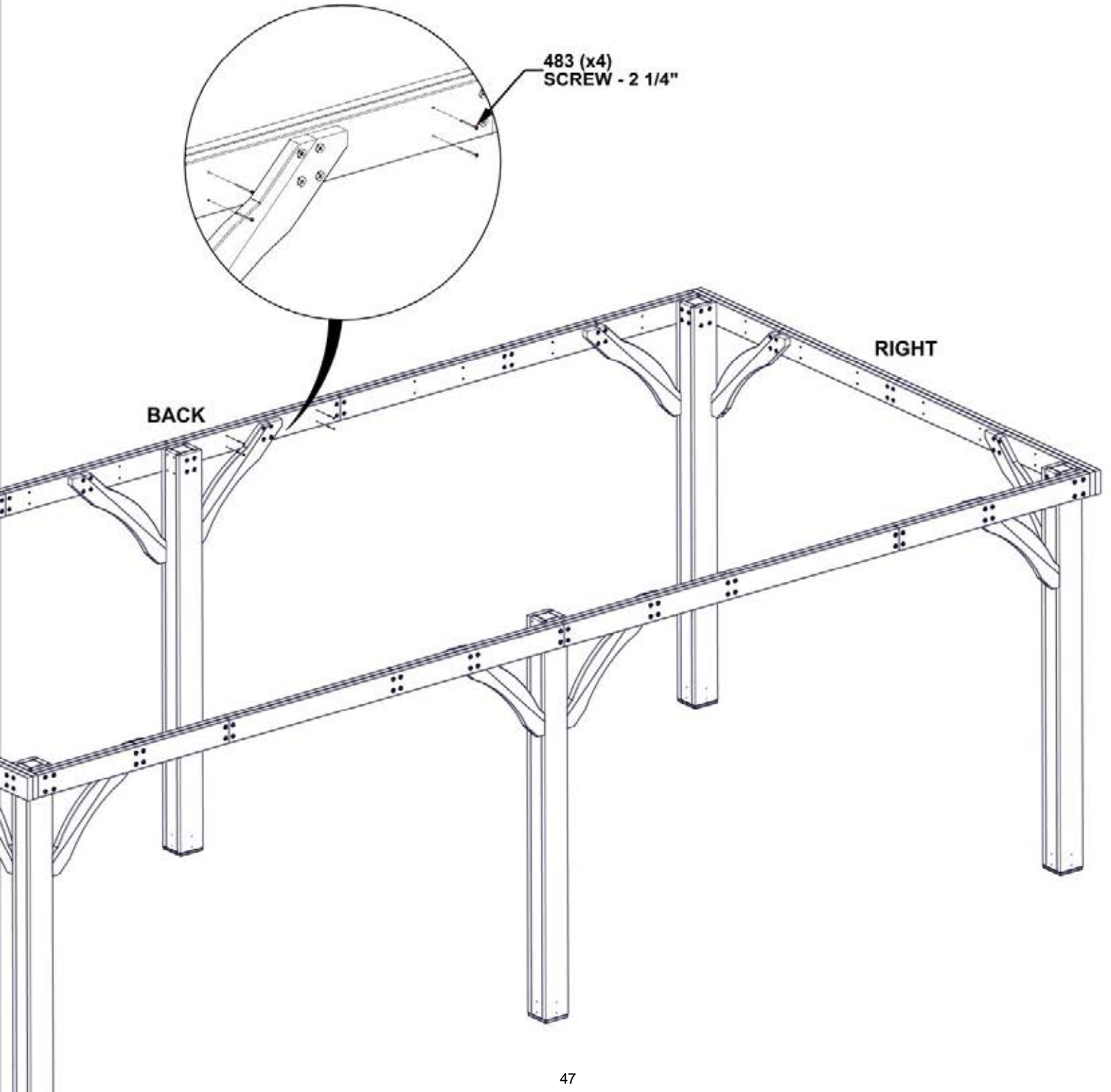

STEP 14 - SQUARE ASSEMBLY

**CRITICAL: SQUARE GAZEBO BEFORE PROCEEDING TO NEXT STEPS.
ONCE SQUARE, TIGHTEN ALL HARDWARE.**

MEASUREMENTS TAKEN FROM INSIDE OF POST TO INSIDE OF POST.

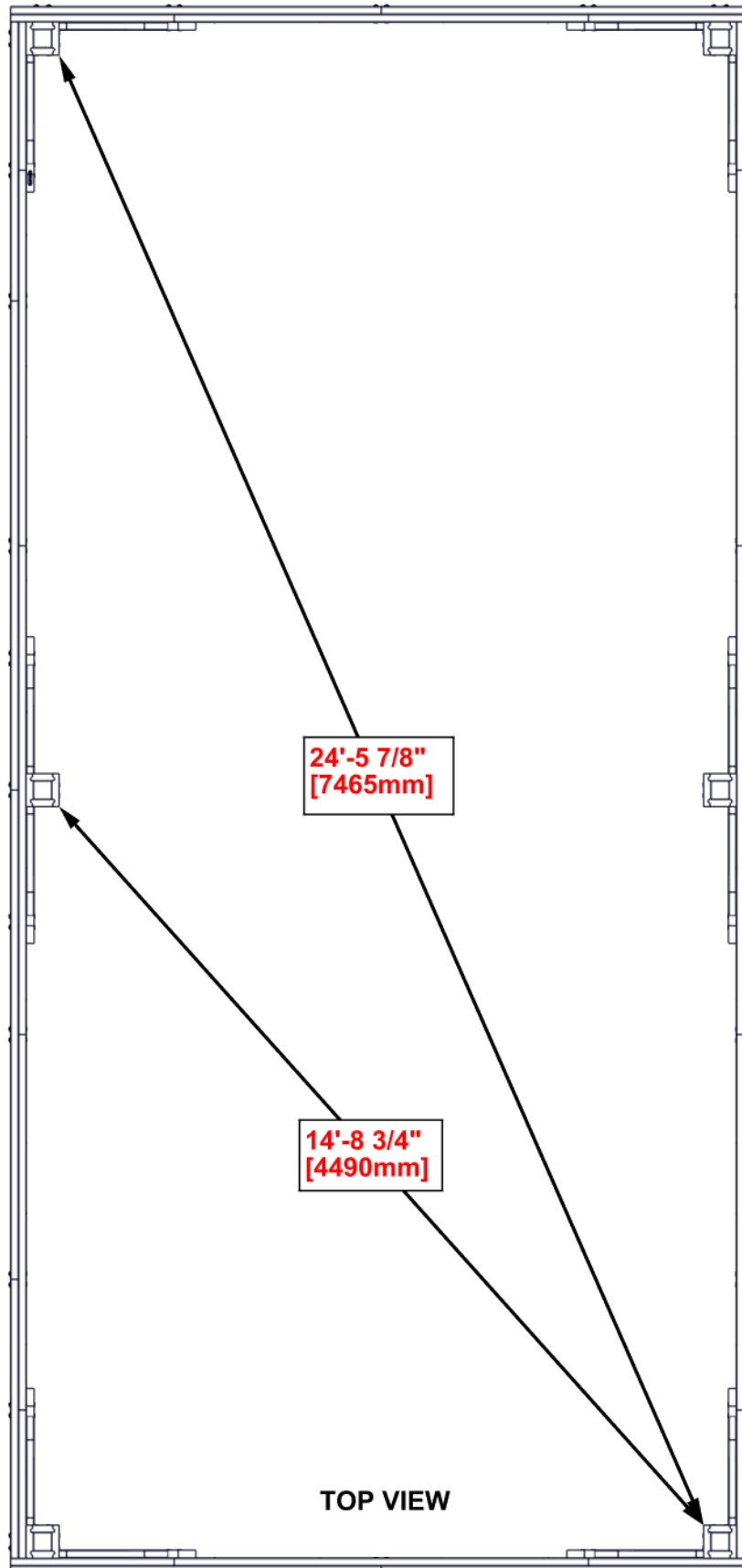

STEP 15A - ROOF SUPPORTS

QTY	PART NUMBER	DESCRIPTION
16	H100460	LAG SCREW WH 1/4x1 BLK

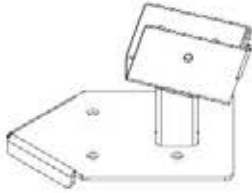

A4M01234 POST CLIP ASSEMBLY
(x4)

DO NOT OVERTIGHTEN

REPEAT ON ALL FOUR CORNER POSTS

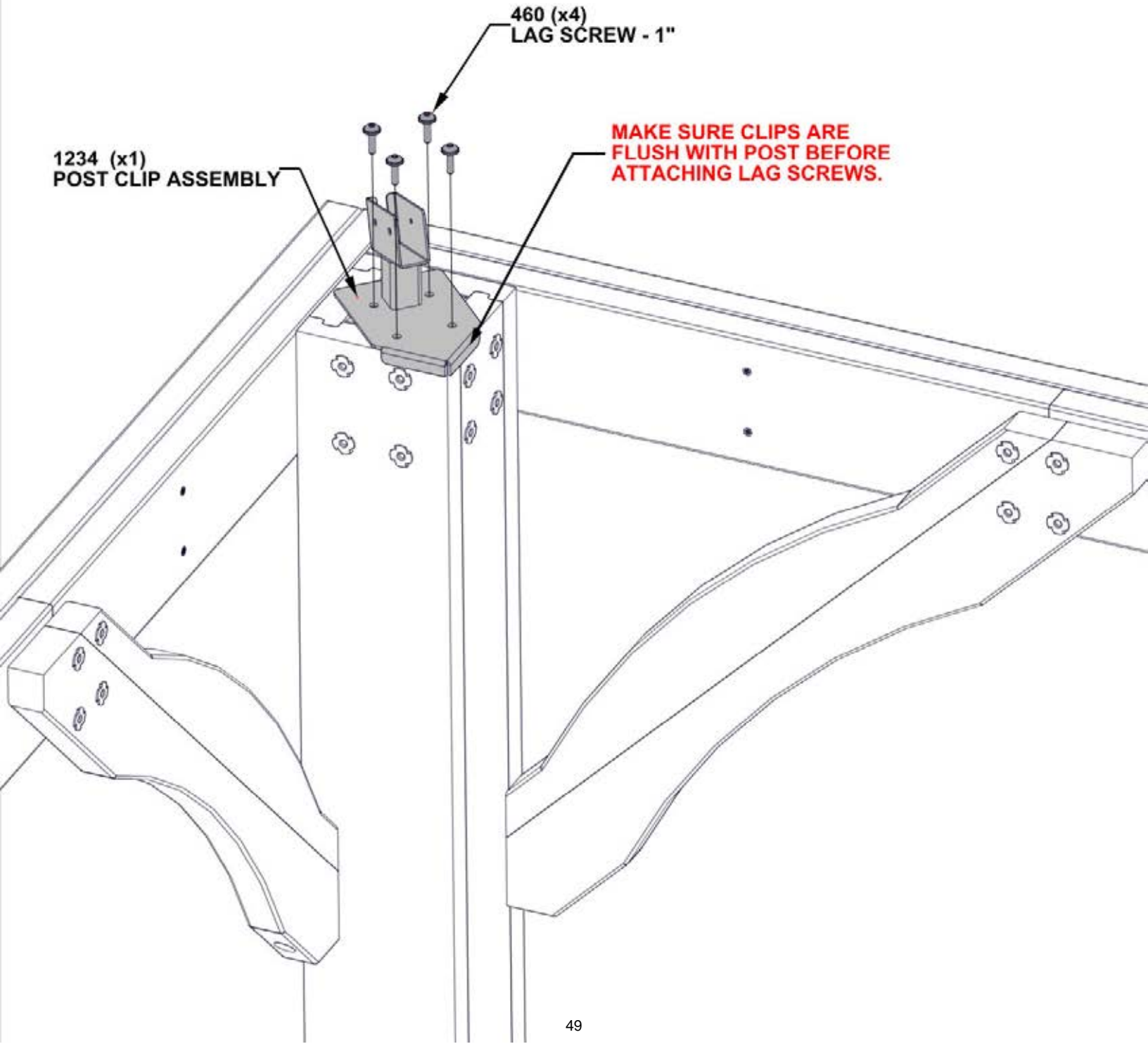

STEP 15B - ROOF SUPPORTS

QTY	PART NUMBER	DESCRIPTION
8	H100460	LAG SCREW WH 1/4x1 BLK

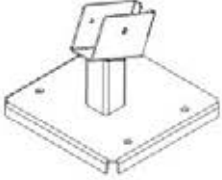

A4M01894 MIDDLE POST CLIP ASSEMBLY
(x2)

**DO NOT OVERTIGHTEN
REPEAT ON OTHER MIDDLE POST**

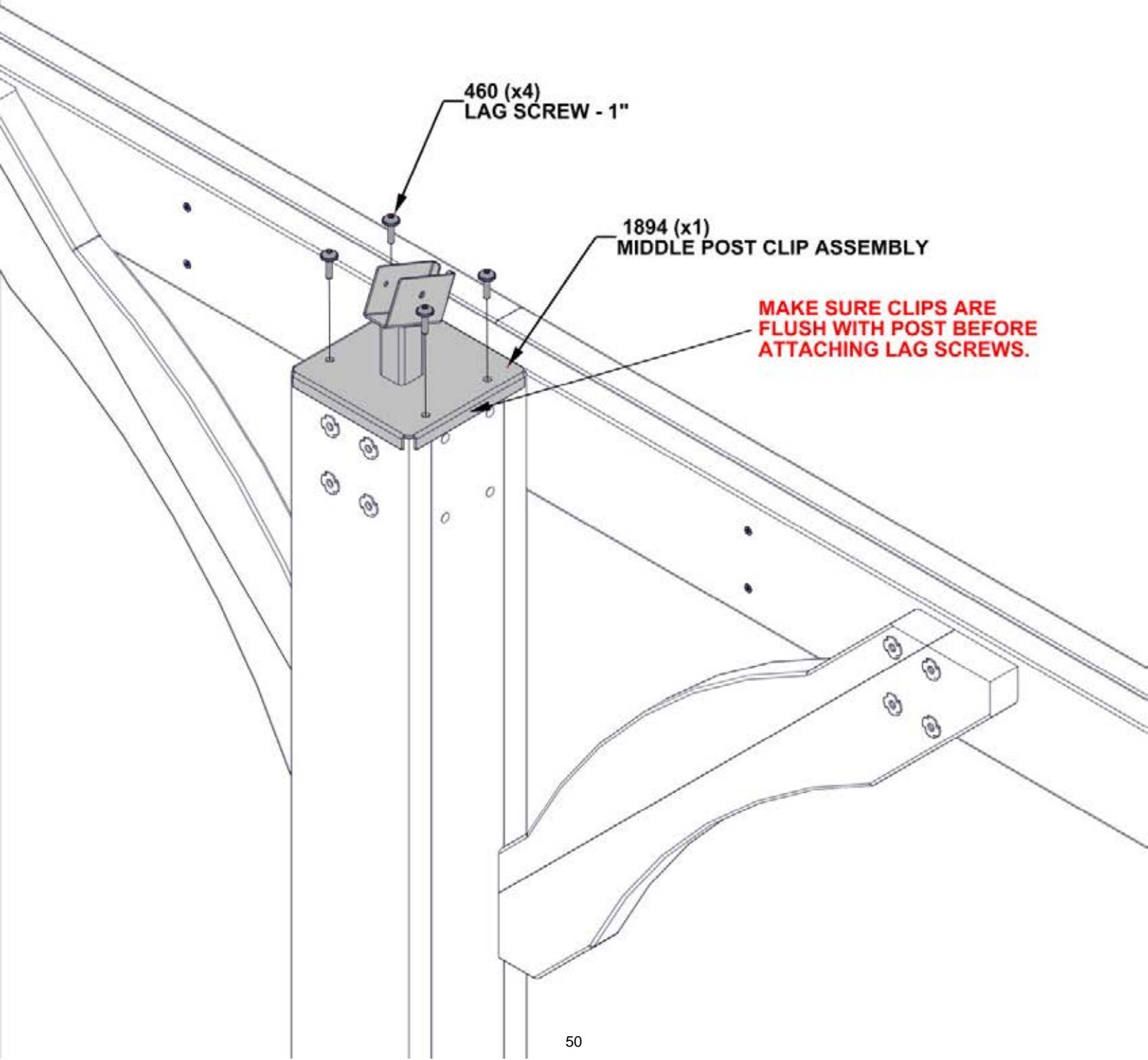

STEP 16A - ROOF SUPPORTS

QTY	PART NUMBER	DESCRIPTION
36	H100382	SCREW PFH 8x1 3/4 BLK



H03 RIDGE BOARD - W4L19452
(x2) 15/16"x3 3/8"x64 1/2" (24x86x1639)

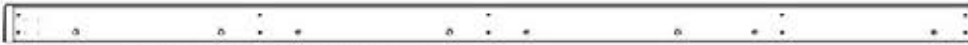

H04 RIDGE BOARD - W4L19453
(x2) 15/16"x3 3/8"x88 9/16" (24x86x2250)



A4M02872 RIDGE BRACE
(x1)

ALIGN PILOT HOLES

FLUSH ENDS AND ALL EDGES BEFORE INSERTING SCREWS

NOTE HOLES CLOSEST TO BOTTOM EDGE

NOTE ORIENTATION OF PILOT HOLES ON TOP SURFACE

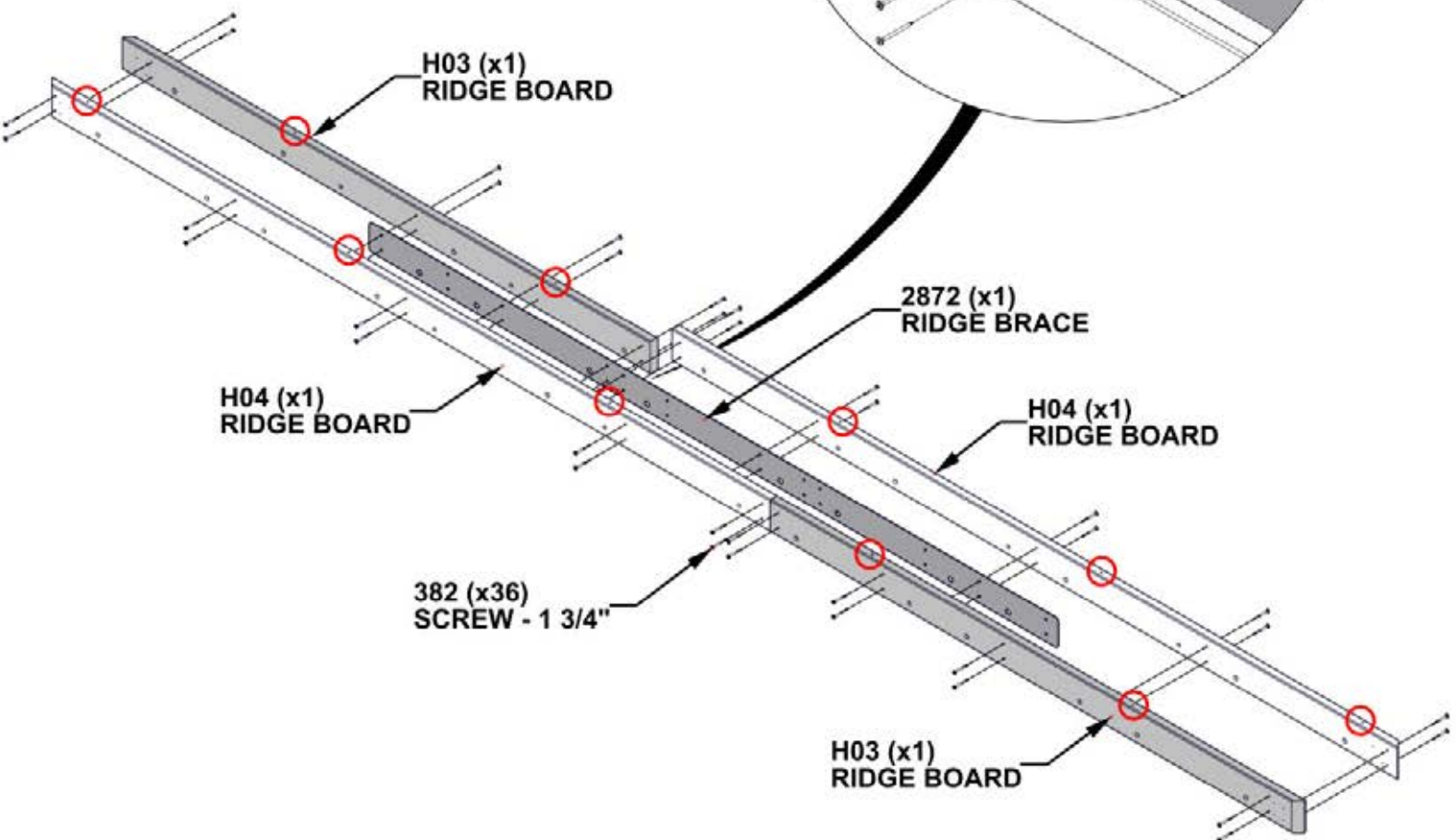
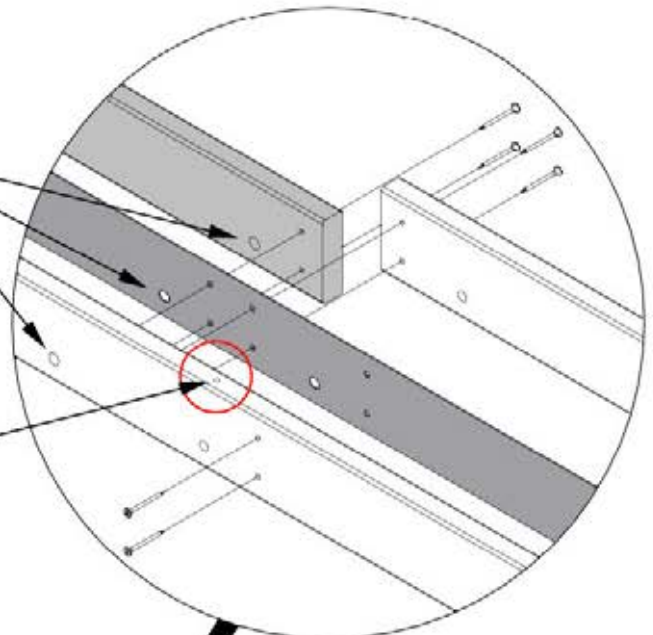

STEP 16B - ROOF SUPPORTS

QTY	PART NUMBER	DESCRIPTION
6	H100379	TNUT-5/16" BLK
16	H100385	SCREW PFH 8x1 BLK

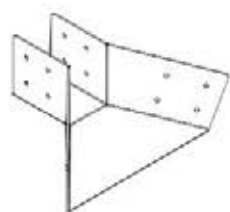

A4M01895 PANEL SUPPORT BRACKET (x2)

INSERT T-NUTS FIRST

USE PILOT HOLES TO ATTACH BRACKETS

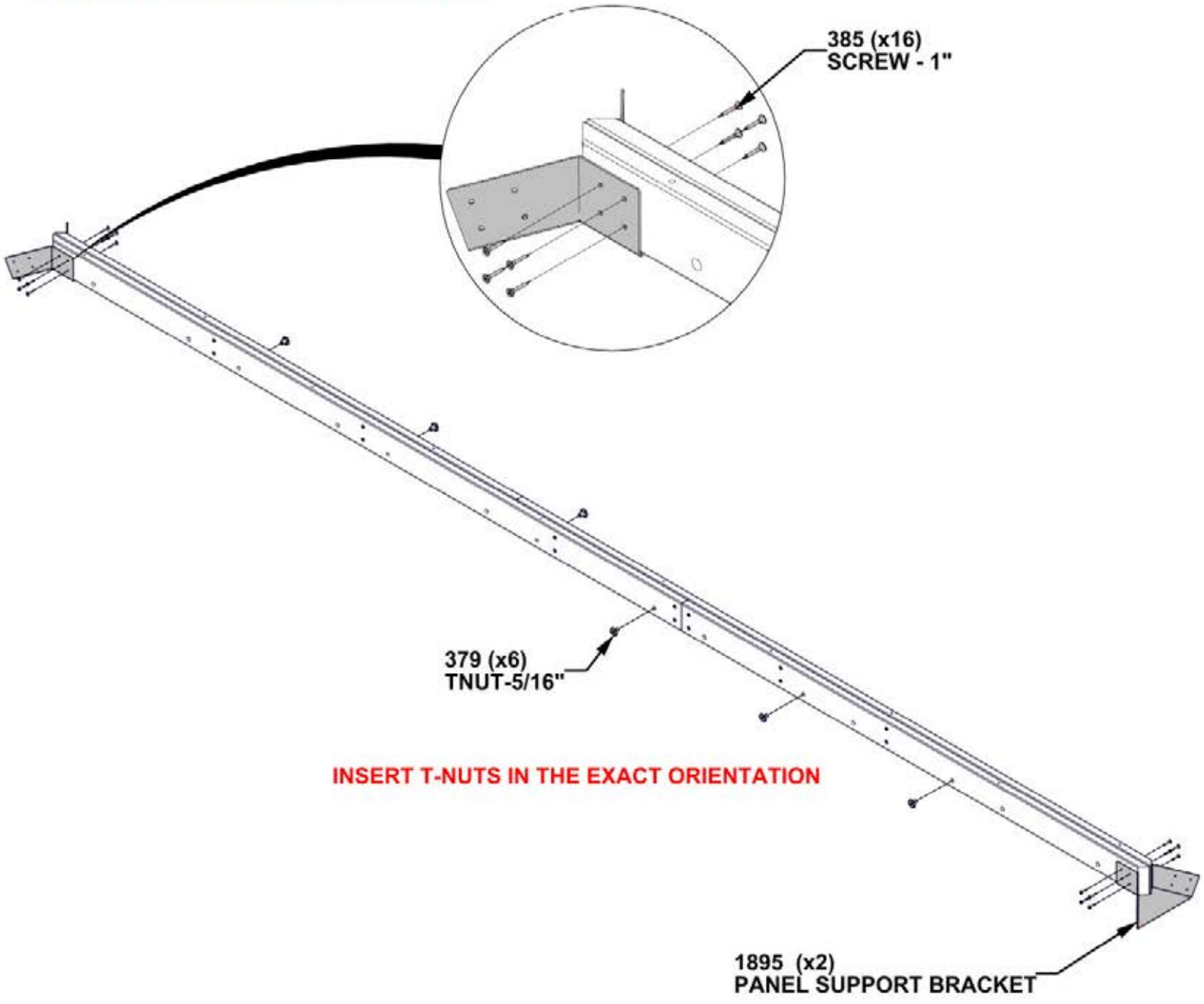

INSERT T-NUTS IN THE EXACT ORIENTATION

STEP 16C - ROOF SUPPORTS

QTY	PART NUMBER	DESCRIPTION
2	H100403	LAG SCREW WH 1/4x1 1/2 BLK

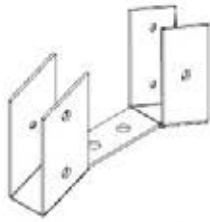

A4M01902 RAFTER HANGER
(x1)

ALIGN PILOT HOLES

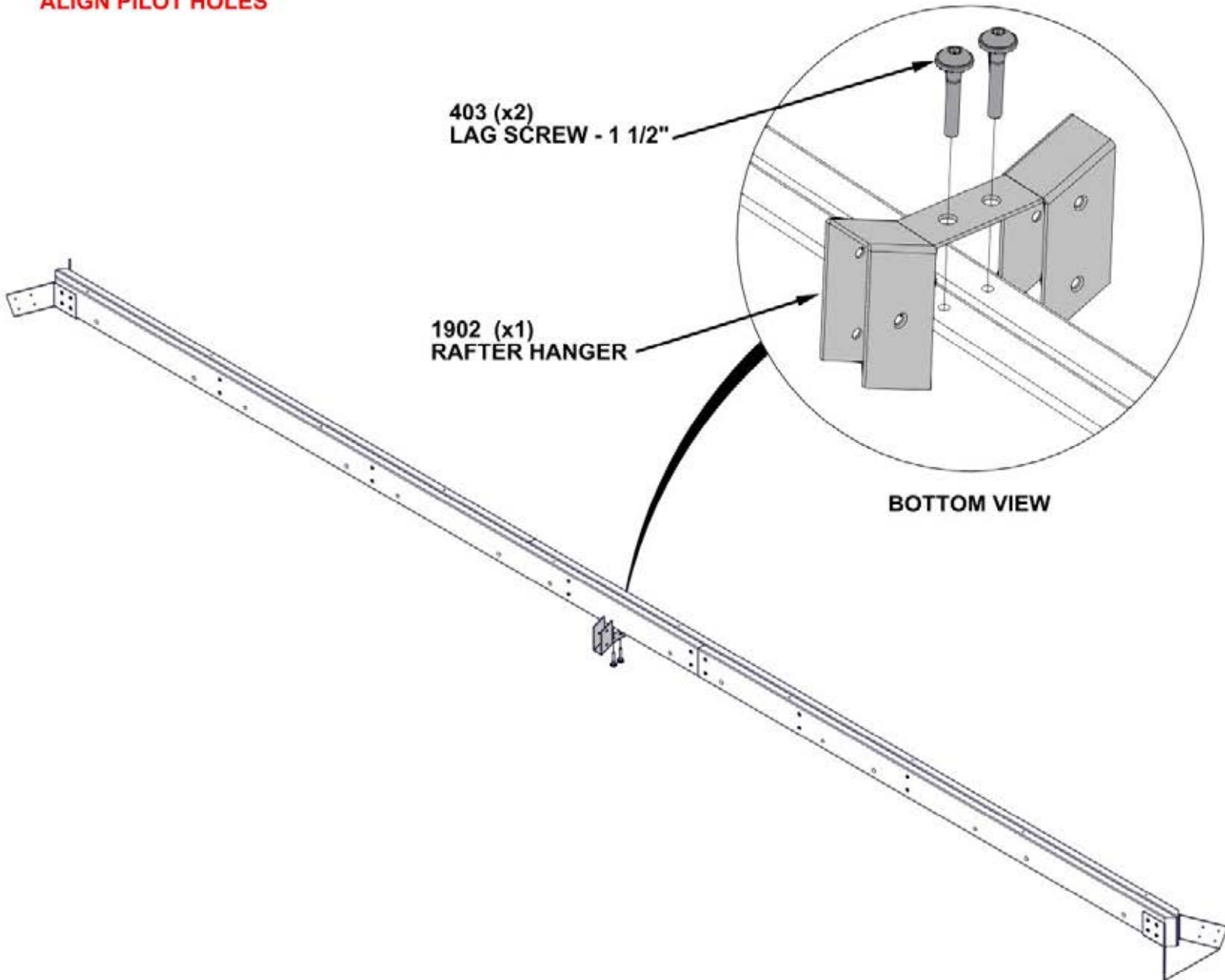

STEP 17 - ROOF SUPPORTS

QTY	PART NUMBER	DESCRIPTION
48	H100385	SCREW PFH 8x1 BLK



H02 RAFTER - W4L17522
(x4) 15/16"x3 3/8"x39 3/8" (24x86x1000)



H01 RAFTER - W4L17521
(x4) 15/16"x3 3/8"x54 1/8" (24x86x1374)

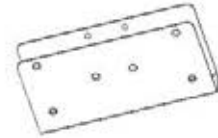

A4M01237 ROOF SUPPORT SPLICE CLIP
(x4)

ALIGN PILOT HOLES

REPEAT THIS STEP 4 TIMES

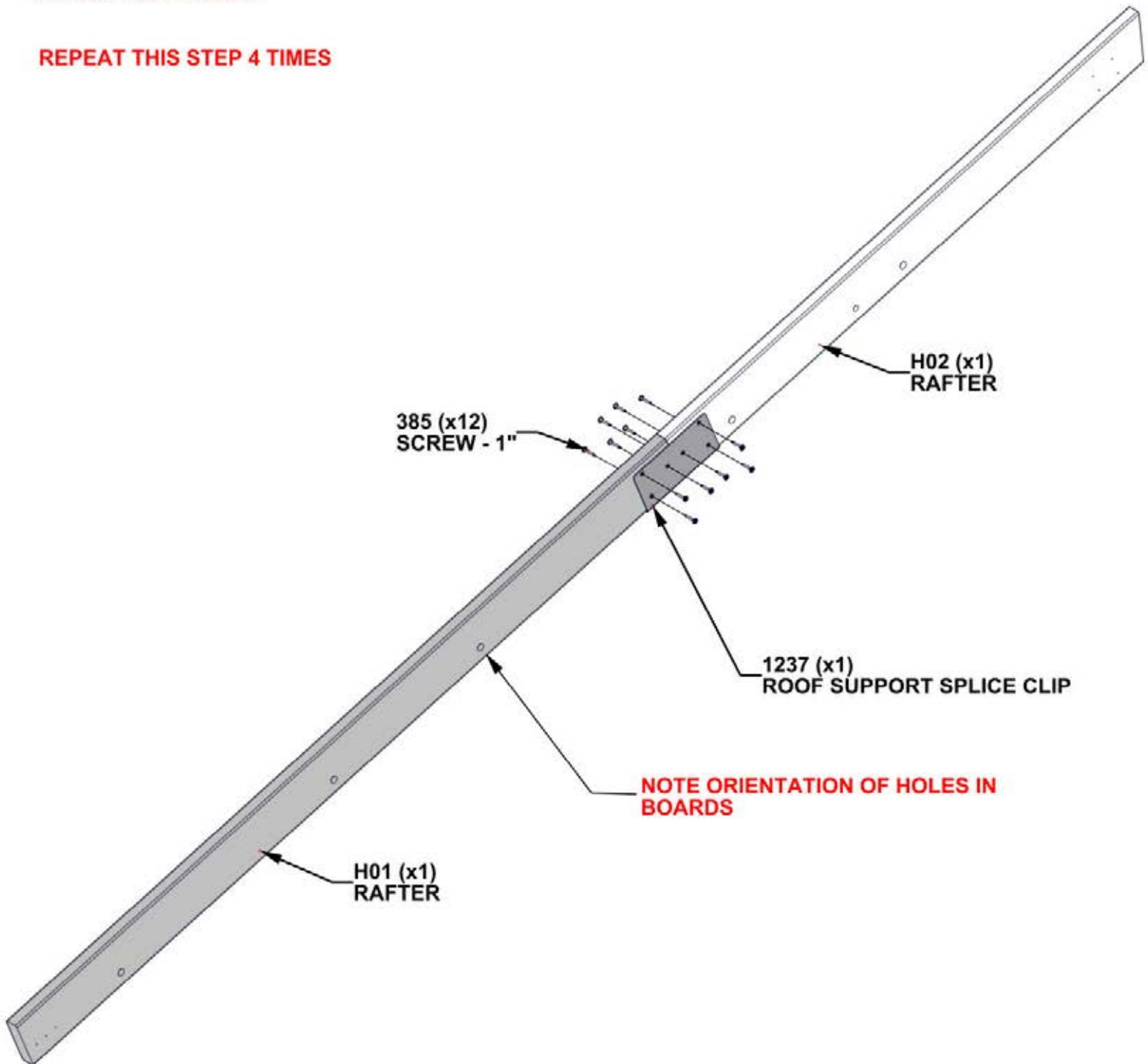

STEP 18 - ROOF SUPPORTS

QTY	PART NUMBER	DESCRIPTION
4	H100379	TNUT-5/16" BLK
16	H100385	SCREW PFH 8x1 BLK

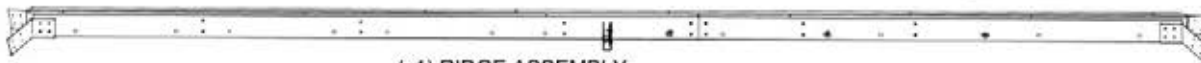

**INSERT T-NUTS FIRST
ALIGN PILOT HOLES**

NOTE HOLES FOR ORIENTATION

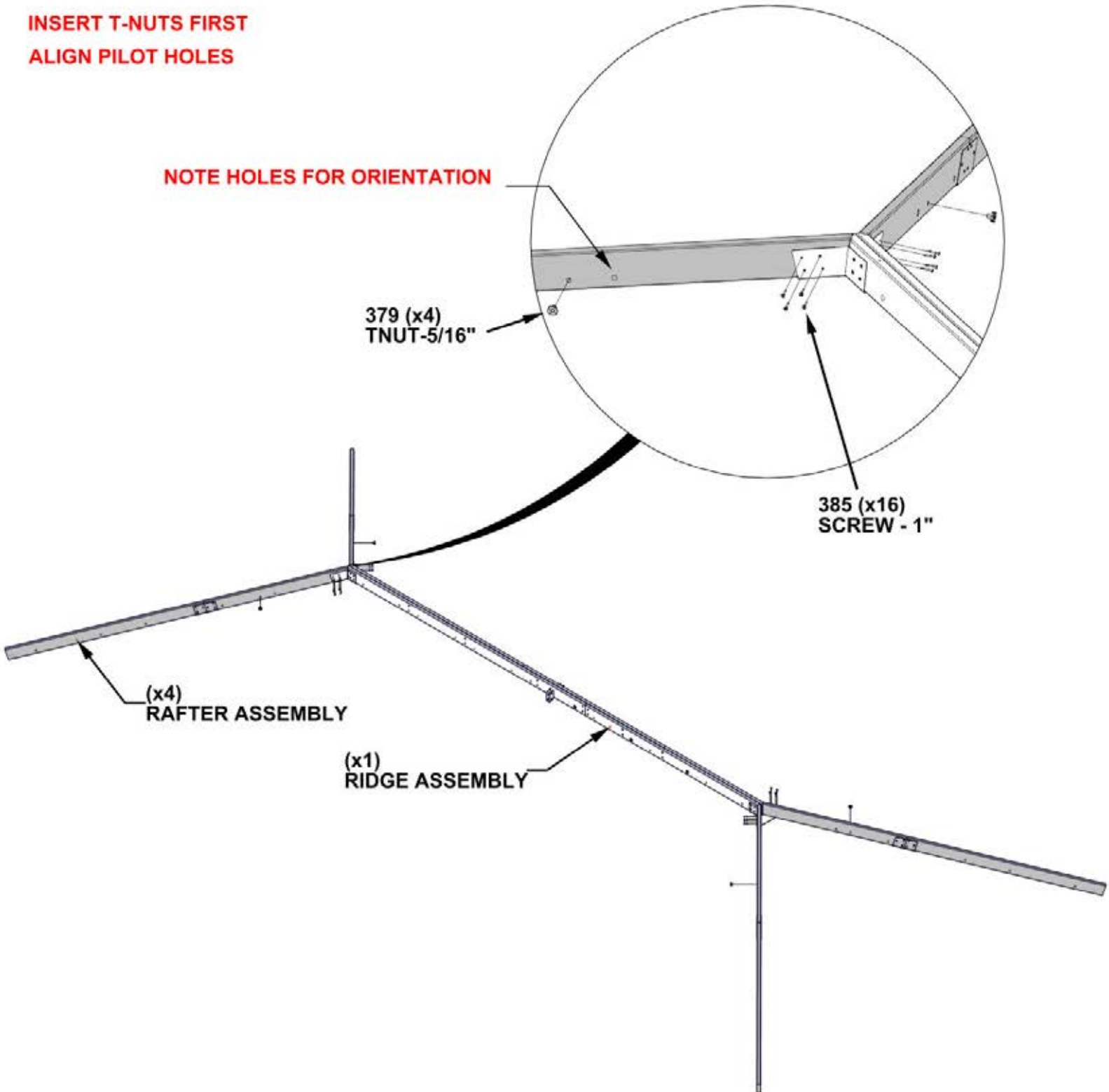

379 (x4)
TNUT-5/16"

385 (x16)
SCREW - 1"

(x4)
RAFTER ASSEMBLY

(x1)
RIDGE ASSEMBLY

STEP 19 - RIDGE CAP ASSEMBLY

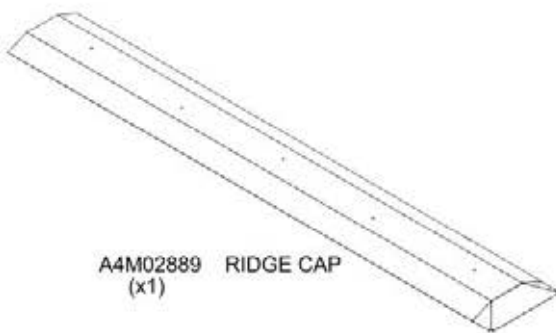
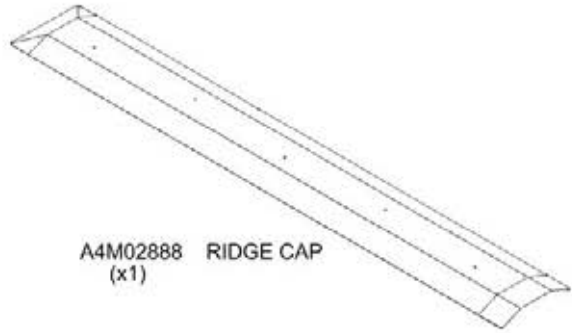

WARNING: GLOVES ARE RECOMMENDED WHEN HANDLING STEEL ROOF PIECES

REMOVE PROTECTIVE BLUE FILM BEFORE ASSEMBLY

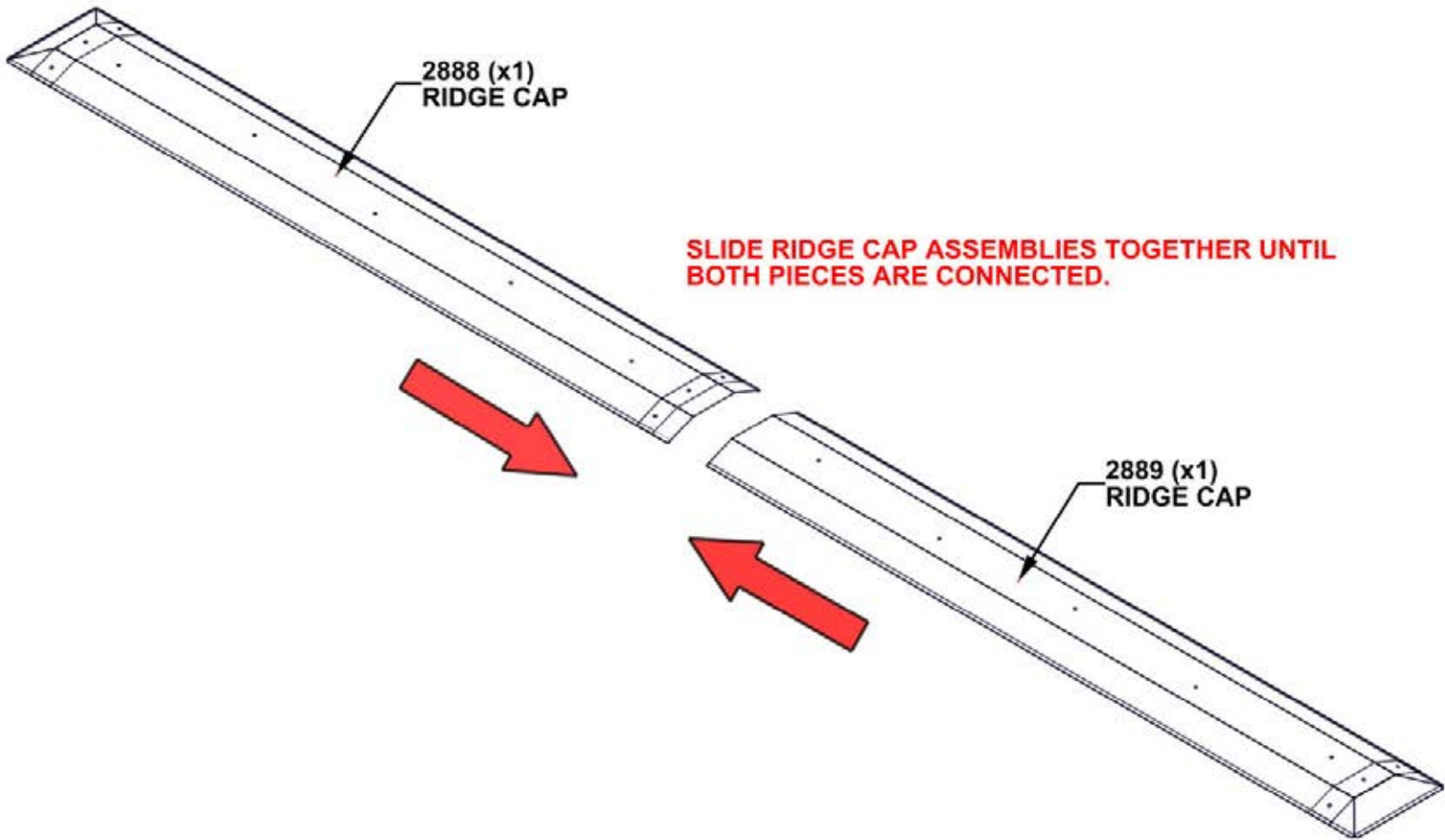

STEP 20 - RIDGE CAP ASSEMBLY

QTY	PART NUMBER	DESCRIPTION
10	H100792	LAG SCREW WH 1/4x3 BLK
10	H101034	WEATHER PROOFING WASHER

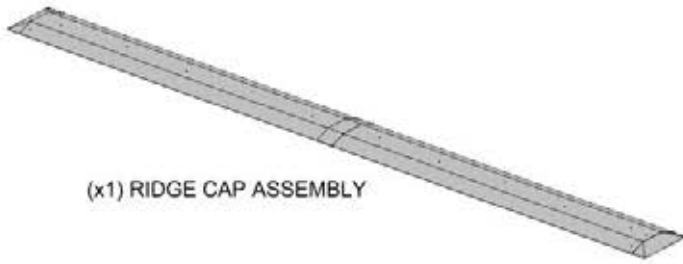

A4M01205 METAL SPACER
(x10)

WARNING: GLOVES ARE RECOMMENDED WHEN HANDLING STEEL ROOF PIECES
LIFT RIDGE CAP ASSEMBLY FROM THE MIDDLE TO PREVENT BENDING

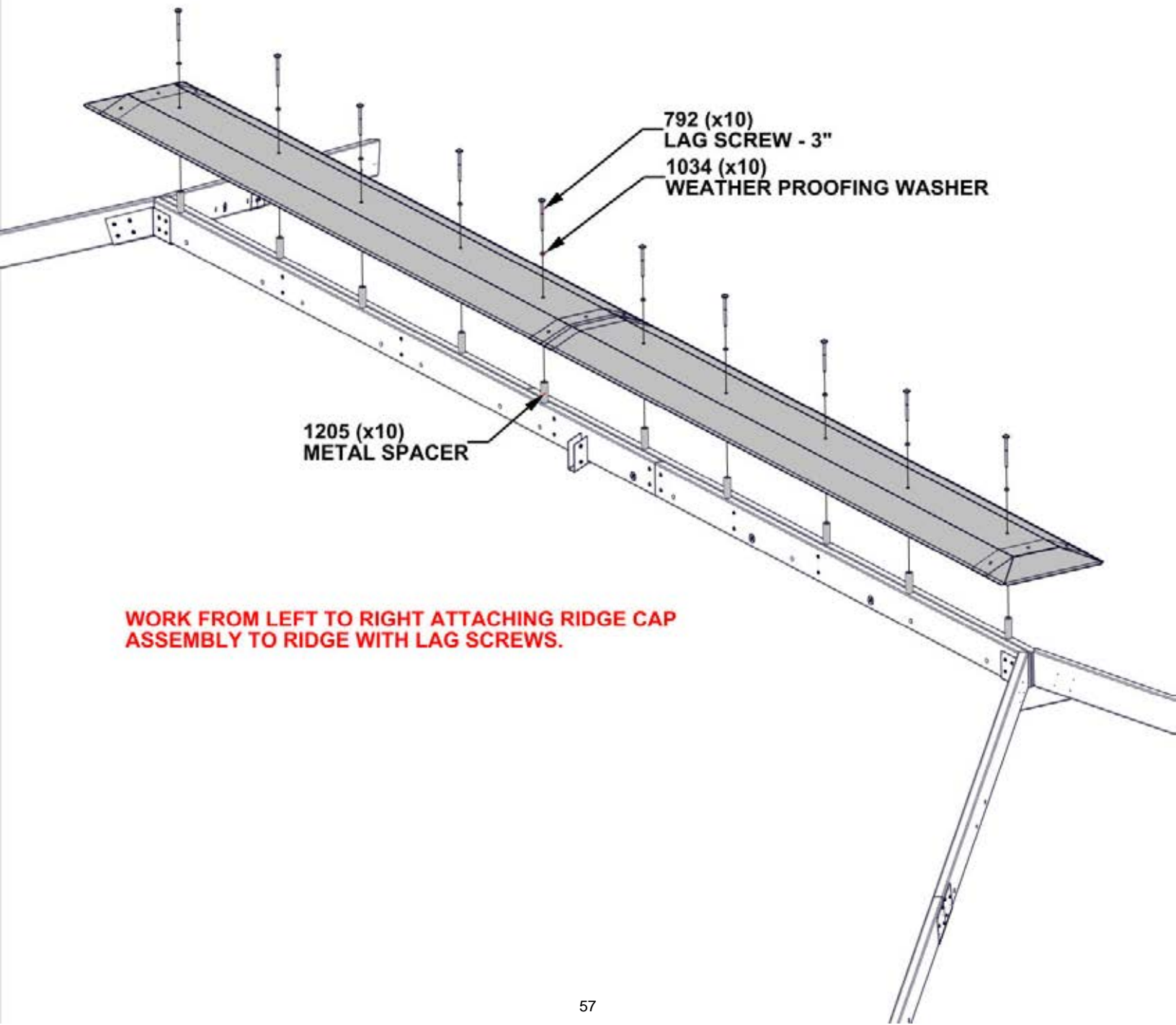

WORK FROM LEFT TO RIGHT ATTACHING RIDGE CAP ASSEMBLY TO RIDGE WITH LAG SCREWS.

STEP 21 - SUPPORT ASSEMBLY

- THREE ADDITIONAL PEOPLE ARE HELPFUL FOR THIS STEP.
- POSITION A PERSON ON A LADDER IN THE CENTER OF THE BASE.
- LIFT ROOF SUPPORT UP AND OVER THE SIDE AND INSERT INTO THE CORNER POST CLIPS.

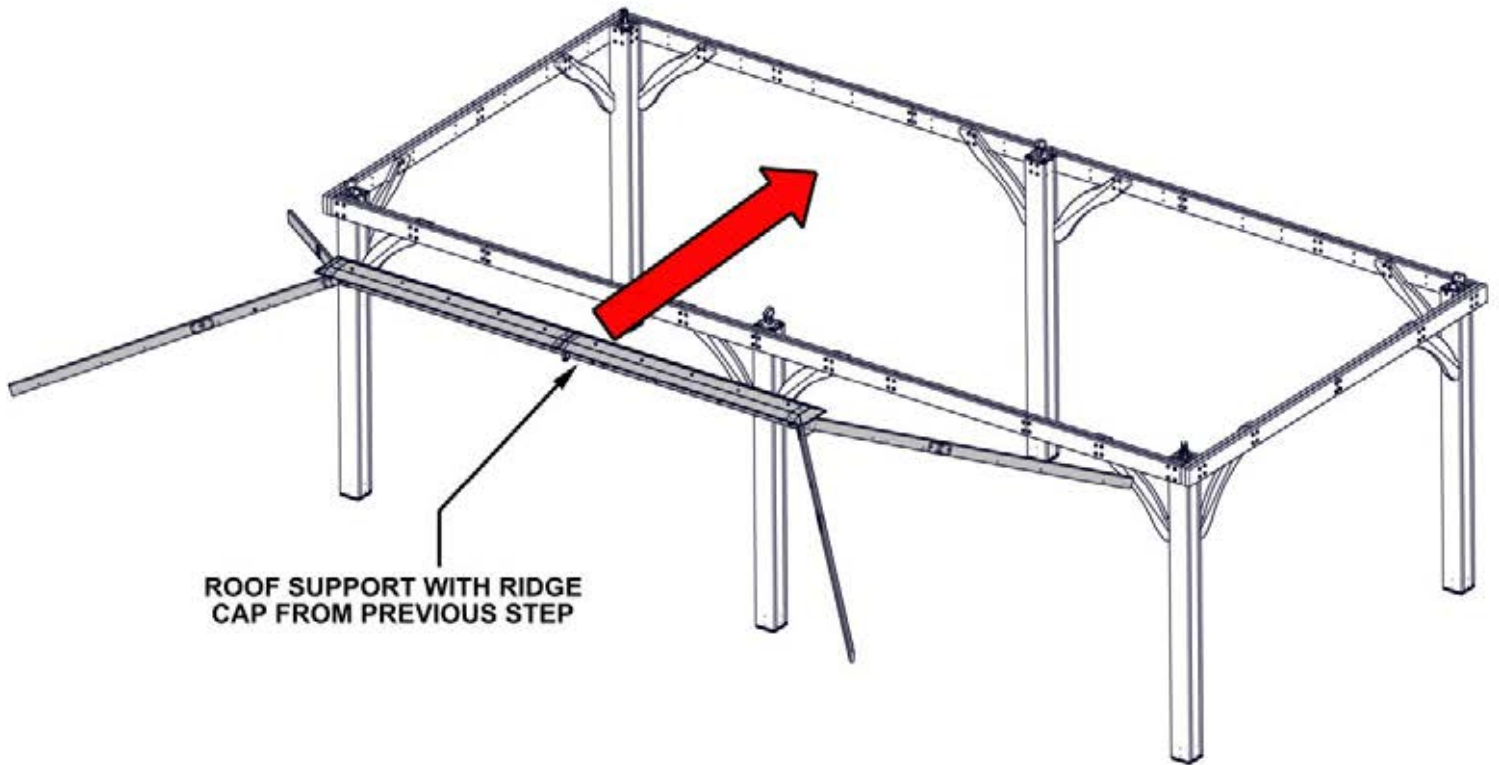

STEP 22 - SUPPORT ASSEMBLY

QTY	PART NUMBER	DESCRIPTION
12	H100385	SCREW PFH 8x1 BLK

REPEAT ON ALL FOUR CORNER POSTS

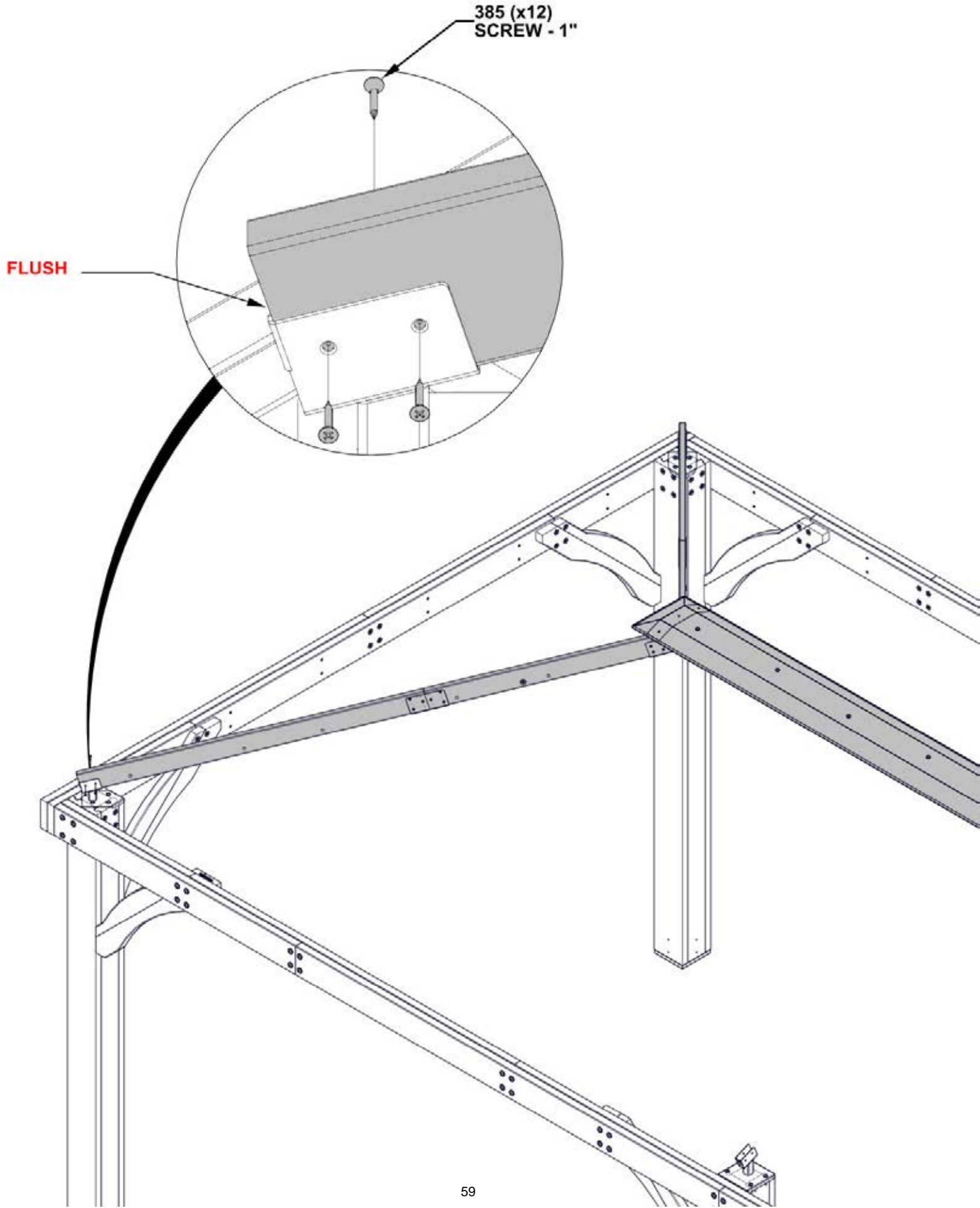

STEP 23 - SUPPORT ASSEMBLY

QTY	PART NUMBER	DESCRIPTION
4	H100379	TNUT-5/16" BLK



H05 RAFTER - W4L20726
(x2) 15/16"x3 3/8"x68 9/16" (24x86x1742)

REPEAT THIS STEP TWICE

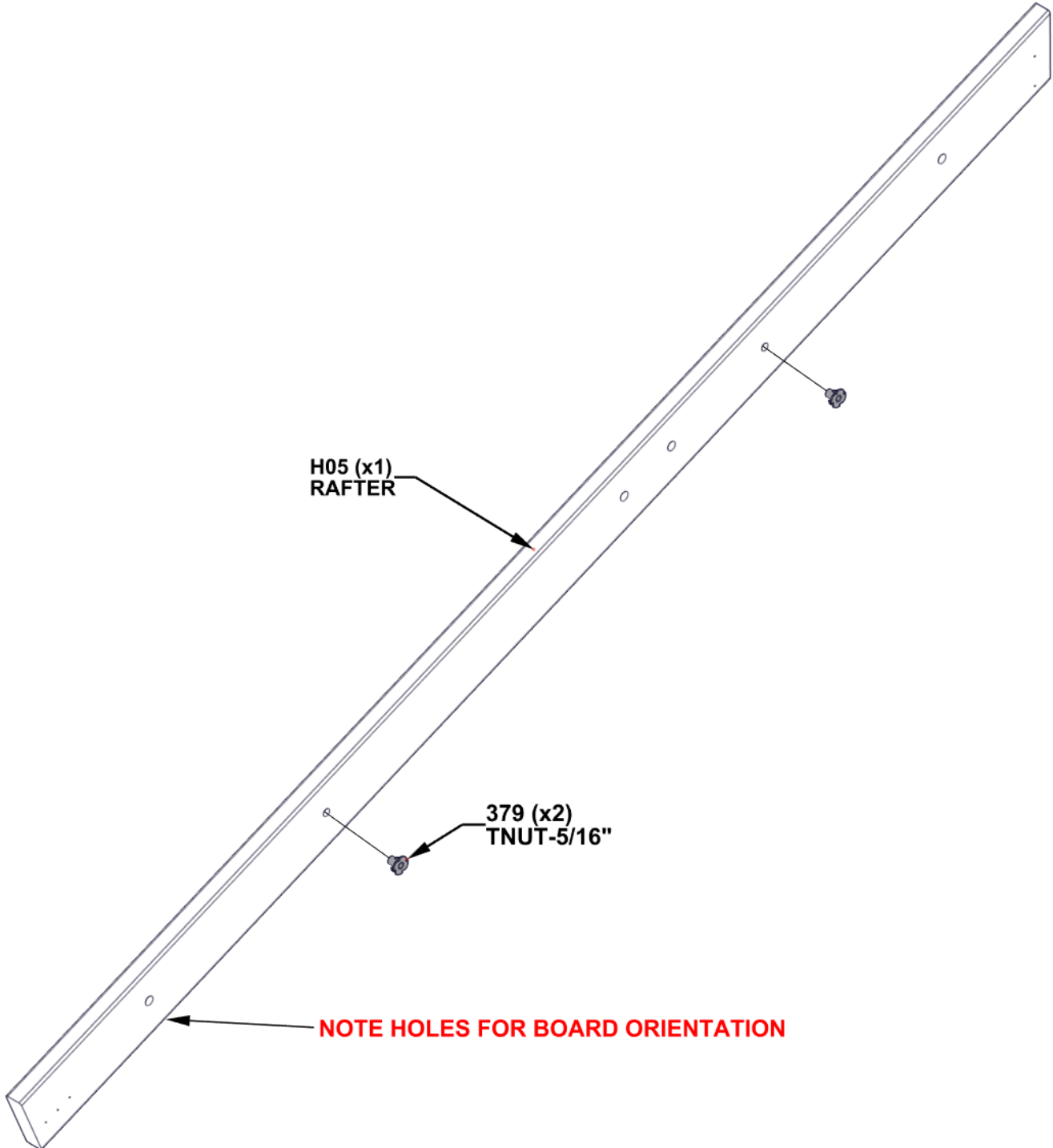

NOTE HOLES FOR BOARD ORIENTATION

STEP 24 - SUPPORT ASSEMBLY

QTY	PART NUMBER	DESCRIPTION
12	H100385	SCREW PFH 8x1 BLK



(x2) RAFTER ASSEMBLY FROM PREVIOUS STEP

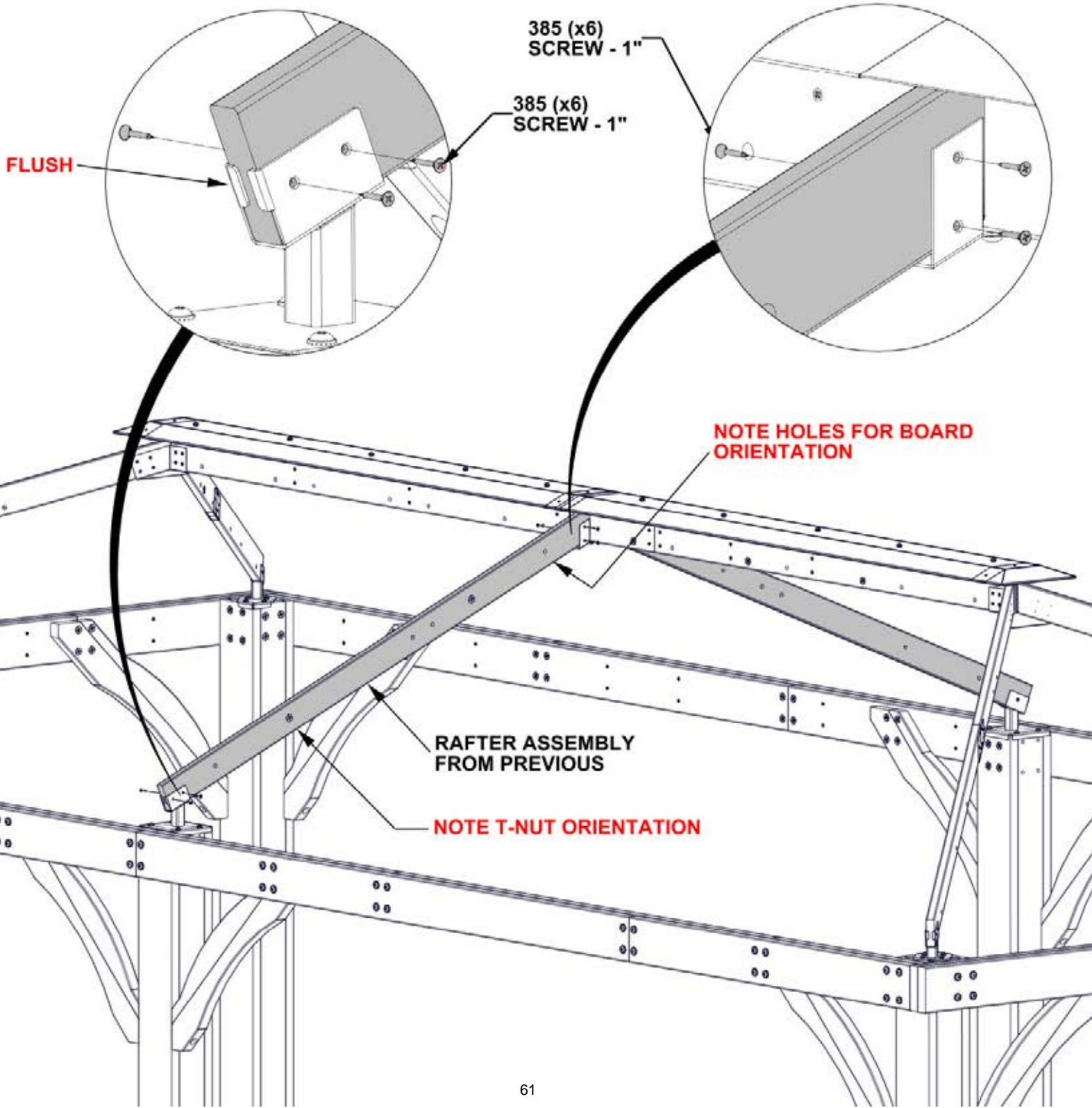

STEP 25A - TRUSS ASSEMBLY

QTY	PART NUMBER	DESCRIPTION
4	H100471	LAG SCREW WH 5/16x1 1/2 BLK



D11 BEAM - W4L20713
(x4) 1 7/16"X5 1/4"X85" (36x134x1651)

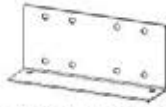

A4M00972 BRACKET
(x2)

REPEAT THIS STEP TWICE

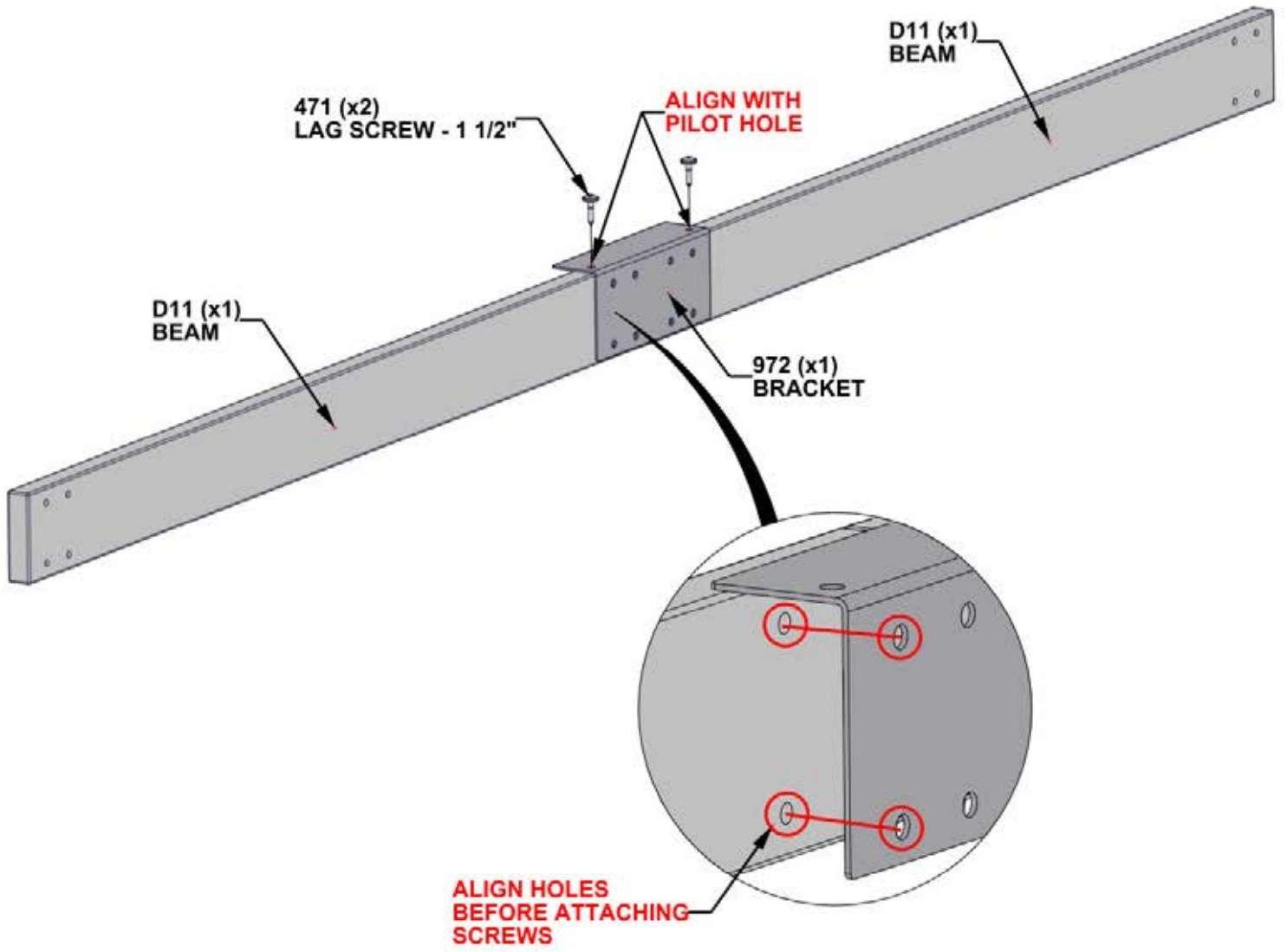

STEP 25B - TRUSS ASSEMBLY

QTY	PART NUMBER	DESCRIPTION
4	H100479	NUT LOCK 5/16 BLK
4	H100770	WASHER FLAT 5/16 BLK
4	H101047	BOLT WH 5/16x9 3/4 BLK



P04 CENTER POST - W2A04461
(x1) 6"x6"x32 5/16" (152x152x820)

SAW DUST CAN BE LEFT BEHIND IN BOLT HOLES. IF YOU HAVE TROUBLE WITH BOLTS ENGAGING, USE A LONG SCREW DRIVER TO REMOVE THE DEBRIS.

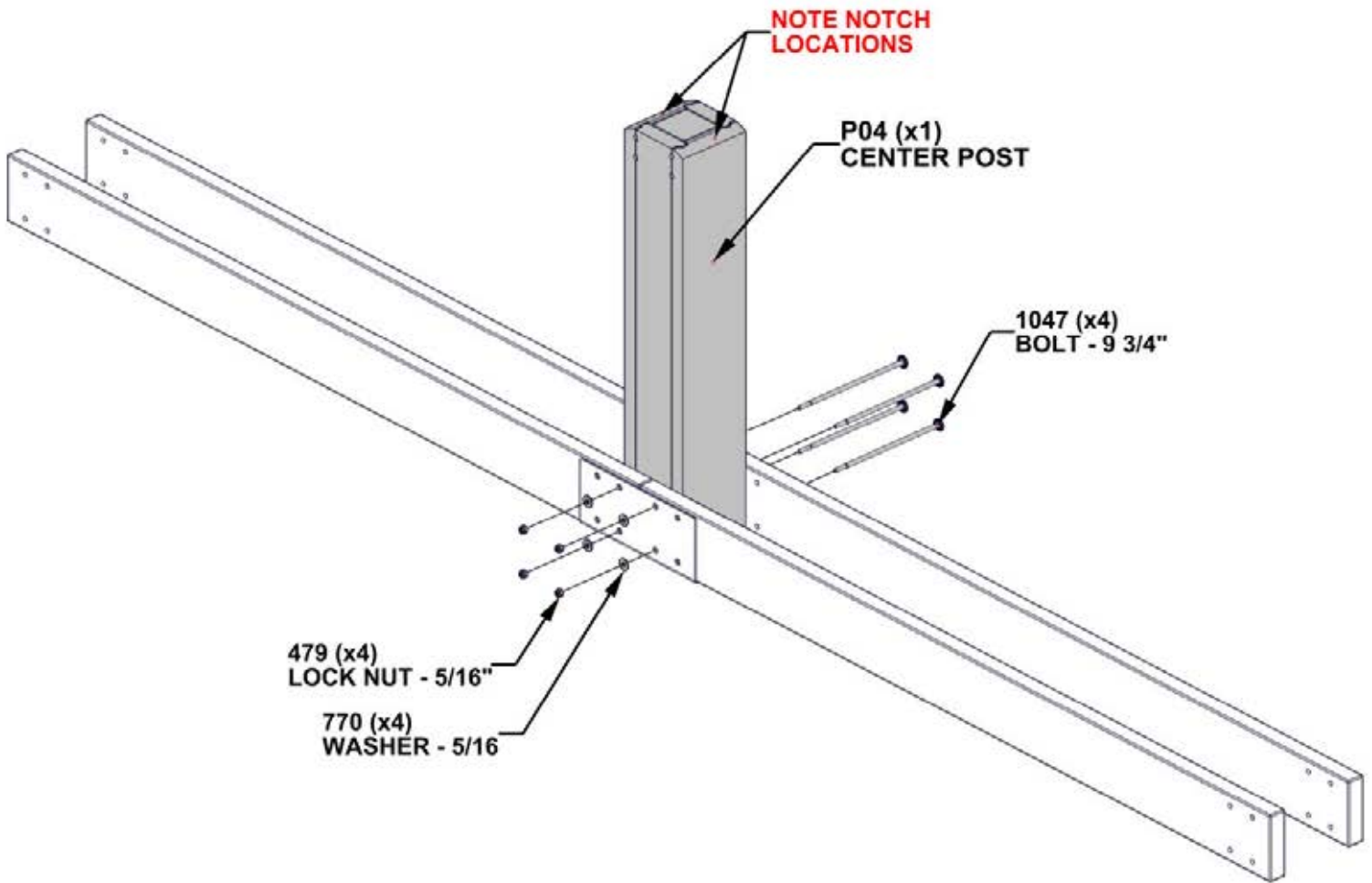

STEP 25C - TRUSS ASSEMBLY

QTY	PART NUMBER	DESCRIPTION
4	H100479	NUT LOCK 5/16 BLK
4	H100770	WASHER FLAT 5/16 BLK
4	H101037	BOLT WH 5/16x6 3/4 BLK

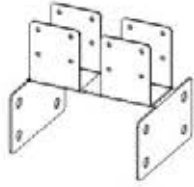

A4M04025 TRUSS BRACKET
(x1)

SAW DUST CAN BE LEFT BEHIND IN BOLT HOLES. IF YOU HAVE TROUBLE WITH BOLTS ENGAGING, USE A LONG SCREW DRIVER TO REMOVE THE DEBRIS.

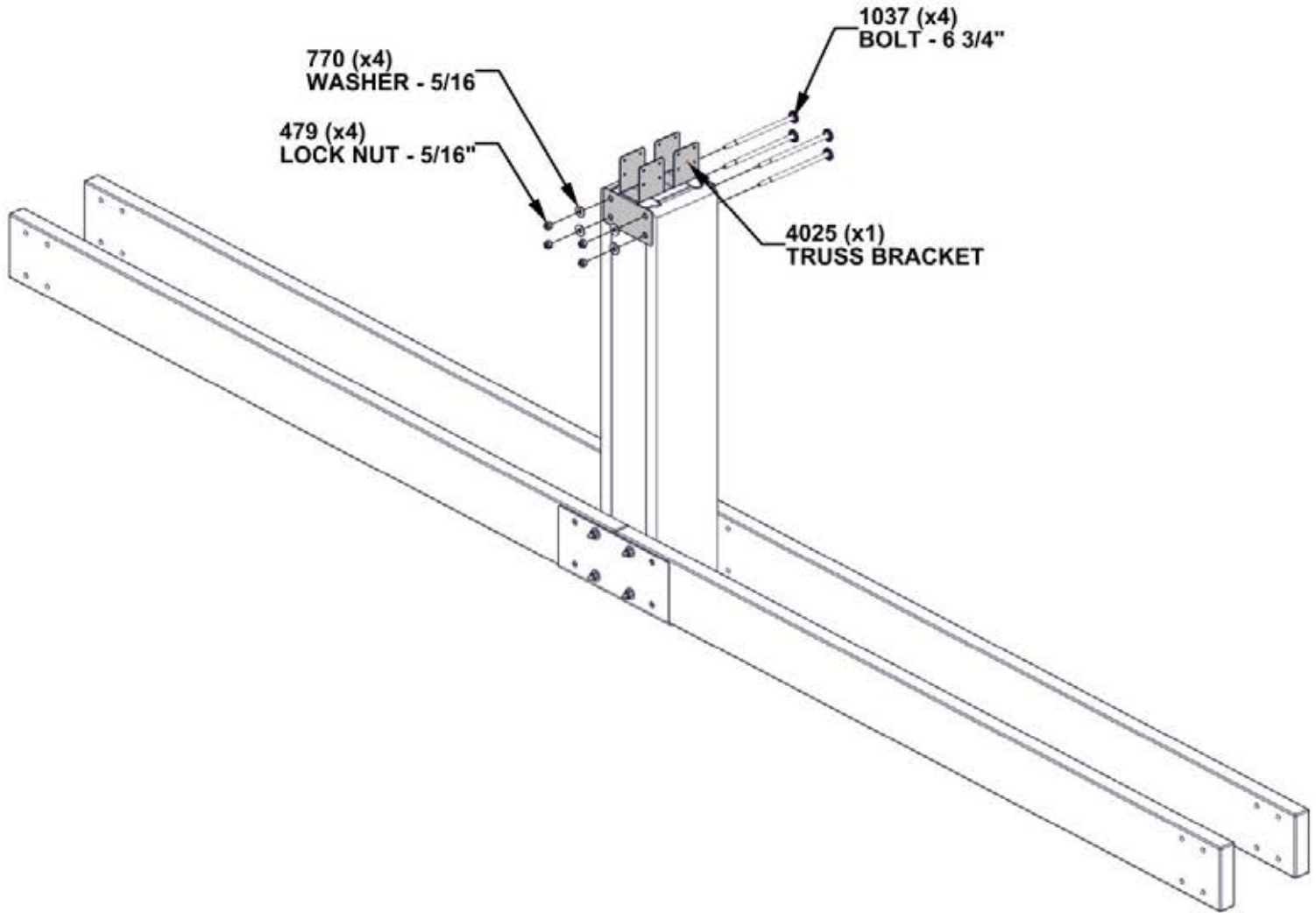

STEP 26A - TRUSS ASSEMBLY

QTY	PART NUMBER	DESCRIPTION
8	H100198	WASHER LOCK EXT 8x19
8	H100379	TNUT-5/16" BLK
8	H101059	BOLT WH 5/16x9 BLK



ASSEMBLY FROM STEP 25C

INSERT T-NUTS FIRST

FOR THIS STEP IT IS HELPFUL TO HAVE 3 ADDITIONAL PEOPLE TO POSITION ASSEMBLY AND ATTACH HARDWARE.

SAW DUST CAN BE LEFT BEHIND IN BOLT HOLES. IF YOU HAVE TROUBLE WITH BOLTS ENGAGING, USE A LONG SCREW DRIVER TO REMOVE THE DEBRIS.

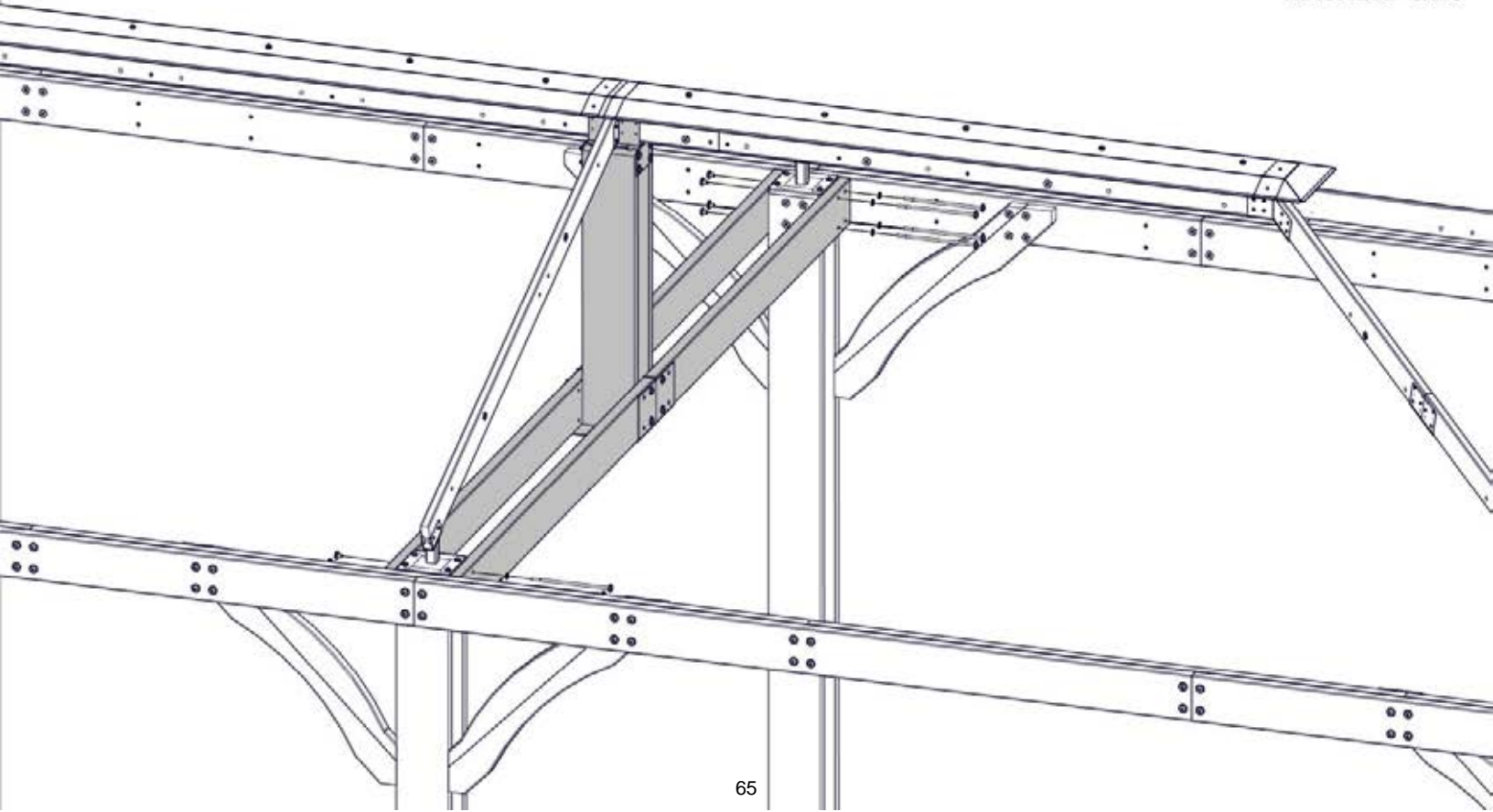
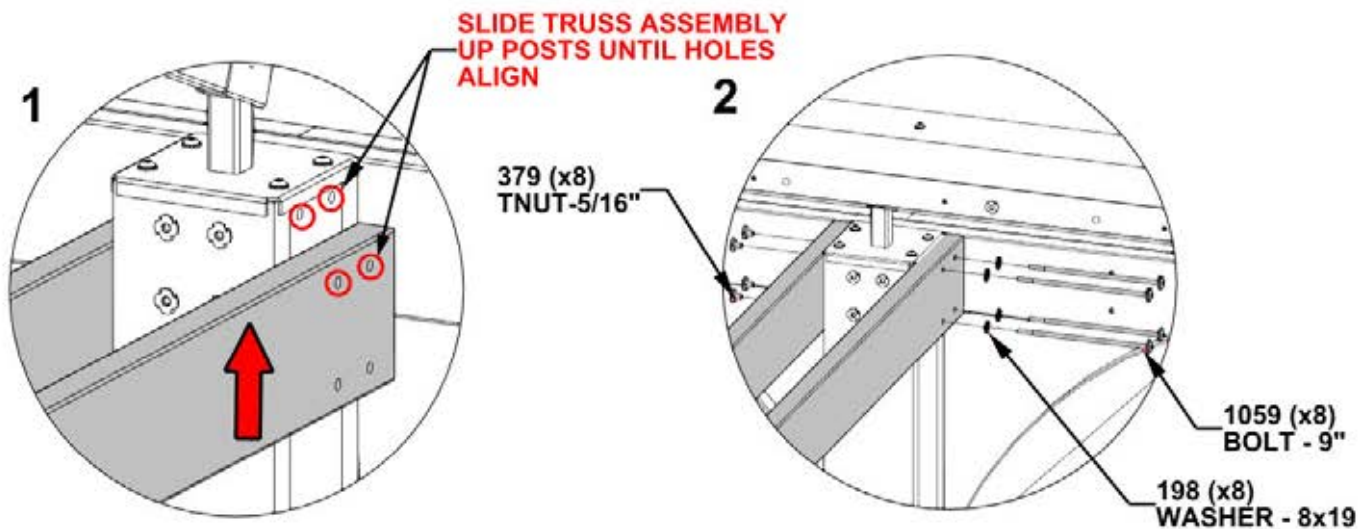

STEP 26B - TRUSS ASSEMBLY

QTY	PART NUMBER	DESCRIPTION
16	H100385	SCREW PFH 8x1 BLK

USING A LADDER, ATTACH SCREWS AS SHOWN.

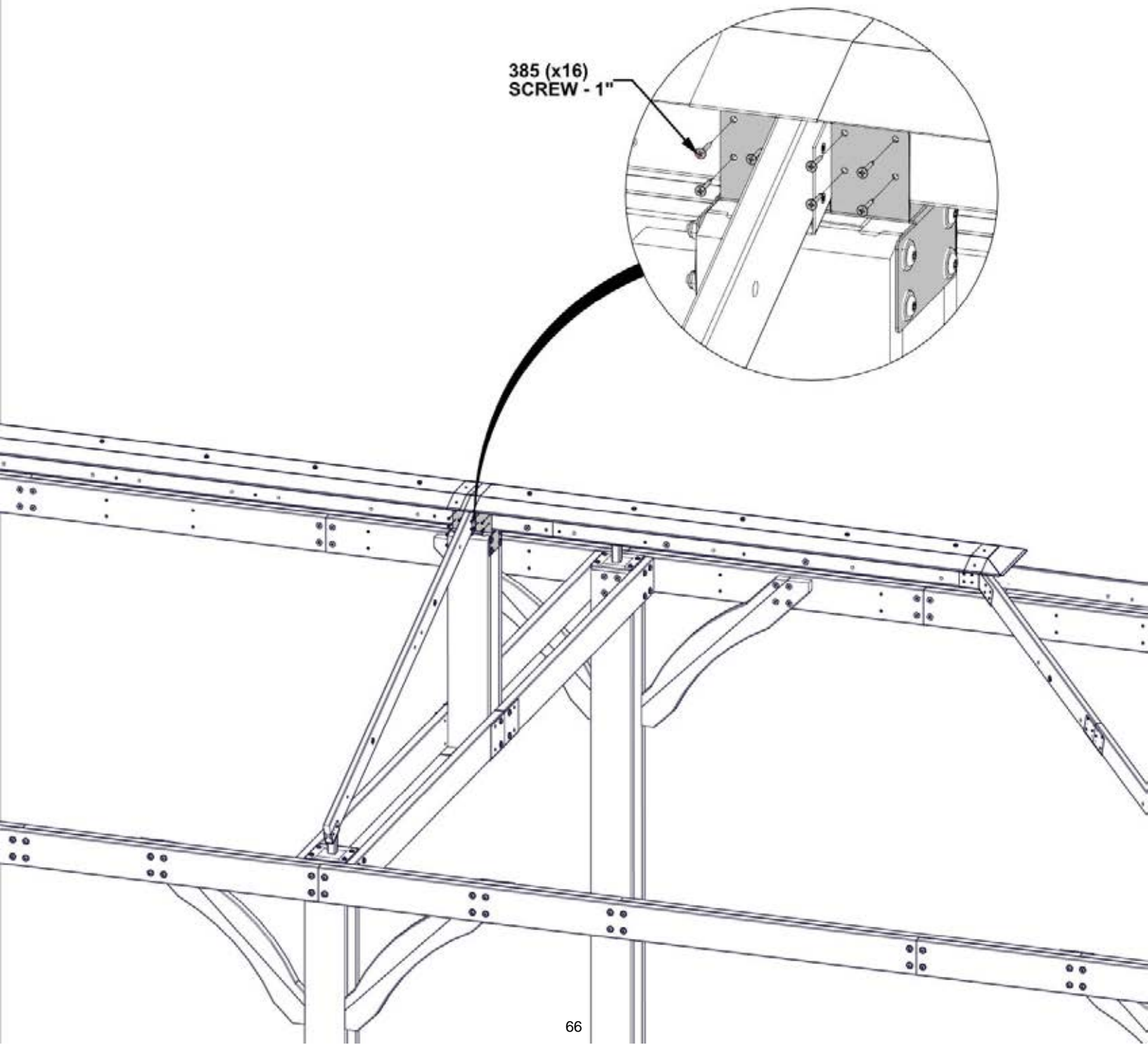

STEP 27 - 12FT ROOF PANEL ASSEMBLY

QTY	PART NUMBER	DESCRIPTION
4	H100171	BOLT WH 1/4x1 BLK
4	H100398	TNUT-1/4" BLK



A4M01239 PANEL BRACKET (x1)

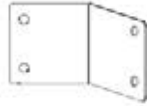

A4M01238 PANEL BRACKET (x1)

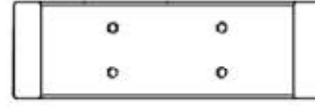

H08 RAFTER SUPPORT - W4L17530 (x1) 15/16"x3 3/8"x10 11/16" (24x86x272)

**INSERT T-NUTS FIRST
HAND TIGHTEN ONLY**

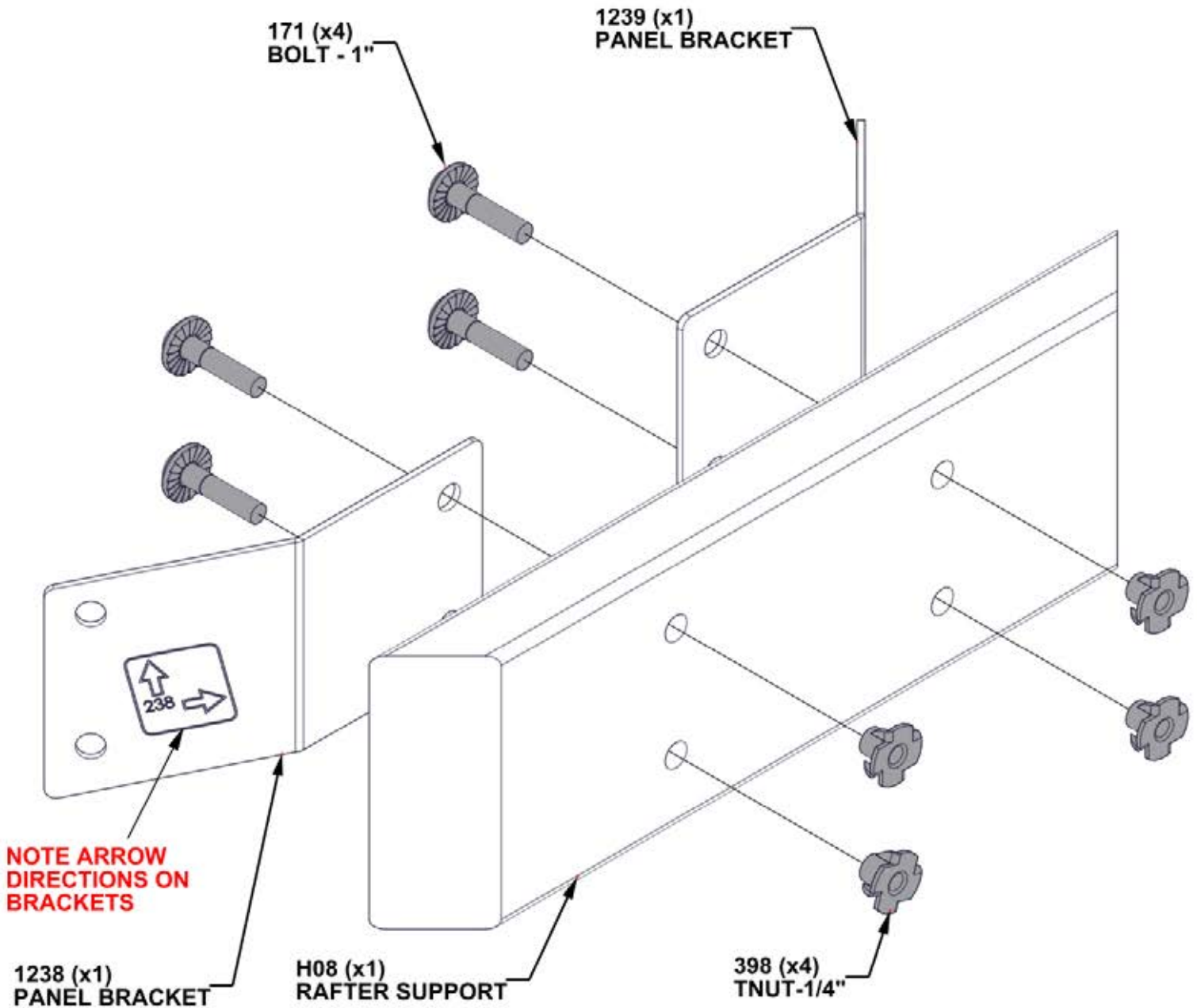

STEP 28 - 12FT ROOF PANEL ASSEMBLY

QTY	PART NUMBER	DESCRIPTION
4	H100171	BOLT WH 1/4x1 BLK
24	H100385	SCREW PFH 8x1 BLK
4	H100398	TNUT-1/4" BLK



H07 RAFTER - W4L17529
(x1) 15/16"x3 3/8"x53 3/16" (24x86x1351)



H09 RAFTER - W4L17531
(x1) 15/16"x3 3/8"x53 3/16" (24x86x1351)



H10 RAFTER - W4L17532
(x1) 15/16"x3 3/8"x44 1/2" (24x86x1130)



H06 RAFTER - W4L17528
(x1) 15/16"x3 3/8"x44 1/2" (24x86x1130)

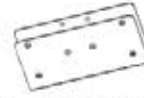

A4M01237 ROOF SUPPORT SPLICE CLIP
(x2)

INSERT T-NUTS FIRST

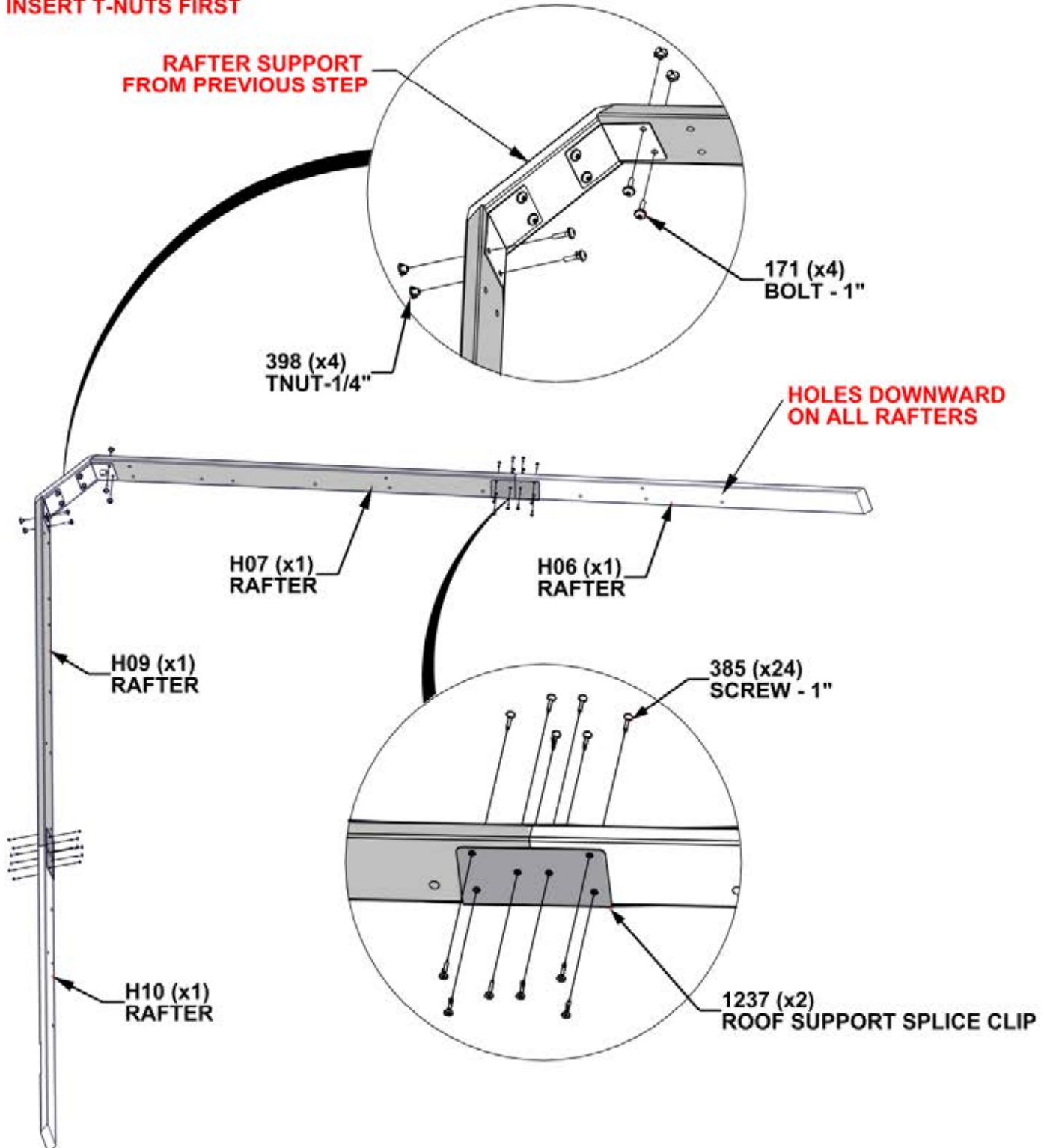

STEP 29 - 12FT ROOF PANEL ASSEMBLY

QTY	PART NUMBER	DESCRIPTION
12	H101030	SCREW CONFIRMAT 7x2 BLK



E01 RAFTER - W4L17533
(x1) 1 3/8"x3 3/8"x22" (36x86x557)



E04 RAFTER - W4L17536
(x1) 1 7/16"x3 3/8"x69" (36x86x1752)

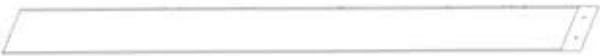

E02 RAFTER - W4L17534
(x1) 1 7/16"x3 3/8"x45 7/16" (36x86x1155)



E05 RAFTER - W4L17537
(x1) 1 7/16"x3 3/8"x45 7/16" (36x86x1155)



E03 RAFTER - W4L17535
(x1) 1 7/16"x3 3/8"x69" (36x86x1752)



E06 RAFTER - W4L17538
(x1) 1 7/16"x3 3/8"x21 15/16" (36x86x557)

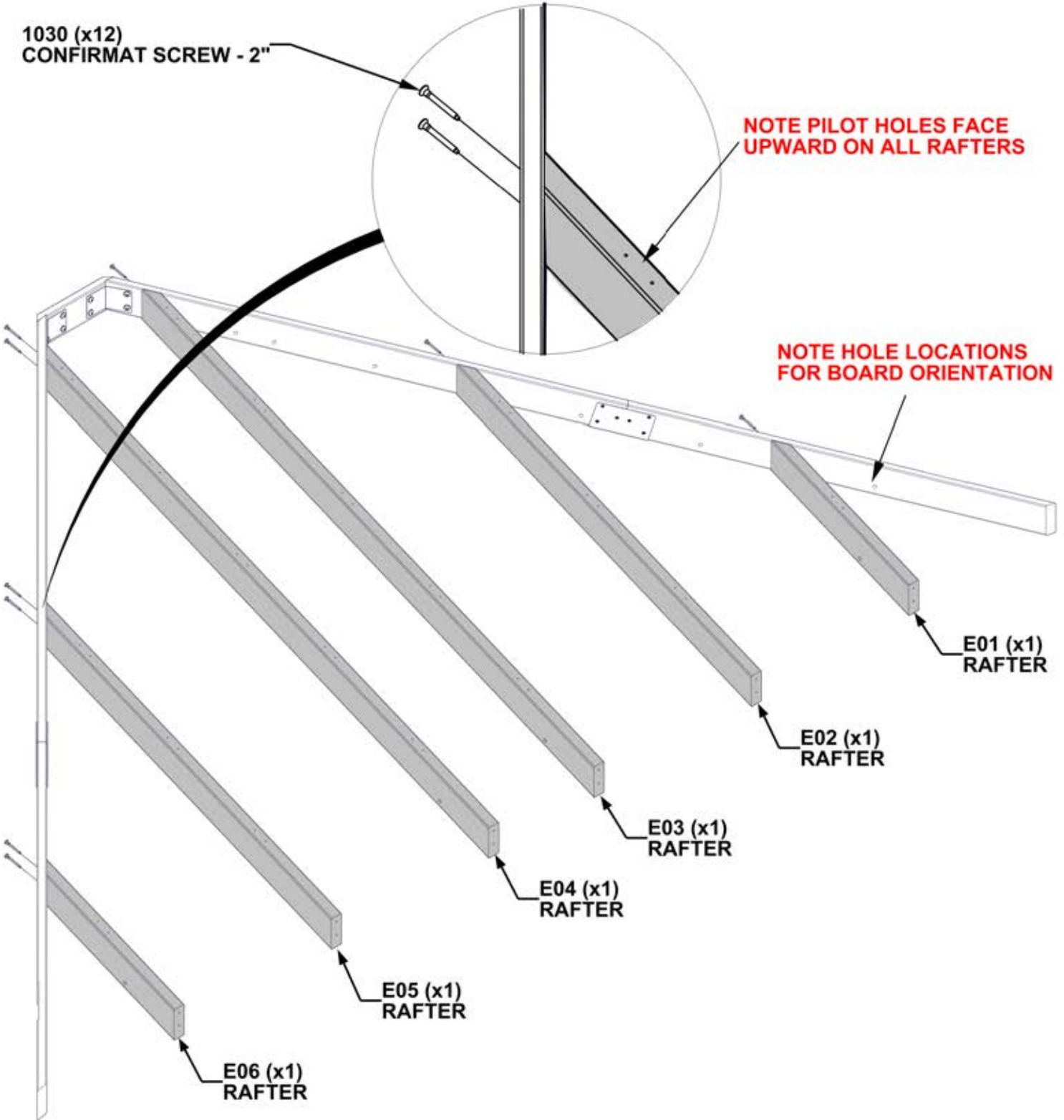

STEP 30 - 12FT ROOF PANEL ASSEMBLY

QTY	PART NUMBER	DESCRIPTION
12	H101030	SCREW CONFIRMAT 7x2 BLK



Q01 FASCIA - W4L17526
(x1) 15/16"x4 7/16"x65 15/16" (24x112x1675)

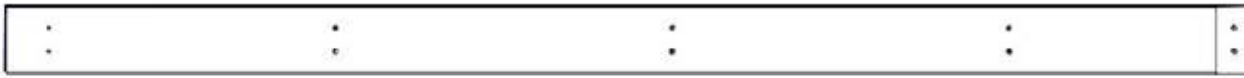

Q02 FASCIA - W4L17527
(x1) 24x4 7/16"x80 1/2" (24x112x2044)

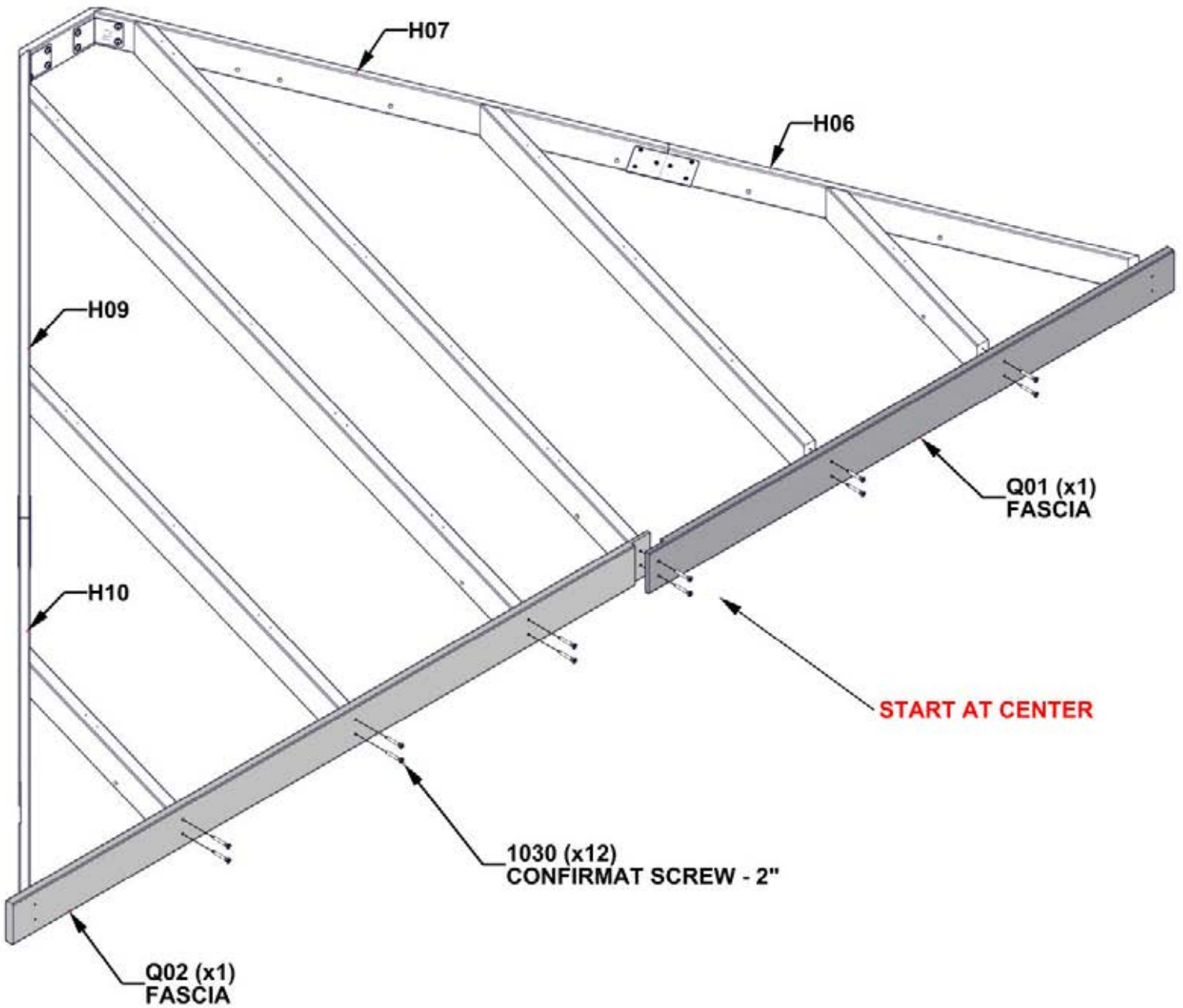

STEP 31 - 12FT ROOF PANEL ASSEMBLY

QTY	PART NUMBER	DESCRIPTION
4	H100382	SCREW PFH 8x1 3/4 BLK

- USING THE Q2 BOARD AS A GUIDE AND A 1/8" DRILL BIT, DRILL PILOT HOLES INTO THE H10 BOARD USING THE DIMENSIONS BELOW.
- REPEAT ON OPPOSITE END USING Q1 AS A GUIDE TO DRILL PILOT HOLE INTO THE H06 BOARD.

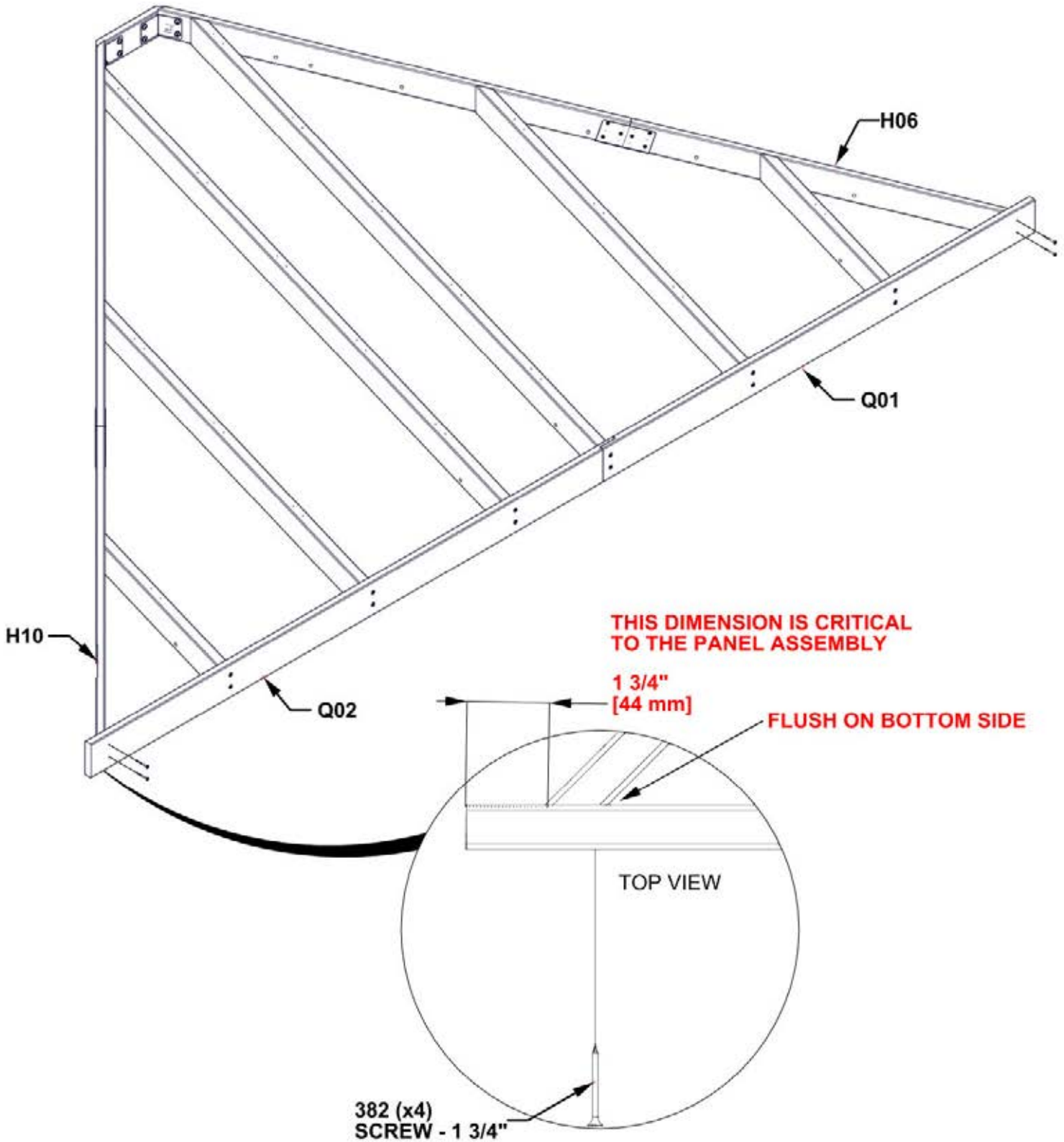

STEP 32 - 12FT ROOF PANEL ASSEMBLY

LOOSEN HARDWARE TO ADJUST FOR SQUARING IF NEEDED.

CRITICAL:

- SQUARE UNIT BEFORE PROCEEDING TO NEXT STEPS.
- THE BELOW DIMENSIONS ARE CRITICAL TO THE FINAL ROOF ASSEMBLY.
- DIMENSIONS ARE FROM CORNER TO CORNER OF ROOF PANEL.
- MEASUREMENTS SHOULD BE WITHIN $\pm 1/4"$.
- MEASUREMENTS OUTSIDE OF TOLERANCE WILL LEAD TO THE INABILITY TO ASSEMBLE THE ROOF.

ONCE SQUARE, TIGHTEN ALL HARDWARE FROM PREVIOUS STEPS

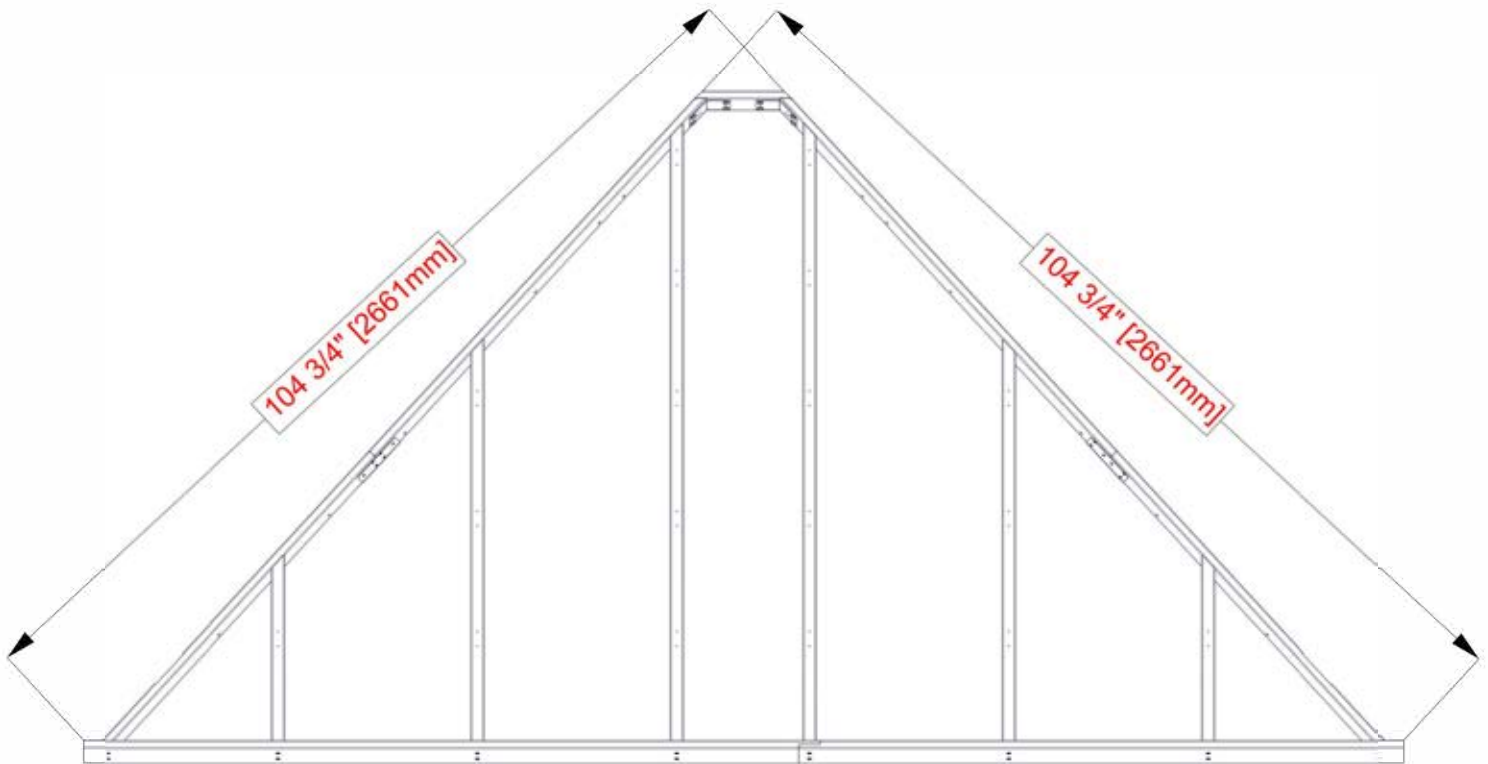

STEP 33 - 12FT ROOF PANEL ASSEMBLY

QTY	PART NUMBER	DESCRIPTION
58	H100391	SCREW PFH 8x2 BLK

T01 PURLIN - W4L17546
(x1) 15/16"x1 5/16"x12 7/8" (24x34x327)

H17 PURLIN - W4L17545
(x1) 15/16"x3 3/8"x27 1/4" (24x86x692)

H16 PURLIN - W4L17544
(x1) 15/16"x3 3/8"x51 7/16" (24x86x1307)

H15 PURLIN - W4L17543
(x1) 15/16"x3 3/8"x75 11/16" (24x86x1922)

H14 PURLIN - W4L17542
(x1) 15/16"x3 3/8"x43 7/8" (24x86x1114)

H13 PURLIN - W4L17541
(x1) 15/16"x3 3/8"x58 3/8" (24x86x1483)

H12 PURLIN - W4L17540
(x1) 15/16"x3 3/8"x70 1/2" (24x86x1791)

H11 PURLIN - W4L17539
(x1) 15/16"x3 3/8"x56" (24x86x1422)

- ALIGN PURLIN PILOT HOLES WITH RAFTER PILOT HOLES.
- ATTACH SCREWS FROM THE CENTER AND WORK OUTWARD.
- H09/H10 & H06/H07 BOARDS DO NOT HAVE PILOT HOLES FOR THE OUTSIDE EDGE SCREWS.
- USING THE PURLINS AS A GUIDE AND A 1/8" [3mm] DRILL BIT, DRILL PILOT HOLES INTO H09/H10 & H06/H07 BOARDS.

NOTE T01 IS TO BE FLUSH AND WILL NOT OVERHANG SIDES

391 (x58)
SCREW - 2"

IF PURLINS OVERHANG MORE THAN 5/8" [15mm] CUT DOWN TO 5/8" [15mm]

5/8" [15mm]

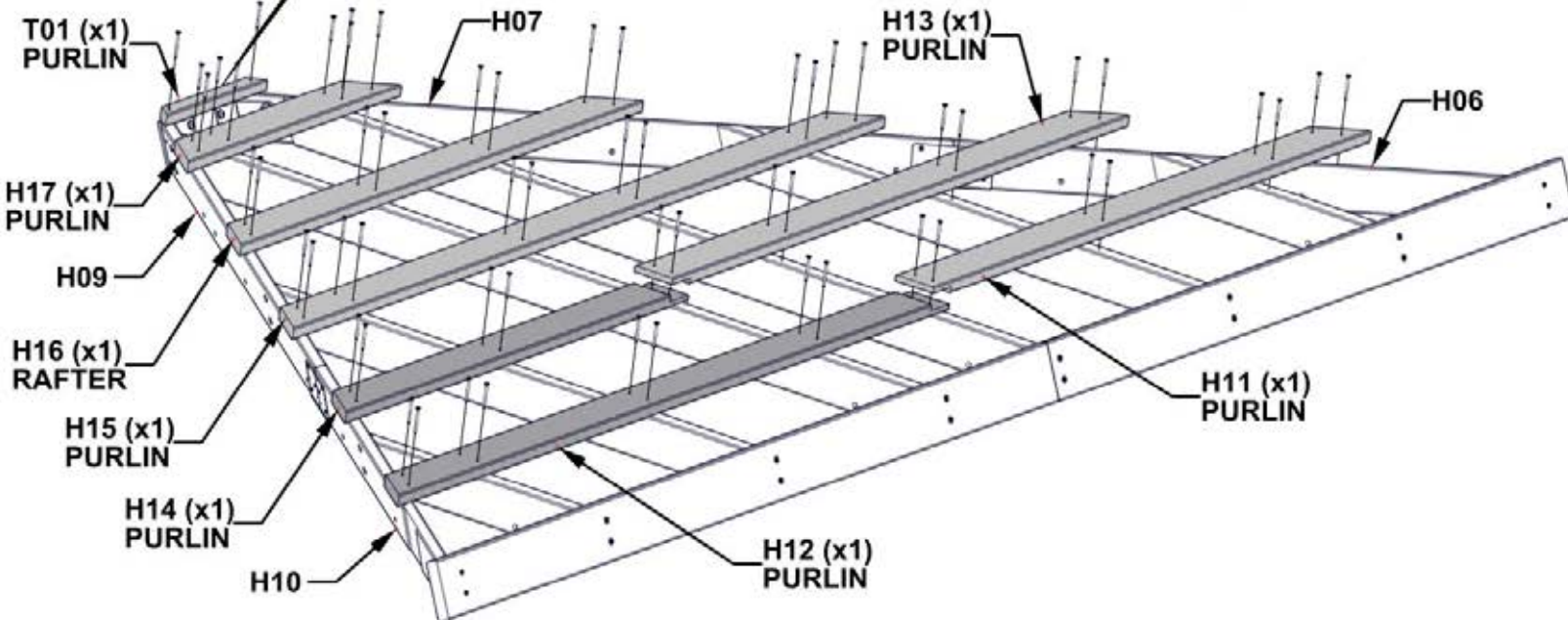

STEP 34 - 12FT ROOF PANEL ASSEMBLY

QTY	PART NUMBER	DESCRIPTION
26	H100833	SCREW WOODGRIP 10-16x3/4"

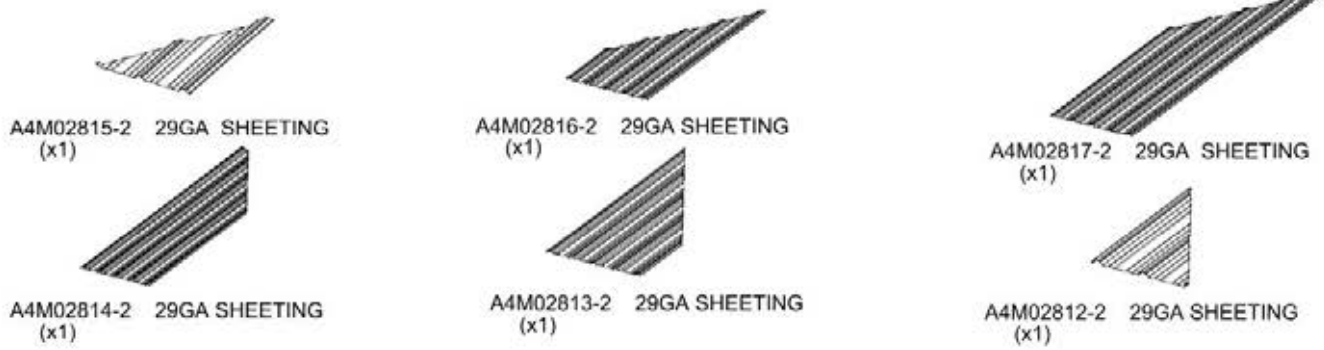

- REMOVE BLUE PROTECTIVE FILM.
- STARTING IN THE CENTER, PLACE SHEETING AS SHOWN.
- OVERLAP SHEETING BY ONE RIDGE.
- SHEETING SHOULD BE FLUSH WITH PURLIN ENDS AND Q02 ROOF FASCIA.
- ONCE SHEETING IS IN PLACE, IT IS RECOMMENDED TO ADD H100833 SCREWS IN THE MIDDLE OF THE SHEETS TO HOLD SHEETING FOR THE NEXT STEP.

WARNING: GLOVES ARE RECOMMENDED WHEN HANDLING STEEL ROOF PIECES

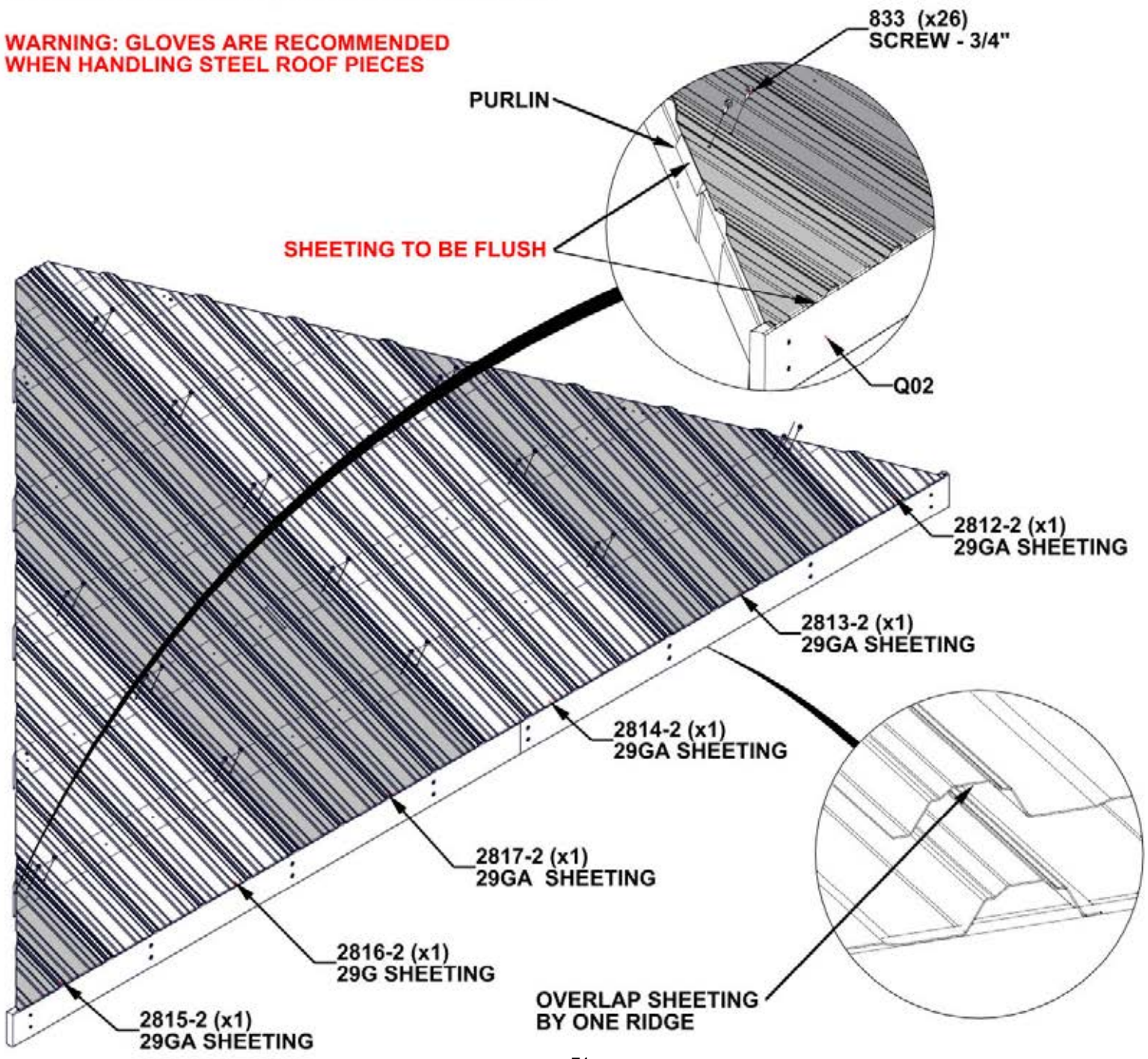

STEP 35 - 12FT ROOF PANEL ASSEMBLY

QTY	PART NUMBER	DESCRIPTION
10	H100833	SCREW WOODGRIP 10-16x3/4"

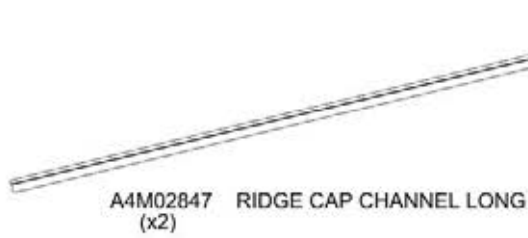

- REMOVE PROTECTIVE BLUE FILM.
- POSITION THE RIDGE CAP CHANNEL OVER THE EDGE OF THE ROOF PANELS WITH THE WIDER SIDE OF THE CHANNEL ON THE BOTTOM.
- MAKE SURE THE PANELS ARE FULLY SEATED INTO THE CHANNEL.

833 (x10)
SCREW - 3/4"

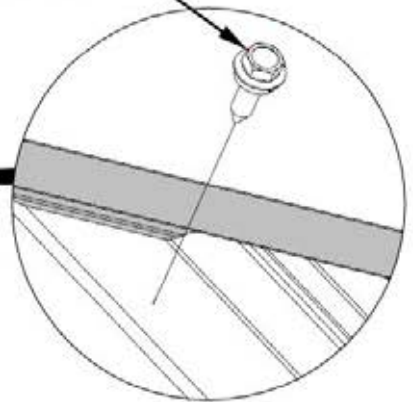

2847 (x1)
RIDGE CAP CHANNEL LONG

2850 (x1)
RIDGE CAP CHANNEL SHORT

LOOSEN SCREW TO EASE INSTALLATION

PURLIN UNDERNEATH SHEETING

2850 (x1)
RIDGE CAP CHANNEL SHORT

2847 (x1)
RIDGE CAP CHANNEL LONG

THIS DIMENSION IS CRITICAL TO THE PANEL ASSEMBLY

2 3/8" [60 mm]

STEP 36 - 12FT ROOF PANEL ASSEMBLY

QTY	PART NUMBER	DESCRIPTION
24	H100833	SCREW WOODGRIP 10-16x3/4"

- INSERT REMAINING SCREWS TO FASTEN SHEET METAL IN PLACE.

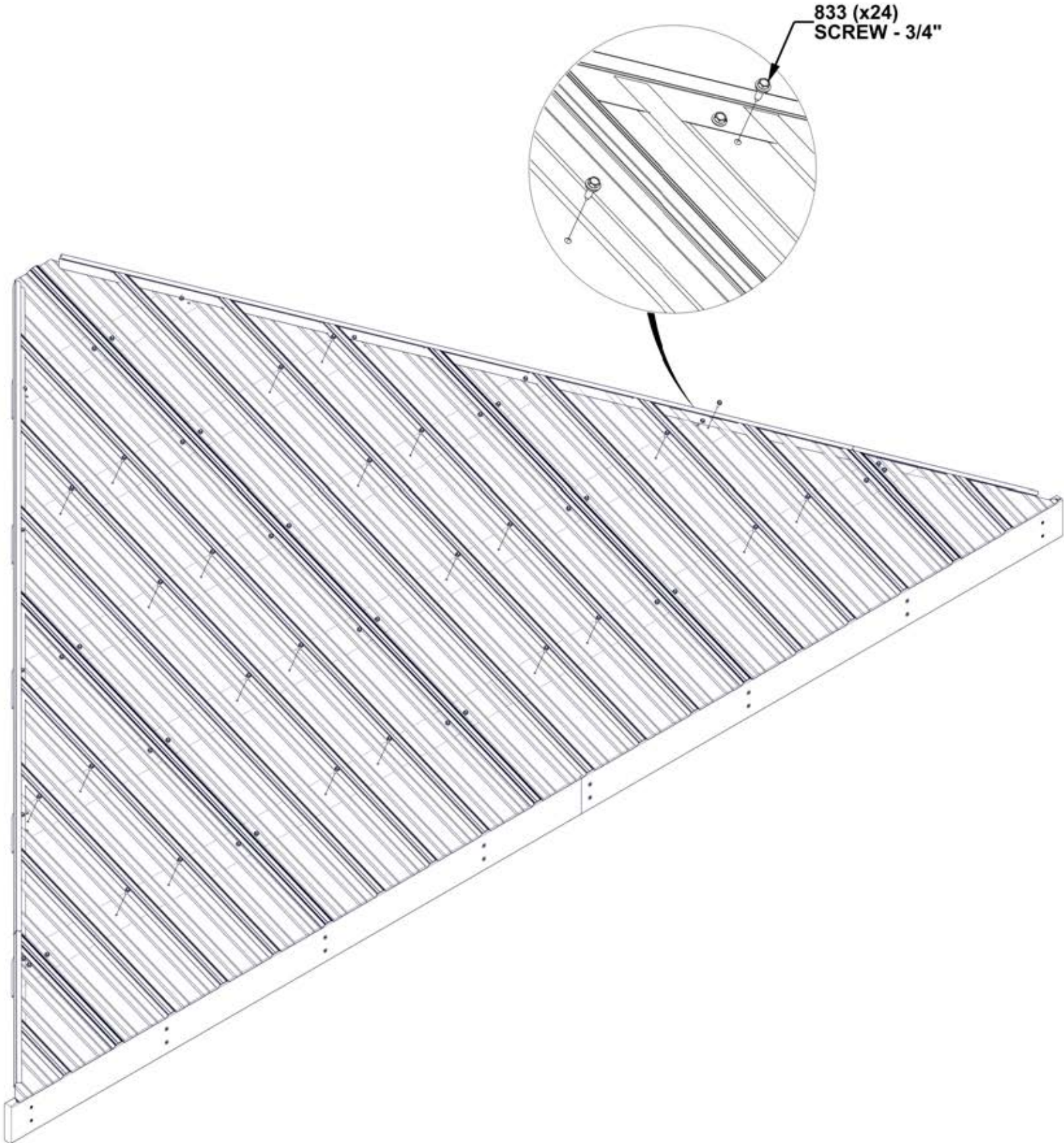

**REPEAT 12FT ROOF PANEL
ASSEMBLY STEP 27 THROUGH 36.**

STEP 37 - LEFT PANEL ASSEMBLY

QTY	PART NUMBER	DESCRIPTION
2	H100171	BOLT WH 1/4x1 BLK
2	H100398	TNUT-1/4" BLK

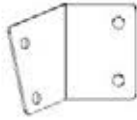

A4M01191 PANEL BRACKET - A4M01191
(x1)



H20 FASCIA - W4L19440
(x1) 15/16"x3 3/8"x74 7/8" (24x86x1902)

**- INSERT T-NUTS FIRST
- HAND TIGHTEN BOLTS**

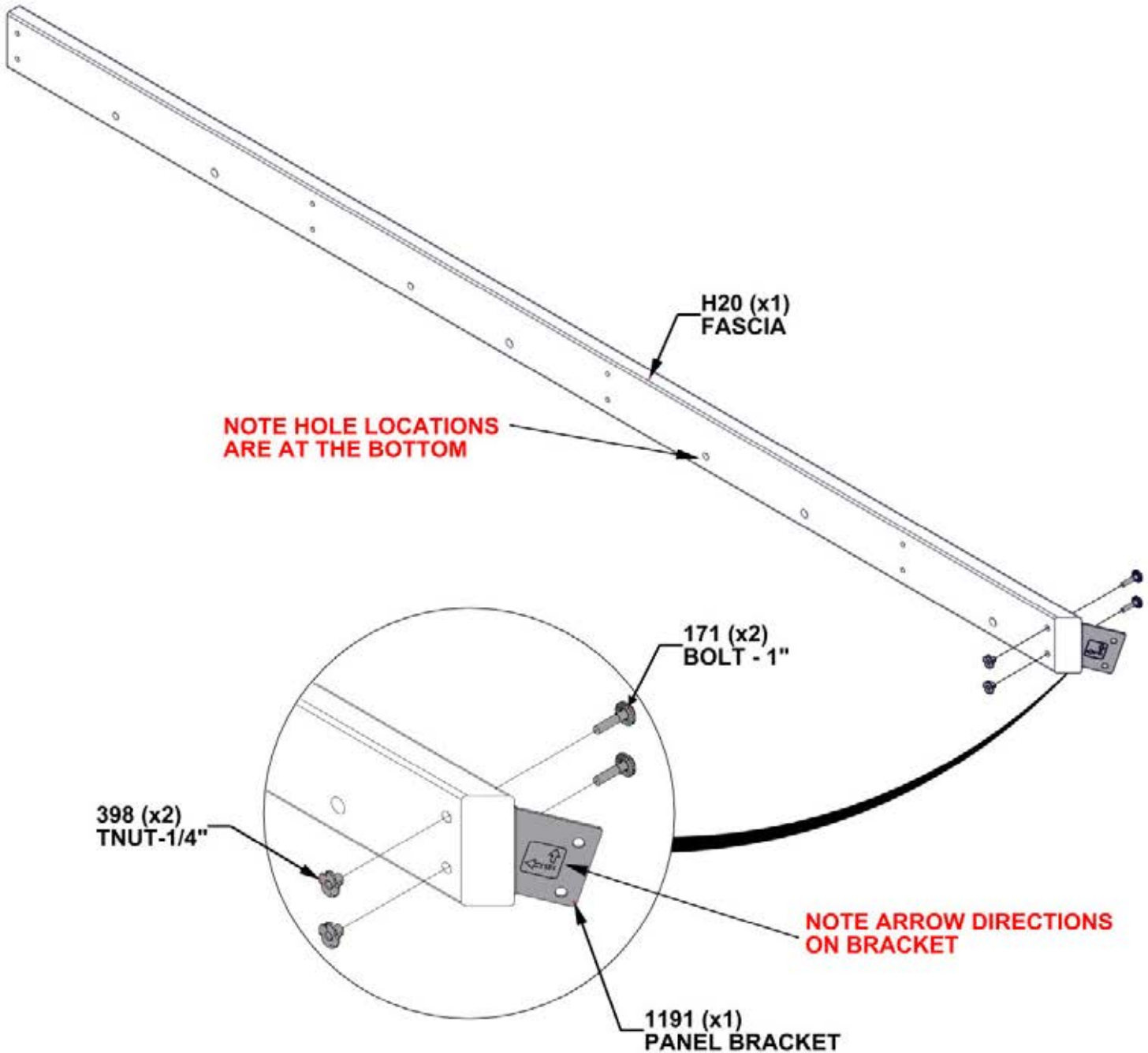

STEP 38 - LEFT PANEL ASSEMBLY

QTY	PART NUMBER	DESCRIPTION
12	H100385	SCREW PFH 8x1 BLK



H18 RAFTER - W4L17547
(x1) 15/16"x3 3/8"x44 1/2" (24x86x1130)



H19 RAFTER - W4L17548
(x1) 15/16"x3 3/8"x60 5/8" (24x86x1540)

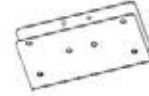

A4M01237 ROOF SUPPORT SPLICE CLIP
(x1)

INSERT T-NUTS FIRST

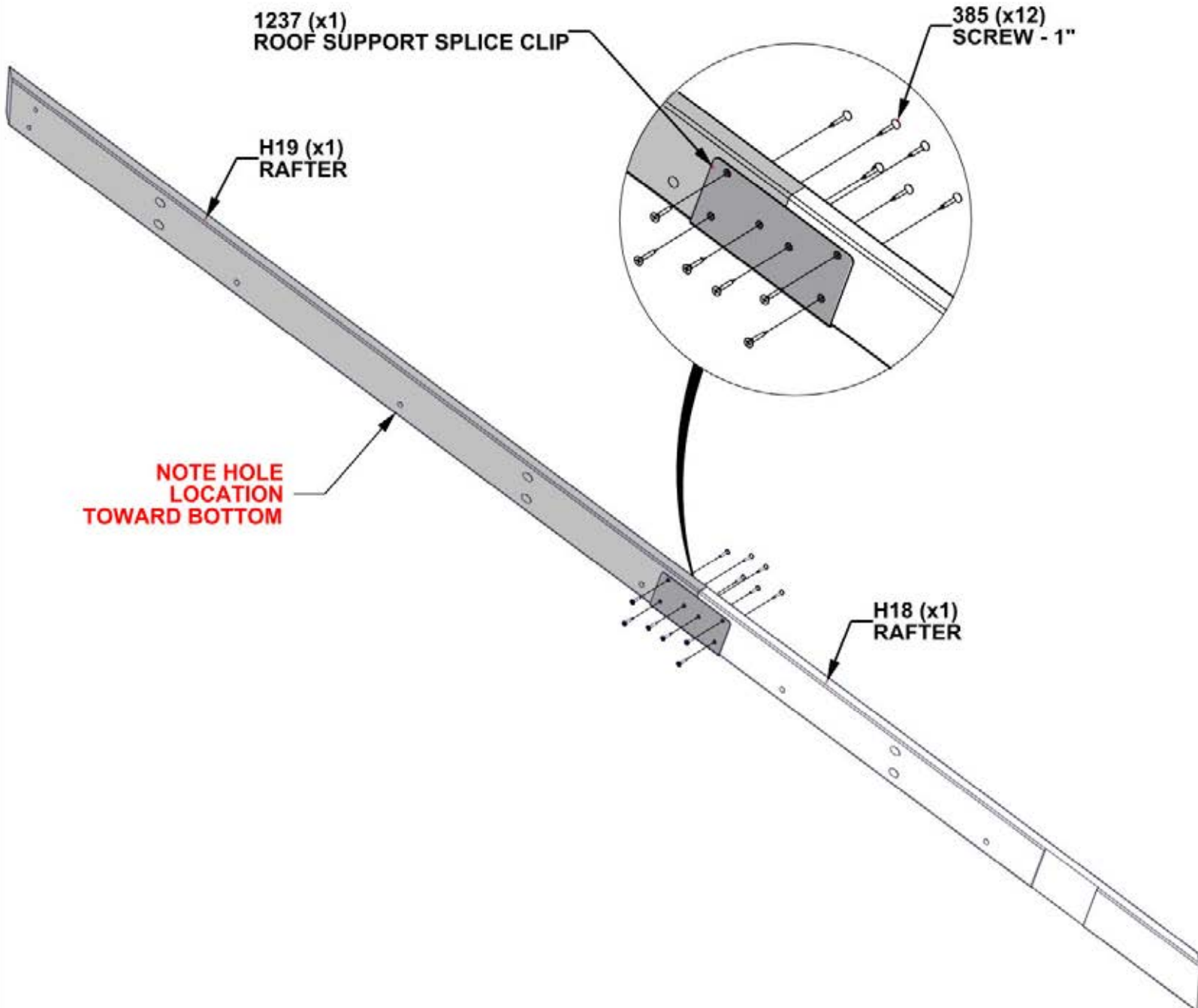

STEP 39 - LEFT PANEL ASSEMBLY

QTY	PART NUMBER	DESCRIPTION
2	H100171	BOLT WH 1/4x1 BLK
2	H100398	TNUT-1/4" BLK



RAFTER ASSEMBLY



RAFTER SUPPORT

INSERT T-NUTS FIRST

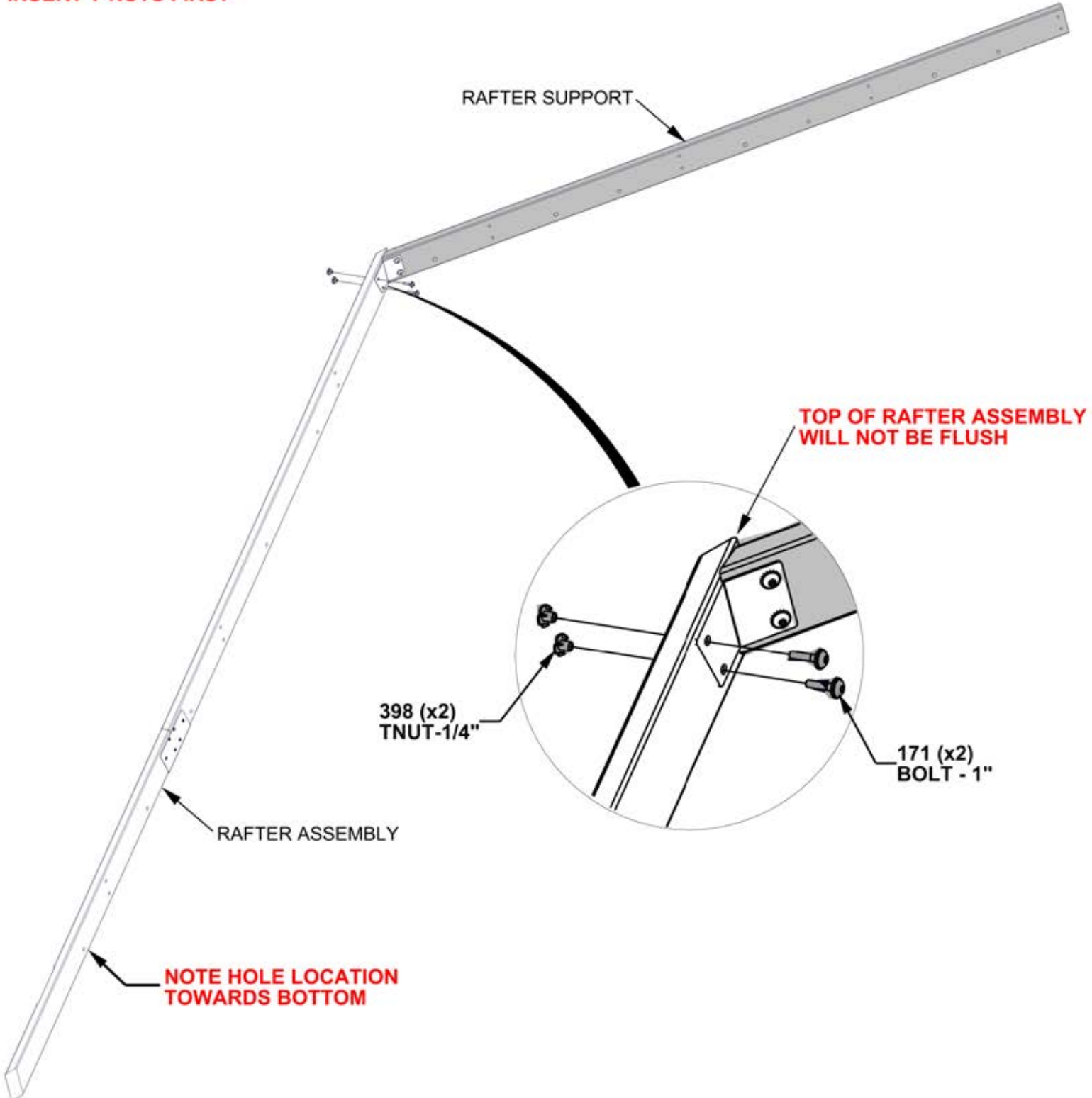

STEP 40 - LEFT PANEL ASSEMBLY

QTY	PART NUMBER	DESCRIPTION
8	H101030	SCREW CONFIRMAT 7x2 BLK

E07 RAFTER - W4L17551
(x1) 1 7/16"x3 3/8"x76 1/8" (36x86x1934)

E08 RAFTER - W4L17552
(x1) 1 7/16"x3 3/8"x76 1/8" (36x86x1934)

E16 RAFTER - W4L17572
(x1) 1 7/16"x76 1/8"x3 3/8" (36x86x1934)

E18 RAFTER - W4L19815
(x1) 1 7/16"x76 1/8"x3 3/8" (36x86x1934)

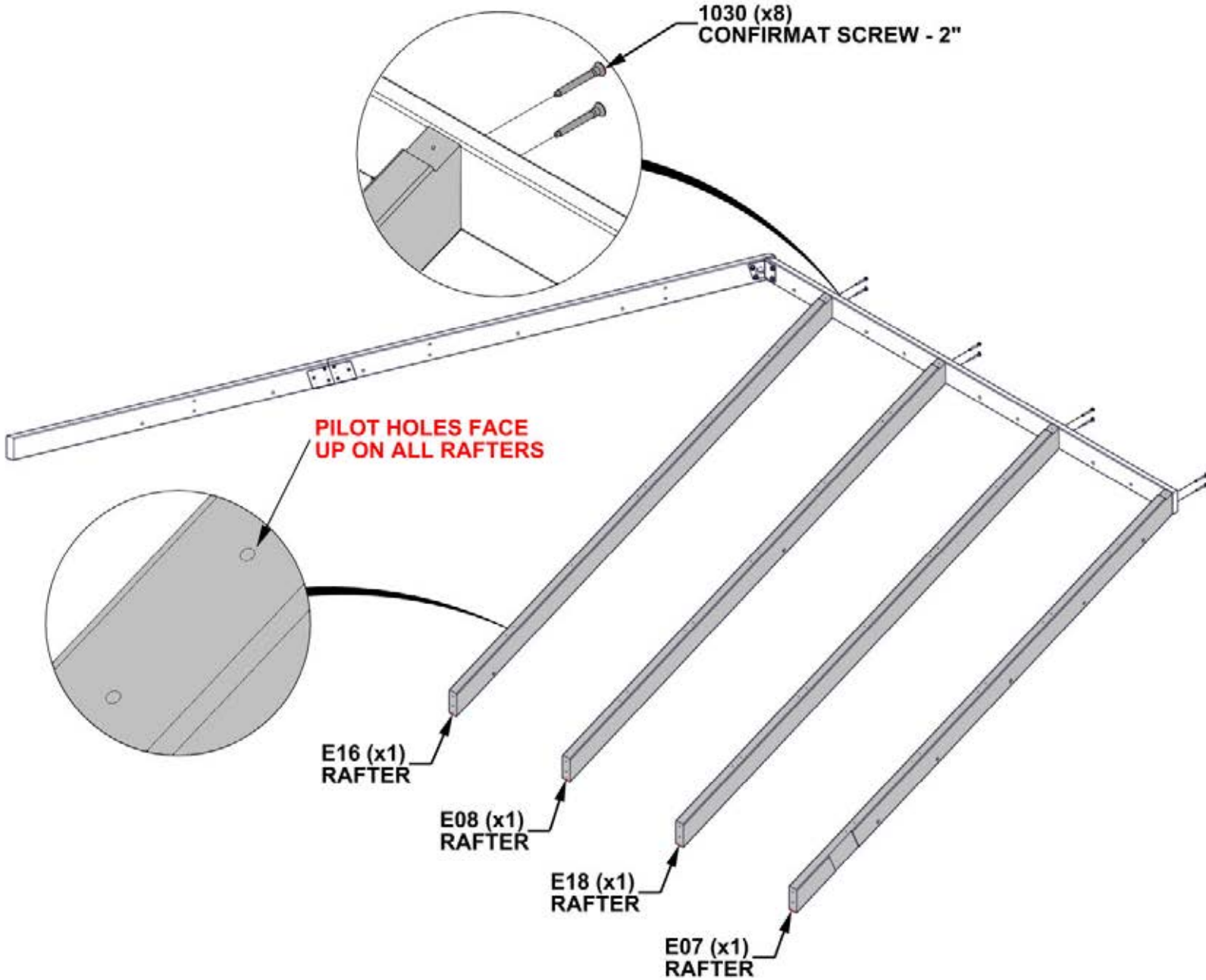

STEP 41 - LEFT PANEL ASSEMBLY

QTY	PART NUMBER	DESCRIPTION
6	H101030	SCREW CONFIRMAT 7x2 BLK



E09 RAFTER - W4L17553
(x1) 1 7/16" x 3 3/8" x 67 1/8" (36x86x1705)



E10 RAFTER - W4L17554
(x1) 1 7/16" x 3 3/8" x 43 5/8" (36x86x1109)



E11 RAFTER - W4L17555
(x1) 1 7/16" x 3 3/8" x 20 3/16" (36x86x512)

**PILOT HOLES ARE UPWARD
ON ALL RAFTERS**

1030 (x6)
CONFIRMAT SCREW - 2"

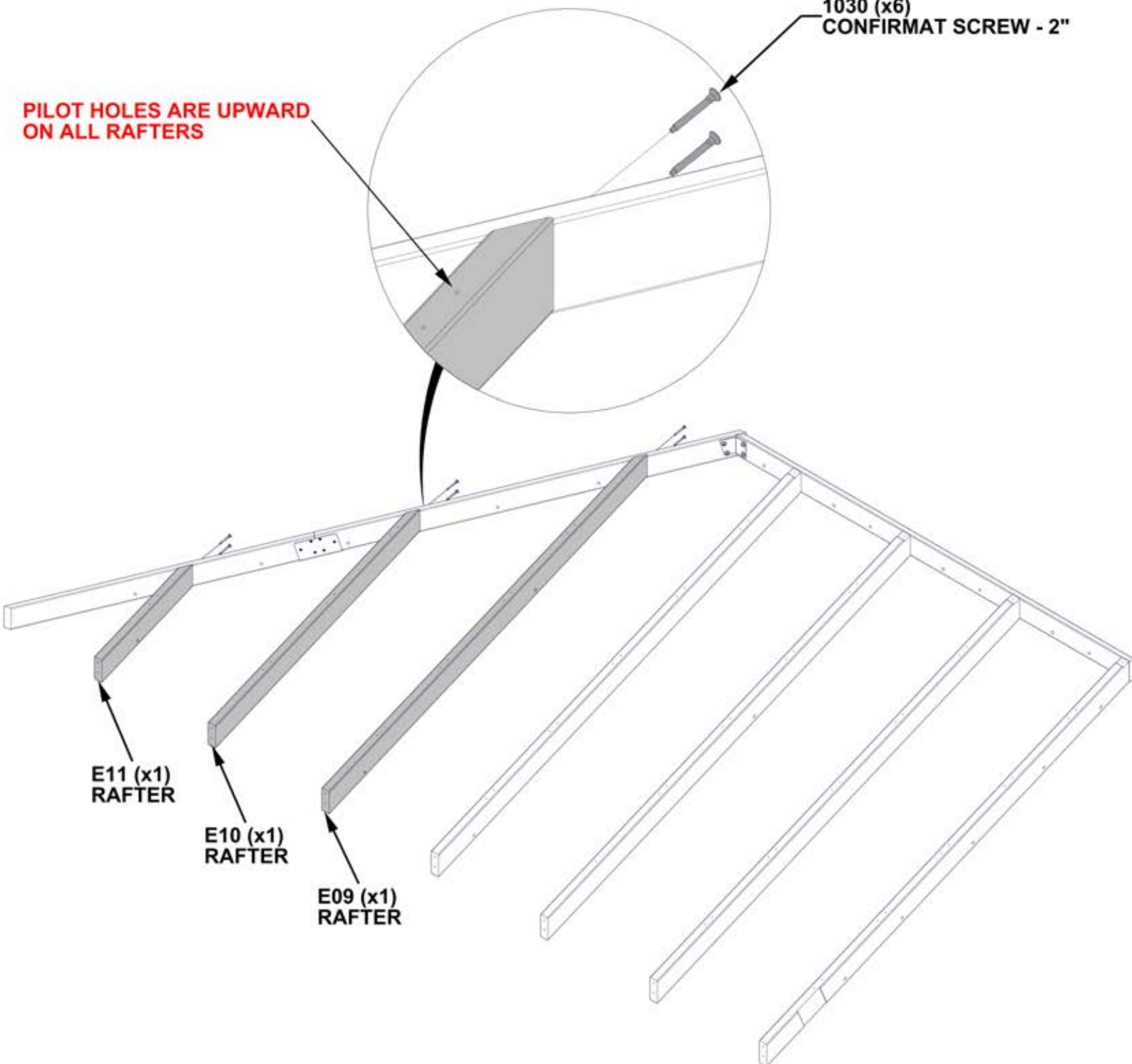

STEP 42 - LEFT PANEL ASSEMBLY

QTY	PART NUMBER	DESCRIPTION
14	H101030	SCREW CONFIRMAT 7x2 BLK



Q03 FASCIA - W4L19441
(x1) 15/16"x4 7/16"x63 3/16" (24x112x1605)



Q04 FASCIA - W4L19442
(x1) 15/16"x4 7/16"x85 13/16" (24x112x2179)

START AT THE RIGHT AND WORK TOWARDS THE LEFT, OVERHANGING END AS SHOWN.

RAFTER MAY NEED TO BE LOOSENED UP TO ATTACH FASCIA BOARDS

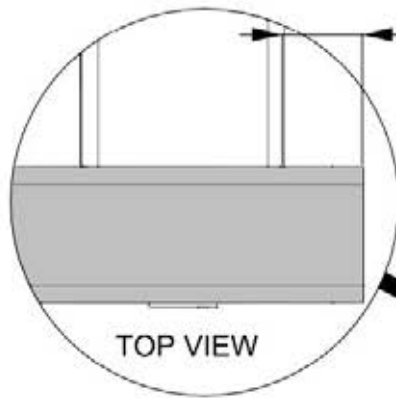

9/16" [14mm]

THIS DIMENSION IS CRITICAL TO THE PANEL ASSEMBLY

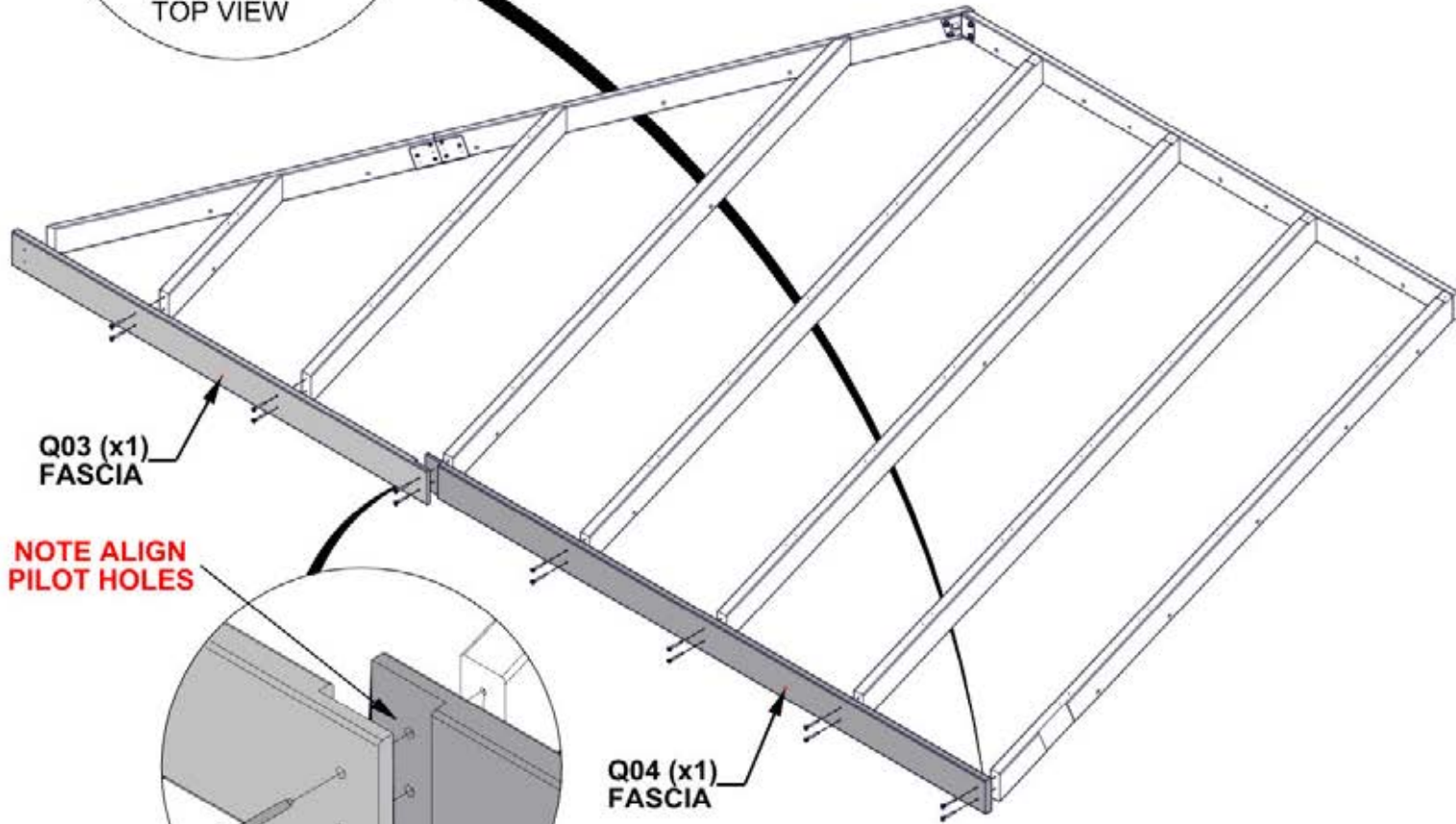

Q03 (x1)
FASCIA

NOTE ALIGN PILOT HOLES

Q04 (x1)
FASCIA

1030 (x14)
CONFIRMAT SCREW - 2"

STEP 43 - LEFT PANEL ASSEMBLY

QTY	PART NUMBER	DESCRIPTION
2	H100382	SCREW PFH 8x1 3/4 BLK

- USING THE Q03 BOARD AS A GUIDE AND A 1/8" DRILL BIT, DRILL PILOT HOLES INTO THE H18 BOARD USING THE DIMENSION BELOW.

THIS DIMENSION IS CRITICAL TO THE PANEL ASSEMBLY

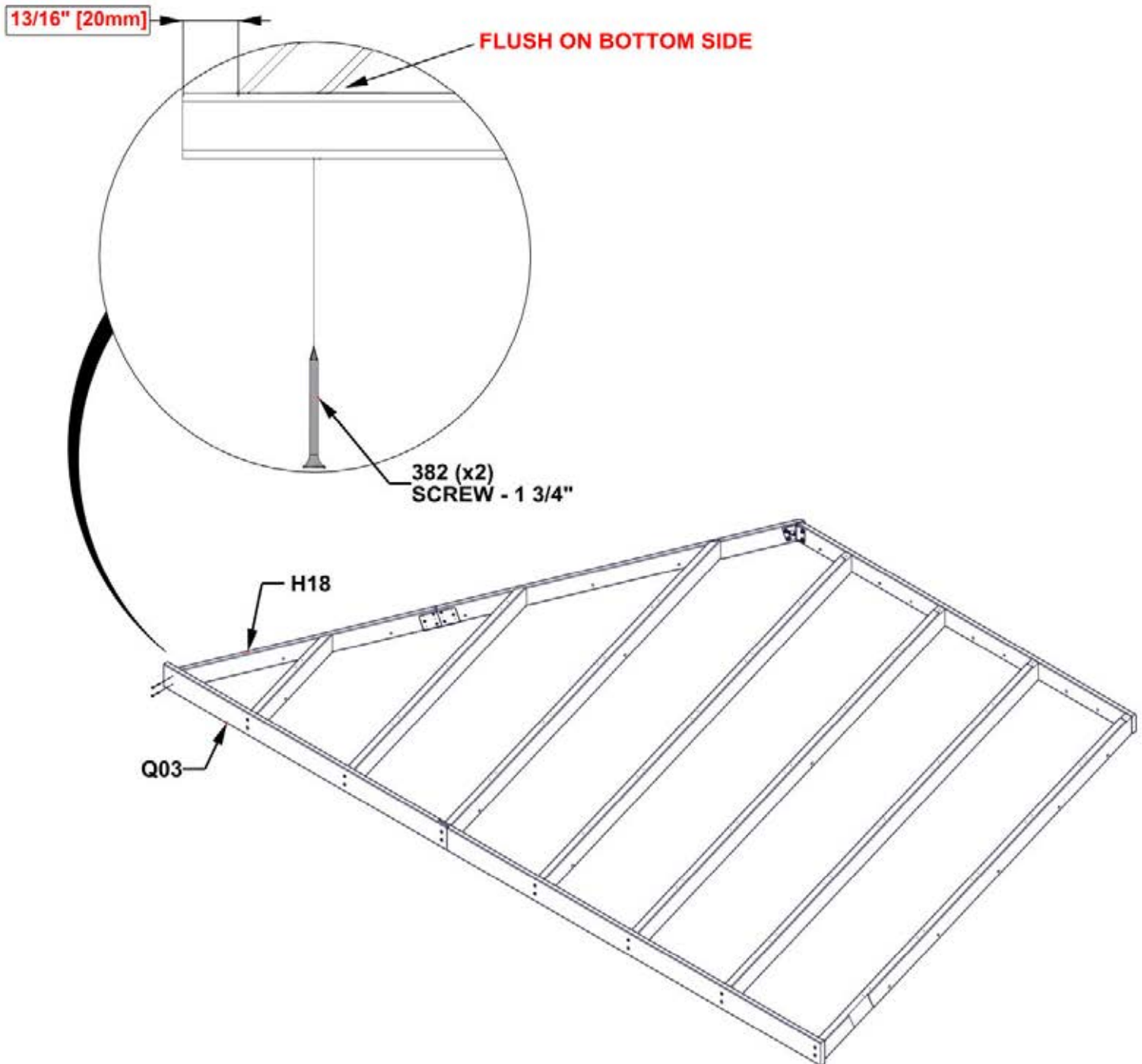

STEP 44 - LEFT PANEL ASSEMBLY

LOOSEN HARDWARE TO ADJUST FOR SQUARING IF NEEDED.

CRITICAL:

- SQUARE UNIT BEFORE PROCEEDING TO NEXT STEPS.
- THE BELOW DIMENSIONS ARE CRITICAL TO THE FINAL ASSEMBLY.
- MEASUREMENTS SHOULD BE WITHIN +/- 1/4" (6mm).
- MEASUREMENTS OUTSIDE OF TOLERANCE WILL LEAD TO ISSUES ON FUTURE ASSEMBLY STEPS.

ONCE SQUARE, TIGHTEN ALL HARDWARE FROM PREVIOUS STEPS

MEASUREMENTS ARE TAKEN FROM OUTSIDE CORNERS AS SHOWN.

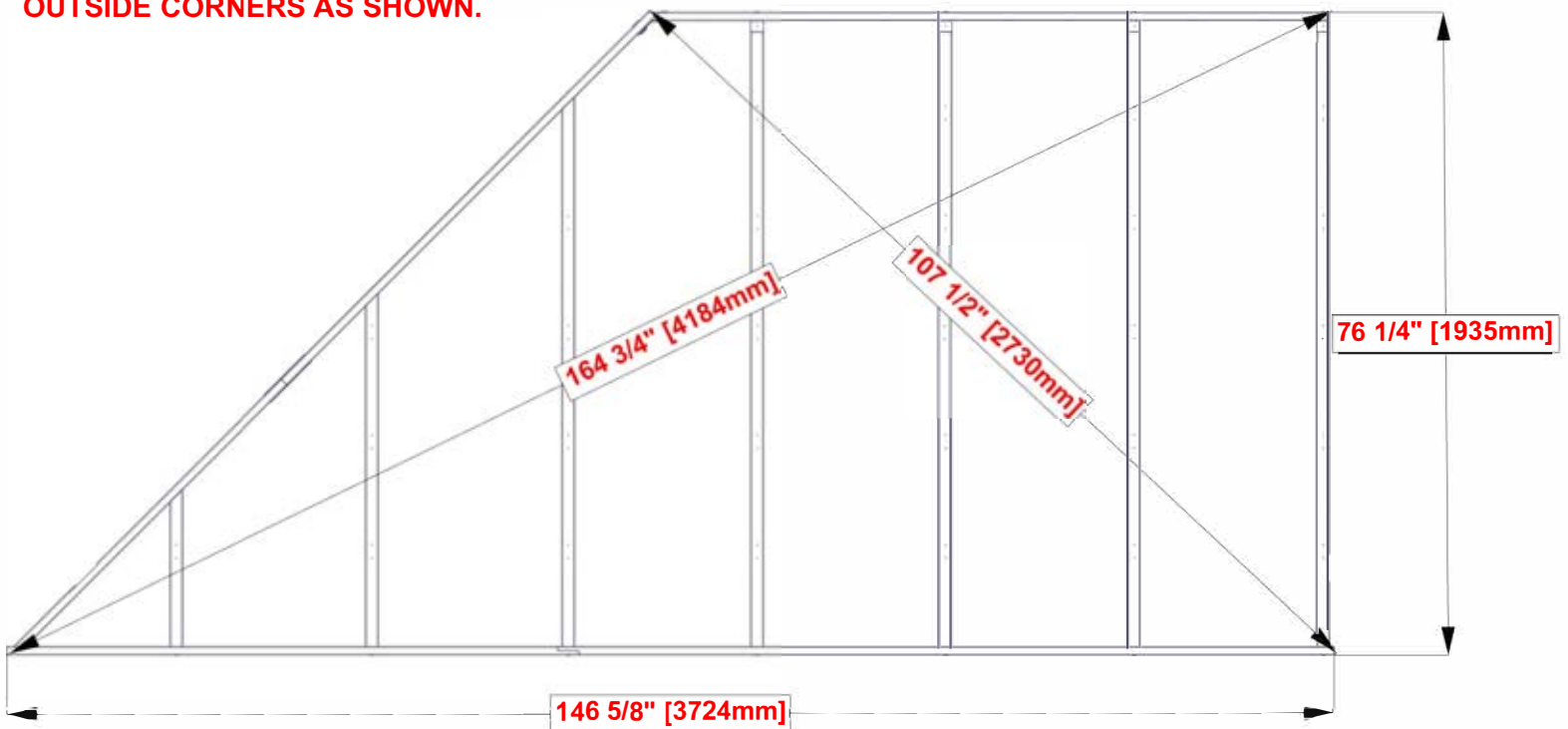

STEP 45 - LEFT PANEL ASSEMBLY

QTY	PART NUMBER	DESCRIPTION
30	H100391	SCREW PFH 8x2 BLK

H21 PURLIN - W4L19443
(x1) 15/16"x3 3/8"x74 13/16" (24x86x1900)

H22 PURLIN - W4L19444
(x1) 15/16"x3 3/8"x64 13/16" (24x86x1646)

H23 PURLIN - W4L19445
(x1) 15/16"x3 3/8"x83 1/2" (24x86x2121)

H24 PURLIN - W4L19446
(x1) 15/16"x3 3/8"x44" (24x86x1117)

- ALIGN PURLIN PILOT HOLES WITH RAFTER PILOT HOLES.
- ATTACH SCREWS FROM THE CENTER AND WORK OUTWARD.
- H18 BOARD DOES NOT HAVE PILOT HOLES FOR OUTSIDE EDGE SCREWS.
- USING PURLINS AS A GUIDE AND A 1/8" [3mm] DRILL BIT, DRILL PILOT HOLES INTO H18 BOARD.

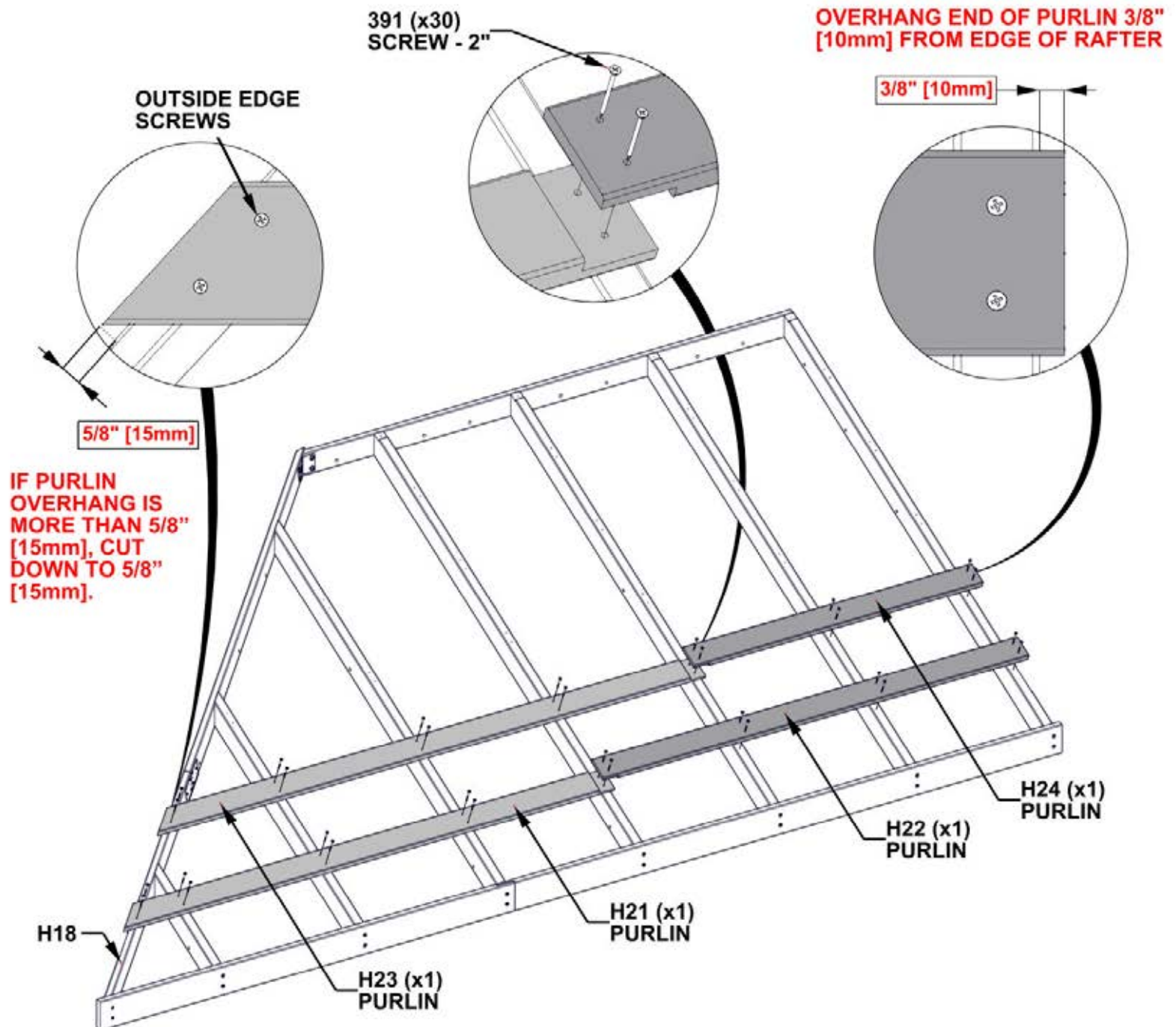

STEP 46 - LEFT PANEL ASSEMBLY

QTY	PART NUMBER	DESCRIPTION
4	H100200	SCREW PFH 8x1 1/2 BLK
37	H100391	SCREW PFH 8x2 BLK

T02 PURLIN - W4L19450
(x1) 15/16"x1 5/16"x78 5/16" (24x34x1989)

H22 PURLIN - W4L19444
(x1) 15/16"x3 3/8"x64 13/16" (24x86x1646)

H25 PURLIN - W4L19447
(x1) 15/16"x3 3/8"x50 9/16" (24x86x1284)

H27 PURLIN - W4L19449
(x1) 15/16"x3 3/8"x88 3/4" (24x86x2255)

H24 PURLIN - W4L19446
(x1) 15/16"x3 3/8"x44" (24x86x1117)

H26 PURLIN - W4L19448
(x1) 15/16"x3 3/8"x59 5/16" (24x86x1506)

- ALIGN PURLIN PILOT HOLES WITH RAFTER PILOT HOLES.
- ATTACH SCREWS FROM THE CENTER AND WORK OUTWARD.
- H19 BOARD DOES NOT HAVE PILOT HOLES FOR OUTSIDE EDGE SCREWS.
- USING PURLINS AS A GUIDE AND A 1/8" [3mm] DRILL BIT, DRILL PILOT HOLES INTO H19 BOARD.

IF PURLIN OVERHANG IS MORE THAN 5/8" [15mm], CUT DOWN TO 5/8" [15mm].

OVERHANG END OF PURLIN 3/8" [10mm] FROM EDGE OF RAFTER

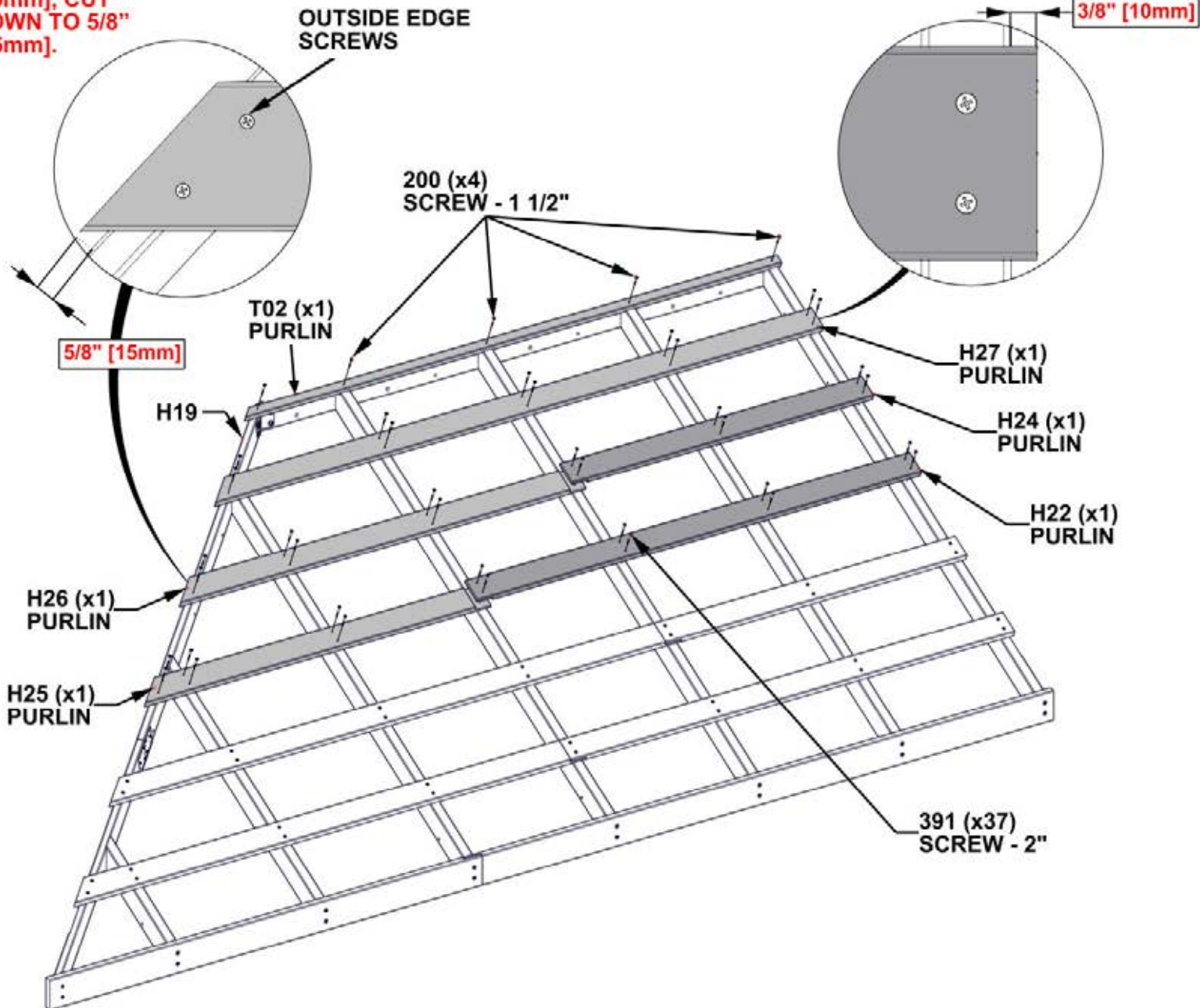

STEP 47 - LEFT PANEL ASSEMBLY

QTY	PART NUMBER	DESCRIPTION
3	H100833	SCREW WOODGRIP 10-16x3/4"



A4M02849 RIDGE CAP CHANNEL
(x1)

WARNING: GLOVES ARE RECOMMENDED WHEN HANDLING STEEL.

- REMOVE BLUE PROTECTIVE FILM.
- POSITION RIDGE CAP CHANNEL FLUSH WITH ENDS OF PURLINS WITH THE WIDER SIDE OF THE CHANNEL ON THE BOTTOM.
- MAKE SURE THE BOTTOM EDGE IS AT THE DISTANCE SHOWN BELOW.

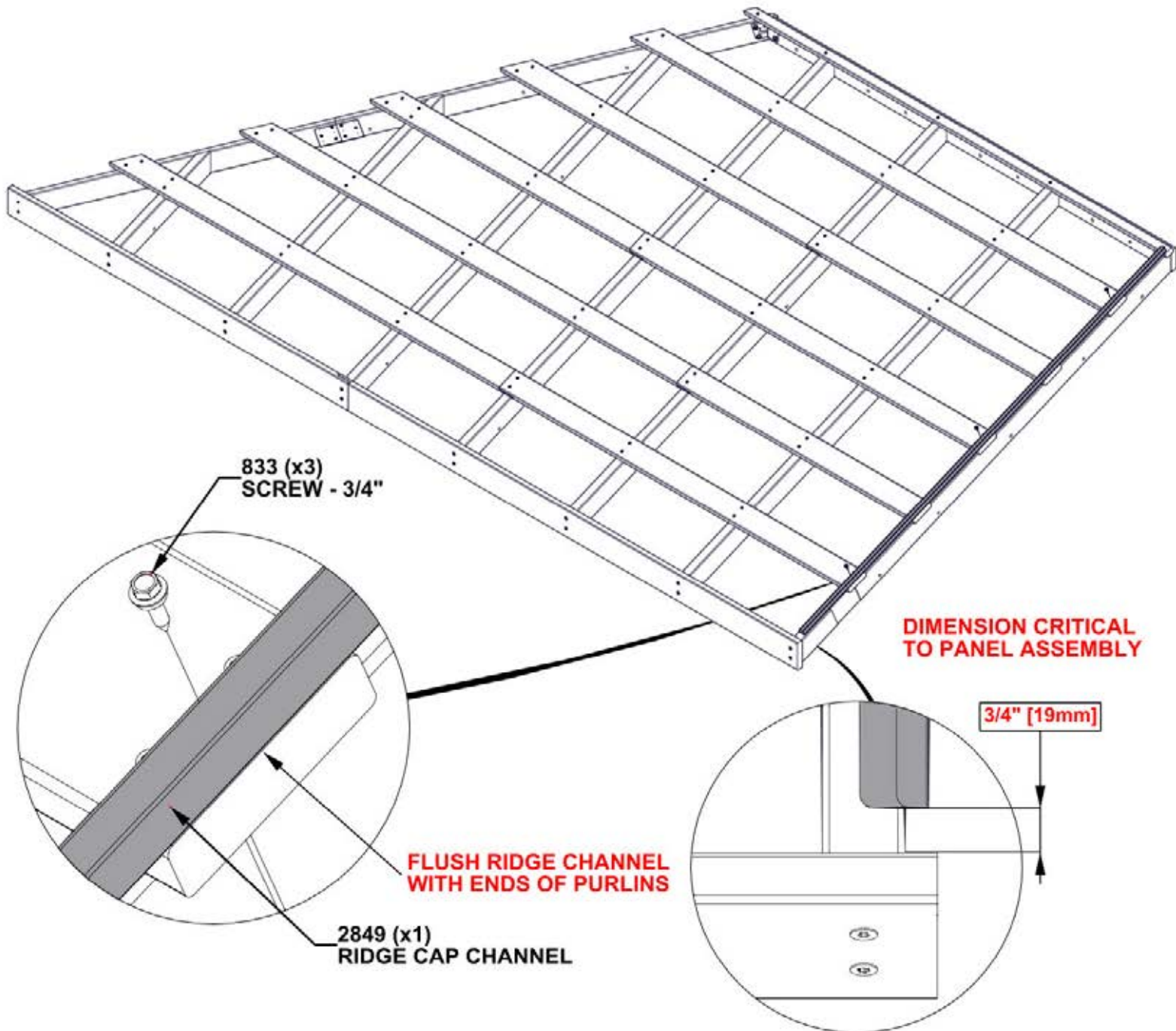

STEP 48 - LEFT PANEL ASSEMBLY

QTY	PART NUMBER	DESCRIPTION
47	H100833	SCREW WOODGRIP 10-16x3/4"

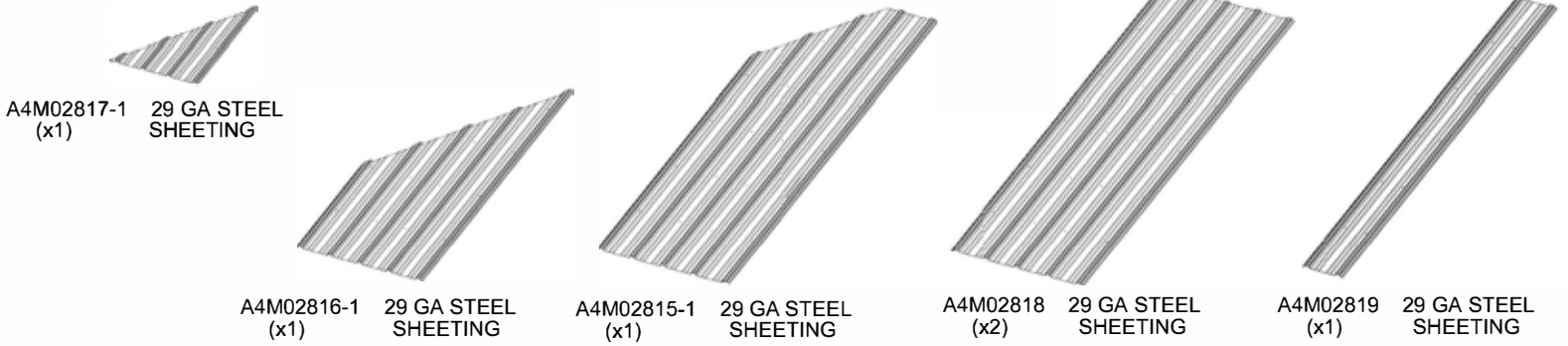

- REMOVE BLUE PROTECTIVE FILM.
- OVERLAP PANELS BY ONE RIDGE.
- PANELS SHOULD BE FLUSH WITH PURLIN ENDS AND Q03 ROOF FASCIA.
- ONCE SHEETING IS IN PLACE, IT IS RECOMMENDED TO ADD H100833 SCREWS IN THE MIDDLE OF THE SHEETS TO HOLD THE SHEETING FOR THE NEXT STEP.

WARNING: GLOVES ARE RECOMMENDED WHEN HANDLING STEEL.

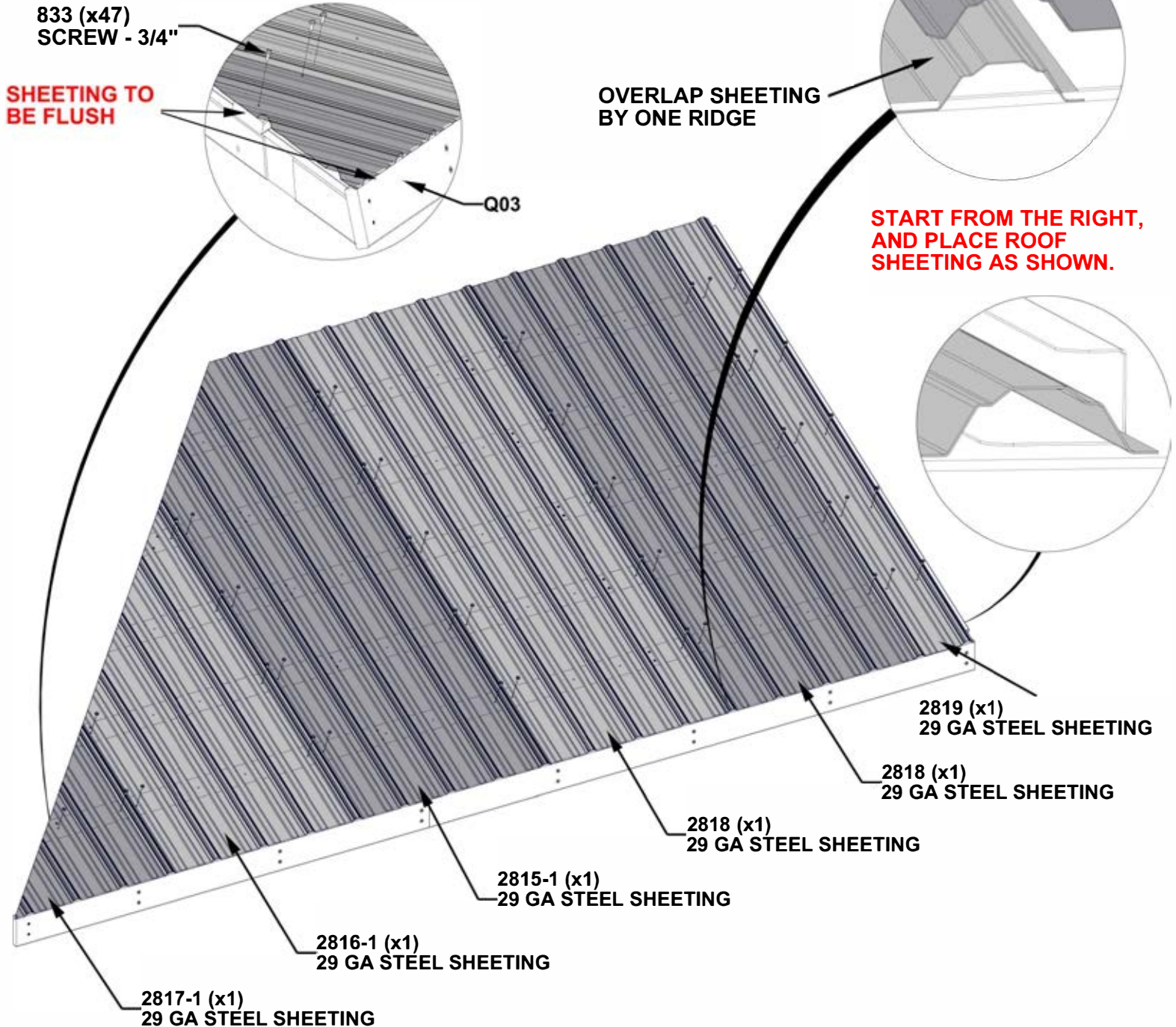

STEP 49 - LEFT PANEL ASSEMBLY

QTY	PART NUMBER	DESCRIPTION
5	H100833	SCREW WOODGRIP 10-16x3/4"

A4M02850 RIDGE CAP CHANNEL SHORT (x1)



A4M02847 RIDGE CAP CHANNEL LONG (x1)

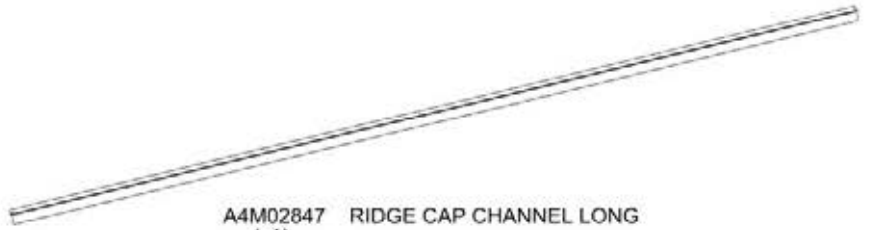

- REMOVE BLUE PROTECTIVE FILM.
- POSITION RIDGE CAP CHANNEL OVER THE EDGE OF THE ROOF SHEETING WITH THE WIDER SIDE OF THE CHANNEL ON THE BOTTOM.
- MAKE SURE THE SHEETING IS FULLY SEATED INTO THE CHANNEL.

DIMENSION CRITICAL TO PANEL ASSEMBLY

2 1/4" [57mm]

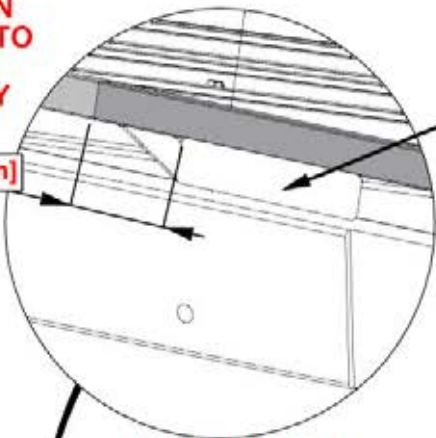

PURLIN UNDERNEATH SHEETING

833 (x5) SCREW - 3/4"

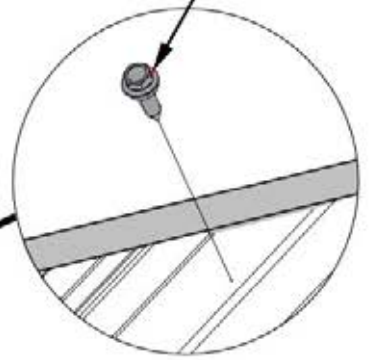

2847 (x1) RIDGE CAP CHANNEL LONG

2850 (x1) RIDGE CAP CHANNEL SHORT

LOOSEN SCREW TO EASE INSTALLATION

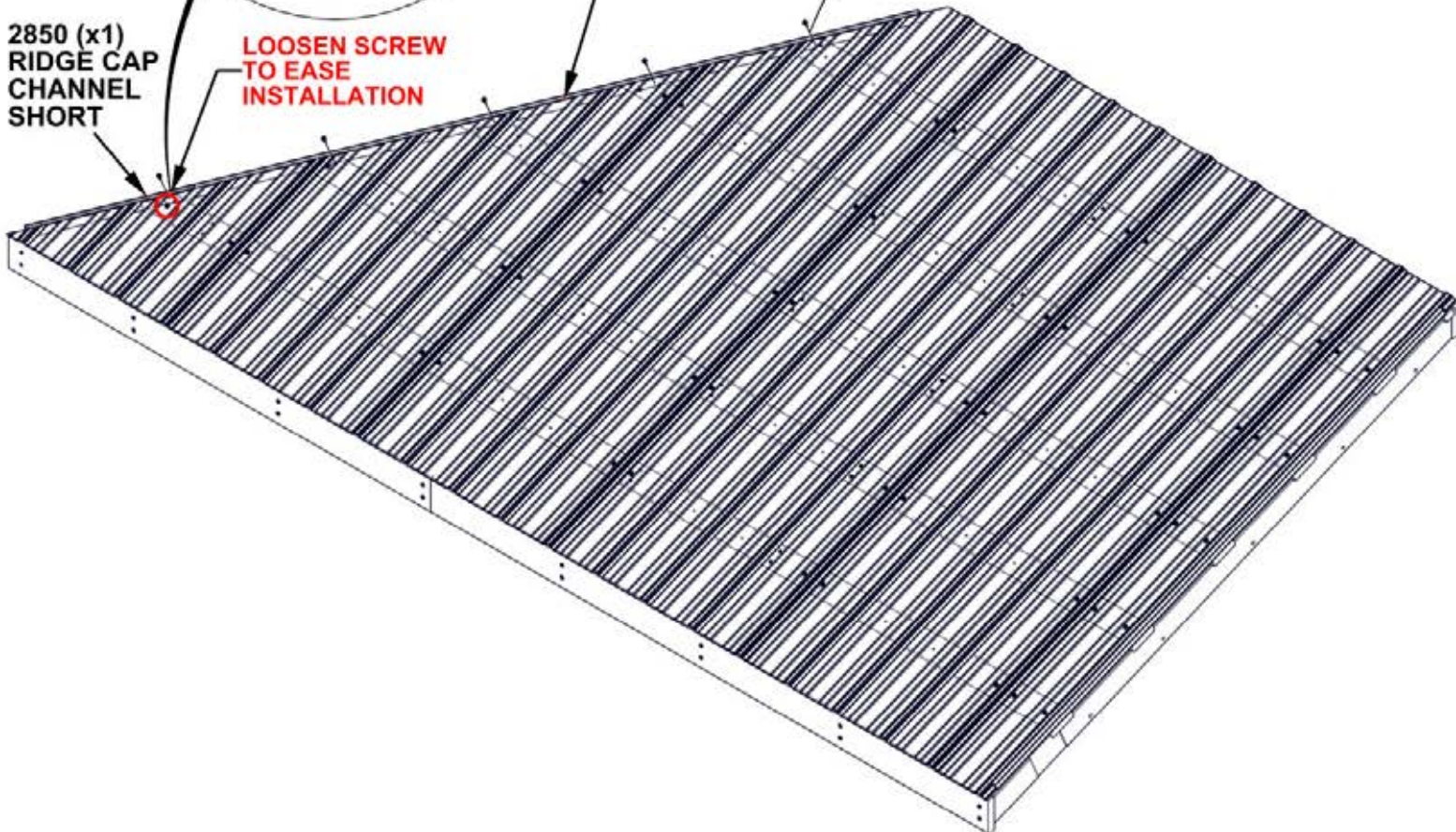

STEP 50 - LEFT PANEL ASSEMBLY

QTY	PART NUMBER	DESCRIPTION
35	H100833	SCREW WOODGRIP 10-16x3/4"

- INSERT REMAINING SCREWS TO FASTEN SHEET METAL IN PLACE.

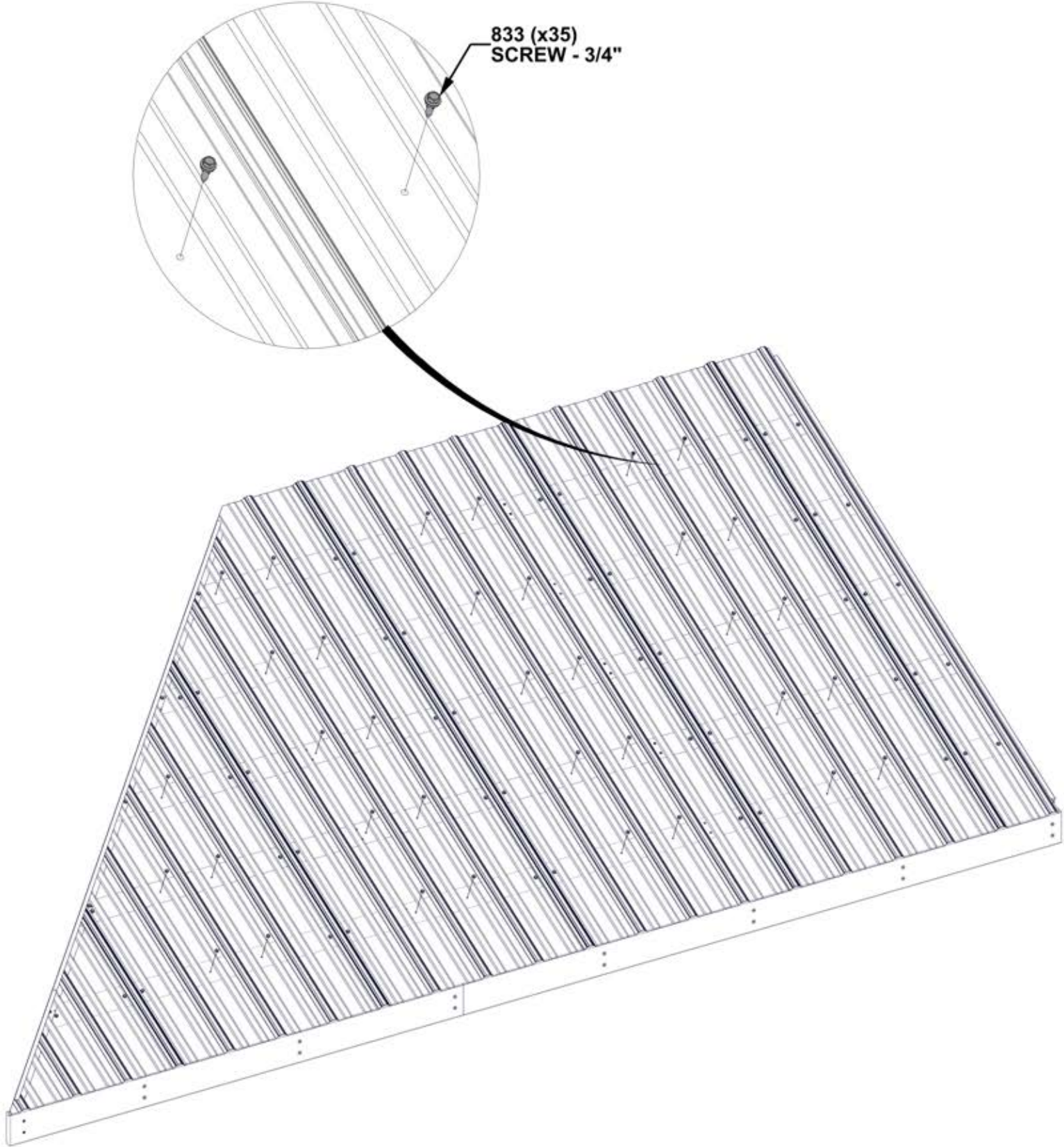

**REPEAT LEFT PANEL ASSEMBLY
STEPS 37 THROUGH 50**

STEP 51 - RIGHT PANEL ASSEMBLY

QTY	PART NUMBER	DESCRIPTION
2	H100171	BOLT WH 1/4x1 BLK
2	H100398	TNUT-1/4" BLK

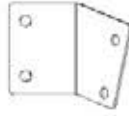

A4M01193 PANEL BRACKET
(x1)



H30 FASCIA - W4L19451
(x1) 15/16"x3 3/8"x74 7/8" (24x86x1902)

- INSERT T-NUTS FIRST
- HAND TIGHTEN BOLTS

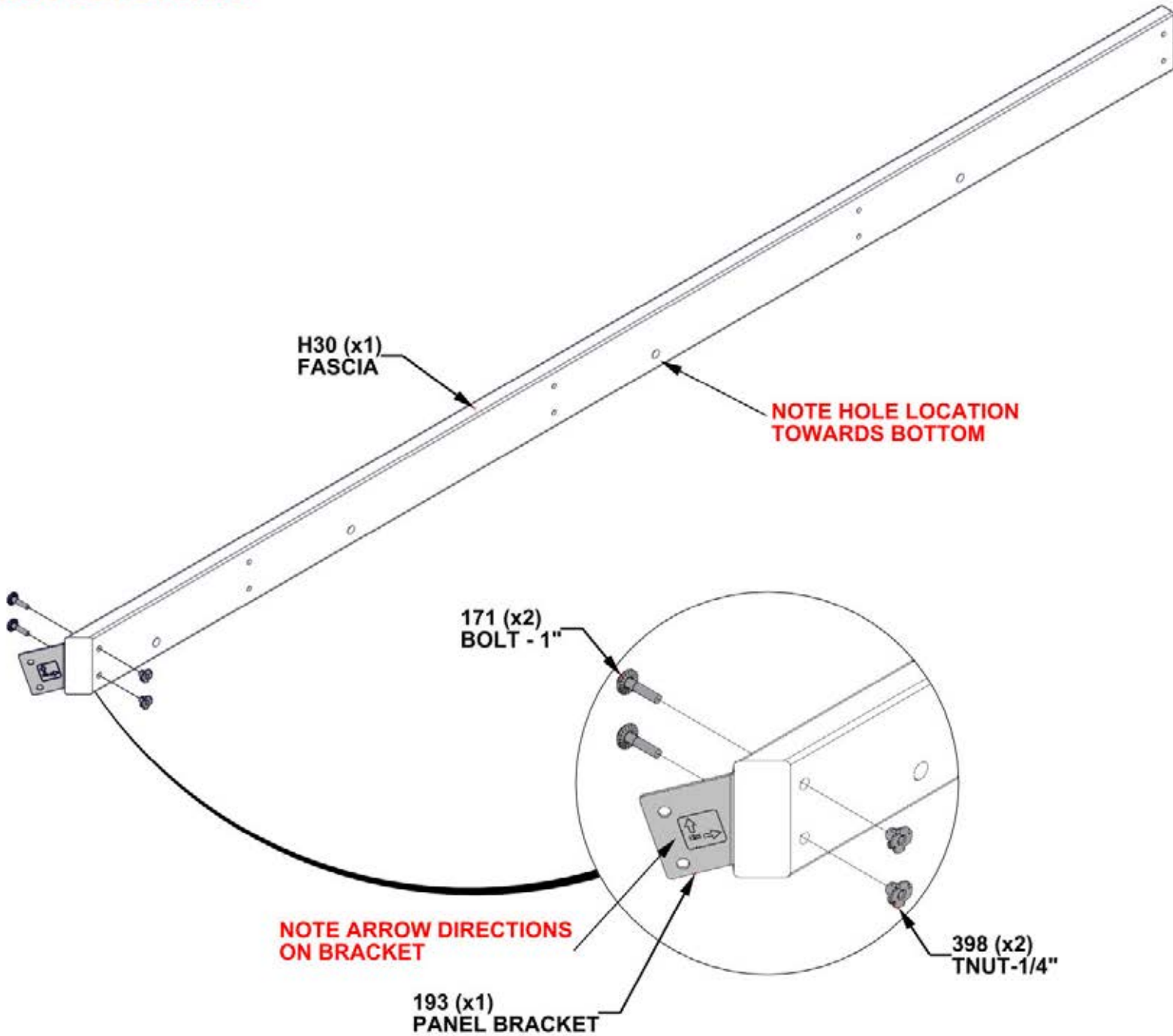

STEP 52 - RIGHT PANEL ASSEMBLY

QTY	PART NUMBER	DESCRIPTION
12	H100385	SCREW PFH 8x1 BLK



H28 RAFTER - W4L17568
(x1) 15/16"x3 3/8"x44 1/2" (24x86x1130)



H29 RAFTER - W4L17569
(x1) 15/16"x3 3/8"x60 5/8" (24x86x1540)



A4M01237 ROOF SUPPORT SPLICE CLIP
(x1)

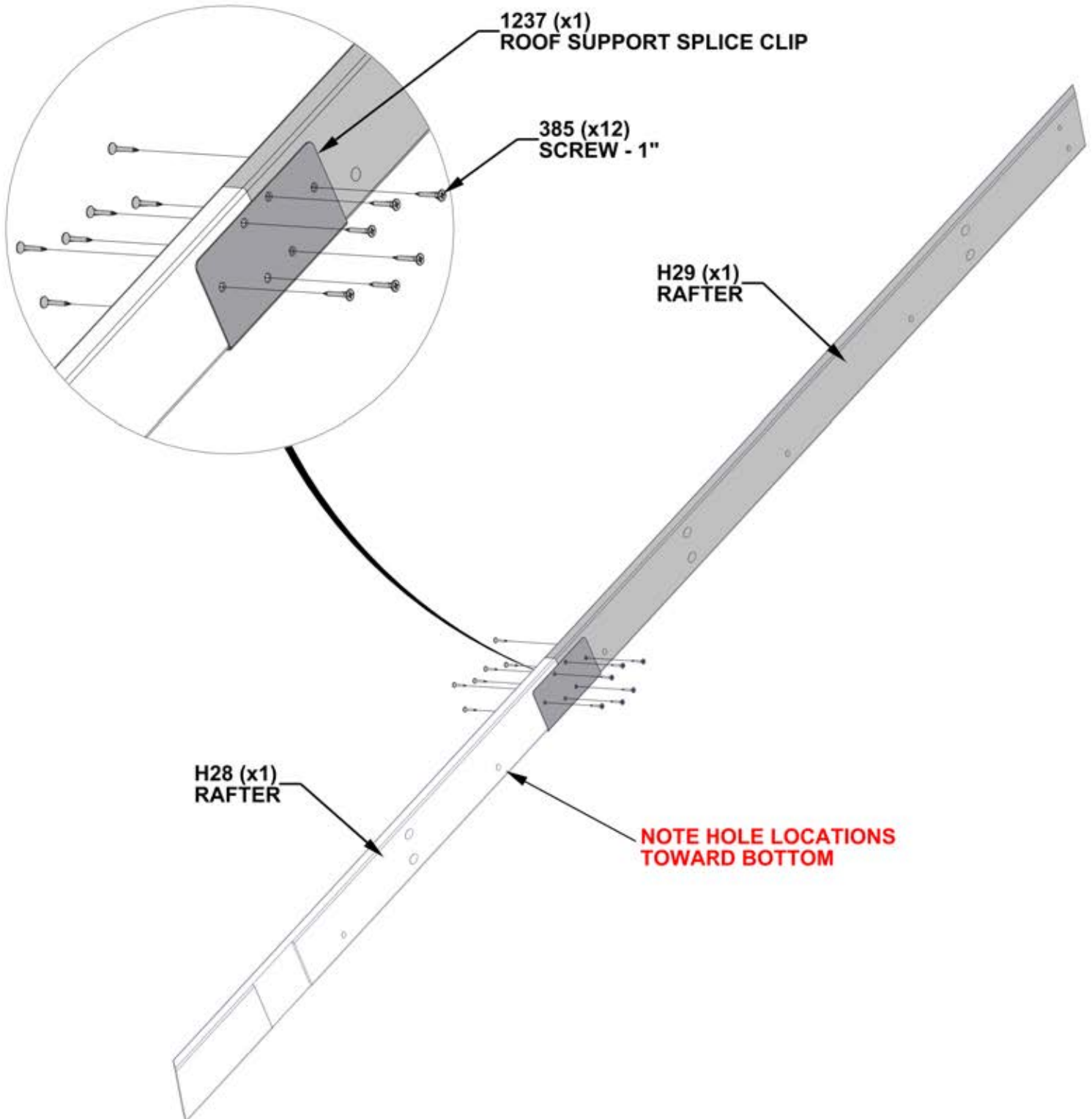

STEP 53 - RIGHT PANEL ASSEMBLY

QTY	PART NUMBER	DESCRIPTION
2	H100171	BOLT WH 1/4x1 BLK
2	H100398	TNUT-1/4" BLK



RAFTER SUPPORT



RAFTER ASSEMBLY

INSERT T-NUTS FIRST

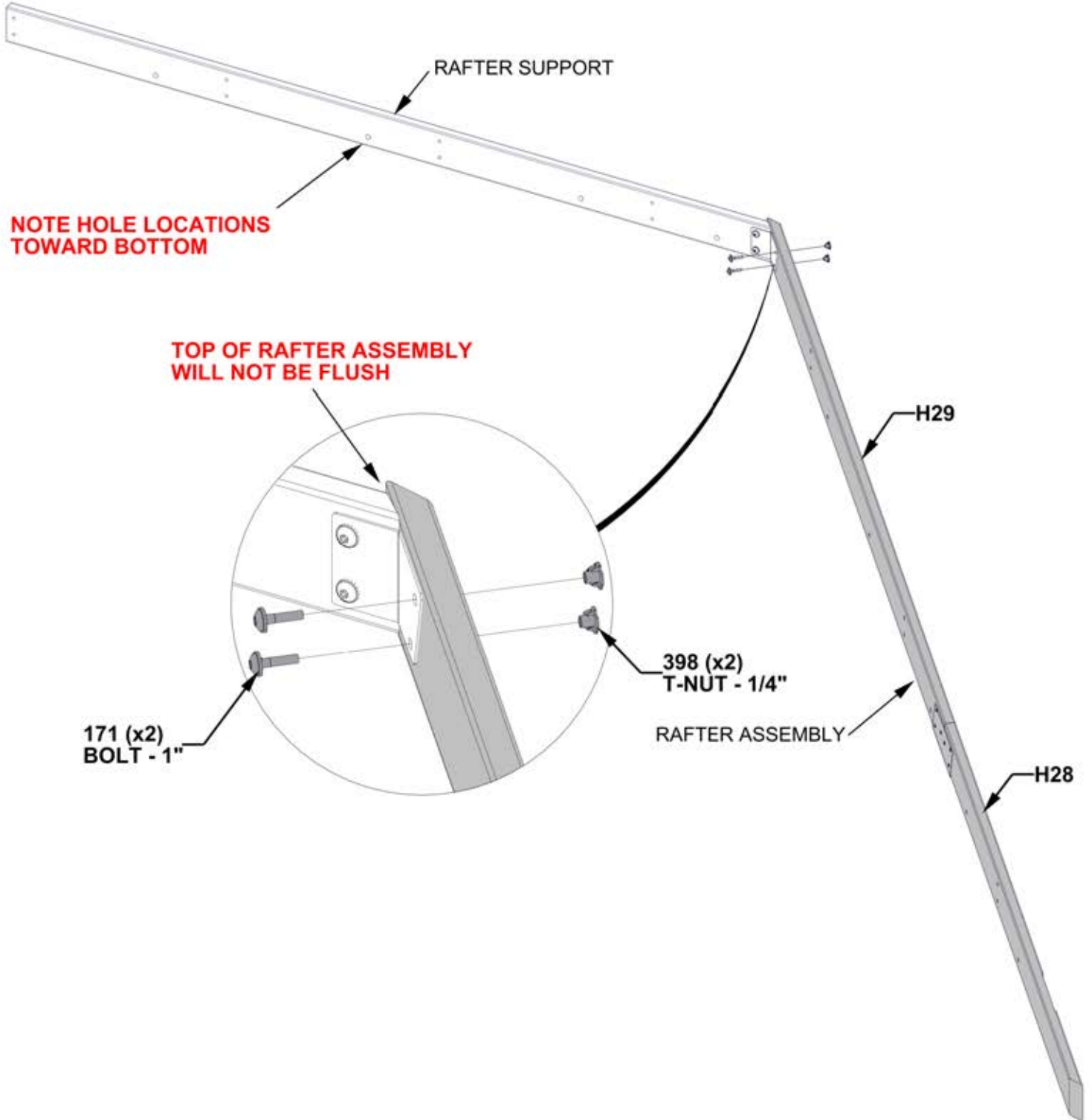

STEP 54 - RIGHT PANEL ASSEMBLY

QTY	PART NUMBER	DESCRIPTION
8	H101030	SCREW CONFIRMAT 7x2 BLK

E08 RAFTER - W4L17552
(x1) 1 7/16"x3 3/8"x76 1/8" (36x86x1934)

E15 RAFTER - W4L17571
(x1) 1 7/16"x3 3/8"x76 1/8" (36x86x1934)

E16 RAFTER - W4L17572
(x1) 1 7/16"x76 1/8"x3 3/8" (36x86x1934)

E18 RAFTER - W4L19815
(x1) 1 7/16"x76 1/8"x3 3/8" (36x86x1934)

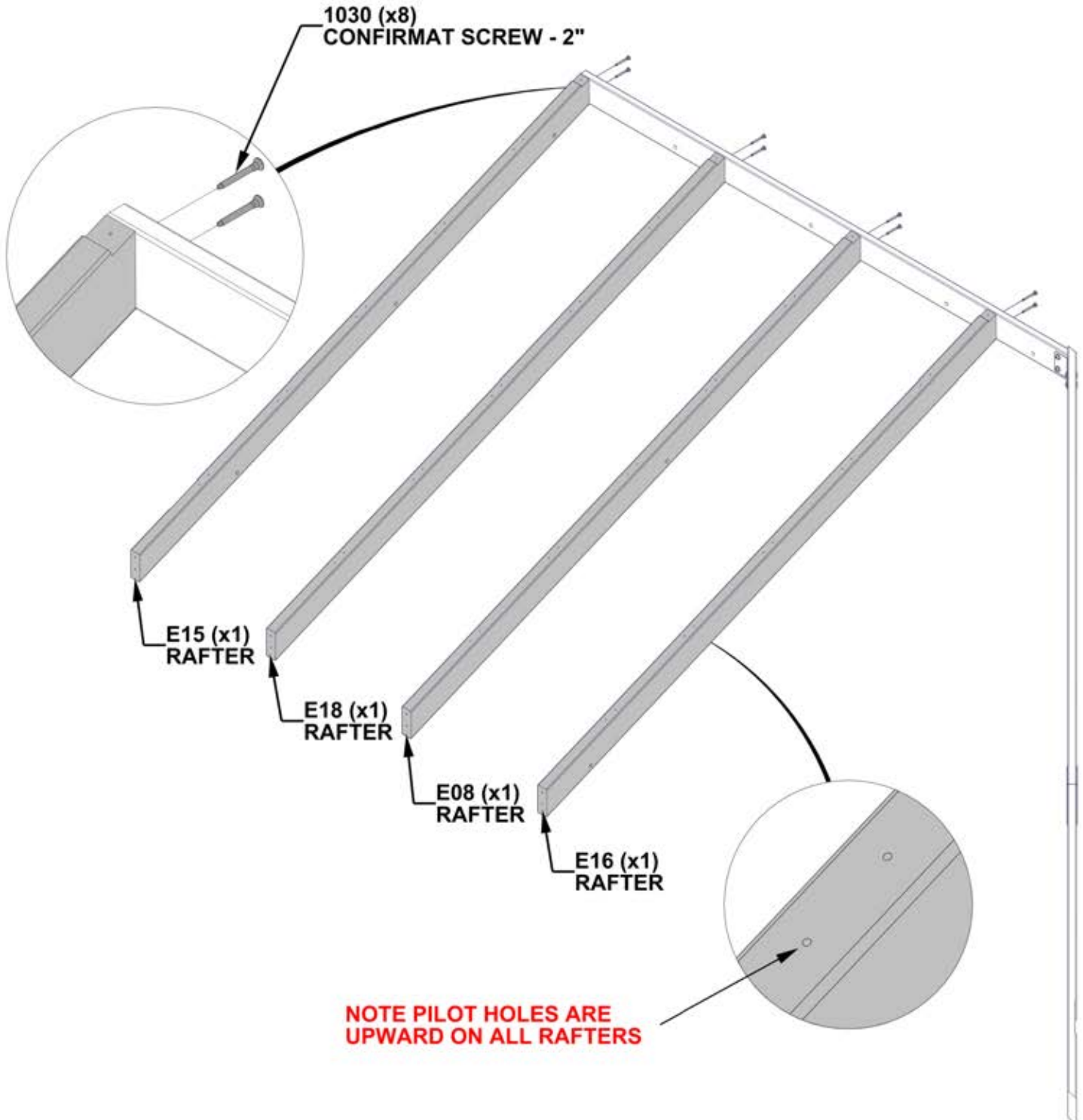

STEP 55 - RIGHT PANEL ASSEMBLY

QTY	PART NUMBER	DESCRIPTION
6	H101030	SCREW CONFIRMAT 7x2 BLK



E12 RAFTER - W4L17565
(x1) 3 3/8"x1 7/16"x20 3/16" (36x86x512)



E13 RAFTER - W4L17566
(x1) 1 7/16"x3 3/8"x43 5/8" (36x86x1109)



E14 RAFTER - W4L17567
(x1) 1 7/16"x3 3/8"x67 1/8" (36x86x1705)

NOTE PILOT HOLES FACE UP ON ALL RAFTERS

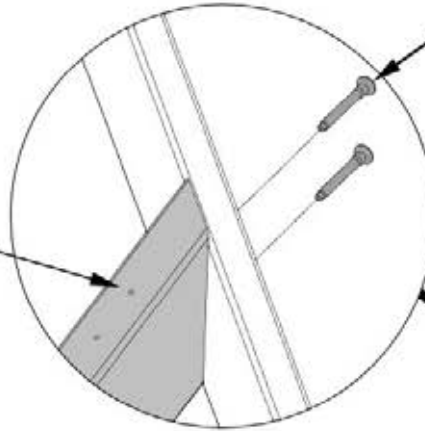

1030 (x6)
CONFIRMAT SCREW - 2"

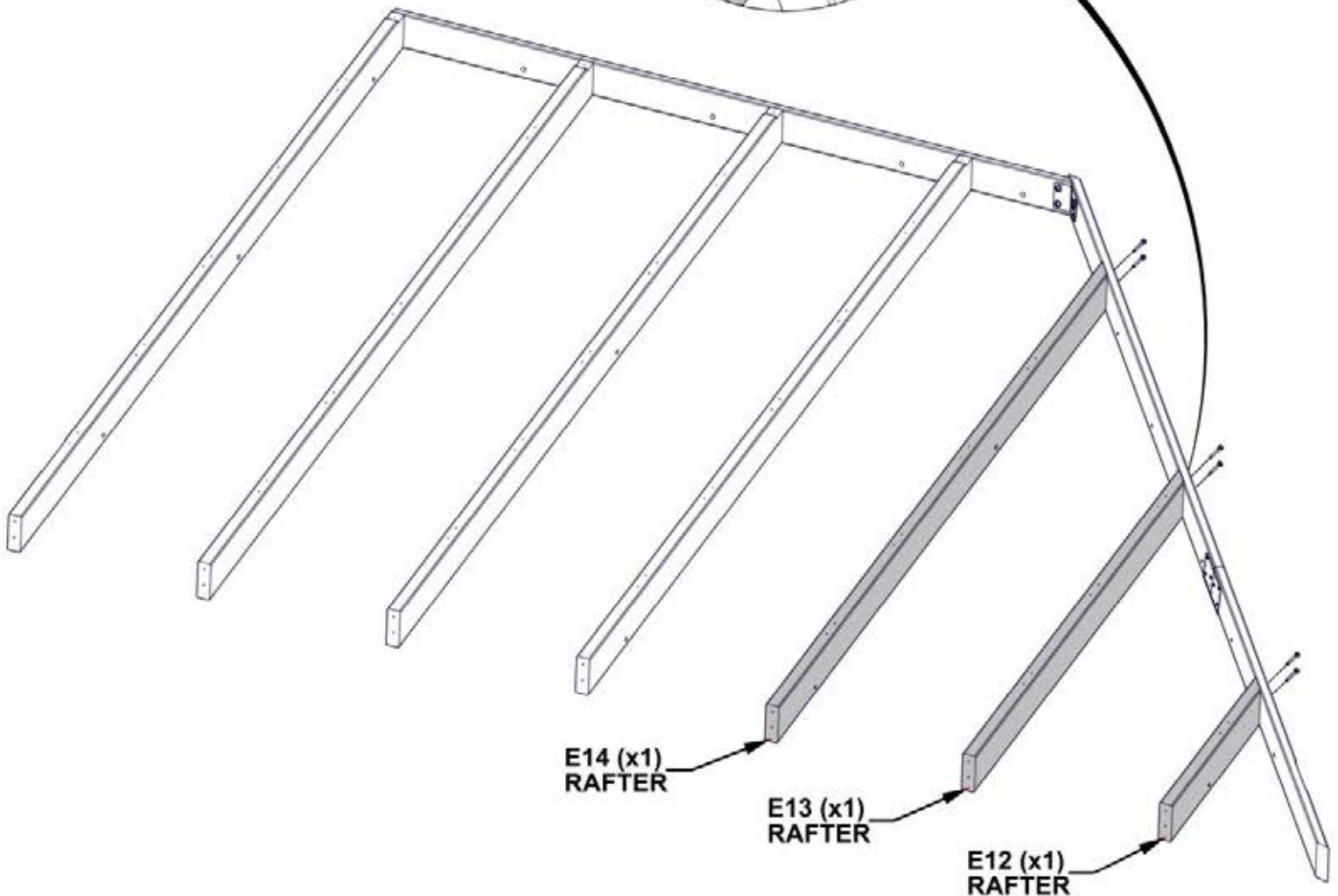

STEP 56 - RIGHT PANEL ASSEMBLY

QTY	PART NUMBER	DESCRIPTION
14	H101030	SCREW CONFIRMAT 7x2 BLK



Q03 FASCIA - W4L19441
 (x1) 15/16"x4 7/16"x63 3/16" (24x112x1605)



Q04 FASCIA - W4L19442
 (x1) 15/16"x4 7/16"x85 13/16" (24x112x2179)

START AT LEFT RAFTER USING DIMENSIONS SHOWN FOR OVERHANG AND CONTINUE TO WORK TOWARDS THE RIGHT.

RAFTER MAY NEED TO BE LOOSENED UP TO ATTACH FASCIA BOARDS

THIS DIMENSION IS CRITICAL TO THE PANEL ASSEMBLY

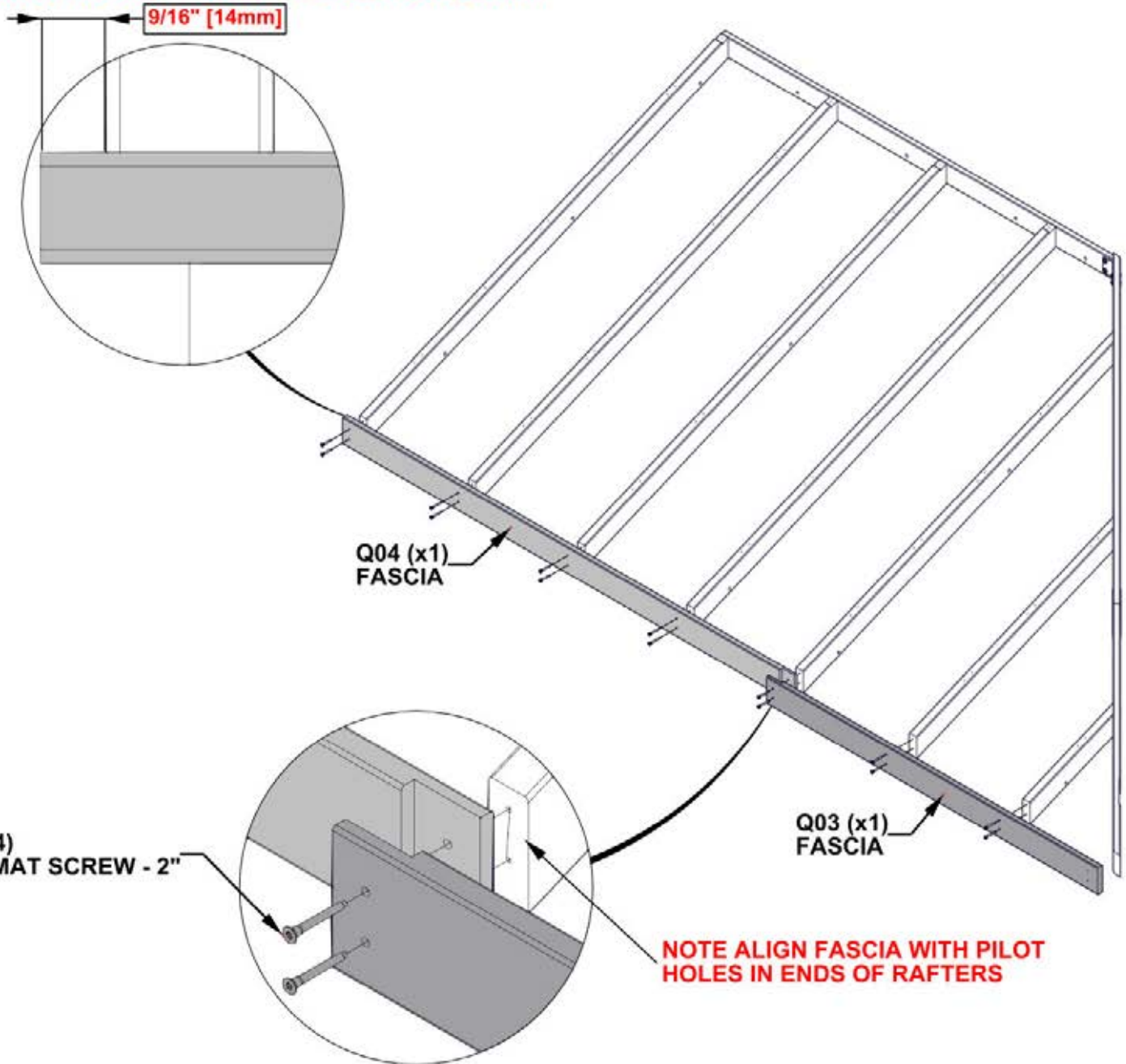

NOTE ALIGN FASCIA WITH PILOT HOLES IN ENDS OF RAFTERS

STEP 57 - RIGHT PANEL ASSEMBLY

QTY	PART NUMBER	DESCRIPTION
2	H100382	SCREW PFH 8x1 3/4 BLK

- USING THE Q03 BOARD AS A GUIDE AND A 1/8" [3mm] DRILL BIT, DRILL PILOT HOLES INTO THE H28 BOARD USING THE DIMENSION BELOW.

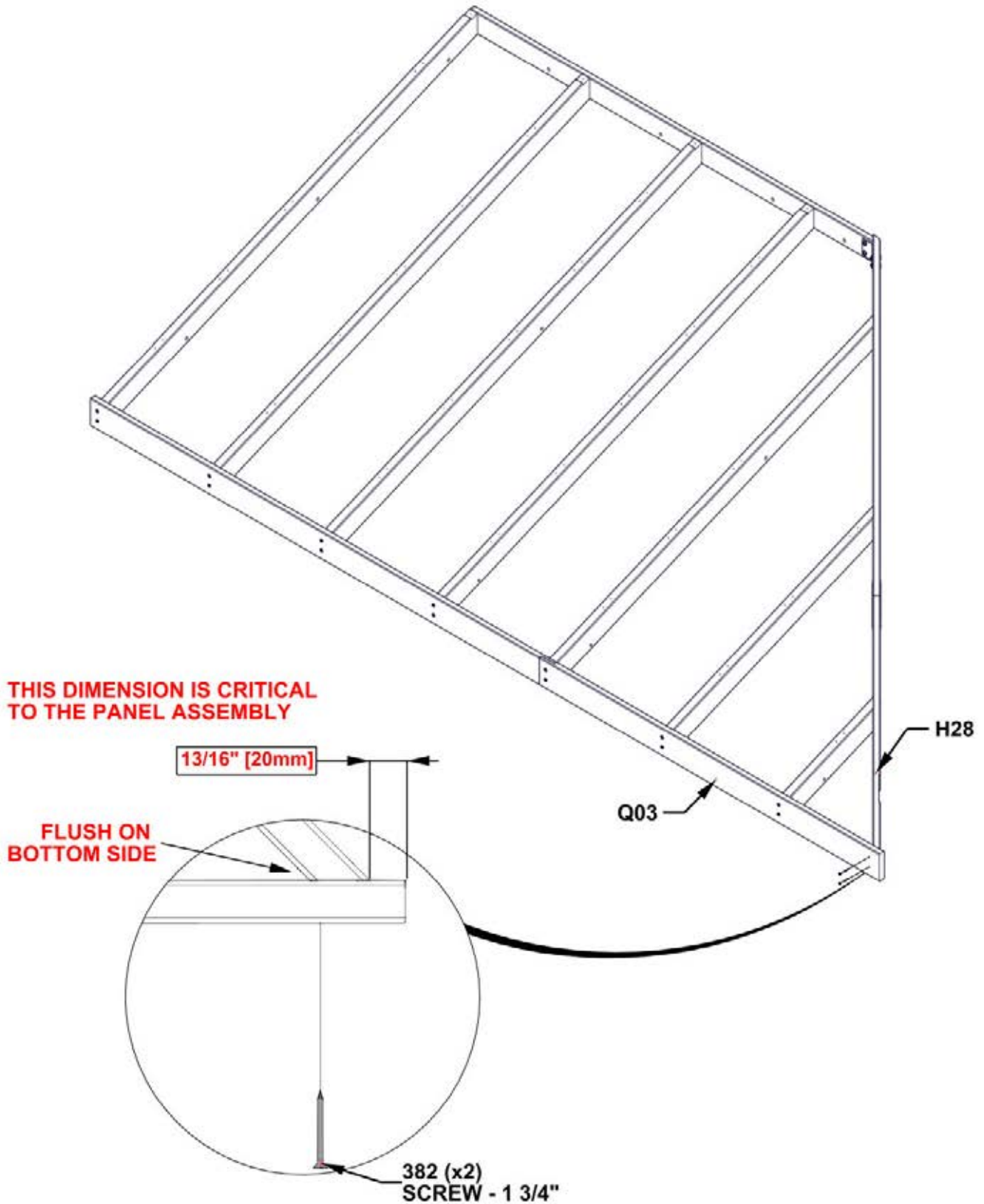

STEP 58 - RIGHT PANEL ASSEMBLY

LOOSEN HARDWARE TO ADJUST FOR SQUARING IF NEEDED.

CRITICAL:

- SQUARE UNIT BEFORE PROCEEDING TO NEXT STEPS.
- THE BELOW DIMENSIONS ARE CRITICAL TO THE FINAL ASSEMBLY.
- MEASUREMENTS SHOULD BE WITHIN $\pm 1/4"$ (6mm).
- MEASUREMENTS OUTSIDE OF TOLERANCE WILL LEAD TO ISSUES ON FUTURE ASSEMBLY STEPS.

ONCE SQUARE, TIGHTEN ALL HARDWARE FROM PREVIOUS STEPS

MEASUREMENTS ARE TAKEN FROM OUTSIDE CORNERS AS SHOWN.

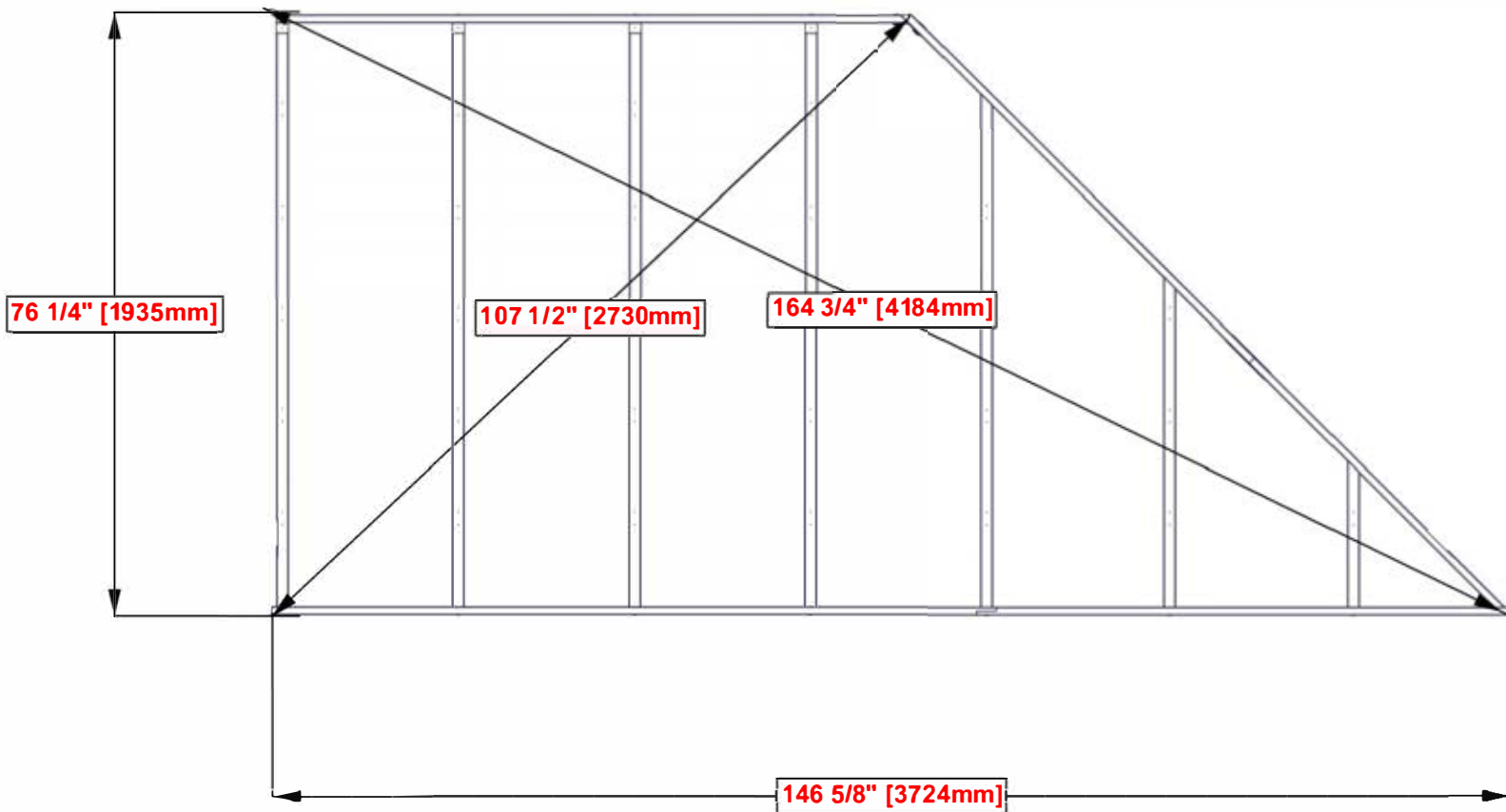

STEP 59 - RIGHT PANEL ASSEMBLY

QTY	PART NUMBER	DESCRIPTION
30	H100391	SCREW PFH 8x2 BLK



H21 PURLIN - W4L19443
(x1) 15/16"x3 3/8"x74 13/16" (24x86x1900)



H22 PURLIN - W4L19444
(x1) 15/16"x3 3/8"x64 13/16" (24x86x1646)



H23 PURLIN - W4L19445
(x1) 15/16"x3 3/8"x83 1/2" (24x86x2121)



H24 PURLIN - W4L19446
(x1) 15/16"x3 3/8"x44" (24x86x1117)

- ALIGN PURLIN PILOT HOLES WITH RAFTER PILOT HOLES.
- ATTACH SCREWS FROM THE CENTER AND WORK OUTWARD.
- H28 BOARD DOES NOT HAVE PILOT HOLES FOR OUTSIDE EDGE SCREWS.
- USING PURLINS AS A GUIDE AND A 1/8" {3mm} DRILL BIT, DRILL PILOT HOLES INTO H28 BOARD.

OVERHANG END OF PURLIN 3/8" [10mm] FROM EDGE OF RAFTER

IF PURLIN OVERHANG IS MORE THAN 5/8" [15mm], CUT DOWN TO 5/8" [15mm].

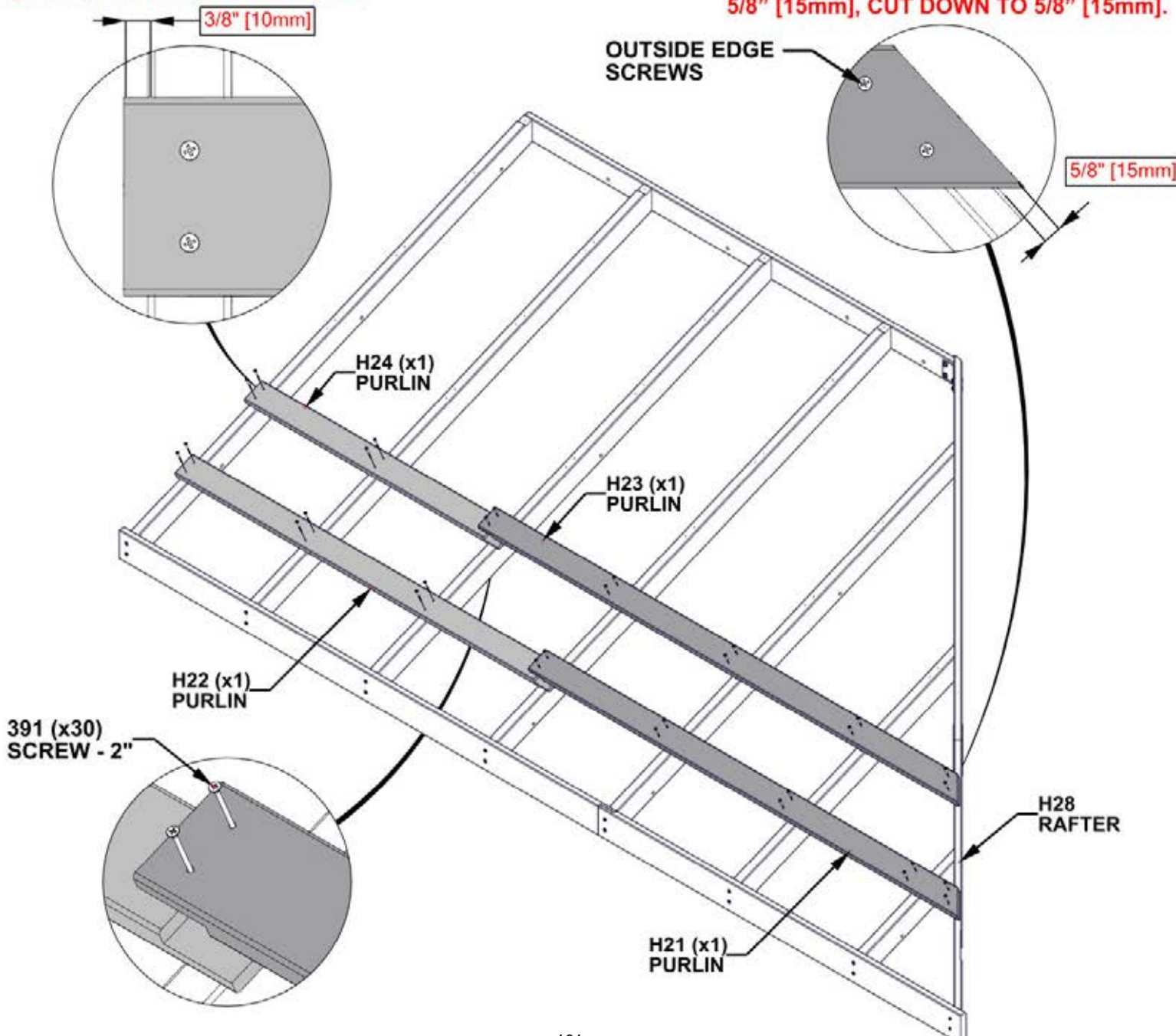

STEP 60 - RIGHT PANEL ASSEMBLY

QTY	PART NUMBER	DESCRIPTION
4	H100200	SCREW PFH 8x1 1/2 BLK
37	H100391	SCREW PFH 8x2 BLK

H27 PURLIN - W4L19449
(x1) 15/16"x3 3/8"x88 3/4" (24x86x2255)

H24 PURLIN - W4L19446
(x1) 15/16"x3 3/8"x44" (24x86x1117)

H26 PURLIN - W4L19448
(x1) 15/16"x3 3/8"x59 5/16" (24x86x1506)

H22 PURLIN - W4L19444
(x1) 15/16"x3 3/8"x64 13/16" (24x86x1646)

H25 PURLIN - W4L19447
(x1) 15/16"x3 3/8"x50 9/16" (24x86x1284)

T02 PURLIN - W4L19450
(x1) 15/16"x1 5/16"x78 5/16" (24x34x1989)

- ALIGN PURLIN PILOT HOLES WITH RAFTER PILOT HOLES.
- ATTACH SCREWS FROM THE CENTER AND WORK OUTWARD.
- H29 BOARD DOES NOT HAVE PILOT HOLES FOR OUTSIDE EDGE SCREWS.
- USING PURLINS AS A GUIDE AND A 1/8" [3mm] DRILL BIT, DRILL PILOT HOLES INTO H29 BOARD.

OVERHANG END OF PURLIN 3/8" [10mm] FROM EDGE OF RAFTER

IF PURLIN OVERHANG IS MORE THAN 5/8" [15mm], CUT DOWN TO 5/8" [15mm].

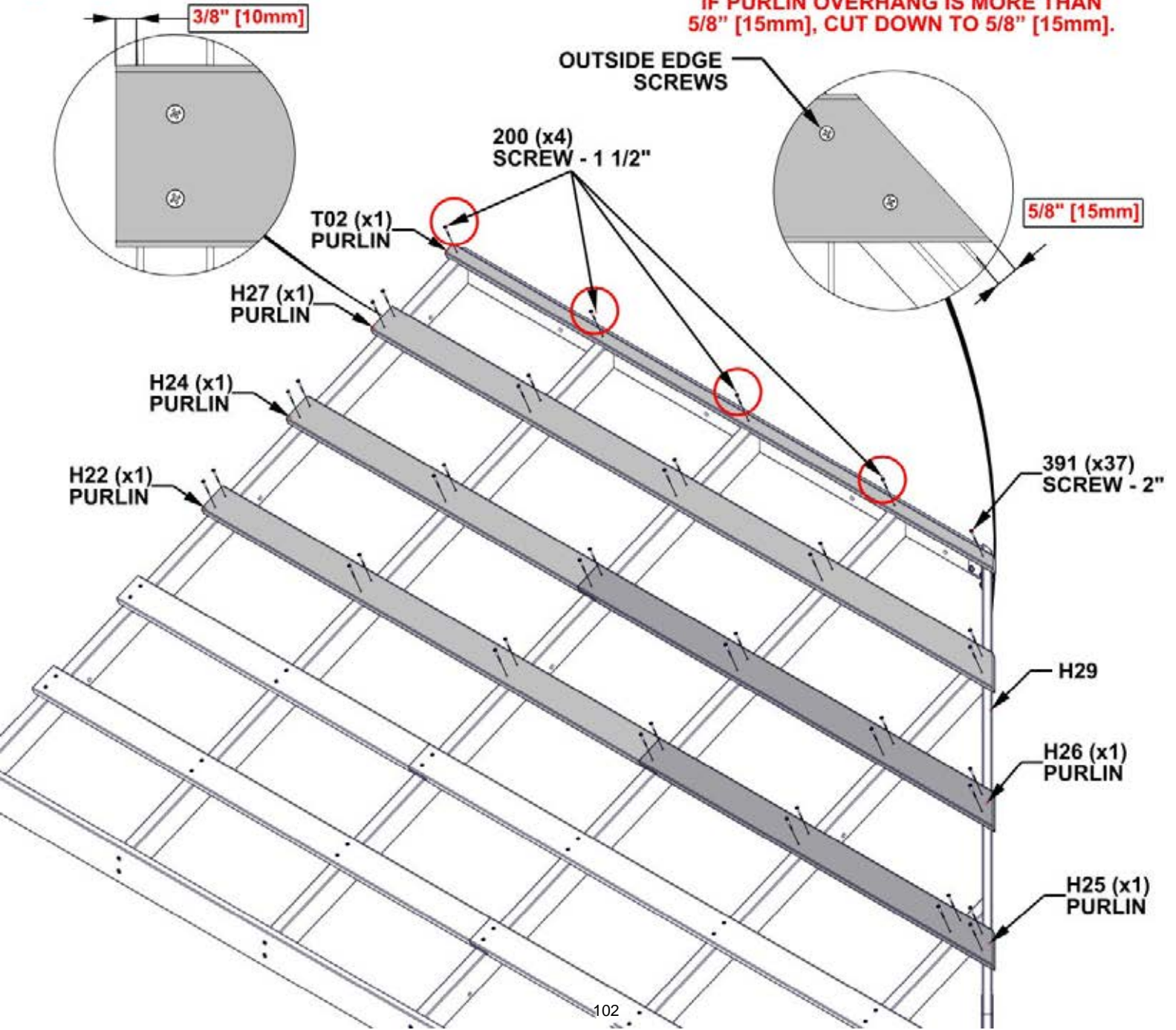

STEP 61 - RIGHT PANEL ASSEMBLY

QTY	PART NUMBER	DESCRIPTION
3	H100833	SCREW WOODGRIP 10-16x3/4"



A4M02849 RIDGE CAP CHANNEL
(x1)

WARNING: GLOVES ARE RECOMMENDED WHEN HANDLING STEEL.

- REMOVE BLUE PROTECTIVE FILM.
- POSITION RIDGE CAP CHANNEL FLUSH WITH ENDS OF PURLINS WITH THE WIDER SIDE OF THE CHANNEL ON THE BOTTOM.
- MAKE SURE THE BOTTOM EDGE IS AT THE DISTANCE SHOWN BELOW.

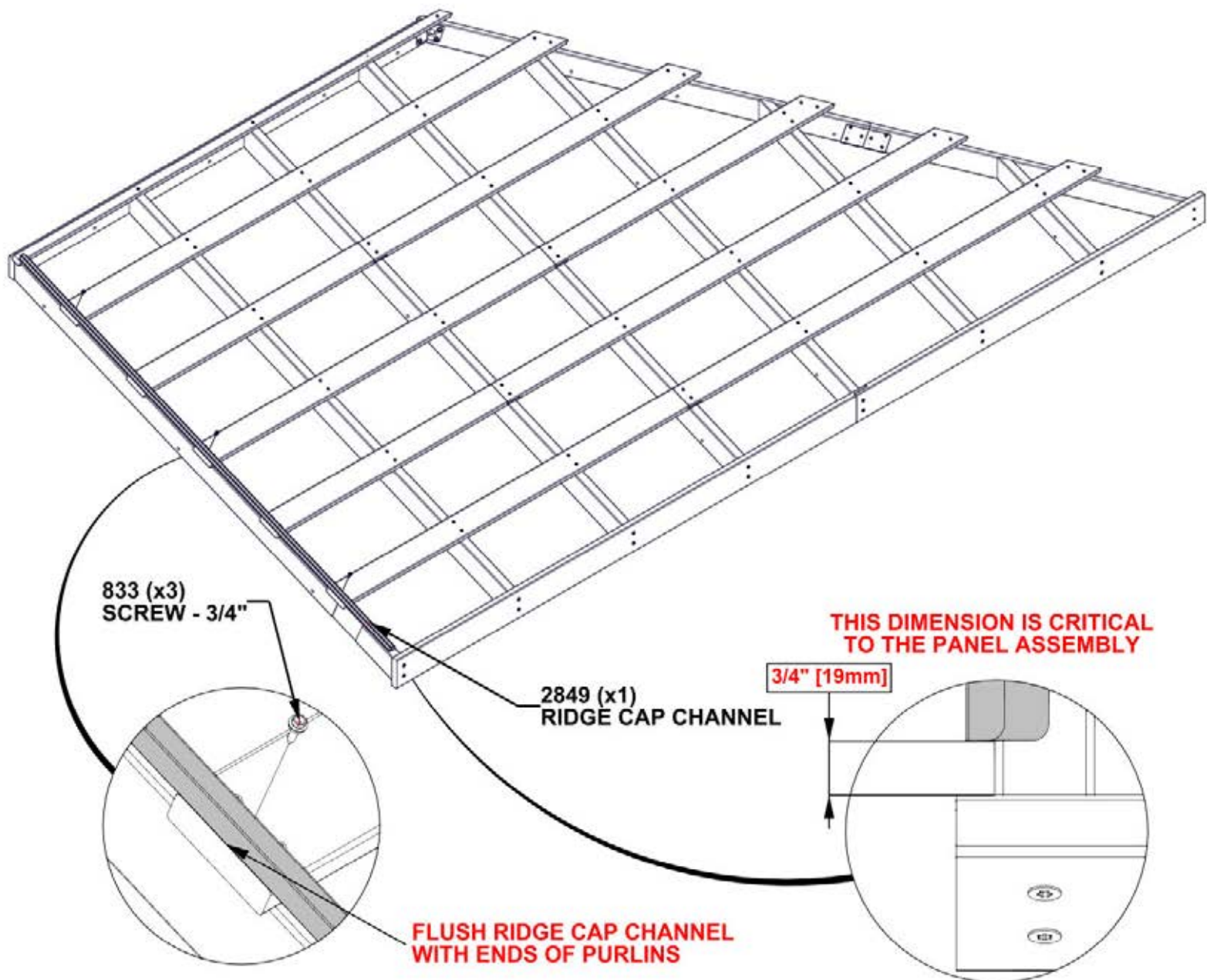

STEP 62 - RIGHT PANEL ASSEMBLY

QTY	PART NUMBER	DESCRIPTION
47	H100833	SCREW WOODGRIP 10-16x3/4"



- A4M02819 29 GA STEEL SHEETING (x1)
- A4M02818 29 GA STEEL SHEETING (x2)
- A4M02812-1 29 GA STEEL SHEETING (x1)
- A4M02813-1 29 GA STEEL SHEETING (x1)
- A4M02814-1 29 GA STEEL SHEETING (x1)

WARNING: GLOVES ARE RECOMMENDED WHEN HANDLING STEEL.

- REMOVE BLUE PROTECTIVE FILM.
- OVERLAP PANELS BY ONE RIDGE.
- PANELS SHOULD BE FLUSH WITH PURLIN ENDS AND Q03 ROOF FASCIA.
- ONCE SHEETING IS IN PLACE, IT IS RECOMMENDED TO ADD H100833 SCREWS IN THE MIDDLE OF THE SHEETS TO HOLD THE SHEETING FOR THE NEXT STEP.

START FROM THE LEFT, AND PLACE ROOF SHEETING AS SHOWN.

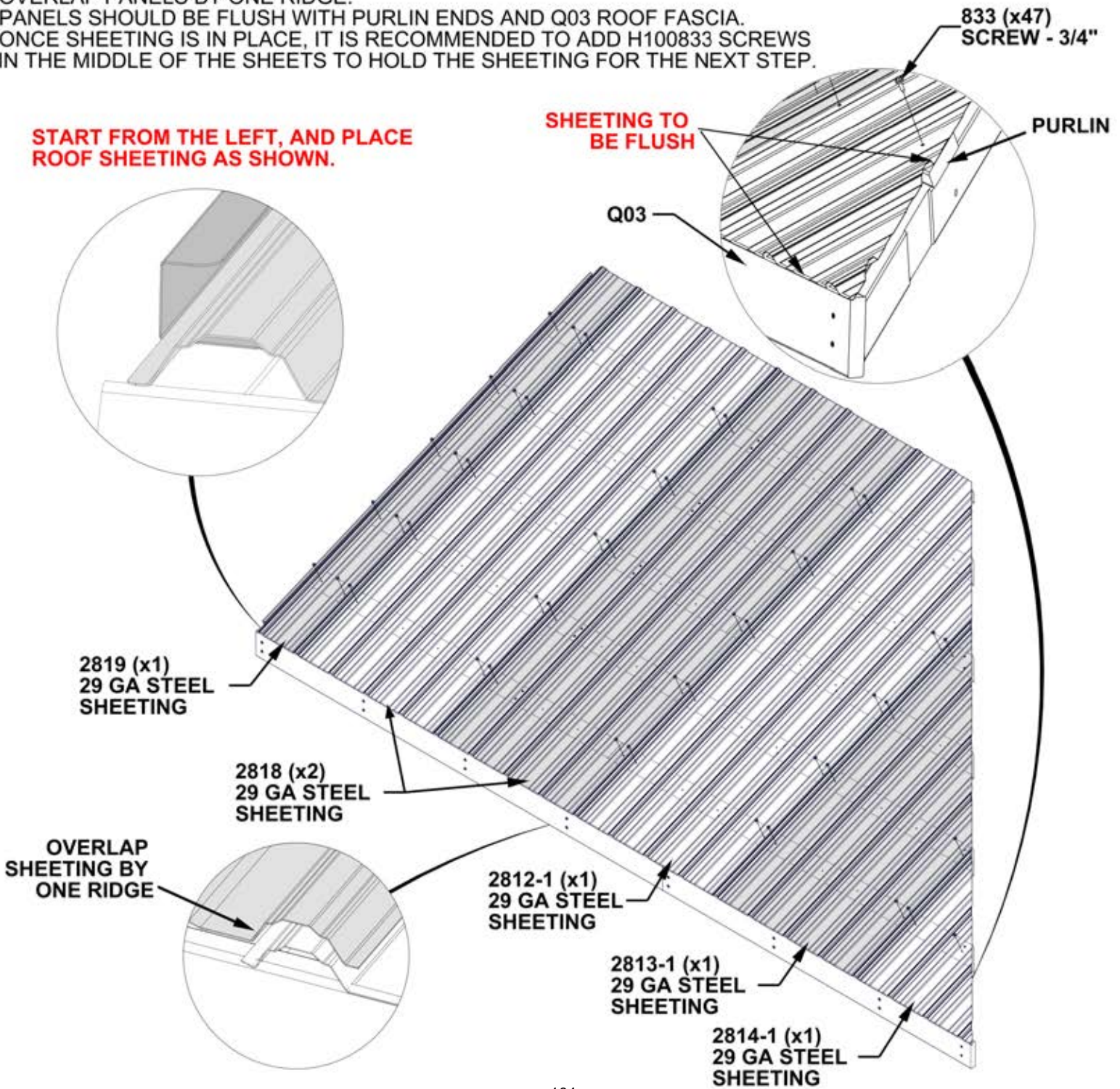

STEP 63 - RIGHT PANEL ASSEMBLY

QTY	PART NUMBER	DESCRIPTION
5	H100833	SCREW WOODGRIP 10-16x3/4"



A4M02850 RIDGE CAP CHANNEL SHORT (x1)

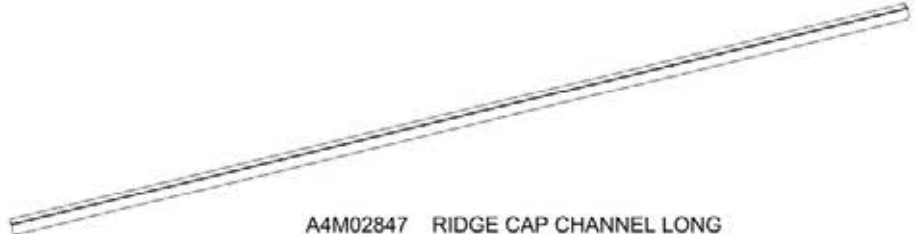

A4M02847 RIDGE CAP CHANNEL LONG (x1)

- POSITION THE RIDGE CAP CHANNEL OVER THE EDGE OF THE ROOF PANELS WITH THE WIDER SIDE OF THE CHANNEL ON THE BOTTOM.
- MAKE SURE THE PANELS ARE FULLY SEATED INTO THE CHANNEL.

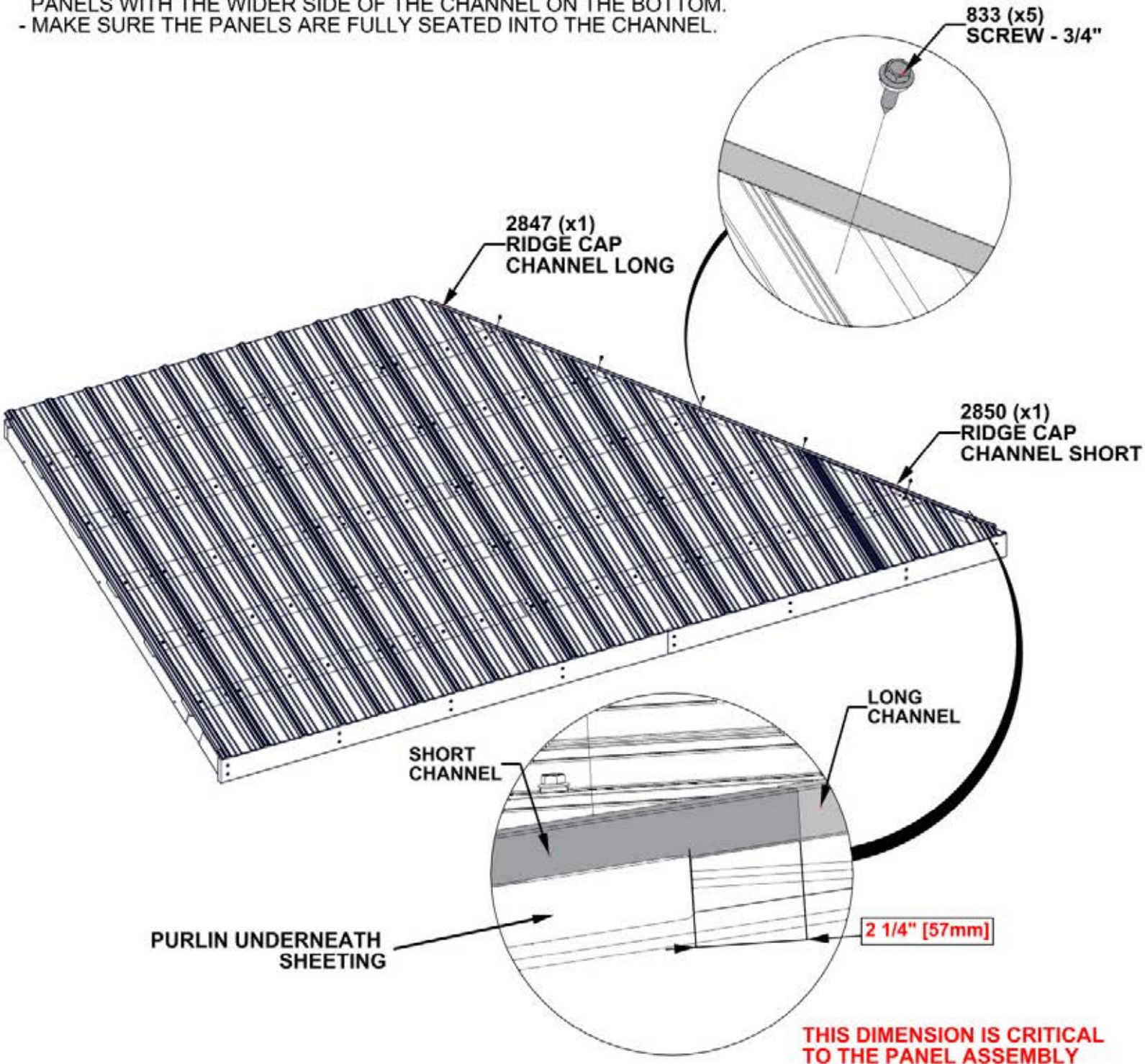

THIS DIMENSION IS CRITICAL TO THE PANEL ASSEMBLY

STEP 64 - RIGHT PANEL ASSEMBLY

QTY	PART NUMBER	DESCRIPTION
35	H100833	SCREW WOODGRIP 10-16x3/4"

- INSERT REMAINING SCREWS TO FASTEN SHEET METAL IN PLACE.

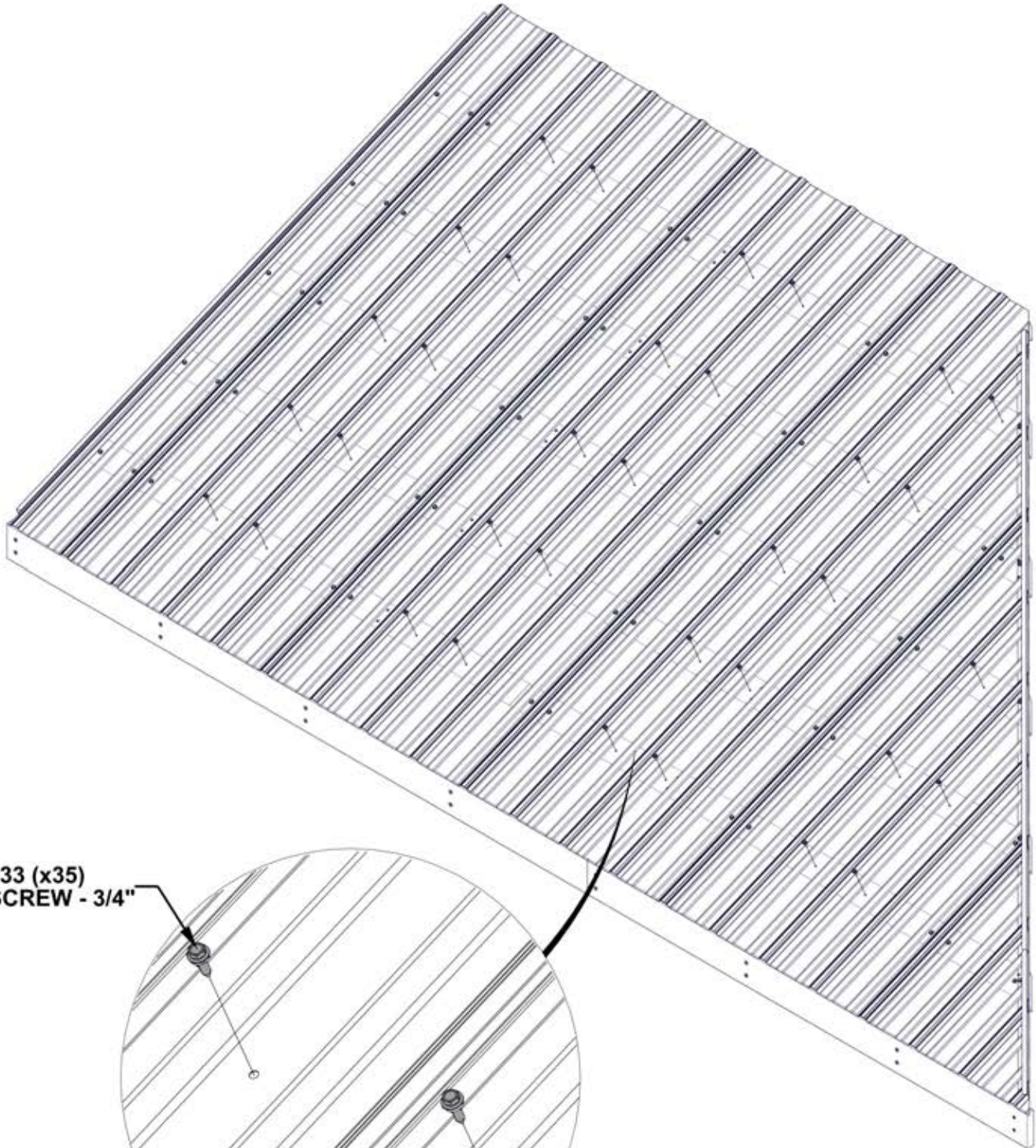

833 (x35)
SCREW - 3/4"

**REPEAT LEFT PANEL ASSEMBLY
STEPS 51 THROUGH 64**

STEP 65 - 12FT ROOF PANEL ATTACHMENT

- THREE PEOPLE ARE HELPFUL FOR THIS STEP.
- POSITION A PERSON ON A LADDER IN THE CENTER OF THE GAZEBO TO HELP SUPPORT THE ROOF PANEL.
- WITH TWO PEOPLE, WORK THE PANEL UP WITHOUT SLIDING OR DRAGGING, UNTIL IT MEETS THE ROOF SUPPORT FRAME.
- MAKE SURE THE ROOF PANEL SLIDES UNDERNEATH THE RIDGE CAP.

WARNING: GLOVES ARE RECOMMENDED WHEN HANDLING STEEL.

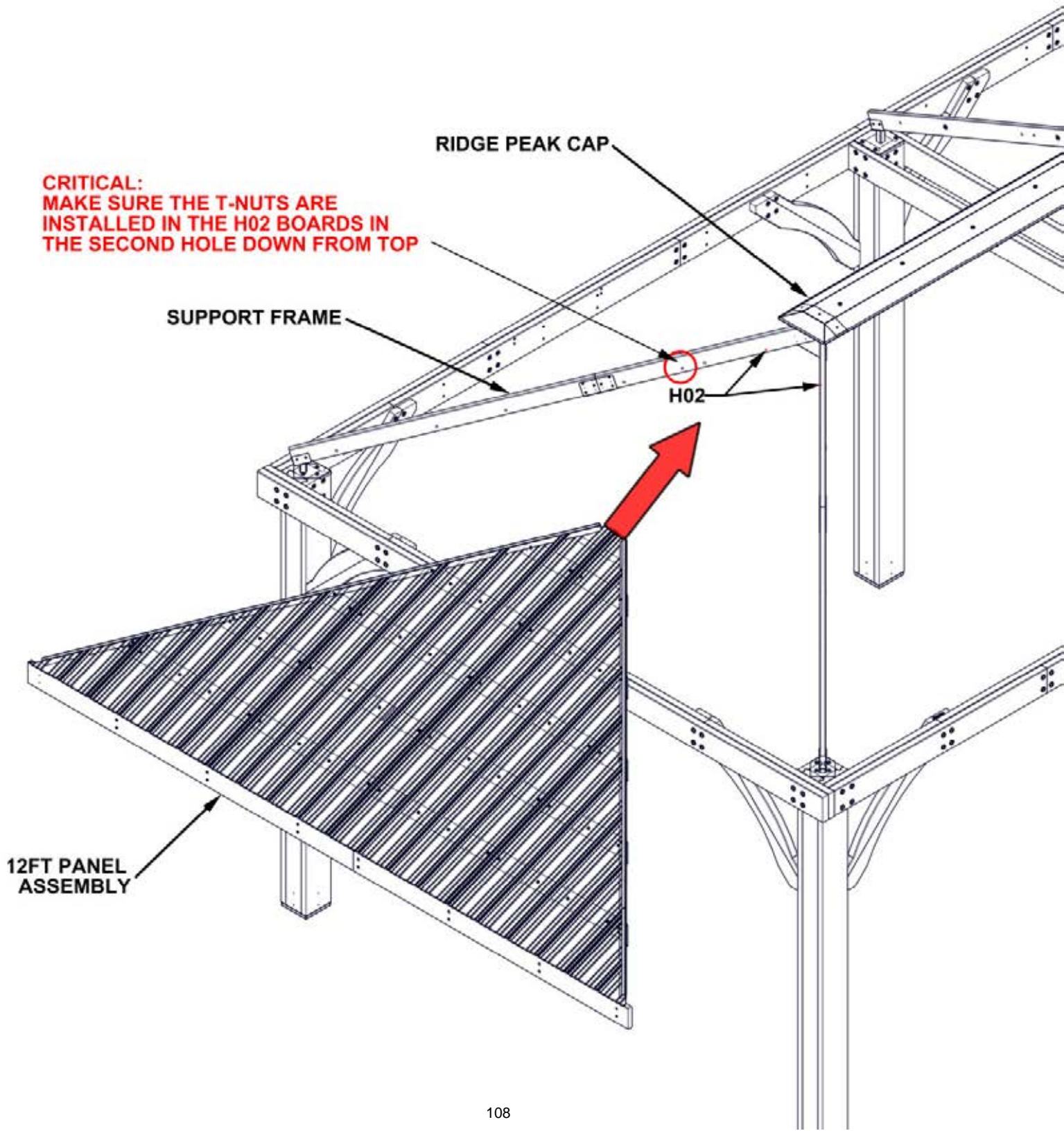

STEP 66 - 12FT ROOF PANEL ATTACHMENT

QTY	PART NUMBER	DESCRIPTION
2	H100198	WASHER LOCK EXT 8x19
2	H100378	BOLT WH 5/16x1 3/4 BLK

- IF NECESSARY, USE A CLAMP TO HOLD PANEL IN PLACE.
- INSERT BOLTS INTO THE SECOND HOLE FROM THE TOP OF THE H07/H09 BOARDS.

HAND TIGHTEN ONLY

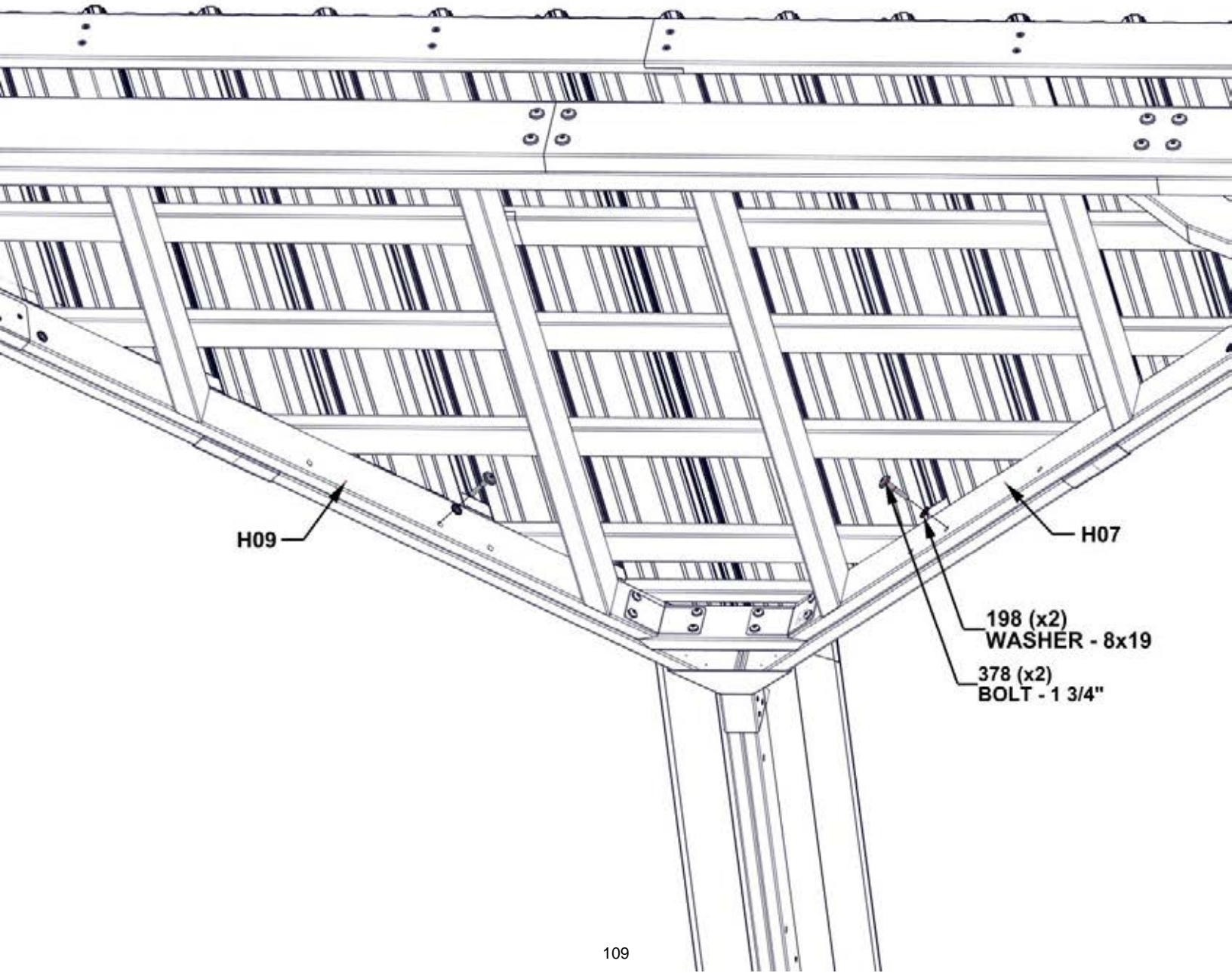

**REPEAT 12FT ROOF PANEL
INSTALLATION STEPS 65 & 66**

STEP 67 - LEFT ROOF PANEL ATTACHMENT

- THREE PEOPLE ARE HELPFUL FOR THIS STEP.
- POSITION A PERSON ON A LADDER IN THE CENTER OF THE GAZEBO TO HELP SUPPORT THE ROOF PANEL.
- WITH TWO PEOPLE, WORK THE PANEL UP WITHOUT SLIDING OR DRAGGING, UNTIL IT MEETS THE ROOF SUPPORT FRAME.
- MAKE SURE THE ROOF PANEL SLIDES UNDERNEATH THE RIDGE CAP.

WARNING: GLOVES ARE RECOMMENDED WHEN HANDLING STEEL.

**CRITICAL:
MAKE SURE THE T-NUTS ARE INSTALLED IN THE
H05 BOARD AND ROOF SUPPORT ASSEMBLY.**

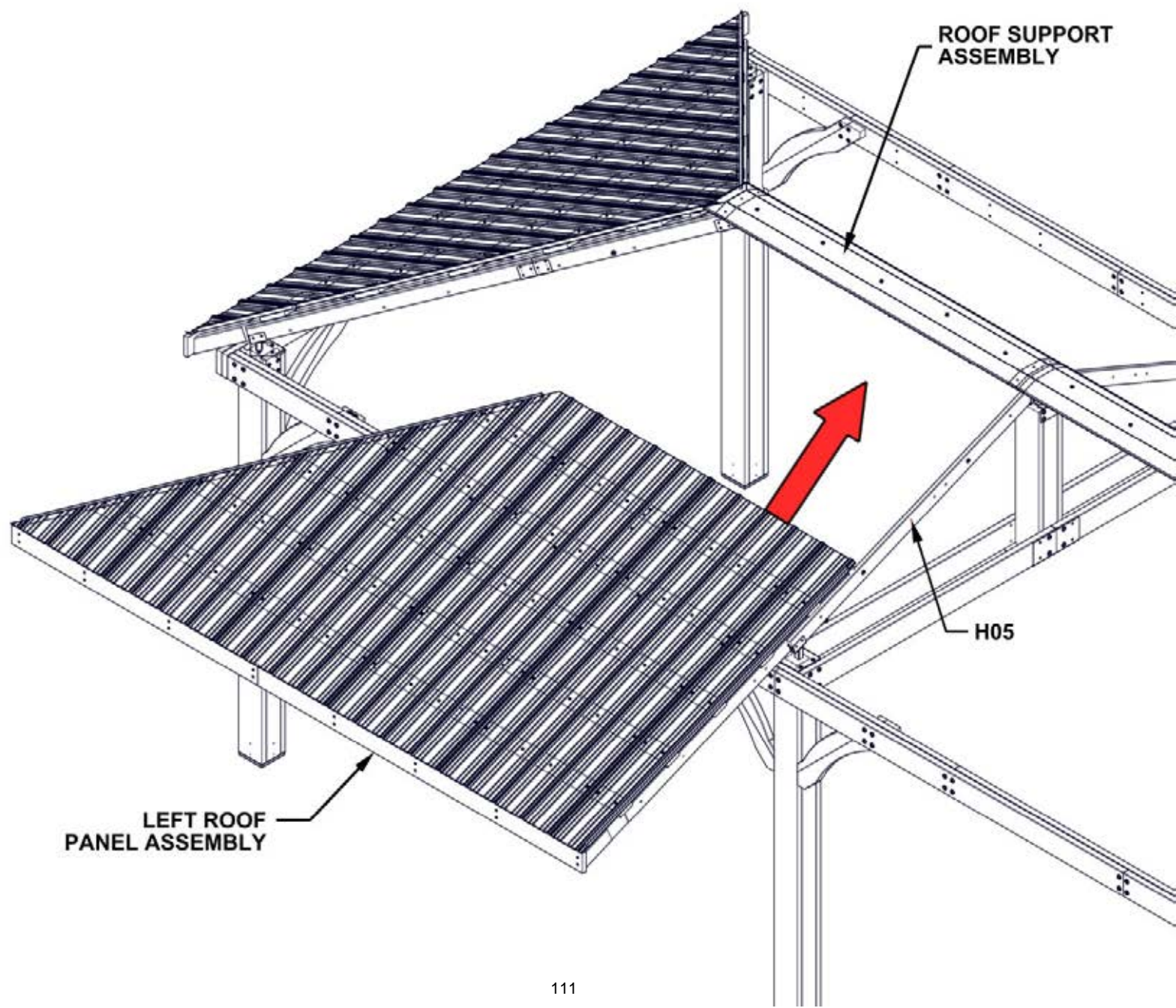

STEP 68 - LEFT ROOF PANEL ATTACHMENT

QTY	PART NUMBER	DESCRIPTION
3	H100195	BOLT WH 5/16x2 3/4 BLK
5	H100198	WASHER LOCK EXT 8x19
2	H100205	BOLT WH 5/16x2 1/4 BLK

- IF NECESSARY, USE A CLAMP TO HOLD PANEL IN PLACE.

HAND TIGHTEN ONLY

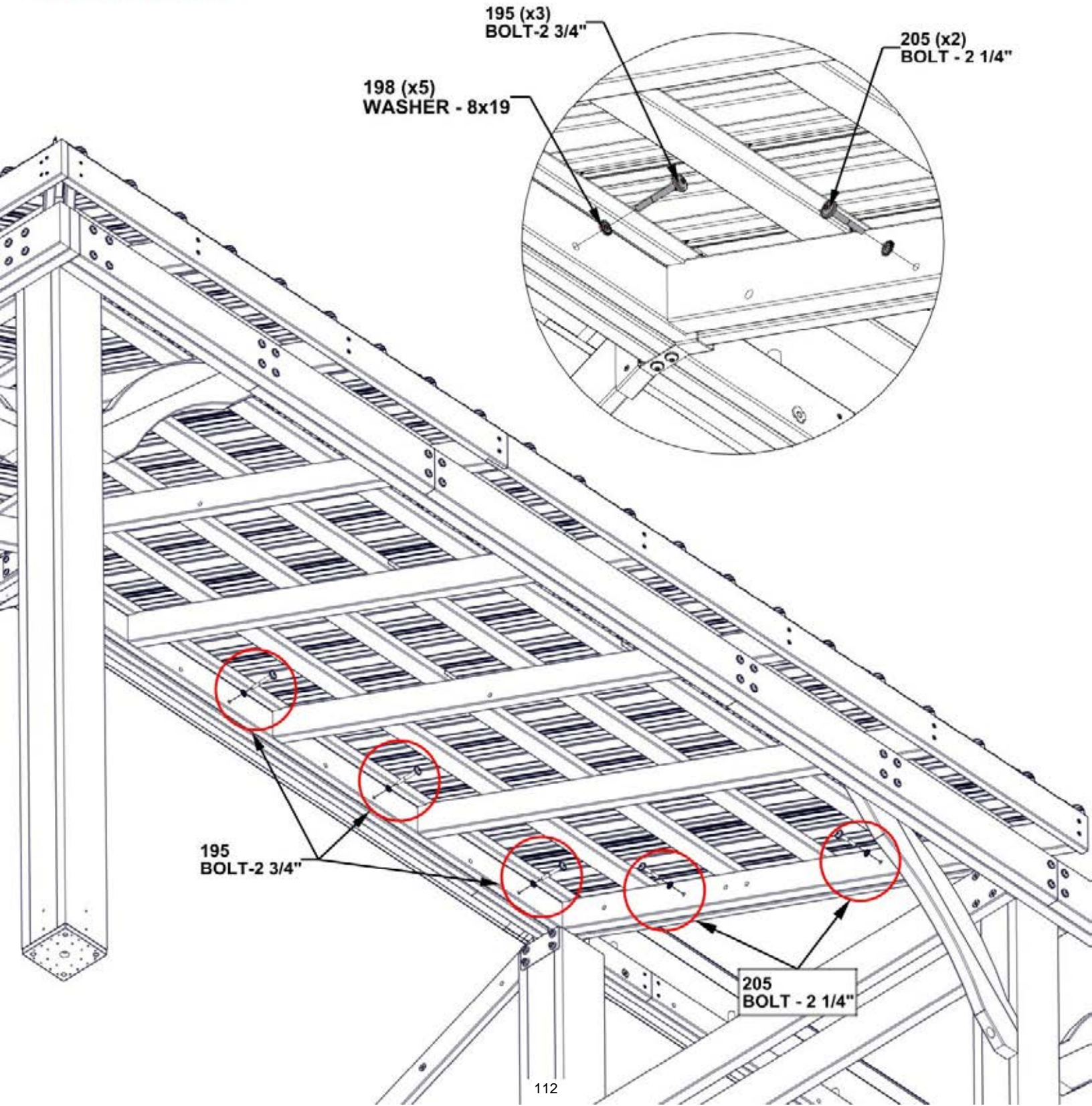

STEP 69 - LEFT ROOF PANEL ATTACHMENT

- THREE PEOPLE ARE HELPFUL FOR THIS STEP.
- POSITION A PERSON ON A LADDER IN THE CENTER OF THE GAZEBO TO HELP SUPPORT THE ROOF PANEL.
- WITH TWO PEOPLE, WORK THE PANEL UP WITHOUT SLIDING OR DRAGGING, UNTIL IT MEETS THE ROOF SUPPORT FRAME.
- MAKE SURE THE ROOF PANEL SLIDES UNDERNEATH THE RIDGE CAP.

WARNING: GLOVES ARE RECOMMENDED WHEN HANDLING STEEL.

**CRITICAL:
MAKE SURE THE T-NUTS ARE INSTALLED IN THE
H05 BOARD AND ROOF SUPPORT ASSEMBLY.**

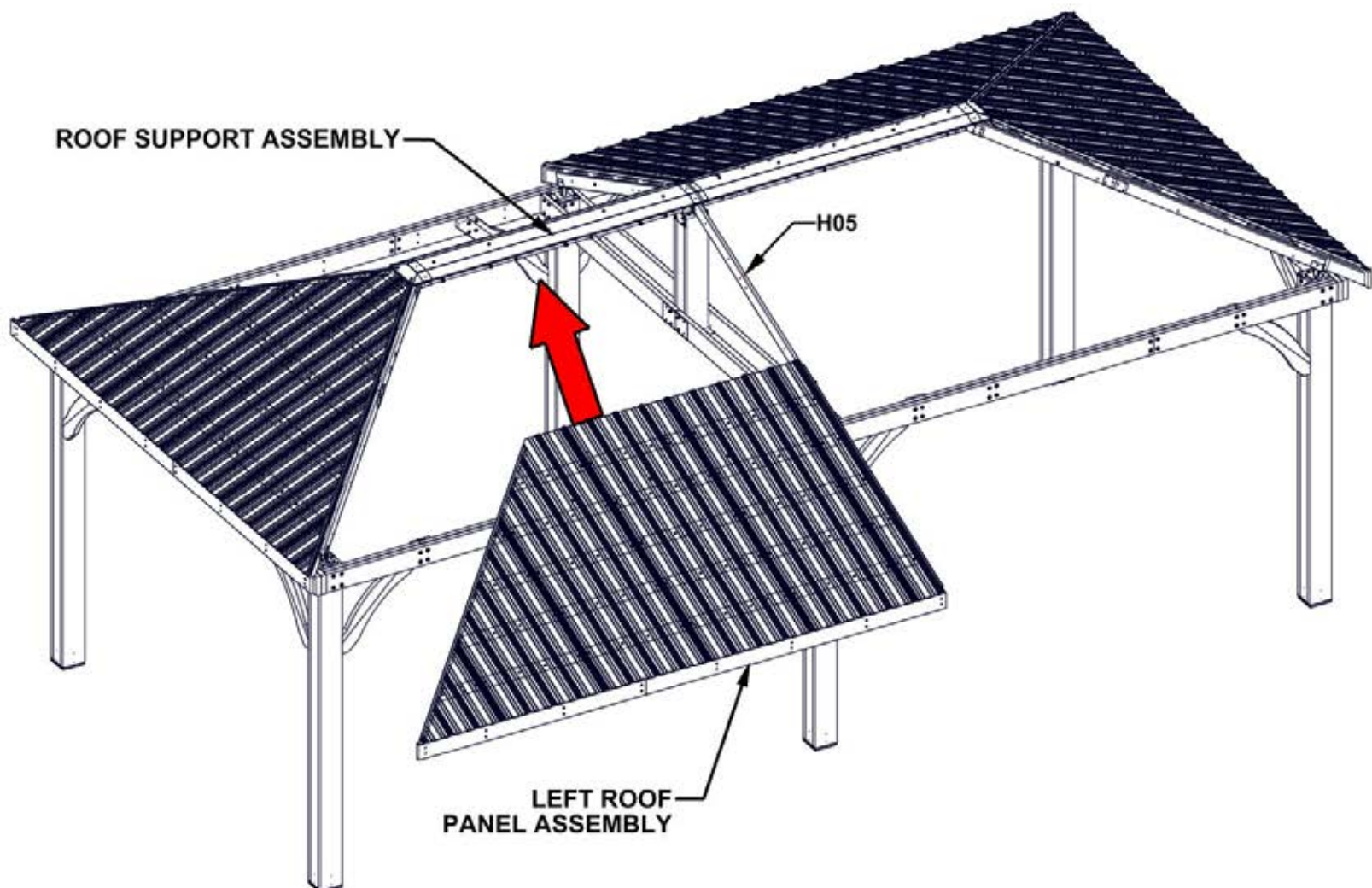

STEP 70 - LEFT ROOF PANEL ATTACHMENT

QTY	PART NUMBER	DESCRIPTION
3	H100195	BOLT WH 5/16x2 3/4 BLK
5	H100198	WASHER LOCK EXT 8x19
2	H100205	BOLT WH 5/16x2 1/4 BLK

- IF NECESSARY, USE A CLAMP TO HOLD PANEL IN PLACE.

HAND TIGHTEN ONLY

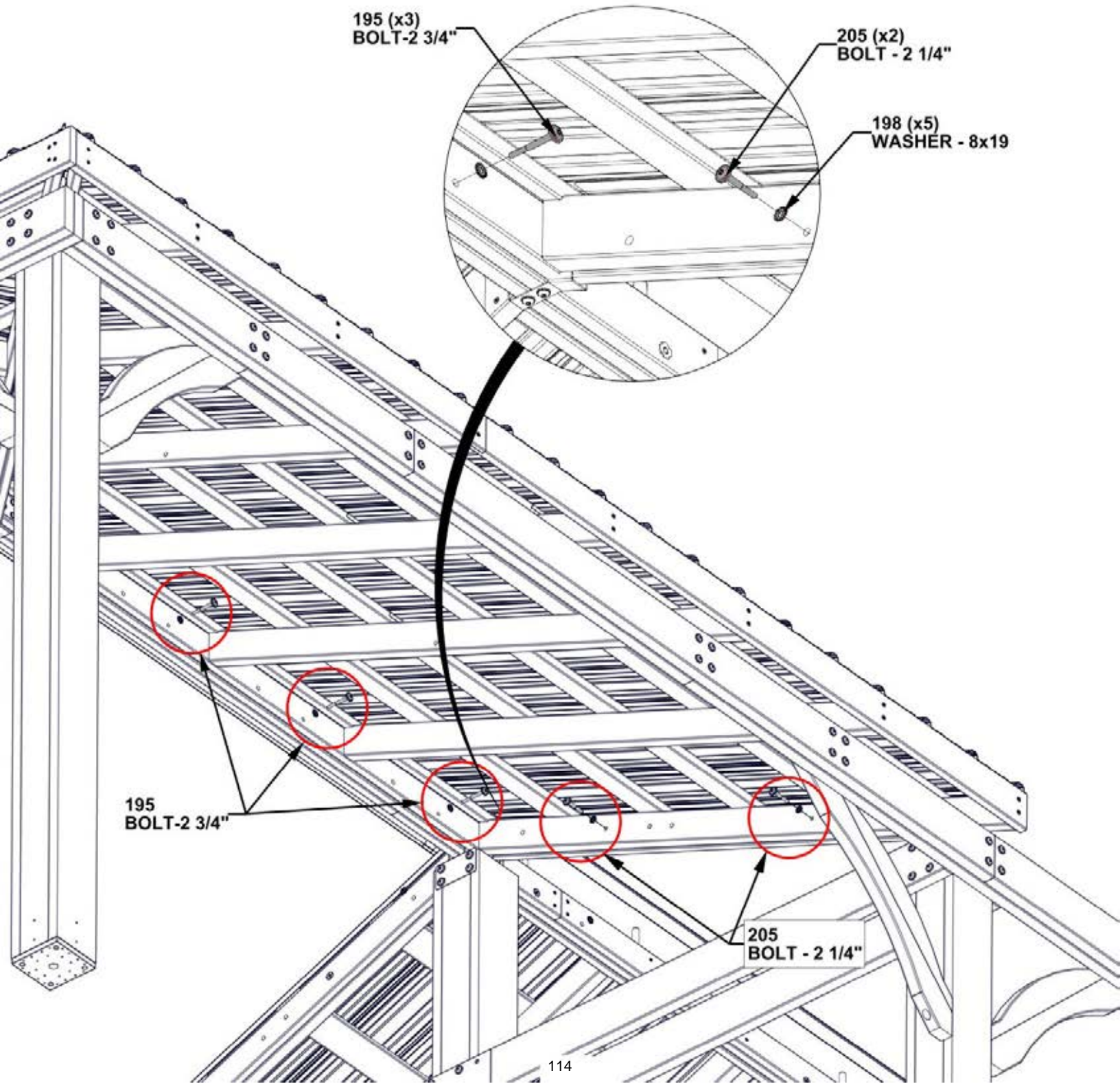

STEP 71 - RIGHT ROOF PANEL ATTACHMENT

- THREE PEOPLE ARE HELPFUL FOR THIS STEP.
- POSITION A PERSON ON A LADDER IN THE CENTER OF THE GAZEBO TO HELP SUPPORT THE ROOF PANEL.
- WITH TWO PEOPLE, WORK THE PANEL UP WITHOUT SLIDING OR DRAGGING, UNTIL IT MEETS THE ROOF SUPPORT FRAME.
- MAKE SURE THE ROOF PANEL SLIDES UNDERNEATH THE RIDGE CAP.

WARNING: GLOVES ARE RECOMMENDED WHEN HANDLING STEEL.

**CRITICAL:
MAKE SURE THE T-NUTS ARE INSTALLED IN THE
H05 BOARD AND ROOF SUPPORT ASSEMBLY.**

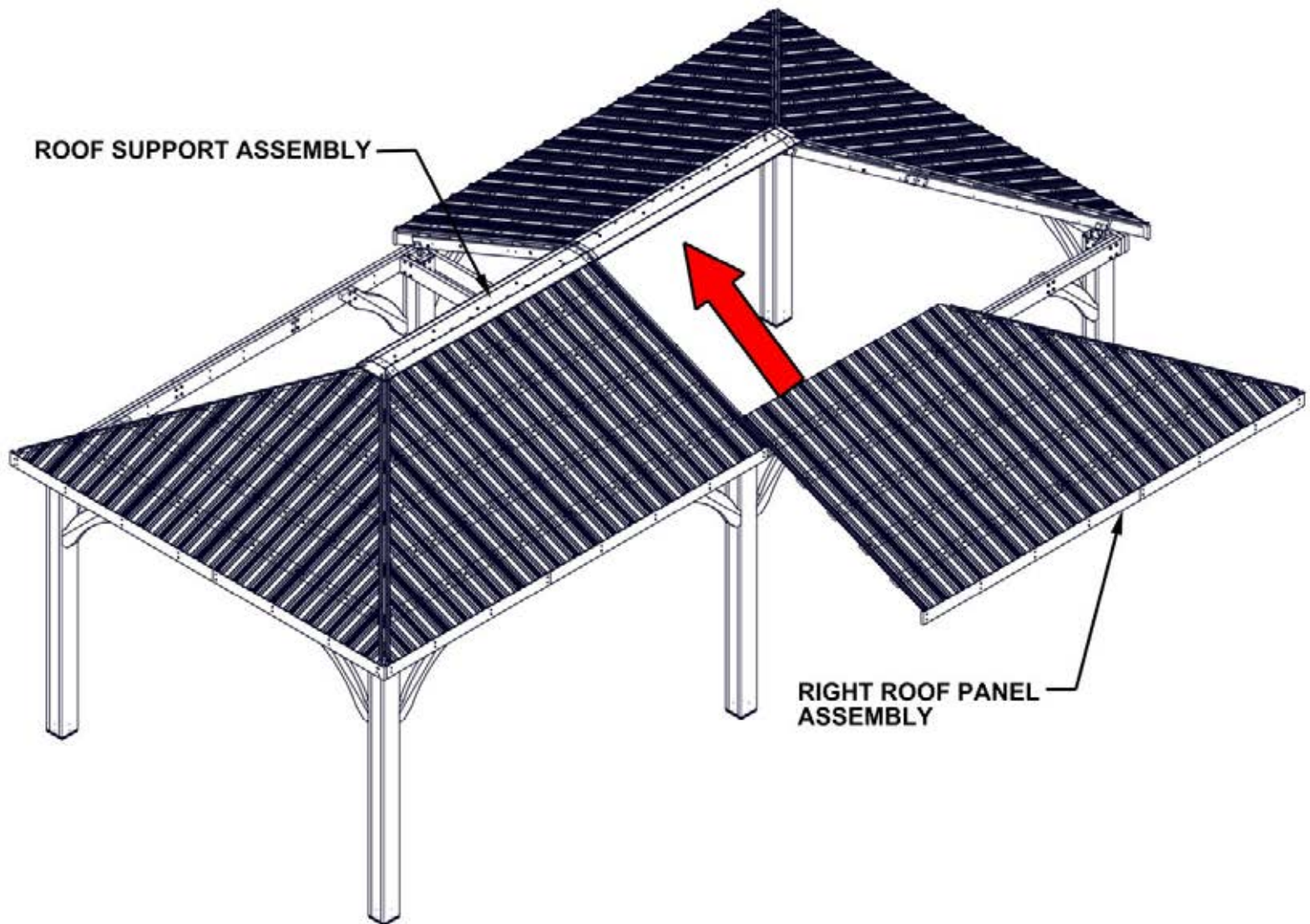

STEP 72 - RIGHT ROOF PANEL ATTACHMENT

QTY	PART NUMBER	DESCRIPTION
4	H100198	WASHER LOCK EXT 8x19
4	H100479	NUT LOCK 5/16 BLK
4	H100480	BOLT WH 5/16x4 3/4 BLK
4	H100770	WASHER FLAT 5/16 BLK

- IF NECESSARY, USE A CLAMP TO HOLD PANEL IN PLACE.

HAND TIGHTEN ONLY

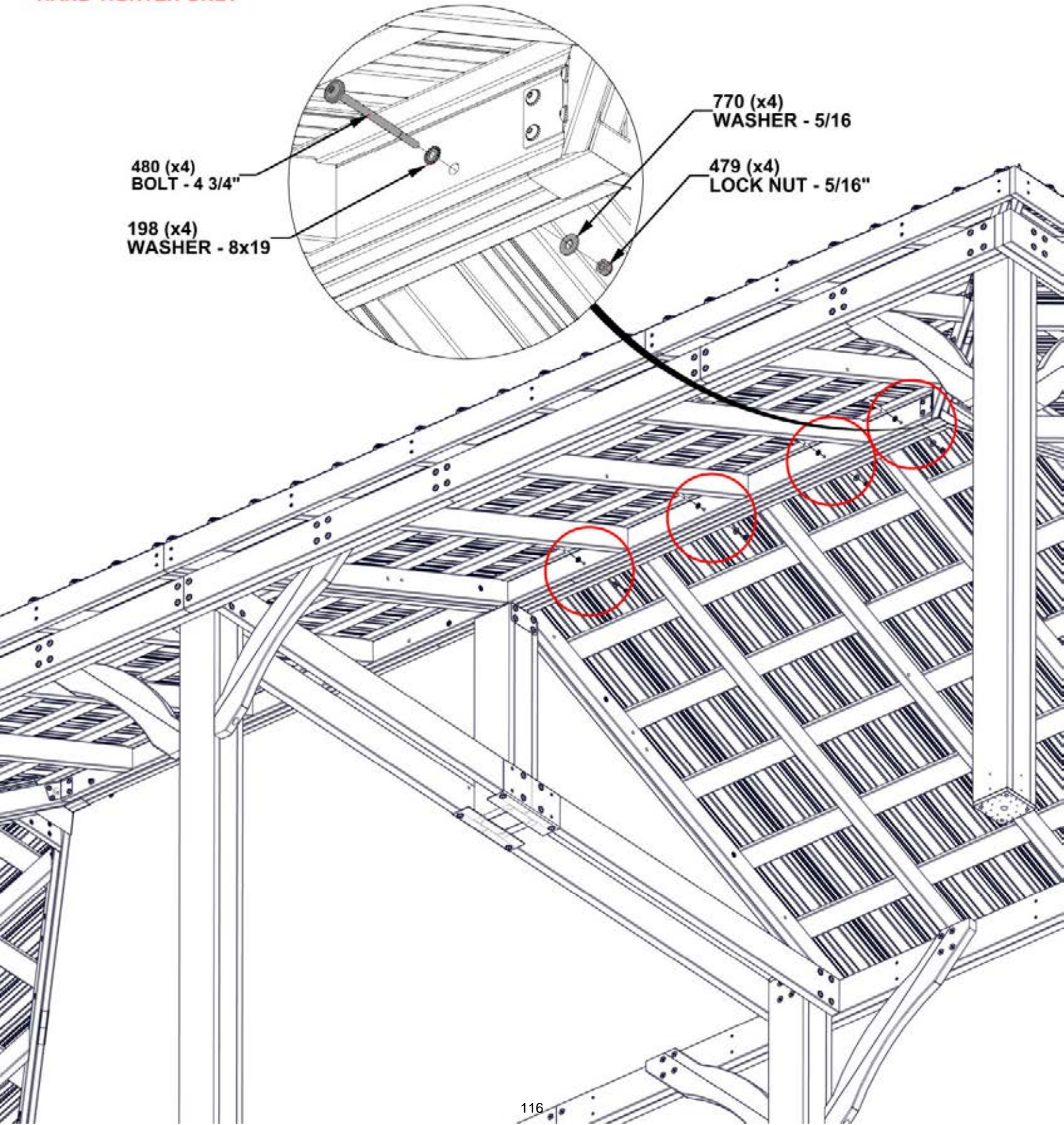

STEP 73 - RIGHT ROOF PANEL ATTACHMENT

- THREE PEOPLE ARE HELPFUL FOR THIS STEP.
- POSITION A PERSON ON A LADDER IN THE CENTER OF THE GAZEBO TO HELP SUPPORT THE ROOF PANEL.
- WITH TWO PEOPLE, WORK THE PANEL UP WITHOUT SLIDING OR DRAGGING, UNTIL IT MEETS THE ROOF SUPPORT FRAME.
- MAKE SURE THE ROOF PANEL SLIDES UNDERNEATH THE RIDGE CAP.

WARNING: GLOVES ARE RECOMMENDED WHEN HANDLING STEEL.

**CRITICAL:
MAKE SURE THE T-NUTS ARE
INSTALLED IN THE ROOF SUPPORT**

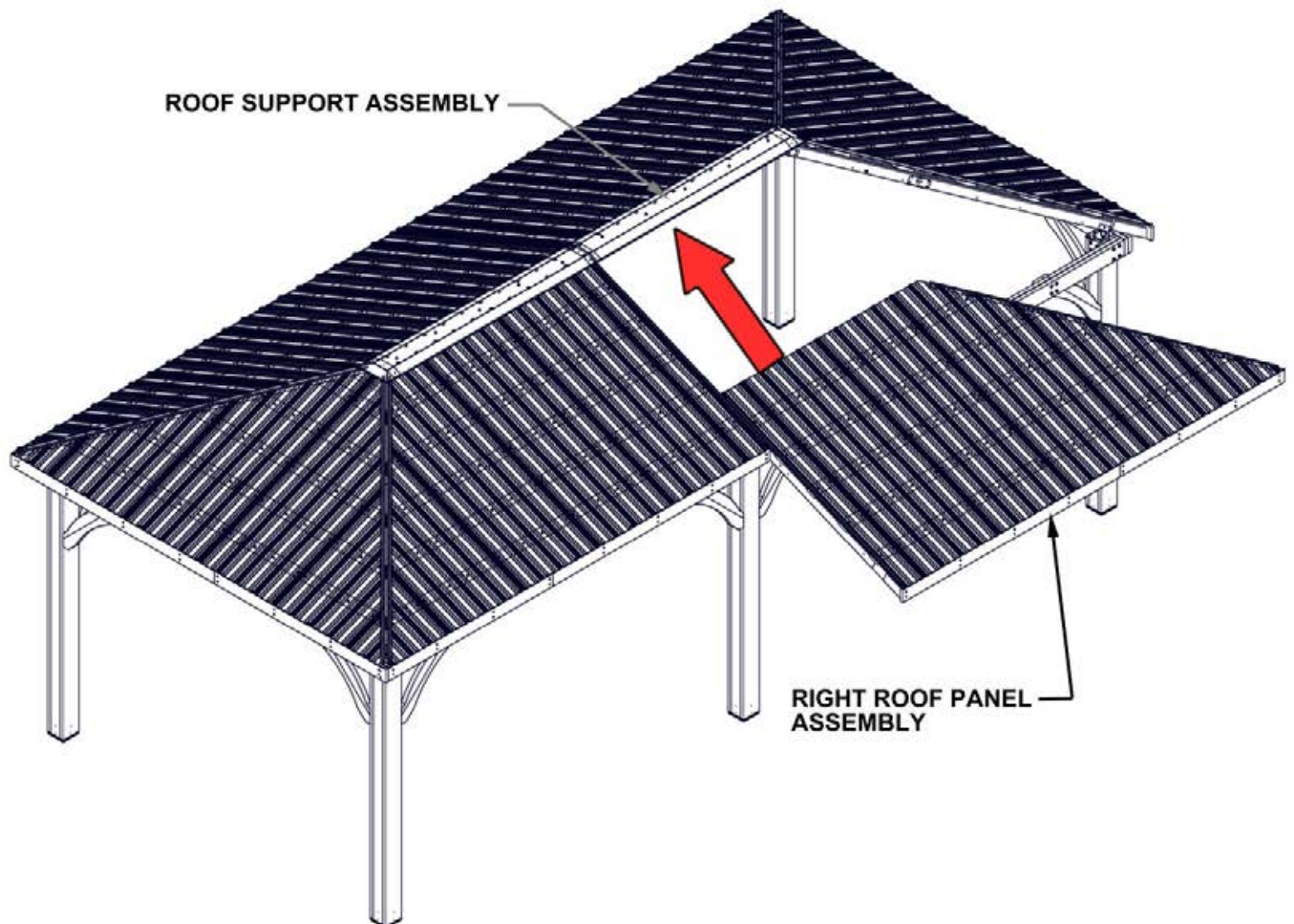

STEP 74 - RIGHT ROOF PANEL ATTACHMENT

QTY	PART NUMBER	DESCRIPTION
4	H100198	WASHER LOCK EXT 8x19
4	H100479	NUT LOCK 5/16 BLK
4	H100480	BOLT WH 5/16x4 3/4 BLK
4	H100770	WASHER FLAT 5/16 BLK

- IF NECESSARY, USE A CLAMP TO HOLD PANEL IN PLACE.

HAND TIGHTEN ONLY

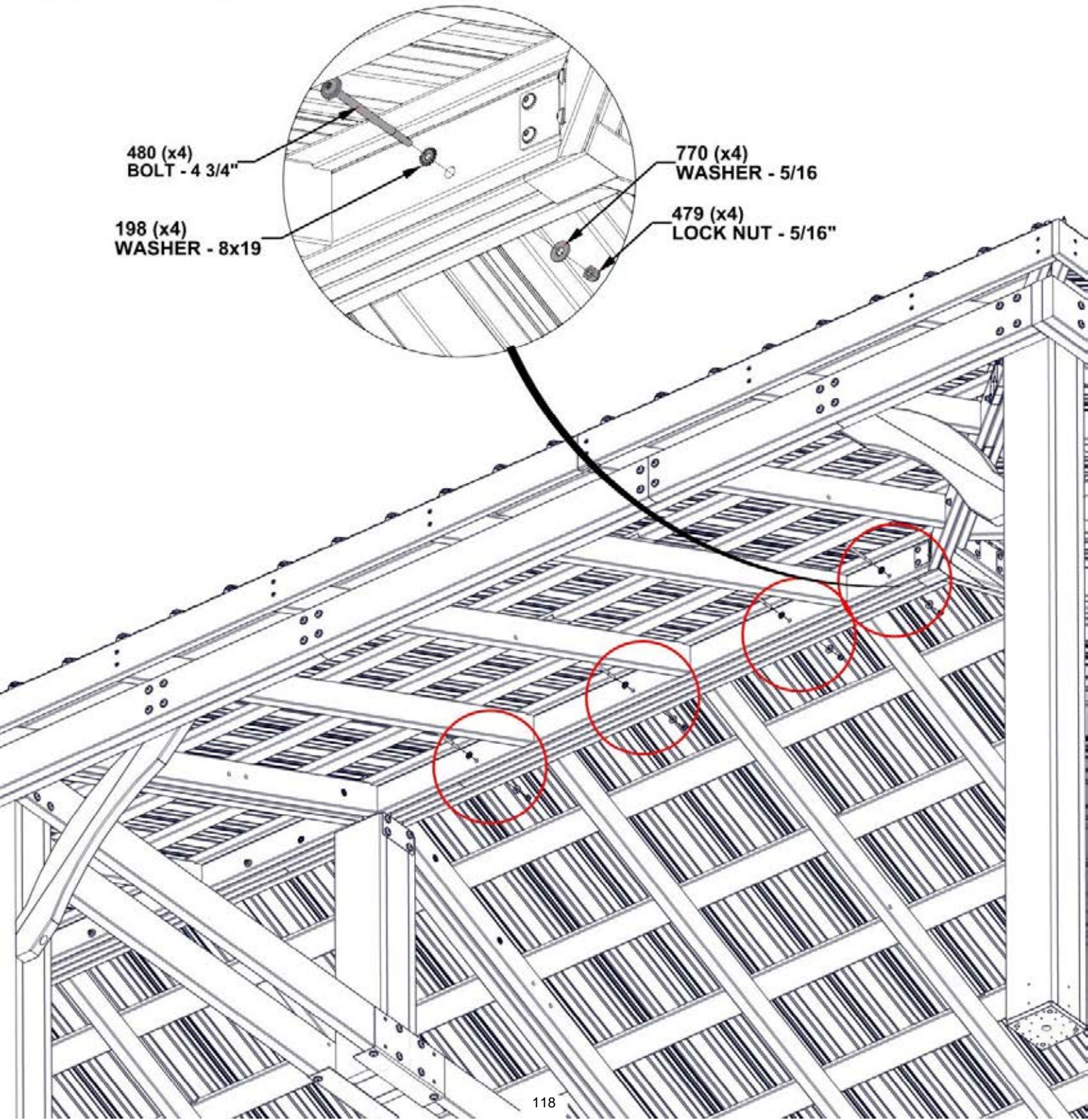

STEP 75 - LEFT ROOF PANEL ATTACHMENT

QTY	PART NUMBER	DESCRIPTION
20	H100198	WASHER LOCK EXT 8x19
20	H100415	BOLT WH 5/16x3 3/4 BLK
20	H100479	NUT LOCK 5/16 BLK
20	H100770	WASHER FLAT 5/16 BLK

REPEAT ON ALL FOUR DIAGONAL ROOF JOISTS

HAND TIGHTEN ONLY

IF HOLES ARE SLIGHTLY OFFSET, USE A SCREWDRIVER TO HELP ALIGN, OR DRILL WITH A 3/8" [10mm] DRILL BIT. THIS WILL ENABLE THE BOLTS TO BE INSERTED.

198 (x5)
WASHER - 8x19

415 (x5)
BOLT - 3 3/4"

770 (x5)
WASHER - 5/16

479 (x5)
LOCK NUT - 5/16"

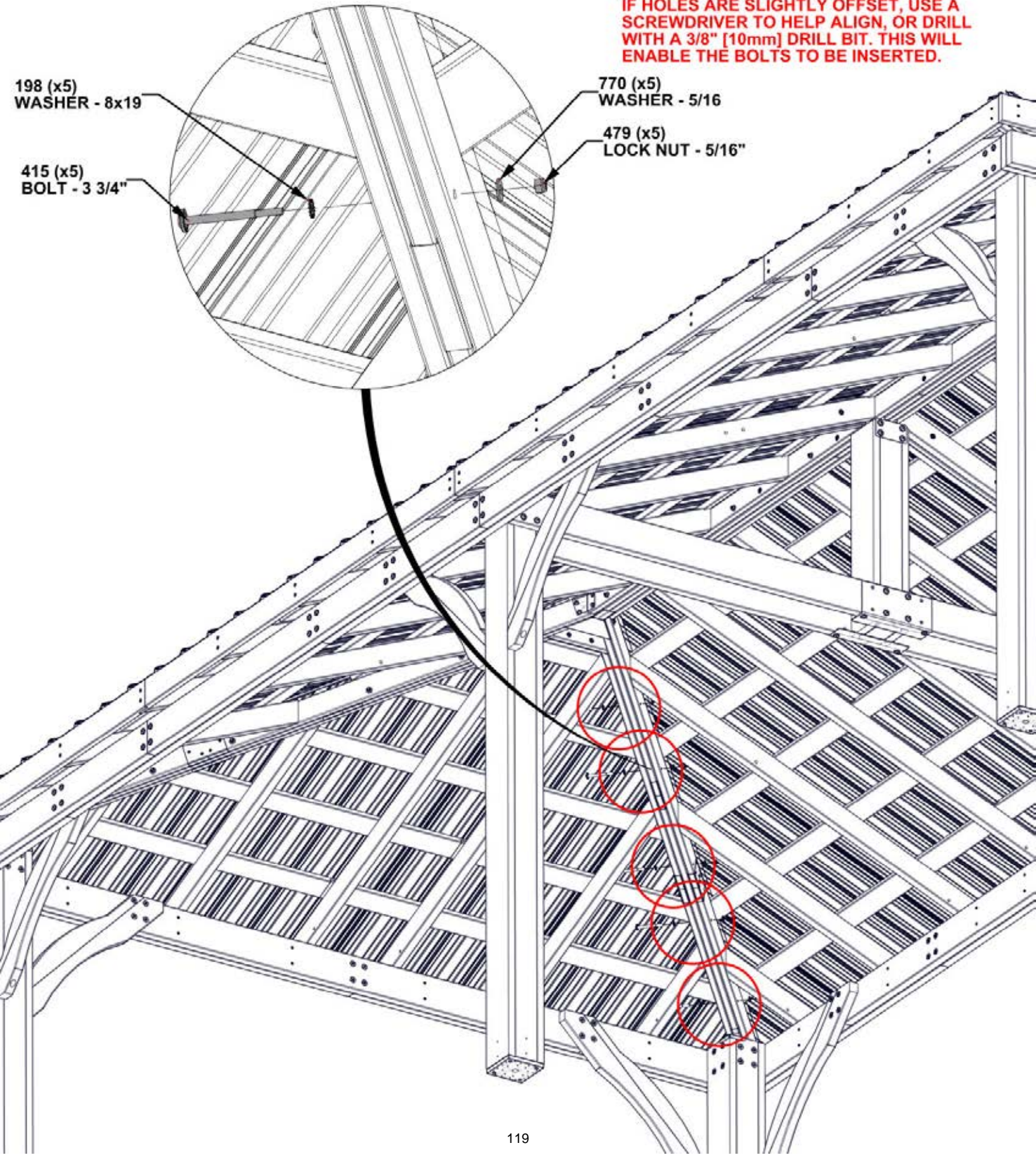

STEP 76 - ROOF PANEL ATTACHMENT

QTY	PART NUMBER	DESCRIPTION
4	H100198	WASHER LOCK EXT 8x19
4	H100479	NUT LOCK 5/16 BLK
4	H100534	BOLT WH 5/16x4 1/2 BLK
4	H100770	WASHER FLAT 5/16 BLK

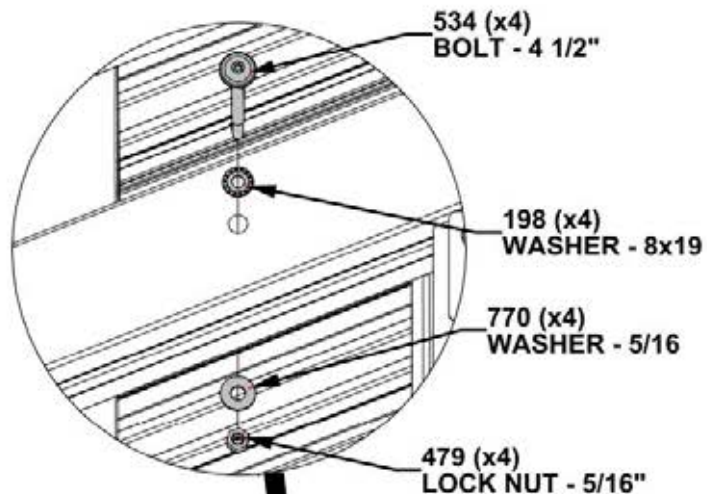

ATTACH PANEL HARDWARE TO CONNECT LEFT AND RIGHT PANEL TO MIDDLE RAFTER

IF HOLES ARE SLIGHTLY OFFSET, USE A SCREWDRIVER TO HELP ALIGN, OR DRILL WITH A 3/8" [10mm] DRILL BIT. THIS WILL ENABLE THE BOLTS TO BE INSERTED.

HAND TIGHTEN ONLY

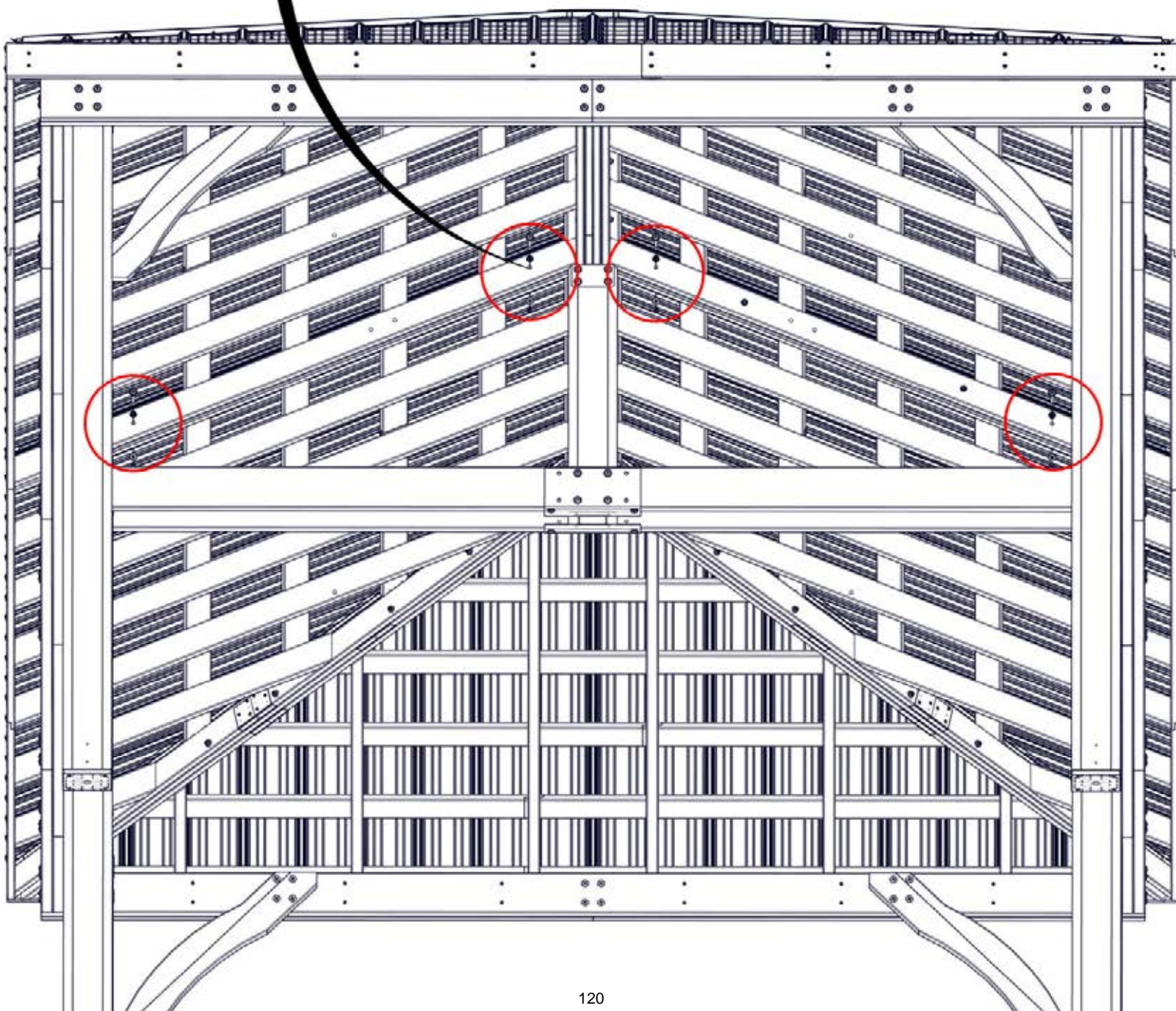

STEP 77 - ROOF PANEL ATTACHMENT

QTY	PART NUMBER	DESCRIPTION
16	H100478	WASHER FLAT 8x27 BLK
8	H100479	NUT LOCK 5/16 BLK
8	H100881	BOLT WH 5/16x5 BLK

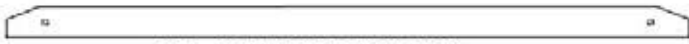

E17 COLLAR TIE - W4L17573
(x4) 1 3/8"x3 3/8"x71 5/8" (36x86x1820)

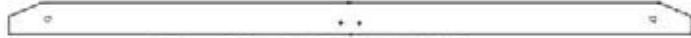

E19 COLLAR TIE - W4L19827
(x4) 1 3/8"x3 3/8"x71 5/8" (36x86x1820)

HAND TIGHTEN ONLY

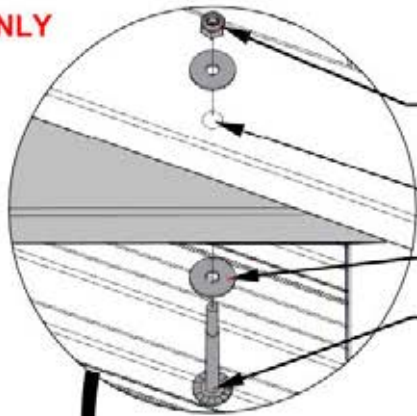

479 (x8)
LOCK NUT - 5/16"

**IF HOLES ARE SLIGHTLY OFFSET,
USE A SCREWDRIVER TO HELP
ALIGN**

478 (x16)
WASHER - 8x27

881 (x8)
BOLT - 5"

**'E17' BOARDS WILL BE
TOWARD THE OUTSIDE.
'E19' BOARDS WILL BE
TOWARD THE INSIDE.**

E17 (x4)
COLLAR TIE

E19 (x4)
COLLAR TIE

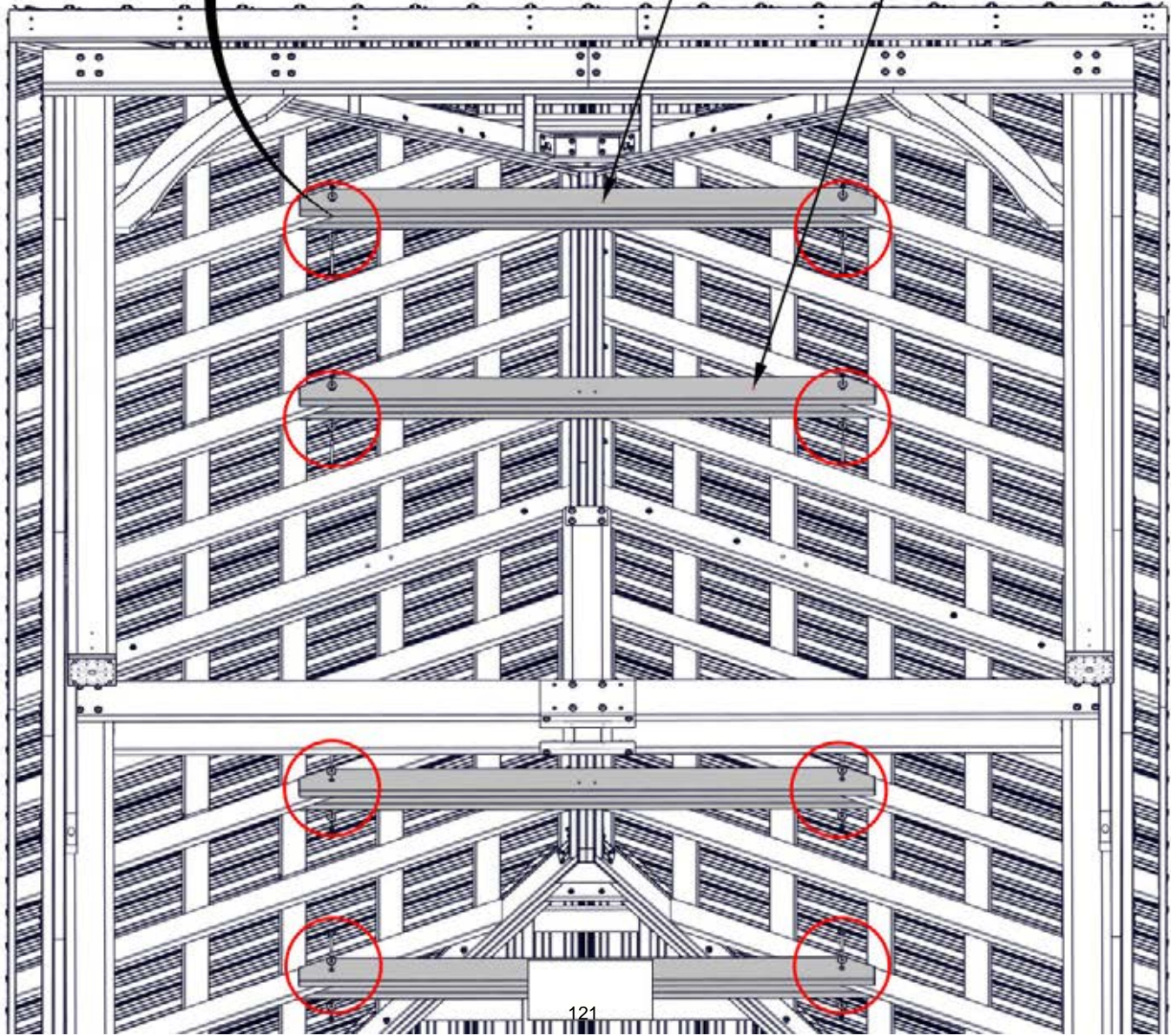

STEP 78 - ROOF PANEL ATTACHMENT

QTY	PART NUMBER	DESCRIPTION
8	H100195	BOLT WH 5/16x2 3/4 BLK
4	H100198	WASHER LOCK EXT 8x19
4	H100354	BOLT WH 5/16x6 1/2 BLK
8	H100379	TNUT-5/16" BLK
4	H100479	NUT LOCK 5/16 BLK
4	H100770	WASHER FLAT 5/16 BLK



D09 TRUSS BRACE - W4L20714
(x2) 1 7/16"X5 1/4"X36 1/4" (36x134x920)



D10 TRUSS BRACE - W4L20715
(x2) 1 7/16"X5 1/4"X36 1/4" (36x134x920)

INSERT T-NUTS FIRST

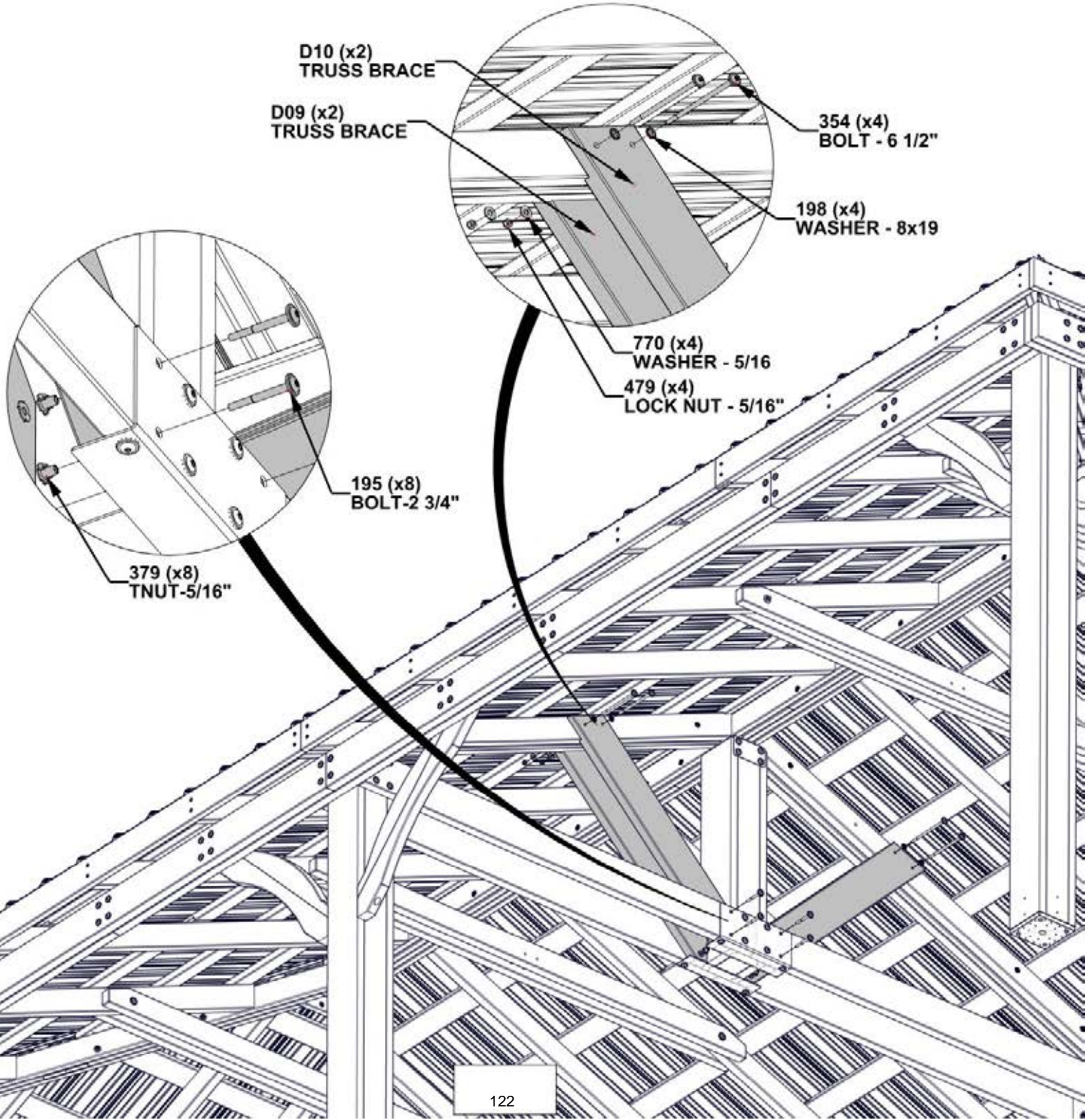

D10 (x2)
TRUSS BRACE

D09 (x2)
TRUSS BRACE

354 (x4)
BOLT - 6 1/2"

198 (x4)
WASHER - 8x19

770 (x4)
WASHER - 5/16

479 (x4)
LOCK NUT - 5/16"

195 (x8)
BOLT-2 3/4"

379 (x8)
TNUT-5/16"

STEP 79 - ROOF PANEL ATTACHMENT

**TIGHTEN ALL THE HARDWARE IN THE ORDER SHOWN BELOW.
START AT THE TOP AND WORK YOUR WAY DOWN.**

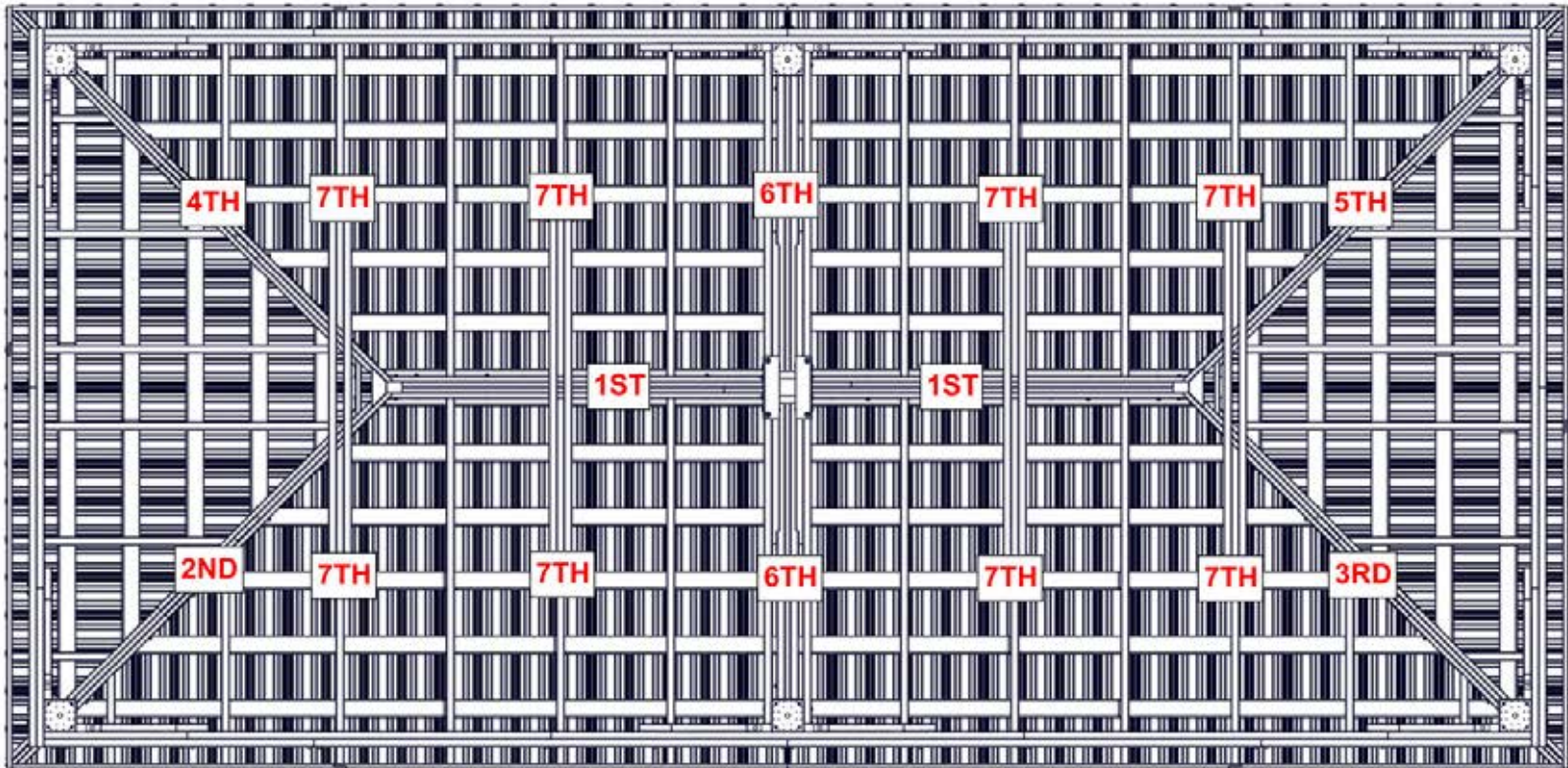

STEP 80 - ROOF ASSEMBLY

QTY	PART NUMBER	DESCRIPTION
20	H100488	BOLT WH 1/4x2 BLK
40	H100536	SCREW PWH 8x1 1/4 BLK
20	H100630	WASHER FLAT 8x19 BLK
20	H100653	NUT LOCK 1/4 BLK



RAFTER CLIP - A4M01228
(x20) 1/16"x4 1/8"x4 7/16" (1.5x104x4 7/16")

RAFTER CLIPS WILL NOT BE PLACED ON ALL RAFTERS, ONLY THOSE WITH THROUGH HOLES.

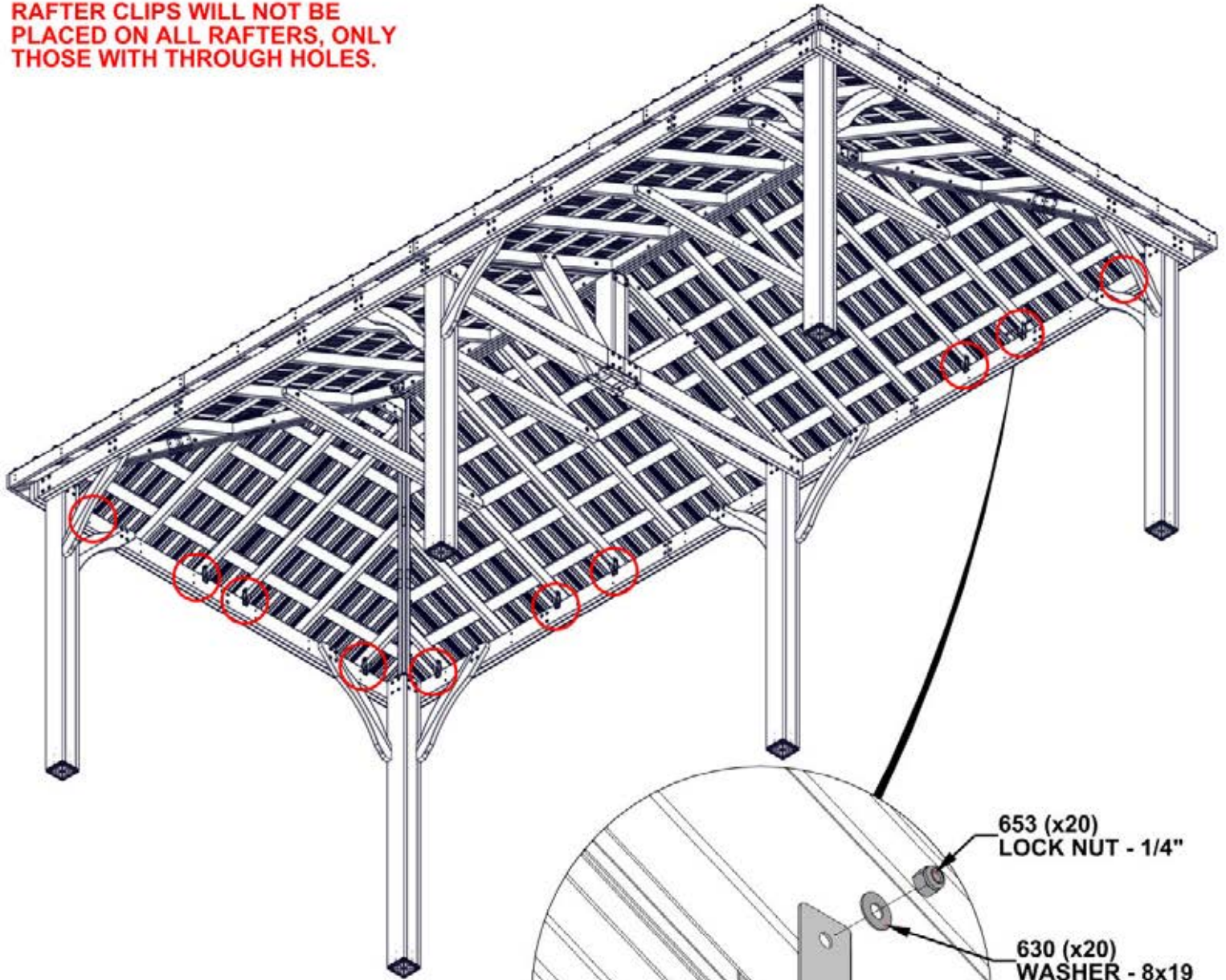

INSERT BOLTS FIRST THEN SCREW IN BRACKET

488 (x20)
BOLT - 2"

536 (x40)
SCREW - 1 1/4"

653 (x20)
LOCK NUT - 1/4"

630 (x20)
WASHER - 8x19

1228 (x20)
RAFTER CLIP

STEP 81 - ROOF ASSEMBLY

QTY	PART NUMBER	DESCRIPTION
16	H100392	SCREW PWH 8x3/4 BLK



A4M01185 CORNER BRACKET
(x4)

REPEAT ON ALL FOUR CORNERS

**USING BRACKET AS A GUIDE. DRILL 1/8"
[3 mm] PILOT HOLES FOR HARDWARE**

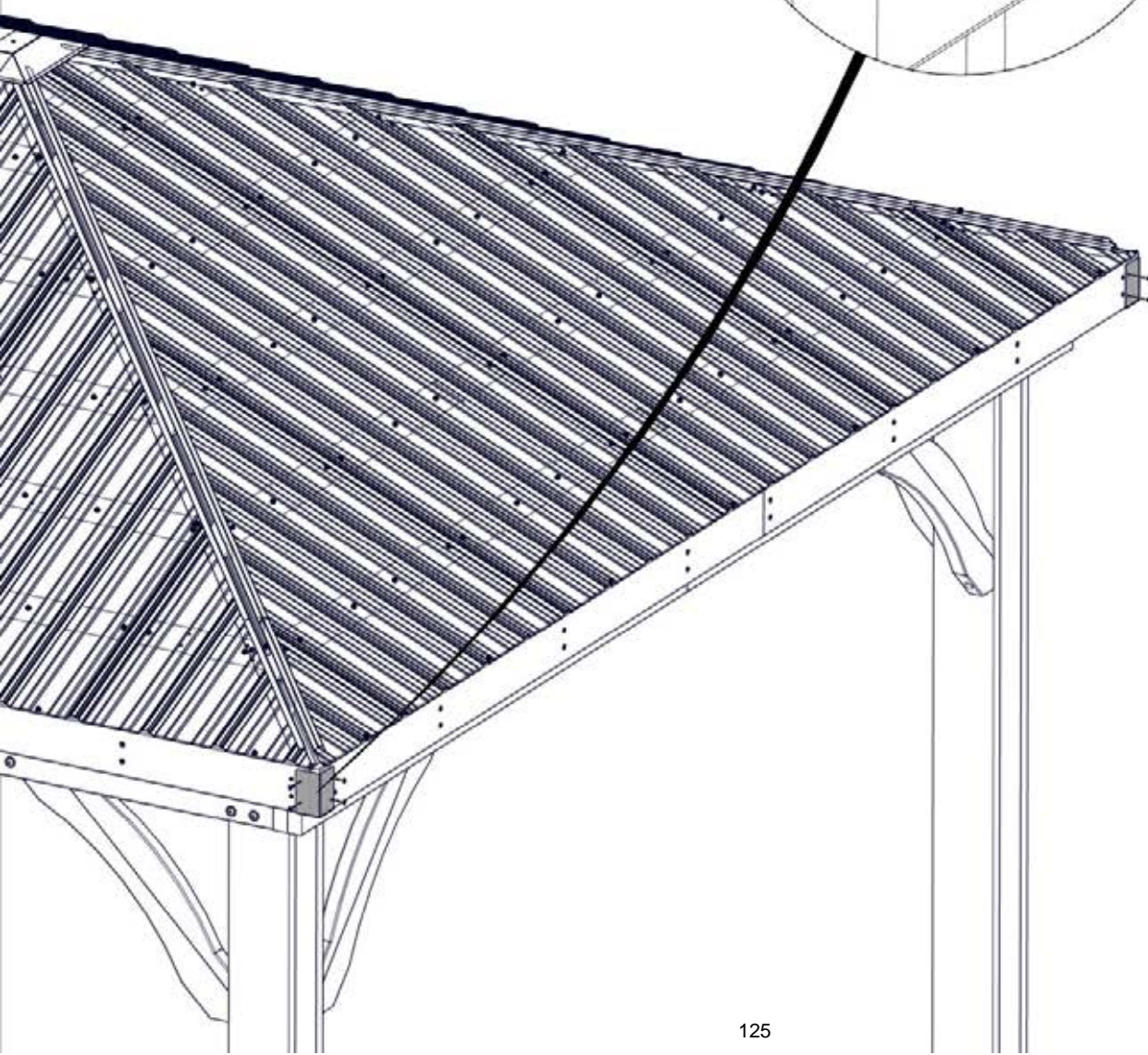
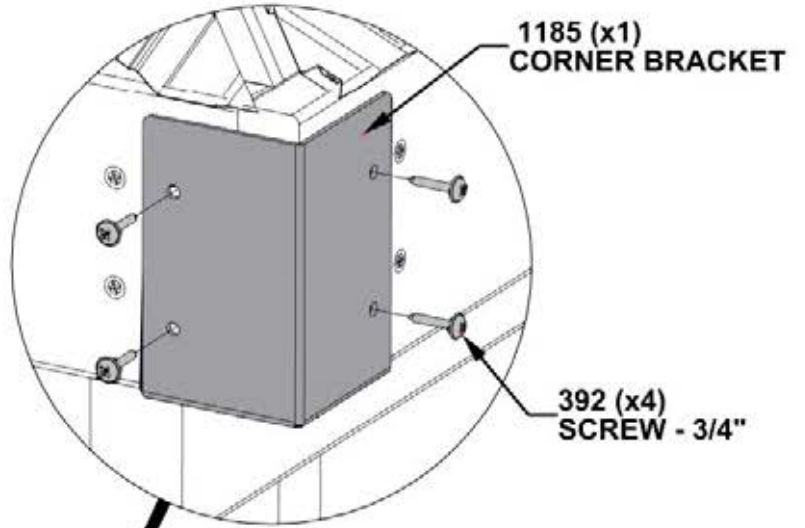

STEP 82 - ROOF ASSEMBLY

QTY	PART NUMBER	DESCRIPTION
8	H100392	SCREW PWH 8x3/4 BLK



A4M01904 SPLICE PLATE
(x2)

REPEAT ON BOTH SIDES

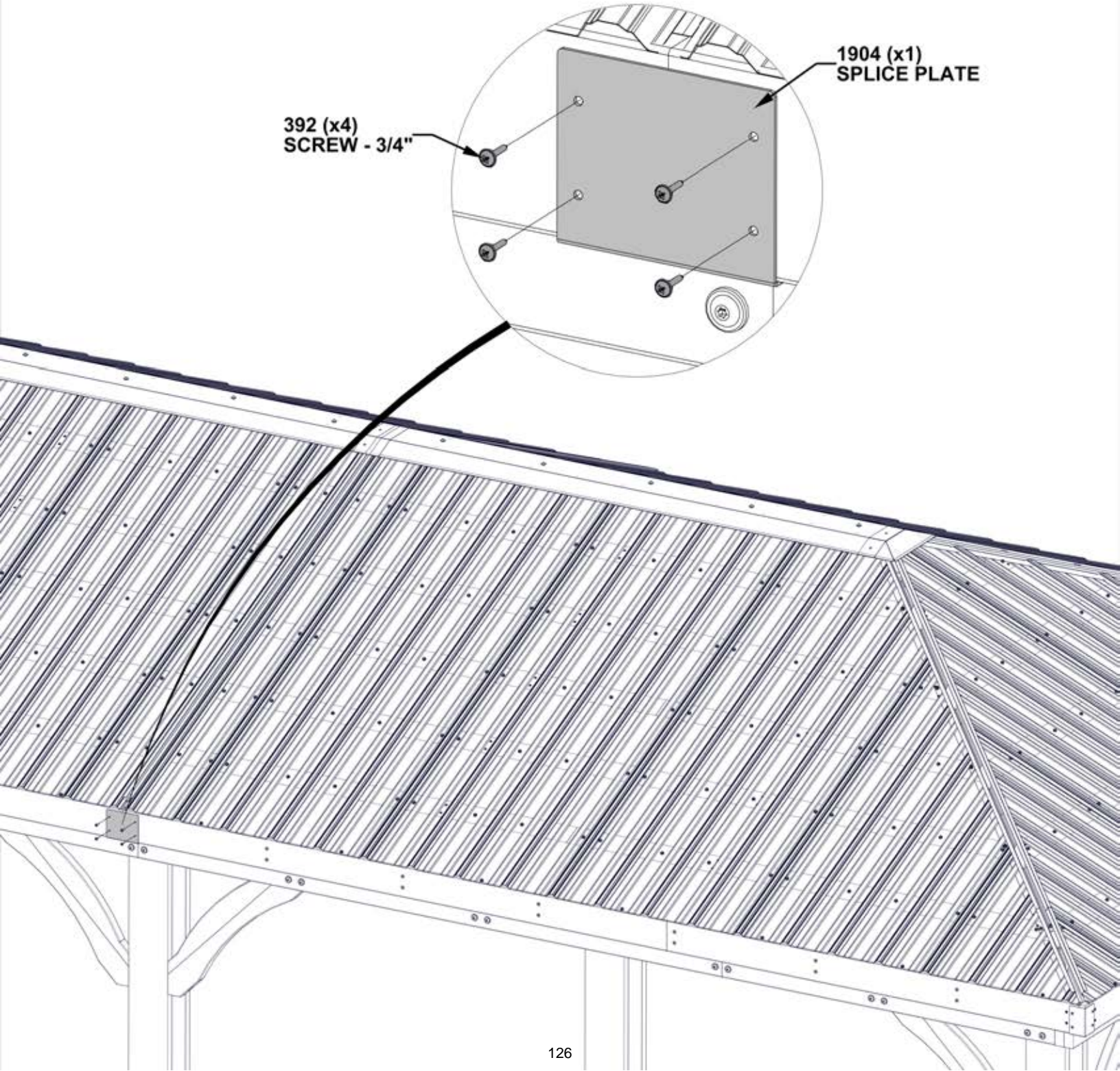

STEP 83 - ROOF TRIM

QTY	PART NUMBER	DESCRIPTION
28	H100833	SCREW WOODGRIP 10-16x3/4"

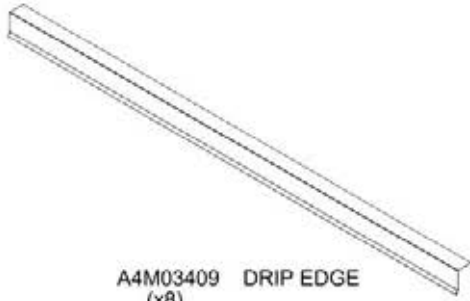

A4M03409 DRIP EDGE
(x8)

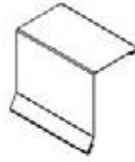

A4M03410 DRIP EDGE SPLICE
(x6)

- START ON THE LEFT END OF THE LONG SIDE.
- SLIDE DRIP EDGE PIECES TOGETHER AS SHOWN.
- INSTALL DRIP EDGE UNDER ROOF SHEETING BEFORE INSTALLING SCREWS.
- INSTALL HARDWARE AS SHOWN.
- LOOSEN ROOF SCREWS AS NEEDED.

REPEAT ON OPPOSITE SIDE

START TO LEFT OF FIRST RIB ON SHEETING. ATTACH AT EVERY THIRD RIB.

833 (x14)
SCREW - 3/4"

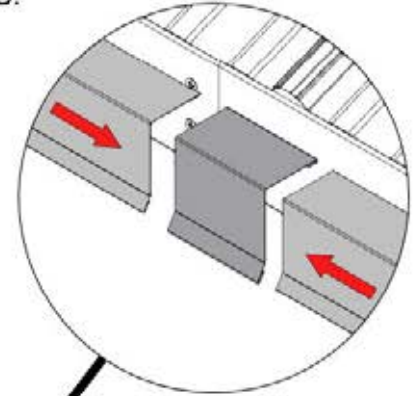
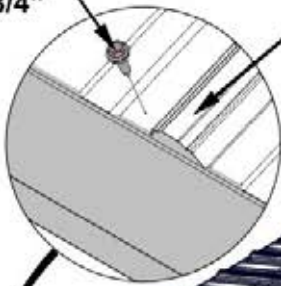

FLUSH EDGE

3409 (x1)
DRIP EDGE

3410 (x1)
DRIP EDGE SPLICE

3409 (x1)
DRIP EDGE

3410 (x1)
DRIP EDGE SPLICE

3409 (x1)
DRIP EDGE

3410 (x1)
DRIP EDGE SPLICE

3409 (x1)
DRIP EDGE

STEP 84 - ROOF TRIM

QTY	PART NUMBER	DESCRIPTION
14	H100833	SCREW WOODGRIP 10-16x3/4"

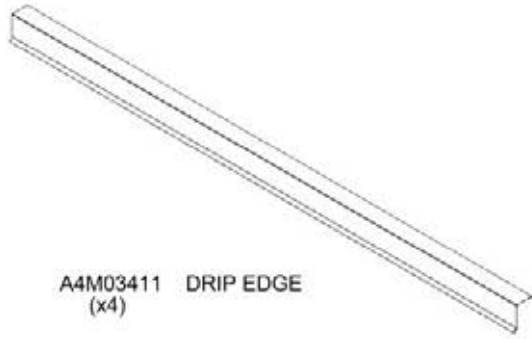

- START ON THE LEFT END OF THE SHORT SIDE.
- SLIDE DRIP EDGE PIECES TOGETHER AS SHOWN.
- INSTALL DRIP EDGE UNDER ROOF SHEETING BEFORE INSTALLING SCREWS.
- INSTALL HARDWARE AS SHOWN.

REPEAT ON OPPOSITE SIDE

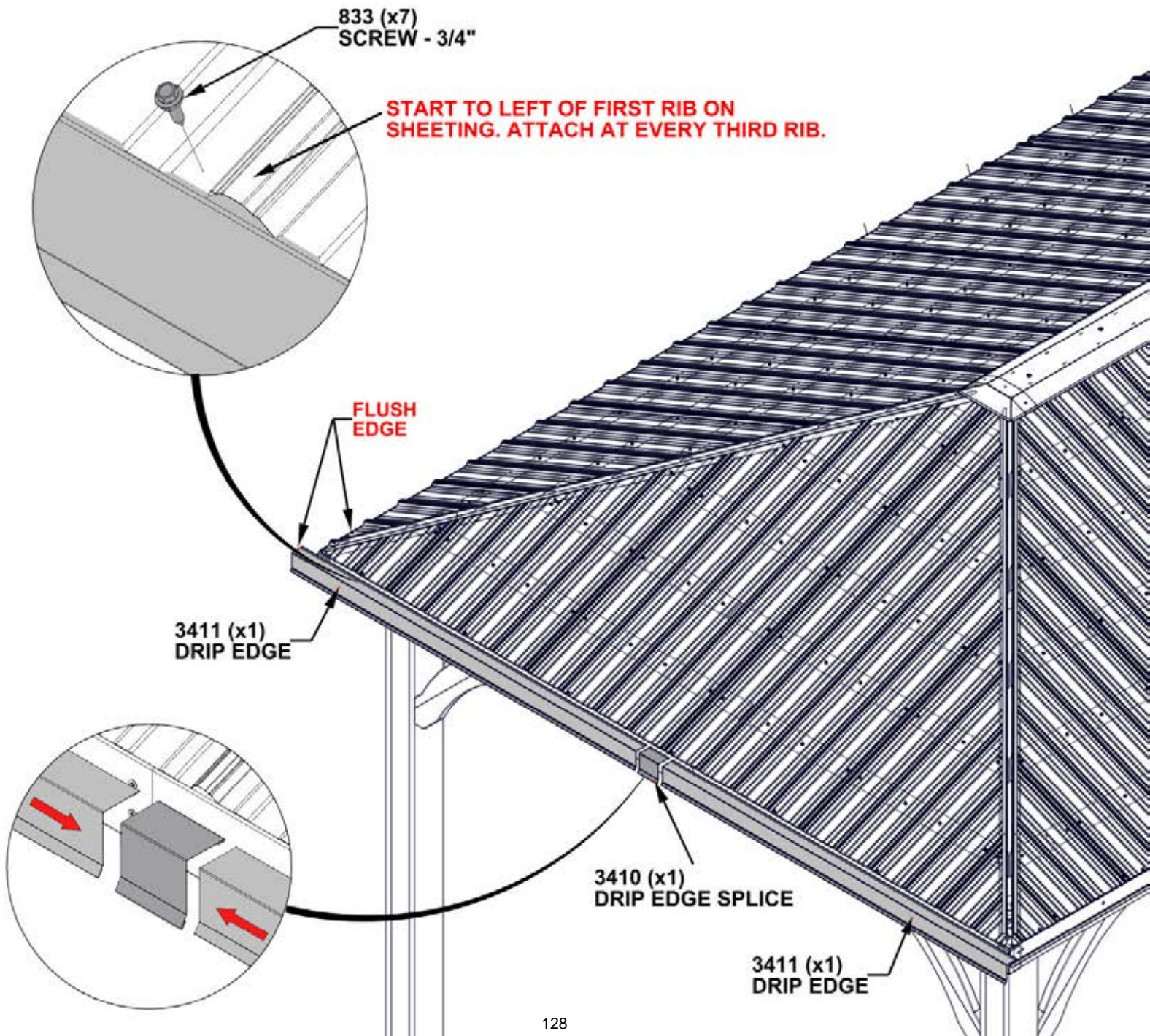

STEP 85 - ROOF TRIM

QTY	PART NUMBER	DESCRIPTION
40	H100759	SCREW SELF TAPPING 1/4x1



A4M02822 TRIM SPLICE
(x6)

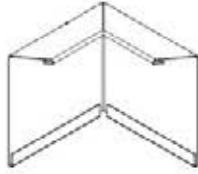

A4M02825 EDGE TRIM
CORNER SPLICE
(x4)

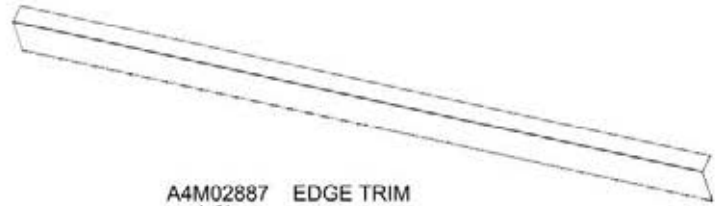

A4M02887 EDGE TRIM
(x8)

- START ON THE LEFT END OF THE LONG SIDE.
- SLIDE EDGE TRIM PIECES TOGETHER AS SHOWN.
- MAKE SURE ALL PANELS ARE COVERED BEFORE INSTALLING SCREWS.
- INSTALL HARDWARE AS SHOWN.

REPEAT ON OPPOSITE SIDE

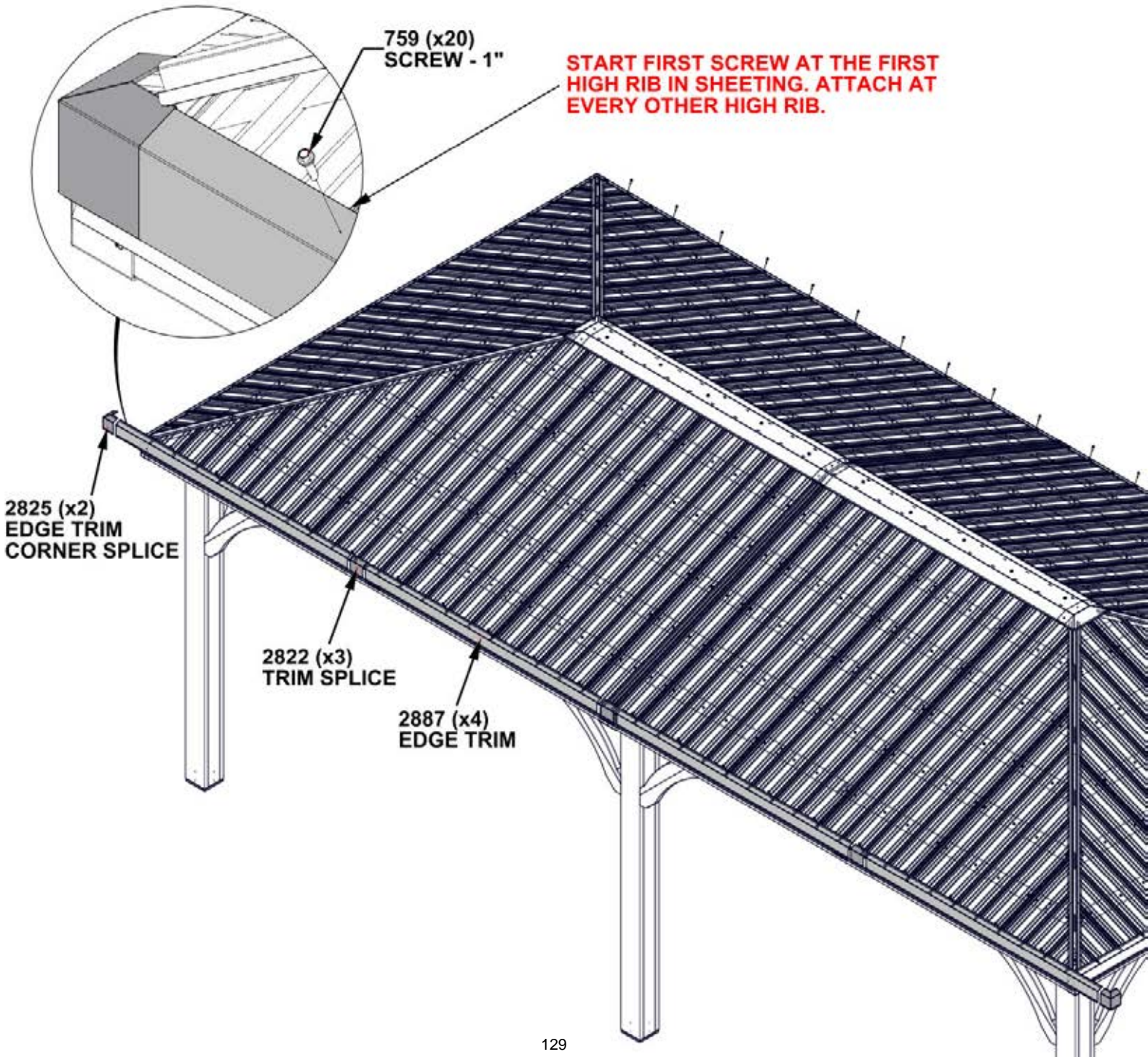

STEP 86 - ROOF TRIM

QTY	PART NUMBER	DESCRIPTION
20	H100759	SCREW SELF TAPPING 1/4x1



A4M02822 TRIM SPLICE
(x2)

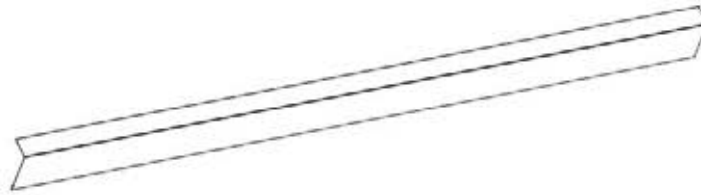

A4M02821 EDGE TRIM
(x4)

- START ON THE LEFT END OF THE SHORT SIDE.
- SLIDE EDGE TRIM PIECES TOGETHER AS SHOWN.
- MAKE SURE ALL PANELS ARE COVERED BEFORE INSTALLING SCREWS.
- INSTALL HARDWARE AS SHOWN.

REPEAT ON OPPOSITE SIDE

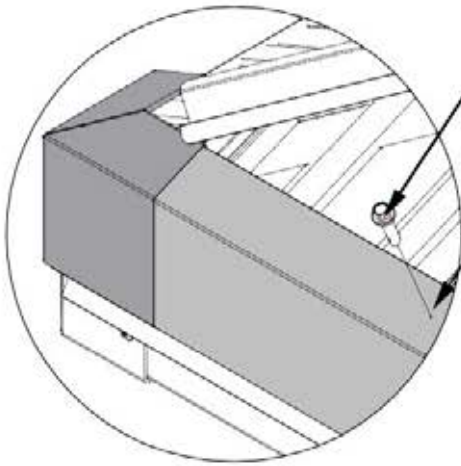

759 (x10)
SCREW - 1"

**START FIRST SCREW AT THE FIRST
HIGH RIB IN SHEETING. ATTACH AT
EVERY OTHER HIGH RIB.**

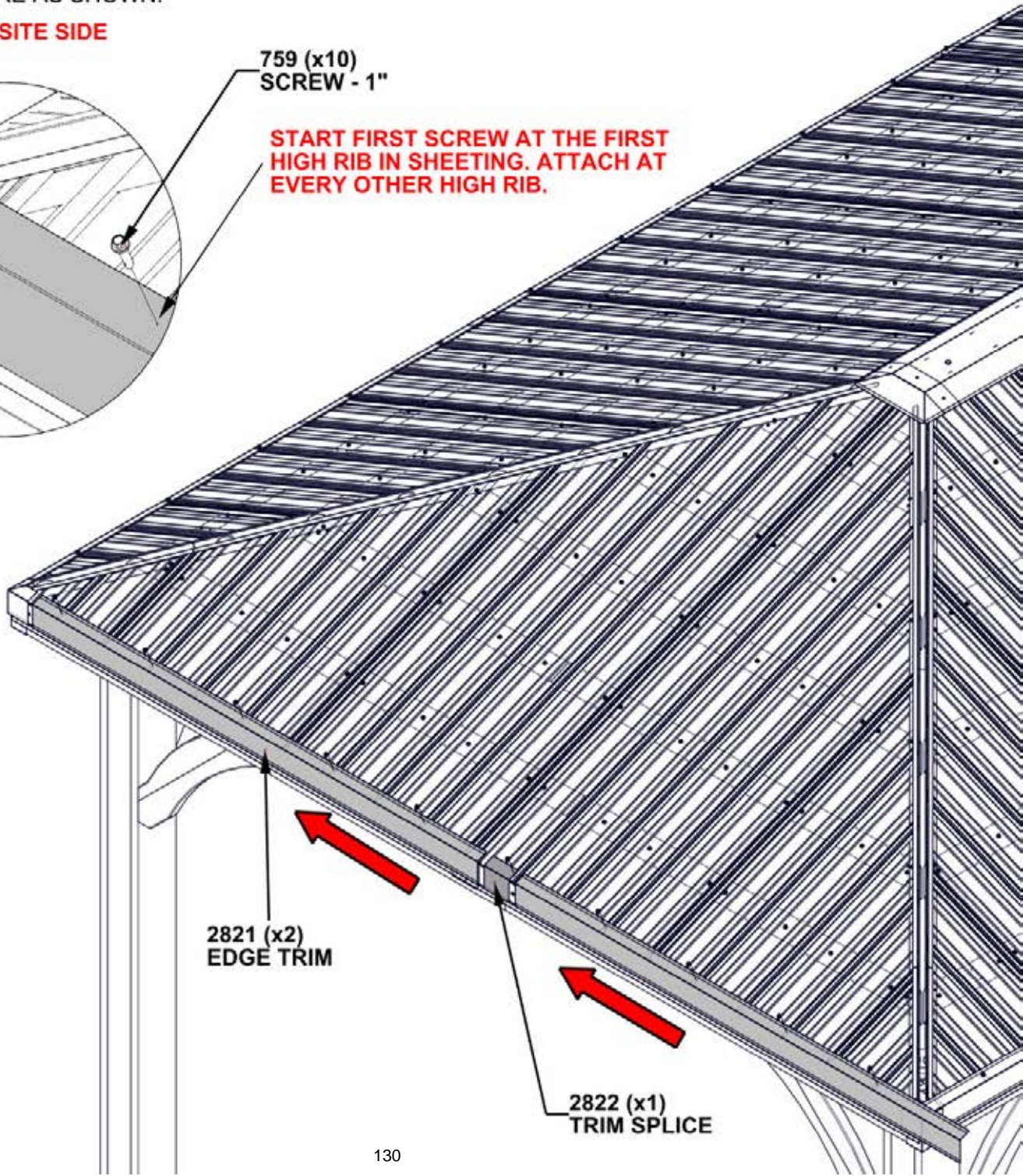

2821 (x2)
EDGE TRIM

2822 (x1)
TRIM SPLICE

STEP 87 - ROOF TRIM



A4M02826 CORNER RIDGE
(x4) CAP LONG

- SLIDE RIDGE CAP ONTO ROOF RIDGE CAP CHANNEL AS SHOWN.

REPEAT ON ALL FOUR CORNERS

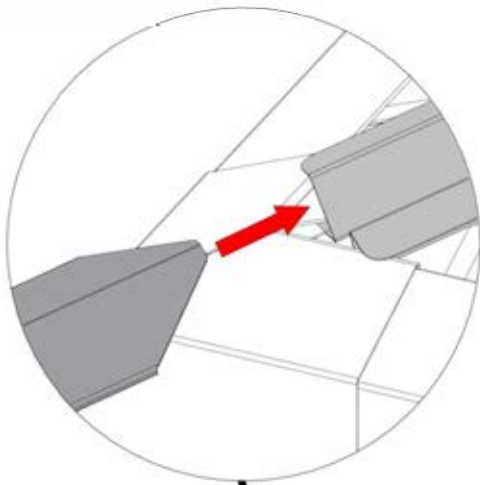

2826 (x1)
CORNER RIDGE
CAP LONG

STEP 88 - ROOF TRIM

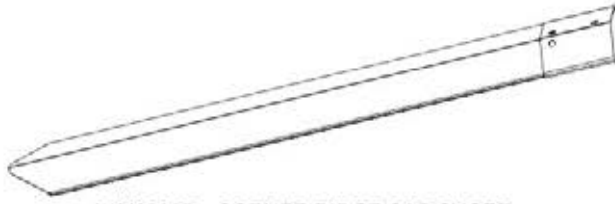

A4M02867 CORNER RIDGE CAP SHORT
(x4)

REPEAT ON ALL FOUR CORNERS

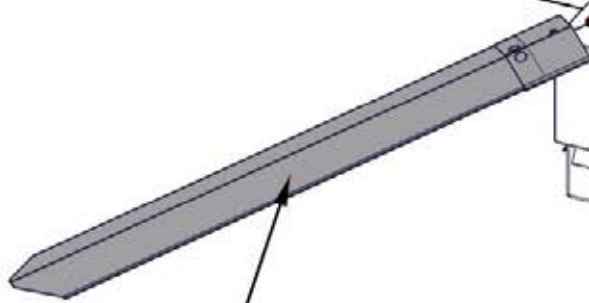
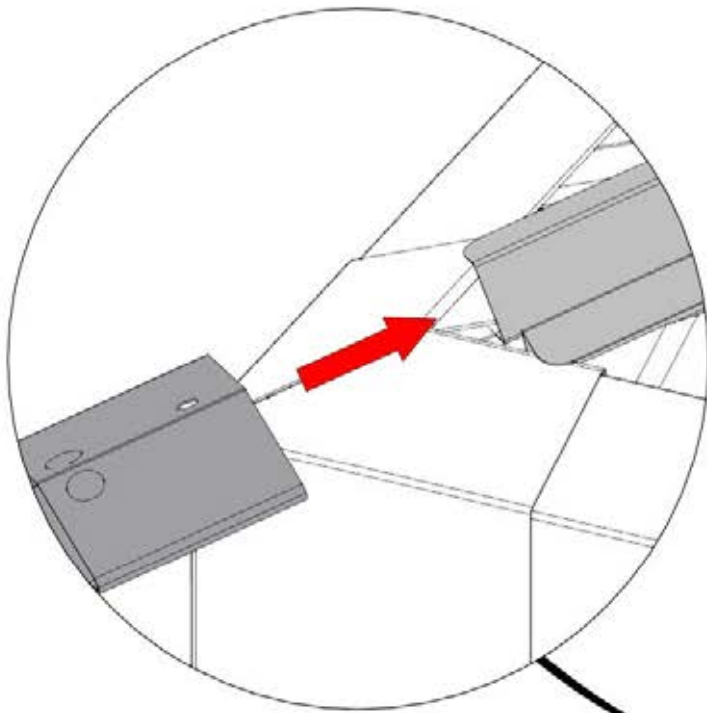

2867 (x1)
CORNER RIDGE CAP SHORT

STEP 89 - ROOF TRIM

QTY	PART NUMBER	DESCRIPTION
12	H100759	SCREW SELF TAPPING 1/4x3/4

REPEAT ON ALL FOUR CORNERS

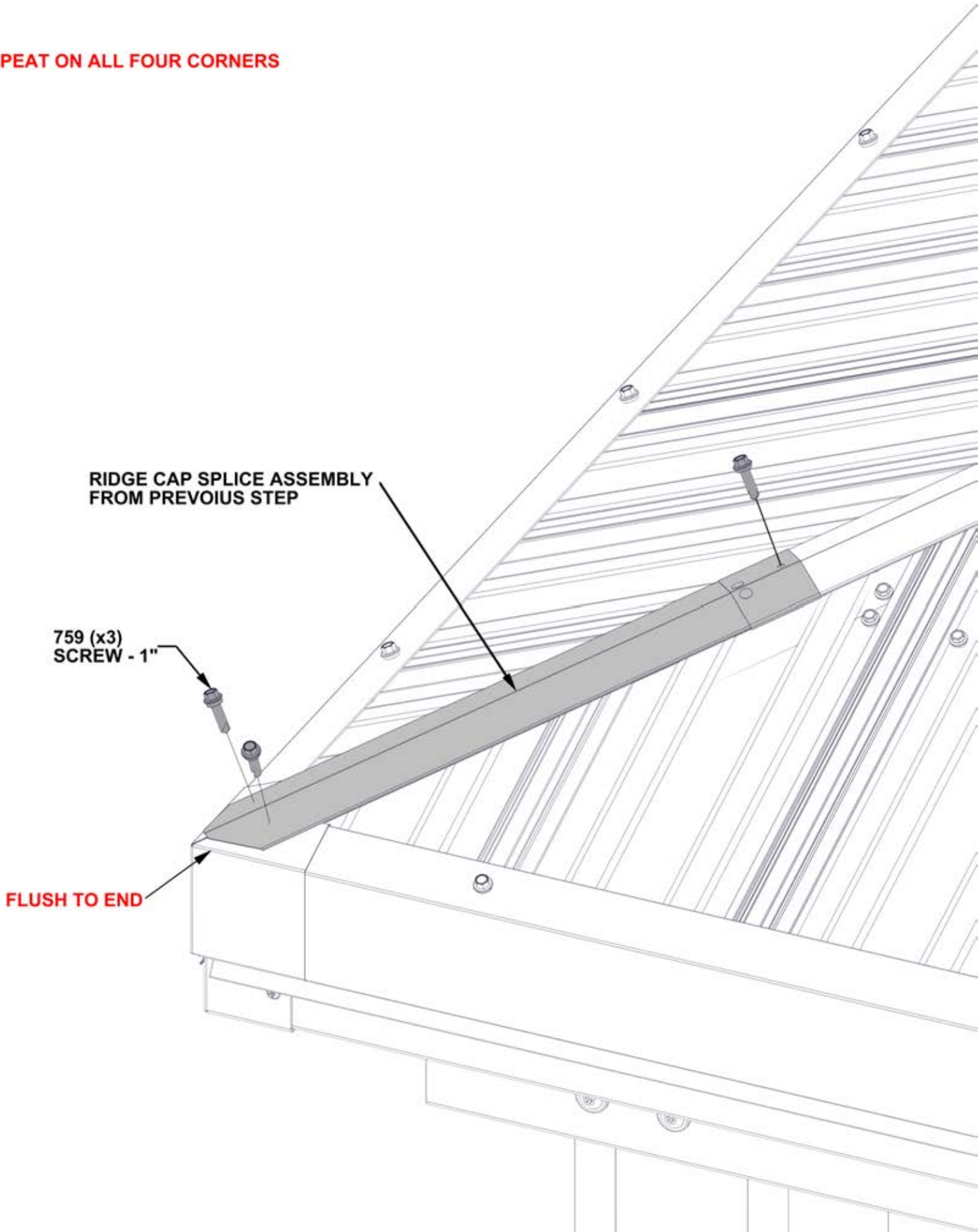

STEP 90 - ROOF TRIM

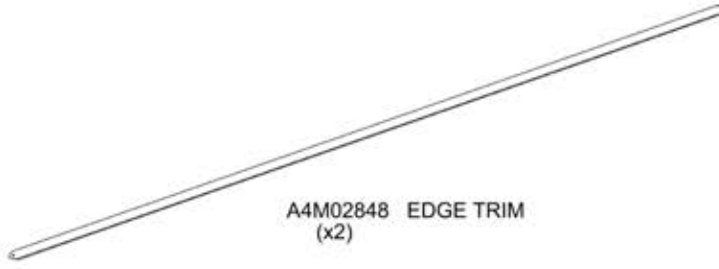

- SLIDE EDGE TRIM ONTO ROOF RIDGE CAP CHANNEL AS SHOWN.
- DO NOT PUSH ALL THE WAY TO THE TOP.
- FLUSH WITH EDGE OF GAZEBO.

REPEAT ON BOTH SIDES

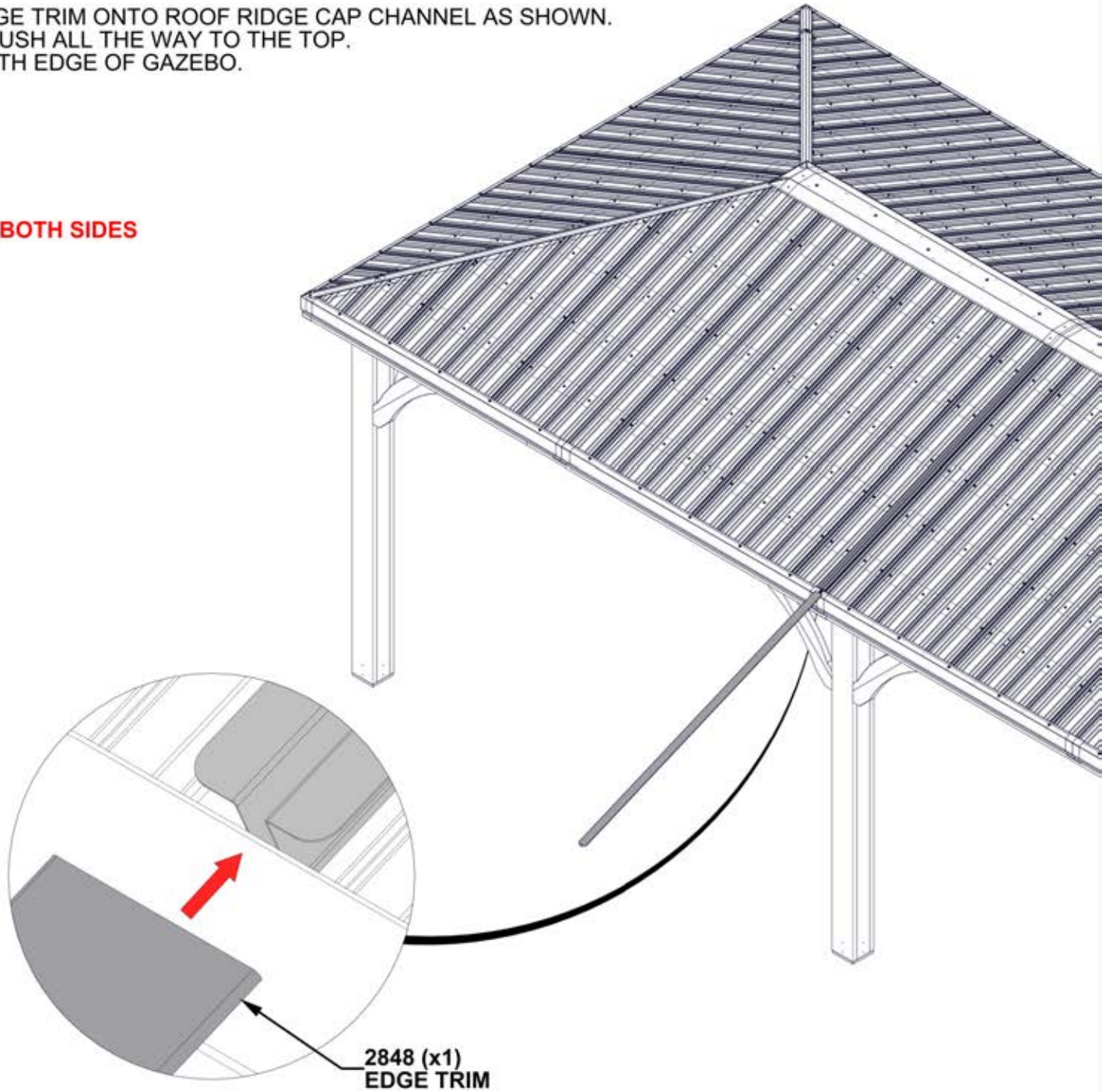

STEP 91 - ROOF TRIM

QTY	PART NUMBER	DESCRIPTION
2	H100759	SCREW SELF TAPPING 1/4x1

REPEAT ON BOTH SIDES

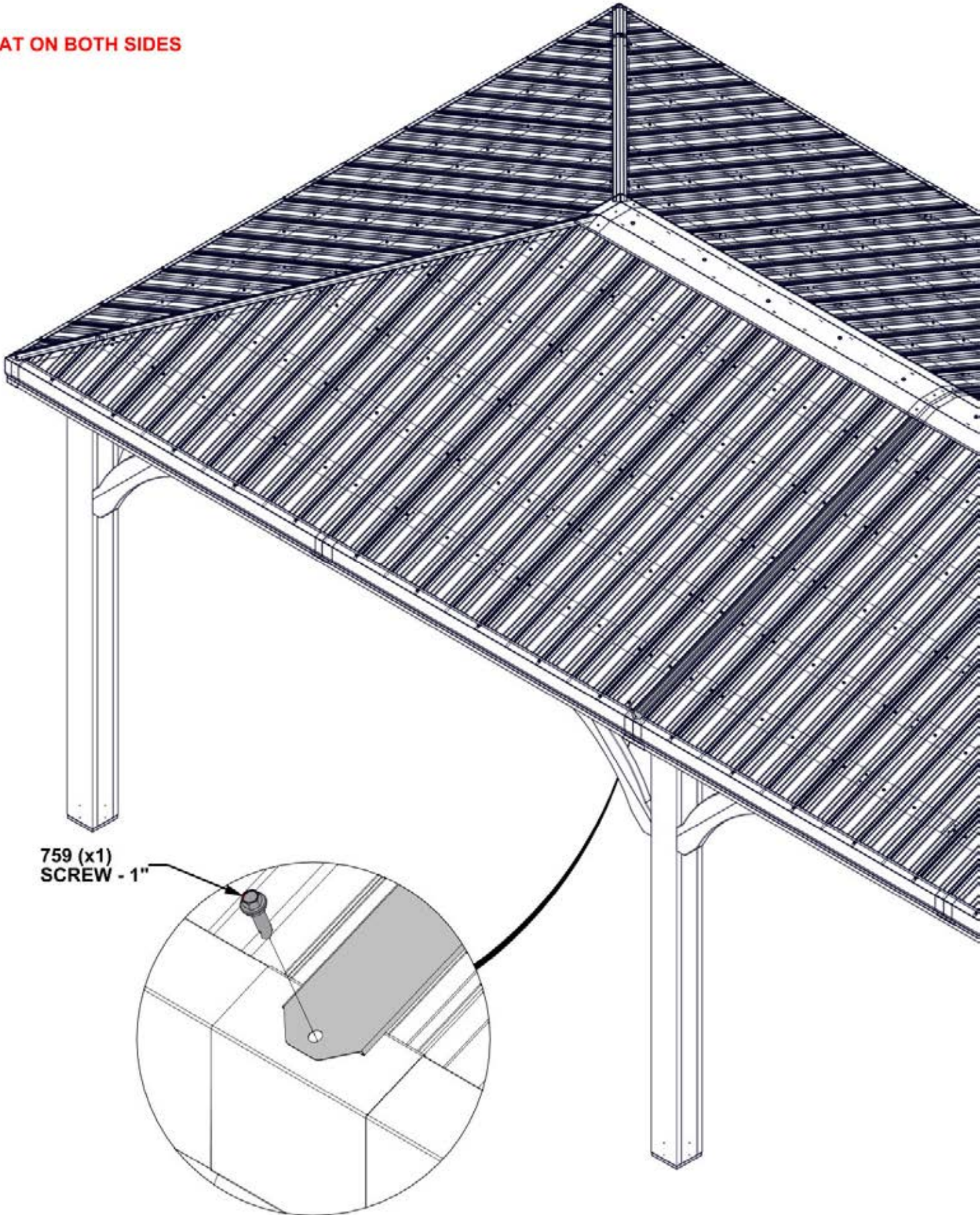

759 (x1)
SCREW - 1"

STEP 92 - GAZEBO ASSEMBLY

QTY	PART NUMBER	DESCRIPTION
48	H100471	LAG SCREW WH 5/16x1 1/2 BLK



A4M01794 POST PLATE
(x12)

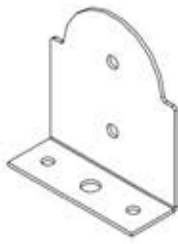

A4M01793 POST ANCHORING PLATE
(x12)

USE PILOT HOLES IN POSTS TO ATTACH POST PLATES.

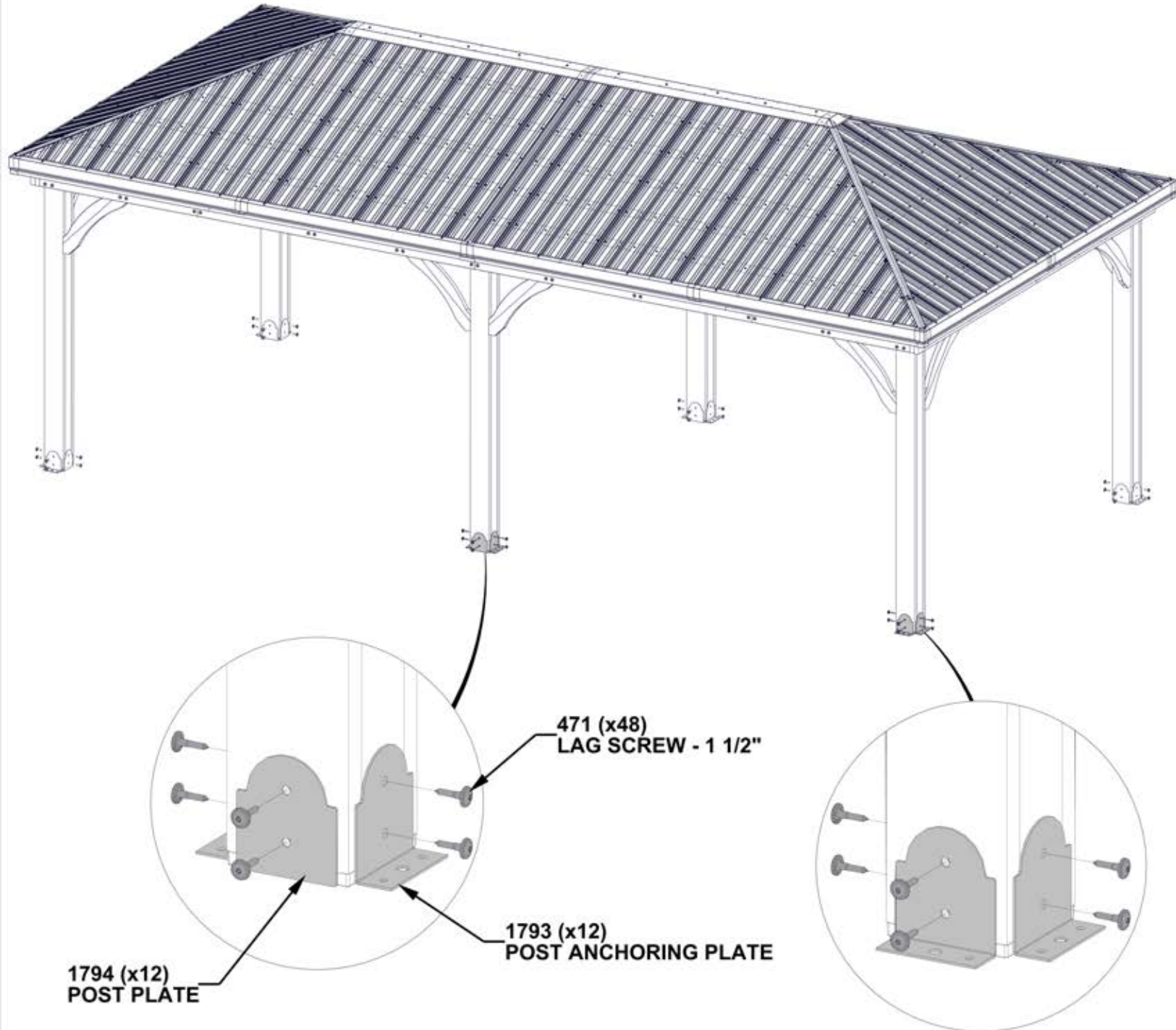

STEP 93 - GAZEBO ASSEMBLY

QTY	PART NUMBER	DESCRIPTION
4	H100202	SCREW PWH 8x5/8 BLK



A4M02158 - BYD ID TAG PATIO
(x1)

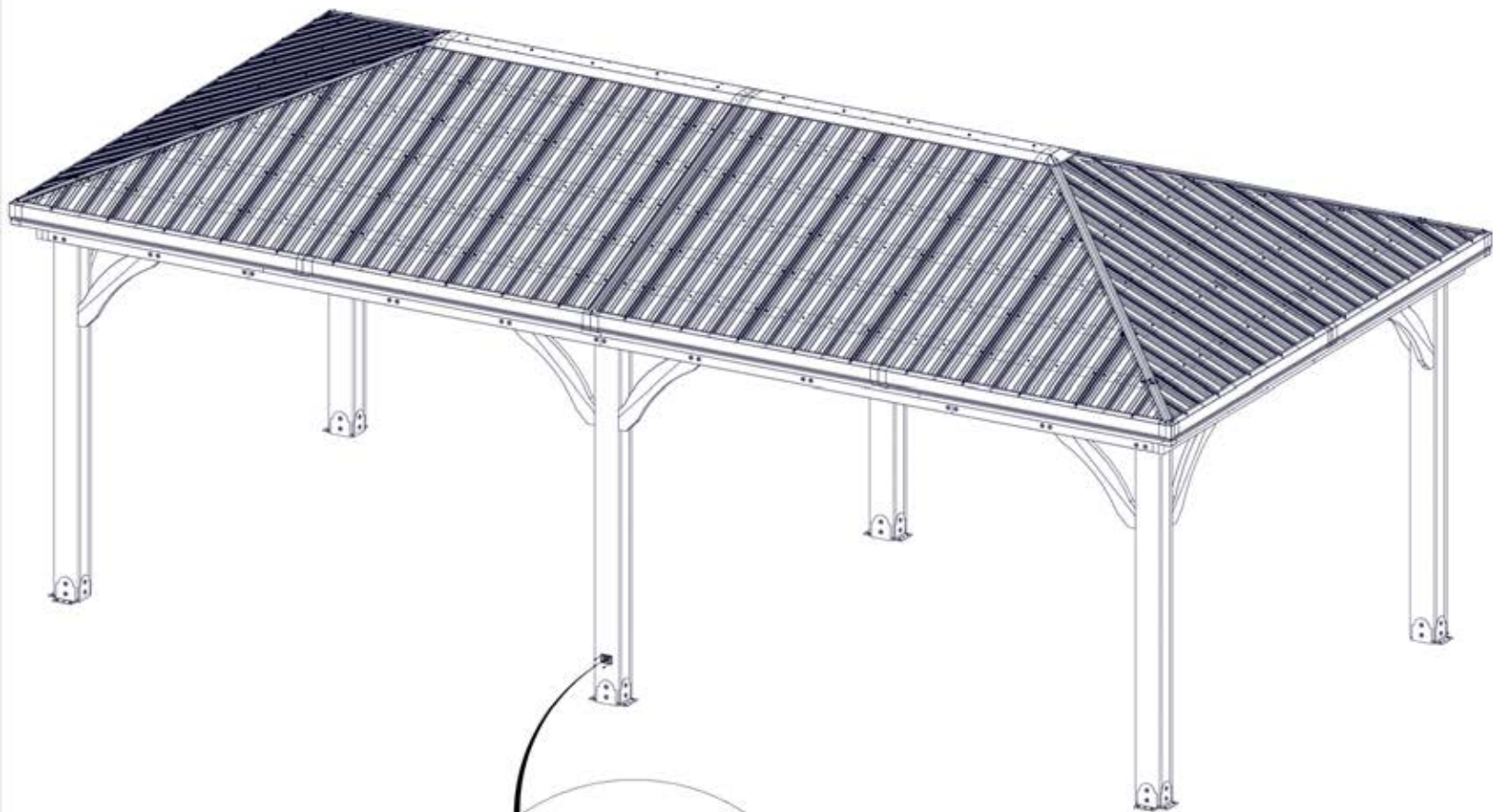

202 (x4)
SCREW - 5/8"

2158 (x1)
BYD ID TAG PATIO

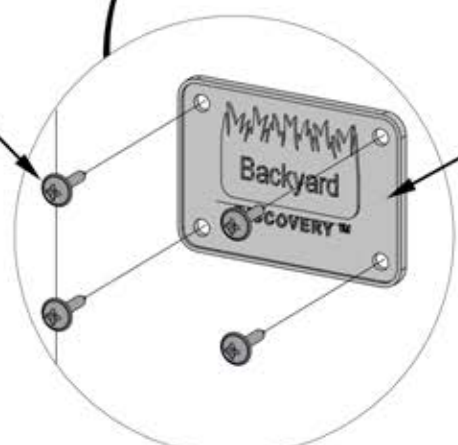

STEP 94 - GAZEBO ASSEMBLY

QTY	PART NUMBER	DESCRIPTION
24	H100120	CONCRETE ANCHOR 1/4"x2"
24	H100630	WASHER FLAT 8x19 BLK

- MANUFACTURER RECOMMENDS INSTALLATION ON CONCRETE SURFACE OR CONCRETE POST PADS AS SHOWN BELOW.
- FOR INSTALLATION ON A WOOD DECK, YOU MUST ENSURE THERE IS AMPLE STRUCTURAL SUPPORT UNDER DECK. HARDWARE NOT PROVIDED FOR DECK ATTACHMENT.



120 (x24)
CONCRETE SCREW-2"

630 (x24)
WASHER - 8x19

PRE-DRILL HOLES FOR CONCRETE ANCHOR USING A 3/16" [5 mm] CONCRETE DRILL BIT.

STEP 95 - GAZEBO ASSEMBLY

QTY	PART NUMBER	DESCRIPTION
8	H100405	WASHER LOCK EXT 6x15
8	H100487	LAG SCREW WH 1/4x2 BLK



AA01 MOUNTING BLOCK - W4L20731
(x2) 2 3/8"x3 3/4"x1 7/16" (60x96x36)

ALIGN PILOT HOLES

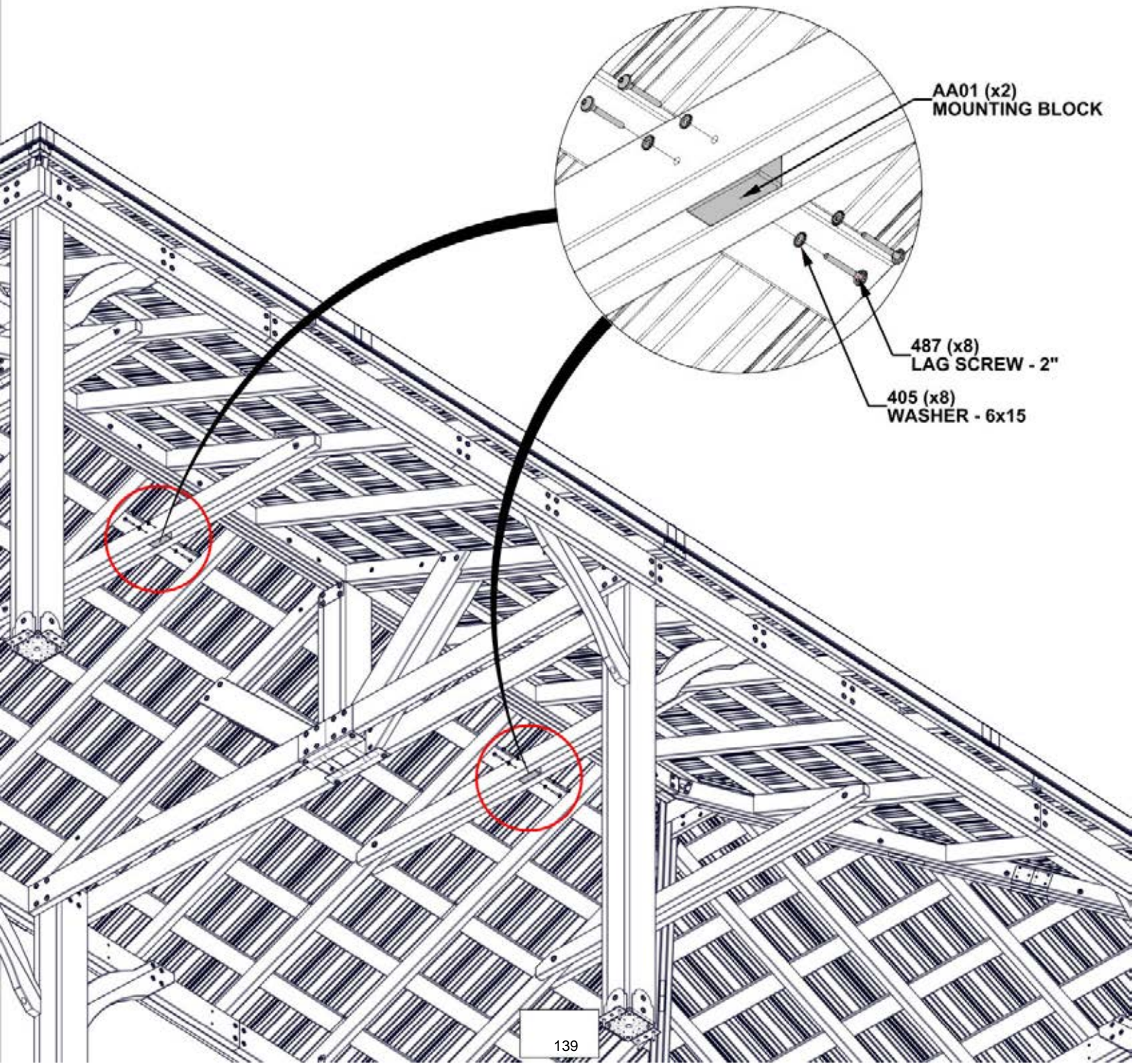

AA01 (x2)
MOUNTING BLOCK

487 (x8)
LAG SCREW - 2"

405 (x8)
WASHER - 6x15

STEP 96 - GAZEBO ASSEMBLY (OPTIONAL)

QTY	PART NUMBER	DESCRIPTION
8	H100536	SCREW PWH 8x1 1/4 BLK

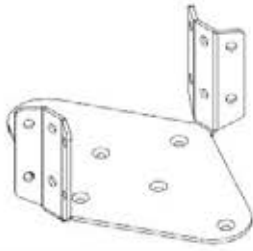

A4M02501 FAN MOUNT BRACKET
(x2)

- ATTACH ELECTRICAL BOX (SOLD SEPARATLY) WITH THE PROVIDED HOLES IN THE FAN MOUNT BRACKET.
- PLACE FAN MOUNT BRACKET ON MOUNTING BLOCK.
- USE AN 1/8" [3mm] DRILL BIT AND DRILL PILOT HOLES AND ATTACH AS SHOWN.

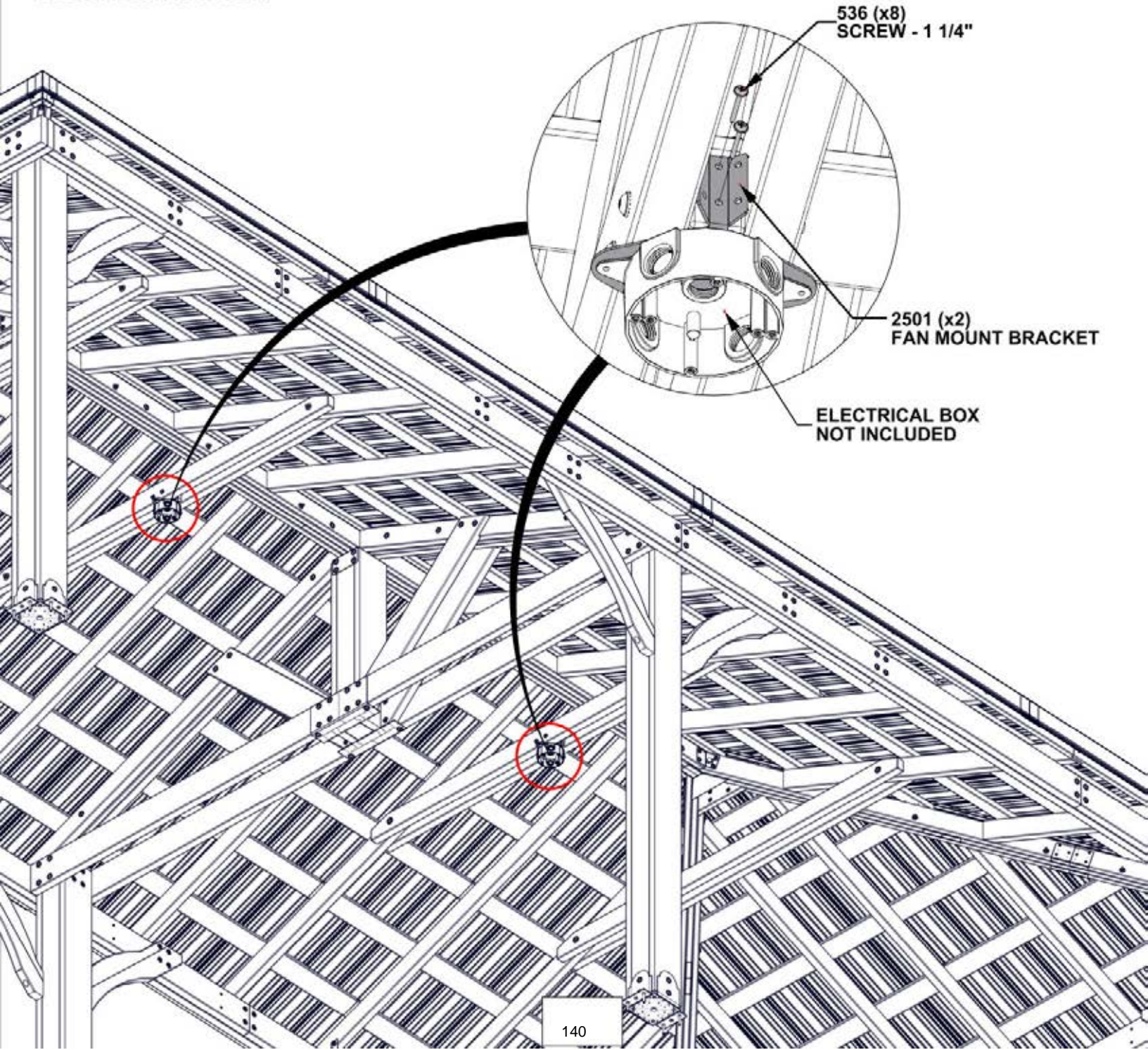

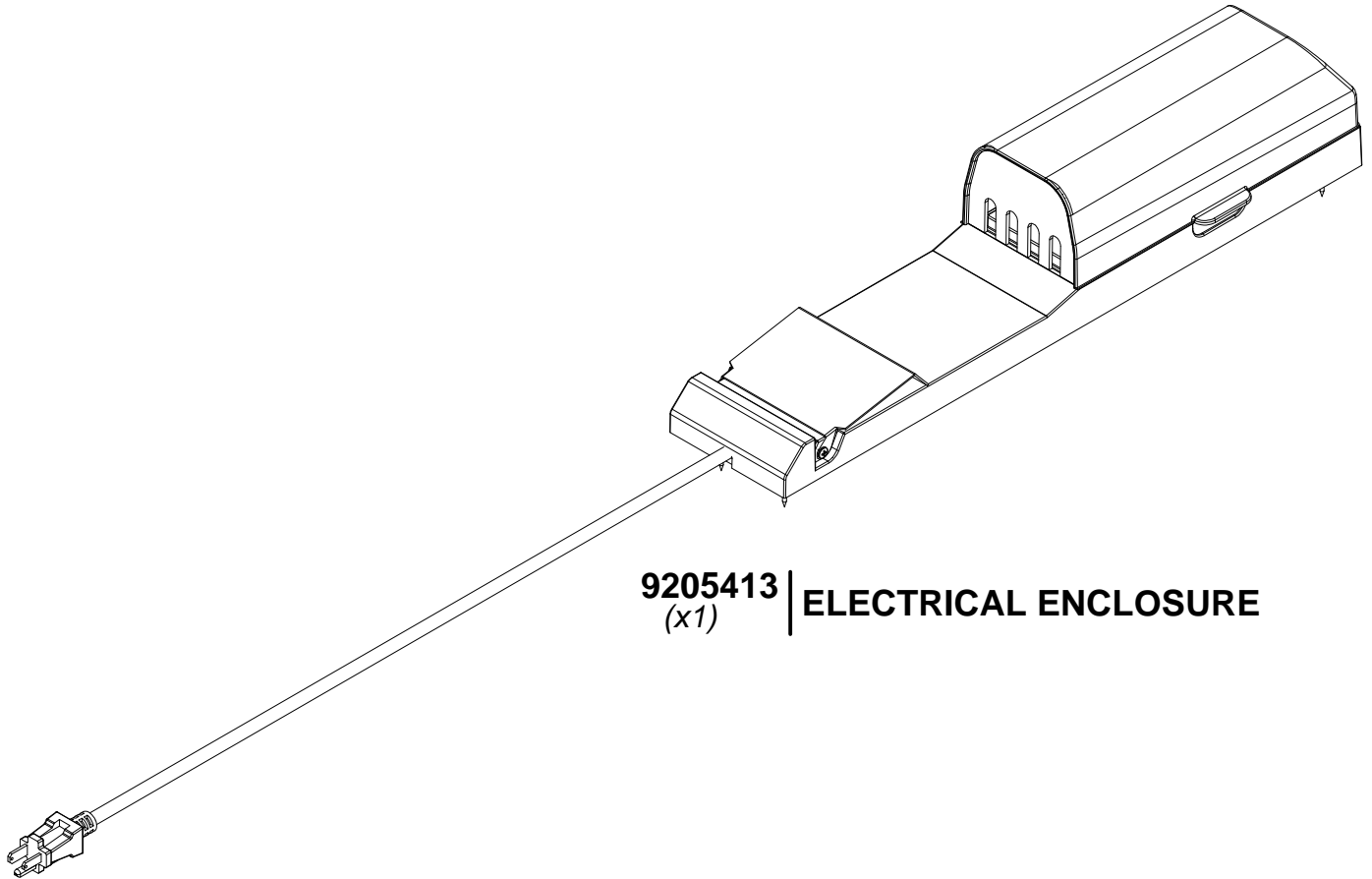

9205413 | **ELECTRICAL ENCLOSURE**
(x1)

FOR POWERPORT INSTALLATION REFER TO ASSEMBLY INSTRUCTIONS THAT COME PACKAGED WITH THE POWERPORT KIT. INSTALL ON ANY POST THAT IS DESIRED. FOLLOW DIRECTIONS FOR PROPER INSTALLATION.