



Manufactured by:
Backyard Discovery
3305 Airport Drive, Pittsburg, KS
66762 800-856-4445

Basepoint Business Centre: Rivermead Drive, Westlea, Swindon SN5 7EX Phone: 0800-118-2476
J.P. Coenstraat 7, The Bridge, The Hague, 2595 WP, Netherlands Phone: 08005678990

24x12 NORWOOD GAZEBO

MODEL # : 2406049

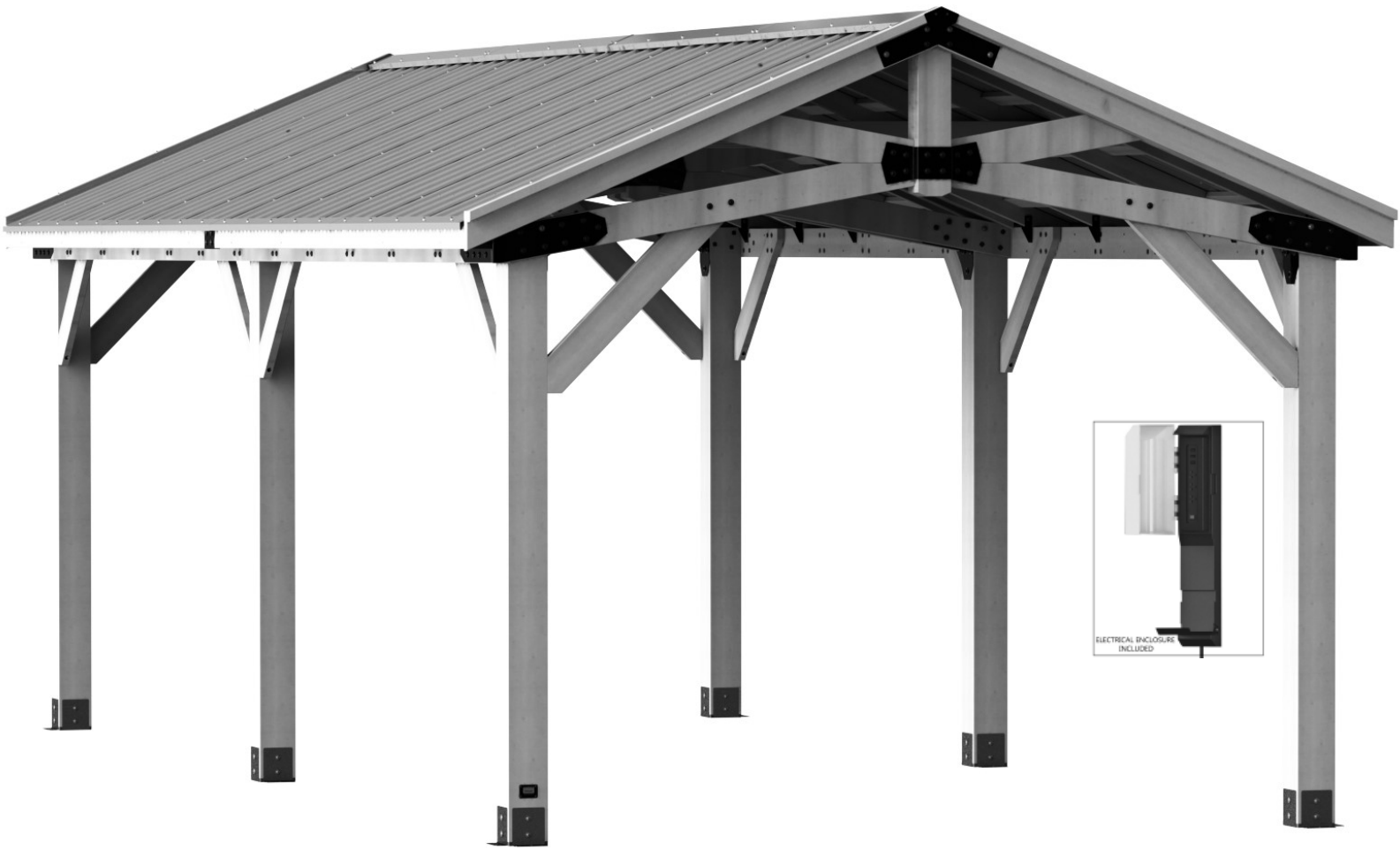

Please visit www.backyarddiscovery.com
For the most up to date assembly manual, to register your product, or to order replacement parts *Para obtener instrucciones en español, visite*
www.backyarddiscovery.com



EASY STEP-BY-STEP
3D INTERACTIVE INSTRUCTIONS
DOWNLOAD THE FREE APP



OWNER'S MANUAL - BASIC SETUP DIMENSIONS & ASSEMBLY NOTES

It is critically important that you start with square and level footings, concrete pad or deck to attach your structure

- Pay close attention to the items needed for each step. Make sure you are using the correct hardware for each step. Using incorrect hardware may result in improper assembly
- Remember to double check for underground utilities and overhead electrical lines

Post mounts are provided with your structure which allows you to permanently install your structure to a pre-existing or new wood or concrete surface. See Anchor Instructions for further details and recommendations.

- The hardware to attach the post mounts to the structure is included.
- The hardware to mount the structure permanently to a concrete surface is included.
- The hardware to mount the structure permanently to a wood deck is NOT included and will need to be purchased separately. You must ensure there is ample structural support under the deck before permanently attaching.

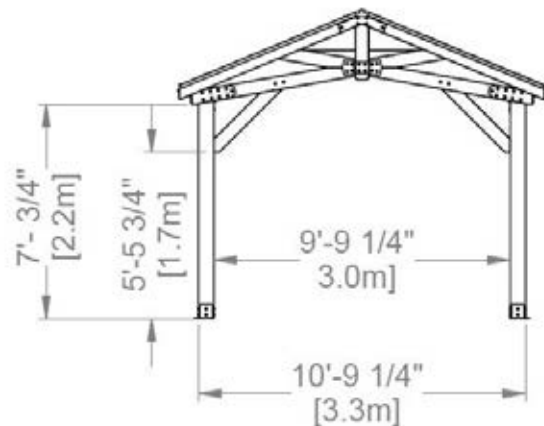
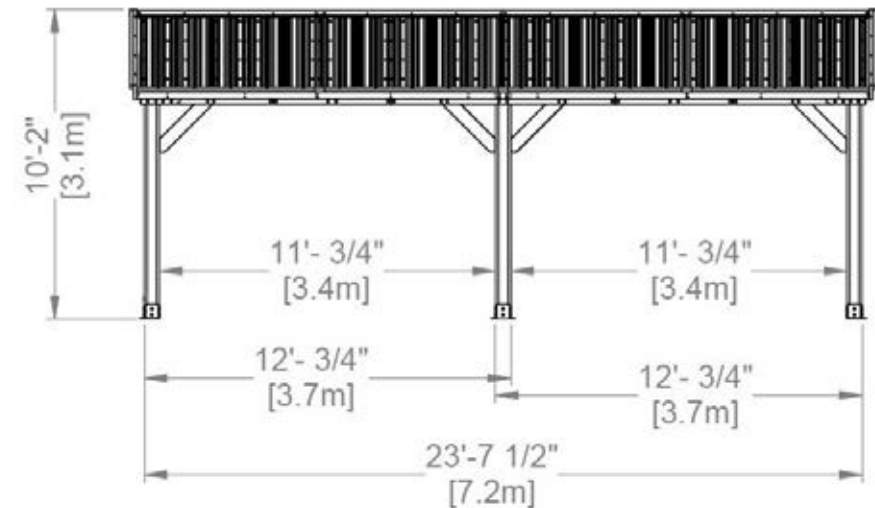
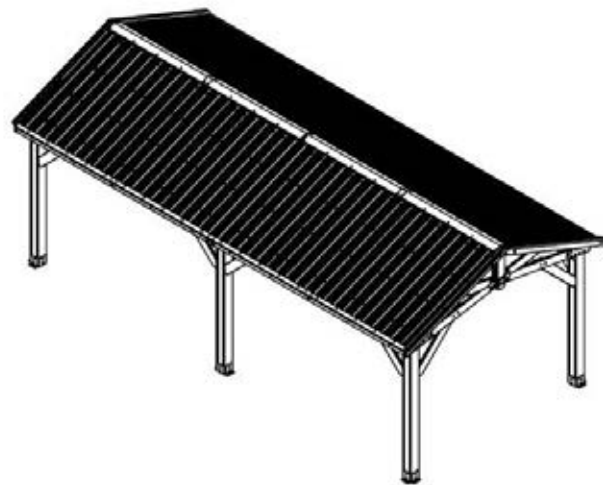
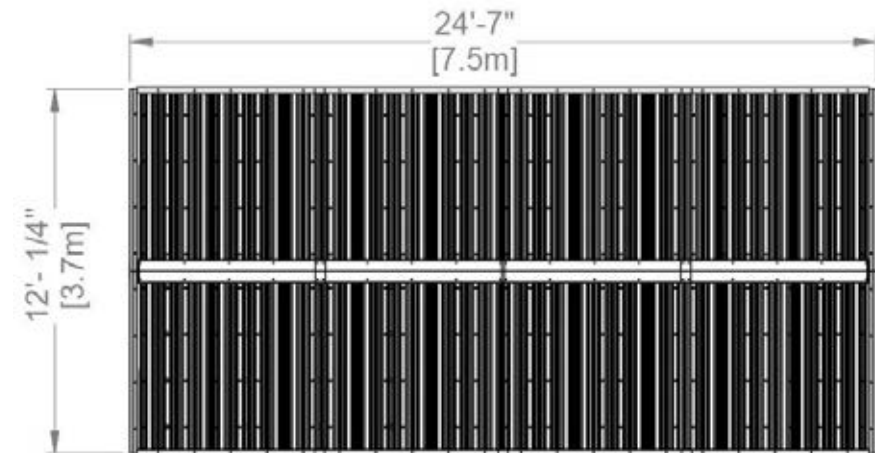

OWNER'S MANUAL - ANCHORING LAYOUT

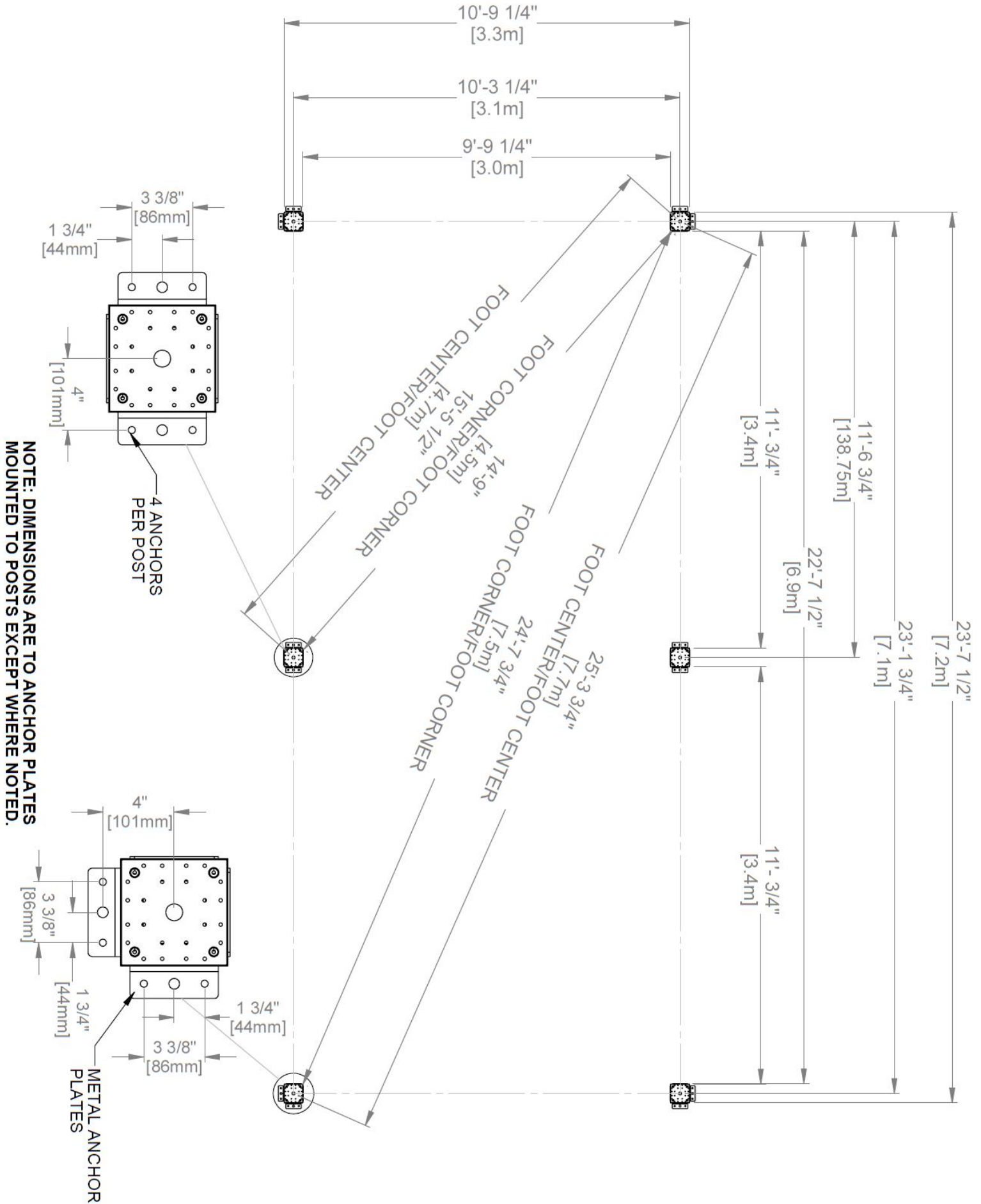

OWNER'S MANUAL - PARTS IDENTIFICATION

WOOD COMPONENTS (NOT TO SCALE)



D01 GABLE BOARD - W4L16415
(x8) 1 3/8"x5 1/4"x24 5/8" (36x134x625)



D02 TOP RAIL - W4L19550
(x4) 1 3/8"x5 1/4"x75 5/8" (36x134x1922)



D03 TOP RAIL - W4L19535
(x4) 1 3/8"x5 1/4"x46 9/16" (36x134x1182)



D04 CORBEL - W4L16944
(x8) 1 3/8"x5 1/4"x34 7/16" (36x134x875)



D05 GABLE BOARD - W4L16753
(x4) 1 3/8"x1 1/2"x5 1/4" (36x38x134)



D06 CORBEL - W4L16375
(x3) 1 3/8"x5 1/4"x44 1/16" (36x134x1119)



D07 TOP RAIL - W4L19536
(x4) 1 3/8"x5 1/4"x67 1/2" (36x134x1716)



D08 TOP RAIL - W4L19548
(x4) 1 3/8"x5 1/4"x52 3/8" (36x134x1331)

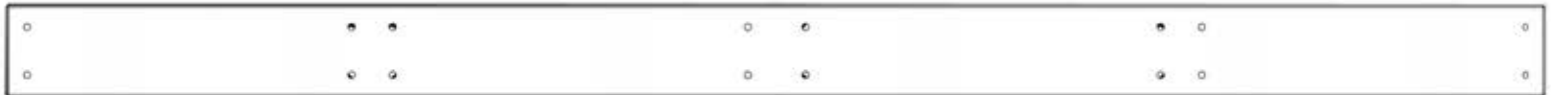

D09 TOP RAIL - W4L19549
(x2) 1 3/8"x5 1/4"x88 9/16" (36x134x2250)



E01 RAFTER - W4L19537
(x8) 1 3/8"x3 3/8"x77 3/8" (36x86x1965)



E08 RAFTER - W4L19547
(x12) 1 3/8"x3 3/8"x77 3/8" (36x86x1965)



E09 ACCESSORY TRUSS - W4L16756
(x12) 1 3/8"x3 3/8"x73 7/8" (36x86x1875)

OWNER'S MANUAL - PARTS IDENTIFICATION

WOOD COMPONENTS (NOT TO SCALE)



F01 TRUSS - W4L16414
(x4) 1 3/8"x2 3/8"x75 1/8" (36x60x1907)



F02 TRUSS - W4L16378
(x4) 1 3/8"x2 3/8"x68" (36x60x1727)



H01 FASCIA - W4L19538
(x4) 1"x3 3/8"x67 7/8" (24x86x1724)



H02 FASCIA - W4L19539
(x4) 1"x3 3/8"x67 7/8" (24x86x1725)



H03 FASCIA - W4L19540
(x4) 1"x3 3/8"x72 1/8" (24x86x1831)



H04 FASCIA - W4L19541
(x4) 1"x3 3/8"x73 7/8" (24x86x1875)



H05 SHEATHING BOARD - W4L19542
(x16) 1"x3 3/8"x43 1/4" (24x86x1098)



H06 SHEATHING BOARD - W4L19543
(x16) 1"x3 3/8"x59" (24x86x1500)



H07 SHEATHING BOARD - W4L19544
(x16) 1"x3 3/8"x44 3/4" (24x86x1137)



H08 NOTCHED SUPPORT BOARD - W4L16915
(x4) 1"x3 3/8"x89 1/2" (24x86x2274)



J01 STIFFENER BOARD - W4L19545
(x4) 1"x2 3/8"x87 5/8" (24x60x2226)



J02 STIFFENER BOARD - W4L19546
(x4) 1"x2 3/8"x56 3/4" (24x60x1441)



GP1 GABLE PANEL - W2A03379
(x2) 2 13/16"x5 1/4"x80 3/16" (72x134x2037)



GP2 GABLE PANEL - W2A03380
(x2) 2 13/16"x5 1/4"x80 3/16" (72x134x2037)

OWNER'S MANUAL - PARTS IDENTIFICATION

WOOD COMPONENTS (NOT TO SCALE)



P01 POST - W2A03456
(x2) 6"x6"x89 1/2" (152x152x2274)



P02 POST - W2A03457
(x2) 6"x6"x89 1/2" (152x152x2274)



P03 POST - W2A03458
(x2) 6"x6"x89 1/2" (152x152x2274)



GT1 GABLE TRUSS - W2A03460
(x4) 1 3/8"x34"x64 5/8" (36x864x1640)

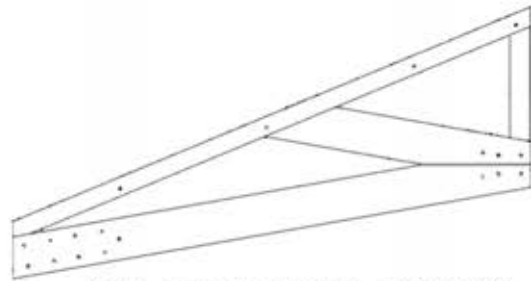

GT2 GABLE TRUSS - W2A03463
(x4) 1 3/8"x34"x64 5/8" (36x864x1640)



CA01 CORBEL WITH TAG - W2A03461
(x1) 1 3/8"x5 1/4"x44 1/16" (36x134x1119)

OWNER'S MANUAL - PARTS IDENTIFICATION

ACCESSORY COMPONENTS (NOT TO SCALE)



A4M00977 POST ANCHORING PLATE
(x12)



A4M00978 POST PLATE
(x12)

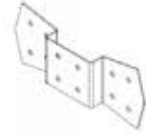

A4M01129 GABLE BRACKET
(x6)

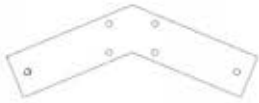

A4M01130 GABLE BRACKET
(x2)



A4M01147 PEAK SEAM BRACKET
(x2)



A4M01148 TRUSS BRACKET
(x4)



A4M01228 RAFTER CLIP
(x20)



A4M01232 LEFT ANGLE BRACKET
(x2)

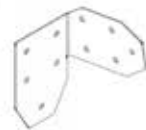

A4M01233 RIGHT ANGLE BRACKET
(x2)

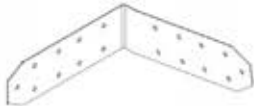

A4M01301 RIGHT OUTSIDE BRACKET
(x2)

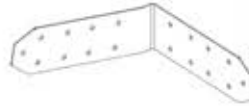

A4M01302 LEFT OUTSIDE BRACKET
(x2)



A4M01510 GABLE TIE BRACKET
(x2)

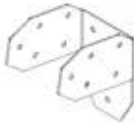

A4M01558 MID POST BRACKET
(x2)



A4M01559 U TIE BRACKET
(x1)

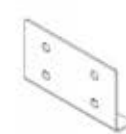

A4M01560 OUTSIDE TIE BRACKET
(x2)

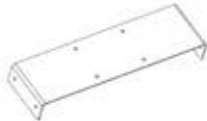

A4M01594 SHEATING BRACKET
(x4)



A4M02158 BYD ID TAG PATIO
(x1)



A4M02501 FAN MOUNT BRACKET
(x1)



A4M02638 ROOF EDGE TRIM SPLICE
(x6)

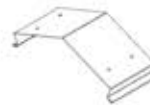

A4M02640 RIDGE CAP SPLICE
(x2)

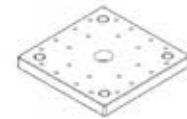

A6P00308 6x6 POST FOOT
(x6)



A6P00398 RIDGE CAP PROTECTOR
(x2)



A6P00514 MID RIDGE CAP PROTECTOR
(x1)

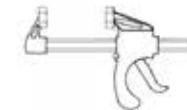

A6P00460 6" QUICK RELEASE
BAR CLAMP
(x4)

OWNER'S MANUAL - PARTS IDENTIFICATION

ACCESSORY COMPONENTS (NOT TO SCALE)

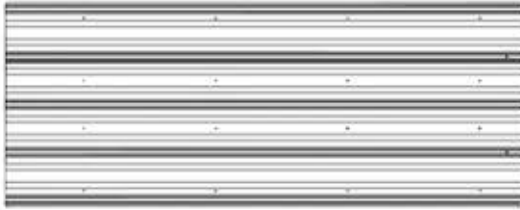

A4M02639 29GA STEEL SHEETING
(x16)

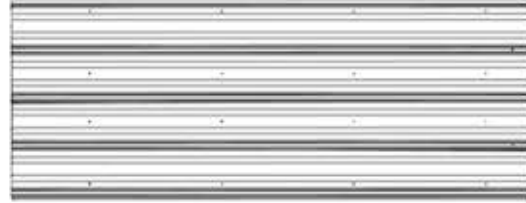

A4M02646 29GA STEEL SHEETING
(x1)

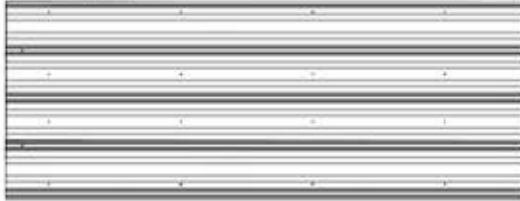

A4M02647 29GA STEEL SHEETING
(x1)

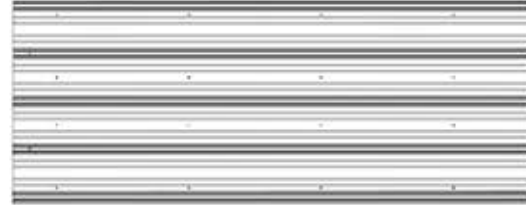

A4M02908 29GA STEEL SHEETING
(x1)

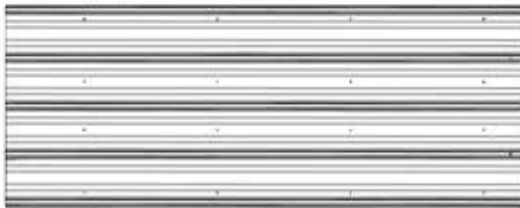

A4M02909 29GA STEEL SHEETING
(x1)



A4M02746 RIDGE CAP 29GA
(x4)



A4M02679 ROOF END TRIM
(x2)



A4M02680 ROOF END TRIM
(x2)



A4M02747 ROOF EDGE TRIM
(x8)



A4M02744 BEAM BRACE METAL
(x4)



A4M02750 RIDGE BRACE METAL
(x2)

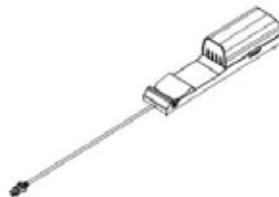

9205413 ELECTRICAL ENCLOSURE
(x1)

OWNER'S MANUAL - PARTS IDENTIFICATION

HARDWARE COMPONENTS

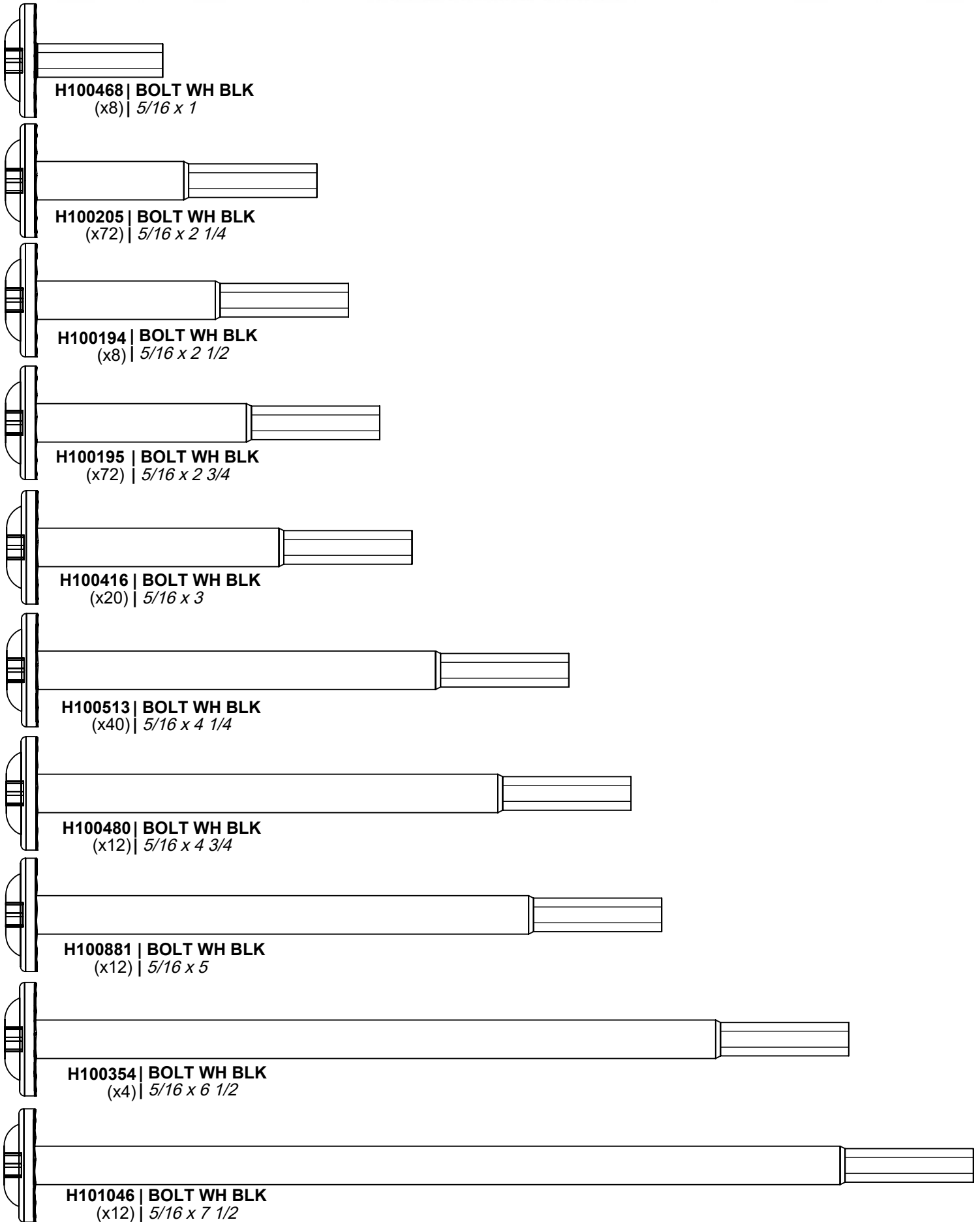

OWNER'S MANUAL - PARTS IDENTIFICATION

HARDWARE COMPONENTS

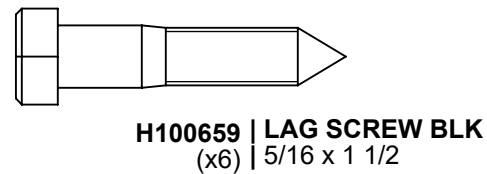
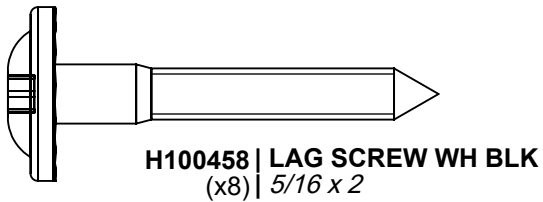
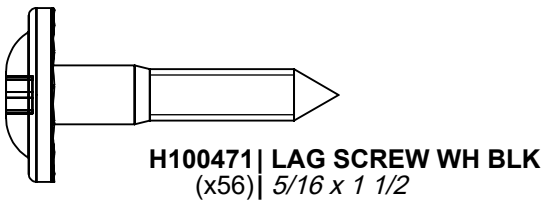
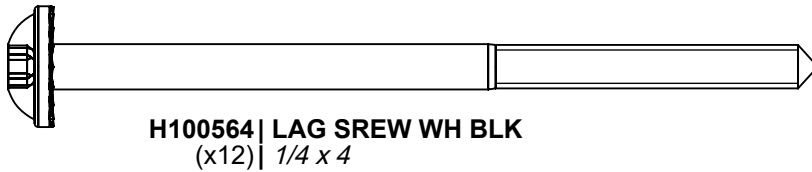
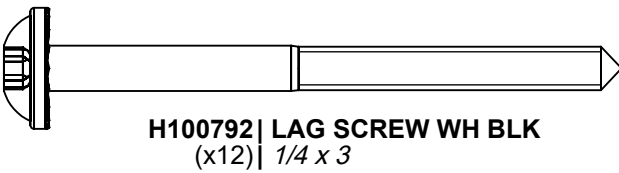
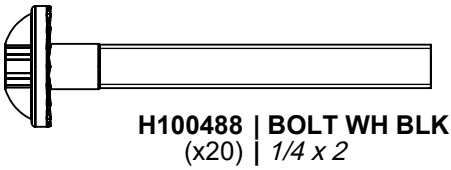
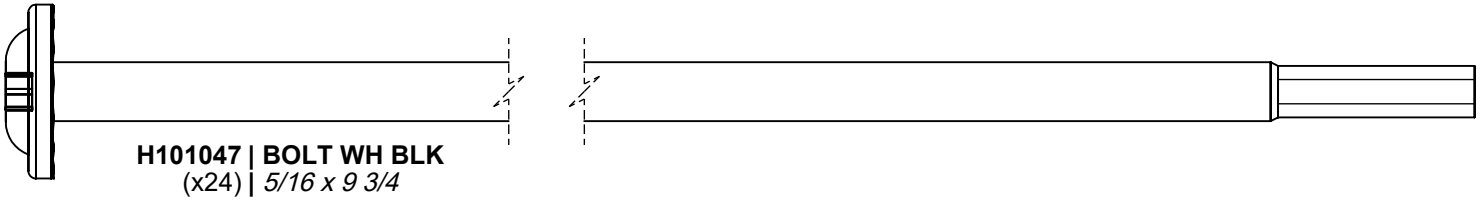
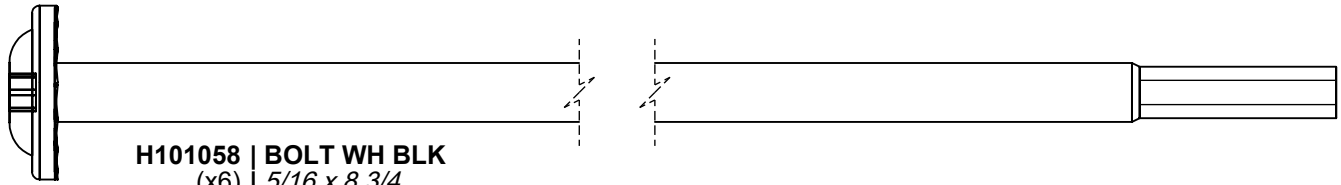

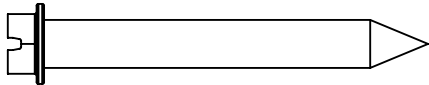

H100120 | CONCRETE ANCHOR
(x24) | 1/4 x 2

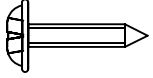

H100202 | SCREW PWH BLK
(x4) | 8 x 5/8

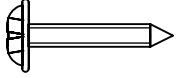

H100392 | SCREW PWH BLK
(x56) | 8 x 3/4

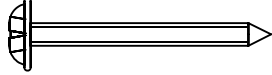

H100536 | SCREW PWH BLK
(x40) | 8 x 1 1/4

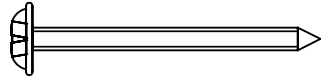

H100823 | SCREW PWH BLK
(x16) | 8 x 1 1/2

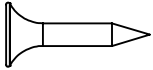

H100395 | SCREW PFH BLK
(x24) | 8 x 3/4

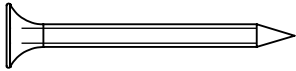

H100200 | SCREW PFH BLK
(x28) | 8 x 1 1/2

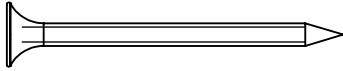

H100382 | SCREW PFH BLK
(x4) | 8 x 1 3/4

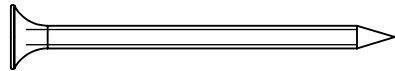

H100391 | SCREW PFH BLK
(x244) | 8 x 2

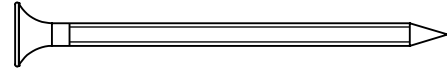

H100483 | SCREW PFH BLK
(x8) | 8 x 2 1/4

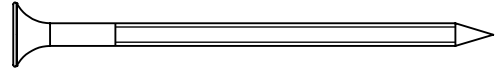

H100201 | SCREW PFH BLK
(x68) | 8 x 2 1/2

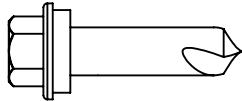

H100759 | SCREW TAPPING
(x40) | 1/4 x 1

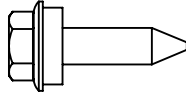

H100833 | SCREW WOODGRIP
(x392) | 10 x 3/4



H100653 | NUT LOCK BLK
(x20) | 1/4



H100479 | NUT LOCK BLK
(x136) | 5/16

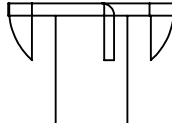

H100379 | T-NUT BLK
(x154) | 5/16

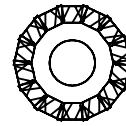

H100405 | WASHER LOCK EXT BLK
(x24) | 6 x 15

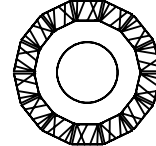

H100198 | WASHER LOCK EXT BLK
(x158) | 8 x 19

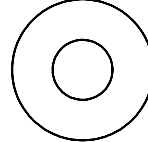

H100630 | WASHER FLAT BLK
(x44) | 8 x 19

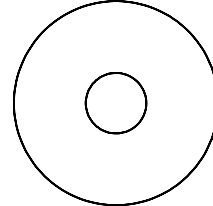

H100478 | WASHER FLAT BLK
(x142) | 8 x 27

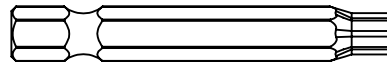

H100147 | TORX BIT
(x1) | T-30

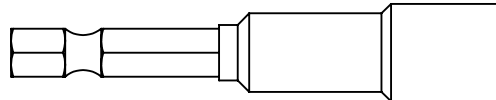

H101106 | SOCKET DRIVER
(x1)

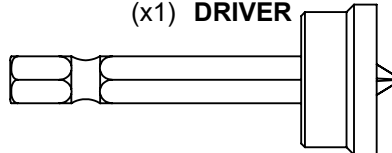

H100764 | SCREW SETTER
(x1)

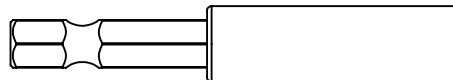

H101100 | MAGNETIC DRIVER
(x1)

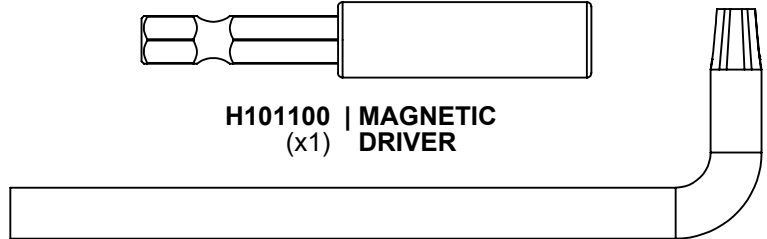

H100114 | TORX WRENCH
(x1) | T-30

PRE-ASSEMBLY STEP 1 - SORTING PARTS

It is critical for ease of assembly that you take the time to sort and organize the wood and hardware.

WOOD PARTS:

- Organize wood parts by the three-digit, alpha-numeric number stamped on each board (ex. P01).
- If there are multiple boards with the same stamped number, stack those pieces together.
- Stamps can be found on the flat surface of the boards or on the end of the boards.
- Allow yourself plenty of room - the wood pieces can take up a significant amount of space.

NOTE: CARTONS ARE NOT ORGANIZED BY BOARD NUMBER.



HARDWARE PARTS:

- We recommend that you have a separate table to organize the hardware.
- Hardware bags are printed with a seven-digit, alpha-numeric part number.
- You can organize your hardware by part number or group by hardware type (i.e. bolts, nuts, etc.).
- During assembly you only need to reference the last four digits of the number.

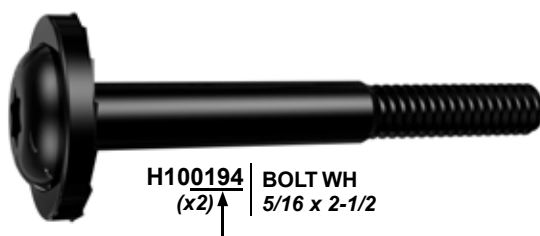

PRE-ASSEMBLY STEP 2 - TOOLS REQUIRED



Cordless Drill
or Electric Drill



Drill
Attachments:
Phillips Head

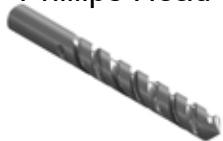

1/8", 3/16", 3/8" &
7/16" Drill Bits



Open End
Wrenches 1/2" &
9/16"



3/8" Drive Ratchet, 1/2" &
7/16" STD Sockets 1/2" & 7/16"
Deep Sockets



Phillips Screw Driver



Claw Hammer



Rubber Mallet
- Optional



Tape Measure

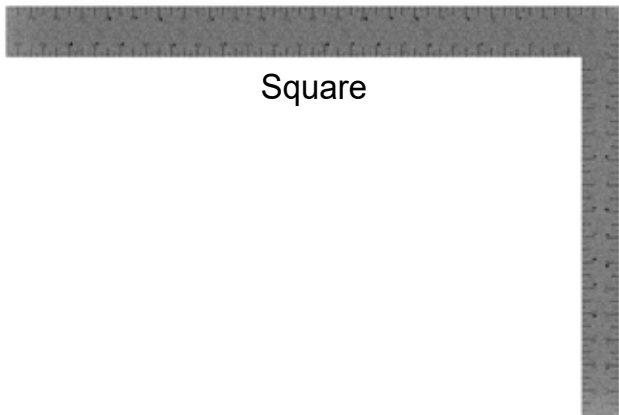

Square



Level 24"

PRE-ASSEMBLY STEP 3 - CHOOSE YOUR ASSEMBLY METHOD

There are several types of assembly instructions available to you.

1. Printed Assembly Manual included with your set
2. BILT APP - 3D interactive instructions
3. Combination of the Printed Manual and BILT APP (Note: Step numbers can differ between the two methods)

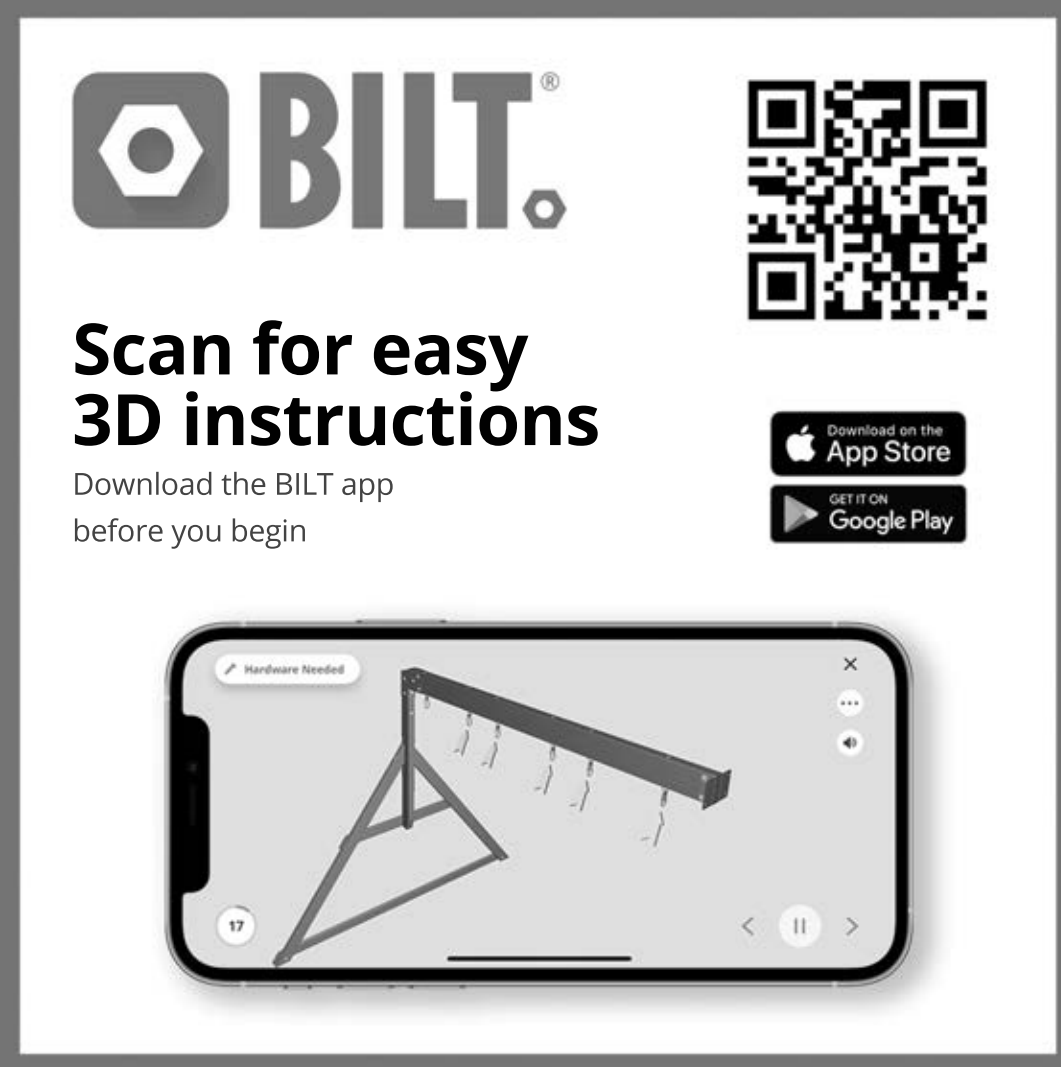

BILT.

**Scan for easy
3D instructions**

Download the BILT app
before you begin

Download on the
App Store

GET IT ON
Google Play

Hardware Needed

17

The advertisement is enclosed in a grey border. It features the BILT logo (a hexagon with a dot inside) and the word "BILT." in a bold, sans-serif font. To the right is a large QR code. Below the QR code are two buttons: "Download on the App Store" with the Apple logo and "GET IT ON Google Play" with the Google Play logo. The central text "Scan for easy 3D instructions" is in a large, bold font. Below it, the text "Download the BILT app before you begin" is in a smaller font. At the bottom, a smartphone is shown displaying a 3D assembly instruction. The instruction shows a metal frame with a horizontal bar and several hanging components. The phone screen has a "Hardware Needed" label at the top left, a close button (X) at the top right, a menu button (three dots) and a volume icon below it, and a page number "17" in a circle at the bottom left. Navigation arrows and a pause button are at the bottom right of the phone screen.

STEP 1 - POST ASSEMBLY

QTY	PART NUMBER	DESCRIPTION
24	H100200	SCREW PFH 8x1 1/2 BLK



P01 POST - W2A03456
(x2) 6"x6"x89 1/2" (152x152x2274)



P02 POST - W2A03457
(x2) 6"x6"x89 1/2" (152x152x2274)



P03 POST - W2A03458
(x2) 6"x6"x89 1/2" (152x152x2274)

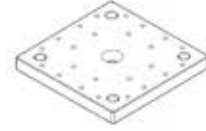

A6P00308 6x6 POST FOOT
(x6)

- FOR EASE OF ASSEMBLY, WE RECOMMEND USING SAWHORSES FOR STEPS 1 - 19

P01 (x2)
POST

P02 (x2)
POST

P03 (x2)
POST

200 (x24)
SCREW - 2"

308 (x6)
6x6 POST FOOT

ALIGN POST FOOT AND DRILL 1/8" (3mm) PILOT HOLES FOR THE ATTACHMENT OF HARDWARE.

STEP 2 - END GABLE ASSEMBLY

QTY	PART NUMBER	DESCRIPTION
2	H100483	SCREW PFH 8x2 1/4 BLK



D01 GABLE BOARD - W4L16415
(x1) 1 3/8"x5 1/4"x24 5/8" (36x134x625)



D05 GABLE BOARD - W4L16753
(x1) 1 3/8"x1 1/2"x5 1/4" (36x38x134)

- ALIGN D05 WITH D01 ENSURING THAT BOTTOM FACES ARE FLUSH.
- DRILL 1/8" (3mm) PILOT HOLES IN D01 USING D05 AS TEMPLATE.

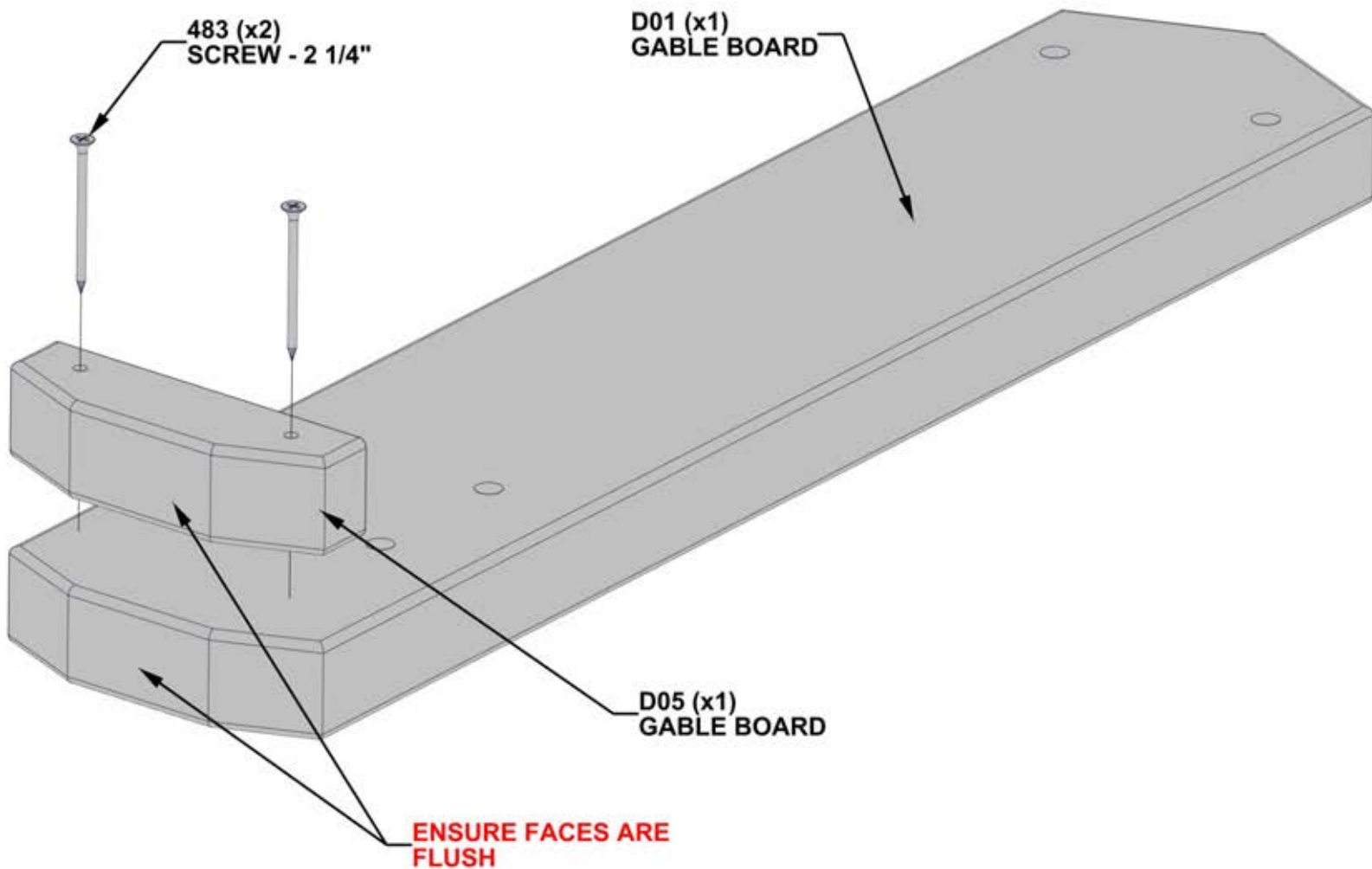

STEP 3 - END GABLE ASSEMBLY

QTY	PART NUMBER	DESCRIPTION
4	H100881	BOLT WH 5/16x5 BLK
4	H100479	NUT LOCK 5/16 BLK
4	H100478	WASHER FLAT 8x27 BLK

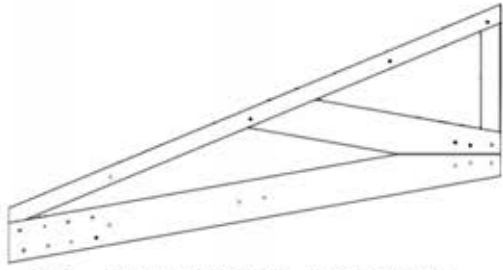

GT1 GABLE TRUSS - W2A03460
(x2) 1 3/8"x34"x64 5/8" (36x864x1640)



D01 GABLE BOARD - W4L16415
(x1) 1 3/8"x5 1/4"x24 5/8" (36x134x625)

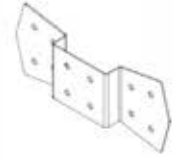

A4M01129 GABLE BRACKET
(x2)

- IF HOLES DO NOT ALIGN, USE THE METAL BRACKET AS A GUIDE AND A 7/16" (10mm) DRILL BIT TO DRILL THROUGH THE BOARDS.

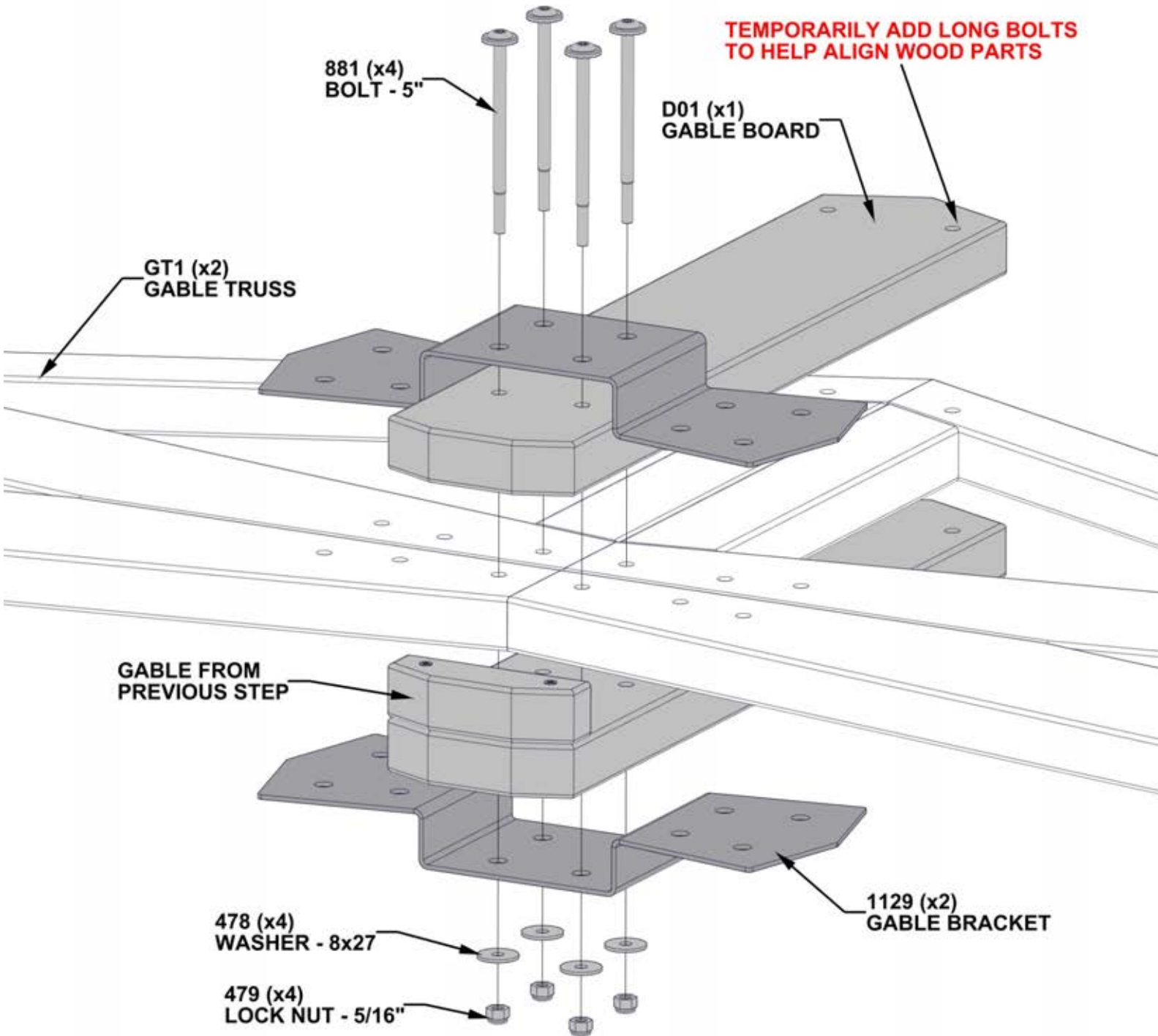

STEP 4 - END GABLE ASSEMBLY

QTY	PART NUMBER	DESCRIPTION
8	H100205	BOLT WH 5/16x2 1/4 BLK
8	H100479	NUT LOCK 5/16 BLK
8	H100478	WASHER FLAT 8x27 BLK

- IF HOLES DO NOT ALIGN, USE THE METAL BRACKET AS A GUIDE AND A 7/16" (10mm) DRILL BIT TO DRILL THROUGH THE BOARDS.

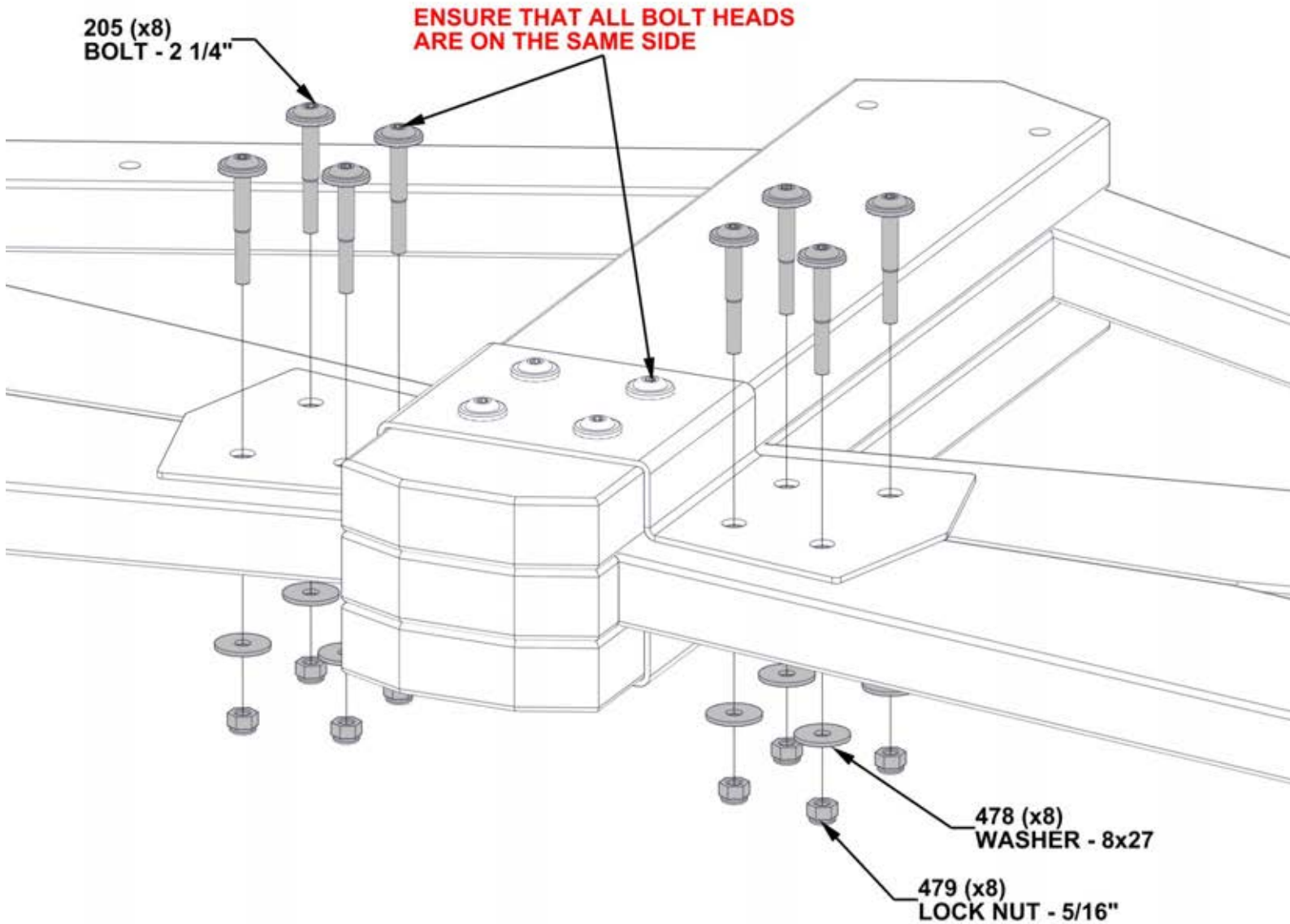

STEP 5A - GABLE ASSEMBLY

QTY	PART NUMBER	DESCRIPTION
1	H100458	LAG SCREW WH 5/16x2 BLK
1	H100659	LAG SCREW HEX 5/16x1 1/2 BLK
3	H101046	BOLT WH 5/16x7 1/2 BLK
4	H101047	BOLT WH 5/16x9 3/4 BLK
5	H100416	BOLT WH 5/16x3 BLK
5	H100205	BOLT WH 5/16x2 1/4 BLK
8	H100379	TNUT-5/16" BLK
9	H100479	NUT LOCK 5/16 BLK
10	H100478	WASHER FLAT 8x27 BLK

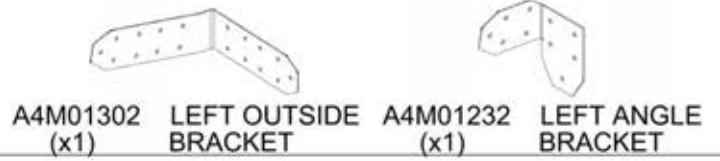
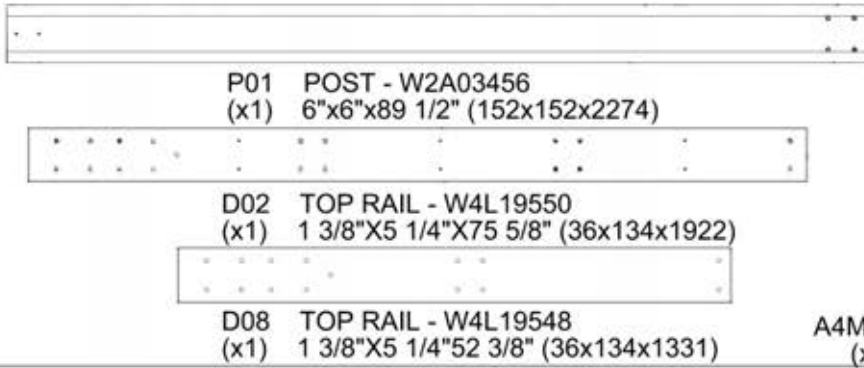

- INSERT T-NUTS FIRST

NOTE PILOT HOLES FOR ORIENTATION

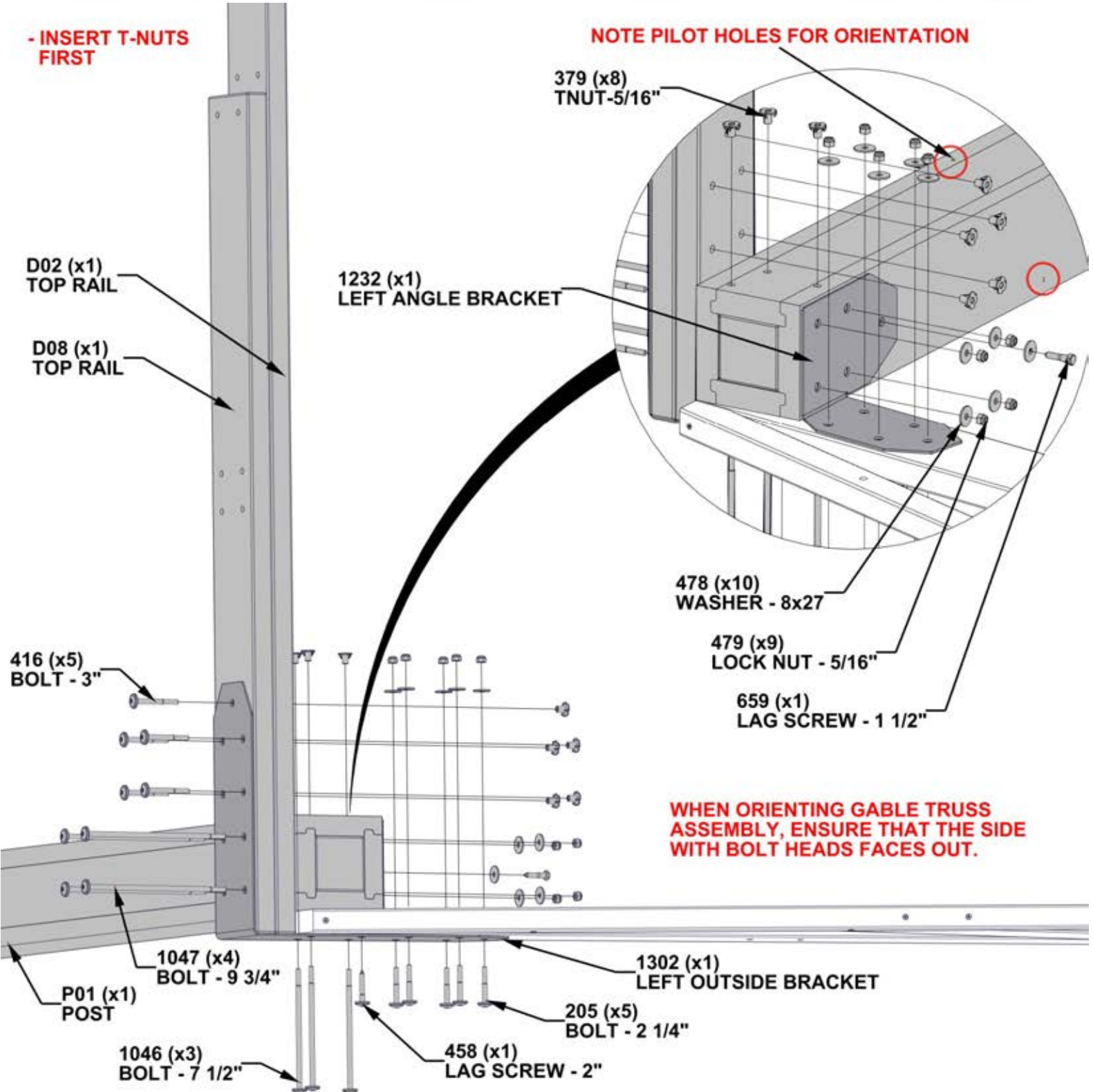

STEP 5B - GABLE ASSEMBLY

QTY	PART NUMBER	DESCRIPTION
1	H100458	LAG SCREW WH 5/16x2 BLK
1	H100659	LAG SCREW HEX 5/16x1 1/2 BLK
3	H101046	BOLT WH 5/16x7 1/2 BLK
4	H101047	BOLT WH 5/16x9 3/4 BLK
5	H100416	BOLT WH 5/16x3 BLK
5	H100205	BOLT WH 5/16x2 1/4 BLK
8	H100379	TNUT-5/16" BLK
9	H100479	NUT LOCK 5/16 BLK
10	H100478	WASHER FLAT 8x27 BLK



P02 POST - W2A03457
(x1) 6"x6"x89 1/2" (152x152x2274)



D02 TOP RAIL - W4L19550
(x1) 1 3/8"x5 1/4"x75 5/8" (36x134x1922)



D08 TOP RAIL - W4L19548
(x1) 1 3/8"x5 1/4"x52 3/8" (36x134x1331)

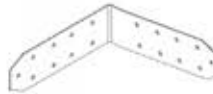

A4M01301 RIGHT OUTSIDE BRACKET
(x1)



A4M01233 RIGHT ANGLE BRACKET
(x1)

- INSERT T-NUTS FIRST

NOTE PILOT HOLES FOR ORIENTATION

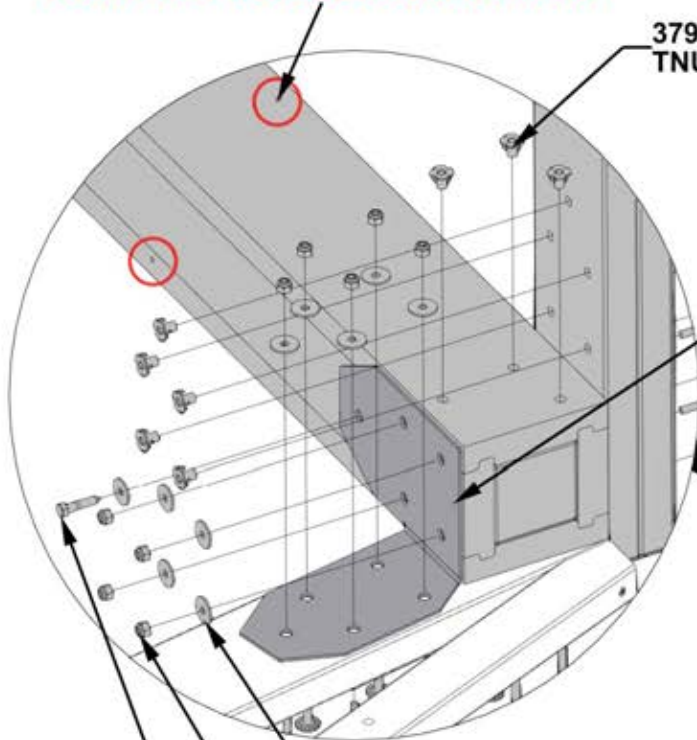

379 (x8)
TNUT-5/16"

1233 (x1)
RIGHT ANGLE BRACKET

478 (x10)
WASHER - 8x27

479 (x9)
LOCK NUT - 5/16"

659 (x1)
LAG SCREW - 1 1/2"

WHEN ORIENTING GABLE TRUSS ASSEMBLY, ENSURE THAT THE SIDE WITH BOLT HEADS FACES OUT.

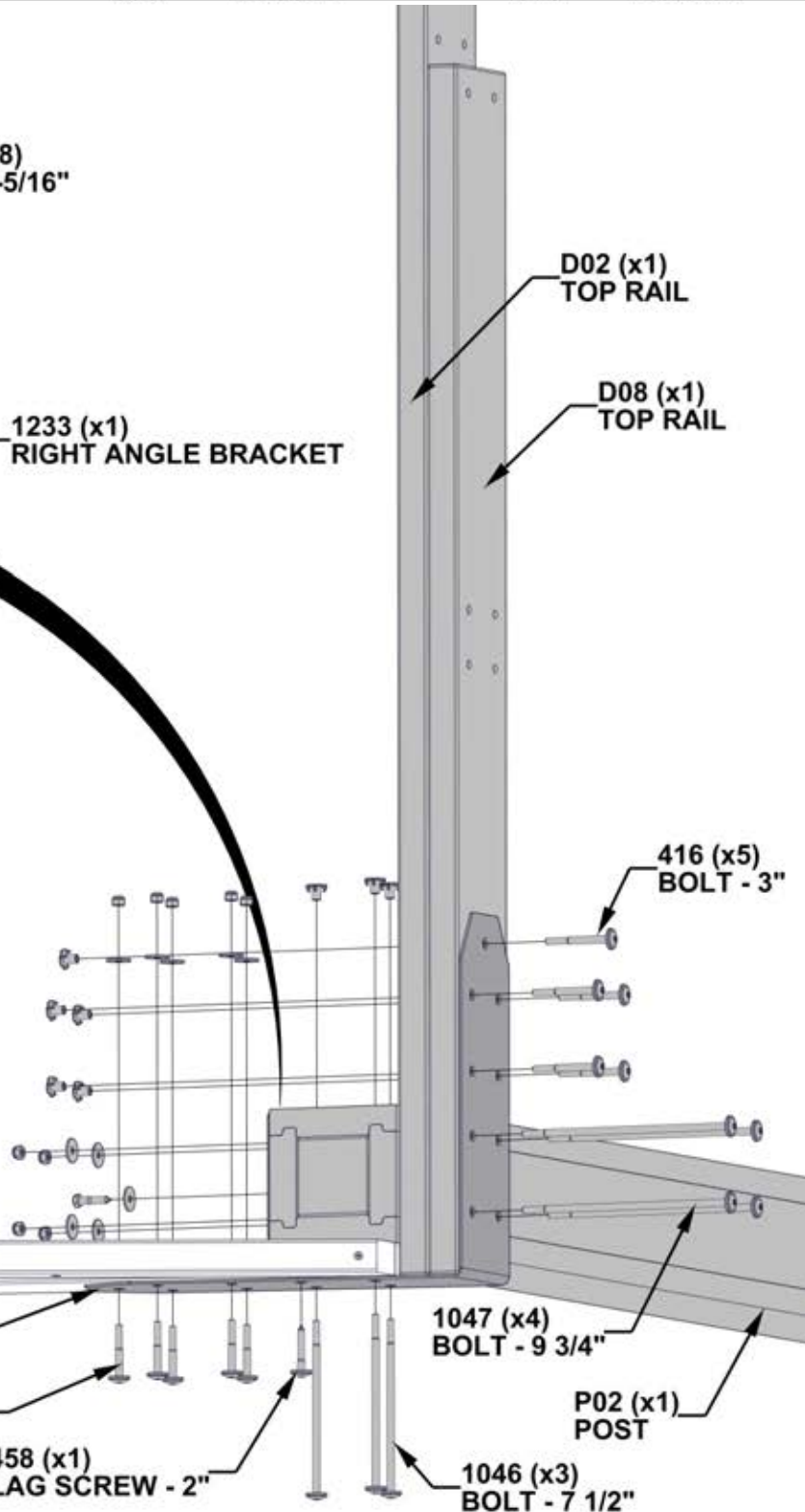

D02 (x1)
TOP RAIL

D08 (x1)
TOP RAIL

416 (x5)
BOLT - 3"

1301 (x1)
RIGHT OUTSIDE BRACKET

1047 (x4)
BOLT - 9 3/4"

205 (x5)
BOLT - 2 1/4"

P02 (x1)
POST

458 (x1)
LAG SCREW - 2"

1046 (x3)
BOLT - 7 1/2"

STEP 6 - GABLE ASSEMBLY

CA01 CORBEL - W2A03461
 (x1) 1 3/8"x5 1/4"x44 1/16" (36x134x1119)

D06 CORBEL - W4L16375
 (x1) 1 3/8"x5 1/4"x44 1/16" (36x134x1119)

QTY	PART NUMBER	DESCRIPTION
2	H100405	WASHER LOCK EXT 6x15
2	H100792	LAG SCREW WH 1/4x3 BLK
4	H100379	TNUT-5/16" BLK
4	H100195	BOLT WH 5/16x2 3/4 BLK
4	H100198	WASHER LOCK EXT 8x19

- WHEN BUILDING THE SECOND END GABLE, TWO D06 CORBELS WILL BE USED.
- INSERT T-NUTS FIRST

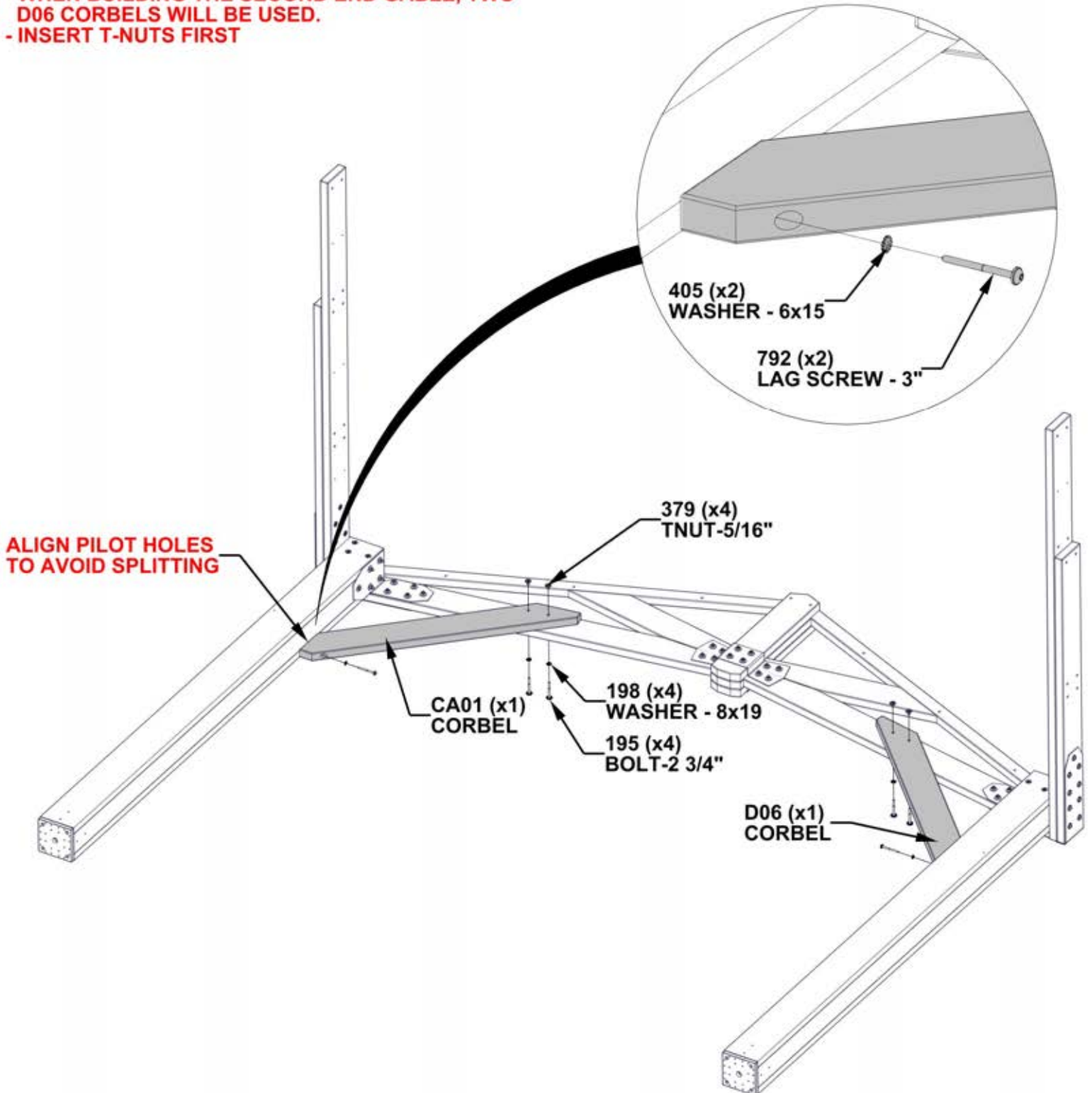

STEP 7 - GABLE ASSEMBLY



D04 CORBEL - W4L16944
(x2) 1 3/8"x5 1/4"x34 7/16" (36x134x875)

QTY	PART NUMBER	DESCRIPTION
2	H100792	LAG SCREW WH 1/4x3 BLK
2	H100405	WASHER LOCK EXT 6x15
8	H100513	BOLT WH 5/16x4 1/4 BLK
8	H100198	WASHER LOCK EXT 8x19
8	H100379	TNUT-5/16" BLK

- INSERT T-NUTS FIRST

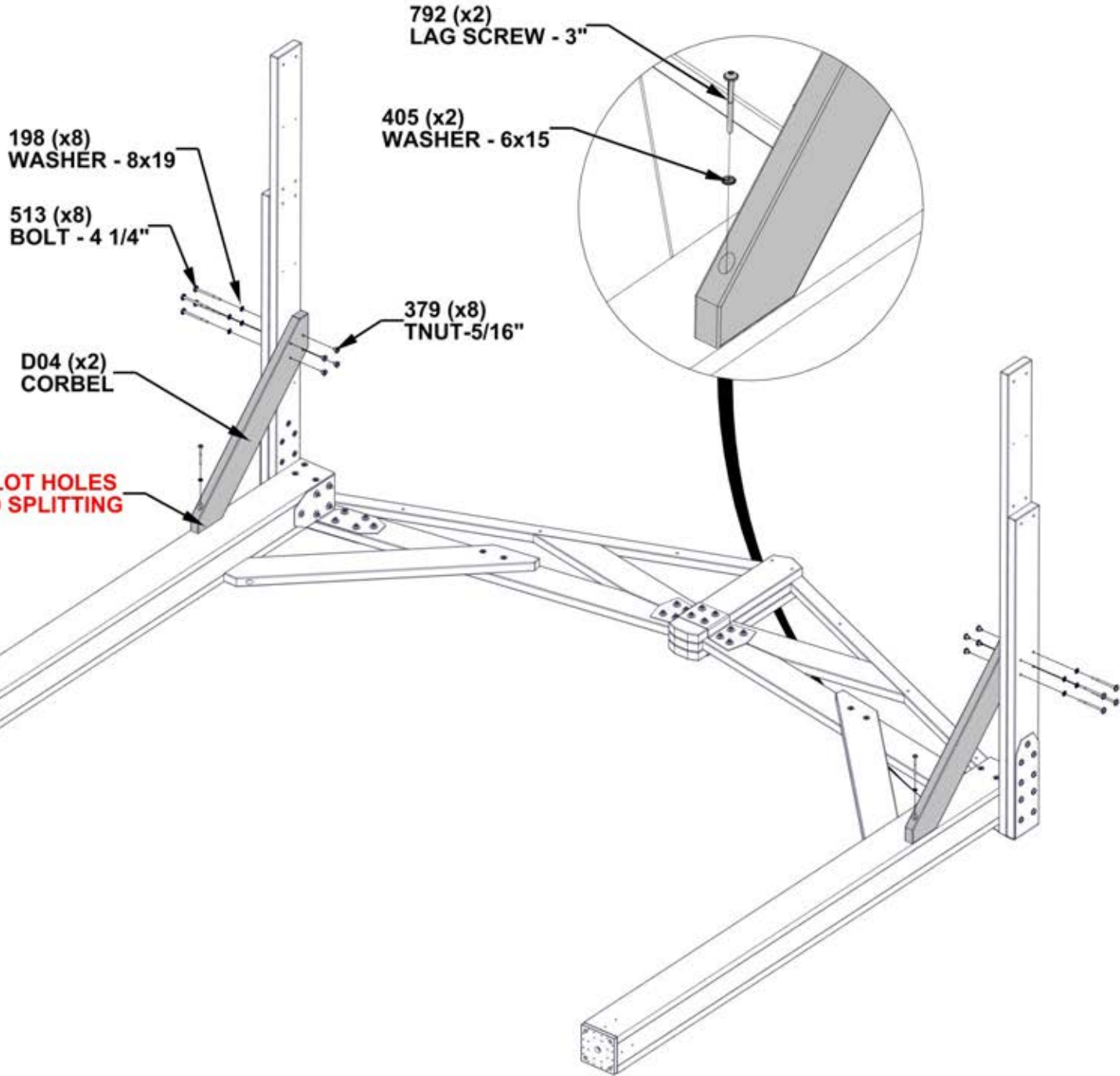

STEP 8 - GABLE ASSEMBLY

QTY	PART NUMBER	DESCRIPTION
4	H100195	BOLT WH 5/16x2 3/4 BLK
4	H100198	WASHER LOCK EXT 8x19
12	H100379	TNUT-5/16" BLK



A4M02744 BEAM BRACE METAL
(x2)

- ATTACH 2744 BRACE BY SLIDING IN BETWEEN BOARDS TO THE FIRST SET OF BOLT HOLES.

- INSERT T-NUTS FIRST

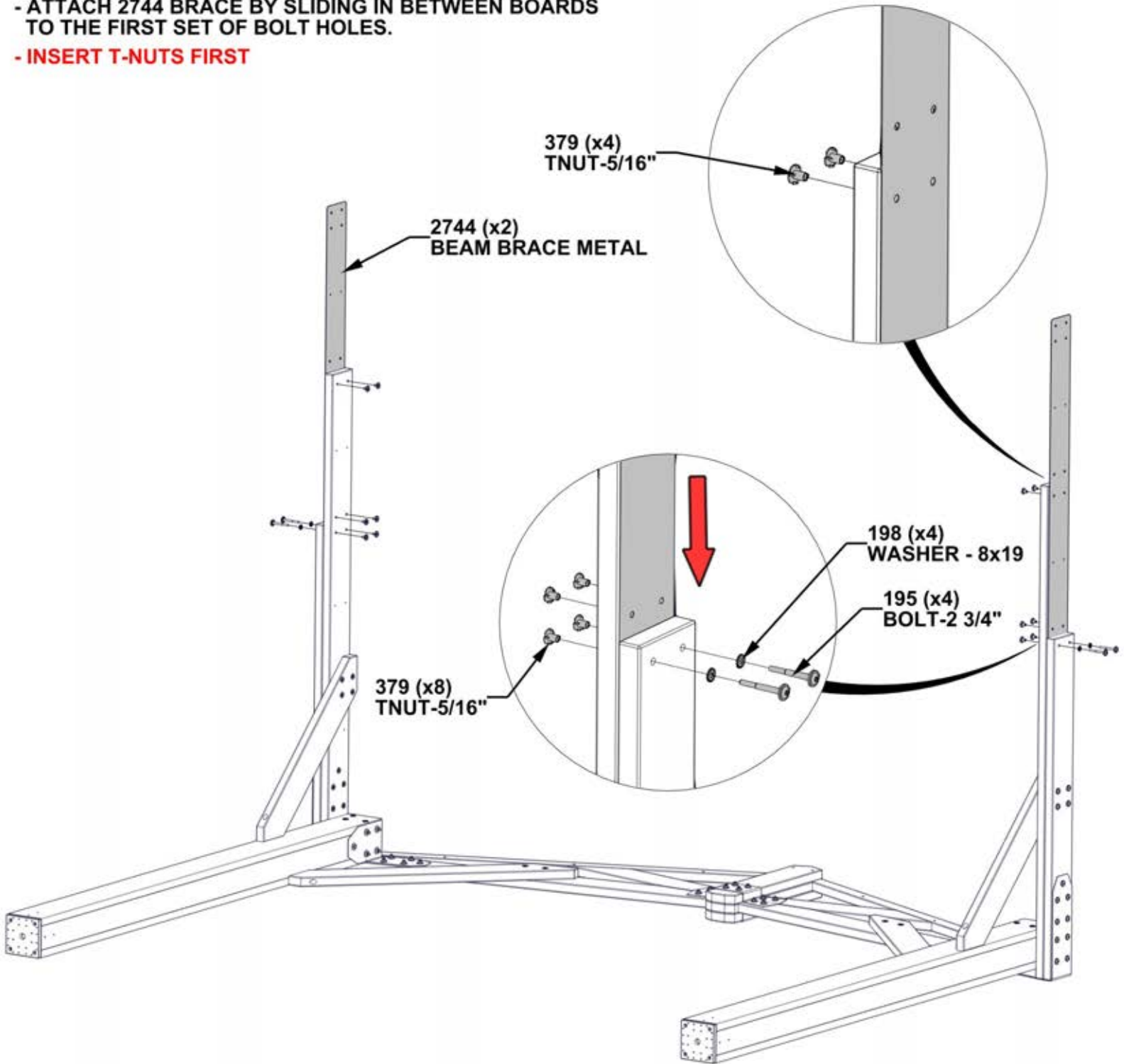

STEP 9 - GABLE ASSEMBLY

QTY	PART NUMBER	DESCRIPTION
8	H100195	BOLT WH 5/16x2 3/4 BLK
8	H100198	WASHER LOCK EXT 8x19



D03 TOP RAIL - W4L19535
(x2) 1 3/8"X5 1/4"X46 9/16" (36x134x1182)

- ATTACH D03 BOARDS TO OUTSIDE OF BEAMS.

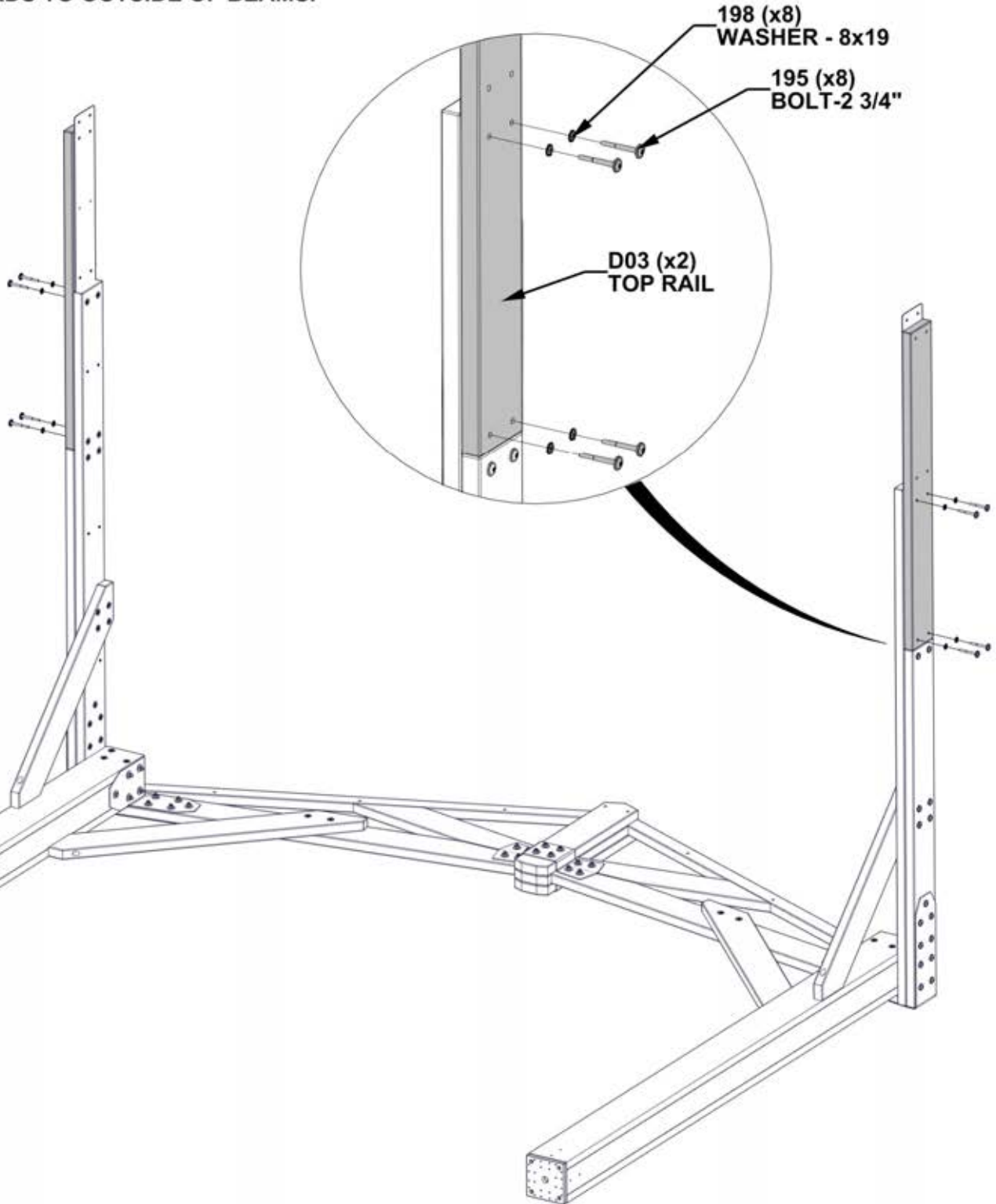

STEP 10 - GABLE ASSEMBLY

QTY	PART NUMBER	DESCRIPTION
12	H100201	SCREW PFH 8x2 1/2 BLK

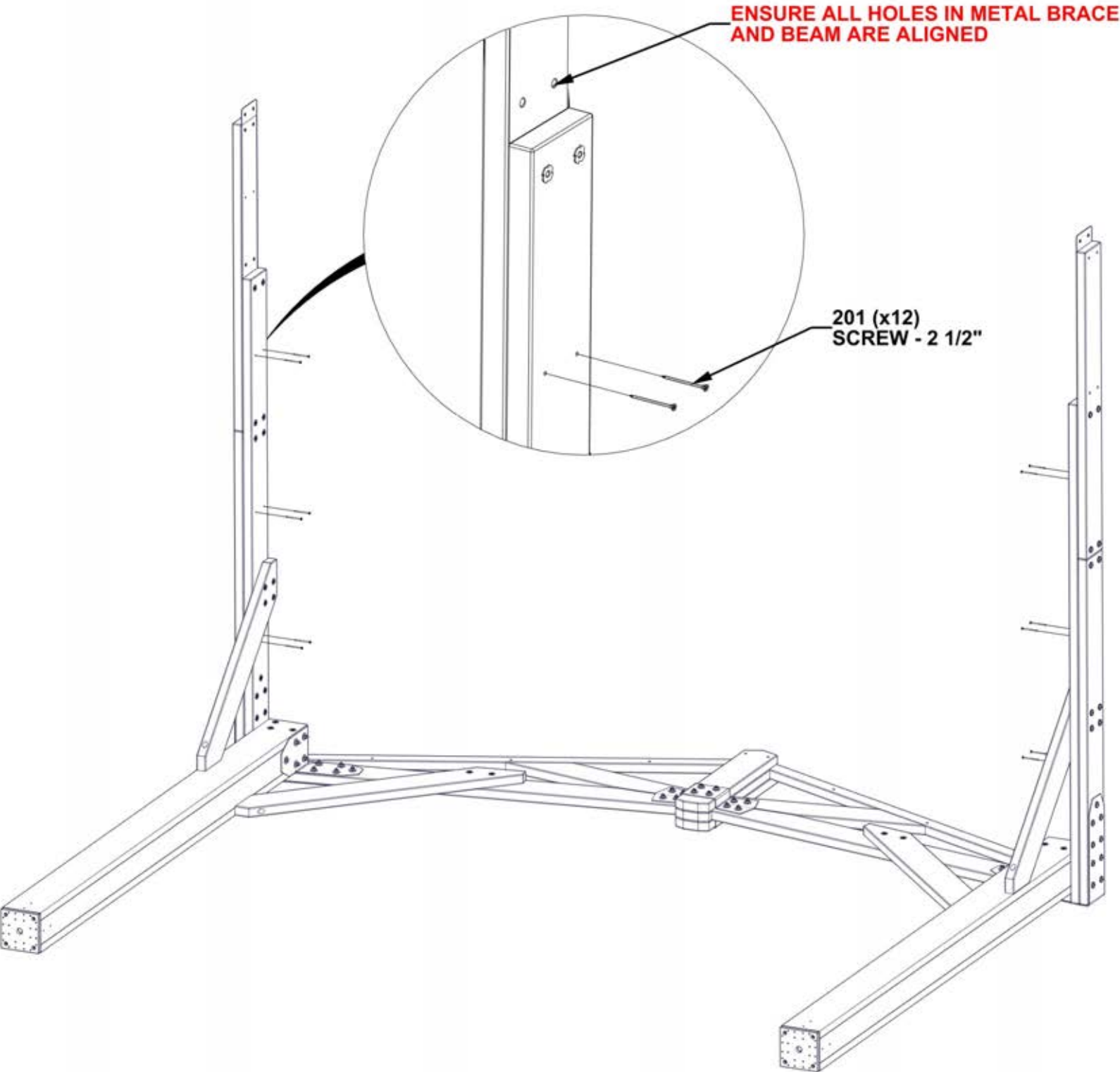

**SET GABLE END ASIDE AND
REPEAT STEPS 2 THROUGH 10**

STEP 11 - CENTER GABLE ASSEMBLY

QTY	PART NUMBER	DESCRIPTION
4	H100483	SCREW PFH 8x2 1/4 BLK



D01 GABLE BOARD - W4L16415
(x2) 1 3/8"x5 1/4"x24 5/8" (36x134x625)



D05 GABLE BOARD - W4L16753
(x2) 1 3/8"x1 1/2"x5 1/4" (36x38x134)

COMPLETE THIS STEP TWICE

- ALIGN D05 WITH D01 ENSURING THAT BOTTOM FACES ARE FLUSH.
- DRILL 1/8" (3mm) PILOT HOLES IN D01 USING D05 AS TEMPLATE.

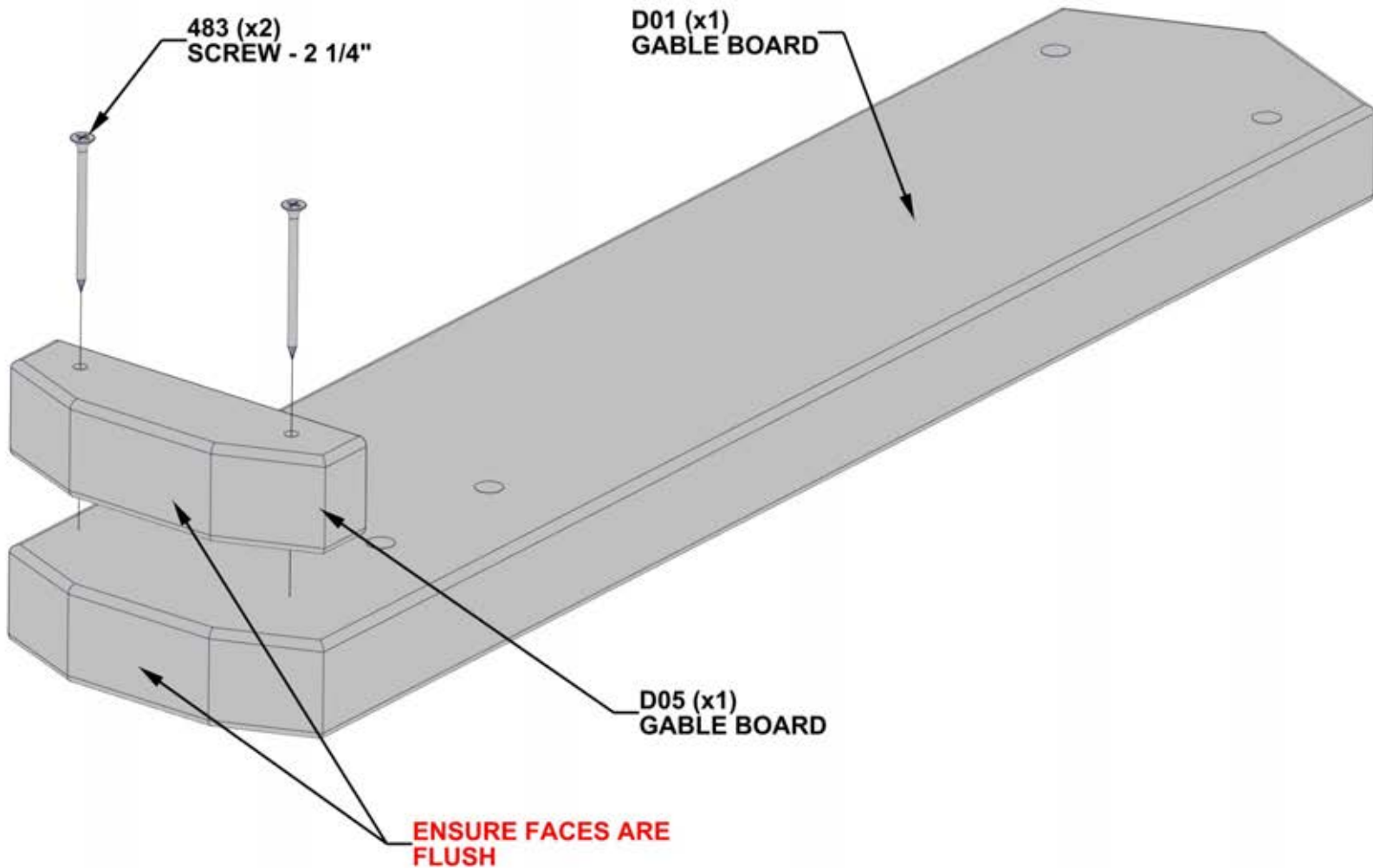

STEP 12 - CENTER GABLE ASSEMBLY

QTY	PART NUMBER	DESCRIPTION
4	H100379	TNUT-5/16" BLK
4	H100513	BOLT WH 5/16x4 1/4 BLK

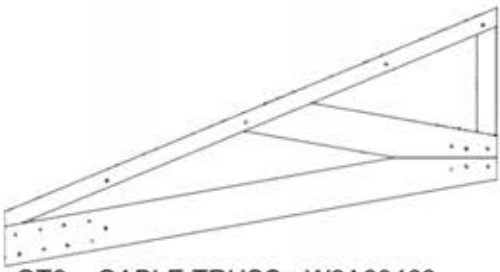

GT2 GABLE TRUSS - W2A03463
(x2) 1 3/8"x34"x64 5/8" (36x864x1640)



D01 GABLE BOARD - W4L16415
(x1) 1 3/8"x5 1/4"x24 5/8" (36x134x625)



A4M01129 GABLE BRACKET
(x1)

- IF HOLES DO NOT ALIGN, USE THE METAL BRACKET AS A GUIDE AND A 7/16" (10mm) DRILL BIT TO DRILL THROUGH THE BOARDS.

- INSERT T-NUTS FIRST

TEMPORARILY ADD LONG BOLTS TO HELP ALIGN WOOD PARTS

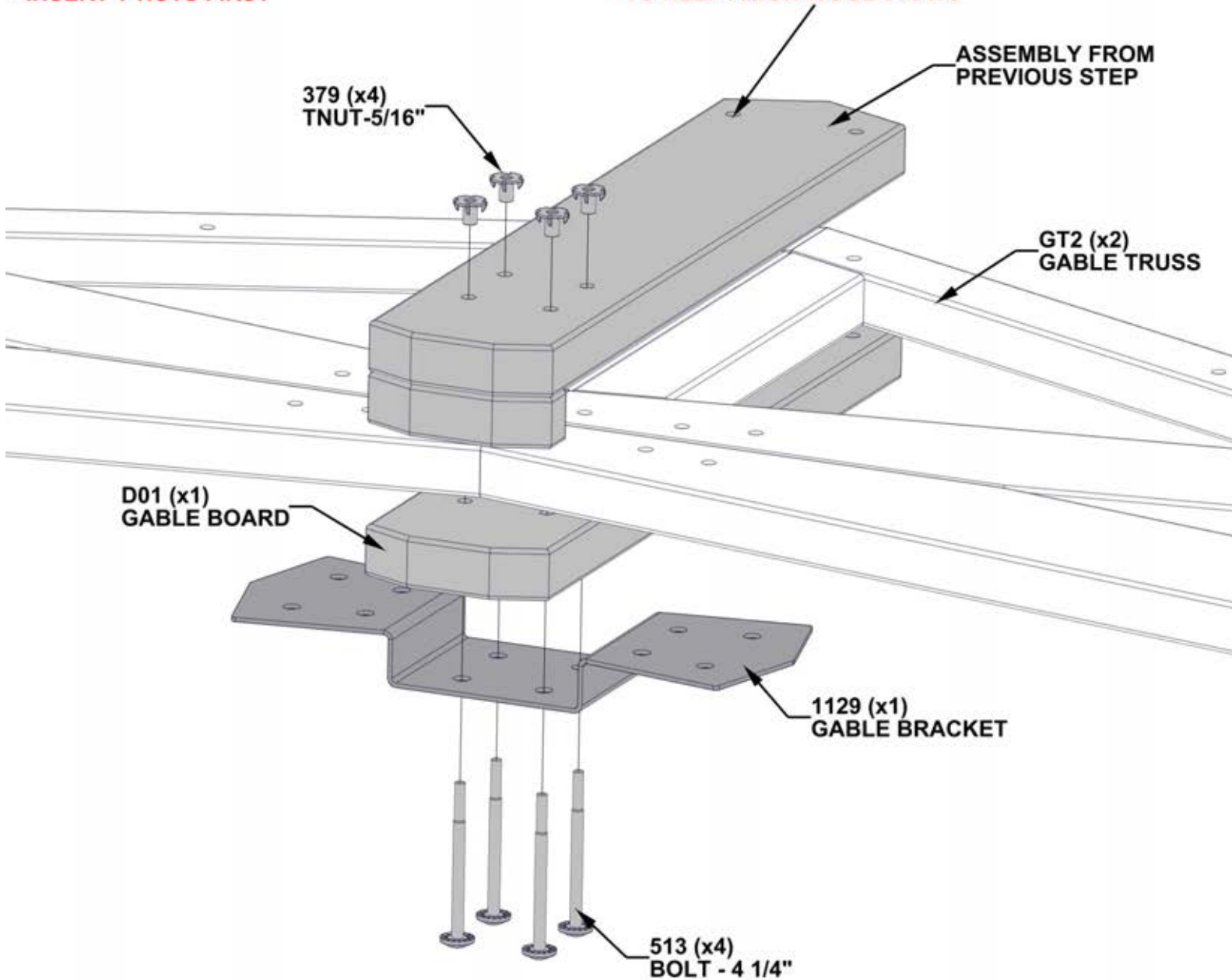

STEP 13 - CENTER GABLE ASSEMBLY

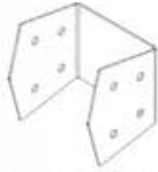

A4M01510 GABLE TIE BRACKET
(x2)

QTY	PART NUMBER	DESCRIPTION
8	H100479	NUT LOCK 5/16 BLK
8	H100478	WASHER FLAT 8x27 BLK
8	H100205	BOLT WH 5/16x2 1/4 BLK

- ENSURE THAT ALL BOLT HEADS ARE ON THE SAME SIDE.

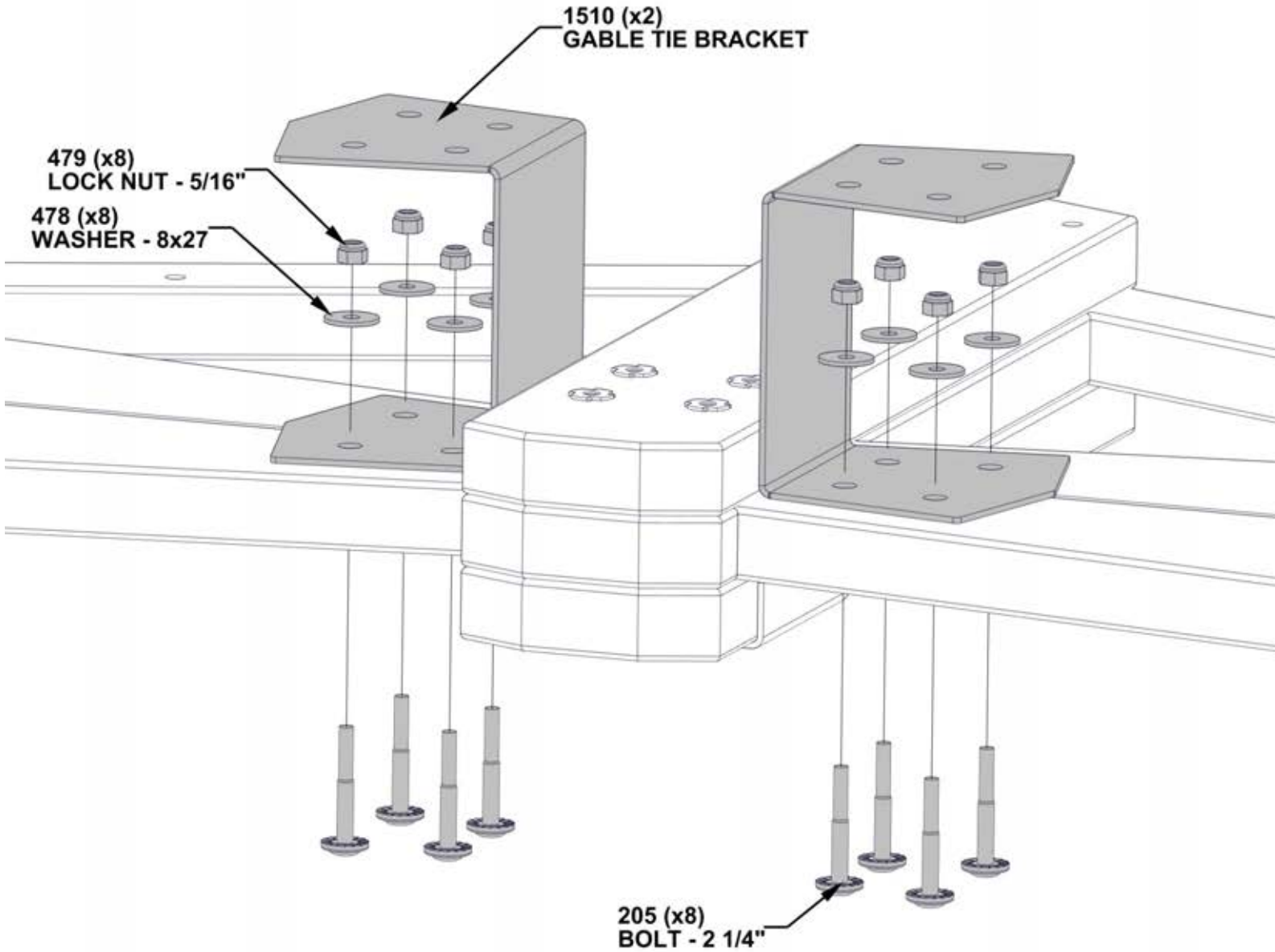

STEP 14 - CENTER GABLE ASSEMBLY

QTY	PART NUMBER	DESCRIPTION
4	H100379	TNUT-5/16" BLK
4	H100513	BOLT WH 5/16x4 1/4 BLK



GT2 GABLE TRUSS - W2A03463
(x2) 1 3/8"x34"x64 5/8" (36x864x1640)



D01 GABLE BOARD - W4L16415
(x1) 1 3/8"x5 1/4"x24 5/8" (36x134x625)

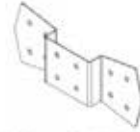

A4M01129 GABLE BRACKET
(x1)

- IF HOLES DO NOT ALIGN, USE THE METAL BRACKET AS A GUIDE AND A 7/16" (10mm) DRILL BIT TO DRILL THROUGH THE BOARDS.

- INSERT T-NUTS FIRST

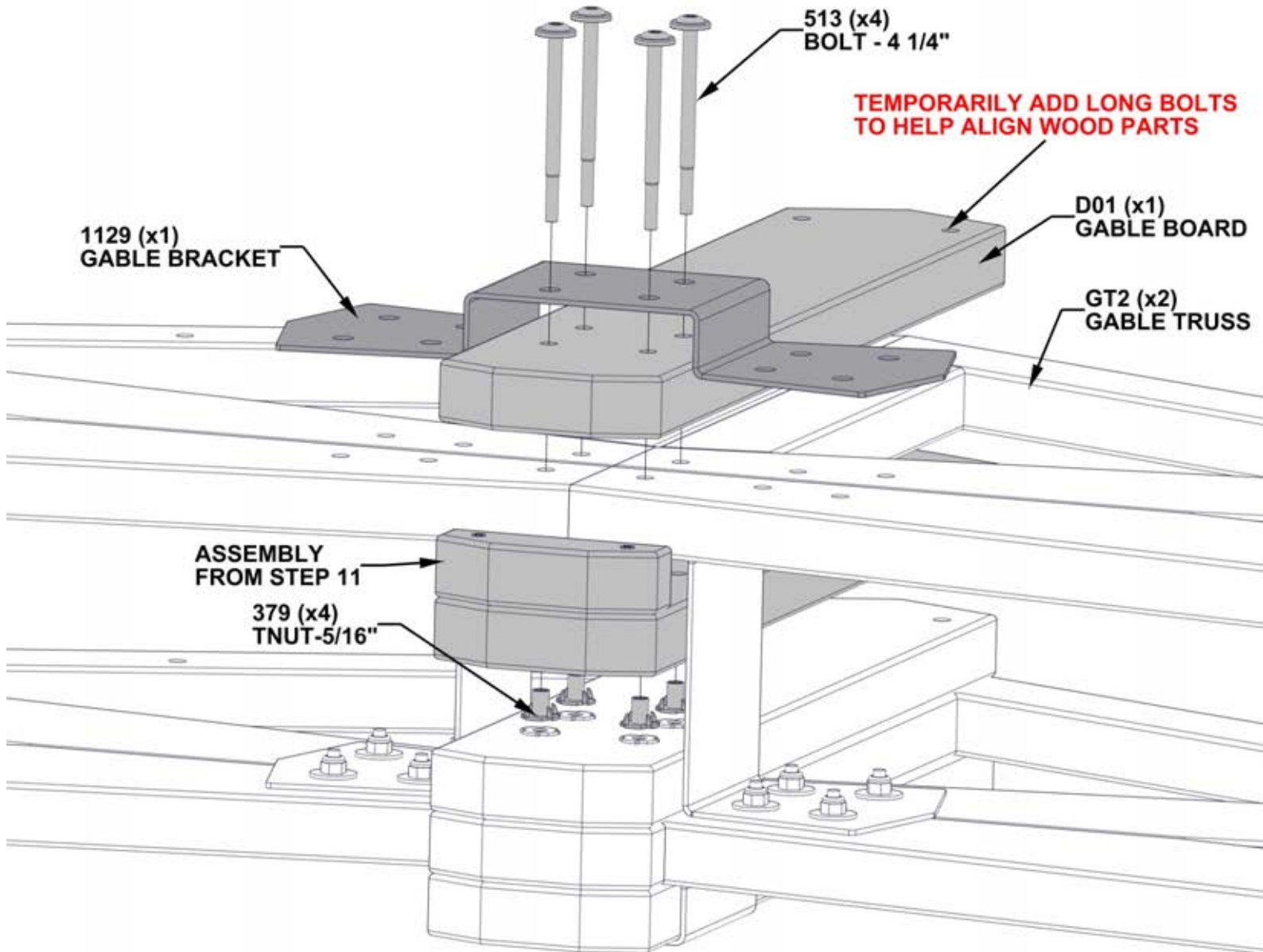

STEP 15 - CENTER GABLE ASSEMBLY

QTY	PART NUMBER	DESCRIPTION
8	H100205	BOLT WH 5/16x2 1/4 BLK
8	H100479	NUT LOCK 5/16 BLK
8	H100478	WASHER FLAT 8x27 BLK

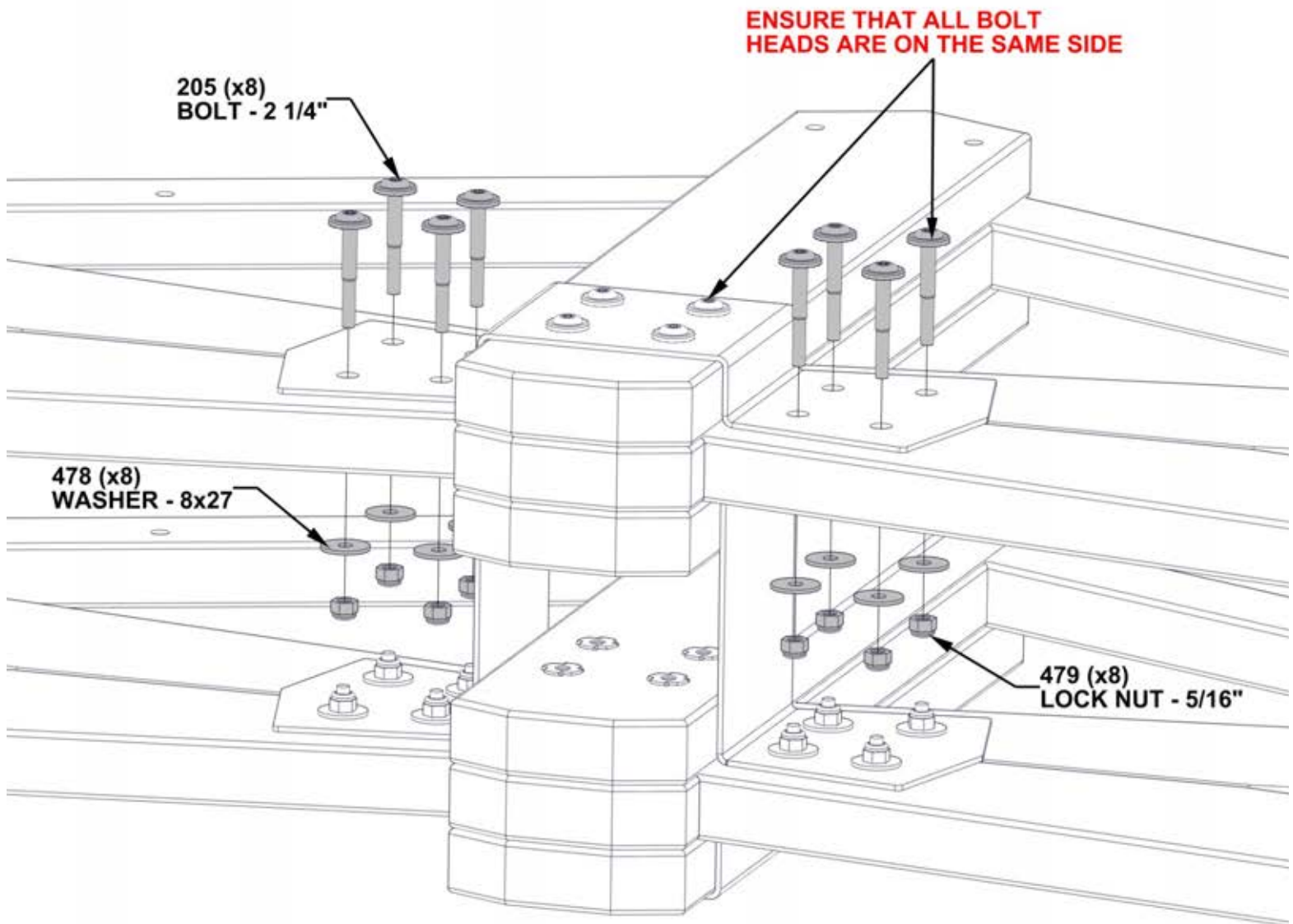

STEP 16 - CENTER GABLE ASSEMBLY



P03 POST - W2A03458
(x2) 6"x6"x89 1/2" (152x152x2274)

QTY	PART NUMBER	DESCRIPTION
4	H100458	LAG SCREW WH 5/16x2 BLK
6	H100379	TNUT-5/16" BLK
6	H101058	BOLT WH 5/16x8 3/4 BLK
10	H100198	WASHER LOCK EXT 8x19

- INSERT T-NUTS FIRST

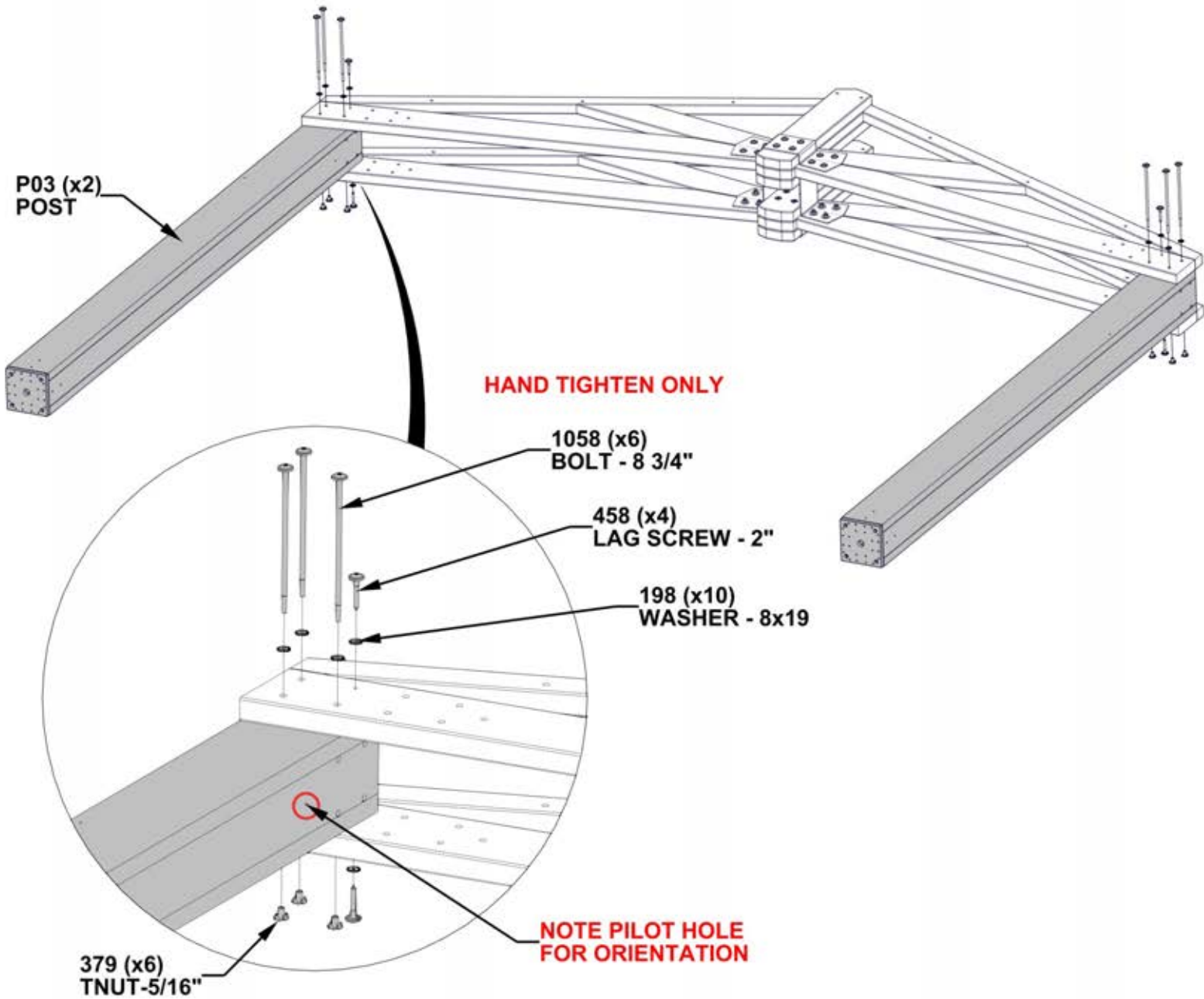

STEP 17 - CENTER GABLE ASSEMBLY



A4M01558 MID POST BRACKET
(x2)

QTY	PART NUMBER	DESCRIPTION
20	H100198	WASHER LOCK EXT 8x19
20	H100205	BOLT WH 5/16x2 1/4 BLK
20	H100478	WASHER FLAT 8x27 BLK
20	H100479	NUT LOCK 5/16 BLK

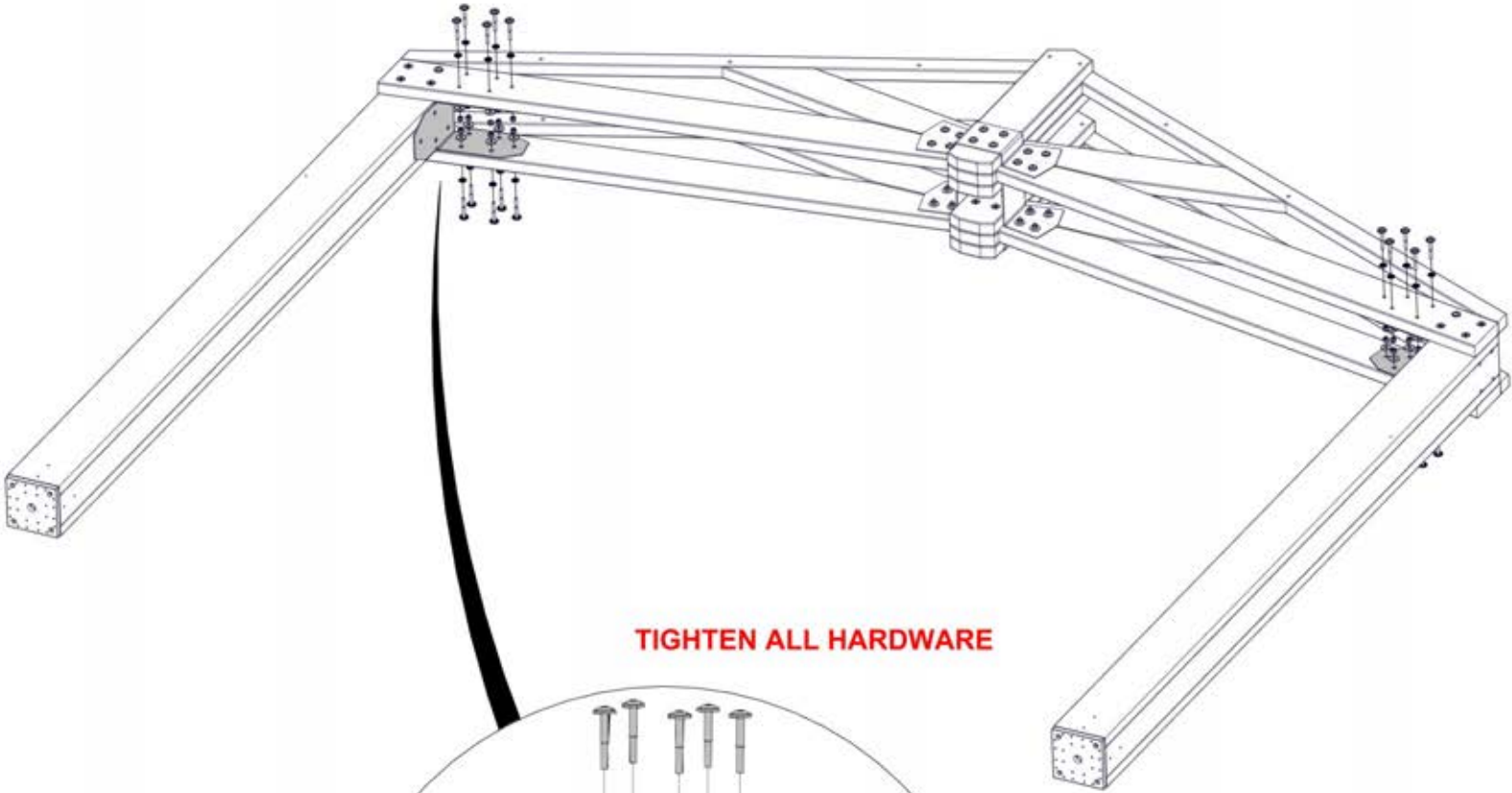

TIGHTEN ALL HARDWARE

1558 (x2)
MID POST
BRACKET

479 (x20)
LOCK NUT - 5/16"

478 (x20)
WASHER - 8x27

198 (x20)
WASHER - 8x19

205 (x20)
BOLT - 2 1/4"

STEP 18 - MIDDLE BEAM ASSEMBLY

QTY	PART NUMBER	DESCRIPTION
16	H100513	BOLT WH 5/16x4 1/4 BLK
16	H100198	WASHER LOCK EXT 8x19
40	H100379	TNUT-5/16" BLK



D07 TOP RAIL - W4L19536
(x4) 1 3/8"X5 1/4"X67 1/2" (36x134x1716)



D09 TOP RAIL - W4L19549
(x2) 1 3/8"X5 1/4"X88 9/16" (36x134x2250)



D04 CORBEL - W4L16944
(x4) 1 3/8"x5 1/4"x34 7/16" (36x134x875)

COMPLETE THIS STEP TWICE

- INSERT T-NUTS FIRST

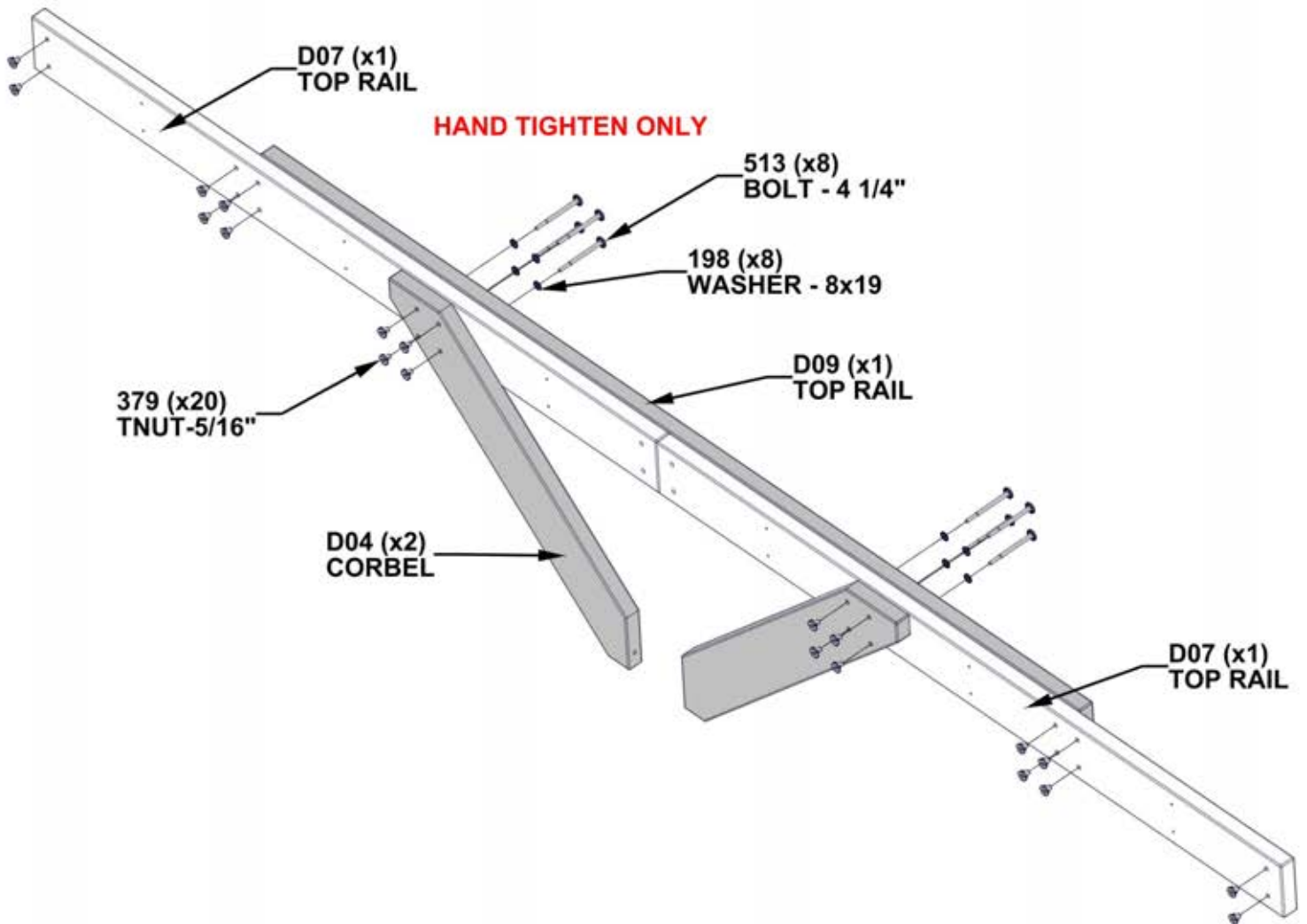

STEP 19 - MIDDLE BEAM ASSEMBLY

QTY	PART NUMBER	DESCRIPTION
16	H100201	SCREW PFH 8x2 1/2 BLK

COMPLETE THIS STEP TWICE

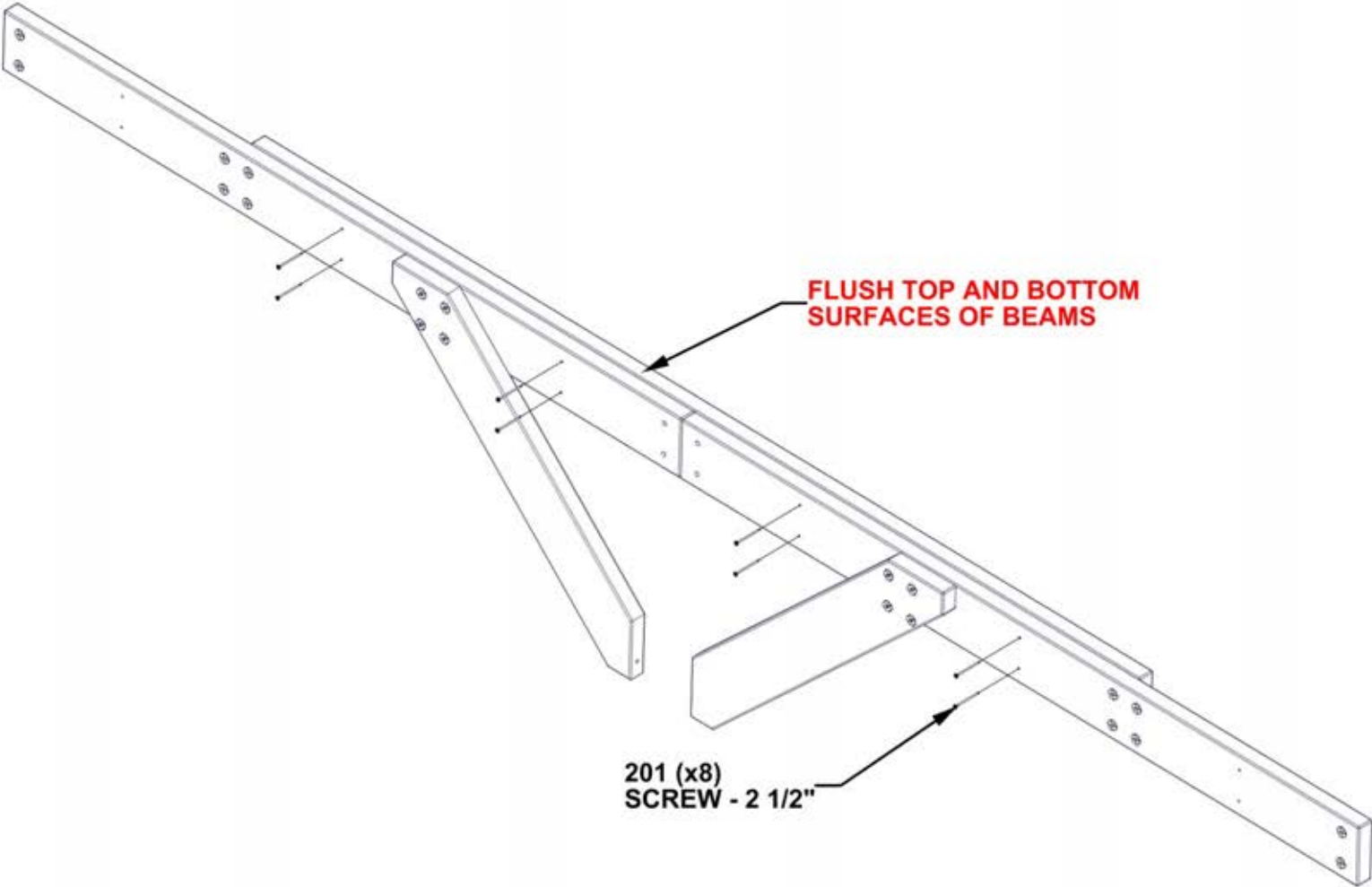

STEP 20 - GAZEBO ASSEMBLY

QTY	PART NUMBER	DESCRIPTION
1	H100659	LAG SCREW HEX 5/16x1 1/2 BLK
2	H100792	LAG SCREW WH 1/4x3 BLK
2	H100405	WASHER LOCK EXT 6x15
4	H101047	BOLT WH 5/16x9 3/4 BLK
4	H100198	WASHER LOCK EXT 8x19
4	H100479	NUT LOCK 5/16 BLK
5	H100478	WASHER FLAT 8x27 BLK



GABLE ASSEMBLY FROM STEP 17

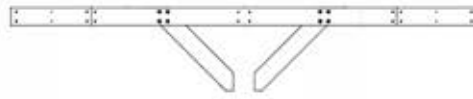

GABLE ASSEMBLY FROM STEP 19

- ADDITIONAL PEOPLE ARE HELPFUL FOR THIS STEP.
- HOLD GABLE ASSEMBLY UPRIGHT AND ATTACH BEAM ASSEMBLY.

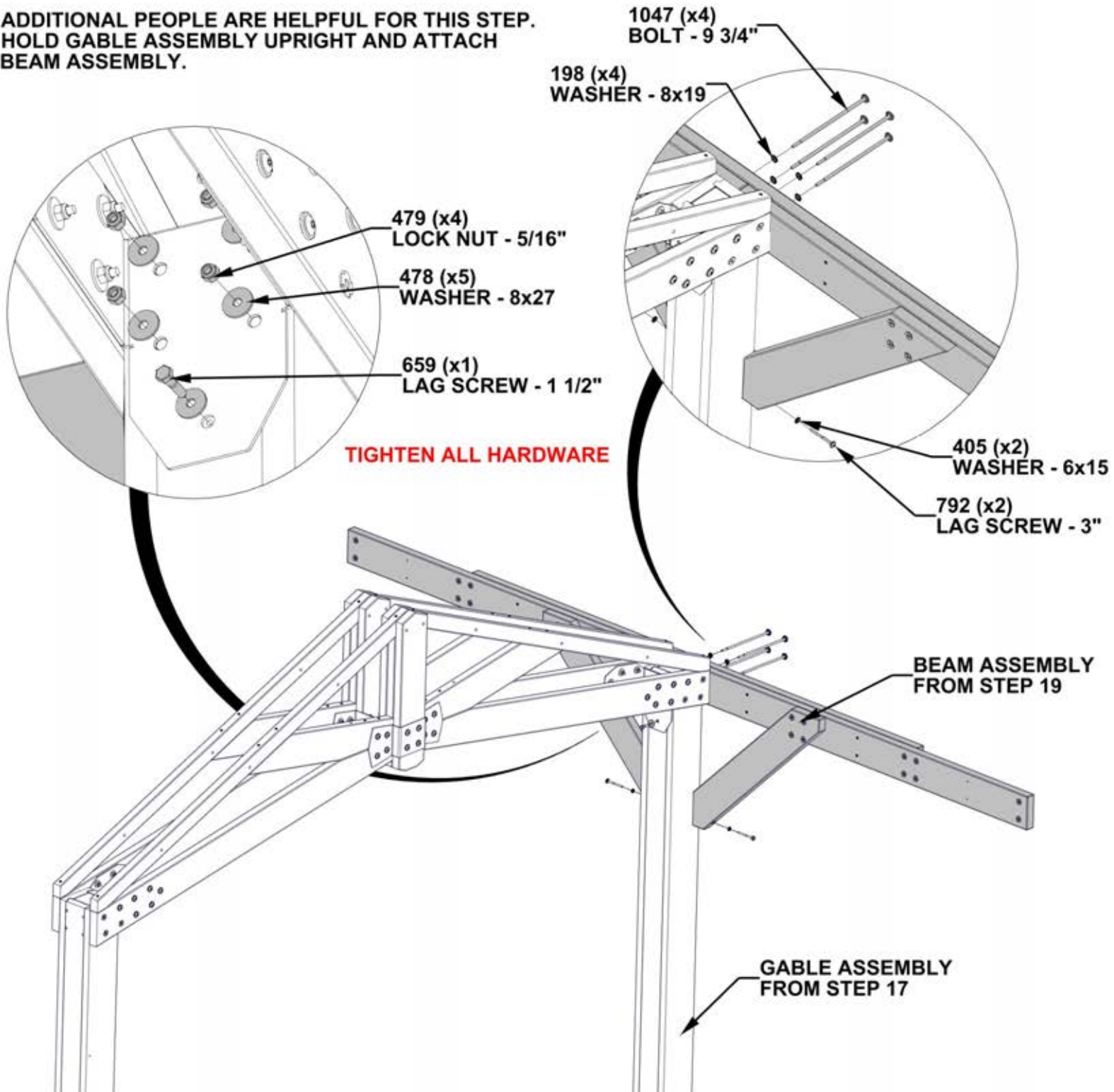

STEP 21 - GAZEBO ASSEMBLY



H08 NOTCHED SUPPORT BOARD - W4L16915
(x2) 1"X3 3/8"X89 1/2" (24x86x2274)

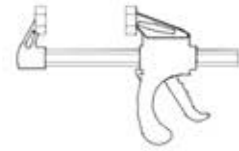

A6P00460 6" QUICK RELEASE
(x2) BAR CLAMP

- ADDITIONAL PEOPLE ARE HELPFUL FOR THIS STEP.
- USING THE INCLUDED CLAMP AND THE H08 BOARDS, SECURE CLAMPS AS SHOWN TO SUPPORT CENTER GABLE AND SIDE BEAM ASSEMBLY.

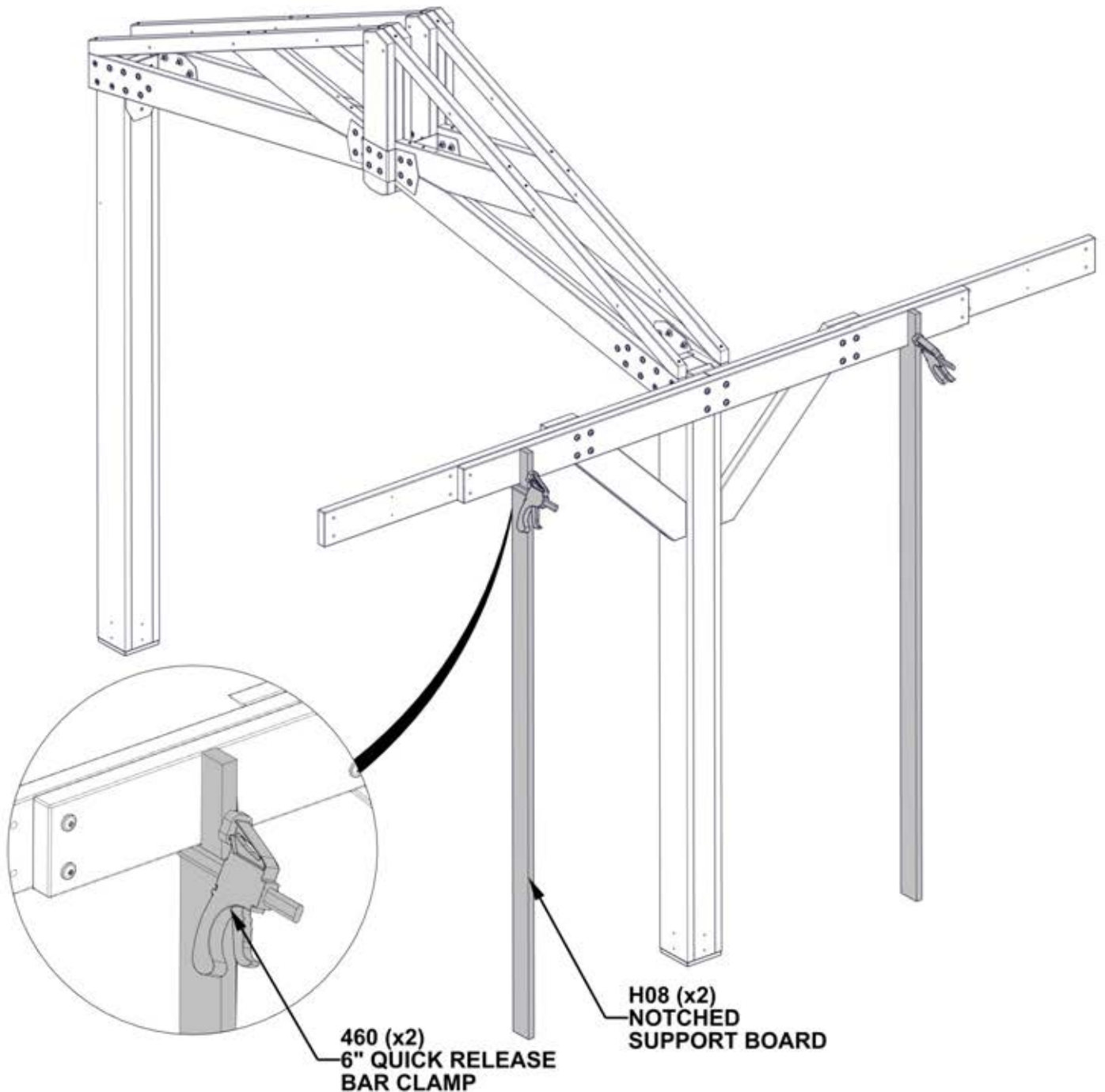

STEP 22 - GAZEBO ASSEMBLY

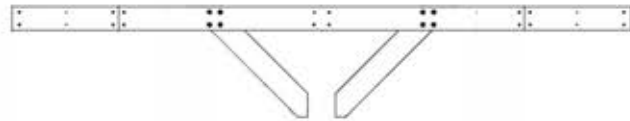

GABLE ASSEMBLY FROM STEP 19

QTY	PART NUMBER	DESCRIPTION
1	H100659	LAG SCREW HEX 5/16x1 1/2 BLK
2	H100792	LAG SCREW WH 1/4x3 BLK
2	H100405	WASHER LOCK EXT 6x15
4	H101047	BOLT WH 5/16x9 3/4 BLK
4	H100198	WASHER LOCK EXT 8x19
4	H100479	NUT LOCK 5/16 BLK
5	H100478	WASHER FLAT 8x27 BLK

- ADDITIONAL PEOPLE ARE HELPFUL FOR THIS STEP.
- HOLD GABLE ASSEMBLY UPRIGHT AND ATTACH BEAM ASSEMBLY.

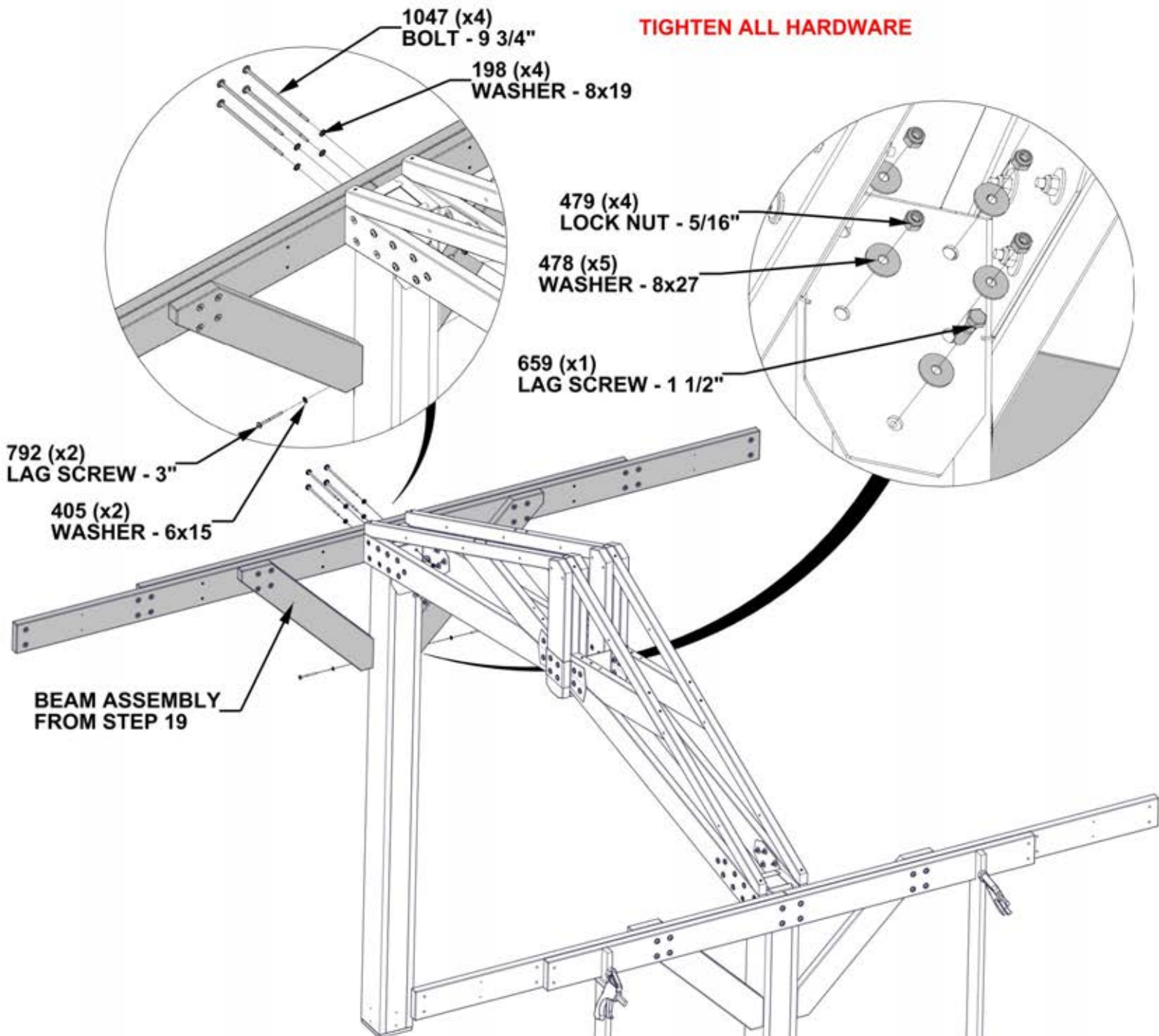

STEP 23 - GAZEBO ASSEMBLY



H08 NOTCHED SUPPORT BOARD - W4L16915
(x2) 1"X3 3/8"X89 1/2" (24x86x2274)

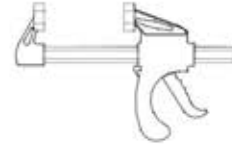

A6P00460 6" QUICK RELEASE
(x2) BAR CLAMP

- ADDITIONAL PEOPLE ARE HELPFUL FOR THIS STEP.
- USING THE INCLUDED CLAMP AND THE H08 BOARDS, SECURE CLAMPS AS SHOWN TO SUPPORT CENTER GABLE AND SIDE BEAM ASSEMBLY.

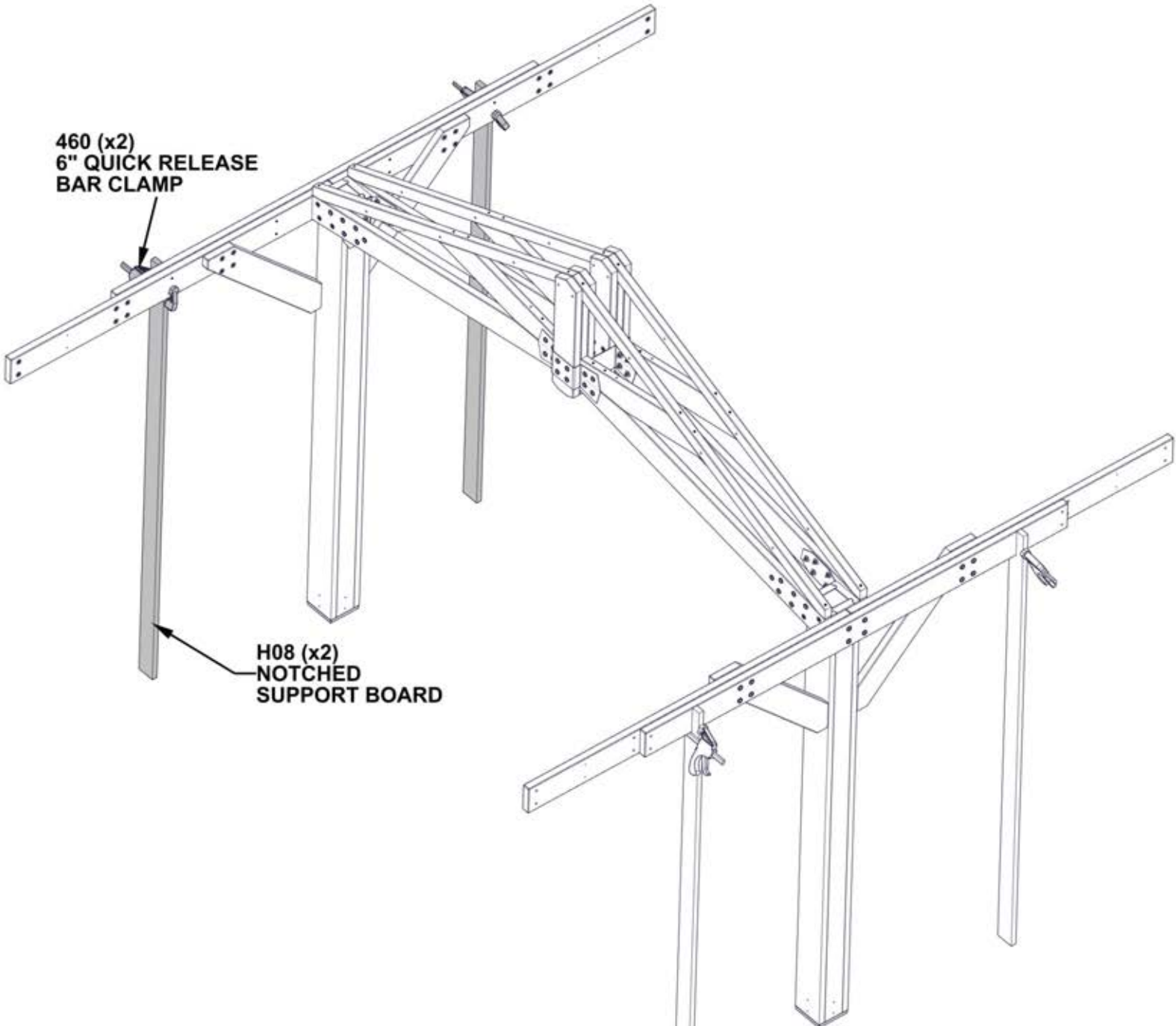

STEP 24A - GAZEBO ASSEMBLY

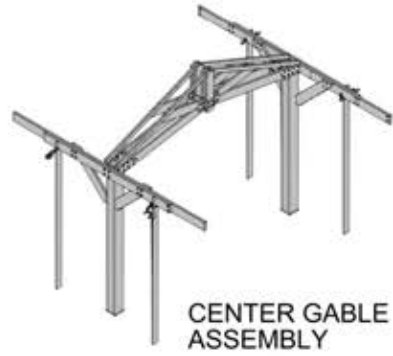

- ADDITIONAL PEOPLE ARE HELPFUL FOR THIS STEP.
- HOLD CENTER GABLE ASSEMBLY UPRIGHT AND ATTACH END GABLE ASSEMBLY.
- END GABLE HARDWARE MAY NEED TO BE LOOSENED ALONG EACH SIDE BEAM TO ALLOW BEAM BRACE TO SLIDE IN PLACE.

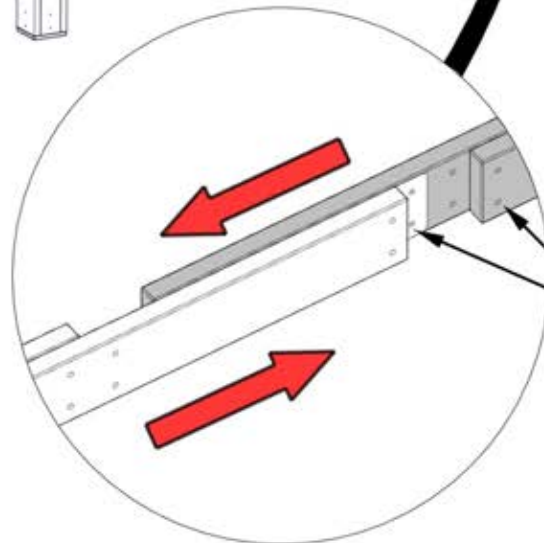
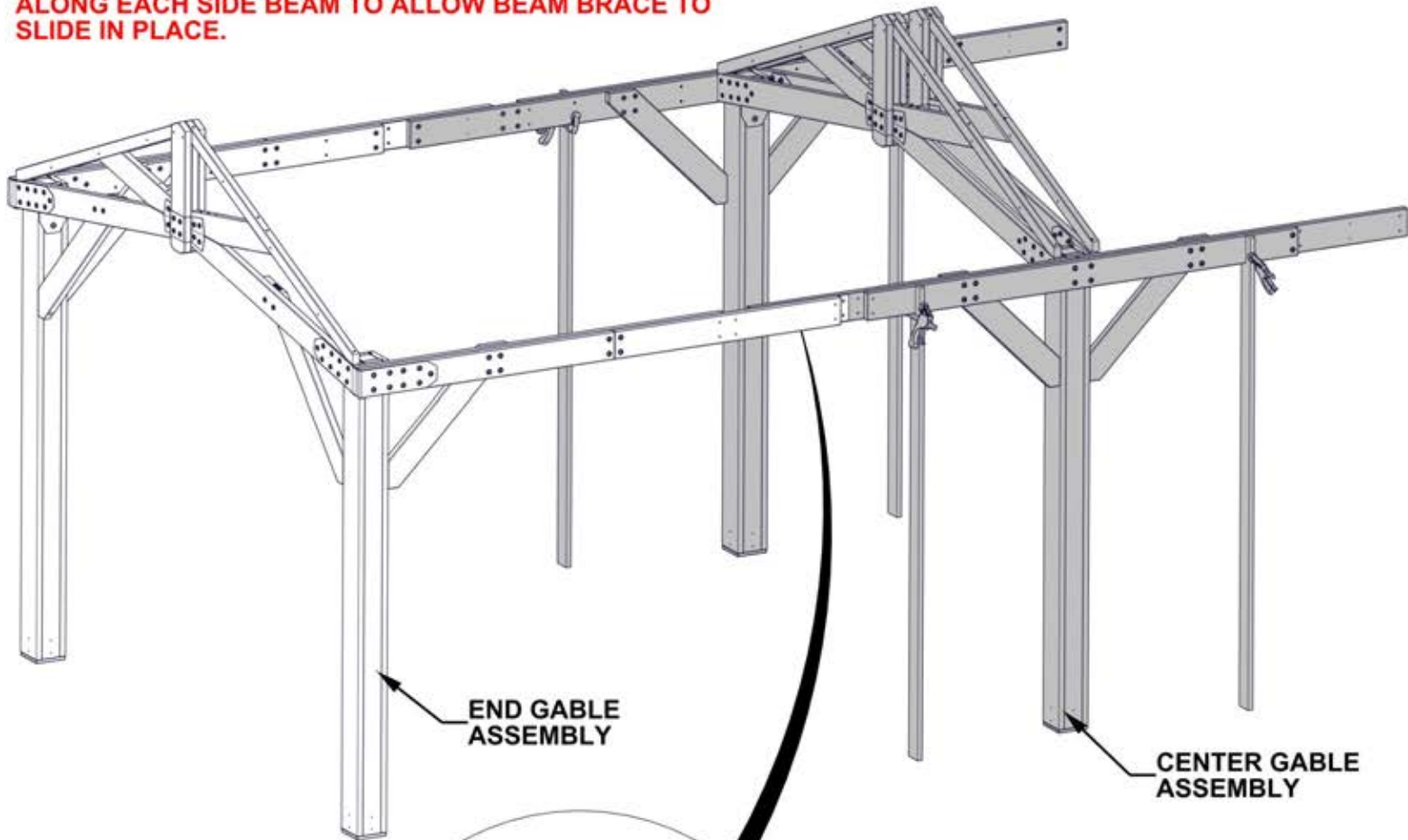

STEP 24B - GAZEBO ASSEMBLY

QTY	PART NUMBER	DESCRIPTION
4	H100201	SCREW PFH 8x2 1/2 BLK
12	H100195	BOLT WH 5/16x2 3/4 BLK
12	H100198	WASHER LOCK EXT 8x19

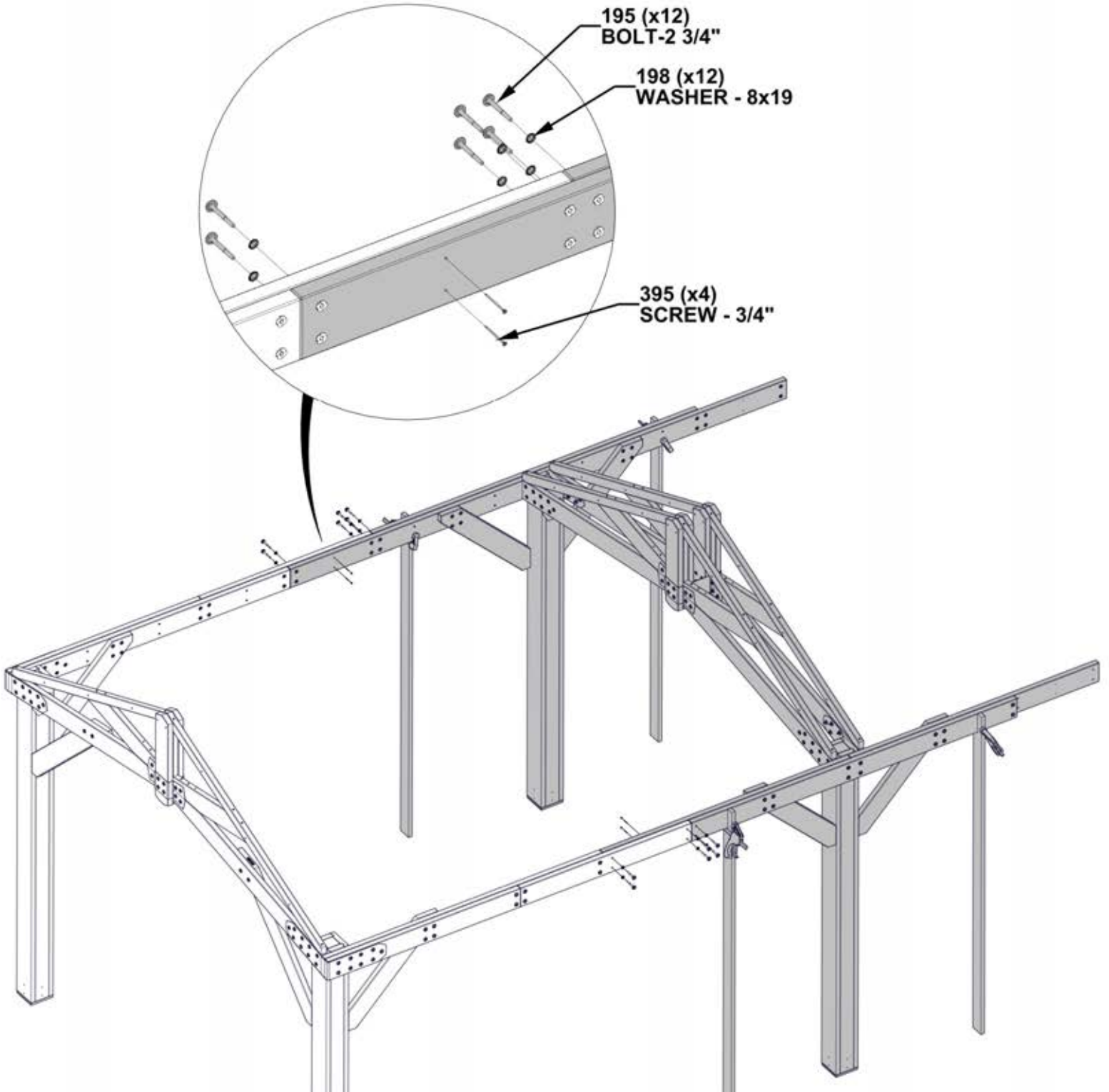

STEP 25A - GAZEBO ASSEMBLY

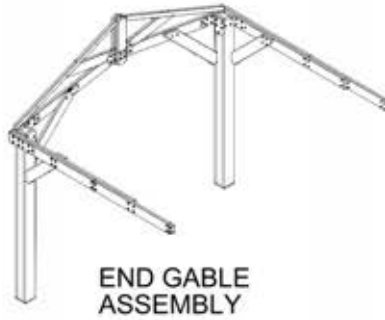

- ADDITIONAL PEOPLE ARE HELPFUL FOR THIS STEP.
- HOLD CENTER GABLE ASSEMBLY UPRIGHT AND ATTACH END GABLE ASSEMBLY.
- END GABLE HARDWARE MAY NEED TO BE LOOSENED ALONG EACH SIDE BEAM TO ALLOW BEAM BRACE TO SLIDE IN PLACE.

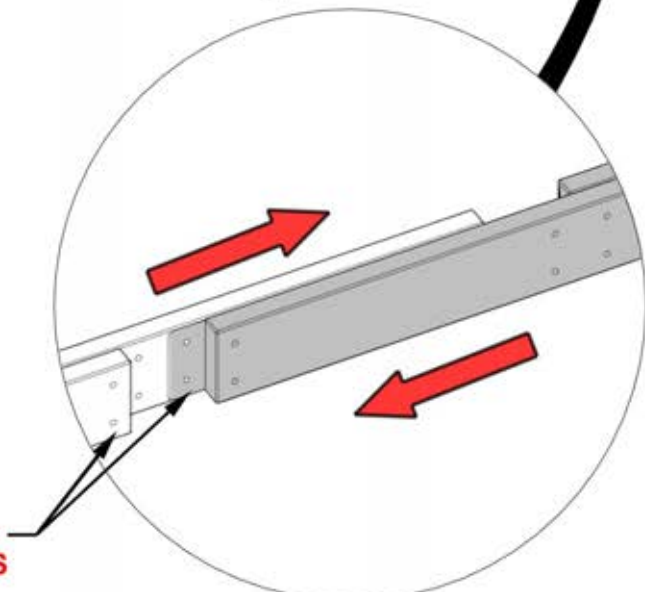
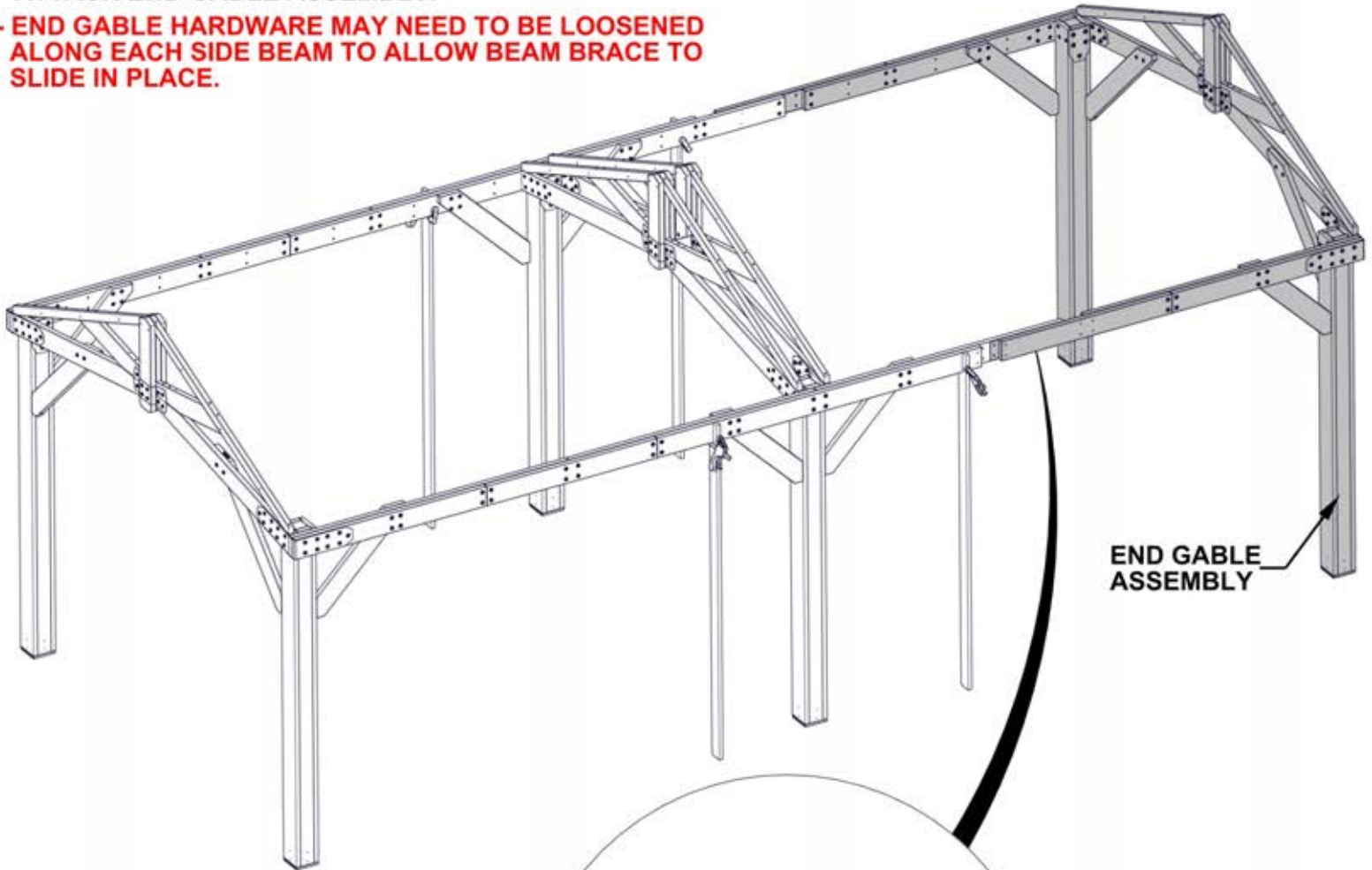

STEP 25B - GAZEBO ASSEMBLY

QTY	PART NUMBER	DESCRIPTION
4	H100201	SCREW PFH 8x2 1/2 BLK
12	H100195	BOLT WH 5/16x2 3/4 BLK
12	H100198	WASHER LOCK EXT 8x19

- ONCE ALL HARDWARE IS SECURELY ATTACHED,
REMOVE CLAMPS AND H08 BOARDS.

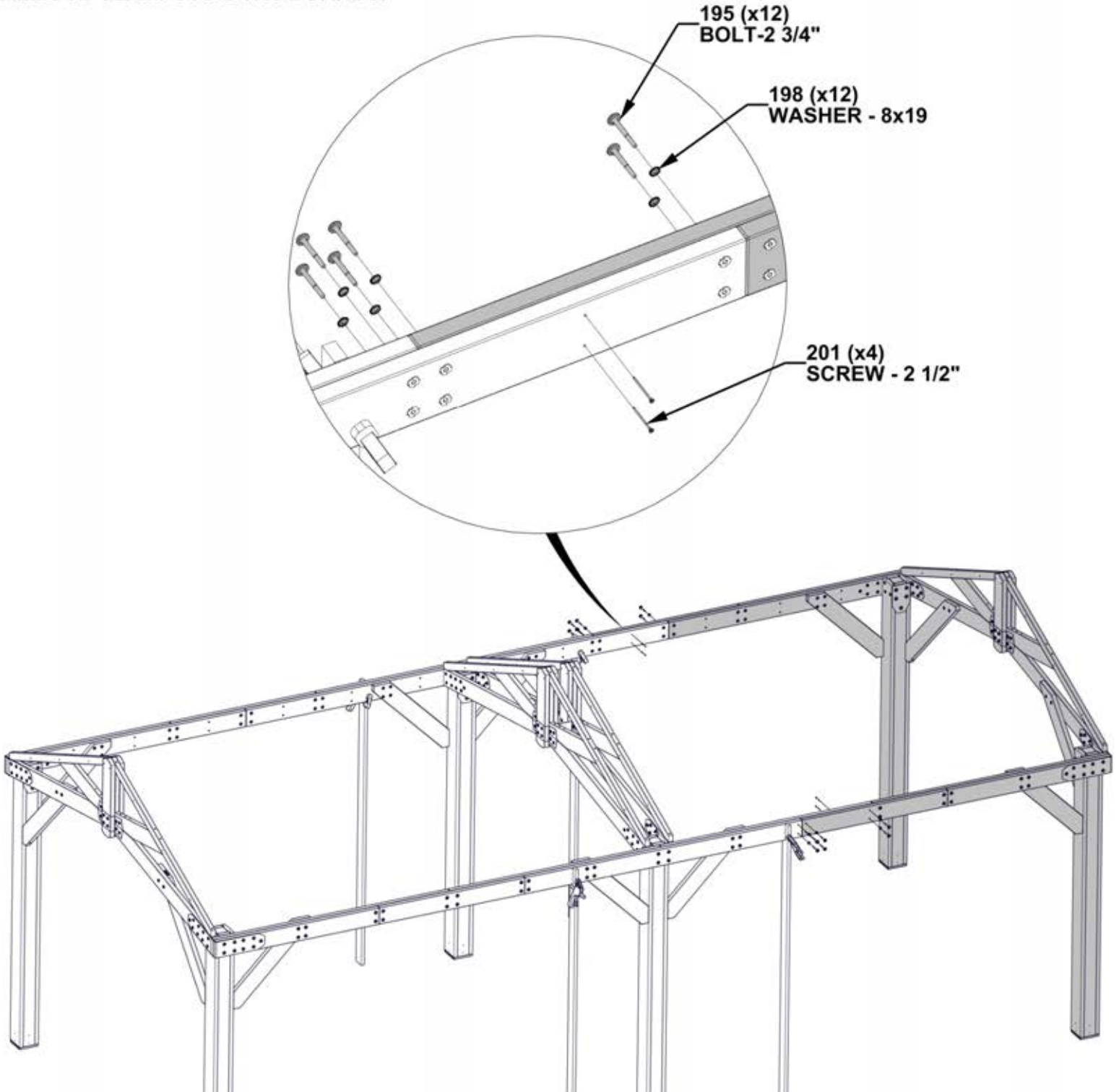

STEP 26 - GAZEBO ASSEMBLY

QTY	PART NUMBER	DESCRIPTION
12	H100195	BOLT WH 5/16x2 3/4 BLK
12	H100198	WASHER LOCK EXT 8x19
12	H100379	TNUT-5/16" BLK



F02 TRUSS - W4L16378
(x4) 1 3/8"x2 3/8"x68" (36x60x1727)

- INSERT T-NUTS FIRST

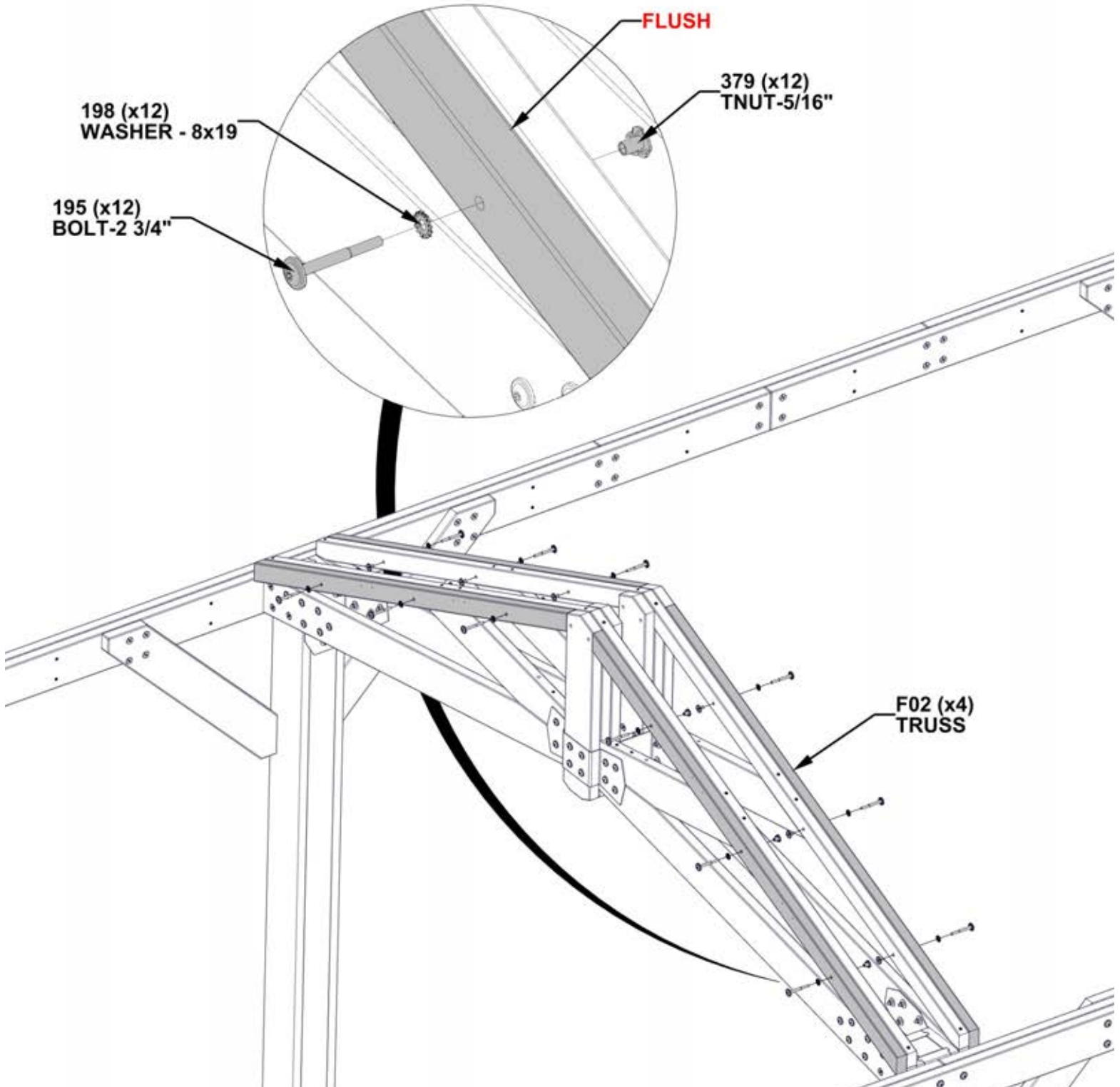

STEP 27 - GAZEBO ASSEMBLY

QTY	PART NUMBER	DESCRIPTION
16	H100201	SCREW PFH 8x2 1/2 BLK



F01 TRUSS - W4L16414
(x4) 1 3/8"x2 3/8"x75 1/8" (36x60x1907)

COMPLETE THIS STEP TWICE FOR OPPOSITE SIDE

**ALIGN HOLES FOR
CORRECT ORIENTATION**

FLUSH TOPS

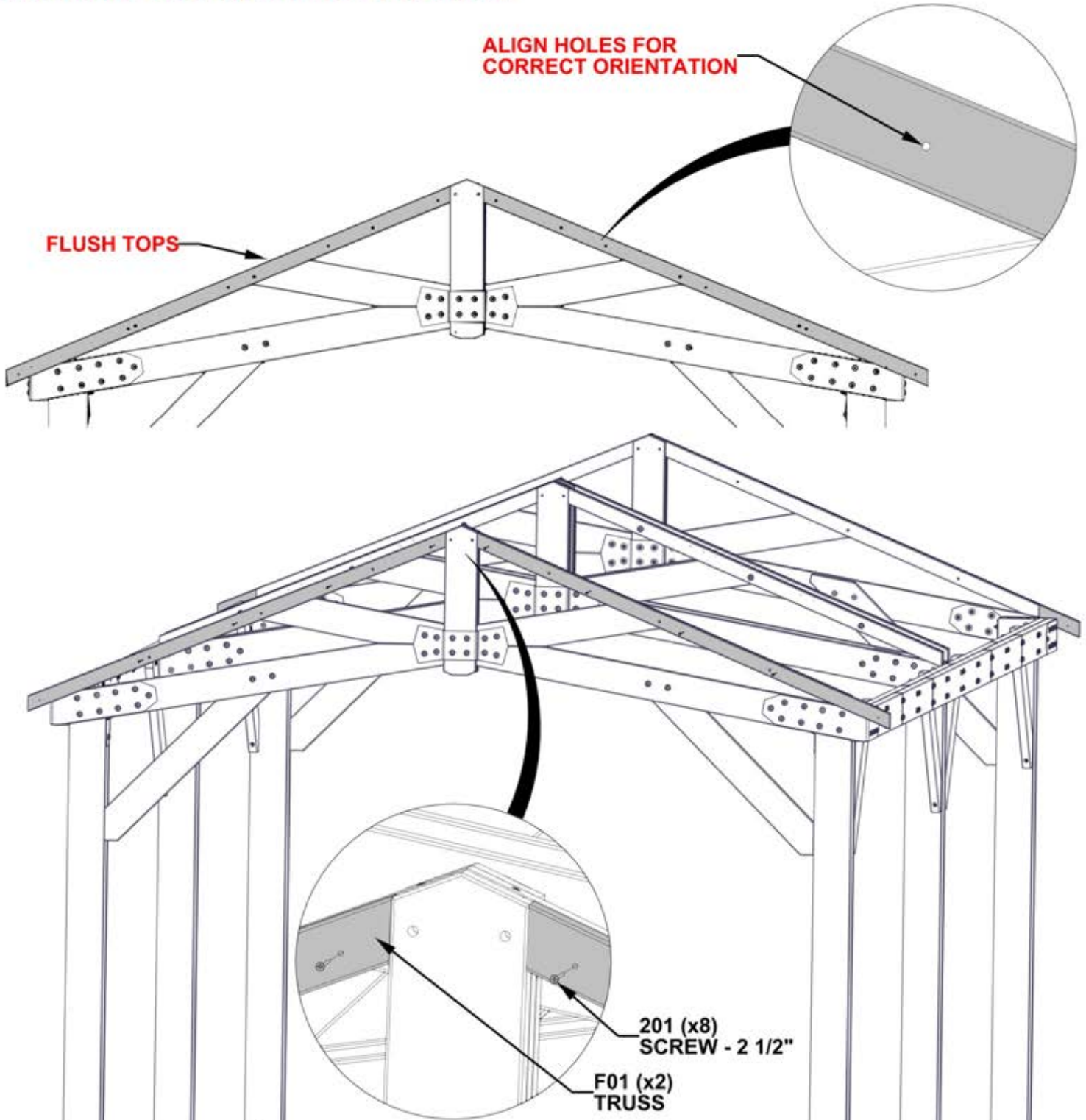

STEP 28 - GAZEBO ASSEMBLY

QTY	PART NUMBER	DESCRIPTION
4	H100201	SCREW PFH 8x2 1/2 BLK
12	H100564	LAG SCREW WH 1/4x4 BLK
12	H100405	WASHER LOCK EXT 6x15



GP1 GABLE PANEL - W2A03379
(x2) 2 13/16"x5 1/4"x80 3/16" (72x134x2037)



GP2 GABLE PANEL - W2A03380
(x2) 2 13/16"x5 1/4"x80 3/16" (72x134x2037)

- ALIGN LAG SCREWS WITH PILOT HOLES IN GABLE PANELS.

TEMPORARILY INSERT 354 BOLTS TO ALIGN GABLE PANEL WITH GABLE

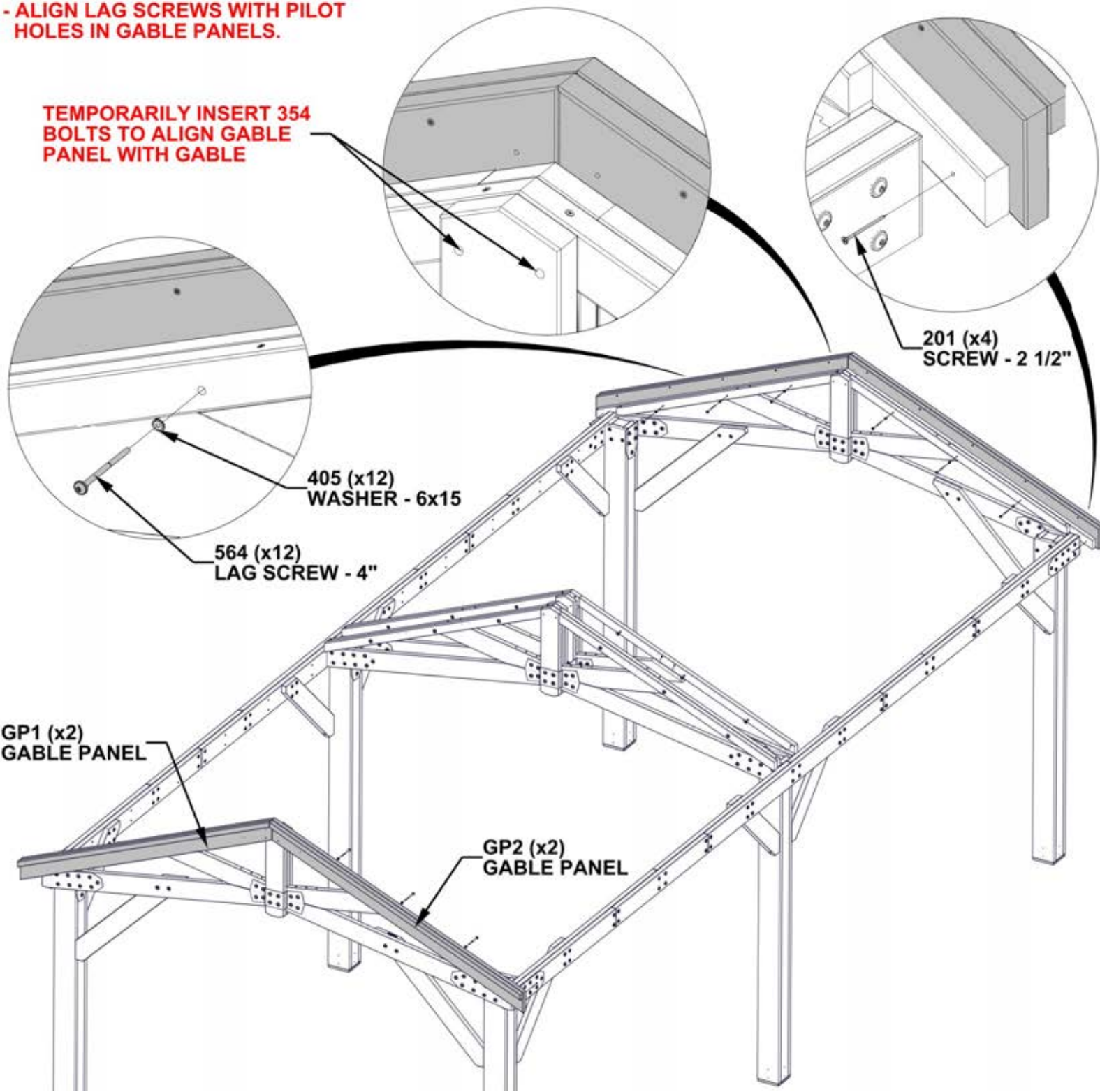

STEP 29 - GAZEBO ASSEMBLY

QTY	PART NUMBER	DESCRIPTION
4	H100200	SCREW PFH 8x1 1/2 BLK
8	H100471	LAG SCREW WH 5/16x1 1/2 BLK

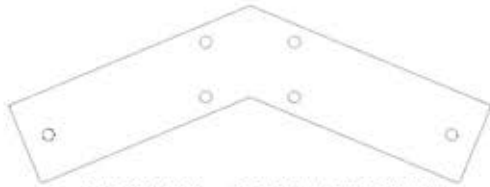

A4M01130 GABLE BRACKET
(x2)

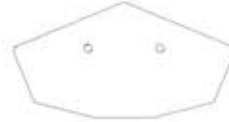

A4M01147 PEAK SEAM BRACKET
(x2)

COMPLETE THIS STEP TWICE FOR OPPOSITE SIDE

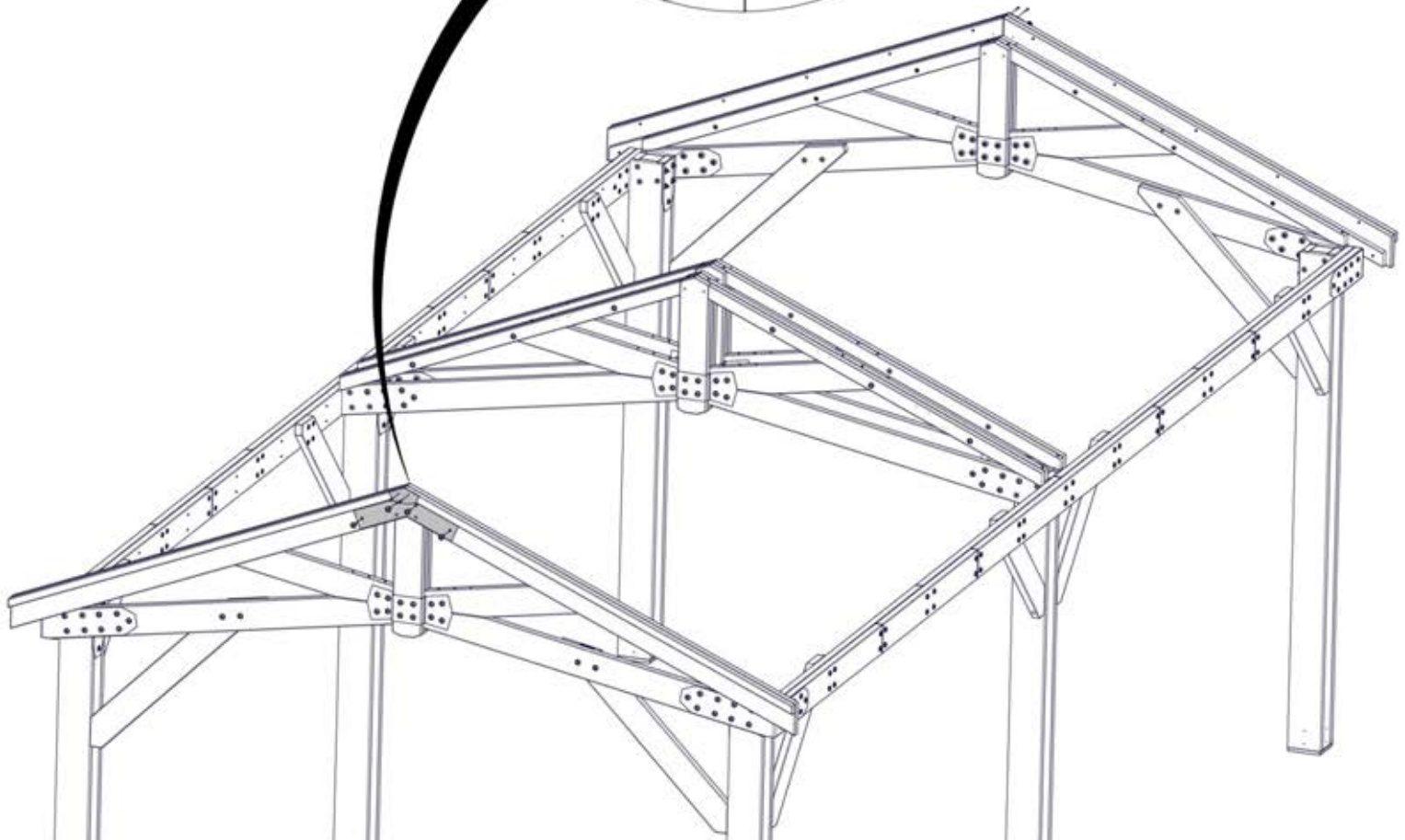
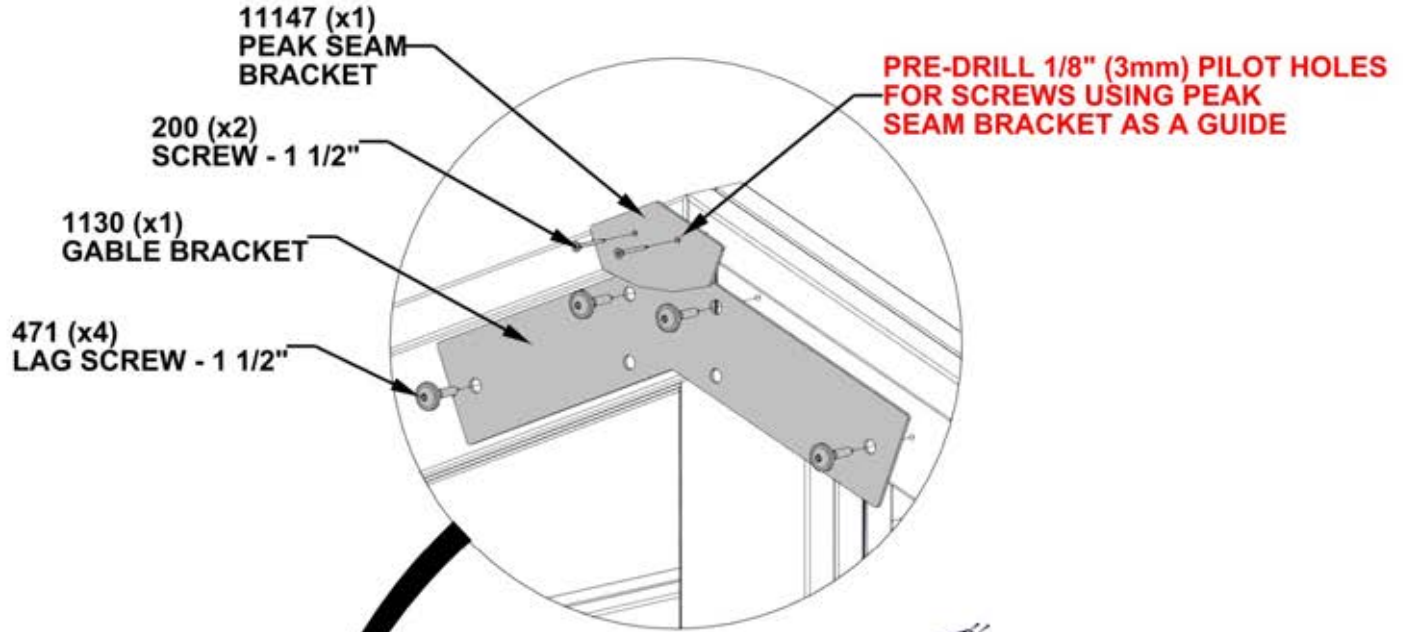

STEP 30 - GAZEBO ASSEMBLY

QTY	PART NUMBER	DESCRIPTION
16	H100823	SCREW PWH 8x1 1/2 BLK

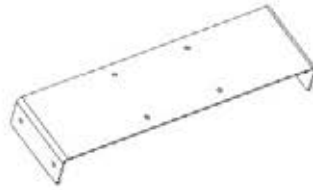

A4M01594 SHEATHING BRACKET
(x4)

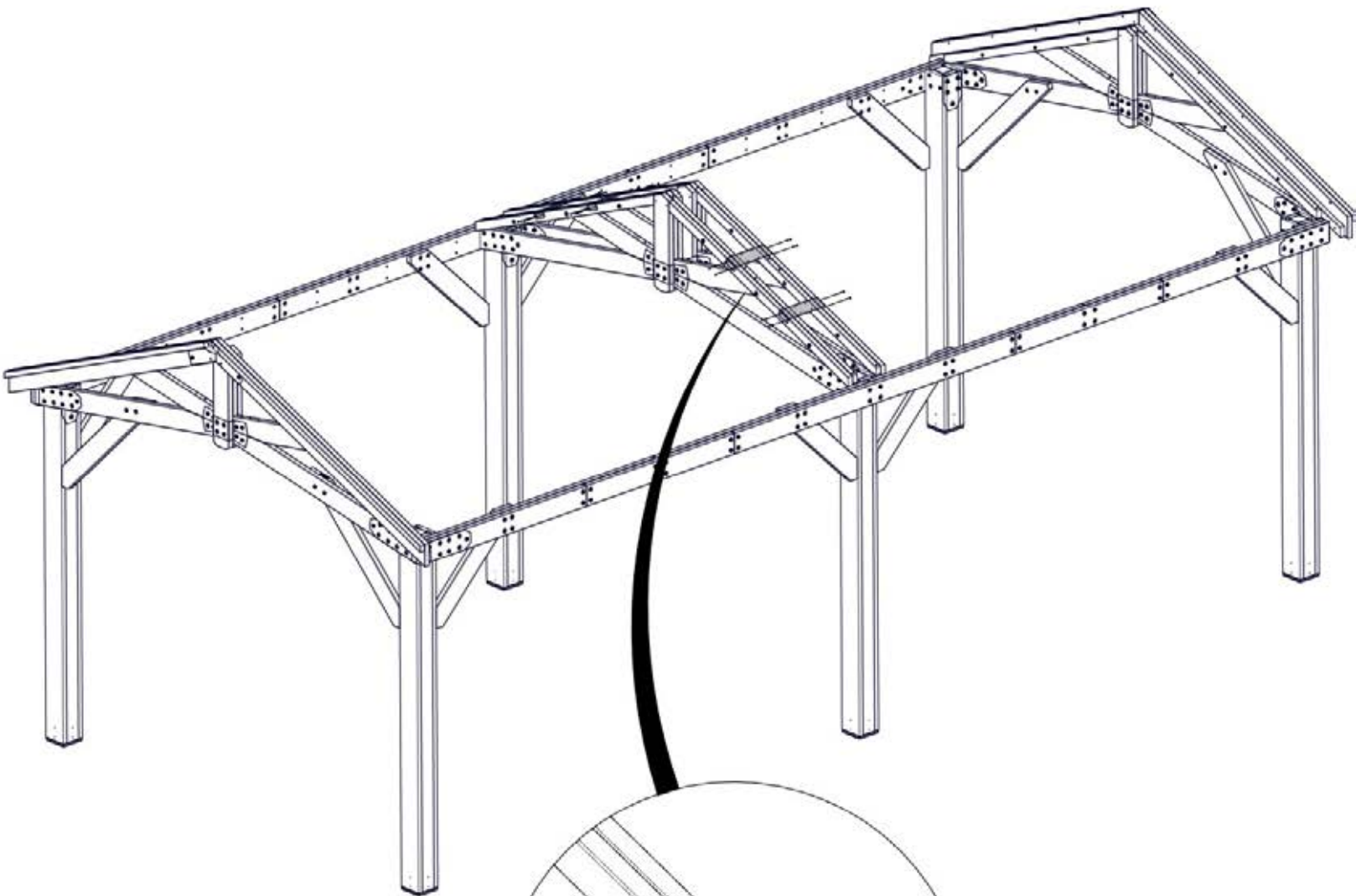

**ATTACH SHEATHING
BRACKETS USING PILOT
HOLES IN GABLE ASSEMBLY**

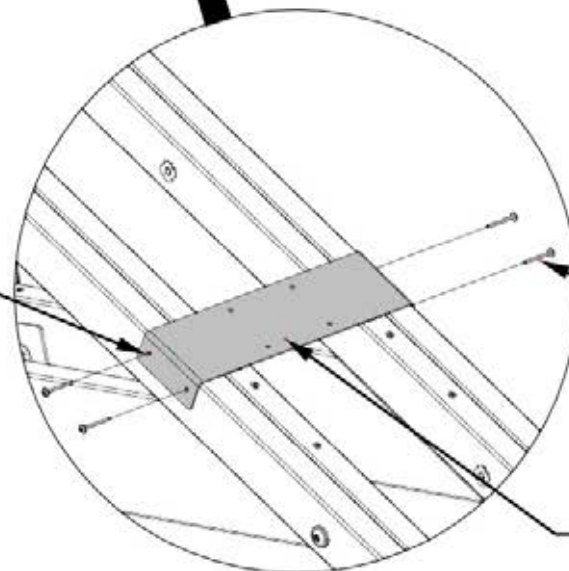

823 (x16)
SCREW - 1 1/2"

1594 (x4)
SHEATHING BRACKET

STEP 31 - SQUARE ASSEMBLY

**CRITICAL: SQUARE ASSEMBLY BEFORE PROCEEDING TO NEXT STEPS.
ONCE SQUARE, ENSURE ALL HARDWARE IS FULLY TIGHTENED.**

MEASUREMENTS TAKEN FROM INSIDE OF POST TO INSIDE OF POST

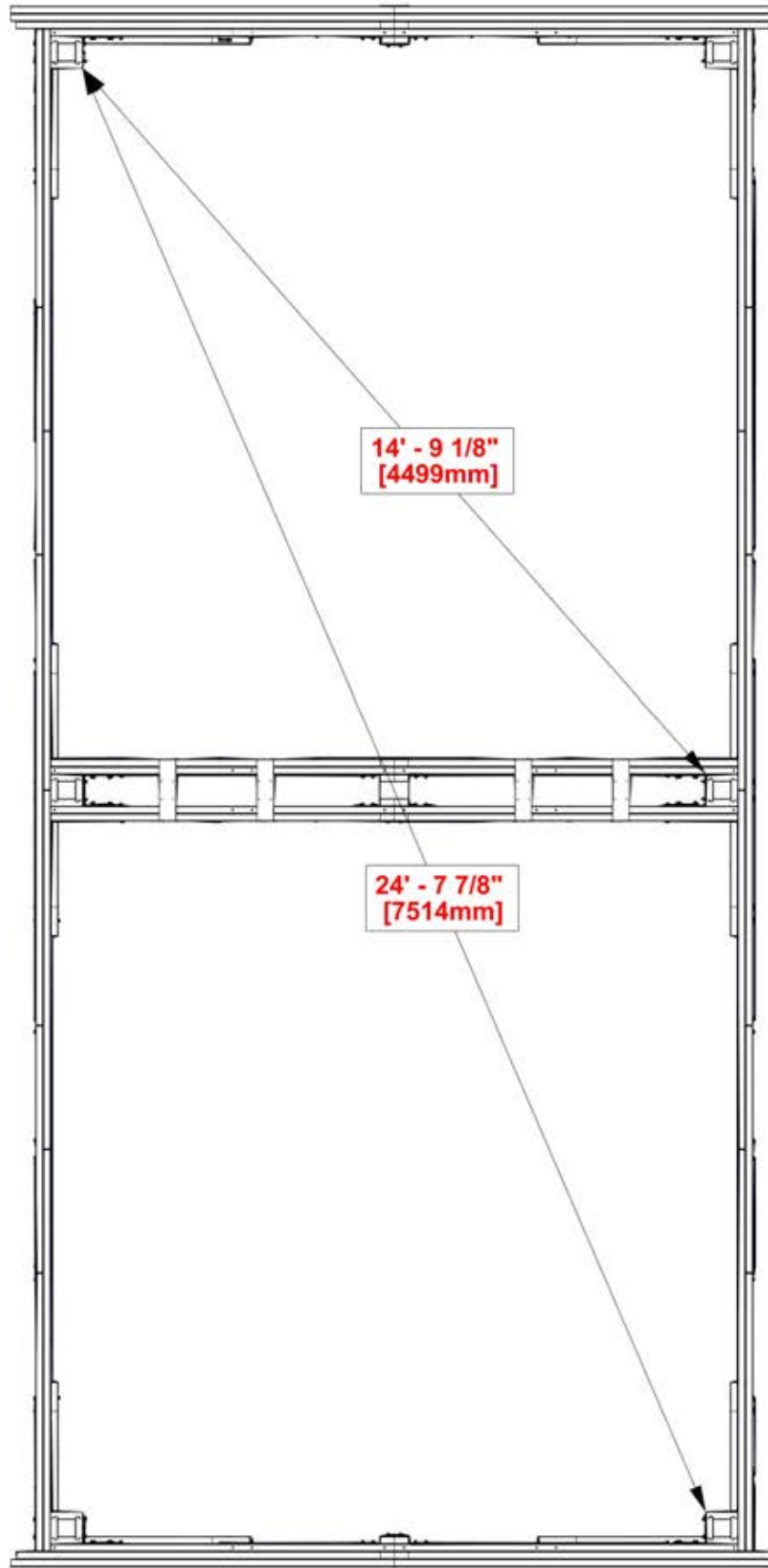

ONCE A ROOF PANEL IS COMPLETE, SET IT TO THE SIDE. KEEP TRACK OF A, B, C, AND D AS THEIR PLACEMENT IS CRITICAL IN LATER STEPS.

STEP 32 - ROOF PANEL A ASSEMBLY

QTY	PART NUMBER	DESCRIPTION
2	H100379	TNUT-5/16" BLK
20	H100391	SCREW PFH 8x2 BLK

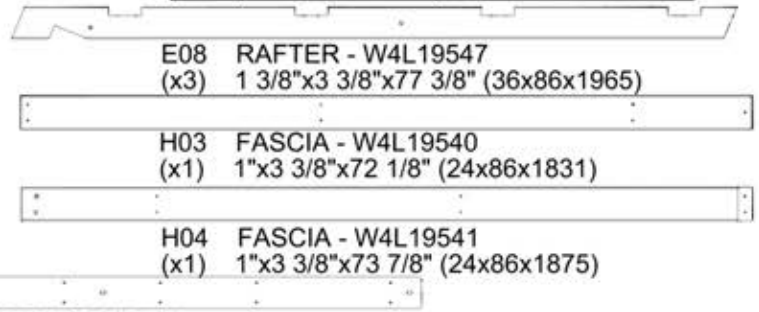
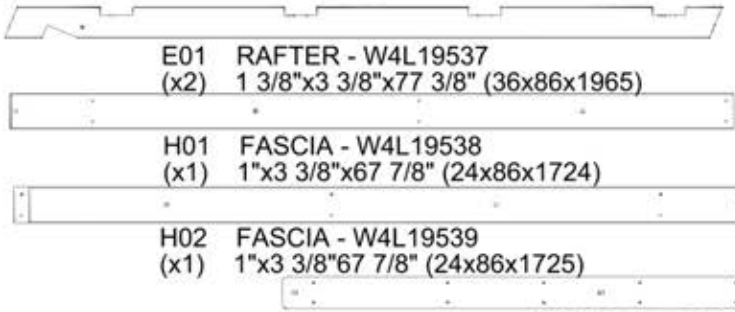

A4M02750 RIDGE BRACE METAL
(x1)

- INSERT T-NUTS FIRST

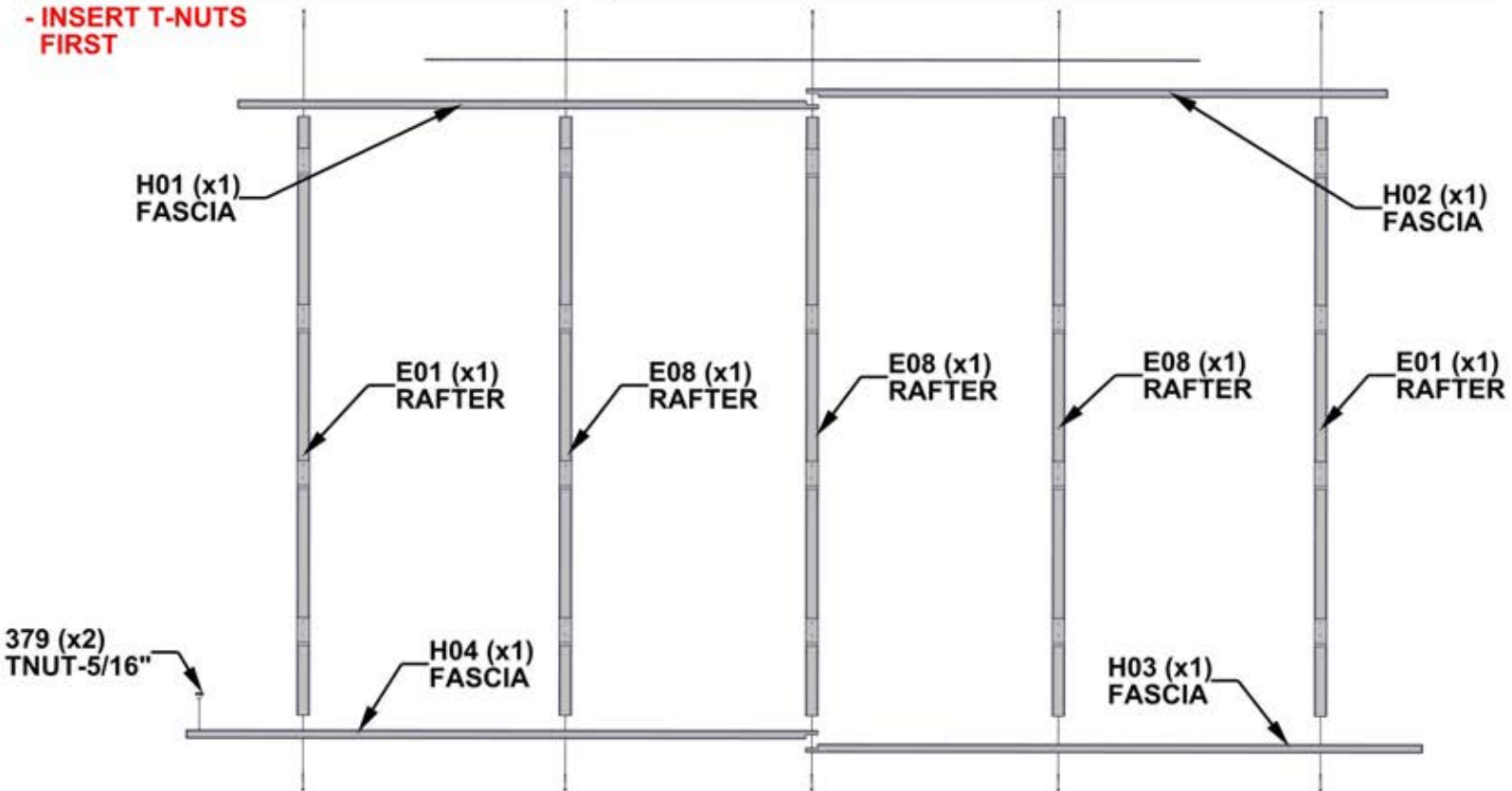

CORRECT ORIENTATION AND PLACEMENT OF H BOARDS IS CRITICAL FOR LATER STEPS

NOTE ORIENTATION OF COUNTERSUNK HOLES IN RIDGE BRACE METAL

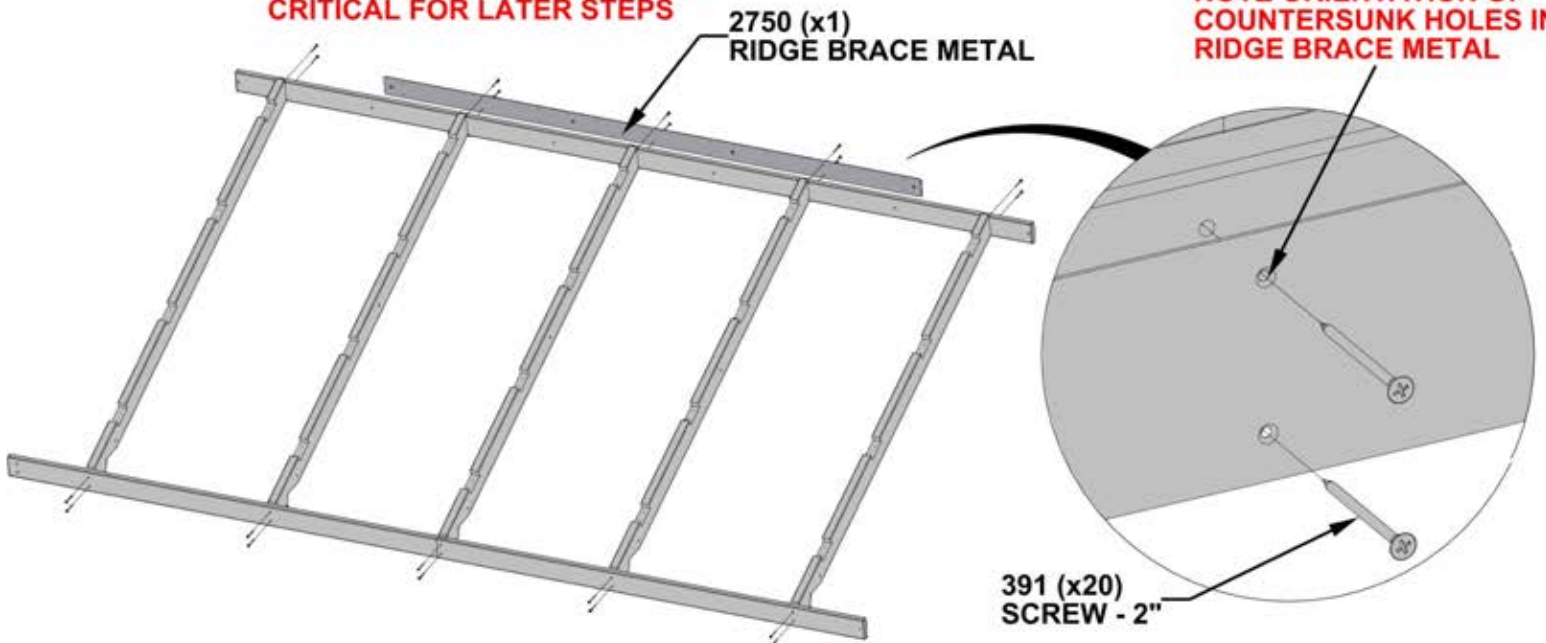

STEP 33 - ROOF PANEL A ASSEMBLY

QTY	PART NUMBER	DESCRIPTION
12	H100395	SCREW PFH 8x3/4 BLK

MAKE SURE ALL HOLES ARE ALIGNED BEFORE INSTALLING SCREWS

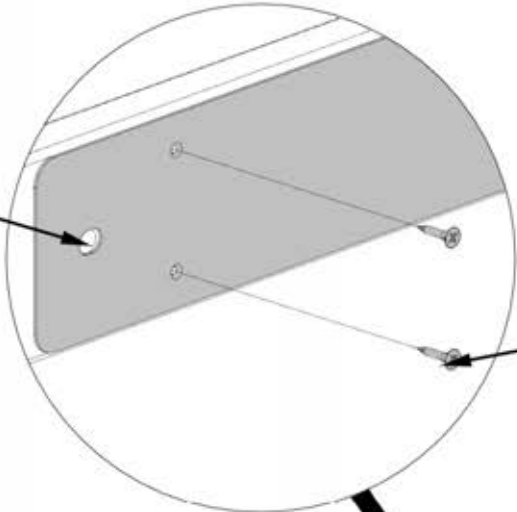

**395 (x12)
SCREW - 3/4"**

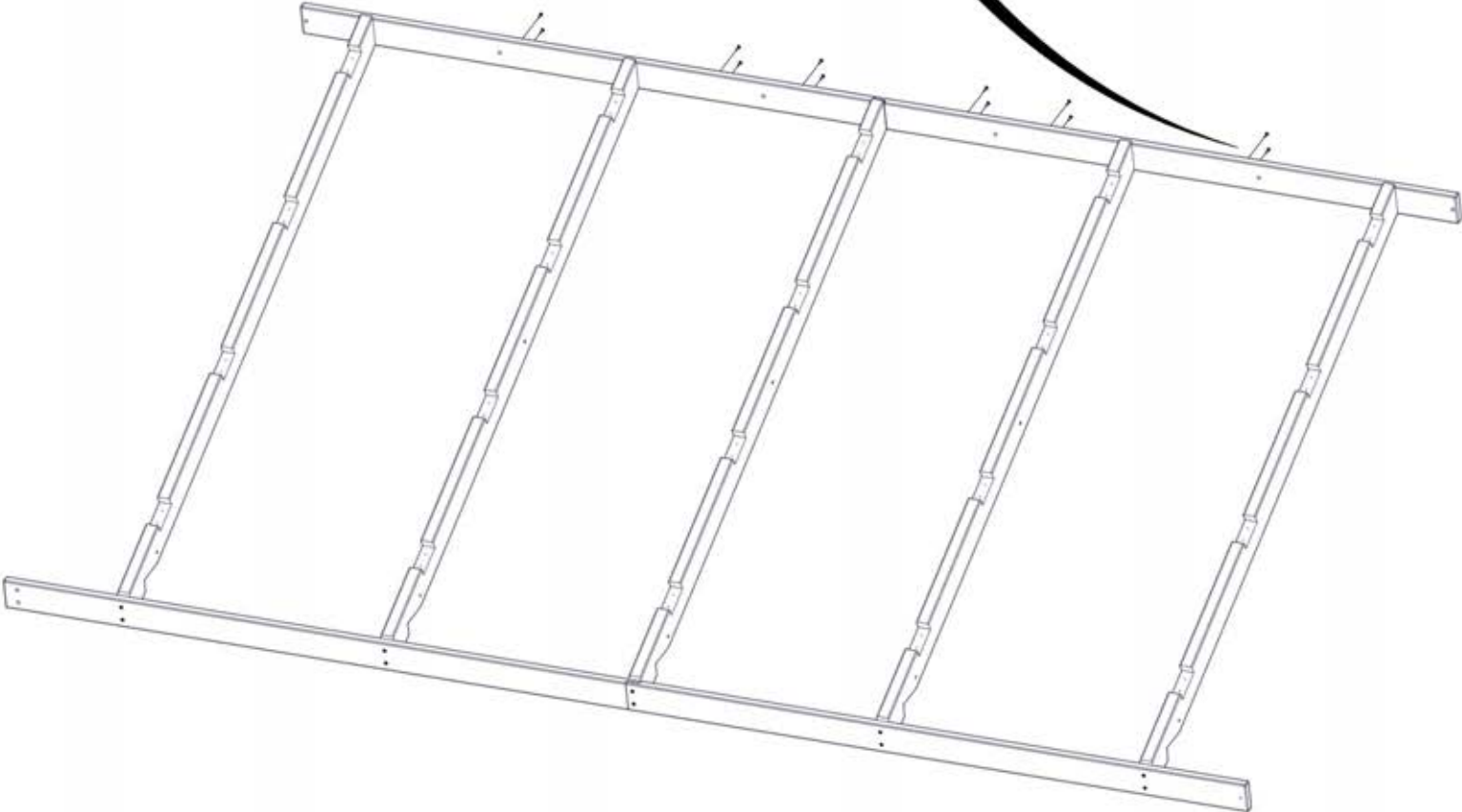

STEP 34A - ROOF PANEL A ASSEMBLY

QTY	PART NUMBER	DESCRIPTION
40	H100391	SCREW PFH 8x2 BLK



H05 SHEATHING BOARD - W4L19542
(x4) 1"x3 3/8"x43 1/4" (24x86x1098)



H07 SHEATHING BOARD - W4L19544
(x4) 1"x3 3/8"x44 3/4" (24x86x1137)



H06 SHEATHING BOARD - W4L19543
(x4) 1"x3 3/8"x59" (24x86x1500)

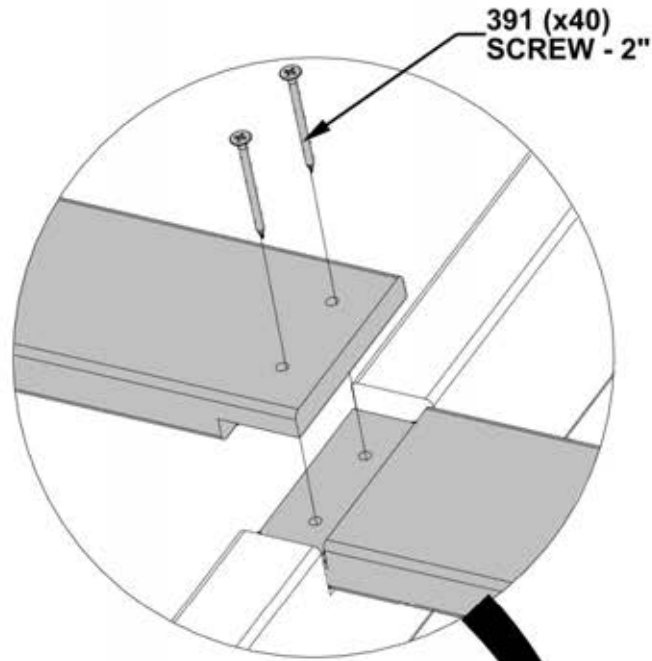

H07 (x4)
SHEATHING BOARD

H06 (x4)
SHEATHING BOARD

H05 (x4)
SHEATHING BOARD

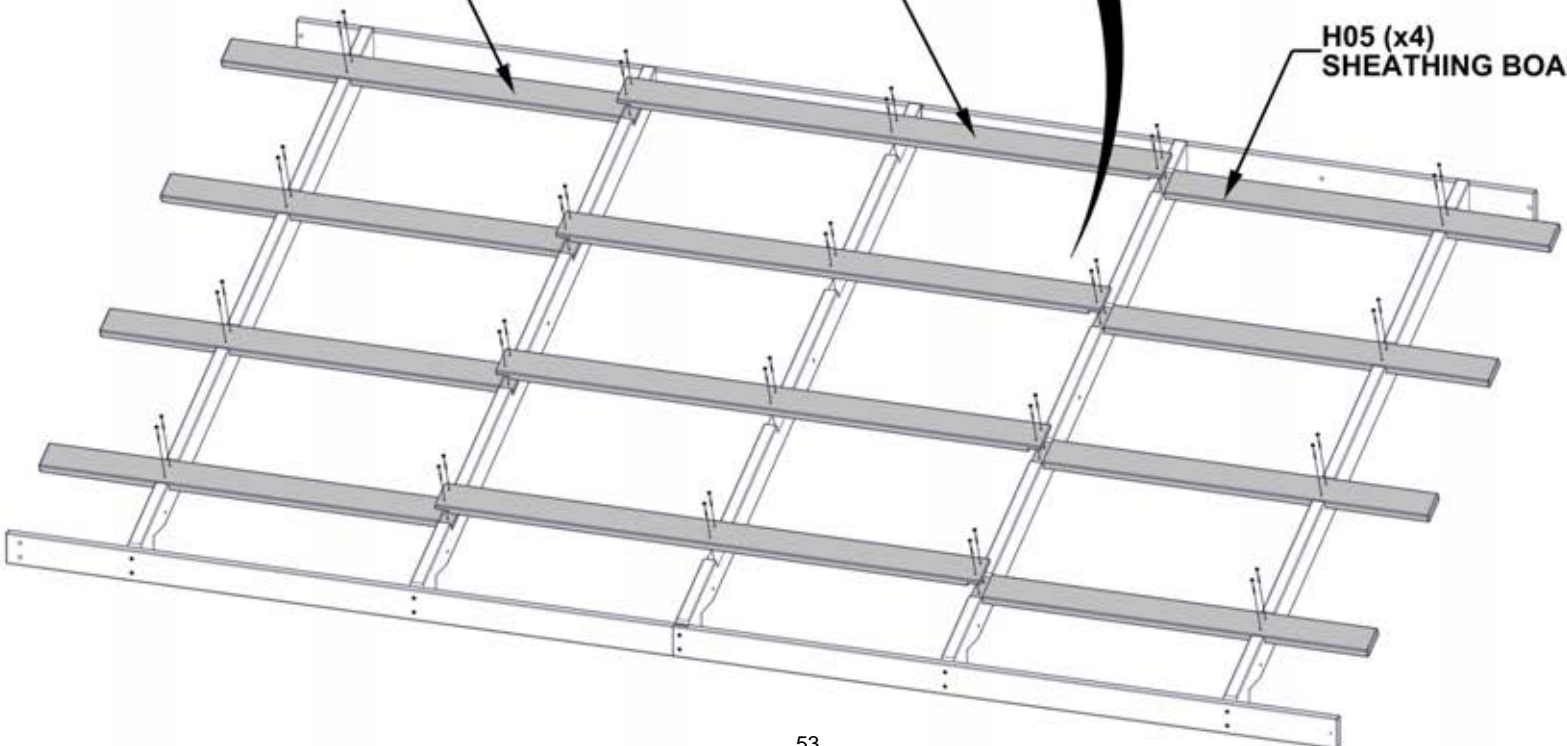

STEP 34B - ROOF PANEL A ASSEMBLY

CRITICAL:

- SQUARE UNIT BEFORE PROCEEDING TO NEXT STEPS.
- THE BELOW DIMENSIONS ARE CRITICAL TO THE FINAL ROOF ASSEMBLY.
- MEASUREMENTS SHOULD BE HELD WITHIN $\pm 1/4"$ (6mm).
- MEASUREMENTS OUTSIDE OF TOLERANCE WILL LEAD TO THE INABILITY TO ASSEMBLE THE ROOF.

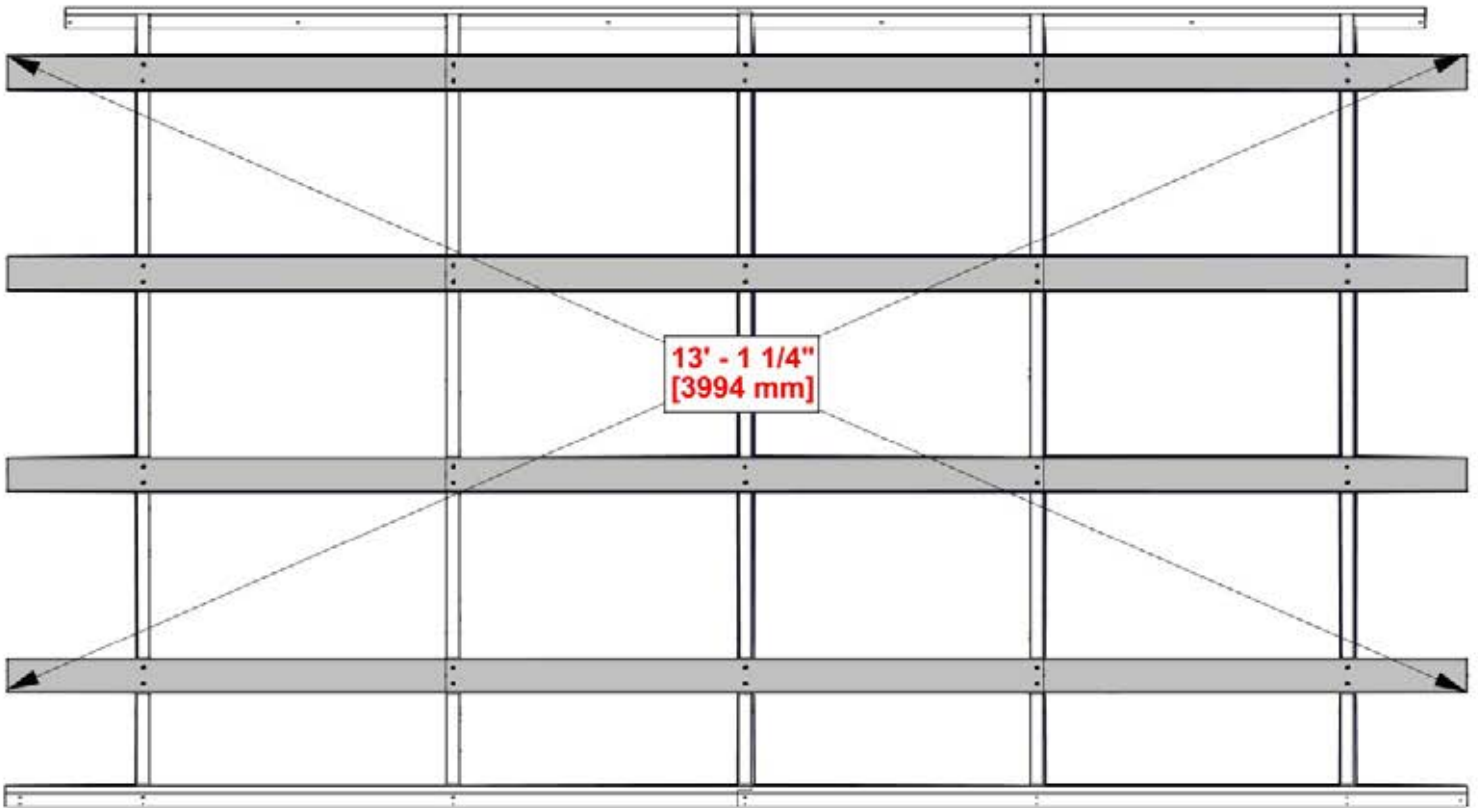

ONCE PANEL IS SQUARED, FULLY TIGHTEN SCREWS.

STEP 35 - ROOF PANEL A ASSEMBLY

ROOF PANEL A

- USE THIS STEP TO FAMILIARIZE YOURSELF WITH THE ROOF PANEL AND ASSIST YOU IN STEPS 36-37.
- REMOVE PROTECTIVE BLUE FILM.
- START AT THE END INDICATED AND ASSEMBLE IN THE DIRECTION OF THE ARROW.
- WHEN LAYING OUT ROOF SHEETS, MAKE SURE EVERY SHEET LANDS AT THE APPROXIMATE DIMENSION BELOW.
- REFER TO THIS STEP FOR EACH ROOF SHEET ATTACHMENT TO ENSURE CORRECT POSITION OF ROOF SHEETS.
- GLOVES SHOULD BE WORN WHEN HANDLING ROOF PANELS. EDGES ARE SHARP.

THE PRE-DRILLED HOLES ON EACH PANEL SHOULD ALWAYS BE POSITIONED ON THE RIDGE SIDE.

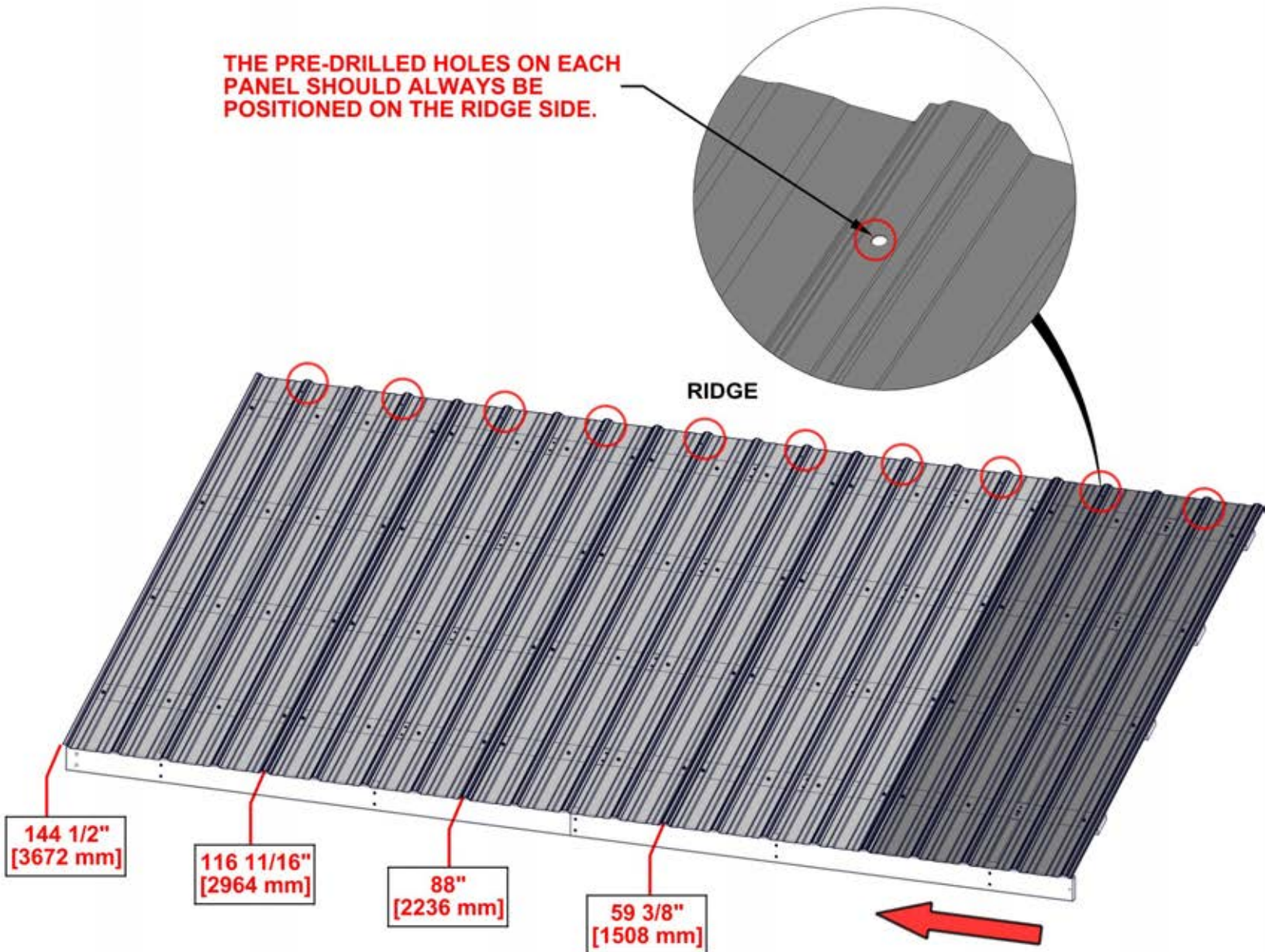

ROOF PANEL STEPS 36 - 37

STEP 36 - ROOF PANEL A ASSEMBLY

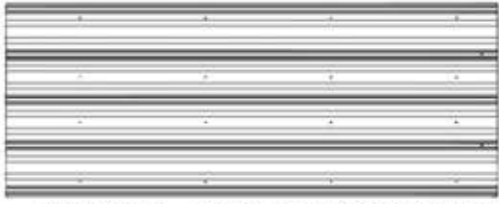

A4M02639 29GA STEEL SHEETING (x2)

QTY	PART NUMBER	DESCRIPTION
32	H100833	SCREW WOODGRIP 10-16x3/4"

- MAKE SURE YOUR ROOF PANEL IS SQUARE BEFORE MOVING ON.

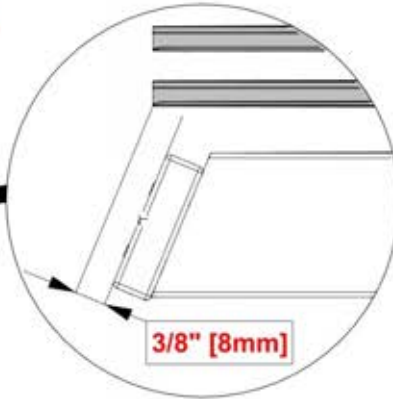

3/8" [8mm]

NOTE RIB OVERLAP

833 (x32)
SCREW - 3/4"

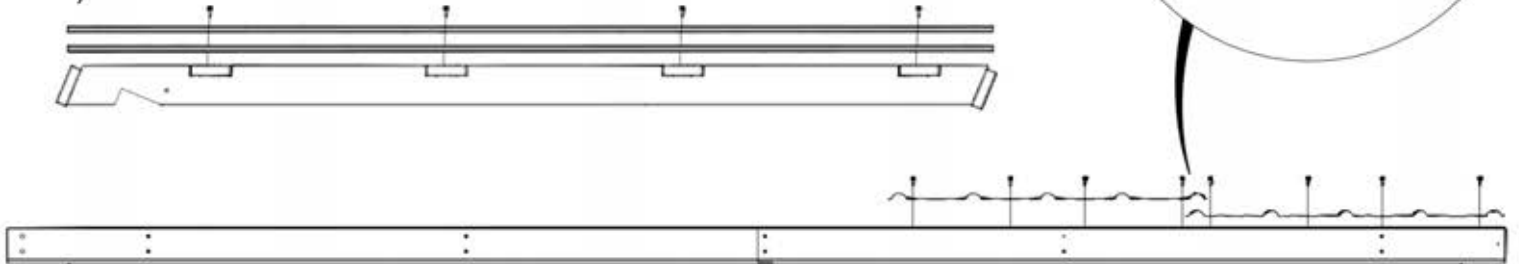
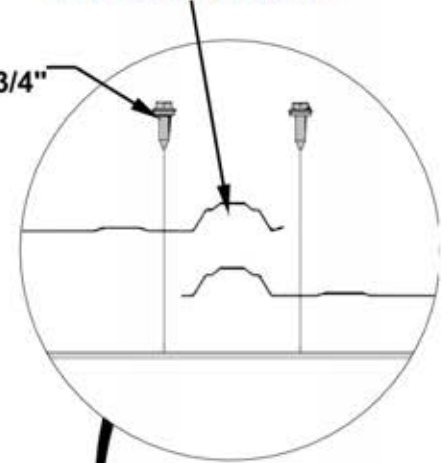

2639 (x2)
29GA STEEL SHEETING

RIDGE

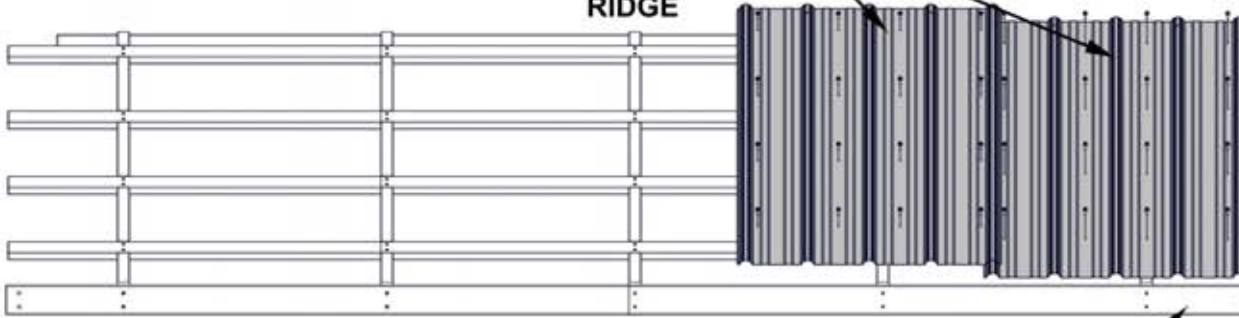

H03
FASCIA

PLACE SHEETING ON ROOF PANEL, ALIGNING EDGE OF RIB 3/8" (8mm) FROM END OF H BOARD

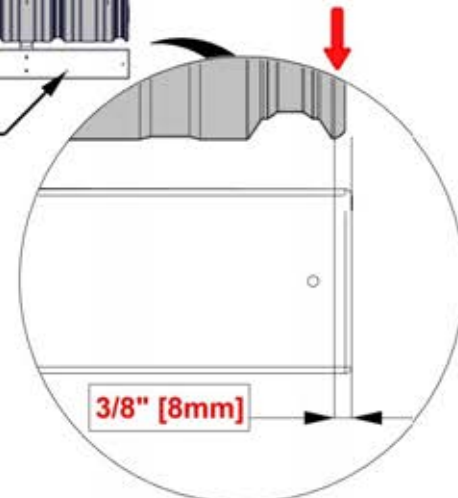

3/8" [8mm]

STEP 37 - ROOF PANEL A ASSEMBLY

QTY	PART NUMBER	DESCRIPTION
48	H100833	SCREW WOODGRIP 10-16x3/4"

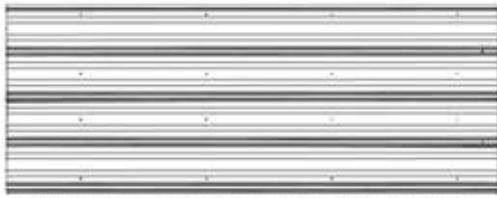

A4M02646 29GA STEEL SHEETING
(x1)

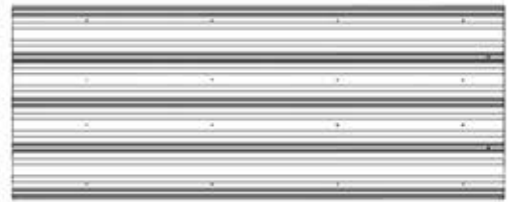

A4M02639 29GA STEEL SHEETING
(x2)

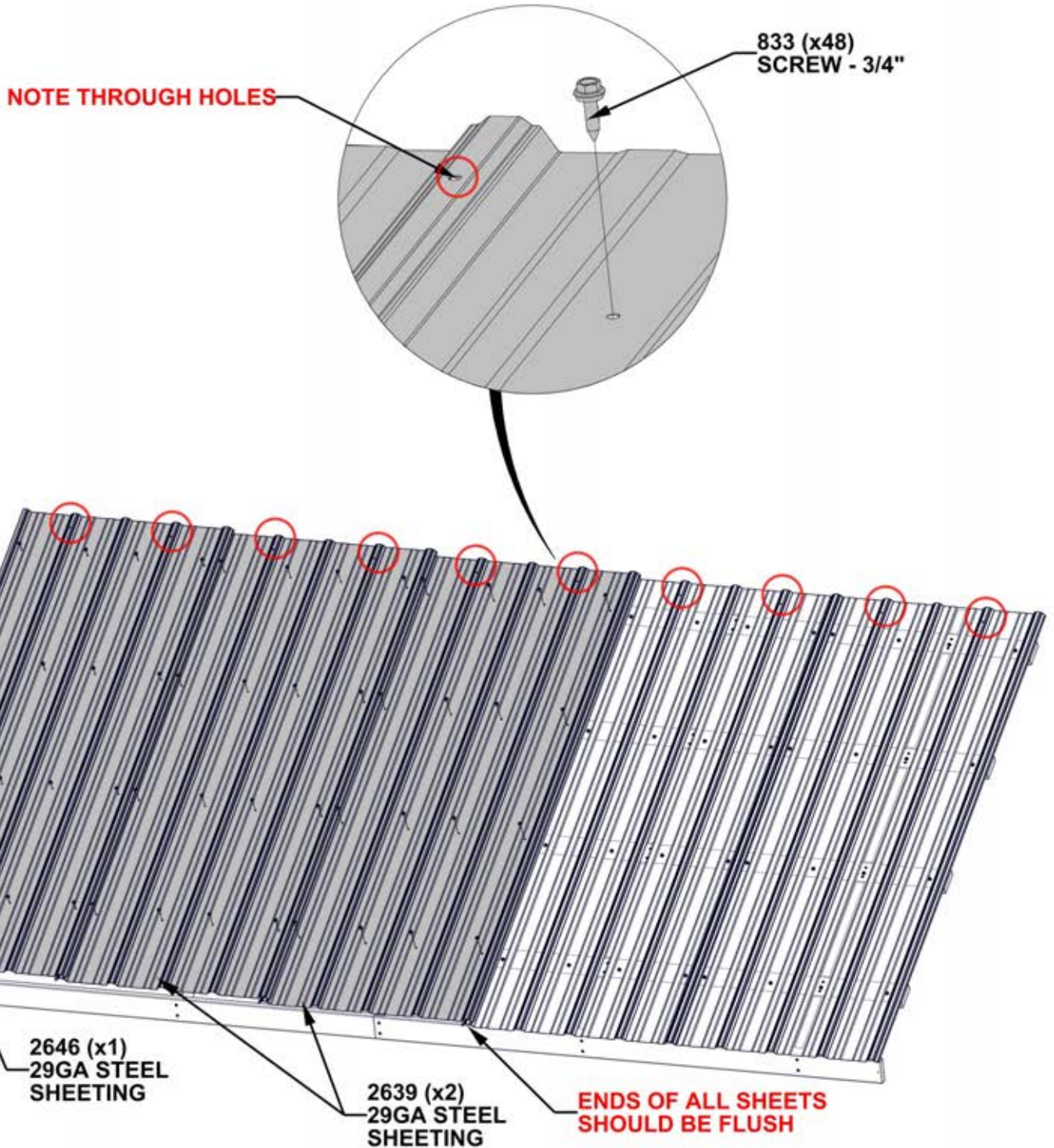

STEP 38 - ROOF PANEL B ASSEMBLY

QTY	PART NUMBER	DESCRIPTION
2	H100379	TNUT-5/16" BLK
20	H100391	SCREW PFH 8x2 BLK

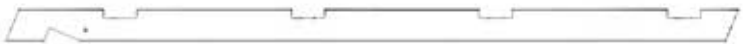

E01 RAFTER - W4L19537
(x2) 1 3/8"x3 3/8"x77 3/8" (36x86x1965)



H01 FASCIA - W4L19538
(x1) 1"x3 3/8"x67 7/8" (24x86x1724)



H02 FASCIA - W4L19539
(x1) 1"x3 3/8"x67 7/8" (24x86x1725)

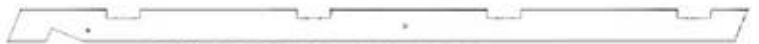

E08 RAFTER - W4L19547
(x3) 1 3/8"x3 3/8"x77 3/8" (36x86x1965)



H03 FASCIA - W4L19540
(x1) 1"x3 3/8"x72 1/8" (24x86x1831)



H04 FASCIA - W4L19541
(x1) 1"x3 3/8"x73 7/8" (24x86x1875)

- INSERT T-NUTS FIRST

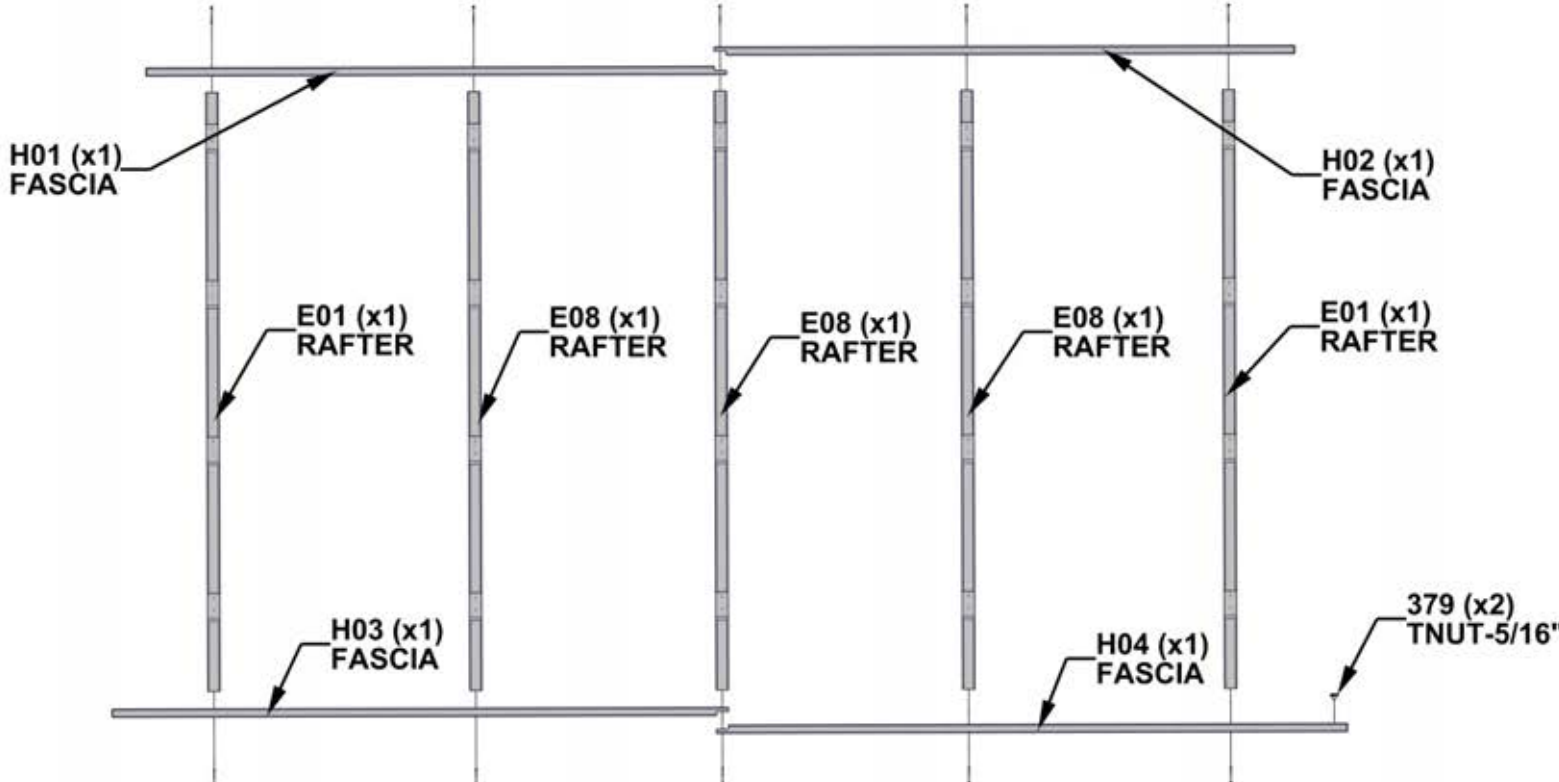

CORRECT ORIENTATION AND PLACEMENT OF H BOARDS IS CRITICAL FOR LATER STEPS

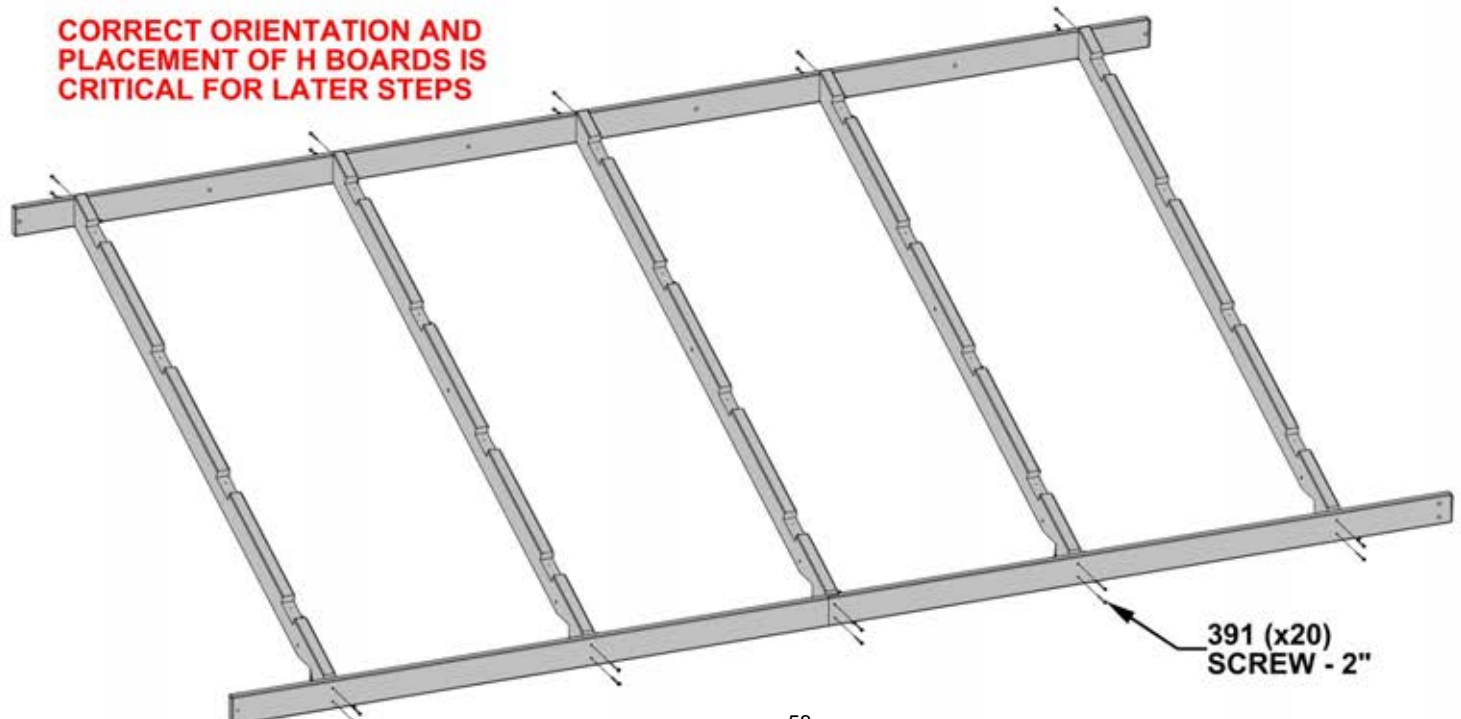

STEP 39A - ROOF PANEL B ASSEMBLY

QTY	PART NUMBER	DESCRIPTION
40	H100391	SCREW PFH 8x2 BLK



H05 SHEATHING BOARD - W4L19542
(x4) 1"x3 3/8"x43 1/4" (24x86x1098)



H07 SHEATHING BOARD - W4L19544
(x4) 1"x3 3/8"x44 3/4" (24x86x1137)



H06 SHEATHING BOARD - W4L19543
(x4) 1"x3 3/8"x59" (24x86x1500)

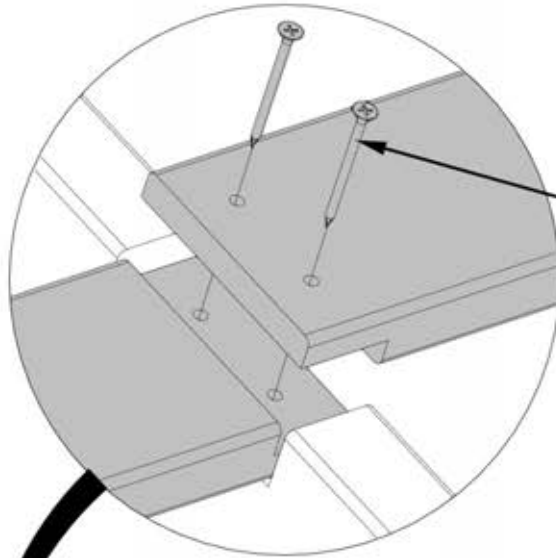

391 (x40)
SCREW - 2"

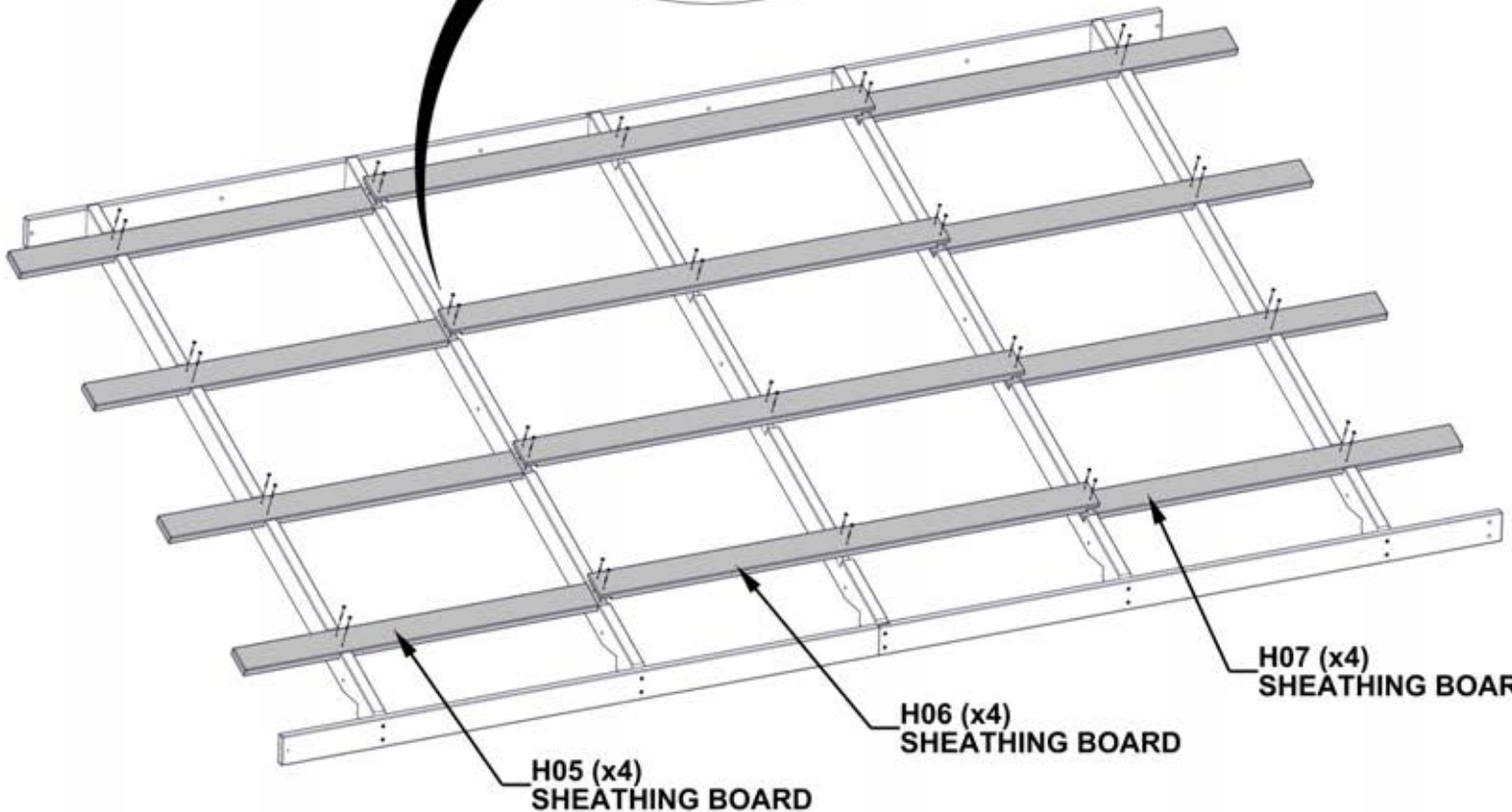

STEP 39B - ROOF PANEL B ASSEMBLY

CRITICAL:

- SQUARE UNIT BEFORE PROCEEDING TO NEXT STEPS.
- THE BELOW DIMENSIONS ARE CRITICAL TO THE FINAL ROOF ASSEMBLY.
- MEASUREMENTS SHOULD BE HELD WITHIN +/- 1/4" (6mm).
- MEASUREMENTS OUTSIDE OF TOLERANCE WILL LEAD TO THE INABILITY TO ASSEMBLE THE ROOF.

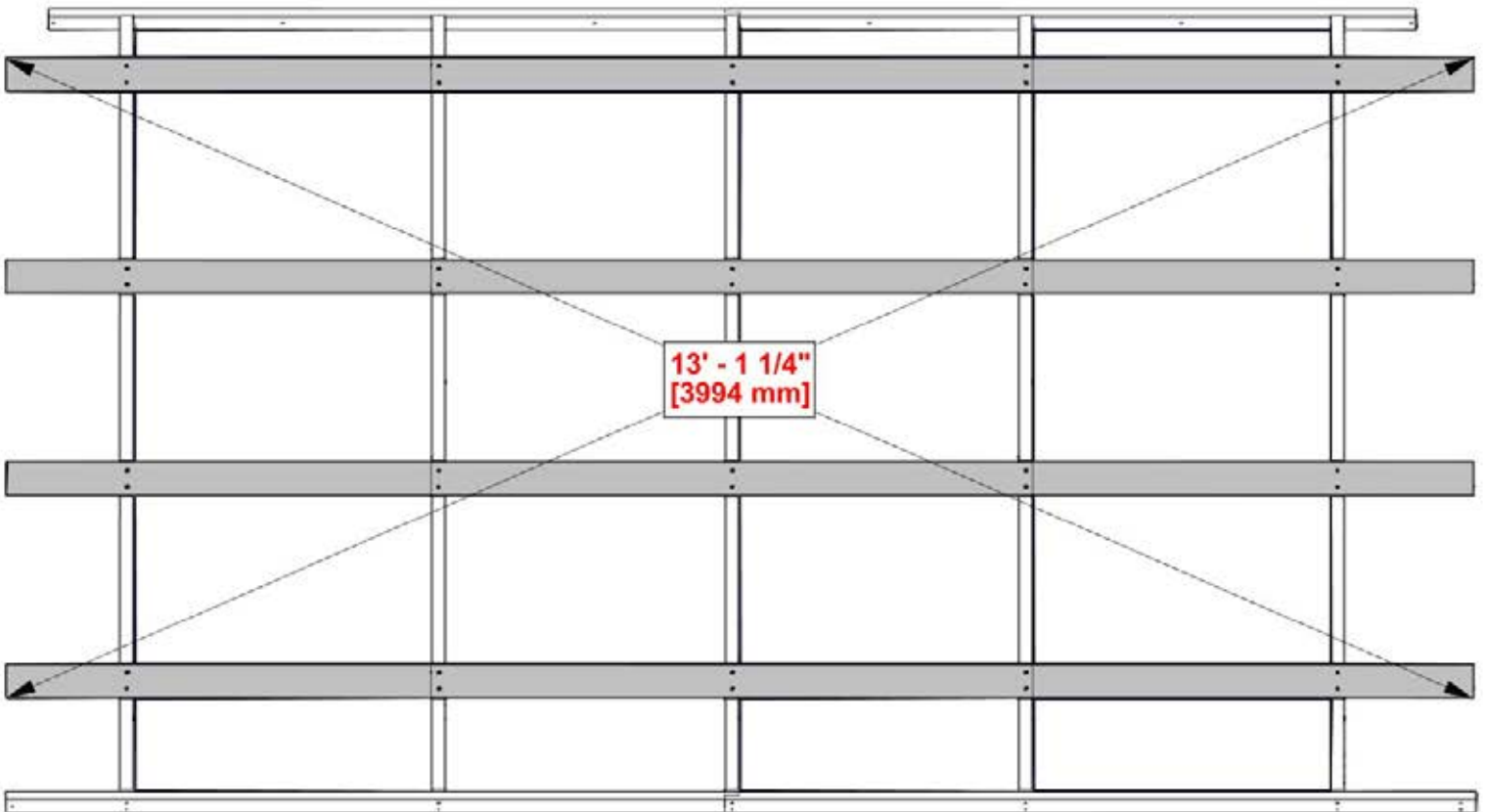

ONCE PANEL IS SQUARED, FULLY TIGHTEN SCREWS.

STEP 40 - ROOF PANEL B ASSEMBLY

ROOF PANEL B

- USE THIS STEP TO FAMILIARIZE YOURSELF WITH THE ROOF PANEL AND ASSIST YOU IN STEPS 41-42.
- REMOVE PROTECTIVE BLUE FILM.
- START AT THE END INDICATED AND ASSEMBLE IN THE DIRECTION OF THE ARROW.
- WHEN LAYING OUT ROOF SHEETS, MAKE SURE EVERY SHEET LANDS AT THE APPROXIMATE DIMENSION BELOW.
- REFER TO THIS STEP FOR EACH ROOF SHEET ATTACHMENT TO ENSURE CORRECT POSITION OF ROOF SHEETS.
- GLOVES SHOULD BE WORN WHEN HANDLING ROOF PANELS. EDGES ARE SHARP.

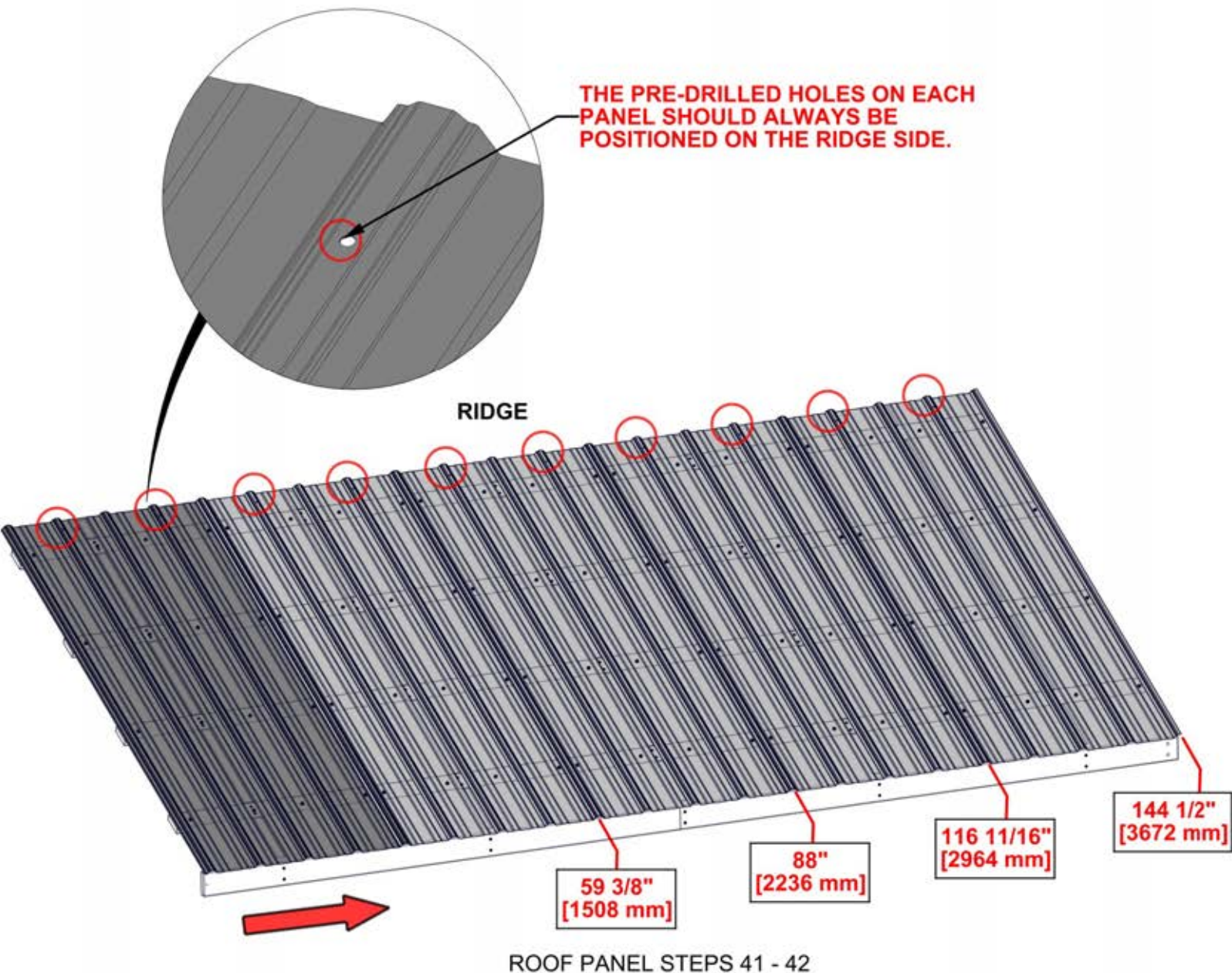

STEP 41 - ROOF PANEL B ASSEMBLY

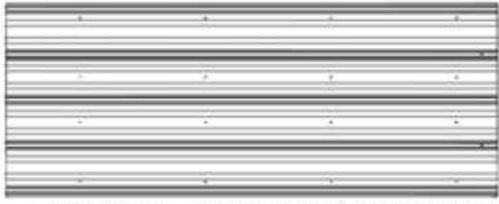

QTY	PART NUMBER	DESCRIPTION
32	H100833	SCREW WOODGRIP 10-16x3/4"

- MAKE SURE YOUR ROOF PANEL IS SQUARE BEFORE MOVING ON.

NOTE RIB OVERLAP

833 (x32)
SCREW - 3/4"

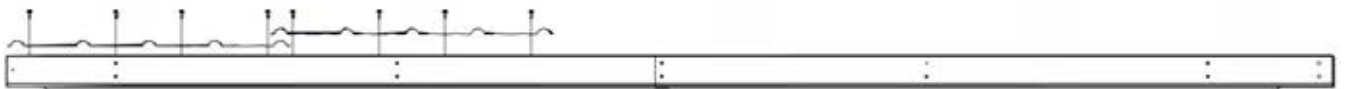
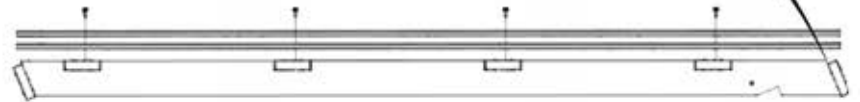
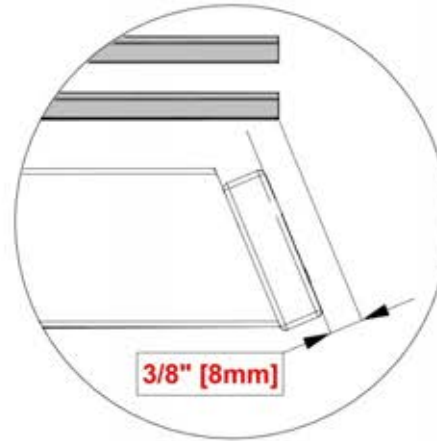
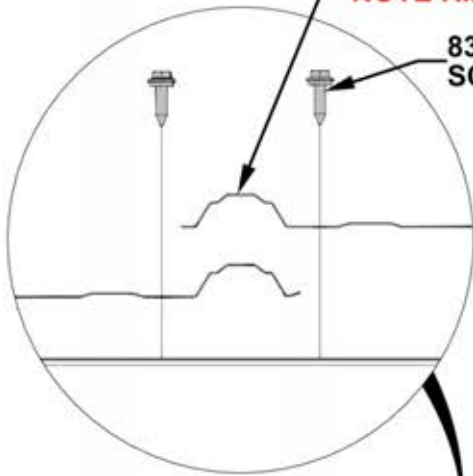

2639 (x2)
29GA STEEL SHEETING

RIDGE



PLACE SHEETING ON ROOF PANEL, ALIGNING EDGE OF RIB 3/8" (8mm) FROM END OF H BOARD

H03
FASCIA

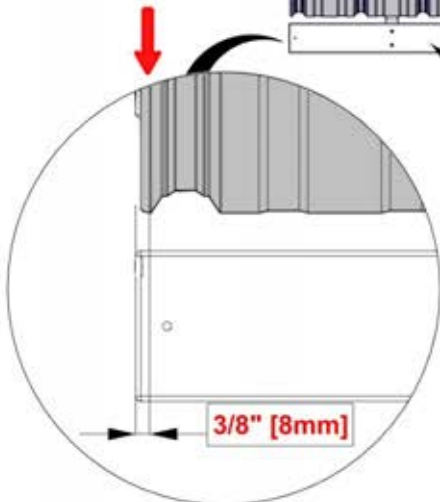

STEP 42 - ROOF PANEL B ASSEMBLY

QTY	PART NUMBER	DESCRIPTION
48	H100833	SCREW WOODGRIP 10-16x3/4"

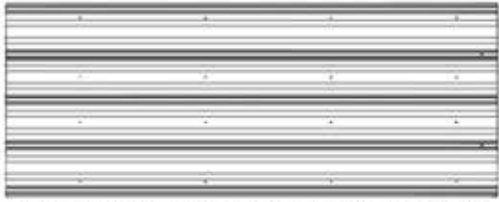

A4M02639 29GA STEEL SHEETING
(x2)



A4M02647 29GA STEEL SHEETING
(x1)

NOTE THROUGH HOLES

833 (x48)
SCREW - 3/4"

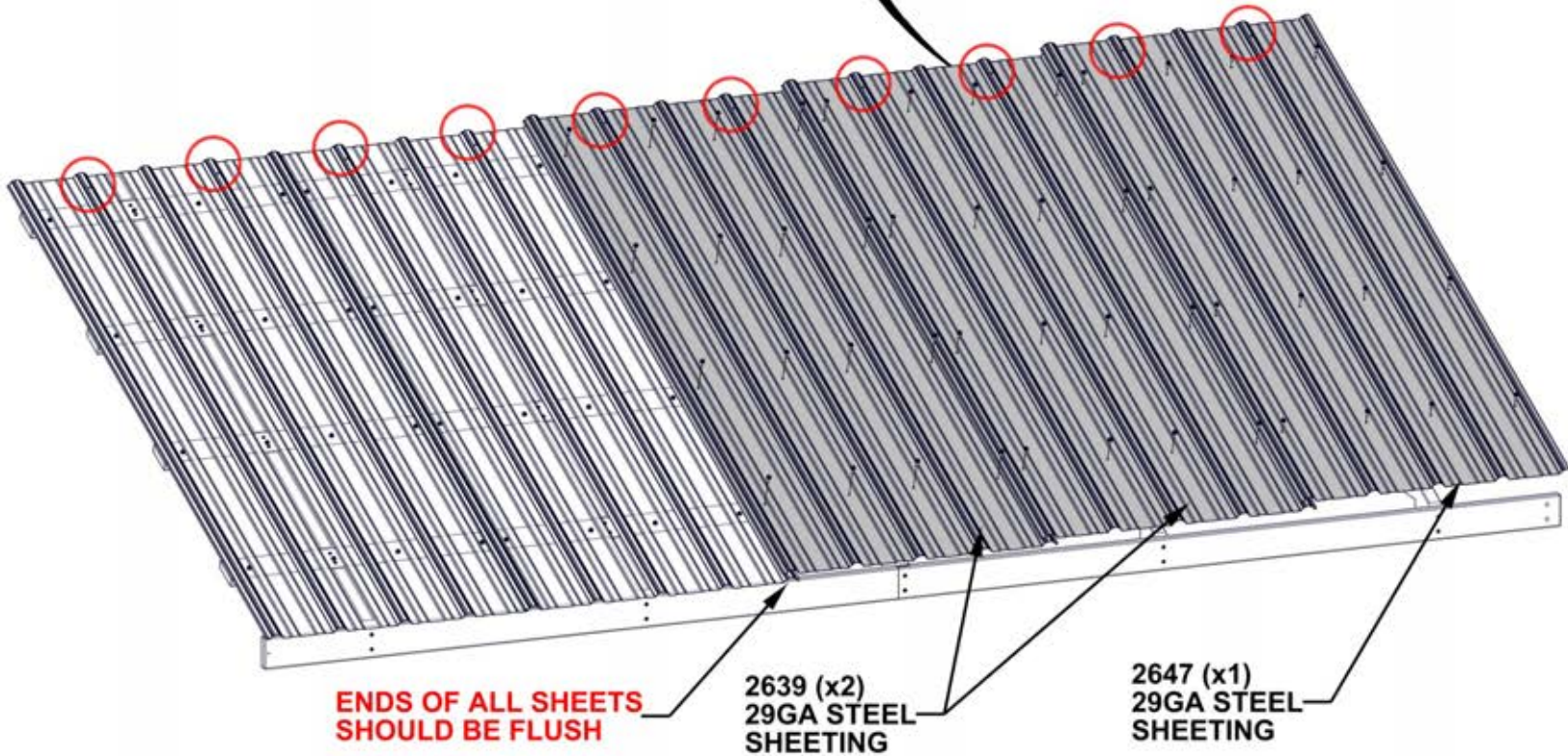
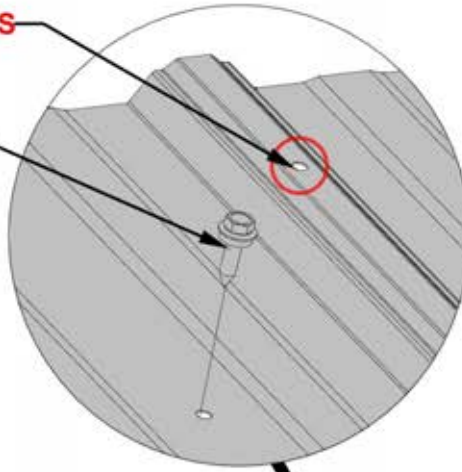

STEP 43 - ROOF PANEL C ASSEMBLY

QTY	PART NUMBER	DESCRIPTION
2	H100379	TNUT-5/16" BLK
20	H100391	SCREW PFH 8x2 BLK

E01 RAFTER - W4L19537
(x2) 1 3/8"x3 3/8"x77 3/8" (36x86x1965)

H01 FASCIA - W4L19538
(x1) 1"x3 3/8"x67 7/8" (24x86x1724)

H02 FASCIA - W4L19539
(x1) 1"x3 3/8"x67 7/8" (24x86x1725)

A4M02750 RIDGE BRACE METAL
(x1)

E08 RAFTER - W4L19547
(x3) 1 3/8"x3 3/8"x77 3/8" (36x86x1965)

H03 FASCIA - W4L19540
(x1) 1"x3 3/8"x72 1/8" (24x86x1831)

H04 FASCIA - W4L19541
(x1) 1"x3 3/8"x73 7/8" (24x86x1875)

- INSERT T-NUTS FIRST

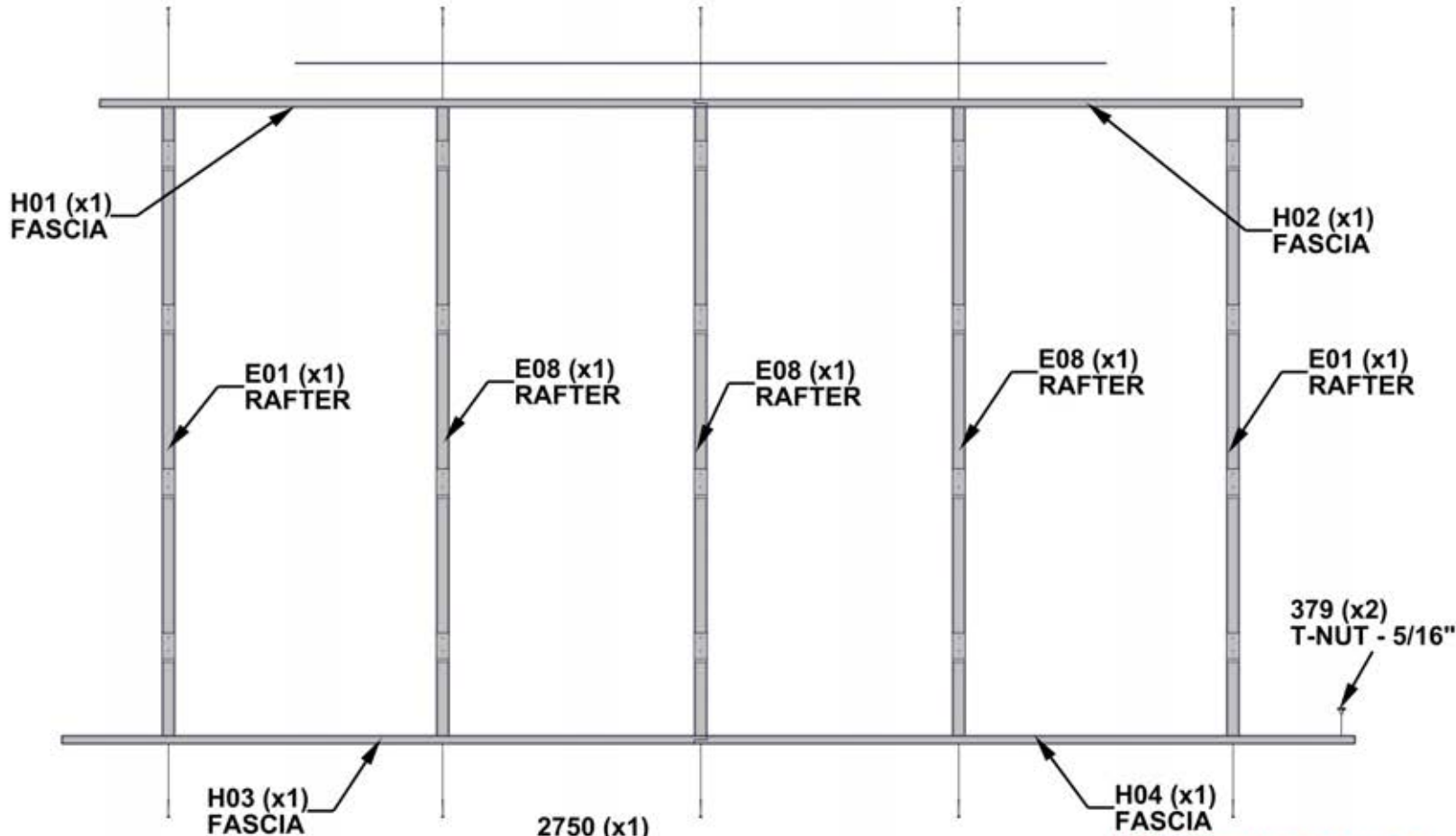

CORRECT ORIENTATION AND PLACEMENT OF H BOARDS IS CRITICAL FOR LATER STEPS

NOTE ORIENTATION OF COUNTERSUNK HOLES IN RIDGE BRACE METAL

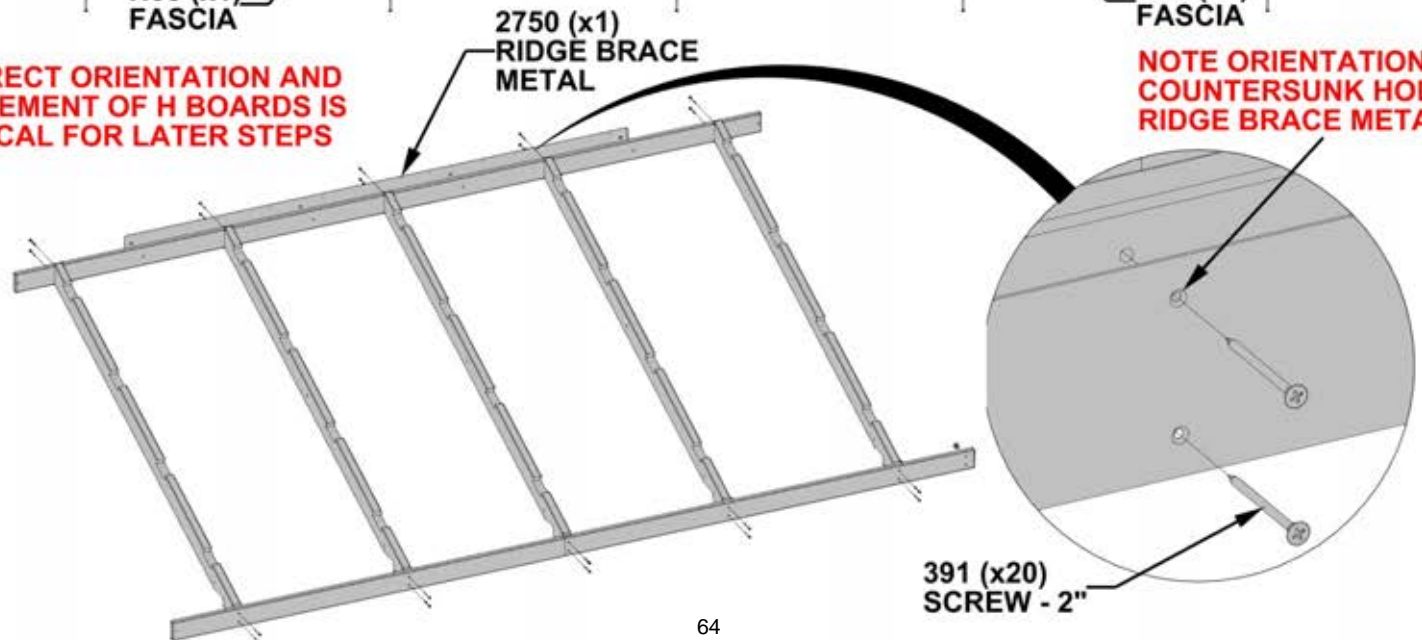

STEP 44 - ROOF PANEL C ASSEMBLY

QTY	PART NUMBER	DESCRIPTION
12	H100395	SCREW PFH 8x3/4 BLK

MAKE SURE ALL HOLES ARE ALIGNED BEFORE INSTALLING SCREWS

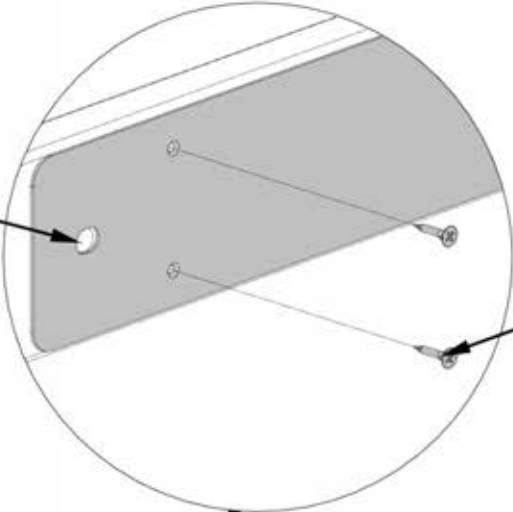

**395 (x12)
SCREW - 3/4"**

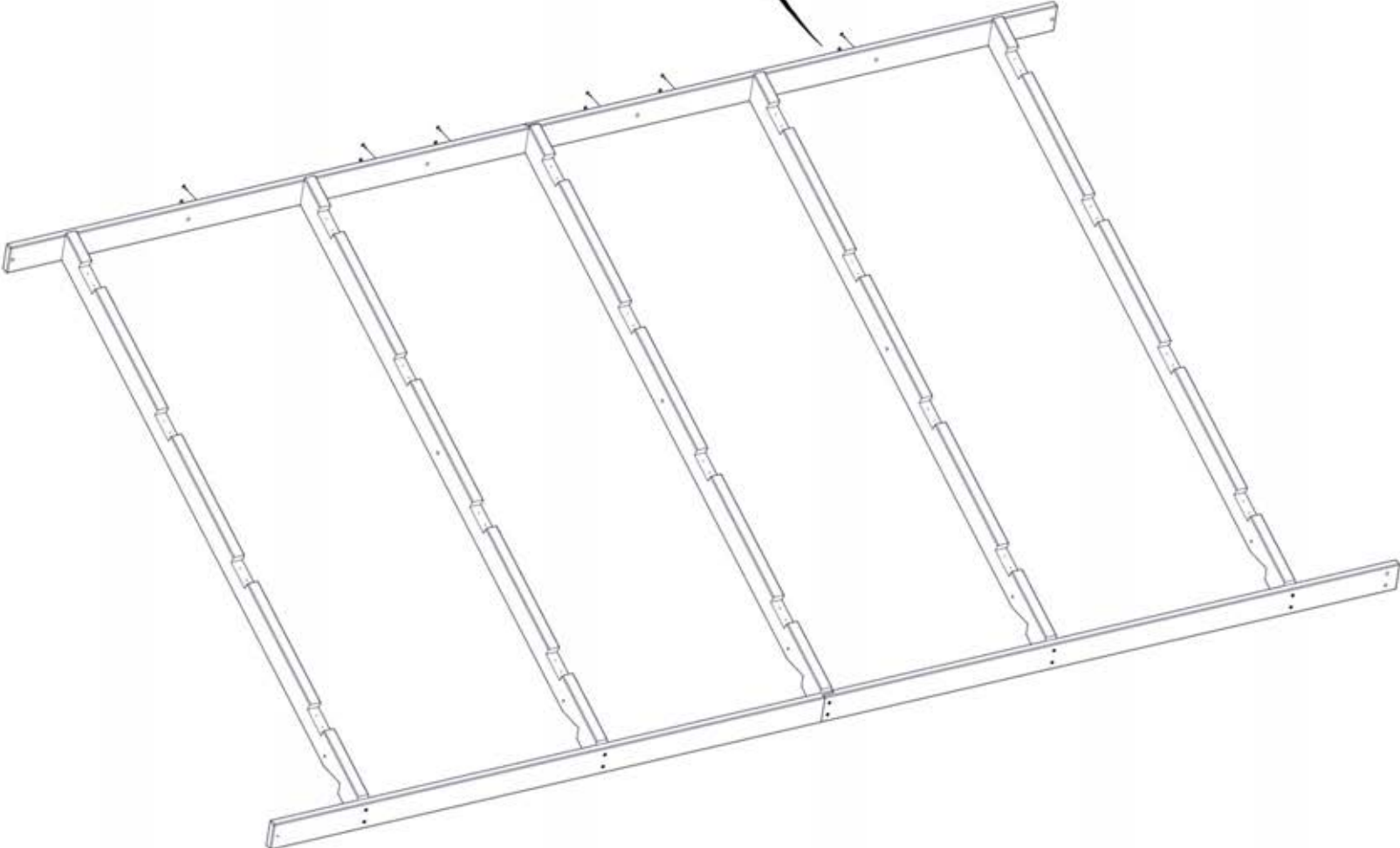

STEP 45A - ROOF PANEL C ASSEMBLY

QTY	PART NUMBER	DESCRIPTION
40	H100391	SCREW PFH 8x2 BLK



H05 SHEATHING BOARD - W4L19542
(x4) 1"x3 3/8"x43 1/4" (24x86x1098)



H07 SHEATHING BOARD - W4L19544
(x4) 1"x3 3/8"x44 3/4" (24x86x1137)



H06 SHEATHING BOARD - W4L19543
(x4) 1"x3 3/8"x59" (24x86x1500)

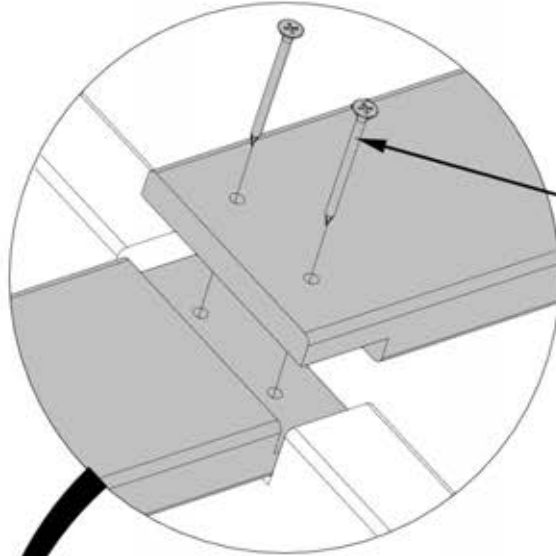

391 (x40)
SCREW - 2"

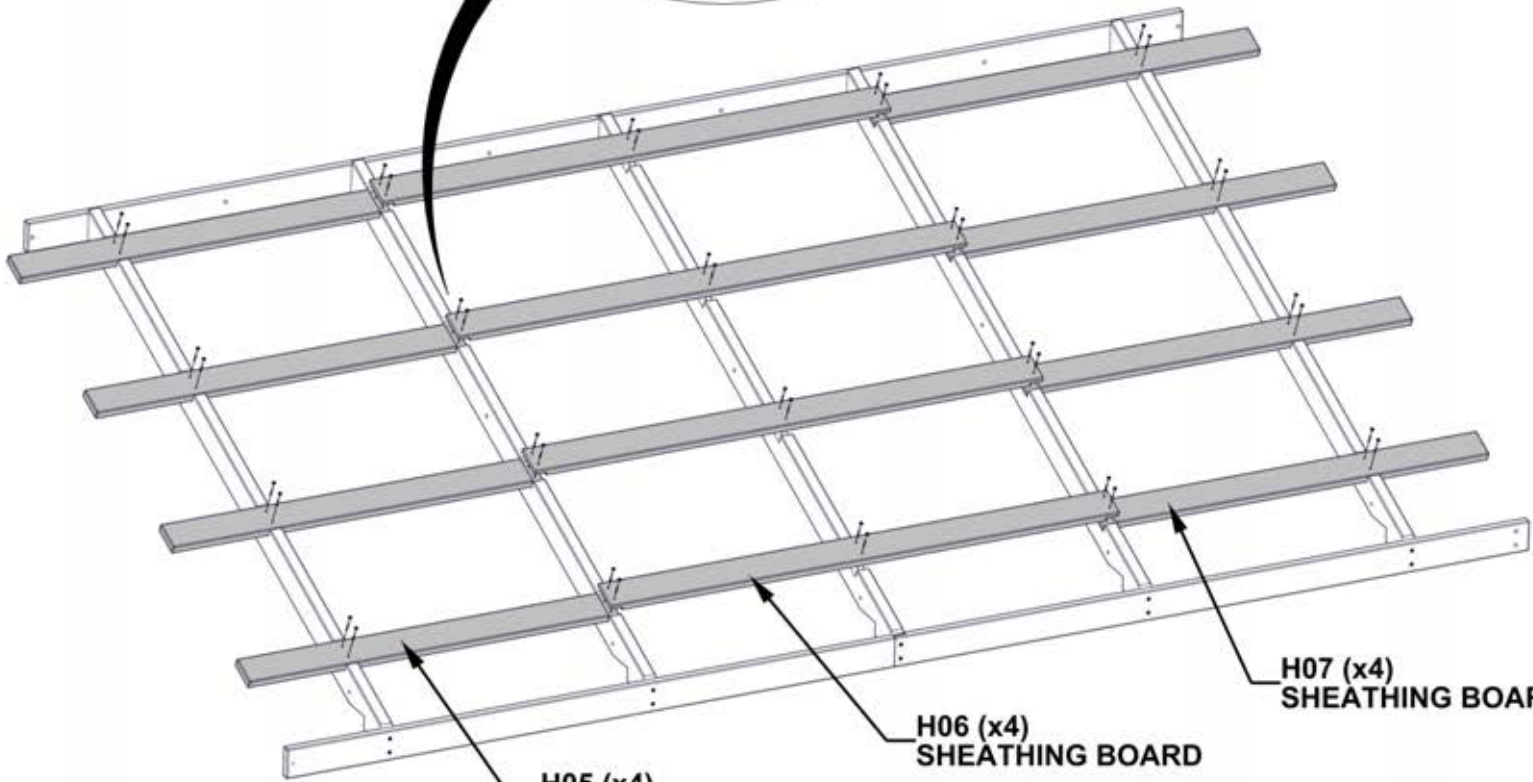

H05 (x4)
SHEATHING BOARD

H06 (x4)
SHEATHING BOARD

H07 (x4)
SHEATHING BOARD

STEP 45B - ROOF PANEL C ASSEMBLY

CRITICAL:

- SQUARE UNIT BEFORE PROCEEDING TO NEXT STEPS.
- THE BELOW DIMENSIONS ARE CRITICAL TO THE FINAL ROOF ASSEMBLY.
- MEASUREMENTS SHOULD BE HELD WITHIN +/- 1/4" (6mm).
- MEASUREMENTS OUTSIDE OF TOLERANCE WILL LEAD TO THE INABILITY TO ASSEMBLE THE ROOF.

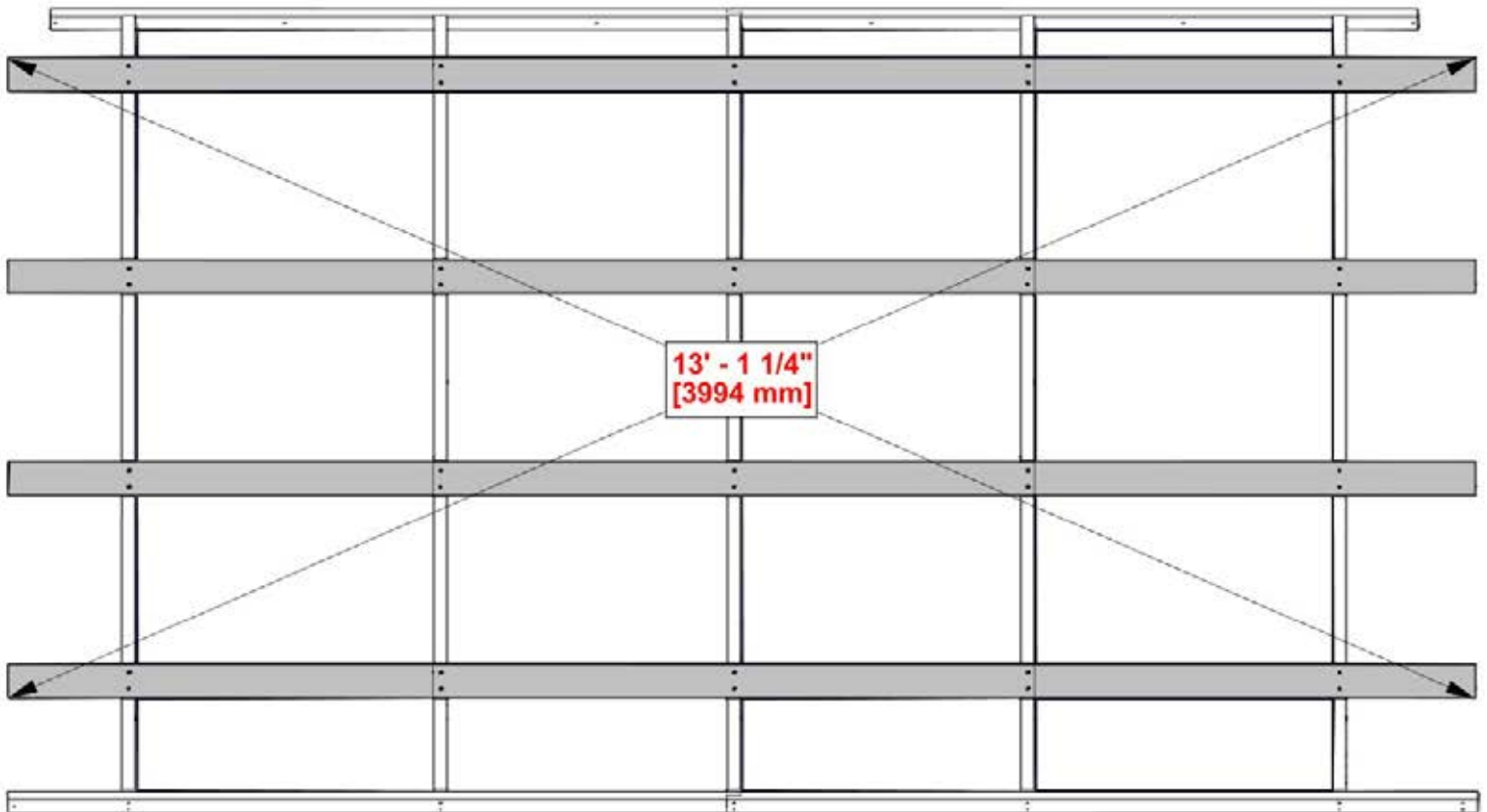

ONCE PANEL IS SQUARED, FULLY TIGHTEN SCREWS.

STEP 46 - ROOF PANEL C ASSEMBLY

ROOF PANEL C

- USE THIS STEP TO FAMILIARIZE YOURSELF WITH THE ROOF PANEL AND ASSIST YOU IN STEPS 47 - 48.
- REMOVE PROTECTIVE BLUE FILM.
- START AT THE END INDICATED AND ASSEMBLE IN THE DIRECTION OF THE ARROW.
- WHEN LAYING OUT ROOF SHEETS, MAKE SURE EVERY SHEET LANDS AT THE APPROXIMATE DIMENSION BELOW.
- REFER TO THIS STEP FOR EACH ROOF SHEET ATTACHMENT TO ENSURE CORRECT POSITION OF ROOF SHEETS.
- GLOVES SHOULD BE WORN WHEN HANDLING ROOF PANELS. EDGES ARE SHARP.

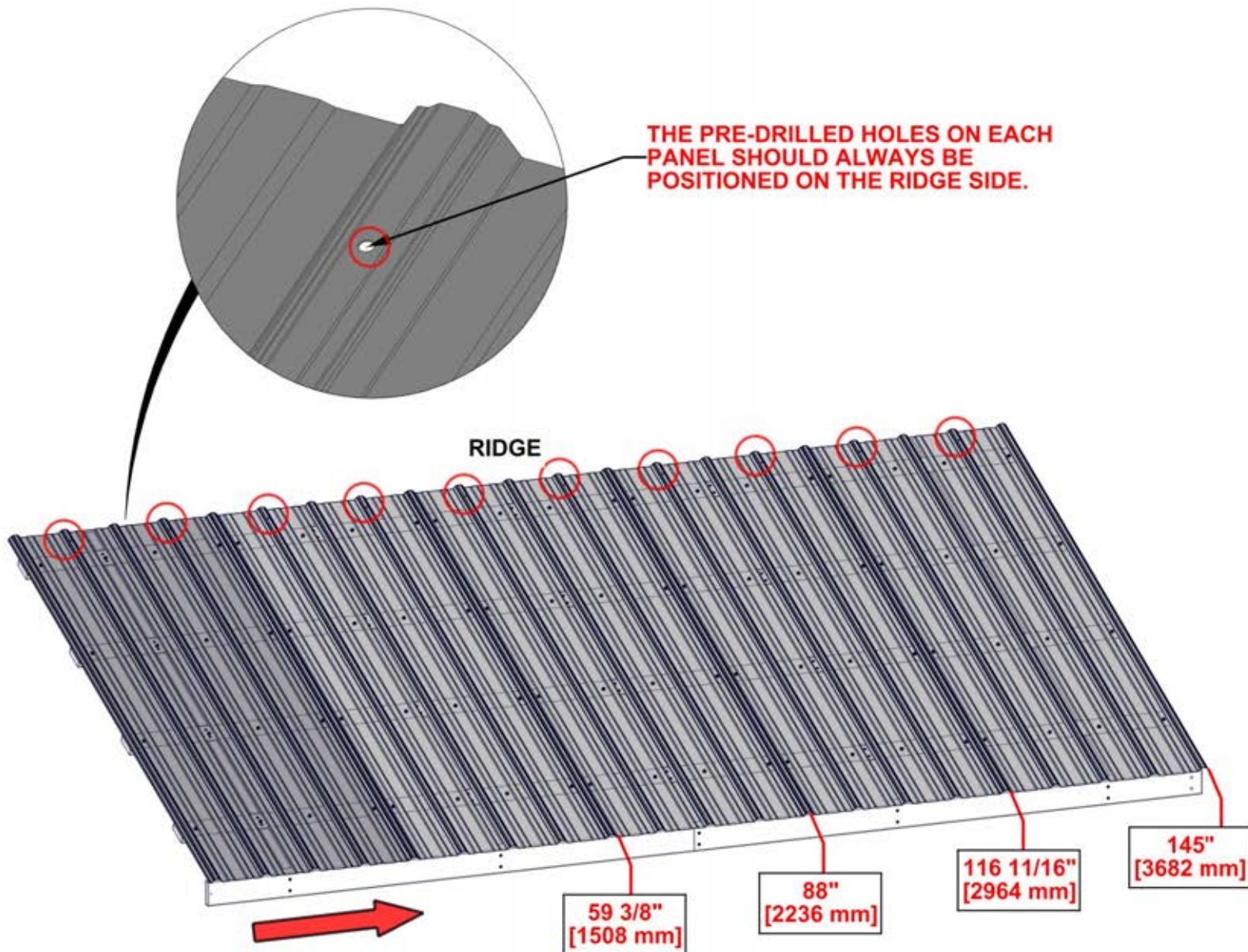

ROOF PANEL STEPS 47 - 48

STEP 47 - ROOF PANEL C ASSEMBLY

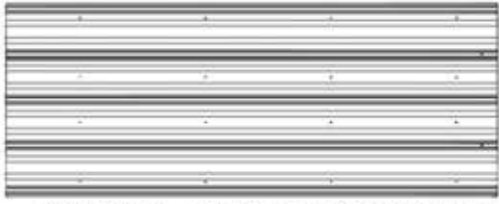

QTY	PART NUMBER	DESCRIPTION
32	H100833	SCREW WOODGRIP 10-16x3/4"

- MAKE SURE YOUR ROOF PANEL IS SQUARE BEFORE MOVING ON.

NOTE RIB OVERLAP

**833 (x32)
SCREW - 3/4"**

3/8" [8mm]

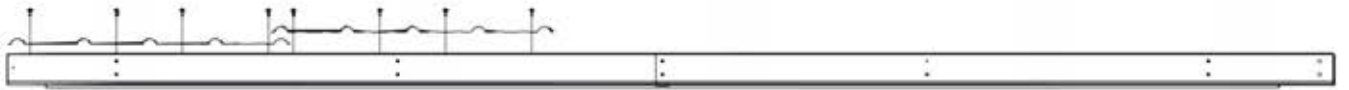
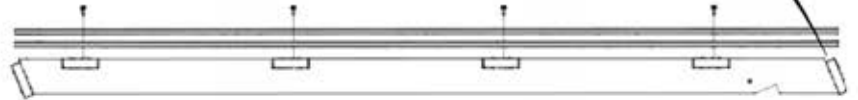
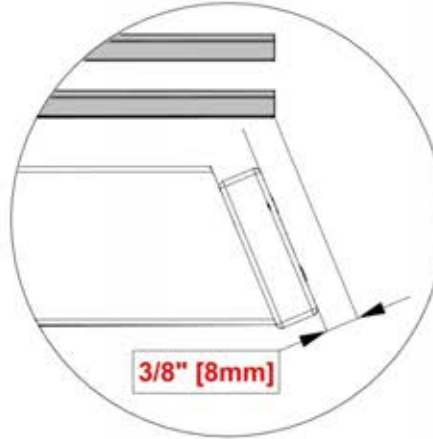
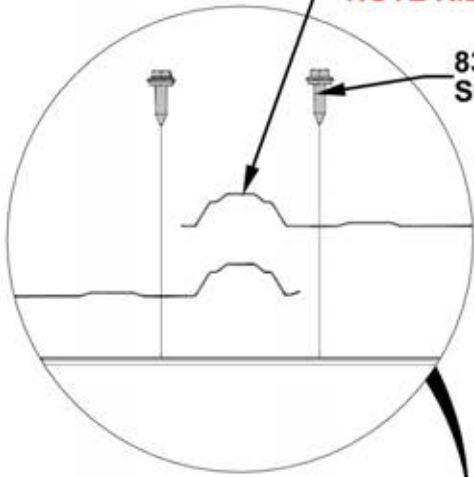

**2639 (x2)
29GA STEEL SHEETING**

RIDGE

PLACE SHEETING ON ROOF PANEL, ALIGNING EDGE OF RIB 3/8" (8mm) FROM END OF H BOARD

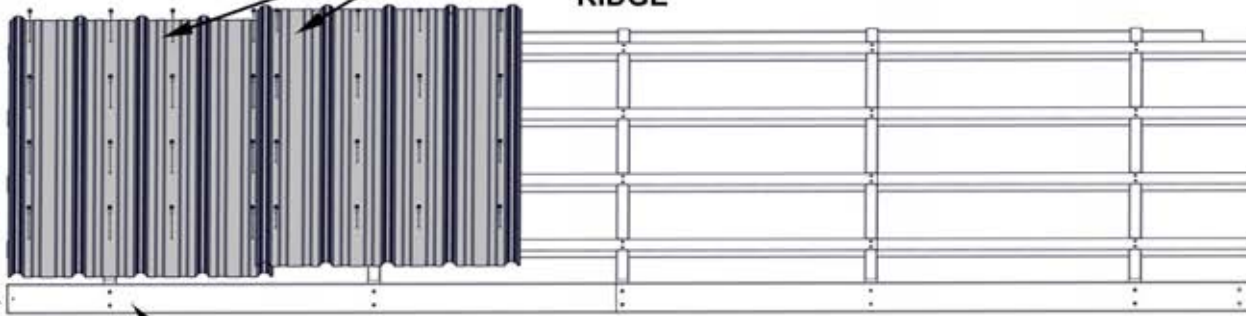

**H03
FASCIA**

3/8" [8mm]

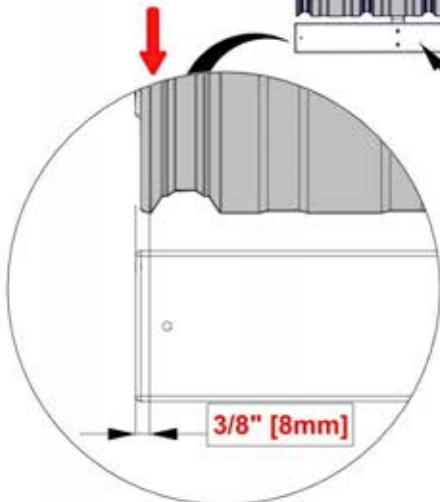

STEP 48 - ROOF PANEL C ASSEMBLY

QTY	PART NUMBER	DESCRIPTION
48	H100833	SCREW WOODGRIP 10-16x3/4"

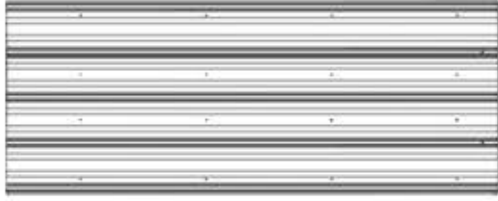

A4M02639 29GA STEEL SHEETING
(x2)



A4M02908 29GA STEEL SHEETING
(x1)

NOTE THROUGH HOLES

833 (x48)
SCREW - 3/4"

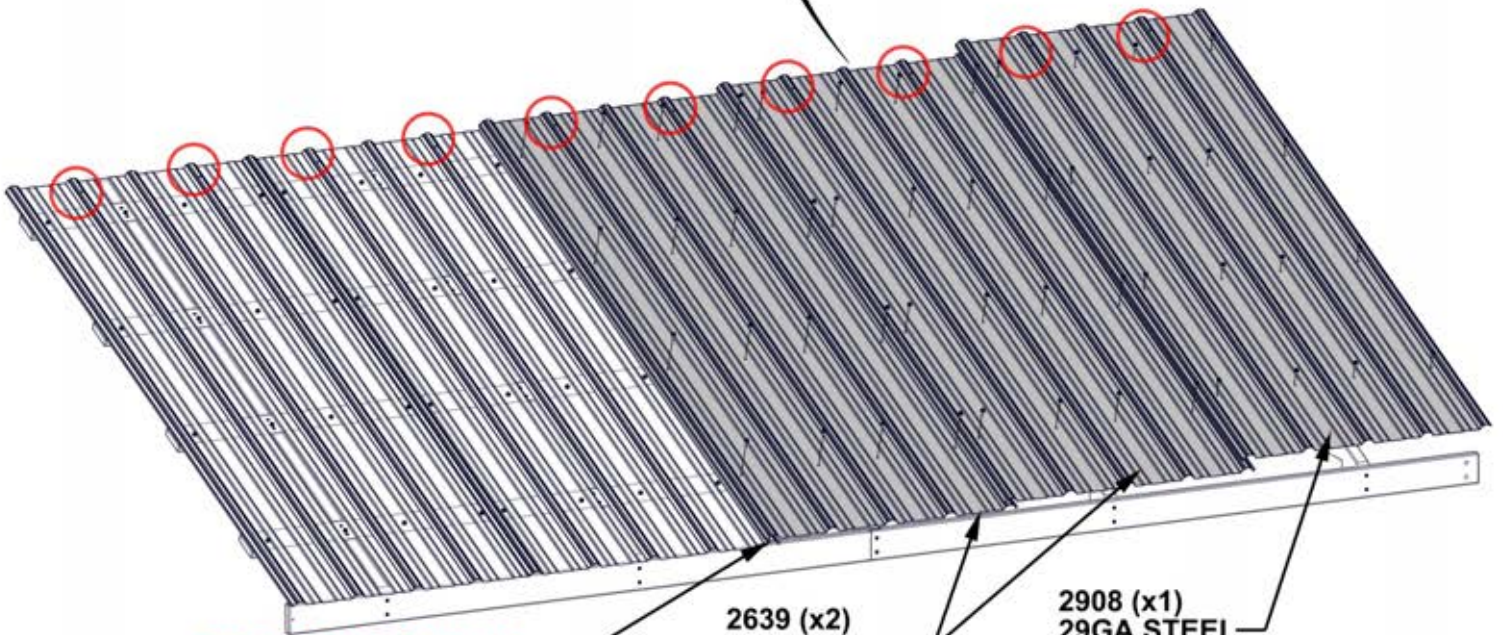
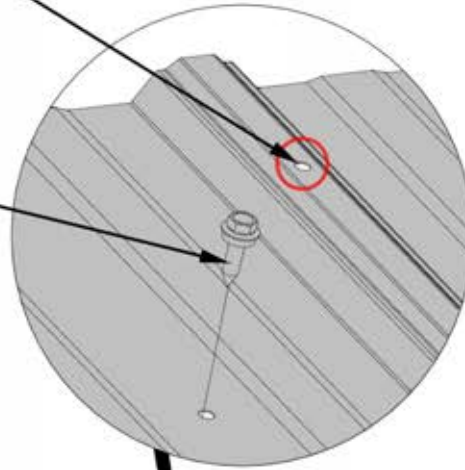

**ENDS OF ALL SHEETS
SHOULD BE FLUSH**

2639 (x2)
29GA STEEL
SHEETING

2908 (x1)
29GA STEEL
SHEETING

STEP 49 - ROOF PANEL D ASSEMBLY

QTY	PART NUMBER	DESCRIPTION
2	H100379	TNUT-5/16" BLK
20	H100391	SCREW PFH 8x2 BLK



E01 RAFTER - W4L19537
(x2) 1 3/8"x3 3/8"x77 3/8" (36x86x1965)



H01 FASCIA - W4L19538
(x1) 1"x3 3/8"x67 7/8" (24x86x1724)



H02 FASCIA - W4L19539
(x1) 1"x3 3/8"x67 7/8" (24x86x1725)



E08 RAFTER - W4L19547
(x3) 1 3/8"x3 3/8"x77 3/8" (36x86x1965)

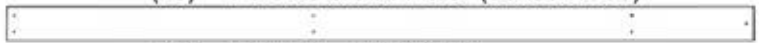

H03 FASCIA - W4L19540
(x1) 1"x3 3/8"x72 1/8" (24x86x1831)



H04 FASCIA - W4L19541
(x1) 1"x3 3/8"x73 7/8" (24x86x1875)

- INSERT T-NUTS FIRST

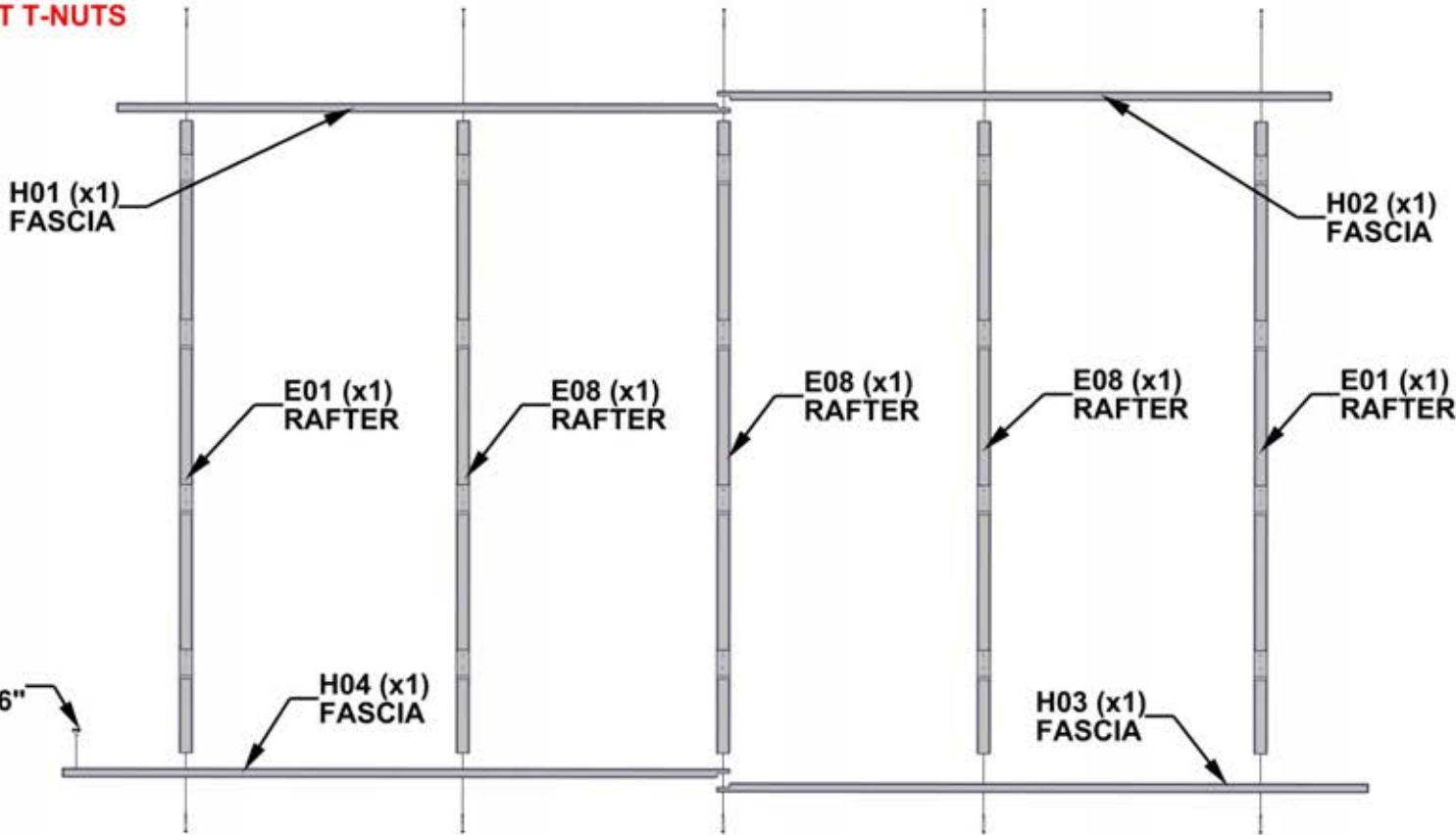

CORRECT ORIENTATION AND PLACEMENT OF H BOARDS IS CRITICAL FOR LATER STEPS

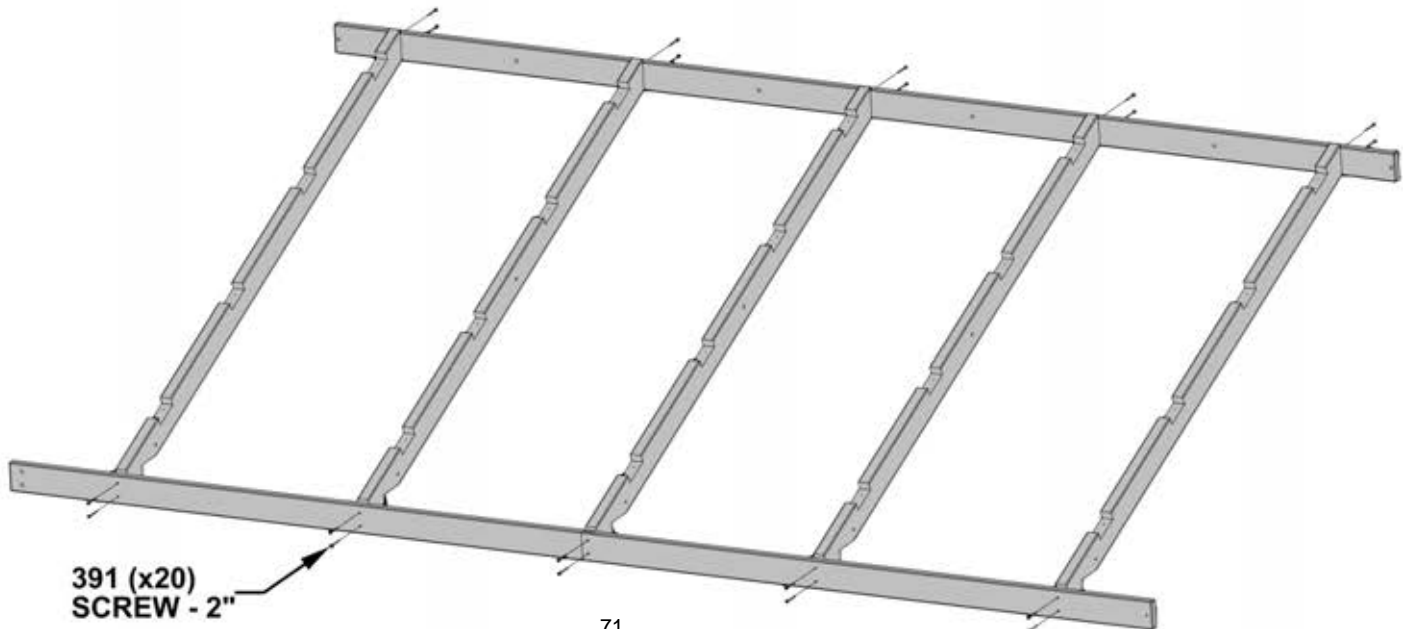

STEP 50A - ROOF PANEL D ASSEMBLY

QTY	PART NUMBER	DESCRIPTION
40	H100391	SCREW PFH 8x2 BLK



H05 SHEATHING BOARD - W4L19542
(x4) 1"x3 3/8"x43 1/4" (24x86x1098)



H07 SHEATHING BOARD - W4L19544
(x4) 1"x3 3/8"x44 3/4" (24x86x1137)



H06 SHEATHING BOARD - W4L19543
(x4) 1"x3 3/8"x59" (24x86x1500)

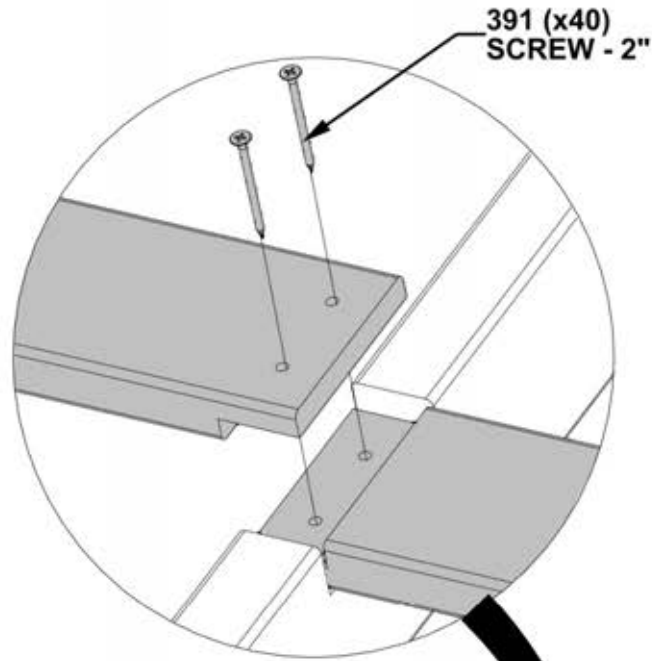

H07 (x4)
SHEATHING BOARD

H06 (x4)
SHEATHING BOARD

H05 (x4)
SHEATHING BOARD

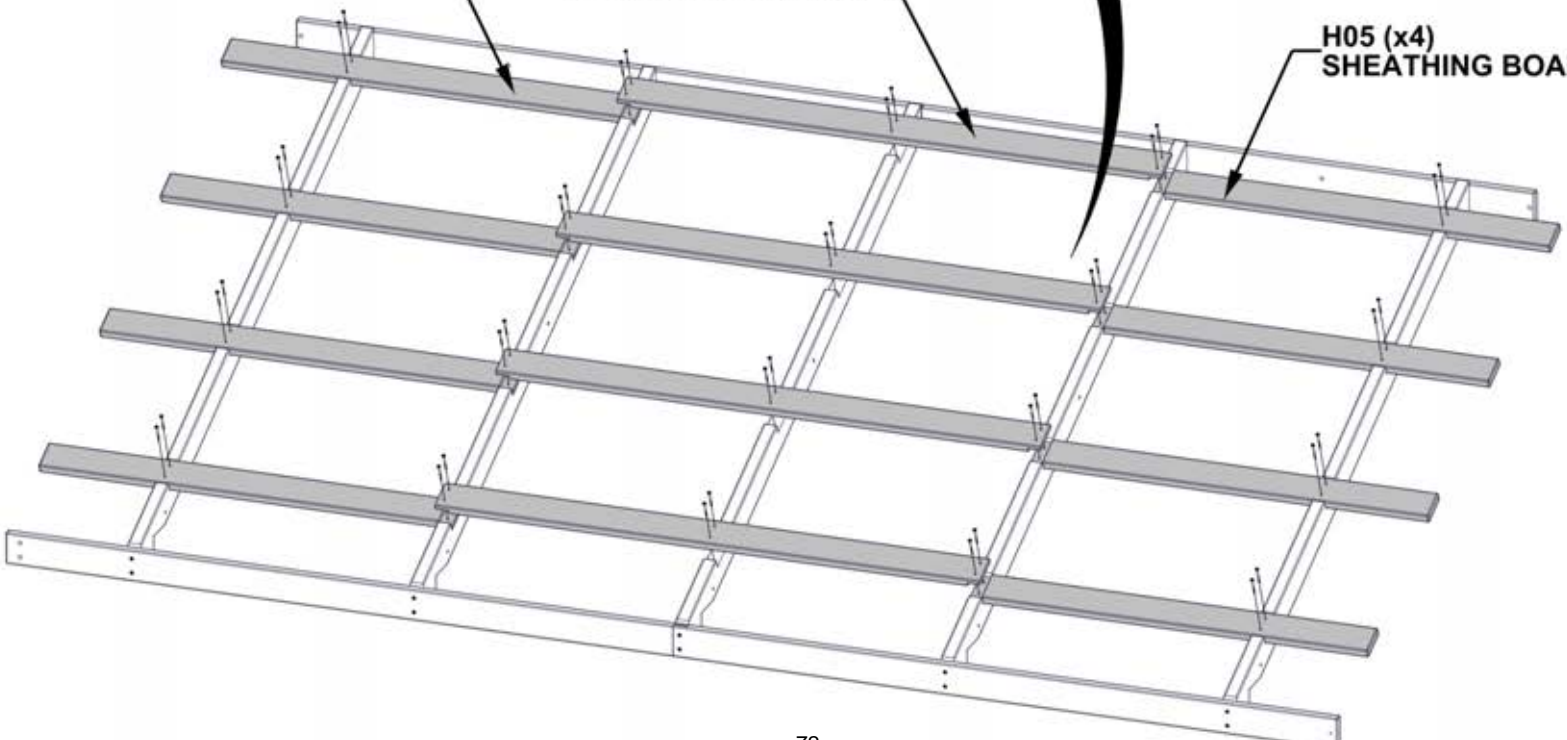

STEP 50B - ROOF PANEL D ASSEMBLY

CRITICAL:

- SQUARE UNIT BEFORE PROCEEDING TO NEXT STEPS.
- THE BELOW DIMENSIONS ARE CRITICAL TO THE FINAL ROOF ASSEMBLY.
- MEASUREMENTS SHOULD BE HELD WITHIN $\pm 1/4"$ (6mm).
- MEASUREMENTS OUTSIDE OF TOLERANCE WILL LEAD TO THE INABILITY TO ASSEMBLE THE ROOF.

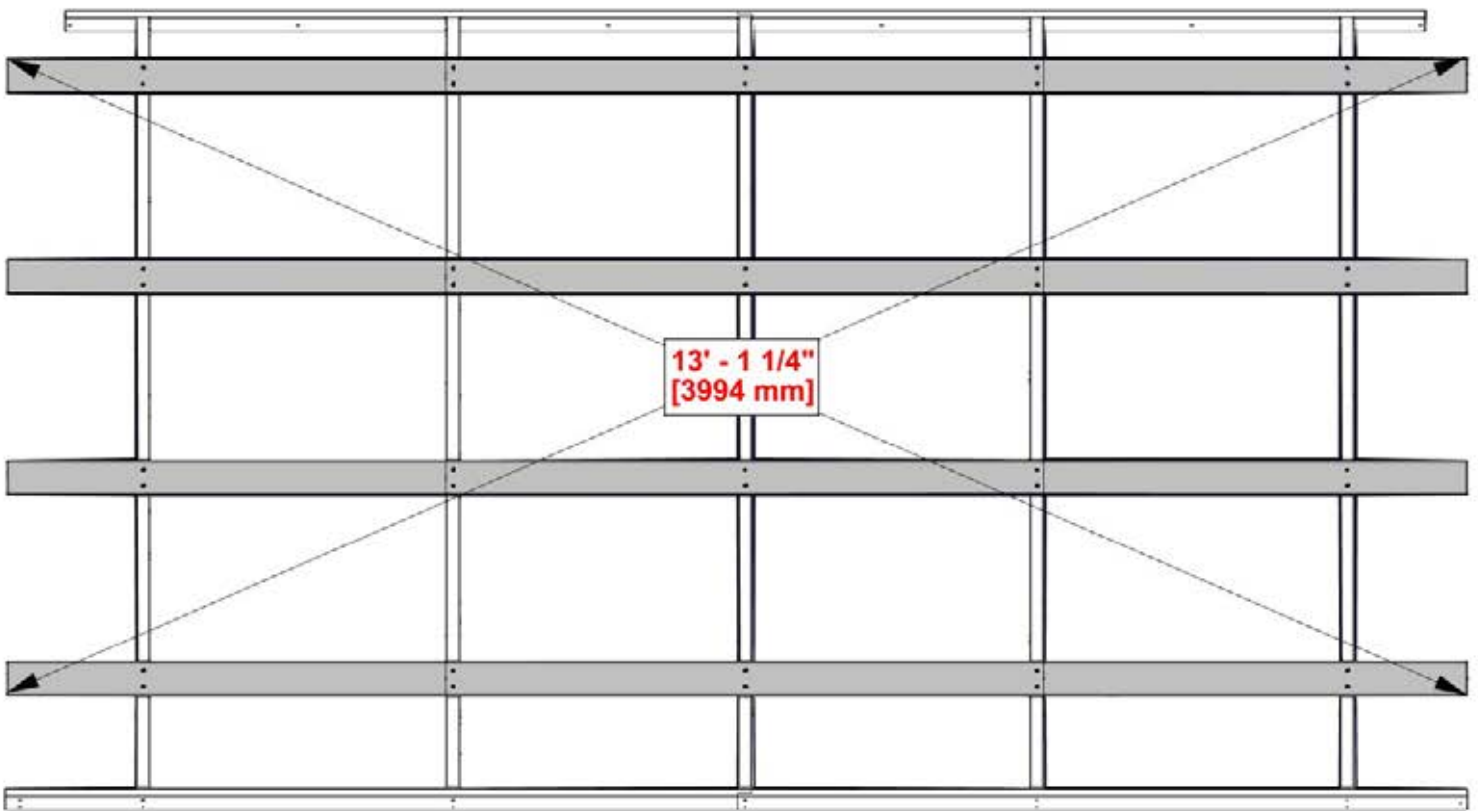

ONCE PANEL IS SQUARED, FULLY TIGHTEN SCREWS.

STEP 51 - ROOF PANEL D ASSEMBLY

ROOF PANEL D

TIPS:

- USE THIS STEP TO FAMILIARIZE YOURSELF WITH THE ROOF PANEL AND ASSIST YOU IN STEPS 52-53.
- REMOVE PROTECTIVE BLUE FILM.
- START AT THE END INDICATED AND ASSEMBLE IN THE DIRECTION OF THE ARROW.
- WHEN LAYING OUT ROOF SHEETS, MAKE SURE EVERY SHEET LANDS AT THE APPROXIMATE DIMENSION BELOW.
- REFER TO THIS STEP FOR EACH ROOF SHEET ATTACHMENT TO ENSURE CORRECT POSITION OF ROOF SHEETS.
- GLOVES SHOULD BE WORN WHEN HANDLING ROOF PANELS. EDGES ARE SHARP.

THE PRE-DRILLED HOLES ON EACH PANEL SHOULD ALWAYS BE POSITIONED ON THE RIDGE SIDE.

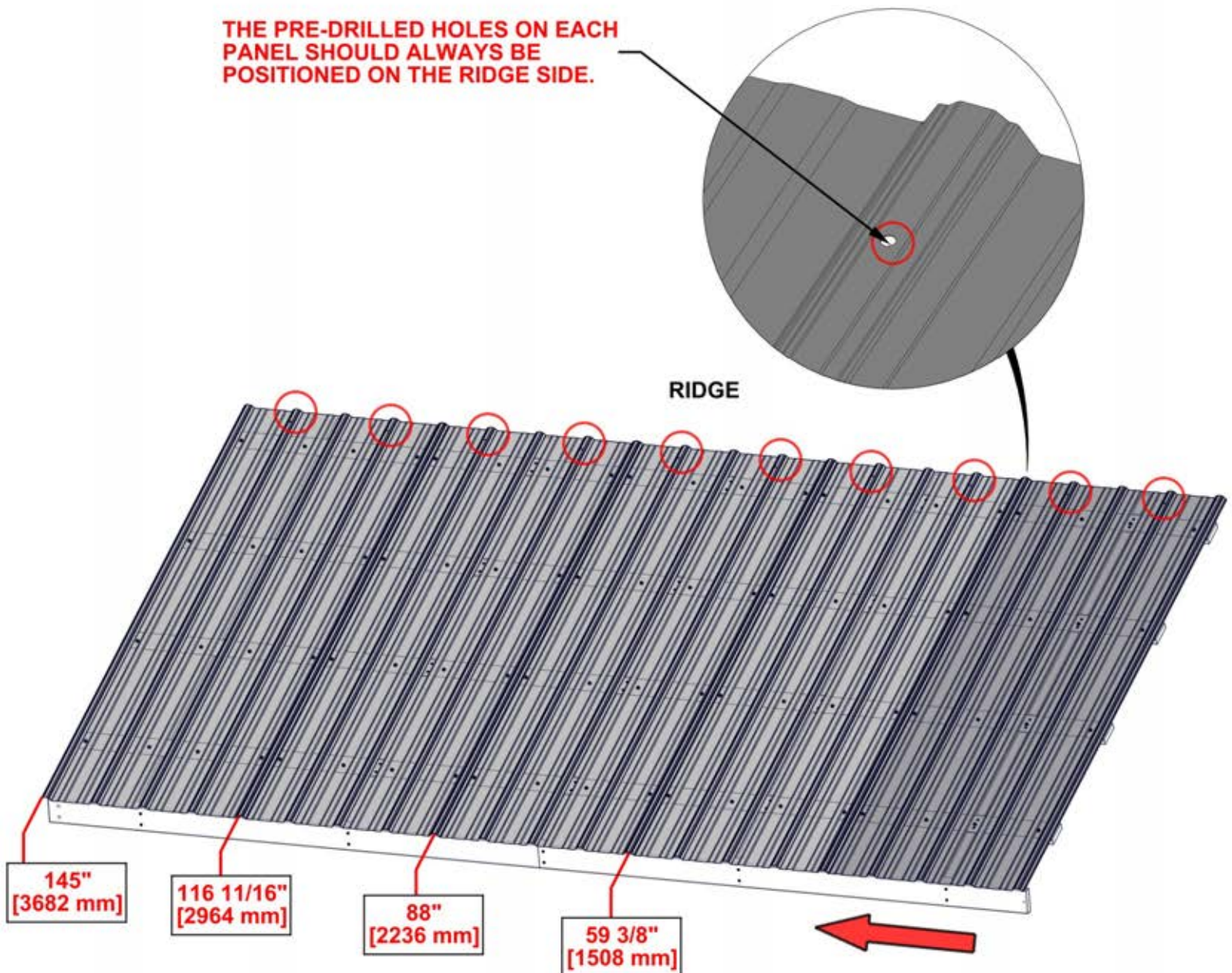

ROOF PANEL STEPS 52 - 53

STEP 52 - ROOF PANEL D ASSEMBLY



A4M02639 29GA STEEL SHEETING (x2)

QTY	PART NUMBER	DESCRIPTION
32	H100833	SCREW WOODGRIP 10-16x3/4"

- MAKE SURE YOUR ROOF PANEL IS SQUARE BEFORE MOVING ON.

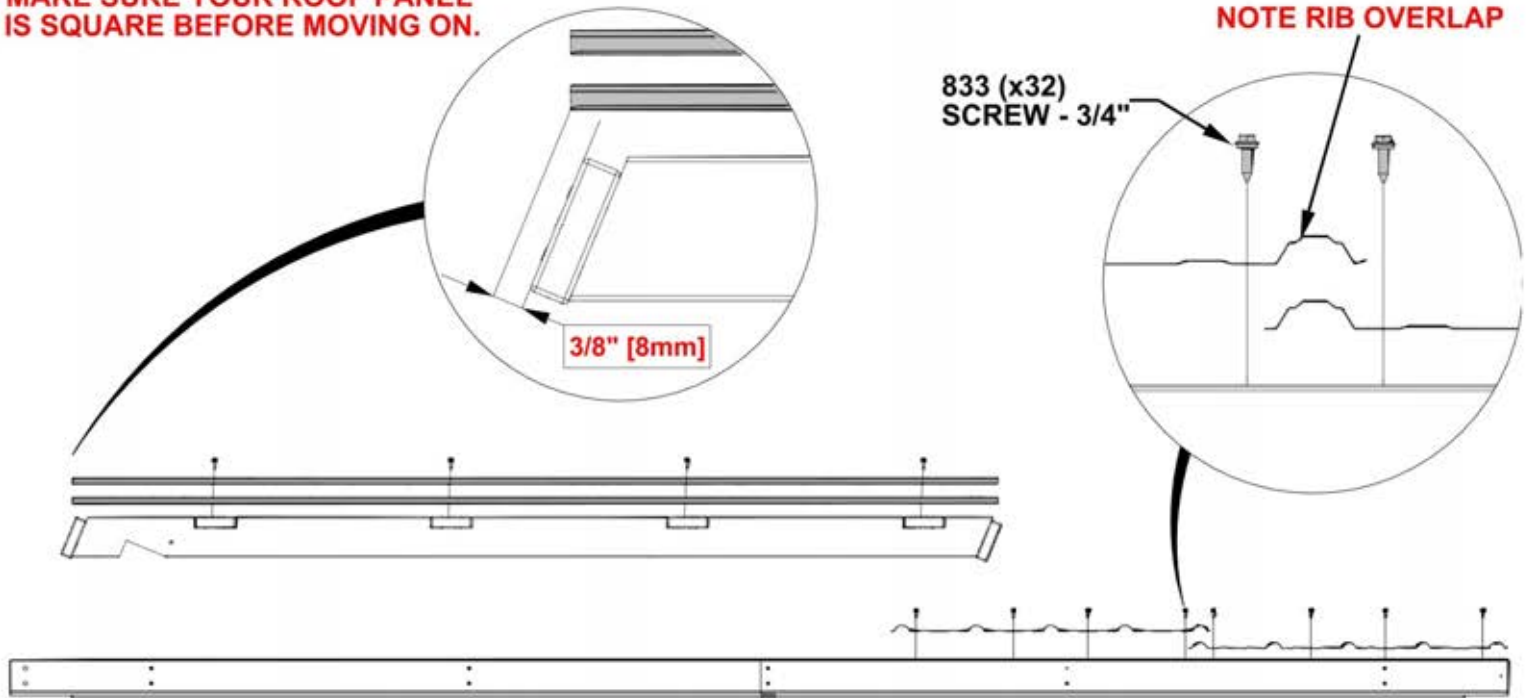

2639 (x2)
29GA STEEL SHEETING

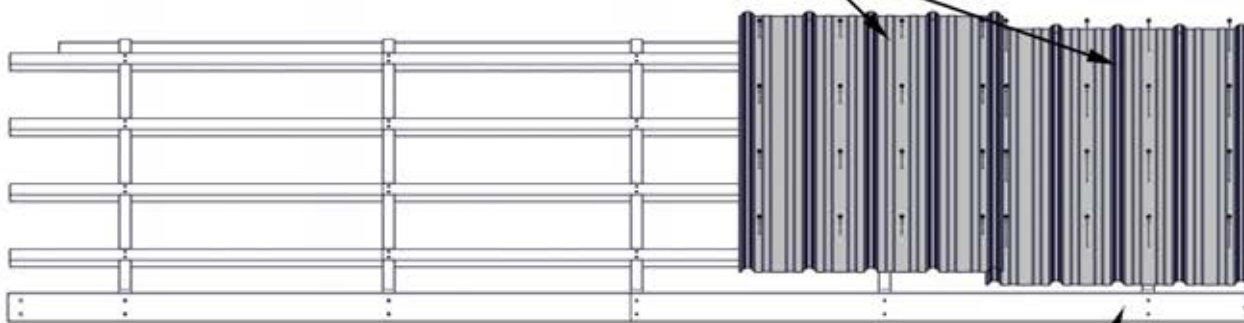

PLACE SHEETING ON ROOF PANEL, ALIGNING EDGE OF RIB 3/8" (8mm) FROM END OF H BOARD

H03 FASCIA

3/8" [8mm]

STEP 53 - ROOF PANEL D ASSEMBLY

QTY	PART NUMBER	DESCRIPTION
48	H100833	SCREW WOODGRIP 10-16x3/4"

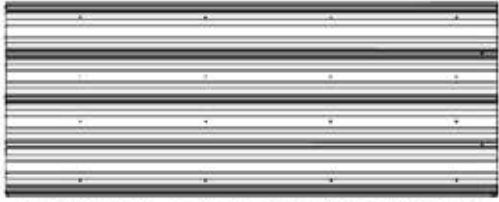

A4M02639 29GA STEEL SHEETING
(x2)

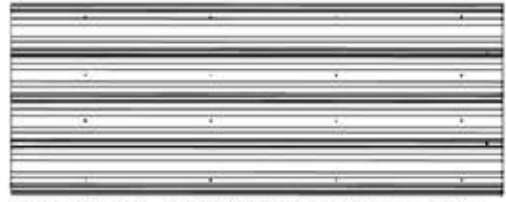

A4M02909 29GA STEEL SHEETING
(x1)

NOTE THROUGH HOLES

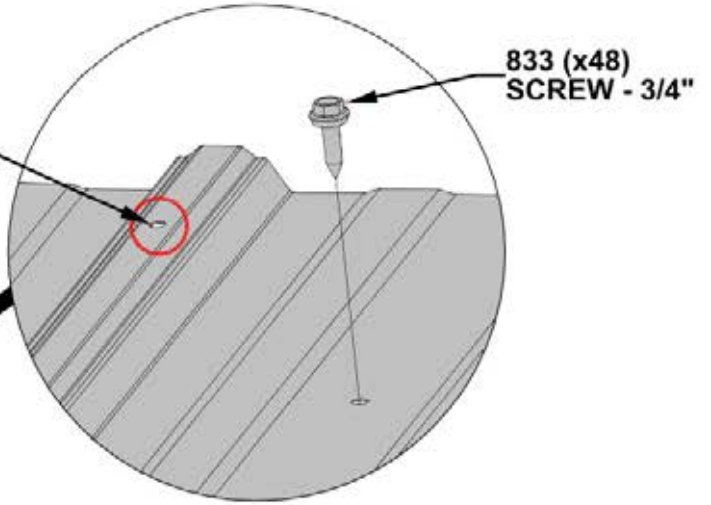

833 (x48)
SCREW - 3/4"

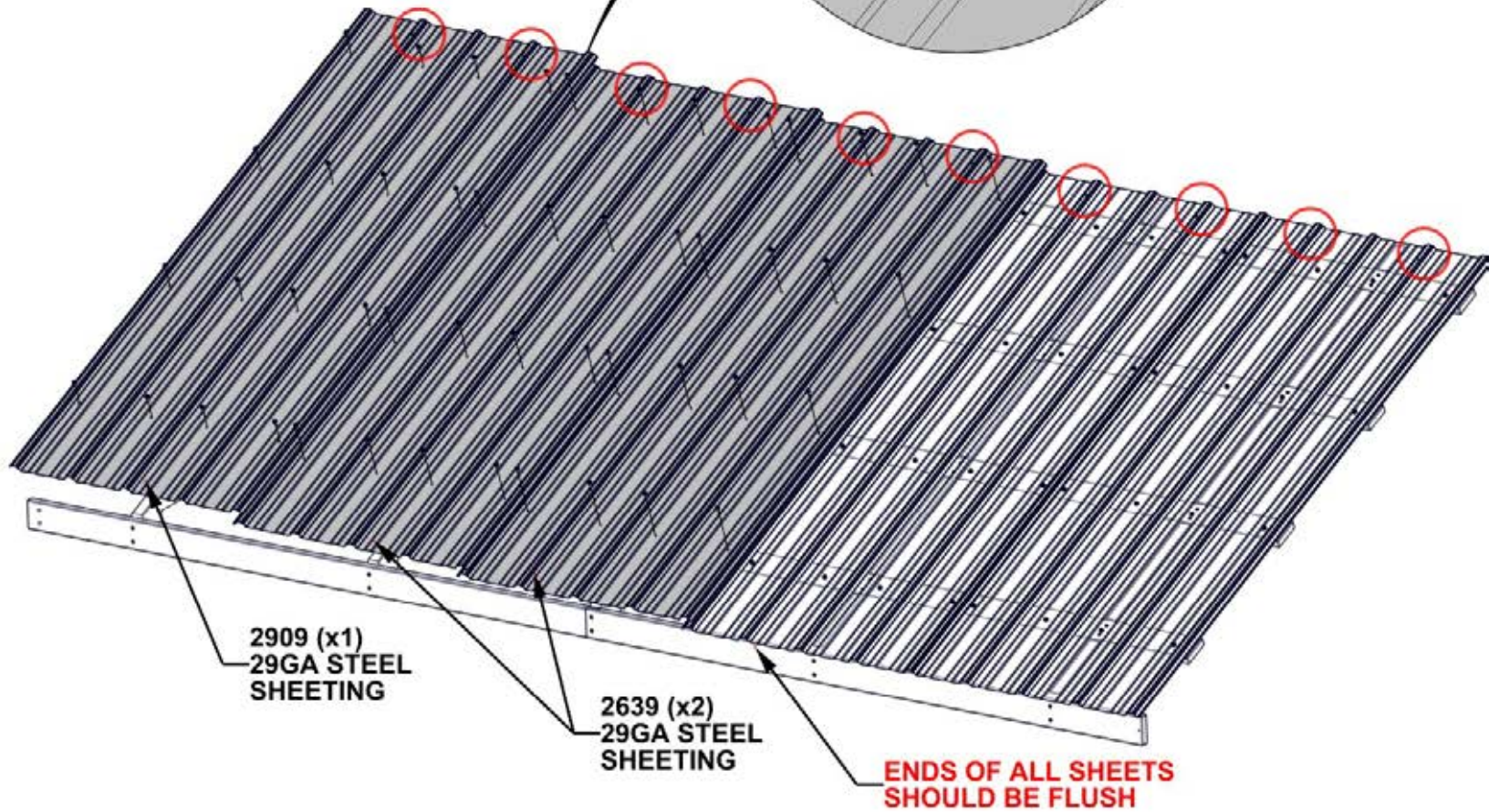

2909 (x1)
29GA STEEL
SHEETING

2639 (x2)
29GA STEEL
SHEETING

**ENDS OF ALL SHEETS
SHOULD BE FLUSH**

STEP 54 - RIDGE CAP ASSEMBLY

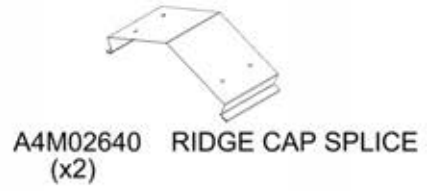
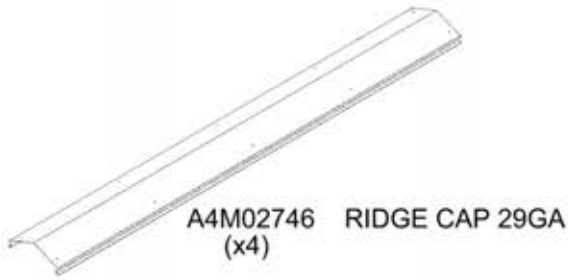

COMPLETE THIS STEP TWICE

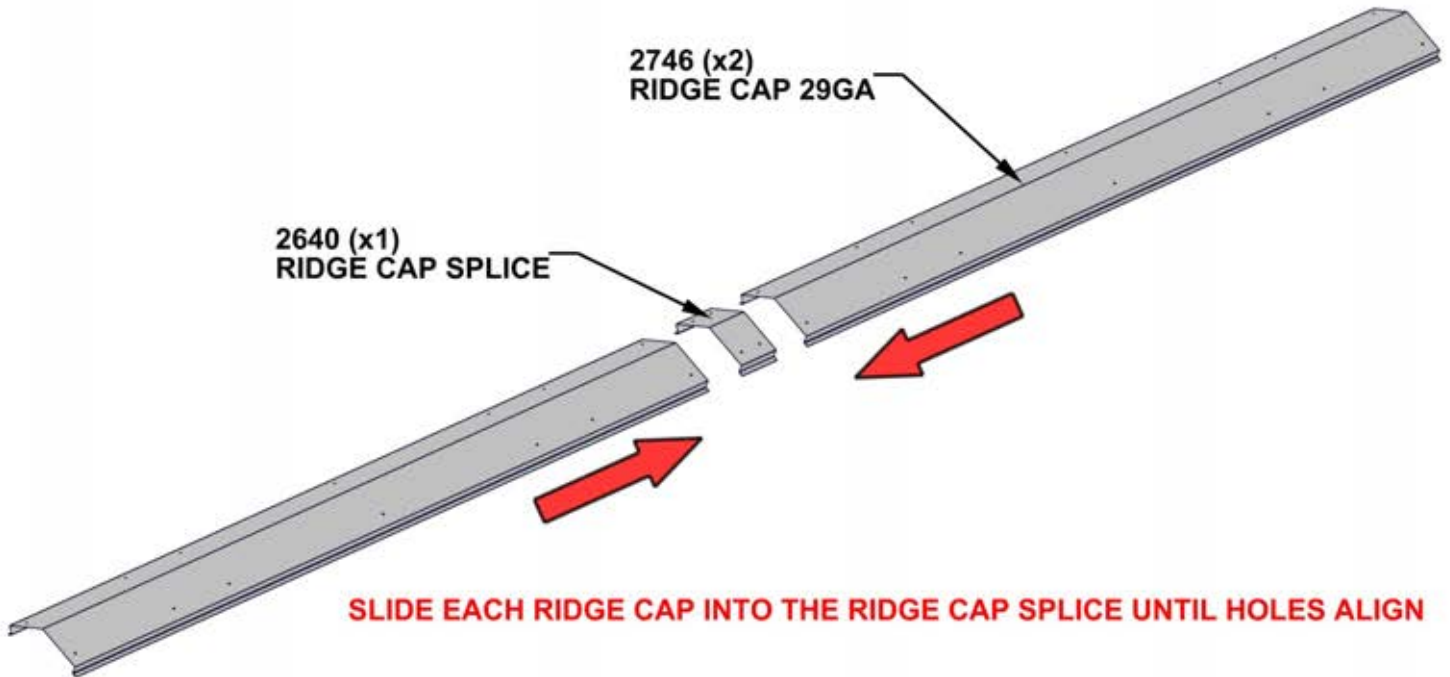

STEP 55 - RIDGE CAP A ASSEMBLY

QTY	PART NUMBER	DESCRIPTION
28	H100833	SCREW WOODGRIP 10-16x3/4"



A6P00398 (x1) RIDGE CAP PROTECTOR



J02 STIFFENER BOARD - W4L19546 (x2) 1"x2 3/8"x56 3/4" (24x60x1441)



J01 STIFFENER BOARD - W4L19545 (x2) 1"x2 3/8"x87 5/8" (24x60x2226)

- REMOVE SPACERS FROM RIDGE CAP PROTECTOR BEFORE INSTALLING.

- FINAL LENGTH - 12' - 1/2" [3670mm]

RIDGE CAP MUST BE LIFTED FROM THE MIDDLE TO PREVENT DAMAGE BEFORE INSTALLATION

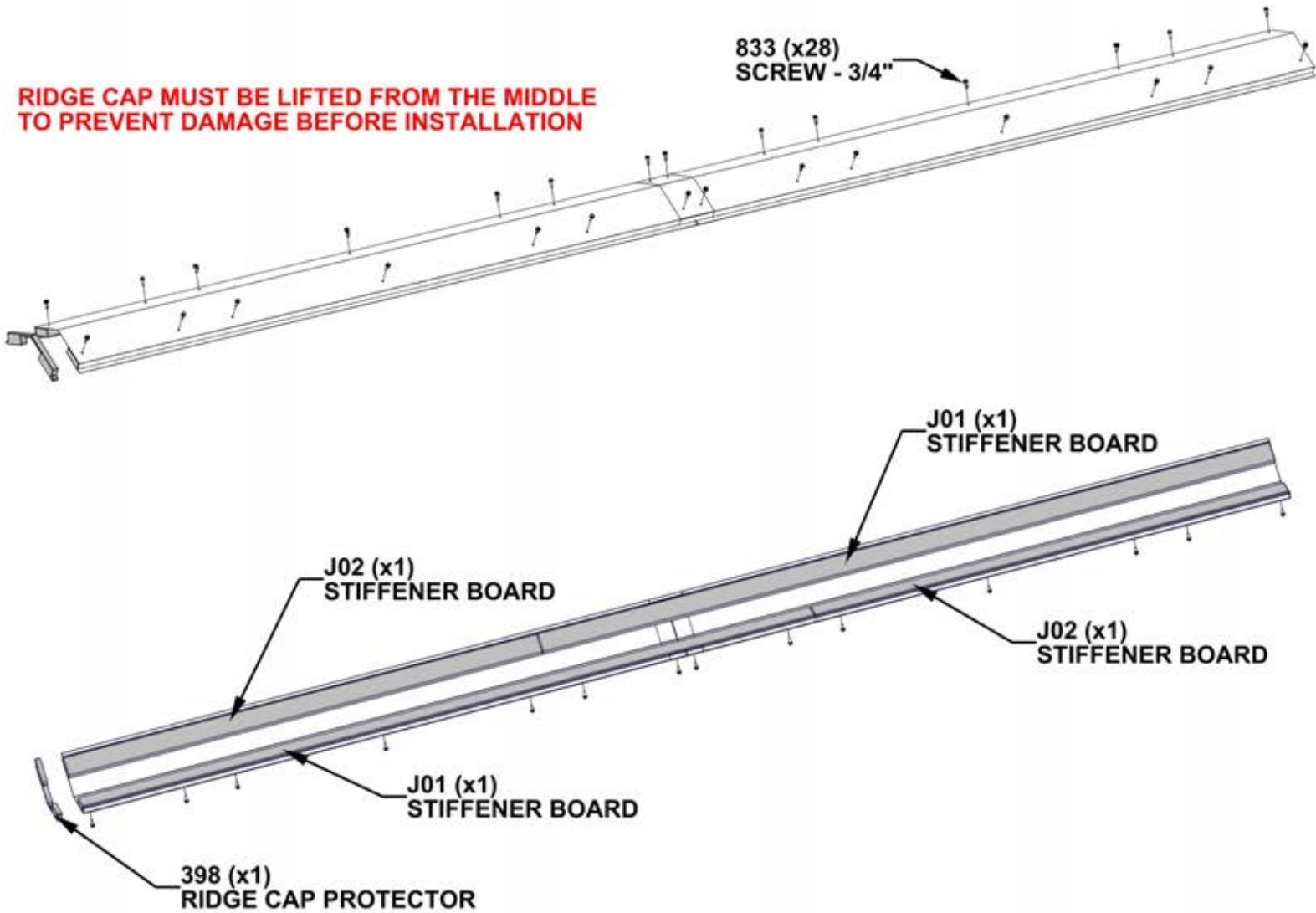

STEP 56 - RIDGE CAP B ASSEMBLY

QTY	PART NUMBER	DESCRIPTION
28	H100833	SCREW WOODGRIP 10-16x3/4"



J01 STIFFENER BOARD - W4L19545
(x2) 1"x2 3/8"x87 5/8" (24x60x2226)



J02 STIFFENER BOARD - W4L19546
(x2) 1"x2 3/8"x56 3/4" (24x60x1441)



A6P00514 MID RIDGE CAP
(x1) PROTECTOR



A6P00398 RIDGE CAP
(x1) PROTECTOR

- REMOVE SPACERS FROM RIDGE CAP PROTECTOR BEFORE INSTALLING.

- FINAL LENGTH - 12' - 1" [3683mm]

RIDGE CAP MUST BE LIFTED FROM THE MIDDLE TO PREVENT DAMAGE BEFORE INSTALLATION

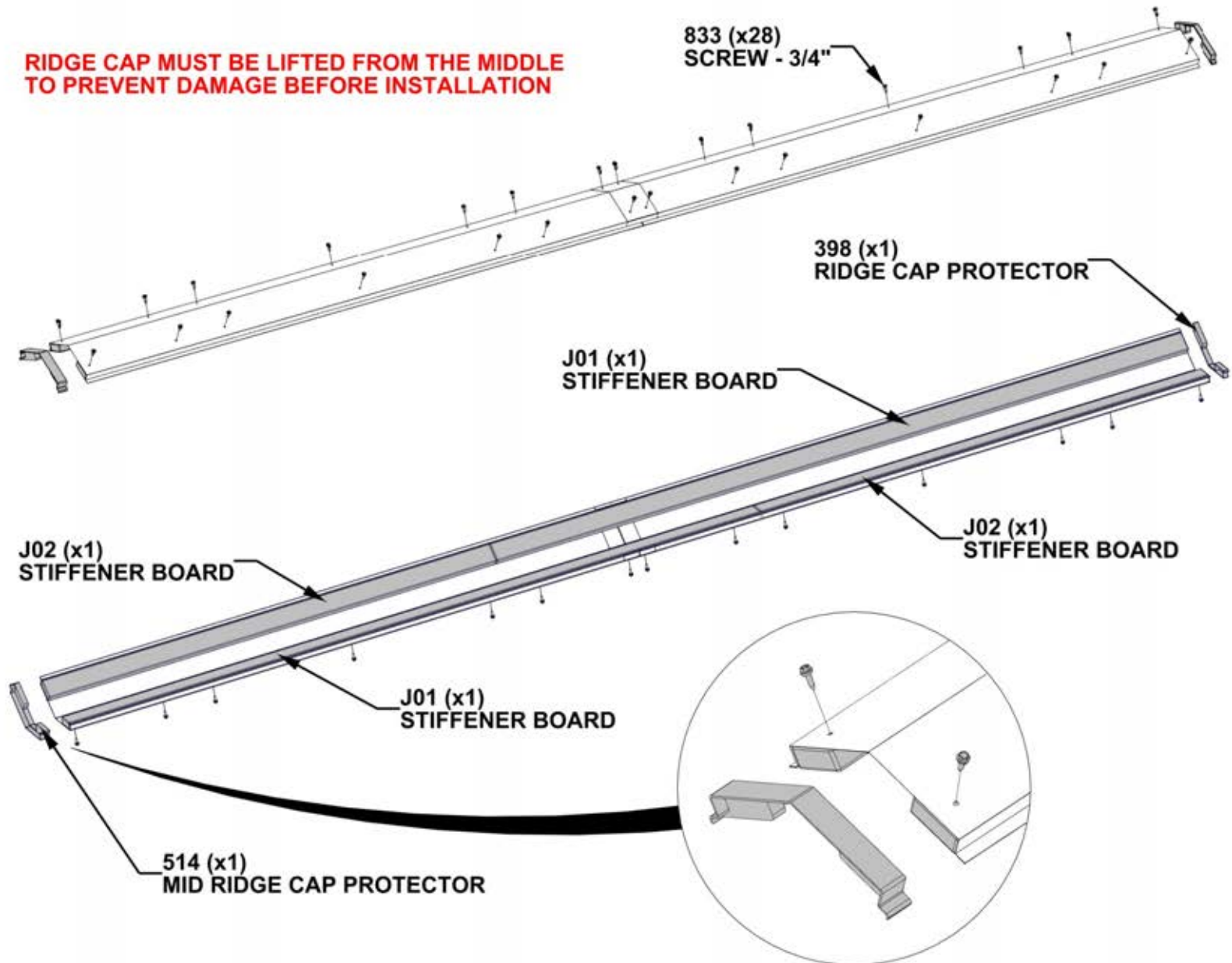

ENSURE THAT MID RIDGE CAP PROTECTOR IS ORIENTED CORRECTLY

STEP 57 - ROOF ATTACHMENT

QTY	PART NUMBER	DESCRIPTION
1	H100391	SCREW PFH 8x2 BLK

- ADDITIONAL PEOPLE ARE HELPFUL FOR THIS STEP.
- SLIDE ROOF PANEL ALONG TRACKS ON RAFTERS.
- ONCE IN PLACE, INSTALL ATTACHMENT HARDWARE AS SHOWN.
- HOLD ROOF PANEL IN PLACE UNTIL NEXT STEP.

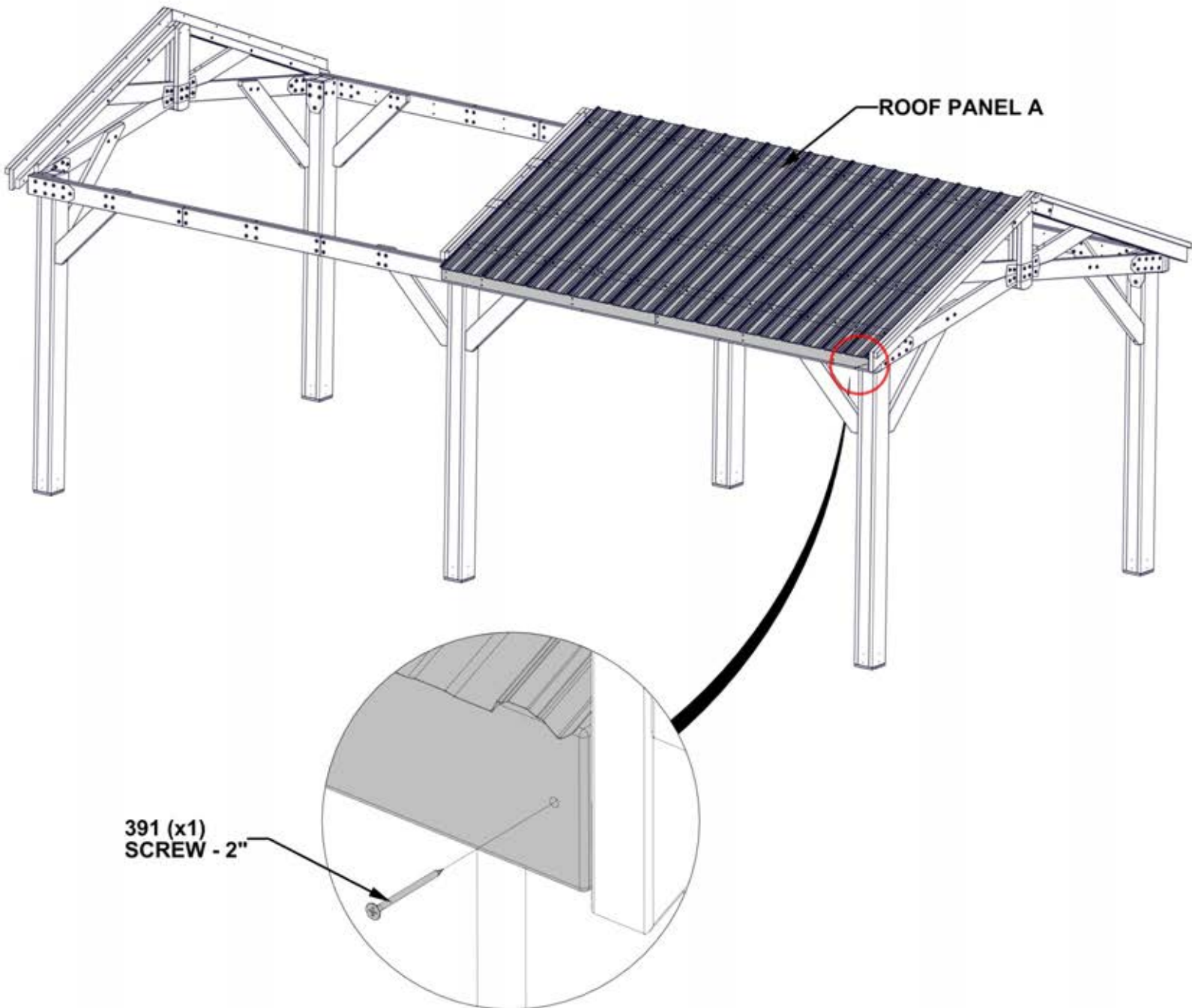

STEP 58 - ROOF ATTACHMENT

QTY	PART NUMBER	DESCRIPTION
1	H100391	SCREW PFH 8x2 BLK
4	H100194	BOLT WH 5/16x2 1/2 BLK
4	H100198	WASHER LOCK EXT 8x19
4	H100478	WASHER FLAT 8x27 BLK
4	H100479	NUT LOCK 5/16 BLK

- ADDITIONAL PEOPLE ARE HELPFUL FOR THIS STEP. ONCE IN PLACE, INSTALL ATTACHMENT HARDWARE AS SHOWN.
- ATTACH BOLT AND LOCK NUT HARDWARE BEFORE ATTACHING SCREW.

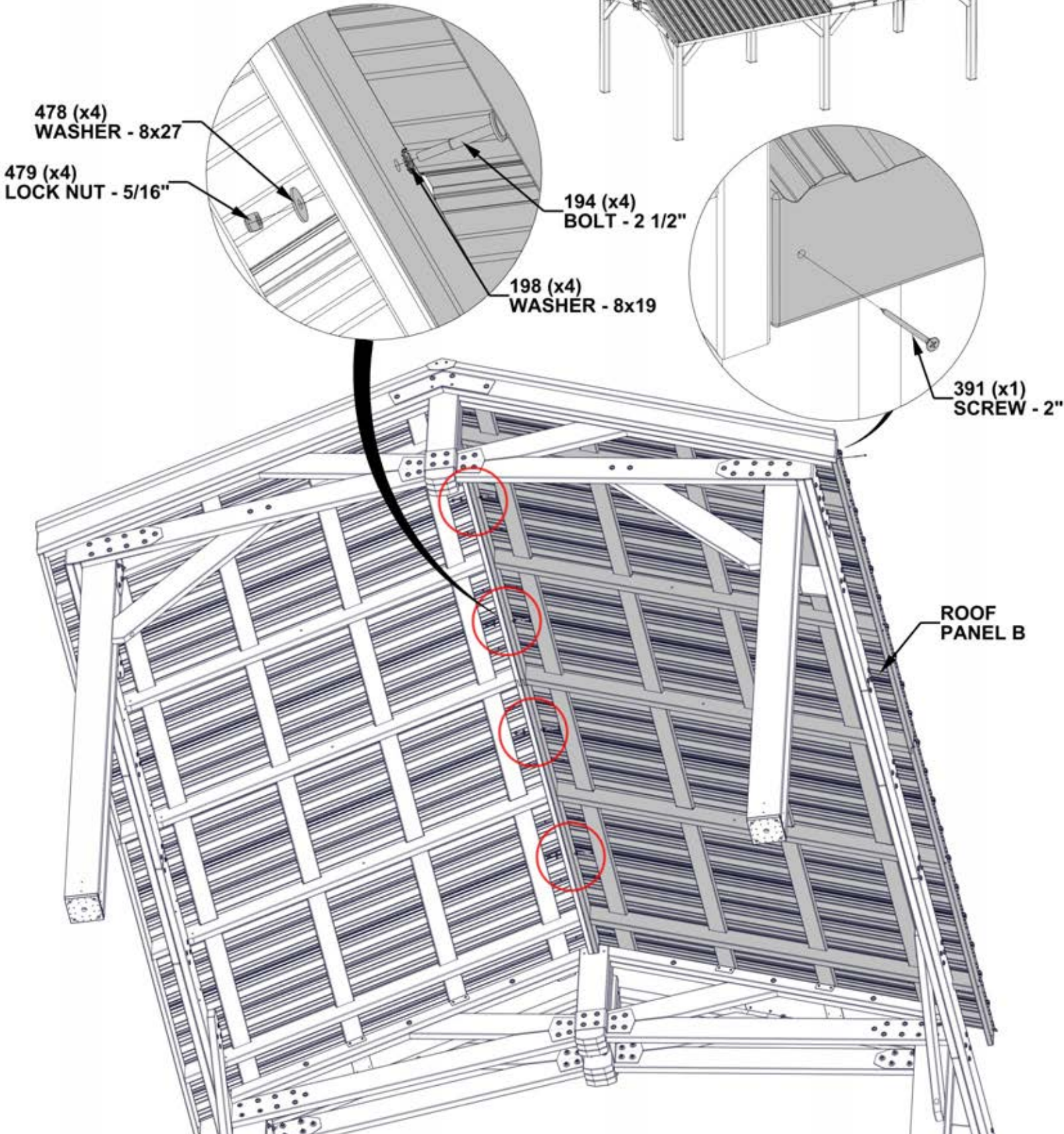
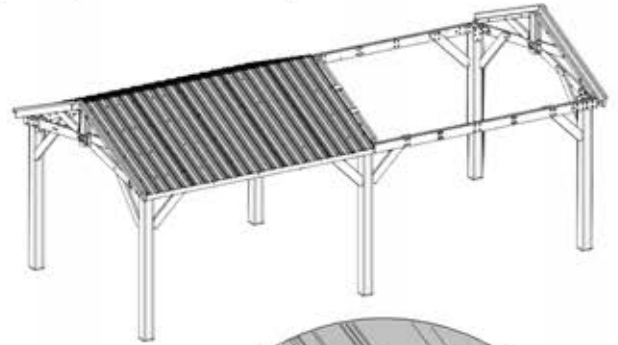

STEP 59 - ROOF ATTACHMENT

QTY	PART NUMBER	DESCRIPTION
8	H100833	SCREW WOODGRIP 10-16x3/4"

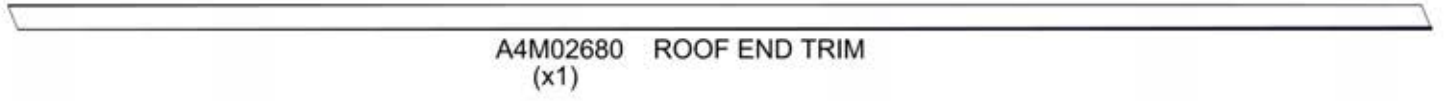
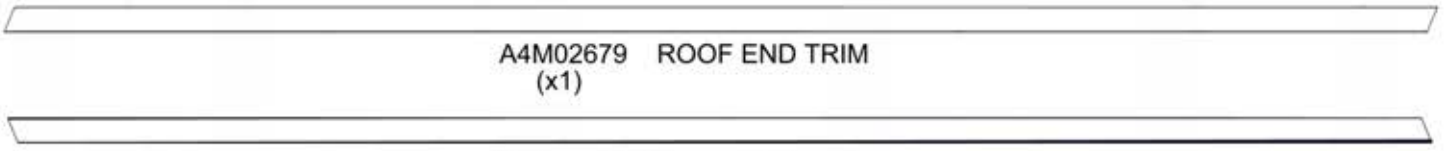

- ATTACH SCREWS IN LINE WITH ROOF PANEL SCREWS.

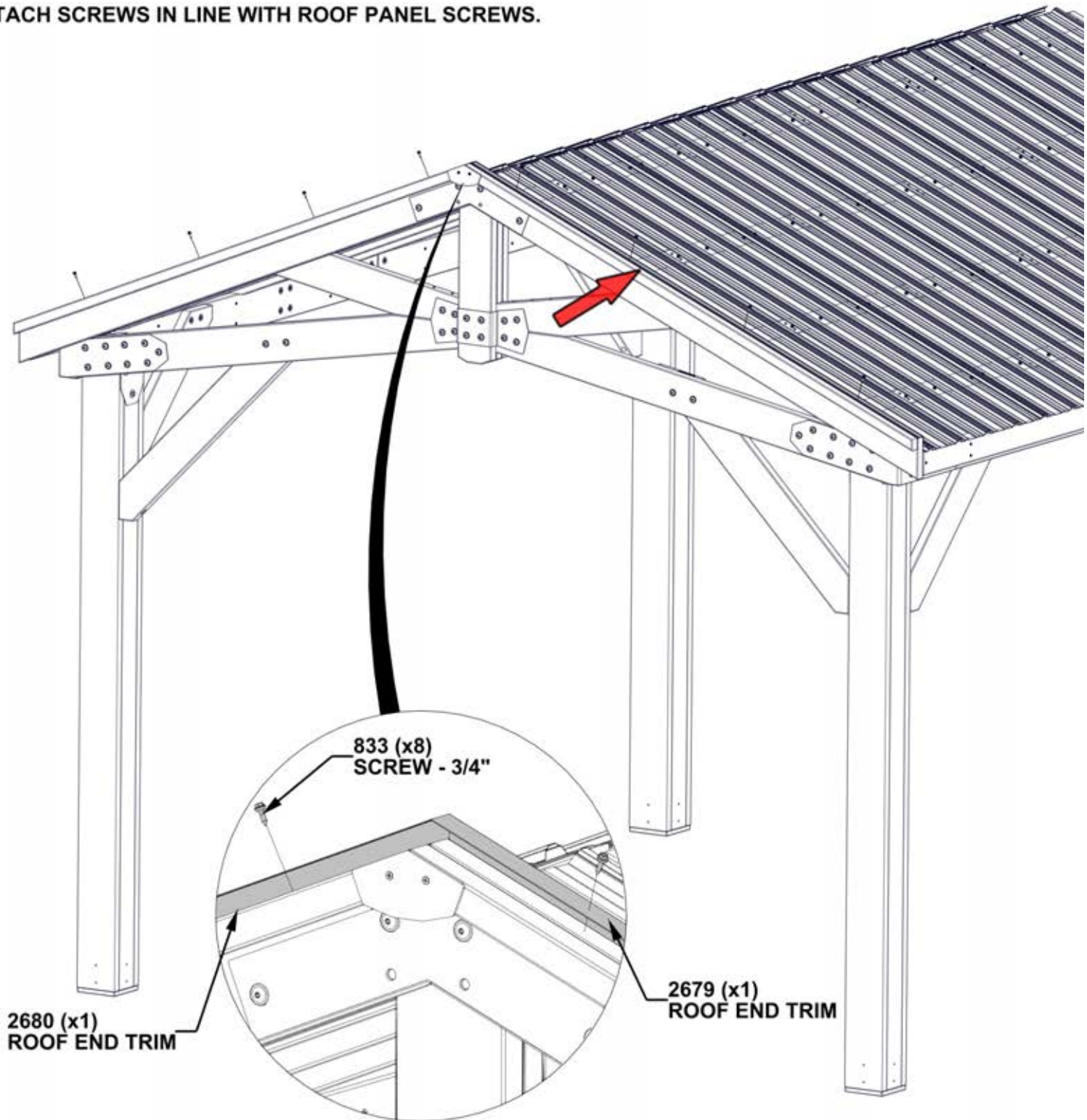

STEP 60 - ROOF ATTACHMENT

QTY	PART NUMBER	DESCRIPTION
20	H100392	SCREW PWH 8x3/4 BLK

12' - 1/2" [3670mm]

ROOF CAP A - FROM STEPS 54 - 55

DO NOT CLIMB ON ROOF TO INSTALL. ROOF CAP HAS BEEN DESIGNED TO INSTALL FROM A LADDER.

- FOR PROPER INSTALLATION, USE AN ADULT HELPER TO KEEP DOWNWARD PRESSURE ON THE RIDGE CAP WHILE SCREWING IN SCREWS.
- SCREWS HOLDING ON RIDGE CAP MAY HAVE TO BE LOOSENED IN NEXT STEP TO SLIDE IN ROOF PANEL.

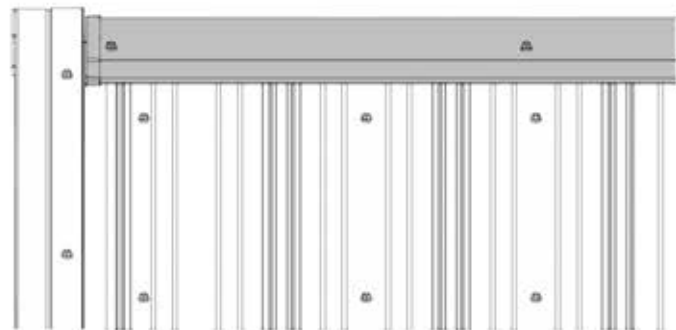
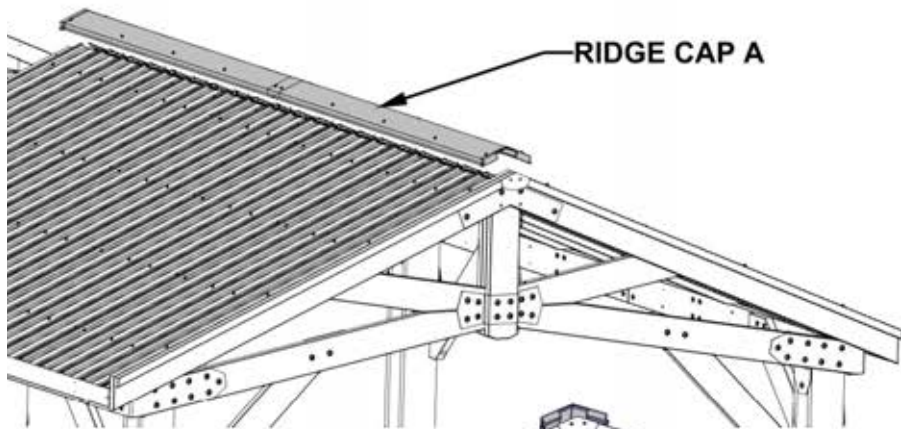

INSTALL SCREWS THROUGH PILOT HOLES IN ROOF PANELS INTO RIDGE CAP STIFFENER BOARDS

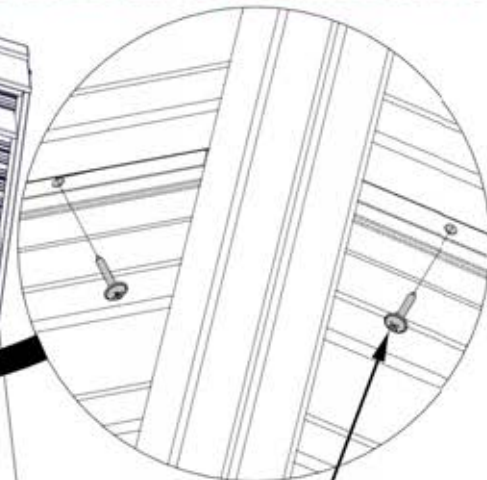
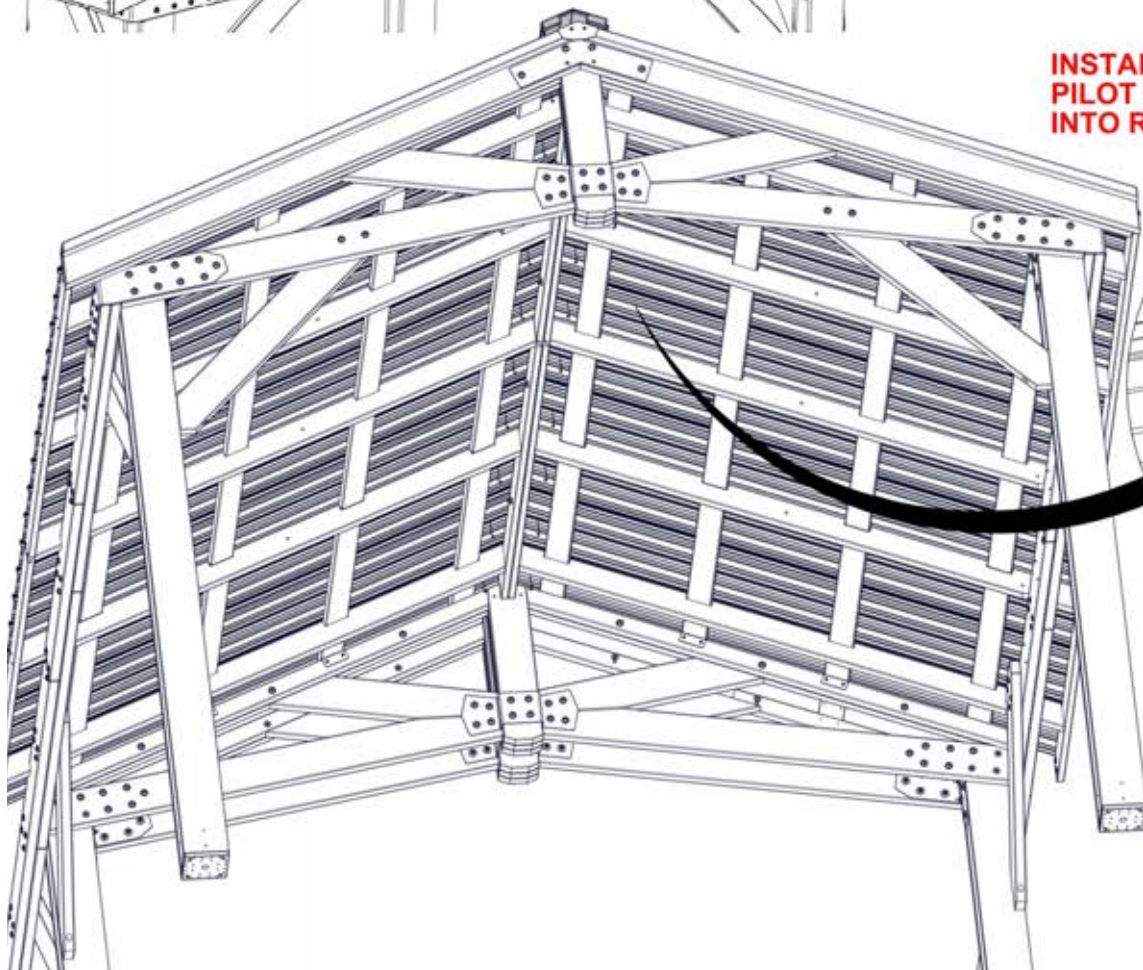

392 (x20)
SCREW - 3/4"

STEP 61 - ROOF ATTACHMENT

QTY	PART NUMBER	DESCRIPTION
1	H100391	SCREW PFH 8x2 BLK
4	H100468	BOLT WH 5/16x1 BLK



A4M01560 OUTSIDE TIE BRACKET (x1)

- ADDITIONAL PEOPLE ARE HELPFUL FOR THIS STEP.
- SLIDE ROOF PANEL ALONG TRACKS ON RAFTERS.
- YOU MAY HAVE TO LIFT THE CORNER OF THE EXISTING ROOF PANEL TO GET IT STARTED.
- ONCE IN PLACE, INSTALL ATTACHMENT HARDWARE AS SHOWN.
- SCREWS HOLDING ON RIDGE CAP MAY HAVE TO BE LOOSENED TO SLIDE IN ROOF PANEL.

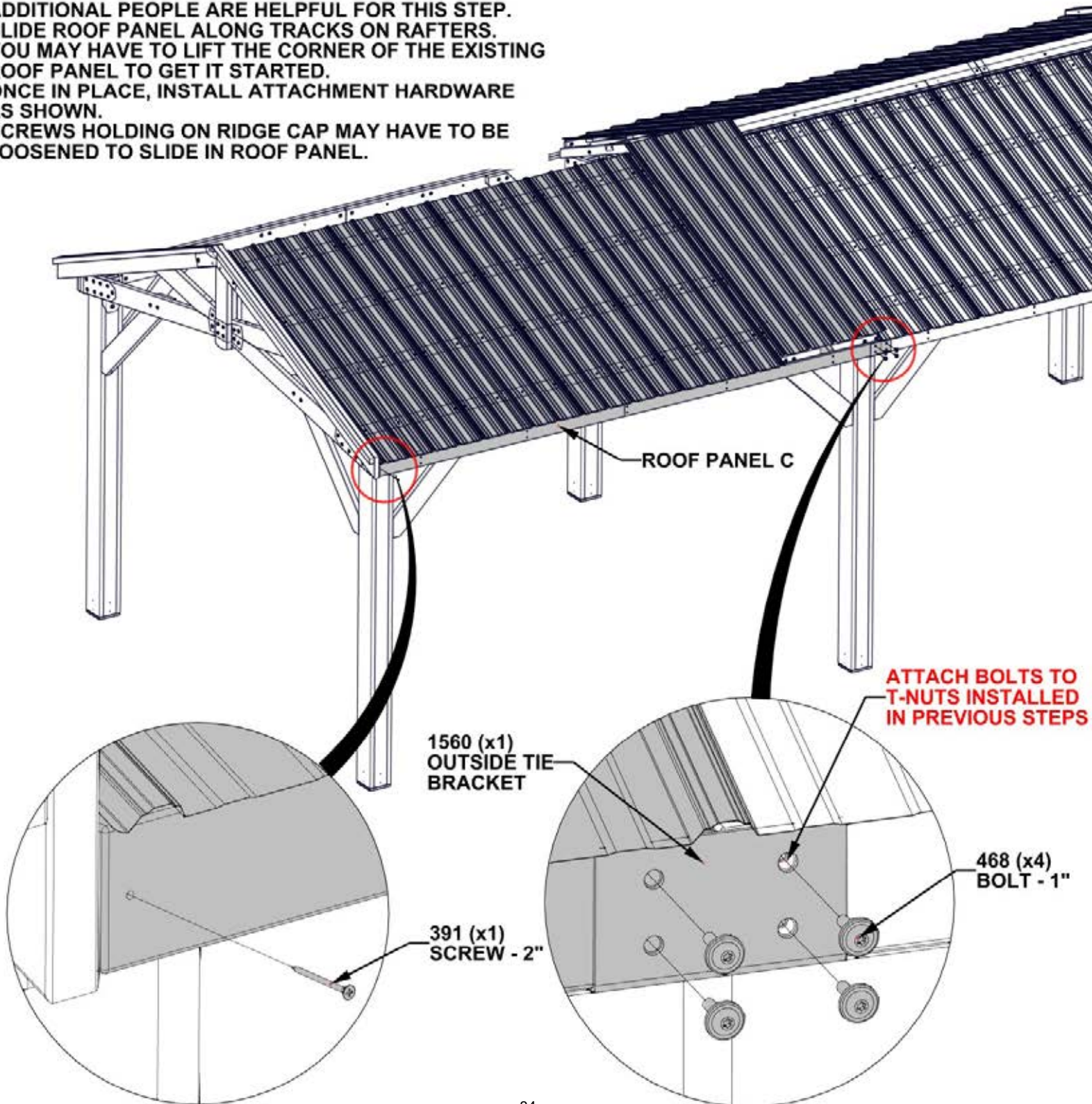

ATTACH BOLTS TO T-NUTS INSTALLED IN PREVIOUS STEPS

1560 (x1)
OUTSIDE TIE
BRACKET

391 (x1)
SCREW - 2"

468 (x4)
BOLT - 1"

STEP 62 - ROOF ATTACHMENT

QTY	PART NUMBER	DESCRIPTION
4	H100833	SCREW WOODGRIP 10-16x3/4"



A4M02679 ROOF END TRIM
(x1)

- ATTACH SCREWS IN LINE WITH ROOF PANEL SCREWS.

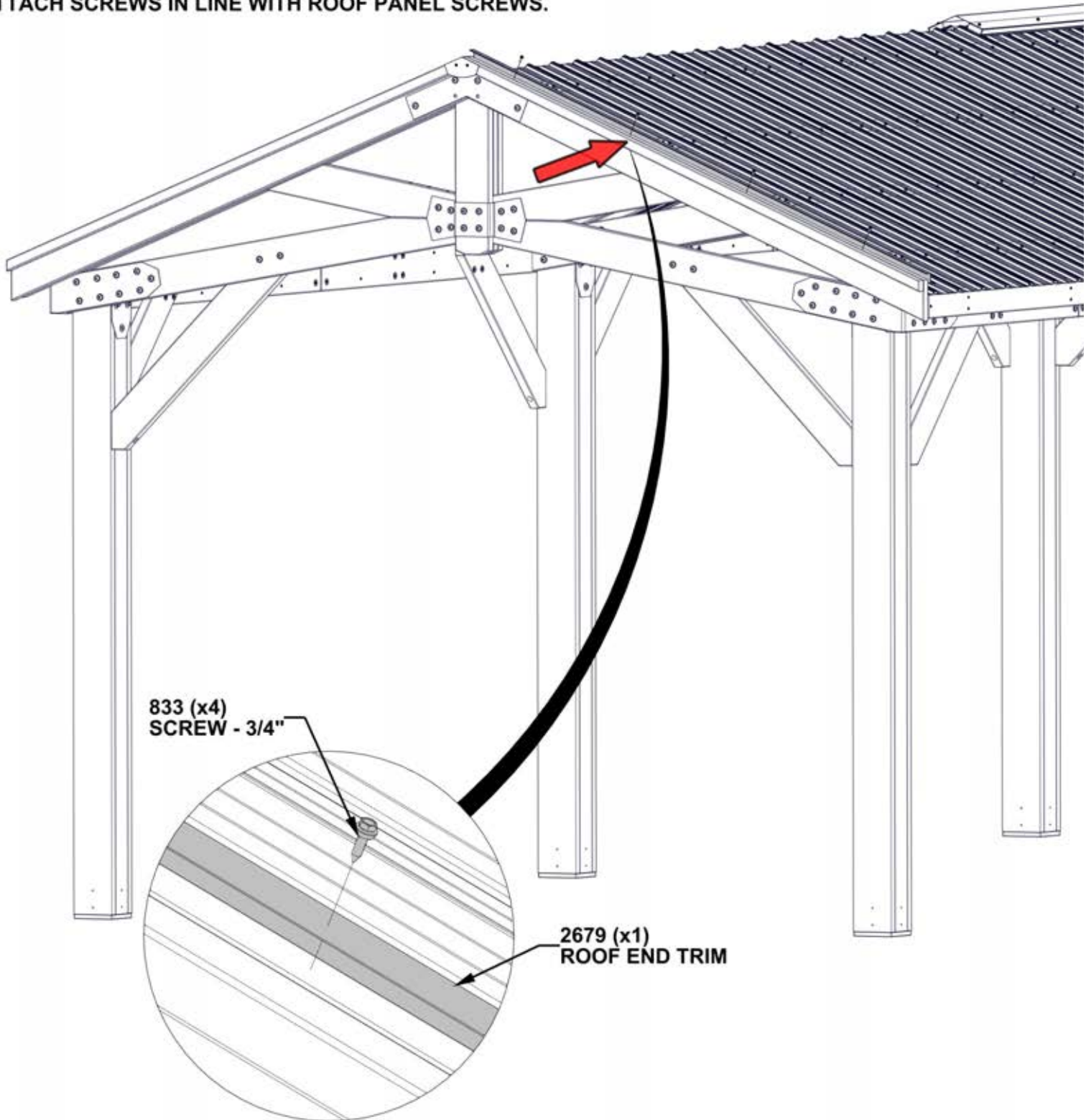

STEP 63 - ROOF ATTACHMENT

QTY	PART NUMBER	DESCRIPTION
10	H100392	SCREW PWH 8x3/4 BLK

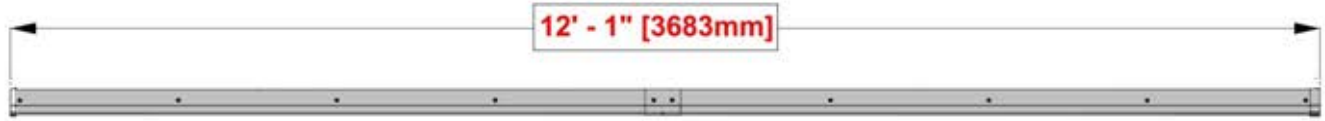

ROOF CAP B - FROM STEP 56

DO NOT CLIMB ON ROOF TO INSTALL. ROOF CAP HAS BEEN DESIGNED TO INSTALL FROM A LADDER.

- FOR PROPER INSTALLATION, USE AN ADULT HELPER TO KEEP DOWNWARD PRESSURE ON THE RIDGE CAP WHILE SCREWING IN SCREWS.

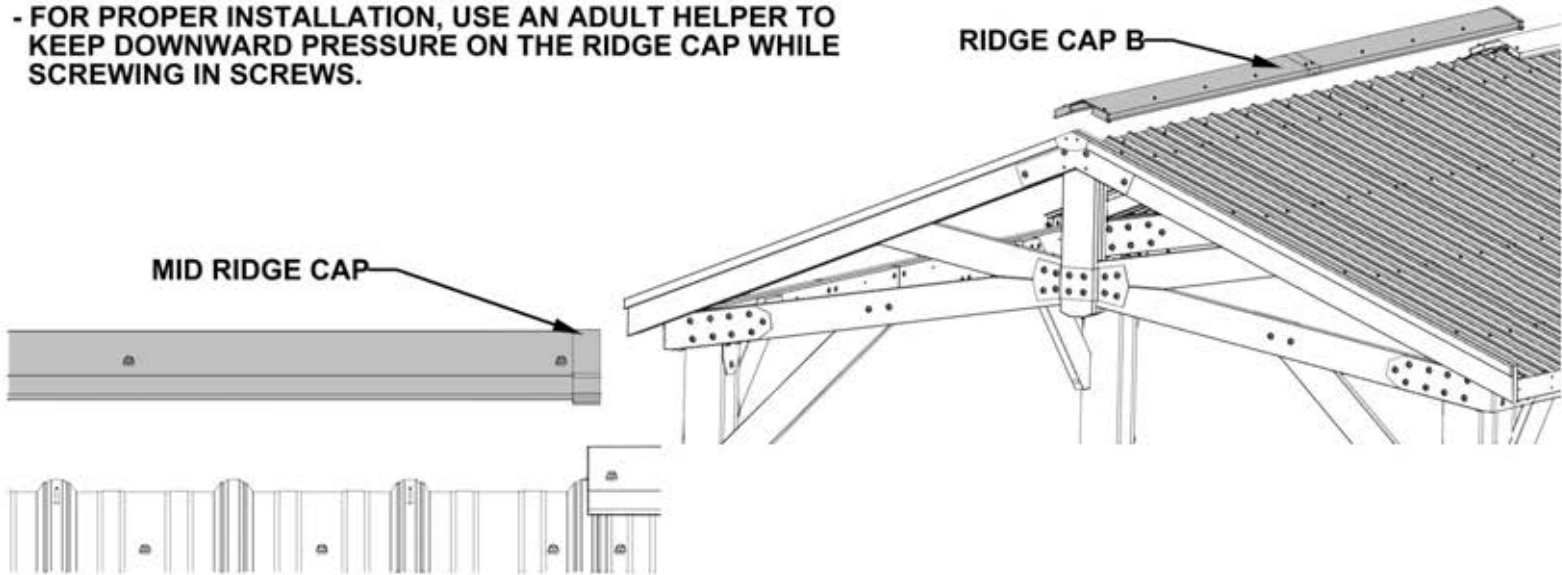

SLIDE RIDGE CAP ASSEMBLY INTO PLACE. ENSURING THAT MID RIDGE CAP PROTECTOR OVERLAPS RIDGE CAP THAT IS ALREADY INSTALLED.

INSTALL SCREWS THROUGH PILOT HOLES IN ROOF PANELS INTO RIDGE CAP STIFFENER BOARDS

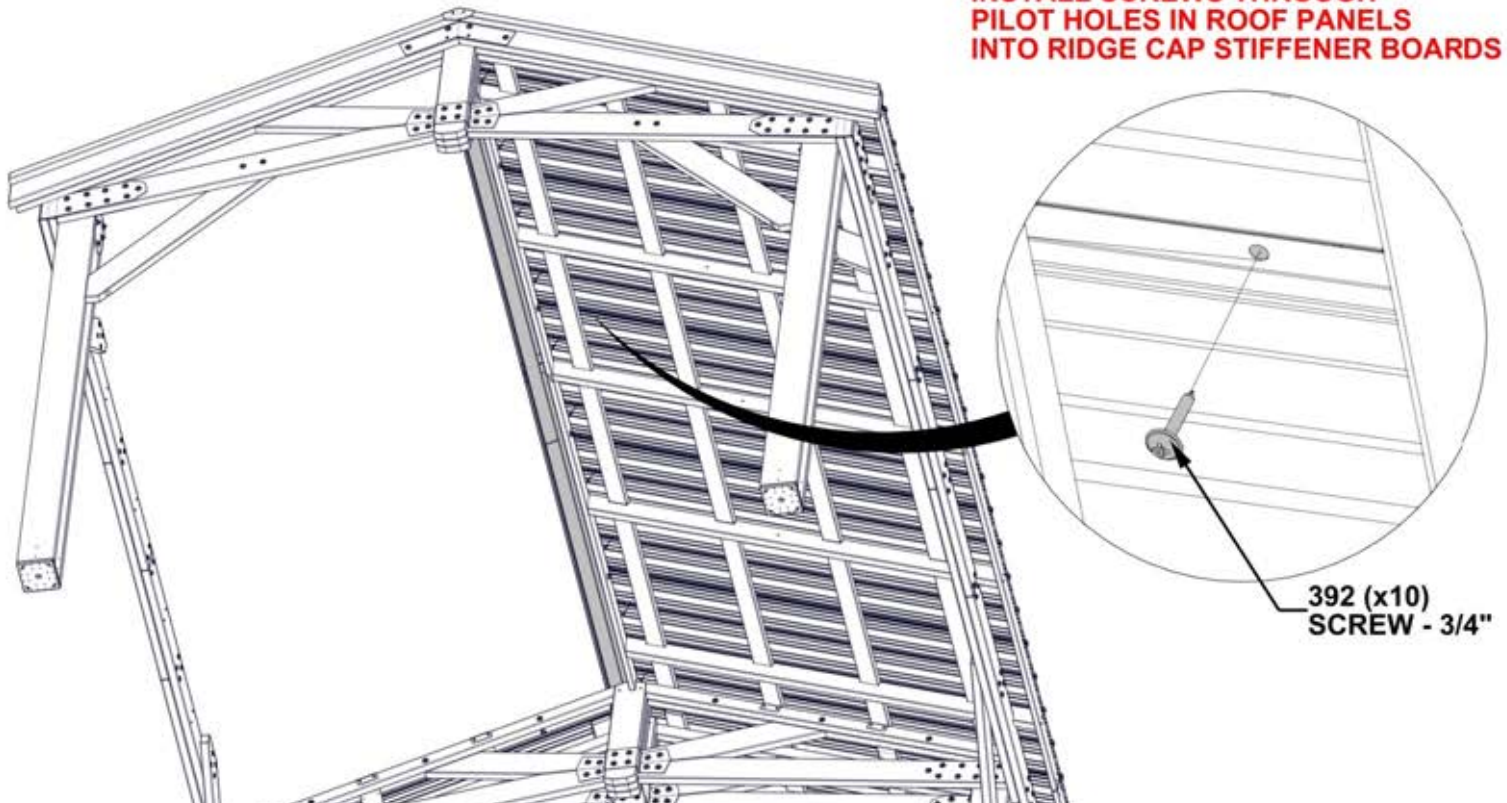

STEP 64 - ROOF ATTACHMENT

QTY	PART NUMBER	DESCRIPTION
4	H100194	BOLT WH 5/16x2 1/2 BLK
4	H100198	WASHER LOCK EXT 8x19
1	H100391	SCREW PFH 8x2 BLK
4	H100478	WASHER FLAT 8x27 BLK
4	H100479	NUT LOCK 5/16 BLK

- ADDITIONAL PEOPLE ARE HELPFUL FOR THIS STEP.
- SLIDE ROOF PANEL ALONG TRACKS ON RAFTERS.
- YOU MAY HAVE TO LIFT THE CORNER OF THE EXISTING ROOF PANEL TO GET IT STARTED.
- ONCE IN PLACE, INSTALL ATTACHMENT HARDWARE AS SHOWN.
- ATTACH BOLT AND LOCK NUT HARDWARE BEFORE ATTACHING SCREW.

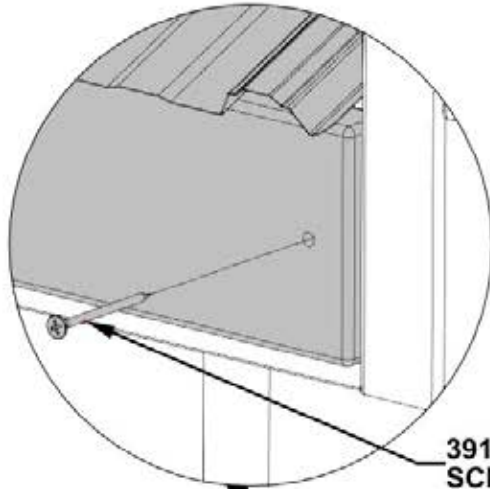
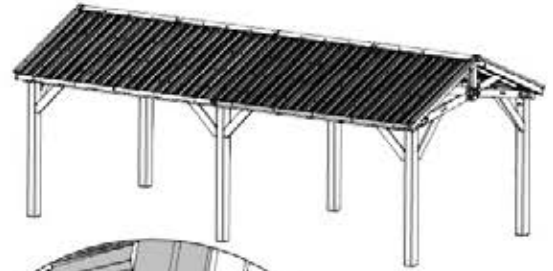

391 (x1)
SCREW - 2"

198 (x4)
WASHER - 8x19

194 (x4)
BOLT - 2 1/2"

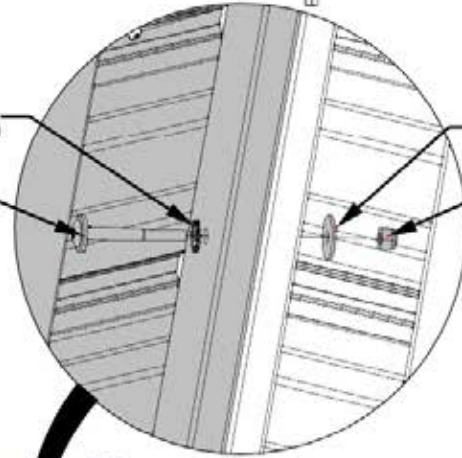

478 (x4)
WASHER - 8x27

479 (x4)
LOCK NUT - 5/16"

ROOF PANEL D

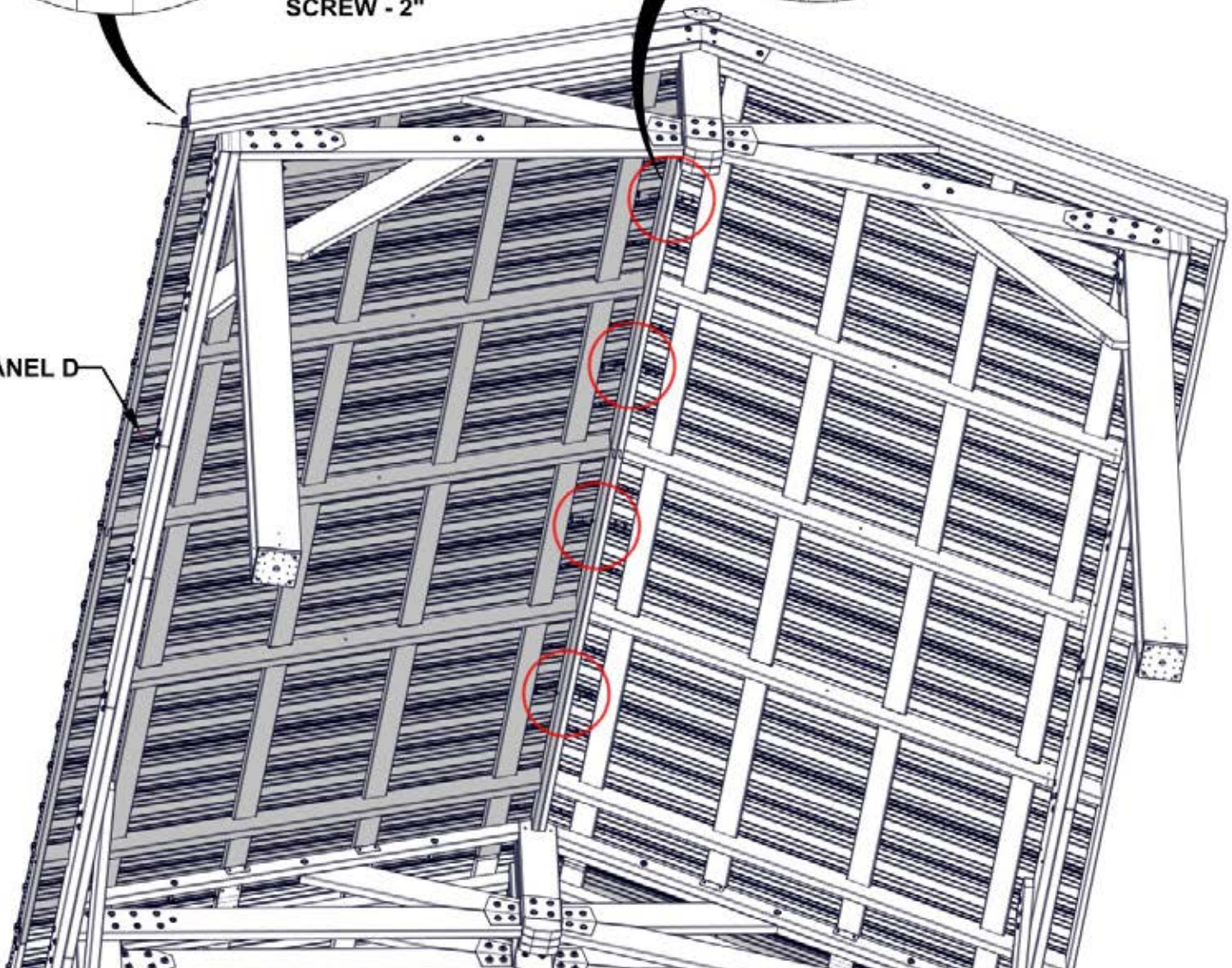

STEP 65 - ROOF ATTACHMENT

QTY	PART NUMBER	DESCRIPTION
10	H100392	SCREW PWH 8x3/4 BLK

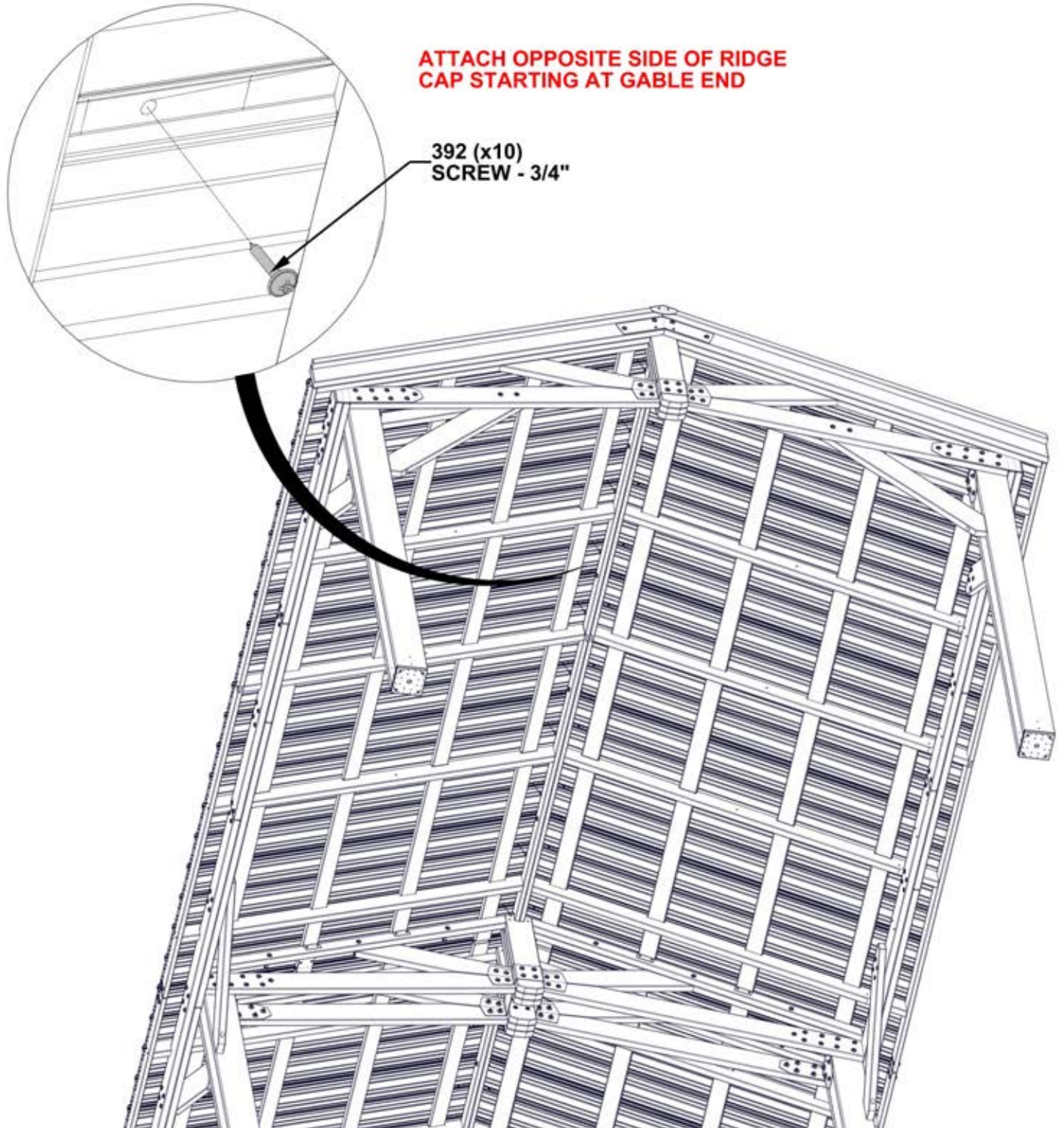

STEP 66 - ROOF ATTACHMENT

QTY	PART NUMBER	DESCRIPTION
4	H100833	SCREW WOODGRIP 10-16x3/4"

A4M02680 ROOF END TRIM
(x1)

- SLIDE ROOF END TRIM UNDER RIDGE CAP ASSEMBLY, THEN SCREW IT INTO PLACE.
- ATTACH SCREWS IN LINE WITH ROOF PANEL SCREWS.

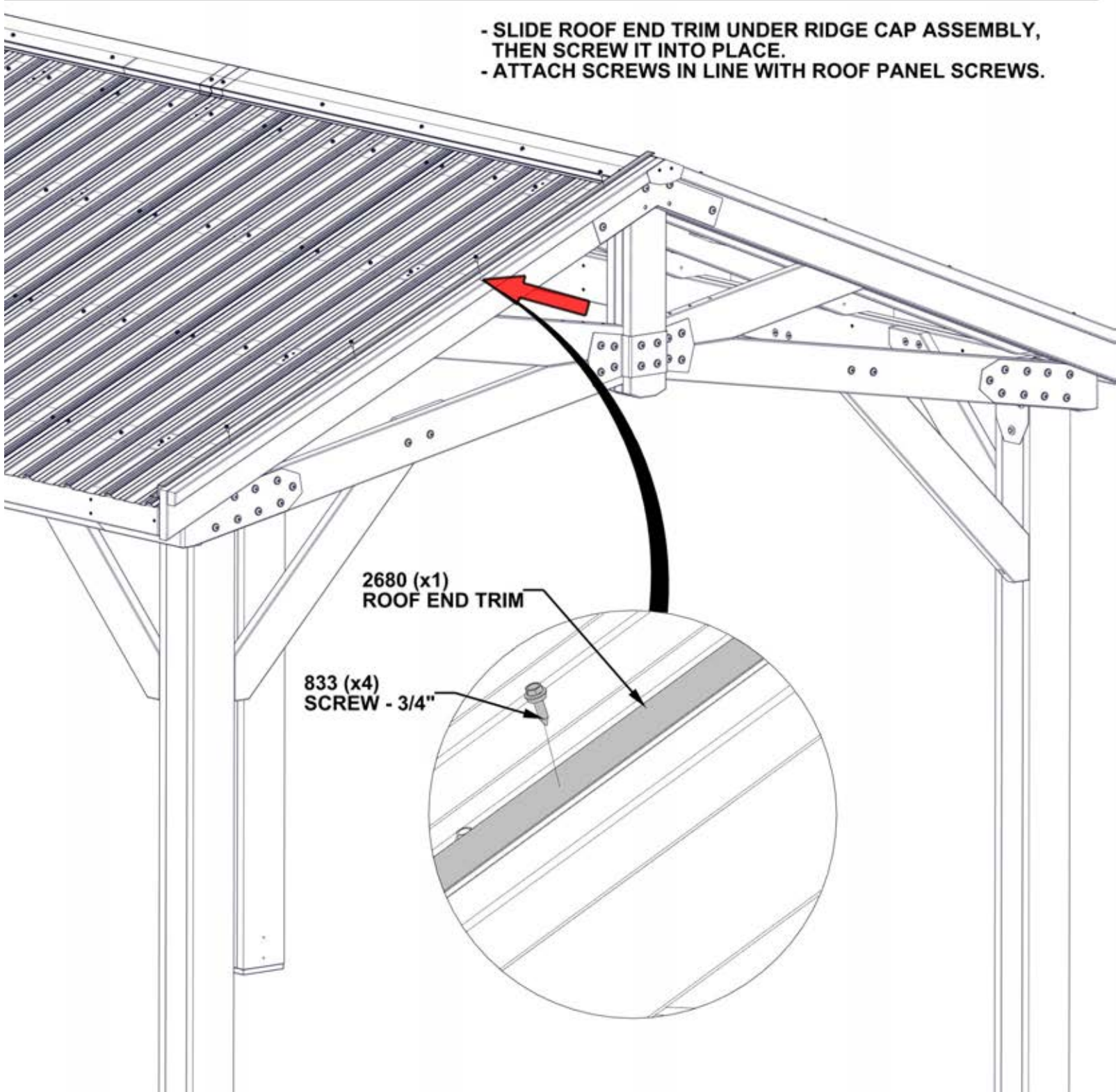

STEP 67 - ROOF ATTACHMENT

QTY	PART NUMBER	DESCRIPTION
2	H100195	BOLT WH 5/16x2 3/4 BLK
4	H100881	BOLT WH 5/16x5 BLK
6	H100478	WASHER FLAT 8x27 BLK
6	H100479	NUT LOCK 5/16 BLK



A4M01148 TRUSS BRACKET
(x2)



A4M01559 U TIE BRACKET
(x1)

- ATTACH TRUSS BRACKET TO BOTH SIDES OF CENTER GABLE
- INSERT 881 BOLTS FIRST TO HOLD BRACKETS, THEN INSERT 195 BOLTS AND ALL WASHERS AND LOCK NUTS.

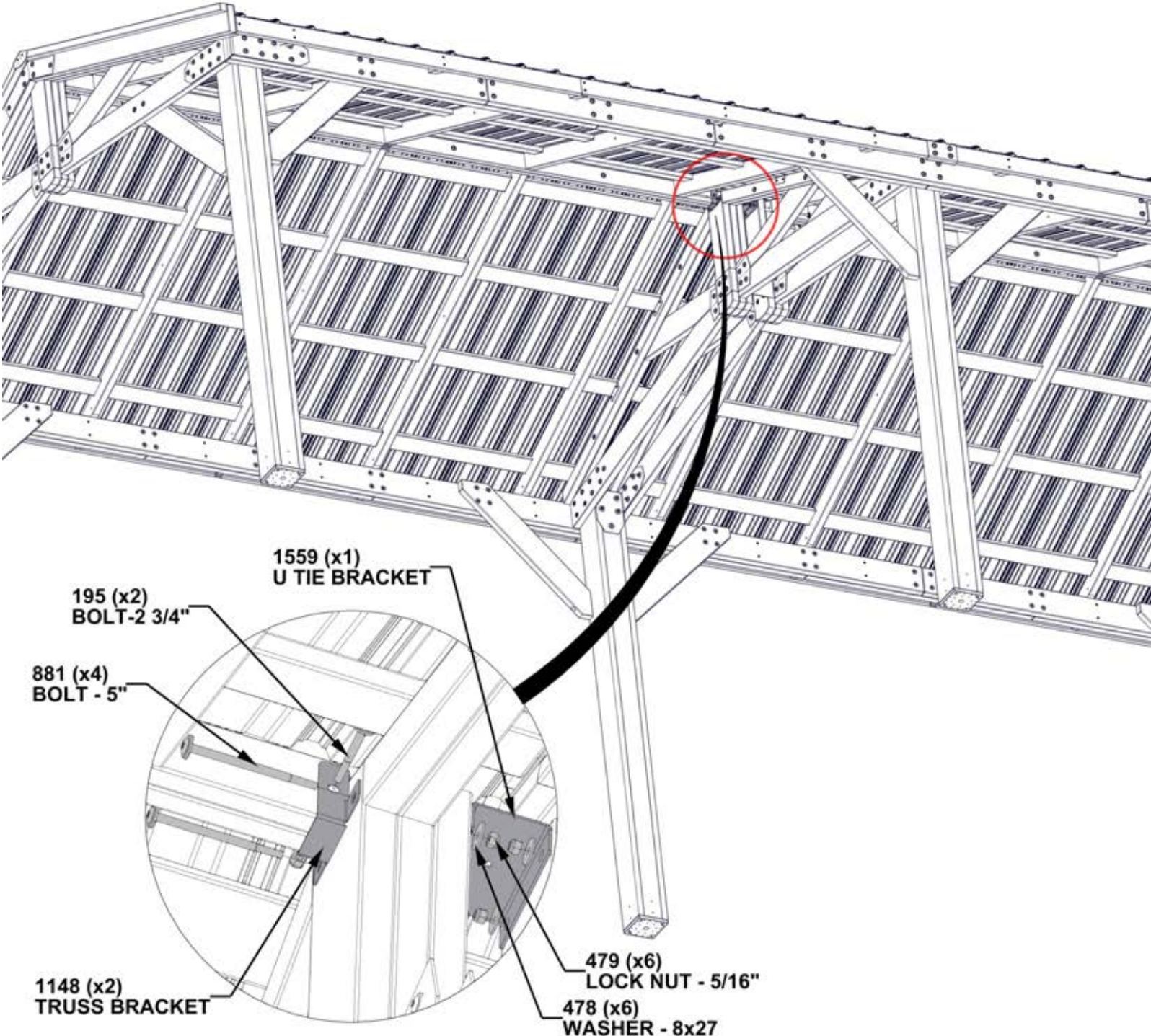

1559 (x1)
U TIE BRACKET

195 (x2)
BOLT-2 3/4"

881 (x4)
BOLT - 5"

1148 (x2)
TRUSS BRACKET

479 (x6)
LOCK NUT - 5/16"

478 (x6)
WASHER - 8x27

STEP 68 - ROOF ATTACHMENT



A4M01148 TRUSS BRACKET
(x2)

QTY	PART NUMBER	DESCRIPTION
2	H100195	BOLT WH 5/16x2 3/4 BLK
4	H100354	BOLT WH 5/16x6 1/2 BLK
6	H100479	NUT LOCK 5/16 BLK
6	H100478	WASHER FLAT 8x27 BLK

- THE USE OF CLAMPS MAY AID IN THE ALIGNMENT OF BOLT HOLES.

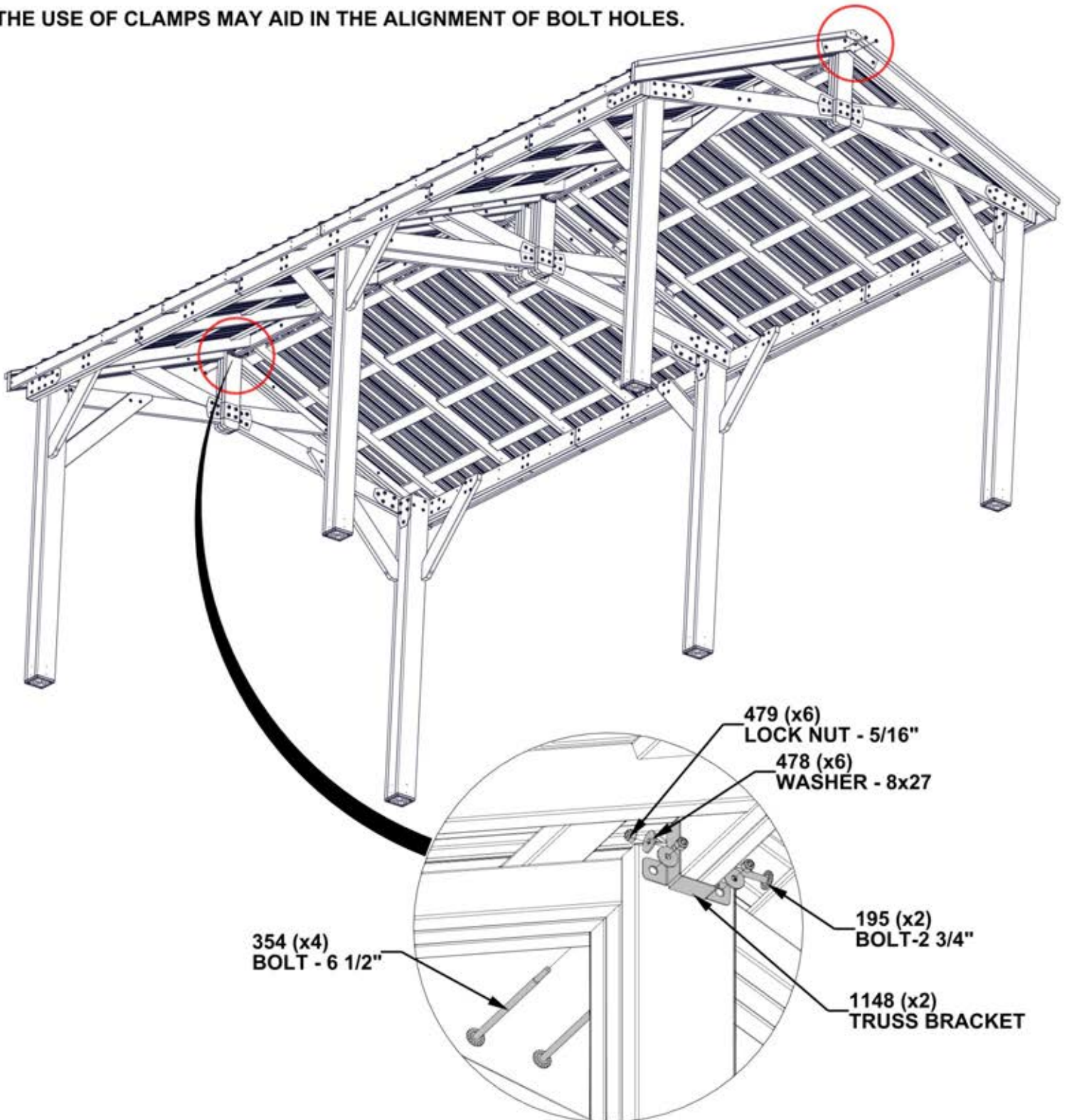

STEP 69 - ROOF ATTACHMENT



A4M01560 OUTSIDE TIE BRACKET
(x1)

QTY	PART NUMBER	DESCRIPTION
4	H100468	BOLT WH 5/16x1 BLK

- ATTACH BOLTS TO T-NUTS
INSTALLED IN PREVIOUS STEPS

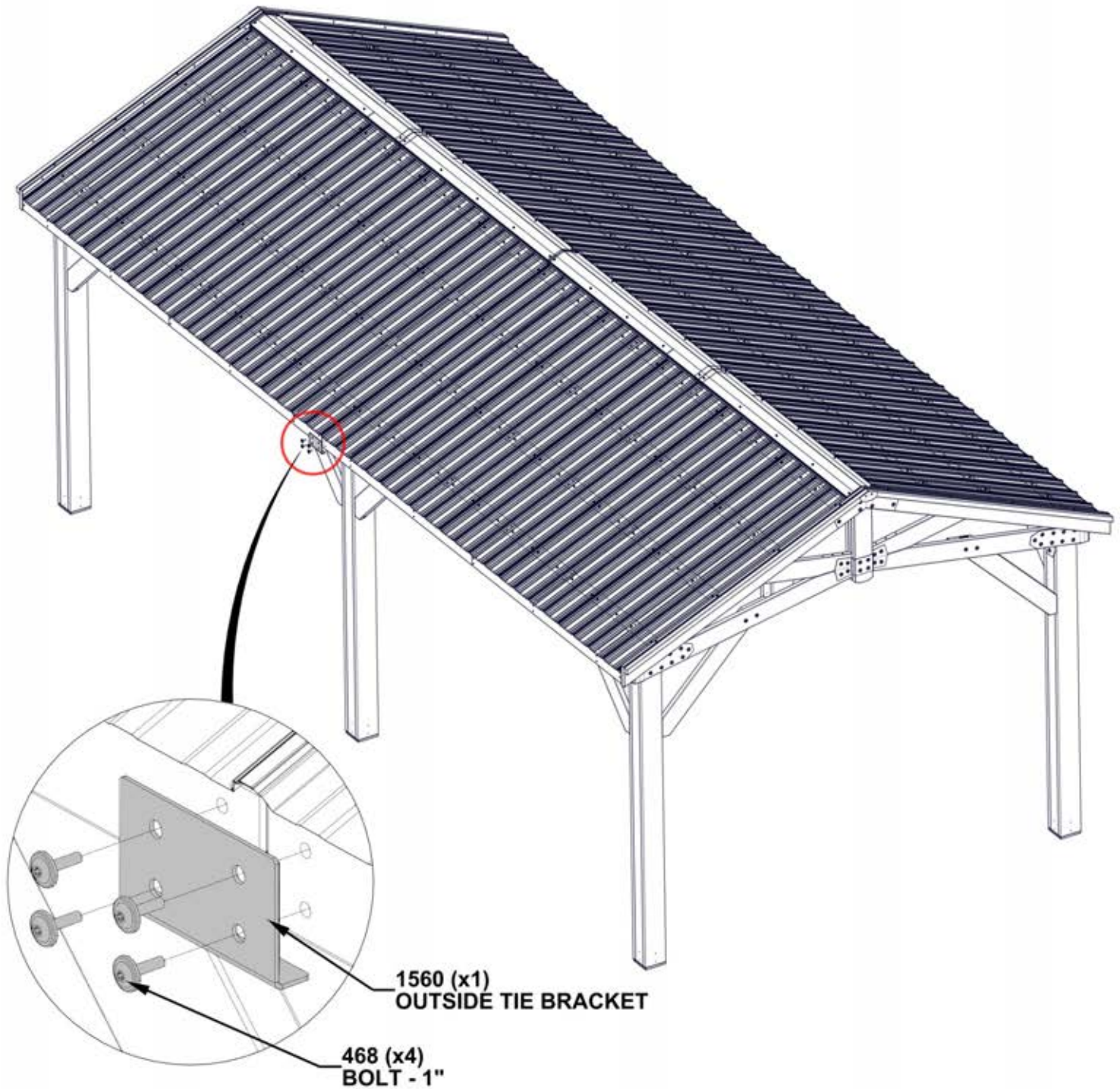

STEP 70 - ROOF ATTACHMENT

QTY	PART NUMBER	DESCRIPTION
16	H100392	SCREW PWH 8x3/4 BLK

- INSTALL SCREWS TO SECURE ROOF PANELS TO SHEATING BRACKETS

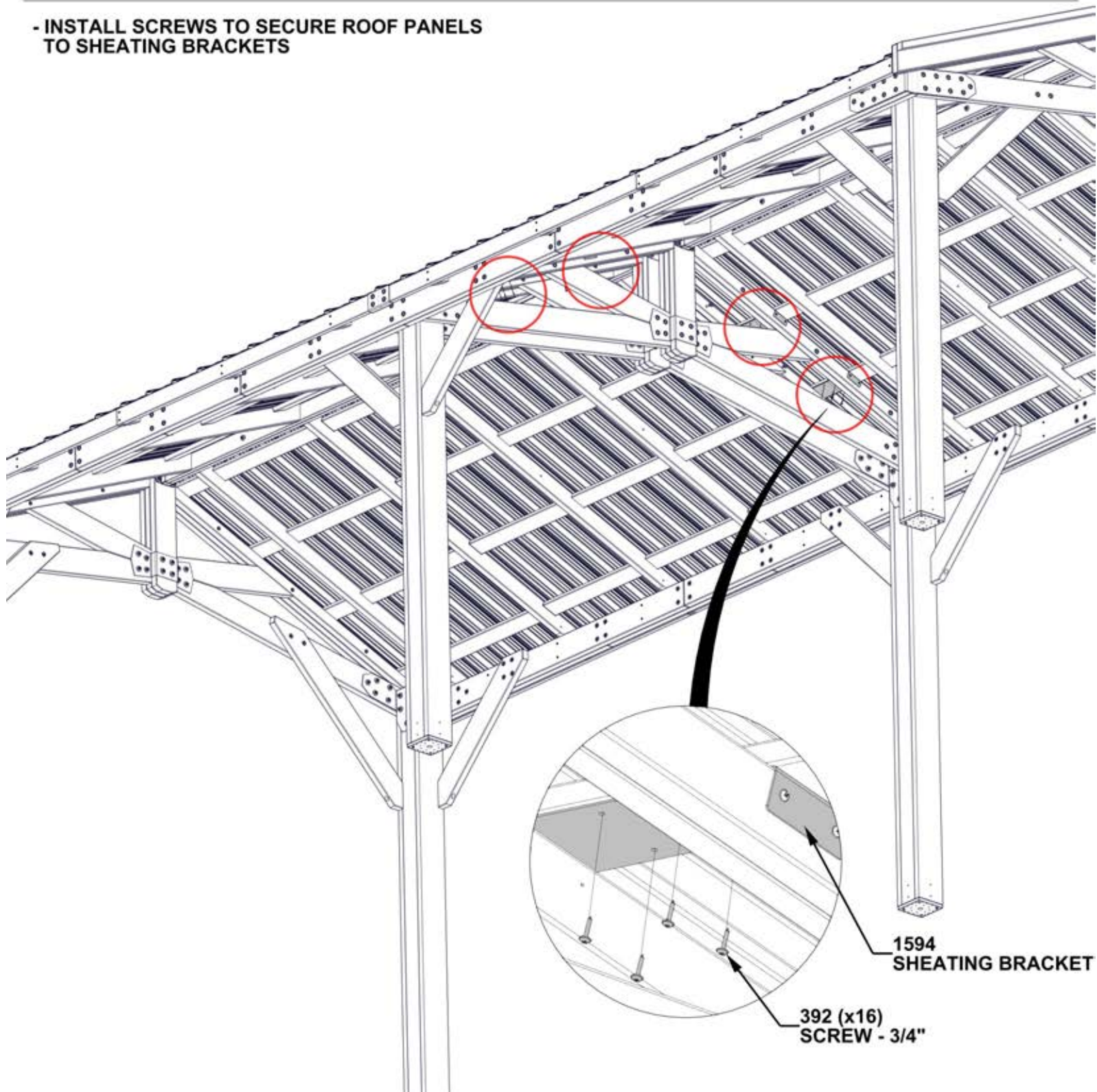

STEP 71 - ROOF ATTACHMENT

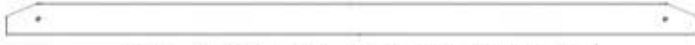

E09 ACCESSORY TRUSS - W4L16756
(x12) 1 3/8"x3 3/8"x73 7/8" (36x86x1875)

QTY	PART NUMBER	DESCRIPTION
12	H100198	WASHER LOCK EXT 8x19
12	H100478	WASHER FLAT 8x27 BLK
12	H100479	NUT LOCK 5/16 BLK
12	H100480	BOLT WH 5/16x4 3/4 BLK

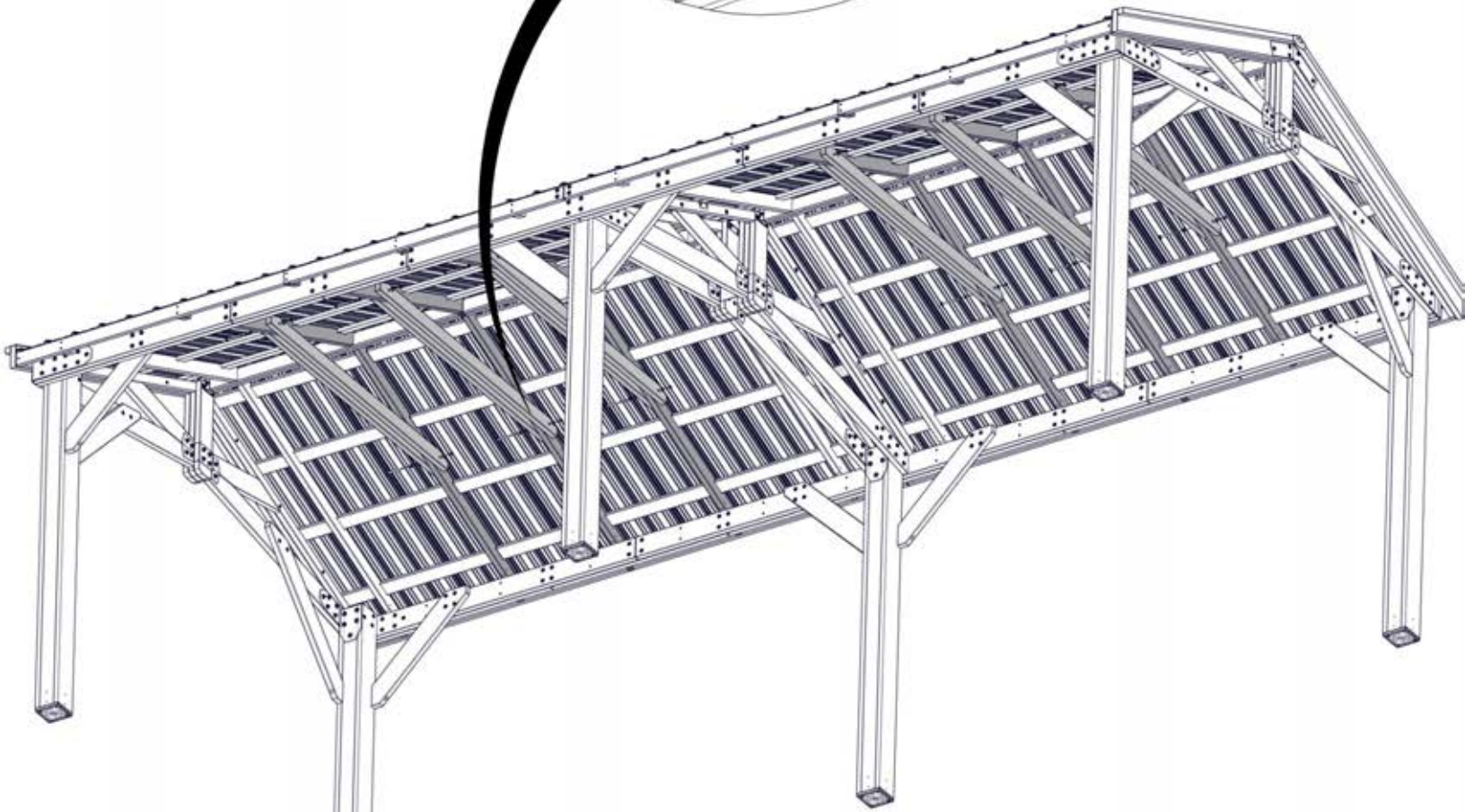
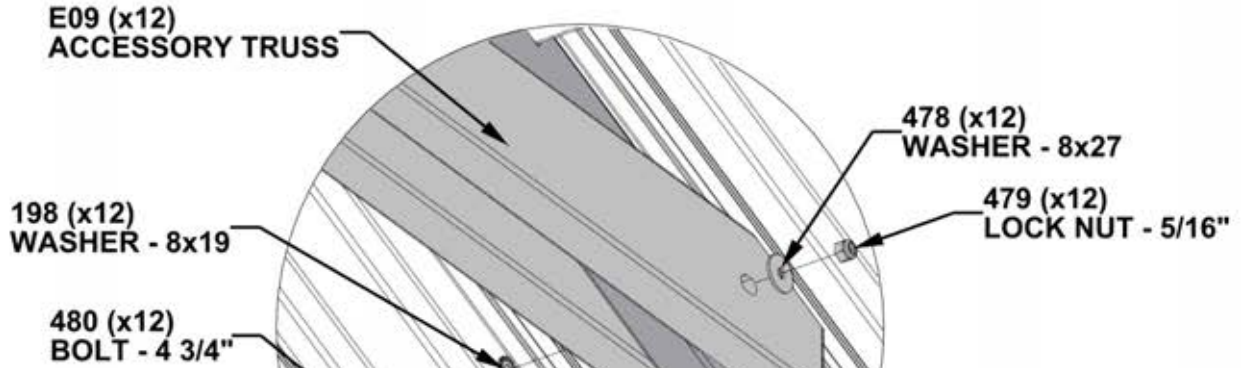

STEP 72 - ROOF ATTACHMENT



A4M01228 RAFTER CLIP
(x20)

QTY	PART NUMBER	DESCRIPTION
20	H100653	NUT LOCK 1/4 BLK
20	H100488	BOLT WH 1/4x2 BLK
20	H100630	WASHER FLAT 8x19 BLK
40	H100536	SCREW PWH 8x1 1/4 BLK

- A RAFTER BRACKET IS INSTALLED AT EACH RAFTER END - 20 TOTAL
- INSERT BOLTS FIRST, THEN SCREW IN BRACKET.

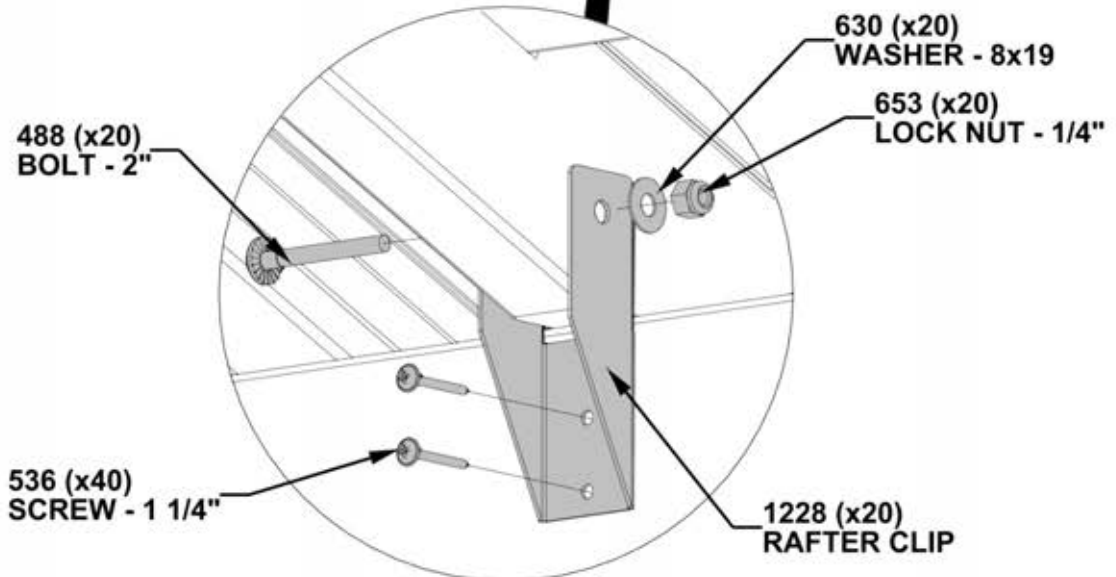
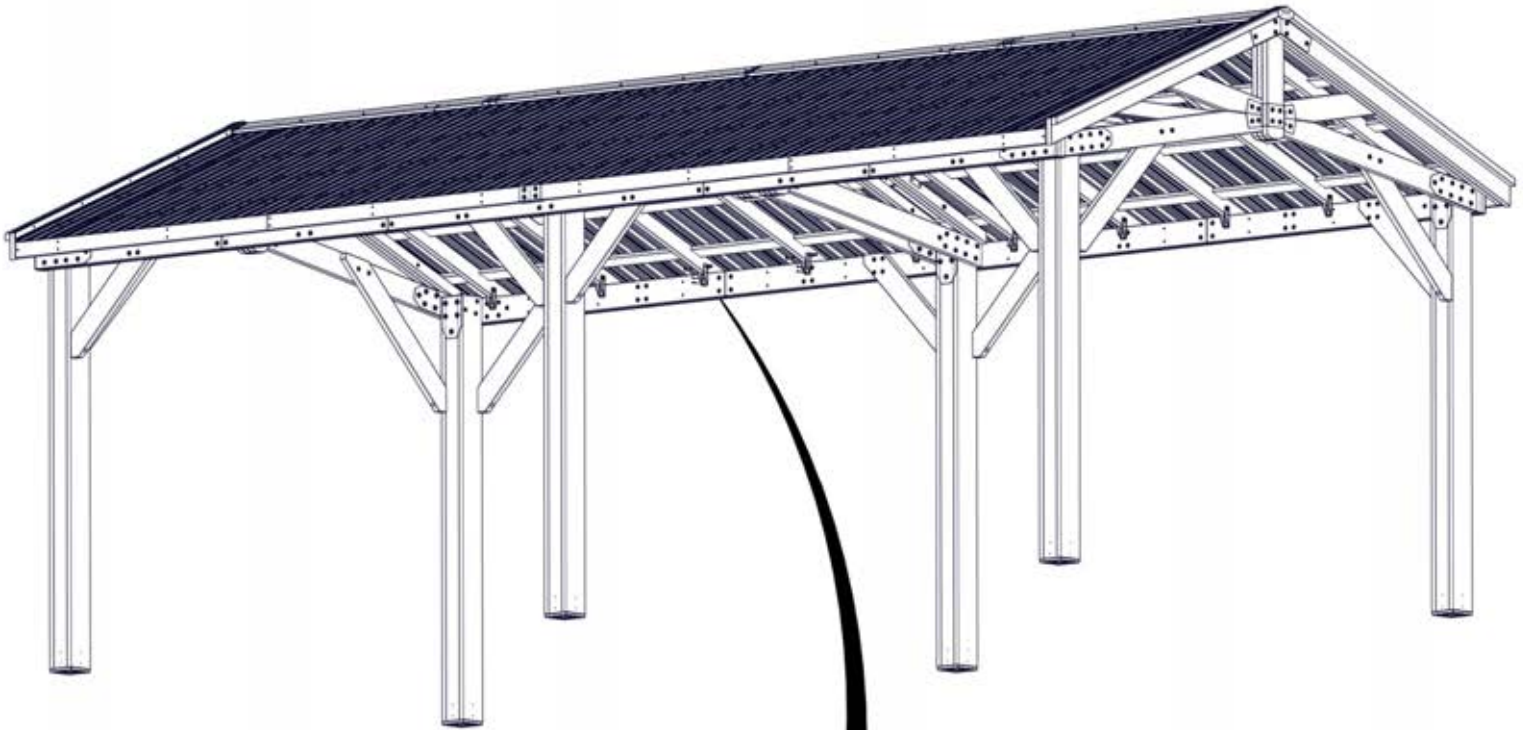

STEP 73 - ROOF ATTACHMENT

QTY	PART NUMBER	DESCRIPTION
40	H100759	SCREW SELF TAPPING 1/4x1

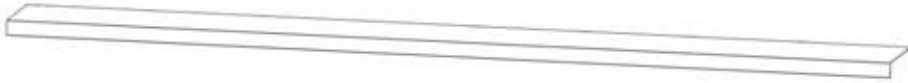

A4M02747 ROOF EDGE TRIM
(x8)



A4M02638 ROOF EDGE TRIM SPLICE
(x6)

COMPLETE THIS STEP TWICE FOR OPPOSITE SIDE

- DUE TO MULTIPLE LAYERS OF METAL ON THE EDGE TRIM, IT IS RECOMMENDED THAT A 1/8" (3mm) DRILL BIT IS USED TO CREATE STARTER HOLES.
- REMOVE PROTECTIVE BLUE FILM.
- GLOVES SHOULD BE WORN WHEN HANDLING ROOF METAL. EDGES ARE SHARP.
- START FIRST SCREW AT THE SECOND RIB FROM END. ATTACH SCREWS ON EVERY OTHER RIB.

SCREWS GO THROUGH EDGE TRIM INTO THE TOP OF THE RIBS IN THE APPROXIMATE LOCATIONS SHOWN.

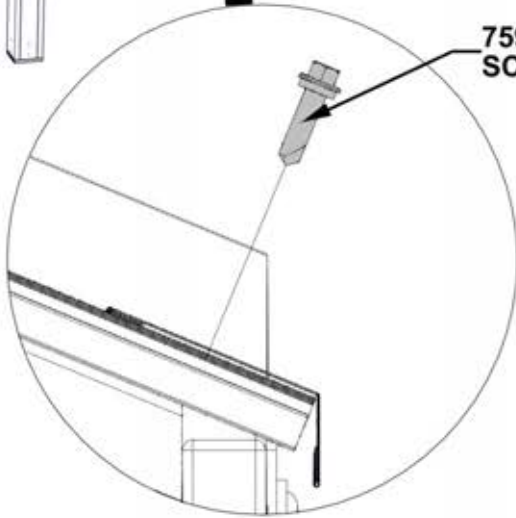
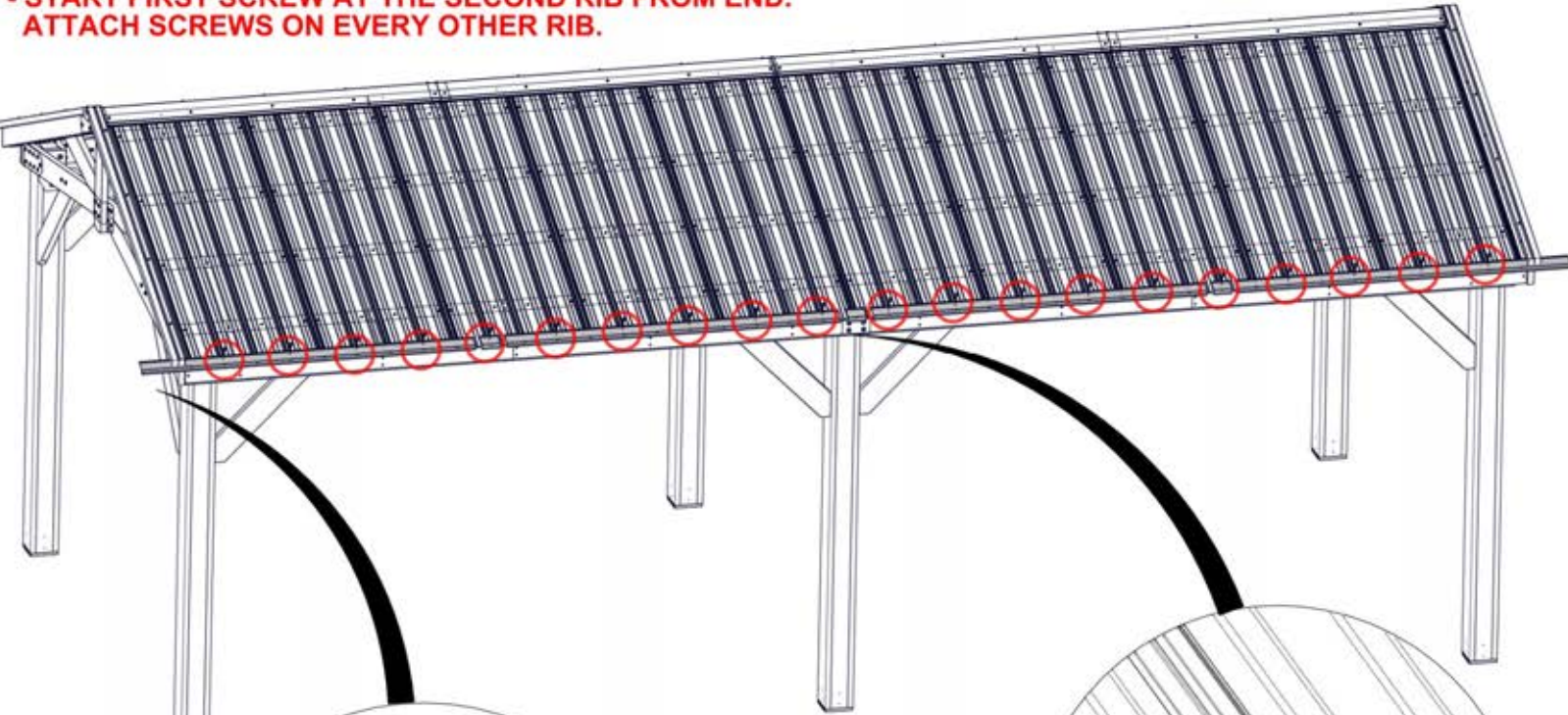

SIDE VIEW

759 (x20)
SCREW - 1"

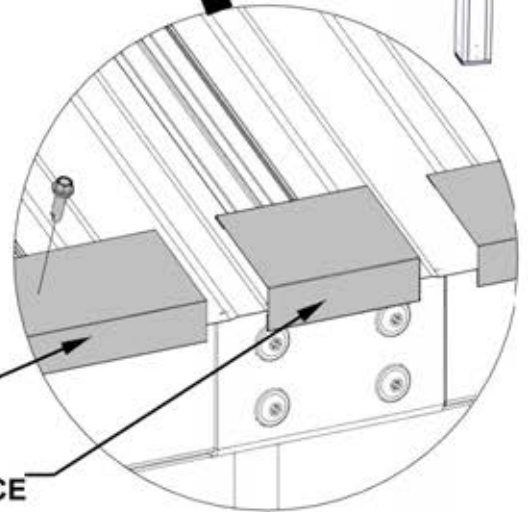

2747 (x4)
ROOF EDGE TRIM

2638 (x3)
ROOF EDGE TRIM SPLICE

SLIDE TRIM INTO SPLICE ENSURING THAT BOTH ENDS ARE FLUSH WITH THE EDGES OF ROOF PANELS

STEP 74 - GAZEBO ASSEMBLY (OPTIONAL)



A4M02501 FAN MOUNT BRACKET
(x1)

QTY	PART NUMBER	DESCRIPTION
4	H100382	SCREW PFH 8x1 3/4 BLK

- ATTACH YOUR ELECTRICAL BOX (SOLD SEPARATELY) WITH THE PROVIDED HOLES IN FAN MOUNT BRACKET.
- PLACE FAN MOUNT BRACKET ON RIDGE BEAMS AND MOVE TO DESIRED FAN LOCATION.
- ROTATE BRACKET UNTIL MOUNTING FLANGES ALIGN BEST WITH RIDGE BEAMS.
- USE AN 1/8" (3mm) DRILL BIT AND DRILL PILOT HOLES AND ATTACH AS SHOWN.

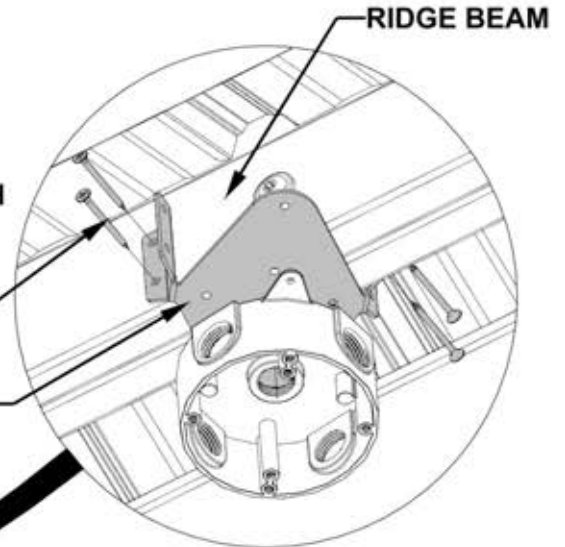

2501 (x1)
FAN MOUNT BRACKET

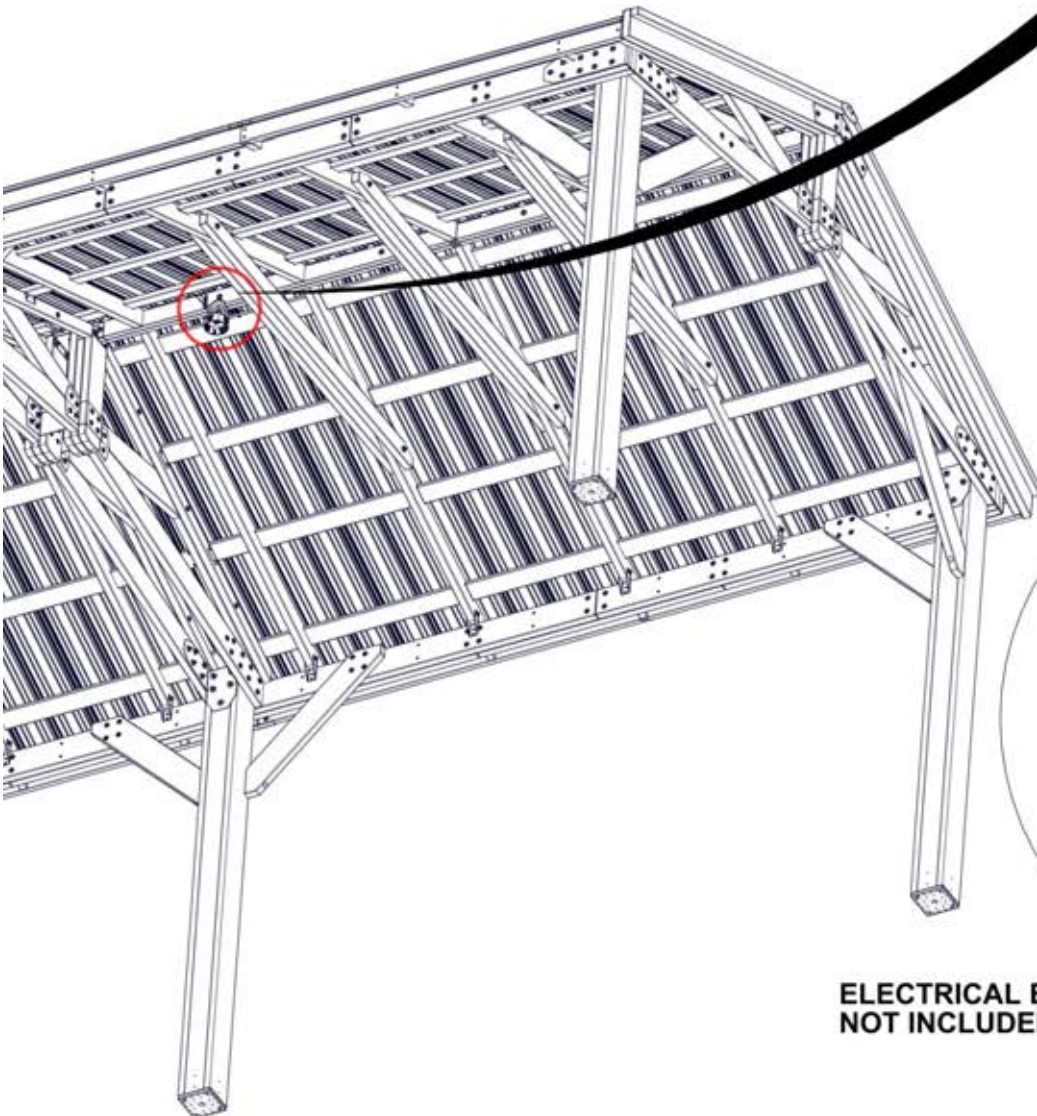

HARDWARE
NOT INCLUDED

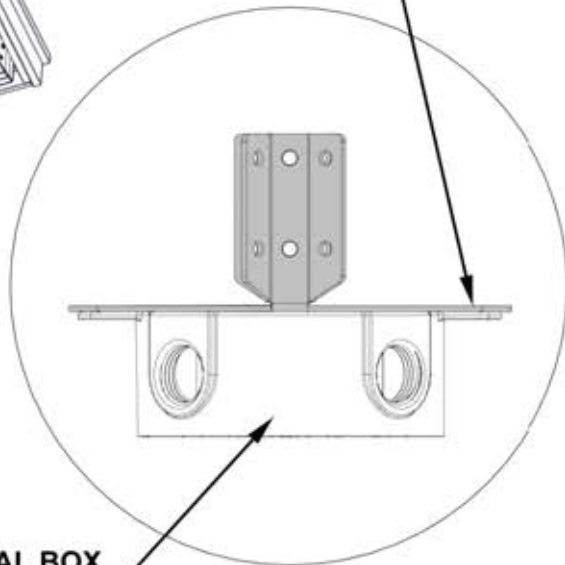

ELECTRICAL BOX
NOT INCLUDED

STEP 75 - GAZEBO ASSEMBLY

QTY	PART NUMBER	DESCRIPTION
48	H100471	LAG SCREW WH 5/16x1 1/2 BLK



A4M00977 POST ANCHORING PLATE
(x12)



A4M00978 POST PLATE
(x12)

- USE PILOT HOLES IN POST TO INSTALL LAG SCREWS

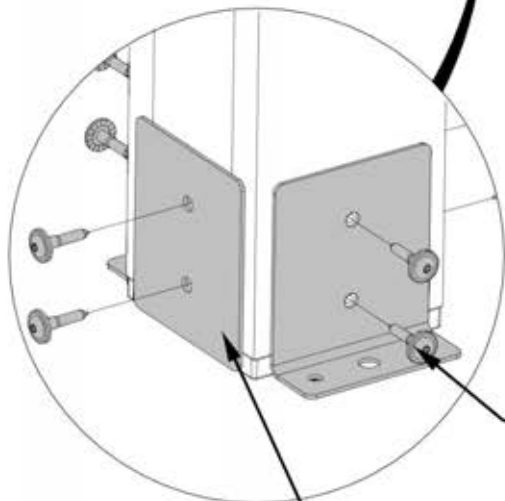
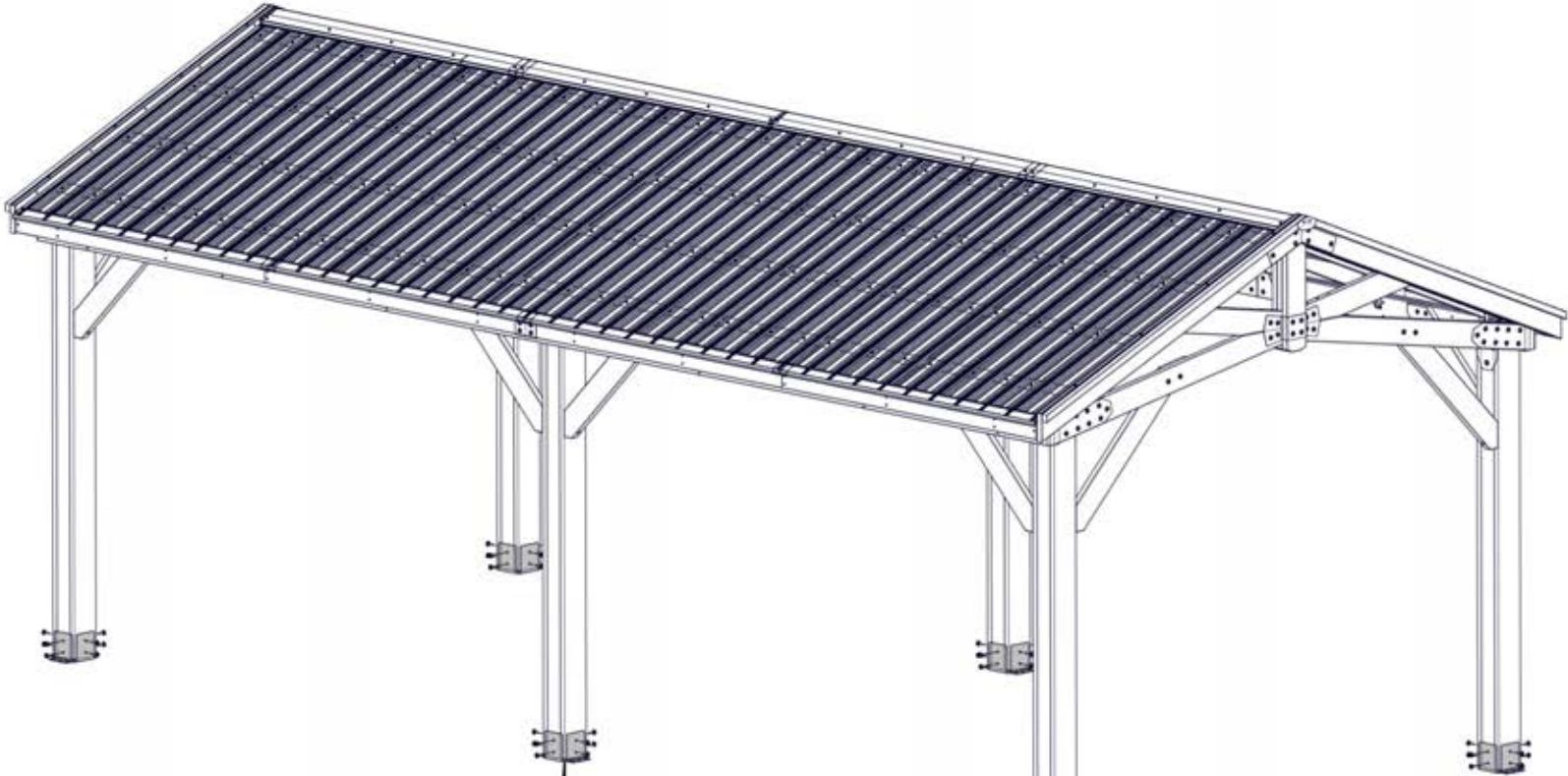

977 (x12)
POST ANCHORING
PLATE

471 (x48)
LAG SCREW - 1 1/2"

978 (x12)
POST PLATE

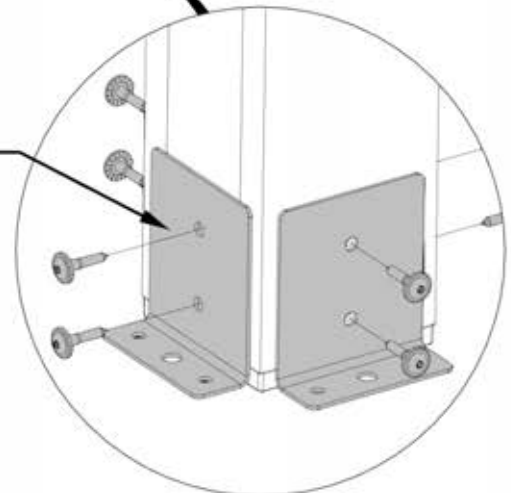

STEP 76 - GAZEBO ASSEMBLY



A4M02158 BYD ID TAG PATIO
(x1)

QTY	PART NUMBER	DESCRIPTION
4	H100202	SCREW PWH 8x5/8 BLK

- PLACE ID TAG IN APPROXIMATE LOCATION SHOWN.

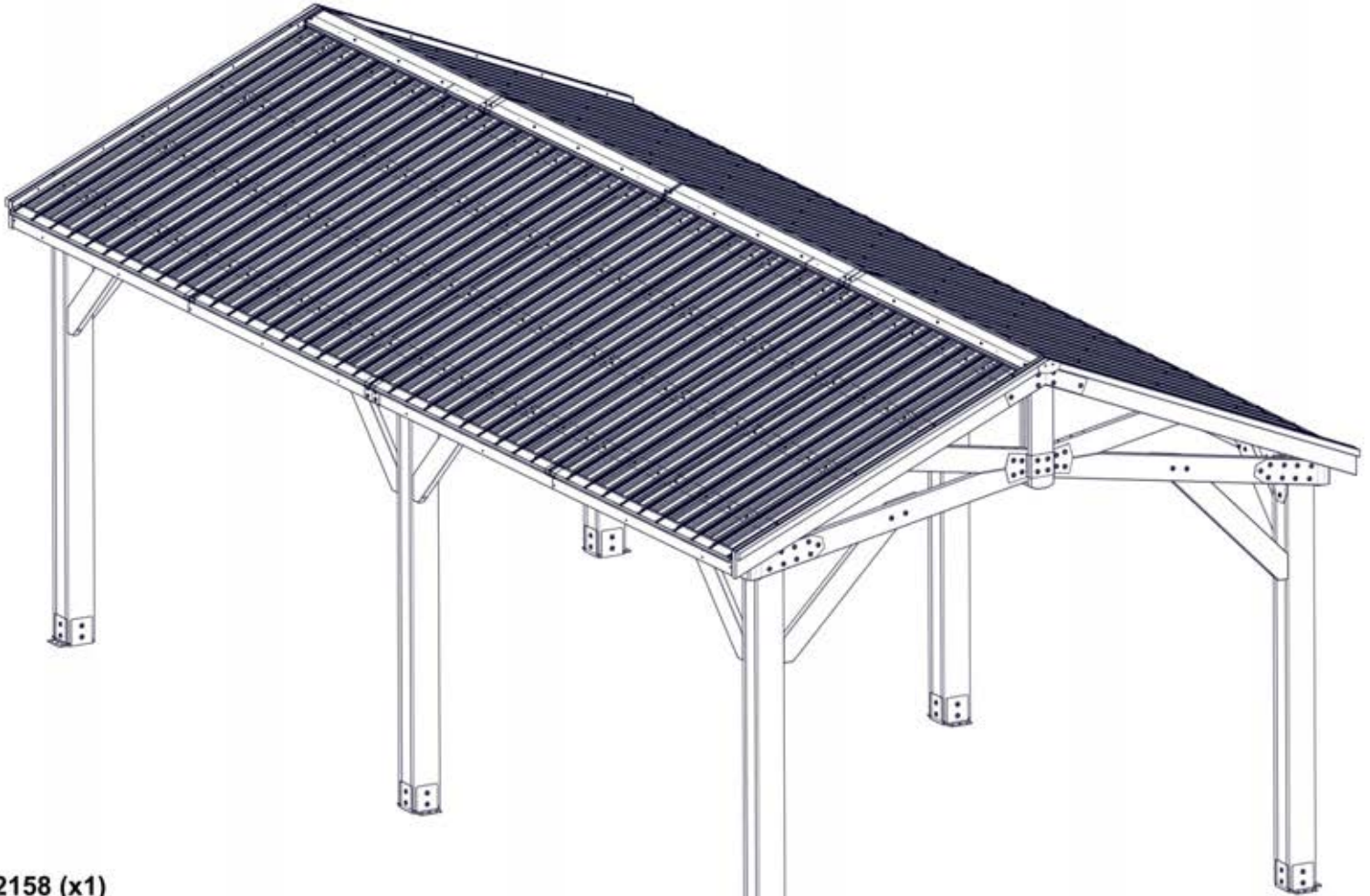

2158 (x1)
BYD ID TAG PATIO

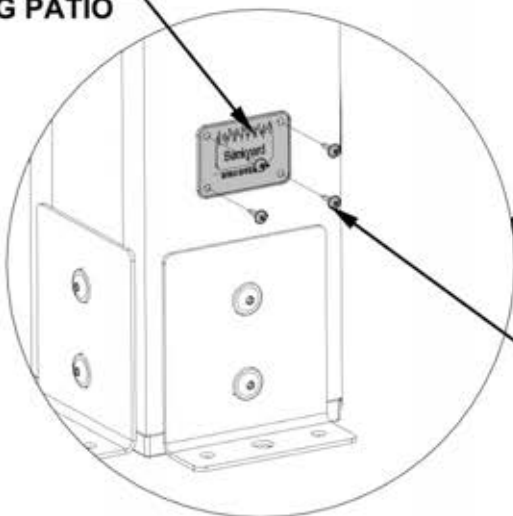

202 (x4)
SCREW - 5/8"

STEP 77 - GAZEBO ASSEMBLY

QTY	PART NUMBER	DESCRIPTION
24	H100120	CONCRETE ANCHOR 1/4"x2"
24	H100630	WASHER FLAT 8x19 BLK

- MANUFACTURER RECOMMENDS INSTALLATION ON CONCRETE SURFACE OR CONCRETE POST PAD AS SHOWN BELOW.
- FOR INSTALLATION ON WOOD DECK, YOU MUST ENSURE THERE IS AMPLE STRUCTURAL SUPPORT UNDER THE DECK. HARDWARE NOT INCLUDED FOR DECK ATTACHMENT.

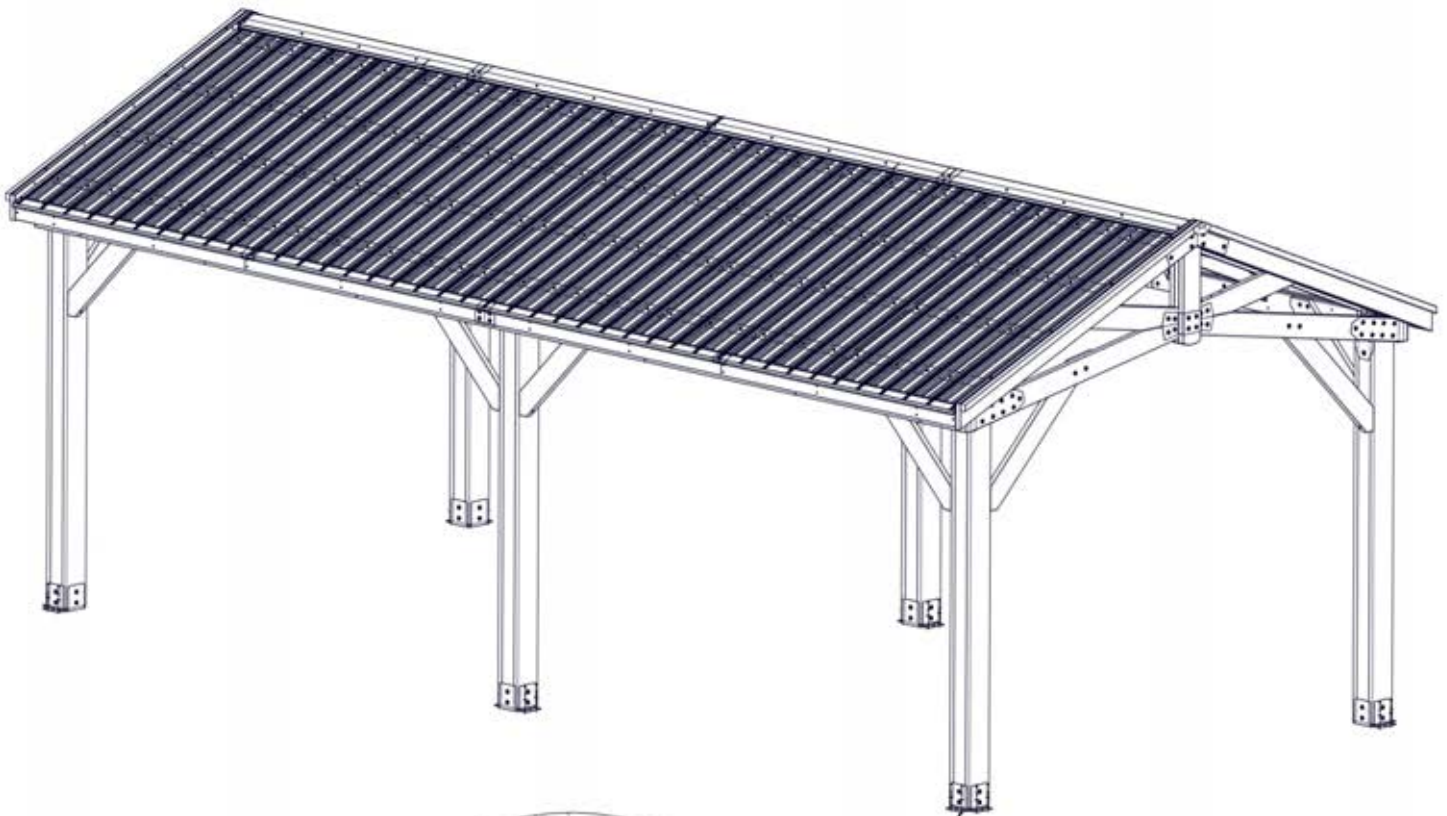

120 (x24)
CONCRETE SCREW-2"

630 (x24)
WASHER - 8x19

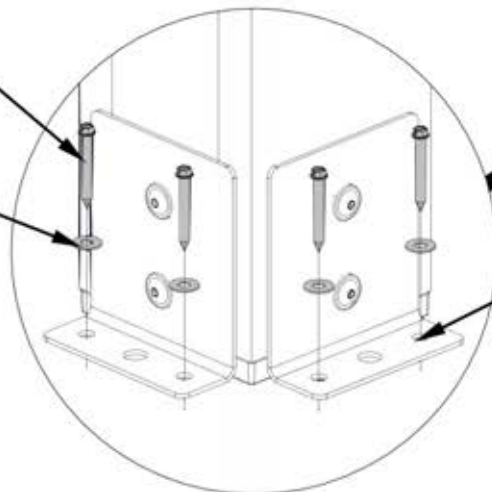

PRE-DRILL HOLES FOR CONCRETE ANCHORS USING A 3/16" CONCRETE DRILL BIT

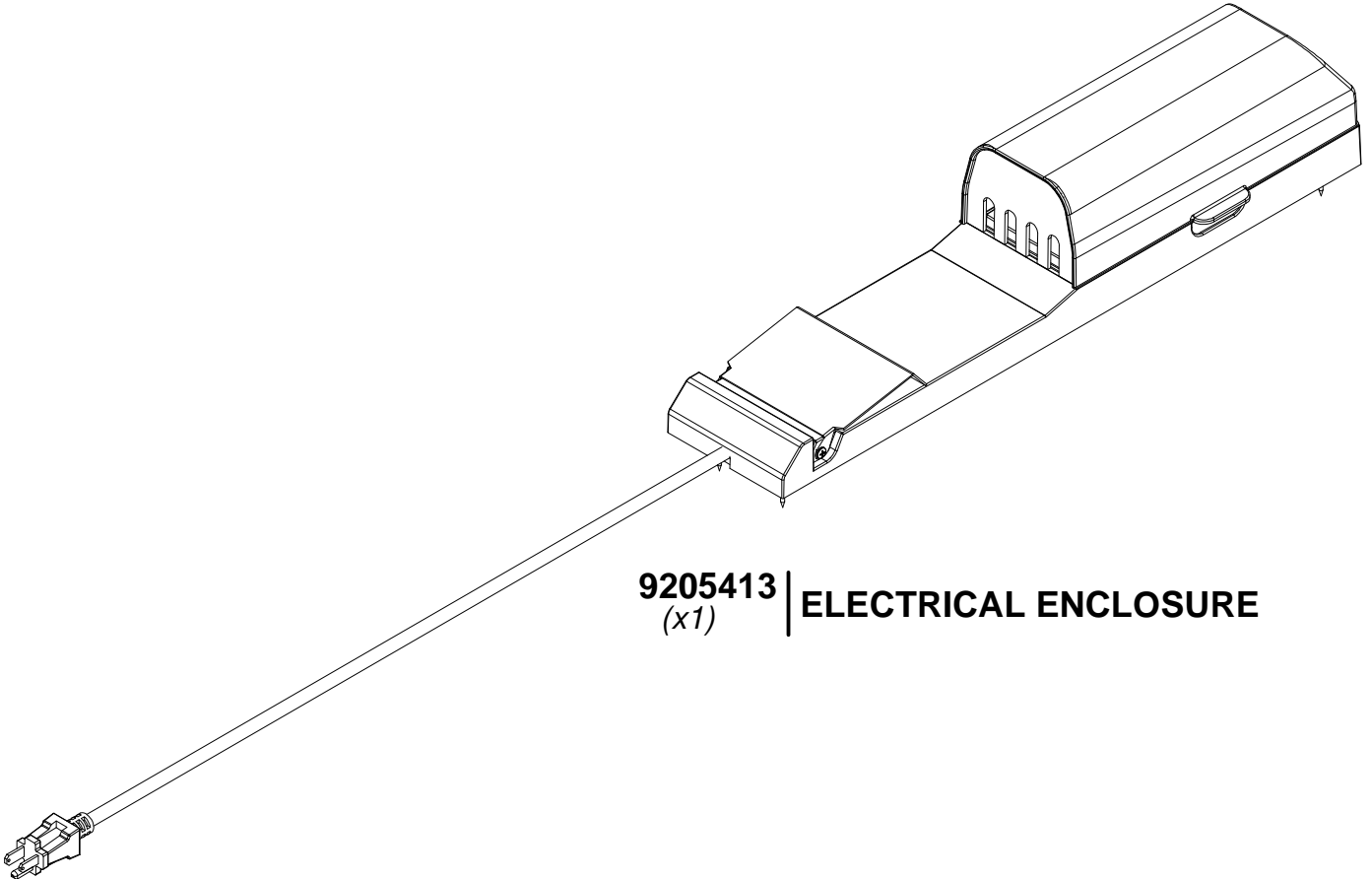

9205413 | **ELECTRICAL ENCLOSURE**
(x1)

FOR POWERPORT INSTALLATION REFER TO ASSEMBLY INSTRUCTIONS THAT COME PACKAGED WITH THE POWERPORT KIT. INSTALL ON ANY POST THAT IS DESIRED. FOLLOW DIRECTIONS FOR PROPER INSTALLATION.