



Manufactured by:
Backyard Discovery
3305 Airport Drive, Pittsburg, KS 66762
800-856-4445

Backyard Discovery Australia Pty Ltd 2/7 Hood Street, Hampton VIC 3188, Phone: 1800-087-941

12x10 NORWOOD GAZEBO

MODEL # : 2406056



Please visit www.backyarddiscovery.com
For the most up to date assembly manual, to register your product, or to order
replacement parts *Para obtener instrucciones en español, visite*
www.backyarddiscovery.com



EASY STEP-BY-STEP
3D INTERACTIVE INSTRUCTIONS
DOWNLOAD THE FREE APP



OWNER'S MANUAL - BASIC SETUP DIMENSIONS & ASSEMBLY NOTES

It is critically important that you start with square and level footings, concrete pad or deck to attach your structure

- Pay close attention to the items needed for each step. Make sure you are using the correct hardware for each step.
- Using incorrect hardware may result in improper assembly
- Remember to double check for underground utilities and overhead electrical lines

Post mounts are provided with your structure which allows you to permanently install your structure to a pre-existing or new wood or concrete surface. See Anchor Instructions for further details and recommendations.

- The hardware to attach the post mounts to the structure is included.
- The hardware to mount the structure permanently to a concrete surface is included.
- The hardware to mount the structure permanently to a wood deck is NOT included and will need to be purchased separately. You must ensure there is ample structural support under the deck before permanently attaching.

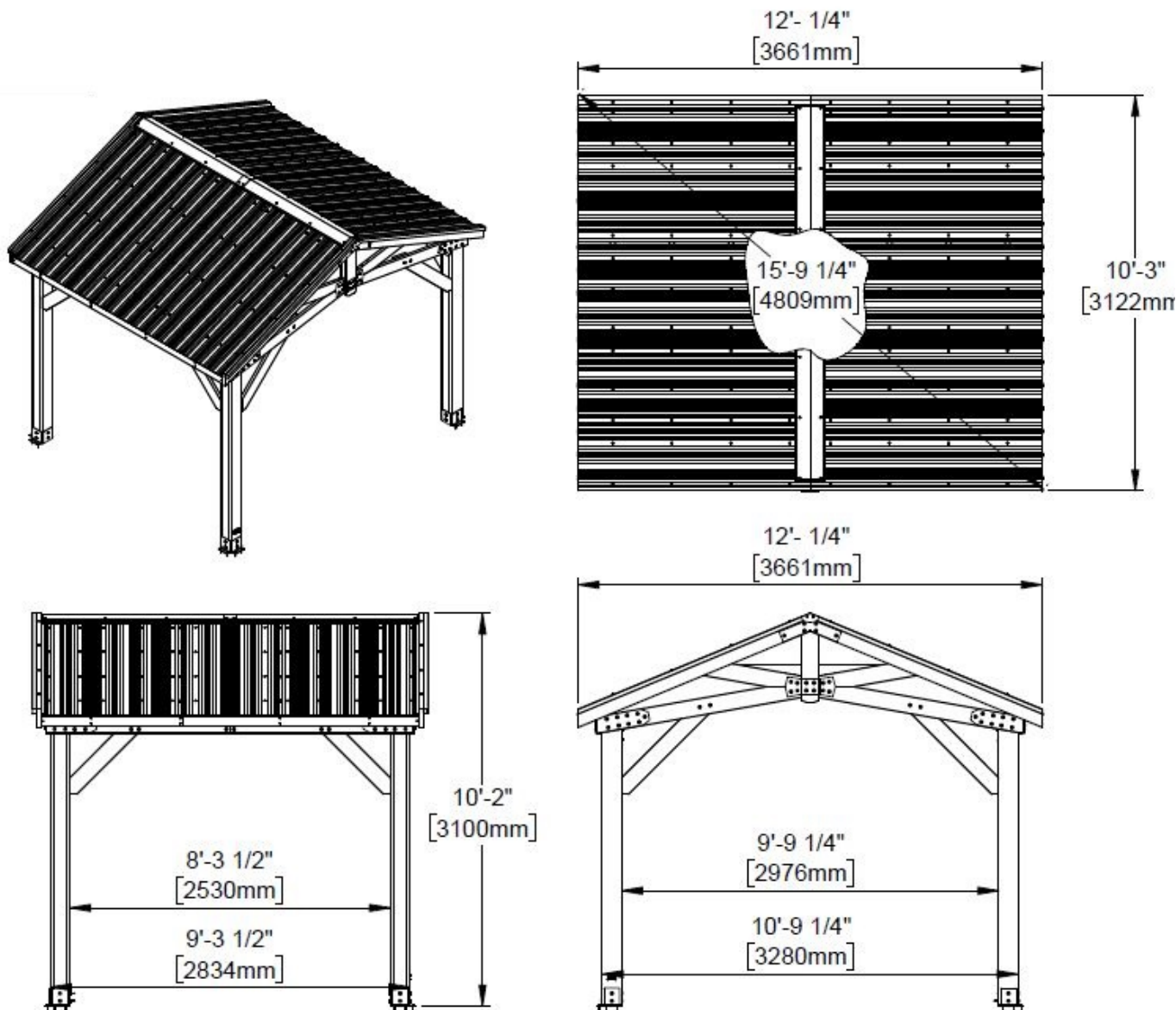

OWNER'S MANUAL - ANCHORING LAYOUT

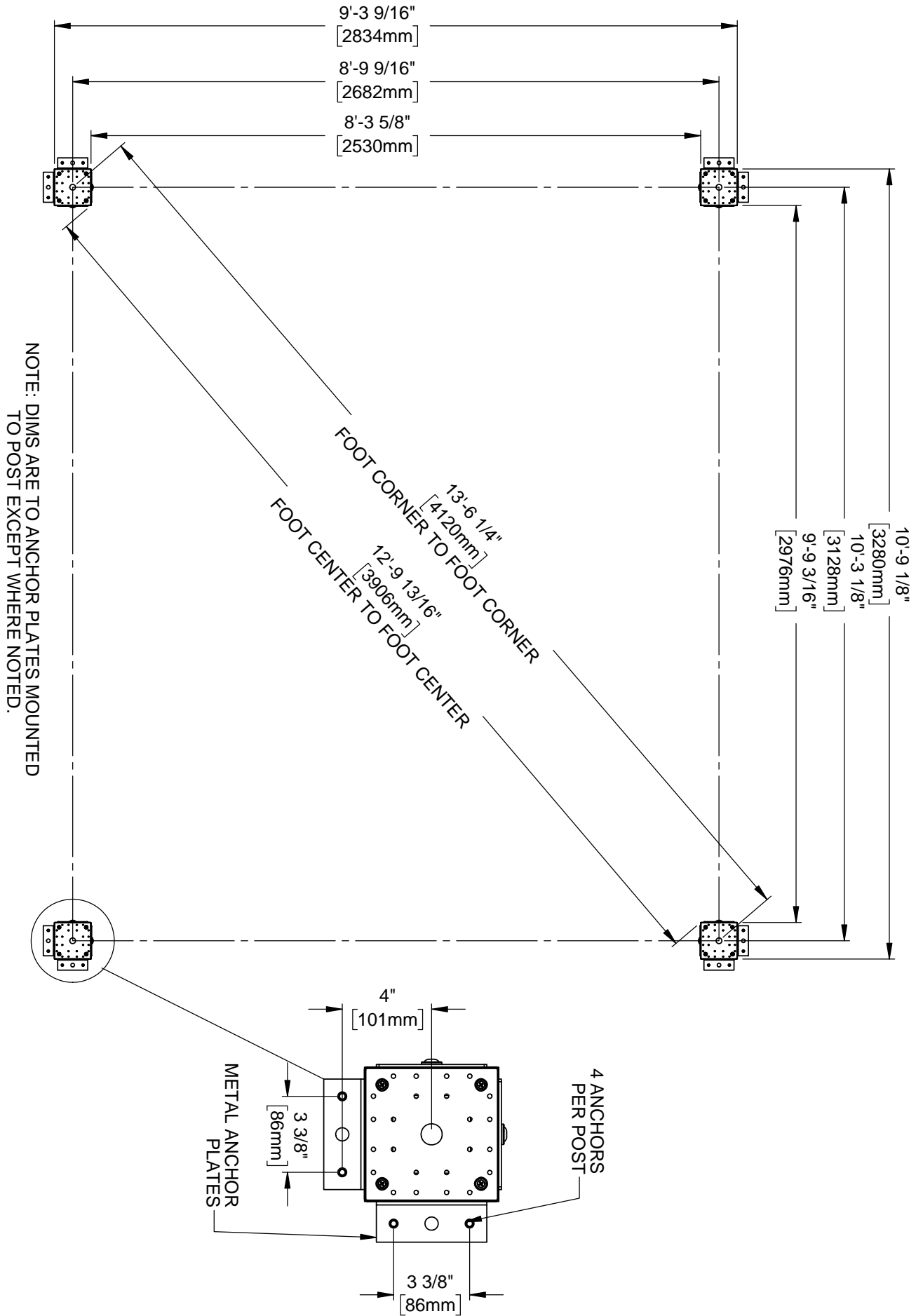

OWNER'S MANUAL - PARTS IDENTIFICATION

WOOD COMPONENTS (NOT TO SCALE)



D01 GABLE BOARD - W4L19640
(x4) 1 3/8"X5 1/4"X24 5/8" (36x134x626)



D04 CORBEL - W4L16234
(x3) 1 7/16"x5 1/4"x34 7/16" (36x134x875)



D05 GABLE BOARD - W4L16235
(x2) 1 7/16"x1 1/2"x5 1/4" (36x38x134)



D06 CORBEL - W4L17223
(x4) 1 7/16"x5 1/4"x44 1/4" (36x134x1124)



D07 CORBEL W/TAG - W2A03384
(x1) 1 7/16"x5 1/4"x34 7/16" (36x134x875)



E01 RAFTER - W4L19518
(x4) 1 7/16"x3 3/8"x77 3/8" (36x86x1965)



E02 TRUSS - W4L19639
(x4) 1 3/8"X2 3/8"x75 3/16" (36x60x1910)



E03 RAFTER - W4L19619
(x4) 1 7/16"x3 3/8"x77 3/8" (36x86x1965)



E06 ACCESSORY TRUSS - W4L16863
(x4) 1 3/8"X3 3/8"X73 7/8" (36x86x1875)



G01 TOP RAIL - W4L19511
(x4) 15/16"x5 1/4"x27 11/16" (24x134x703)



G02 TOP RAIL - W4L19512
(x2) 15/16"x5 1/4"x59 1/16" (24x134x1500)



G03 TOP RAIL - W4L19515
(x4) 15/16"x5 1/4"x57 3/16" (24x134x1453)



H02 FASCIA - W4L19516
(x2) 15/16"x3 3/8"x74 3/4" (24x86x1898)



H03 FASCIA - W4L19517
(x2) 15/16"x3 3/8"x43 3/4" (24x86x1111)



H04 RIDGE BEAM - W4L19513
(x2) 15/16"x3 3/8"x39 1/2" (24x86x1003)



H05 RIDGE BEAM - W4L19514
(x2) 15/16"x3 3/8"x70 1/2" (24x86x1791)

OWNER'S MANUAL - PARTS IDENTIFICATION

WOOD COMPONENTS (NOT TO SCALE)



H06 PURLIN - W4L19519
(x8) 15/16"x3 3/8"x74 9/16" (24x86x1894)



H07 PURLIN - W4L19520
(x8) 15/16"x3 3/8"x43 9/16" (24x86x1107)



H08 NOTCHED SUPPORT BOARD - W4L16915
(x2) 1"x3 3/8"x89 1/2" (24x86x2274)



J09 RIDGE CAP STIFFENER - W4L13590
(x2) 15/16"x2 3/8"x47 5/8" (24x60x1210)



J10 RIDGE CAP STIFFENER - W4L13591
(x2) 15/16"x2 3/8"x69 5/16" (24x60x1760)



GP1 GABLE PANEL - W2A04177
(x2) 2 13/16"x5 1/4"x80 3/16" (72x134x2037)



GP2 GABLE PANEL - W2A04178
(x2) 2 13/16"x5 1/4"x80 3/16" (72x134x2037)

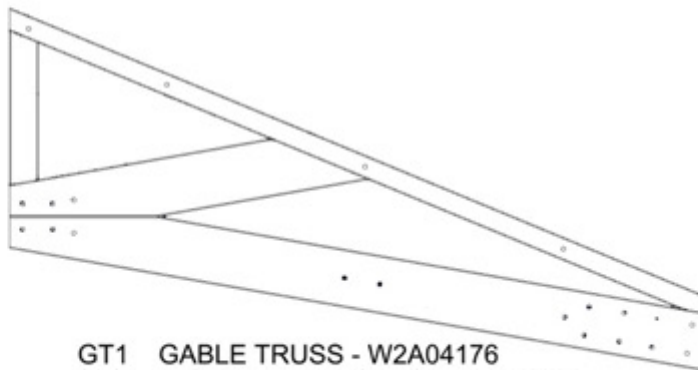

GT1 GABLE TRUSS - W2A04176
(x4) 1 3/8"x34"x64 9/16" (36x864x1640)



P1 POST - W2A03517
(x2) 6"x6"x89 1/2" (152x152x2274)



P2 POST - W2A03518
(x2) 6"x6"x89 1/2" (152x152x2274)

OWNER'S MANUAL - PARTS IDENTIFICATION

Hardware Components

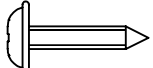

H100202 | SCREW PWH BLK
(x4) | 8x5/8

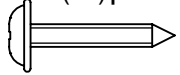

H100392 | SCREW PWH BLK
(x16) | 8x3/4

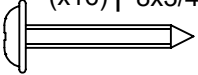

H101069 | SCREW PWH BLK
(x8) | 8x7/8

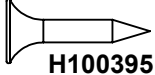

H100395 | SCREW PFH BLK
(x6) | 8x3/4

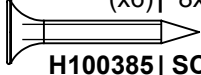

H100385 | SCREW PFH BLK
(x4) | 8x1

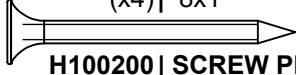

H100200 | SCREW PFH BLK
(x20) | 8x1-1/2

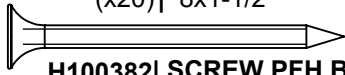

H100382 | SCREW PFH BLK
(x24) | 8x1-3/4

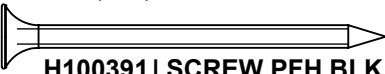

H100391 | SCREW PFH BLK
(x100) | 8x2

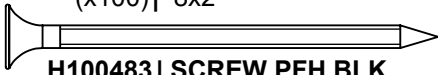

H100483 | SCREW PFH BLK
(x4) | 8x2-1/4

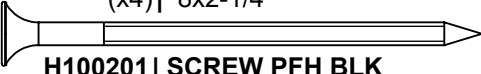

H100201 | SCREW PFH BLK
(x20) | 8x2-1/2

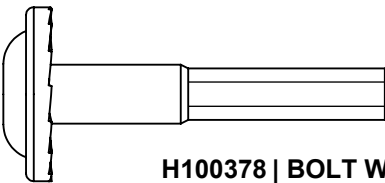

H100378 | BOLT WH BLK
(x8) | 5/16x1-3/4

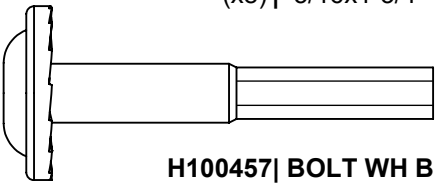

H100457 | BOLT WH BLK
(x20) | 5/16x2

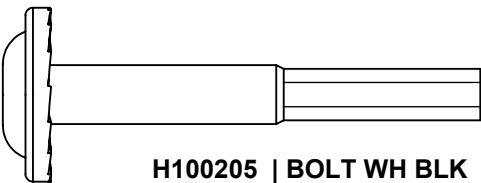

H100205 | BOLT WH BLK
(x36) | 5/16x2-1/4

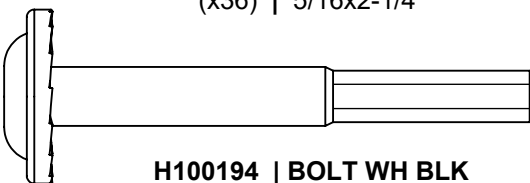

H100194 | BOLT WH BLK
(x4) | 5/16x2-1/2

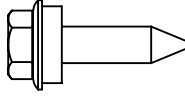

H100833 | SCREW WOODGRIP
(x160) | 10x3/4

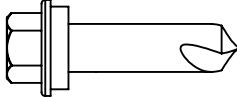

H100759 | SCREW TAPPING
(x16) | 1/4x1

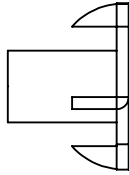

H100379 | T-NUT BLK
(x64) | 5/16

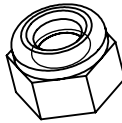

H100479 | NUT LOCK BLK
(x74) | 5/16



H100653 | NUT LOCK BLK
(x4) | 1/4

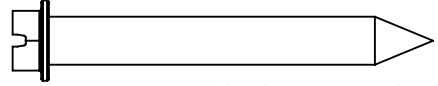

H100120 | CONCRETE ANCHOR
(x16) | 1/4x2

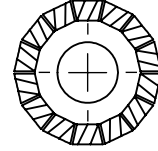

H100198 | WASHER LOCK EXT BLK
(x40) | 8x19

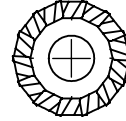

H100405 | WASHER LOCK EXT BLK
(x20) | 6x15

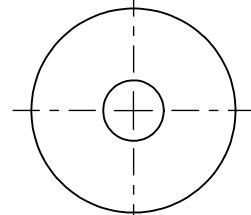

H100478 | WASHER FLAT BLK
(x78) | 8x27

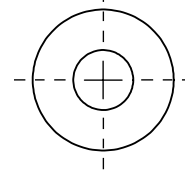

H100630 | WASHER FLAT BLK
(x20) | 8x19

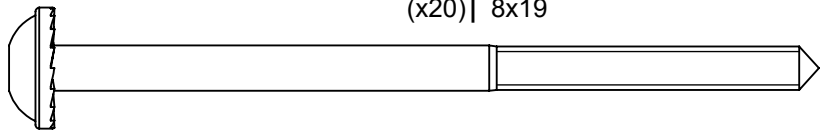

H100564 | LAG SREW WH BLK
(x12) | 1/4x4

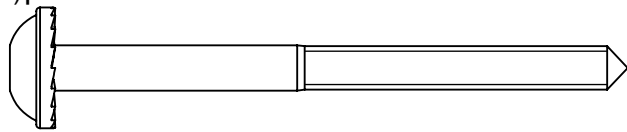

H100792 | LAG SCREW WH BLK
(x8) | 1/4x3

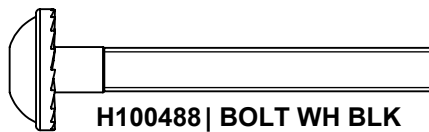

H100488 | BOLT WH BLK
(x4) | 1/4x2

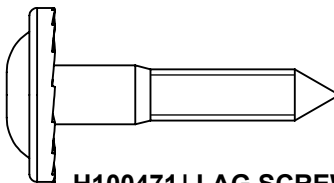

H100471 | LAG SCREW WH BLK
(x44) | 5/16x1-1/2

OWNER'S MANUAL - PARTS IDENTIFICATION

Hardware Components

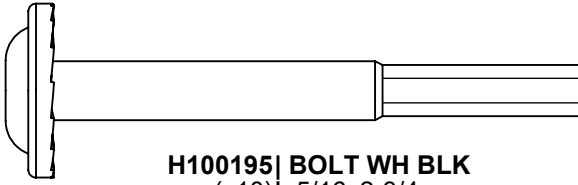

H100195 | BOLT WH BLK
(x10) | 5/16x2-3/4

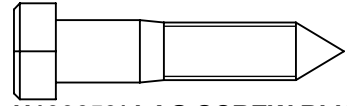

H100659 | LAG SCREW BLK
(x4) | 5/16x1-1/2



H100484 | BOLT WH BLK
(x16) | 5/16x3-1/4



H100480 | BOLT WH BLK
(x4) | 5/16x4-3/4



H100881 | BOLT WH BLK
(x8) | 5/16x5

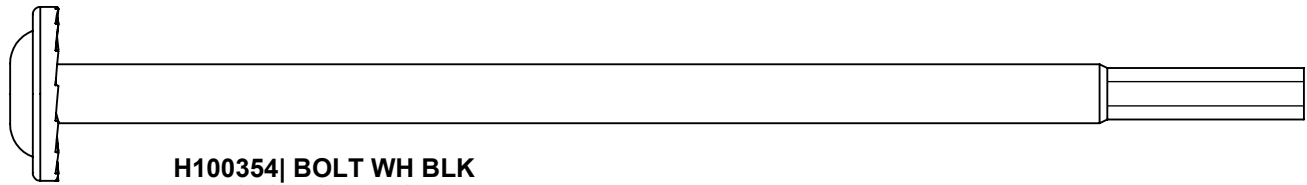

H100354 | BOLT WH BLK
(x4) | 5/16x6-1/2

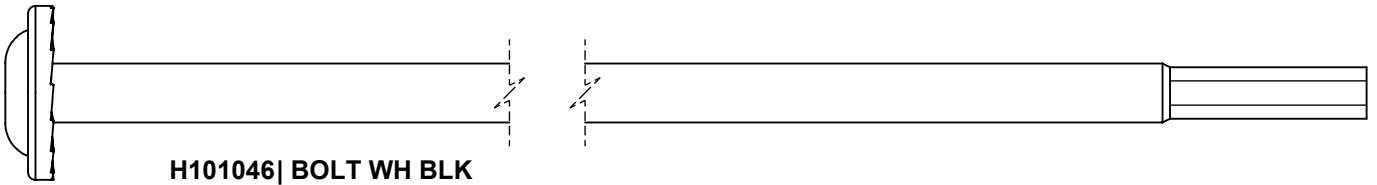

H101046 | BOLT WH BLK
(x12) | 5/16x7-1/2



H101058 | BOLT WH BLK
(x16) | 5/16x8-3/4

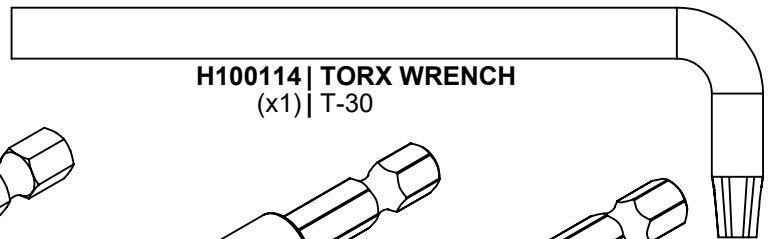

H100114 | TORX WRENCH
(x1) | T-30

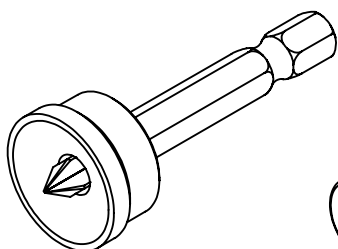

H100764 | SCREW SETTER
(x1) |

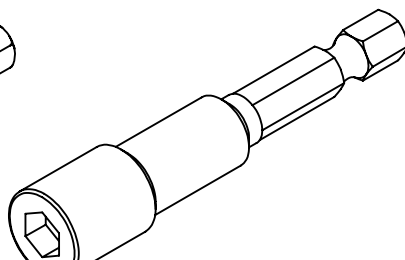

H101106 | SOCKET DRIVER
(x1) |

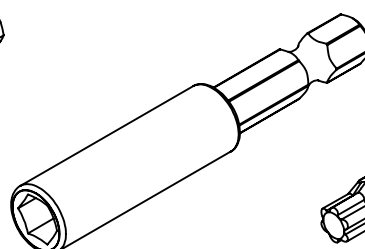

H101100 | MAGNETIC DRIVER
(x1) |

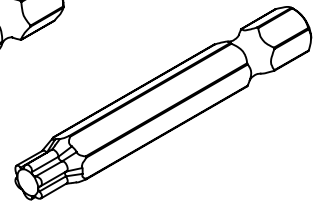

H100147 | TORX BIT
(x1) | T-30

OWNER'S MANUAL - PARTS IDENTIFICATION

ACCESSORY COMPONENTS (NOT TO SCALE)

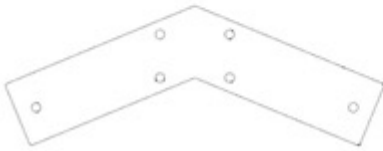

A4M01130 GABLE BRACKET
(x2)

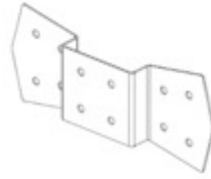

A4M01129 GABLE BRACKET
(x4)



A4M01228 RAFTER CLIP
(x4)

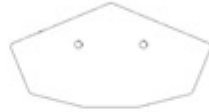

A4M01147 PEAK SEAM BRACKET
(x2)



A4M01148 TRUSS BRACKET
(x2)

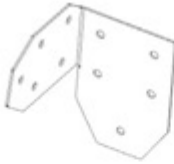

A4M01232 LEFT ANGLE BRACKET
(x2)

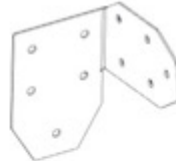

A4M01233 RIGHT ANGLE BRACKET
(x2)



A4M00977 POST ANCHORING
PLATE
(x8)



A4M00978 POST PLATE
(x8)



A4M02158 BYD ID TAG PATIO
(x1)



A4M02501 FAN MOUNT BRACKET
(x1)



A4M02636 RIDGE CAP 29GA
(x2)



A4M02637 ROOF EDGE TRIM
(x4)



A4M02639 29GA STEEL SHEETING
(x8)



A4M02638 ROOF EDGE TRIM SPLICE
(x2)

OWNER'S MANUAL - PARTS IDENTIFICATION

ACCESSORY COMPONENTS (NOT TO SCALE)



A4M02640 RIDGE CAP SPLICE
(x1)

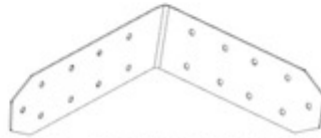

A4M02717 RIGHT OUTSIDE BRACKET
(x2)

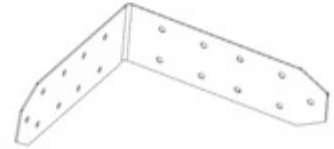

A4M02718 LEFT OUTSIDE BRACKET
(x2)



A4M02719 GAZEBO BRACE
(x2)



A4M02720 GAZEBO BRACE
(x1)

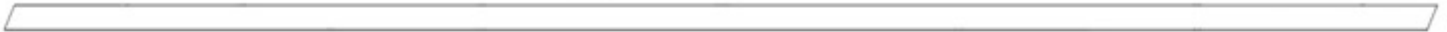

A4M02679 ROOF END TRIM
(x2)



A4M02680 ROOF END TRIM
(x2)



A6P00398 RIDGE CAP PROTECTOR
(x2)

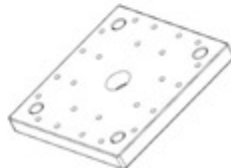

A6P00308 6x6 POST FOOT
(x4)

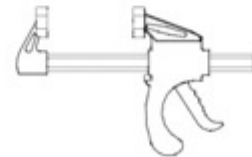

A6P00460 6" QUICK RELEASE BAR CLAMP
(x2)

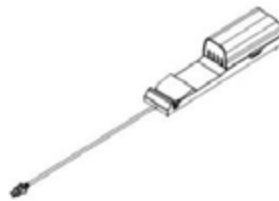

9220409 ELECTRICAL ENCLOSURE
(x1)

PRE-ASSEMBLY STEP 1 - SORTING PARTS

It is critical for ease of assembly that you take the time to sort and organize the wood and hardware.

WOOD PARTS:

- Organize wood parts by the three-digit, alpha-numeric number stamped on each board (ex. P01).
- If there are multiple boards with the same stamped number, stack those pieces together.
- Stamps can be found on the flat surface of the boards or on the end of the boards.
- Allow yourself plenty of room - the wood pieces can take up a significant amount of space.

NOTE: CARTONS ARE NOT ORGANIZED BY BOARD NUMBER.



HARDWARE PARTS:

- We recommend that you have a separate table to organize the hardware.
- Hardware bags are printed with a seven-digit, alpha-numeric part number.
- You can organize your hardware by part number or group by hardware type (i.e. bolts, nuts, etc.).
- During assembly you only need to reference the last four digits of the number.

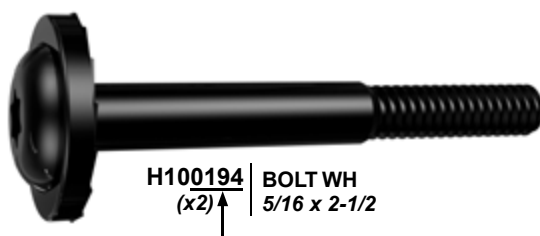

H100194 | BOLT WH
(x2) ↑ 5/16 x 2-1/2

PRE-ASSEMBLY STEP 2 - TOOLS REQUIRED



Cordless Drill or Electric Drill



Drill Attachments:
Phillips Head



1/8", 3/16", 3/8" &
7/16" Drill Bits



Phillips Screw Driver



Open End
Wrenches 1/2" &
7/16"



3/8" Drive Ratchet, 1/2" &
7/16" STD Sockets, 1/2" &
7/16" Deep Sockets



Tape Measure



Claw Hammer



3/8 & 5/16" Nut Drivers

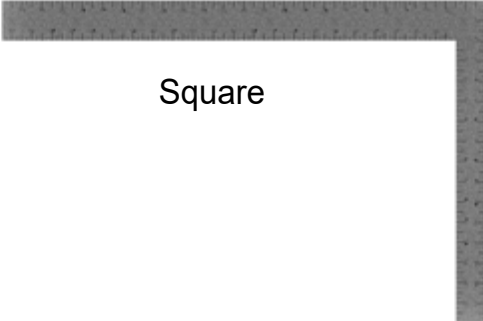

Square



Level 24"



Rubber Mallet -
Optional

PRE-ASSEMBLY STEP 3 - CHOOSE YOUR ASSEMBLY METHOD

There are several types of assembly instructions available to you.

1. Printed Assembly Manual included with your set
2. BILT APP - 3D interactive instructions
3. Combination of the Printed Manual and BILT APP (Note: Step numbers can differ between the two methods)

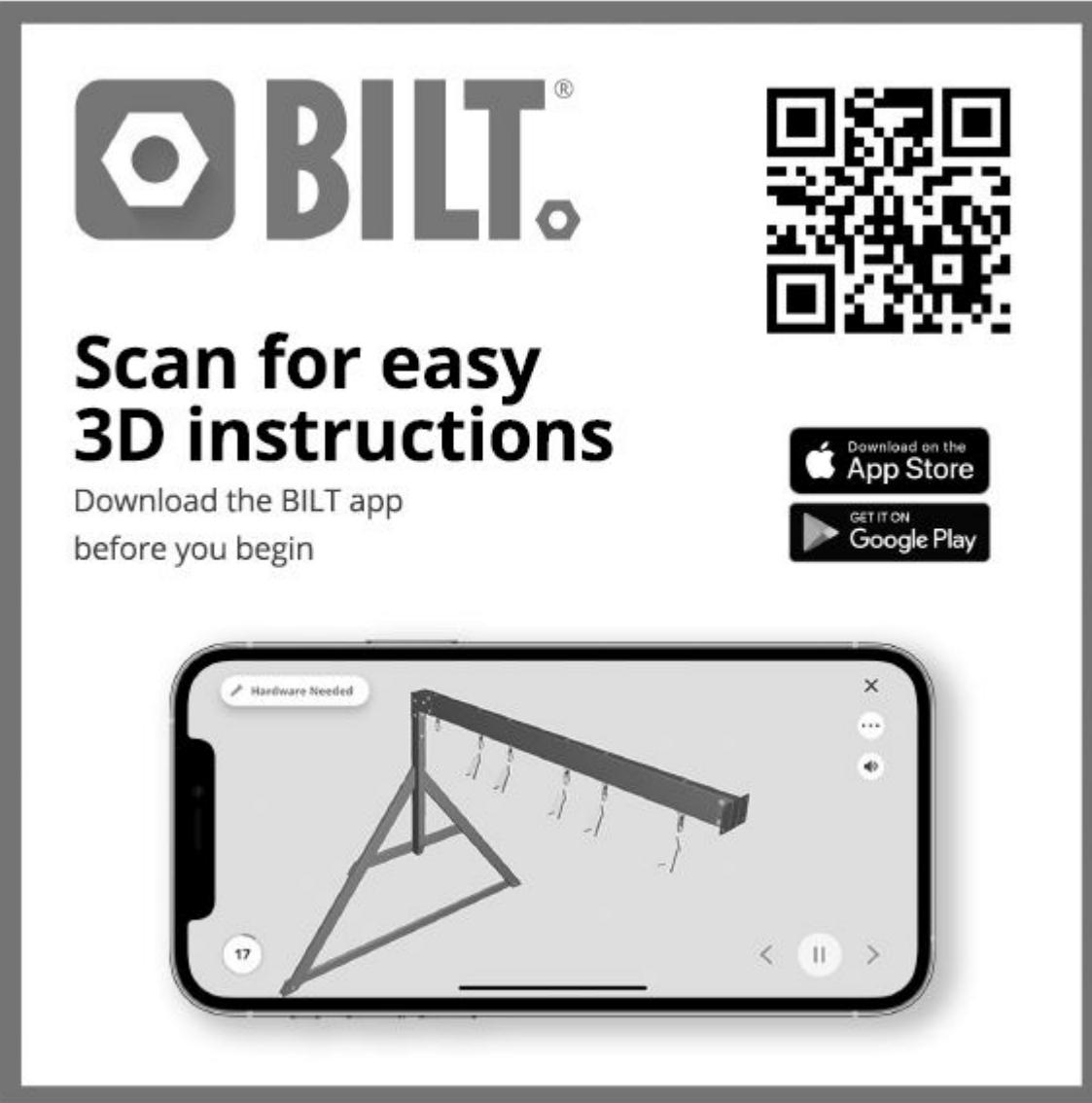

The graphic is a rectangular advertisement for the BILT app. At the top left is the BILT logo, which consists of a stylized hexagonal bolt head icon followed by the word "BILT." in a bold, sans-serif font with a registered trademark symbol. To the right of the logo is a large QR code. Below the logo and QR code, the text "Scan for easy 3D instructions" is written in a large, bold, black font. Underneath this, in a smaller font, it says "Download the BILT app before you begin". To the right of this text are two buttons: "Download on the App Store" with the Apple logo and "GET IT ON Google Play" with the Google Play logo. At the bottom of the graphic is a smartphone displaying a 3D assembly instruction. The screen shows a grey metal frame with a horizontal bar and several hanging components. The interface includes a "Hardware Needed" label at the top left, a close button (X) at the top right, a list of three dots, a back arrow, and a play/pause button at the bottom. A small circle with the number "17" is visible in the bottom left corner of the phone screen.

STEP 1 - GAZEBO ASSEMBLY

QTY	PART NUMBER	DESCRIPTION
16	H100200	SCREW PFH 8x1 1/2 BLK



P1 POST - W2A03517
(x2) 6"x6"x89 1/2" (152x152x2274)



P2 POST - W2A03518
(x2) 6"x6"x89 1/2" (152x152x2274)

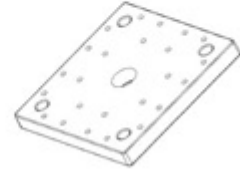

A6P00308 6x6 POST FOOT
(x4)

- FOR EASE OF ASSEMBLY , WE RECOMMEND USING SAW HORSES FOR STEPS 1-6

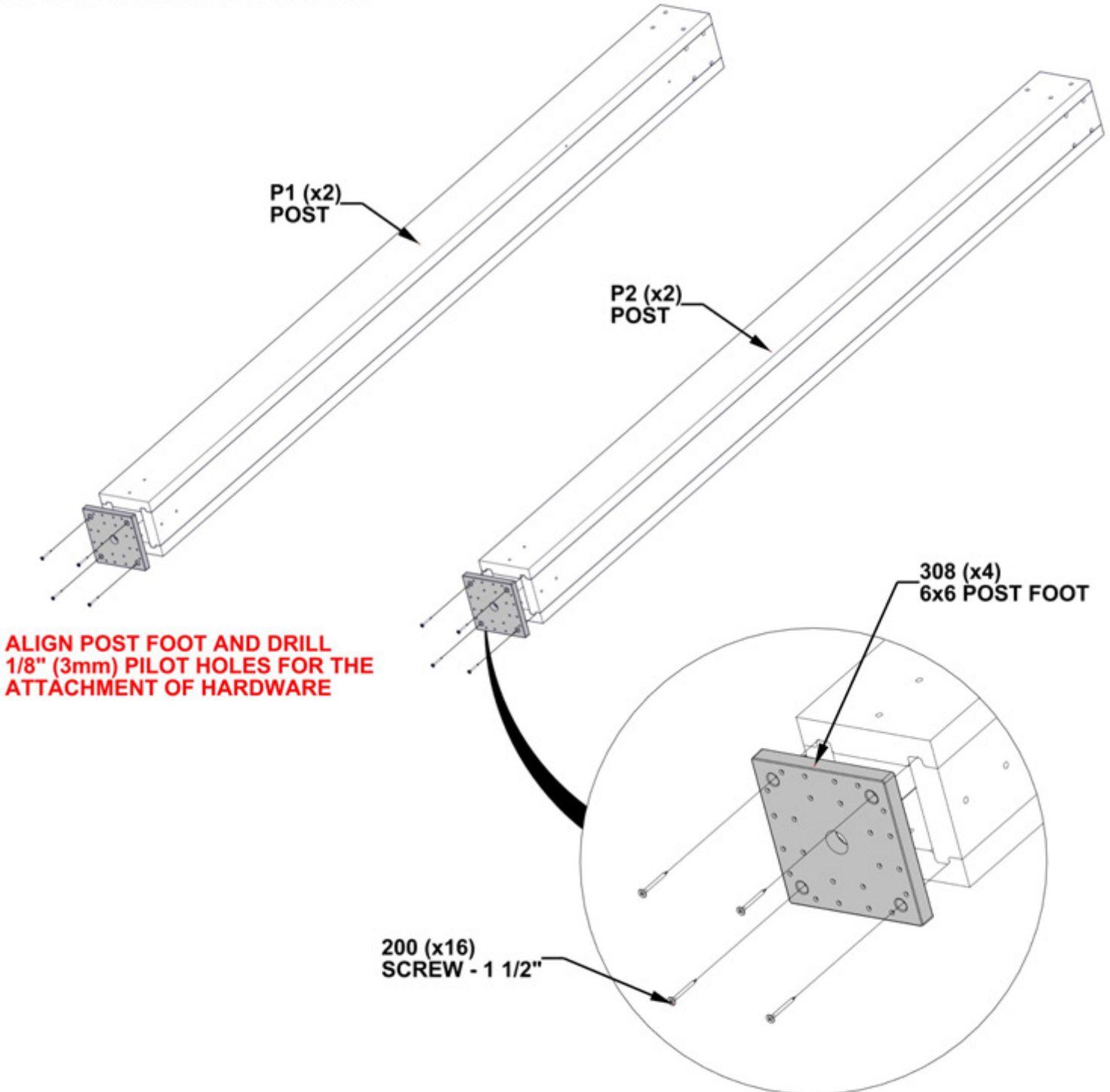

STEP 2 - GAZEBO ASSEMBLY

QTY	PART NUMBER	DESCRIPTION
2	H100483	SCREW PFH 8x2 1/4 BLK



D01 GABLE BOARD - W4L19640
(x1) 1 3/8"X5 1/4"X24 5/8" (36x134x626)



D05 GABLE BOARD - W4L16235
(x1) 1 7/16"x1 1/2"x5 1/4" (36x38x134)

- ALIGN D05 WITH D01 ENSURING THAT BOTTOM FACES ARE FLUSH.
- DRILL 1/8" (3mm) PILOT HOLES IN D01 USING D05 AS TEMPLATE.

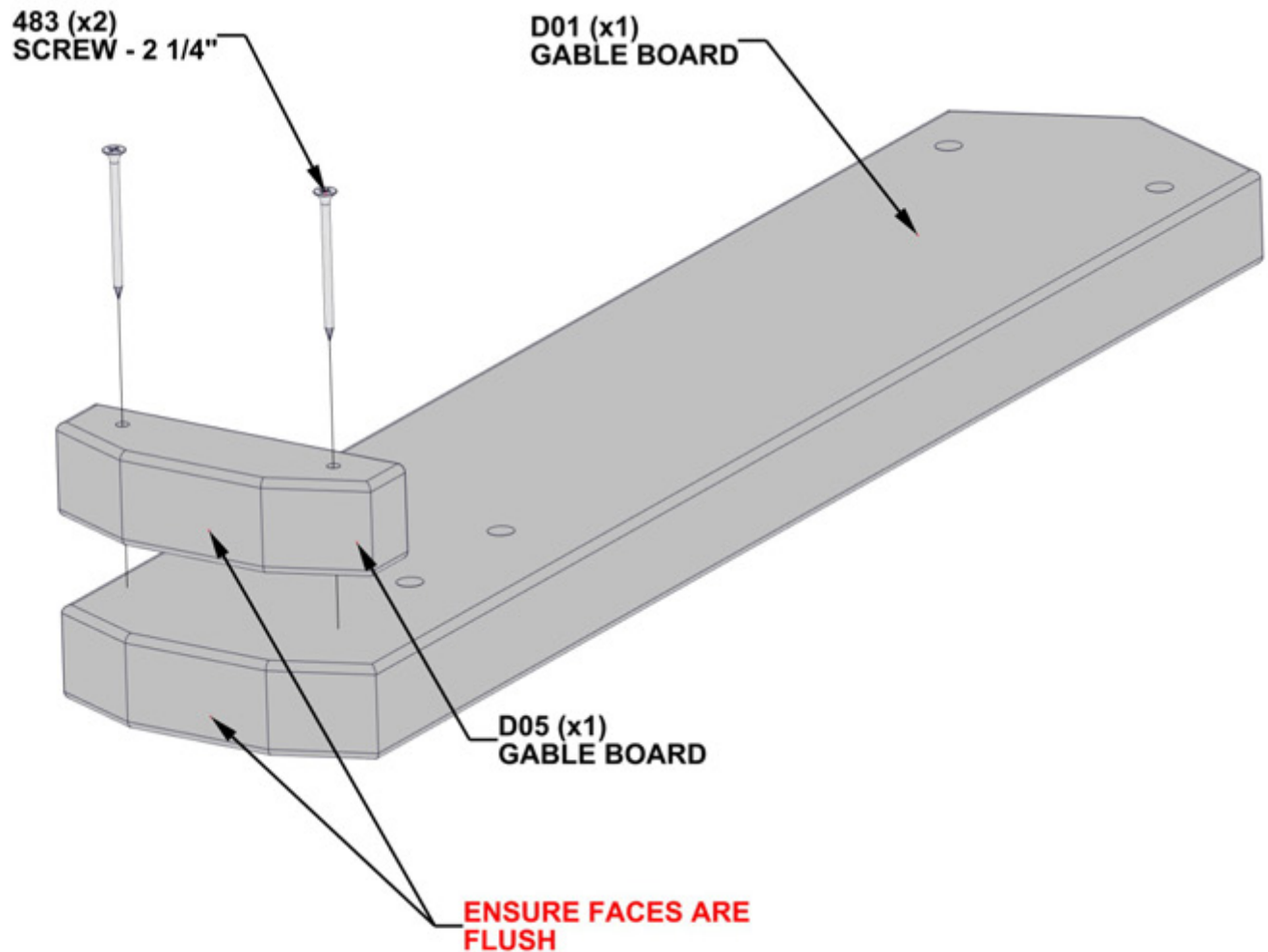

STEP 3 - GAZEBO ASSEMBLY

QTY	PART NUMBER	DESCRIPTION
4	H100479	NUT LOCK 5/16 BLK
4	H100881	BOLT WH 5/16x5 BLK
4	H100478	WASHER FLAT 8x27 BLK

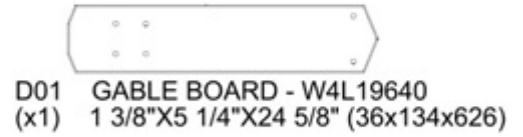

- IF HOLES DO NOT ALIGN, USE THE METAL BRACKET AS A GUIDE AND A 7/16" (10mm) DRILL BIT TO DRILL THROUGH THE BOARDS.

TEMPORARILY ADD LONG BOLTS TO HELP ALIGN WOOD PARTS.

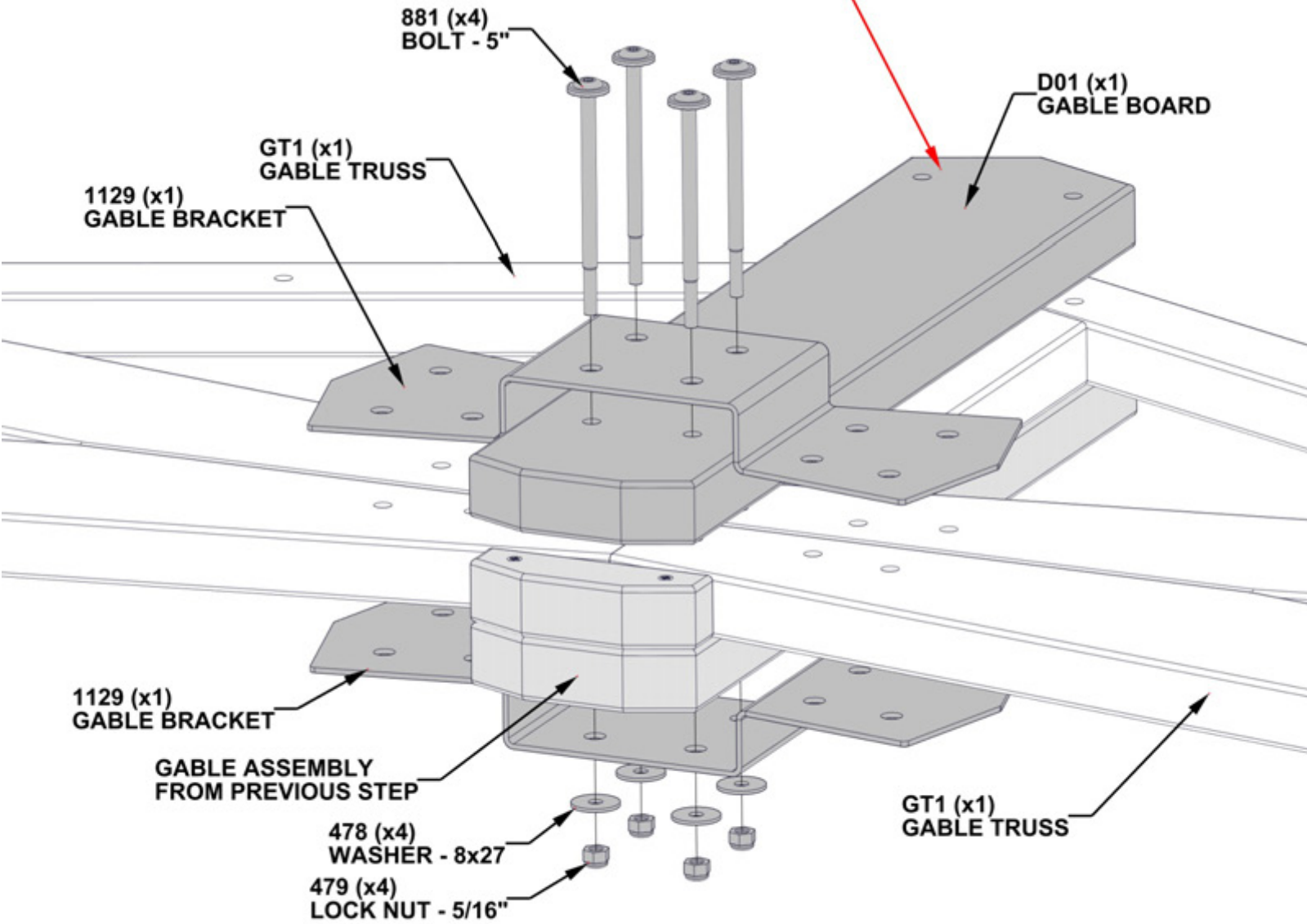

STEP 4 - GAZEBO ASSEMBLY

QTY	PART NUMBER	DESCRIPTION
8	H100479	NUT LOCK 5/16 BLK
8	H100205	BOLT WH 5/16x2 1/4 BLK
8	H100478	WASHER FLAT 8x27 BLK

- IF HOLES DO NOT ALIGN, USE THE METAL BRACKET AS A GUIDE AND A 7/16" (10mm) DRILL BIT TO DRILL THROUGH THE BOARDS.

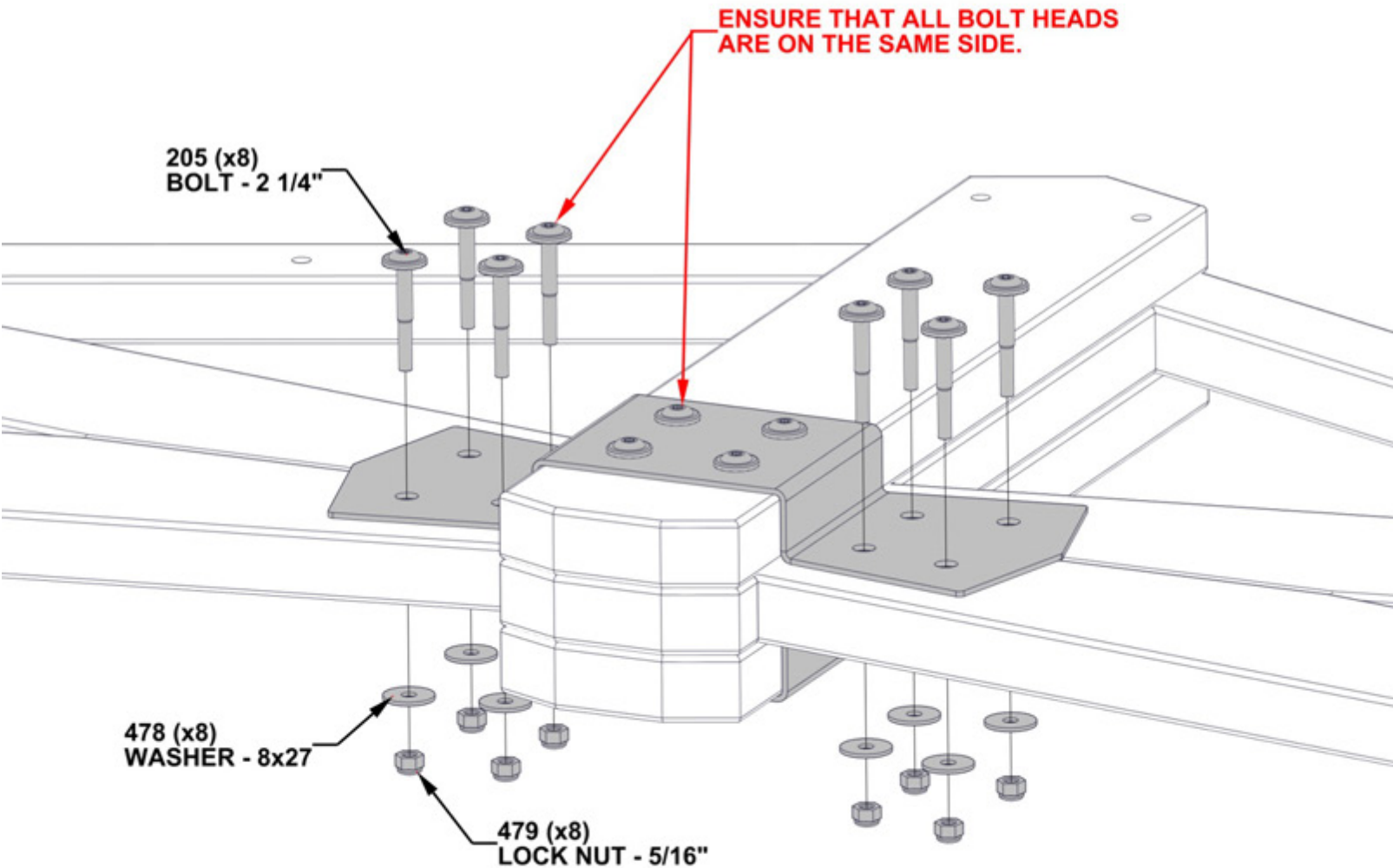

STEP 5 - GAZEBO ASSEMBLY

QTY	PART NUMBER	DESCRIPTION
10	H100379	T-NUT 5/16 BLK



G01 TOP RAIL - W4L19511
(x2) 15/16"x5 1/4"x27 11/16" (24x134x703)

COMPLETE THIS STEP TWO TIMES.

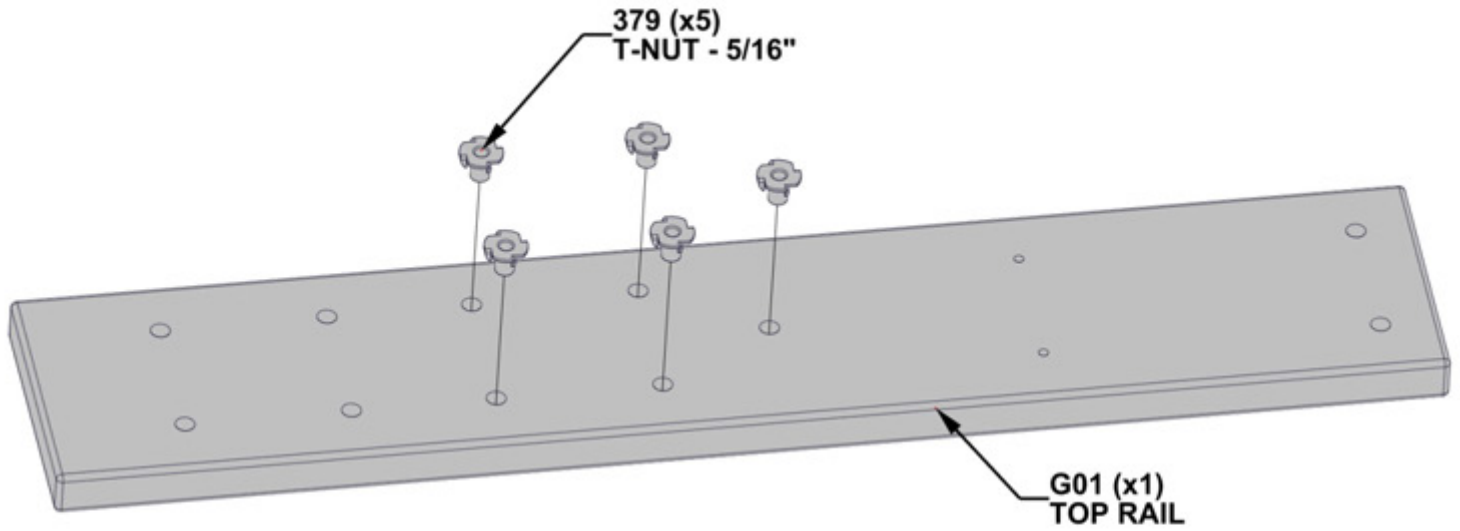

STEP 6A - GAZEBO ASSEMBLY

QTY	PART NUMBER	DESCRIPTION
1	H100471	LAG SCREW WH 5/16x1 1/2 BLK
1	H100659	LAG SCREW HEX 5/16x1 1/2 BLK
3	H101046	BOLT WH 5/16x7 1/2 BLK
3	H100379	T-NUT 5/16 BLK
4	H101058	BOLT WH 5/16x8 3/4 BLK
4	H100479	NUT LOCK 5/16 BLK
5	H100478	WASHER FLAT 8x27 BLK



P1 POST - W2A03517
(x1) 6"x6"x89 1/2" (152x152x2274)



G03 TOP RAIL - W4L19515
(x1) 15/16"x5 1/4"x57 3/16" (24x134x1453)



G01 (x1)
TOP RAIL W/TNUTS
FROM PREVIOUS STEP



A4M01232 LEFT ANGLE BRACKET
(x1)

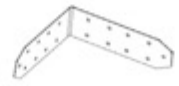

A4M02718 LEFT OUTSIDE BRACKET
(x1)

- INSERT T-NUTS FIRST

ENSURE CORRECT ORIENTATION OF POST

NOTE T-NUT ORIENTATION IN G01 TOP RAIL

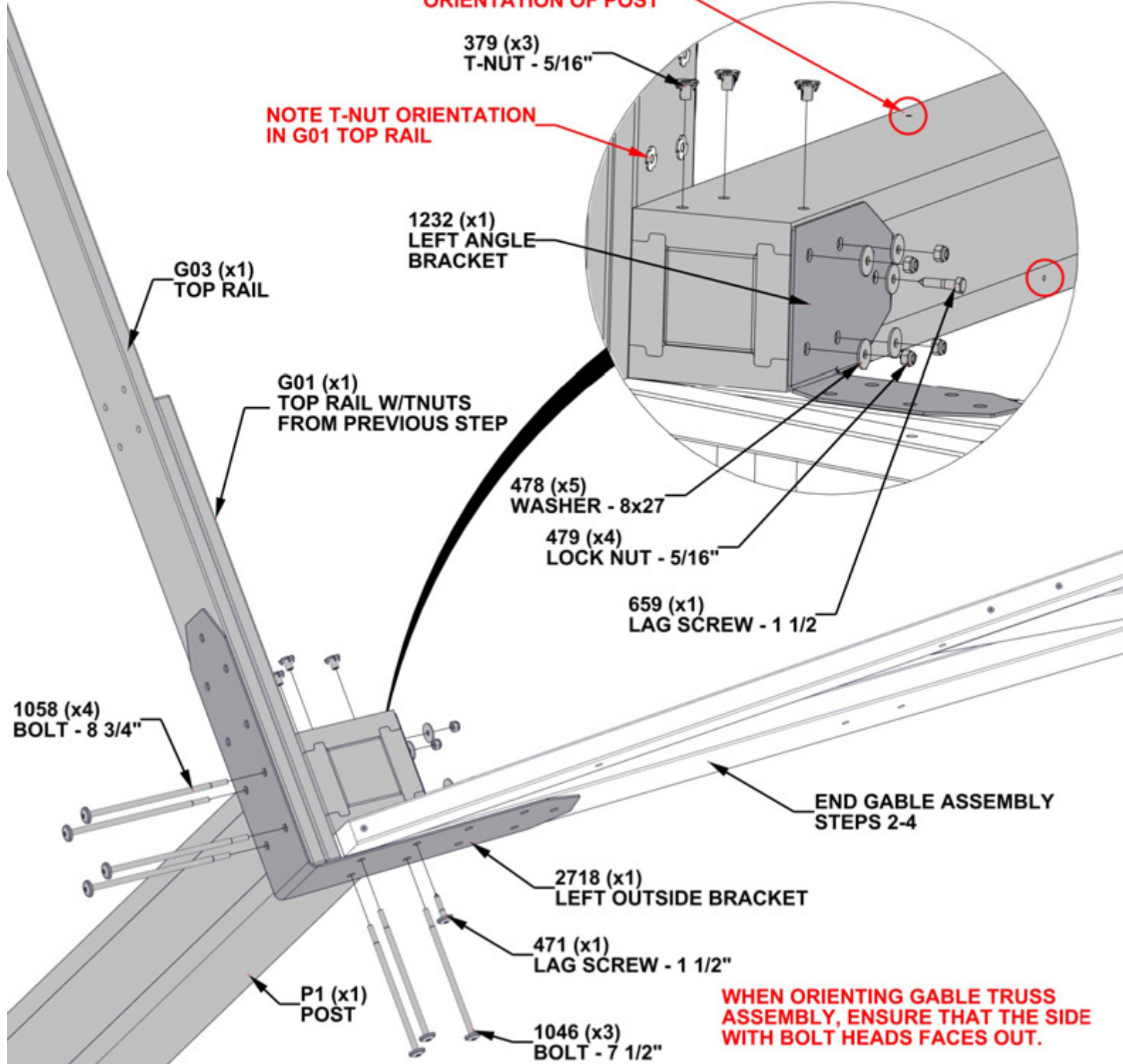

379 (x3)
T-NUT - 5/16"

G03 (x1)
TOP RAIL

1232 (x1)
LEFT ANGLE BRACKET

G01 (x1)
TOP RAIL W/TNUTS
FROM PREVIOUS STEP

478 (x5)
WASHER - 8x27

479 (x4)
LOCK NUT - 5/16"

659 (x1)
LAG SCREW - 1 1/2"

1058 (x4)
BOLT - 8 3/4"

END GABLE ASSEMBLY
STEPS 2-4

2718 (x1)
LEFT OUTSIDE BRACKET

471 (x1)
LAG SCREW - 1 1/2"

P1 (x1)
POST

1046 (x3)
BOLT - 7 1/2"

WHEN ORIENTING GABLE TRUSS ASSEMBLY, ENSURE THAT THE SIDE WITH BOLT HEADS FACES OUT.

STEP 6B - GAZEBO ASSEMBLY

QTY	PART NUMBER	DESCRIPTION
5	H100479	NUT LOCK 5/16 BLK
5	H100457	BOLT WH 5/16x2 BLK
5	H100205	BOLT WH 5/16x2 1/4 BLK
5	H100478	WASHER FLAT 8x27 BLK

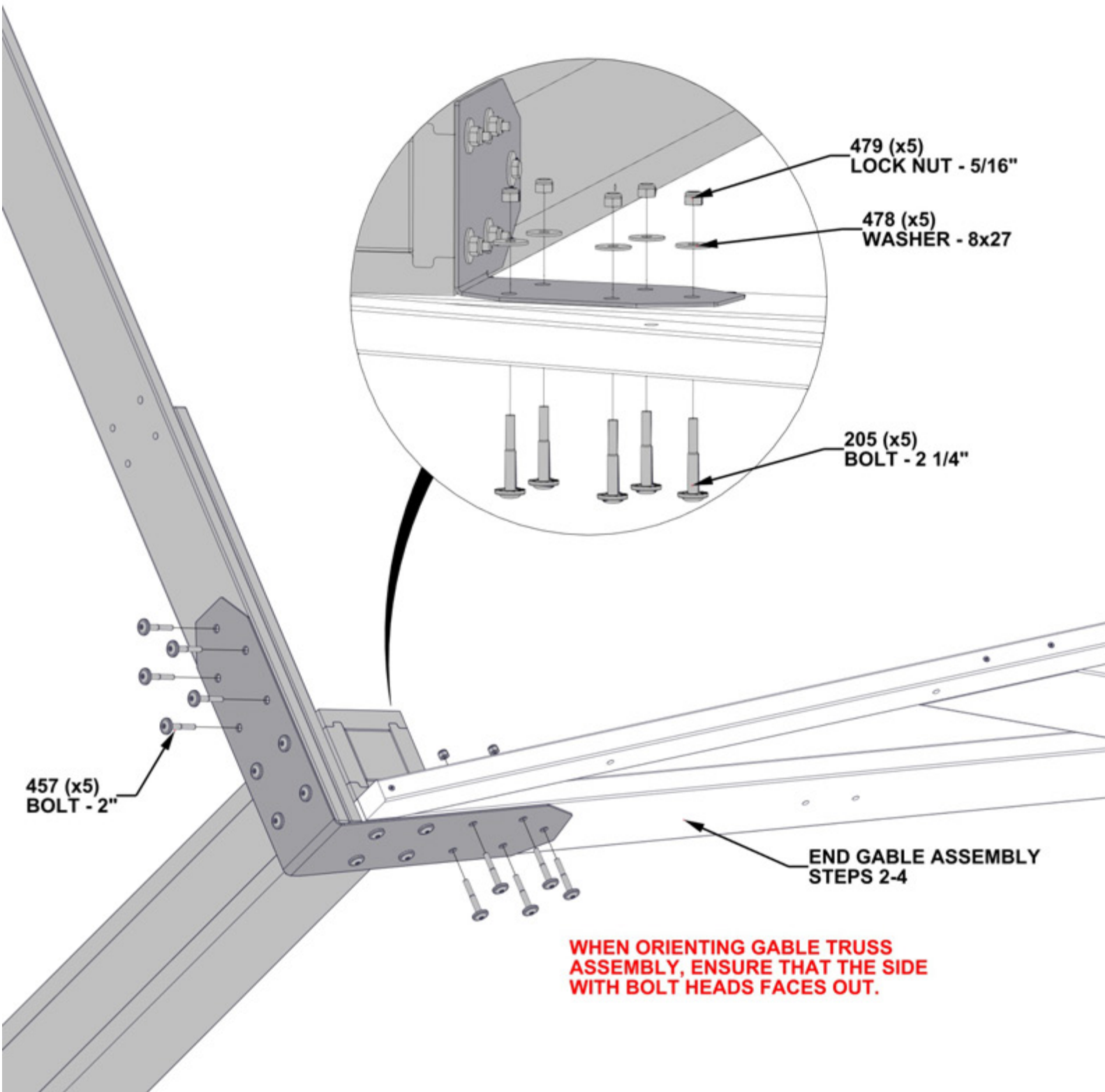

WHEN ORIENTING GABLE TRUSS ASSEMBLY, ENSURE THAT THE SIDE WITH BOLT HEADS FACES OUT.

STEP 7A - GAZEBO ASSEMBLY

QTY	PART NUMBER	DESCRIPTION
1	H100471	LAG SCREW WH 5/16x1 1/2 BLK
1	H100659	LAG SCREW HEX 5/16x1 1/2 BLK
3	H101046	BOLT WH 5/16x7 1/2 BLK
3	H100379	T-NUT 5/16 BLK
4	H101058	BOLT WH 5/16x8 3/4 BLK
4	H100479	NUT LOCK 5/16 BLK
5	H100478	WASHER FLAT 8x27 BLK

P2 POST - W2A03518
(x1) 6"x6"x89 1/2" (152x152x2274)

G03 TOP RAIL - W4L19515
(x1) 15/16"x5 1/4"x57 3/16" (24x134x1453)

G01 TOP RAIL - W4L19511
(x1) 15/16"x5 1/4"x27 11/16" (24x134x703)

A4M01233
(x1)

RIGHT ANGLE BRACKET

A4M02717
(x1)

RIGHT OUTSIDE BRACKET

- INSERT T-NUTS FIRST

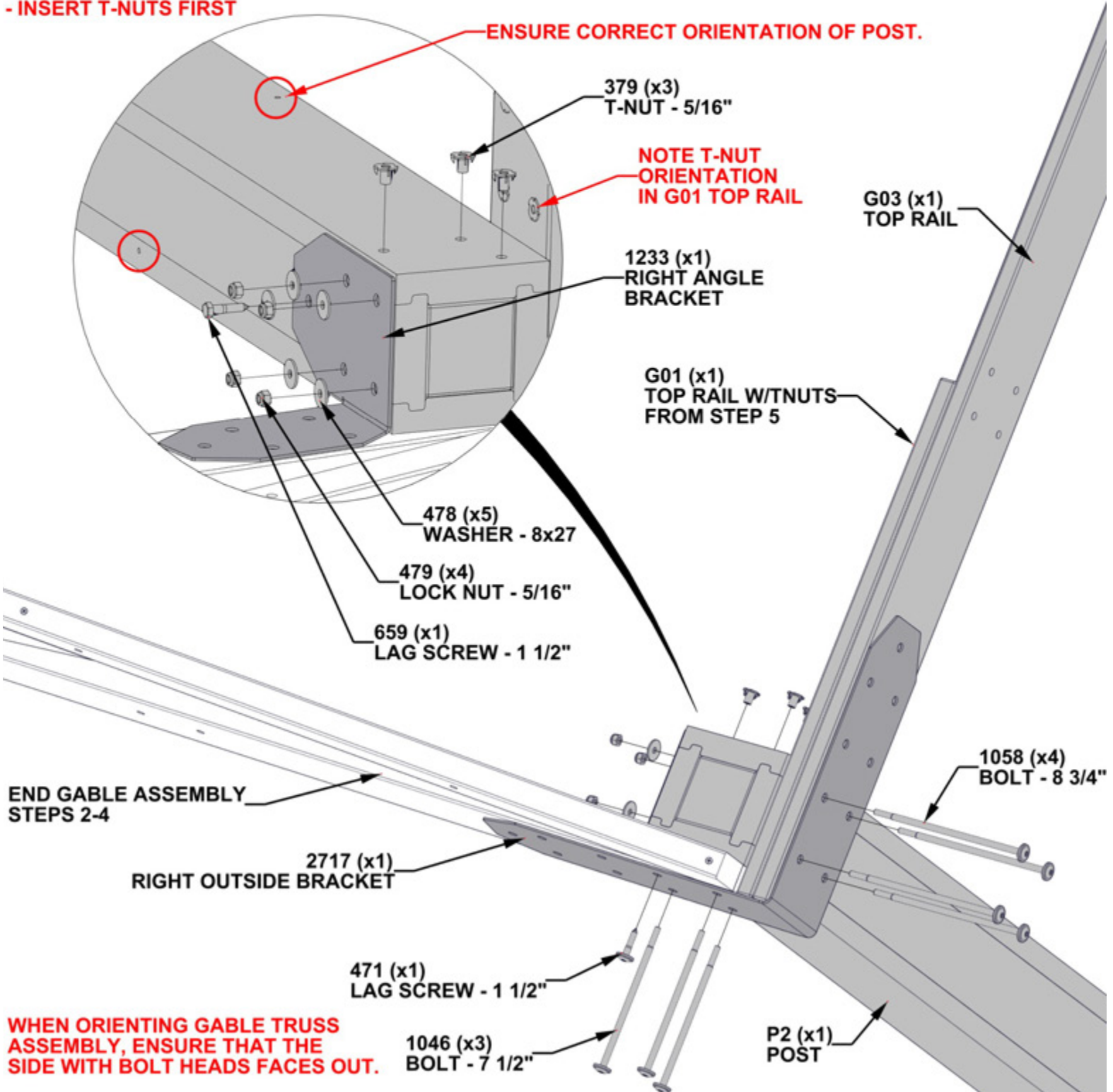

STEP 7B - GAZEBO ASSEMBLY

QTY	PART NUMBER	DESCRIPTION
5	H100479	NUT LOCK 5/16 BLK
5	H100478	WASHER FLAT 8x27 BLK
5	H100457	BOLT WH 5/16x2 BLK
5	H100205	BOLT WH 5/16x2 1/4 BLK

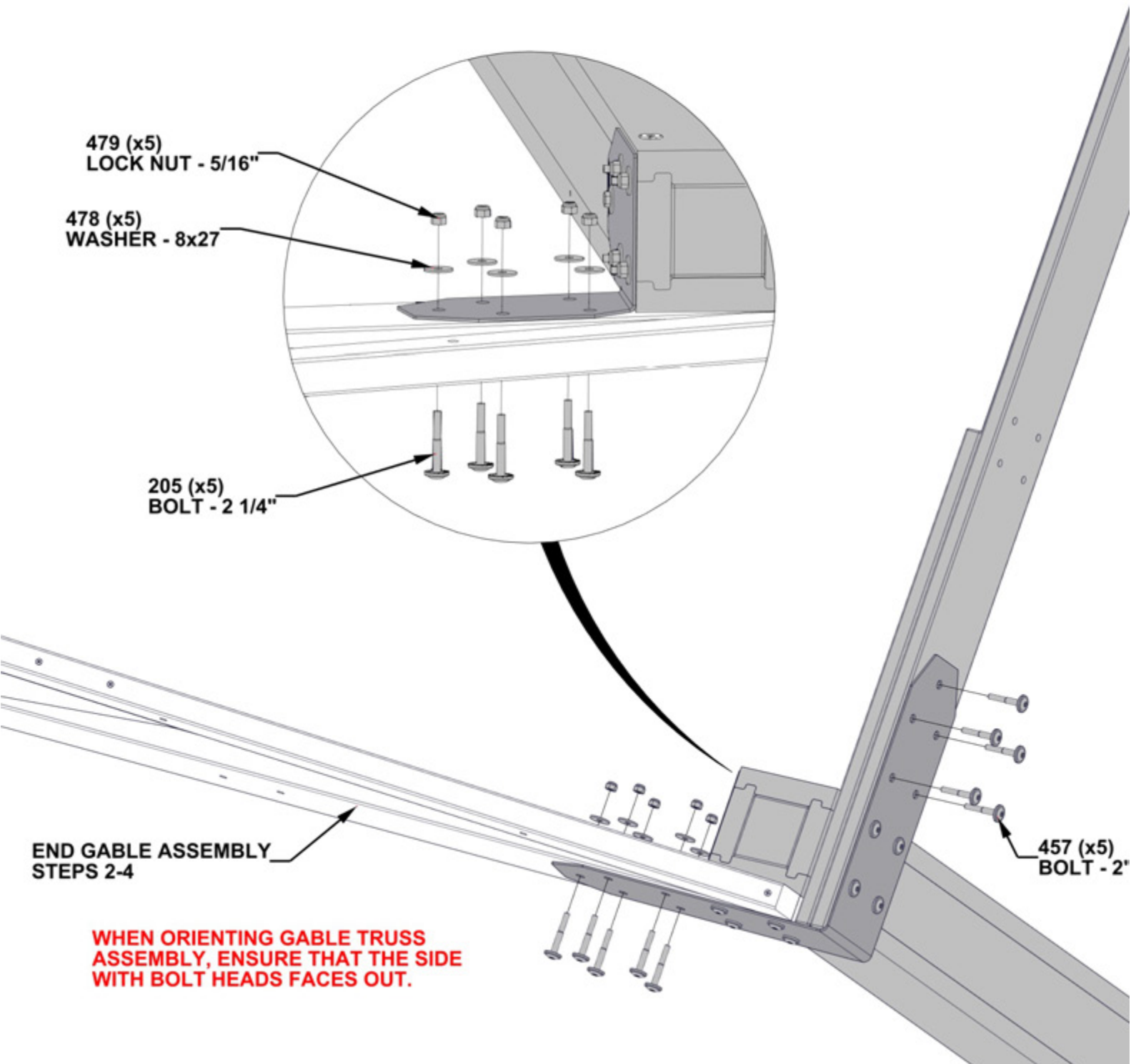

STEP 8 - GAZEBO ASSEMBLY

QTY	PART NUMBER	DESCRIPTION
2	H100792	LAG SCREW WH 1/4x3 BLK
2	H100405	WASHER LOCK EXT 6x15
4	H100379	TNUT-5/16" BLK
4	H100195	BOLT WH 5/16x2 3/4 BLK
4	H100198	WASHER LOCK EXT 8x19



D06 CORBEL - W4L17223
 (x2) 1 7/16"x5 1/4"x44 1/4" (36x134x1124)

INSTALL T-NUTS FIRST

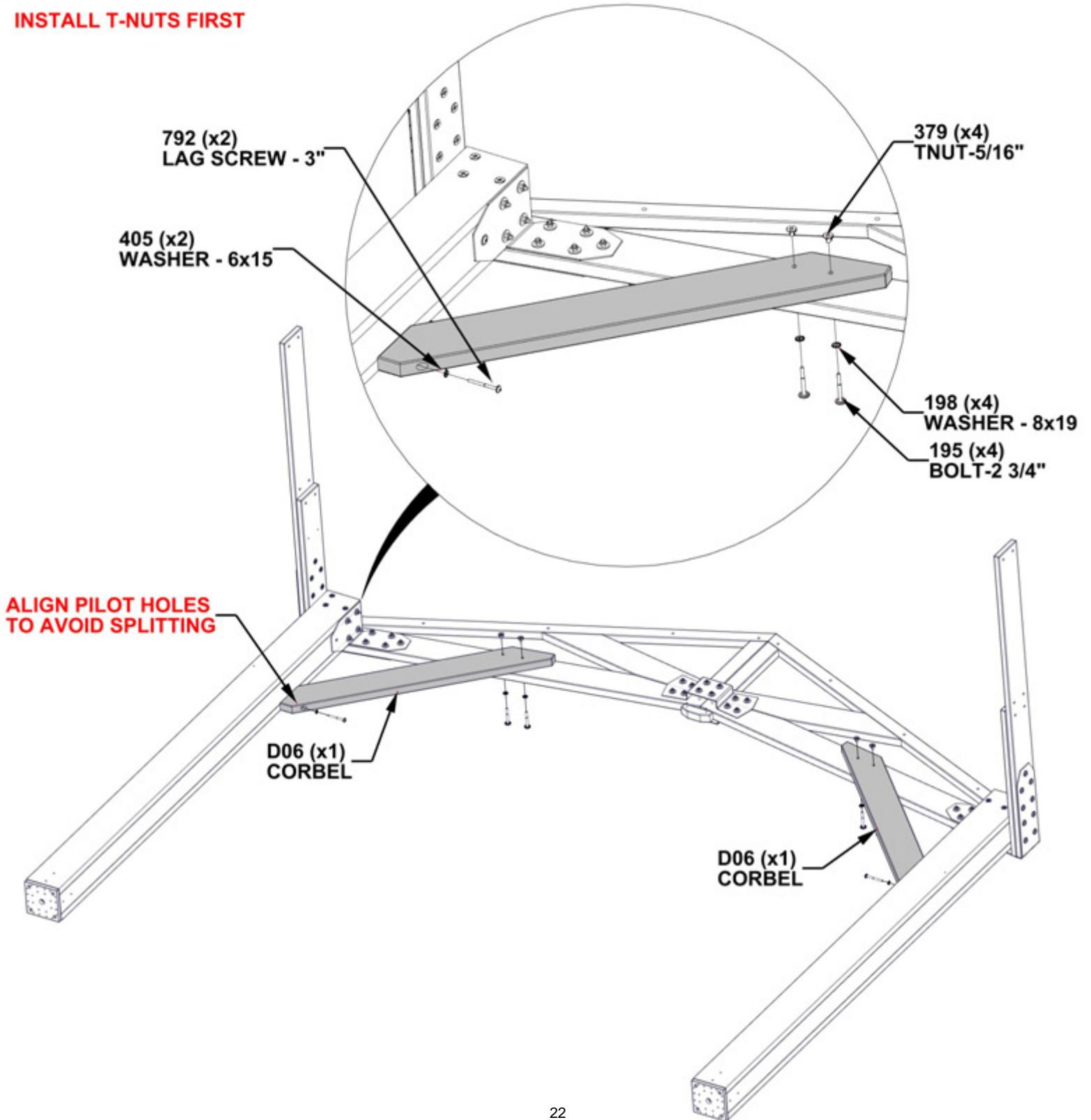

**SET GABLE END ASIDE AND
REPEAT STEPS 2 THROUGH 8**

STEP 9 - GAZEBO ASSEMBLY

QTY	PART NUMBER	DESCRIPTION
2	H100792	LAG SCREW WH 1/4x3 BLK
2	H100405	WASHER LOCK EXT 6x15
4	H100379	T-NUT 5/16 BLK
4	H100484	BOLT WH 5/16x3 1/4 BLK
4	H100198	WASHER LOCK EXT 8x19



POST AND GABLE ASSEMBLY FROM PREVIOUS STEPS

D07 (x1) CORBEL W/TAG - W2A03384
1 7/16"x5 1/4"x34 7/16" (36x134x875)



D04 (x1) CORBEL - W4L16234
1 7/16"x5 1/4"x34 7/16" (36x134x875)



A4M02719 GAZEBO BRACE (x2)

INSTALL T-NUTS FIRST

ATTACH 2719 BRACE BY SLIDING IT IN BETWEEN WOOD TO FIRST SET OF BOLT HOLES.

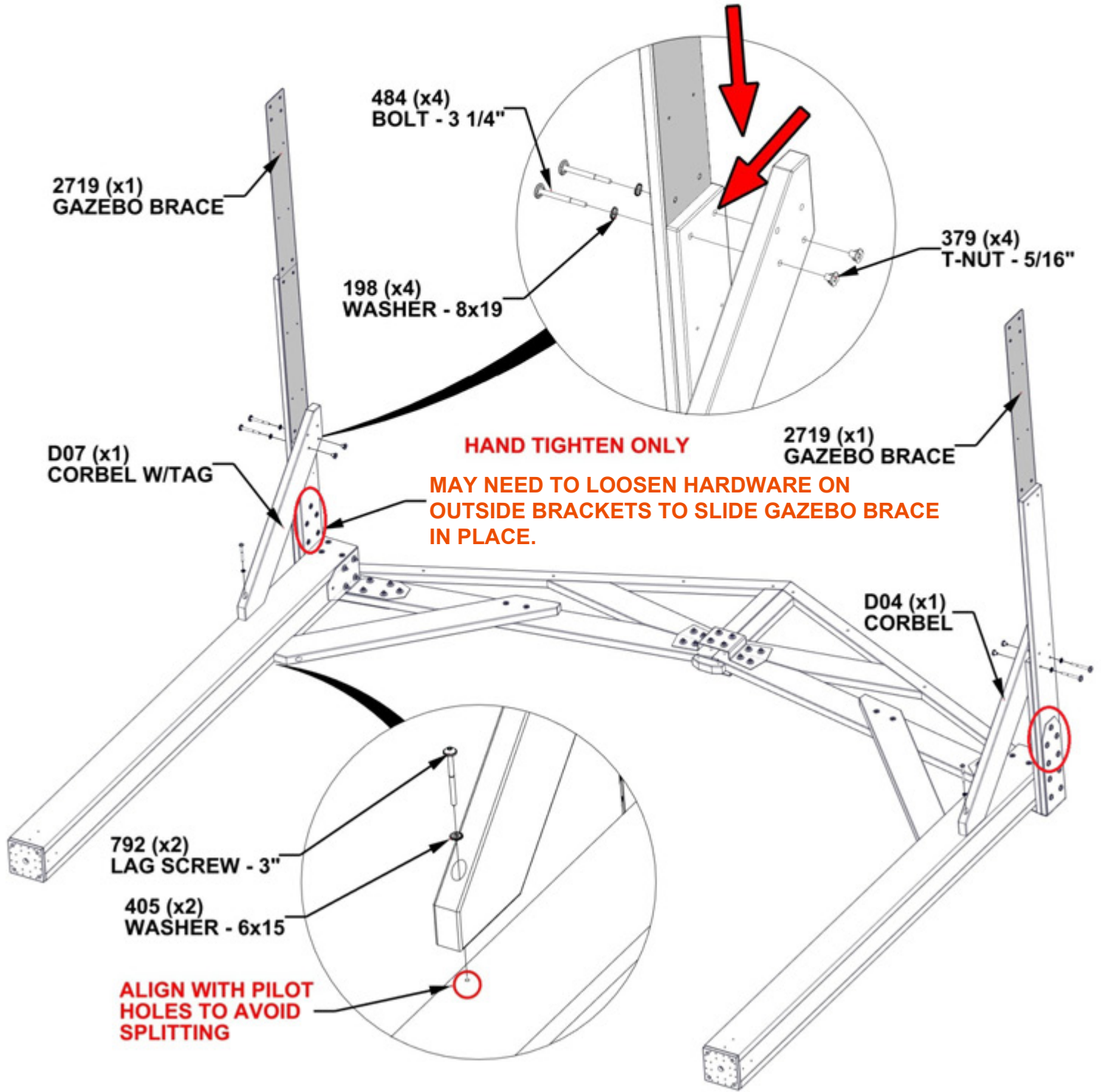

STEP 10 - GAZEBO ASSEMBLY

QTY	PART NUMBER	DESCRIPTION
4	H100484	BOLT WH 5/16x3 1/4 BLK
4	H100378	BOLT WH 5/16x1 3/4 BLK
8	H100379	T-NUT 5/16 BLK
8	H100198	WASHER LOCK EXT 8x19
12	H100382	SCREW PFH 8x1 3/4 BLK



G02 TOP RAIL - W4L19512
 (x2) 15/16"x5 1/4"x59 1/16" (24x134x1500)

INSTALL T-NUTS FIRST

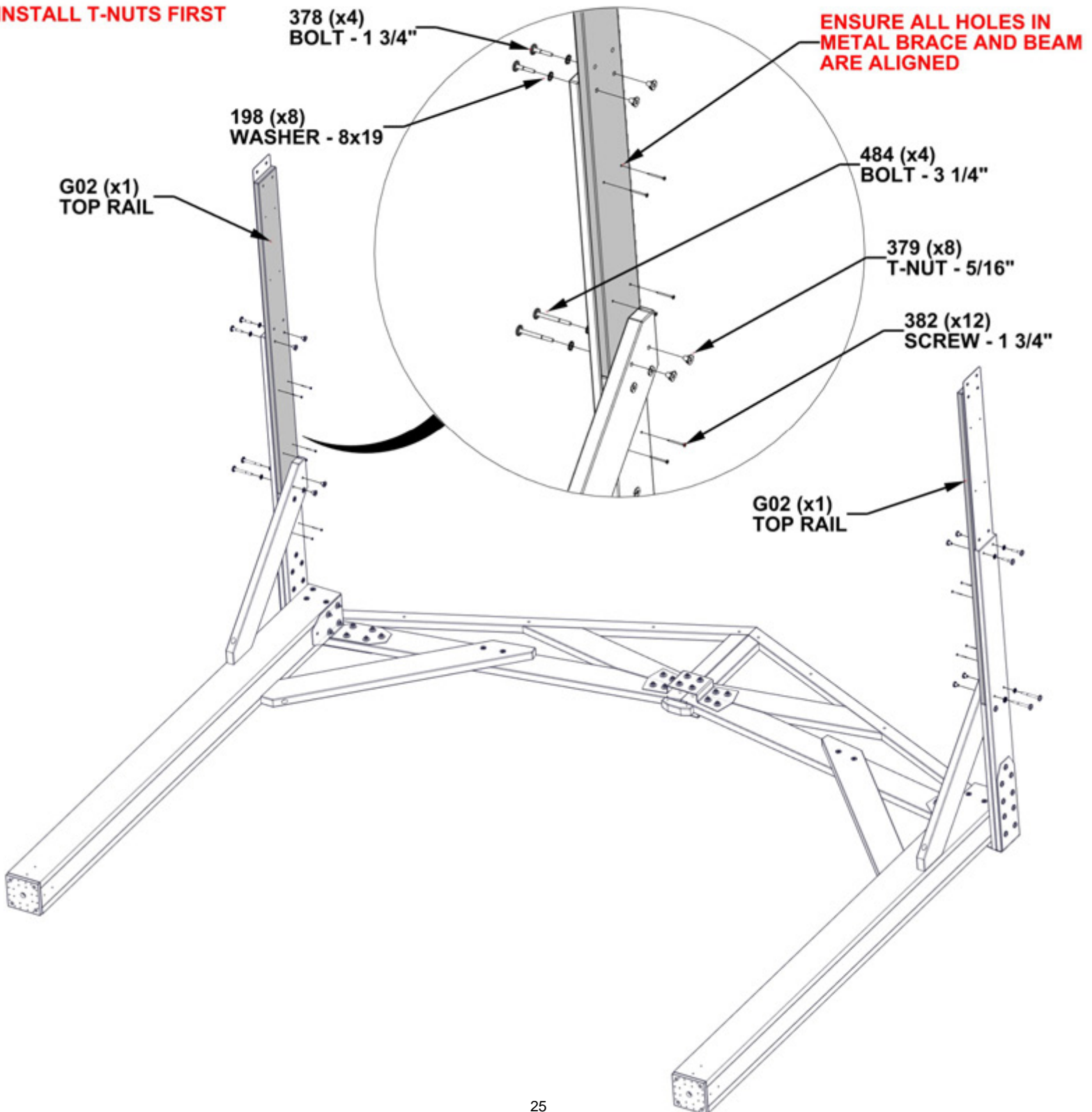

STEP 11 - GAZEBO ASSEMBLY



H08 NOTCHED SUPPORT BOARD - W4L16915
(x2) 1"X3 3/8"X89 1/2" (24x86x2274)

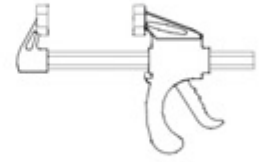

A6P00460 6" QUICK RELEASE BAR CLAMP
(x2)

USING THE INCLUDED CLAMPS AND H08 BOARDS, STAND UP ONE GABLE END AND SECURELY CLAMP AS SHOWN. ADDITIONAL HELPERS ARE RECOMMENDED FOR THIS STEP.

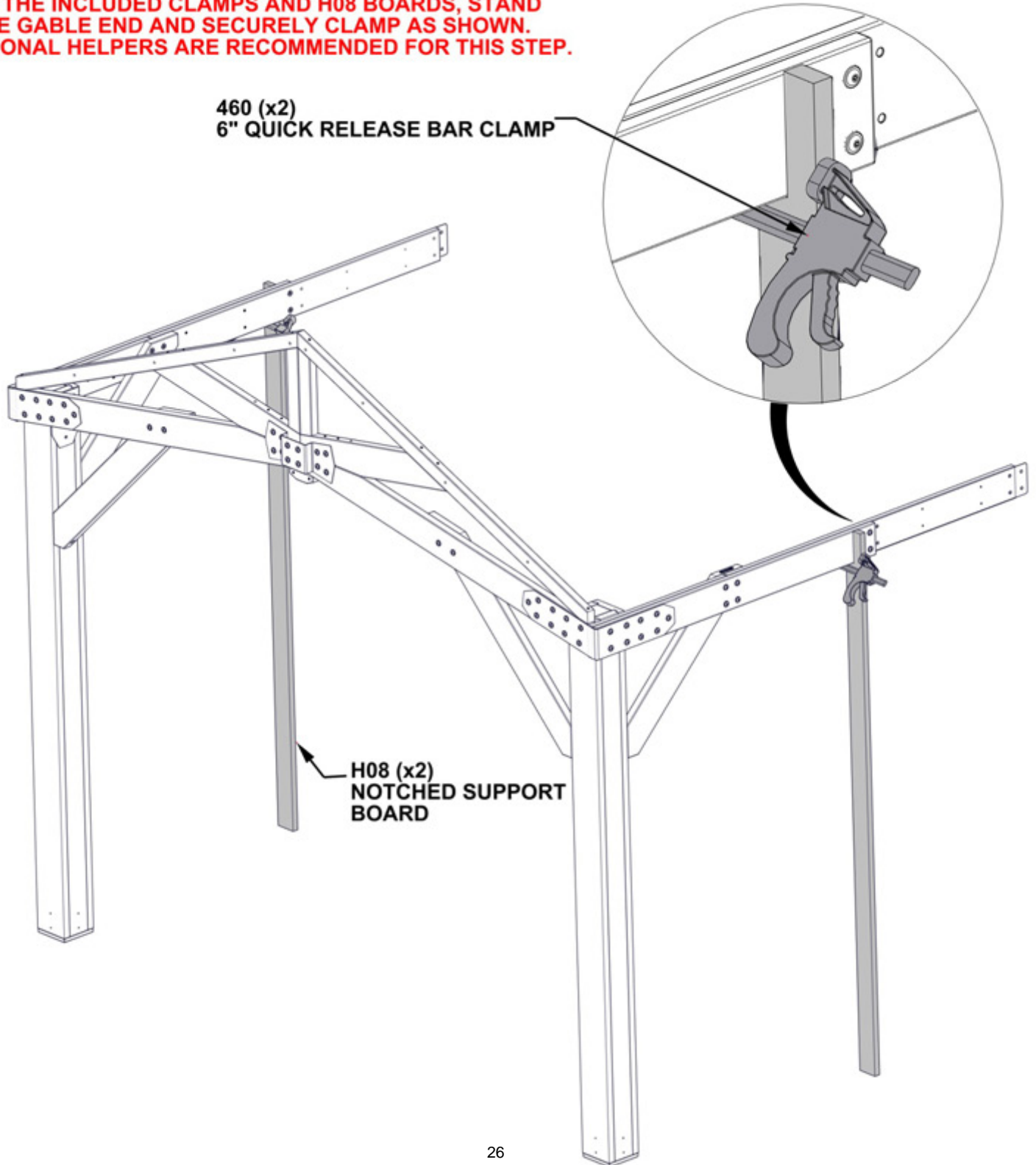

STEP 12 - GAZEBO ASSEMBLY

QTY	PART NUMBER	DESCRIPTION
2	H100792	LAG SCREW WH 1/4x3 BLK
2	H100405	WASHER LOCK EXT 6x15
4	H100378	BOLT WH 5/16x1 3/4 BLK
8	H100484	BOLT WH 5/16x3 1/4 BLK
12	H100379	T-NUT 5/16 BLK
12	H100198	WASHER LOCK EXT 8x19
12	H100382	SCREW PFH 8x1 3/4 BLK



POST AND GABLE ASSEMBLY FROM PREVIOUS STEPS



D04 CORBEL - W4L16234
(x2) 1 7/16"x5 1/4"x34 7/16" (36x134x875)

STAND UP OTHER GABLE END AND ATTACH HARDWARE AS SHOWN. ONCE ALL HARDWARE IS SECURELY ATTACHED, REMOVE CLAMPS AND H08 BOARDS.

METAL BRACE TO SLIDE BETWEEN BOARDS AND ALIGN WITH HOLES IN CORBELS

INSTALL T-NUTS FIRST

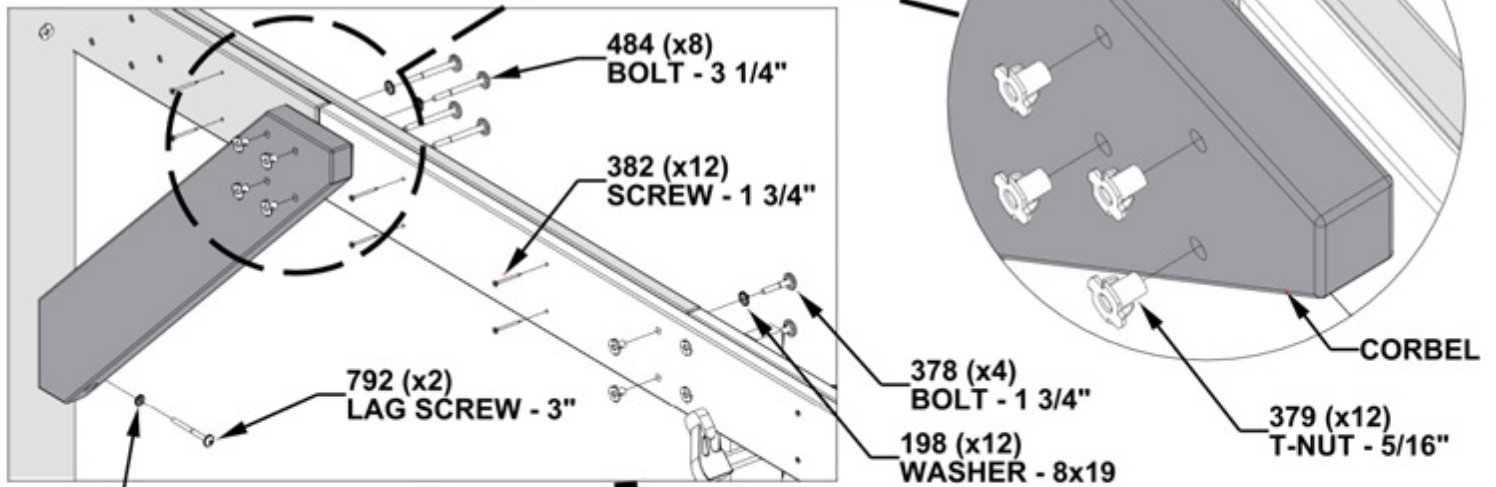

405 (x2)
WASHER - 6x15

ALIGN PILOT HOLES TO AVOID SPLITTING

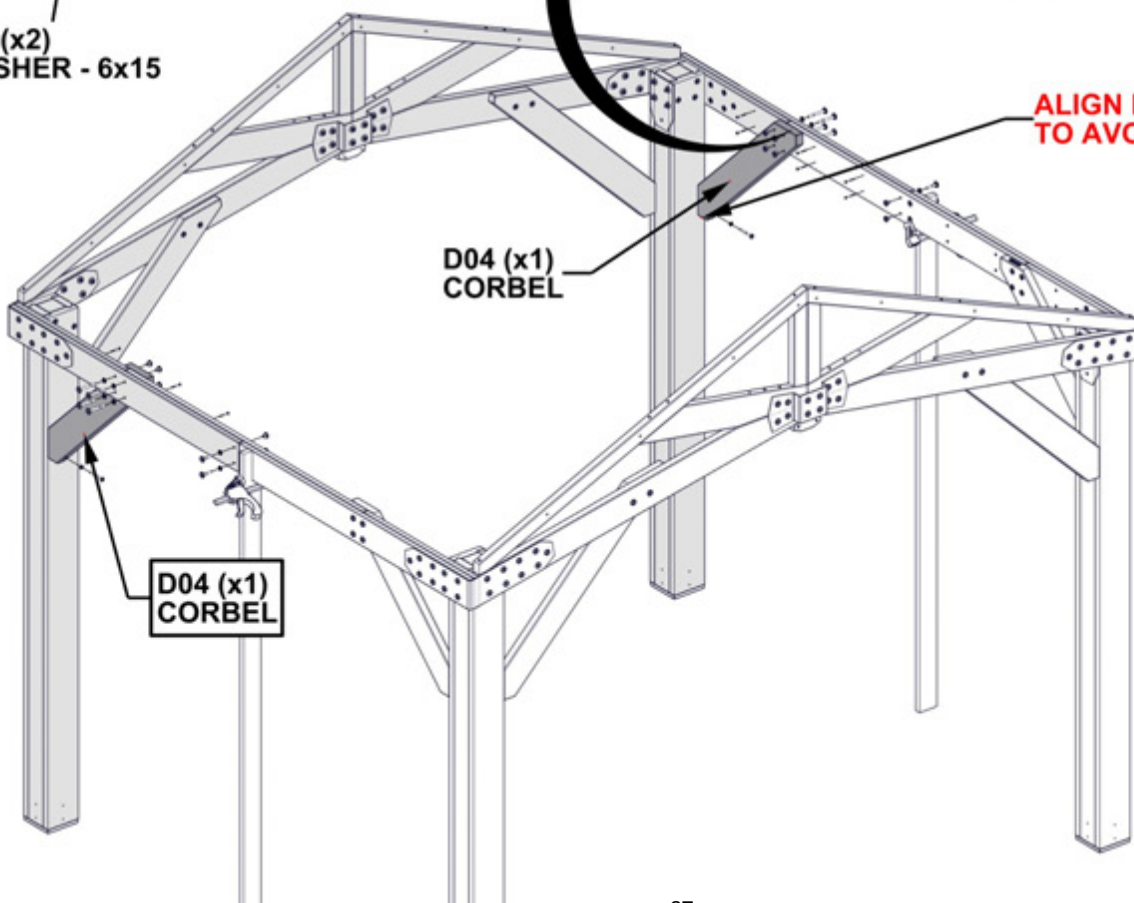

STEP 13 - GAZEBO ASSEMBLY

QTY	PART NUMBER	DESCRIPTION
16	H100201	SCREW PFH 8x2 1/2 BLK



E02 TRUSS - W4L19639
(x4) 1 3/8"X2 3/8"x75 3/16" (36x60x1910)

FLUSH TOPS

ALIGN HOLES FOR
CORRECT ORIENTATION

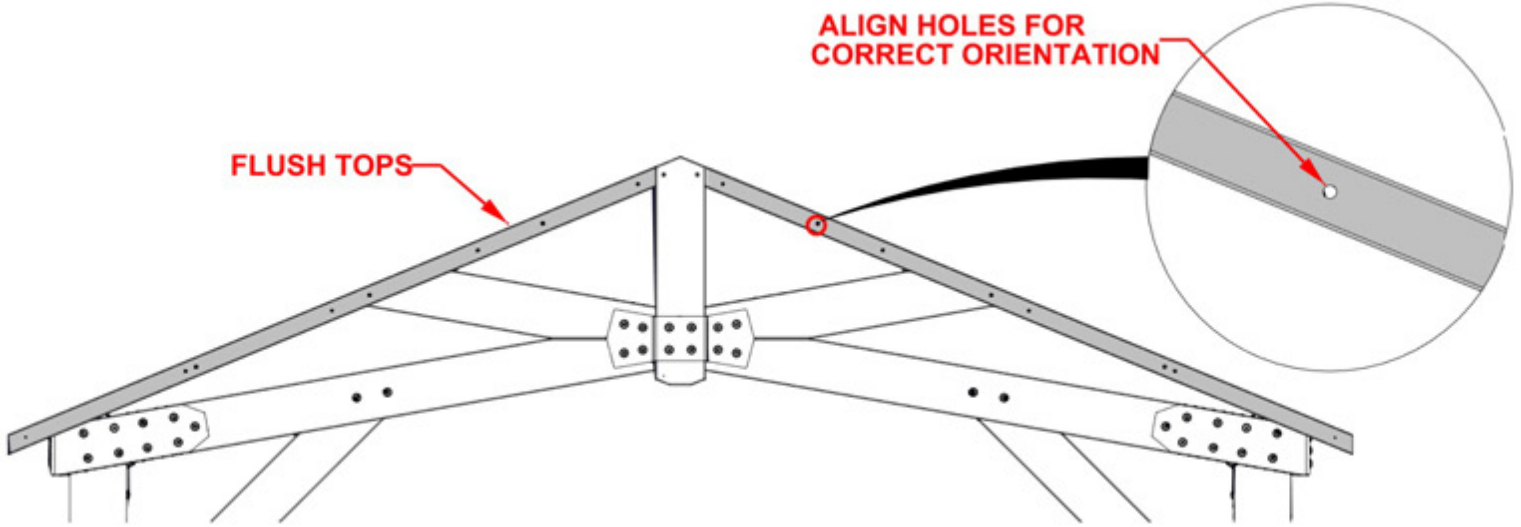

201 (x16)
SCREW - 2 1/2"

E02 (x4)
TRUSS

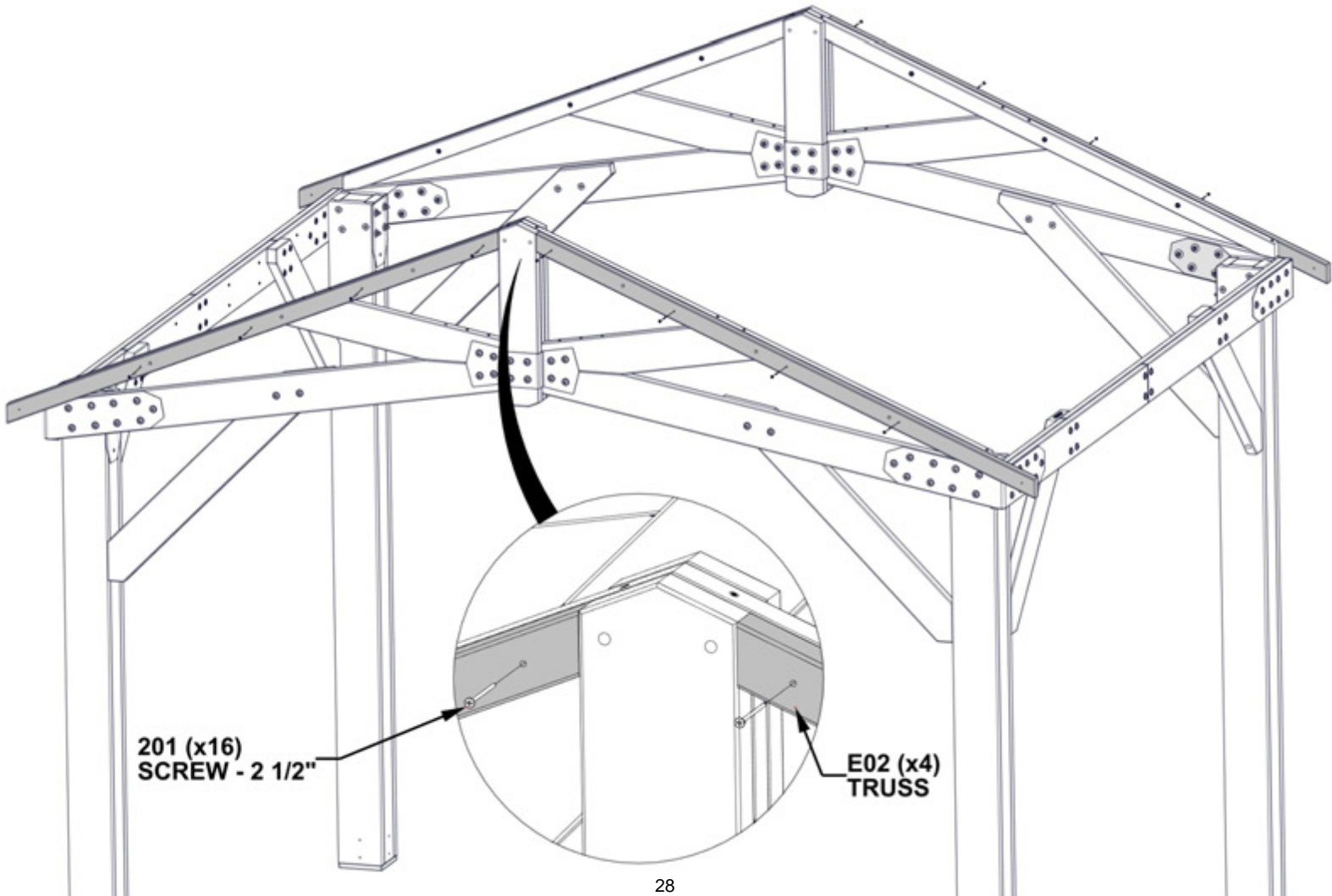

STEP 14 - GAZEBO ASSEMBLY

QTY	PART NUMBER	DESCRIPTION
4	H100201	SCREW PFH 8x2 1/2 BLK
12	H100564	LAG SCREW WH 1/4x4 BLK
12	H100405	WASHER LOCK EXT 6x15



GP1 GABLE PANEL - W2A04177
(x2) 2 13/16"X5 1/4"X80 3/16" (72x134x2037)



GP2 GABLE PANEL - W2A04178
(x2) 2 13/16"X5 1/4"X80 3/16" (72x134x2037)

- ALIGN LAG SCREWS WITH PILOT HOLES IN GABLE PANELS

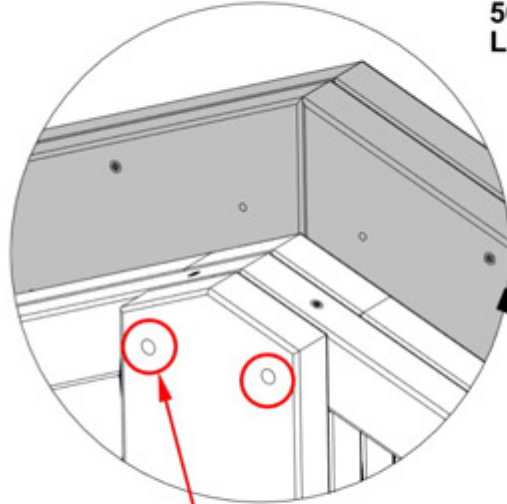

TEMPORARILY INSERT 354 BOLTS TO ALIGN GABLE PANEL WITH GABLE.

405 (x12)
WASHER - 6x15
564 (x12)
LAG SCREW - 4"

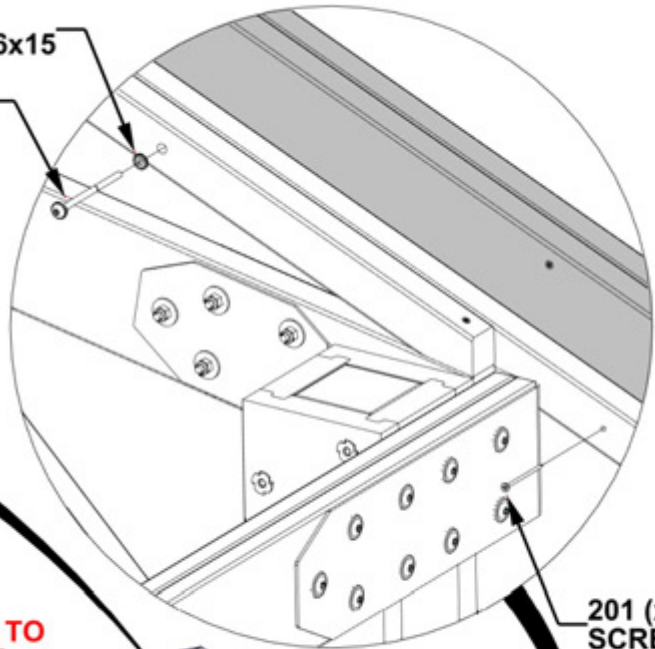

201 (x4)
SCREW - 2 1/2"

GP1 (x2)
GABLE PANEL

GP2 (x2)
GABLE PANEL

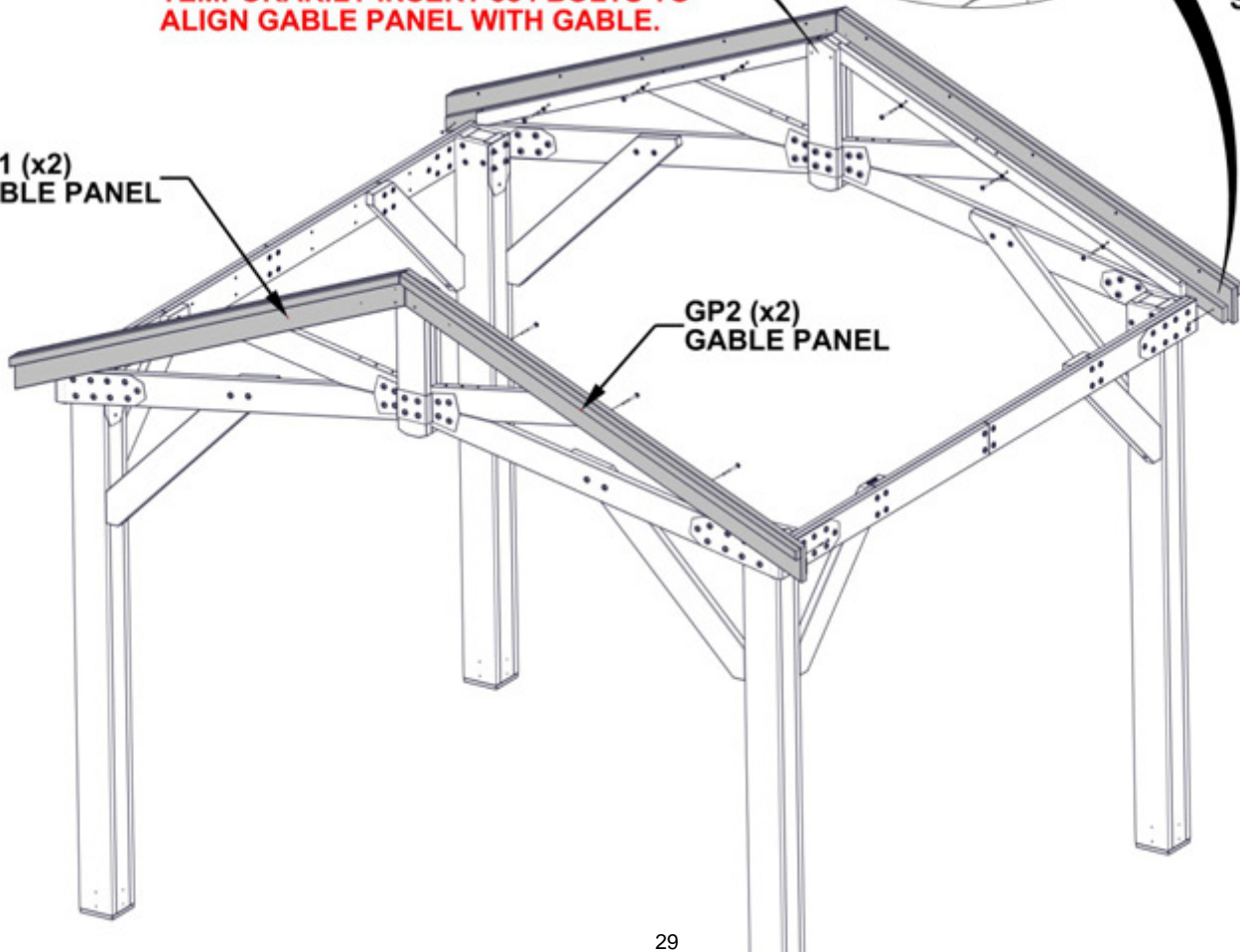

STEP 15 - GAZEBO ASSEMBLY

QTY	PART NUMBER	DESCRIPTION
4	H100354	BOLT WH 5/16x6 1/2 BLK
4	H100200	SCREW PFH 8x1 1/2 BLK
4	H100479	NUT LOCK 5/16 BLK
4	H100478	WASHER FLAT 8x27 BLK
8	H100471	LAG SCREW WH 5/16x1 1/2 BLK

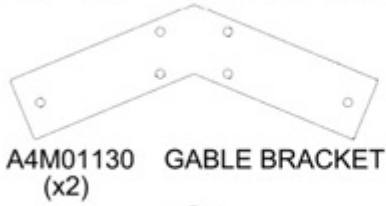

A4M01130 GABLE BRACKET (x2)



A4M01148 TRUSS BRACKET (x2)



A4M01147 PEAK SEAM BRACKET (x2)

PRE-DRILL 1/8" (3mm) PILOT HOLES FOR SCREWS USING PEAK SEAM BRACKET AS A GUIDE.

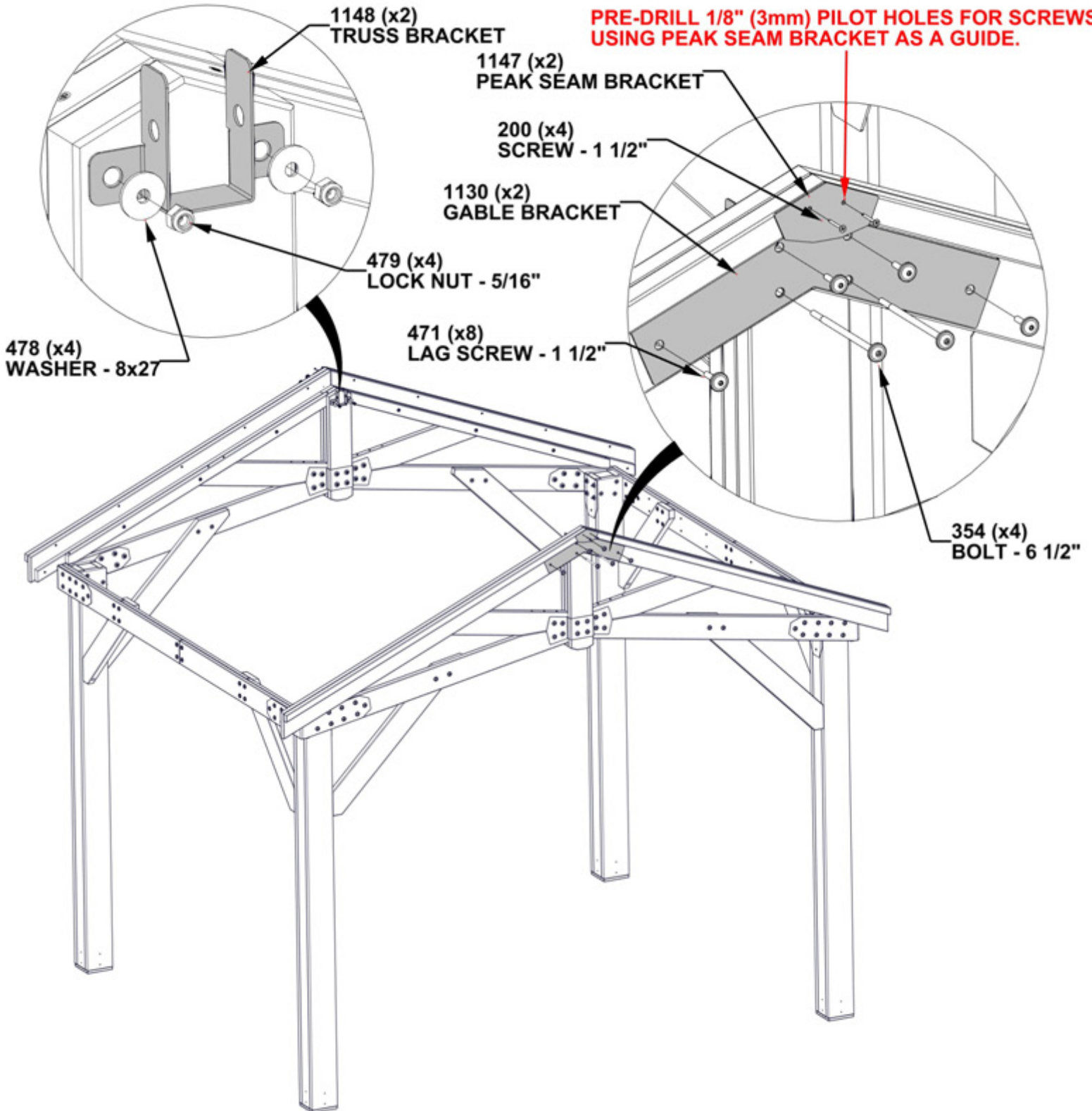

STEP 16 - ROOF PANEL ASSEMBLY

QTY	PART NUMBER	DESCRIPTION
16	H100391	SCREW PFH 8x2 BLK

E01 RAFTER - W4L19518
(x2) 1 7/16"x3 3/8"x77 3/8" (36x86x1965)

E03 RAFTER - W4L19619
(x2) 1 7/16"x3 3/8"x77 3/8" (36x86x1965)

H02 FASCIA - W4L19516
(x1) 15/16"x3 3/8"x74 3/4" (24x86x1898)

H03 FASCIA - W4L19517
(x1) 15/16"x3 3/8"x43 3/4" (24x86x1111)

H04 RIDGE BEAM - W4L19513
(x1) 15/16"x3 3/8"x39 1/2" (24x86x1003)

H05 RIDGE BEAM - W4L19514
(x1) 15/16"x3 3/8"x70 1/2" (24x86x1791)

ROOF PANEL A

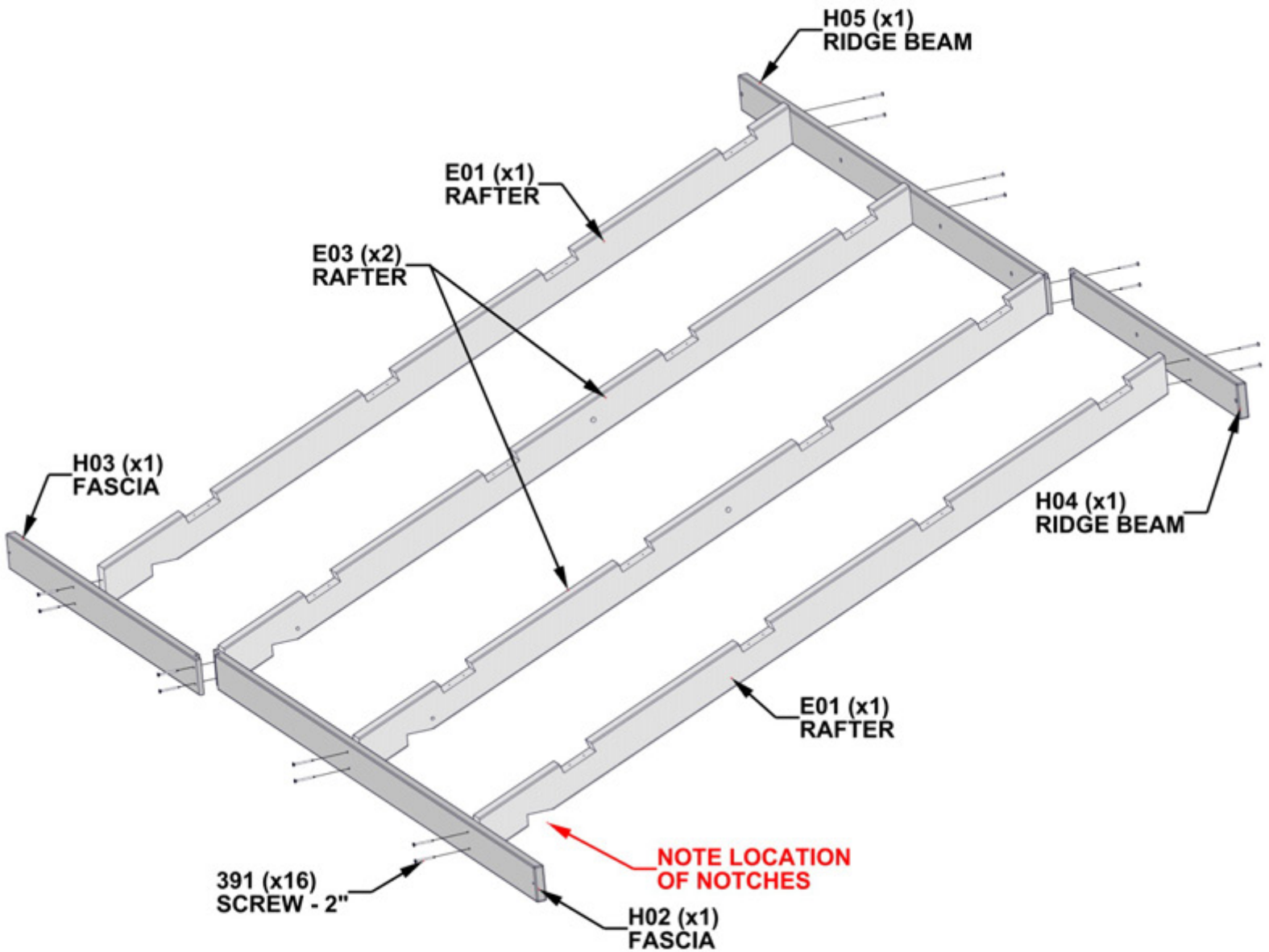

STEP 17 - ROOF PANEL ASSEMBLY

QTY	PART NUMBER	DESCRIPTION
6	H100395	SCREW PFH 8x3/4 BLK



A4M02720 GAZEBO BRACE
(x1)

ROOF PANEL A

ALIGN HOLES ON GAZEBO BRACE
WITH HOLES ON RIDGE BOARD.
FASTEN AS SHOWN.

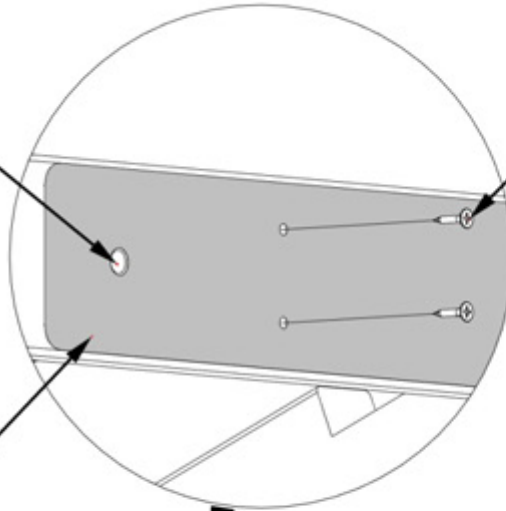

395 (x6)
SCREW - 3/4"

2720 (x1)
GAZEBO BRACE

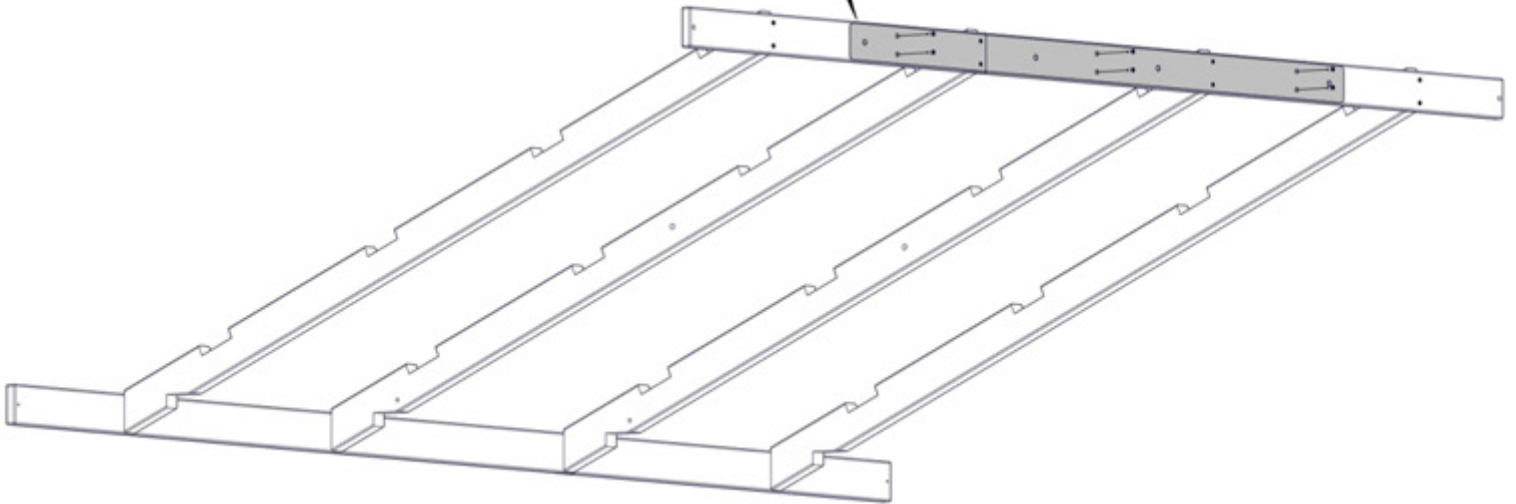

STEP 18A - ROOF PANEL ASSEMBLY

QTY	PART NUMBER	DESCRIPTION
32	H100391	SCREW PFH 8x2 BLK



H07 PURLIN - W4L19520
(x4) 15/16"x3 3/8"x43 9/16" (24x86x1107)



H06 PURLIN - W4L19519
(x4) 15/16"x3 3/8"x74 9/16" (24x86x1894)

ROOF PANEL A

DO NOT FULLY TIGHTEN SCREWS

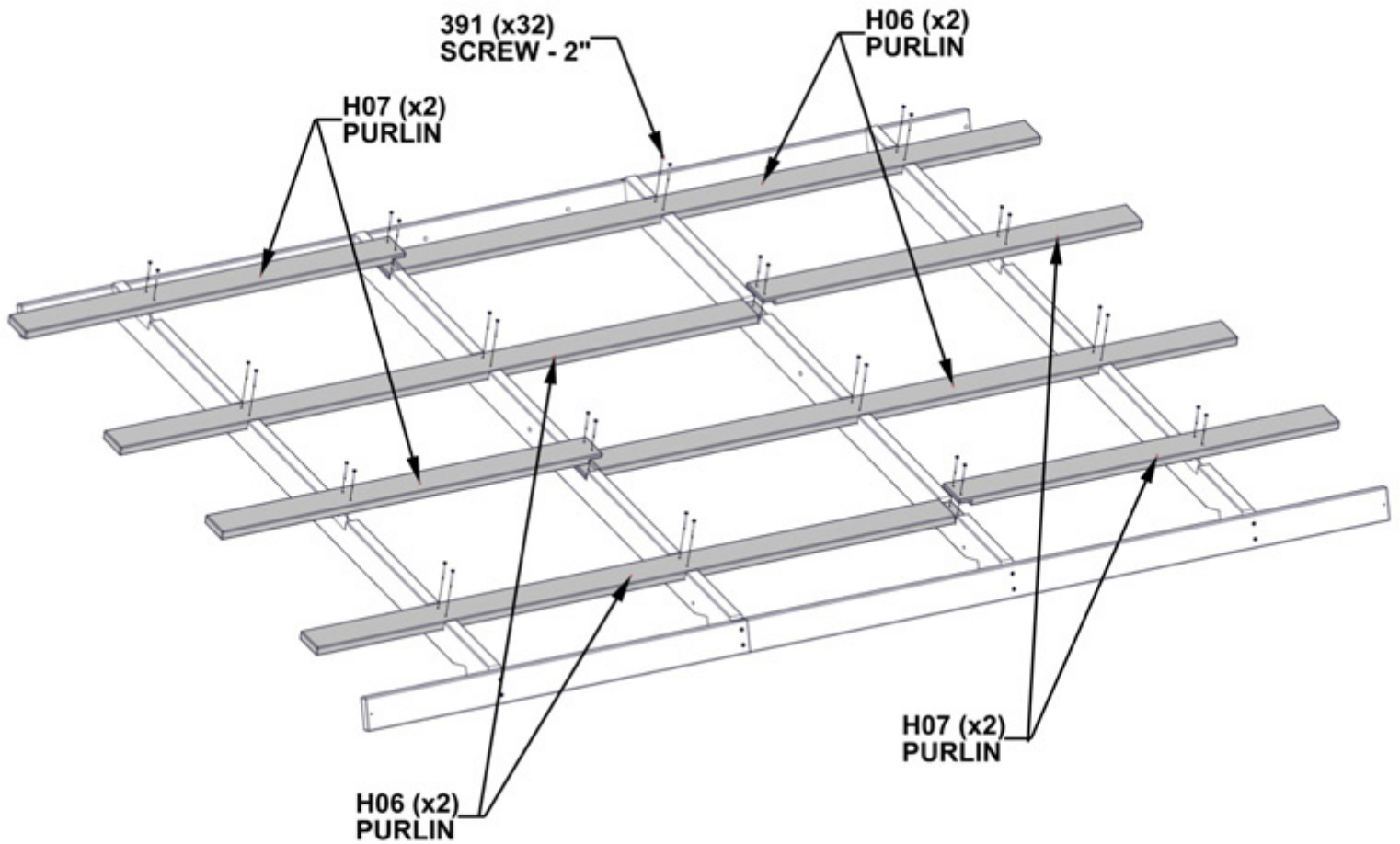

STEP 18B - ROOF PANEL ASSEMBLY

ROOF PANEL A

CRITICAL:

- SQUARE UNIT BEFORE PROCEEDING TO NEXT STEPS.
- THE BELOW DIMENSIONS ARE CRITICAL TO THE FINAL ROOF ASSEMBLY.
- MEASUREMENTS SHOULD BE HELD WITH IN +/- 1/4" (6mm).
- MEASUREMENTS OUTSIDE OF TOLERANCE WILL LEAD TO THE INABILITY TO ASSEMBLY THE ROOF.

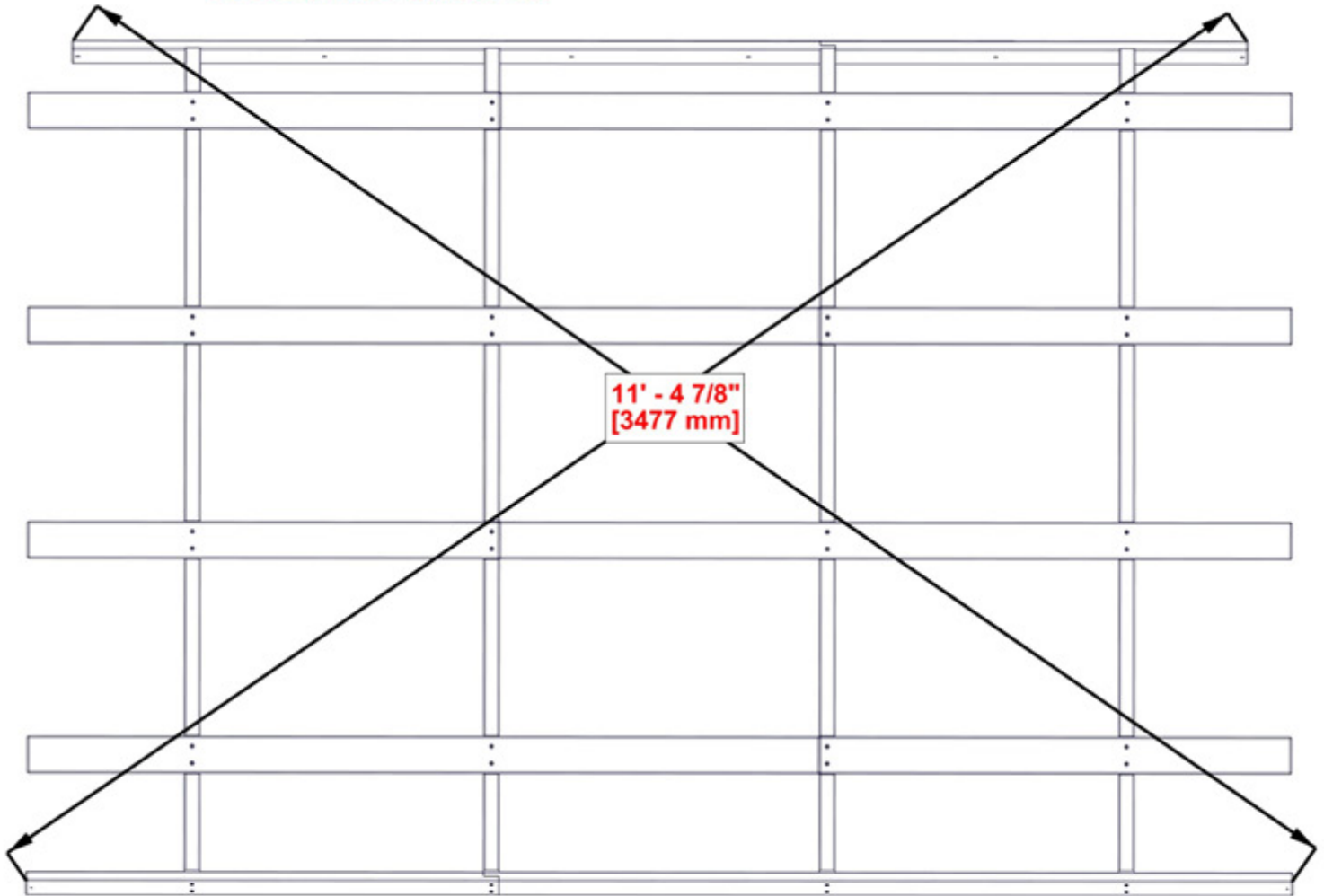

ONCE PANEL IS SQUARED, FULLY TIGHTEN SCREWS.

STEP 19 - ROOF PANEL ASSEMBLY

ROOF PANEL A

- USE THIS STEP TO FAMILIARIZE YOURSELF WITH THE ROOF PANEL AND ASSIST YOU IN STEPS 20-22.
- REMOVE PROTECTIVE BLUE FILM.
- START AT THE END INDICATED AND ASSEMBLE IN THE DIRECTION OF THE ARROW.
- **GLOVES SHOULD BE WORN WHEN HANDLING ROOF PANELS: EDGES ARE SHARP.**

THE PRE-DRILLED HOLES ON EACH PANEL SHOULD ALWAYS BE POSITIONED ON THE RIDGE SIDE.

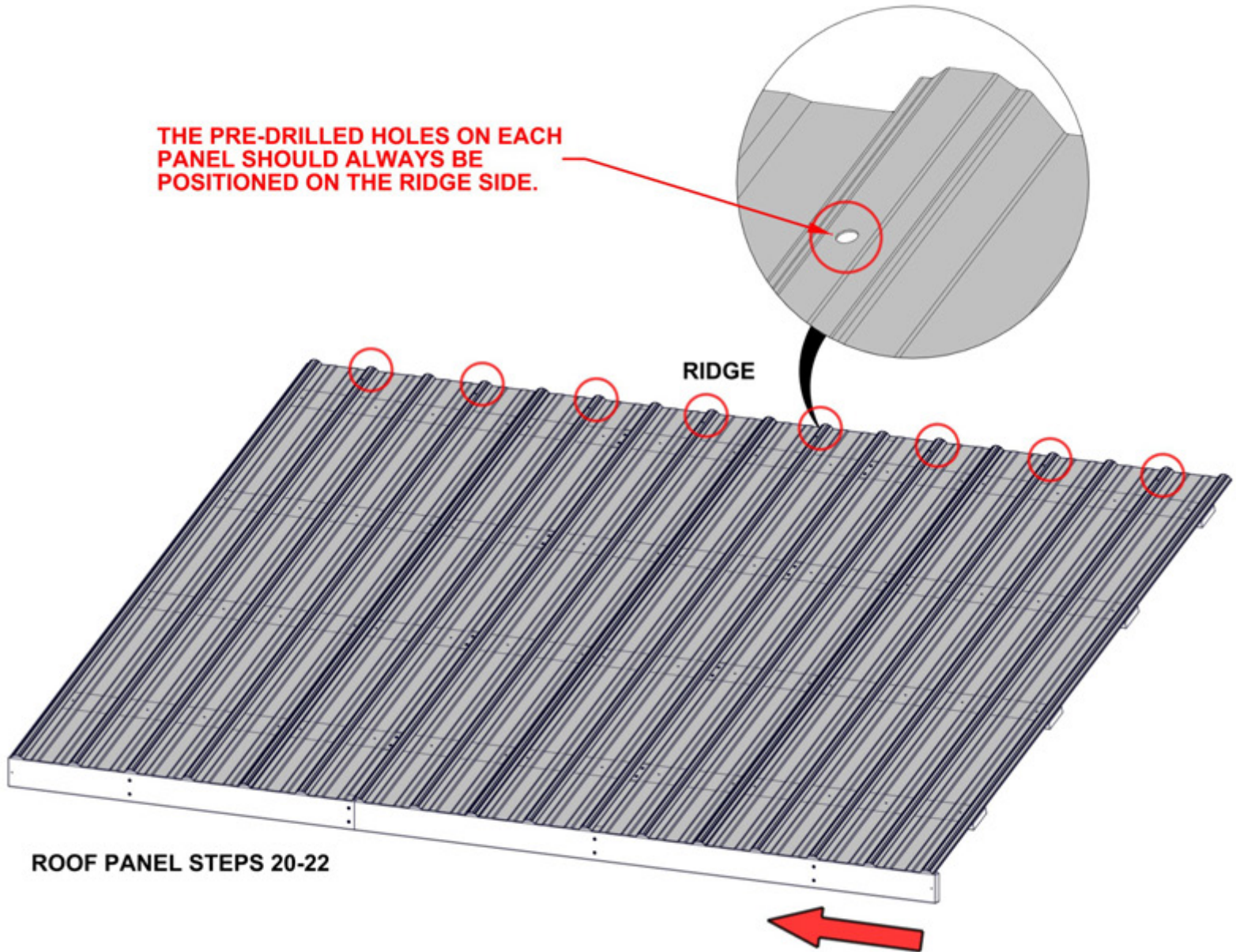

STEP 20 - ROOF PANEL ASSEMBLY

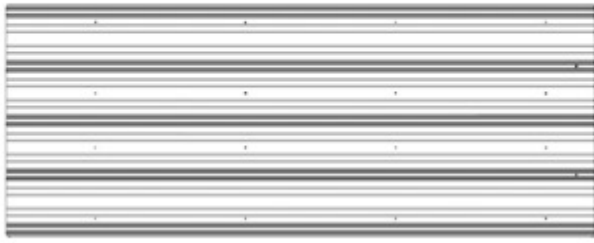

A4M02639 29GA STEEL SHEETING
(x2)

QTY	PART NUMBER	DESCRIPTION
32	H100833	SCREW WOODGRIP 10-16x3/4"

ROOF PANEL A

- MAKE SURE YOUR ROOF PANEL IS SQUARE BEFORE MOVING ON.

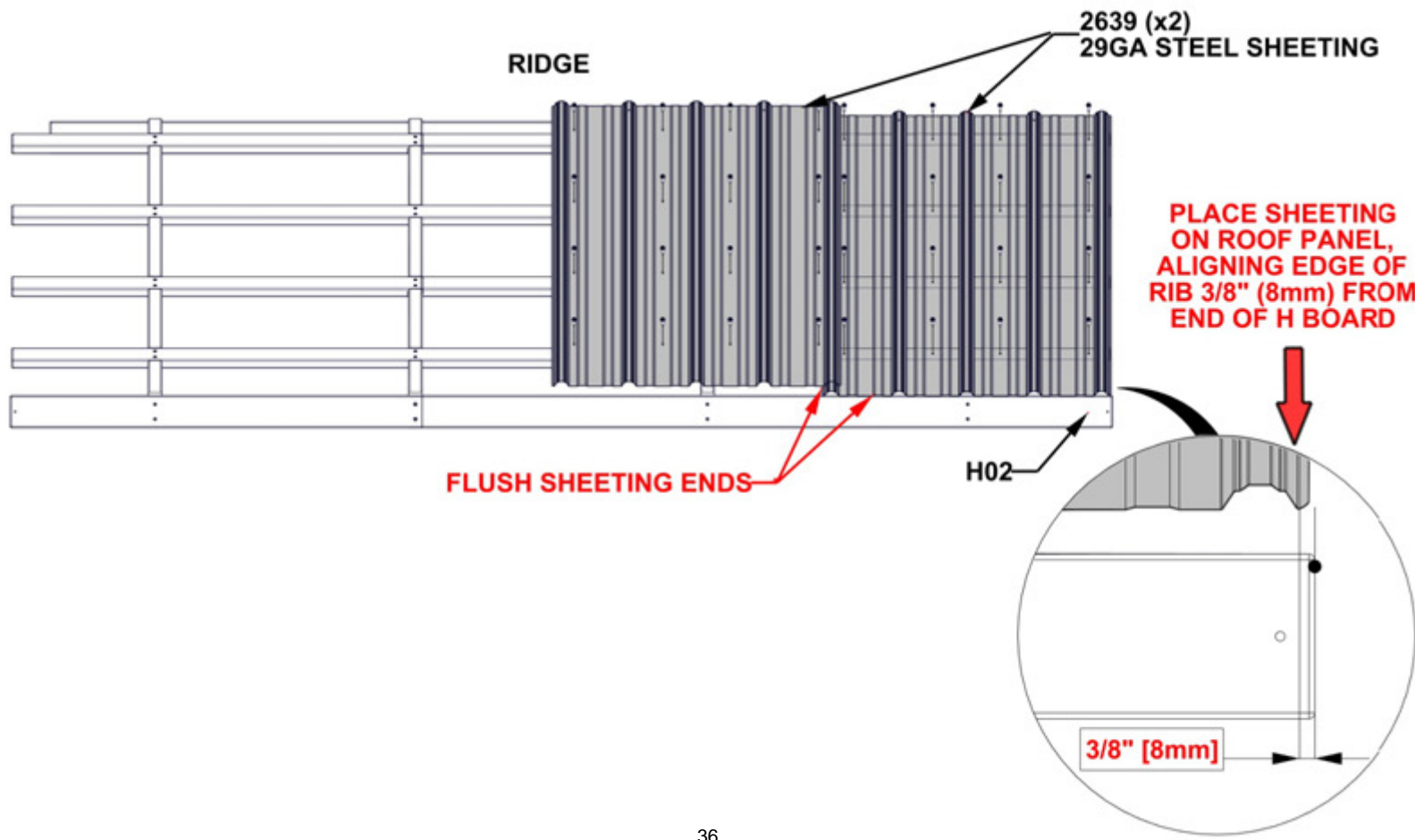
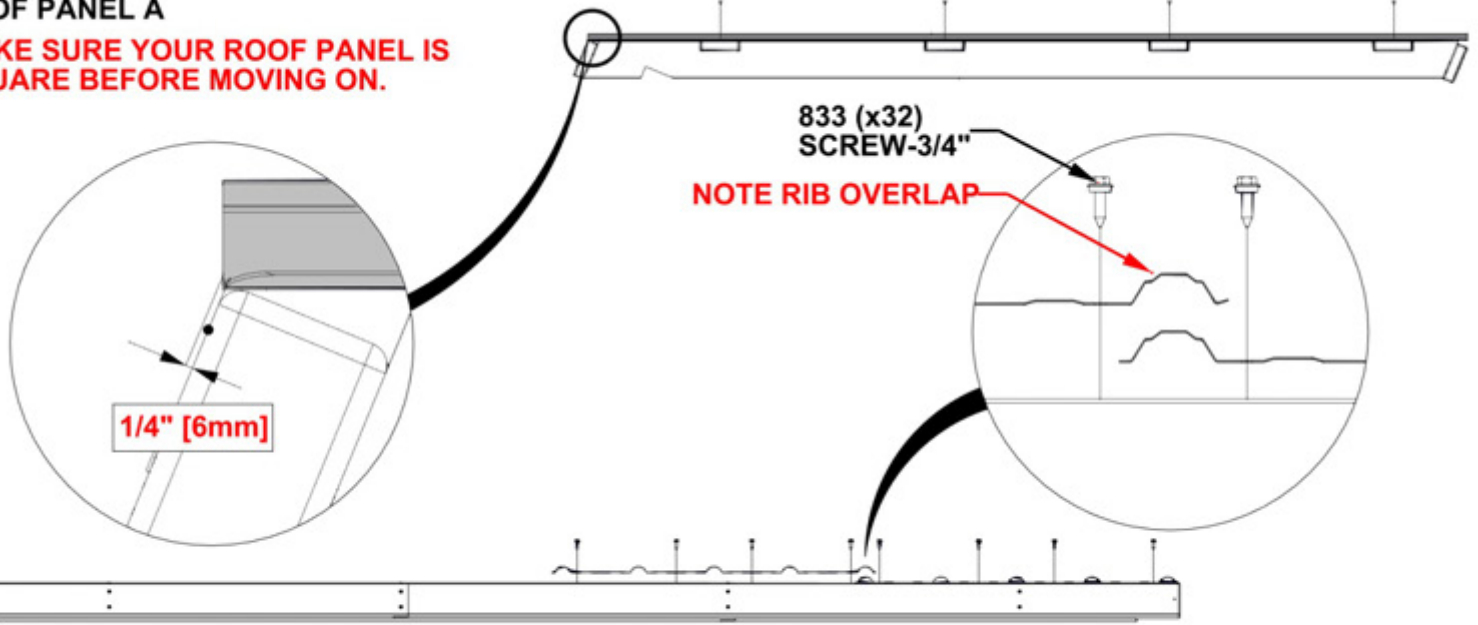

STEP 21 - ROOF PANEL ASSEMBLY

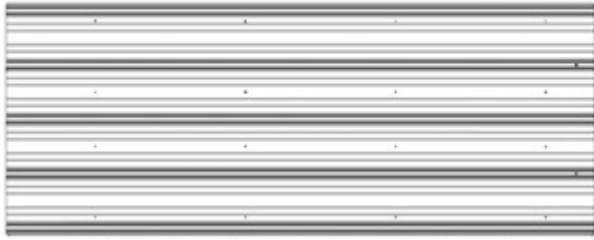

A4M02639 29GA STEEL SHEETING
(x2)

QTY	PART NUMBER	DESCRIPTION
32	H100833	SCREW WOODGRIP 10-16x3/4"

ROOF PANEL A

NOTE RIB OVERLAP

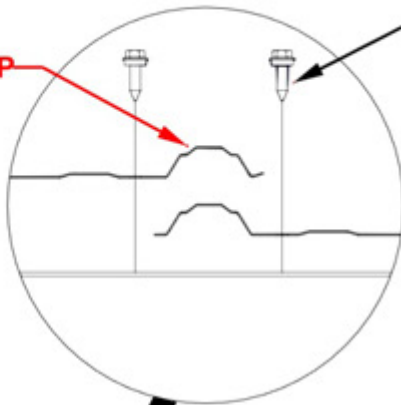

833 (x32)
SCREW-3/4"



2639 (x2)
29GA STEEL SHEETING

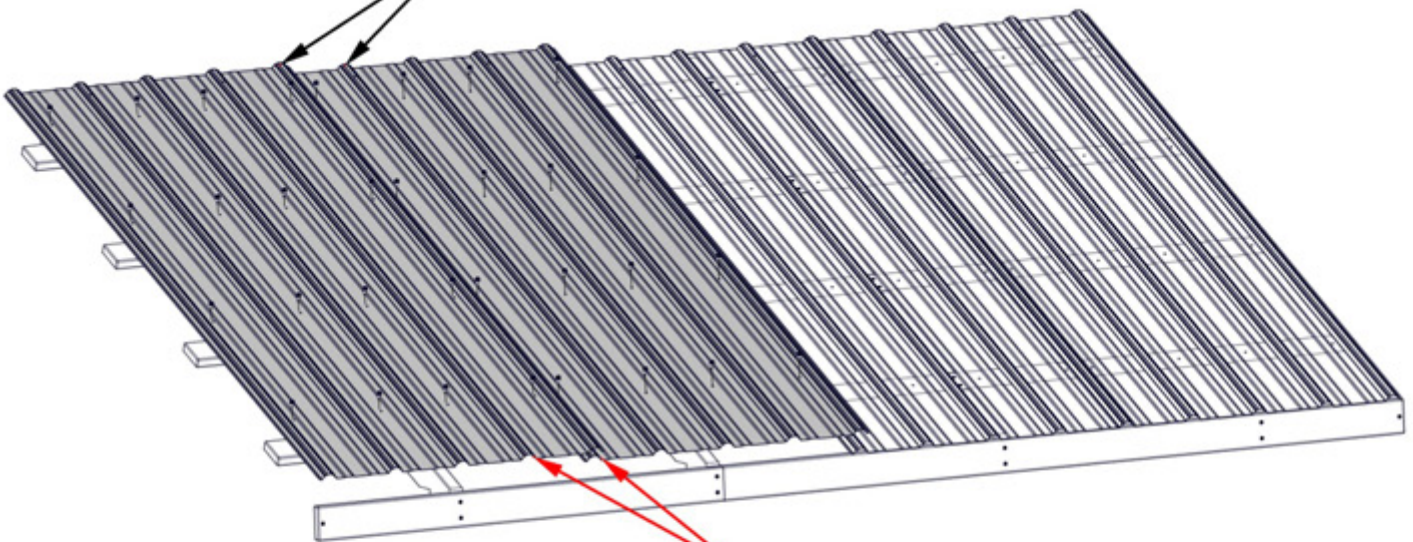

FLUSH SHEETING ENDS

STEP 22 - ROOF PANEL ASSEMBLY

QTY	PART NUMBER	DESCRIPTION
8	H100759	SCREW SELF TAPPING 1/4x1



A4M02637 ROOF EDGE TRIM
(x2)

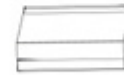

A4M02638 ROOF EDGE TRIM SPLICE
(x1)

ROOF PANEL A

DUE TO MULTIPLE LAYERS OF METAL ON THE EDGE TRIM, IT IS RECOMMENDED THAT AN 1/8" (3mm) DRILL BIT IS USED TO CREATE STARTER HOLES.

SLIDE EDGE TRIM INTO SPLICE. ENSURE THAT BOTH ENDS ARE FLUSH WITH EDGE OF ROOF PANELS.

SCREWS GO THROUGH EDGE TRIM INTO THE TOP OF THE RIBS IN THE APPROXIMATE LOCATIONS SHOWN

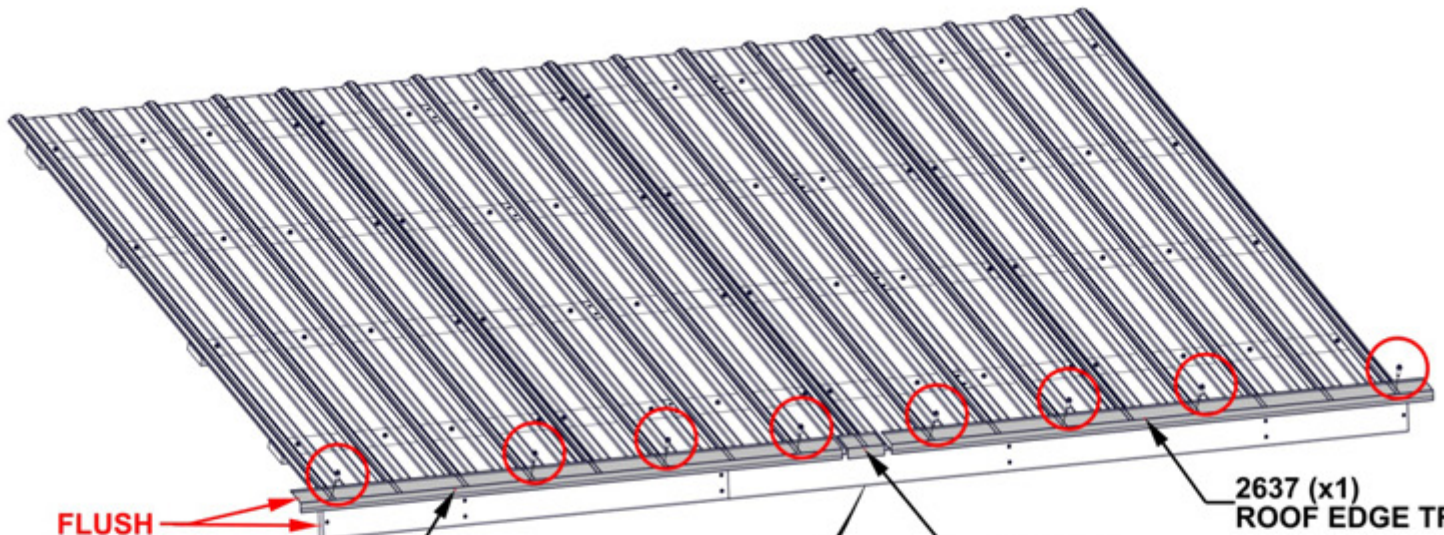

FLUSH

2637 (x1)
ROOF EDGE TRIM

2638 (x1)
ROOF EDGE TRIM SPLICE

2637 (x1)
ROOF EDGE TRIM

759(x8)
SCREW-1"

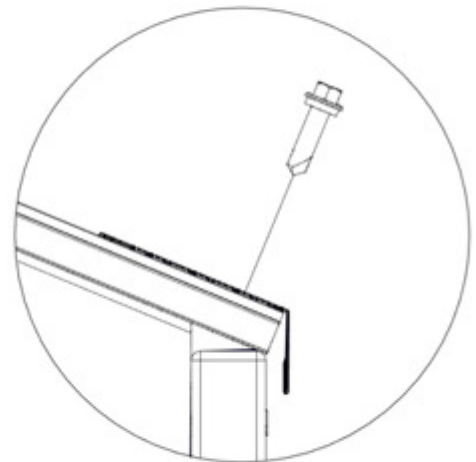
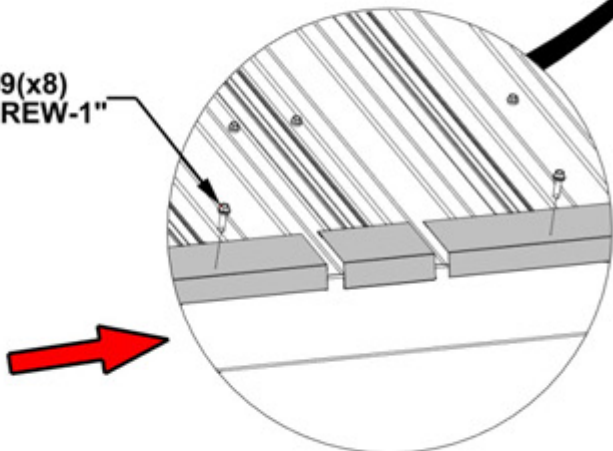

SIDE VIEW

STEP 23 - ROOF PANEL ASSEMBLY

QTY	PART NUMBER	DESCRIPTION
16	H100391	SCREW PFH 8x2 BLK

E01 RAFTER - W4L19518
(x2) 1 7/16"x3 3/8"x77 3/8" (36x86x1965)

E03 RAFTER - W4L19619
(x2) 1 7/16"x3 3/8"x77 3/8" (36x86x1965)

H02 FASCIA - W4L19516
(x1) 15/16"x3 3/8"x74 3/4" (24x86x1898)

H03 FASCIA - W4L19517
(x1) 15/16"x3 3/8"x43 3/4" (24x86x1111)

H04 RIDGE BEAM - W4L19513
(x1) 15/16"x3 3/8"x39 1/2" (24x86x1003)

H05 RIDGE BEAM - W4L19514
(x1) 15/16"x3 3/8"x70 1/2" (24x86x1791)

ROOF PANEL B

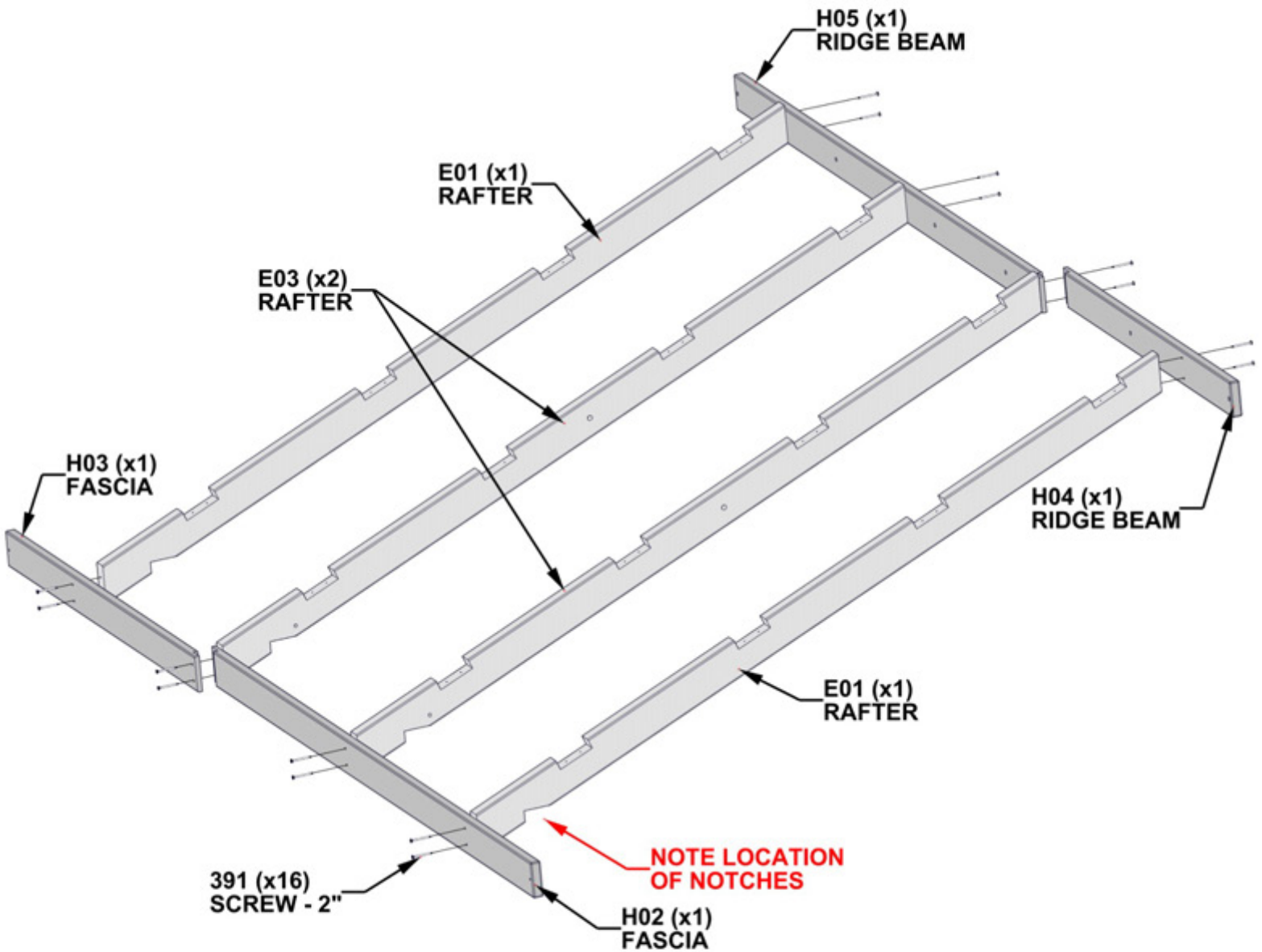

STEP 24A - ROOF PANEL ASSEMBLY

QTY	PART NUMBER	DESCRIPTION
32	H100391	SCREW PFH 8x2 BLK



H07 PURLIN - W4L19520
(x4) 15/16"x3 3/8"x43 9/16" (24x86x1107)



H06 PURLIN - W4L19519
(x4) 15/16"x3 3/8"x74 9/16" (24x86x1894)

ROOF PANEL B

DO NOT FULLY TIGHTEN SCREWS

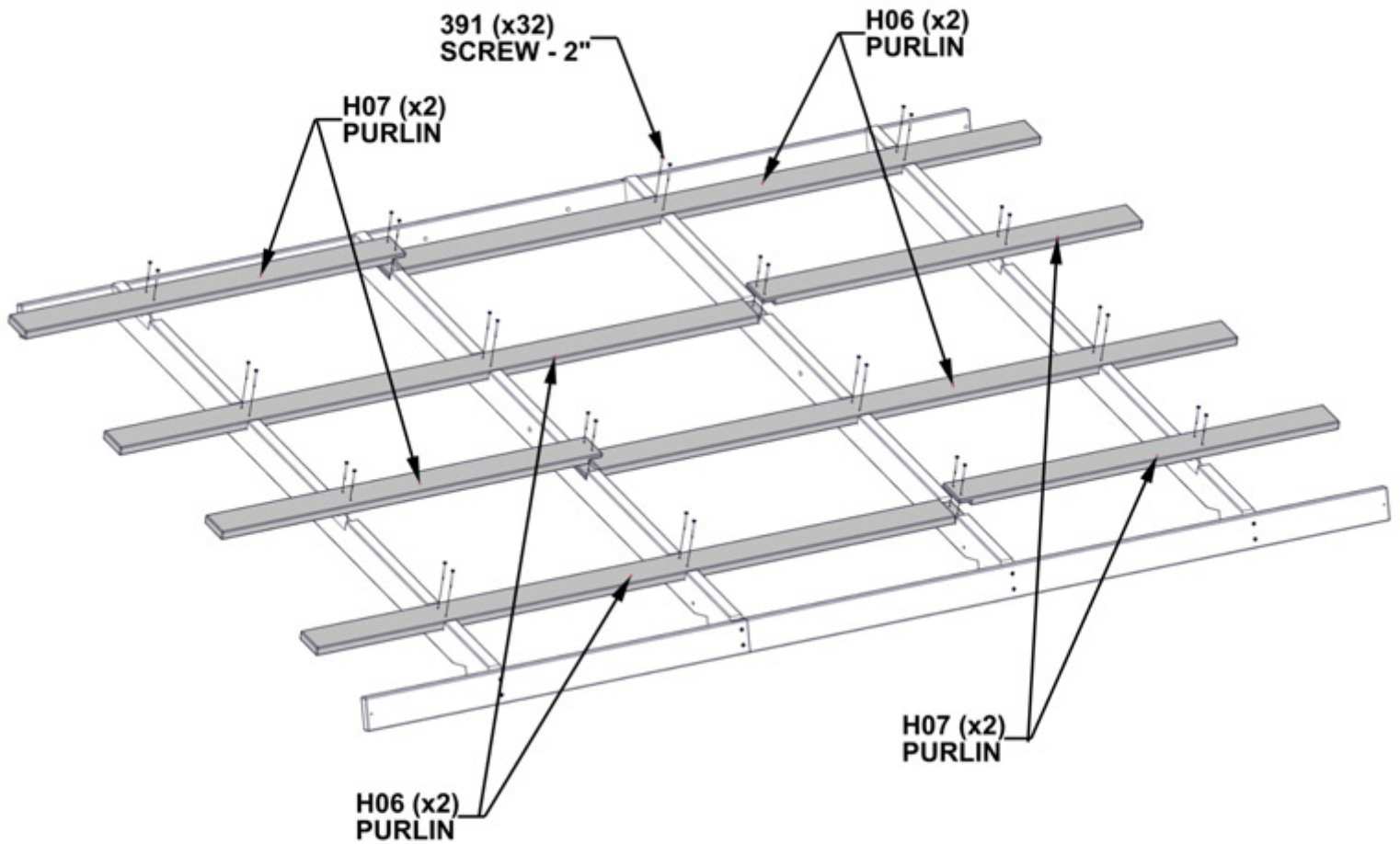

STEP 24B - ROOF PANEL ASSEMBLY

ROOF PANEL B

CRITICAL:

- SQUARE UNIT BEFORE PROCEEDING TO NEXT STEPS.
- THE BELOW DIMENSIONS ARE CRITICAL TO THE FINAL ROOF ASSEMBLY.
- MEASUREMENTS SHOULD BE HELD WITH IN +/- 1/4" (6mm).
- MEASUREMENTS OUTSIDE OF TOLERANCE WILL LEAD TO THE INABILITY TO ASSEMBLY THE ROOF.

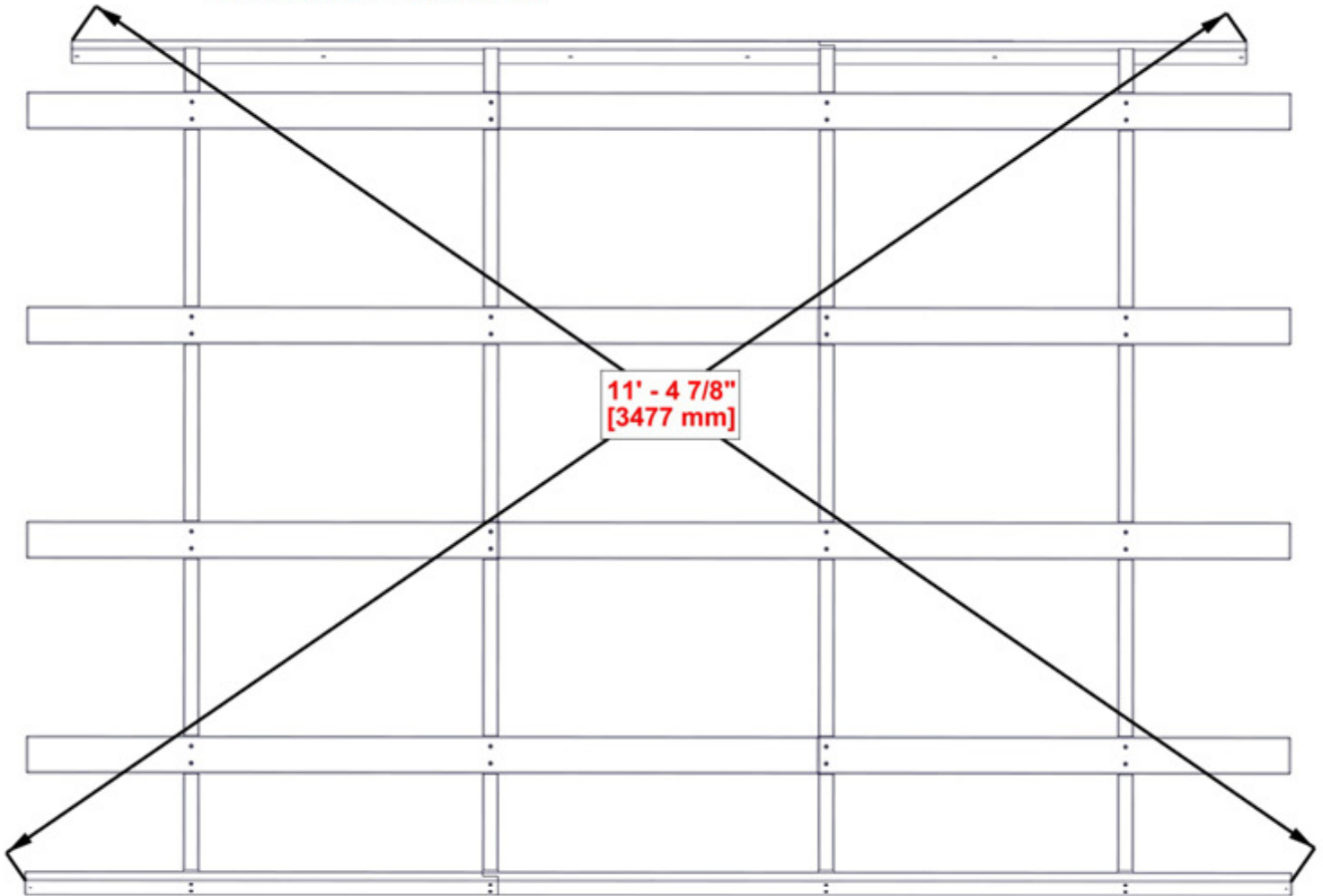

ONCE PANEL IS SQUARED, FULLY TIGHTEN SCREWS.

STEP 25 - ROOF PANEL ASSEMBLY

ROOF PANEL B

- USE THIS STEP TO FAMILIARIZE YOURSELF WITH THE ROOF PANEL AND ASSIST YOU IN STEPS 26-28.
- REMOVE PROTECTIVE BLUE FILM.
- START AT THE END INDICATED AND ASSEMBLE IN THE DIRECTION OF THE ARROW.
- **GLOVES SHOULD BE WORN WHEN HANDLING ROOF PANELS: EDGES ARE SHARP.**

THE PRE-DRILLED HOLES ON EACH PANEL SHOULD ALWAYS BE POSITIONED ON THE RIDGE SIDE.

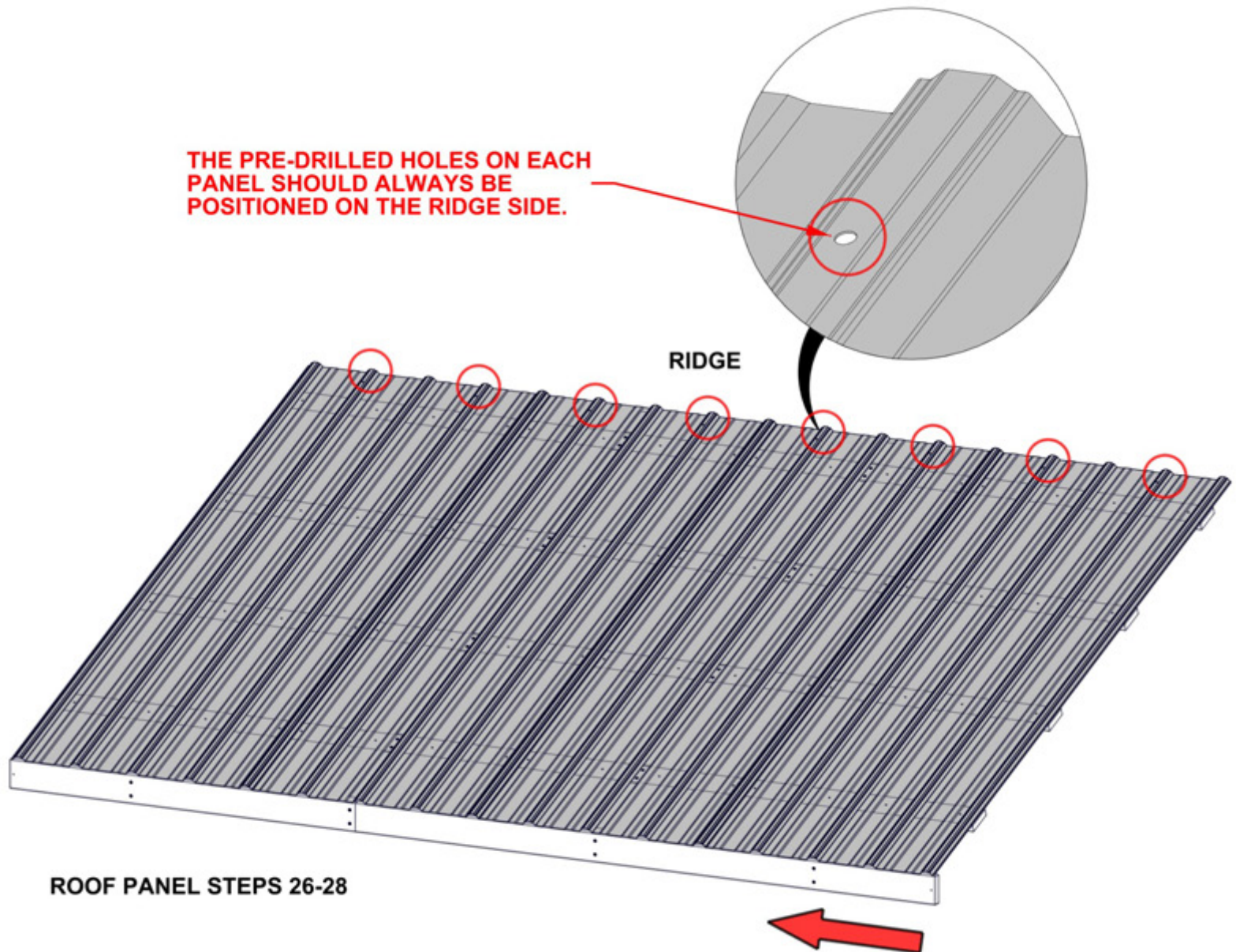

STEP 26 - ROOF PANEL ASSEMBLY

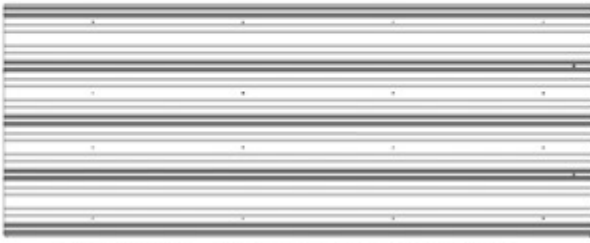

QTY	PART NUMBER	DESCRIPTION
32	H100833	SCREW WOODGRIP 10-16x3/4"

ROOF PANEL B

- MAKE SURE YOUR ROOF PANEL IS SQUARE BEFORE MOVING ON.

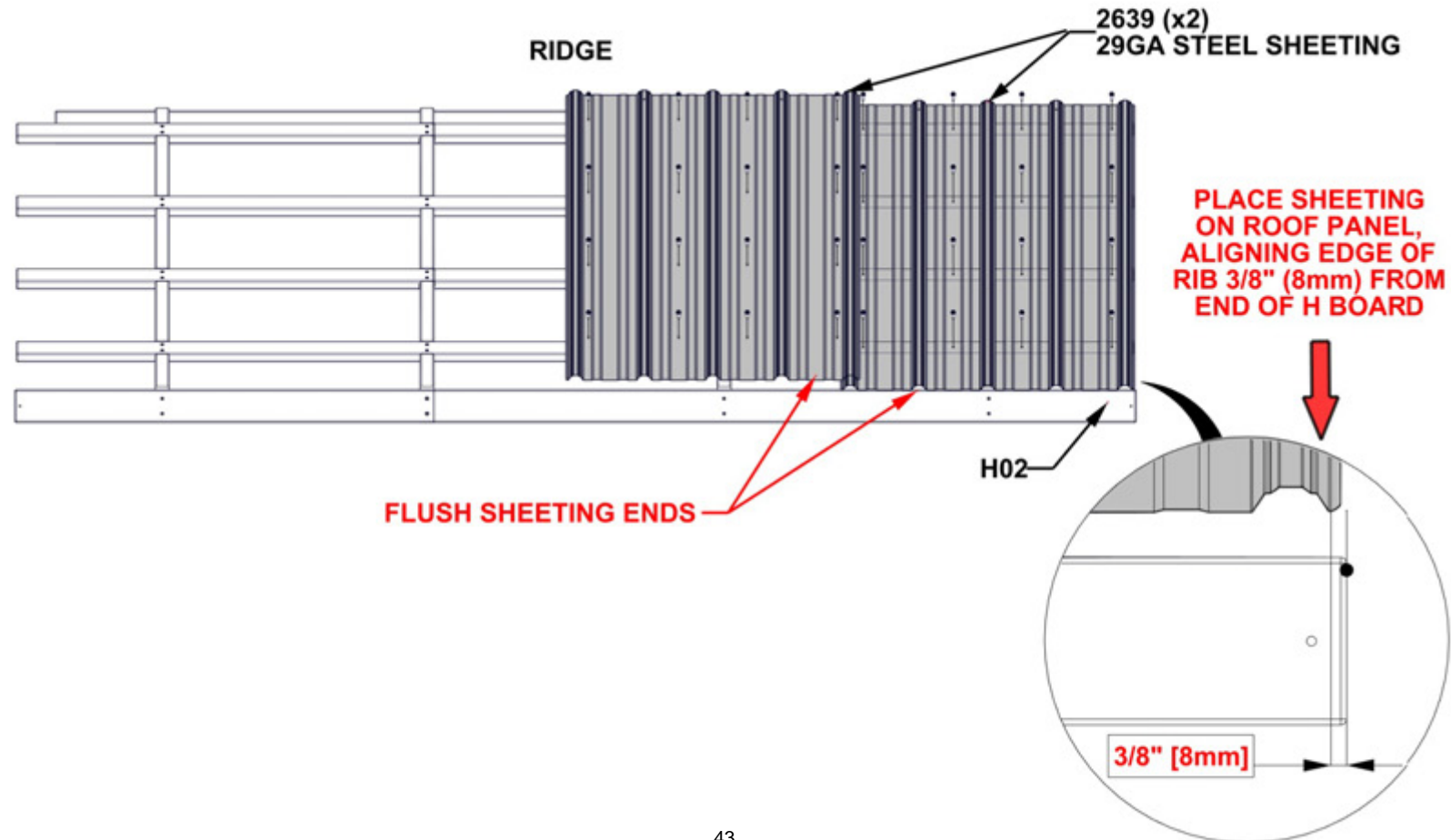
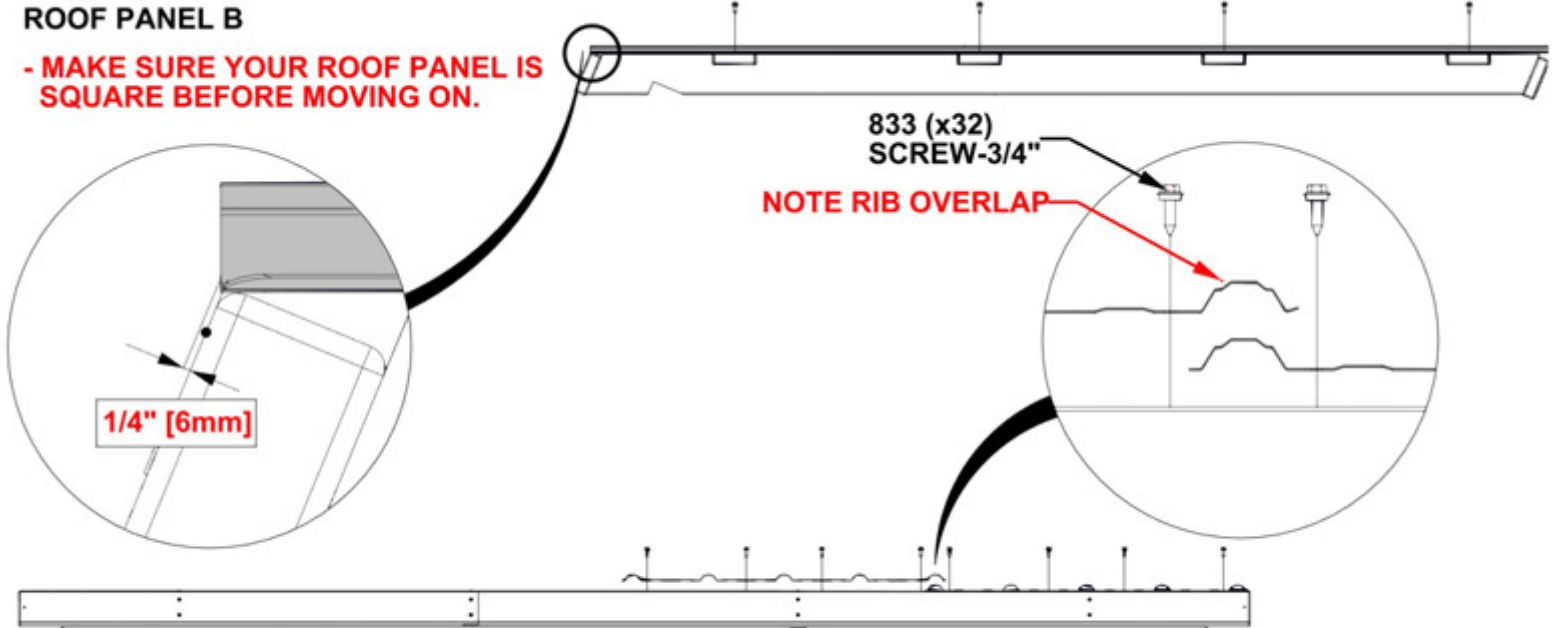

STEP 27 - ROOF PANEL ASSEMBLY



A4M02639 29GA STEEL SHEETING
(x2)

QTY	PART NUMBER	DESCRIPTION
32	H100833	SCREW WOODGRIP 10-16x3/4"

ROOF PANEL B

NOTE RIB OVERLAP

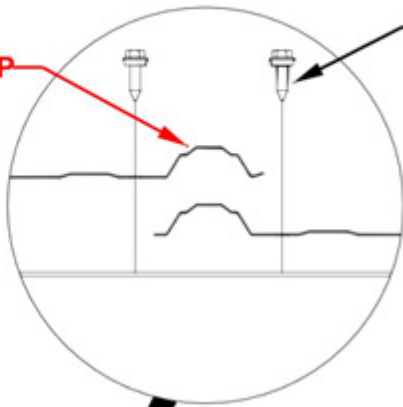

833 (x32)
SCREW-3/4"



2639 (x2)
29GA STEEL SHEETING

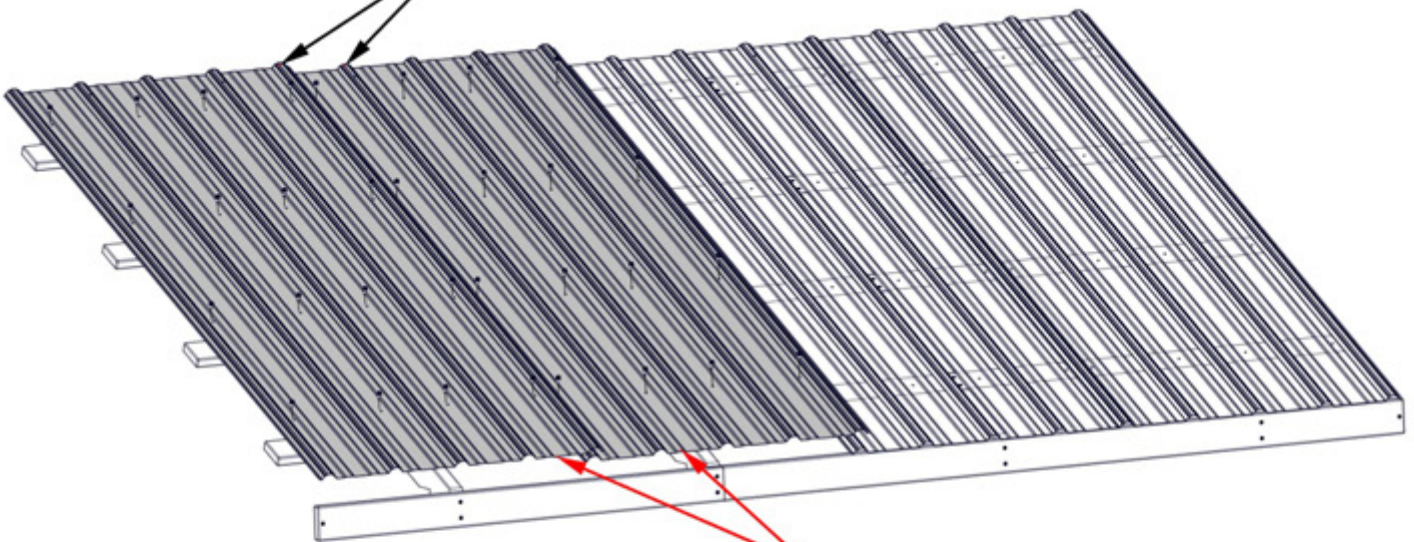

FLUSH SHEETING ENDS

STEP 28 - ROOF PANEL ASSEMBLY

QTY	PART NUMBER	DESCRIPTION
8	H100759	SCREW SELF TAPPING 1/4x1



A4M02637 ROOF EDGE TRIM
(x2)

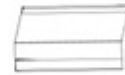

A4M02638 ROOF EDGE TRIM SPLICE
(x1)

ROOF PANEL B

DUE TO MULTIPLE LAYERS OF METAL ON THE EDGE TRIM, IT IS RECOMMENDED THAT AN 1/8" DRILL BIT IS USED TO CREATE STARTER HOLES.

SLIDE EDGE TRIM INTO SPLICE. ENSURE THAT BOTH ENDS ARE FLUSH WITH EDGE OF ROOF PANELS.

SCREWS GO THROUGH EDGE TRIM INTO THE TOP OF THE RIBS IN THE APPROXIMATE LOCATIONS SHOWN.

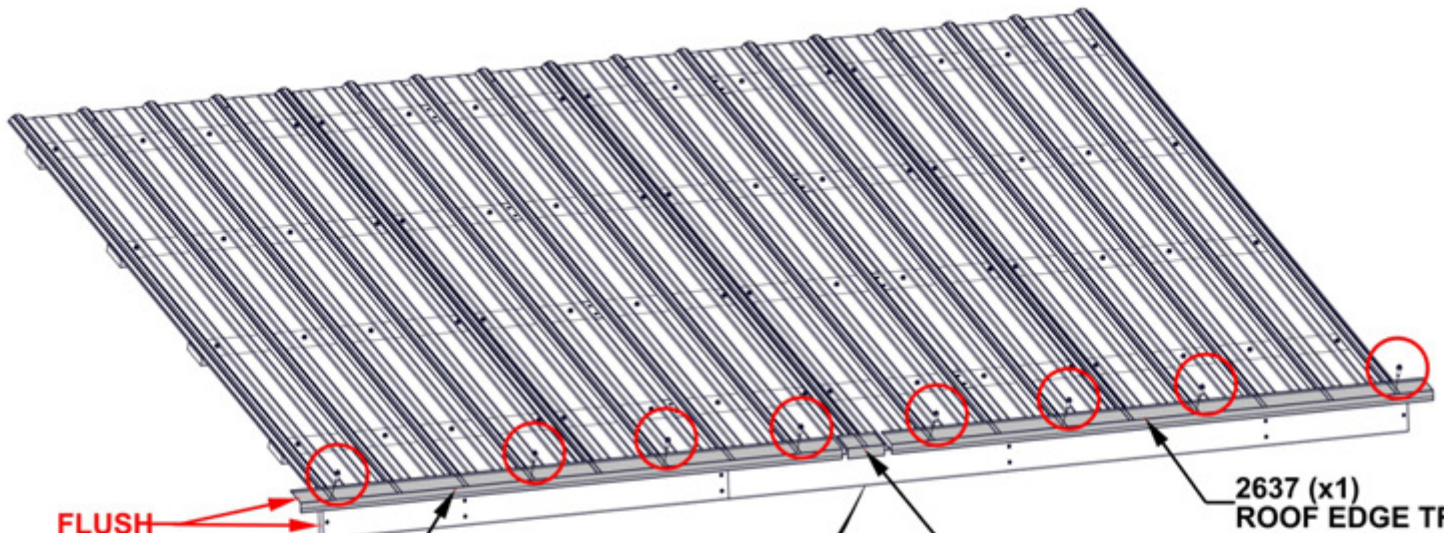

FLUSH

2637 (x1)
ROOF EDGE TRIM

2638 (x1)
ROOF EDGE TRIM SPLICE

2637 (x1)
ROOF EDGE TRIM

759(x8)
SCREW-1"

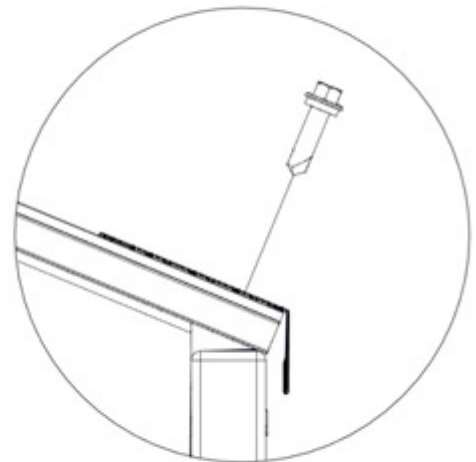
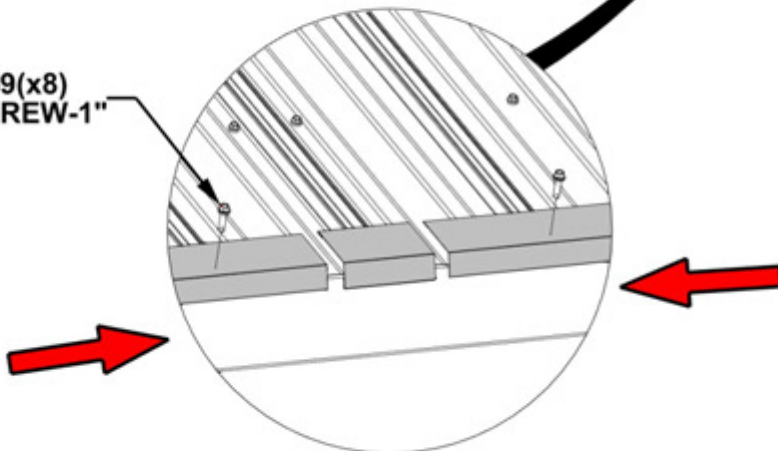

SIDE VIEW

STEP 29 - ROOF ASSEMBLY

QTY	PART NUMBER	DESCRIPTION
4	H100391	SCREW PFH 8x2 BLK



ROOF PANEL A

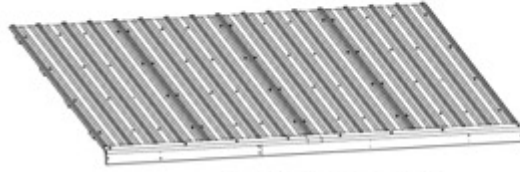

ROOF PANEL B

- WITH AT LEAST TWO PEOPLE, LIFT ASSEMBLED ROOF PANEL AND SLIDE IT INTO THE TRACKS ON THE RAFTERS. ONCE IN PLACE, INSTALL ATTACHMENT HARDWARE AS SHOWN.
- A THIRD PERSON IS HELPFUL TO ATTACH ROOF ONCE IN PLACE.

REPEAT THIS STEP FOR ROOF PANEL B.

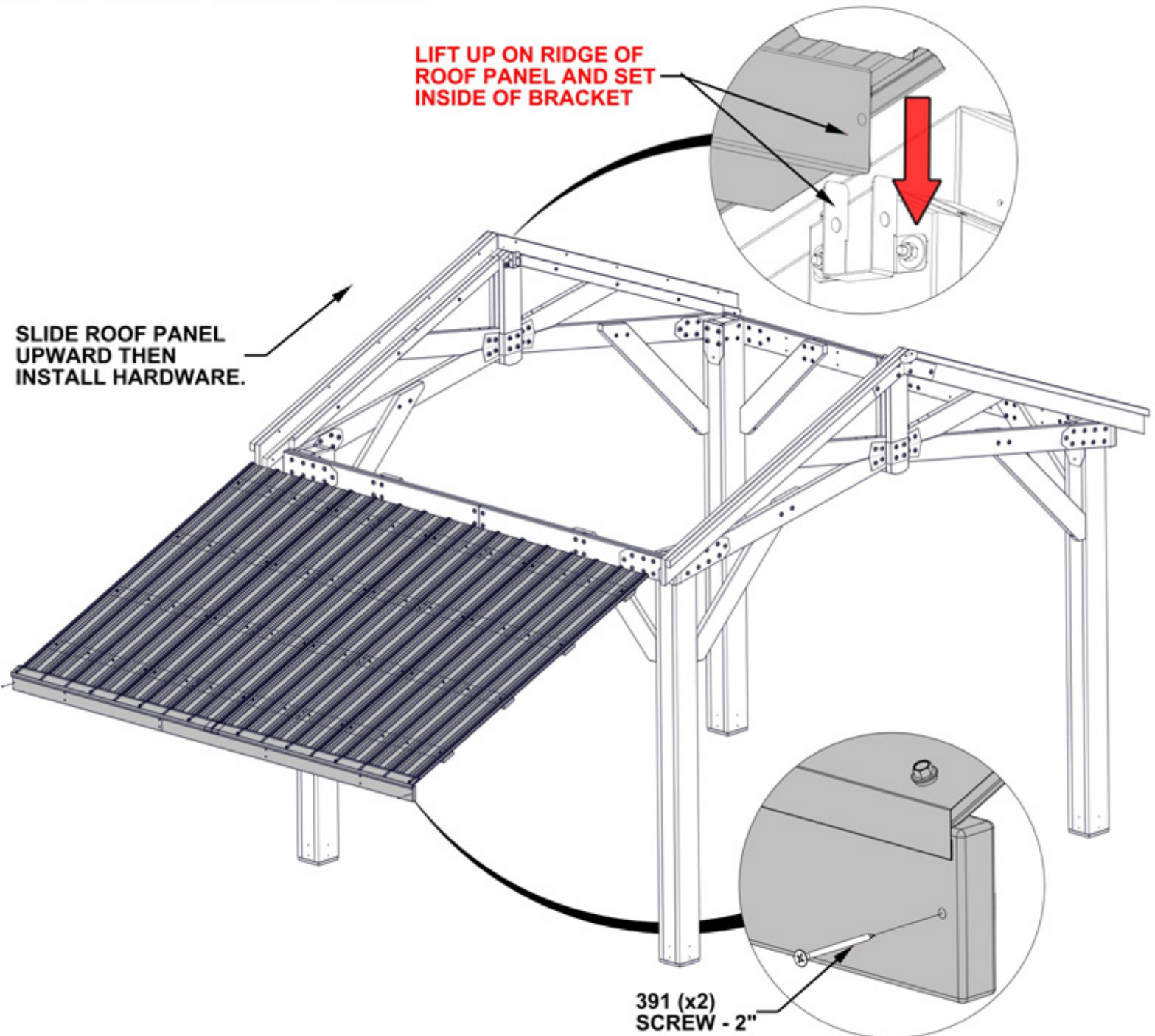

STEP 30 - ROOF ASSEMBLY

QTY	PART NUMBER	DESCRIPTION
4	H100479	NUT LOCK 5/16 BLK
4	H100194	BOLT WH 5/16x2 1/2 BLK
4	H100198	WASHER LOCK EXT 8x19
4	H100478	WASHER FLAT 8x27 BLK

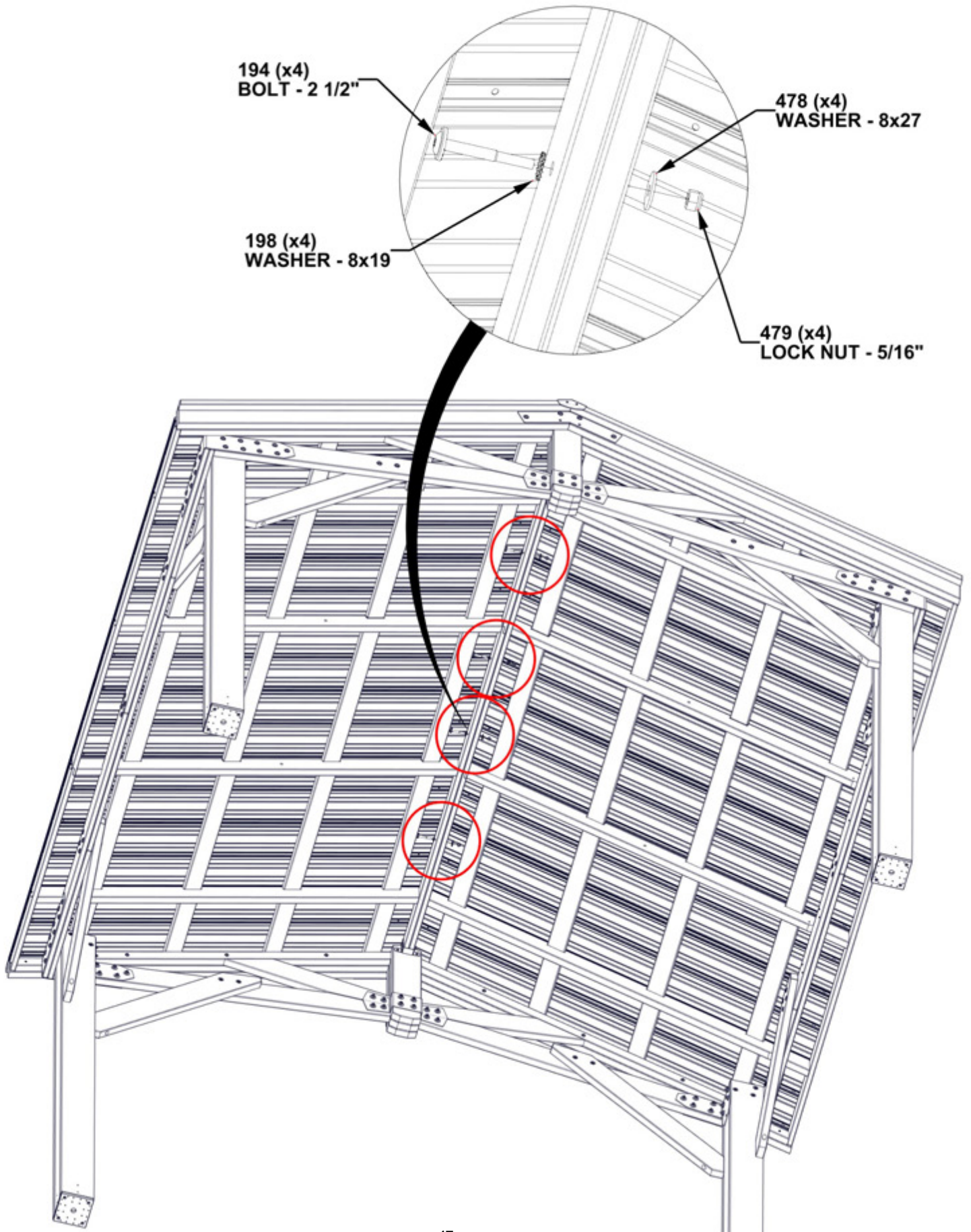

STEP 31 - ROOF ASSEMBLY

QTY	PART NUMBER	DESCRIPTION
2	H100478	WASHER FLAT 8x27 BLK
2	H100479	NUT LOCK 5/16 BLK
2	H100195	BOLT WH 5/16x2 3/4 BLK

COMPLETE THIS STEP TWICE FOR OPPOSITE SIDE

- THE USE OF CLAMPS MAY AID IN THE ALIGNMENT OF BOLT HOLES

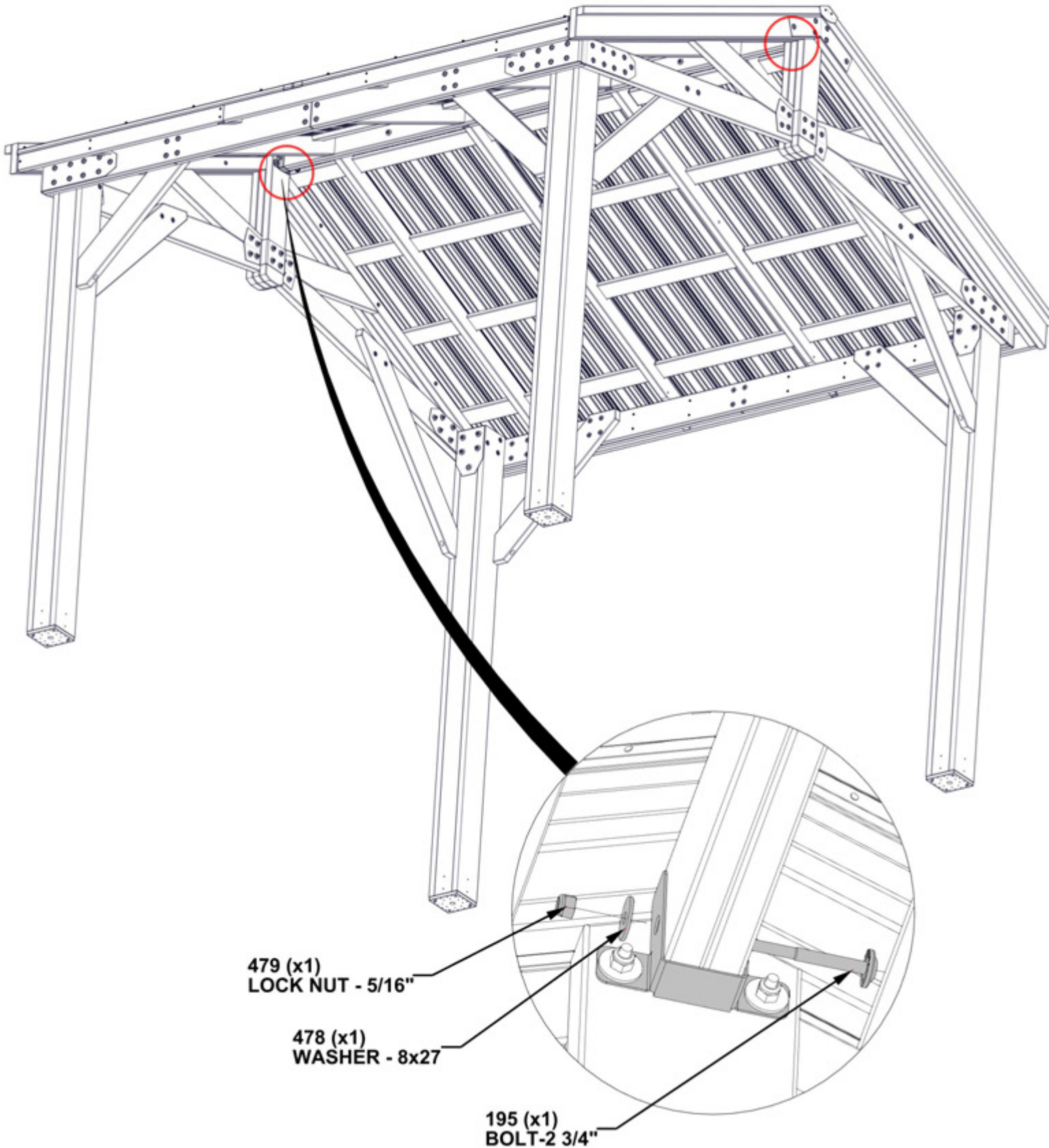

STEP 32 - ROOF ASSEMBLY

QTY	PART NUMBER	DESCRIPTION
4	H100479	NUT LOCK 5/16 BLK
4	H100480	BOLT WH 5/16x4 3/4 BLK
4	H100198	WASHER LOCK EXT 8x19
4	H100478	WASHER FLAT 8x27 BLK



E06 ACCESSORY TRUSS - W4L16863
 (x4) 1 3/8"X3 3/8"X73 7/8" (36x86x1875)

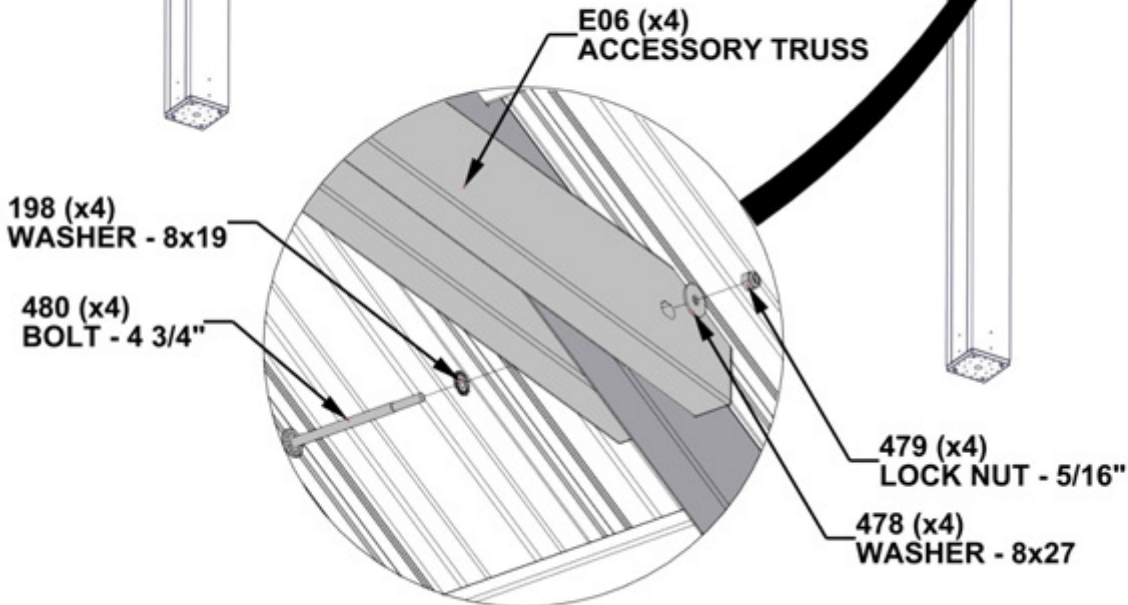
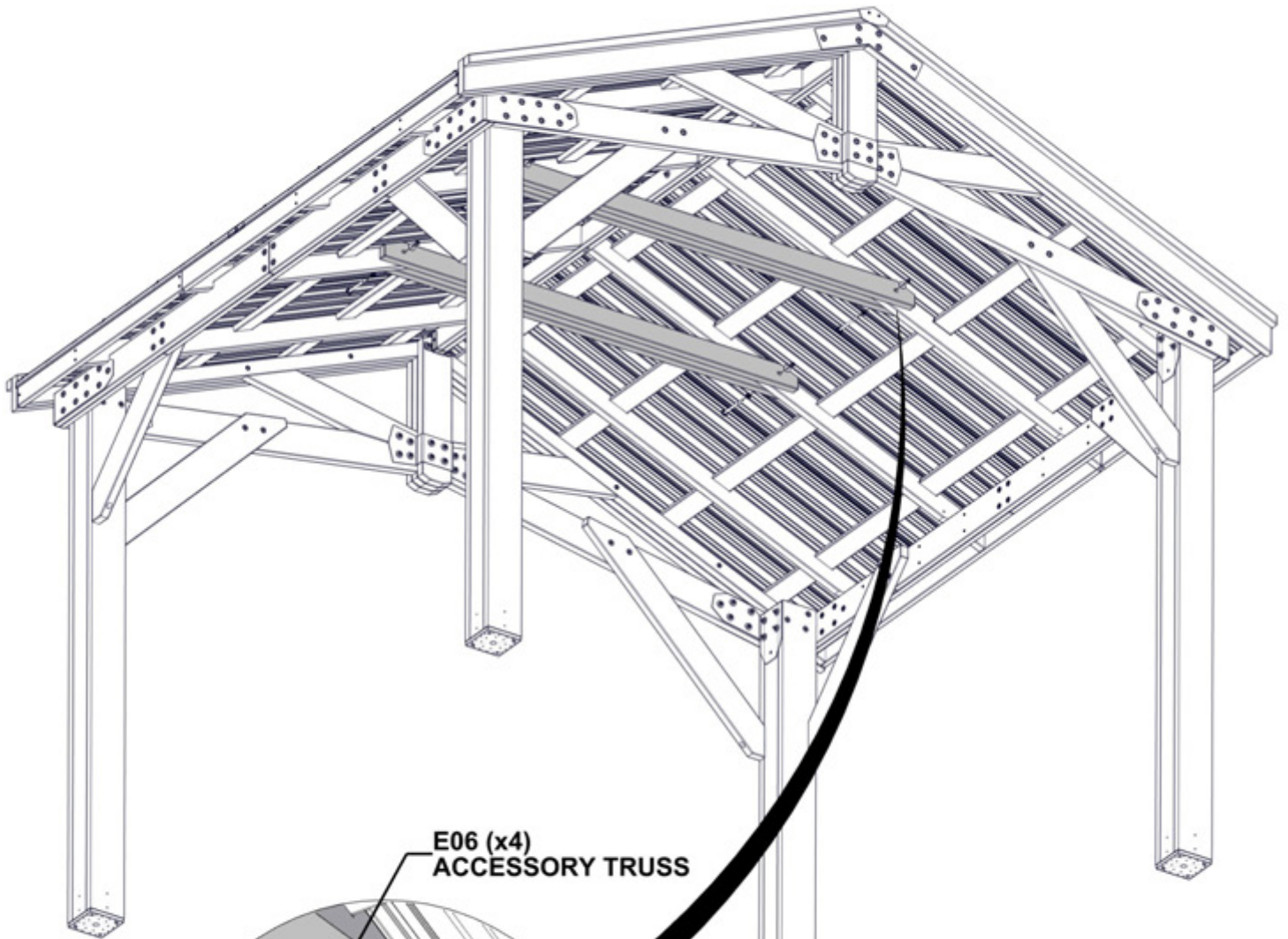

STEP 33 - ROOF ASSEMBLY

QTY	PART NUMBER	DESCRIPTION
4	H100653	NUT LOCK 1/4 BLK
4	H100488	BOLT WH 1/4x2 BLK
4	H100630	WASHER FLAT 8x19 BLK
8	H101069	SCREW PWH 8x7/8 BLK



A4M01228 RAFTER CLIP
(x4)

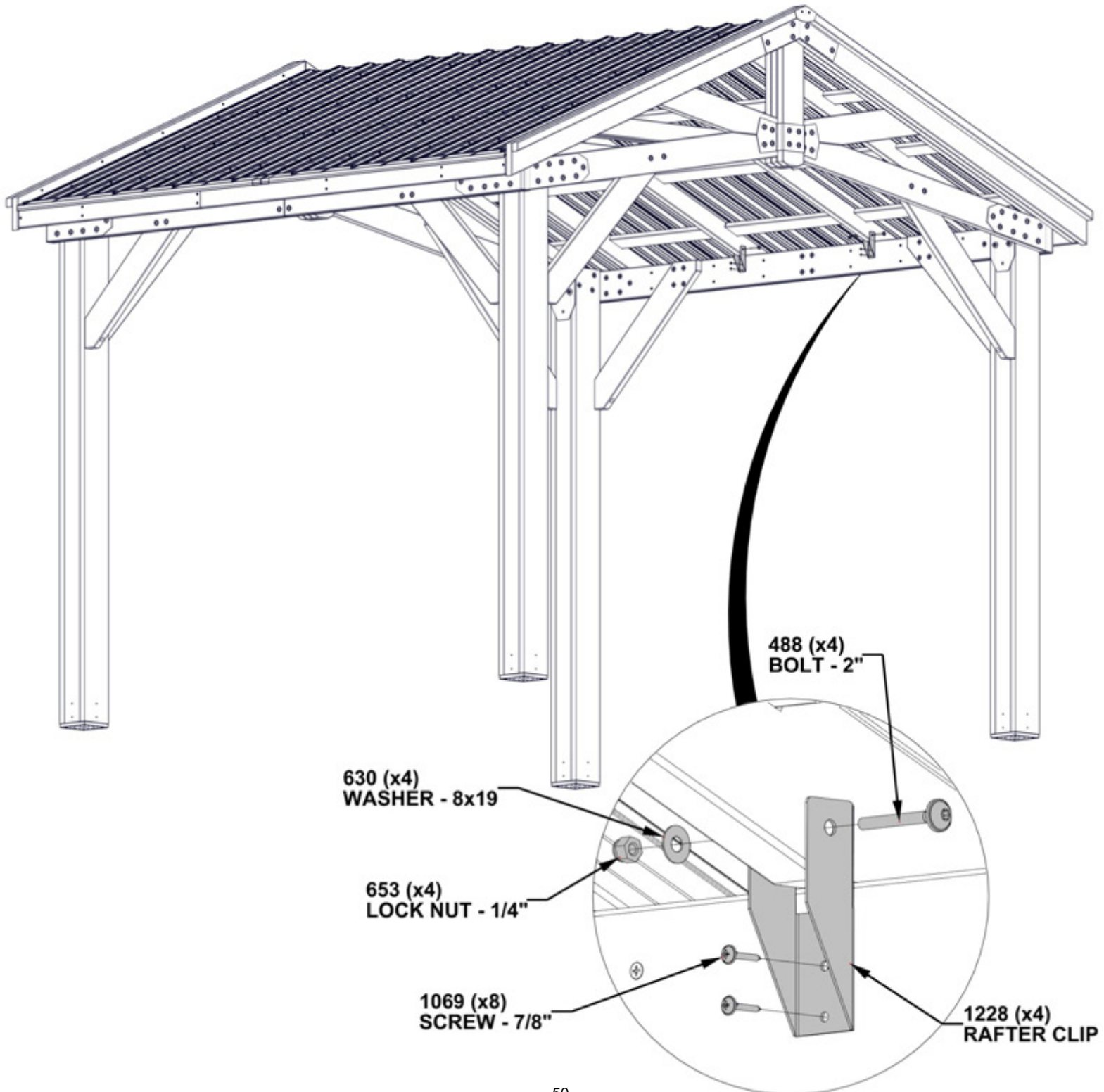

STEP 34 - ROOF ASSEMBLY

QTY	PART NUMBER	DESCRIPTION
16	H100833	SCREW WOODGRIP 10-16x3/4"

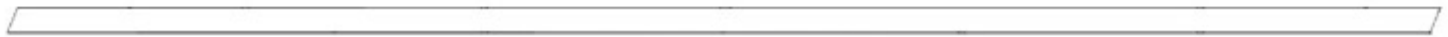

A4M02679 ROOF END TRIM
(x2)



A4M02680 ROOF END TRIM
(x2)

COMPLETE THIS STEP FOR OPPOSITE SIDE

- ATTACH SCREWS IN LINE WITH ROOF PANEL SCREWS.

REMOVE ALL FOUR SCREWS PREVIOUSLY INSTALLED AND REATTACH SECURING ROOF END TRIM TO PREVIOUSLY INSTALLED ROOF EDGE TRIM

833 (x8)
SCREW - 3/4"

2680 (x1)
ROOF END TRIM

PREVIOUSLY INSTALLED
ROOF EDGE TRIM

2679 (x1)
ROOF END TRIM

2680
ROOF END TRIM

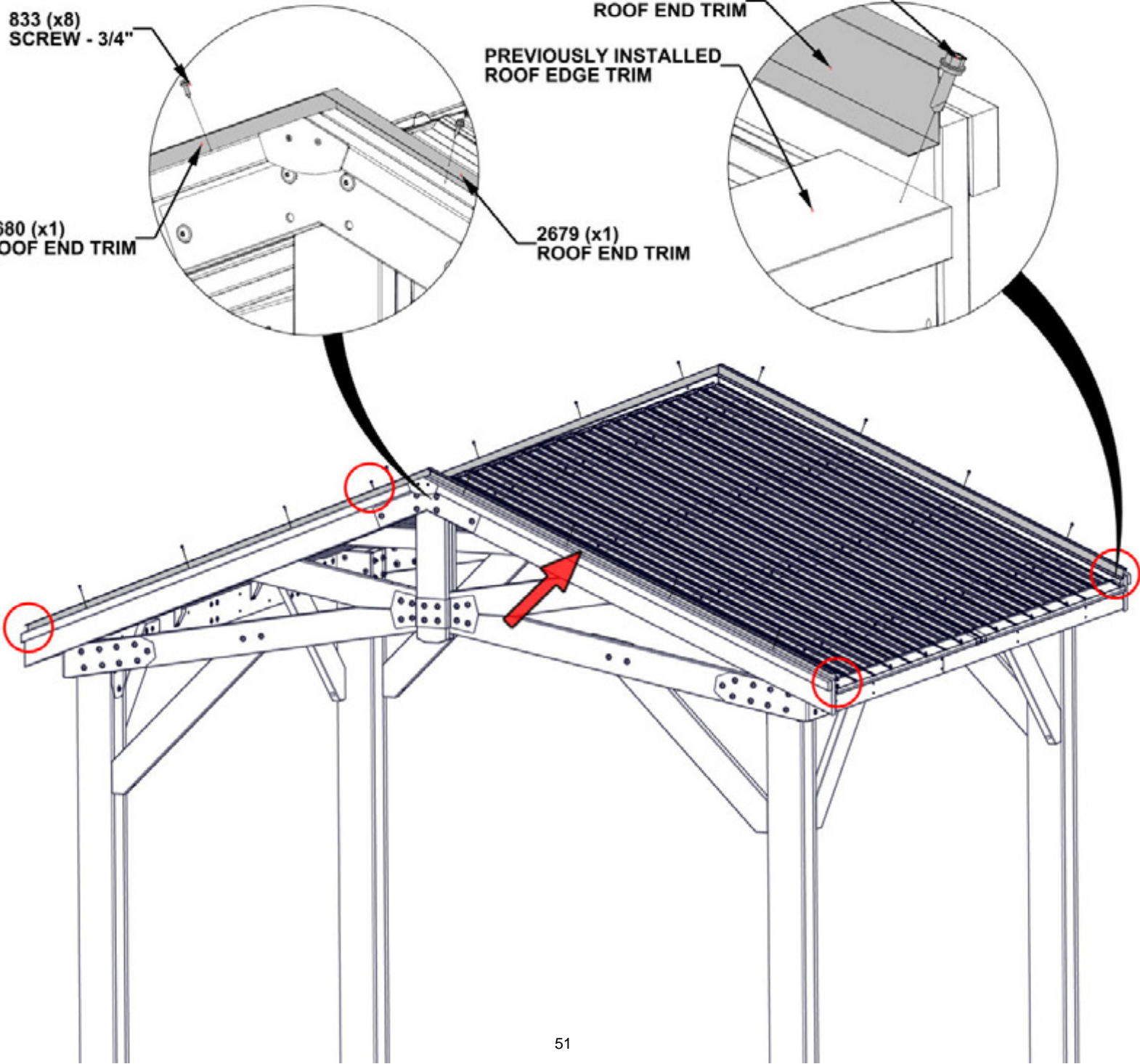

STEP 35 - GAZEBO ASSEMBLY

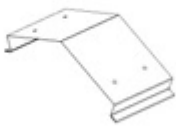

A4M02640 RIDGE CAP SPLICE
(x1)

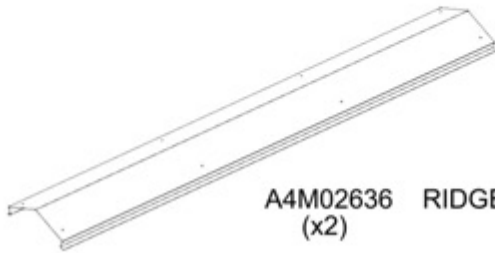

A4M02636 RIDGE CAP 29GA
(x2)

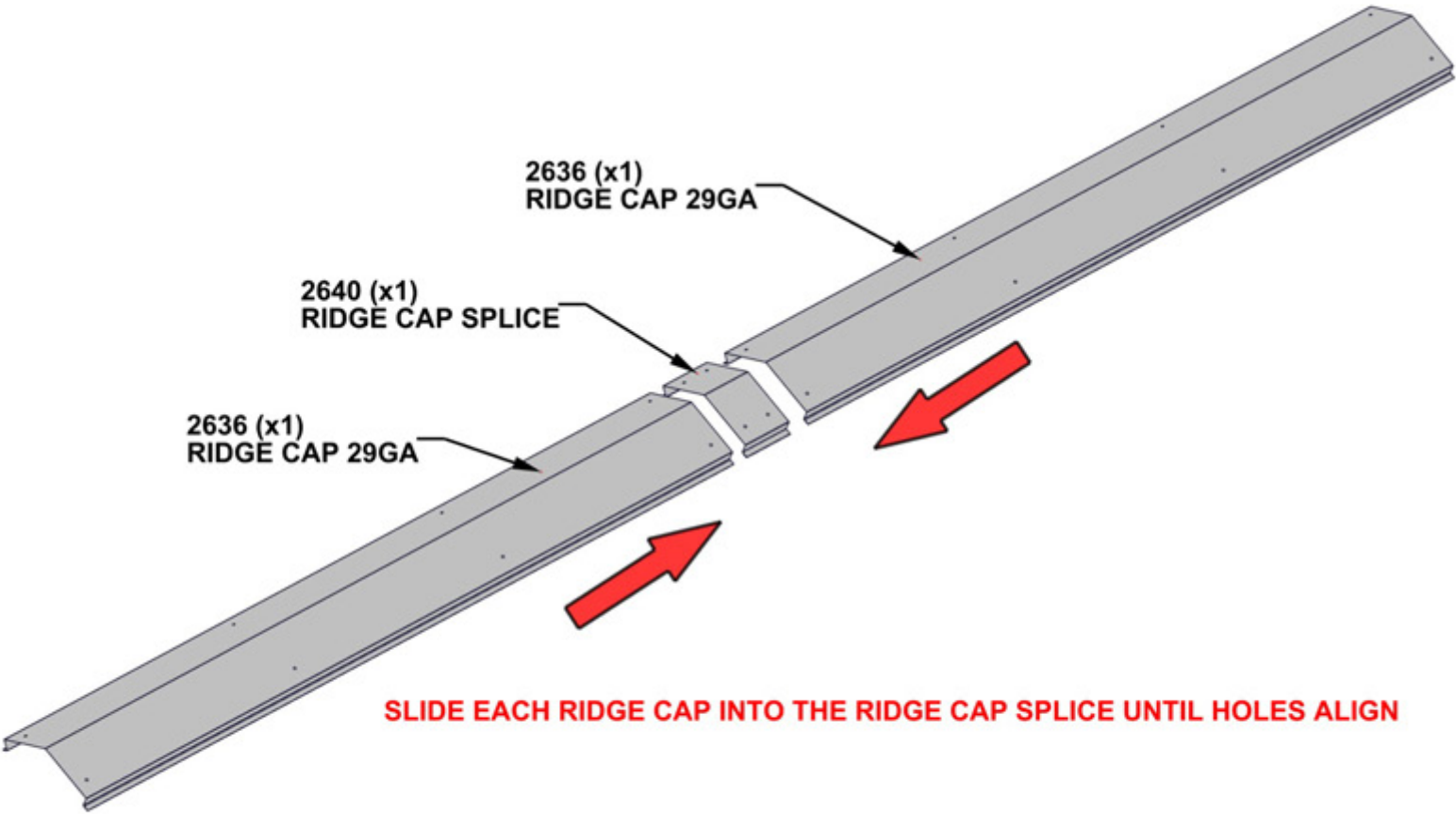

SLIDE EACH RIDGE CAP INTO THE RIDGE CAP SPLICE UNTIL HOLES ALIGN

STEP 36 - GAZEBO ASSEMBLY

QTY	PART NUMBER	DESCRIPTION
16	H100833	SCREW WOODGRIP 10-16x3/4



J09 RIDGE CAP STIFFENER - W4L13590
(x2) 15/16"x2 3/8"x47 5/8" (24x60x1210)



J10 RIDGE CAP STIFFENER - W4L13591
(x2) 15/16"x2 3/8"x69 5/16" (24x60x1760)



A6P00398 RIDGE CAP PROTECTOR
(x2)

- REMOVE SPACERS FROM RIDGE CAP PROTECTORS BEFORE INSTALLING

- FINAL LENGTH - 9'-9" [2974mm]

RIDGE CAP MUST BE LIFTED FROM THE MIDDLE TO PREVENT DAMAGE BEFORE INSTALLATION

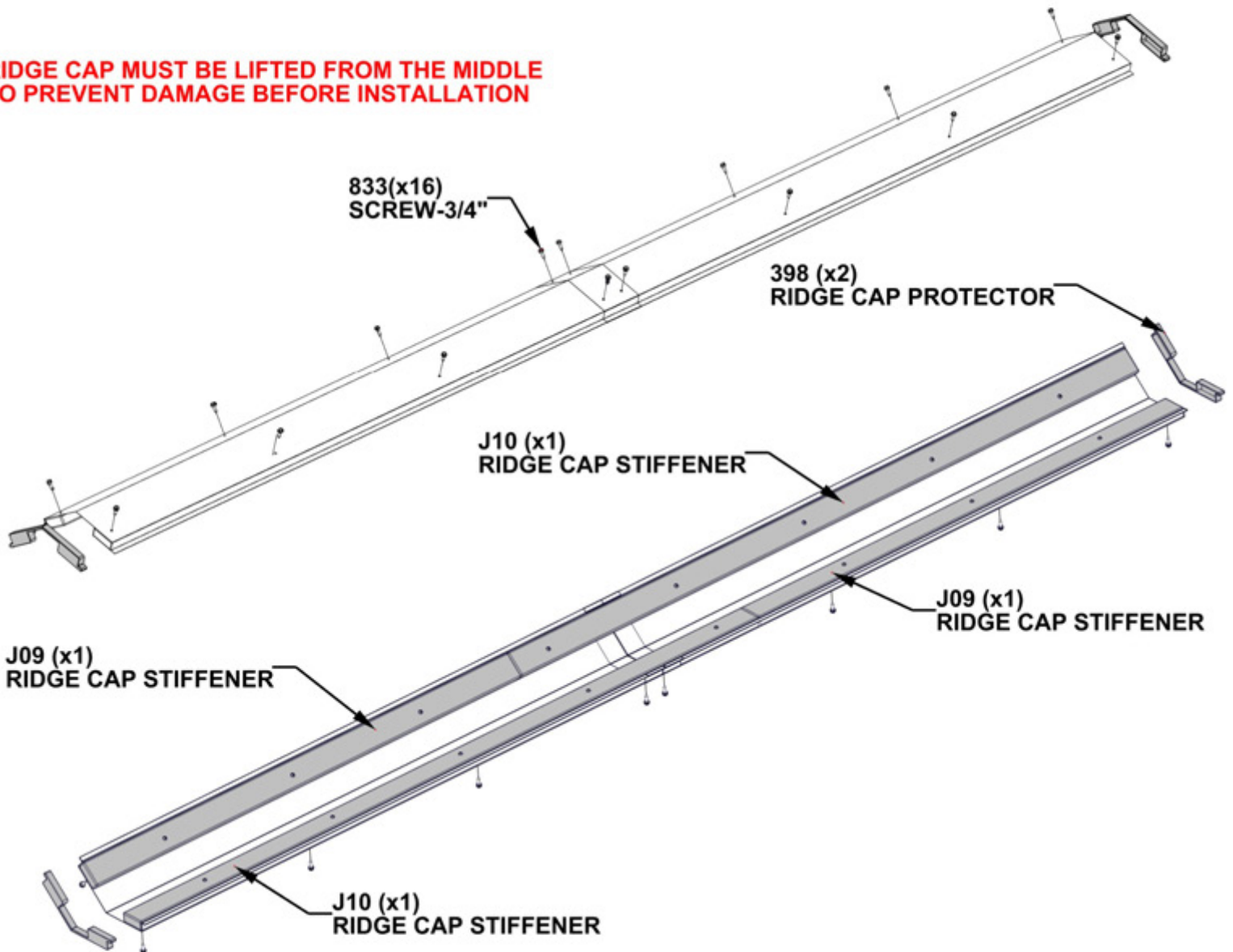

STEP 37 - GAZEBO ASSEMBLY

QTY	PART NUMBER	DESCRIPTION
16	H100392	SCREW PWH 8x3/4 BLK

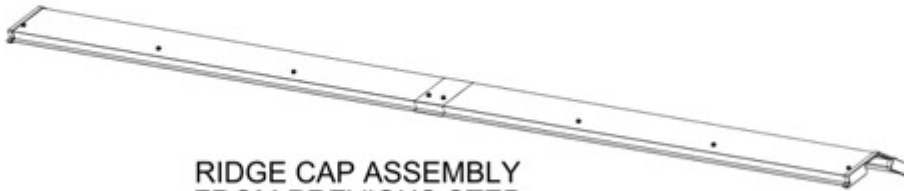

RIDGE CAP ASSEMBLY
FROM PREVIOUS STEP

DO NOT CLIMB ON ROOF TO INSTALL. ROOF CAP HAS BEEN DESIGNED TO INSTALL FROM A LADDER.

- FOR PROPER INSTALLATION, USE AN ADULT HELPER TO KEEP DOWNWARD PRESSURE ON THE RIDGE CAP WHILE SCREWING IN SCREWS.

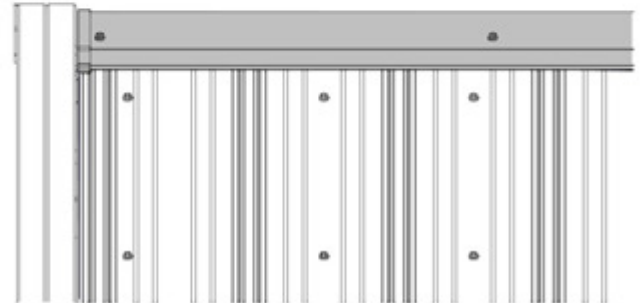
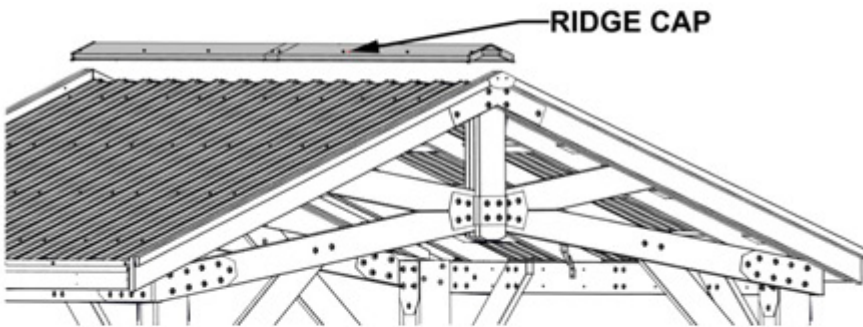

**INSTALL SCREWS THROUGH
PILOT HOLES IN ROOF PANELS
INTO RIDGE CAP STIFFENER BOARDS**

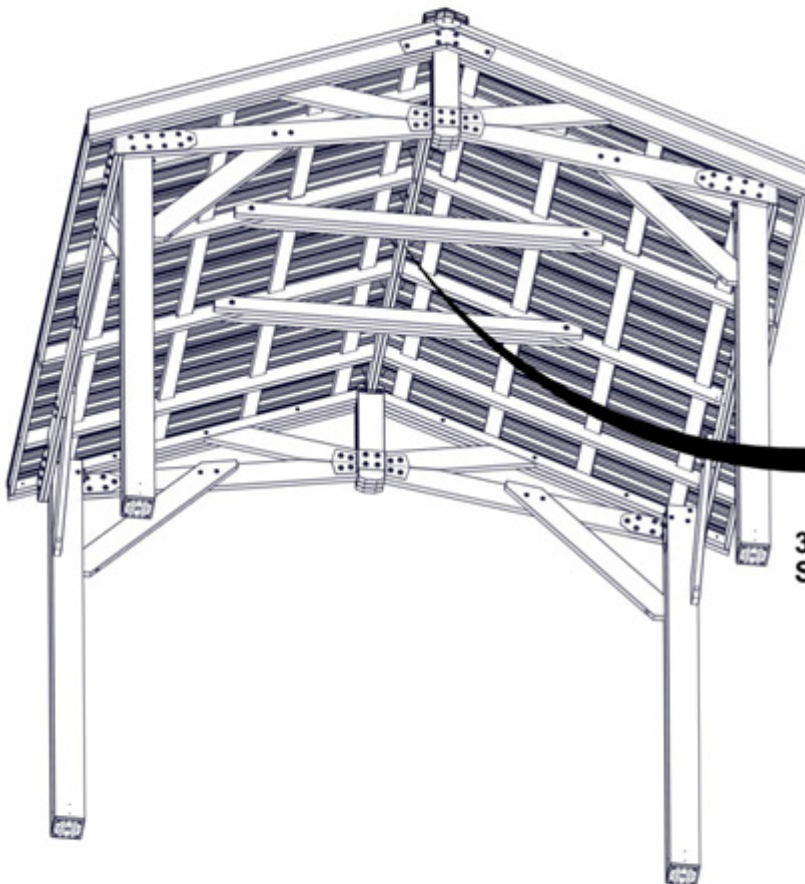

392 (x16)
SCREW - 3/4"

STEP 38 - GAZEBO ASSEMBLY (OPTIONAL)

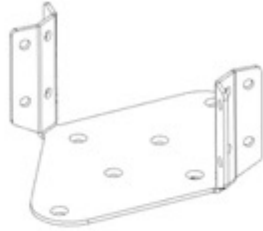

QTY	PART NUMBER	DESCRIPTION
4	H100385	SCREW PFH 8x1 BLK

A4M02501 FAN MOUNT BRACKET
(x1)

- ATTACH YOUR ELECTRICAL BOX (SOLD SEPARATELY) WITH THE PROVIDED HOLES IN FAN MOUNT BRACKET.
- PLACE FAN MOUNT BRACKET ON RIDGE BEAMS AND MOVE TO DESIRED FAN LOCATION.
- ROTATE BRACKET UNTIL MOUNTING FLANGES ALIGN BEST WITH RIDGE BEAMS.
- USE AN 1/8" (3mm) DRILL BIT AND DRILL PILOT HOLES AND ATTACH AS SHOWN.

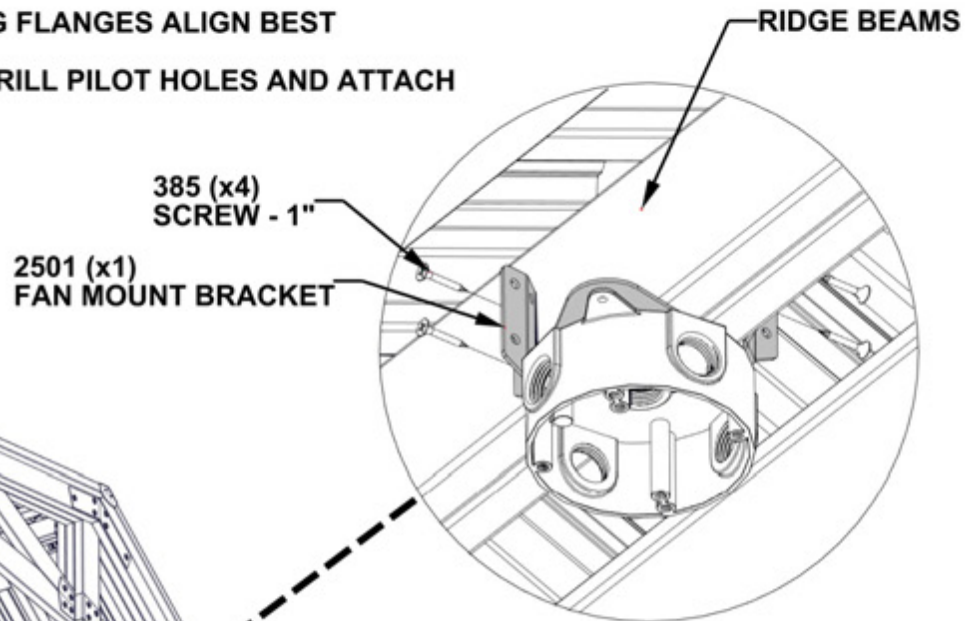

385 (x4)
SCREW - 1"
2501 (x1)
FAN MOUNT BRACKET

HARDWARE
NOT INCLUDED

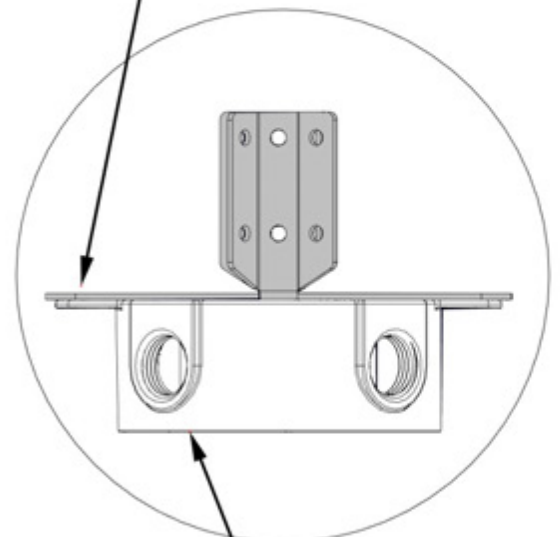

ELECTRICAL BOX
NOT INCLUDED

STEP 39 - GAZEBO ASSEMBLY

QTY	PART NUMBER	DESCRIPTION
32	H100471	LAG SCREW WH 5/16x1 1/2 BLK



A4M00978 POST PLATE
(x8)



A4M00977 POST ANCHORING PLATE
(x8)

- USE PILOT HOLES IN POST TO INSTALL LAG SCREWS

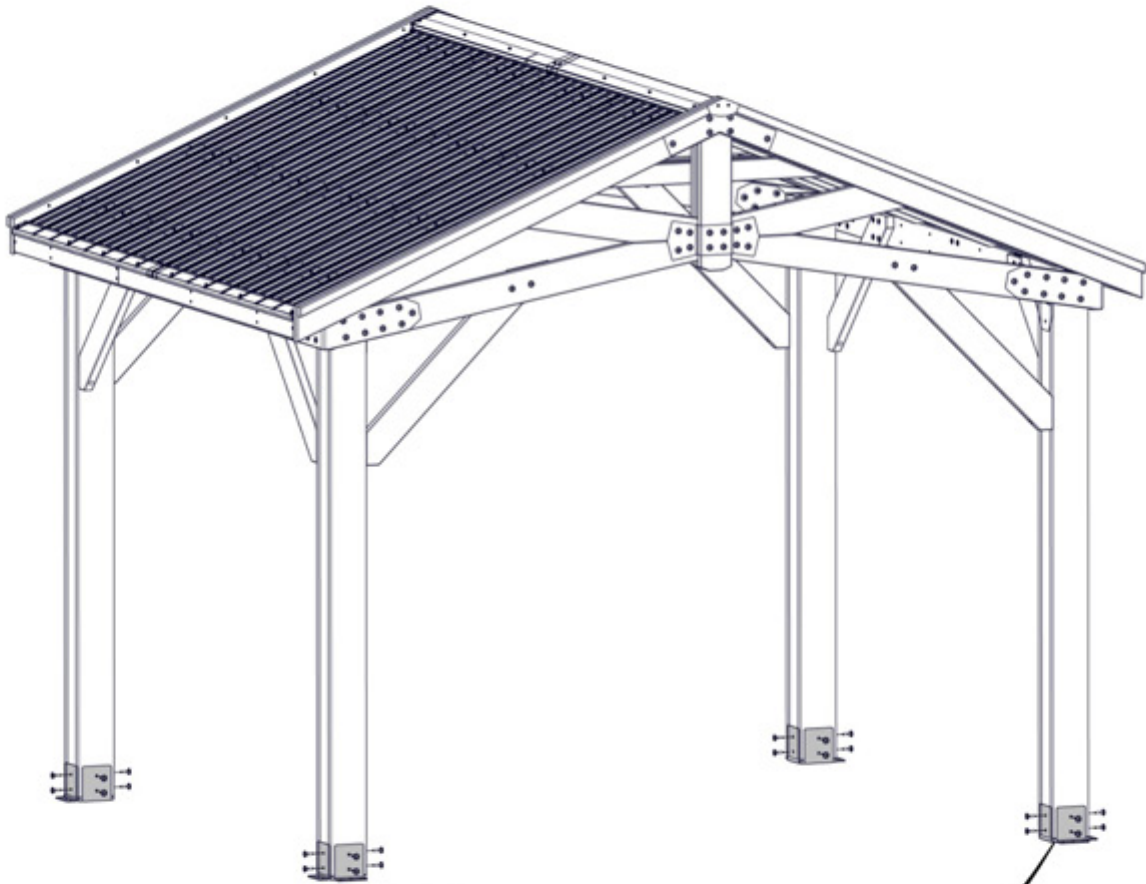

471 (x32)
LAG SCREW - 1 1/2"

978 (x8)
POST PLATE

977 (x8)
POST ANCHORING
PLATE

STEP 40 - GAZEBO ASSEMBLY

QTY	PART NUMBER	DESCRIPTION
4	H100202	SCREW PWH 8x5/8 BLK



A4M02158 BYD ID TAG PATIO
(x1)

- PLACE ID TAG IN APPROXIMATE LOCATION SHOWN.

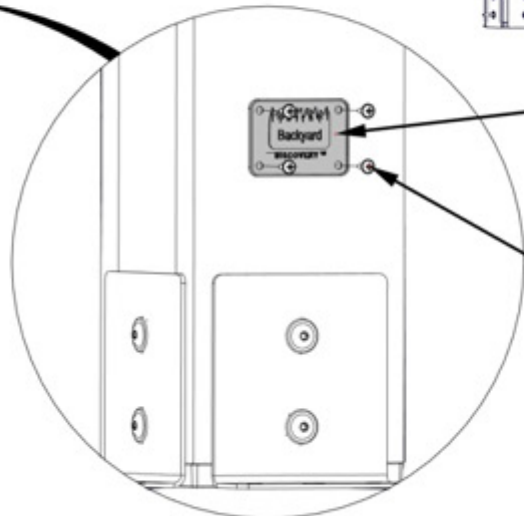
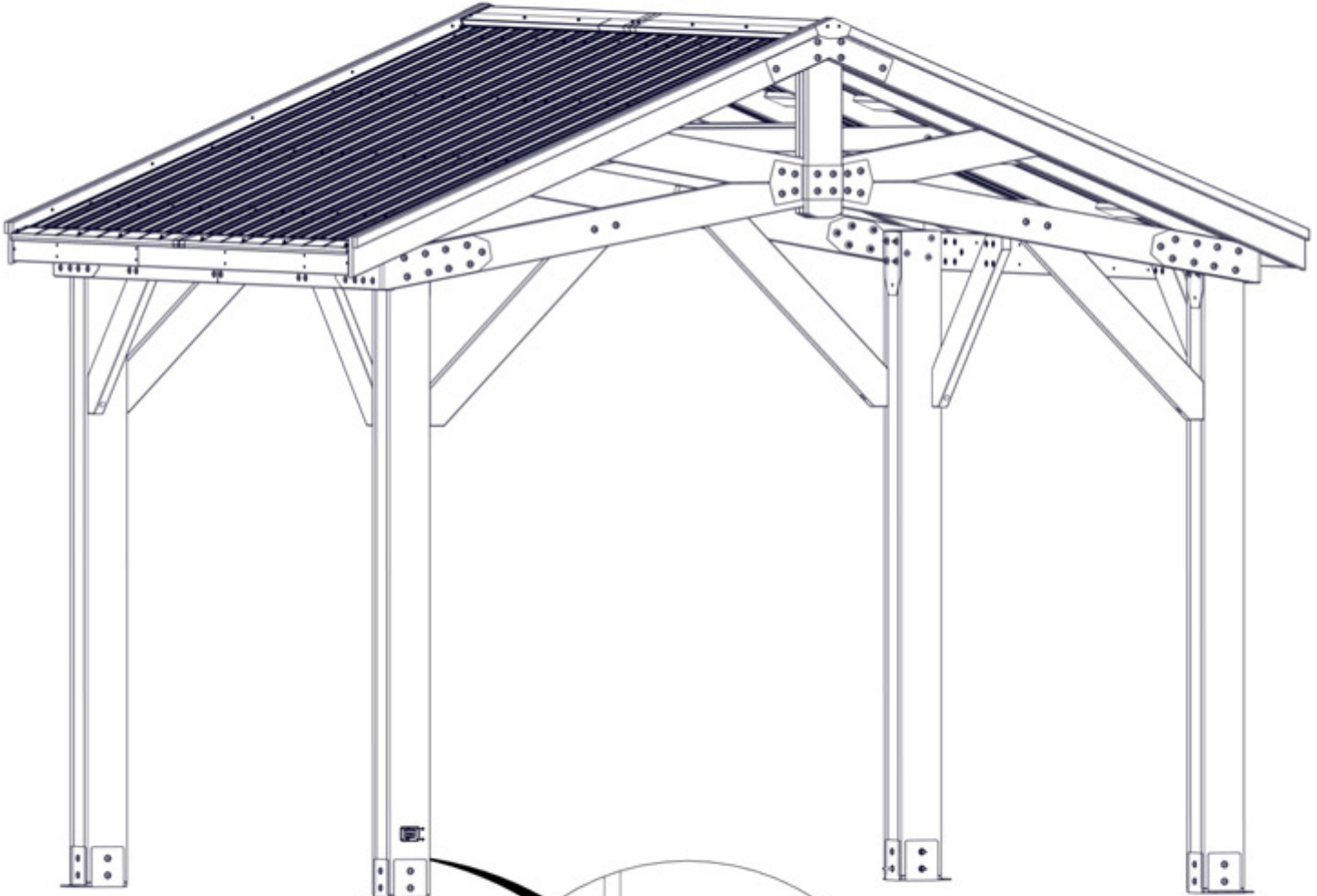

2158 (x1)
BYD ID TAG PATIO

202 (x4)
SCREW - 5/8"

STEP 41 - GAZEBO ASSEMBLY

QTY	PART NUMBER	DESCRIPTION
16	H100120	CONCRETE ANCHOR 1/4"x2"
16	H100630	WASHER FLAT 8x19 BLK

- MANUFACTURER RECOMMENDS INSTALLATION ON CONCRETE SURFACE OR CONCRETE POST PAD AS SHOWN BELOW.
- FOR INSTALLATION ON WOOD DECK, YOU MUST ENSURE THERE IS AMPLE STRUCTURAL SUPPORT UNDER THE DECK. HARDWARE NOT INCLUDED FOR DECK ATTACHMENT.

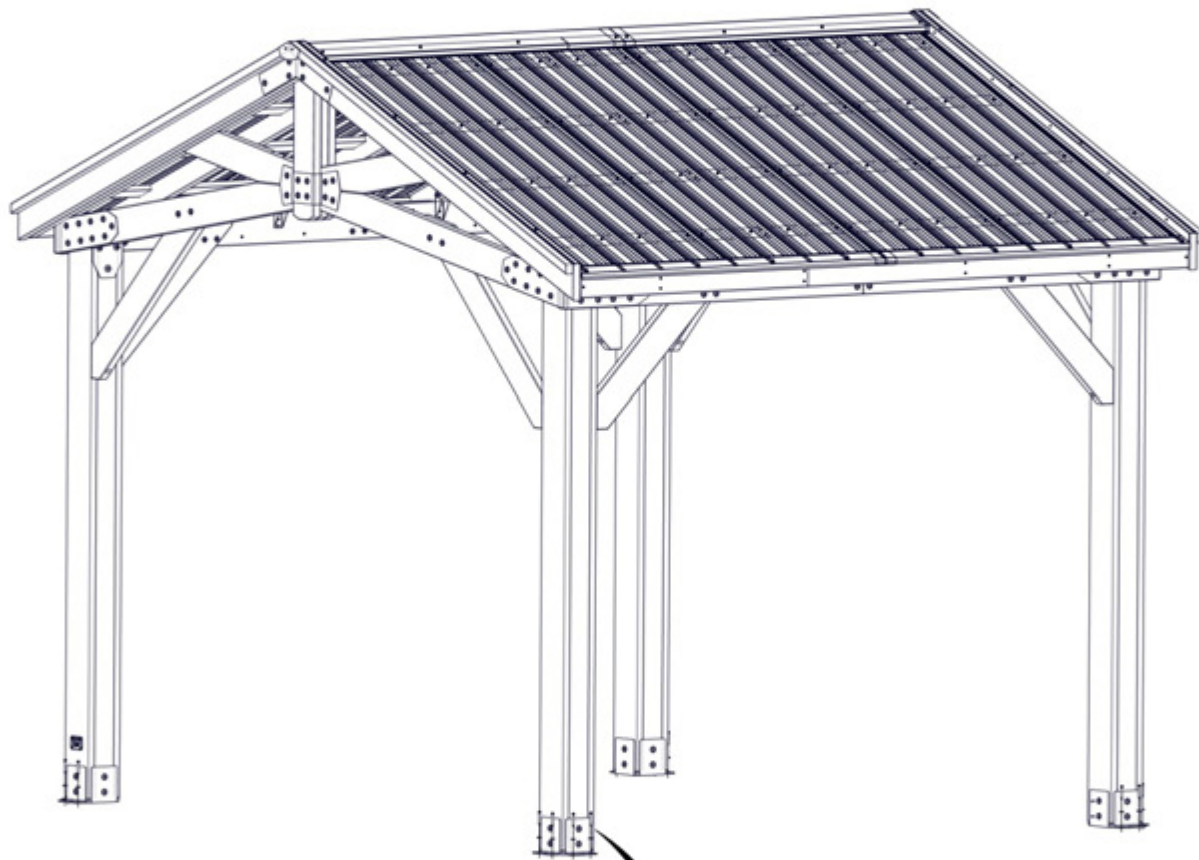

120 (x16)
CONCRETE SCREW - 2"

630 (x24)
WASHER - 8x19

PRE-DRILL HOLES FOR CONCRETE
ANCHORS USING A 3/16"
CONCRETE DRILL BIT

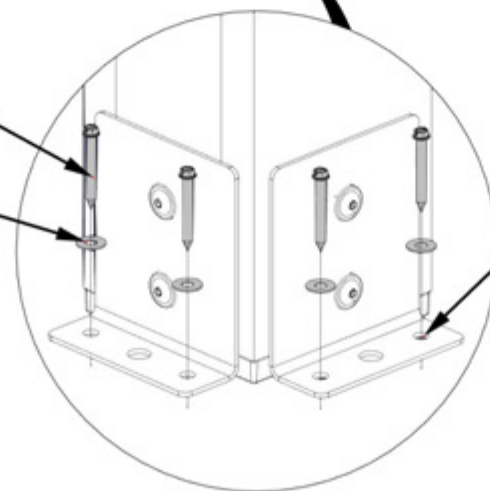

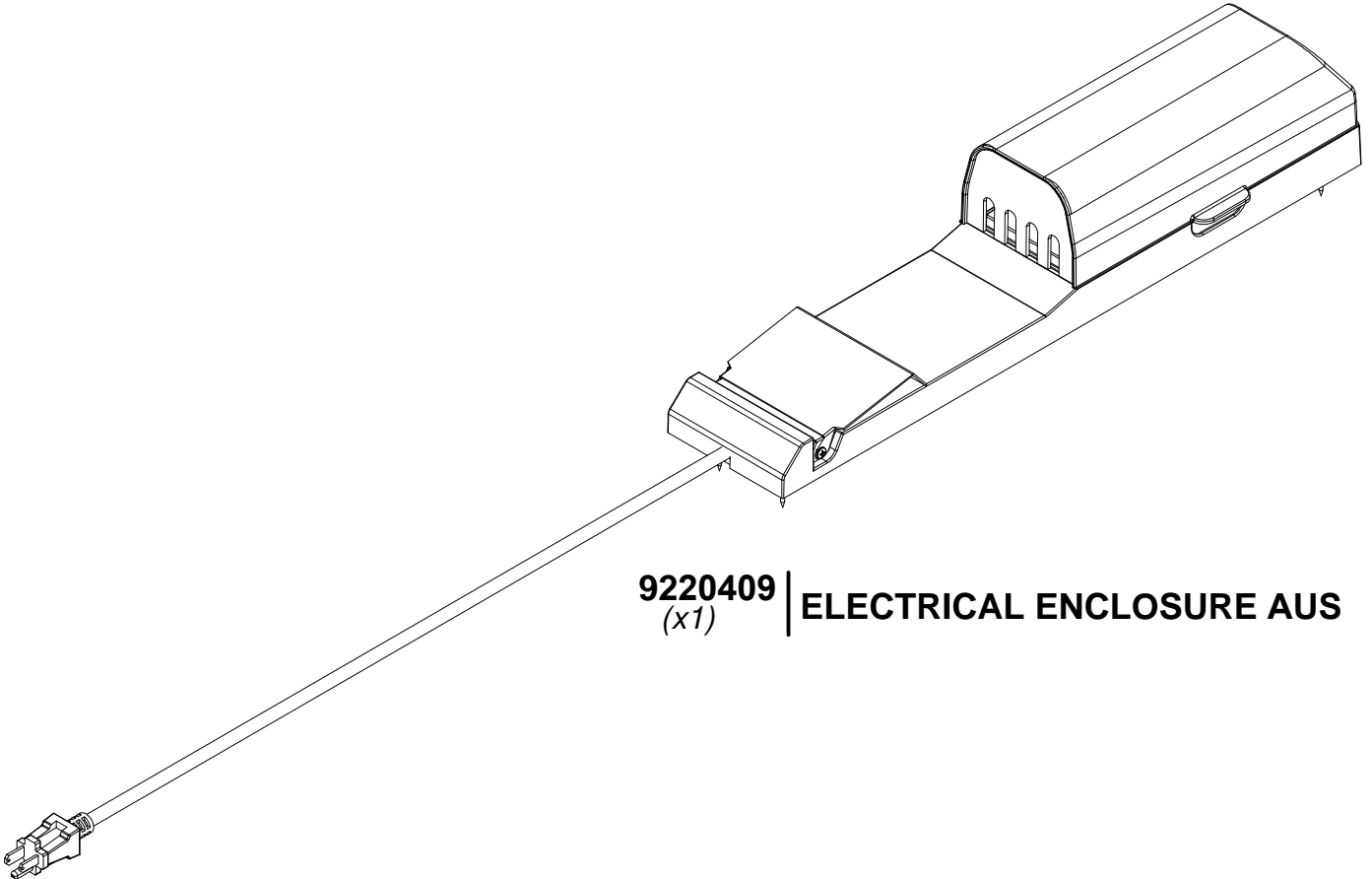

9220409 | **ELECTRICAL ENCLOSURE AUS**
(x1)

FOR POWERPORT INSTALLATION REFER TO ASSEMBLY INSTRUCTIONS THAT COME PACKAGED WITH THE POWERPORT KIT. INSTALL ON ANY POST THAT IS DESIRED. FOLLOW DIRECTIONS FOR PROPER INSTALLATION.