



Manufactured by:
 Backyard Discovery
 3305 Airport Drive, Pittsburg, KS 66762
 800-856-4445

Basepoint Business Centre: Rivermead Drive, Westlea, Swindon SN5 7EX Phone: 0800-118-2476
 J.P. Coenstraat 7, The Bridge, The Hague, 2595 WP, Netherlands Phone: 08005678990

14' 12" 5 f WUXJU Gazebo

MODEL # : 2406063



Please visit www.backyarddiscovery.com
 For the most up to date assembly manual, to register your product, or to order replacement parts *Para obtener instrucciones en español, visite* www.backyarddiscovery.com



EASY STEP-BY-STEP
 3D INTERACTIVE INSTRUCTIONS
 DOWNLOAD THE FREE APP



OWNER'S MANUAL - BASIC SETUP DIMENSIONS & ASSEMBLY NOTES

It is critically important that you start with square and level footings or concrete pad to attach your structure

- Pay close attention to the items needed for each step. Make sure you are using the correct hardware for each step. Using incorrect hardware may result in improper assembly
- Remember to double check for underground utilities and overhead electrical lines

Post mounts are provided with your structure which allows you to permanently install your structure to a pre-existing or new wood or concrete surface. See Anchor Instructions for further details and recommendations.

- The hardware to attach the post mounts to the structure is included.
- The hardware to mount the structure permanently to a concrete surface is included.
- The hardware to mount the structure permanently to a wood deck is NOT included and will need to be purchased separately. You must ensure there is ample structural support under the deck before permanently attaching.

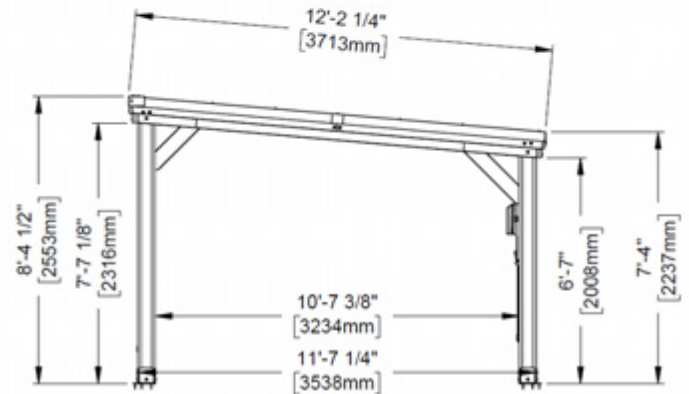
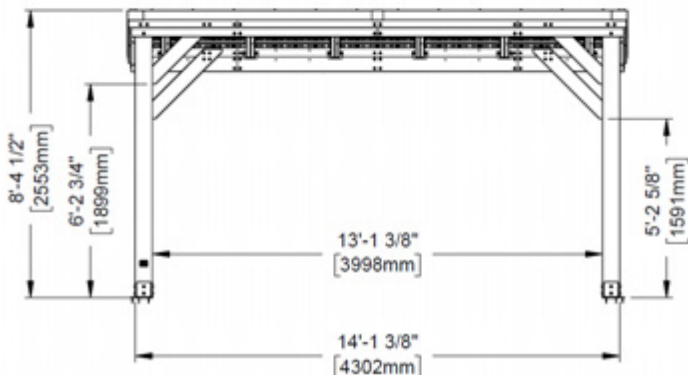
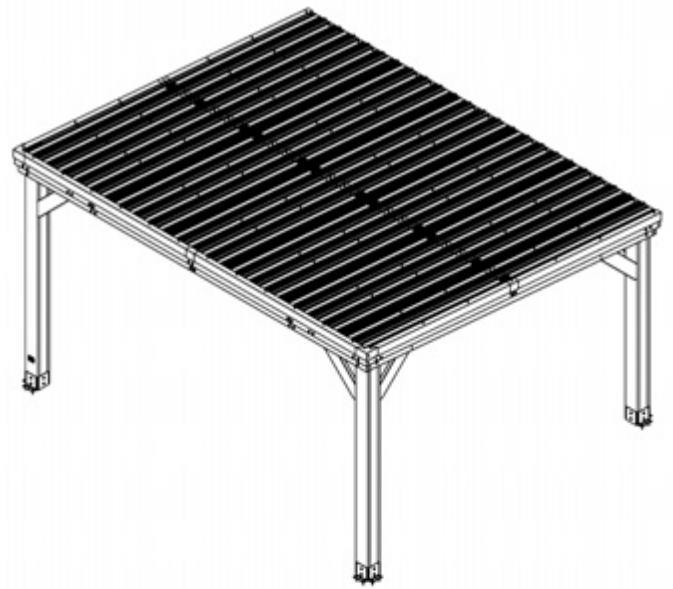
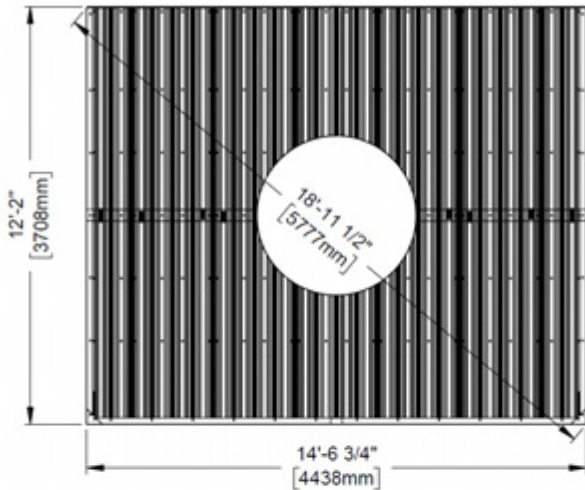

OWNER'S MANUAL - ANCHORING LAYOUT

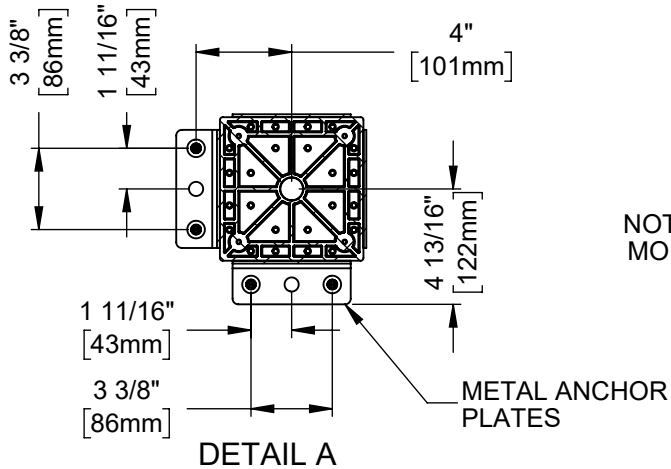
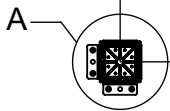
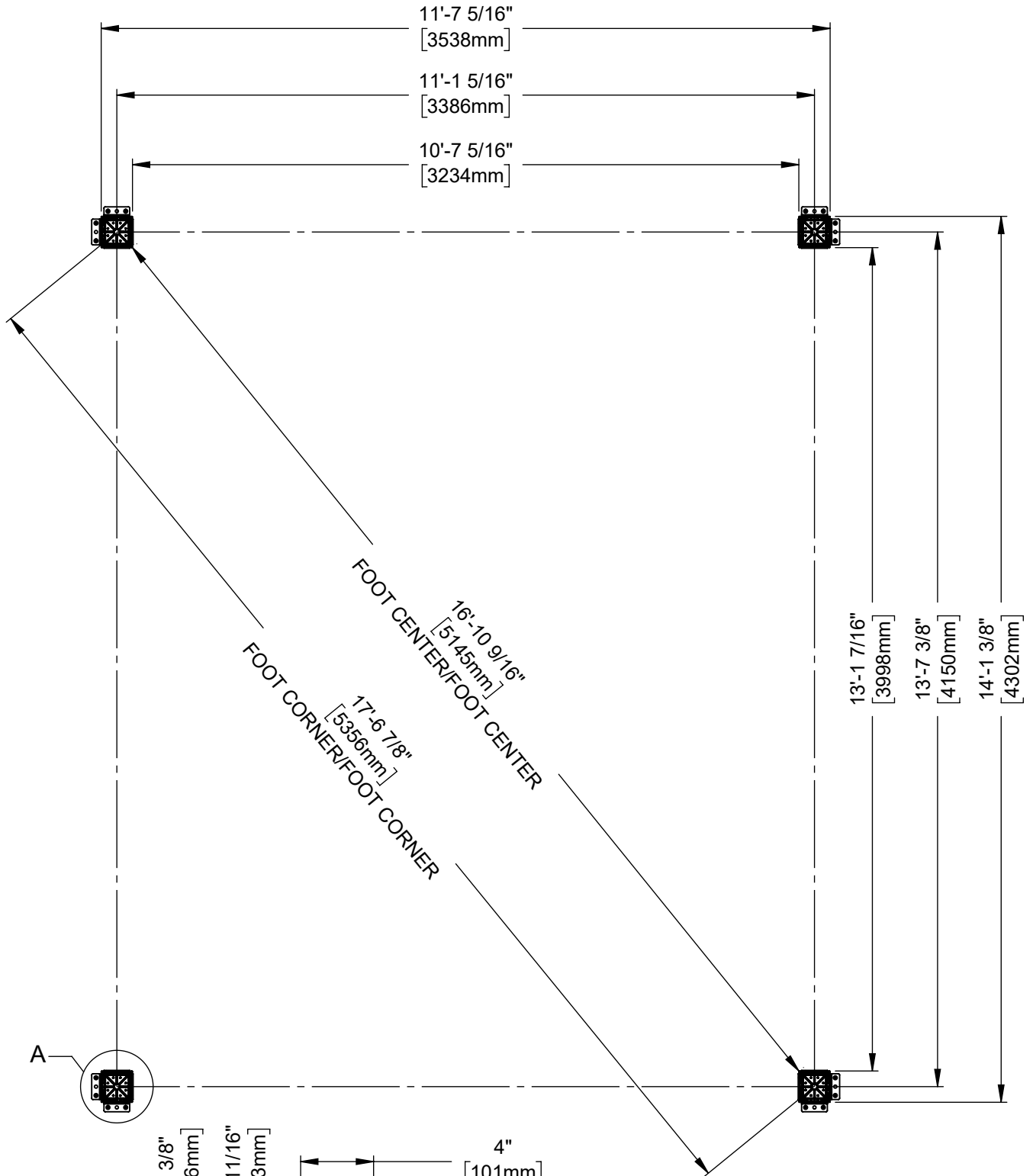

NOTE: DIMENSIONS ARE TO ANCHOR PLATES MOUNTED TO POST EXCEPT WHERE NOTED.

OWNER'S MANUAL - PARTS IDENTIFICATION

WOOD COMPONENTS (NOT TO SCALE)



D01 CORBEL - W4L20742
(x3) 1 7/16"x5 1/4"x34 7/16" (36x134x874)



D03 CORBEL - W4L20024
(x2) 1 3/8"x5 1/4"x27 1/4" (36x134x692)



D04 CORBEL - W4L19947
(x2) 1 3/8"x5 1/4"x33 1/2" (36x134x850)



E01 RAFTER - W4L19946
(x6) 1 7/16"x3 3/8"x85 5/8" (36x86x2176)



E02 RAFTER - W4L19992
(x6) 1 7/16"x3 3/8"x54 3/8" (36x86x1380)



E03 RAFTER - W4L19993
(x6) 1 7/16"x3 3/8"x85 5/8" (36x86x2176)



E04 RAFTER - W4L19994
(x6) 1 7/16"x3 3/8"x54 3/8" (36x86x1380)



G01 FASCIA - W4L20732
(x2) 15/16"x5 1/4"x72 5/16" (24x134x1837)



G02 FASCIA - W4L20733
(x2) 15/16"x5 1/4"x72 5/16" (24x134x1837)



G03 FASCIA - W4L20734
(x2) 15/16"x5 1/4"x38 1/16" (24x134x967)



G04 FASCIA - W4L20735
(x1) 15/16"x5 1/4"x98" (24x134x2489)



G05 FASCIA - W4L20736
(x2) 15/16"x5 1/4"x38 1/16" (24x134x967)

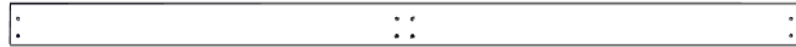

G06 FASCIA - W4L20739
(x1) 15/16"x5 1/4"x98" (24x134x2489)



H01 PURLIN - W4L20227
(x5) 15/16"x3 3/8"x71 3/16" (24x86x1809)



H02 PURLIN - W4L20125
(x5) 15/16"x3 3/8"x100 13/16" (24x86x2561)



J17 CLEAT - W4L20022
(x2) 15/16"x2 3/8"x68 1/2" (24x60x1740)



J18 CLEAT - W4L20119
(x2) 15/16"x2 3/8"x59" (24x60x1498)

OWNER'S MANUAL - PARTS IDENTIFICATION

WOOD COMPONENTS (NOT TO SCALE)



J01 JOIST END ASSEMBLY - W2A04462
(x2) 15/16"x8 7/16"x37 1/8" (24x214x943)



J06 JOIST END ASSEMBLY - W2A04464
(x2) 15/16"x8 7/16"x37 1/8" (24x214x943)

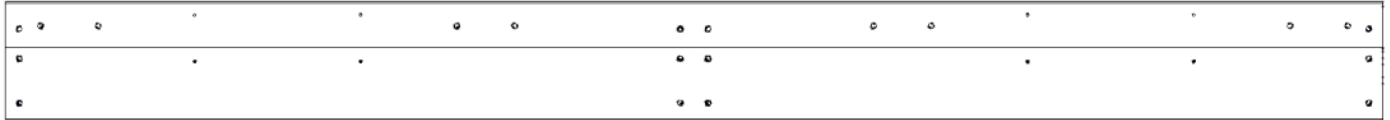

J02 JOIST CENTER ASSEMBLY - W2A04466
(x1) 15/16"x8 7/16"x8'-2" (24x214x2489)



J05 JOIST ASSEMBLY - W2A04467
(x2) 15/16"x8 7/16"x7'-2 1/8" (24x214x2187)



J07 JOIST CENTER ASSEMBLY - W2A04468
(x1) 15/16"x8 7/16"x8'-2" (24x214x2489)

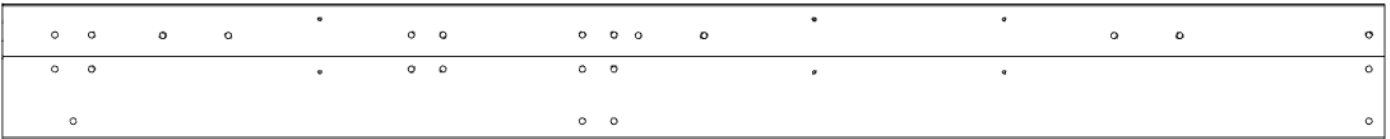

J08 JOIST ASSEMBLY - W2A04469
(x2) 15/16"x8 7/16"x7'-2 1/8" (24x214x2187)

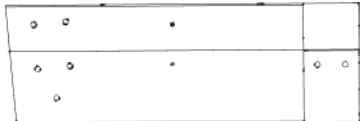

J11 JOIST ASSEMBLY - W2A04305
(x1) 1 7/16"x8 7/16"x25" (36x214x635)

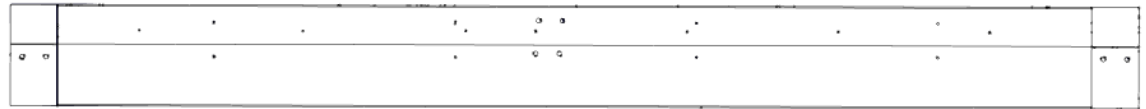

J13 JOIST ASSEMBLY - W2A04320
(x1) 1 7/16"x8 7/16"x93 7/8" (36x214x2385)

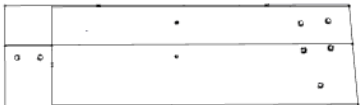

J12 JOIST ASSEMBLY - W2A04321
(x1) 1 7/16"x8 7/16"x29 1/2" (36x214x750)

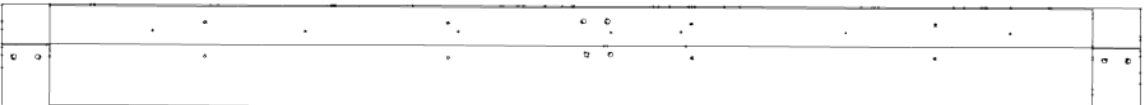

J15 JOIST ASSEMBLY - W2A04323
(x1) 1 7/16"x8 7/16"x93 7/8" (36x214x2385)

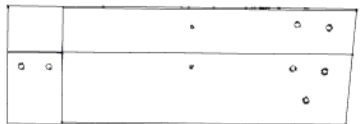

J14 JOIST ASSEMBLY - W2A04322
(x1) 1 7/16"x8 7/16"x25" (36x214x635)



P01 POST - W2A03634
(x1) 6"x6"x98 1/2" (152x152x2502)



P02 POST - W2A04315
(x1) 6"x6"x86 11/16" (152x152x2202)

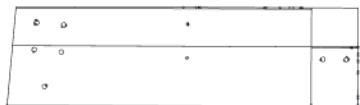

J16 JOIST ASSEMBLY - W2A04304
(x1) 1 7/16"x8 7/16"x29 1/2" (36x214x750)



P03 POST - W2A03635
(x1) 6"x6"x98 1/2" (152x152x2502)



D02 CORBEL - W2A04473
(x1) 1 7/16"x5 1/4"x34 7/16" (36x134x874)



P04 POST - W2A04316
(x1) 6"x6"x86 11/16" (152x152x2202)

OWNER'S MANUAL - PARTS IDENTIFICATION

ACCESSORY COMPONENTS (NOT TO SCALE)

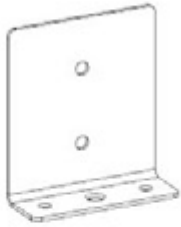

A4M00977 POST ANCHORING PLATE WITH FLANGE (x8)

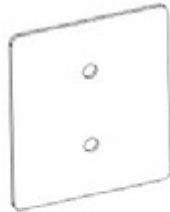

A4M00978 POST PLATE (x8)



A4M02158 BYD ID TAG PATIO (x1)

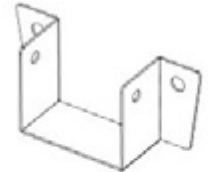

A4M02764 RAFTER BRACKET (x12)

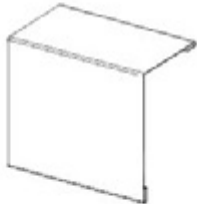

A4M02734 TRIM SPLICE (x3)

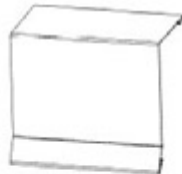

A4M02794 DRIP EDGE TRIM (x1)

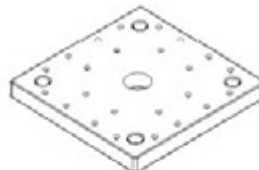

A6P00308 6x6 POST FOOT (x4)



A6P00556 WEATHER TAPE (x1)



9205413 ELECTRICAL ENCLOSURE (x1)



A4M03430 RAFTER BRACE (x6)

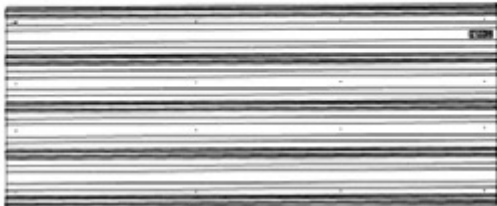

A4M04047 29GA SHEETING (x10)



A4M04065 29GA SHEETING (x2)

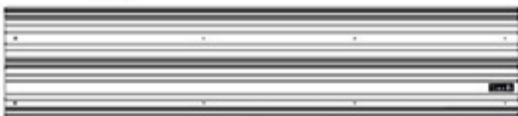

A4M04046 29GA SHEETING (x2)

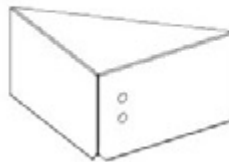

A4M02736 CORNER SPLICE TRIM LH (x1)



A4M02735 CORNER SPLICE TRIM RH (x1)

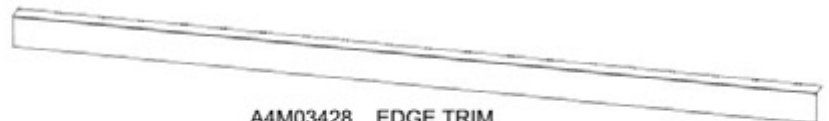

A4M03428 EDGE TRIM (x2)



A4M03429 DRIP EDGE TRIM (x2)

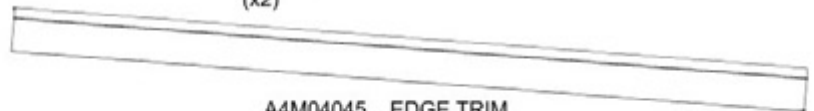

A4M04045 EDGE TRIM (x4)



A4M04044 FRONT BEAM METAL BRACKET (x1)



A4M04060 BACK BEAM METAL BRACKET (x1)

OWNER'S MANUAL - PARTS IDENTIFICATION

HARDWARE COMPONENTS

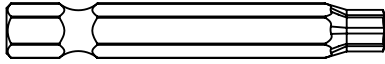

H100147 | TORX BIT
(x1) | T-30

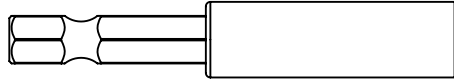

H101100 | MAGNETIC DRIVER
(x1)

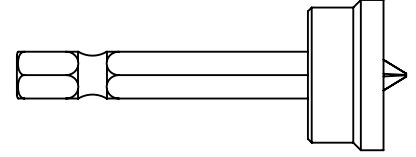

H100764 | SCREW SETTER
(x1)

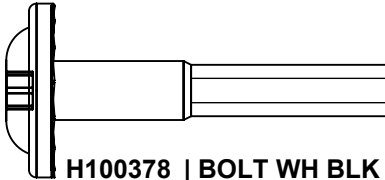

H100378 | BOLT WH BLK
(x12) | 5/16 x 1 3/4

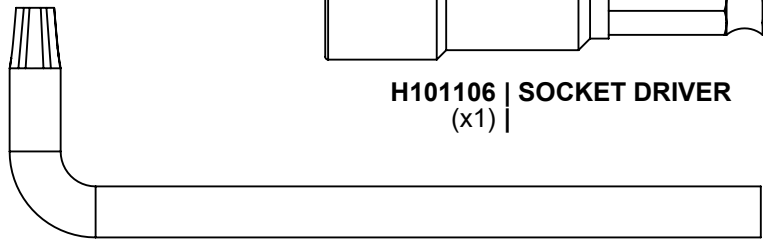

H100114 | TORX WRENCH
(x1) | T-30

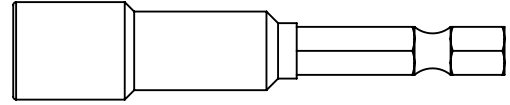

H101106 | SOCKET DRIVER
(x1)

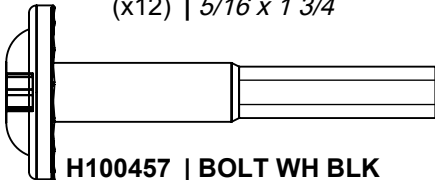

H100457 | BOLT WH BLK
(x24) | 5/16 x 2

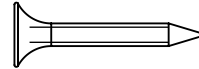

H100385 | SCREW PFH BLK
(x24) | 8 x 1

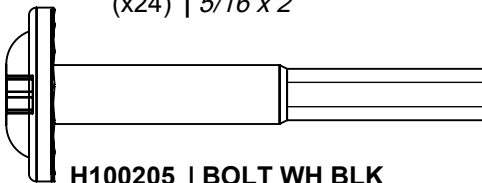

H100205 | BOLT WH BLK
(x8) | 5/16 x 2 1/4

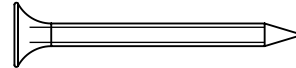

H100200 | SCREW PFH BLK
(x16) | 8 x 1 1/2

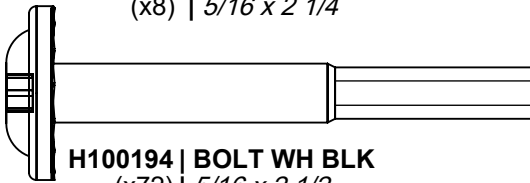

H100194 | BOLT WH BLK
(x72) | 5/16 x 2 1/2

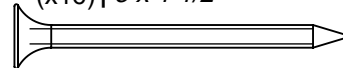

H100382 | SCREW PFH BLK
(x80) | 8 x 1 3/4

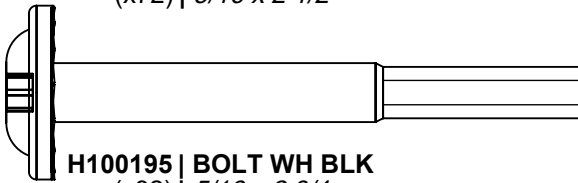

H100195 | BOLT WH BLK
(x32) | 5/16 x 2 3/4

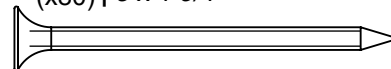

H100391 | SCREW PFH BLK
(x46) | 8 x 2

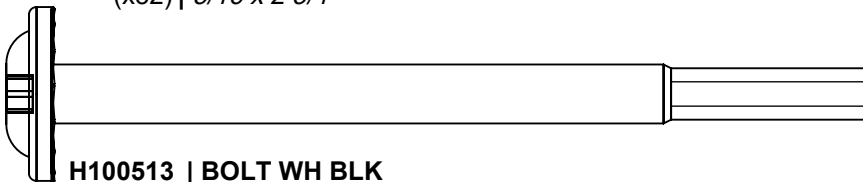

H100513 | BOLT WH BLK
(x8) | 5/16 x 4 1/4

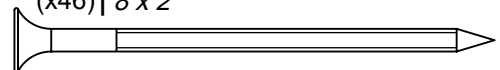

H100201 | SCREW PFH BLK
(x192) | 8 x 2 1/2

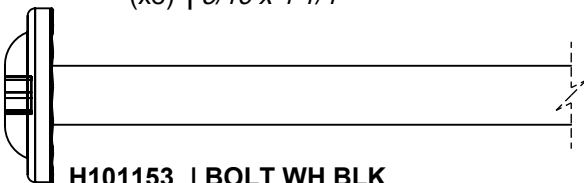

H101153 | BOLT WH BLK
(x16) | 5/16 x 8 1/4

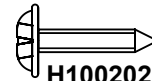

H100202 | SCREW PWH BLK
(x4) | 8 x 5/8

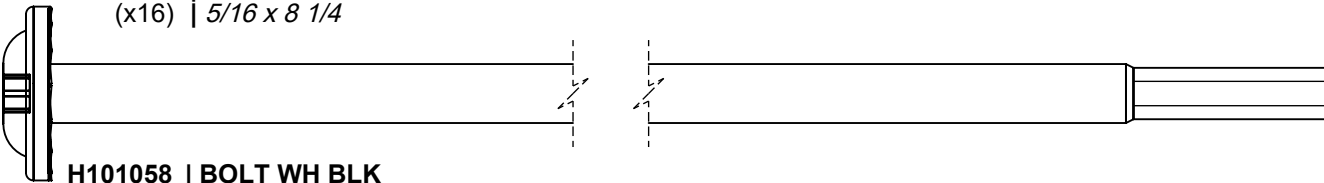

H101058 | BOLT WH BLK
(x16) | 5/16 x 8 3/4

OWER'S MANUAL - PARTS IDENTIFICATION

HARDWARE COMPONENTS

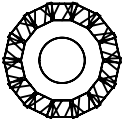

H100405 | WASHER LOCK EXT BLK
(x8) | 6 x 15

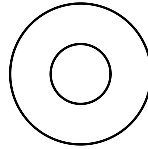

H100630 | WASHER FLAT BLK
(x28) | 8 x 19



H100653 | NUT LOCK BLK
(x12) | 1/4

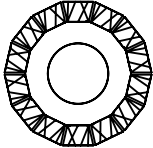

H100198 | WASHER LOCK EXT BLK
(x180) | 8 x 19

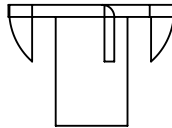

H100379 | T-NUT BLK
(x124) | 5/16

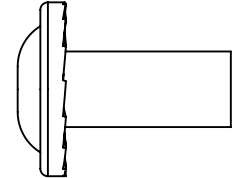

H100192 | BARREL NUT WH
(x72) | 5/16 X 7/8

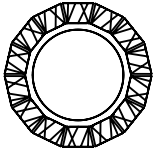

H100199 | WASHER LOCK EXT BLK
(x72) | 12 x 19

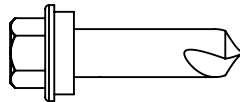

H101116 | SCREW TAPPING
(x28) | 1/4 x 1

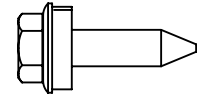

H101117 | SCREW WOODGRIP
(x168) | 10 - 16 x 3/4

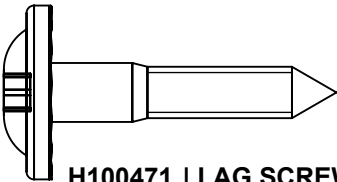

H100471 | LAG SCREW WH BLK
(x32) | 5/16 x 1 1/2

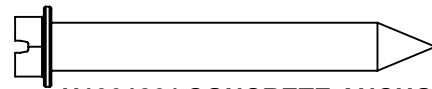

H100120 | CONCRETE ANCHOR
(x16) | 1/4 x 2

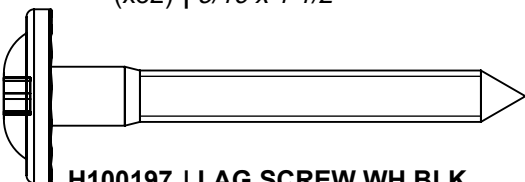

H100197 | LAG SCREW WH BLK
(x4) | 5/16 x 2 1/2

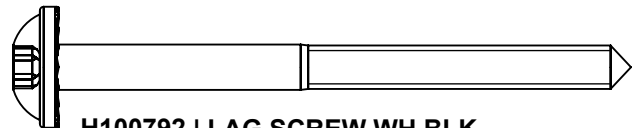

H100792 | LAG SCREW WH BLK
(x8) | 1/4 x 3

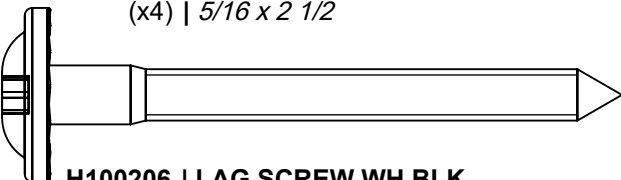

H100206 | LAG SCREW WH BLK
(x4) | 5/16 x 3



H101127 | BOLT WH BLK
(x12) | 1/4 x 3 1/2

PRE-ASSEMBLY STEP 1 - SORTING PARTS

It is critical for ease of assembly that you take the time to sort and organize the wood and hardware.

WOOD PARTS:

- Organize wood parts by the three-digit, alpha-numeric number stamped on each board (ex. P01).
- If there are multiple boards with the same stamped number, stack those pieces together.
- Stamps can be found on the flat surface of the boards or on the end of the boards.
- Allow yourself plenty of room - the wood pieces can take up a significant amount of space.

NOTE: CARTONS ARE NOT ORGANIZED BY BOARD OR STEP NUMBER.



HARDWARE PARTS:

- We recommend that you have a separate table to organize the hardware.
- Hardware bags are printed with a seven-digit, alpha-numeric part number.
- You can organize your hardware by part number or group by hardware type (e.g. bolts, nuts, etc.).
- During assembly you only need to reference the last four digits of the number.

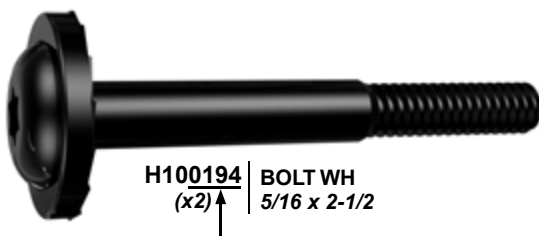

PRE-ASSEMBLY STEP 2 - TOOLS REQUIRED



Cordless Drill or
Electric Drill



Drill Attachments:
Phillips Head



1/8", 3/16", 3/8" &
7/16" Drill Bits



Phillips Screw Driver



Tape Measure



Claw Hammer



Open End
Wrenches 1/2" &
7/16"



3/8" Drive Ratchet, 1/2" &
7/16" STD Sockets, 1/2" &
7/16" Deep Sockets



3/8 & 5/16" Nut Drivers

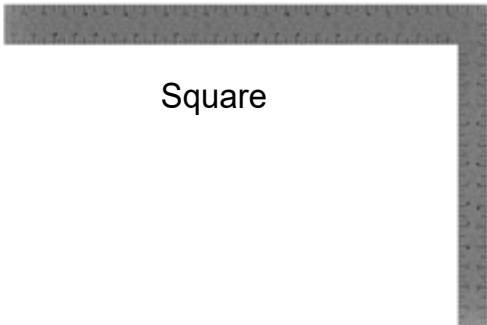

Square



Level 24"



Rubber Mallet -
Optional

PRE-ASSEMBLY STEP 3 - CHOOSE YOUR ASSEMBLY METHOD

There are several types of assembly instructions available to you.

1. Printed Assembly Manual included with your set
2. BILT APP - 3D interactive instructions
3. Combination of the Printed Manual and BILT APP (Note: Step numbers can differ between the two methods)



STEP 1 - LEFT SIDE ASSEMBLY

QTY	PART NUMBER	DESCRIPTION
8	H100200	SCREW PFH 8x1 1/2 BLK



P01 POST - W2A03634
(x1) 6"x6"x98 1/2" (152x152x2502)

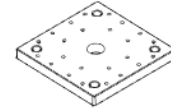

A6P00308 6x6 POST FOOT
(x2)



P02 POST - W2A04315
(x1) 6"x6"x86 11/16" (152x152x2202)

- FOR EASE OF ASSEMBLY, WE RECOMMEND USING SAWHORSES FOR STEPS.

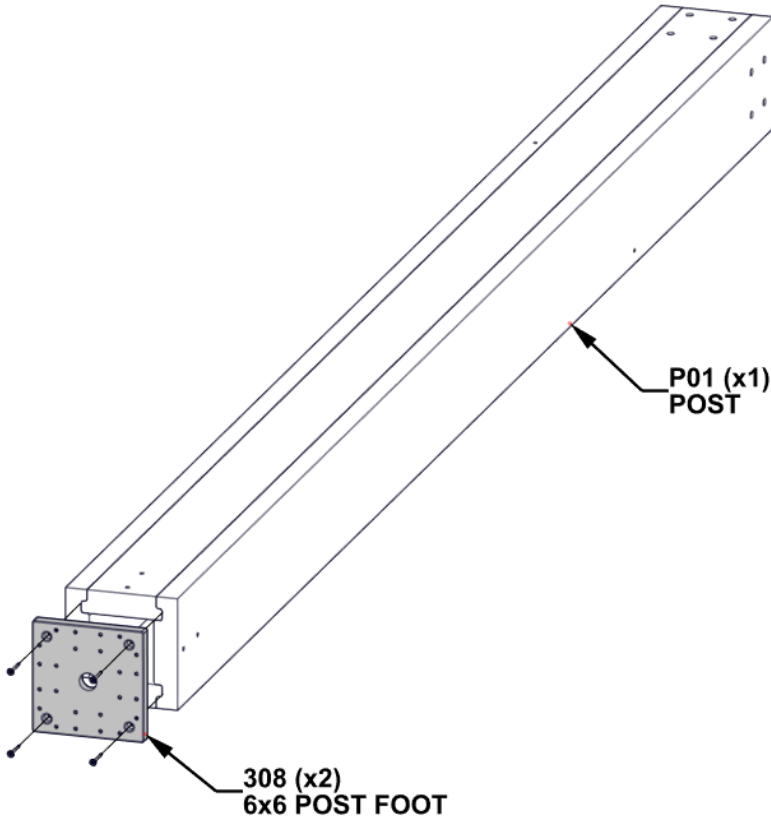

ALIGN POST FOOT AND DRILL 1/8" [3mm] PILOT HOLES FOR THE ATTACHMENT OF HARDWARE.

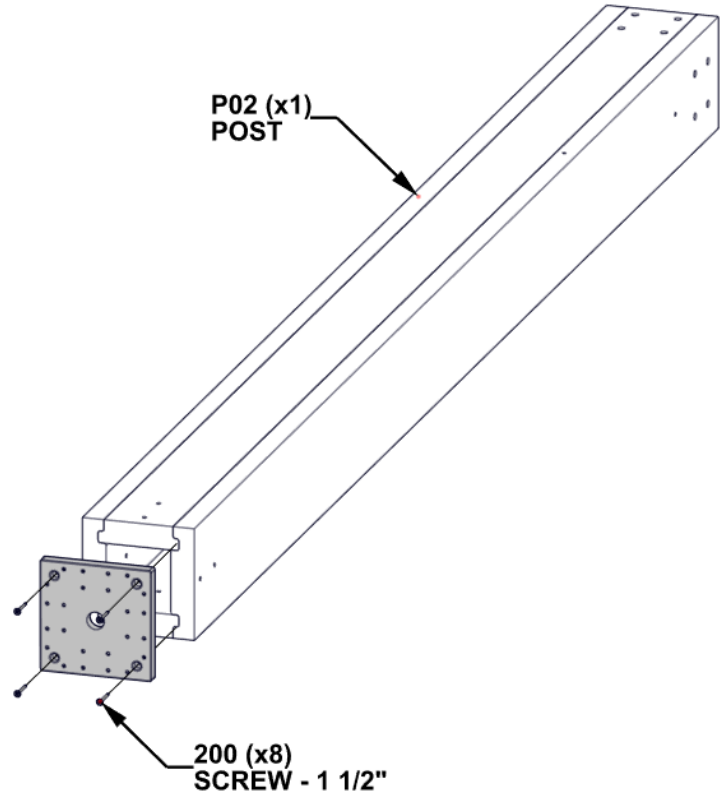

STEP 2A - LEFT SIDE ASSEMBLY

QTY	PART NUMBER	DESCRIPTION
4	H100195	BOLT WH 5/16x2 3/4 BLK
4	H100198	WASHER LOCK EXT 8x19
4	H100379	TNUT-5/16" BLK

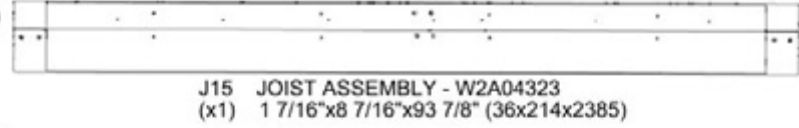
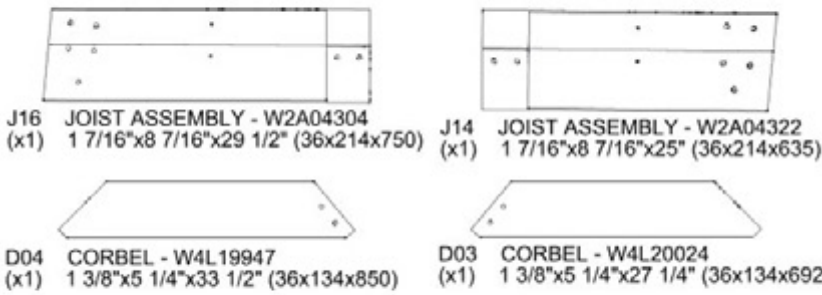

**- INSERT T-NUTS FIRST.
- SQUARE BEFORE TIGHTENING.**

**THROUGH HOLES TOWARDS TOP
FOR CORRECT ORIENTATION**

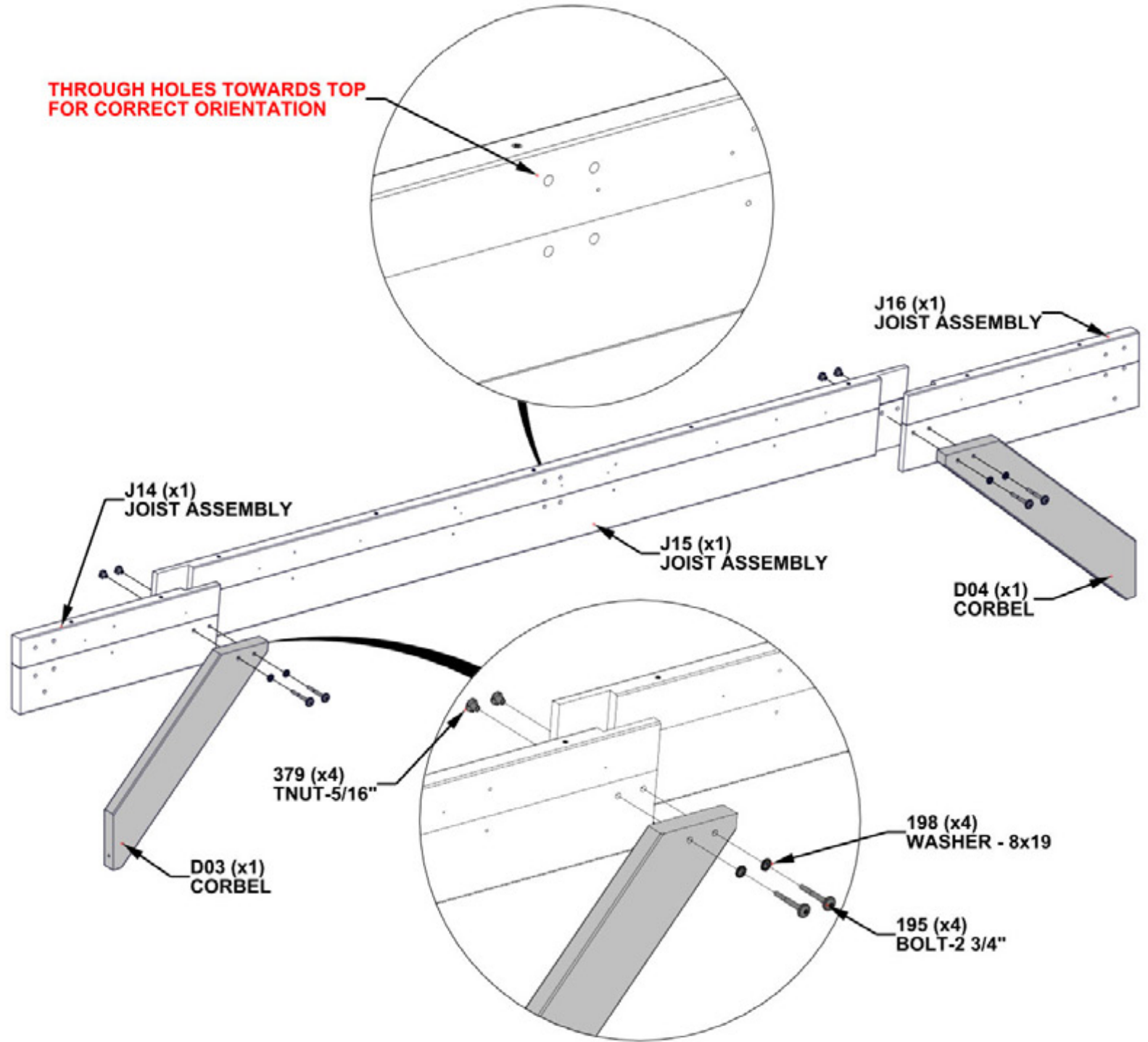

STEP 2B - LEFT SIDE ASSEMBLY

QTY	PART NUMBER	DESCRIPTION
4	H100379	TNUT-5/16" BLK
4	H100205	BOLT WH 5/16x2 1/4 BLK
4	H100198	WASHER LOCK EXT 8x19



G01 FASCIA - W4L20732
(x1) 15/16"x5 1/4"x72 5/16" (24x134x1837)

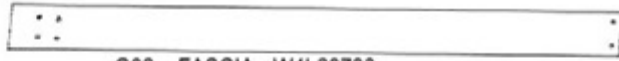

G02 FASCIA - W4L20733
(x1) 15/16"x5 1/4"x72 5/16" (24x134x1837)

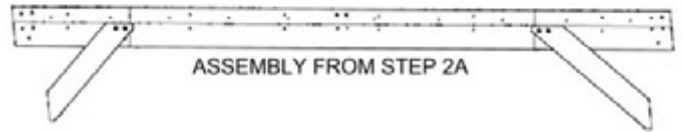

- INSERT T-NUTS FIRST.
- HAND TIGHTEN ONLY.

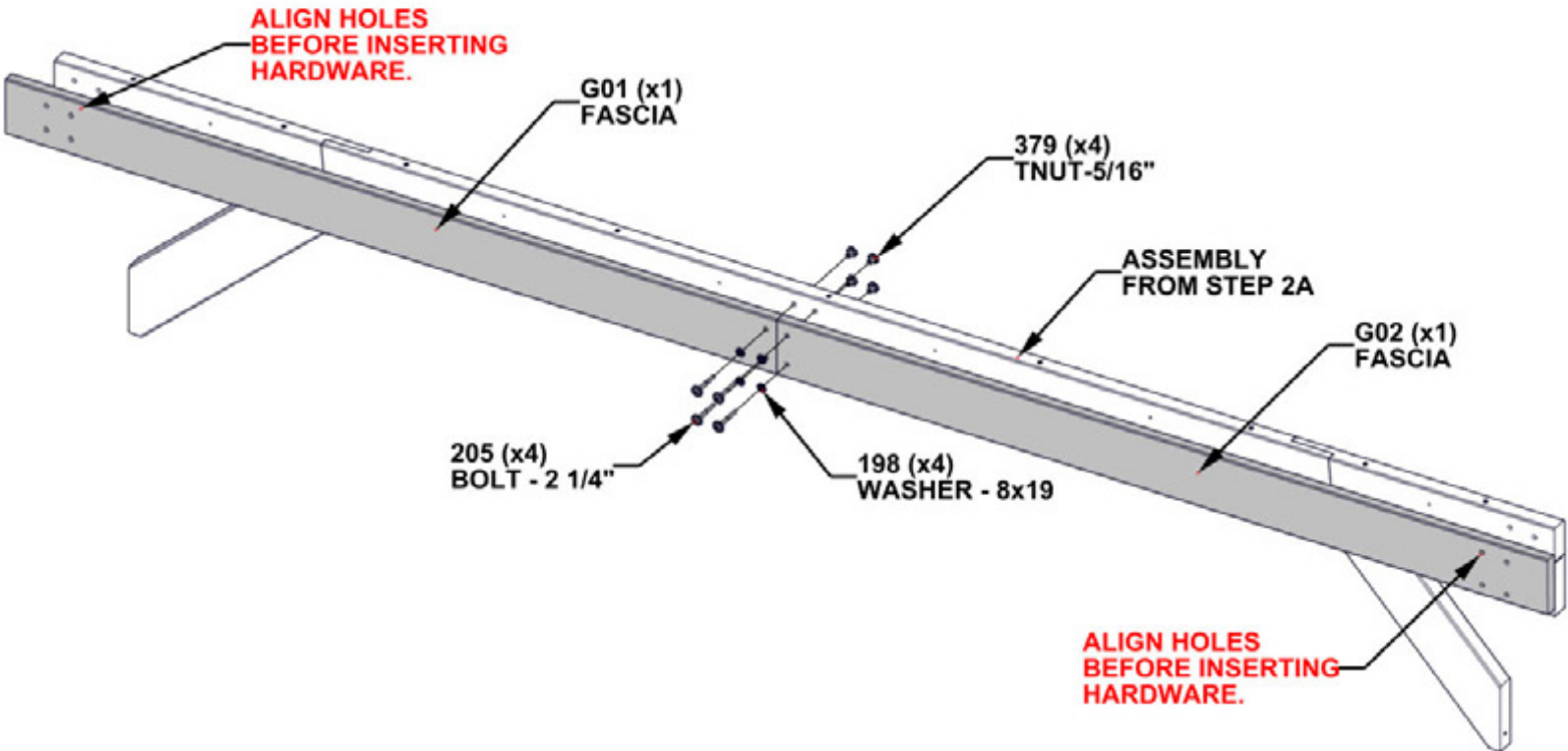

STEP 2C - LEFT SIDE ASSEMBLY

QTY	PART NUMBER	DESCRIPTION
12	H100391	SCREW PFH 8x2 BLK

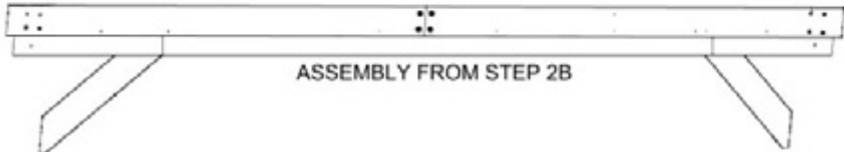

- TIGHTEN ALL HARDWARE.

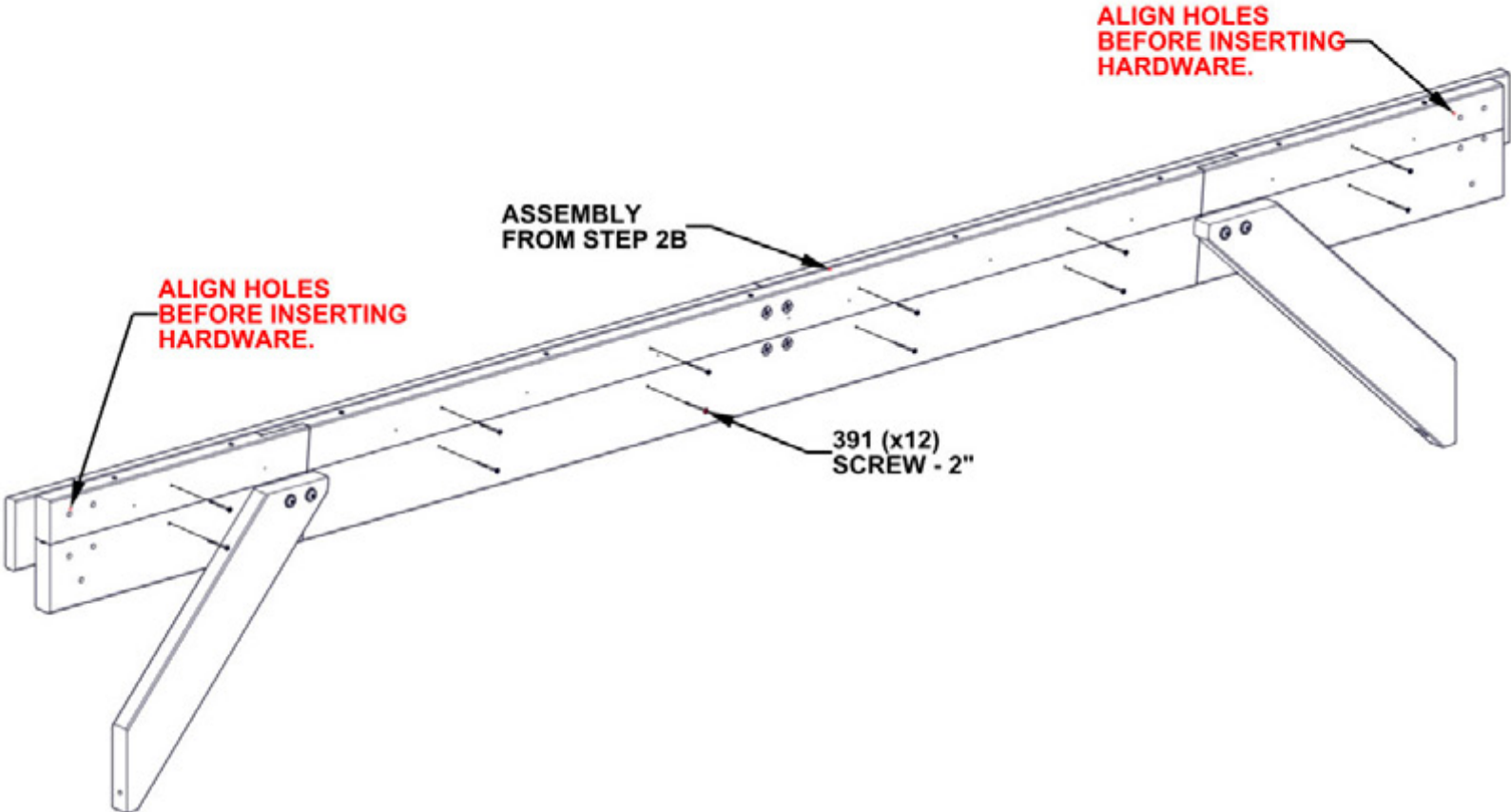

STEP 3 - LEFT SIDE ASSEMBLY

QTY	PART NUMBER	DESCRIPTION
2	H100197	LAG SCREW WH 5/16x2 1/2 BLK
2	H100405	WASHER LOCK EXT 6x15
2	H100792	LAG SCREW WH 1/4x3 BLK
8	H100379	TNUT-5/16" BLK
8	H101153	BOLT WH 5/16x8 1/4 BLK
10	H100198	WASHER LOCK EXT 8x19

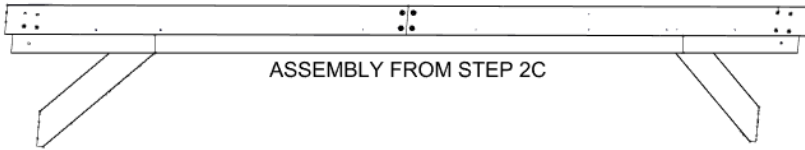

- TO AVOID SPLITTING, MAKE SURE LAG SCREWS GO INTO PILOT HOLES.
- IF BOLT DOES NOT ENGAGE WITH T-NUT, CHECK FOR SAWDUST BUILD UP IN HOLES. CLEAN WITH A LONG SCREWDRIVER IF NEEDED.
- INSERT T-NUTS FIRST.
- SQUARE LEGS BEFORE TIGHTENING BOLTS.
- TIGHTEN CORBELS AT END OF STEP.

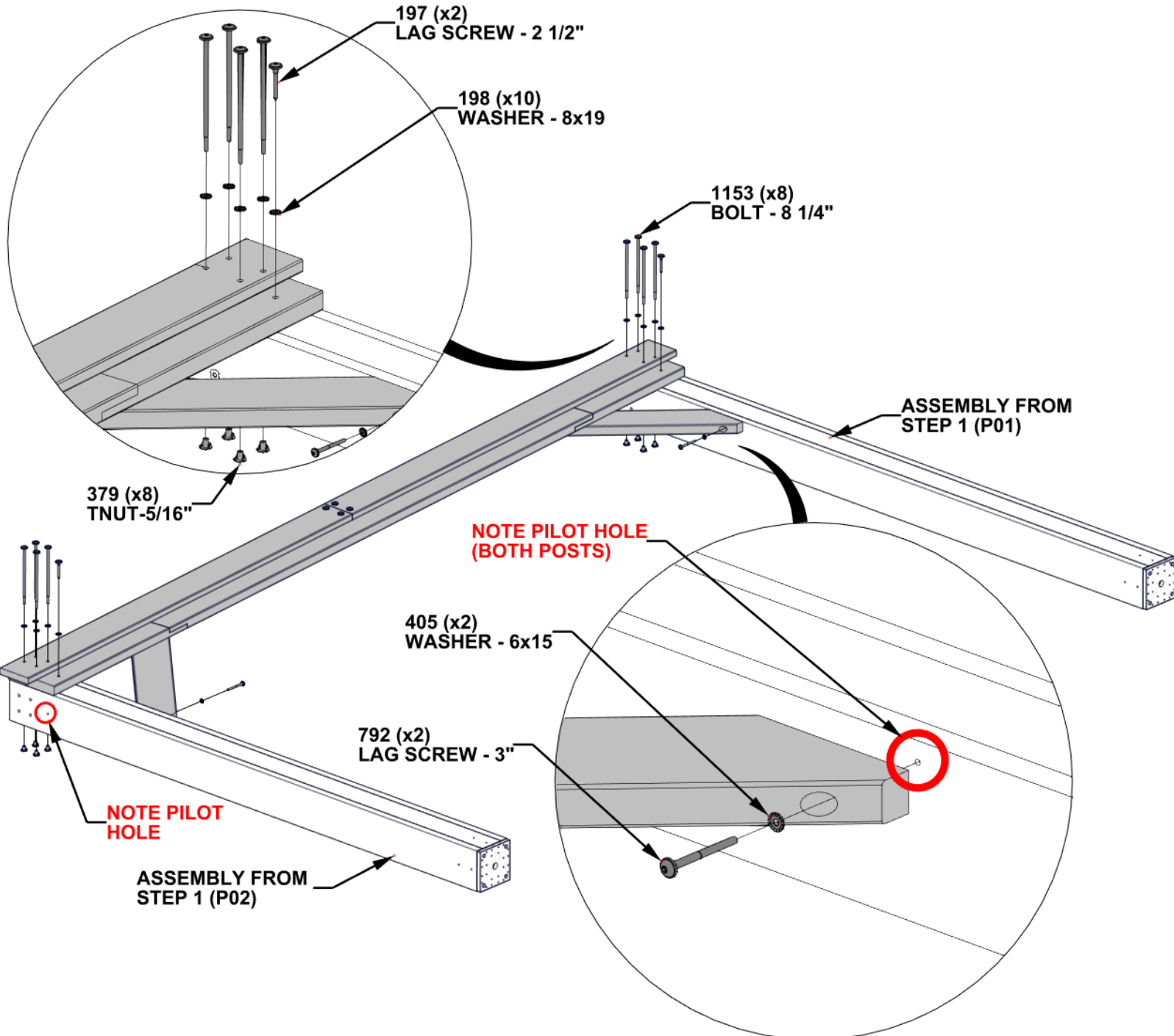

**SET LEFT SIDE
ASSEMBLY TO THE SIDE**

STEP 4 - RIGHT SIDE ASSEMBLY

QTY	PART NUMBER	DESCRIPTION
8	H100200	SCREW PFH 8x1 1/2 BLK



P03 POST - W2A03635
(x1) 6"x6"x98 1/2" (152x152x2502)



P04 POST - W2A04316
(x1) 6"x6"x86 11/16" (152x152x2202)



A6P00308 6x6 POST FOOT
(x2)

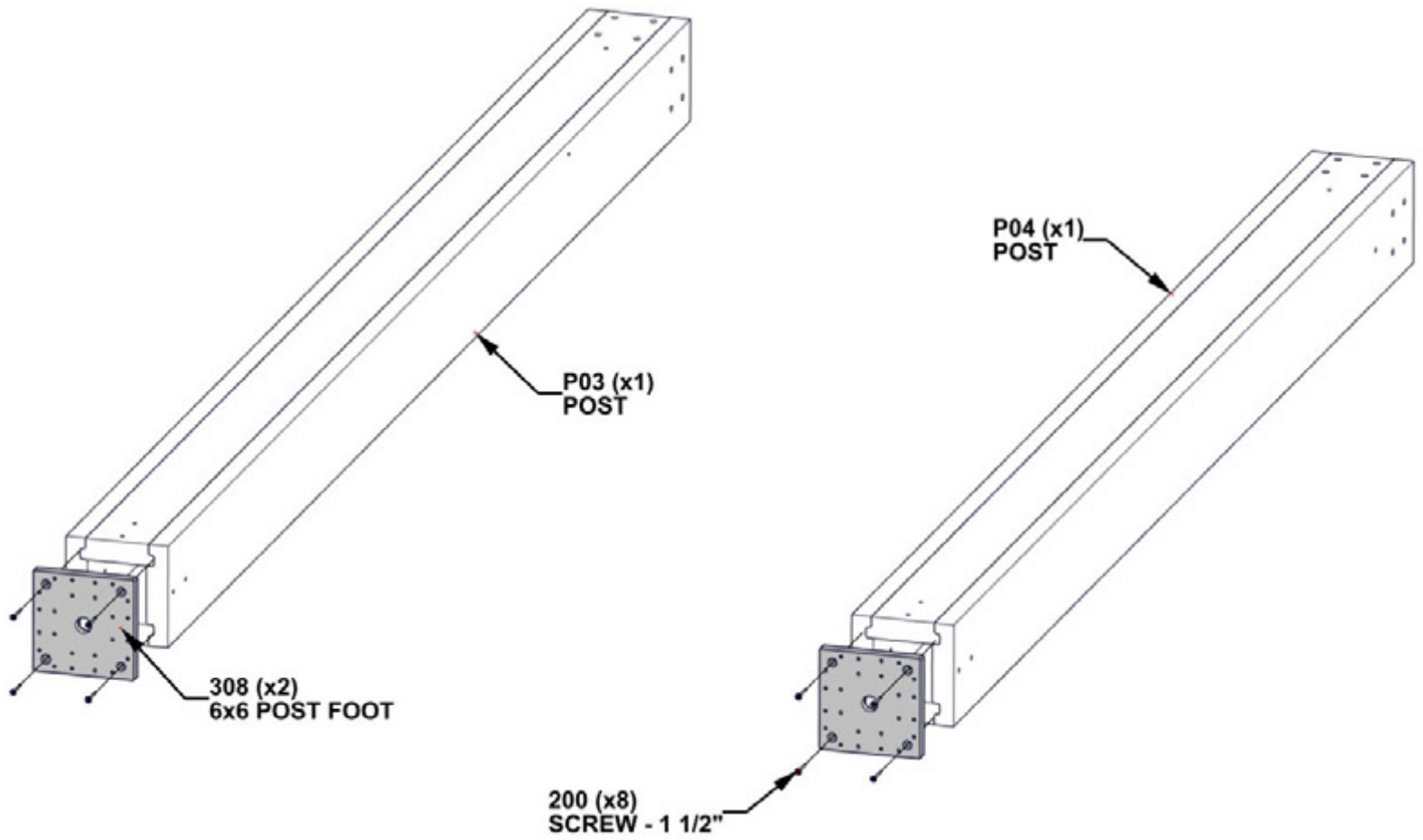

ALIGN POST FOOT AND DRILL 1/8" [3mm] PILOT HOLES FOR THE ATTACHMENT OF HARDWARE.

STEP 5A - RIGHT SIDE ASSEMBLY

QTY	PART NUMBER	DESCRIPTION
4	H100379	TNUT-5/16" BLK
4	H100195	BOLT WH 5/16x2 3/4 BLK
4	H100198	WASHER LOCK EXT 8x19

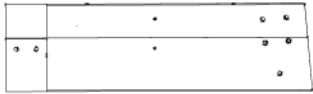

J12 JOIST ASSEMBLY - W2A04321
(x1) 1 7/16"x8 7/16"x29 1/2" (36x214x750)

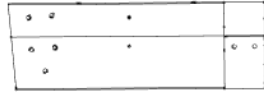

J11 JOIST ASSEMBLY - W2A04305
(x1) 1 7/16"x8 7/16"x25" (36x214x635)



D04 CORBEL - W4L19947
(x1) 1 3/8"x5 1/4"x33 1/2" (36x134x850)



D03 CORBEL - W4L20024
(x1) 1 3/8"x5 1/4"x27 1/4" (36x134x692)

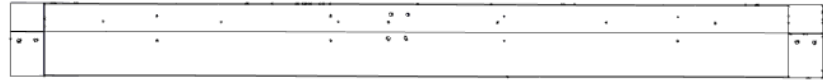

J13 JOIST ASSEMBLY - W2A04320
(x1) 1 7/16"x8 7/16"x93 7/8" (36x214x2385)

**- INSERT T-NUTS FIRST.
- SQUARE BEFORE TIGHTENING.**

**THROUGH HOLES TOWARDS TOP
FOR CORRECT ORIENTATION**

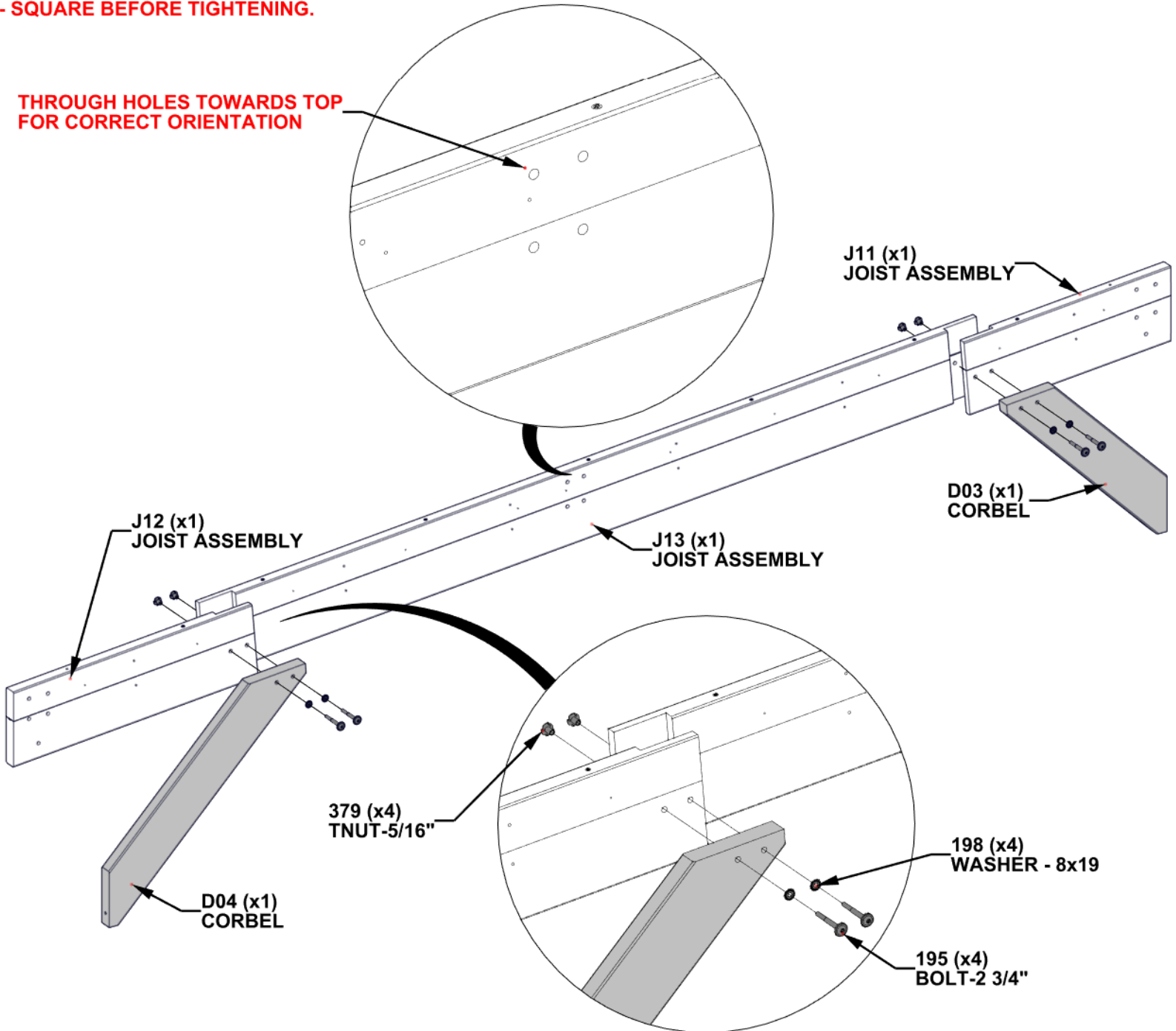

STEP 5B - RIGHT SIDE ASSEMBLY

QTY	PART NUMBER	DESCRIPTION
4	H100205	BOLT WH 5/16x2 1/4 BLK
4	H100198	WASHER LOCK EXT 8x19
4	H100379	TNUT-5/16" BLK

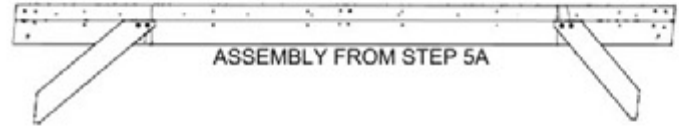
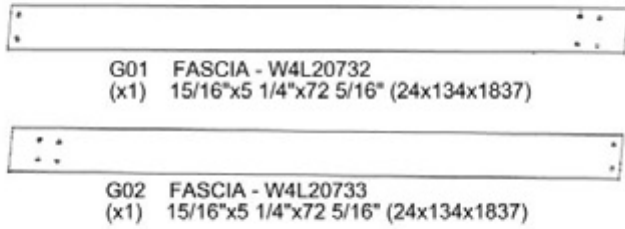

- INSERT T-NUTS FIRST.
- HAND TIGHTEN ONLY.

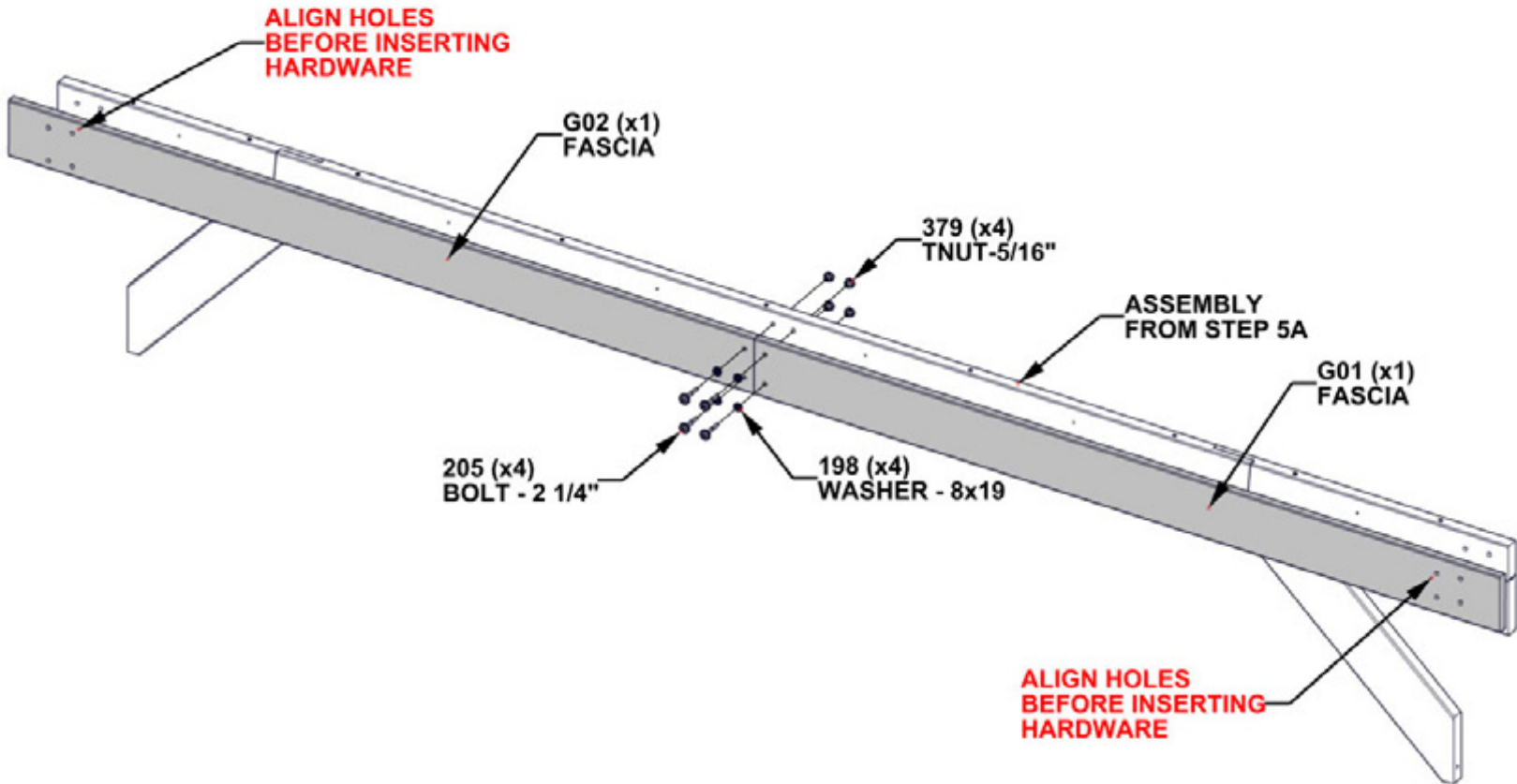

STEP 5C - RIGHT SIDE ASSEMBLY

QTY	PART NUMBER	DESCRIPTION
12	H100391	SCREW PFH 8x2 BLK

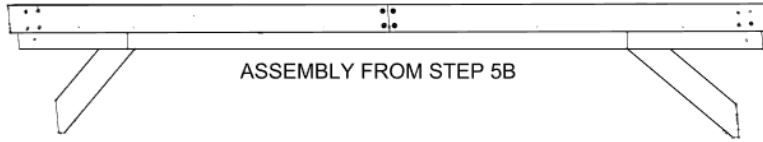

- TIGHTEN ALL HARDWARE.

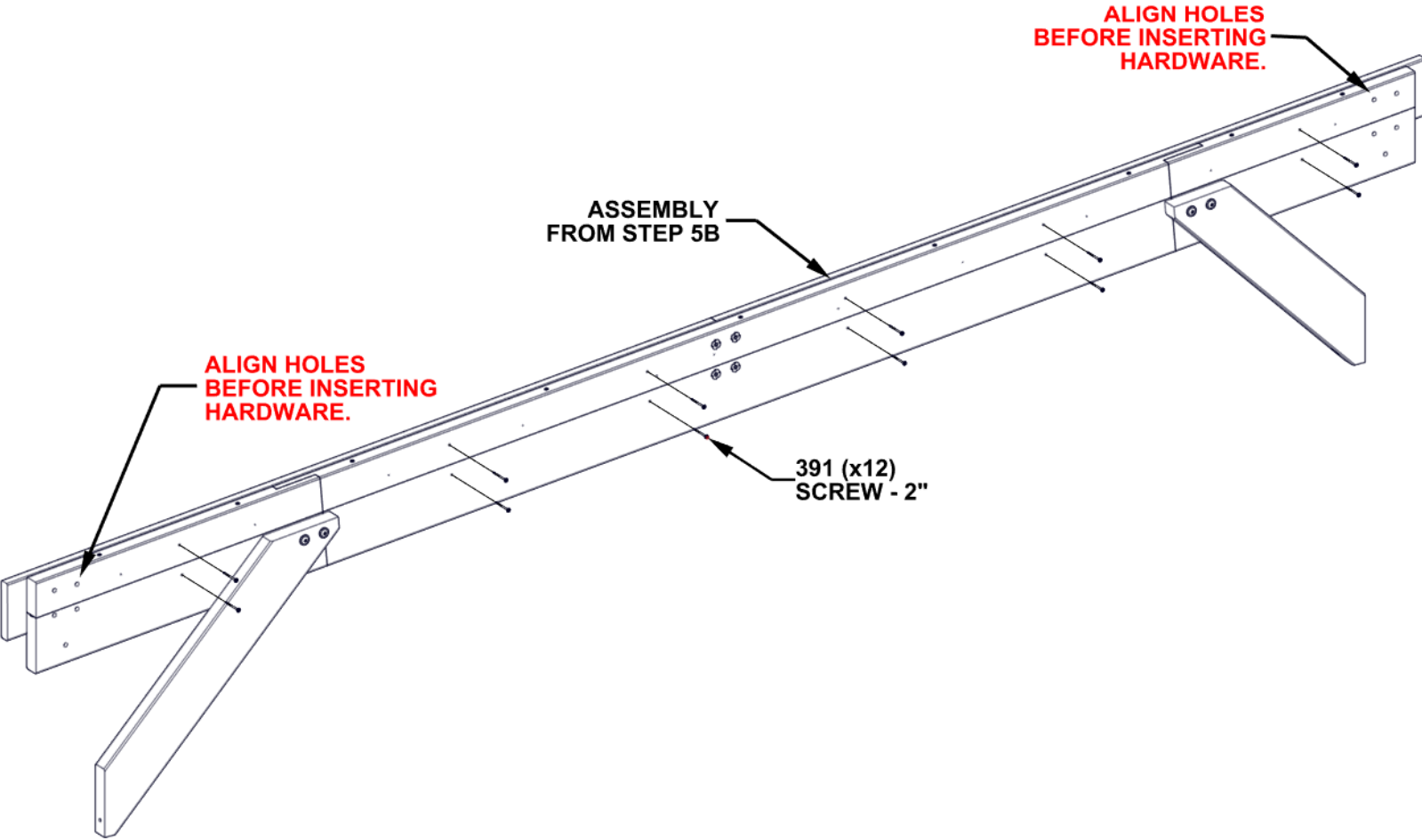

STEP 6 - RIGHT SIDE ASSEMBLY

QTY	PART NUMBER	DESCRIPTION
2	H100197	LAG SCREW WH 5/16x2 1/2" BLK
2	H100792	LAG SCREW WH 1/4x3 BLK
2	H100405	WASHER LOCK EXT 6x15
8	H100379	TNUT-5/16" BLK
8	H101153	BOLT WH 5/16x8 1/4 BLK
10	H100198	WASHER LOCK EXT 8x19

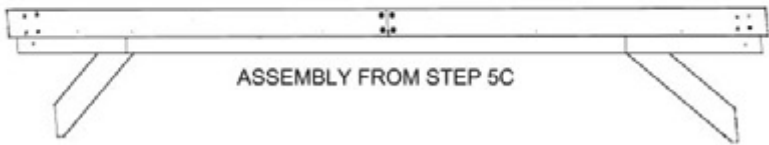

- TO AVOID SPLITTING, MAKE SURE LAG SCREWS GO INTO PILOT HOLES.
- IF BOLT DOES NOT ENGAGE WITH T-NUT, CHECK FOR SAWDUST BUILD UP IN HOLES. CLEAN WITH A LONG SCREWDRIVER IF NEEDED.
- INSERT T-NUTS FIRST.
- SQUARE LEGS BEFORE TIGHTENING BOLTS.
- TIGHTEN CORBELS AT END OF STEP.

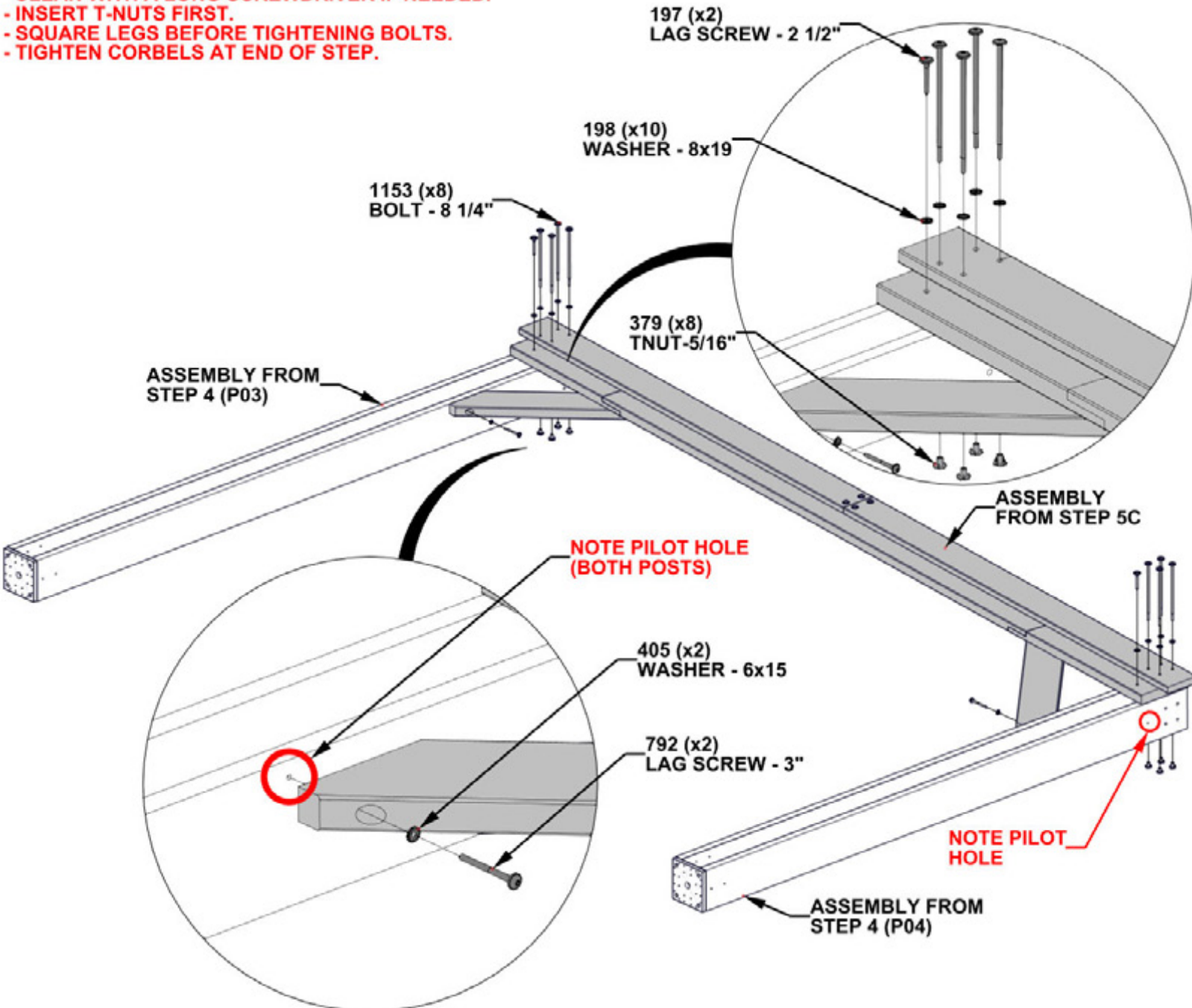

**SET RIGHT SIDE
ASSEMBLY TO THE SIDE**

STEP 7A - JOIST ASSEMBLY

QTY	PART NUMBER	DESCRIPTION
12	H100379	T-NUT 5/16 BLK



J08 JOIST ASSEMBLY - W2A04469
(x2) 15/16"x8 7/16"x7'-2 1/8" (24x214x2187)

- INSERT T-NUTS ONLY IN THIS STEP. DO NOT ASSEMBLE JOISTS.
- JOISTS ARE FASTENED IN NEXT STEP.

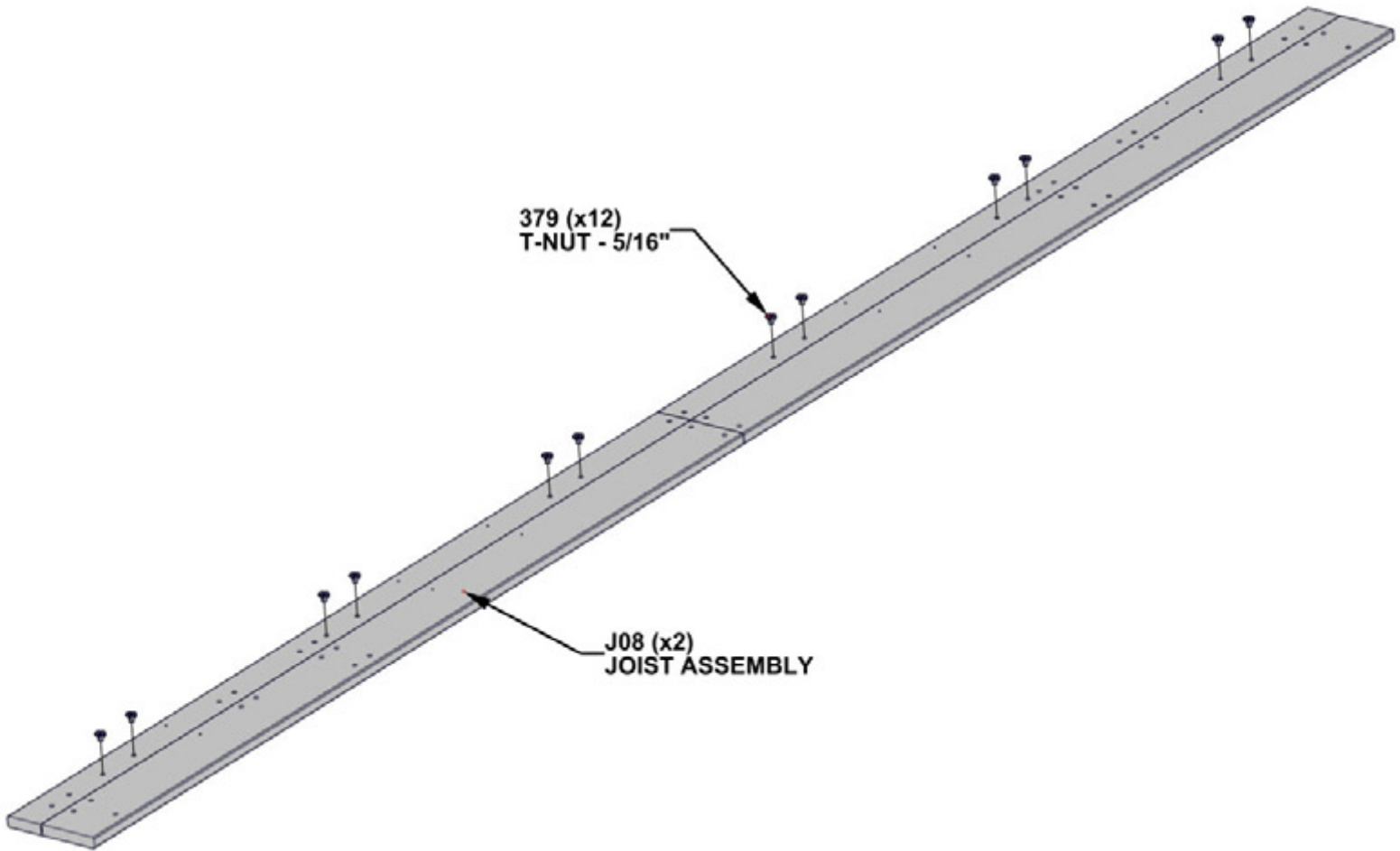

STEP 7B - JOIST ASSEMBLY

QTY	PART NUMBER	DESCRIPTION
4	H100378	BOLT WH 5/16x1 3/4 BLK
8	H100195	BOLT WH 5/16x2 3/4 BLK
12	H100379	TNUT-5/16" BLK
12	H100198	WASHER LOCK EXT 8x19



A4M04060 BACK BEAM METAL BRACKET
(x1)



G06 FASCIA - W4L20739
(x1) 15/16"x5 1/4"x98" (24x134x2489)

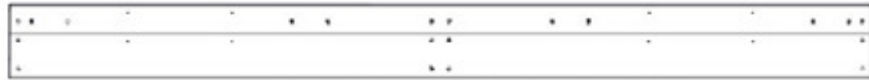

J07 JOIST CENTER ASSEMBLY - W2A04468
(x1) 15/16"x8 7/16"x8'-2" (24x214x2489)

- INSERT T-NUTS FIRST.
- SQUARE BEFORE TIGHTENING BOLTS.

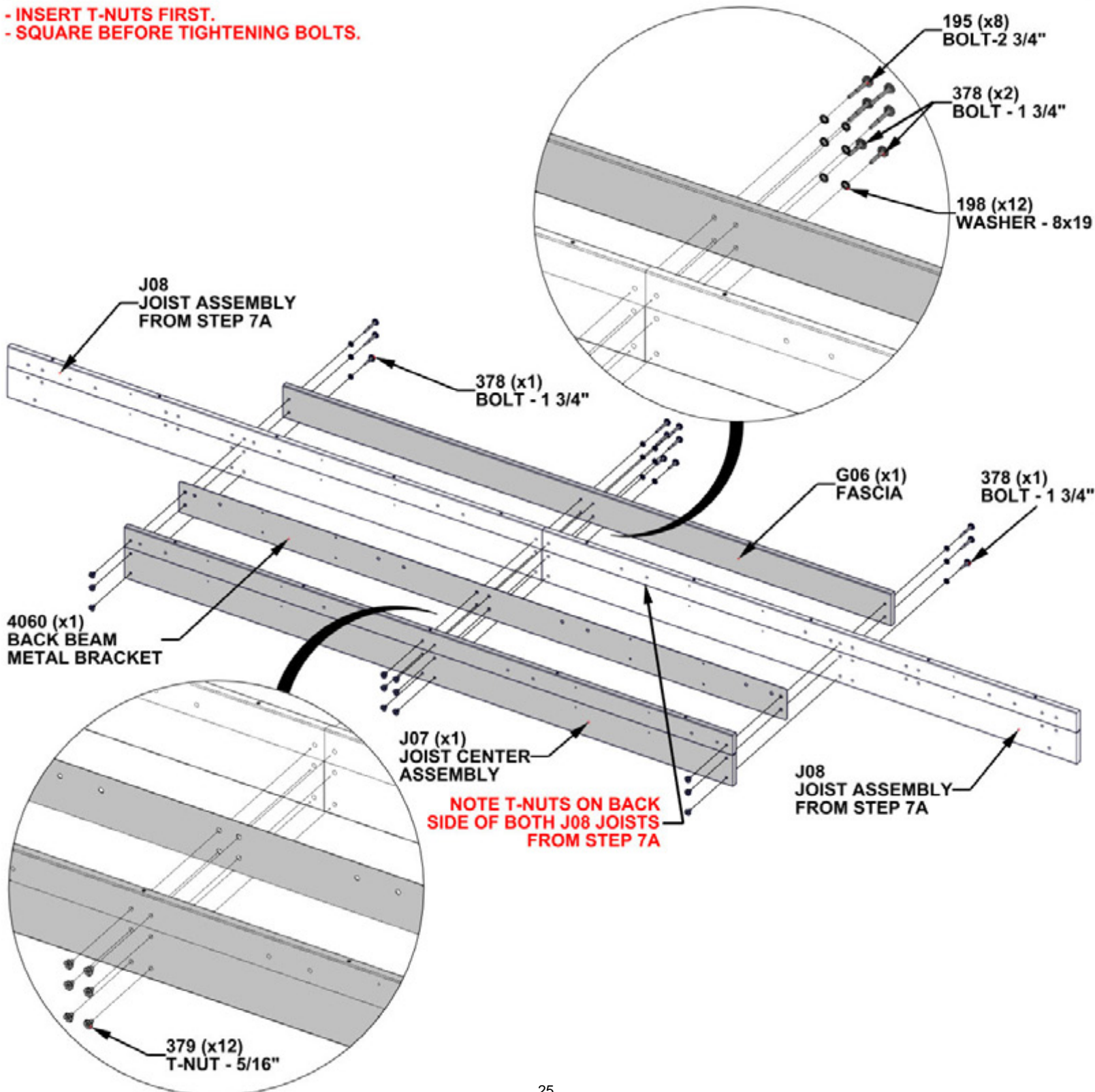

STEP 7C - JOIST ASSEMBLY



G05 FASCIA - W4L20736
(x2) 15/16"x5 1/4"x38 1/16" (24x134x967)



J06 JOIST END ASSEMBLY - W2A04464
(x2) 15/16"x8 7/16"x37 1/8" (24x214x943)

QTY	PART NUMBER	DESCRIPTION
2	H100378	BOLT WH 5/16x1 3/4 BLK
4	H100195	BOLT WH 5/16x2 3/4 BLK
6	H100379	TNUT-5/16" BLK
6	H100198	WASHER LOCK EXT 8x19

- INSERT T-NUTS FIRST.
- SQUARE BEFORE TIGHTENING BOLTS.

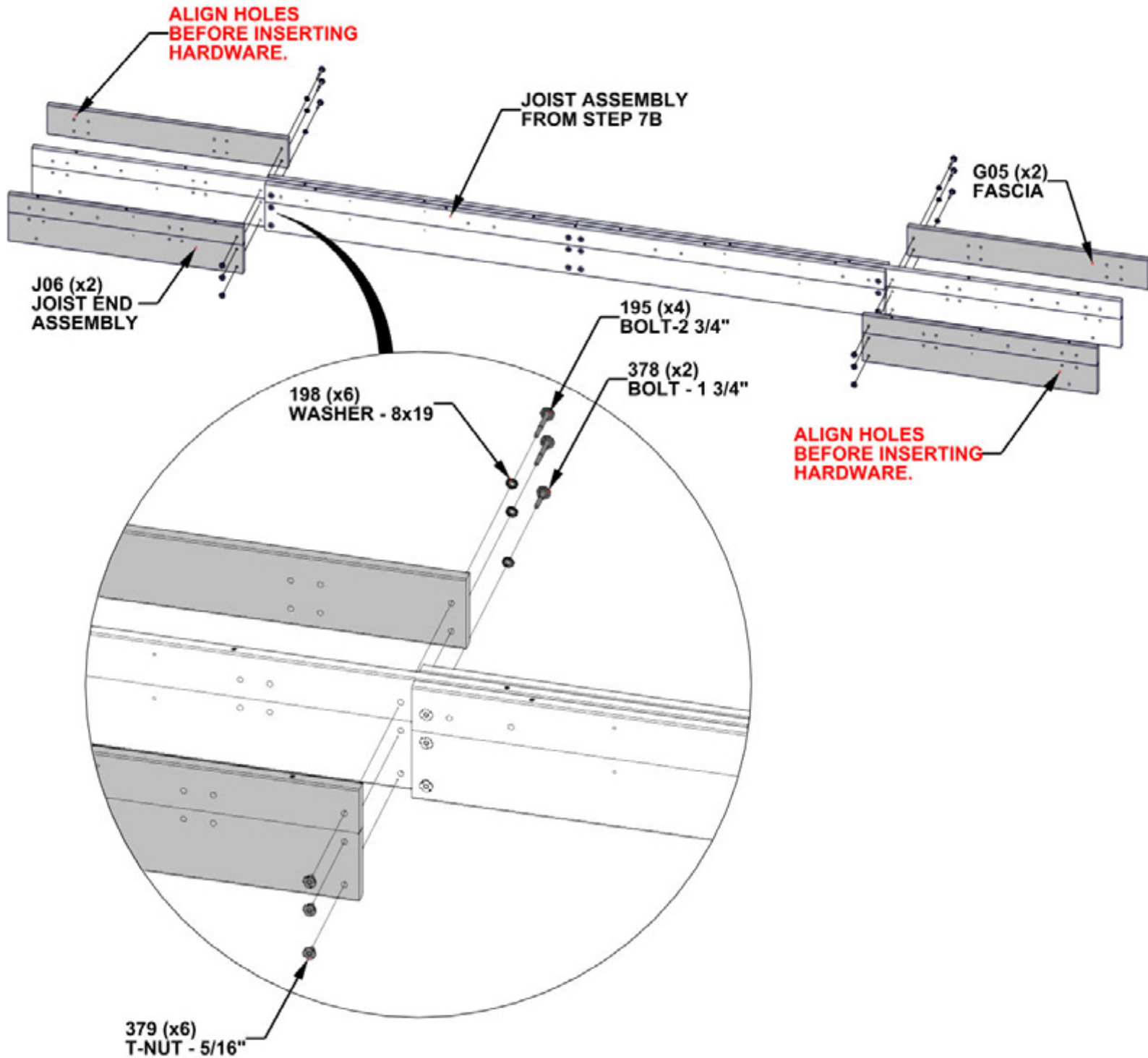

STEP 7D - JOIST ASSEMBLY

QTY	PART NUMBER	DESCRIPTION
8	H100379	TNUT-5/16" BLK
8	H100513	BOLT WH 5/16x4 1/4 BLK
8	H100198	WASHER LOCK EXT 8x19



D01 CORBEL - W4L20742
(x2) 1 7/16"x5 1/4"x34 7/16" (36x134x874)

- INSERT T-NUTS FIRST.
- SQUARE BEFORE TIGHTENING BOLTS.

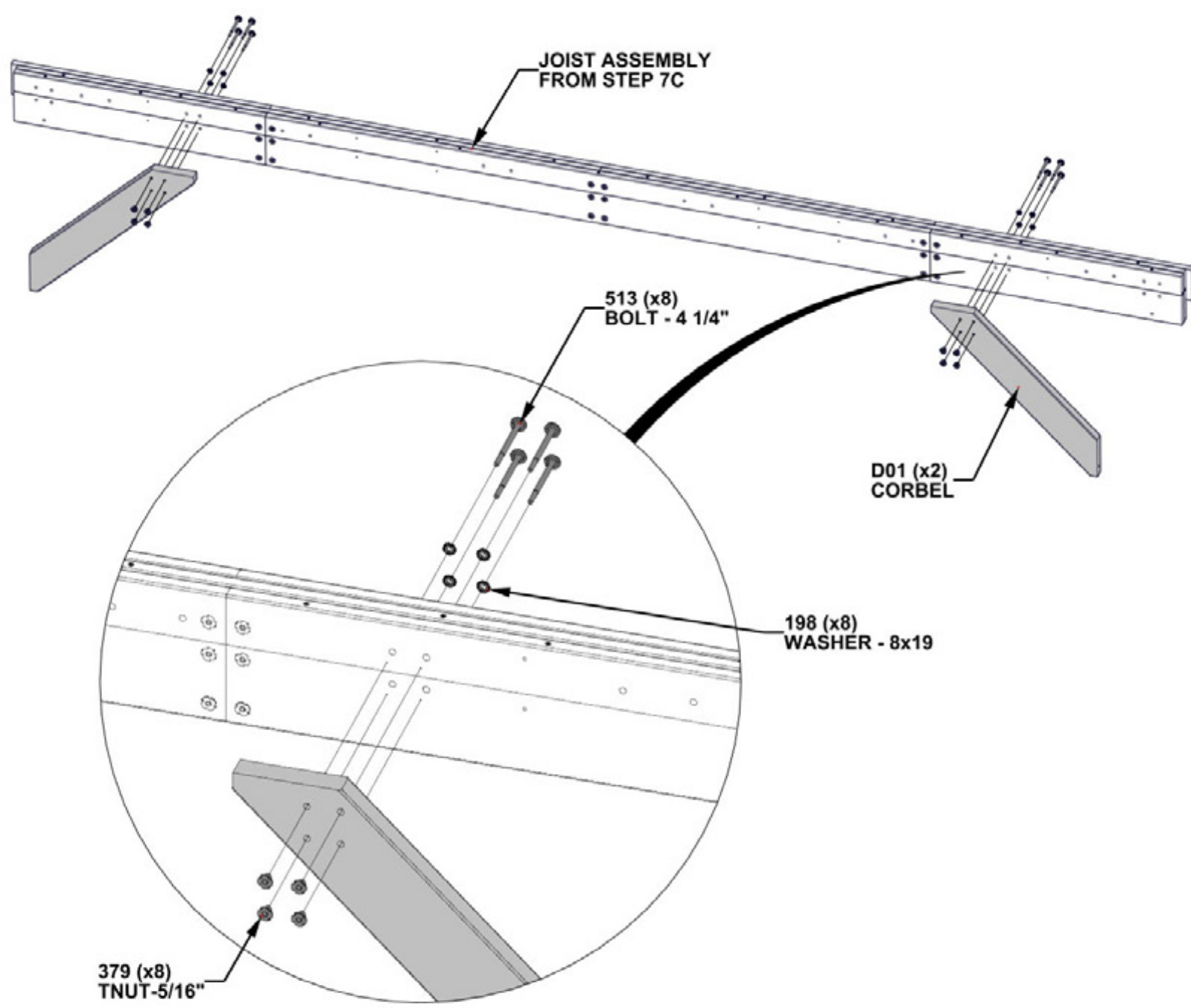

STEP 7E - JOIST ASSEMBLY

QTY	PART NUMBER	DESCRIPTION
12	H100201	SCREW PFH 8x2 1/2 BLK

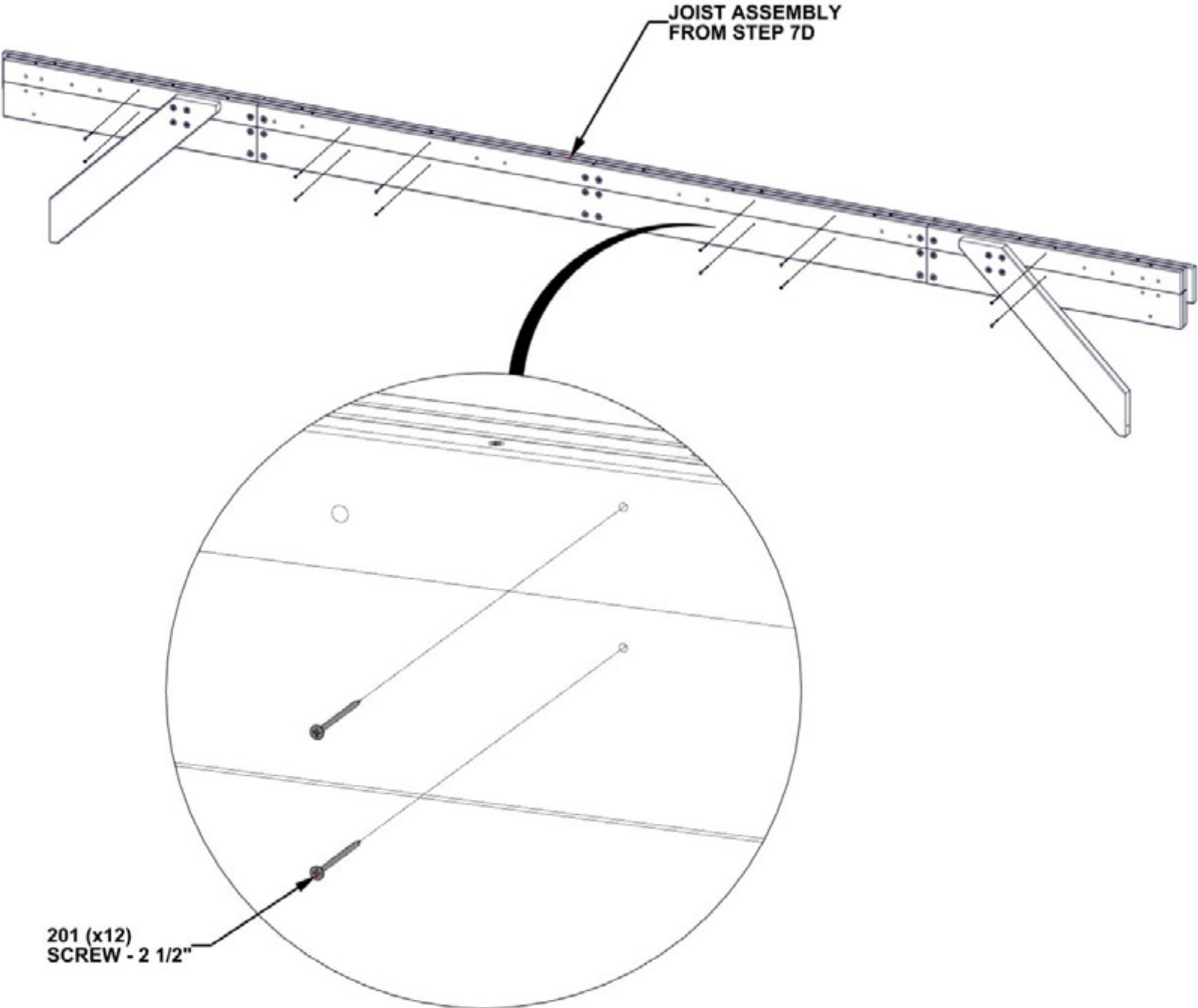

STEP 7F - JOIST ASSEMBLY

QTY	PART NUMBER	DESCRIPTION
12	H100457	BOLT WH 5/16x2 BLK

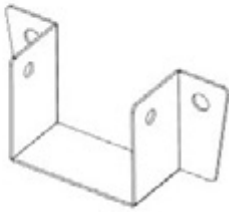

A4M02764 RAFTER BRACKET
(x6)

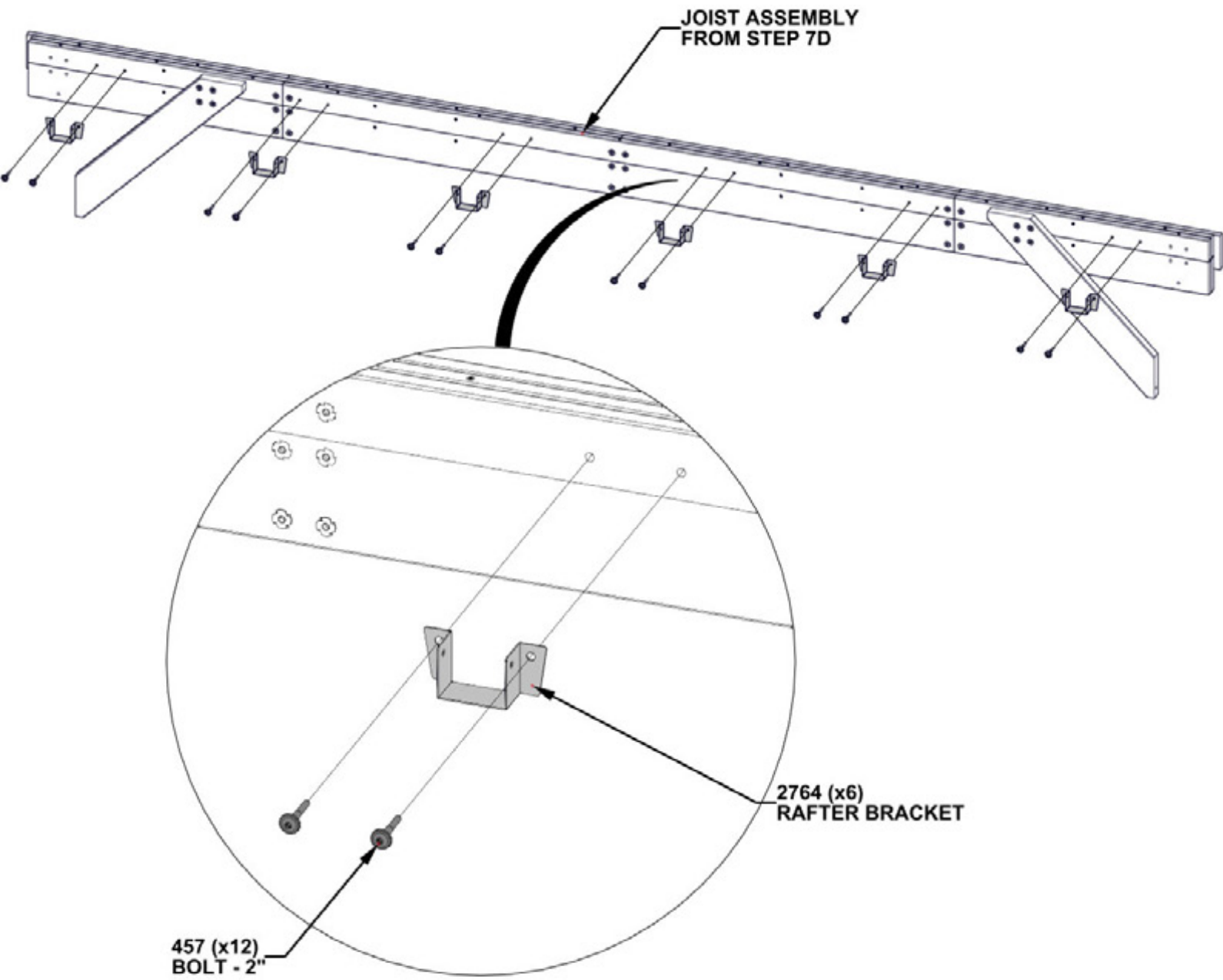

STEP 8 - GAZEBO ASSEMBLY

QTY	PART NUMBER	DESCRIPTION
2	H100206	LAG SCREW WH 5/16x3 BLK
2	H100792	LAG SCREW WH 1/4x3 BLK
2	H100405	WASHER LOCK EXT 6x15
8	H100379	TNUT-5/16" BLK
8	H101058	BOLT WH 5/16x8 3/4 BLK
10	H100198	WASHER LOCK EXT 8x19

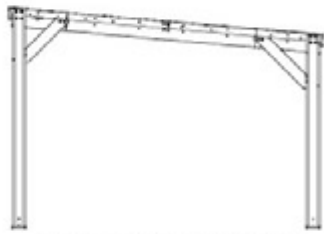

ASSEMBLY FROM STEP 3

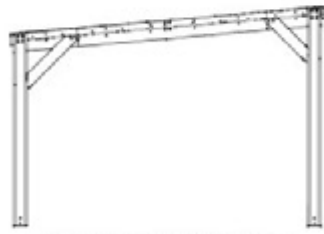

ASSEMBLY FROM STEP 6

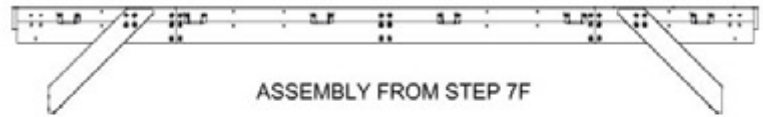

ASSEMBLY FROM STEP 7F

- THE FRONT OF THE GAZEBO IS DETERMINED BY THE TALLER POSTS.
- EXTRA PEOPLE ARE HELPFUL FOR THIS STEP.
- **INSERT T-NUTS FIRST**

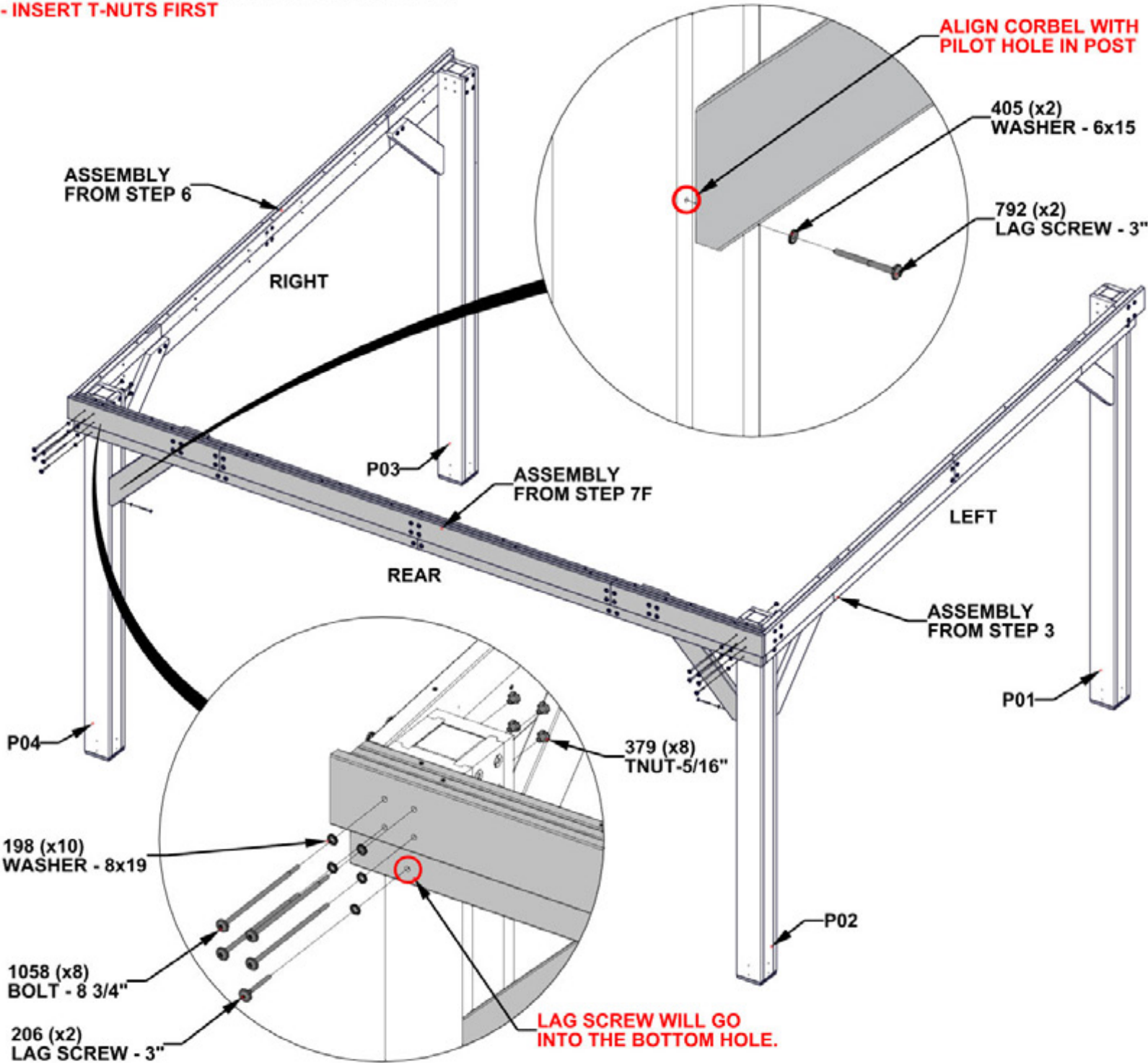

STEP 9A - JOIST ASSEMBLY

QTY	PART NUMBER	DESCRIPTION
12	H100379	T-NUT 5/16 BLK



J05 JOIST ASSEMBLY - W2A04467
(x2) 15/16"x8 7/16"x7'-2 1/8" (24x214x2187)

- INSERT T-NUTS ONLY IN THIS STEP. DO NOT ASSEMBLE JOISTS.
- JOISTS ARE FASTENED IN NEXT STEP.

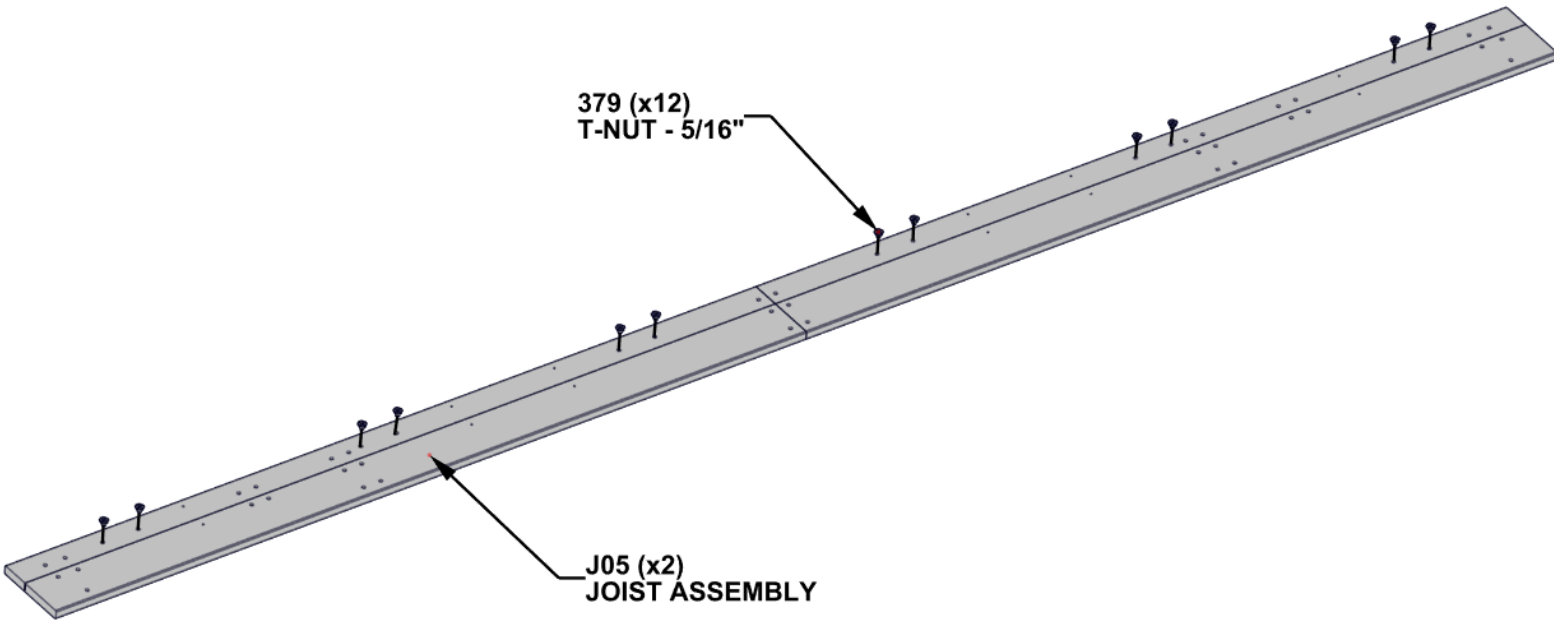

STEP 9B - JOIST ASSEMBLY

QTY	PART NUMBER	DESCRIPTION
4	H100378	BOLT WH 5/16x1 3/4 BLK
8	H100195	BOLT WH 5/16x2 3/4 BLK
12	H100379	TNUT-5/16" BLK
12	H100198	WASHER LOCK EXT 8x19

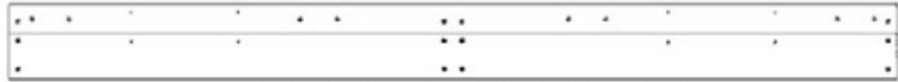
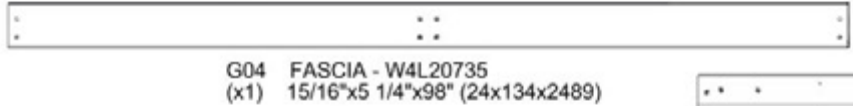

- INSERT T-NUTS FIRST.
- SQUARE BEFORE TIGHTENING BOLTS.

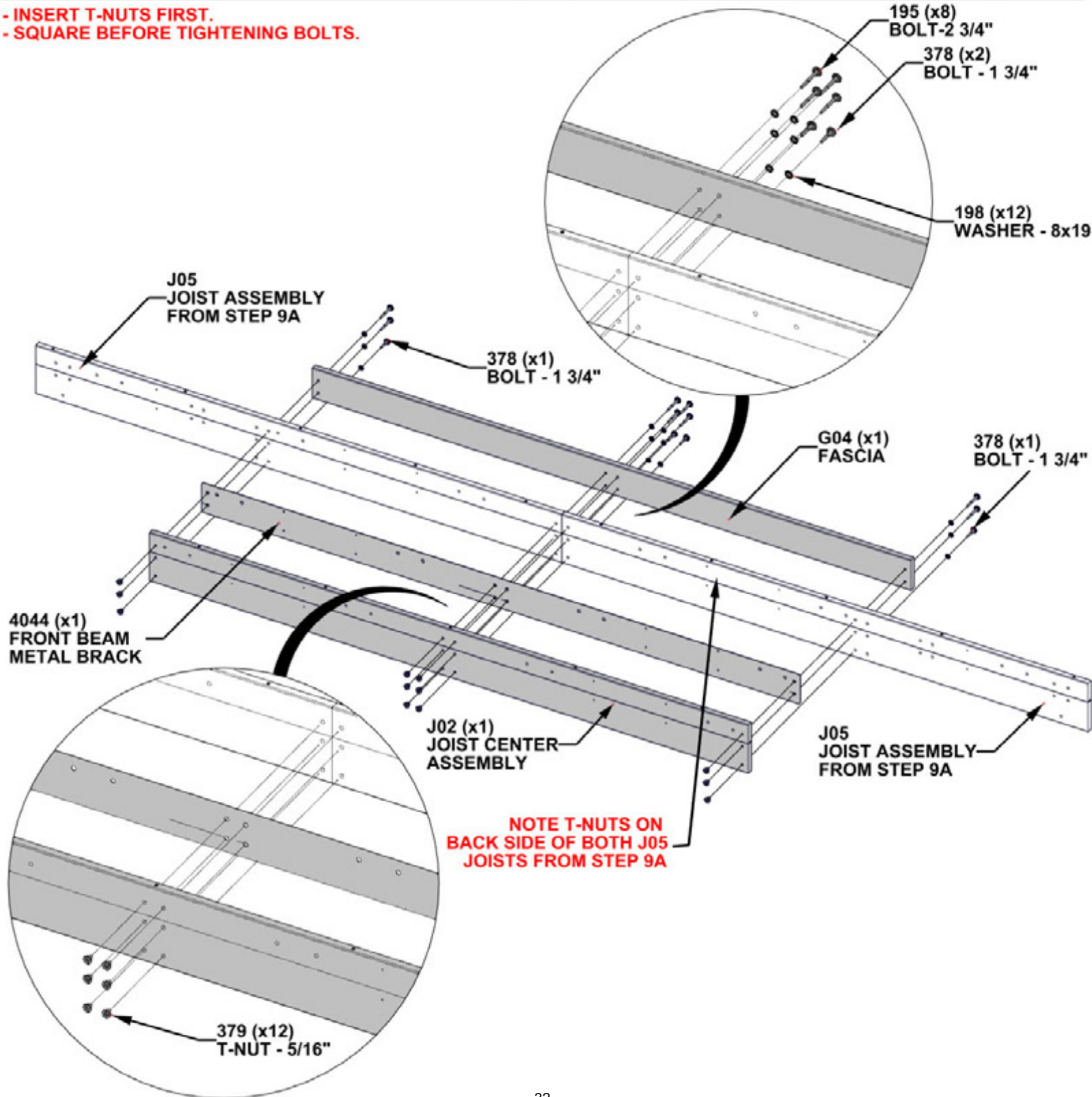

STEP 9C - JOIST ASSEMBLY



G03 FASCIA - W4L20734
(x2) 15/16"x5 1/4"x38 1/16" (24x134x967)



J01 JOIST END ASSEMBLY - W2A04462
(x2) 15/16"x8 7/16"x37 1/8" (24x214x943)

QTY	PART NUMBER	DESCRIPTION
2	H100378	BOLT WH 5/16x1 3/4 BLK
4	H100195	BOLT WH 5/16x2 3/4 BLK
6	H100379	TNUT-5/16" BLK
6	H100198	WASHER LOCK EXT 8x19

- INSERT T-NUTS FIRST.
- SQUARE BEFORE TIGHTENING BOLTS.

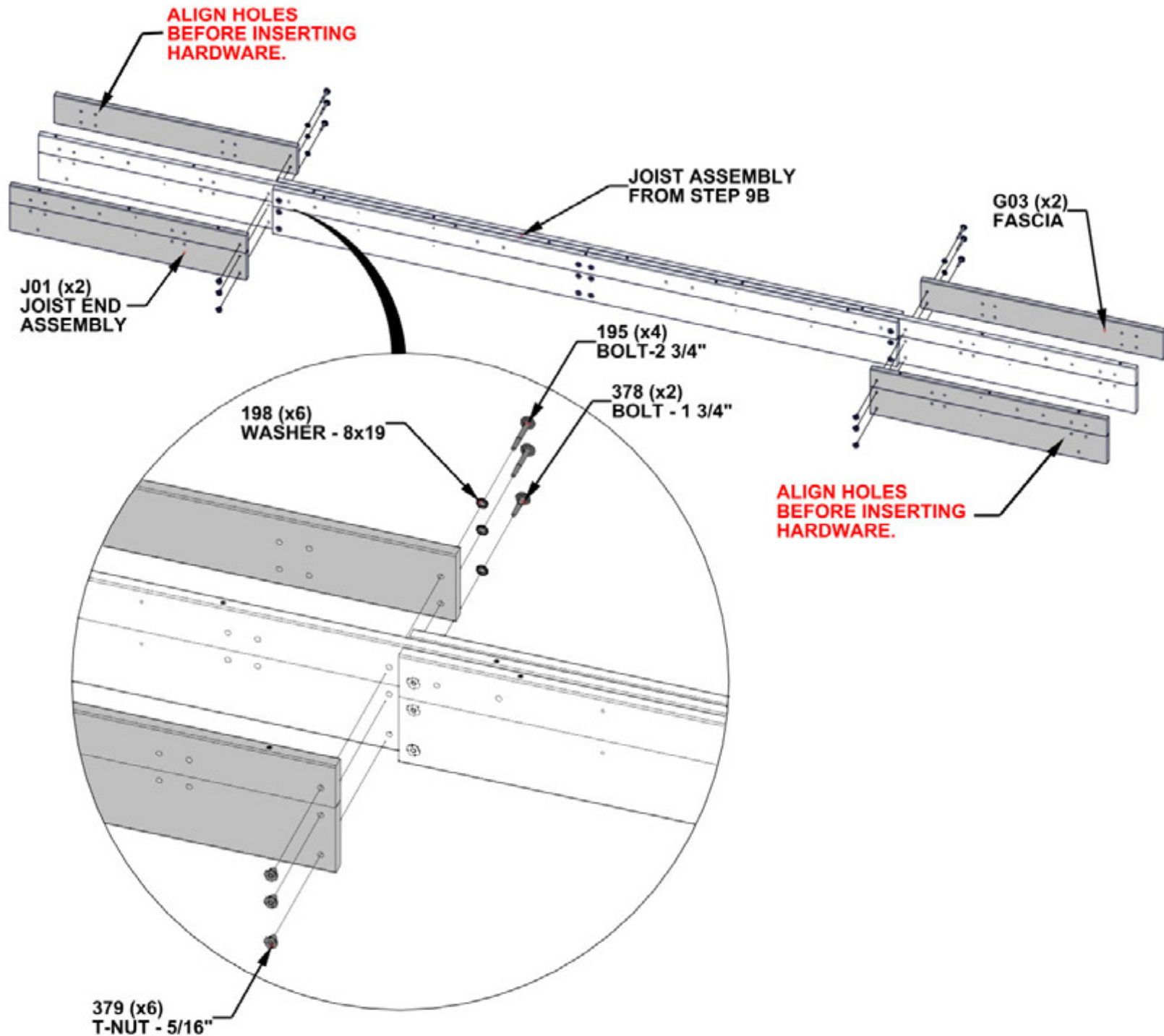

STEP 9D - JOIST ASSEMBLY

QTY	PART NUMBER	DESCRIPTION
8	H100198	WASHER LOCK EXT 8x19
8	H100379	TNUT-5/16" BLK
8	H100513	BOLT WH 5/16x4 1/4 BLK



D01 CORBEL - W4L20742
(x1) 1 7/16"x5 1/4"x34 7/16" (36x134x874)



D02 CORBEL - W2A04473
(x1) 1 7/16"x5 1/4"x34 7/16" (36x134x874)

- INSERT T-NUTS FIRST.
- SQUARE BEFORE TIGHTENING BOLTS.

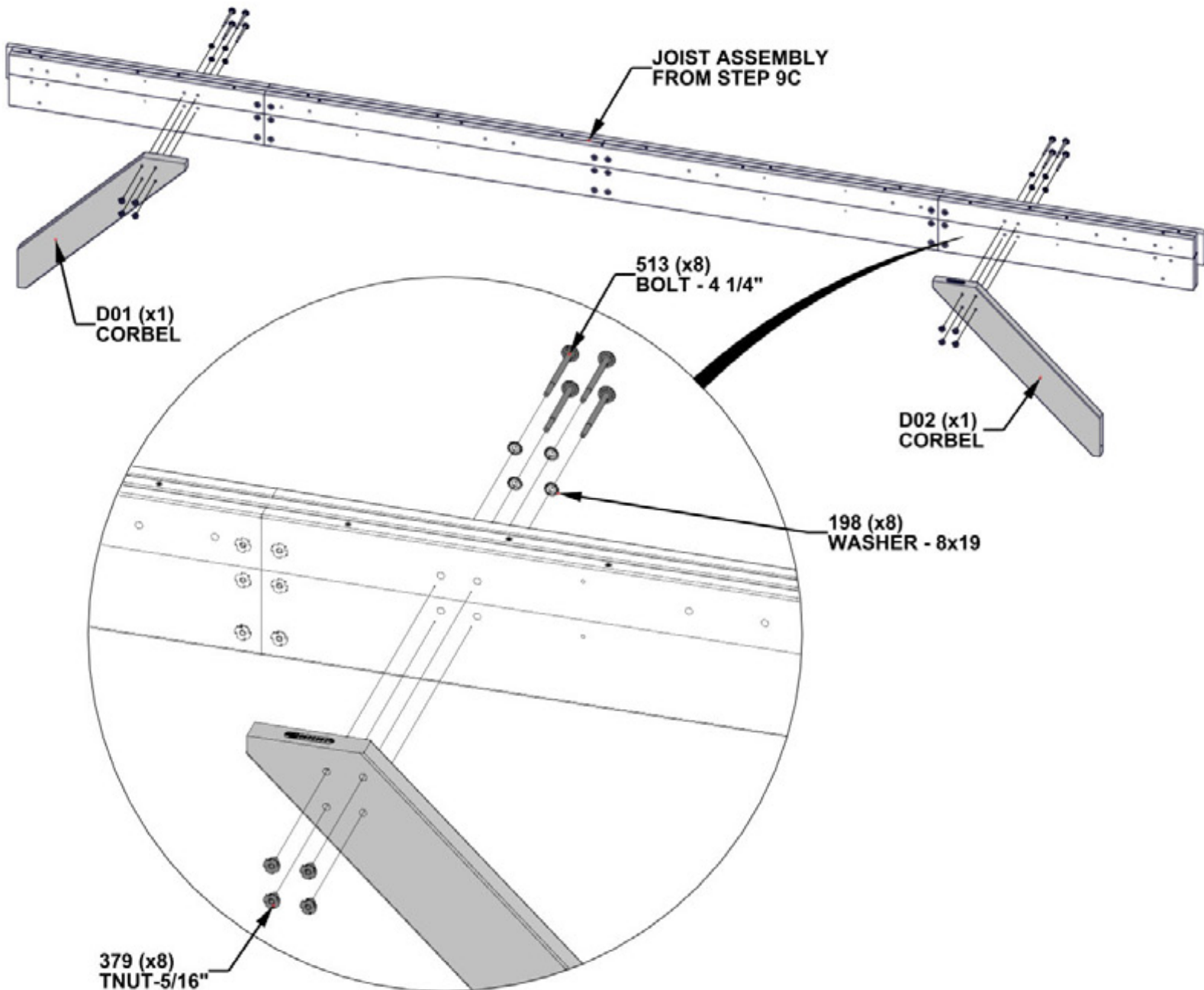

STEP 9E - JOIST ASSEMBLY

QTY	PART NUMBER	DESCRIPTION
12	H100201	SCREW PFH 8x2 1/2 BLK

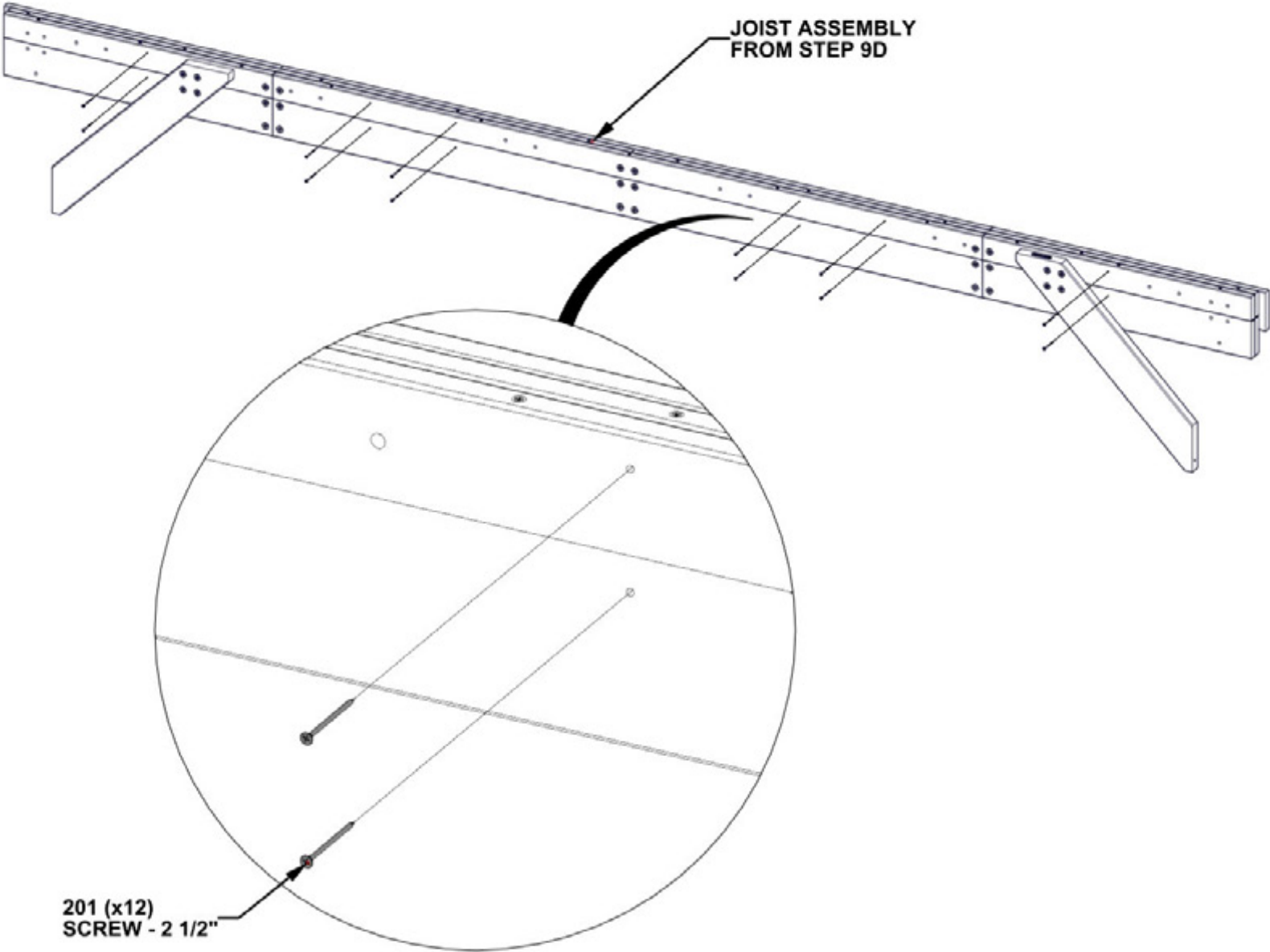

STEP 9F - JOIST ASSEMBLY

QTY	PART NUMBER	DESCRIPTION
12	H100457	BOLT WH 5/16x2 BLK

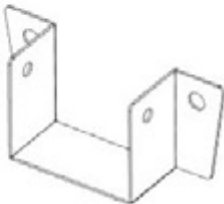

A4M02764 RAFTER BRACKET
(x6)

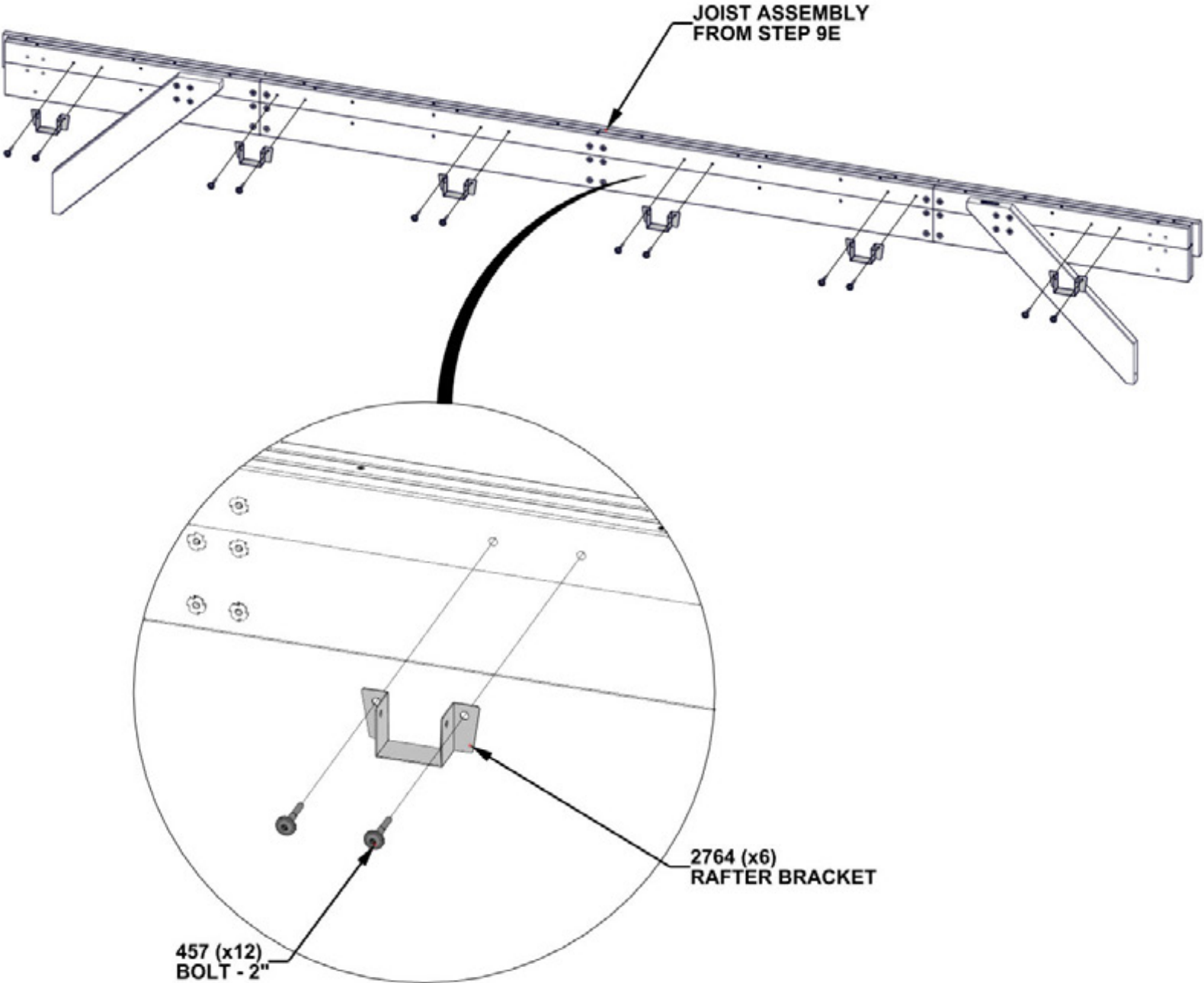

STEP 10 - GAZEBO ASSEMBLY

QTY	PART NUMBER	DESCRIPTION
2	H100206	LAG SCREW WH 5/16x3 BLK
2	H100405	WASHER LOCK EXT 6x15
2	H100792	LAG SCREW WH 1/4x3 BLK
8	H100379	TNUT-5/16" BLK
8	H101058	BOLT WH 5/16x8 3/4 BLK
10	H100198	WASHER LOCK EXT 8x19

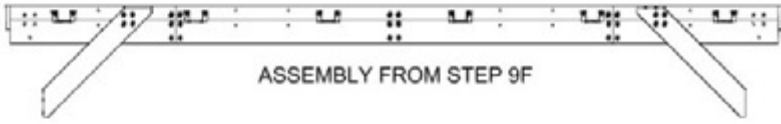

- THE FRONT OF THE GAZEBO IS DETERMINED BY THE TALLER POSTS.
- EXTRA PEOPLE ARE HELPFUL FOR THIS STEP.
- **INSERT T-NUTS FIRST.**

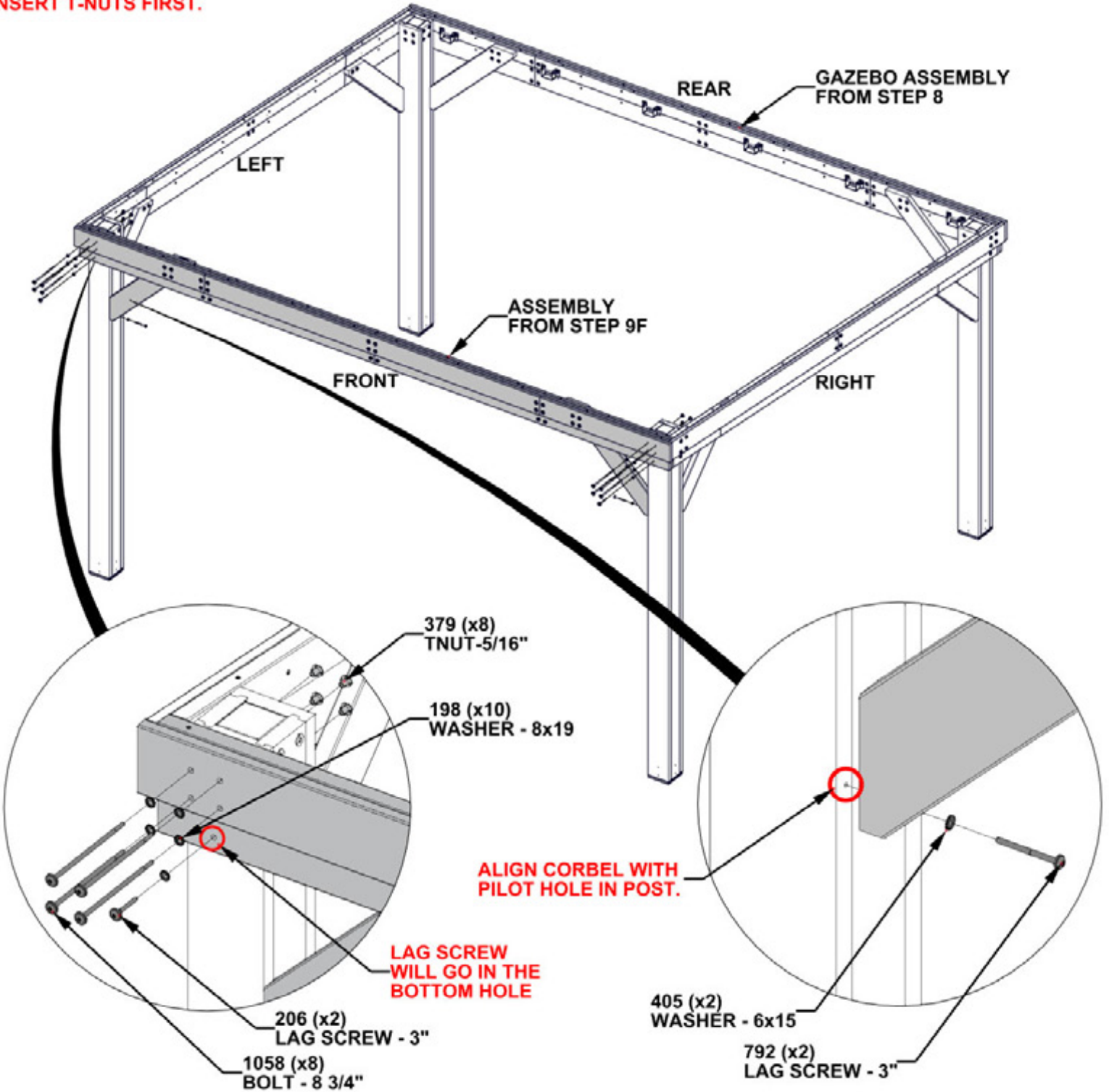

STEP 11 - GAZEBO ASSEMBLY

CRITICAL:

- SQUARE UNIT BEFORE PROCEEDING TO NEXT STEPS.
- THE BELOW DIMENSIONS ARE CRITICAL TO THE FINAL ASSEMBLY.
- MEASUREMENTS SHOULD BE WITHIN +/- 1/4" (6mm).
- MEASUREMENTS OUTSIDE OF TOLERANCE WILL LEAD TO ISSUES ON FUTURE ASSEMBLY STEPS.
- MEASUREMENTS TAKEN FROM INSIDE POST CORNER TO INSIDE POST CORNER

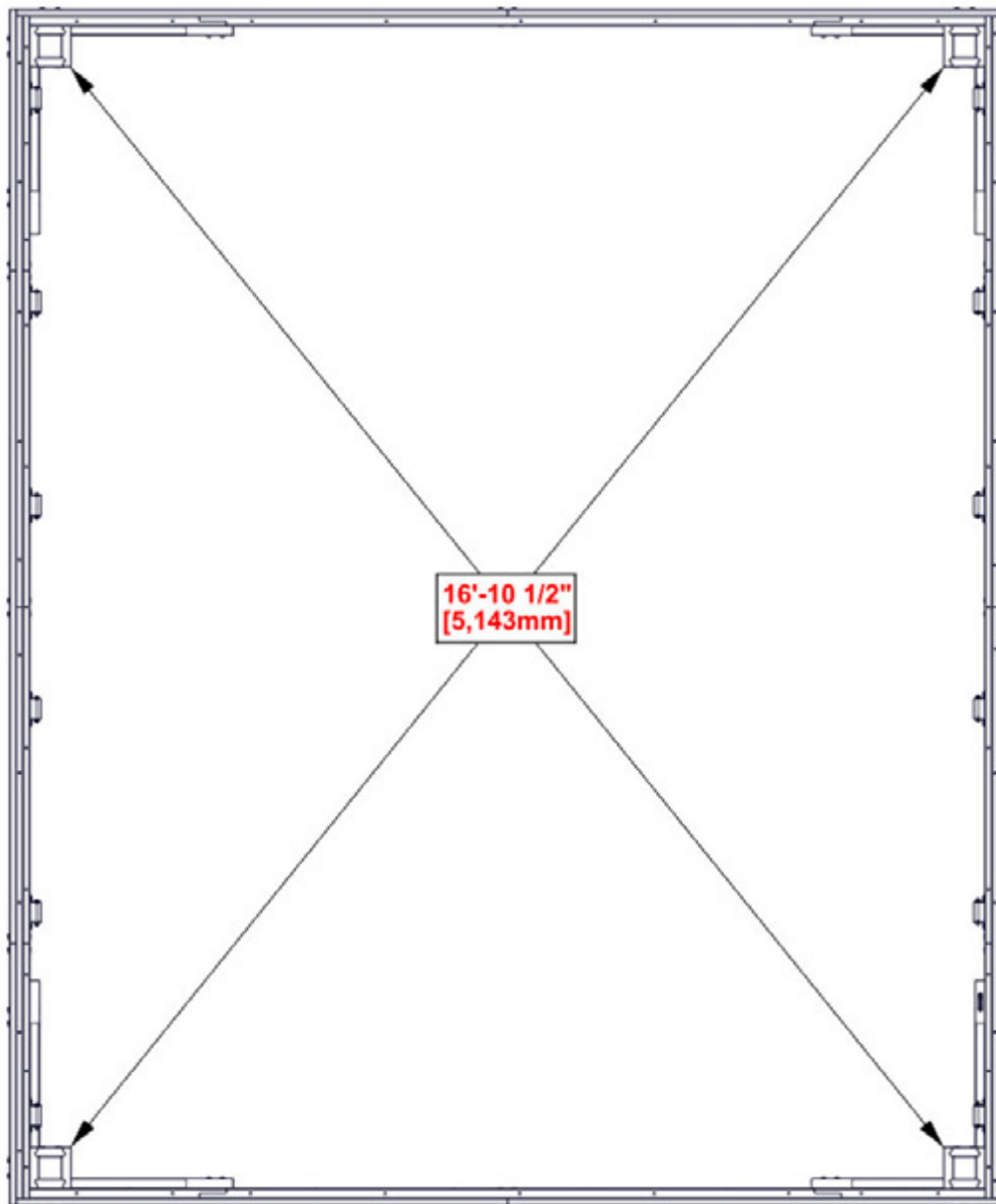

STEP 12 - GAZEBO ASSEMBLY

QTY	PART NUMBER	DESCRIPTION
22	H100391	SCREW PFH 8x2 BLK



J17 CLEAT - W4L20022
(x2) 15/16"x2 3/8"x68 1/2" (24x60x1740)



J18 CLEAT - W4L20119
(x2) 15/16"x2 3/8"x59" (24x60x1498)

- ALIGN PILOT HOLES.

NOTE PILOT HOLE LOCATIONS

CLEAT SHOULD REST ON TOP OF CORBEL

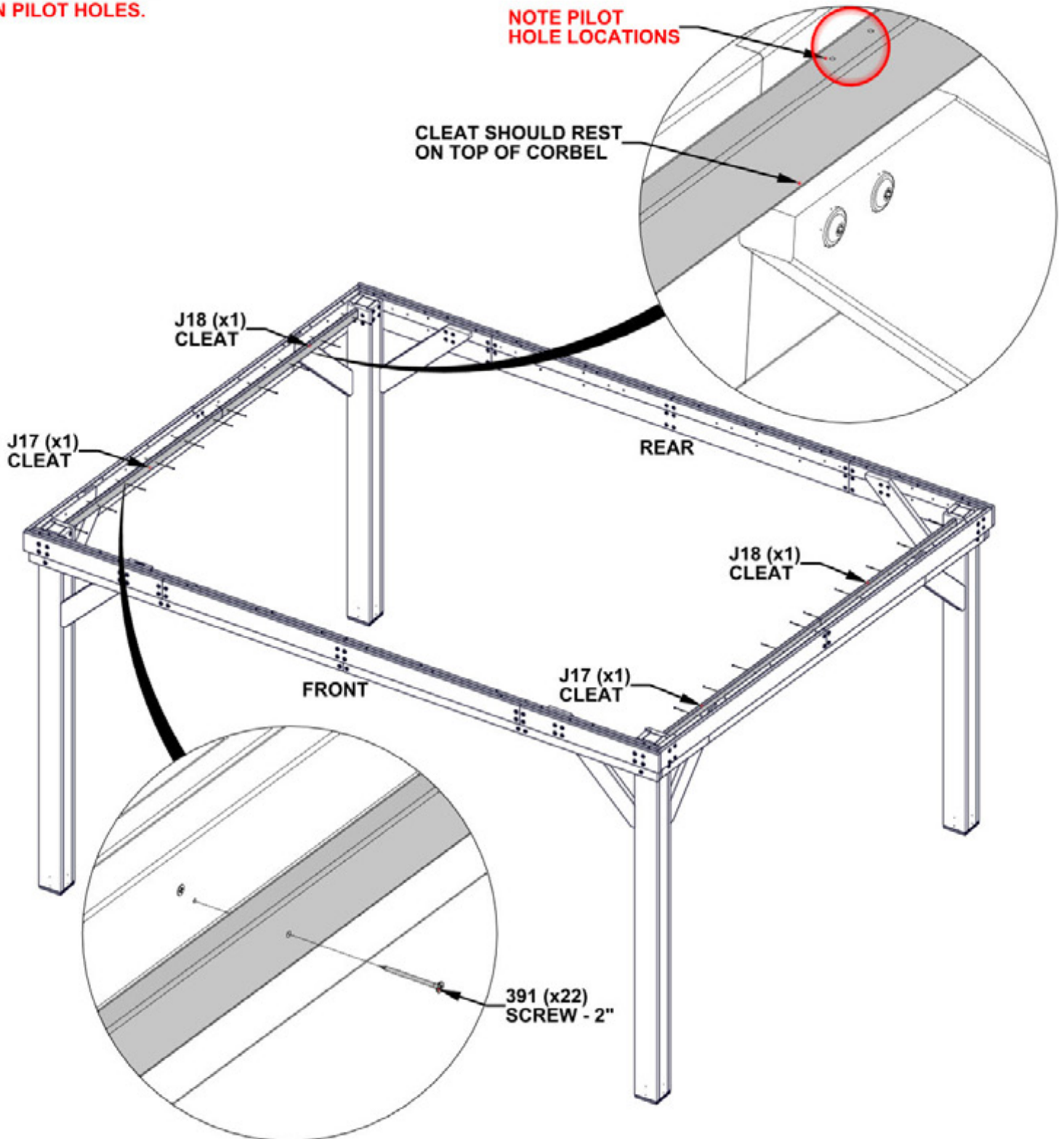

STEP 13A - RAFTER ASSEMBLY

QTY	PART NUMBER	DESCRIPTION
4	H100385	SCREW PFH 8x1 BLK



E01 RAFTER - W4L19946
(x1) 1 7/16"x3 3/8"x85 5/8" (36x86x2176)



E02 RAFTER - W4L19992
(x1) 1 7/16"x3 3/8"x54 3/8" (36x86x1380)



A4M03430 RAFTER BRACE
(x1)

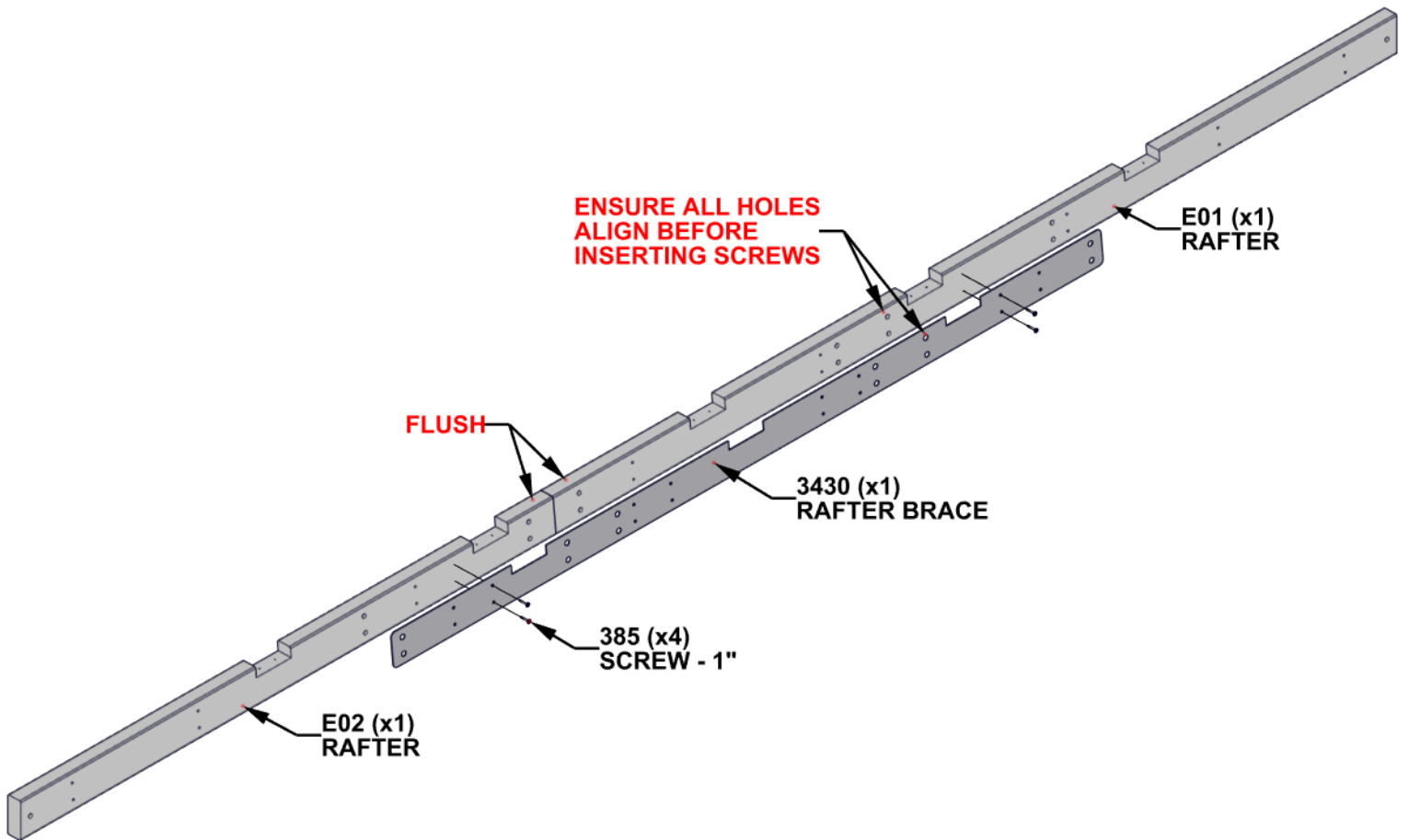

STEP 13B - RAFTER ASSEMBLY

QTY	PART NUMBER	DESCRIPTION
12	H100192	NUT BARREL WH 5/16X7/8 BLK
12	H100194	BOLT WH 5/16x2 1/2 BLK
12	H100199	WASHER LOCK EXT 12x19
12	H100198	WASHER LOCK EXT 8x19

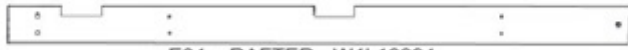

E04 RAFTER - W4L19994
(x1) 1 7/16"x3 3/8"x54 3/8" (36x86x1380)



E03 RAFTER - W4L19993
(x1) 1 7/16"x3 3/8"x85 5/8" (36x86x2176)

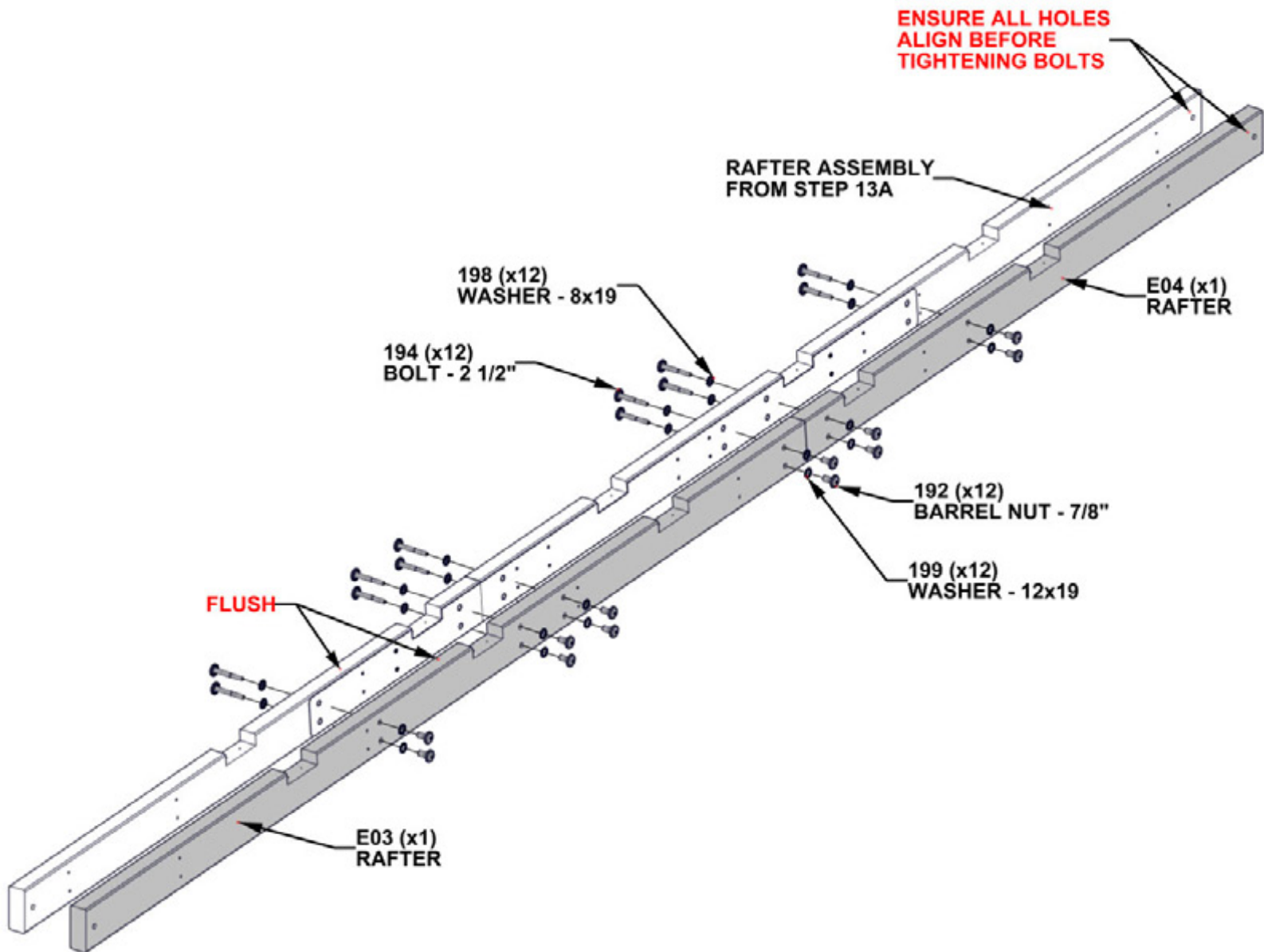

STEP 13C - RAFTER ASSEMBLY

QTY	PART NUMBER	DESCRIPTION
28	H100201	SCREW PFH 8x2 1/2 BLK



ASSEMBLY FROM STEP 13B

- AFTER COMPLETION OF STEP 13C, REPEAT STEPS (13A - 13C) TO COMPLETE (6) RAFTER ASSEMBLIES.

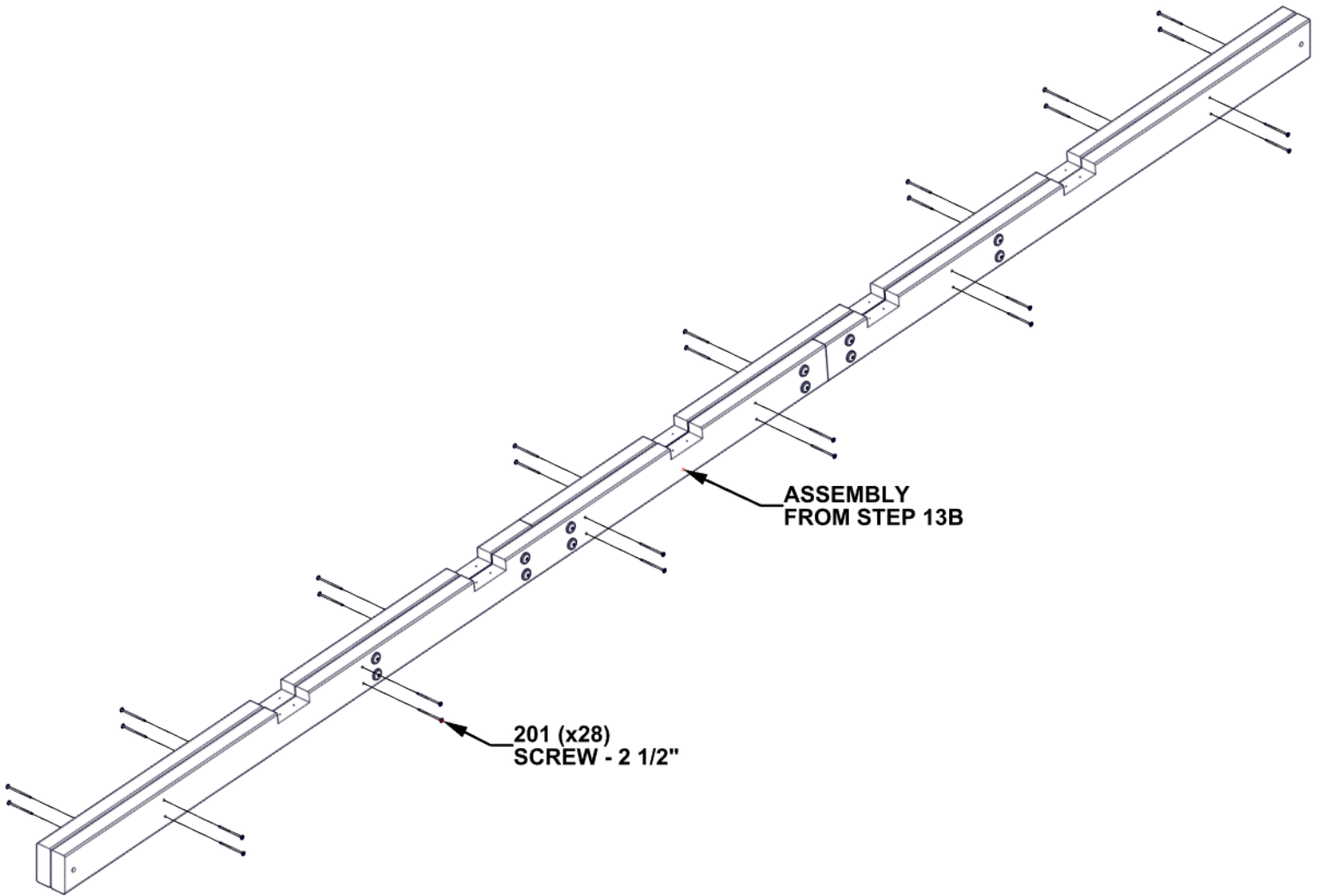

STEP 14 - GAZEBO ASSEMBLY

QTY	PART NUMBER	DESCRIPTION
12	H100653	NUT LOCK 1/4 BLK
12	H101127	BOLT WH 1/4x3-1/2 BLK
12	H100630	WASHER FLAT 8x19 BLK



ASSEMBLY FROM STEP 13C

FOR OUTSIDE RAFTERS, LOCK NUT AND WASHER GO BETWEEN POST AND RAFTER BRACKET AS SHOWN.

- INSERT RAFTERS INTO BRACKETS.
- ATTACH RAFTERS TO BRACKETS USING PROVIDED HARDWARE.
- NOTCHES IN ALL RAFTERS WILL FACE UPWARDS.

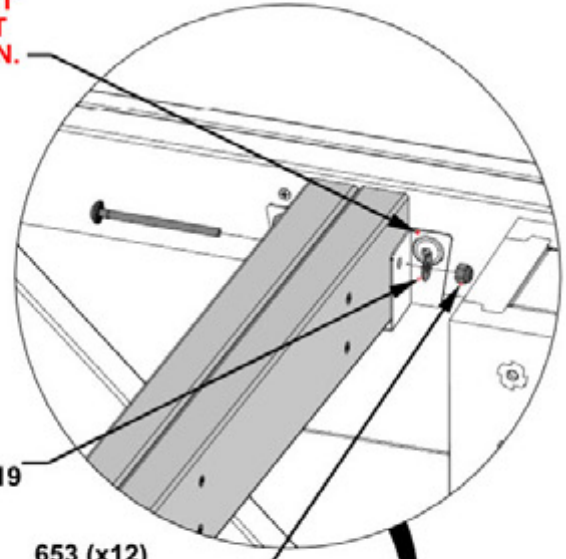
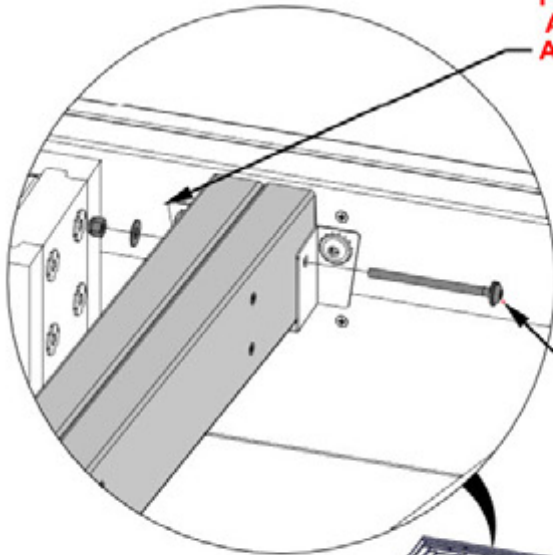

1127 (x12)
BOLT - 3-1/2"

630 (x12)
WASHER - 8x19

653 (x12)
LOCK NUT - 1/4"

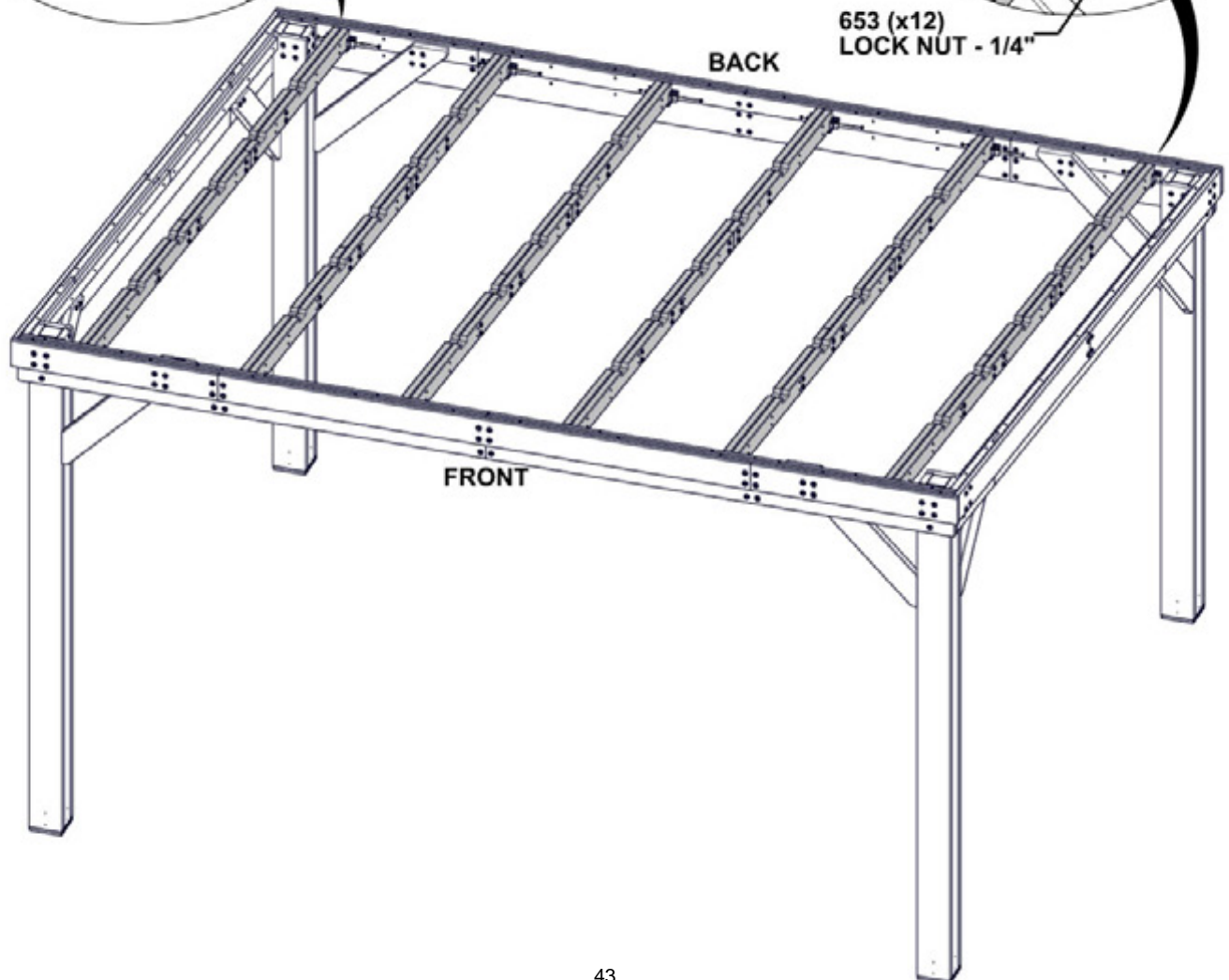

STEP 15 - GAZEBO ASSEMBLY

QTY	PART NUMBER	DESCRIPTION
40	H100382	SCREW PFH 8x1 3/4 BLK



H02 PURLIN - W4L20125
(x5) 15/16"x3 3/8"x100 13/16" (24x86x2561)

- NOTE ALTERNATING PURLIN POSITIONS

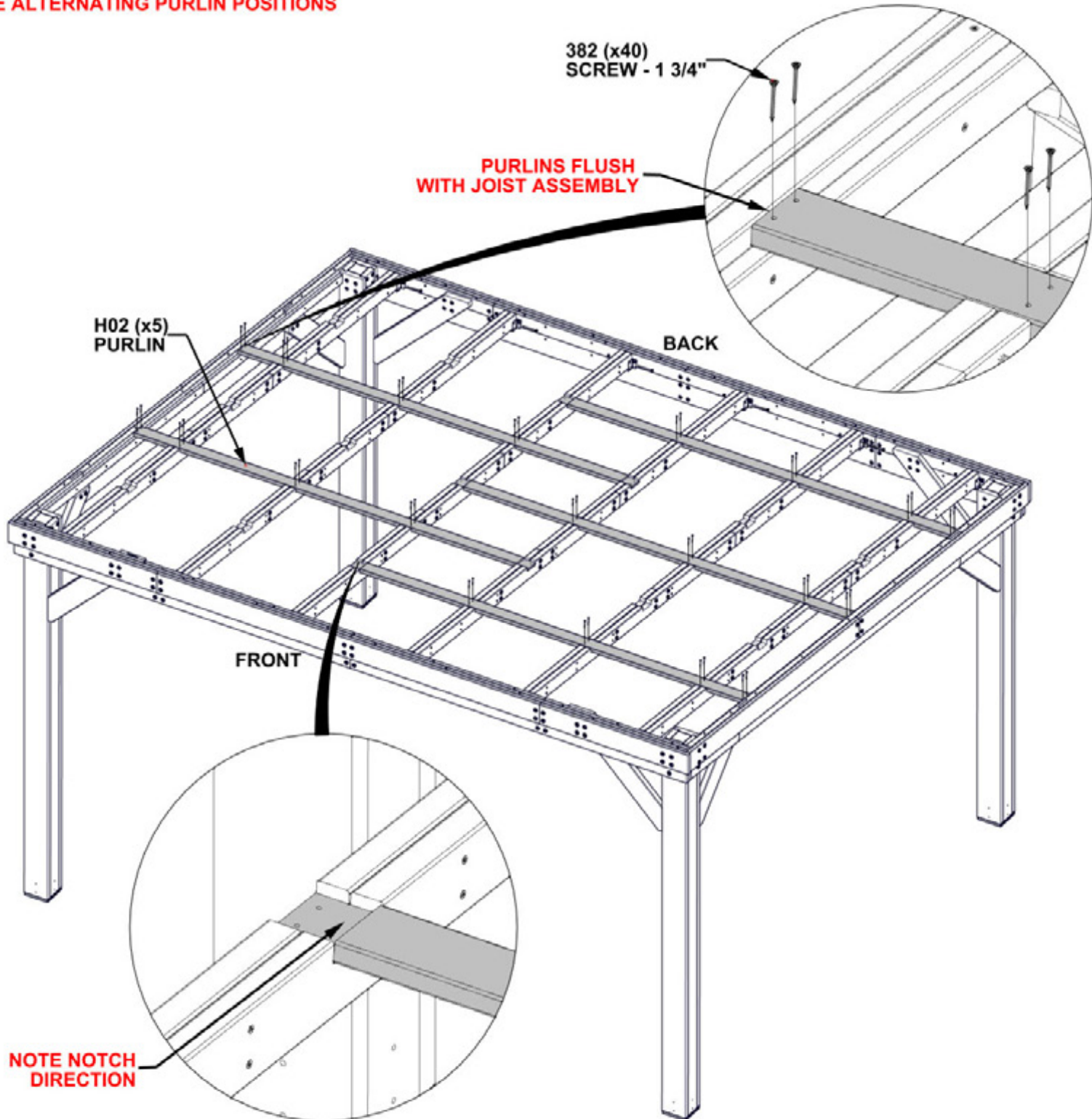

STEP 16 - GAZEBO ASSEMBLY

QTY	PART NUMBER	DESCRIPTION
40	H100382	SCREW PFH 8x1 3/4 BLK



H01 PURLIN - W4L20227
(x5) 15/16"x3 3/8"x71 3/16" (24x86x1809)

- NOTE ALTERNATING PURLIN POSITIONS

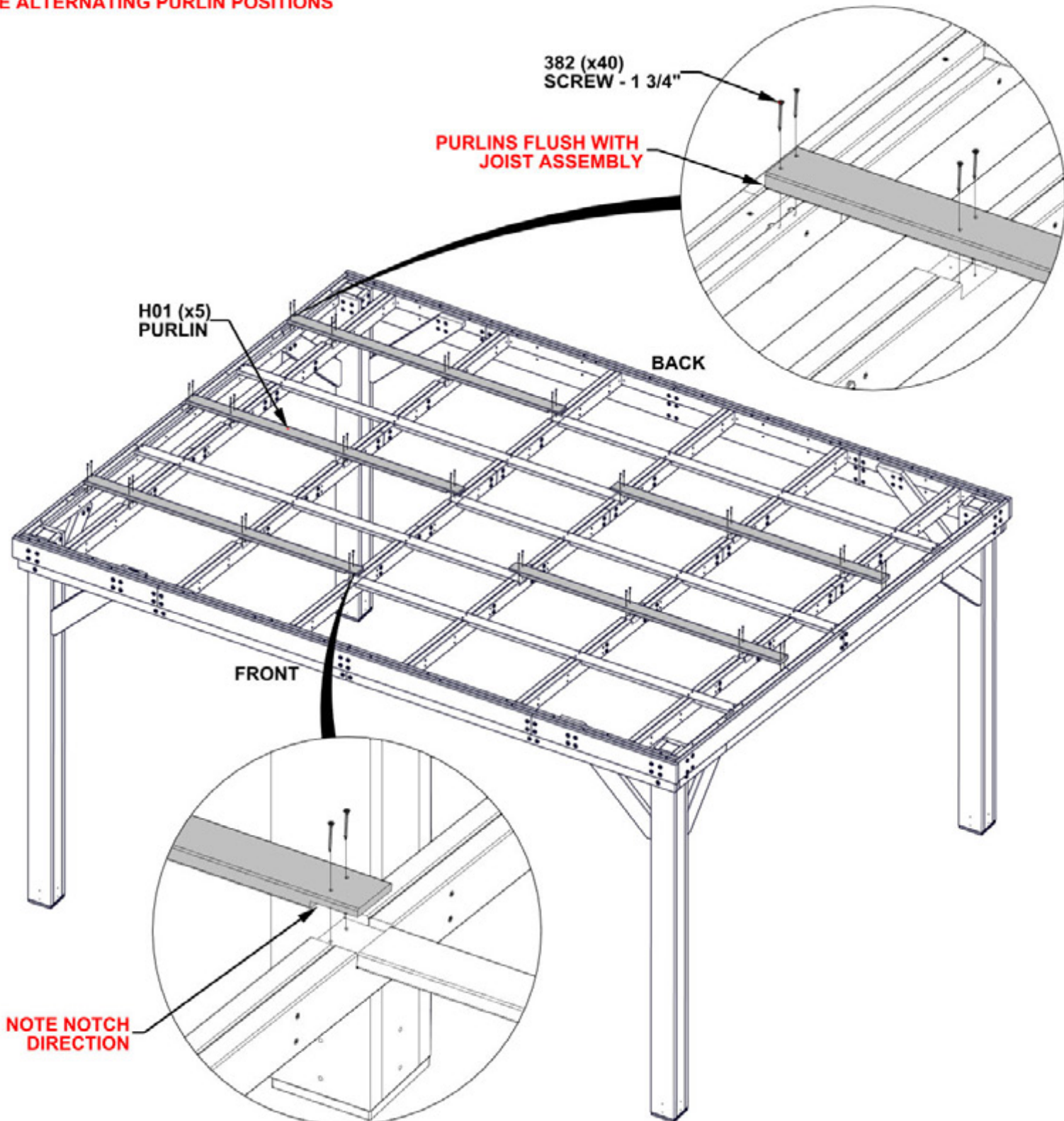

STEP 17A - GAZEBO ASSEMBLY

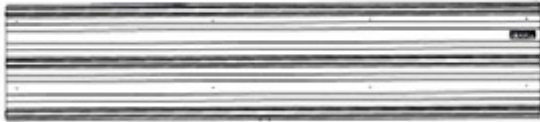

A4M04065 29GA SHEETING
(x1)



A4M04046 29GA SHEETING
(x1)

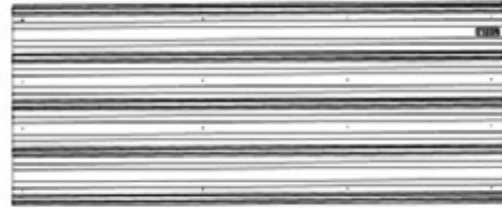

A4M04047 29GA SHEETING
(x5)

WARNING:

- GLOVES ARE RECOMMENDED WHEN HANDLING STEEL ROOF SHEETS.
- REMOVE BLUE FILM FROM ROOF PANELS.
- ORIENT ROOF PANELS AS SHOWN BELOW.
- START BY FLUSHING THE FIRST SHEET WITH THE SIDE OF THE BEAM, THEN MARK WHERE EVERY OTHER SHEET WILL LAND AS SHOWN BELOW TO ENSURE THE PANELS WILL ALIGN CORRECTLY. THE LAST SHEET SHOULD ALIGN CLOSE TO THE EDGE OF THE BEAM.
- IT IS IMPORTANT TO HOLD THE 1/4" OVERHANG AT THE BACK OF THE UNIT SO TRIM PIECES WILL FIT CORRECTLY IN FUTURE STEPS.
- SEE NEXT STEP FOR FASTENING REQUIREMENTS.

4065 (x1)
29GA
SHEETING

FIRST SHEET
TO BE FLUSH
WITH THE SIDE.

FRONT

1/4"
[6.4mm]

129 1/8"
[3280mm]

4047 (x5)
29GA
SHEETING

BACK

45 1/16"
[1145mm]

4046 (x1)
29GA
SHEETING

MIDDLE

NOTE LOCATION OF "MIDDLE"
STICKER FOR ORIENTATION
OF SHEETING

STEP 17B - GAZEBO ASSEMBLY

QTY	PART NUMBER	DESCRIPTION
48	H101117	SCREW WOODGRIP 10-16x3/4" BLK

WARNING:
- GLOVES ARE RECOMMENDED WHEN HANDLING STEEL ROOF SHEETS.
- DO NOT GET ON THE ROOF TO ATTACH SCREWS.

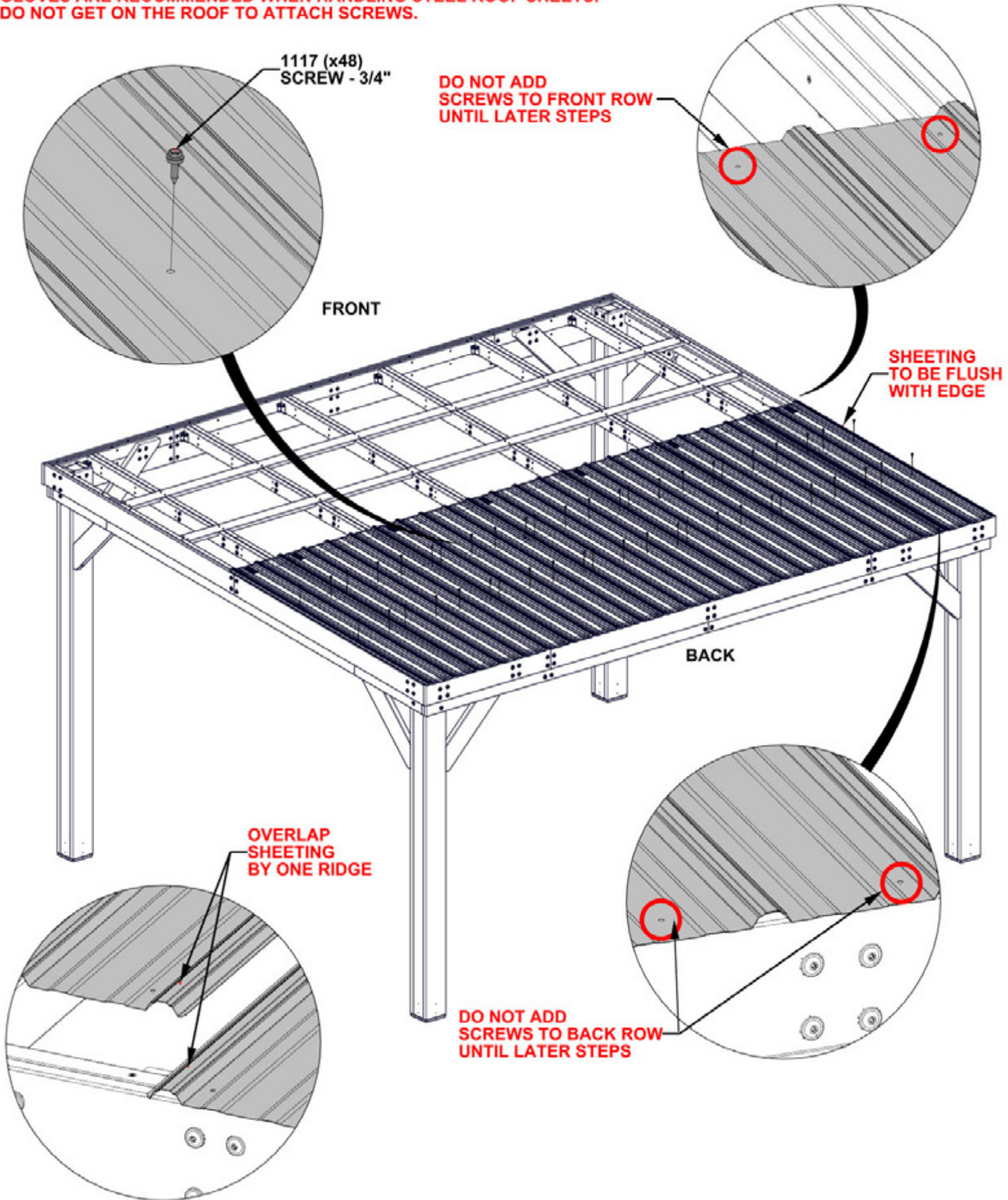

STEP 18 - GAZEBO ASSEMBLY

QTY	PART NUMBER	DESCRIPTION
24	H101117	SCREW WOODGRIP 10-16x3/4" BLK



A4M03429 DRIP EDGE TRIM (x2)



A4M02794 DRIP EDGE TRIM (x1)

- WARNING:**
- GLOVES ARE RECOMMENDED WHEN HANDLING STEEL ROOF SHEETS.
 - DO NOT GET ON THE ROOF TO ATTACH SCREWS.
 - REMOVE BLUE FILM FROM DRIP EDGE AND DRIP EDGE SPLICE.
 - ORIENT DRIP EDGE AND DRIP EDGE SPLICE AS SHOWN BELOW.
 - ATTACH USING HOLES IN SHEETING.

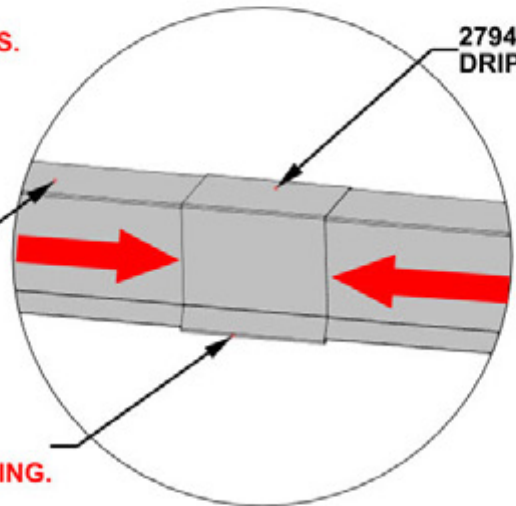

SLIDE DRIP EDGE INTO DRIP EDGE SPLICE BEFORE PUSHING UNDERNEATH SHEETING.

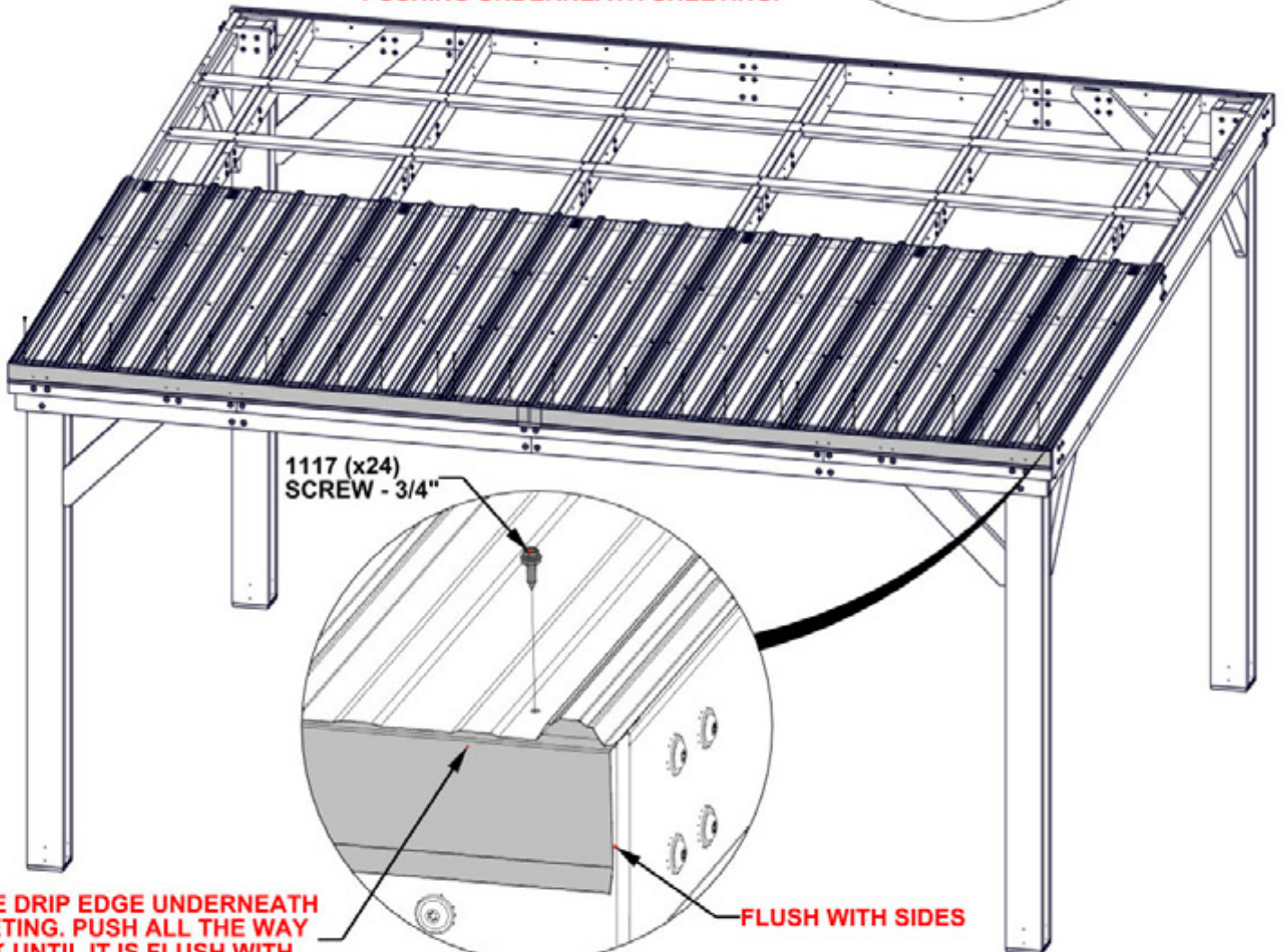

SLIDE DRIP EDGE UNDERNEATH SHEETING. PUSH ALL THE WAY BACK UNTIL IT IS FLUSH WITH BACKSIDE OF SHEETING.

FLUSH WITH SIDES

STEP 19 - GAZEBO ASSEMBLY



A6P00556 WEATHER TAPE
(x1)

556 (x1)
WEATHER TAPE

APPLY WEATHER TAPE APPROXIMATELY 1" [24mm] FROM EDGE AS SHOWN. APPLY ACROSS ALL SHEETS BEFORE INSTALLING NEXT ROW OF SHEETING.

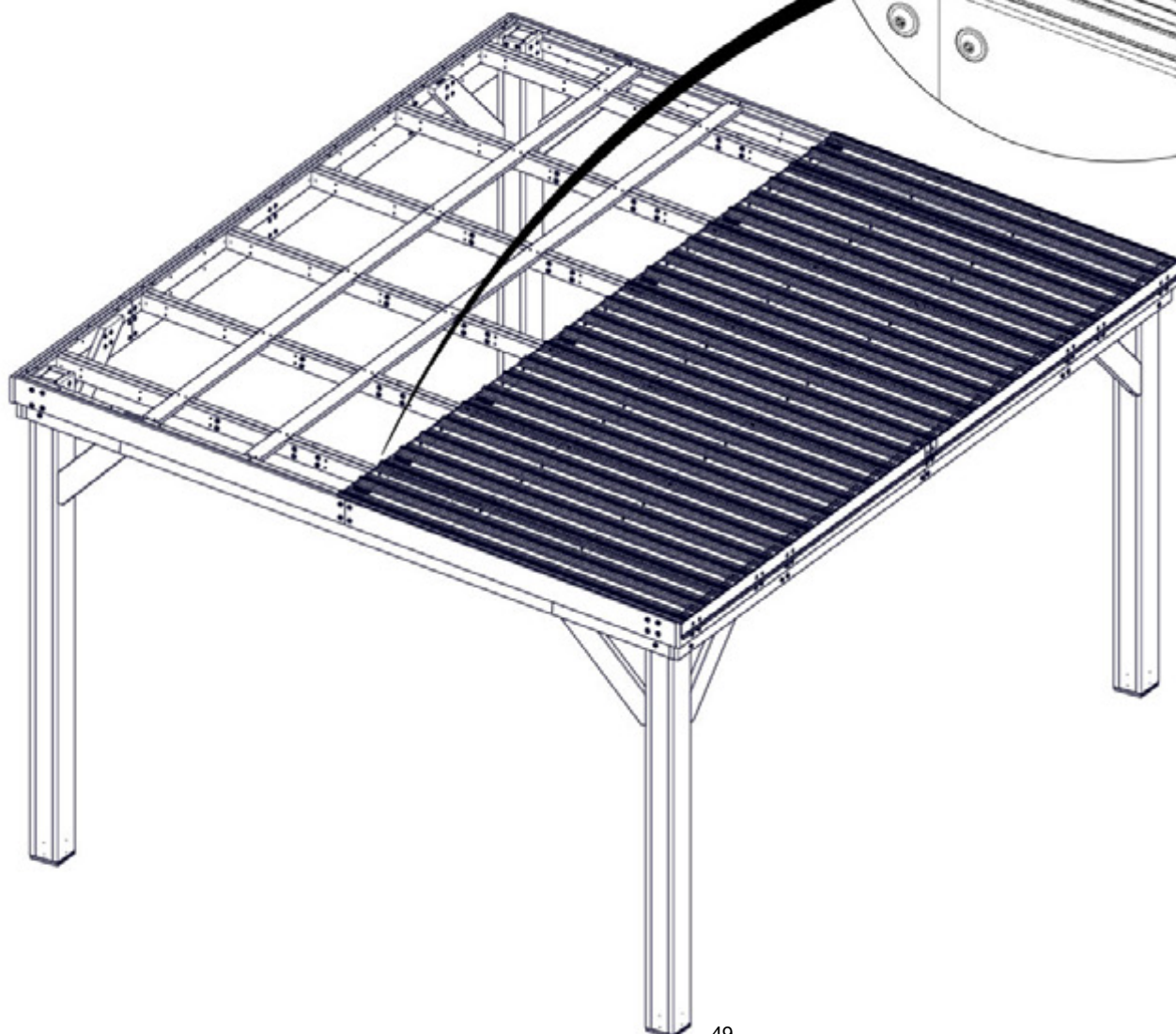
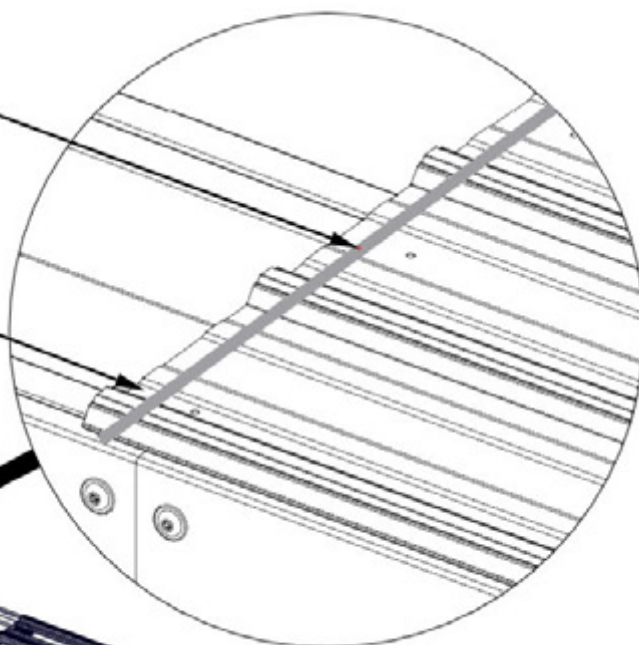

STEP 20A - GAZEBO ASSEMBLY

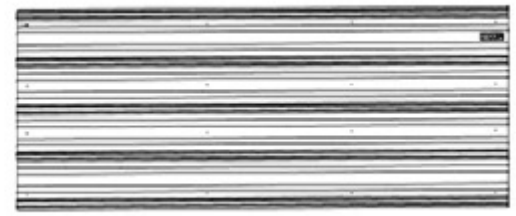

A4M04065 29GA SHEETING (x1)

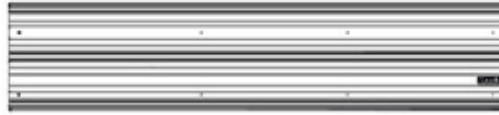

A4M04046 29GA SHEETING (x1)

A4M04047 29GA SHEETING (x5)

WARNING: GLOVES ARE RECOMMENDED WHEN HANDLING STEEL ROOF SHEETS.

- REMOVE BLUE FILM FROM ROOF PANELS.
- ORIENT ROOF PANELS AS SHOWN BELOW.
- START BY FLUSHING THE FIRST SHEET WITH THE SIDE OF THE BEAM, THEN MARK WHERE EVERY OTHER SHEET WILL LAND AS SHOWN BELOW TO ENSURE THE PANELS WILL ALIGN CORRECTLY. THE LAST SHEET SHOULD ALIGN CLOSE TO THE EDGE OF THE BEAM.
- SEE NEXT STEP FOR FASTENING REQUIREMENTS.

NOTE LOCATION OF "MIDDLE" STICKER FOR ORIENTATION OF SHEETING

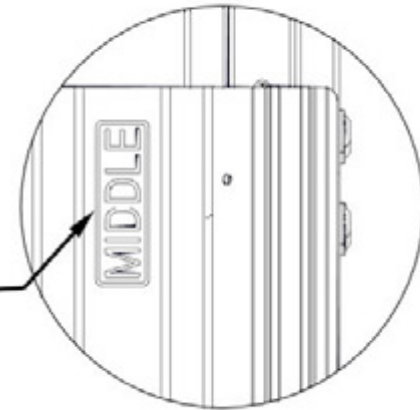

OVERLAP SHEETING BY ONE RIDGE

ALIGN HOLES WITH PREVIOUSLY INSTALLED SHEETING

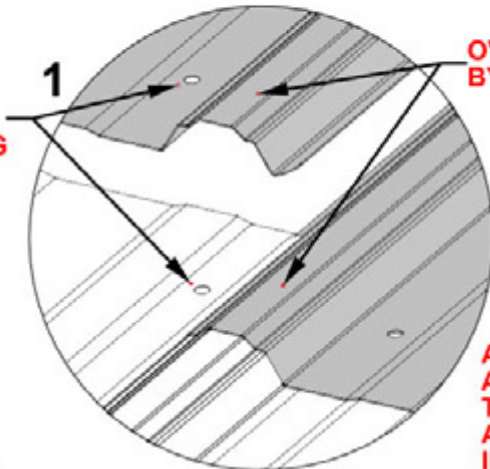

AFTER SHEET HOLES ARE ALIGNED, USE THE TOP SHEET AS A GUIDE AND DRILL AN 1/8" HOLE IN THE BOTTOM SHEET.

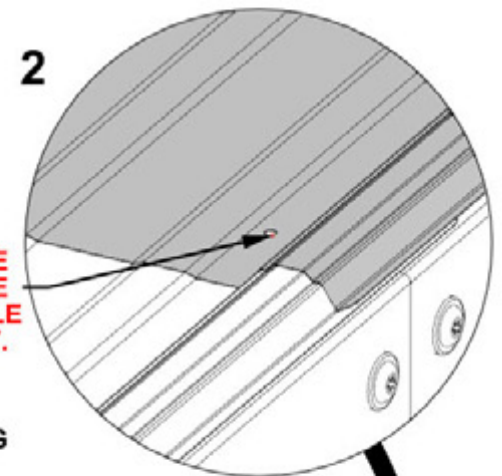

4046 (x1) 29GA SHEETING

129 1/8" [3280mm]

4047 (x5) 29GA SHEETING

FRONT

45 1/16" [1145mm]

4065 (x1) 29GA SHEETING

BACK

STEP 20B - GAZEBO ASSEMBLY

QTY	PART NUMBER	DESCRIPTION
96	H101117	SCREW WOODGRIP 10-16x3/4" BLK

WARNING:

- GLOVES ARE RECOMMENDED WHEN HANDLING STEEL ROOF SHEETS.
- DO NOT GET ON THE ROOF TO ATTACH SCREWS.
- FULLY ATTACH EACH SHEET BEFORE ATTACHING THE NEXT. SHEETS MAY NEED TO BE MOVED OUT OF THE WAY TO REACH ALL SCREWS. RECONFIRM MEASUREMENTS AND ALIGNMENT FROM PREVIOUS STEP IF A SHEET IS MOVED.

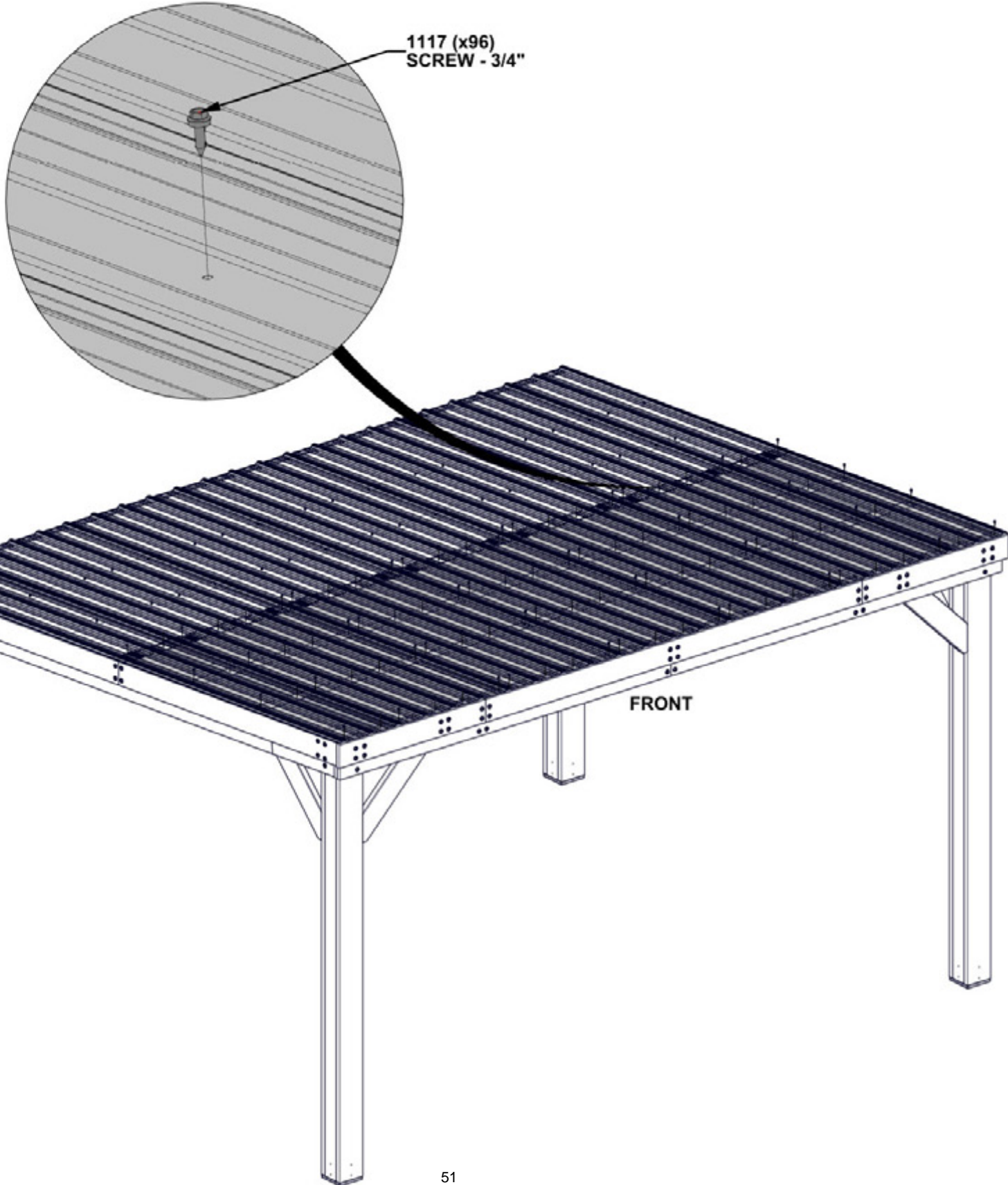

STEP 21 - GAZEBO ASSEMBLY

QTY	PART NUMBER	DESCRIPTION
12	H101116	SCREW SELF TAPPING 1/4 x 1

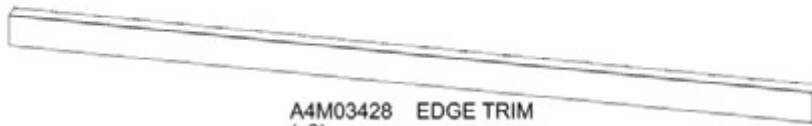

A4M03428 EDGE TRIM (x2)



A4M02734 TRIM SPLICE (x1)



A4M02735 CORNER SPLICE TRIM RH (x1)



A4M02736 CORNER SPLICE TRIM LH (x1)

WARNING: GLOVES ARE RECOMMENDED WHEN HANDLING STEEL ROOF SHEETS.

- REMOVE BLUE FILM FROM EDGE TRIM, EDGE TRIM SPLICE, AND CORNER SPLICE TRIM.
- ORIENT EDGE TRIM, EDGE TRIM SPLICE, AND CORNER SPLICE TRIM AS SHOWN BELOW.
- SLIDE TRIM PIECES INTO SPLICES. ATTACH CORNER SPLICES BY SLIDING ONTO EDGE TRIM. INSERT SCREWS AS NOTED IN DETAIL.

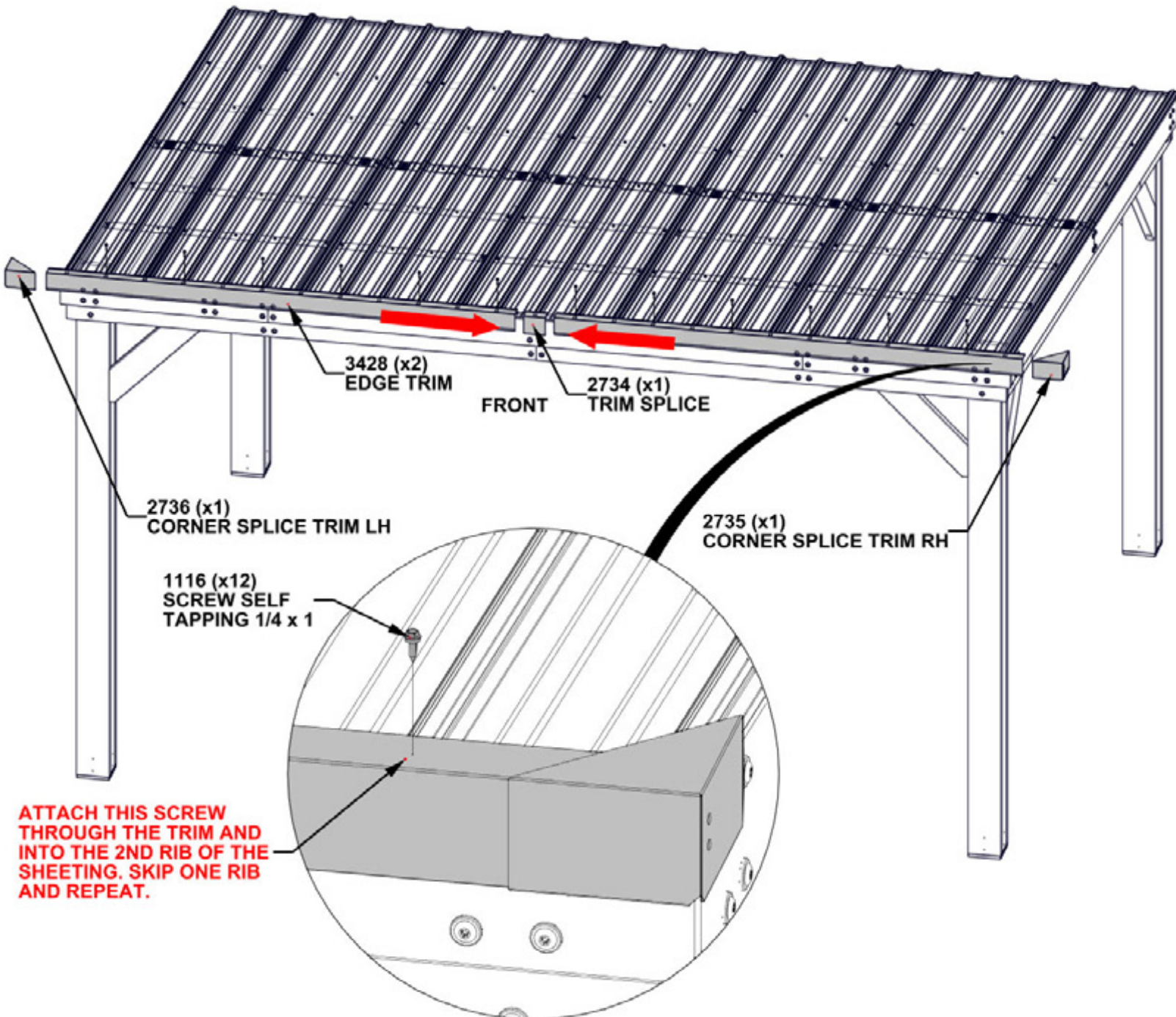

ATTACH THIS SCREW THROUGH THE TRIM AND INTO THE 2ND RIB OF THE SHEETING. SKIP ONE RIB AND REPEAT.

STEP 22 - GAZEBO ASSEMBLY

QTY	PART NUMBER	DESCRIPTION
16	H101116	SCREW SELF TAPPING 1/4 x 1

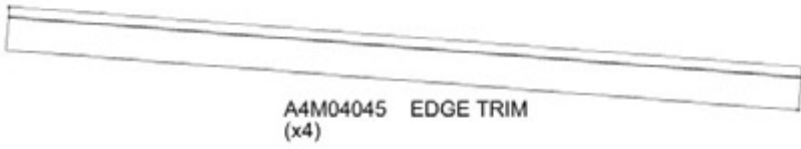

WARNING: GLOVES ARE RECOMMENDED WHEN HANDLING STEEL ROOF SHEETS.

- REMOVE BLUE FILM FROM EDGE TRIM, EDGE TRIM SPLICE, AND CORNER SPLICE TRIM.
- ORIENT EDGE TRIM AND EDGE TRIM SPLICE AS SHOWN BELOW. SLIDE EDGE TRIM INTO SPLICES.
- FLUSH LAST PIECE WITH THE REAR DRIP EDGE. SCREWS GO THROUGH EDGE TRIM INTO RIB AT THE APPROXIMATE LOCATIONS SHOWN.
- REPEAT ON OPPOSITE SIDE.

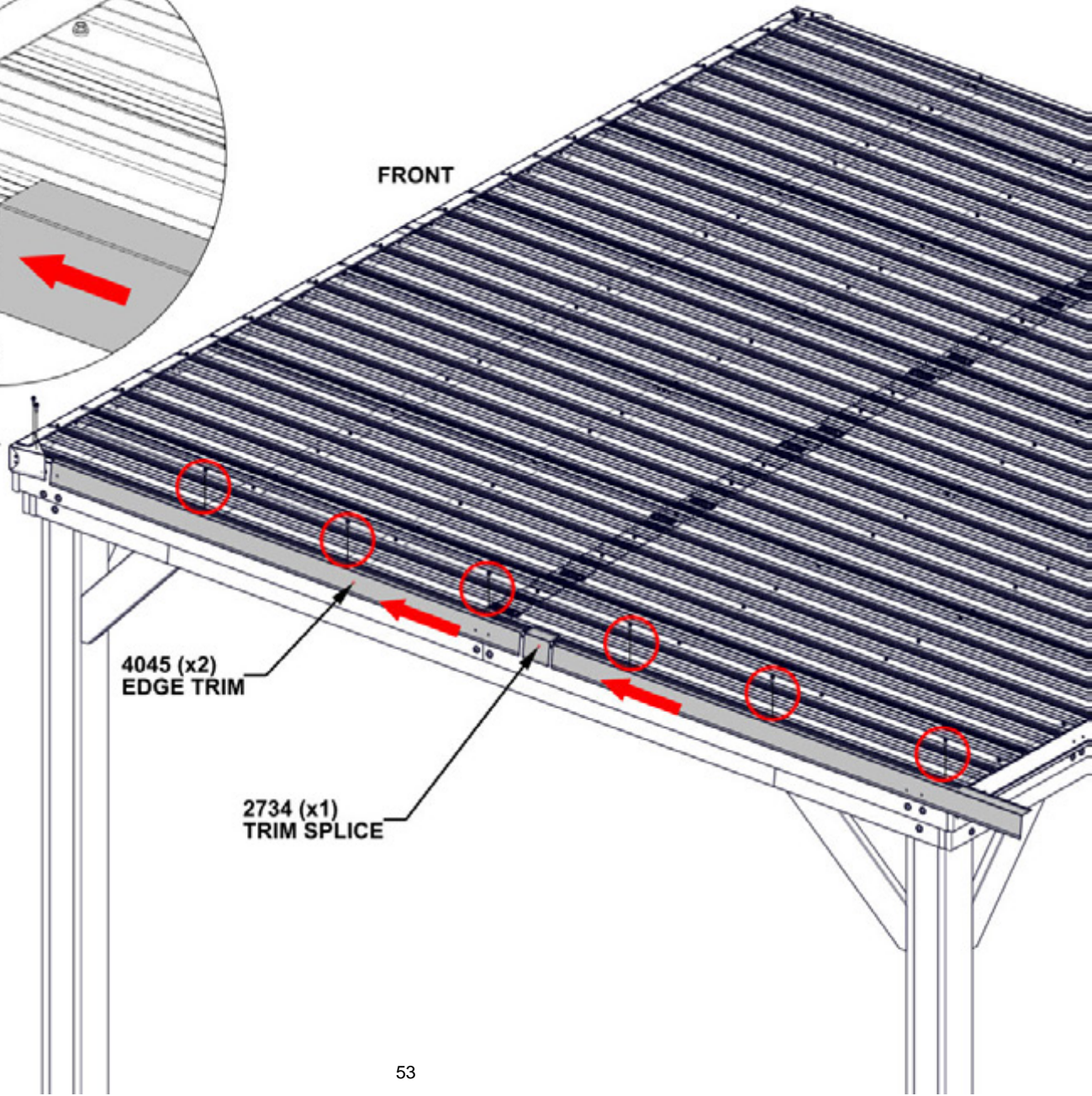
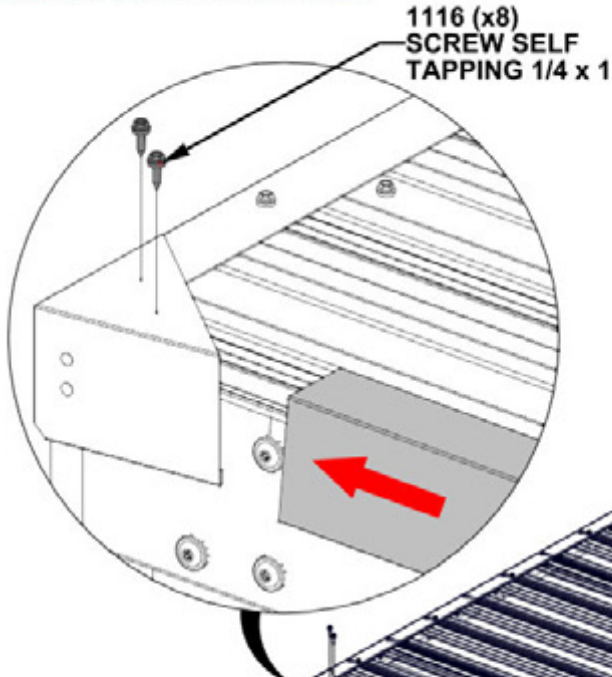

STEP 23 - GAZEBO ASSEMBLY

QTY	PART NUMBER	DESCRIPTION
32	H100471	LAG SCREW WH 5/16x1 1/2 BLK

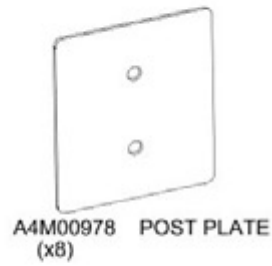
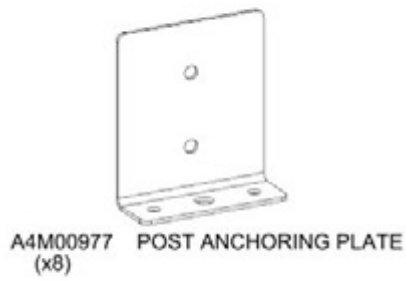

- 977 POST ANCHORING PLATE WITH FLANGE MOUNTS ON OUTSIDE OF POST AS SHOWN.
- 978 POST PLATES GO ON INSIDE OF POST AS SHOWN

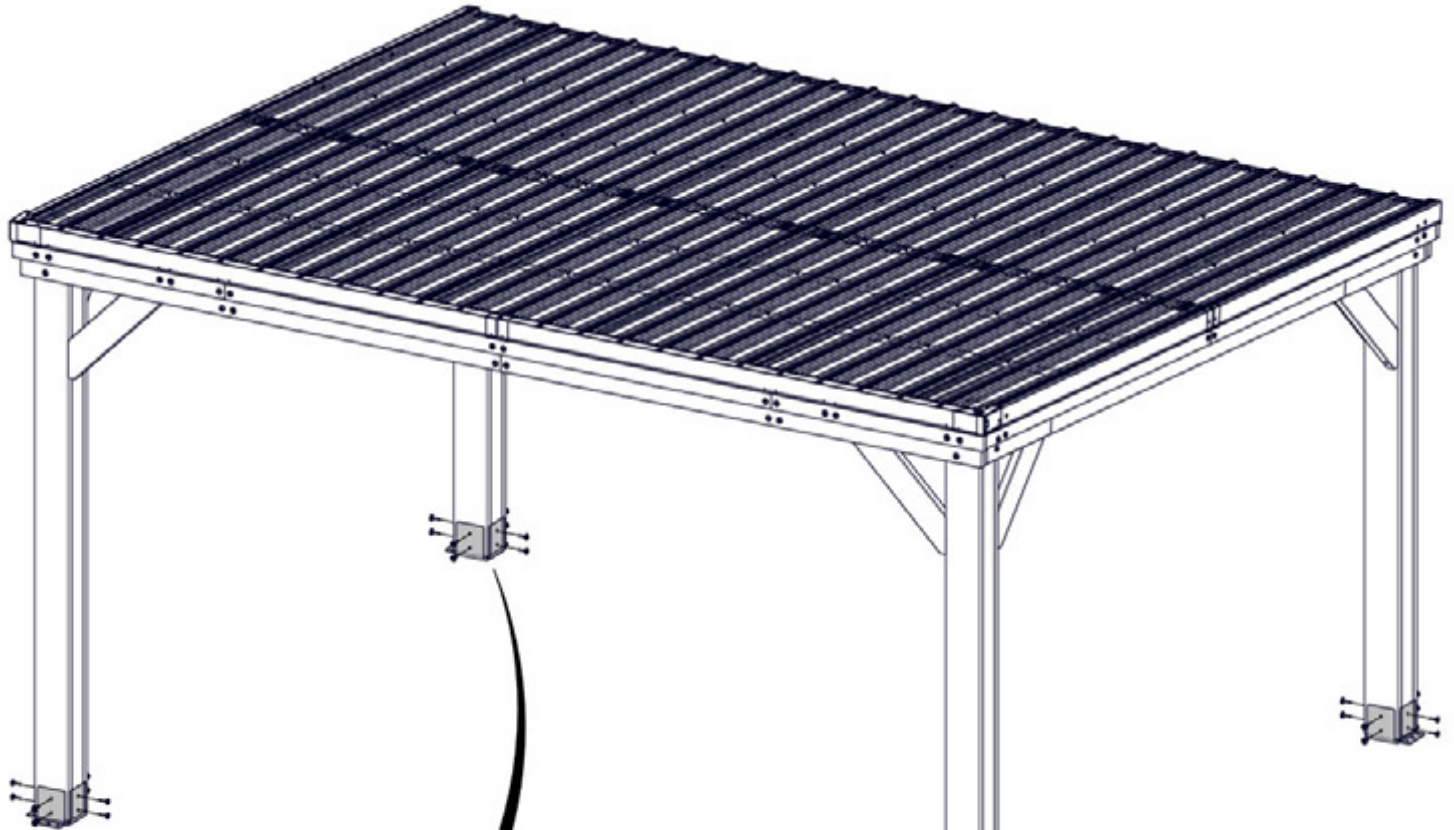

ALIGN EACH PLATE WITH PILOT HOLES IN POST.

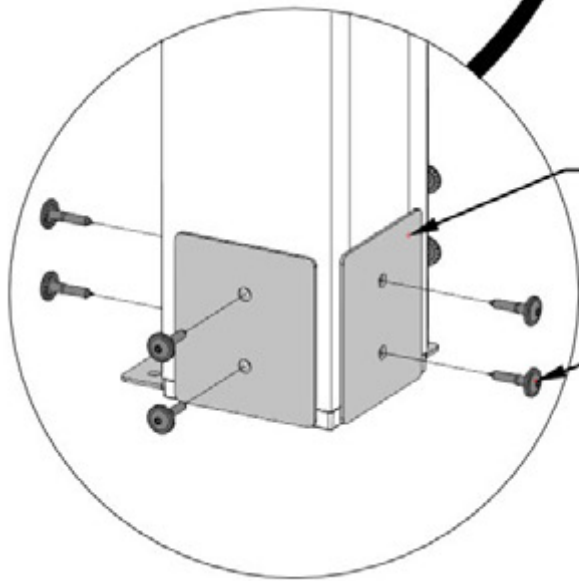

471 (x32) LAG SCREW - 1 1/2"

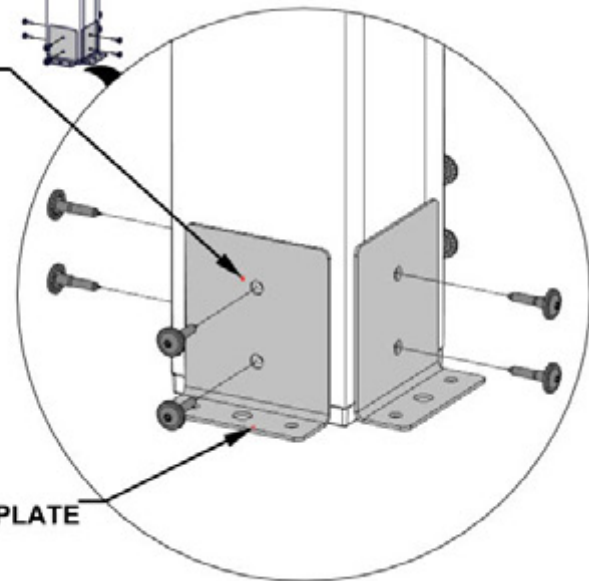

STEP 24 - GAZEBO ASSEMBLY

QTY	PART NUMBER	DESCRIPTION
4	H100202	SCREW PWH 8x5/8 BLK



A4M02158 BYD ID TAG PATIO
(x1)

- PLACE ID TAG IN APPROXIMATE LOCATION SHOWN.

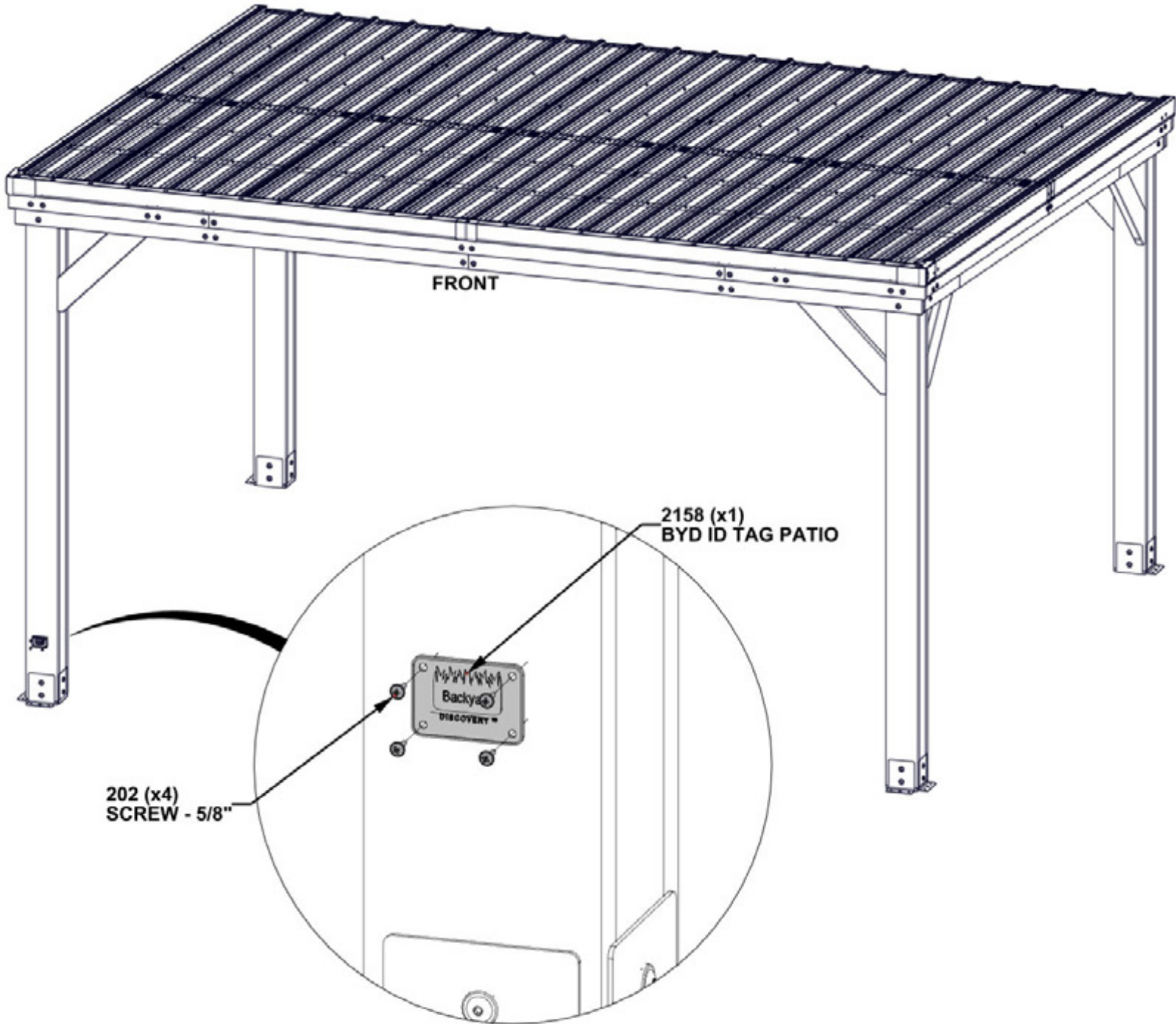

STEP 25 - GAZEBO ASSEMBLY

QTY	PART NUMBER	DESCRIPTION
16	H100630	WASHER FLAT 8x19 BLK
16	H100120	CONCRETE ANCHOR 1/4"x2"

MANUFACTURER RECOMMENDS INSTALLATION ON CONCRETE SURFACE OR CONCRETE POST PADS AS SHOWN BELOW.

FOR INSTALLATION ON WOOD DECK, YOU MUST ENSURE THERE IS AMPLE STRUCTURAL SUPPORT UNDER THE DECK. HARDWARE NOT INCLUDED FOR DECK ATTACHMENT

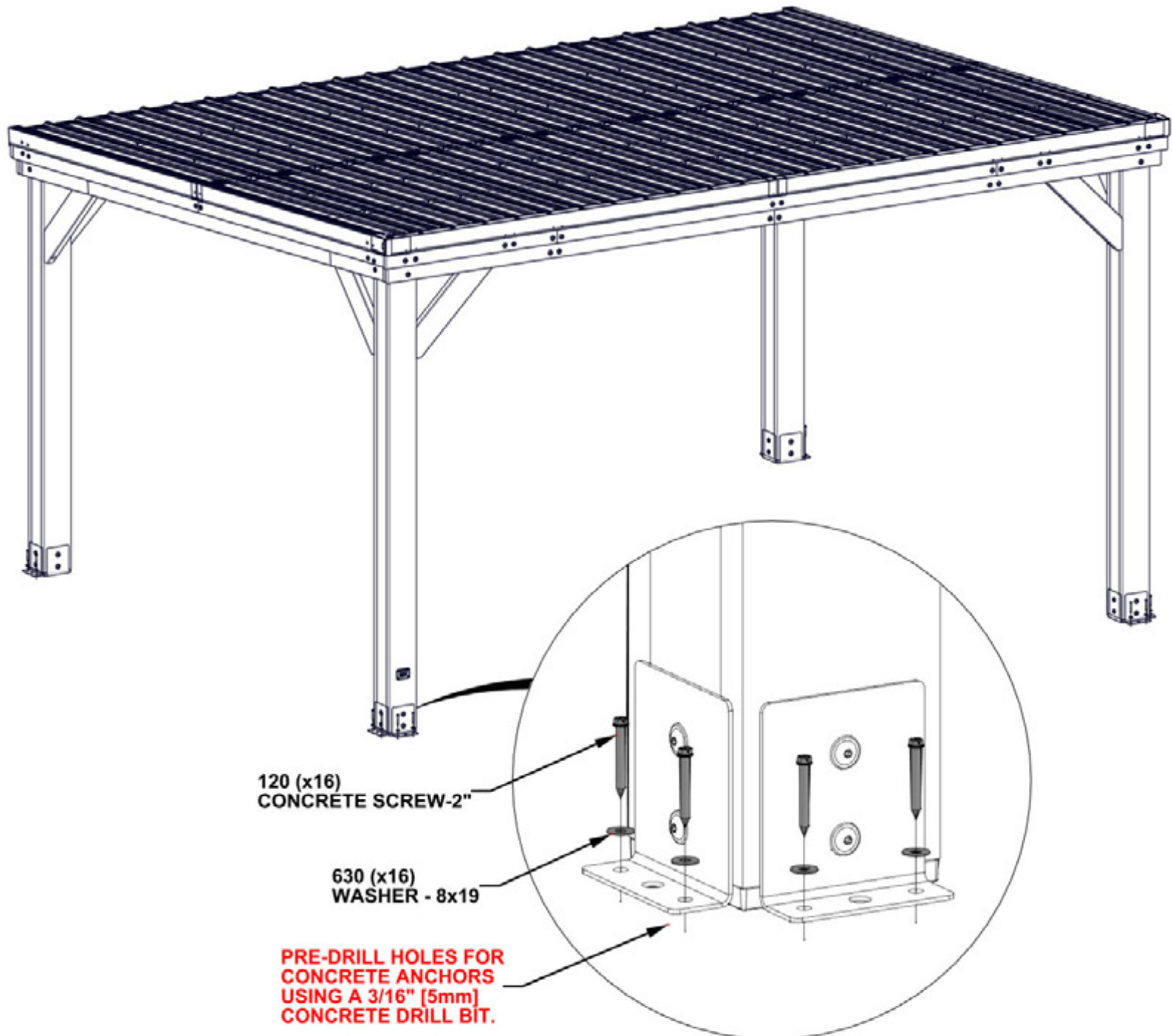

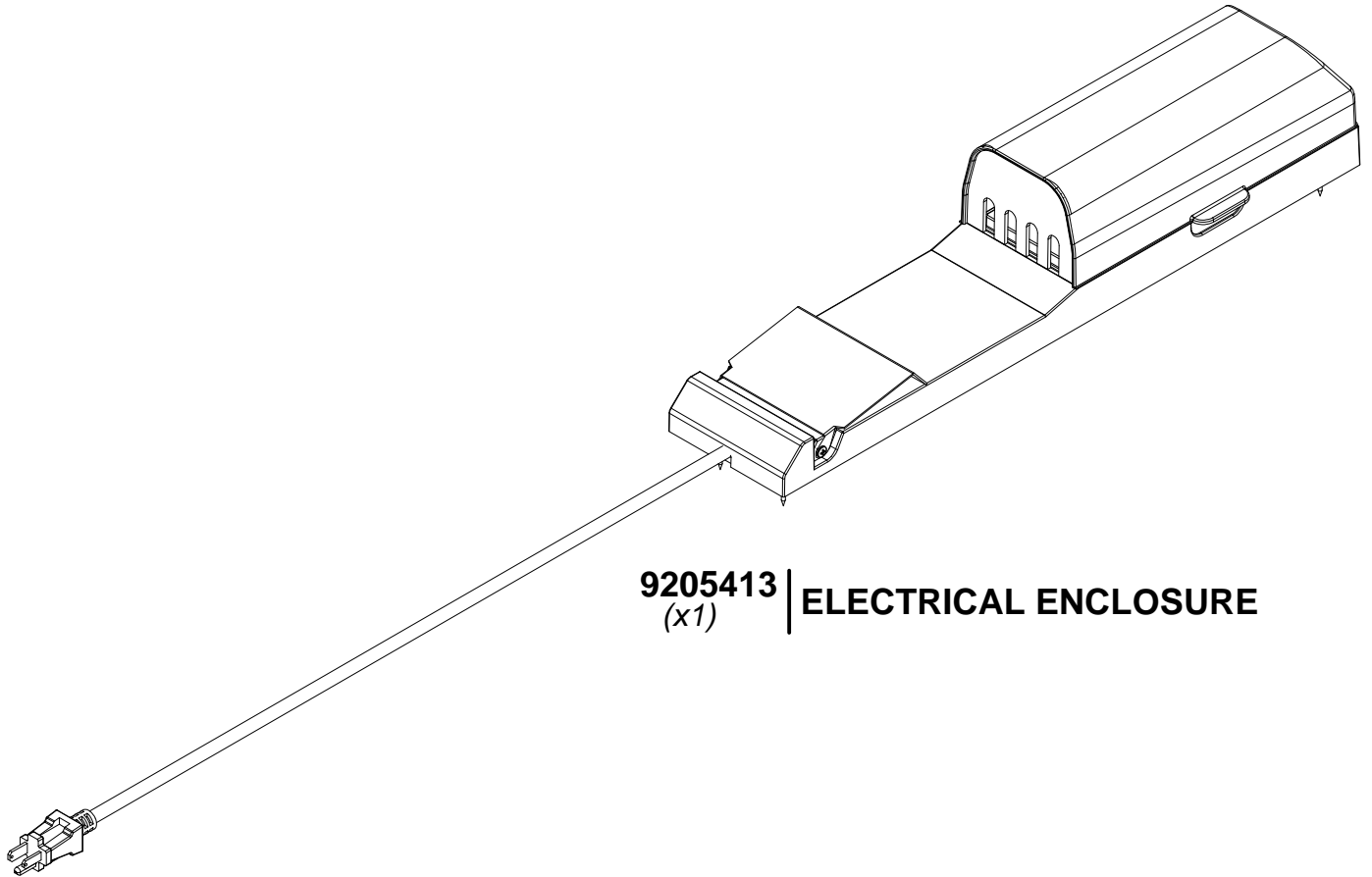

9205413 | **ELECTRICAL ENCLOSURE**
(x1)

FOR POWERPORT INSTALLATION REFER TO ASSEMBLY INSTRUCTIONS THAT COME PACKAGED WITH THE POWERPORT KIT. INSTALL ON ANY POST THAT IS DESIRED. FOLLOW DIRECTIONS FOR PROPER INSTALLATION.