



Manufactured by:
Backyard Discovery
3305 Airport Drive, Pittsburg, KS
66762 800-856-4445

Backyard Discovery Australia Pty Ltd 2/7 Hood Street, Hampton VIC 3188, Phone: 1800-087-941

20x12 NORWOOD CARPORT/GAZEBO

MODEL # : 2406087



Please visit www.backyarddiscovery.com
For the most up to date assembly manual, to register your product, or to order replacement parts *Para obtener instrucciones en español, visite*
www.backyarddiscovery.com



EASY STEP-BY-STEP
3D INTERACTIVE INSTRUCTIONS
DOWNLOAD THE FREE APP



OWNER'S MANUAL - BASIC SETUP DIMENSIONS & ASSEMBLY NOTES

It is critically important that you start with square and level footings, concrete pad or deck to attach your structure

- Pay close attention to the items needed for each step. Make sure you are using the correct hardware for each step. Using incorrect hardware may result in improper assembly
- Remember to double check for underground utilities and overhead electrical lines

Post mounts are provided with your structure which allows you to permanently install your structure to a pre-existing or new wood or concrete surface. See Anchor Instructions for further details and recommendations.

- The hardware to attach the post mounts to the structure is included.
- The hardware to mount the structure permanently to a concrete surface is included.
- The hardware to mount the structure permanently to a wood deck is NOT included and will need to be purchased separately. You must ensure there is ample structural support under the deck before permanently attaching.

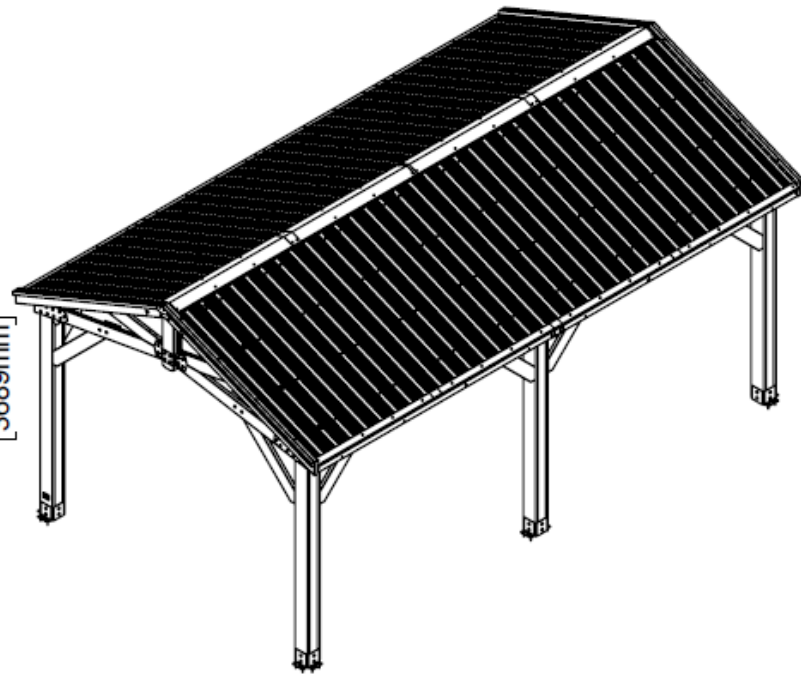
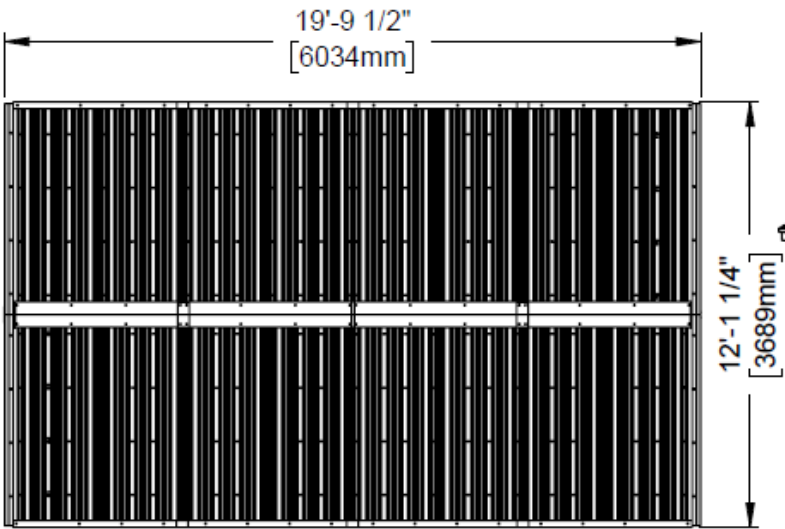
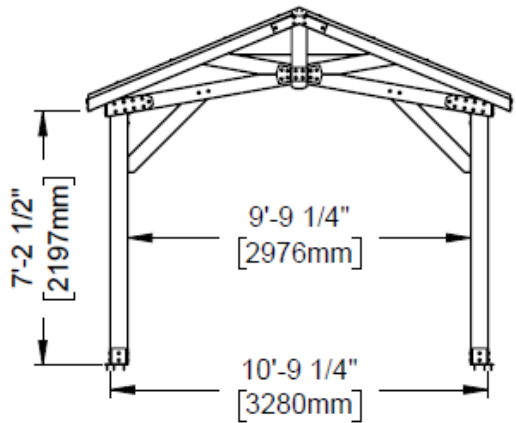
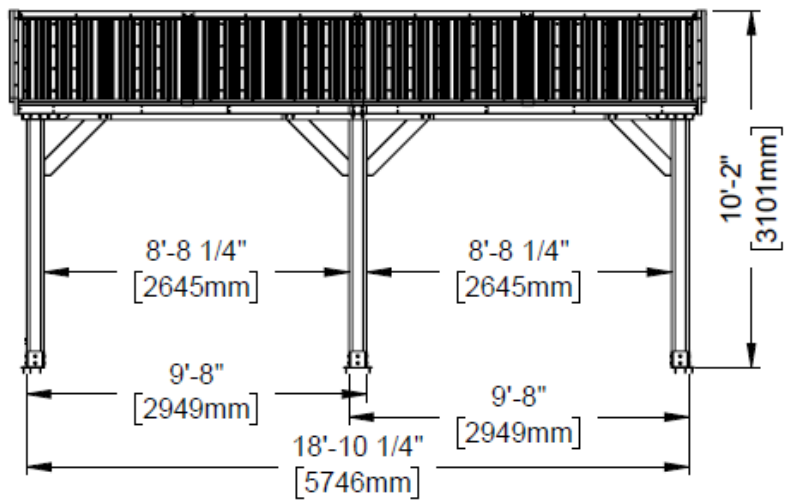

OWNER'S MANUAL - ANCHORING LAYOUT

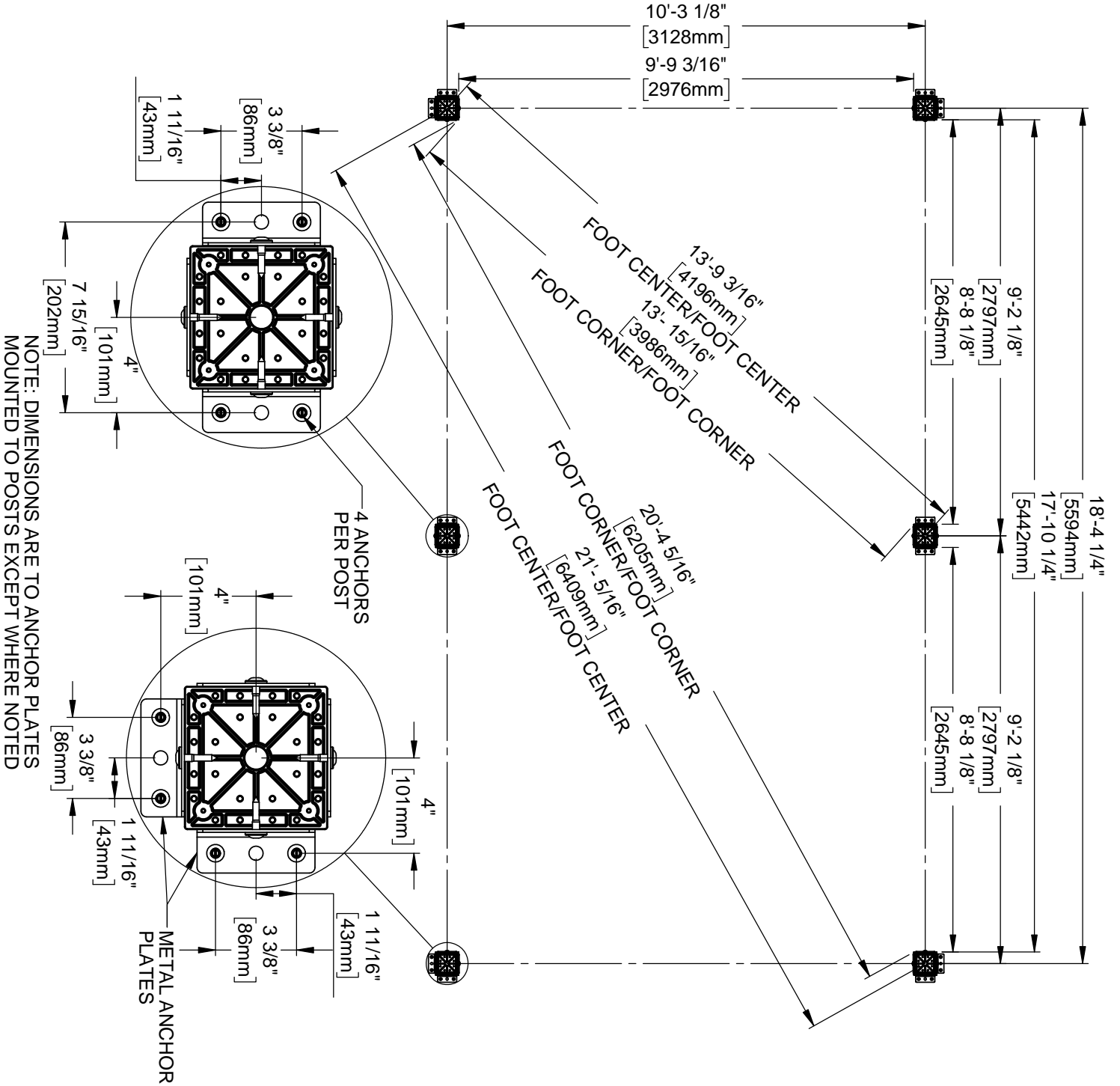

OWNER'S MANUAL - PARTS IDENTIFICATION

WOOD COMPONENTS (NOT TO SCALE)



D01 GABLE BOARD - W4L16415
(x8) 1 3/8"x5 1/4"x24 5/8" (36x134x625)



D02 TOP RAIL - W4L16379
(x4) 1 3/8"x5 1/4"x30 3/8" (36x134x770)



D03 TOP RAIL - W4L16380
(x4) 1 3/8"x5 1/4"x68 7/8" (36x134x1749)



D04 CORBEL - W4L16944
(x8) 1 3/8"x5 1/4"x34 7/16" (36x134x875)



D05 GABLE BOARD - W4L16753
(x4) 1 3/8"x1 1/2"x5 1/4" (36x38x134)



D06 CORBEL - W4L16375
(x3) 1 3/8"x5 1/4"x44 1/16" (36x134x1119)



D07 TOP RAIL - W4L16381
(x2) 1 3/8"x5 1/4"x51 3/4" (36x134x1316)



E01 RAFTER - W4L16382
(x8) 1 3/8"x3 3/8"x77 3/8" (36x86x1965)



E08 RAFTER - W4L16755
(x8) 1 3/8"x3 3/8"x77 3/8" (36x86x1965)



E09 ACCESSORY TRUSS - W4L16756
(x8) 1 3/8"x3 3/8"x73 7/8" (36x86x1875)

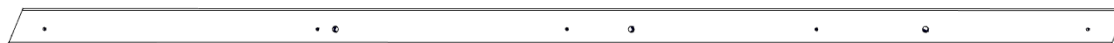

F01 TRUSS - W4L16414
(x4) 1 3/8"x2 3/8"x75 1/8" (36x60x1907)



F02 TRUSS - W4L16378
(x4) 1 3/8"x2 3/8"x68" (36x60x1727)



H01 FASCIA - W4L16383
(x4) 1"x3 3/8"x68 5/8" (24x86x1742)



H02 FASCIA - W4L16384
(x4) 1"x3 3/8"x38 1/2" (24x86x978)



H03 FASCIA - W4L16385
(x4) 1"x3 3/8"x72 3/4" (24x86x1849)

OWNER'S MANUAL - PARTS IDENTIFICATION

WOOD COMPONENTS (NOT TO SCALE)



H04 FASCIA - W4L16386
(x4) 1"x3 3/8"x44 3/8" (24x86x1128)



H05 SHEATHING BOARD - W4L16392
(x8) 1"x3 3/8"x72 3/4" (24x86x1849)



H06 SHEATHING BOARD - W4L16393
(x8) 1"x3 3/8"x74 3/8" (24x86x1888)



H07 SHEATHING BOARD - W4L16394
(x8) 1"x3 3/8"x42 3/4" (24x86x1085)



H08 SHEATHING BOARD - W4L16395
(x8) 1"x3 3/8"x44 1/4" (24x86x1124)



J01 STIFFENER BOARD - W4L16401
(x4) 1"x2 3/8"x68 5/8" (24x60x1744)



J02 STIFFENER BOARD - W4L16402
(x4) 1"x2 3/8"x47" (24x60x1194)



GP1 GABLE PANEL - W2A03379
(x2) 2 13/16"x5 1/4"x80 3/16" (72x134x2037)



GP2 GABLE PANEL - W2A03380
(x2) 2 13/16"x5 1/4"x80 3/16" (72x134x2037)

OWNER'S MANUAL - PARTS IDENTIFICATION

WOOD COMPONENTS (NOT TO SCALE)

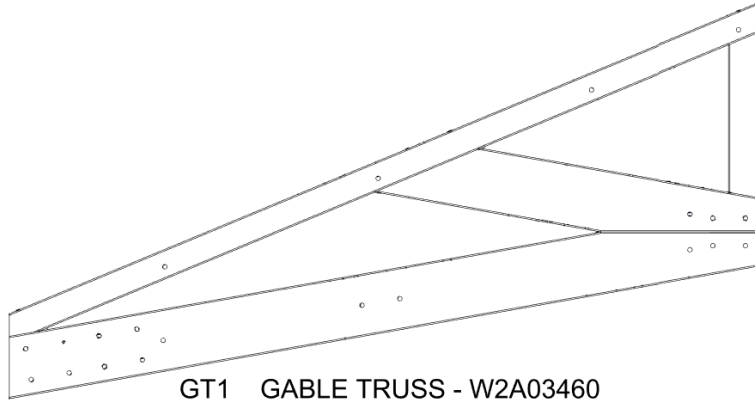

GT1 GABLE TRUSS - W2A03460
(x4) 1 3/8"x34"x64 5/8" (36x864x845)

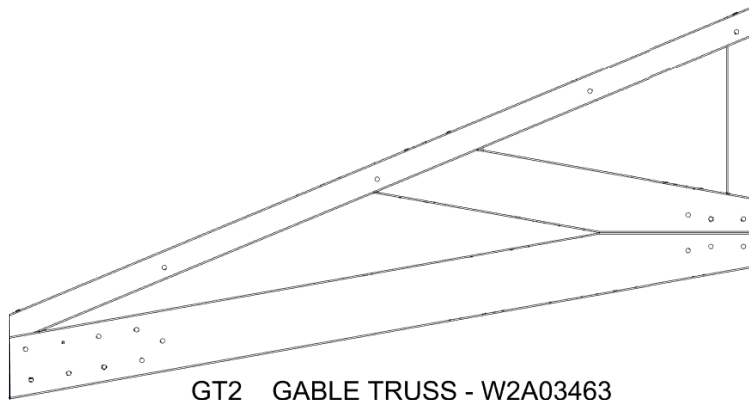

GT2 GABLE TRUSS - W2A03463
(x4) 1 3/8"x34"x64 5/8" (36x864x1678)



P01 POST - W2A03456
(x2) 6"x6"x89 1/2" (152x152x2274)

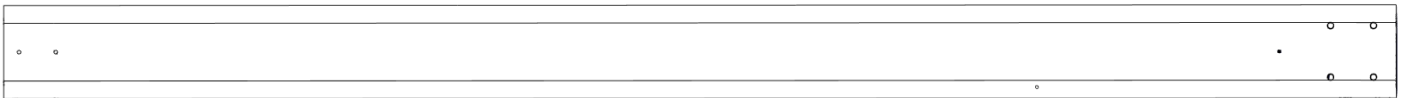

P02 POST - W2A03457
(x2) 6"x6"x89 1/2" (152x152x2274)



P03 POST - W2A03458
(x2) 6"x6"x89 1/2" (152x152x2274)



CA01 CORBEL WITH TAG - W2A03461
(x1) 1 3/8"x5 1/4"x44 1/16" (36x134x1119)

OWNER'S MANUAL - PARTS IDENTIFICATION

Hardware Components



H100195 BOLT WH BLK
(x56) 5/16x2-3/4

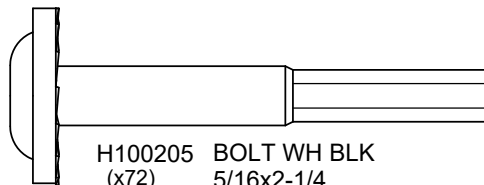

H100205 BOLT WH BLK
(x72) 5/16x2-1/4

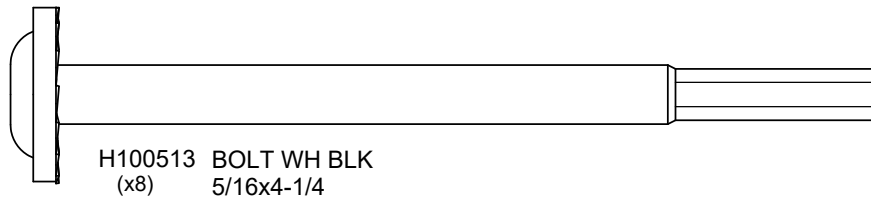

H100513 BOLT WH BLK
(x8) 5/16x4-1/4

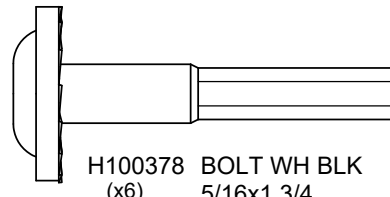

H100378 BOLT WH BLK
(x6) 5/16x1 3/4

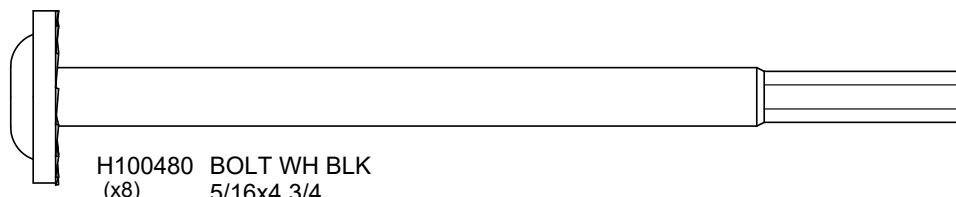

H100480 BOLT WH BLK
(x8) 5/16x4 3/4

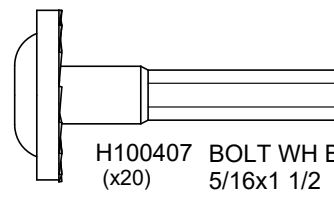

H100407 BOLT WH BLK
(x20) 5/16x1 1/2

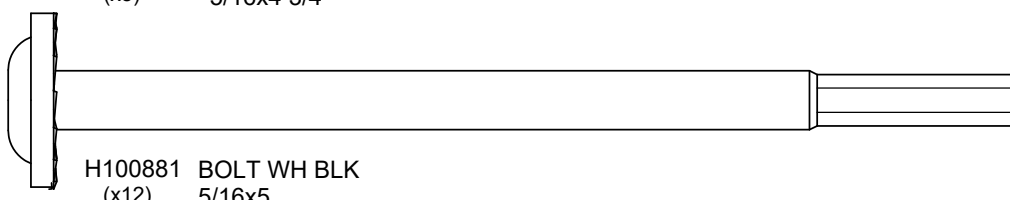

H100881 BOLT WH BLK
(x12) 5/16x5

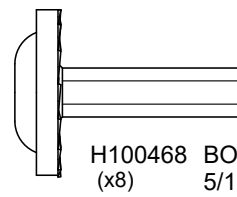

H100468 BOLT WH BLK
(x8) 5/16x1



H100354 BOLT WH BLK
(x4) 5/16x6 1/2

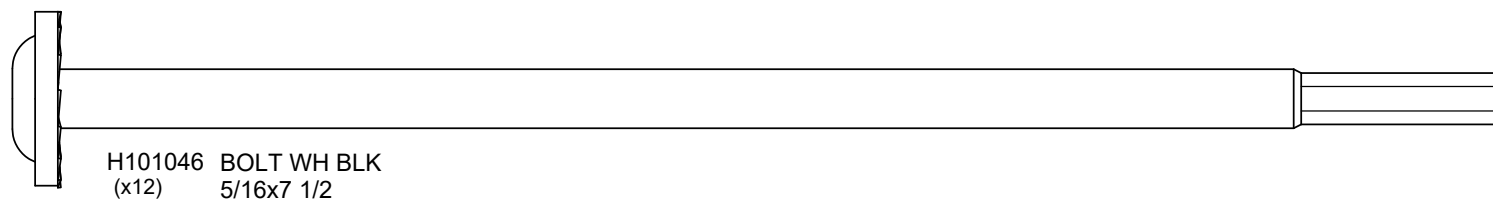

H101046 BOLT WH BLK
(x12) 5/16x7 1/2

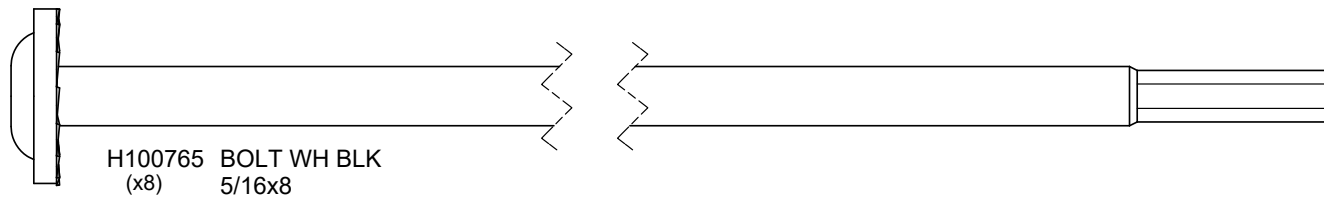

H100765 BOLT WH BLK
(x8) 5/16x8

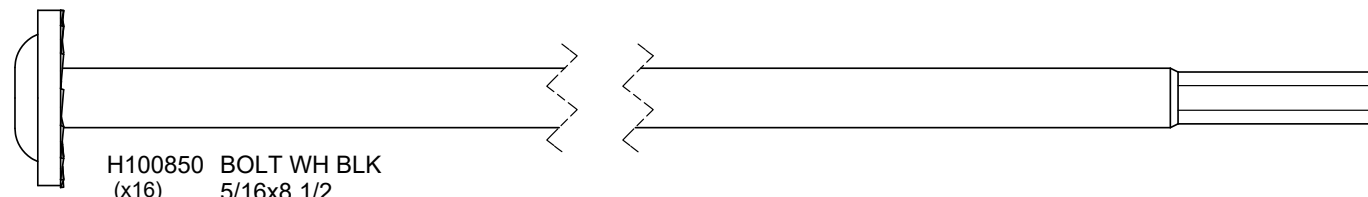

H100850 BOLT WH BLK
(x16) 5/16x8 1/2

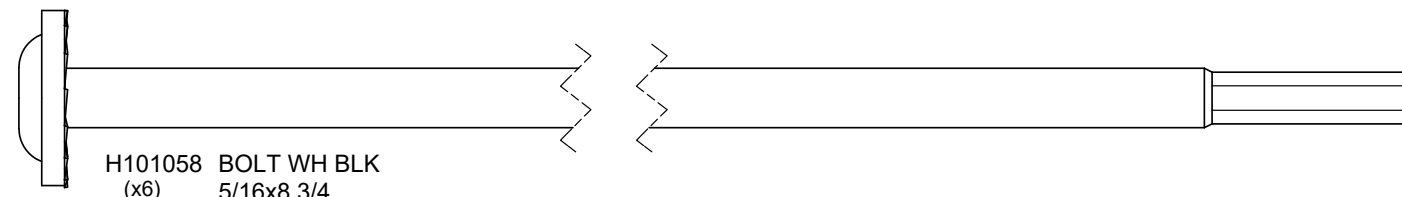

H101058 BOLT WH BLK
(x6) 5/16x8 3/4

OWNER'S MANUAL - PARTS IDENTIFICATION

Hardware Components

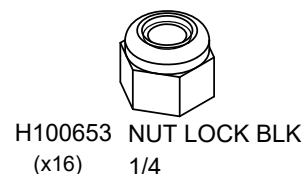
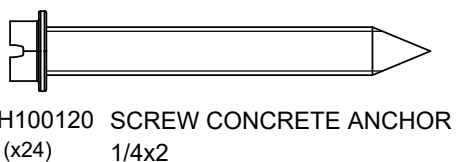
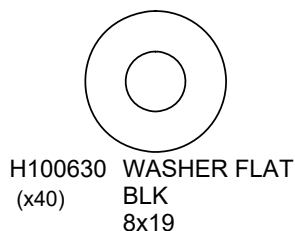
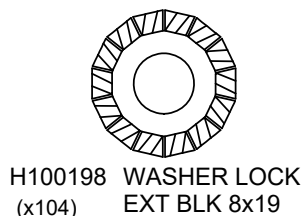
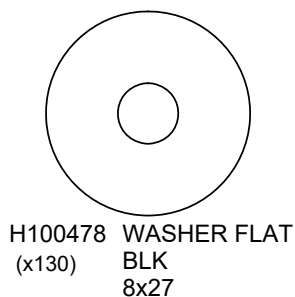
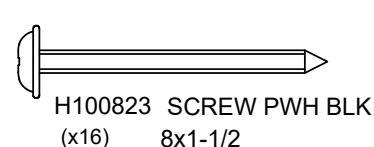
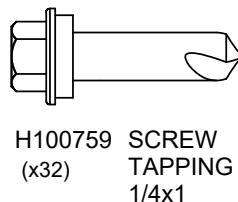
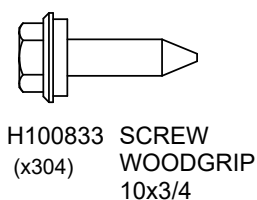
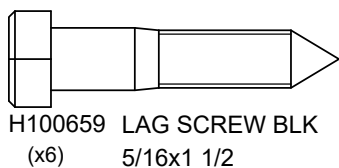
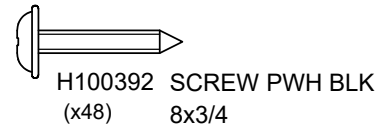
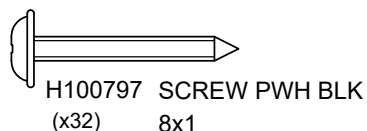
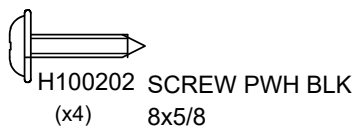
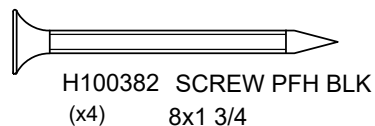
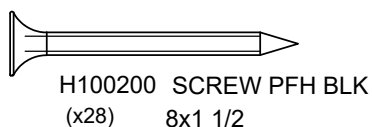
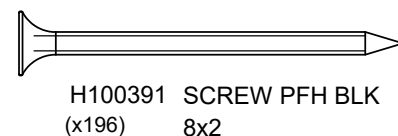
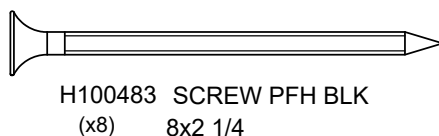
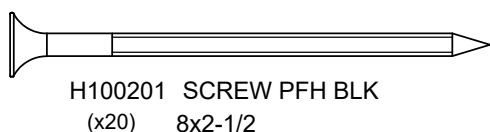
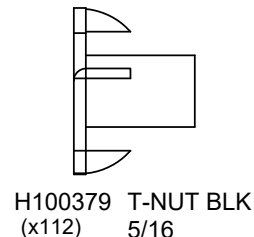
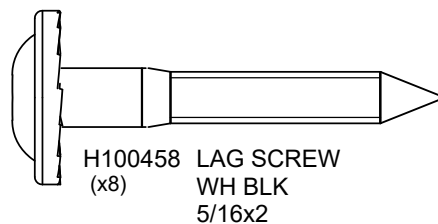
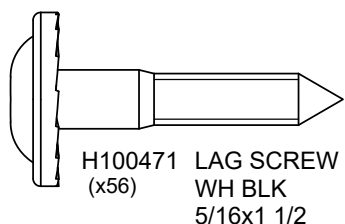
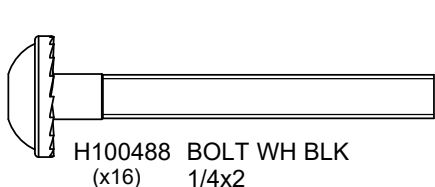
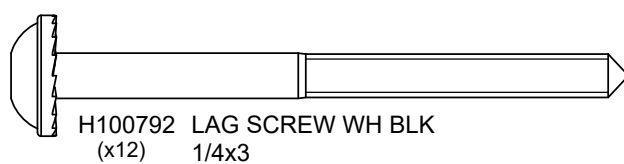
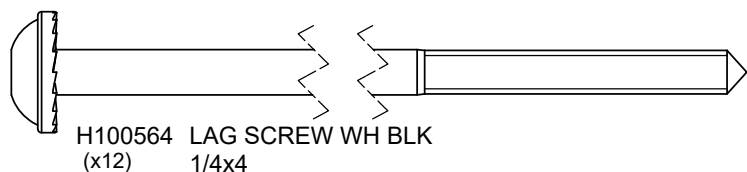

OWNER'S MANUAL - PARTS IDENTIFICATION

Hardware Components

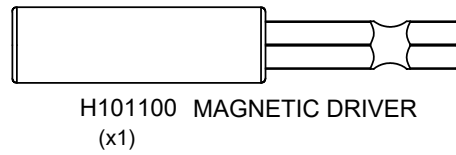
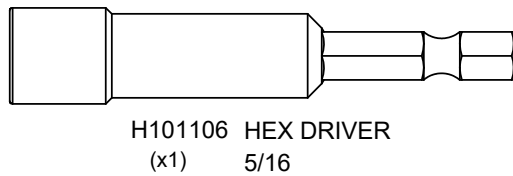
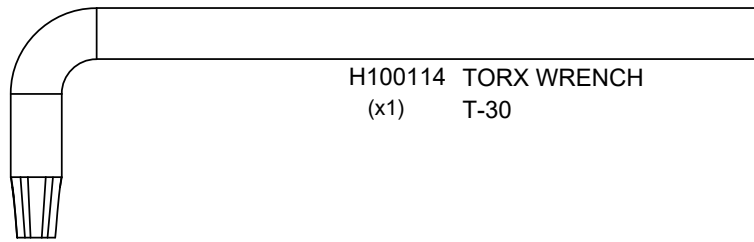
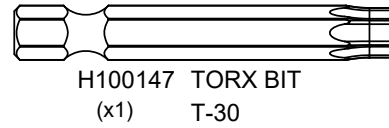
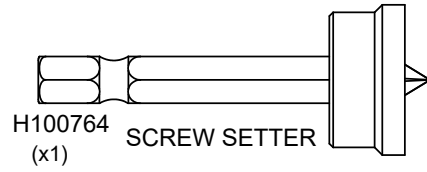

OWNER'S MANUAL - PARTS IDENTIFICATION

ACCESSORY COMPONENTS (NOT TO SCALE)

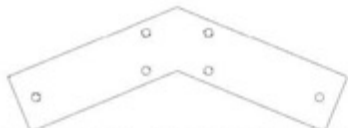

A4M01130 GABLE BRACKET
(x2)



A4M01147 PEAK SEAM BRACKET
(x2)

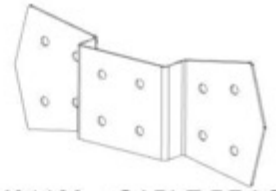

A4M01129 GABLE BRACKET
(x6)



A4M00977 POST ANCHORING PLATE
(x12)



A4M00978 POST PLATE
(x12)



A6P00308 6x6 POST FOOT
(x6)

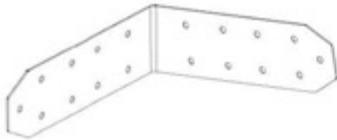

A4M01554 RIGHT OUTSIDE BRACKET
(x2)

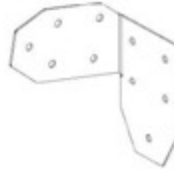

A4M01232 LEFT ANGLE BRACKET
(x2)



A4M01228 RAFTER BRACKET
(x16)

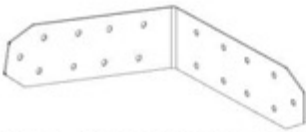

A4M01555 LEFT OUTSIDE BRACKET
(x2)

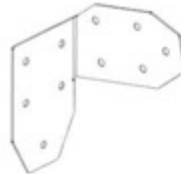

A4M01233 RIGHT ANGLE BRACKET
(x2)



A4M01148 TRUSS BRACKET
(x4)

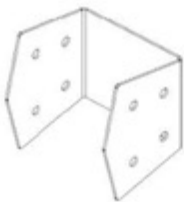

A4M01510 GABLE TIE BRACKET
(x2)

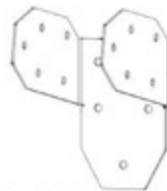

A4M01558 MID POST BRACKET
(x2)

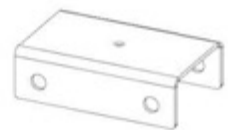

A4M01559 U TIE BRACKET
(x1)



A4M02158 BYD ID TAG PATIO
(x1)



9220409 ELECTRICAL ENCLOSURE
(x1)

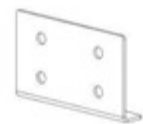

A4M01560 OUTSIDE TIE BRACKET
(x2)



A4M02501 FAN MOUNT BRACKET
(x1)

OWNER'S MANUAL - PARTS IDENTIFICATION

ACCESSORY COMPONENTS (NOT TO SCALE)



A4M02639 29 GA STEEL SHEETING
(x12)

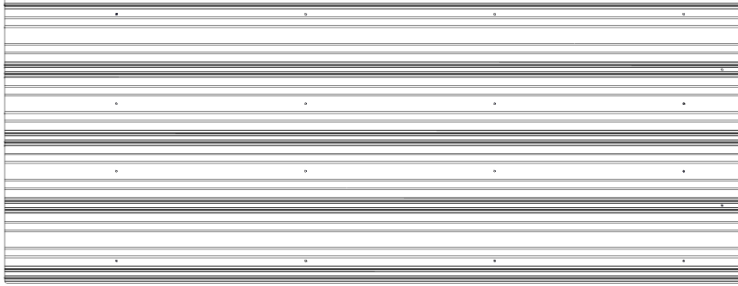

A4M02646 29 GA STEEL SHEETING
(x1)

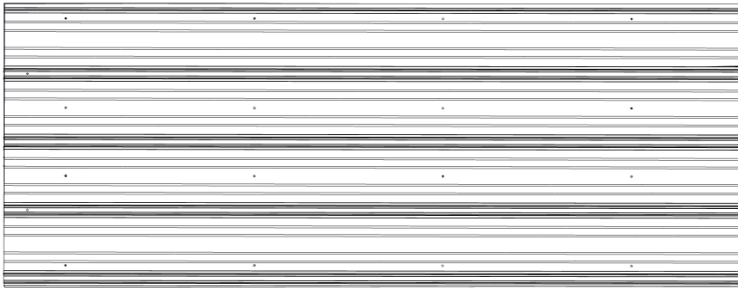

A4M02647 29 GA STEEL SHEETING
(x1)

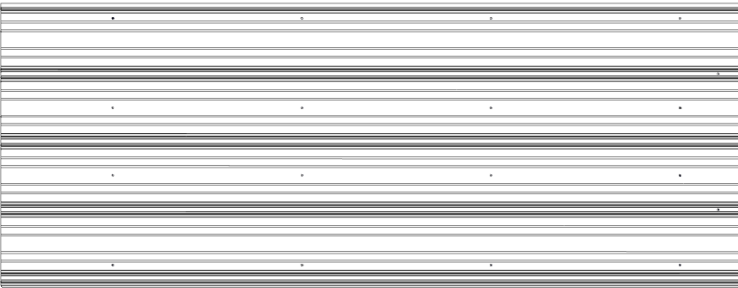

A4M02908 29 GA STEEL SHEETING
(x1)

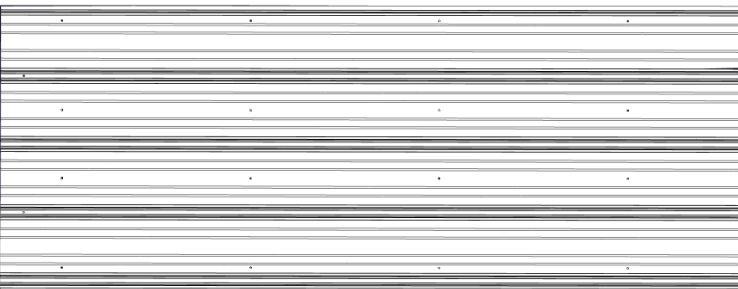

A4M02909 29 GA STEEL SHEETING
(x1)

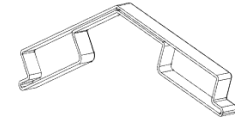

A6P00398 RIDGE CAP PROTECTOR
(x2)

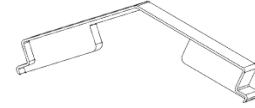

A6P00514 MID RIDGE CAP PROTECTOR
(x1)



A4M02638 ROOF EDGE TRIM SPLICE
(x6)

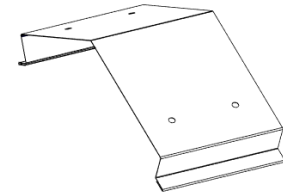

A4M02640 RIDGE CAP SPLICE
(x2)

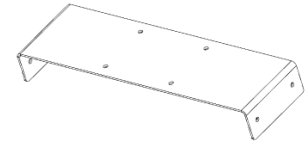

A4M01594 SHEATING BRACKET
(x4)

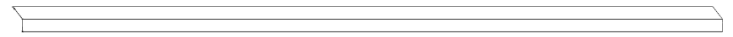

A4M02678 ROOF EDGE TRIM
(x8)

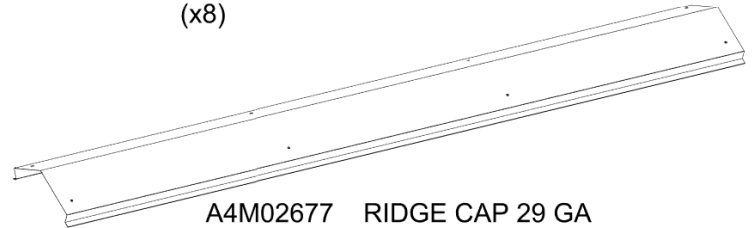

A4M02677 RIDGE CAP 29 GA
(x4)



A4M02679 ROOF END TRIM
(x2)



A4M02680 ROOF END TRIM
(x2)

PRE-ASSEMBLY STEP 1 - SORTING PARTS

It is critical for ease of assembly that you take the time to sort and organize the wood and hardware.

WOOD PARTS:

- Organize wood parts by the three-digit, alpha-numeric number stamped on each board (ex. P01).
- If there are multiple boards with the same stamped number, stack those pieces together.
- Stamps can be found on the flat surface of the boards or on the end of the boards.
- Allow yourself plenty of room - the wood pieces can take up a significant amount of space.

NOTE: CARTONS ARE NOT ORGANIZED BY BOARD NUMBER.



HARDWARE PARTS:

- We recommend that you have a separate table to organize the hardware.
- Hardware bags are printed with a seven-digit, alpha-numeric part number.
- You can organize your hardware by part number or group by hardware type (i.e. bolts, nuts, etc.).
- During assembly you only need to reference the last four digits of the number.

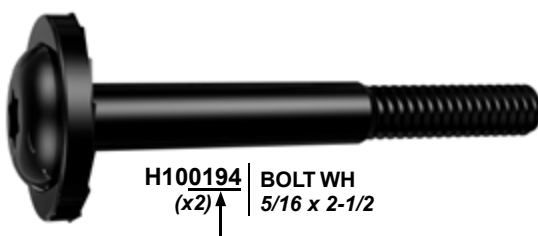

PRE-ASSEMBLY STEP 2 - TOOLS REQUIRED



Cordless Drill
or Electric Drill



Drill
Attachments:
Phillips Head

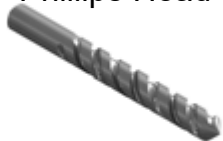

1/8", 3/16", 3/8" &
7/16" Drill Bits



Phillips Screw Driver



Open End
Wrenches 1/2" &
9/16"



3/8" Drive Ratchet, 1/2" &
7/16" STD Sockets 1/2" & 7/16"
Deep Sockets



Claw Hammer



Rubber Mallet
- Optional



Tape Measure

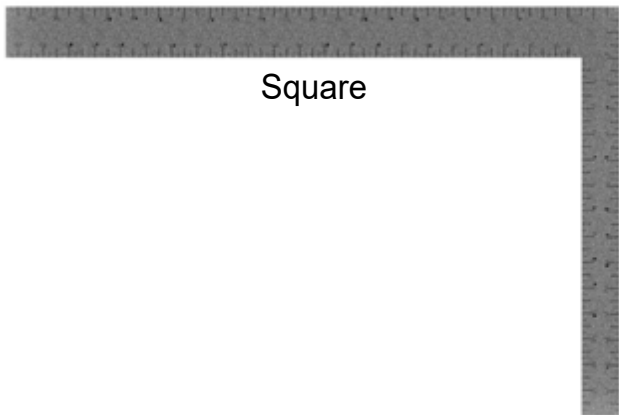

Square



Level 24"

PRE-ASSEMBLY STEP 3 - CHOOSE YOUR ASSEMBLY METHOD

There are several types of assembly instructions available to you.

1. Printed Assembly Manual included with your set
2. BILT APP - 3D interactive instructions
3. Combination of the Printed Manual and BILT APP (Note: Step numbers can differ between the two methods)

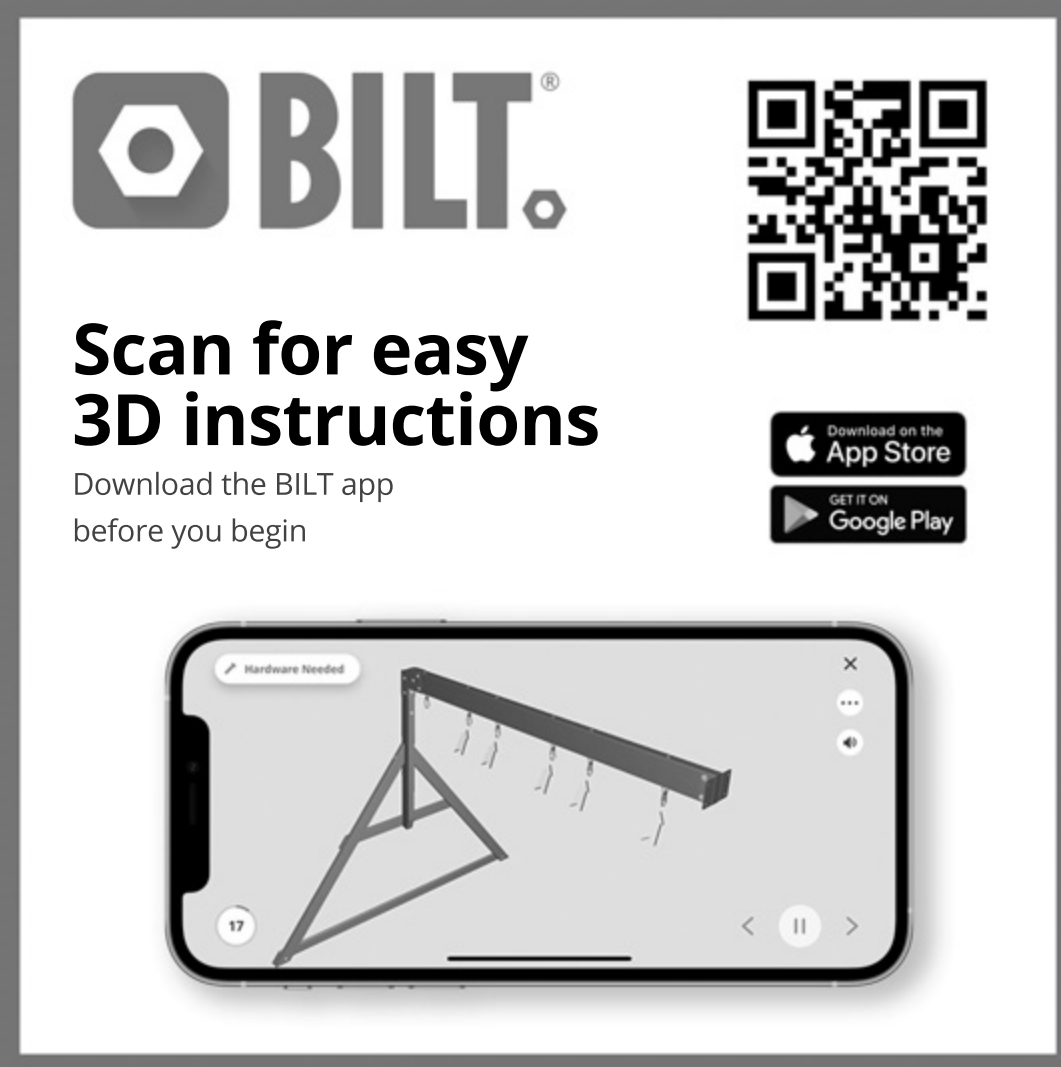

The graphic features the BILT logo (a hexagon with a white dot inside) and the word "BILT." in a bold, sans-serif font. To the right is a large QR code. Below the logo, the text "Scan for easy 3D instructions" is written in a large, bold font. Underneath this, it says "Download the BILT app before you begin". To the right of the text are two buttons: "Download on the App Store" and "GET IT ON Google Play". At the bottom, a smartphone screen displays a 3D assembly instruction for step 17, showing a metal frame with a horizontal bar and several screws being attached. The screen has a "Hardware Needed" label at the top left and navigation icons at the bottom.

STEP 4 - POST ASSEMBLY

QTY	PART NUMBER	DESCRIPTION
12	H100200	SCREW PFH 8x1 1/2 BLK



P01 POST - W2A03456
(x1) 6"x6"x89 1/2" (152x152x2274)



P02 POST - W2A03457
(x1) 6"x6"x89 1/2" (152x152x2274)



P03 POST - W2A03458
(x1) 6"x6"x89 1/2" (152x152x2274)

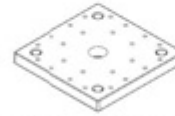

A6P00308 6x6 POST FOOT
(x3)

- FOR EASE OF ASSEMBLY, WE RECOMMEND USING SAW HORSES FOR STEPS 4 - 17.

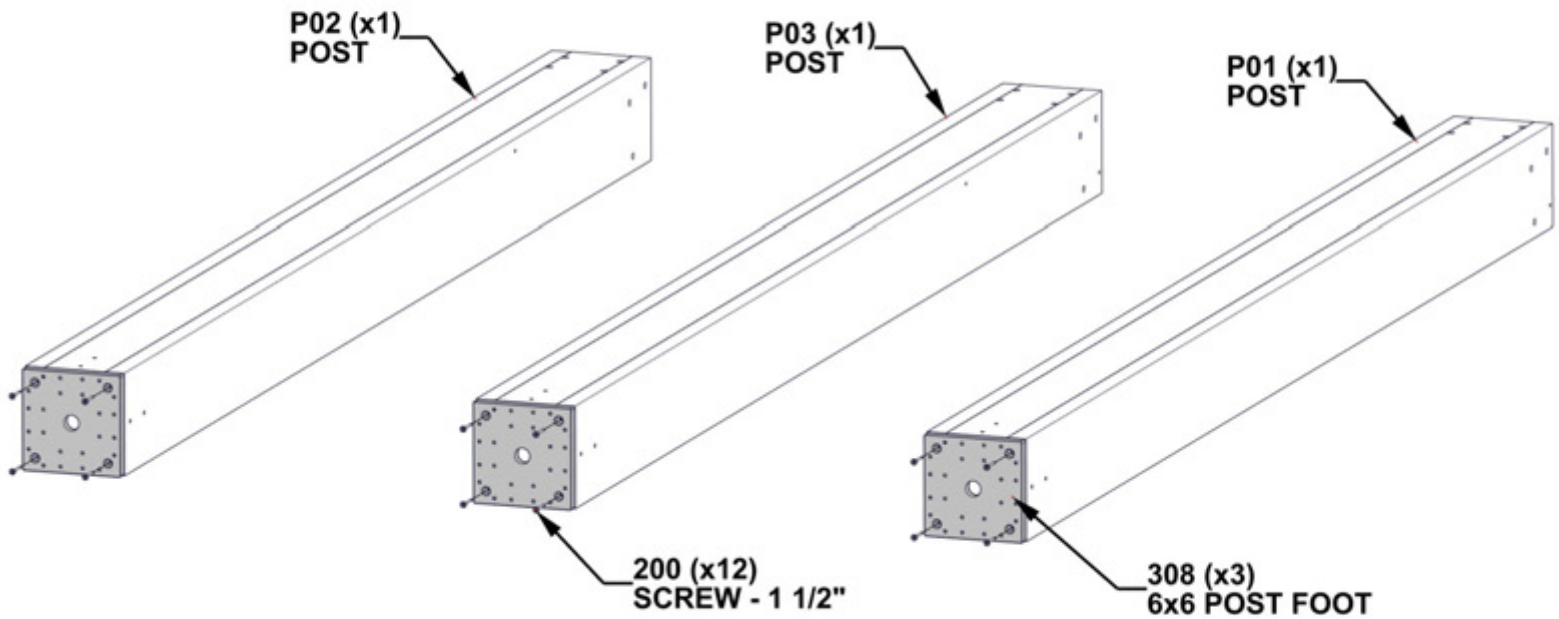

ALIGN POST FOOT AND DRILL 1/8" (3mm) PILOT HOLES FOR THE ATTACHMENT OF HARDWARE.

STEP 5 - END GABLE ASSEMBLY

QTY	PART NUMBER	DESCRIPTION
2	H100483	SCREW PFH 8x2 1/4 BLK



D01 GABLE BOARD - W4L16415
(x1) 1 3/8"x5 1/4"x24 5/8" (36x134x625)



D05 GABLE BOARD - W4L16753
(x1) 1 3/8"x1 1/2"x5 1/4" (36x38x134)

- ALIGN D05 WITH D01 ENSURING THAT BOTTOM FACES ARE FLUSH.
- DRILL 1/8" PILOT HOLES IN D01 USING D05 AS TEMPLATE.

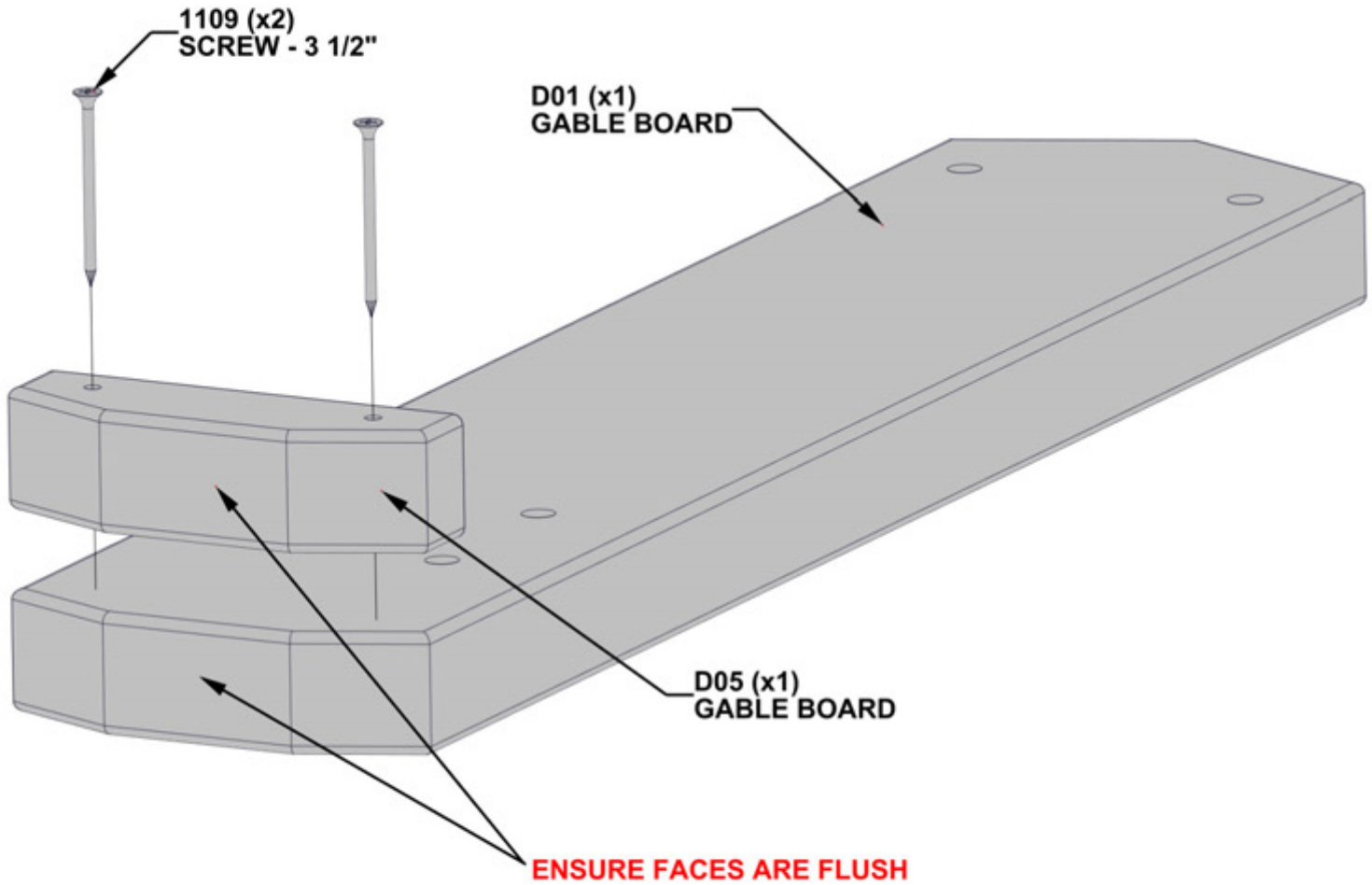

STEP 6 - END GABLE ASSEMBLY

QTY	PART NUMBER	DESCRIPTION
4	H100478	WASHER FLAT 8x27 BLK
4	H100479	NUT LOCK 5/16 BLK
4	H100881	BOLT WH 5/16x5 BLK



GT1 GABLE TRUSS - W2A03460
(x2) 1 3/8"x34"x64 5/8" (36x864x845)



D01 GABLE BOARD - W4L16415
(x1) 1 3/8"x5 1/4"x24 5/8" (36x134x625)

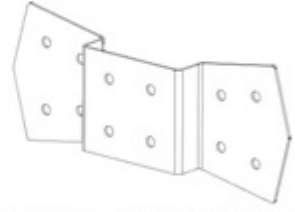

A4M01129 GABLE BRACKET
(x2)

- IF HOLES DO NOT ALIGN, USE METAL BRACKET AS A GUIDE AND DRILL THROUGH USING A 7/16" - (10mm) DRILL BIT, THEN ASSEMBLE.

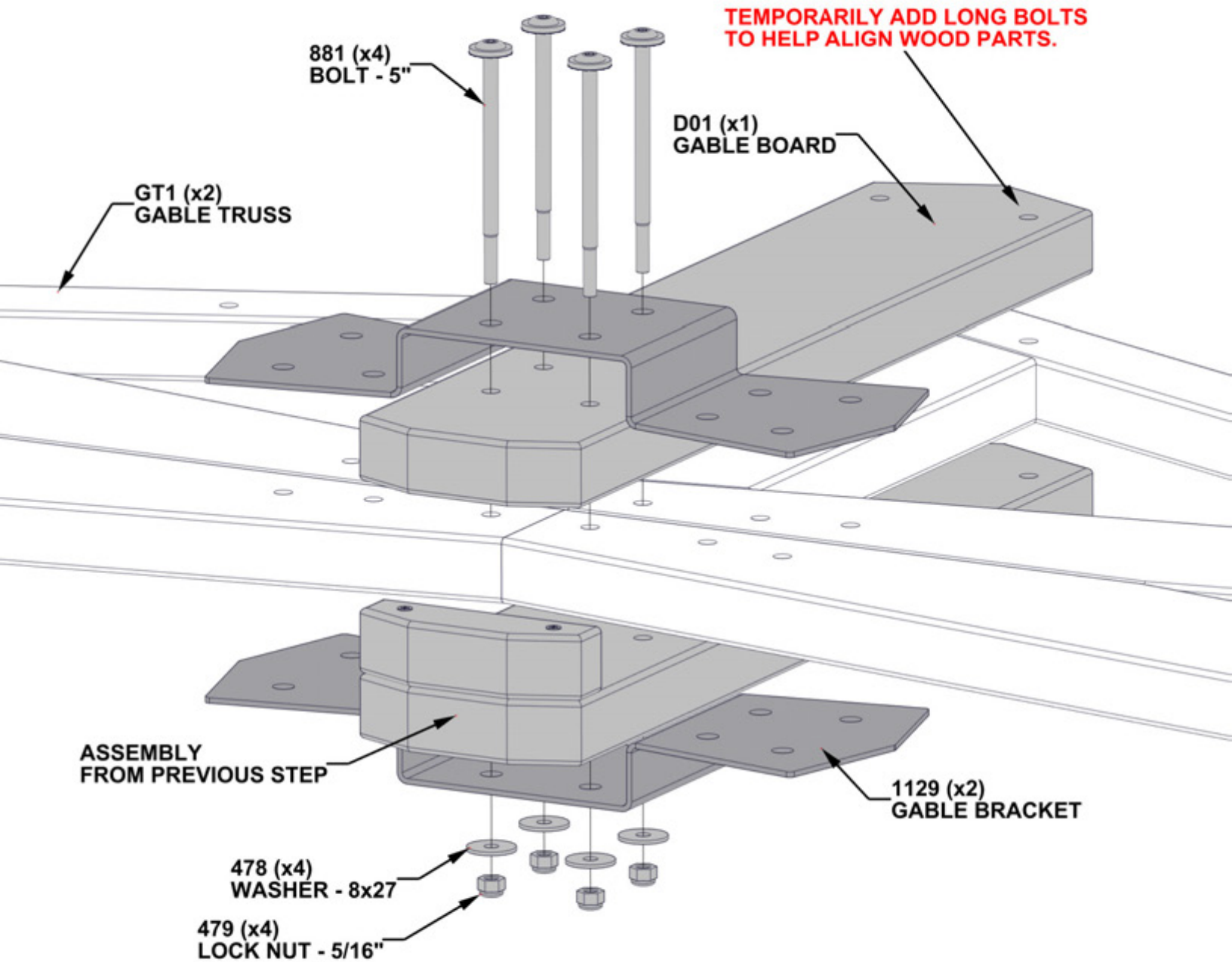

STEP 7 - END GABLE ASSEMBLY

QTY	PART NUMBER	DESCRIPTION
8	H100205	BOLT WH 5/16x2 1/4 BLK
8	H100478	WASHER FLAT 8x27 BLK
8	H100479	NUT LOCK 5/16 BLK

- IF HOLES DO NOT ALIGN, USE METAL BRACKET AS A GUIDE AND DRILL THROUGH USING A 7/16" - (10mm) DRILL BIT, THEN ASSEMBLE.

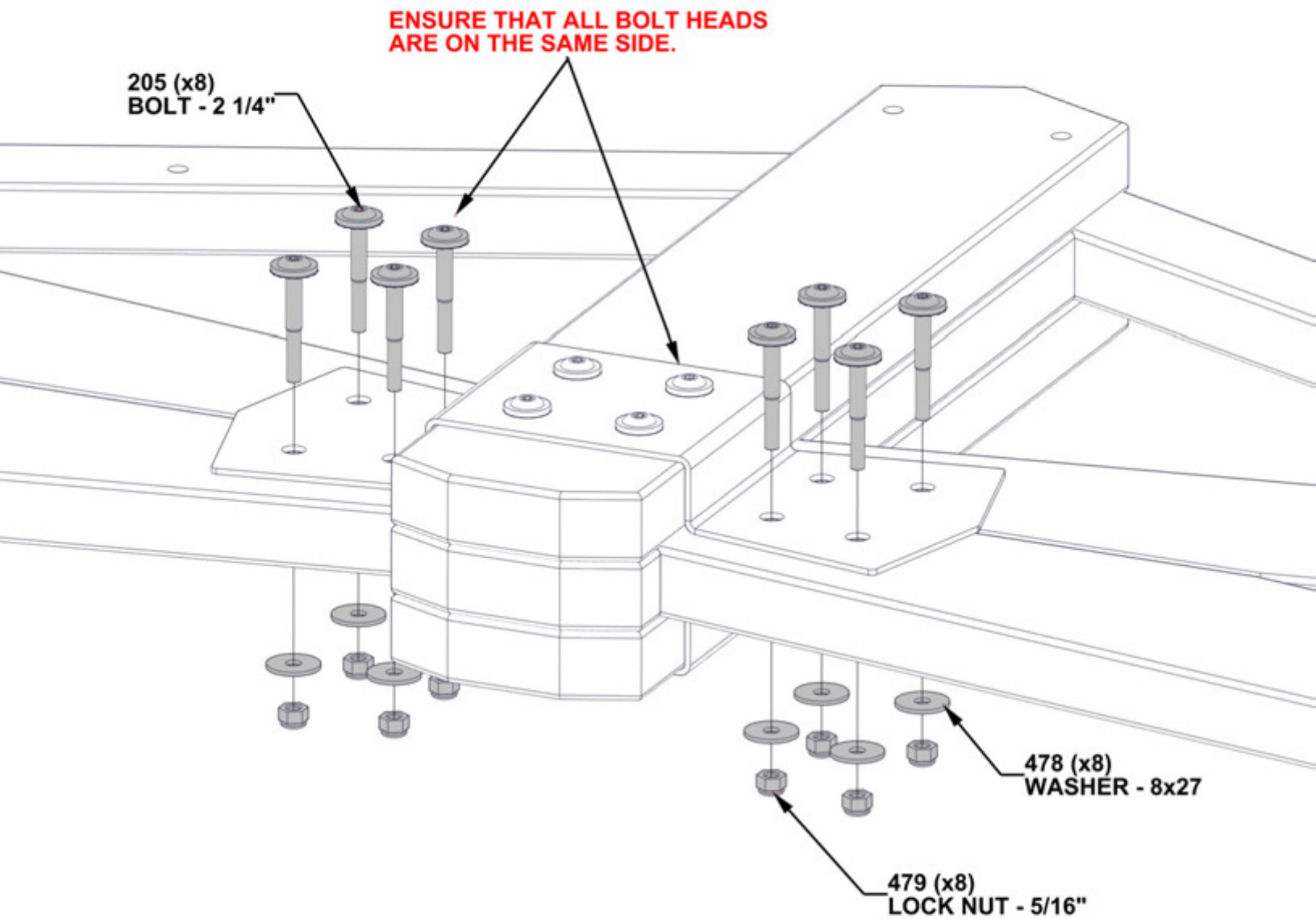

STEP 8A - END GABLE ASSEMBLY

QTY	PART NUMBER	DESCRIPTION
5	H100205	BOLT WH 5/16x2 1/4 BLK
8	H100379	T-NUT 5/16 BLK
5	H100407	BOLT WH 5/16x1 1/2 BLK
1	H100458	LAG SCREW WH 5/16x2 BLK
10	H100478	WASHER FLAT 8x27 BLK
9	H100479	NUT LOCK 5/16 BLK
1	H100659	LAG SCREW HEX 5/16x1 1/2 BLK
4	H100850	BOLT WH 5/16x8 1/2 BLK
3	H101046	BOLT WH 5/16x7 1/2 BLK

P01 POST - W2A03456
(x1) 6"x6"x89 1/2" (152x152x2274)

A4M01555 LEFT OUTSIDE BRACKET
(x1)

D02 TOP RAIL - W4L16379
(x1) 1 3/8"x5 1/4"x30 3/8" (36x134x770)

A4M01232 LEFT ANGLE BRACKET
(x1)

- INSERT T-NUTS FIRST

NOTE ORIENTATION OF D02

WHEN ORIENTING END GABLE TRUSS ASSEMBLY, ENSURE THAT THE SIDE WITH BOLT HEADS FACES OUT.

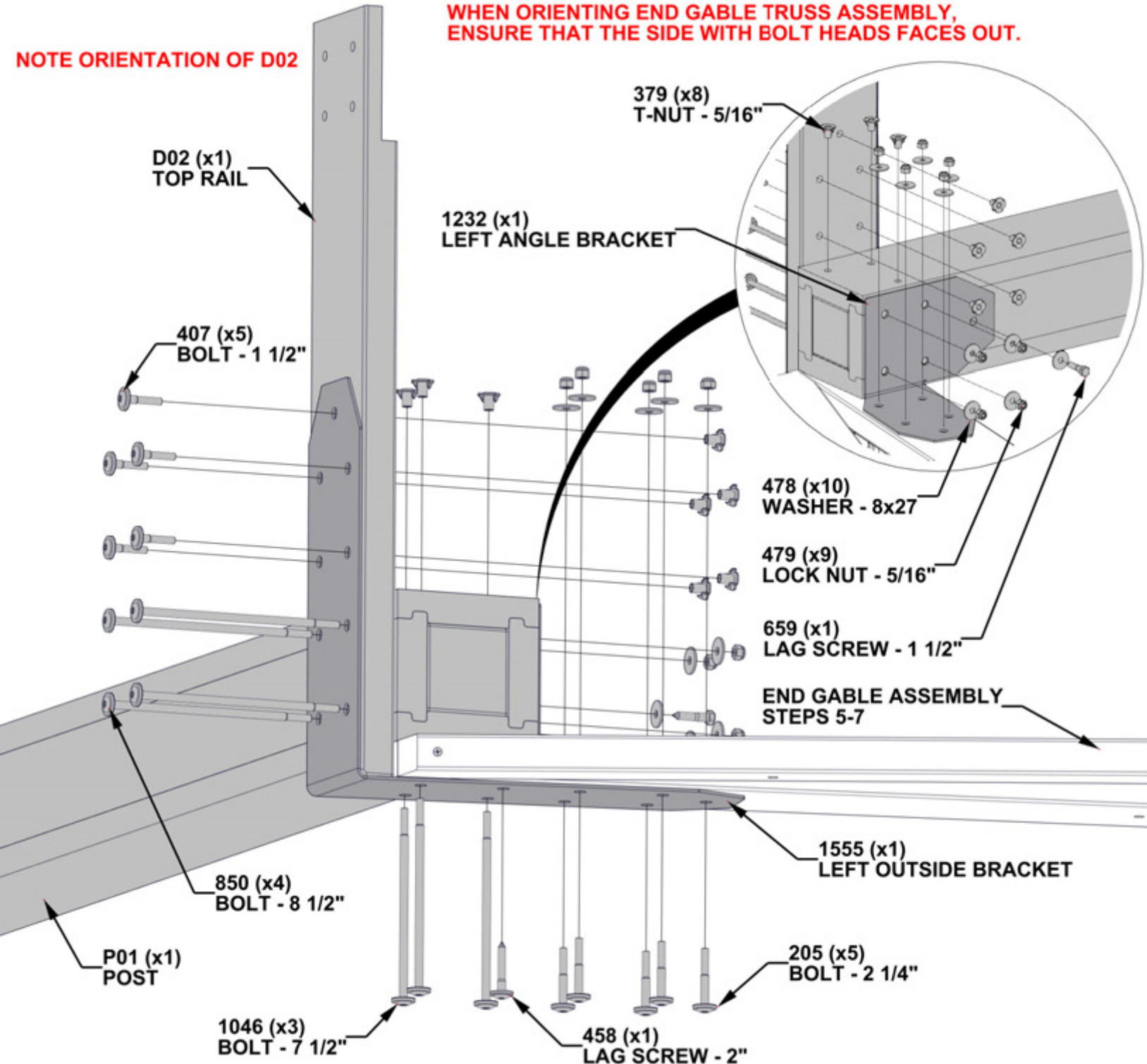

STEP 8B - END GABLE ASSEMBLY

QTY	PART NUMBER	DESCRIPTION
5	H100205	BOLT WH 5/16x2 1/4 BLK
8	H100379	T-NUT 5/16 BLK
5	H100407	BOLT WH 5/16x1 1/2 BLK
1	H100458	LAG SCREW WH 5/16x2 BLK
10	H100478	WASHER FLAT 8x27 BLK
9	H100479	NUT LOCK 5/16 BLK
1	H100659	LAG SCREW HEX 5/16x1 1/2 BLK
4	H100850	BOLT WH 5/16x8 1/2 BLK
3	H101046	BOLT WH 5/16x7 1/2 BLK

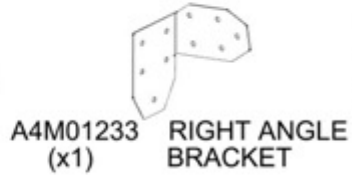
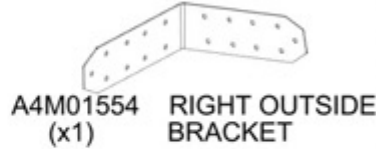
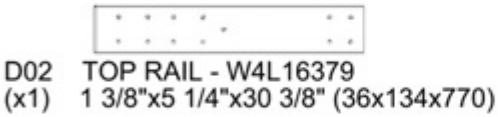
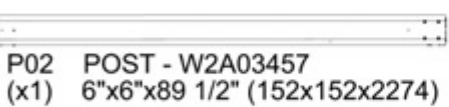

- INSERT T-NUTS FIRST

WHEN ORIENTING END GABLE ASSEMBLY, ENSURE THAT THE SIDE WITH BOLT HEADS FACES OUT.

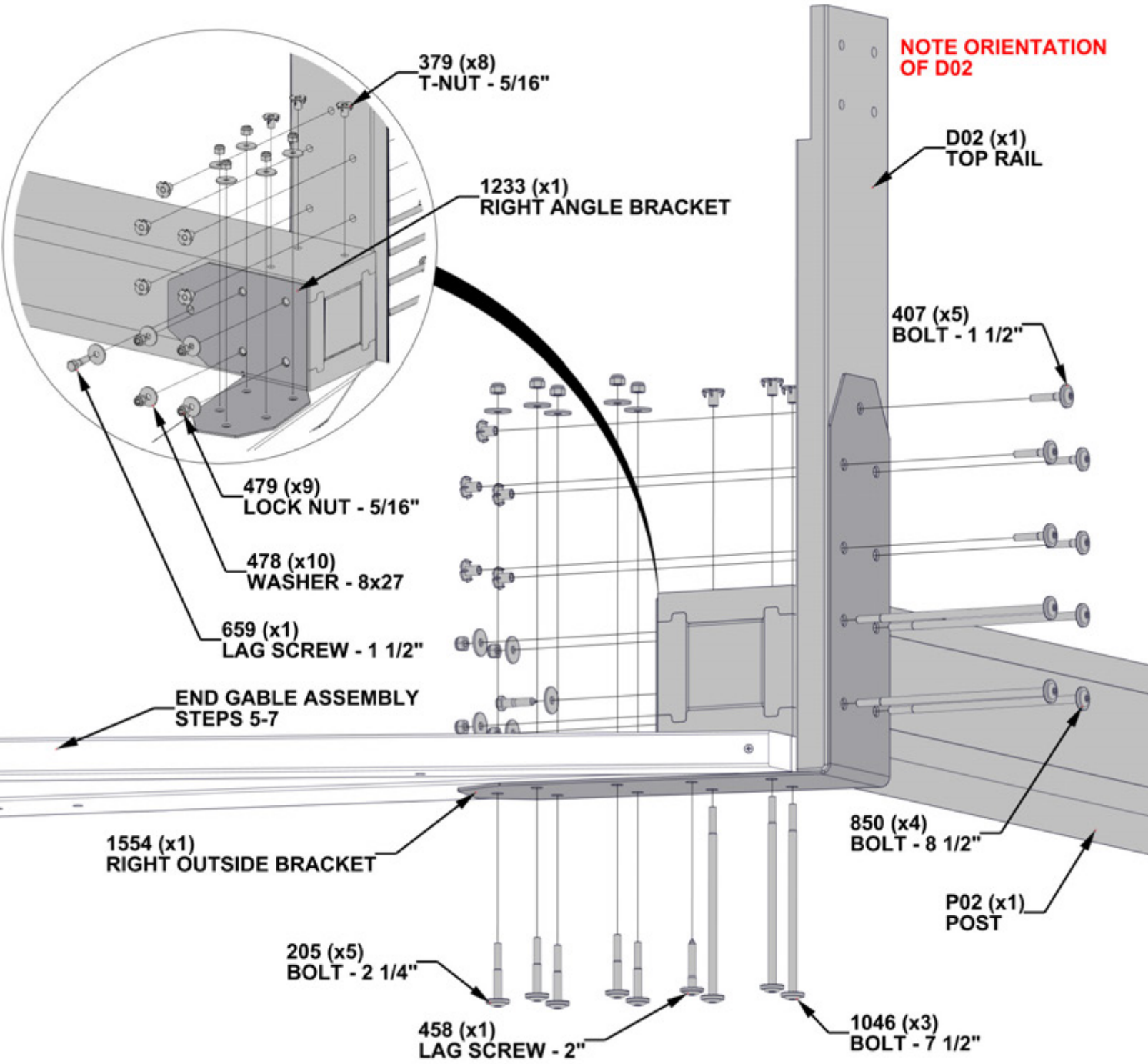

STEP 9 - END GABLE ASSEMBLY

QTY	PART NUMBER	DESCRIPTION
4	H100195	BOLT WH 5/16x2 3/4 BLK
4	H100198	WASHER LOCK EXT 8x19
4	H100379	T-NUT 5/16 BLK
2	H100405	WASHER LOCK EXT 6x15
2	H100792	LAG SCREW WH 1/4x3 BLK



D06 CORBEL - W4L16375
(x3) 1 3/8"x5 1/4"x44 1/16" (36x134x1119)



CA01 CORBEL WITH TAG - W2A03461
(x1) 1 3/8"x5 1/4"x44 1/16" (36x134x1119)

- WHEN BUILDING THE SECOND END GABLE, TWO D06 BOARDS WILL BE USED.
- INSERT T-NUTS FIRST

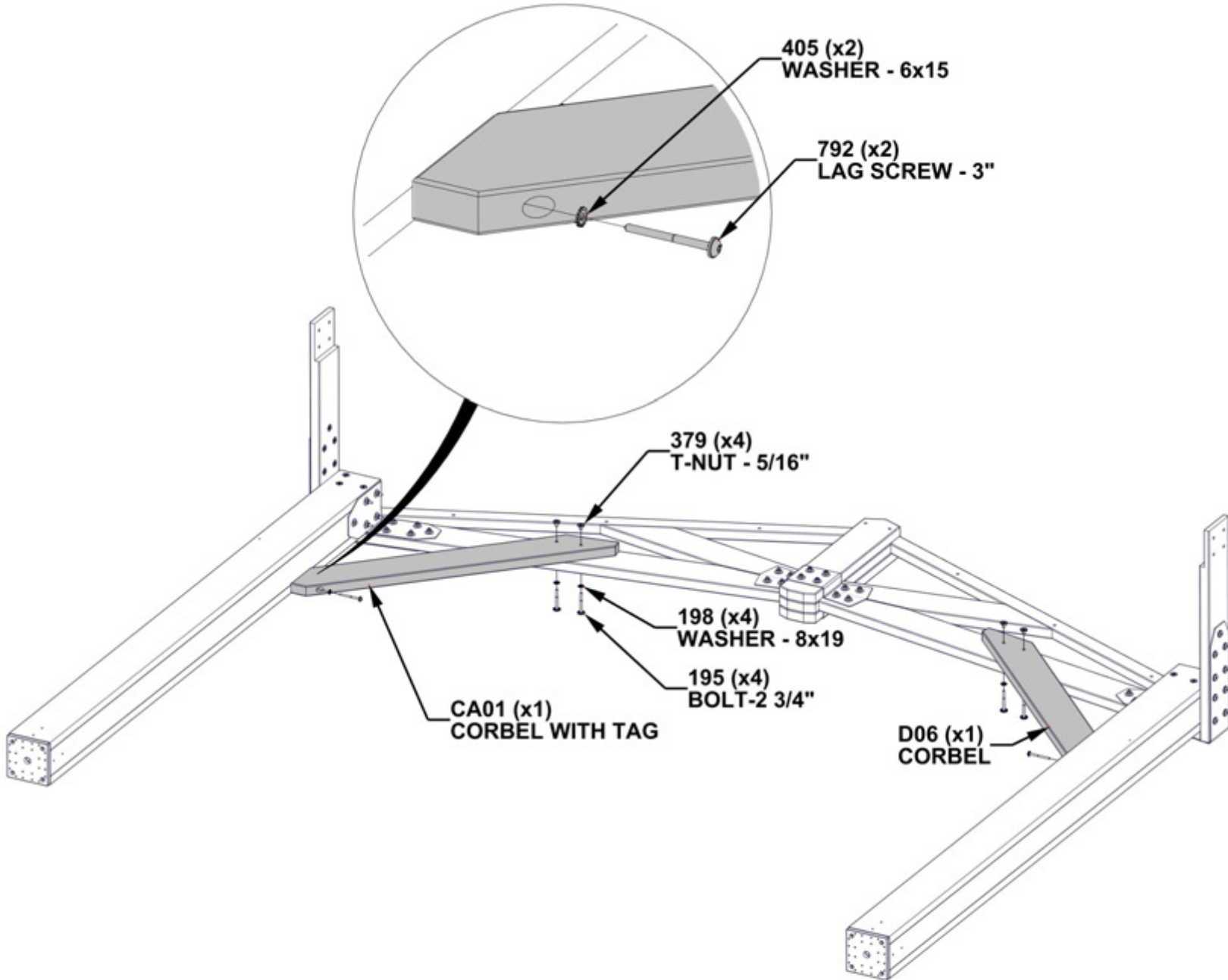

STEP 10 - END GABLE ASSEMBLY

QTY	PART NUMBER	DESCRIPTION
8	H100195	BOLT WH 5/16x2 3/4 BLK
8	H100198	WASHER LOCK EXT 8x19
8	H100379	T-NUT 5/16 BLK
2	H100405	WASHER LOCK EXT 6x15
2	H100792	LAG SCREW WH 1/4x3 BLK



D03 TOP RAIL - W4L16380
(x2) 1 3/8"x5 1/4"x68 7/8" (36x134x1749)



D04 CORBEL - W4L16944
(x2) 1 3/8"x5 1/4"x34 7/16" (36x134x875)

- INSERT T-NUTS FIRST

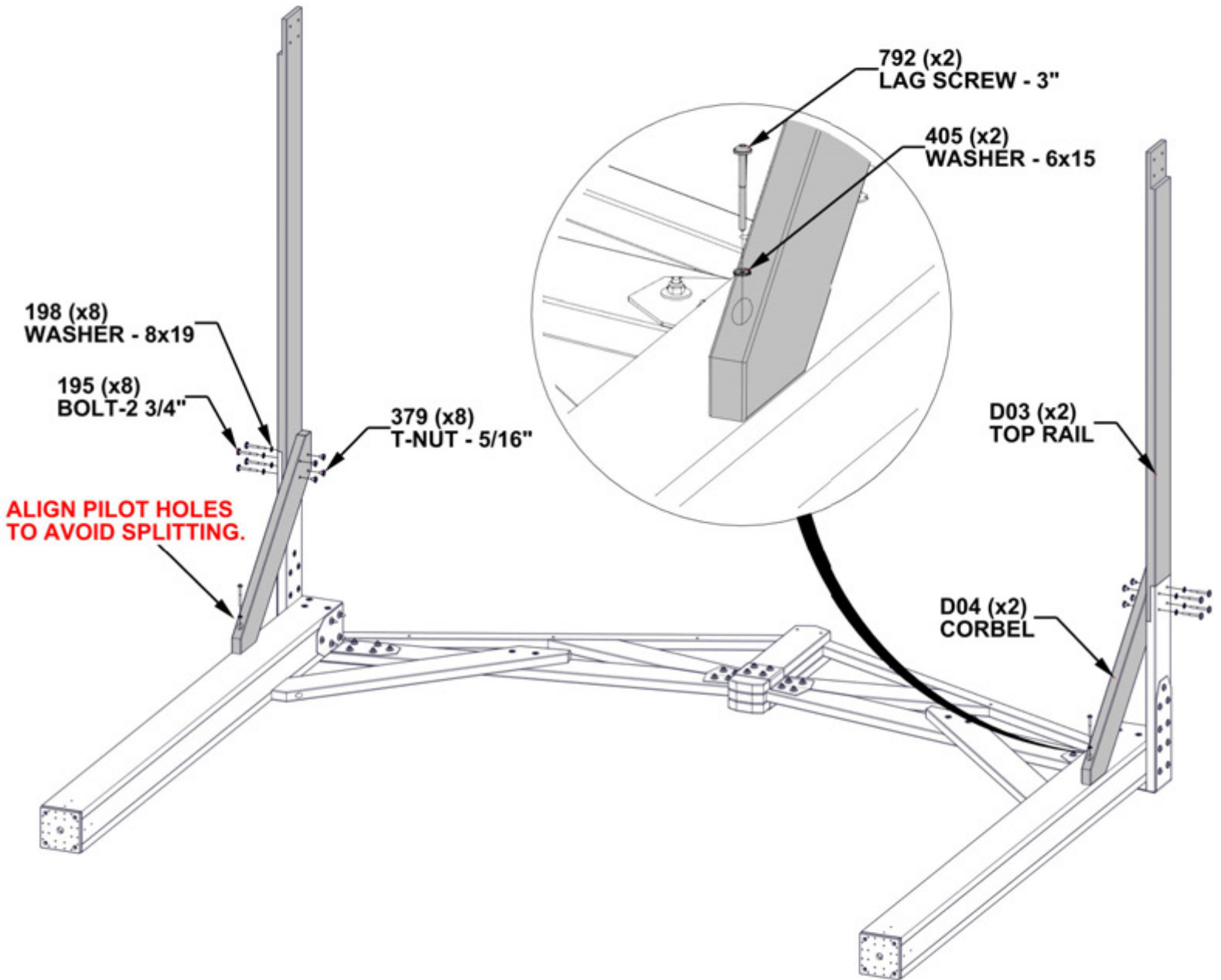

**REPEAT POST AND END GABLE
ASSEMBLY STEPS 4 THROUGH 10**

STEP 11 - CENTER GABLE ASSEMBLY

QTY	PART NUMBER	DESCRIPTION
4	H100483	SCREW PFH 8x2 1/4 BLK



D01 GABLE BOARD - W4L16415
(x2) 1 3/8"x5 1/4"x24 5/8" (36x134x625)



D05 GABLE BOARD - W4L16753
(x2) 1 3/8"x1 1/2"x5 1/4" (36x38x134)

- COMPLETE THIS STEP TWICE

- ALIGN D05 WITH D01 ENSURING THAT BOTTOM FACES ARE FLUSH.
- DRILL 1/8" PILOT HOLES IN D01 USING D05 AS TEMPLATE.

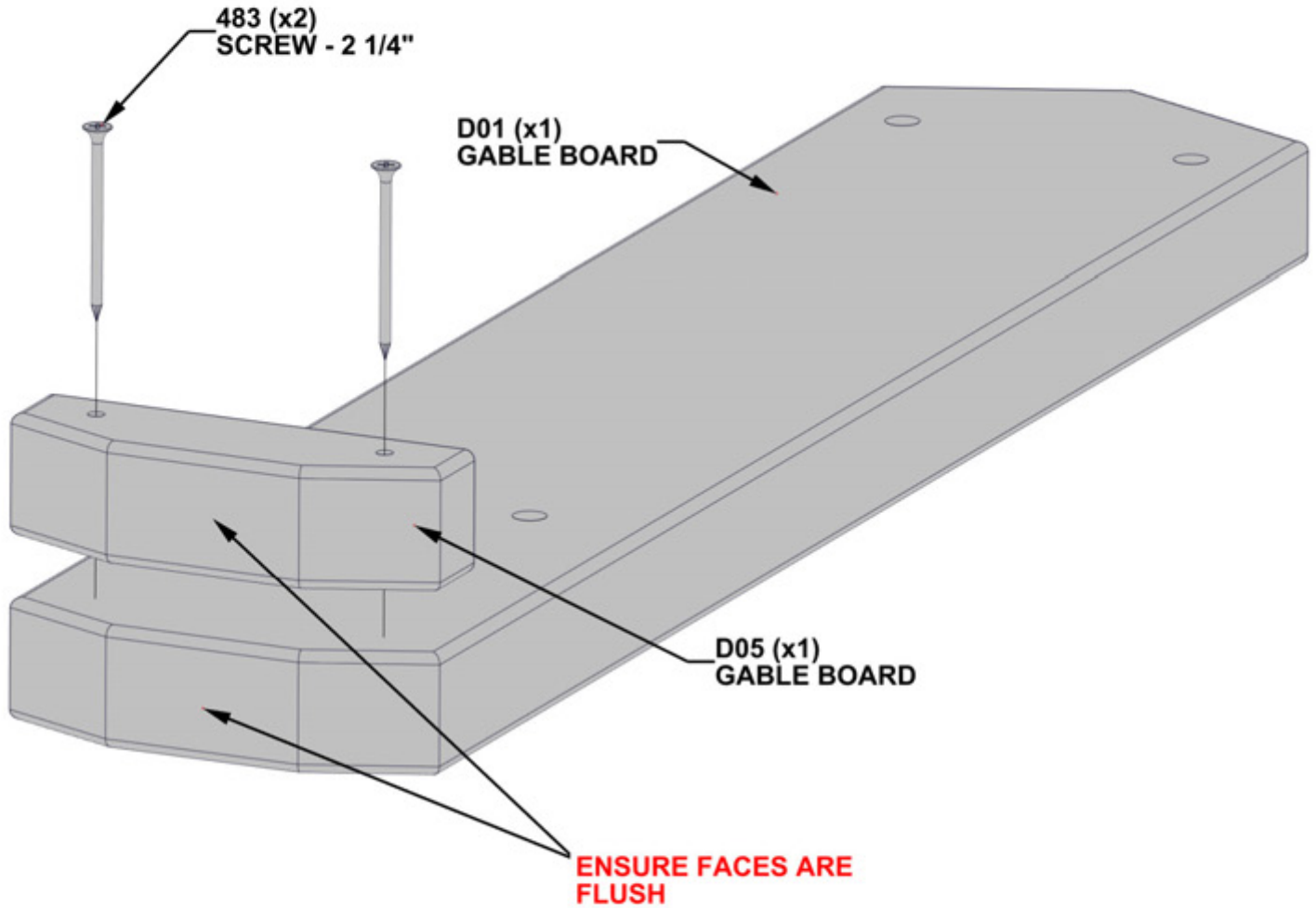

STEP 12 - CENTER GABLE ASSEMBLY

QTY	PART NUMBER	DESCRIPTION
4	H100379	T-NUT 5/16 BLK
4	H100513	BOLT WH 5/16x4 1/4 BLK

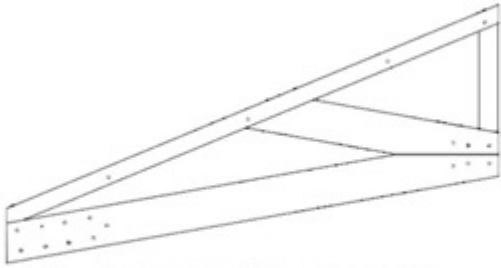

GT2 GABLE TRUSS - W2A03463
(x2) 1 3/8"x34"x64 5/8" (36x864x1794)



D01 GABLE BOARD - W4L16415
(x1) 1 3/8"x5 1/4"x24 5/8" (36x134x625)

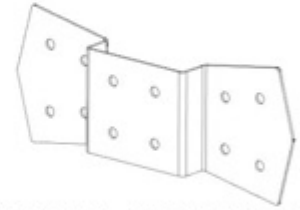

A4M01129 GABLE BRACKET
(x1)

- IF HOLES DO NOT ALIGN, USE THE METAL BRACKET AS A GUIDE AND A 7/16" (10mm) DRILL BIT TO DRILL THROUGH THE BOARDS.

- INSERT T-NUTS FIRST

TEMPORARILY ADD LONG BOLTS TO HELP ALIGN WOOD PARTS.

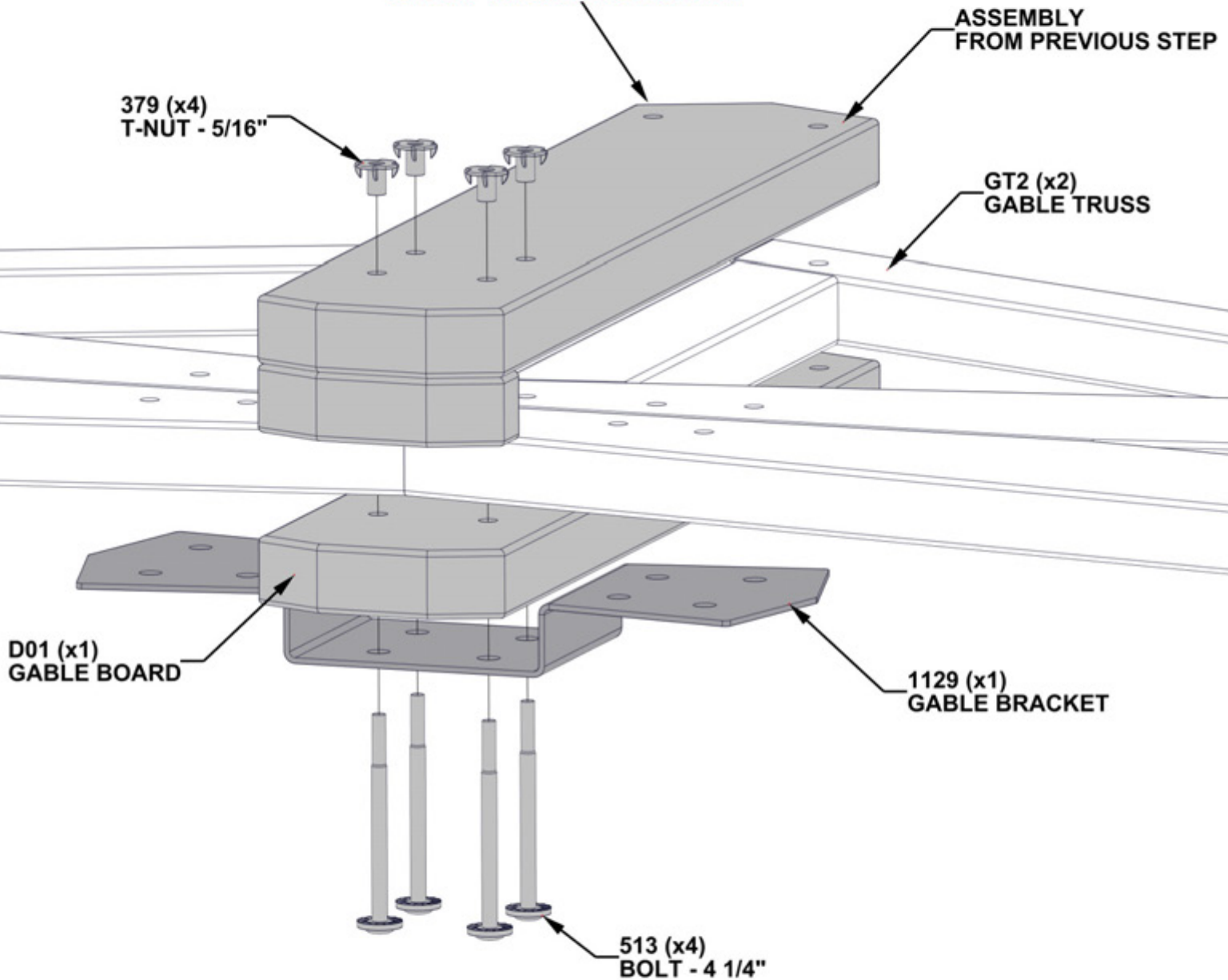

STEP 13 - CENTER GABLE ASSEMBLY

QTY	PART NUMBER	DESCRIPTION
8	H100205	BOLT WH 5/16x2 1/4 BLK
8	H100478	WASHER FLAT 8x27 BLK
8	H100479	NUT LOCK 5/16 BLK

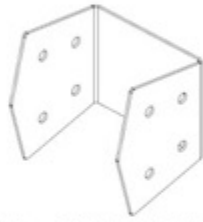

A4M01510 GABLE TIE BRACKET
(x2)

- ENSURE THAT ALL BOLT HEADS ARE ON THE SAME SIDE AT THIS STEP.

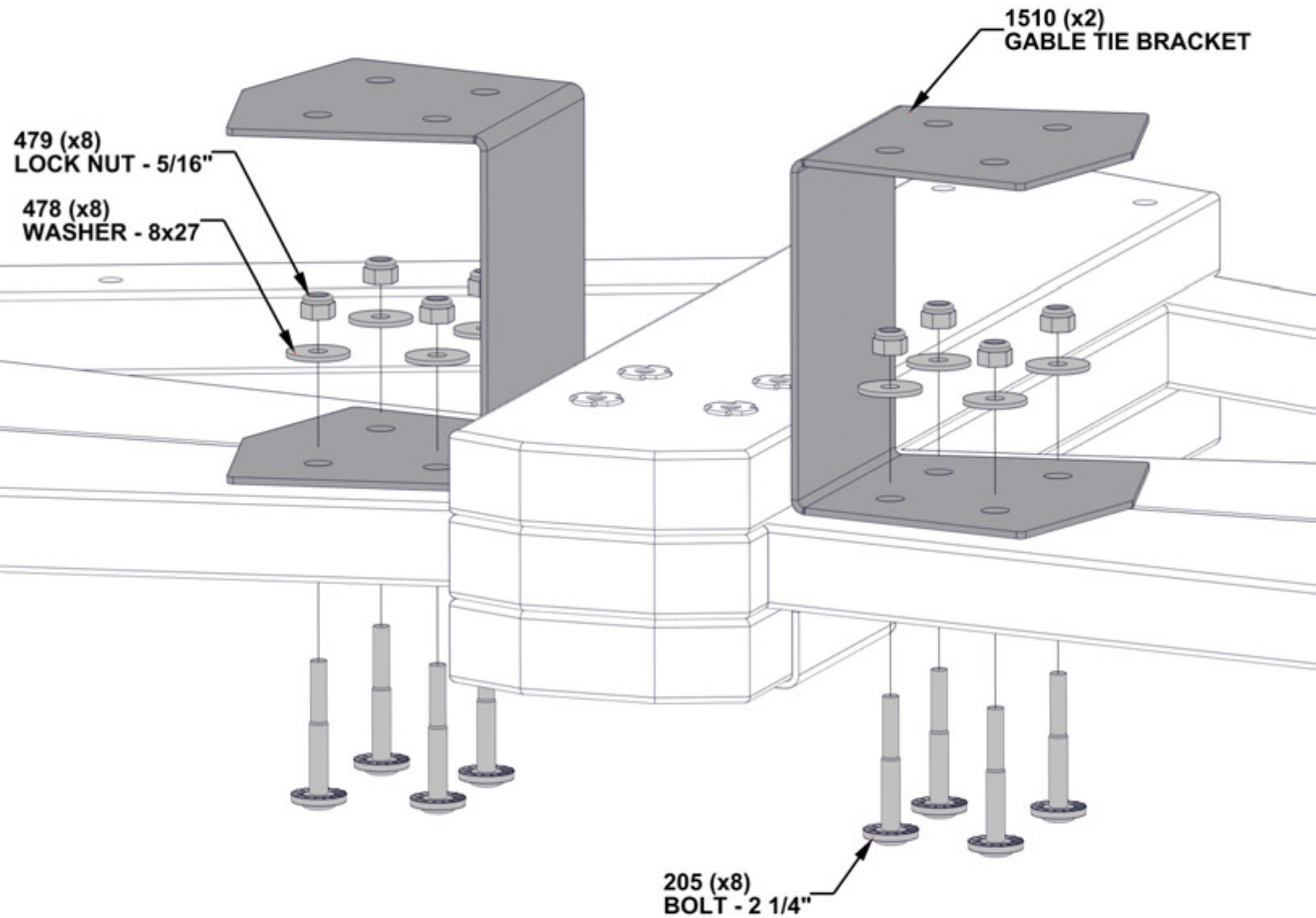

STEP 14 - CENTER GABLE ASSEMBLY

QTY	PART NUMBER	DESCRIPTION
4	H100379	T-NUT 5/16 BLK
4	H100513	BOLT WH 5/16x4 1/4 BLK

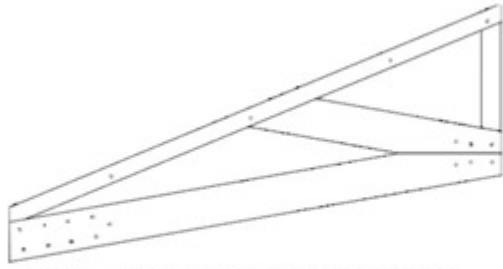

GT2 GABLE TRUSS - W2A03463
(x2) 1 3/8"x34"x64 5/8" (36x864x845)



D01 GABLE BOARD - W4L16415
(x1) 1 3/8"x5 1/4"x24 5/8" (36x134x625)

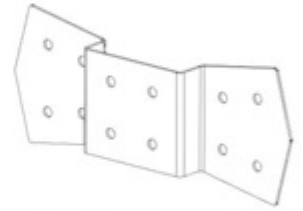

A4M01129 GABLE BRACKET
(x1)

- IF HOLES DO NOT ALIGN, USE THE METAL BRACKET AS A GUIDE AND A 7/16" (10mm) DRILL BIT TO DRILL THROUGH THE BOARDS.

- INSERT T-NUTS FIRST

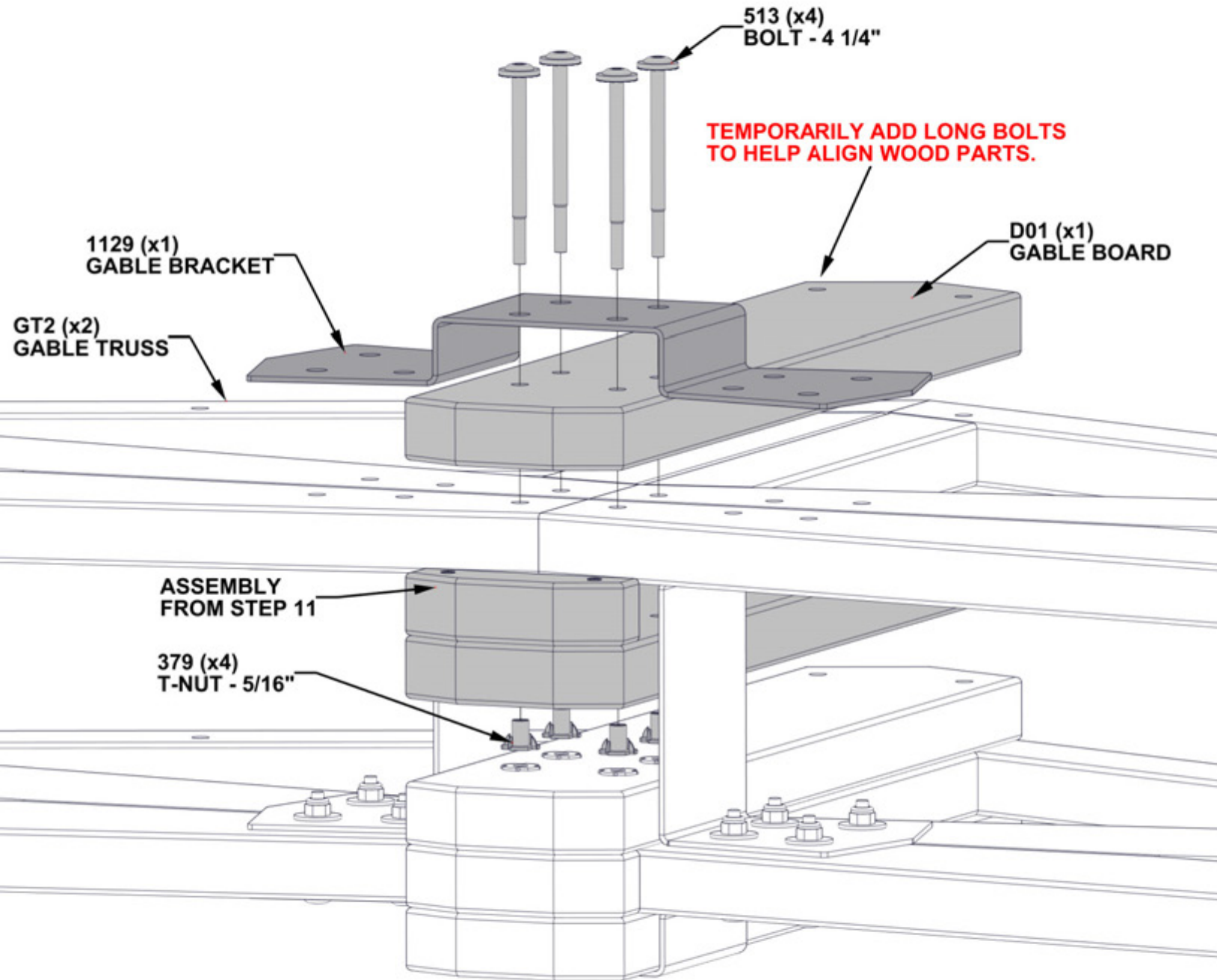

STEP 15 - CENTER GABLE ASSEMBLY

QTY	PART NUMBER	DESCRIPTION
8	H100205	BOLT WH 5/16x2 1/4 BLK
8	H100478	WASHER FLAT 8x27 BLK
8	H100479	NUT LOCK 5/16 BLK

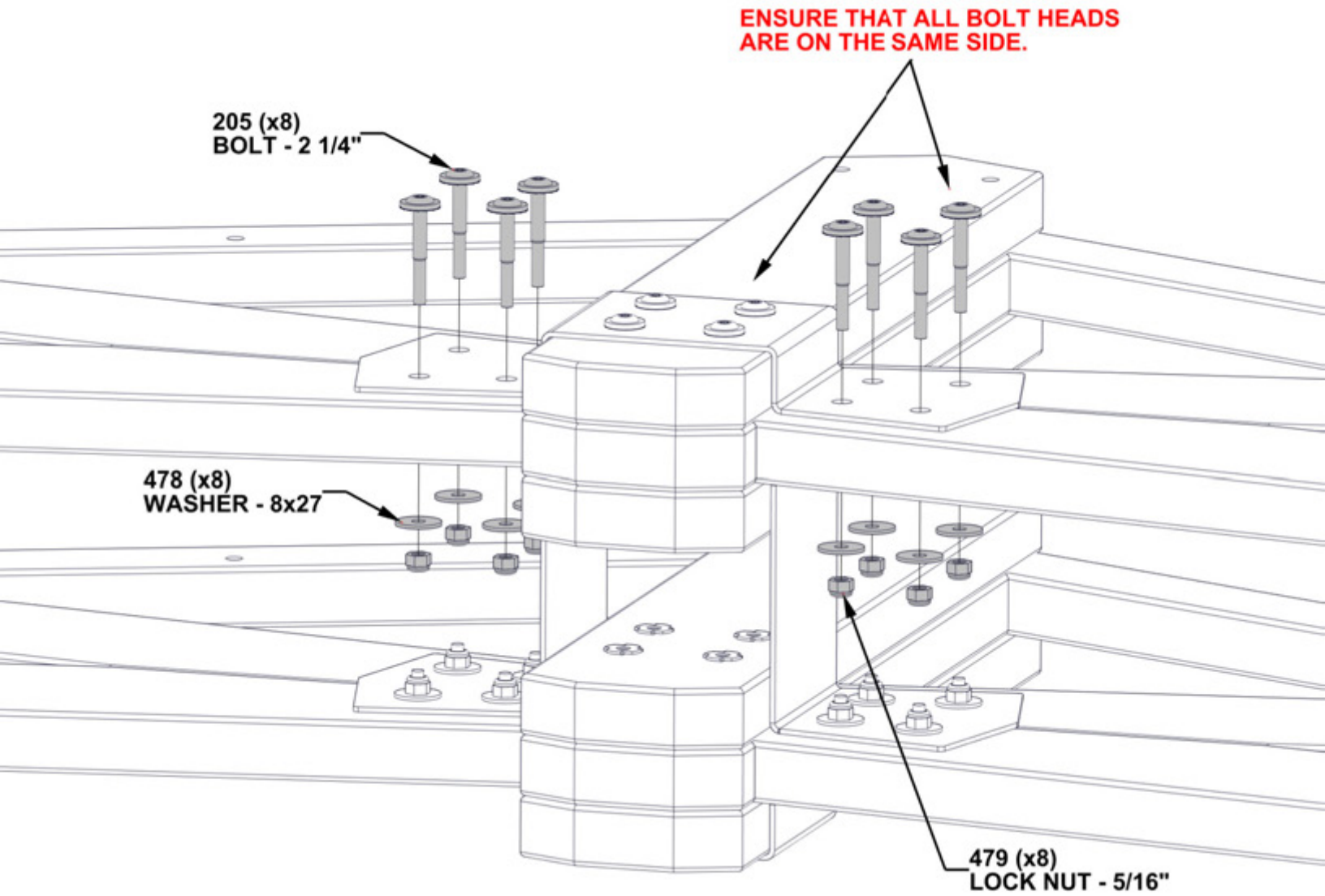

STEP 16 - CENTER GABLE ASSEMBLY

QTY	PART NUMBER	DESCRIPTION
10	H100198	WASHER LOCK EXT 8x19
6	H100379	T-NUT 5/16 BLK
4	H100458	LAG SCREW WH 5/16x2 BLK
6	H101058	BOLT WH 5/16x8 3/4 BLK



P03 POST - W2A03458
(x2) 6"x6"x89 1/2" (152x152x2274)

- INSERT T-NUTS FIRST

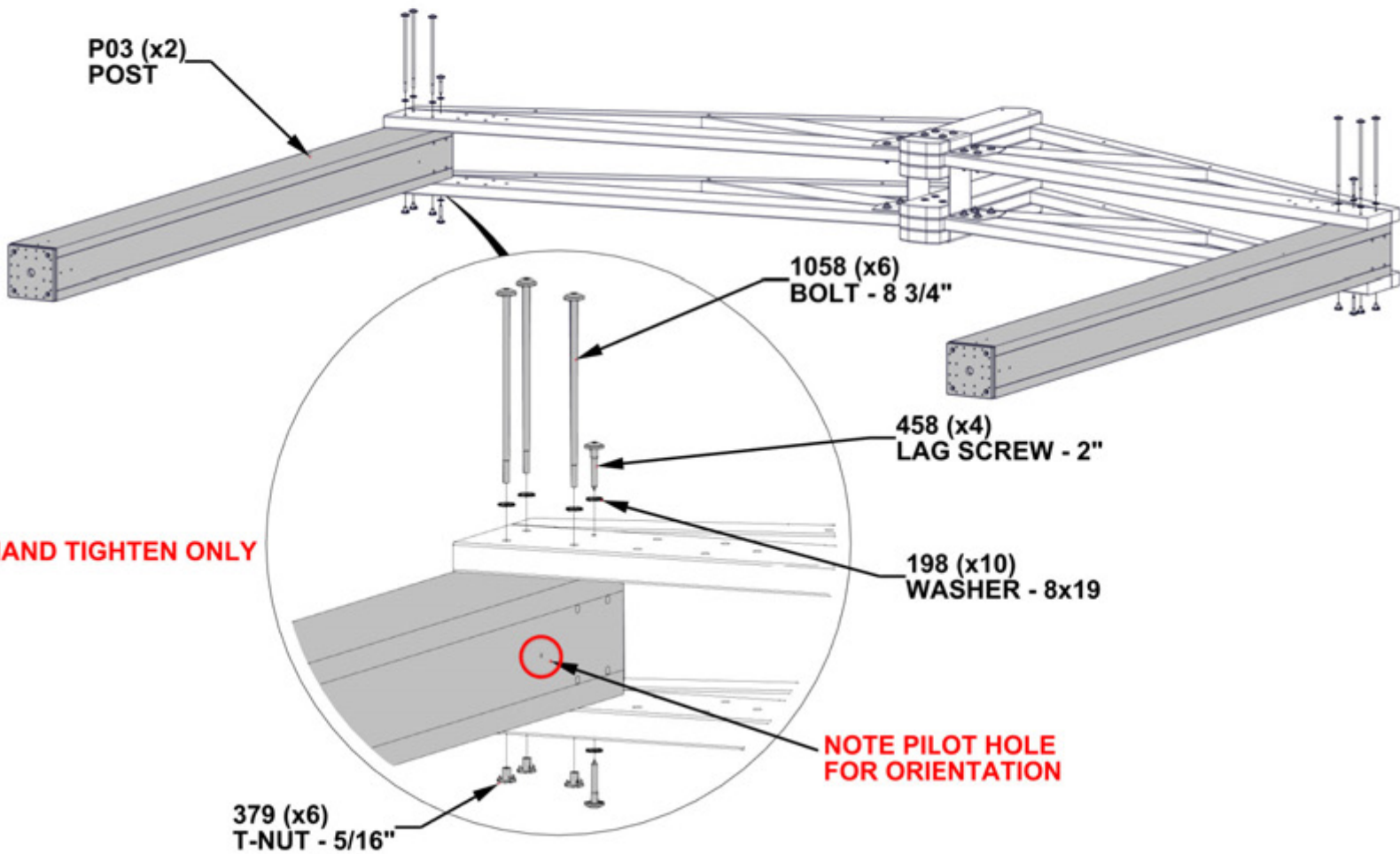

STEP 17 - CENTER GABLE ASSEMBLY

QTY	PART NUMBER	DESCRIPTION
28	H100198	WASHER LOCK EXT 8x19
20	H100205	BOLT WH 5/16x2 1/4 BLK
30	H100478	WASHER FLAT 8x27 BLK
28	H100479	NUT LOCK 5/16 BLK
2	H100659	LAG SCREW HEX 5/16x1 1/2 BLK
8	H100765	BOLT WH 5/16x8 BLK

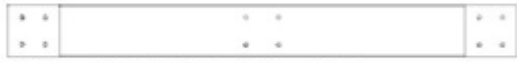

D07 TOP RAIL - W4L16381
(x2) 1 3/8"x5 1/4"x51 3/4" (36x134x1316)



A4M01558 MID POST BRACKET
(x2)

- FULLY TIGHTEN ALL HARDWARE.

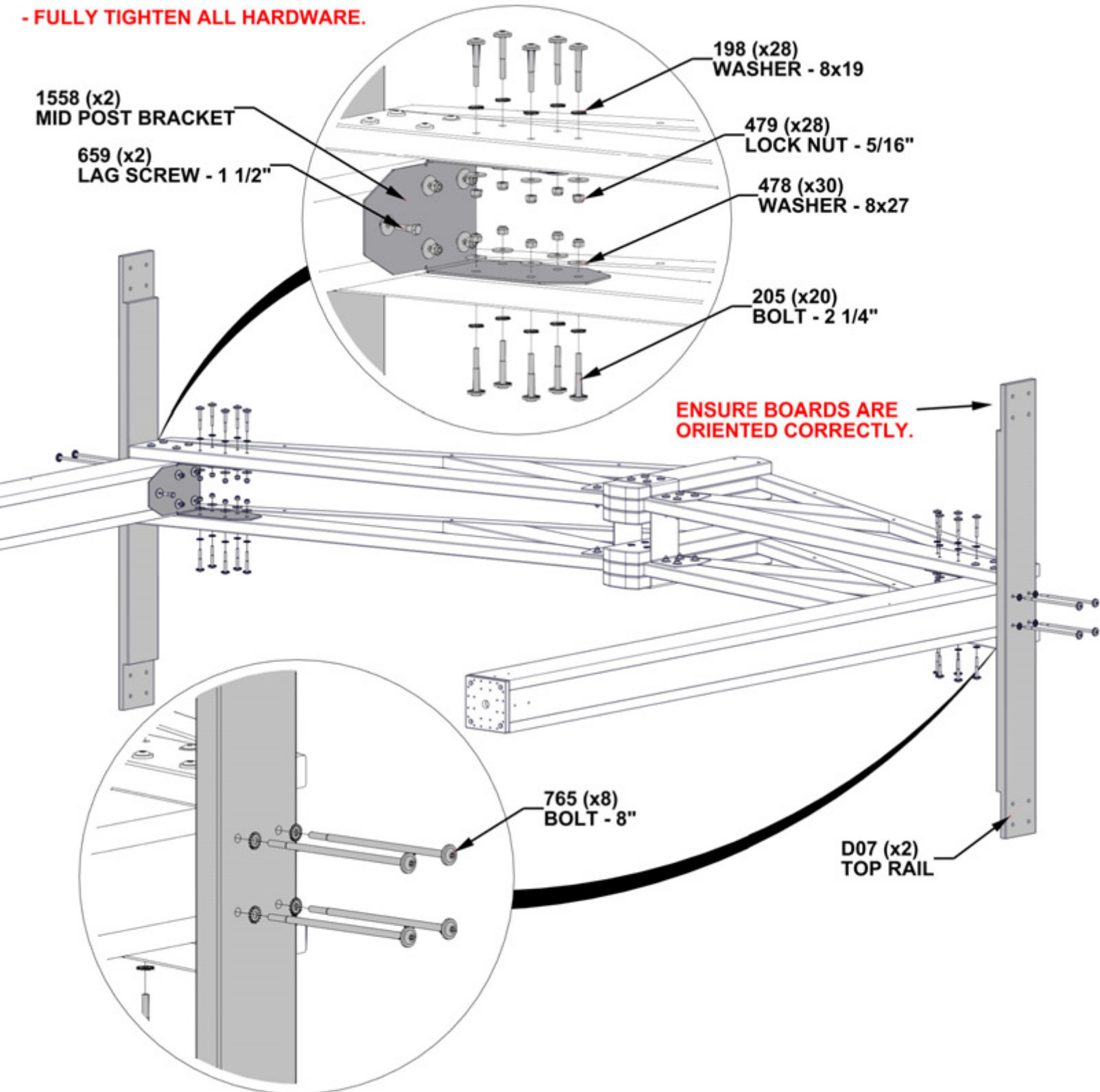

STEP 18 - GAZEBO ASSEMBLY

QTY	PART NUMBER	DESCRIPTION
8	H100195	BOLT WH 5/16x2 3/4 BLK
8	H100198	WASHER LOCK EXT 8x19
8	H100379	T-NUT 5/16 BLK
2	H100405	WASHER LOCK EXT 6x15
2	H100792	LAG SCREW WH 1/4x3 BLK

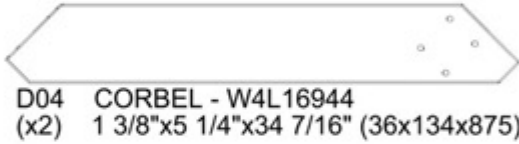

- ADDITIONAL PEOPLE ARE HELPFUL FOR THIS STEP.
- INSERT T-NUTS FIRST

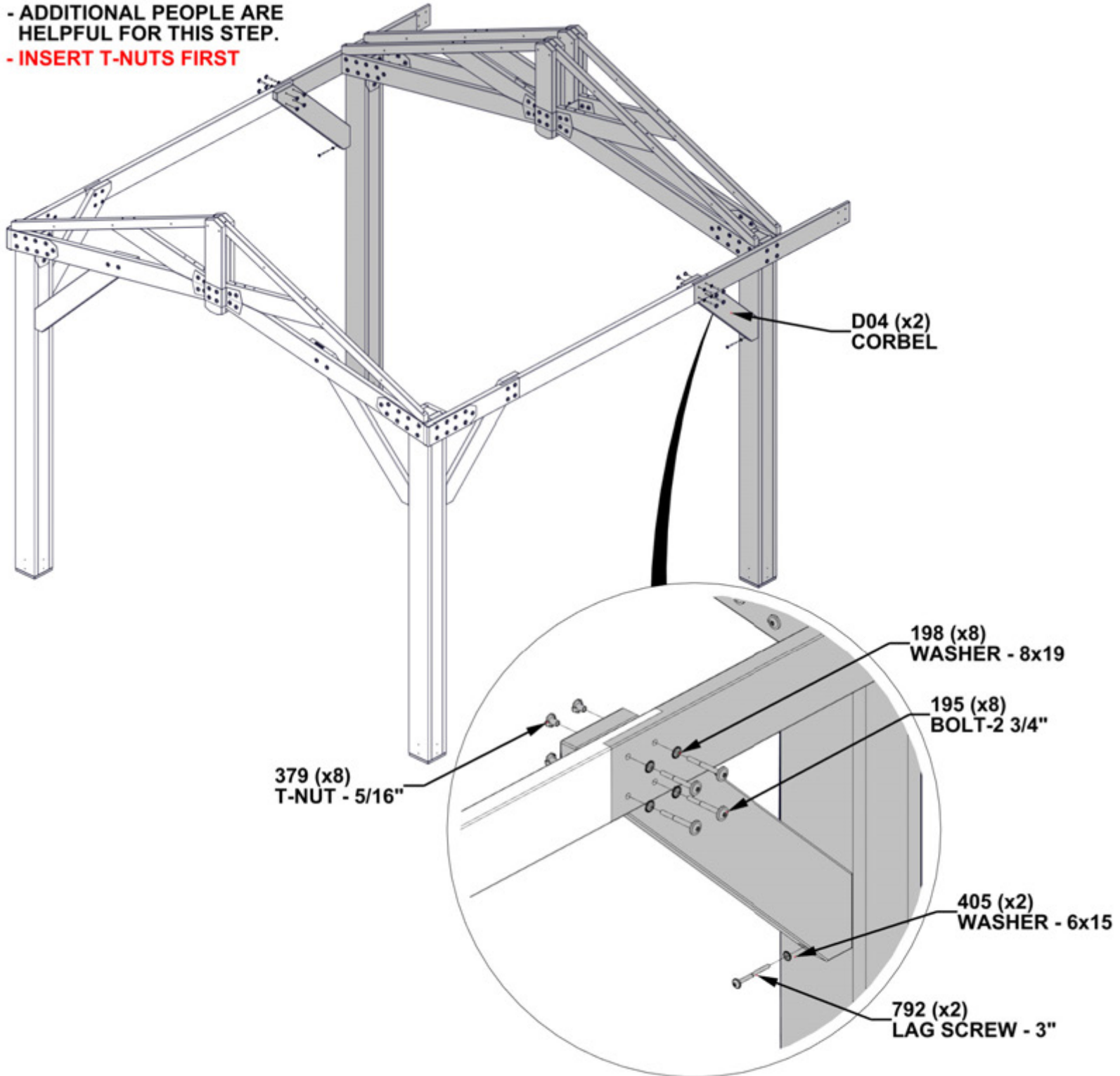

STEP 19 - GAZEBO ASSEMBLY

QTY	PART NUMBER	DESCRIPTION
12	H100195	BOLT WH 5/16x2 3/4 BLK
12	H100198	WASHER LOCK EXT 8x19
12	H100379	T-NUT 5/16 BLK



F02 TRUSS - W4L16378
(x4) 1 3/8"x2 3/8"x68" (36x60x1727)

- INSERT T-NUTS FIRST

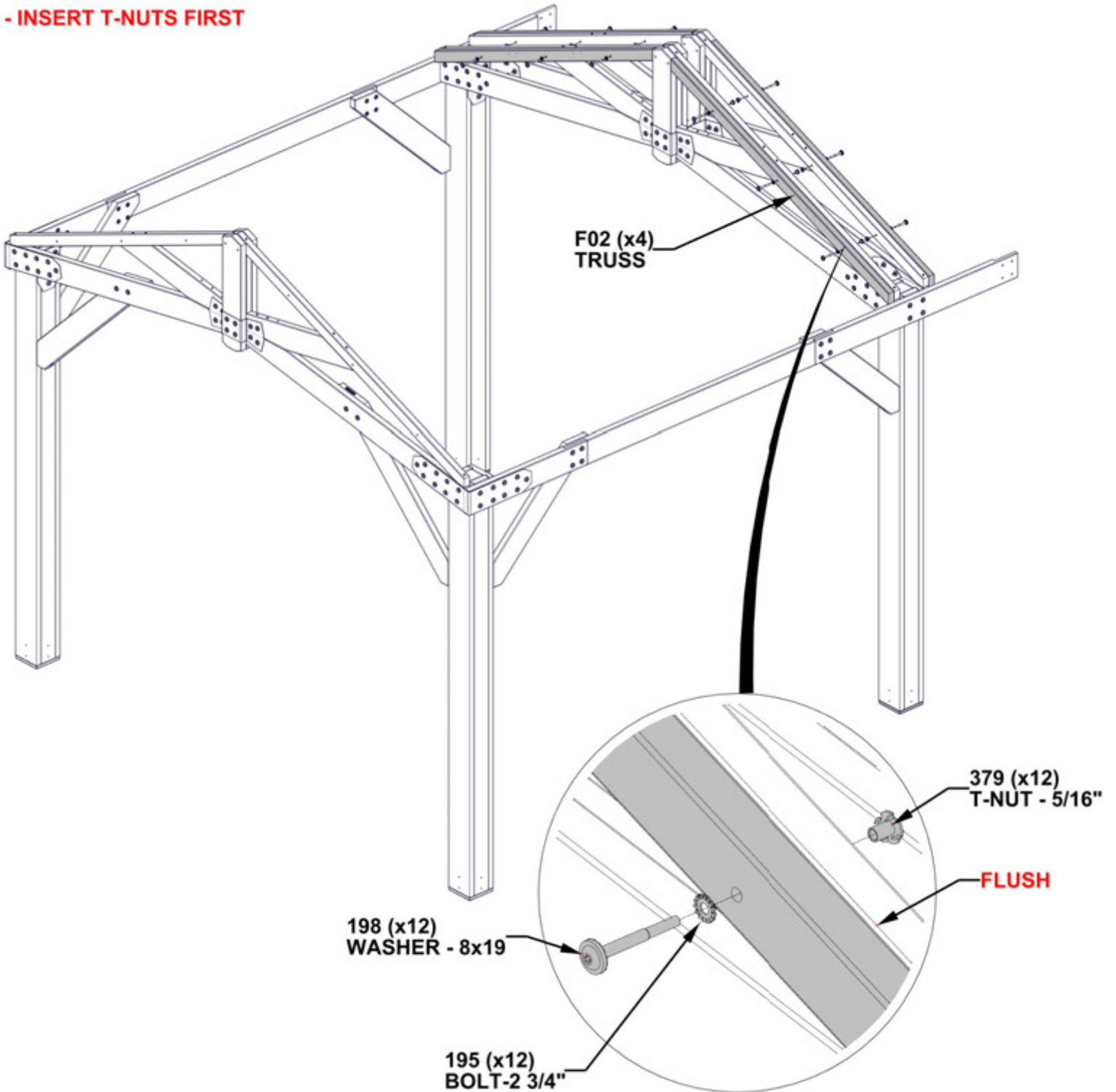

STEP 20 - GAZEBO ASSEMBLY

QTY	PART NUMBER	DESCRIPTION
8	H100195	BOLT WH 5/16x2 3/4 BLK
8	H100198	WASHER LOCK EXT 8x19
8	H100379	T-NUT 5/16 BLK
2	H100405	WASHER LOCK EXT 6x15
2	H100792	LAG SCREW WH 1/4x3 BLK



D04 CORBEL - W4L16944
(x2) 1 3/8"x5 1/4"x34 7/16" (36x134x875)

- ADDITIONAL PEOPLE ARE HELPFUL FOR THIS STEP.
- INSERT T-NUTS FIRST

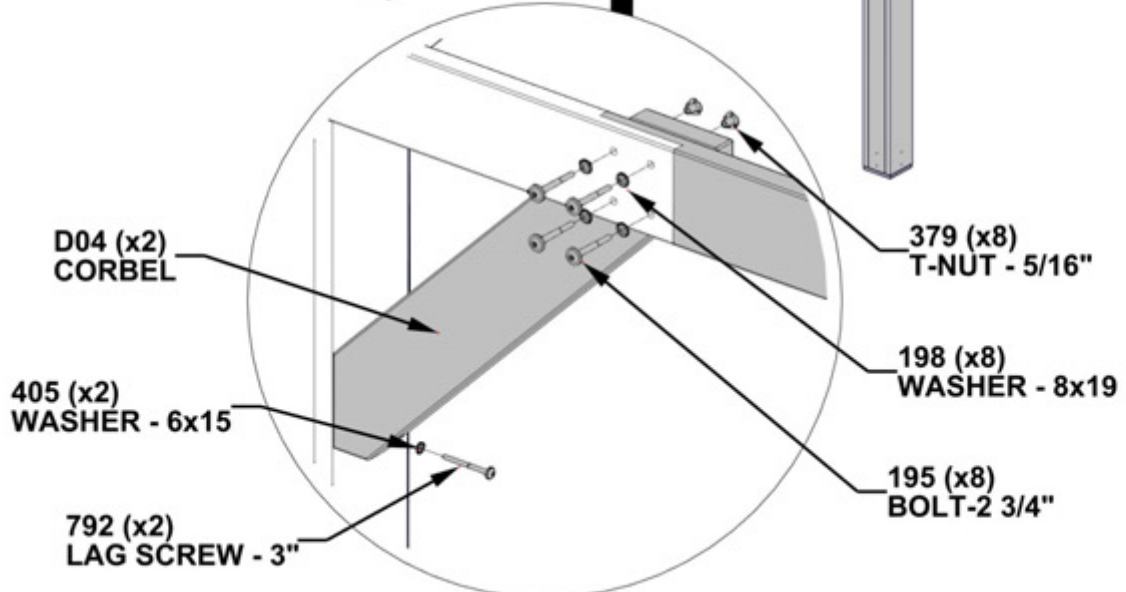
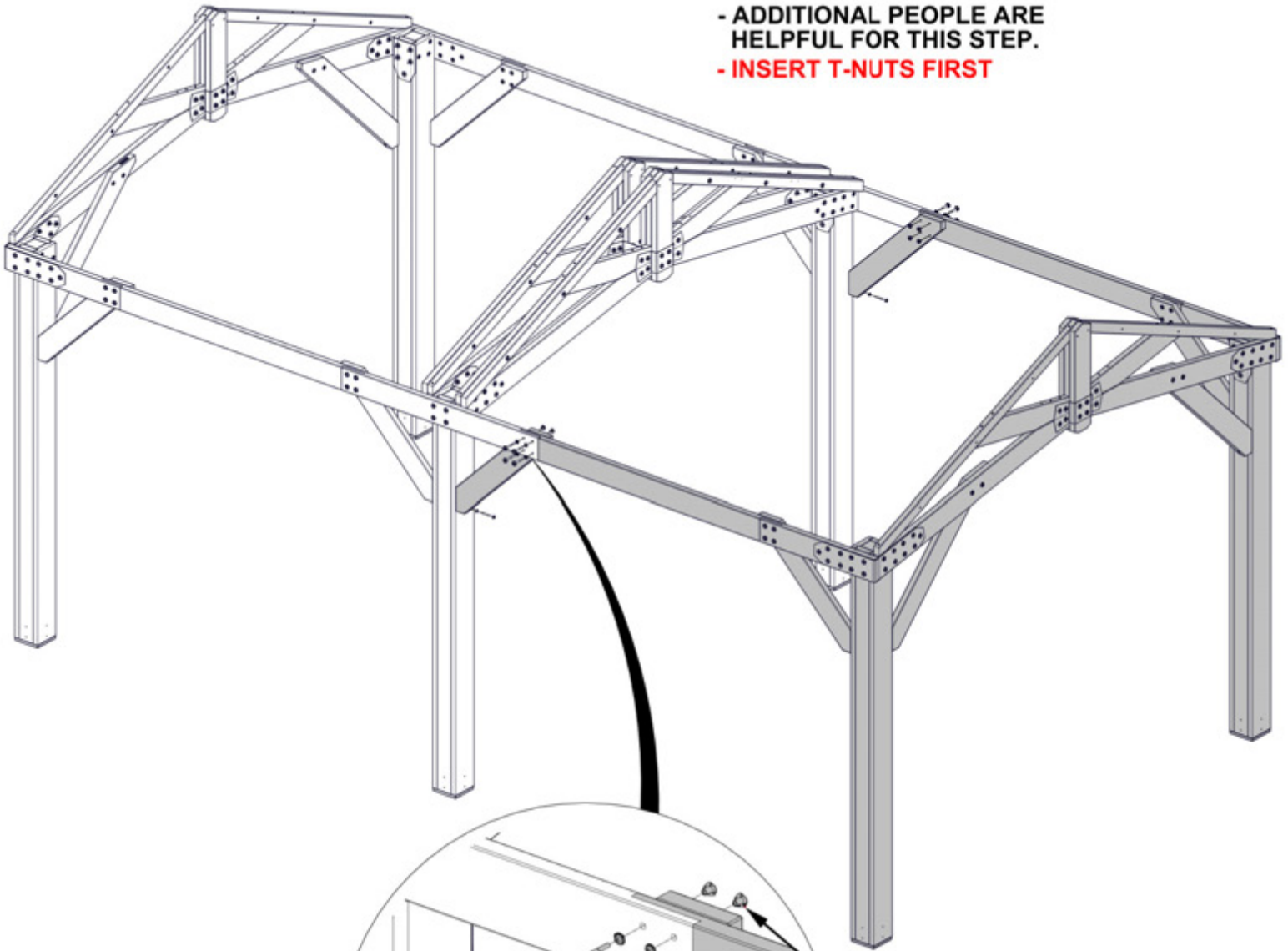

D04 (x2)
CORBEL

405 (x2)
WASHER - 6x15

792 (x2)
LAG SCREW - 3"

379 (x8)
T-NUT - 5/16"

198 (x8)
WASHER - 8x19

195 (x8)
BOLT - 2 3/4"

STEP 21 - GAZEBO ASSEMBLY

QTY	PART NUMBER	DESCRIPTION
16	H100201	SCREW PFH 8x2 1/2 BLK

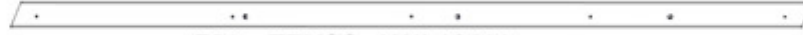

F01 TRUSS - W4L16414
(x4) 1 3/8"x2 3/8"x75 1/8" (36x60x1907)

- COMPLETE THIS STEP TWICE FOR OPPOSITE SIDE.

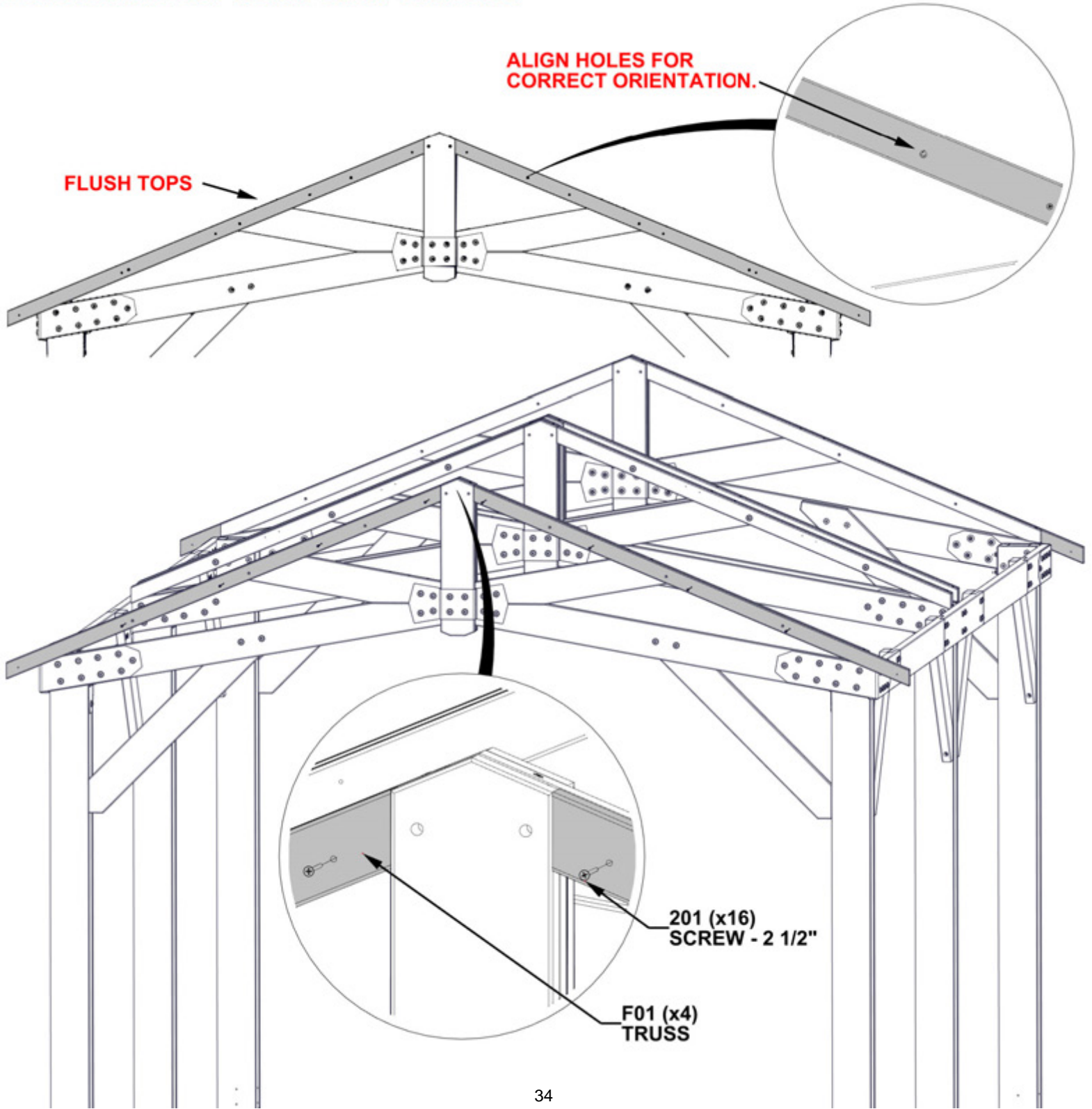

STEP 22 - GAZEBO ASSEMBLY

QTY	PART NUMBER	DESCRIPTION
4	H100201	SCREW PFH 8x2 1/2 BLK
12	H100405	WASHER LOCK EXT 6x15
12	H100564	LAG SCREW WH 1/4x4 BLK



GP1 GABLE PANEL - W2A03379
(x2) 2 13/16"x5 1/4"x80 3/16" (72x134x2037)



GP2 GABLE PANEL - W2A03380
(x2) 2 13/16"x5 1/4"x80 3/16" (72x134x2037)

- ALIGN LAG SCREWS WITH PILOT HOLES IN GABLE PANELS.

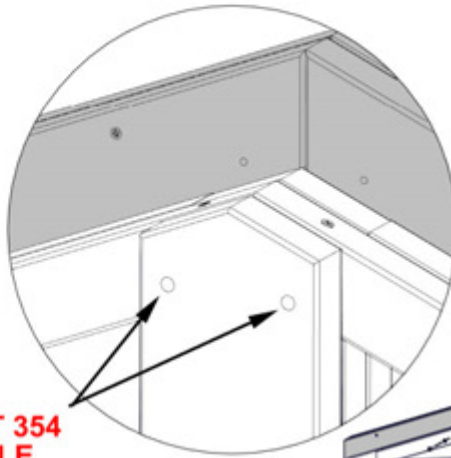

TEMPORARILY INSERT 354 BOLTS TO ALIGN GABLE PANEL WITH GABLE.

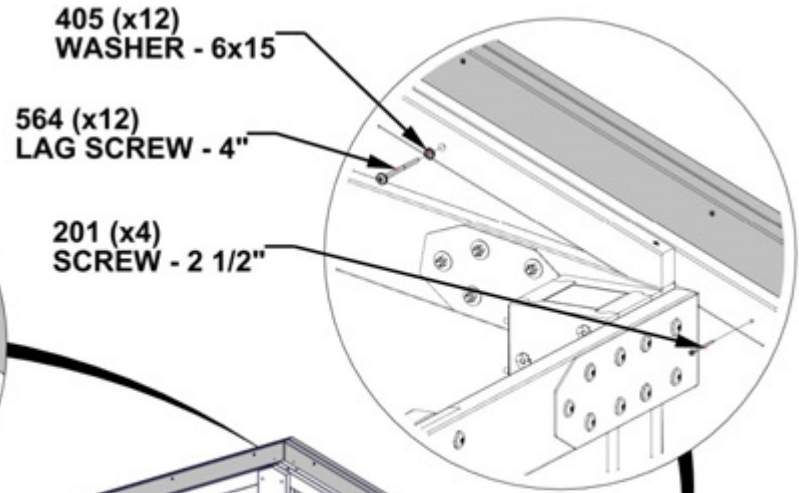

405 (x12)
WASHER - 6x15

564 (x12)
LAG SCREW - 4"

201 (x4)
SCREW - 2 1/2"

GP1 (x2)
GABLE PANEL

GP2 (x2)
GABLE PANEL

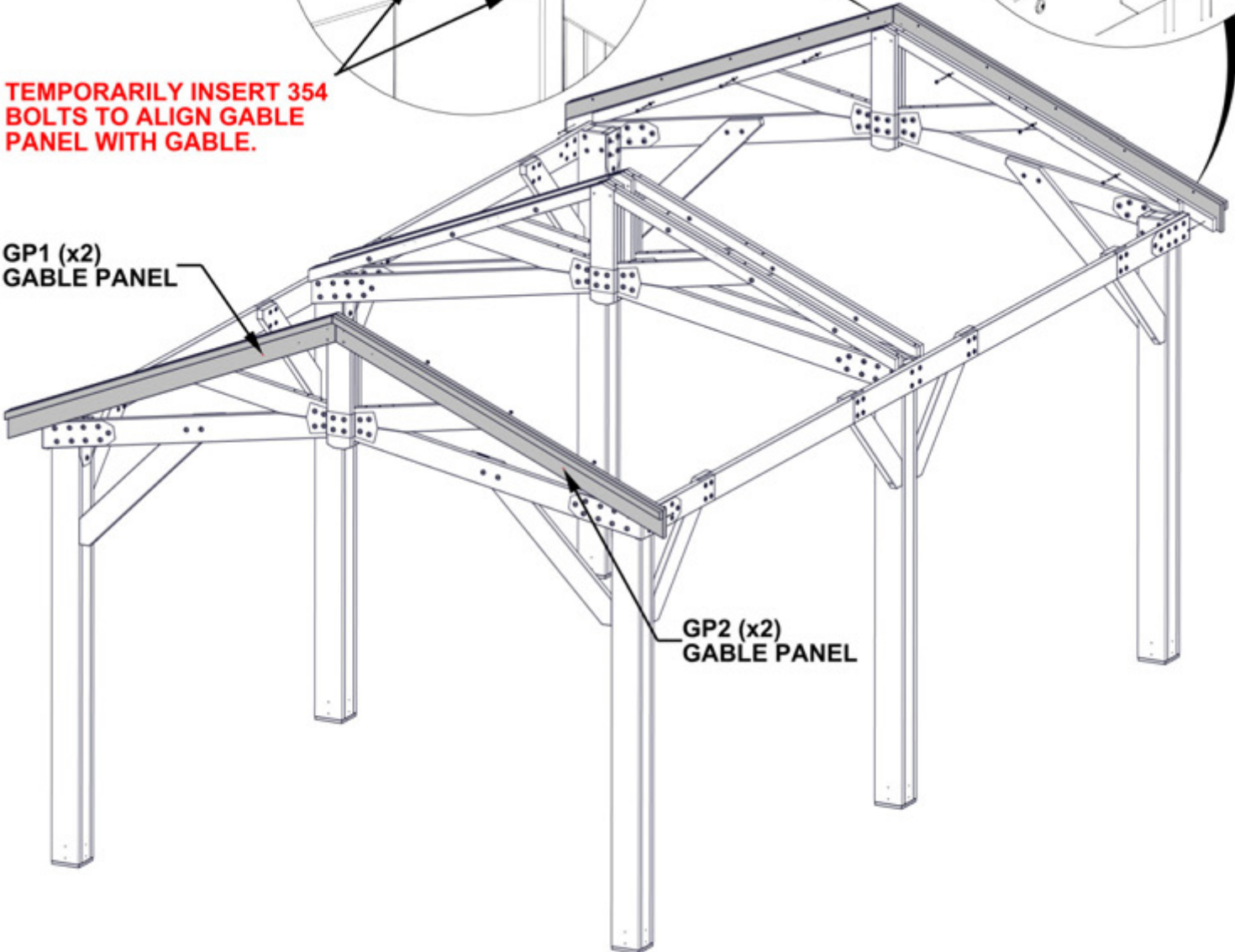

STEP 23 - GAZEBO ASSEMBLY

QTY	PART NUMBER	DESCRIPTION
4	H100200	SCREW PFH 8x1 1/2 BLK
8	H100471	LAG SCREW WH 5/16x1 1/2 BLK

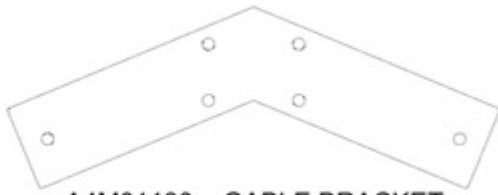

A4M01130 GABLE BRACKET
(x2)



A4M01147 PEAK SEAM BRACKET
(x2)

- COMPLETE THIS STEP TWICE FOR OPPOSITE SIDE.

PRE-DRILL 1/8" (3mm) PILOT HOLES FOR SCREWS USING PEAK SEAM BRACKET AS A GUIDE.

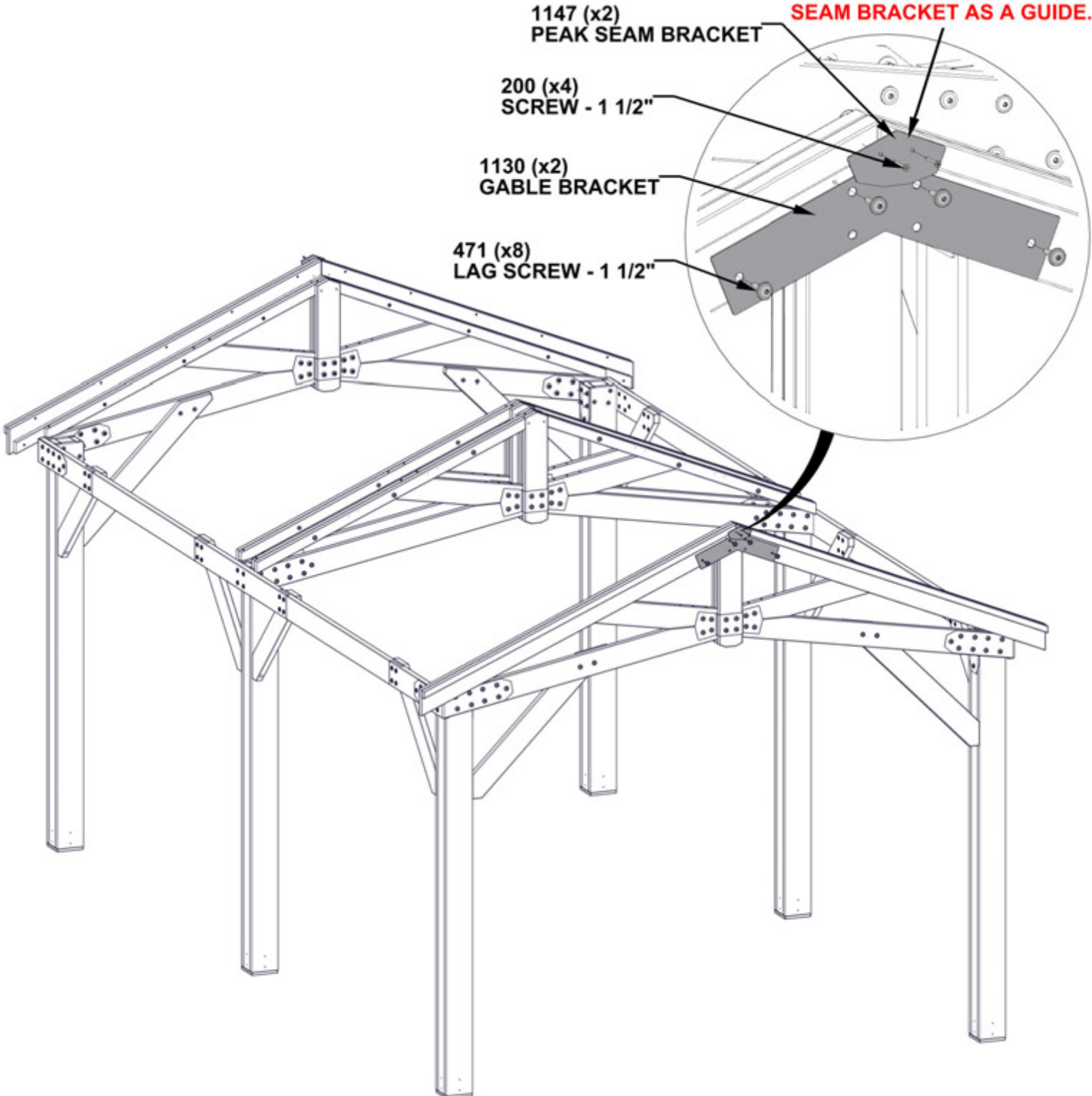

STEP 24 - GAZEBO ASSEMBLY

QTY	PART NUMBER	DESCRIPTION
16	H100823	SCREW PWH 8x1 1/2 BLK

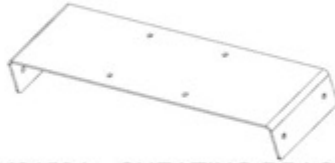

A4M01594 SHEATING BRACKET
(x4)

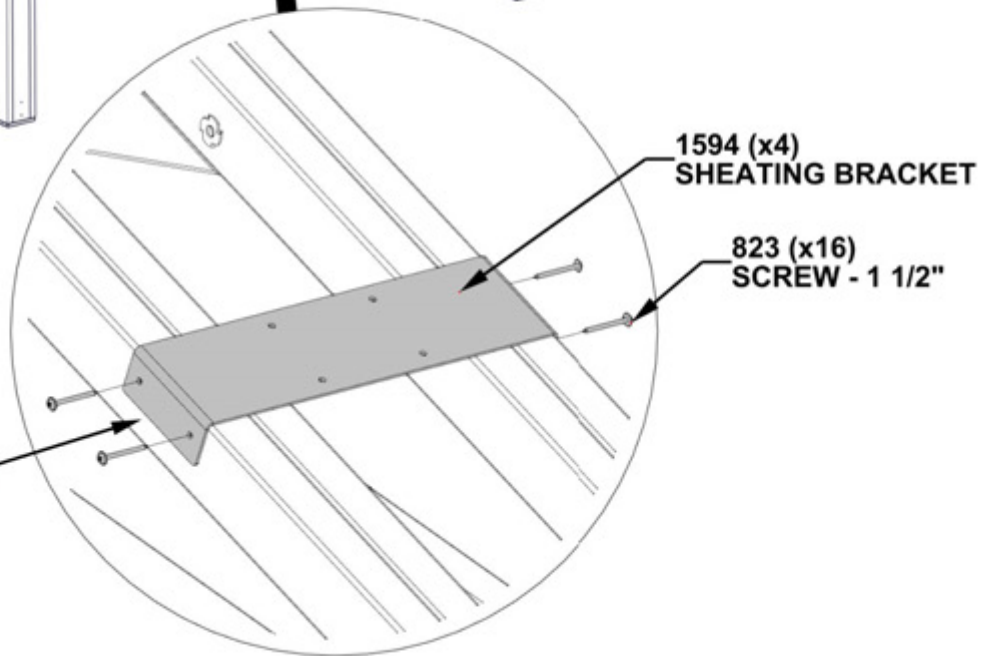
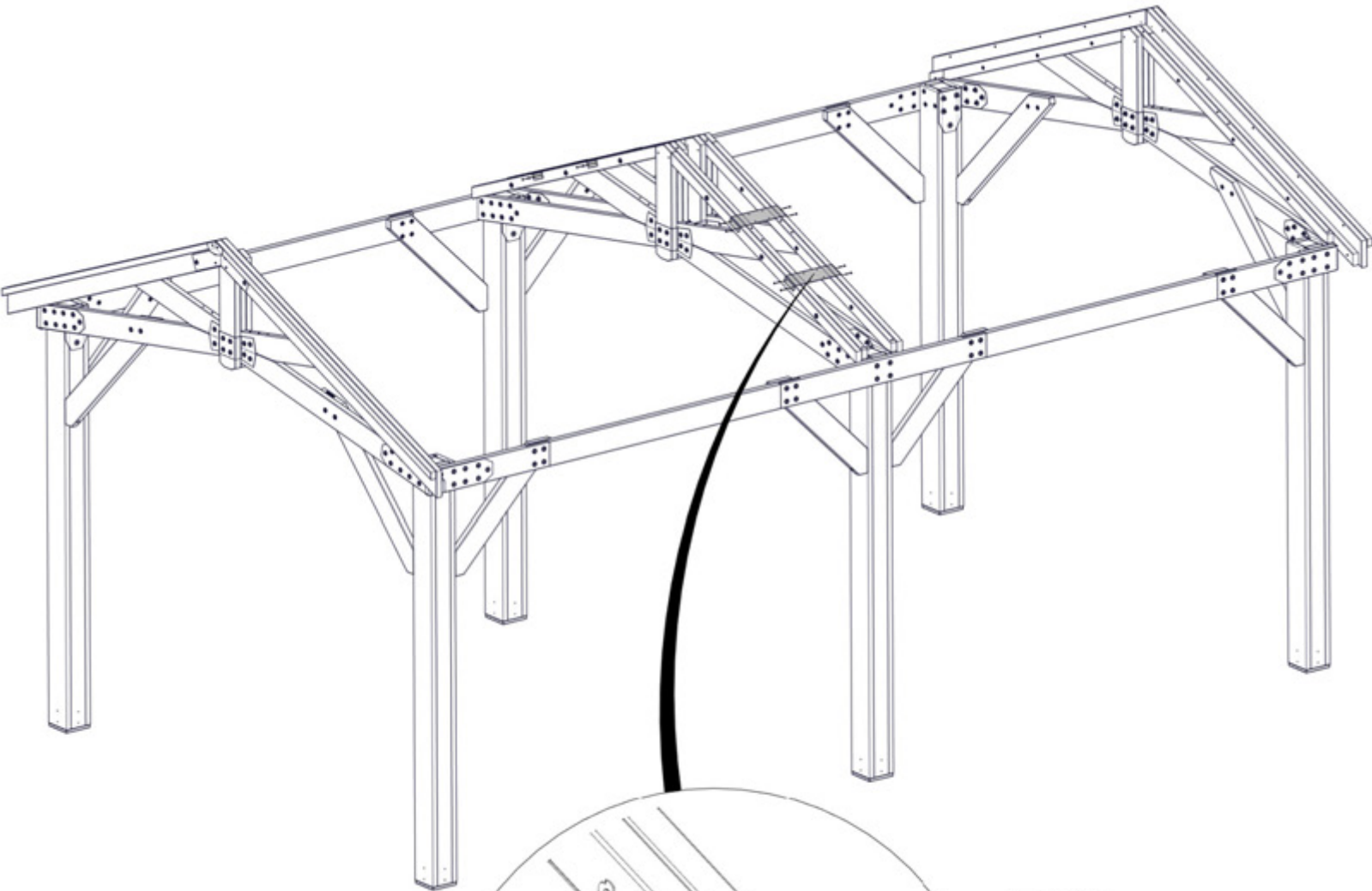

**ATTACH SHEATING BRACKETS
USING PILOT HOLES IN GABLE
ASSEMBLY.**

STEP 25 - SQUARE ASSEMBLY

CRITICAL: SQUARE ASSEMBLY BEFORE PROCEEDING TO NEXT STEPS. ONCE SQUARE, ENSURE ALL HARDWARE IS FULLY TIGHTENED.

MEASUREMENTS TAKEN FROM INSIDE OF POST TO INSIDE OF POST.

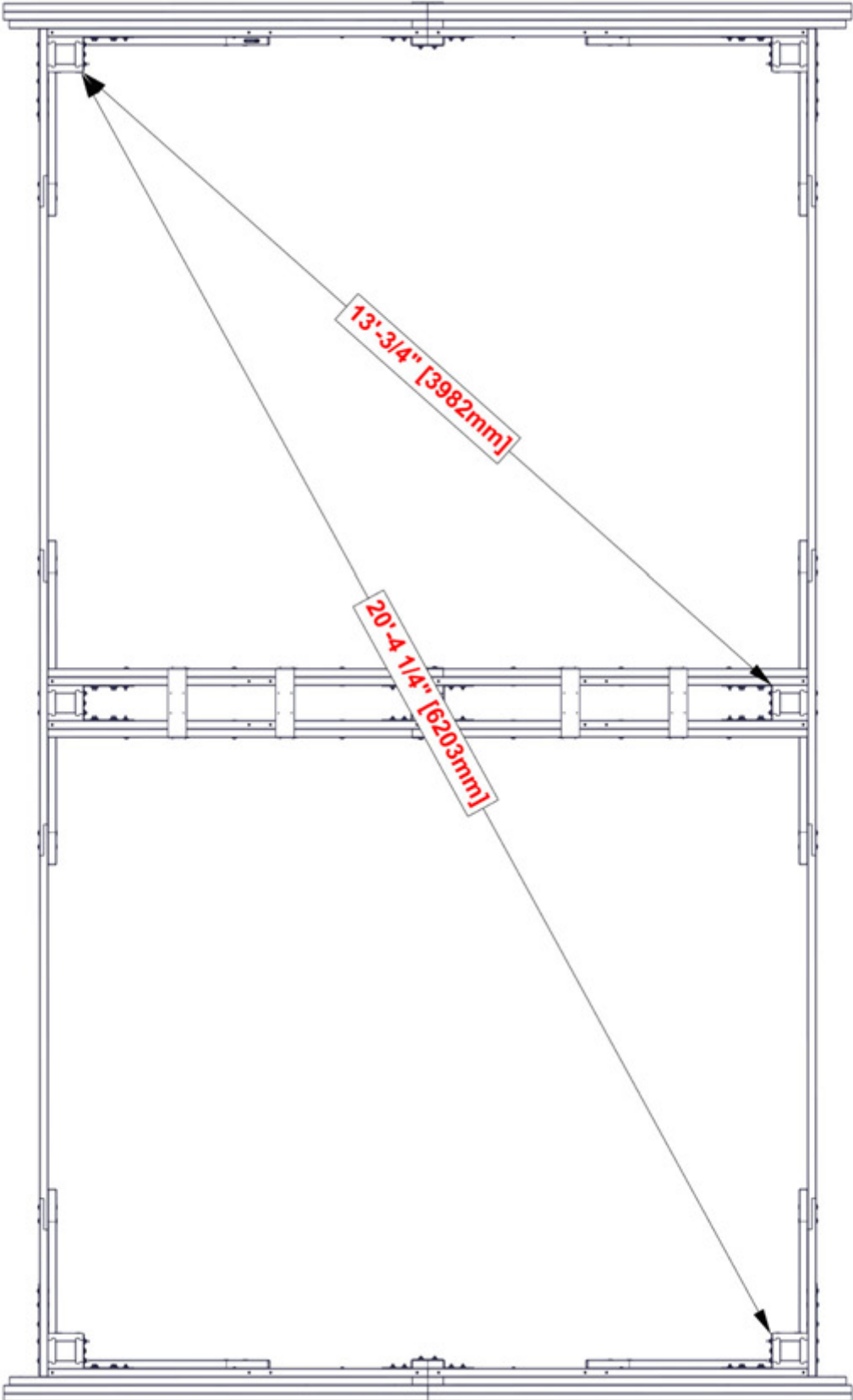

ONCE A ROOF PANEL IS COMPLETE, SET IT TO THE SIDE. KEEP TRACK OF A, B, C, AND D AS THEIR PLACEMENT IS CRITICAL IN LATER STEPS.

STEP 26 - ROOF PANEL A ASSEMBLY

QTY	PART NUMBER	DESCRIPTION
2	H100379	T-NUT 5/16 BLK
16	H100391	SCREW PFH 8x2 BLK



E01 RAFTER - W4L16382
(x2) 1 3/8"x3 3/8"x77 3/8" (36x86x1965)



H01 FASCIA - W4L16383
(x1) 1"x3 3/8"x68 5/8" (24x86x1742)

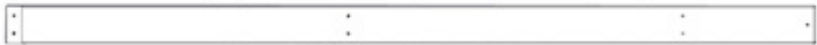

H03 FASCIA - W4L16385
(x1) 1"x3 3/8"x72 3/4" (24x86x1849)



E08 RAFTER - W4L16755
(x2) 1 3/8"x3 3/8"x77 3/8" (36x86x1965)



H02 FASCIA - W4L16384
(x1) 1"x3 3/8"x38 1/2" (24x86x978)

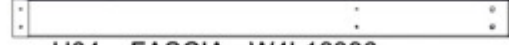

H04 FASCIA - W4L16386
(x1) 1"x3 3/8"x44 3/8" (24x86x1128)

- INSERT T-NUTS FIRST

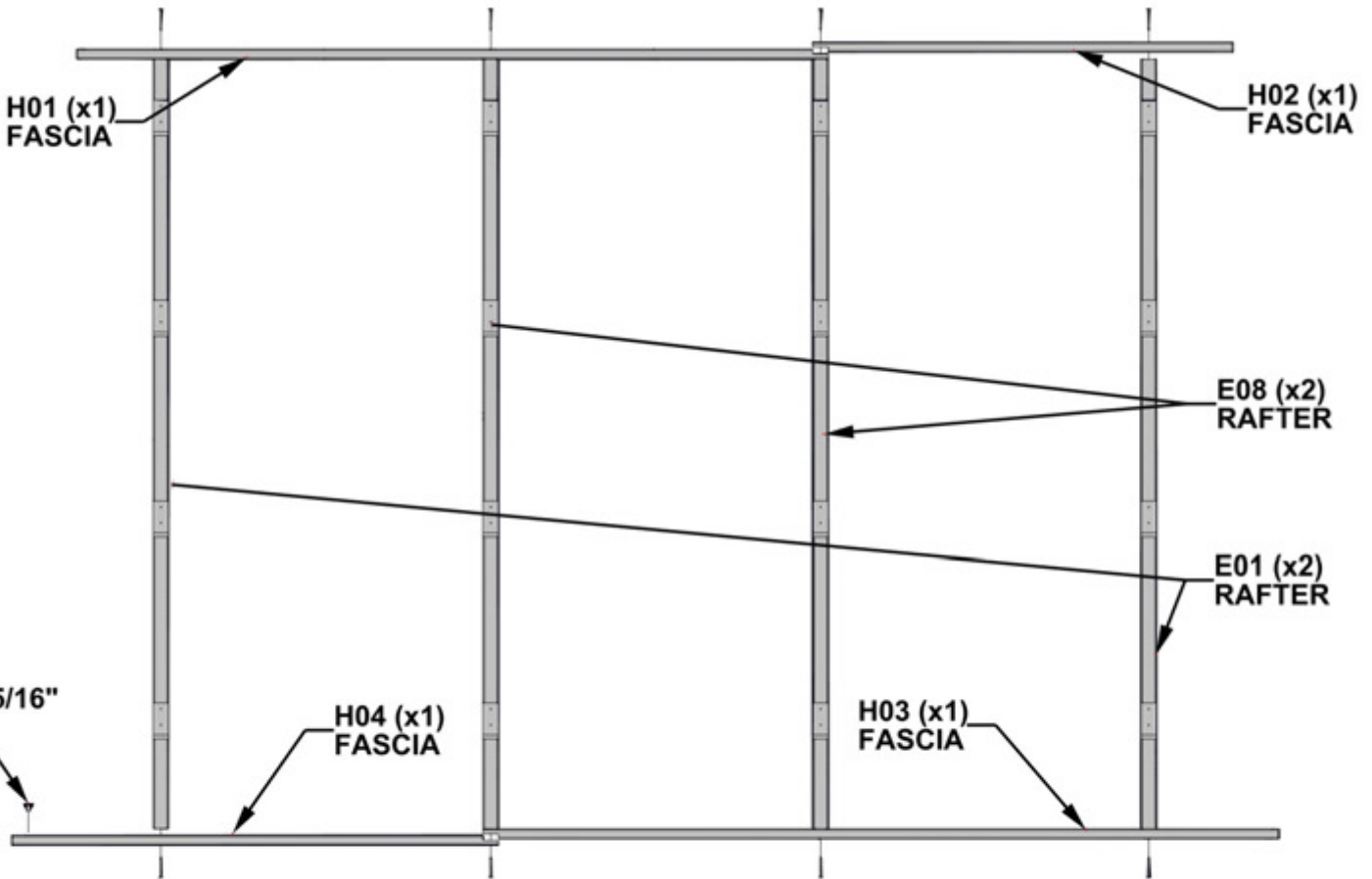

CORRECT ORIENTATION AND PLACEMENT OF H BOARDS IS CRITICAL FOR LATER STEPS.

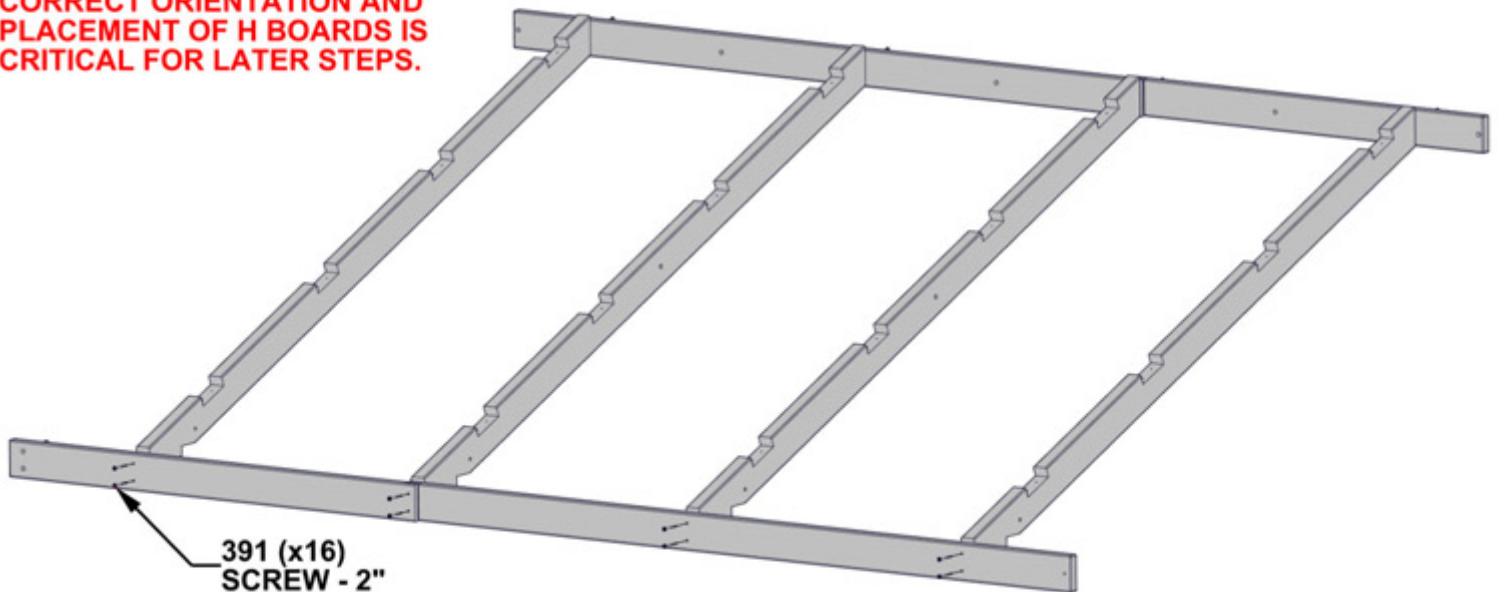

STEP 27A - ROOF PANEL A ASSEMBLY

QTY	PART NUMBER	DESCRIPTION
32	H100391	SCREW PFH 8x2 BLK



H05 SHEATHING BOARD - W4L16392
(x2) 1"x3 3/8"x72 3/4" (24x86x1849)



H07 SHEATHING BOARD - W4L16394
(x2) 1"x3 3/8"x42 3/4" (24x86x1085)



H06 SHEATHING BOARD - W4L16393
(x2) 1"x3 3/8"x74 3/8" (24x86x1888)



H08 SHEATHING BOARD - W4L16395
(x2) 1"x3 3/8"x44 1/4" (24x86x1124)

- DO NOT FULLY TIGHTEN SCREWS.

391 (x32)
SCREW - 2"

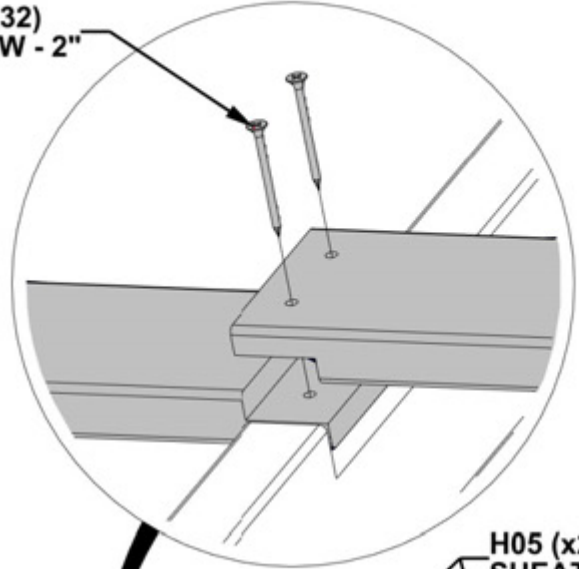

H05 (x2)
SHEATHING BOARD

H07 (x2)
SHEATHING BOARD

H06 (x2)
SHEATHING BOARD

H08 (x2)
SHEATHING BOARD

**H06 AND H08 BOARDS
GO ON THE SIDE WITH
TWO PILOT HOLES.**

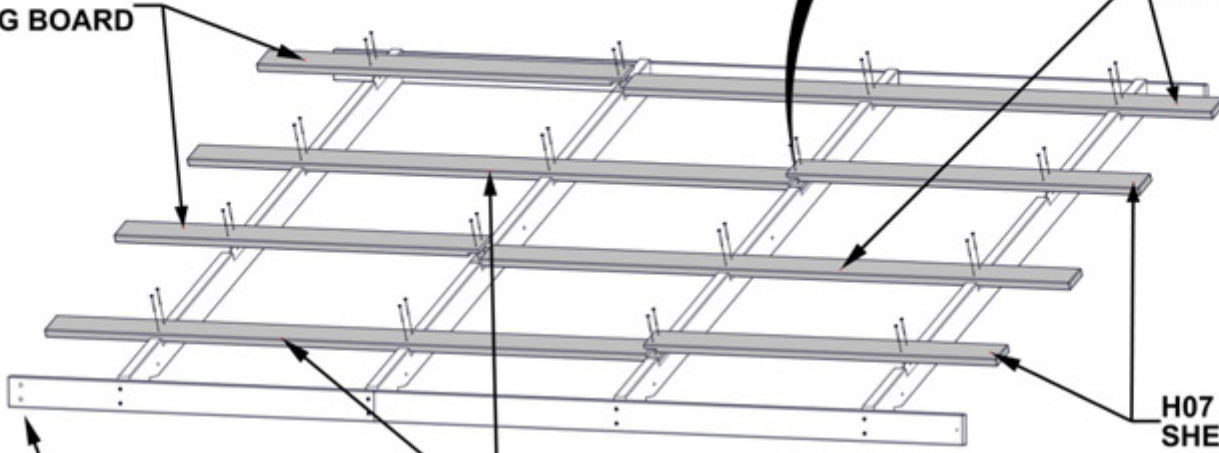

STEP 27B - ROOF PANEL A ASSEMBLY

CRITICAL:

- SQUARE UNIT BEFORE PROCEEDING TO NEXT STEPS.
- THE BELOW DIMENSIONS ARE CRITICAL TO THE FINAL ROOF ASSEMBLY.
- MEASUREMENTS SHOULD BE HELD WITHIN +/- 1/4" (6mm).
- MEASUREMENTS OUTSIDE OF TOLERANCE WILL LEAD TO THE INABILITY TO ASSEMBLE THE ROOF.

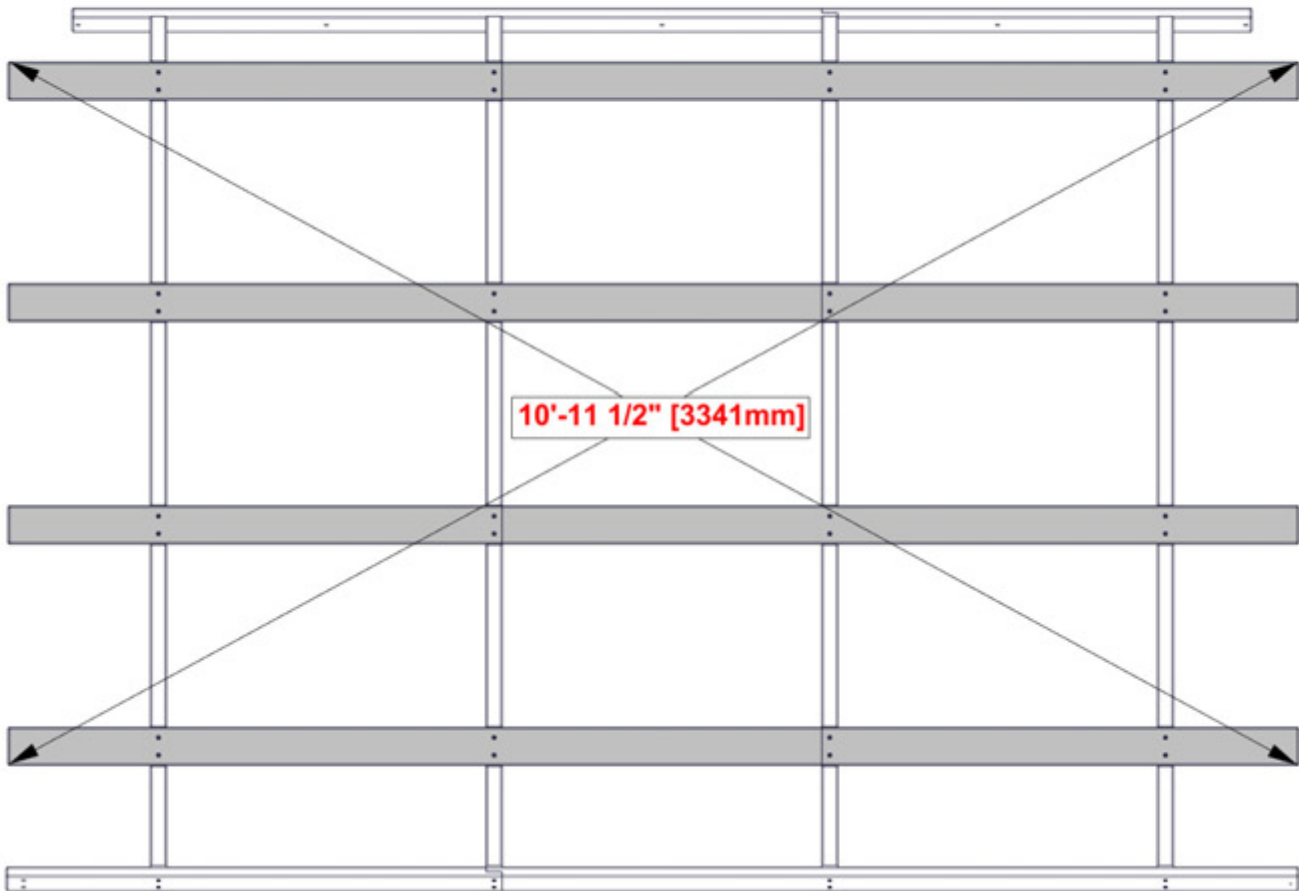

ONCE PANEL IS SQUARED, FULLY TIGHTEN SCREWS.

STEP 28 - ROOF PANEL A ASSEMBLY

ROOF PANEL A

- USE THIS STEP TO FAMILIARIZE YOURSELF WITH THE ROOF PANEL AND ASSIST YOU IN STEPS 29-30.
- REMOVE PROTECTIVE BLUE FILM.
- START AT THE END INDICATED AND ASSEMBLY IN THE DIRECTION OF THE ARROW.
- **GLOVES SHOULD BE WORN WHEN HANDLING ROOF PANELS: EDGES ARE SHARP.**

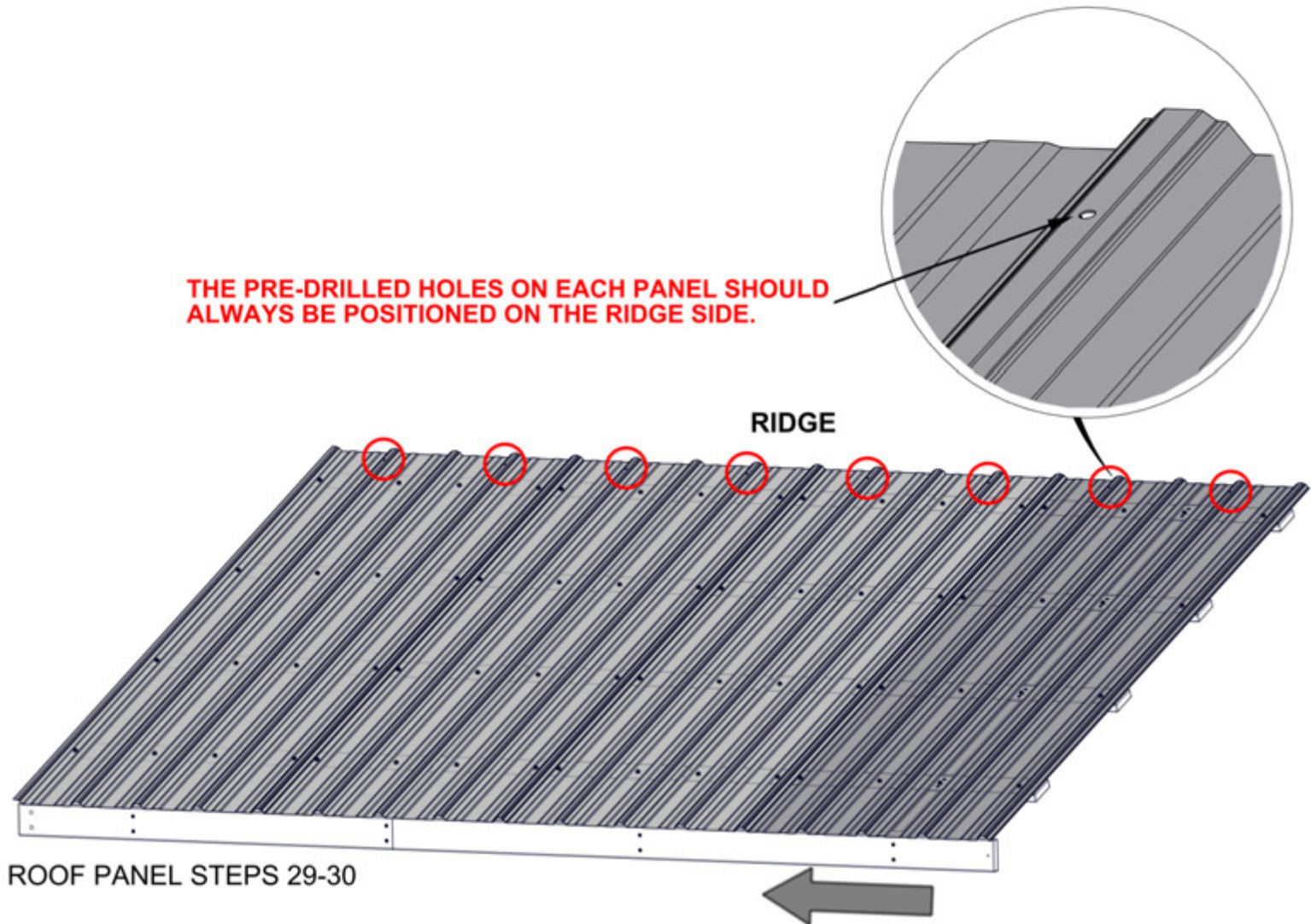

STEP 29 - ROOF PANEL A ASSEMBLY

QTY	PART NUMBER	DESCRIPTION
32	H100833	SCREW WOODGRIP 10-16x3/4"

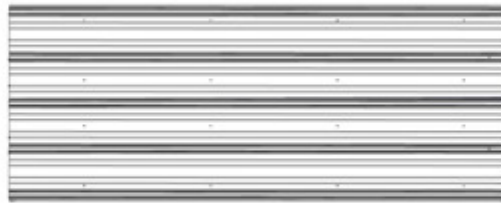

A4M02639 29 GA STEEL SHEETING (x2)

- MAKE SURE YOUR ROOF PANEL IS SQUARE BEFORE MOVING ON.

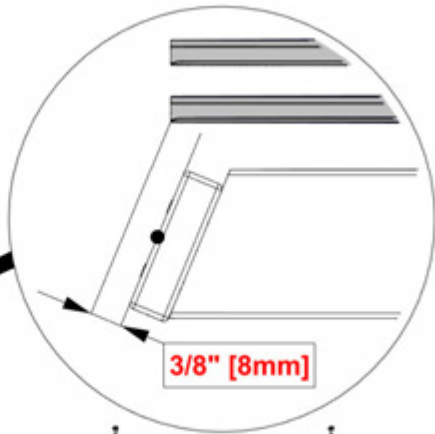

3/8" [8mm]

NOTE RIB OVERLAP

833 (x32)
SCREW - 3/4"

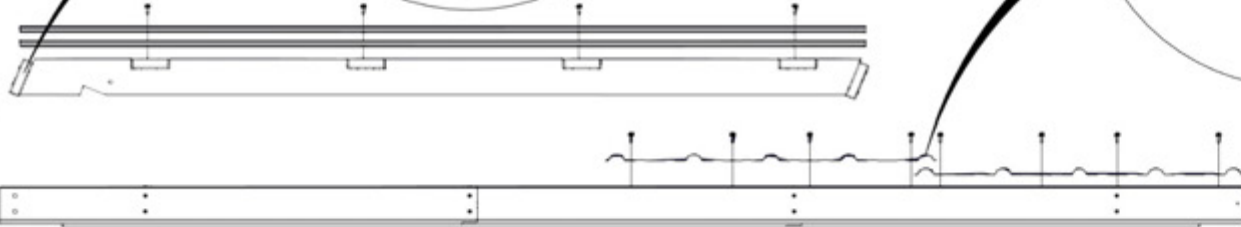
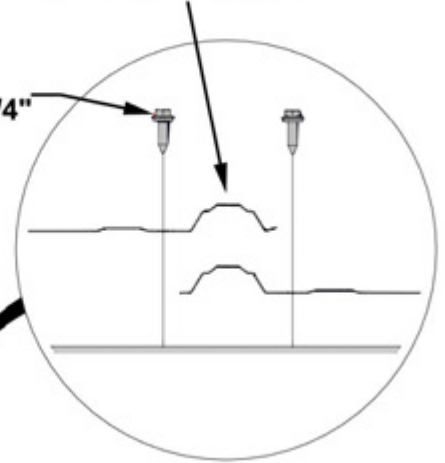

2639 (x2)
29 GA STEEL SHEETING

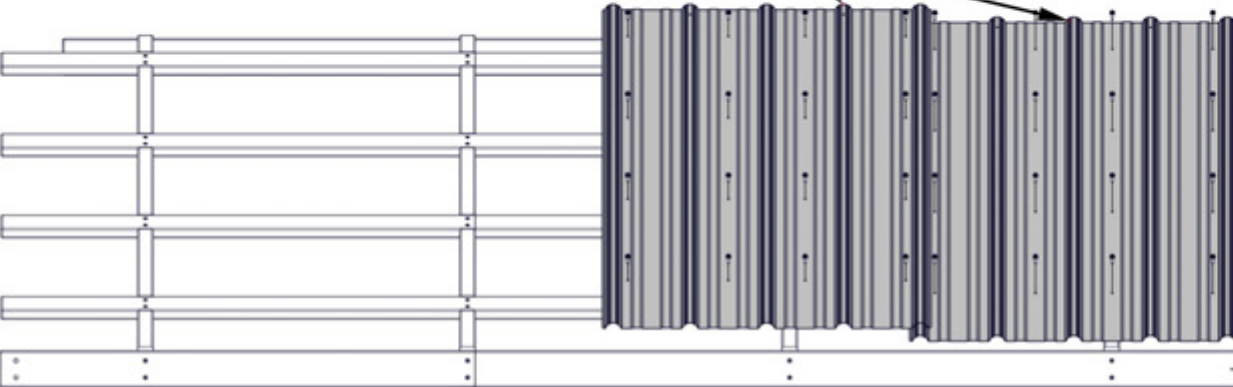

PLACE SHEETING ON ROOF PANEL, ALIGNING EDGE OF RIB 3/8" (8mm) FROM END OF H BOARD.

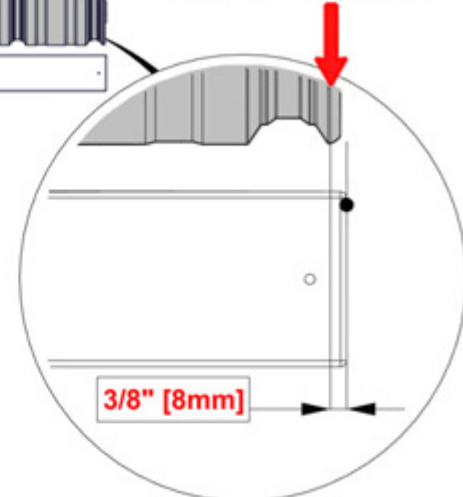

3/8" [8mm]

STEP 30 - ROOF PANEL A ASSEMBLY

QTY	PART NUMBER	DESCRIPTION
32	H100833	SCREW WOODGRIP 10-16x3/4



A4M02646 29 GA STEEL SHEETING
(x1)

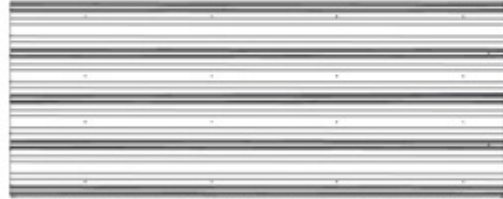

A4M02639 29 GA STEEL SHEETING
(x1)

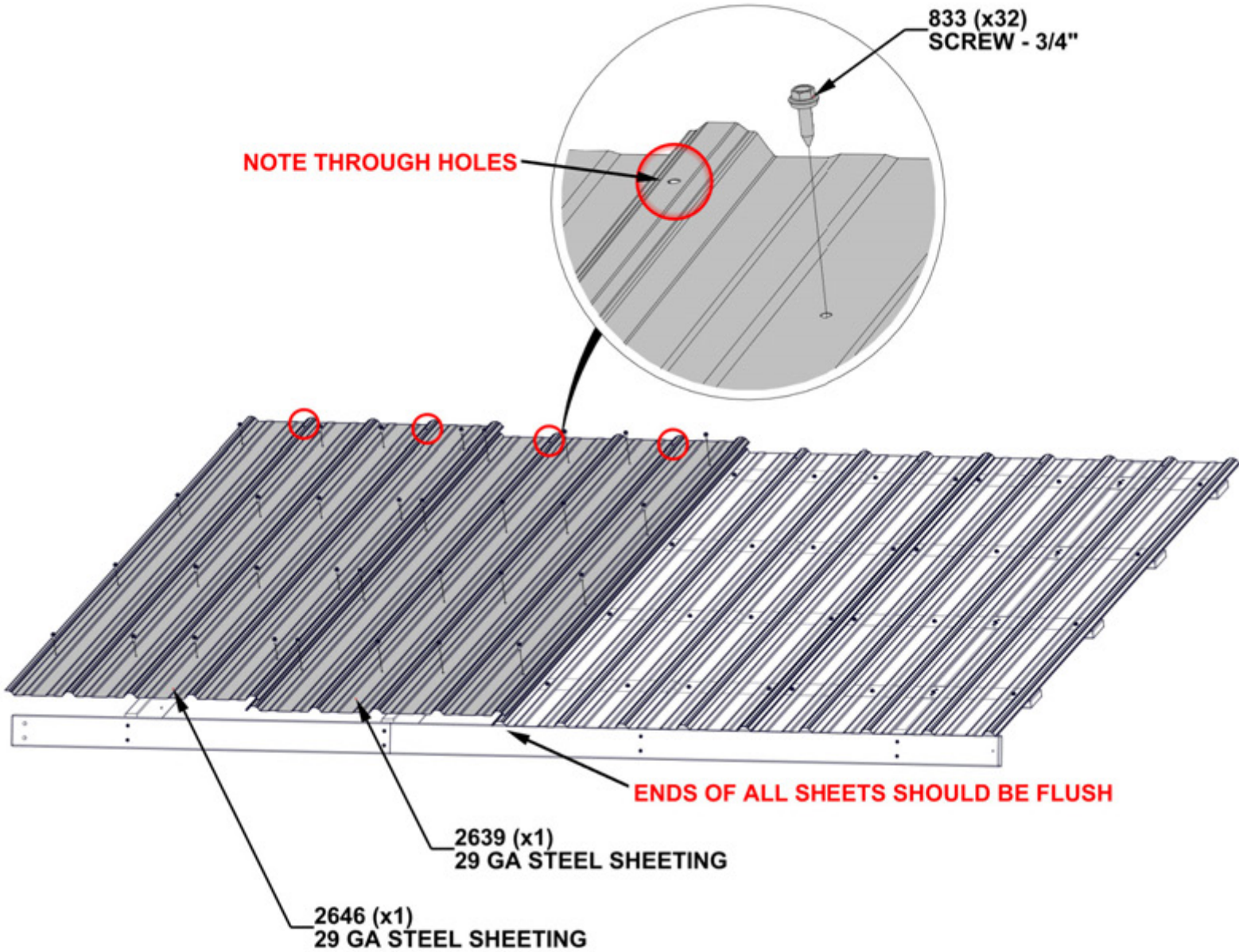

STEP 31 - ROOF PANEL B ASSEMBLY

QTY	PART NUMBER	DESCRIPTION
2	H100379	T-NUT 5/16 BLK
16	H100391	SCREW PFH 8x2 BLK

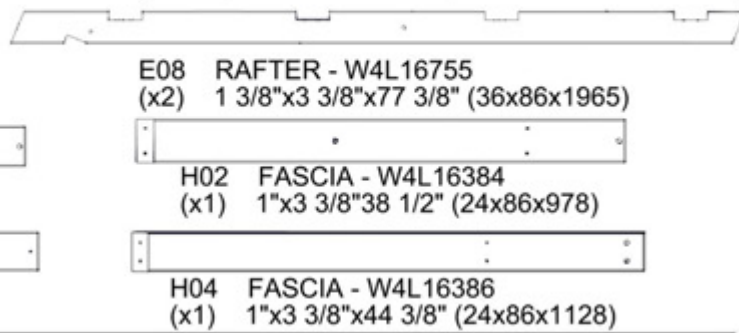
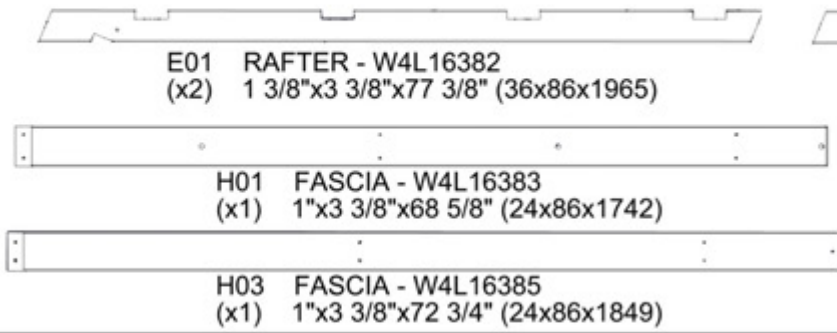

- INSERT T-NUTS FIRST

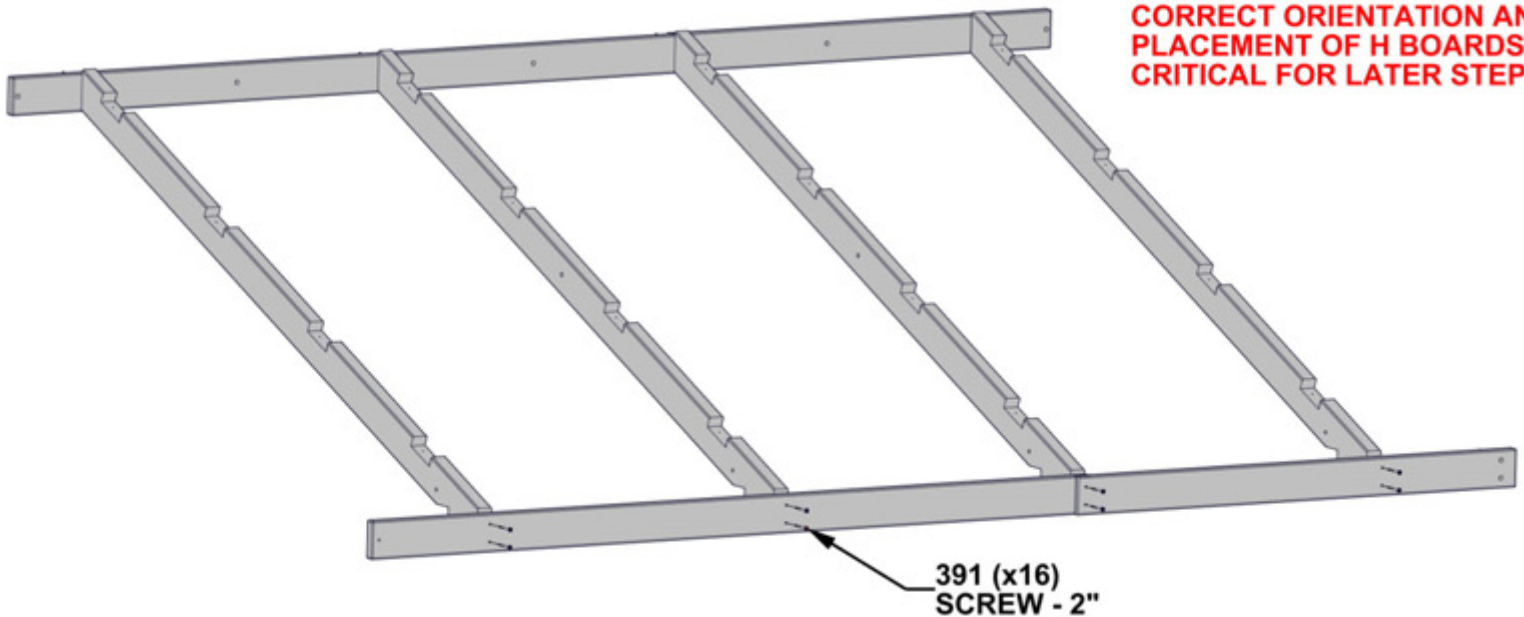
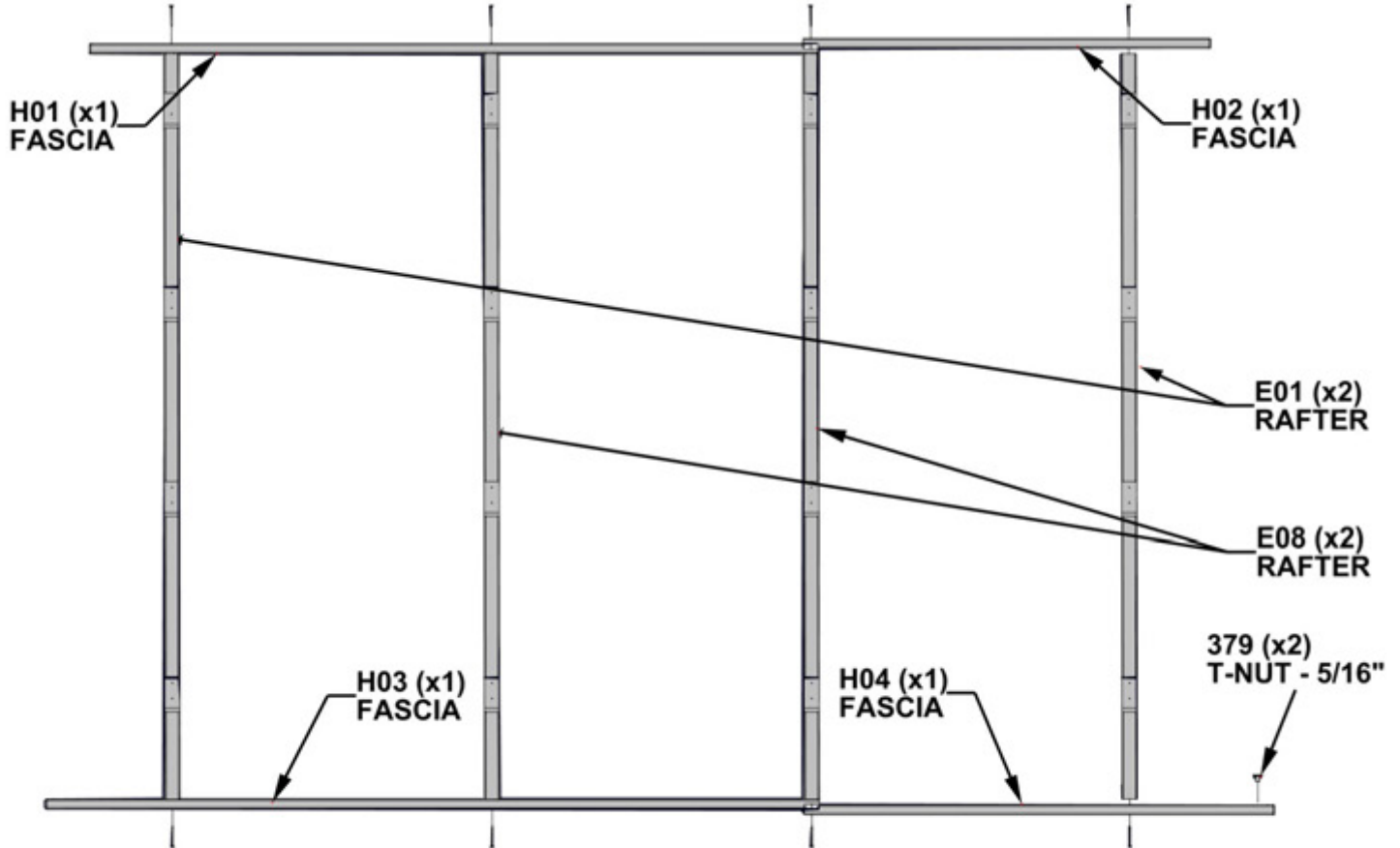

STEP 32A - ROOF PANEL B ASSEMBLY

QTY	PART NUMBER	DESCRIPTION
32	H100391	SCREW PFH 8x2 BLK

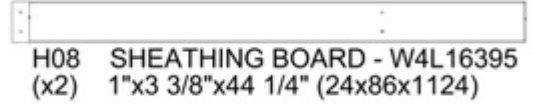
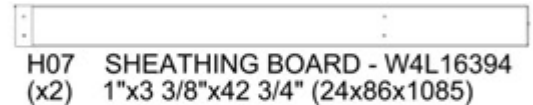
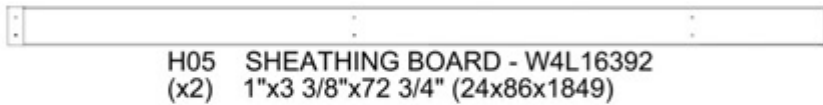

- DO NOT FULLY TIGHTEN SCREWS.

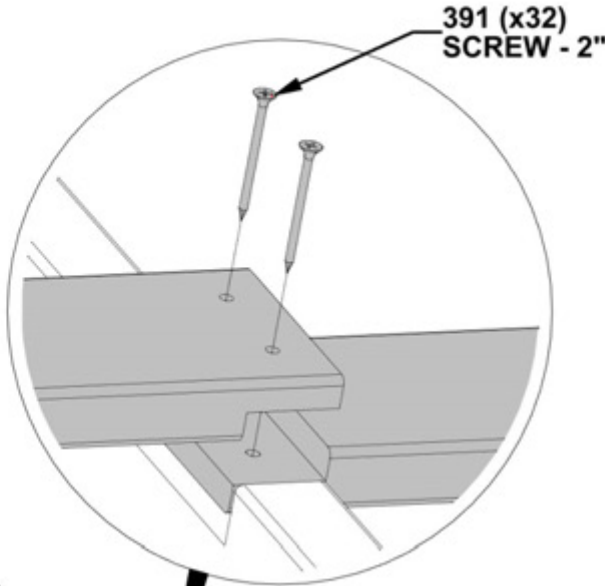

H05 (x2)
SHEATHING BOARD

H08 (x2)
SHEATHING BOARD

H07 (x2)
SHEATHING BOARD

H06 (x2)
SHEATHING BOARD

**H06 AND H08 BOARDS
GO ON THE SIDE WITH
TWO PILOT HOLES.**

STEP 32B - ROOF PANEL B ASSEMBLY

CRITICAL:

- SQUARE UNIT BEFORE PROCEEDING TO NEXT STEPS.
- THE BELOW DIMENSIONS ARE CRITICAL TO THE FINAL ROOF ASSEMBLY.
- MEASUREMENTS SHOULD BE HELD WITHIN $\pm 1/4"$.
- MEASUREMENTS OUTSIDE OF TOLERANCE WILL LEAD TO THE INABILITY TO ASSEMBLE THE ROOF.

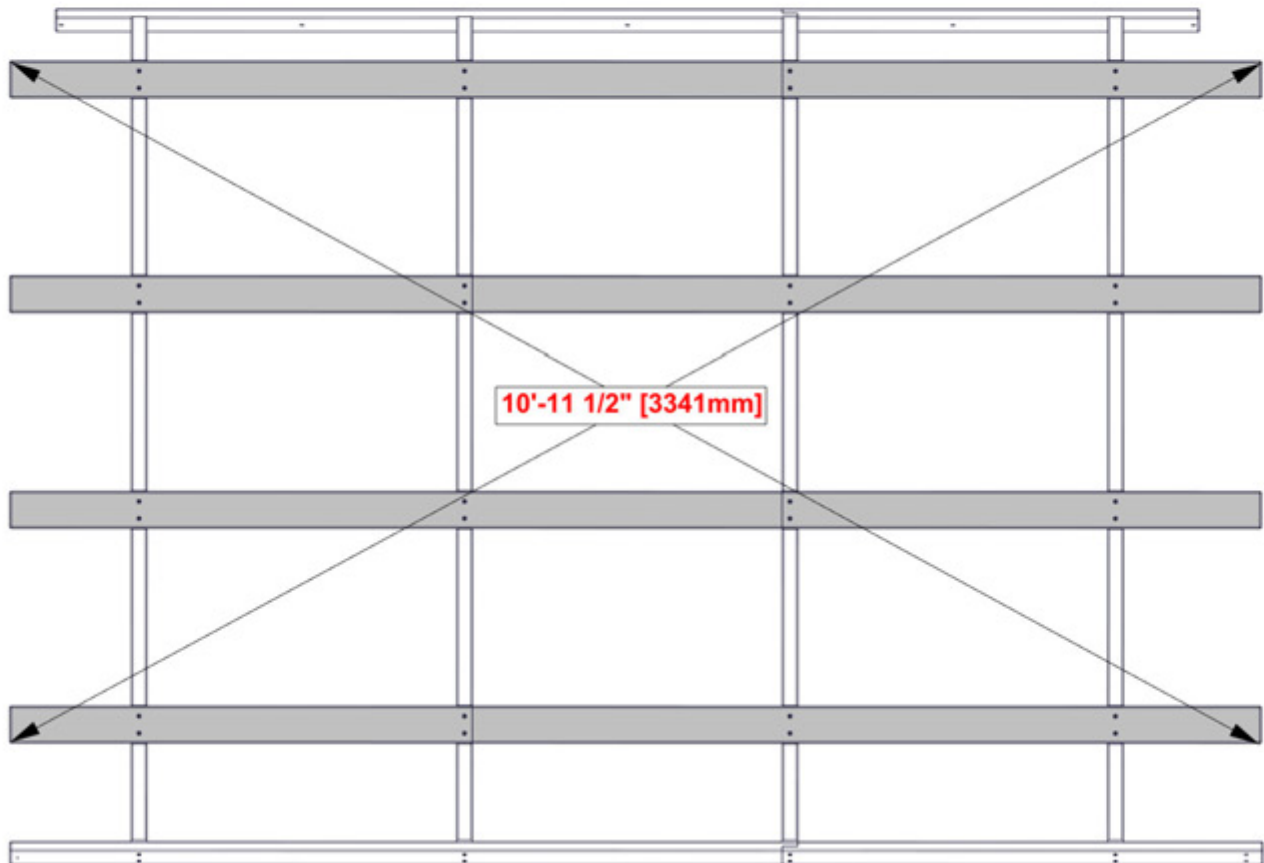

ONCE PANEL IS SQUARED, FULLY TIGHTEN SCREWS.

STEP 33 - ROOF PANEL B ASSEMBLY

ROOF PANEL B

- USE THIS STEP TO FAMILIARIZE YOURSELF WITH THE ROOF PANEL AND ASSIST YOU IN STEPS 34-35.
- REMOVE PROTECTIVE BLUE FILM.
- START AT THE END INDICATED AND ASSEMBLY IN THE DIRECTION OF THE ARROW.
- **GLOVES SHOULD BE WORN WHEN HANDLING ROOF PANELS: EDGES ARE SHARP.**

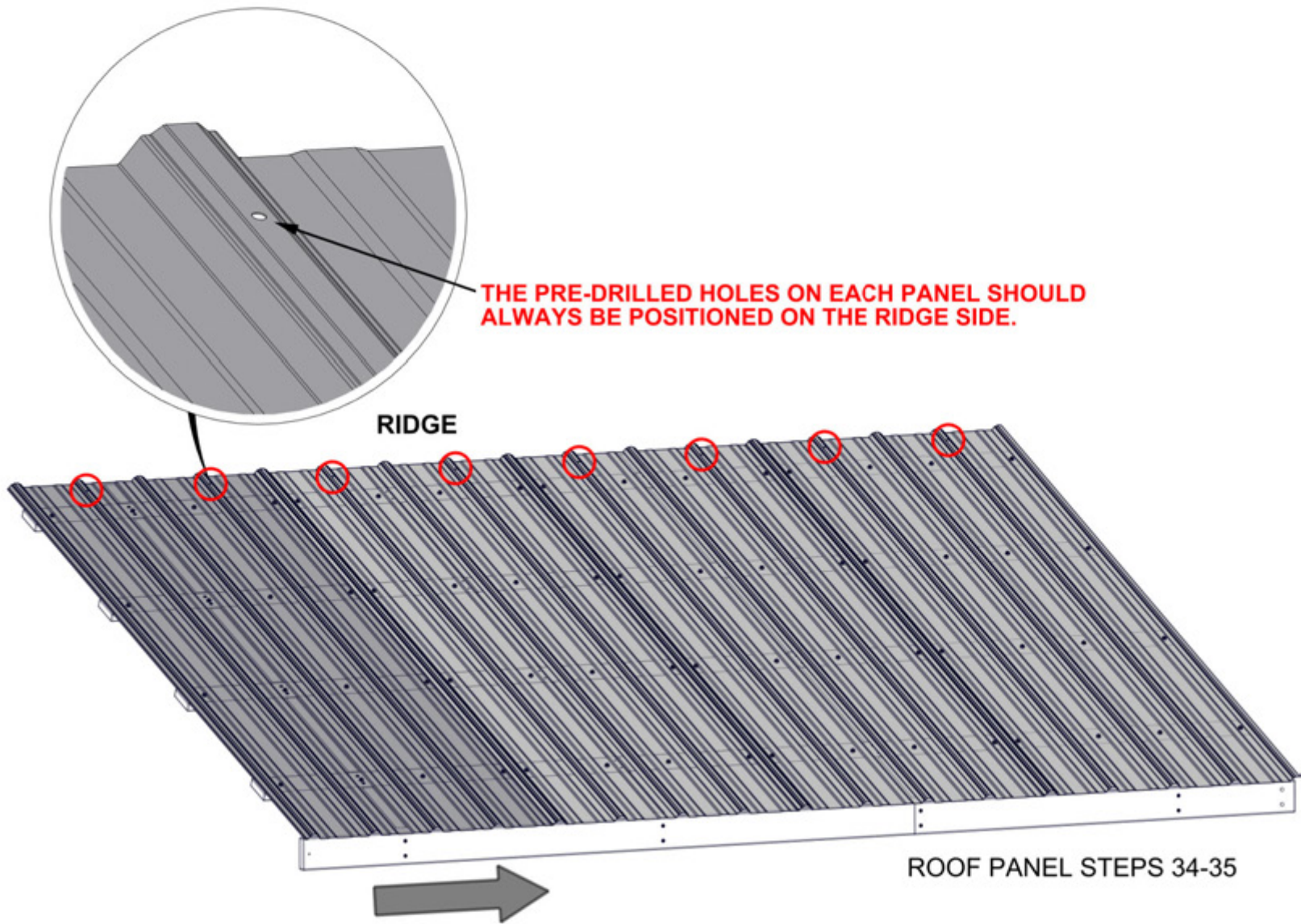

STEP 34 - ROOF PANEL B ASSEMBLY

QTY	PART NUMBER	DESCRIPTION
32	H100833	SCREW WOODGRIP 10-16x3/4"



A4M02639 29 GA STEEL SHEETING
(x2)

- MAKE SURE YOUR ROOF PANEL IS SQUARE BEFORE MOVING ON.

NOTE RIB OVERLAP

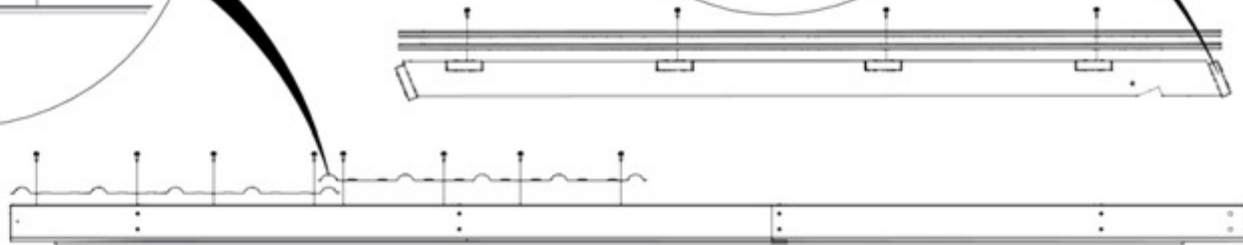
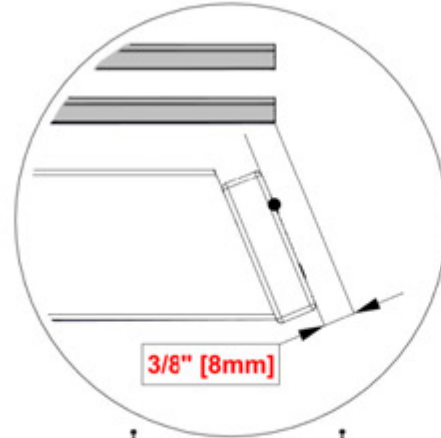
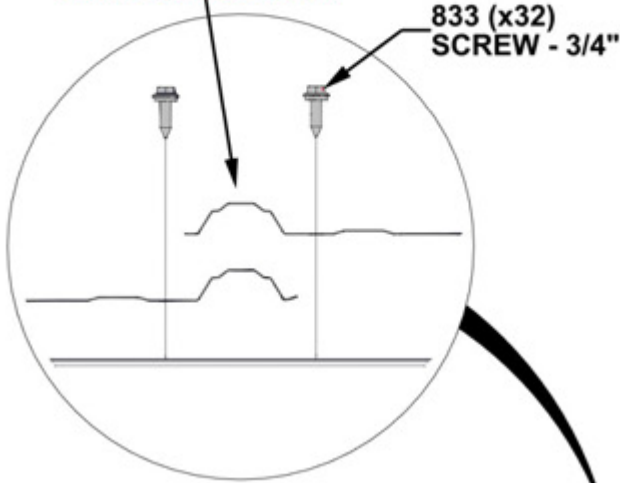

2639 (x2)
29 GA STEEL SHEETING

PLACE SHEETING ON ROOF PANEL, ALIGNING EDGE OF RIB 3/8" (8mm) FROM END OF H BOARD.

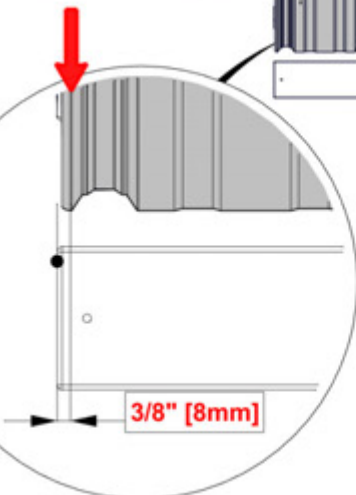
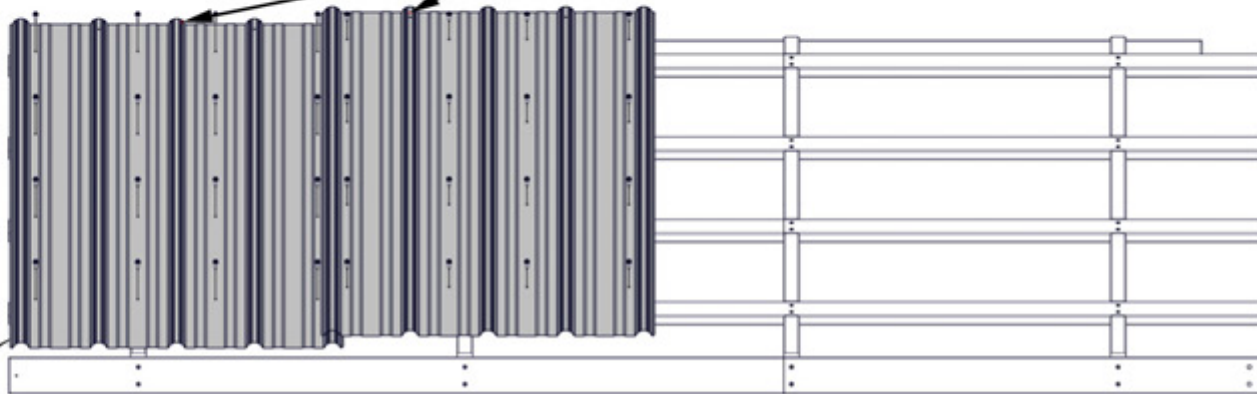

STEP 35 - ROOF PANEL B ASSEMBLY

QTY	PART NUMBER	DESCRIPTION
32	H100833	SCREW WOODGRIP 10-16x3/4



A4M02639 29 GA STEEL SHEETING
(x1)



A4M02647 29 GA STEEL SHEETING
(x1)

833 (x32)
SCREW - 3/4"

NOTE THROUGH HOLES

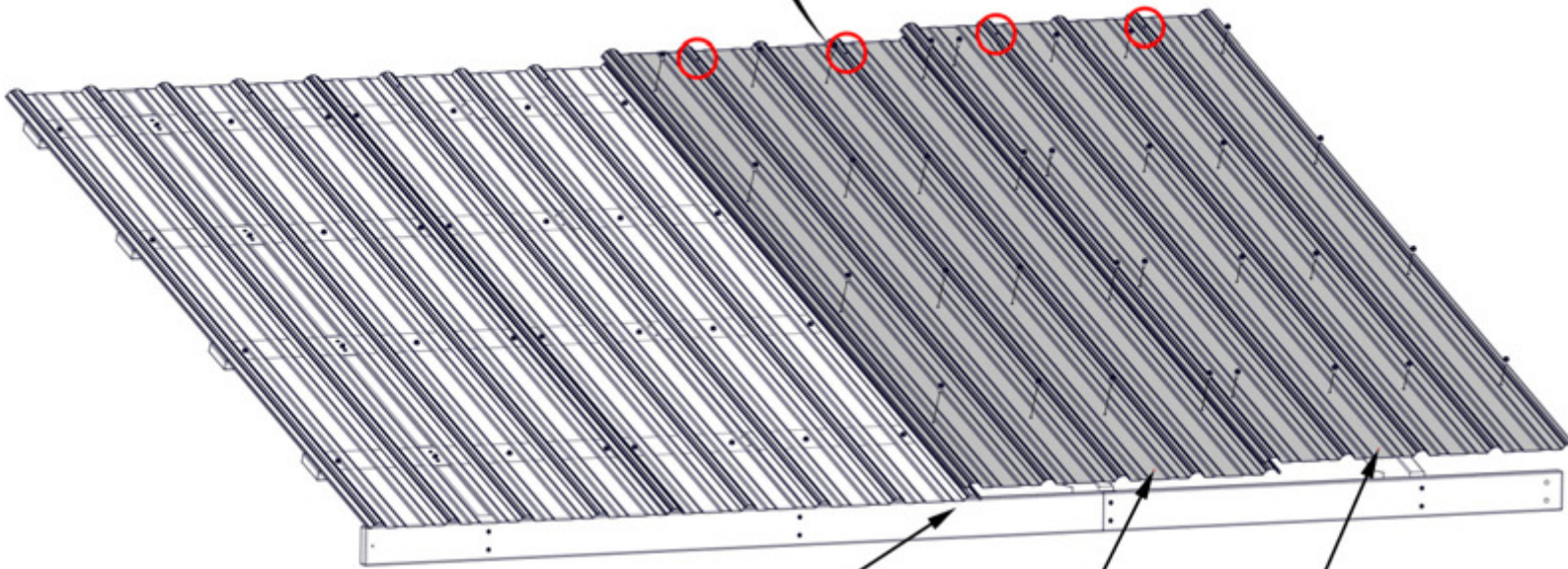
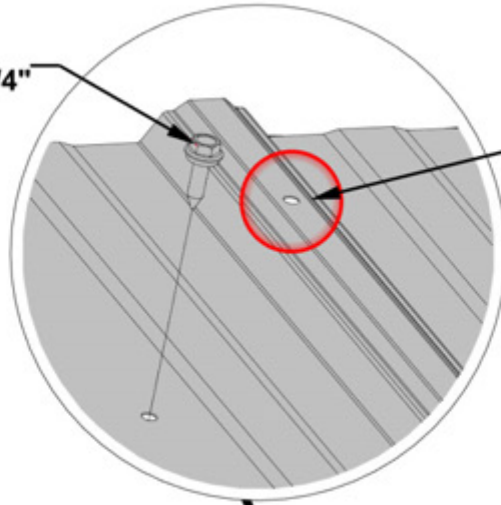

ENDS OF ALL SHEETS SHOULD BE FLUSH

2639 (x1)
29 GA STEEL SHEETING

2647 (x1)
29 GA STEEL SHEETING

STEP 36 - ROOF PANEL C ASSEMBLY

QTY	PART NUMBER	DESCRIPTION
2	H100379	T-NUT 5/16 BLK
16	H100391	SCREW PFH 8x2 BLK



E01 RAFTER - W4L16382
(x2) 1 3/8"x3 3/8"x77 3/8" (36x86x1965)



E08 RAFTER - W4L16755
(x2) 1 3/8"x3 3/8"x77 3/8" (36x86x1965)



H01 FASCIA - W4L16383
(x1) 1"x3 3/8"x68 5/8" (24x86x1742)



H02 FASCIA - W4L16384
(x1) 1"x3 3/8"x38 1/2" (24x86x978)



H03 FASCIA - W4L16385
(x1) 1"x3 3/8"x72 3/4" (24x86x1849)

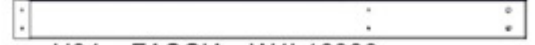

H04 FASCIA - W4L16386
(x1) 1"x3 3/8"x44 3/8" (24x86x1128)

- INSERT T-NUTS FIRST

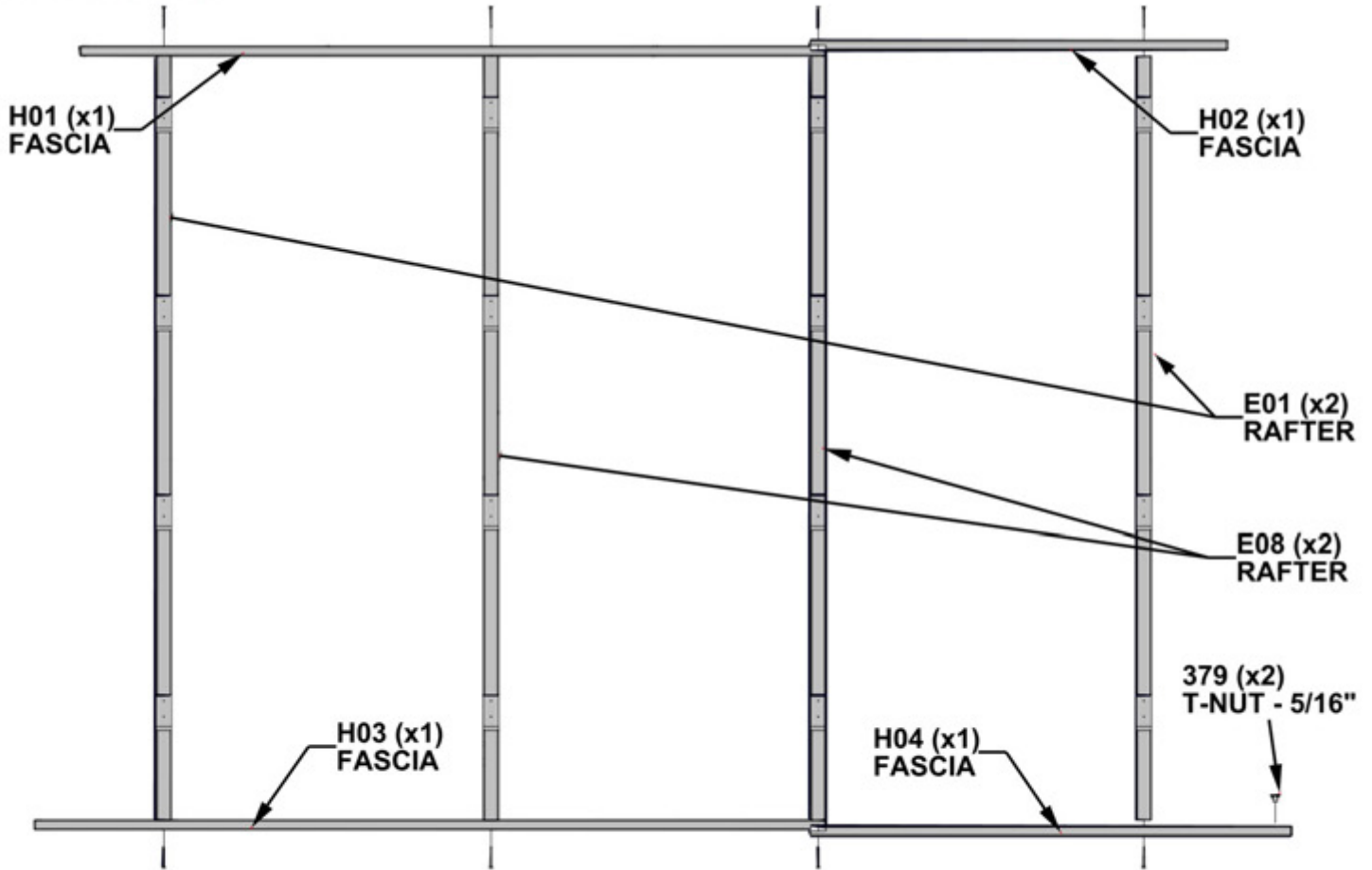

CORRECT ORIENTATION AND PLACEMENT OF H BOARDS IS CRITICAL FOR LATER STEPS.

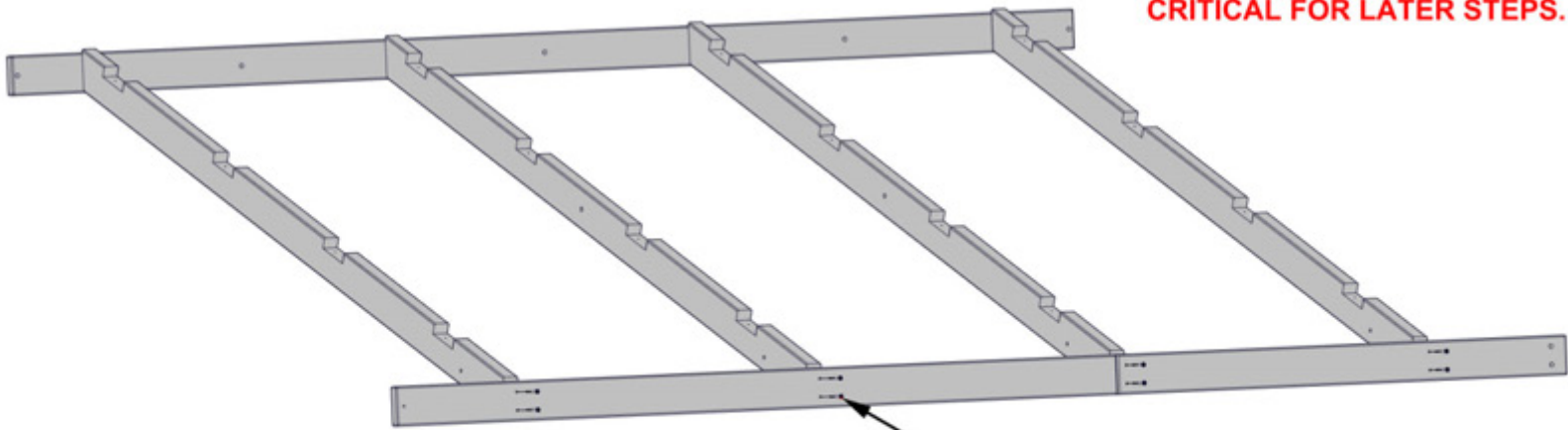

391 (x16)
SCREW - 2"

STEP 37A - ROOF PANEL C ASSEMBLY

QTY	PART NUMBER	DESCRIPTION
32	H100391	SCREW PFH 8x2 BLK



H05 SHEATHING BOARD - W4L16392
(x2) 1"x3 3/8"x72 3/4" (24x86x1849)



H06 SHEATHING BOARD - W4L16393
(x2) 1"x3 3/8"x74 3/8" (24x86x1888)



H07 SHEATHING BOARD - W4L16394
(x2) 1"x3 3/8"x42 3/4" (24x86x1085)



H08 SHEATHING BOARD - W4L16395
(x2) 1"x3 3/8"x44 1/4" (24x86x1124)

- DO NOT FULLY TIGHTEN SCREWS.

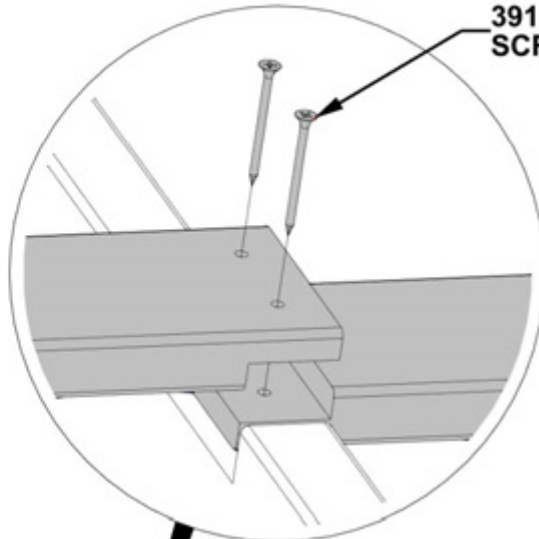

391 (x32)
SCREW - 2"

H05 (x2)
SHEATHING BOARD

H08 (x2)
SHEATHING BOARD

H07 (x2)
SHEATHING BOARD

H06 (x2)
SHEATHING BOARD

**H06 AND H08 BOARDS
GO ON THE SIDE WITH
TWO PILOT HOLES.**

STEP 37B - ROOF PANEL C ASSEMBLY

CRITICAL:

- SQUARE UNIT BEFORE PROCEEDING TO NEXT STEPS.
- THE BELOW DIMENSIONS ARE CRITICAL TO THE FINAL ROOF ASSEMBLY.
- MEASUREMENTS SHOULD BE HELD WITHIN $\pm 1/4"$.
- MEASUREMENTS OUTSIDE OF TOLERANCE WILL LEAD TO THE INABILITY TO ASSEMBLE THE ROOF.

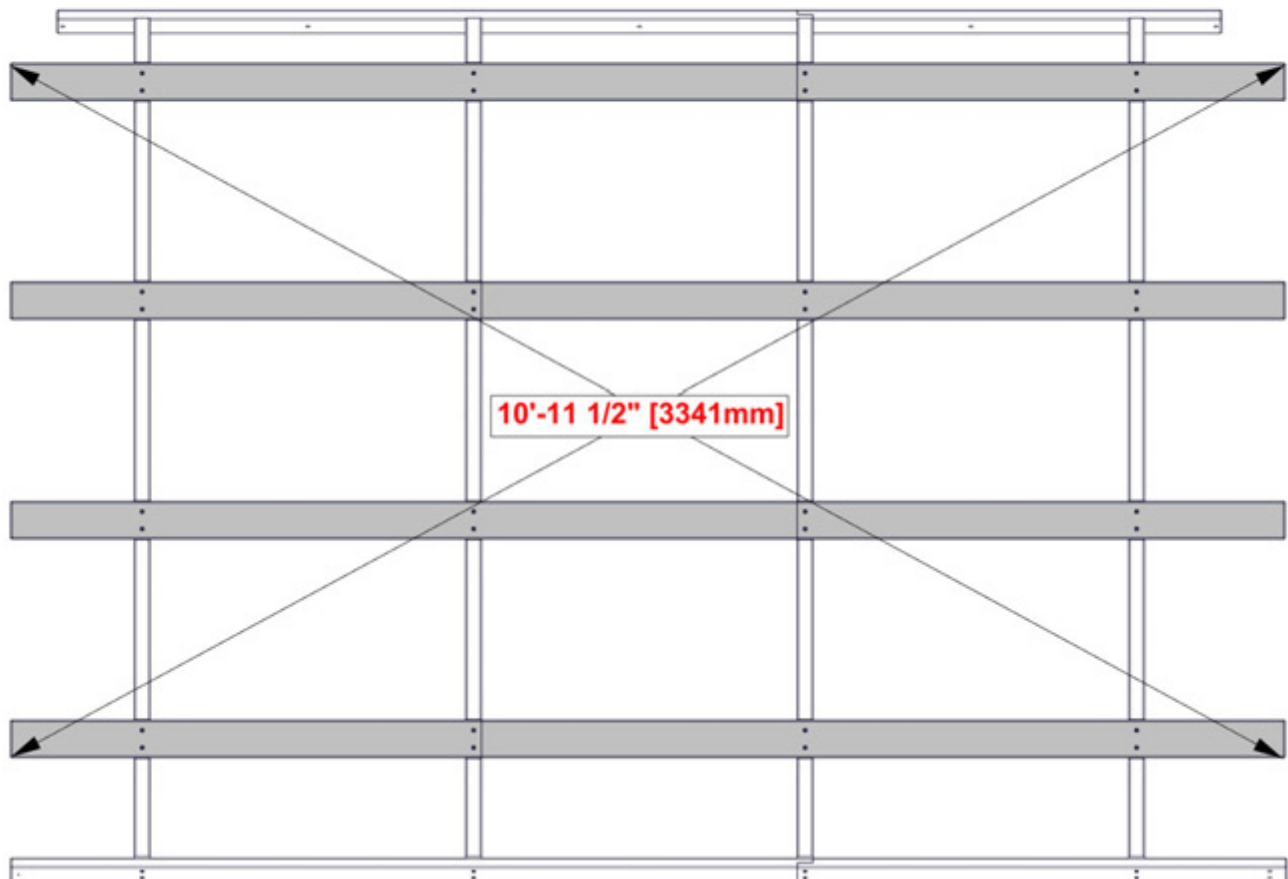

ONCE PANEL IS SQUARED, FULLY TIGHTEN SCREWS.

STEP 38 ROOF PANEL C ASSEMBLY

ROOF PANEL C

- USE THIS STEP TO FAMILIARIZE YOURSELF WITH THE ROOF PANEL AND ASSIST YOU IN STEPS 39-40.
- REMOVE PROTECTIVE BLUE FILM.
- START AT THE END INDICATED AND ASSEMBLY IN THE DIRECTION OF THE ARROW.
- **GLOVES SHOULD BE WORN WHEN HANDLING ROOF PANELS: EDGES ARE SHARP.**

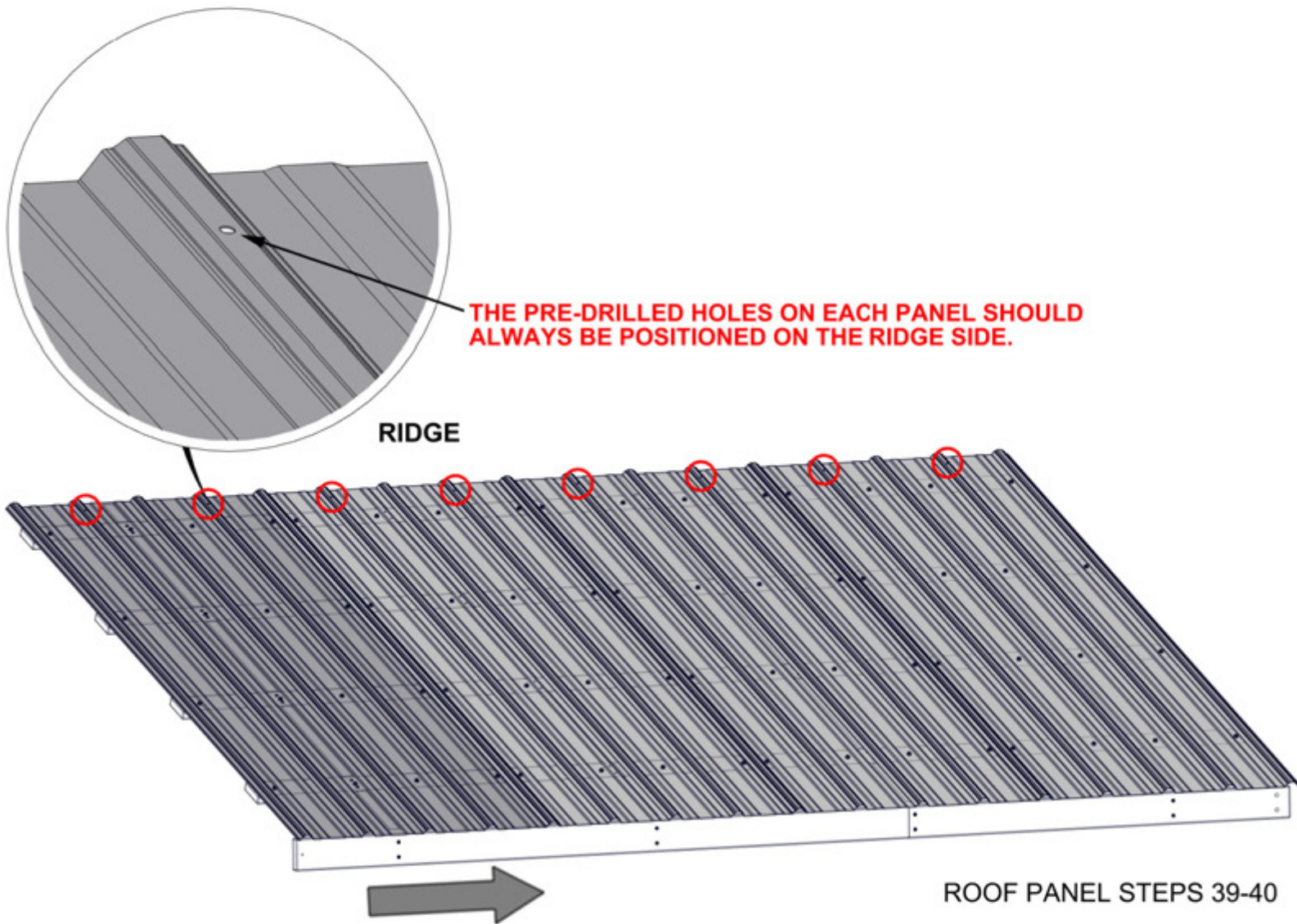

STEP 39 - ROOF PANEL C ASSEMBLY

QTY	PART NUMBER	DESCRIPTION
32	H100833	SCREW WOODGRIP 10-16x3/4"



A4M02639 29 GA STEEL SHEETING (x2)

- MAKE SURE YOUR ROOF PANEL IS SQUARE BEFORE MOVING ON.

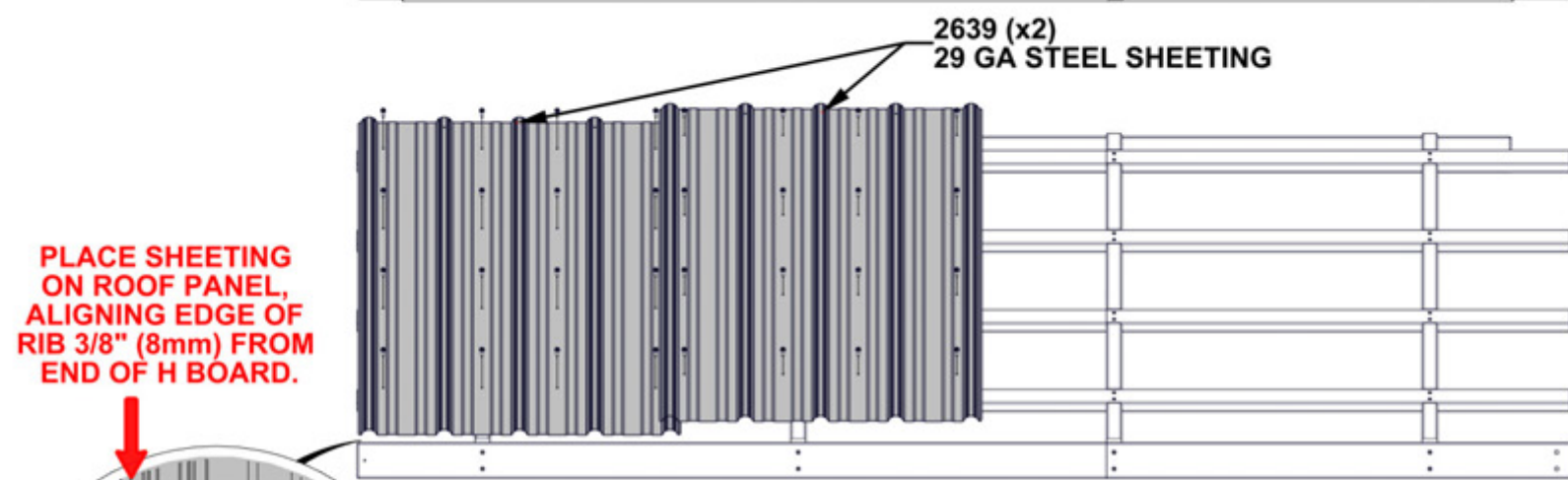
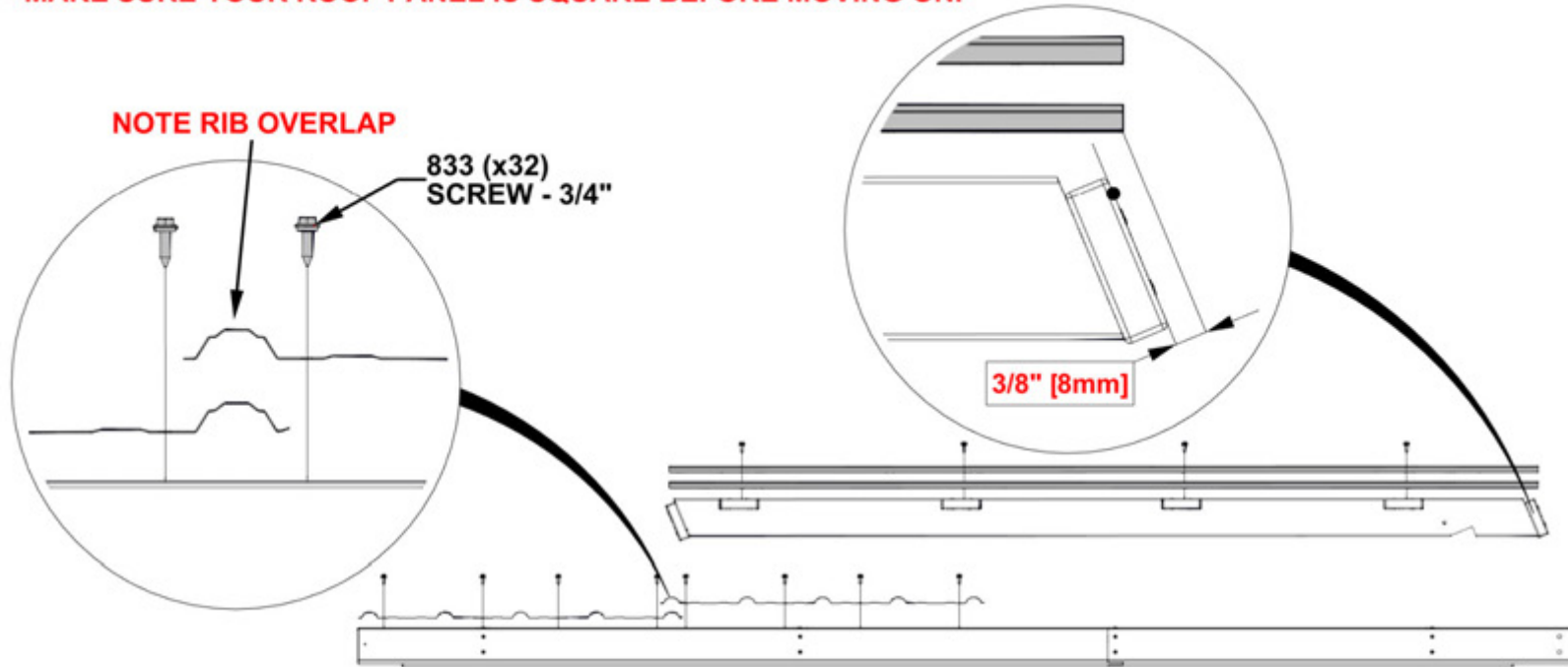

STEP 40 - ROOF PANEL C ASSEMBLY

QTY	PART NUMBER	DESCRIPTION
32	H100833	SCREW WOODGRIP 10-16x3/4



A4M02639 29 GA STEEL SHEETING
(x1)

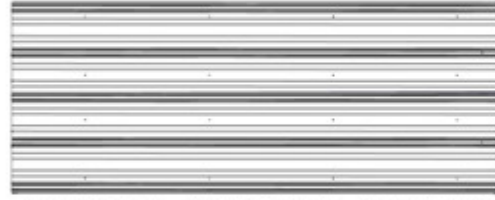

A4M02908 29 GA STEEL SHEETING
(x1)

833 (x32)
SCREW - 3/4"

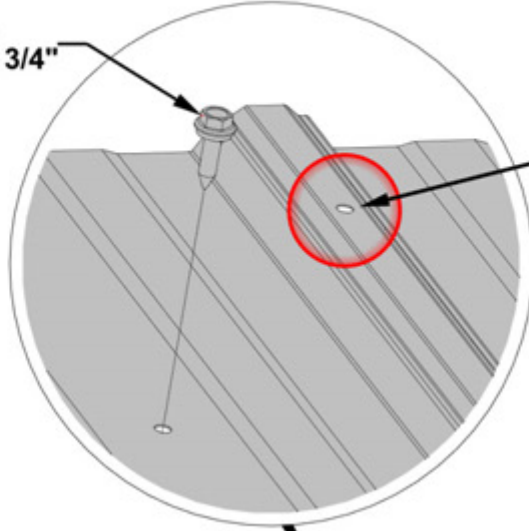

NOTE THROUGH HOLES

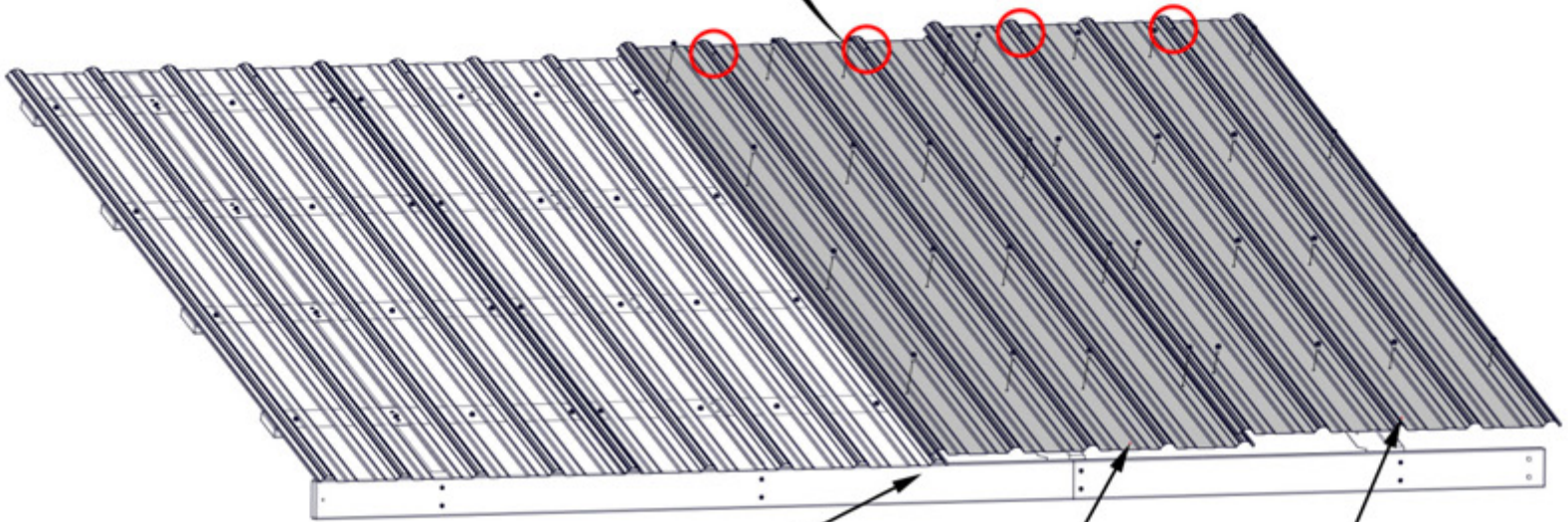

ENDS OF ALL SHEETS SHOULD BE FLUSH

2639 (x1)
29 GA STEEL SHEETING

2908 (x1)
29 GA STEEL SHEETING

STEP 41 - ROOF PANEL D ASSEMBLY

QTY	PART NUMBER	DESCRIPTION
2	H100379	T-NUT 5/16 BLK
16	H100391	SCREW PFH 8x2 BLK

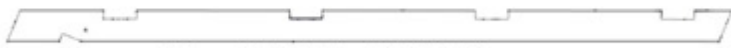

E01 RAFTER - W4L16382
(x2) 1 3/8"x3 3/8"x77 3/8" (36x86x1965)

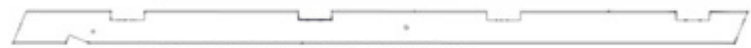

E08 RAFTER - W4L16755
(x2) 1 3/8"x3 3/8"x77 3/8" (36x86x1965)



H01 FASCIA - W4L16383
(x1) 1"x3 3/8"x68 5/8" (24x86x1742)



H02 FASCIA - W4L16384
(x1) 1"x3 3/8"x38 1/2" (24x86x978)



H03 FASCIA - W4L16385
(x1) 1"x3 3/8"x72 3/4" (24x86x1849)



H04 FASCIA - W4L16386
(x1) 1"x3 3/8"x44 3/8" (24x86x1128)

- INSERT T-NUTS FIRST

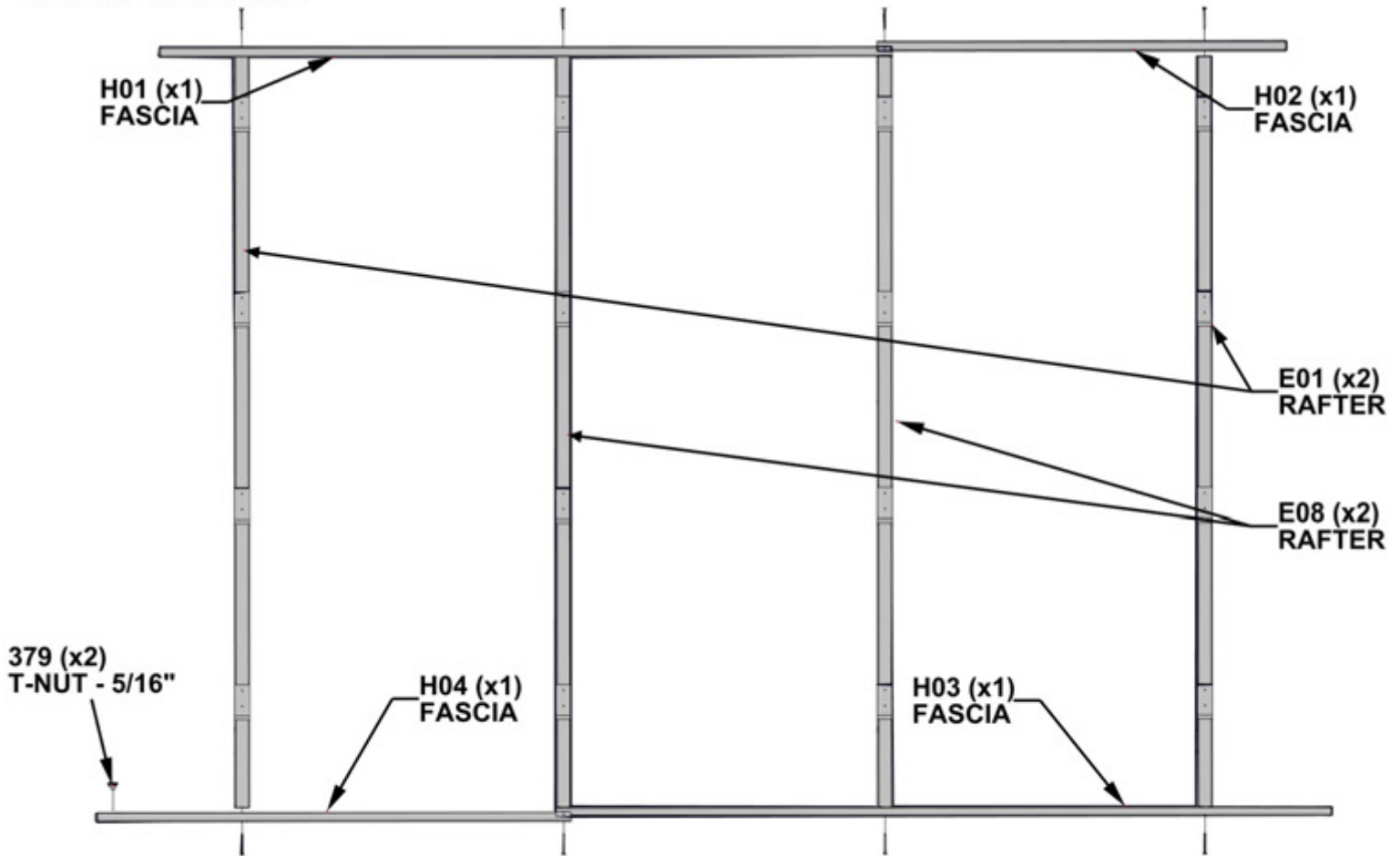

CORRECT ORIENTATION AND PLACEMENT OF H BOARDS IS CRITICAL FOR LATER STEPS.

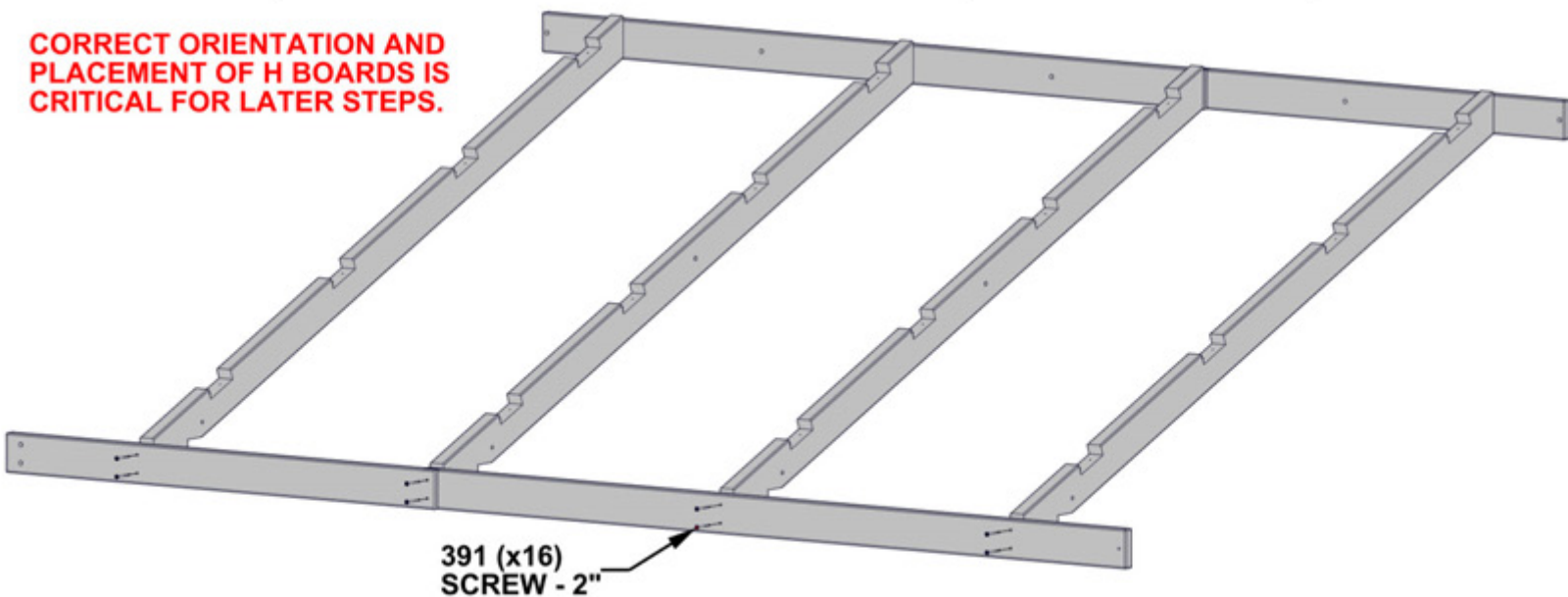

STEP 42A - ROOF PANEL D ASSEMBLY

QTY	PART NUMBER	DESCRIPTION
32	H100391	SCREW PFH 8x2 BLK



H05 SHEATHING BOARD - W4L16392
(x2) 1"x3 3/8"x72 3/4" (24x86x1849)



H07 SHEATHING BOARD - W4L16394
(x2) 1"x3 3/8"x42 3/4" (24x86x1085)



H06 SHEATHING BOARD - W4L16393
(x2) 1"x3 3/8"x74 3/8" (24x86x1888)



H08 SHEATHING BOARD - W4L16395
(x2) 1"x3 3/8"x44 1/4" (24x86x1124)

- DO NOT FULLY TIGHTEN SCREWS.

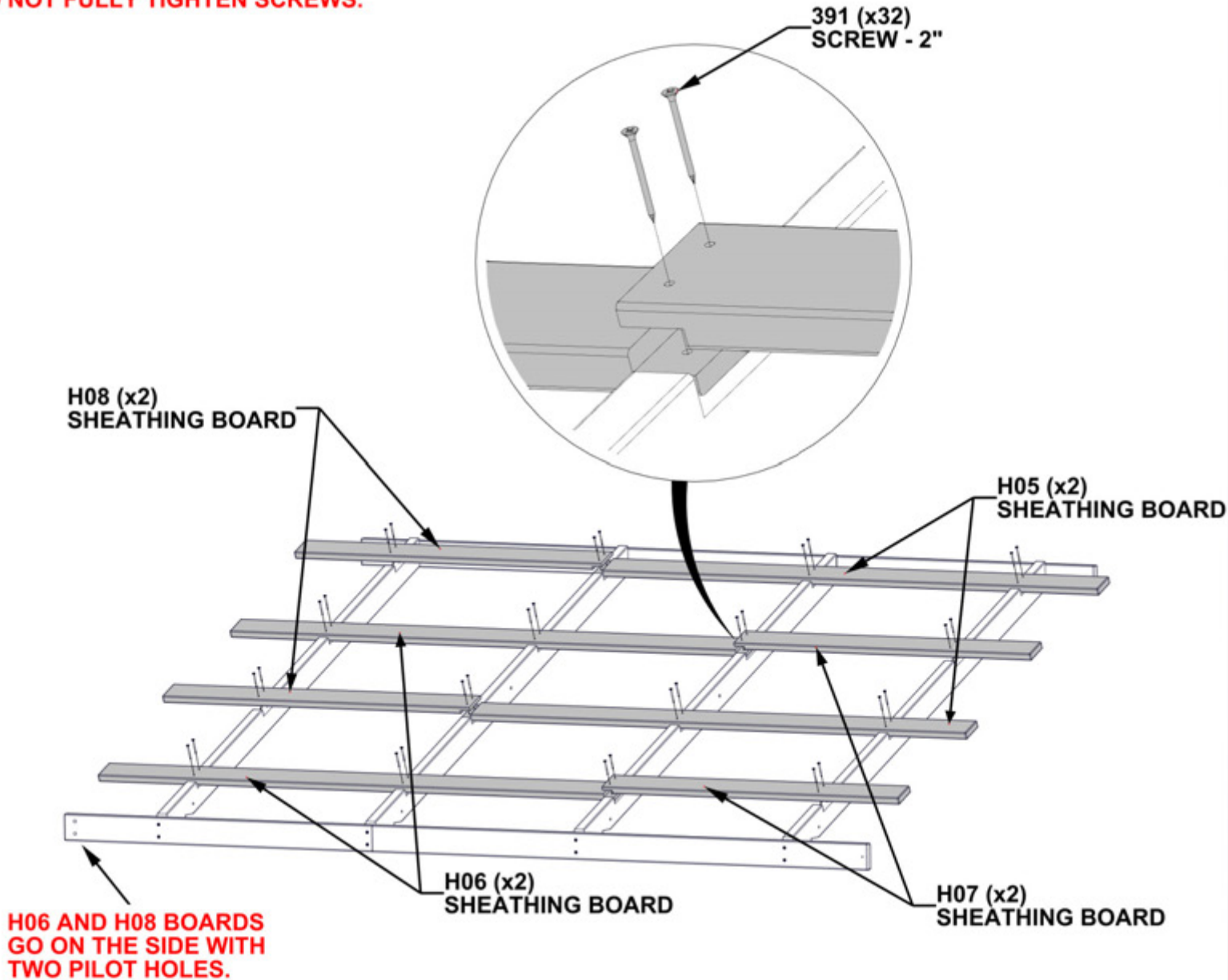

STEP 42B - ROOF PANEL D ASSEMBLY

CRITICAL:

- SQUARE UNIT BEFORE PROCEEDING TO NEXT STEPS.
- THE BELOW DIMENSIONS ARE CRITICAL TO THE FINAL ROOF ASSEMBLY.
- MEASUREMENTS SHOULD BE HELD WITHIN +/- 1/4".
- MEASUREMENTS OUTSIDE OF TOLERANCE WILL LEAD TO THE INABILITY TO ASSEMBLE THE ROOF.

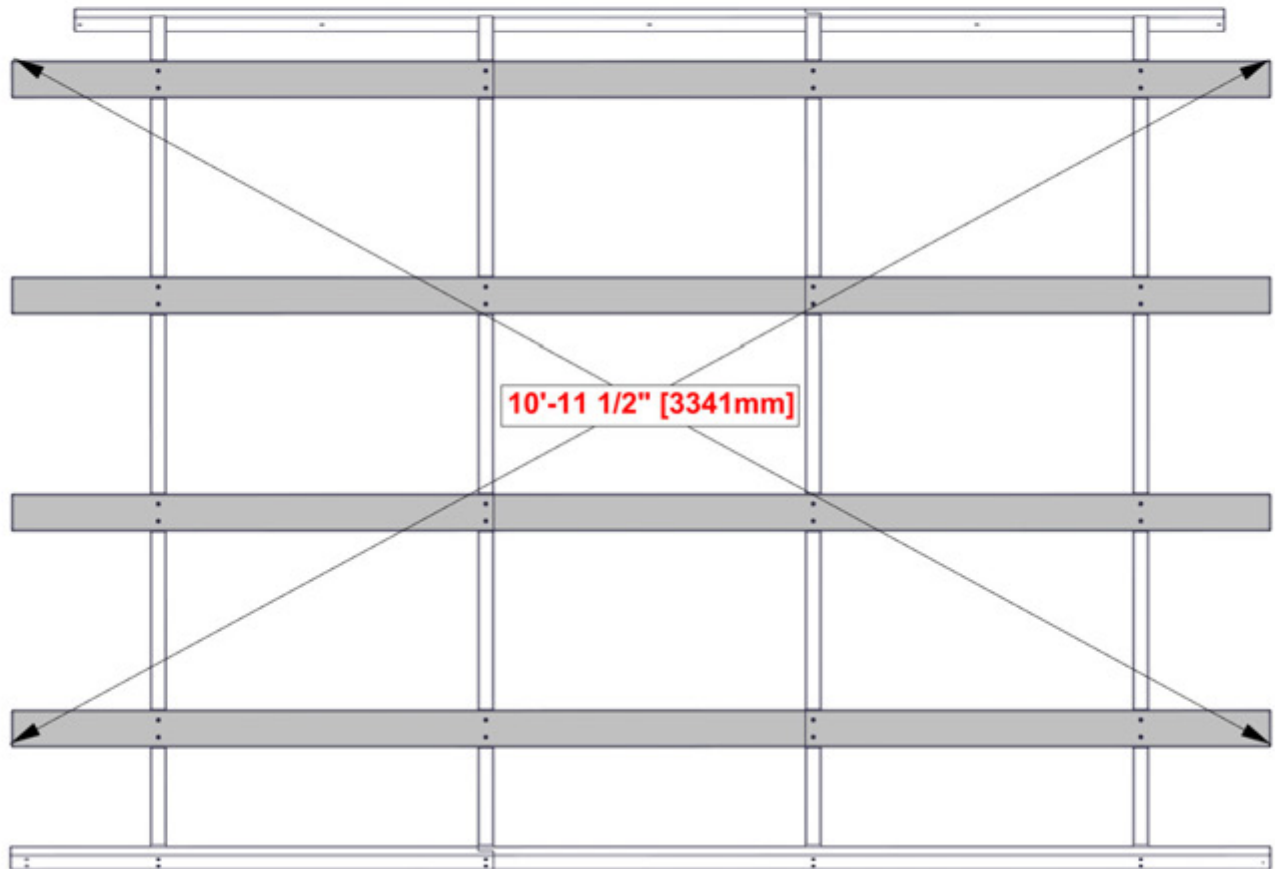

ONCE PANEL IS SQUARED, FULLY TIGHTEN SCREWS.

STEP 43 - ROOF PANEL D ASSEMBLY

ROOF PANEL D

- USE THIS STEP TO FAMILIARIZE YOURSELF WITH THE ROOF PANEL AND ASSIST YOU IN STEPS 44-45.
- REMOVE PROTECTIVE BLUE FILM.
- START AT THE END INDICATED AND ASSEMBLY IN THE DIRECTION OF THE ARROW.
- **GLOVES SHOULD BE WORN WHEN HANDLING ROOF PANELS: EDGES ARE SHARP.**

THE PRE-DRILLED HOLES ON EACH PANEL SHOULD ALWAYS BE POSITIONED ON THE RIDGE SIDE.

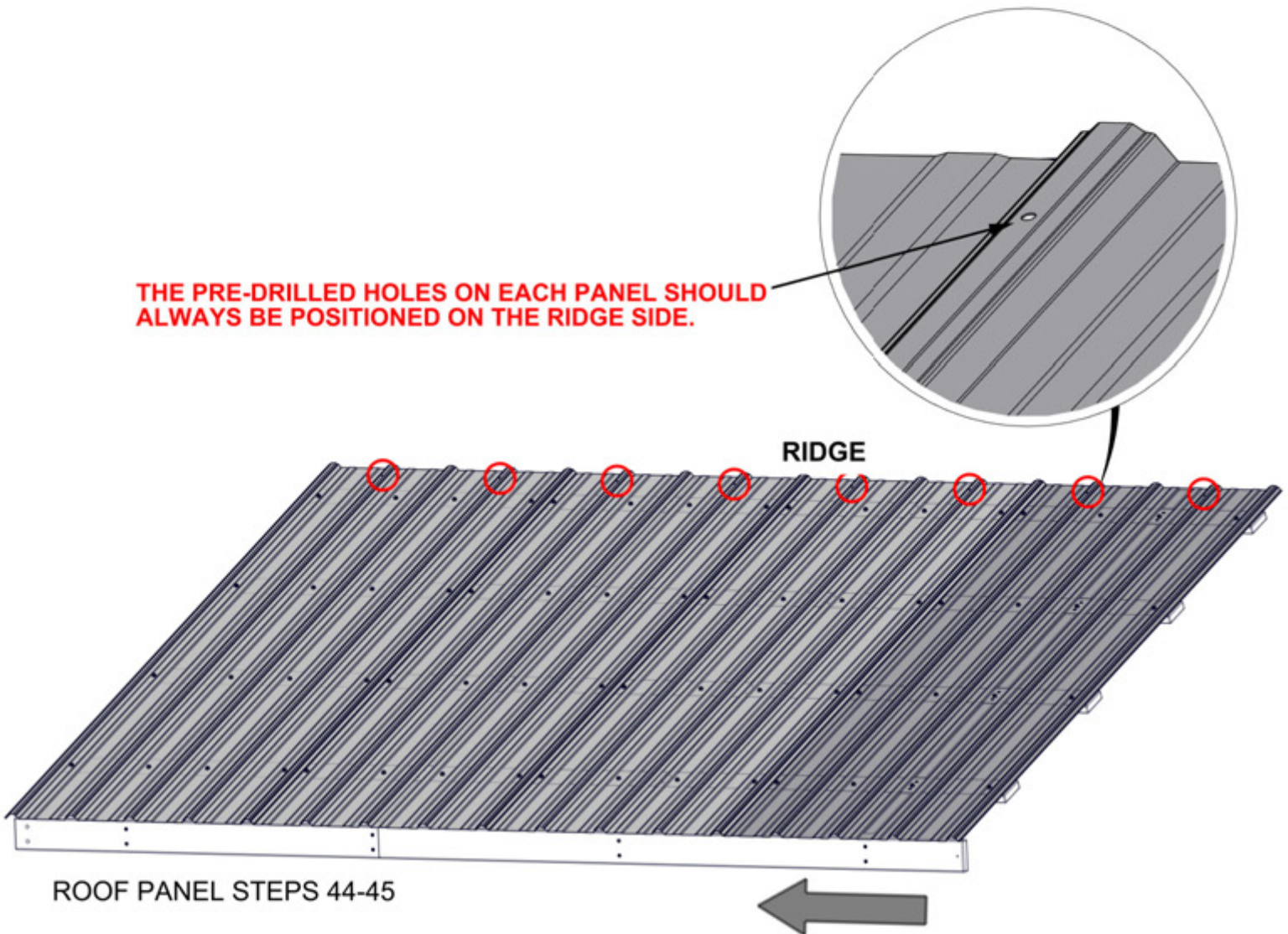

STEP 44 - ROOF PANEL D ASSEMBLY

QTY	PART NUMBER	DESCRIPTION
32	H100833	SCREW WOODGRIP 10-16x3/4"

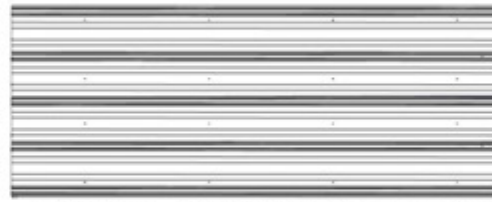

A4M02639 29 GA STEEL SHEETING
(x2)

- MAKE SURE YOUR ROOF PANEL IS SQUARE BEFORE MOVING ON.

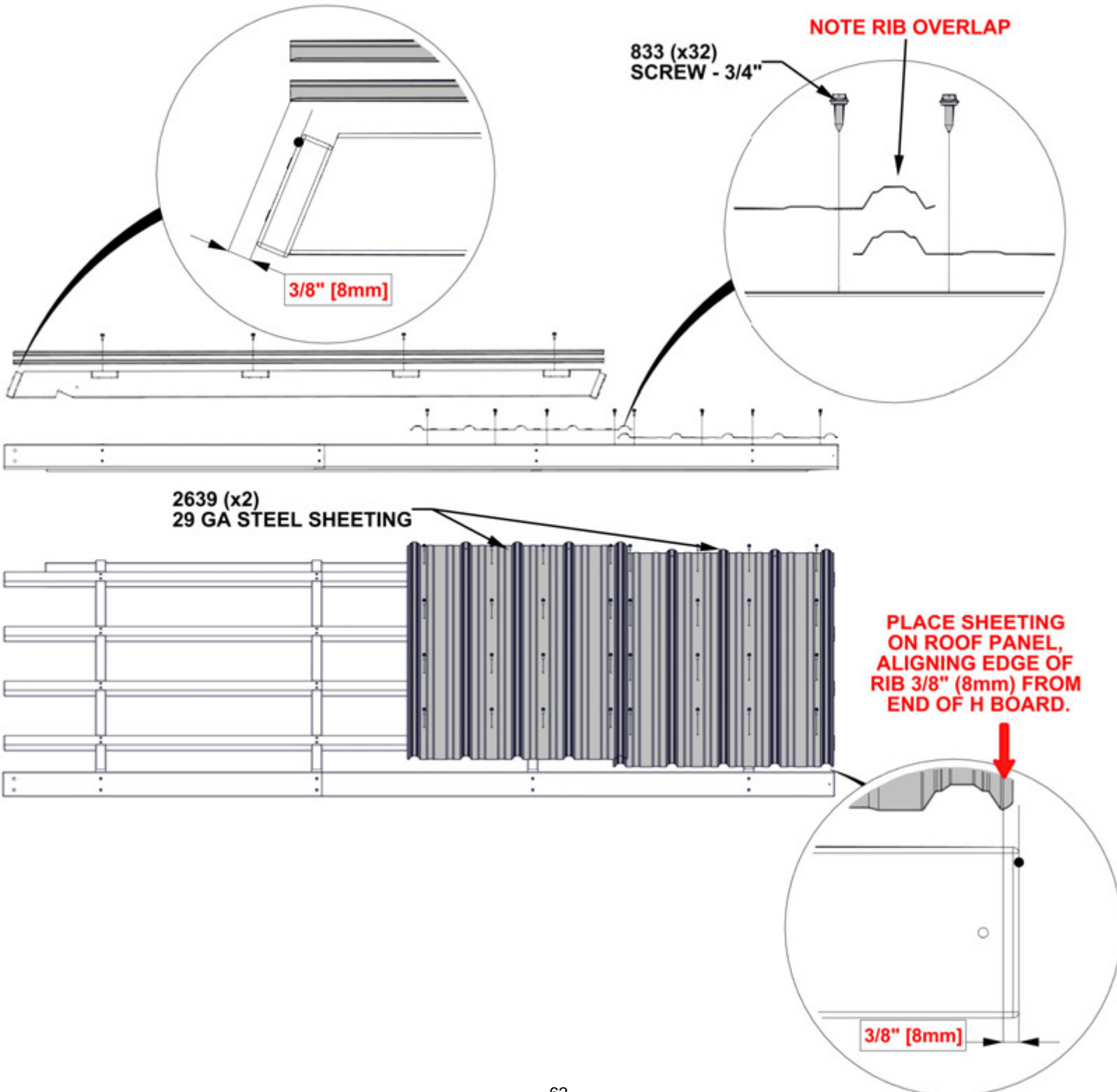

STEP 45 - ROOF PANEL D ASSEMBLY

QTY	PART NUMBER	DESCRIPTION
32	H100833	SCREW WOODGRIP 10-16x3/4



A4M02639 29 GA STEEL SHEETING
(x1)

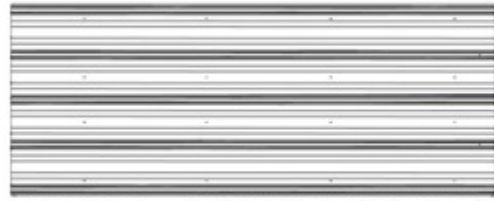

A4M02909 29 GA STEEL SHEETING
(x1)

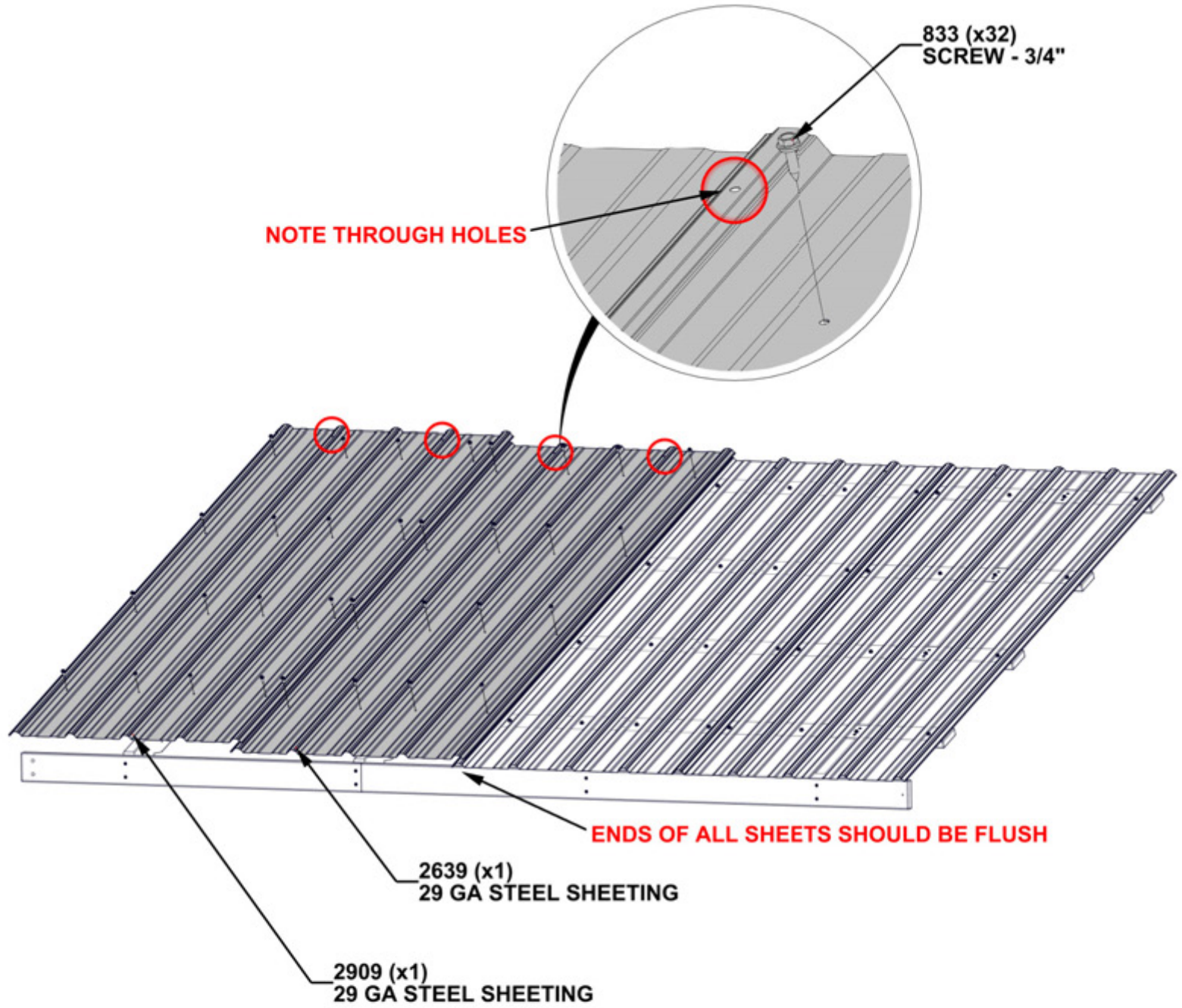

STEP 46 - RIDGE CAP ASSEMBLY

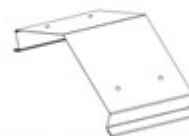
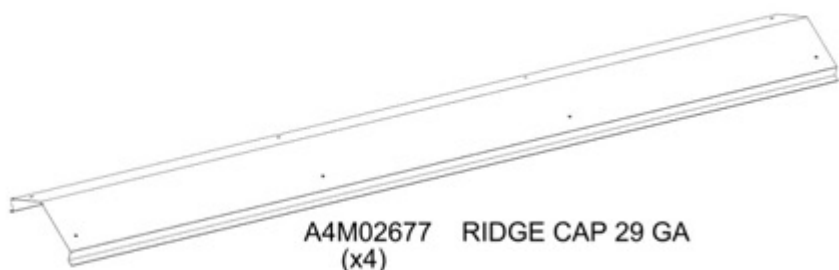

- COMPLETE THIS STEP TWICE.

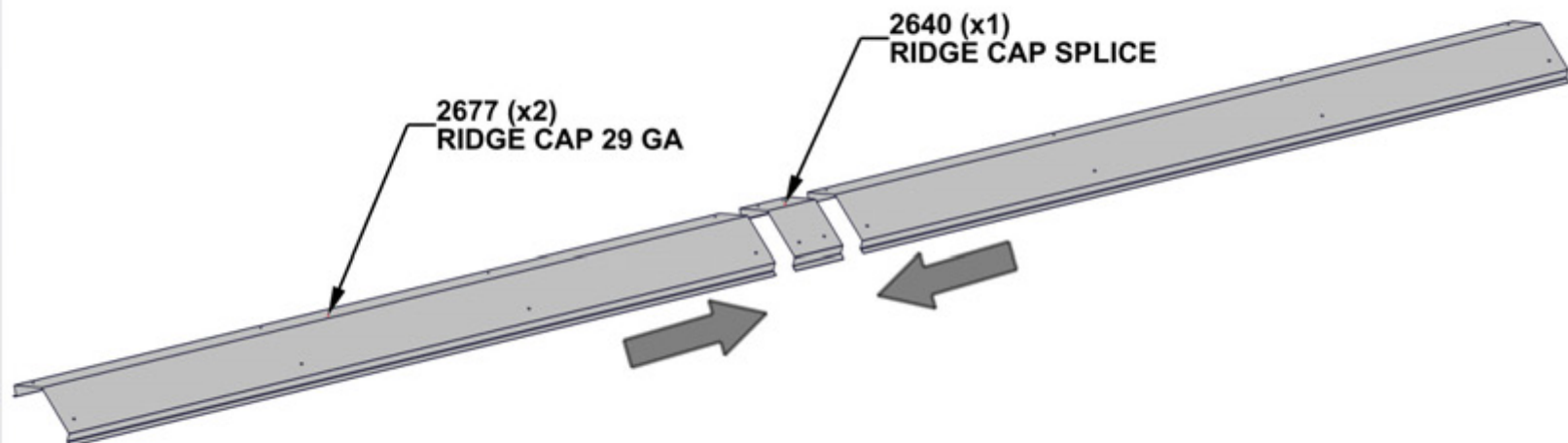

SLIDE EACH RIDGE CAP INTO THE RIDGE CAP SPLICE UNTIL CENTERED.

STEP 47 - RIDGE CAP A ASSEMBLY

QTY	PART NUMBER	DESCRIPTION
16	H100833	SCREW WOODGRIP 10-16x3/4"



J01 STIFFENER BOARD - W4L16401
(x2) 1"x2 3/8"x68 5/8" (24x60x1744)



J02 STIFFENER BOARD - W4L16402
(x2) 1"x2 3/8"x47" (24x60x1194)



A6P00398 RIDGE CAP PROTECTOR
(x1)

- REMOVE SPACERS FROM RIDGE CAP PROTECTOR BEFORE INSTALLING.
- FINAL LENGTH - 9'-7 3/4" [2940mm]

RIDGE CAP MUST BE LIFTED FROM THE MIDDLE TO PREVENT DAMAGE BEFORE INSTALLATION.

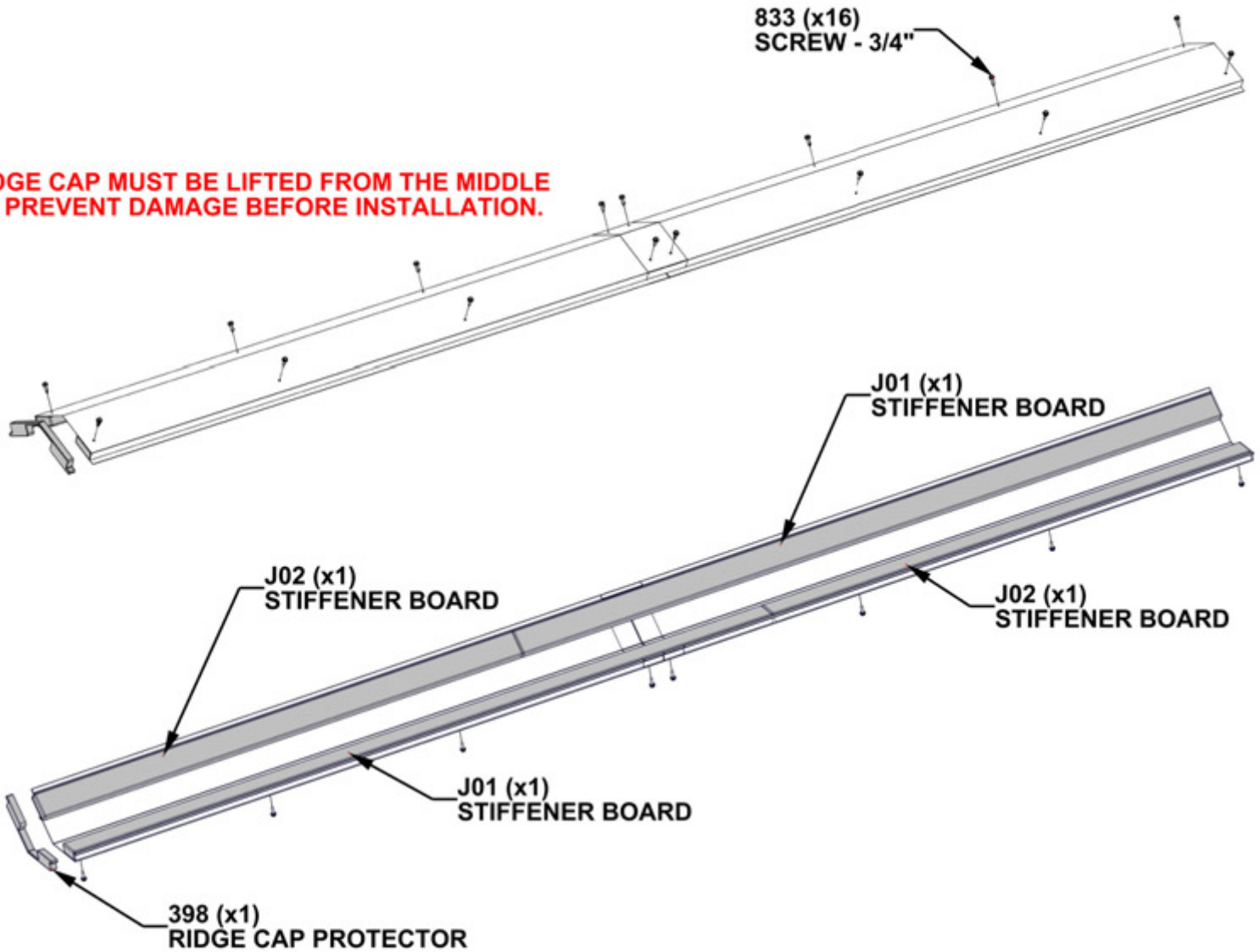

STEP 48 - RIDGE CAP B ASSEMBLY

QTY	PART NUMBER	DESCRIPTION
16	H100833	SCREW WOODGRIP 10-16x3/4"

J01 STIFFENER BOARD - W4L16401
(x2) 1"x2 3/8"x68 5/8" (24x60x1744)

J02 STIFFENER BOARD - W4L16402
(x2) 1"x2 3/8"x47" (24x60x1194)



A6P00398 RIDGE CAP PROTECTOR
(x1)



A6P00514 MID RIDGE CAP PROTECTOR
(x1)

- REMOVE SPACERS FROM RIDGE CAP PROTECTORS BEFORE INSTALLING.
- **FINAL LENGTH - 9'-8 1/2" [2955mm]**

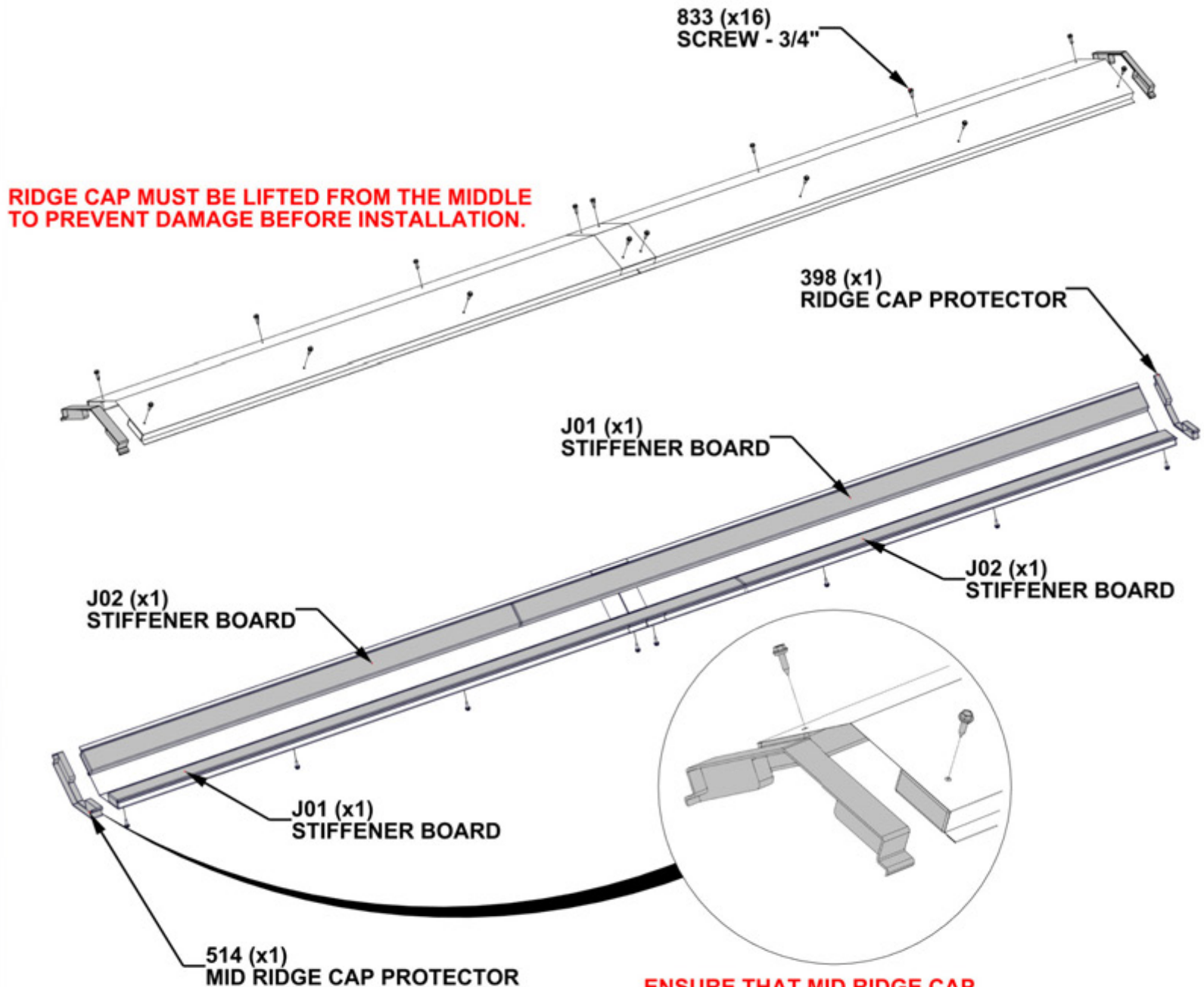

ENSURE THAT MID RIDGE CAP PROTECTOR IS ORIENTED CORRECTLY.

STEP 49 - ROOF PANEL A ATTACHMENT

QTY	PART NUMBER	DESCRIPTION
1	H100391	SCREW PFH 8x2 BLK

- ADDITIONAL PEOPLE ARE HELPFUL FOR THIS STEP.
- SLIDE ROOF PANEL ALONG TRACKS ON RAFTERS.
- ONCE IN PLACE INSTALL ATTACHMENT HARDWARE AS SHOWN.
- HOLD ROOF PANEL IN PLACE UNTIL NEXT STEP.

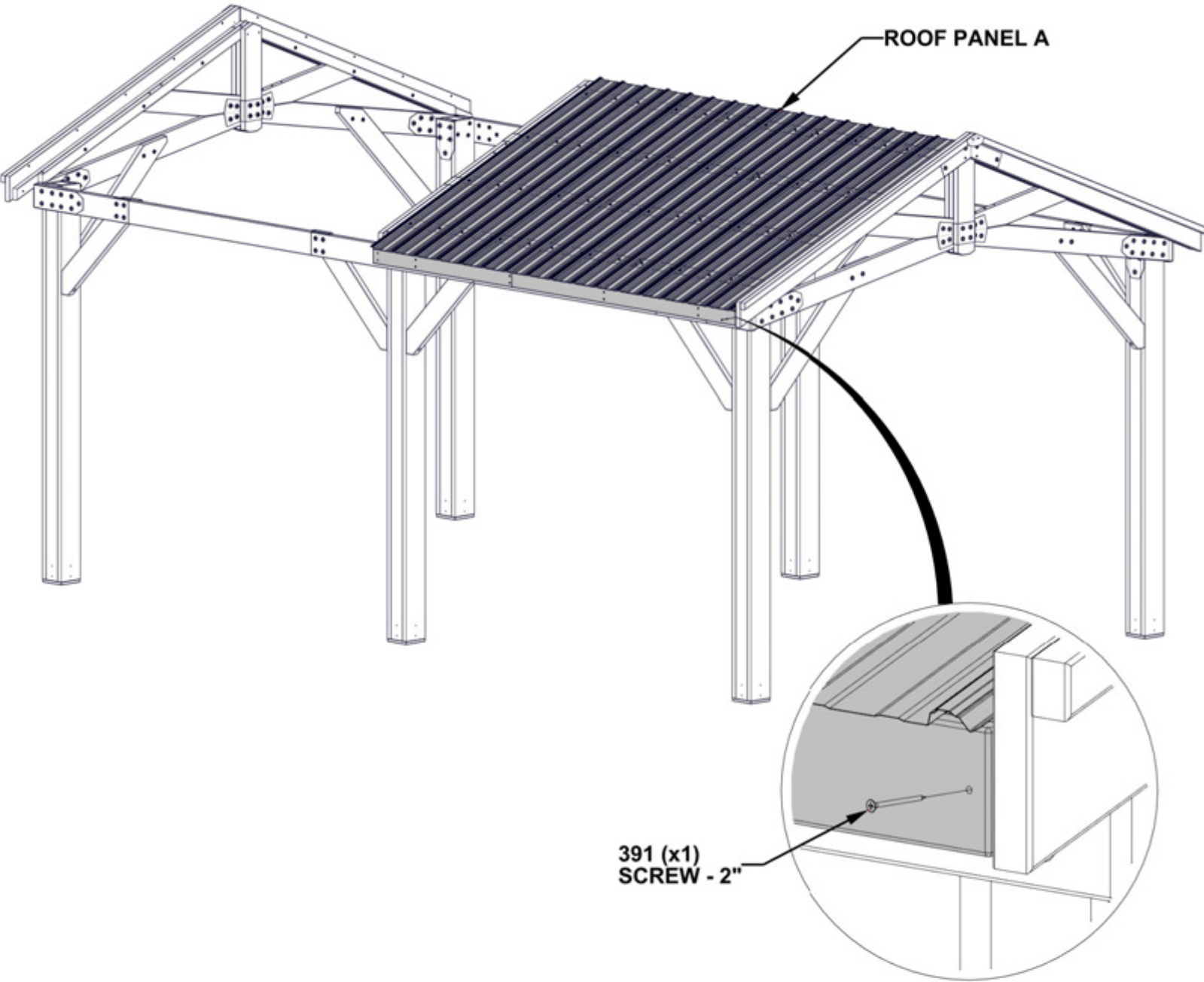

STEP 50 - ROOF ATTACHMENT

QTY	PART NUMBER	DESCRIPTION
3	H100198	WASHER LOCK EXT 8x19
3	H100378	BOLT WH 5/16x1 3/4 BLK
3	H100379	T-NUT 5/16 BLK
1	H100391	SCREW PFH 8x2 BLK

- ADDITIONAL PEOPLE ARE HELPFUL FOR THIS STEP.
- ONCE IN PLACE, INSTALL ATTACHMENT HARDWARE AS SHOWN.
- ATTACH BOLT AND LOCK NUT HARDWARE BEFORE ATTACHING SCREW.

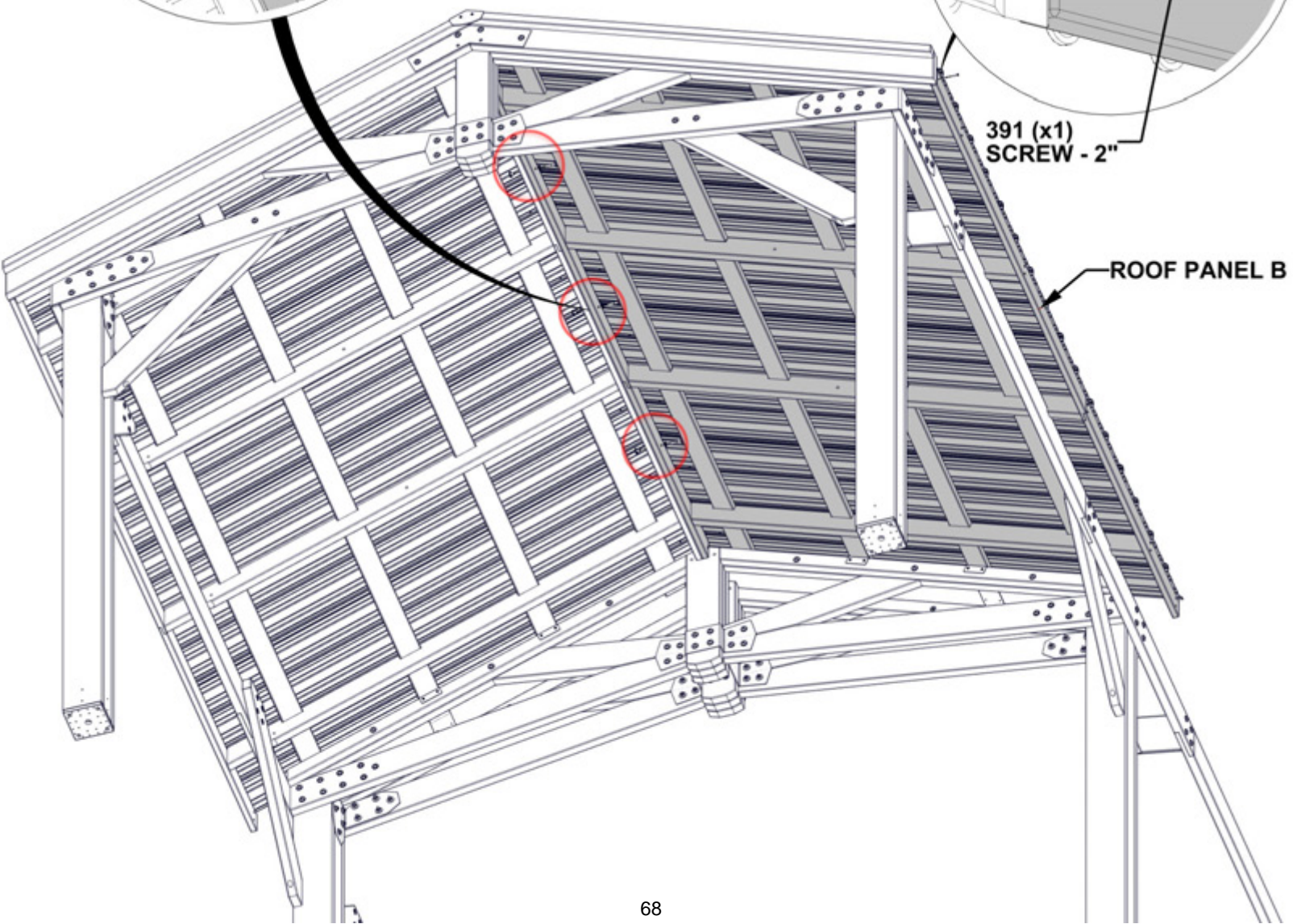
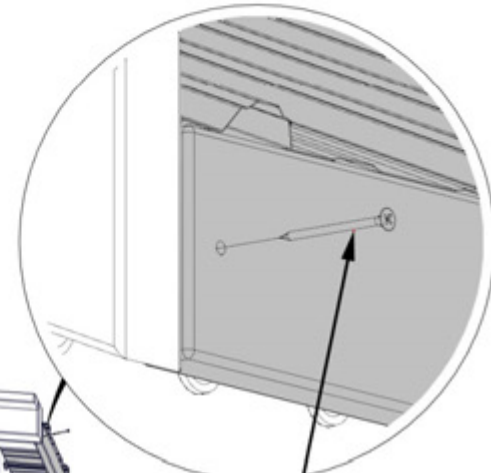
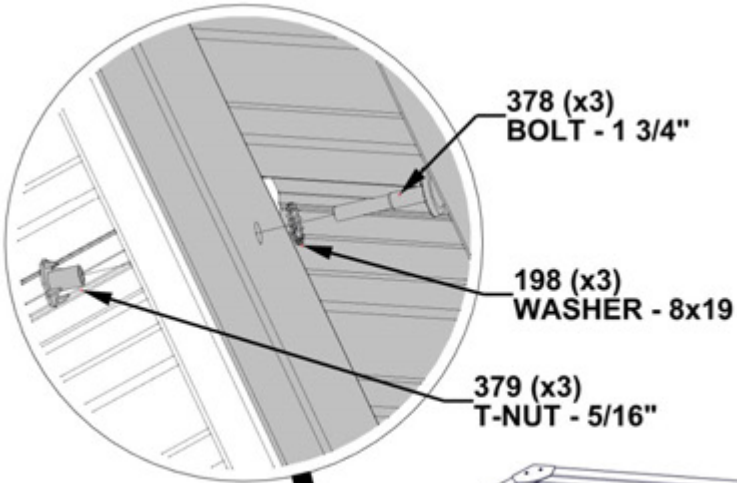

STEP 51 - ROOF ATTACHMENT

QTY	PART NUMBER	DESCRIPTION
8	H100833	SCREW WOODGRIP 10-16x3/4"

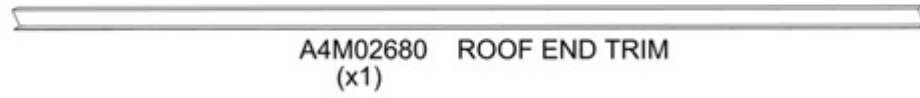
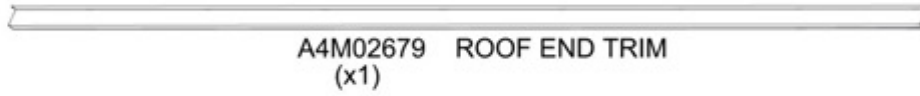

- ATTACH SCREWS IN LINE WITH ROOF PANEL SCREWS.

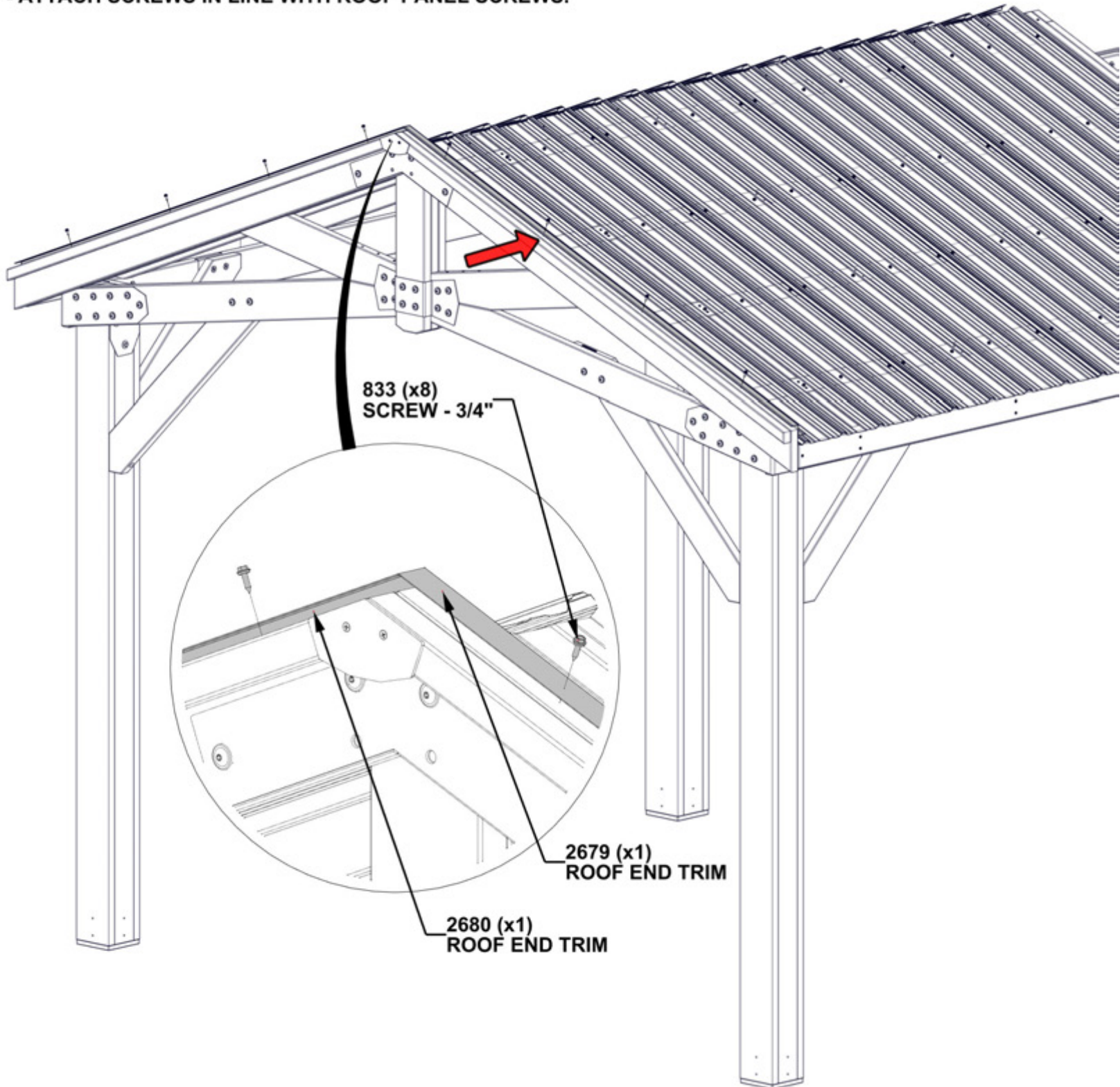

STEP 52 - ROOF ATTACHMENT

QTY	PART NUMBER	DESCRIPTION
16	H100392	SCREW PWH 8x3/4 BLK

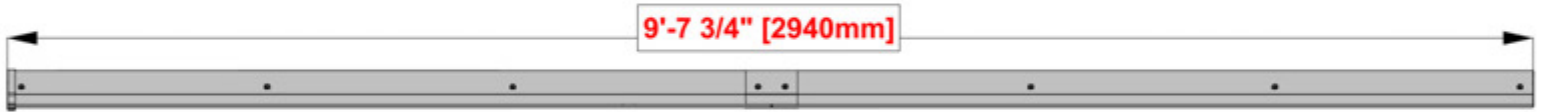

RIDGE CAP A - FROM STEPS 46-47

DO NOT CLIMB ON ROOF TO INSTALL. ROOF CAP HAS BEEN DESIGNED TO INSTALL FROM A LADDER.

- FOR PROPER INSTALLATION, USE AN ADULT HELPER TO KEEP DOWNWARD PRESSURE ON THE RIDGE CAP WHILE SCREWING IN SCREWS.
- SCREWS HOLDING ON RIDGE CAP MAY HAVE TO BE LOOSENED IN NEXT STEP TO SLIDE IN ROOF PANEL.

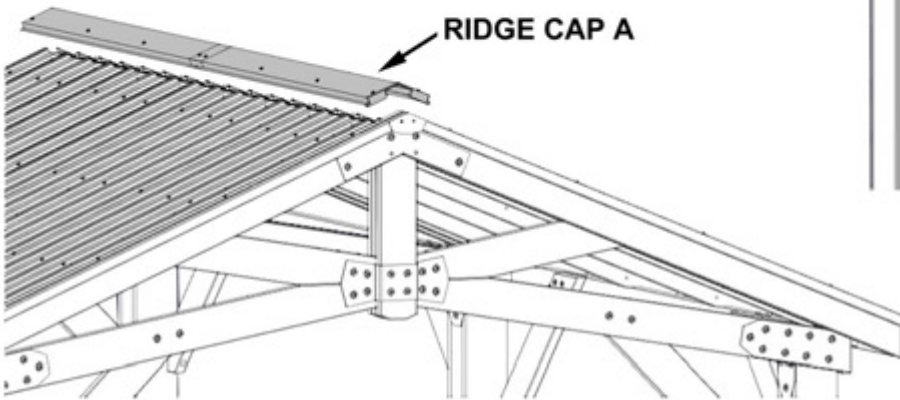
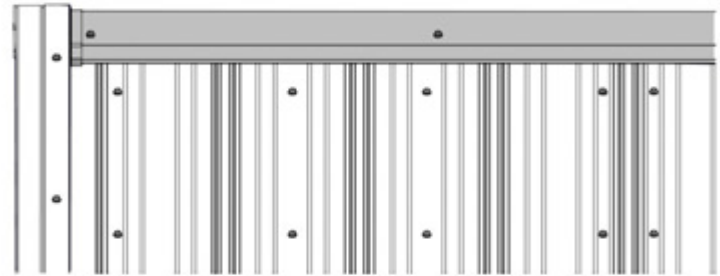

392 (x16)
SCREW - 3/4"

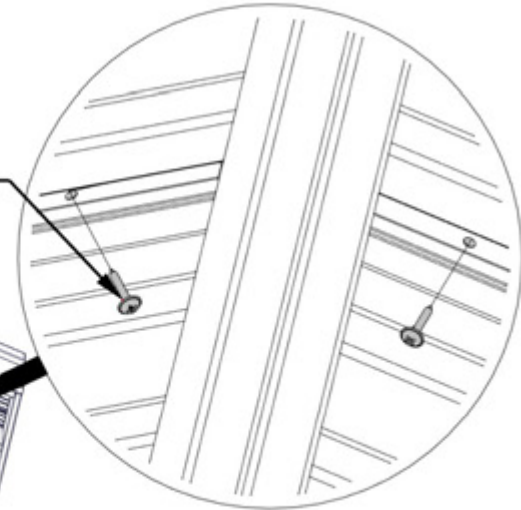

INSTALL SCREWS THROUGH PILOT HOLES IN ROOF PANELS INTO RIDGE CAP STIFFENER BOARDS.

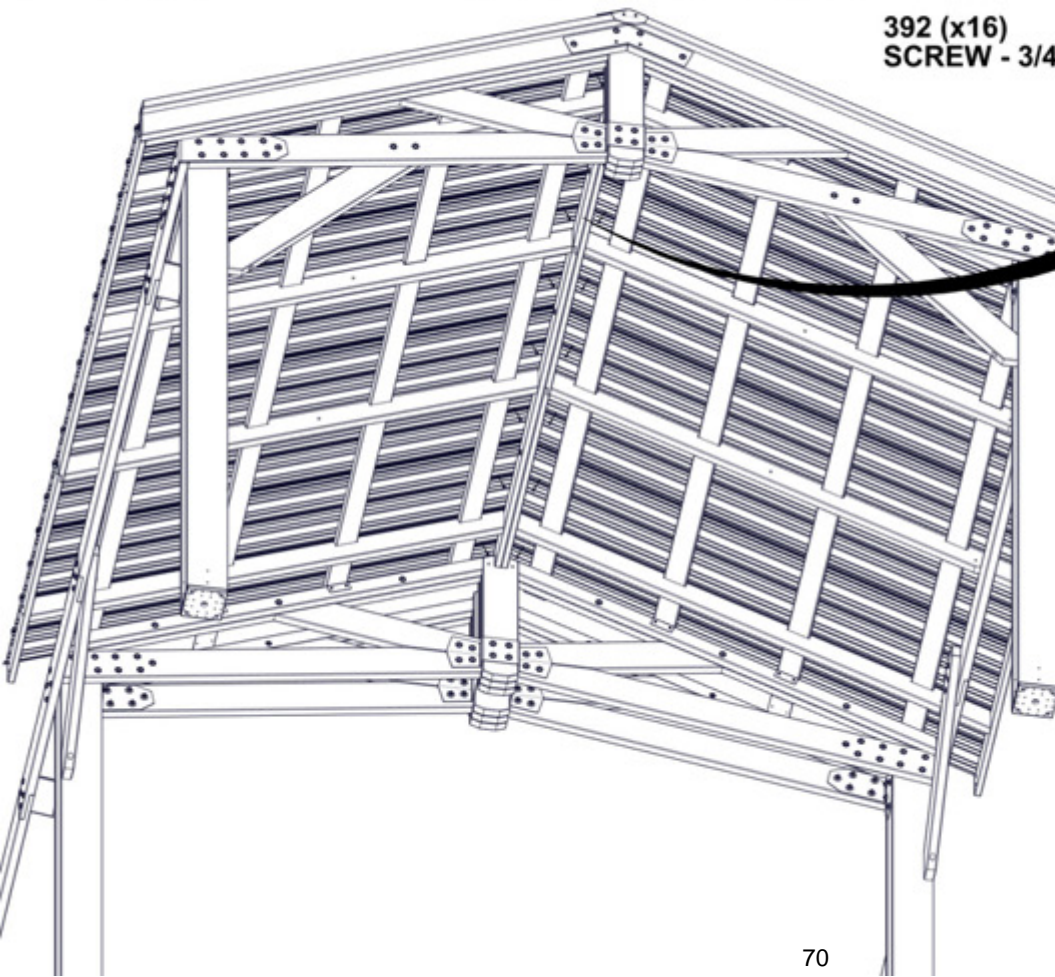

STEP 53 - ROOF ATTACHMENT

QTY	PART NUMBER	DESCRIPTION
1	H100391	SCREW PFH 8x2 BLK

- ADDITIONAL PEOPLE ARE HELPFUL FOR THIS STEP.
- SLIDE ROOF PANEL ALONG TRACKS ON RAFTERS.
- ONCE IN PLACE INSTALL ATTACHMENT HARDWARE AS SHOWN.
- SCREWS HOLDING ON RIDGE CAP MAY HAVE TO BE LOOSENED TO SLIDE IN ROOF PANEL.
- THE CORNER OF THE EXISTING ROOF PANEL MAY NEED TO BE LIFTED UP TO GET THE ROOF PANEL STARTED SLIDING UP.

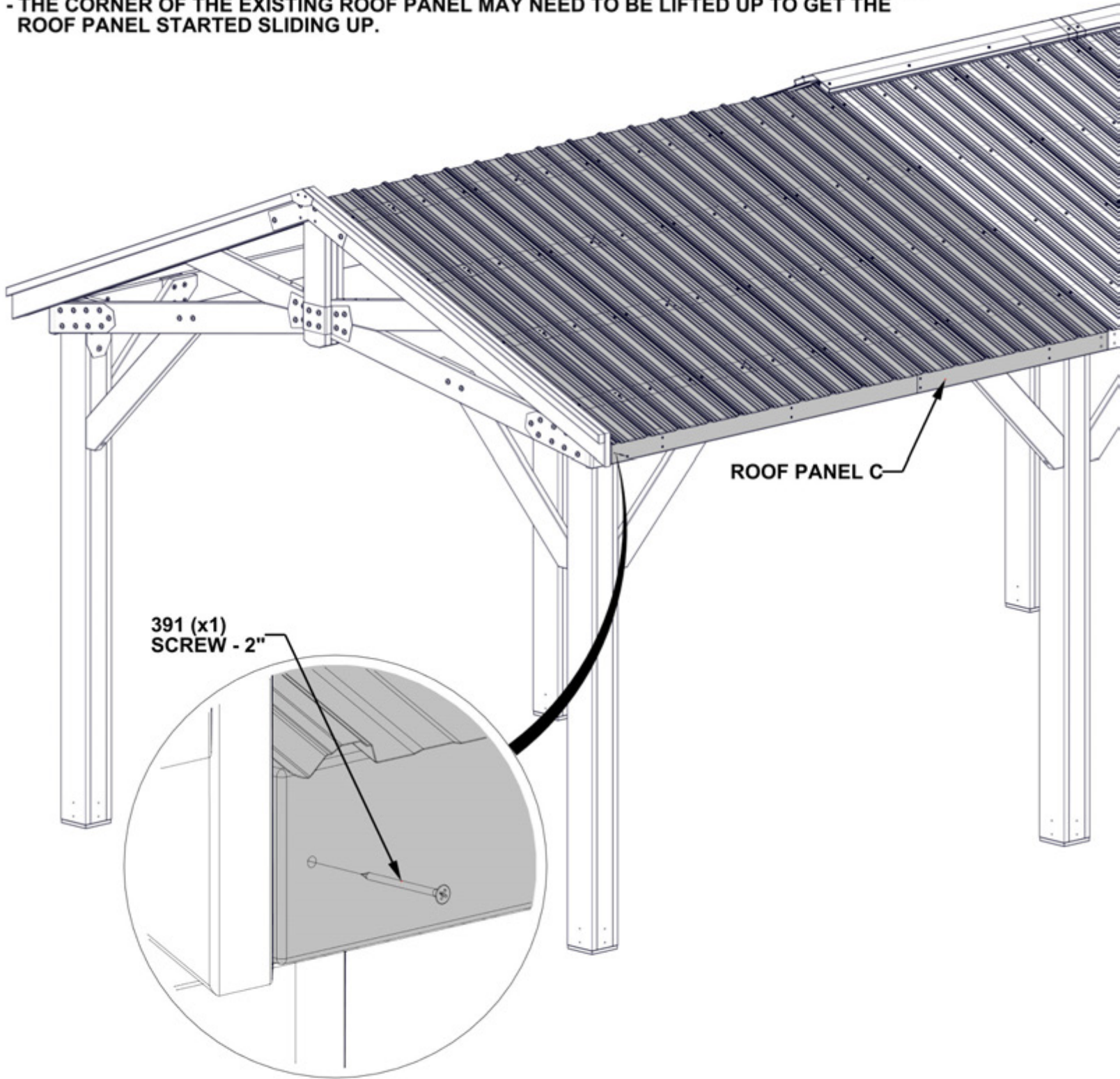

STEP 54 - ROOF ATTACHMENT

QTY	PART NUMBER	DESCRIPTION
4	H100833	SCREW WOODGRIP 10-16x3/4"



A4M02679 ROOF END TRIM
(x1)

- ATTACH SCREWS IN LINE WITH ROOF PANEL SCREWS.

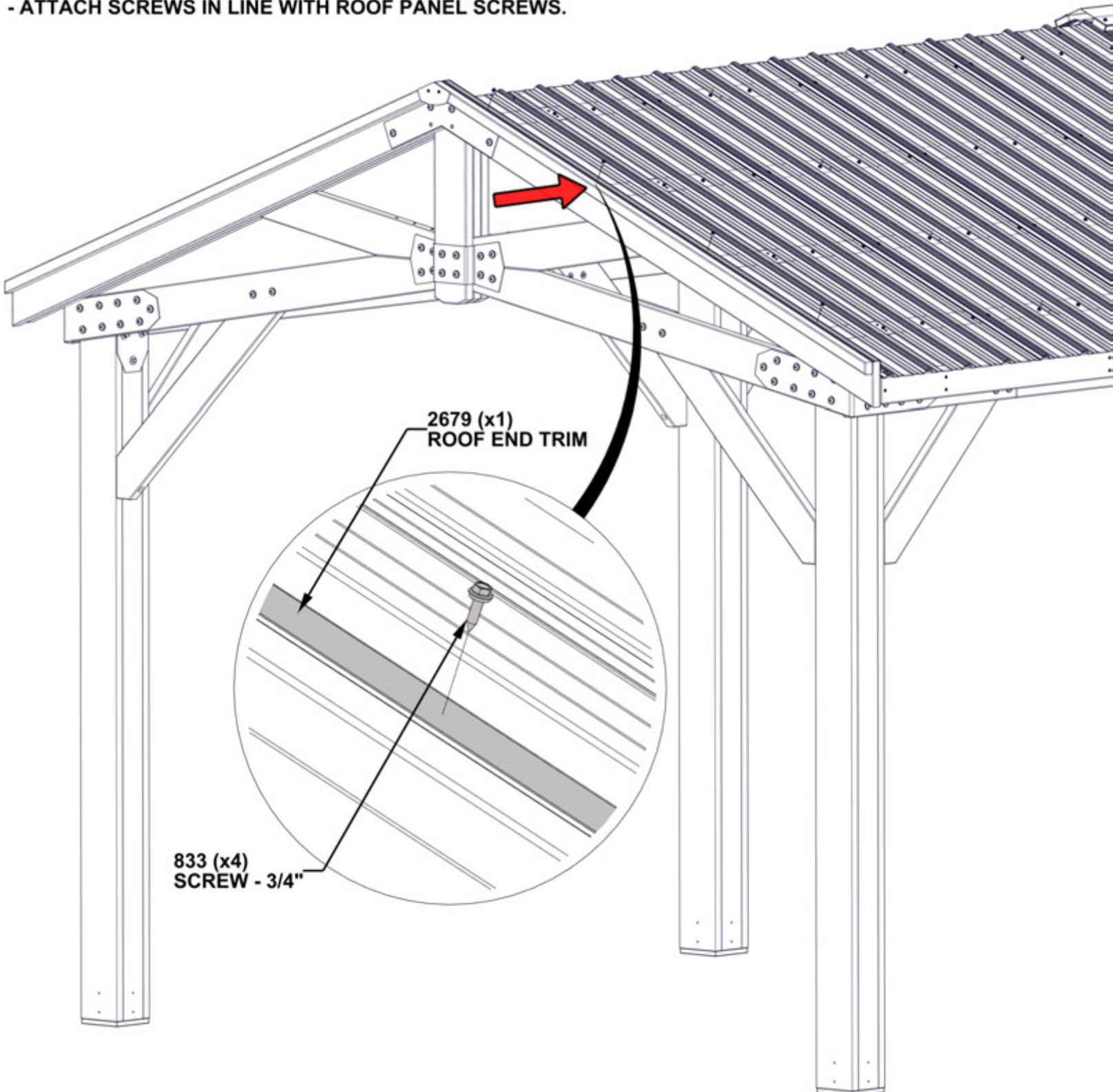

STEP 55 - ROOF ATTACHMENT

QTY	PART NUMBER	DESCRIPTION
8	H100392	SCREW PWH 8x3/4 BLK



9'-8 1/2" [2955mm]

RIDGE CAP B - FROM STEPS 46 & 48

DO NOT CLIMB ON ROOF TO INSTALL. ROOF CAP HAS BEEN DESIGNED TO INSTALL FROM A LADDER.

- FOR PROPER INSTALLATION, USE AN ADULT HELPER TO KEEP DOWNWARD PRESSURE ON THE RIDGE CAP WHILE SCREWING IN SCREWS.

RIDGE CAP B

MID RIDGE CAP

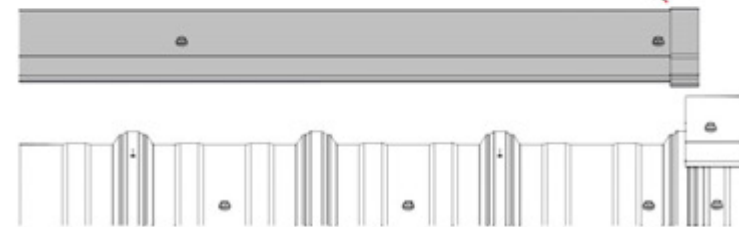
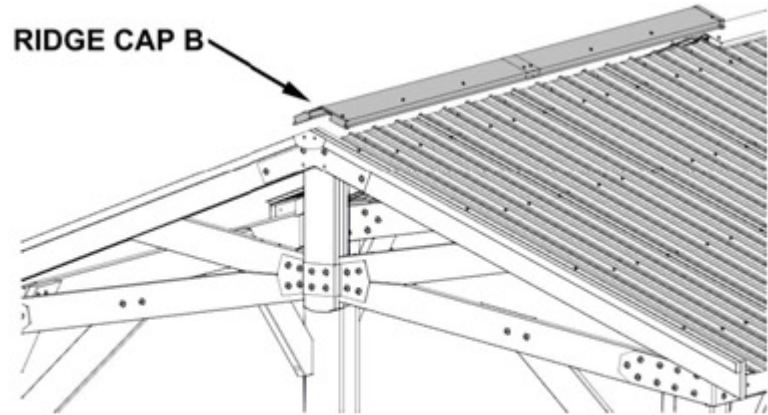

SLIDE RIDGE CAP ASSEMBLY INTO PLACE. ENSURE THAT MID RIDGE CAP PROTECTOR OVERLAPS RIDGE CAP THAT IS ALREADY INSTALLED.

INSTALL SCREWS THROUGH PILOT HOLES IN ROOF PANELS INTO RIDGE CAP STIFFENER BOARDS.

392 (x8)
SCREW - 3/4"

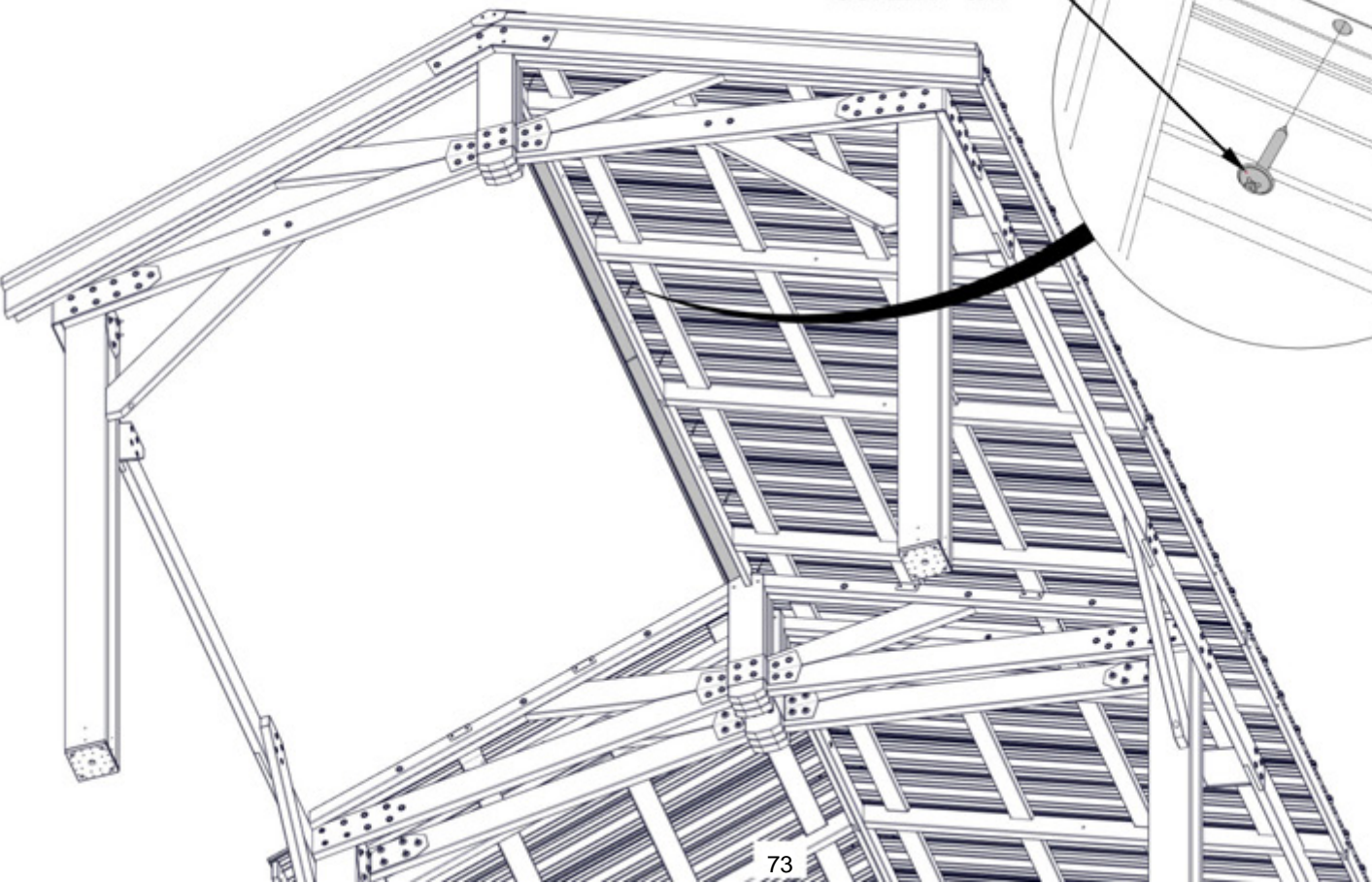
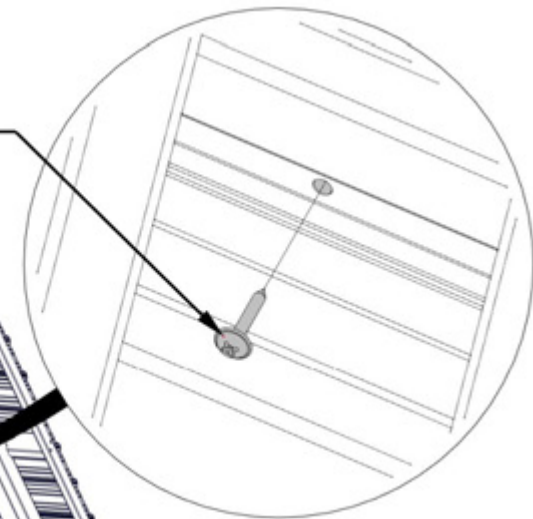

STEP 56 - ROOF ATTACHMENT

QTY	PART NUMBER	DESCRIPTION
3	H100198	WASHER LOCK EXT 8x19
3	H100378	BOLT WH 5/16x1 3/4 BLK
3	H100379	T-NUT 5/16 BLK
1	H100391	SCREW PFH 8x2 BLK

- ADDITIONAL PEOPLE ARE HELPFUL FOR THIS STEP.
- ONCE IN PLACE, INSTALL ATTACHMENT HARDWARE AS SHOWN.
- ATTACH BOLT AND LOCK NUT HARDWARE BEFORE ATTACHING SCREW.
- THE CORNER OF THE EXISTING ROOF PANEL MAY NEED TO BE LIFTED UP TO GET THE ROOF PANEL STARTED SLIDING UP.

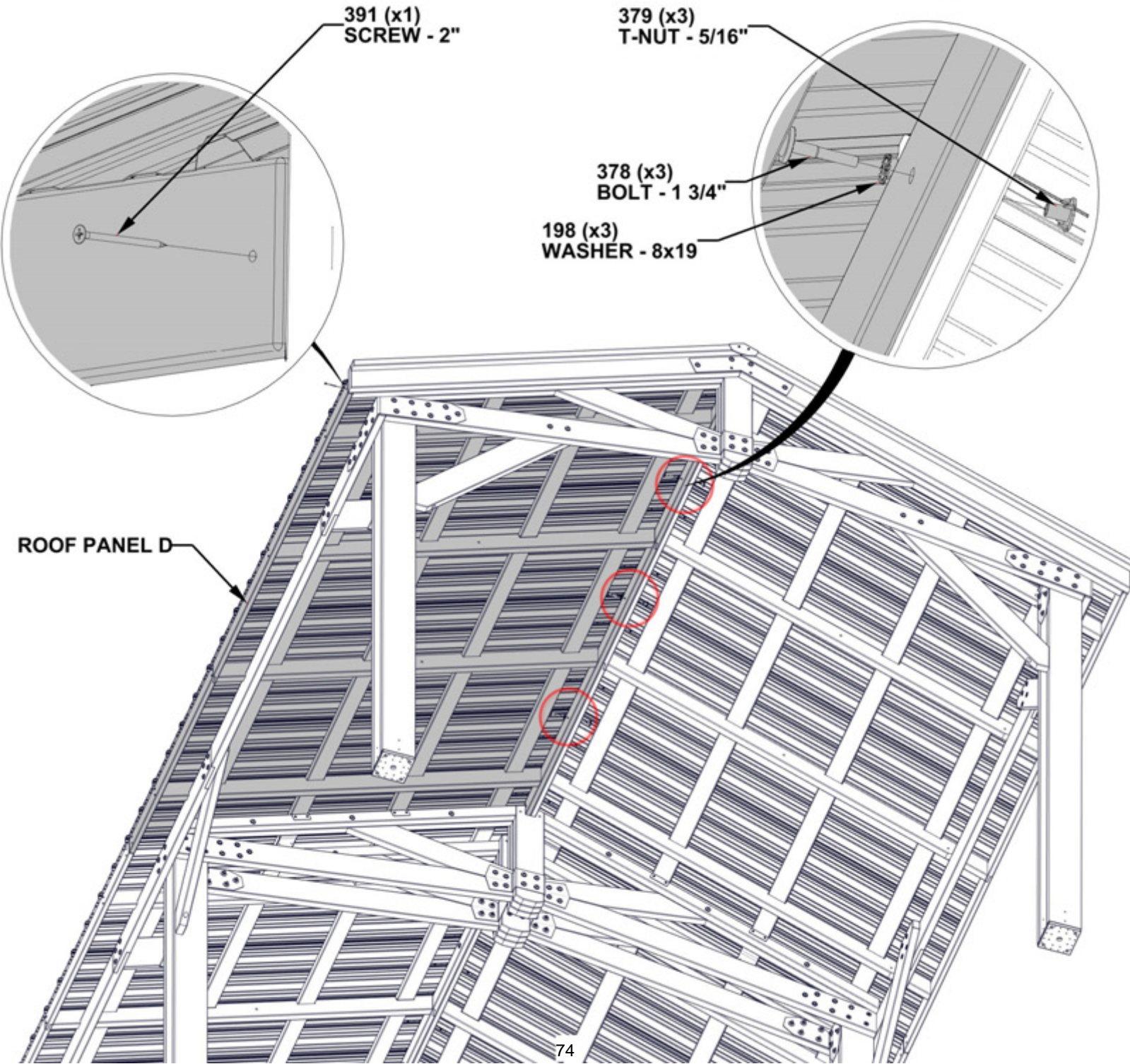

STEP 57 - ROOF ATTACHMENT

QTY	PART NUMBER	DESCRIPTION
8	H100392	SCREW PWH 8x3/4 BLK

**ATTACH OPPOSITE SIDE OF
RIDGE CAP STARTING AT GABLE**

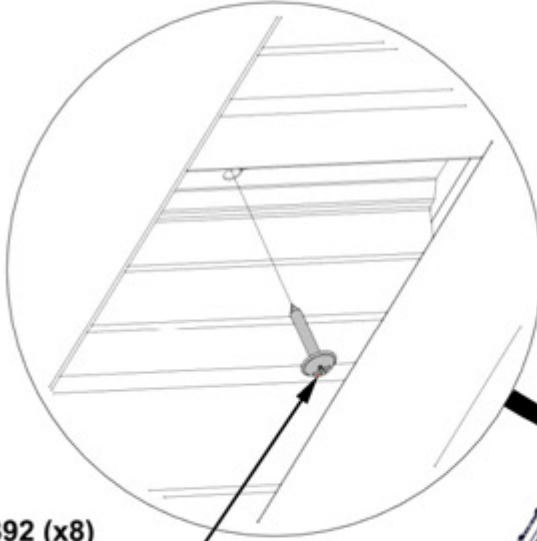

**392 (x8)
SCREW - 3/4"**

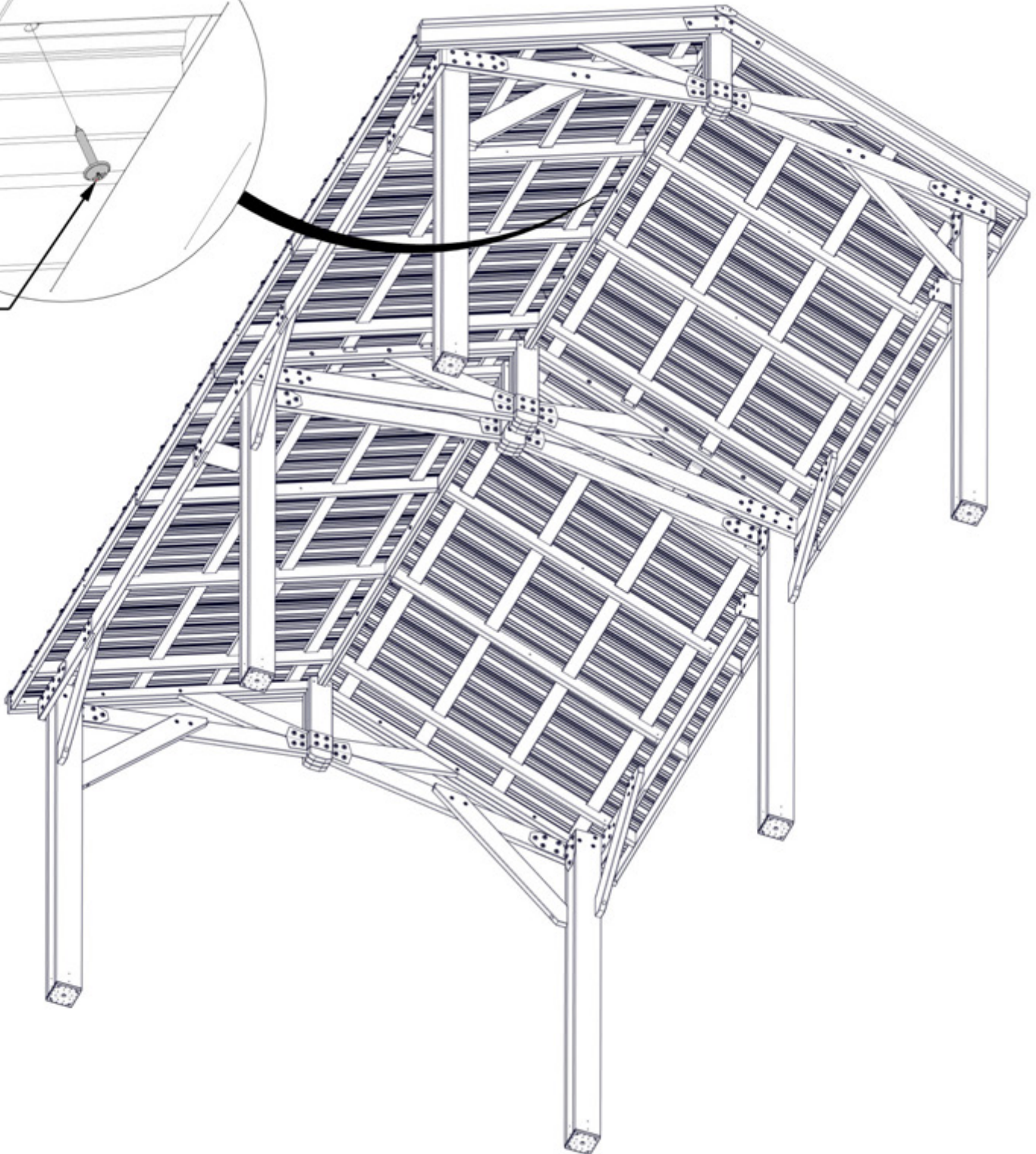

STEP 58 - ROOF ATTACHMENT

QTY	PART NUMBER	DESCRIPTION
4	H100833	SCREW WOODGRIP 10-16x3/4"



A4M02680 ROOF END TRIM
(x1)

- SLIDE ROOF END TRIM UNDER RIDGE CAP ASSEMBLY, THEN SCREW IT INTO PLACE.
- ATTACH SCREWS IN LINE WITH ROOF PANEL SCREWS.

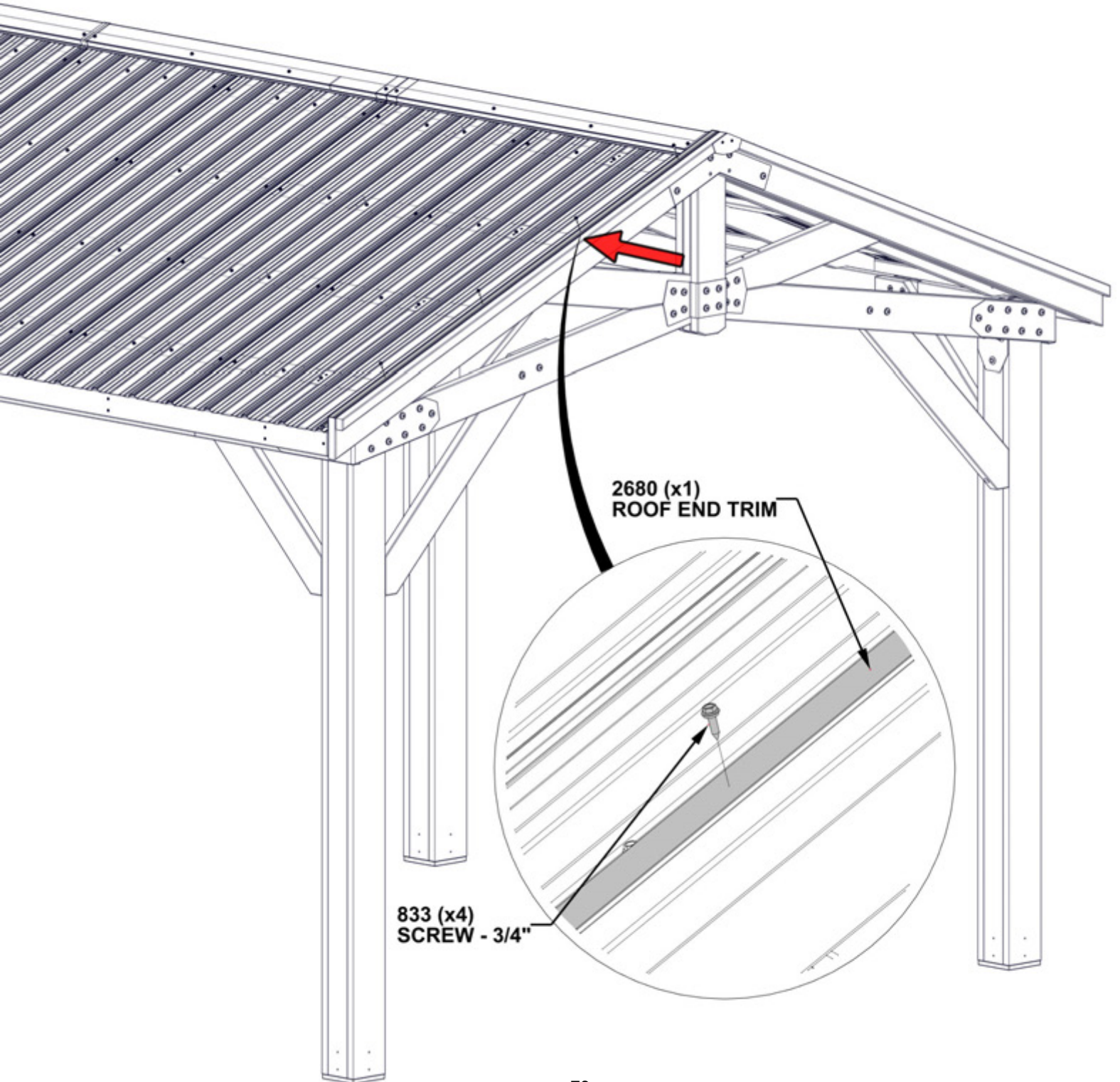

STEP 59 - ROOF ATTACHMENT

QTY	PART NUMBER	DESCRIPTION
2	H100195	BOLT WH 5/16x2 3/4 BLK
6	H100478	WASHER FLAT 8x27 BLK
6	H100479	NUT LOCK 5/16 BLK
4	H100881	BOLT WH 5/16x5 BLK



A4M01148 TRUSS BRACKET
(x2)

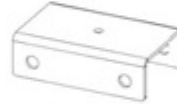

A4M01559 U TIE BRACKET
(x1)

- ATTACH TRUSS BRACKET TO BOTH SIDES OF CENTER GABLE.
- INSERT 881 BOLTS FIRST TO HOLD BRACKETS, THEN INSERT 195 BOLTS AND ALL WASHERS AND LOCK NUTS.

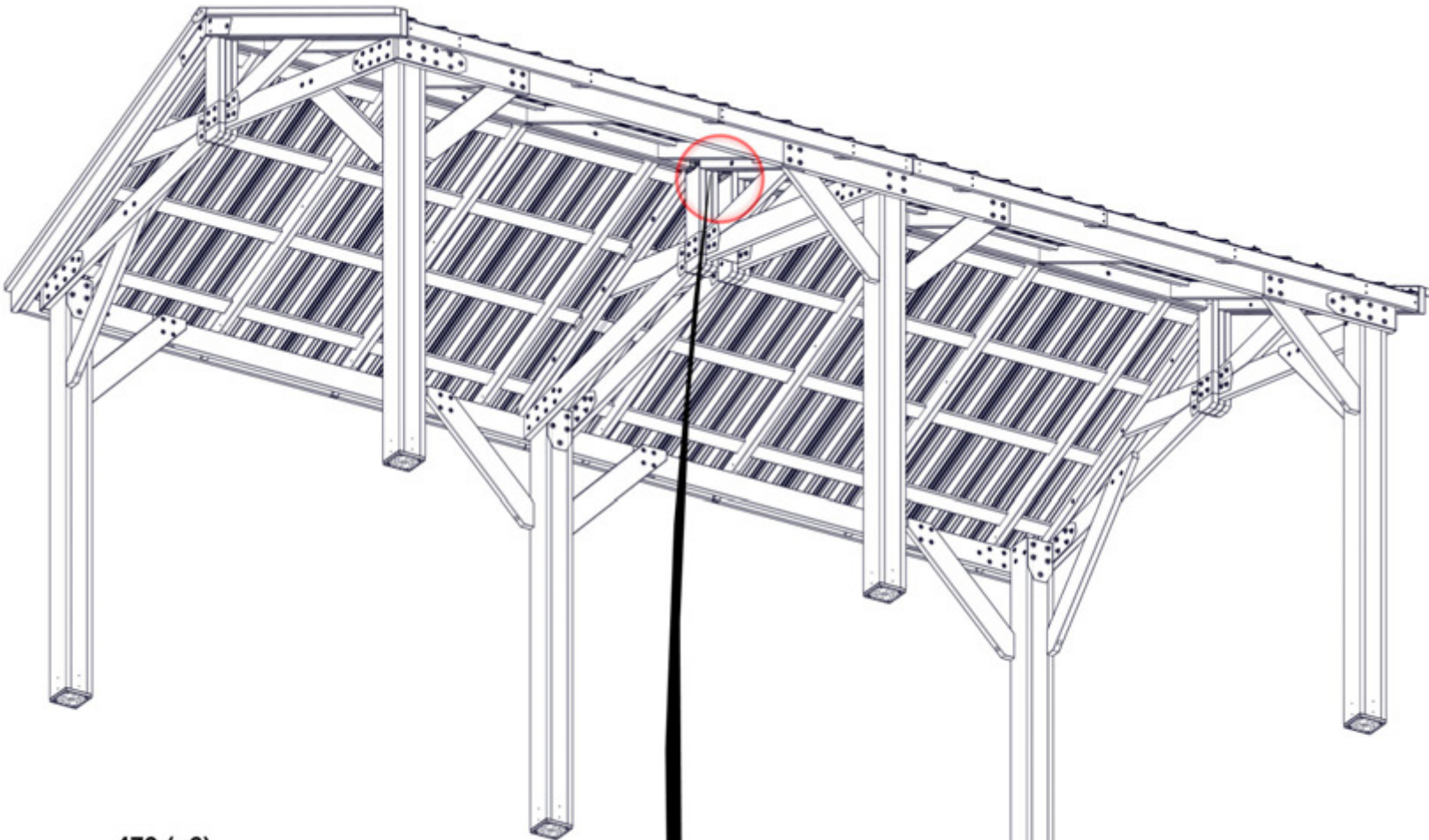

479 (x6)
LOCK NUT - 5/16"

478 (x6)
WASHER - 8x27

1559 (x1)
U TIE BRACKET

1148 (x2)
TRUSS BRACKET

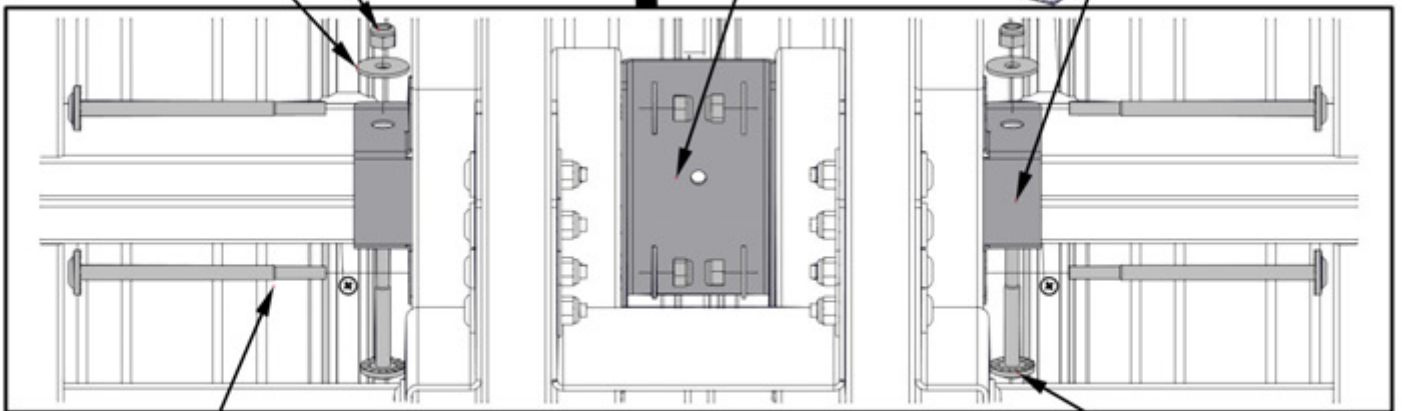

881 (x4)
BOLT - 5"

195 (x2)
BOLT - 2 3/4"

STEP 60 - ROOF ATTACHMENT

QTY	PART NUMBER	DESCRIPTION
2	H100195	BOLT WH 5/16x2 3/4 BLK
4	H100354	BOLT WH 5/16x6 1/2 BLK
6	H100478	WASHER FLAT 8x27 BLK
6	H100479	NUT LOCK 5/16 BLK

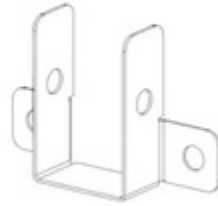

A4M01148 TRUSS BRACKET
(x2)

- THE USE OF CLAMPS MAY AID IN ALIGNING BOLT HOLES.

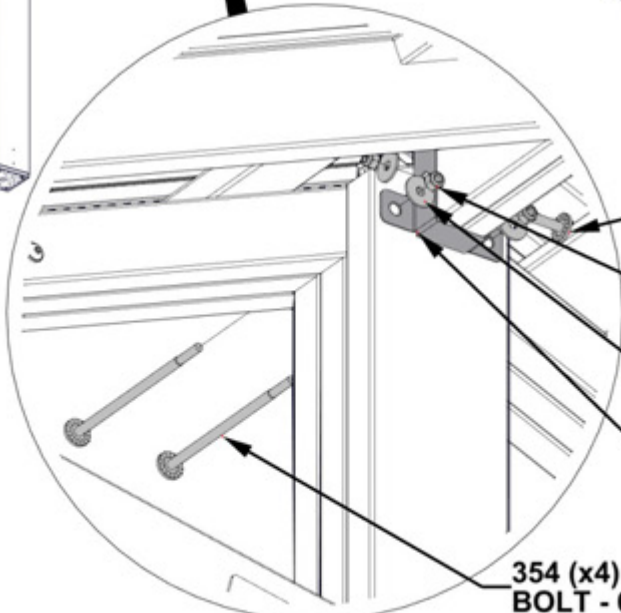
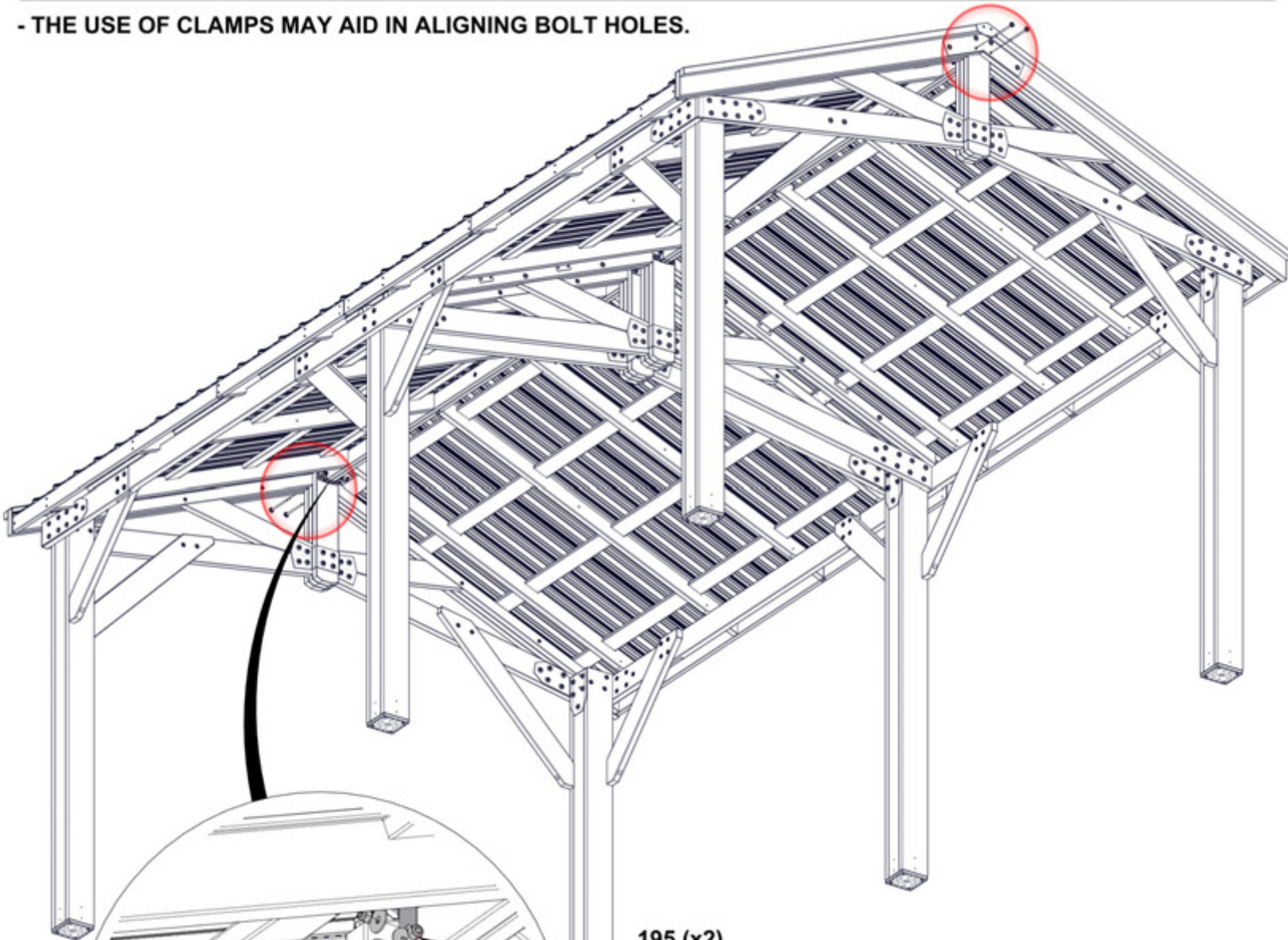

- 195 (x2)
BOLT-2 3/4"
- 479 (x6)
LOCK NUT - 5/16"
- 478 (x6)
WASHER - 8x27
- 1148 (x2)
TRUSS BRACKET
- 354 (x4)
BOLT - 6 1/2"

STEP 61 - ROOF ATTACHMENT

QTY	PART NUMBER	DESCRIPTION
16	H100392	SCREW PWH 8x3/4 BLK
8	H100468	BOLT WH 5/16x1 BLK

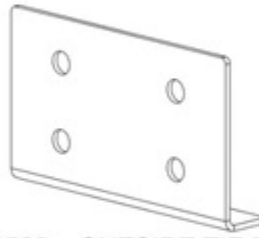

A4M01560 OUTSIDE TIE BRACKET
(x2)

- ATTACH BOLTS TO T-NUTS INSTALLED IN PREVIOUS STEPS.
- INSTALL SCREWS TO SECURE ROOF PANELS TO SHEATHING BRACKETS.

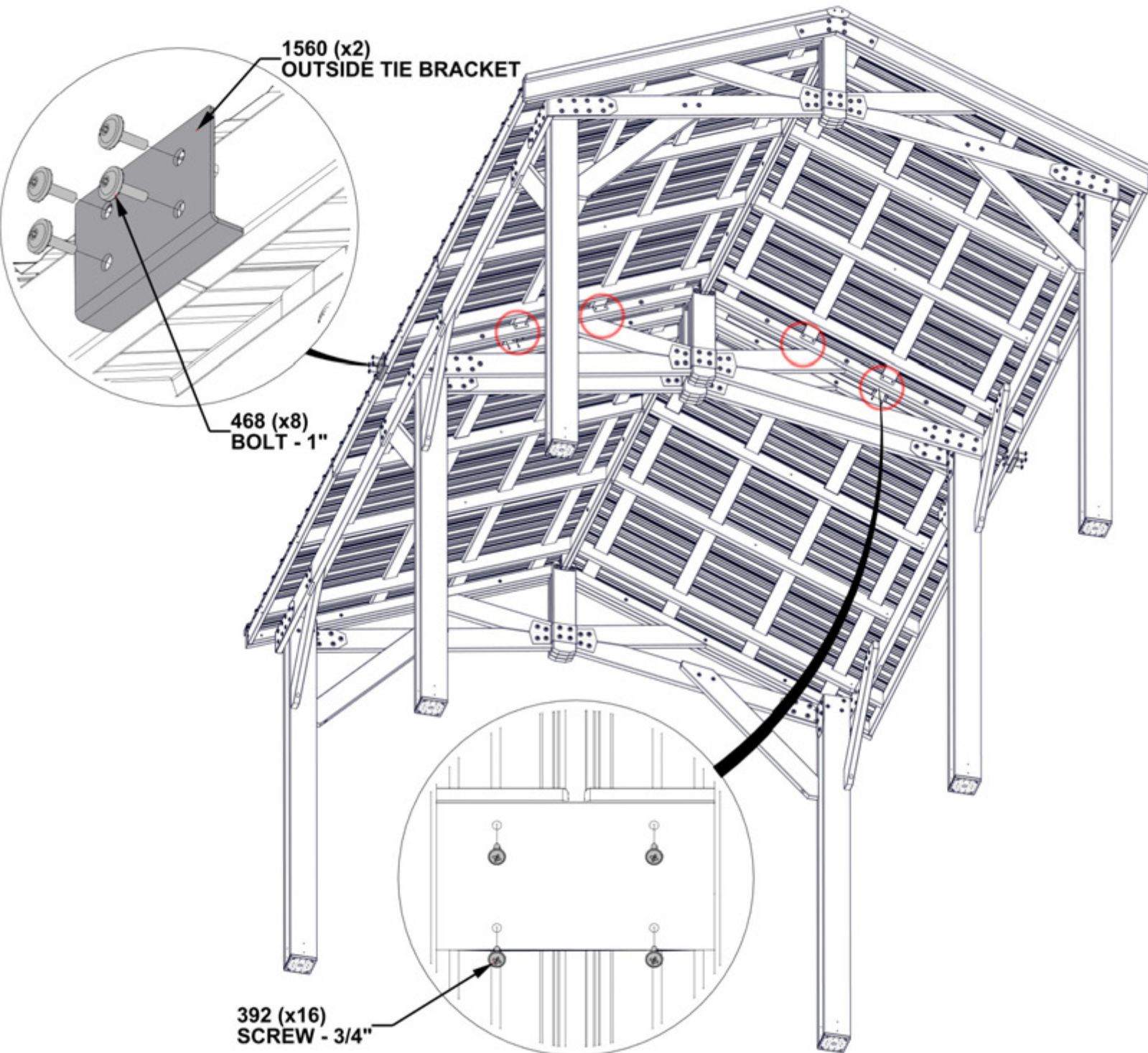

1560 (x2)
OUTSIDE TIE BRACKET

468 (x8)
BOLT - 1"

392 (x16)
SCREW - 3/4"

STEP 62 - ROOF ATTACHMENT

QTY	PART NUMBER	DESCRIPTION
8	H100198	WASHER LOCK EXT 8x19
8	H100478	WASHER FLAT 8x27 BLK
8	H100479	NUT LOCK 5/16 BLK
8	H100480	BOLT WH 5/16x4 3/4 BLK



E09 ACCESSORY TRUSS - W4L16756
(x8) 1 3/8"x3 3/8"x73 7/8" (36x86x1875)

E09 (x8)
ACCESSORY TRUSS

198 (x8)
WASHER - 8x19

480 (x8)
BOLT - 4 3/4"

479 (x8)
LOCK NUT - 5/16"

478 (x8)
WASHER - 8x27

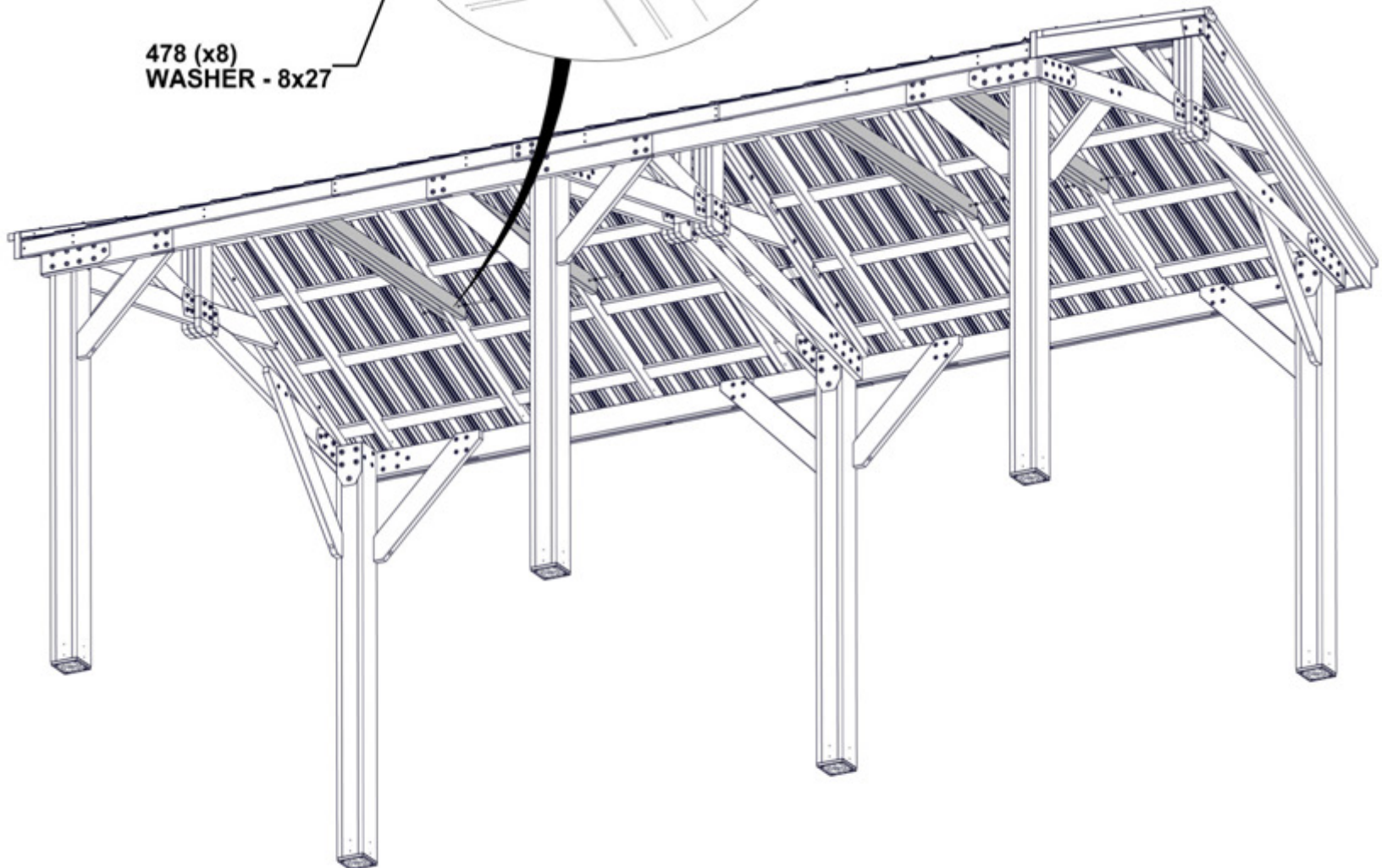
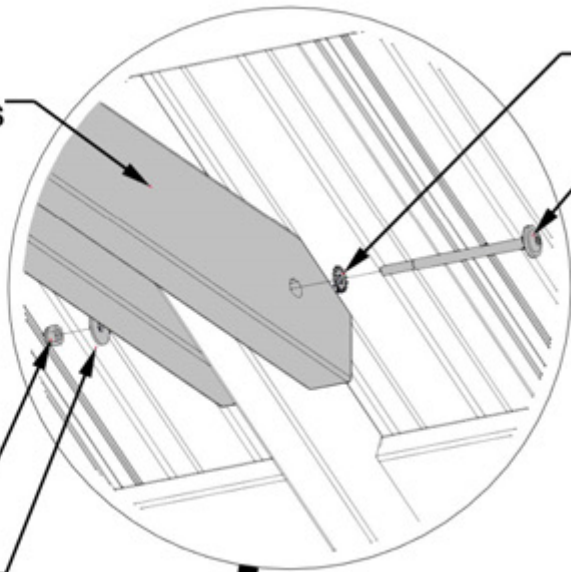

STEP 63 - ROOF ATTACHMENT

QTY	PART NUMBER	DESCRIPTION
16	H100488	BOLT WH 1/4x2 BLK
16	H100630	WASHER FLAT 8x19 BLK
16	H100653	NUT LOCK 1/4 BLK
32	H100797	SCREW PWH 8x1 BLK



A4M01228 RAFTER BRACKET
(x16)

- A RAFTER BRACKET IS INSTALLED AT EACH RAFTER END - 16 TOTAL.
- INSERT BOLTS FIRST, THEN SCREW IN BRACKET.

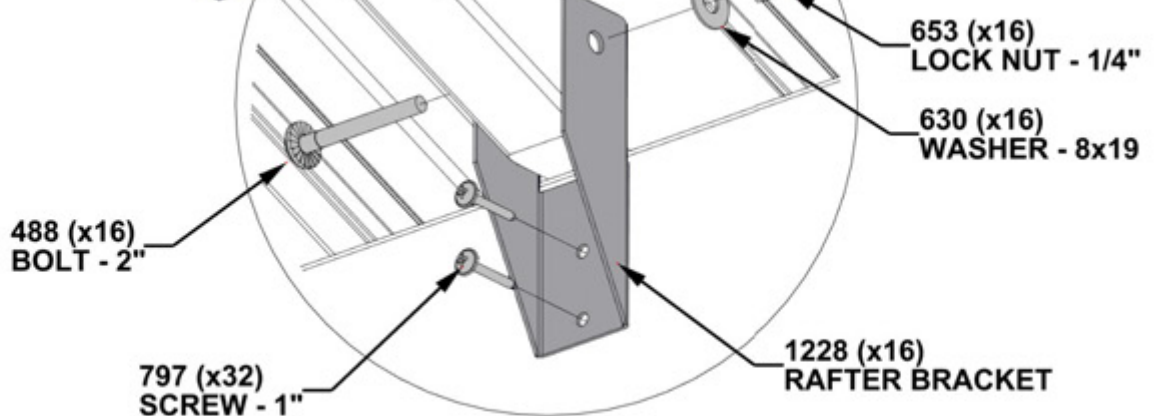
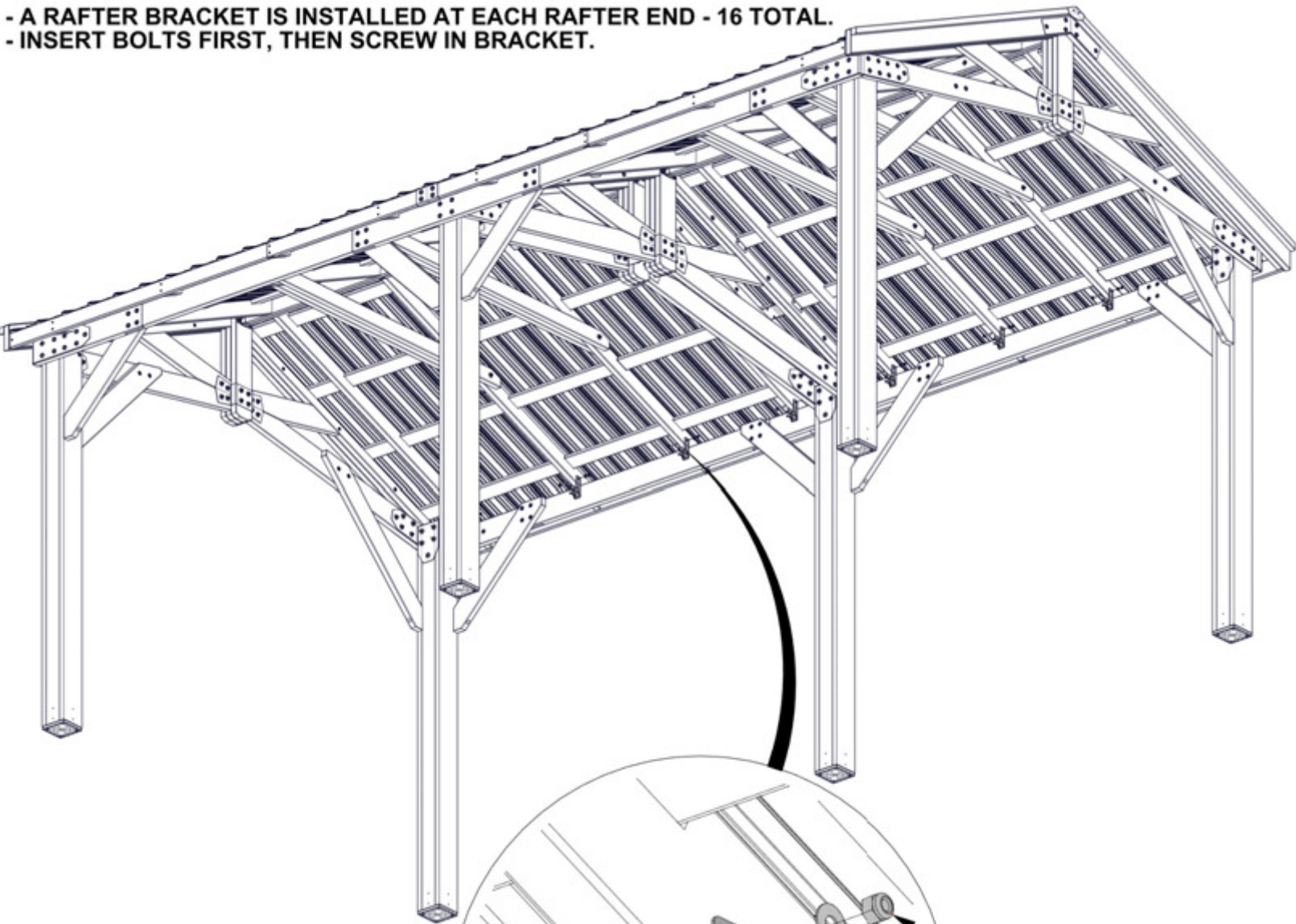

STEP 64 - ROOF ATTACHMENT

QTY	PART NUMBER	DESCRIPTION
32	H100759	SCREW SELF TAPPING 1/4x1



A4M02678 ROOF EDGE TRIM
(x8)



A4M02638 ROOF EDGE TRIM SPLICE
(x6)

- COMPLETE THIS STEP FOR OPPOSITE SIDE.
- DUE TO MULTIPLE LAYERS OF METAL ON THE EDGE TRIM, IT IS RECOMMENDED THAT A 1/8" (3mm) DRILL BIT IS USED TO CREATE STARTER HOLES.
- REMOVE PROTECTIVE BLUE FILM.
- GLOVES SHOULD BE WORN WHEN HANDLING ROOF METAL. EDGES ARE SHARP.
- START FIRST SCREW AT THE SECOND RIB FROM END.
- ATTACH SCREWS ON EVERY OTHER RIB.

SCREWS GO THROUGH EDGE TRIM INTO THE TOP OF THE RIBS IN THE APPROXIMATE LOCATIONS SHOWN.

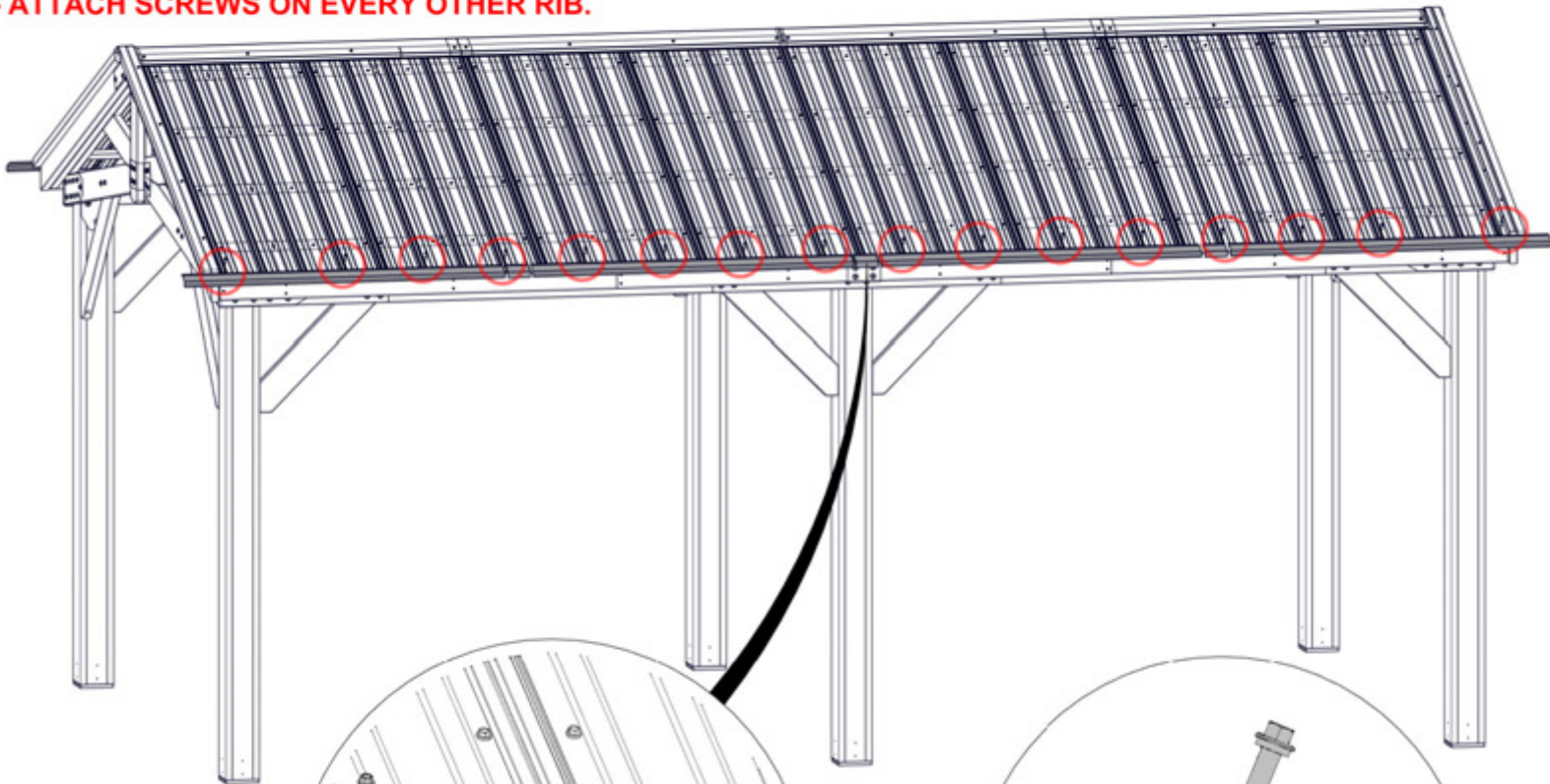

759 (x16)
SCREW - 1"

2678 (x4)
ROOF EDGE TRIM

2638 (x3)
ROOF EDGE TRIM SPLICE

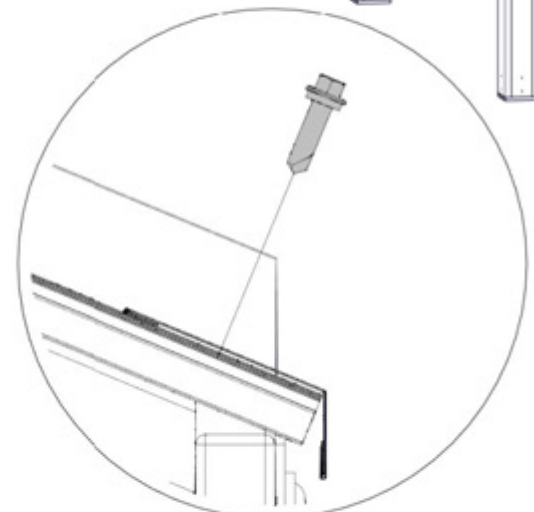
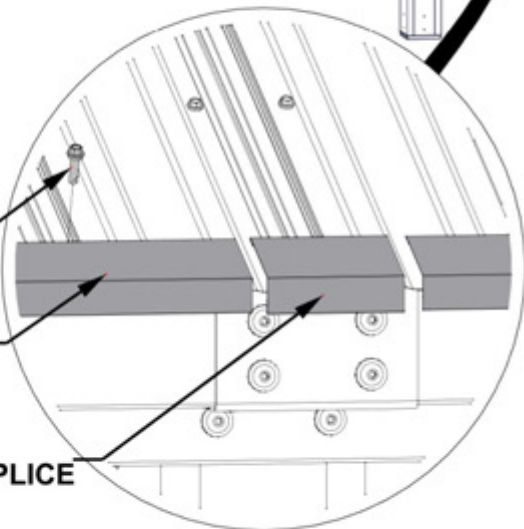

SIDE VIEW

SLIDE TRIM INTO SPLICE ENSURING THAT BOTH ENDS ARE FLUSH WITH THE EDGES OF ROOF PANELS.

STEP 65 - GAZEBO ASSEMBLY (OPTIONAL)

QTY	PART NUMBER	DESCRIPTION
4	H100382	SCREW PFH 8x1 3/4 BLK

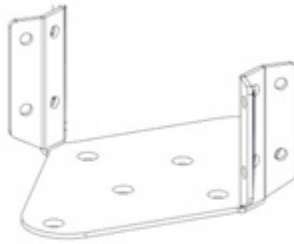

A4M02501 FAN MOUNT BRACKET
(x1)

- ATTACH YOUR ELECTRICAL BOX (SOLD SEPARATELY) WITH THE PROVIDED HOLES IN FAN MOUNT BRACKET.
- PLACE FAN MOUNT BRACKET ON RIDGE BEAMS AND MOVE TO DESIRED FAN LOCATION.
- ROTATE BRACKET UNTIL MOUNTING FLANGES ALIGN BEST WITH RIDGE BEAMS
- USE AN 1/8" (3mm) DRILL BIT AND DRILL PILOT HOLES AND ATTACH AS SHOWN.

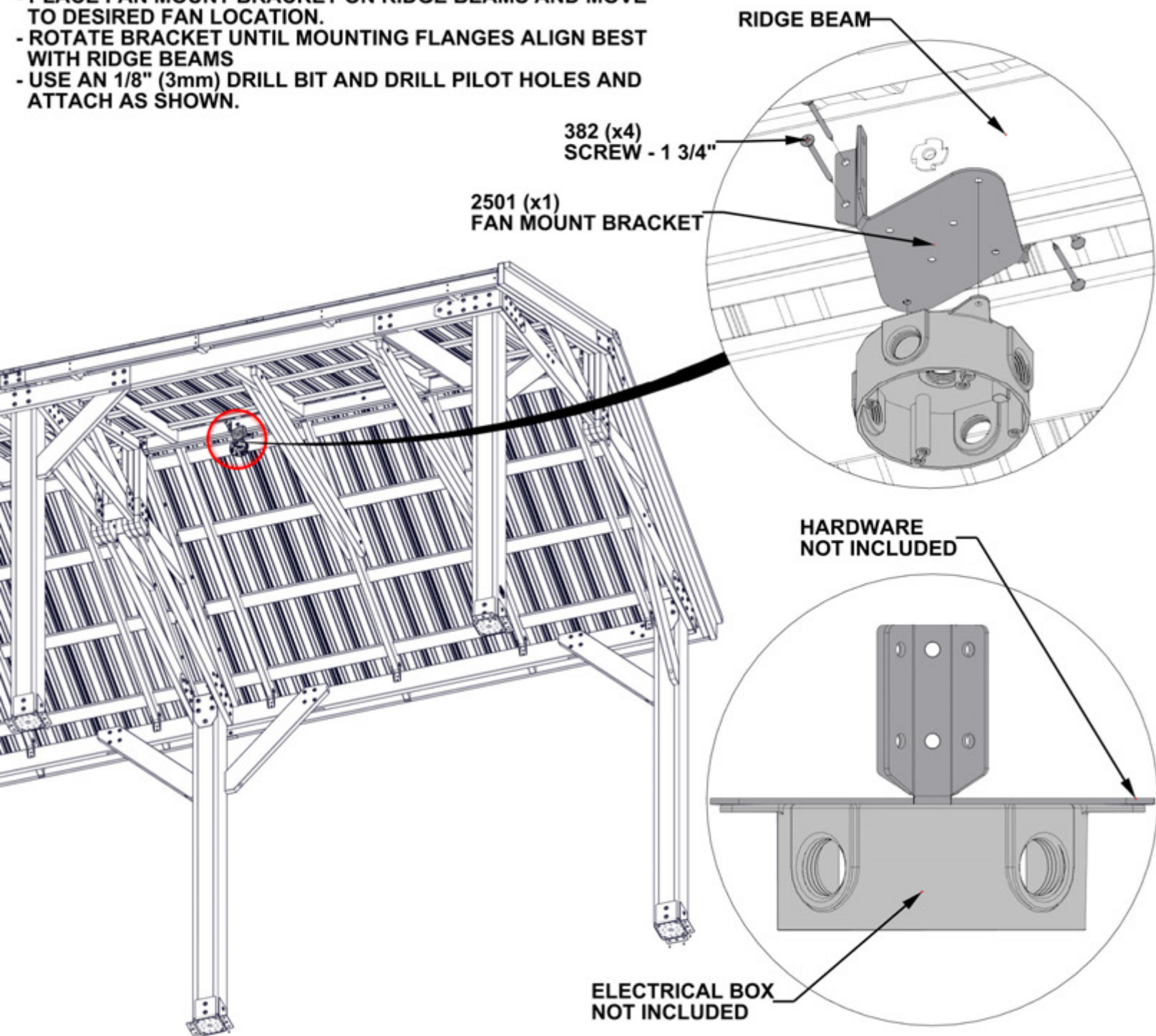

382 (x4)
SCREW - 1 3/4"

2501 (x1)
FAN MOUNT BRACKET

RIDGE BEAM

HARDWARE
NOT INCLUDED

ELECTRICAL BOX
NOT INCLUDED

STEP 66 - GAZEBO ASSEMBLY

QTY	PART NUMBER	DESCRIPTION
48	H100471	LAG SCREW WH 5/16x1 1/2 BLK



A4M00977 POST ANCHORING PLATE
(x12)



A4M00978 POST PLATE
(x12)

- USE PILOT HOLES IN POST TO INSTALL LAG SCREWS.

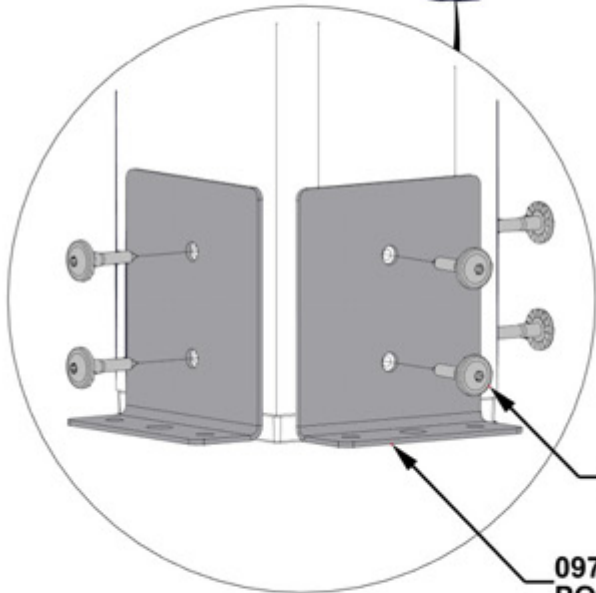
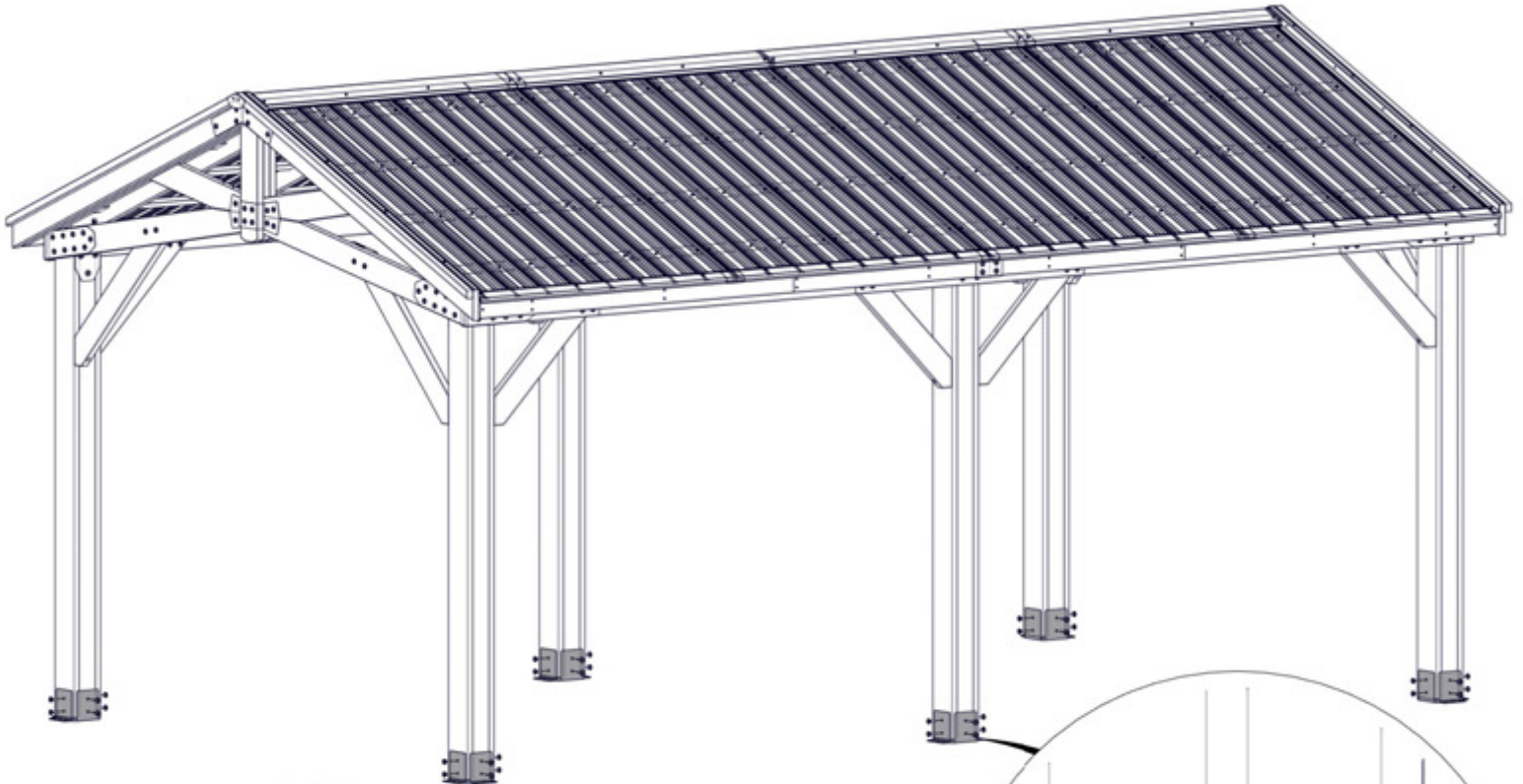

471 (x48)
LAG SCREW - 1 1/2"

0977 (x12)
POST ANCHORING PLATE

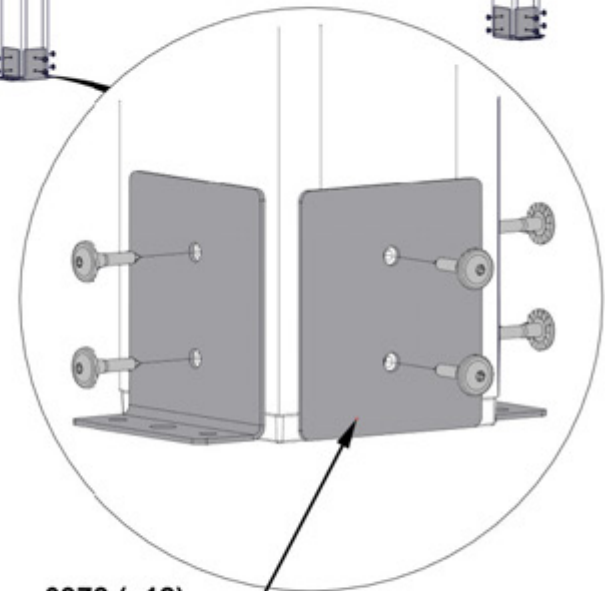

0978 (x12)
POST PLATE

STEP 67 - GAZEBO ASSEMBLY

QTY	PART NUMBER	DESCRIPTION
4	H100202	SCREW PWH 8x5/8 BLK



A4M02158 BYD ID TAG PATIO
(x1)

- PLACE ID TAG IN APPROXIMATE LOCATION SHOWN.

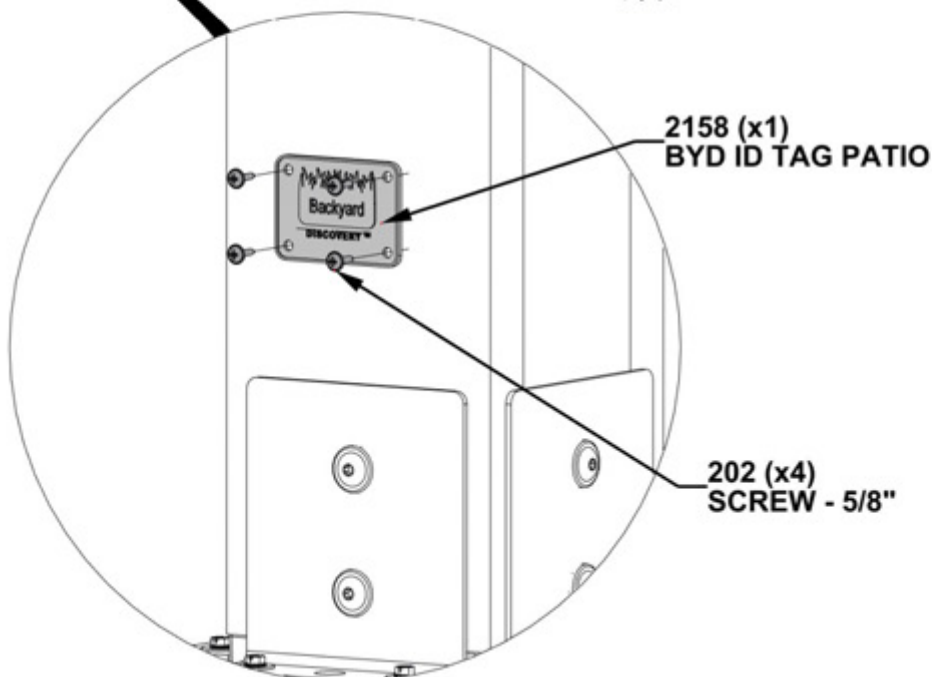
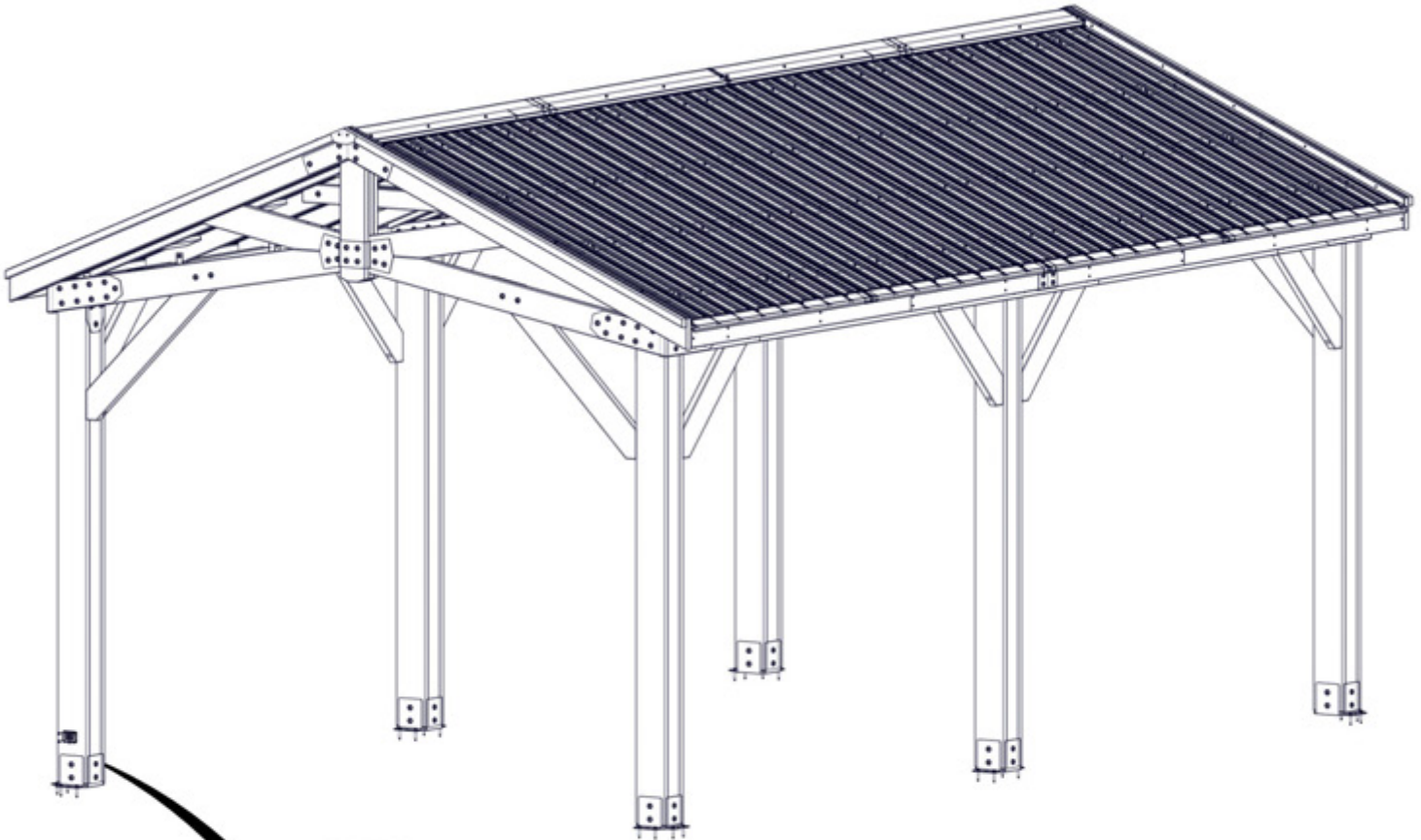

STEP 68 - GAZEBO ASSEMBLY

QTY	PART NUMBER	DESCRIPTION
24	H100120	CONCRETE ANCHOR 1/4"x2"
24	H100630	WASHER FLAT 8x19 BLK

- MANUFACTURER RECOMMENDS INSTALLATION ON CONCRETE SURFACE OR CONCRETE POST PAD AS SHOWN BELOW.
- FOR INSTALLATION ON WOOD DECK, YOU MUST ENSURE THERE IS AMPLE STRUCTURAL SUPPORT UNDER THE DECK. HARDWARE NOT INCLUDED FOR DECK ATTACHMENT.

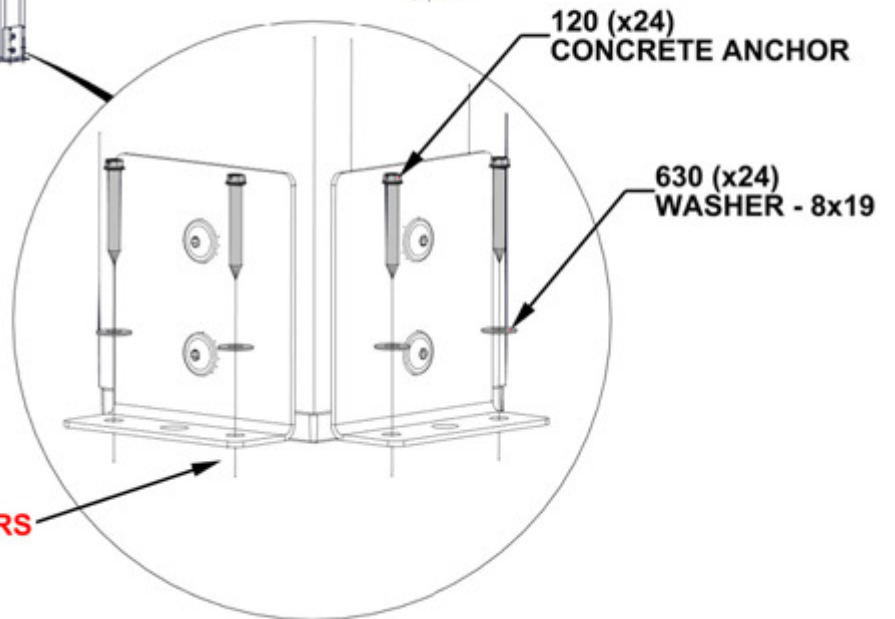
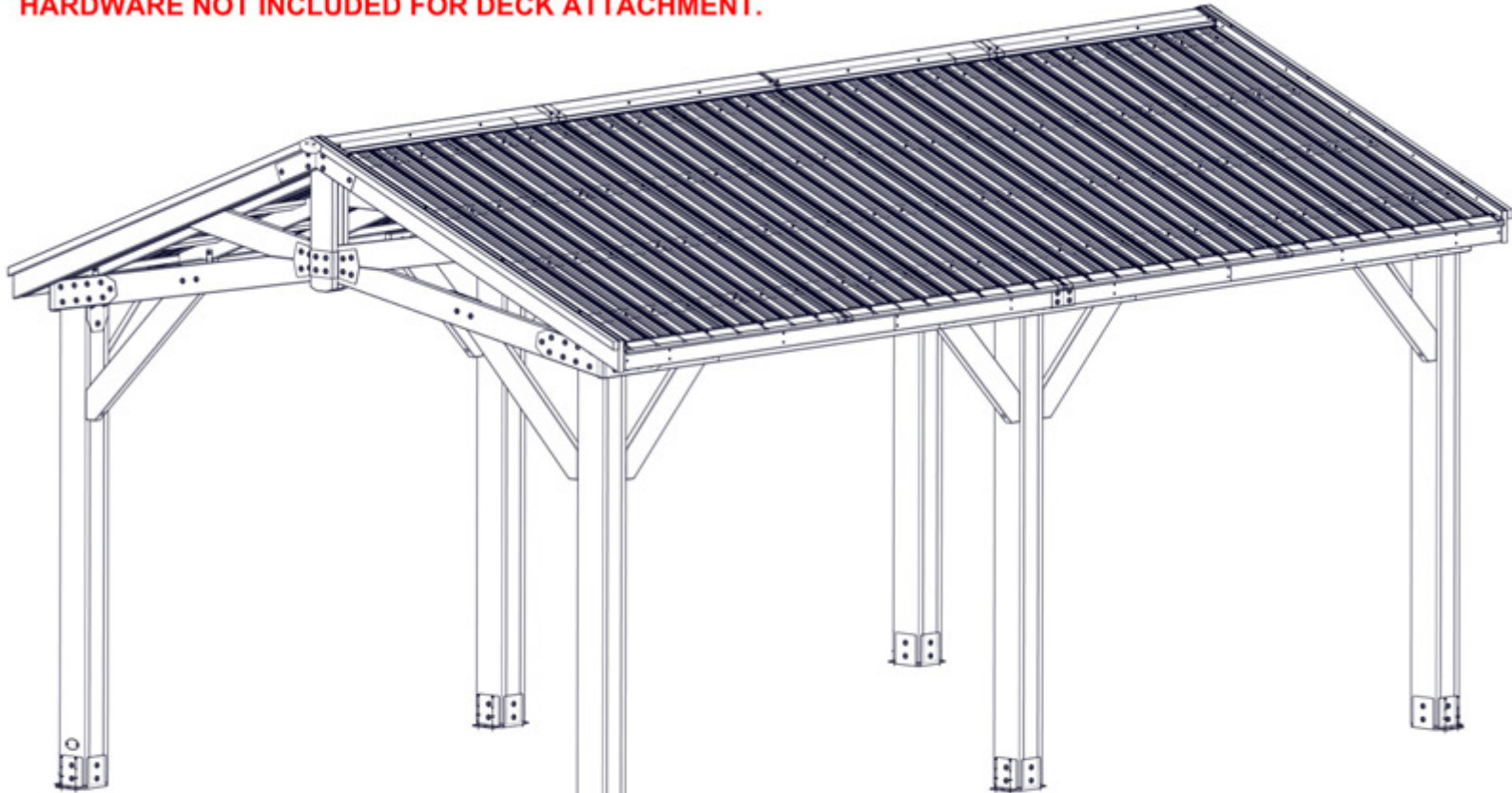

PRE-DRILL HOLES FOR CONCRETE ANCHORS USING A 3/16" CONCRETE DRILL BIT.

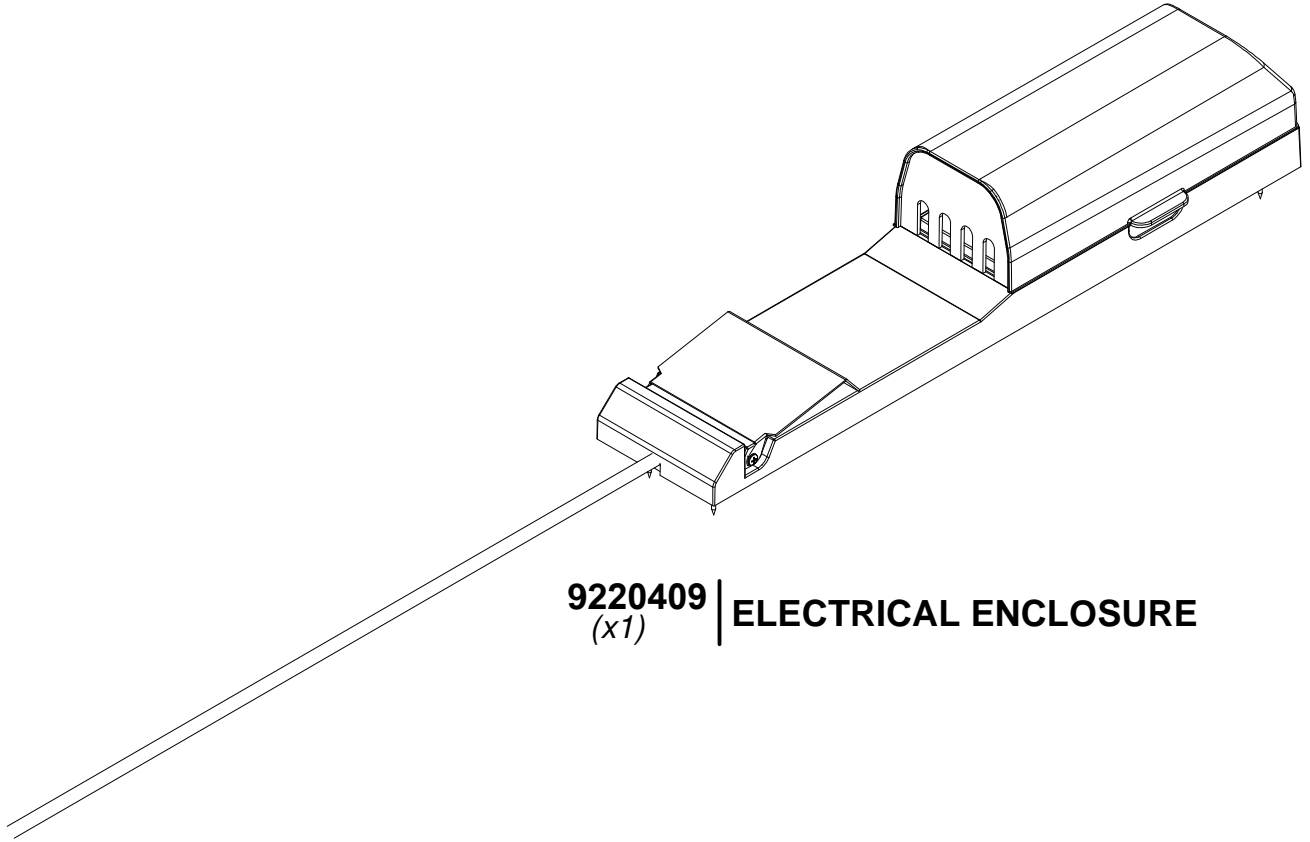

9220409 | **ELECTRICAL ENCLOSURE**
(x1)

FOR POWERPORT INSTALLATION REFER TO ASSEMBLY INSTRUCTIONS THAT COME PACKAGED WITH THE POWERPORT KIT. INSTALL ON ANY POST THAT IS DESIRED. FOLLOW DIRECTIONS FOR PROPER INSTALLATION.